

# HG214 DEUTERON ACER TENDL-2023 LIBRARY; T=0.K

## Principal cross sections

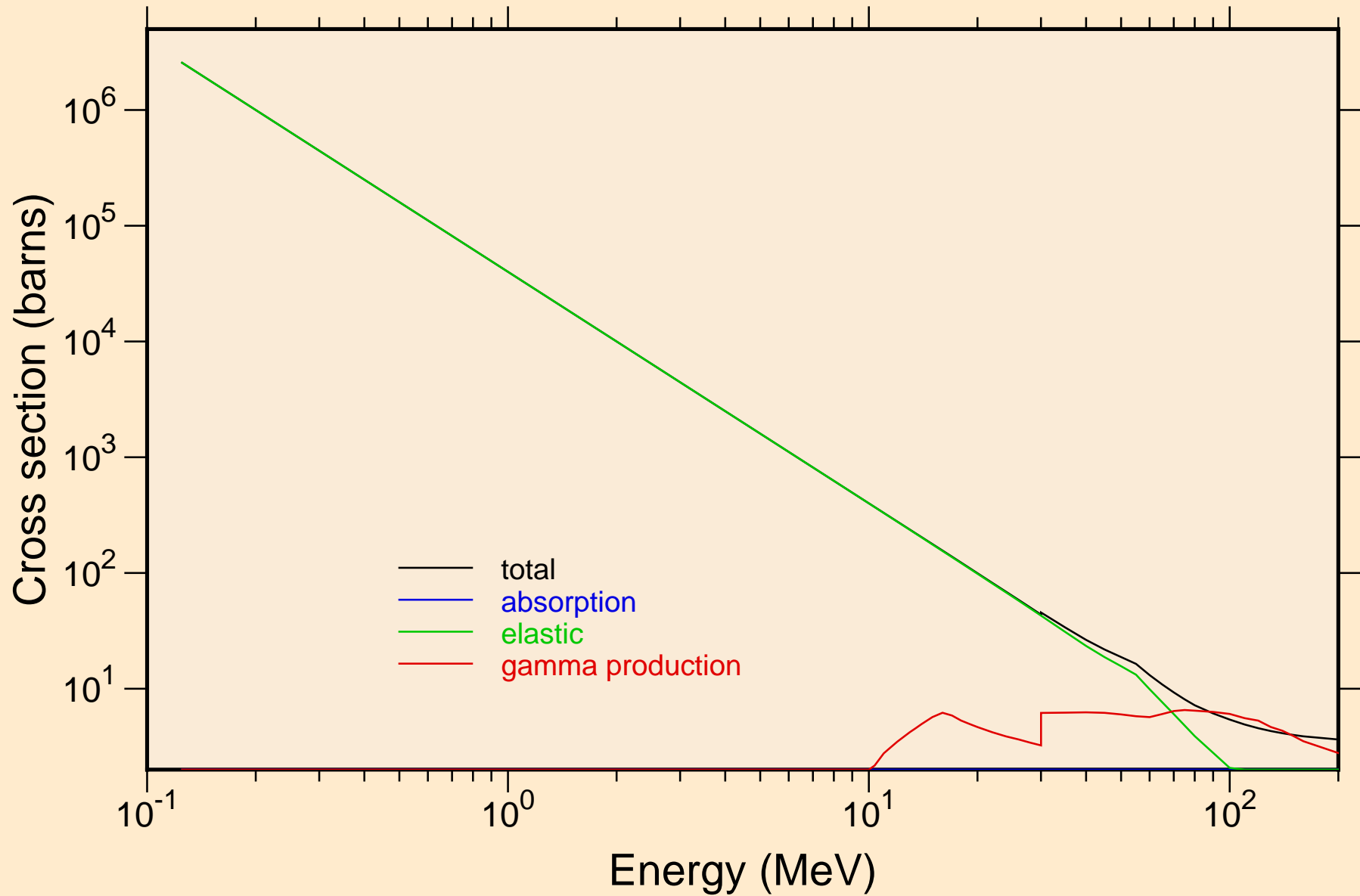

# HG214 DEUTERON ACER TENDL-2023 LIBRARY; T=0.K

## Heating

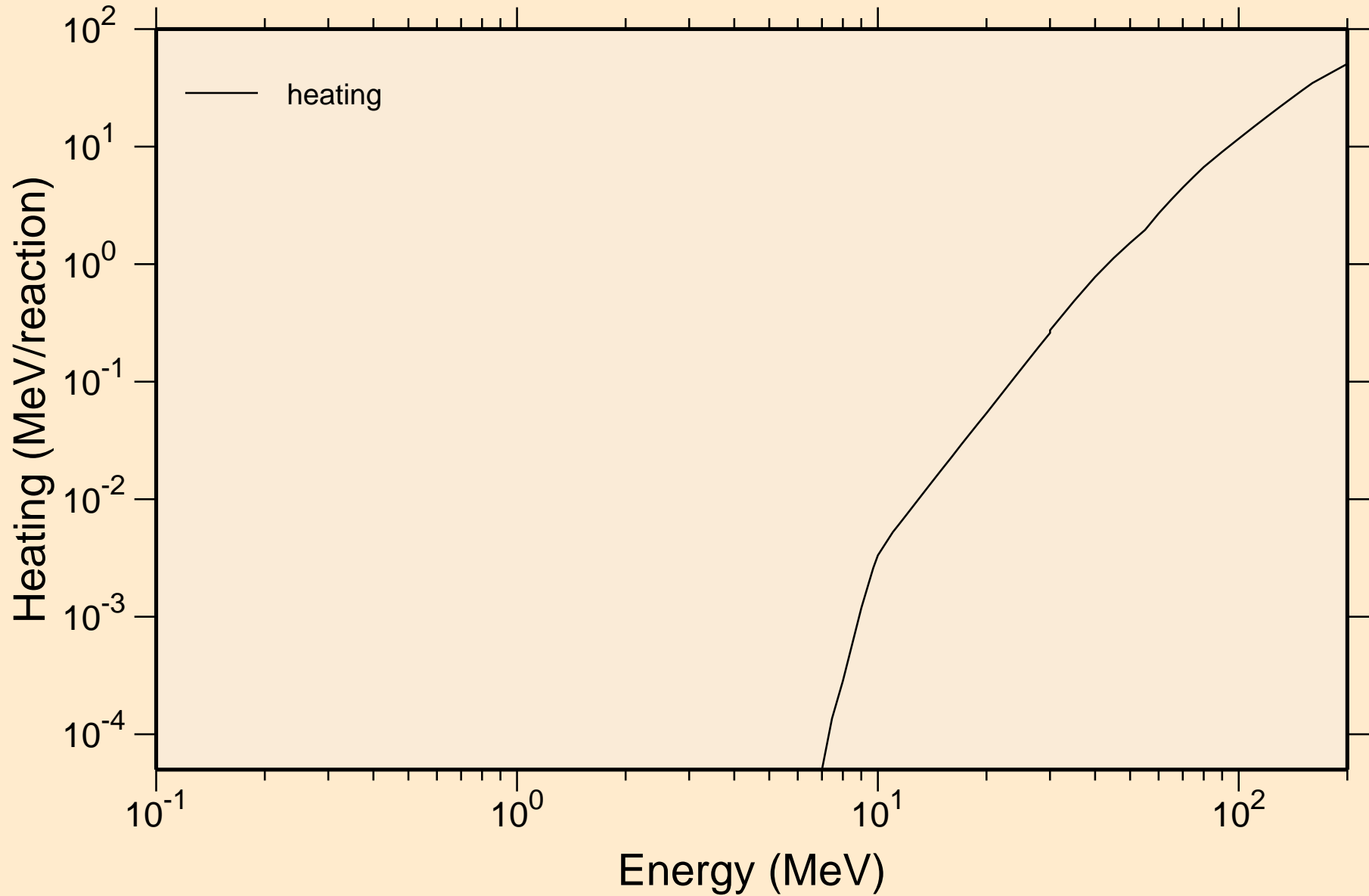

# HG214 DEUTERON ACER TENDL-2023 LIBRARY; T=0.K

## Principal cross sections

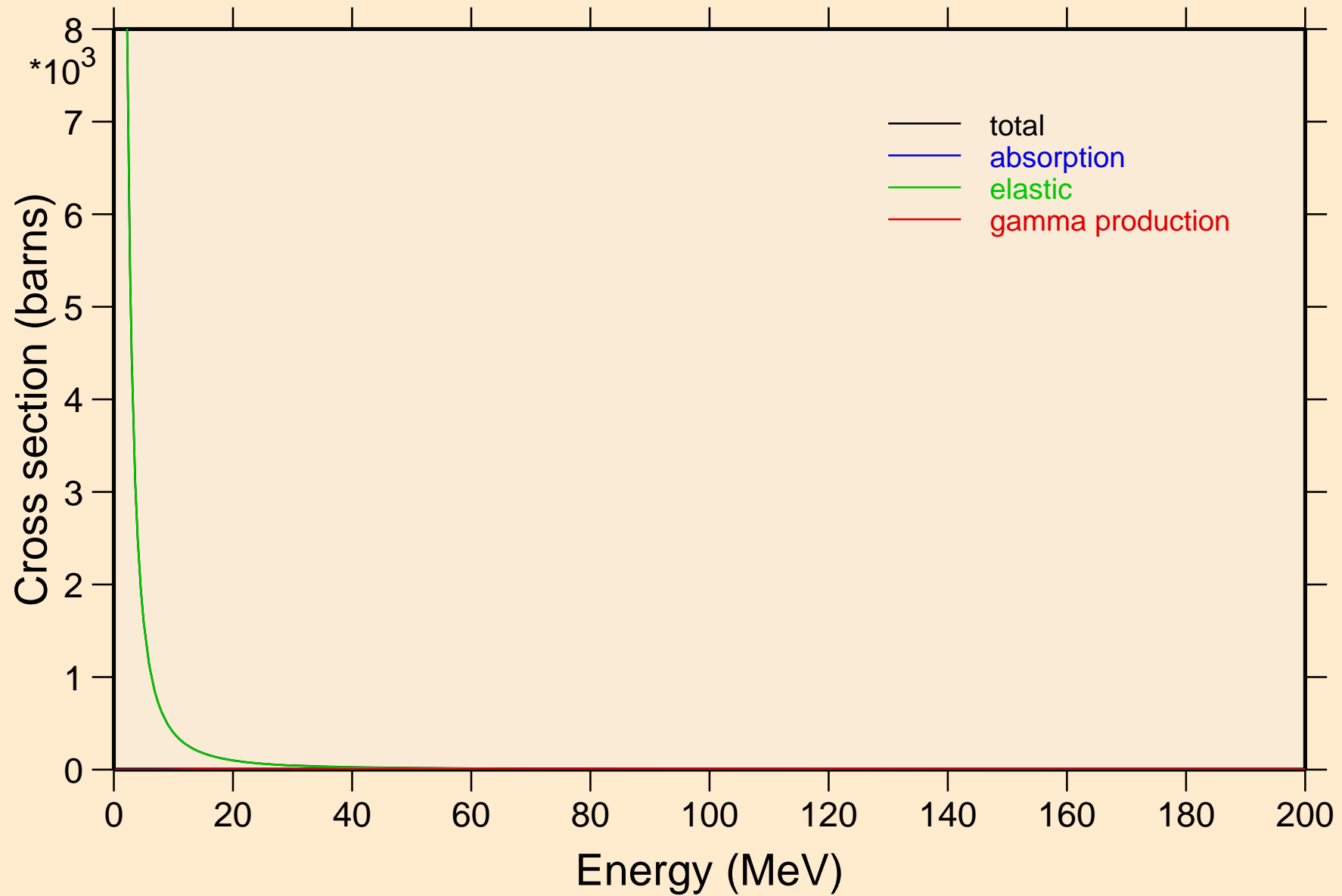

# HG214 DEUTERON ACER TENDL-2023 LIBRARY; T=0.K

## Heating

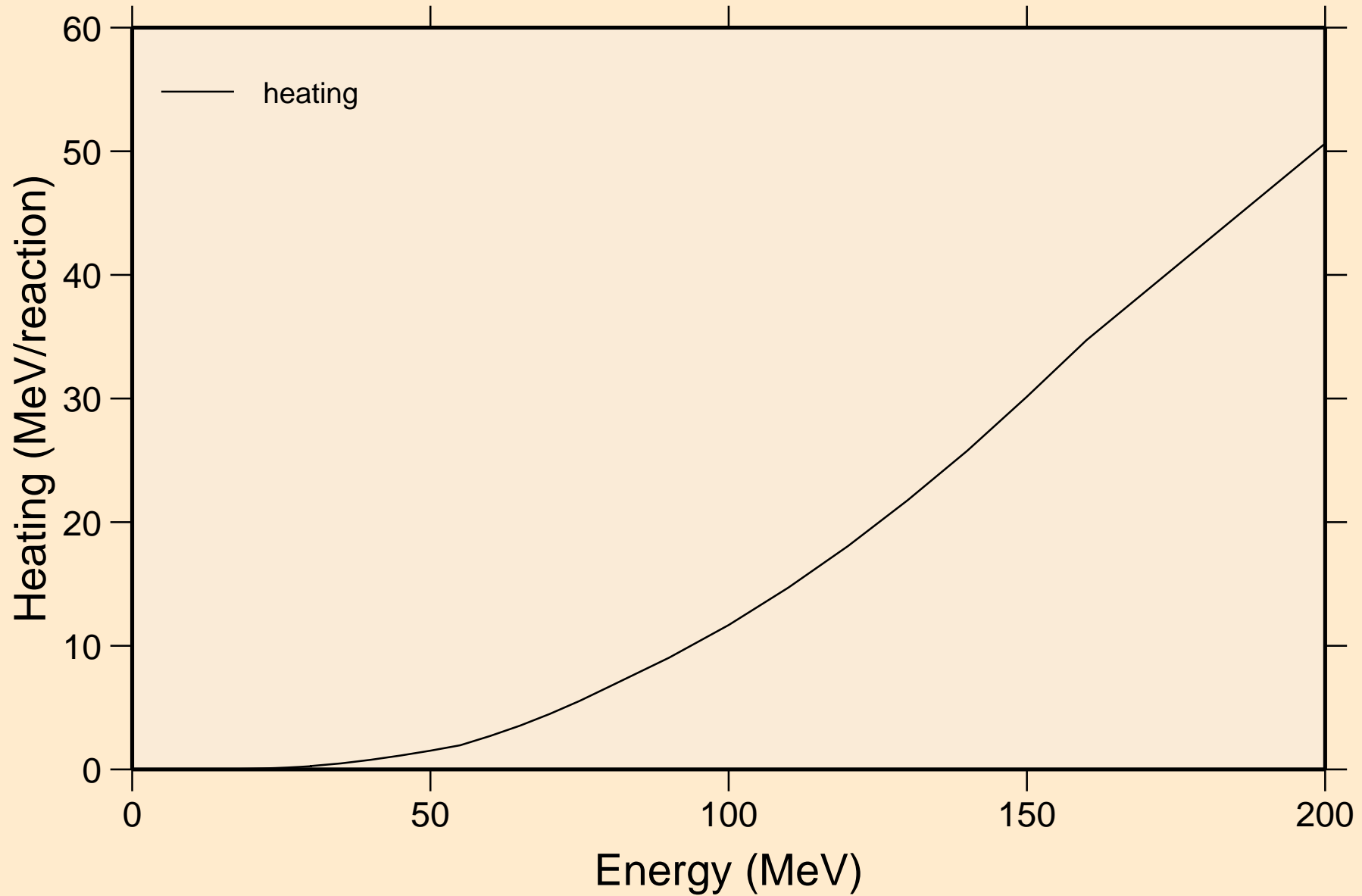

# HG214 DEUTERON ACER TENDL-2023 LIBRARY; T=0.K

## Threshold reactions

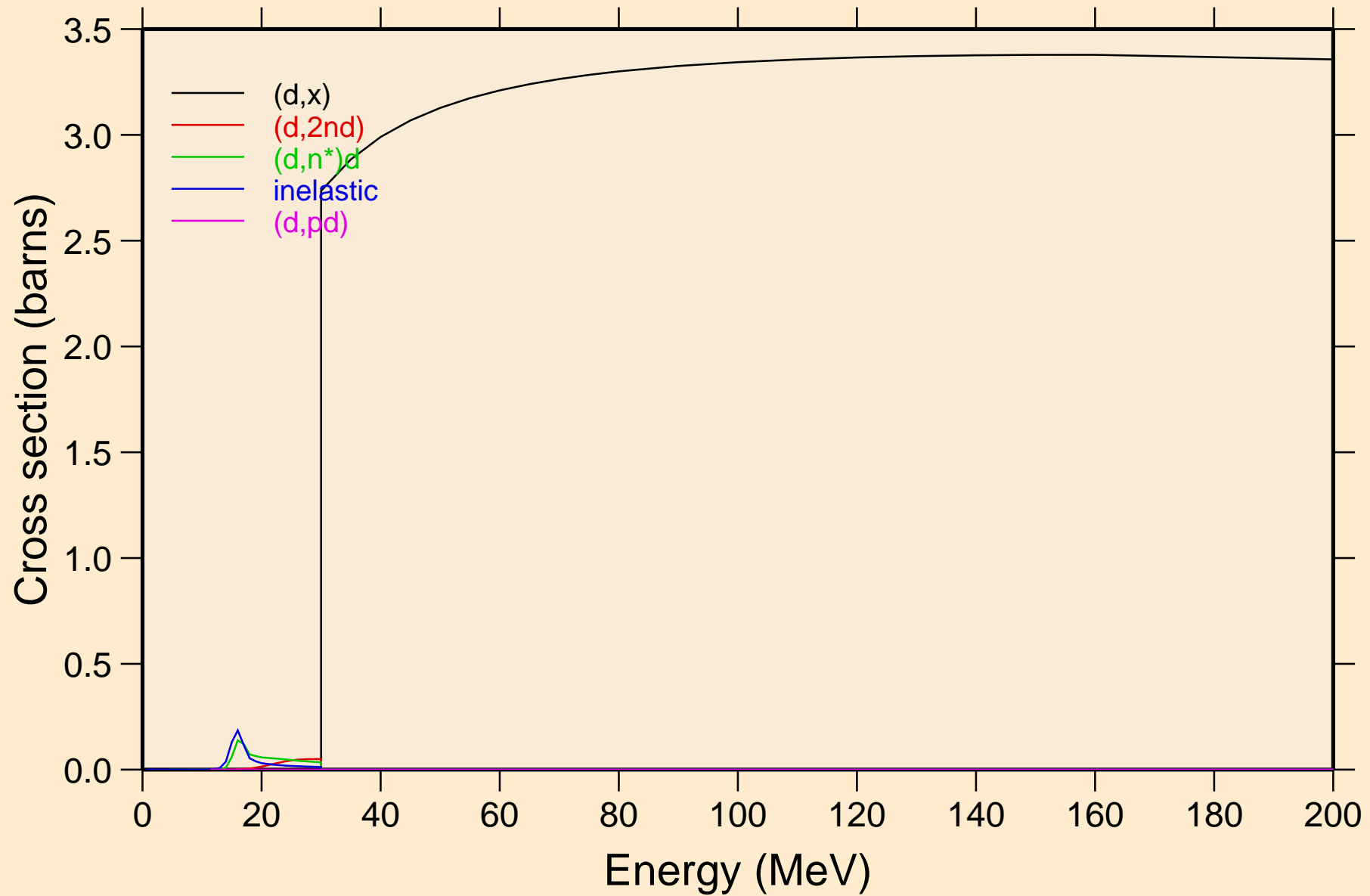

HG214 DEUTERON ACER TENDL-2023 LIBRARY; T=0.K  
angular distribution for elastic

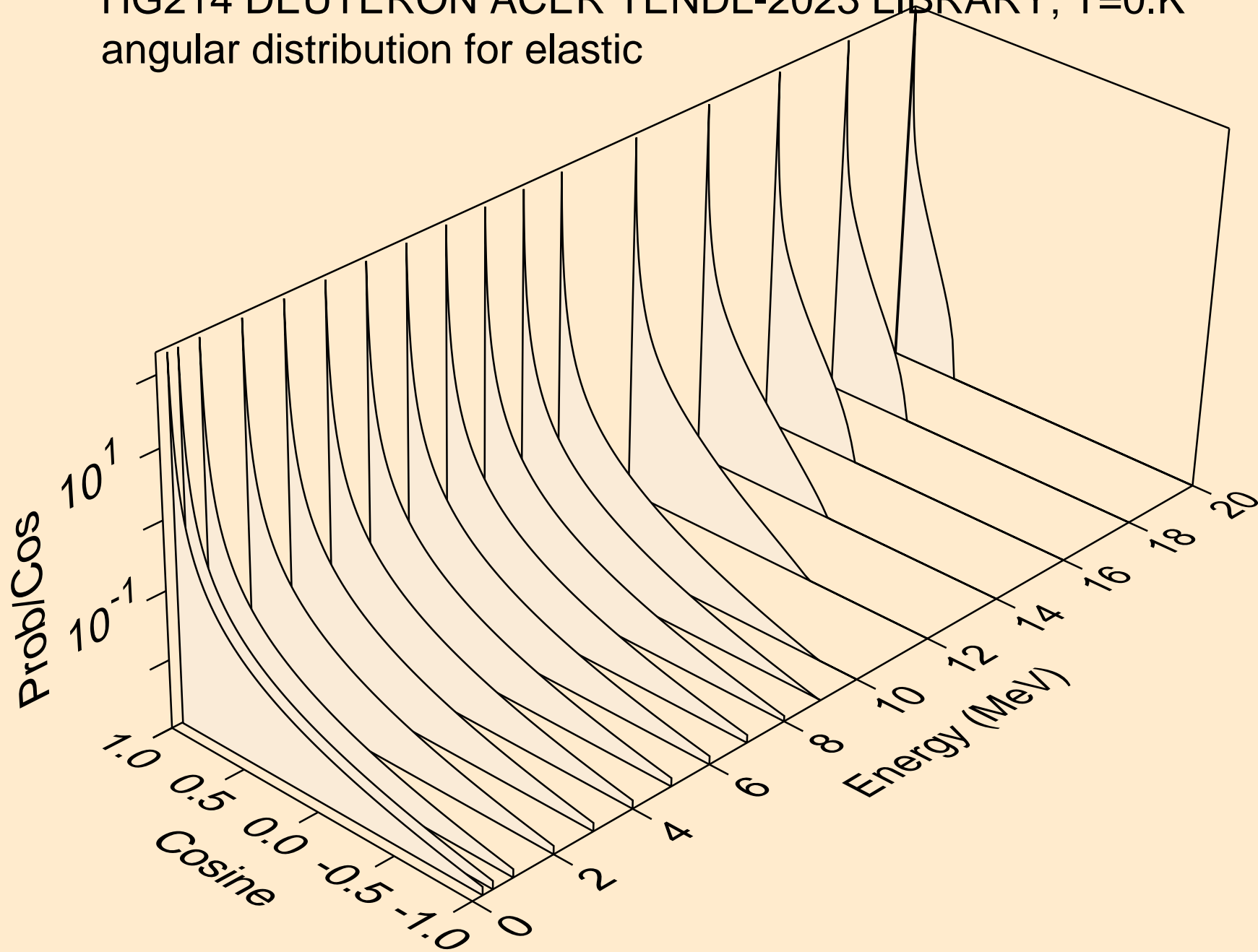

HG214 DEUTERON ACER TENDL-2023 LIBRARY; T=0.K  
angular distribution for elastic

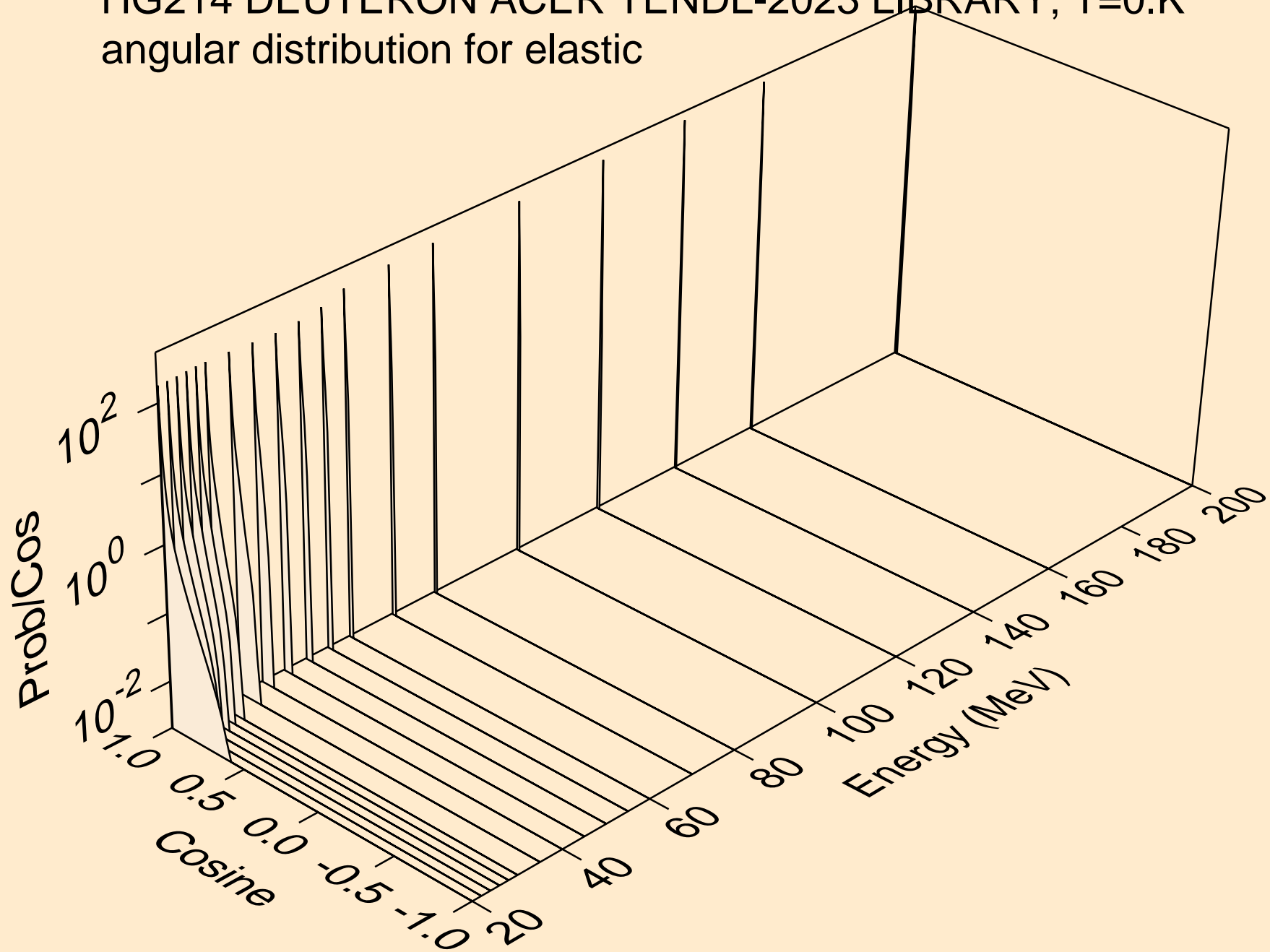

HG214 DEUTERON ACER TENDL-2023 LIBRARY; T=0.K  
Deuteron emission for (d,x)

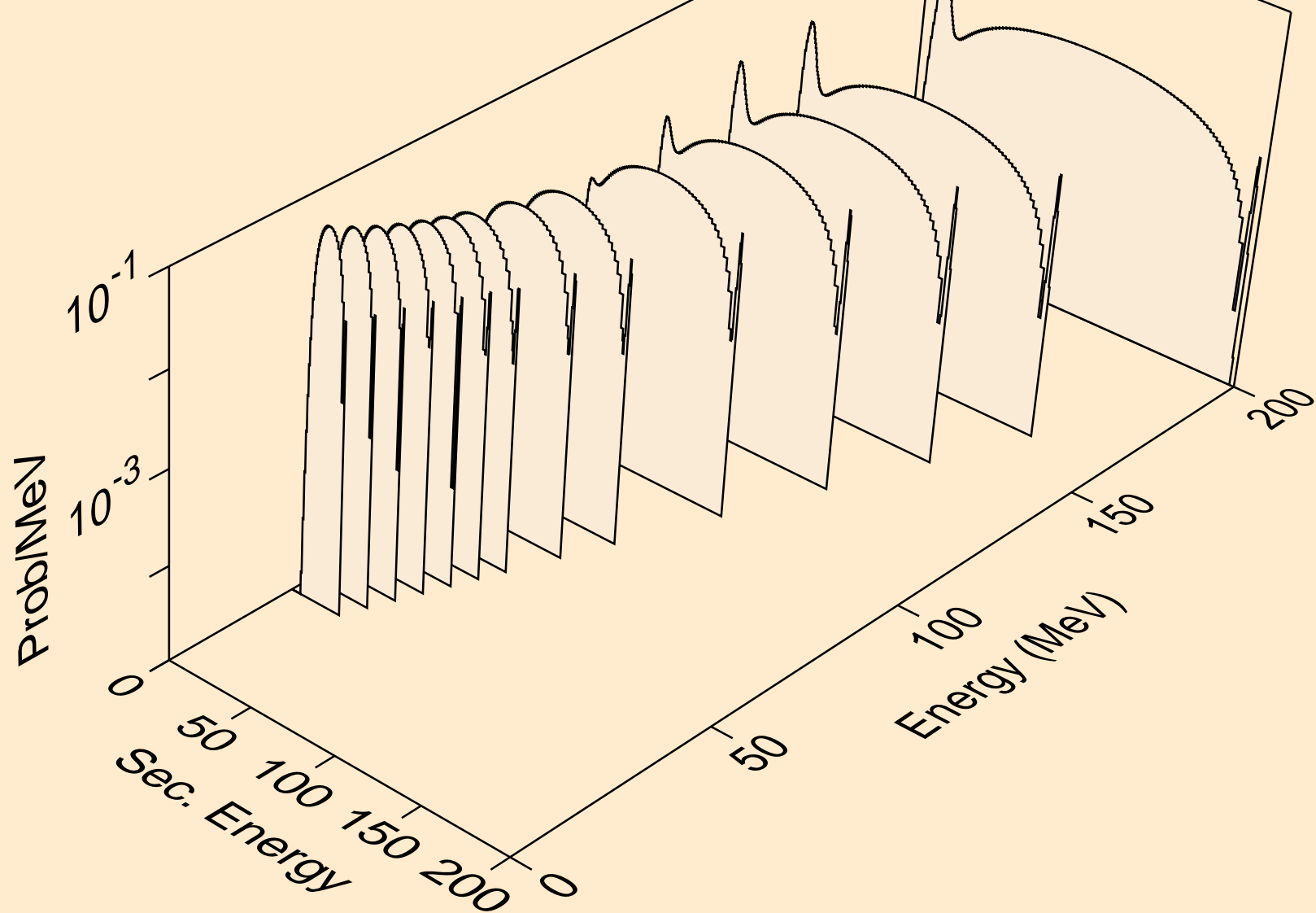



HG214 DEUTERON ACER TENDL-2023 LIBRARY; T=0.K  
Deuteron emission for (d,2nd)

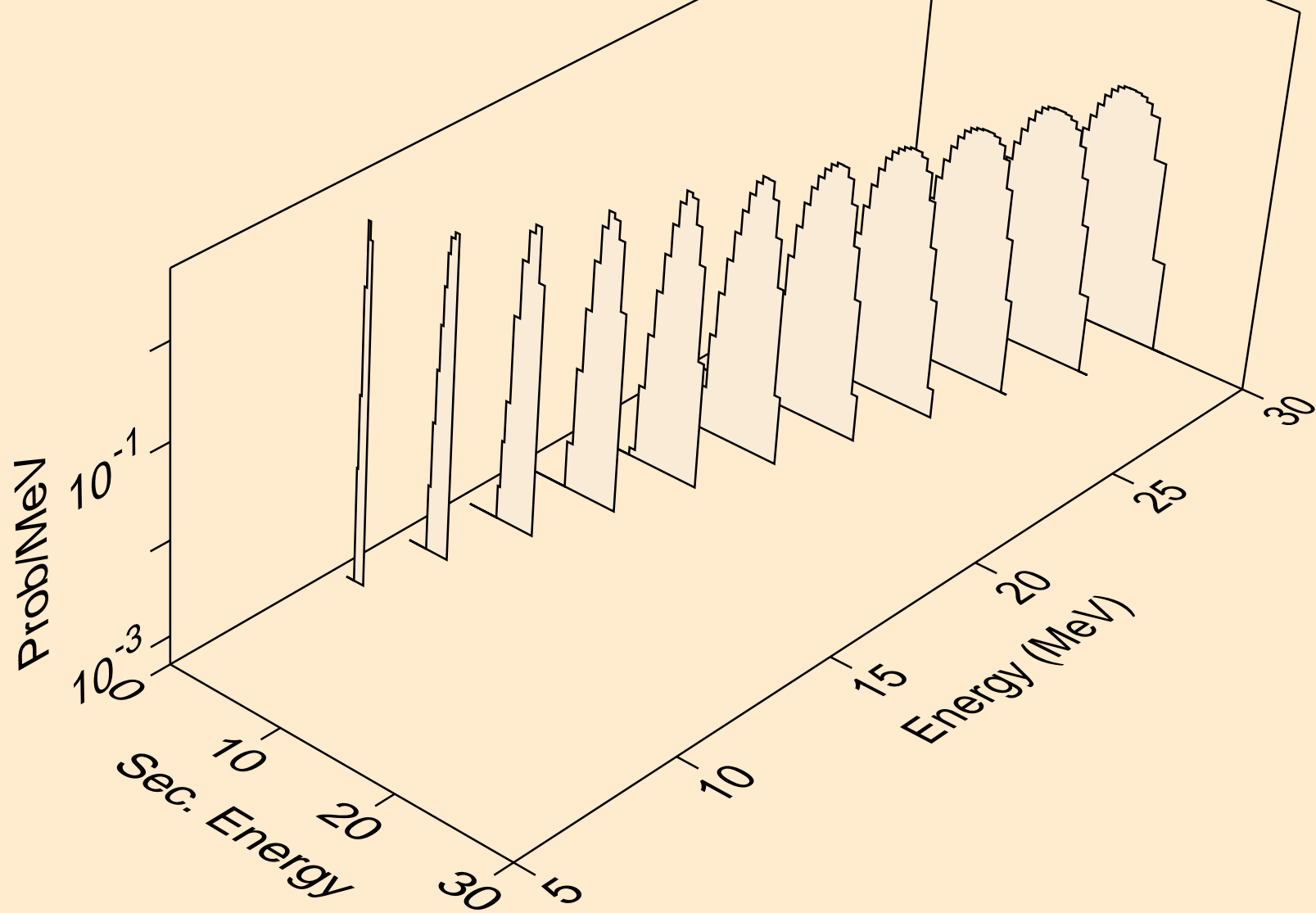

HG214 DEUTERON ACER TENDL-2023 LIBRARY; T=0.K  
Deuteron emission for (d,n\*)d

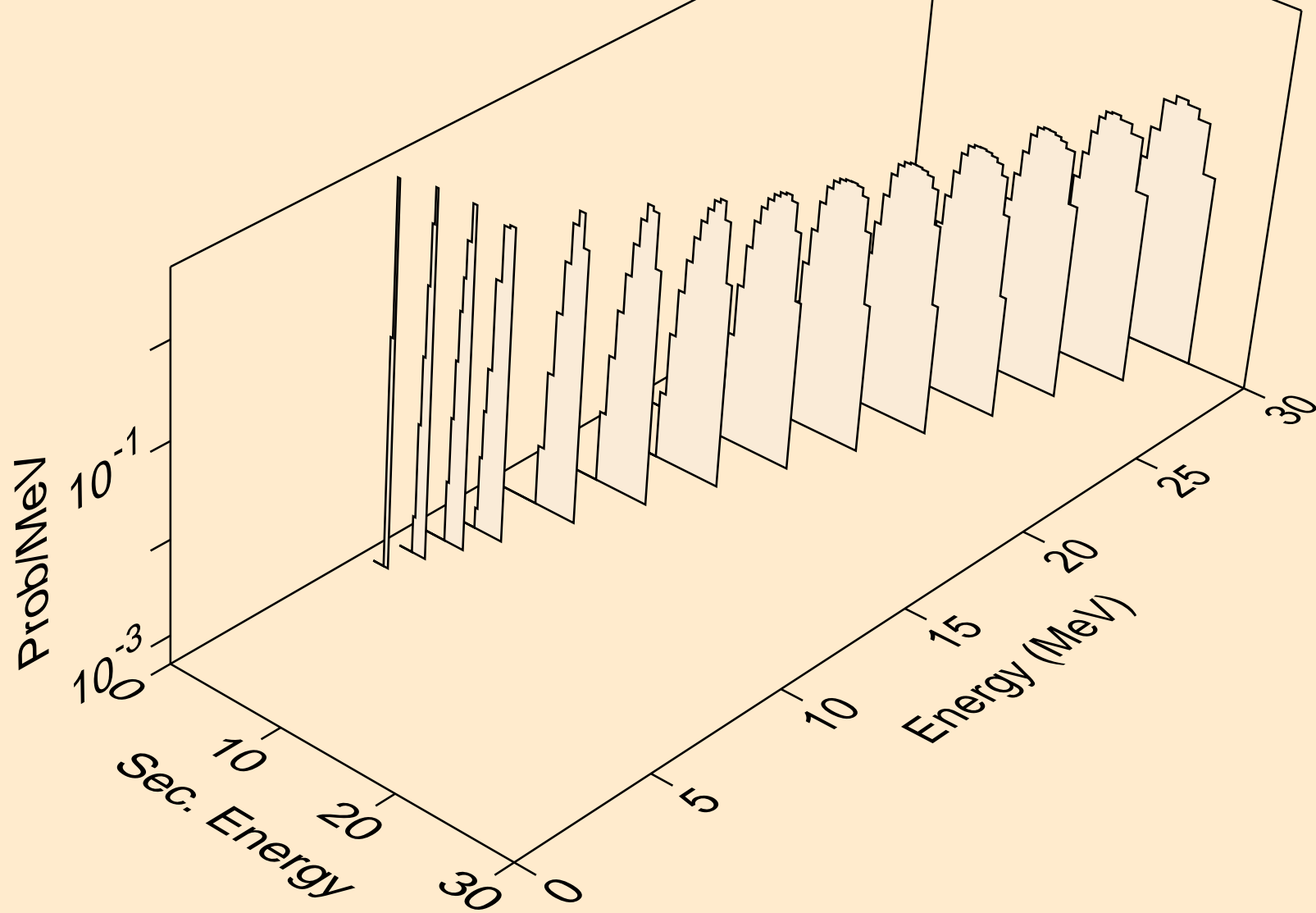

HG214 DEUTERON ACER TENDL-2023 LIBRARY; T=0.K  
Deuteron emission for inelastic

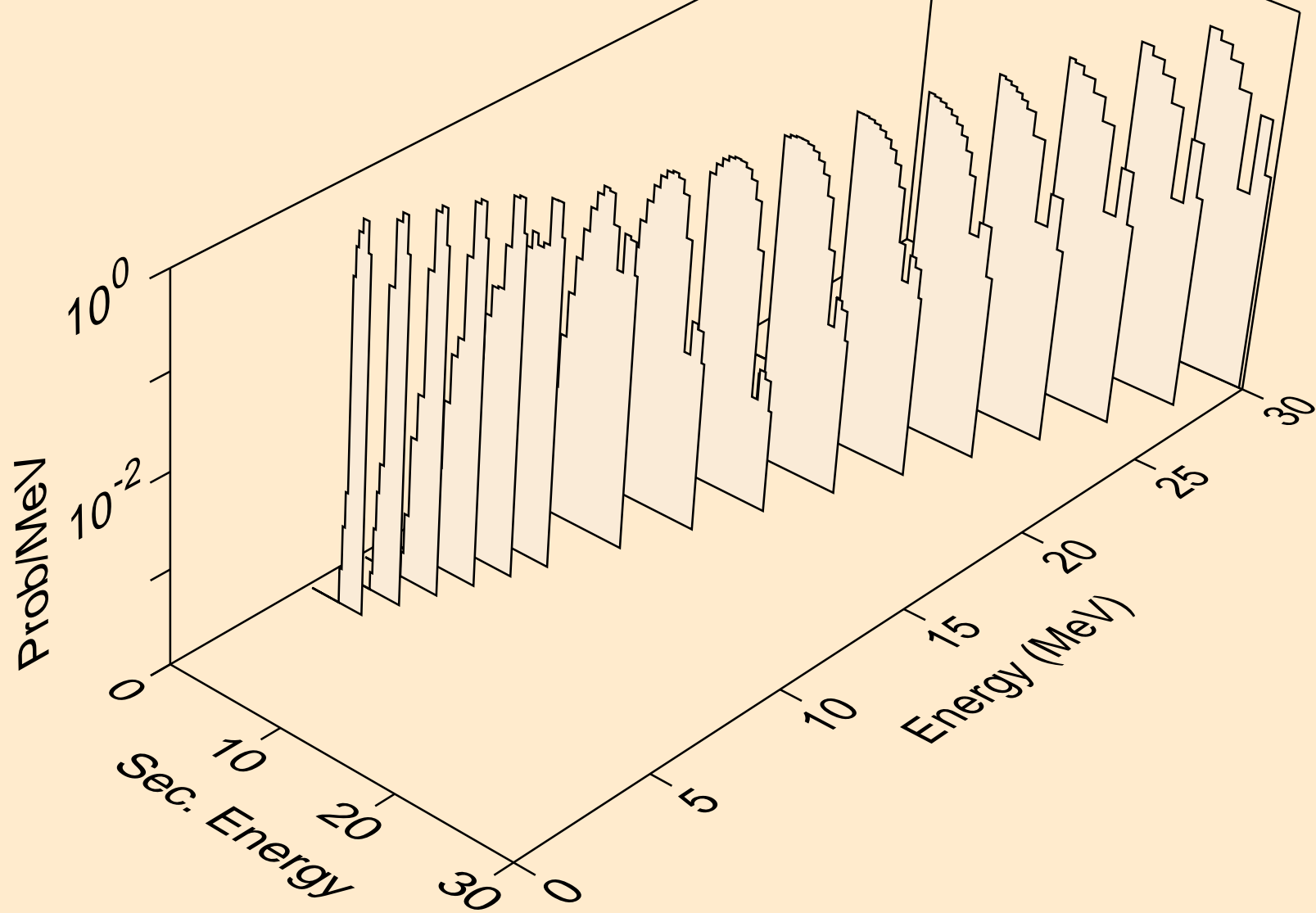

HG214 DEUTERON ACER TENDL-2023 LIBRARY; T=0.K  
Deuteron emission for (d,pd)

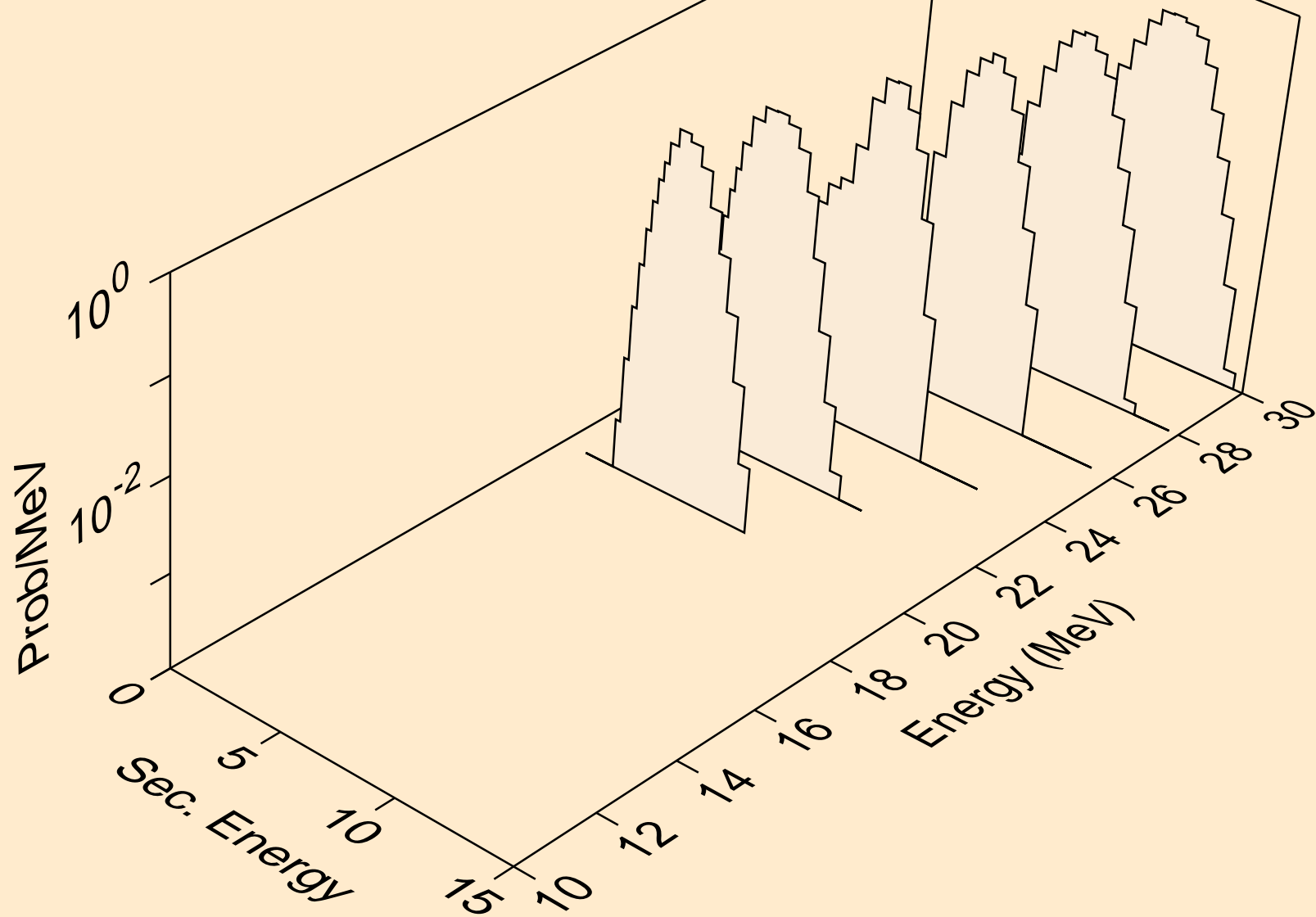

HG214 DEUTERON ACER TENDL-2023 LIBRARY; T=0.K  
Photon emission for (z,n)

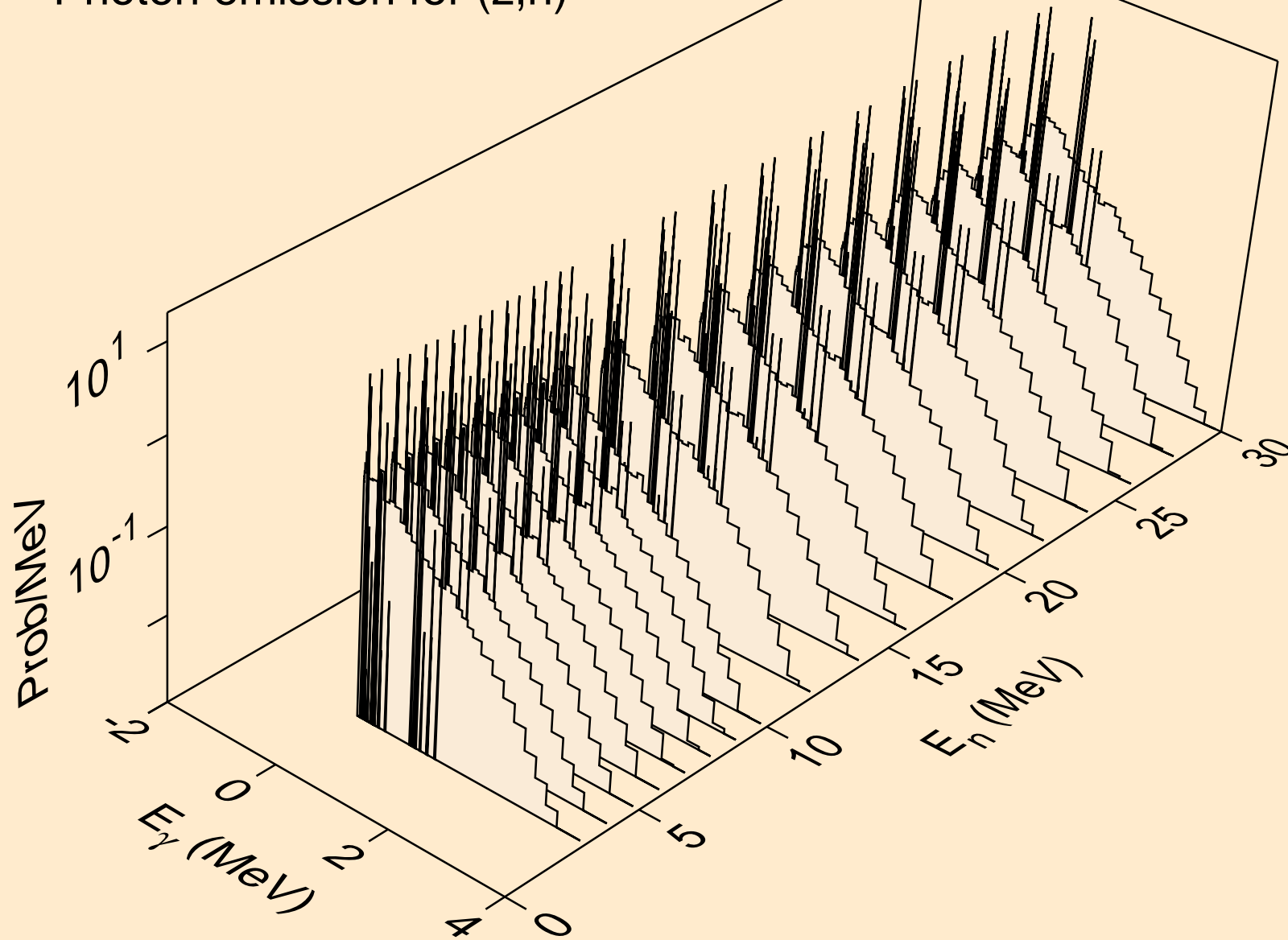

HG214 DEUTERON ACER TENDL-2023 LIBRARY; T=0.K  
Photon emission for (z,x)

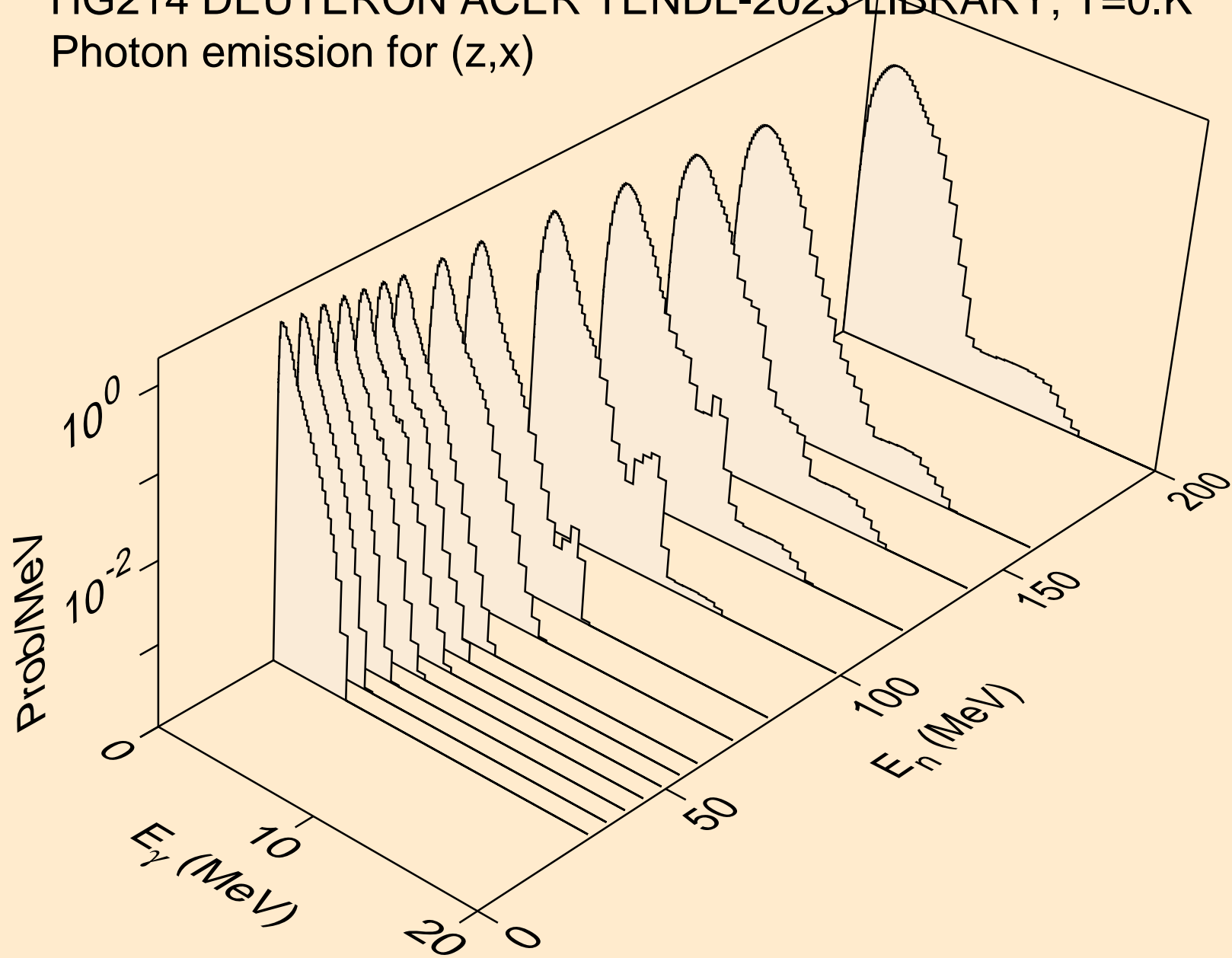

HG214 DEUTERON ACER TENDL-2023 LIBRARY; T=0.K  
Photon emission for (n,2nd)

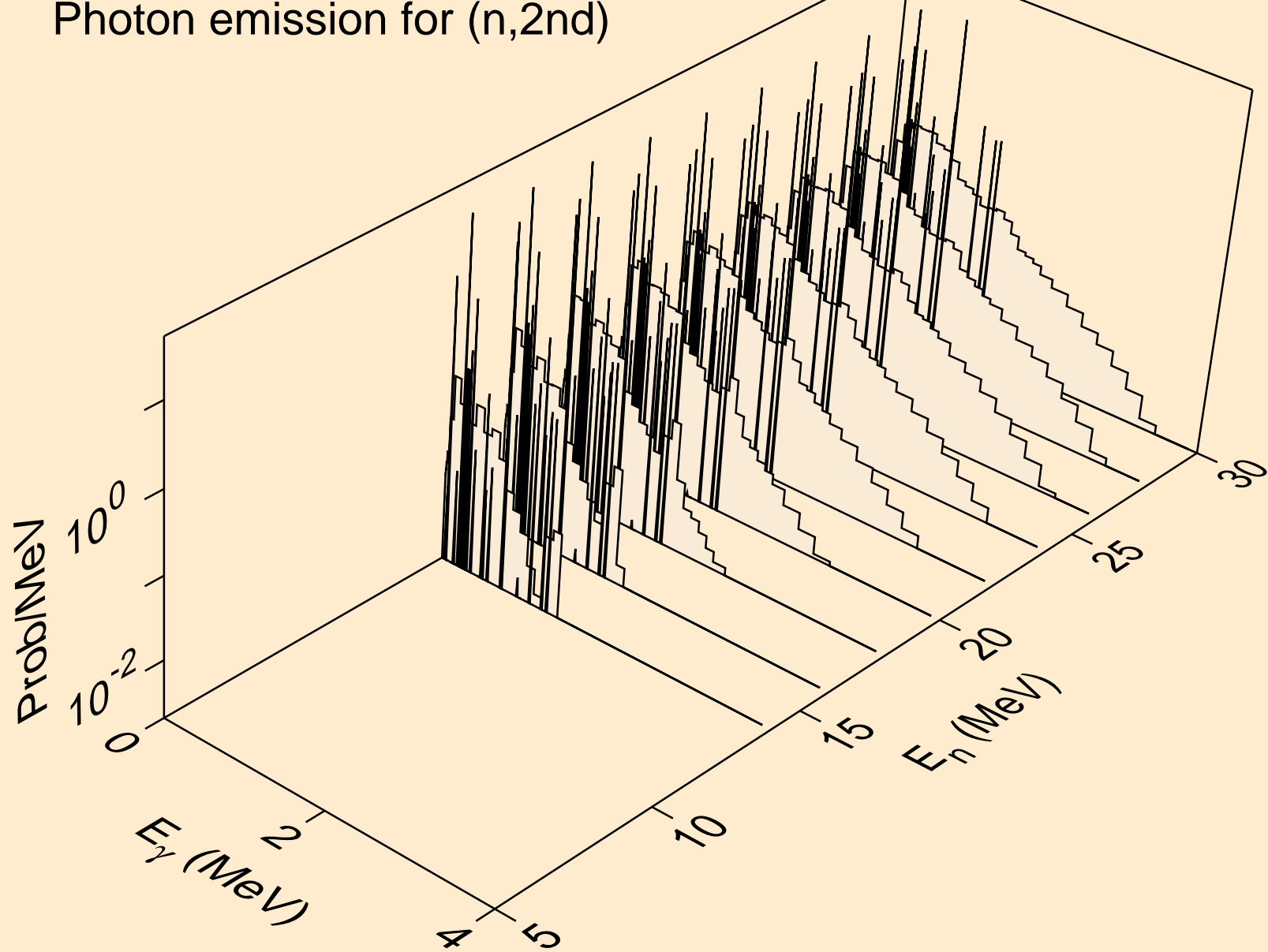

HG214 DEUTERON ACER TENDL-2023 LIBRARY; T=0.K  
Photon emission for (n,2n)

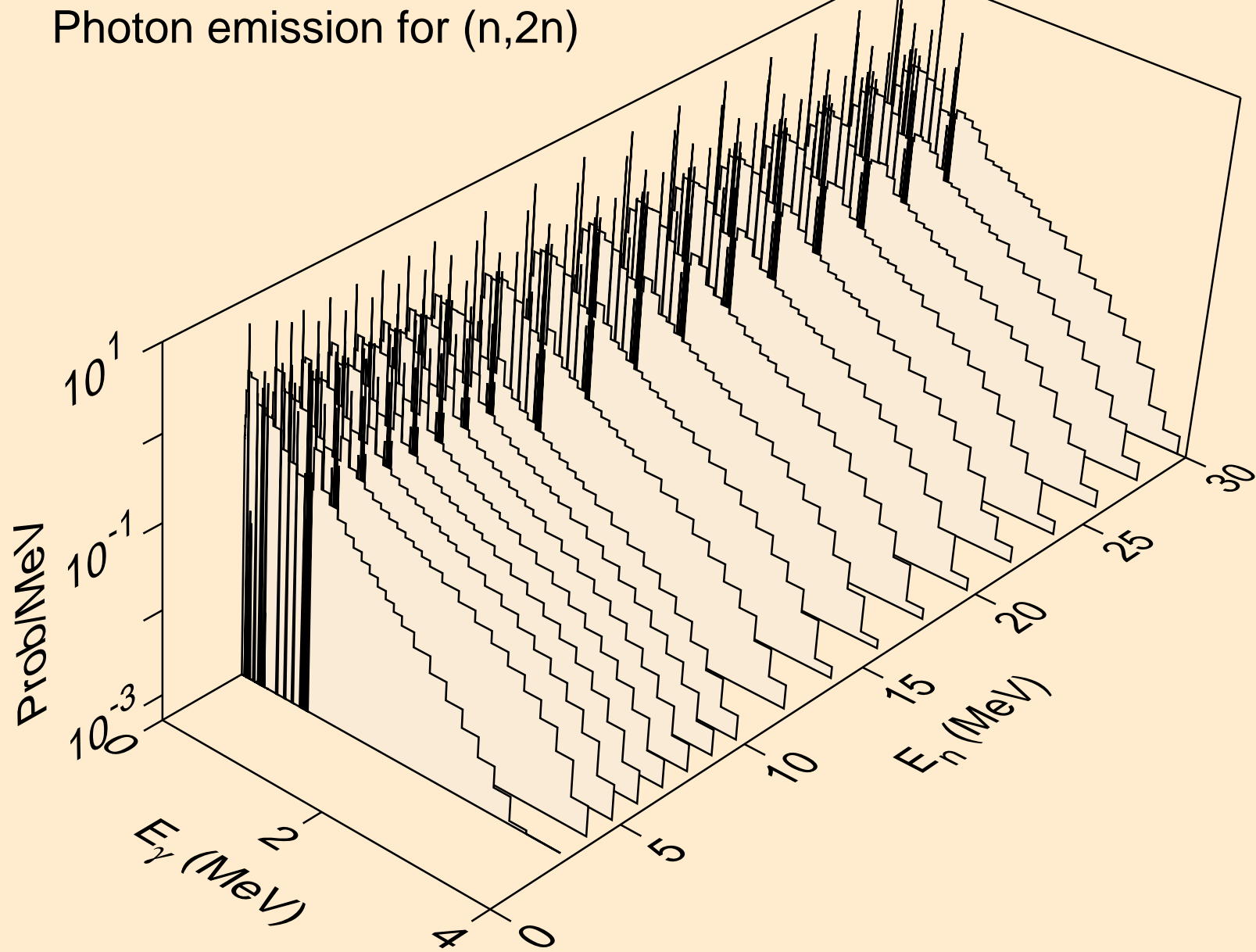



HG214 DEUTERON ACER TENDL-2023 LIBRARY; T=0.K  
Photon emission for (n,3n)

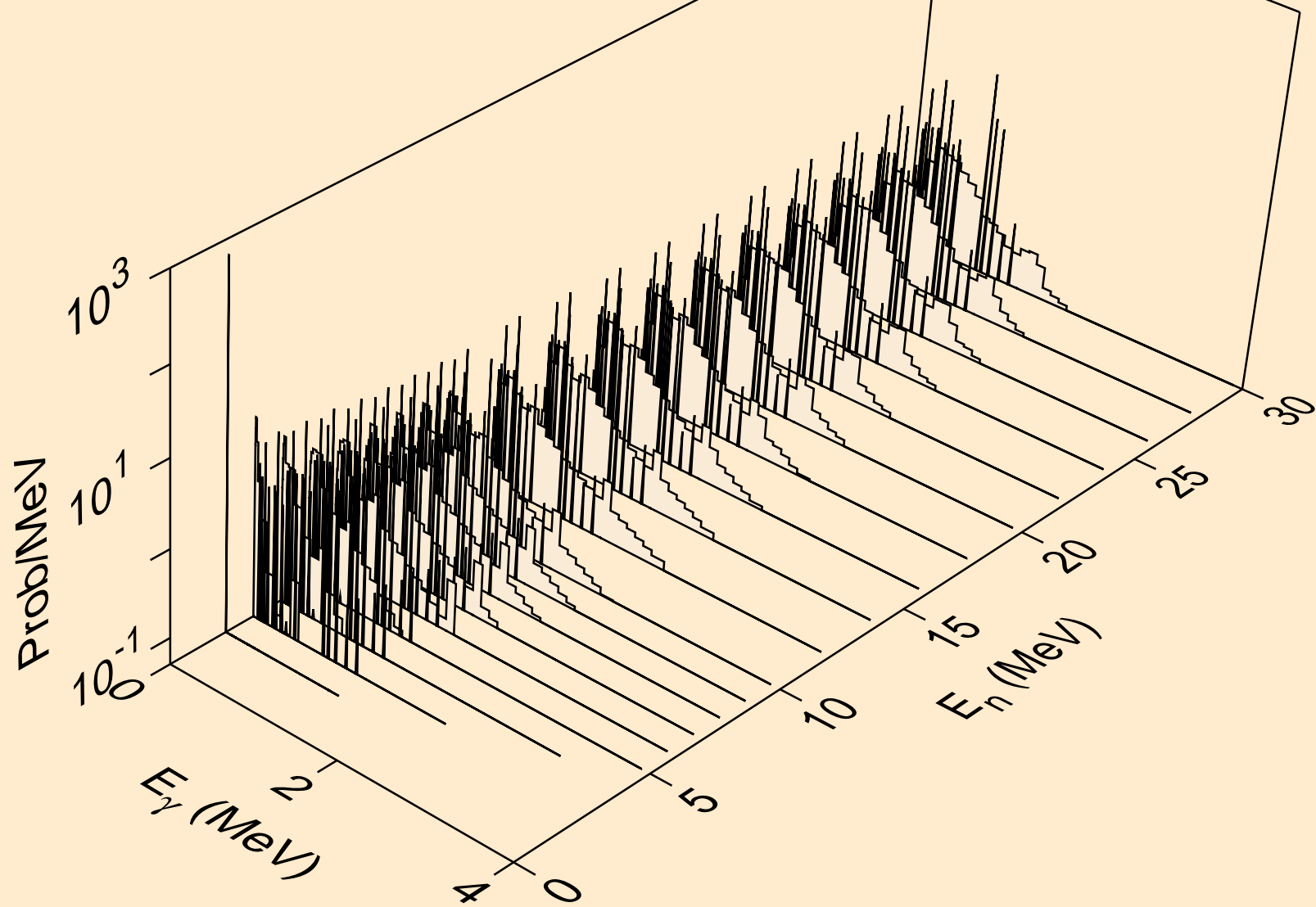

HG214 DEUTERON ACER TENDL-2023 LIBRARY; T=0.K  
Photon emission for (n,n\*)a

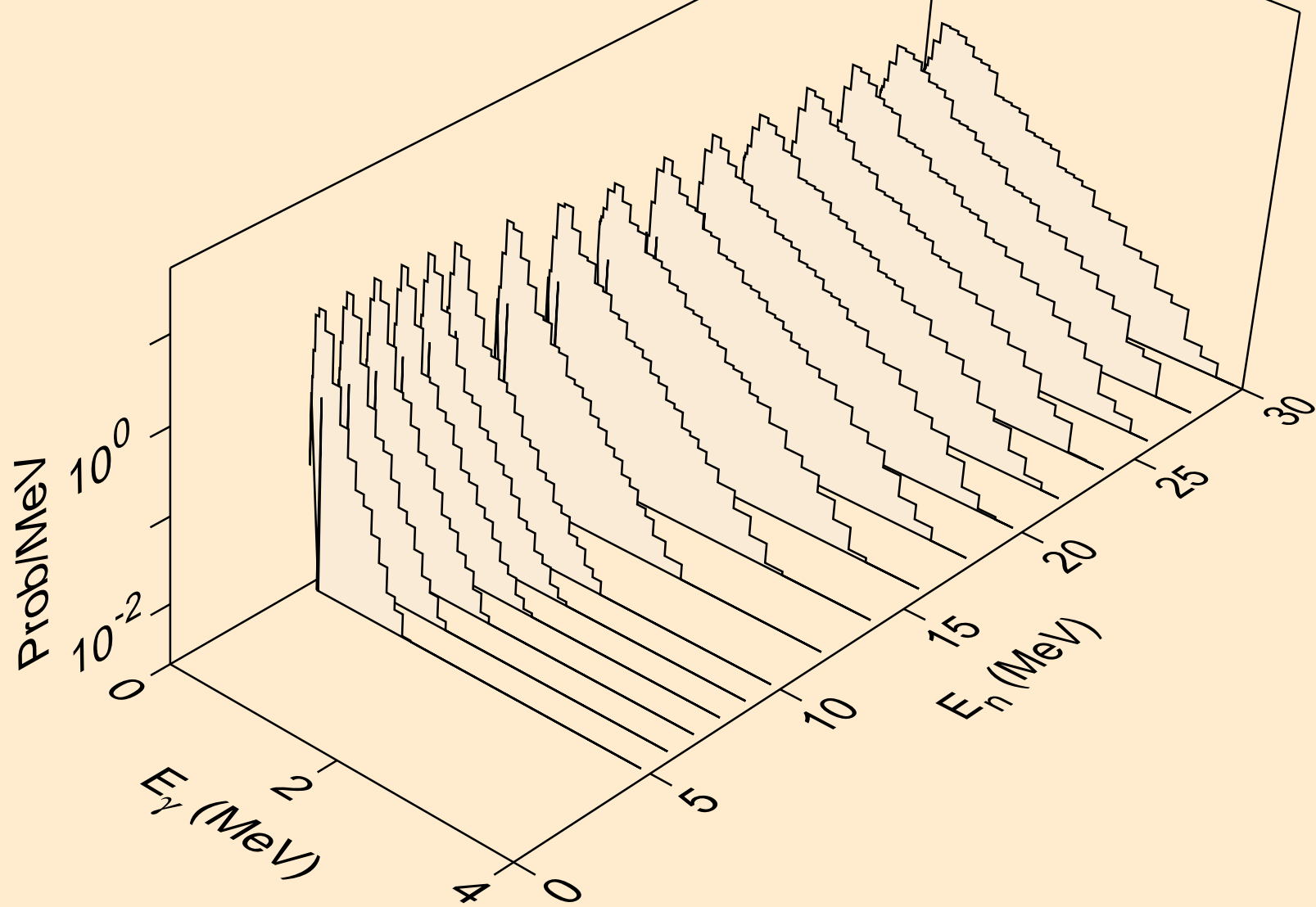

HG214 DEUTERON ACER TENDL-2023 LIBRARY; T=0.K  
Photon emission for (n,2n) $\alpha$

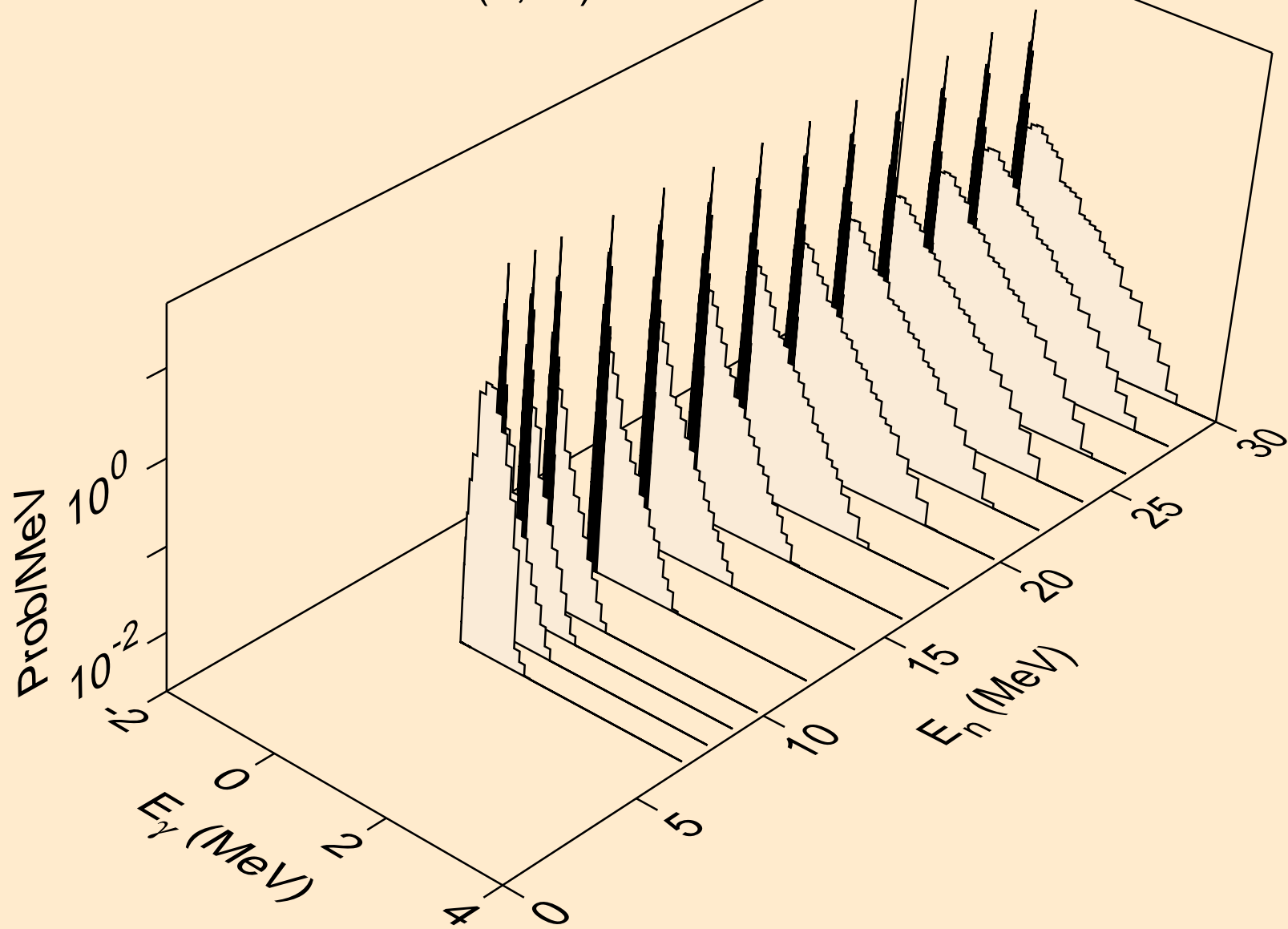

HG214 DEUTERON ACER TENDL-2023 LIBRARY; T=0.K  
Photon emission for (n,3n)a

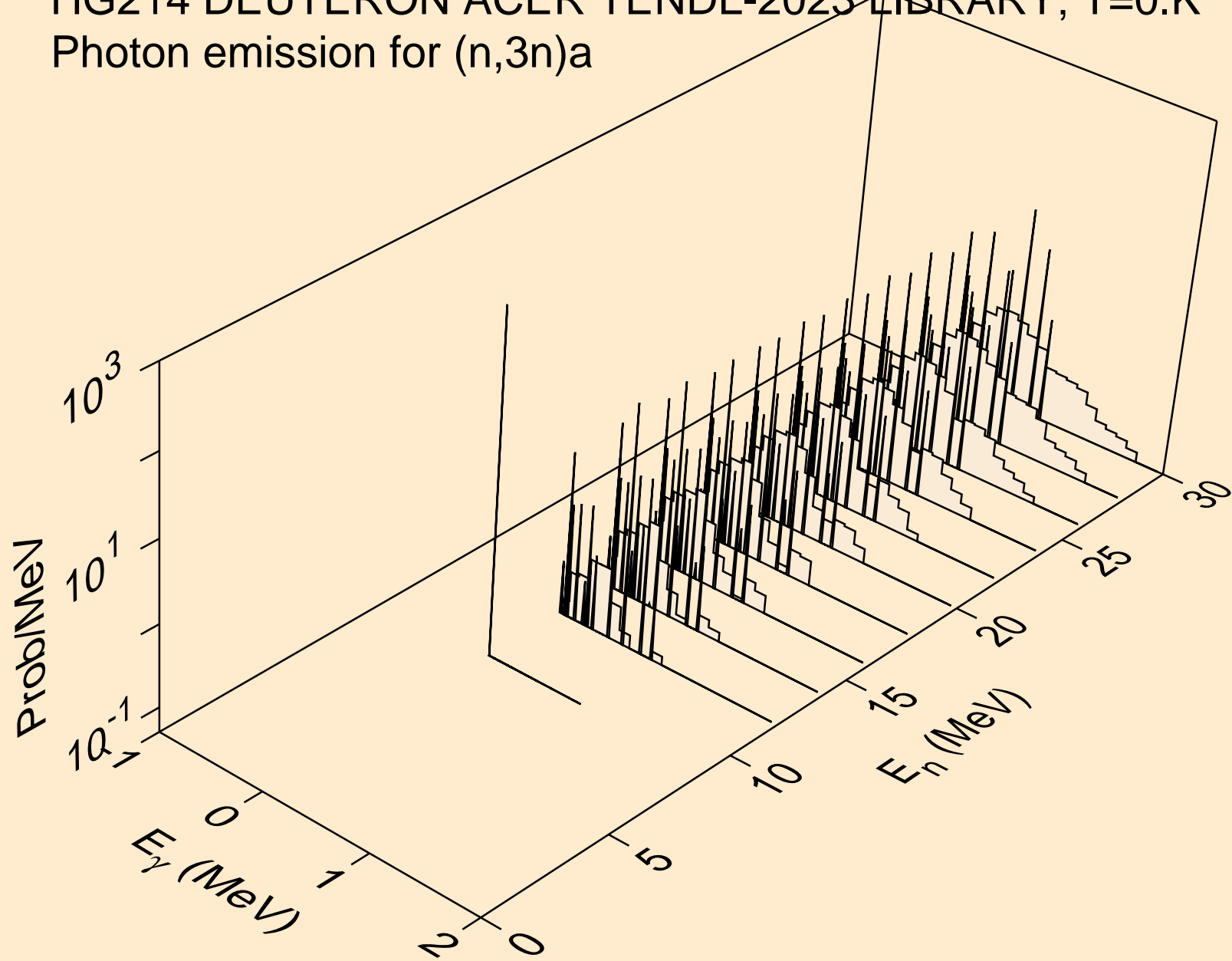

HG214 DEUTERON ACER TENDL-2023 LIBRARY; T=0.K  
Photon emission for (n,n\*)p

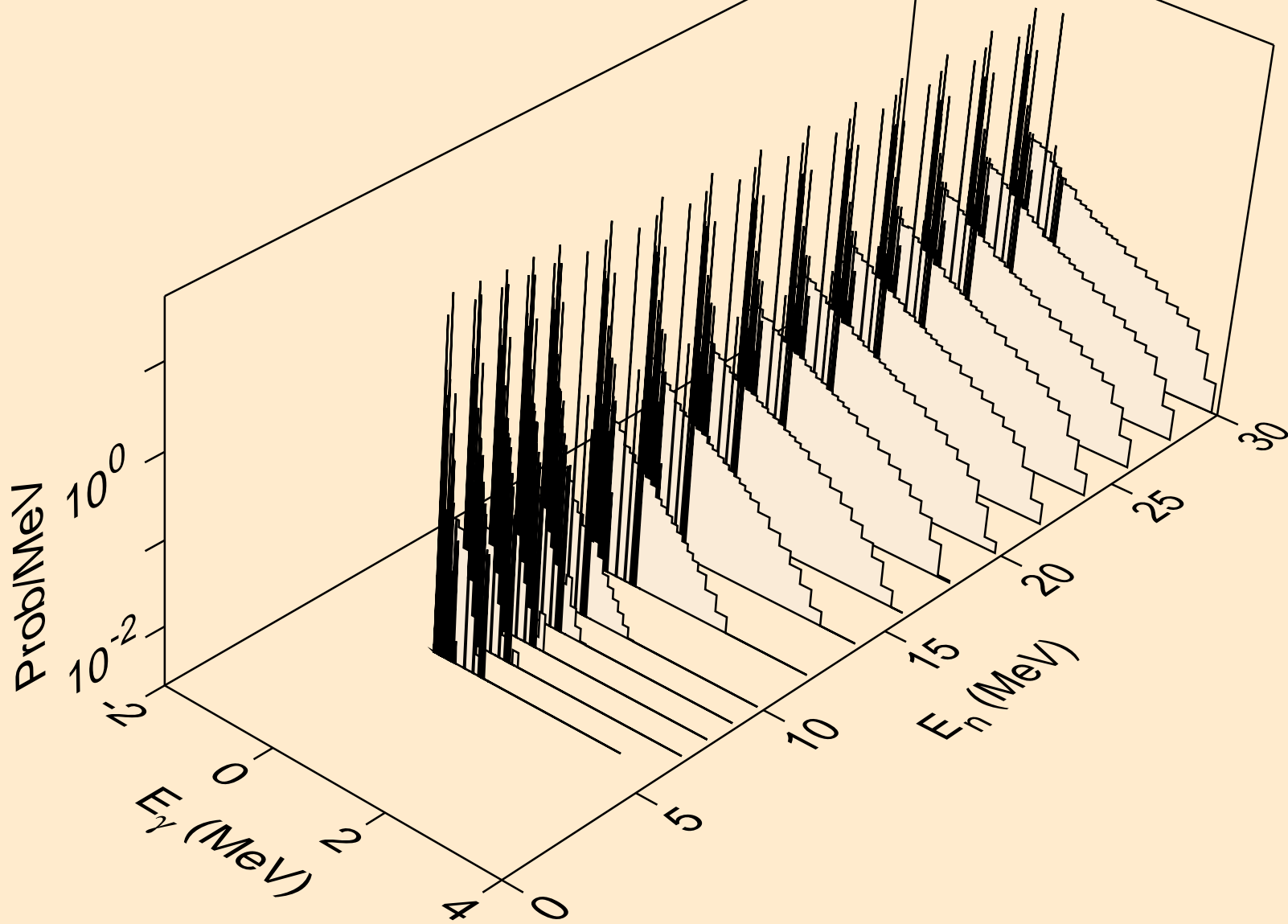

HG214 DEUTERON ACER TENDL-2023 LIBRARY; T=0.K  
Photon emission for (n,n\*)d

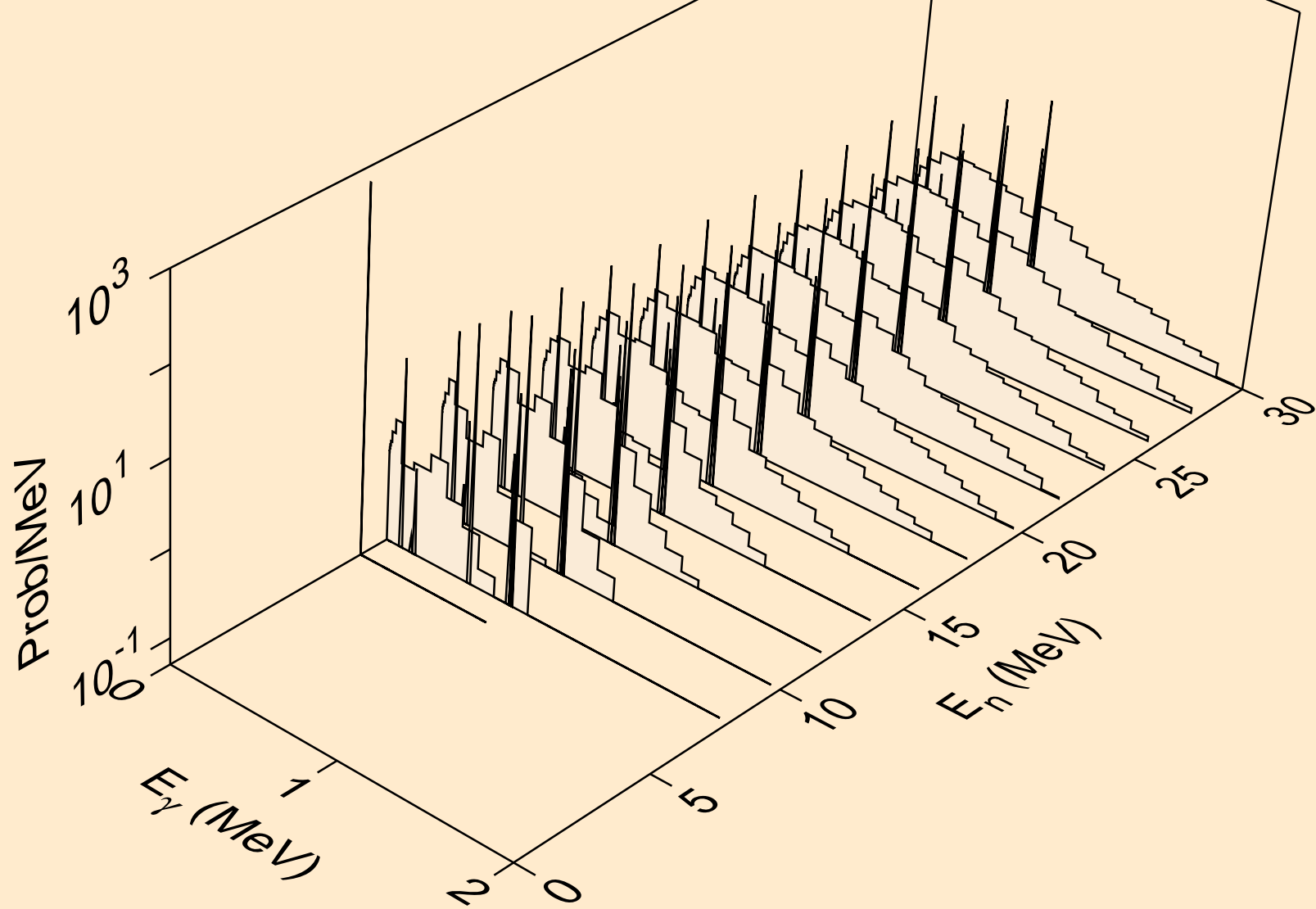

HG214 DEUTERON ACER TENDL-2023 LIBRARY; T=0.K  
Photon emission for (n,n\*)t

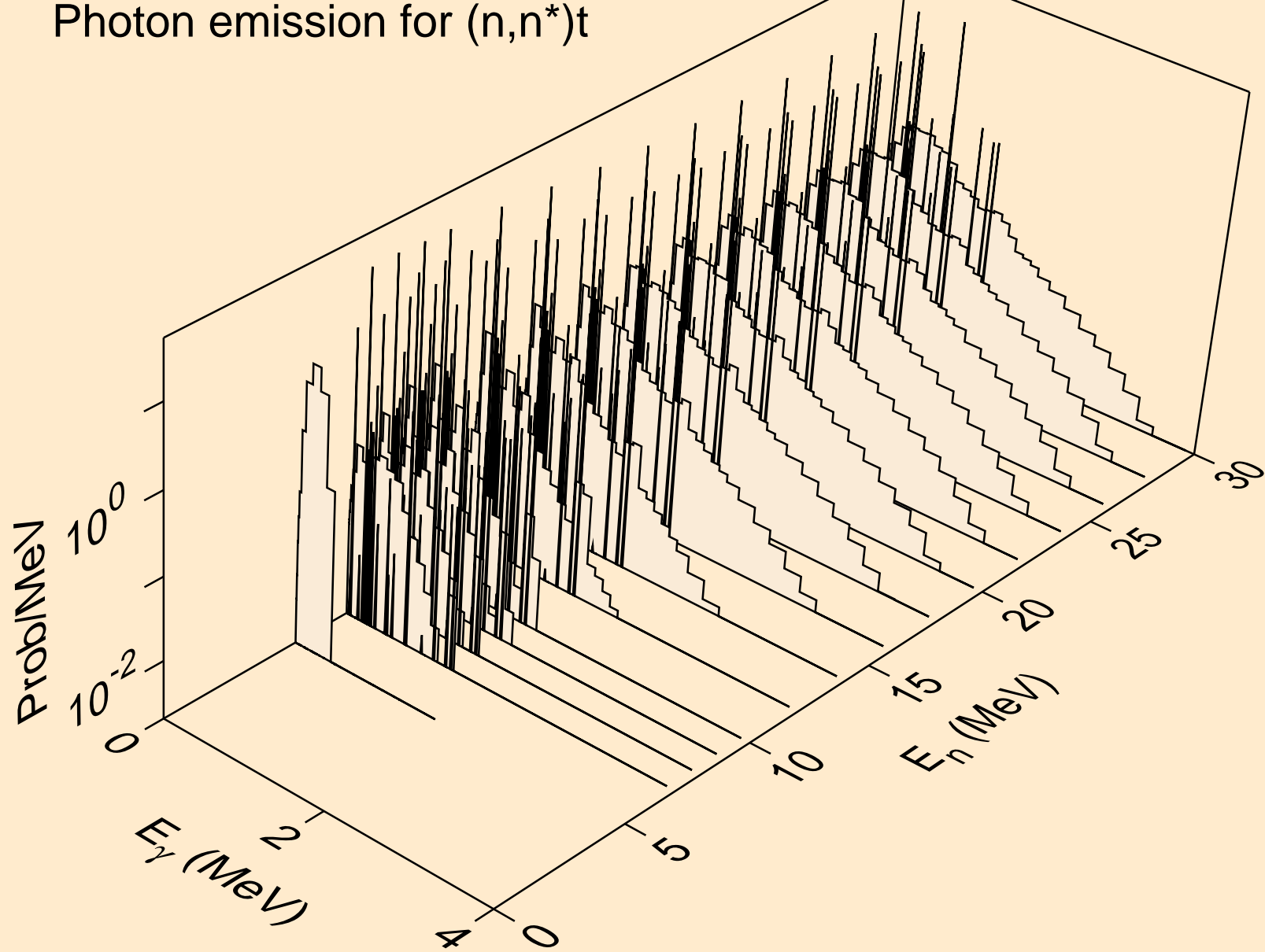

HG214 DEUTERON ACER TENDL-2023 LIBRARY; T=0.K  
Photon emission for (n,n\*)he3

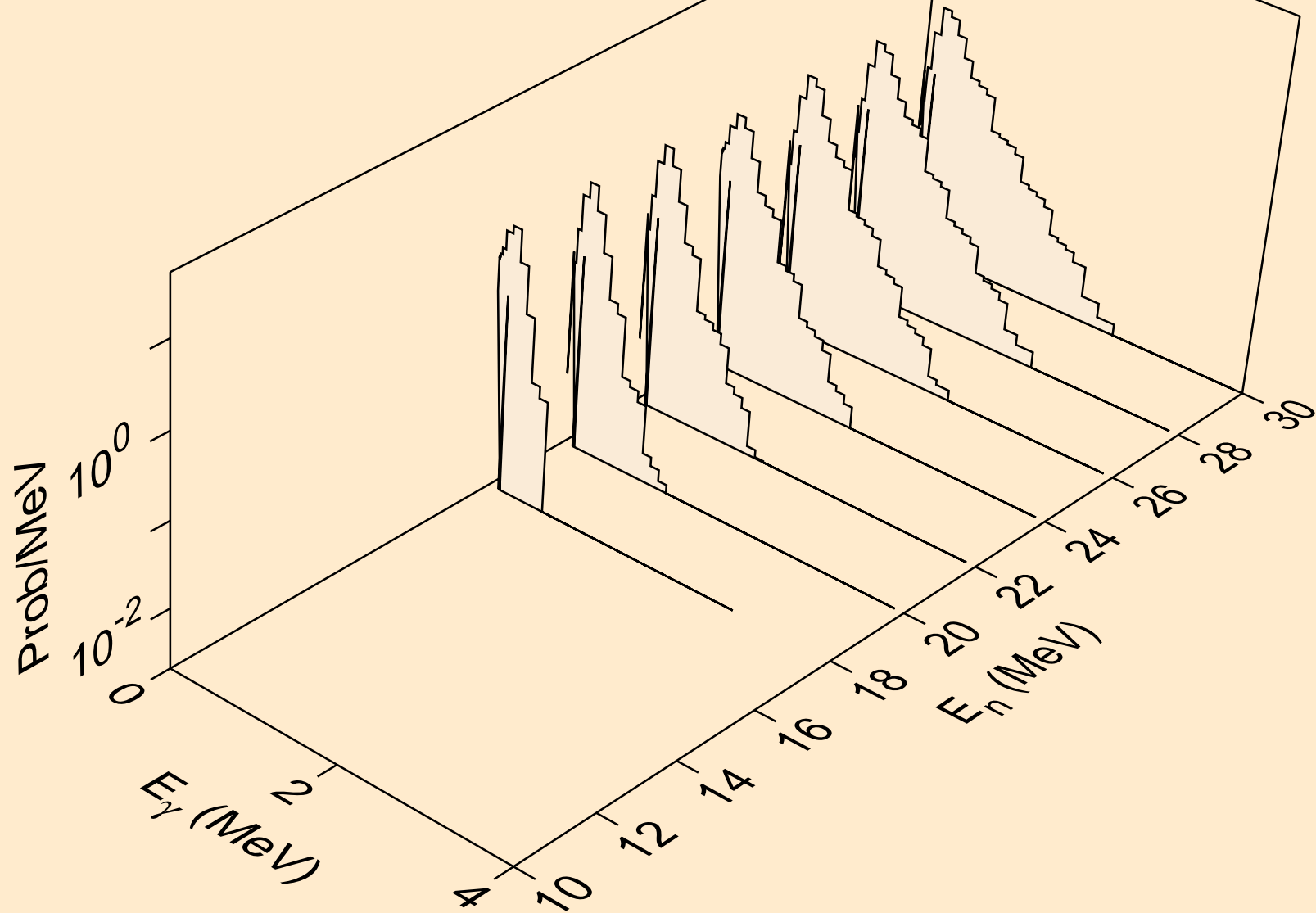



HG214 DEUTERON ACER TENDL-2023 LIBRARY; T=0.K  
Photon emission for (n,4n)

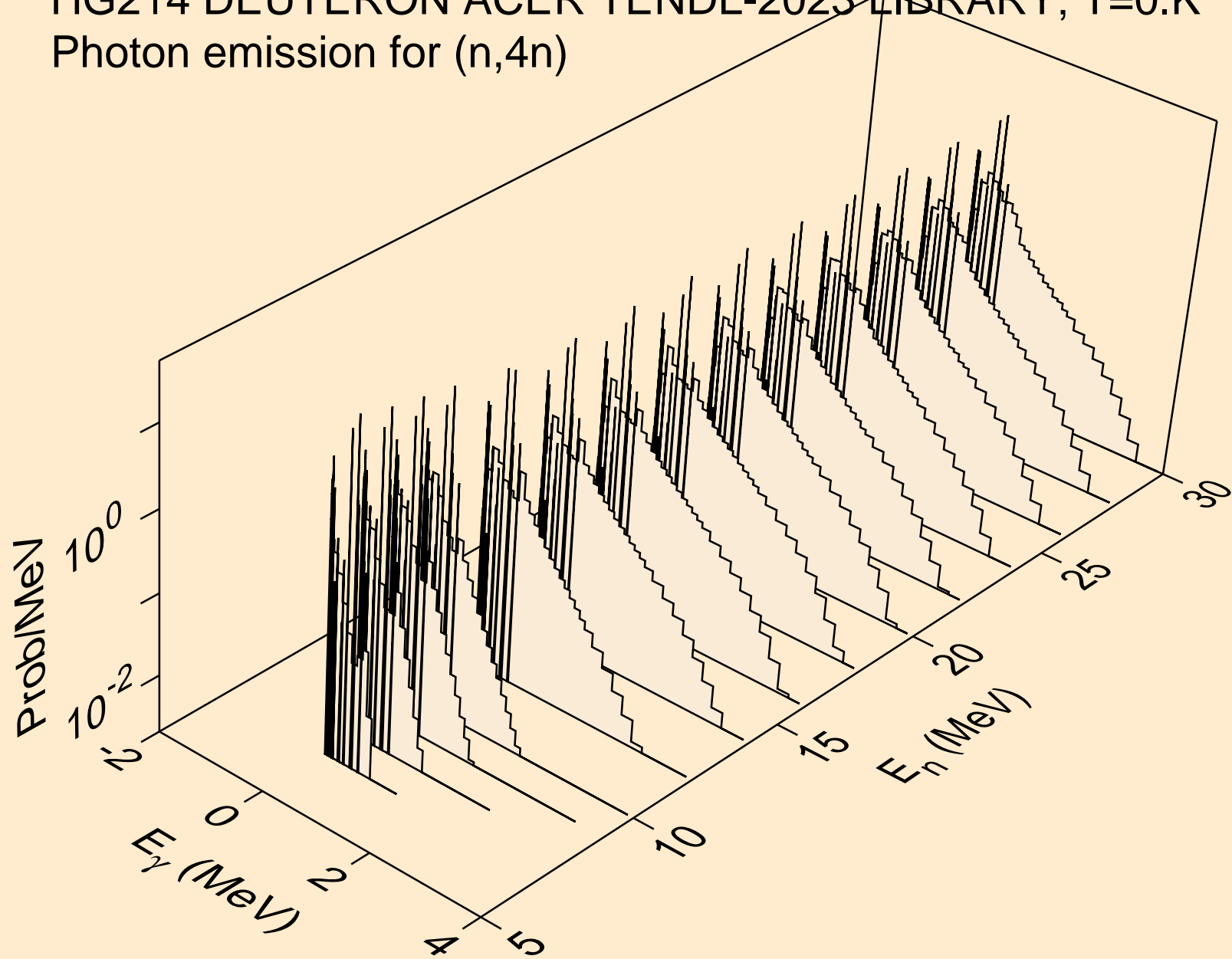

HG214 DEUTERON ACER TENDL-2023 LIBRARY; T=0.K  
Photon emission for (n,2np)

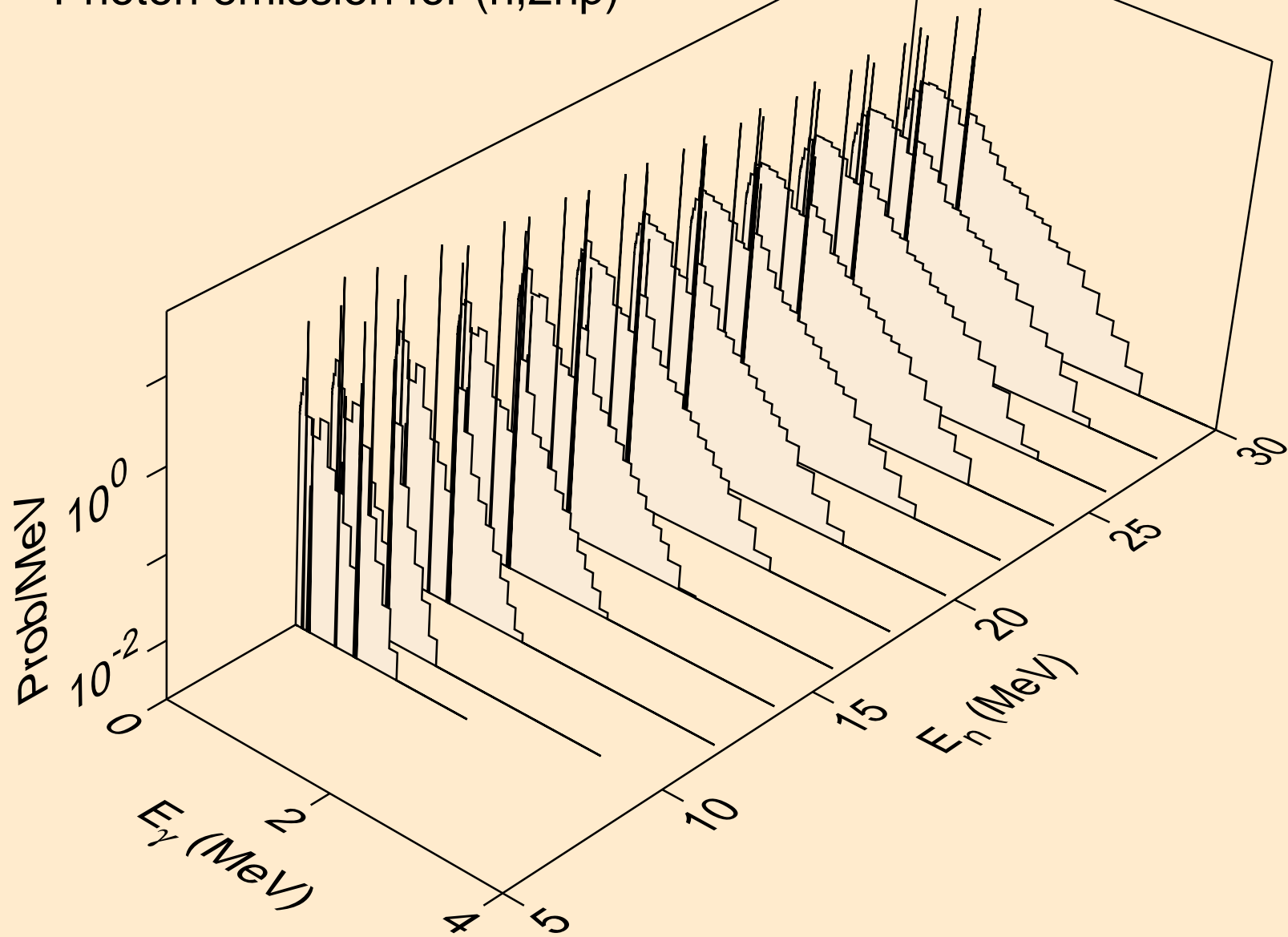

HG214 DEUTERON ACER TENDL-2023 LIBRARY; T=0.K  
Photon emission for (n,3np)

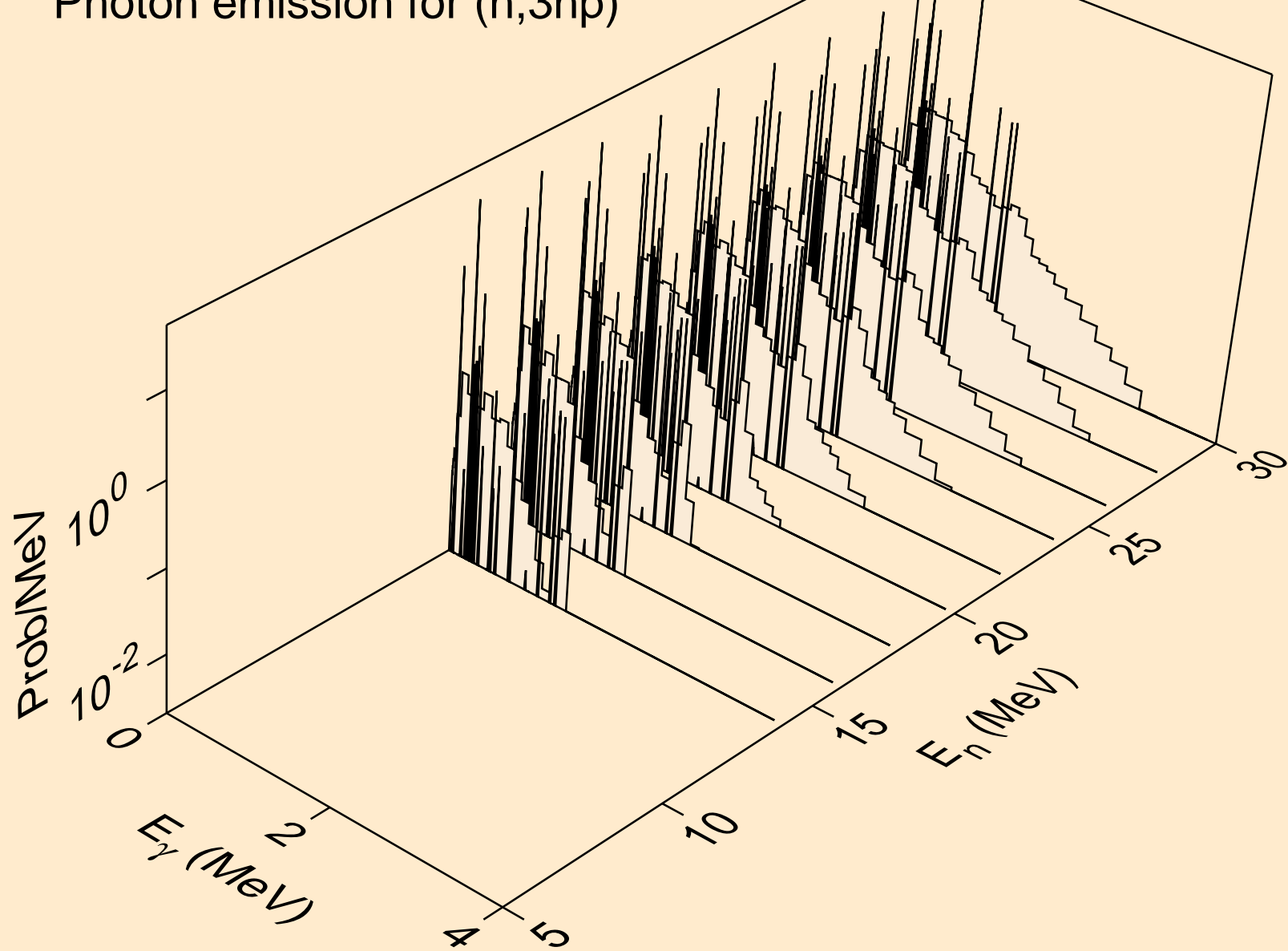

HG214 DEUTERON ACER TENDL-2023 LIBRARY; T=0.K  
Photon emission for (n,n2p)

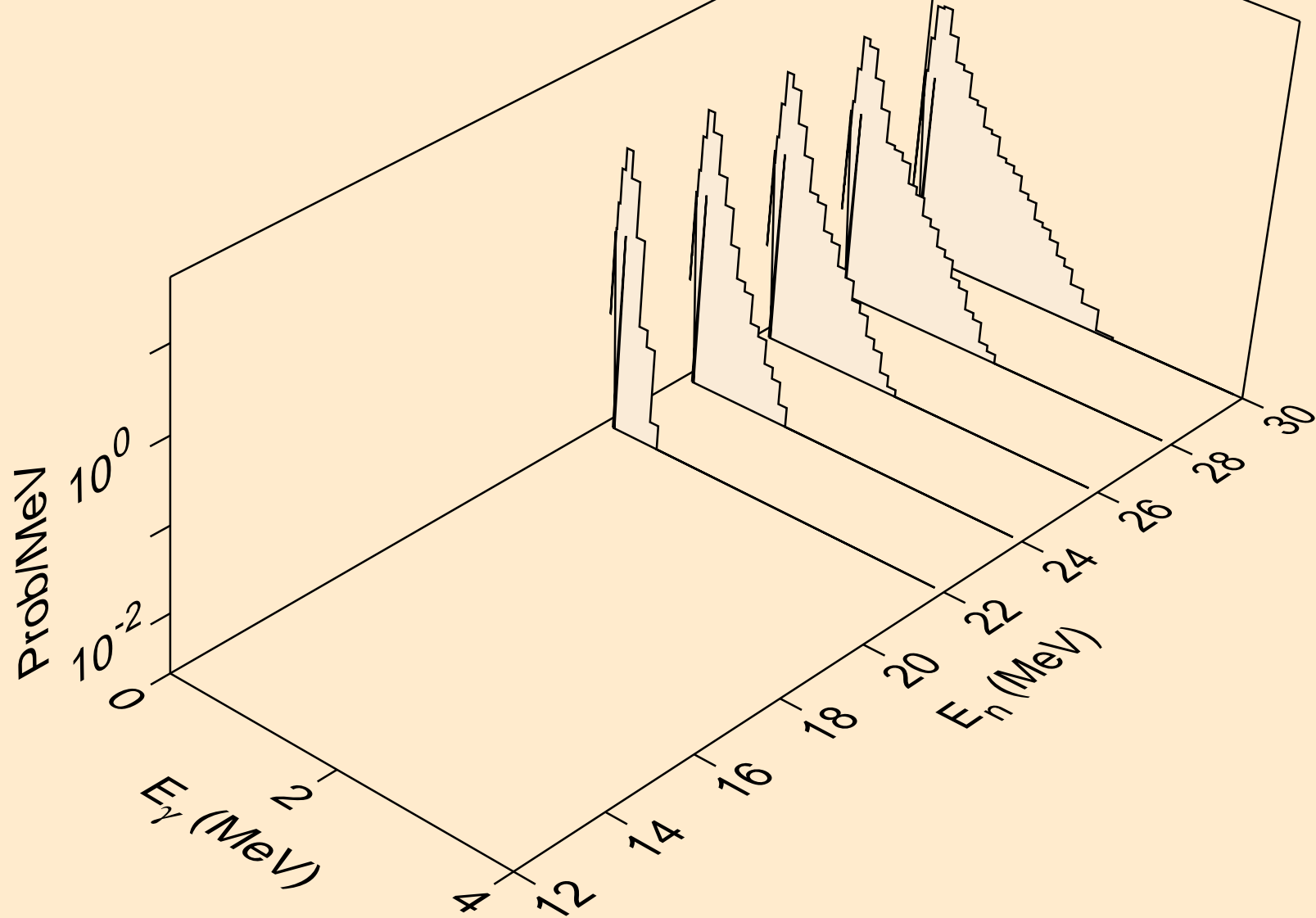

HG214 DEUTERON ACER TENDL-2023 LIBRARY; T=0.K  
Photon emission for (n,gma)

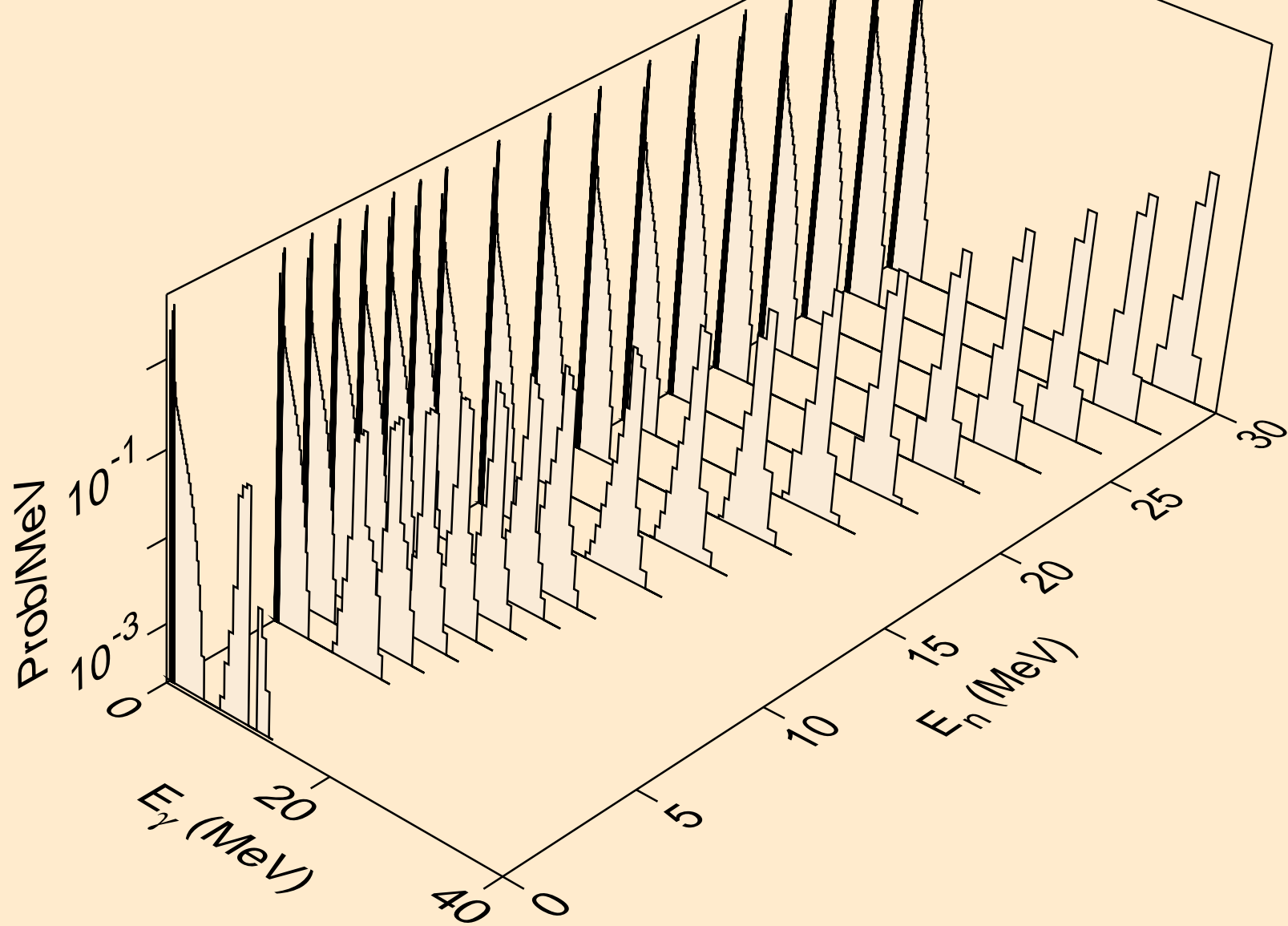

HG214 DEUTERON ACER TENDL-2023 LIBRARY; T=0.K  
Photon emission for (n,p)

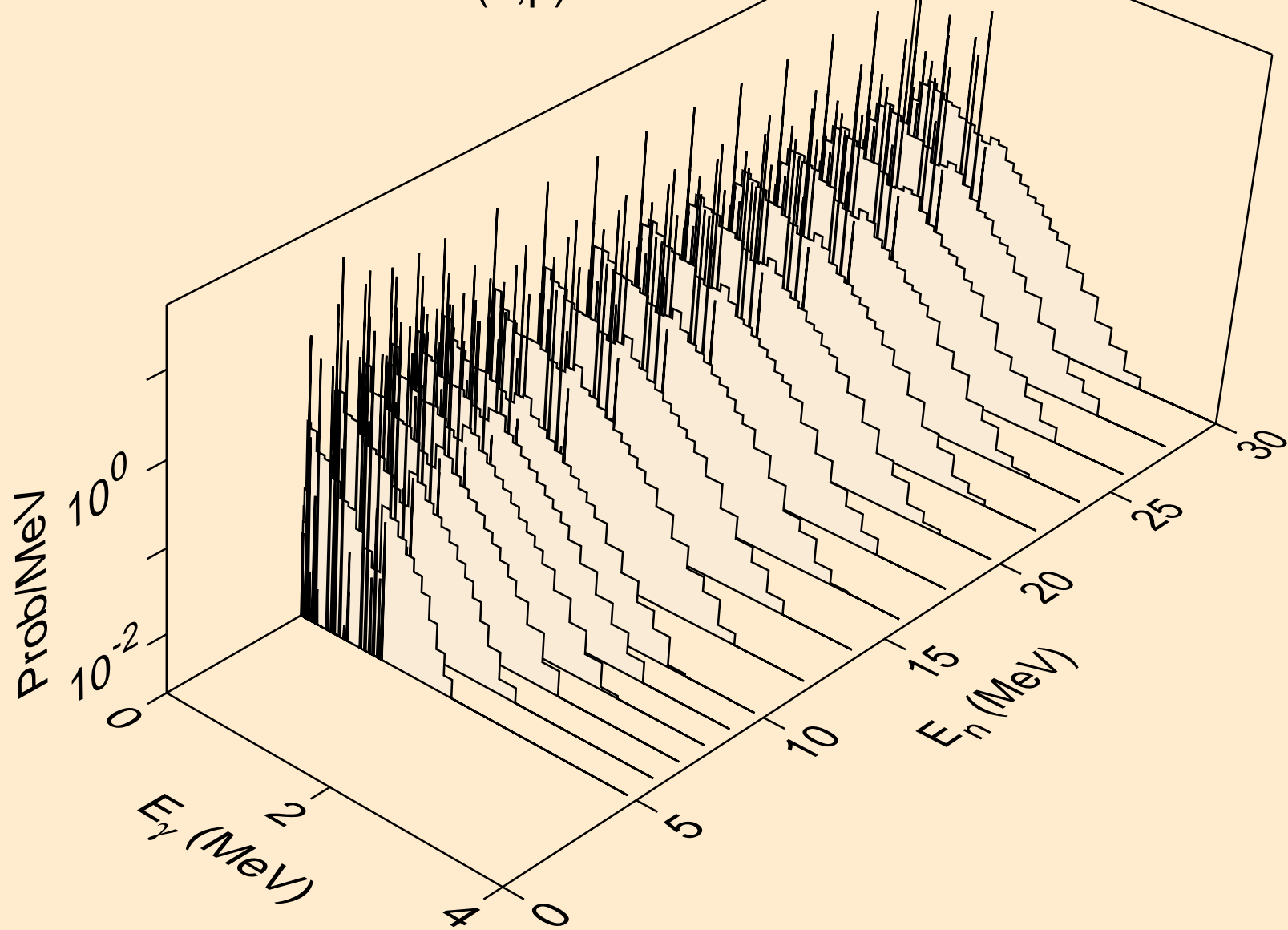

HG214 DEUTERON ACER TENDL-2023 LIBRARY; T=0.K  
Photon emission for inelastic

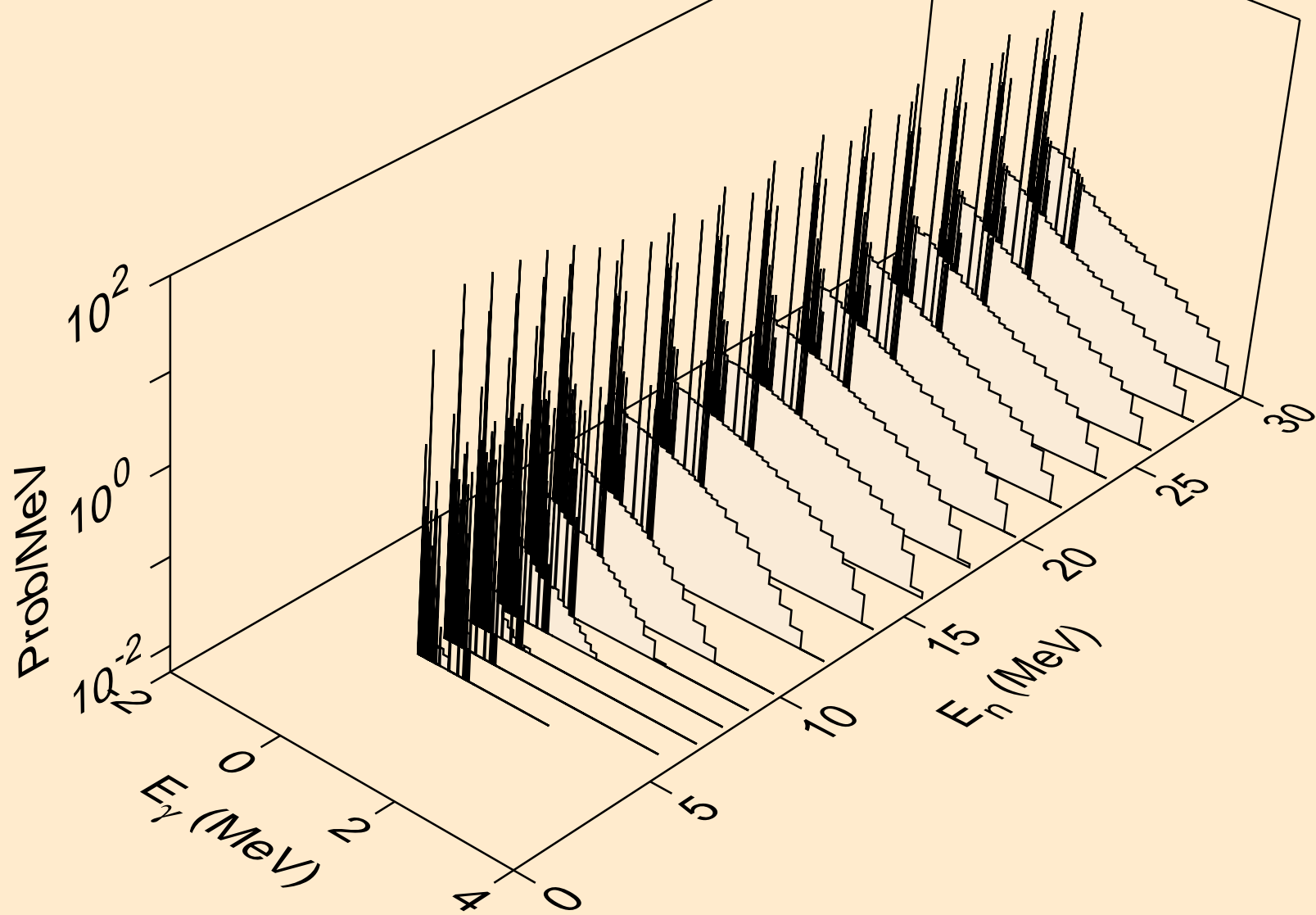

HG214 DEUTERON ACER TENDL-2023 LIBRARY; T=0.K  
Photon emission for (n,t)

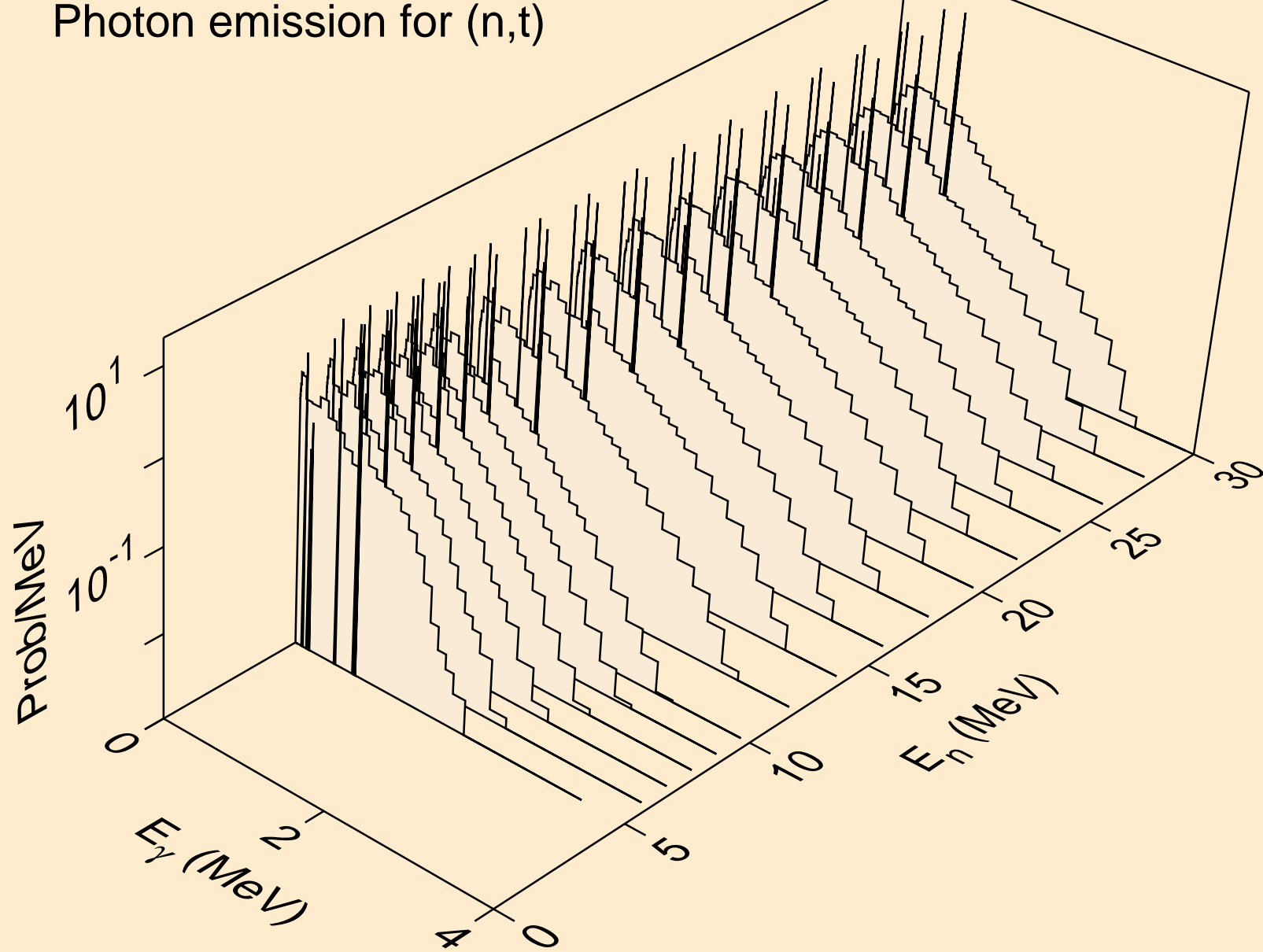



HG214 DEUTERON ACER TENDL-2023 LIBRARY; T=0.K  
Photon emission for (n,he3)

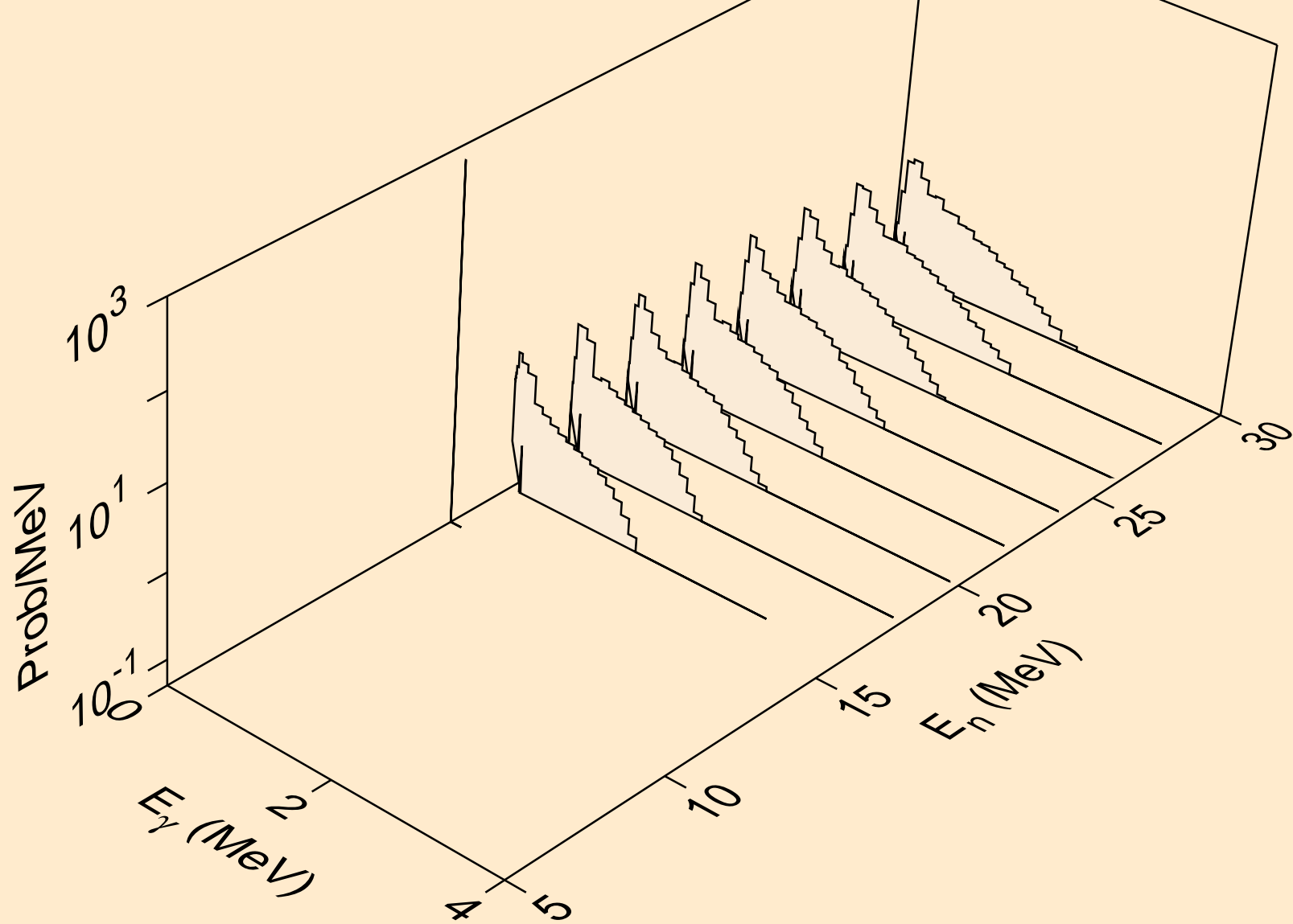

HG214 DEUTERON ACER TENDL-2023 LIBRARY; T=0.K  
Photon emission for (n,a)

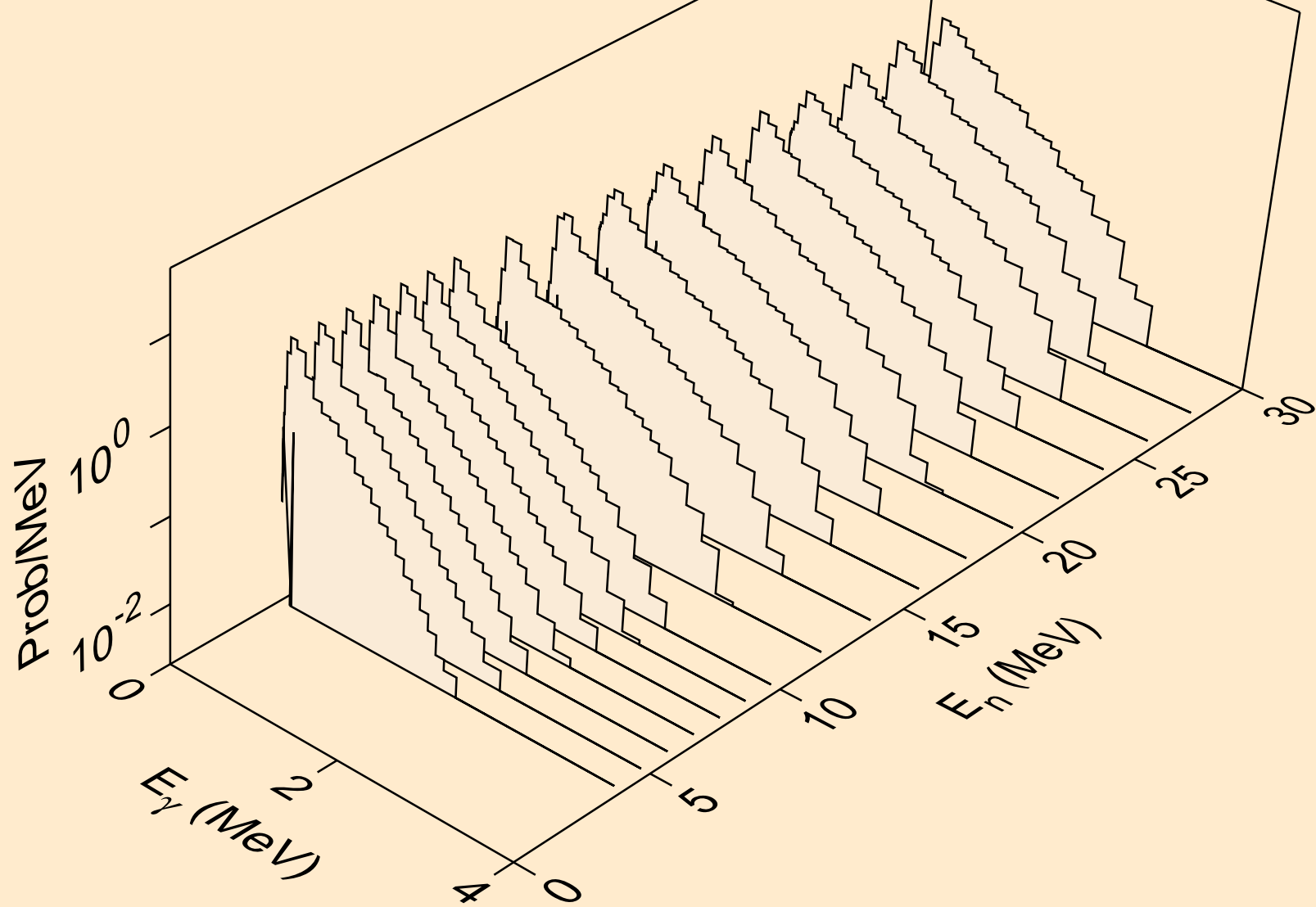

HG214 DEUTERON ACER TENDL-2023 LIBRARY; T=0.K  
Photon emission for (n,2p)

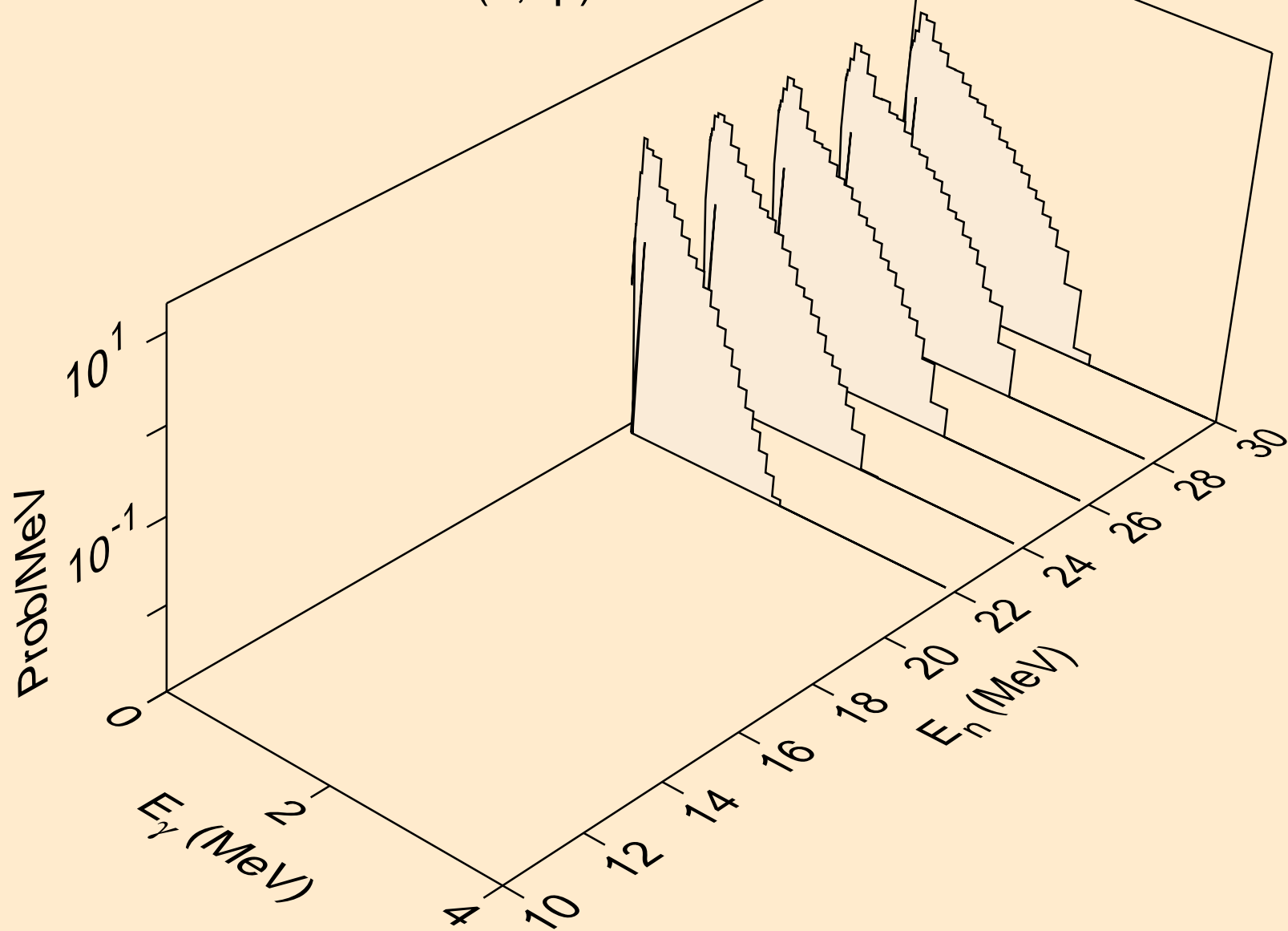

HG214 DEUTERON ACER TENDL-2023 LIBRARY; T=0.K  
Photon emission for (n,pd)

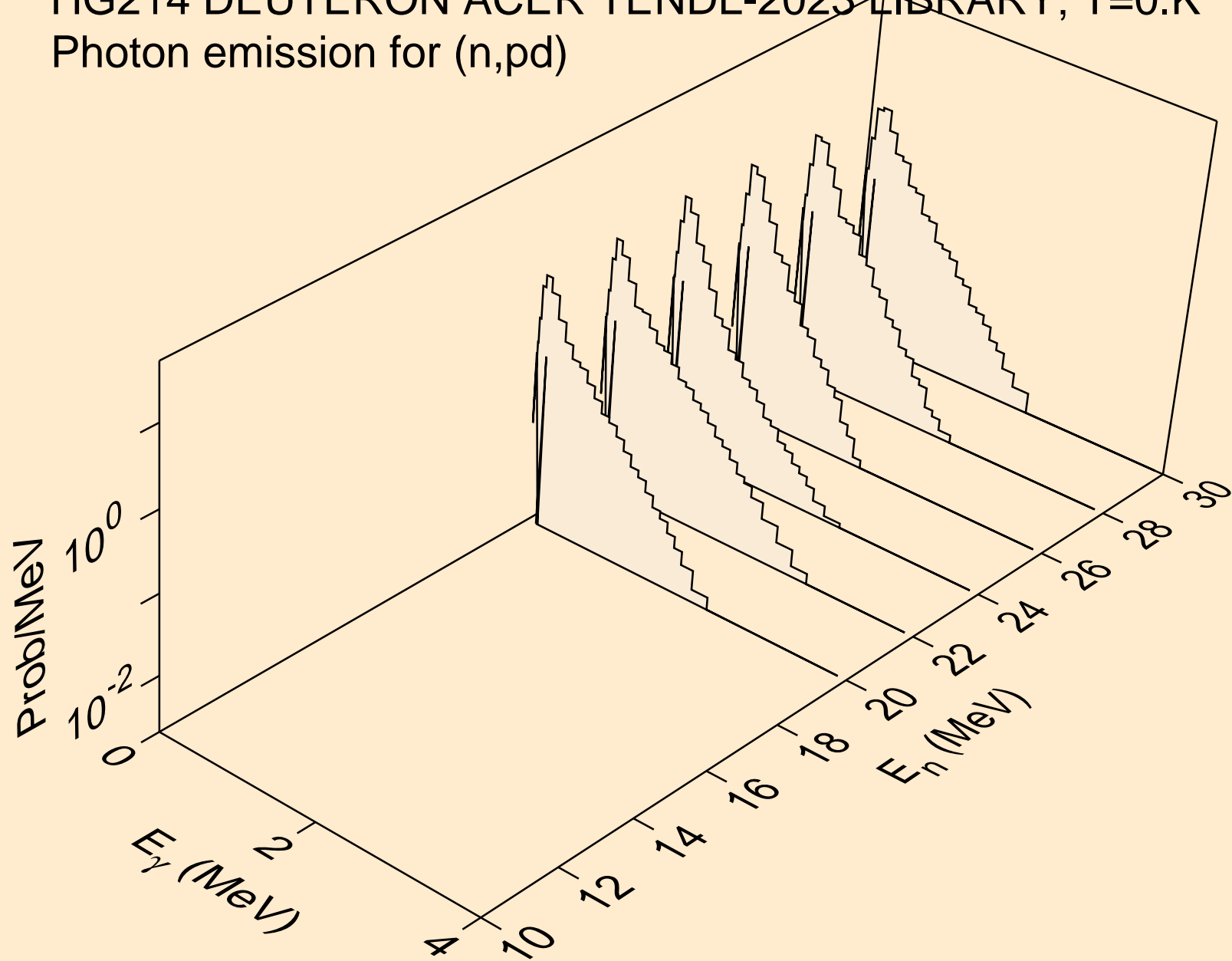

# HG214 DEUTERON ACER TENDL-2023 LIBRARY; T=0.K

## Particle heating contributions

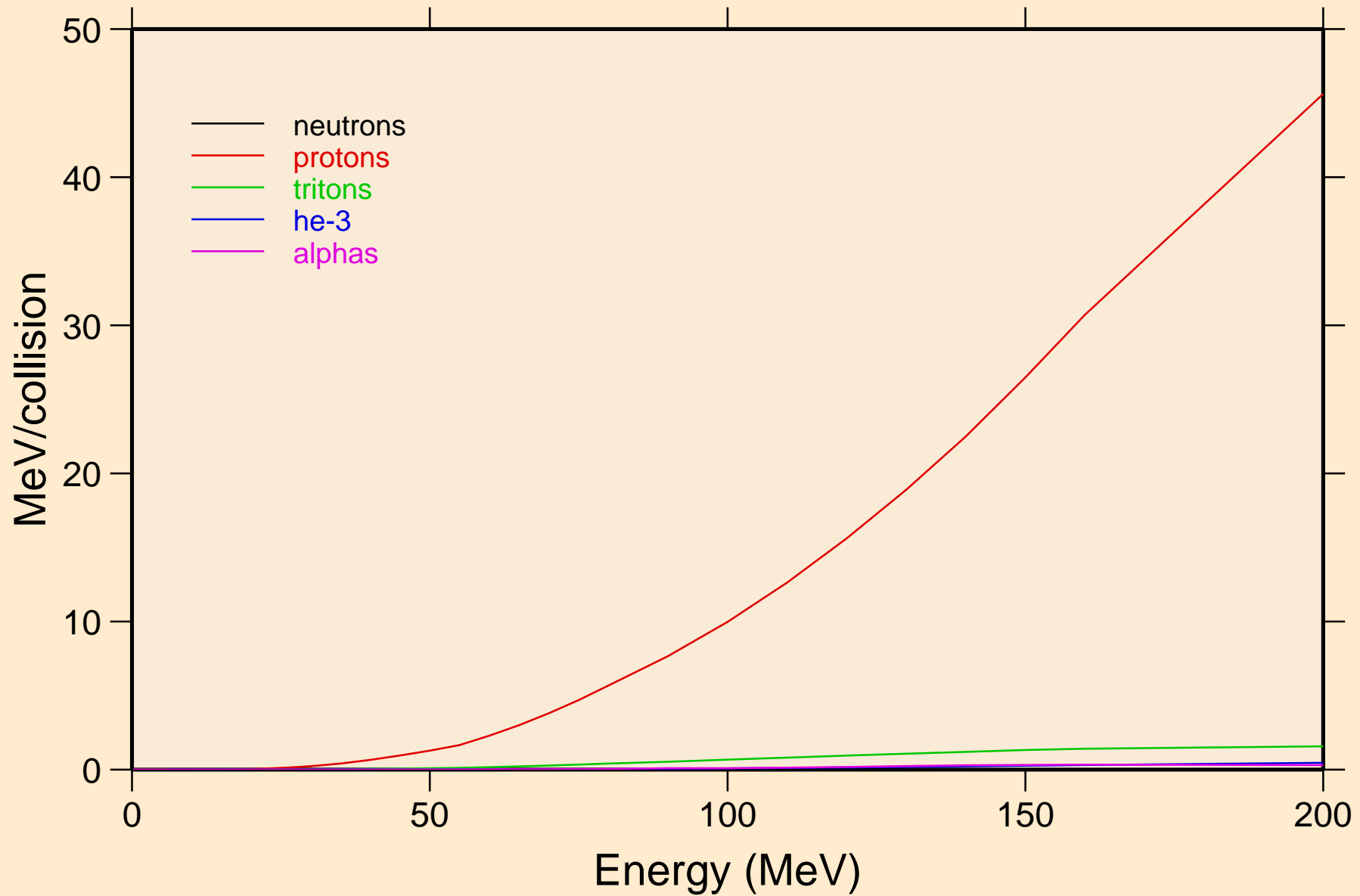

HG214 DEUTERON ACER TENDL-2023 LIBRARY; T=0.K  
Recoil Heating

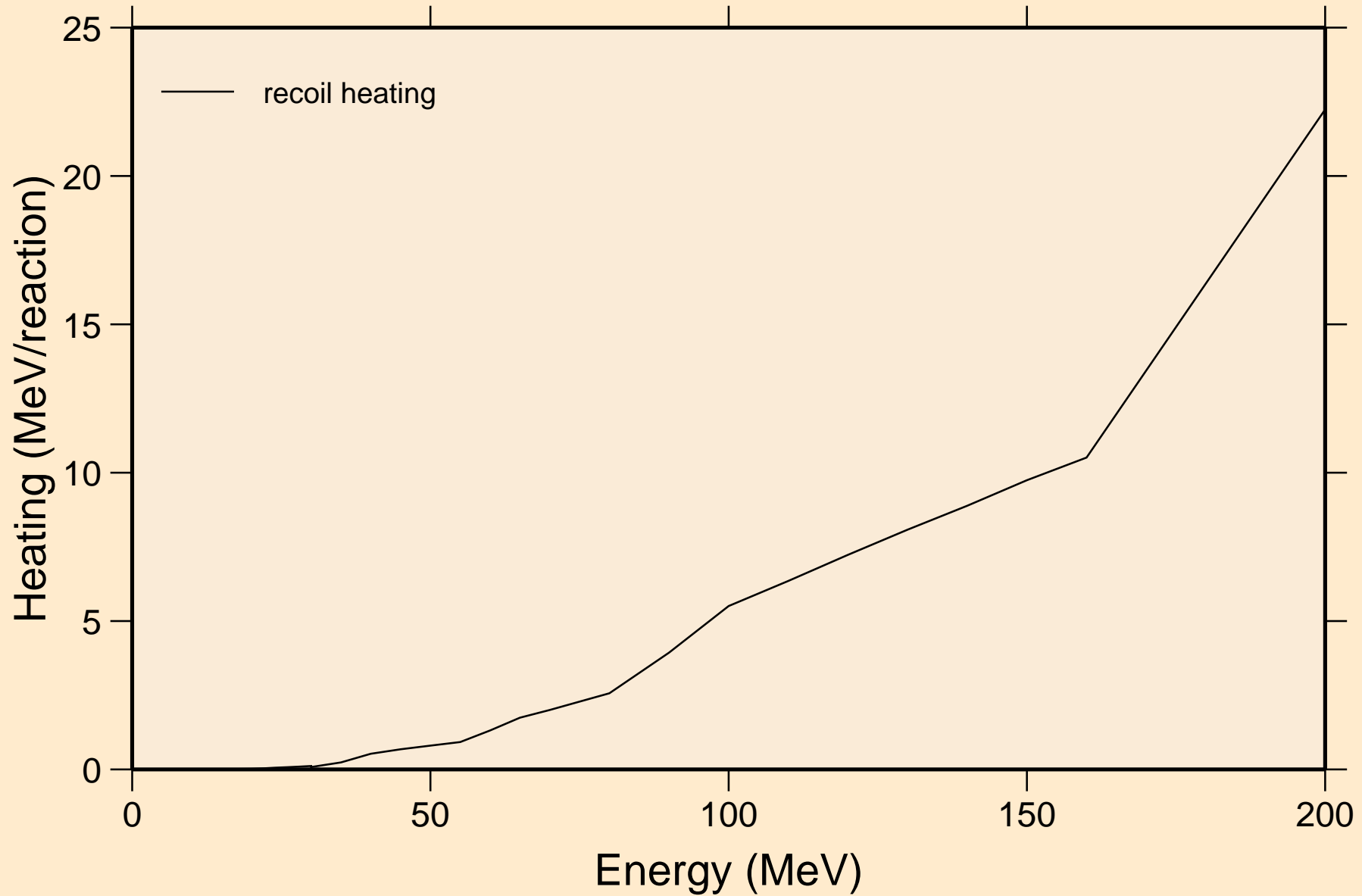

# HG214 DEUTERON ACER TENDL-2023 LIBRARY; T=0.K

## Particle production cross sections

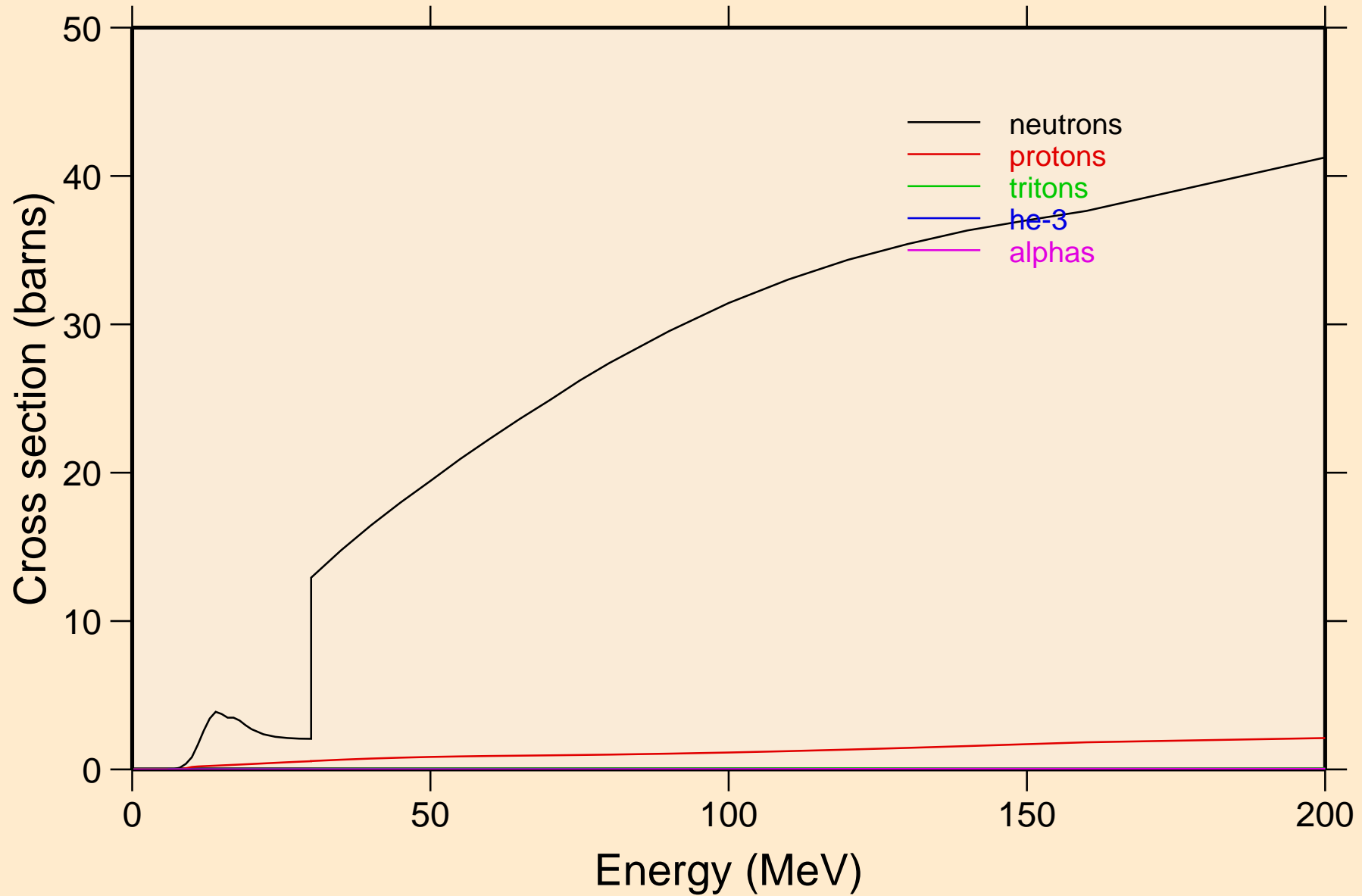

HG214 DEUTERON ACER TENDL-2023 LIBRARY; T=0.K  
neutrons from (d,n)

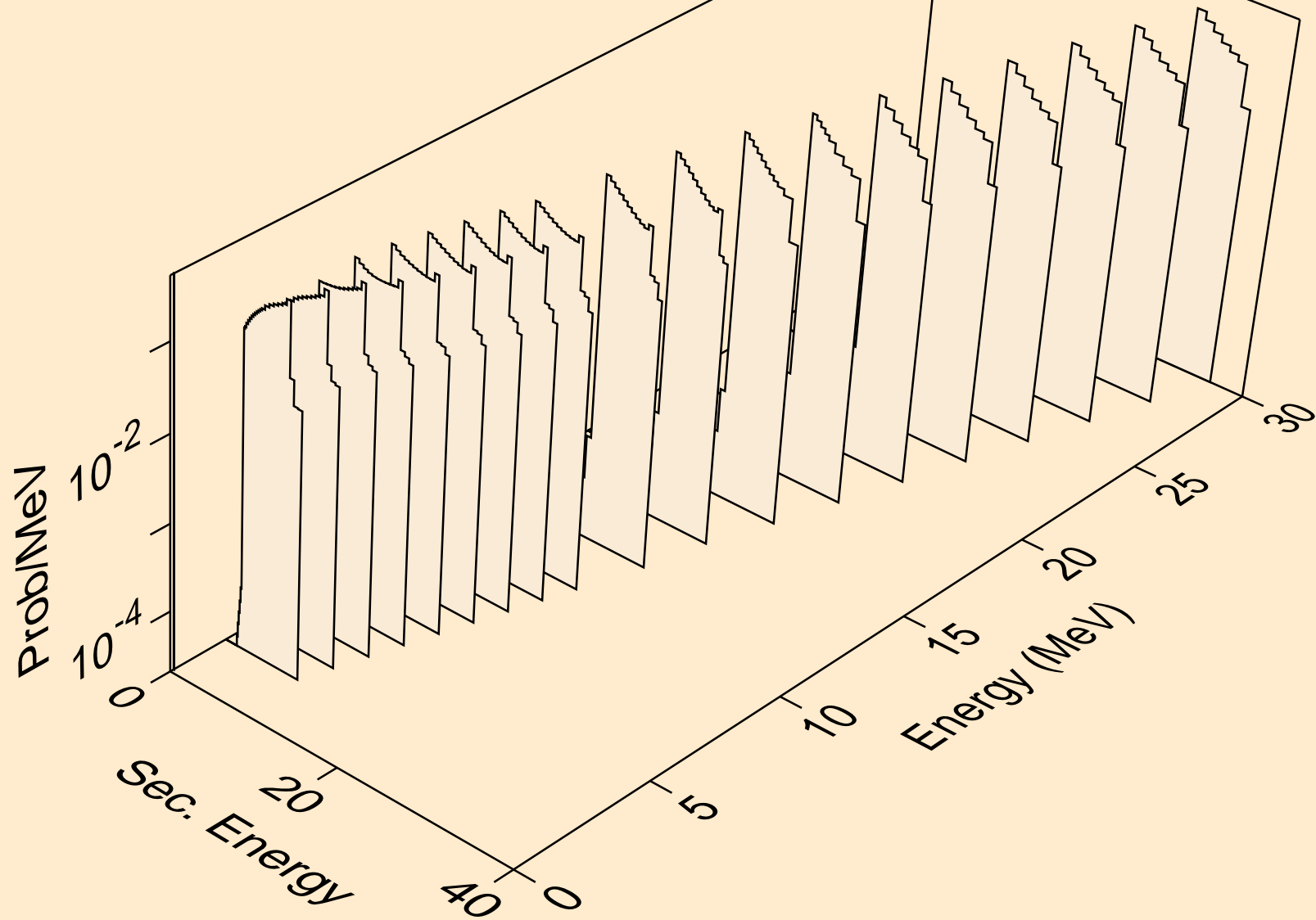



HG214 DEUTERON ACER TENDL-2023 LIBRARY; T=0.K  
neutrons from (d,x)

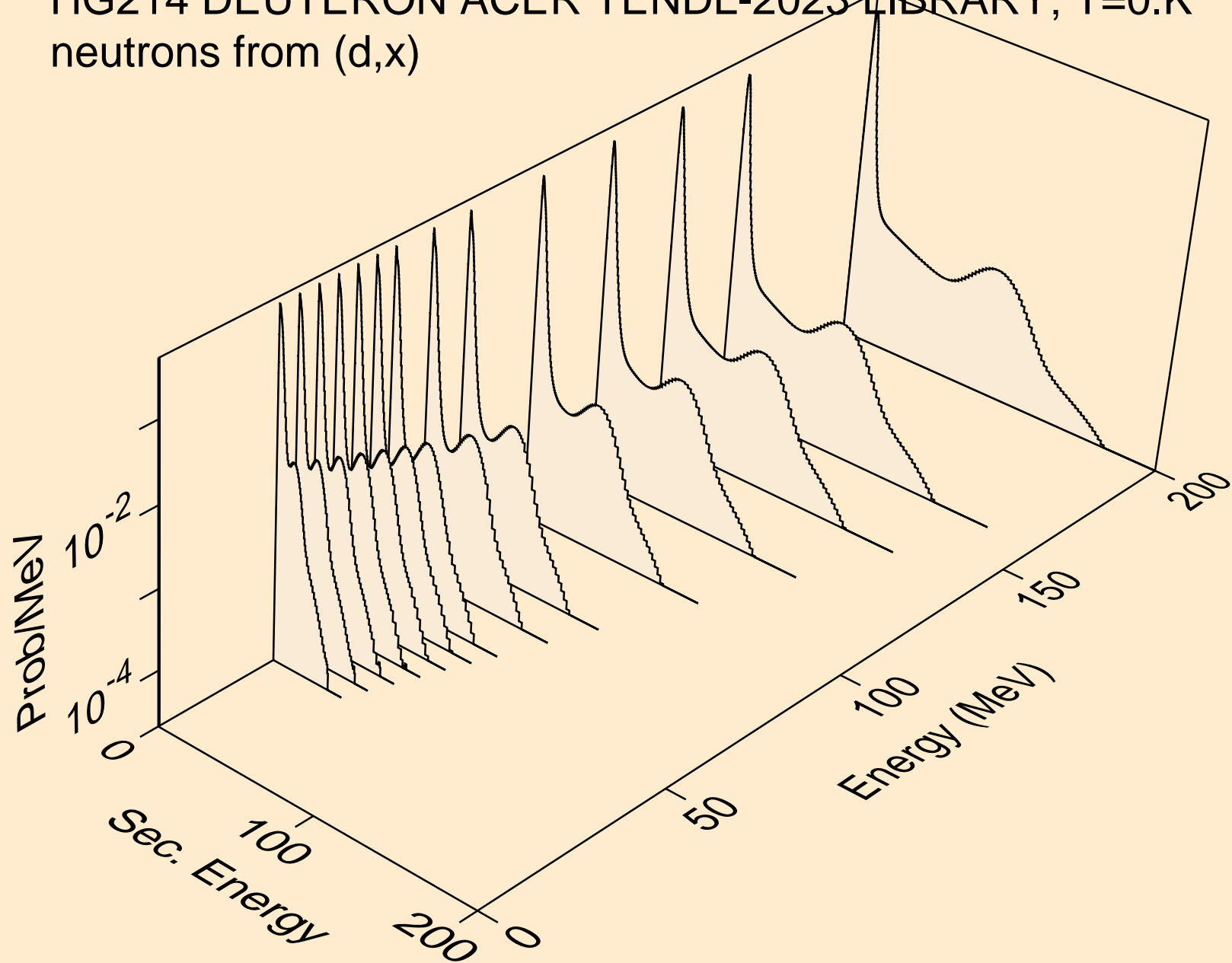

HG214 DEUTERON ACER TENDL-2023 LIBRARY; T=0.K  
neutrons from (d,2nd)

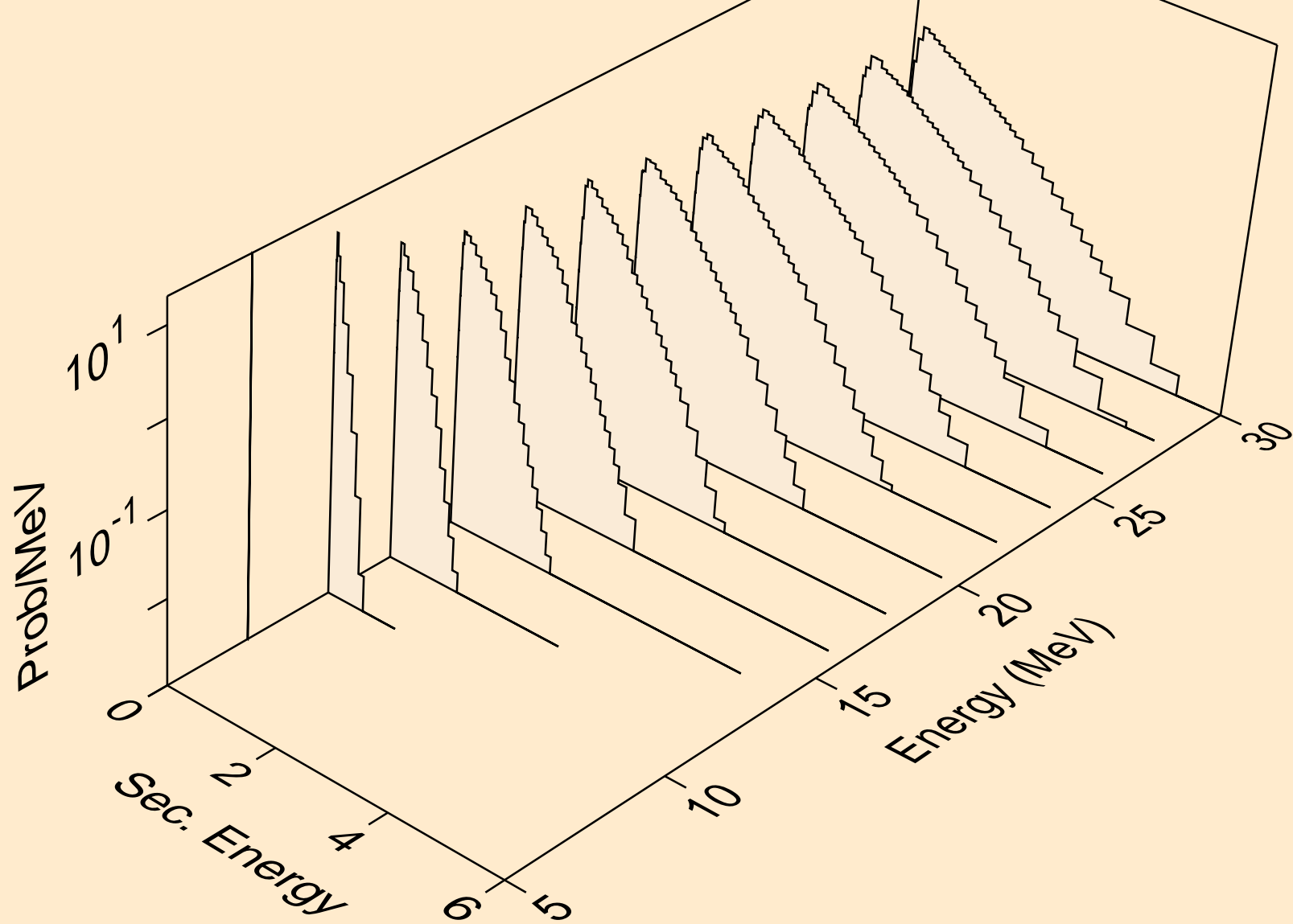

HG214 DEUTERON ACER TENDL-2023 LIBRARY; T=0.K  
neutrons from (d,2n)

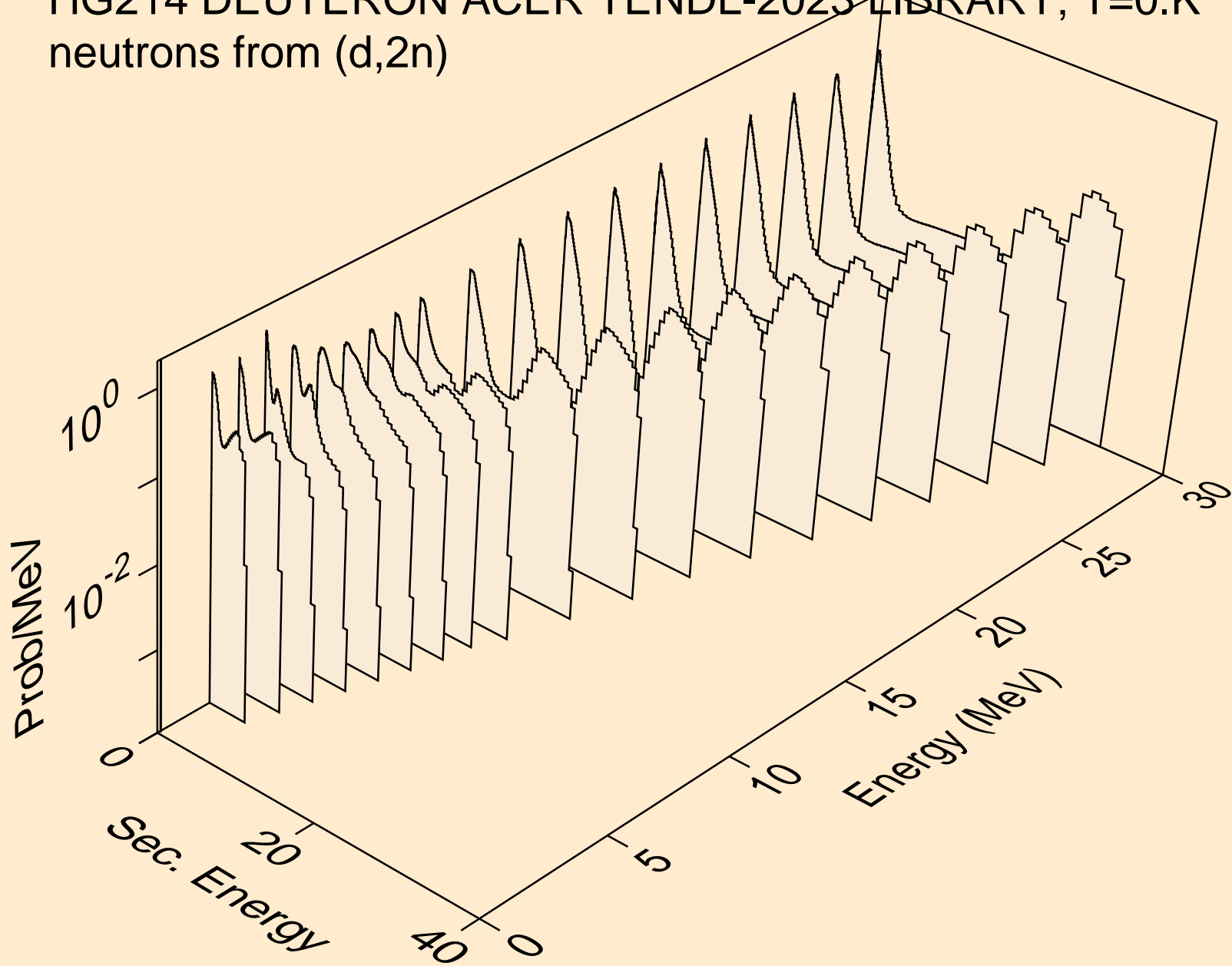

HG214 DEUTERON ACER TENDL-2023 LIBRARY; T=0.K  
neutrons from (d,3n)

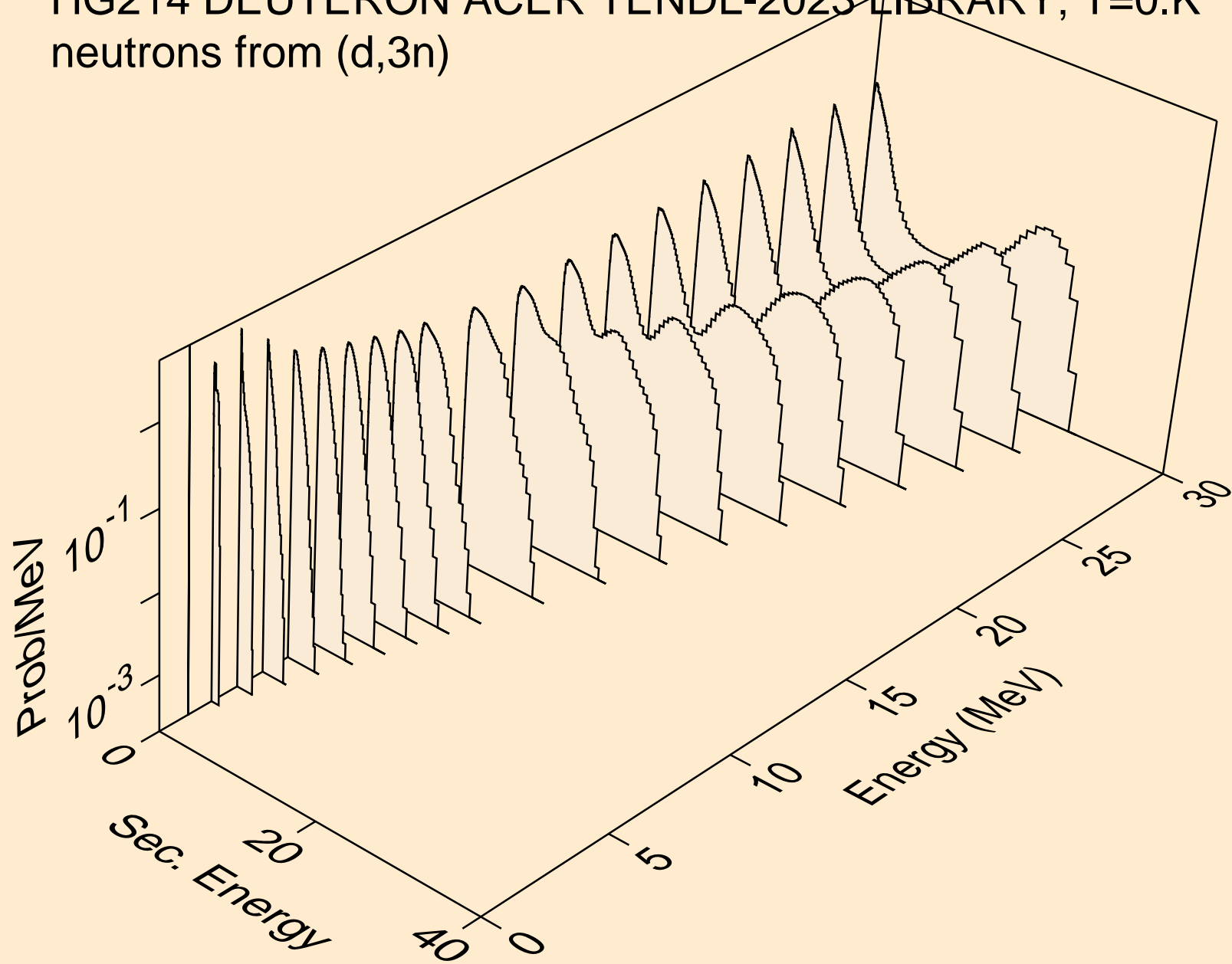

HG214 DEUTERON ACER TENDL-2023 LIBRARY; T=0.K  
neutrons from (d,n\*)a

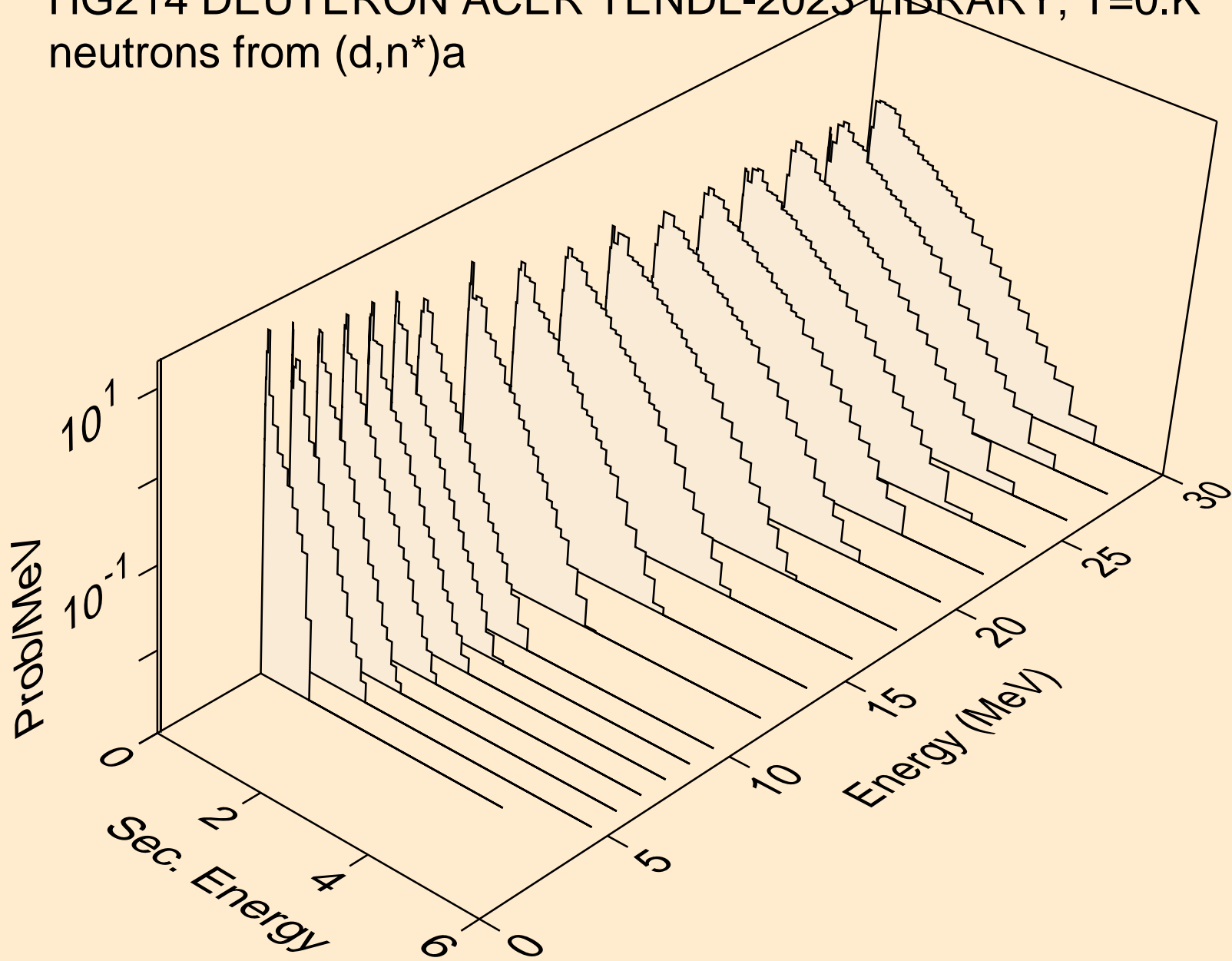

HG214 DEUTERON ACER TENDL-2023 LIBRARY; T=0.K  
neutrons from (d,2n)a

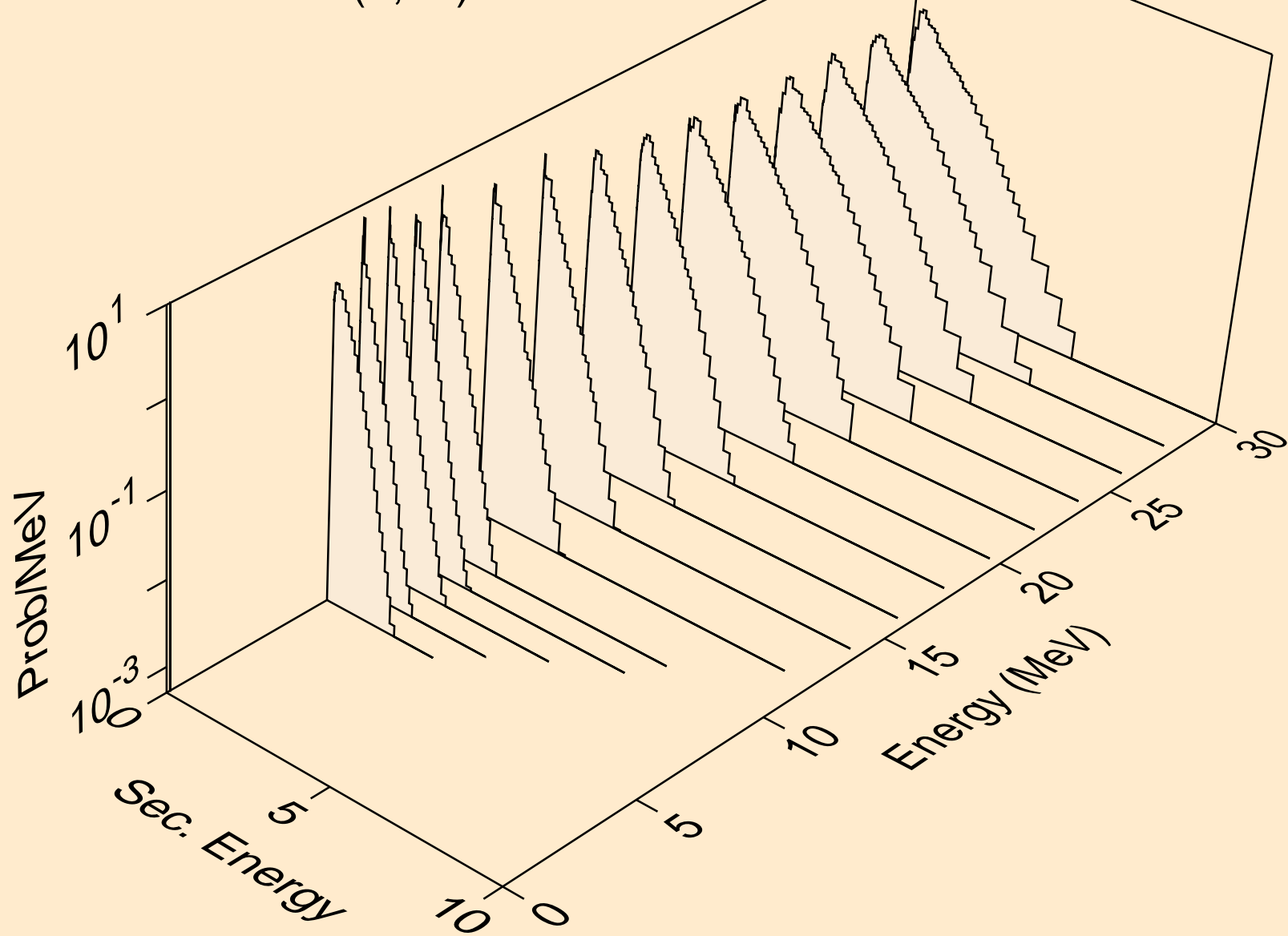

HG214 DEUTERON ACER TENDL-2023 LIBRARY; T=0.K  
neutrons from (d,3n)a

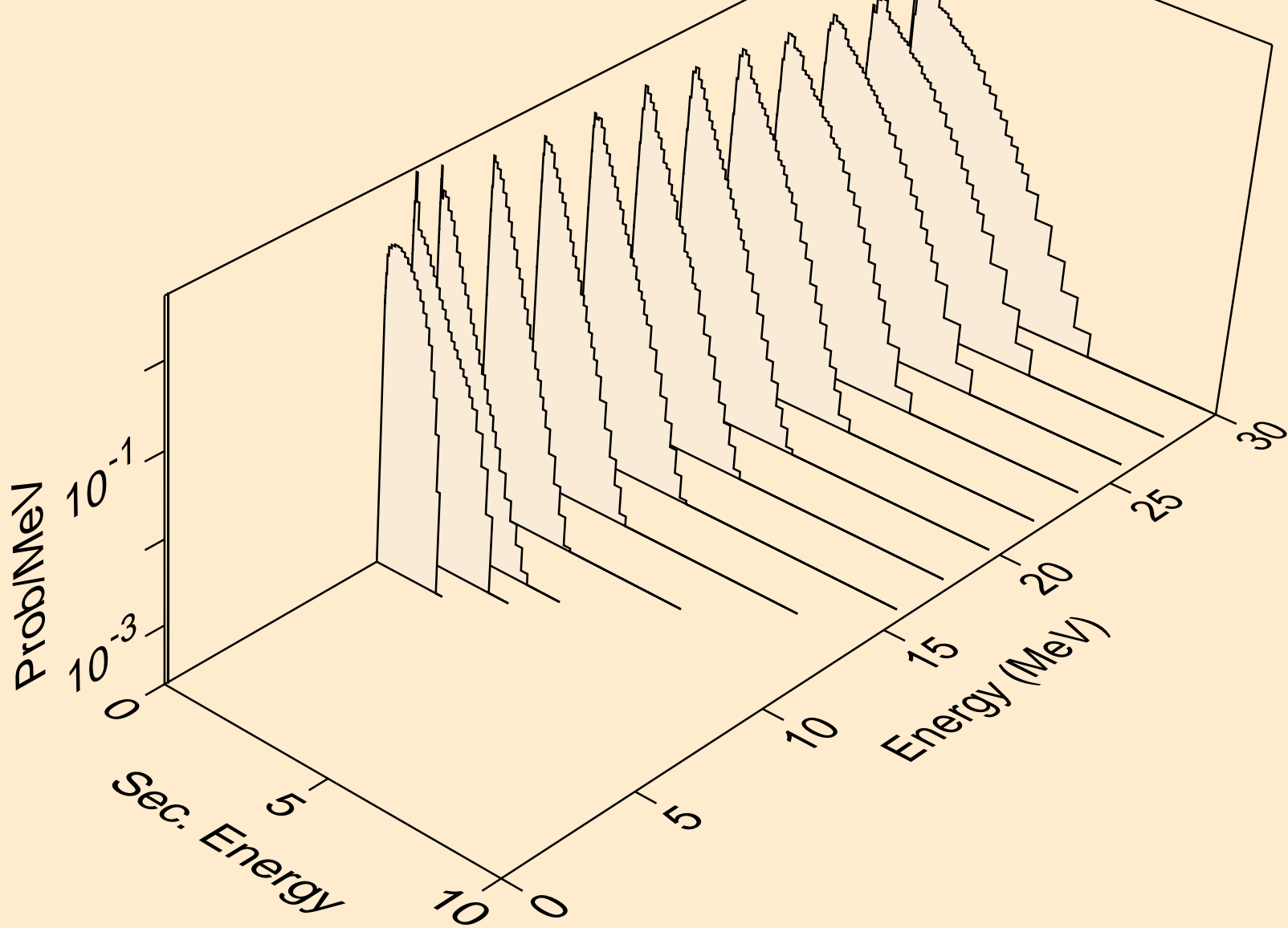

HG214 DEUTERON ACER TENDL-2023 LIBRARY; T=0.K  
neutrons from (d,n\*)p

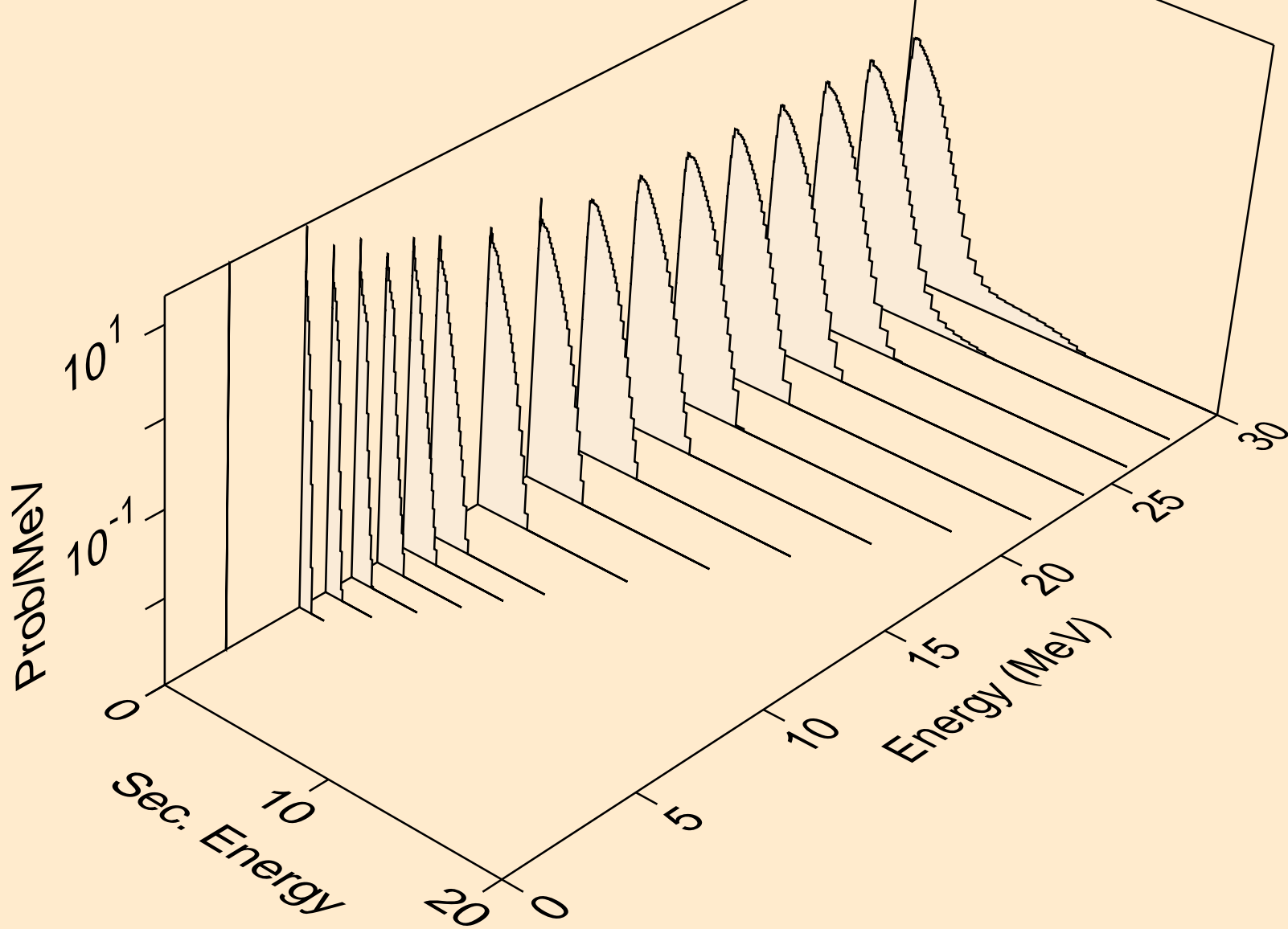



HG214 DEUTERON ACER TENDL-2023 LIBRARY; T=0.K  
neutrons from (d,n\*)d

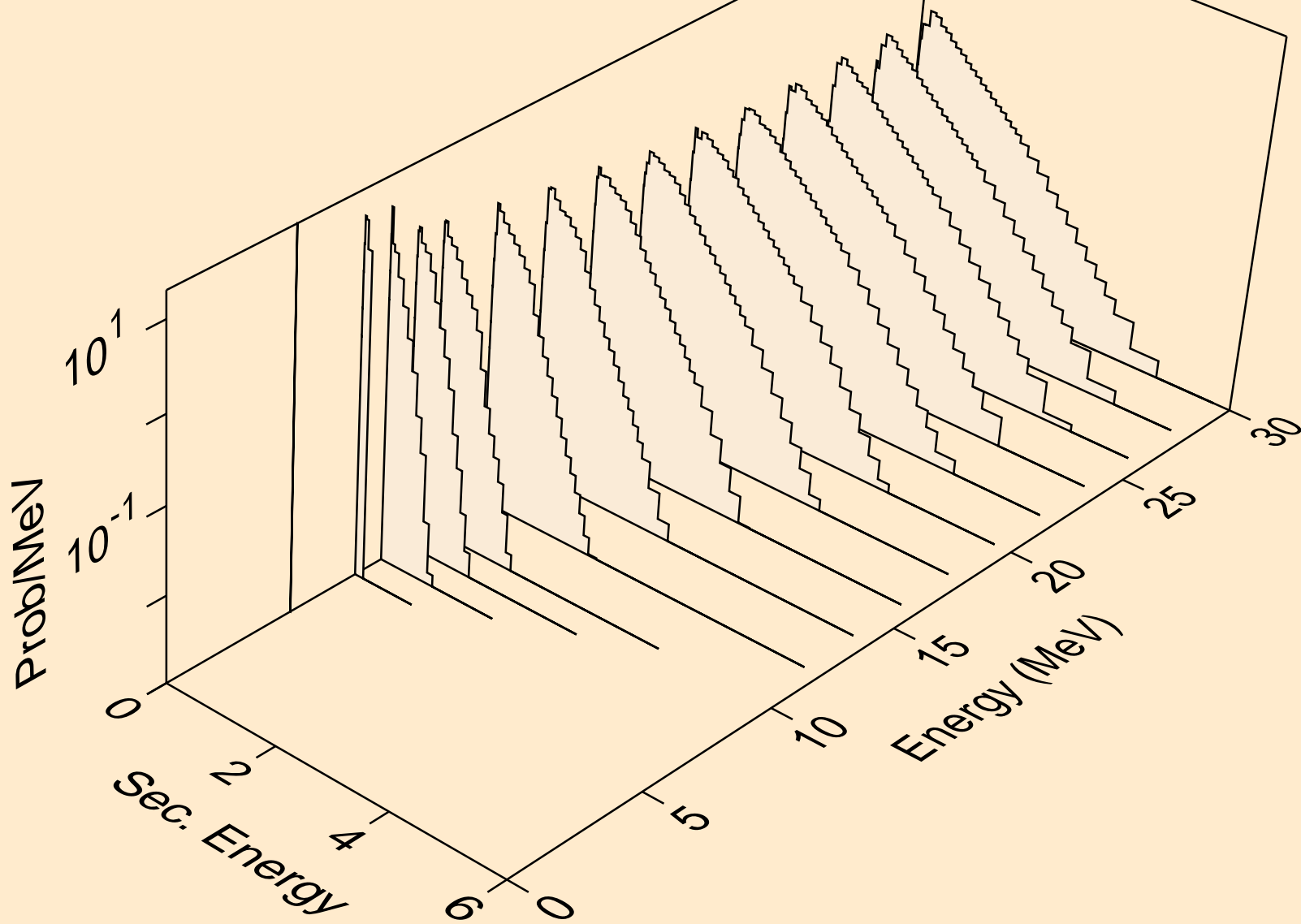

HG214 DEUTERON ACER TENDL-2023 LIBRARY; T=0.K  
neutrons from (d,n\*)t

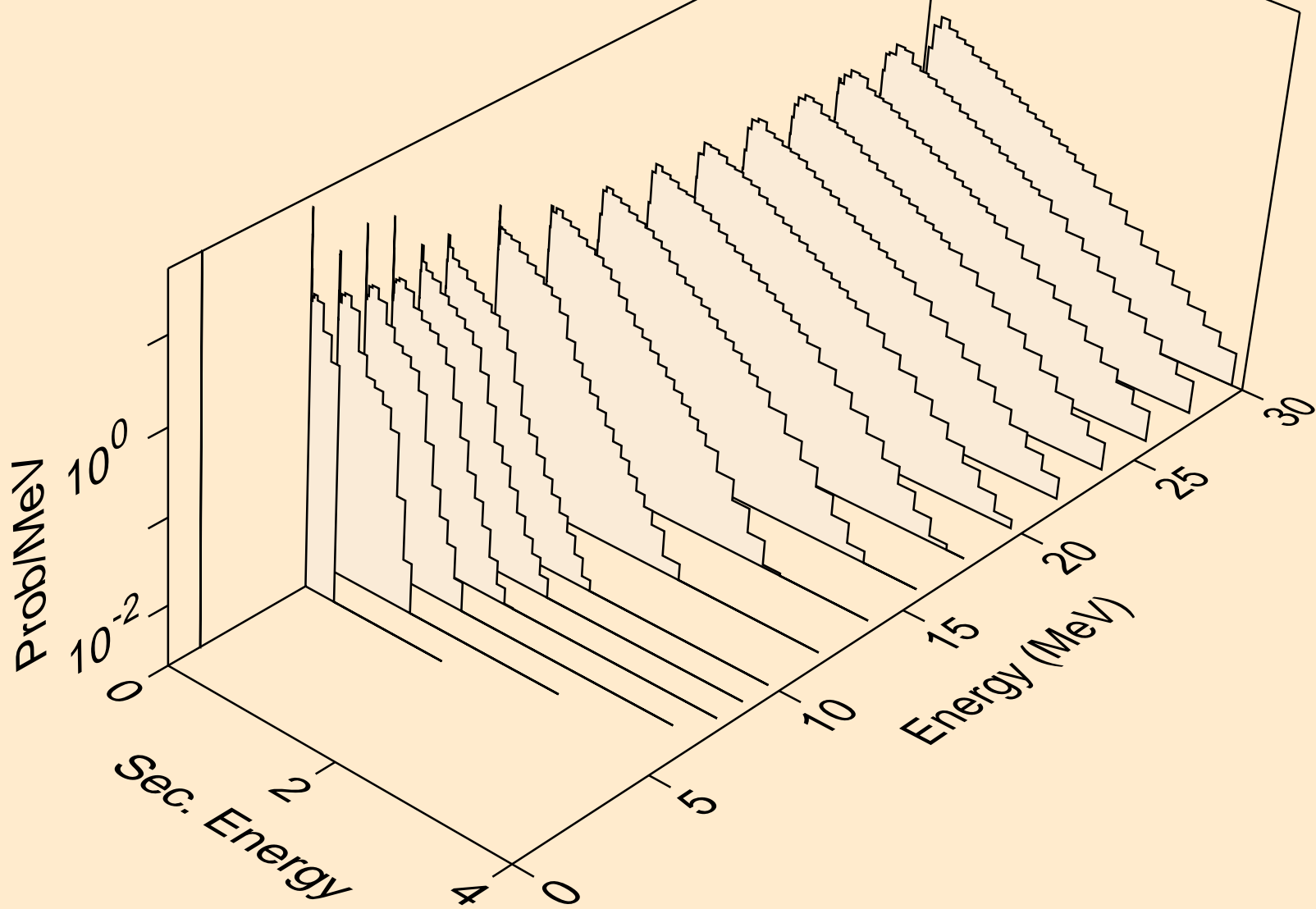

HG214 DEUTERON ACER TENDL-2023 LIBRARY; T=0.K  
neutrons from (d,n\*)he3

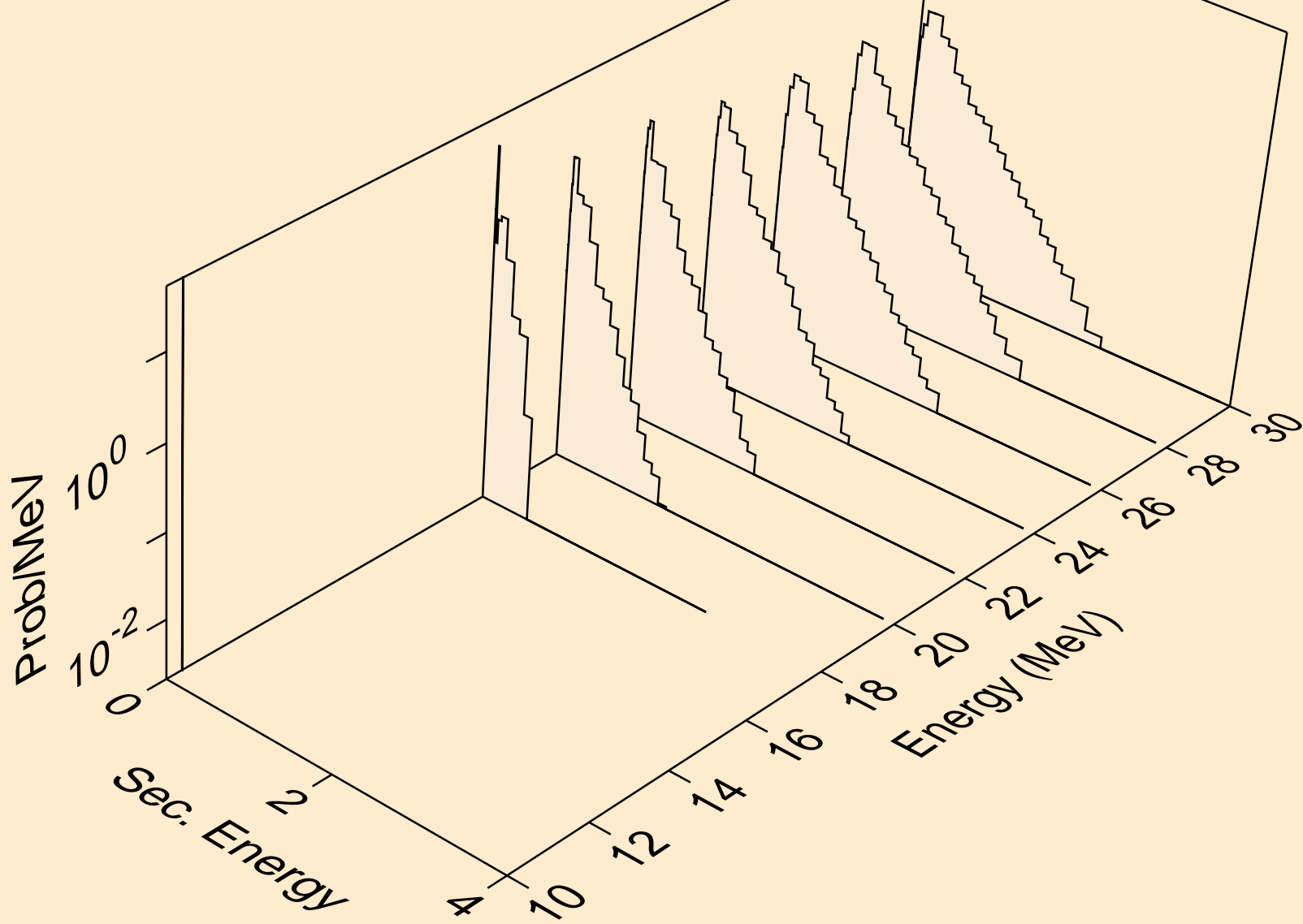

HG214 DEUTERON ACER TENDL-2023 LIBRARY; T=0.K  
neutrons from (d,4n)

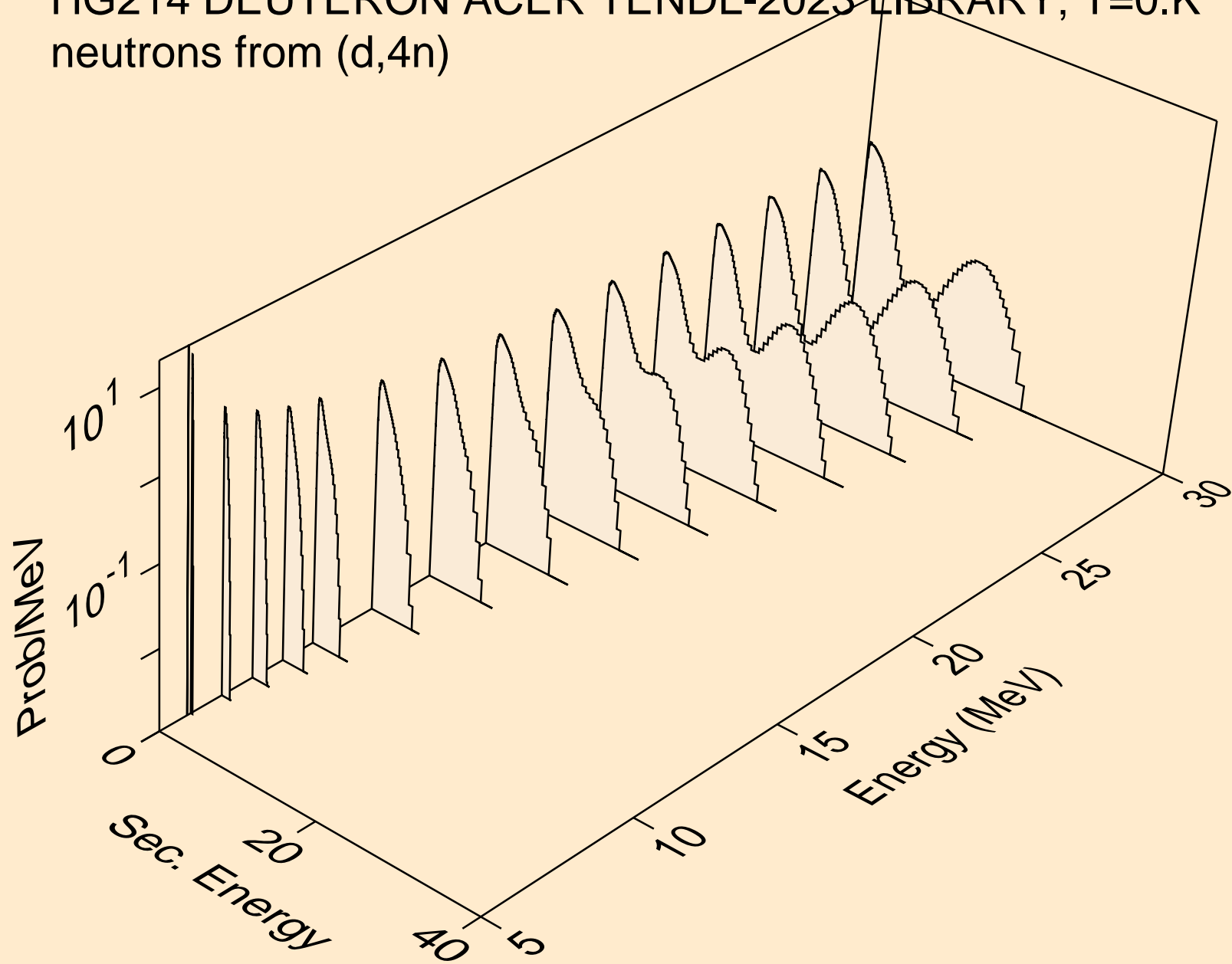

HG214 DEUTERON ACER TENDL-2023 LIBRARY; T=0.K  
neutrons from (d,2np)

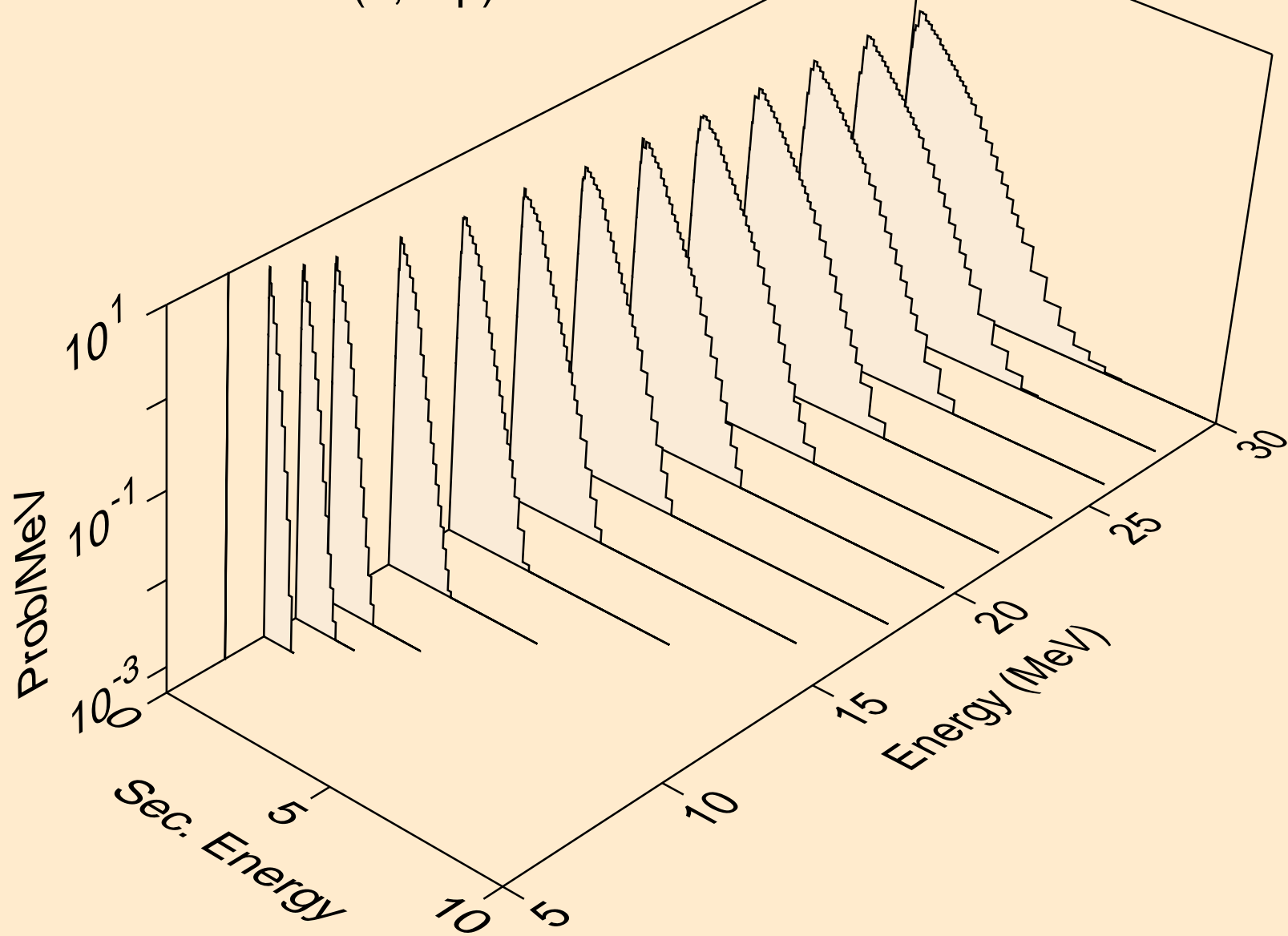

HG214 DEUTERON ACER TENDL-2023 LIBRARY; T=0.K  
neutrons from (d,3np)

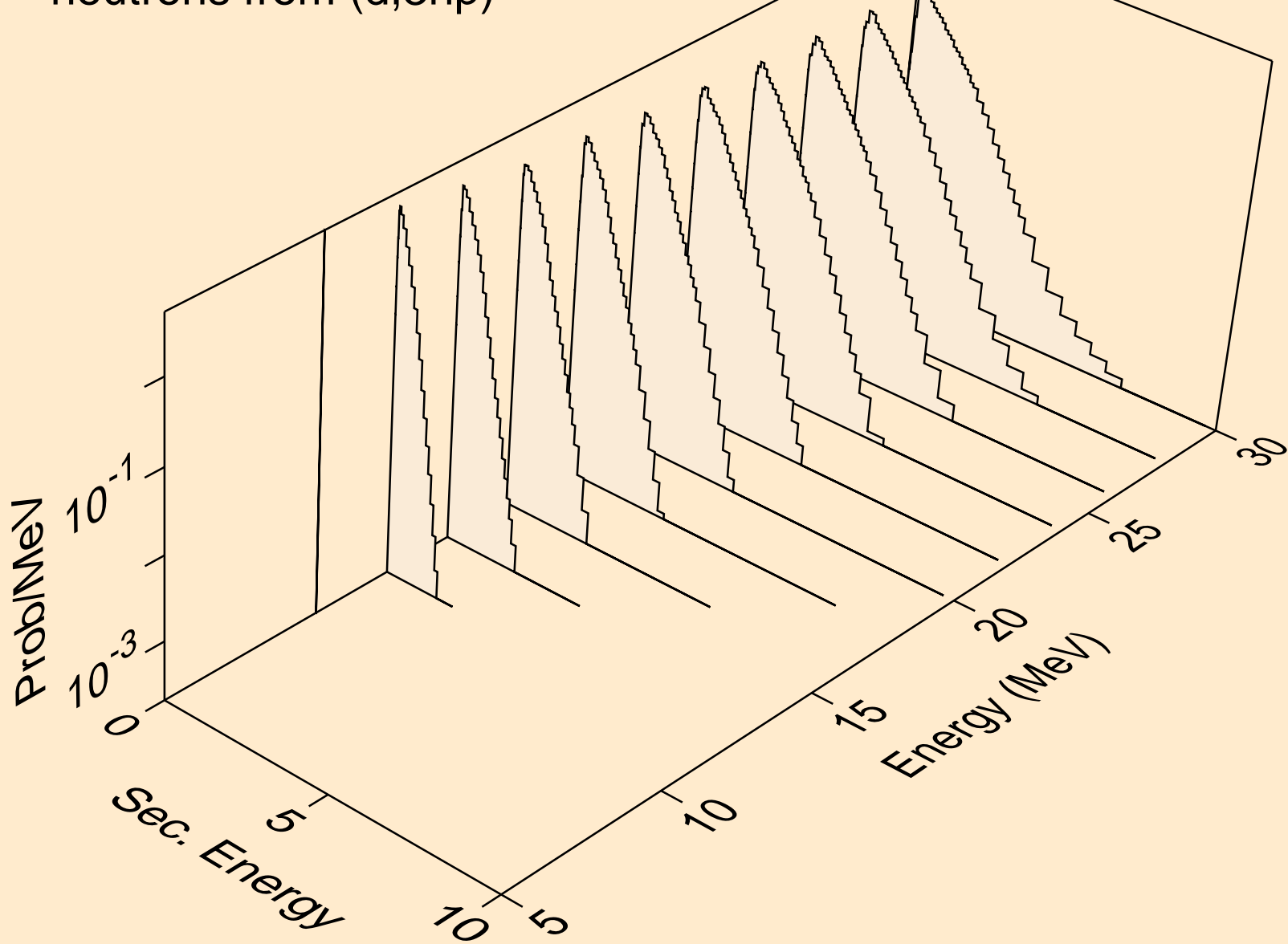

HG214 DEUTERON ACER TENDL-2023 LIBRARY; T=0.K  
neutrons from (d,n2p)

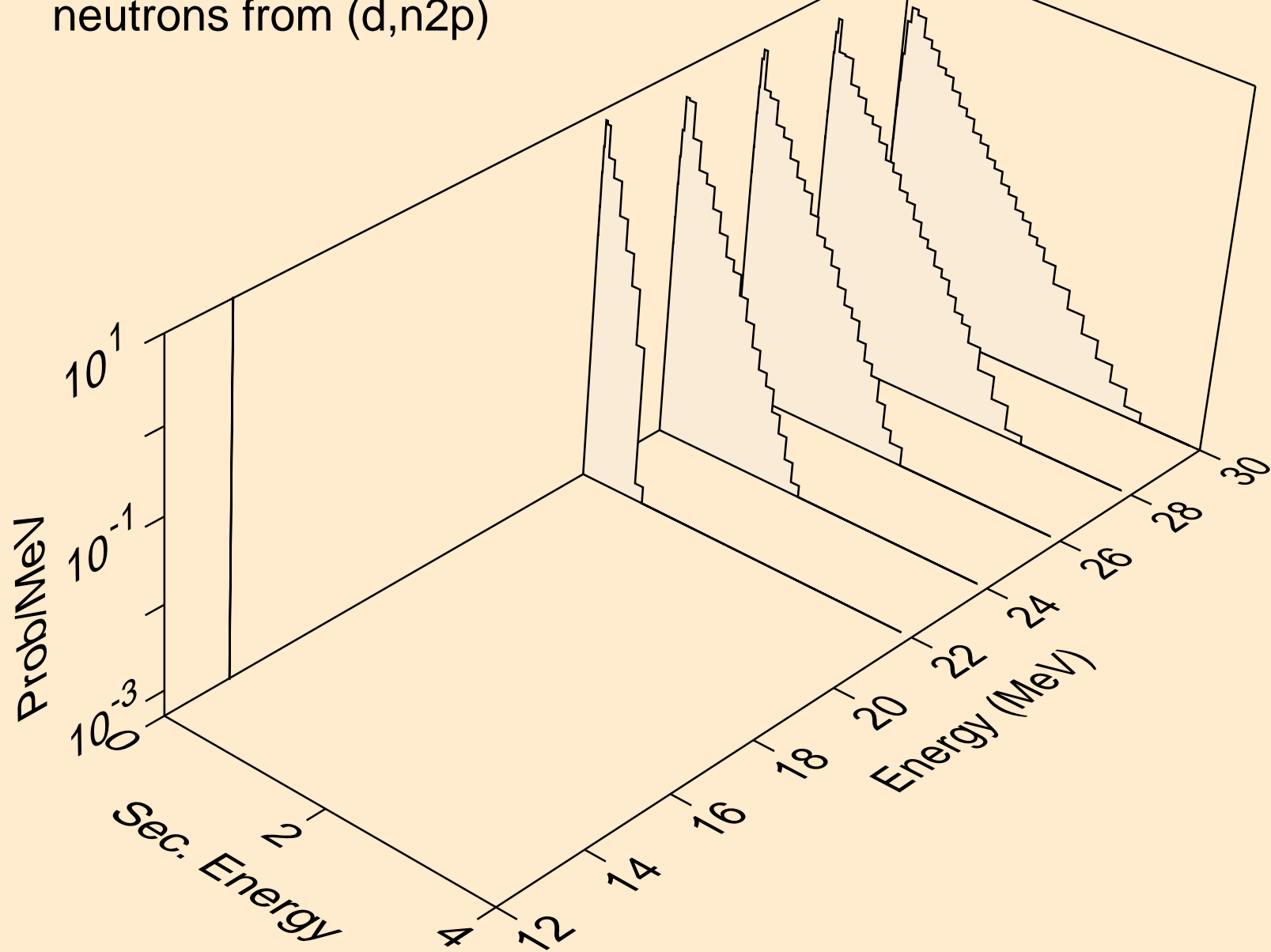

HG214 DEUTERON ACER TENDL-2023 LIBRARY; T=0.K  
protons from (d,x)

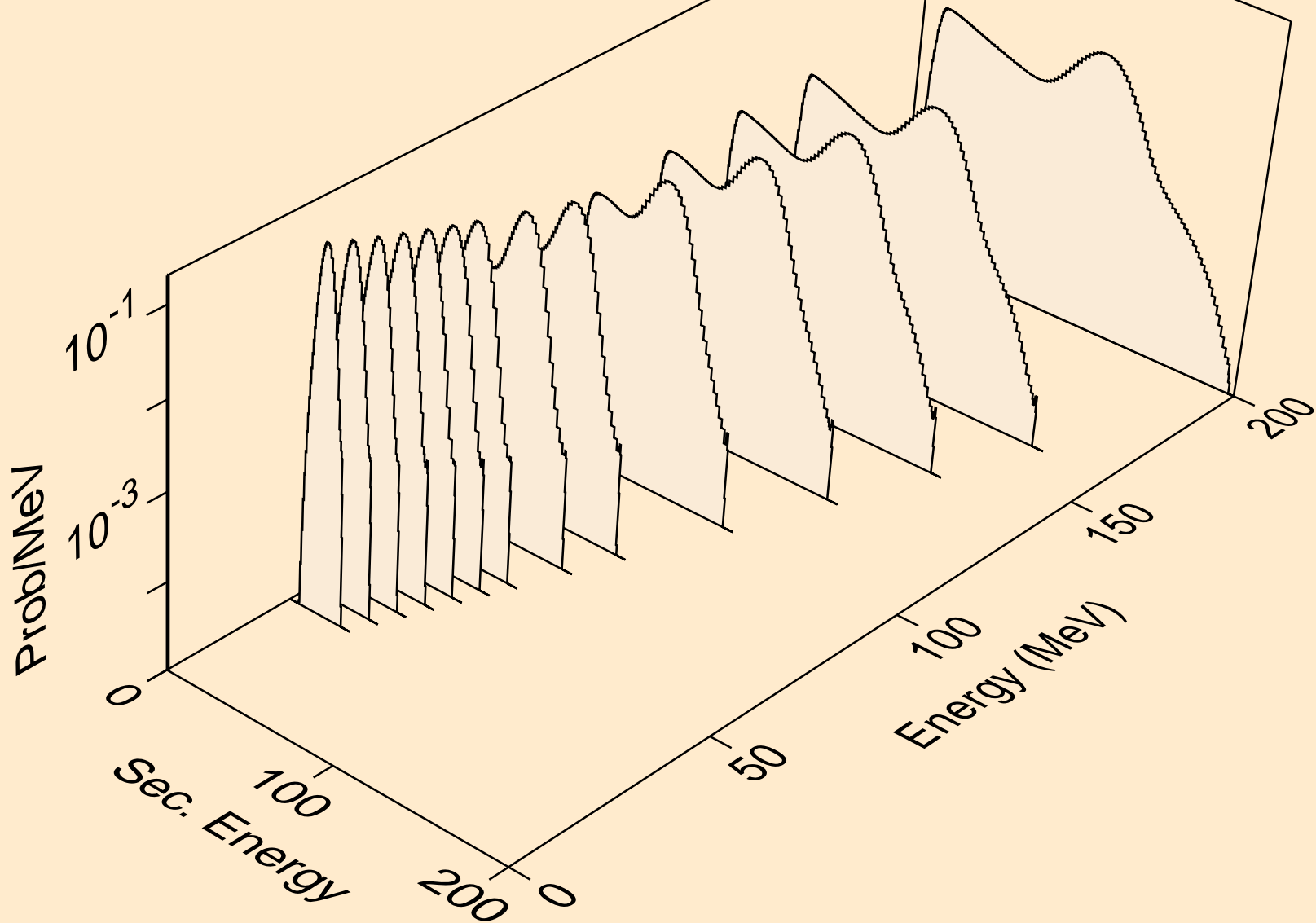



HG214 DEUTERON ACER TENDL-2023 LIBRARY; T=0.K  
protons from (d,n\*)p

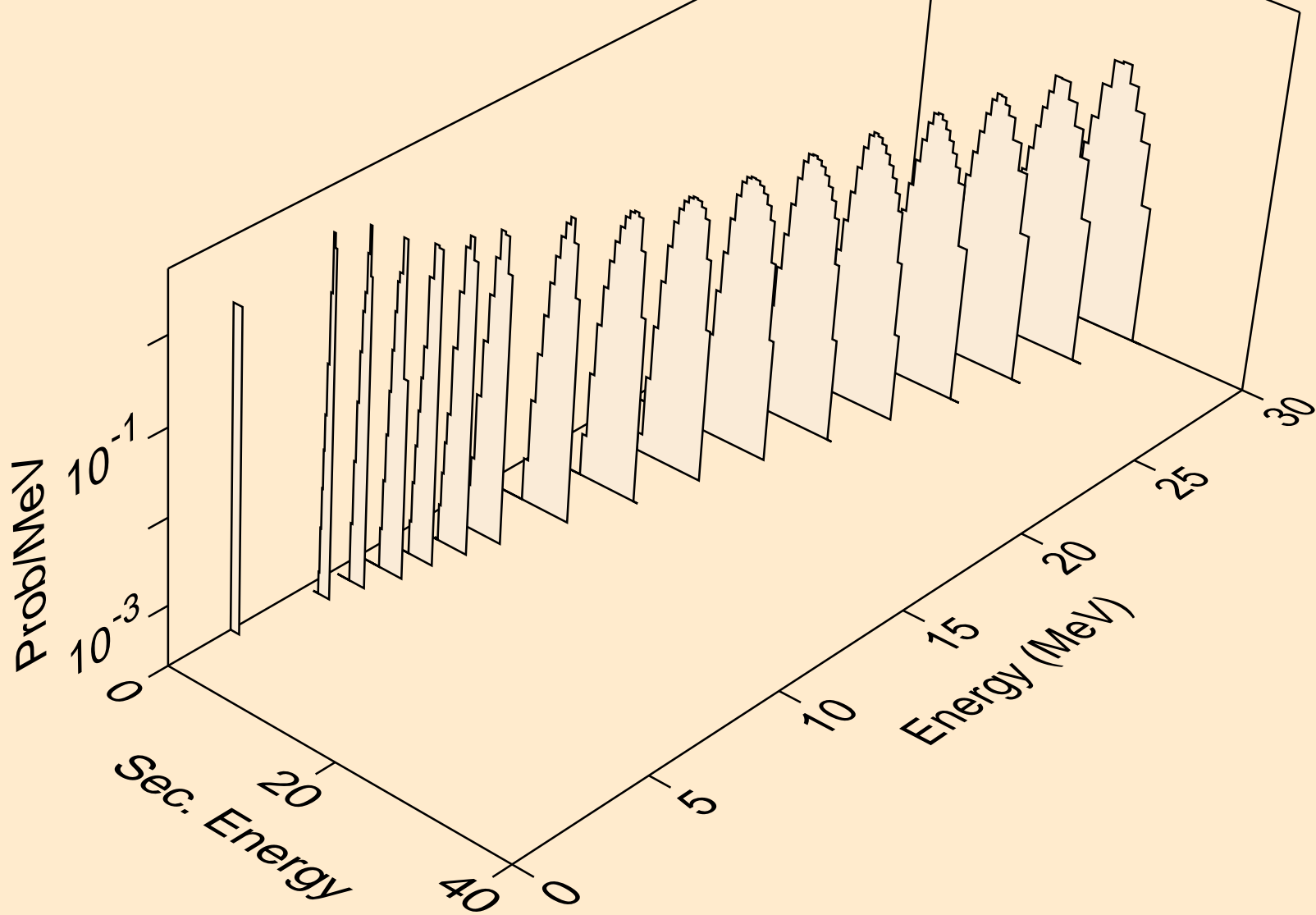

HG214 DEUTERON ACER TENDL-2023 LIBRARY; T=0.K  
protons from (d,2np)

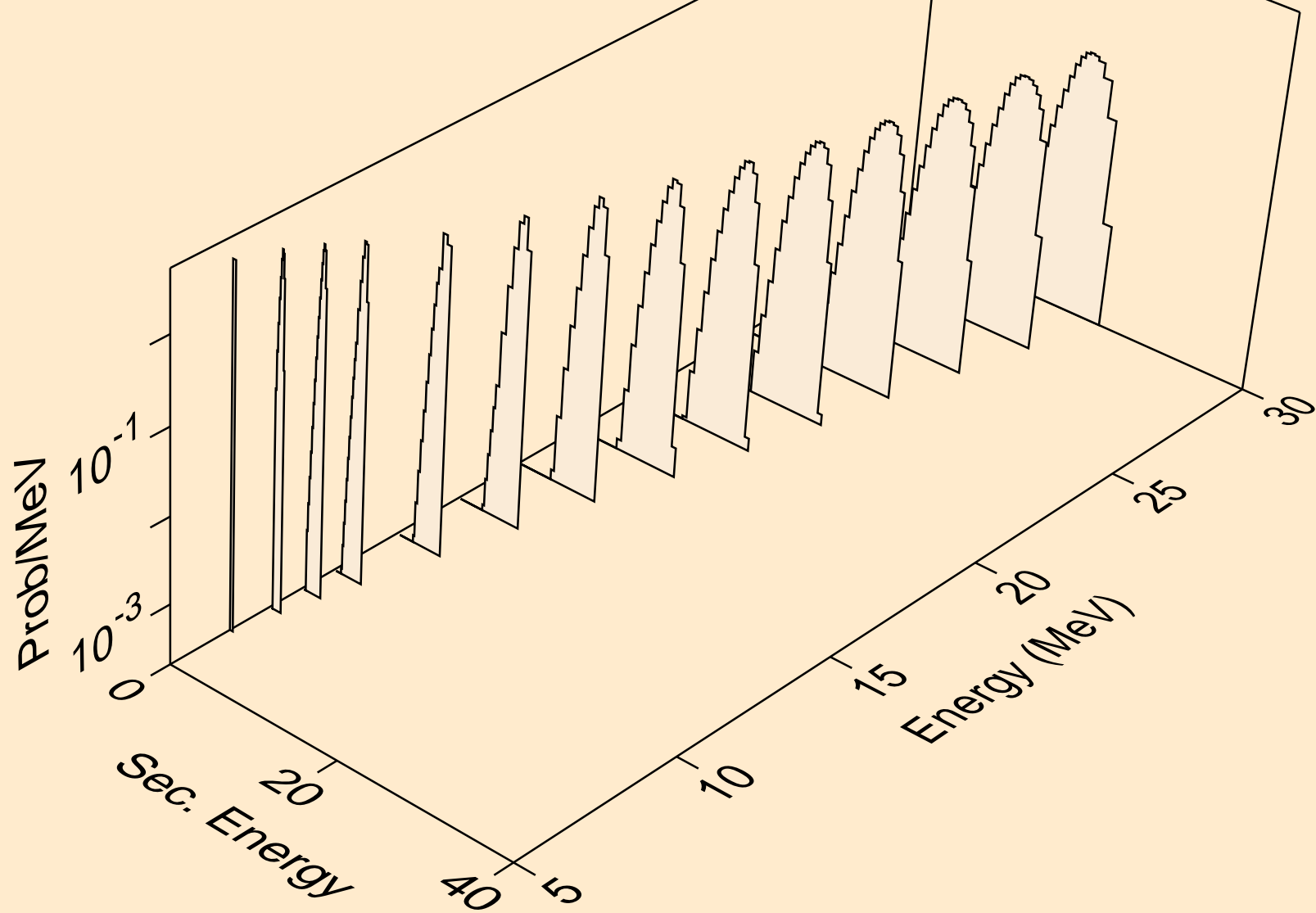

HG214 DEUTERON ACER TENDL-2023 LIBRARY; T=0.K  
protons from (d,3np)

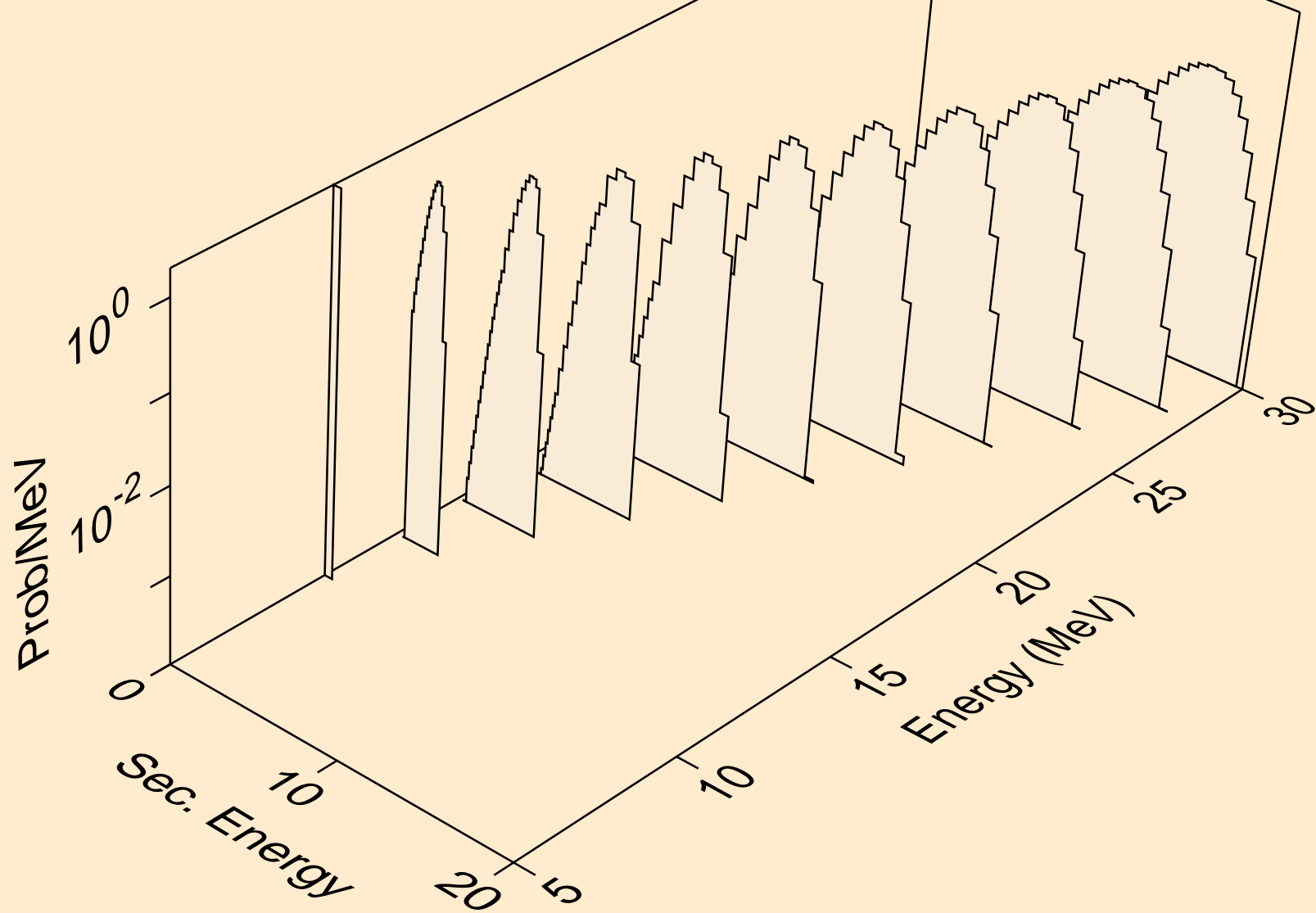

HG214 DEUTERON ACER TENDL-2023 LIBRARY; T=0.K  
protons from (d,n2p)

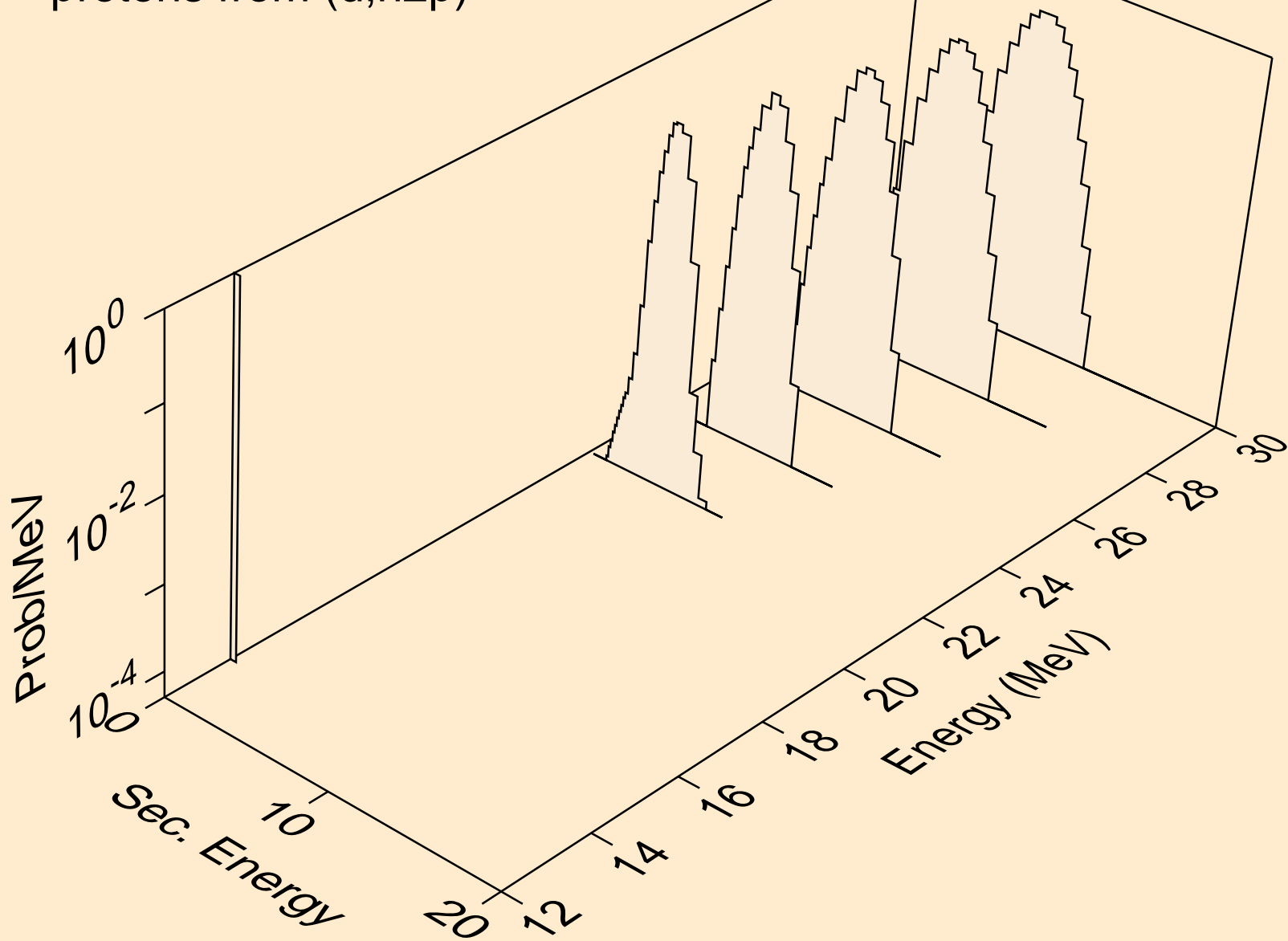

HG214 DEUTERON ACER TENDL-2023 LIBRARY; T=0.K  
protons from (d,p)

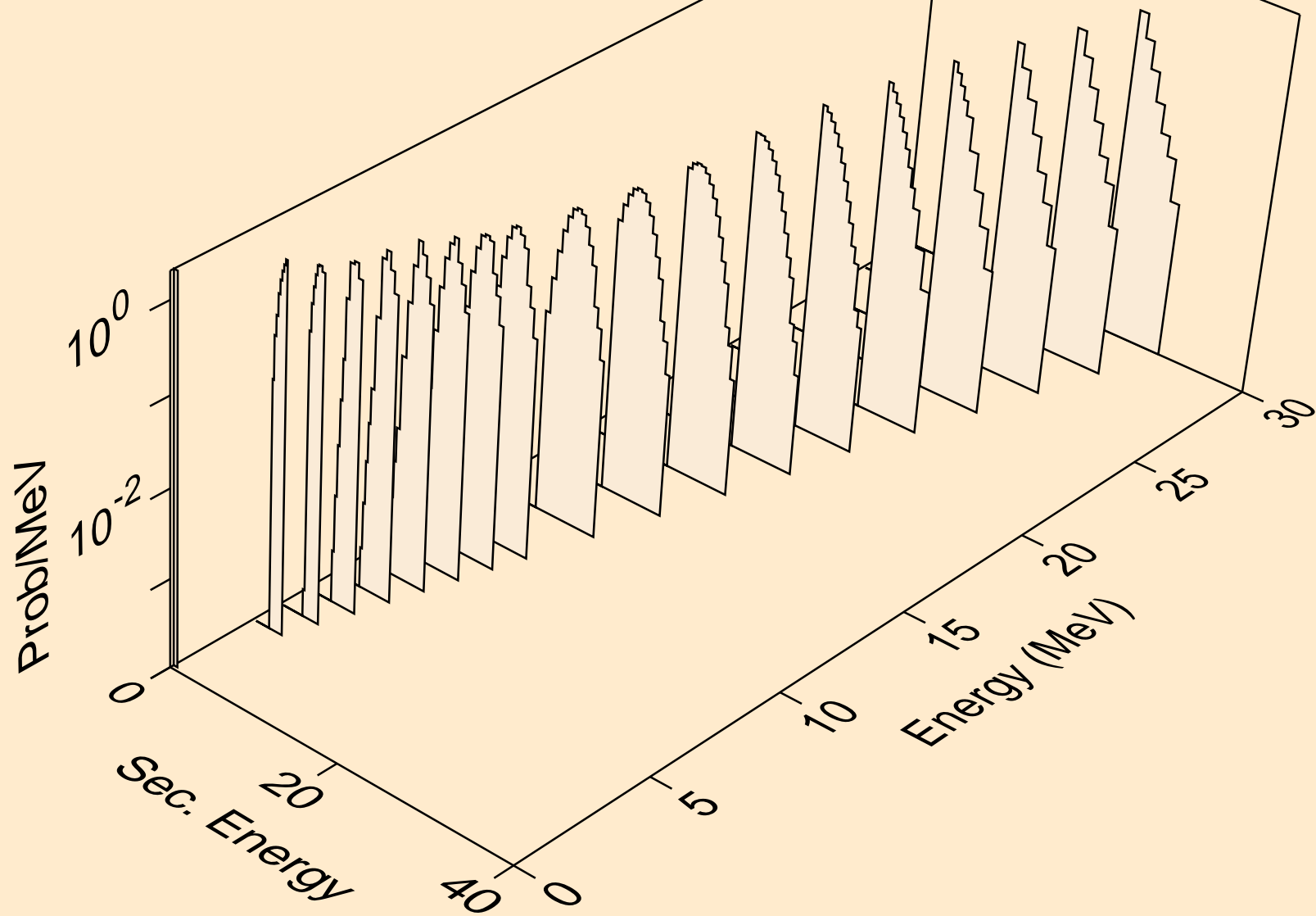

HG214 DEUTERON ACER TENDL-2023 LIBRARY; T=0.K  
protons from (d,2p)

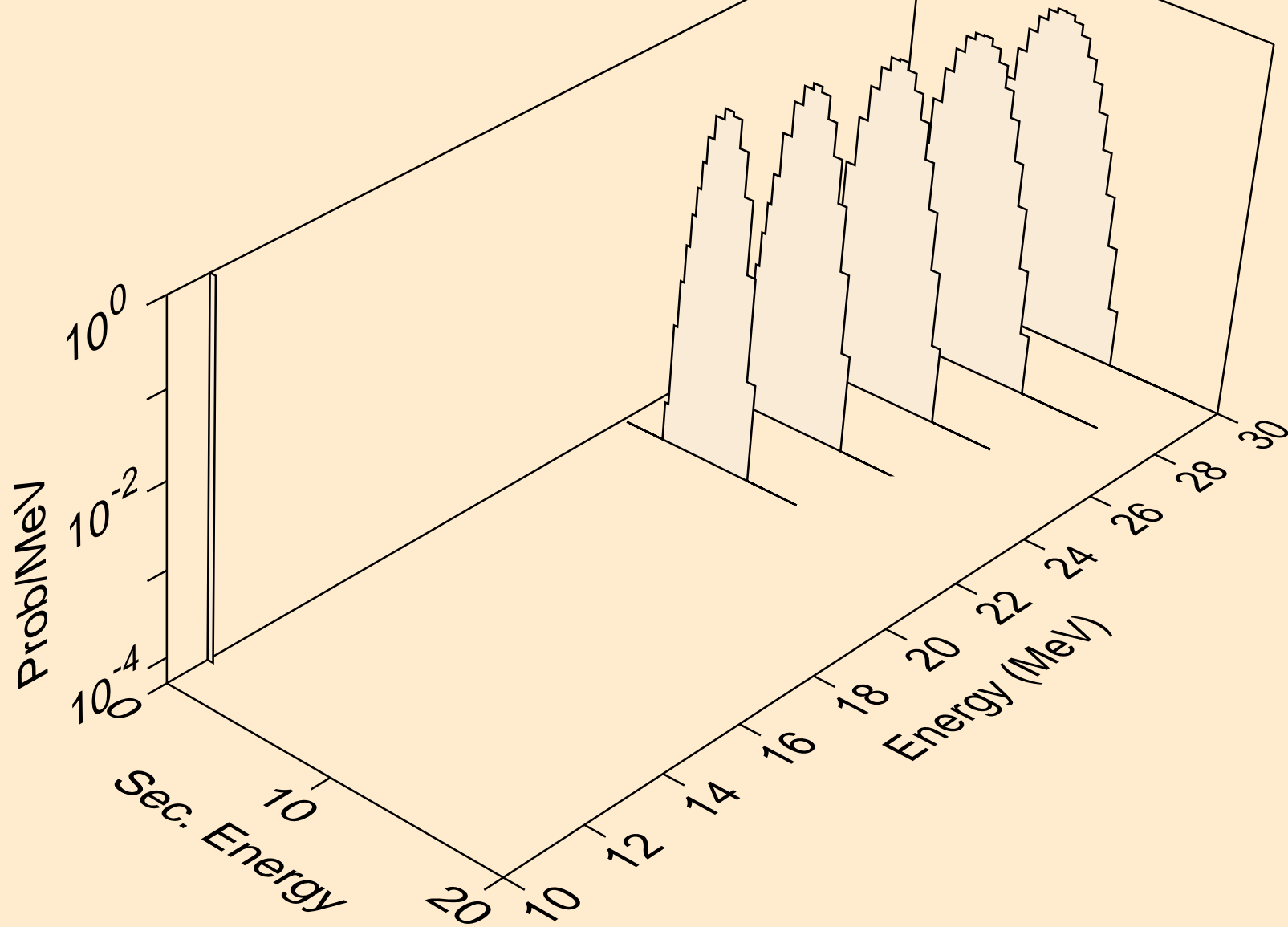

HG214 DEUTERON ACER TENDL-2023 LIBRARY; T=0.K  
protons from (d,pd)

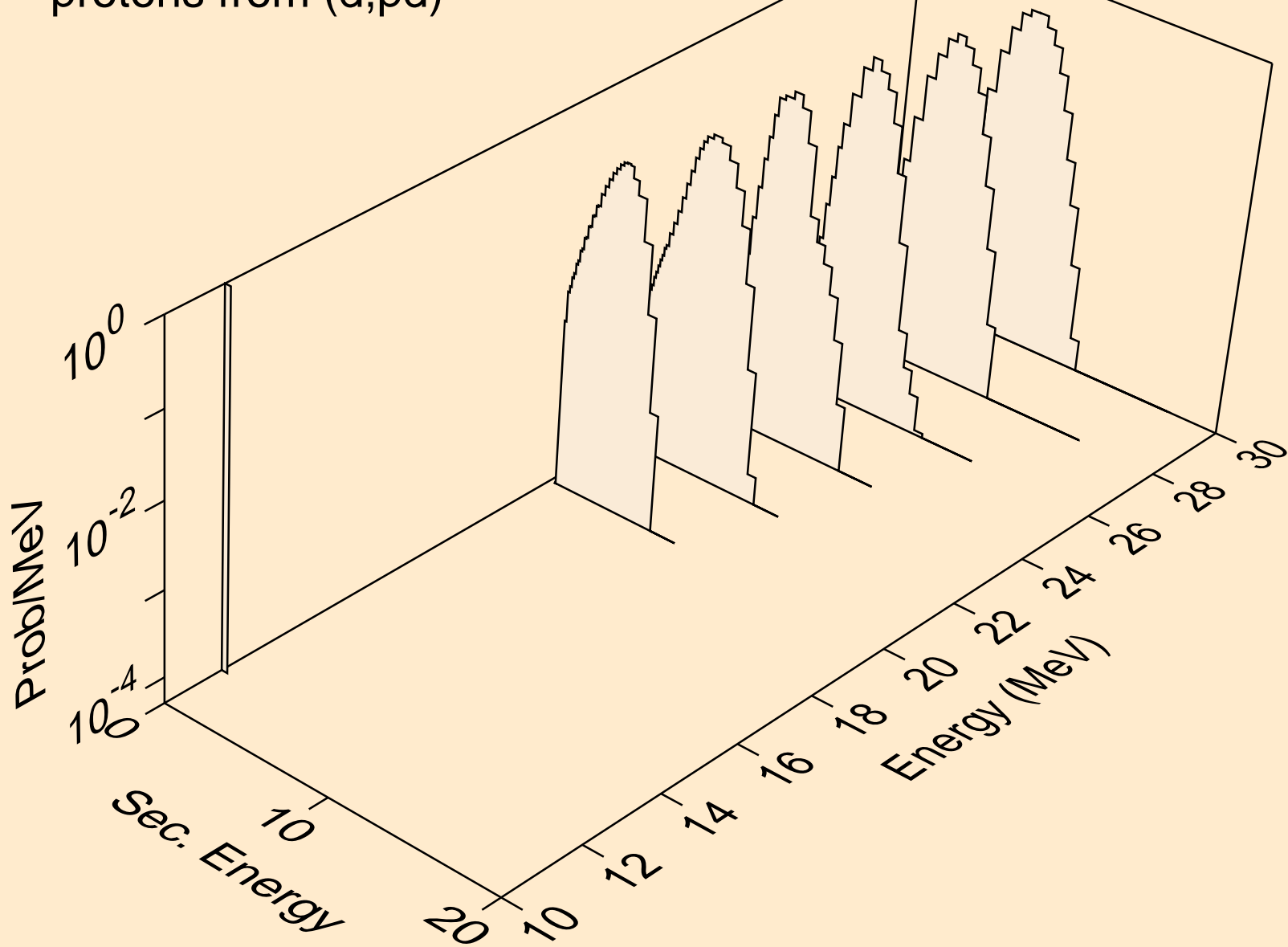

HG214 DEUTERON ACER TENDL-2023 LIBRARY; T=0.K  
tritons from (d,x)

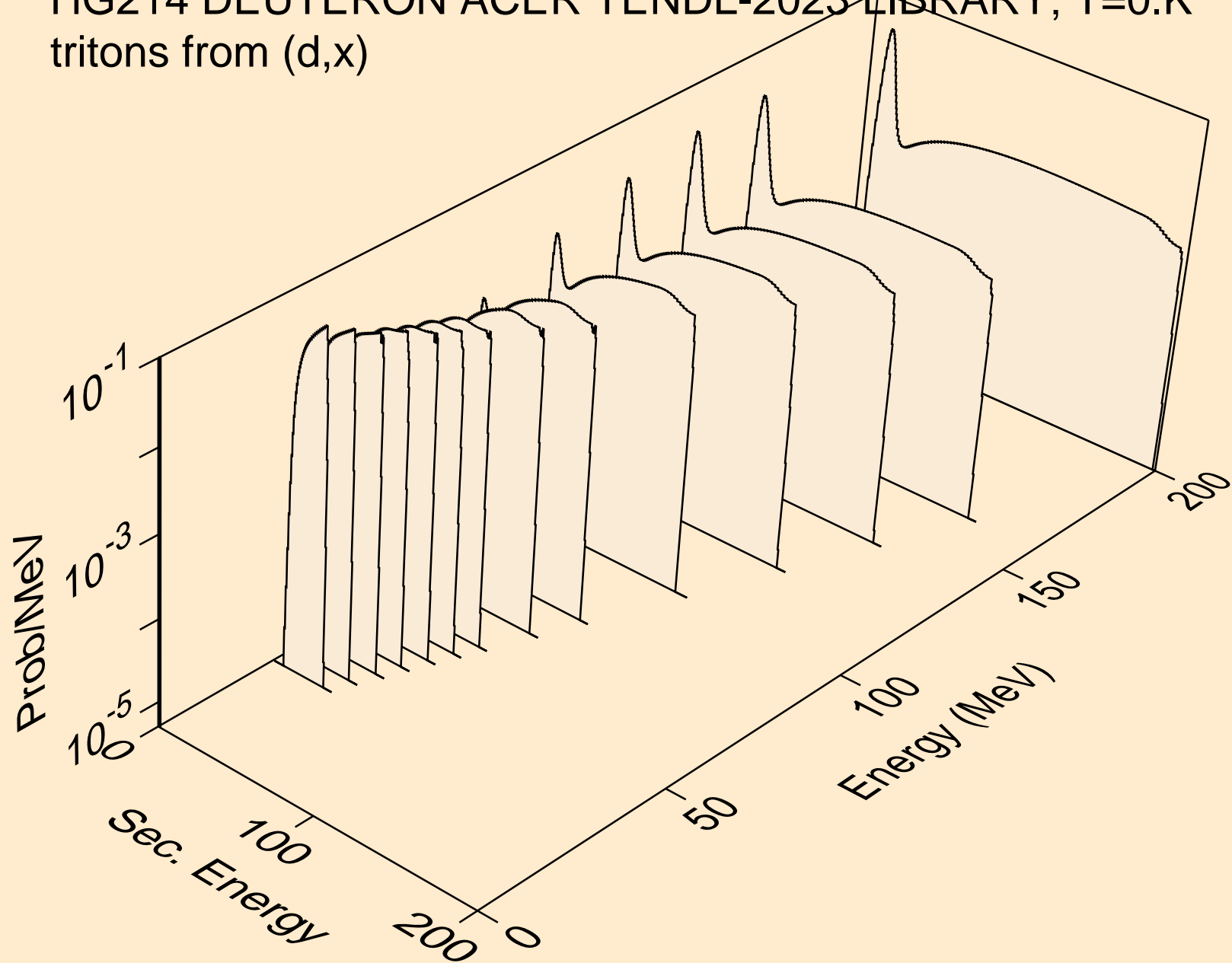



HG214 DEUTERON ACER TENDL-2023 LIBRARY; T=0.K  
tritons from (d,n\*)t

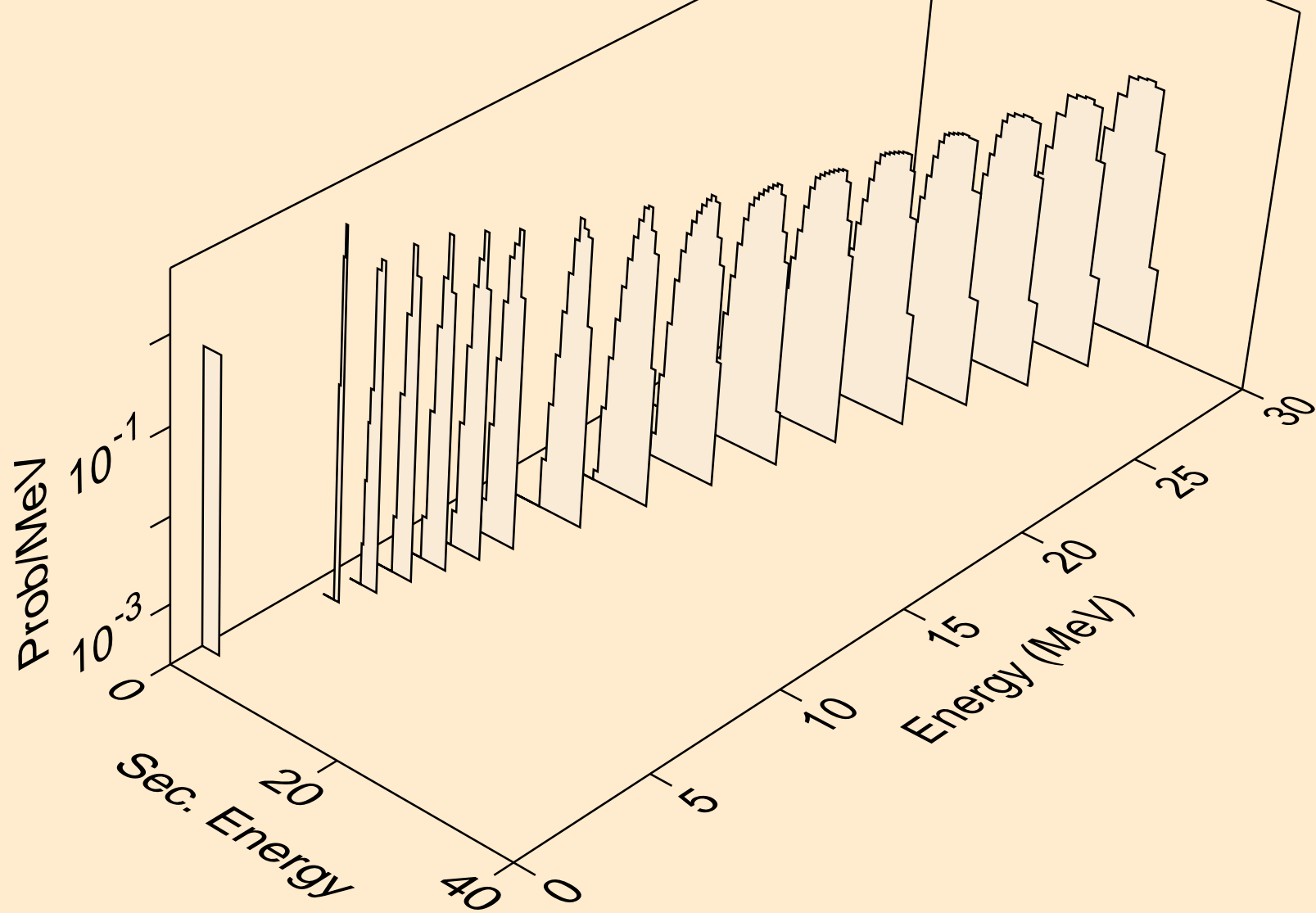

HG214 DEUTERON ACER TENDL-2023 LIBRARY; T=0.K  
tritons from (d,t)

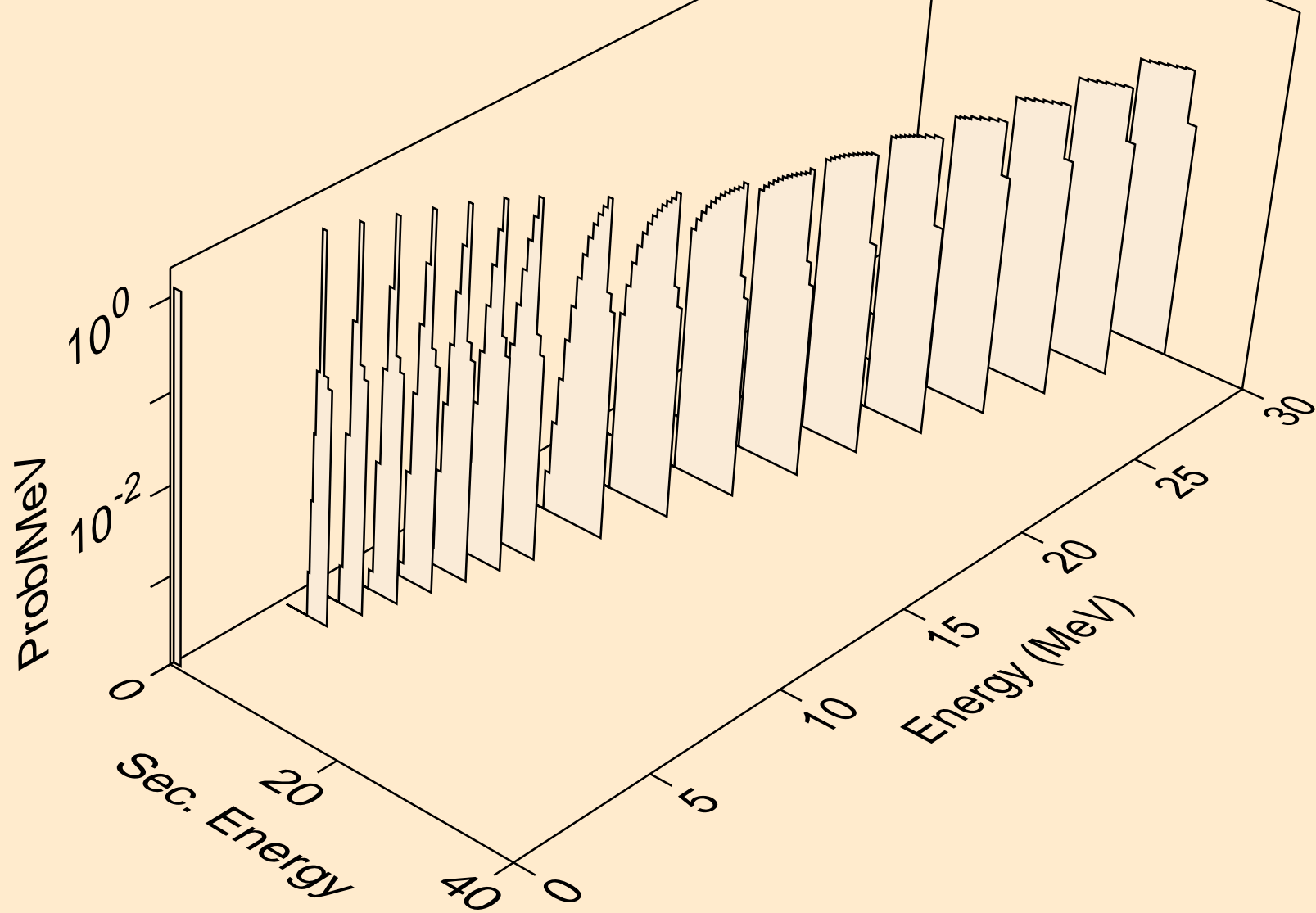

HG214 DEUTERON ACER TENDL-2023 LIBRARY; T=0.K  
he3s from (d,x)

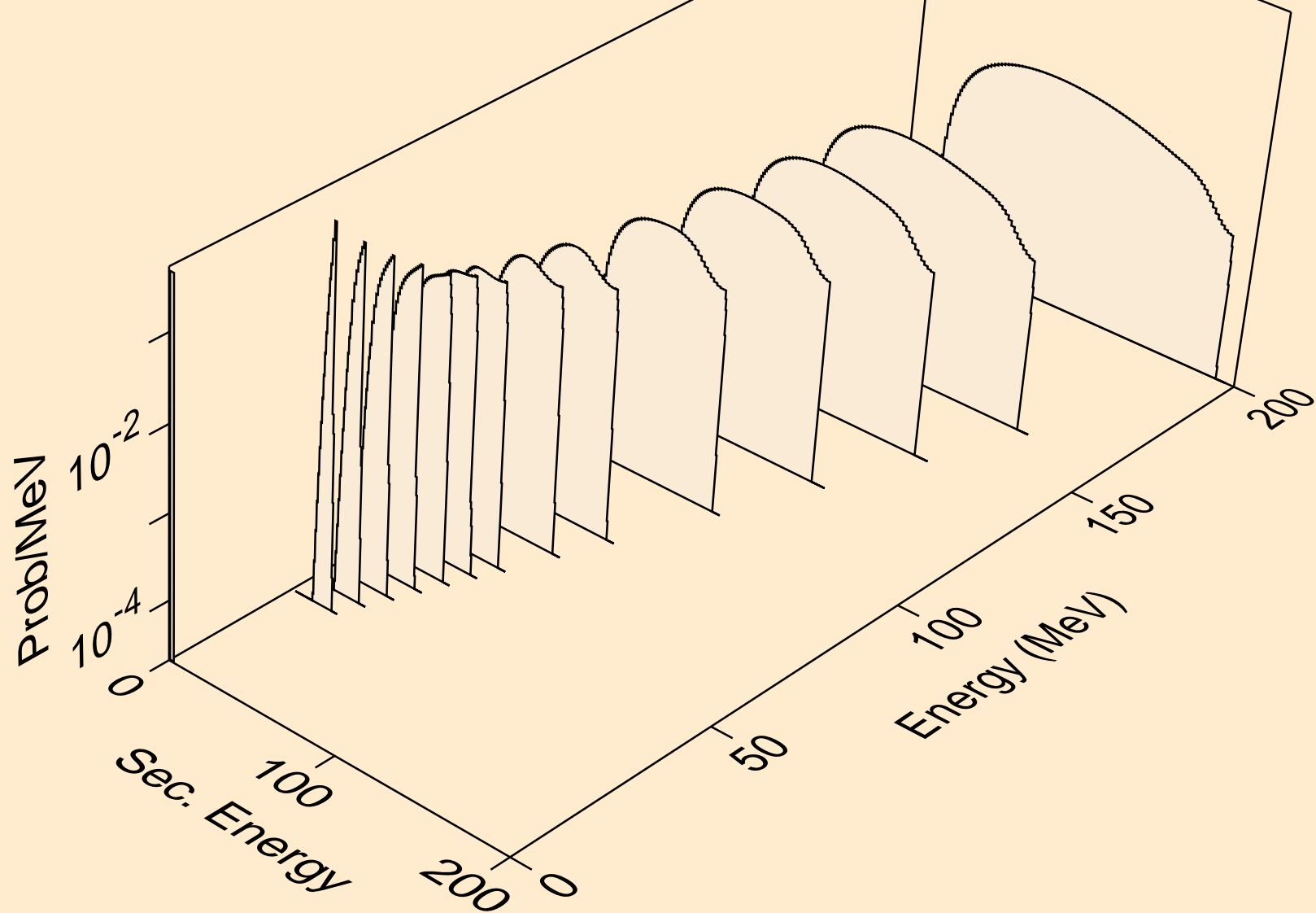

HG214 DEUTERON ACER TENDL-2023 LIBRARY; T=0.K  
he3s from (d,n\*)he3

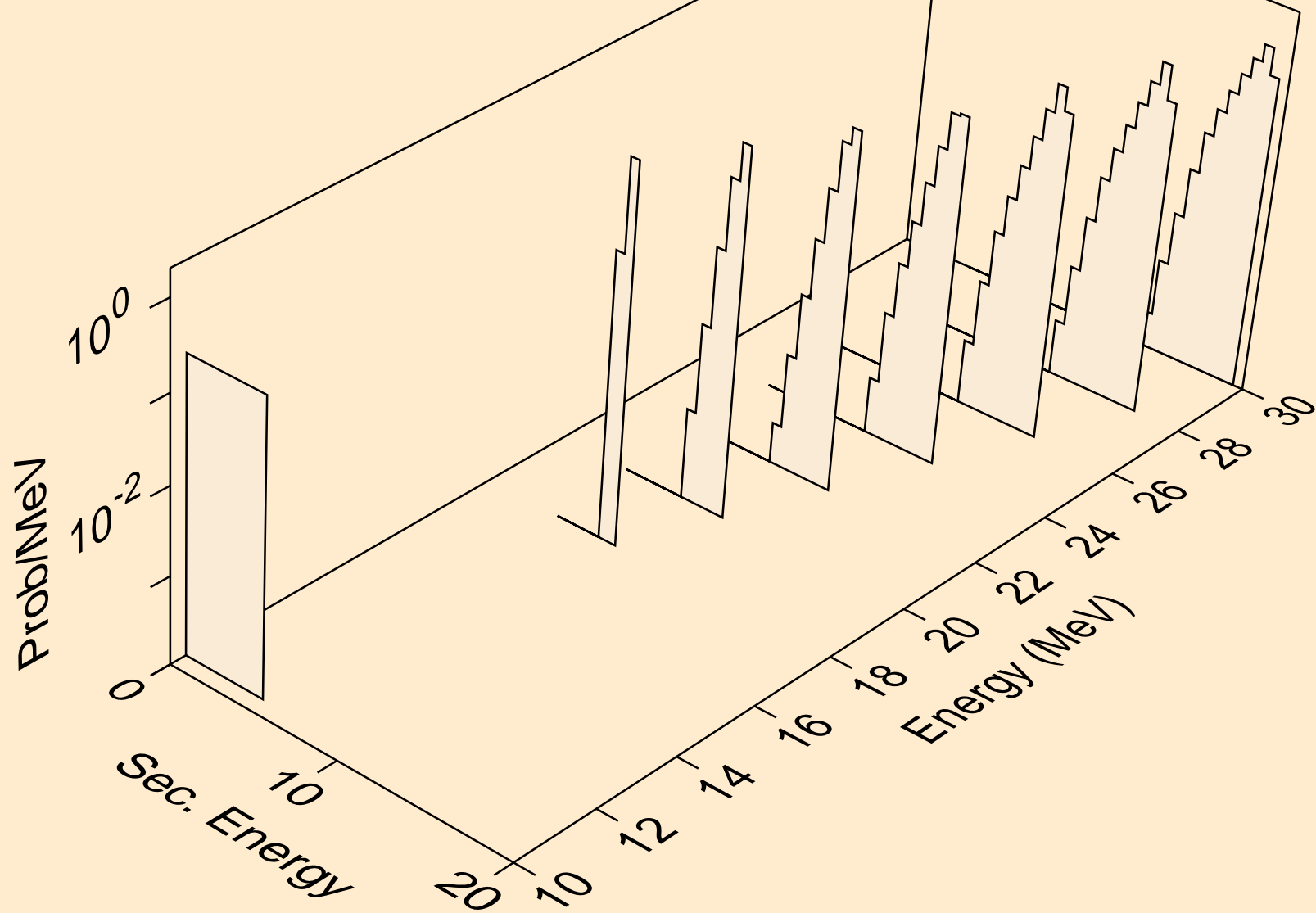

HG214 DEUTERON ACER TENDL-2023 LIBRARY; T=0.K  
he3s from (d,he3)

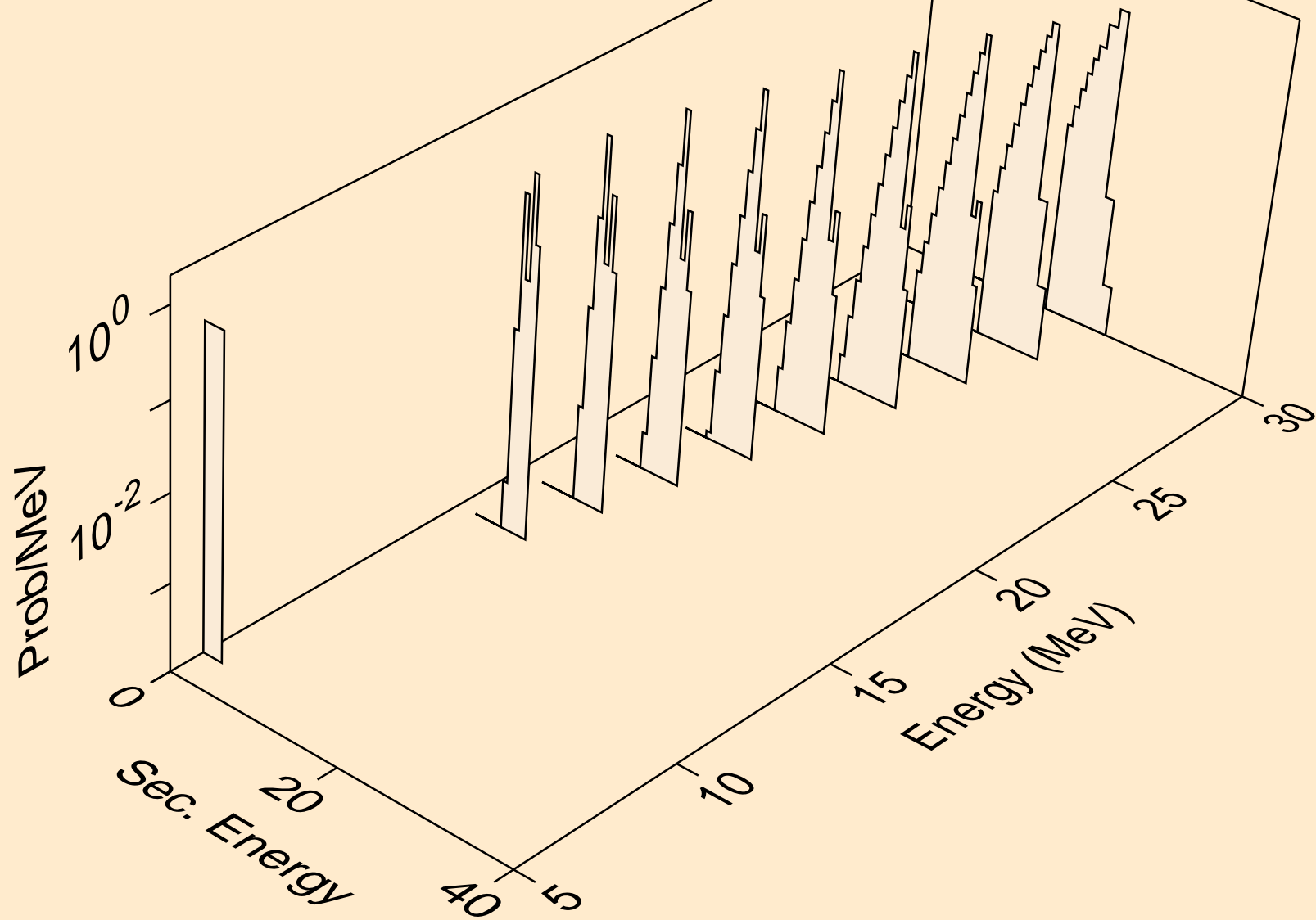

HG214 DEUTERON ACER TENDL-2023 LIBRARY; T=0.K  
alphas from (d,x)

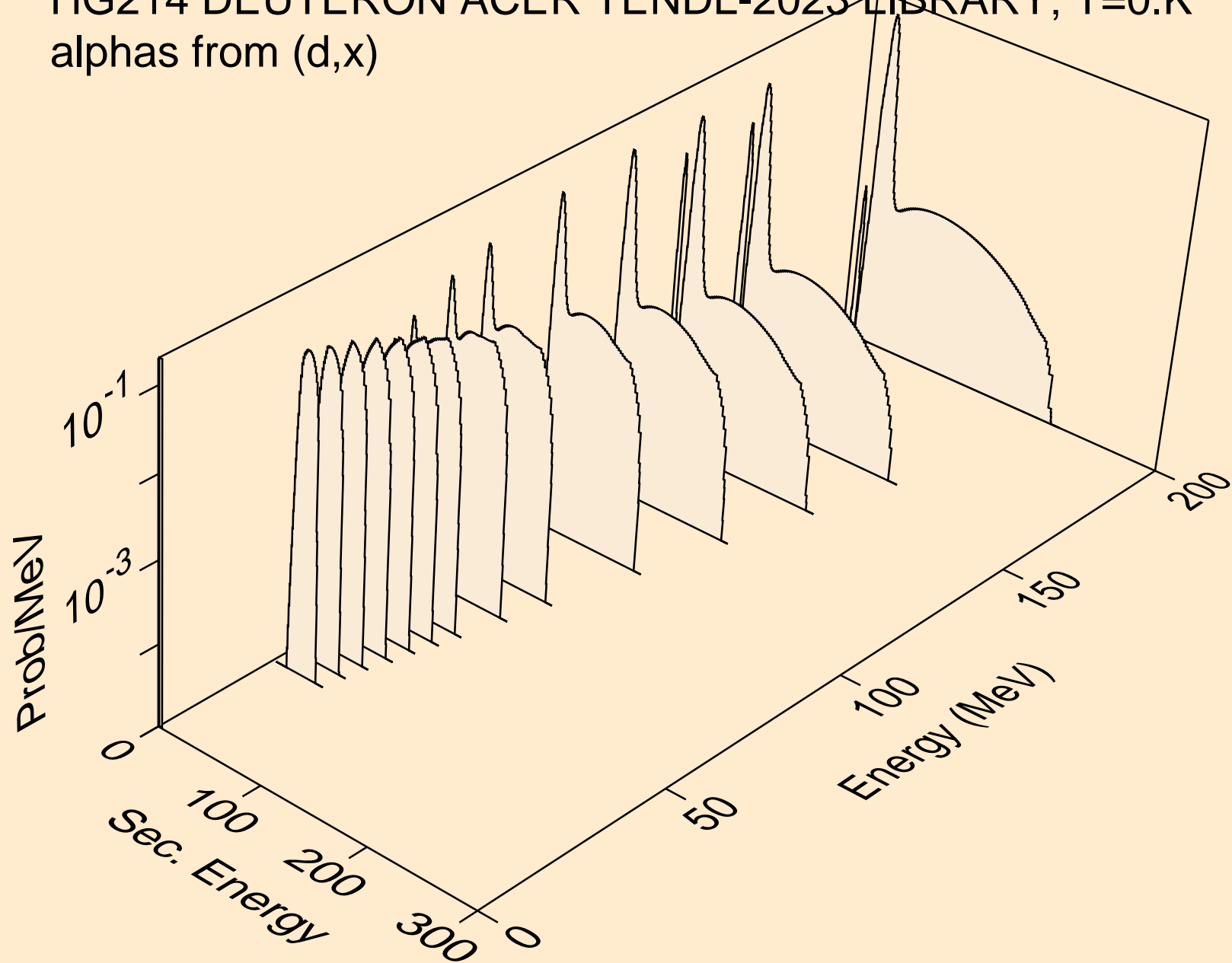

HG214 DEUTERON ACER TENDL-2023 LIBRARY; T=0.K  
alphas from (d,n\*)a

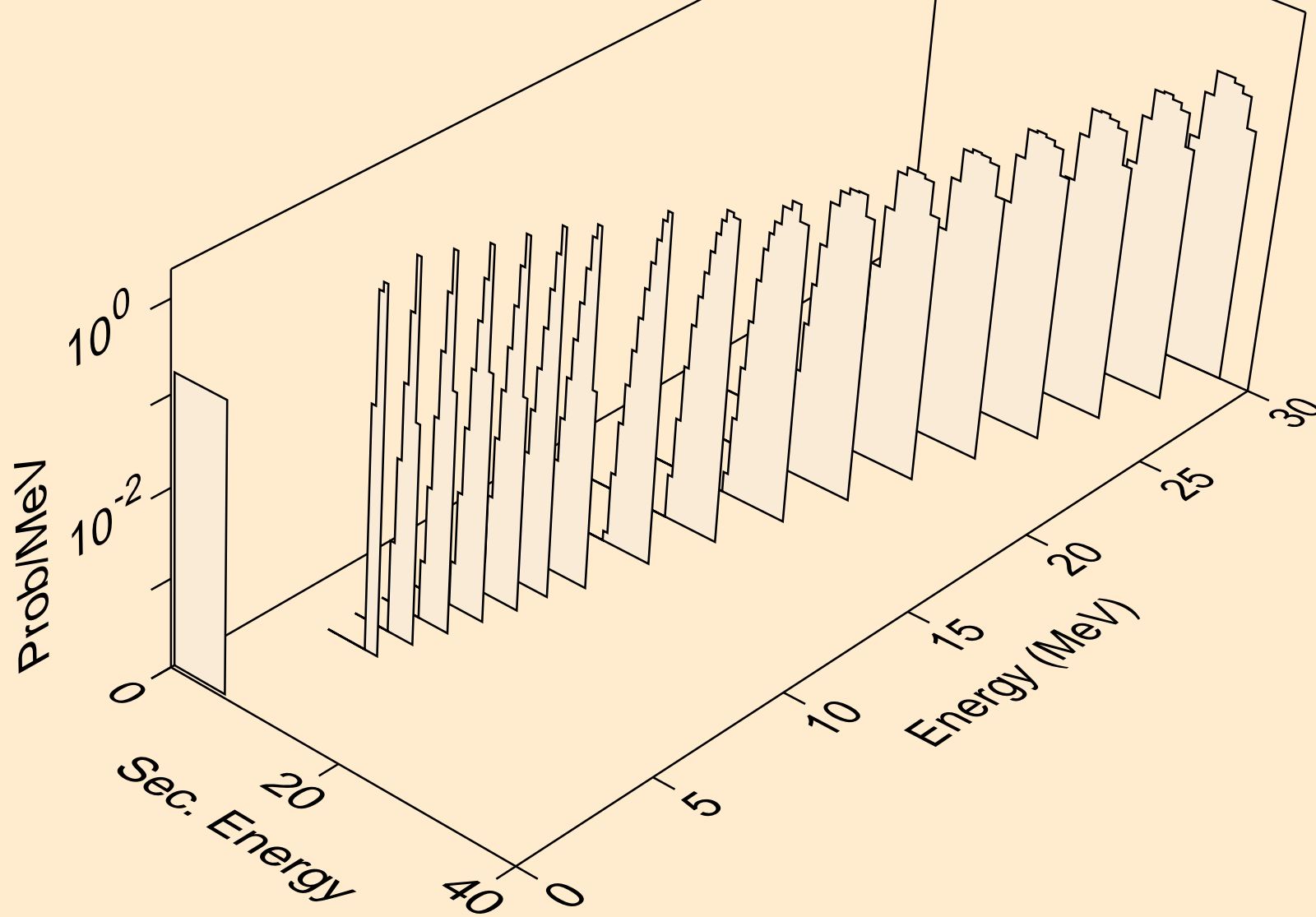

HG214 DEUTERON ACER TENDL-2023 LIBRARY; T=0.K  
alphas from (d,2n)a

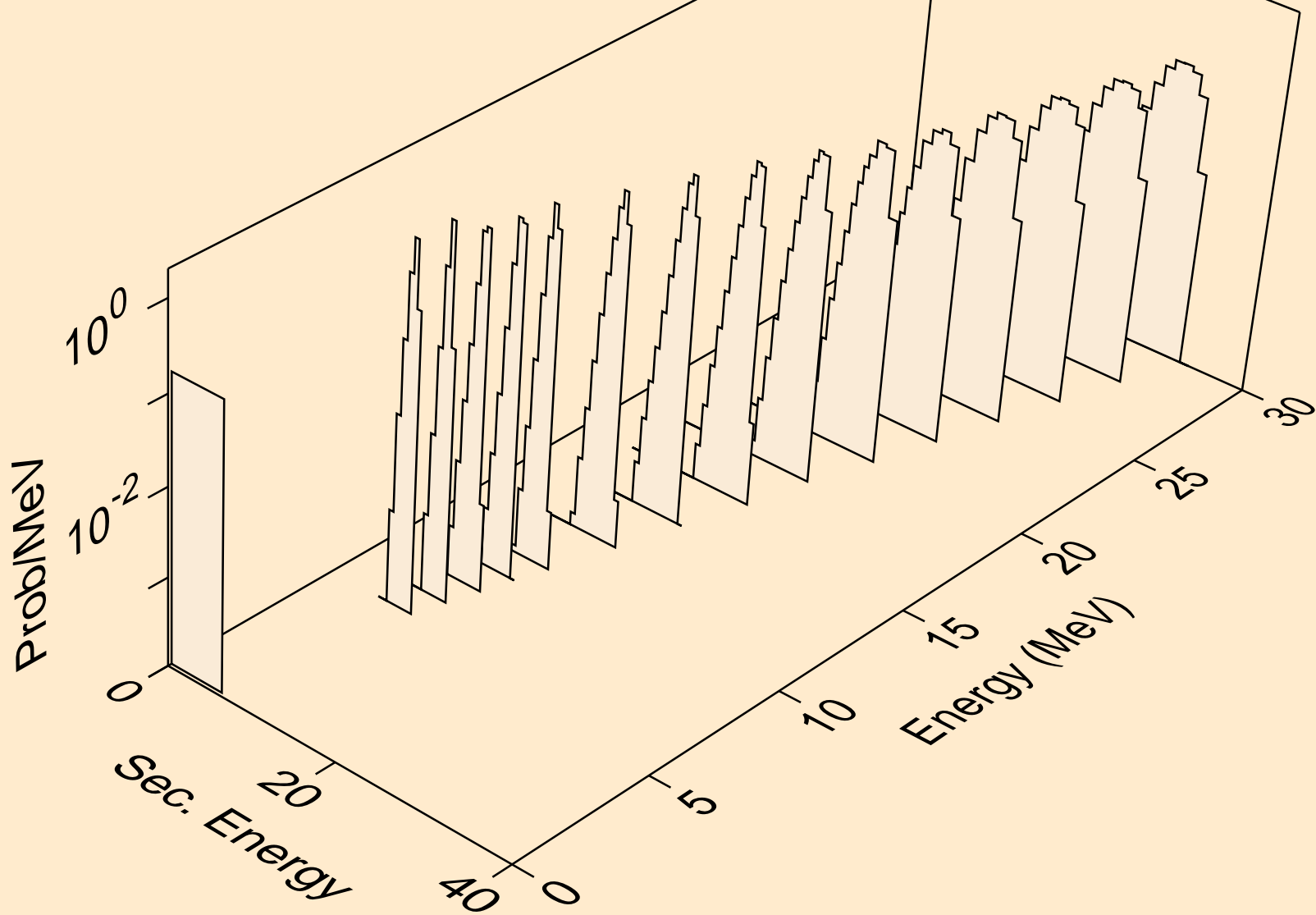



HG214 DEUTERON ACER TENDL-2023 LIBRARY; T=0.K  
alphas from (d,3n)a

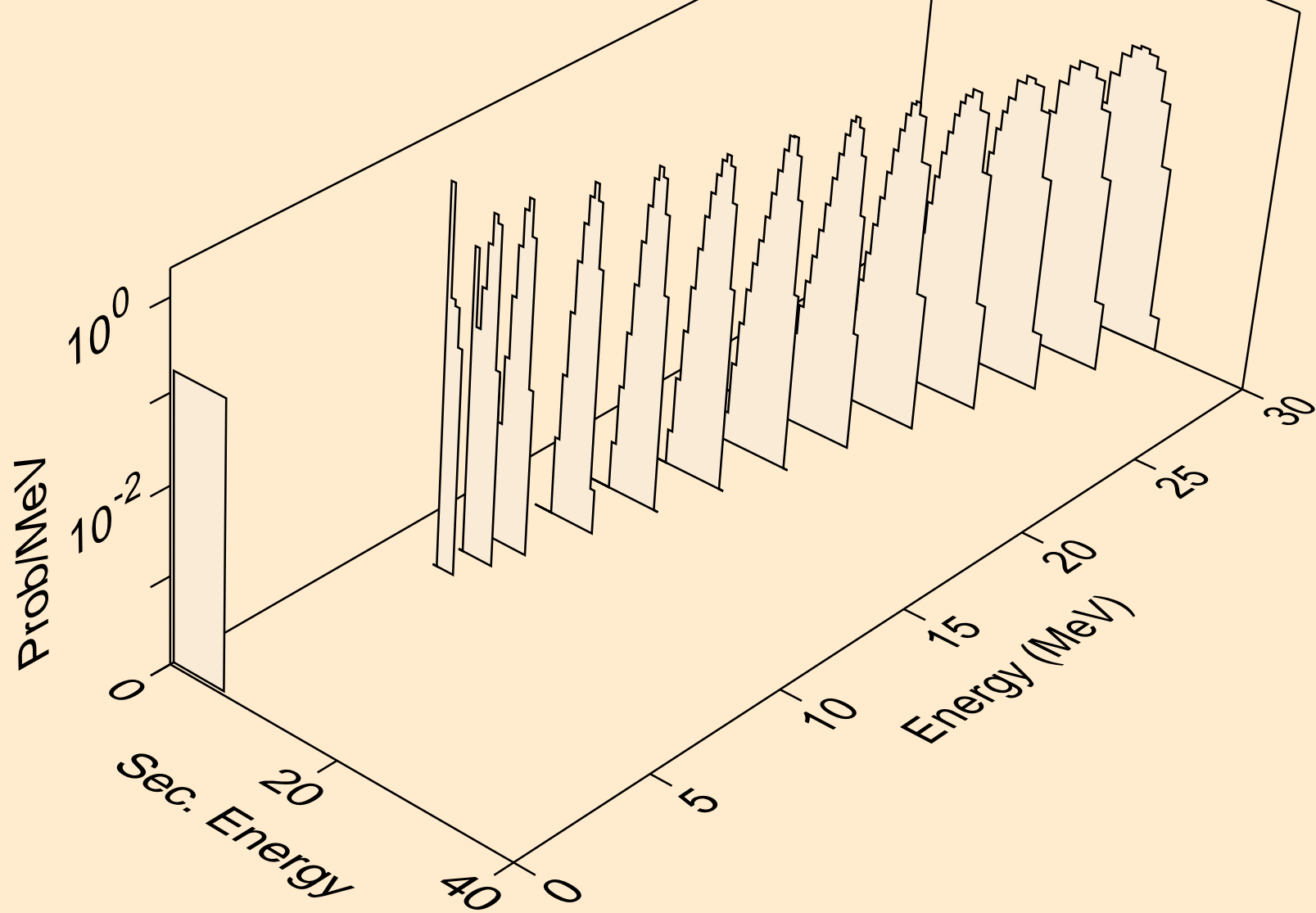

HG214 DEUTERON ACER TENDL-2023 LIBRARY; T=0.K  
alphas from (d,a)

