

# HG216 DEUTERON ACER TENDL-2023 LIBRARY; T=0.K

## Principal cross sections

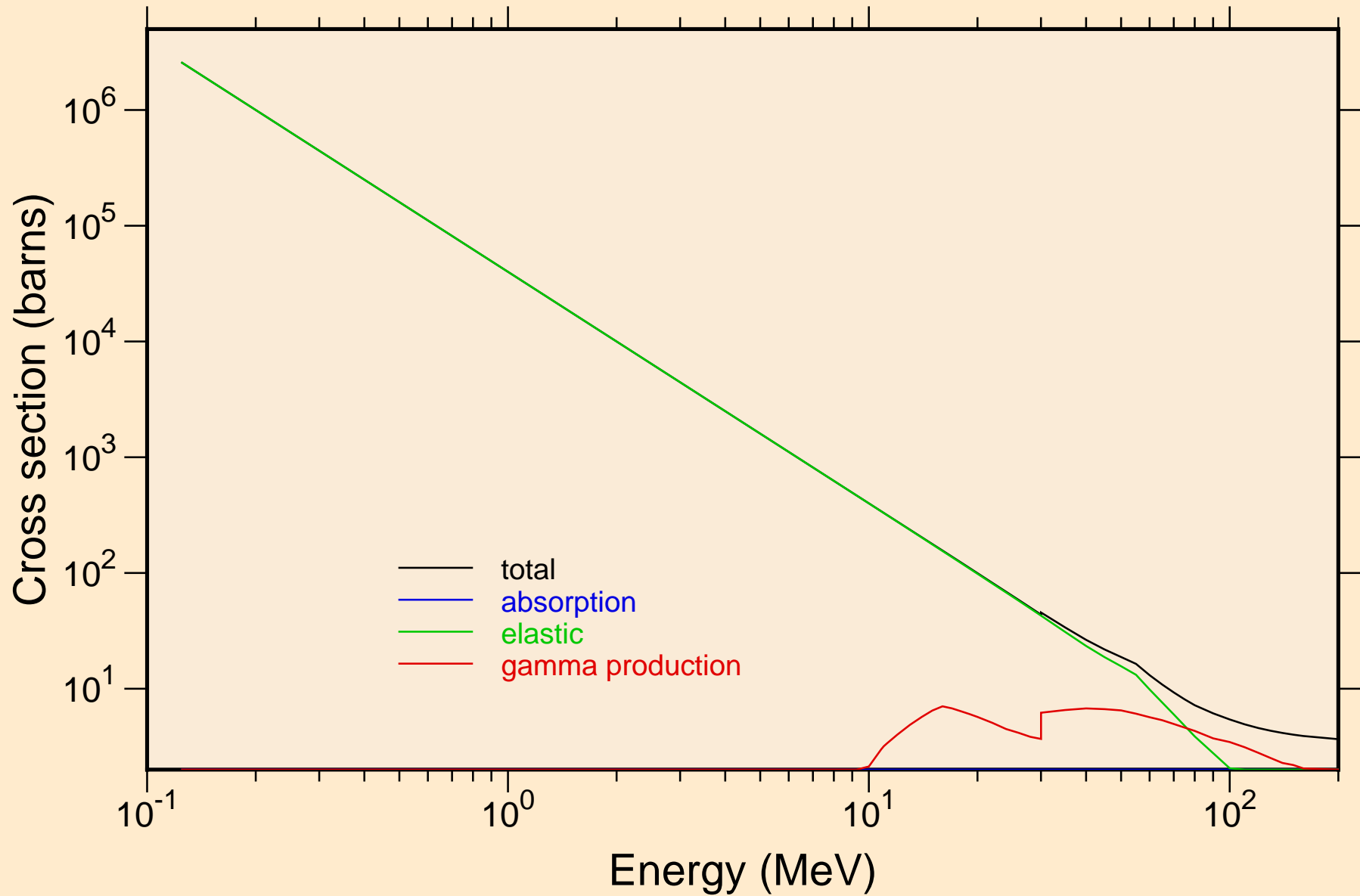

# HG216 DEUTERON ACER TENDL-2023 LIBRARY; T=0.K

## Heating

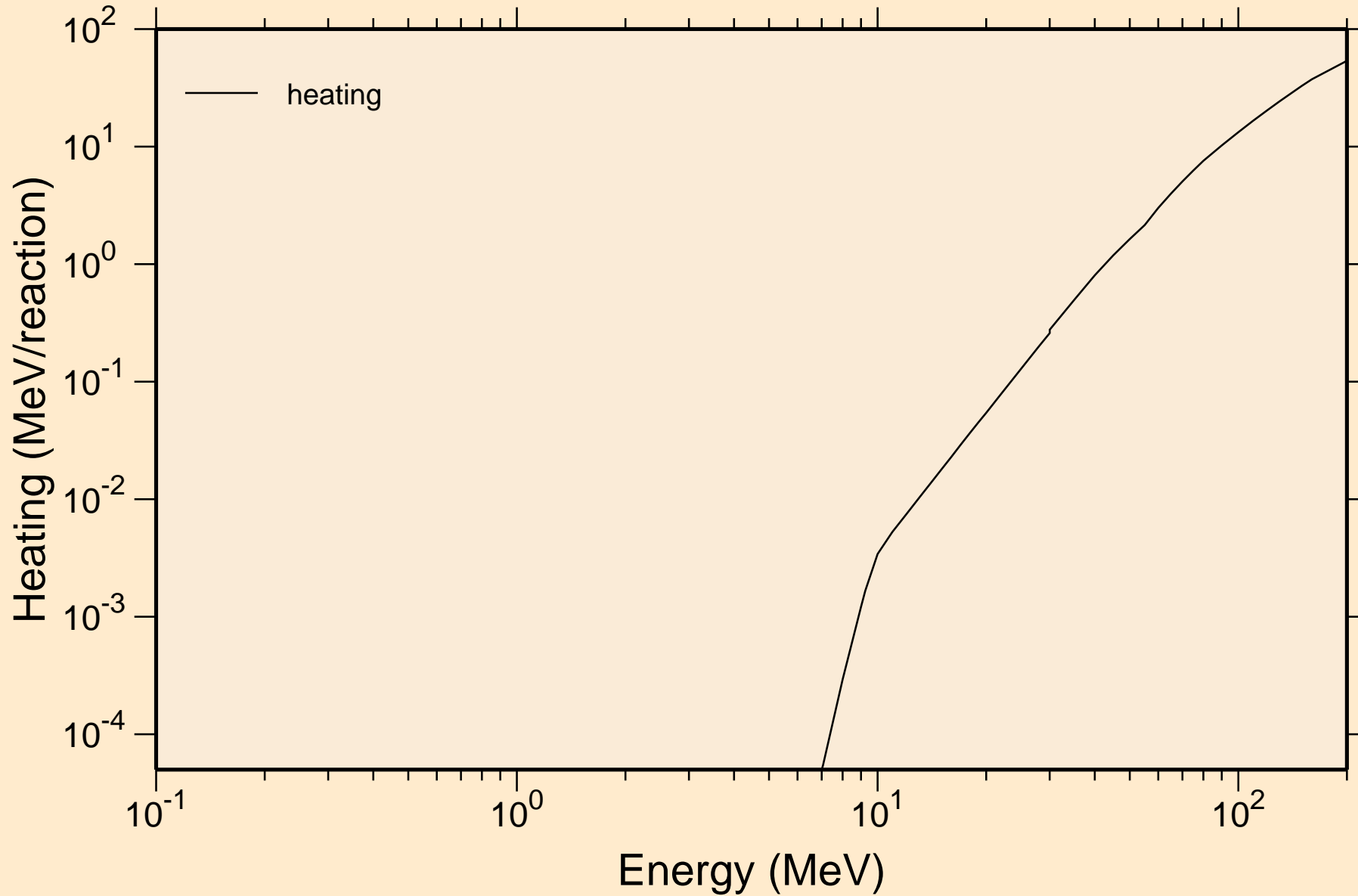

# HG216 DEUTERON ACER TENDL-2023 LIBRARY; T=0.K

## Principal cross sections

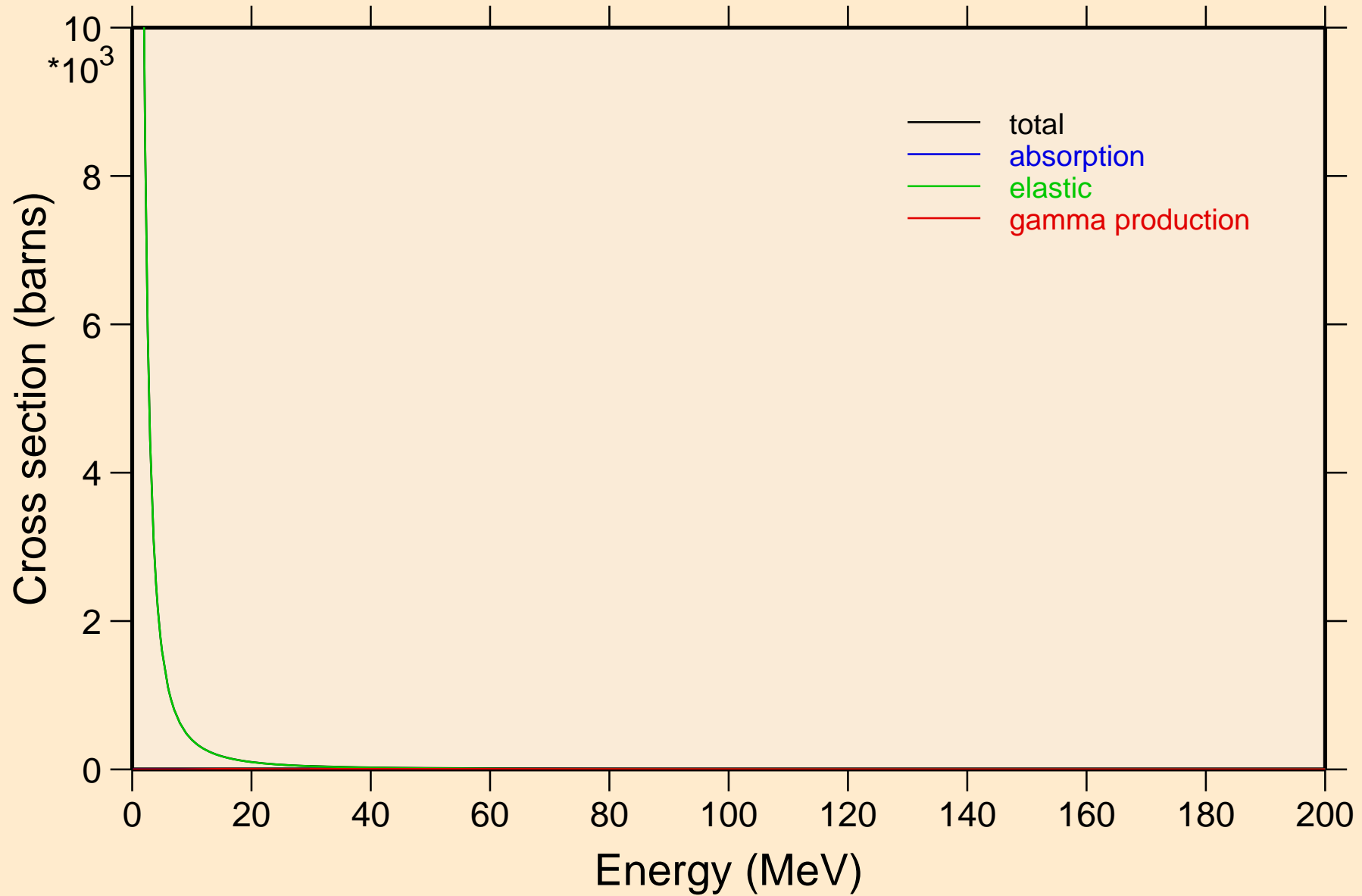

# HG216 DEUTERON ACER TENDL-2023 LIBRARY; T=0.K

## Heating

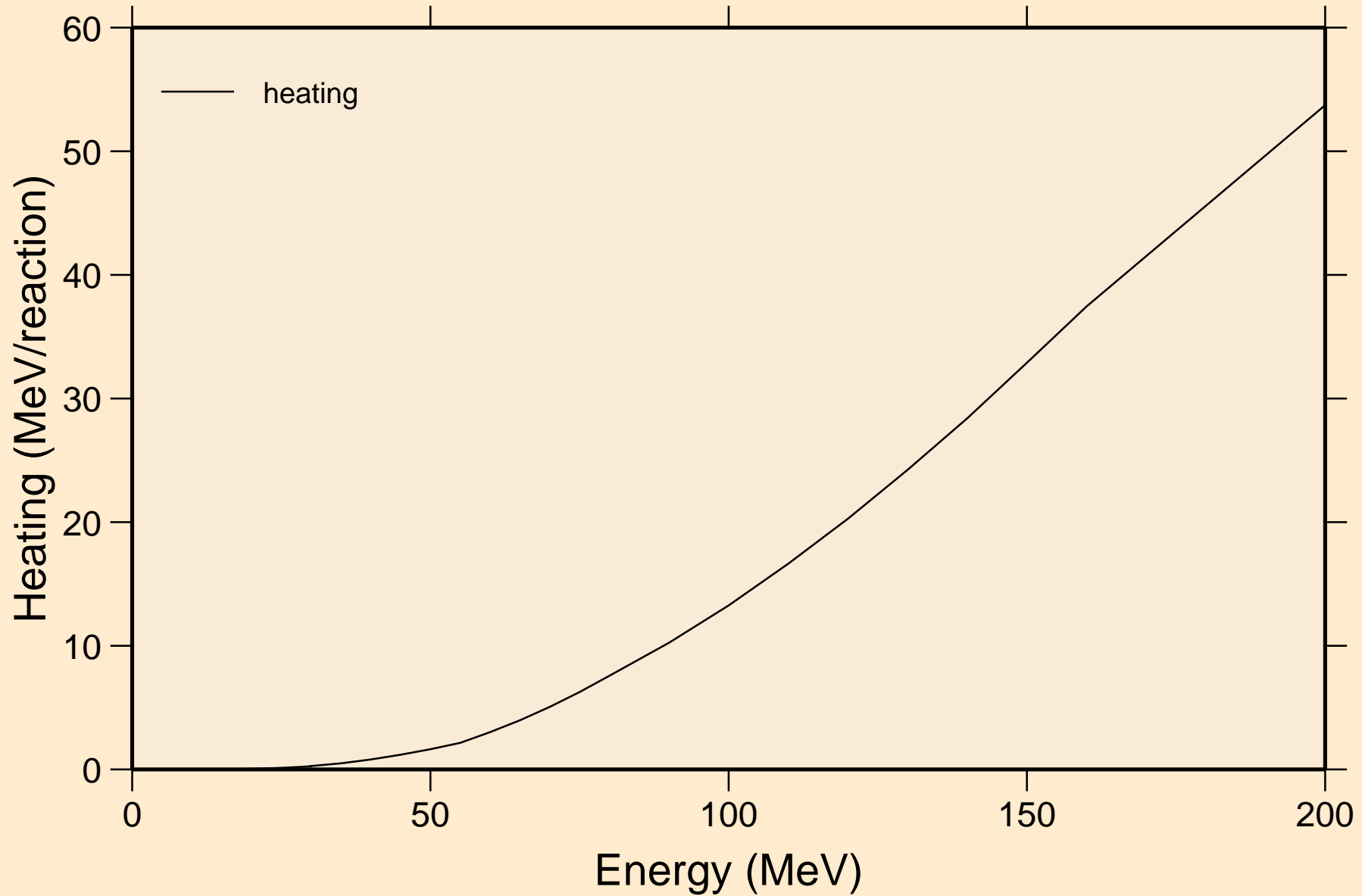

# HG216 DEUTERON ACER TENDL-2023 LIBRARY; T=0.K

## Threshold reactions

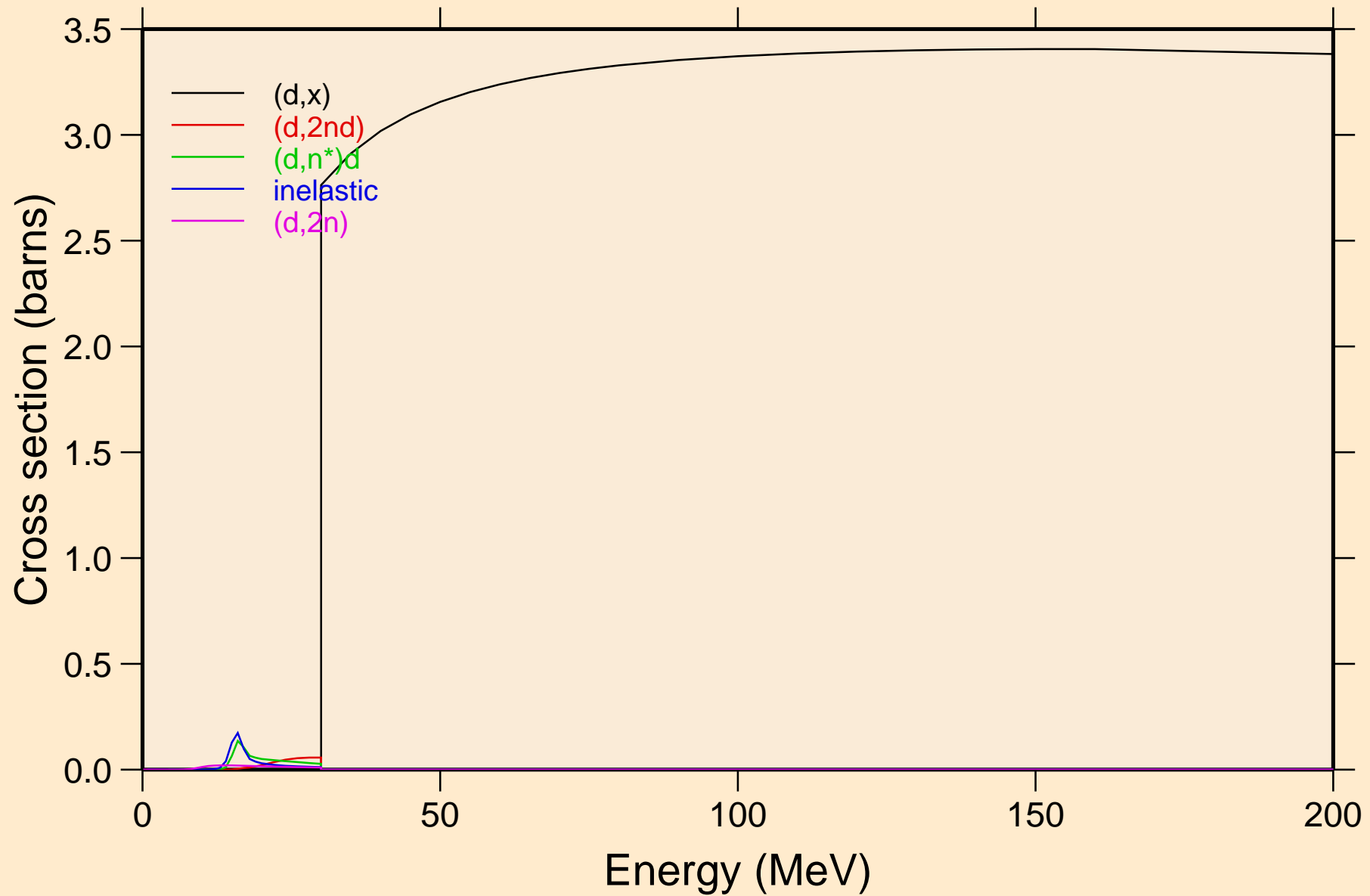

# HG216 DEUTERON ACER TENDL-2023 LIBRARY; T=0.K

## Threshold reactions

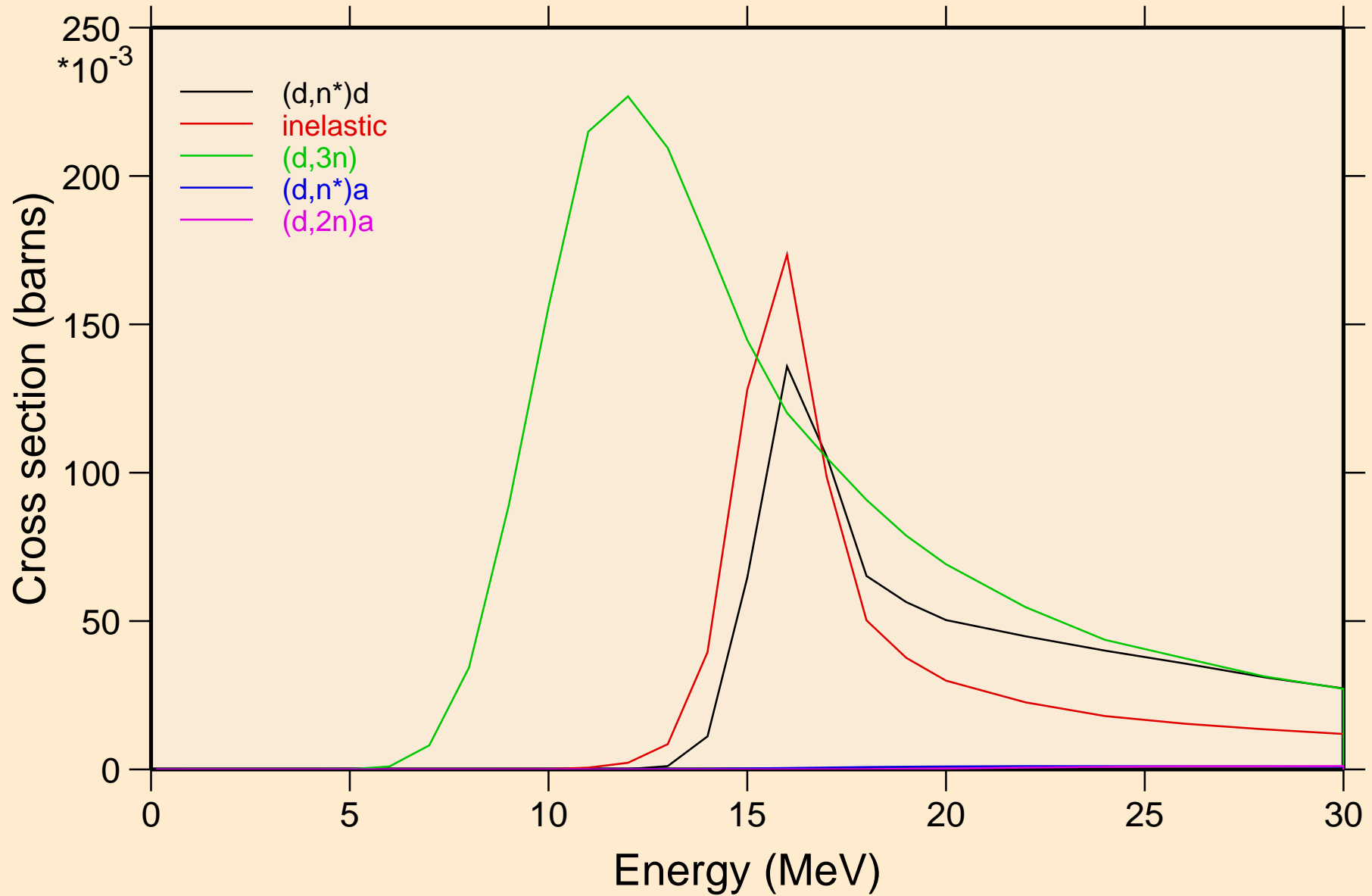

# HG216 DEUTERON ACER TENDL-2023 LIBRARY; T=0.K

## Threshold reactions

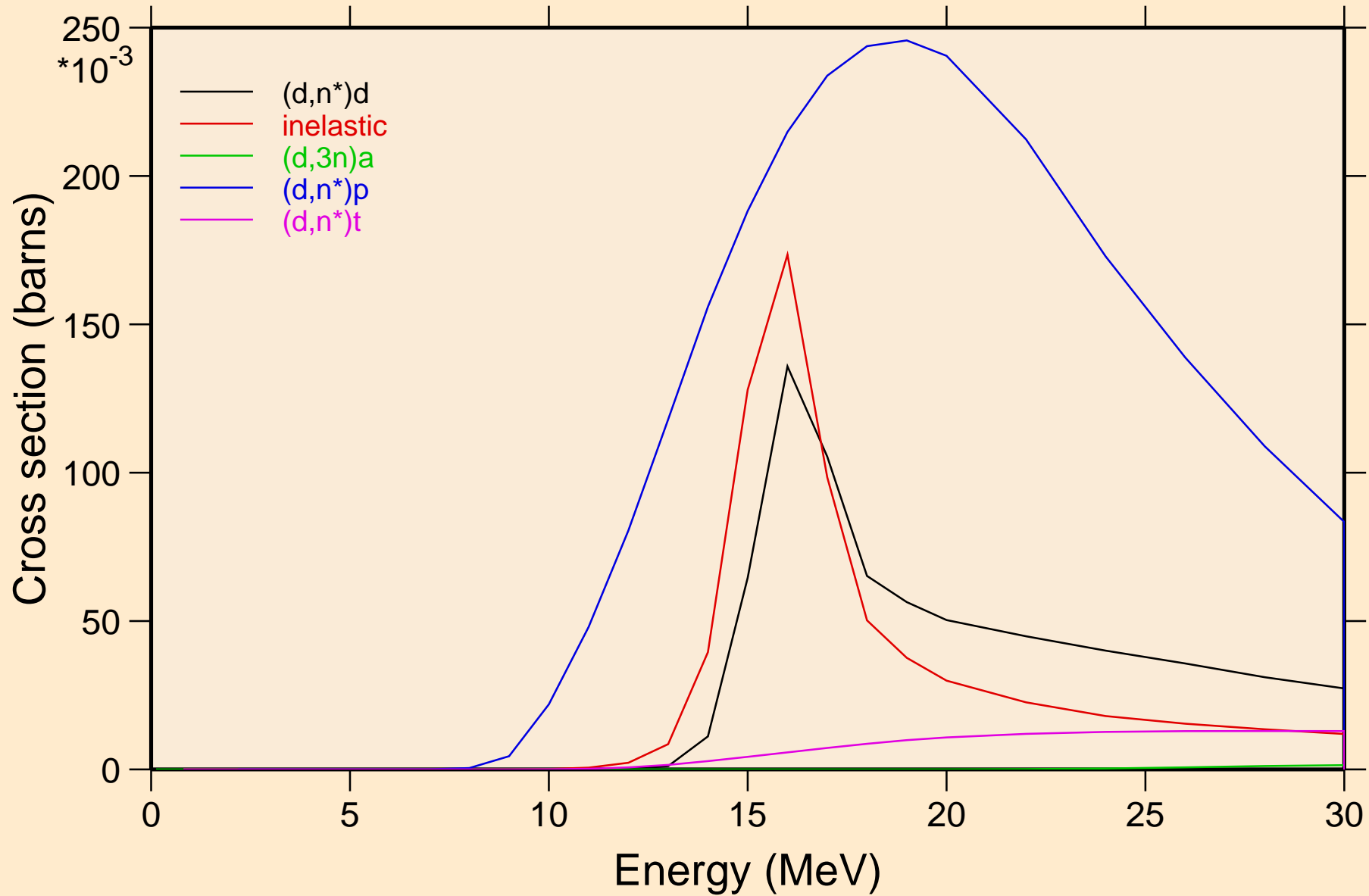

# HG216 DEUTERON ACER TENDL-2023 LIBRARY; T=0.K

## Threshold reactions

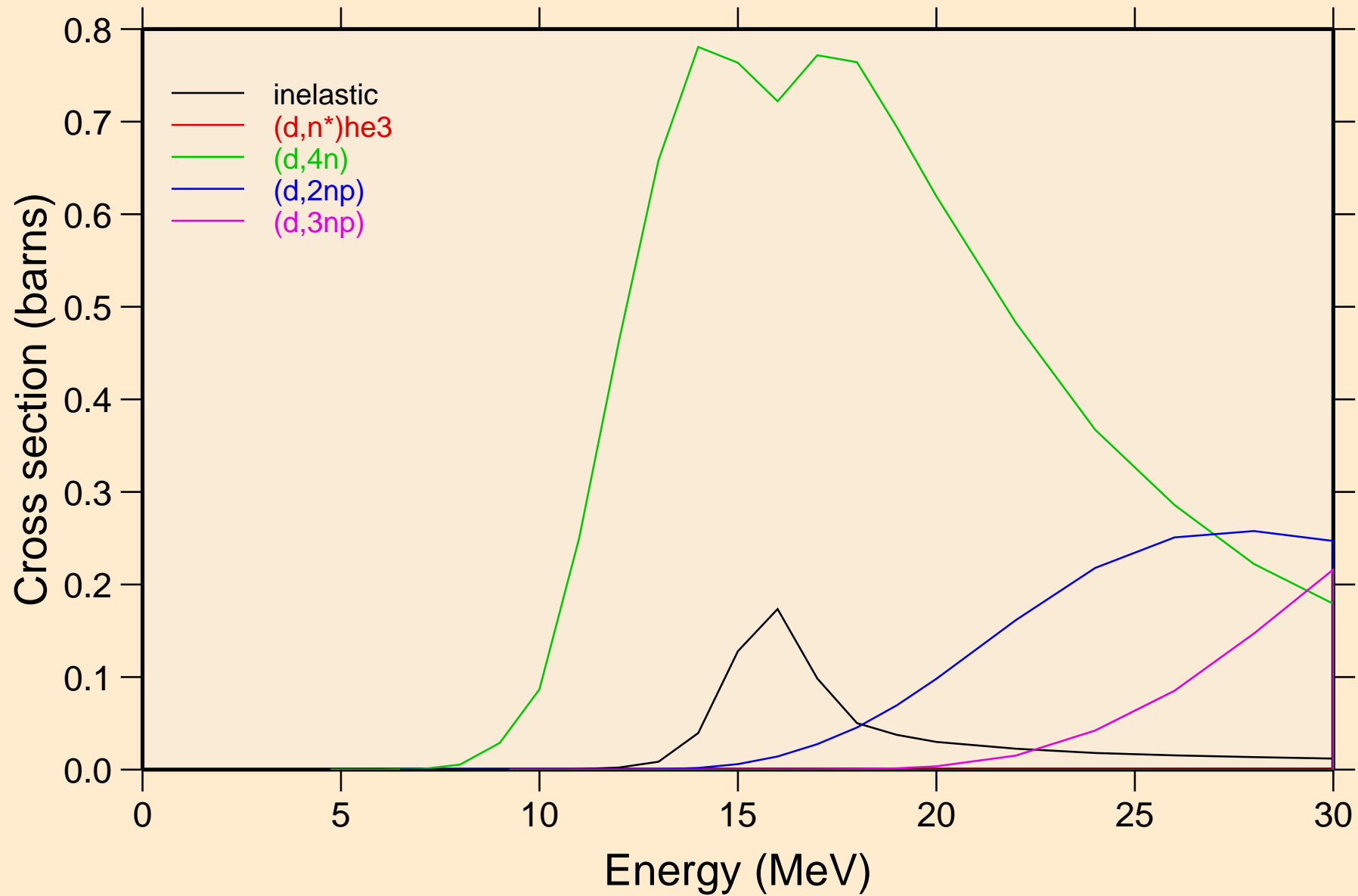



# HG216 DEUTERON ACER TENDL-2023 LIBRARY; T=0.K

## Threshold reactions

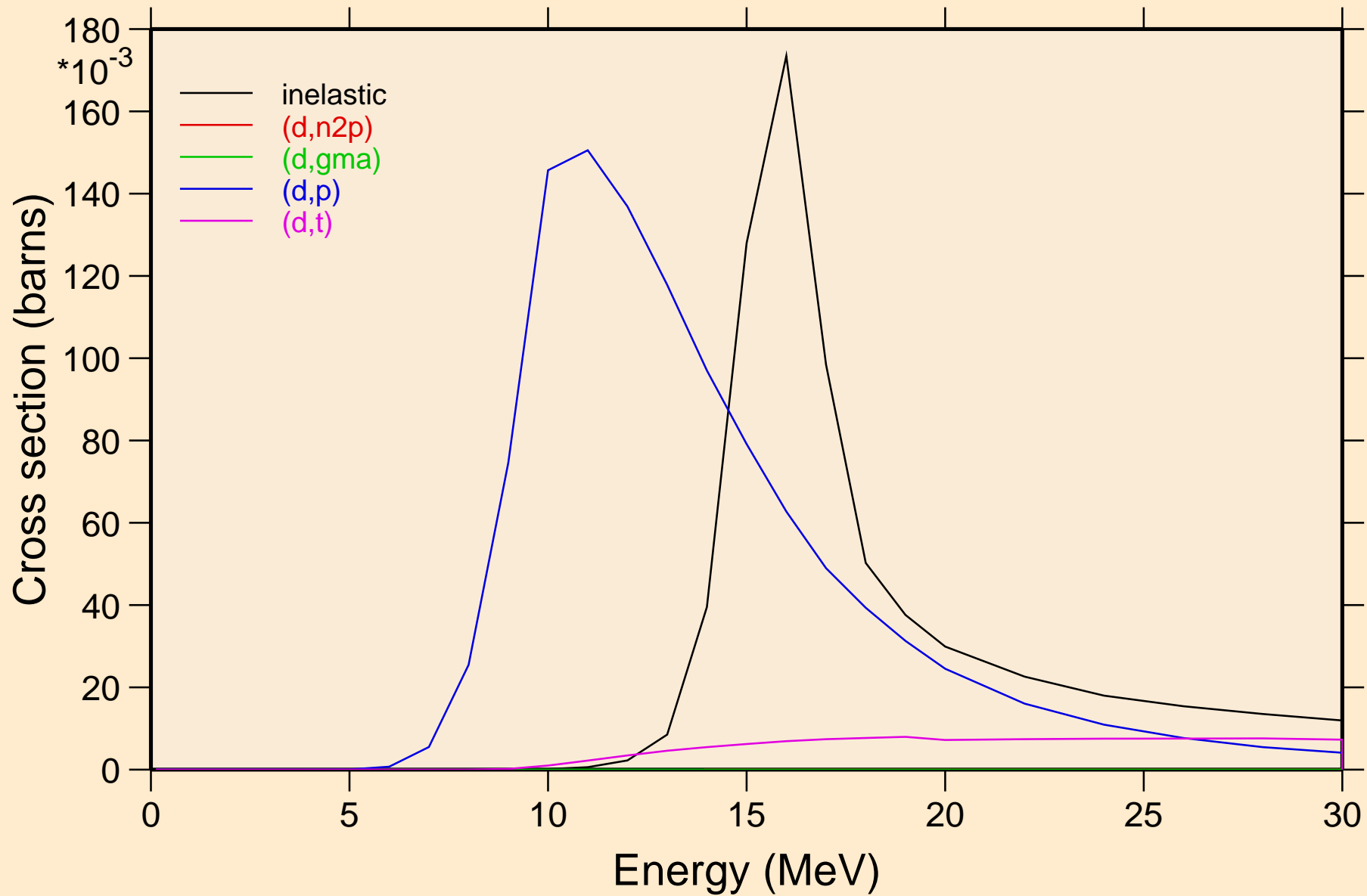

# HG216 DEUTERON ACER TENDL-2023 LIBRARY; T=0.K

## Threshold reactions

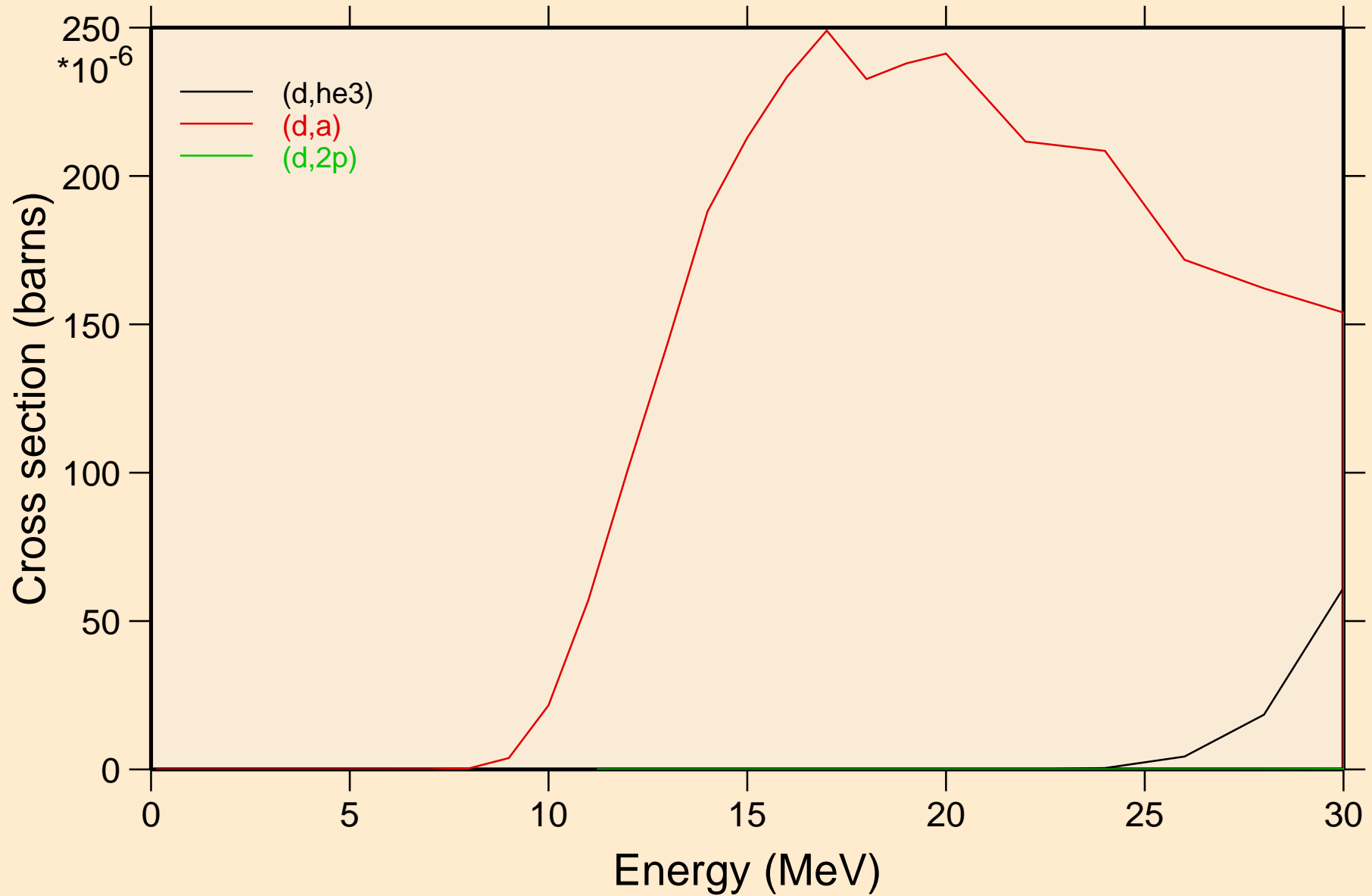

HG216 DEUTERON ACER TENDL-2023 LIBRARY; T=0.K  
angular distribution for elastic

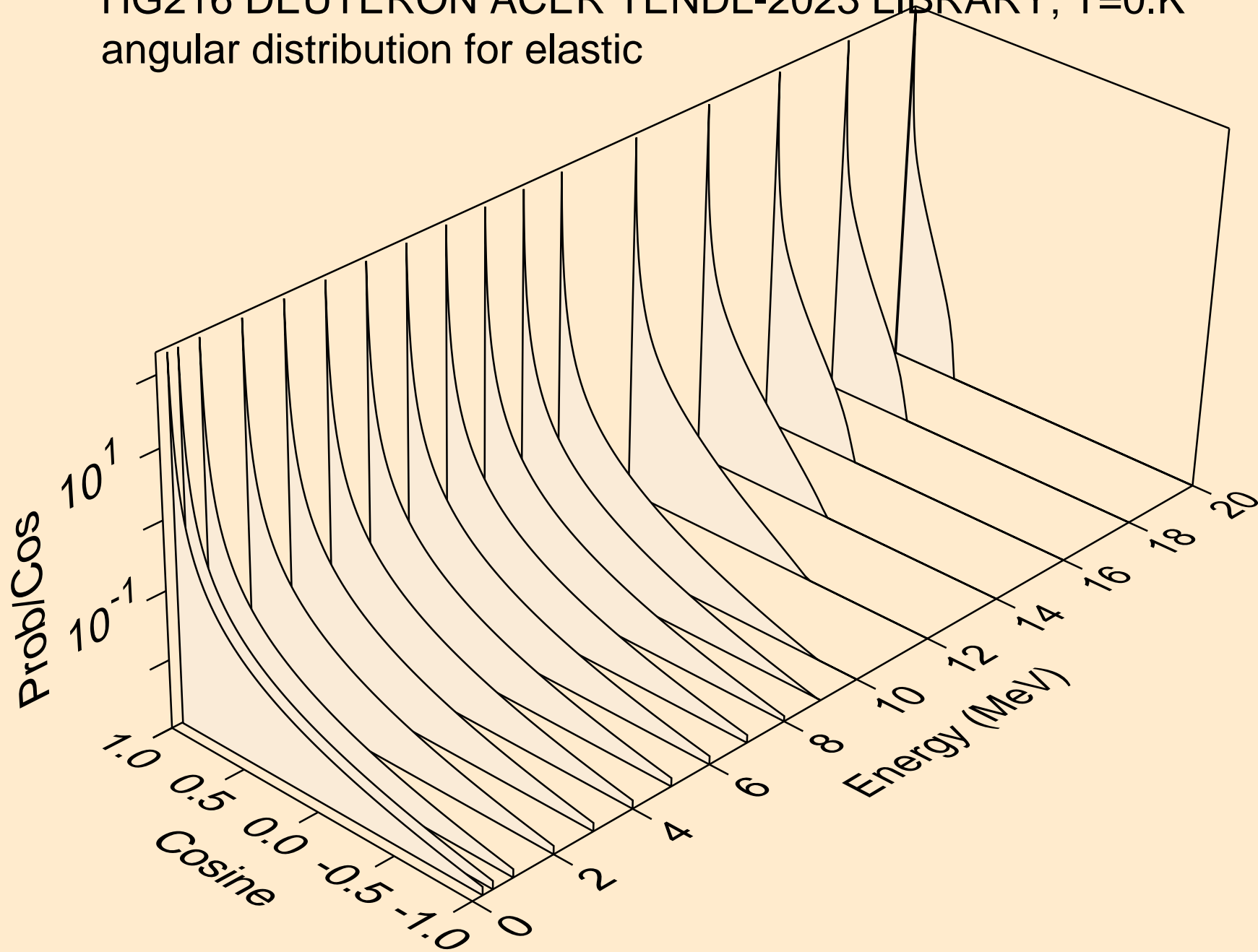

HG216 DEUTERON ACER TENDL-2023 LIBRARY; T=0.K  
angular distribution for elastic

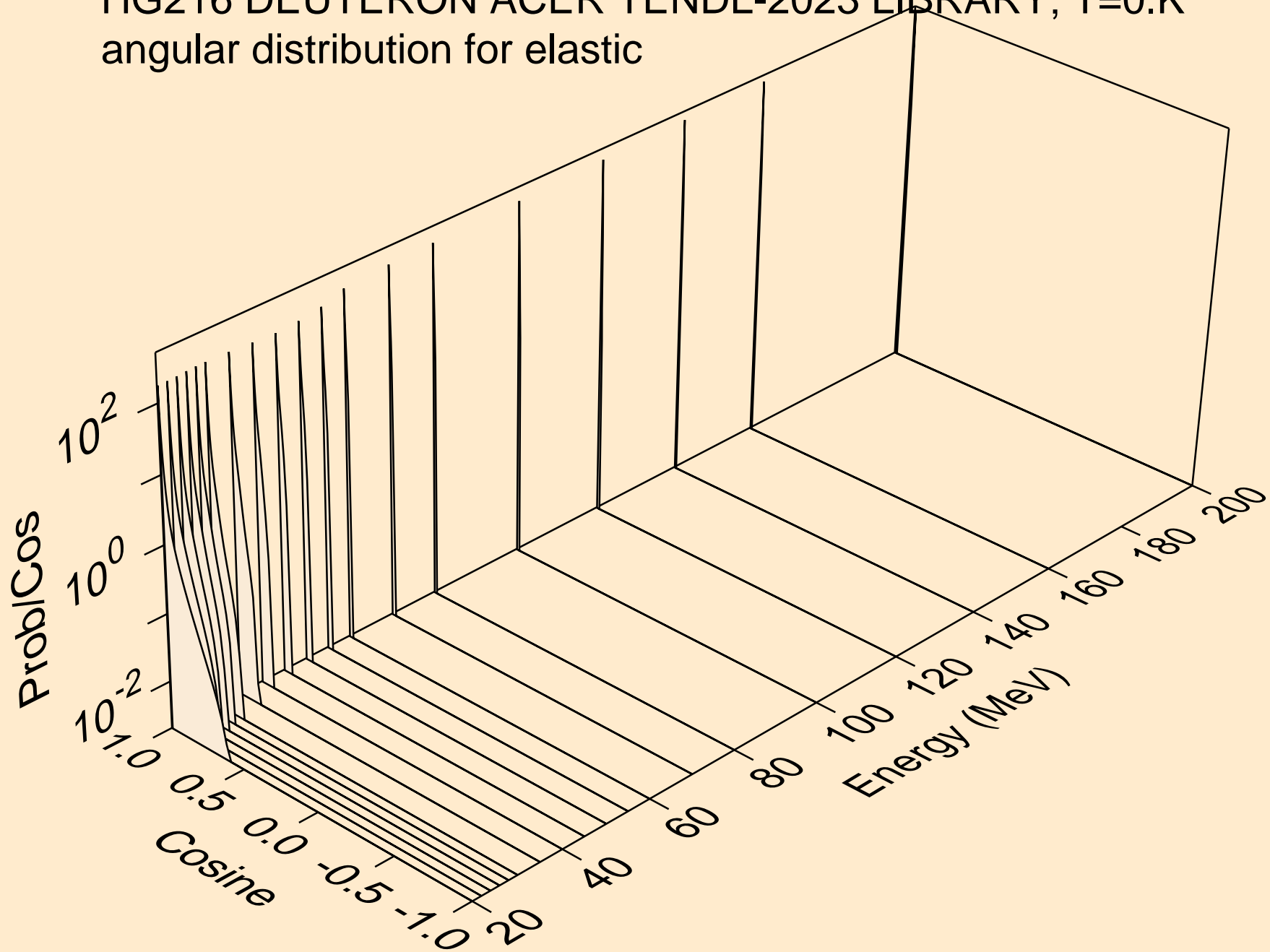

HG216 DEUTERON ACER TENDL-2023 LIBRARY; T=0.K  
Deuteron emission for (d,x)

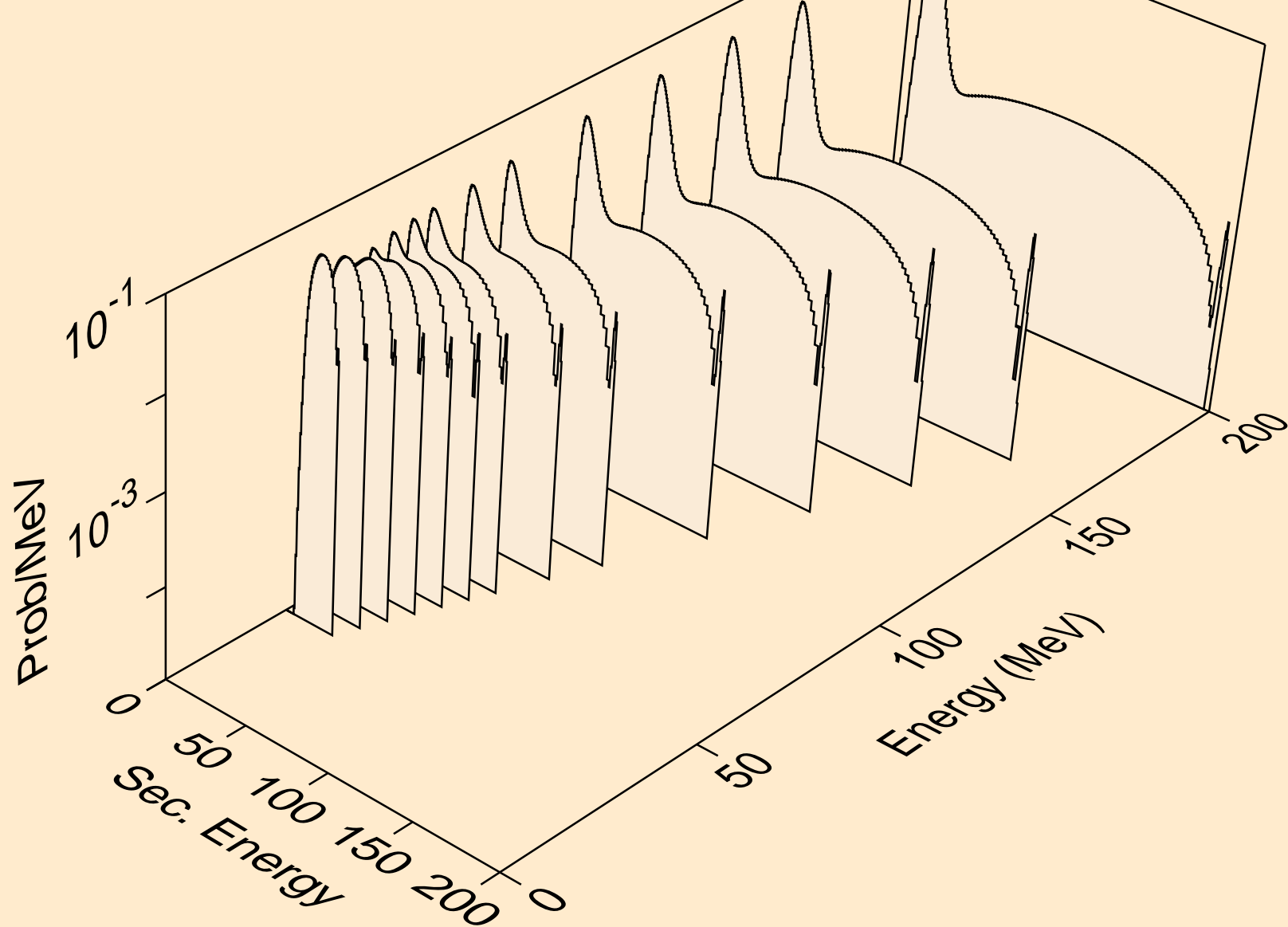

HG216 DEUTERON ACER TENDL-2023 LIBRARY; T=0.K  
Deuteron emission for (d,2nd)

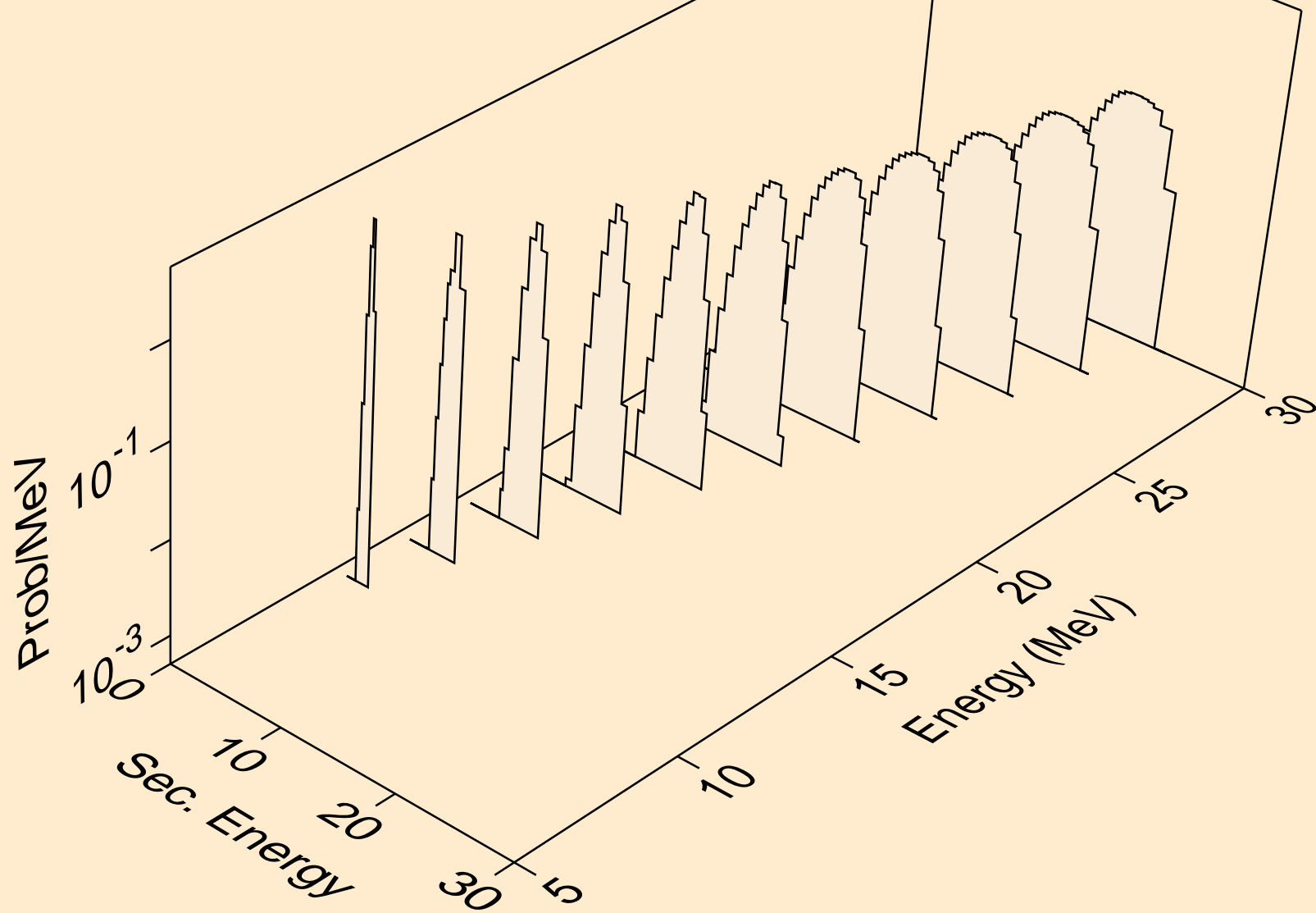

HG216 DEUTERON ACER TENDL-2023 LIBRARY; T=0.K  
Deuteron emission for (d,n\*)d

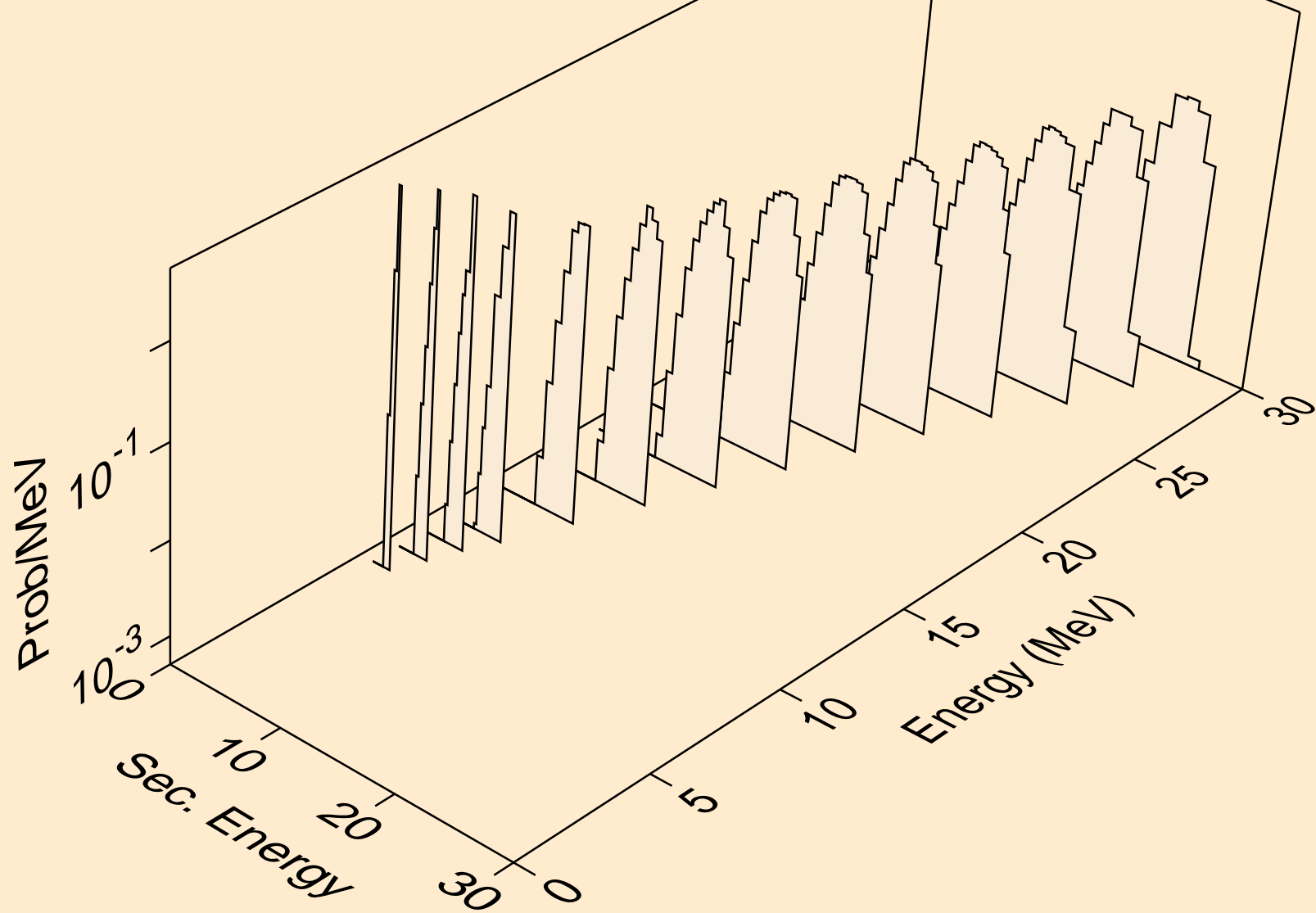

HG216 DEUTERON ACER TENDL-2023 LIBRARY; T=0.K  
Deuteron emission for inelastic

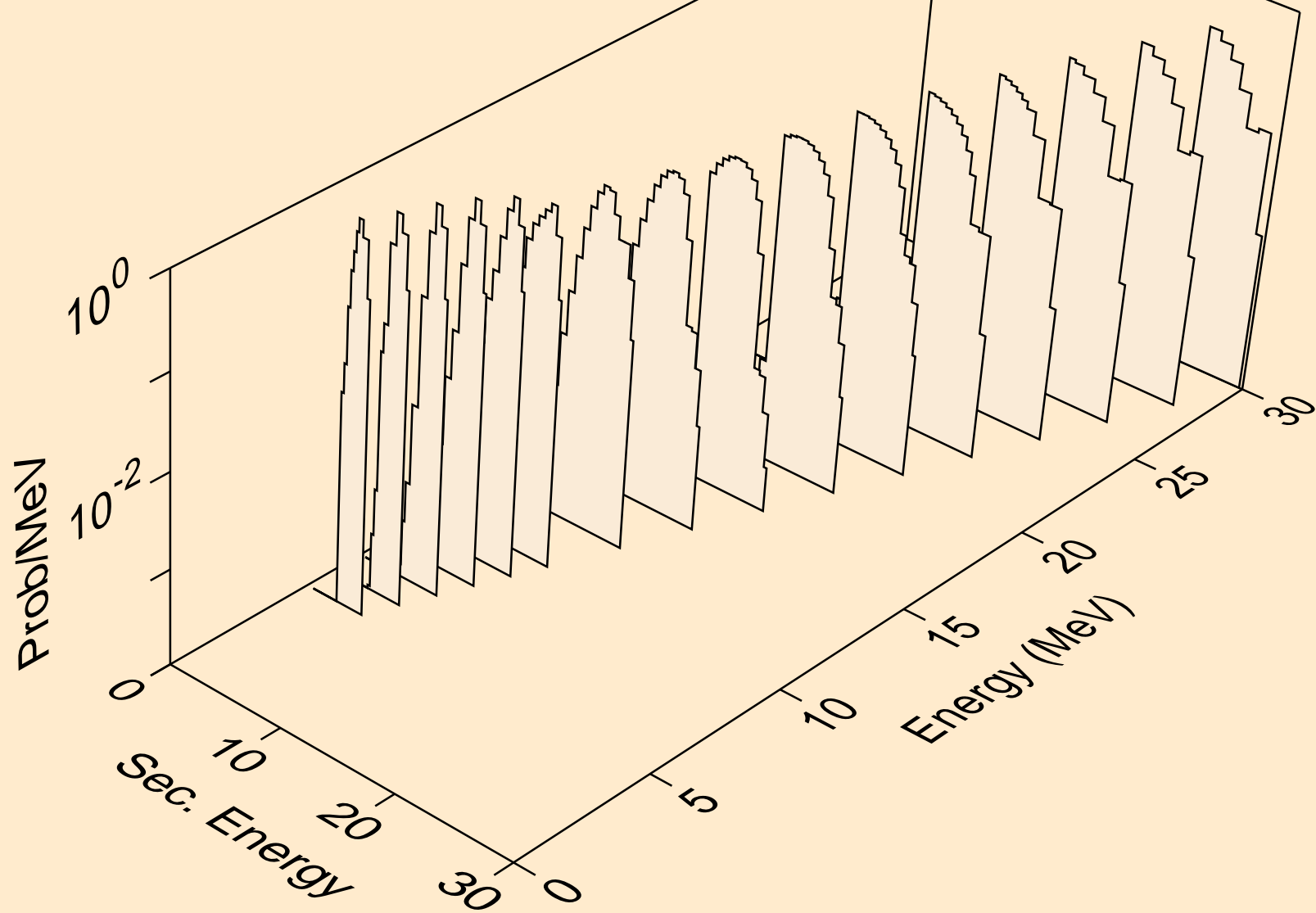



HG216 DEUTERON ACER TENDL-2023 LIBRARY; T=0.K  
Photon emission for (z,n)

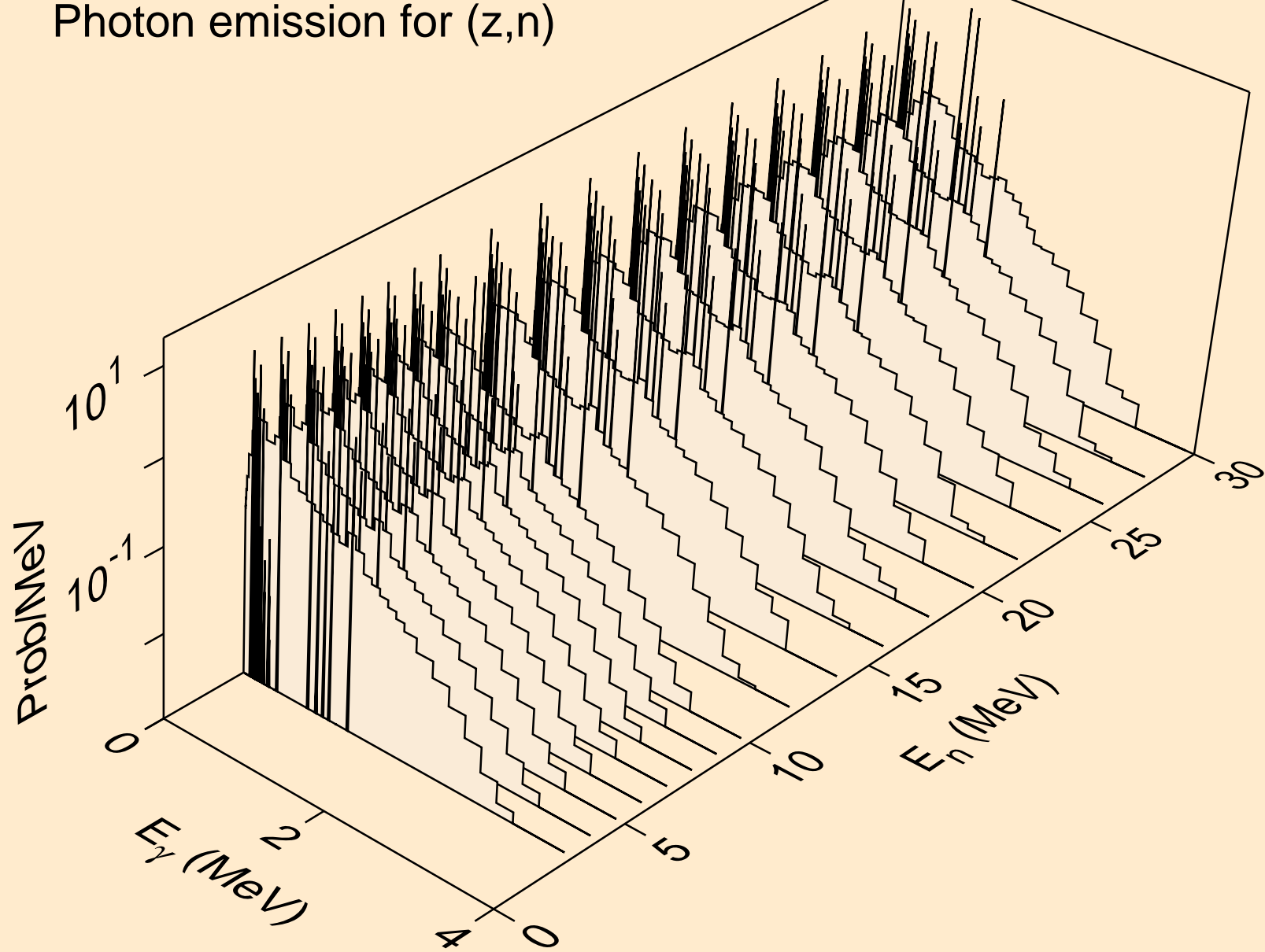

HG216 DEUTERON ACER TENDL-2023 LIBRARY; T=0.K  
Photon emission for (z,x)

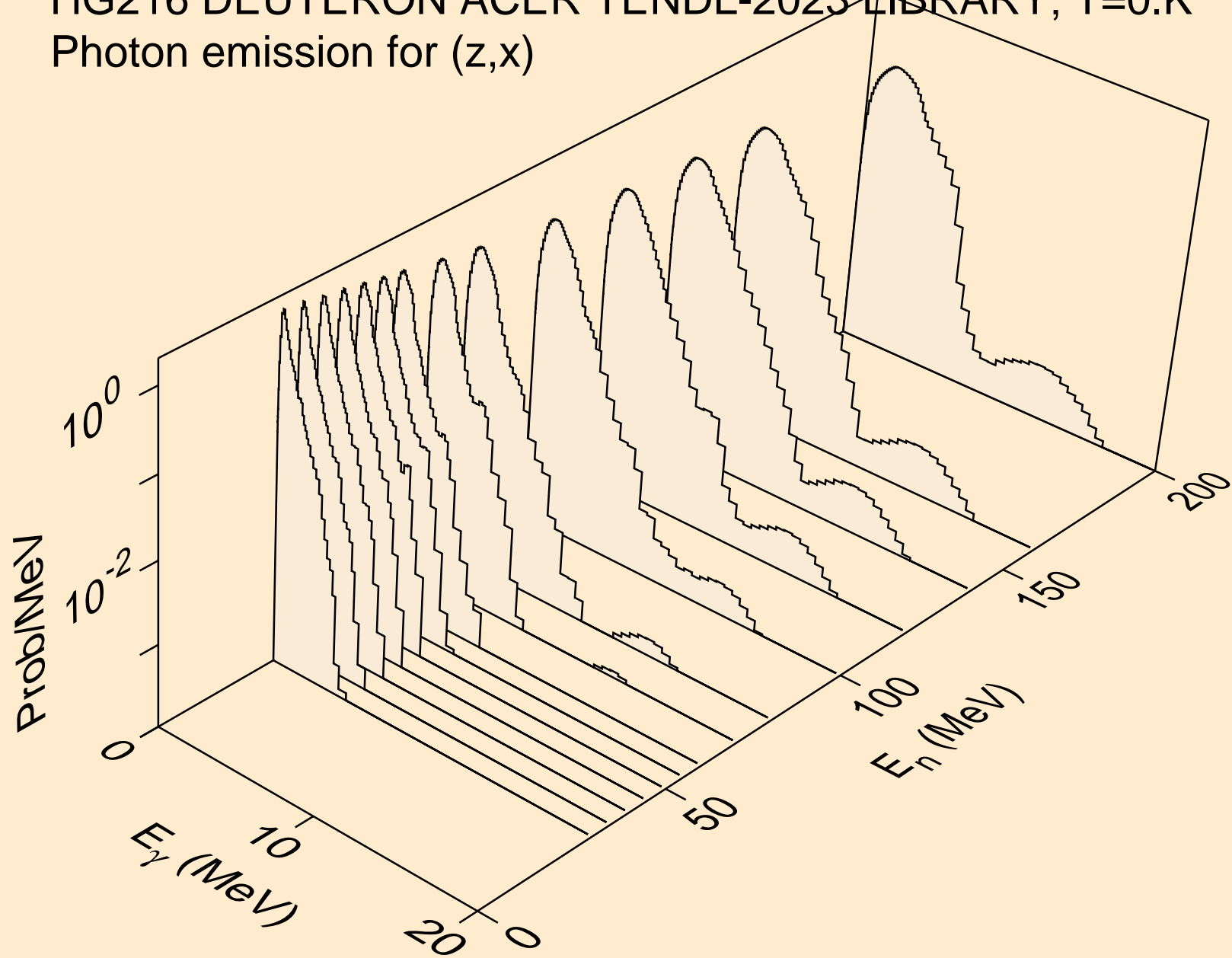

HG216 DEUTERON ACER TENDL-2023 LIBRARY; T=0.K  
Photon emission for (n,2nd)

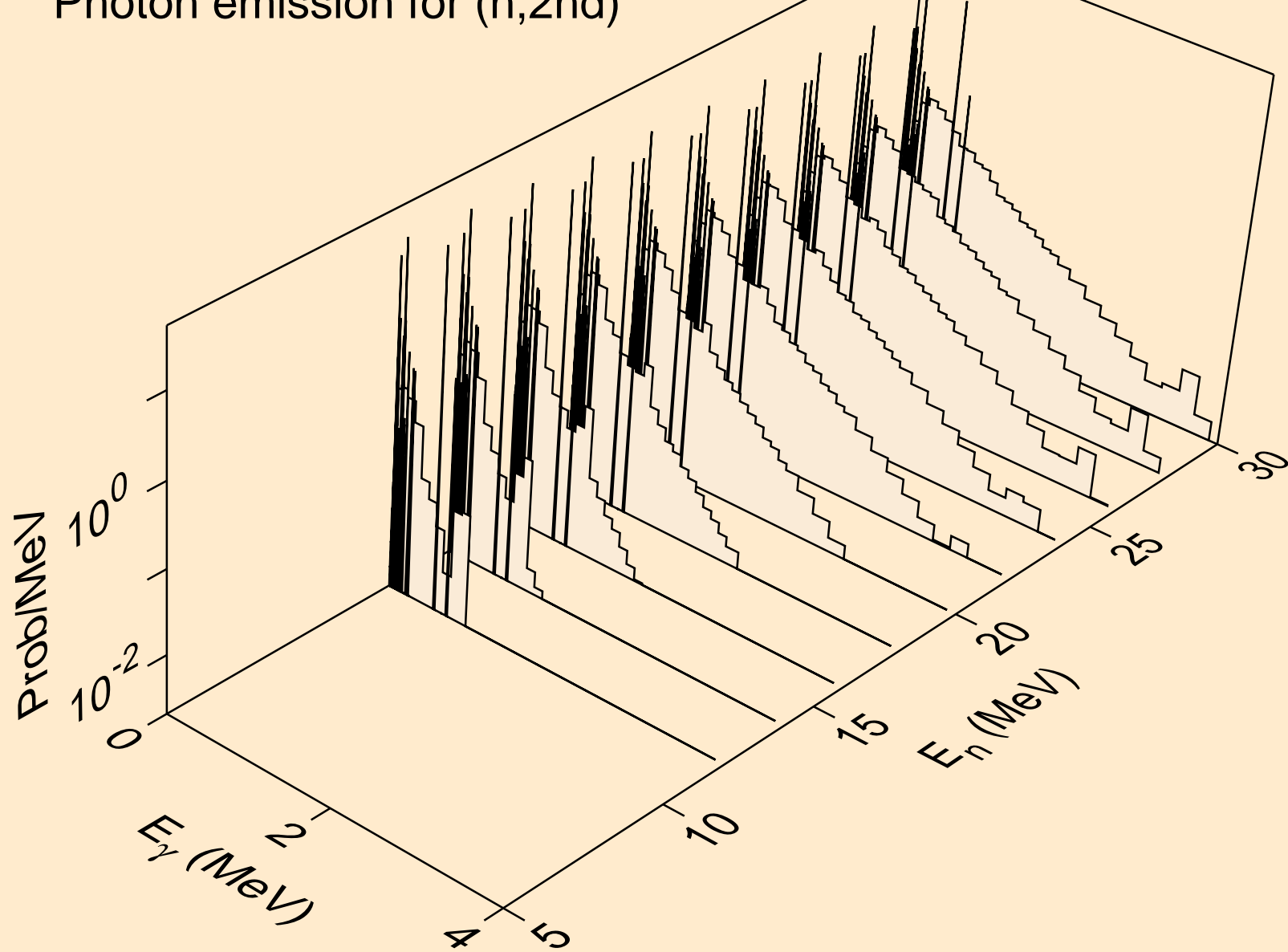

HG216 DEUTERON ACER TENDL-2023 LIBRARY; T=0.K  
Photon emission for (n,2n)

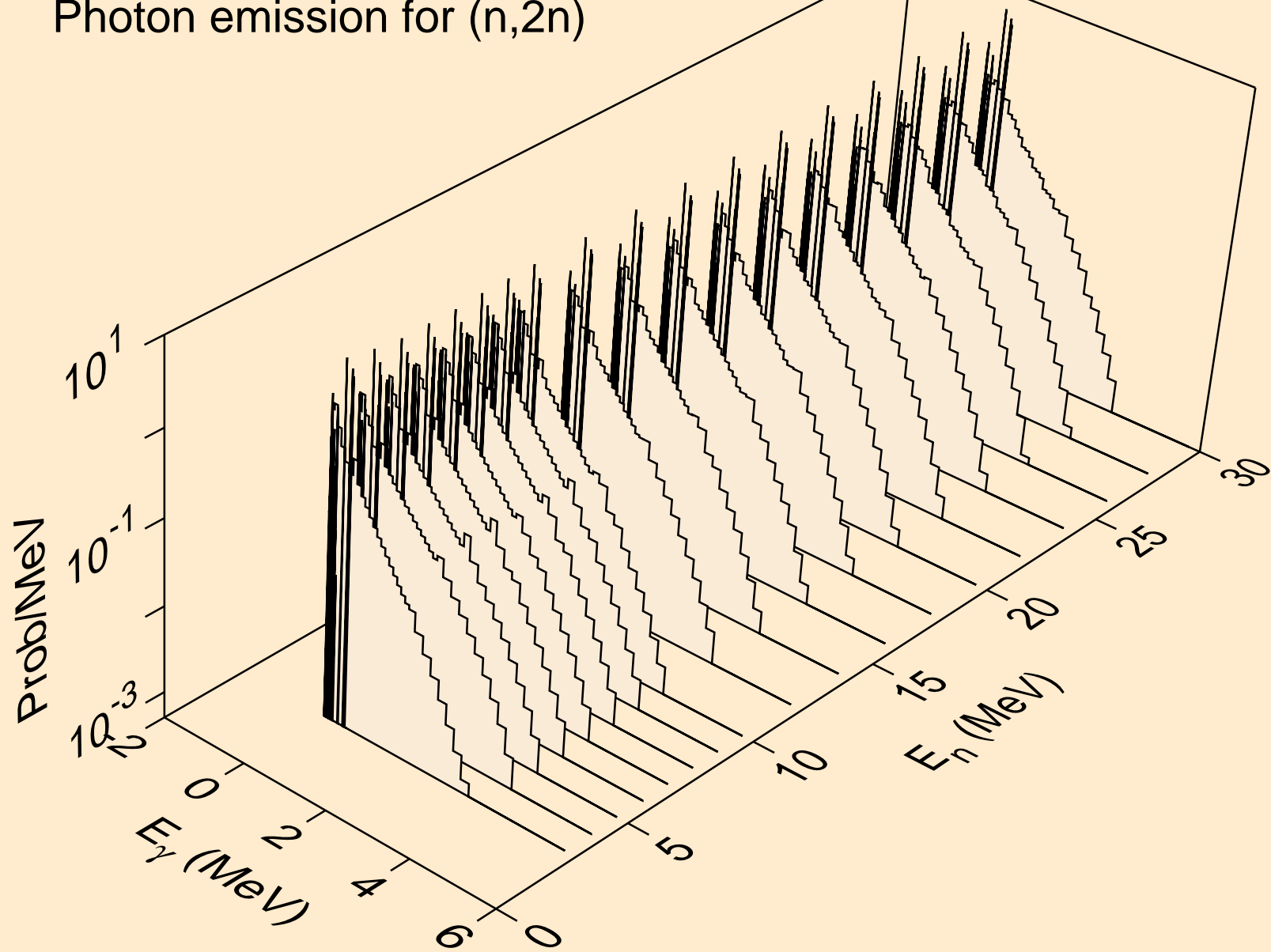

HG216 DEUTERON ACER TENDL-2023 LIBRARY; T=0.K  
Photon emission for (n,3n)

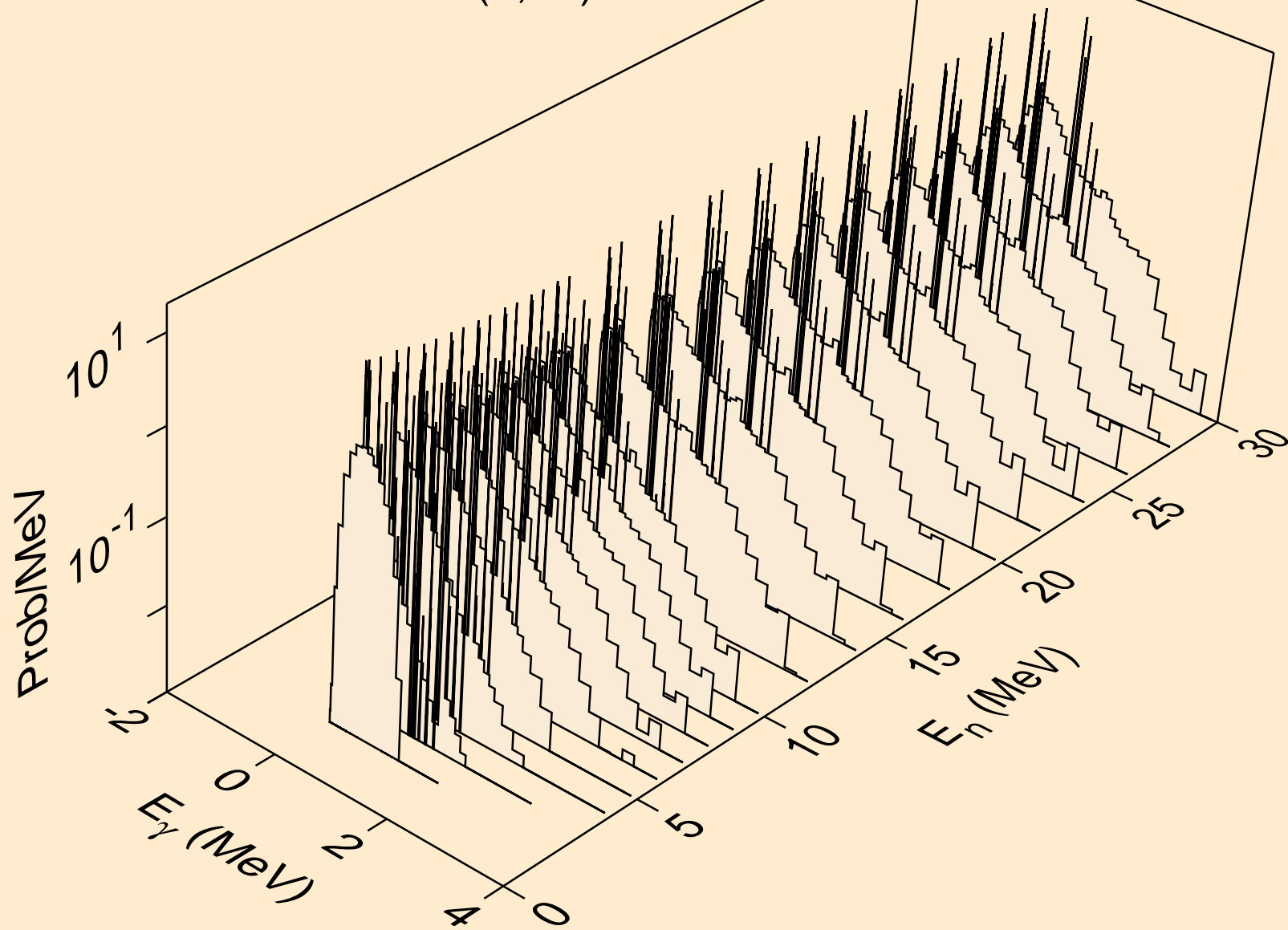

HG216 DEUTERON ACER TENDL-2023 LIBRARY; T=0.K  
Photon emission for (n,n\*)a

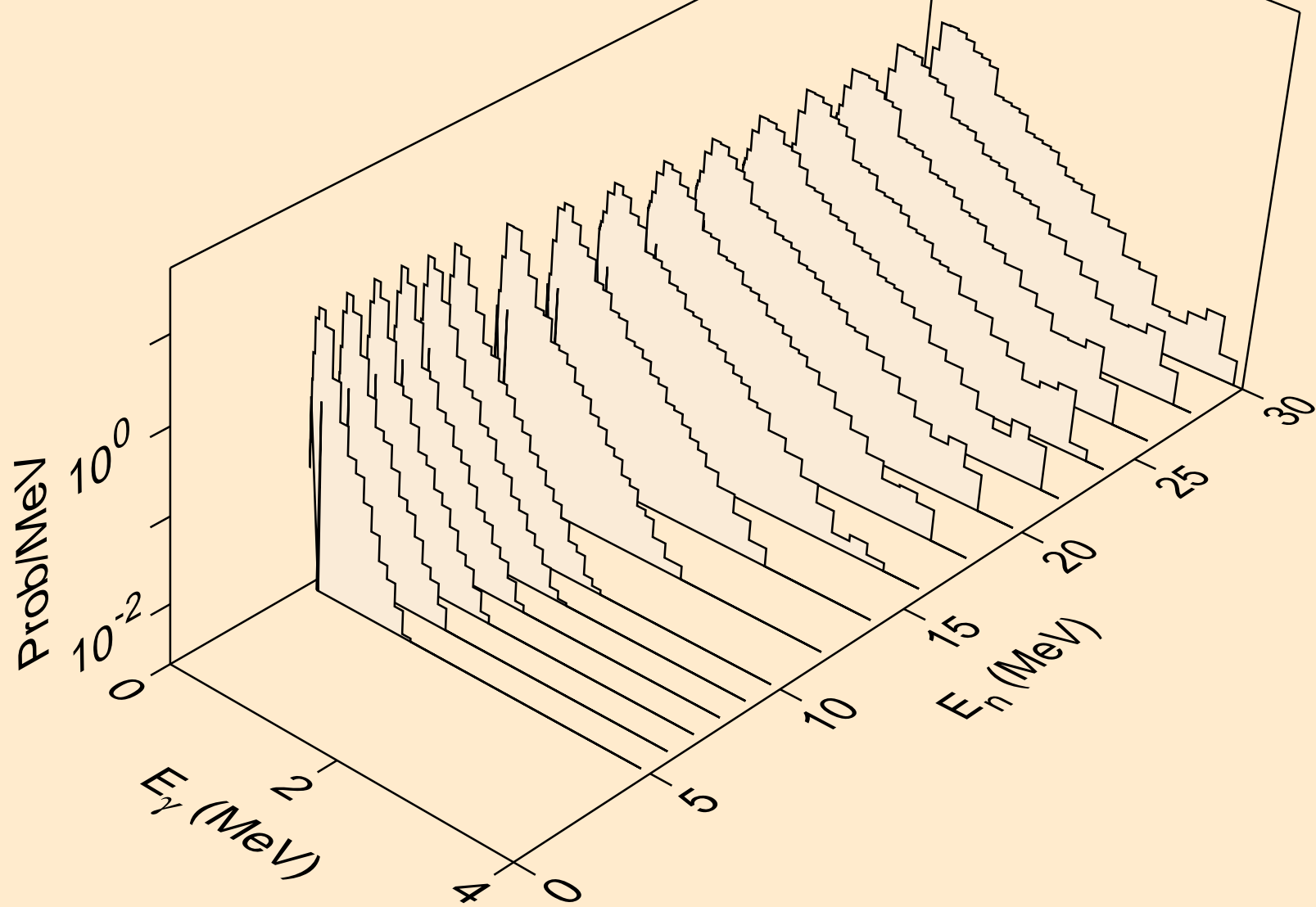

HG216 DEUTERON ACER TENDL-2023 LIBRARY; T=0.K  
Photon emission for (n,2n)a

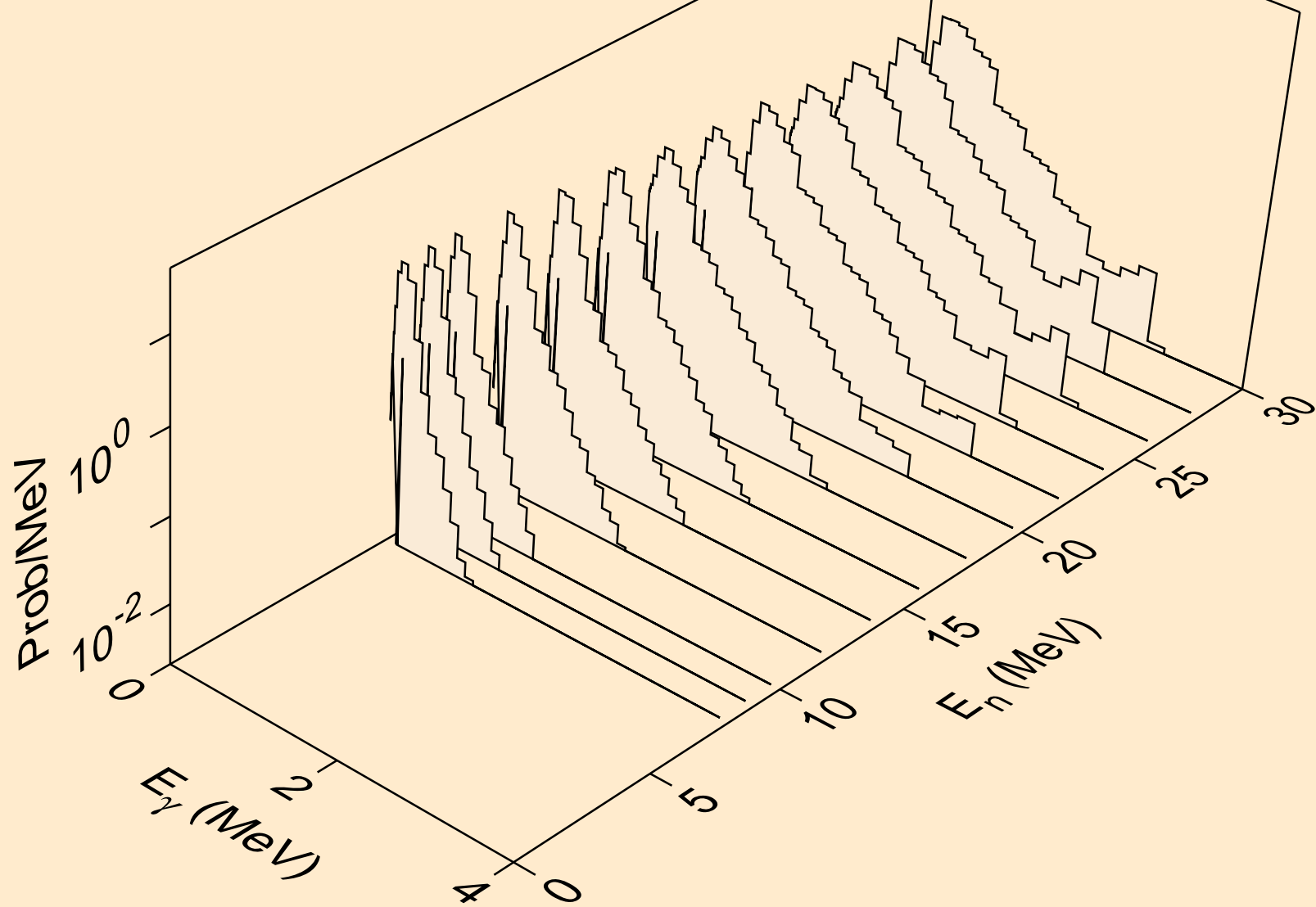

HG216 DEUTERON ACER TENDL-2023 LIBRARY; T=0.K  
Photon emission for (n,3n)a

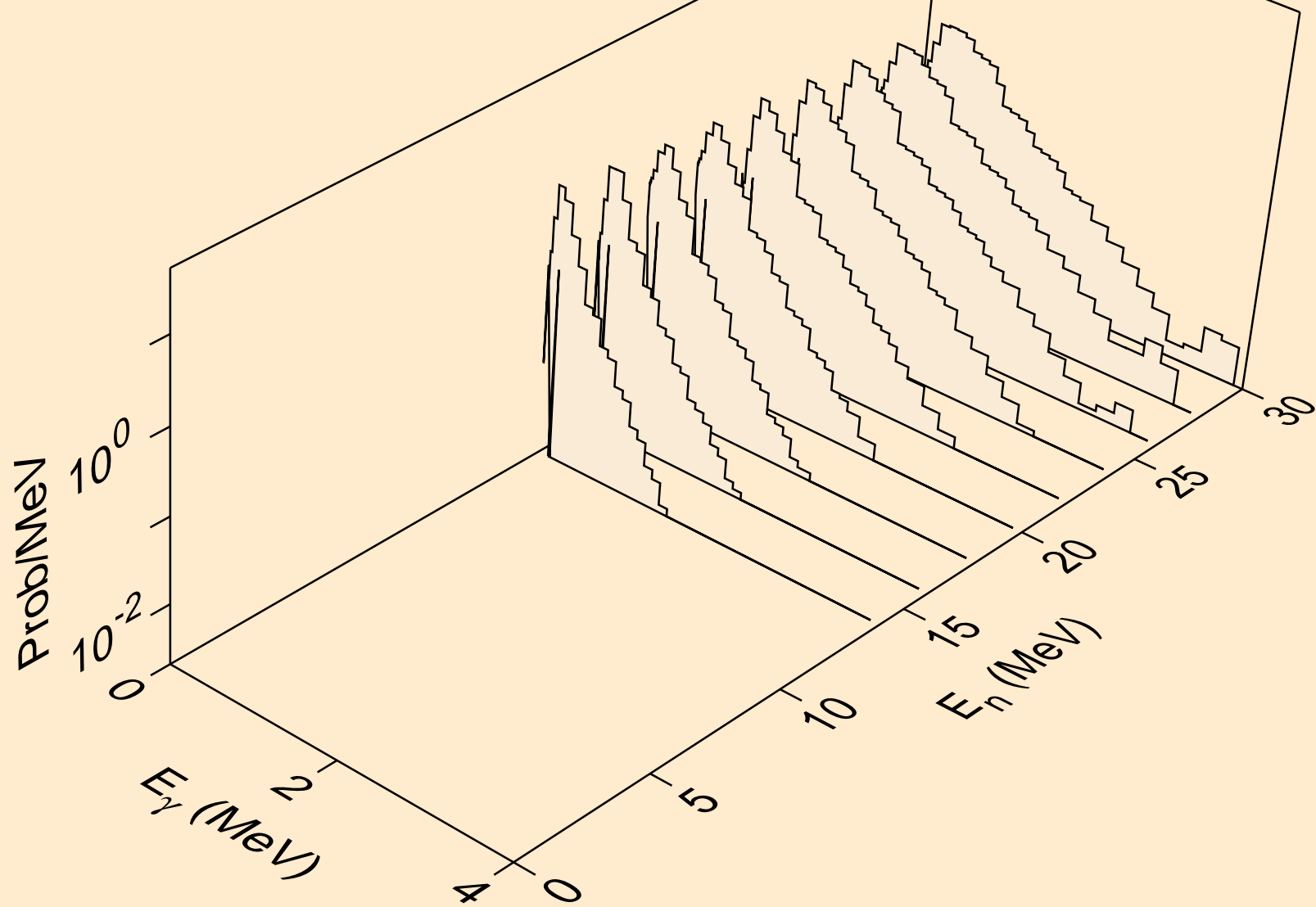



HG216 DEUTERON ACER TENDL-2023 LIBRARY; T=0.K  
Photon emission for (n,n\*)p

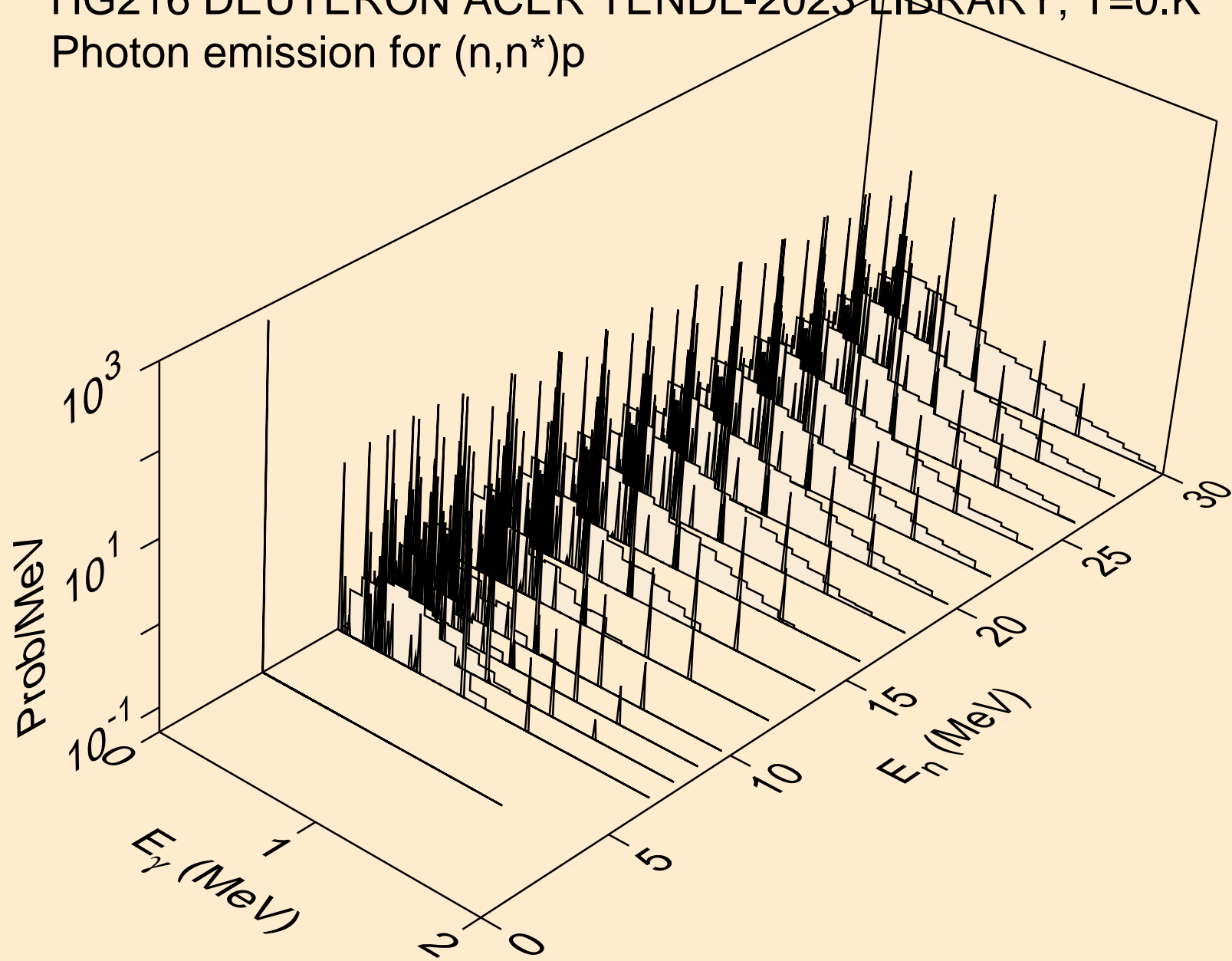

HG216 DEUTERON ACER TENDL-2023 LIBRARY; T=0.K  
Photon emission for (n,n\*)d

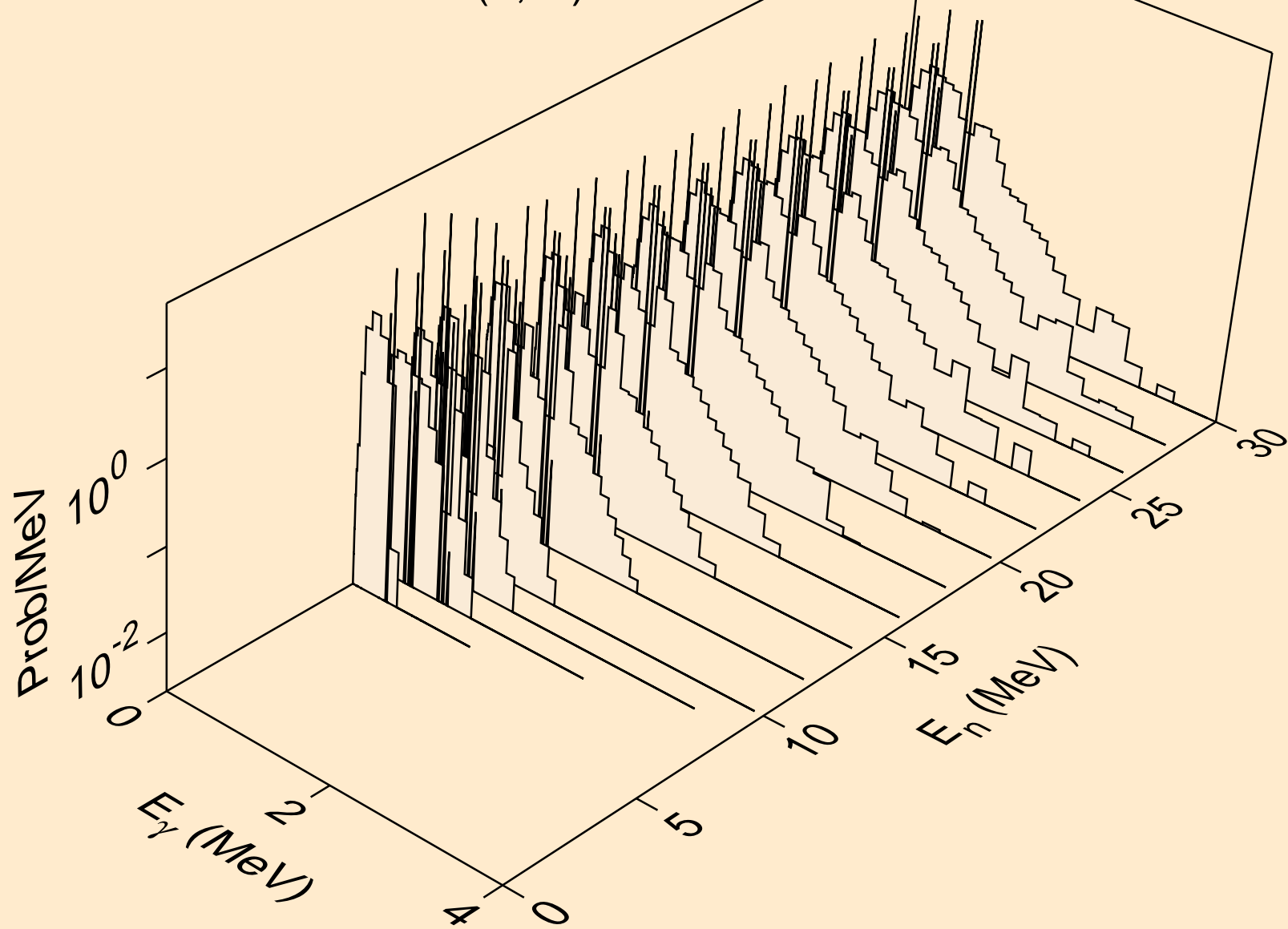

HG216 DEUTERON ACER TENDL-2023 LIBRARY; T=0.K  
Photon emission for (n,n\*)t

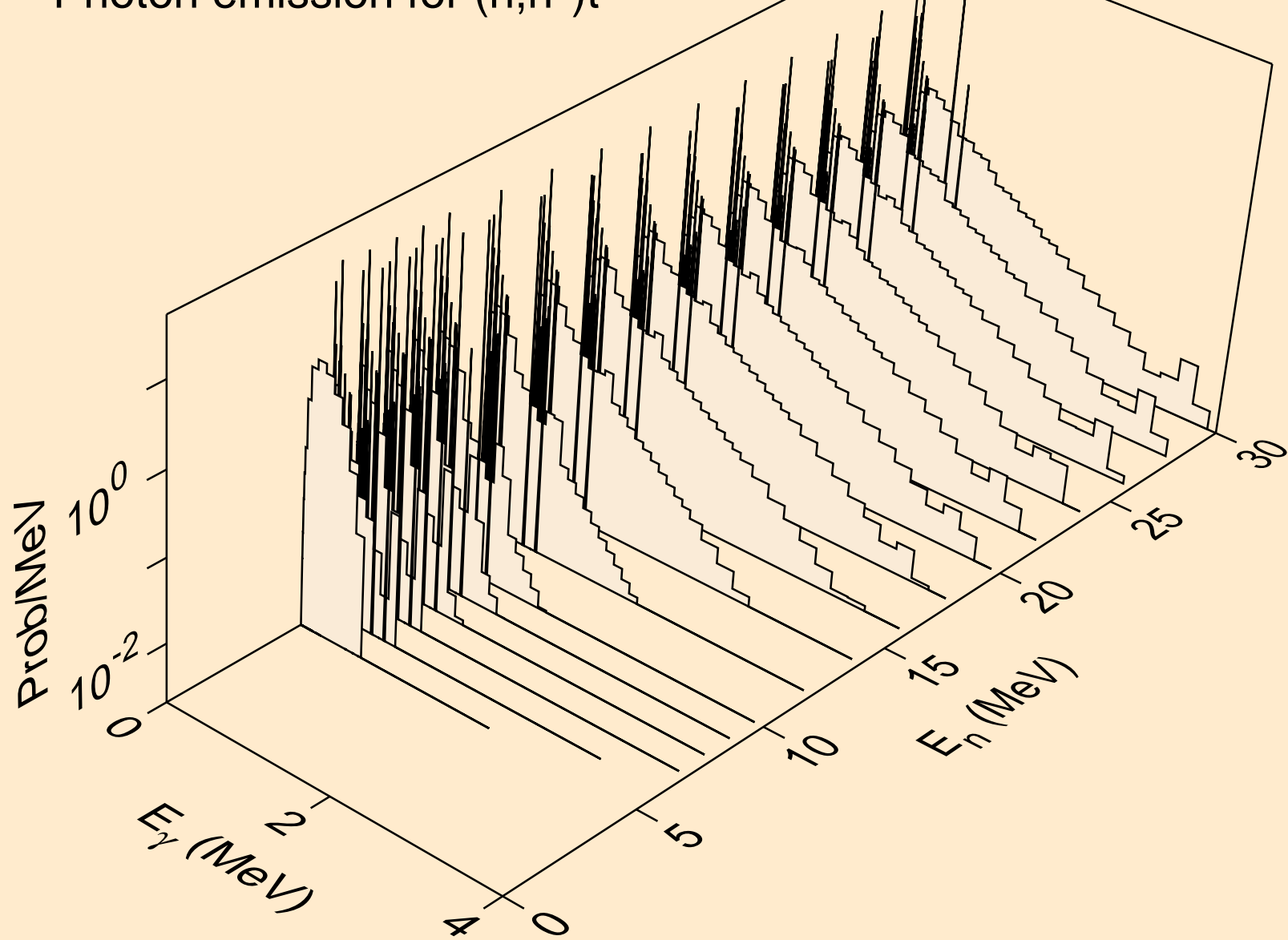

HG216 DEUTERON ACER TENDL-2023 LIBRARY; T=0.K  
Photon emission for (n,n\*)he3

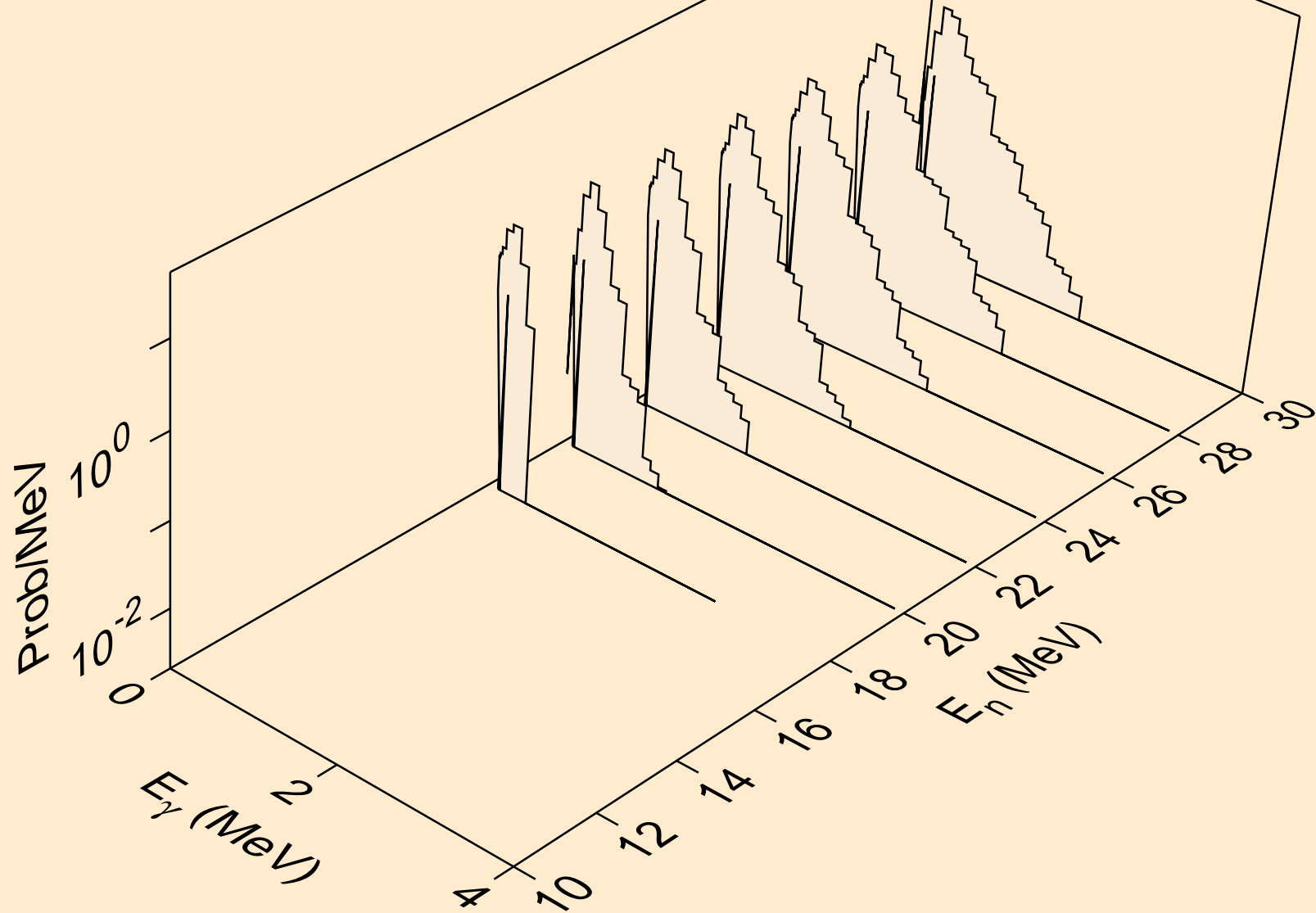

HG216 DEUTERON ACER TENDL-2023 LIBRARY; T=0.K  
Photon emission for (n,4n)

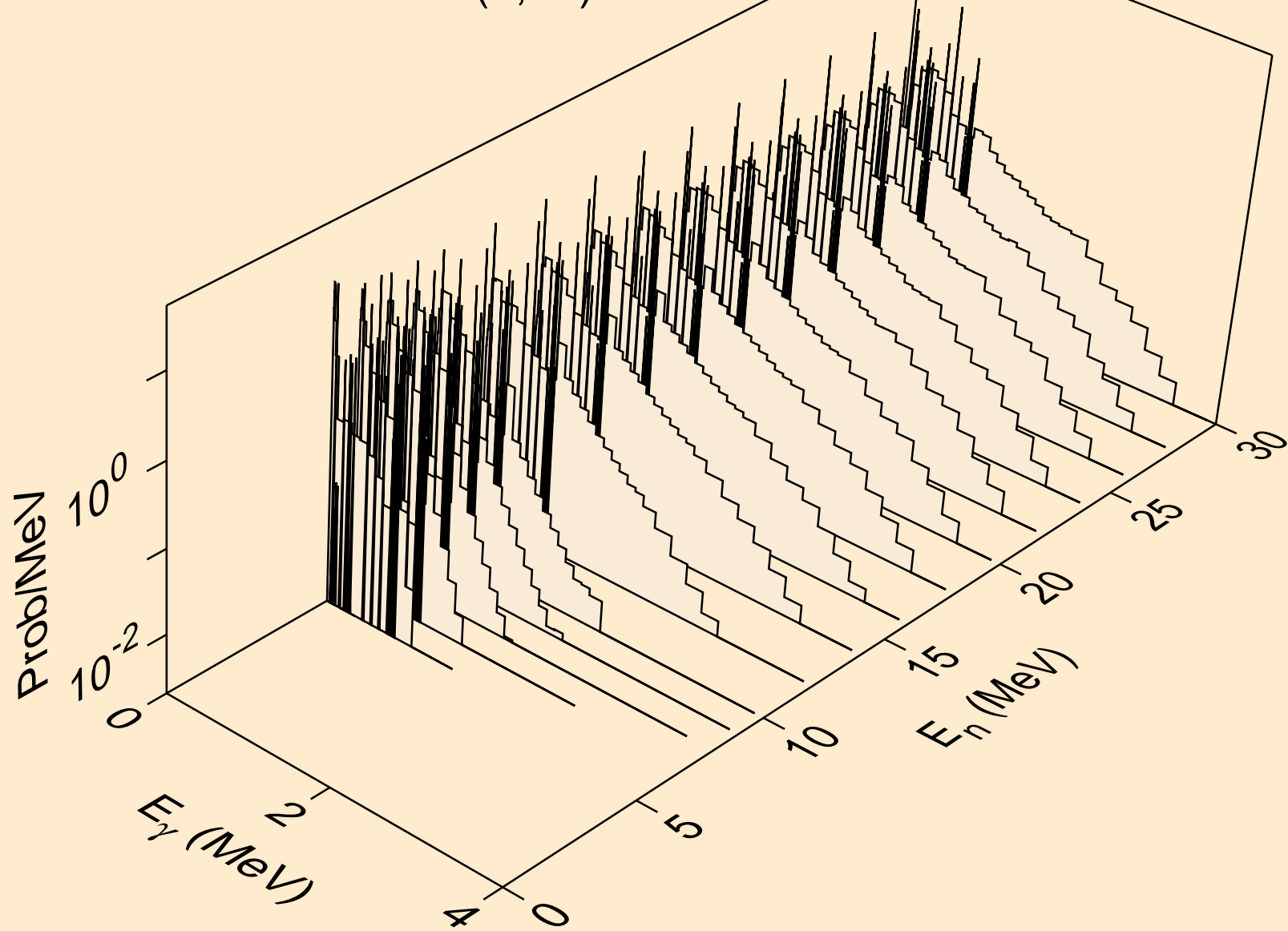

HG216 DEUTERON ACER TENDL-2023 LIBRARY; T=0.K  
Photon emission for (n,2np)

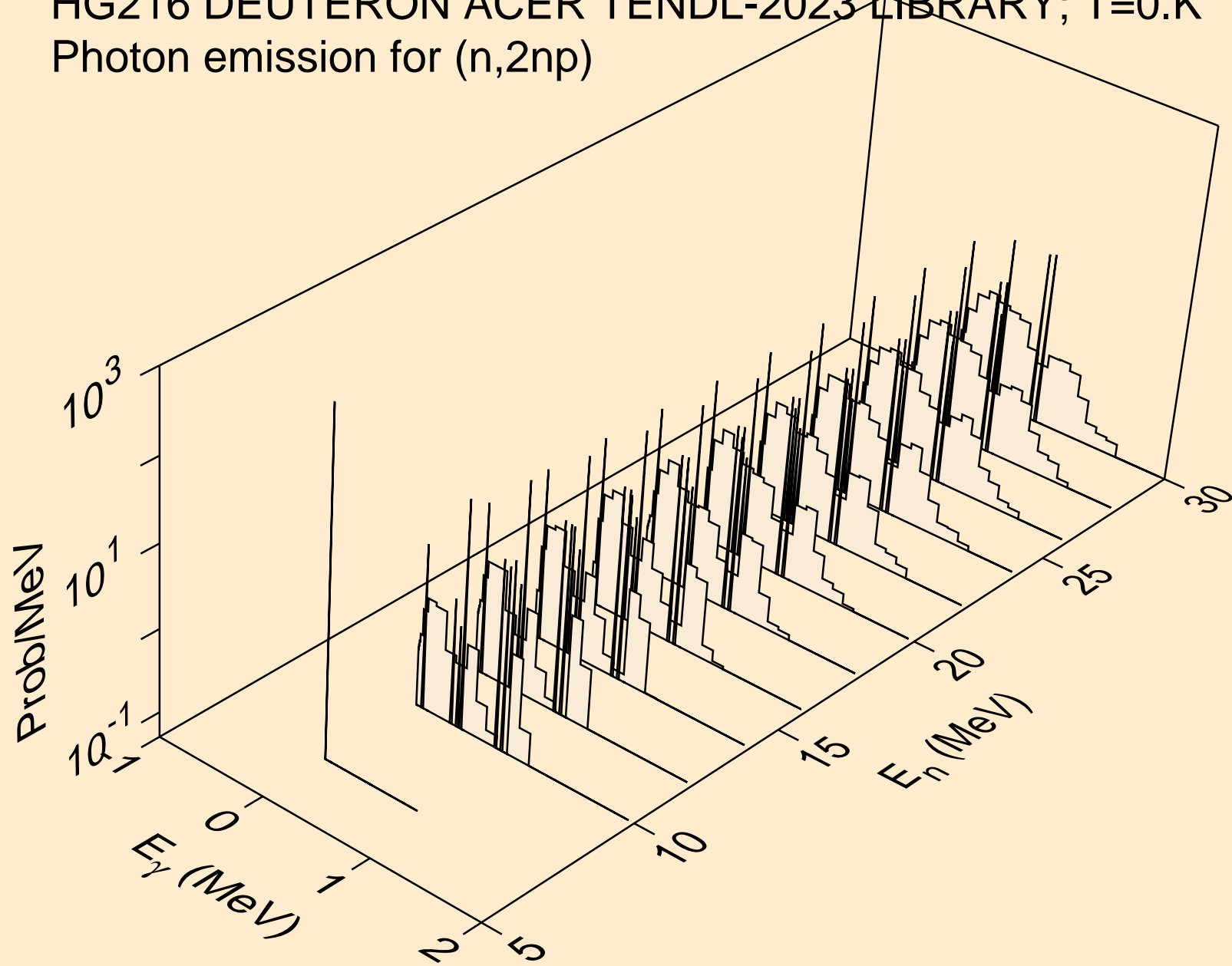

HG216 DEUTERON ACER TENDL-2023 LIBRARY; T=0.K  
Photon emission for (n,3np)

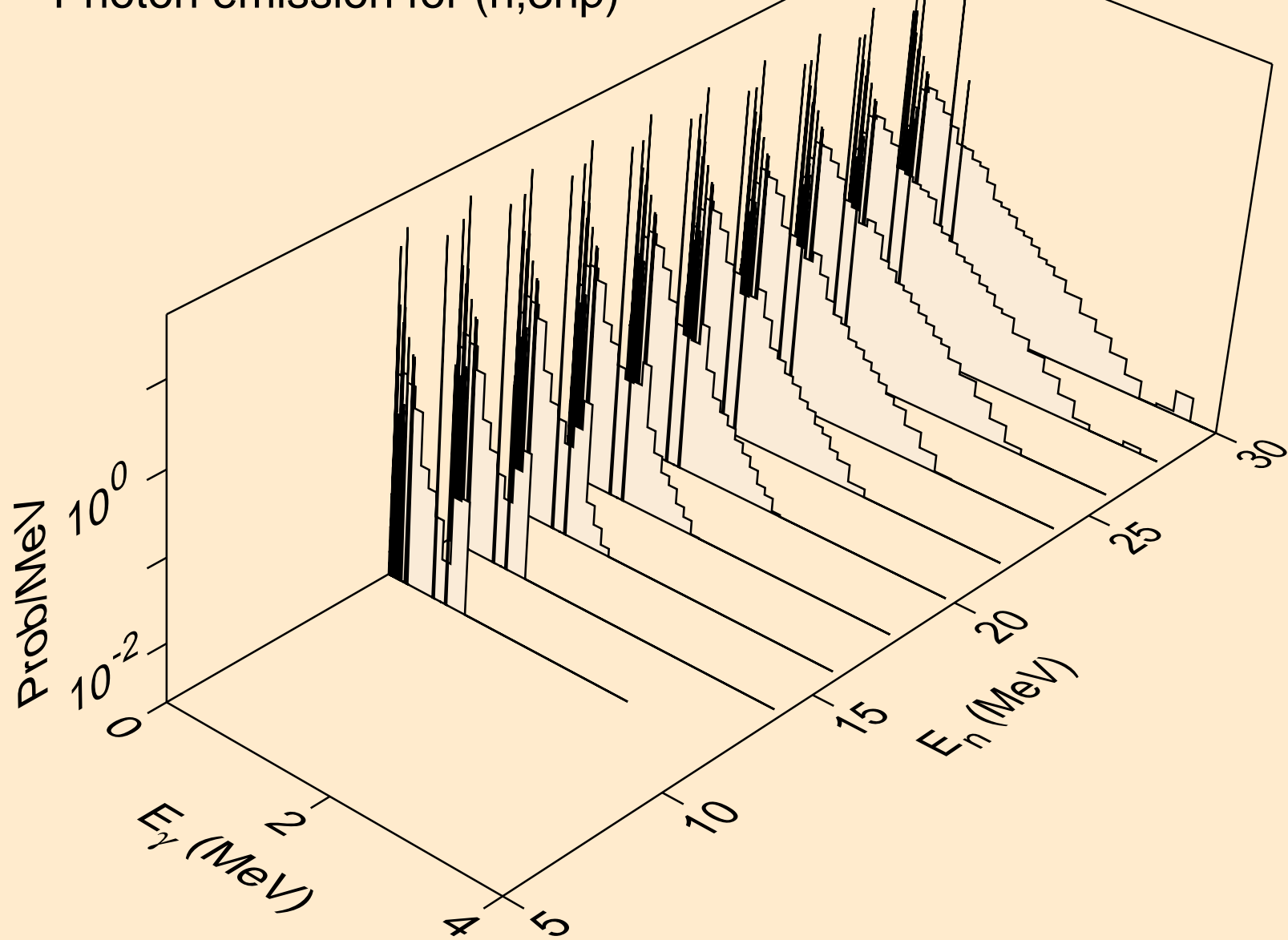

HG216 DEUTERON ACER TENDL-2023 LIBRARY; T=0.K  
Photon emission for (n,n2p)

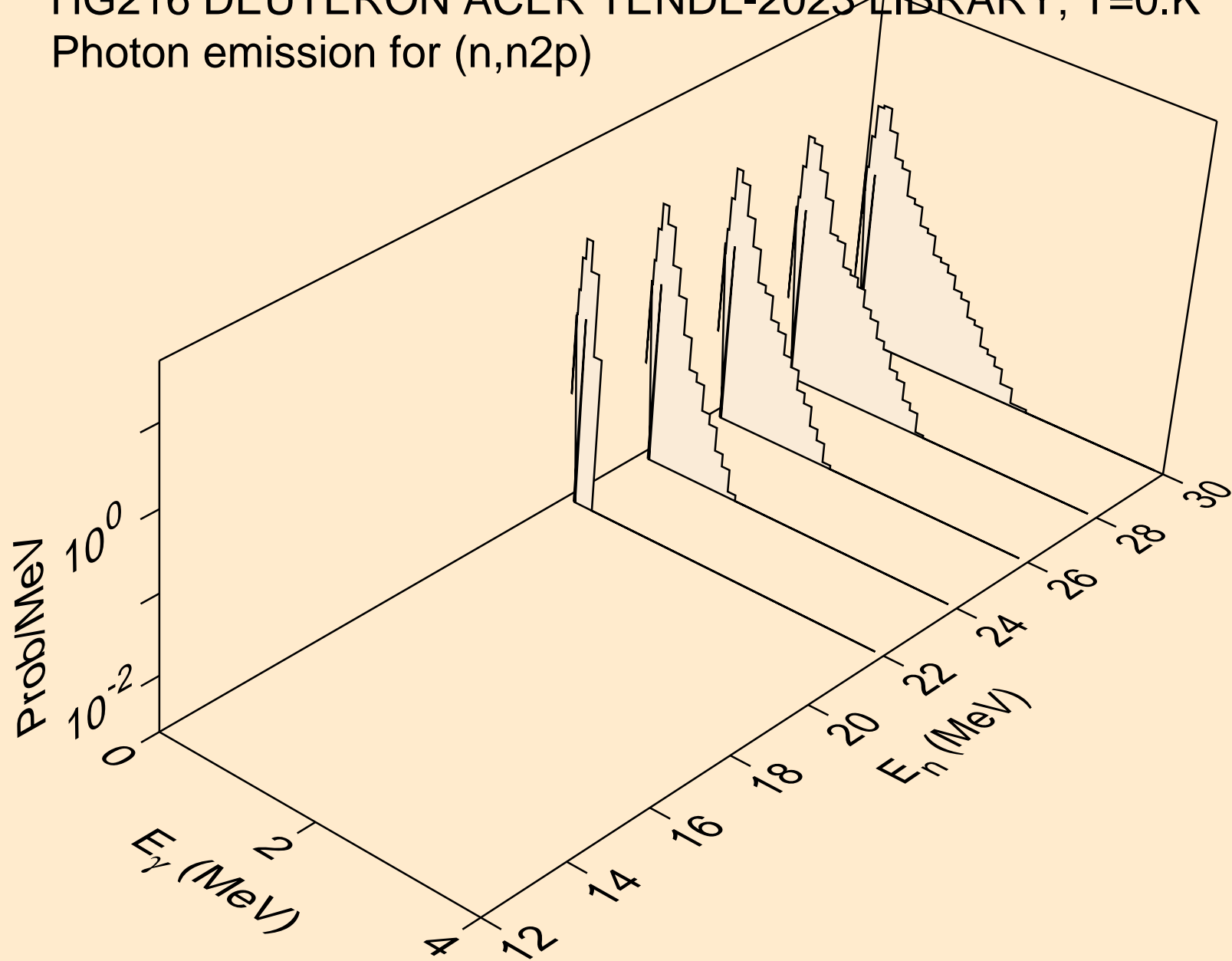



HG216 DEUTERON ACER TENDL-2023 LIBRARY; T=0.K  
Photon emission for (n,gma)

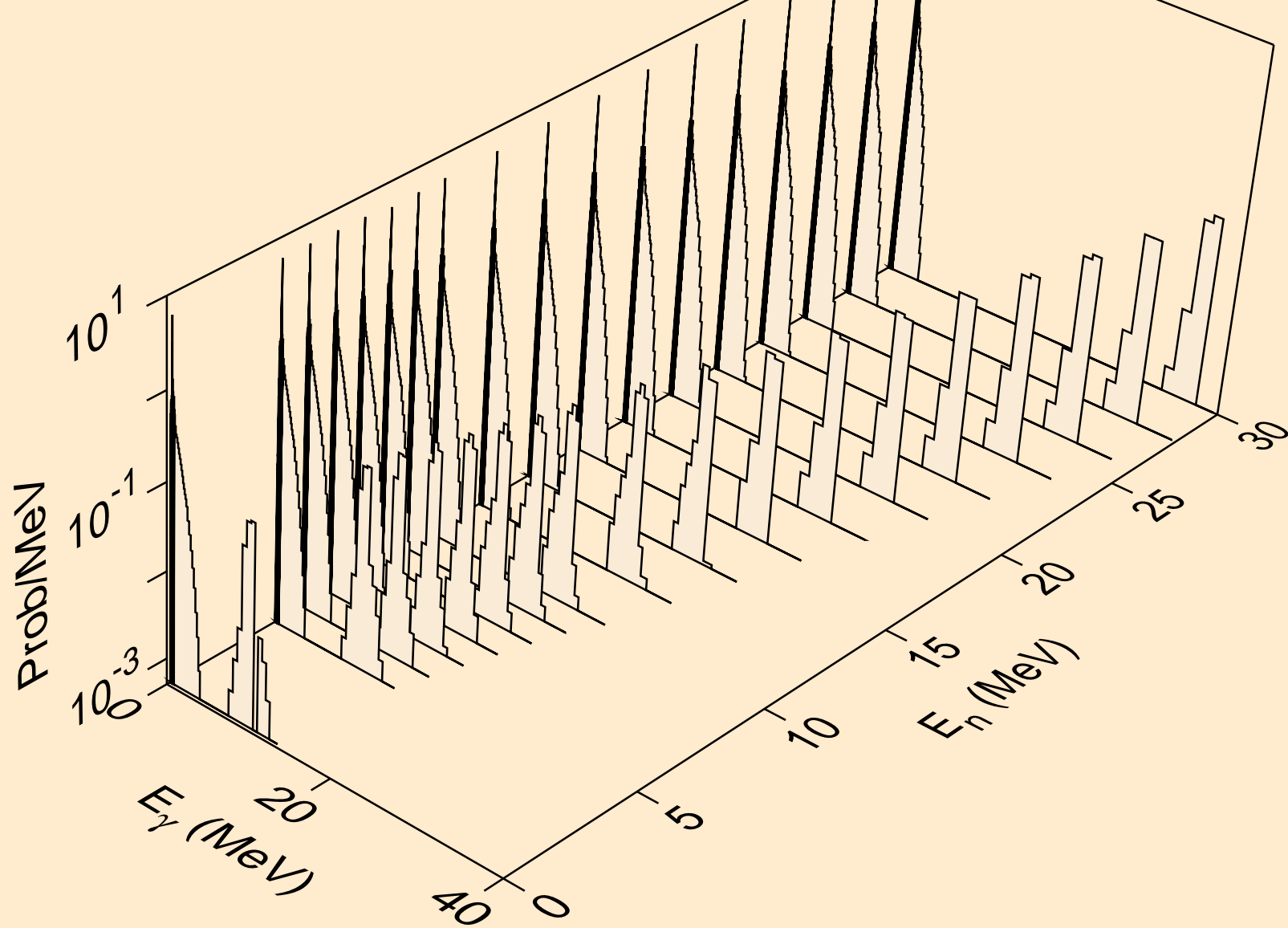

HG216 DEUTERON ACER TENDL-2023 LIBRARY; T=0.K  
Photon emission for (n,p)

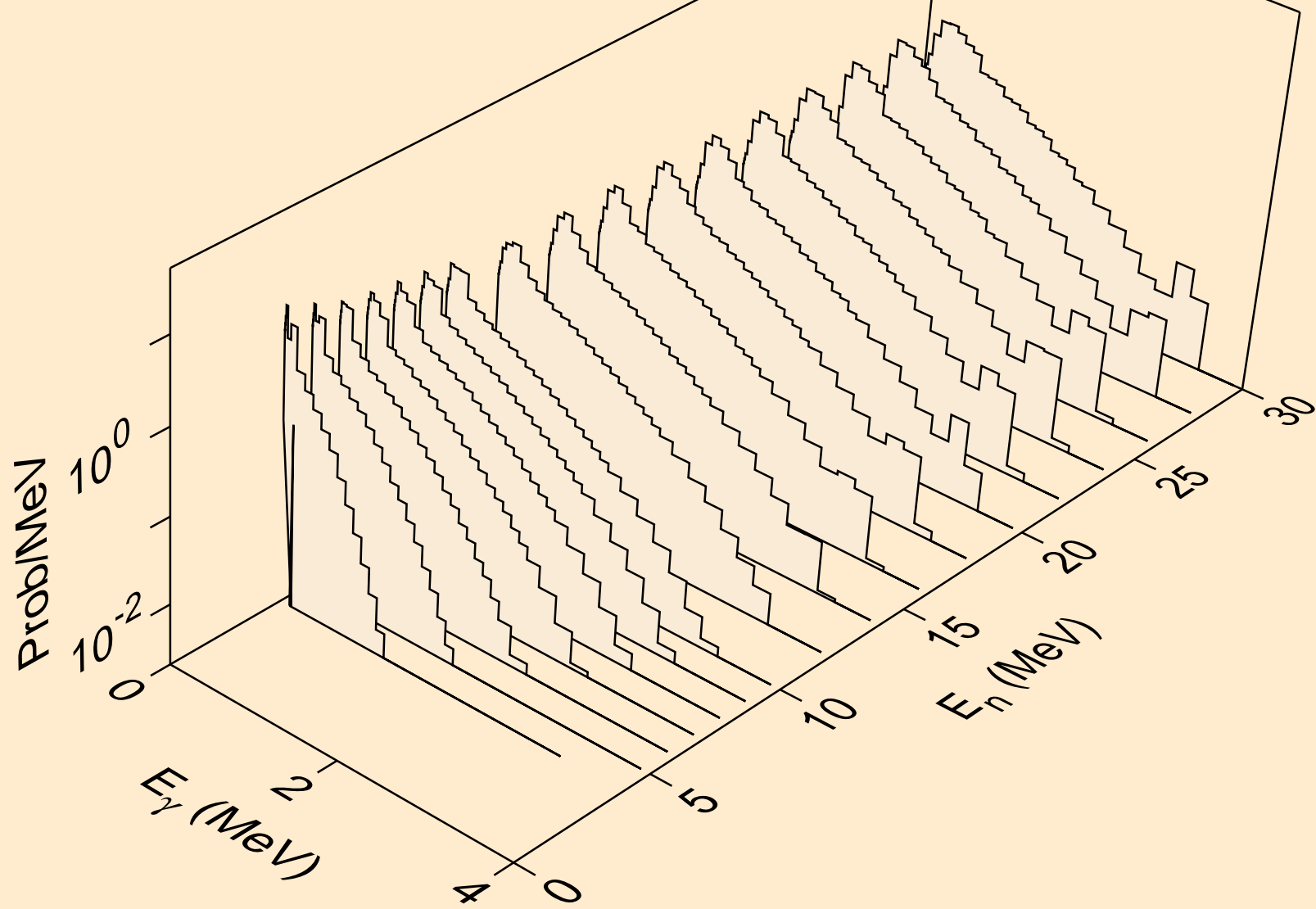

HG216 DEUTERON ACER TENDL-2023 LIBRARY; T=0.K  
Photon emission for inelastic

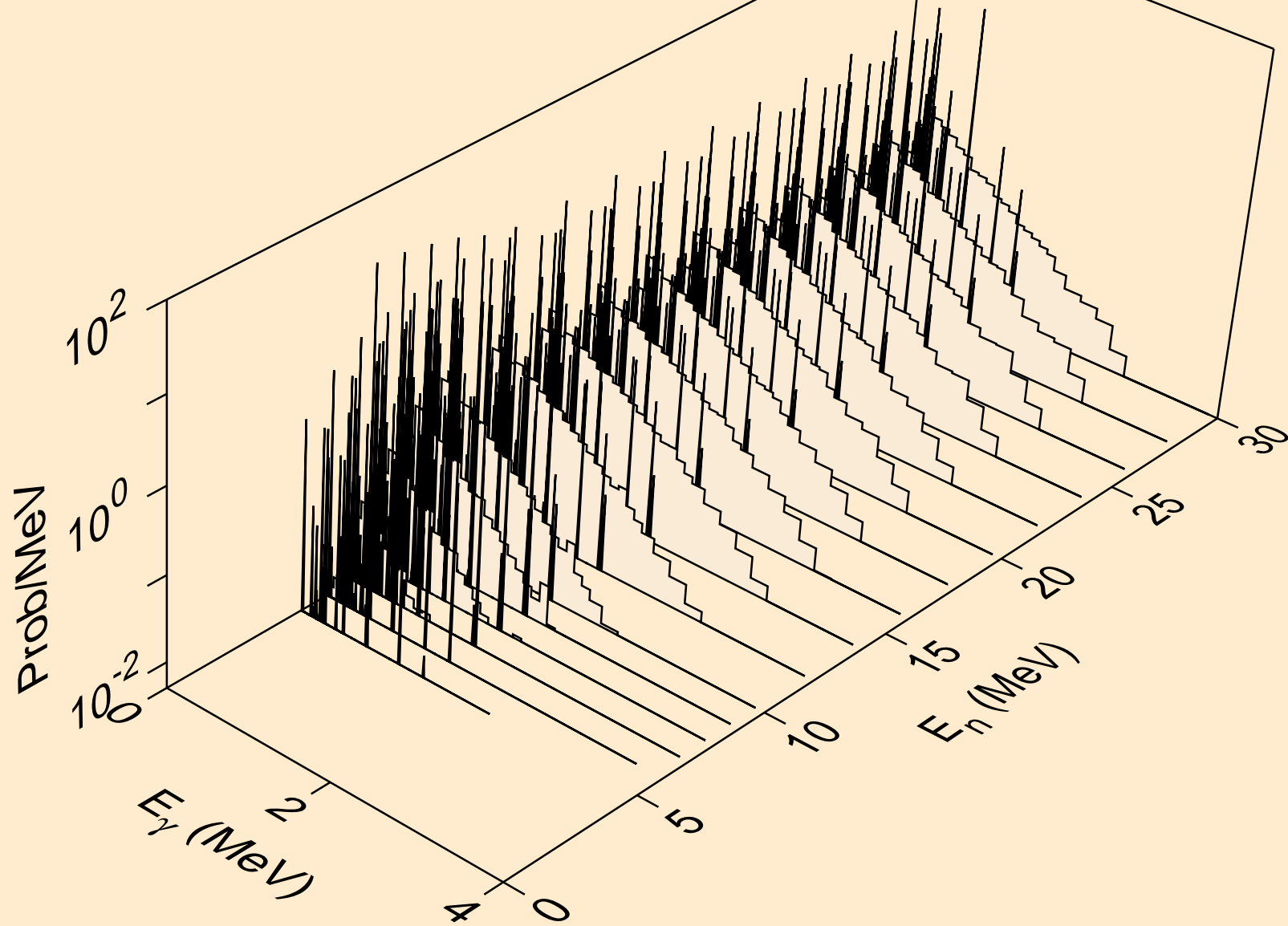

HG216 DEUTERON ACER TENDL-2023 LIBRARY; T=0.K  
Photon emission for (n,t)

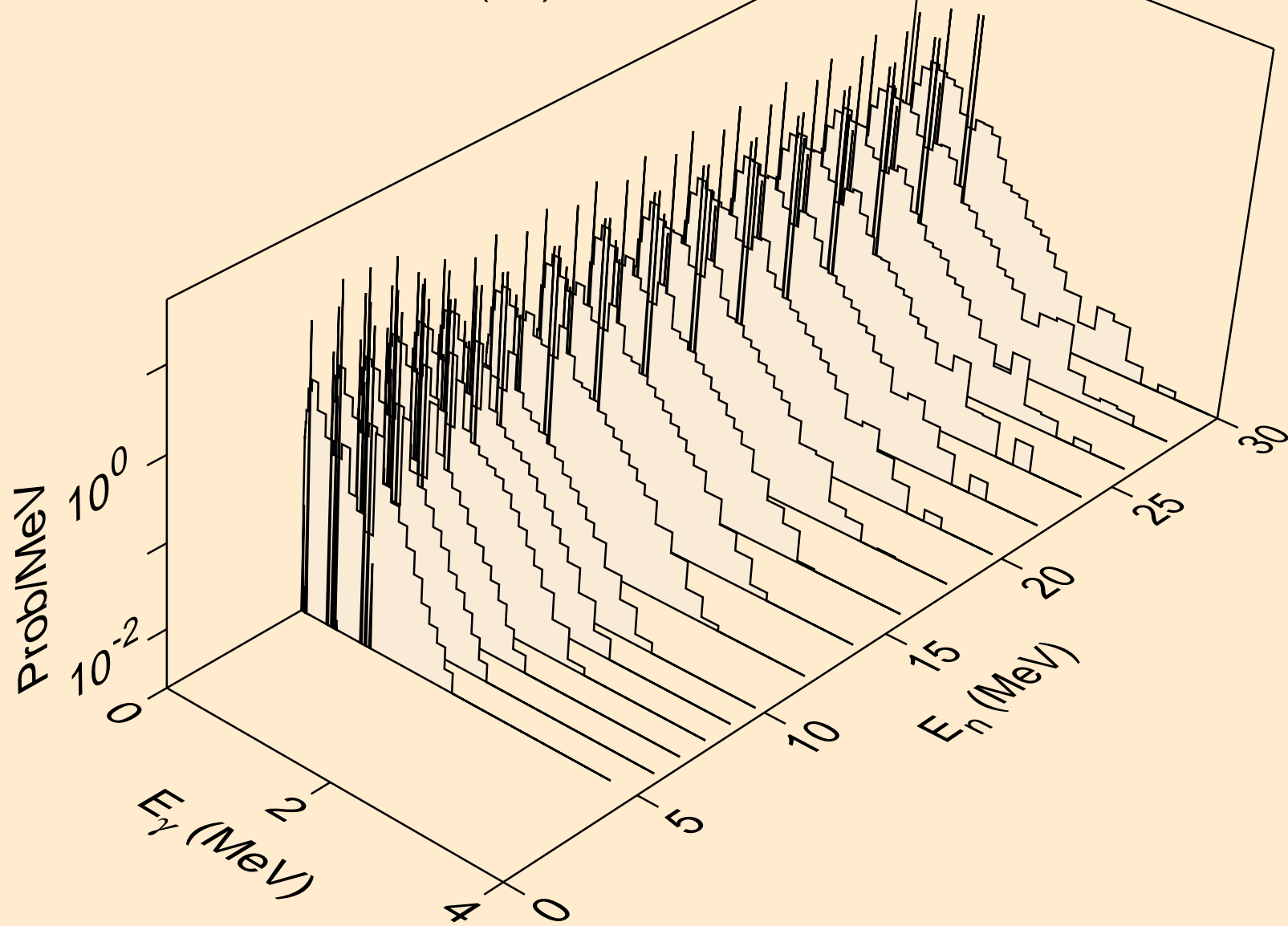

HG216 DEUTERON ACER TENDL-2023 LIBRARY; T=0.K  
Photon emission for (n,he3)

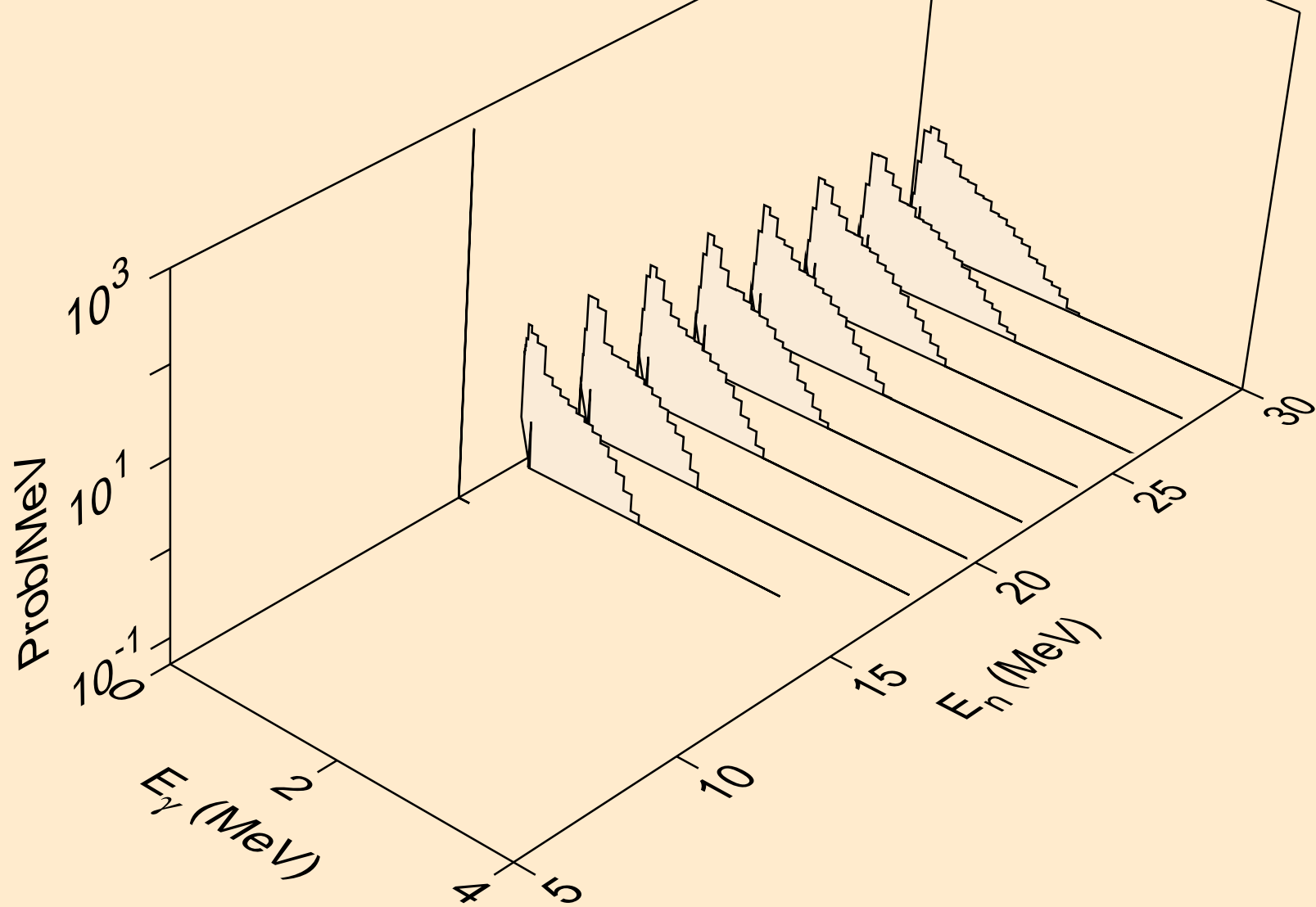

HG216 DEUTERON ACER TENDL-2023 LIBRARY; T=0.K  
Photon emission for (n,a)

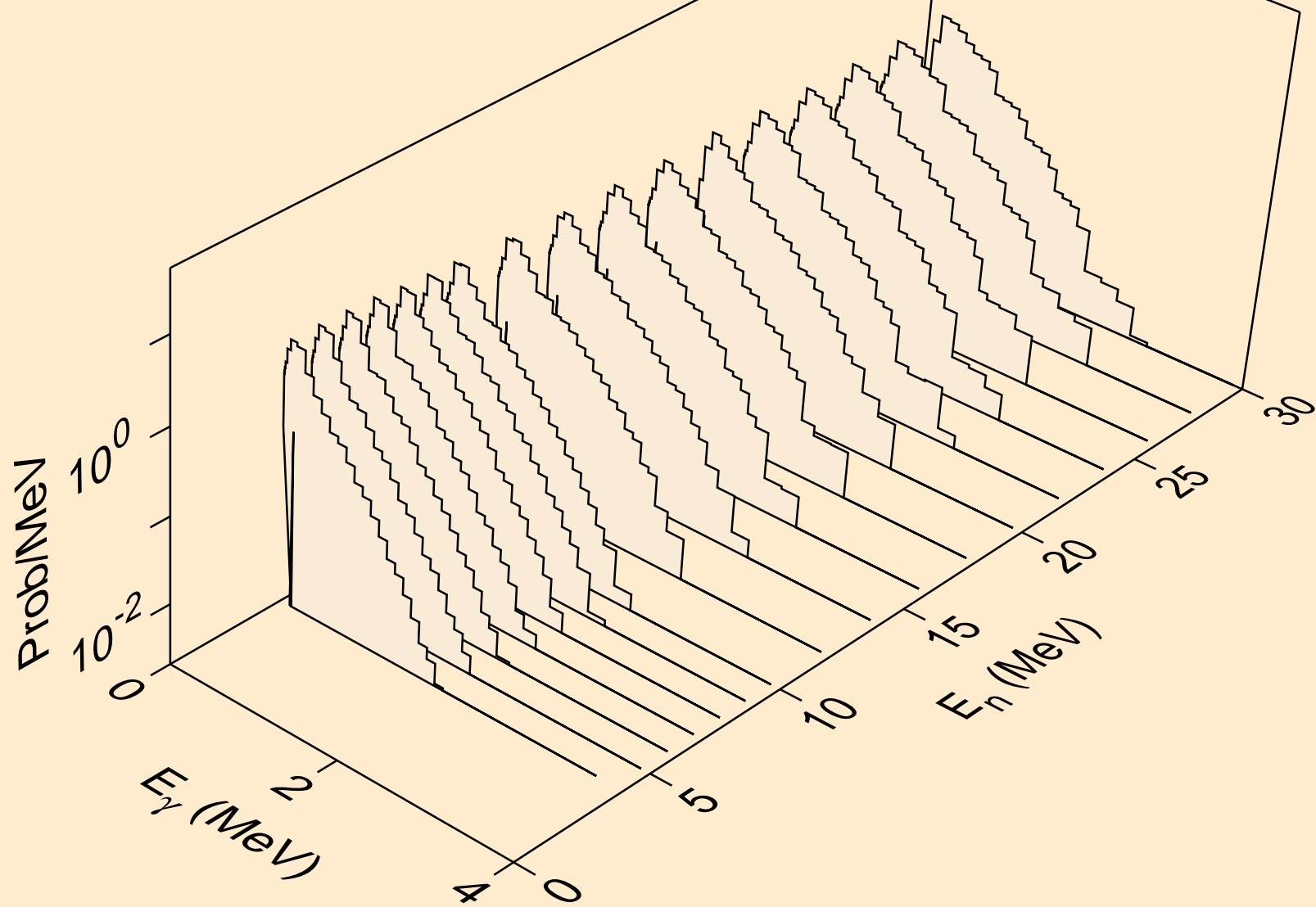

HG216 DEUTERON ACER TENDL-2023 LIBRARY; T=0.K  
Photon emission for (n,2p)

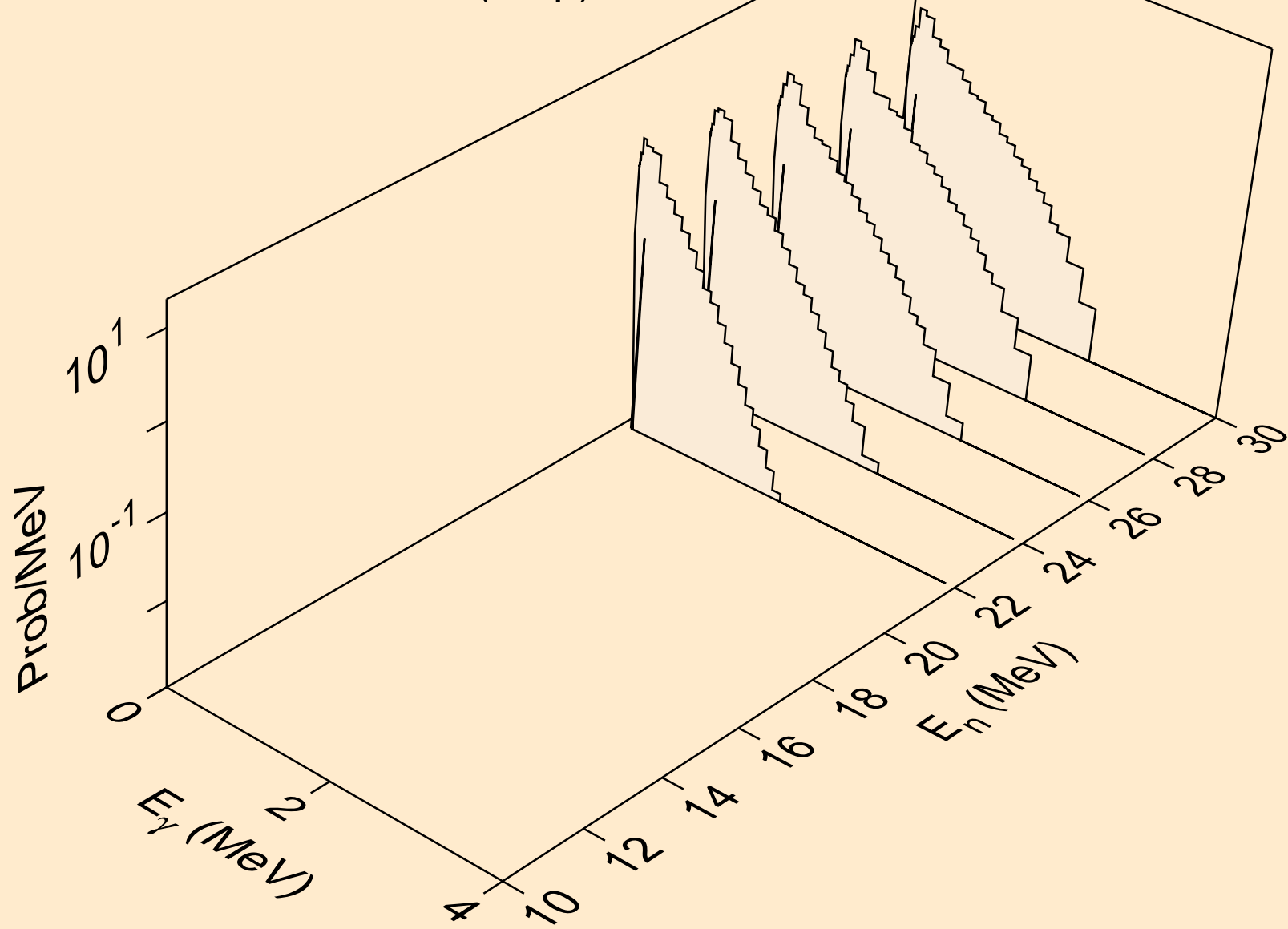

# HG216 DEUTERON ACER TENDL-2023 LIBRARY; T=0.K

## Particle heating contributions

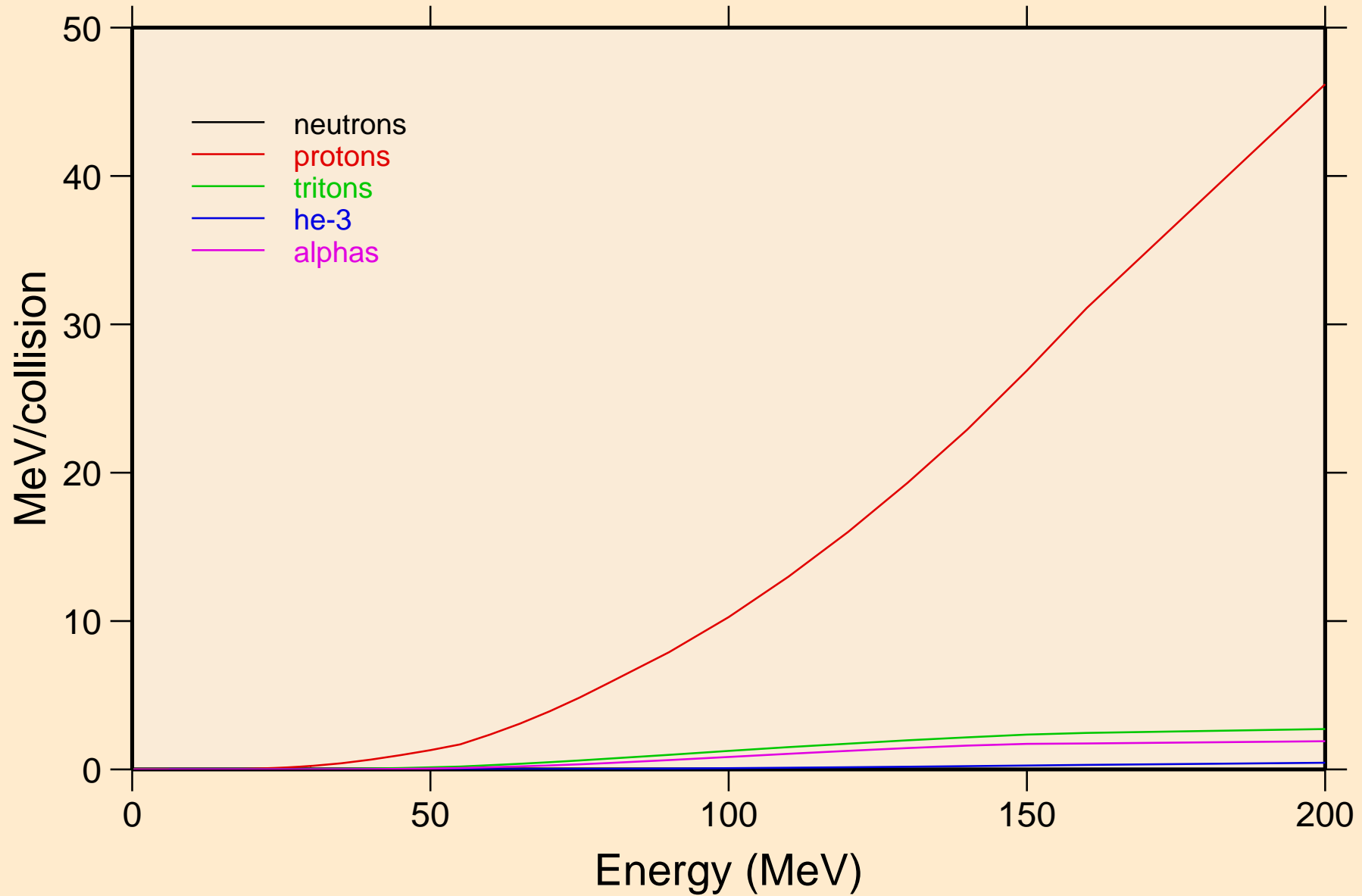



HG216 DEUTERON ACER TENDL-2023 LIBRARY; T=0.K  
Recoil Heating

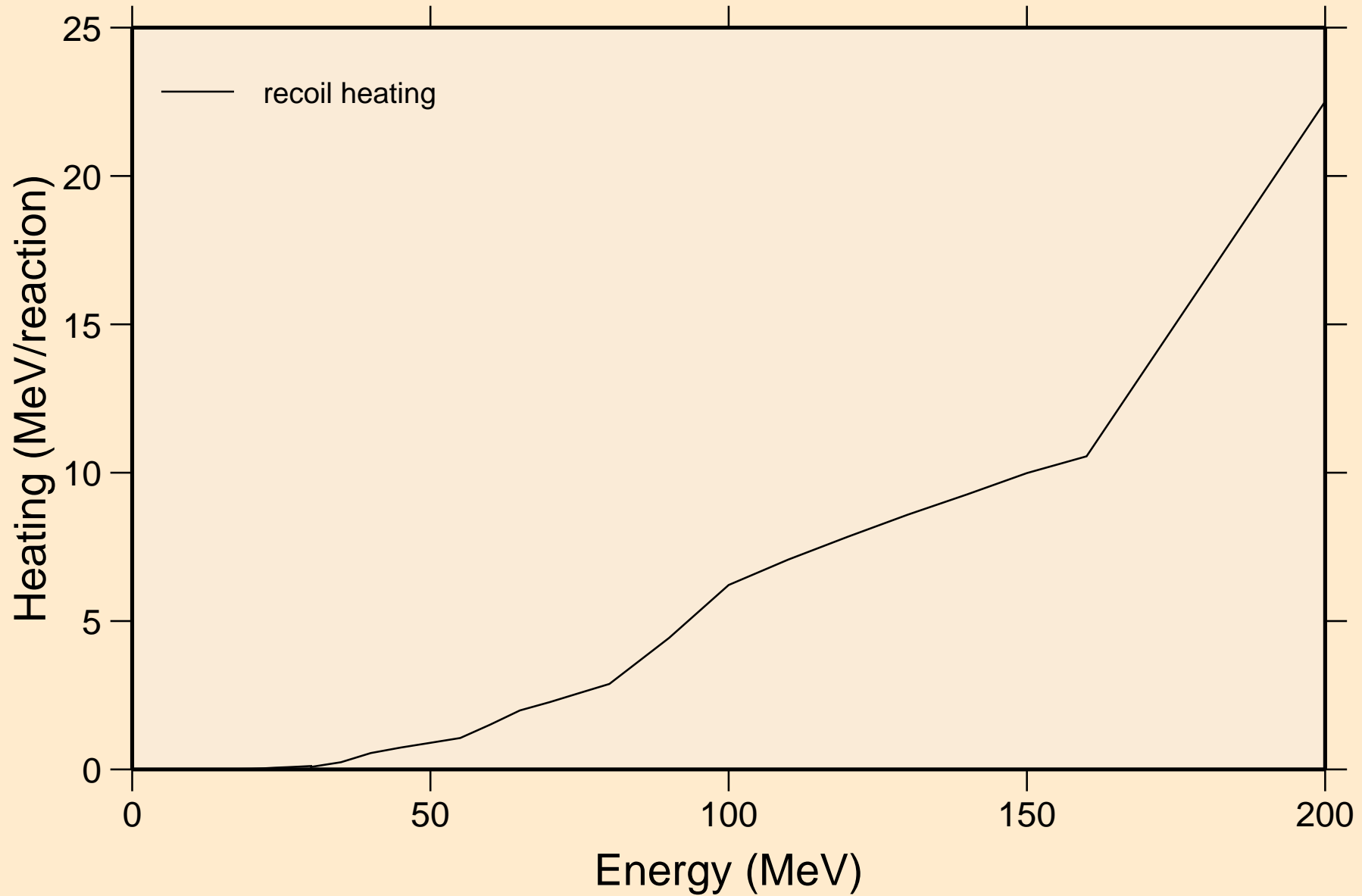

# HG216 DEUTERON ACER TENDL-2023 LIBRARY; T=0.K

## Particle production cross sections

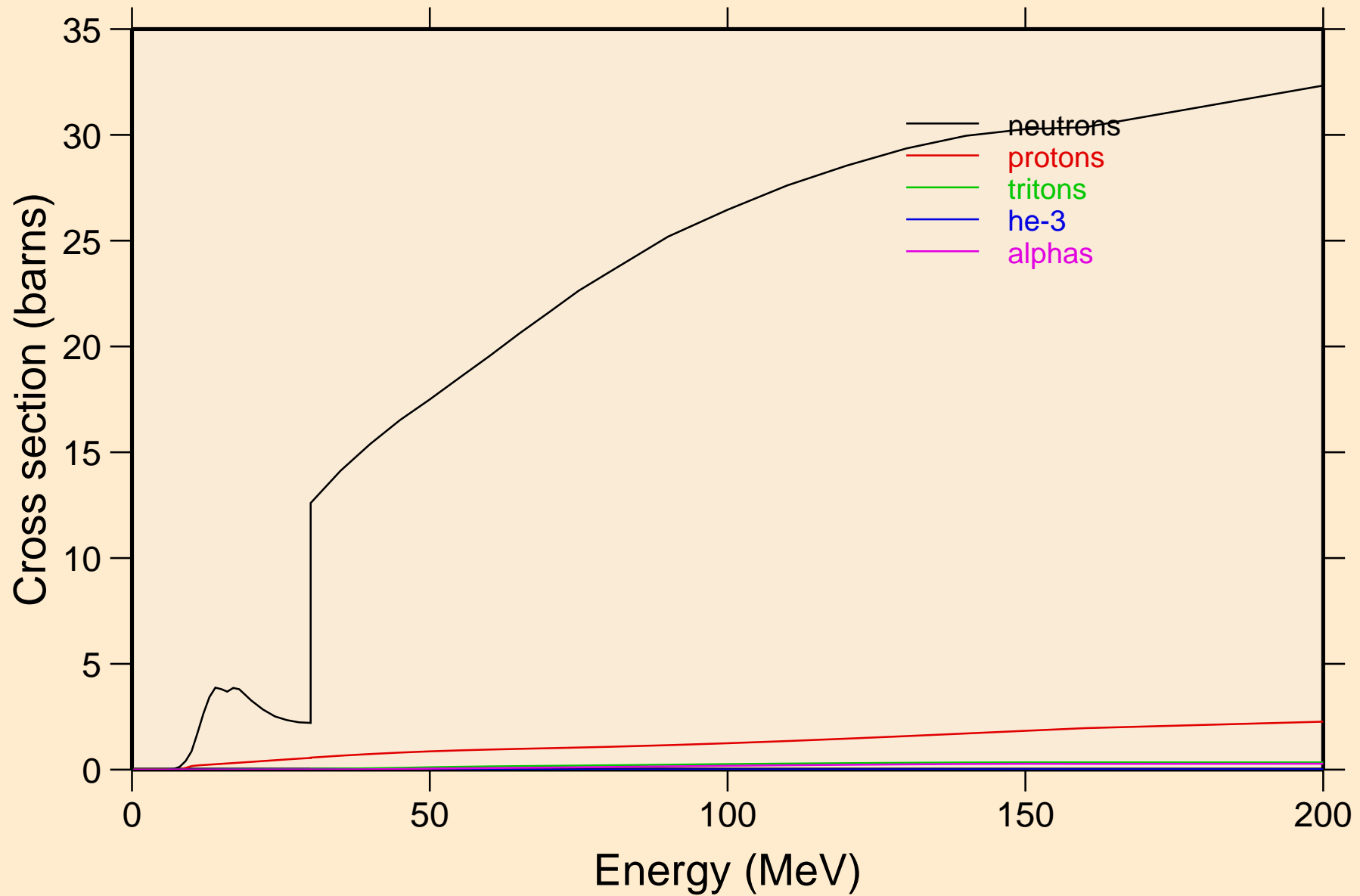

HG216 DEUTERON ACER TENDL-2023 LIBRARY; T=0.K  
neutrons from (d,n)

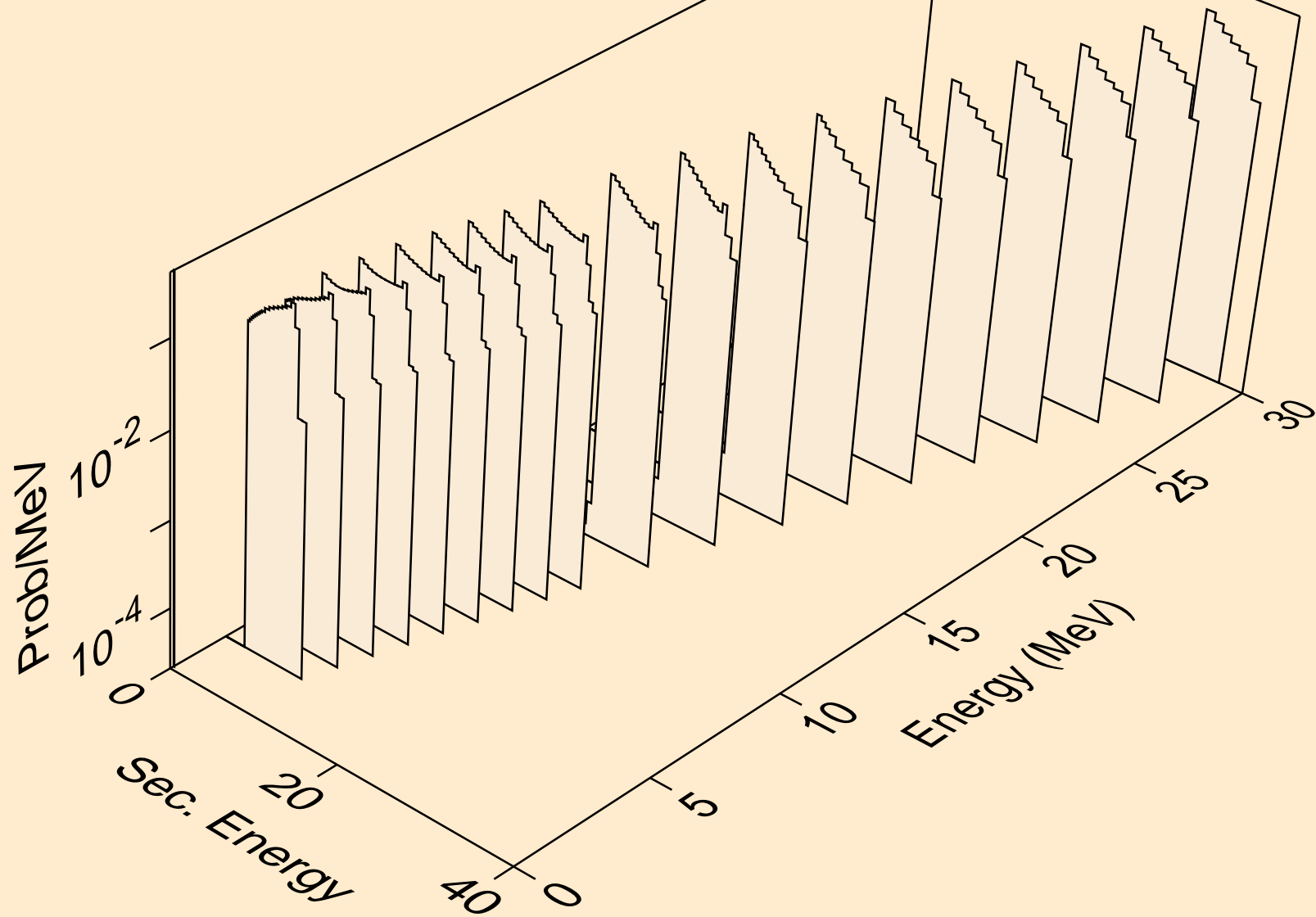

HG216 DEUTERON ACER TENDL-2023 LIBRARY; T=0.K  
neutrons from (d,x)

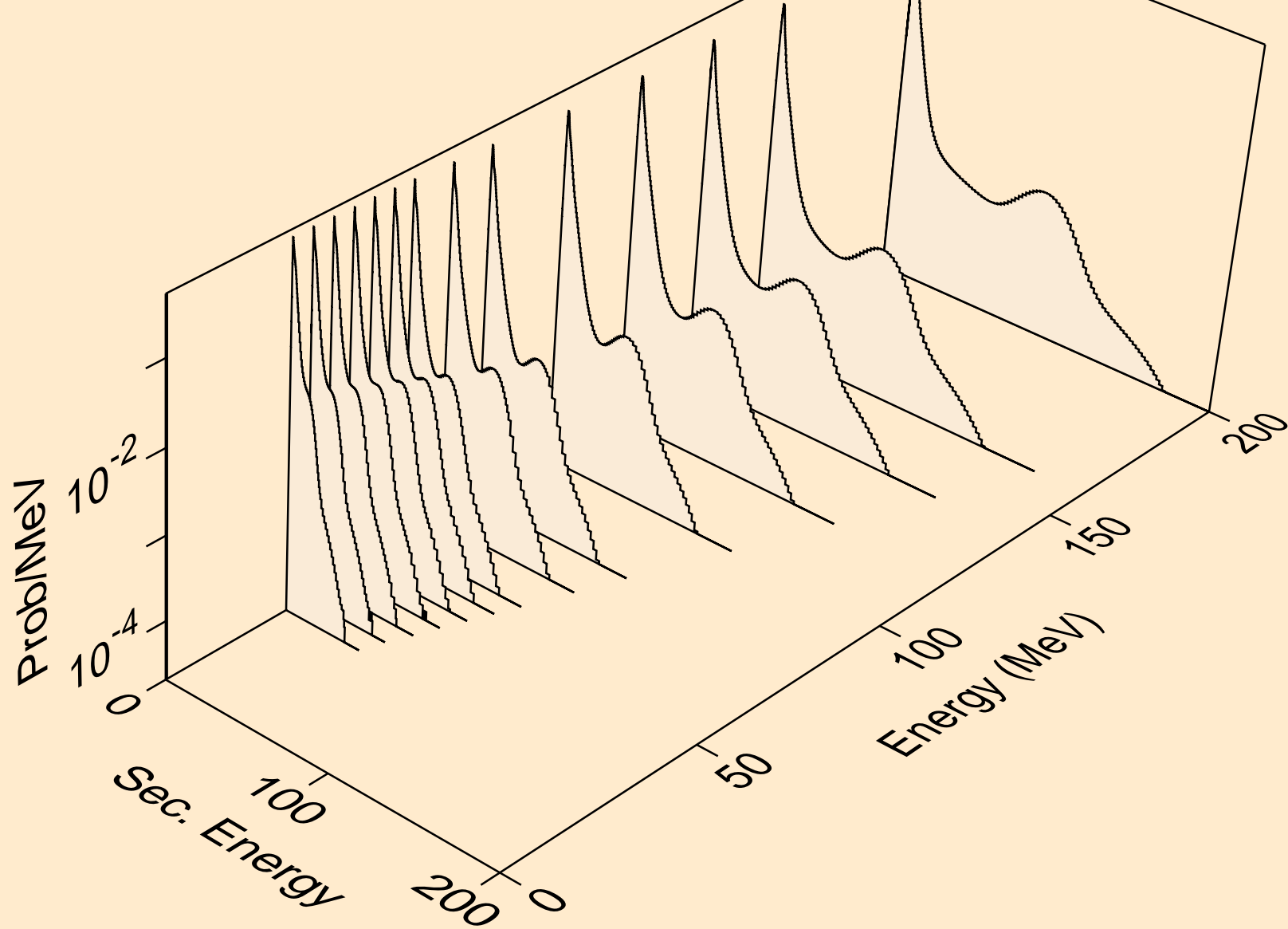

HG216 DEUTERON ACER TENDL-2023 LIBRARY; T=0.K  
neutrons from (d,2nd)

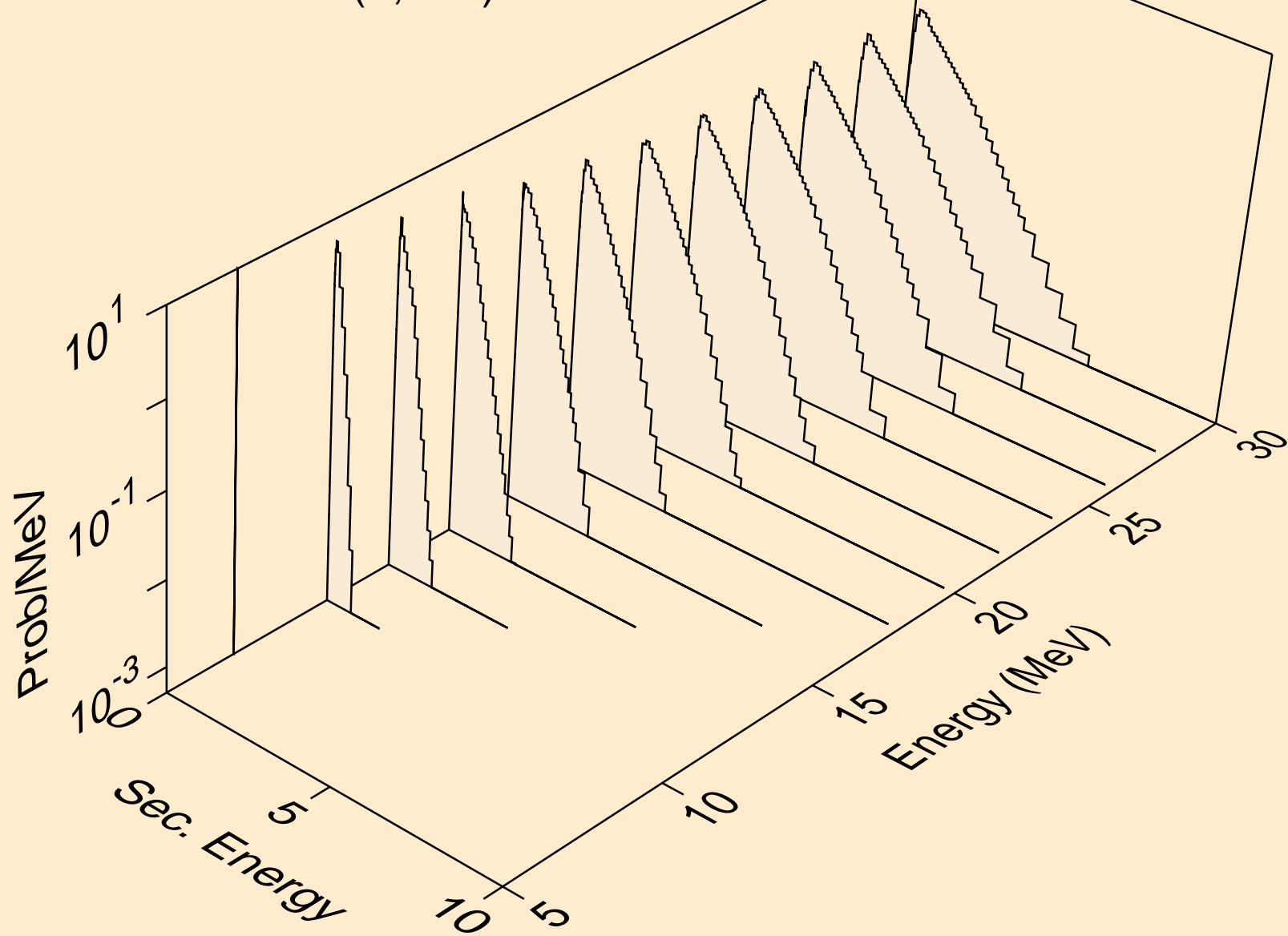

HG216 DEUTERON ACER TENDL-2023 LIBRARY; T=0.K  
neutrons from (d,2n)

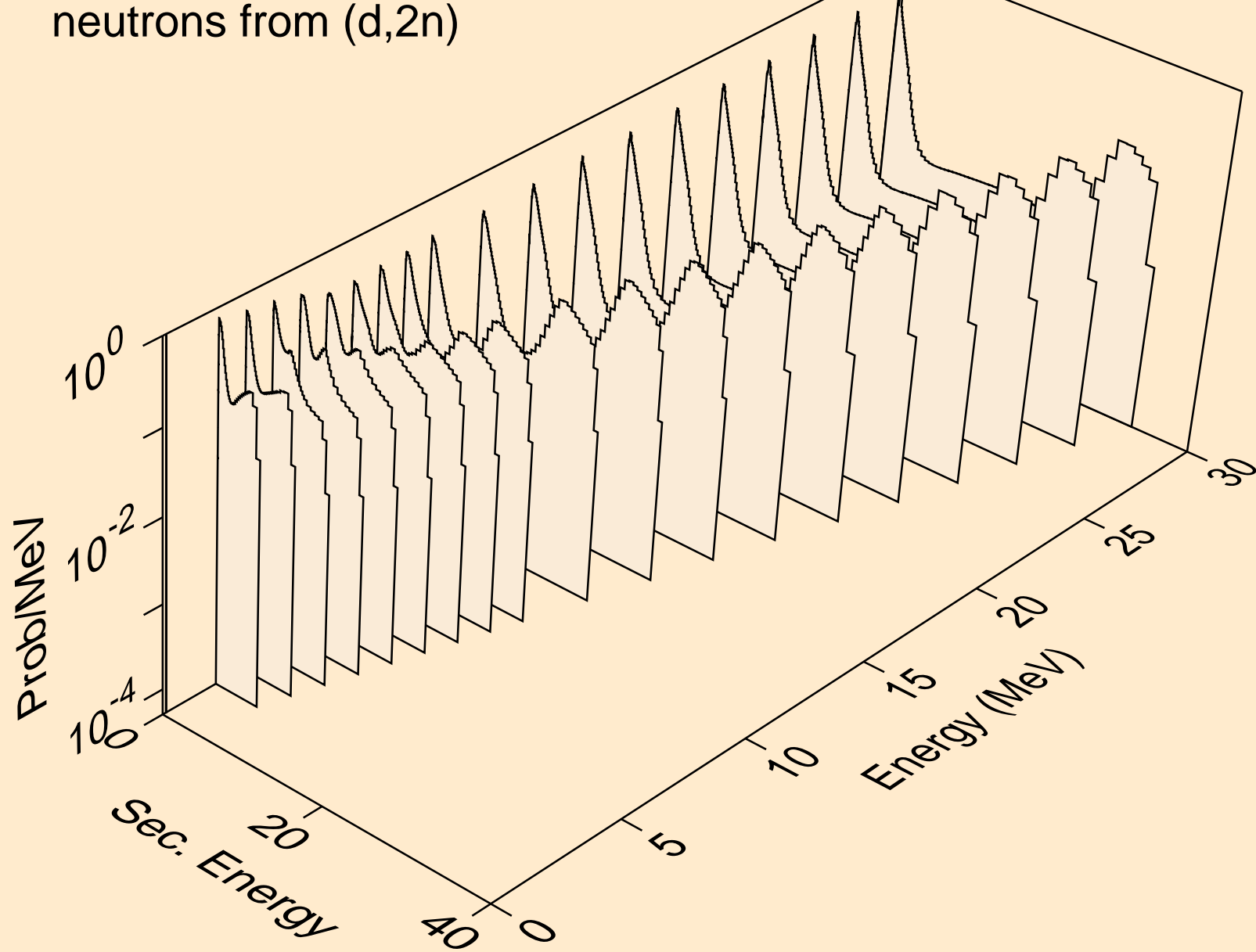

HG216 DEUTERON ACER TENDL-2023 LIBRARY; T=0.K  
neutrons from (d,3n)

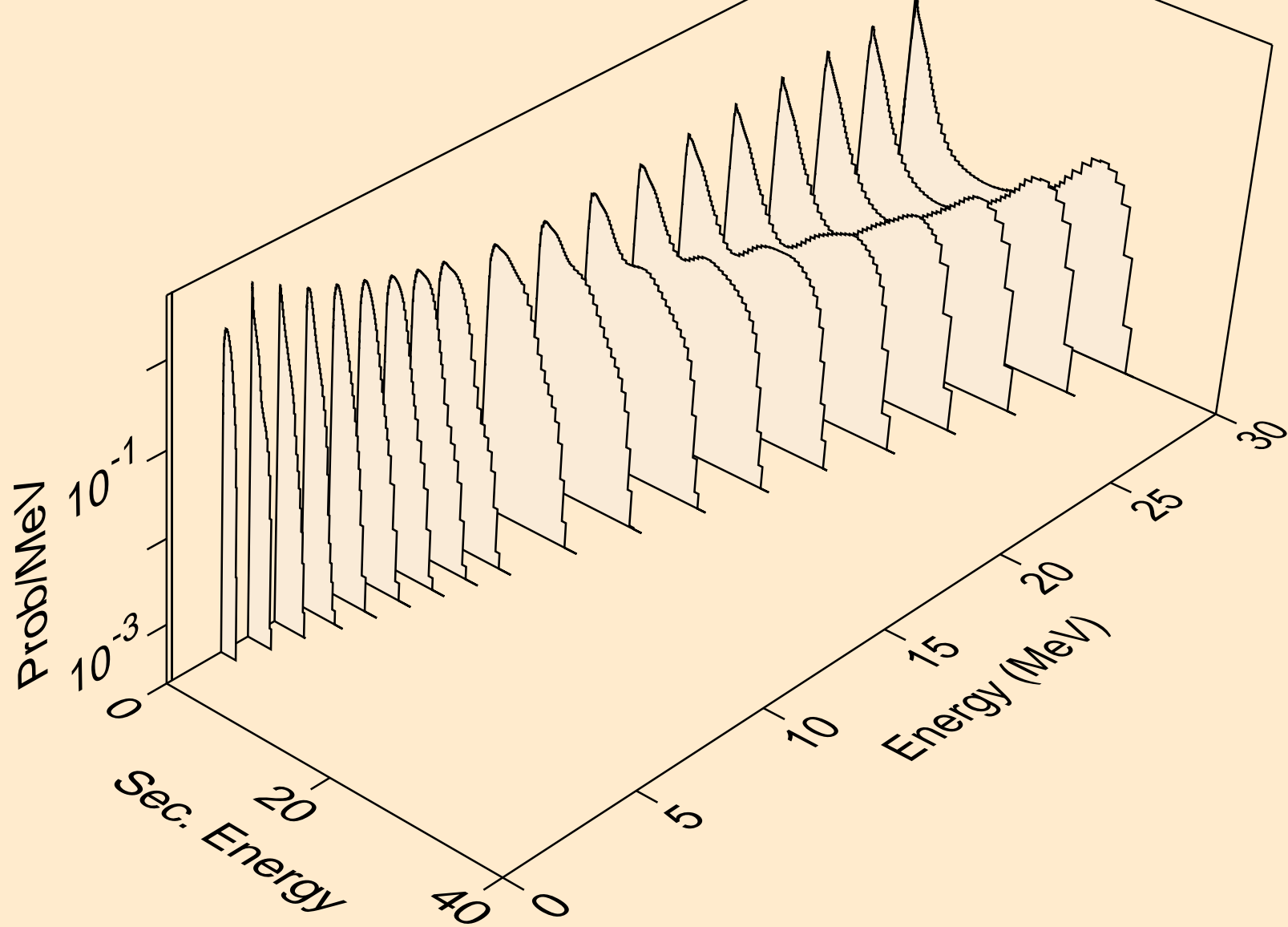

HG216 DEUTERON ACER TENDL-2023 LIBRARY; T=0.K  
neutrons from (d,n\*)a

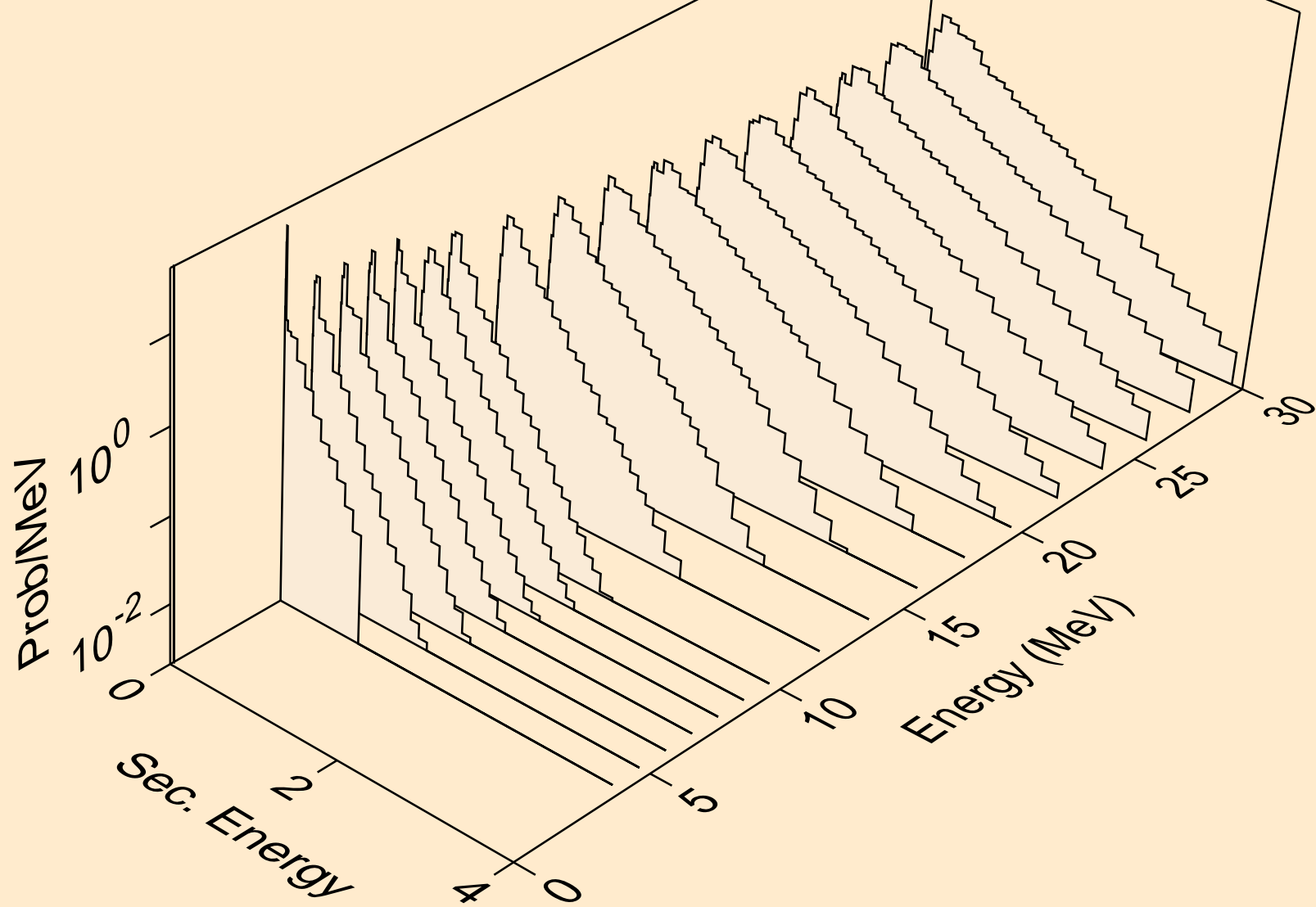



HG216 DEUTERON ACER TENDL-2023 LIBRARY; T=0.K  
neutrons from (d,2n)a

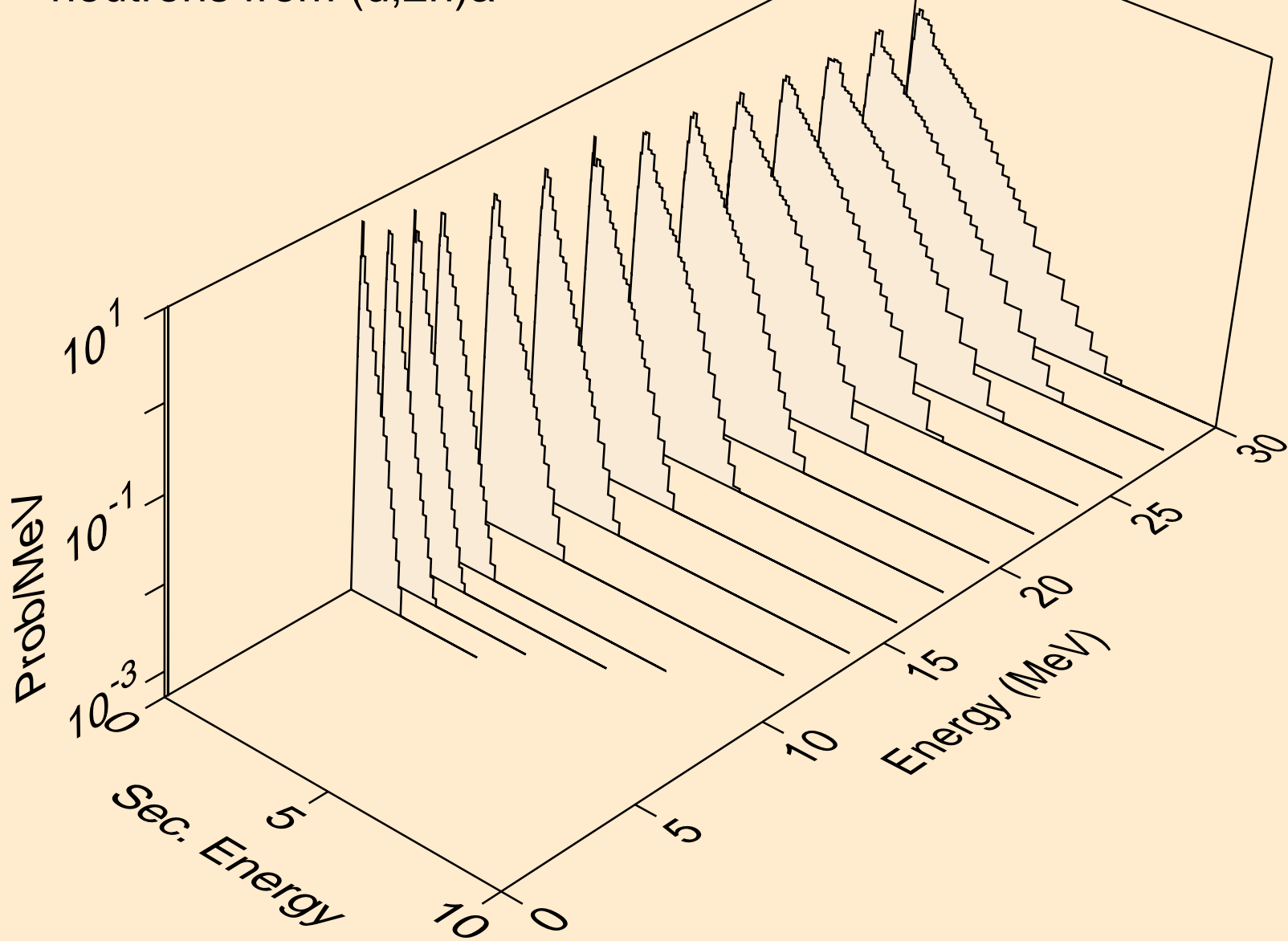

HG216 DEUTERON ACER TENDL-2023 LIBRARY; T=0.K  
neutrons from (d,3n)a

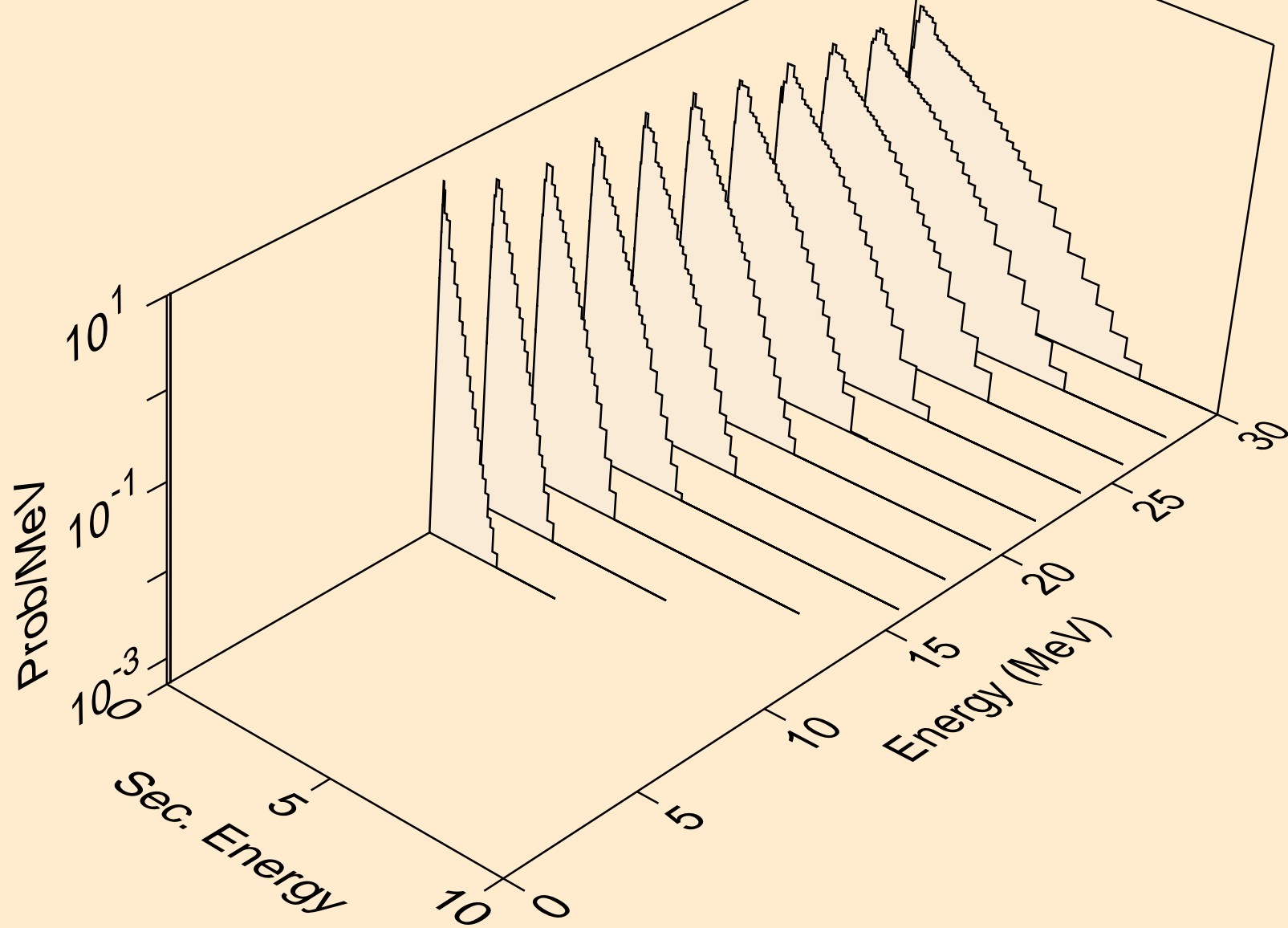

HG216 DEUTERON ACER TENDL-2023 LIBRARY; T=0.K  
neutrons from (d,n\*)p

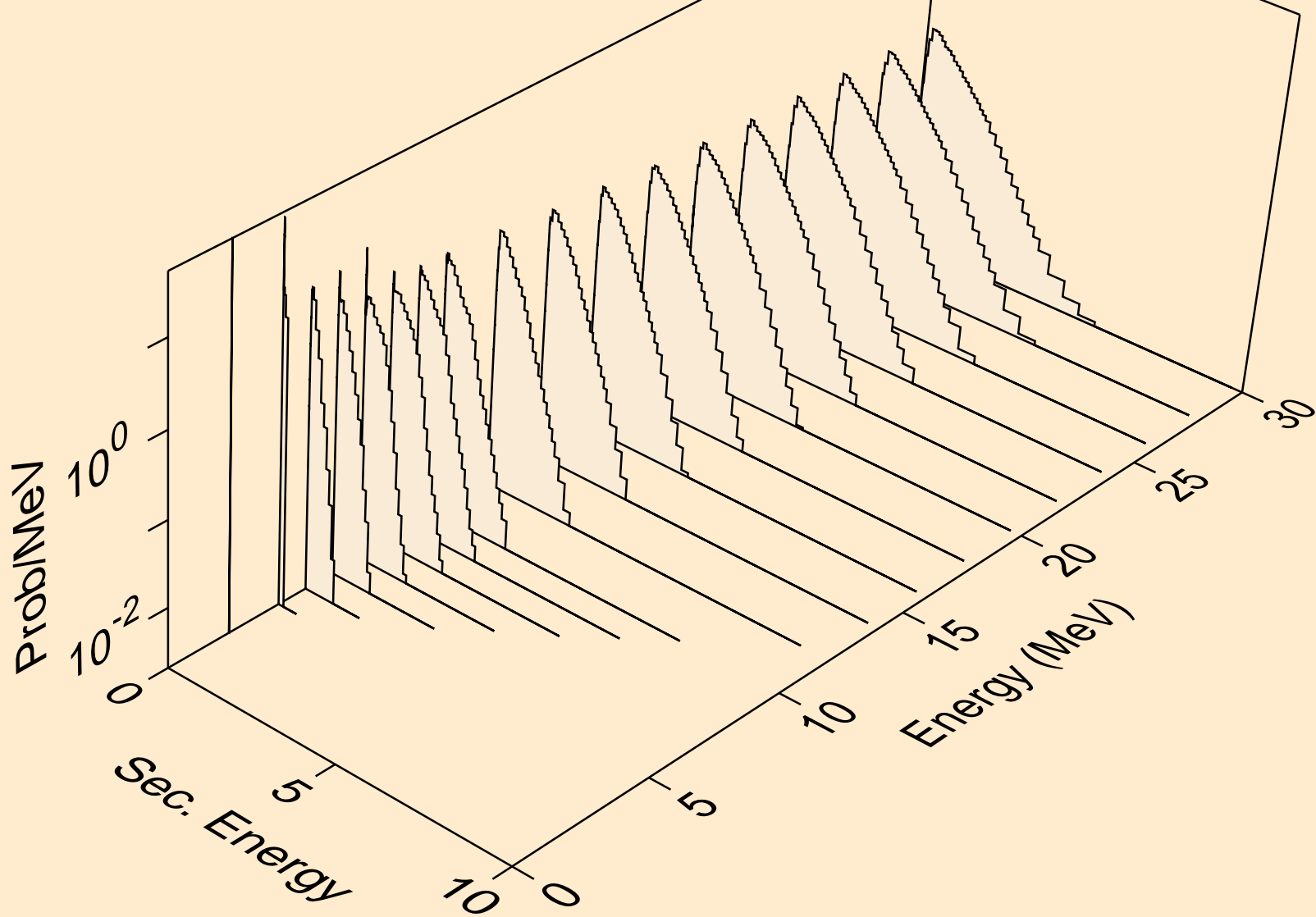

HG216 DEUTERON ACER TENDL-2023 LIBRARY; T=0.K  
neutrons from (d,n\*)d

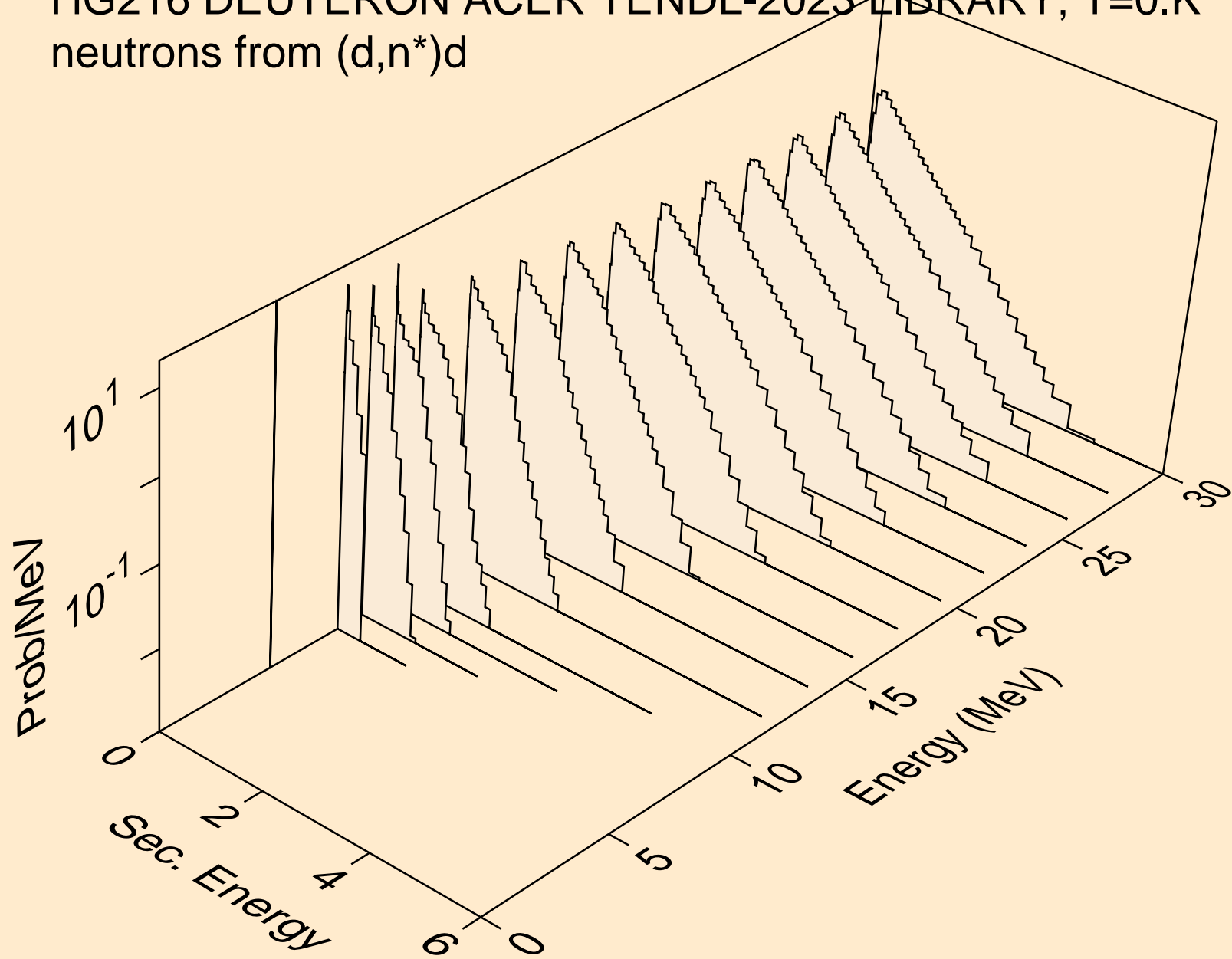

HG216 DEUTERON ACER TENDL-2023 LIBRARY; T=0.K  
neutrons from (d,n\*)t

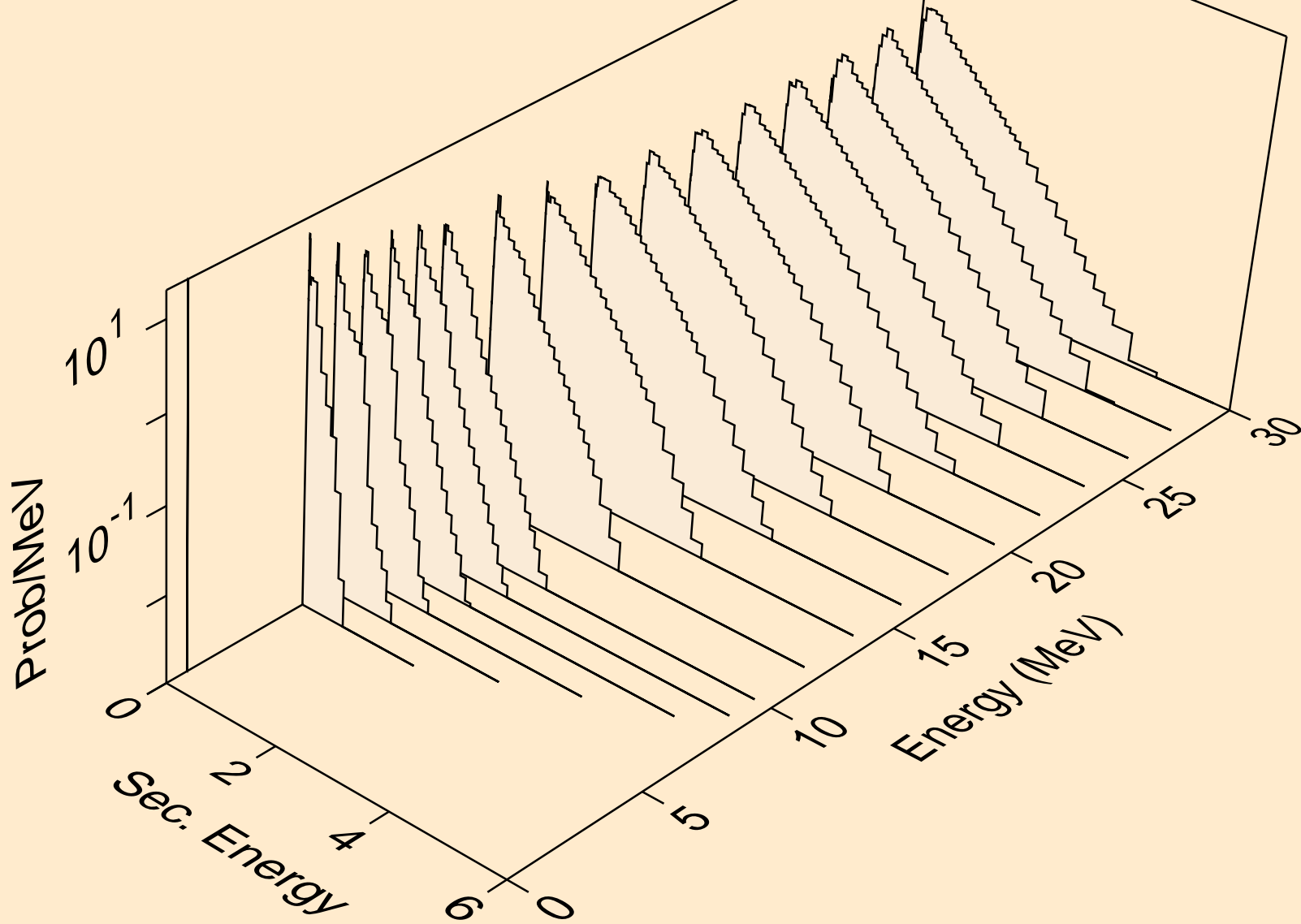

HG216 DEUTERON ACER TENDL-2023 LIBRARY; T=0.K  
neutrons from (d,n\*)he3

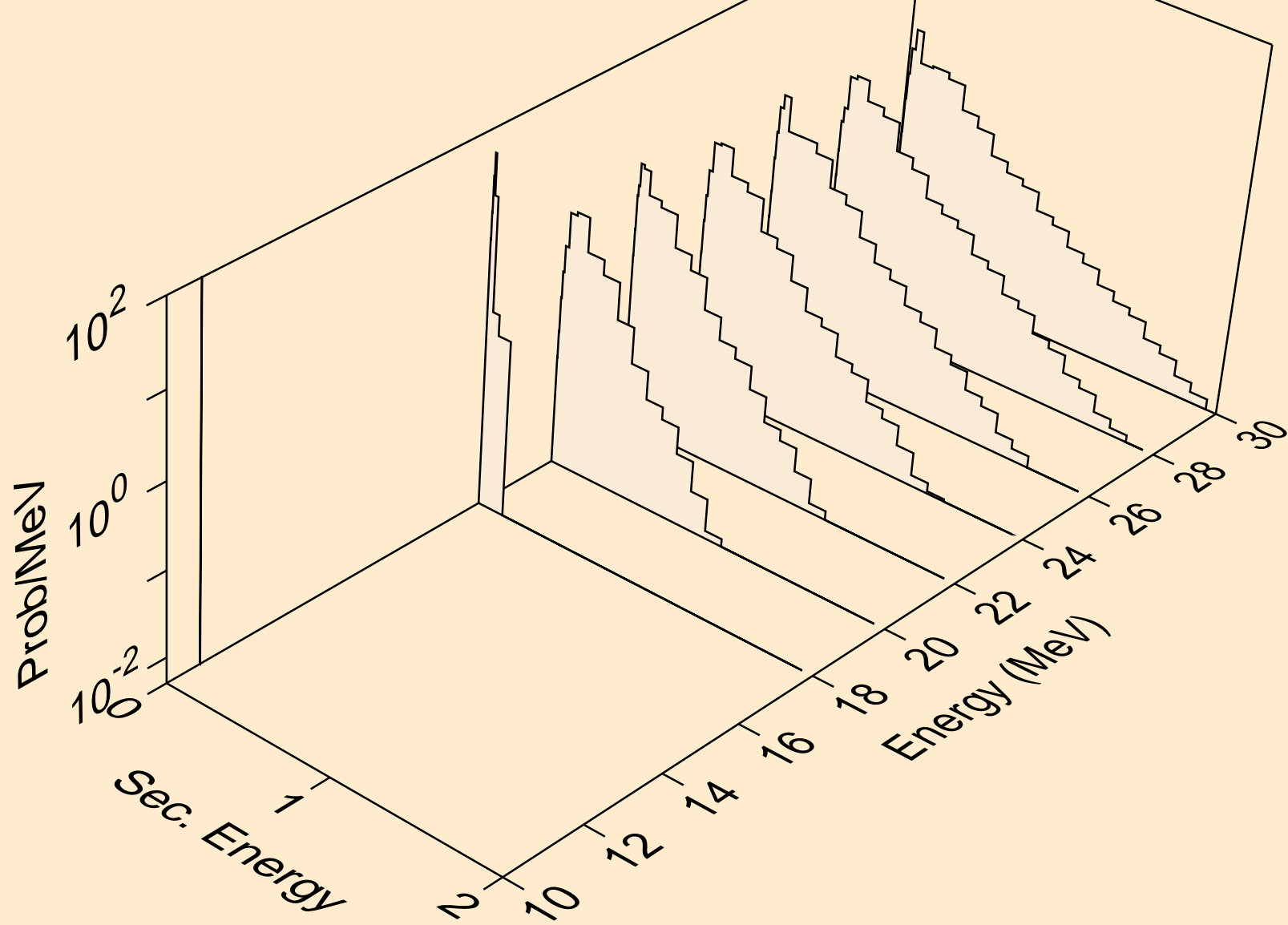

HG216 DEUTERON ACER TENDL-2023 LIBRARY; T=0.K  
neutrons from (d,4n)

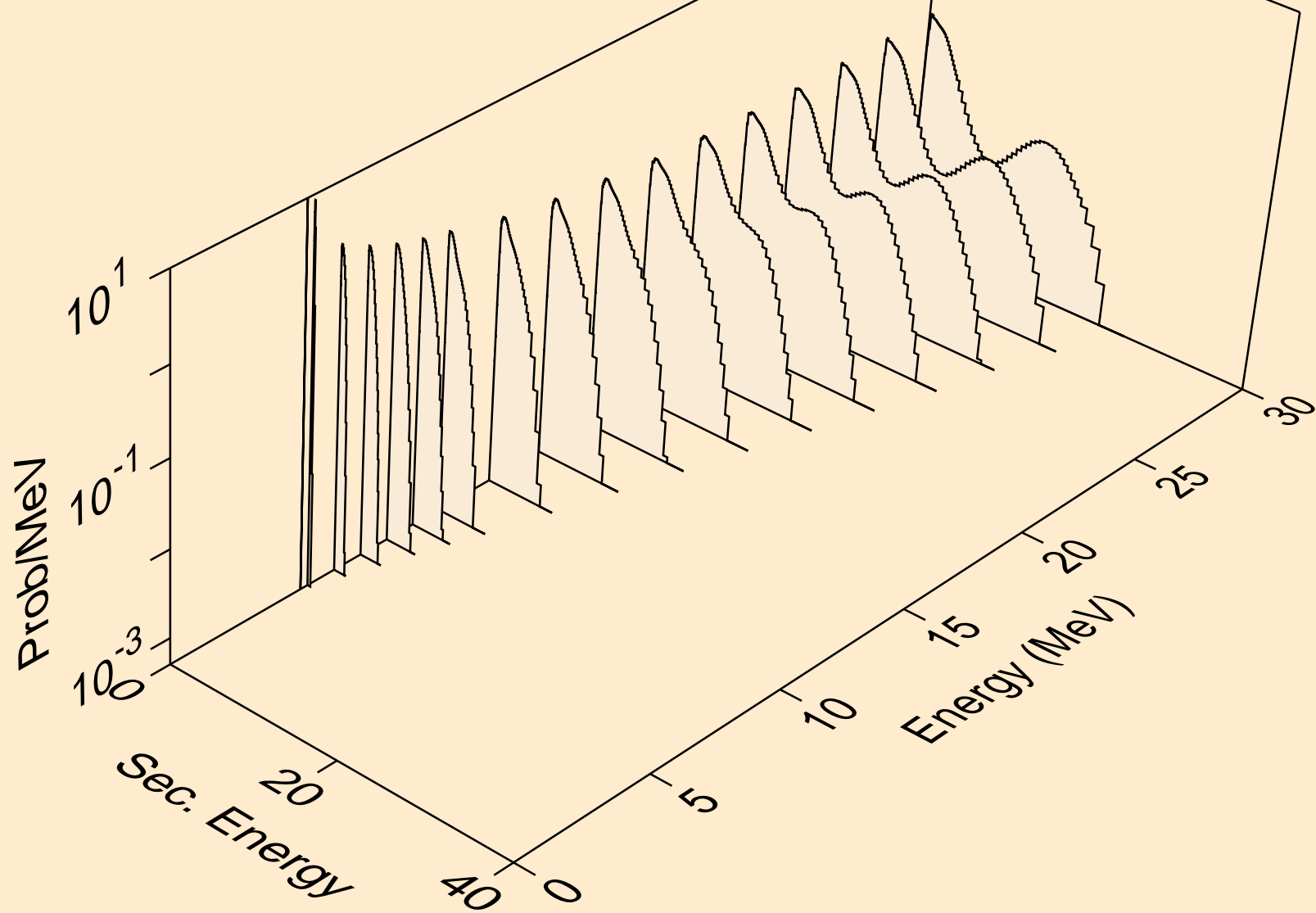

HG216 DEUTERON ACER TENDL-2023 LIBRARY; T=0.K  
neutrons from (d,2np)

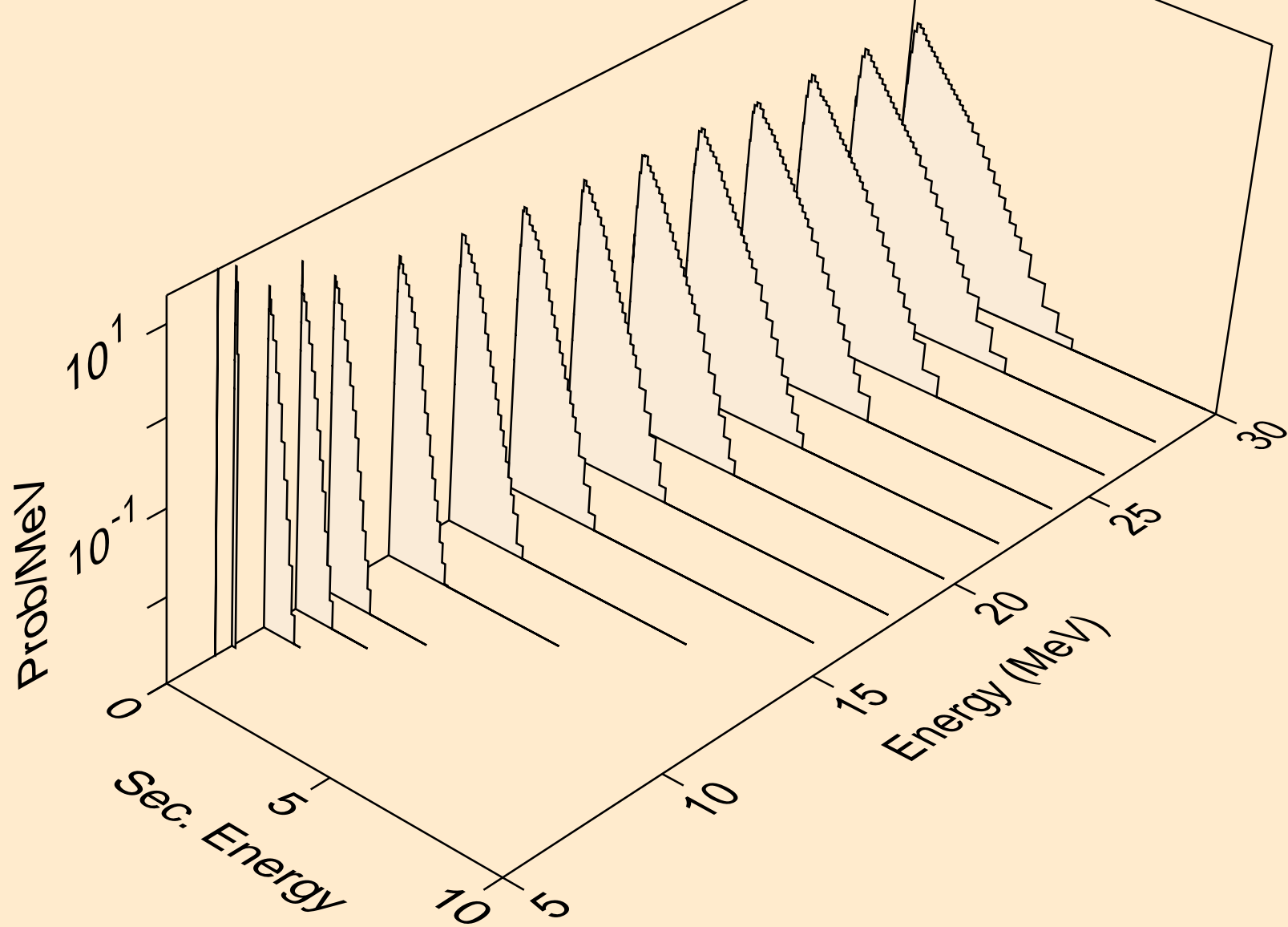



HG216 DEUTERON ACER TENDL-2023 LIBRARY; T=0.K  
neutrons from (d,3np)

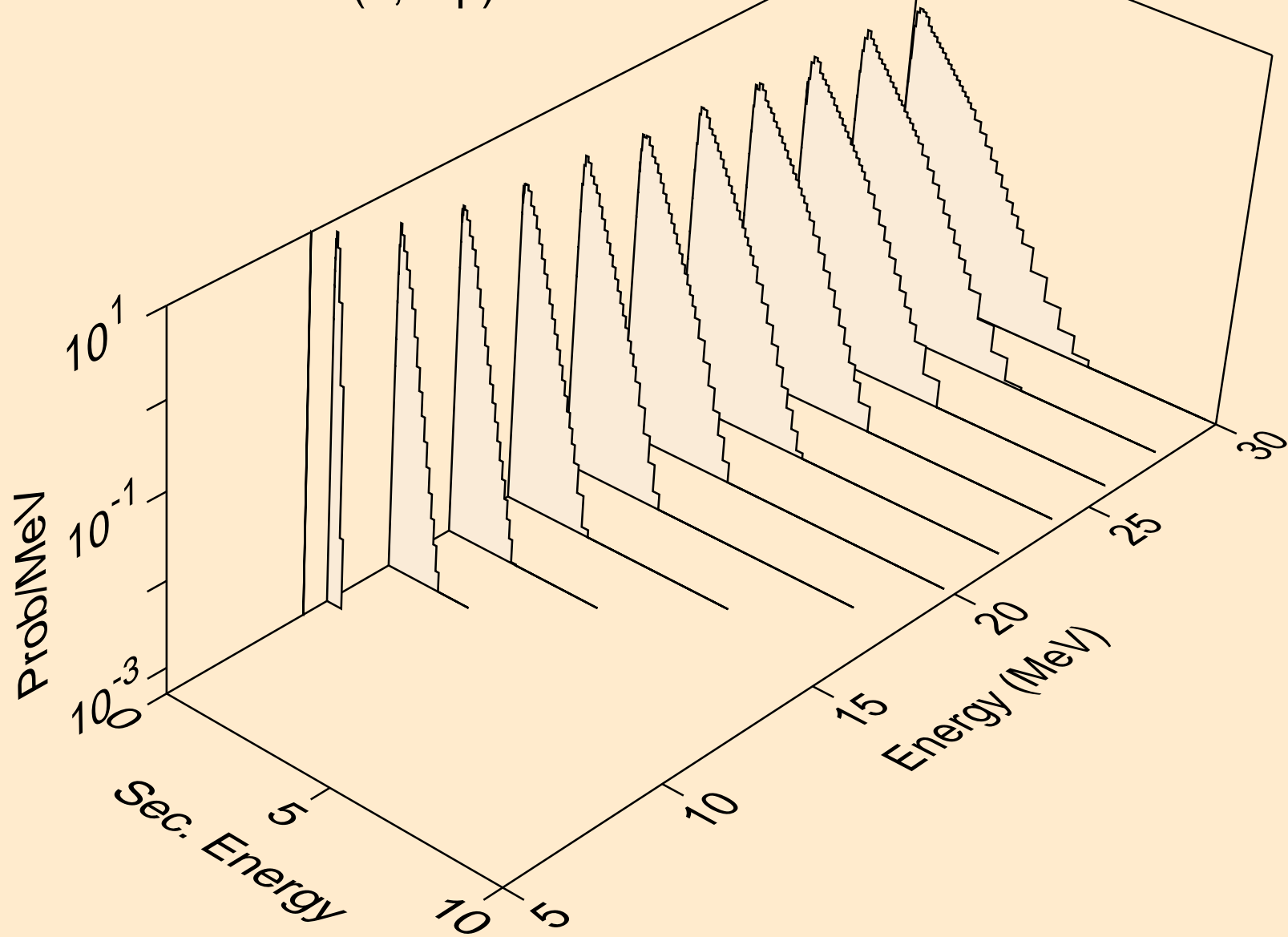

HG216 DEUTERON ACER TENDL-2023 LIBRARY; T=0.K  
neutrons from (d,n2p)

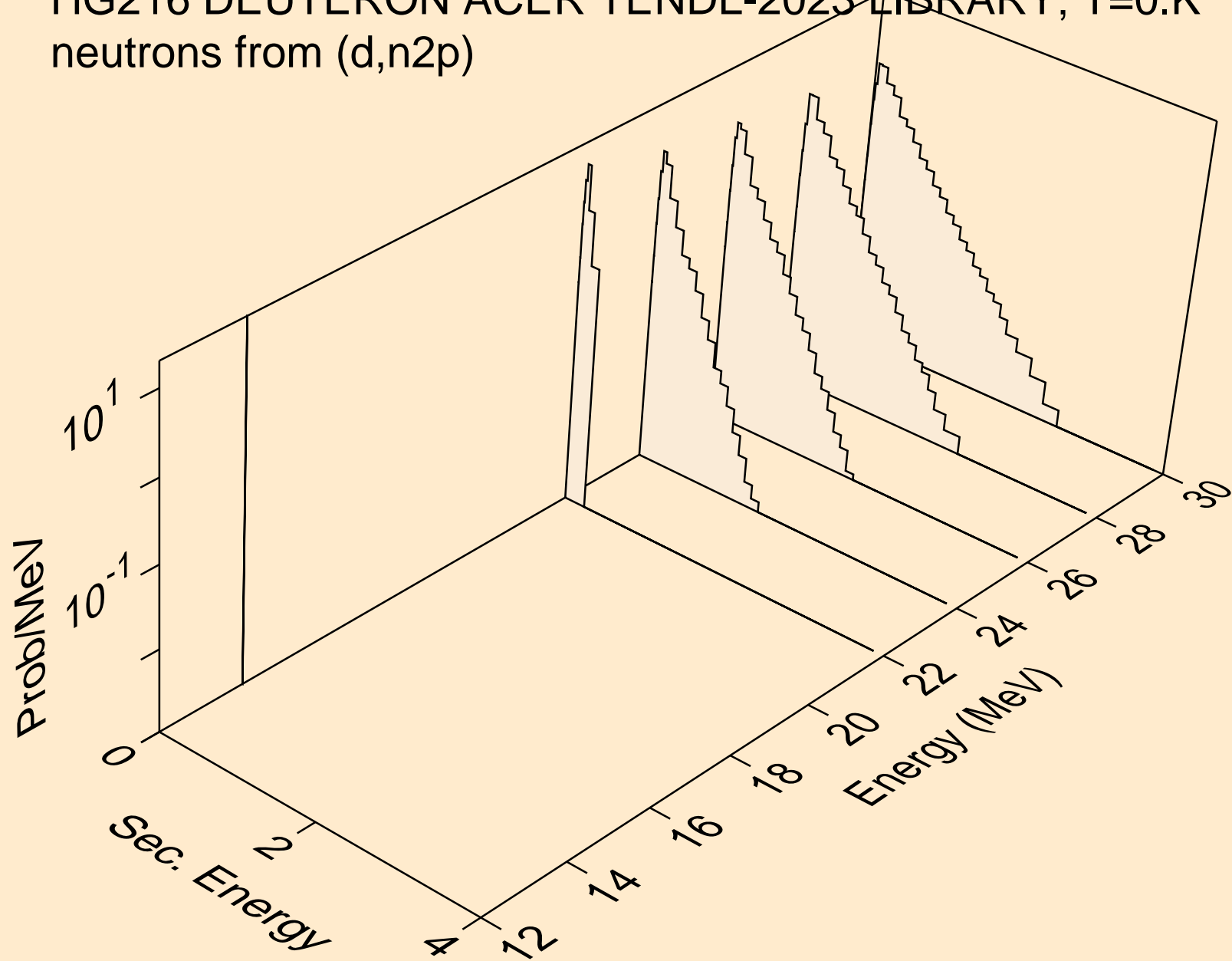

HG216 DEUTERON ACER TENDL-2023 LIBRARY; T=0.K  
protons from (d,x)

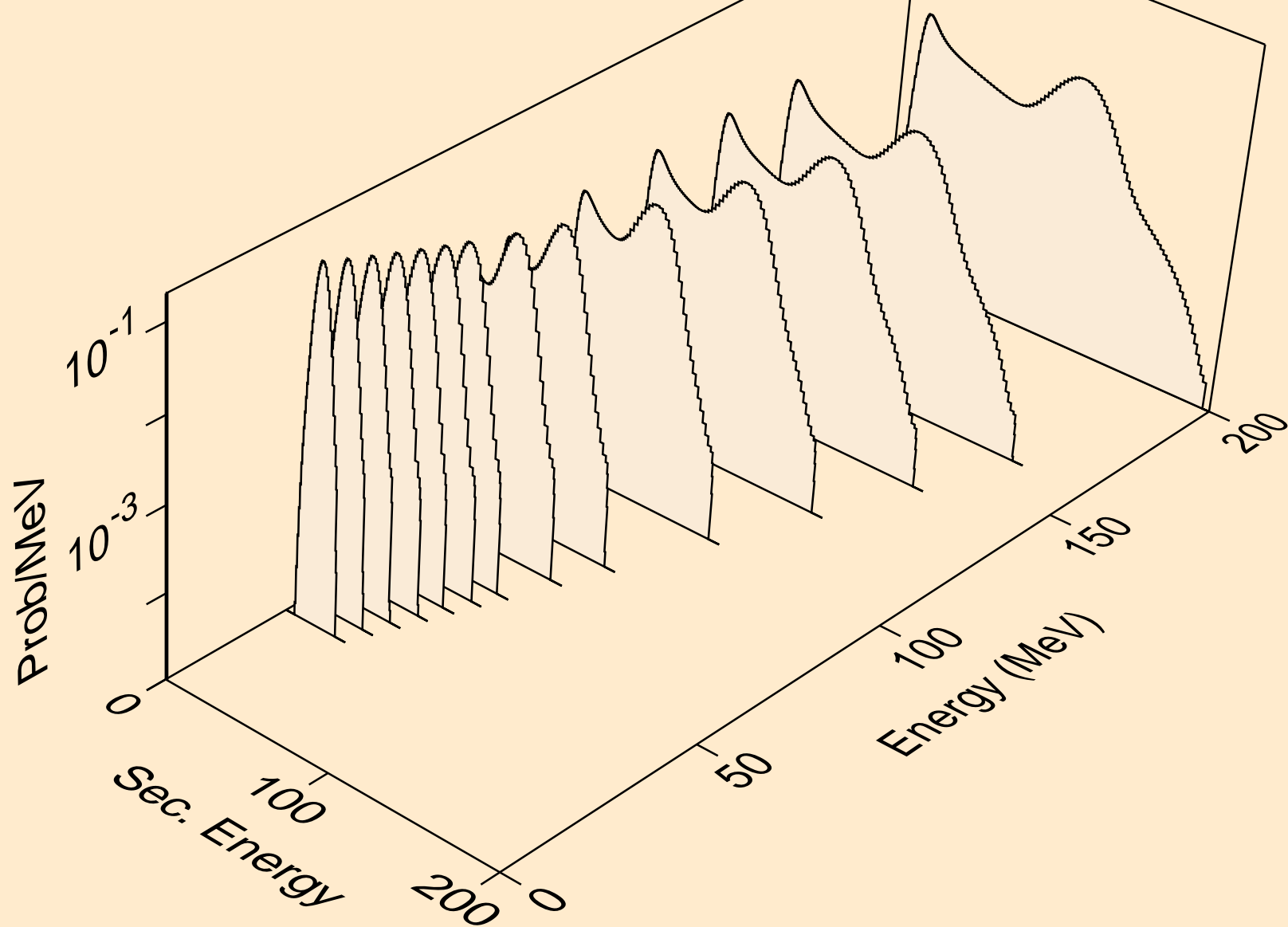

HG216 DEUTERON ACER TENDL-2023 LIBRARY; T=0.K  
protons from (d,n\*)p

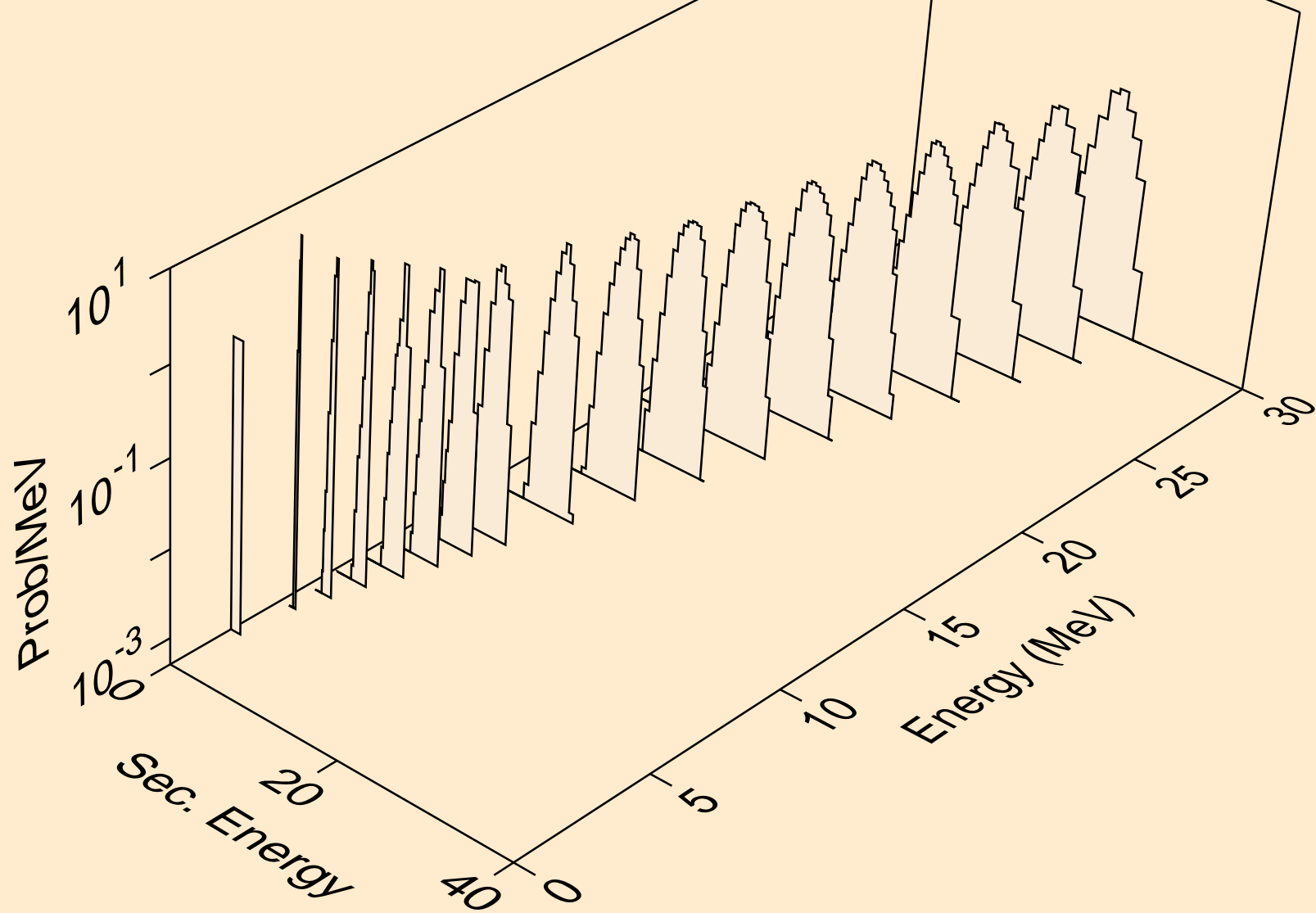

HG216 DEUTERON ACER TENDL-2023 LIBRARY; T=0.K  
protons from (d,2np)

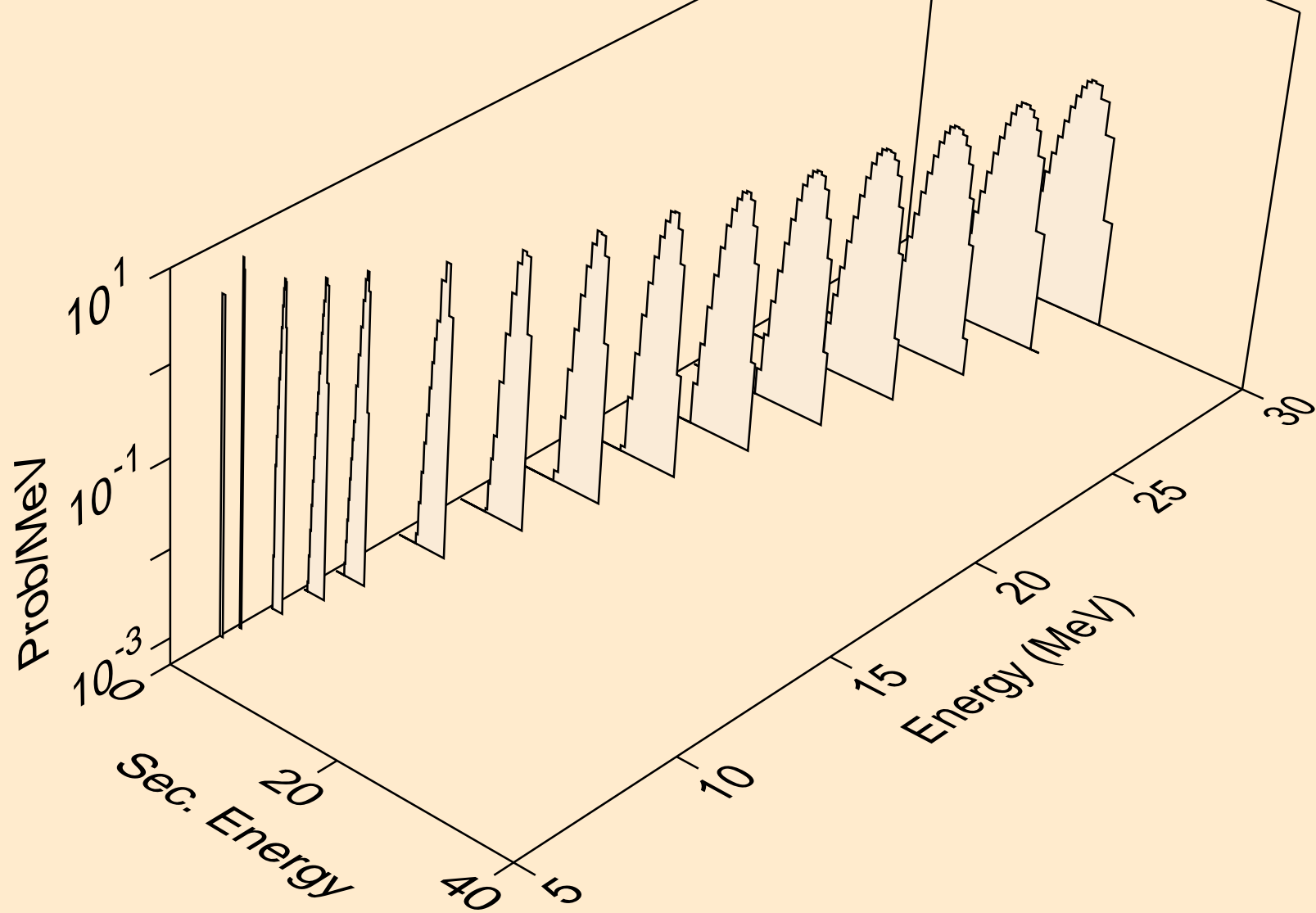

HG216 DEUTERON ACER TENDL-2023 LIBRARY; T=0.K  
protons from (d,3np)

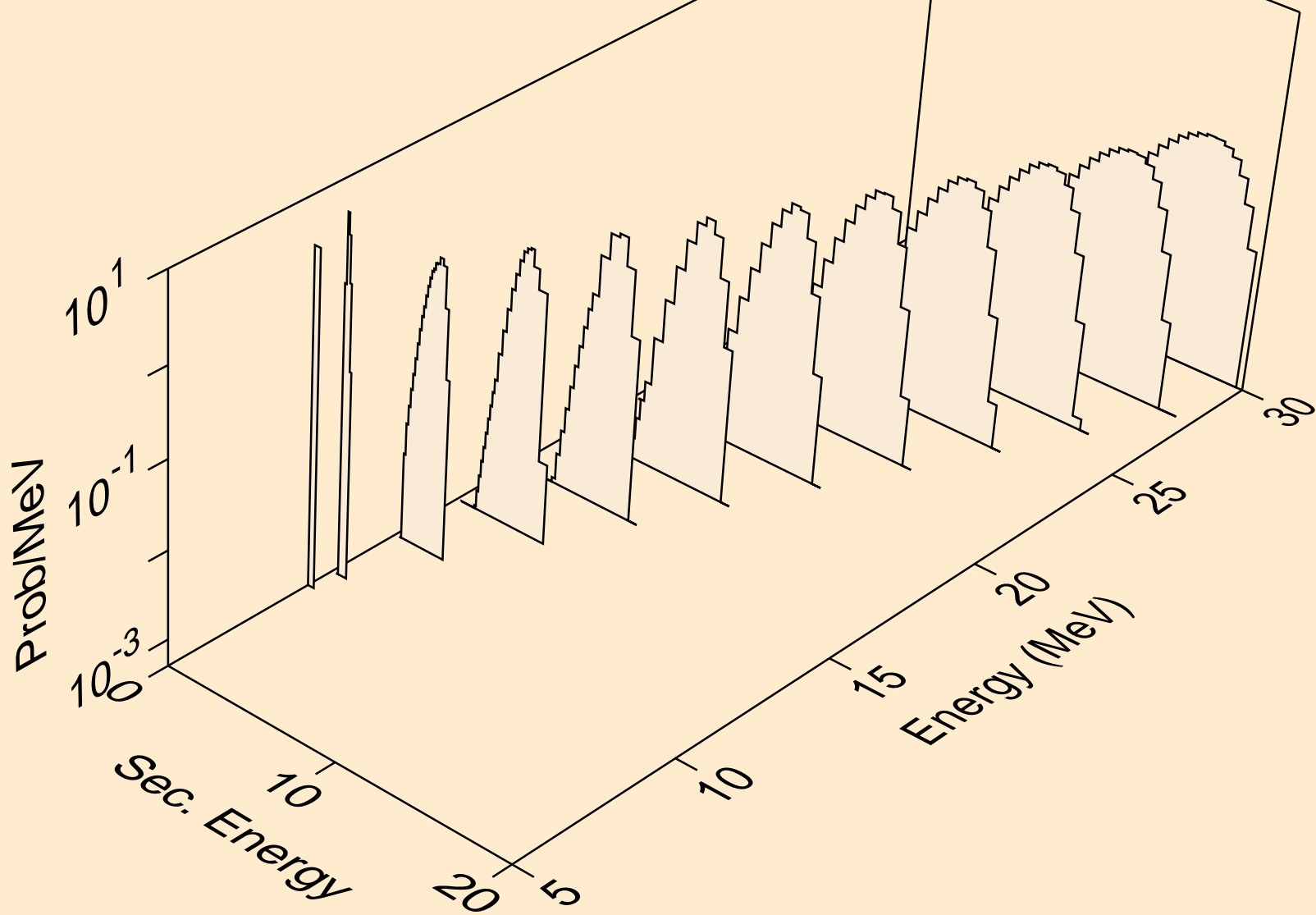

HG216 DEUTERON ACER TENDL-2023 LIBRARY; T=0.K  
protons from (d,n2p)

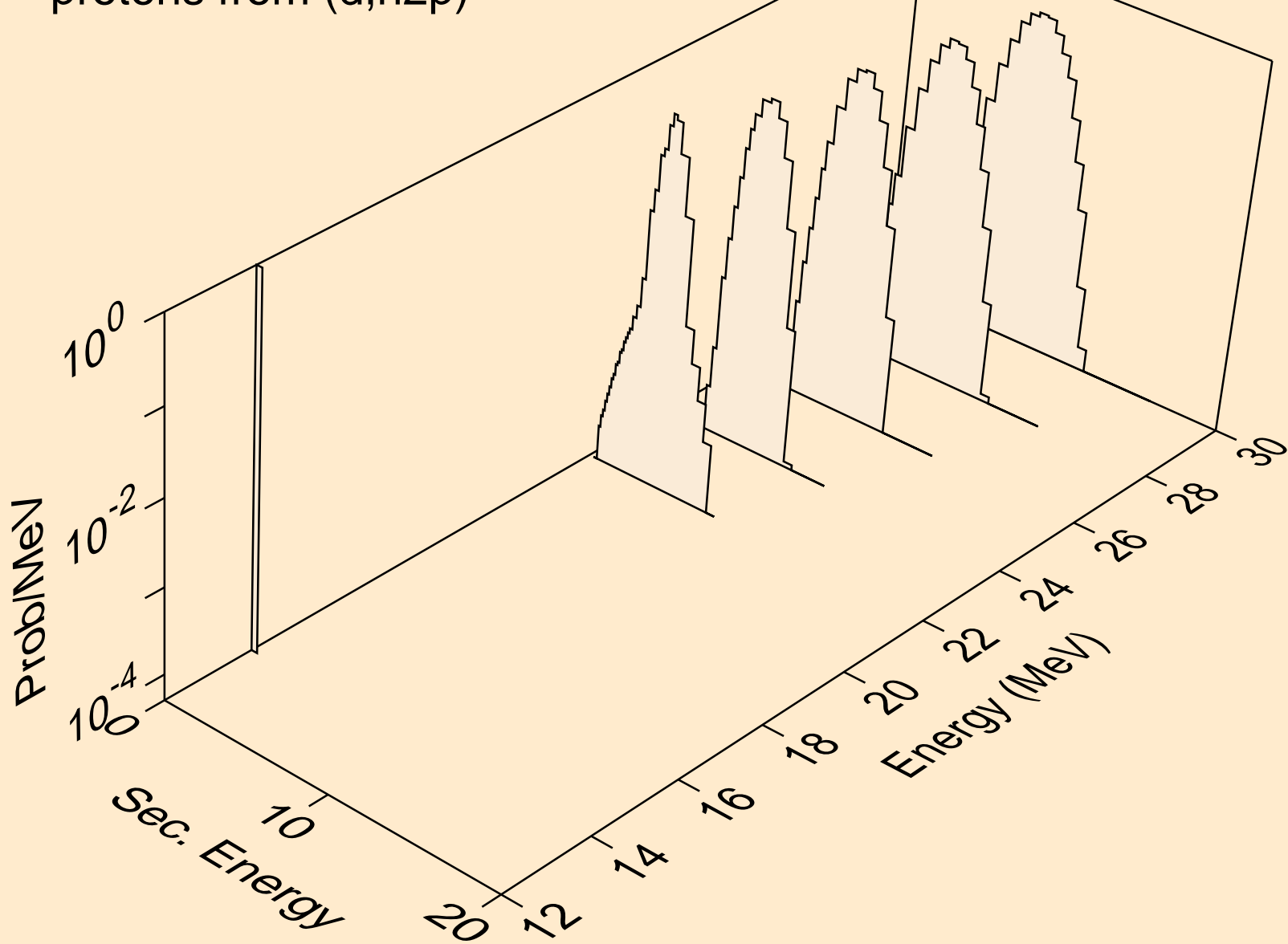

HG216 DEUTERON ACER TENDL-2023 LIBRARY; T=0.K  
protons from (d,p)

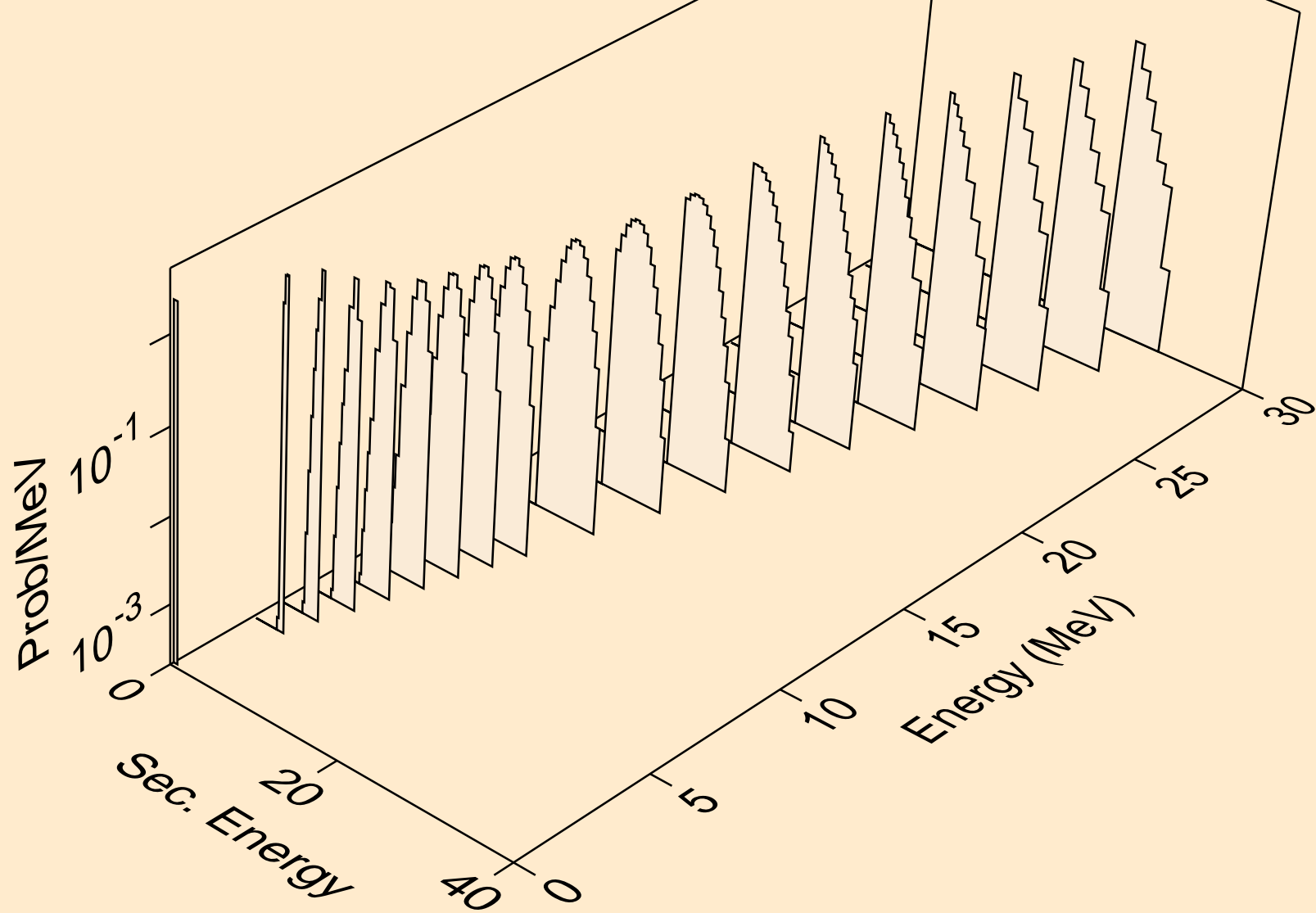



HG216 DEUTERON ACER TENDL-2023 LIBRARY; T=0.K  
protons from (d,2p)

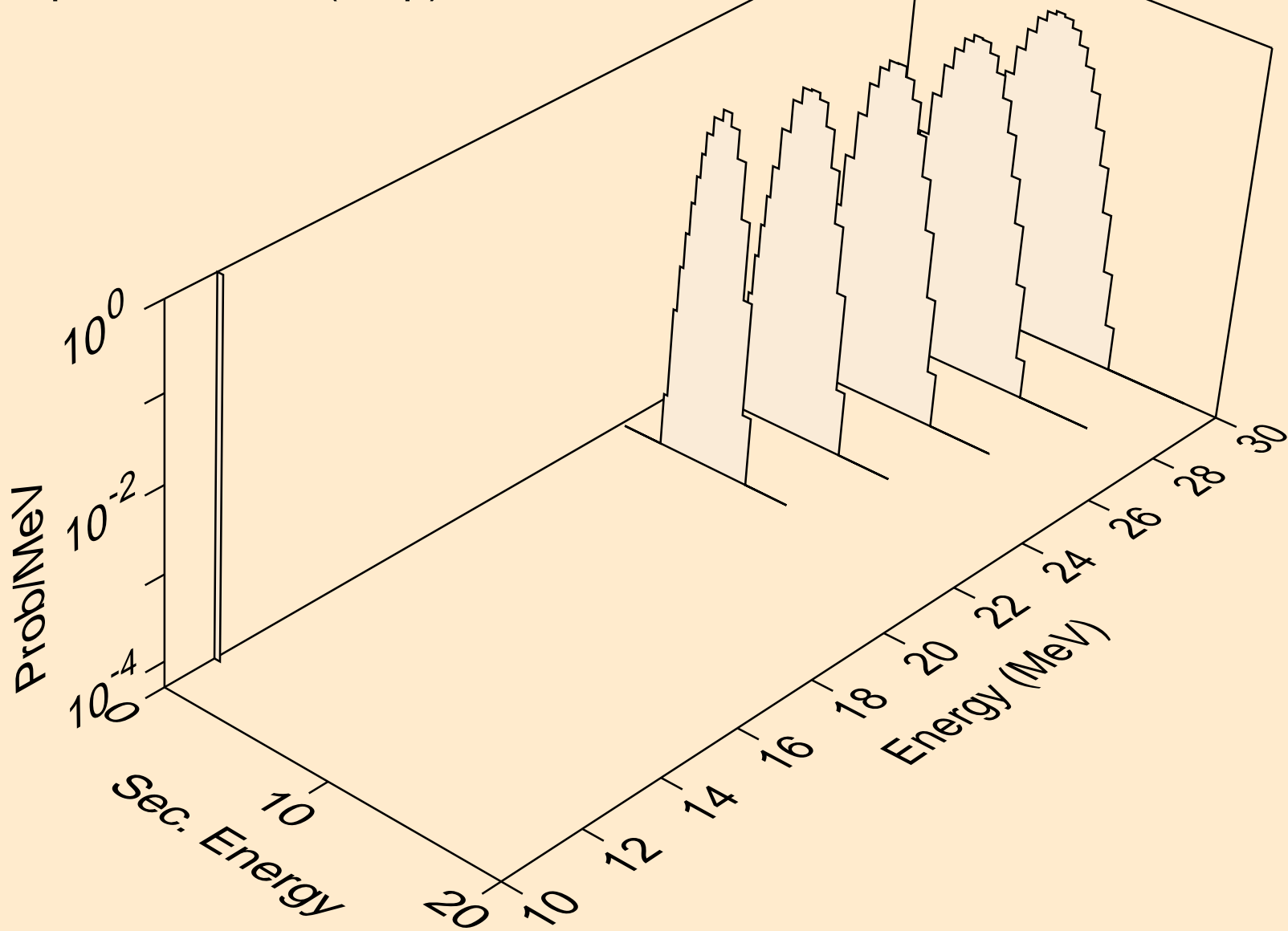

HG216 DEUTERON ACER TENDL-2023 LIBRARY; T=0.K  
tritons from (d,x)

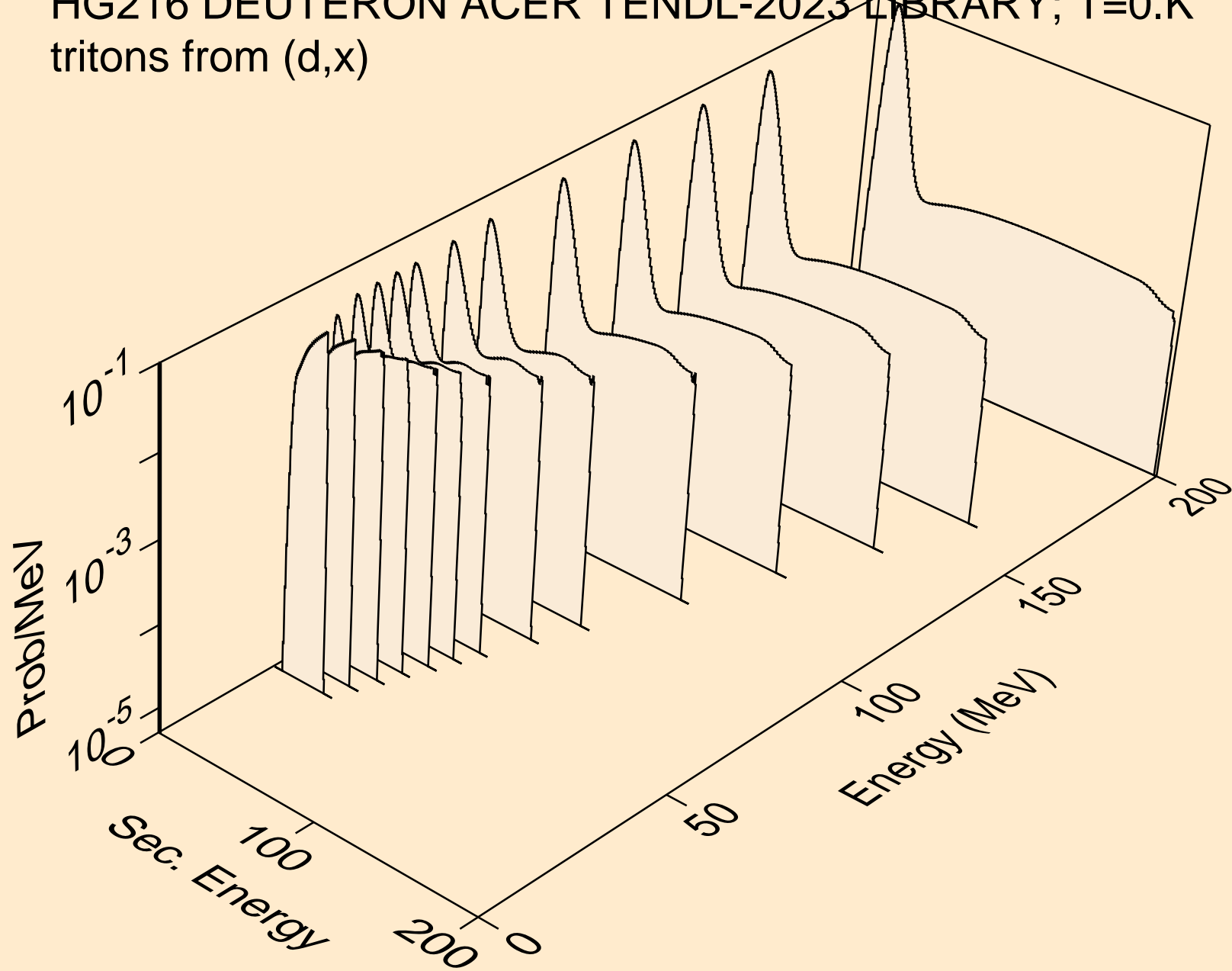

HG216 DEUTERON ACER TENDL-2023 LIBRARY; T=0.K  
tritons from (d,n\*)t

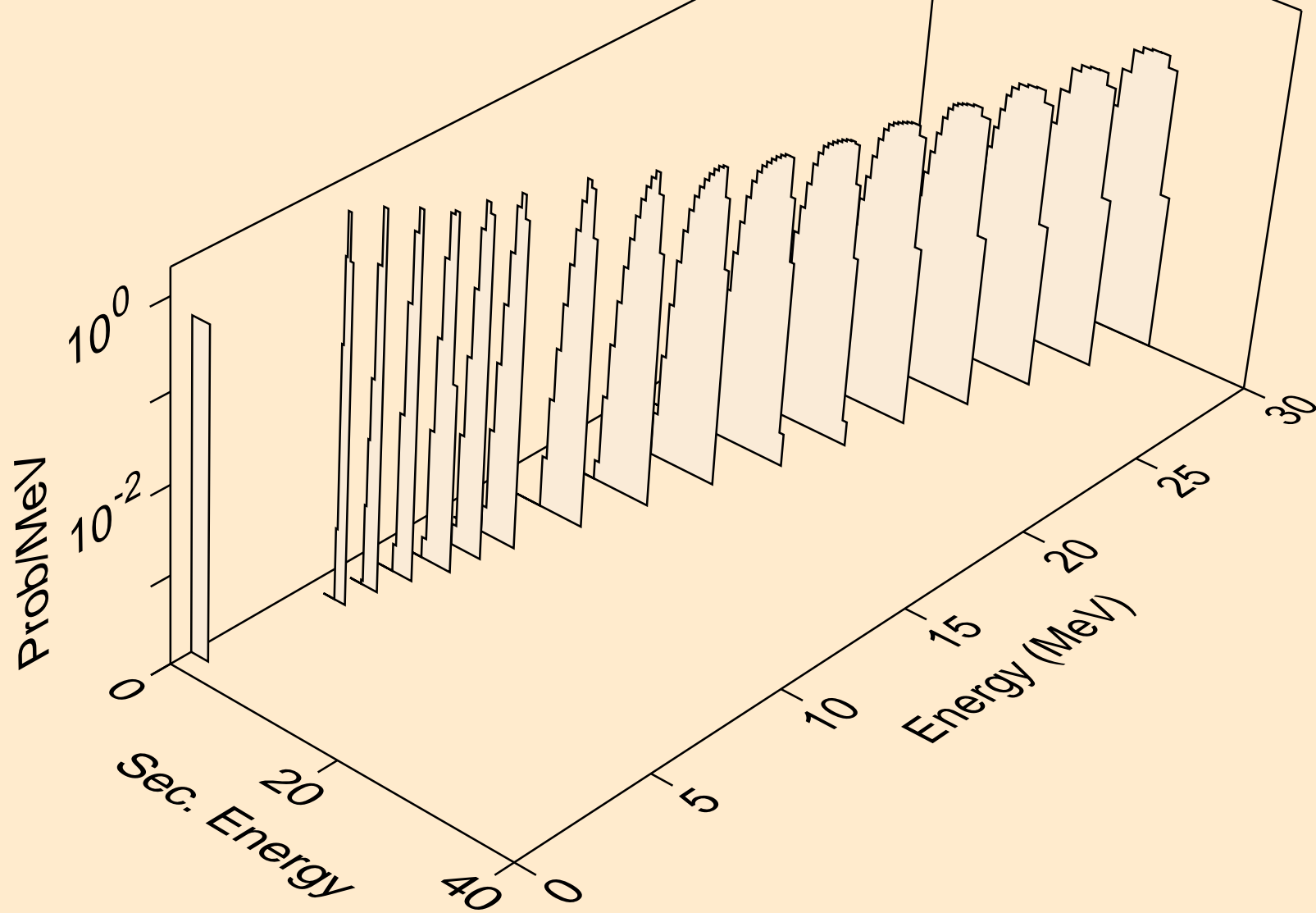

HG216 DEUTERON ACER TENDL-2023 LIBRARY; T=0.K  
tritons from (d,t)

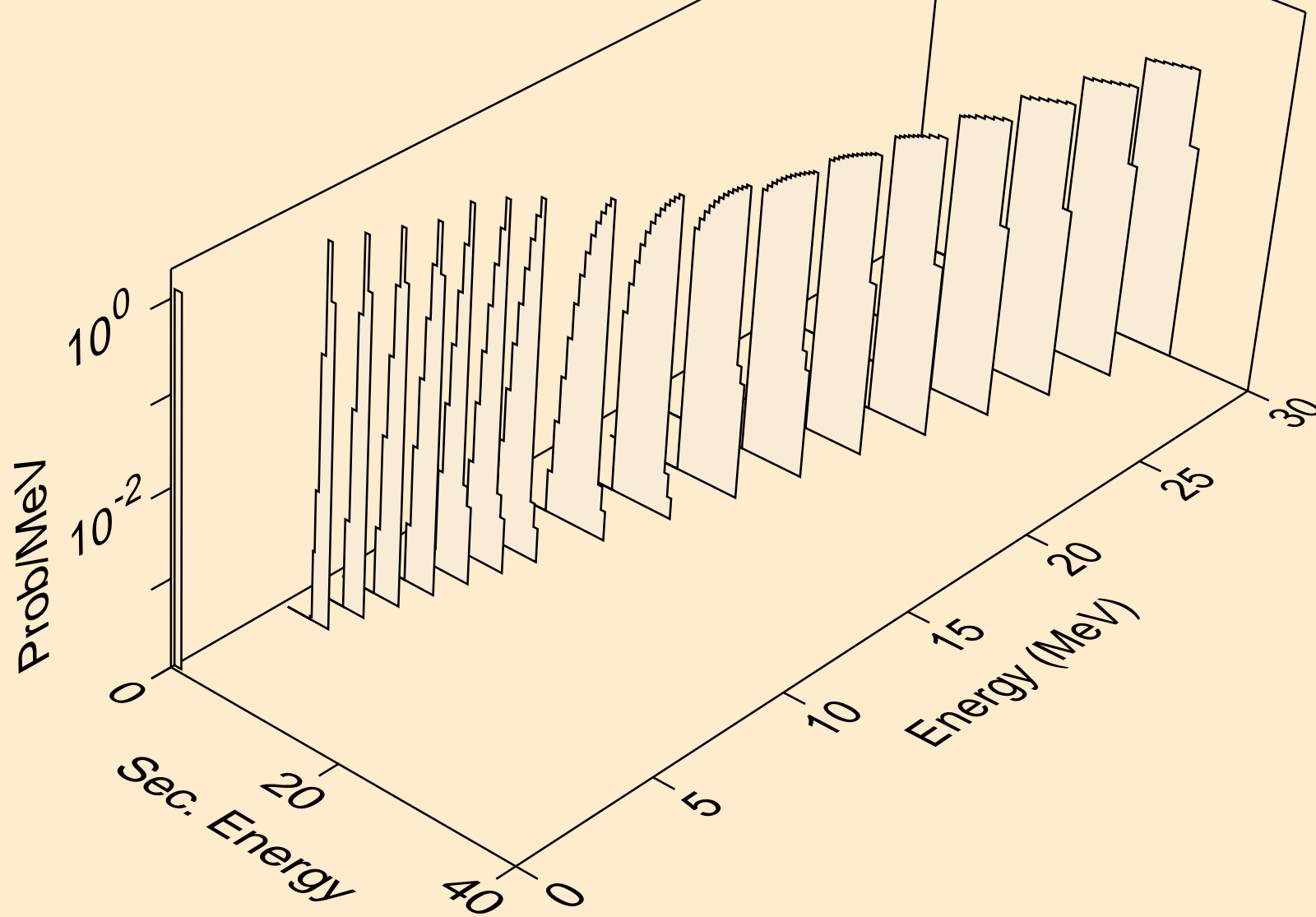

HG216 DEUTERON ACER TENDL-2023 LIBRARY; T=0.K  
he3s from (d,x)

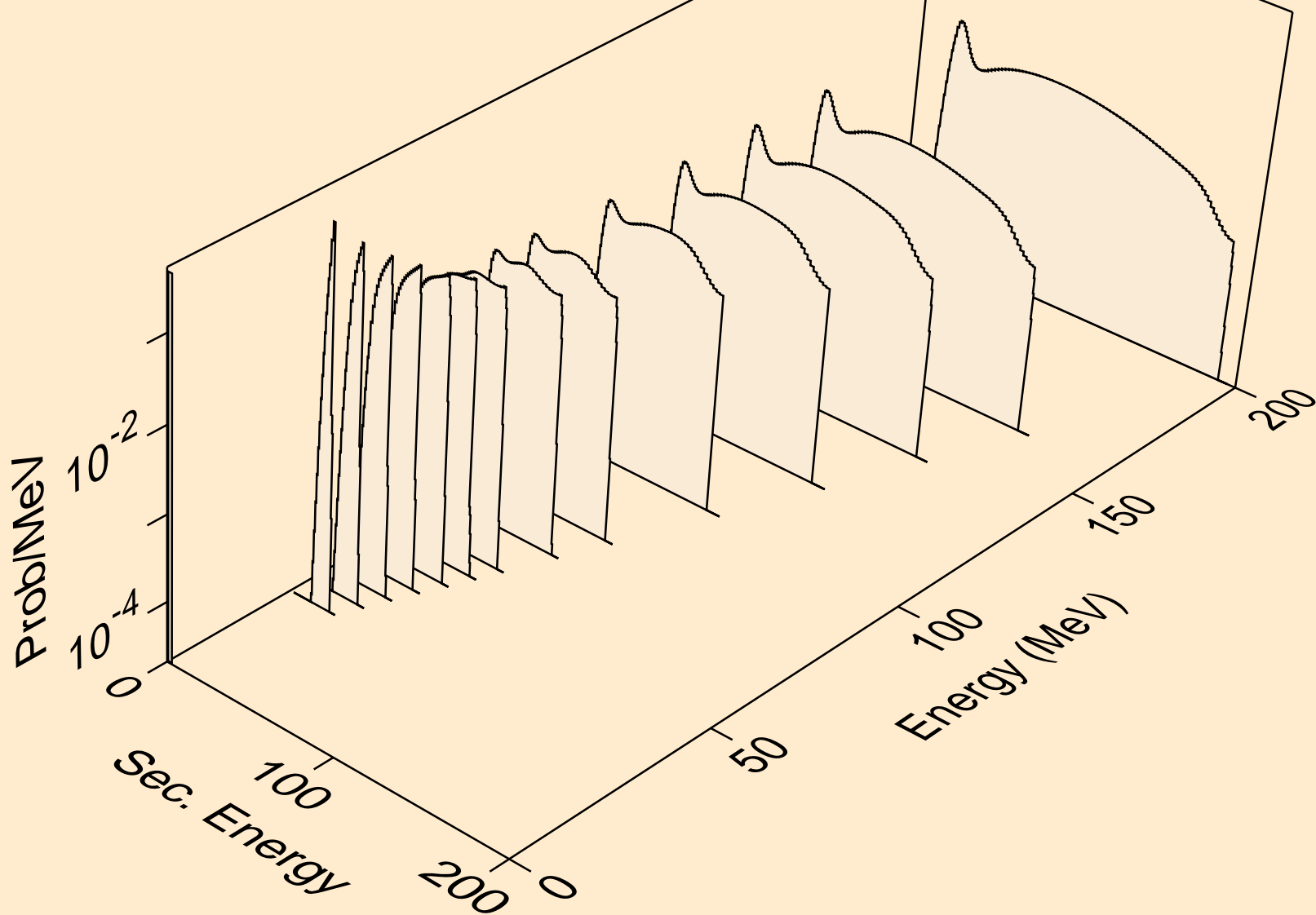

HG216 DEUTERON ACER TENDL-2023 LIBRARY; T=0.K  
he3s from (d,n\*)he3

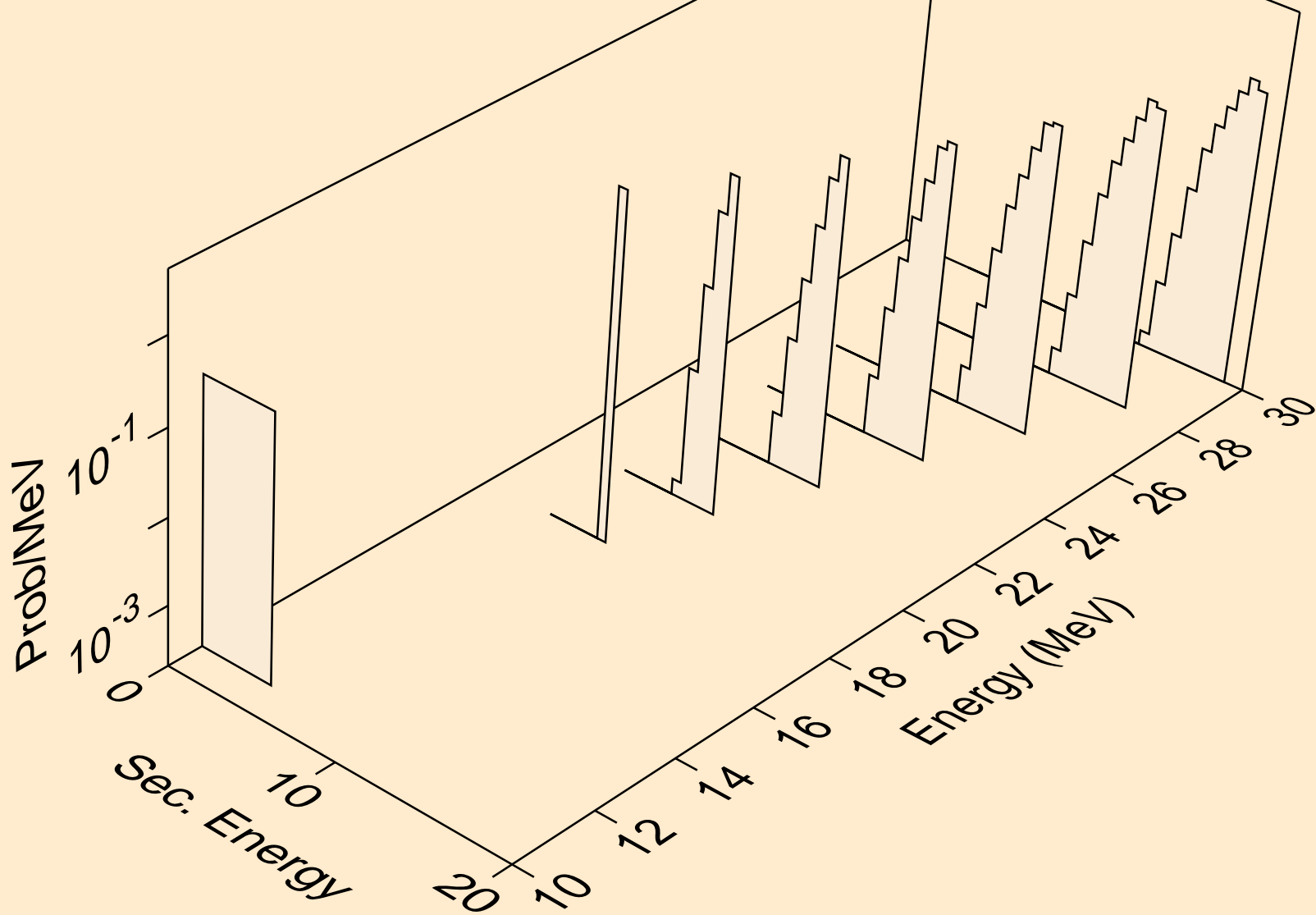

HG216 DEUTERON ACER TENDL-2023 LIBRARY; T=0.K  
he3s from (d,he3)

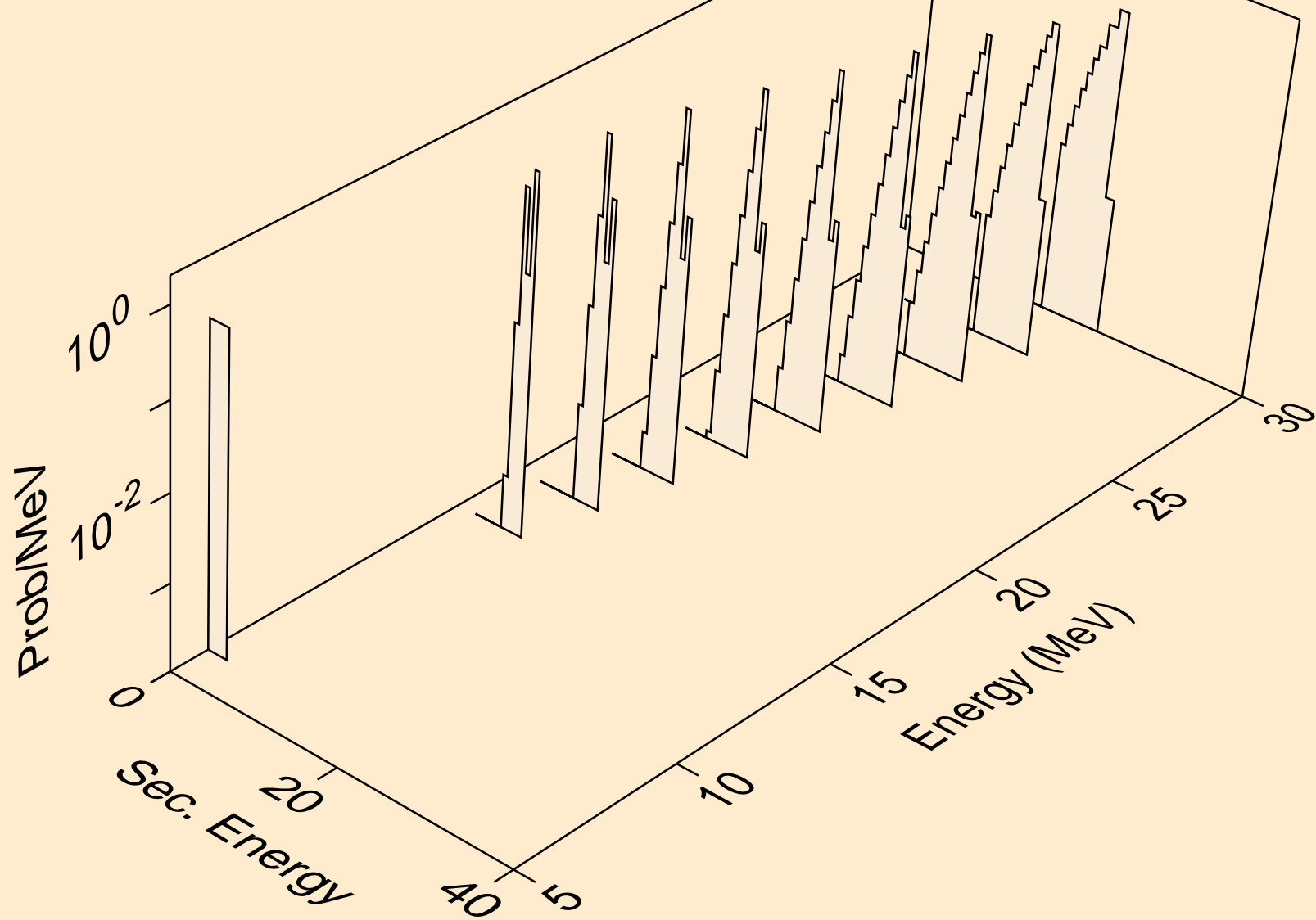

HG216 DEUTERON ACER TENDL-2023 LIBRARY; T=0.K  
alphas from (d,x)

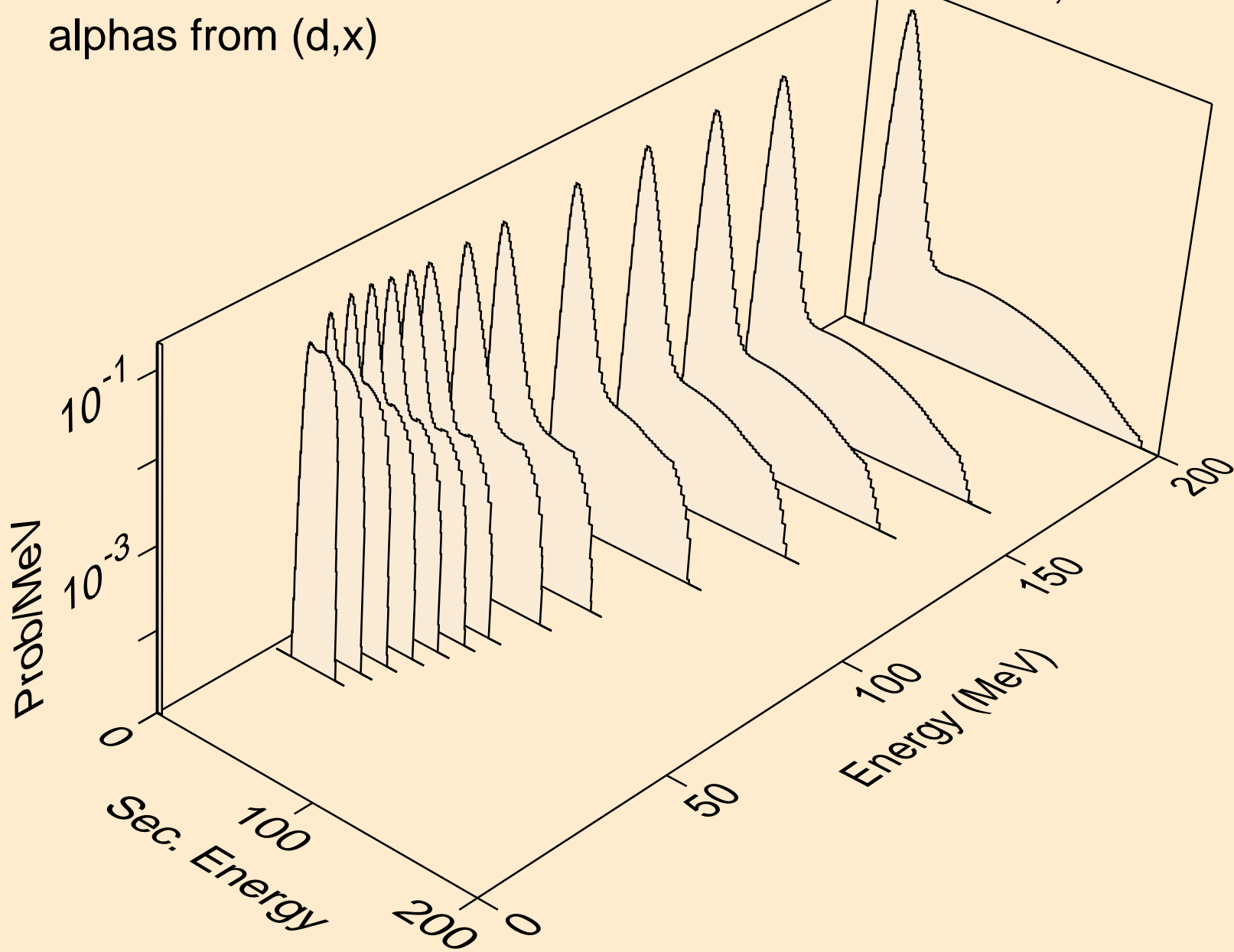



HG216 DEUTERON ACER TENDL-2023 LIBRARY; T=0.K  
alphas from (d,n\*)a

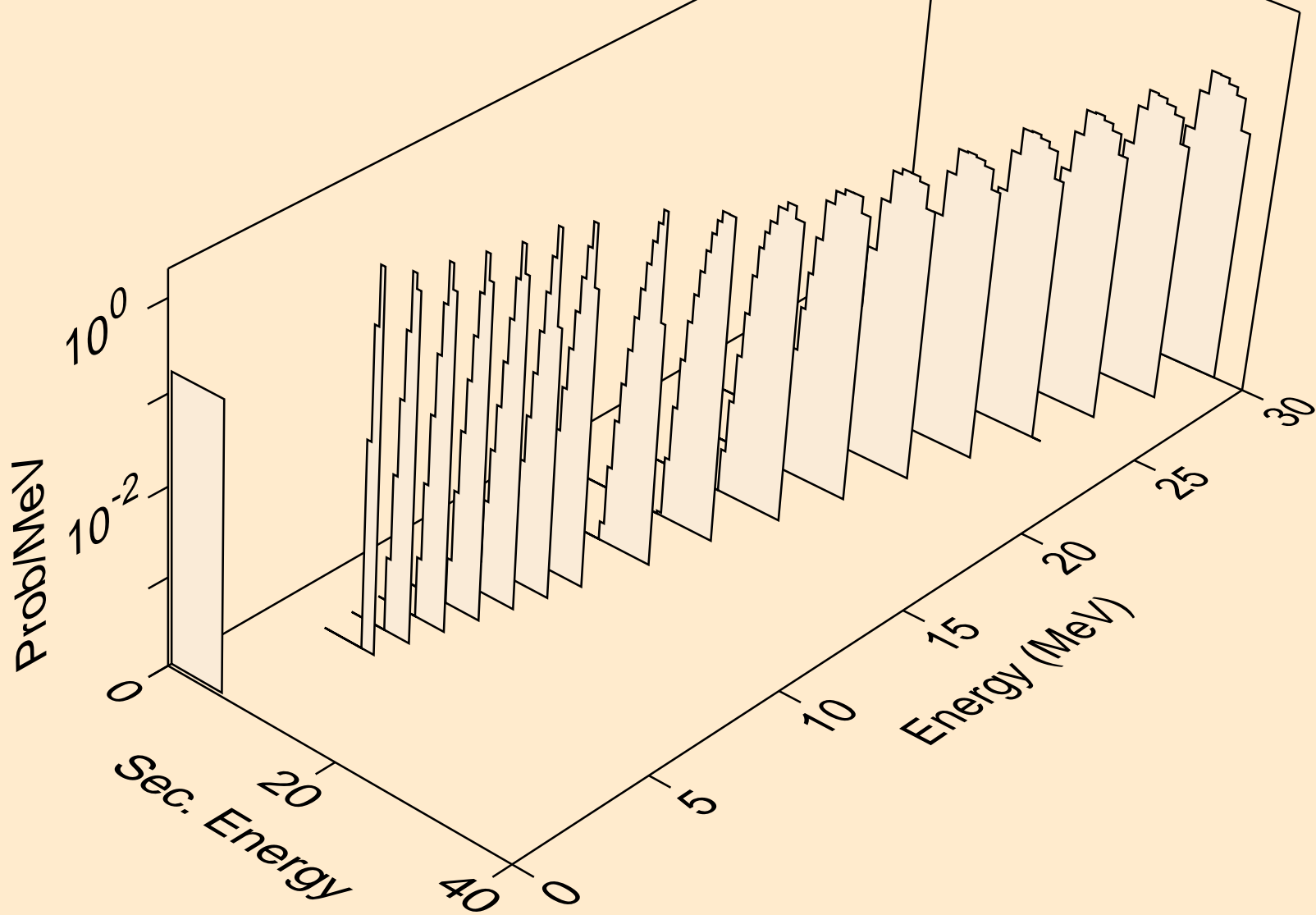

HG216 DEUTERON ACER TENDL-2023 LIBRARY; T=0.K  
alphas from (d,2n)a

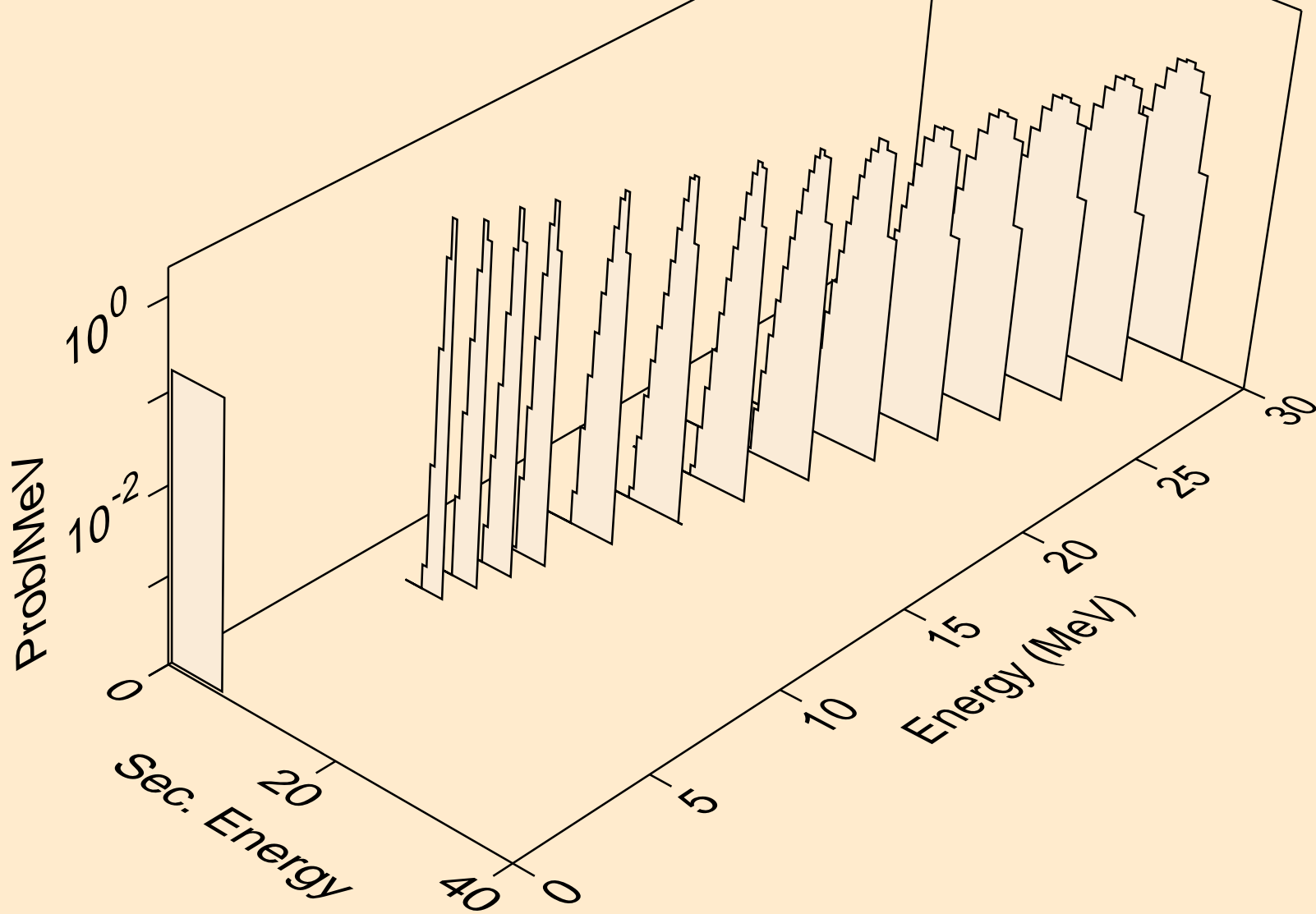

HG216 DEUTERON ACER TENDL-2023 LIBRARY; T=0.K  
alphas from (d,3n)a

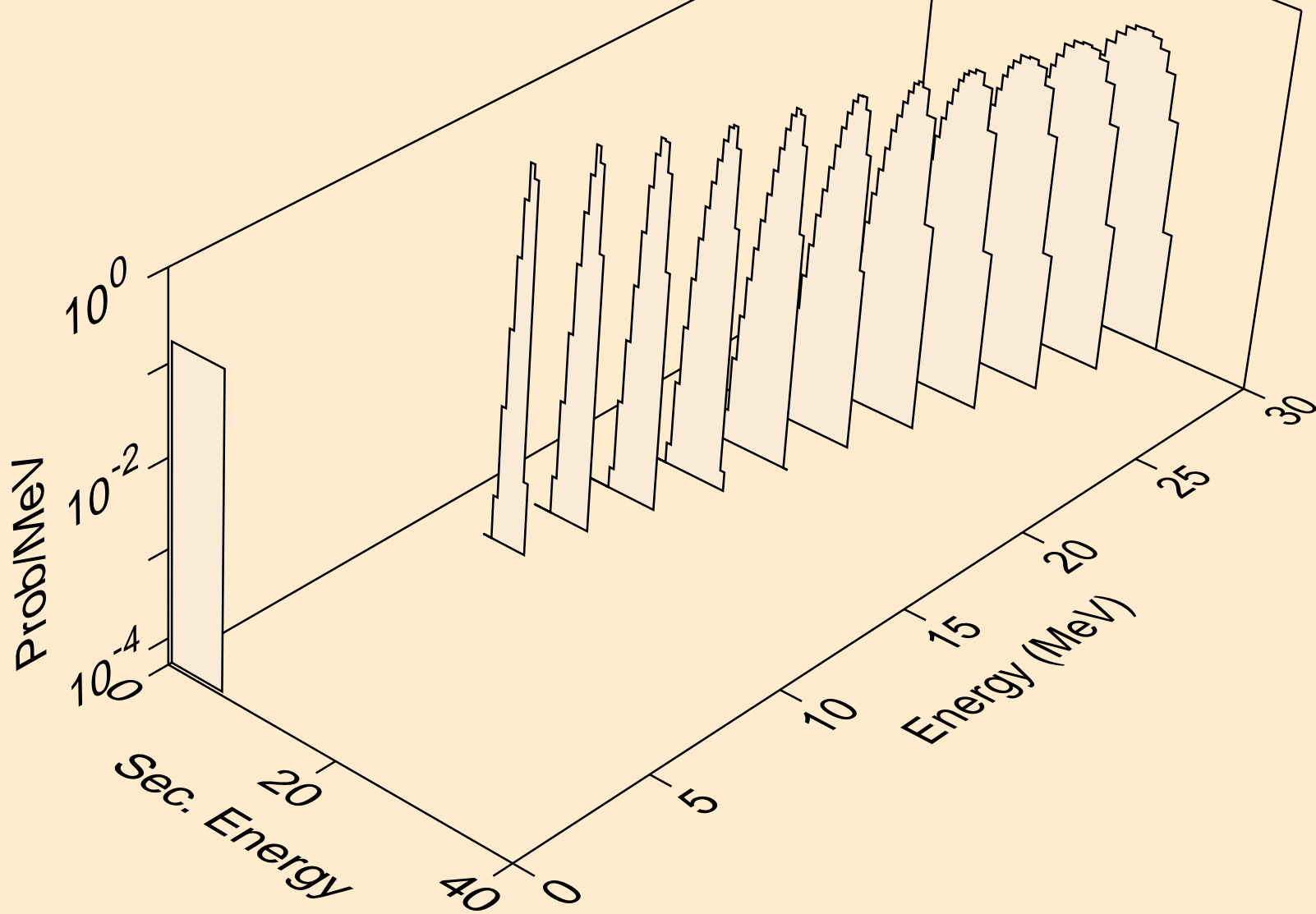

HG216 DEUTERON ACER TENDL-2023 LIBRARY; T=0.K  
alphas from (d,a)

