

HO175 DEUTERON ACER TENDL-2023 LIBRARY; T=0.K

Principal cross sections

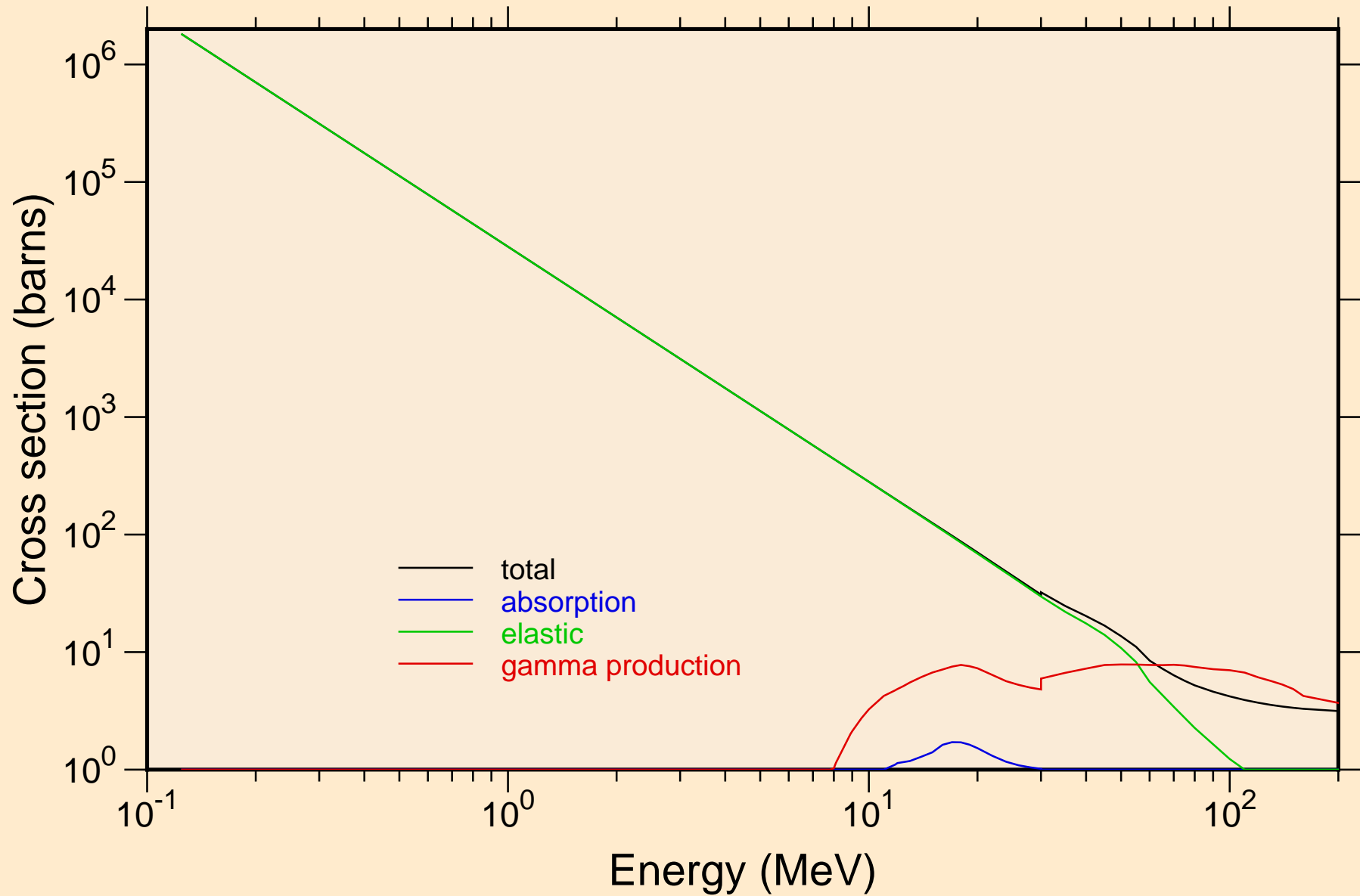

HO175 DEUTERON ACER TENDL-2023 LIBRARY; T=0.K

Heating

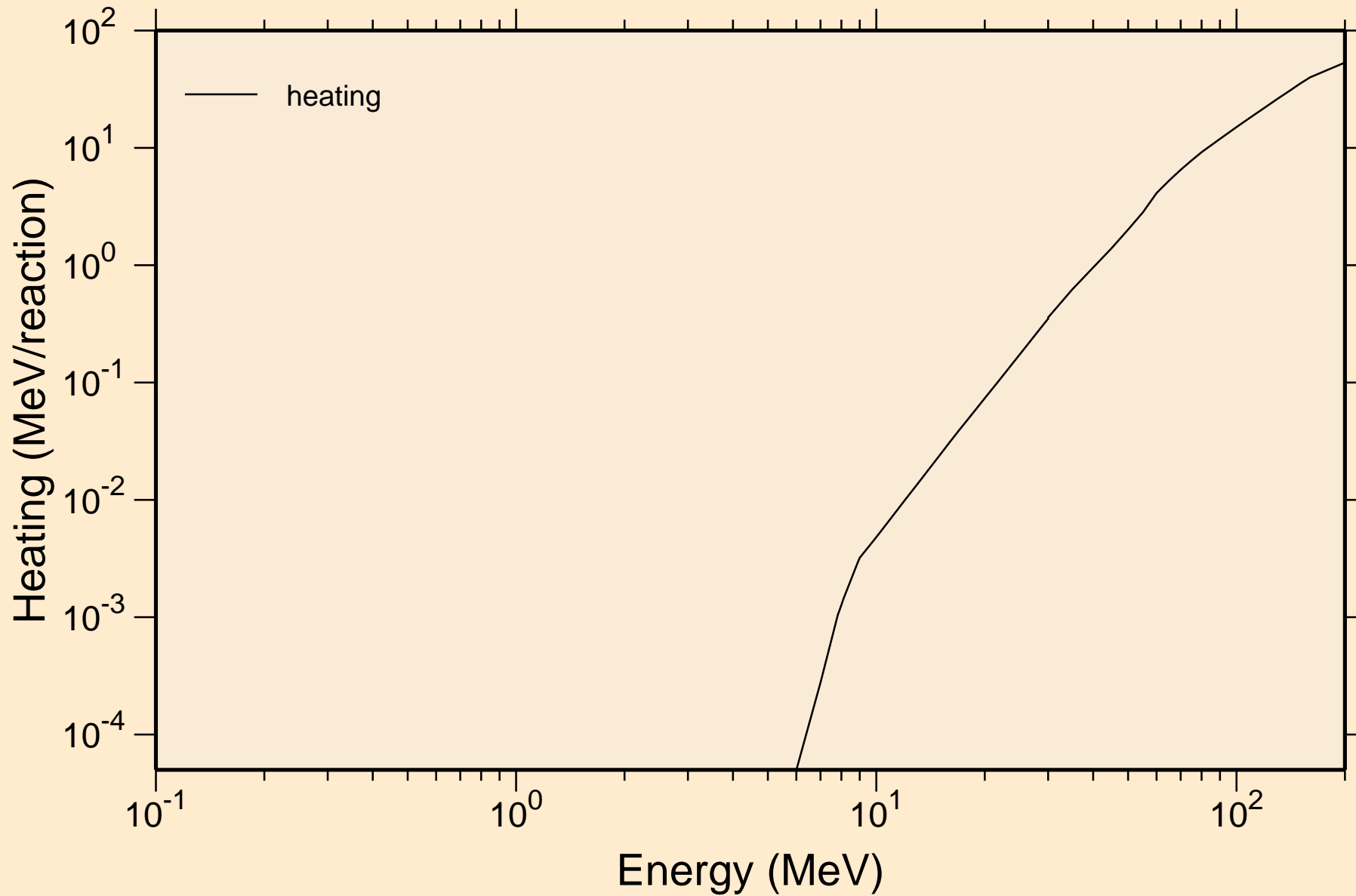

HO175 DEUTERON ACER TENDL-2023 LIBRARY; T=0.K

Principal cross sections

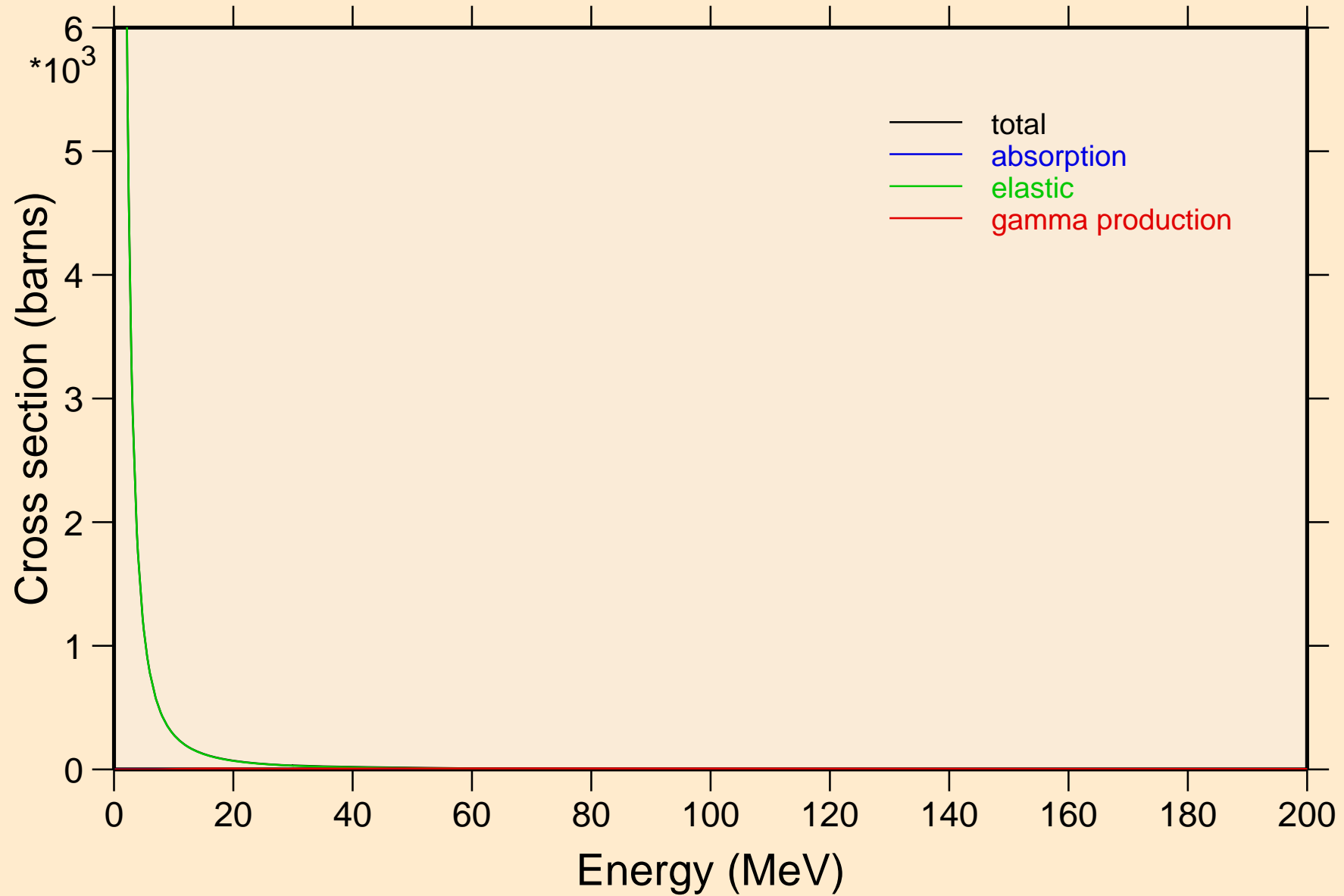

HO175 DEUTERON ACER TENDL-2023 LIBRARY; T=0.K

Heating

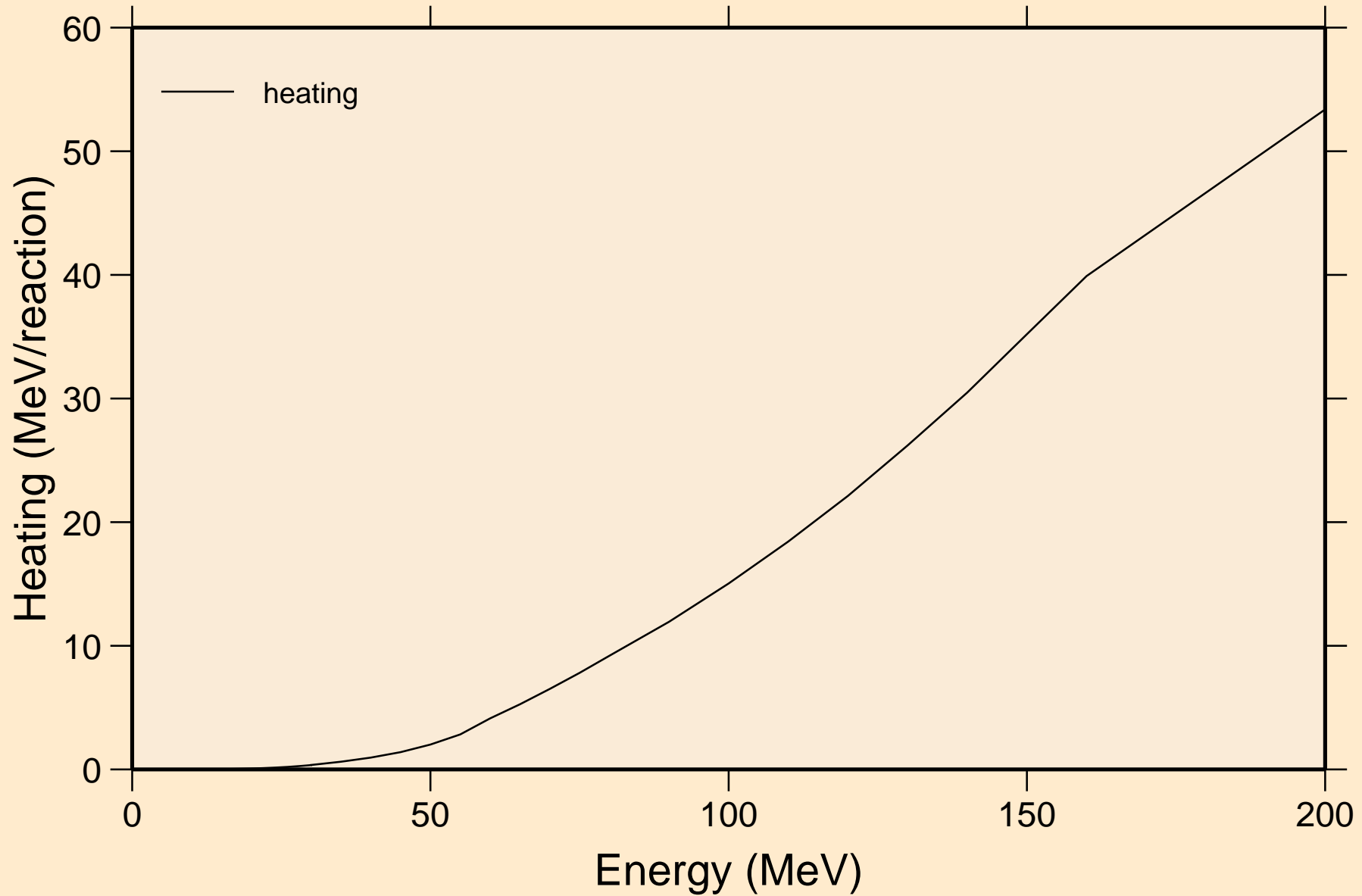

HO175 DEUTERON ACER TENDL-2023 LIBRARY; T=0.K

Threshold reactions

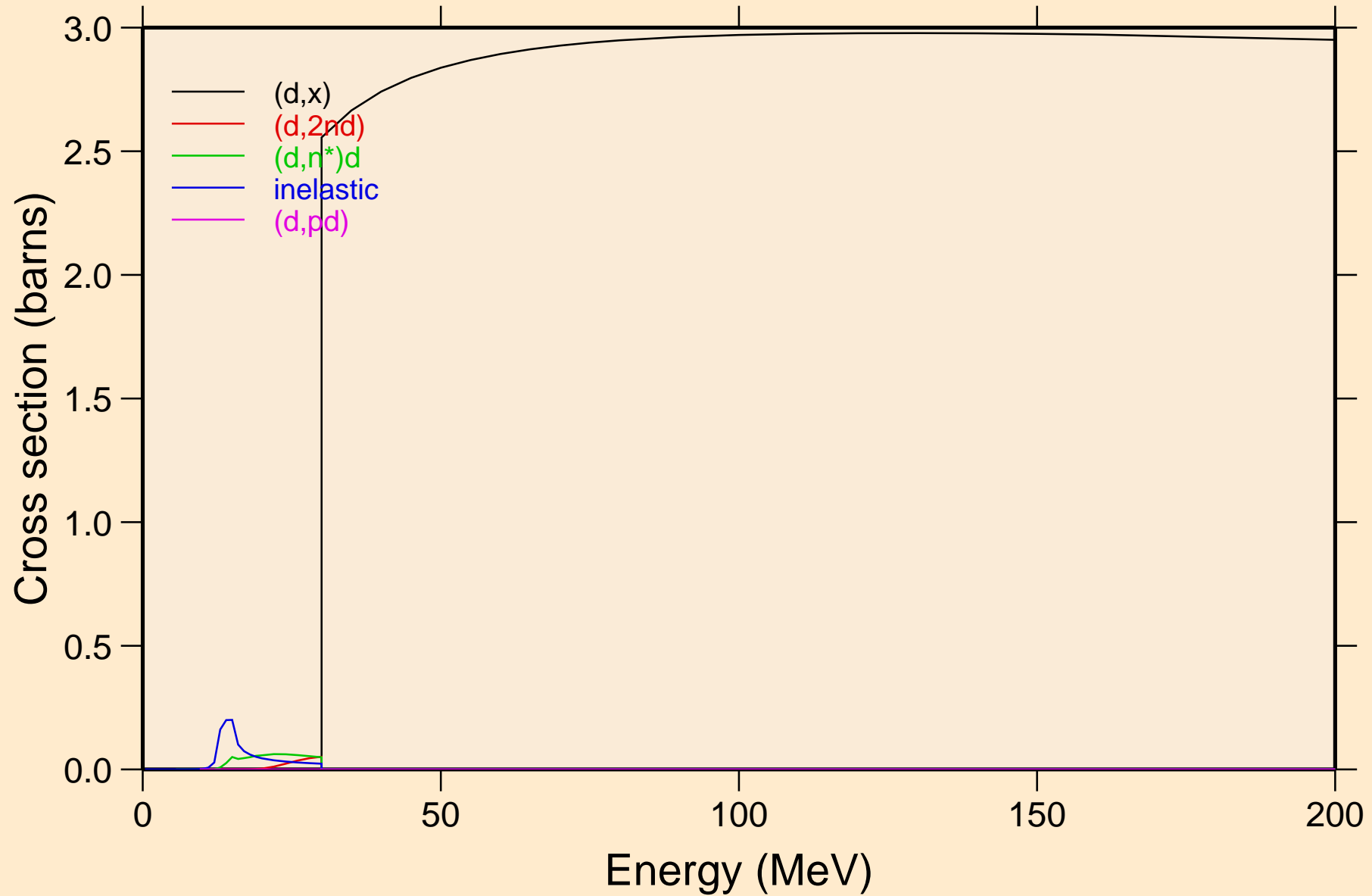

HO175 DEUTERON ACER TENDL-2023 LIBRARY; T=0.K
angular distribution for elastic

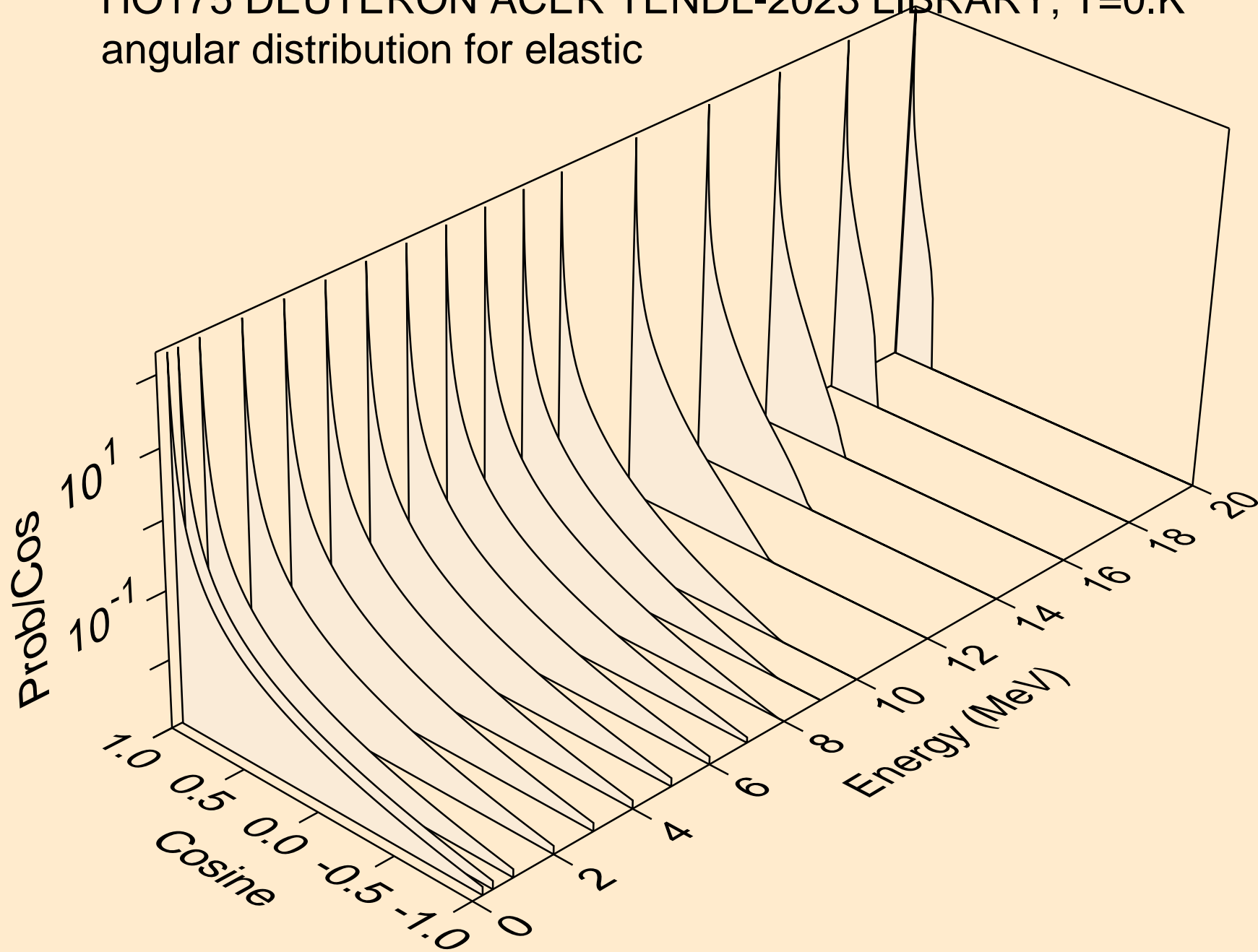

HO175 DEUTERON ACER TENDL-2023 LIBRARY; T=0.K
angular distribution for elastic

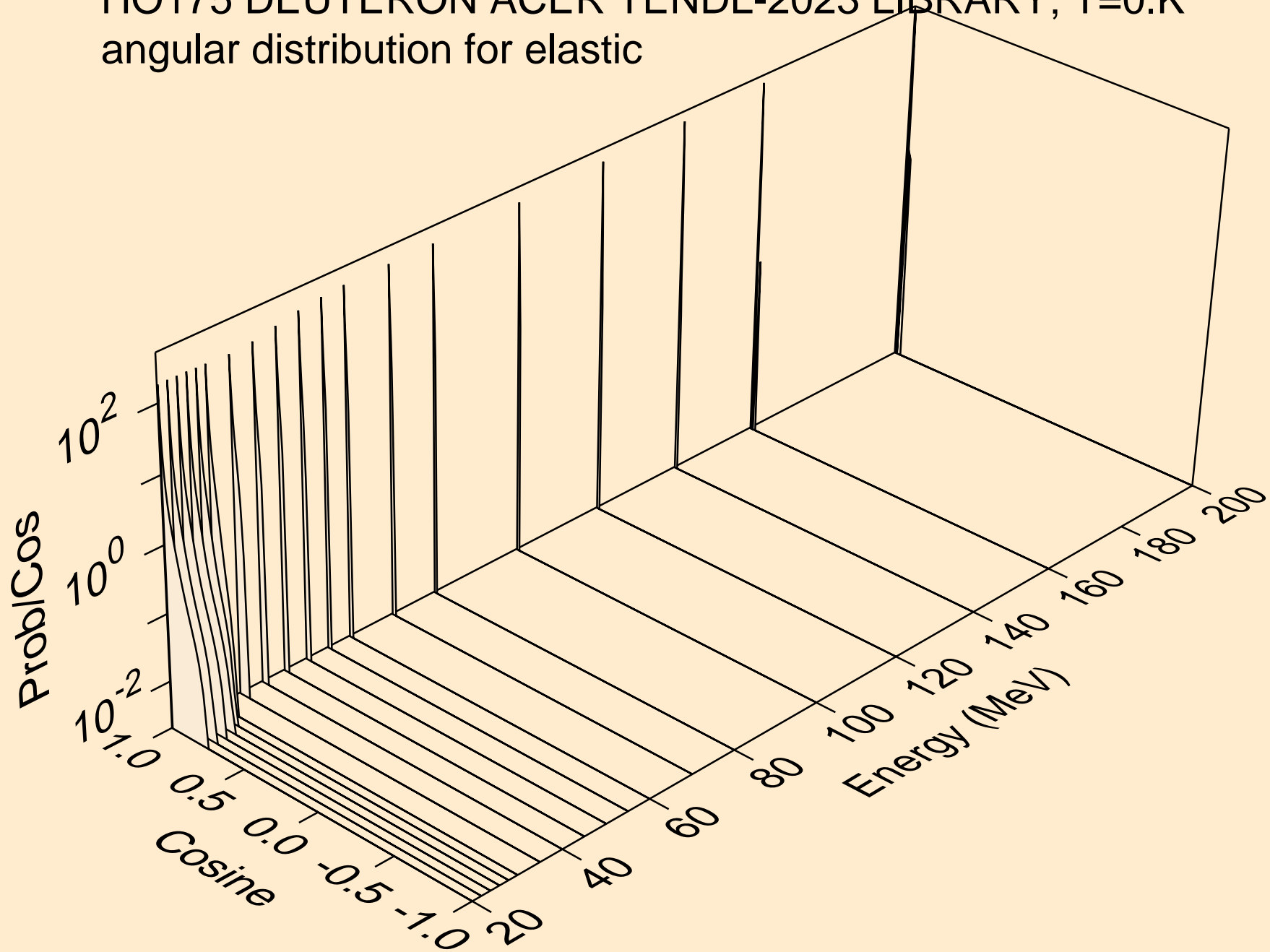

HO175 DEUTERON ACER TENDL-2023 LIBRARY; T=0.K
Deuteron emission for (d,x)

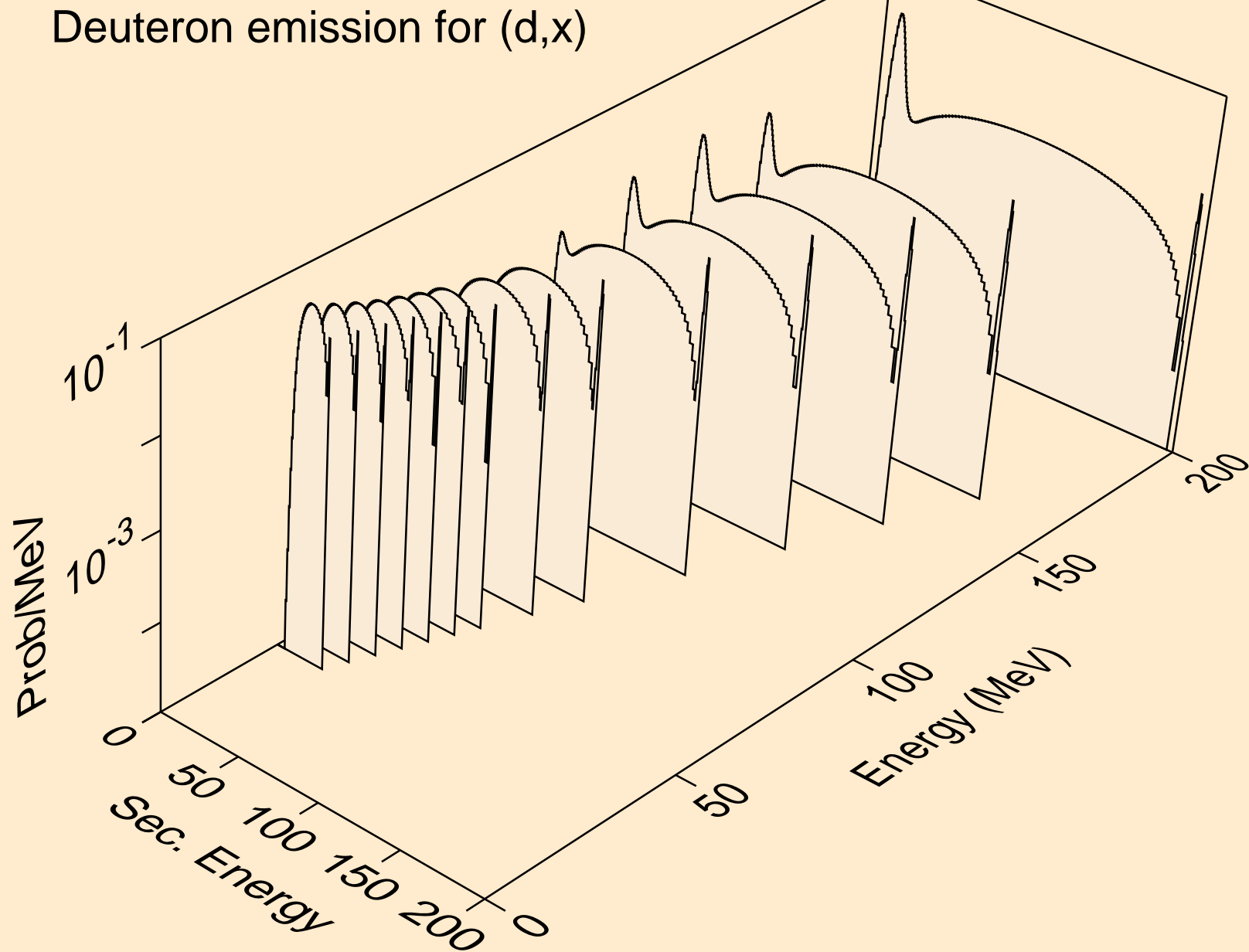

HO175 DEUTERON ACER TENDL-2023 LIBRARY; T=0.K
Deuteron emission for (d,2nd)

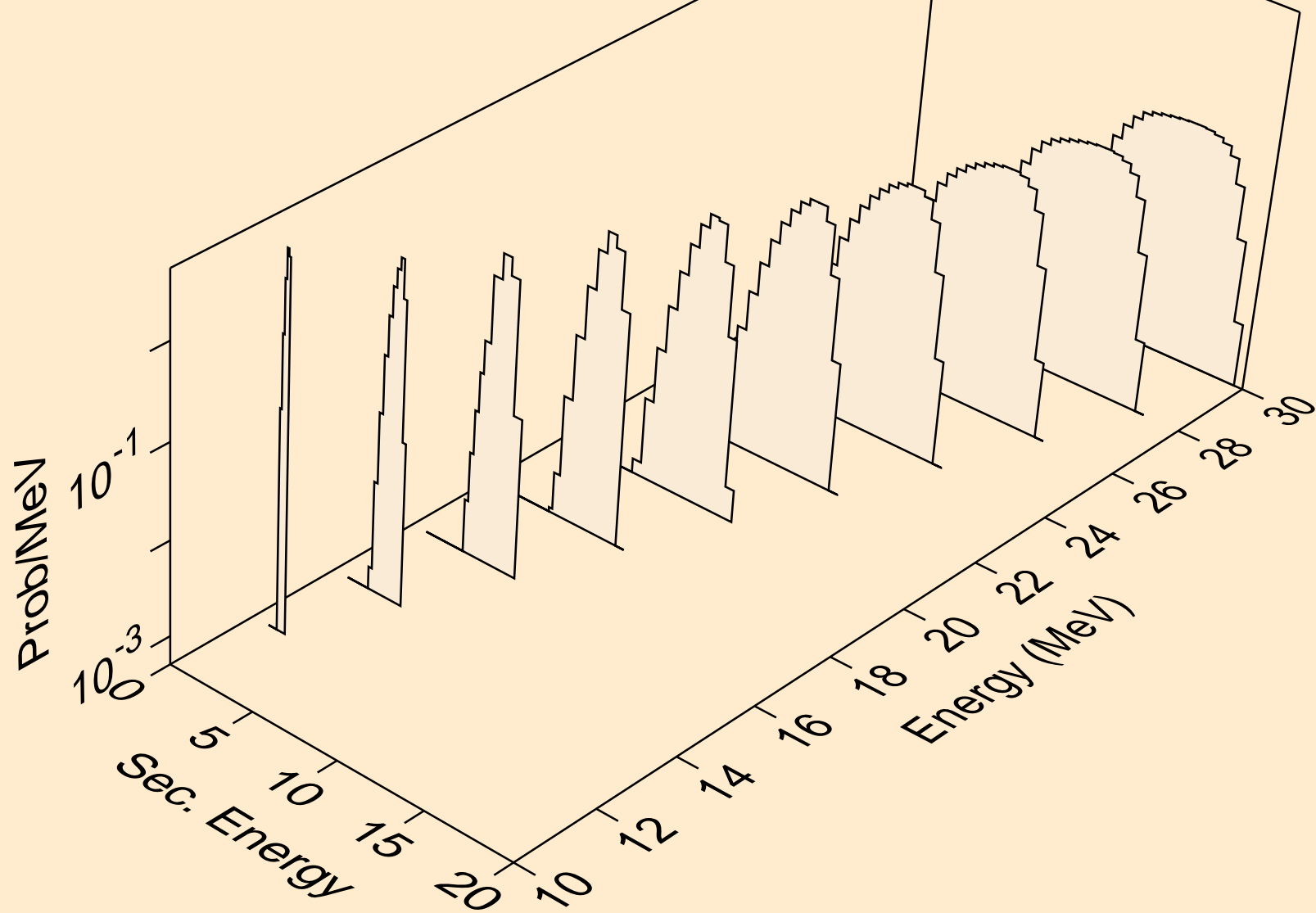

HO175 DEUTERON ACER TENDL-2023 LIBRARY; T=0.K
Deuteron emission for (d,n*)d

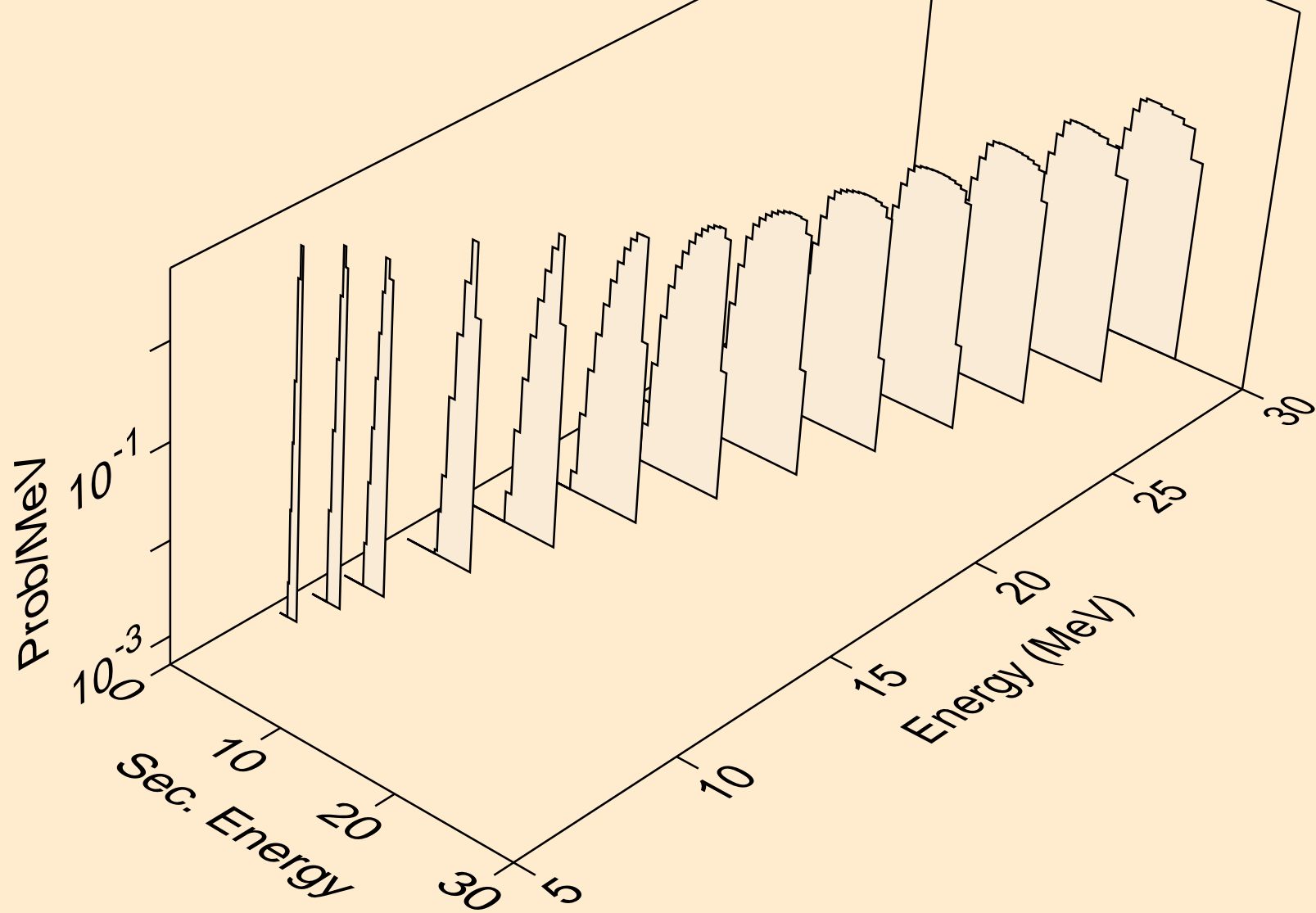

HO175 DEUTERON ACER TENDL-2023 LIBRARY; T=0.K
Deuteron emission for inelastic

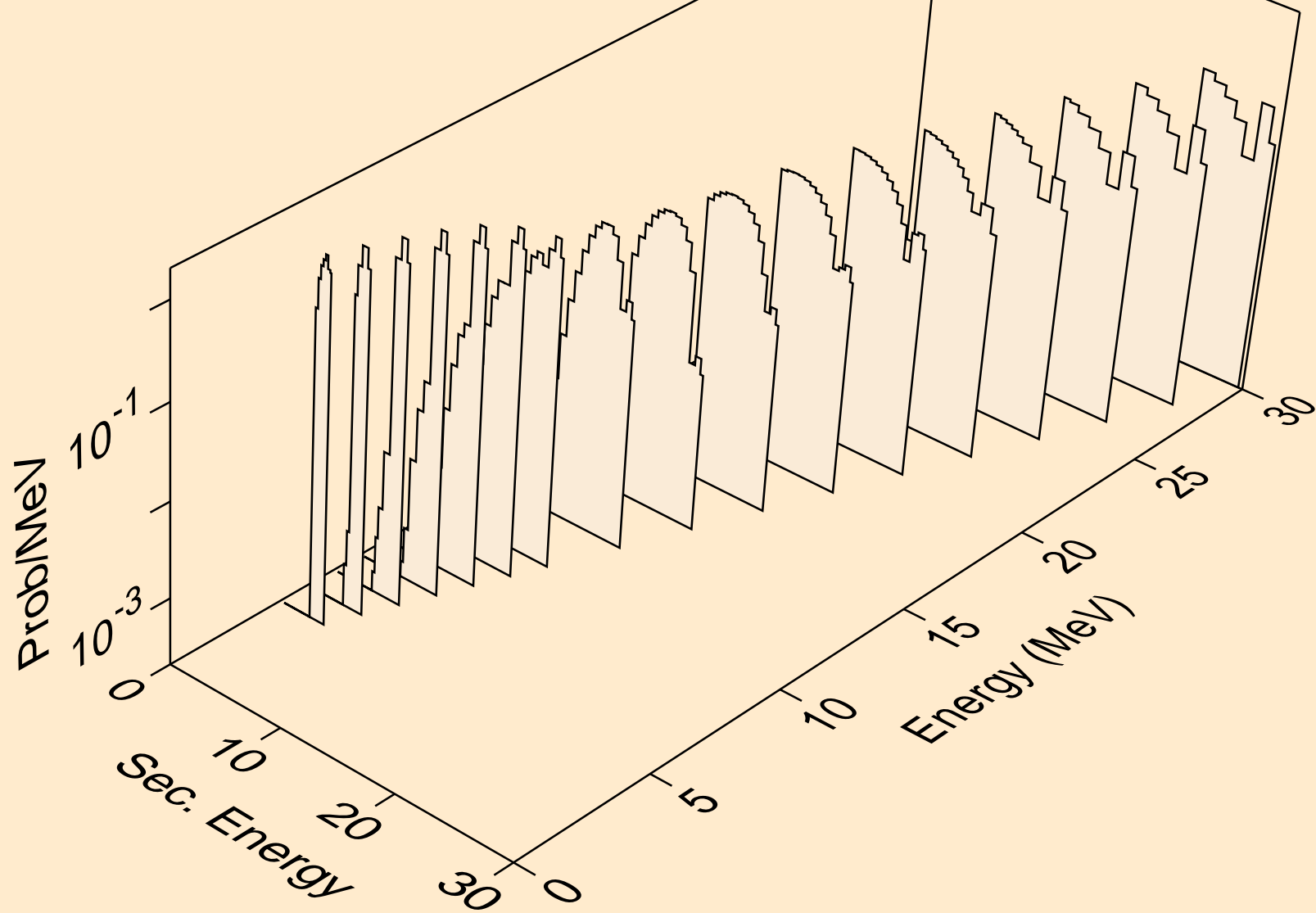

HO175 DEUTERON ACER TENDL-2023 LIBRARY; T=0.K
Deuteron emission for (d,pd)

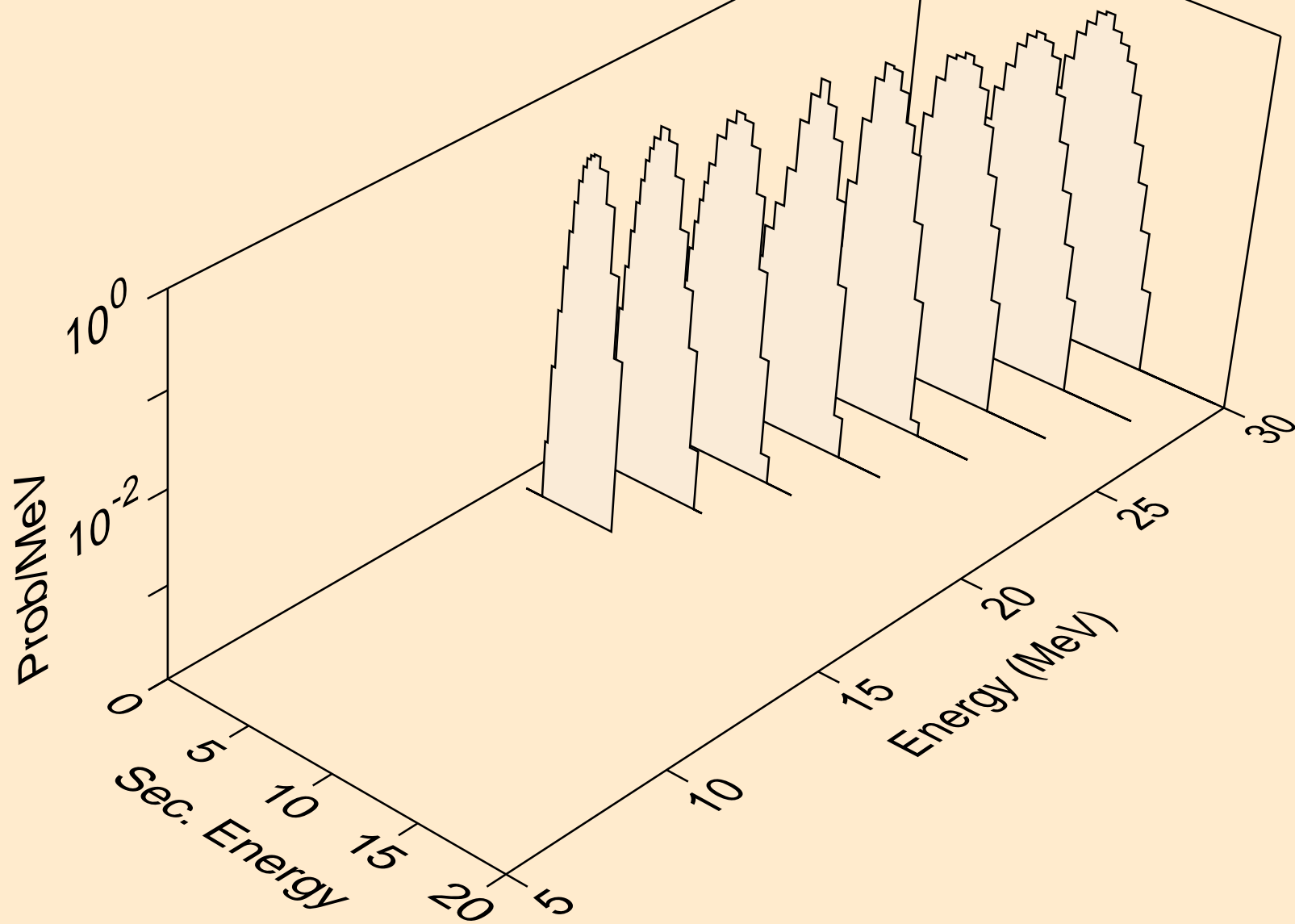

HO175 DEUTERON ACER TENDL-2023 LIBRARY; T=0.K
Photon emission for (z,n)

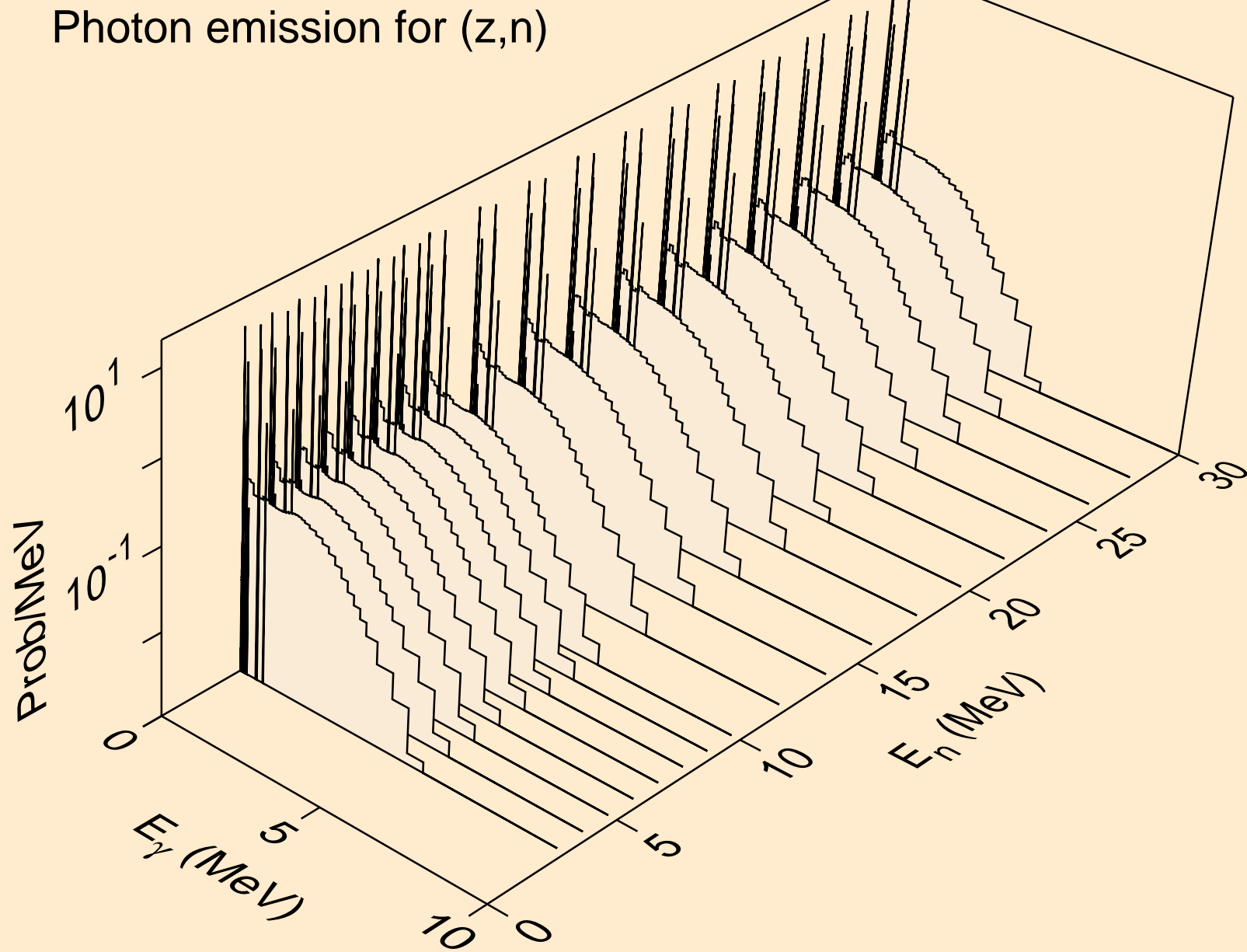

HO175 DEUTERON ACER TENDL-2023 LIBRARY; T=0.K
Photon emission for (z,x)

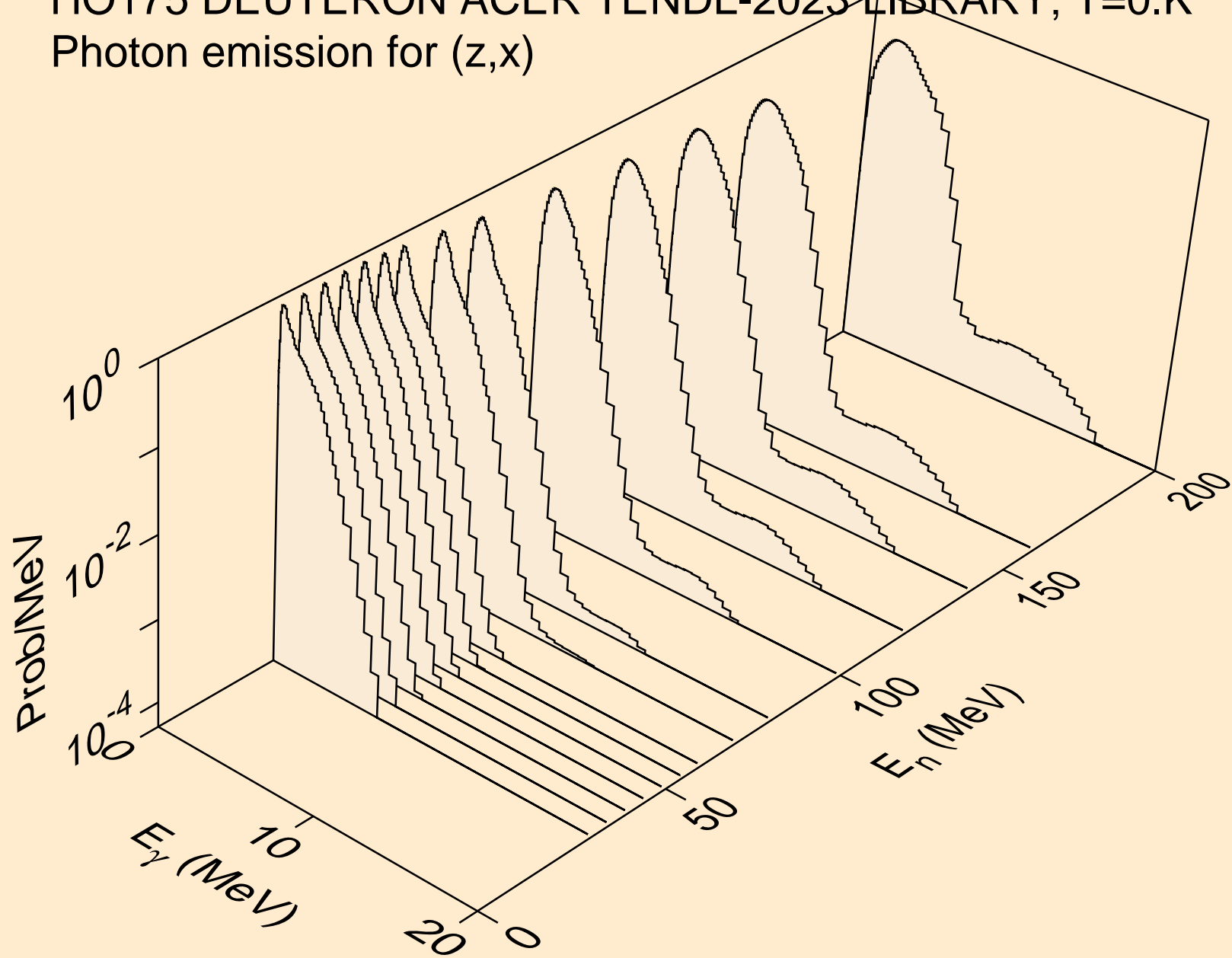

HO175 DEUTERON ACER TENDL-2023 LIBRARY; T=0.K
Photon emission for (n,2nd)

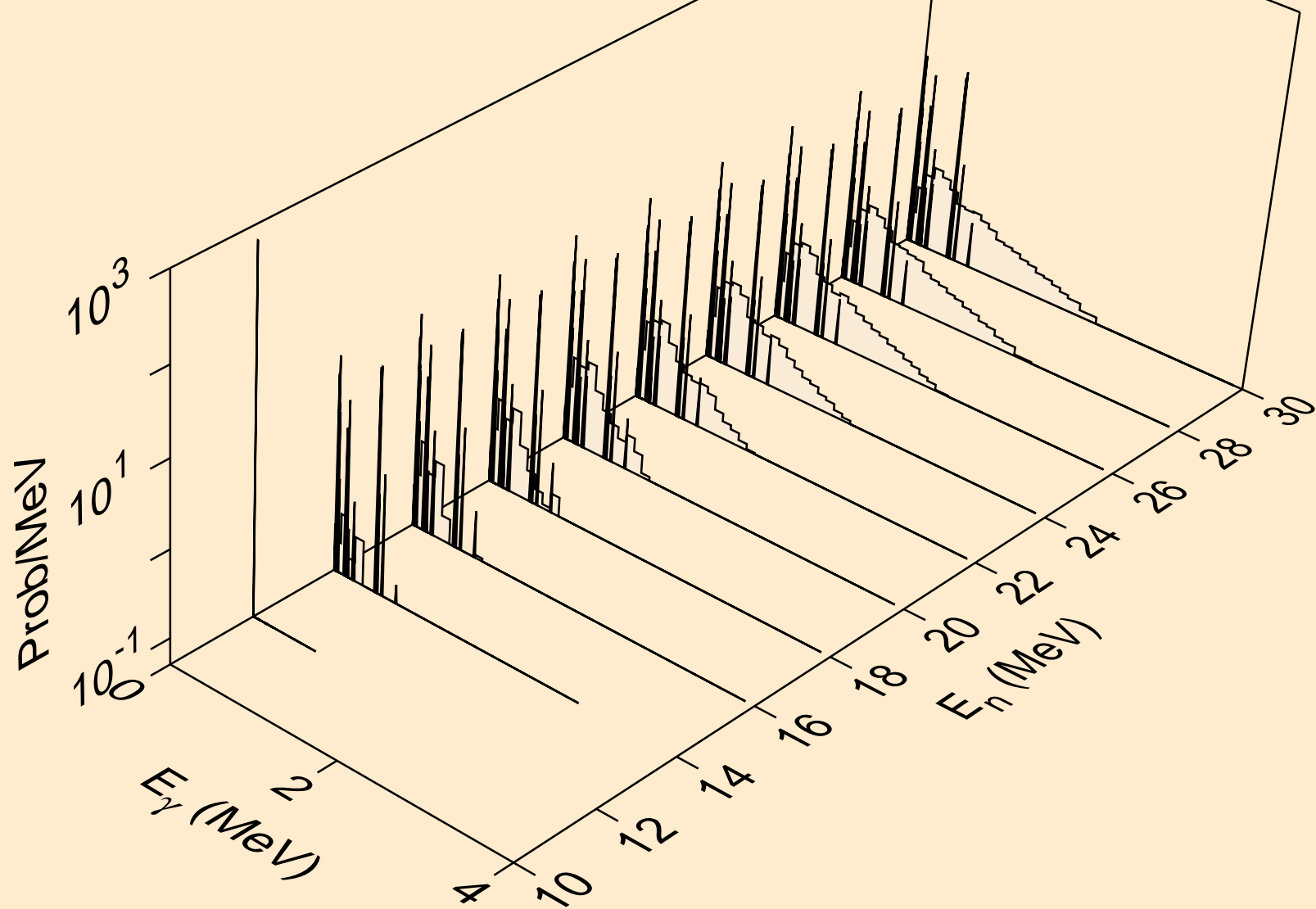

HO175 DEUTERON ACER TENDL-2023 LIBRARY; T=0.K
Photon emission for (n,2n)

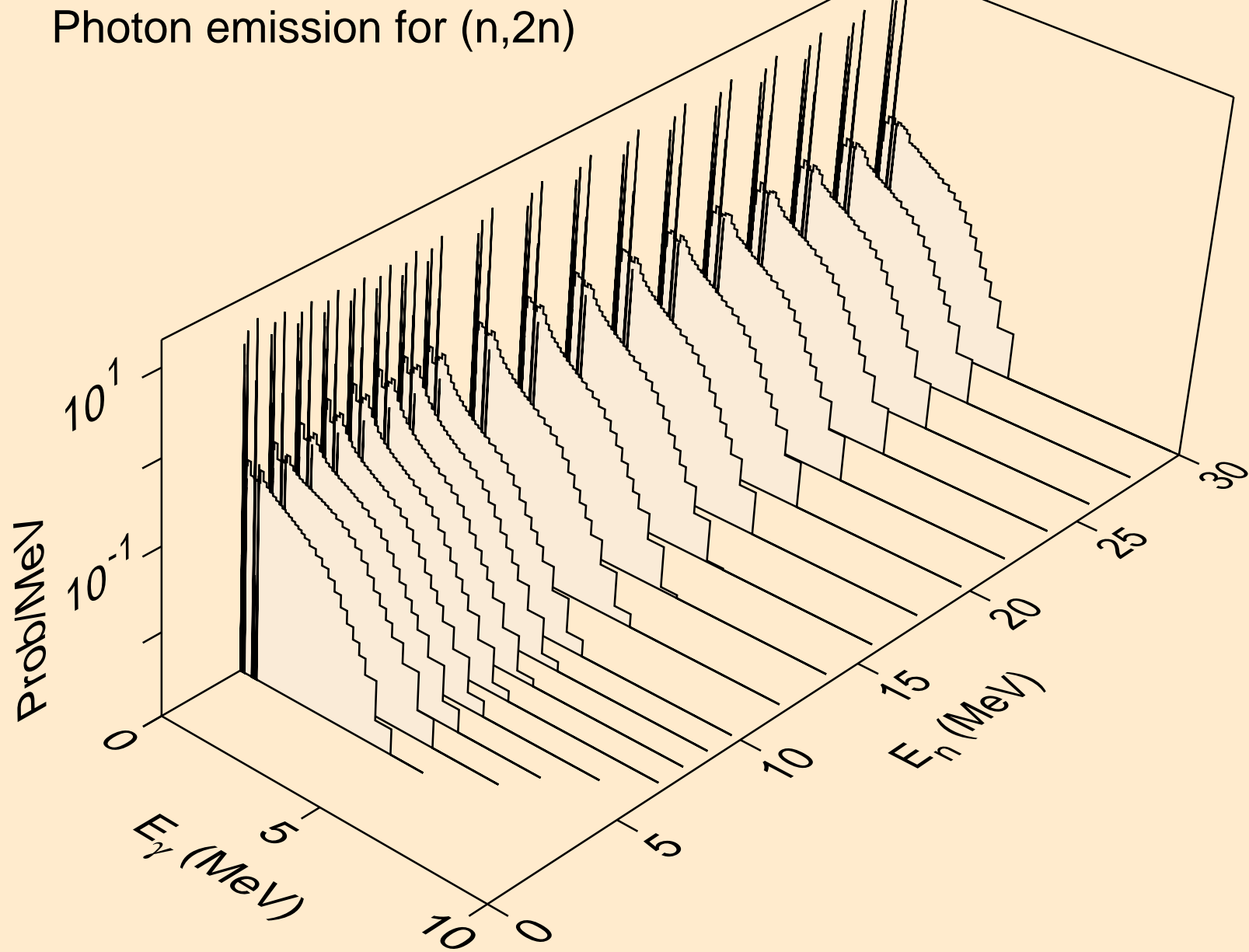

HO175 DEUTERON ACER TENDL-2023 LIBRARY; T=0.K
Photon emission for (n,3n)

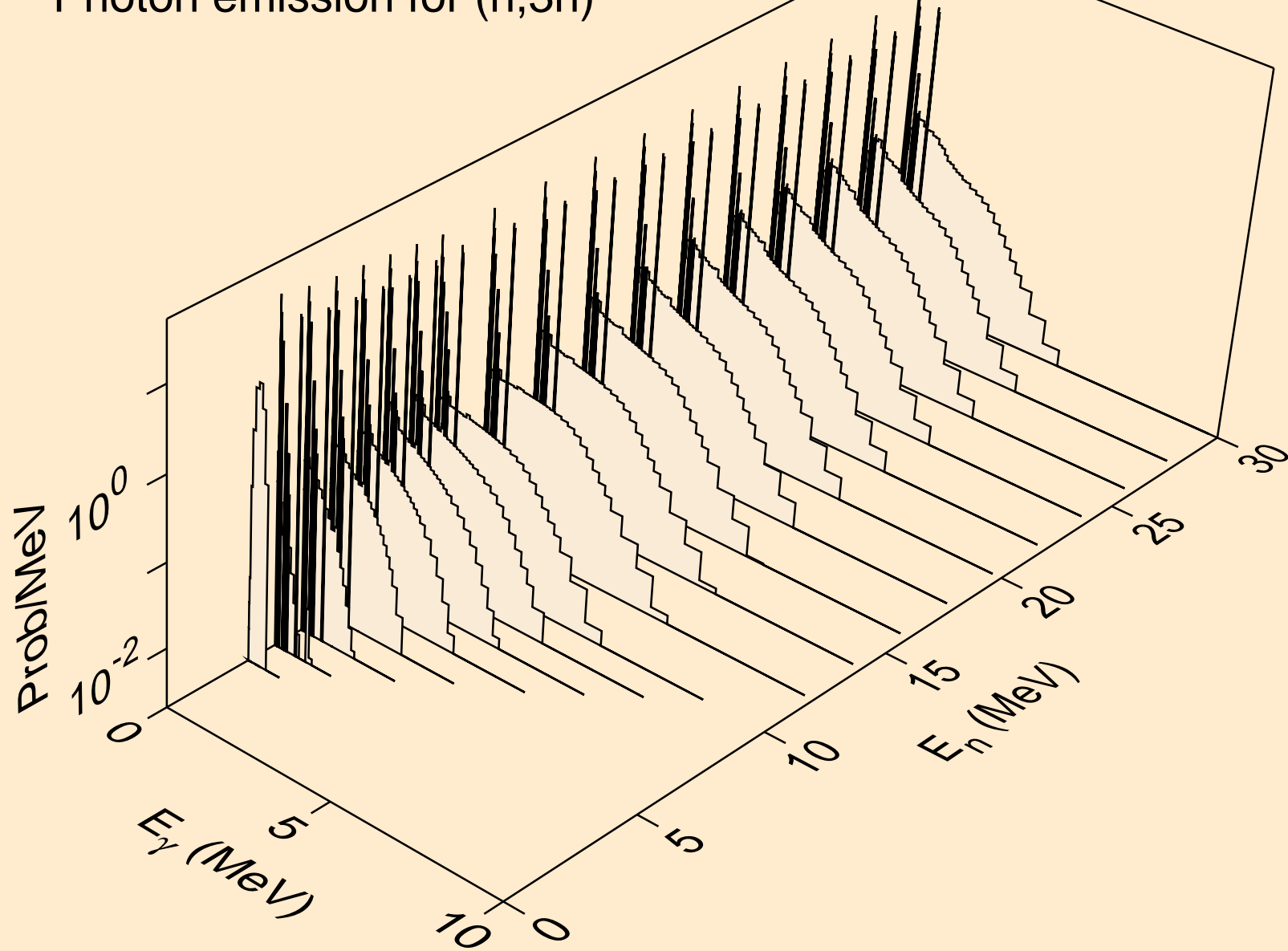

HO175 DEUTERON ACER TENDL-2023 LIBRARY; T=0.K
Photon emission for (n,n*)a

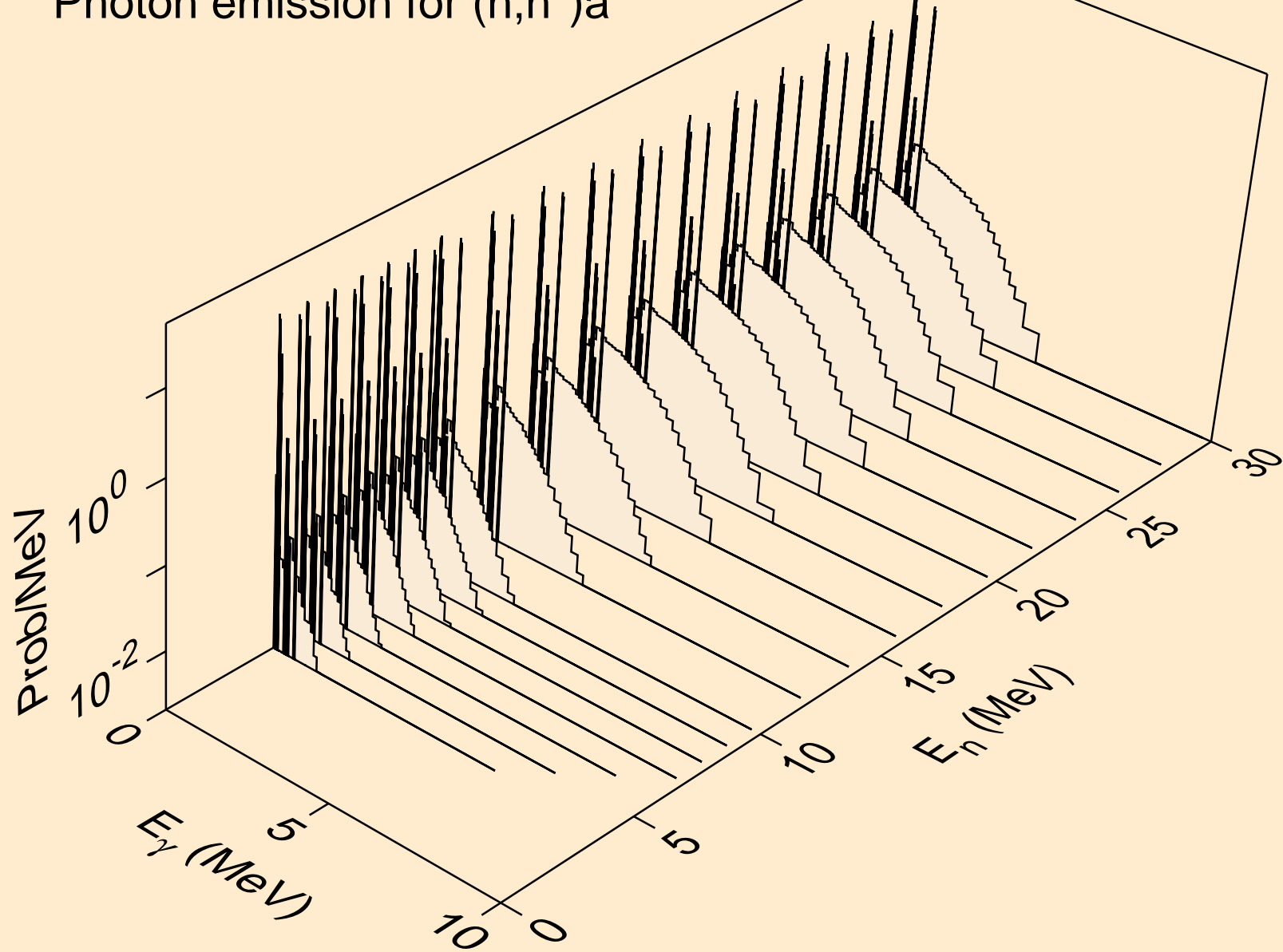

HO175 DEUTERON ACER TENDL-2023 LIBRARY; T=0.K
Photon emission for (n,2n)a

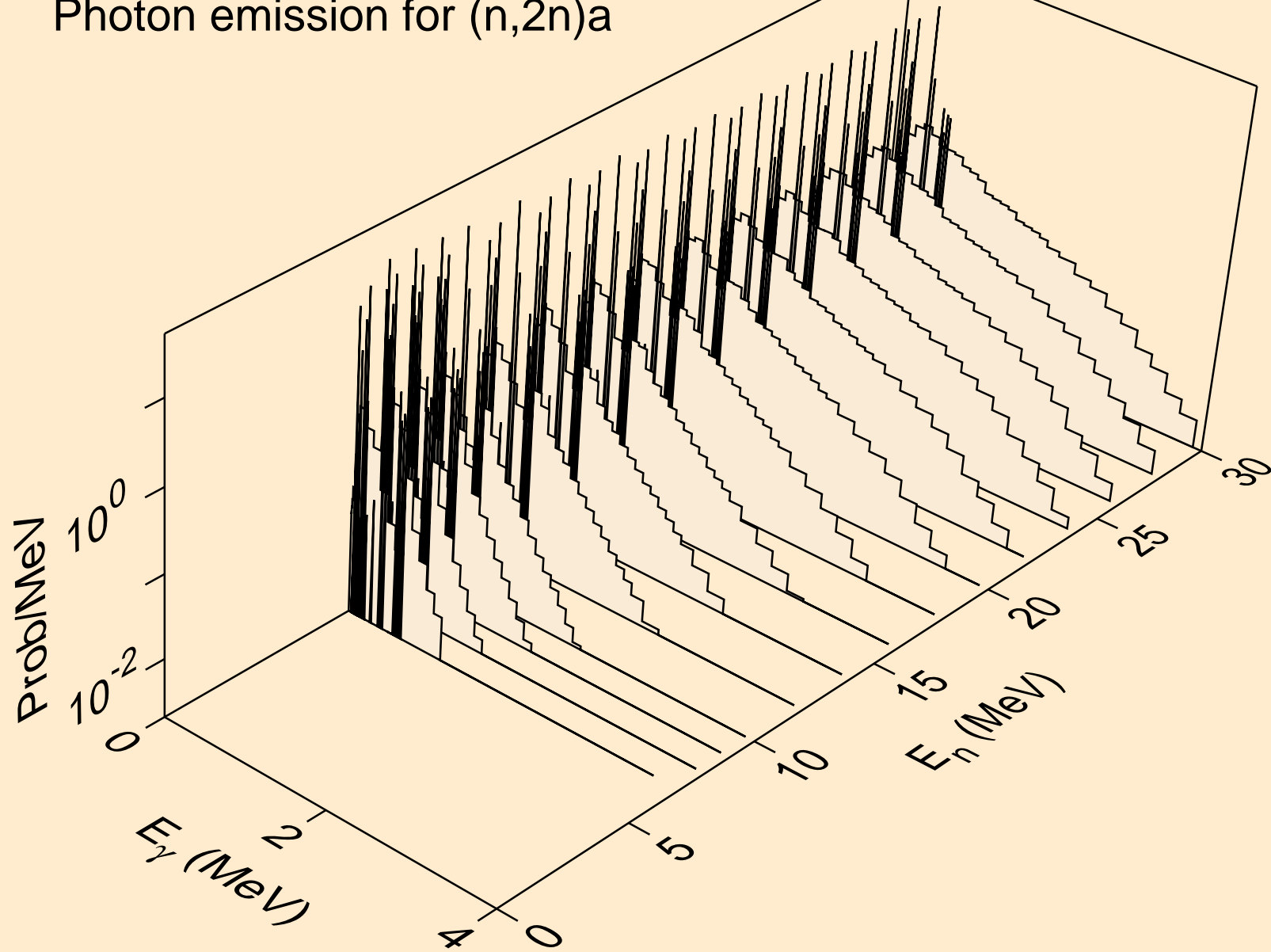

HO175 DEUTERON ACER TENDL-2023 LIBRARY; T=0.K
Photon emission for (n,3n)a

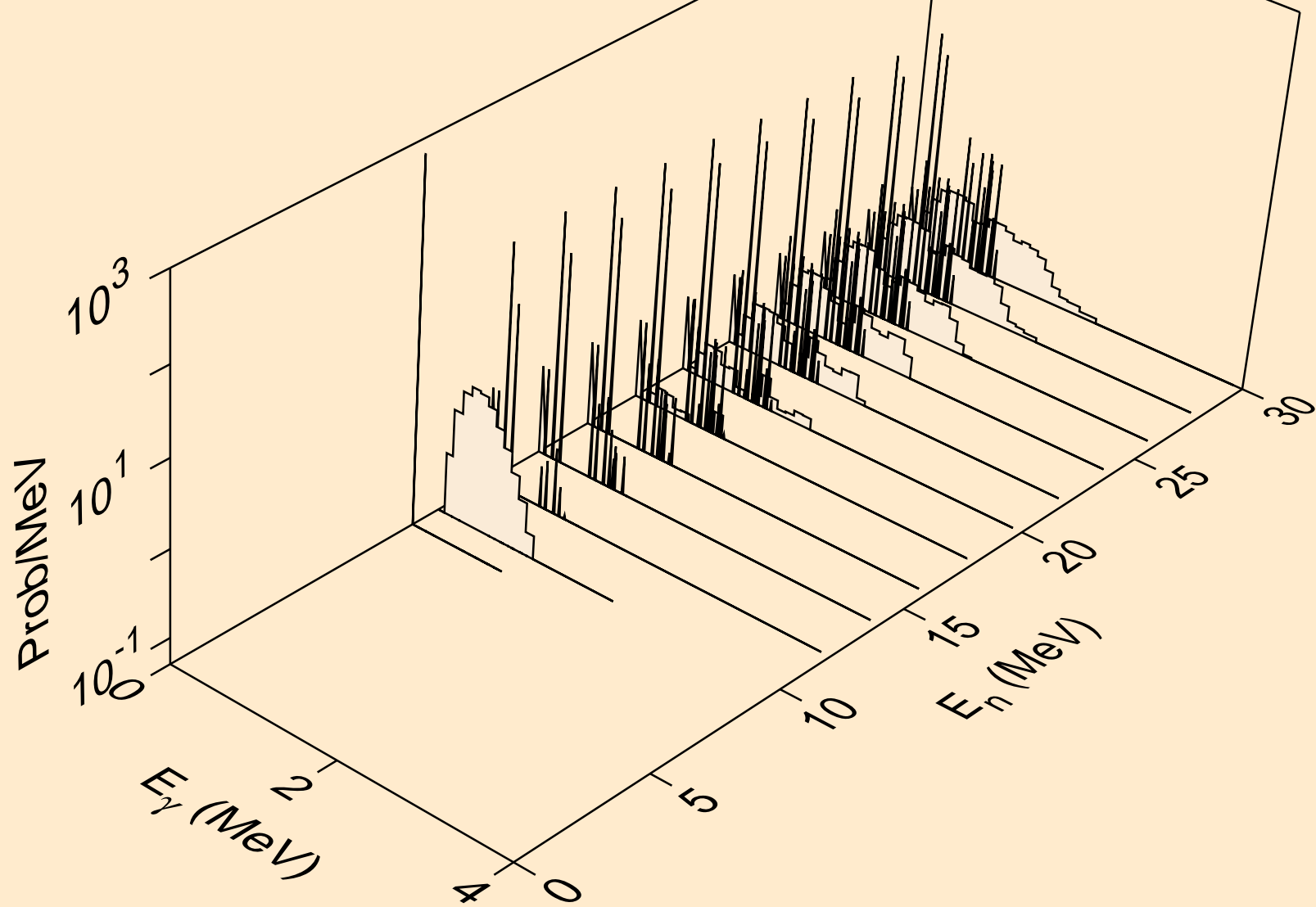

HO175 DEUTERON ACER TENDL-2023 LIBRARY; T=0.K
Photon emission for (n,n*)p

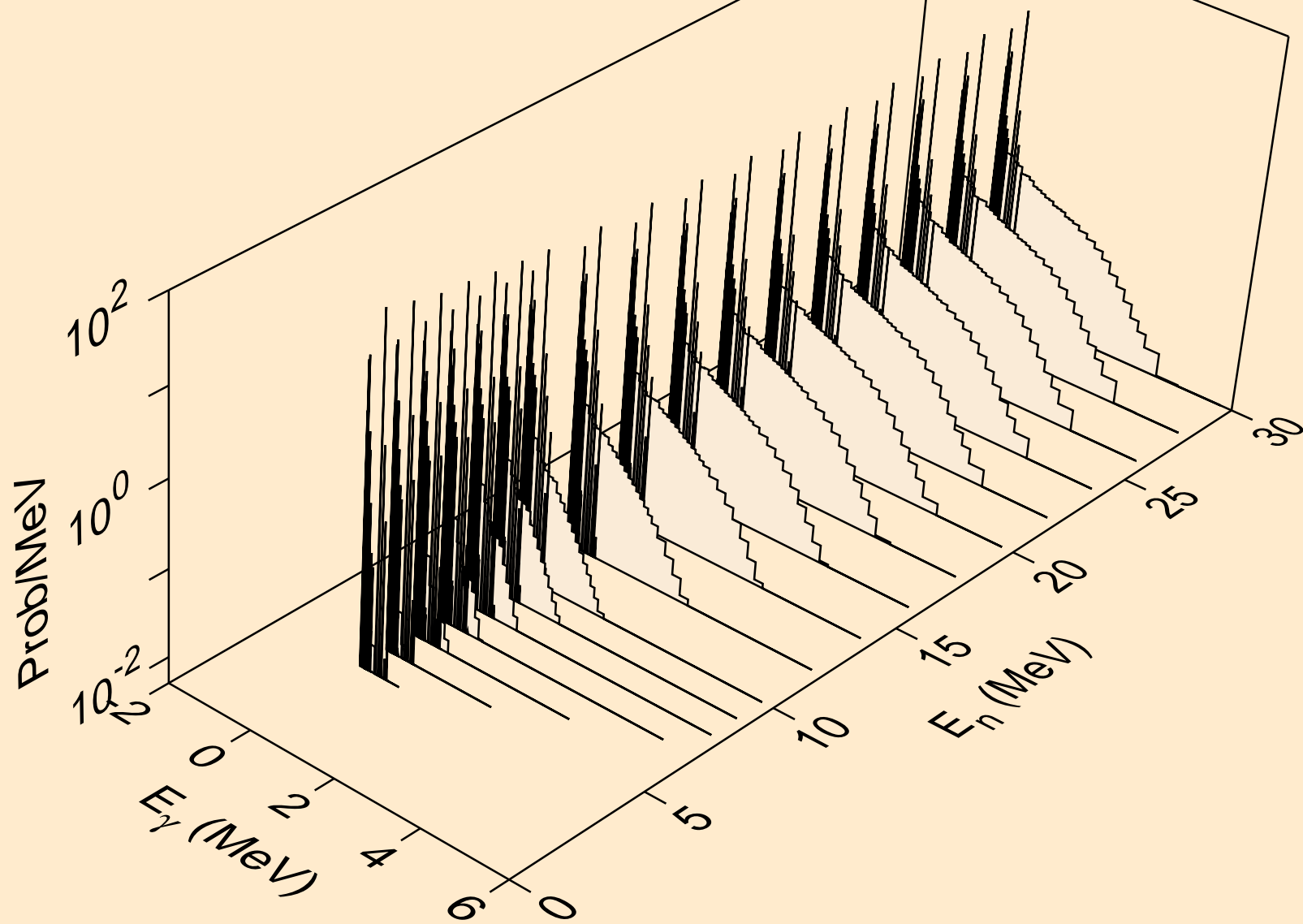

HO175 DEUTERON ACER TENDL-2023 LIBRARY; T=0.K
Photon emission for (n,n*)d

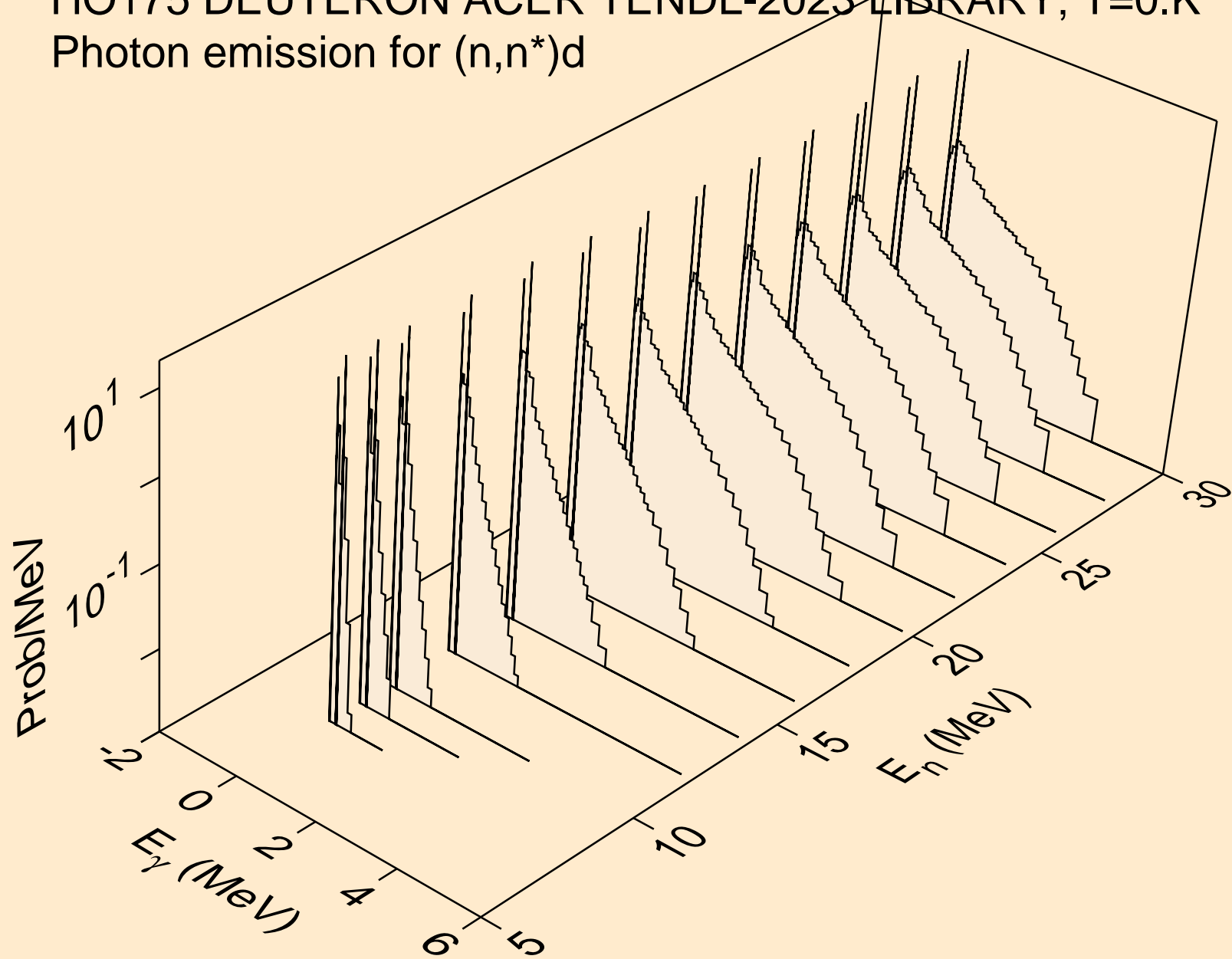

HO175 DEUTERON ACER TENDL-2023 LIBRARY; T=0.K
Photon emission for (n,n*)t

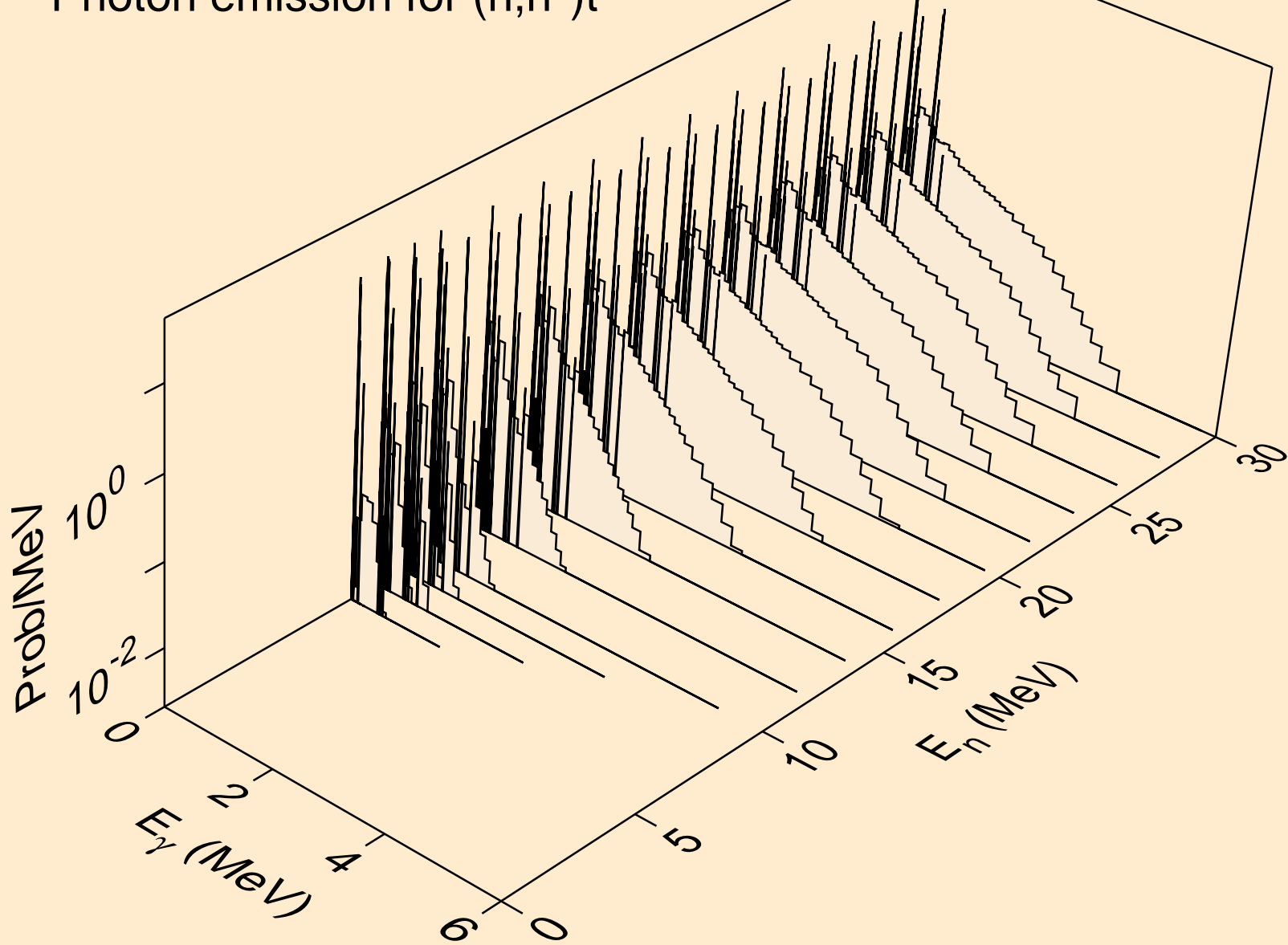

HO175 DEUTERON ACER TENDL-2023 LIBRARY; T=0.K
Photon emission for (n,n*)he3

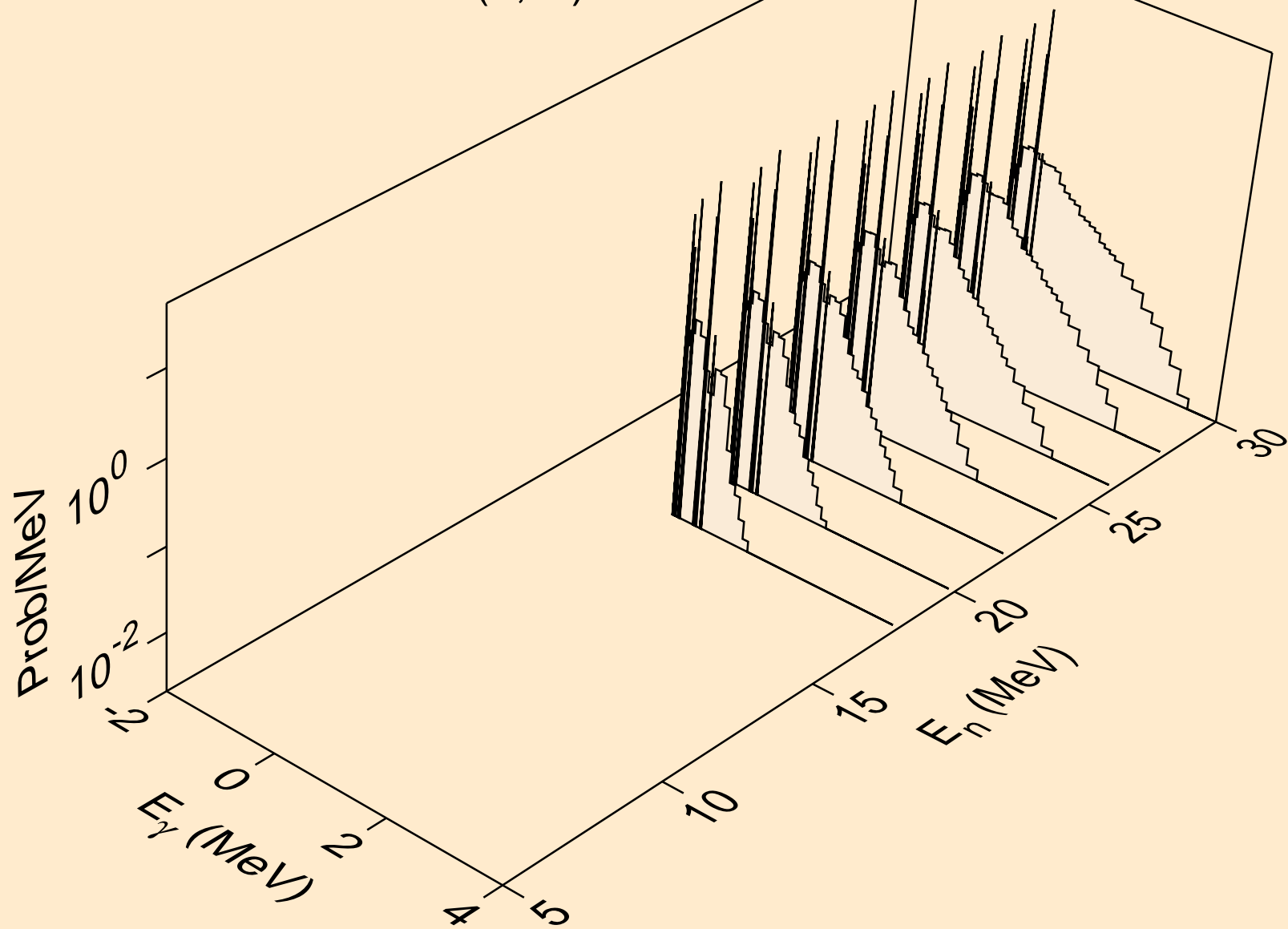

HO175 DEUTERON ACER TENDL-2023 LIBRARY; T=0.K
Photon emission for (n,4n)

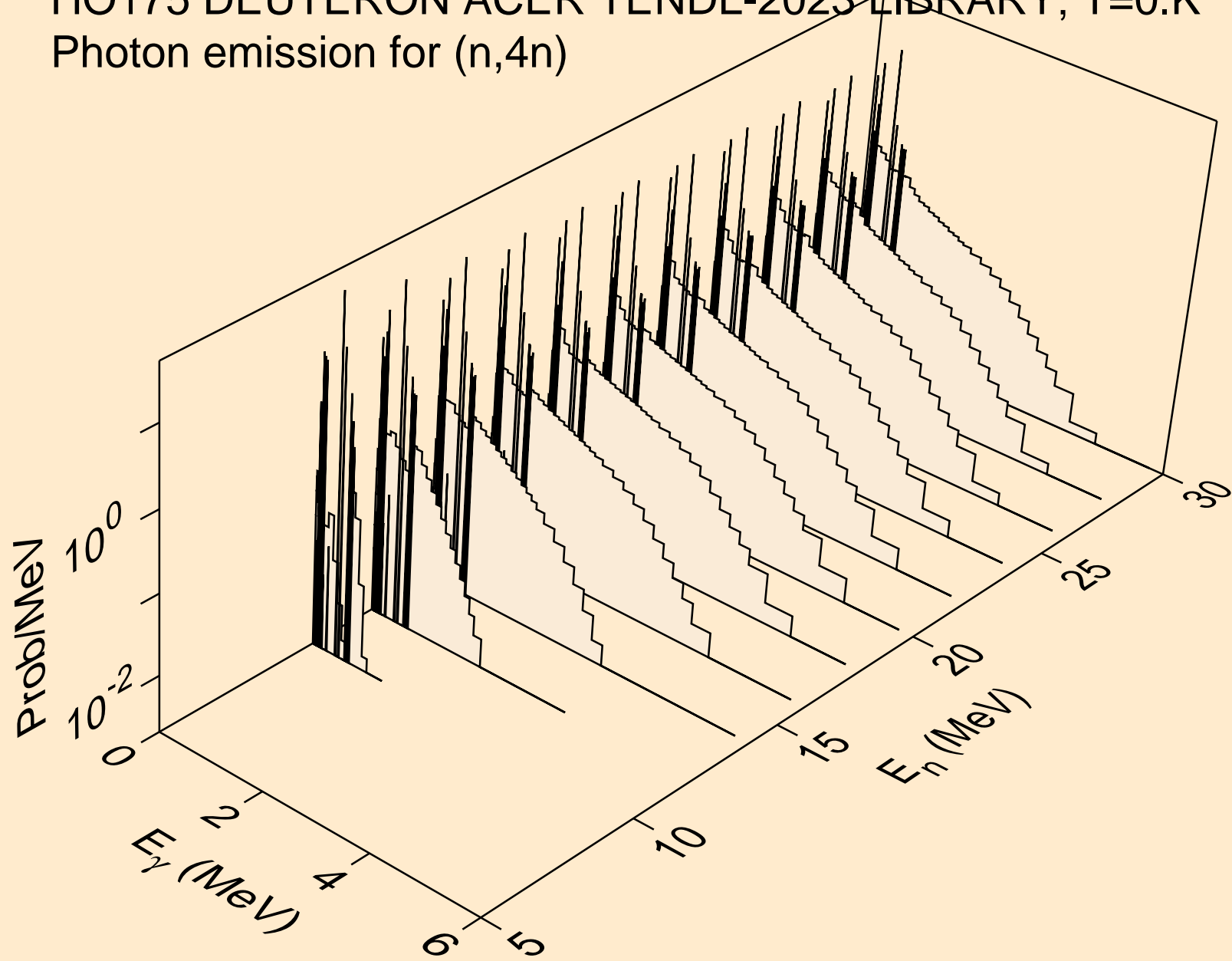

HO175 DEUTERON ACER TENDL-2023 LIBRARY; T=0.K
Photon emission for (n,2np)

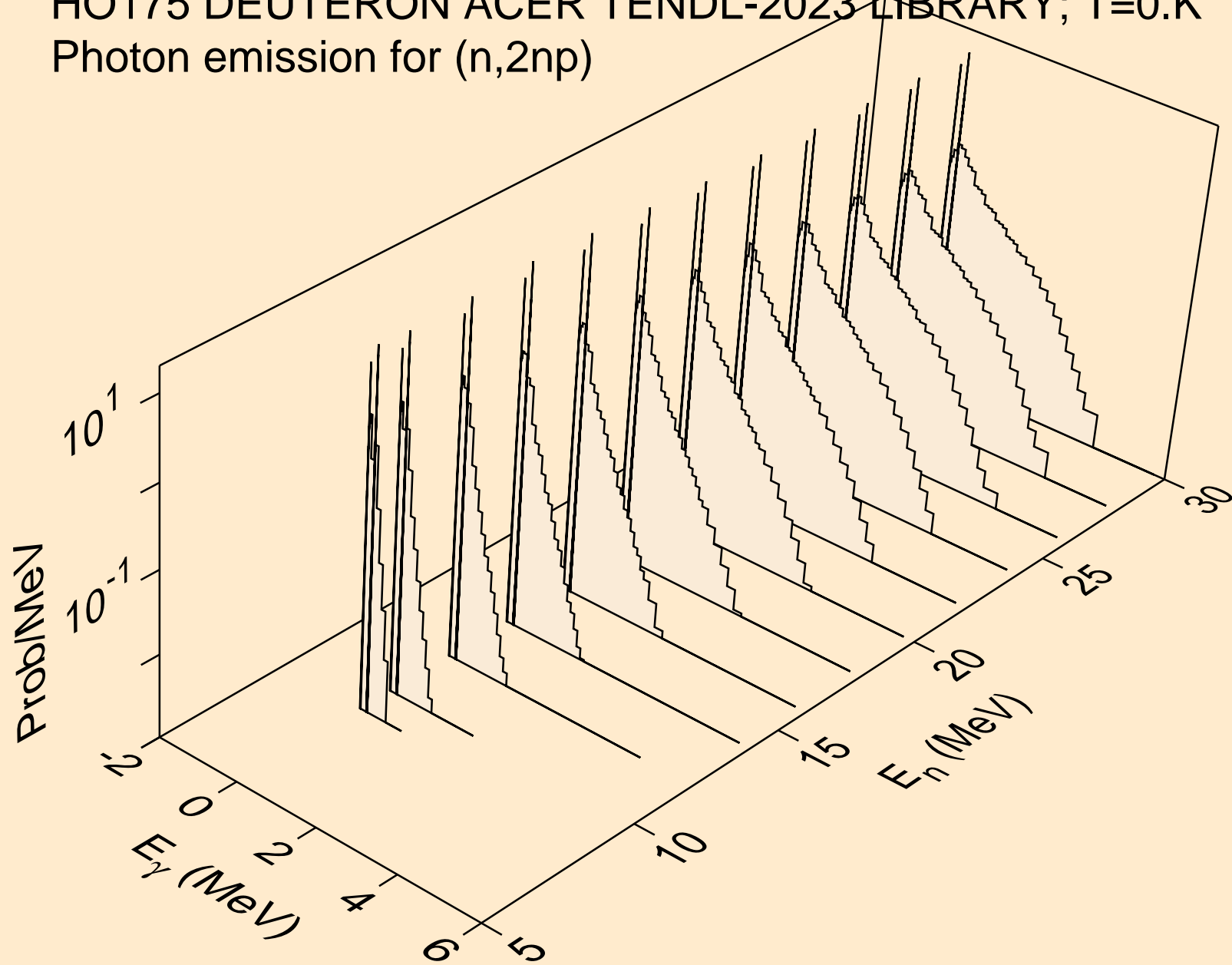

HO175 DEUTERON ACER TENDL-2023 LIBRARY; T=0.K
Photon emission for (n,3np)

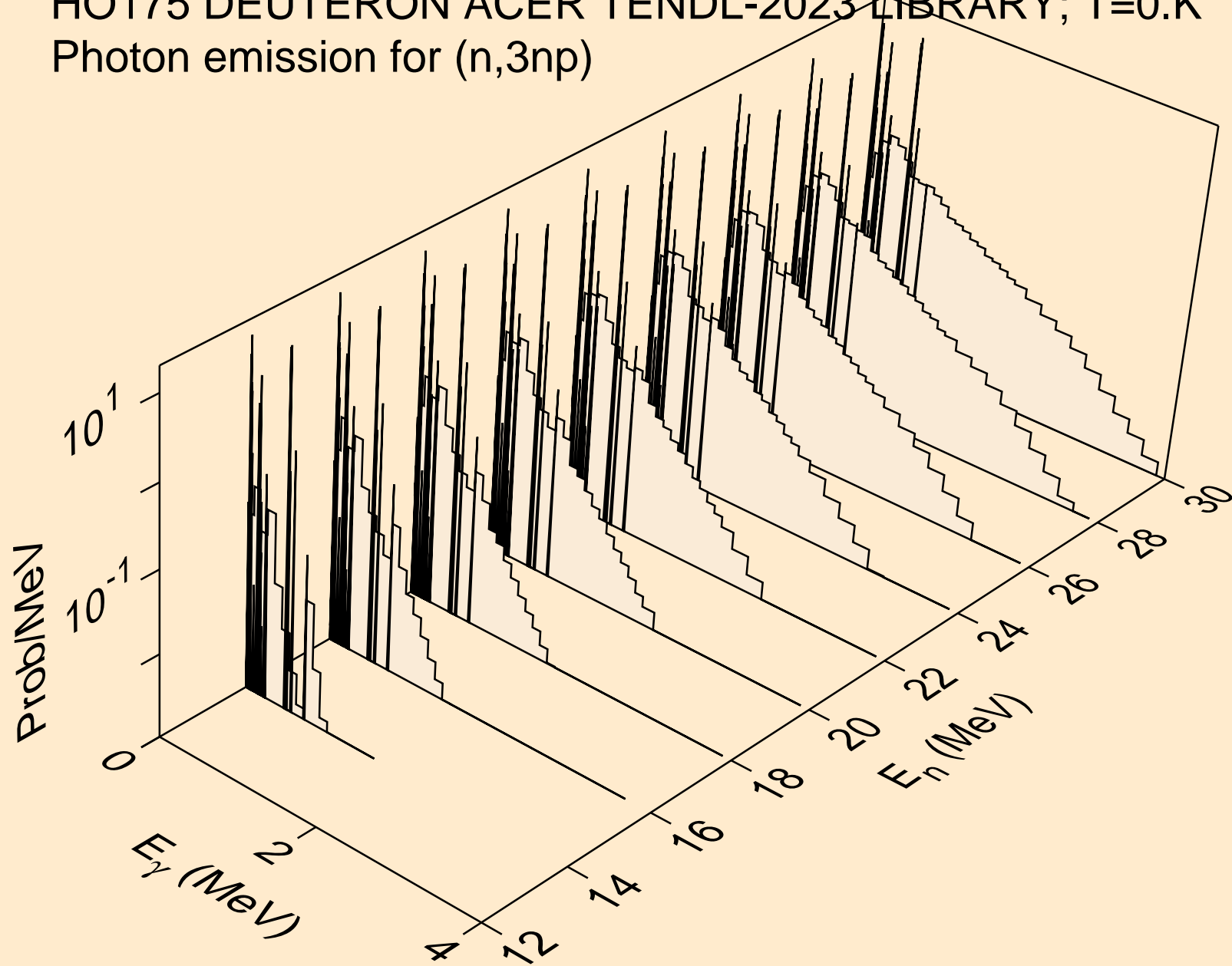

HO175 DEUTERON ACER TENDL-2023 LIBRARY; T=0.K
Photon emission for (n,n2p)

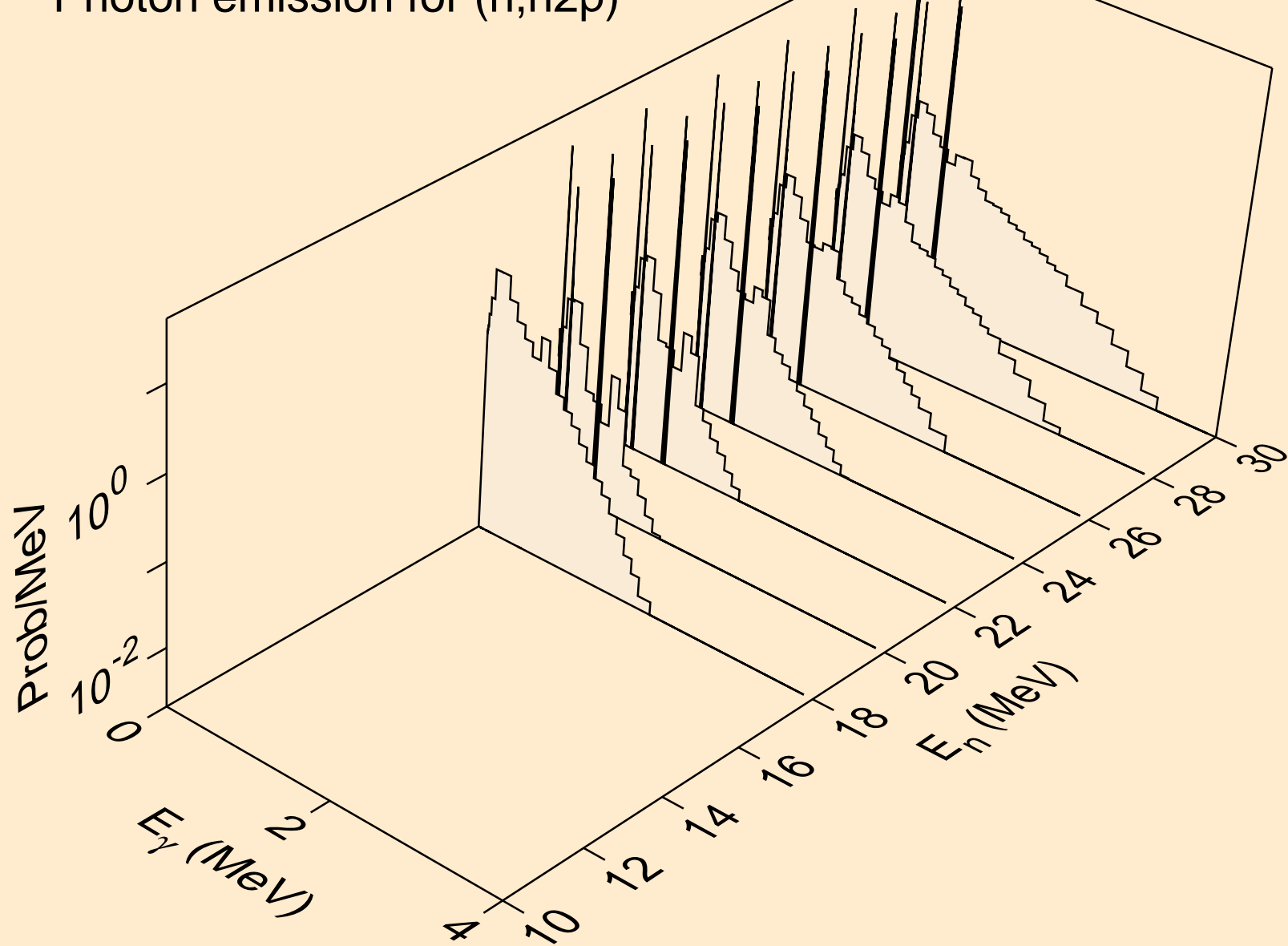

HO175 DEUTERON ACER TENDL-2023 LIBRARY; T=0.K
Photon emission for (n,gma)

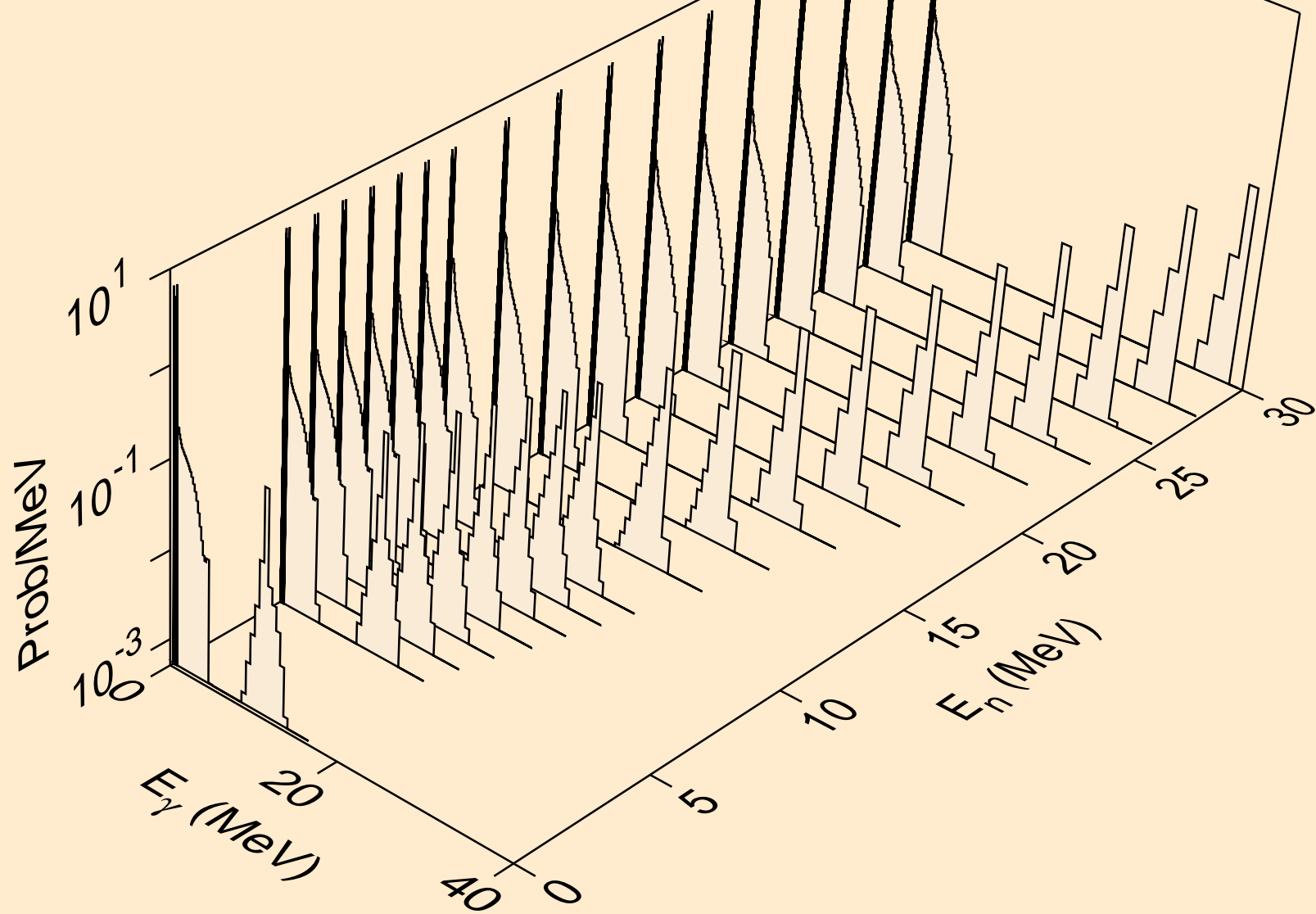

HO175 DEUTERON ACER TENDL-2023 LIBRARY; T=0.K
Photon emission for (n,p)

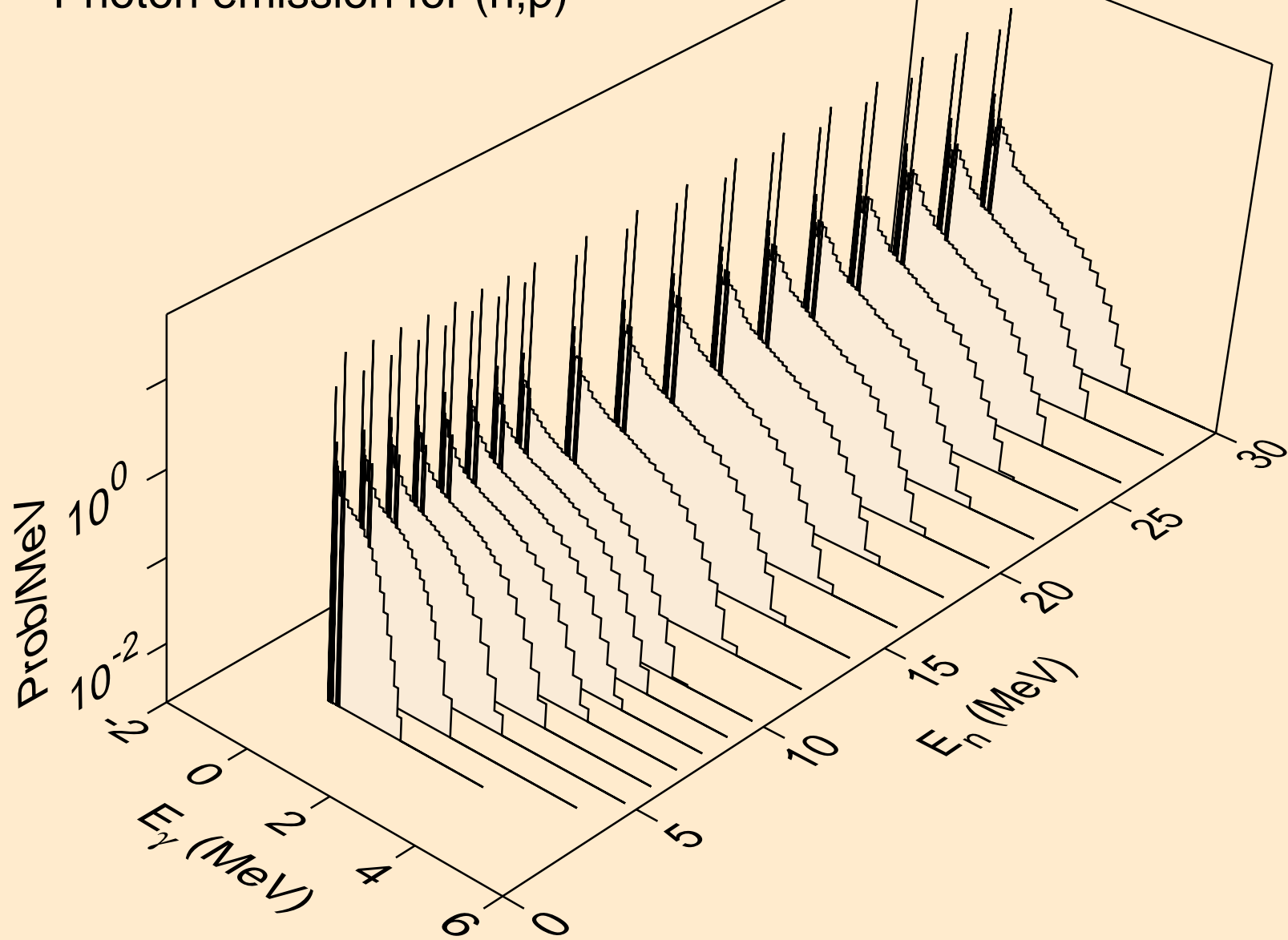

HO175 DEUTERON ACER TENDL-2023 LIBRARY; T=0.K
Photon emission for inelastic

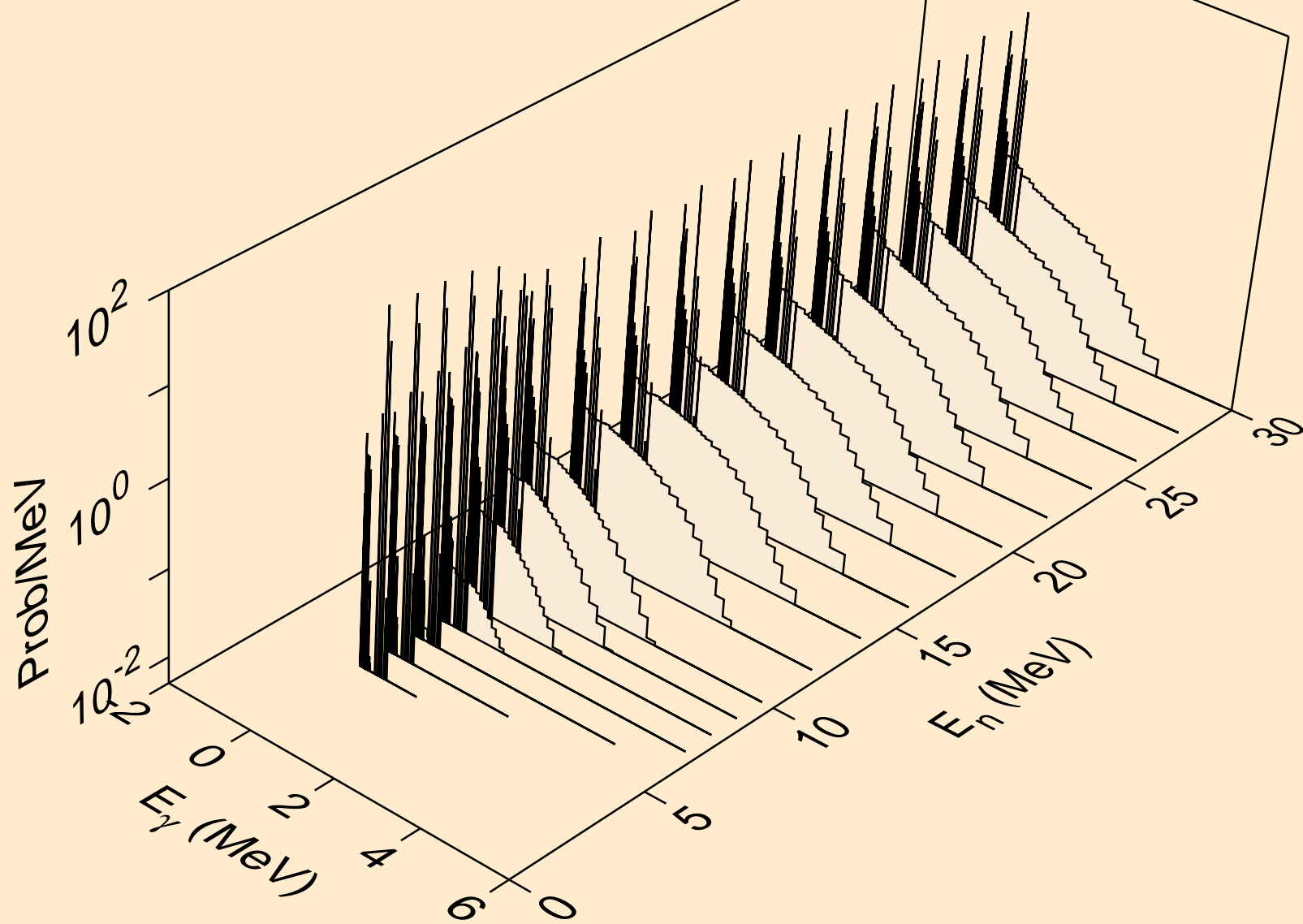

HO175 DEUTERON ACER TENDL-2023 LIBRARY; T=0.K
Photon emission for (n,t)

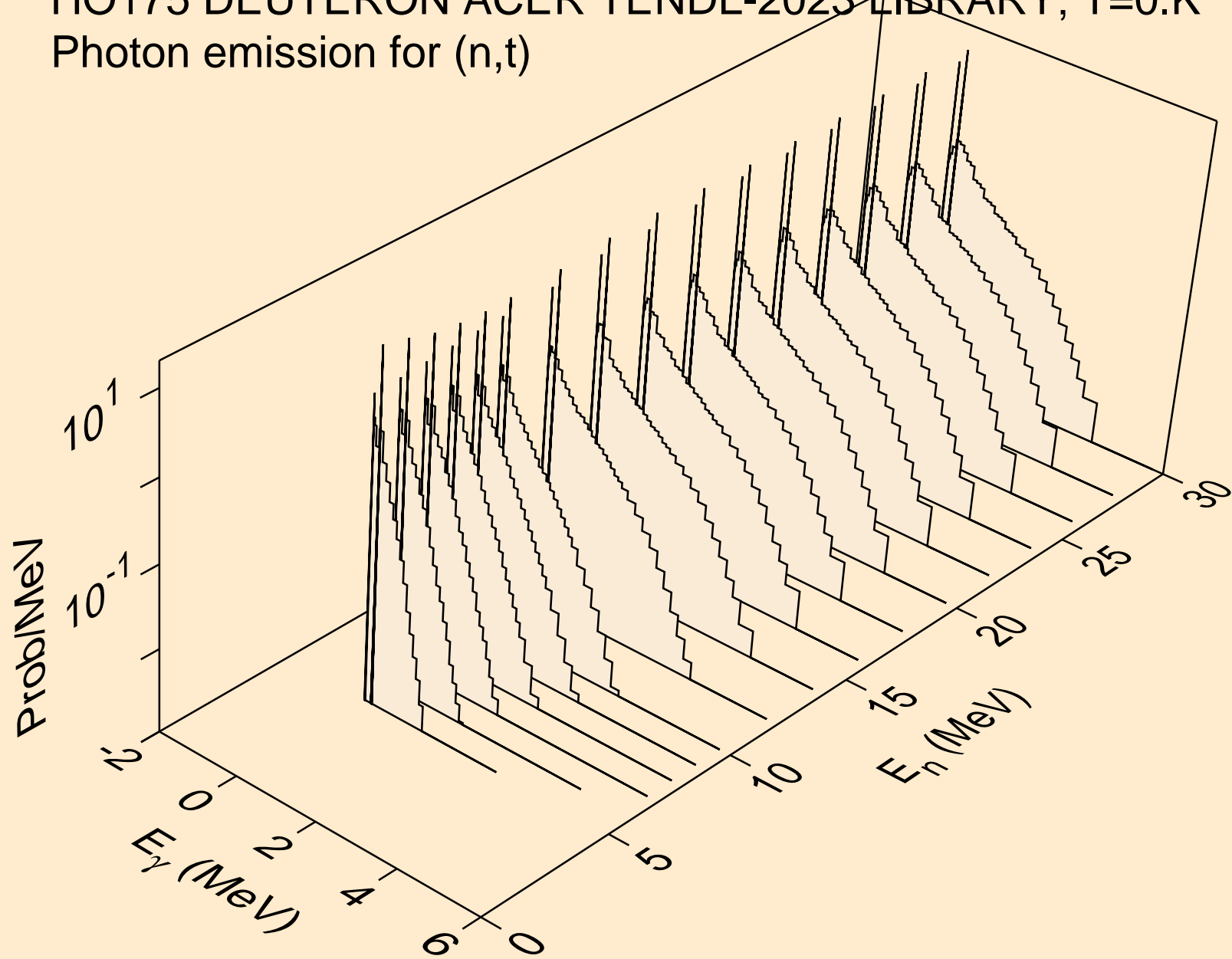

HO175 DEUTERON ACER TENDL-2023 LIBRARY; T=0.K
Photon emission for (n,he3)

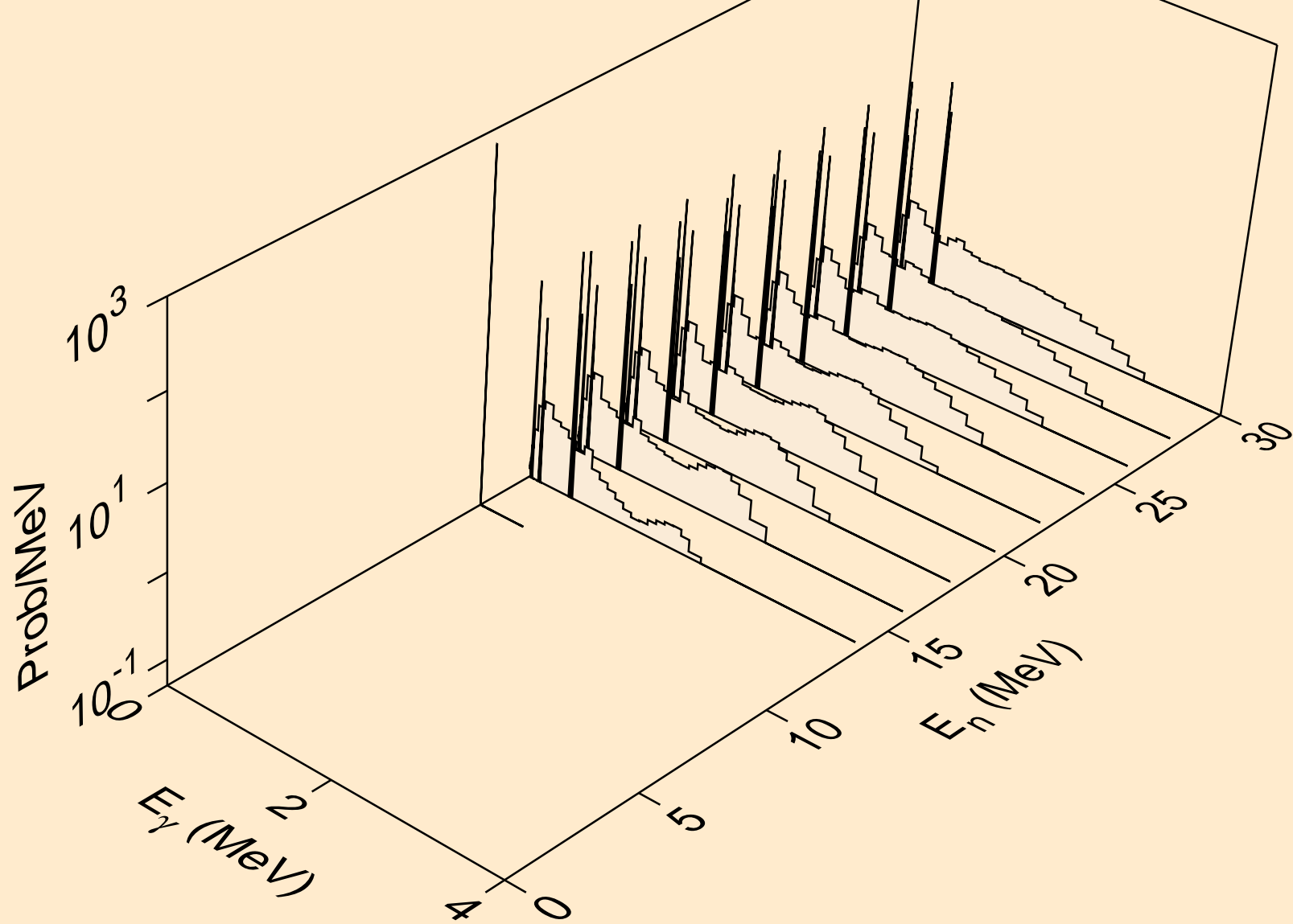

HO175 DEUTERON ACER TENDL-2023 LIBRARY; T=0.K
Photon emission for (n,a)

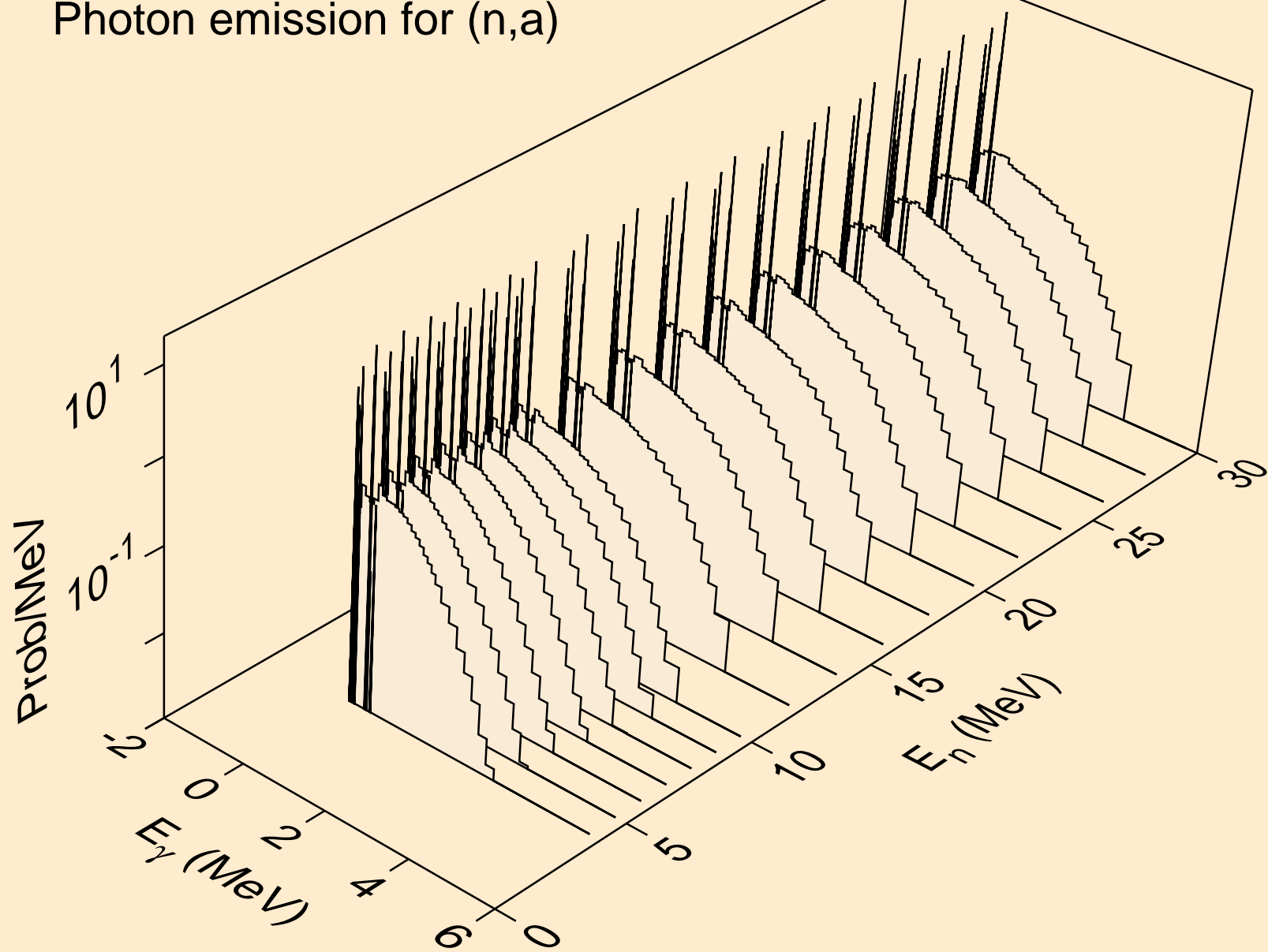

HO175 DEUTERON ACER TENDL-2023 LIBRARY; T=0.K
Photon emission for (n,2p)

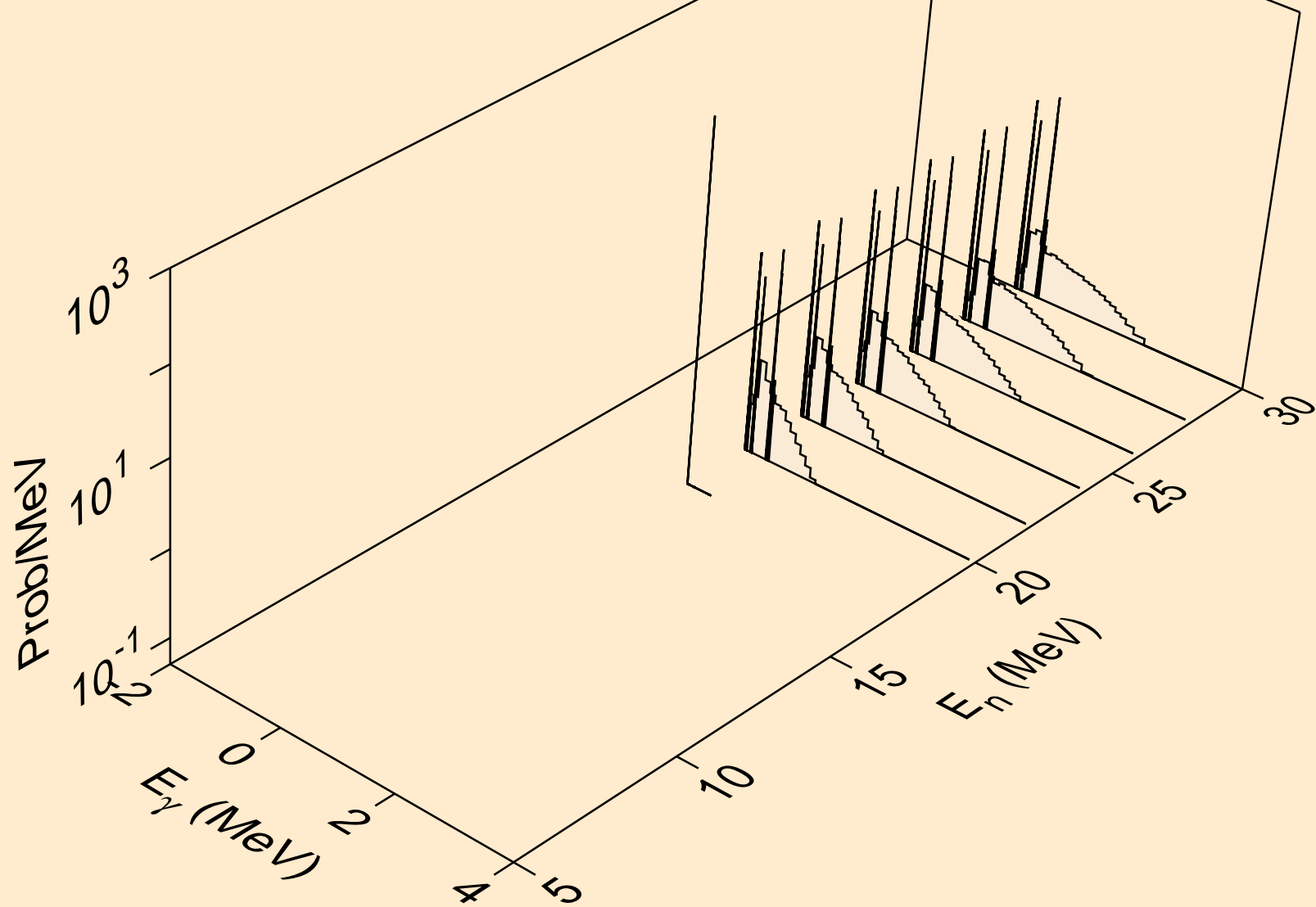

HO175 DEUTERON ACER TENDL-2023 LIBRARY; T=0.K
Photon emission for (n,pd)

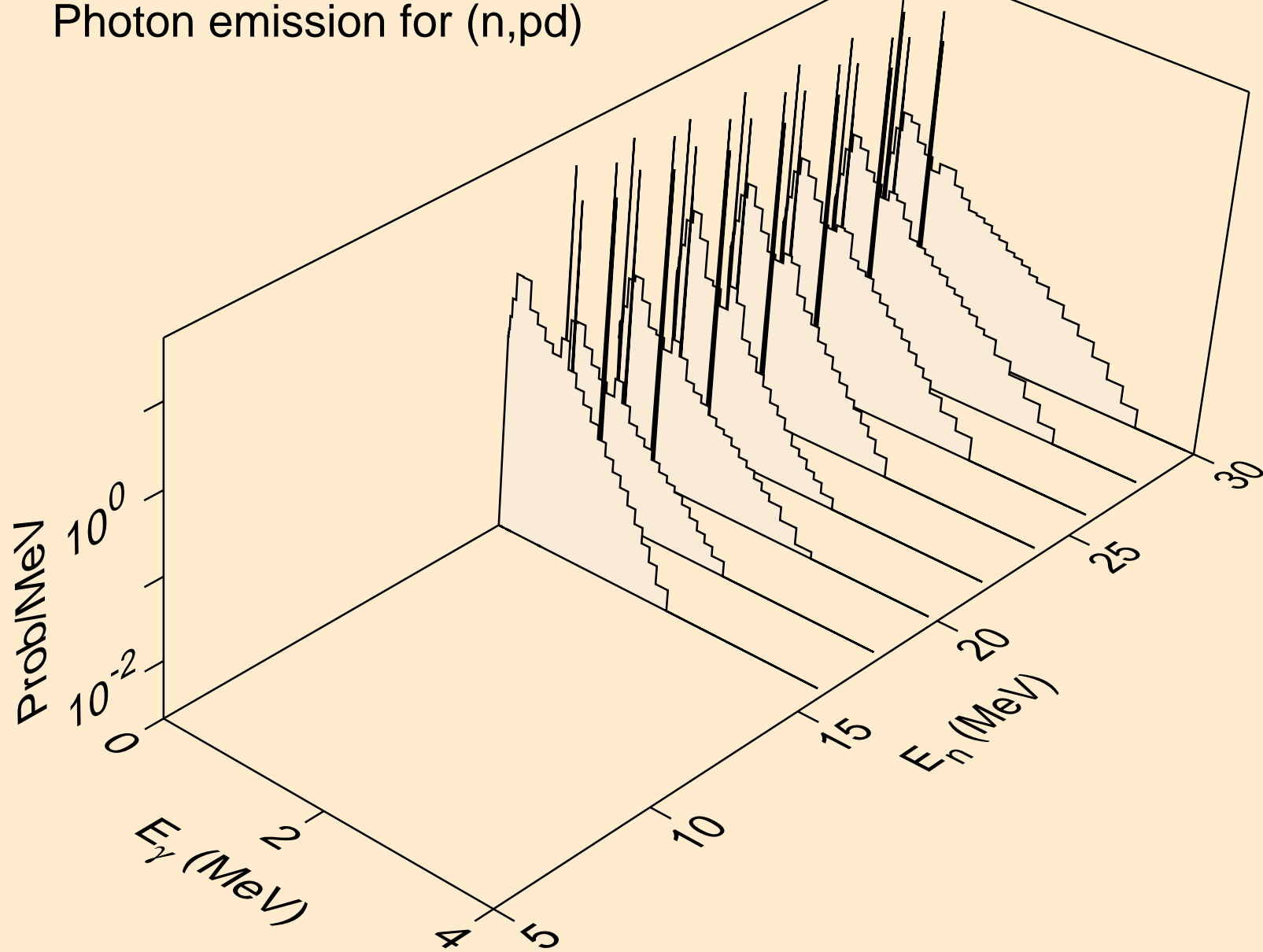

HO175 DEUTERON ACER TENDL-2023 LIBRARY; T=0.K

Particle heating contributions

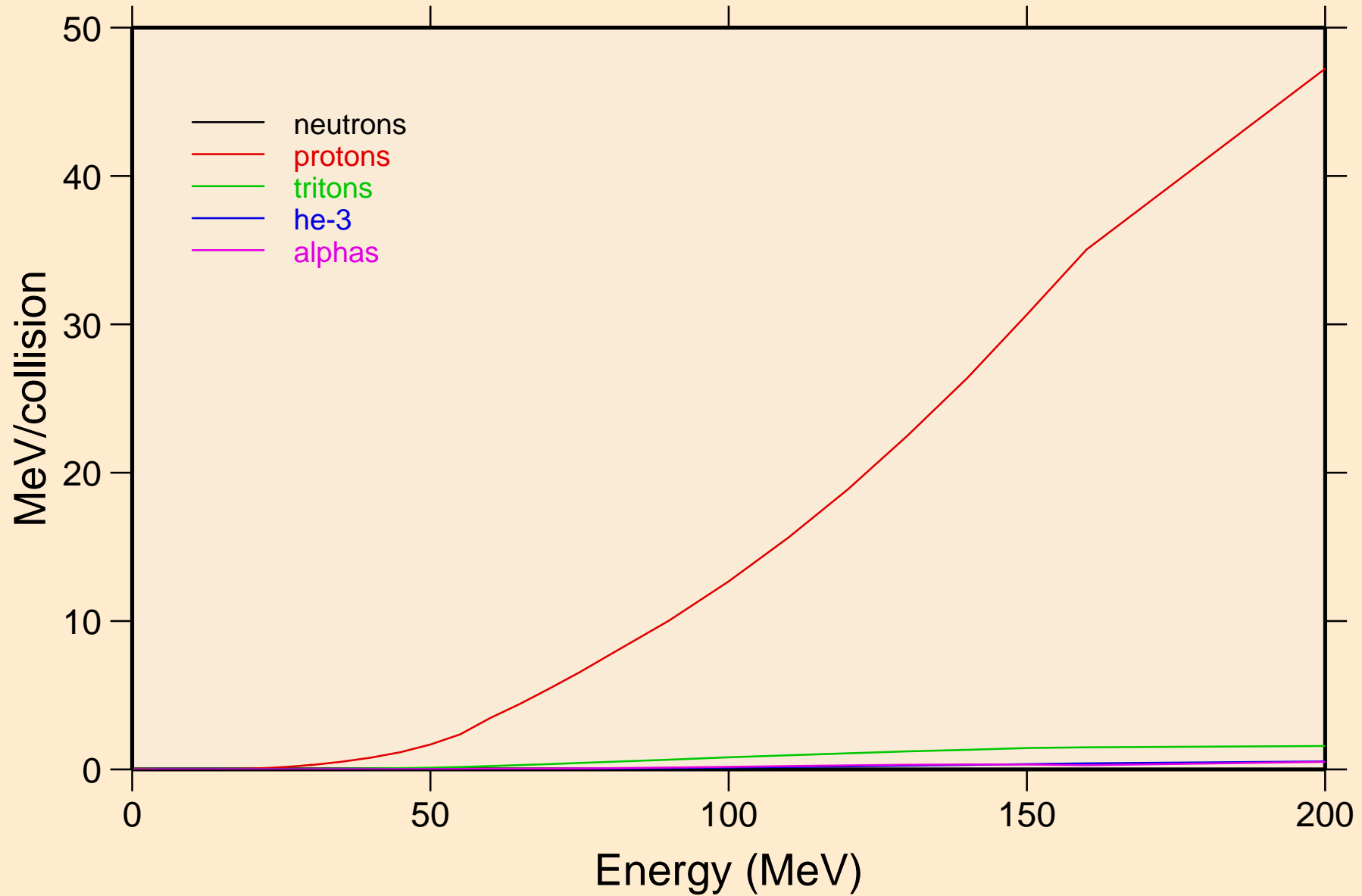

HO175 DEUTERON ACER TENDL-2023 LIBRARY; T=0.K
Recoil Heating

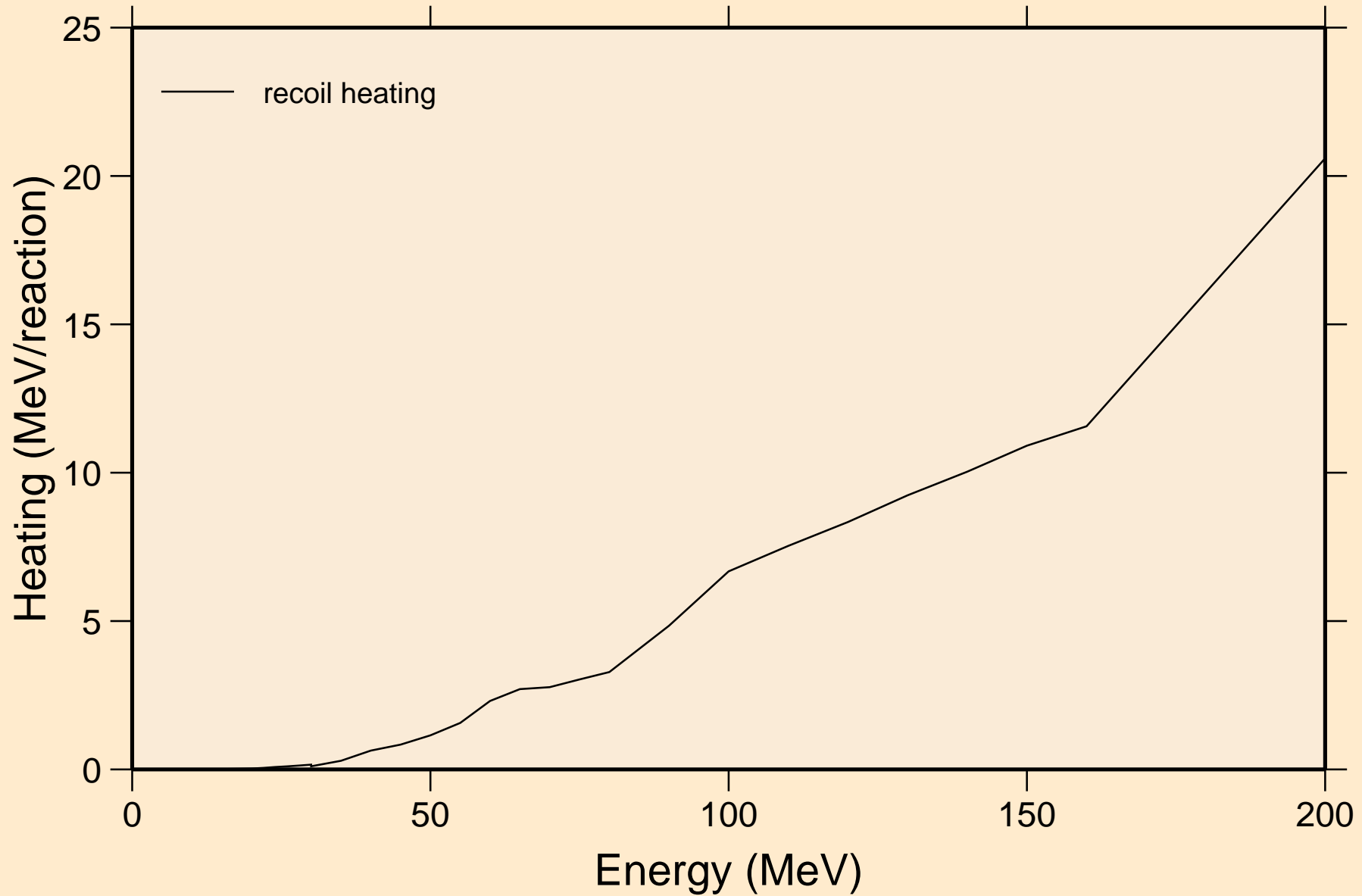

HO175 DEUTERON ACER TENDL-2023 LIBRARY; T=0.K

Particle production cross sections

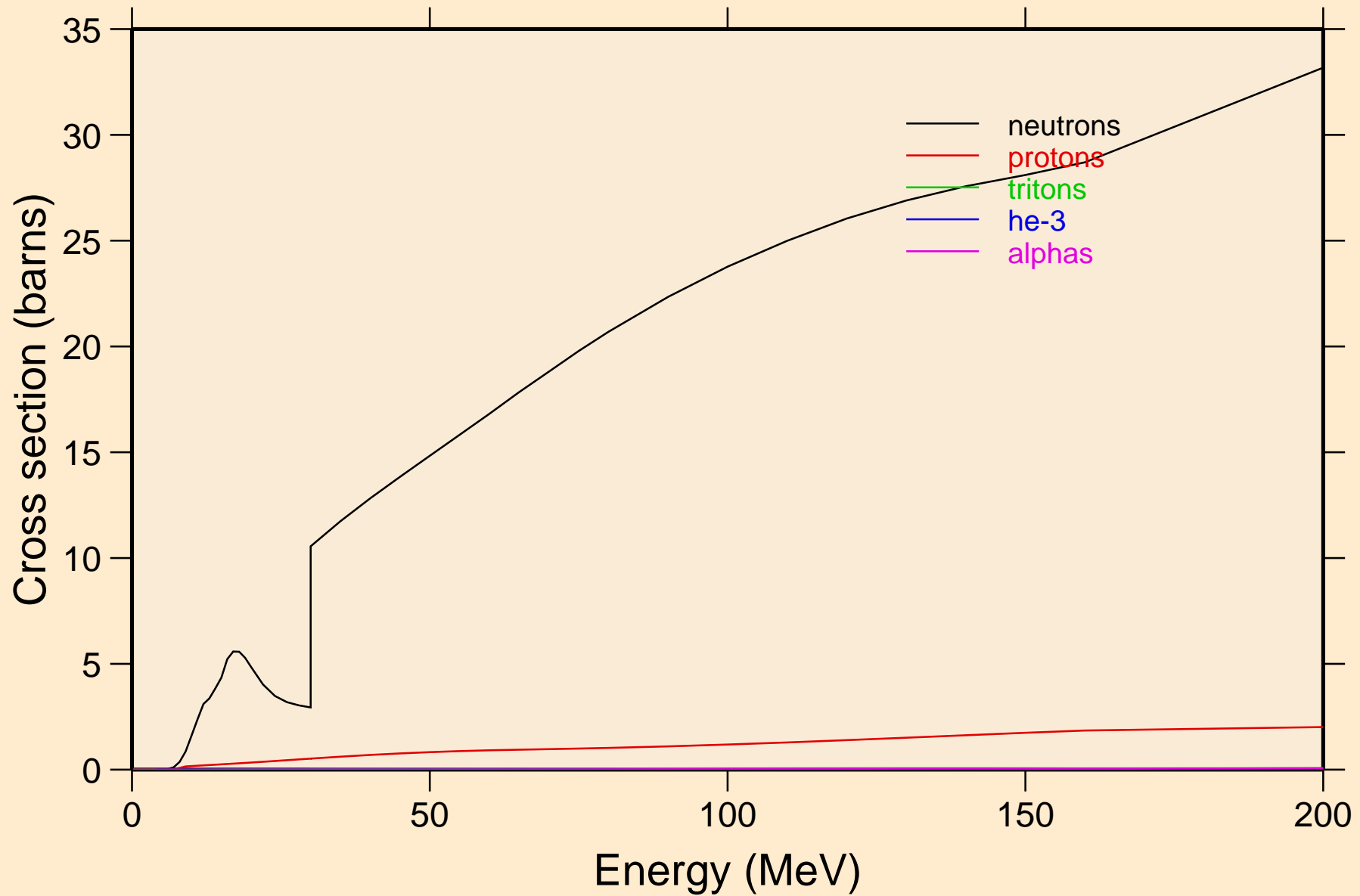

HO175 DEUTERON ACER TENDL-2023 LIBRARY; T=0.K
neutrons from (d,n)

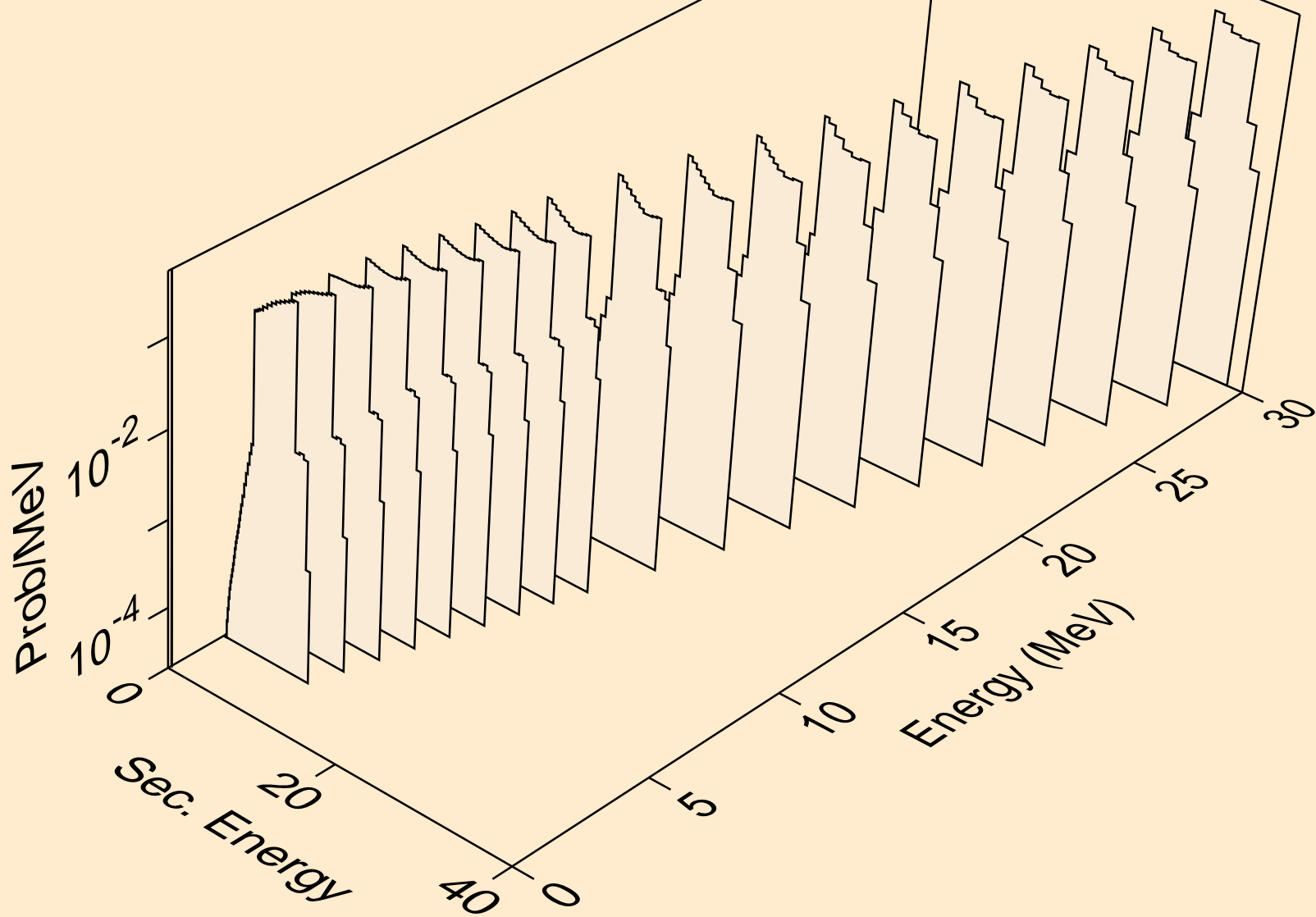

HO175 DEUTERON ACER TENDL-2023 LIBRARY; T=0.K
neutrons from (d,x)

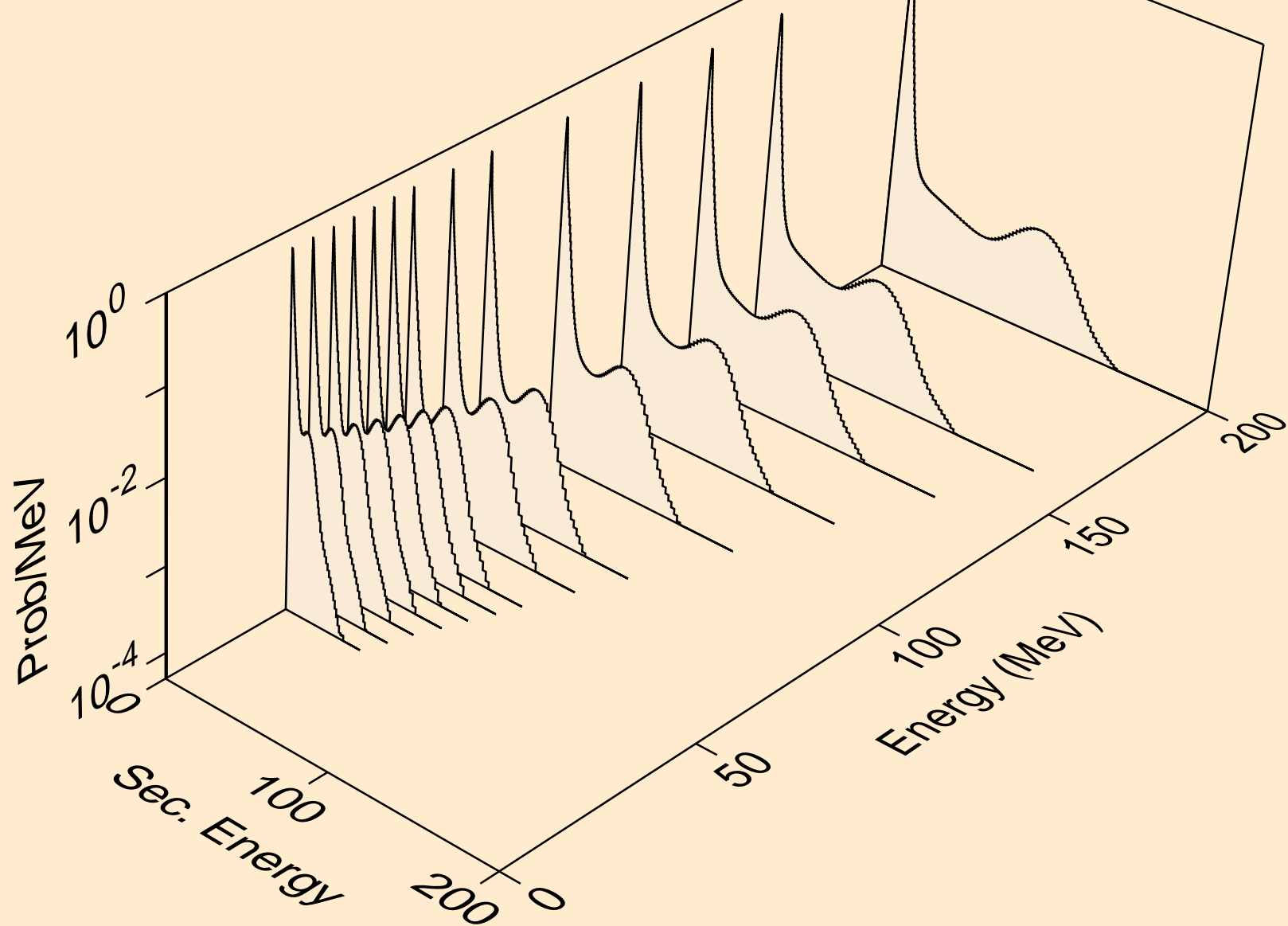

HO175 DEUTERON ACER TENDL-2023 LIBRARY; T=0.K
neutrons from (d,2nd)

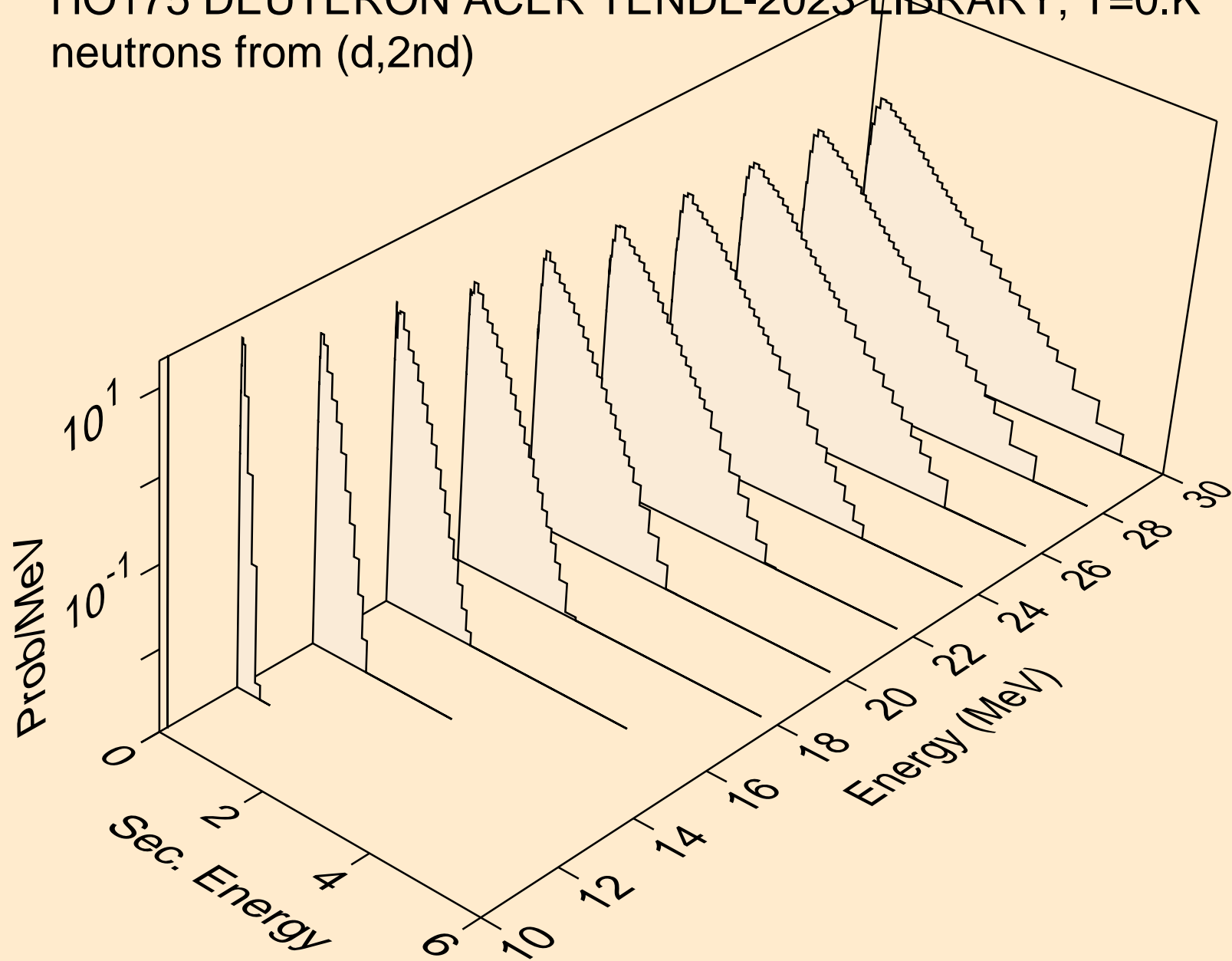

HO175 DEUTERON ACER TENDL-2023 LIBRARY; T=0.K
neutrons from (d,2n)

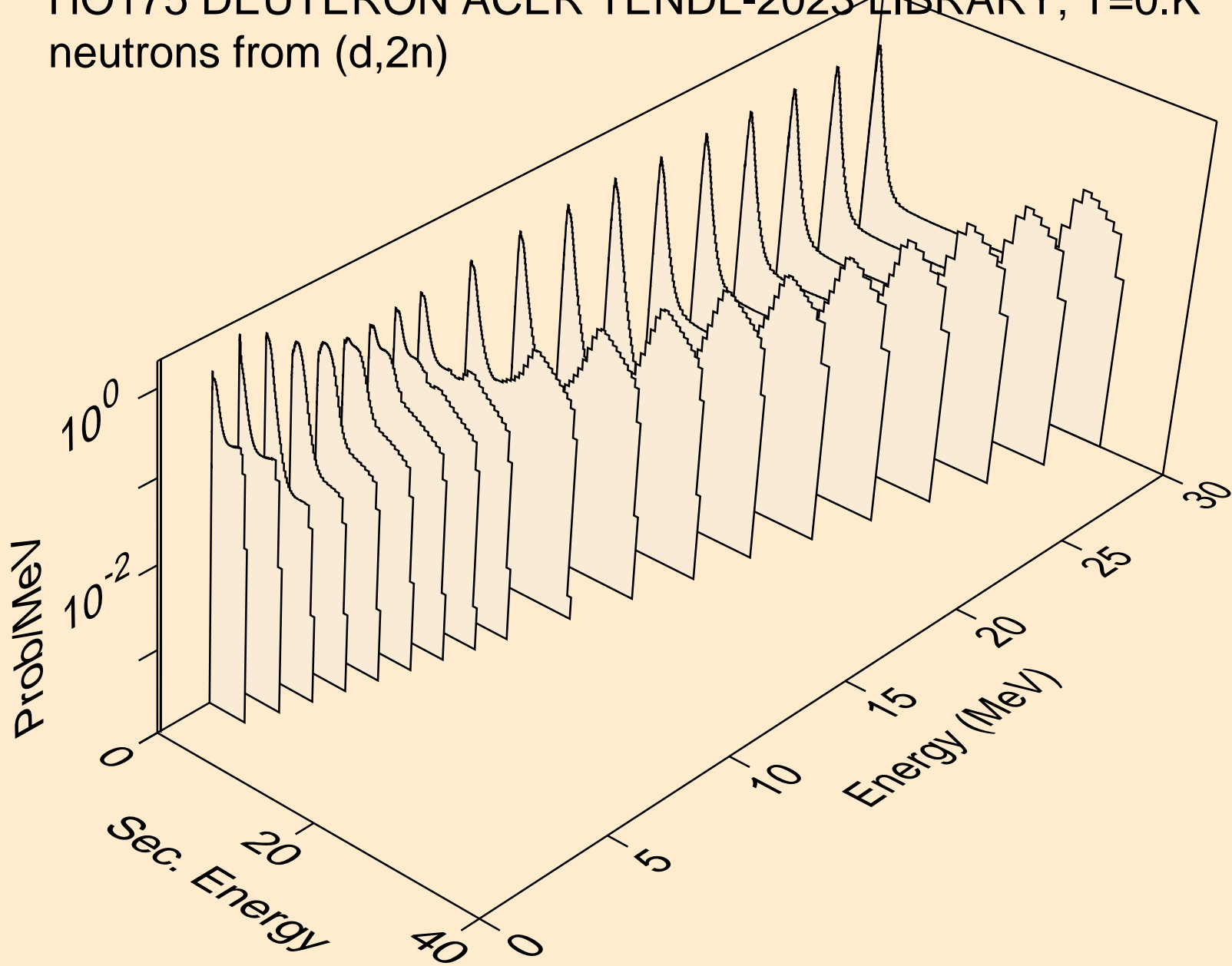

HO175 DEUTERON ACER TENDL-2023 LIBRARY; T=0.K
neutrons from (d,3n)

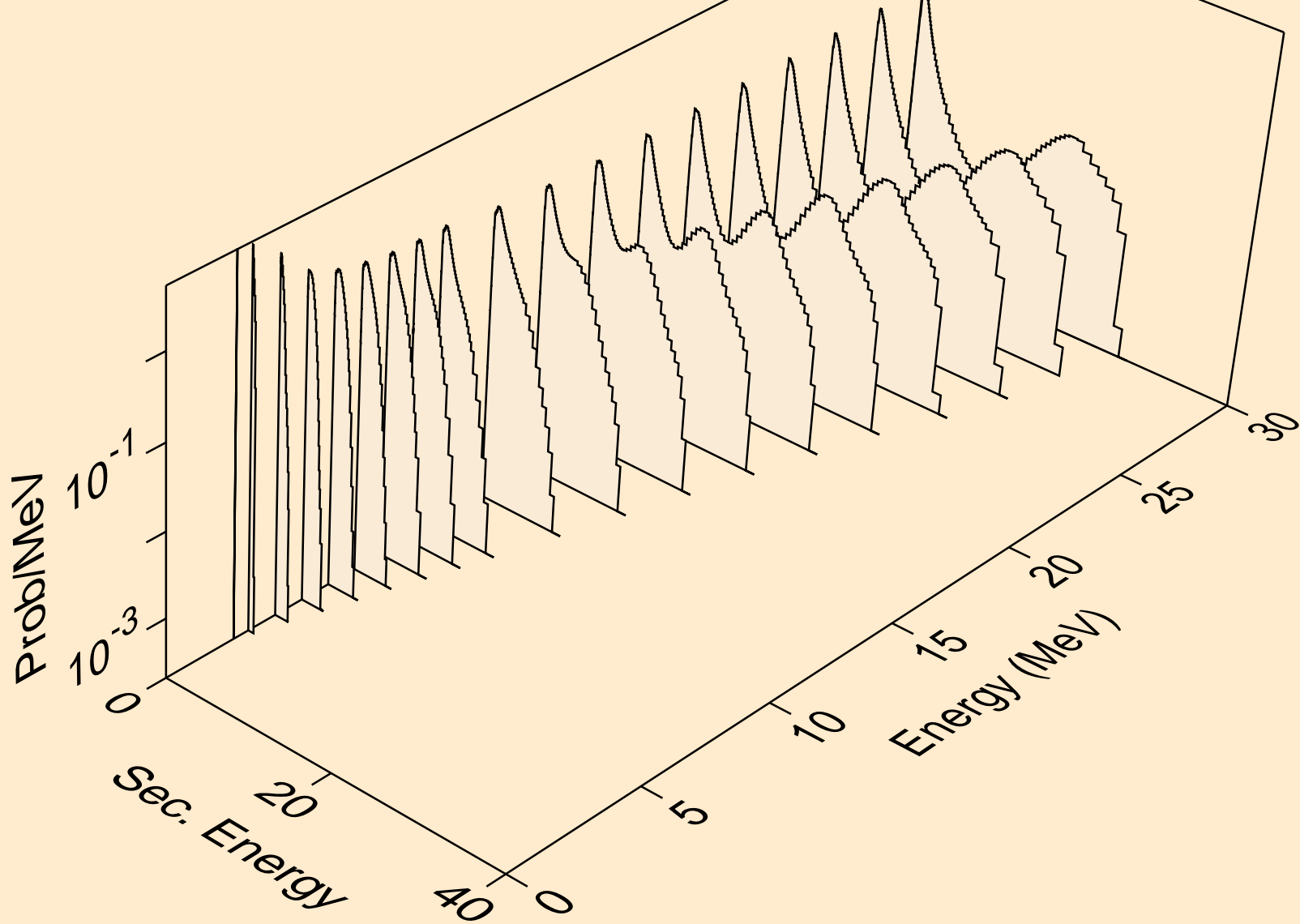

HO175 DEUTERON ACER TENDL-2023 LIBRARY; T=0.K
neutrons from (d,n*)a

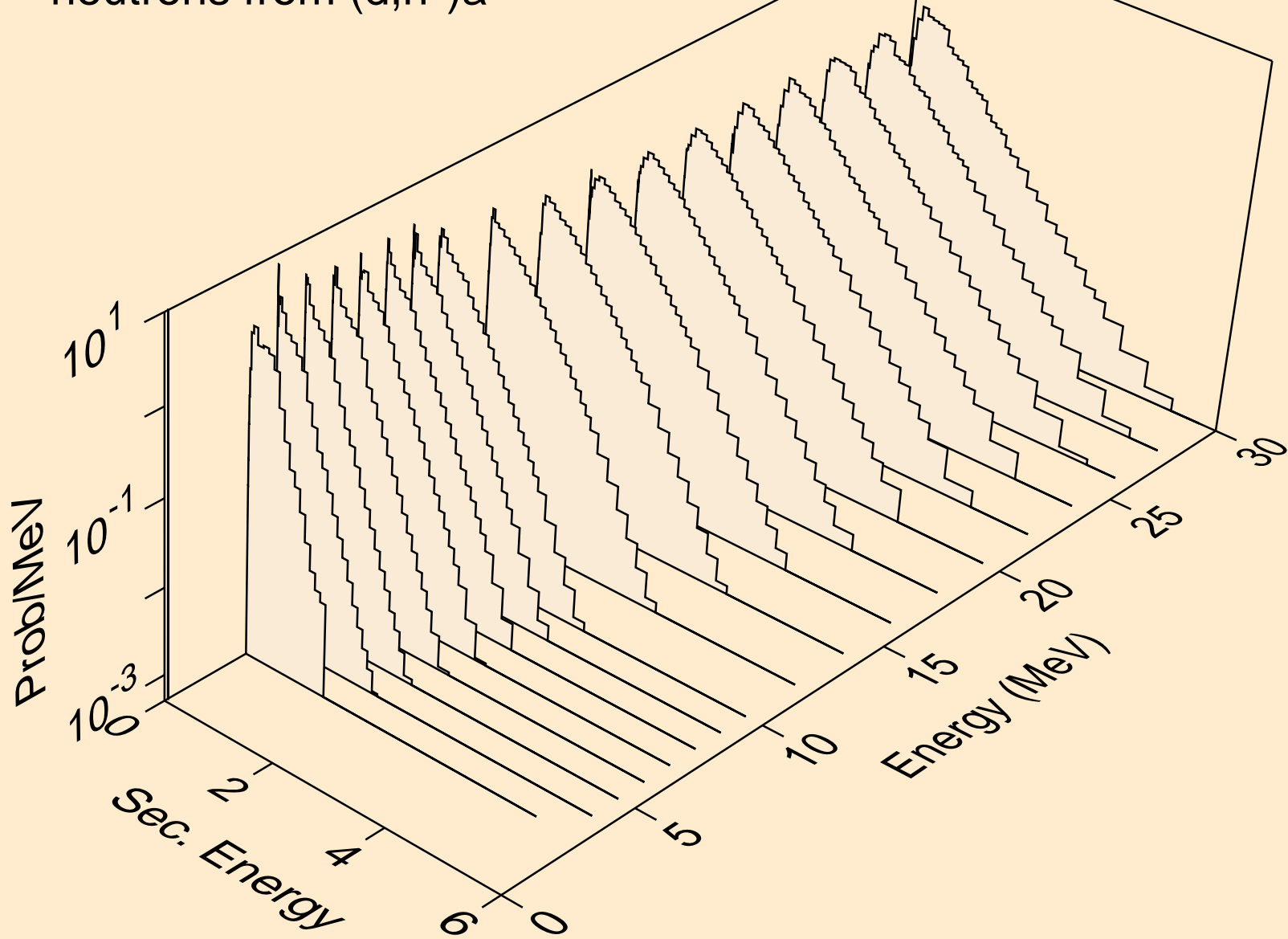

HO175 DEUTERON ACER TENDL-2023 LIBRARY; T=0.K
neutrons from (d,2n)a

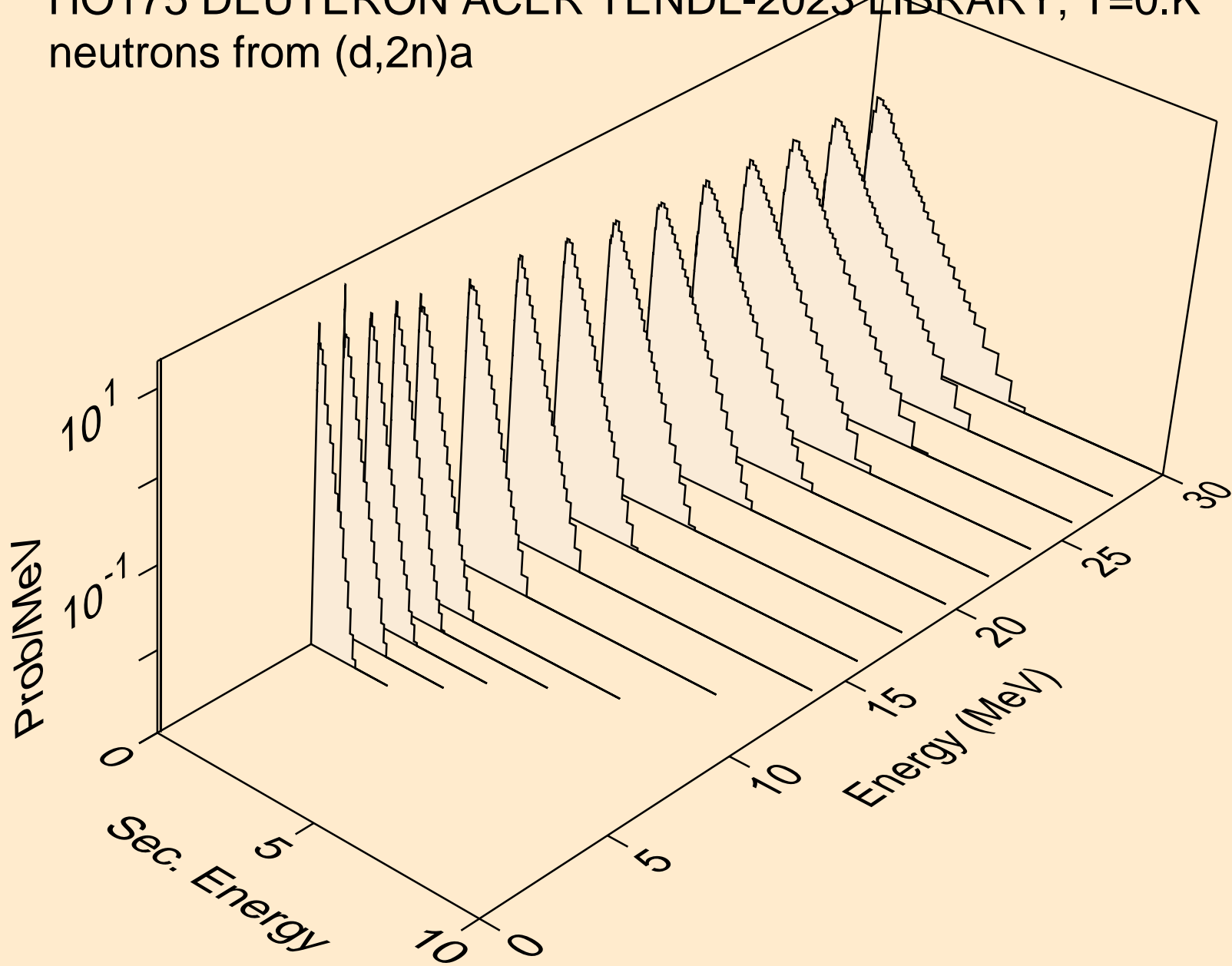

HO175 DEUTERON ACER TENDL-2023 LIBRARY; T=0.K
neutrons from (d,3n)a

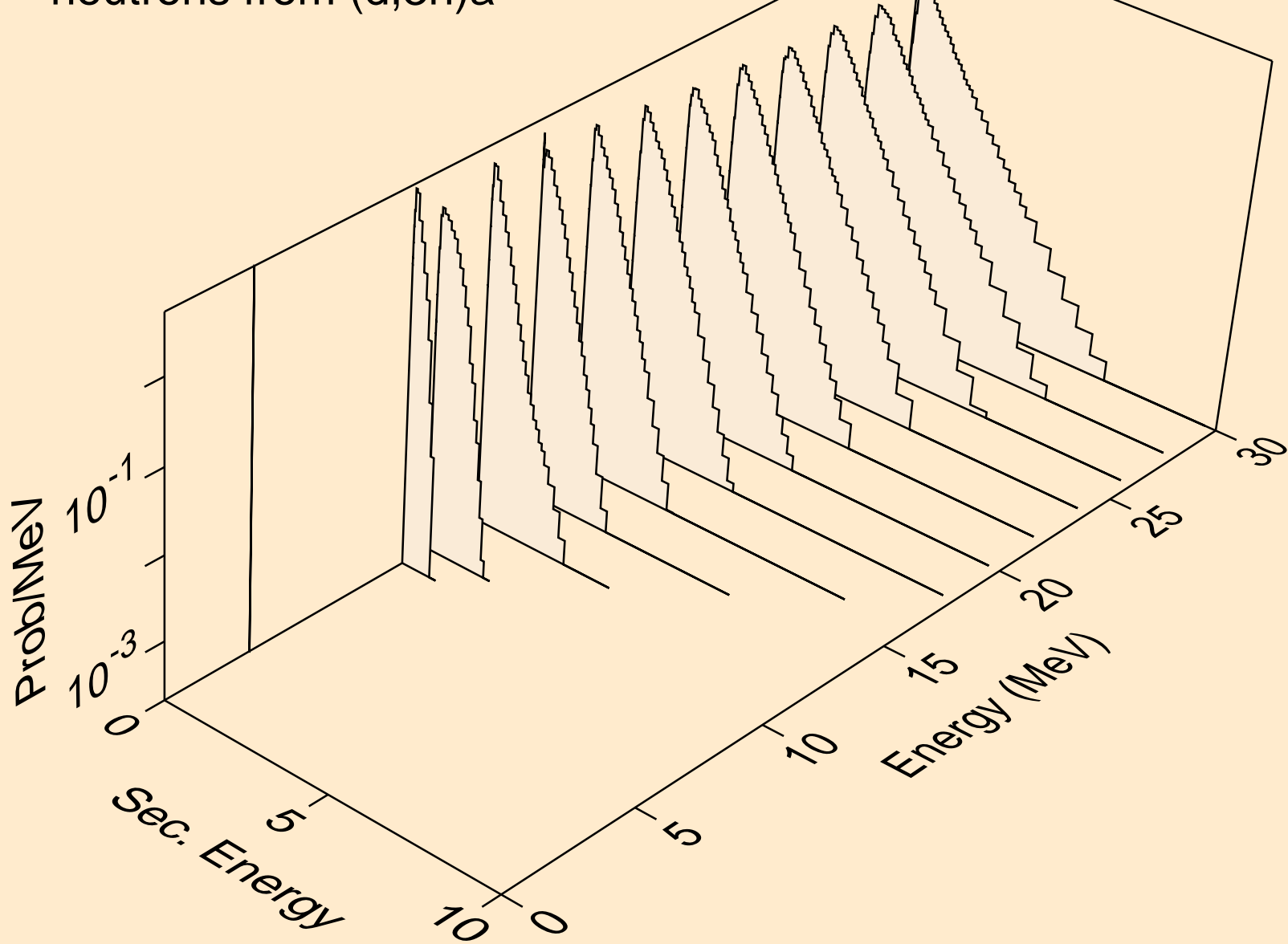

HO175 DEUTERON ACER TENDL-2023 LIBRARY; T=0.K
neutrons from (d,n*)p

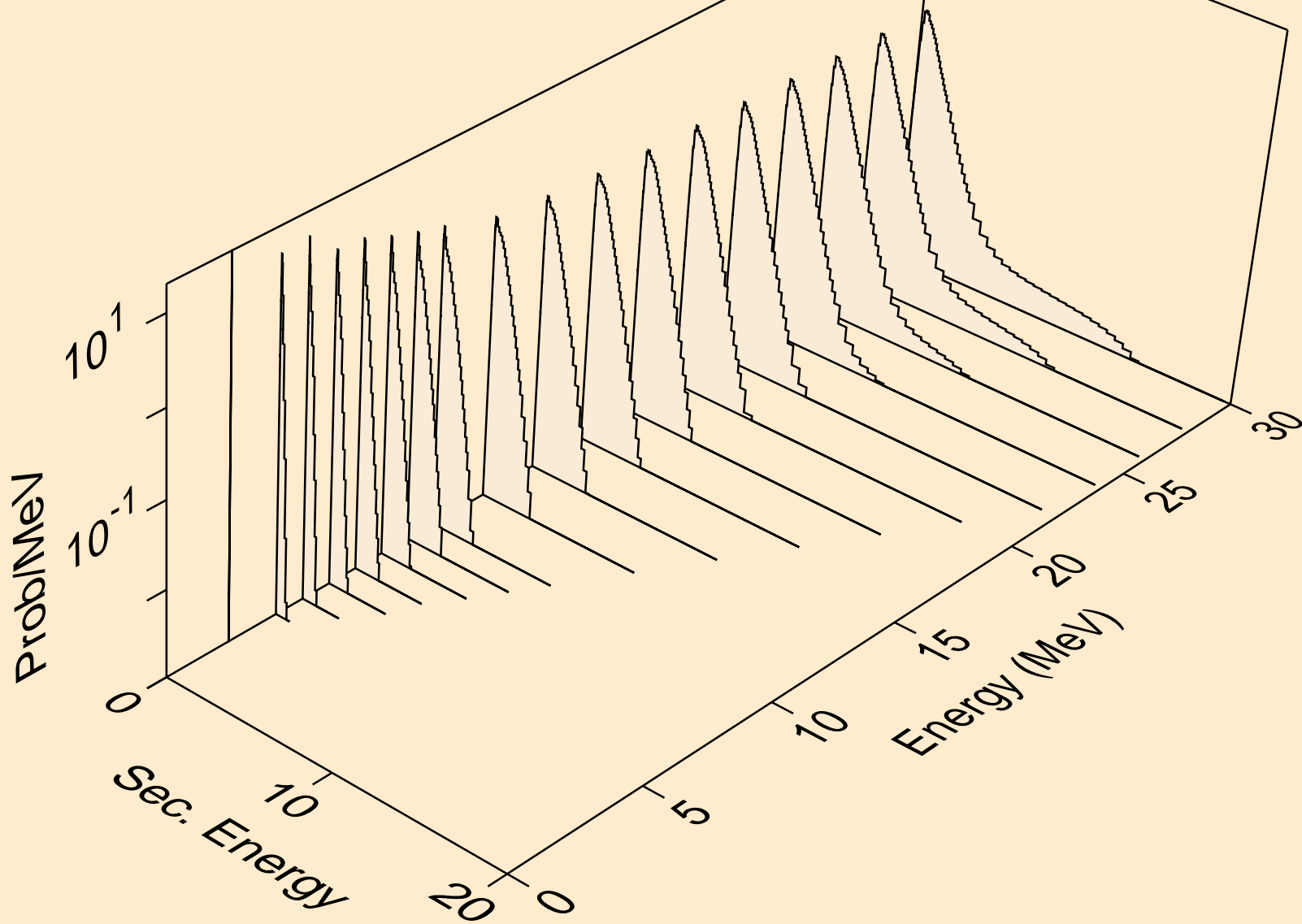

HO175 DEUTERON ACER TENDL-2023 LIBRARY; T=0.K
neutrons from (d,n*)d

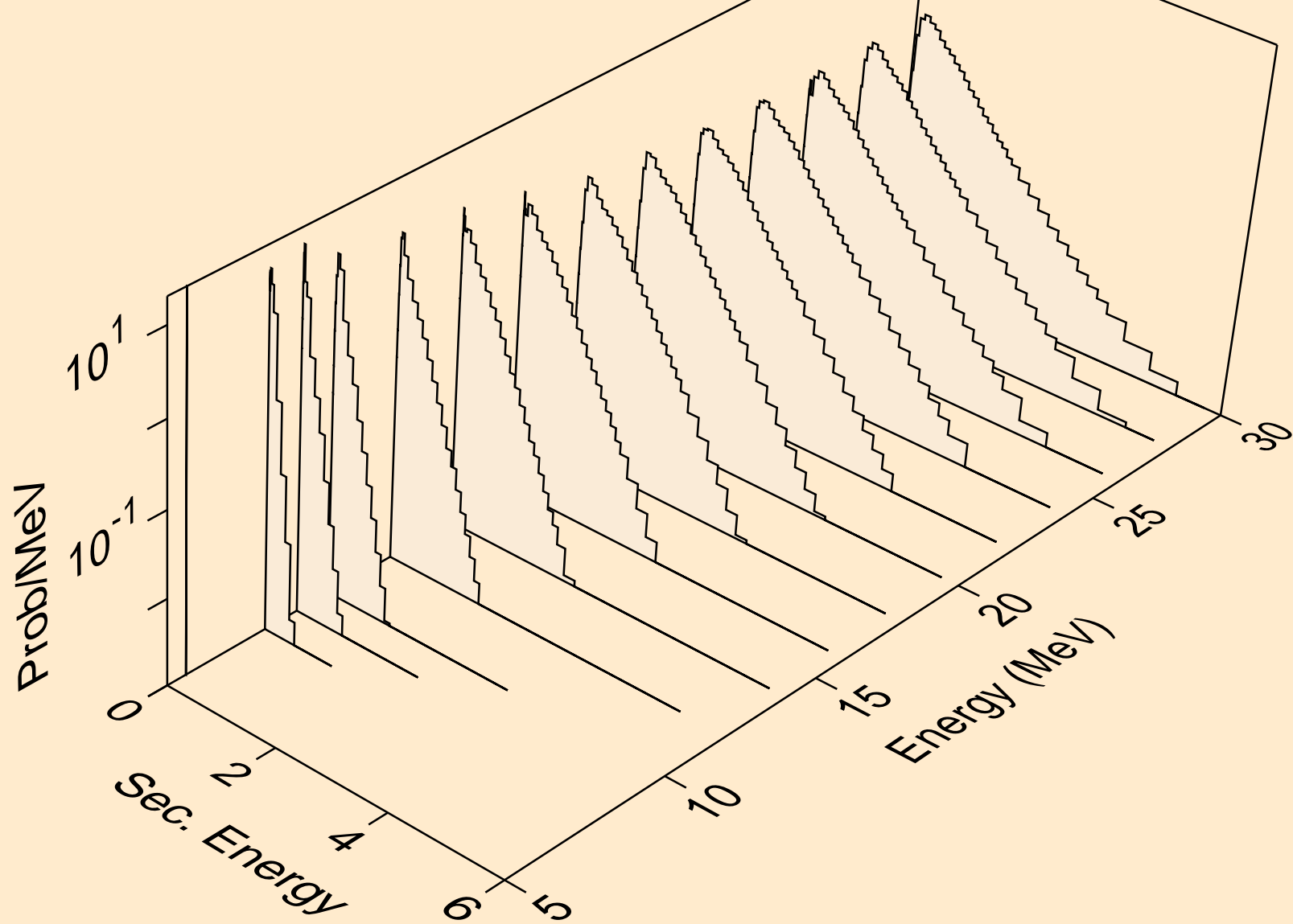

HO175 DEUTERON ACER TENDL-2023 LIBRARY; T=0.K
neutrons from (d,n*)t

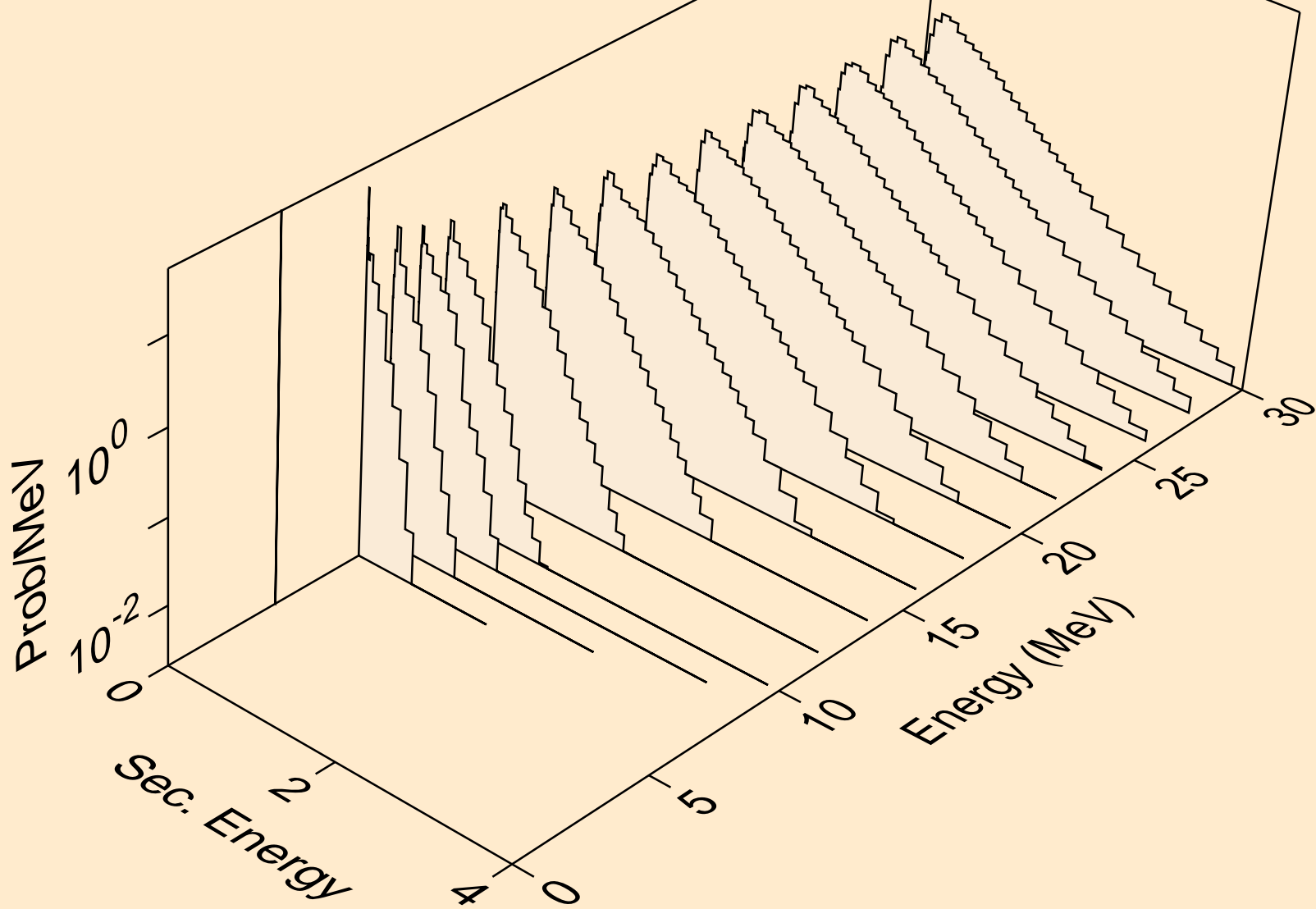

HO175 DEUTERON ACER TENDL-2023 LIBRARY; T=0.K
neutrons from (d,n*)he3

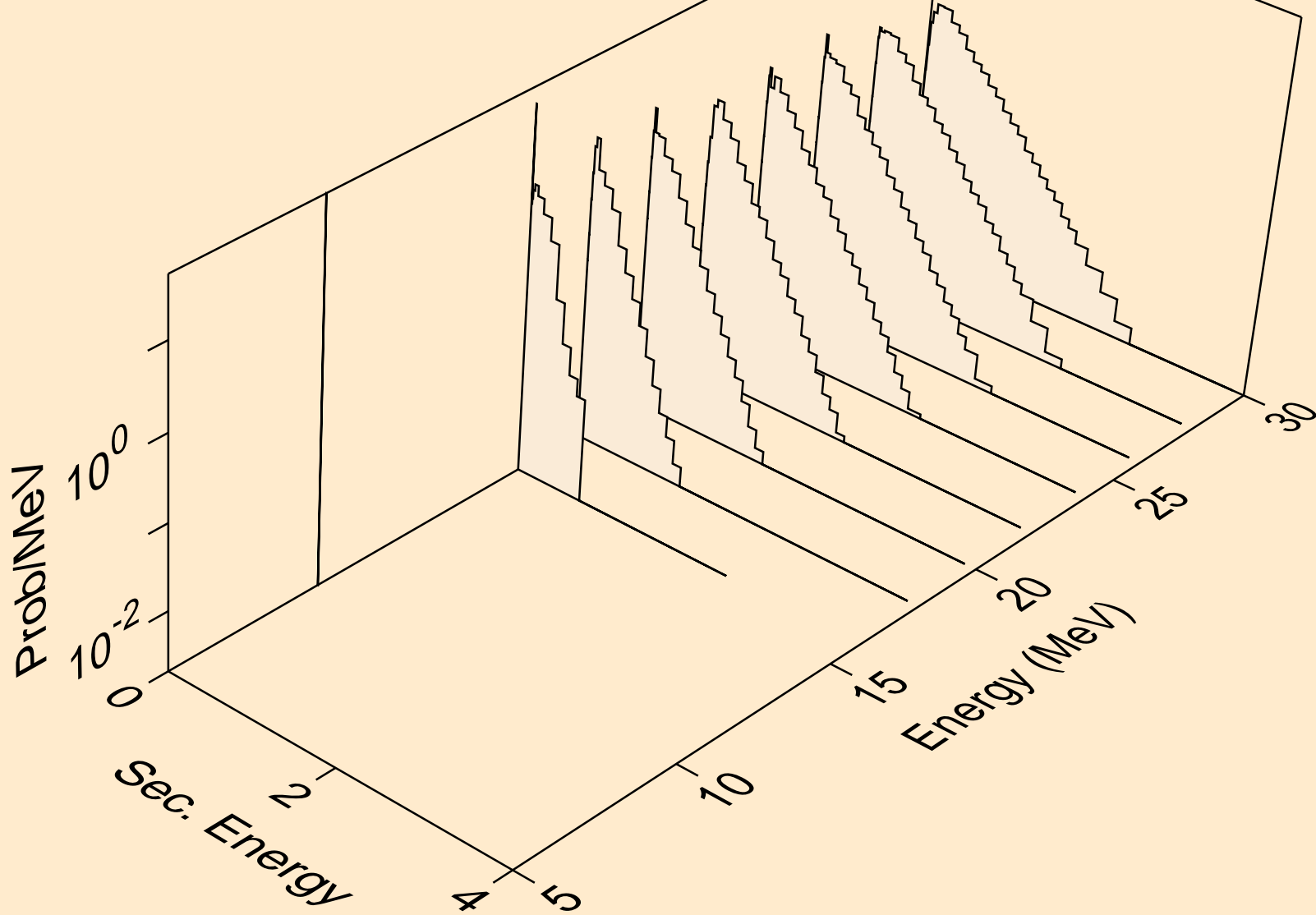

HO175 DEUTERON ACER TENDL-2023 LIBRARY; T=0.K
neutrons from (d,4n)

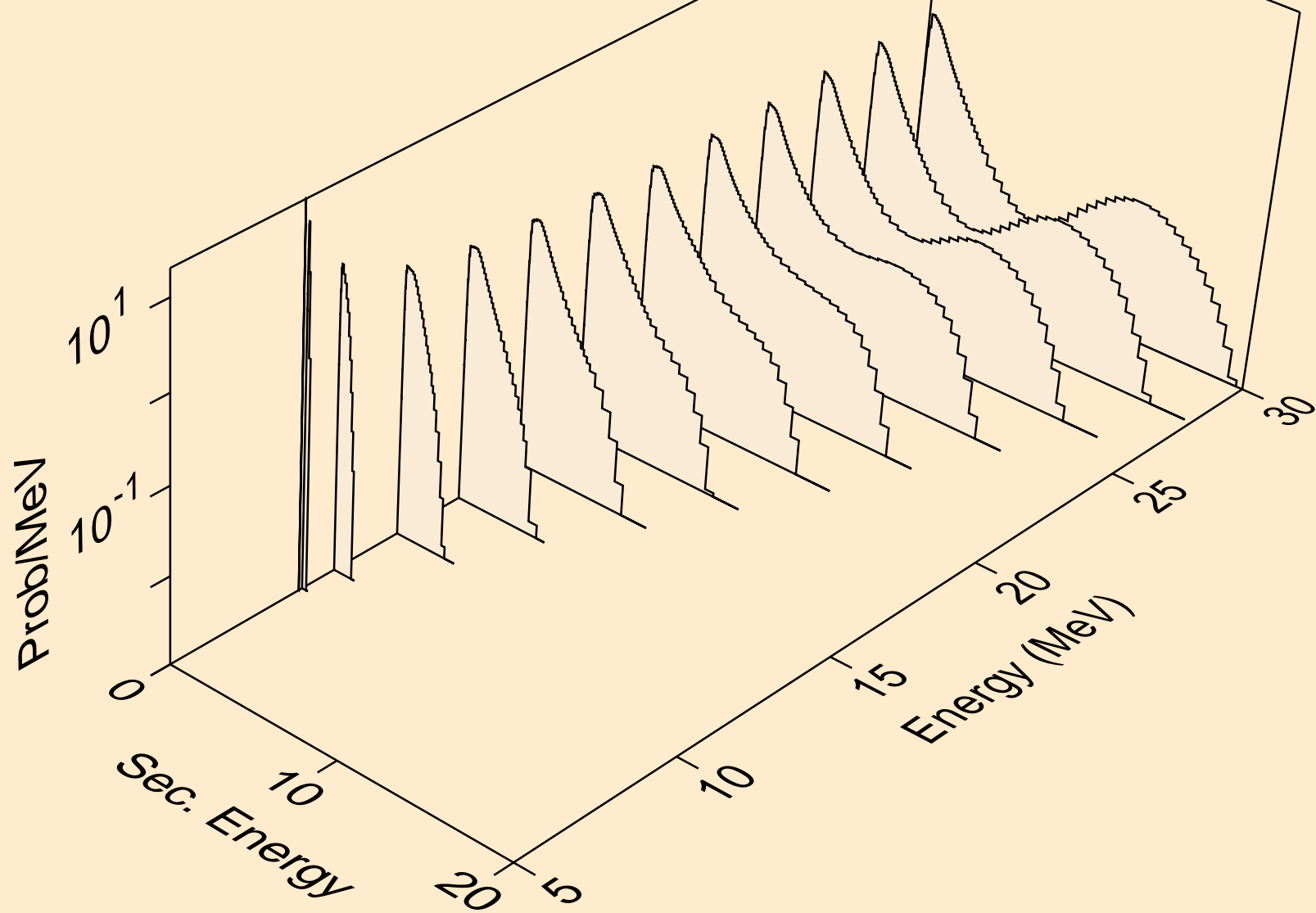

HO175 DEUTERON ACER TENDL-2023 LIBRARY; T=0.K
neutrons from (d,2np)

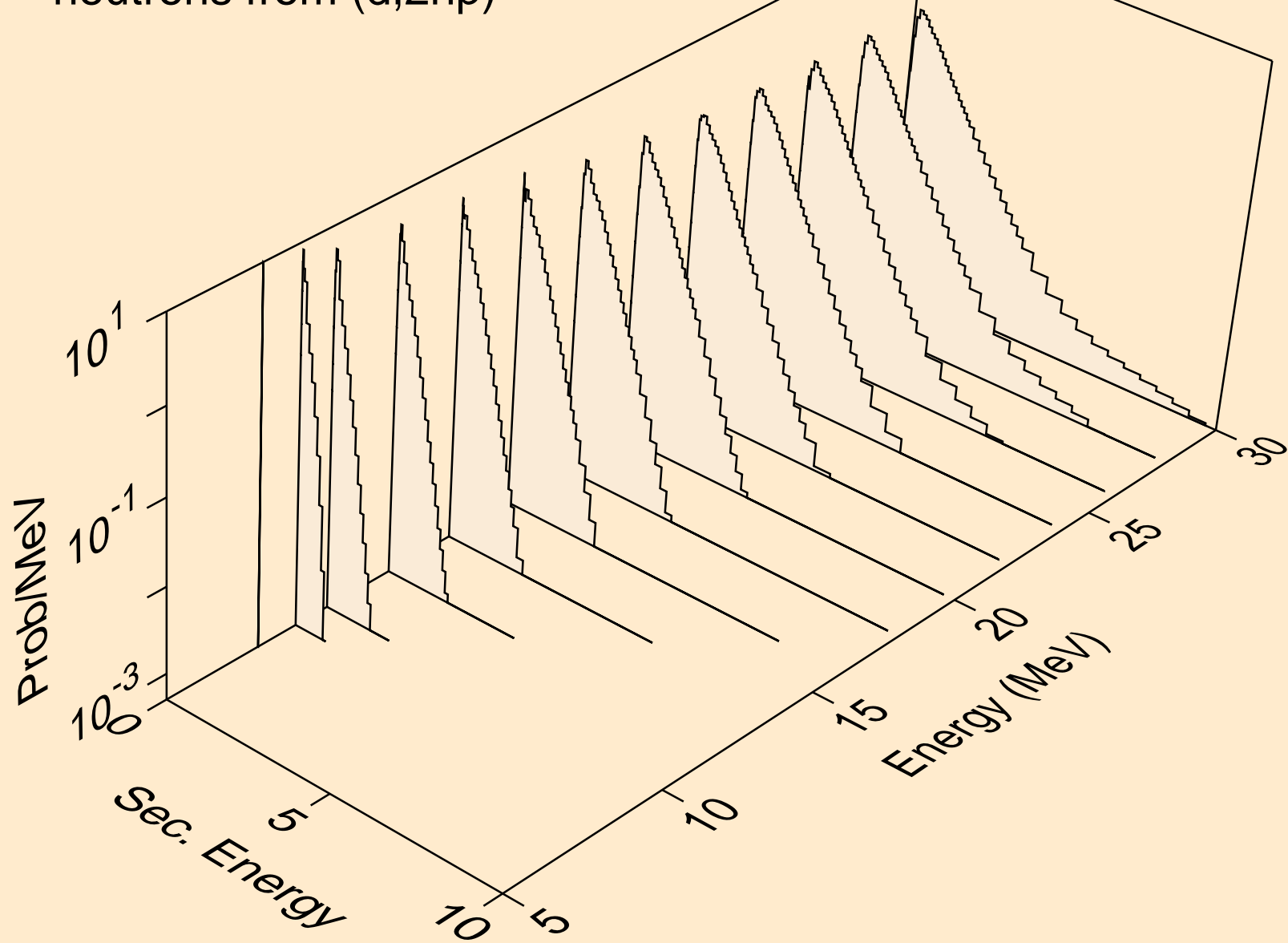

HO175 DEUTERON ACER TENDL-2023 LIBRARY; T=0.K
neutrons from (d,3np)

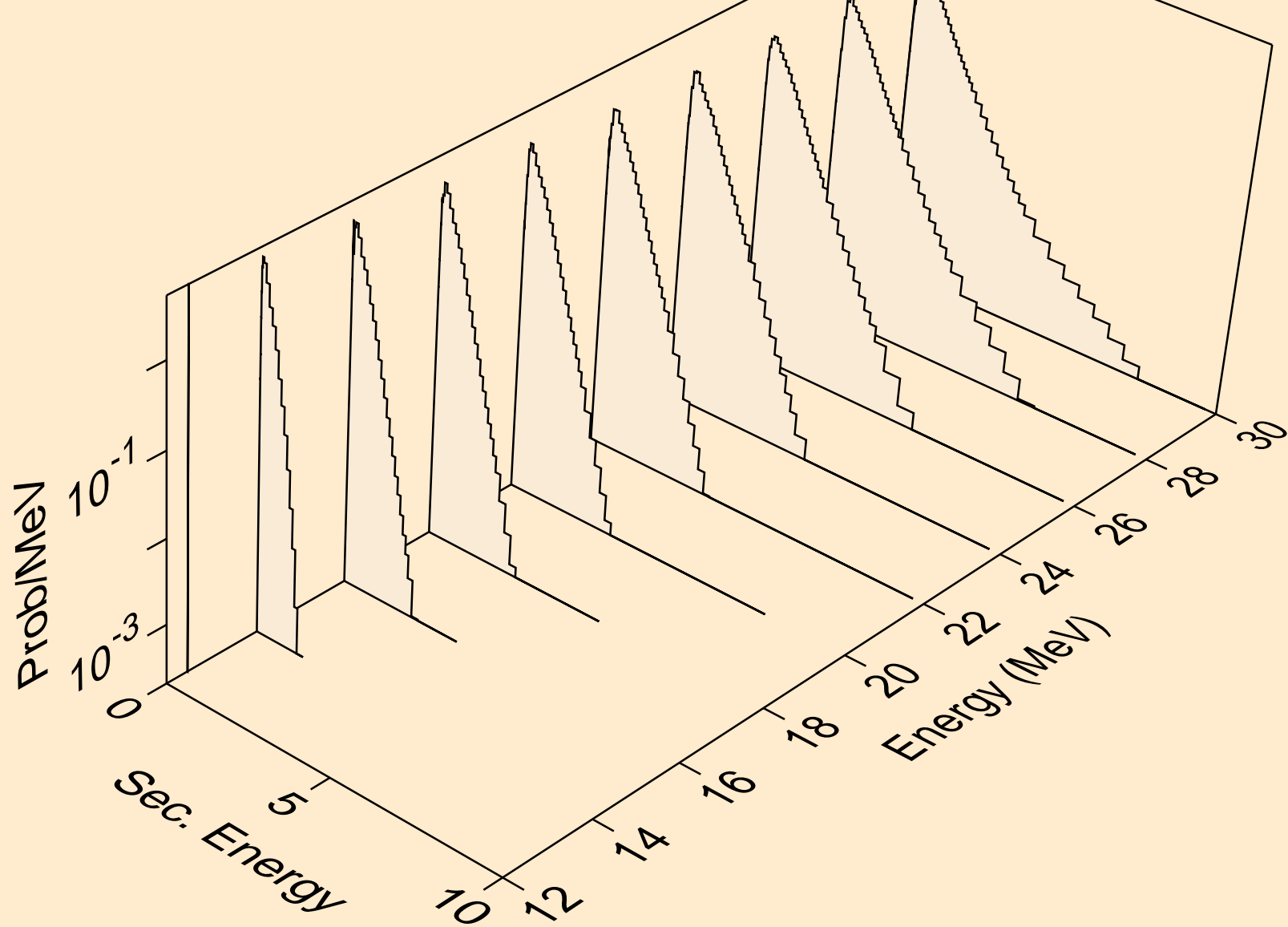

HO175 DEUTERON ACER TENDL-2023 LIBRARY; T=0.K
neutrons from (d,n2p)

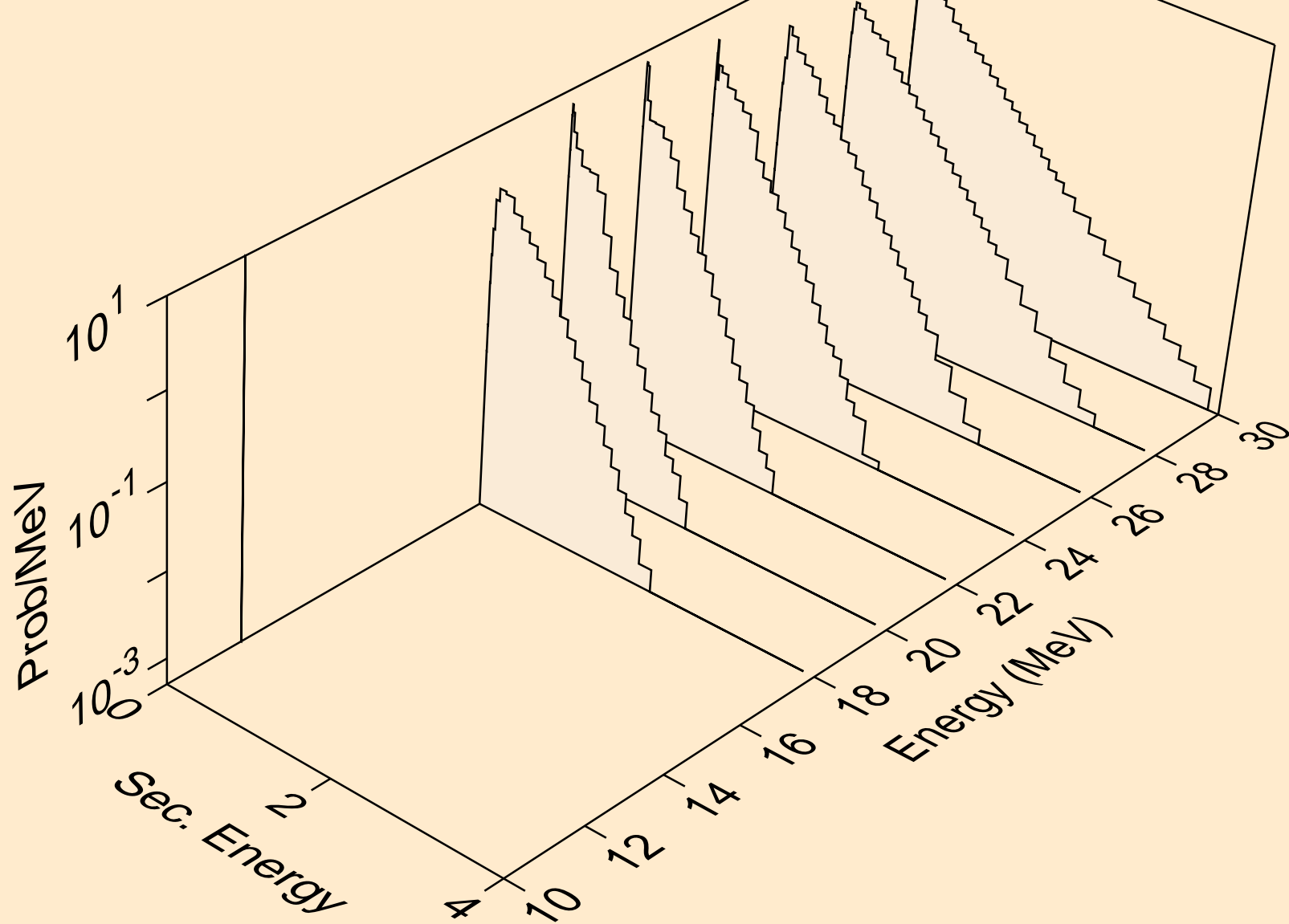

HO175 DEUTERON ACER TENDL-2023 LIBRARY; T=0.K
protons from (d,x)

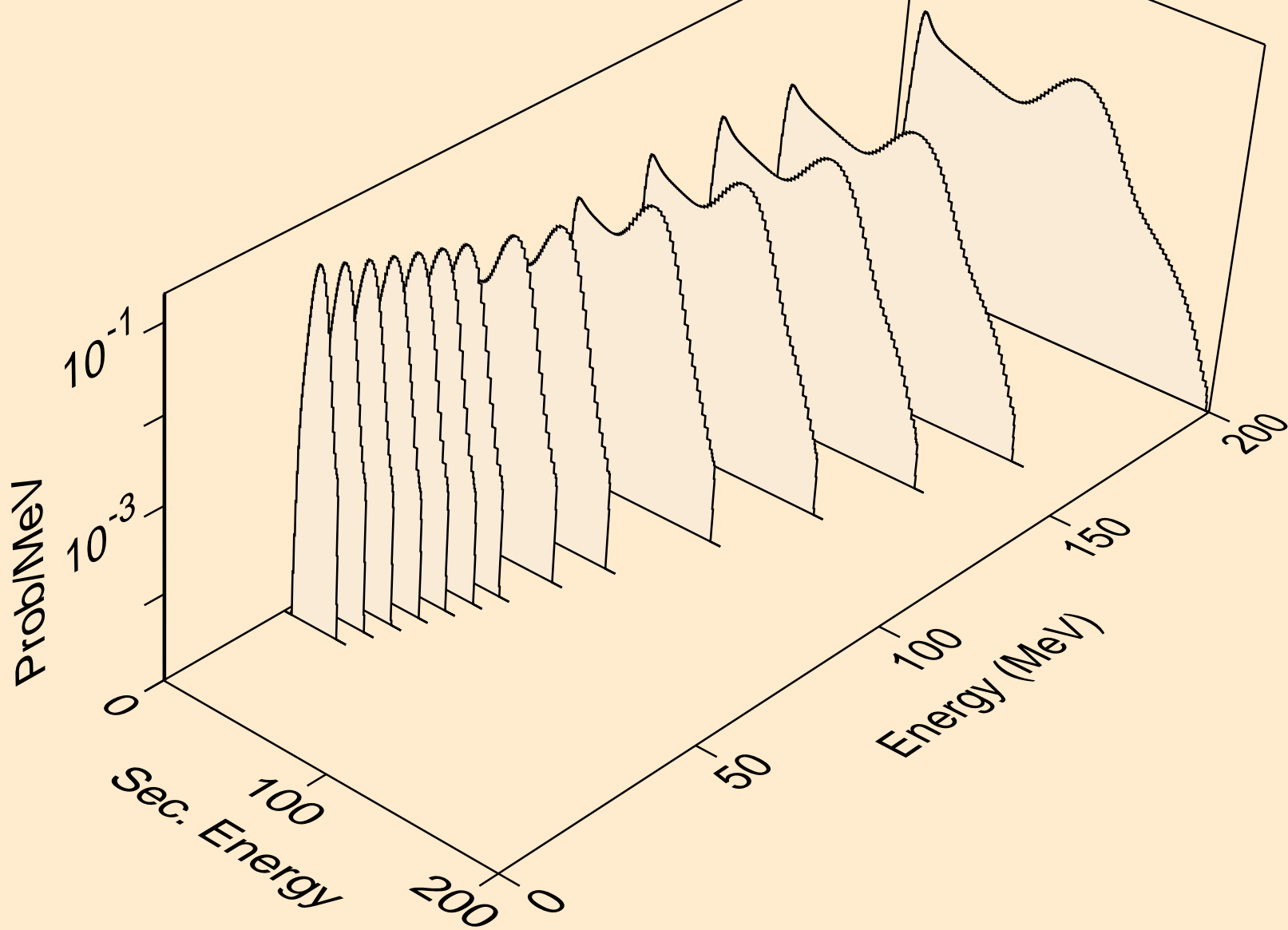

HO175 DEUTERON ACER TENDL-2023 LIBRARY; T=0.K
protons from (d,n*)p

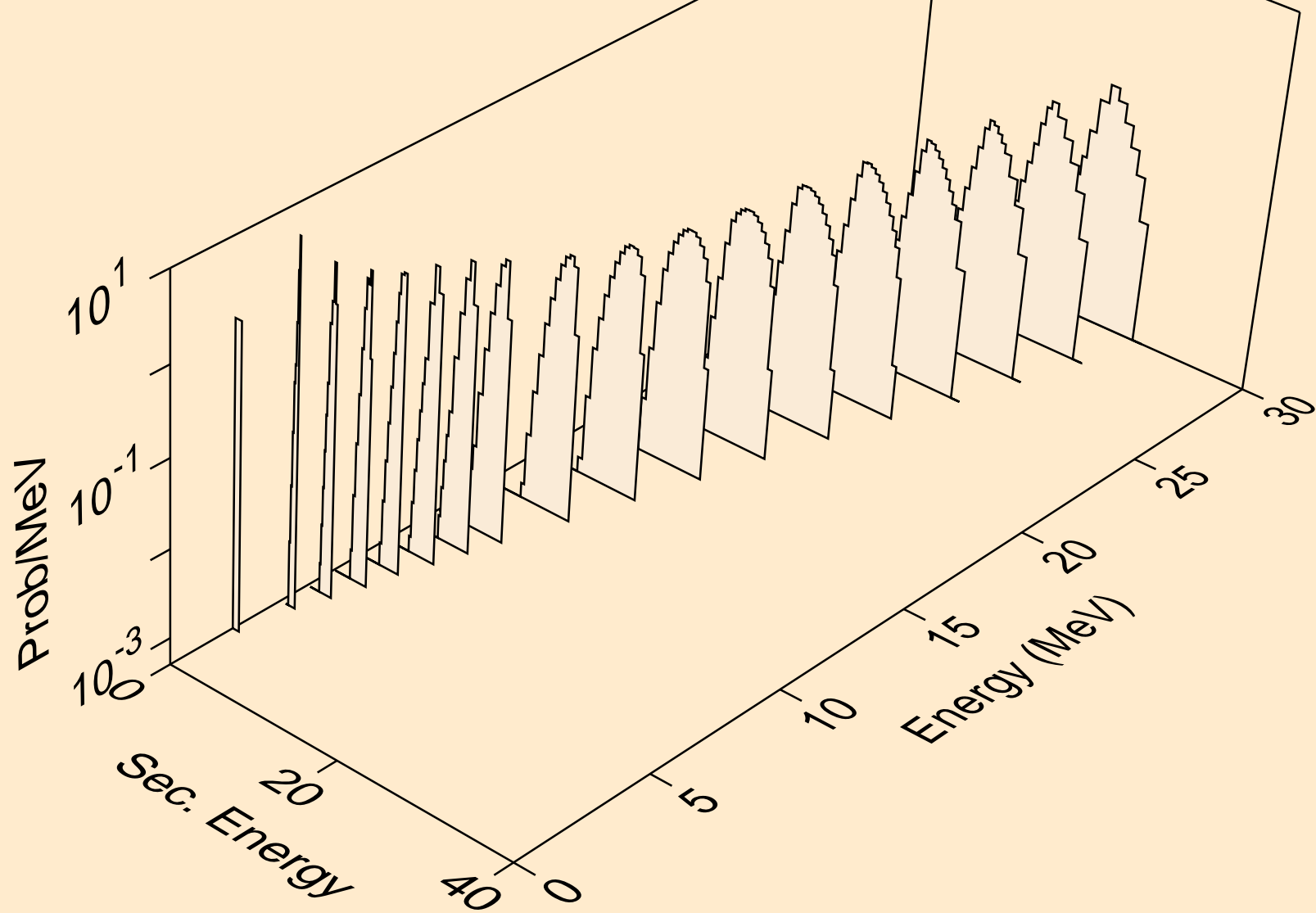

HO175 DEUTERON ACER TENDL-2023 LIBRARY; T=0.K
protons from (d,2np)

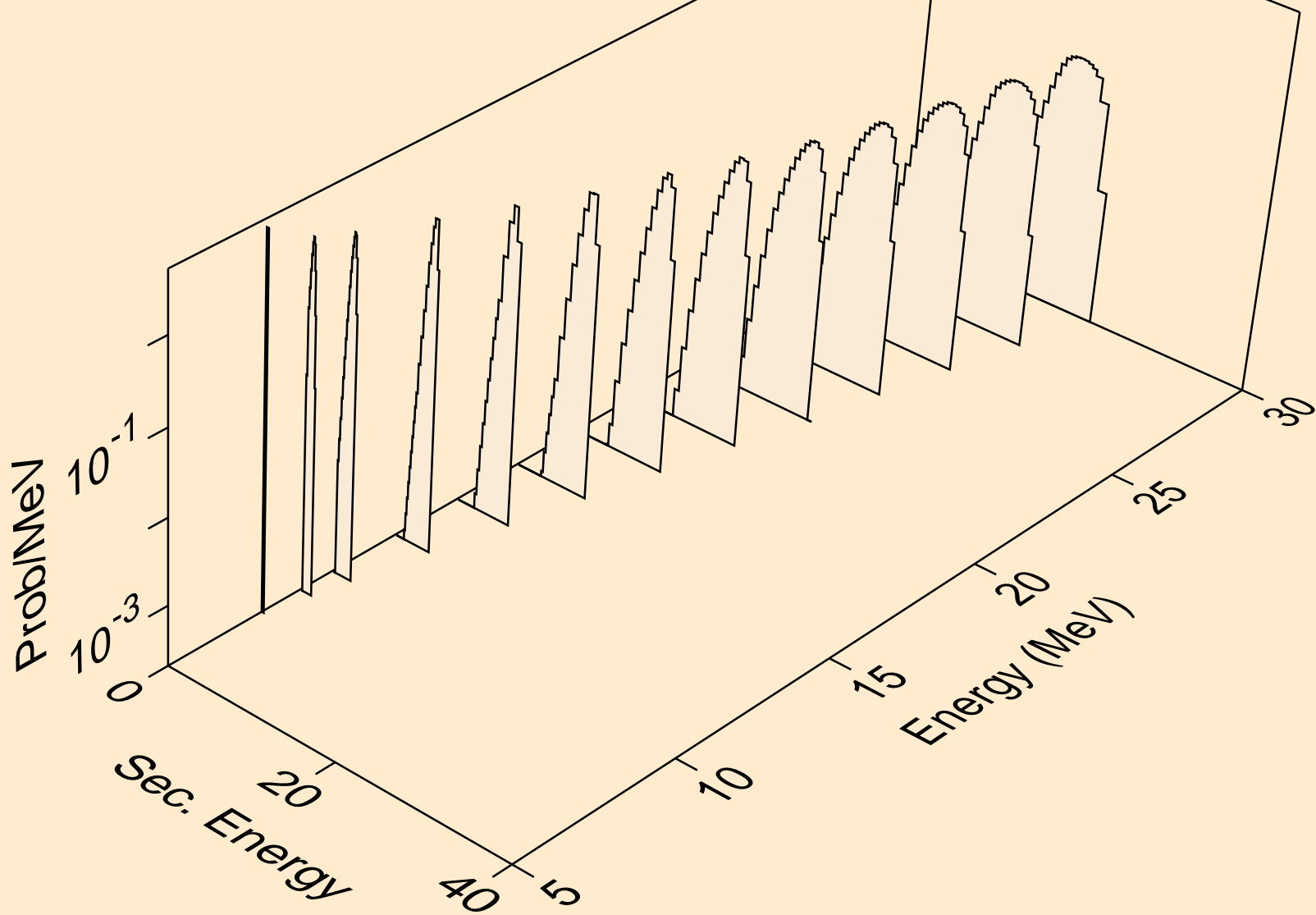

HO175 DEUTERON ACER TENDL-2023 LIBRARY; T=0.K
protons from (d,3np)

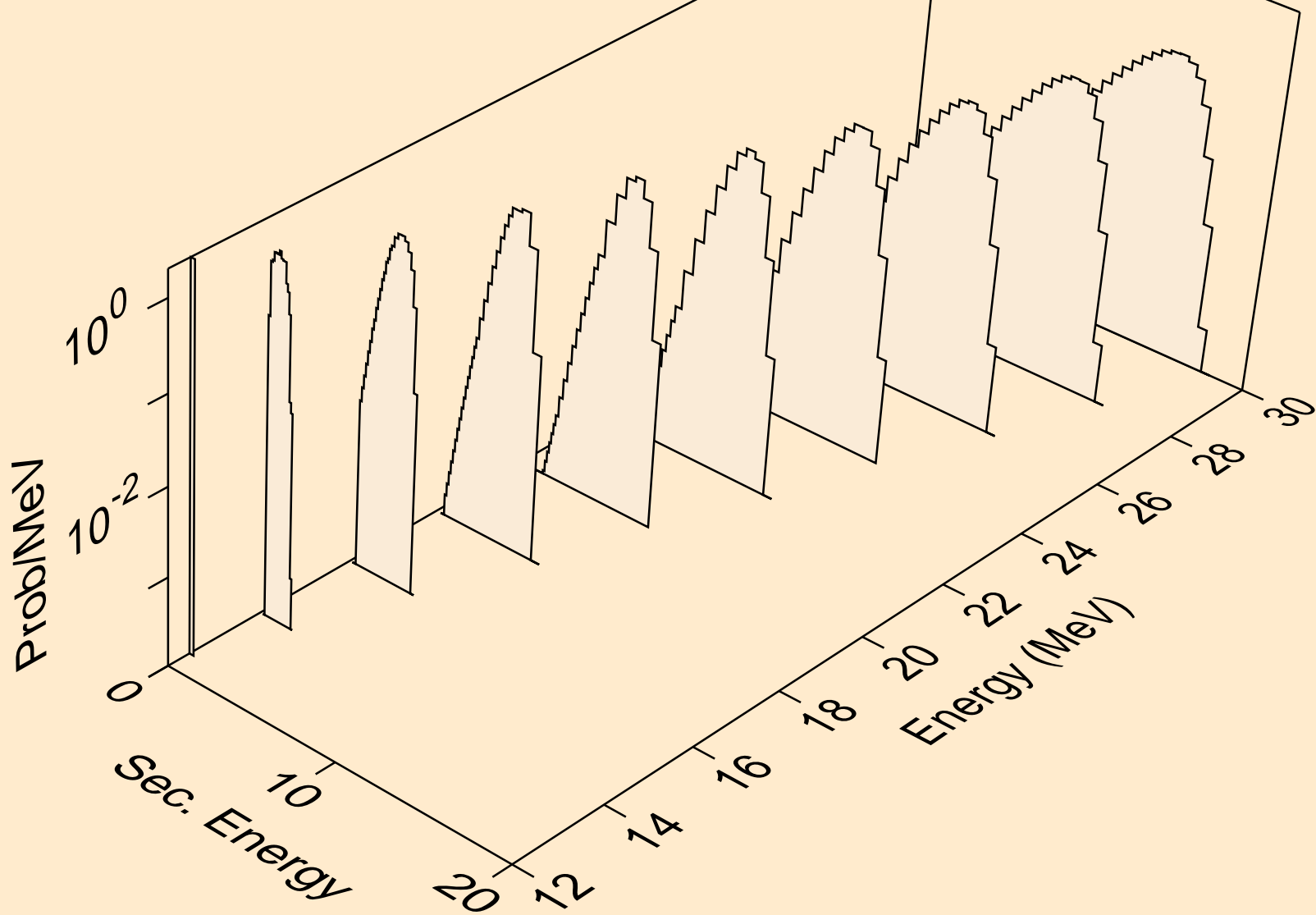

HO175 DEUTERON ACER TENDL-2023 LIBRARY; T=0.K
protons from (d,n2p)

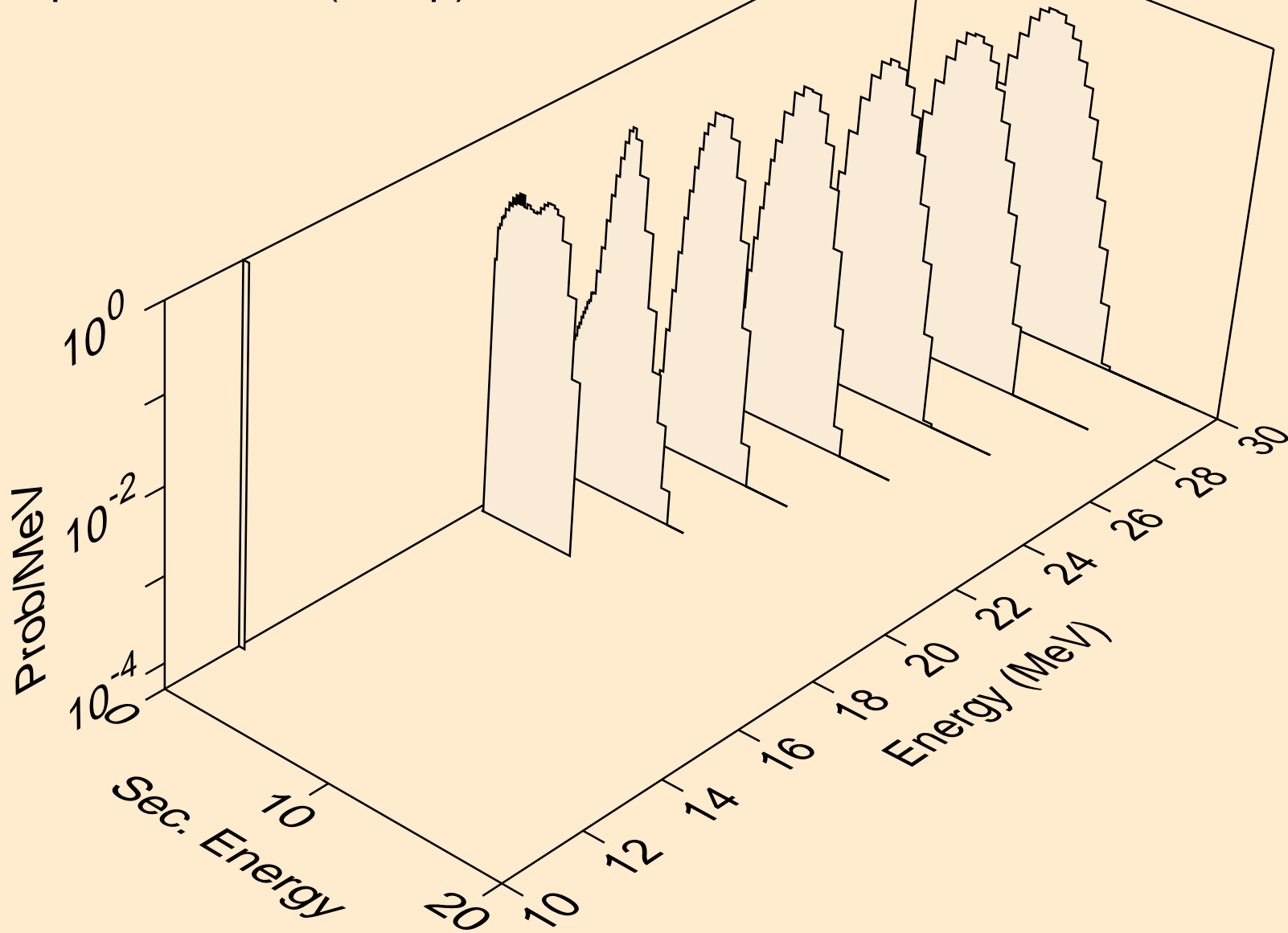

HO175 DEUTERON ACER TENDL-2023 LIBRARY; T=0.K
protons from (d,p)

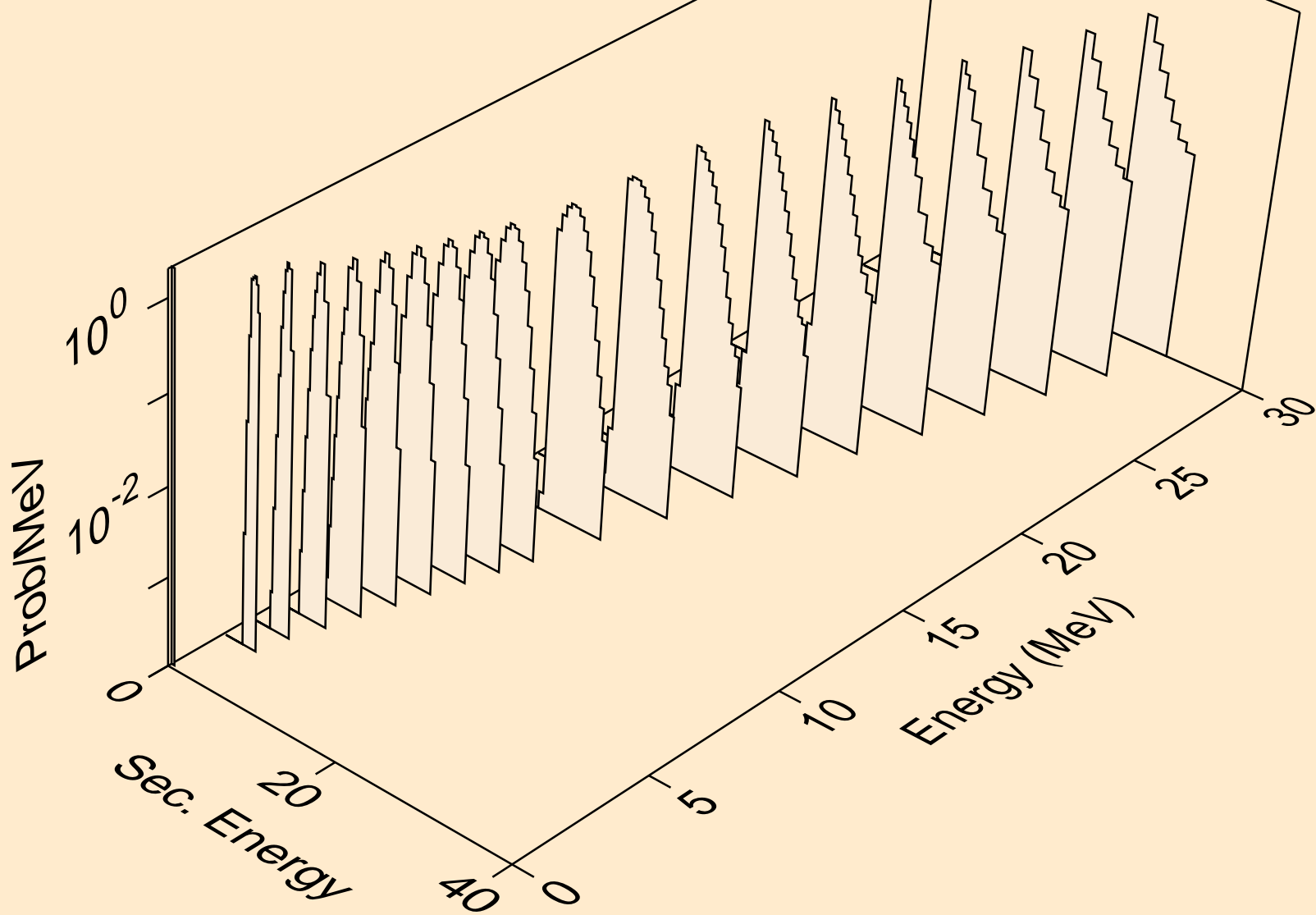

HO175 DEUTERON ACER TENDL-2023 LIBRARY; T=0.K
protons from (d,2p)

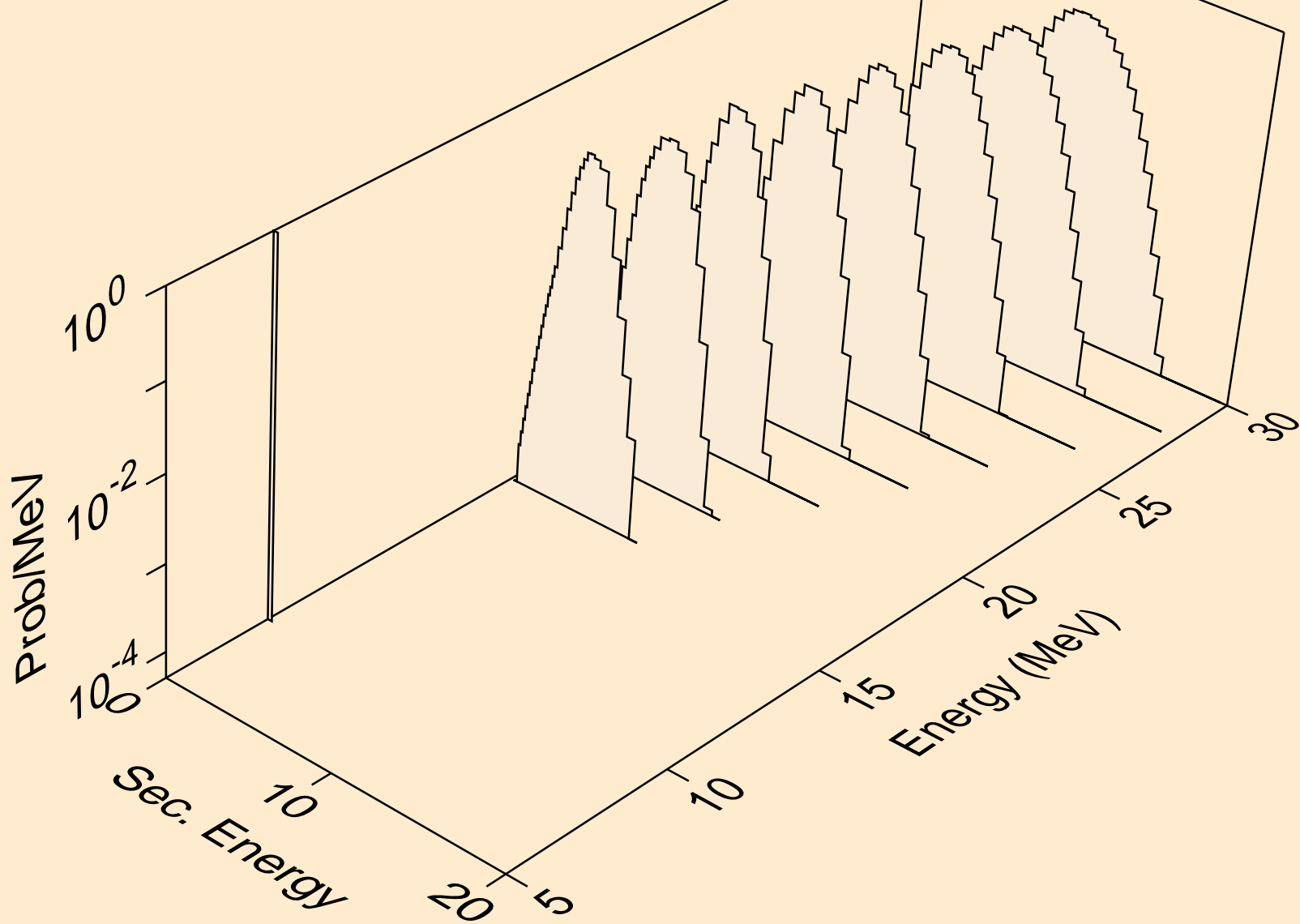

HO175 DEUTERON ACER TENDL-2023 LIBRARY; T=0.K
protons from (d,pd)

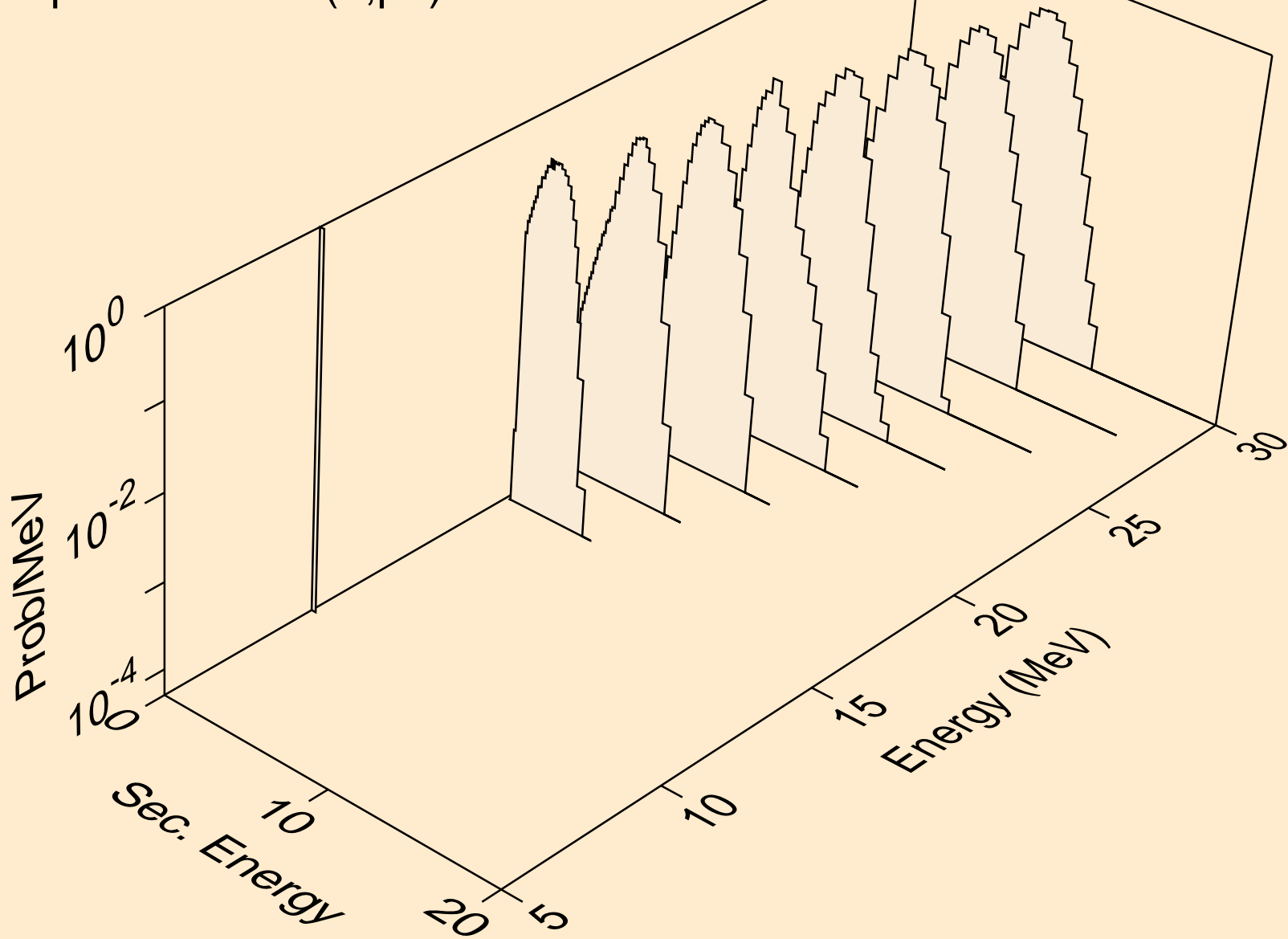

HO175 DEUTERON ACER TENDL-2023 LIBRARY; T=0.K
tritons from (d,x)

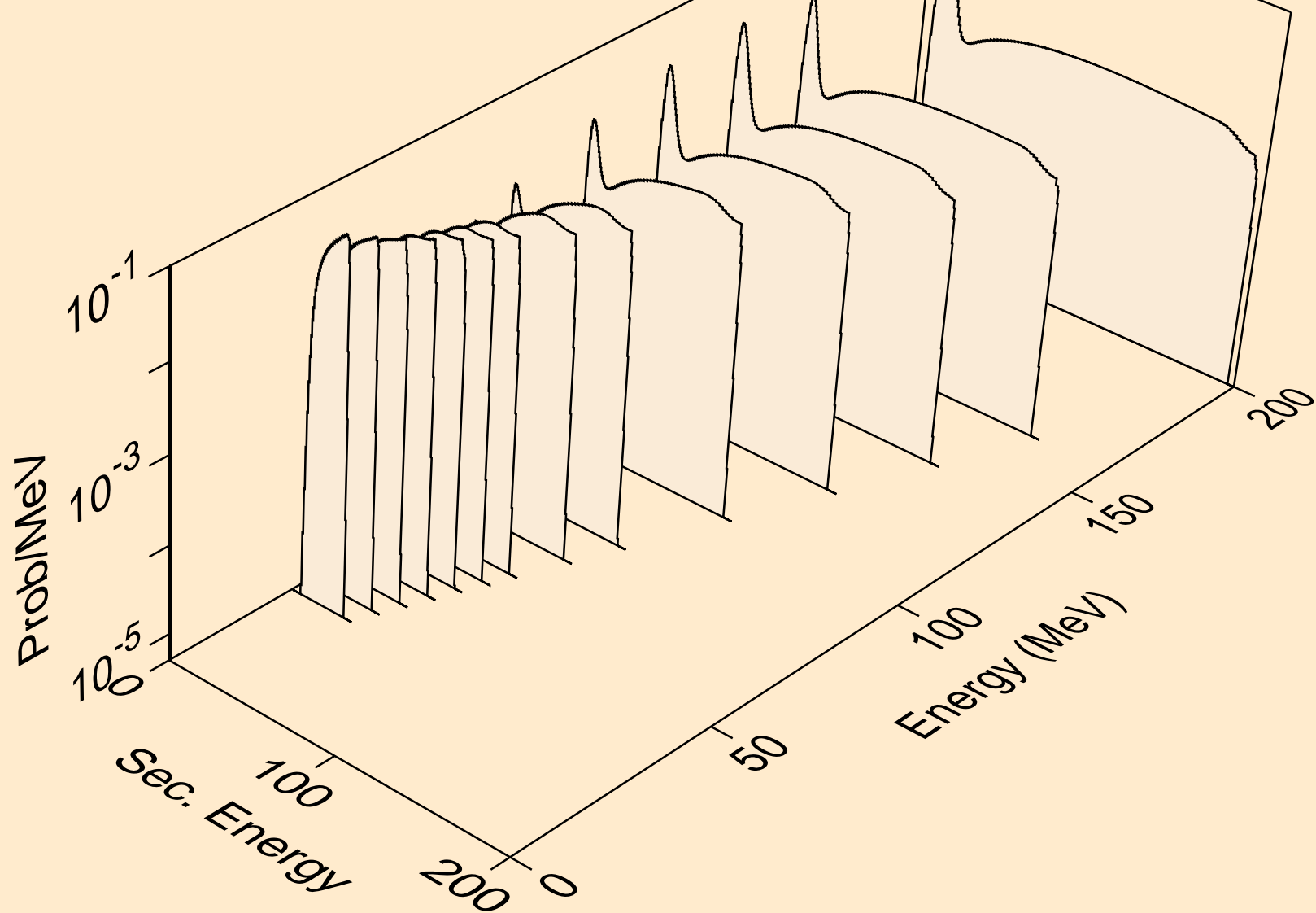

HO175 DEUTERON ACER TENDL-2023 LIBRARY; T=0.K
tritons from (d,n*)t

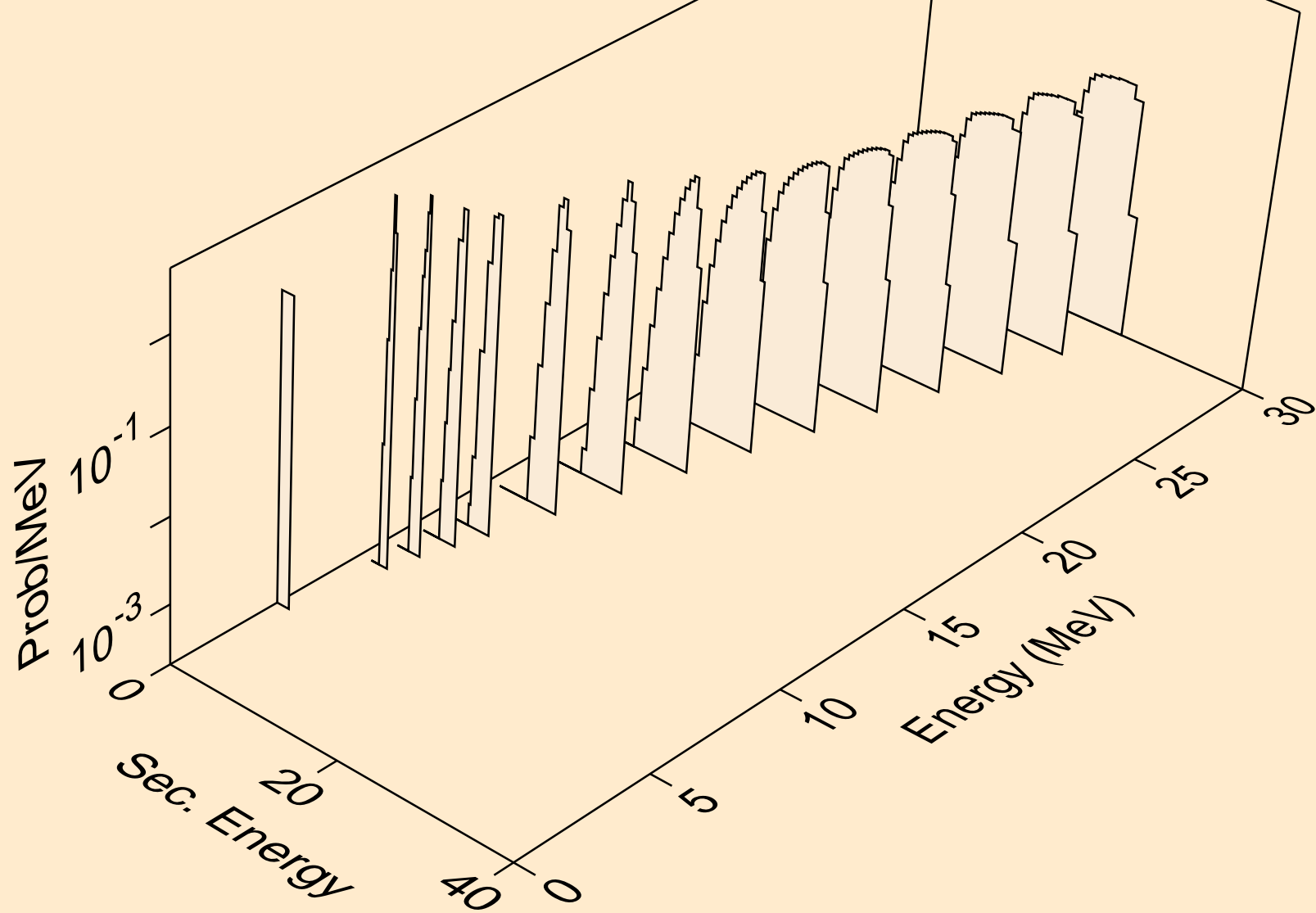

HO175 DEUTERON ACER TENDL-2023 LIBRARY; T=0.K
tritons from (d,t)

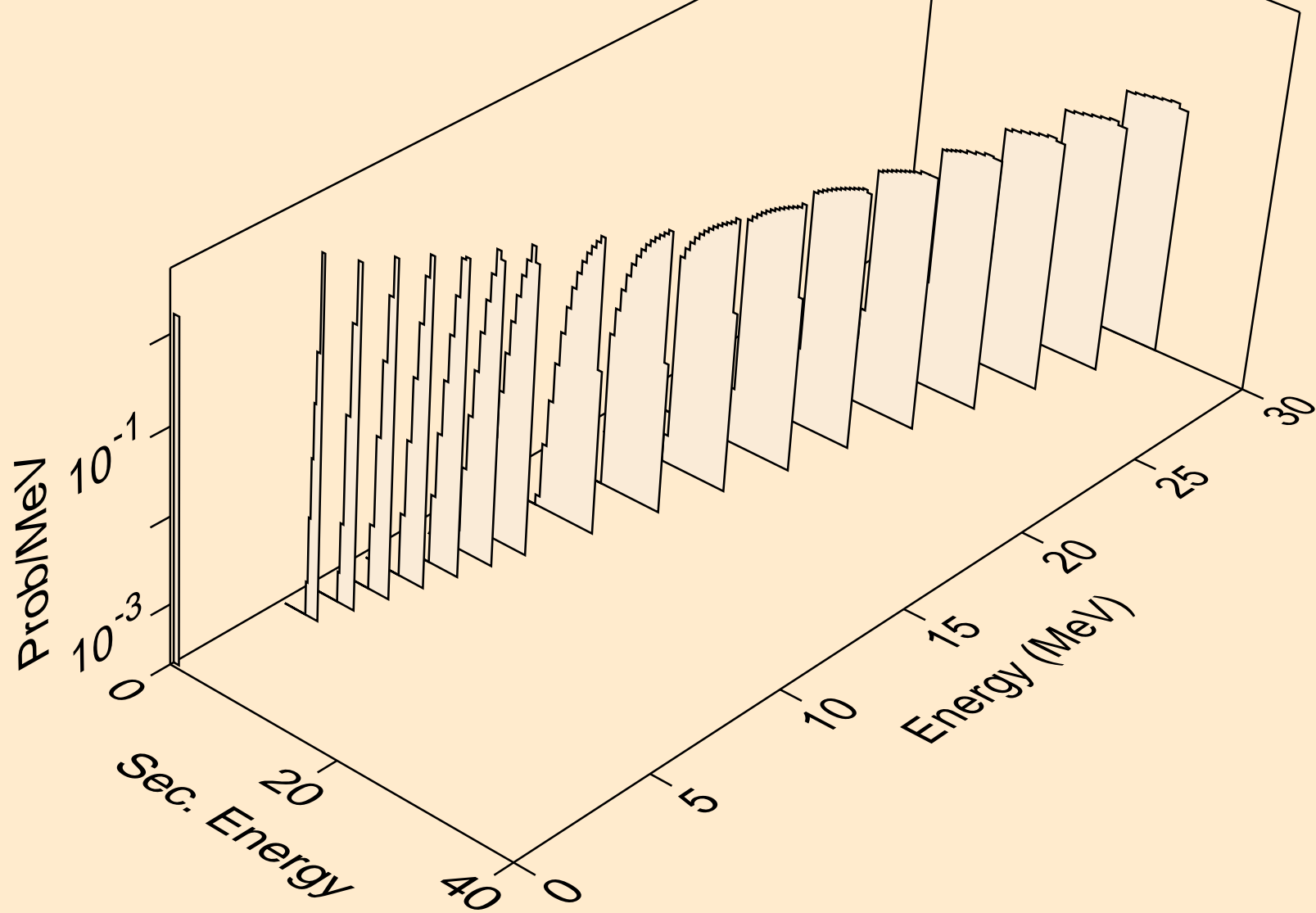

HO175 DEUTERON ACER TENDL-2023 LIBRARY; T=0.K
he3s from (d,x)

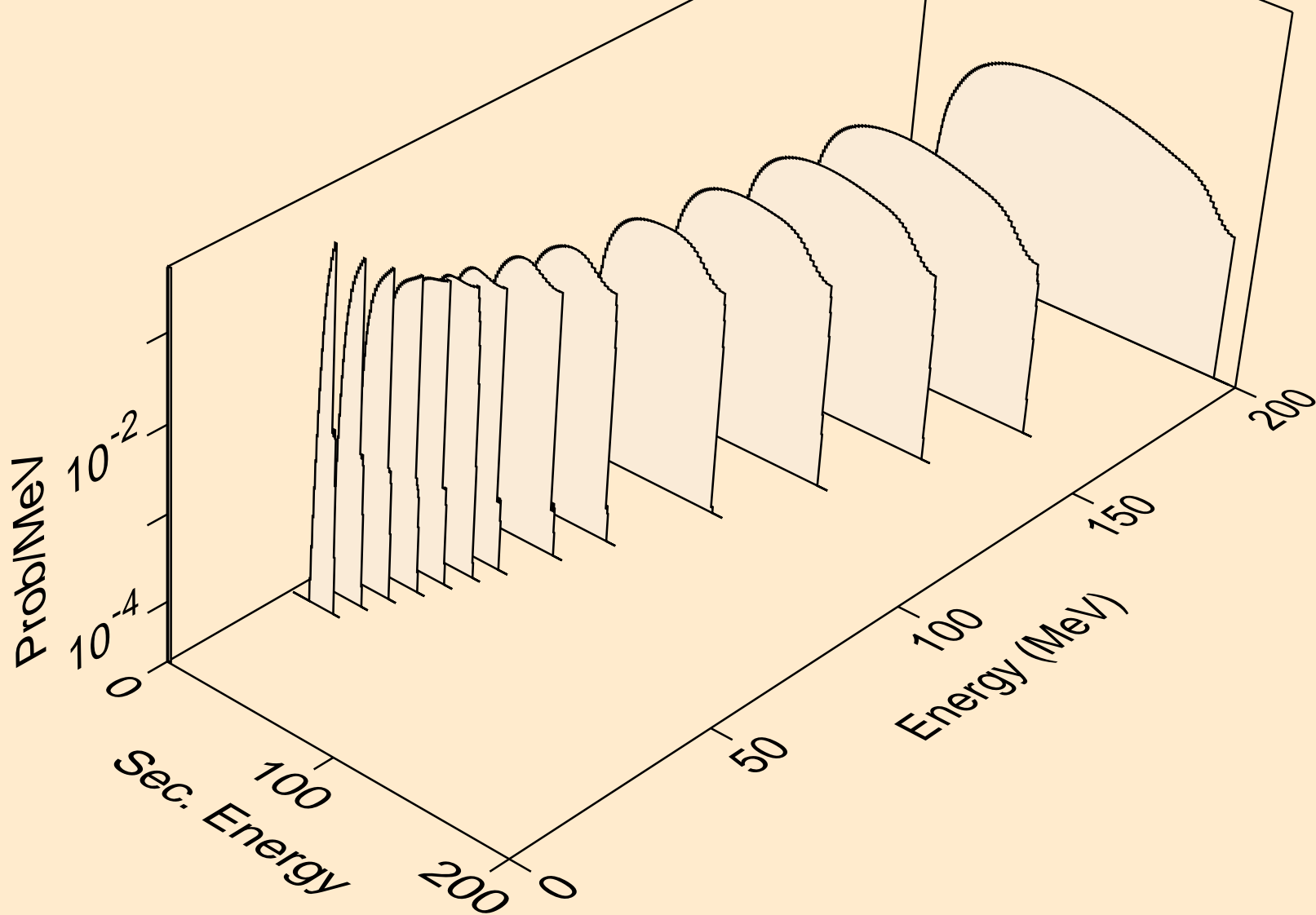

HO175 DEUTERON ACER TENDL-2023 LIBRARY; T=0.K
he3s from (d,n*)he3

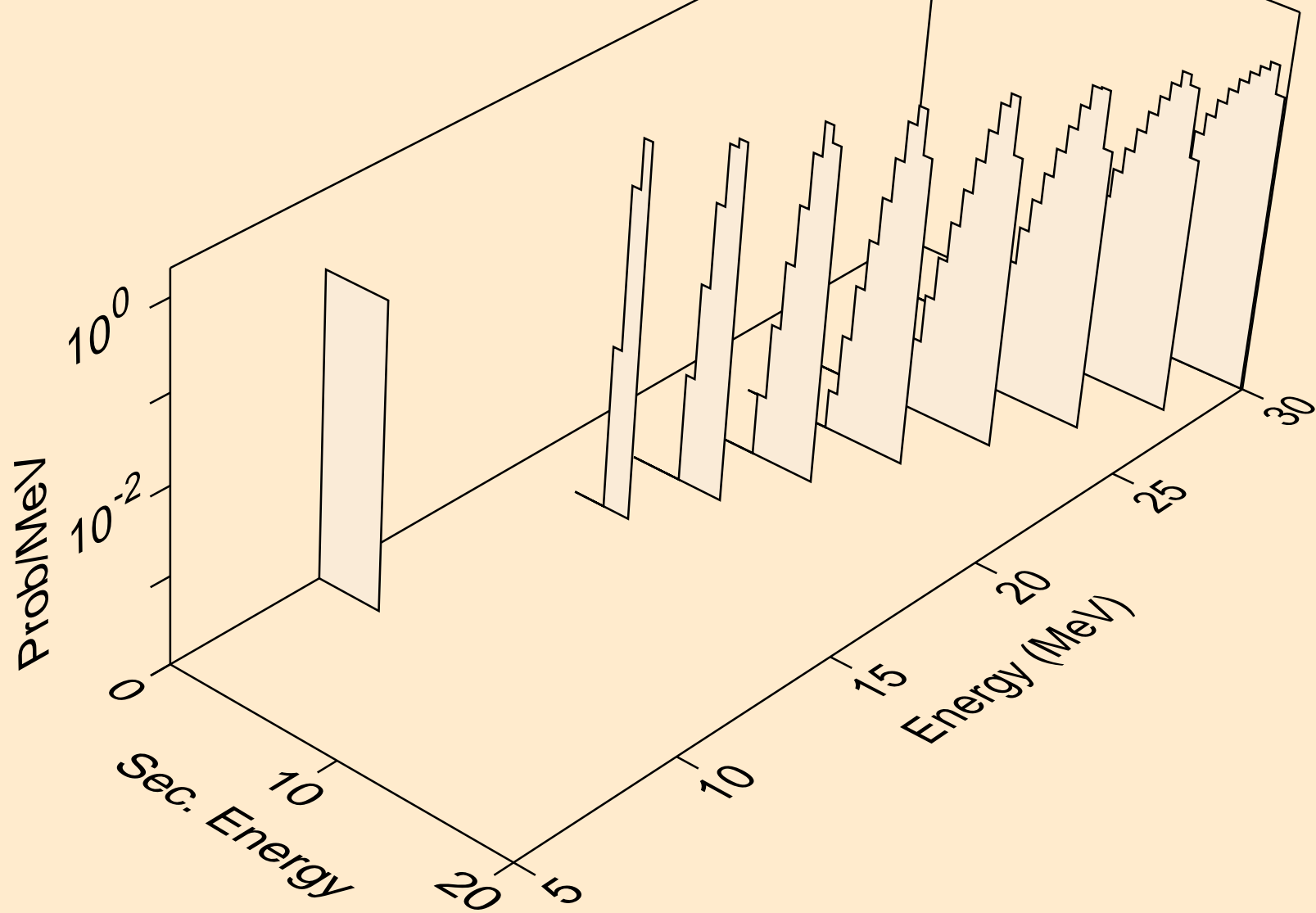

HO175 DEUTERON ACER TENDL-2023 LIBRARY; T=0.K
he3s from (d,he3)

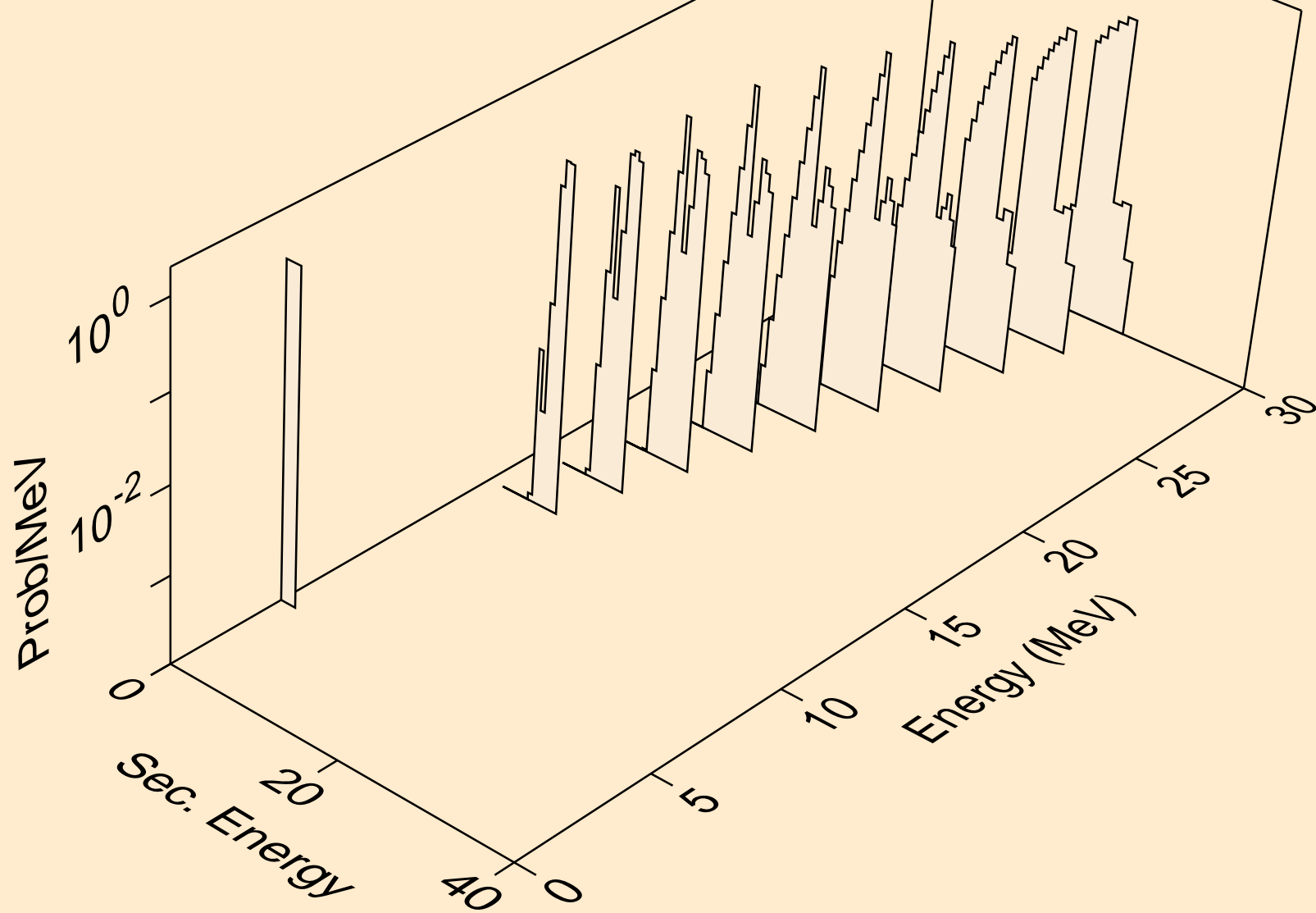

HO175 DEUTERON ACER TENDL-2023 LIBRARY; T=0.K
alphas from (d,x)

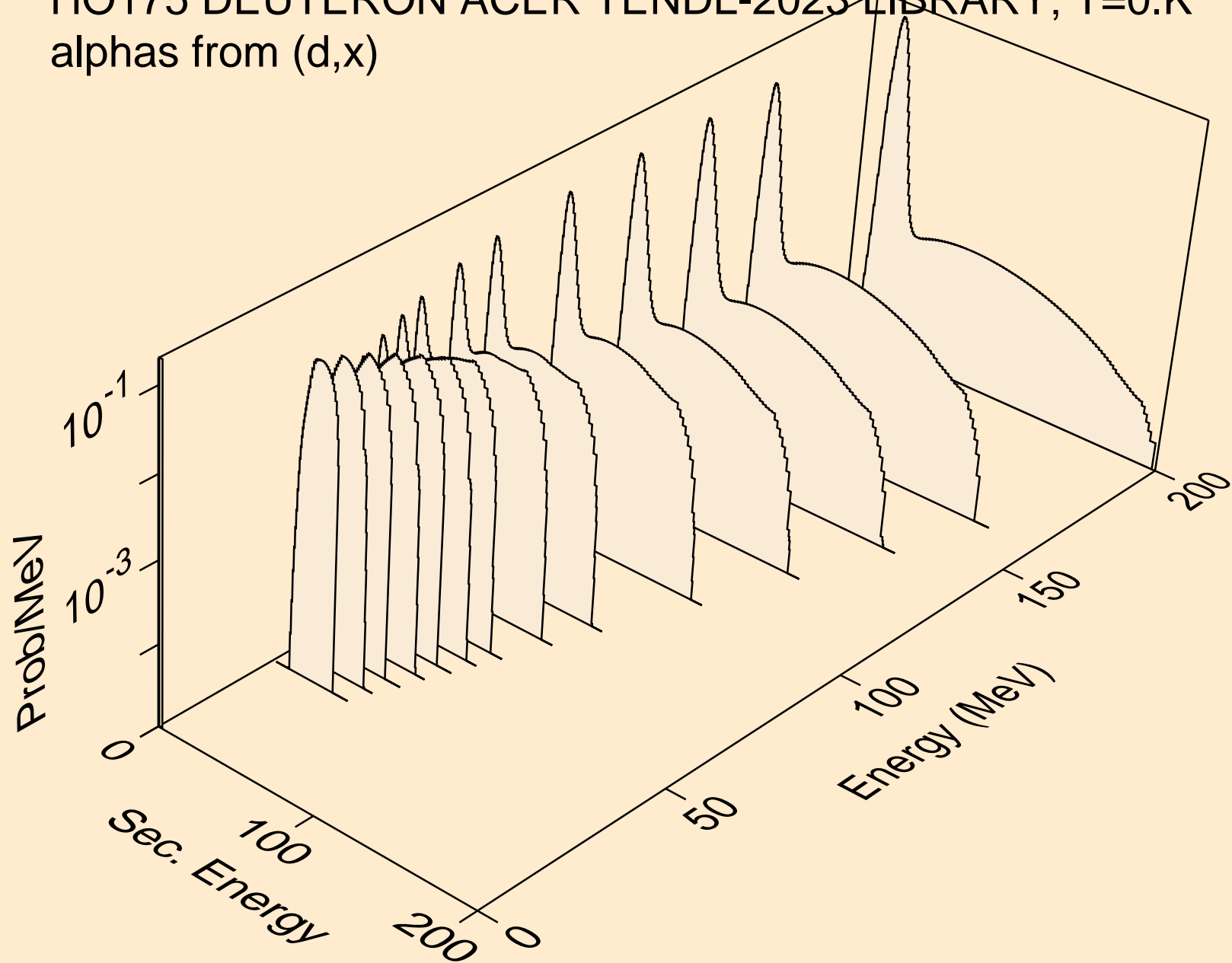

HO175 DEUTERON ACER TENDL-2023 LIBRARY; T=0.K
alphas from (d,n*)a

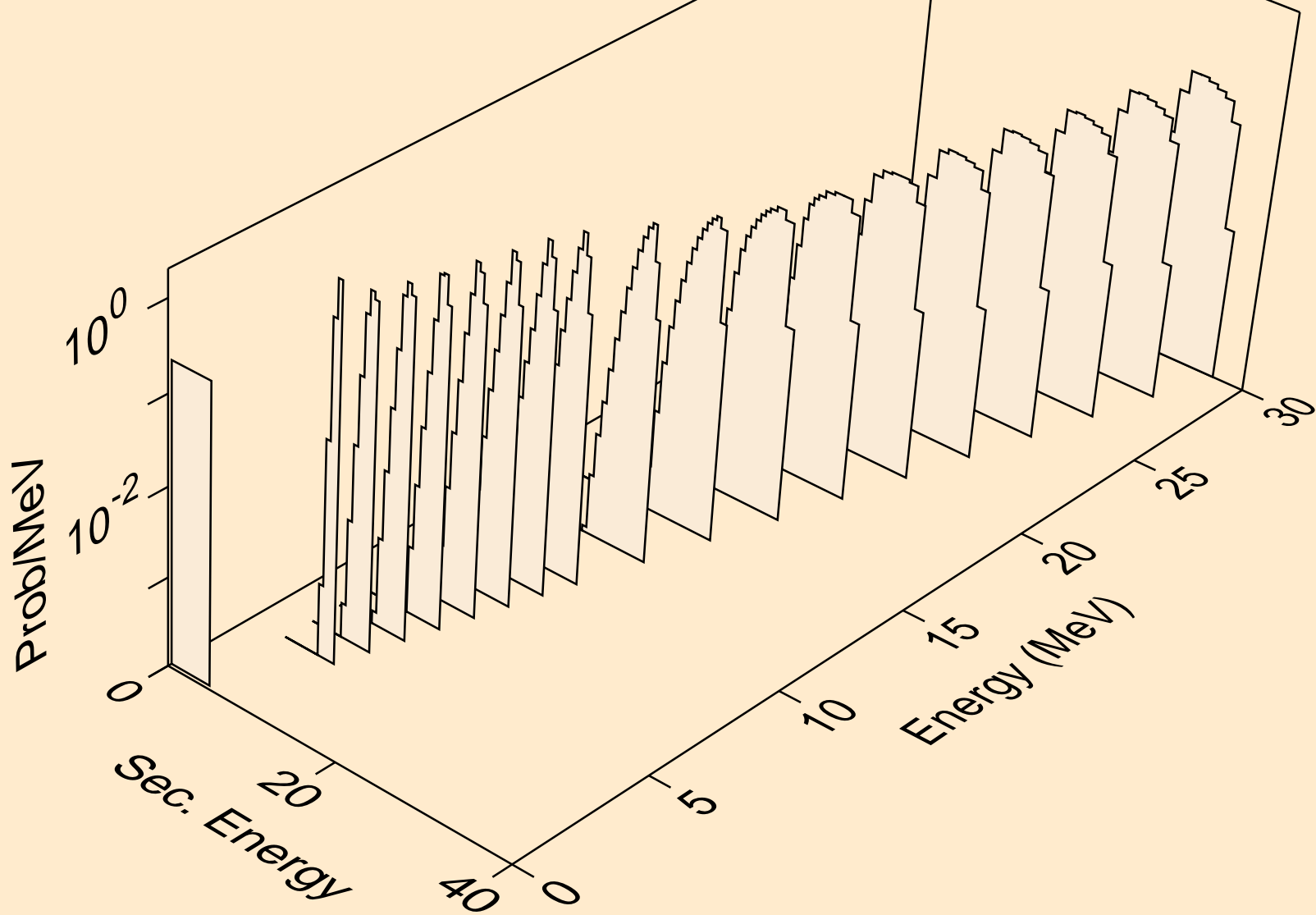

HO175 DEUTERON ACER TENDL-2023 LIBRARY; T=0.K
alphas from (d,2n)a

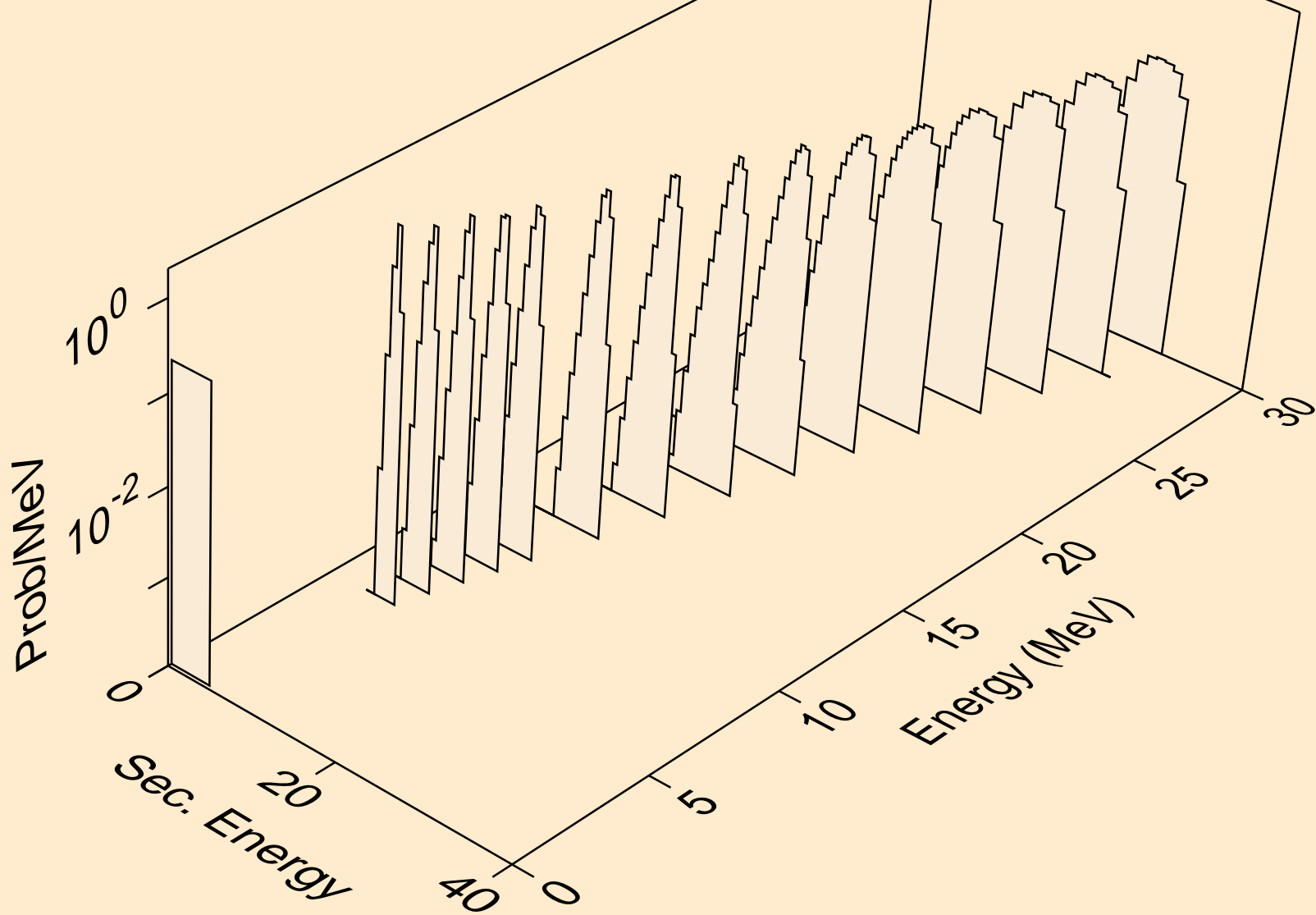

HO175 DEUTERON ACER TENDL-2023 LIBRARY; T=0.K
alphas from (d,3n)a

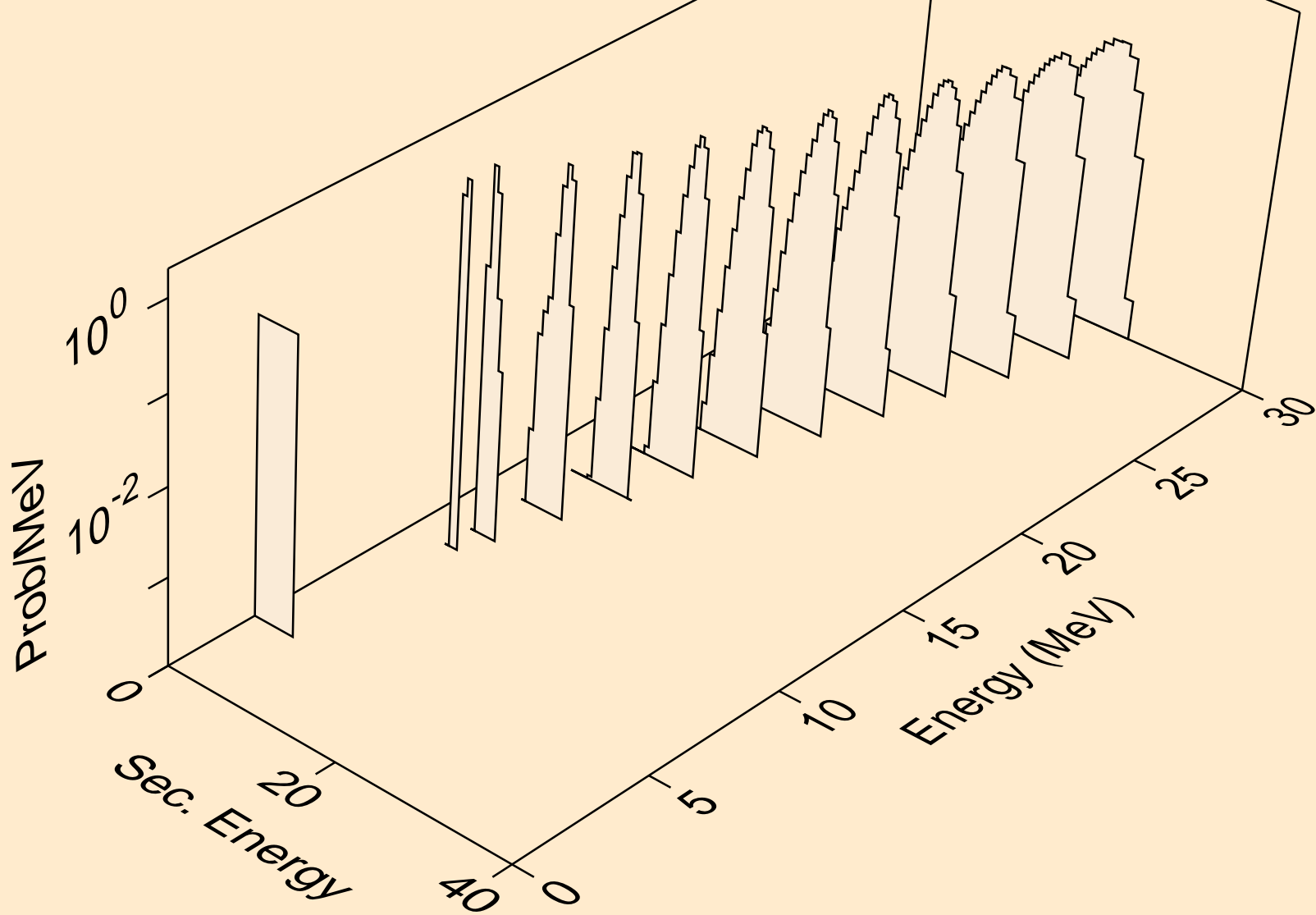

HO175 DEUTERON ACER TENDL-2023 LIBRARY; T=0.K
alphas from (d,a)

