

PT185M DEUTERON ACER TENDL-2023 LIBRARY; T=0.K  
Principal cross sections

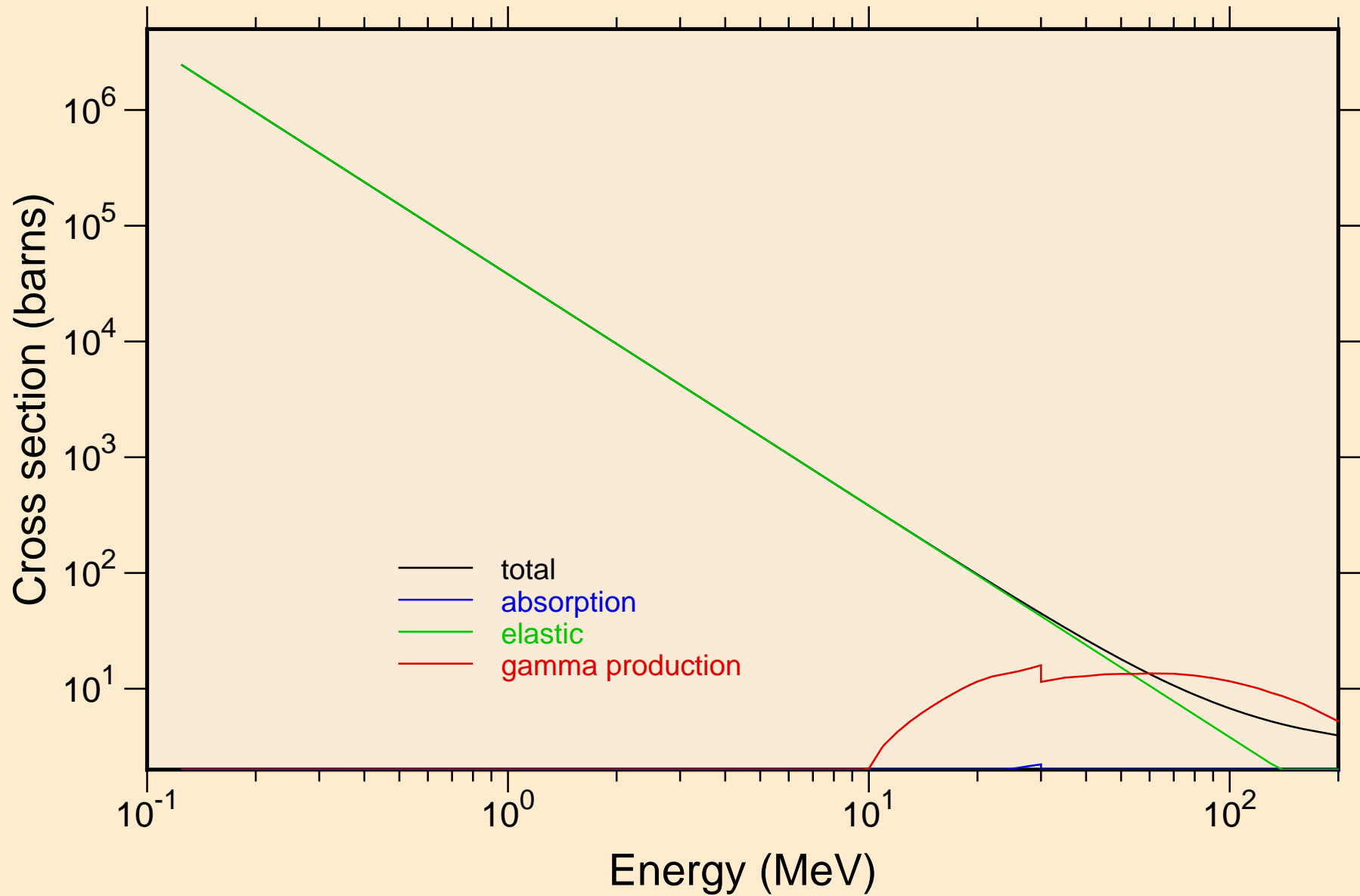

PT185M DEUTERON ACER TENDL-2023 LIBRARY; T=0.K  
Heating

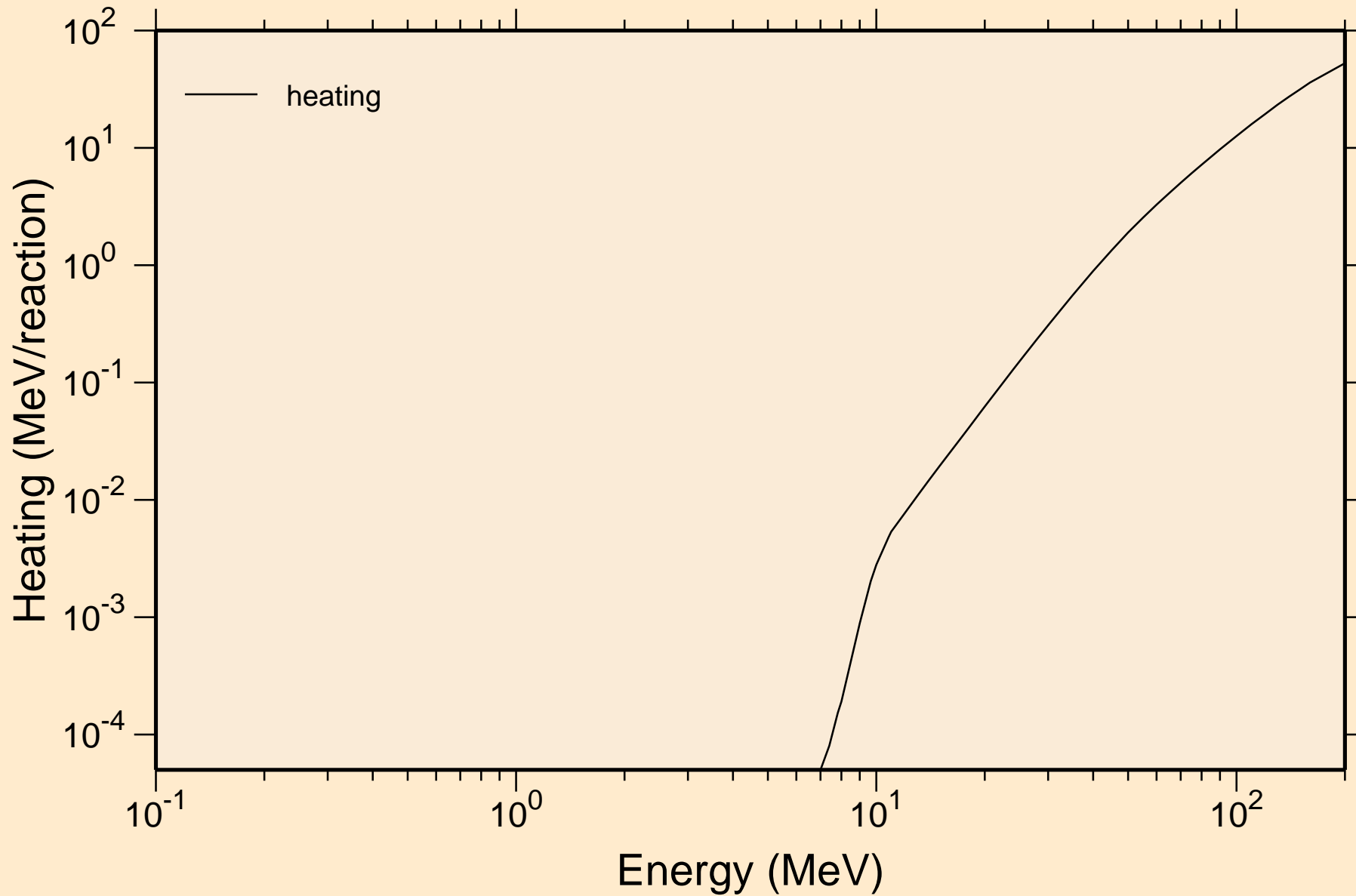

PT185M DEUTERON ACER TENDL-2023 LIBRARY; T=0.K  
Principal cross sections

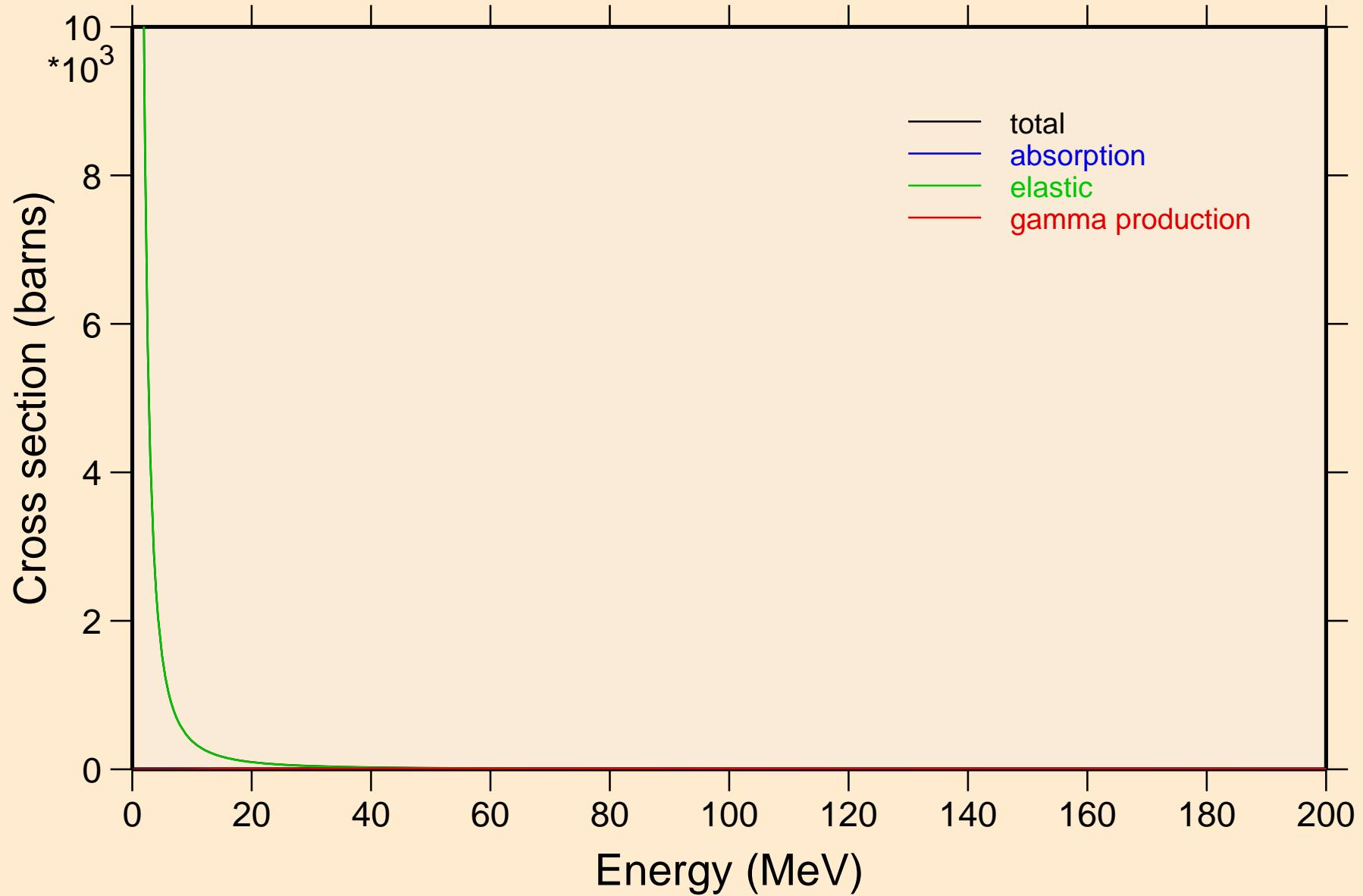

PT185M DEUTERON ACER TENDL-2023 LIBRARY; T=0.K  
Heating

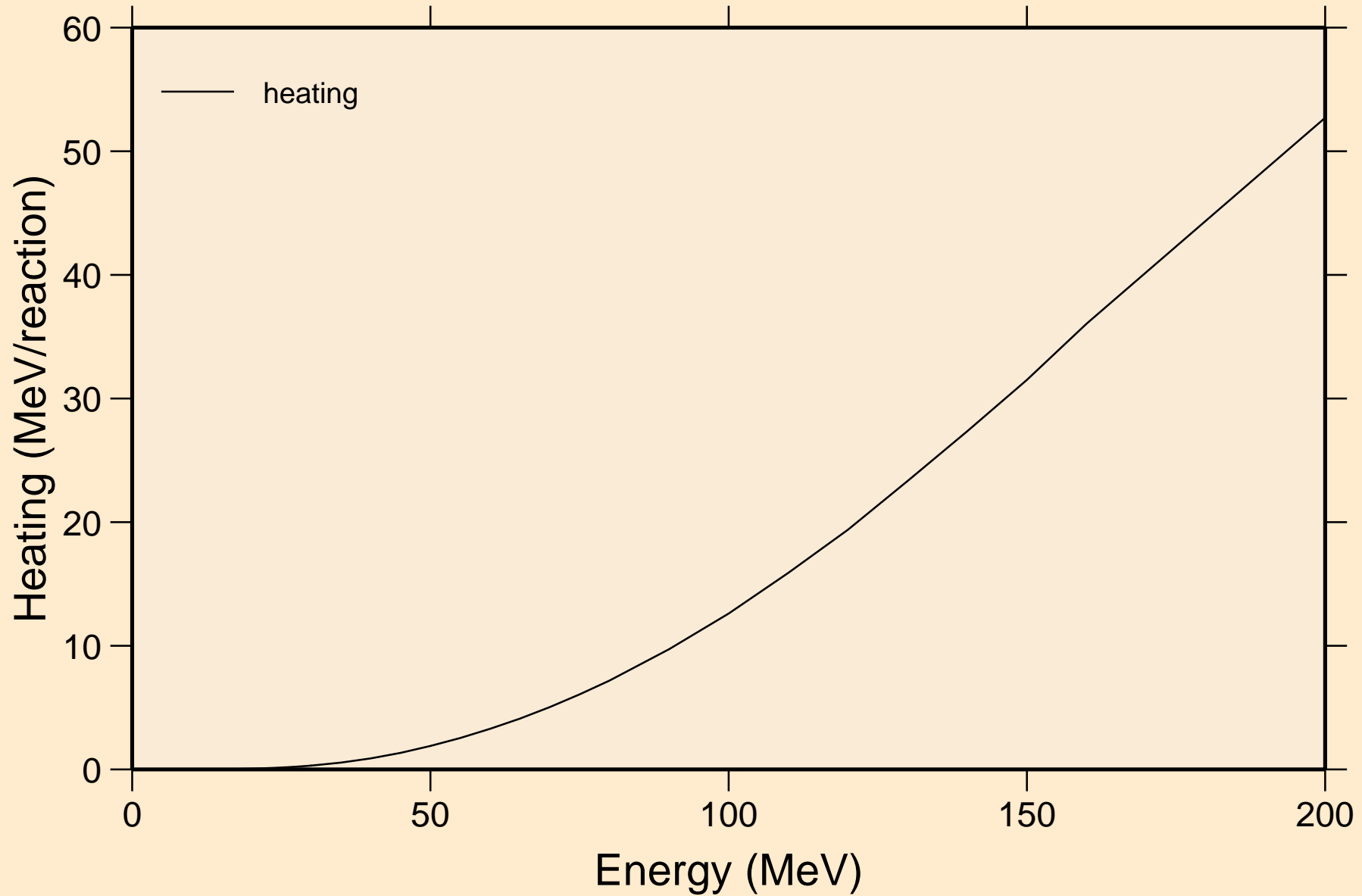

PT185M DEUTERON ACER TENDL-2023 LIBRARY; T=0.K  
Threshold reactions

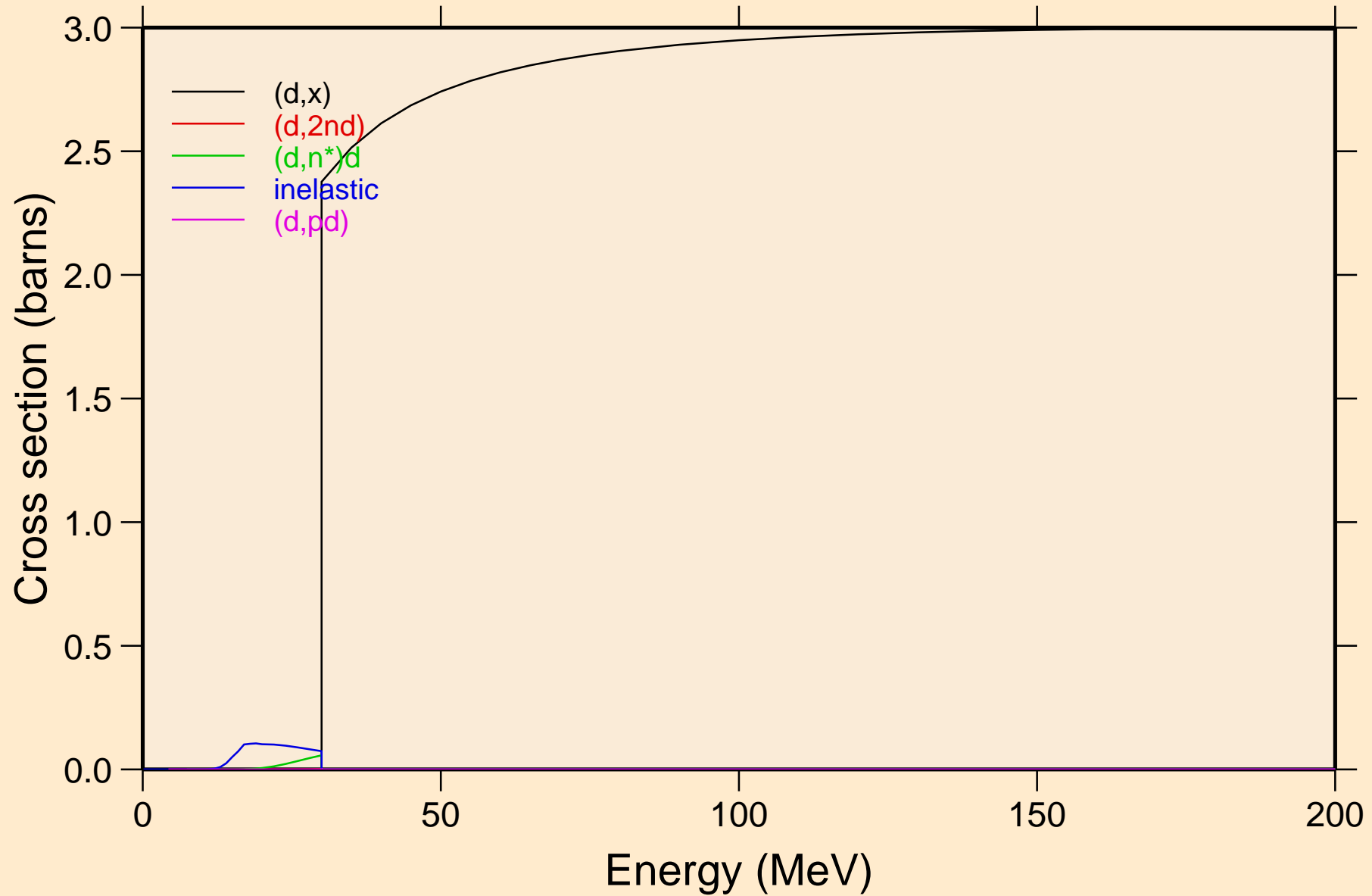

PT185M DEUTERON ACER TENDL-2023 LIBRARY; T=0.K  
Threshold reactions

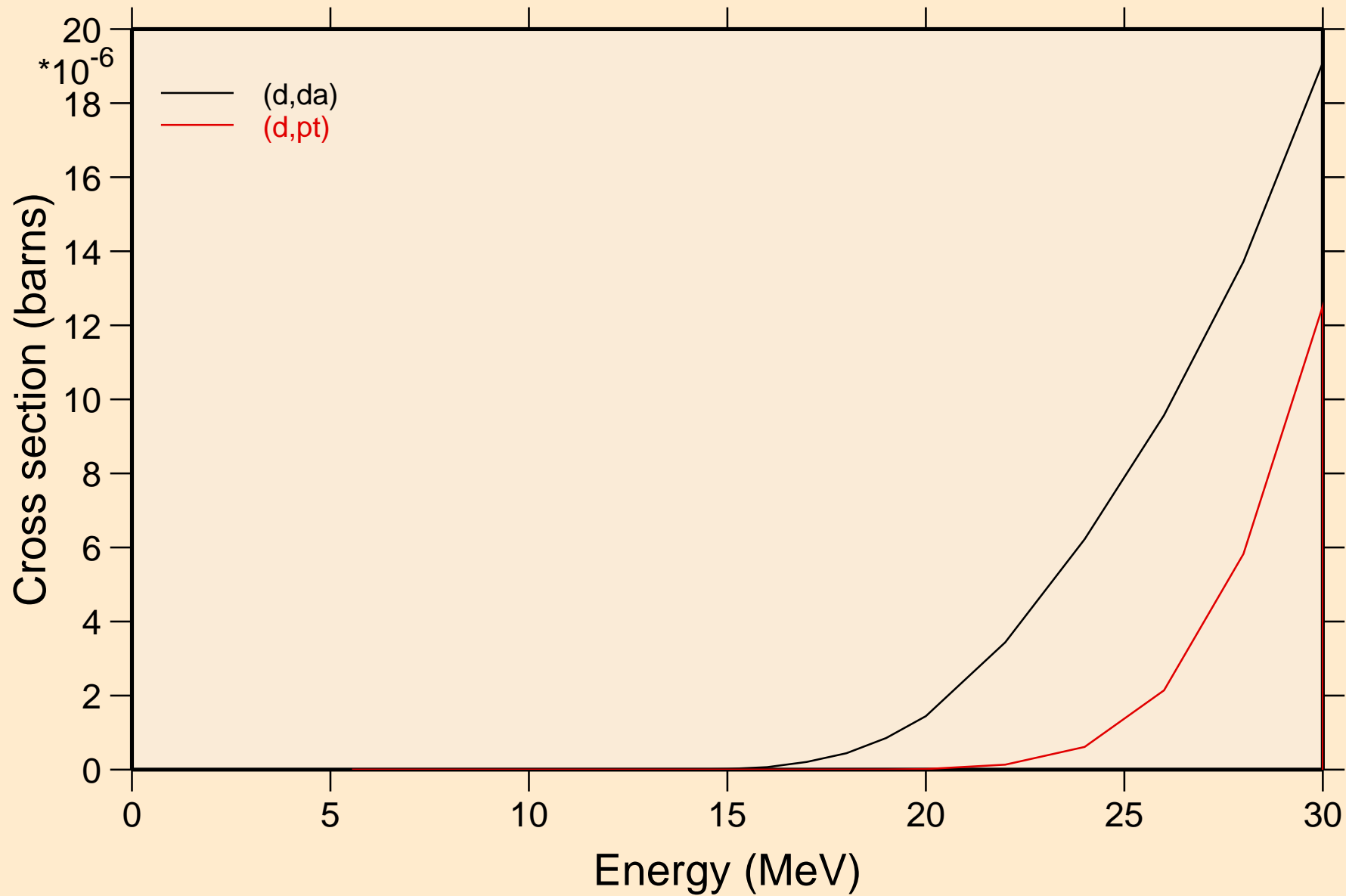

PT185M DEUTERON ACER TENDL-2023 LIBRARY; T=0.K  
Threshold reactions

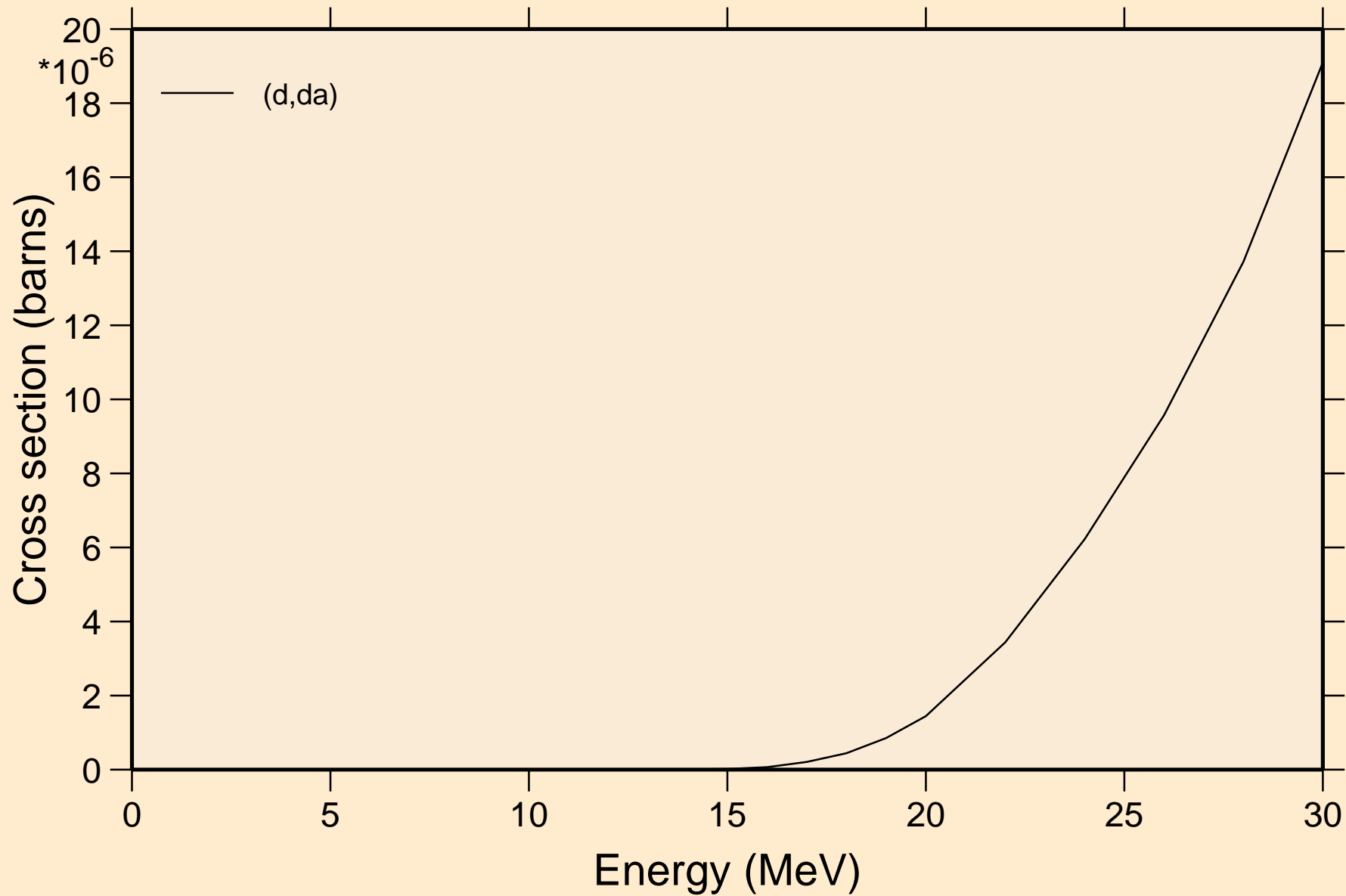

PT185M DEUTERON ACER TENDL-2023 LIBRARY; T=0.K  
angular distribution for elastic

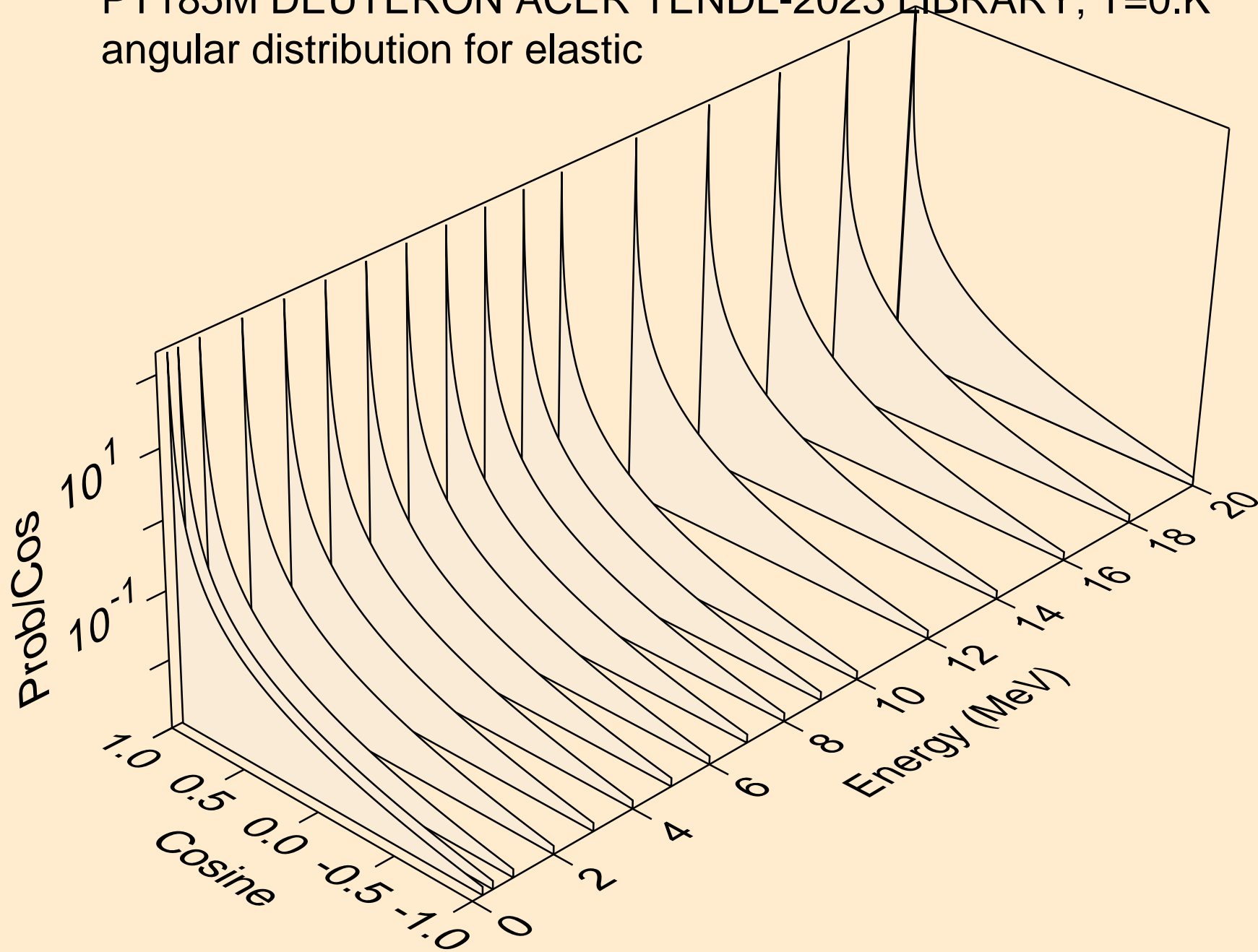



PT185M DEUTERON ACER TENDL-2023 LIBRARY; T=0.K  
angular distribution for elastic

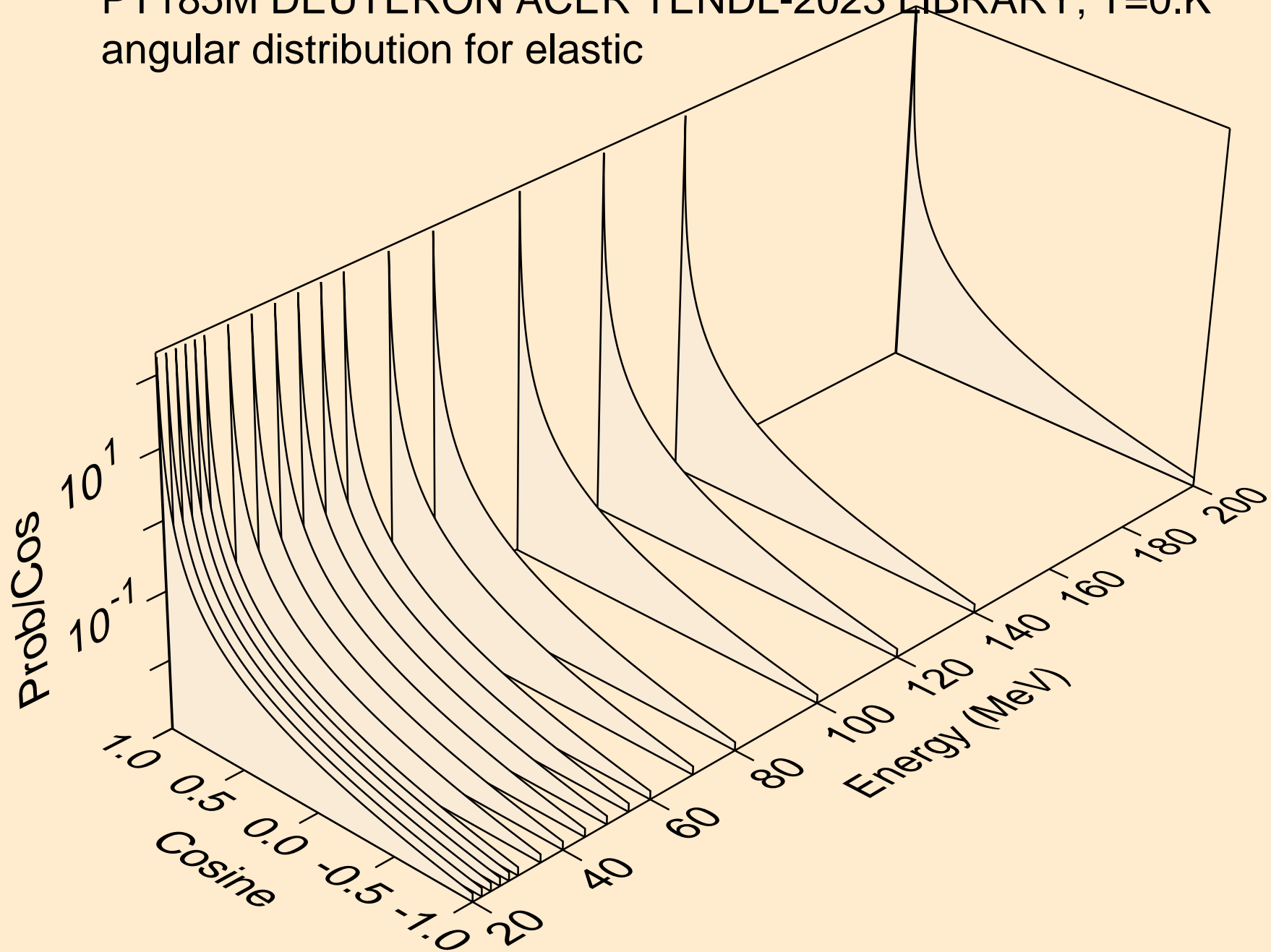

PT185M DEUTERON ACER TENDL-2023 LIBRARY; T=0.K  
Deuteron emission for (d,x)

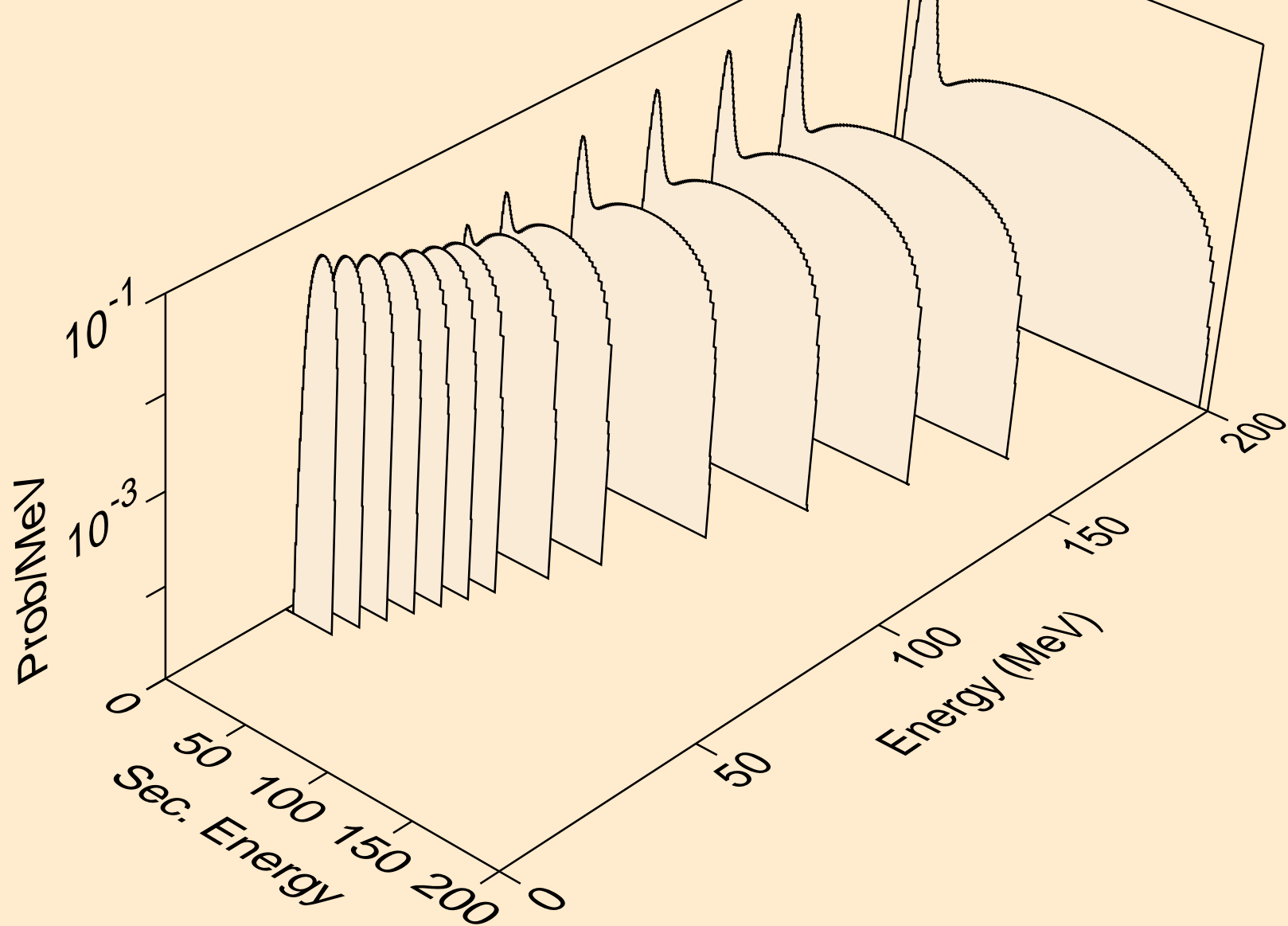

PT185M DEUTERON ACER TENDL-2023 LIBRARY; T=0.K  
Deuteron emission for (d,2nd)

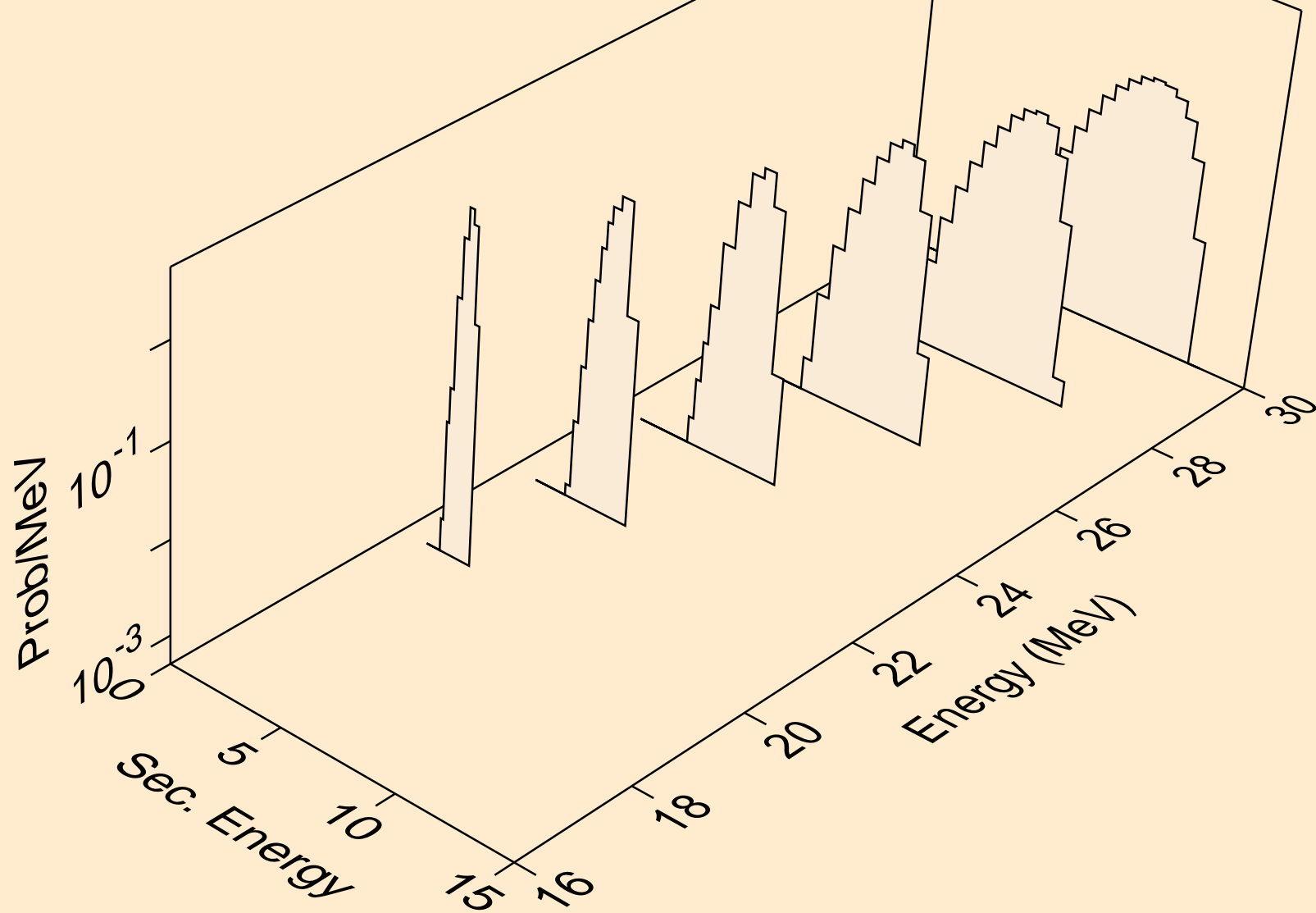

PT185M DEUTERON ACER TENDL-2023 LIBRARY; T=0.K  
Deuteron emission for (d,n\*)d

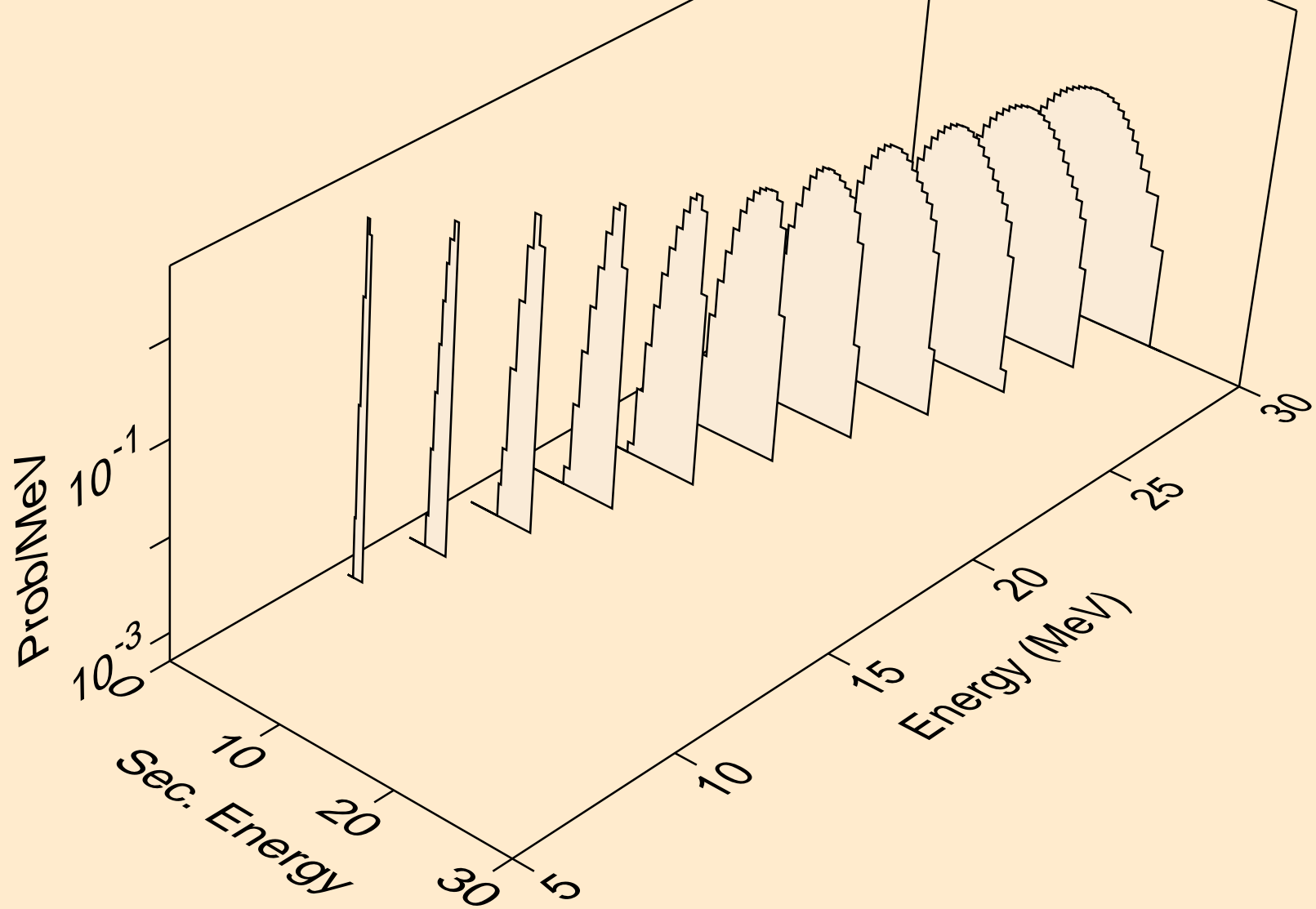

PT185M DEUTERON ACER TENDL-2023 LIBRARY; T=0.K  
Deuteron emission for inelastic

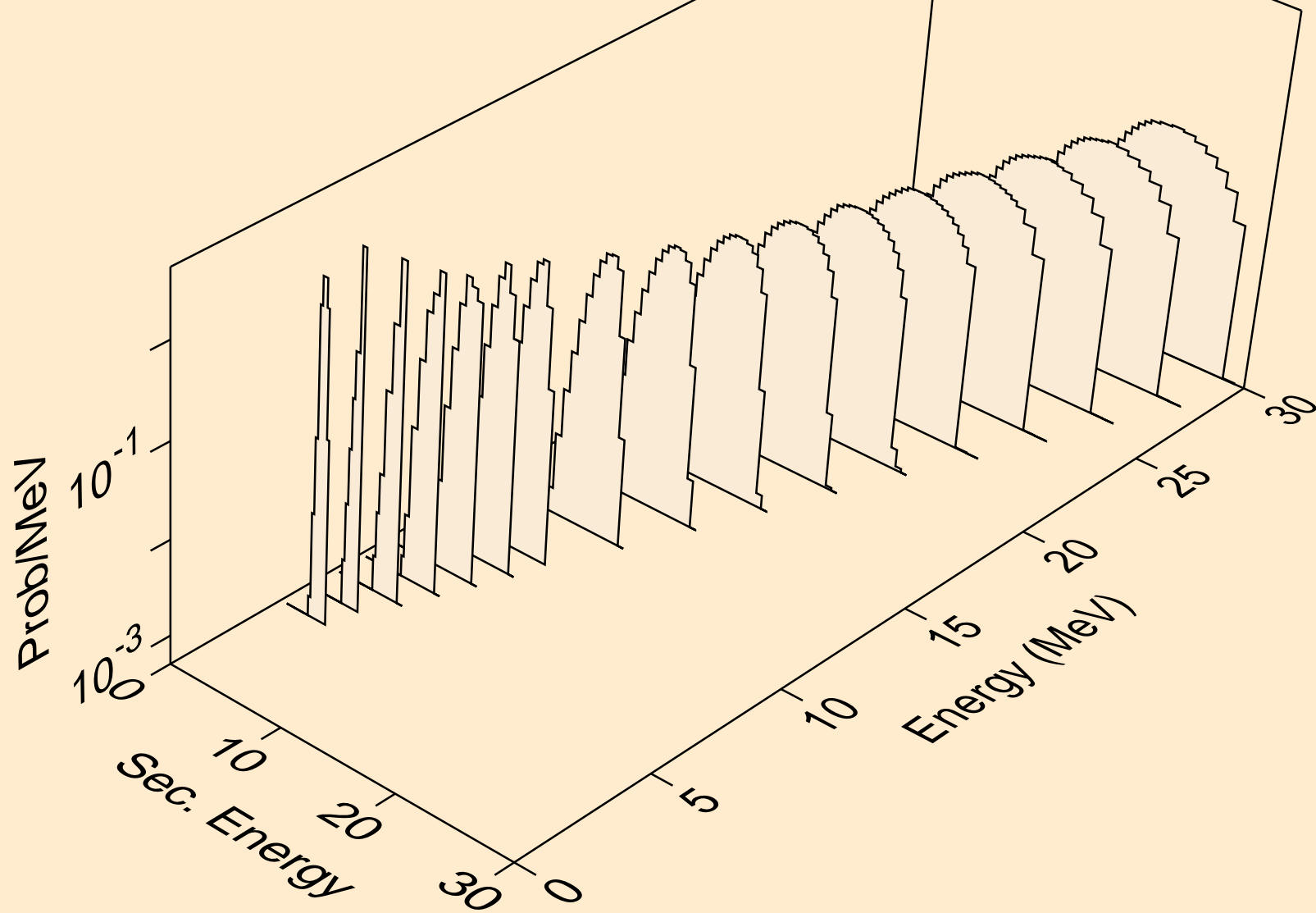

PT185M DEUTERON ACER TENDL-2023 LIBRARY; T=0.K  
Deuteron emission for (d,pd)

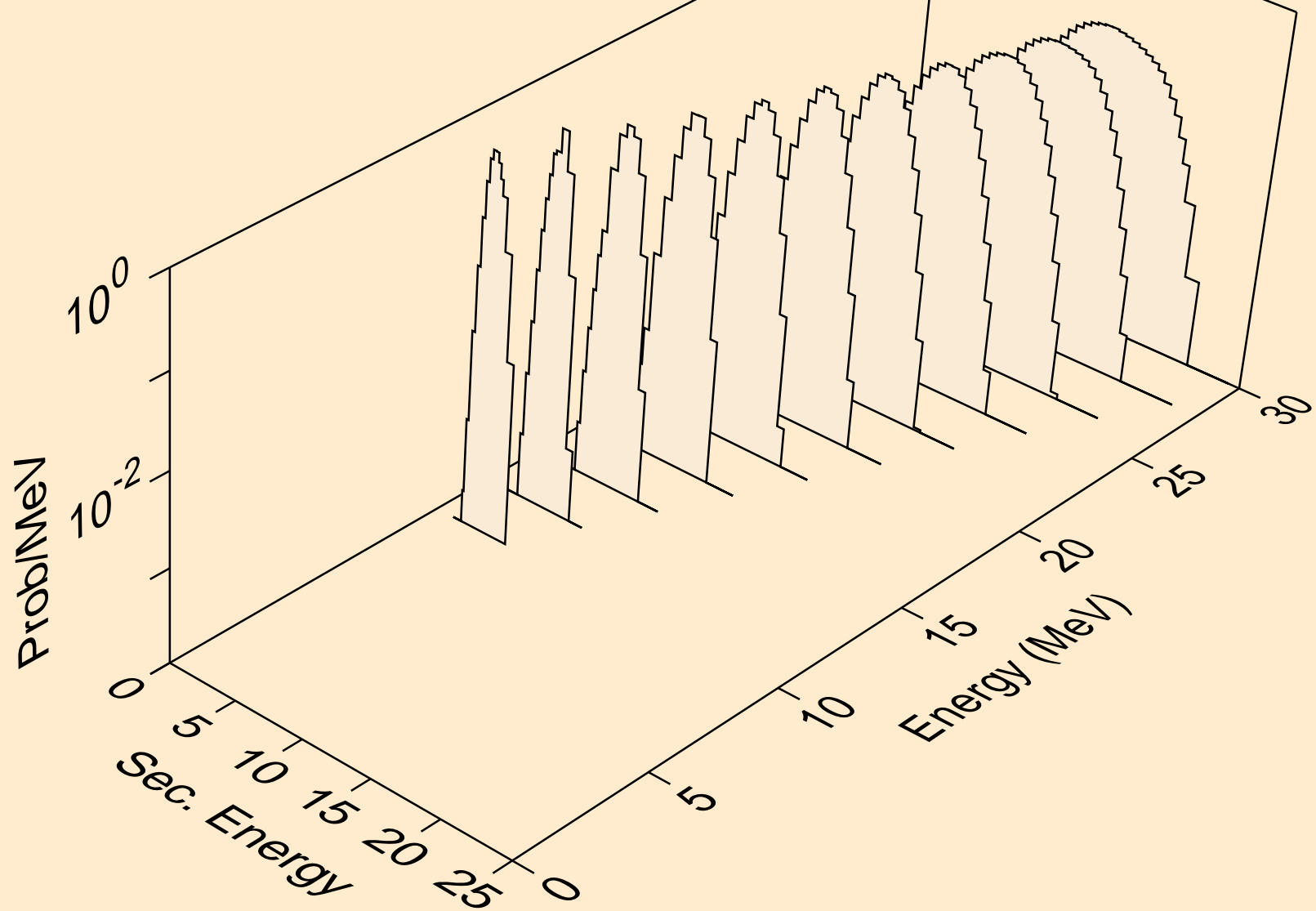

PT185M DEUTERON ACER TENDL-2023 LIBRARY; T=0.K  
Deuteron emission for (d,da)

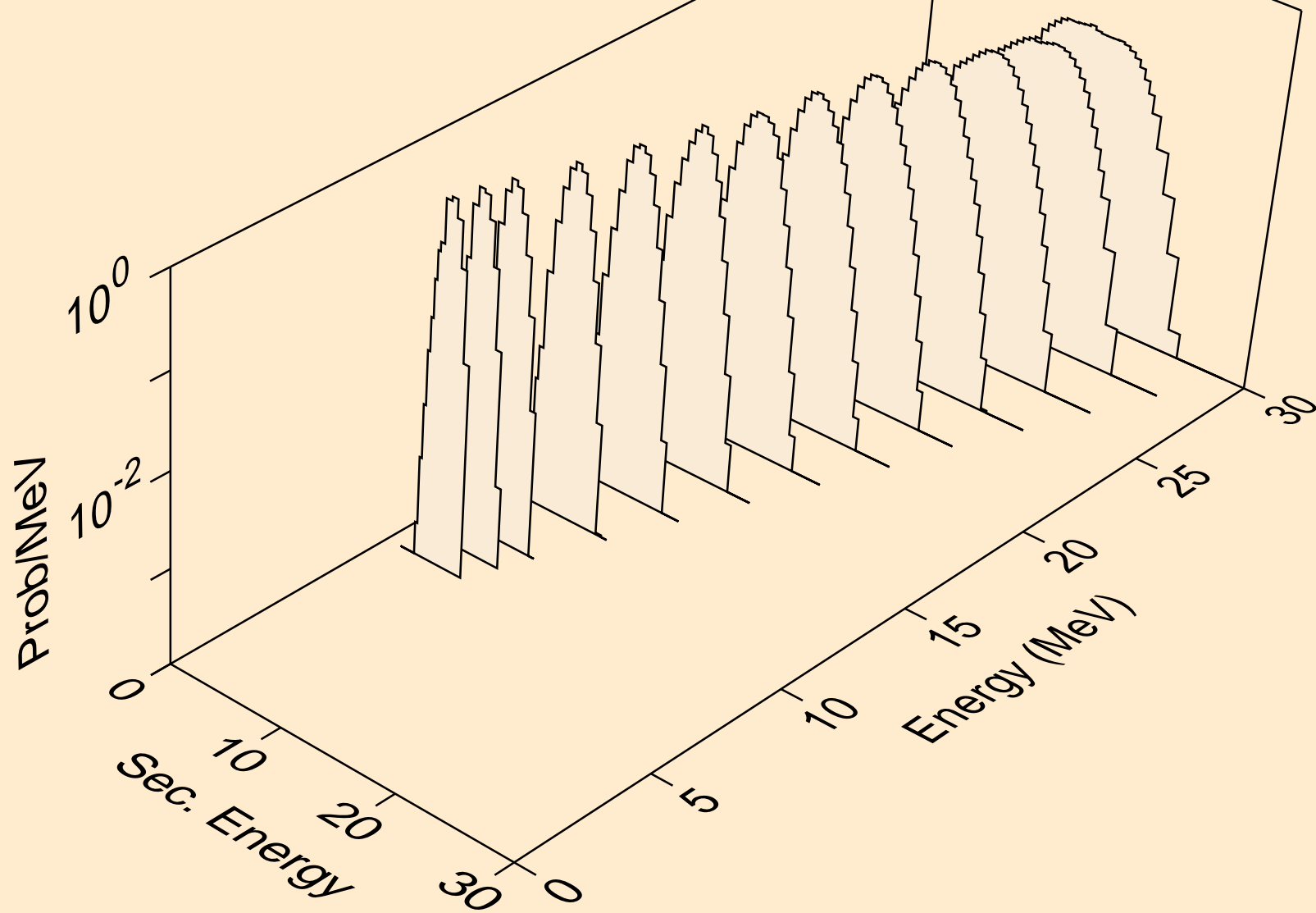

PT185M DEUTERON ACER TENDL-2023 LIBRARY; T=0.K  
Photon emission for (z,n)

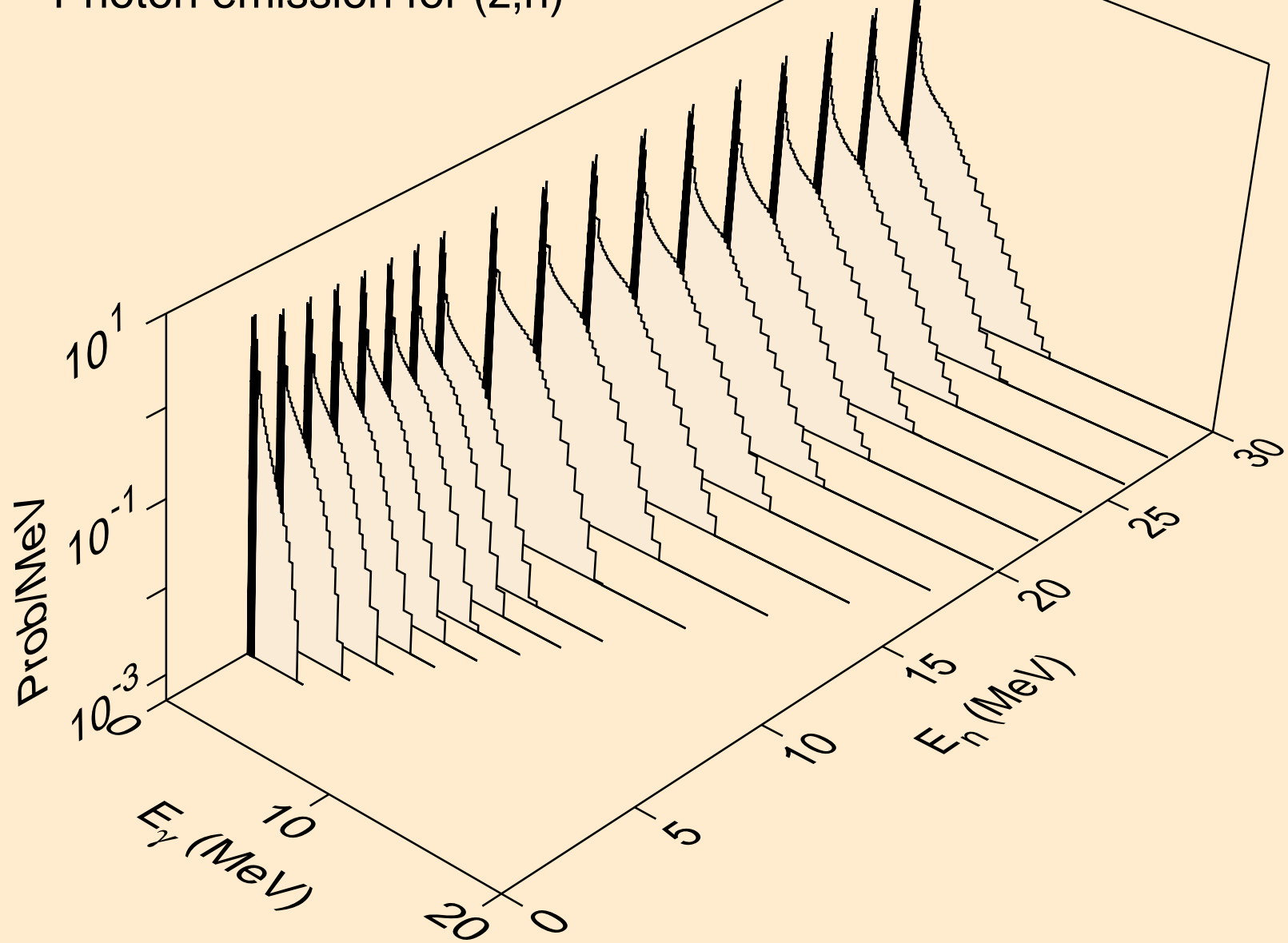



PT185M DEUTERON ACER TENDL-2023 LIBRARY; T=0.K  
Photon emission for (z,x)

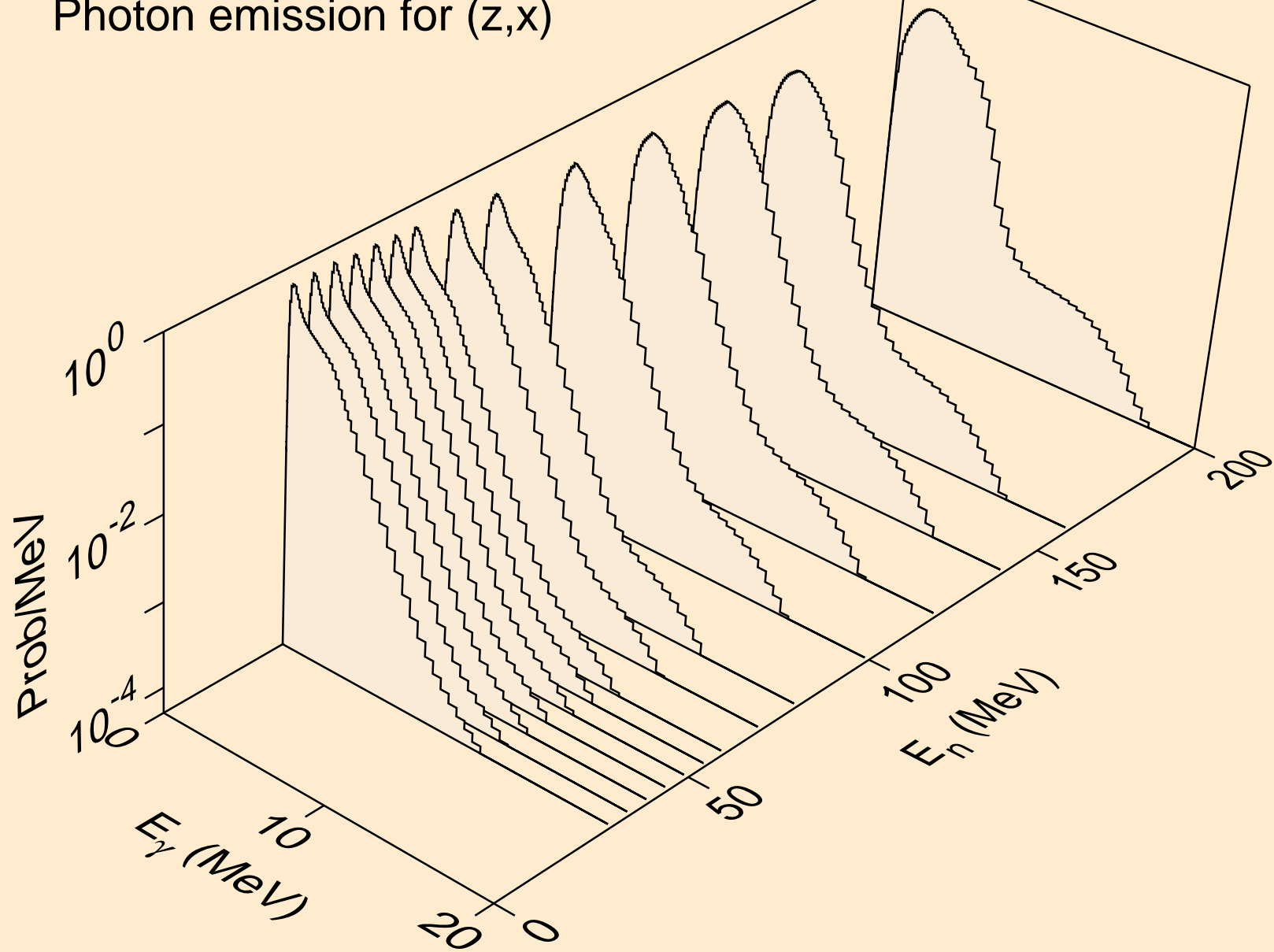

PT185M DEUTERON ACER TENDL-2023 LIBRARY; T=0.K  
Photon emission for (n,2nd)

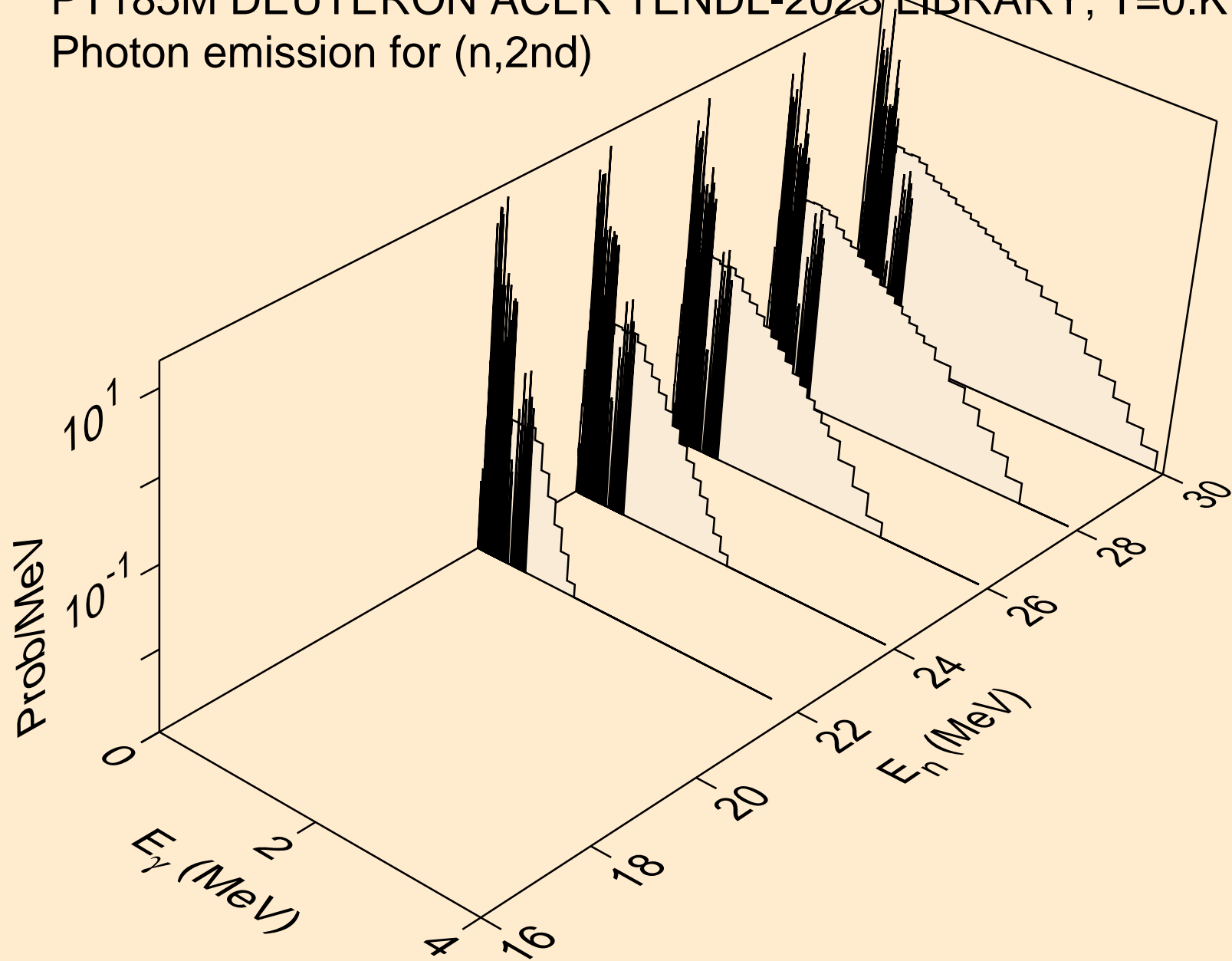

PT185M DEUTERON ACER TENDL-2023 LIBRARY; T=0.K  
Photon emission for (n,2n)

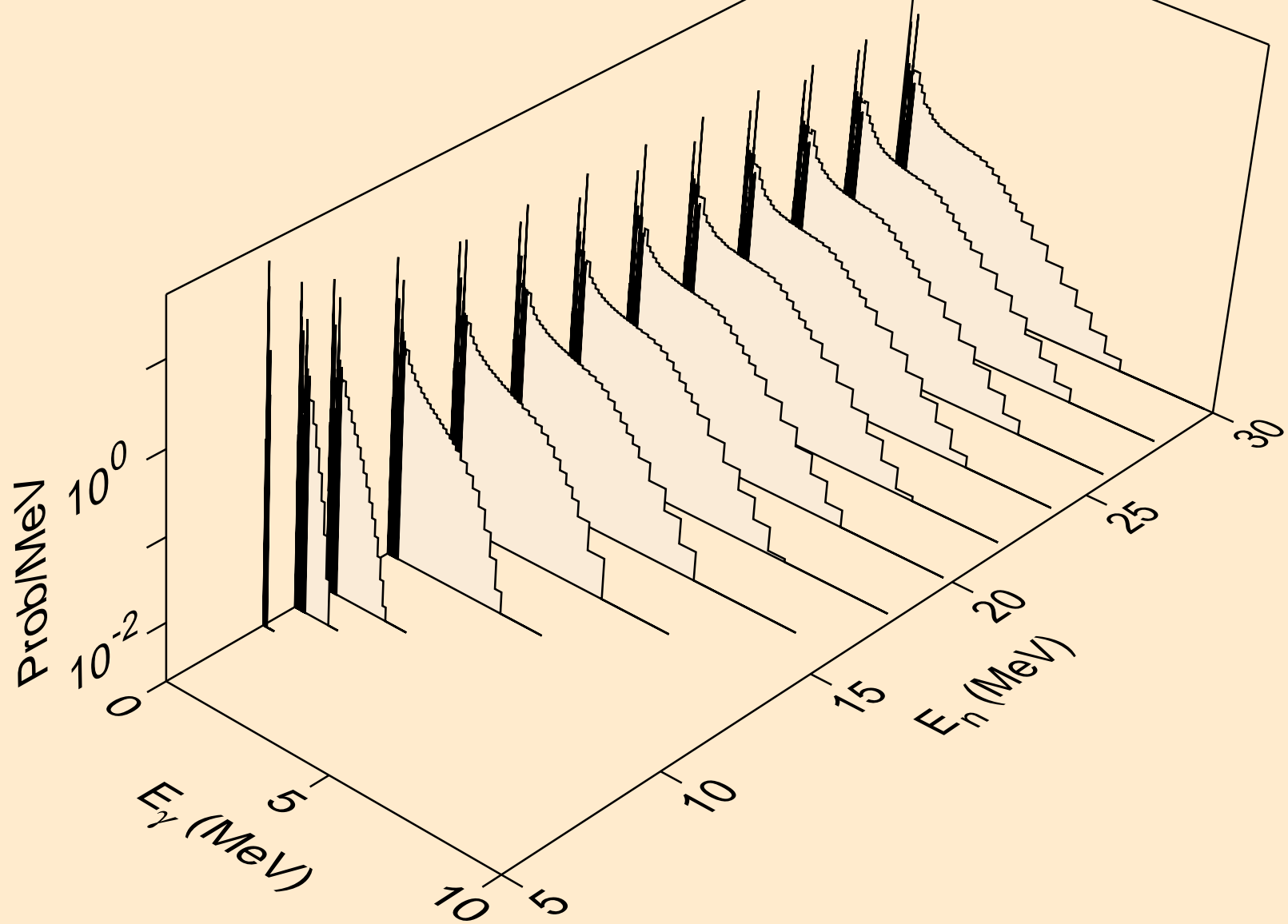

PT185M DEUTERON ACER TENDL-2023 LIBRARY; T=0.K  
Photon emission for (n,3n)

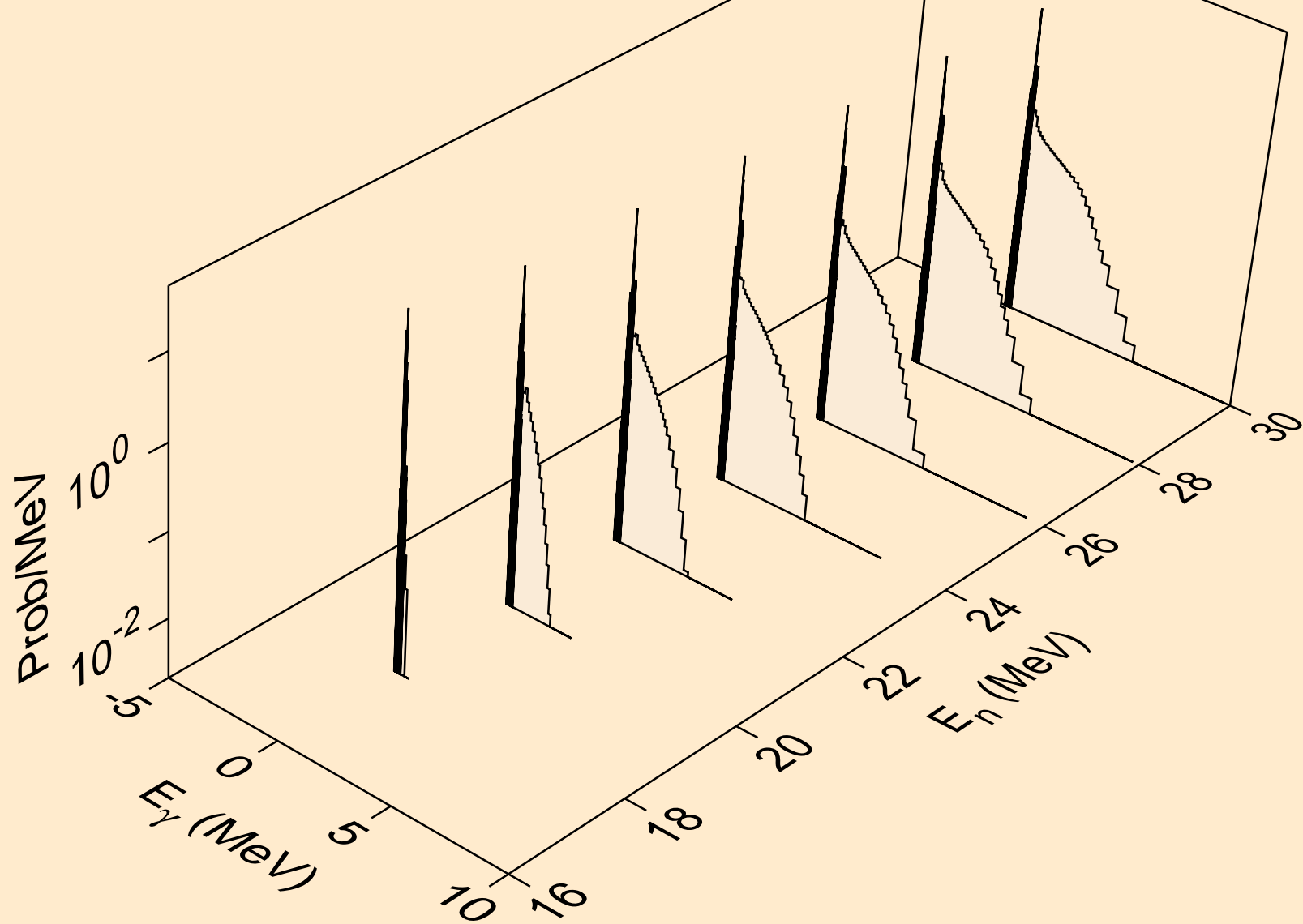

PT185M DEUTERON ACER TENDL-2023 LIBRARY; T=0.K  
Photon emission for (n,n\*)a

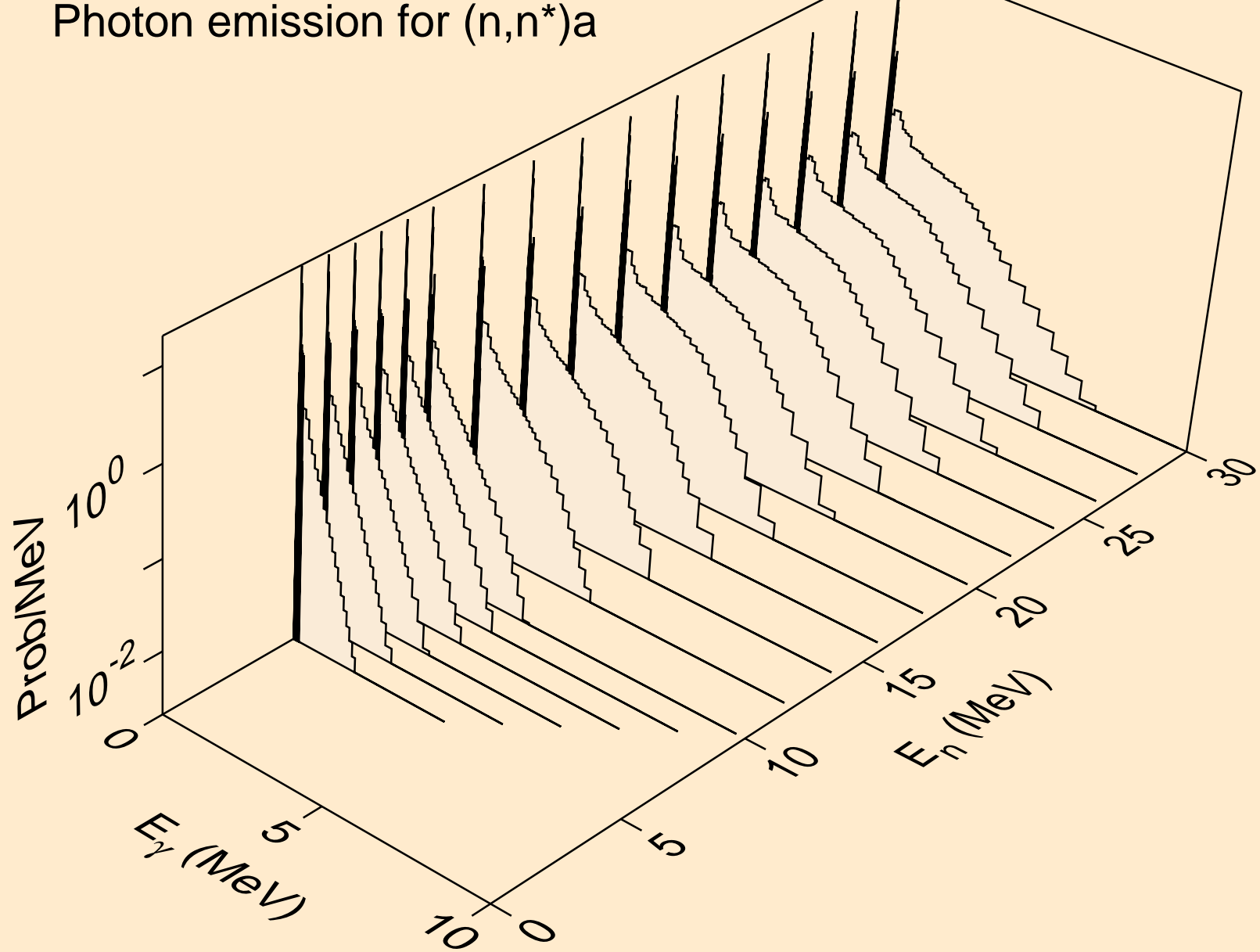

PT185M DEUTERON ACER TENDL-2023 LIBRARY; T=0.K  
Photon emission for (n,2n)a

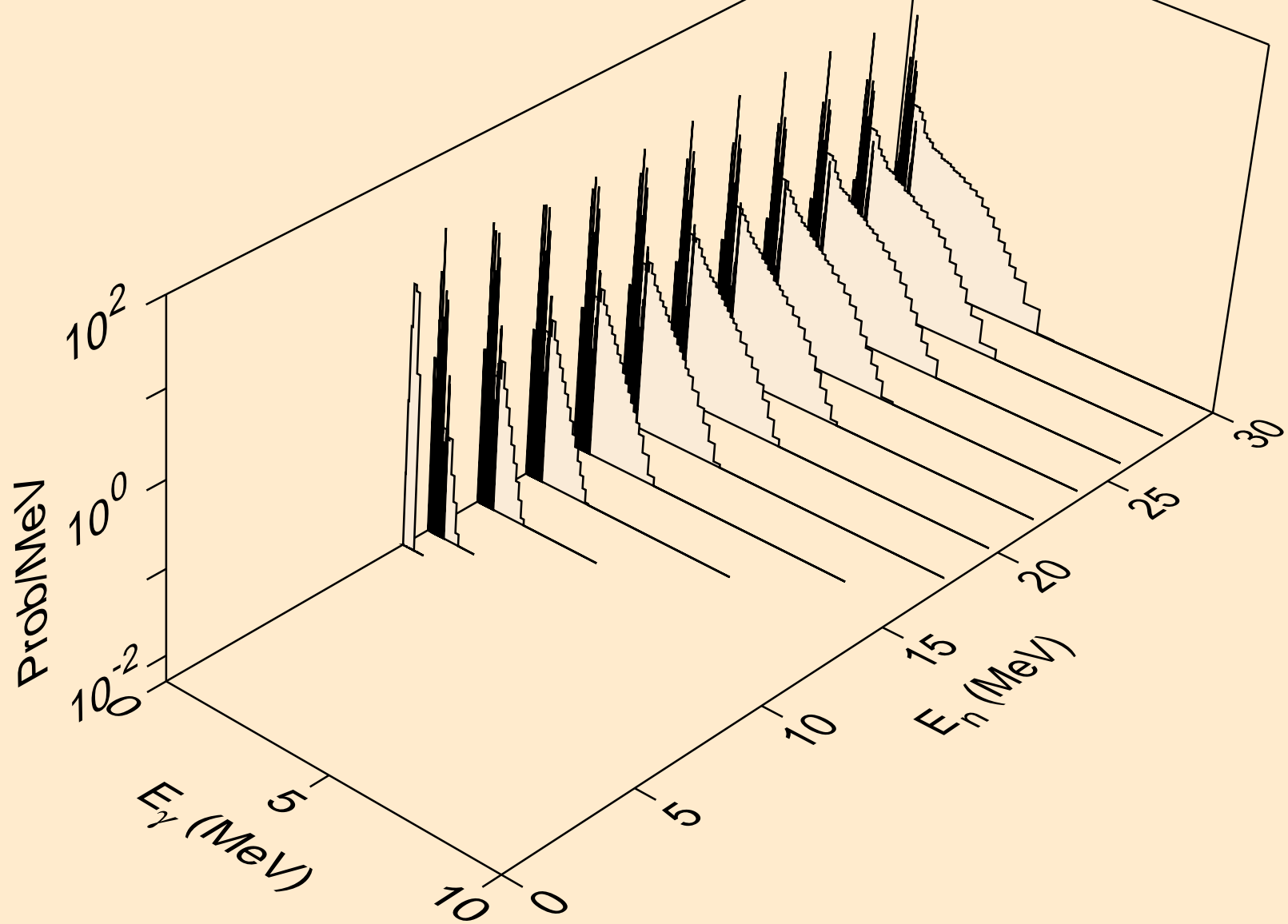

PT185M DEUTERON ACER TENDL-2023 LIBRARY; T=0.K  
Photon emission for (n,3n)a

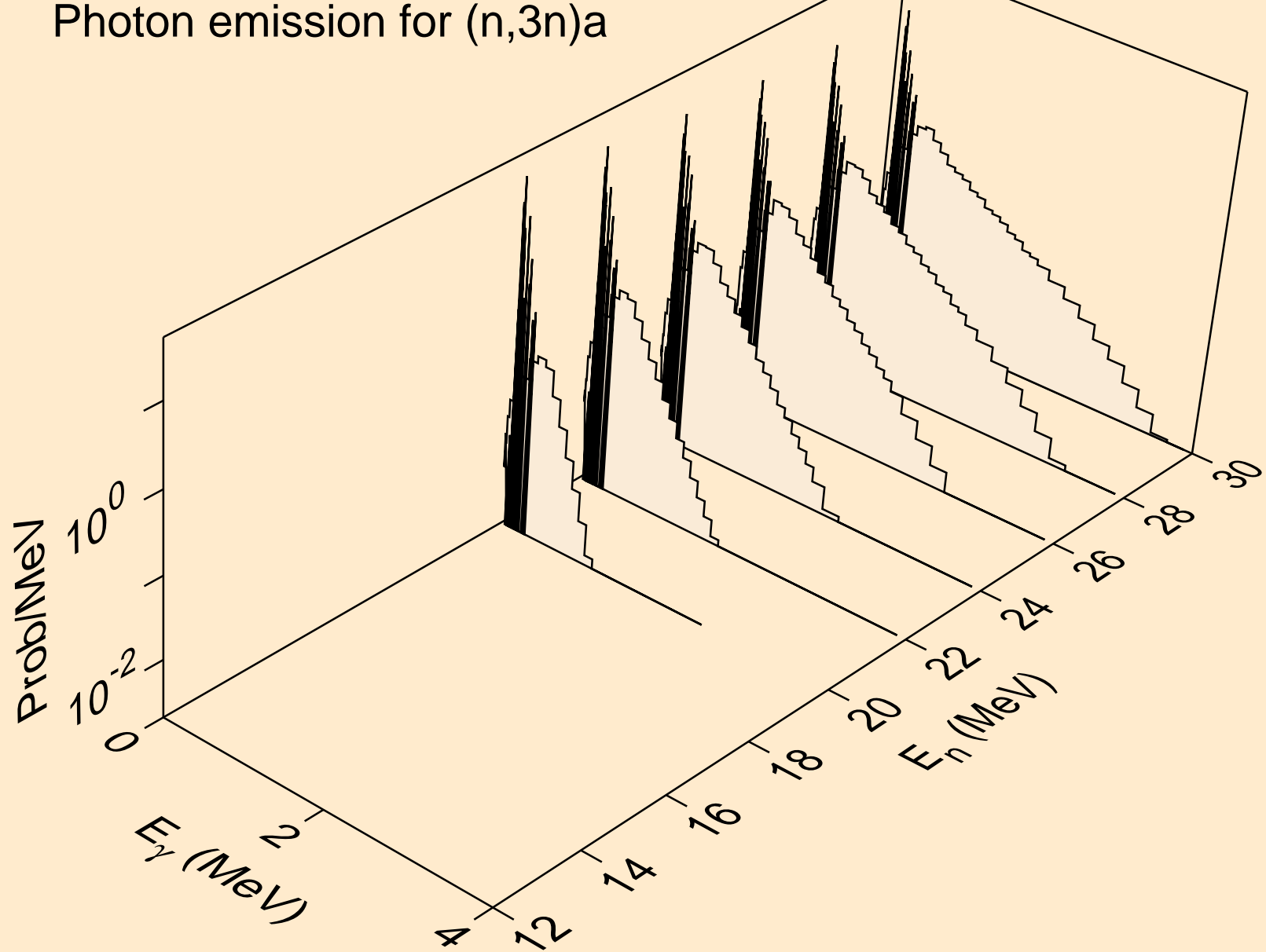

PT185M DEUTERON ACER TENDL-2023 LIBRARY; T=0.K  
Photon emission for (n,n\*)p

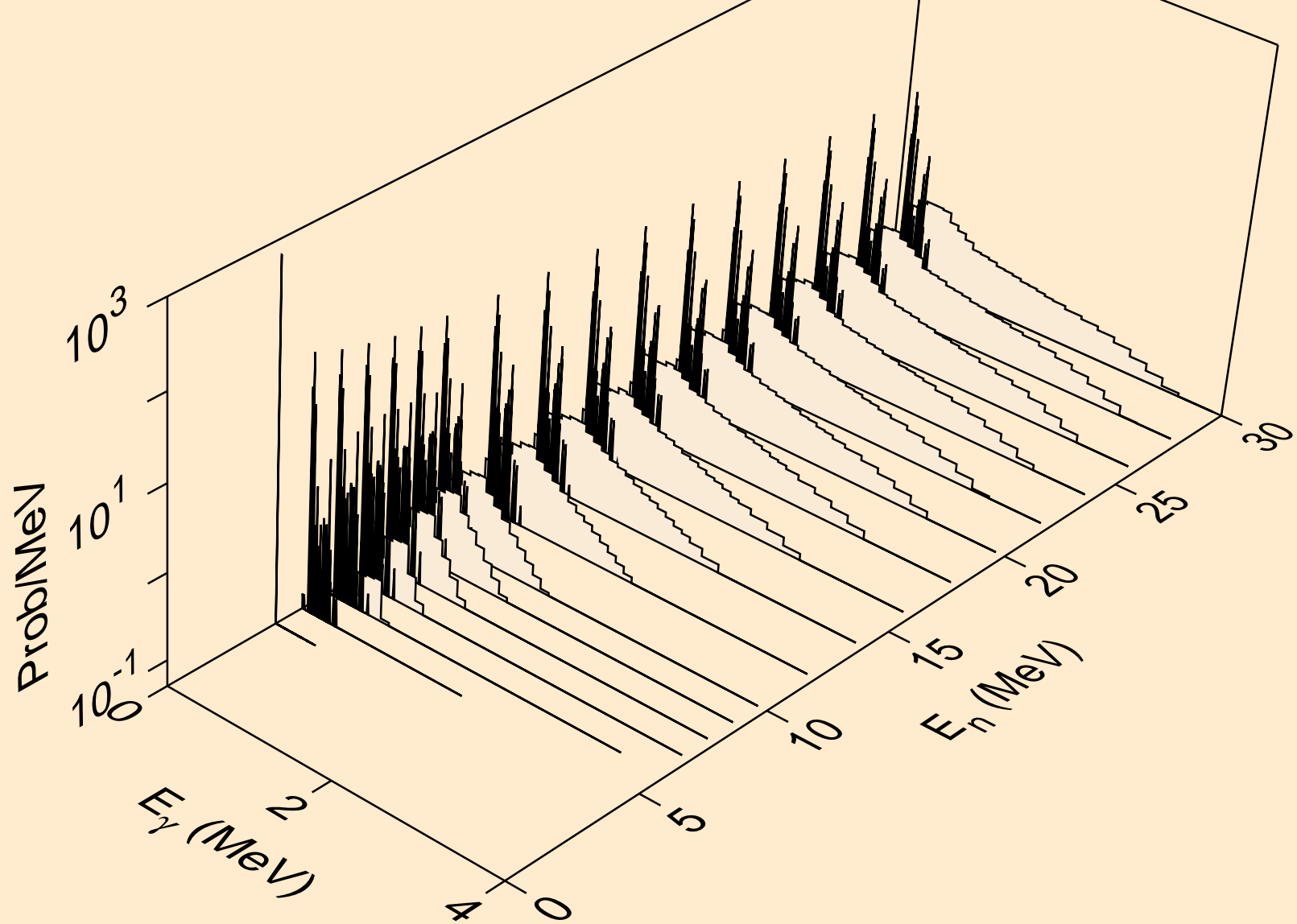



PT185M DEUTERON ACER TENDL-2023 LIBRARY; T=0.K  
Photon emission for (n,n\*)2a

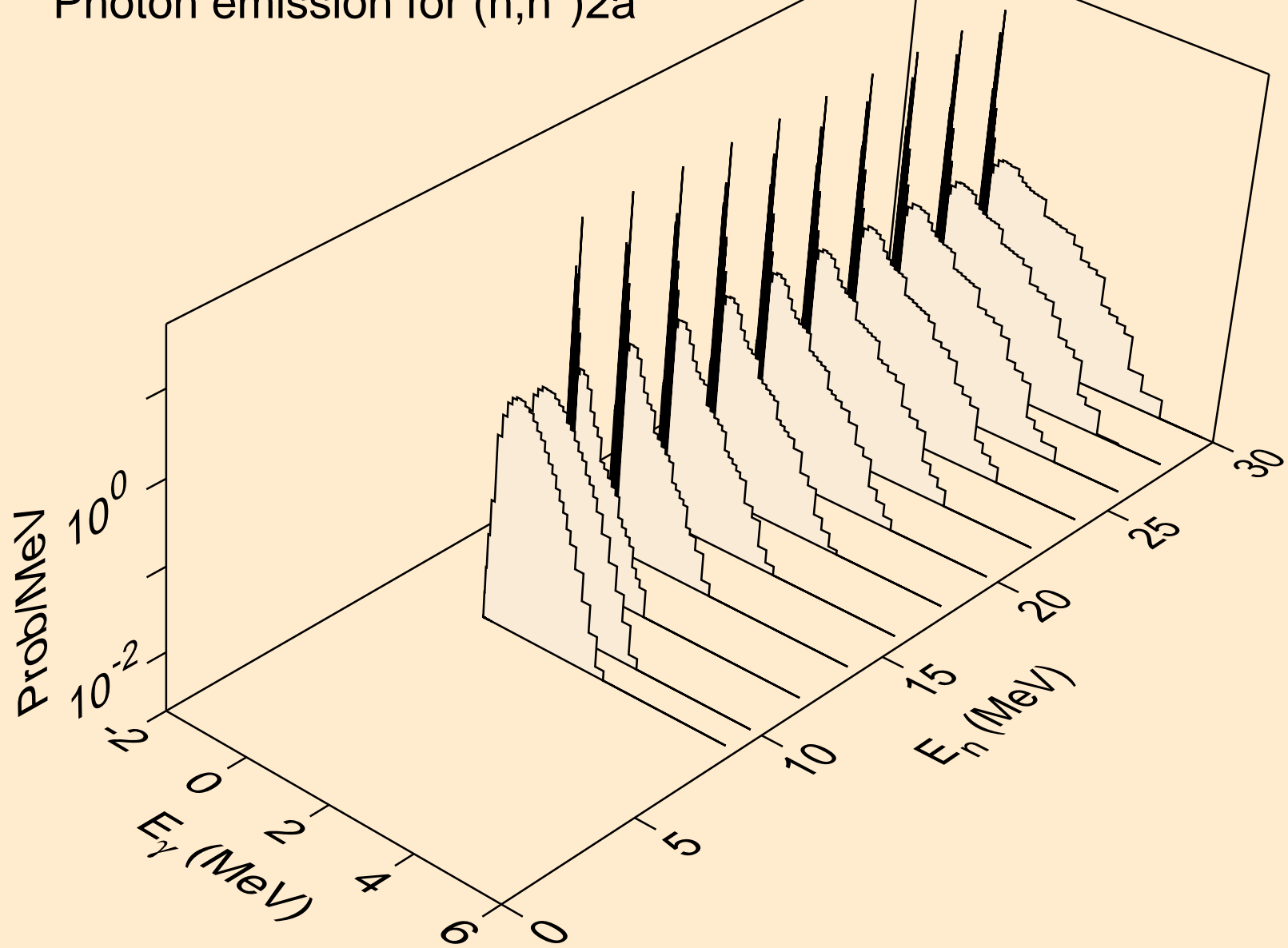

PT185M DEUTERON ACER TENDL-2023 LIBRARY; T=0.K  
Photon emission for (n,2n)2a

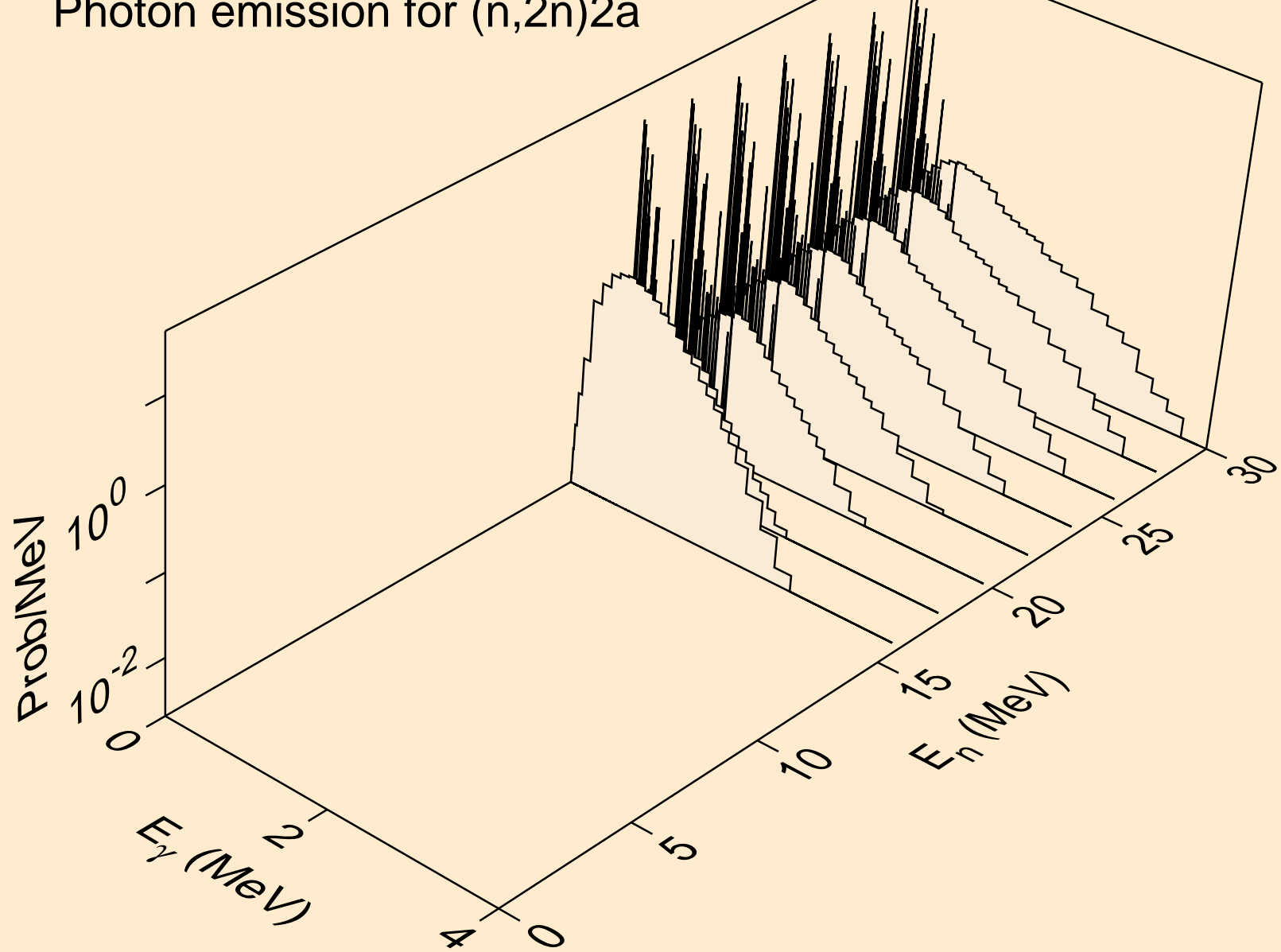

PT185M DEUTERON ACER TENDL-2023 LIBRARY; T=0.K  
Photon emission for (n,n\*)d

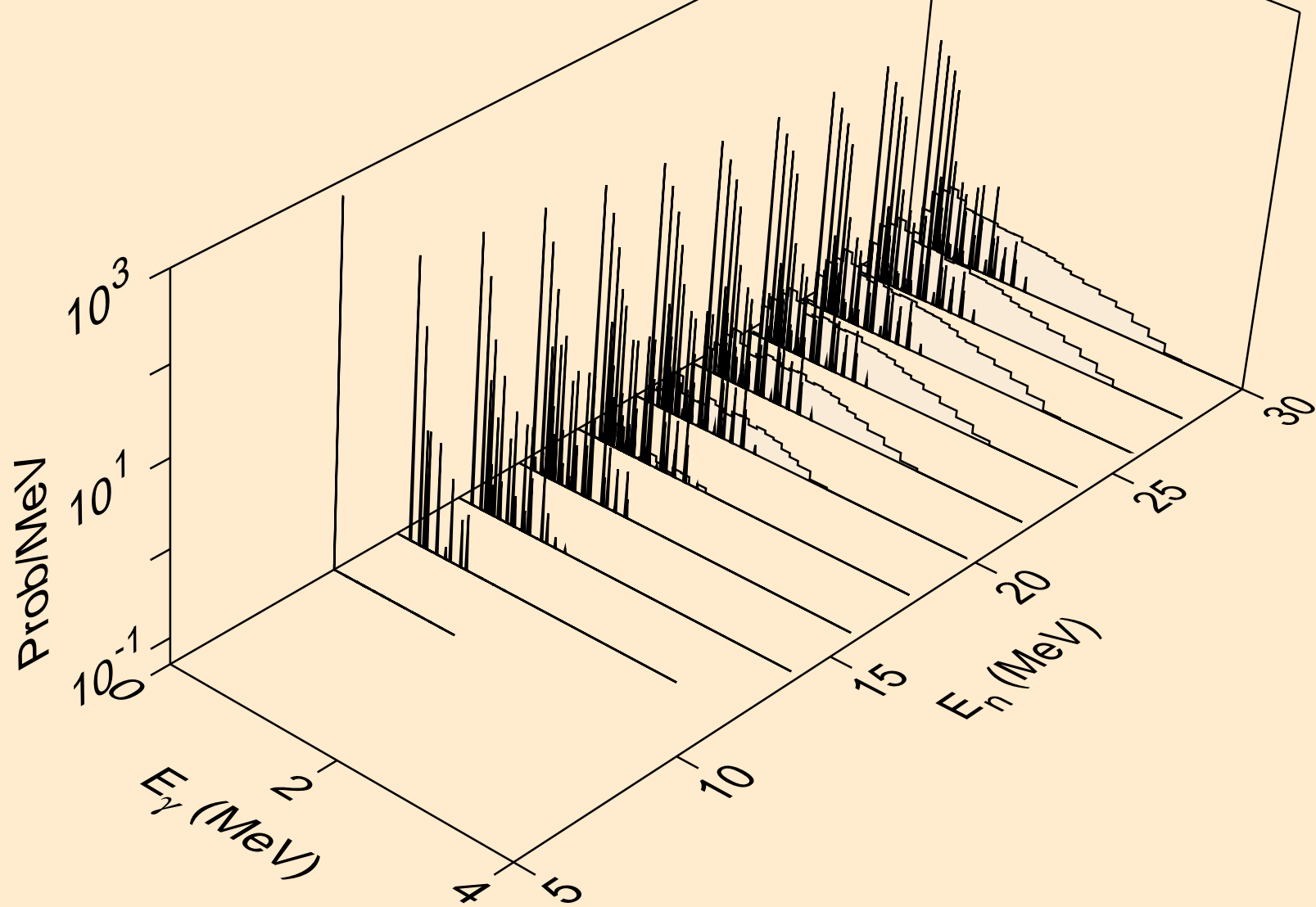

PT185M DEUTERON ACER TENDL-2023 LIBRARY; T=0.K  
Photon emission for (n,n\*)t

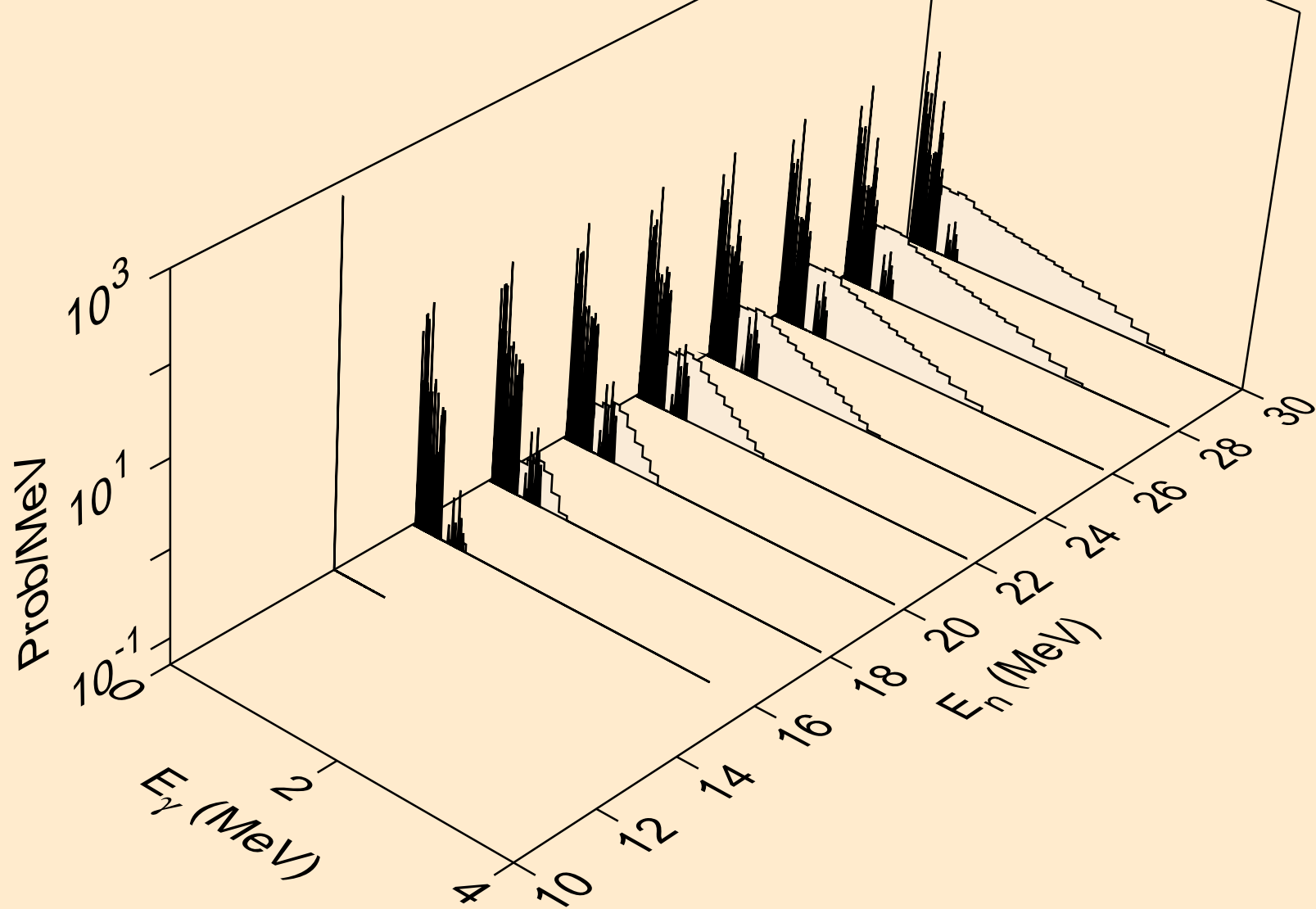

PT185M DEUTERON ACER TENDL-2023 LIBRARY; T=0.K  
Photon emission for (n,n\*)he3

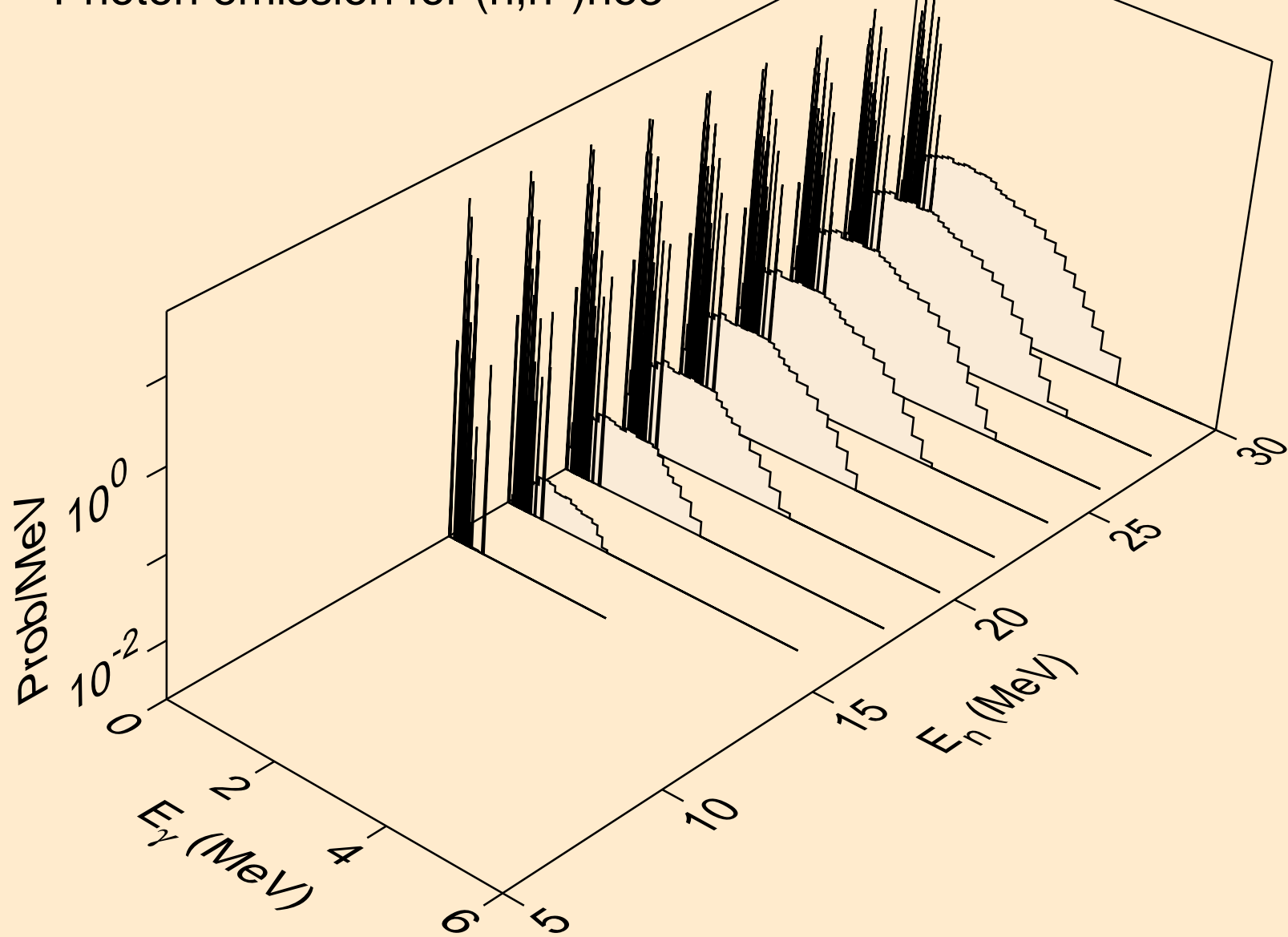

PT185M DEUTERON ACER TENDL-2023 LIBRARY; T=0.K  
Photon emission for (n,4n)

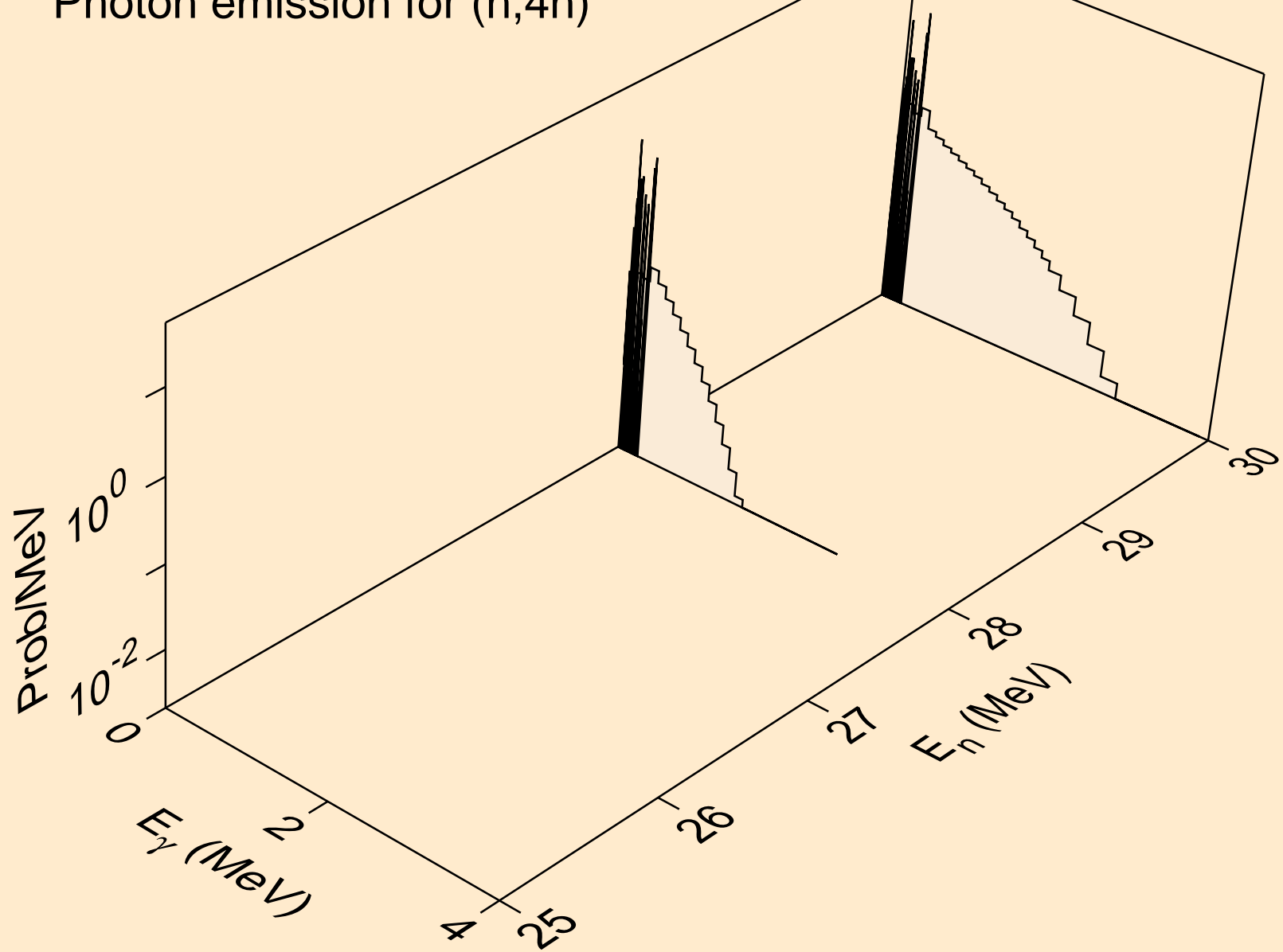

PT185M DEUTERON ACER TENDL-2023 LIBRARY; T=0.K  
Photon emission for (n,2np)

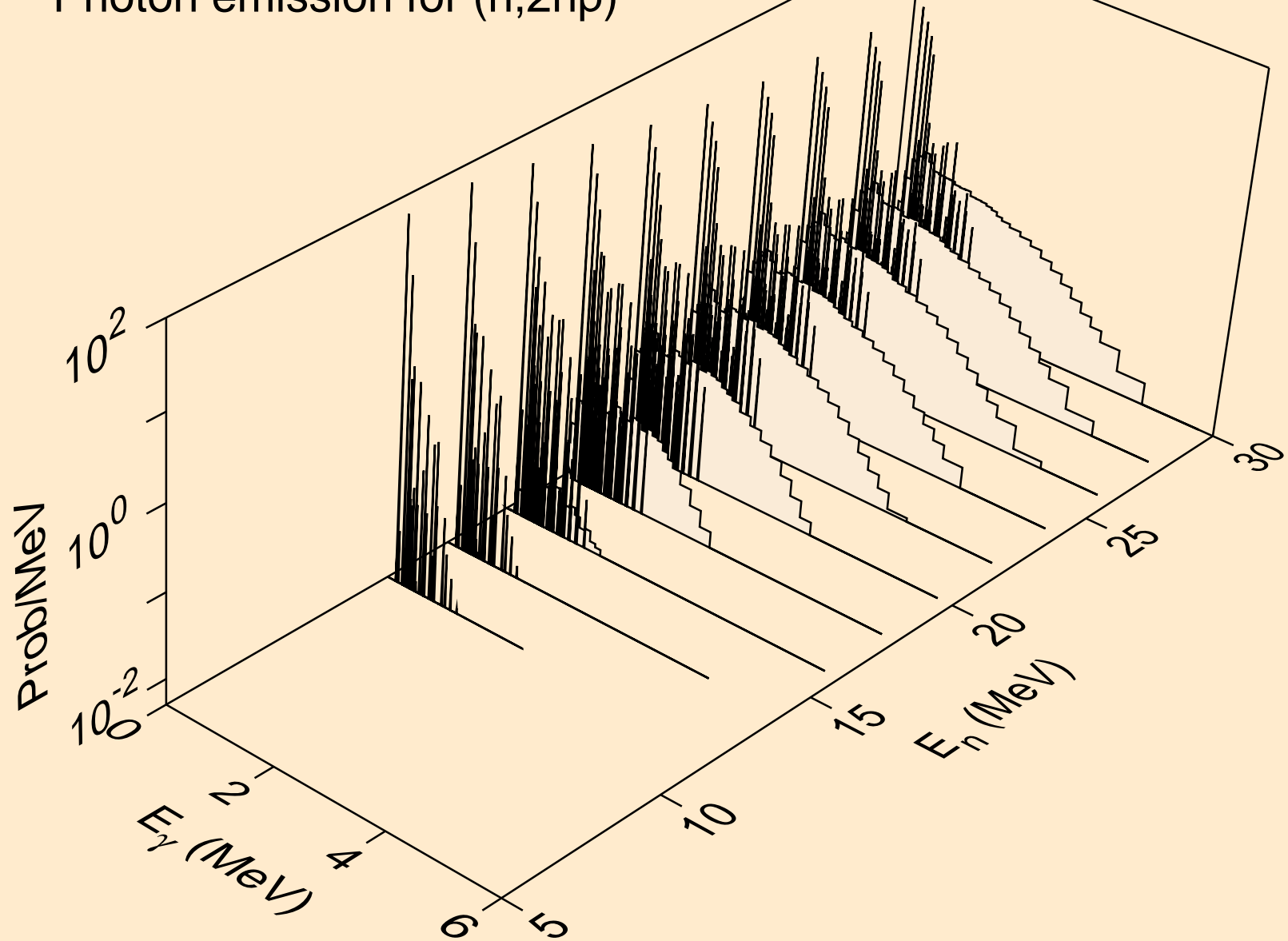

PT185M DEUTERON ACER TENDL-2023 LIBRARY; T=0.K  
Photon emission for (n,3np)

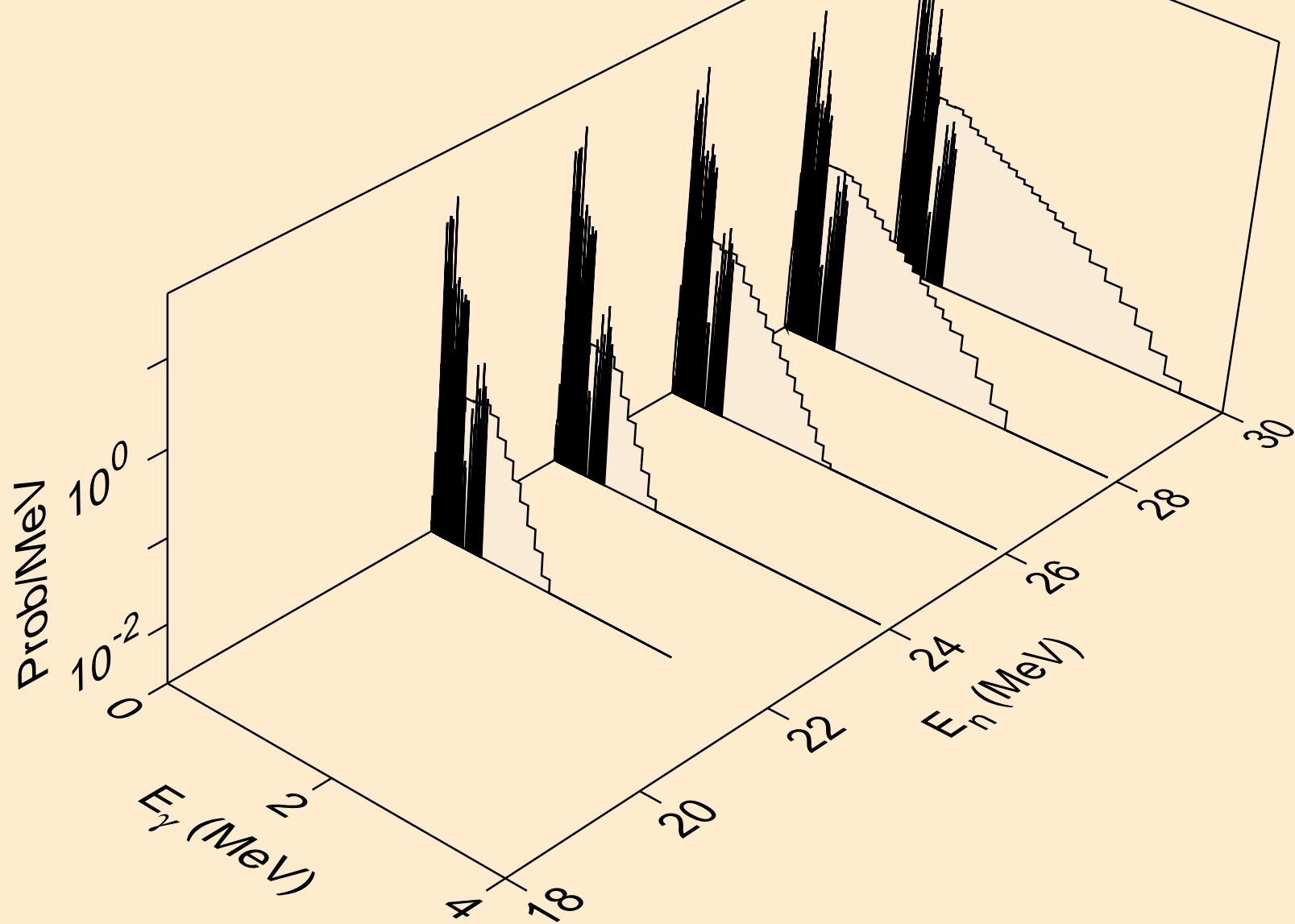



PT185M DEUTERON ACER TENDL-2023 LIBRARY; T=0.K  
Photon emission for (n,n2p)

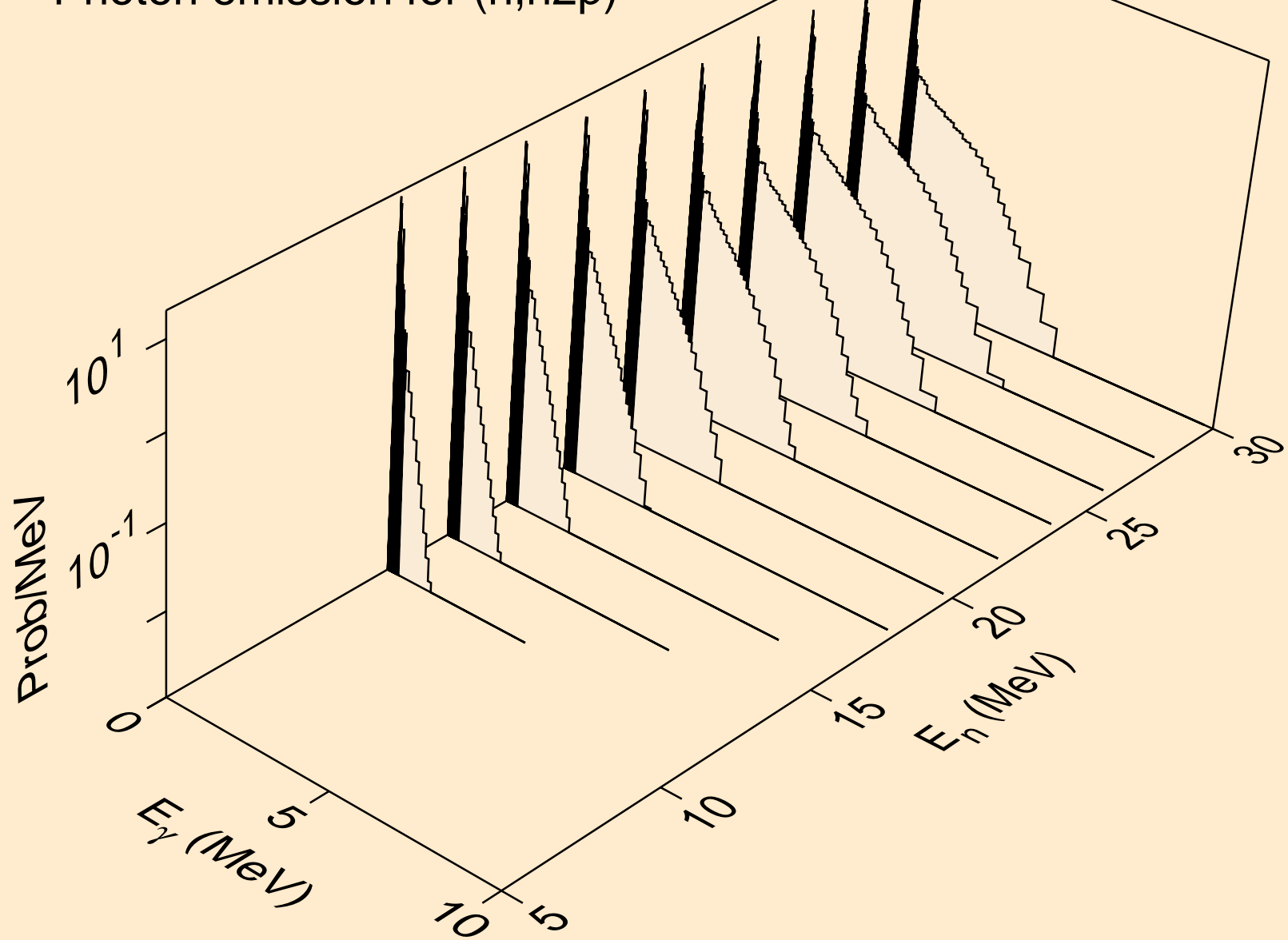

PT185M DEUTERON ACER TENDL-2023 LIBRARY; T=0.K  
Photon emission for (n,npa)

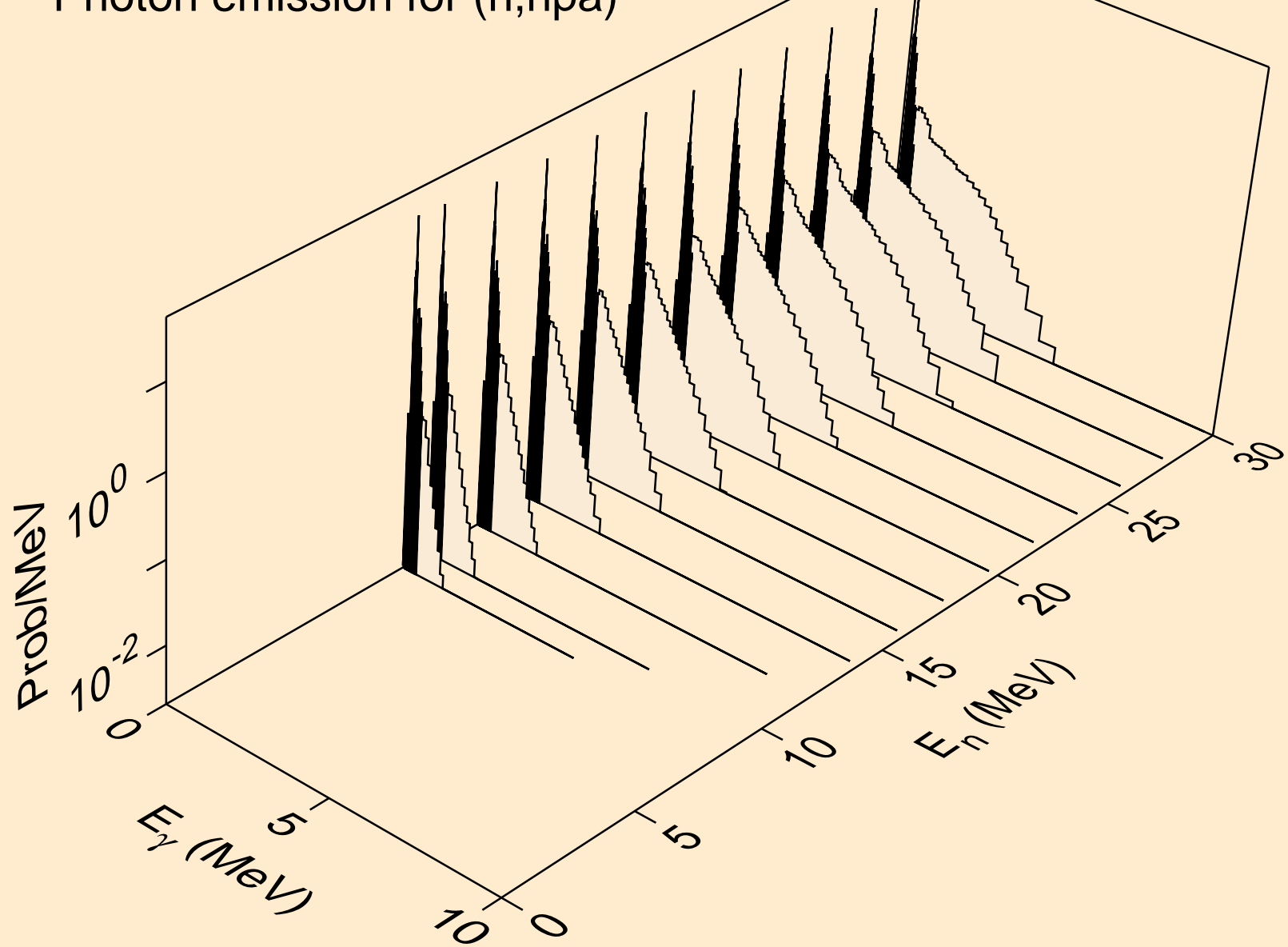

PT185M DEUTERON ACER TENDL-2023 LIBRARY; T=0.K  
Photon emission for (n,gma)

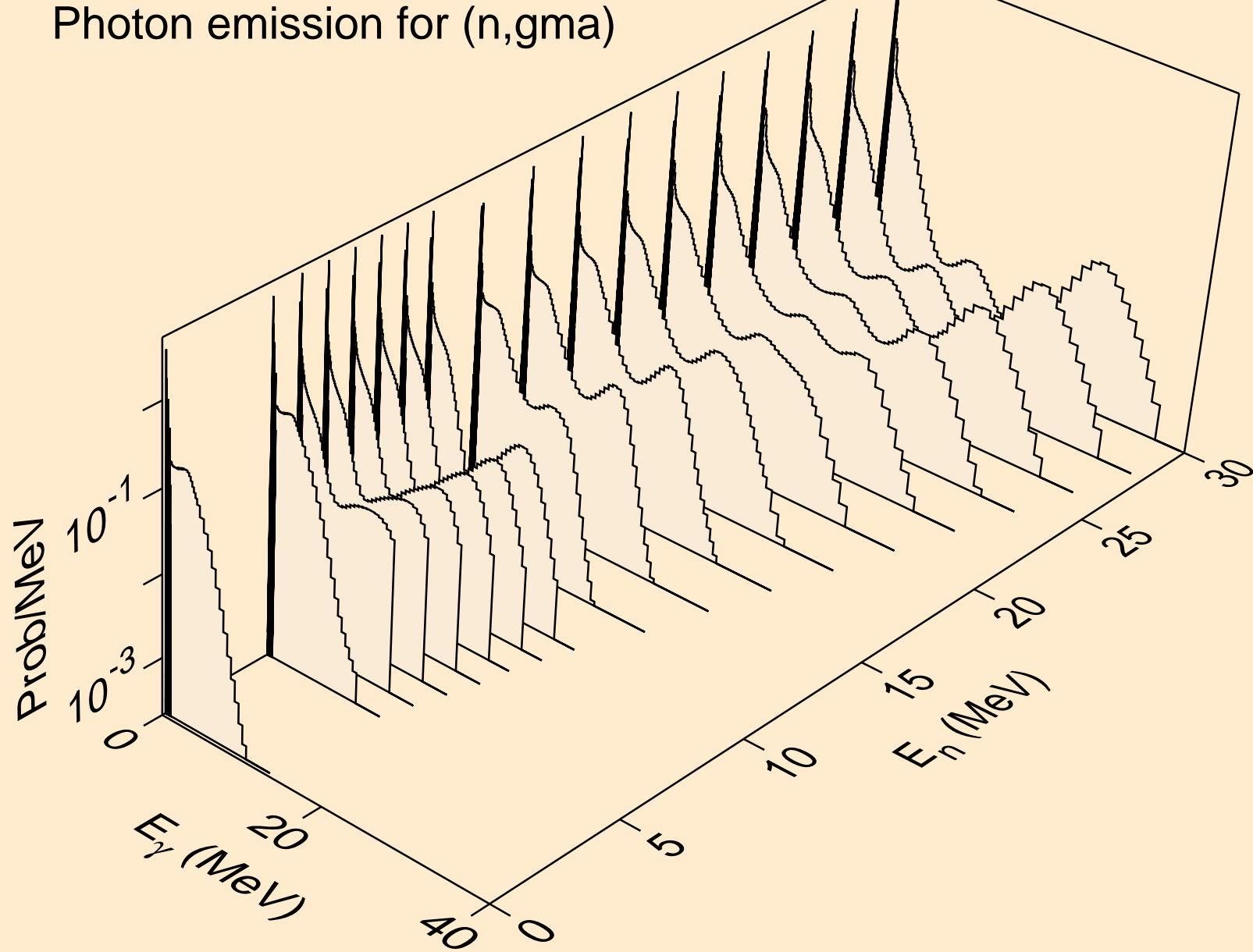

PT185M DEUTERON ACER TENDL-2023 LIBRARY; T=0.K  
Photon emission for (n,p)

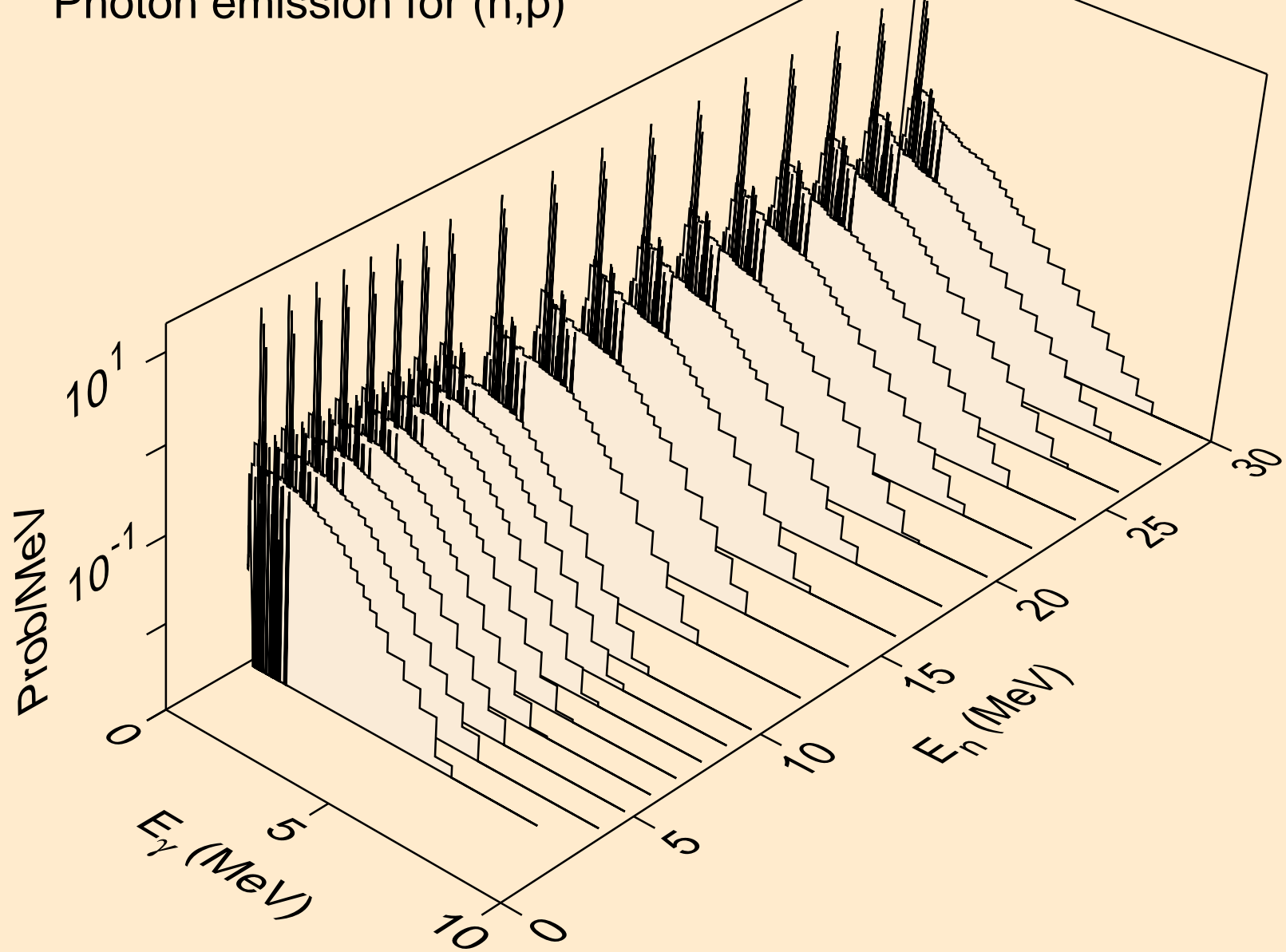

PT185M DEUTERON ACER TENDL-2023 LIBRARY; T=0.K  
Photon emission for inelastic

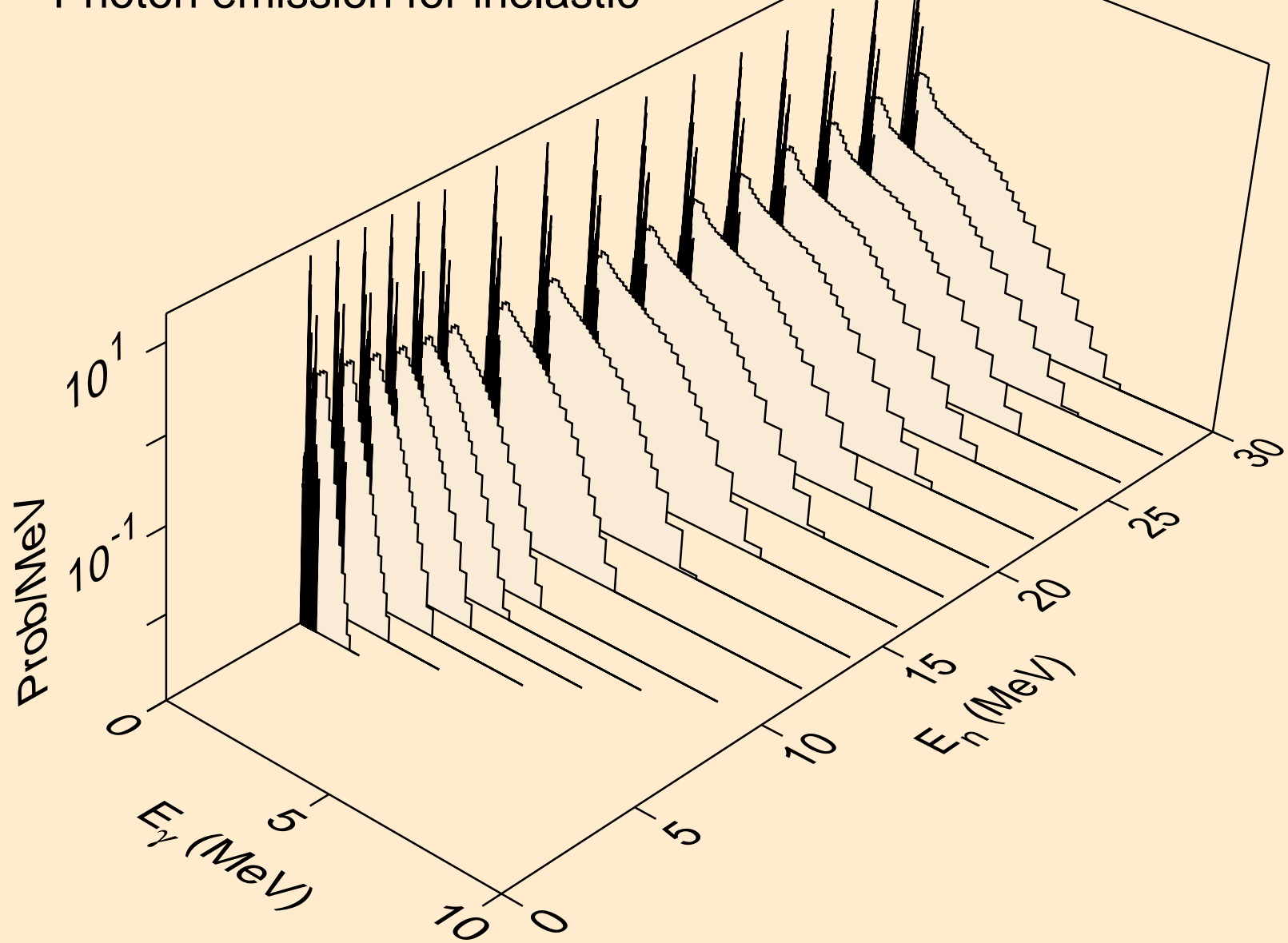

PT185M DEUTERON ACER TENDL-2023 LIBRARY; T=0.K  
Photon emission for (n,t)

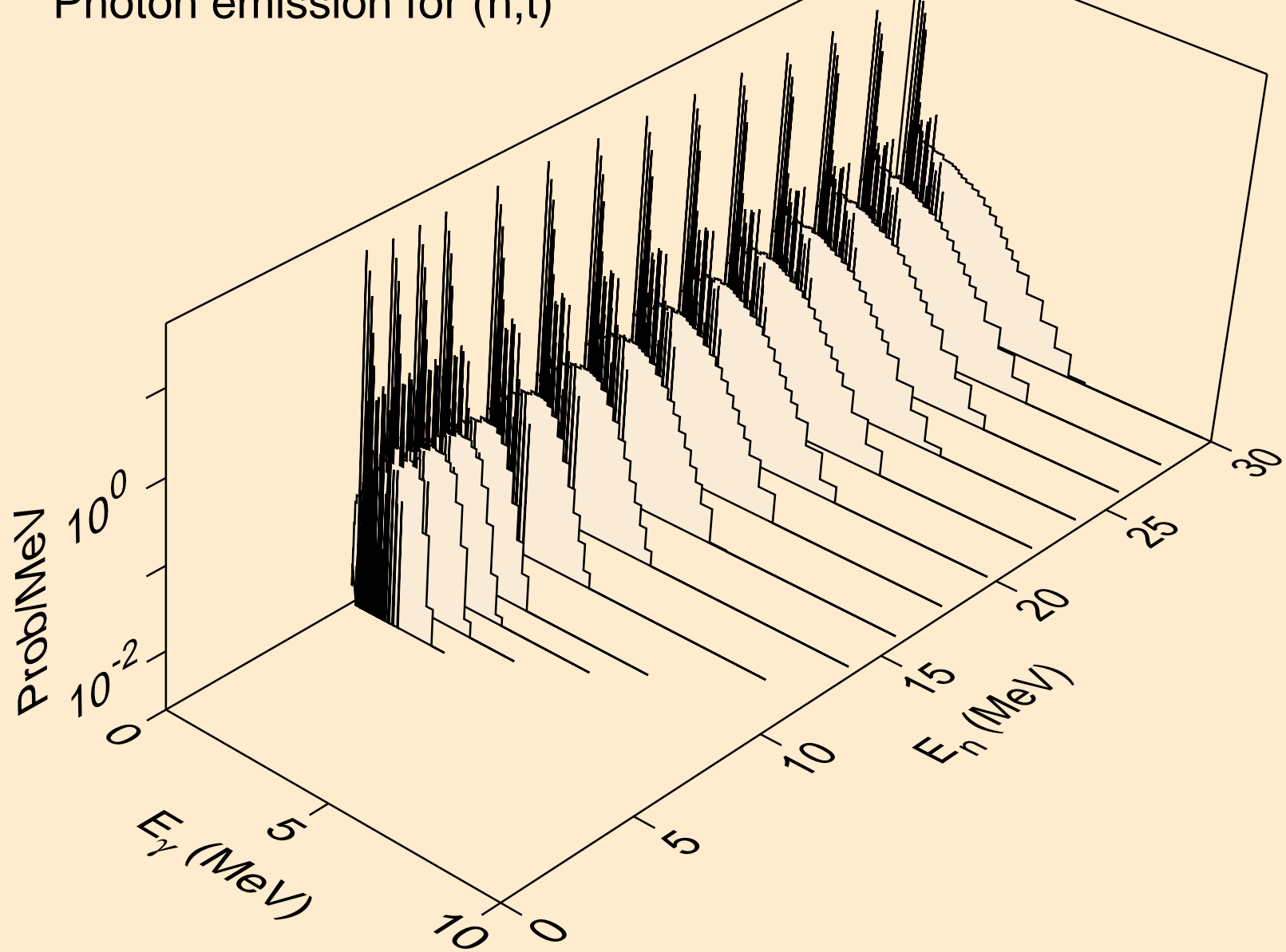

PT185M DEUTERON ACER TENDL-2023 LIBRARY; T=0.K  
Photon emission for (n,he3)

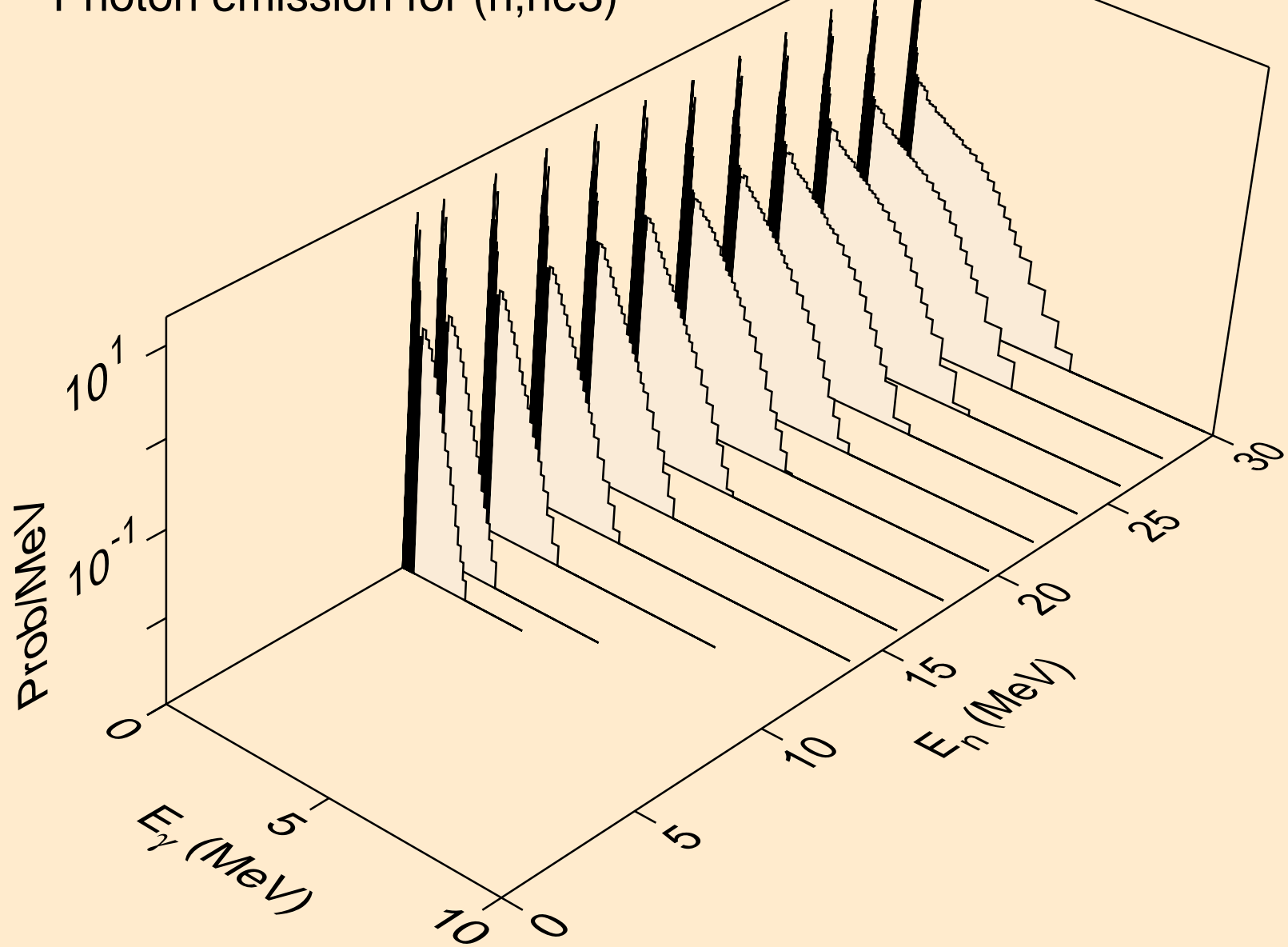

PT185M DEUTERON ACER TENDL-2023 LIBRARY; T=0.K  
Photon emission for (n,a)

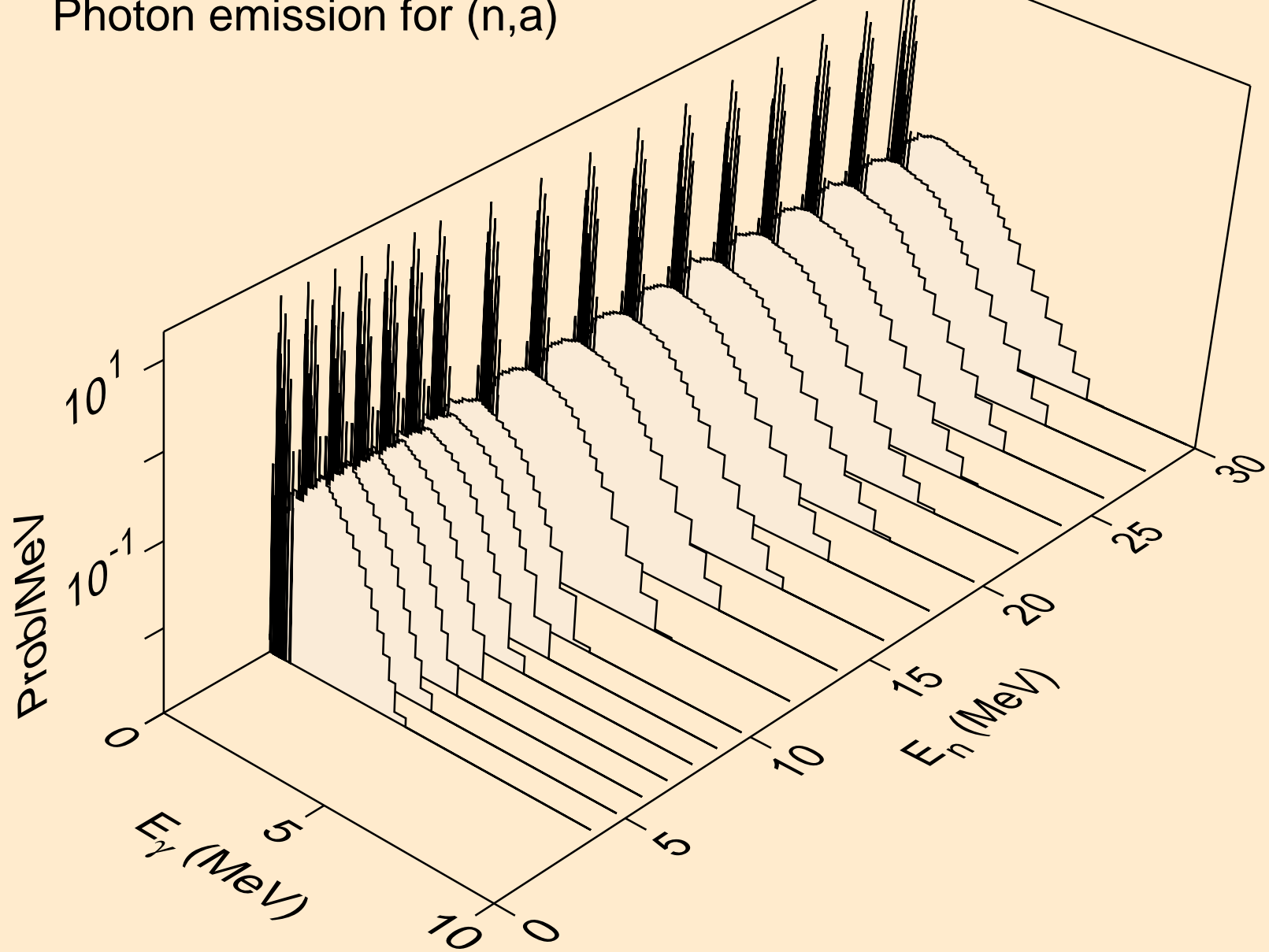



PT185M DEUTERON ACER TENDL-2023 LIBRARY; T=0.K  
Photon emission for (n,2a)

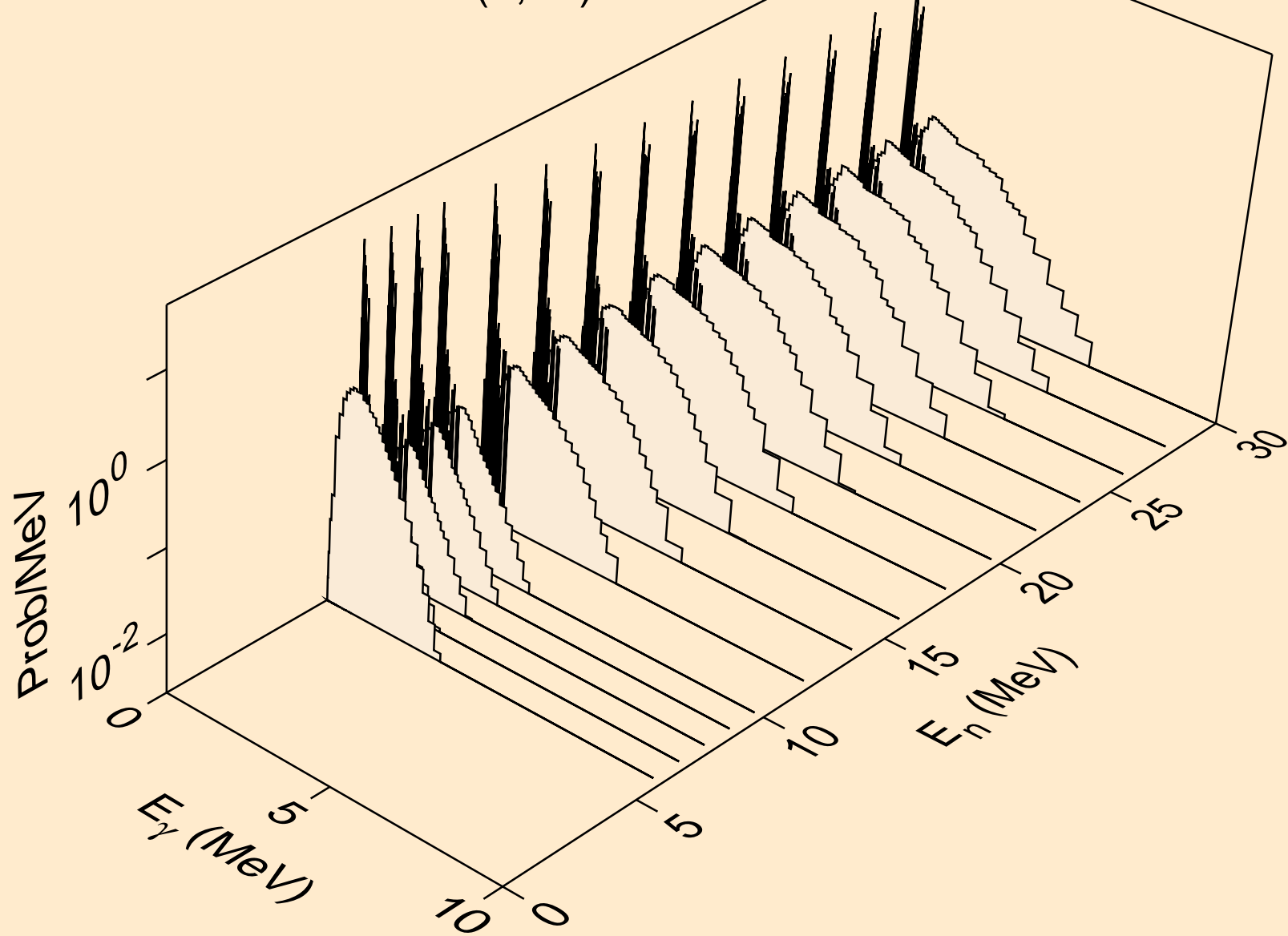

PT185M DEUTERON ACER TENDL-2023 LIBRARY; T=0.K  
Photon emission for (n,2p)

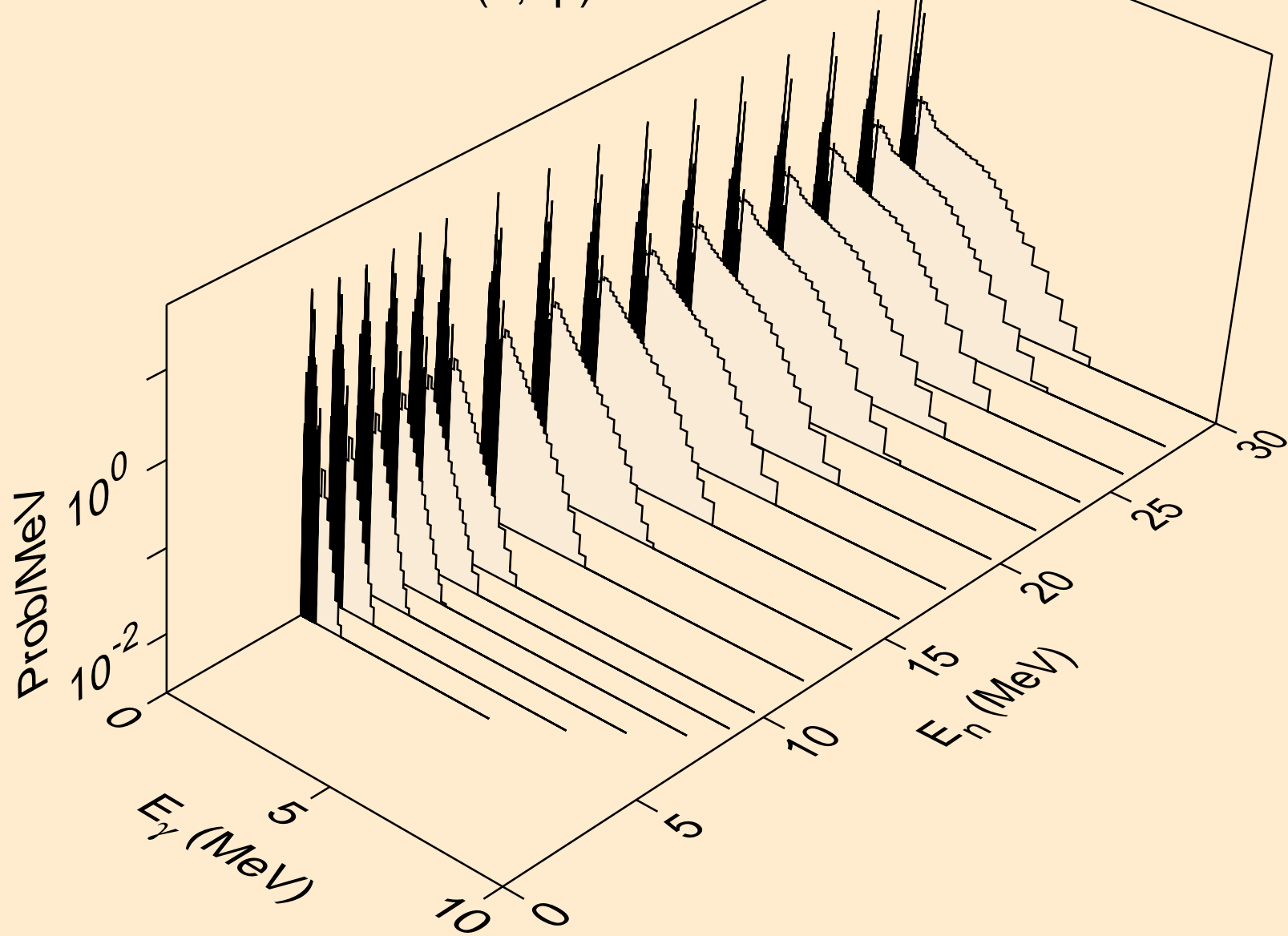

PT185M DEUTERON ACER TENDL-2023 LIBRARY; T=0.K  
Photon emission for (n,p)

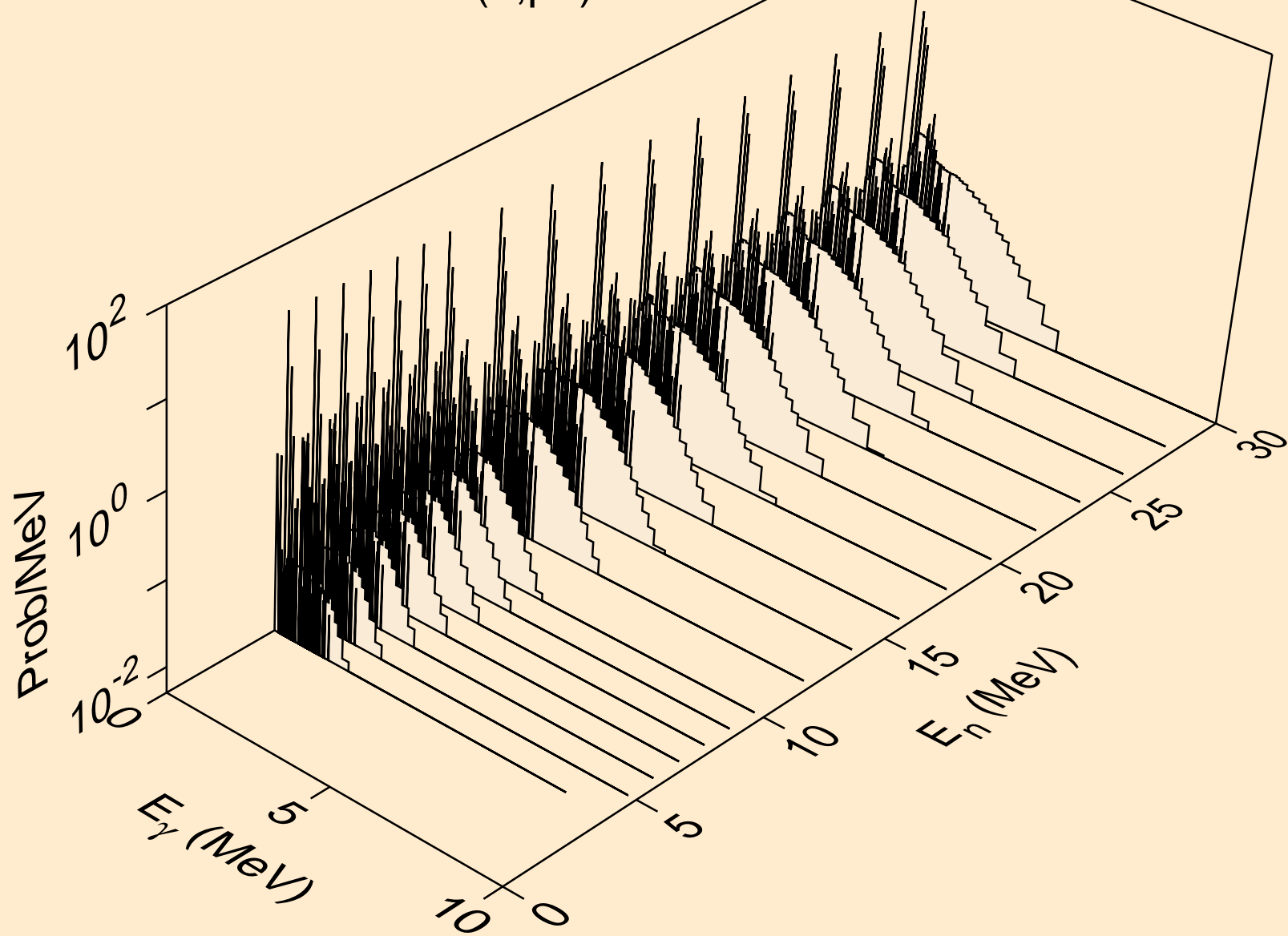

PT185M DEUTERON ACER TENDL-2023 LIBRARY; T=0.K  
Photon emission for (n,pd)

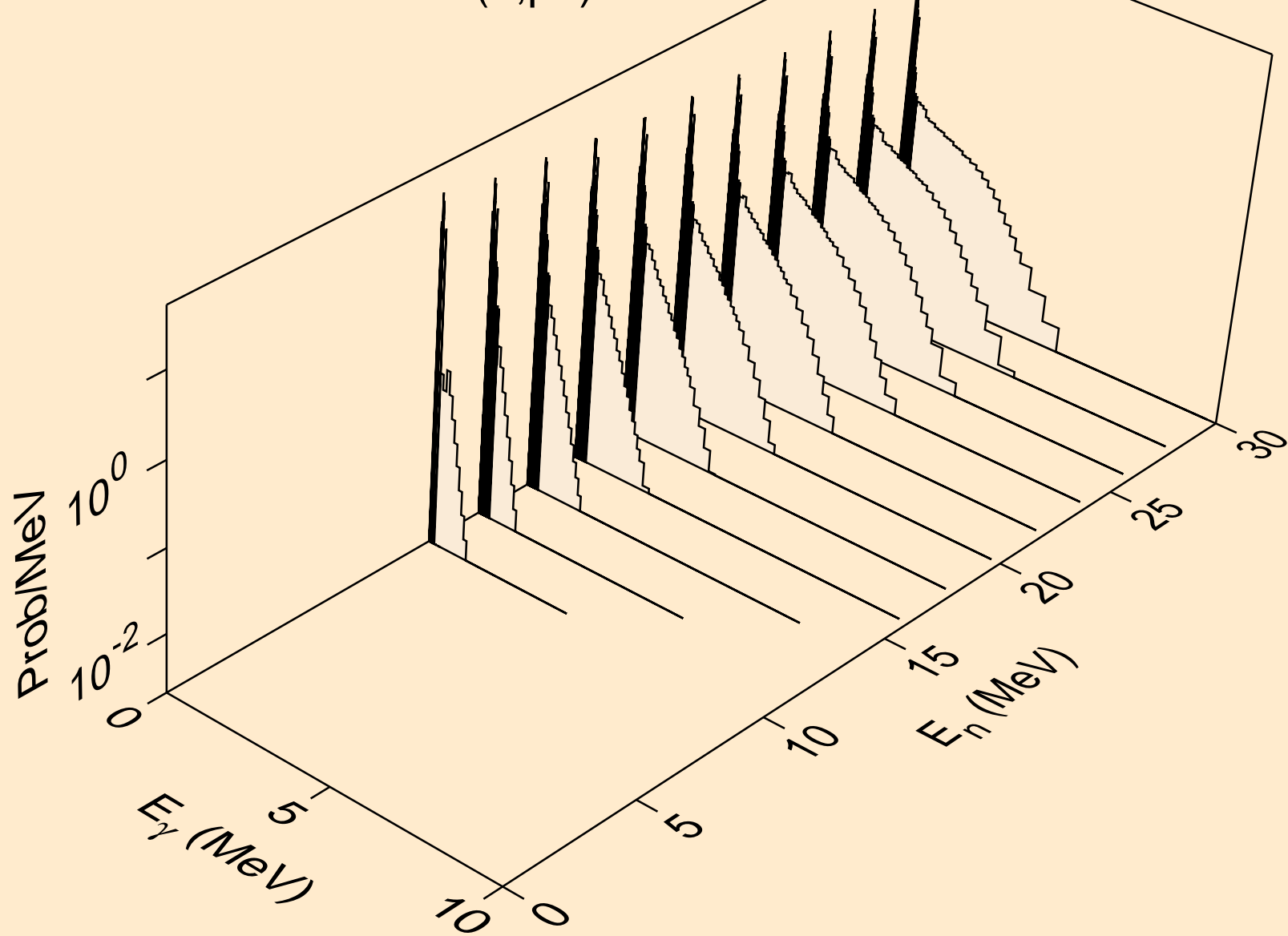

PT185M DEUTERON ACER TENDL-2023 LIBRARY; T=0.K  
Photon emission for (n,pt)

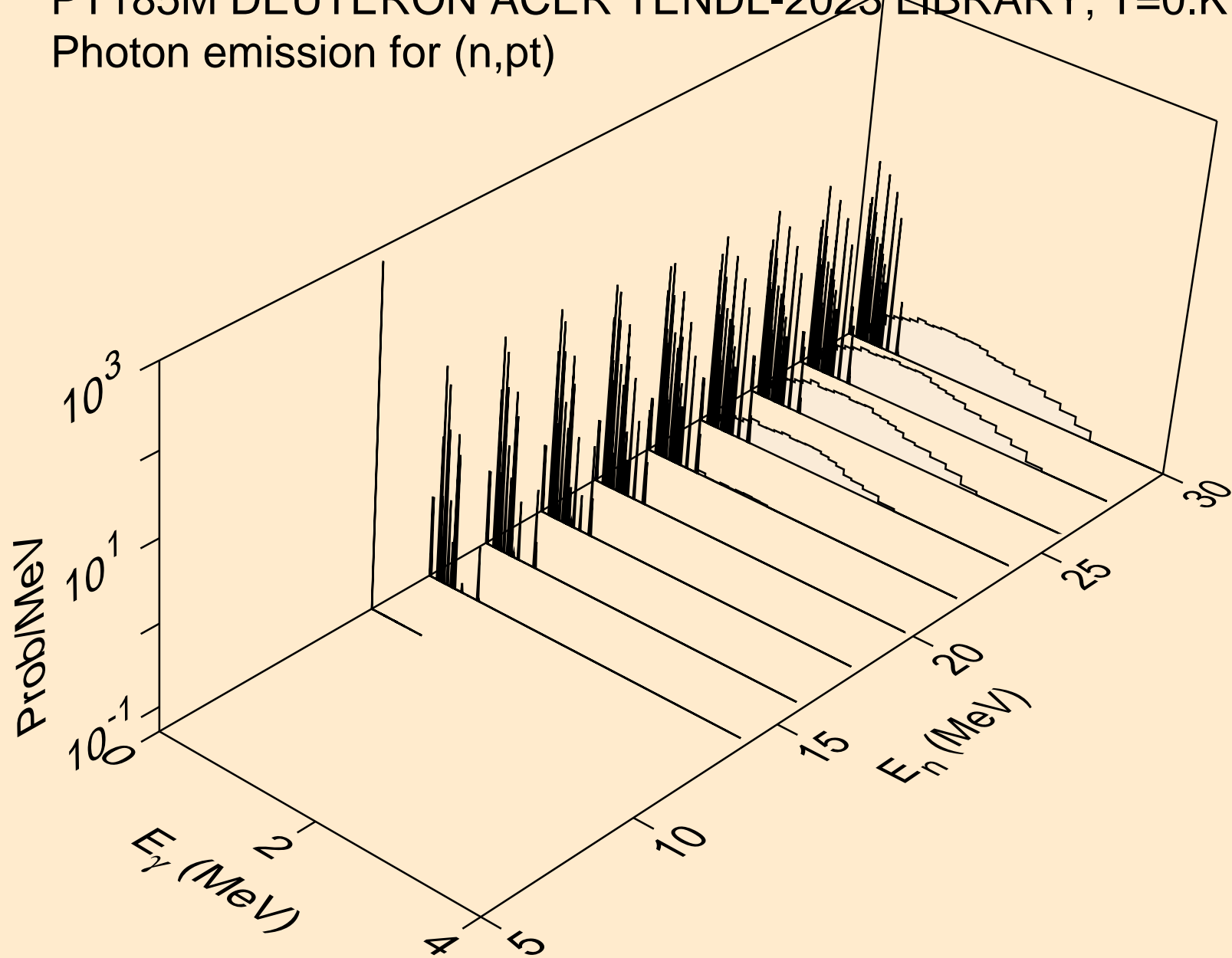

PT185M DEUTERON ACER TENDL-2023 LIBRARY; T=0.K  
Photon emission for (n,da)

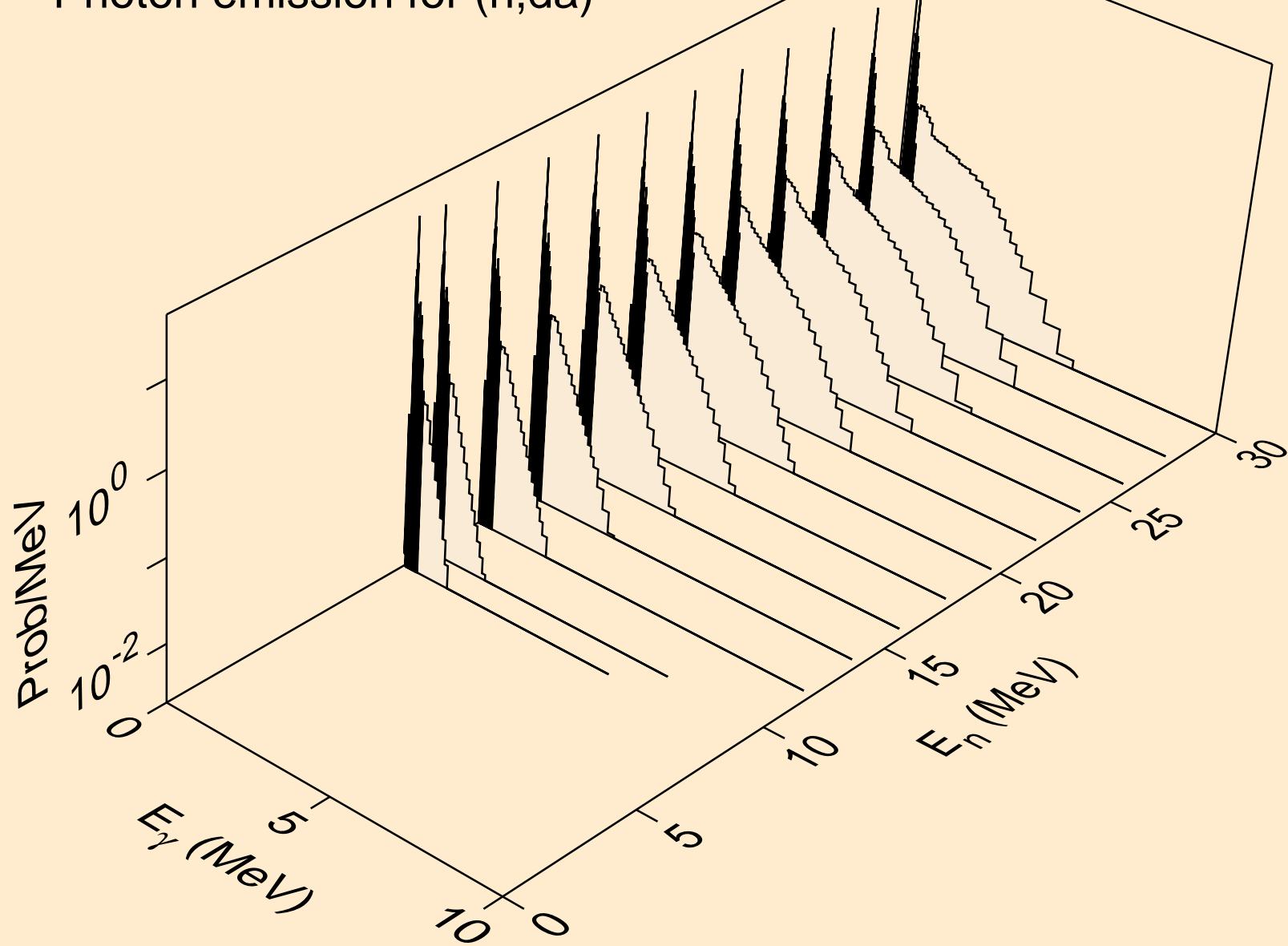

PT185M DEUTERON ACER TENDL-2023 LIBRARY; T=0.K  
Particle heating contributions

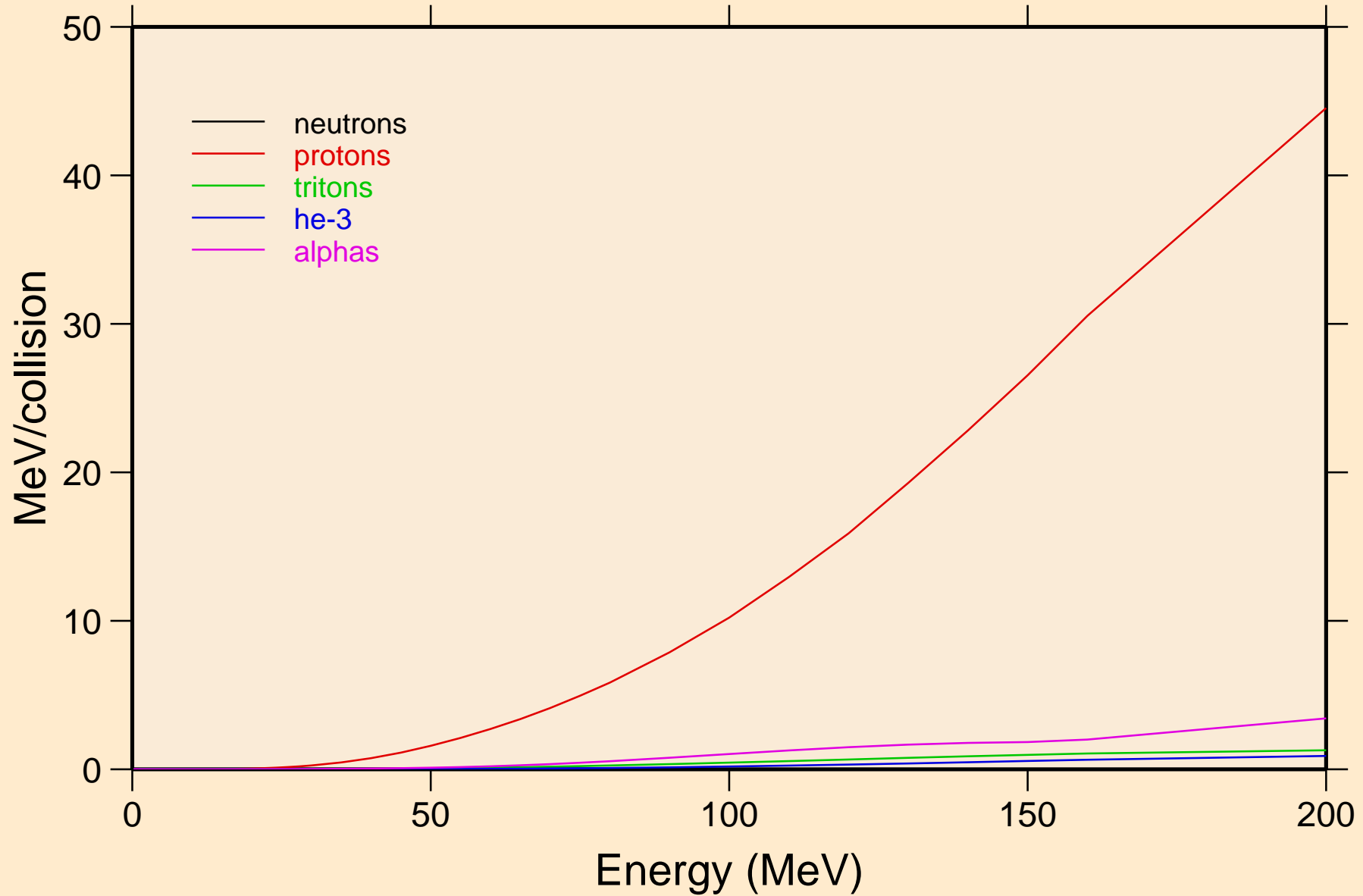

PT185M DEUTERON ACER TENDL-2023 LIBRARY; T=0.K  
Recoil Heating

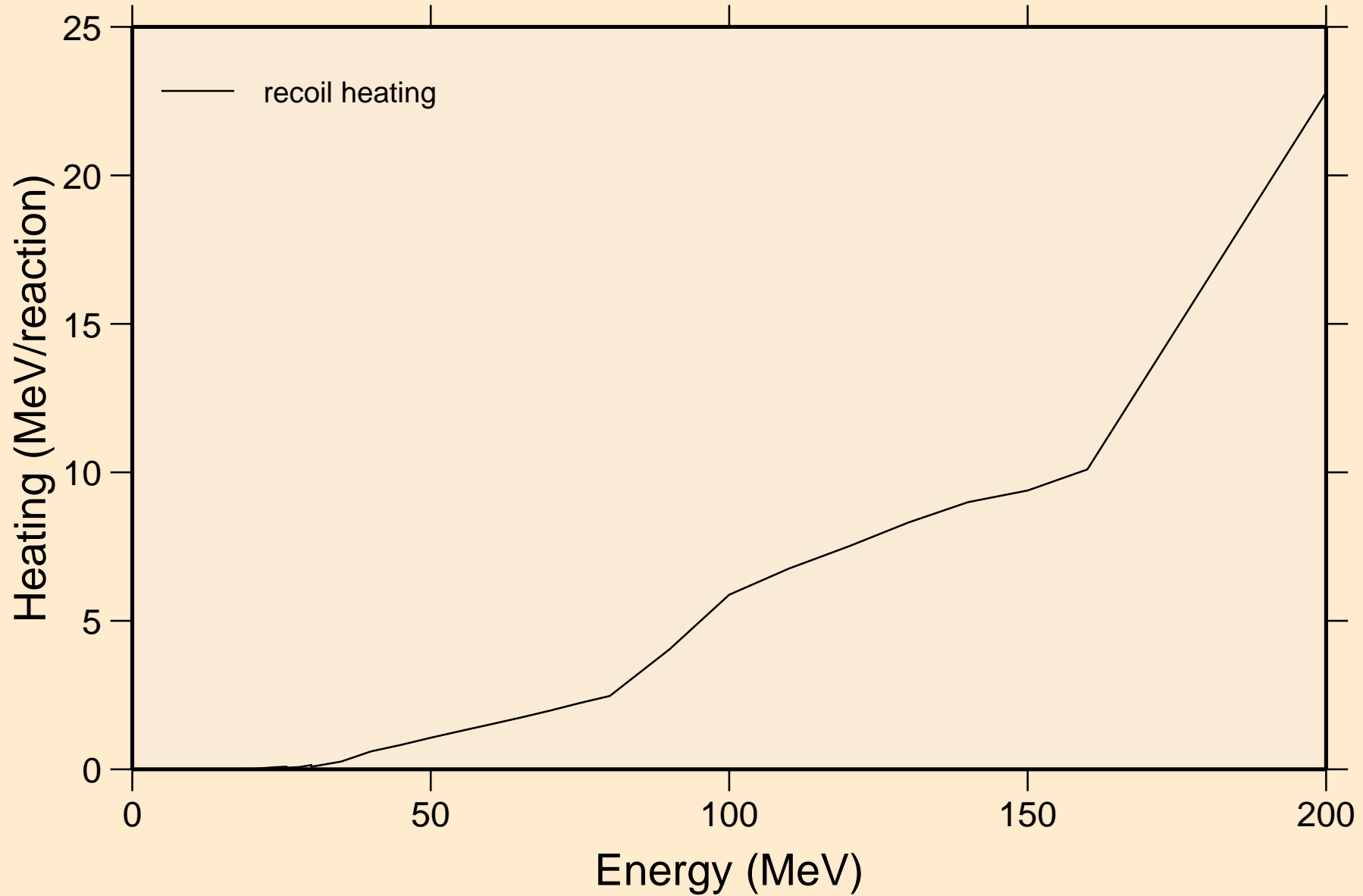



PT185M DEUTERON ACER TENDL-2023 LIBRARY; T=0.K  
Particle production cross sections

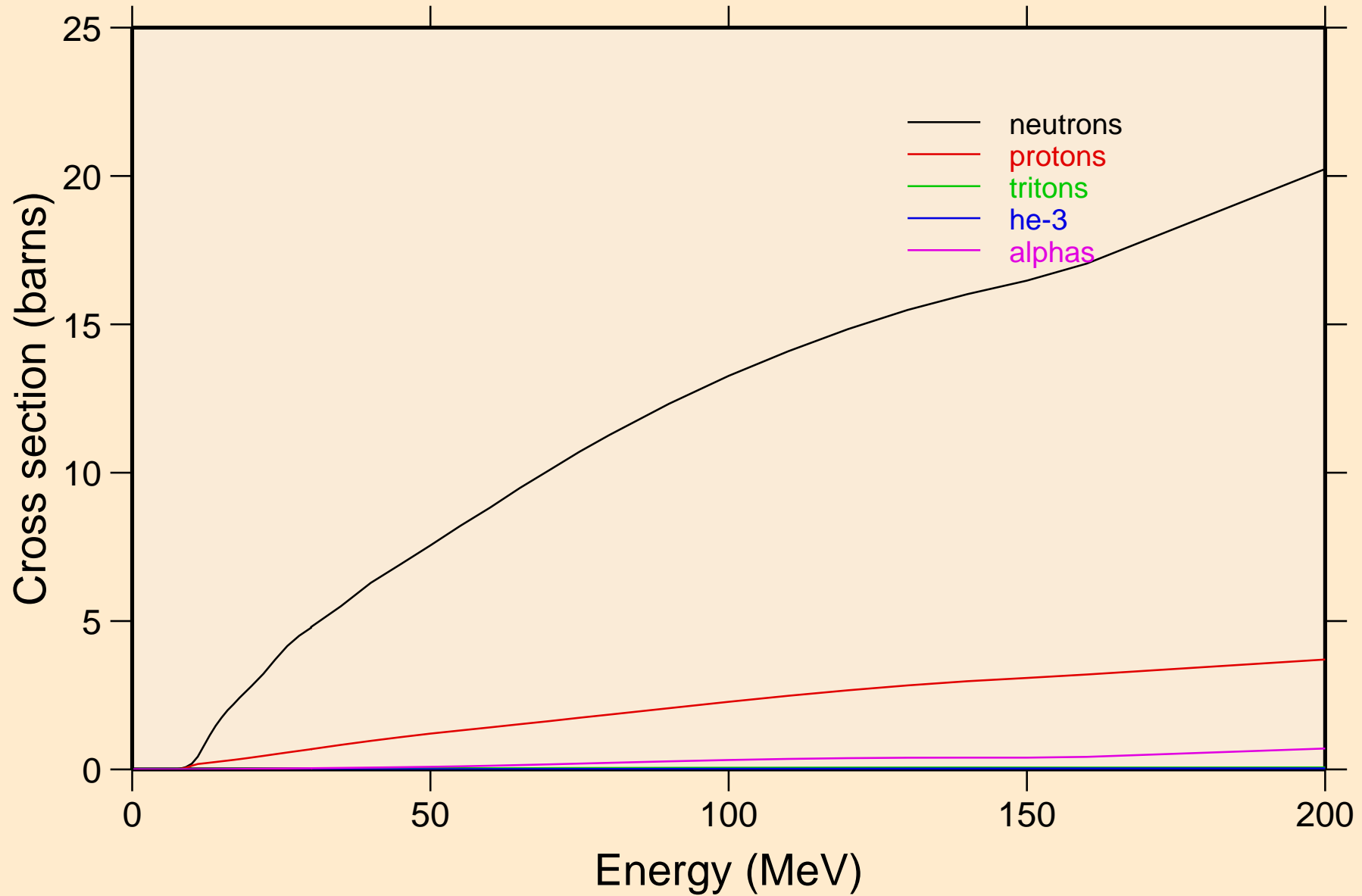

PT185M DEUTERON ACER TENDL-2023 LIBRARY; T=0.K  
neutrons from (d,n)

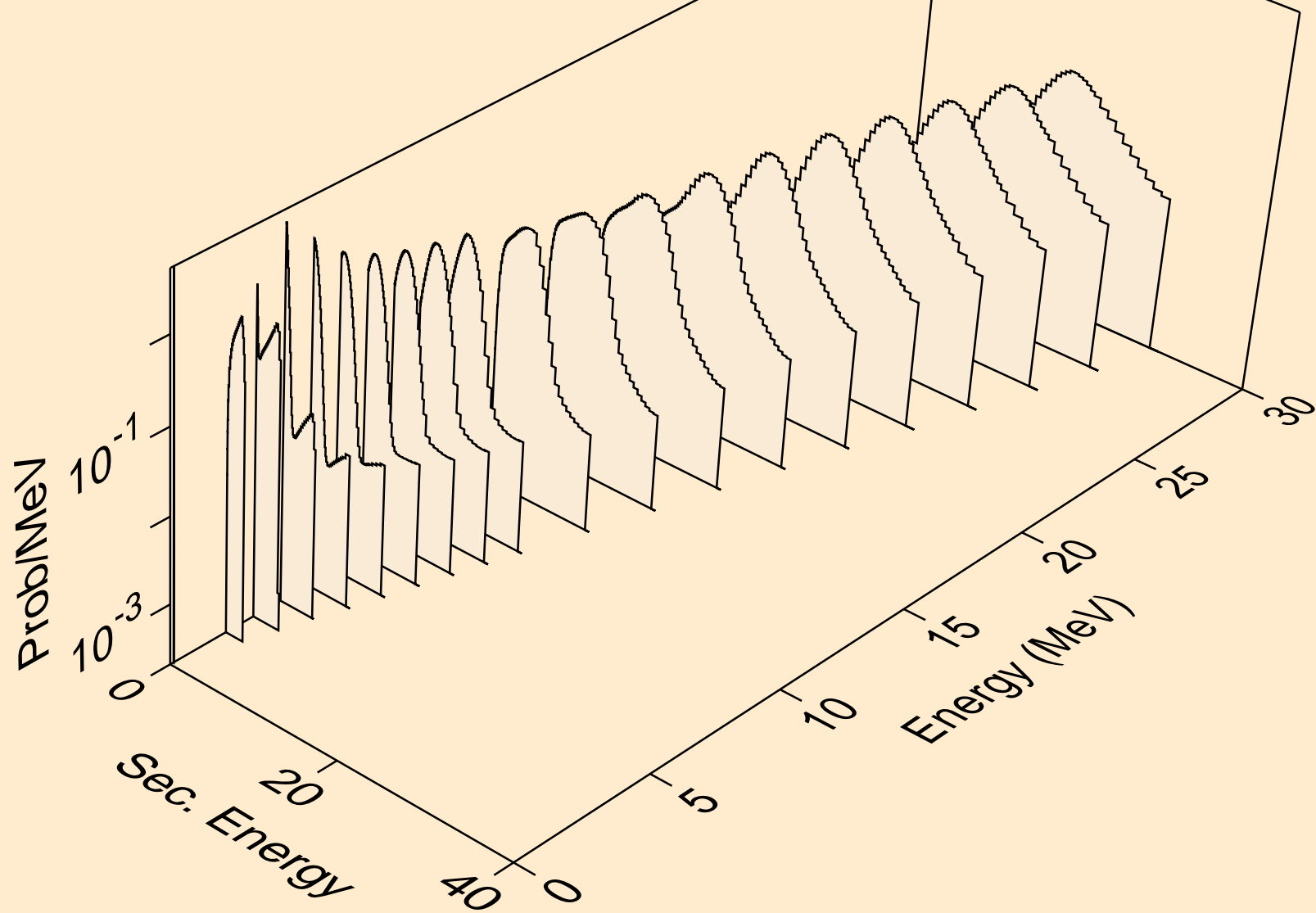

PT185M DEUTERON ACER TENDL-2023 LIBRARY; T=0.K  
neutrons from (d,x)

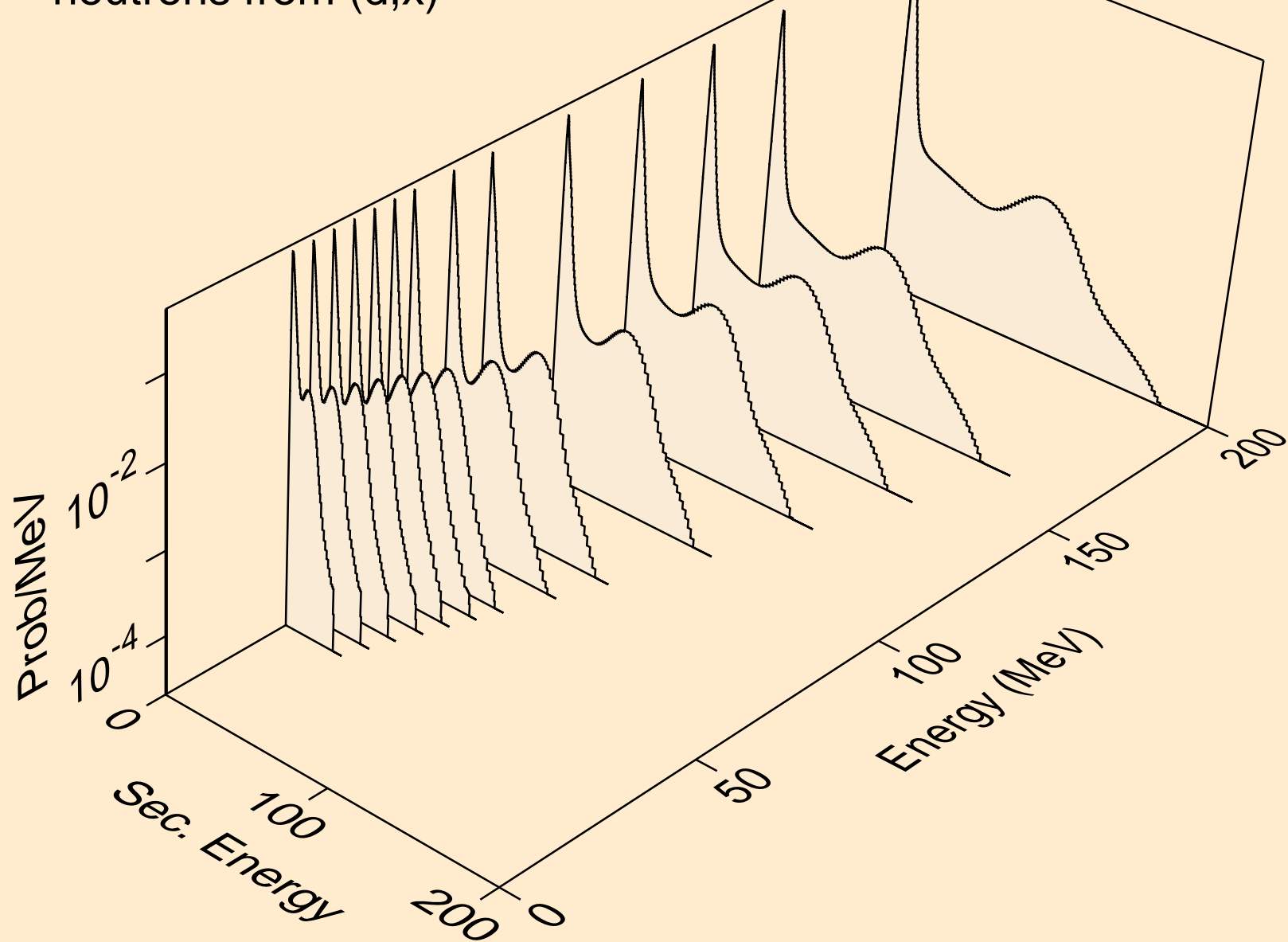

PT185M DEUTERON ACER TENDL-2023 LIBRARY; T=0.K  
neutrons from (d,2nd)

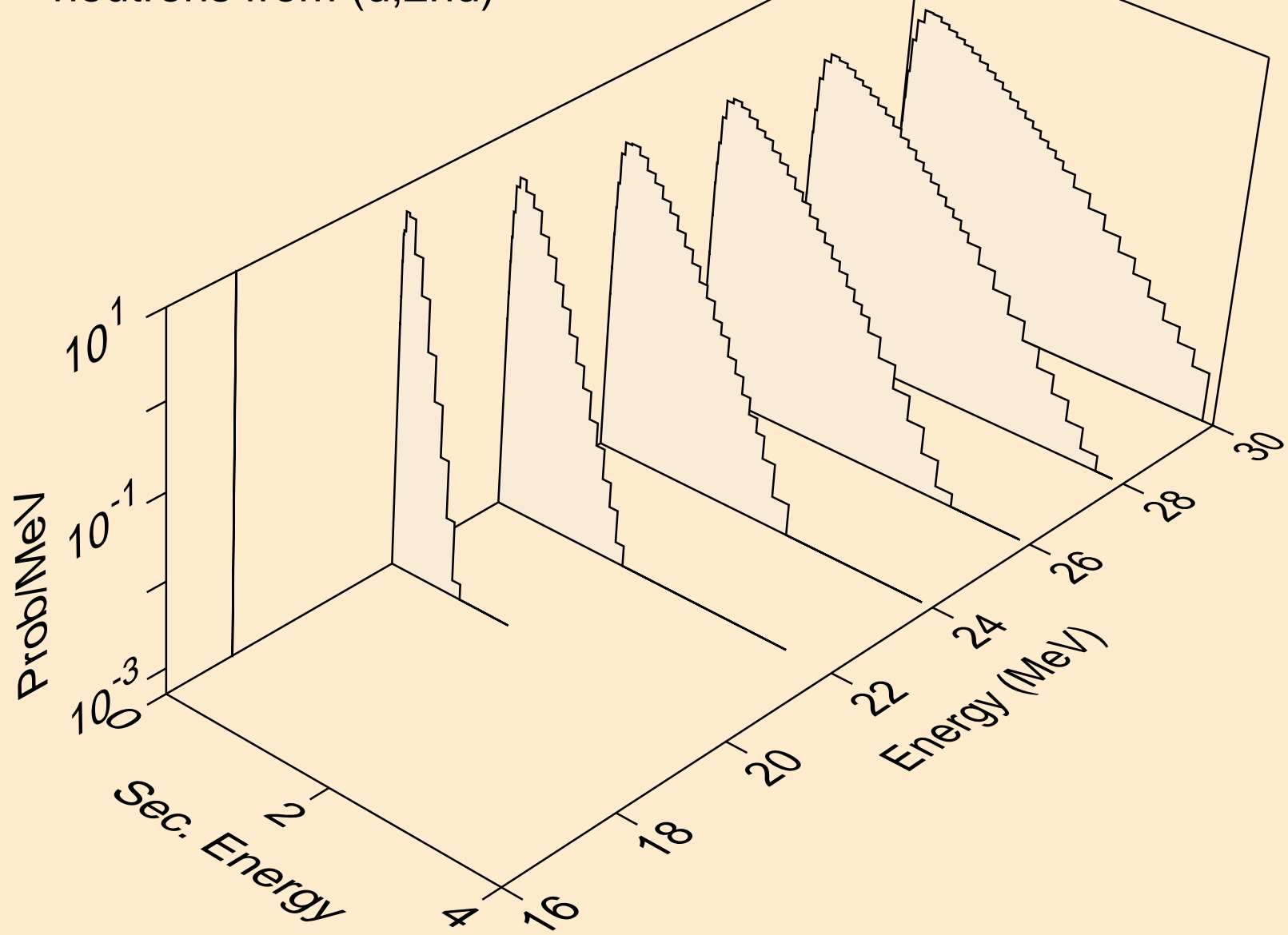

PT185M DEUTERON ACER TENDL-2023 LIBRARY; T=0.K  
neutrons from (d,2n)

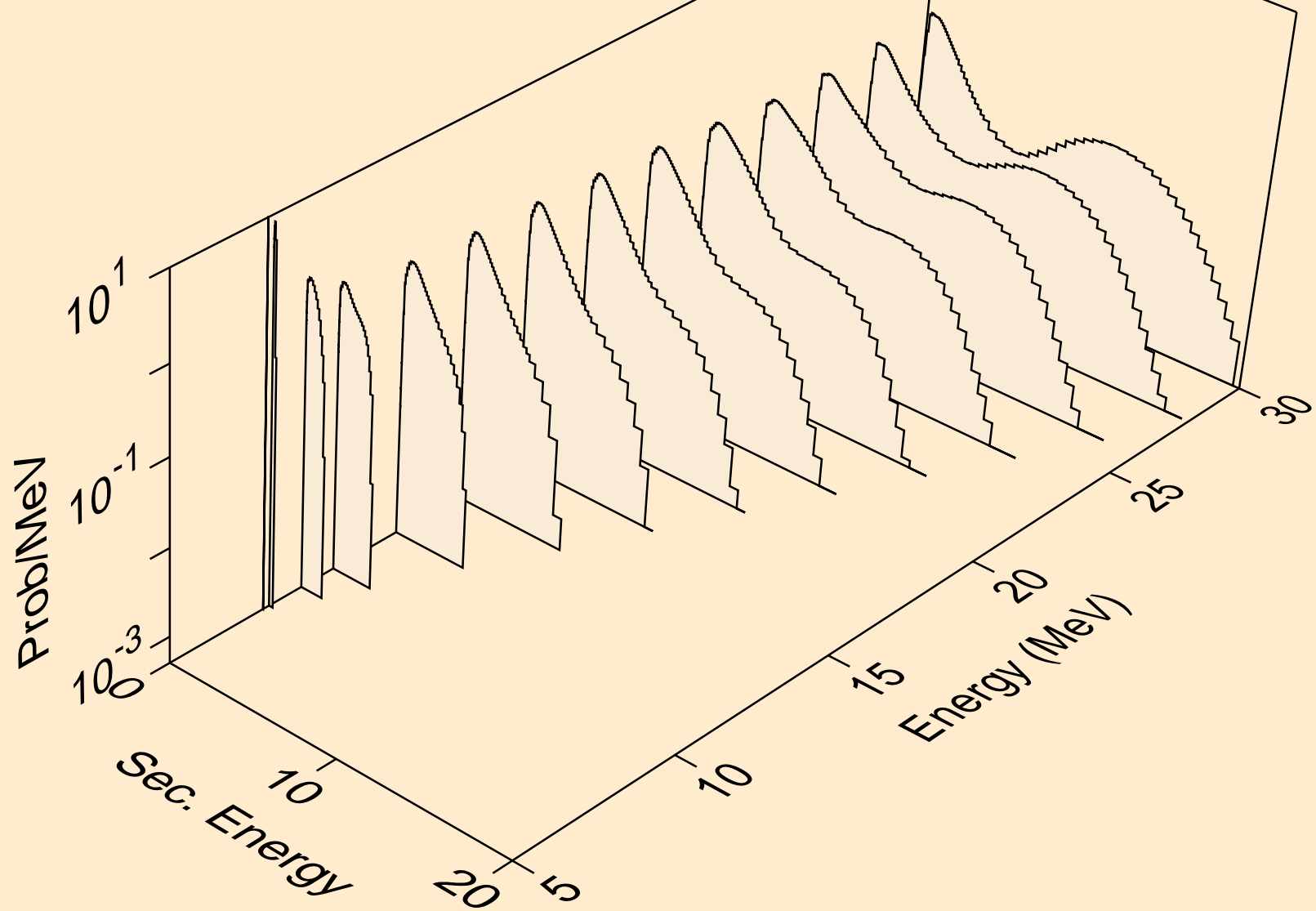

PT185M DEUTERON ACER TENDL-2023 LIBRARY; T=0.K  
neutrons from (d,3n)

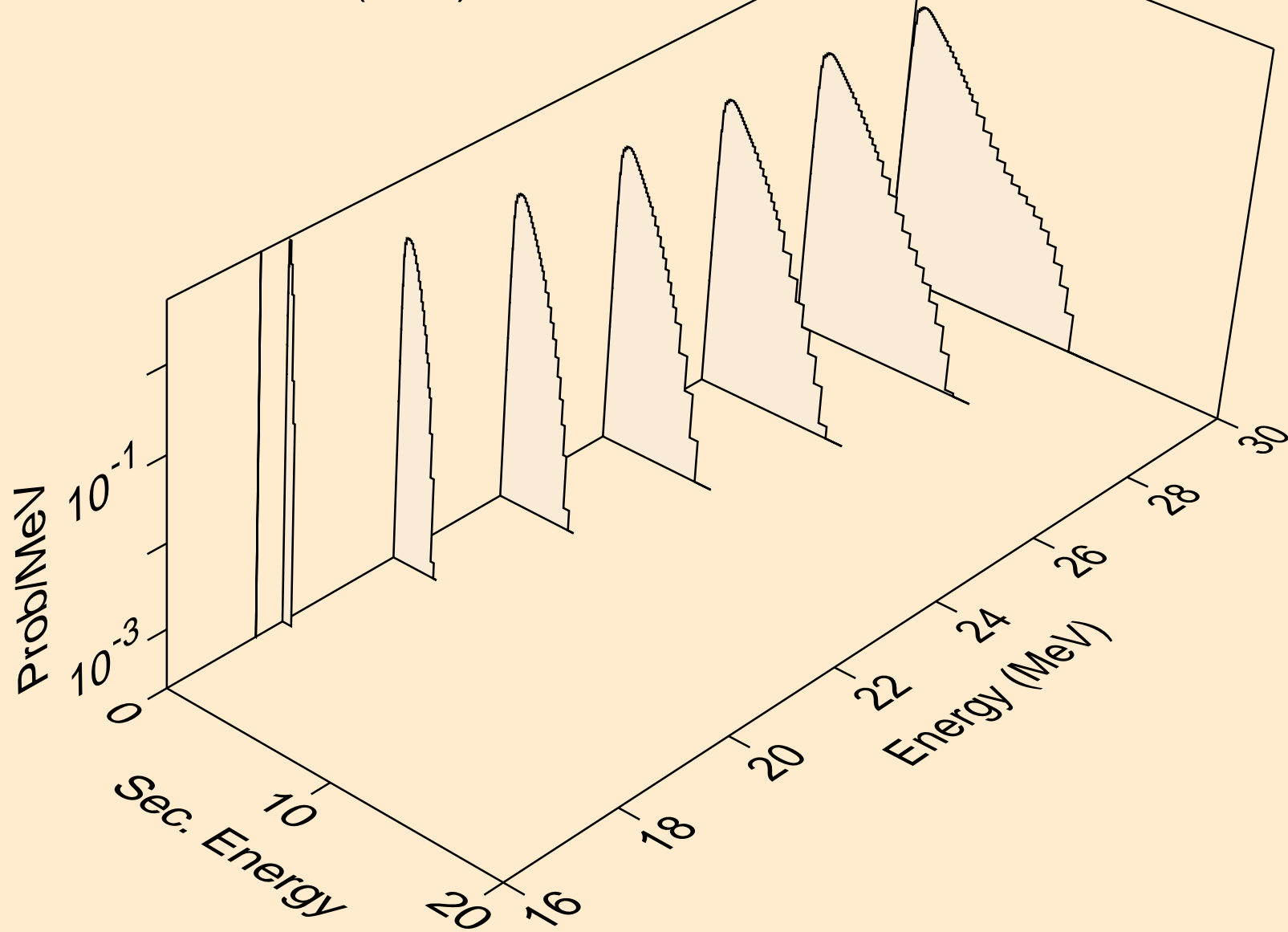

PT185M DEUTERON ACER TENDL-2023 LIBRARY; T=0.K  
neutrons from (d,n\*)a

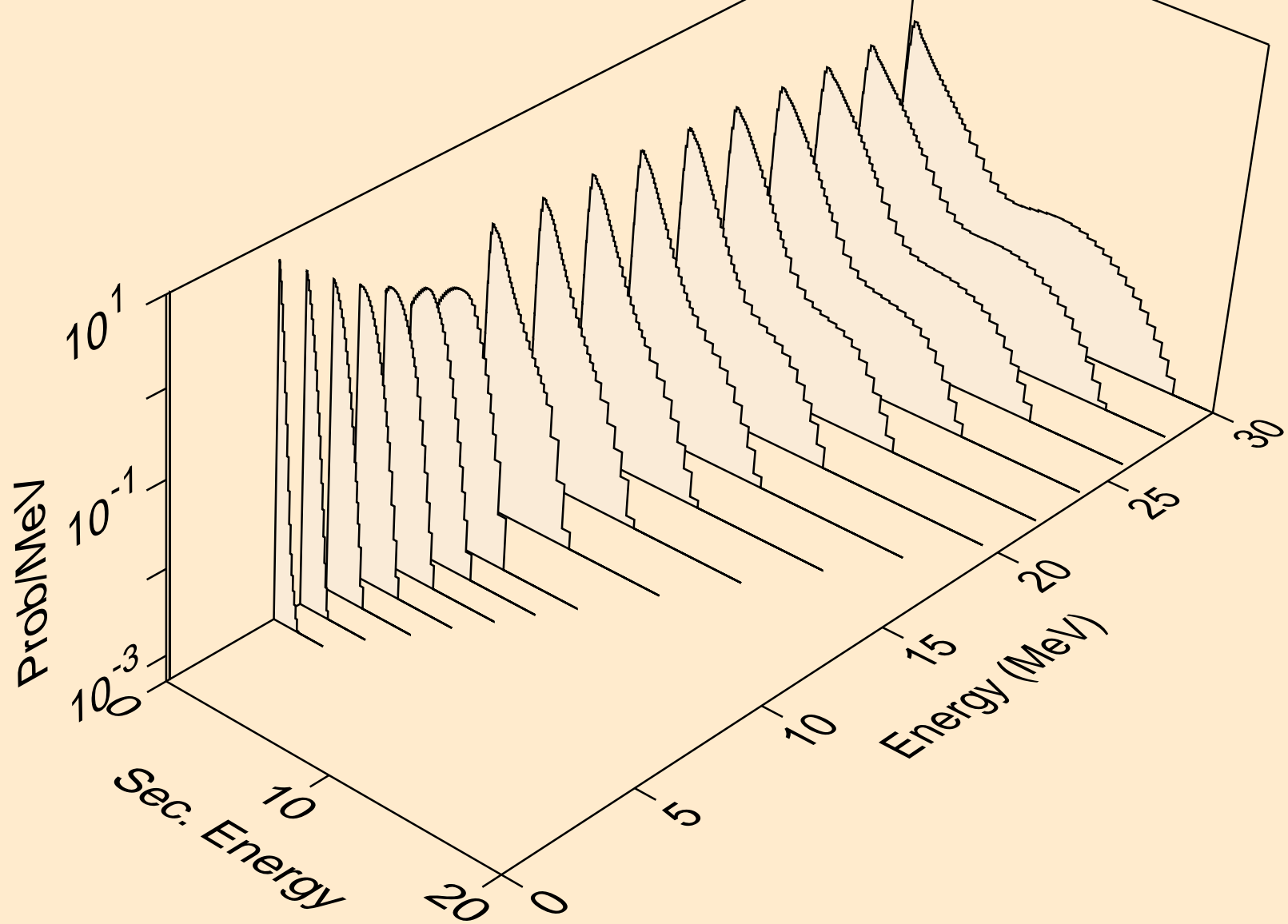

PT185M DEUTERON ACER TENDL-2023 LIBRARY; T=0.K  
neutrons from (d,2n)a

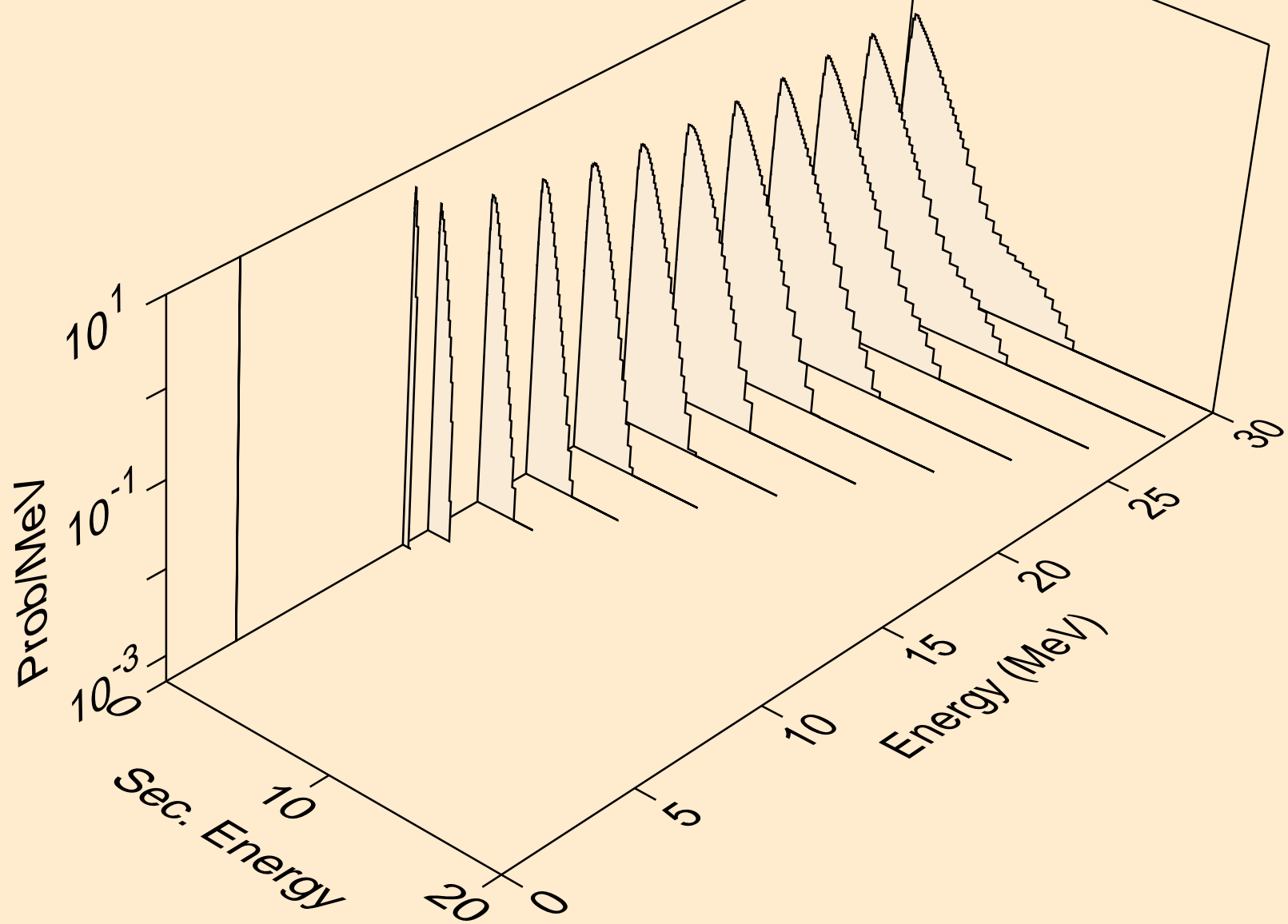



PT185M DEUTERON ACER TENDL-2023 LIBRARY; T=0.K  
neutrons from (d,3n)a

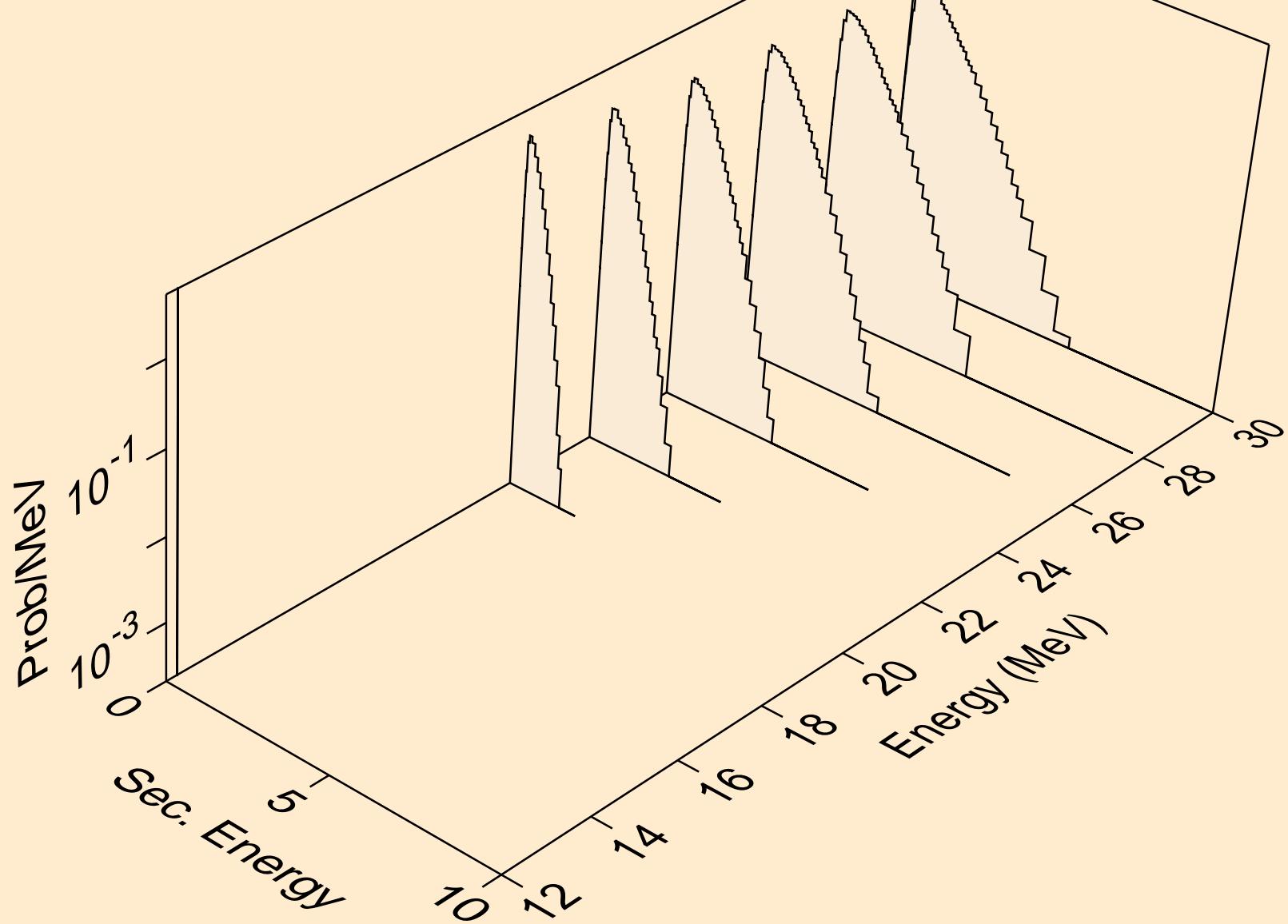

PT185M DEUTERON ACER TENDL-2023 LIBRARY; T=0.K  
neutrons from (d,n\*)p

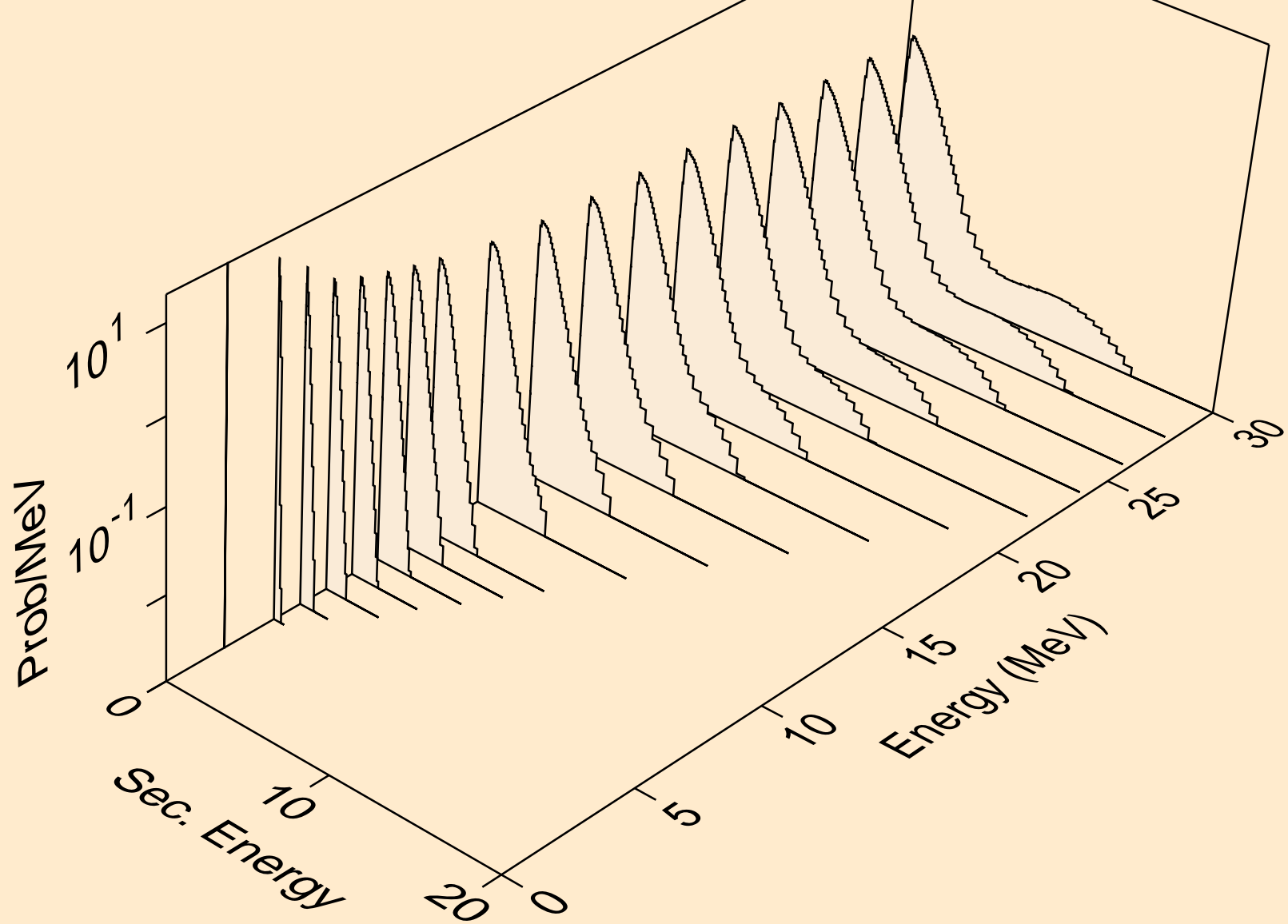

PT185M DEUTERON ACER TENDL-2023 LIBRARY; T=0.K  
neutrons from (d,n\*)2a

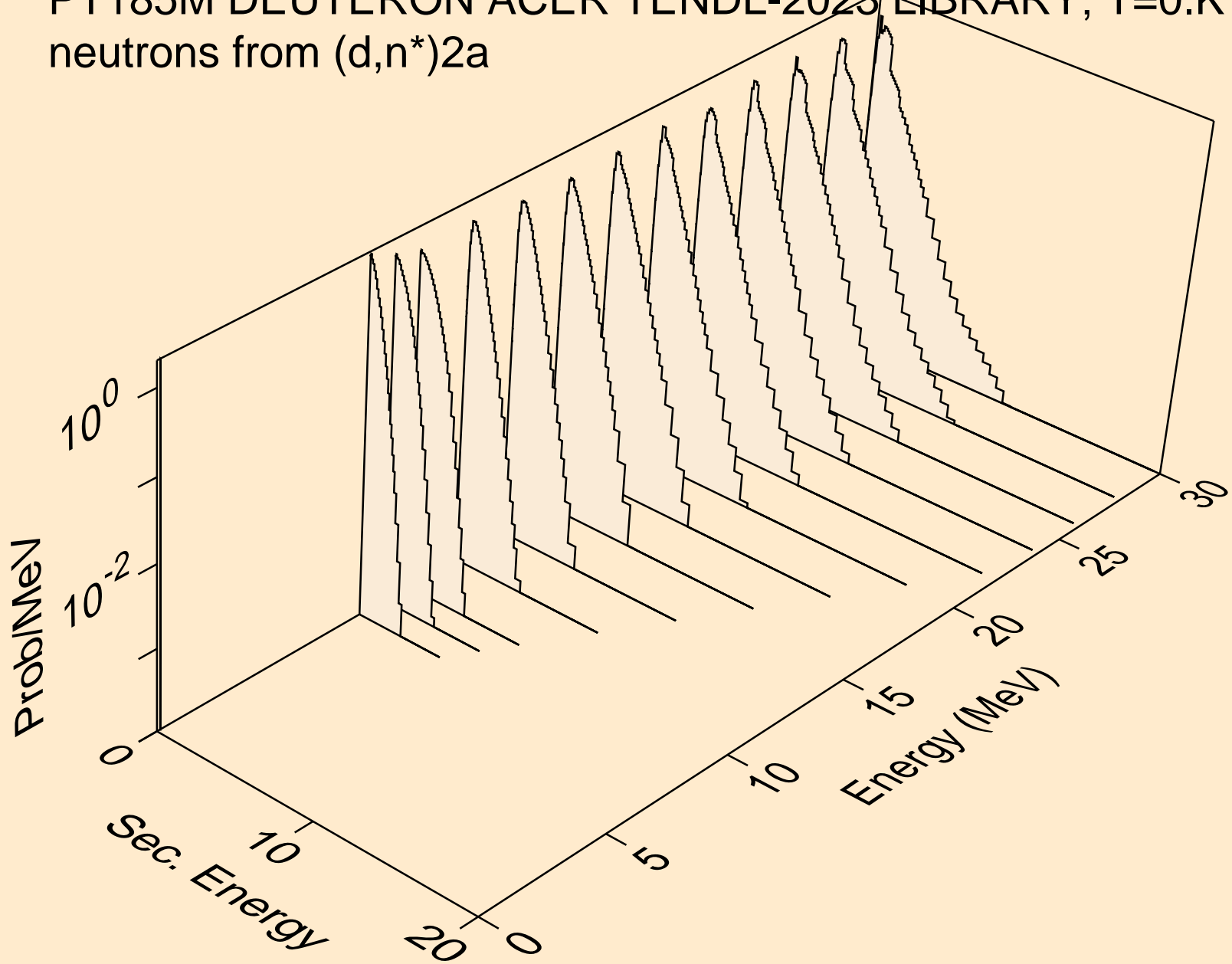

PT185M DEUTERON ACER TENDL-2023 LIBRARY; T=0.K  
neutrons from (d,2n)2a

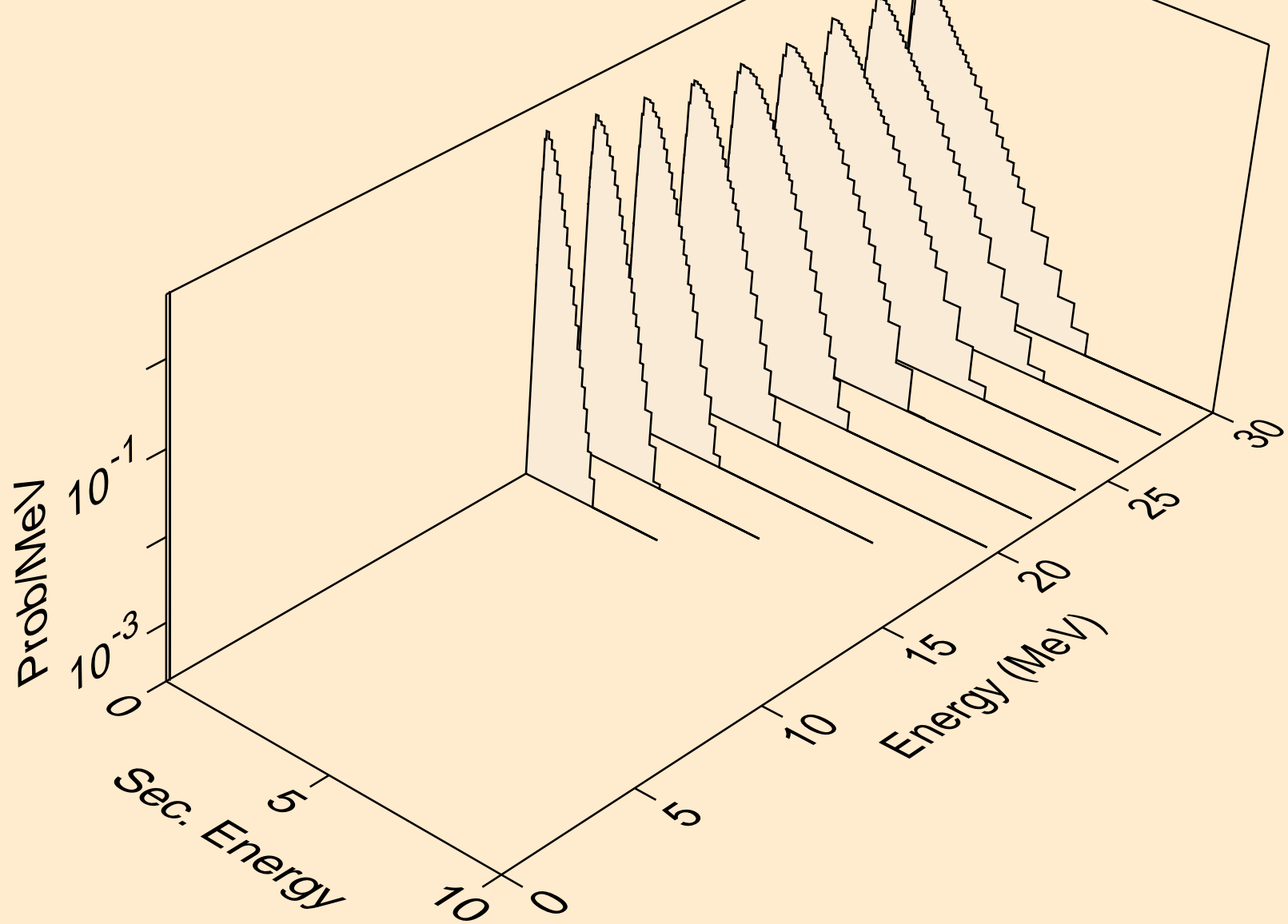

PT185M DEUTERON ACER TENDL-2023 LIBRARY; T=0.K  
neutrons from (d,n\*)d

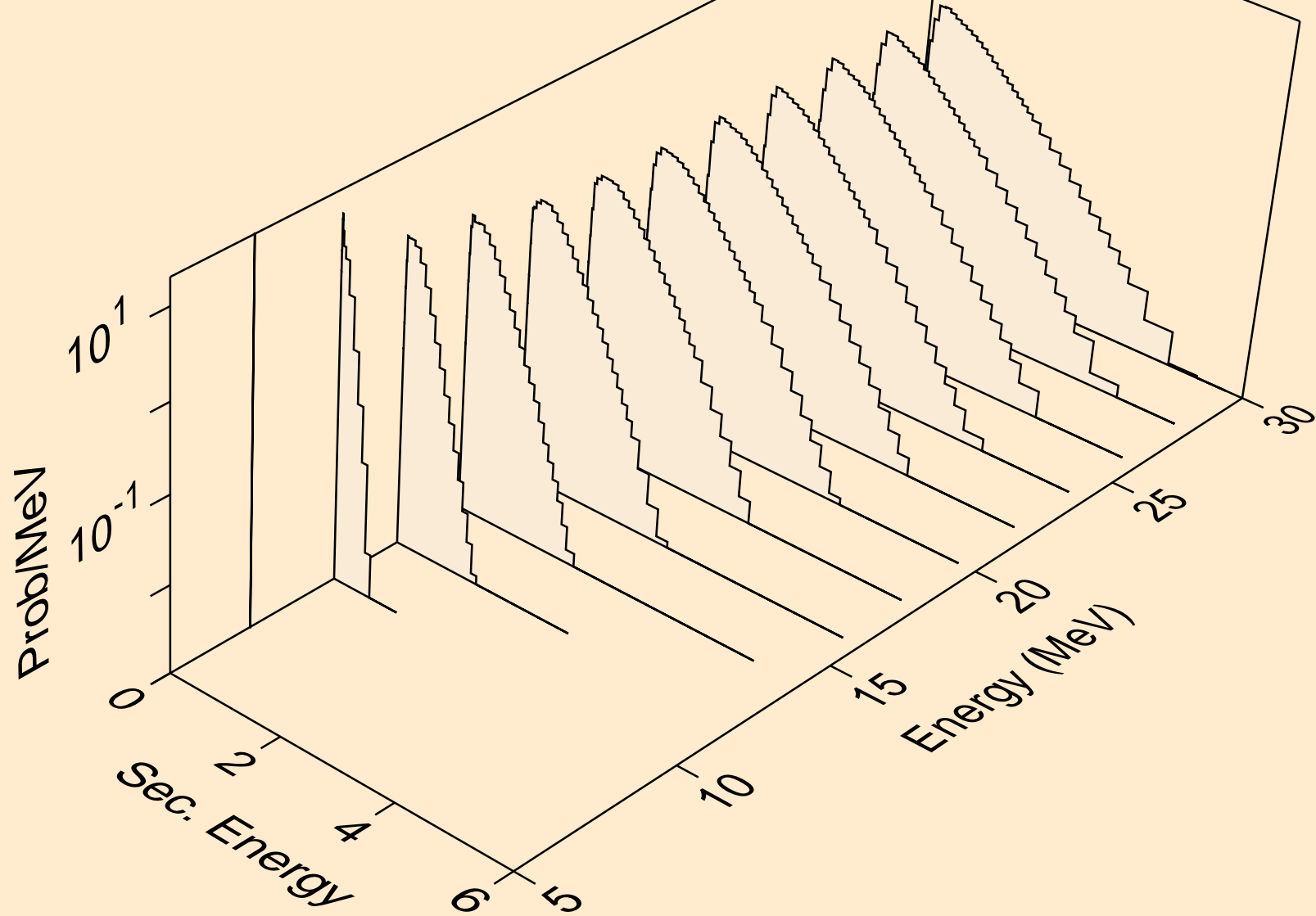

PT185M DEUTERON ACER TENDL-2023 LIBRARY; T=0.K  
neutrons from (d,n\*)t

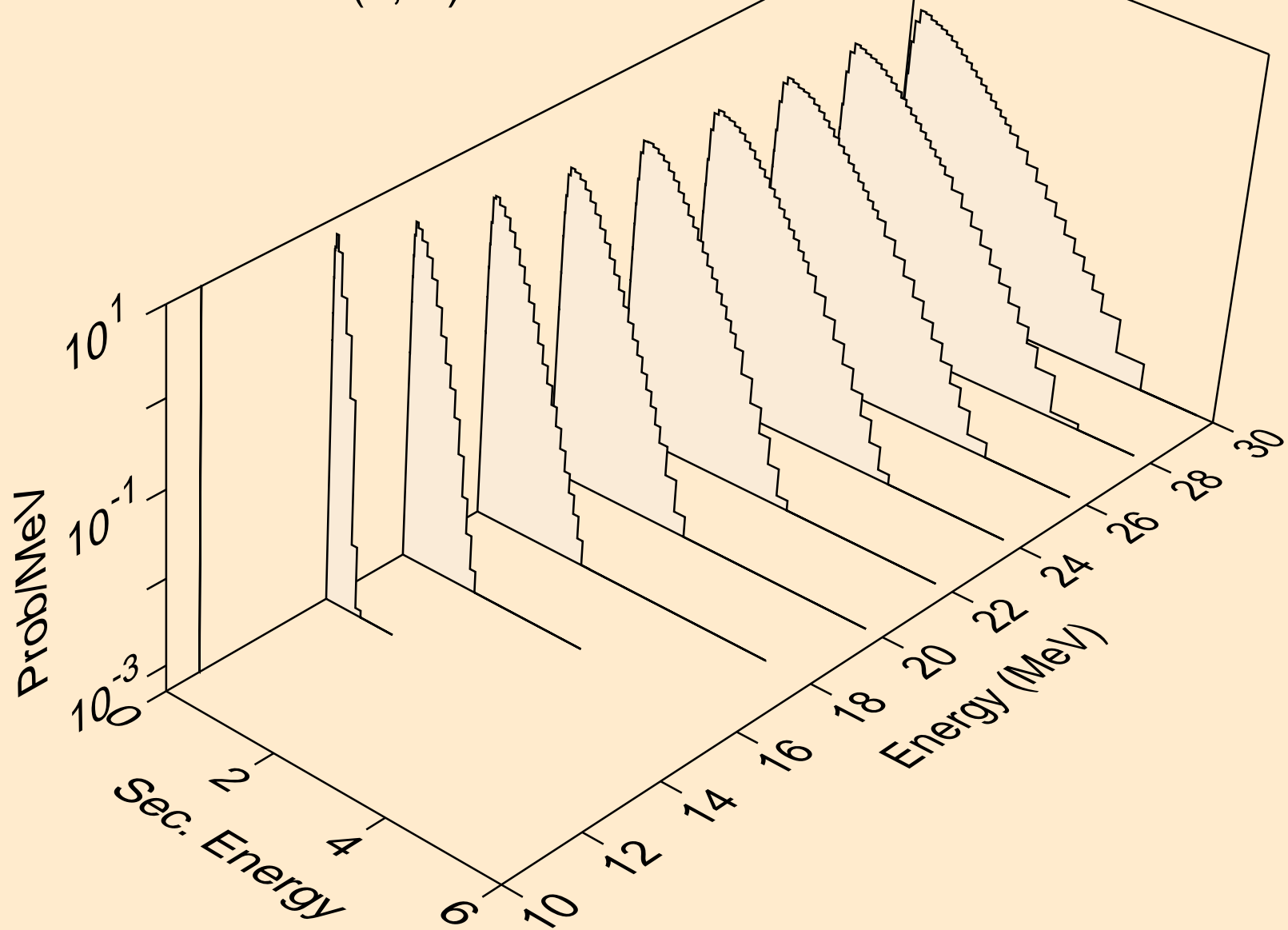

PT185M DEUTERON ACER TENDL-2023 LIBRARY; T=0.K  
neutrons from (d,n\*)he3

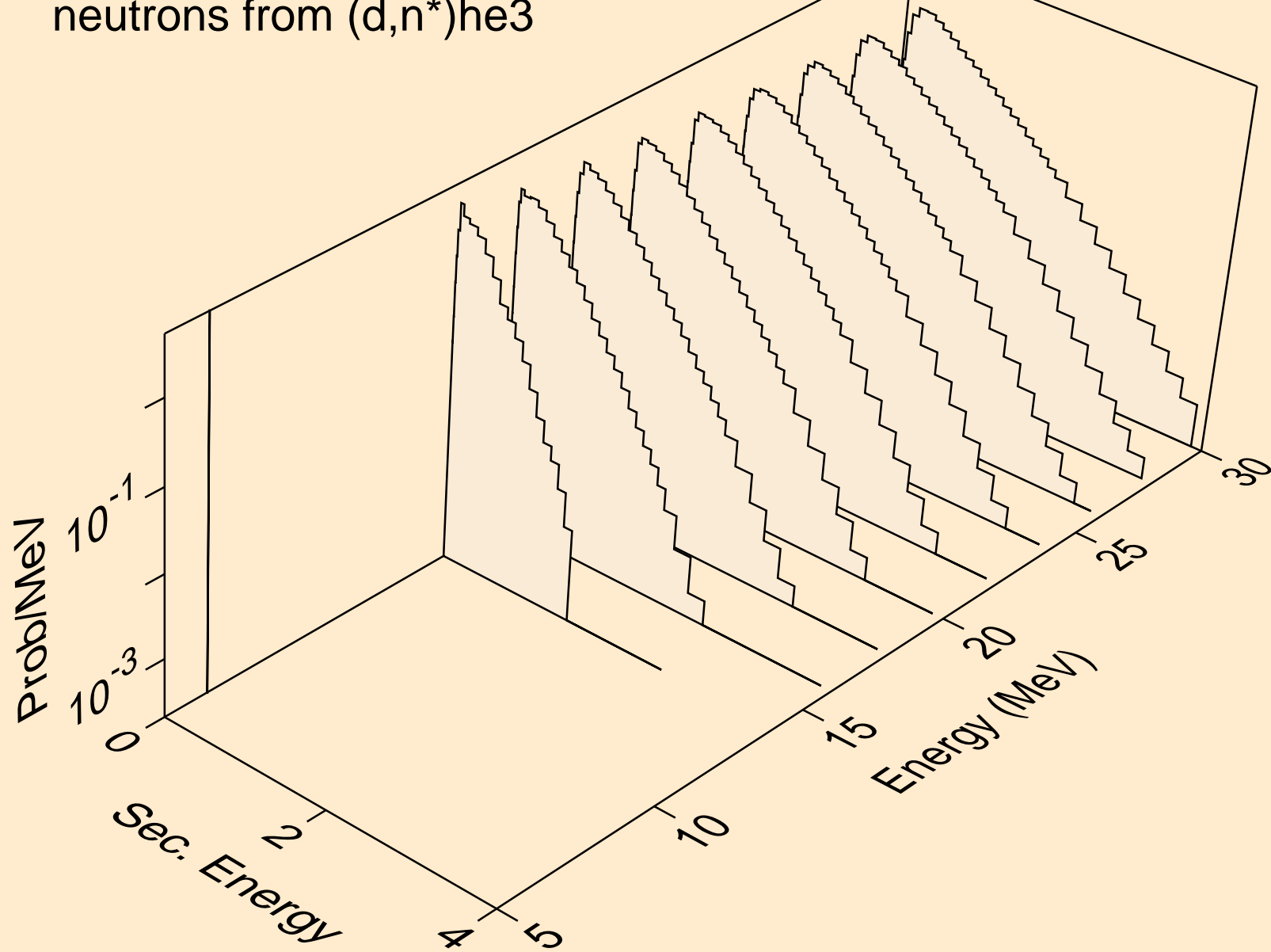

PT185M DEUTERON ACER TENDL-2023 LIBRARY; T=0.K  
neutrons from (d,4n)

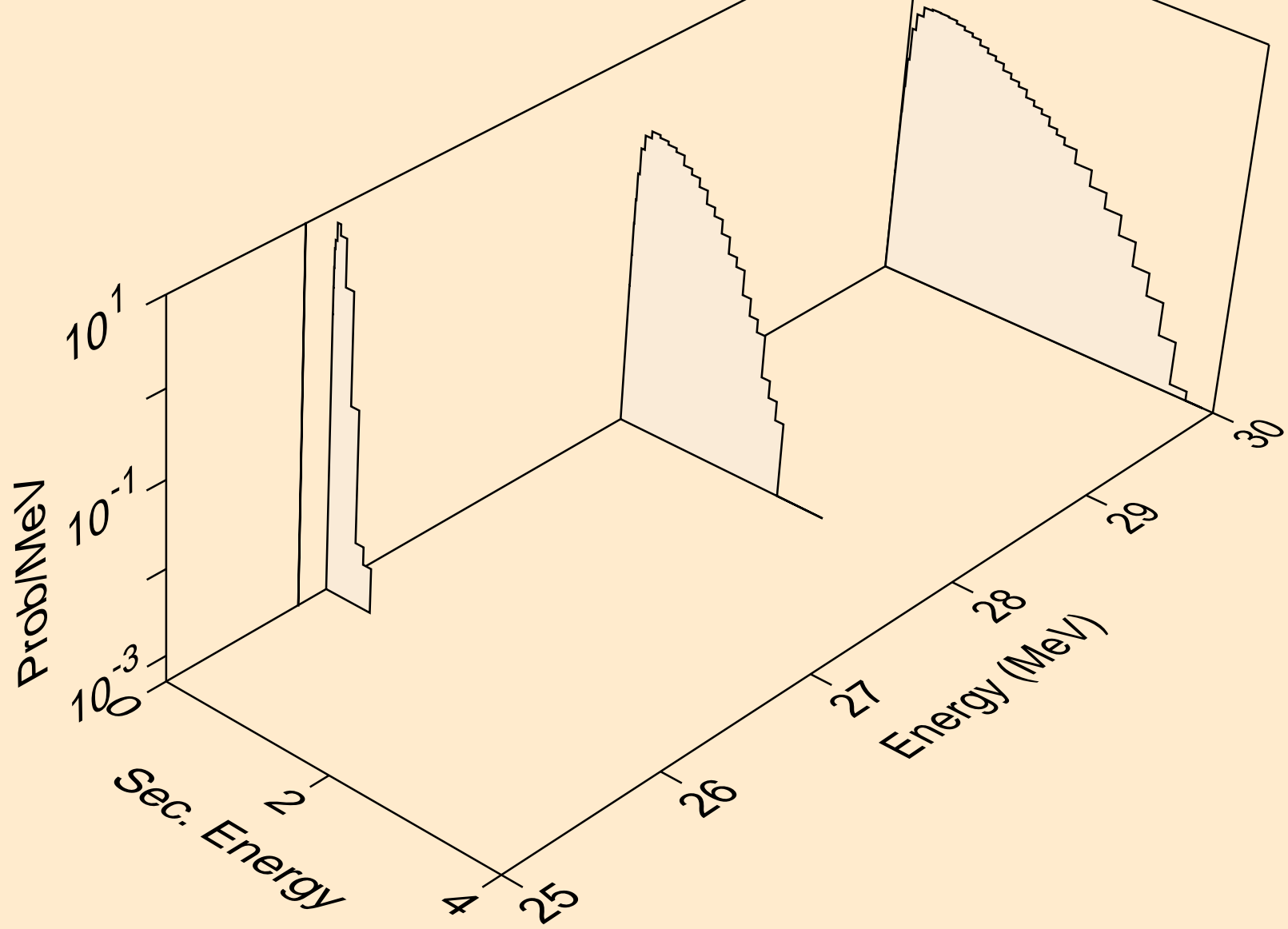



PT185M DEUTERON ACER TENDL-2023 LIBRARY; T=0.K  
neutrons from (d,2np)

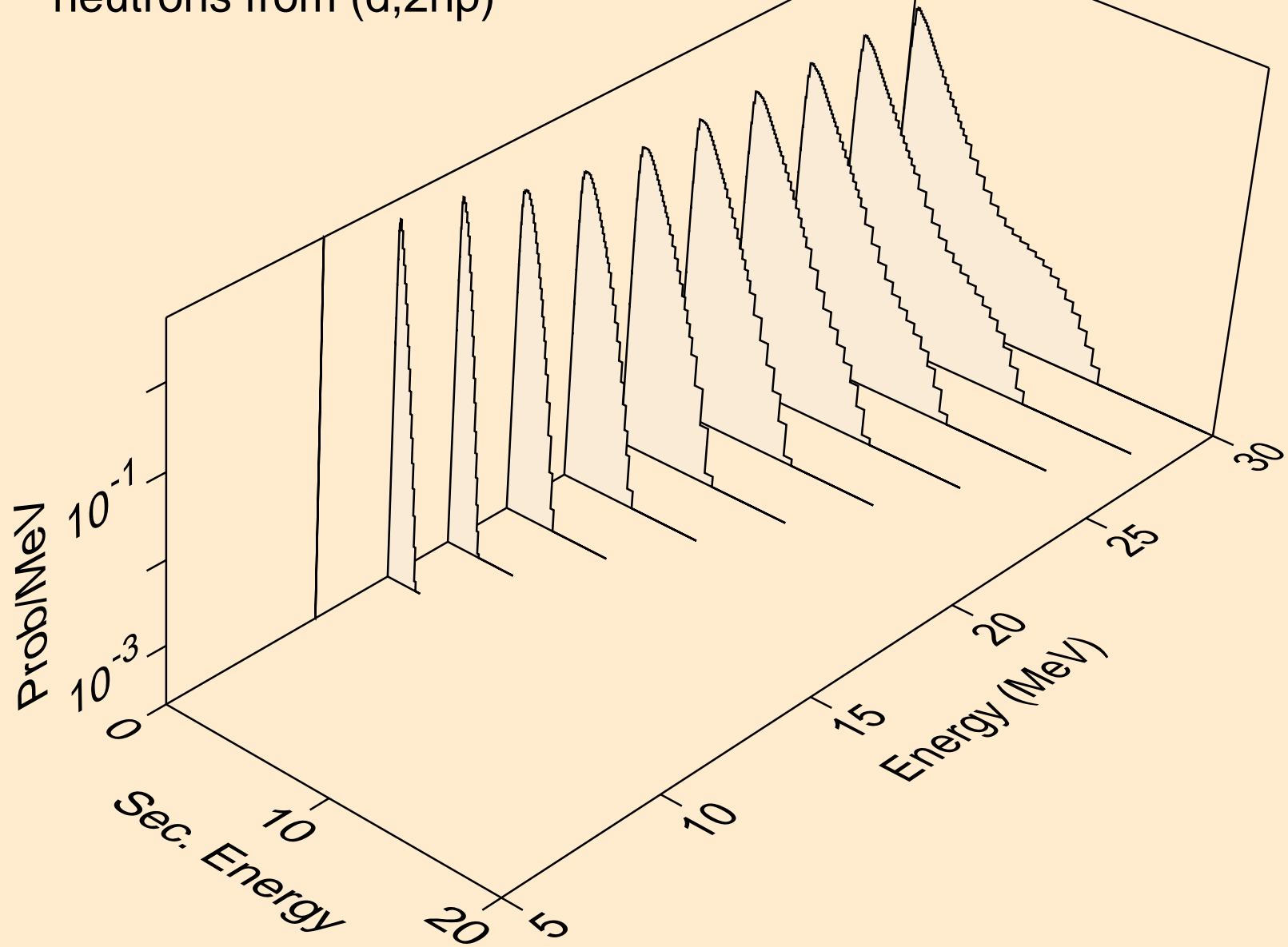

PT185M DEUTERON ACER TENDL-2023 LIBRARY; T=0.K  
neutrons from (d,3np)

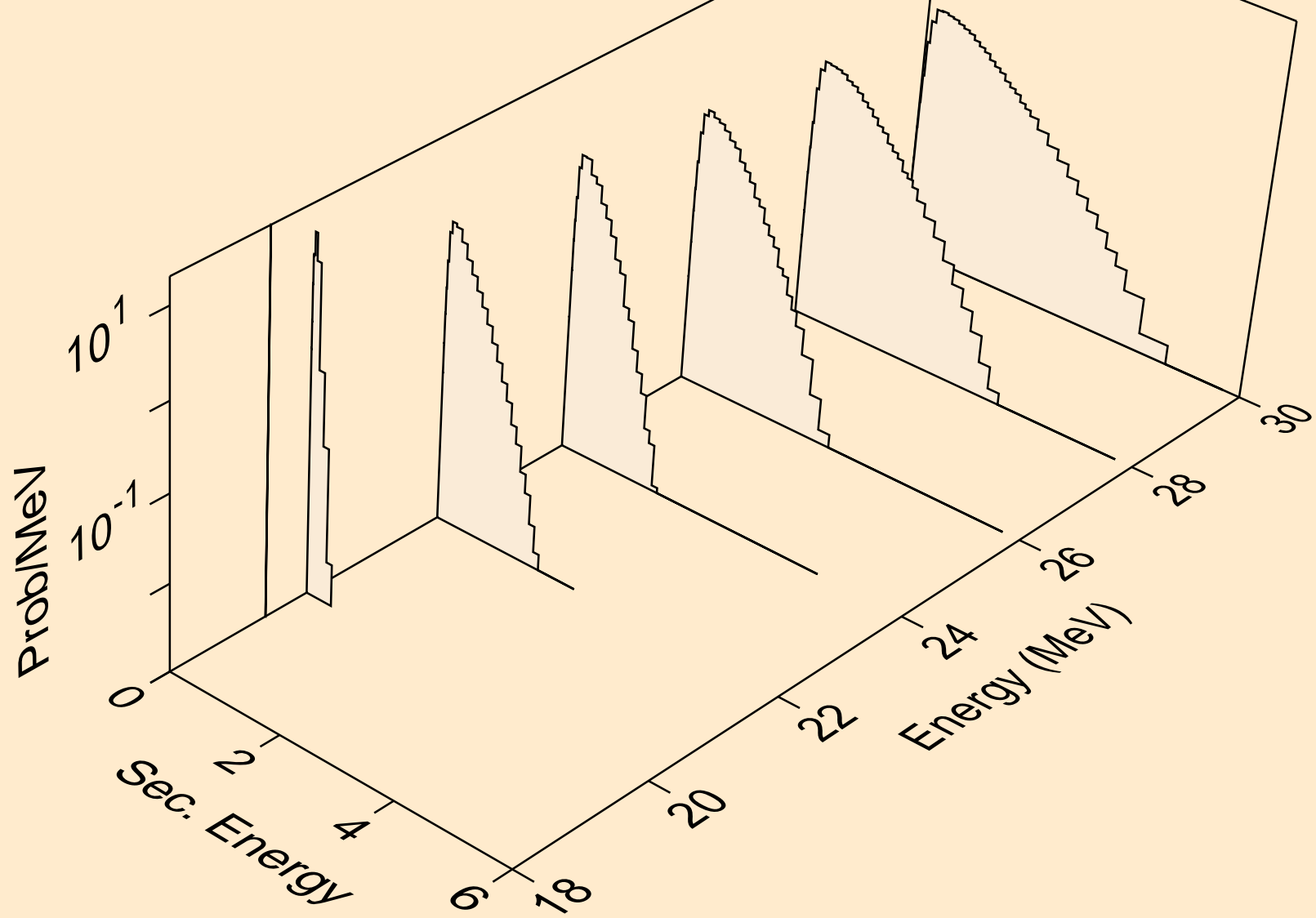

PT185M DEUTERON ACER TENDL-2023 LIBRARY; T=0.K  
neutrons from (d,n2p)

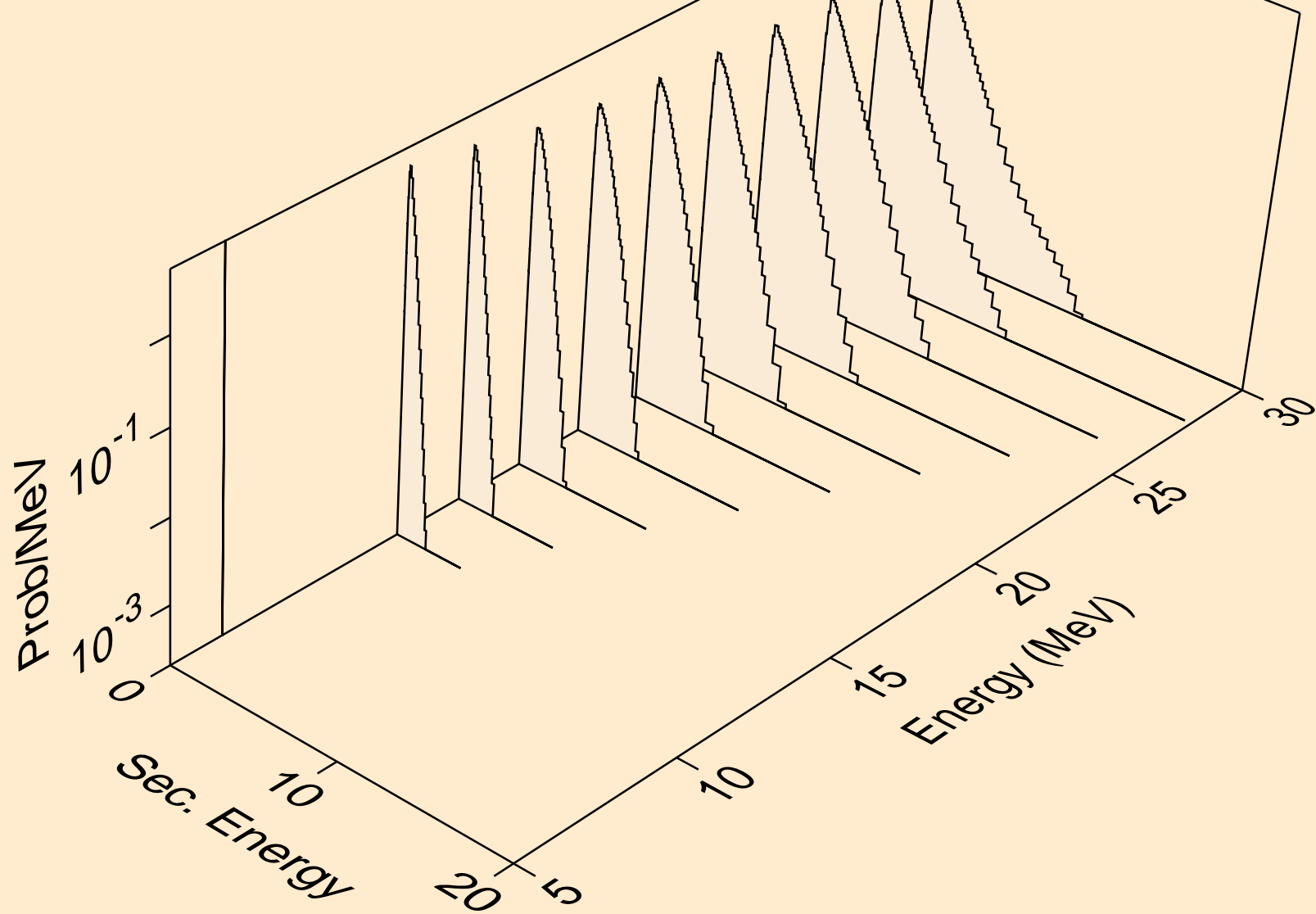

PT185M DEUTERON ACER TENDL-2023 LIBRARY; T=0.K  
neutrons from (d,npa)

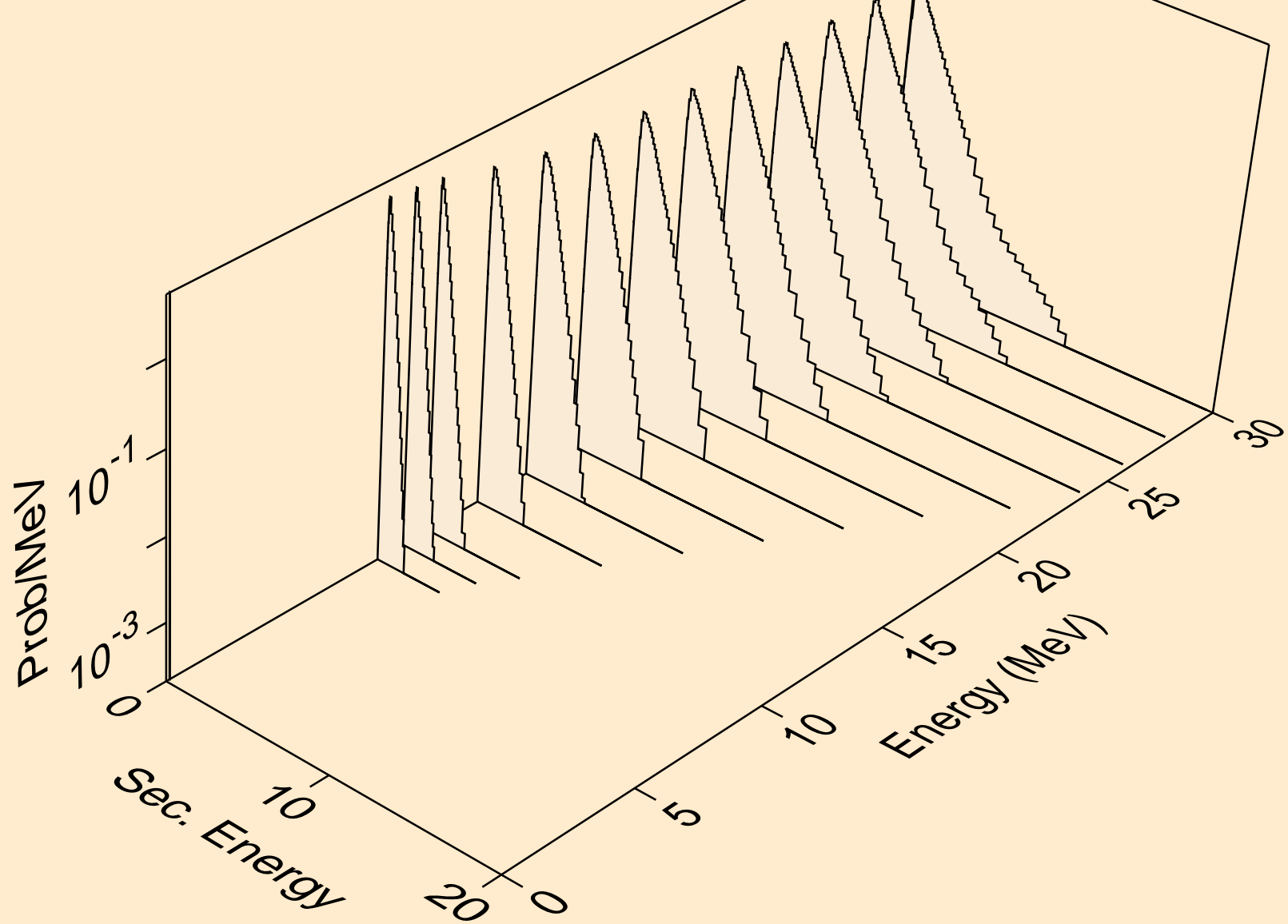

PT185M DEUTERON ACER TENDL-2023 LIBRARY; T=0.K  
protons from (d,x)

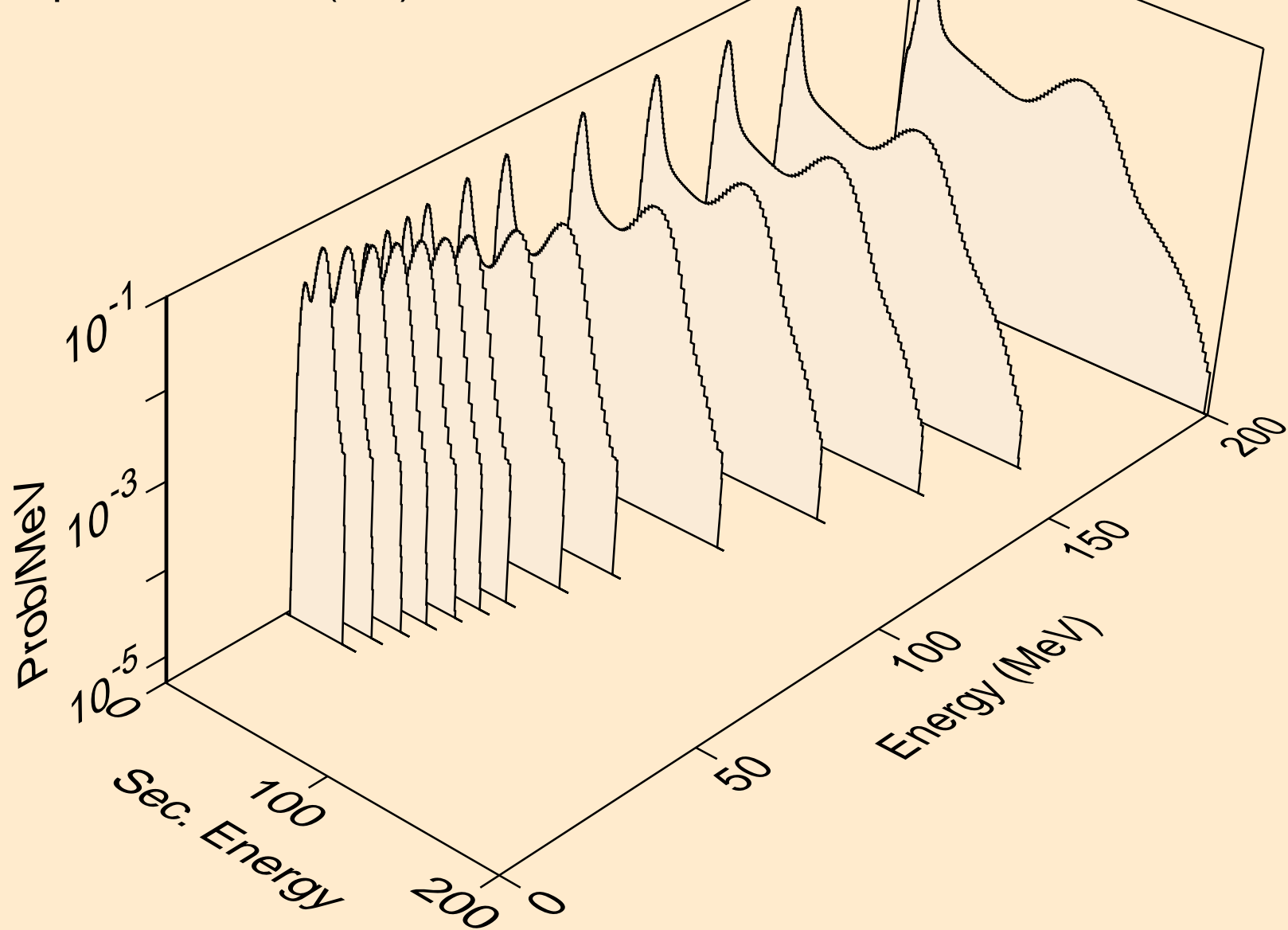

PT185M DEUTERON ACER TENDL-2023 LIBRARY; T=0.K  
protons from (d,n\*)p

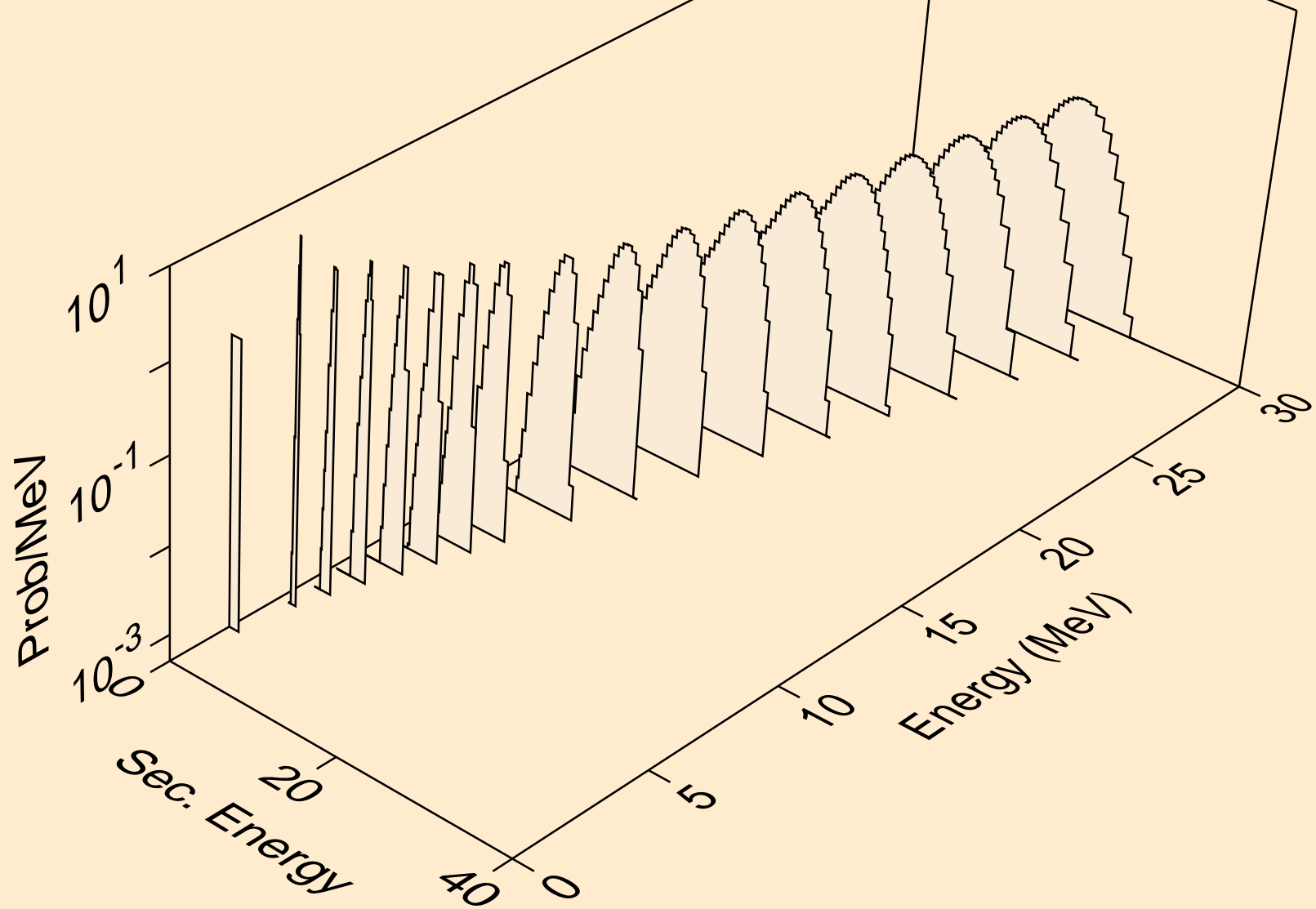

PT185M DEUTERON ACER TENDL-2023 LIBRARY; T=0.K  
protons from (d,2np)

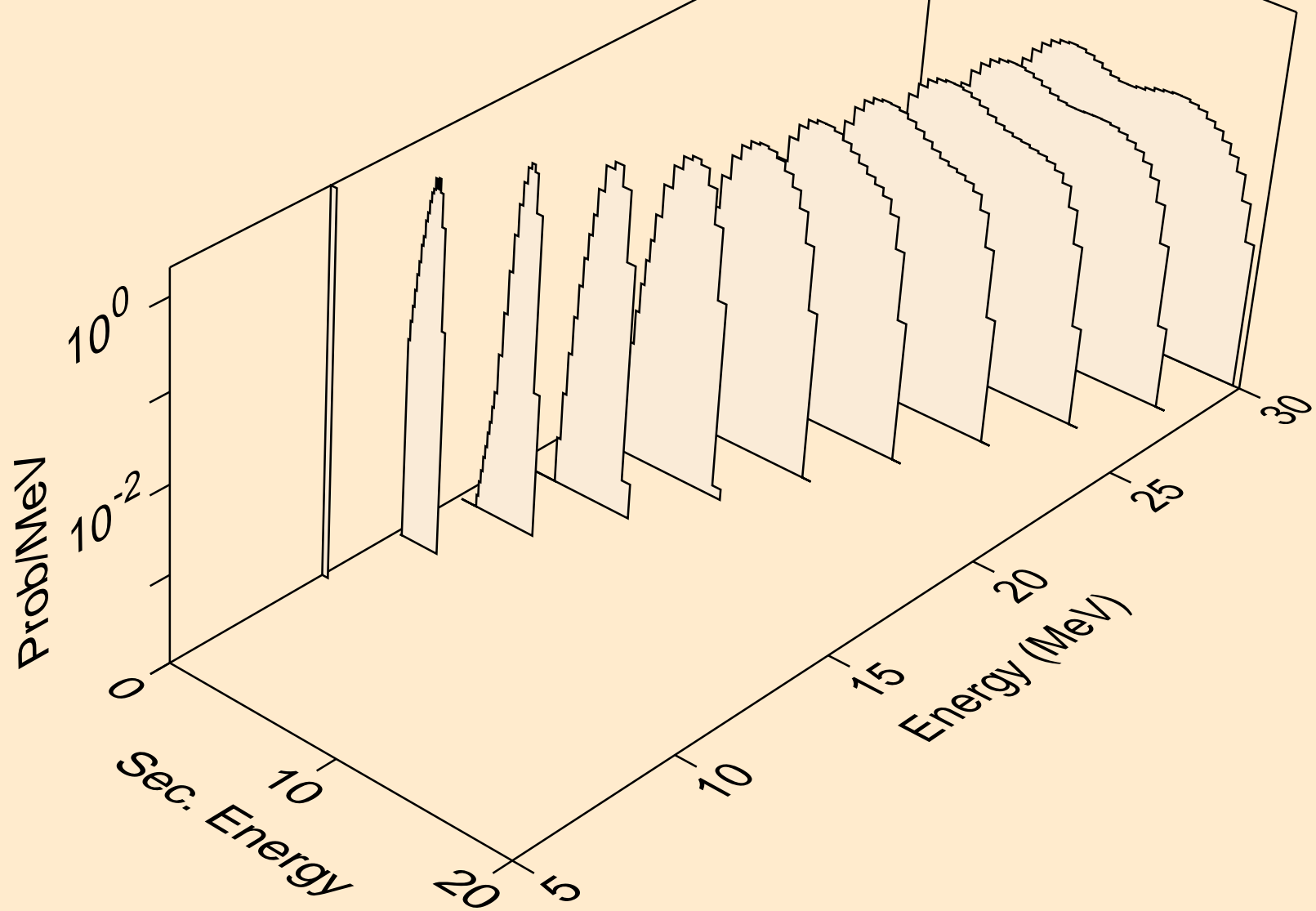

PT185M DEUTERON ACER TENDL-2023 LIBRARY; T=0.K  
protons from (d,3np)

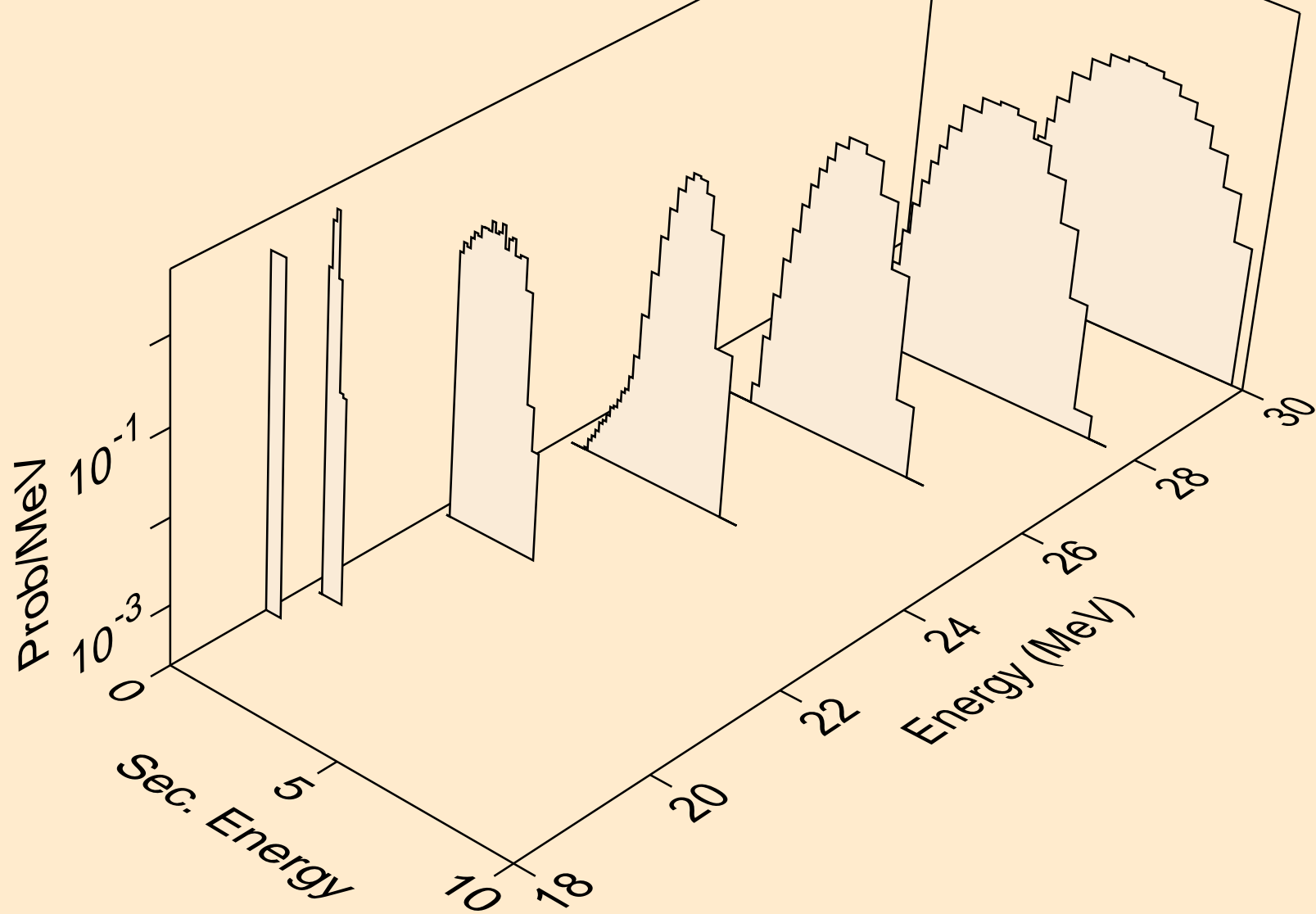



PT185M DEUTERON ACER TENDL-2023 LIBRARY; T=0.K  
protons from (d,n2p)

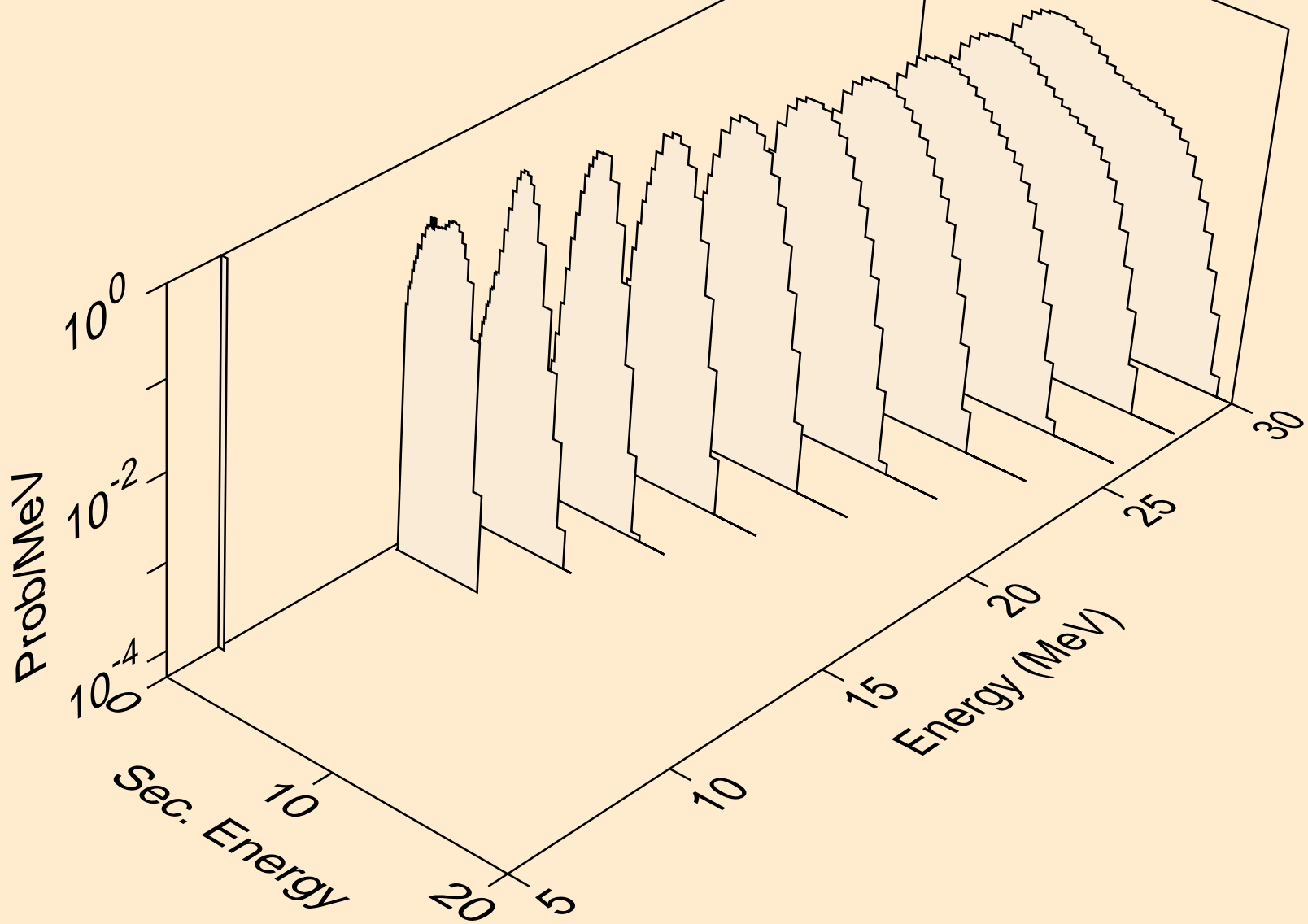

PT185M DEUTERON ACER TENDL-2023 LIBRARY; T=0.K  
protons from (d,npa)

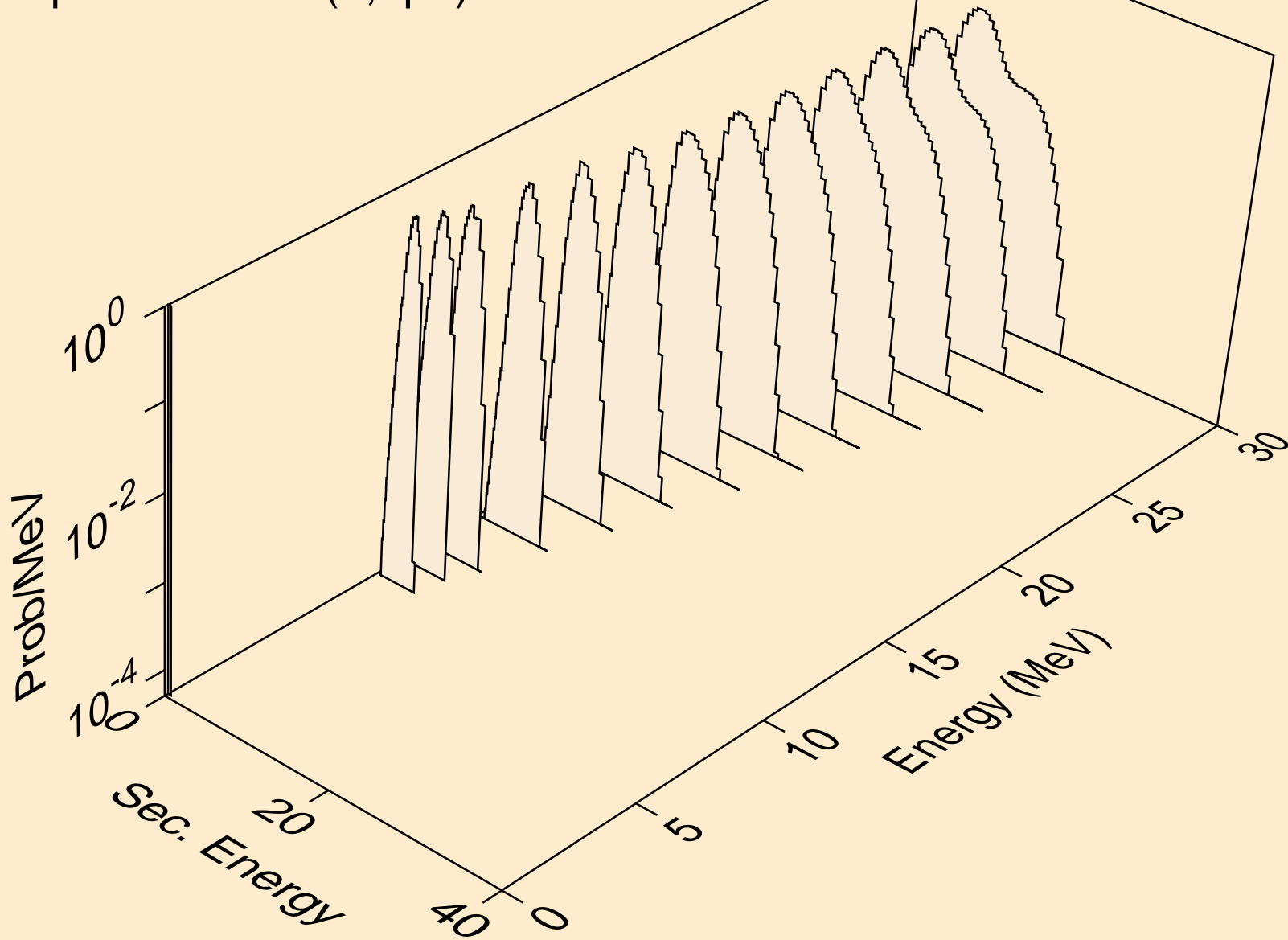

PT185M DEUTERON ACER TENDL-2023 LIBRARY; T=0.K  
protons from (d,p)

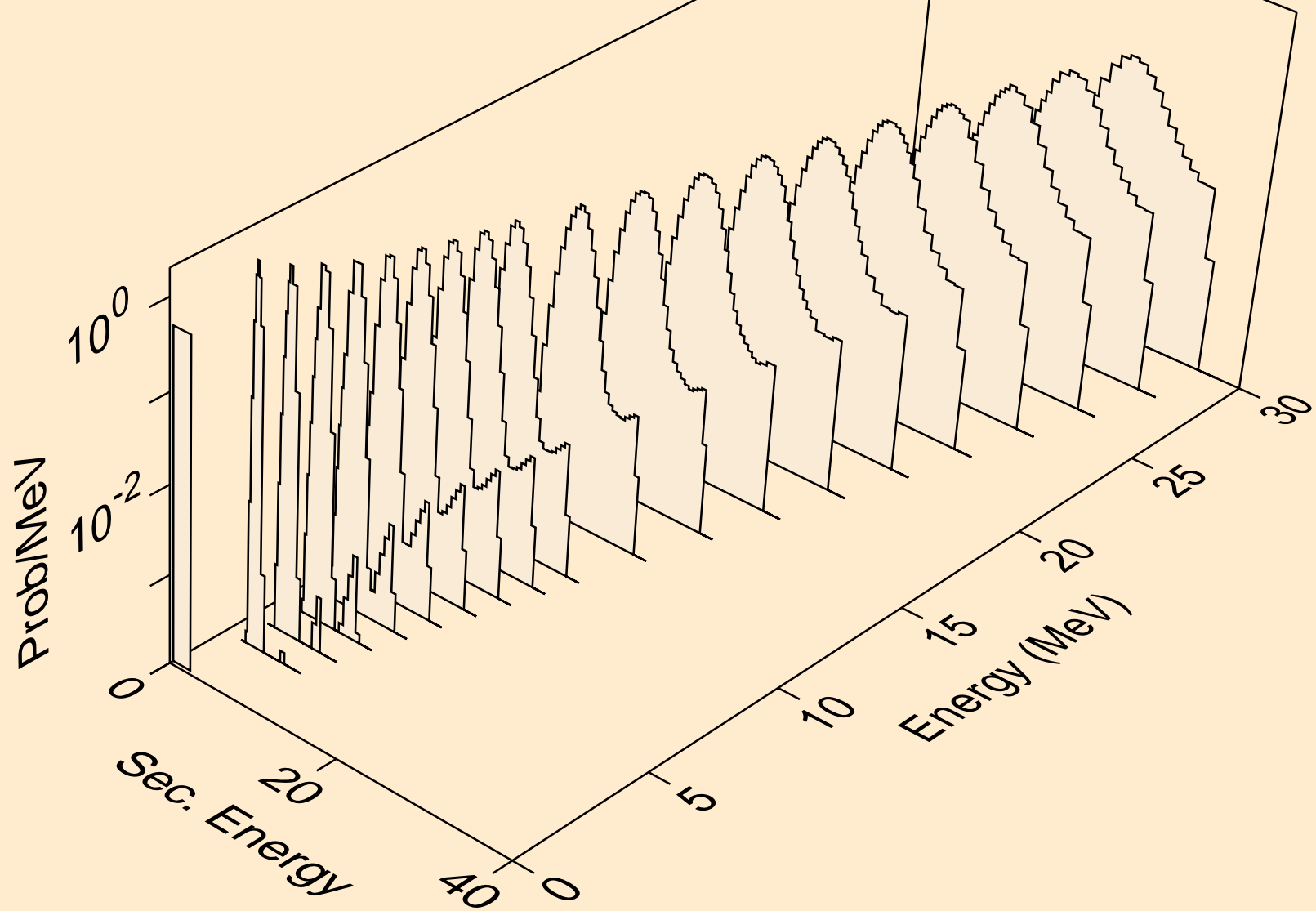

PT185M DEUTERON ACER TENDL-2023 LIBRARY; T=0.K  
protons from (d,2p)

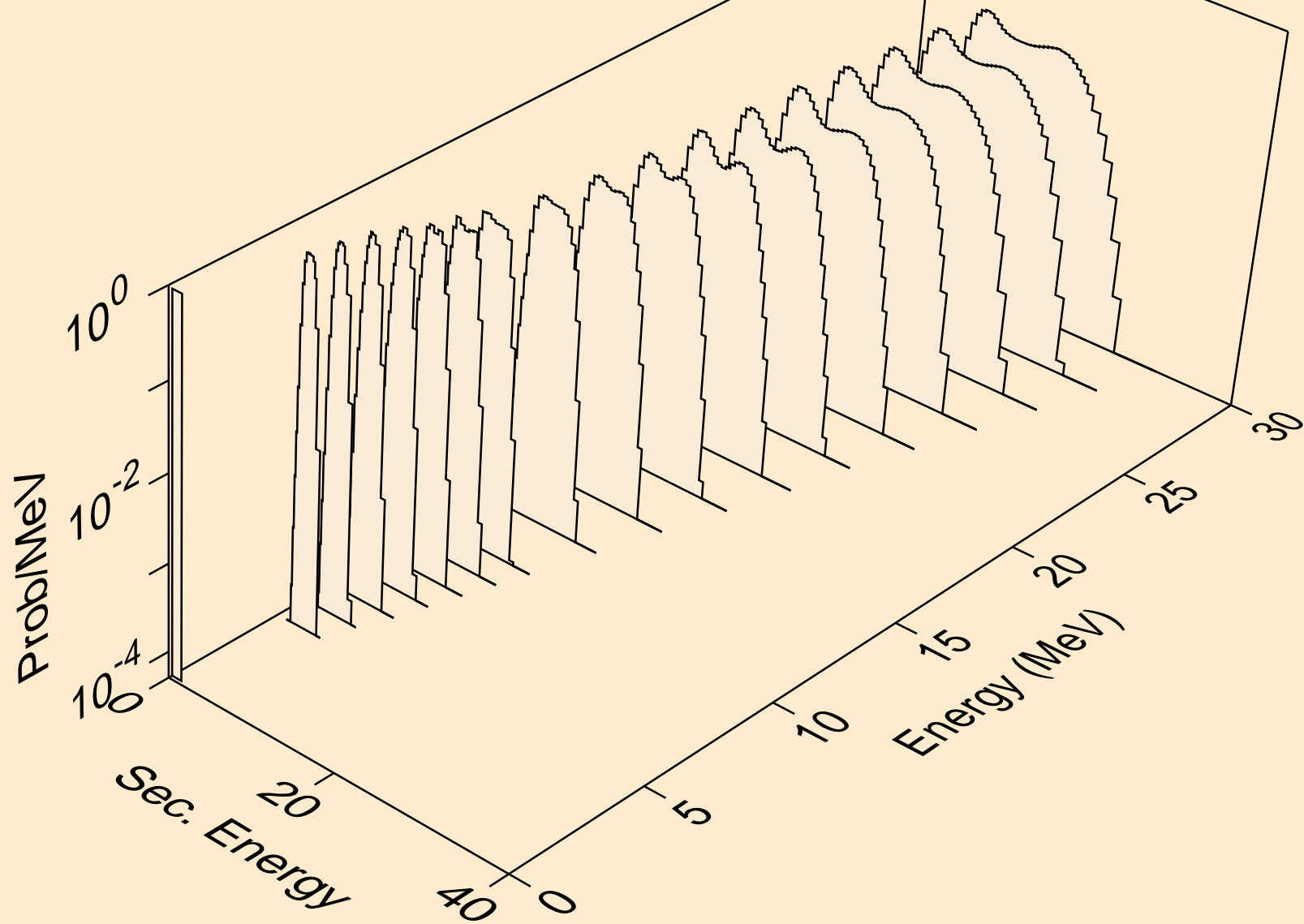

PT185M DEUTERON ACER TENDL-2023 LIBRARY; T=0.K  
protons from (d,pa)

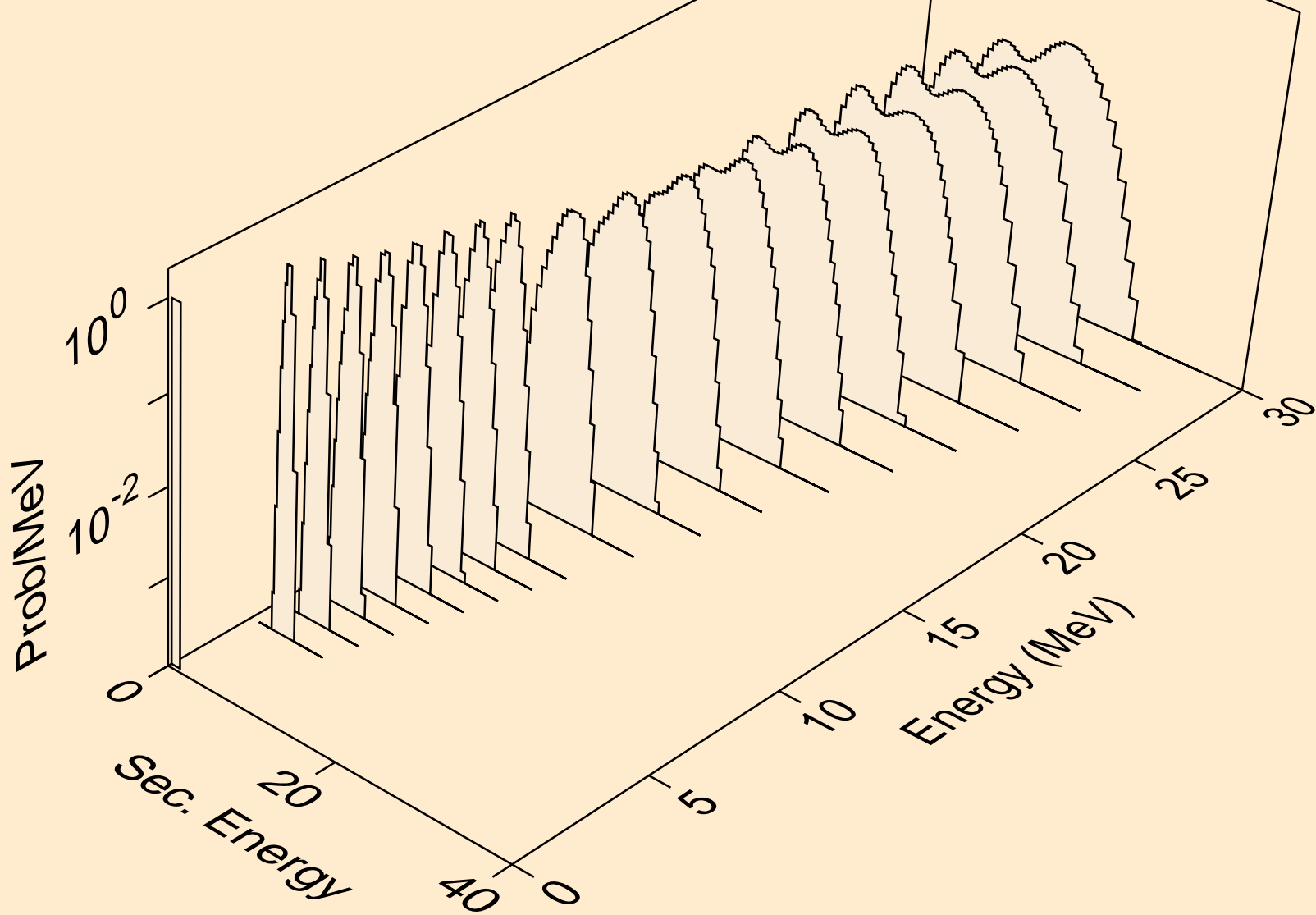

PT185M DEUTERON ACER TENDL-2023 LIBRARY; T=0.K  
protons from (d,pd)

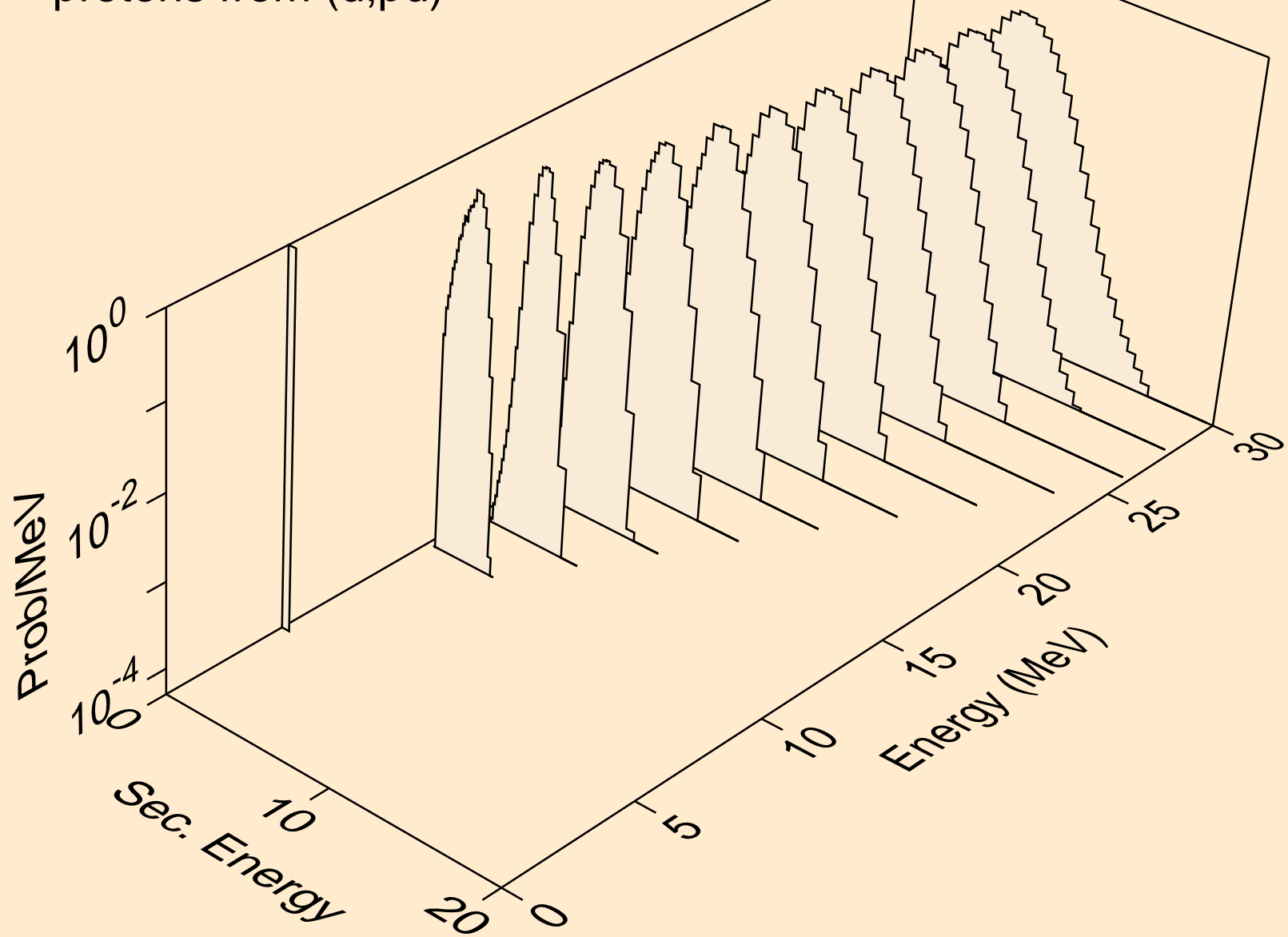

PT185M DEUTERON ACER TENDL-2023 LIBRARY; T=0.K  
protons from (d,pt)

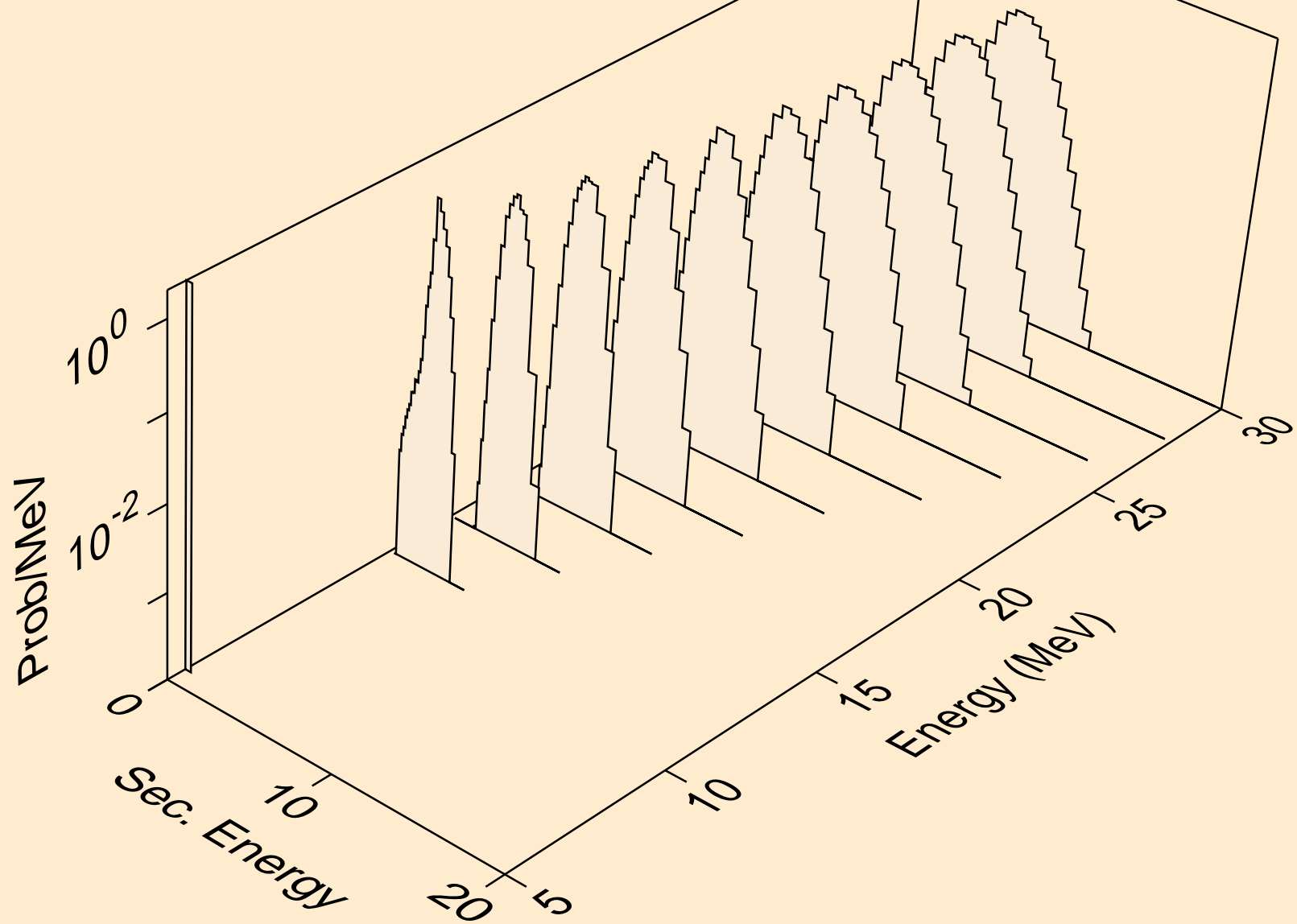

PT185M DEUTERON ACER TENDL-2023 LIBRARY; T=0.K  
tritons from (d,x)

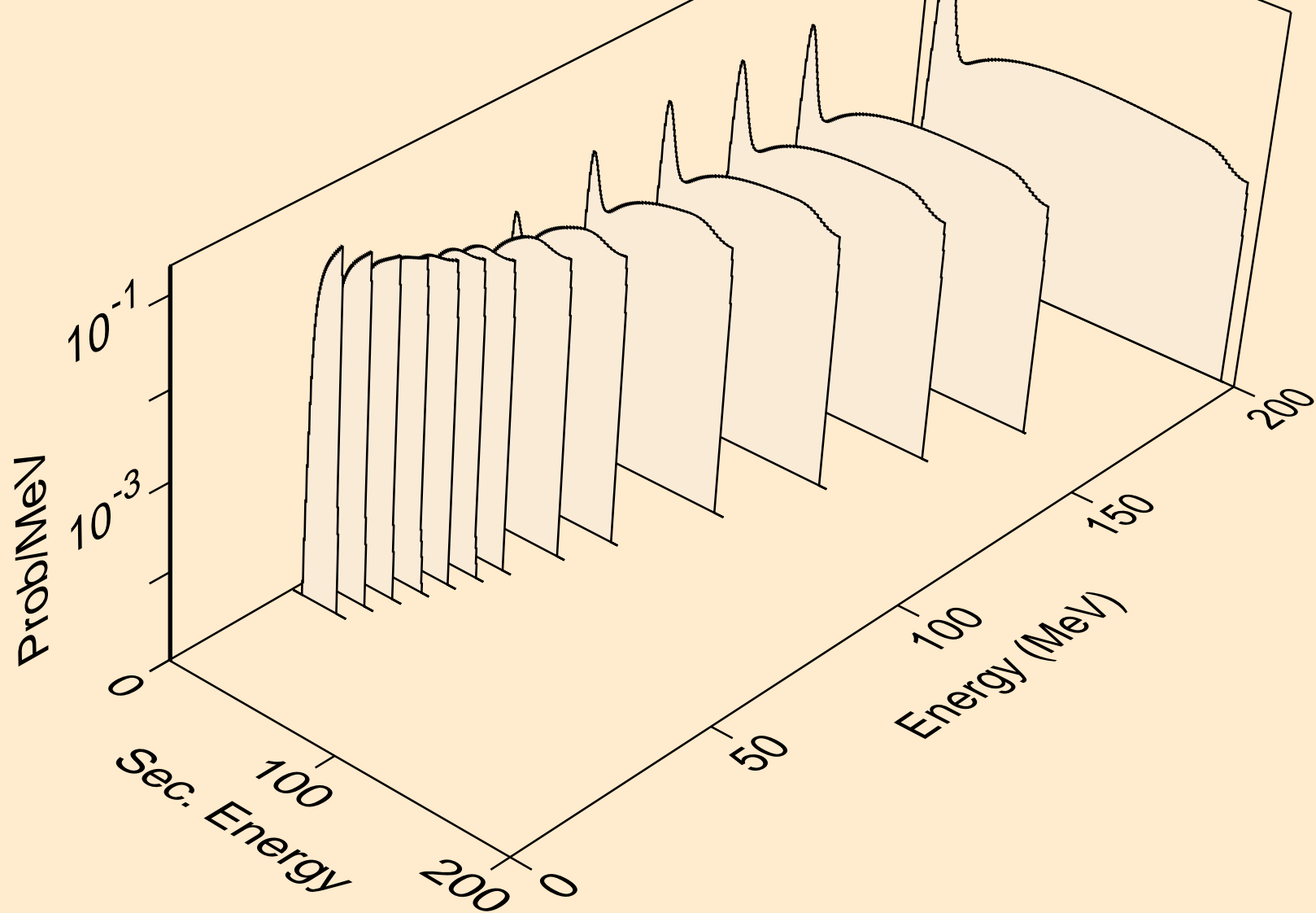



PT185M DEUTERON ACER TENDL-2023 LIBRARY; T=0.K  
tritons from (d,n\*)t

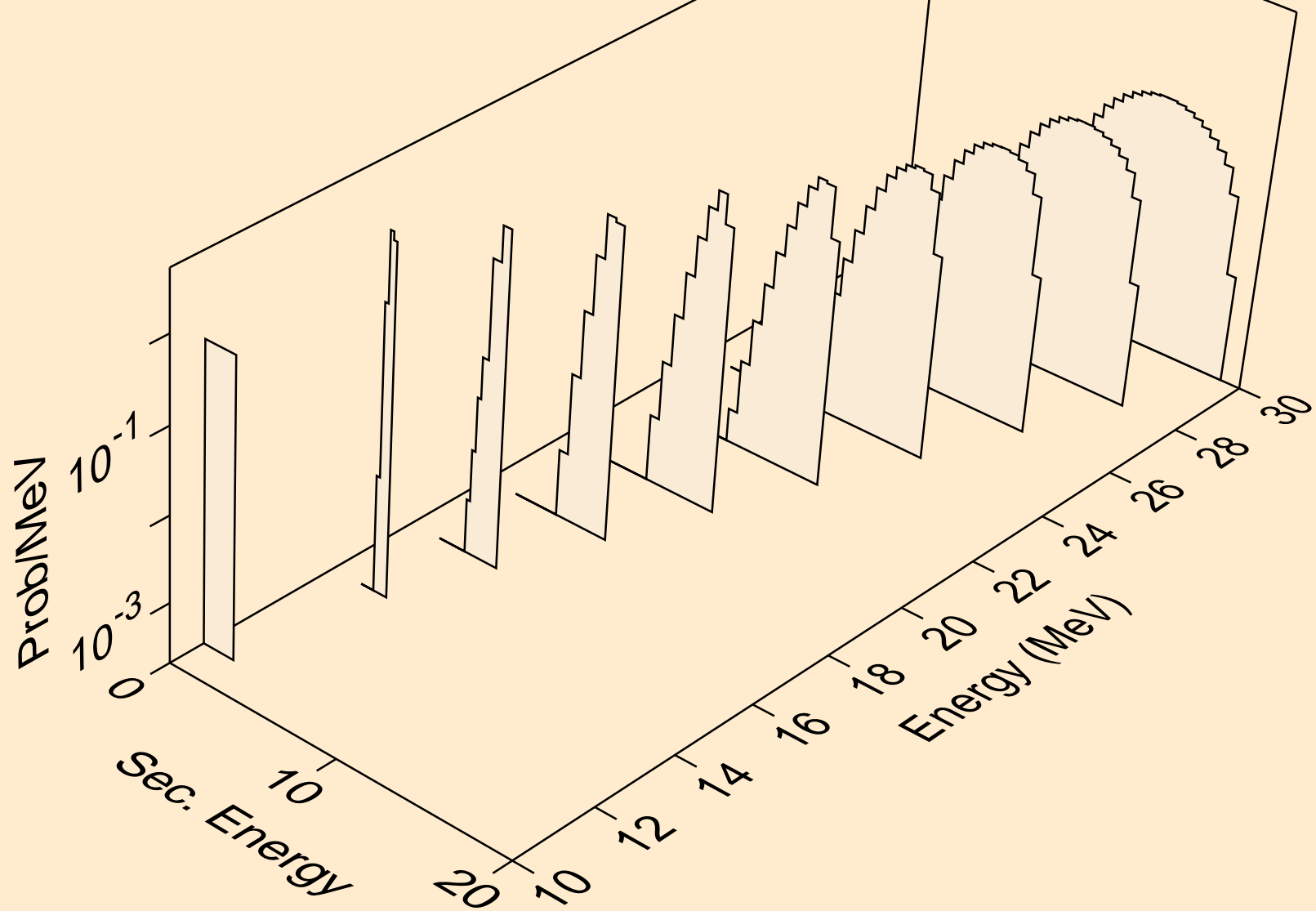

PT185M DEUTERON ACER TENDL-2023 LIBRARY; T=0.K  
tritons from (d,t)

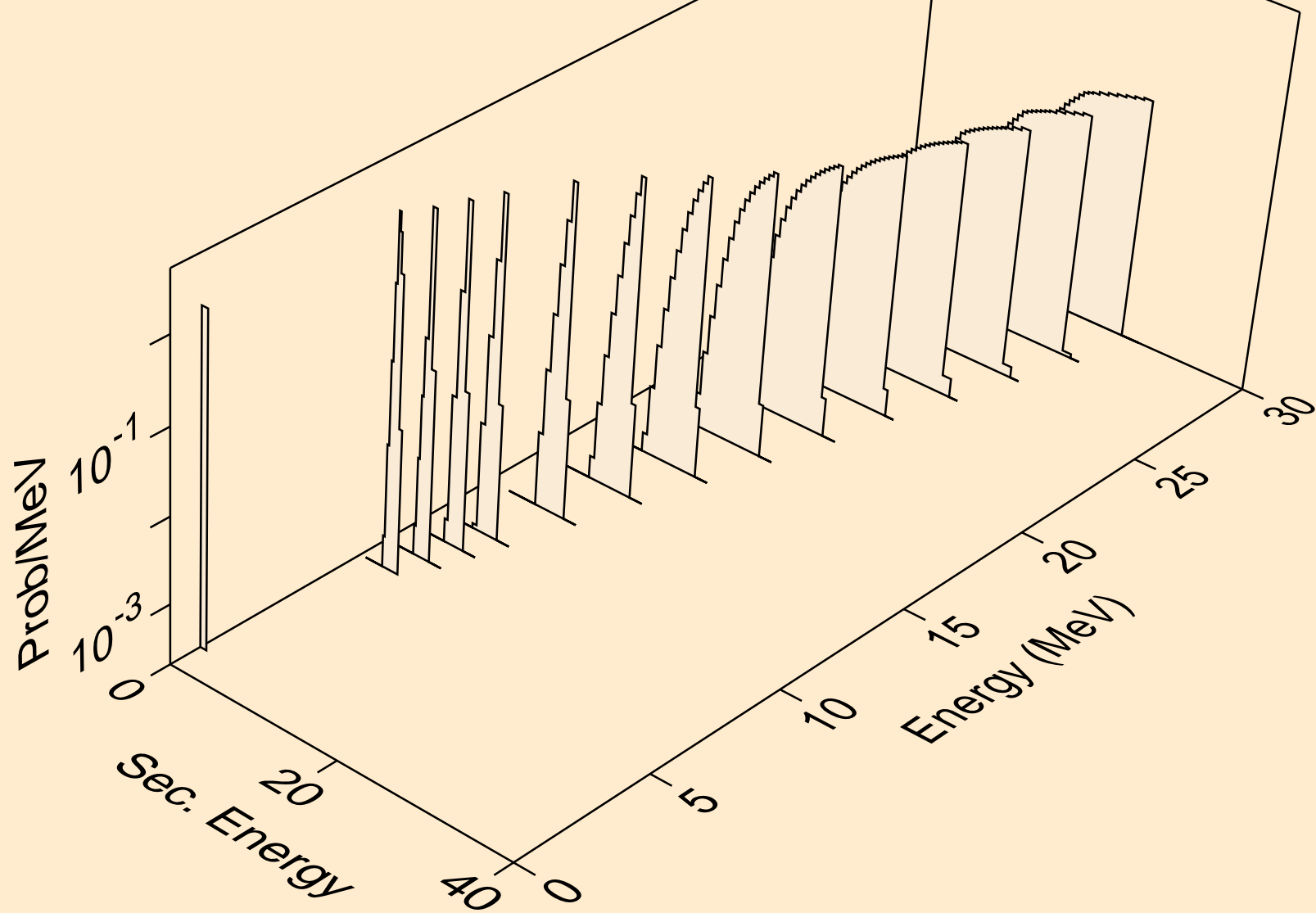

PT185M DEUTERON ACER TENDL-2023 LIBRARY; T=0.K  
tritons from (d,pt)

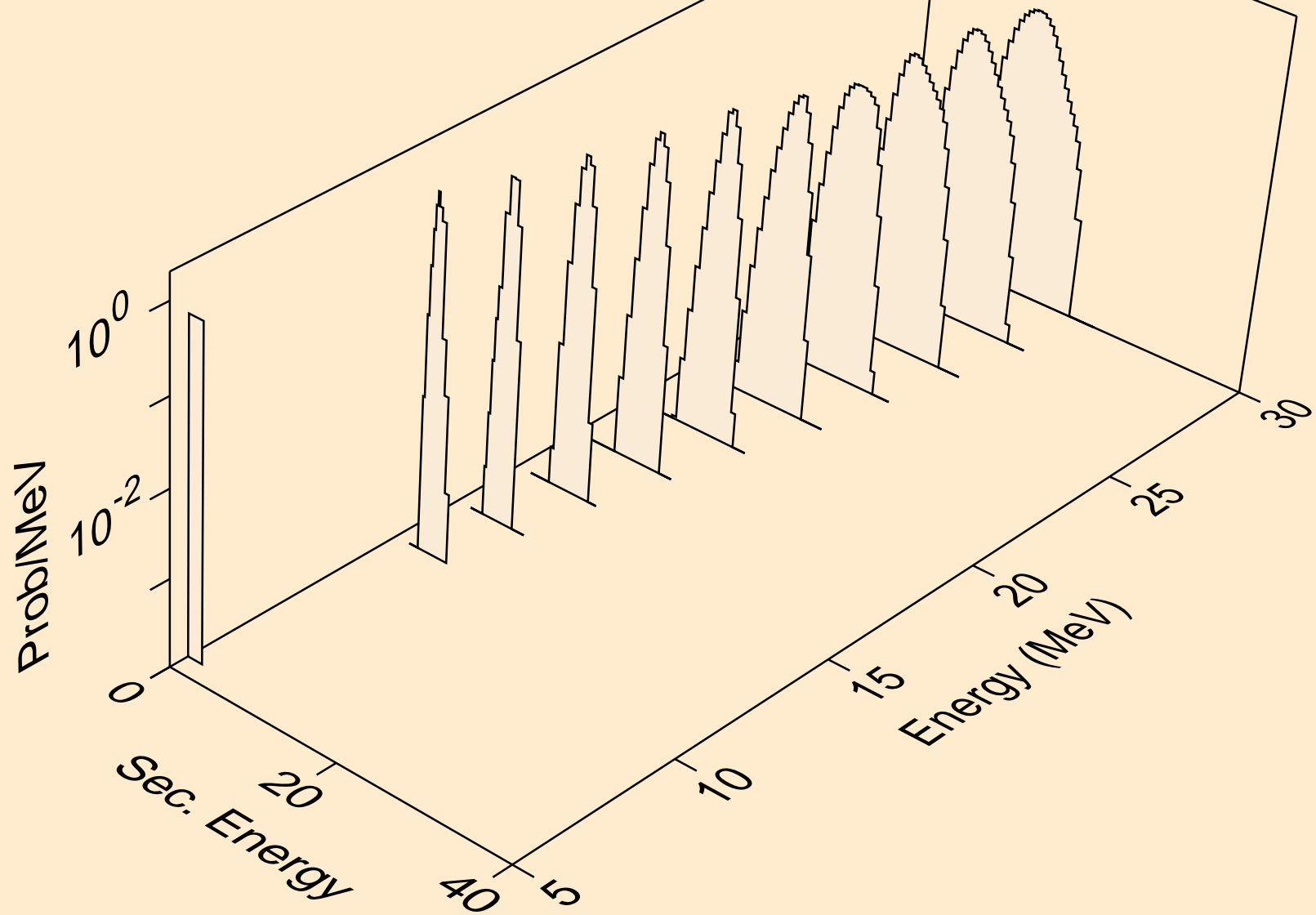

PT185M DEUTERON ACER TENDL-2023 LIBRARY; T=0.K  
he3s from (d,x)

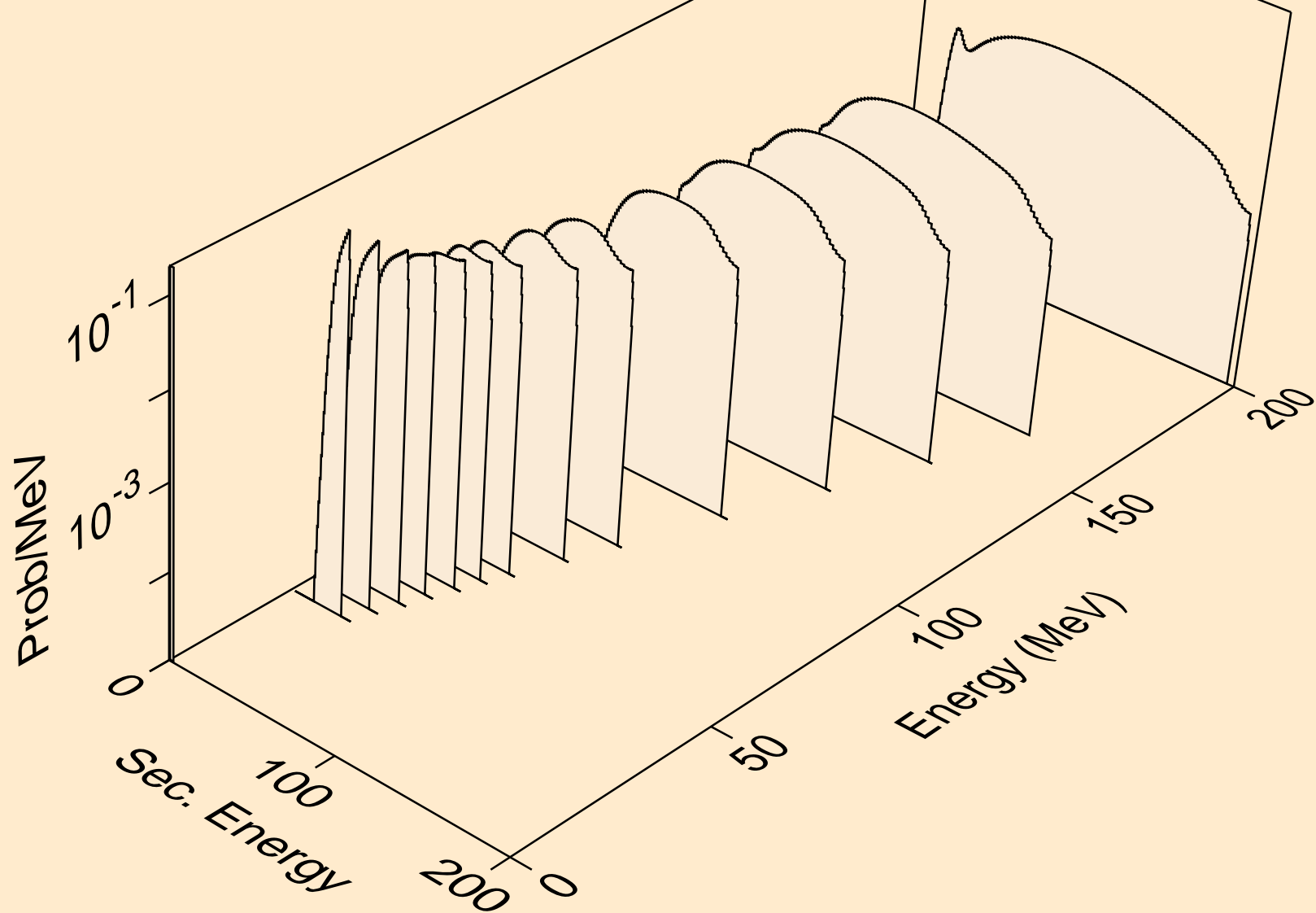

PT185M DEUTERON ACER TENDL-2023 LIBRARY; T=0.K  
he3s from (d,n\*)he3

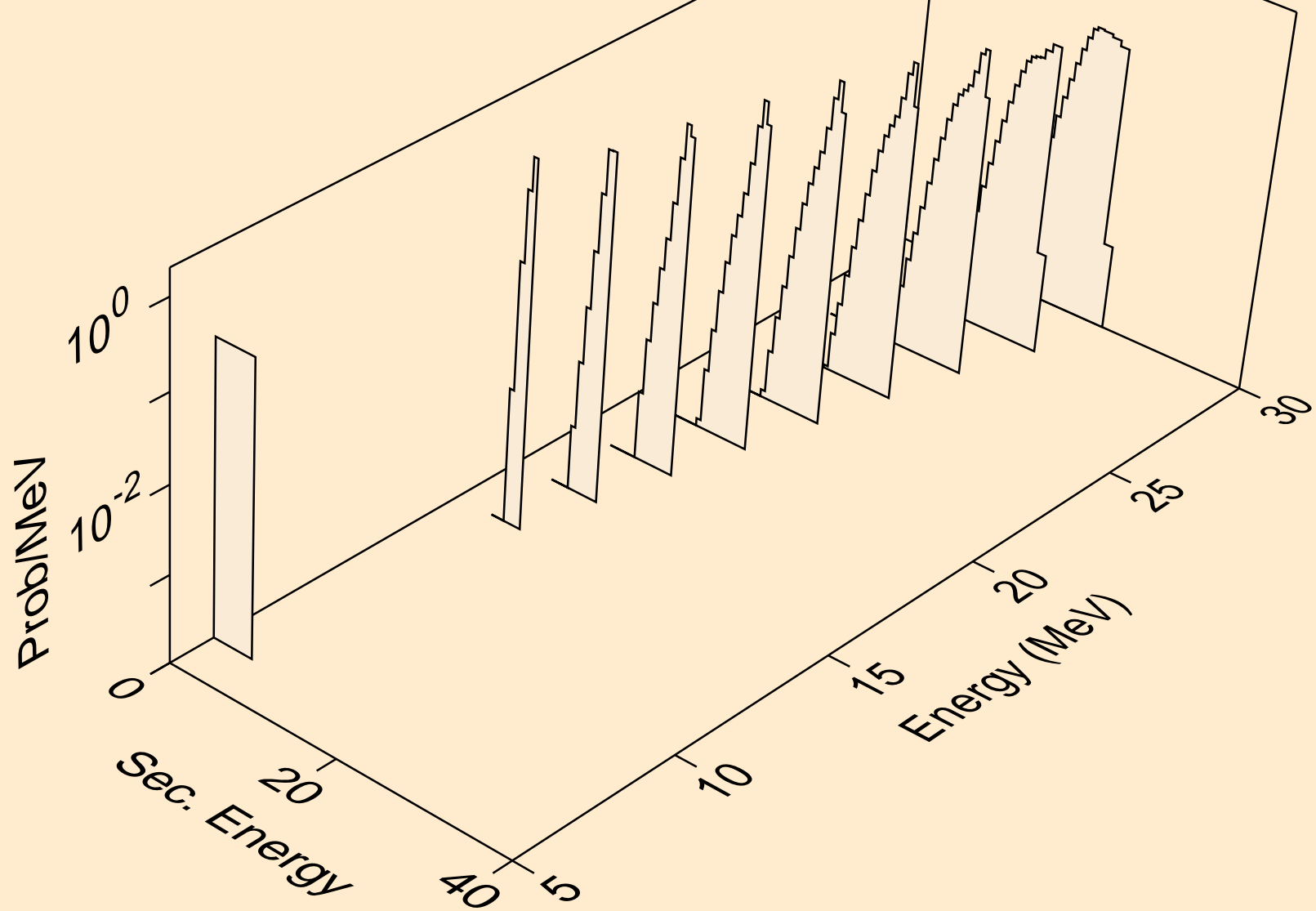

PT185M DEUTERON ACER TENDL-2023 LIBRARY; T=0.K  
he3s from (d,he3)

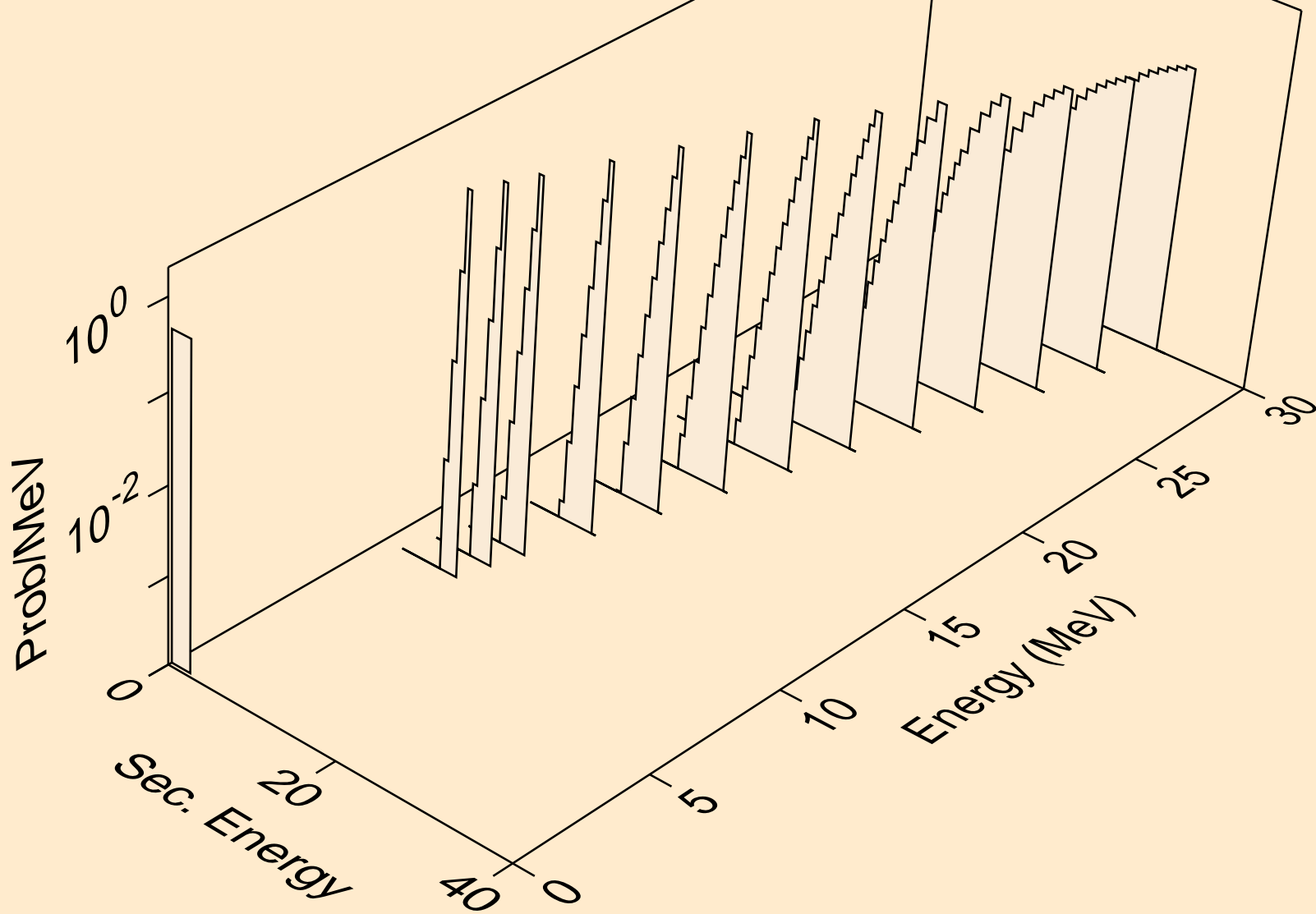

PT185M DEUTERON ACER TENDL-2023 LIBRARY; T=0.K  
alphas from (d,x)

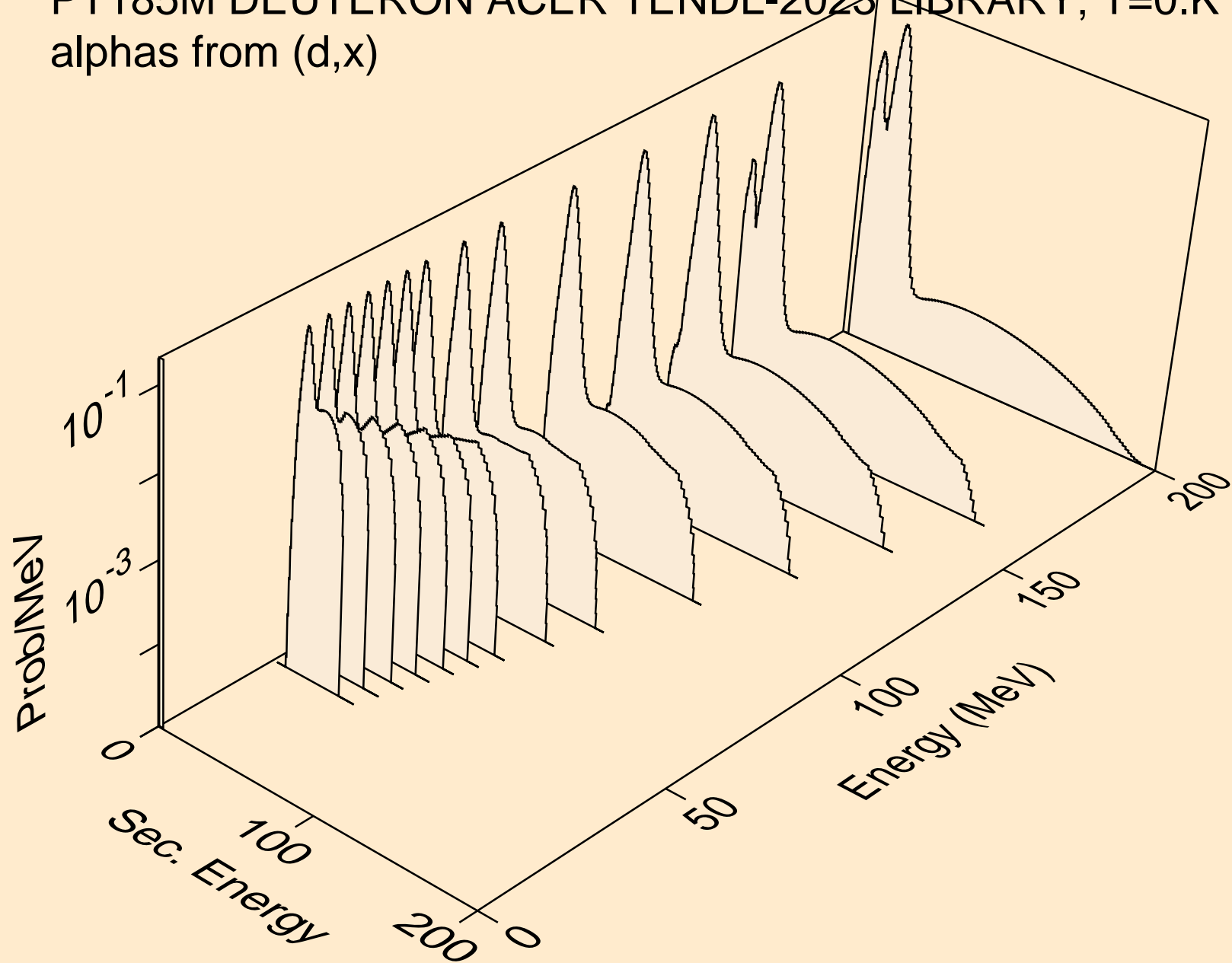

PT185M DEUTERON ACER TENDL-2023 LIBRARY; T=0.K  
alphas from (d,n\*)a

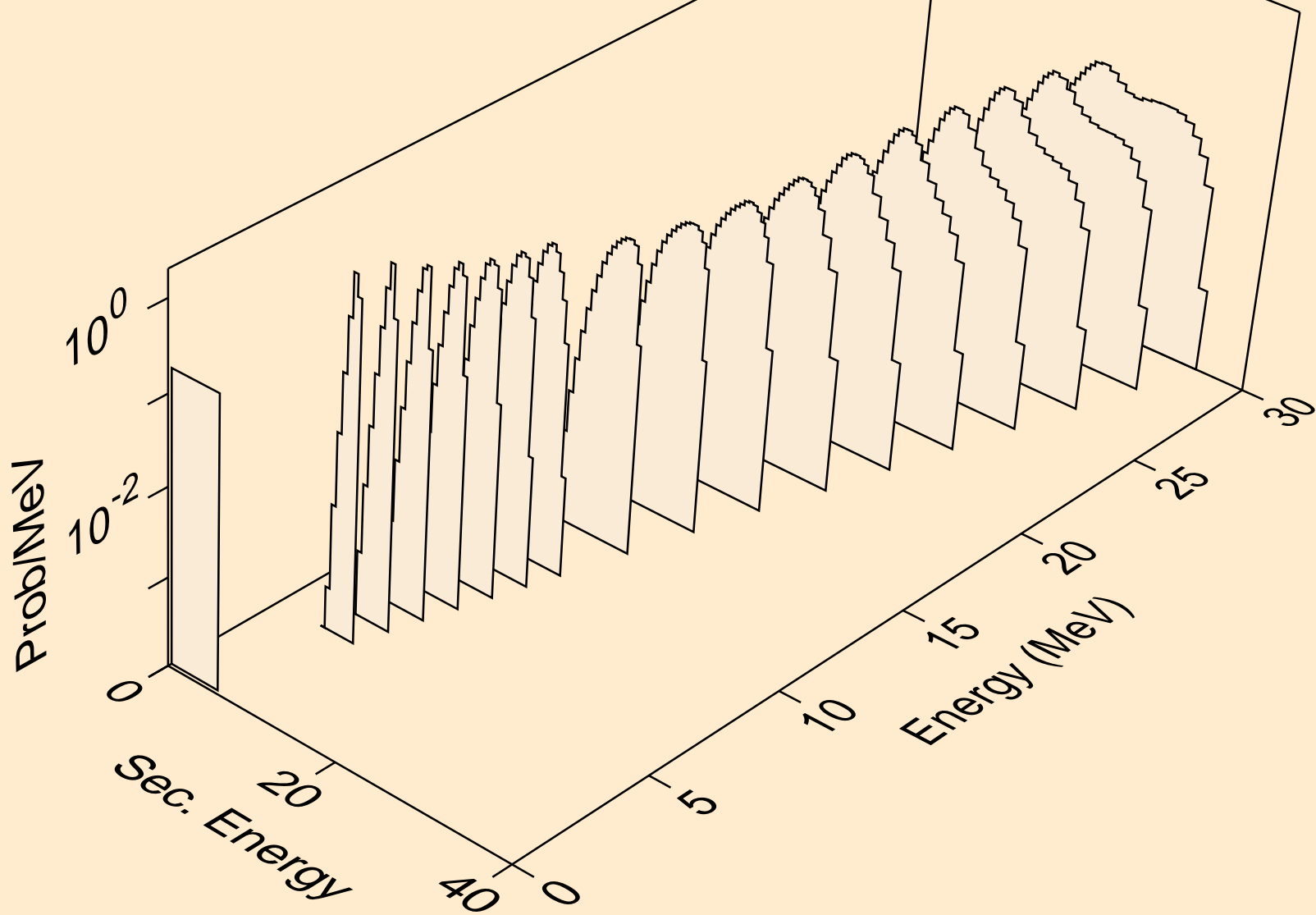



PT185M DEUTERON ACER TENDL-2023 LIBRARY; T=0.K  
alphas from (d,2n)a

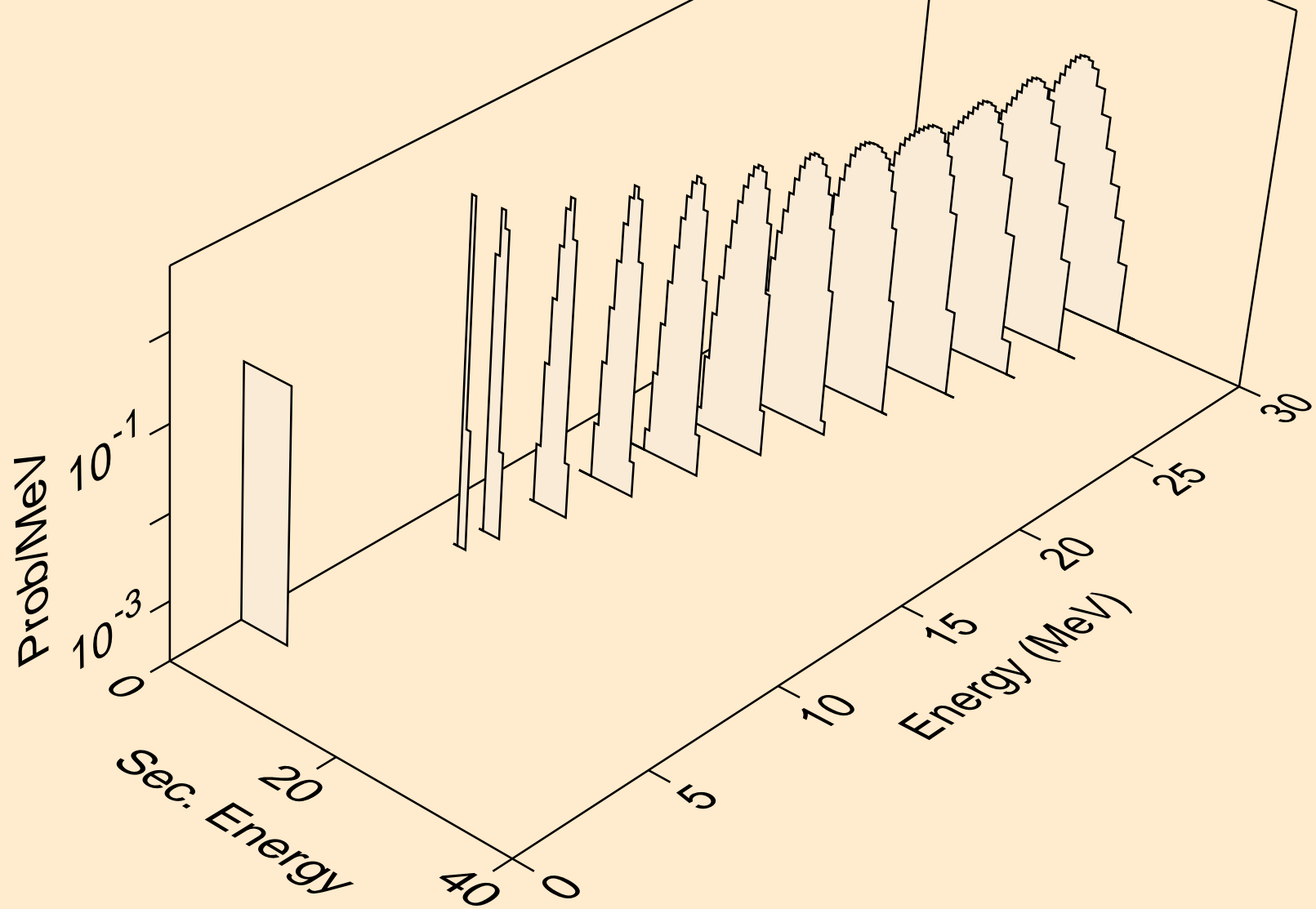

PT185M DEUTERON ACER TENDL-2023 LIBRARY; T=0.K  
alphas from (d,3n)a

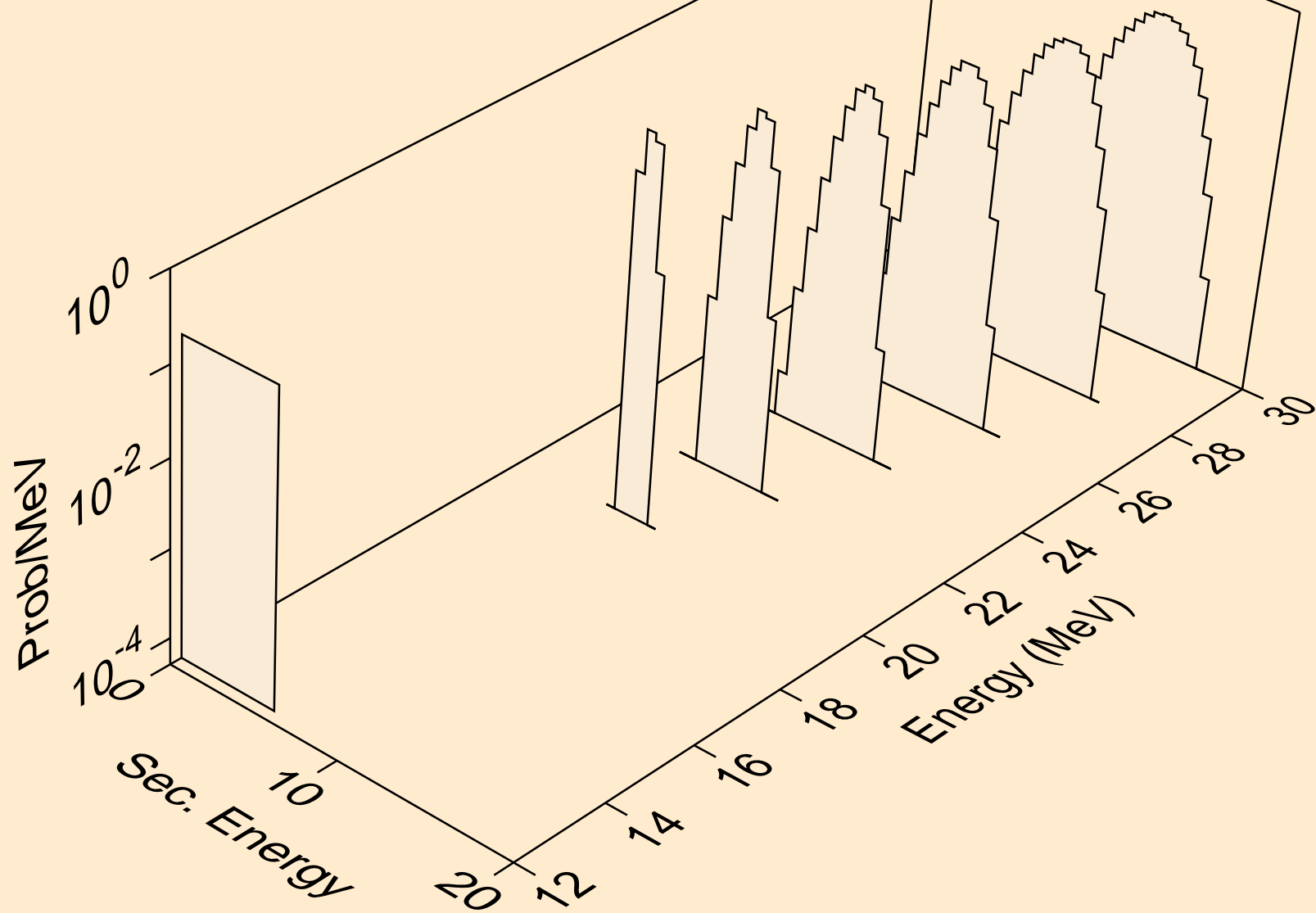

PT185M DEUTERON ACER TENDL-2023 LIBRARY; T=0.K  
alphas from (d,n\*)2a

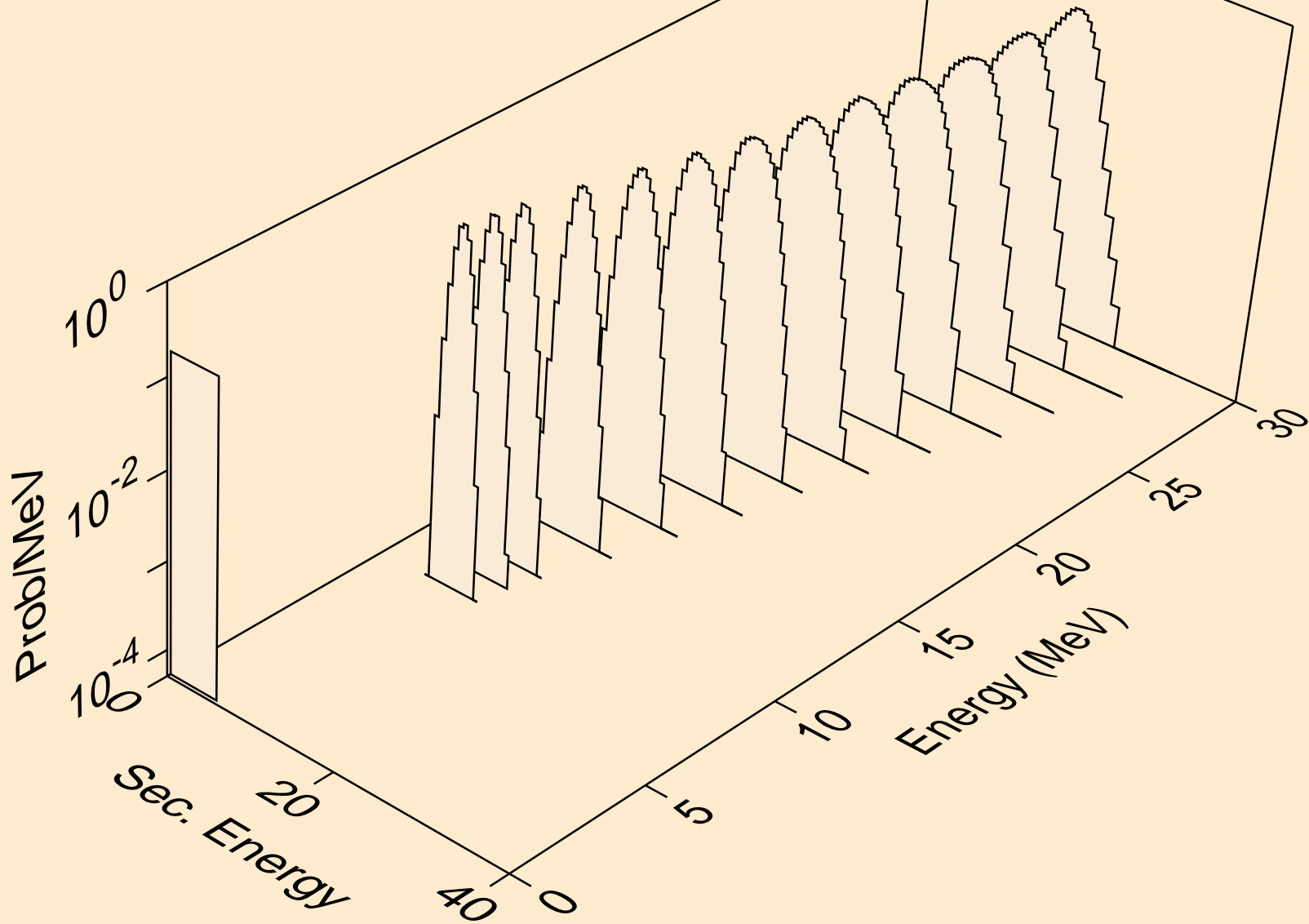

PT185M DEUTERON ACER TENDL-2023 LIBRARY; T=0.K  
alphas from (d,2n)2a

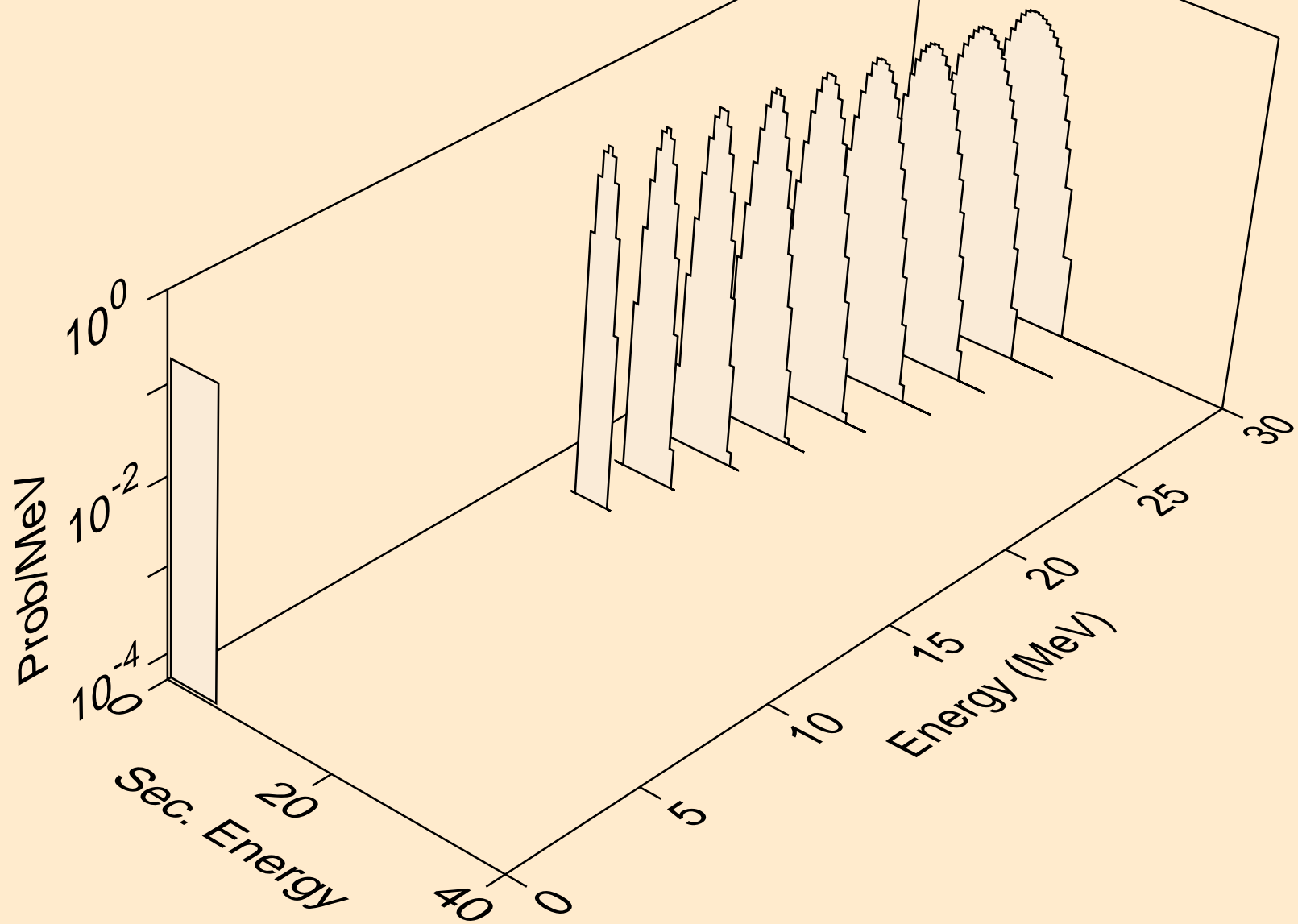

PT185M DEUTERON ACER TENDL-2023 LIBRARY; T=0.K  
alphas from (d,npa)

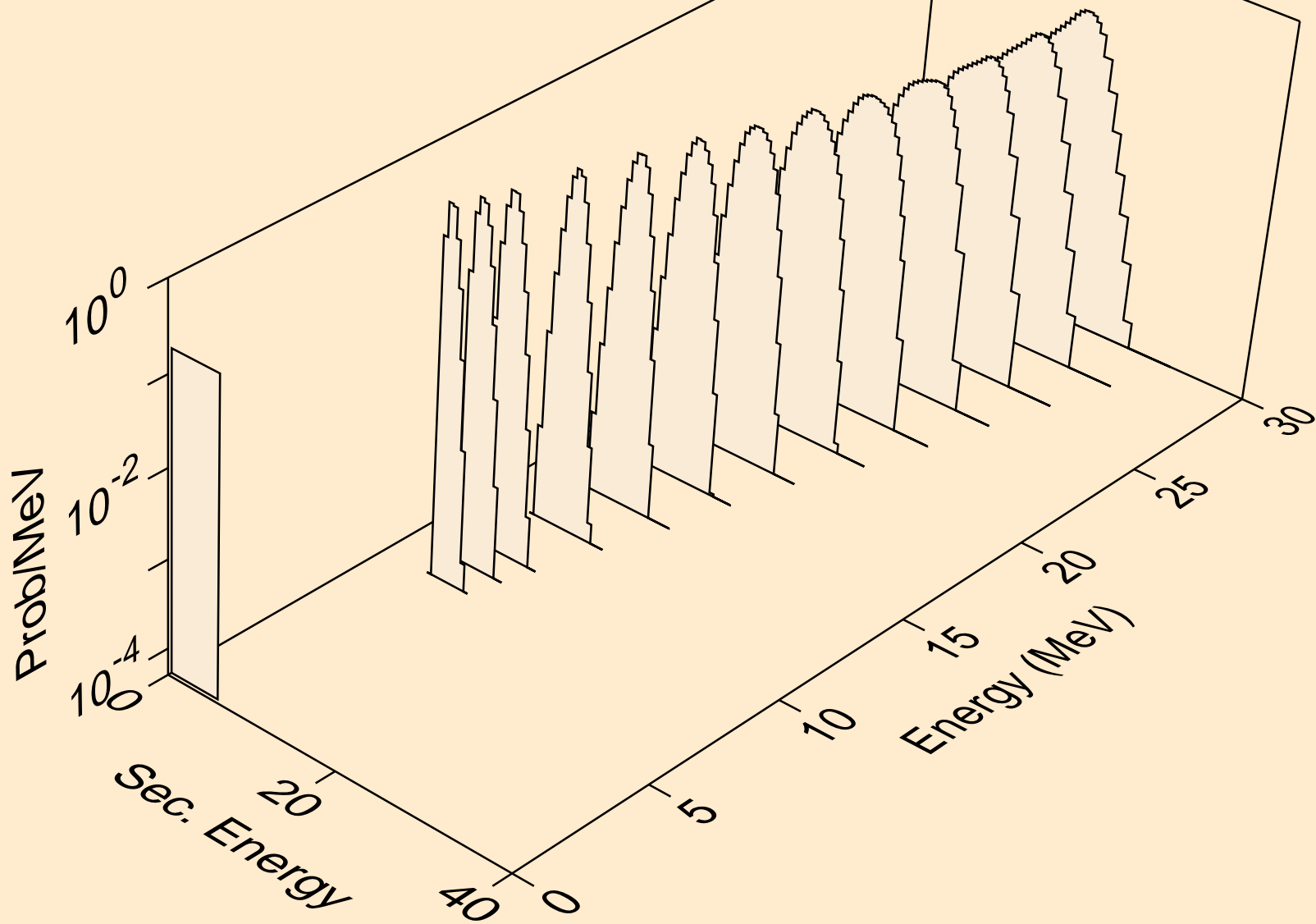

PT185M DEUTERON ACER TENDL-2023 LIBRARY; T=0.K  
alphas from (d,a)

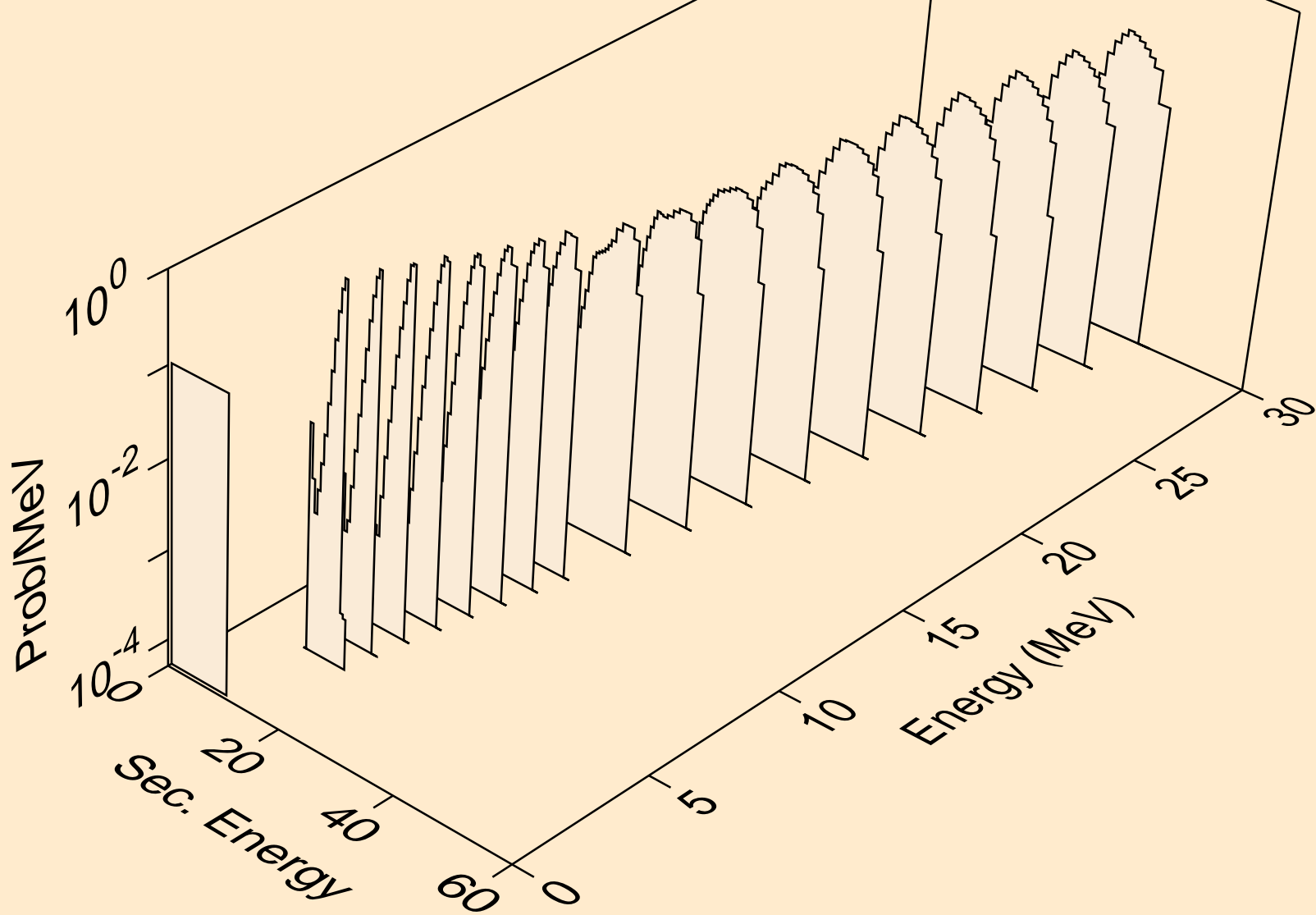

PT185M DEUTERON ACER TENDL-2023 LIBRARY; T=0.K  
alphas from (d,2a)

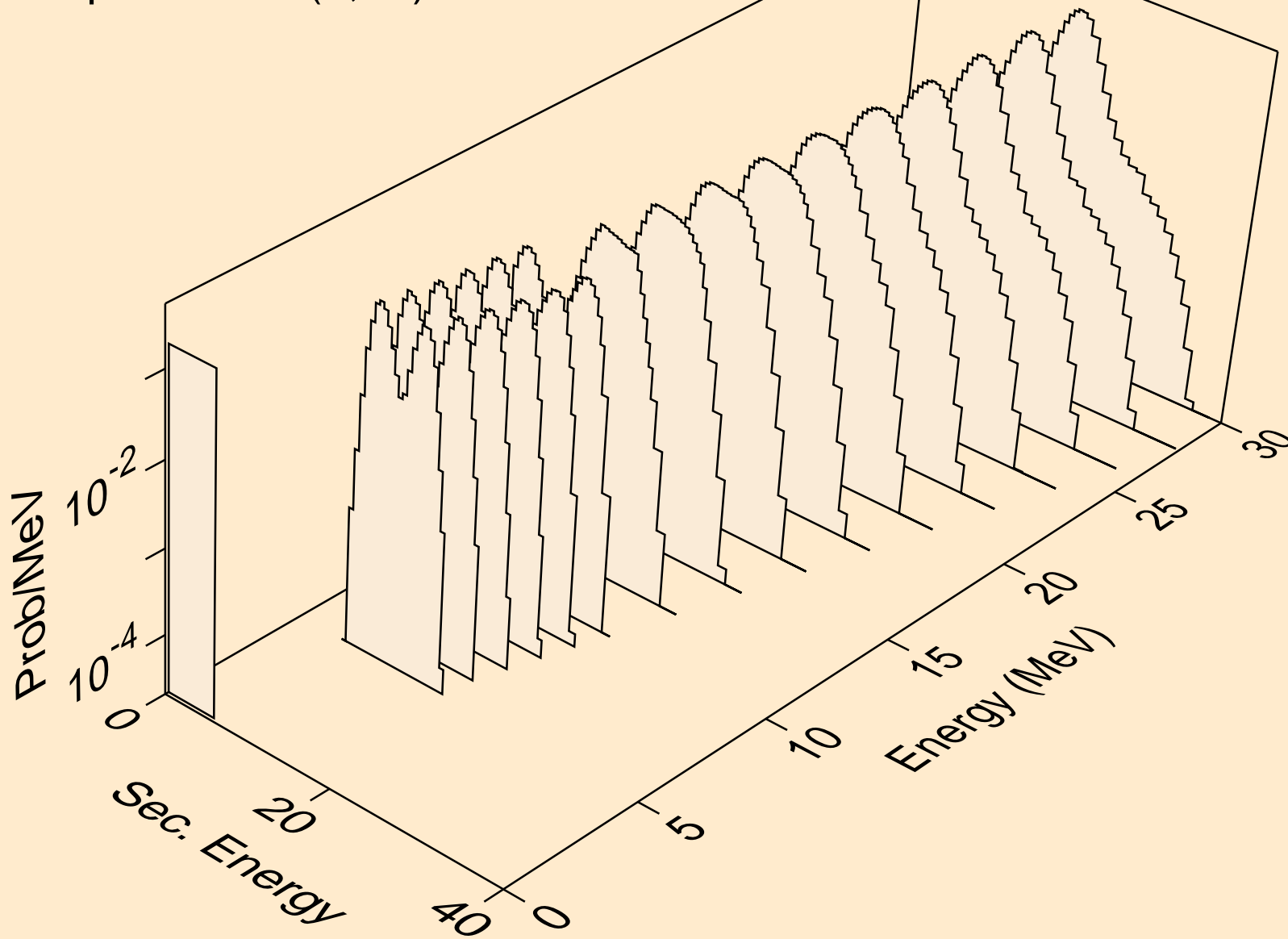

PT185M DEUTERON ACER TENDL-2023 LIBRARY; T=0.K  
alphas from (d,pa)

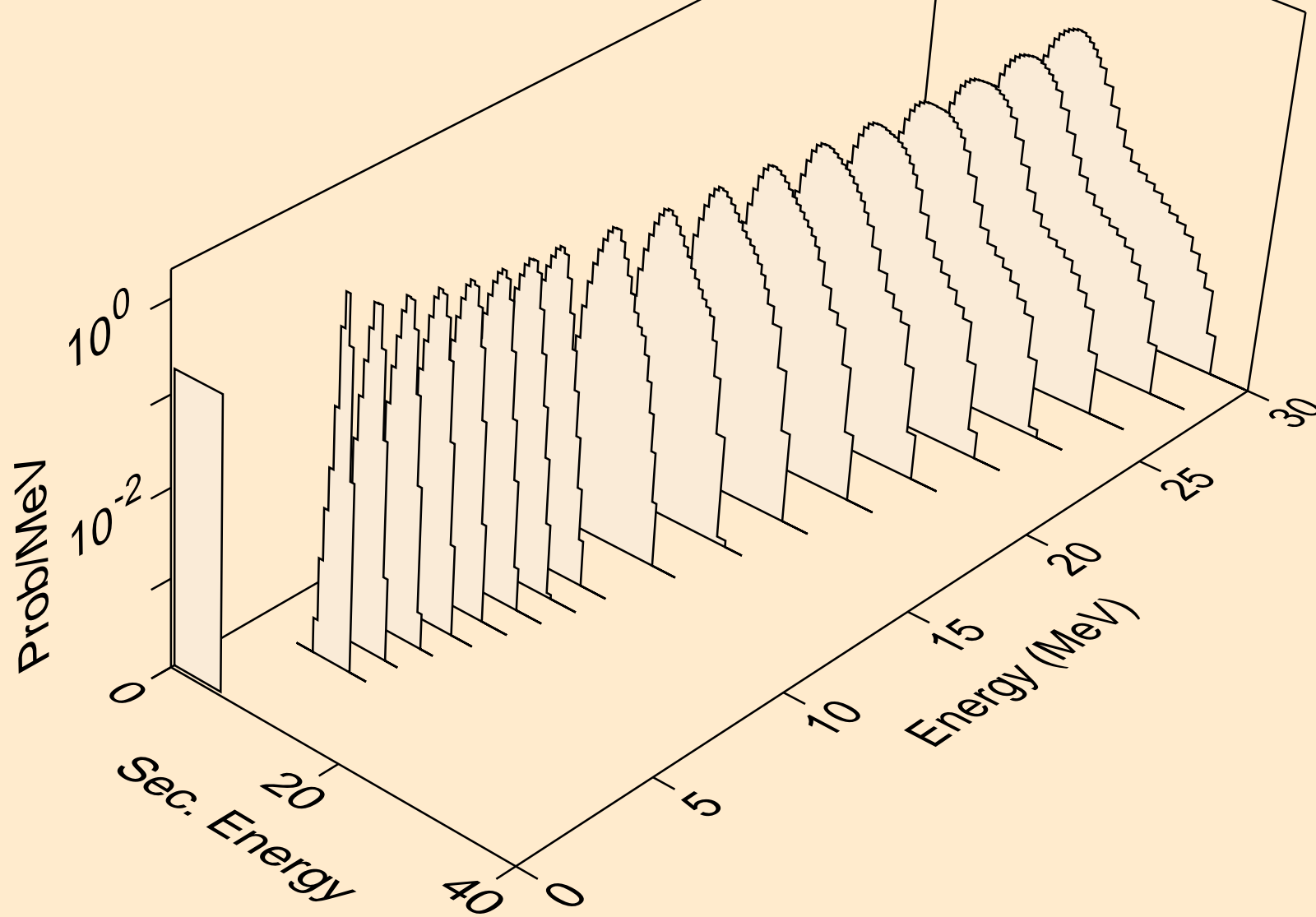



PT185M DEUTERON ACER TENDL-2023 LIBRARY; T=0.K  
alphas from (d,da)

