

RF268 DEUTERON ACER TENDL-2023 LIBRARY; T=0.K  
Principal cross sections

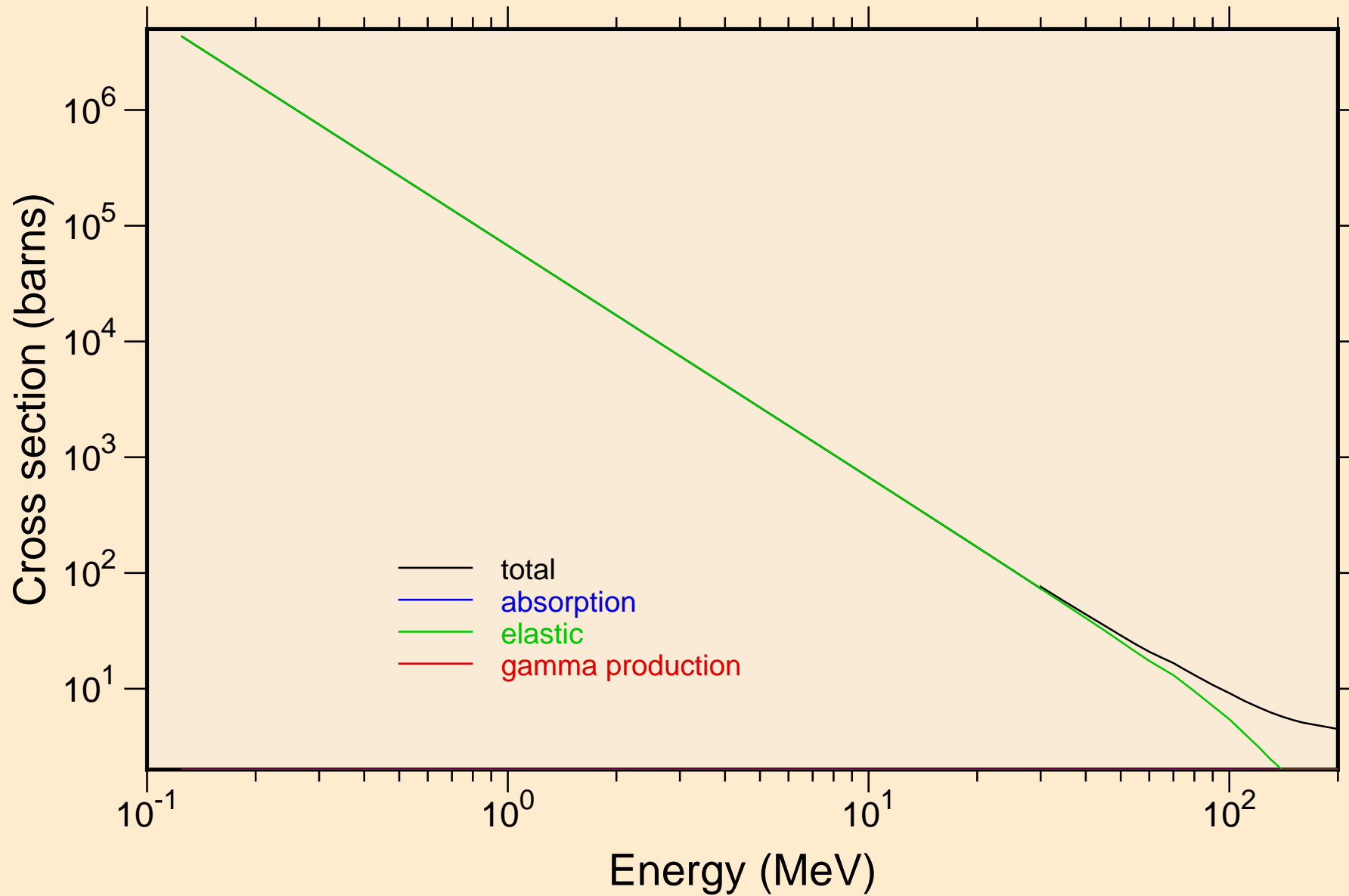

RF268 DEUTERON ACER TENDL-2023 LIBRARY; T=0.K  
Heating

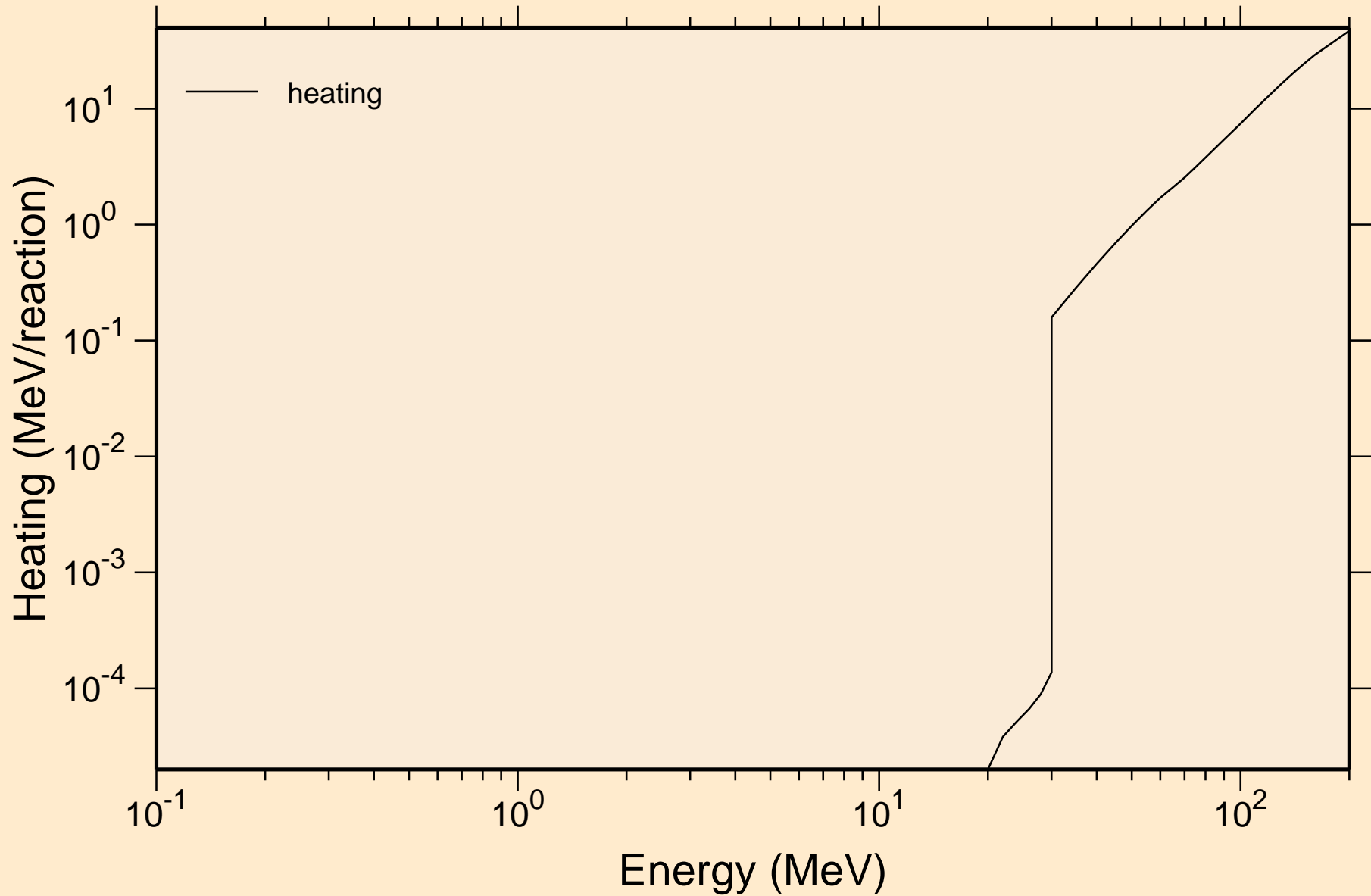

RF268 DEUTERON ACER TENDL-2023 LIBRARY; T=0.K  
Principal cross sections

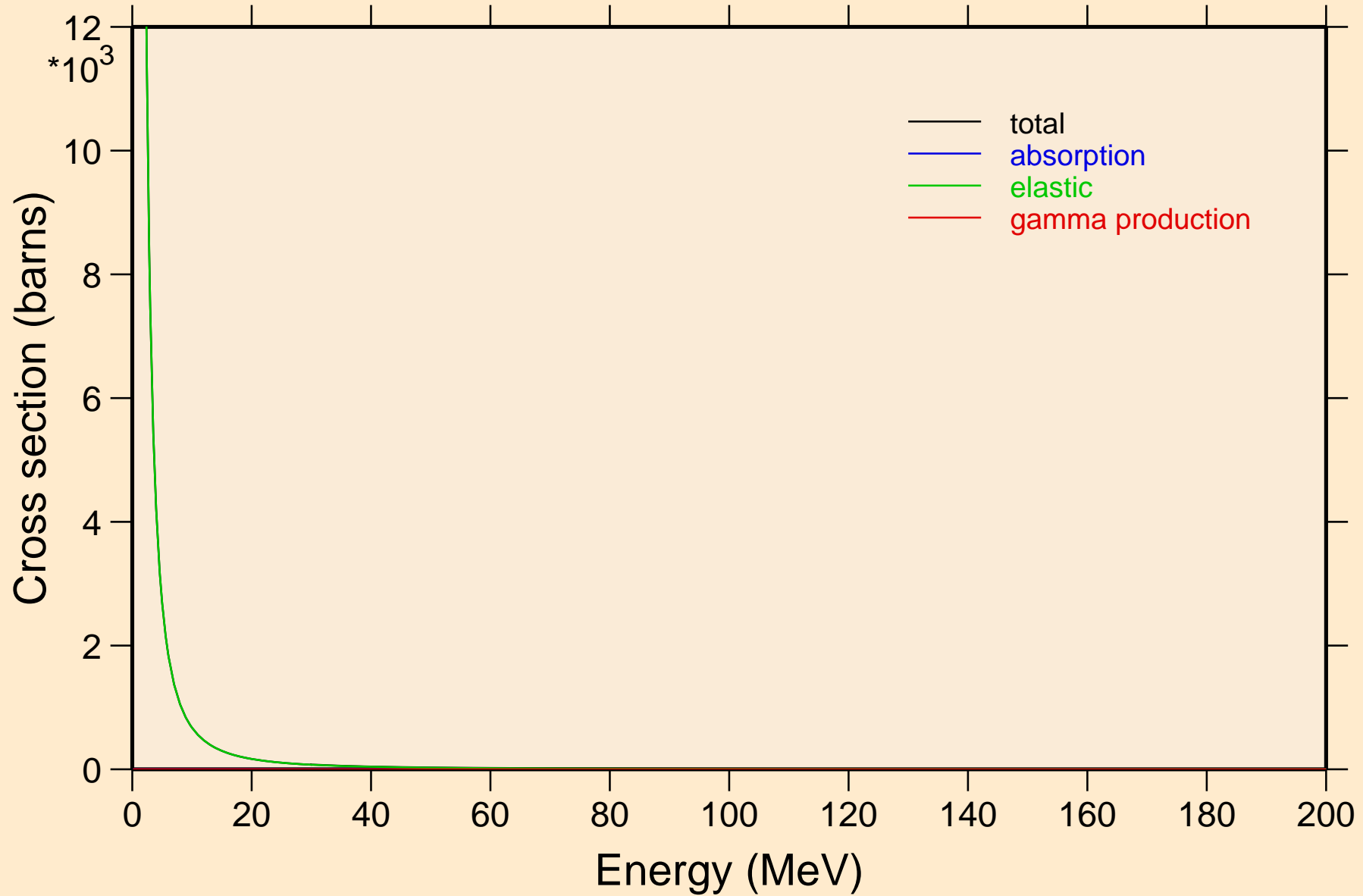

# RF268 DEUTERON ACER TENDL-2023 LIBRARY; T=0.K

## Heating

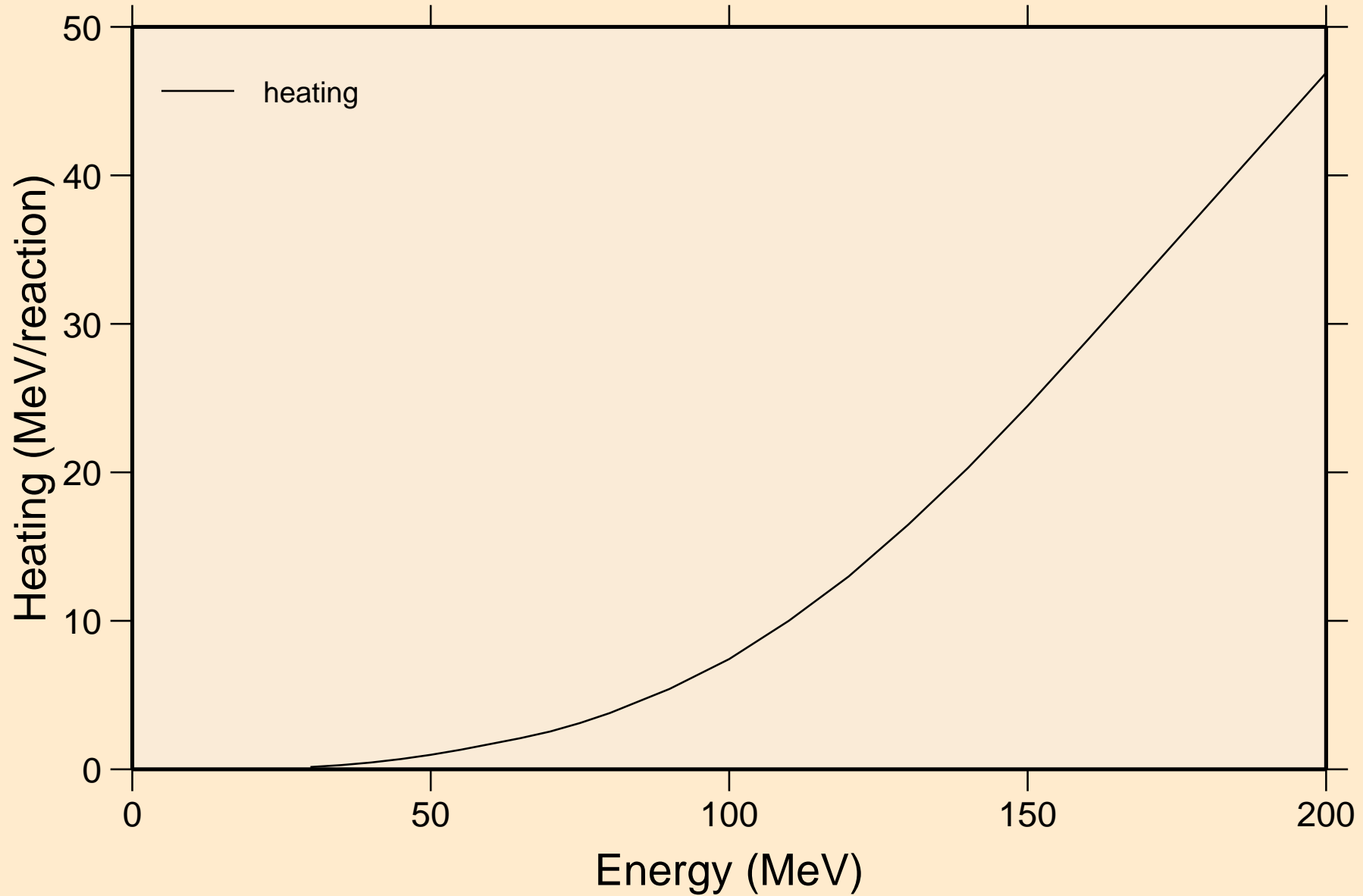

RF268 DEUTERON ACER TENDL-2023 LIBRARY; T=0.K  
Threshold reactions

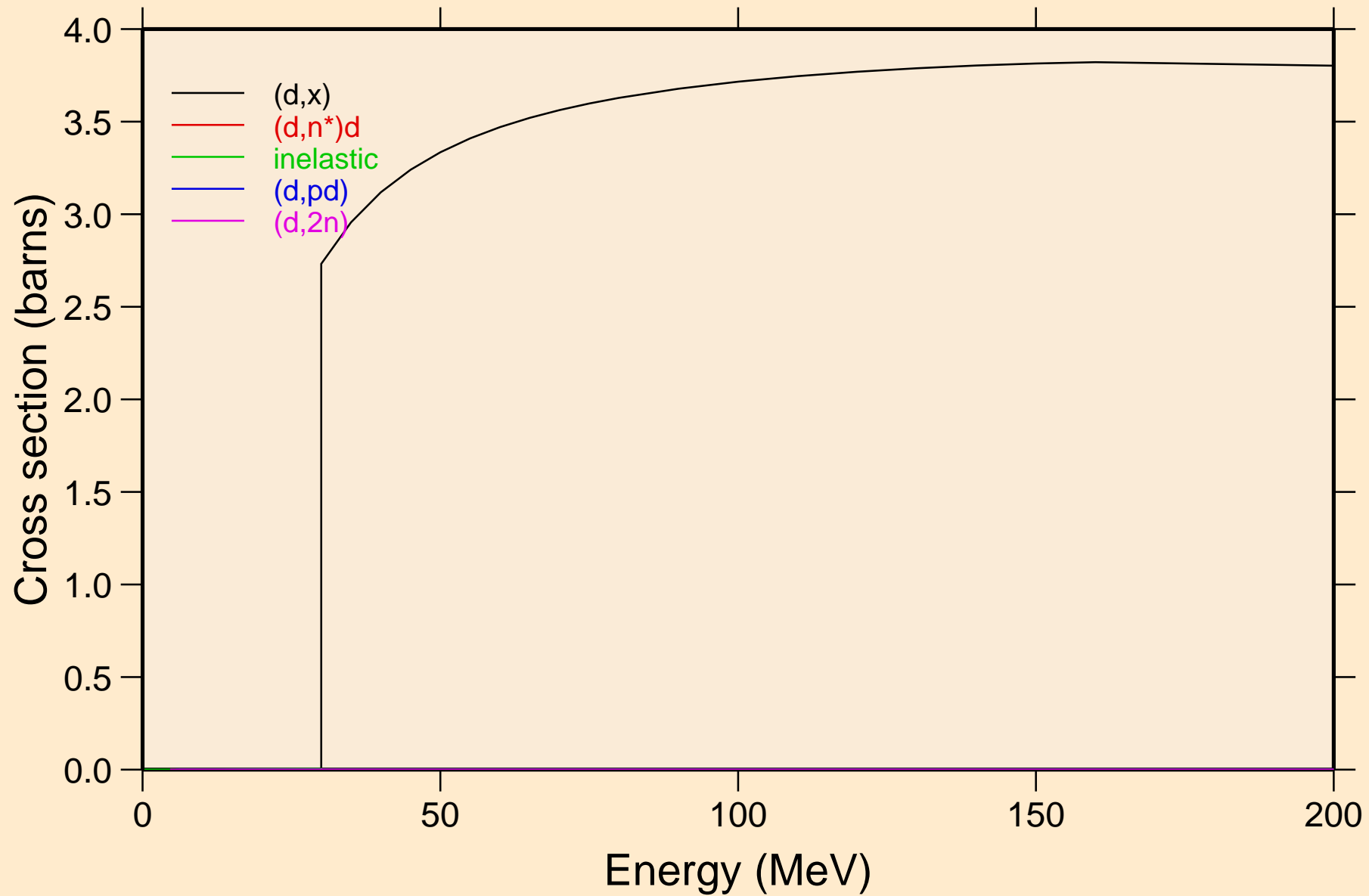

RF268 DEUTERON ACER TENDL-2023 LIBRARY; T=0.K  
Threshold reactions

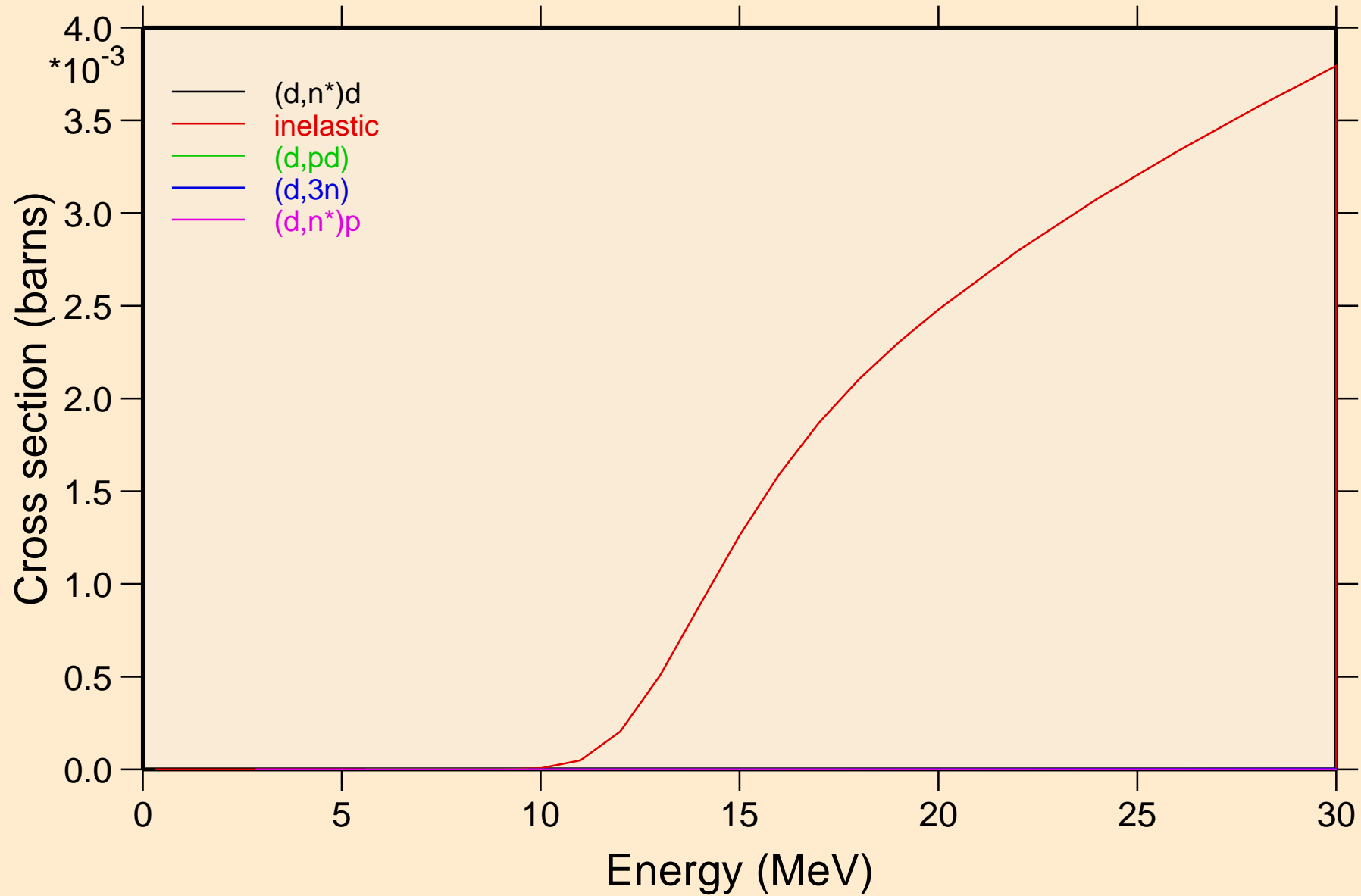

# RF268 DEUTERON ACER TENDL-2023 LIBRARY; T=0.K

## Threshold reactions

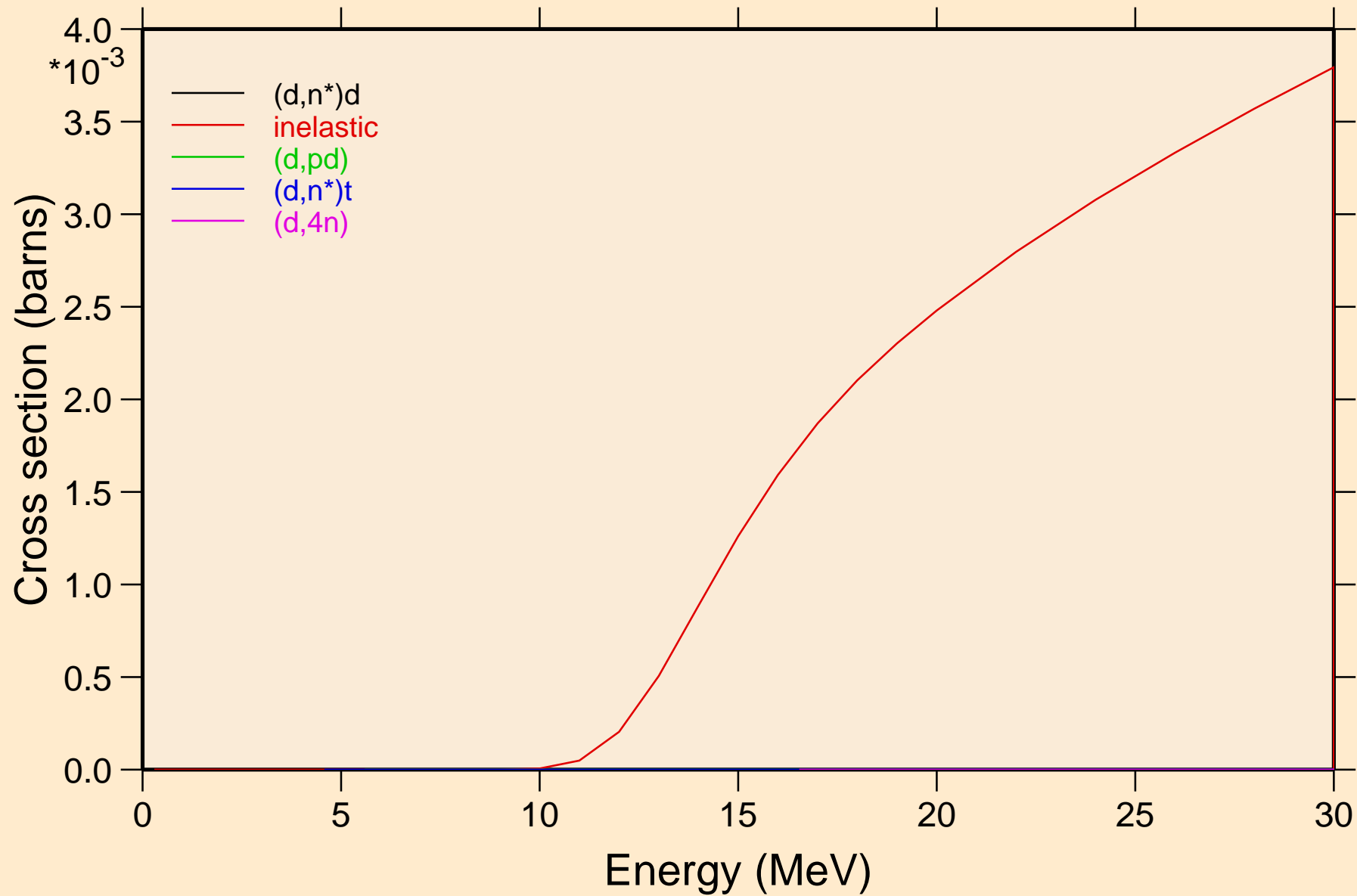

# RF268 DEUTERON ACER TENDL-2023 LIBRARY; T=0.K

## Threshold reactions

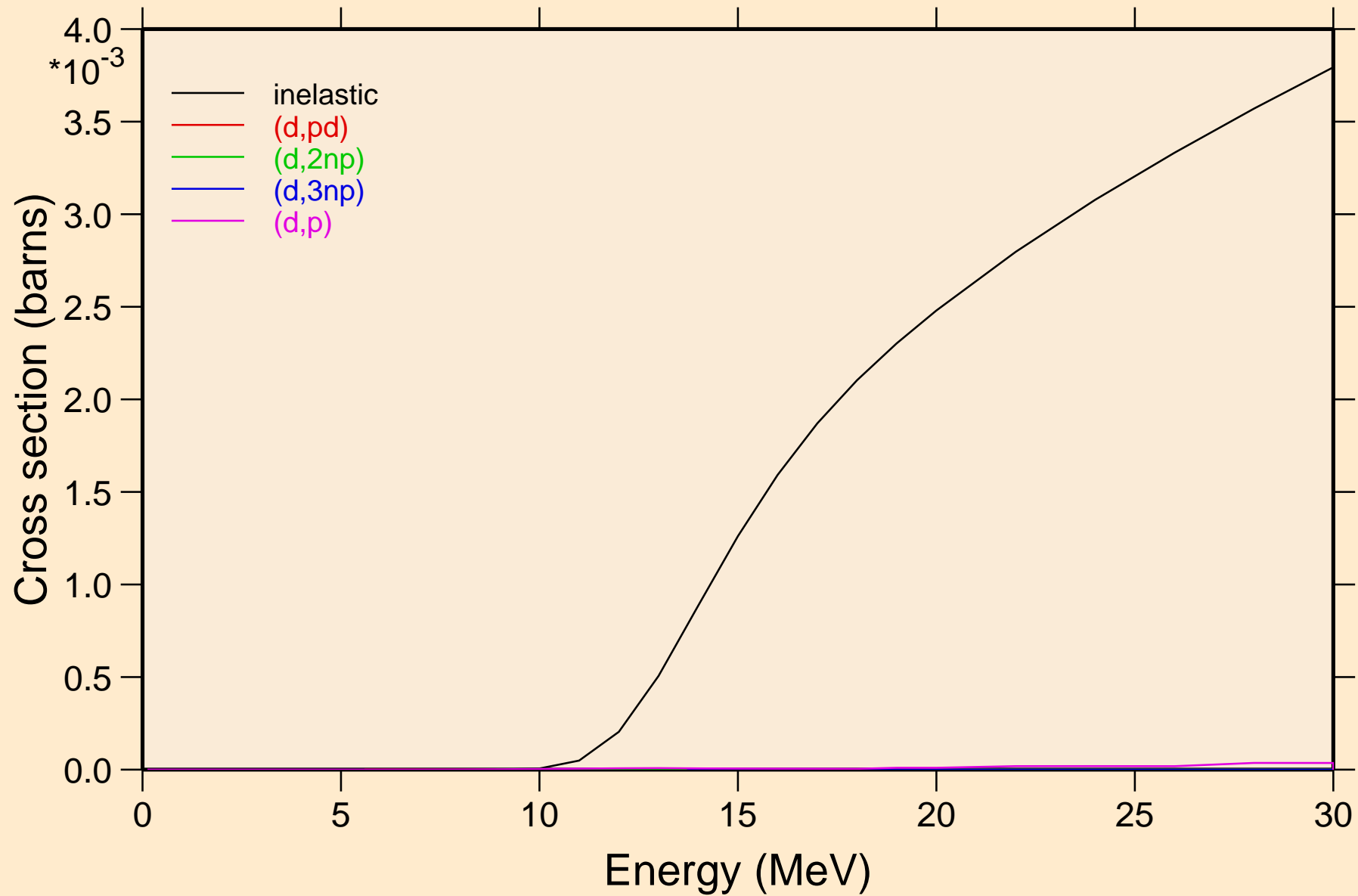



# RF268 DEUTERON ACER TENDL-2023 LIBRARY; T=0.K

## Threshold reactions

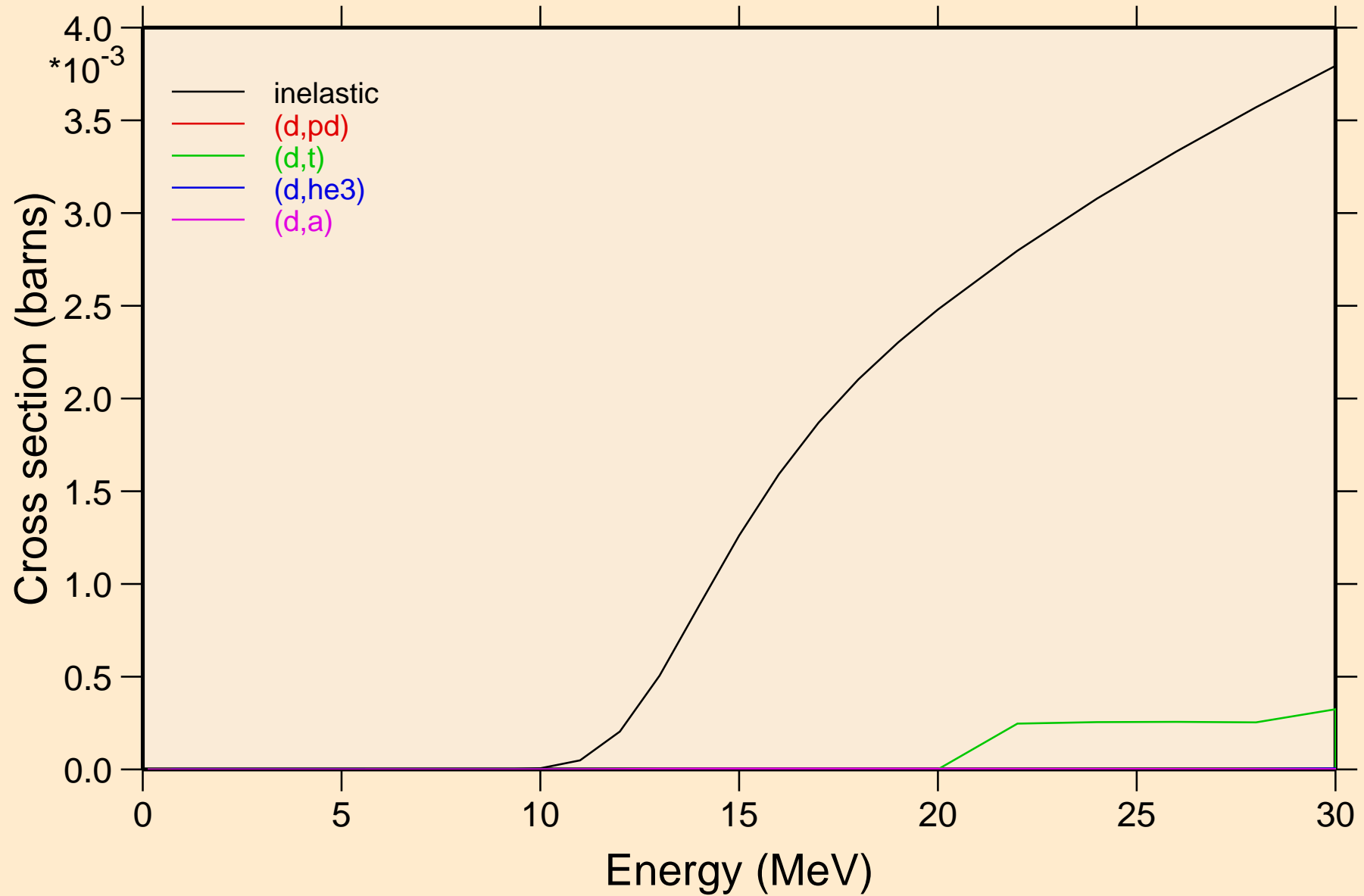

RF268 DEUTERON ACER TENDL-2023 LIBRARY; T=0.K  
Threshold reactions

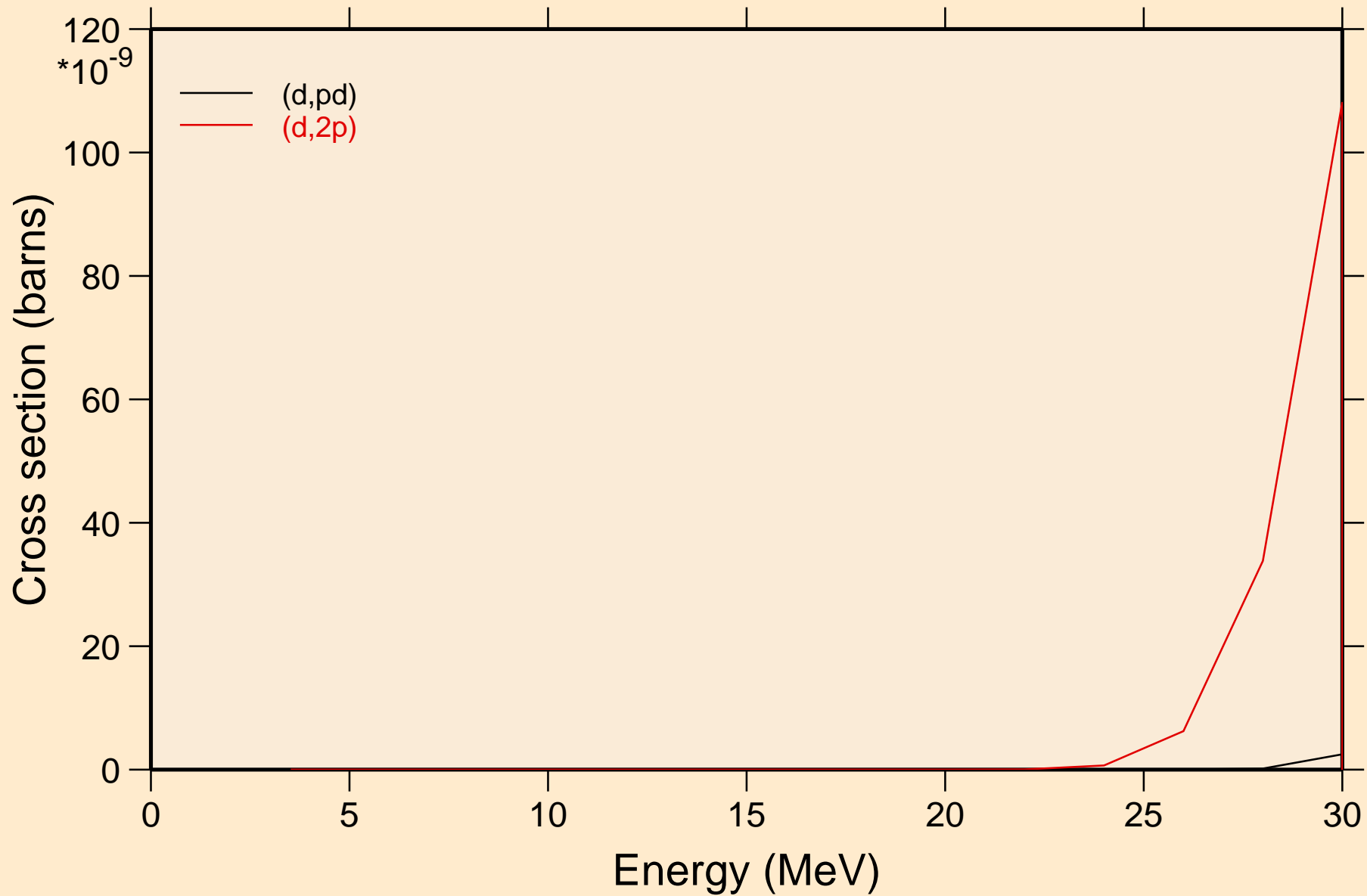

RF268 DEUTERON ACER TENDL-2023 LIBRARY; T=0.K  
Threshold reactions

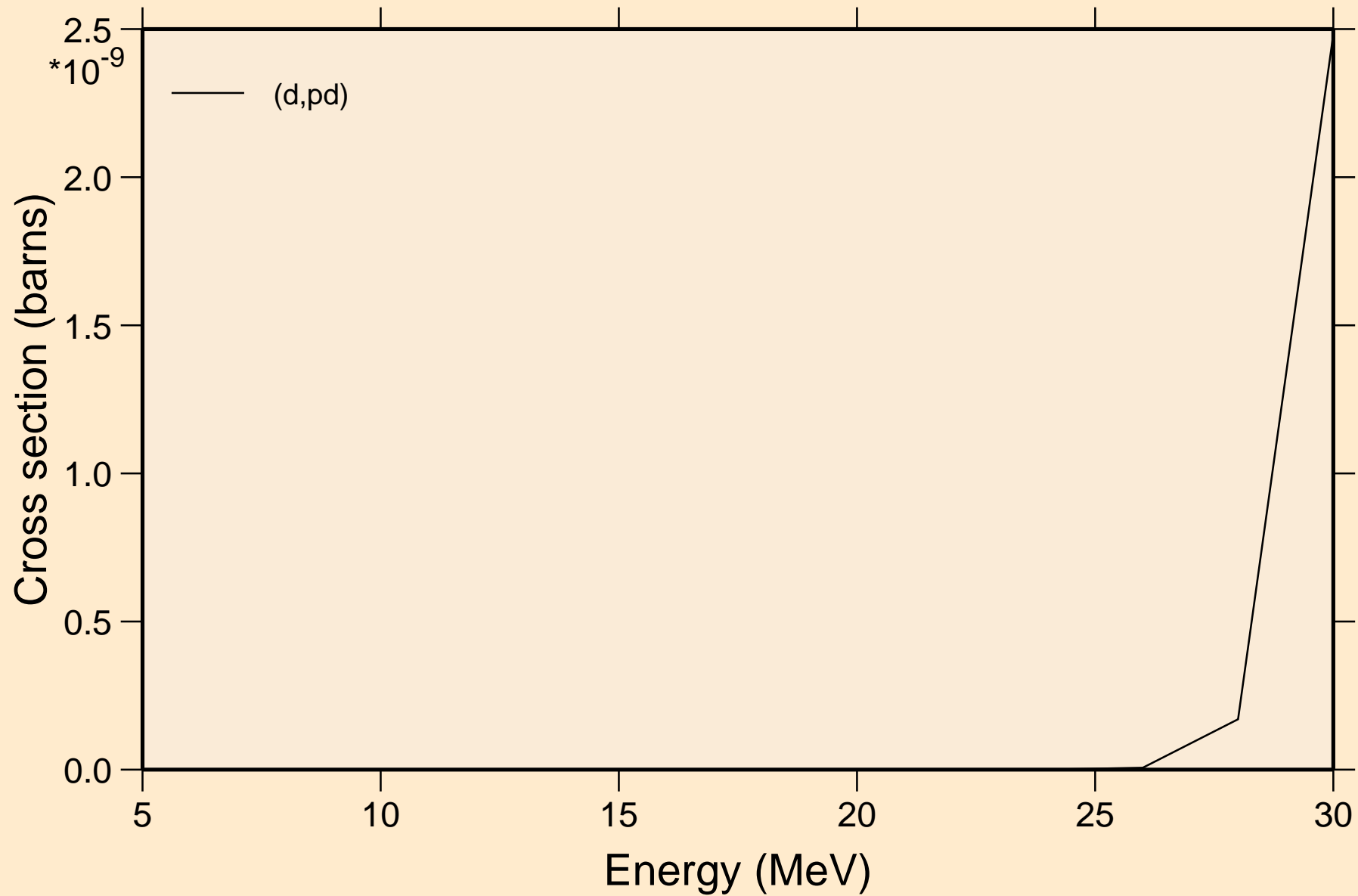

RF268 DEUTERON ACER TENDL-2023 LIBRARY; T=0.K  
angular distribution for elastic

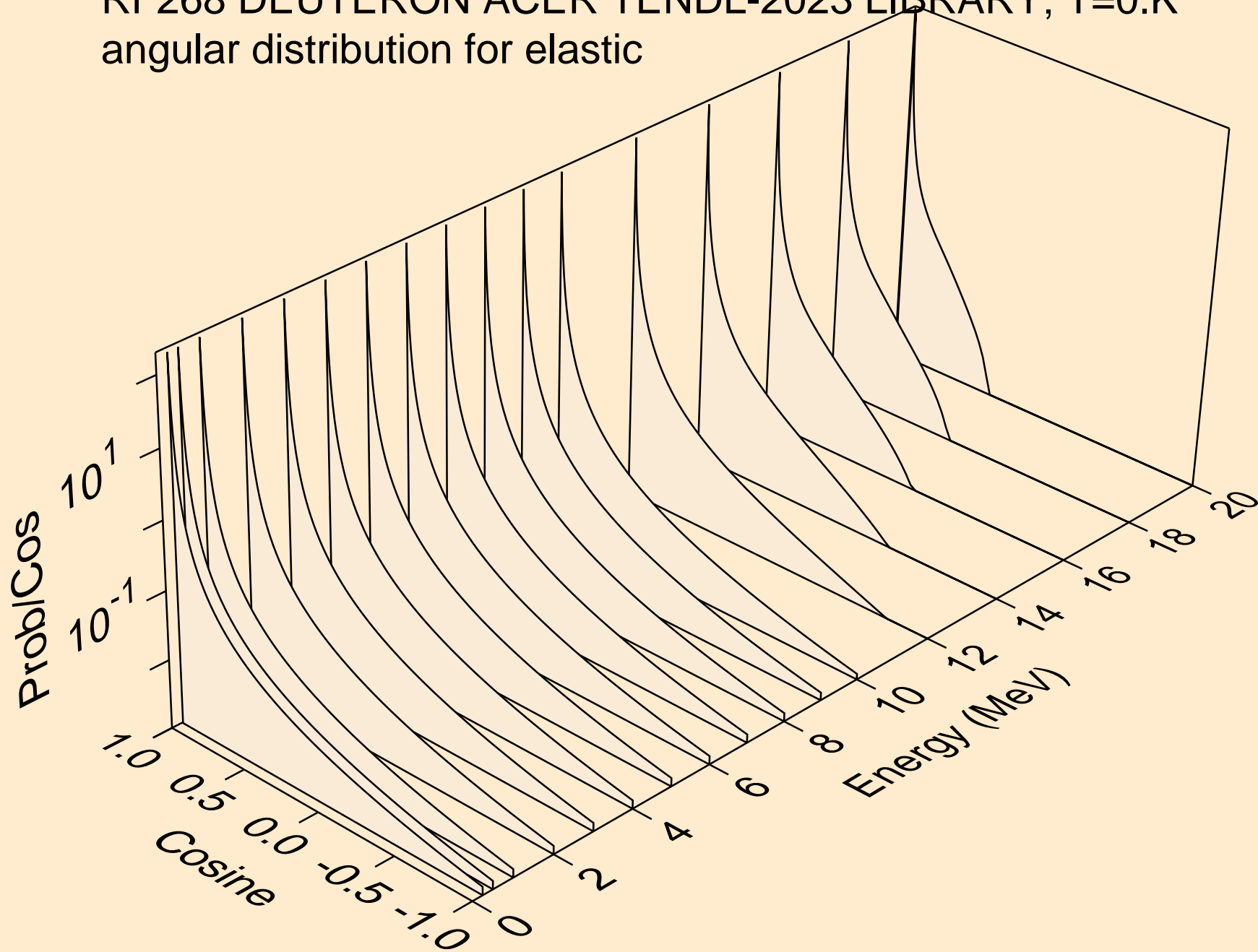

RF268 DEUTERON ACER TENDL-2023 LIBRARY; T=0.K  
angular distribution for elastic

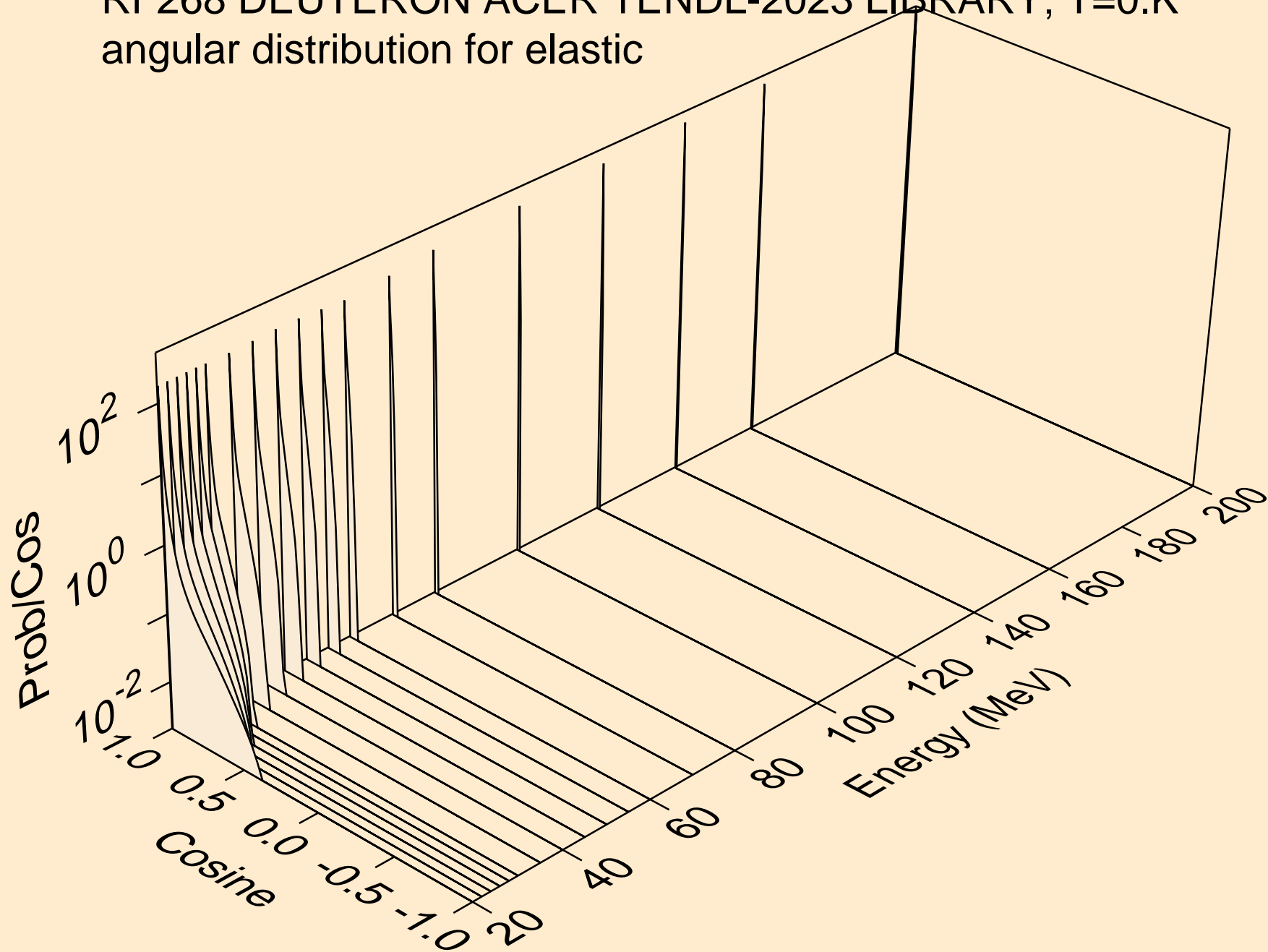

RF268 DEUTERON ACER TENDL-2023 LIBRARY; T=0.K  
Deuteron emission for (d,x)

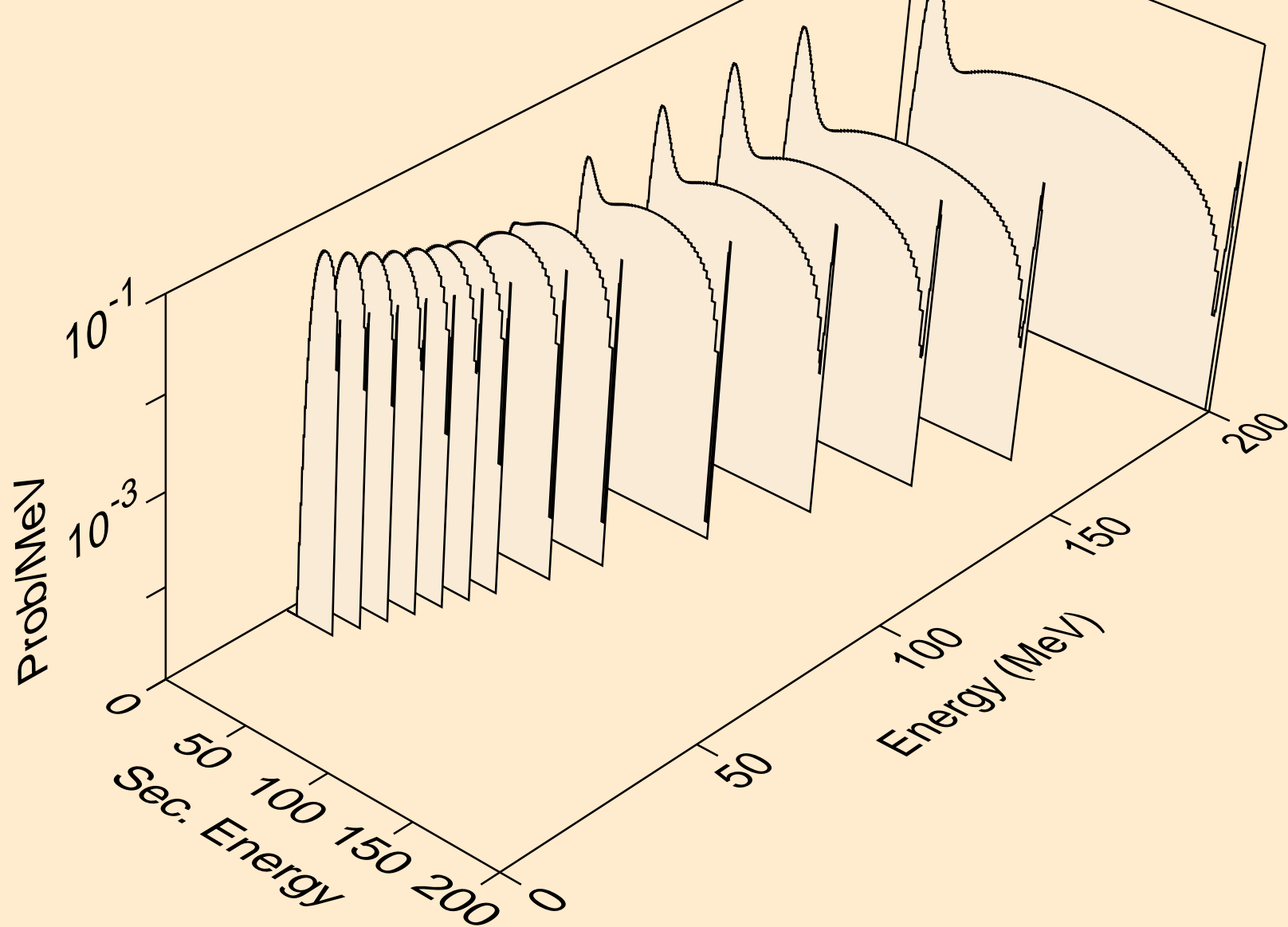

RF268 DEUTERON ACER TENDL-2023 LIBRARY; T=0.K  
Deuteron emission for (d,n\*)d

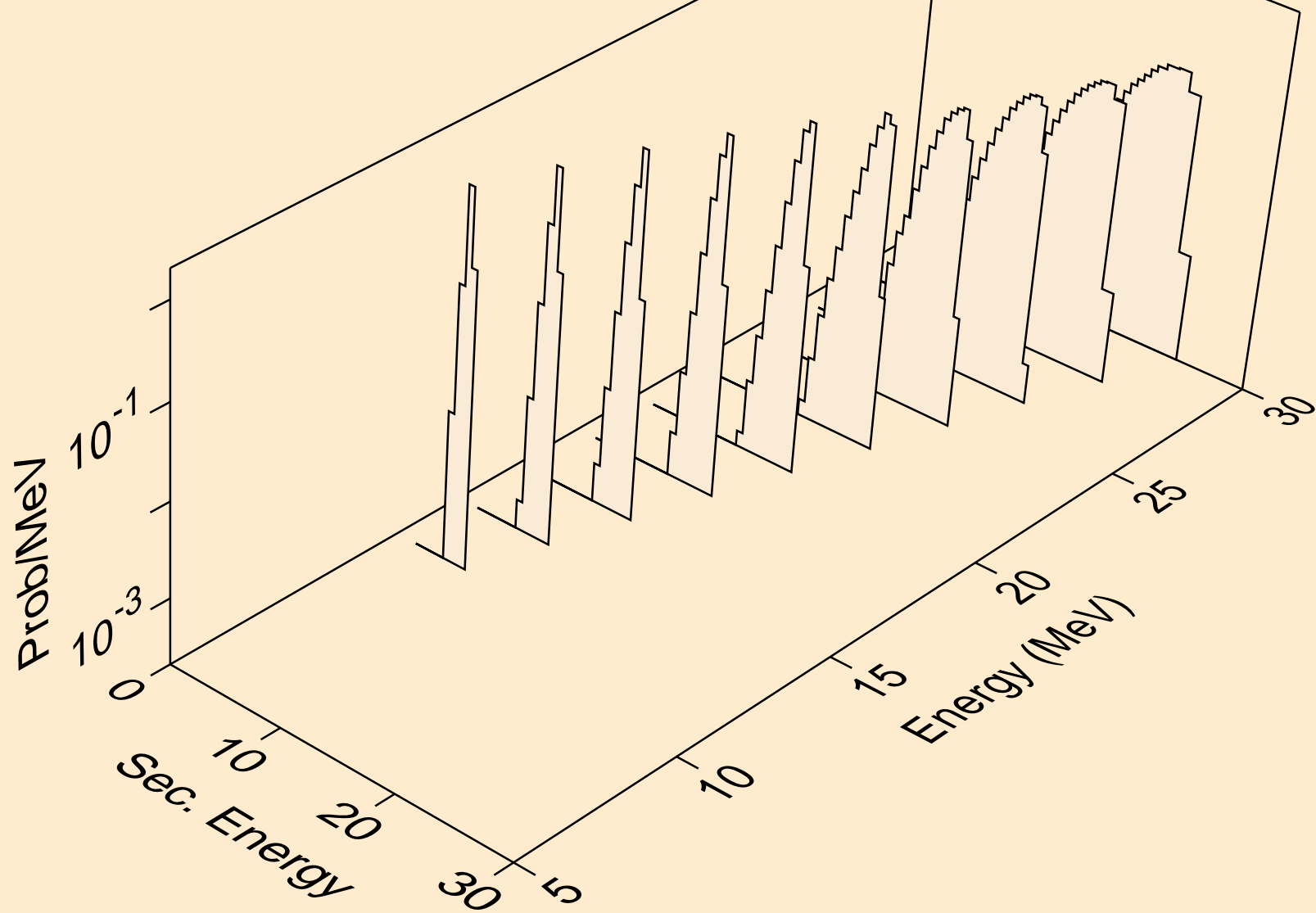

RF268 DEUTERON ACER TENDL-2023 LIBRARY; T=0.K  
Deuteron emission for inelastic

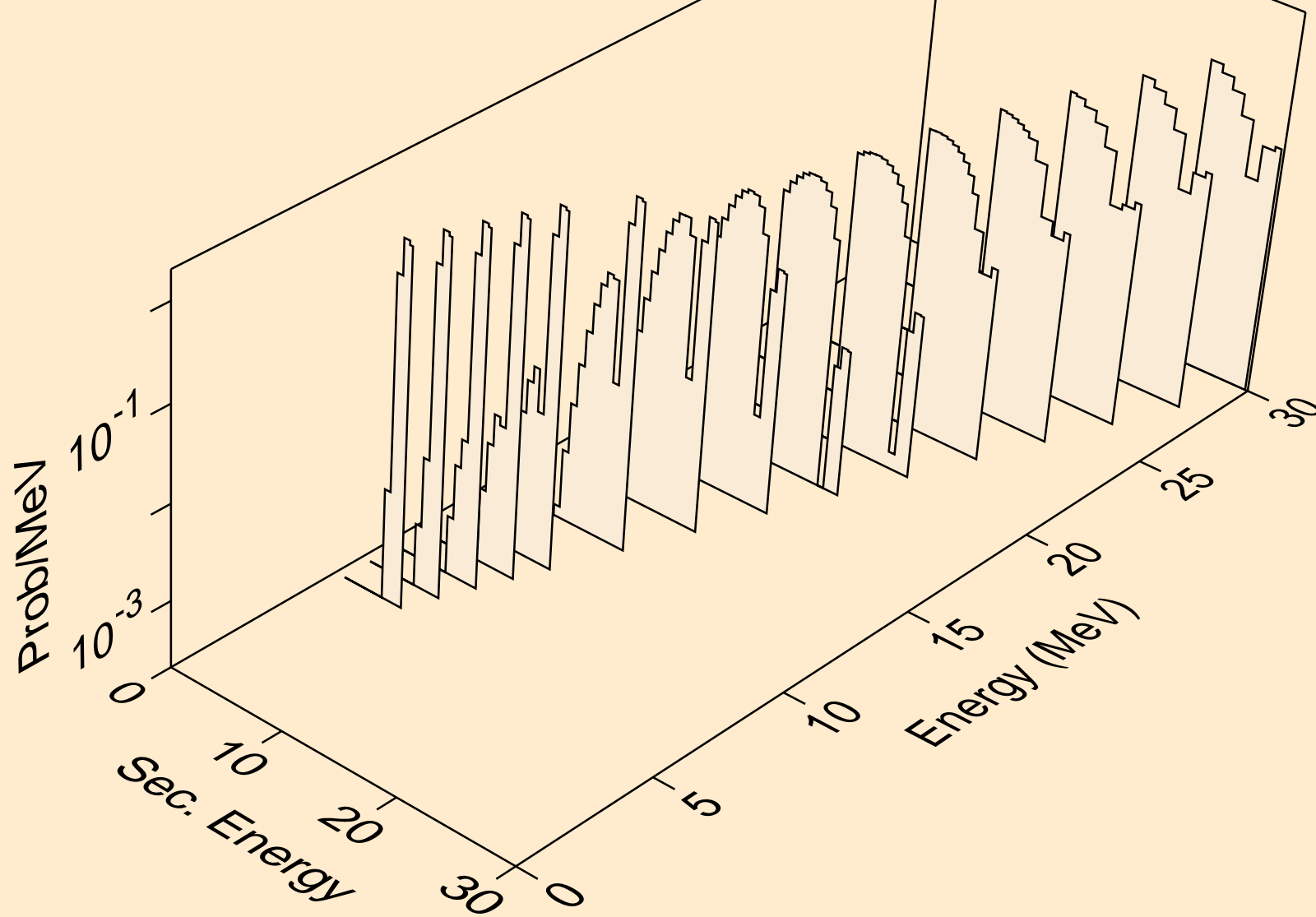



RF268 DEUTERON ACER TENDL-2023 LIBRARY; T=0.K  
Deuteron emission for (d,pd)

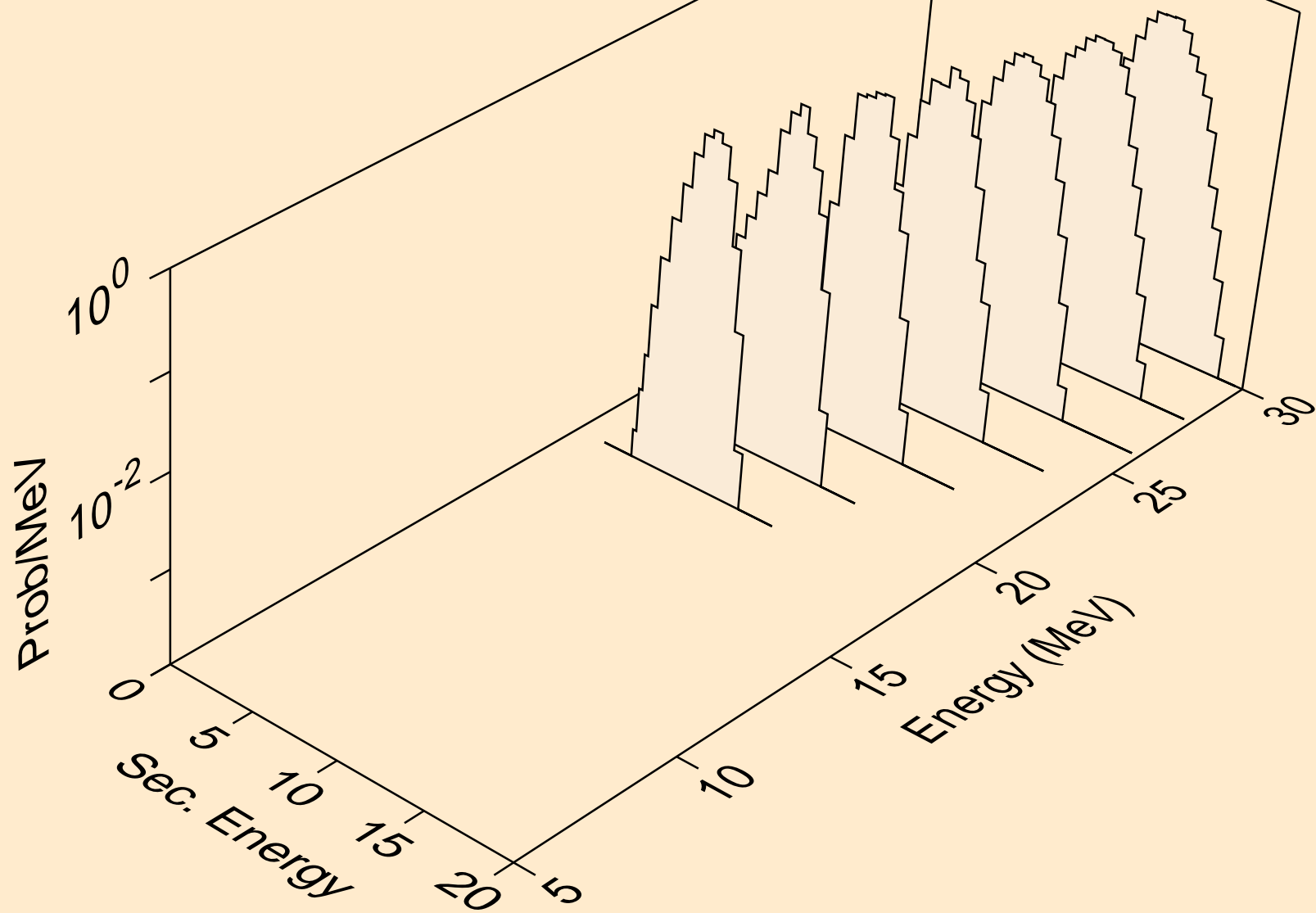

RF268 DEUTERON ACER TENDL-2023 LIBRARY; T=0.K  
Photon emission for (z,n)

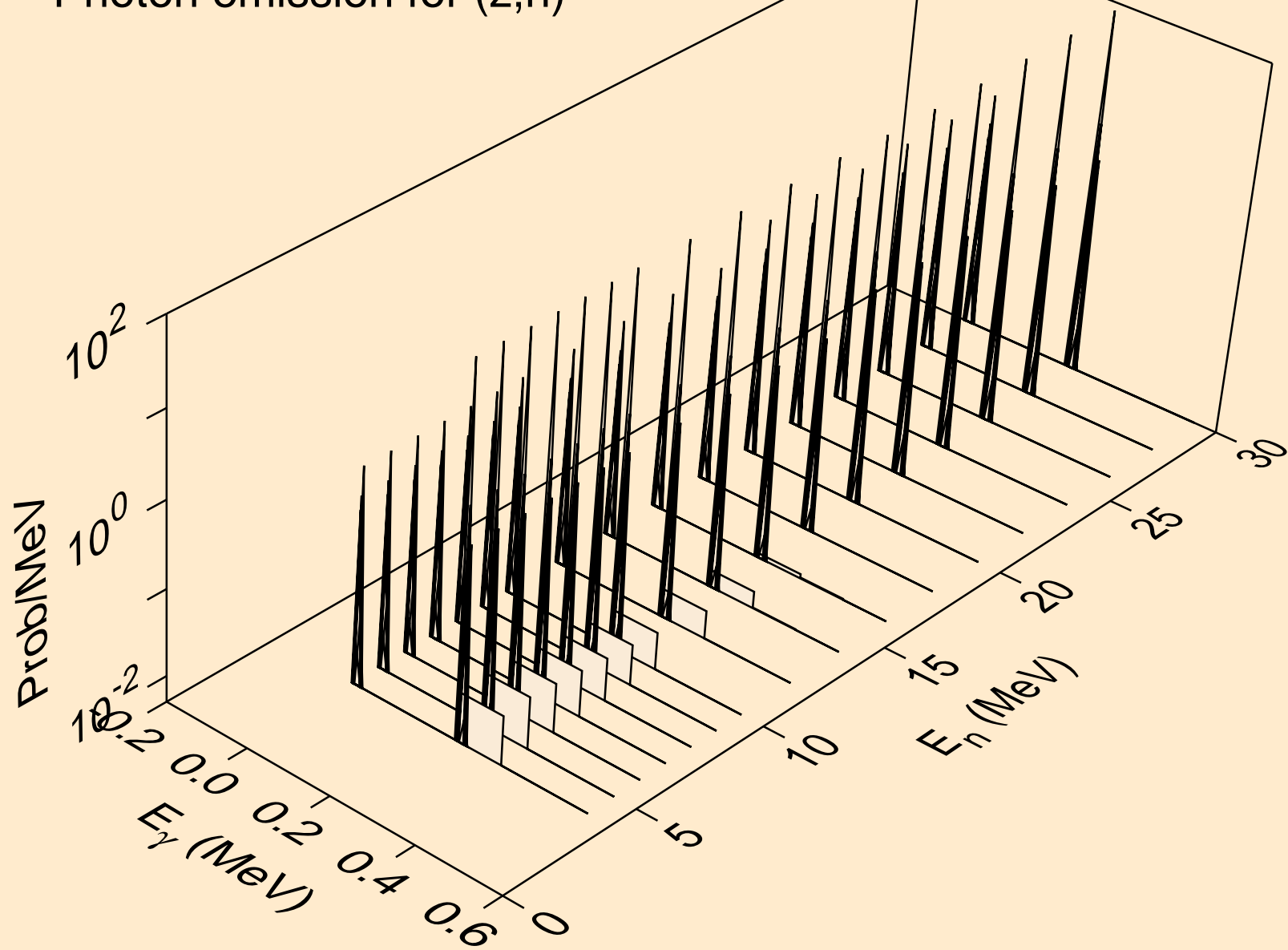

RF268 DEUTERON ACER TENDL-2023 LIBRARY; T=0.K  
Photon emission for (z,x)

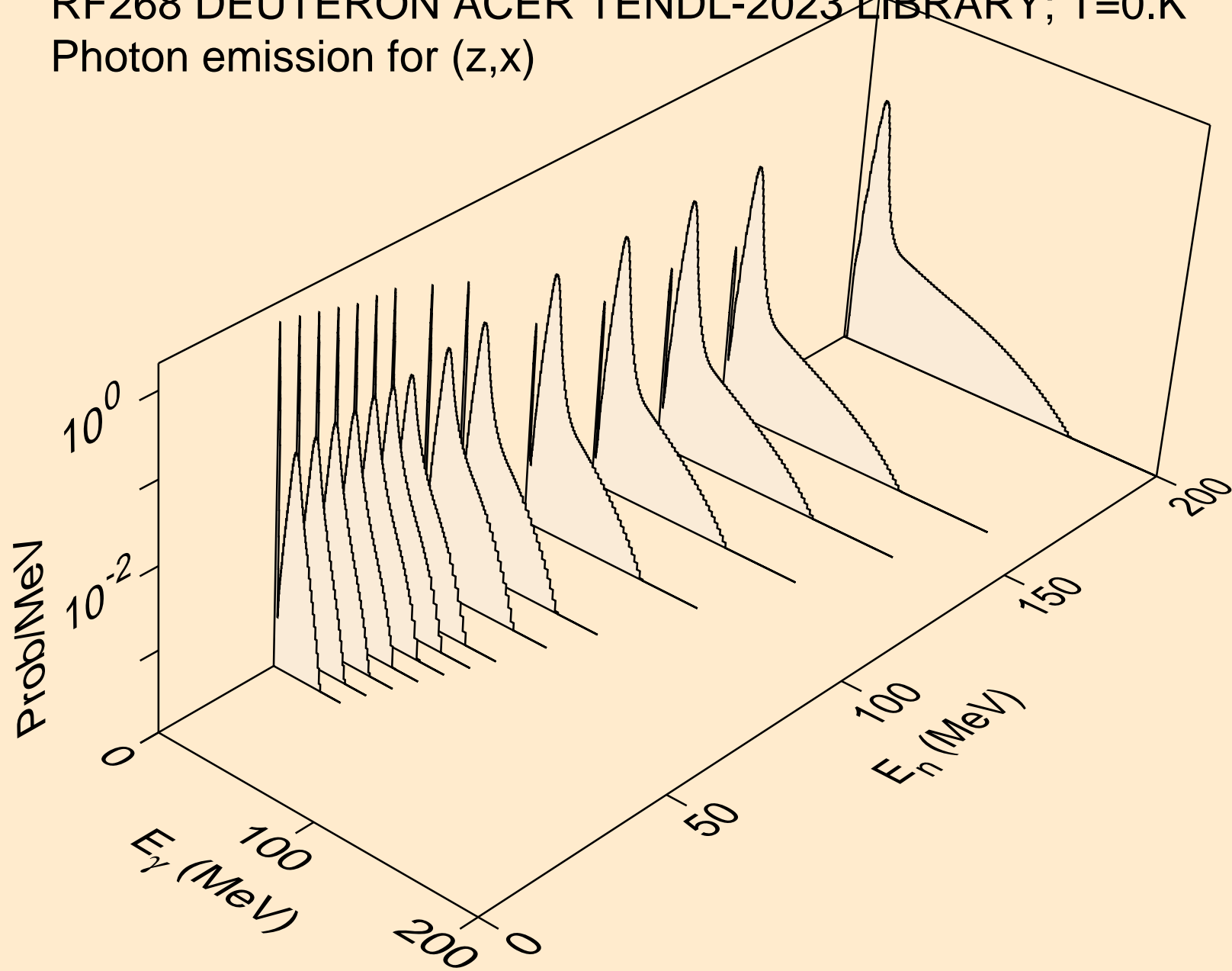

RF268 DEUTERON ACER TENDL-2023 LIBRARY; T=0.K  
Photon emission for (n,2n)

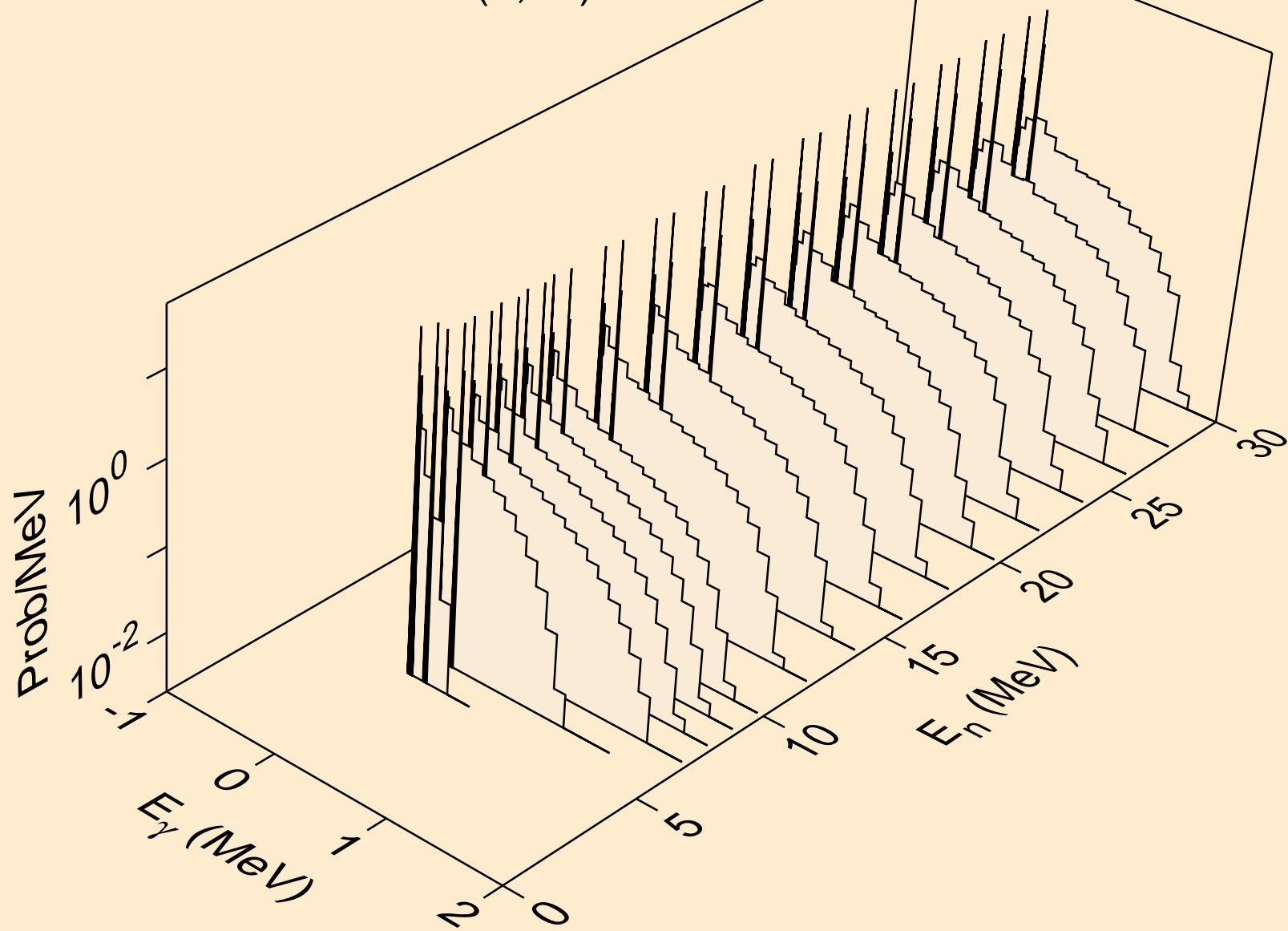

RF268 DEUTERON ACER TENDL-2023 LIBRARY; T=0.K  
Photon emission for (n,3n)

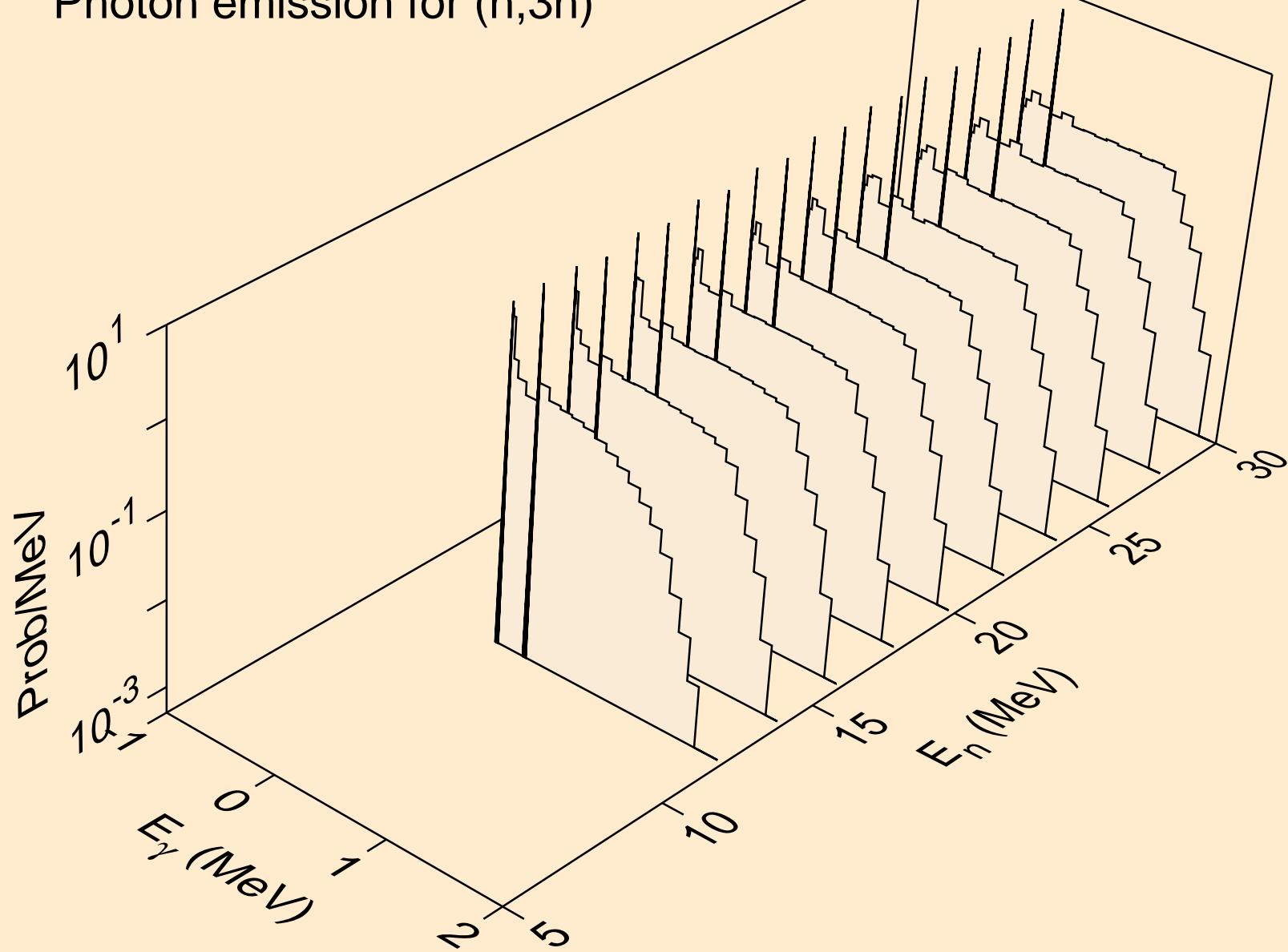

RF268 DEUTERON ACER TENDL-2023 LIBRARY; T=0.K  
Photon emission for (n,n\*)p

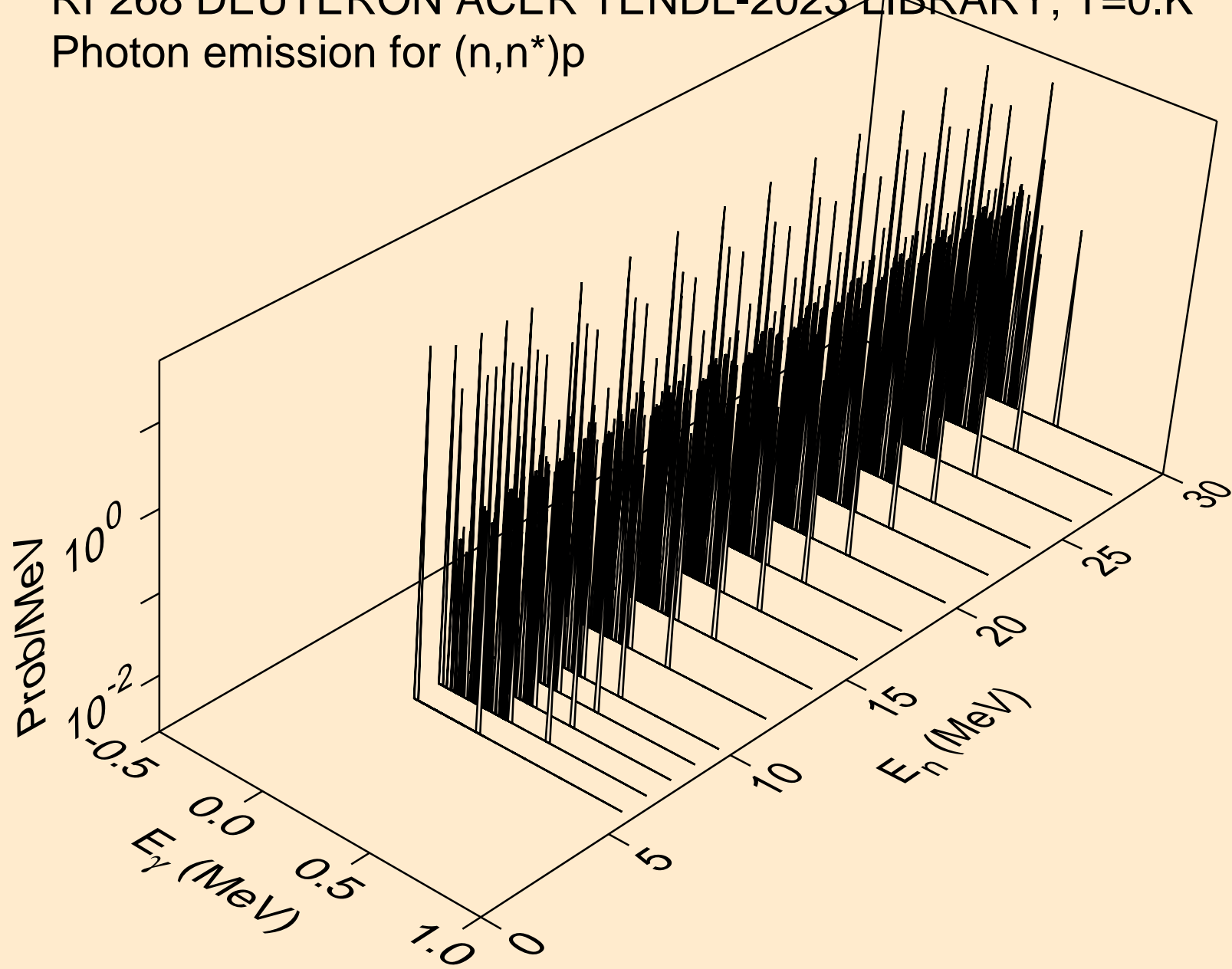

RF268 DEUTERON ACER TENDL-2023 LIBRARY; T=0.K  
Photon emission for (n,n\*)d

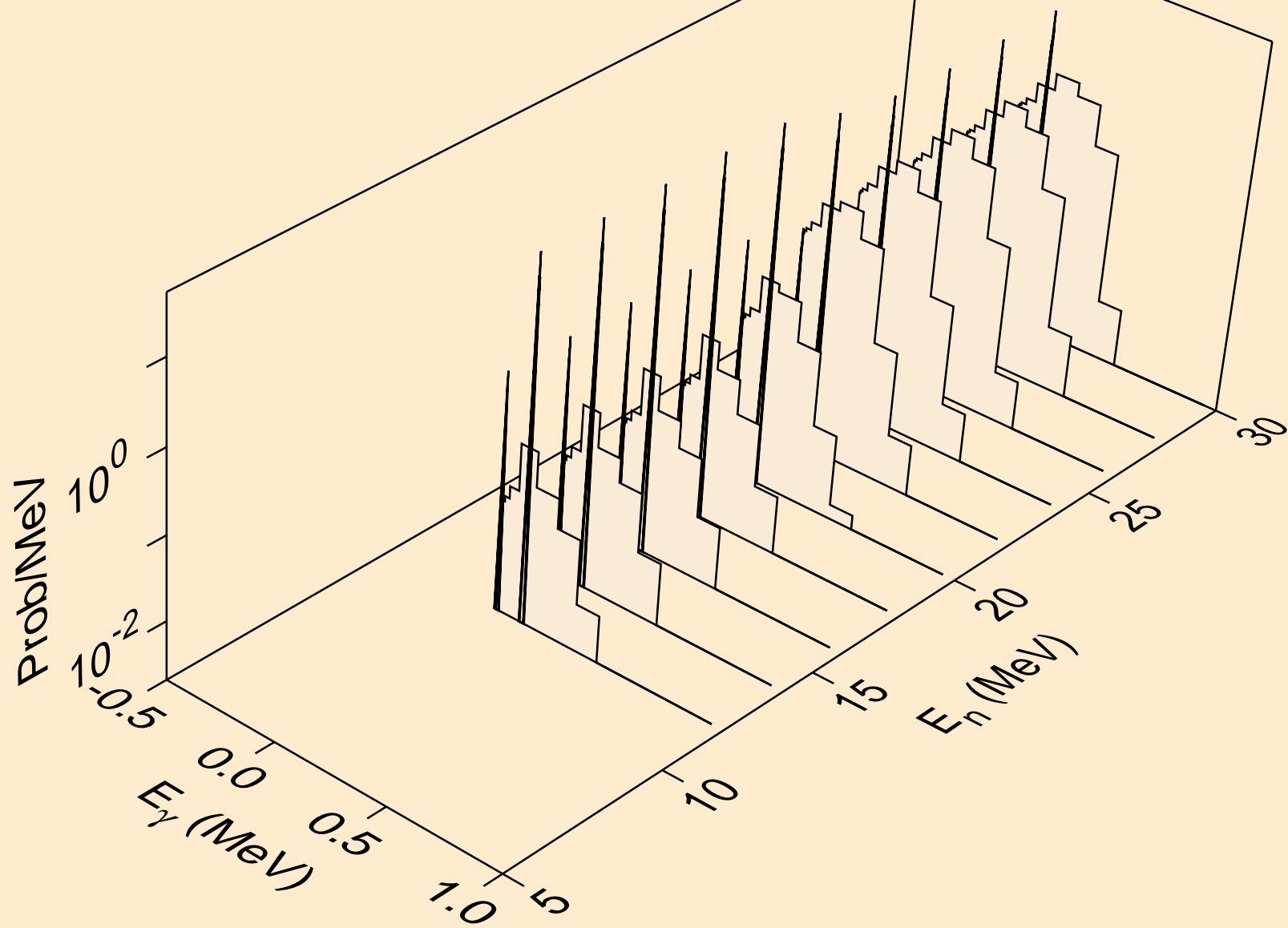

RF268 DEUTERON ACER TENDL-2023 LIBRARY; T=0.K  
Photon emission for (n,n\*)t

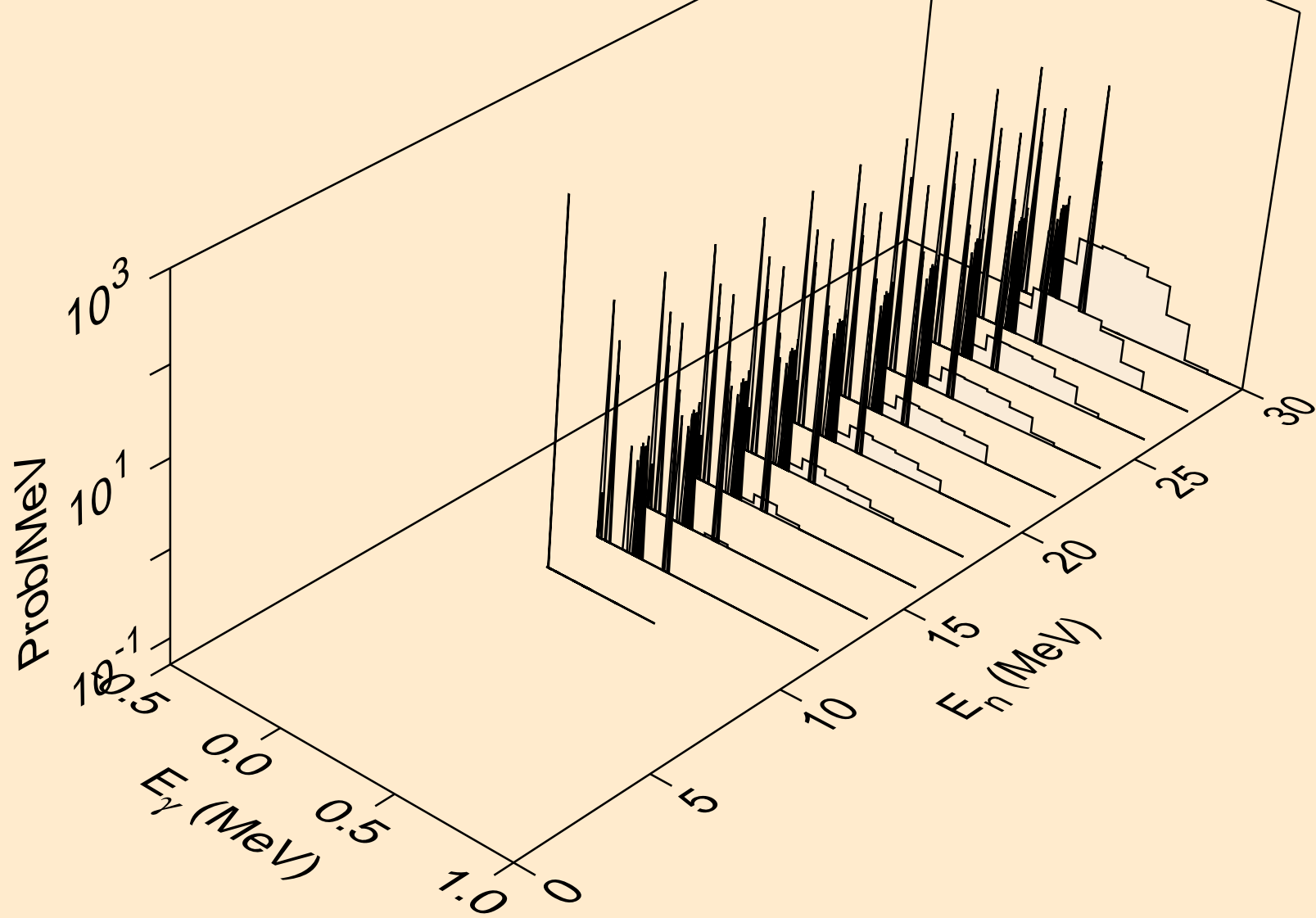



RF268 DEUTERON ACER TENDL-2023 LIBRARY; T=0.K  
Photon emission for (n,4n)

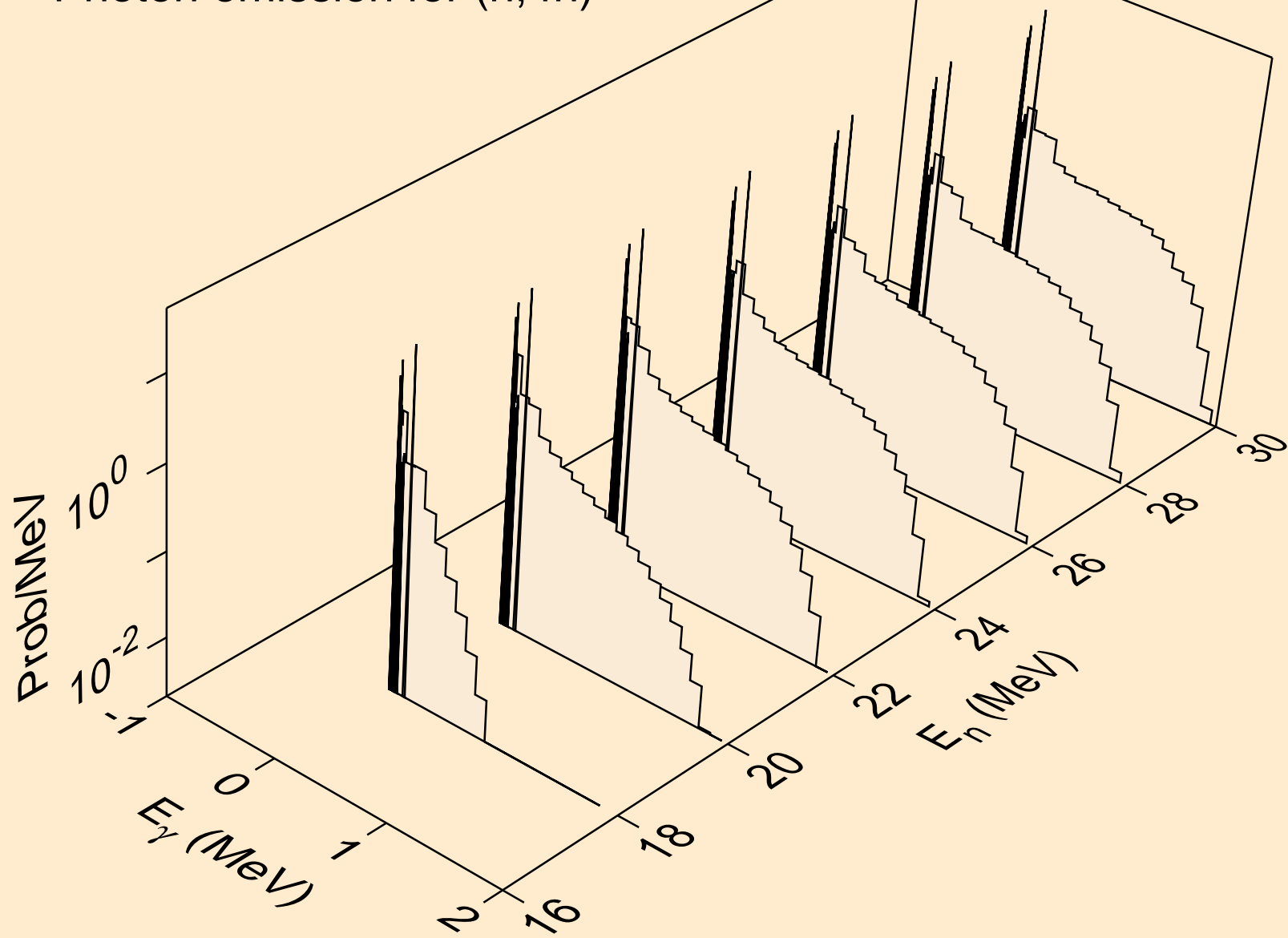

RF268 DEUTERON ACER TENDL-2023 LIBRARY; T=0.K  
Photon emission for (n,2np)

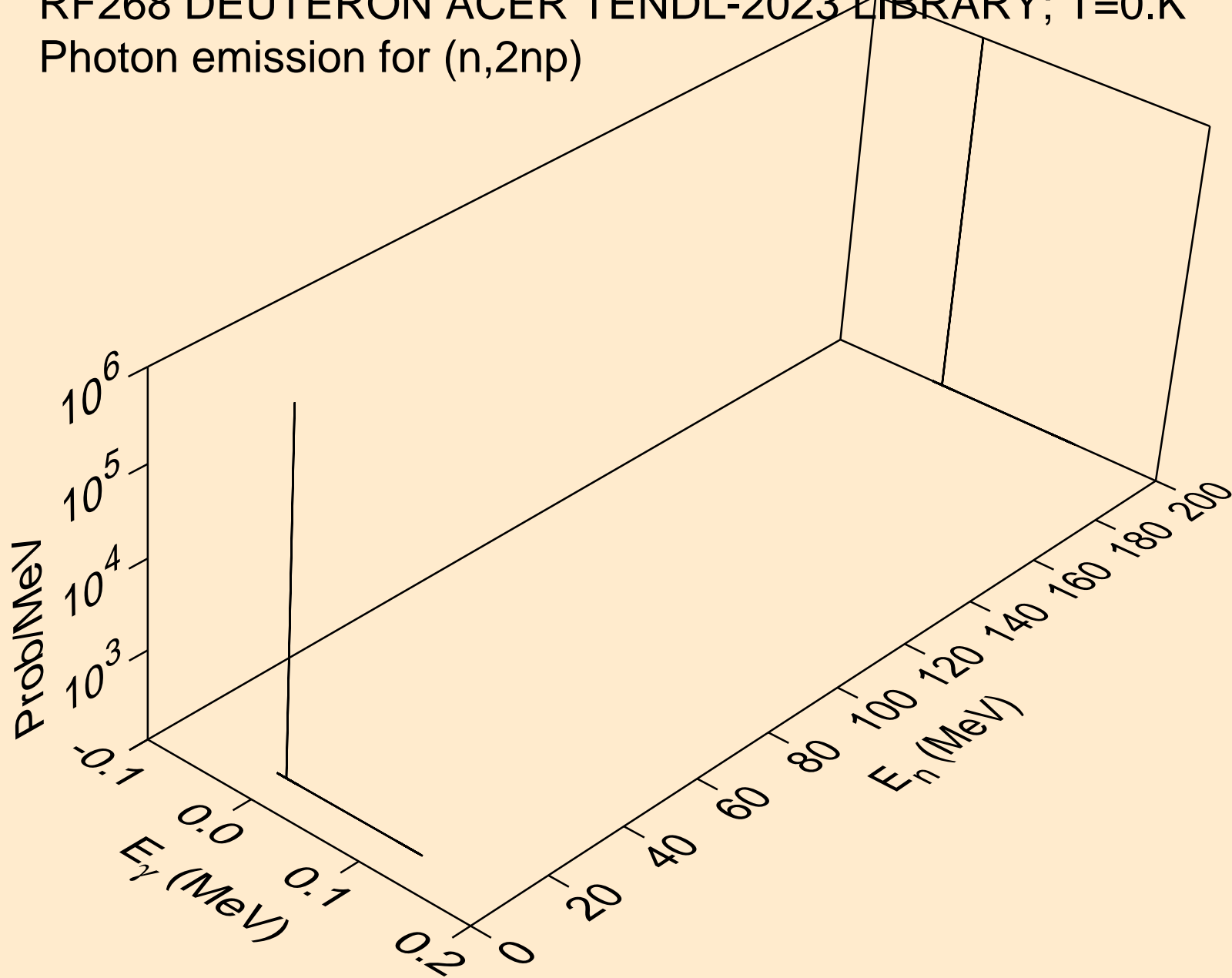

RF268 DEUTERON ACER TENDL-2023 LIBRARY; T=0.K  
Photon emission for (n,3np)

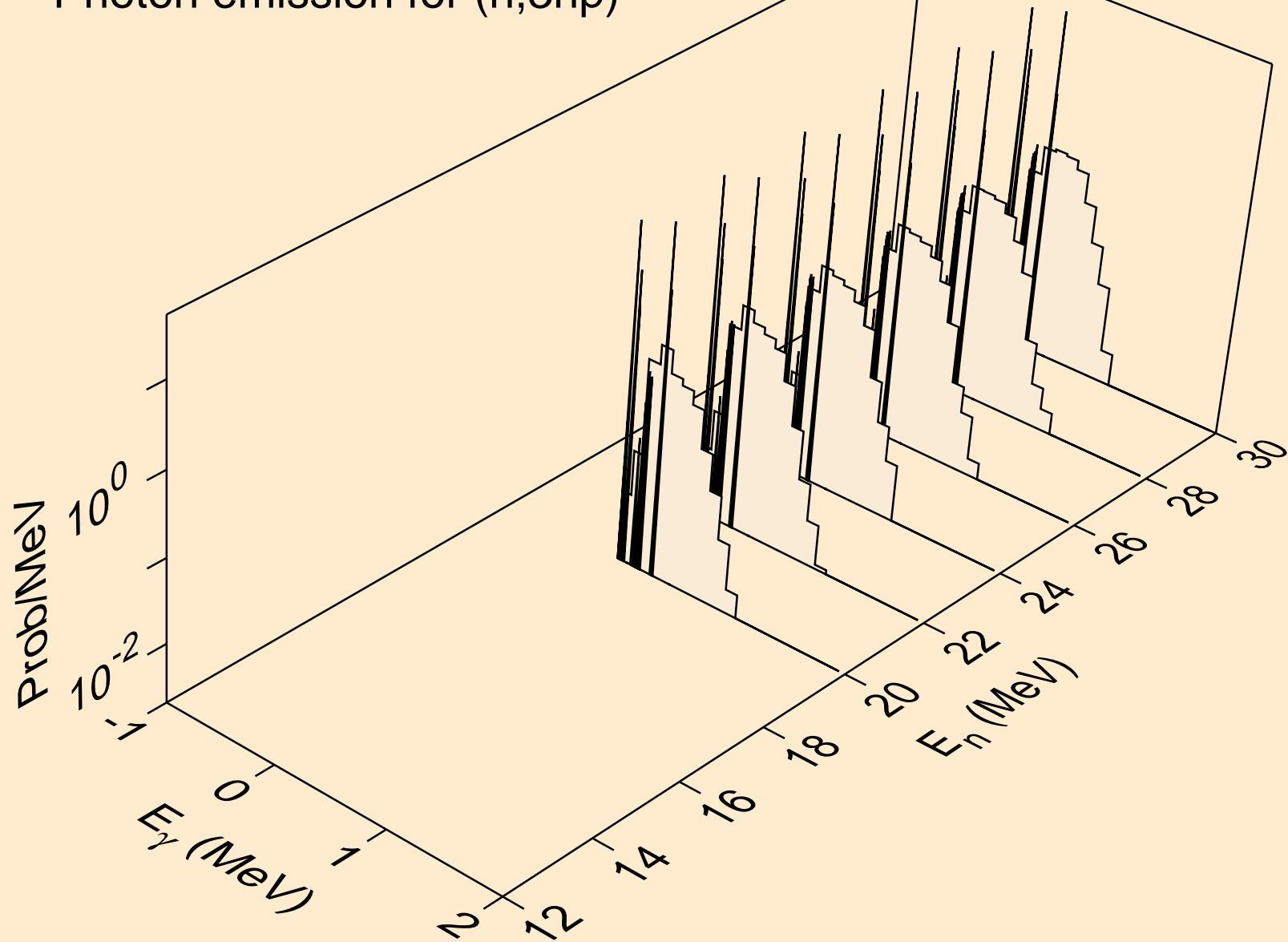

RF268 DEUTERON ACER TENDL-2023 LIBRARY; T=0.K  
Photon emission for (n,p)

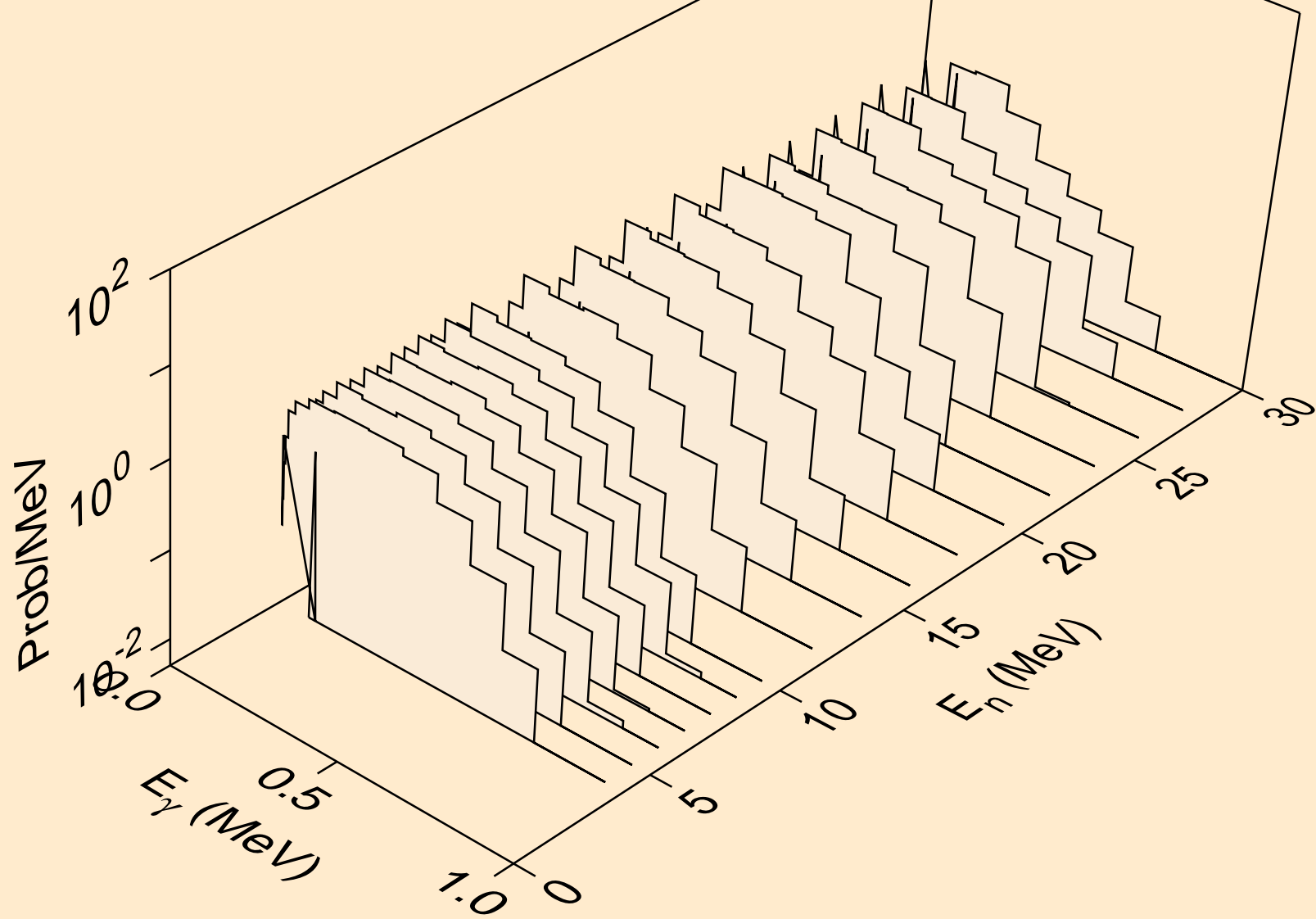

RF268 DEUTERON ACER TENDL-2023 LIBRARY; T=0.K  
Photon emission for inelastic

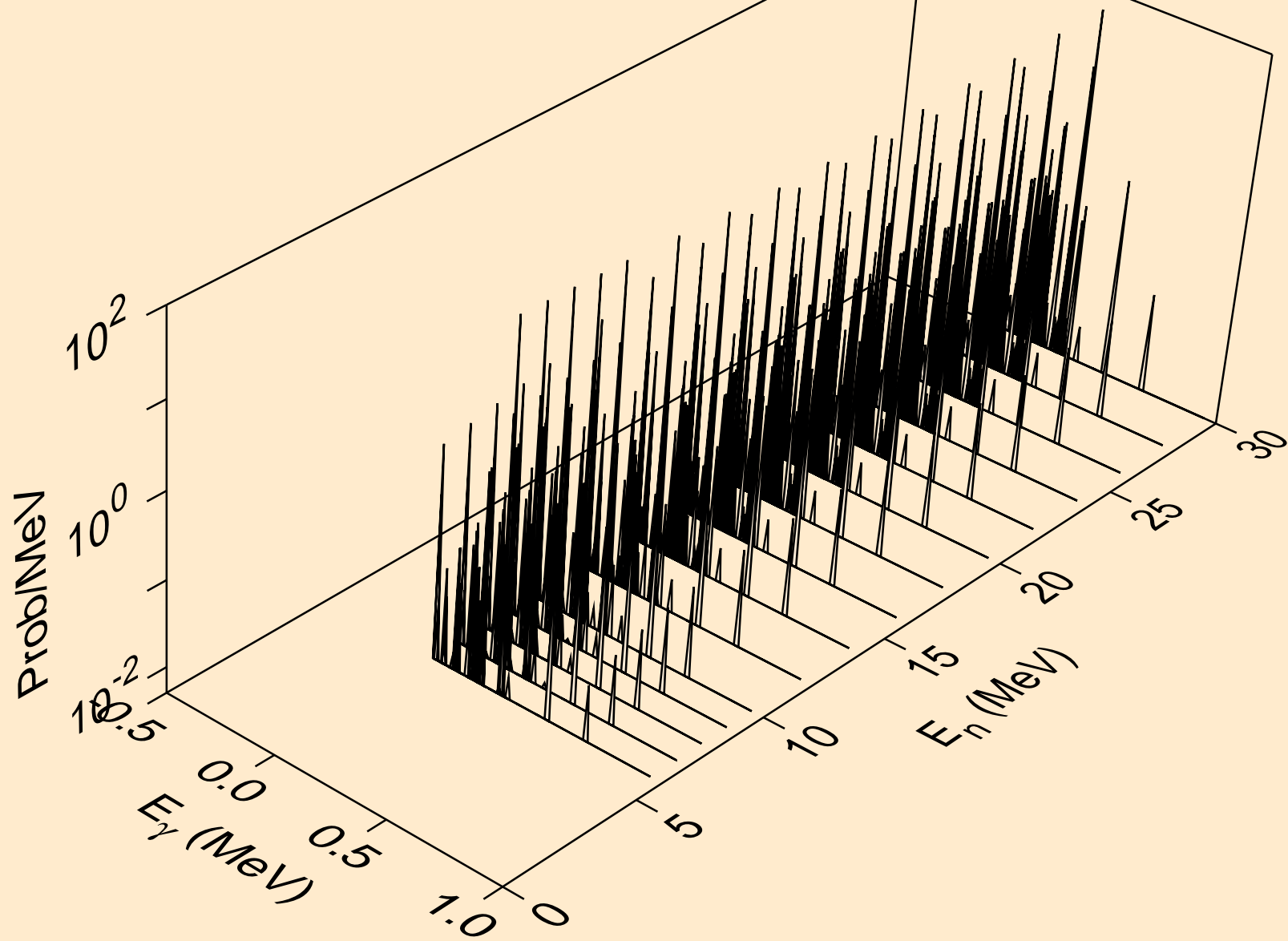

RF268 DEUTERON ACER TENDL-2023 LIBRARY; T=0.K  
Photon emission for (n,t)

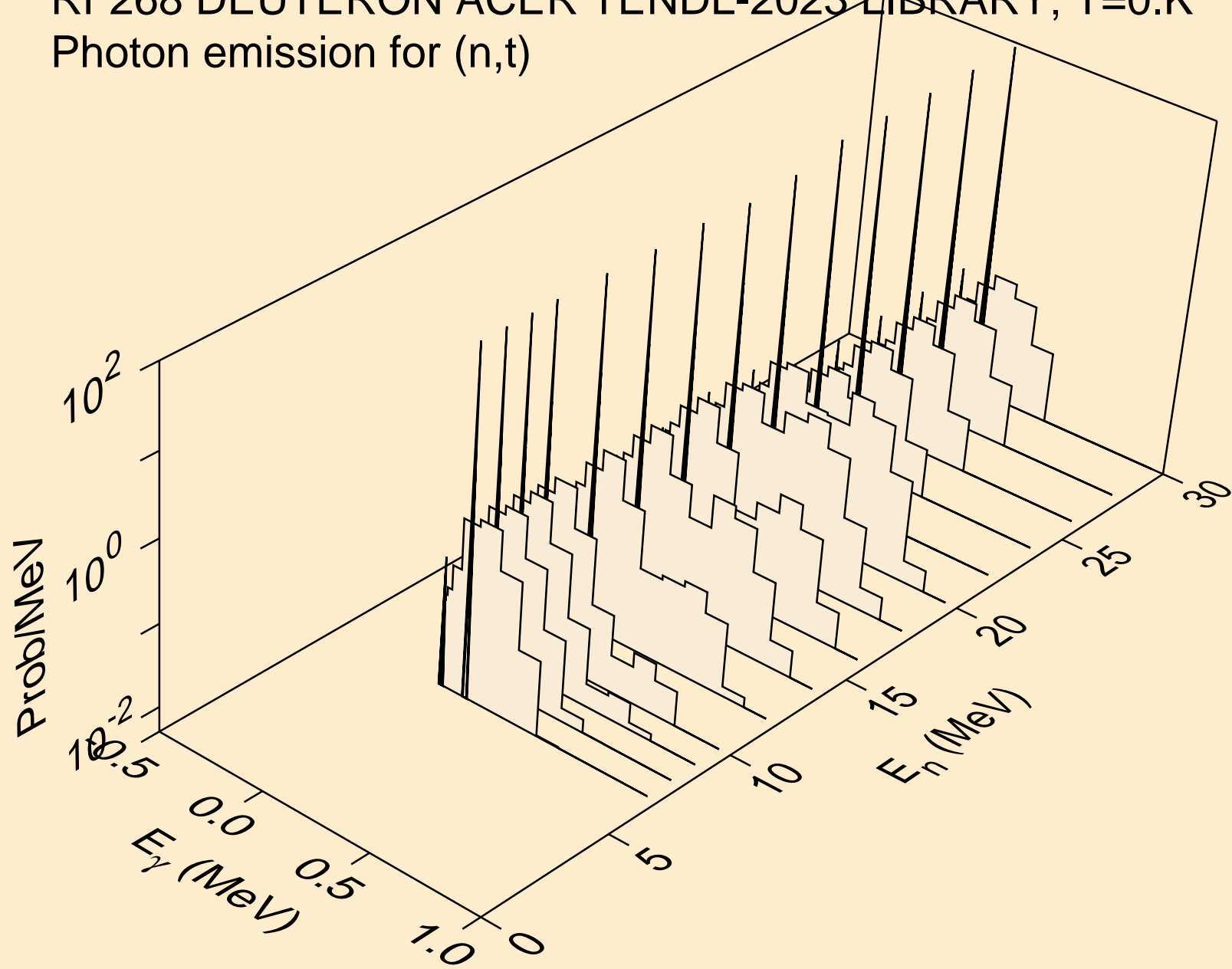

RF268 DEUTERON ACER TENDL-2023 LIBRARY; T=0.K  
Photon emission for (n,he3)

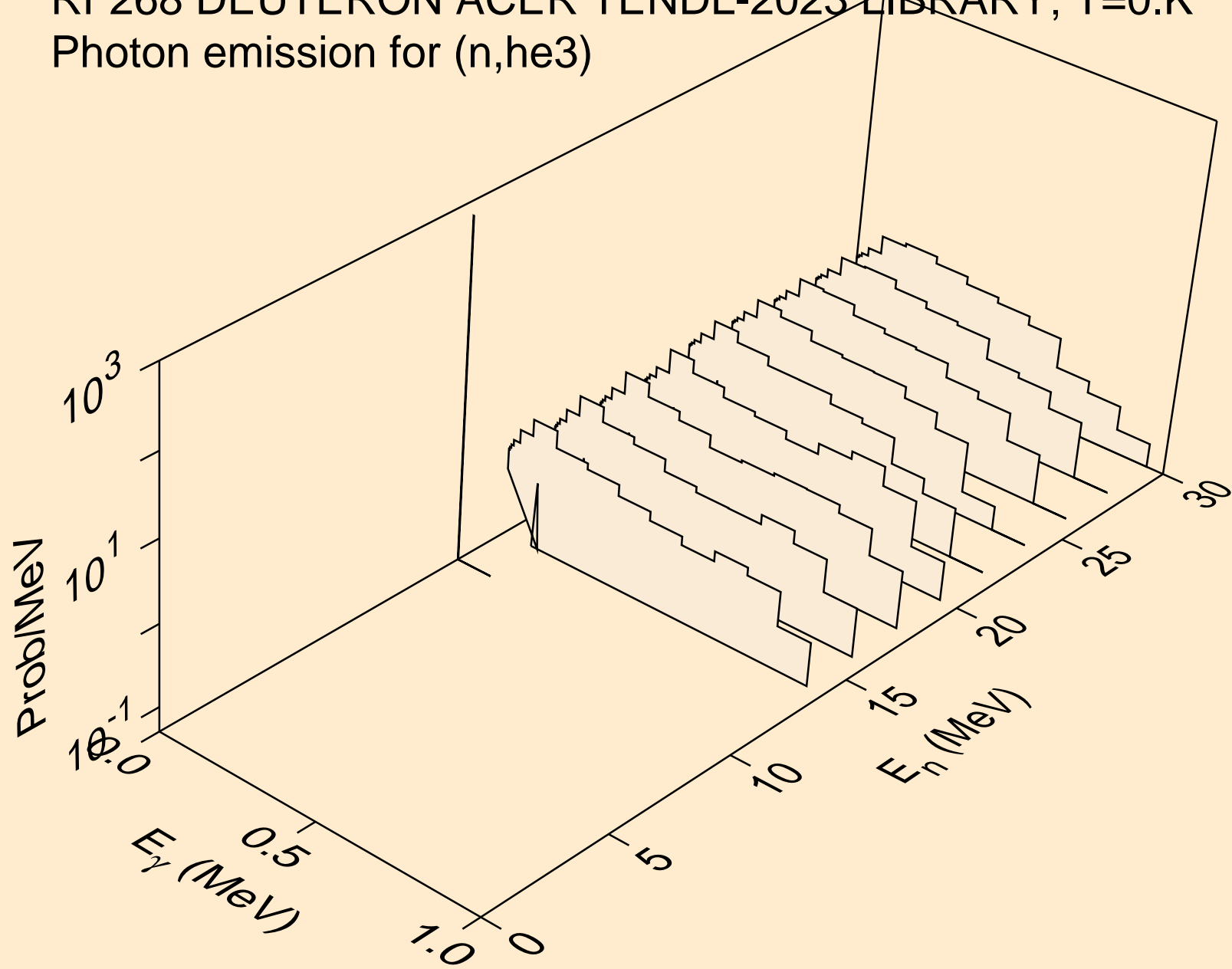

RF268 DEUTERON ACER TENDL-2023 LIBRARY; T=0.K  
Photon emission for (n,a)

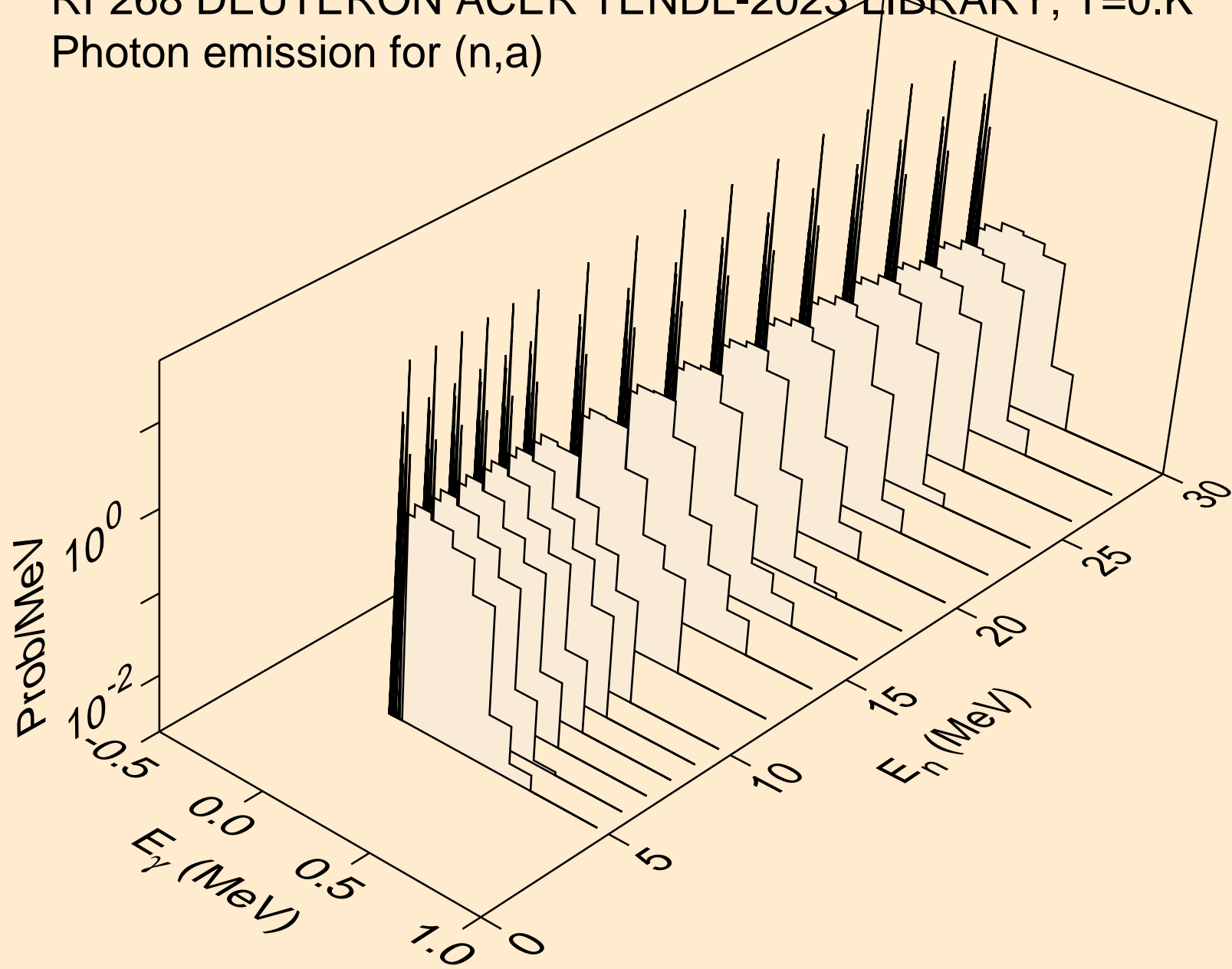



RF268 DEUTERON ACER TENDL-2023 LIBRARY; T=0.K  
Photon emission for (n,2p)

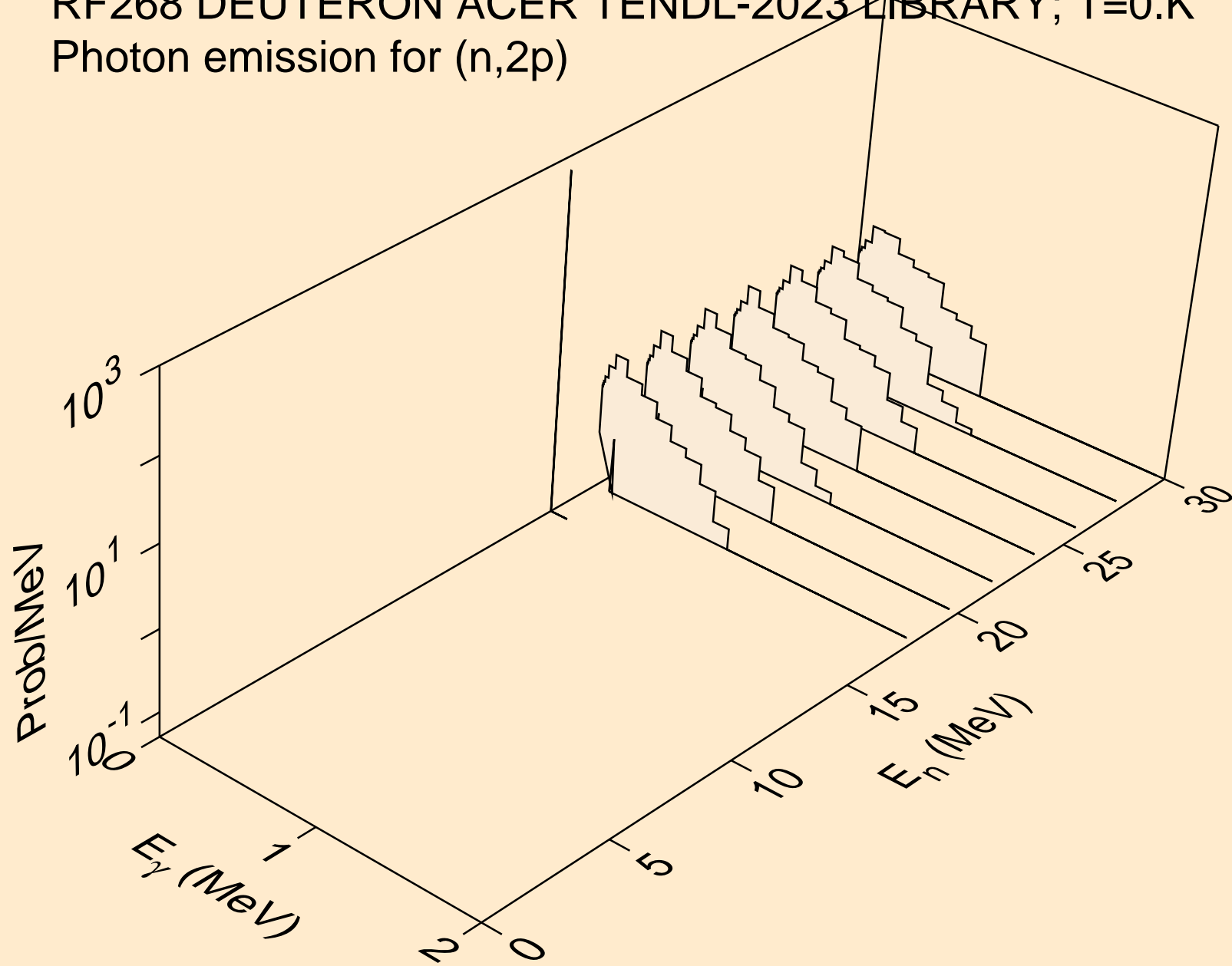

RF268 DEUTERON ACER TENDL-2023 LIBRARY; T=0.K  
Photon emission for (n,pd)

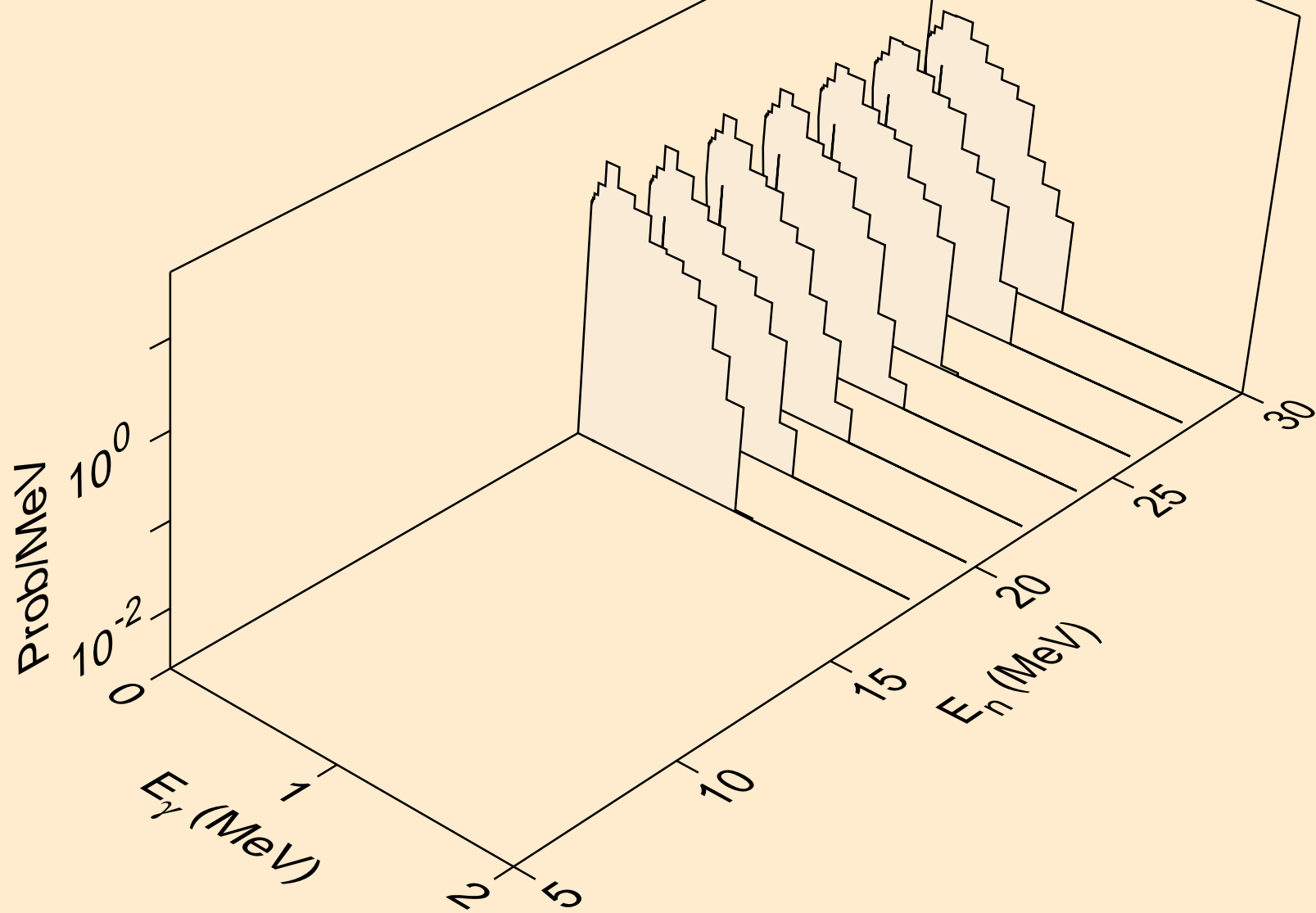

# RF268 DEUTERON ACER TENDL-2023 LIBRARY; T=0.K

## Particle heating contributions

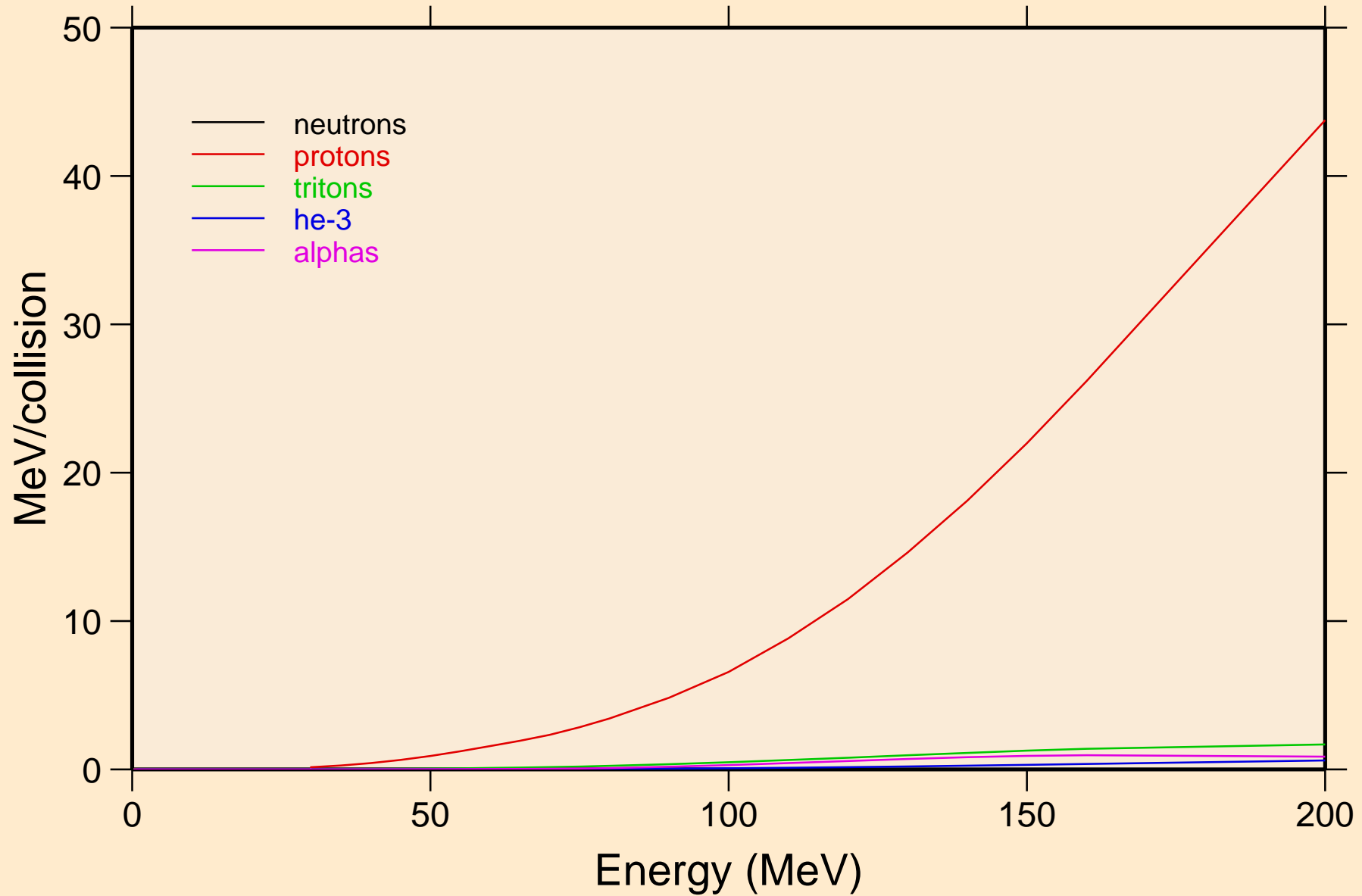

RF268 DEUTERON ACER TENDL-2023 LIBRARY; T=0.K  
Recoil Heating

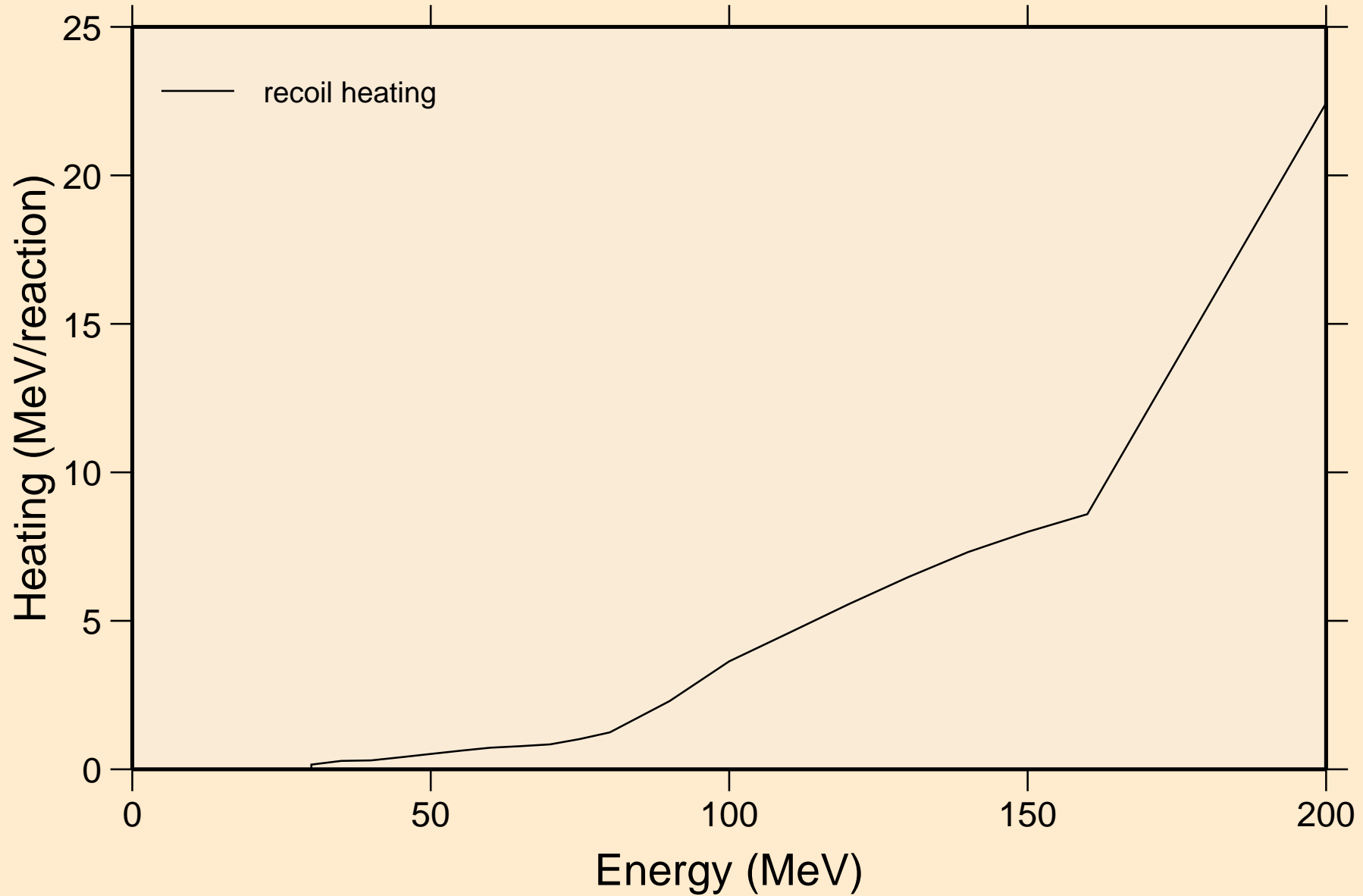

RF268 DEUTERON ACER TENDL-2023 LIBRARY; T=0.K  
Particle production cross sections

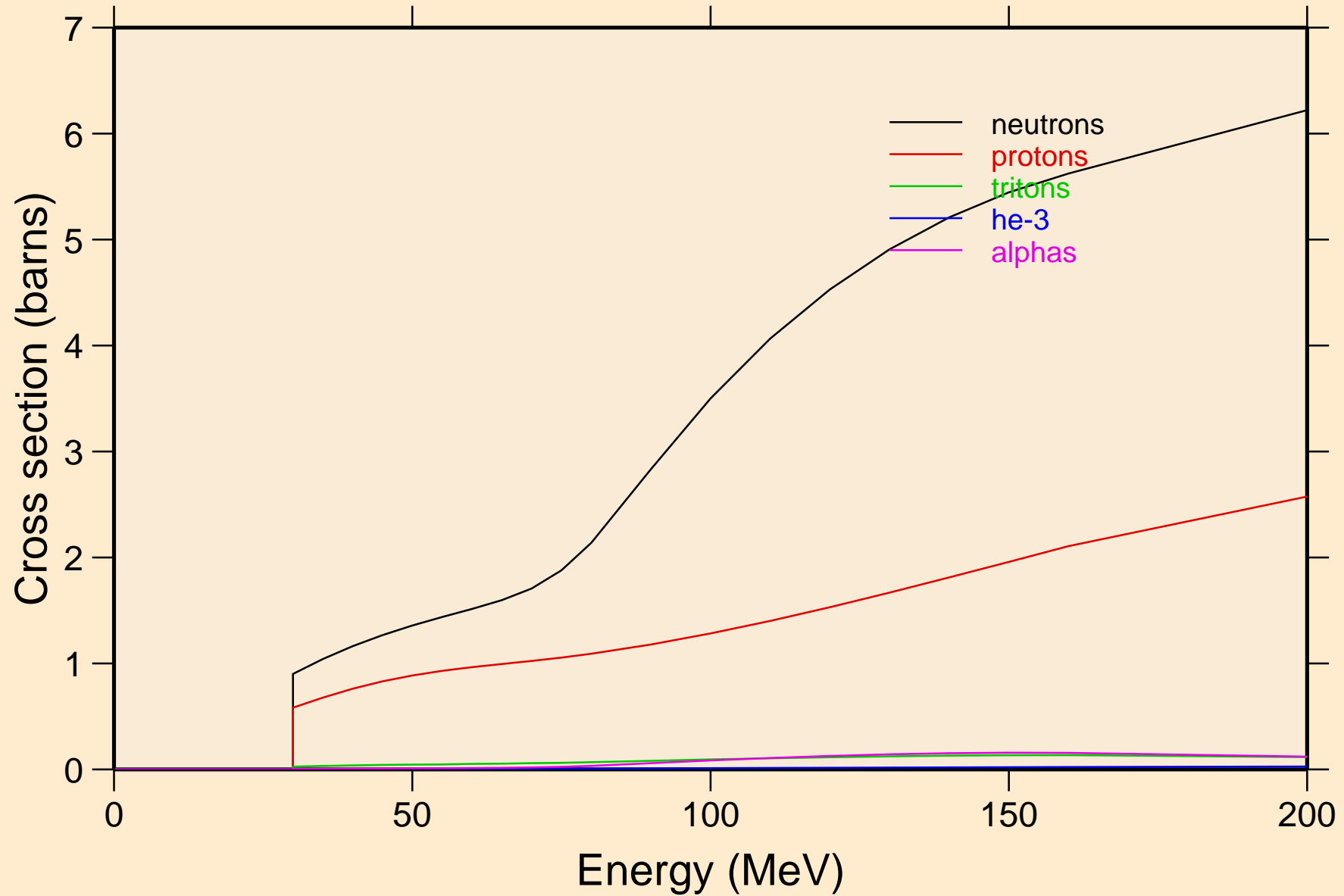

RF268 DEUTERON ACER TENDL-2023 LIBRARY; T=0.K  
neutrons from (d,n)

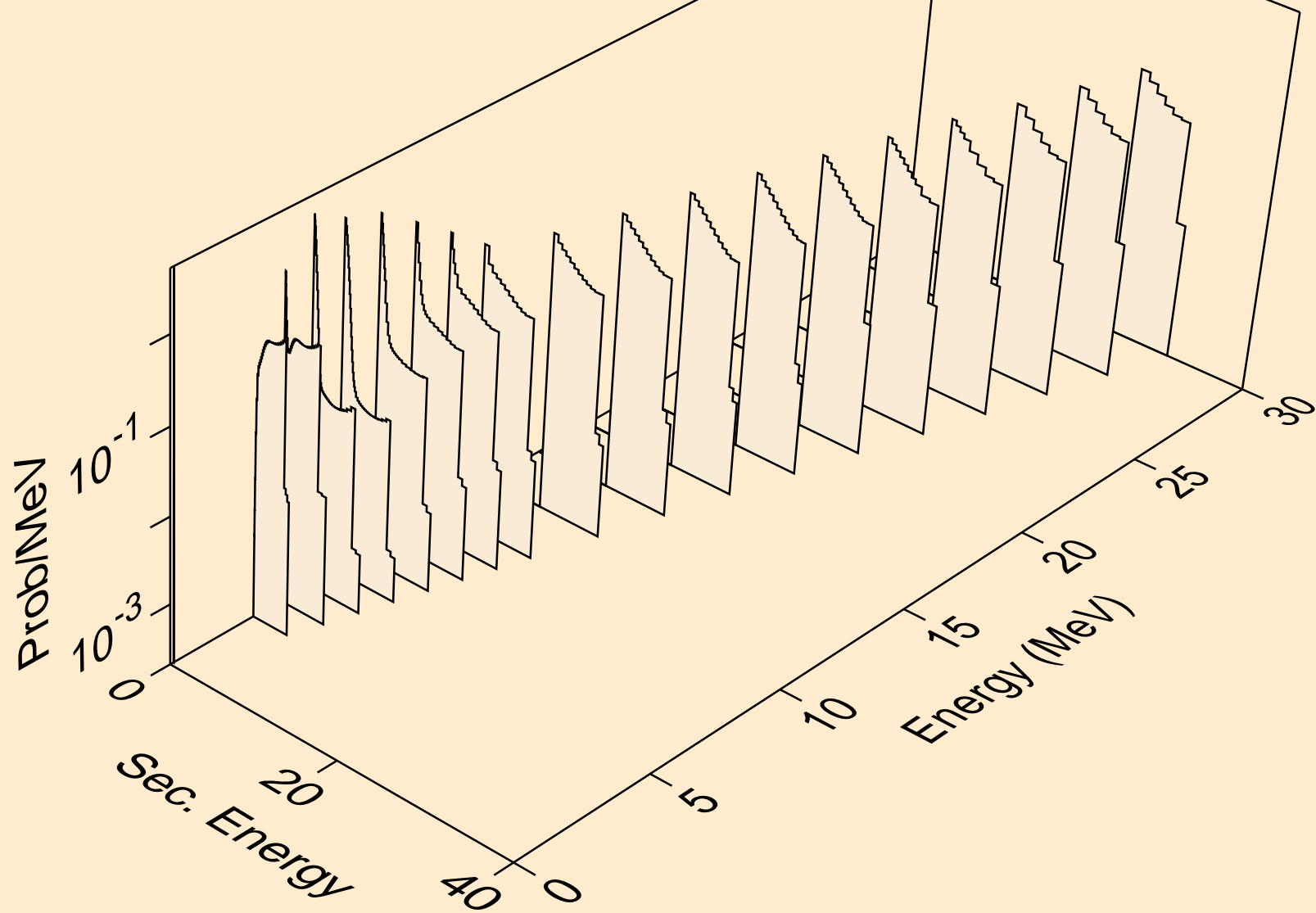

RF268 DEUTERON ACER TENDL-2023 LIBRARY; T=0.K  
neutrons from (d,x)

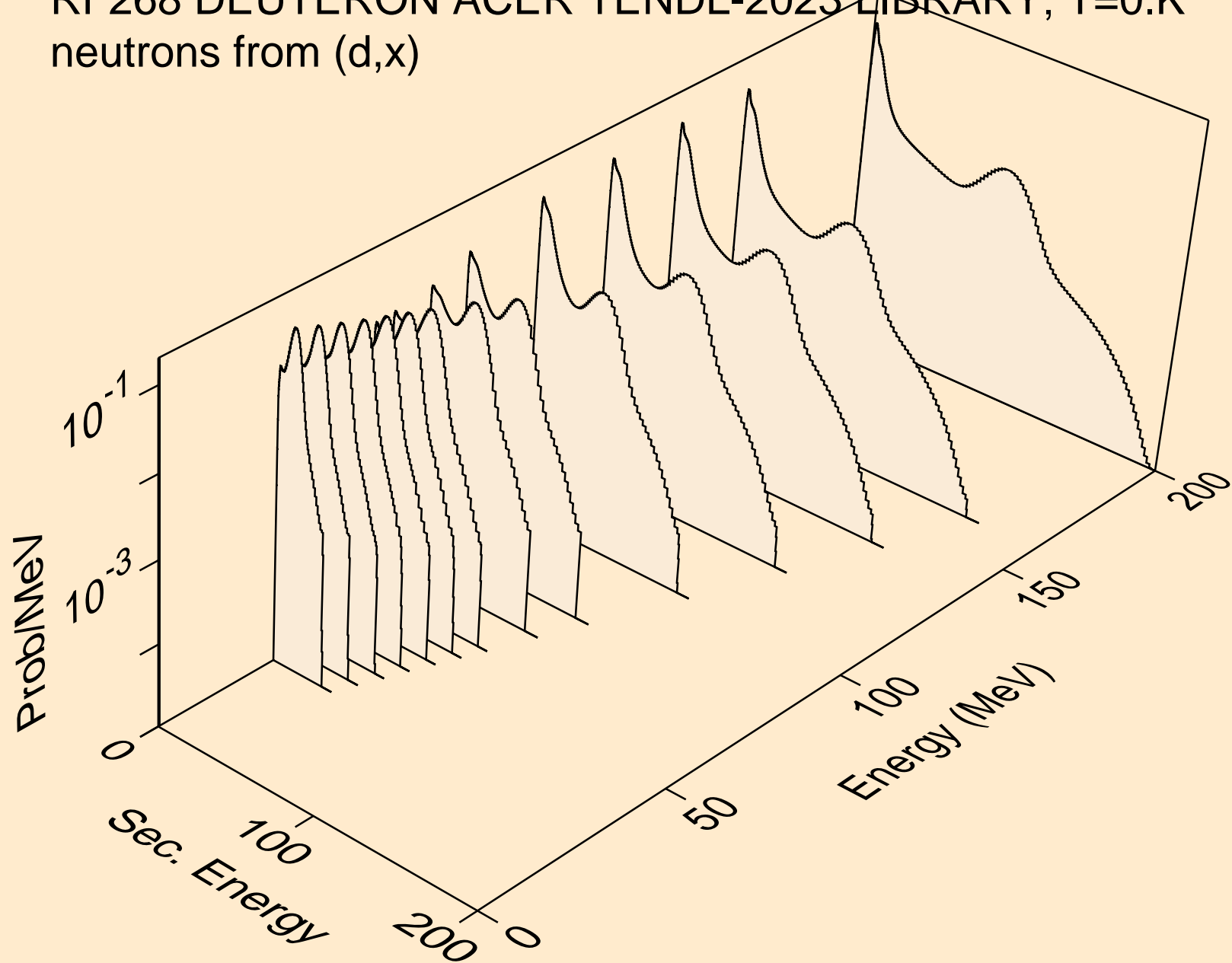

RF268 DEUTERON ACER TENDL-2023 LIBRARY; T=0.K  
neutrons from (d,2n)

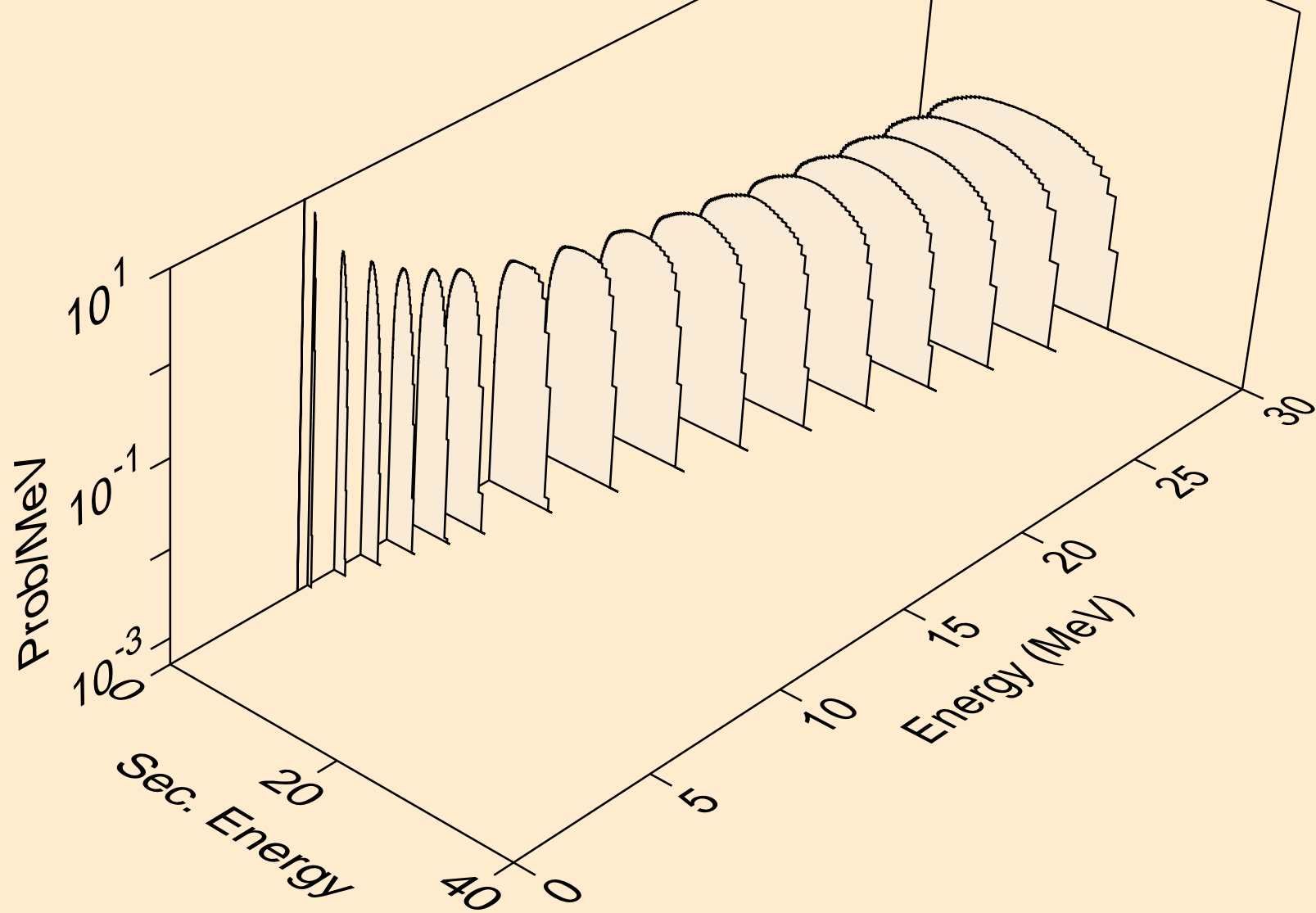



RF268 DEUTERON ACER TENDL-2023 LIBRARY; T=0.K  
neutrons from (d,3n)

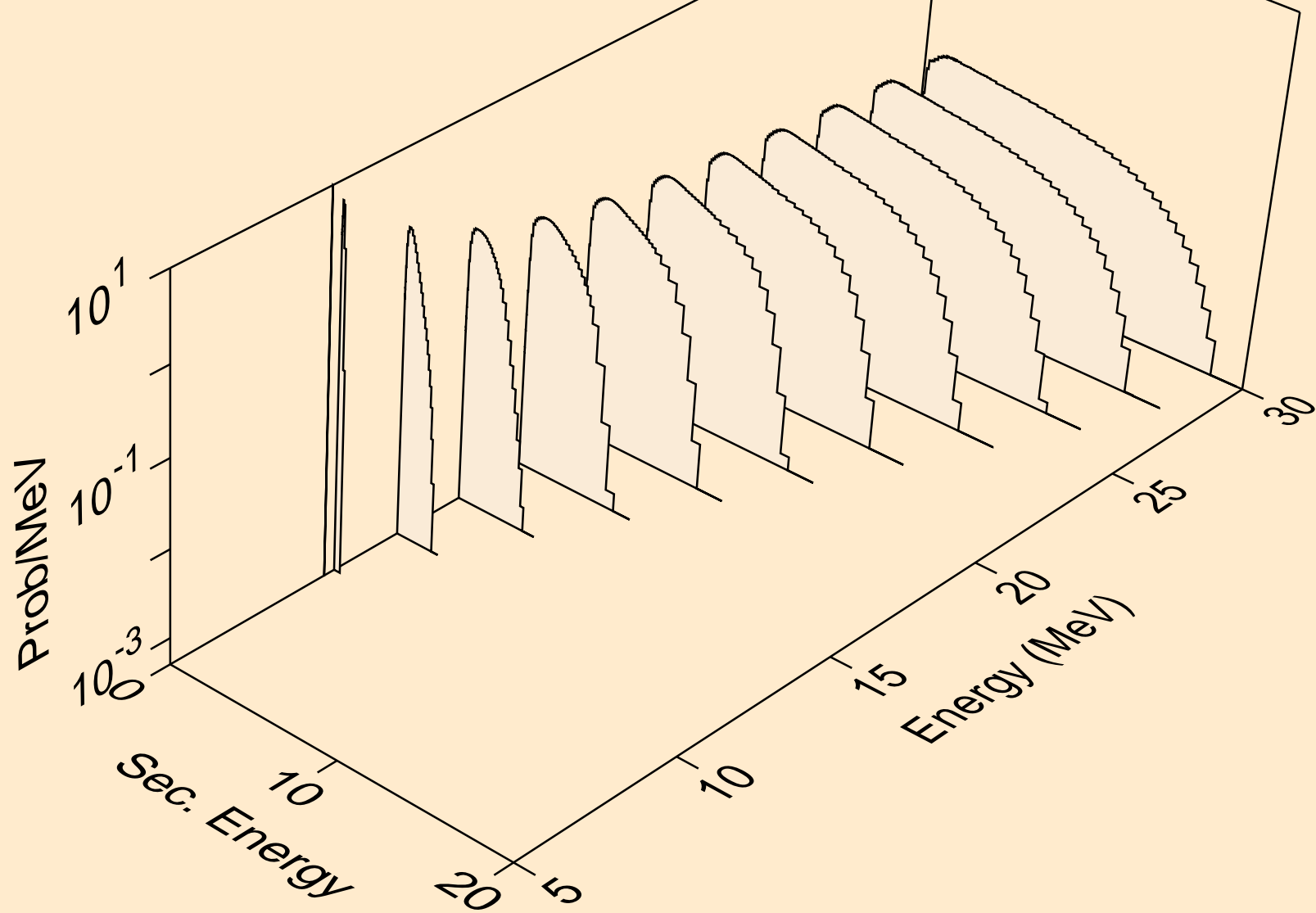

RF268 DEUTERON ACER TENDL-2023 LIBRARY; T=0.K  
neutrons from (d,n\*)p

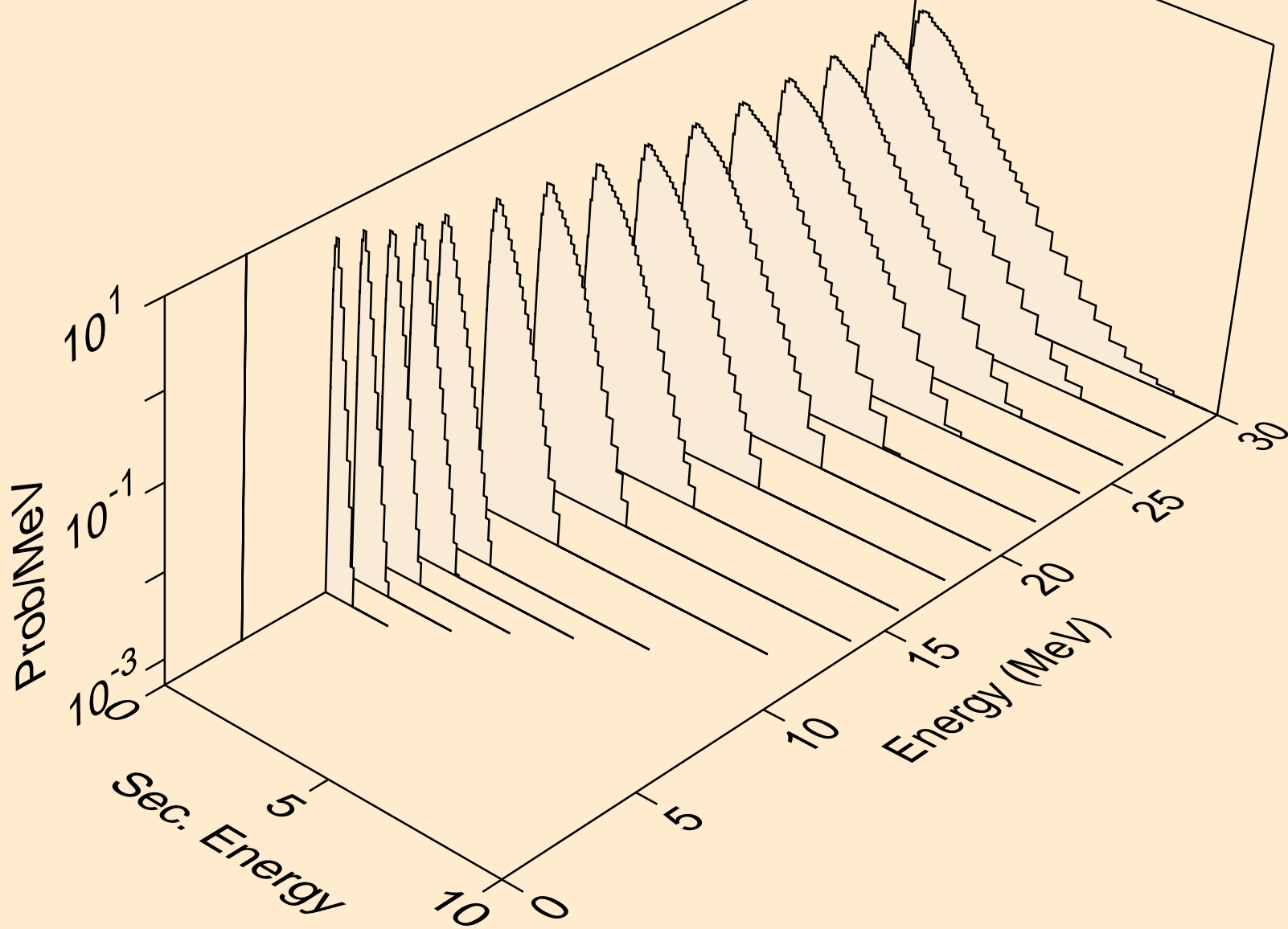

RF268 DEUTERON ACER TENDL-2023 LIBRARY; T=0.K  
neutrons from (d,n\*)d

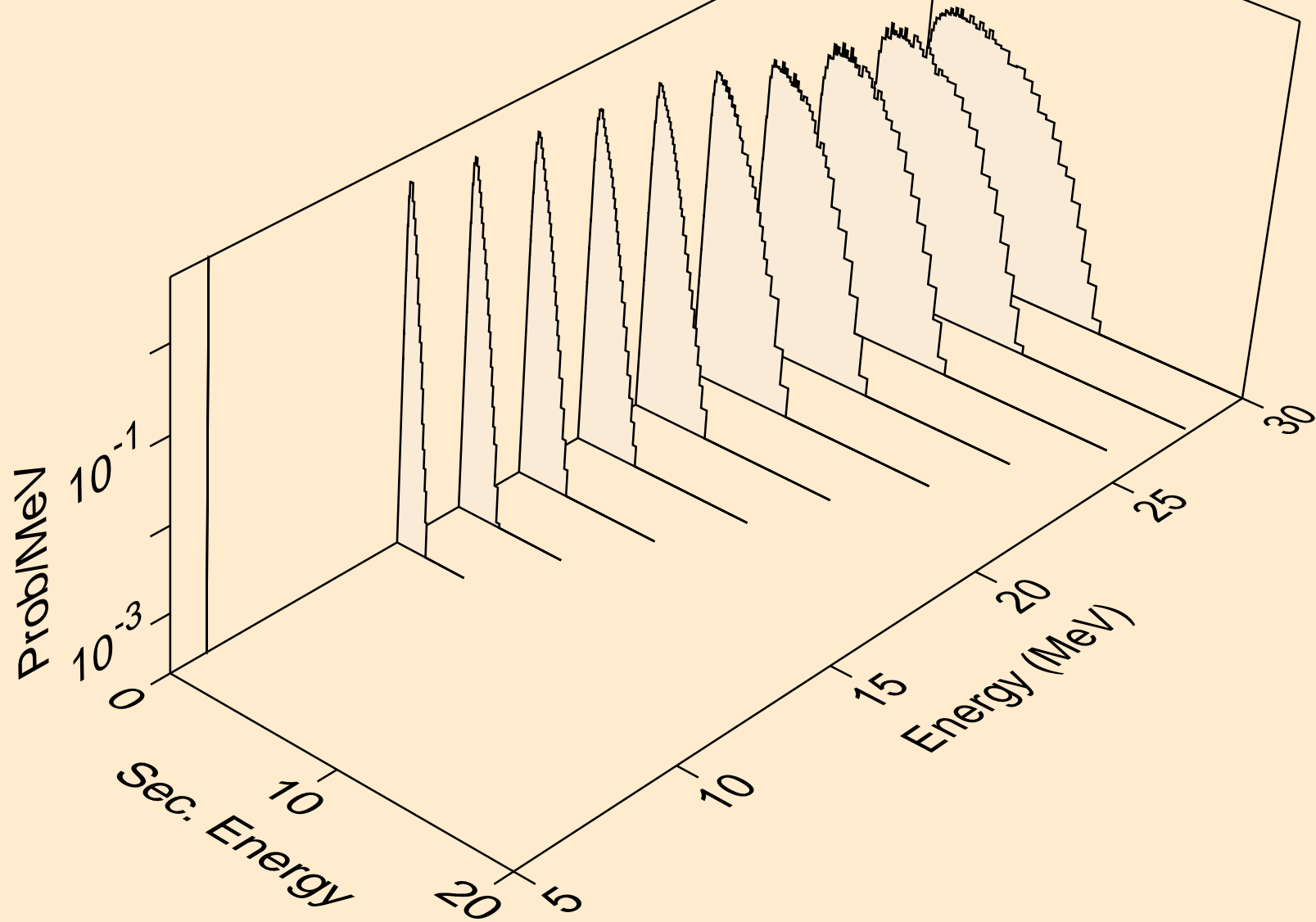

RF268 DEUTERON ACER TENDL-2023 LIBRARY; T=0.K  
neutrons from (d,n\*)t

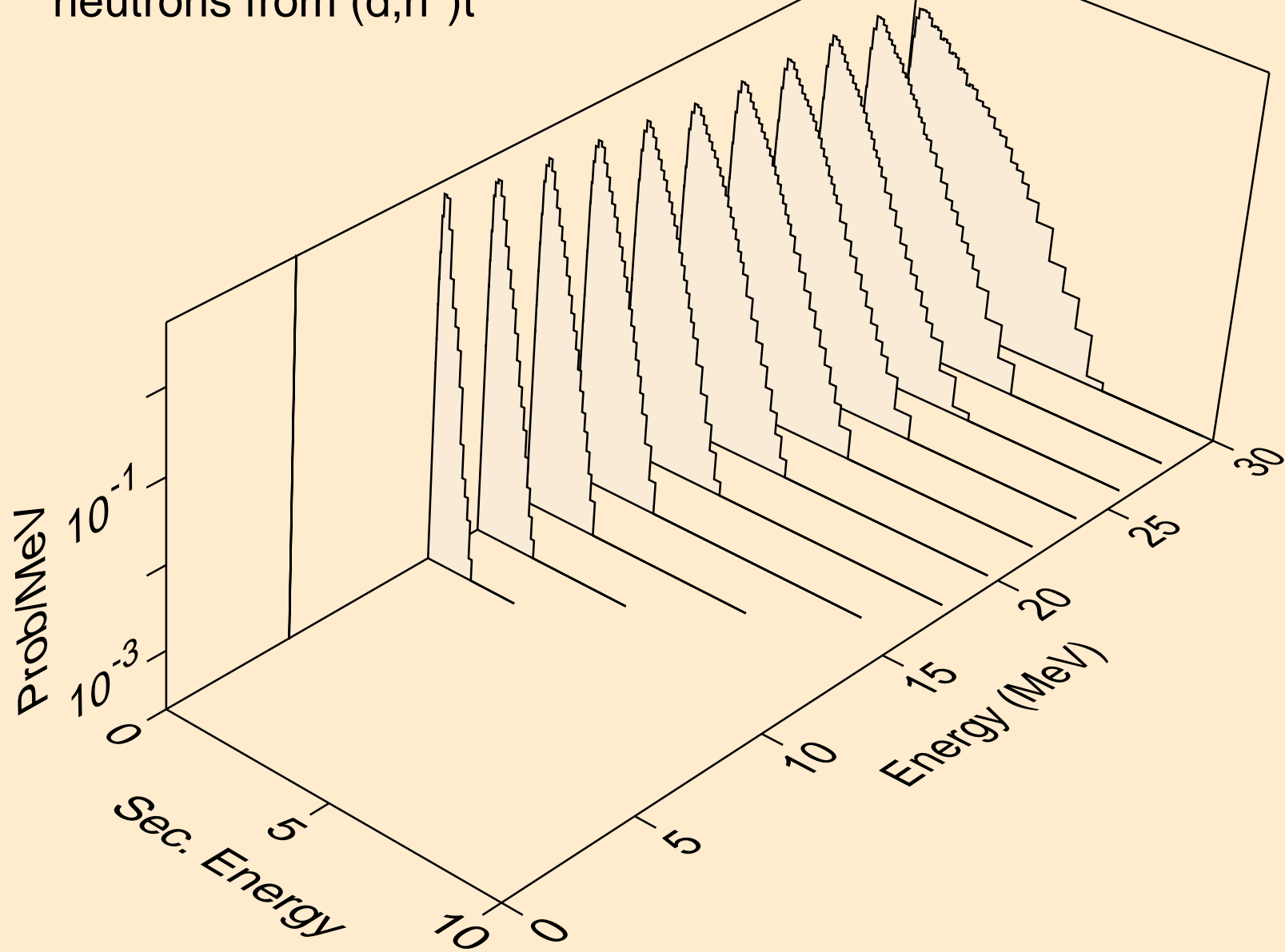

RF268 DEUTERON ACER TENDL-2023 LIBRARY; T=0.K  
neutrons from (d,4n)

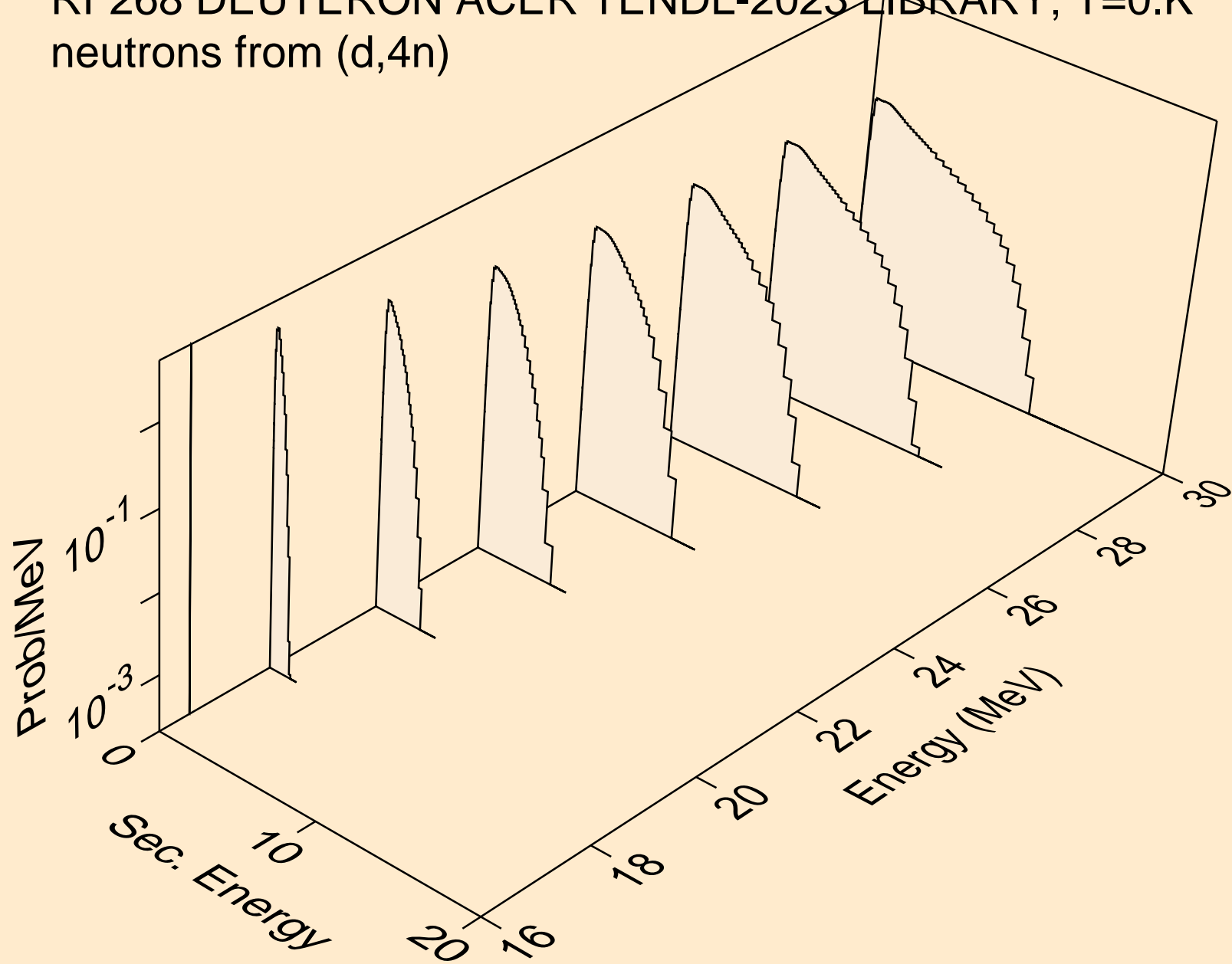

RF268 DEUTERON ACER TENDL-2023 LIBRARY; T=0.K  
neutrons from (d,2np)

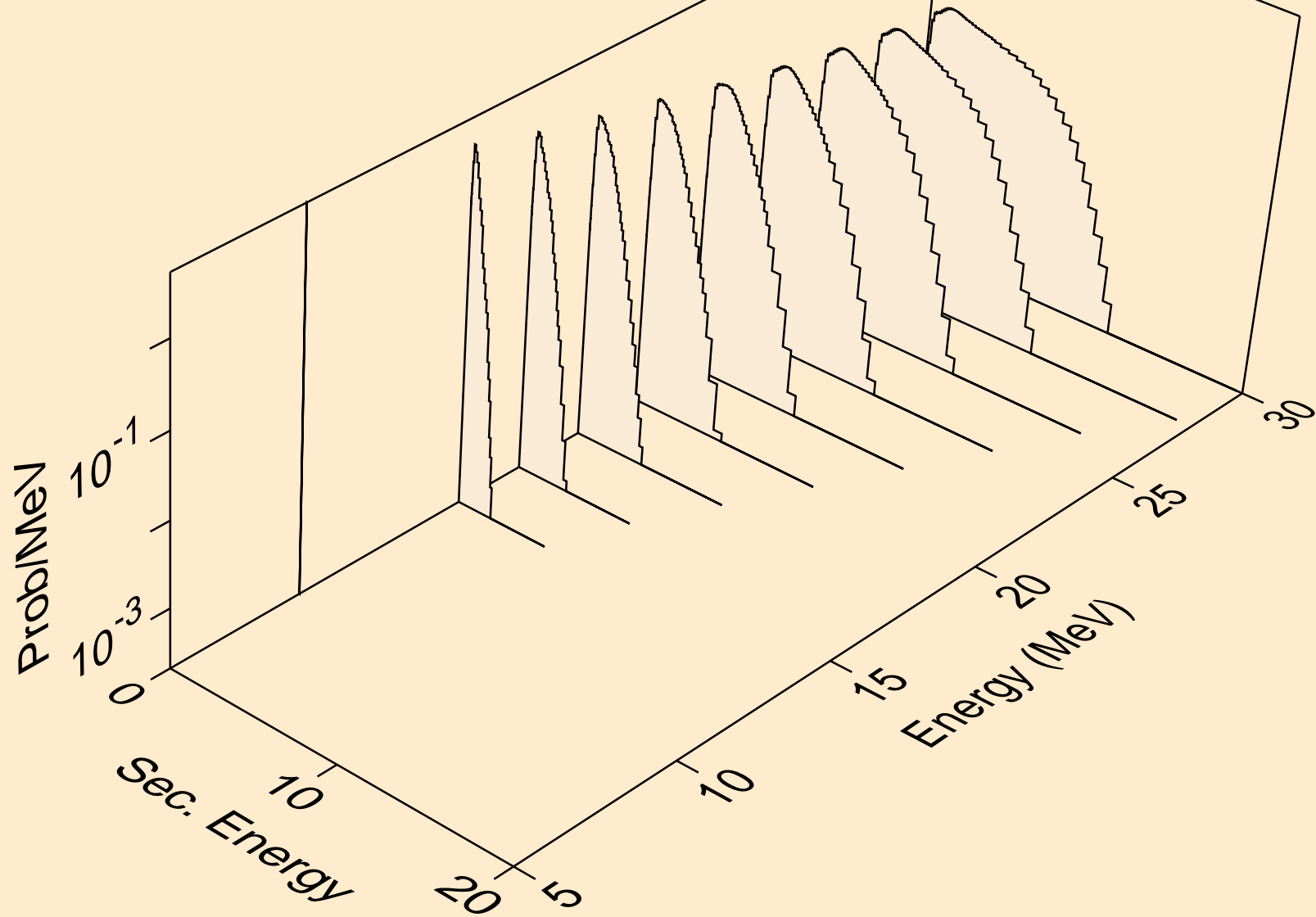

RF268 DEUTERON ACER TENDL-2023 LIBRARY; T=0.K  
neutrons from (d,3np)

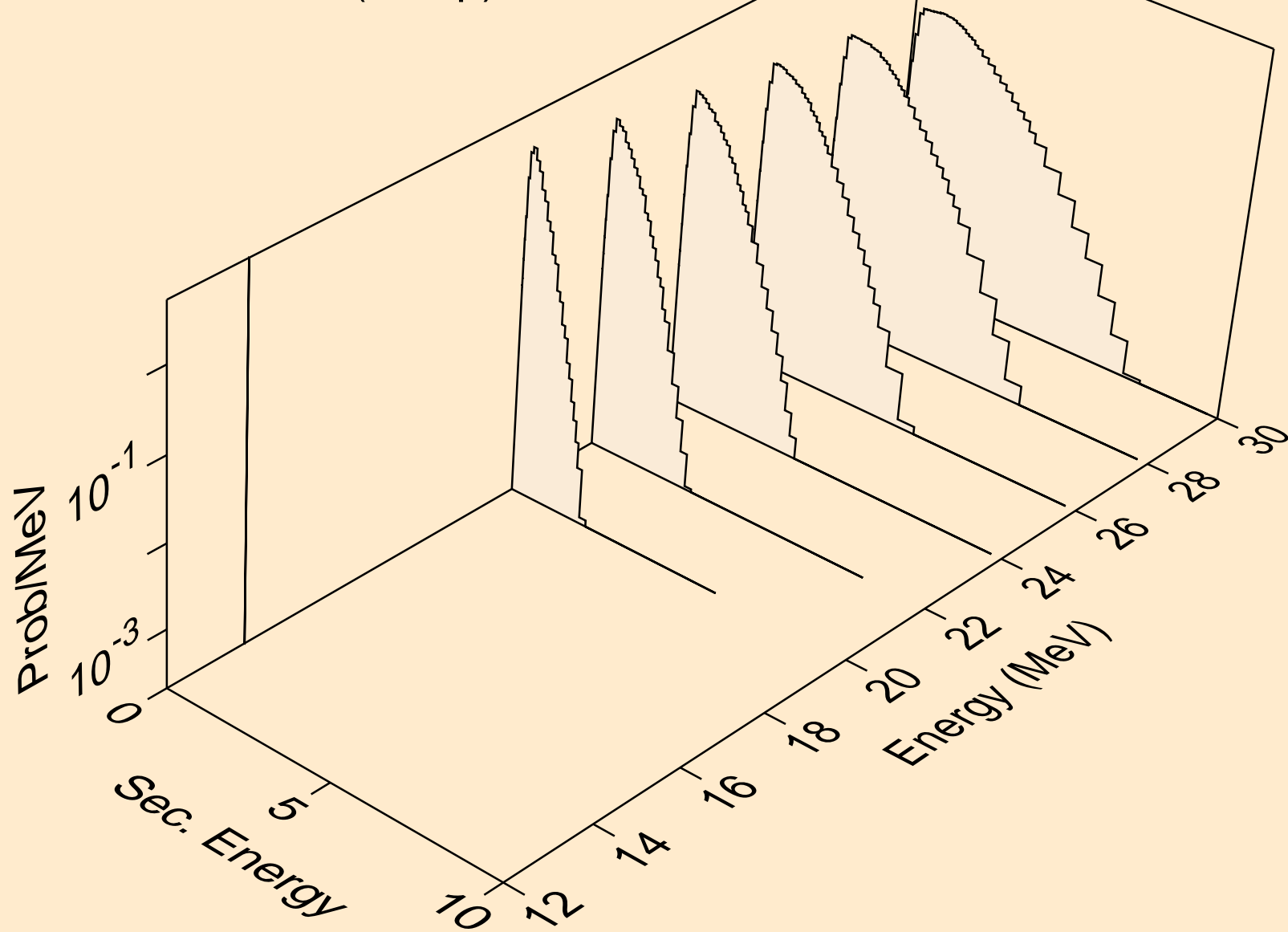

RF268 DEUTERON ACER TENDL-2023 LIBRARY; T=0.K  
protons from (d,x)

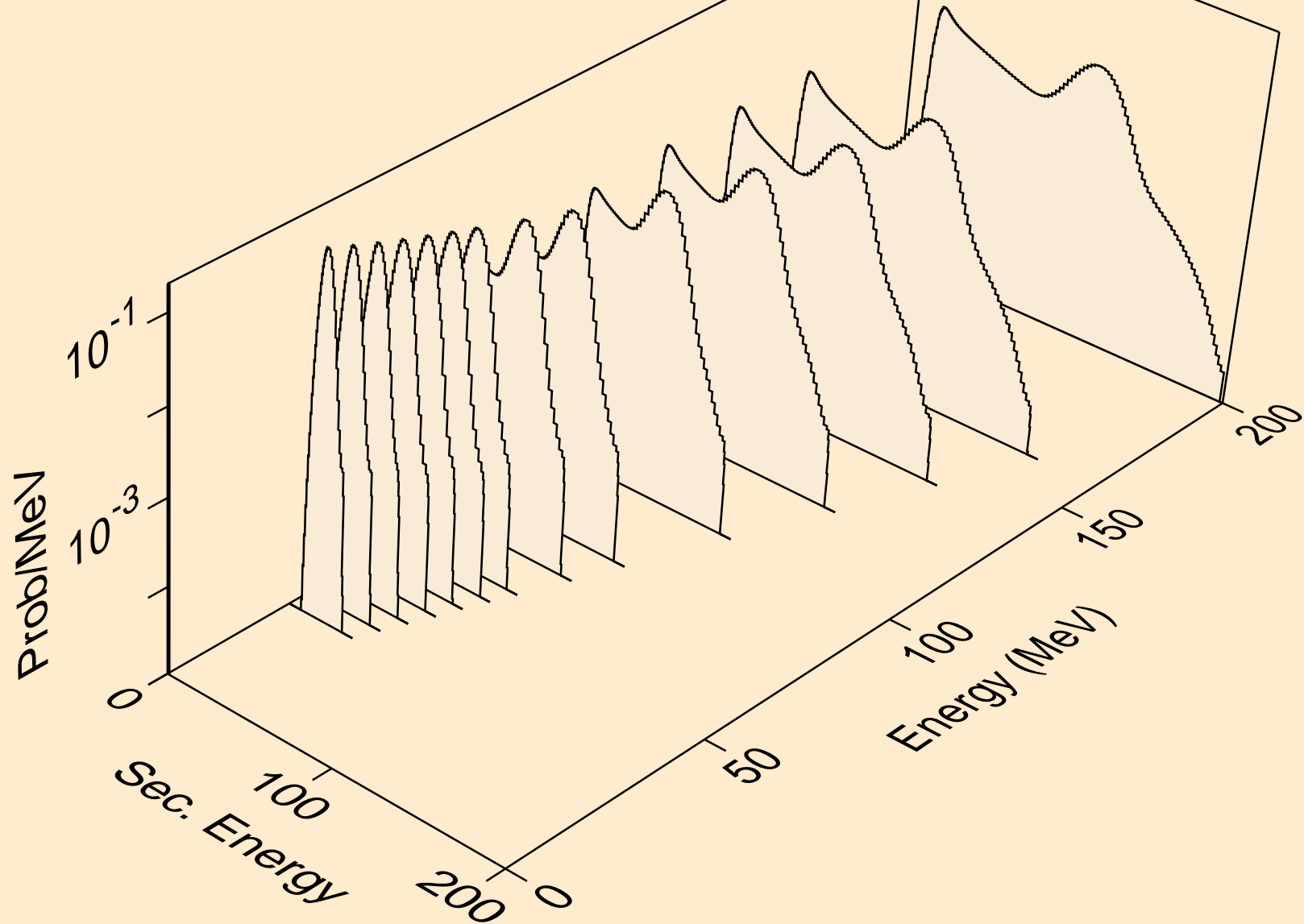



RF268 DEUTERON ACER TENDL-2023 LIBRARY; T=0.K  
protons from (d,n\*)p

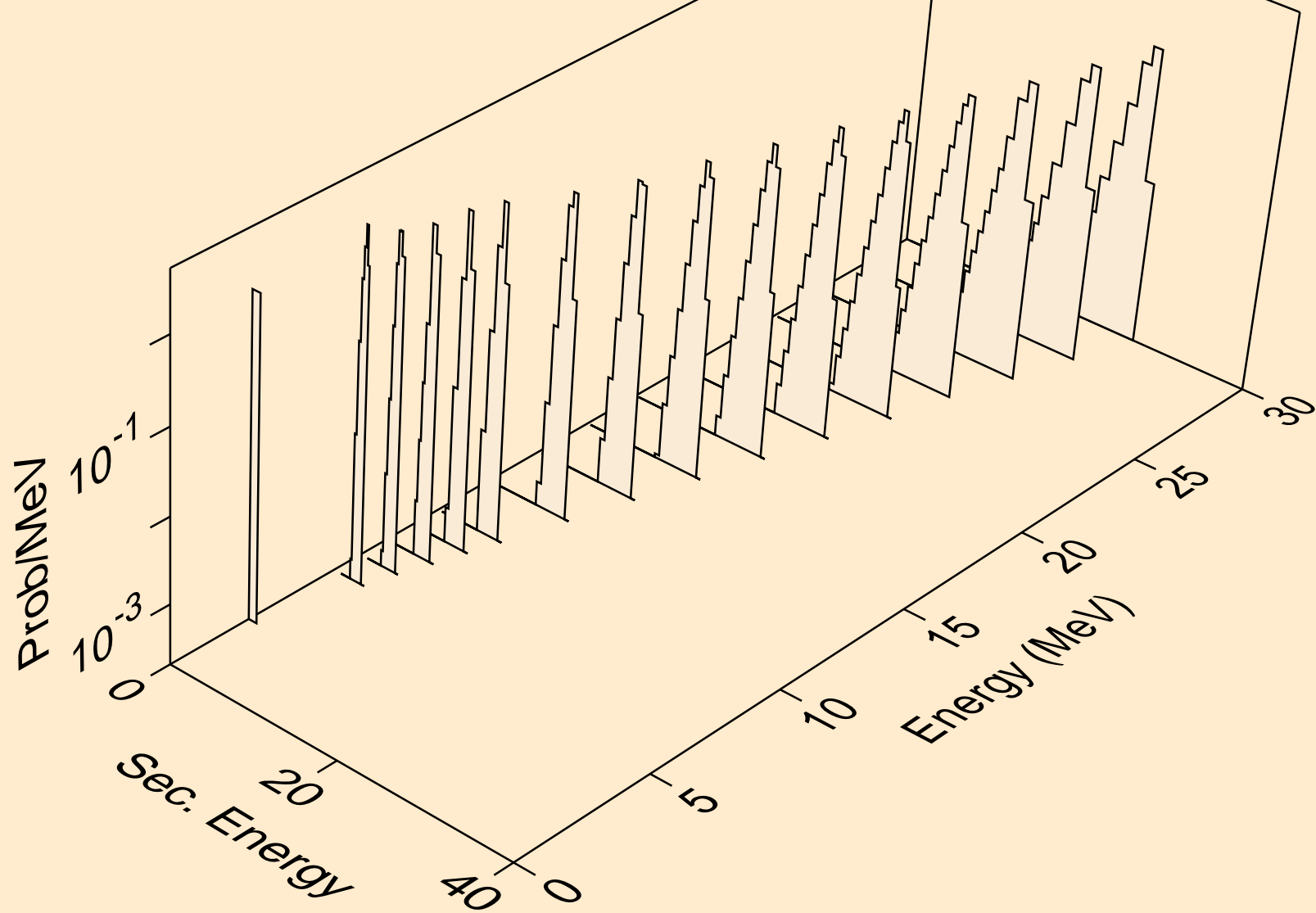

RF268 DEUTERON ACER TENDL-2023 LIBRARY; T=0.K  
protons from (d,2np)

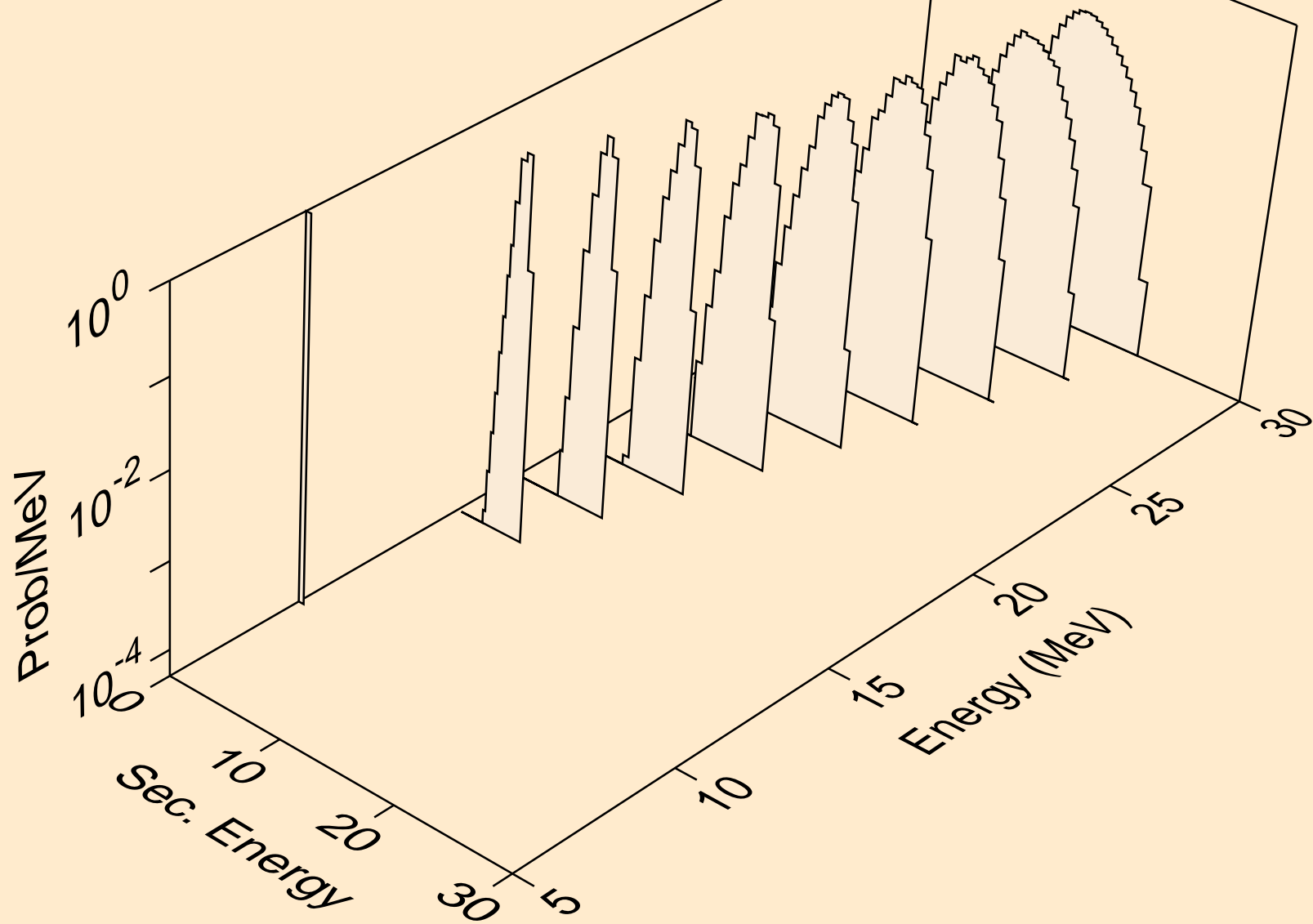

RF268 DEUTERON ACER TENDL-2023 LIBRARY; T=0.K  
protons from (d,3np)

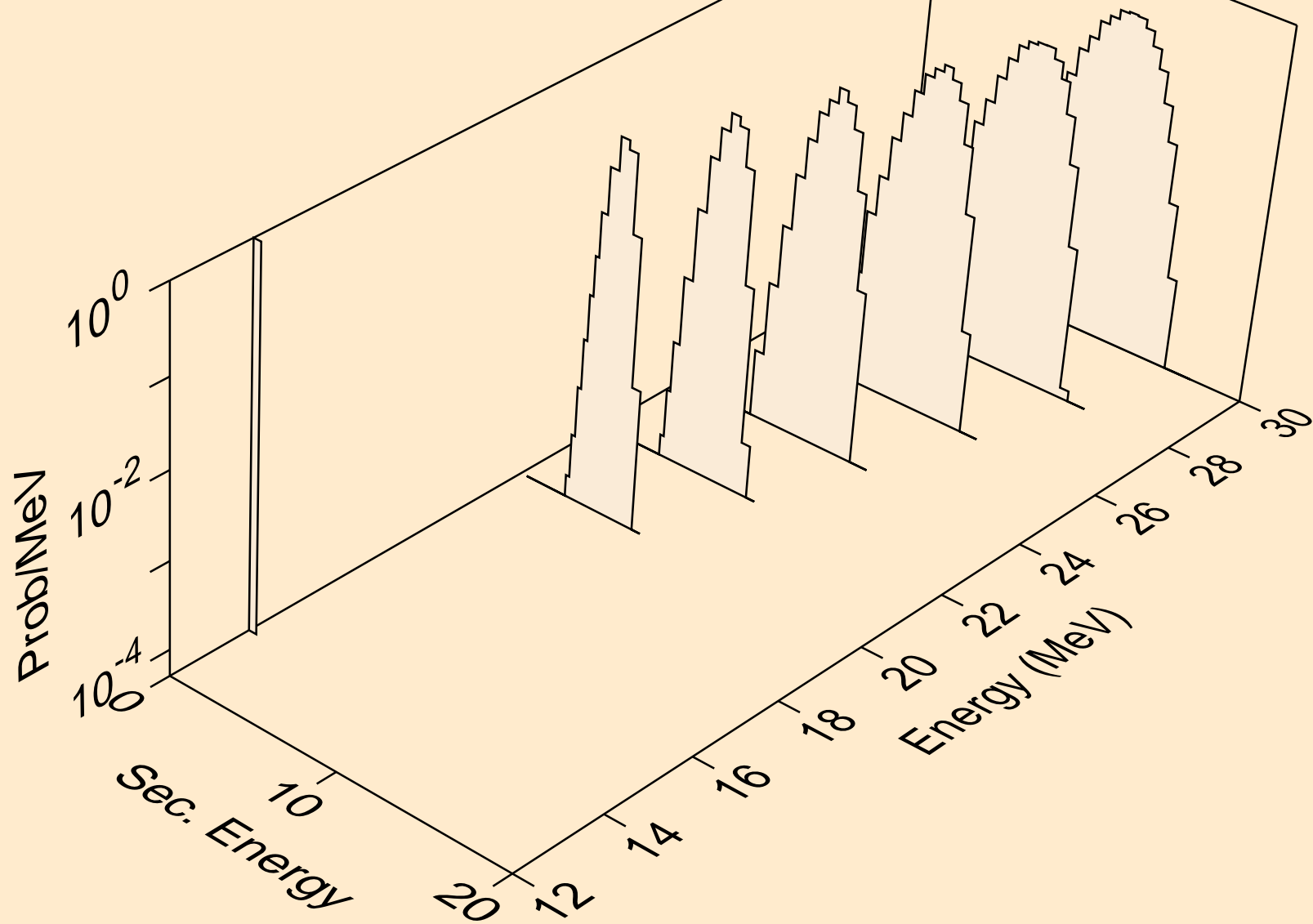

RF268 DEUTERON ACER TENDL-2023 LIBRARY; T=0.K  
protons from (d,p)

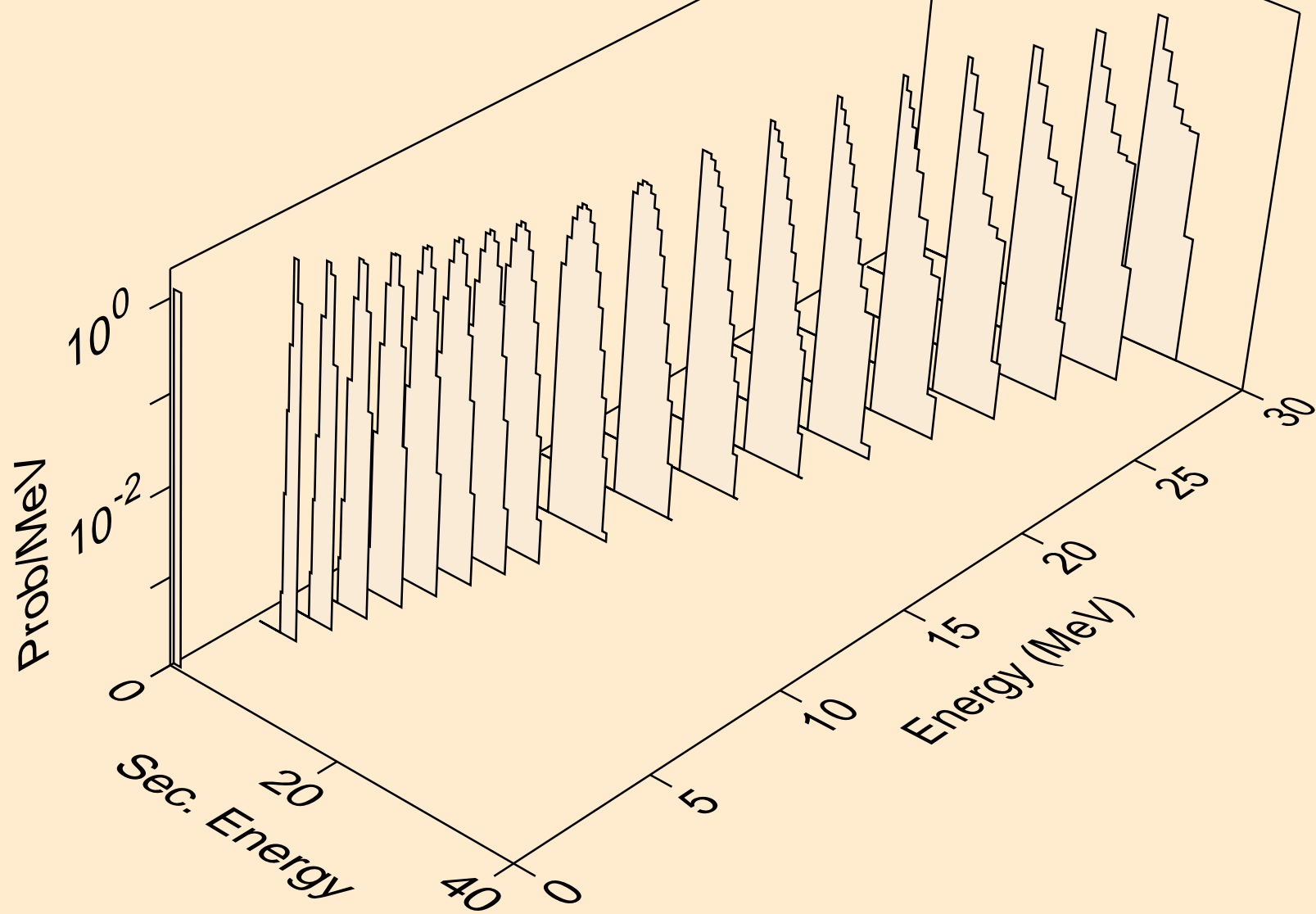

RF268 DEUTERON ACER TENDL-2023 LIBRARY; T=0.K  
protons from (d,2p)

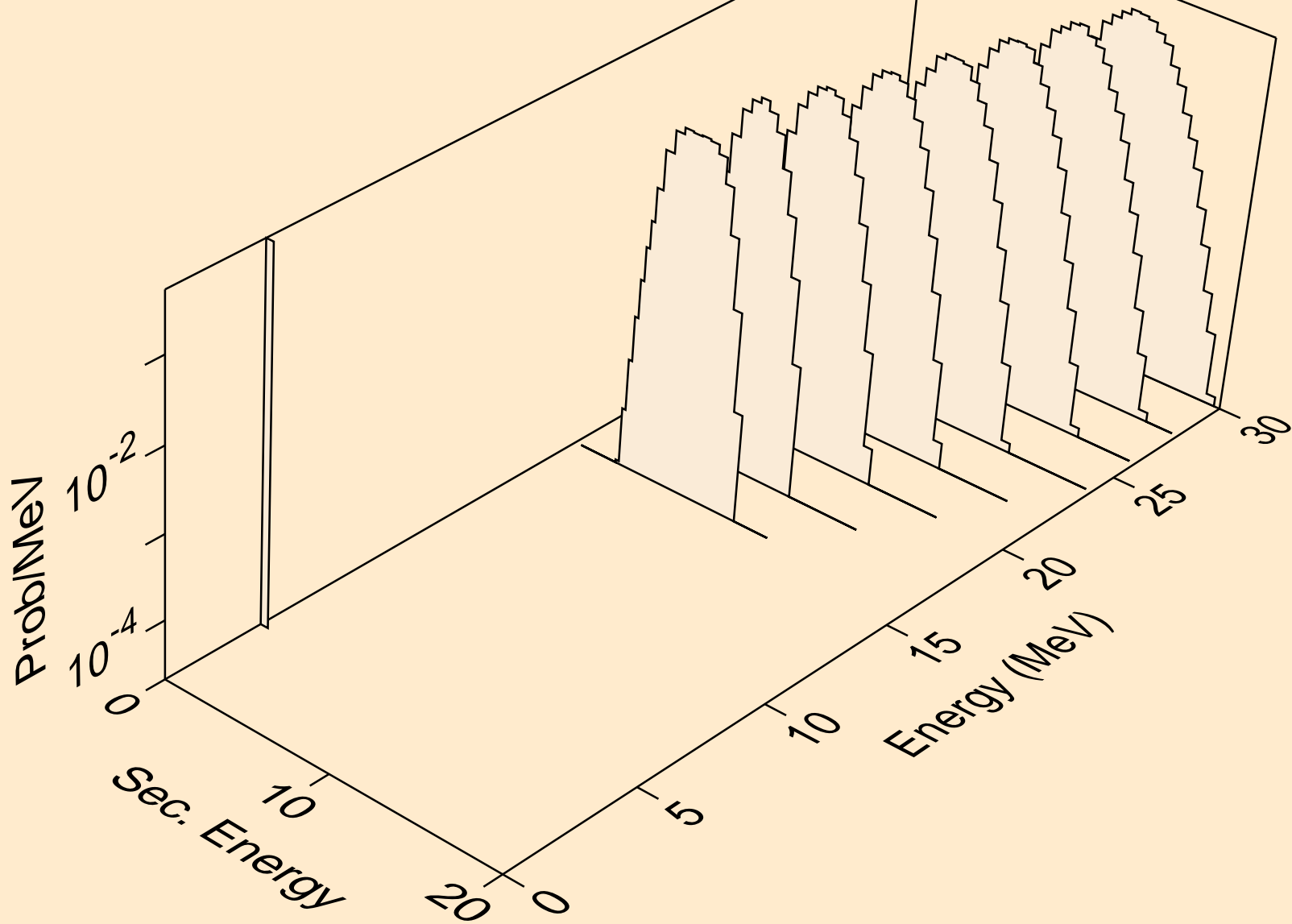

RF268 DEUTERON ACER TENDL-2023 LIBRARY; T=0.K  
protons from (d,pd)

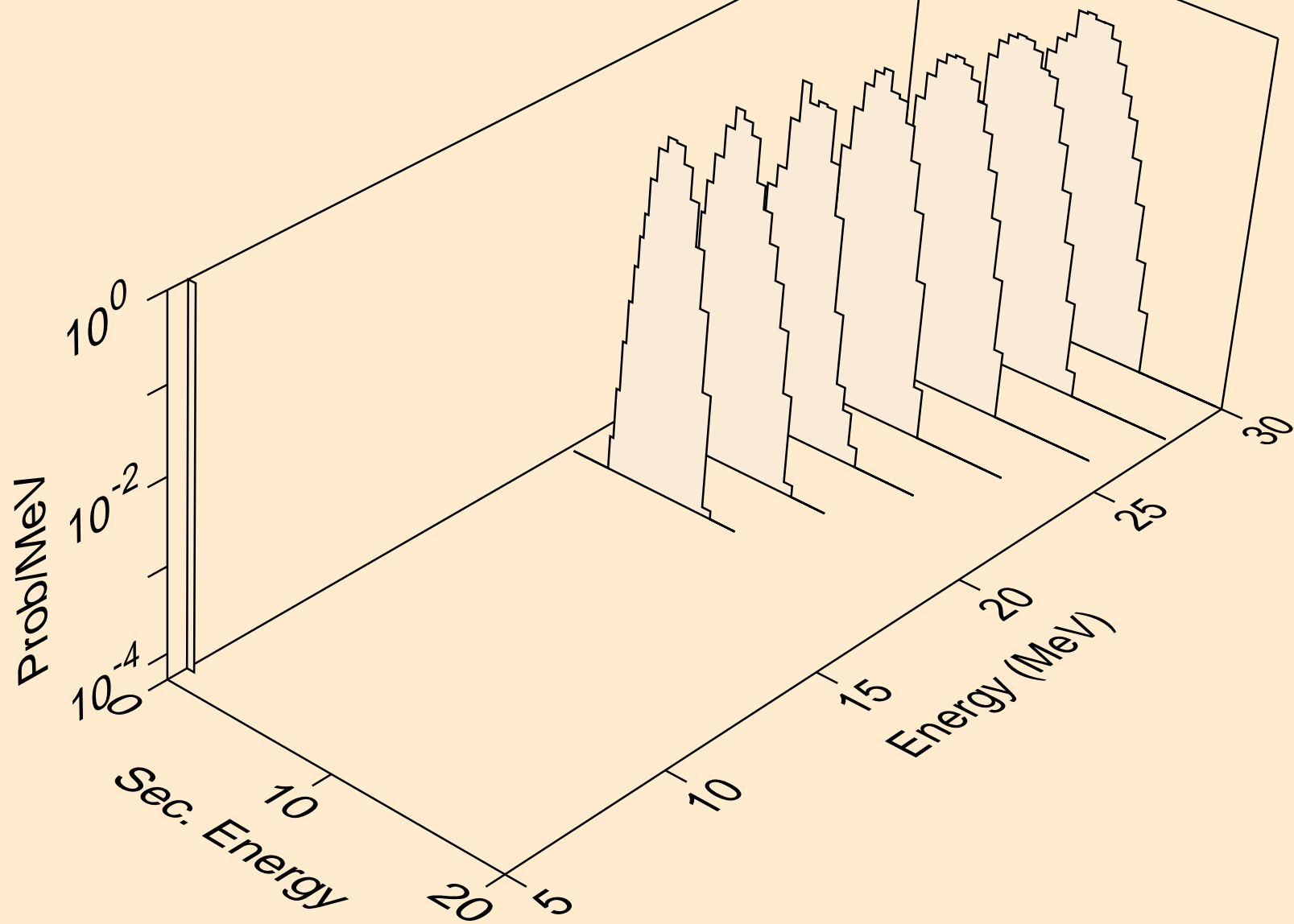

RF268 DEUTERON ACER TENDL-2023 LIBRARY; T=0.K  
tritons from (d,x)

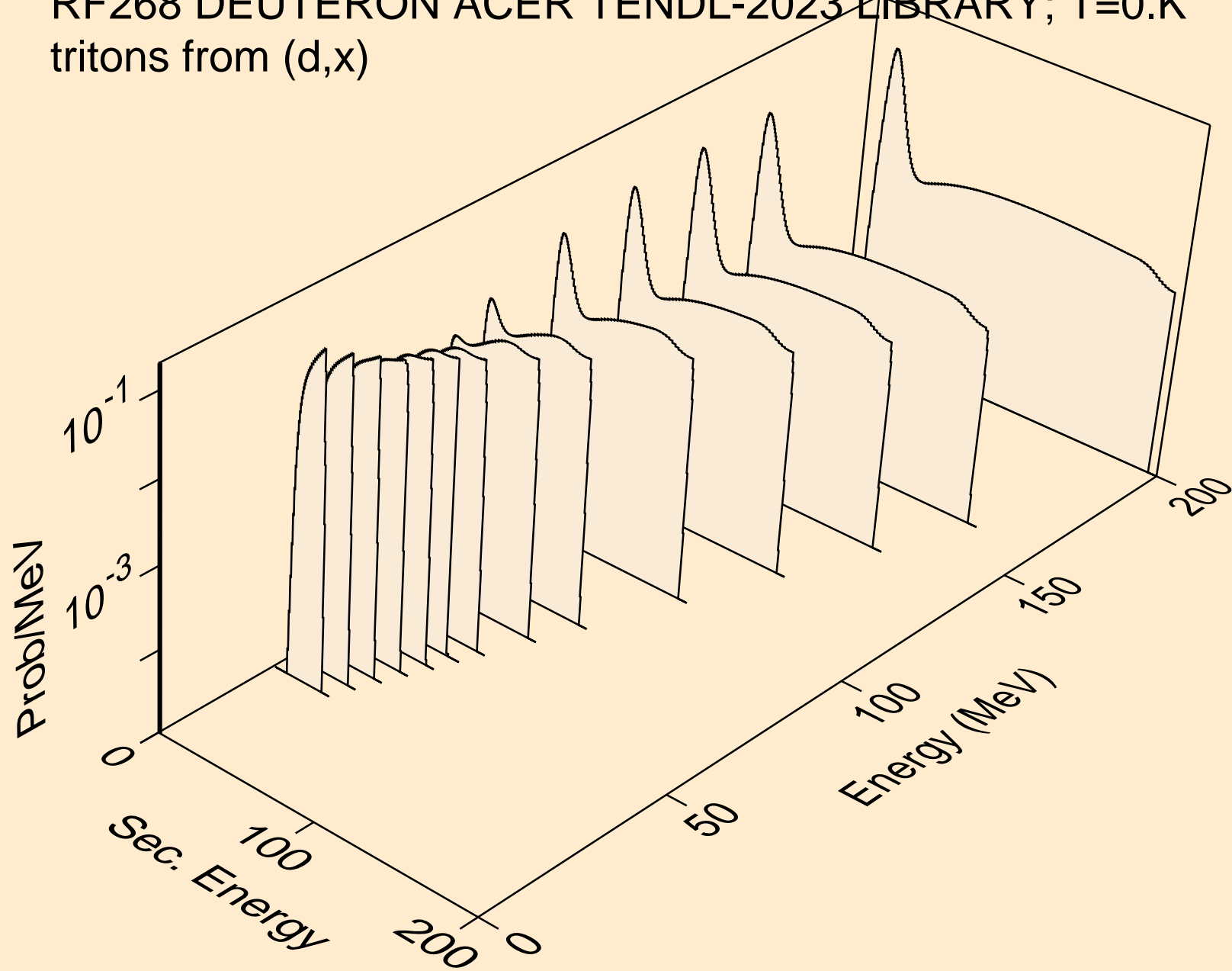

RF268 DEUTERON ACER TENDL-2023 LIBRARY; T=0.K  
tritons from (d,n\*)t

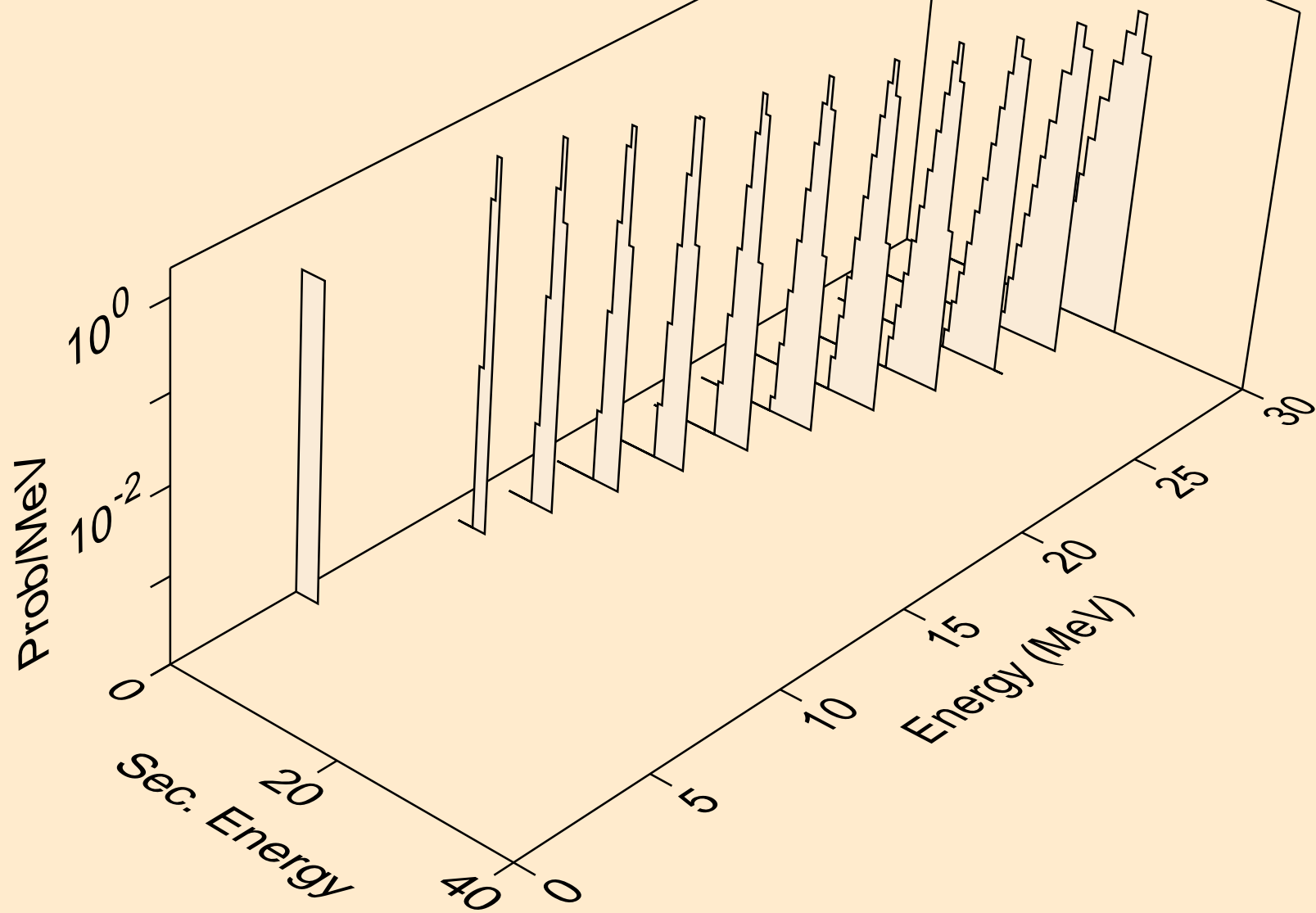



RF268 DEUTERON ACER TENDL-2023 LIBRARY; T=0.K  
tritons from (d,t)

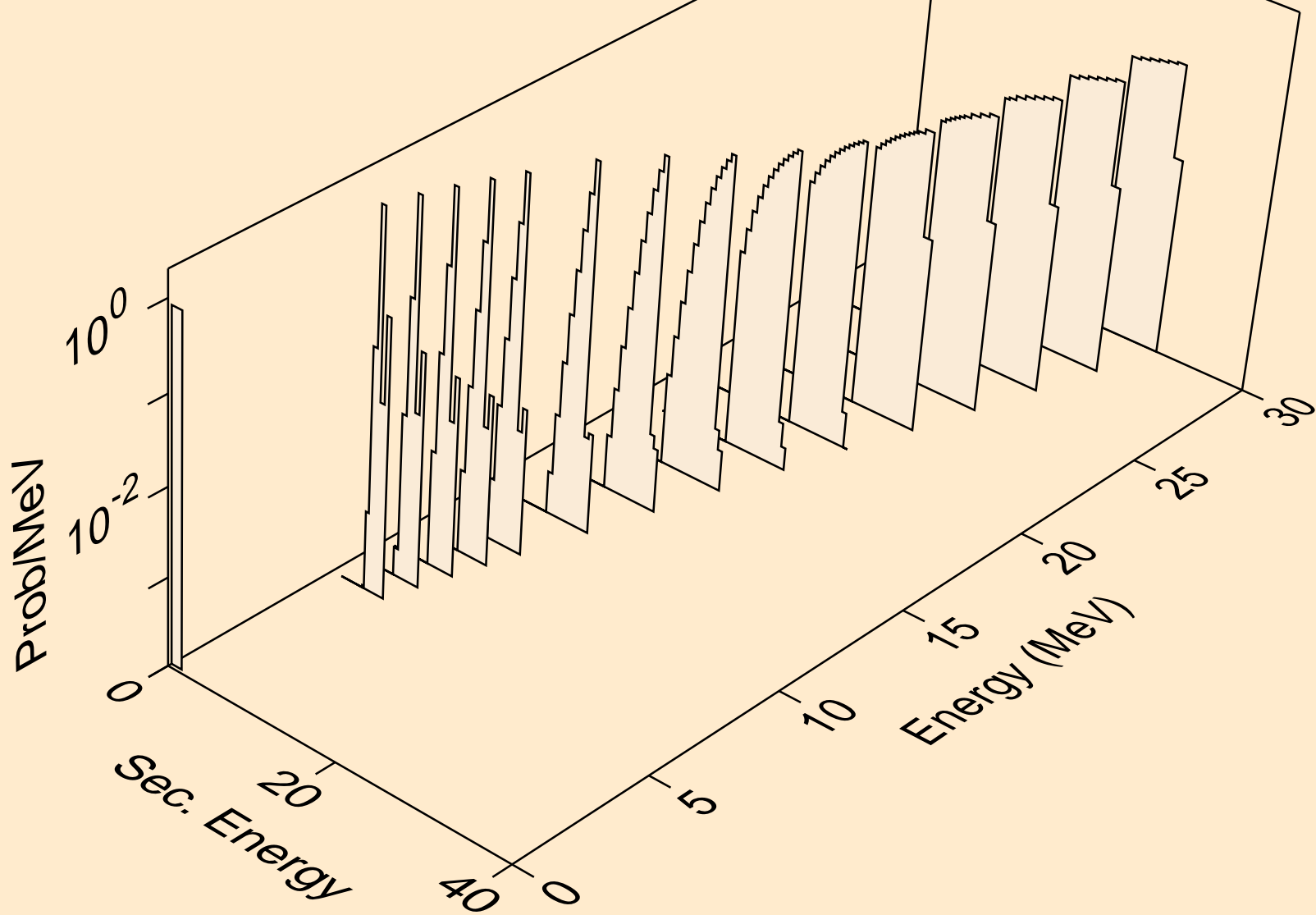

RF268 DEUTERON ACER TENDL-2023 LIBRARY; T=0.K  
he3s from (d,x)

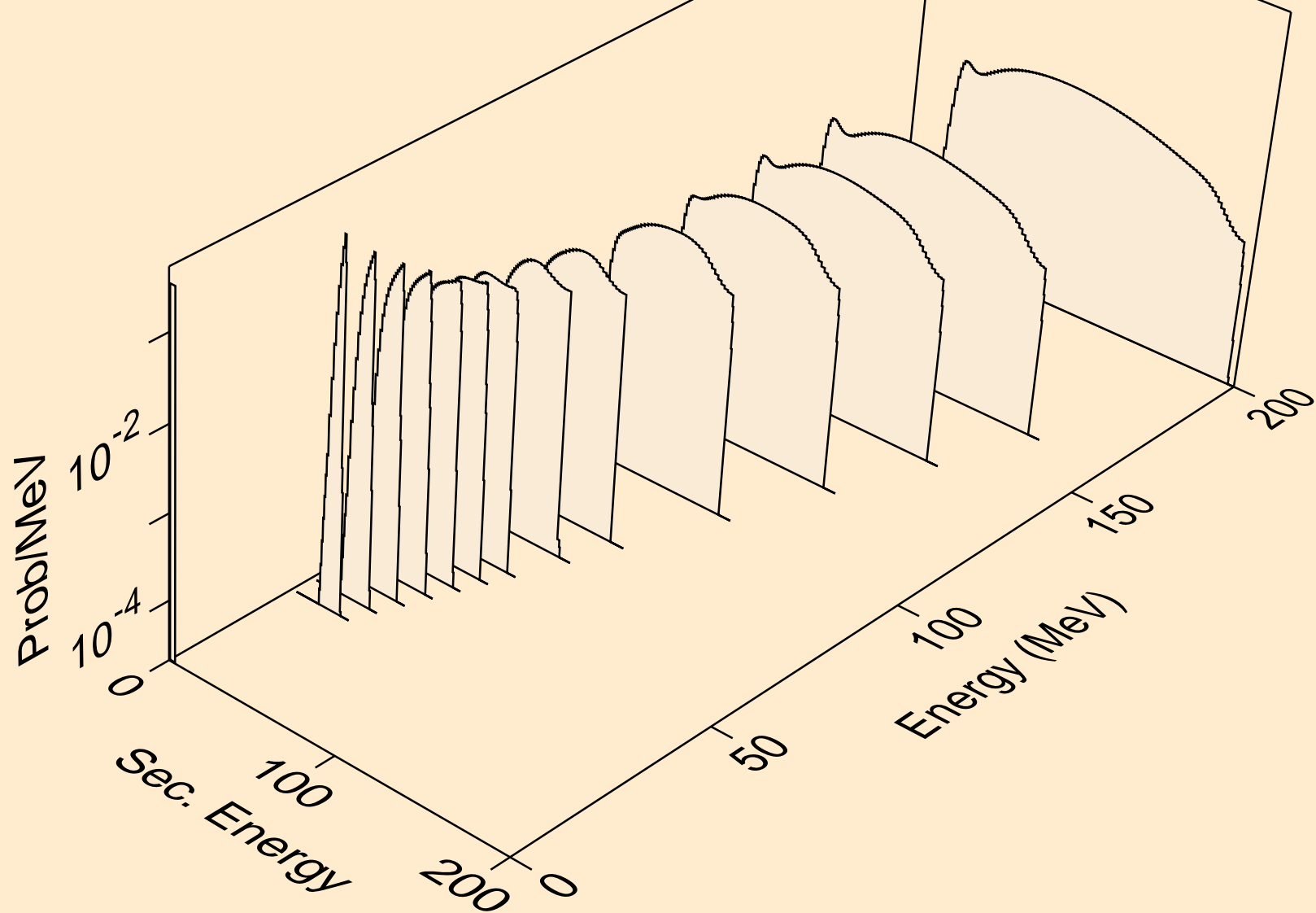

RF268 DEUTERON ACER TENDL-2023 LIBRARY; T=0.K  
he3s from (d,he3)

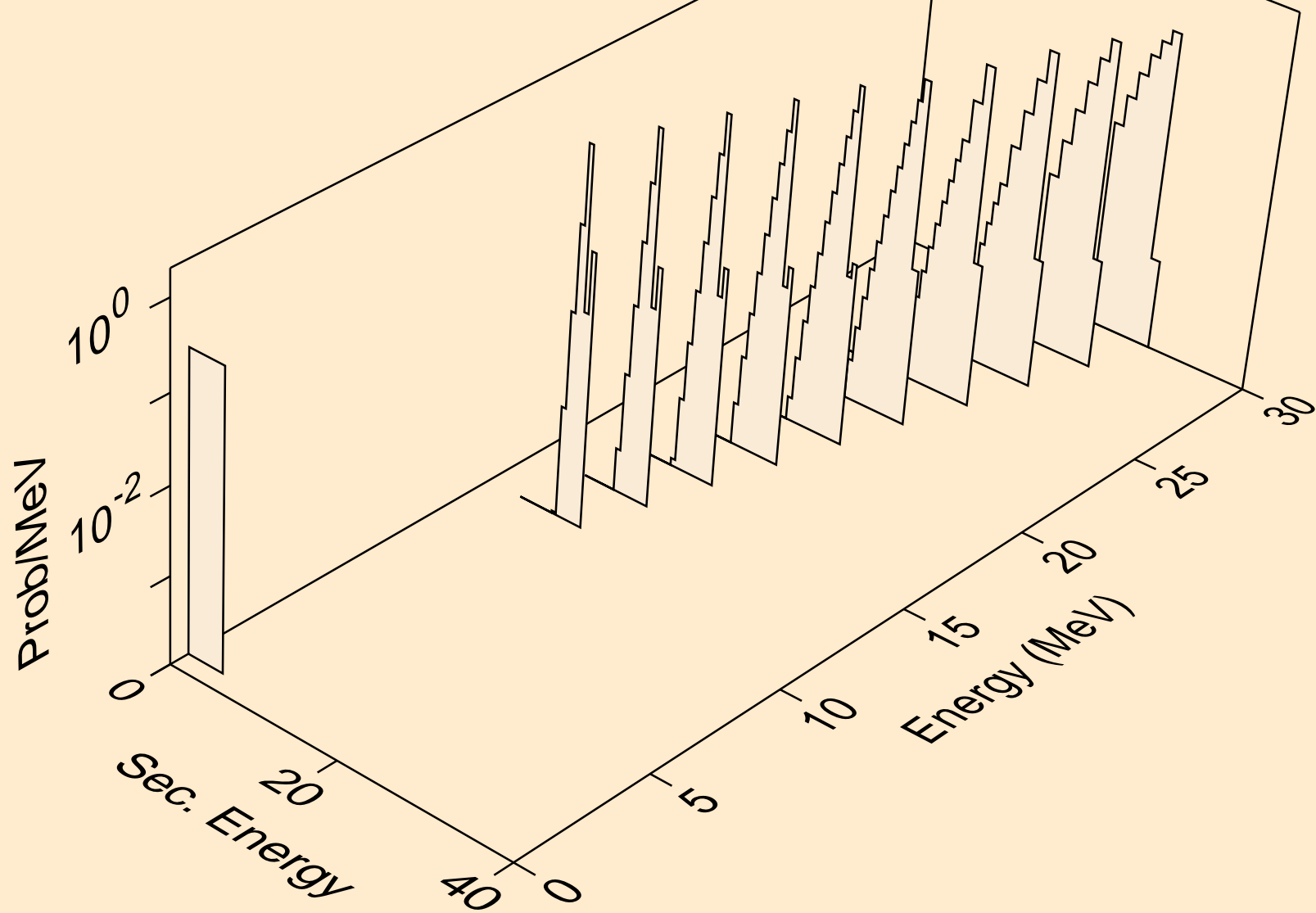

RF268 DEUTERON ACER TENDL-2023 LIBRARY; T=0.K  
alphas from (d,x)

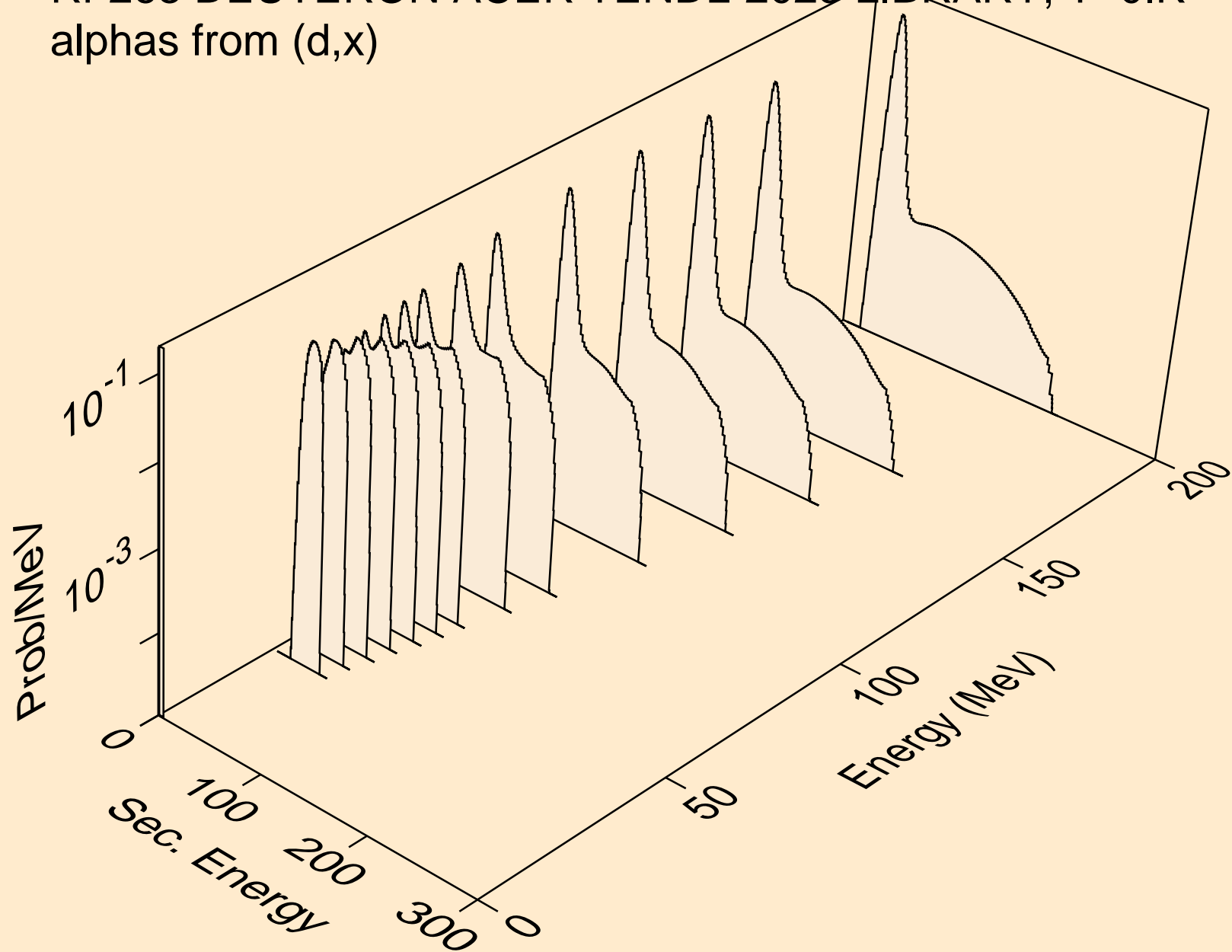

RF268 DEUTERON ACER TENDL-2023 LIBRARY; T=0.K  
alphas from (d,a)

