

# TL218 DEUTERON ACER TENDL-2023 LIBRARY; T=0.K

## Principal cross sections

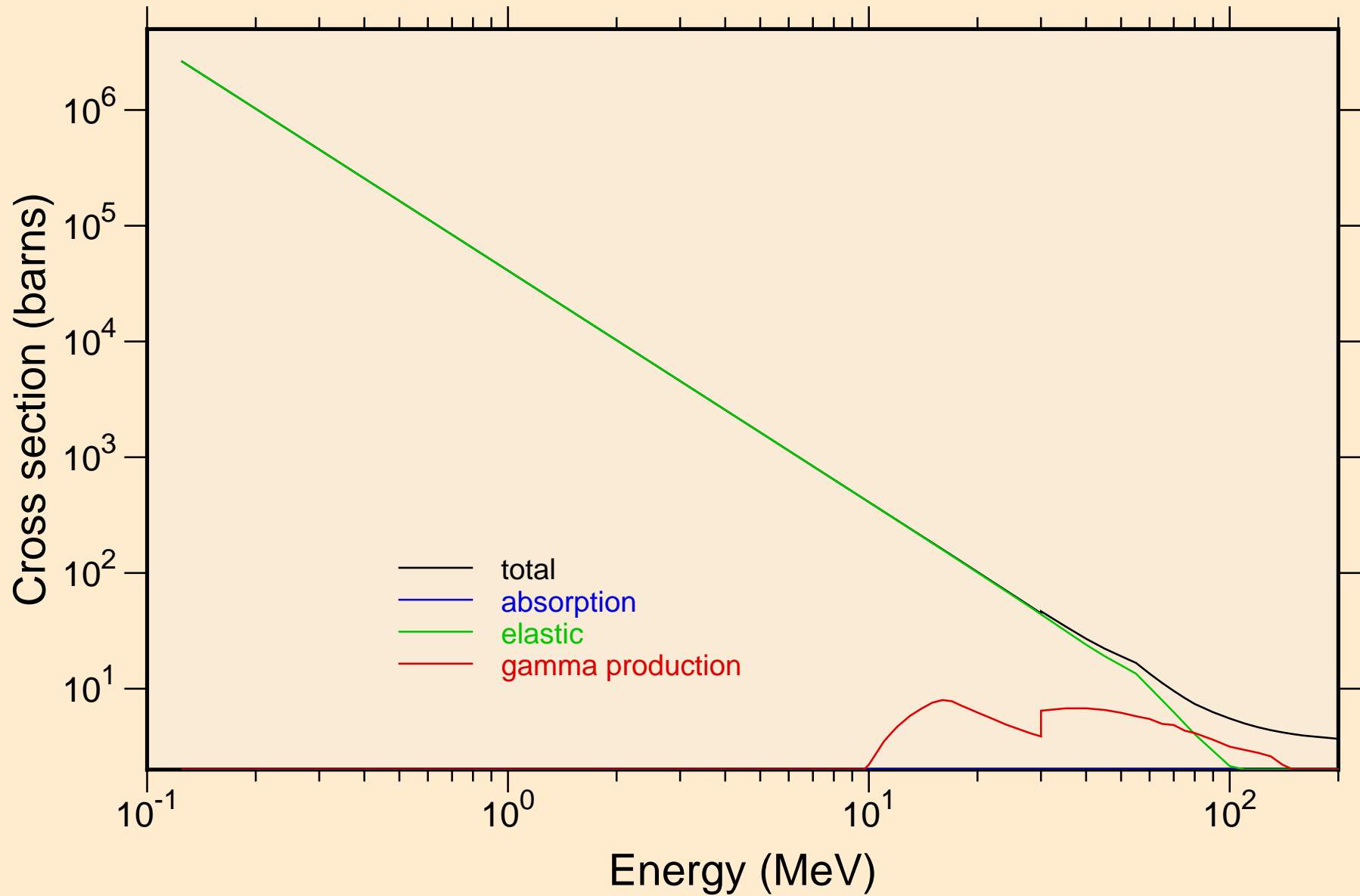

# TL218 DEUTERON ACER TENDL-2023 LIBRARY; T=0.K

## Heating

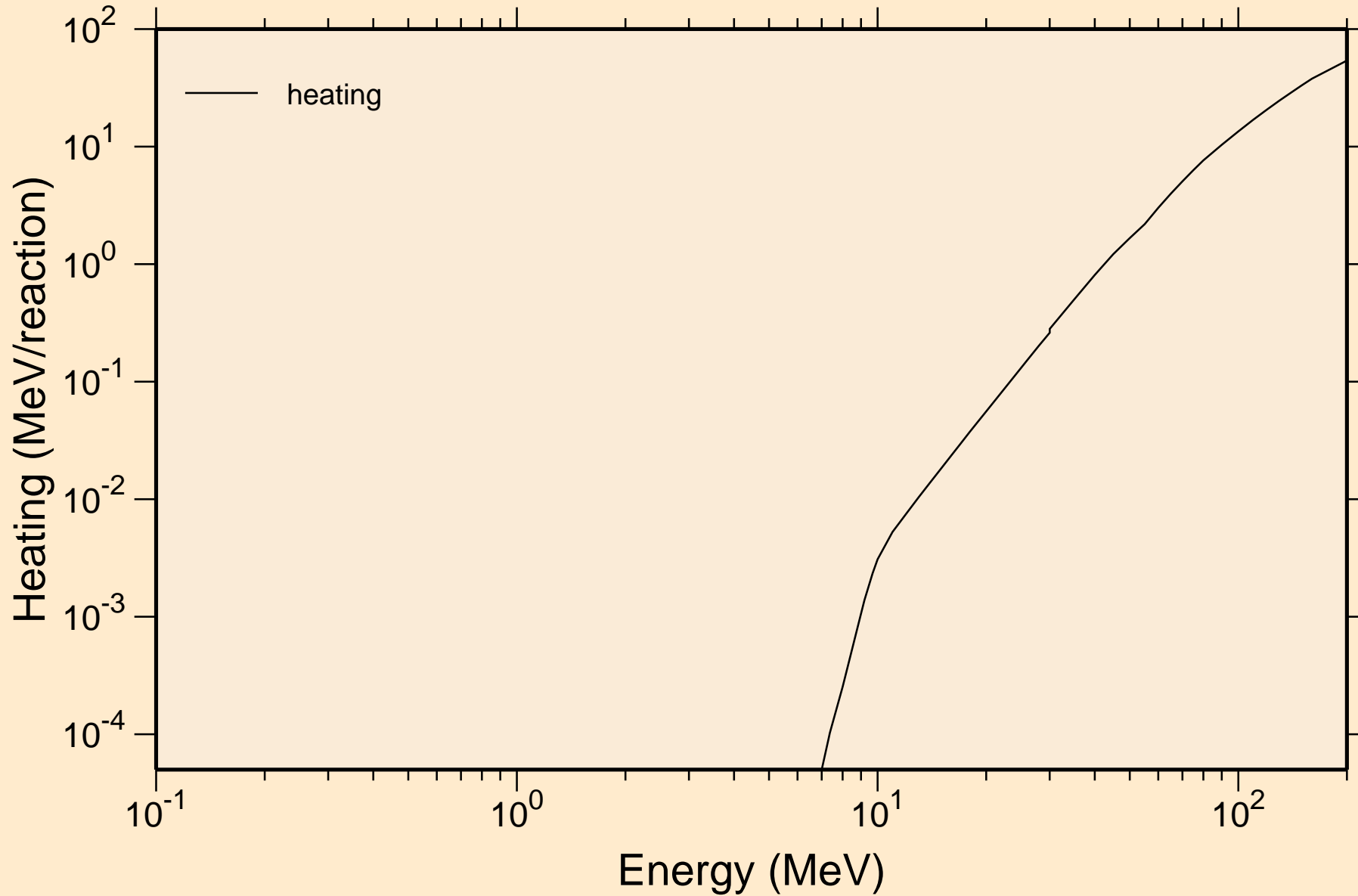

# TL218 DEUTERON ACER TENDL-2023 LIBRARY; T=0.K

## Principal cross sections

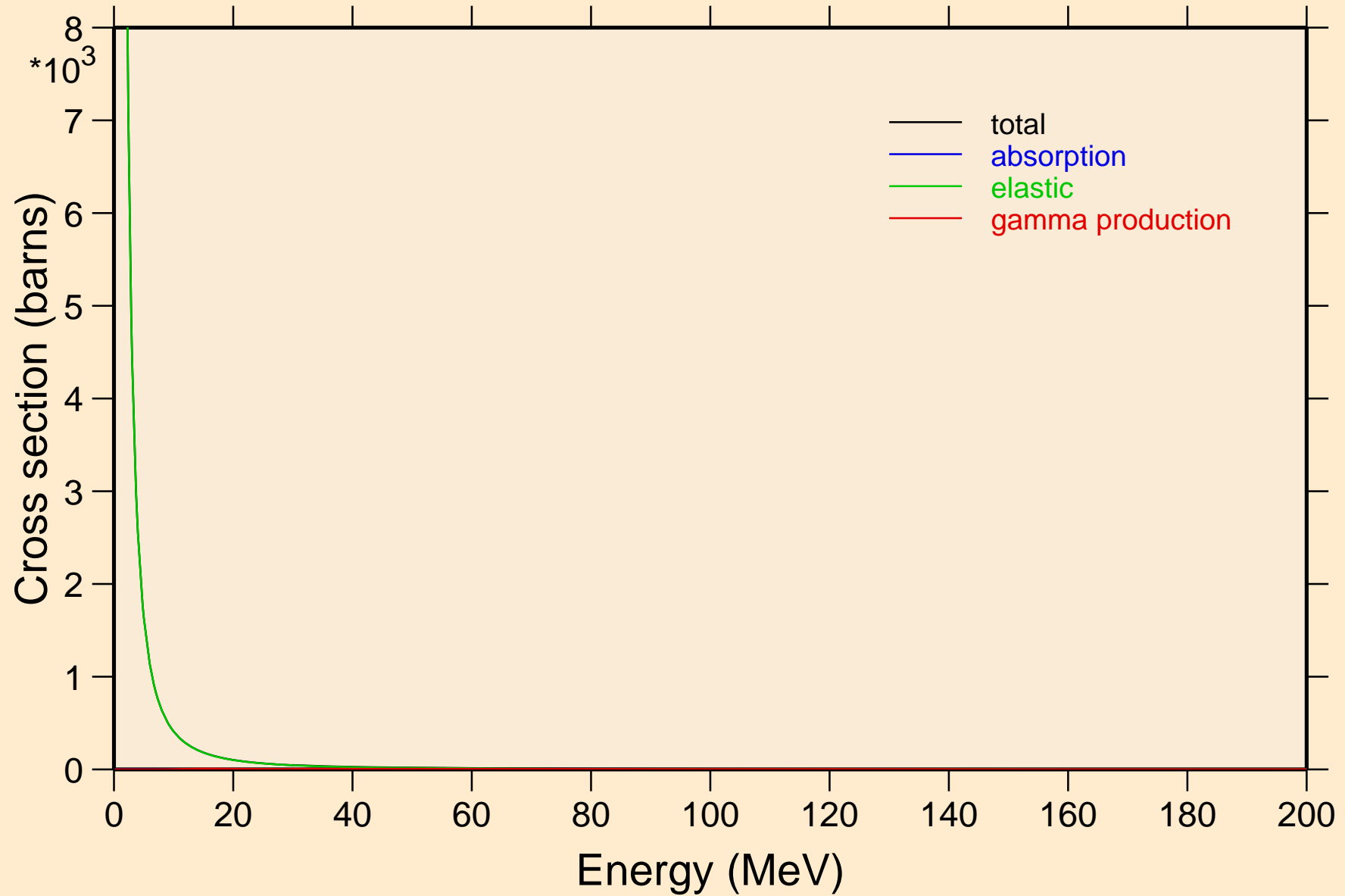

TL218 DEUTERON ACER TENDL-2023 LIBRARY; T=0.K

Heating

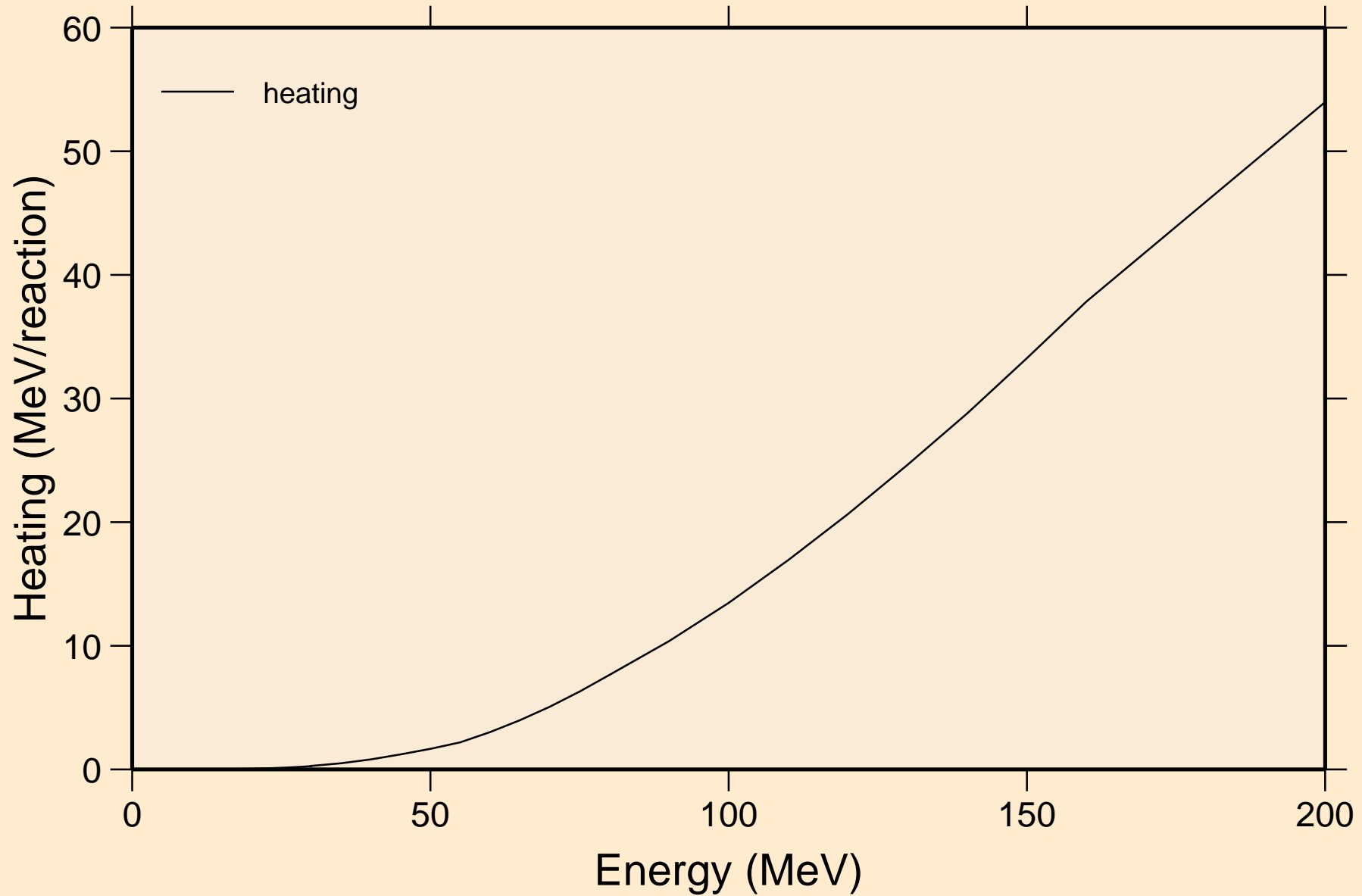

TL218 DEUTERON ACER TENDL-2023 LIBRARY; T=0.K  
Threshold reactions

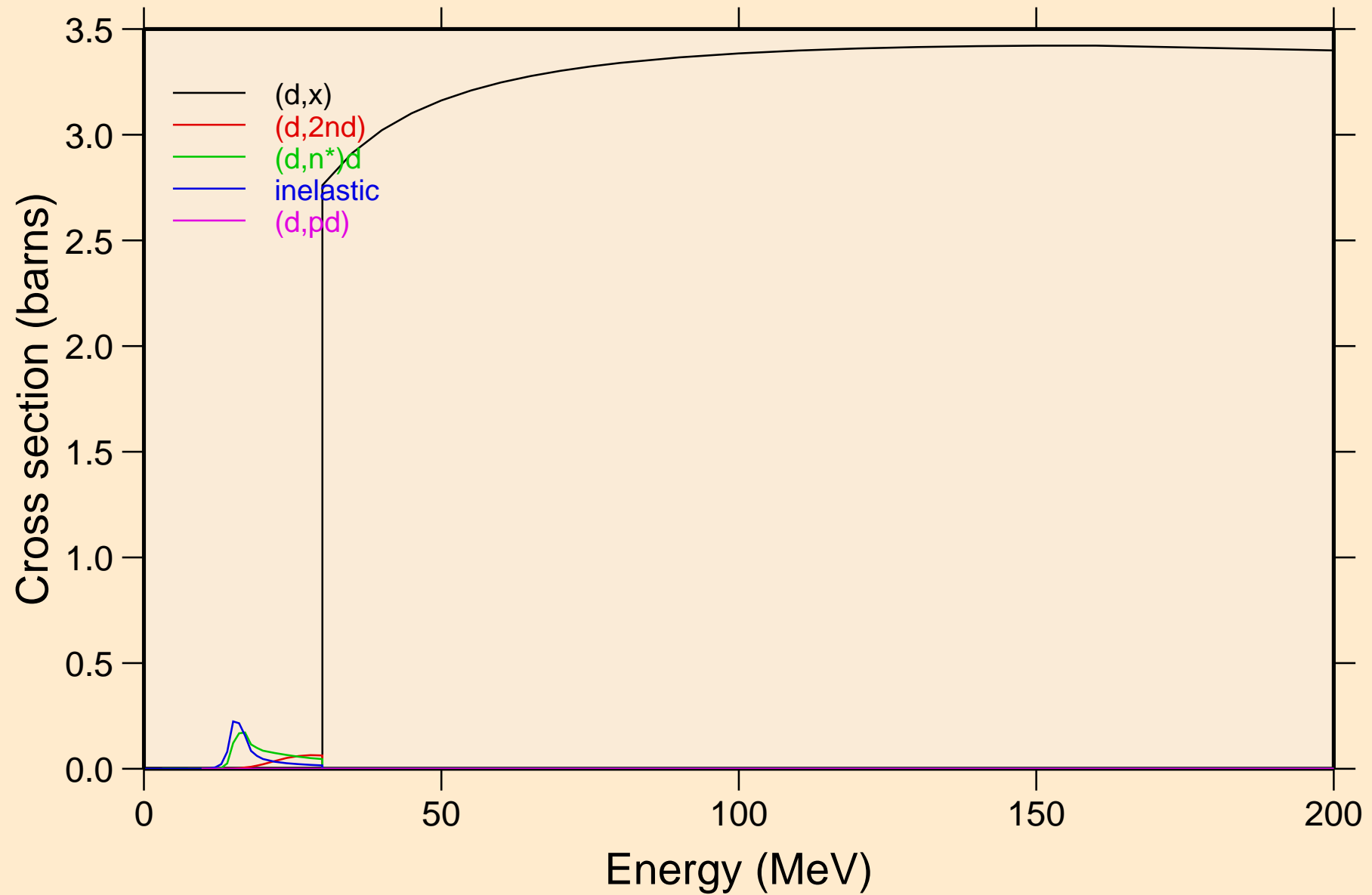

TL218 DEUTERON ACER TENDL-2023 LIBRARY; T=0.K  
angular distribution for elastic

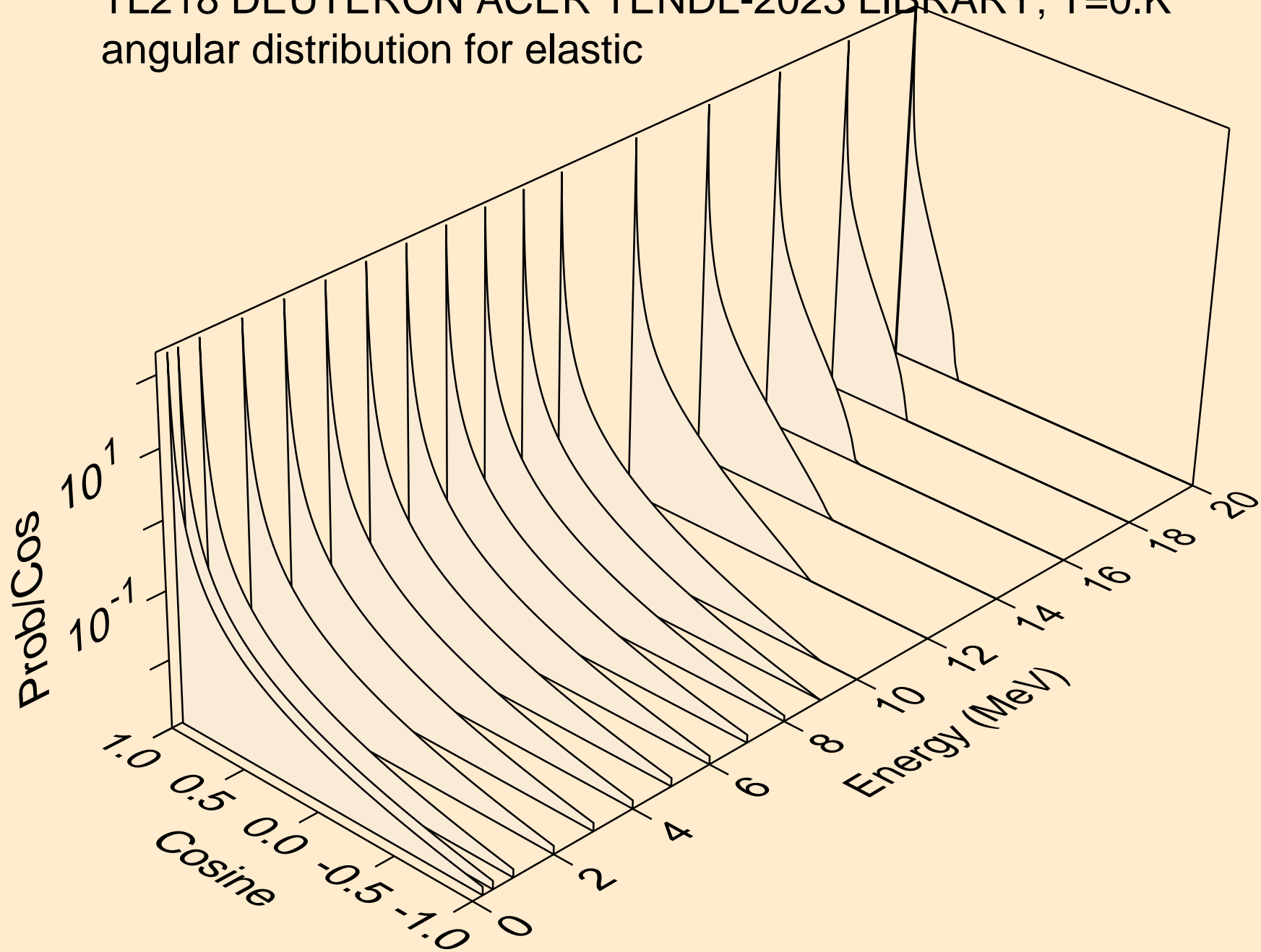

TL218 DEUTERON ACER TENDL-2023 LIBRARY; T=0.K  
angular distribution for elastic

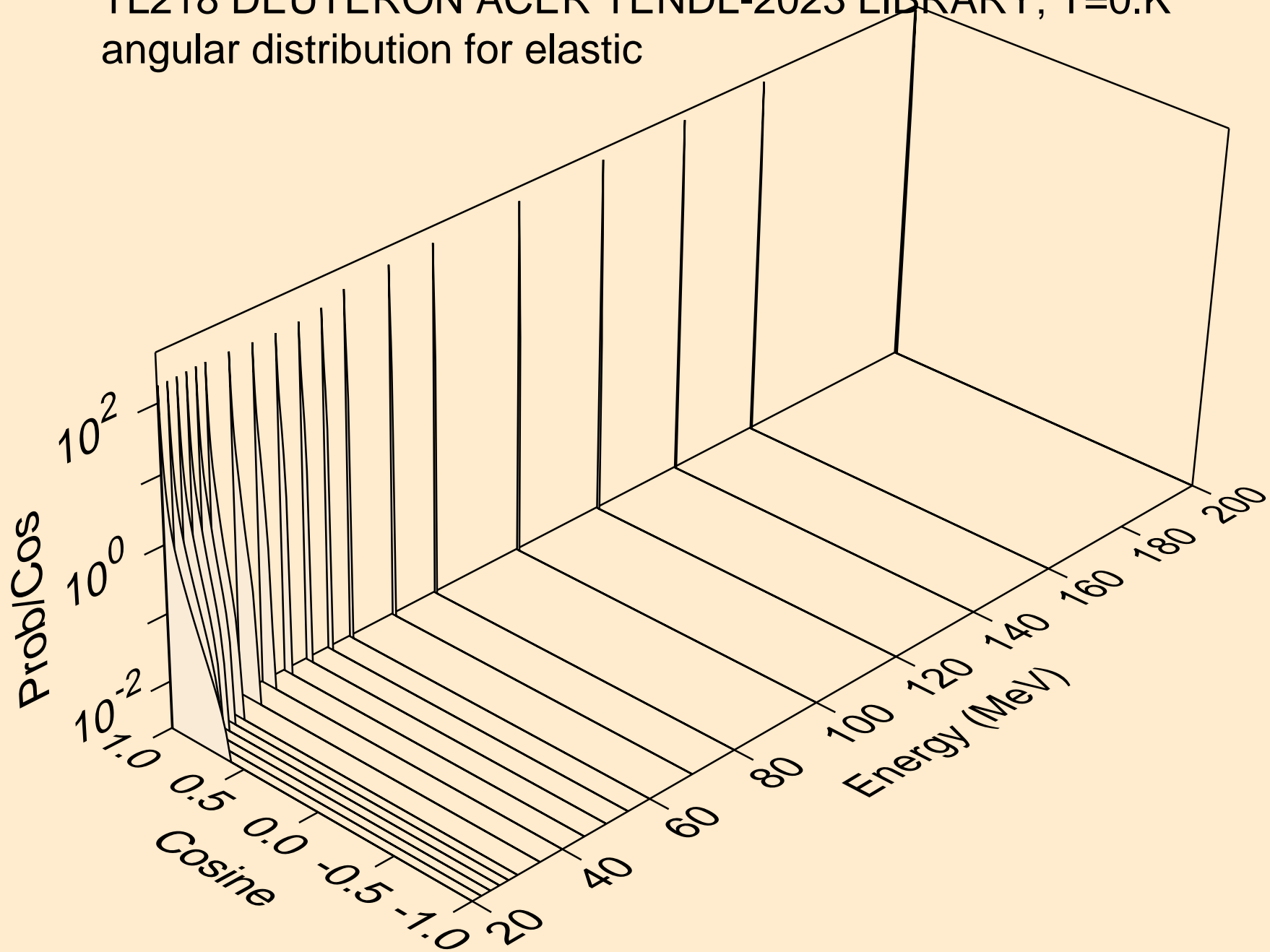

TL218 DEUTERON ACER TENDL-2023 LIBRARY; T=0.K  
Deuteron emission for (d,x)

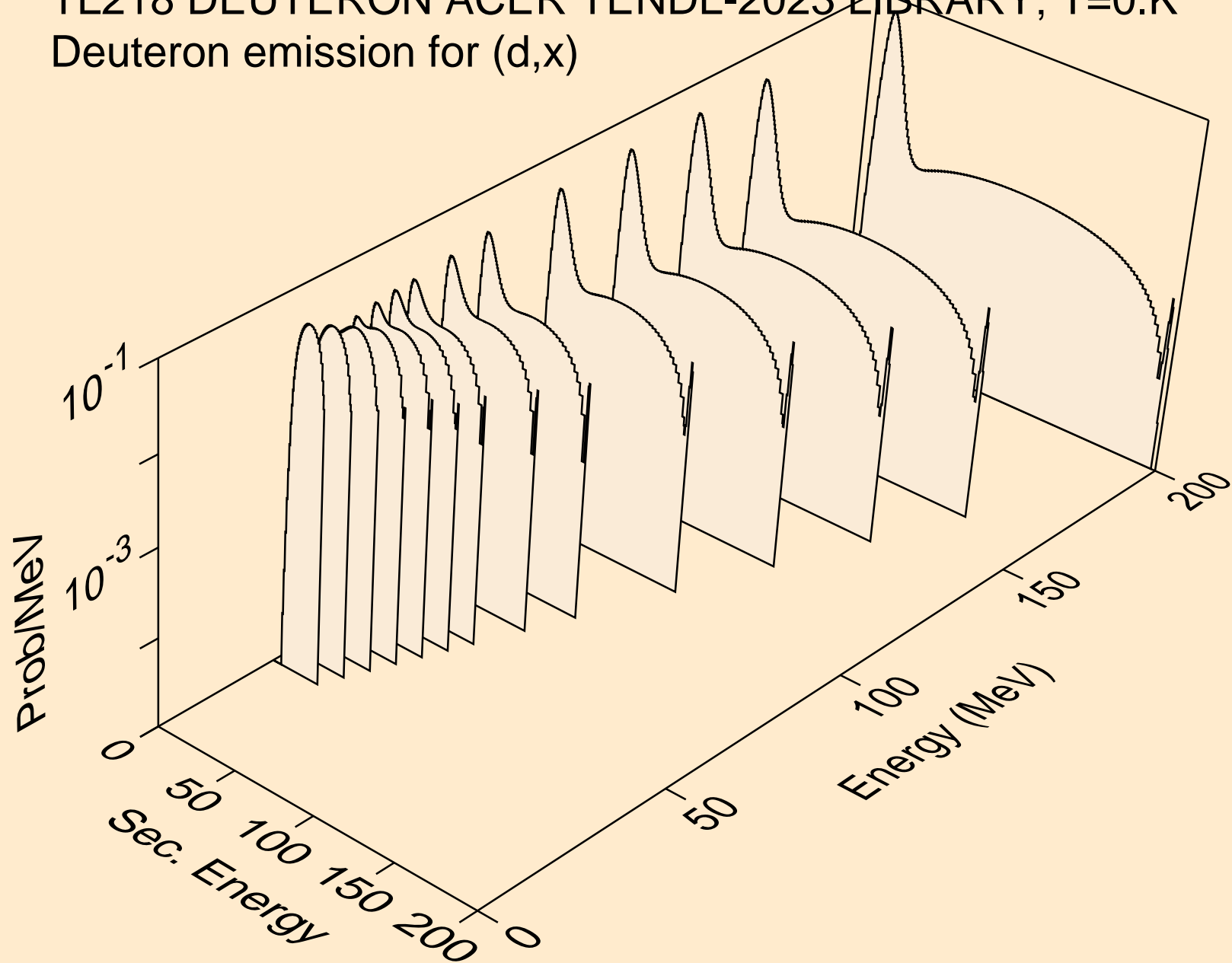



TL218 DEUTERON ACER TENDL-2023 LIBRARY; T=0.K  
Deuteron emission for (d,2nd)

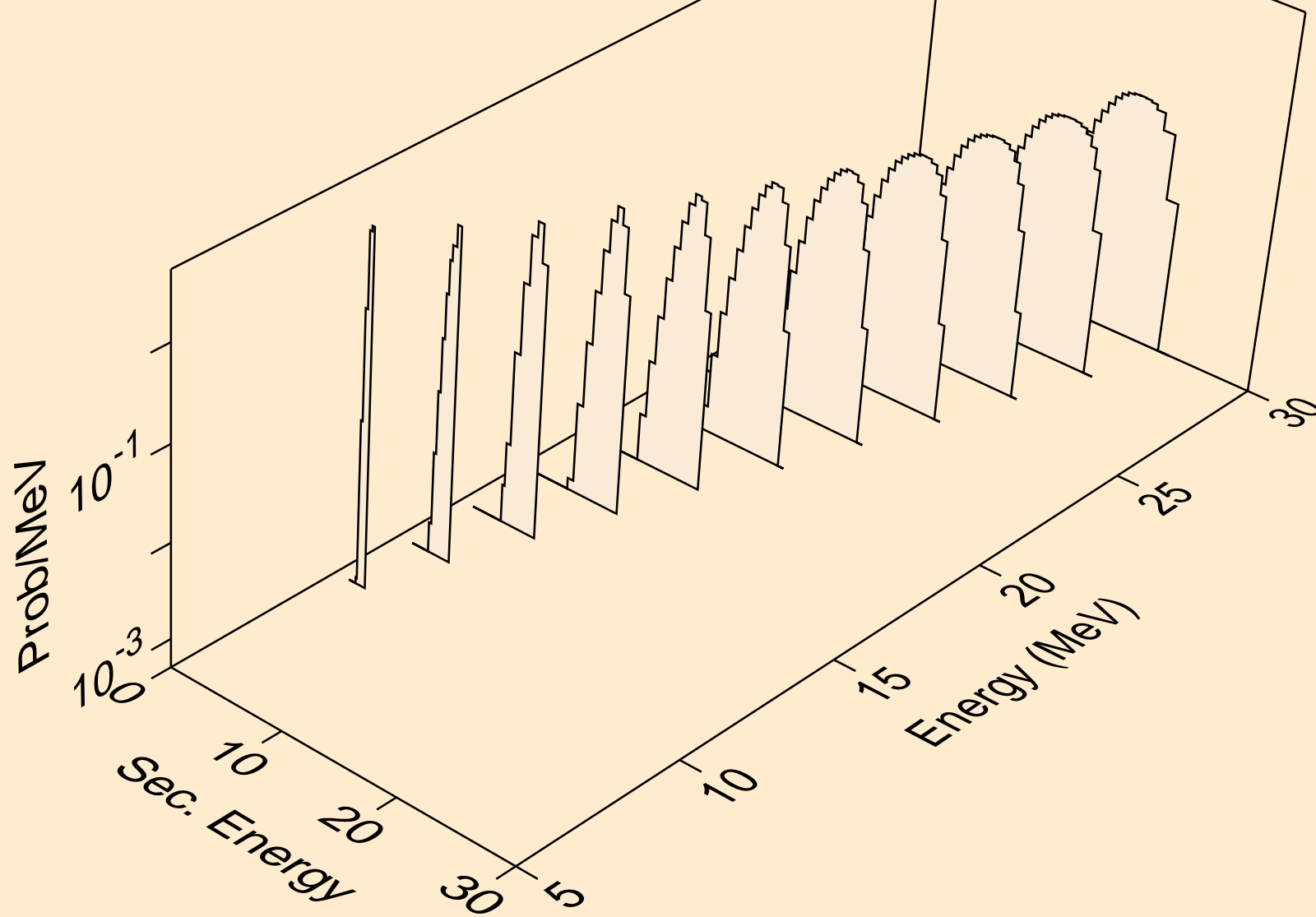

TL218 DEUTERON ACER TENDL-2023 LIBRARY; T=0.K  
Deuteron emission for (d,n\*)d

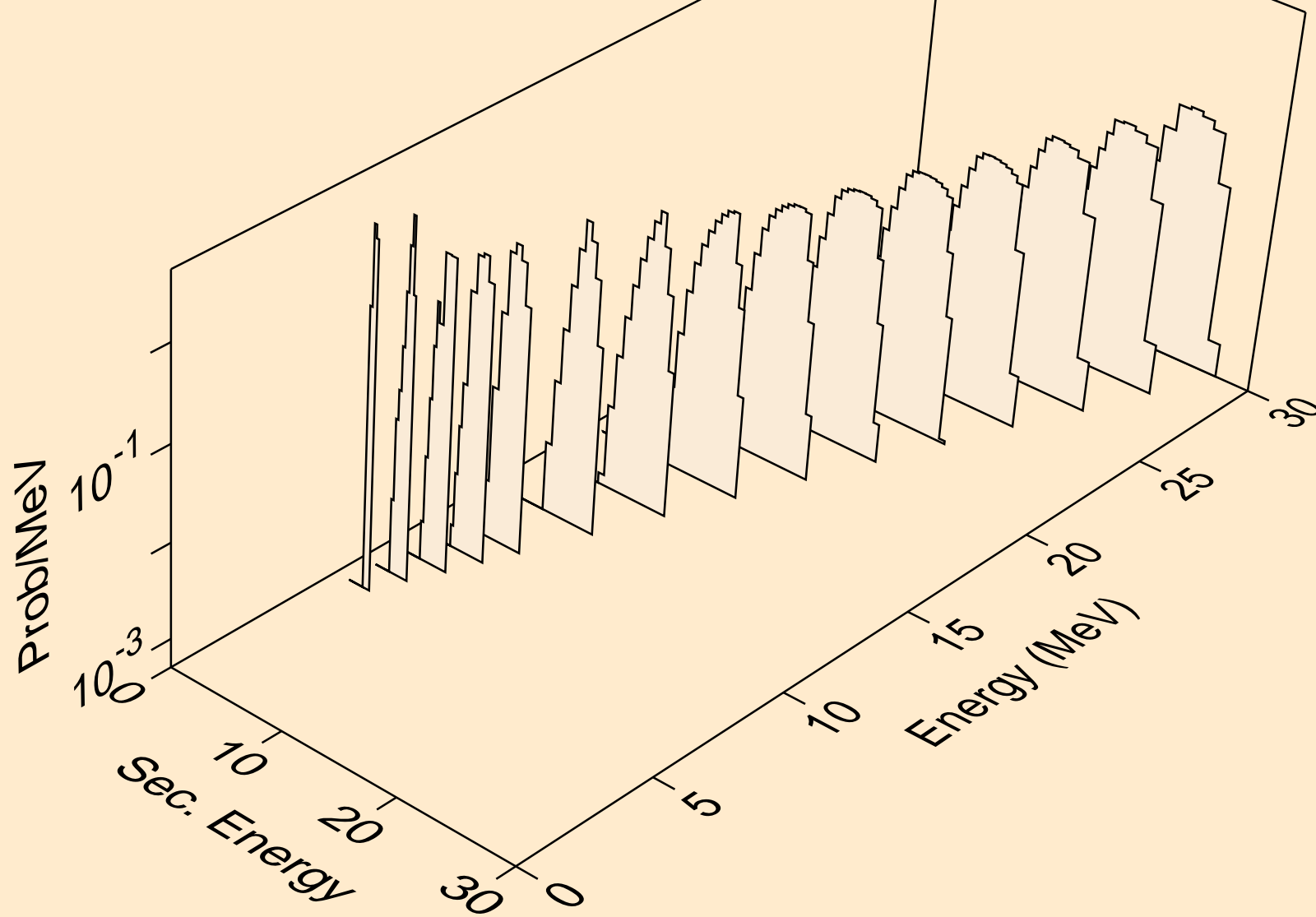

TL218 DEUTERON ACER TENDL-2023 LIBRARY; T=0.K  
Deuteron emission for inelastic

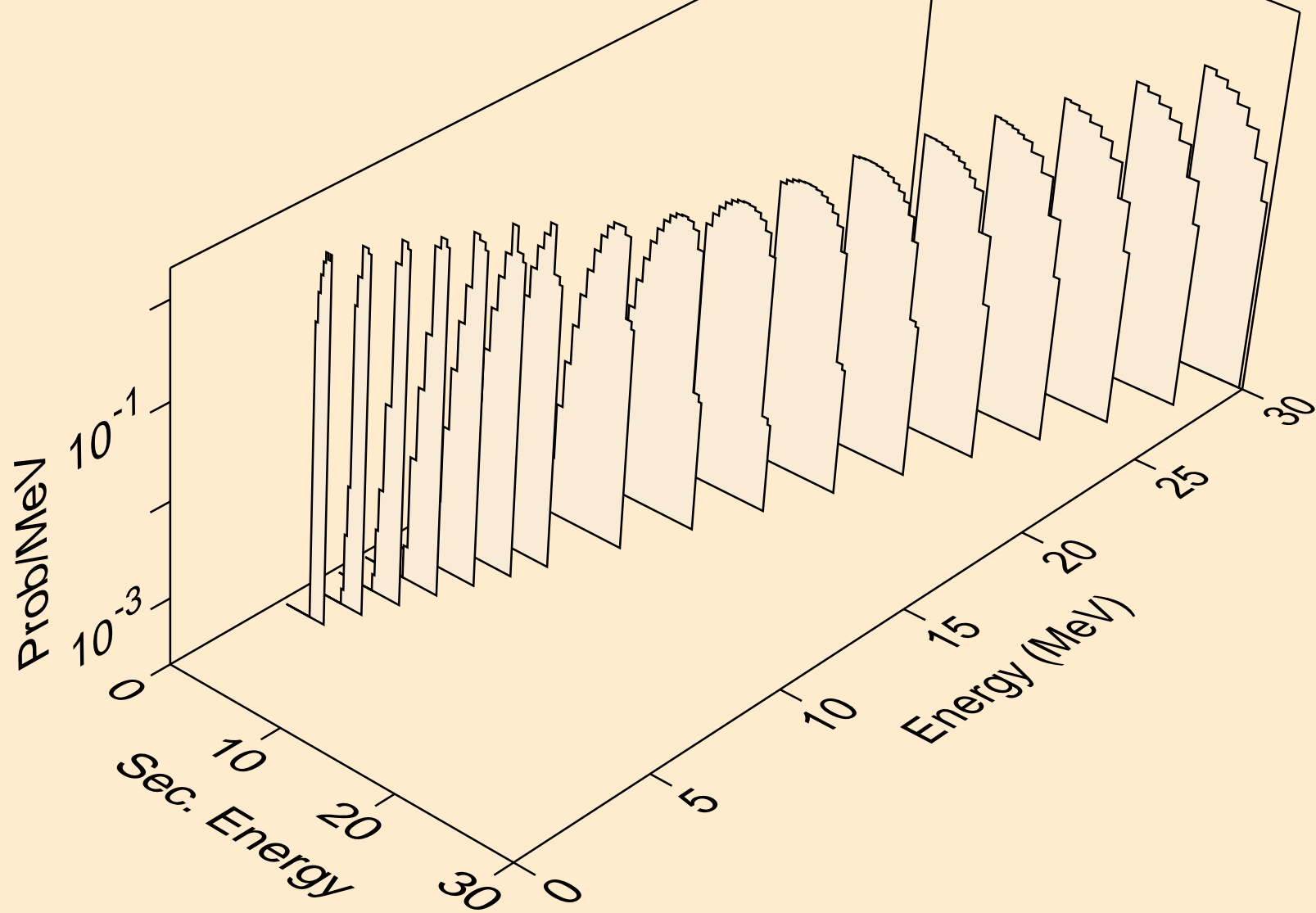

TL218 DEUTERON ACER TENDL-2023 LIBRARY; T=0.K  
Deuteron emission for (d,pd)

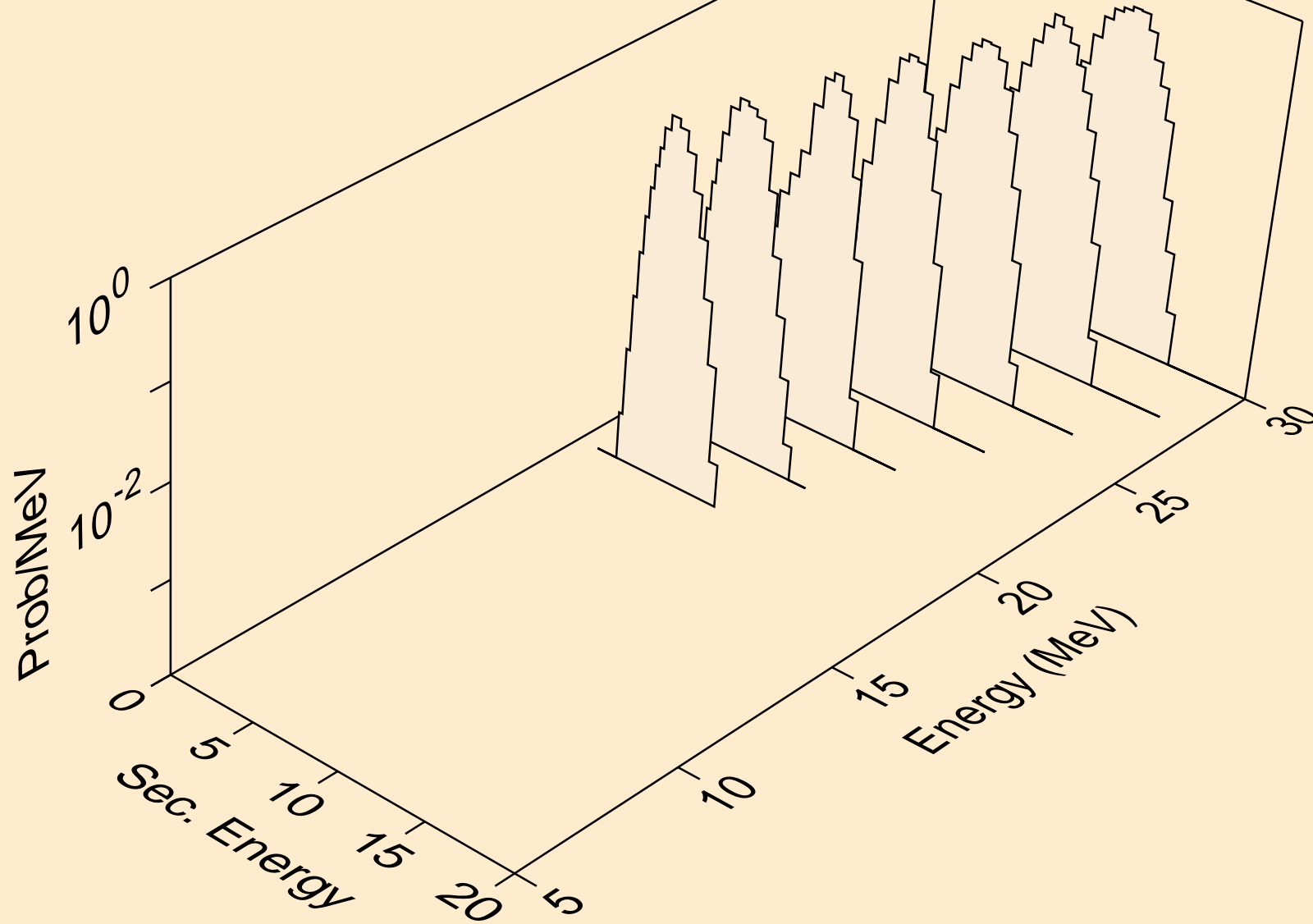

TL218 DEUTERON ACER TENDL-2023 LIBRARY; T=0.K  
Photon emission for (z,n)

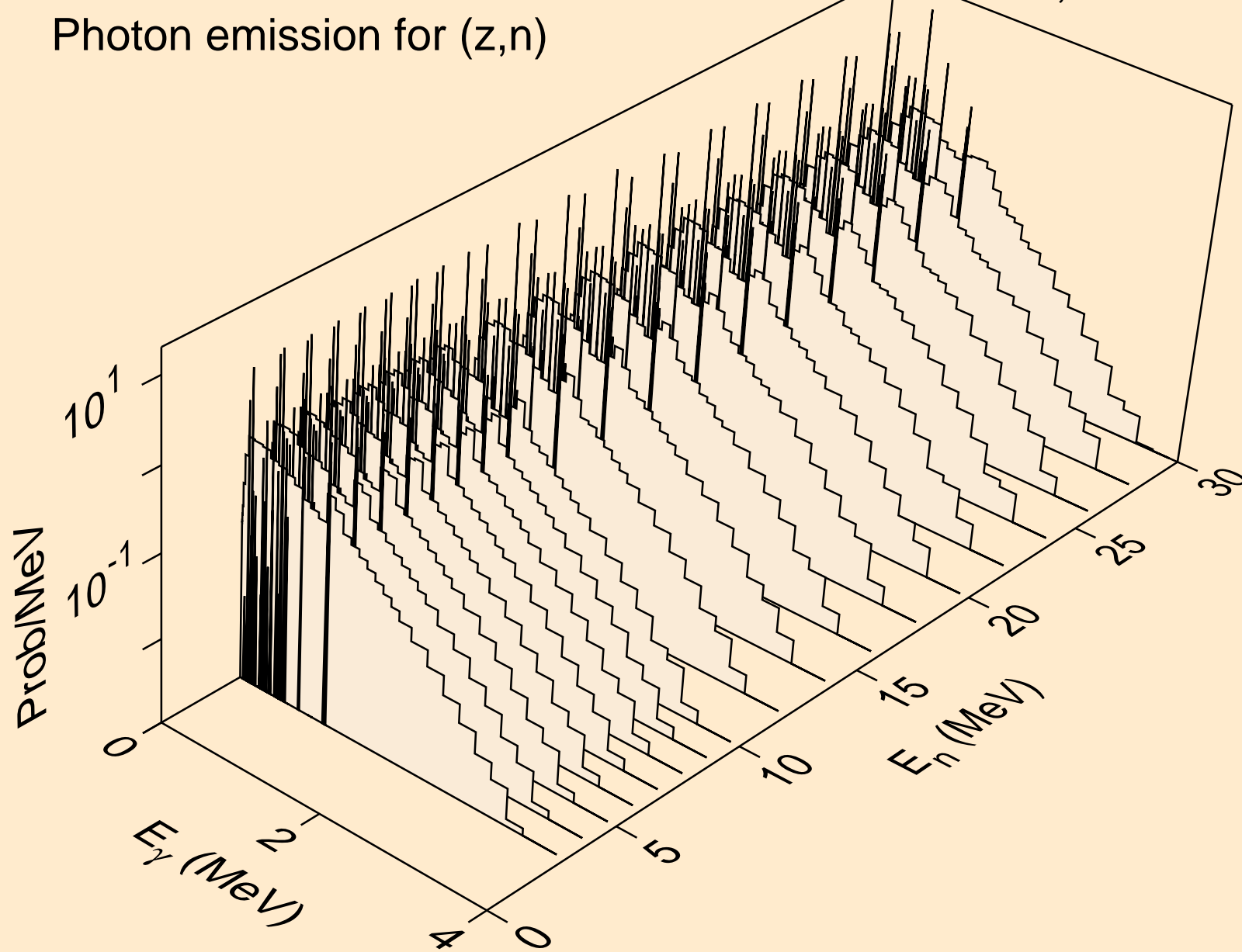

TL218 DEUTERON ACER TENDL-2023 LIBRARY; T=0.K  
Photon emission for (z,x)

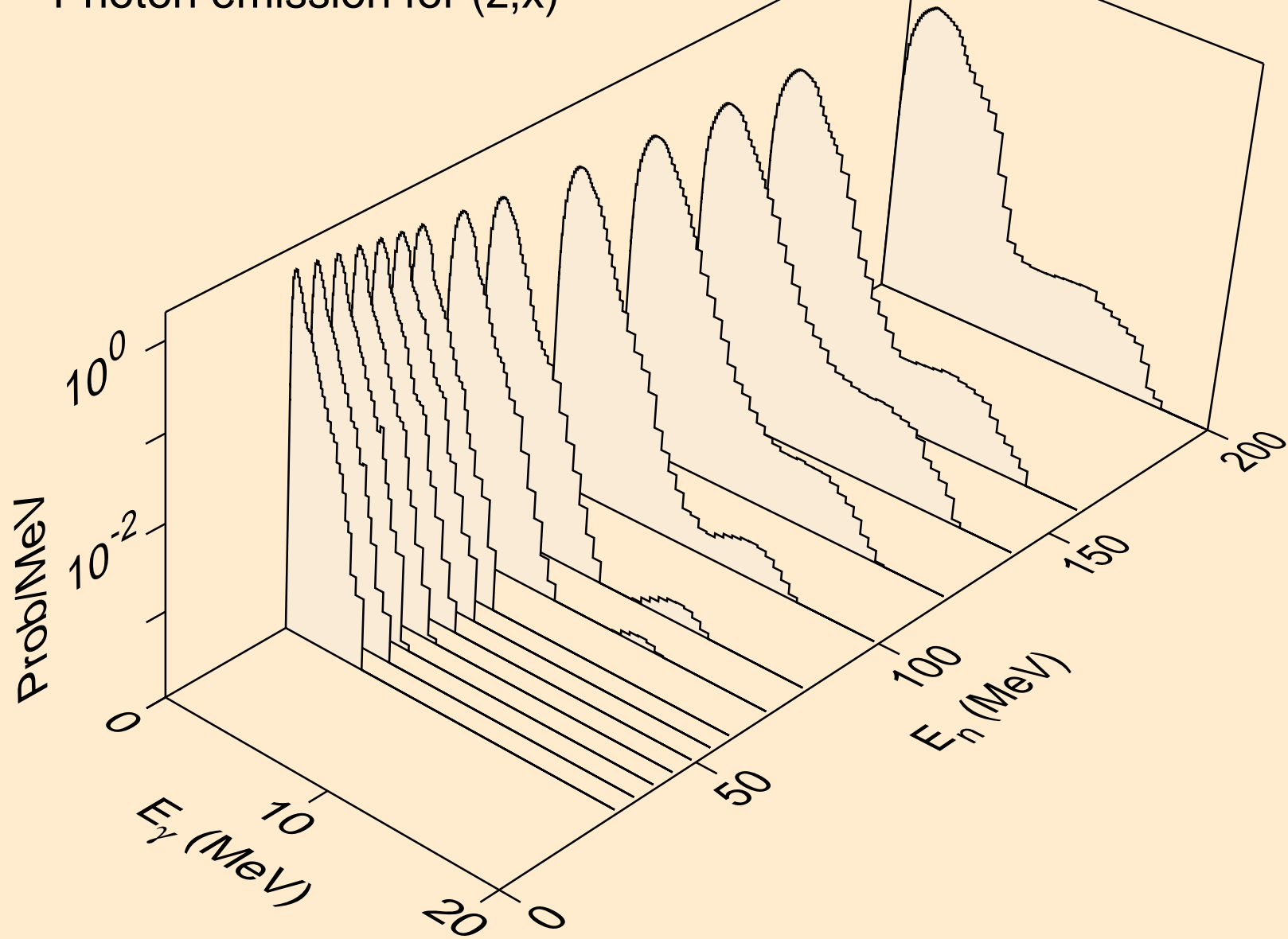

TL218 DEUTERON ACER TENDL-2023 LIBRARY; T=0.K  
Photon emission for (n,2nd)

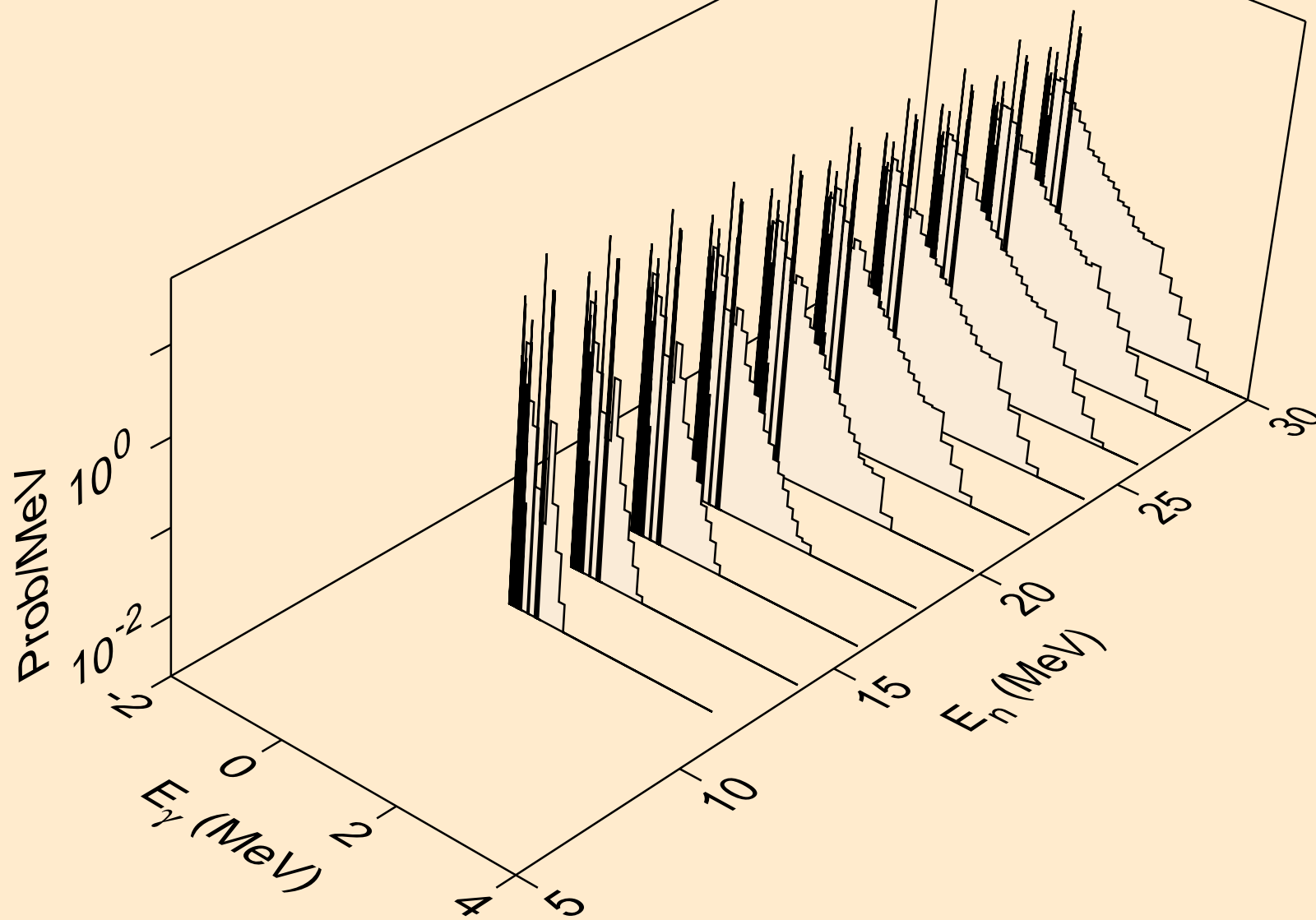

TL218 DEUTERON ACER TENDL-2023 LIBRARY; T=0.K  
Photon emission for (n,2n)

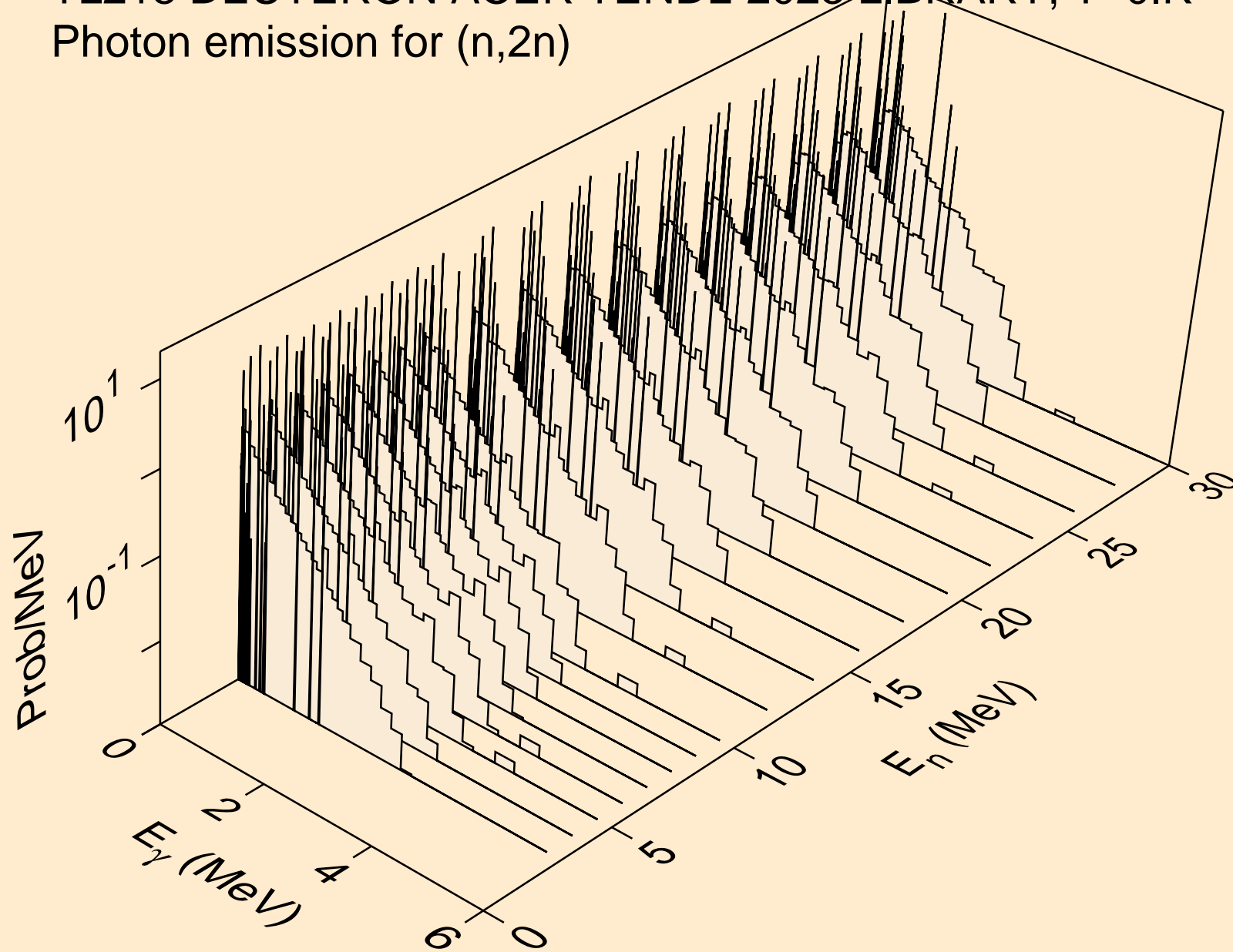



TL218 DEUTERON ACER TENDL-2023 LIBRARY; T=0.K  
Photon emission for (n,3n)

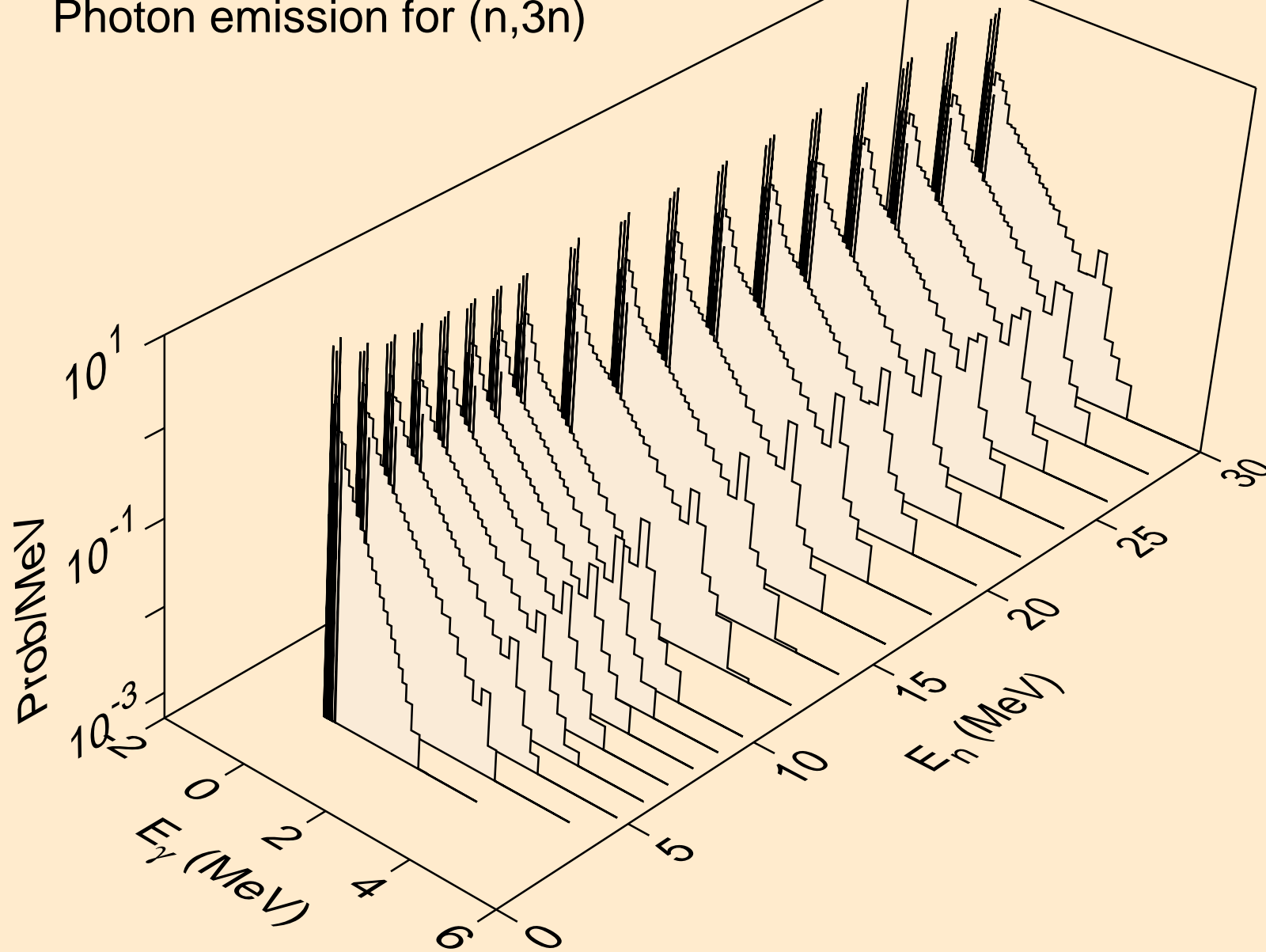

TL218 DEUTERON ACER TENDL-2023 LIBRARY; T=0.K  
Photon emission for (n,n\*)a

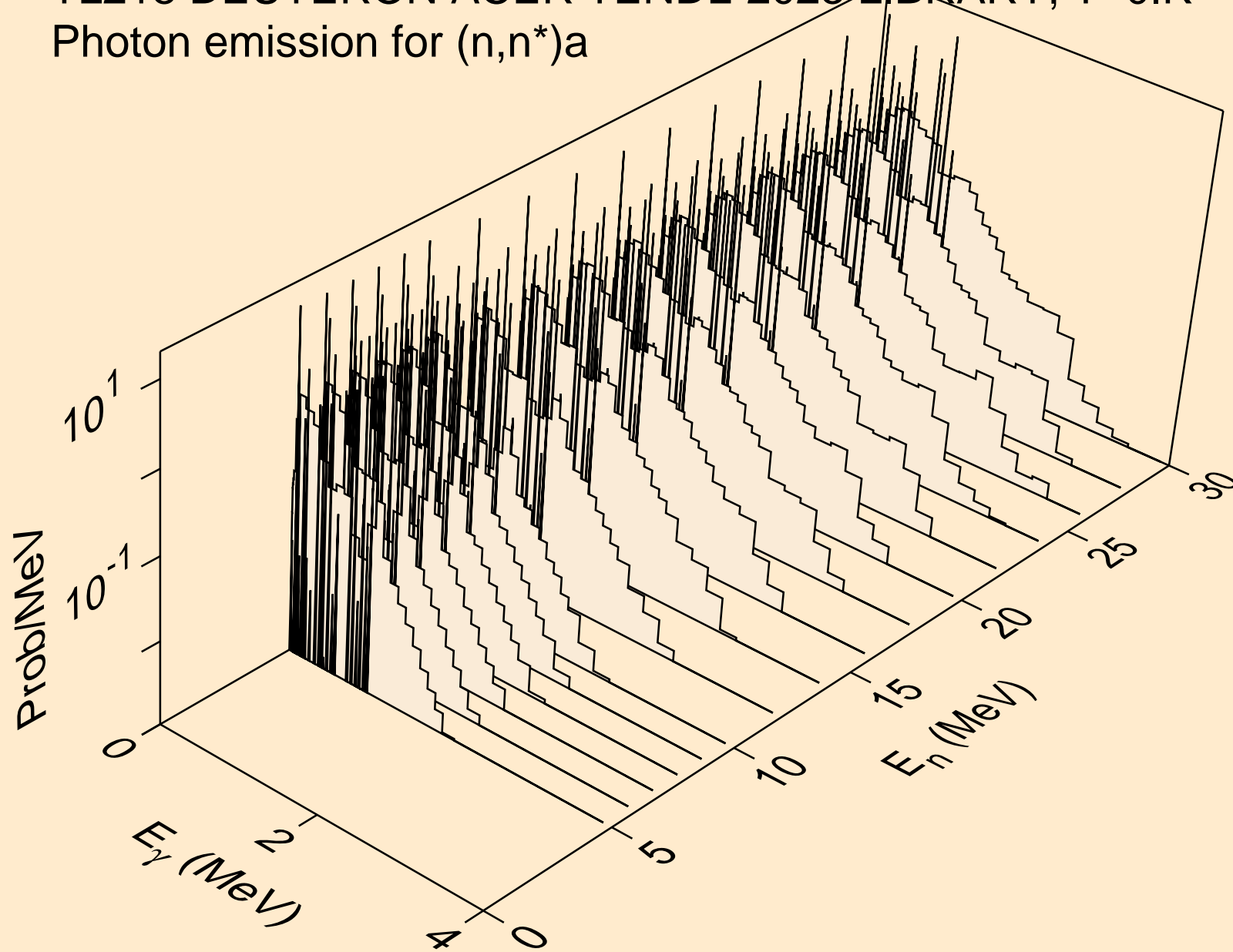

TL218 DEUTERON ACER TENDL-2023 LIBRARY; T=0.K  
Photon emission for (n,2n)a

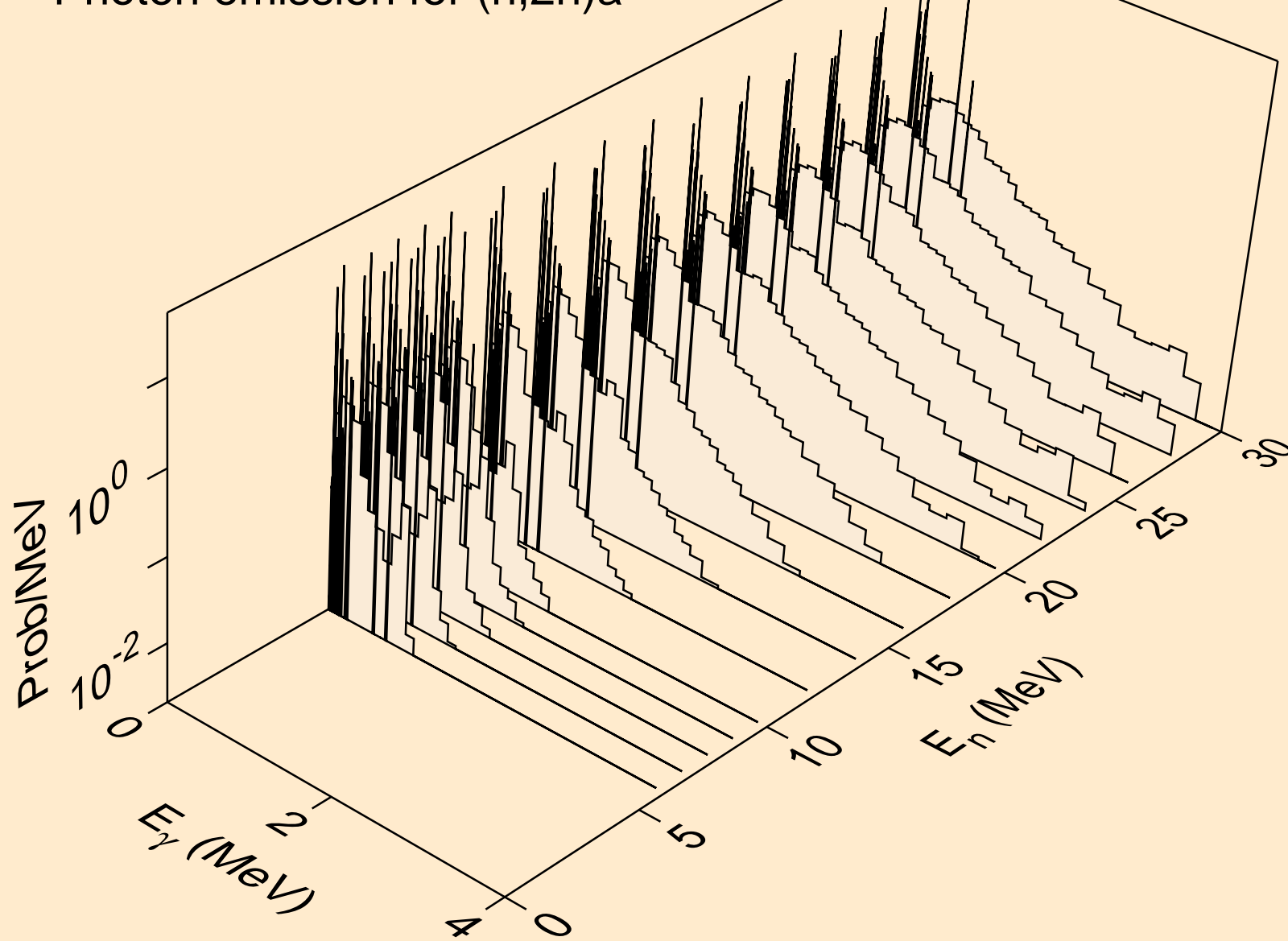

TL218 DEUTERON ACER TENDL-2023 LIBRARY; T=0.K  
Photon emission for (n,3n)a

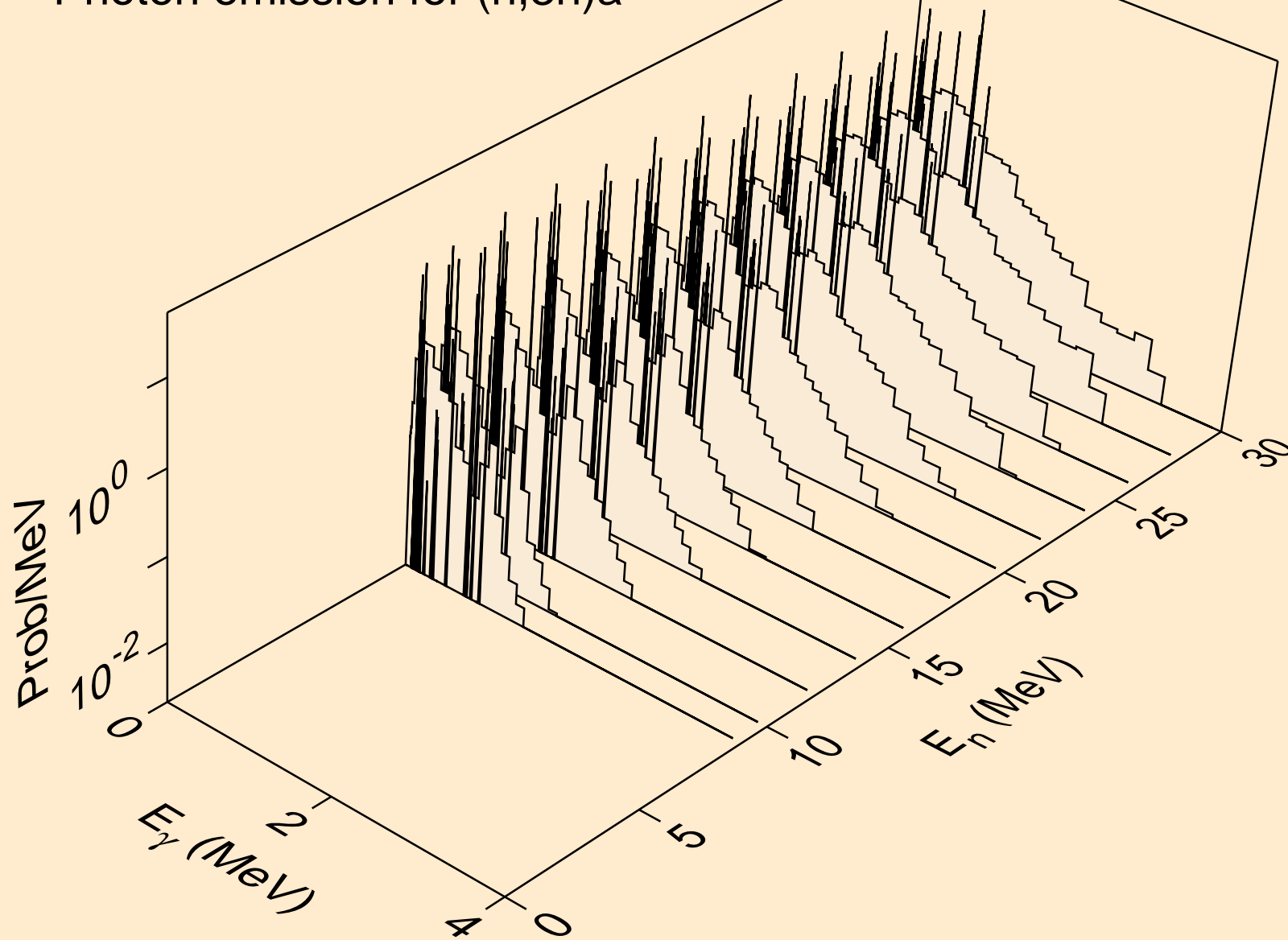

TL218 DEUTERON ACER TENDL-2023 LIBRARY; T=0.K  
Photon emission for (n,n\*)p

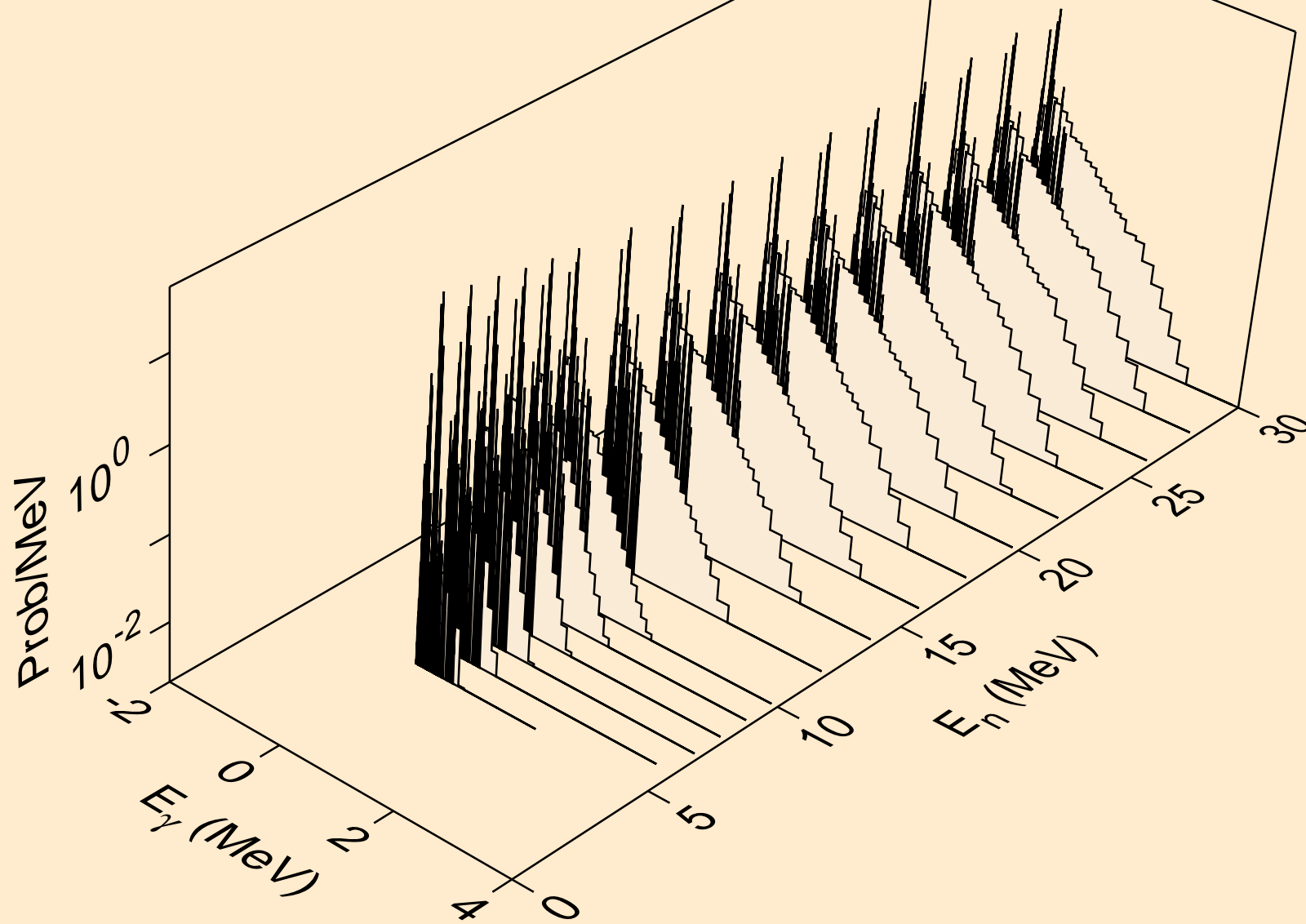

TL218 DEUTERON ACER TENDL-2023 LIBRARY; T=0.K  
Photon emission for (n,n\*)d

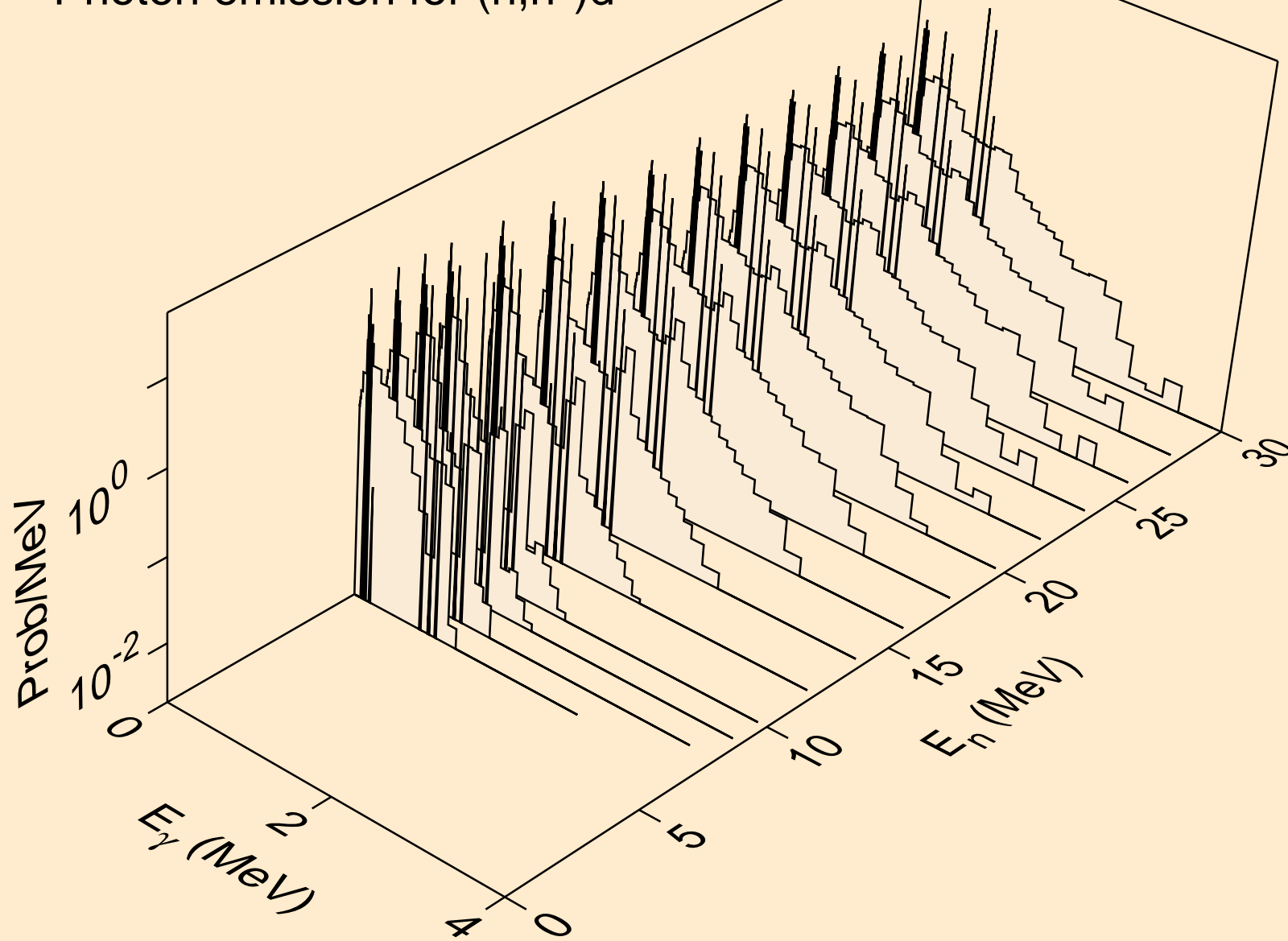

TL218 DEUTERON ACER TENDL-2023 LIBRARY; T=0.K  
Photon emission for (n,n\*)t

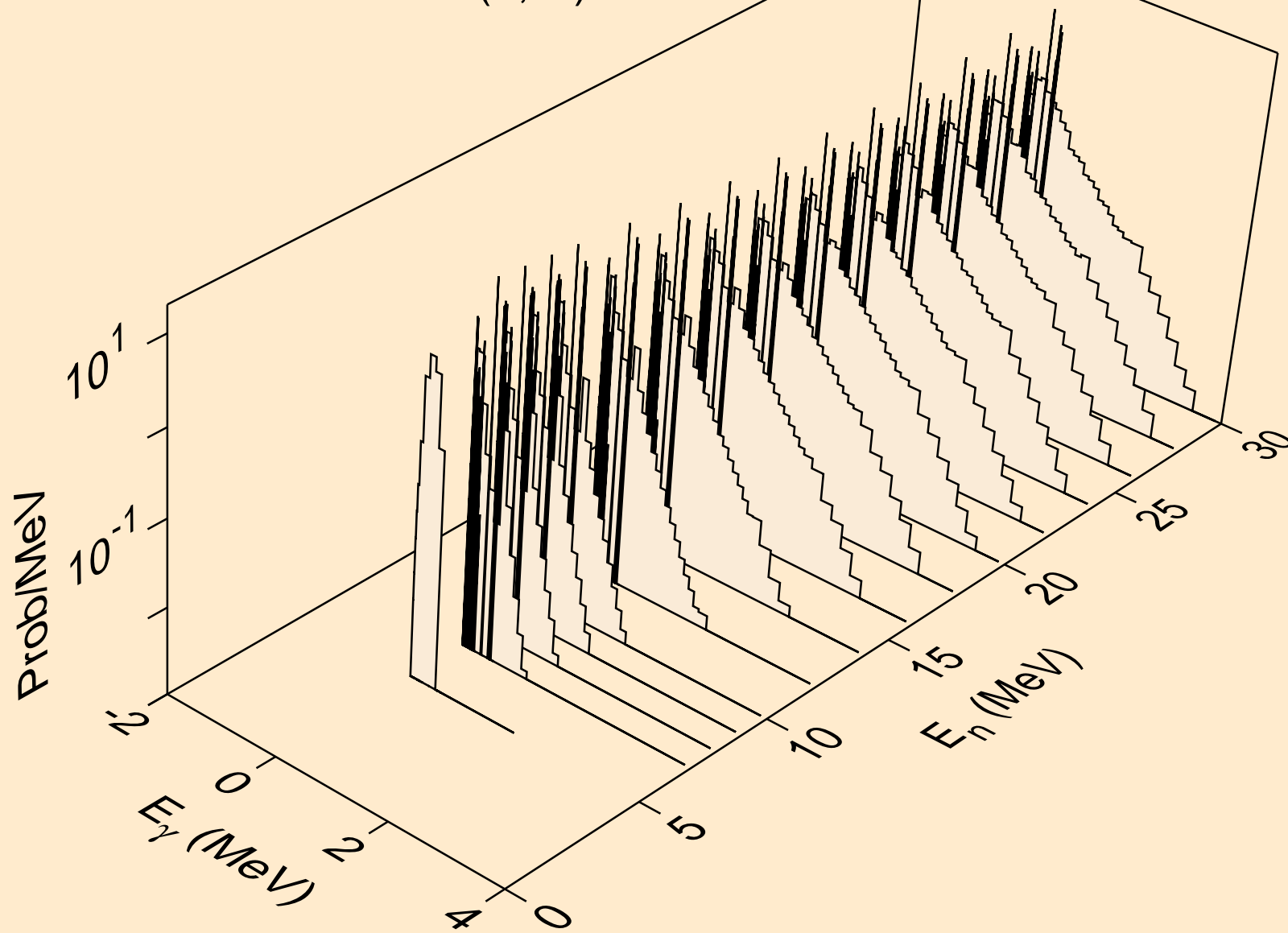

TL218 DEUTERON ACER TENDL-2023 LIBRARY; T=0.K  
Photon emission for (n,n\*)he3

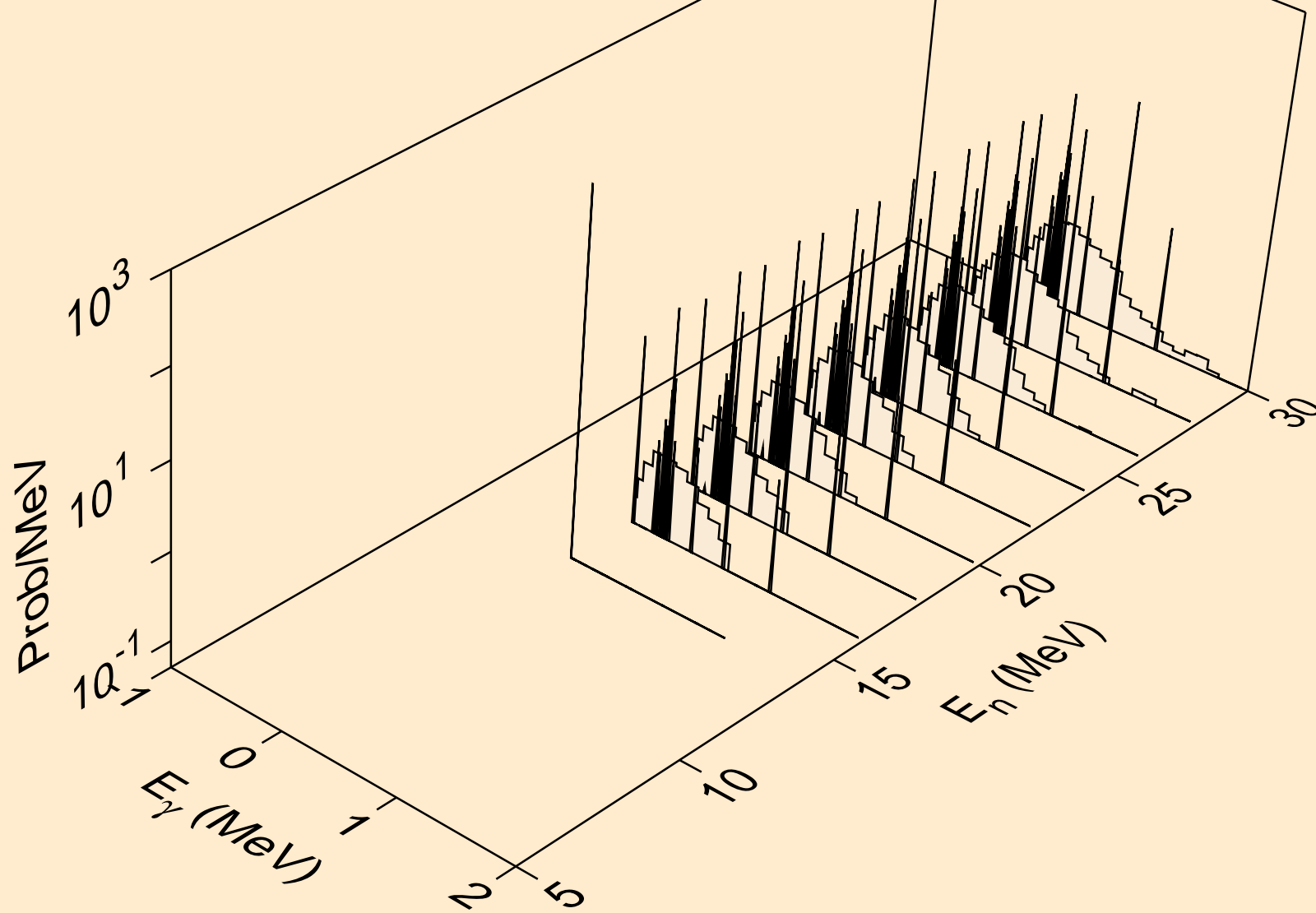



TL218 DEUTERON ACER TENDL-2023 LIBRARY; T=0.K  
Photon emission for (n,4n)

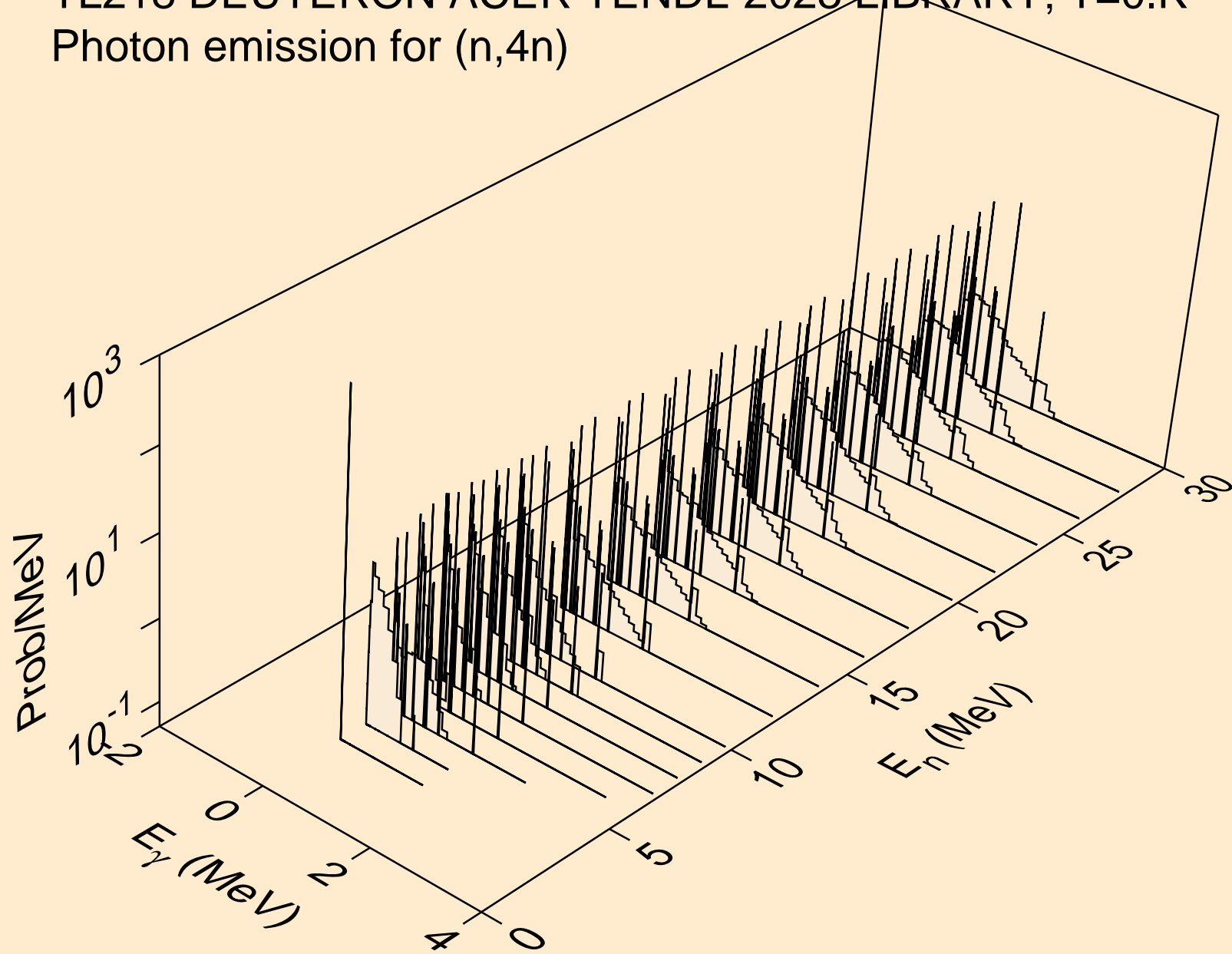

TL218 DEUTERON ACER TENDL-2023 LIBRARY; T=0.K  
Photon emission for (n,2np)

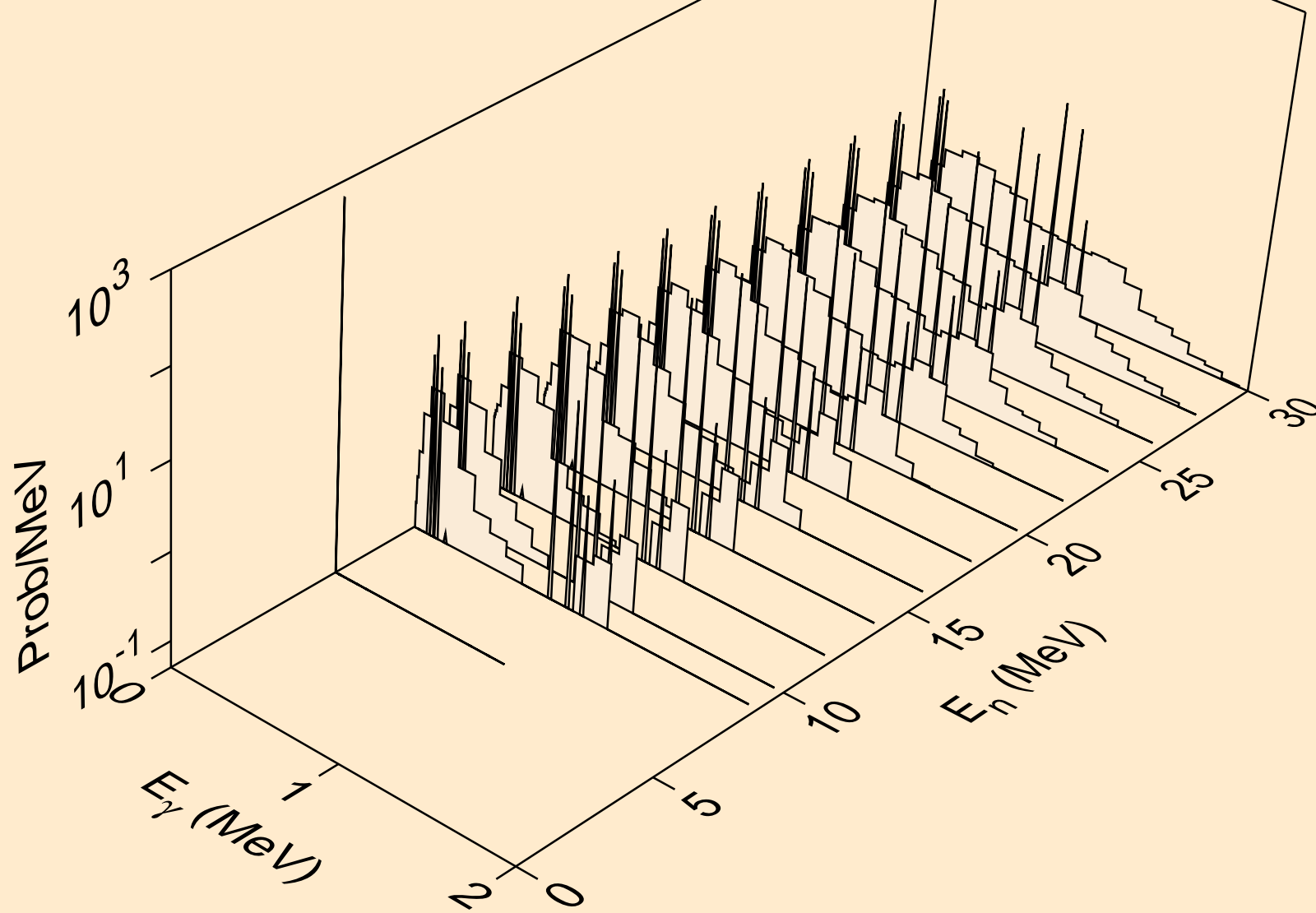

TL218 DEUTERON ACER TENDL-2023 LIBRARY; T=0.K  
Photon emission for (n,3np)

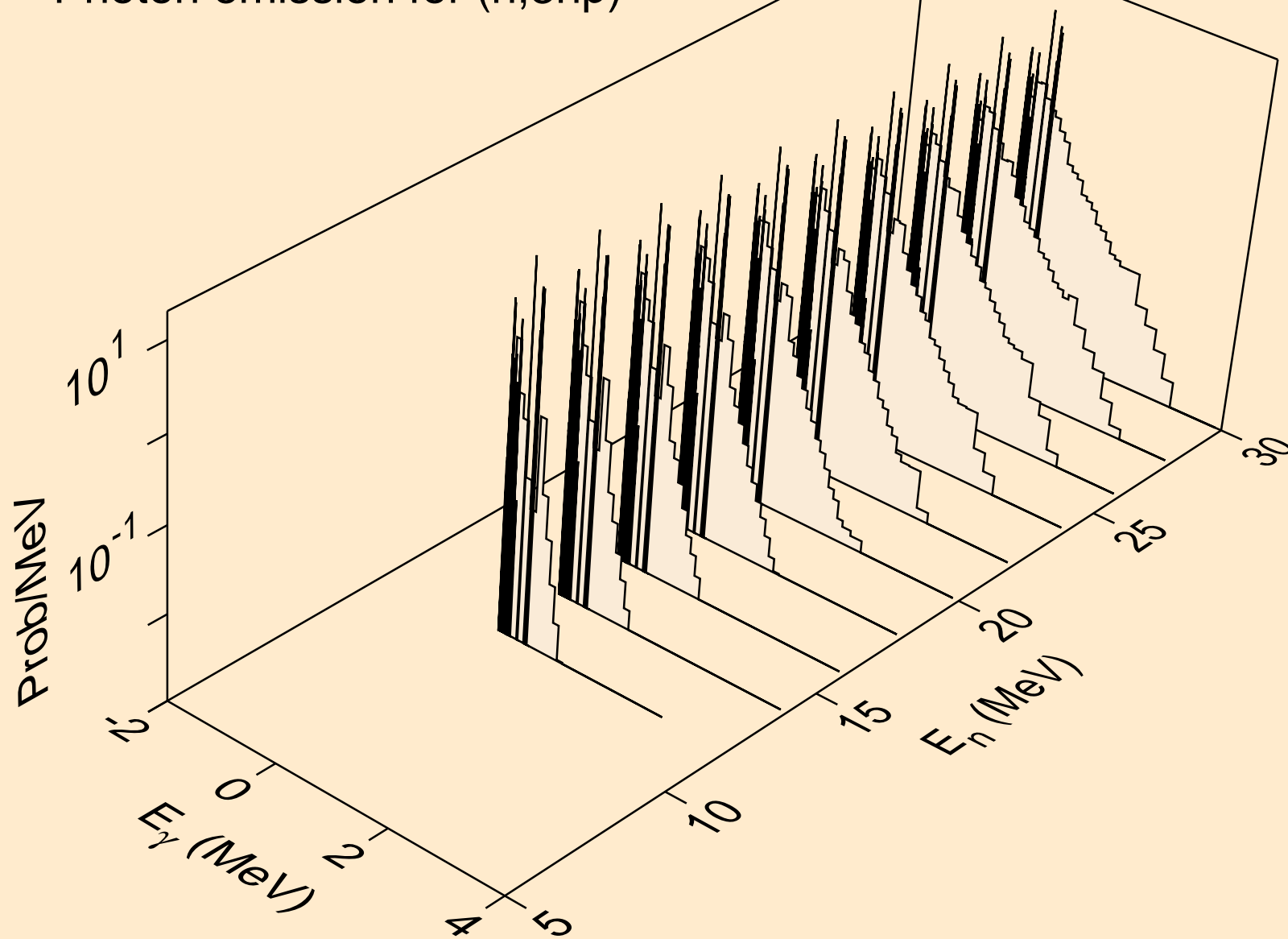

TL218 DEUTERON ACER TENDL-2023 LIBRARY; T=0.K  
Photon emission for (n,n2p)

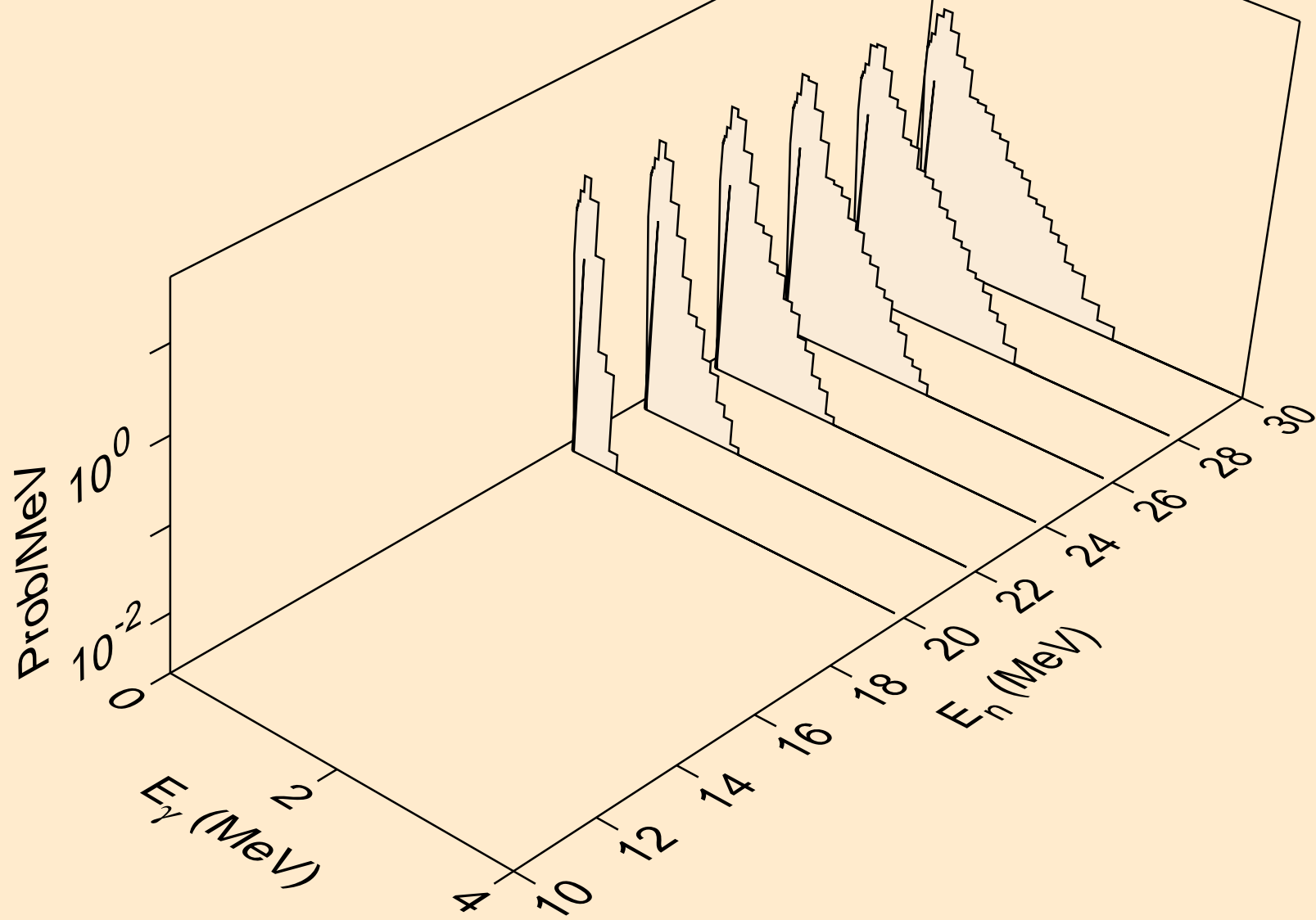

TL218 DEUTERON ACER TENDL-2023 LIBRARY; T=0.K  
Photon emission for (n,gma)

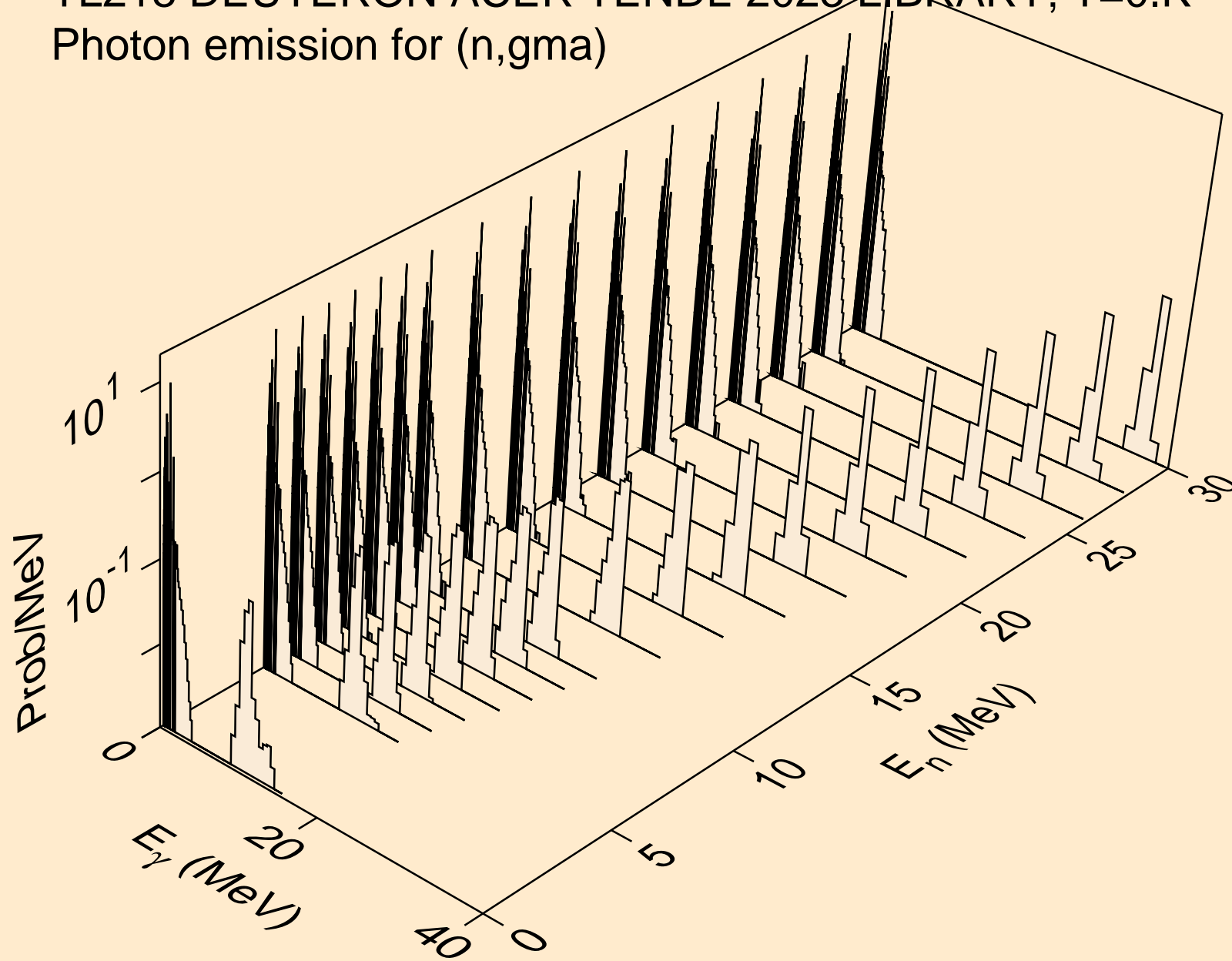

TL218 DEUTERON ACER TENDL-2023 LIBRARY; T=0.K  
Photon emission for (n,p)

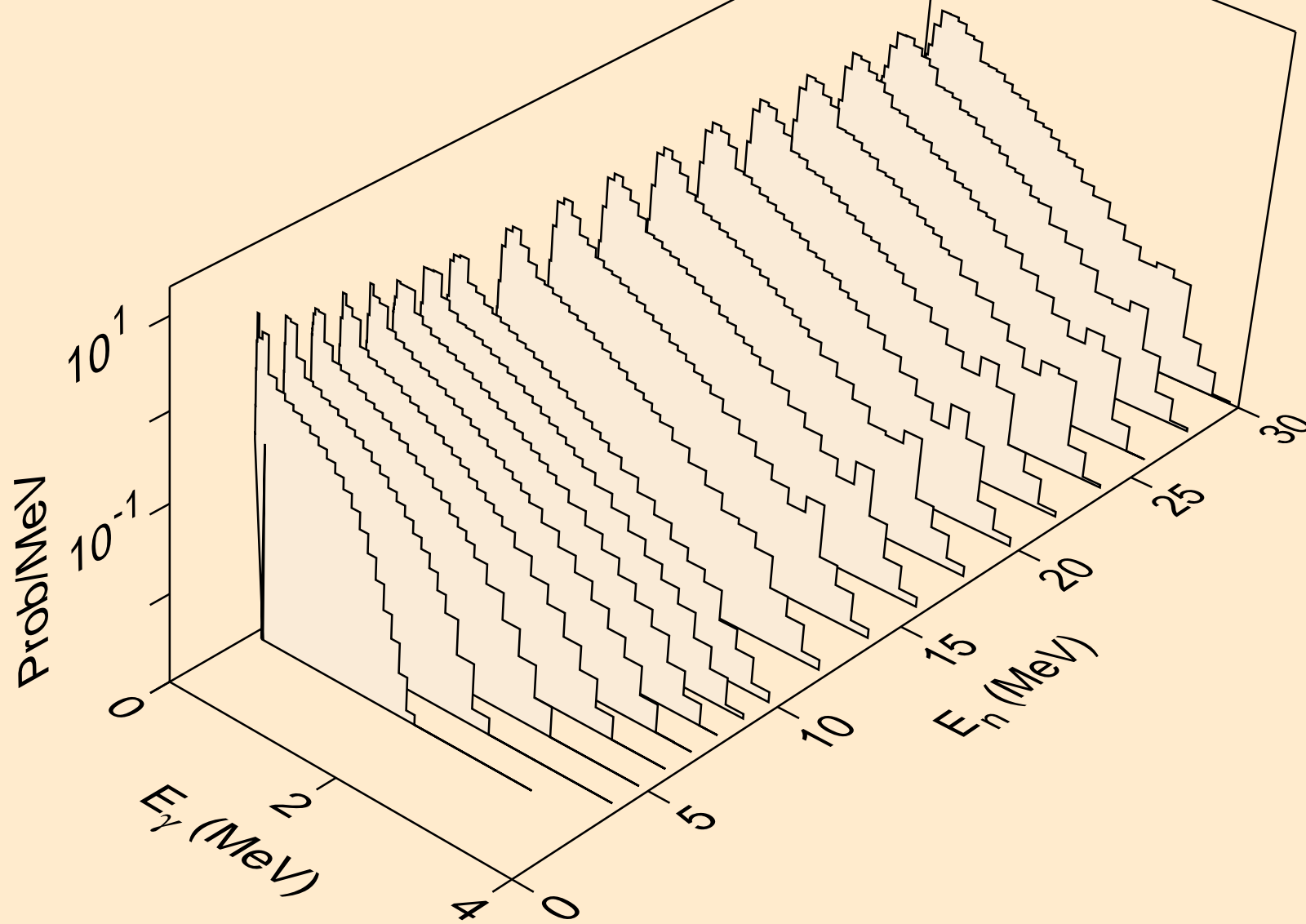

TL218 DEUTERON ACER TENDL-2023 LIBRARY; T=0.K  
Photon emission for inelastic

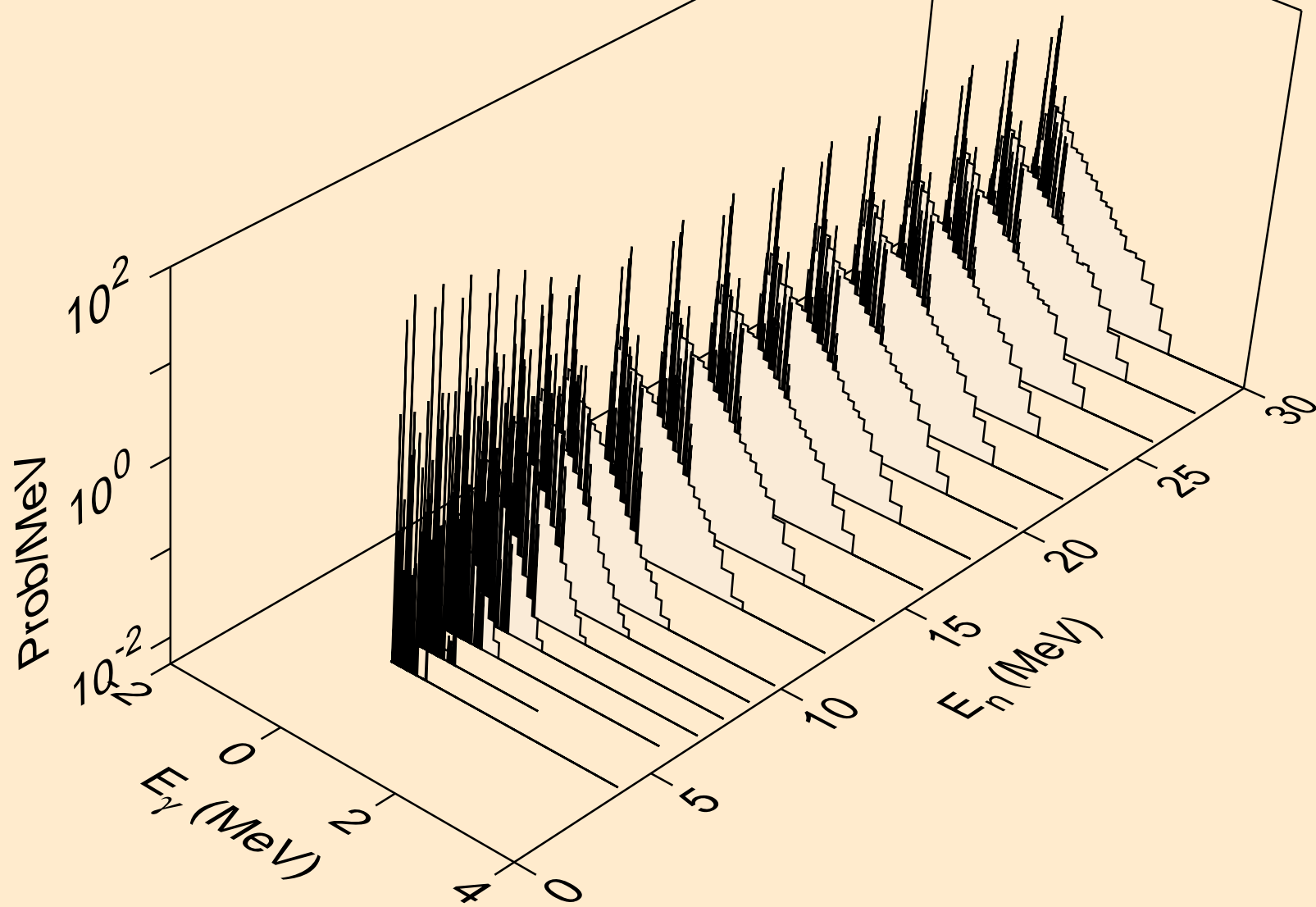

TL218 DEUTERON ACER TENDL-2023 LIBRARY; T=0.K  
Photon emission for (n,t)

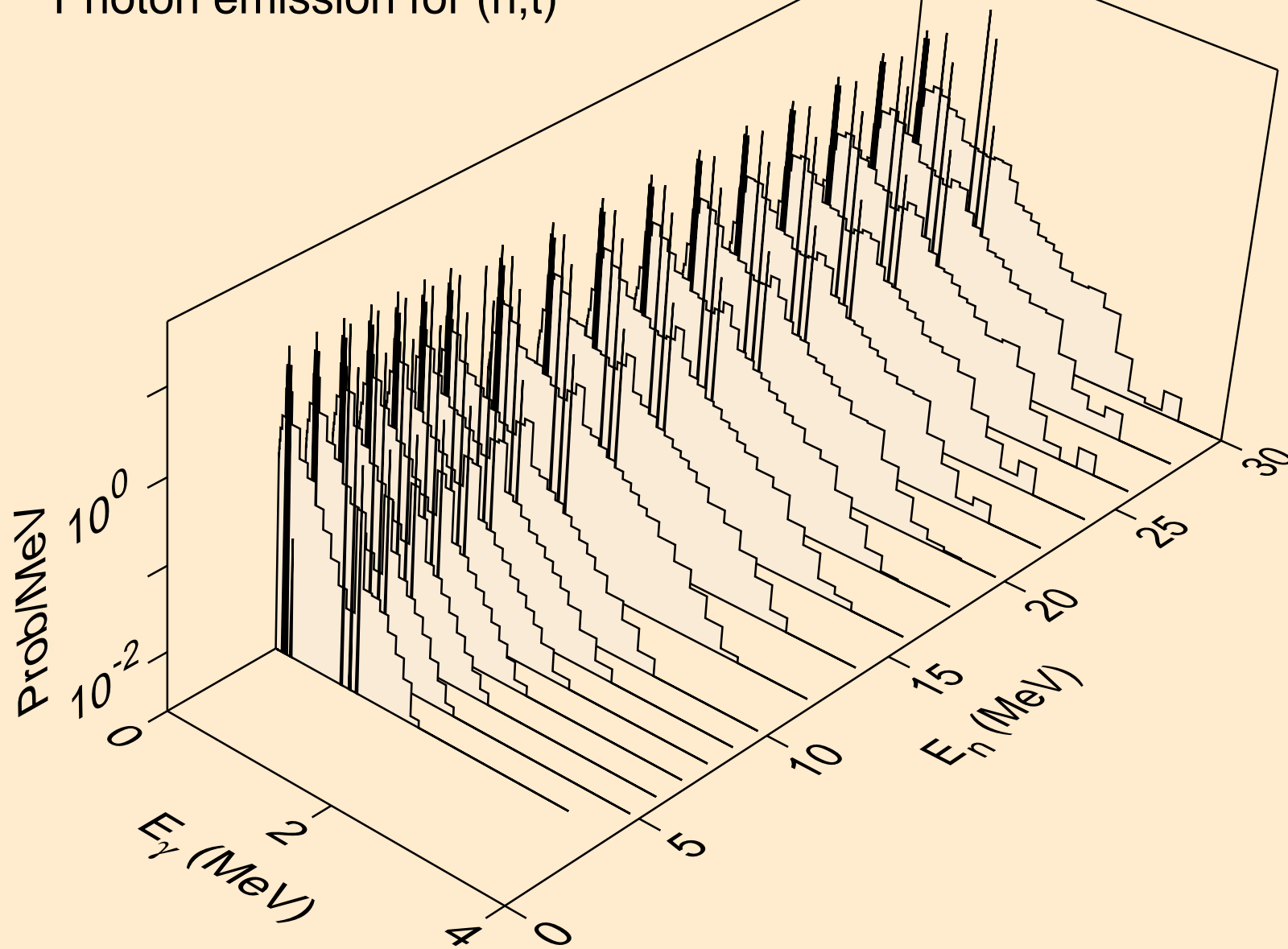



TL218 DEUTERON ACER TENDL-2023 LIBRARY; T=0.K  
Photon emission for (n,he3)

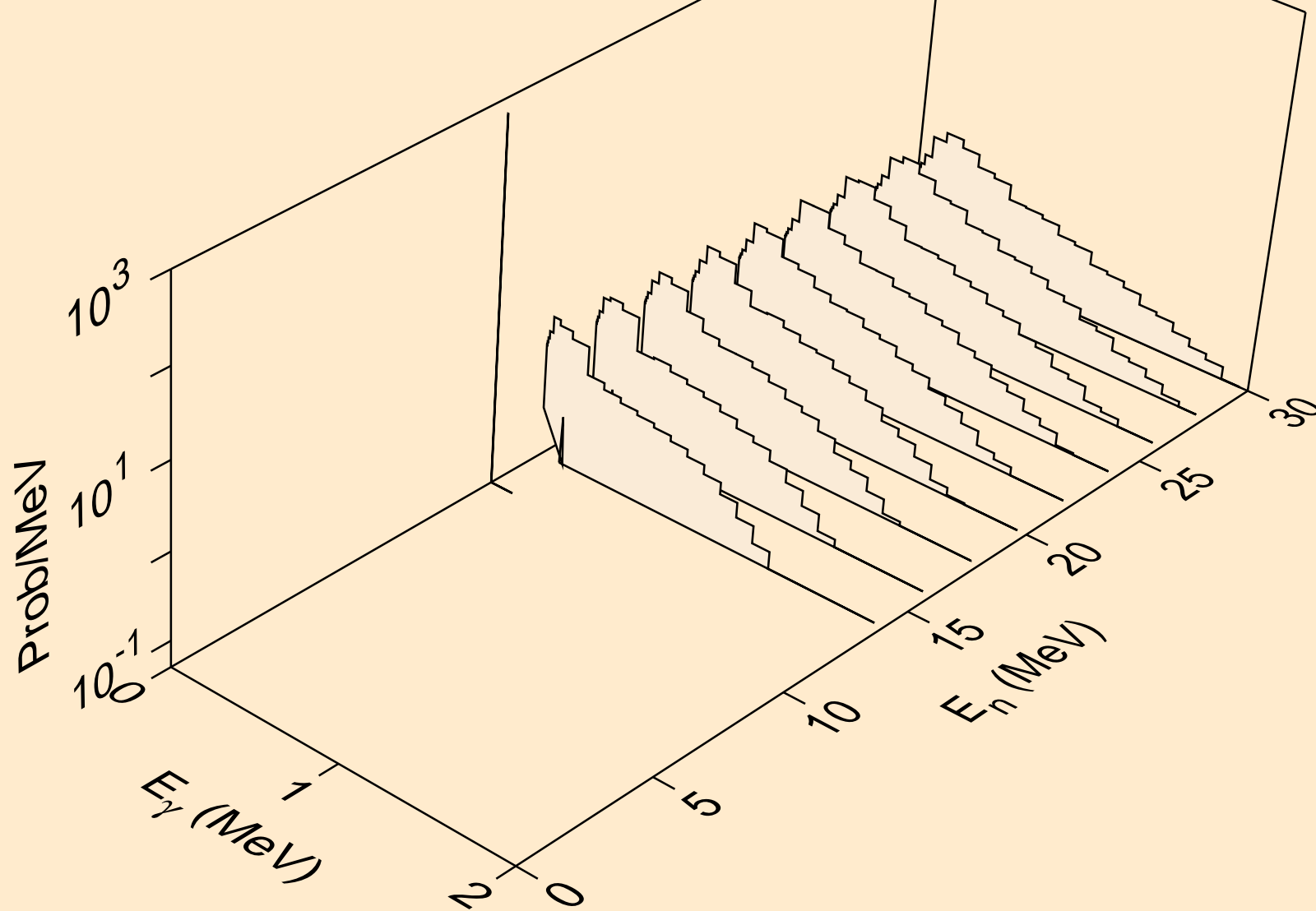

TL218 DEUTERON ACER TENDL-2023 LIBRARY; T=0.K  
Photon emission for (n,a)

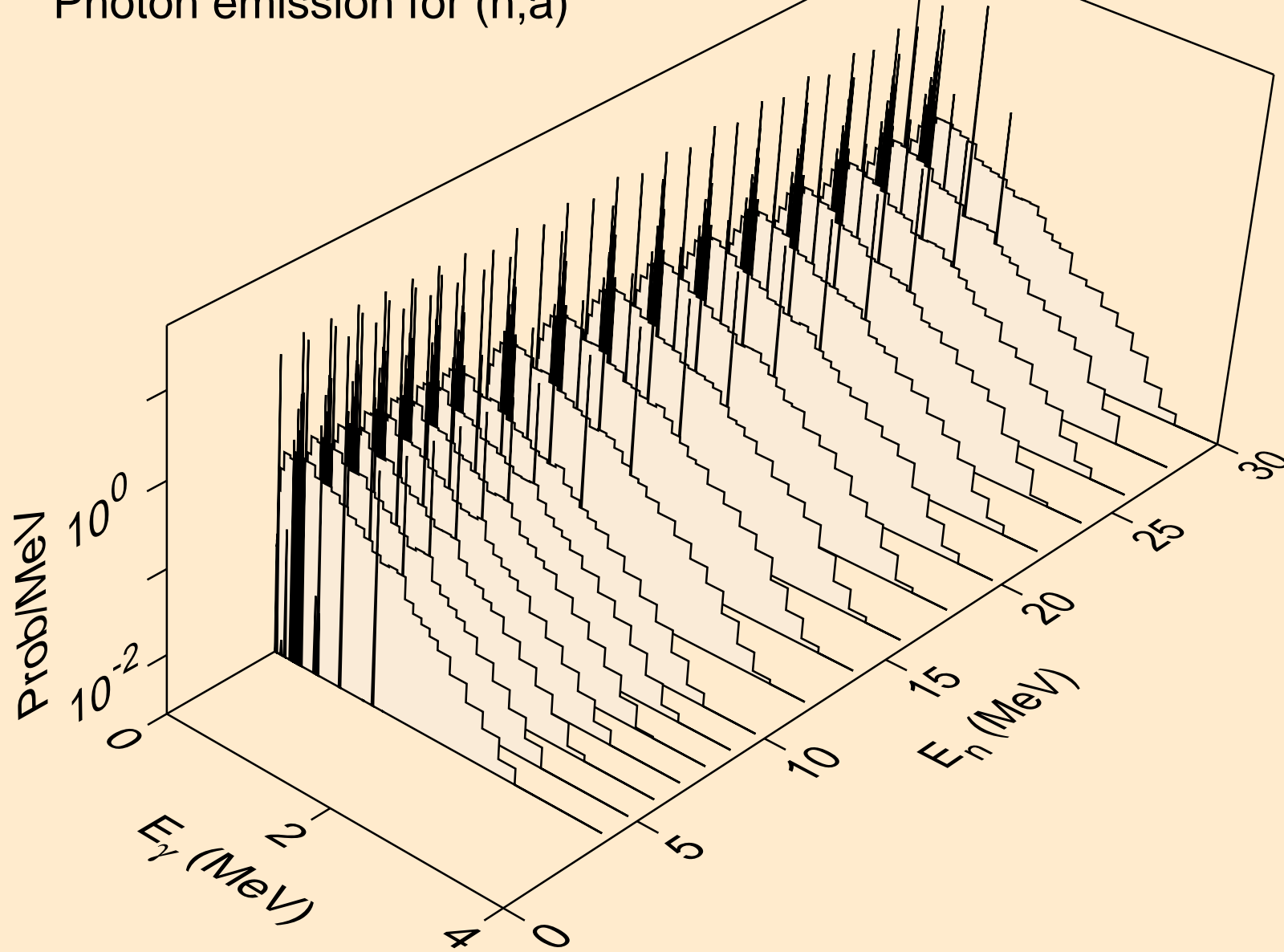

TL218 DEUTERON ACER TENDL-2023 LIBRARY; T=0.K  
Photon emission for (n,2p)

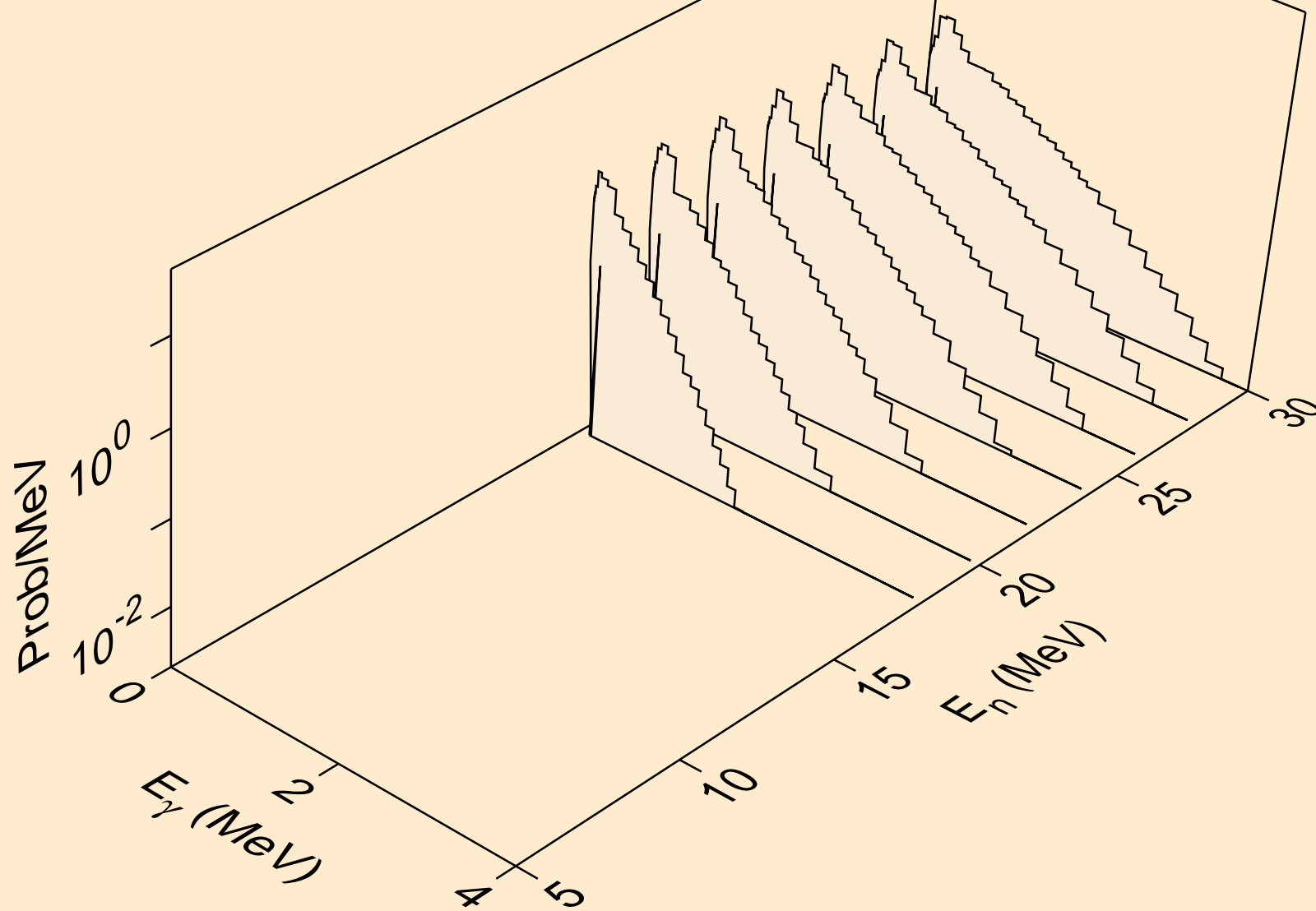

TL218 DEUTERON ACER TENDL-2023 LIBRARY; T=0.K  
Photon emission for (n,pd)

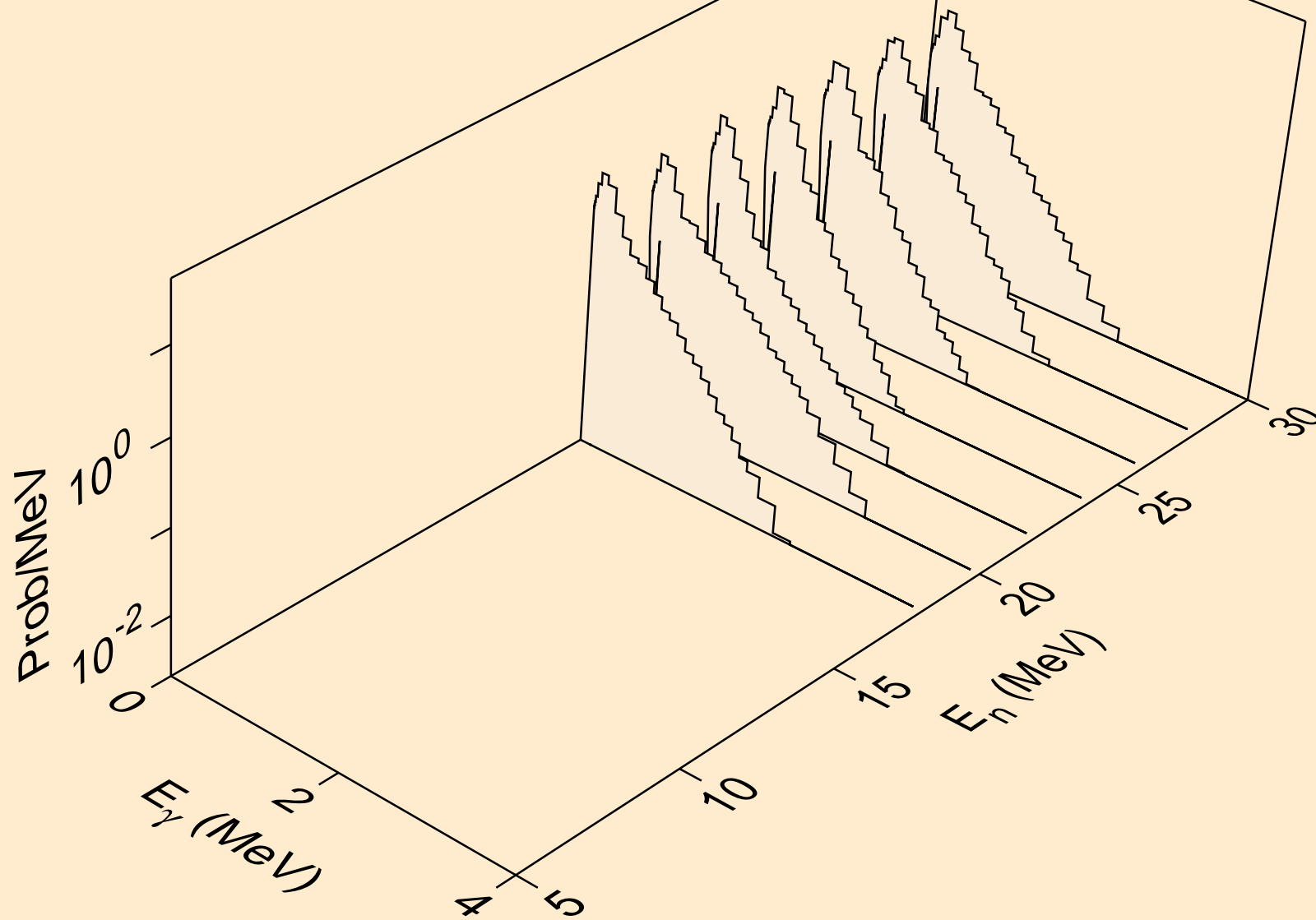

# TL218 DEUTERON ACER TENDL-2023 LIBRARY; T=0.K

## Particle heating contributions

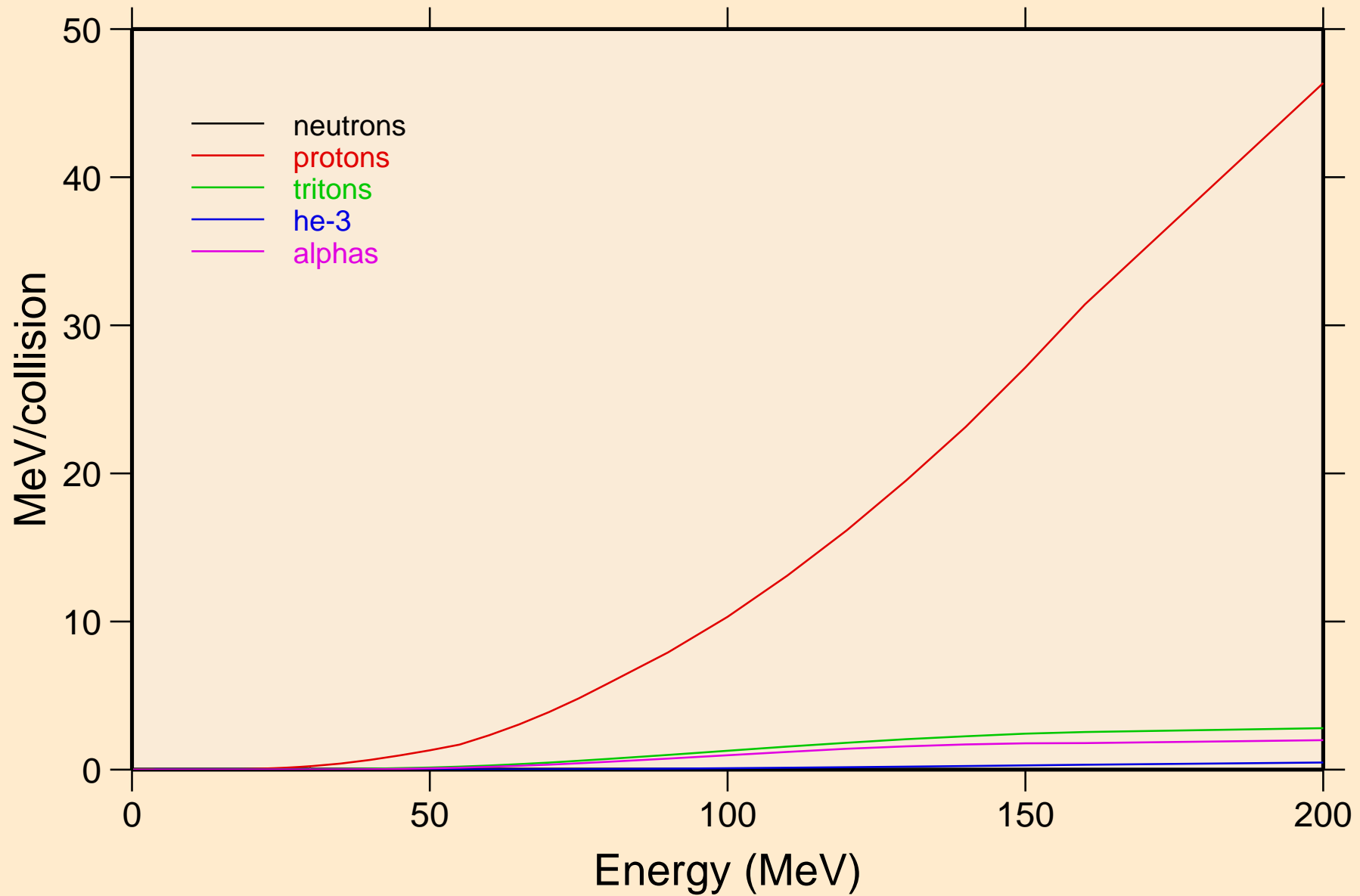

TL218 DEUTERON ACER TENDL-2023 LIBRARY; T=0.K  
Recoil Heating

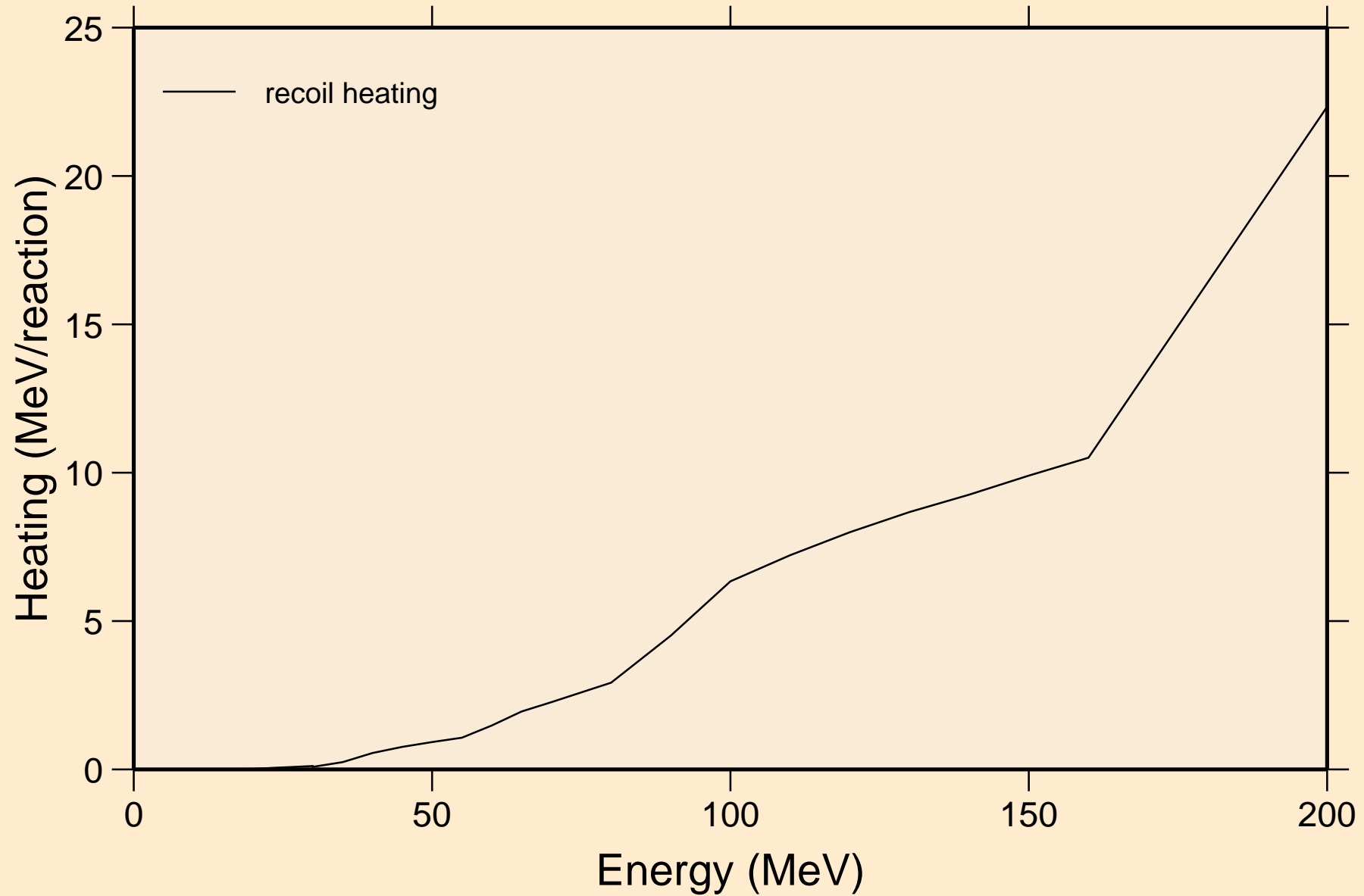

TL218 DEUTERON ACER TENDL-2023 LIBRARY; T=0.K  
Particle production cross sections

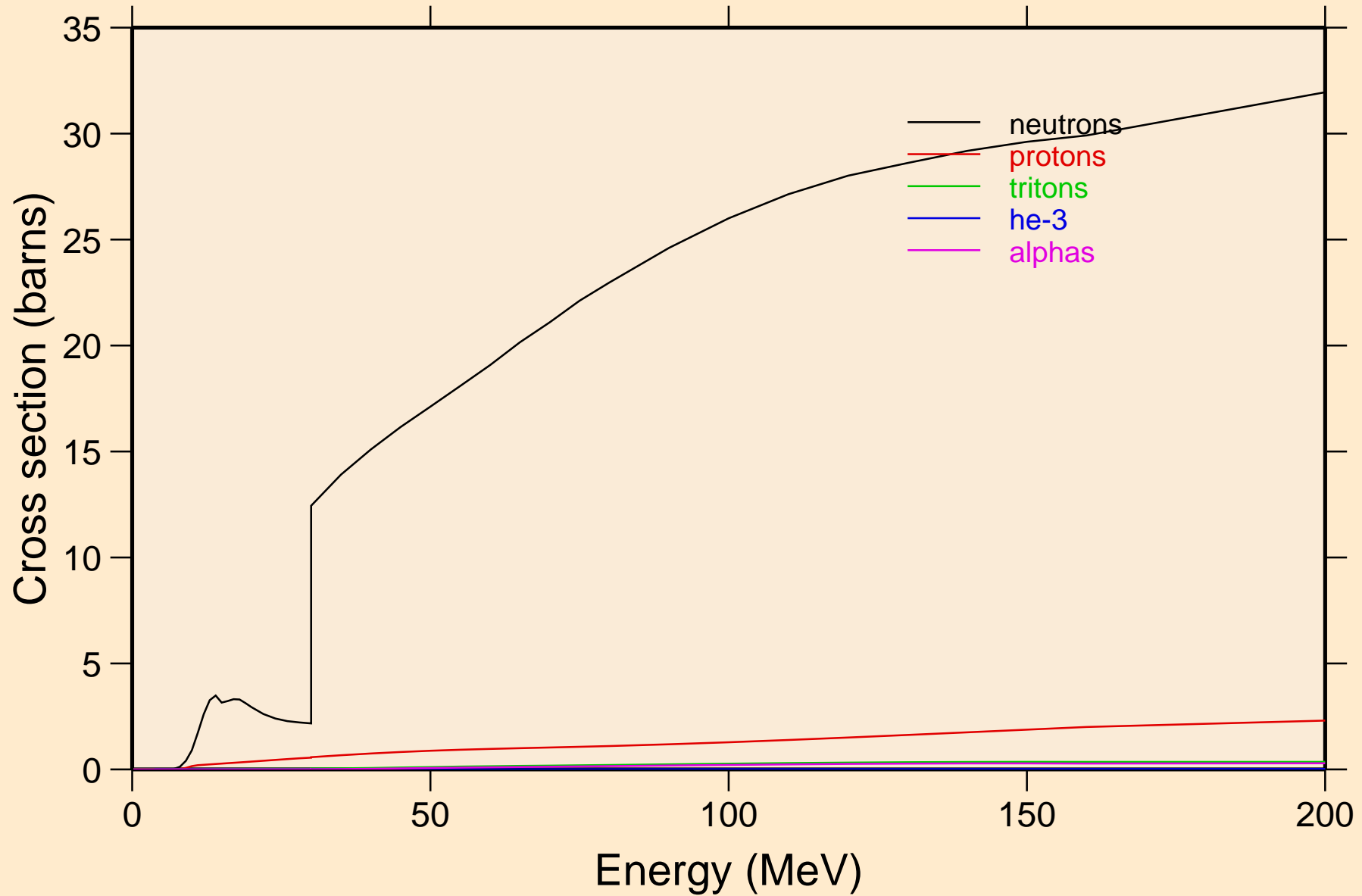

TL218 DEUTERON ACER TENDL-2023 LIBRARY; T=0.K  
neutrons from (d,n)

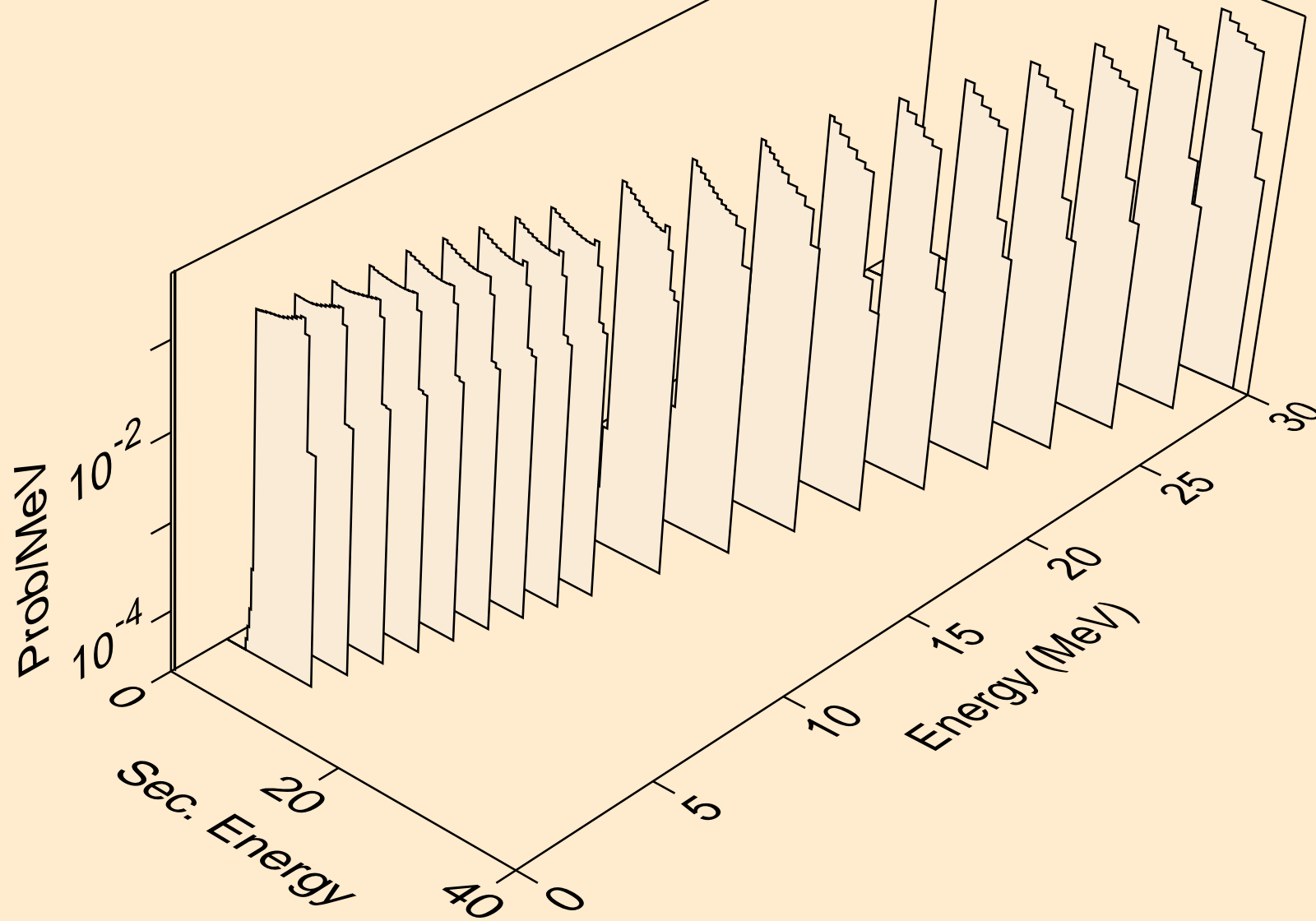



TL218 DEUTERON ACER TENDL-2023 LIBRARY; T=0.K  
neutrons from (d,x)

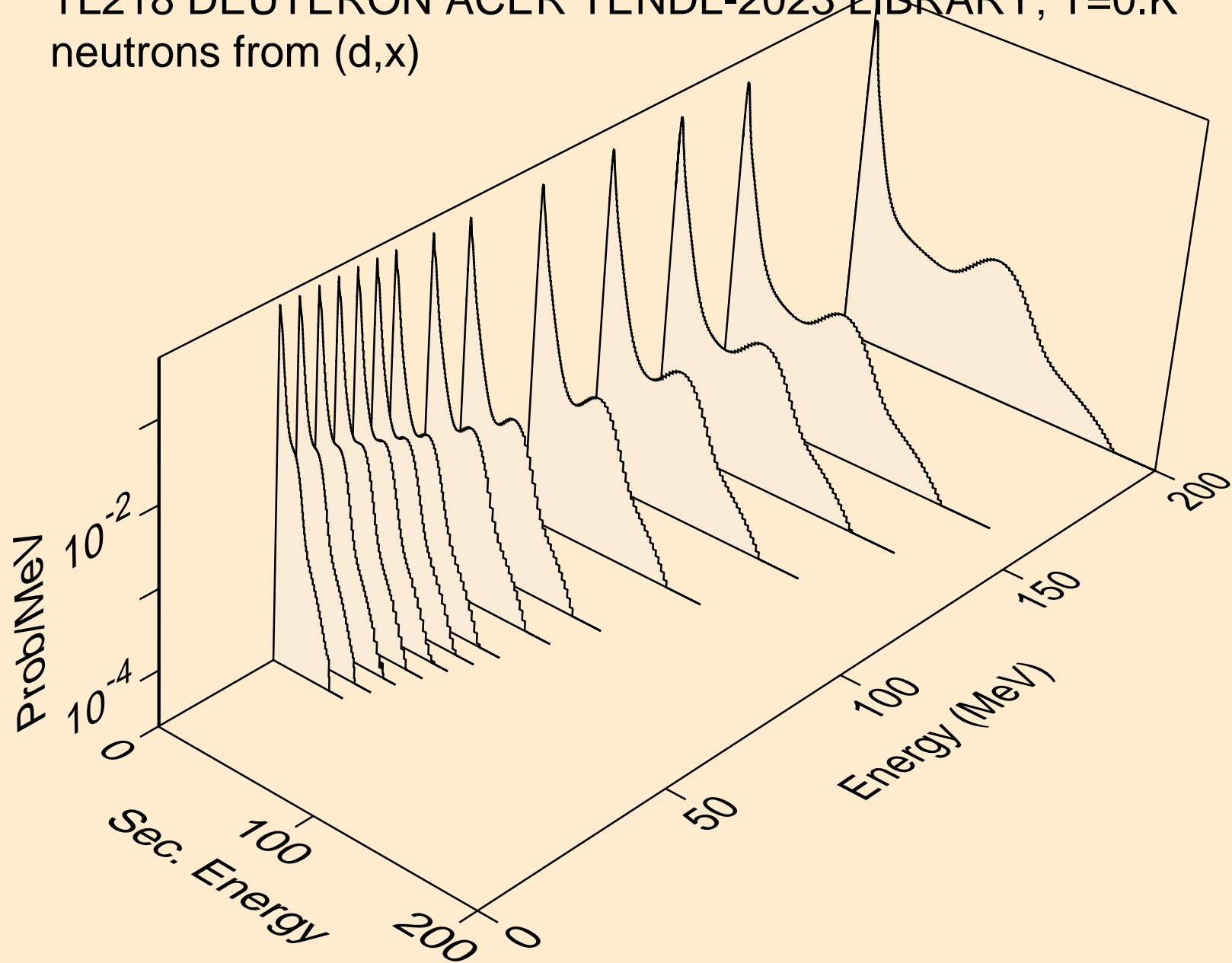

TL218 DEUTERON ACER TENDL-2023 LIBRARY; T=0.K  
neutrons from (d,2nd)

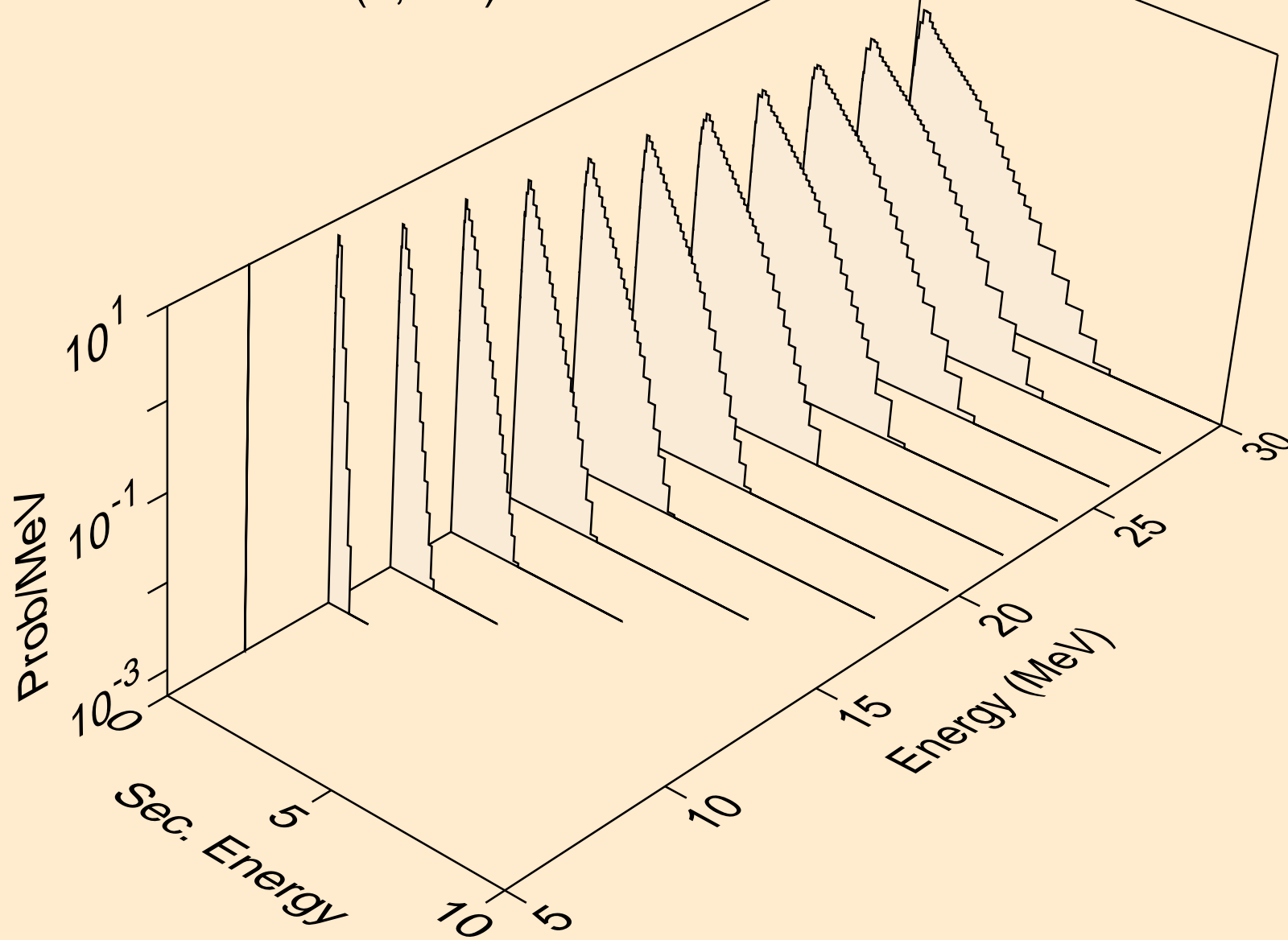

TL218 DEUTERON ACER TENDL-2023 LIBRARY; T=0.K  
neutrons from (d,2n)

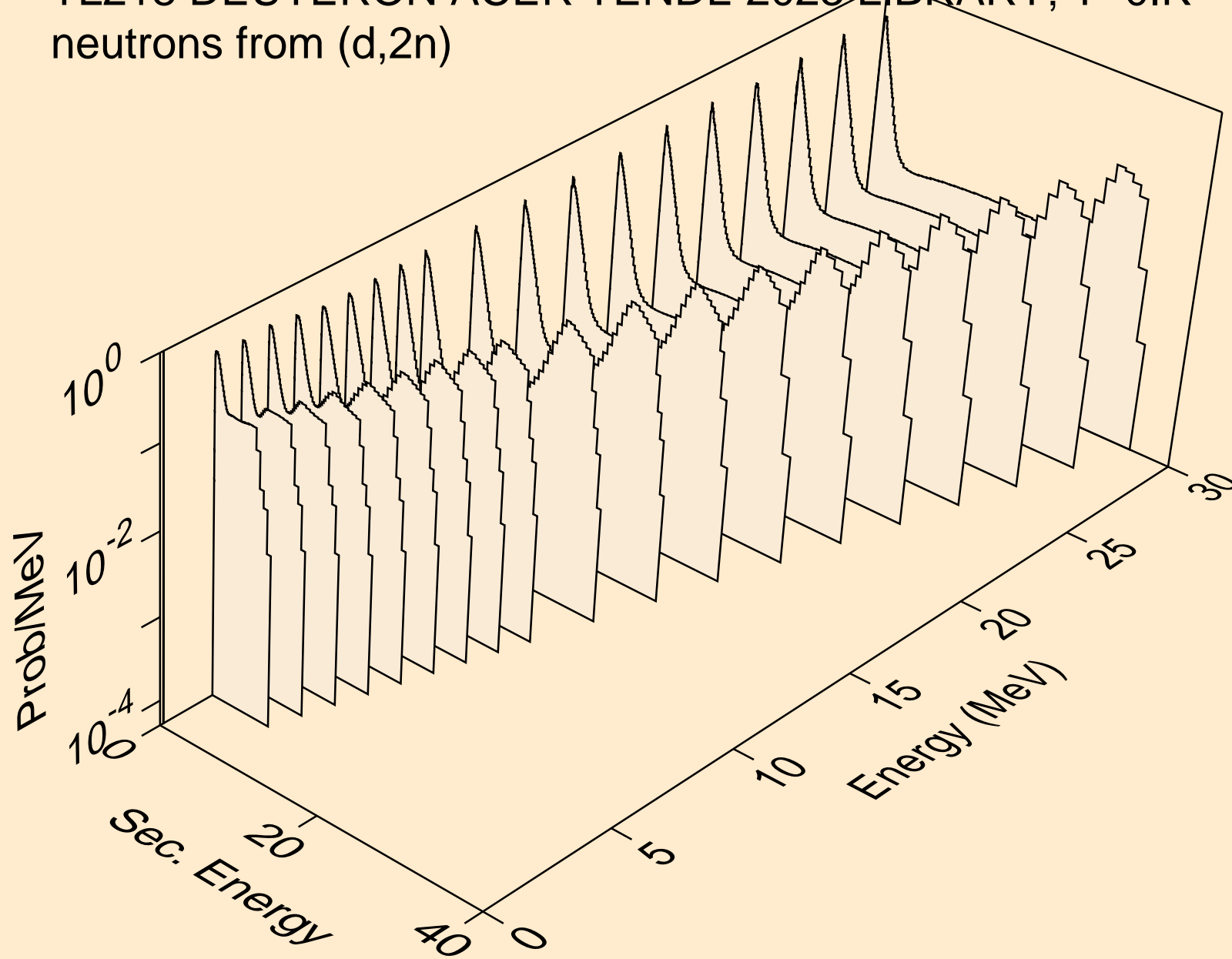

TL218 DEUTERON ACER TENDL-2023 LIBRARY; T=0.K  
neutrons from (d,3n)

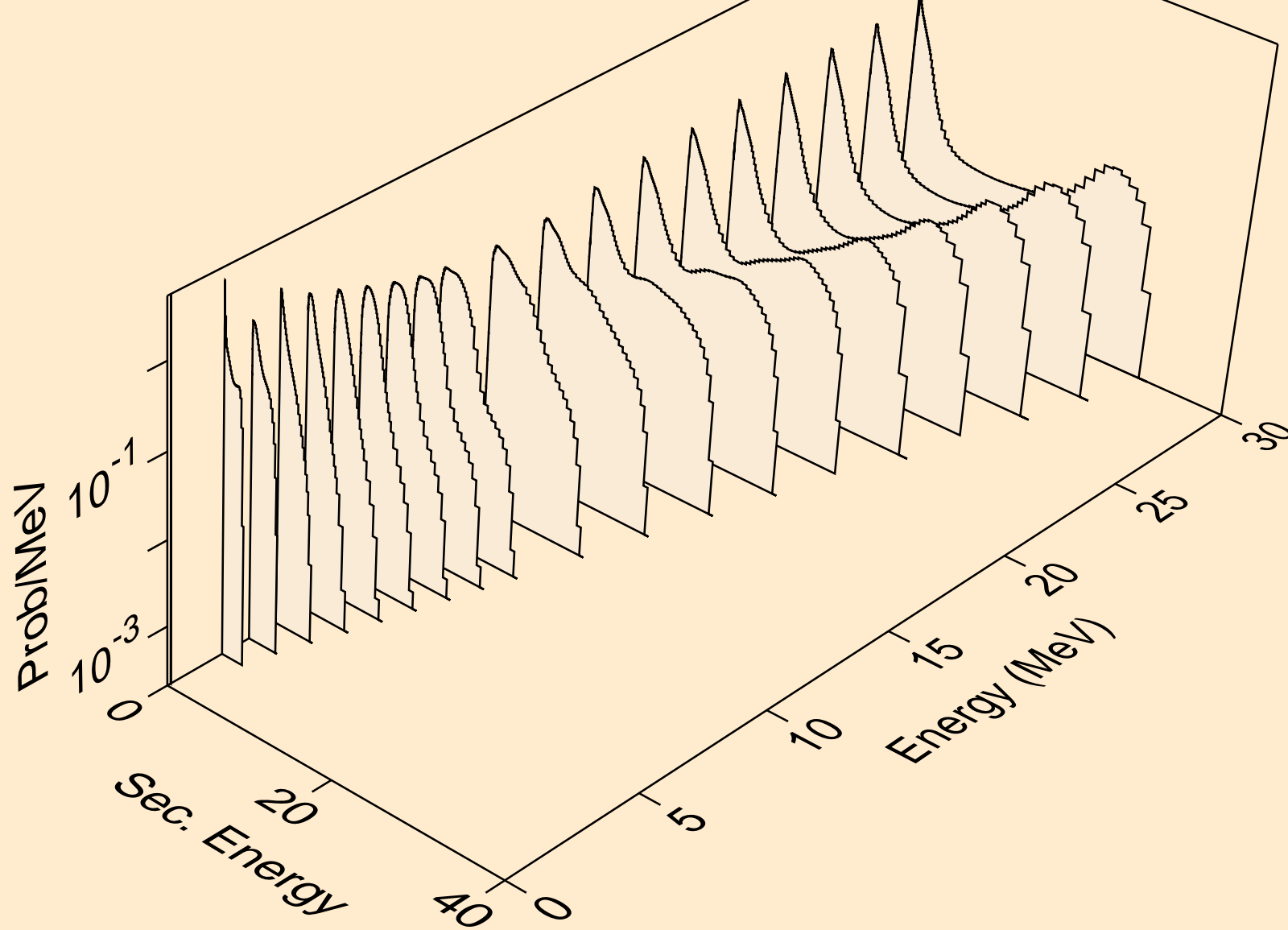

TL218 DEUTERON ACER TENDL-2023 LIBRARY; T=0.K  
neutrons from (d,n\*)a

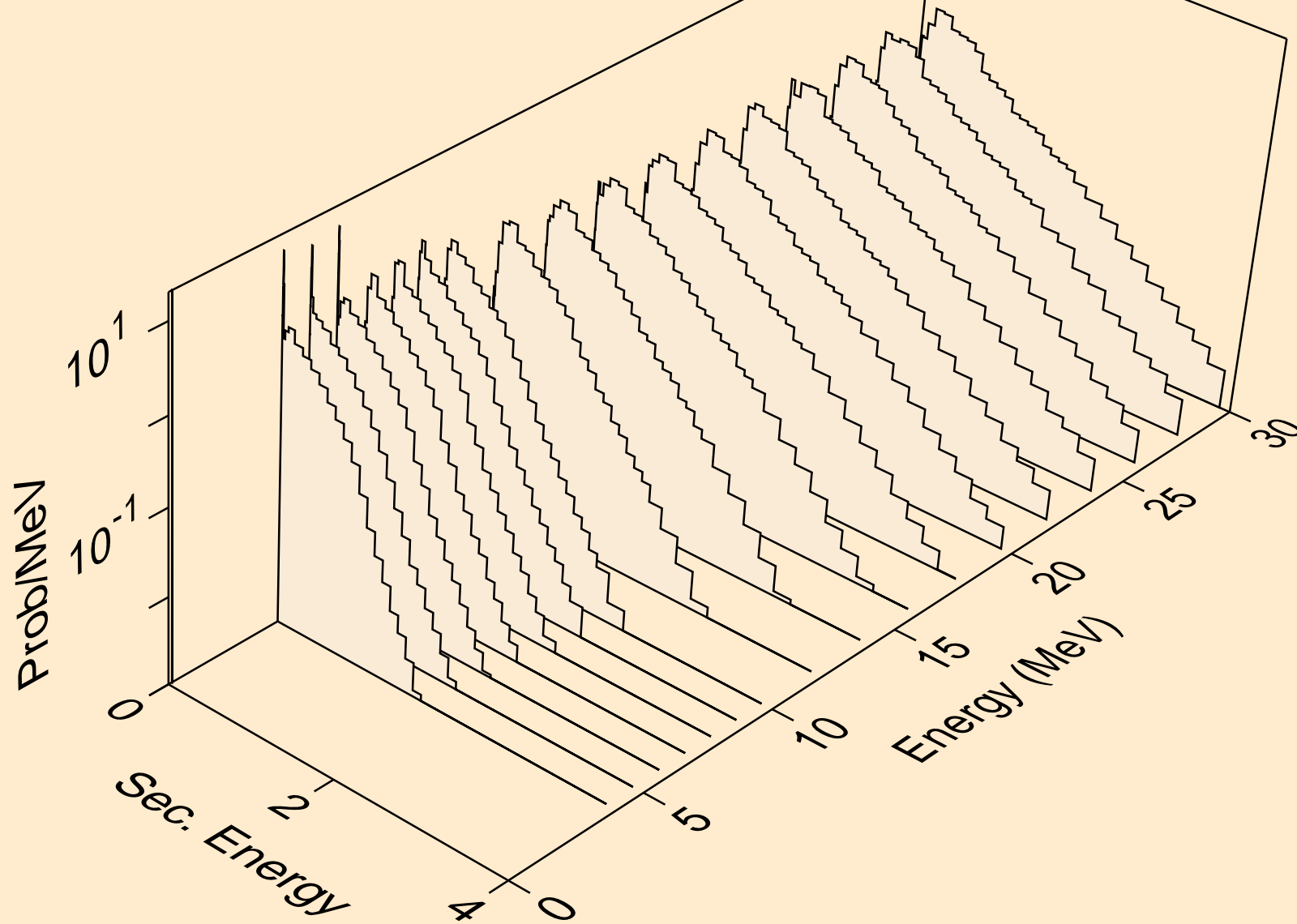

TL218 DEUTERON ACER TENDL-2023 LIBRARY; T=0.K  
neutrons from (d,2n)a

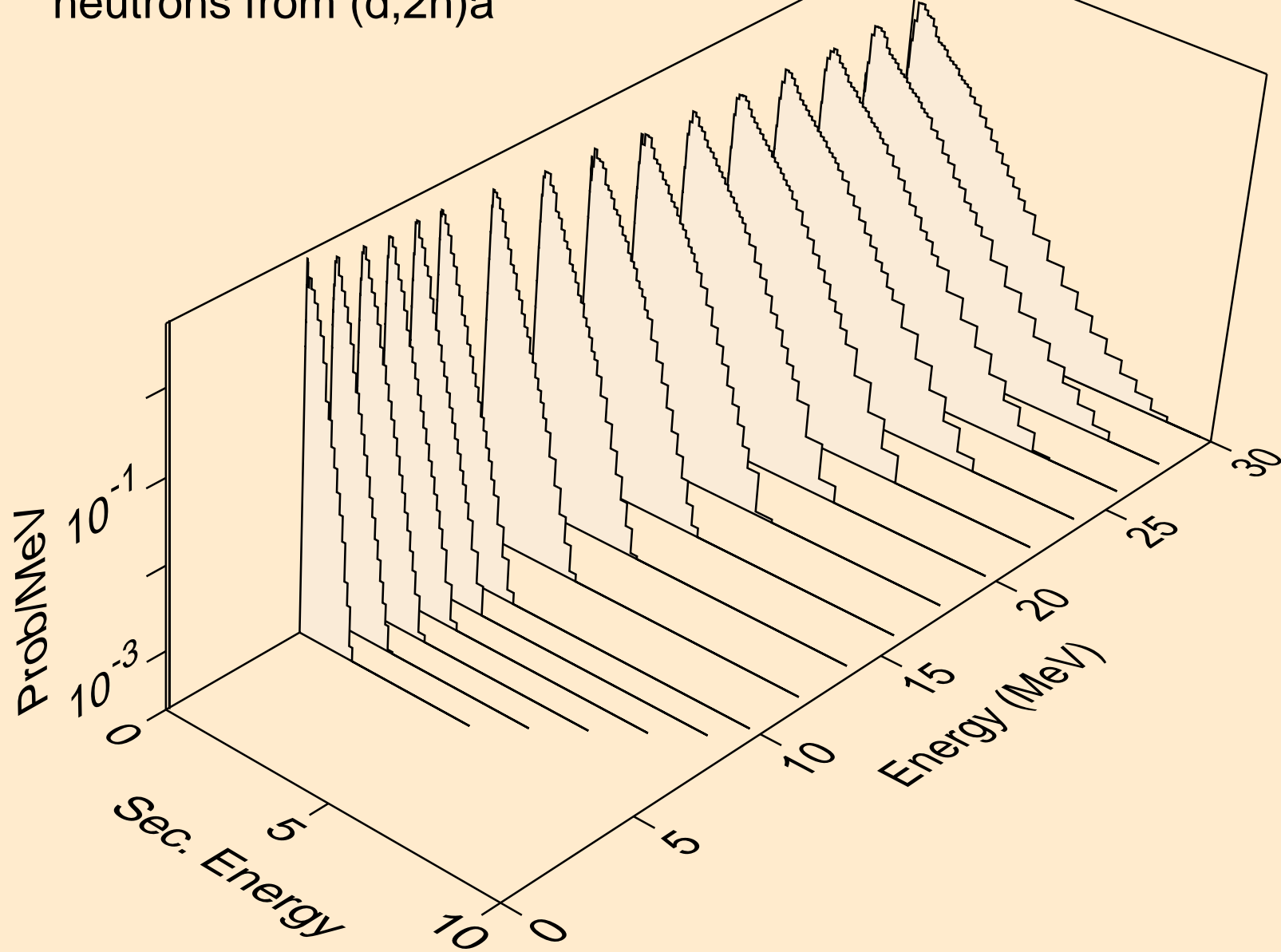

TL218 DEUTERON ACER TENDL-2023 LIBRARY; T=0.K  
neutrons from (d,3n)a

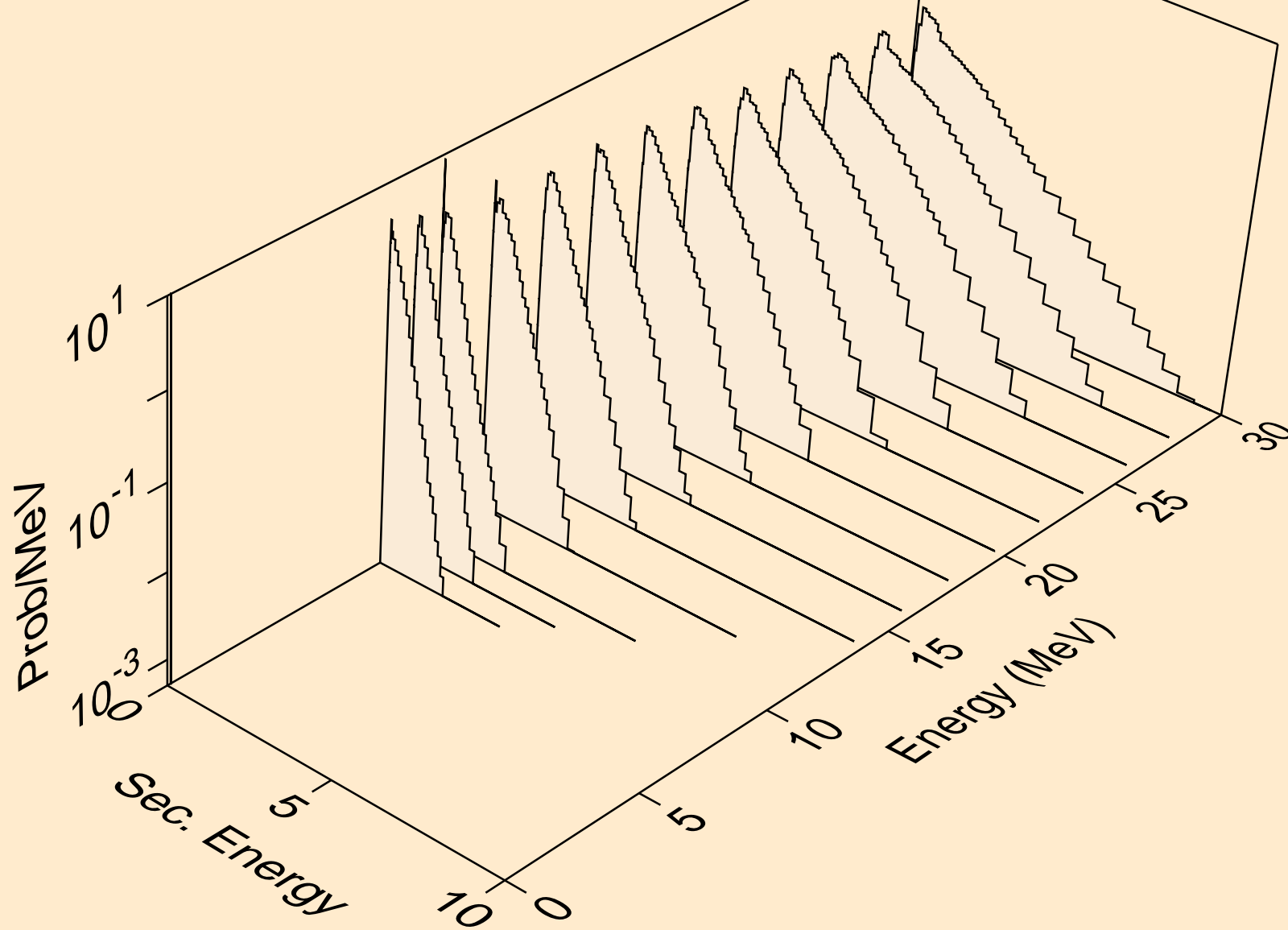

TL218 DEUTERON ACER TENDL-2023 LIBRARY; T=0.K  
neutrons from (d,n\*)p

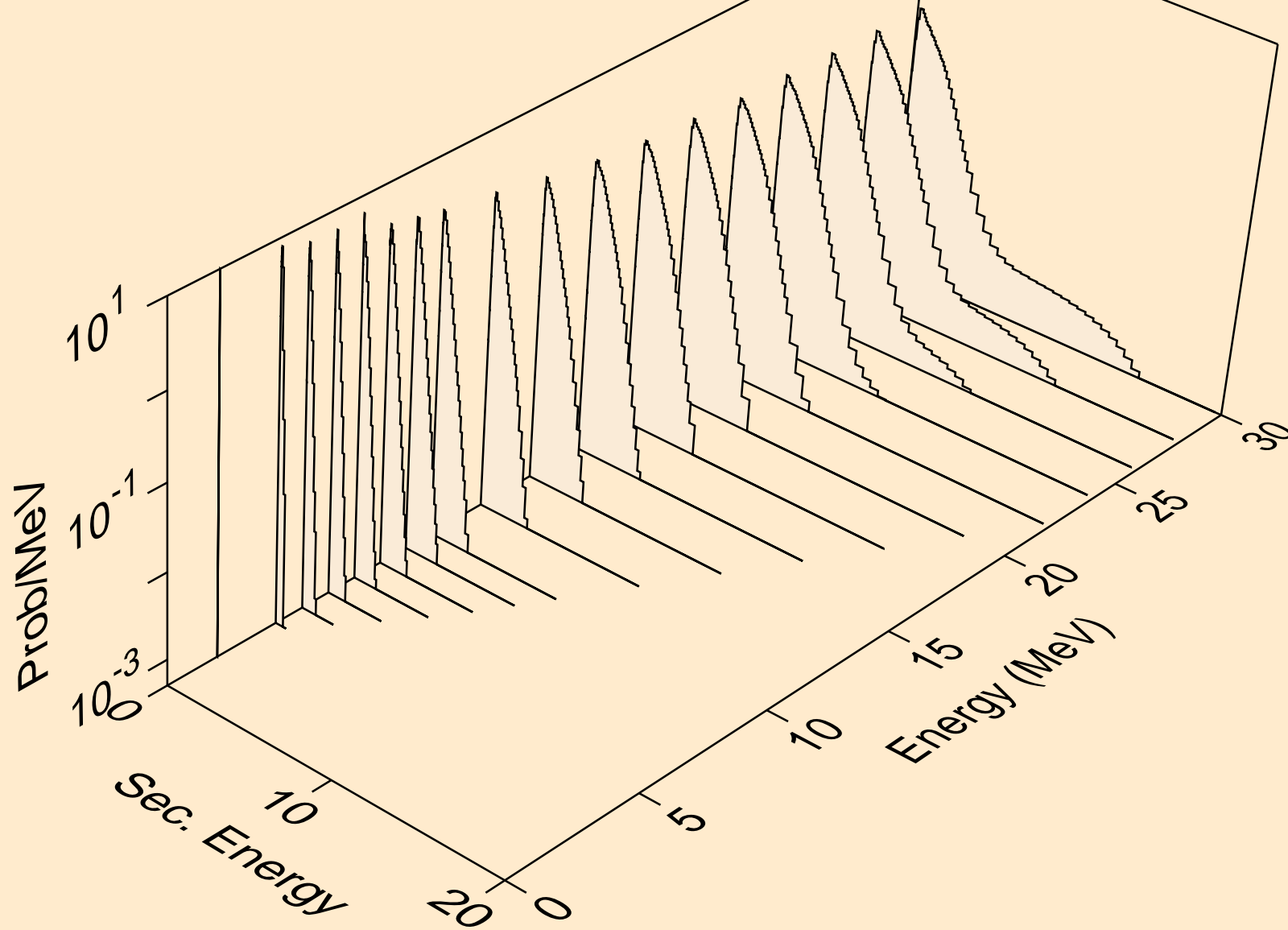



TL218 DEUTERON ACER TENDL-2023 LIBRARY; T=0.K  
neutrons from (d,n\*)d

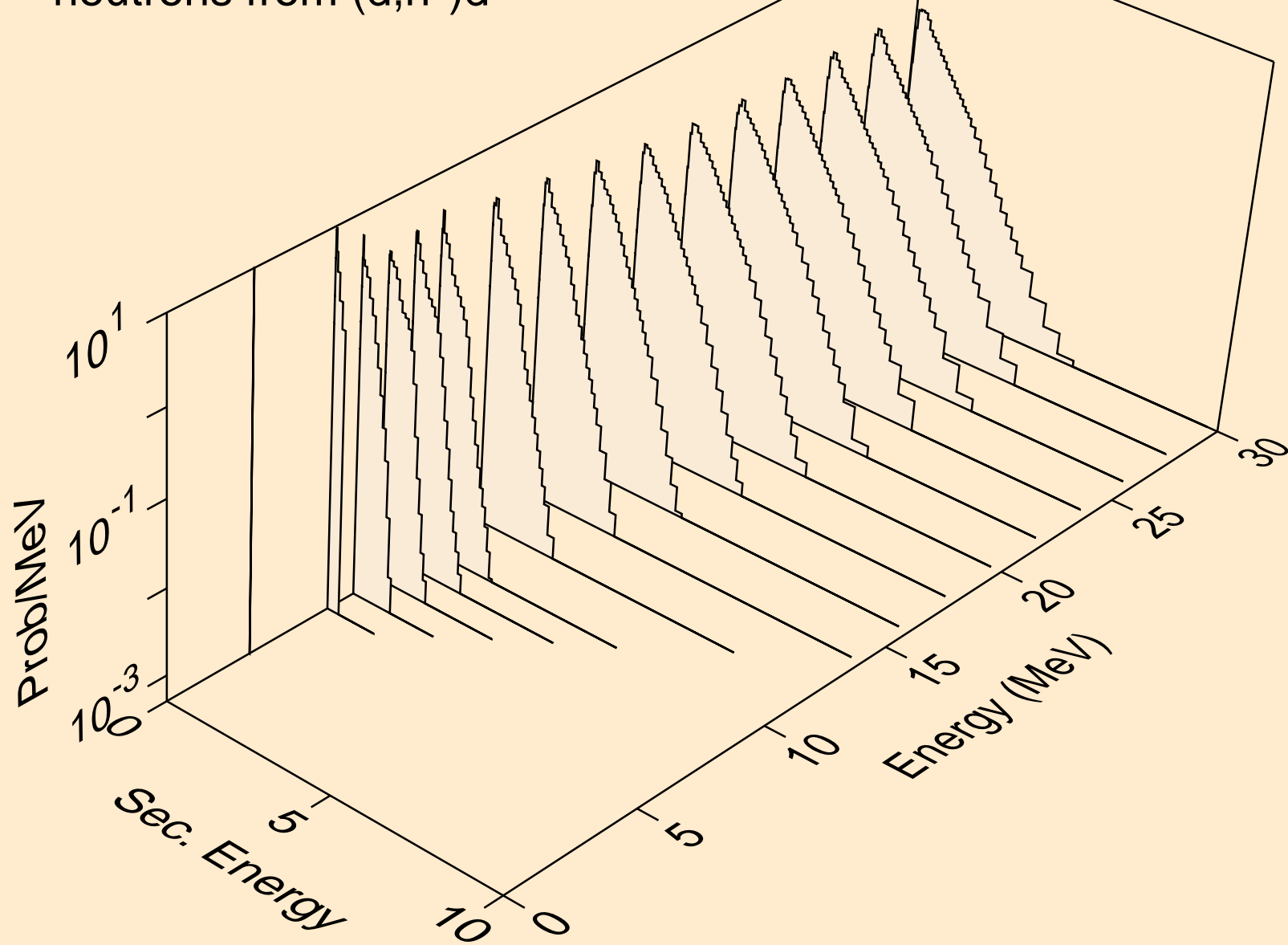

TL218 DEUTERON ACER TENDL-2023 LIBRARY; T=0.K  
neutrons from (d,n\*)t

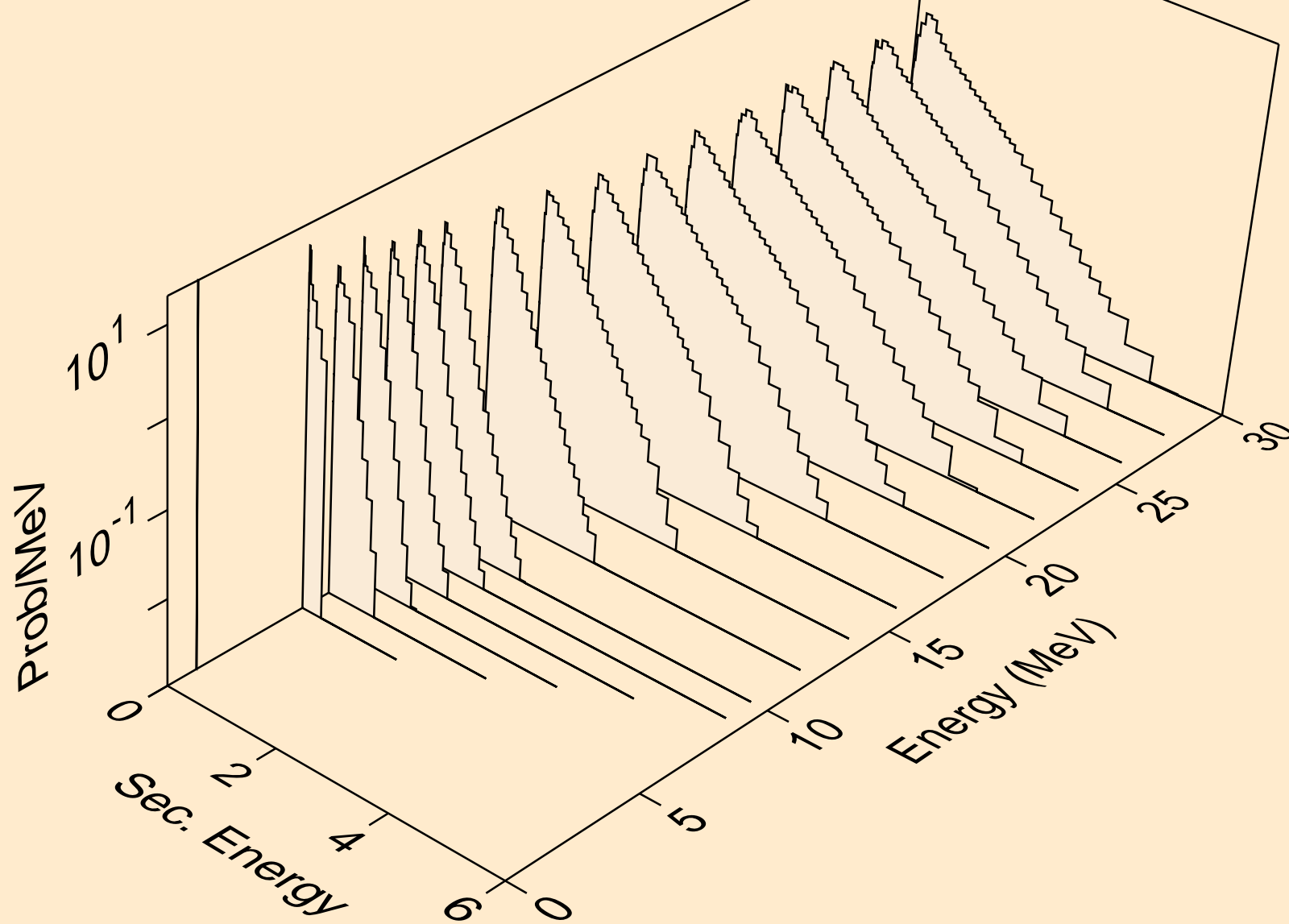

TL218 DEUTERON ACER TENDL-2023 LIBRARY; T=0.K  
neutrons from (d,n\*)he3

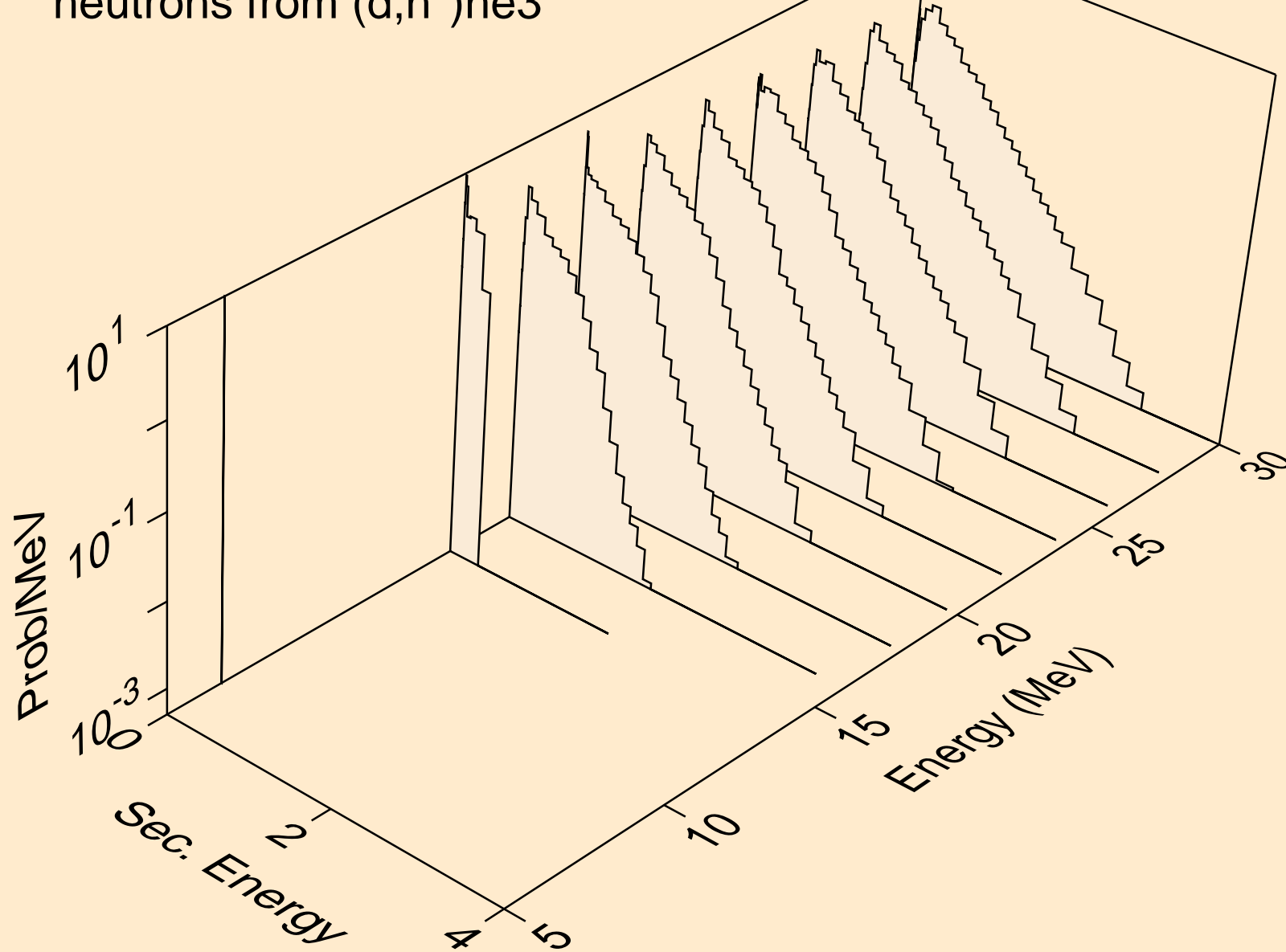

TL218 DEUTERON ACER TENDL-2023 LIBRARY; T=0.K  
neutrons from (d,4n)

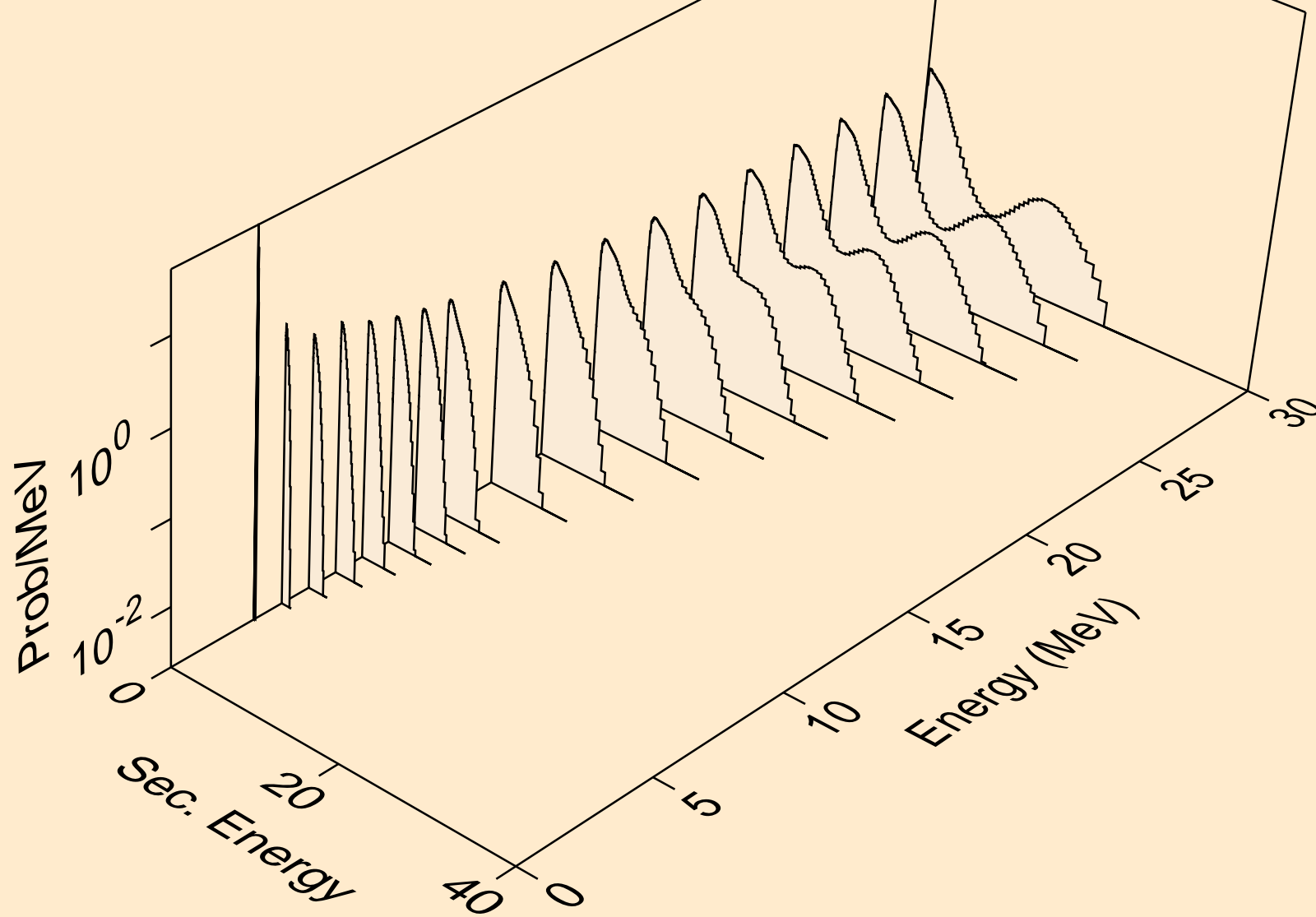

TL218 DEUTERON ACER TENDL-2023 LIBRARY; T=0.K  
neutrons from (d,2np)

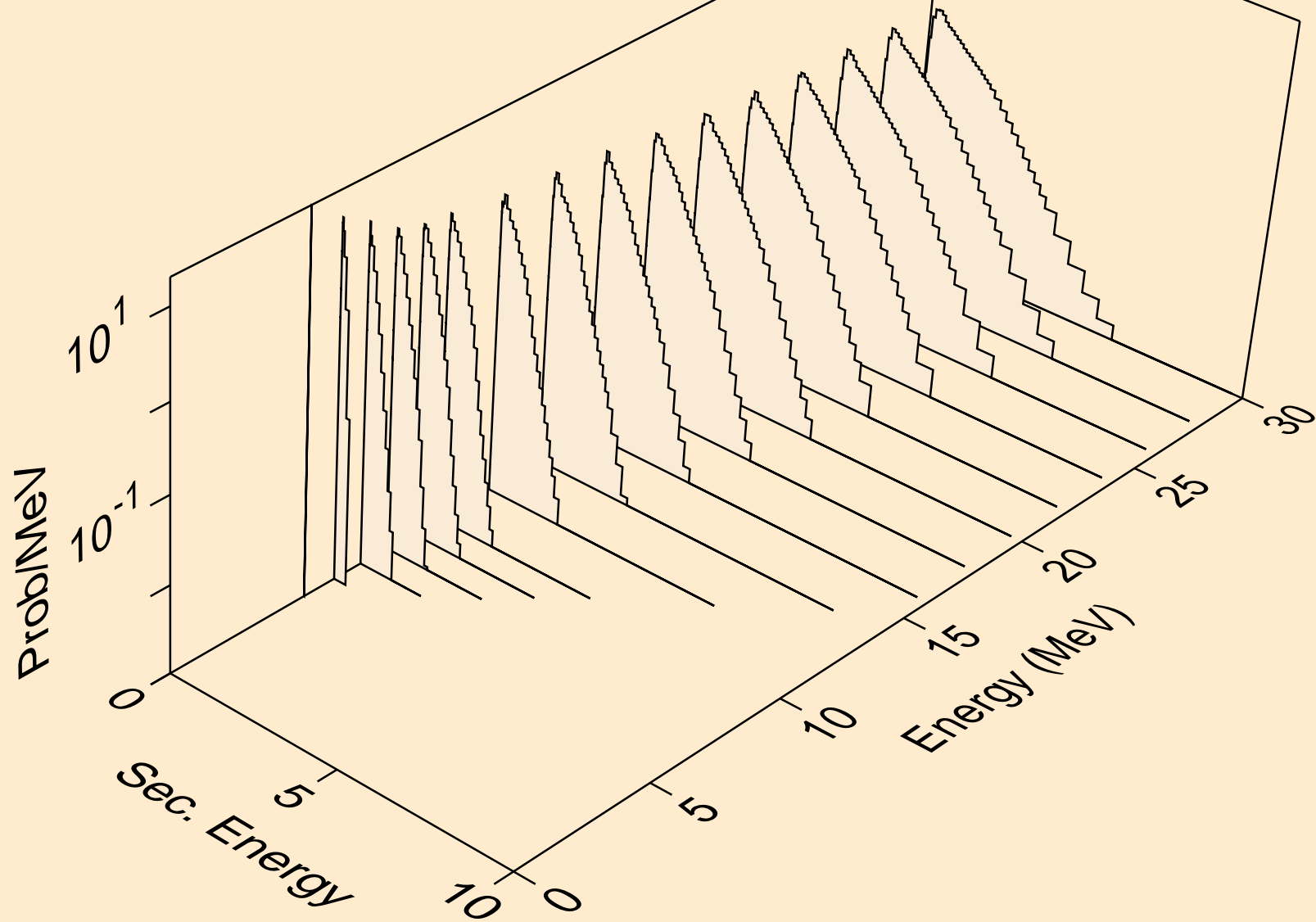

TL218 DEUTERON ACER TENDL-2023 LIBRARY; T=0.K  
neutrons from (d,3np)

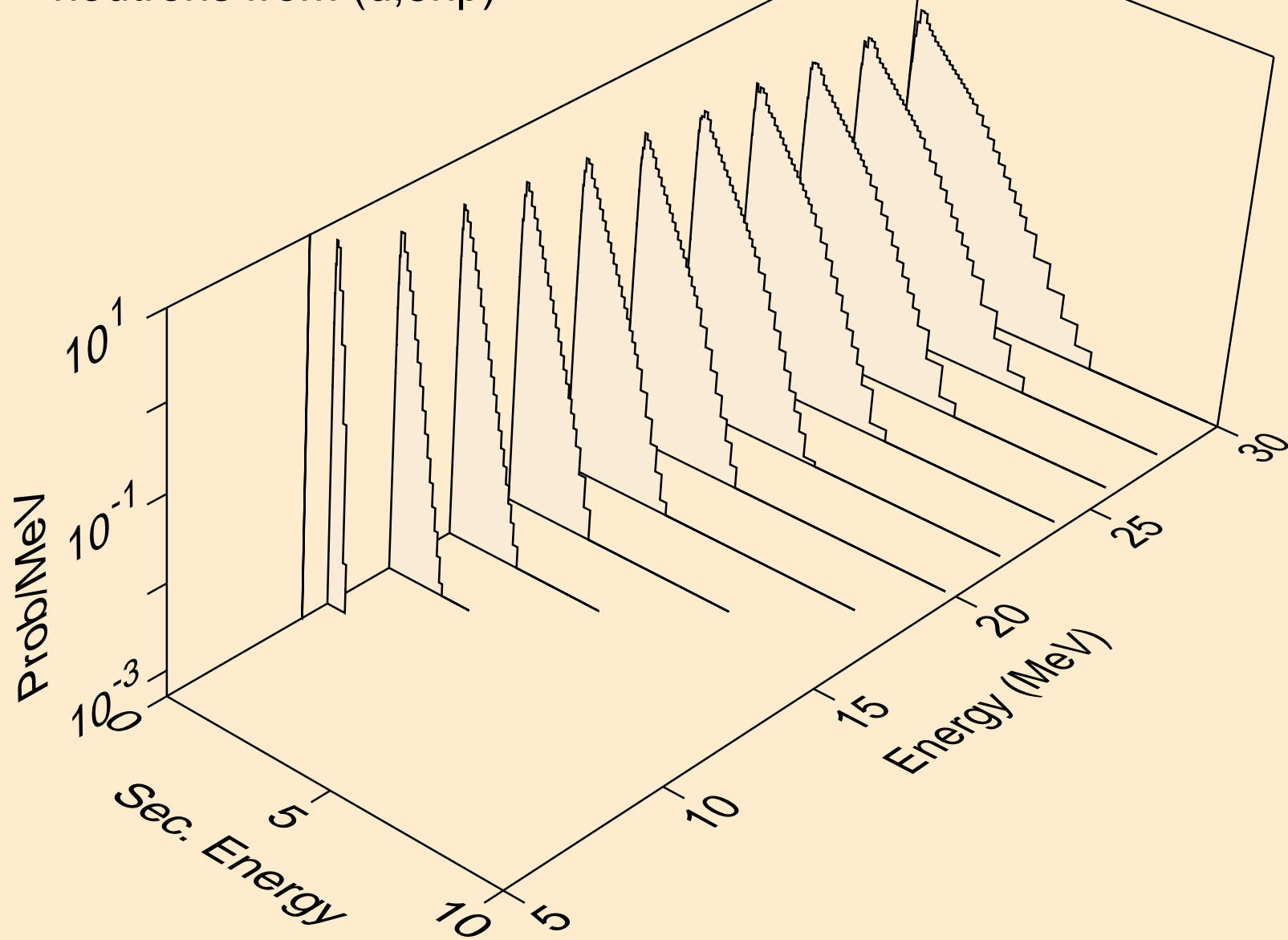

TL218 DEUTERON ACER TENDL-2023 LIBRARY; T=0.K  
neutrons from (d,n2p)

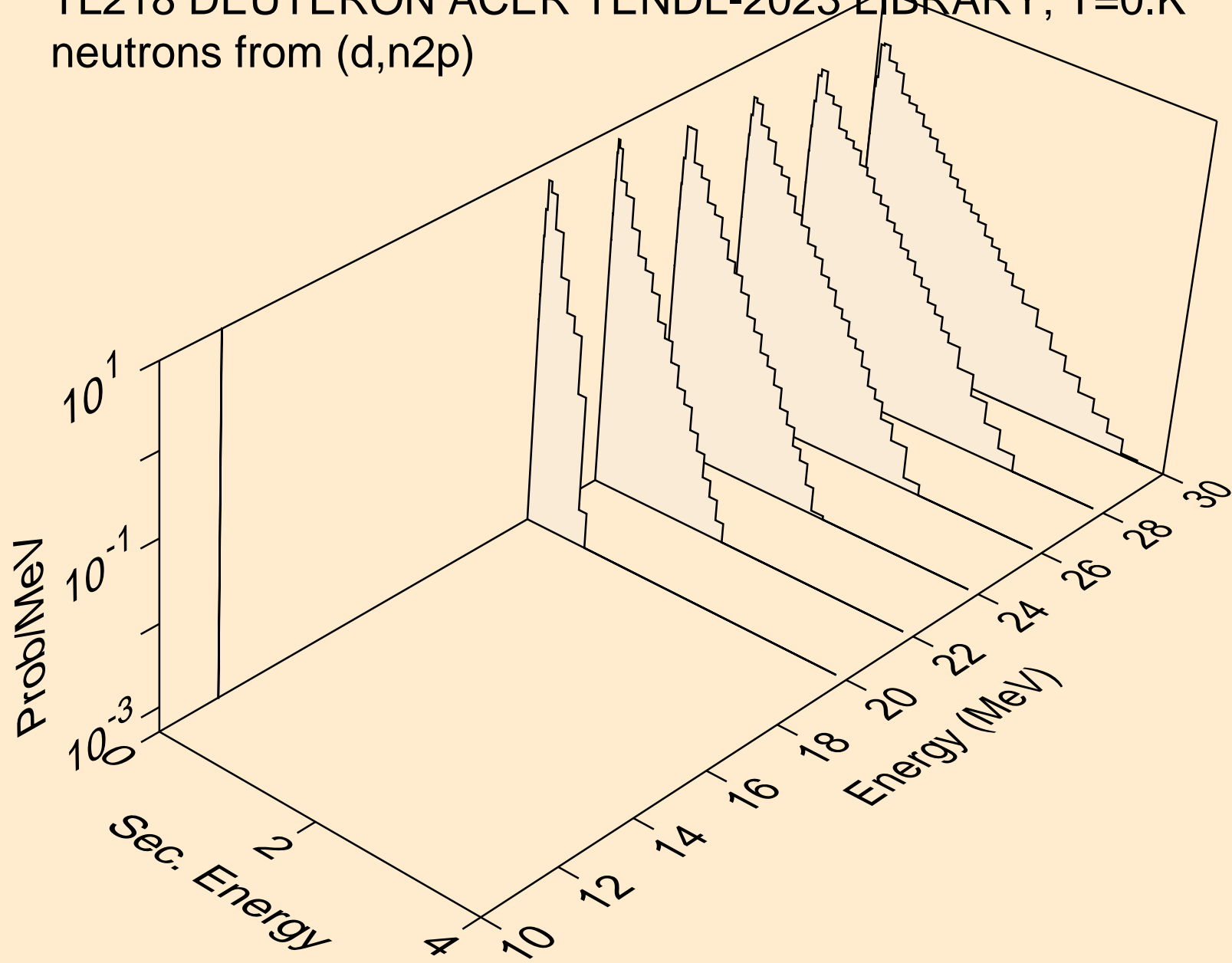

TL218 DEUTERON ACER TENDL-2023 LIBRARY; T=0.K  
protons from (d,x)

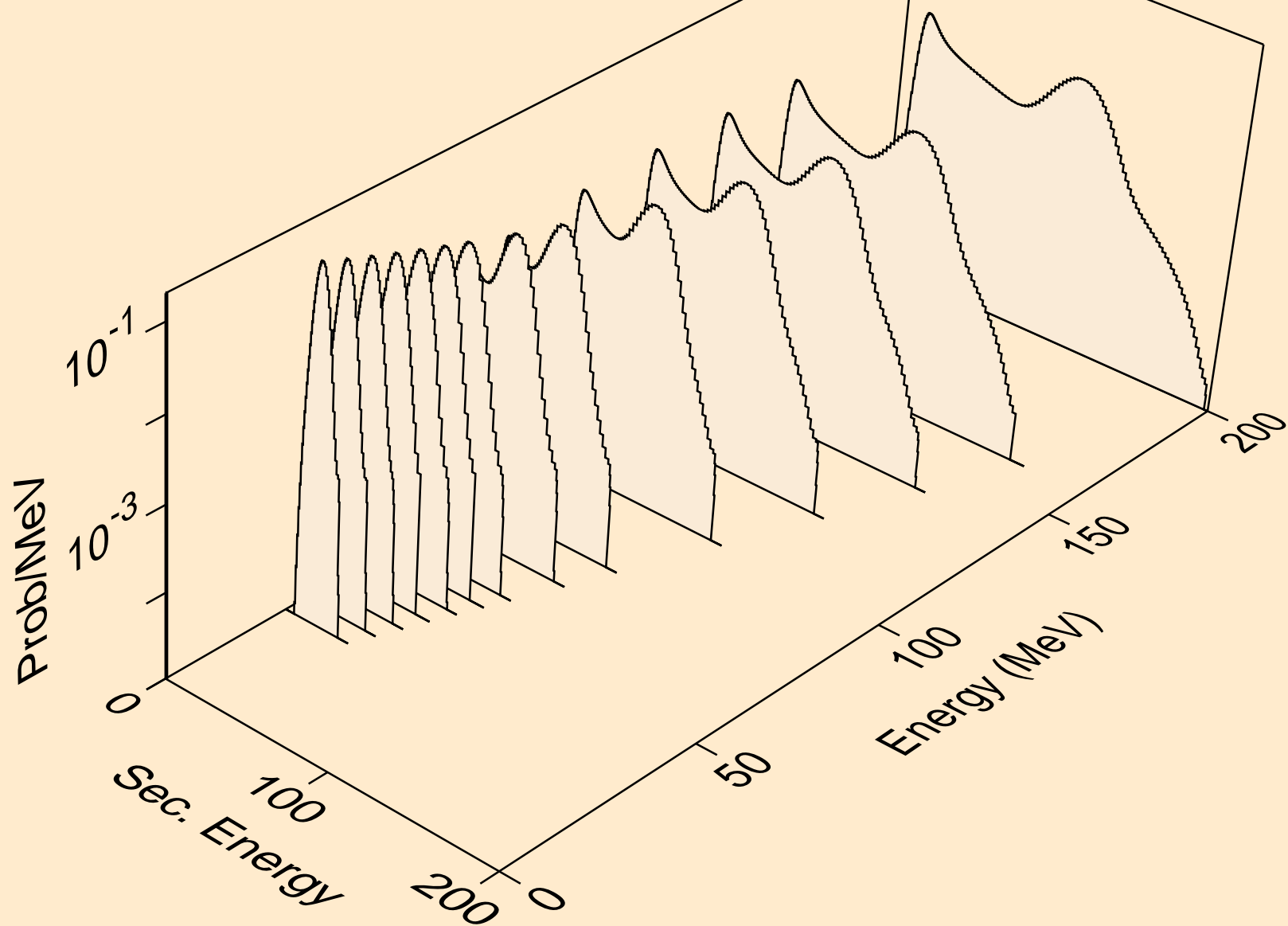



TL218 DEUTERON ACER TENDL-2023 LIBRARY; T=0.K  
protons from (d,n\*)p

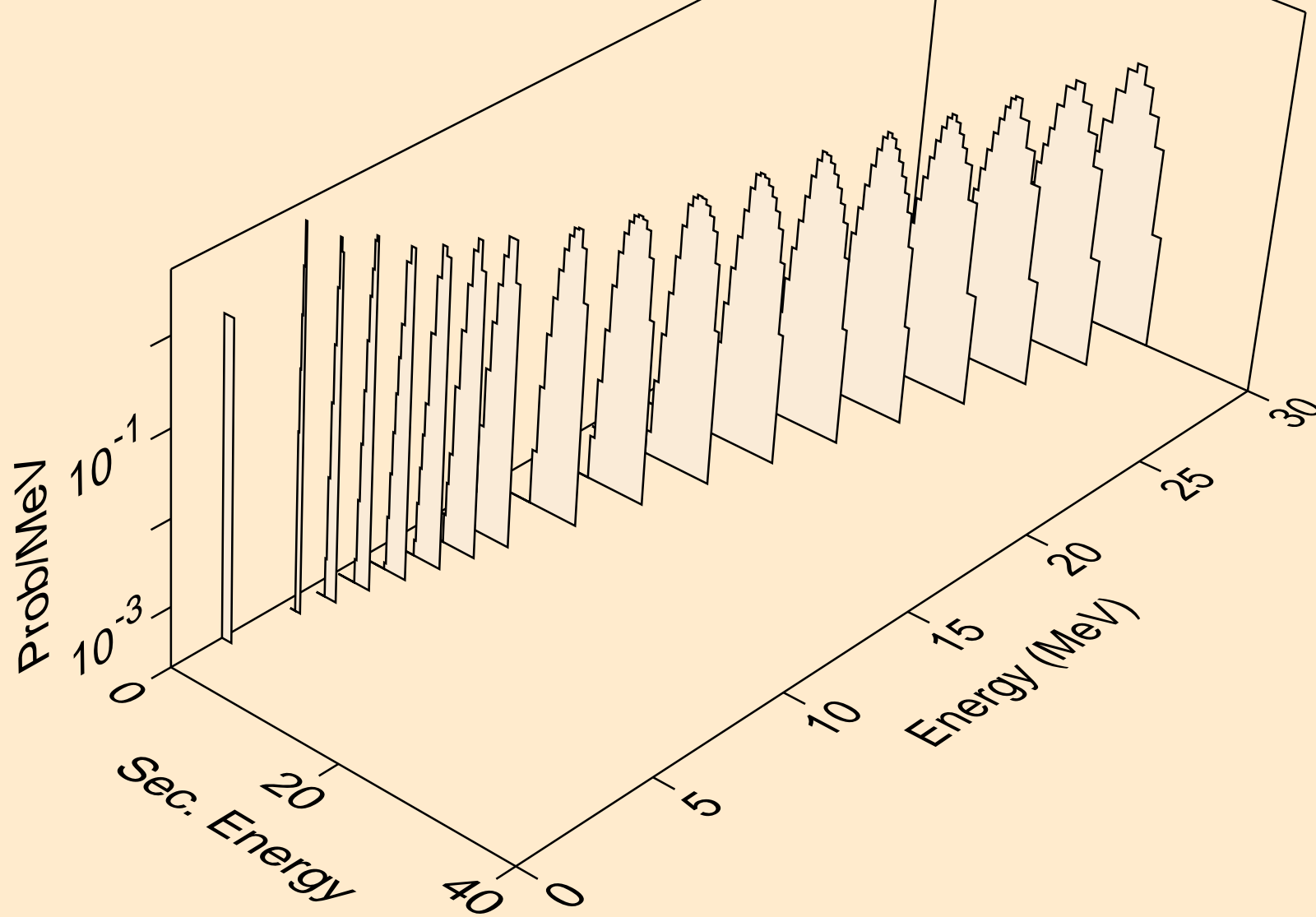

TL218 DEUTERON ACER TENDL-2023 LIBRARY; T=0.K  
protons from (d,2np)

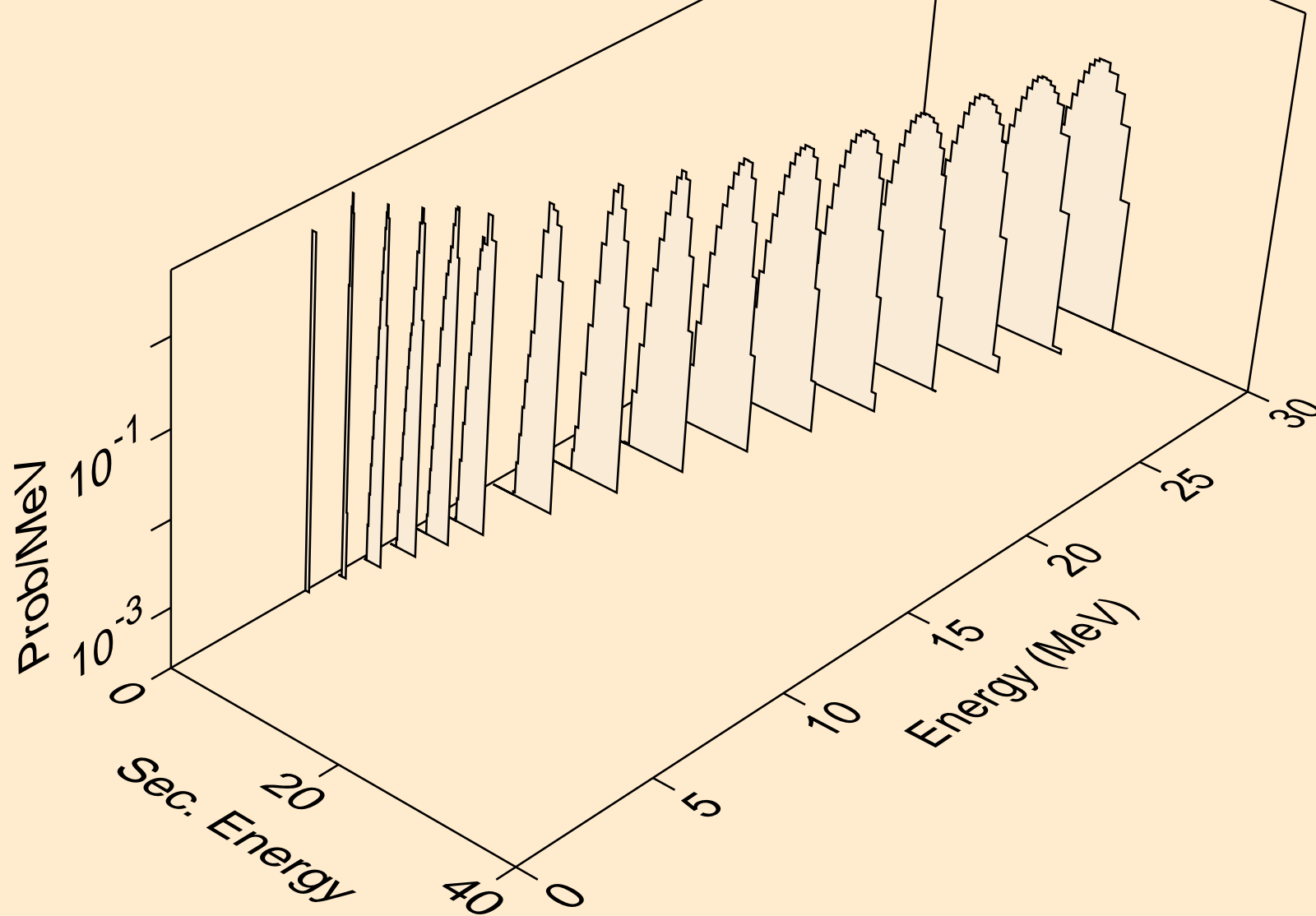

TL218 DEUTERON ACER TENDL-2023 LIBRARY; T=0.K  
protons from (d,3np)

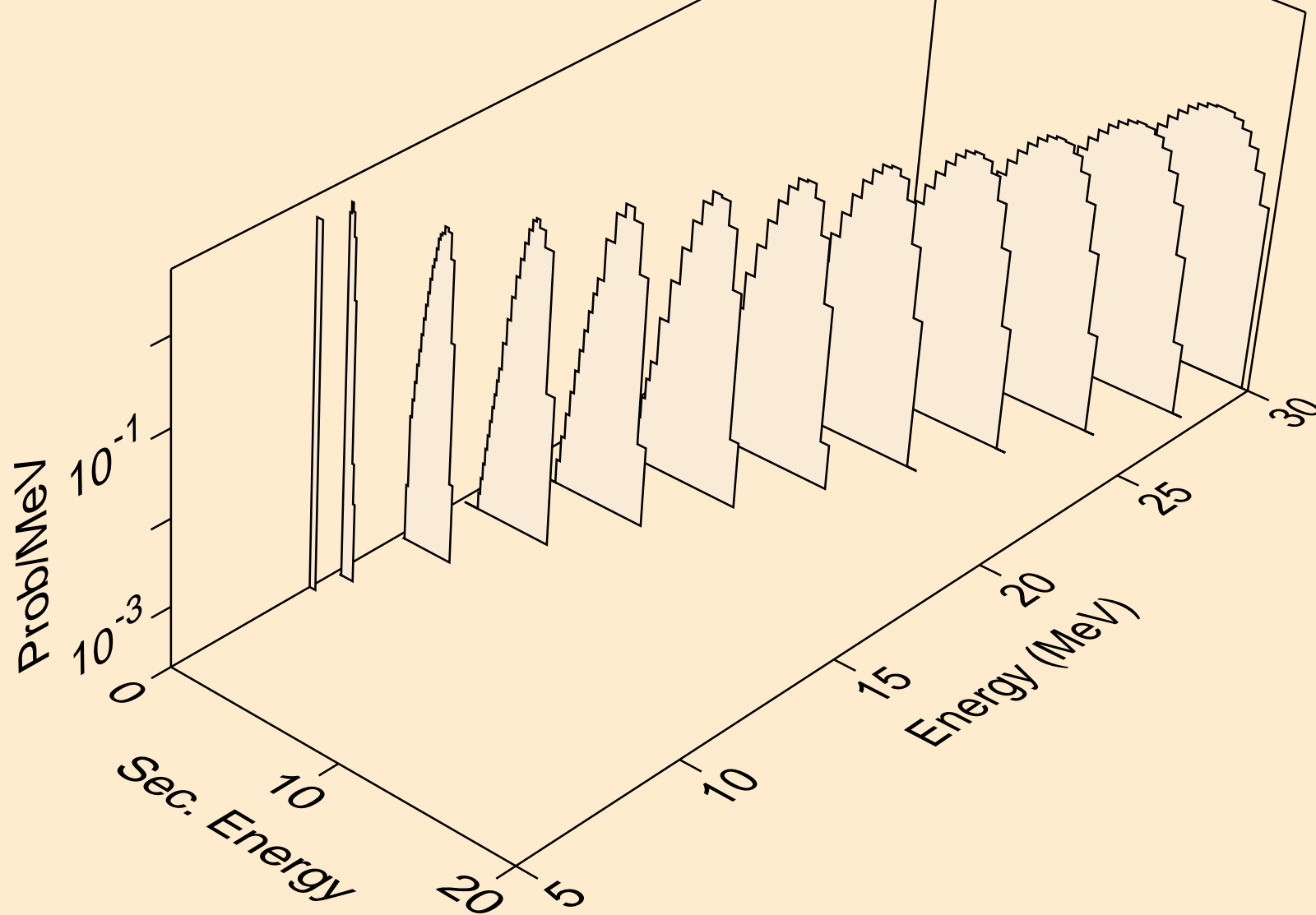

TL218 DEUTERON ACER TENDL-2023 LIBRARY; T=0.K  
protons from (d,n2p)

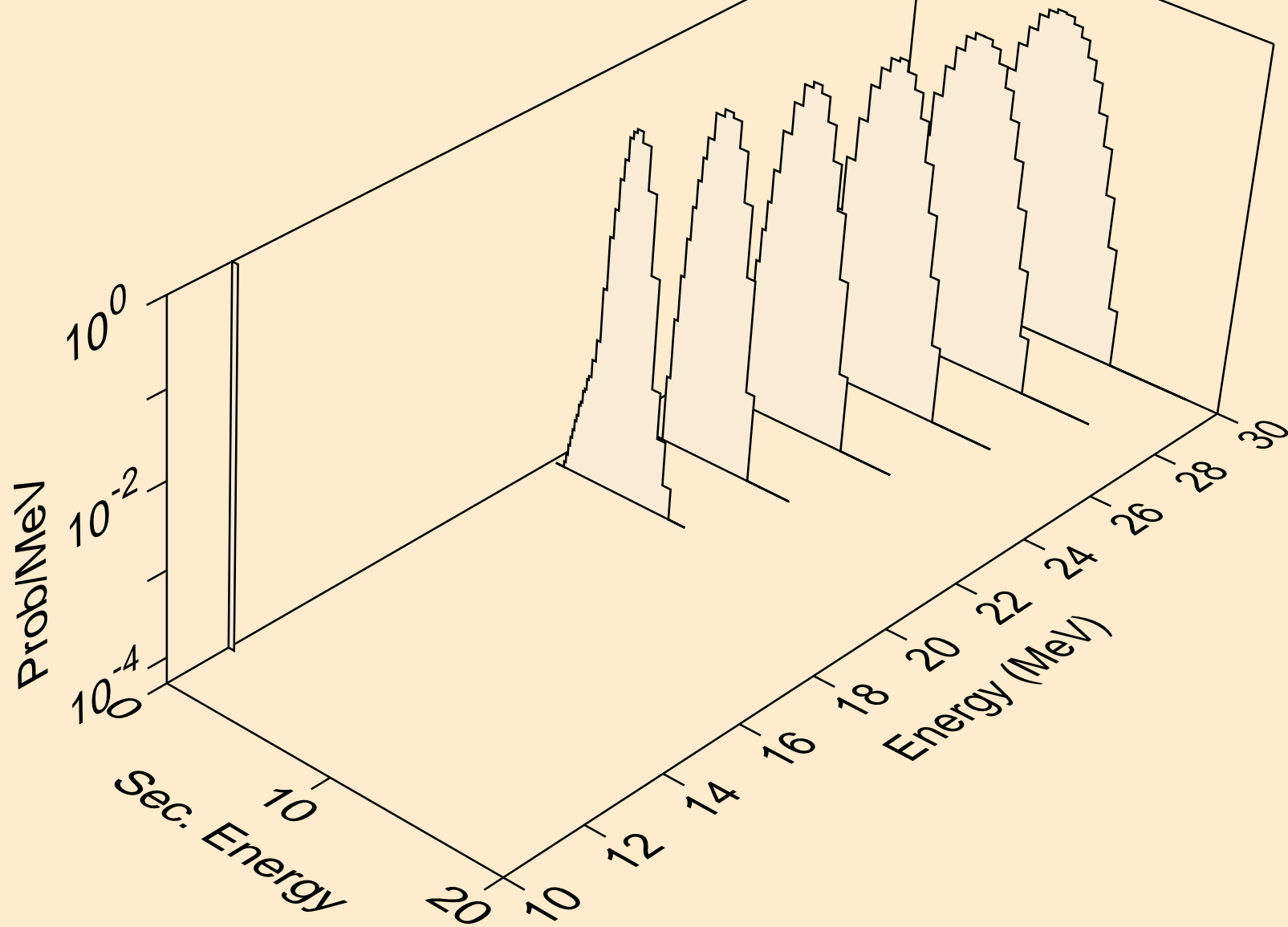

TL218 DEUTERON ACER TENDL-2023 LIBRARY; T=0.K  
protons from (d,p)

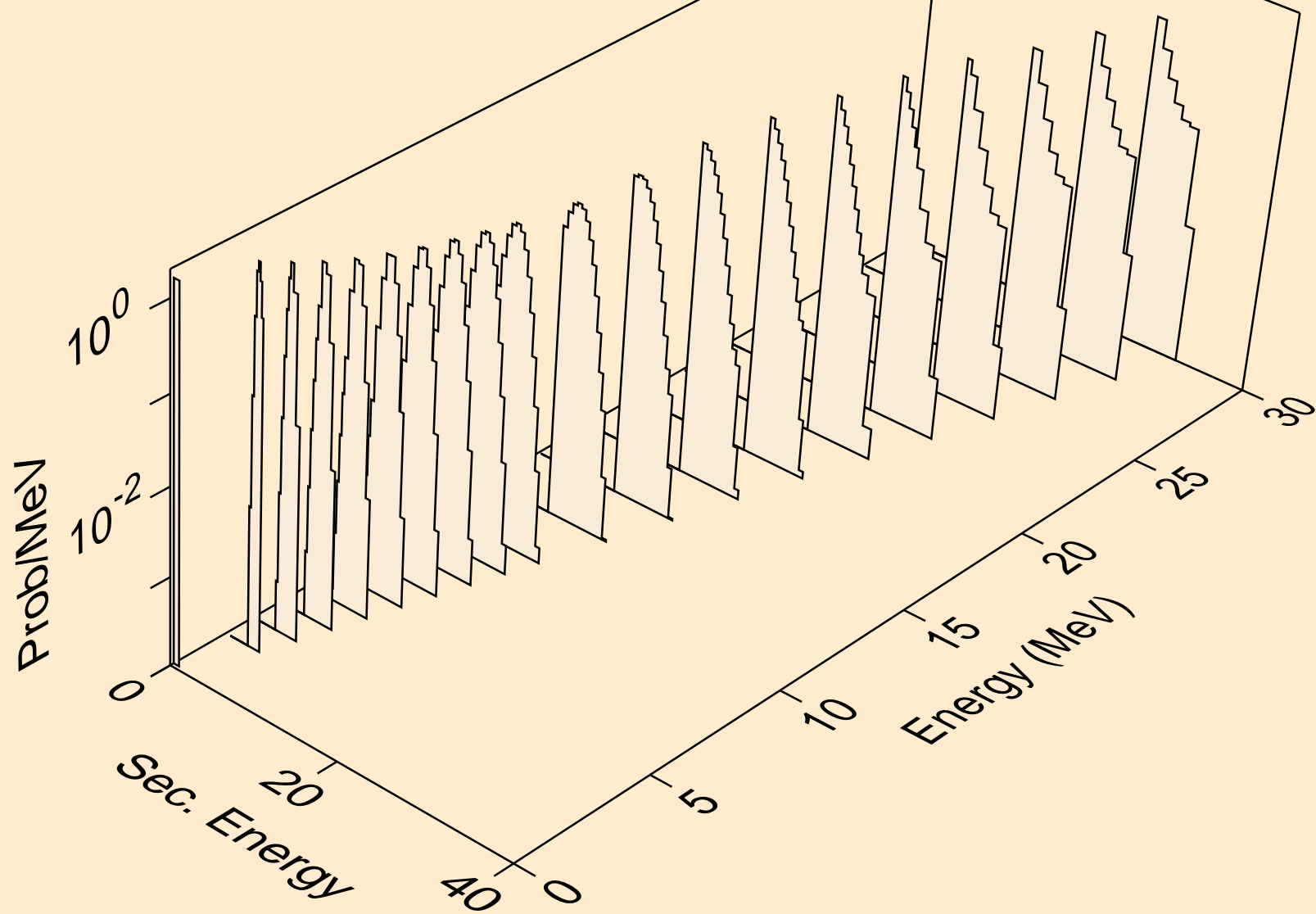

TL218 DEUTERON ACER TENDL-2023 LIBRARY; T=0.K  
protons from (d,2p)

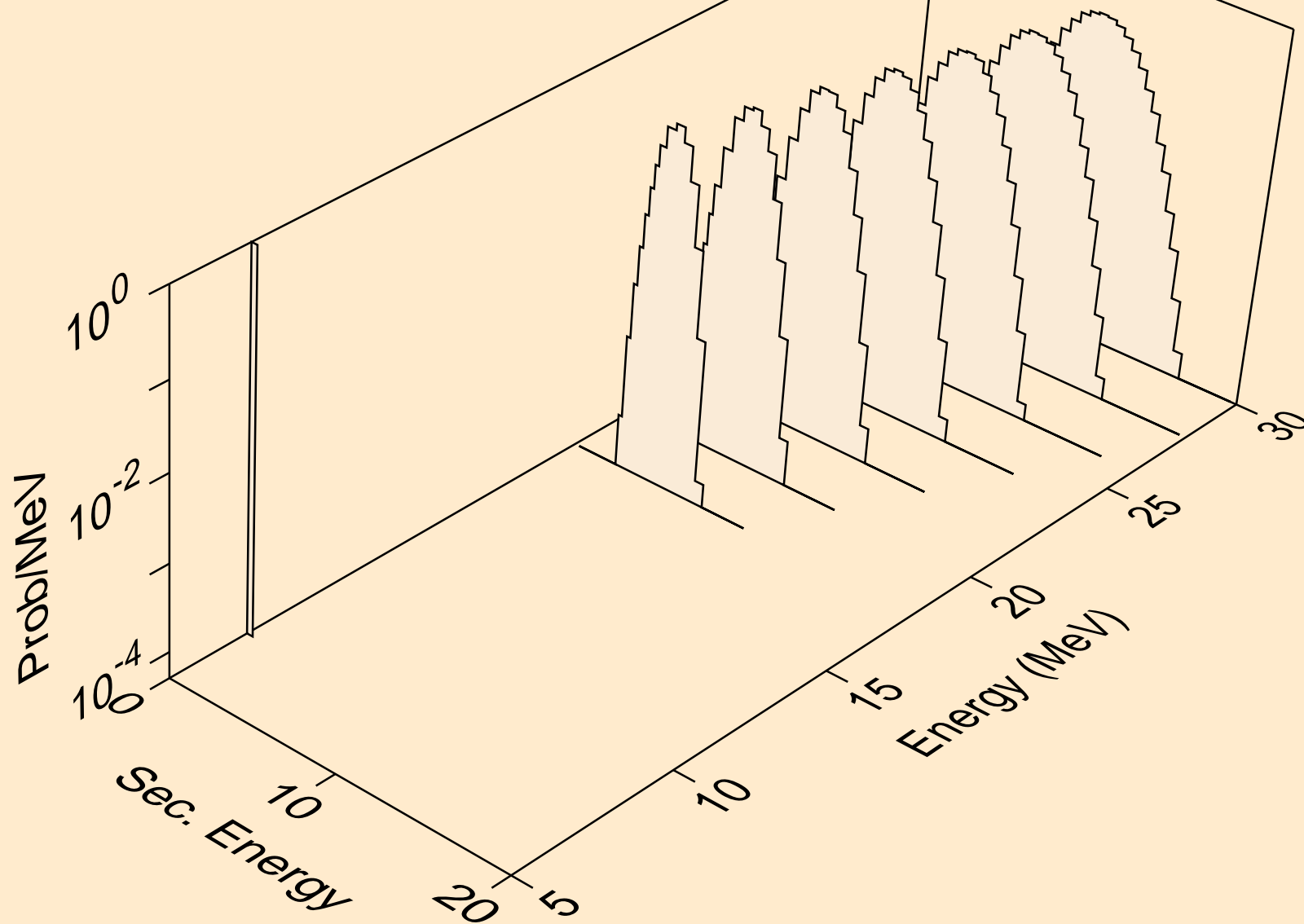

TL218 DEUTERON ACER TENDL-2023 LIBRARY; T=0.K  
protons from (d,pd)

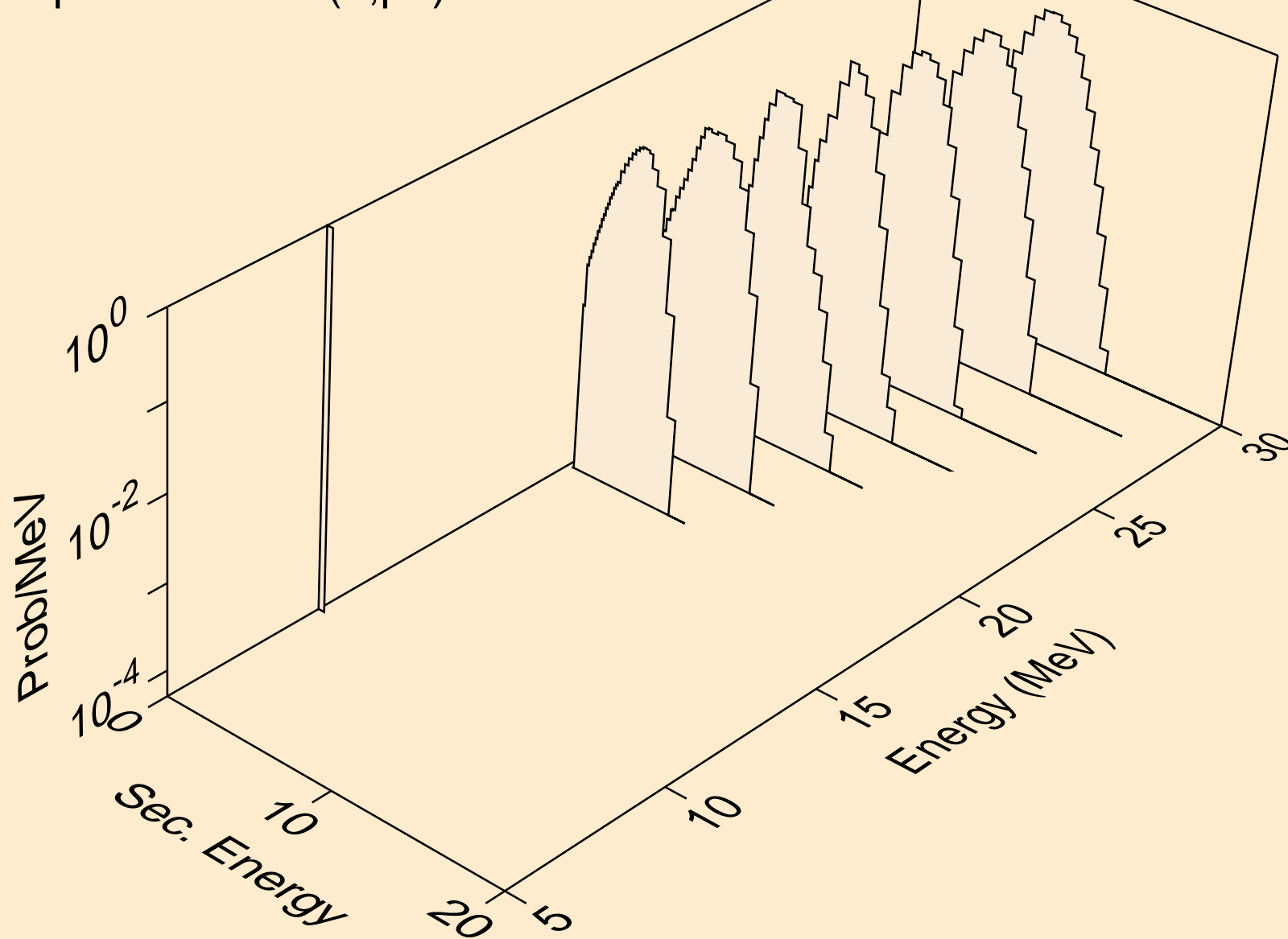

TL218 DEUTERON ACER TENDL-2023 LIBRARY; T=0.K  
tritons from (d,x)

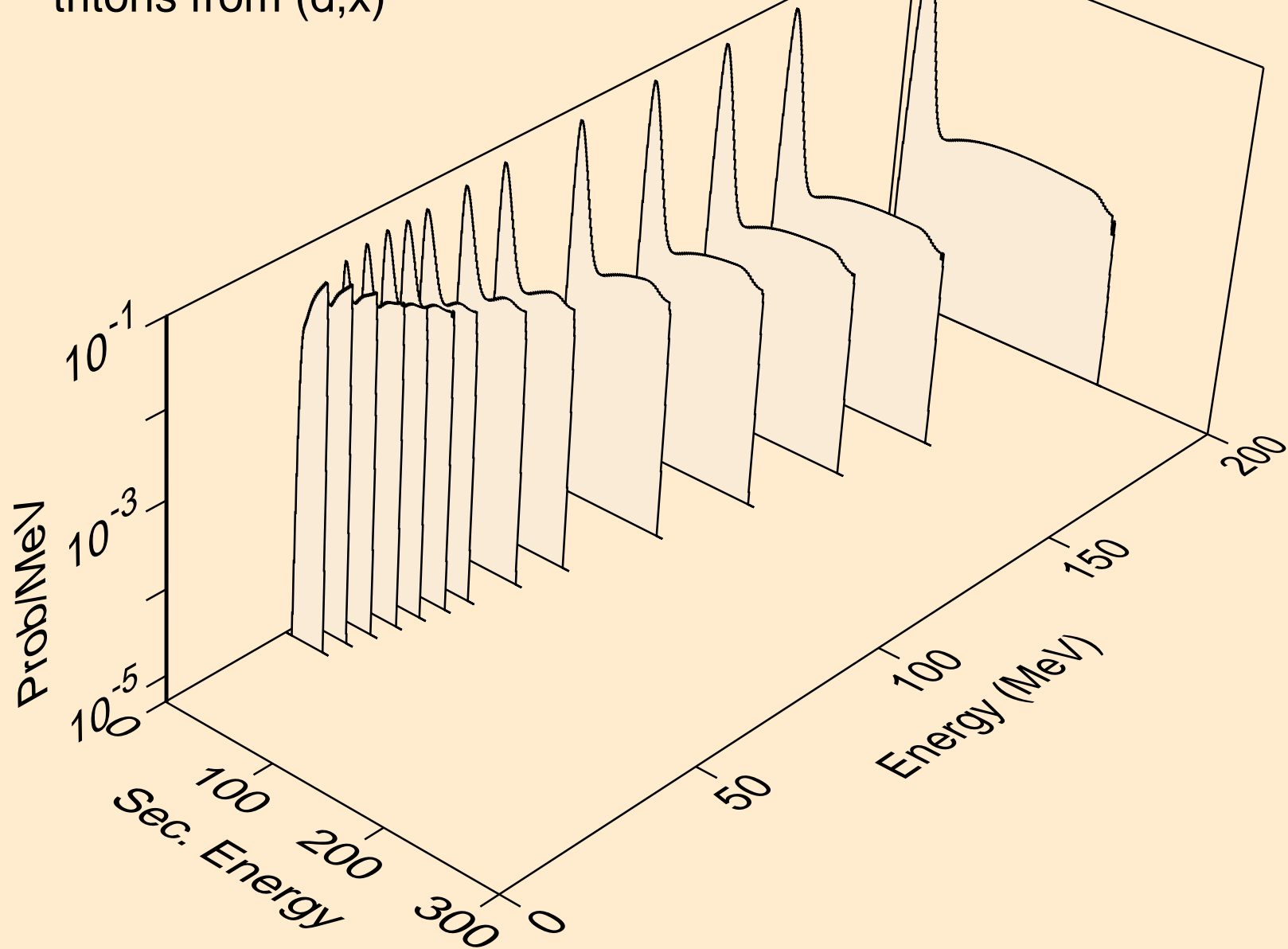



TL218 DEUTERON ACER TENDL-2023 LIBRARY; T=0.K  
tritons from (d,n\*)t

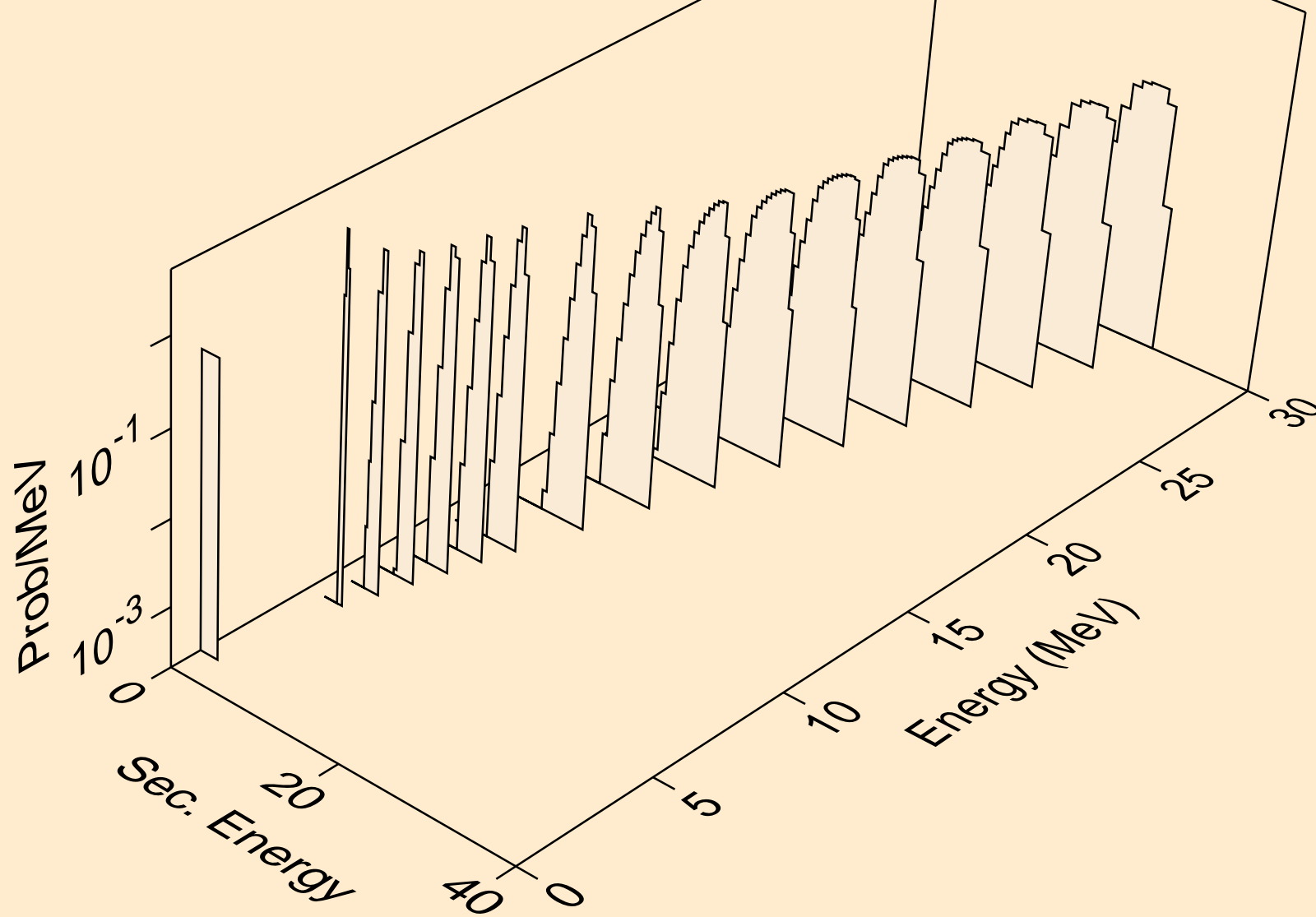

TL218 DEUTERON ACER TENDL-2023 LIBRARY; T=0.K  
tritons from (d,t)

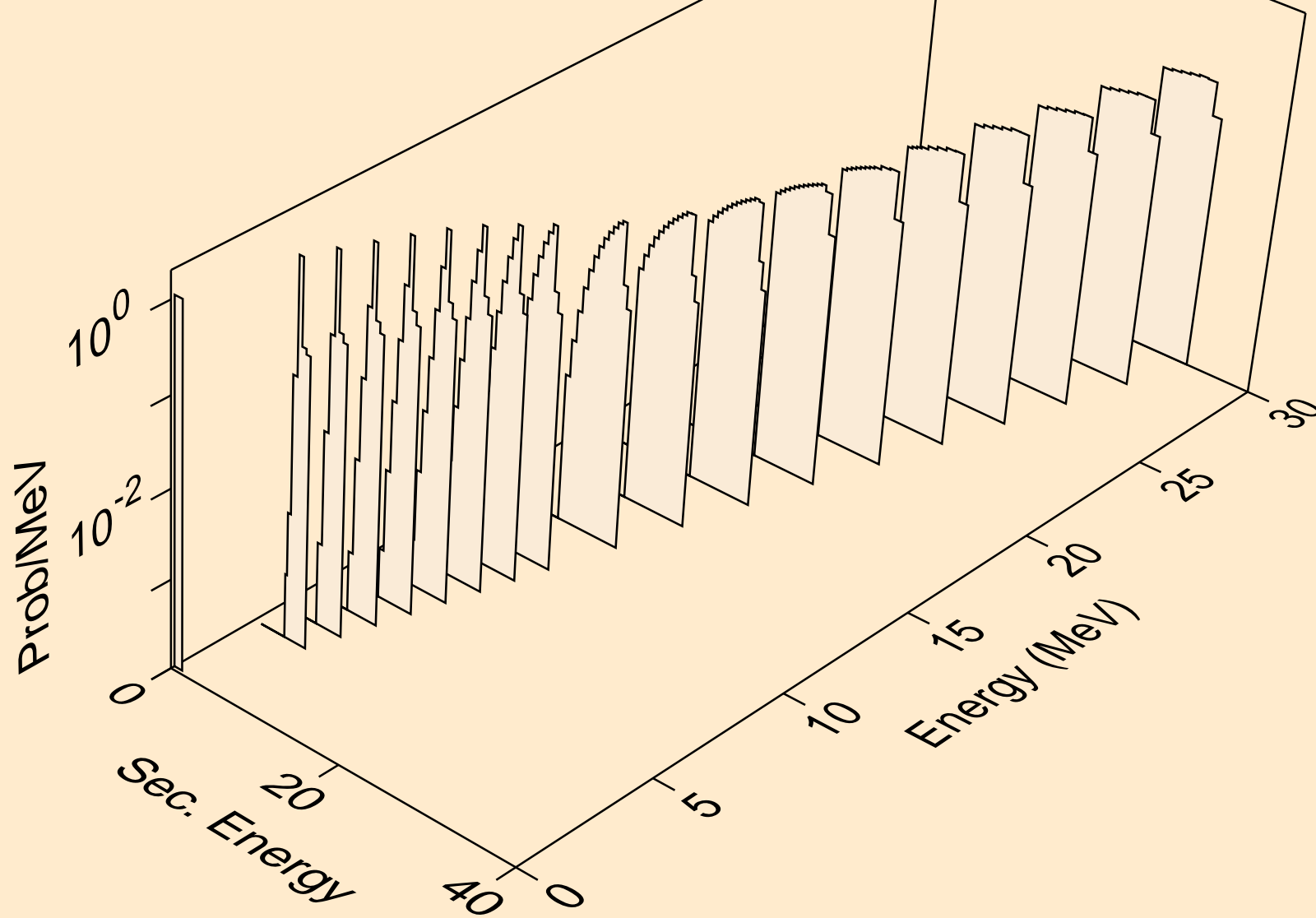

TL218 DEUTERON ACER TENDL-2023 LIBRARY; T=0.K  
he3s from (d,x)

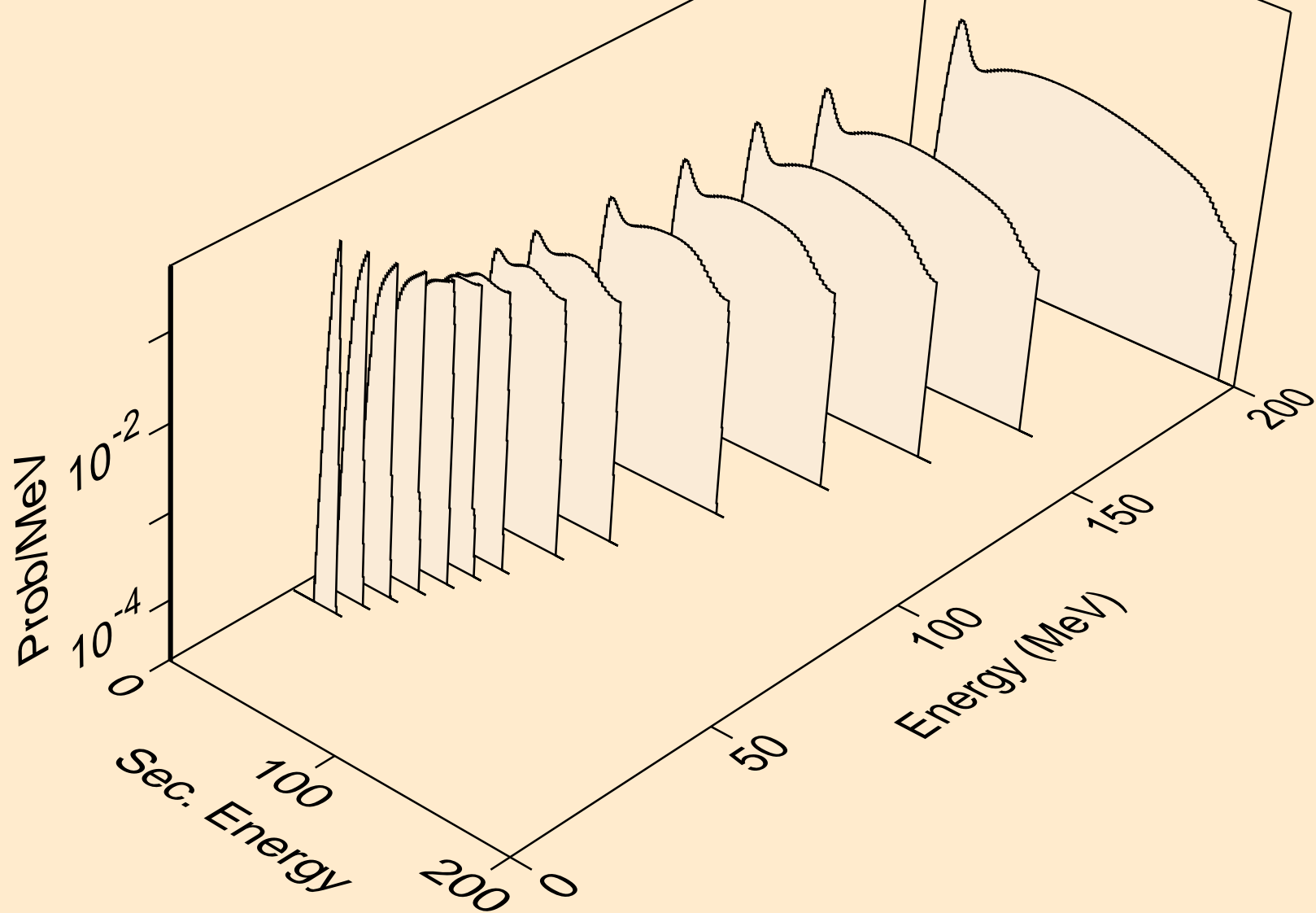

TL218 DEUTERON ACER TENDL-2023 LIBRARY; T=0.K  
he3s from (d,n\*)he3

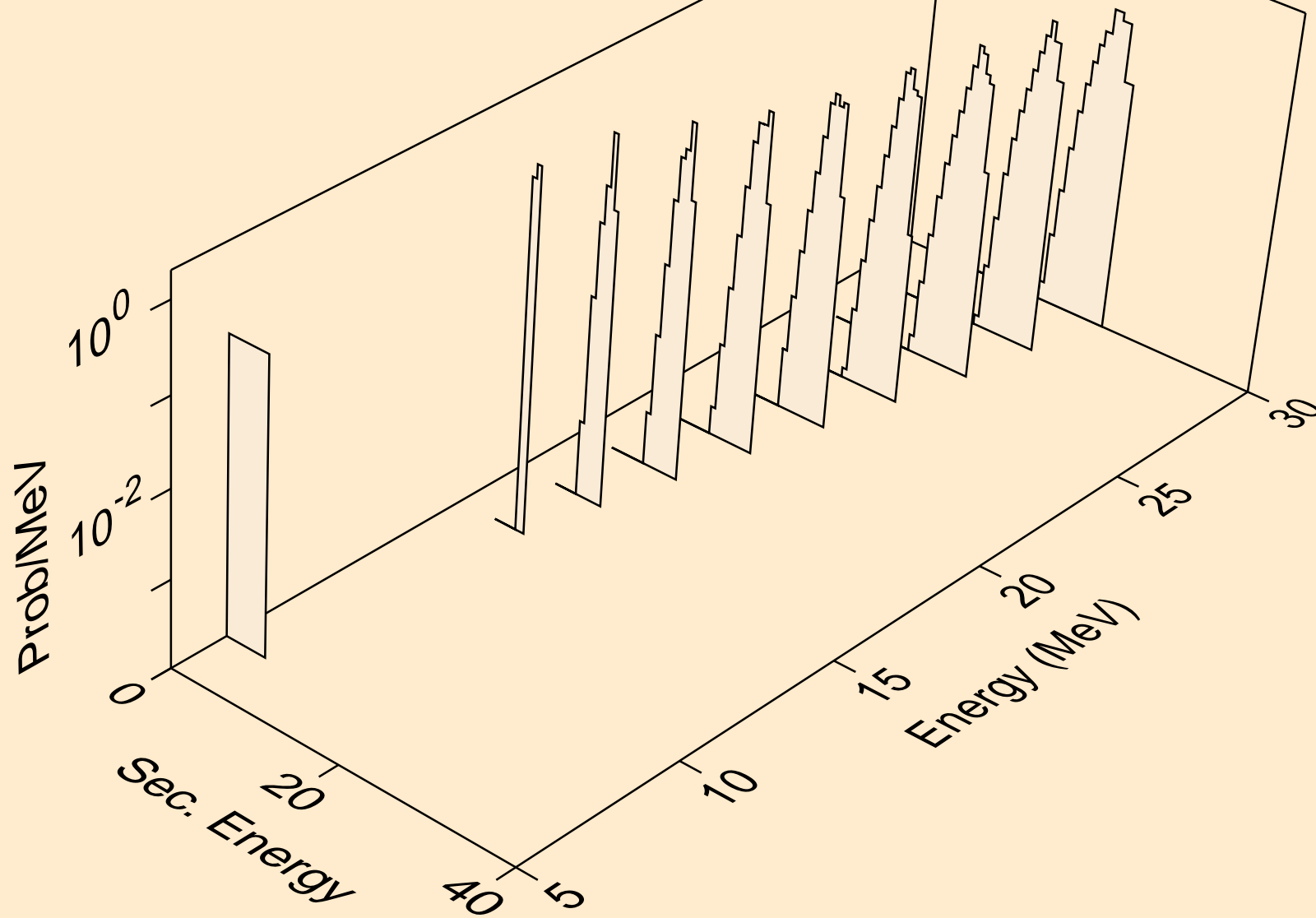

TL218 DEUTERON ACER TENDL-2023 LIBRARY; T=0.K  
he3s from (d,he3)

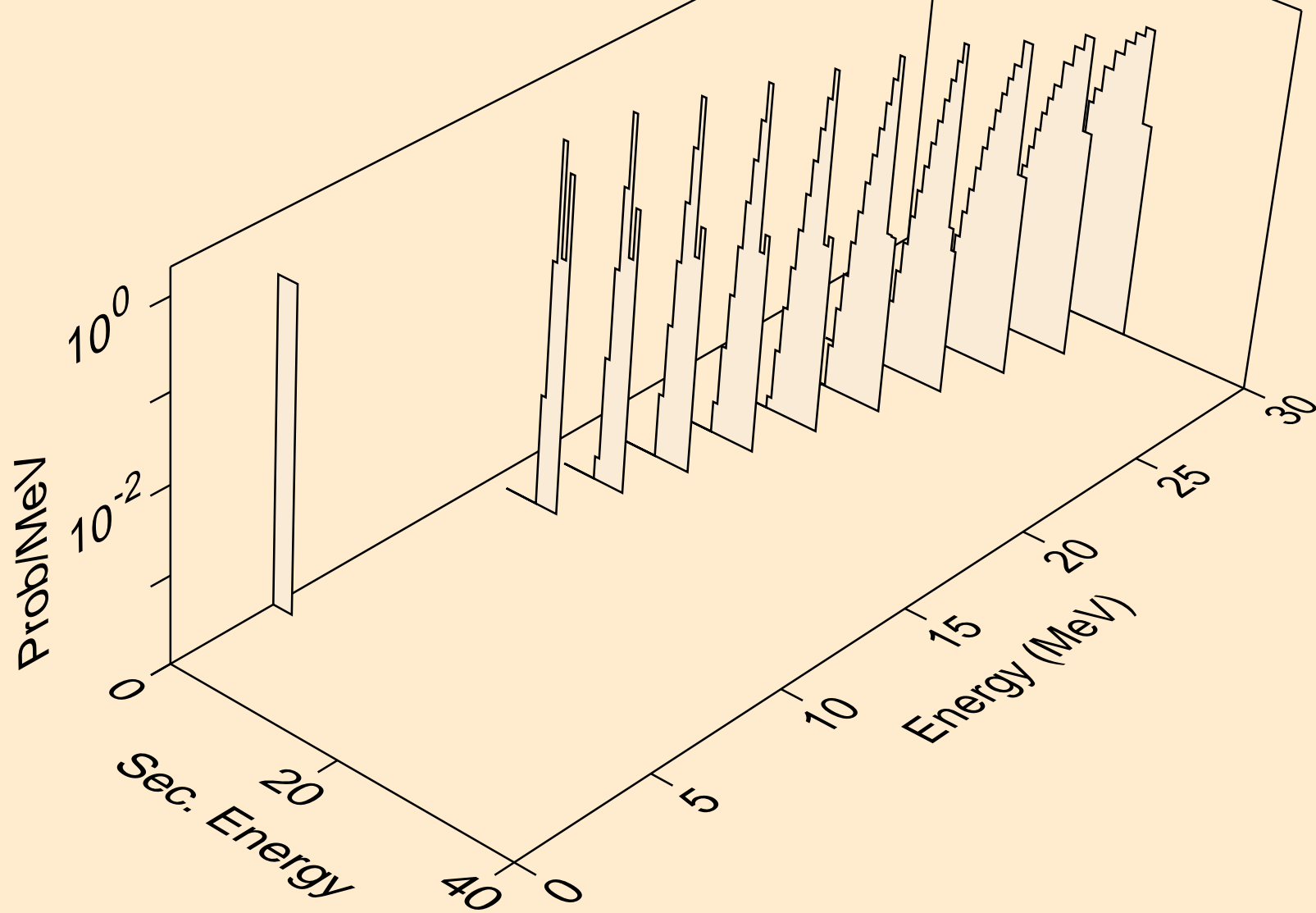

TL218 DEUTERON ACER TENDL-2023 LIBRARY; T=0.K  
alphas from (d,x)

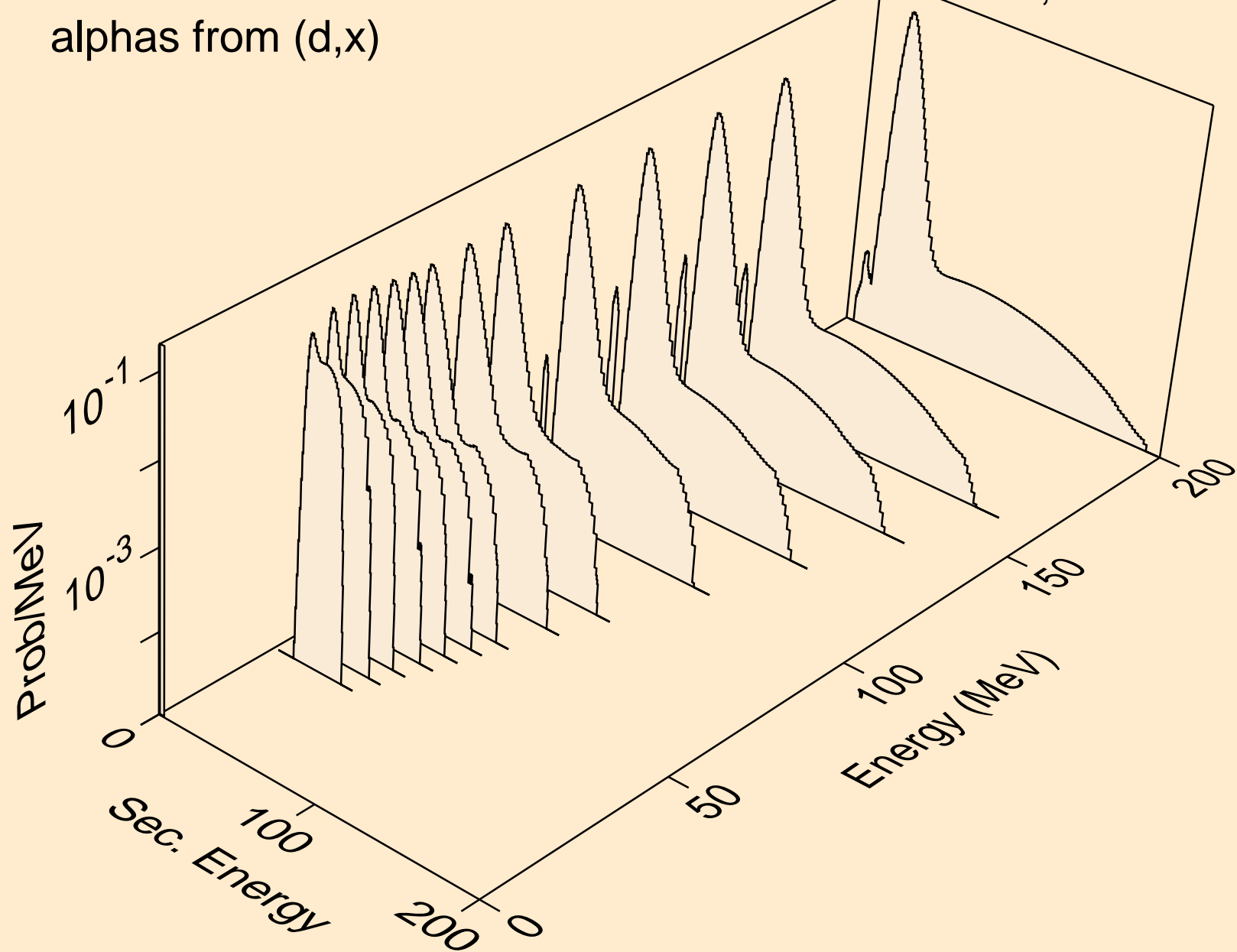

TL218 DEUTERON ACER TENDL-2023 LIBRARY; T=0.K  
alphas from (d,n\*)a

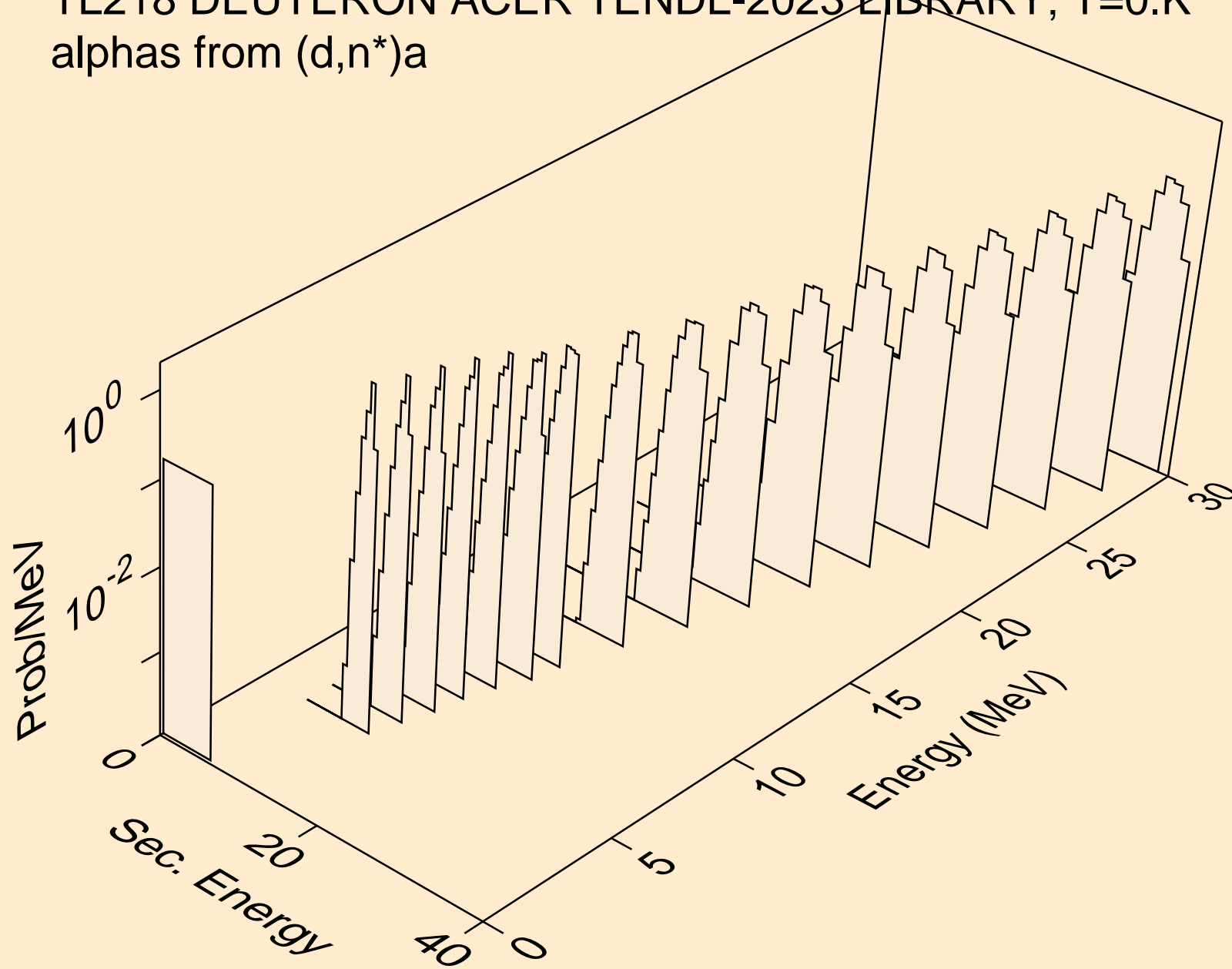

TL218 DEUTERON ACER TENDL-2023 LIBRARY; T=0.K  
alphas from (d,2n)a

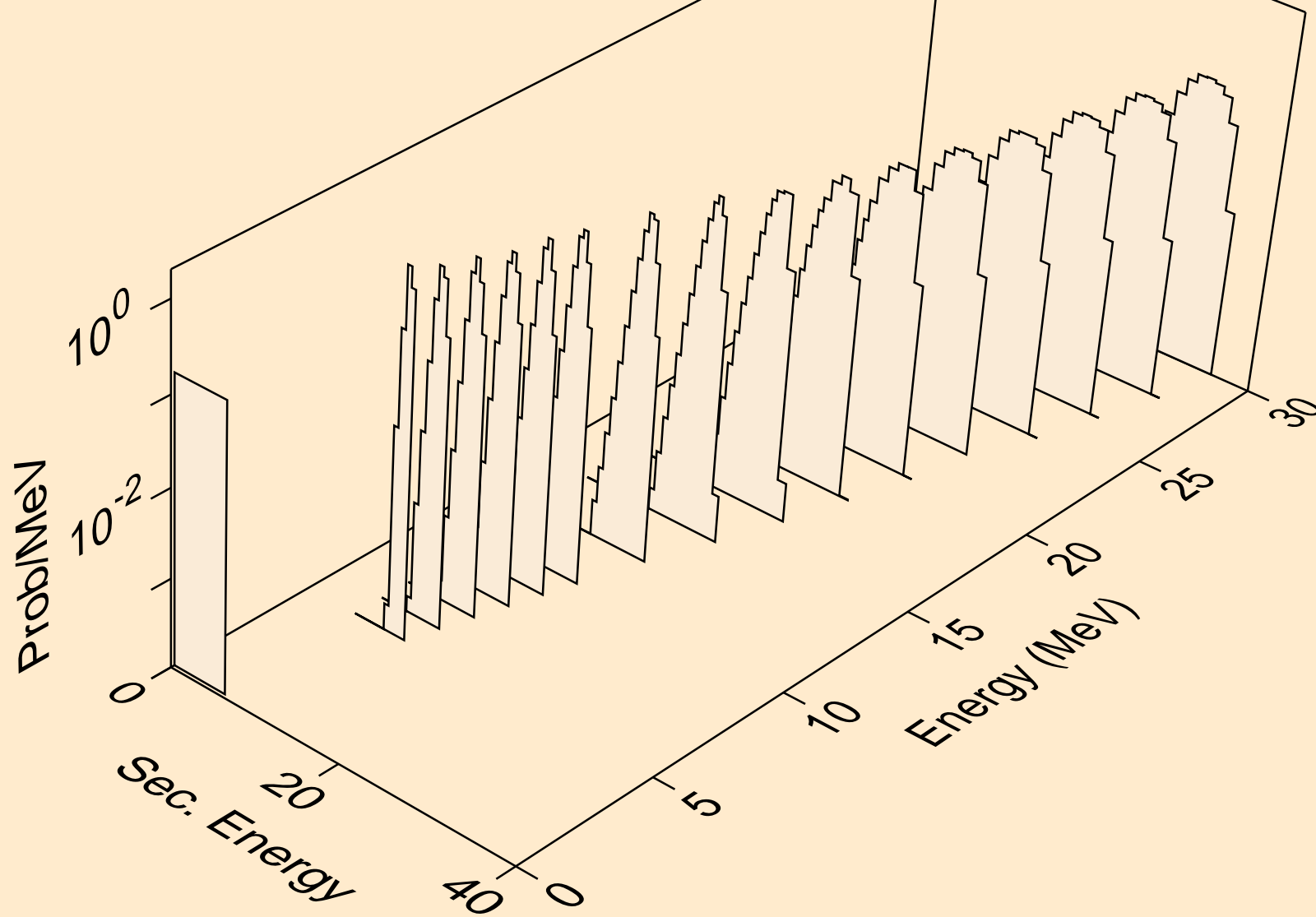



TL218 DEUTERON ACER TENDL-2023 LIBRARY; T=0.K  
alphas from (d,3n)a

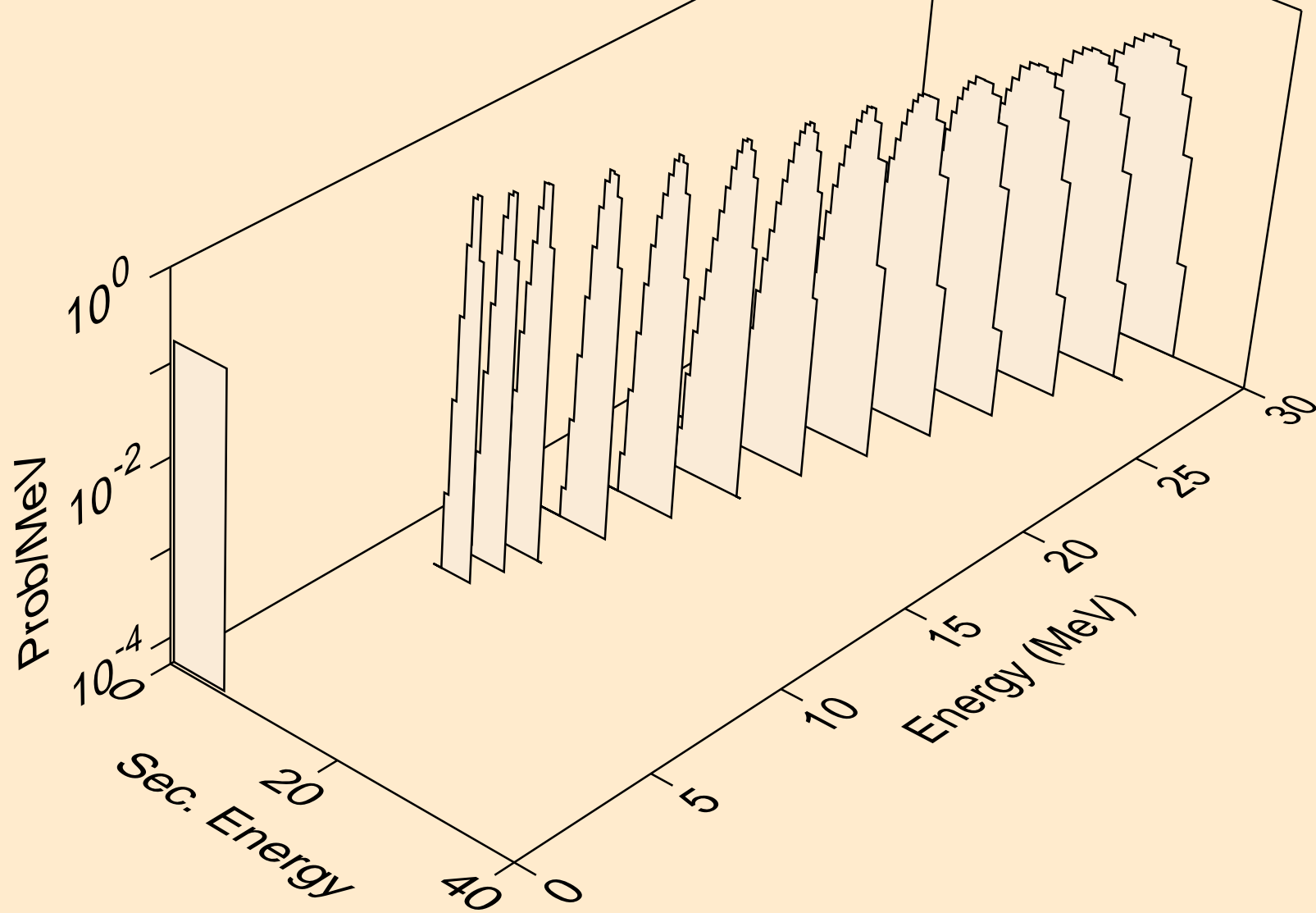

TL218 DEUTERON ACER TENDL-2023 LIBRARY; T=0.K  
alphas from (d,a)

