

CA044 PHOTON ACER TENDL-2023 LIBRARY; T=0.K

Principal cross sections

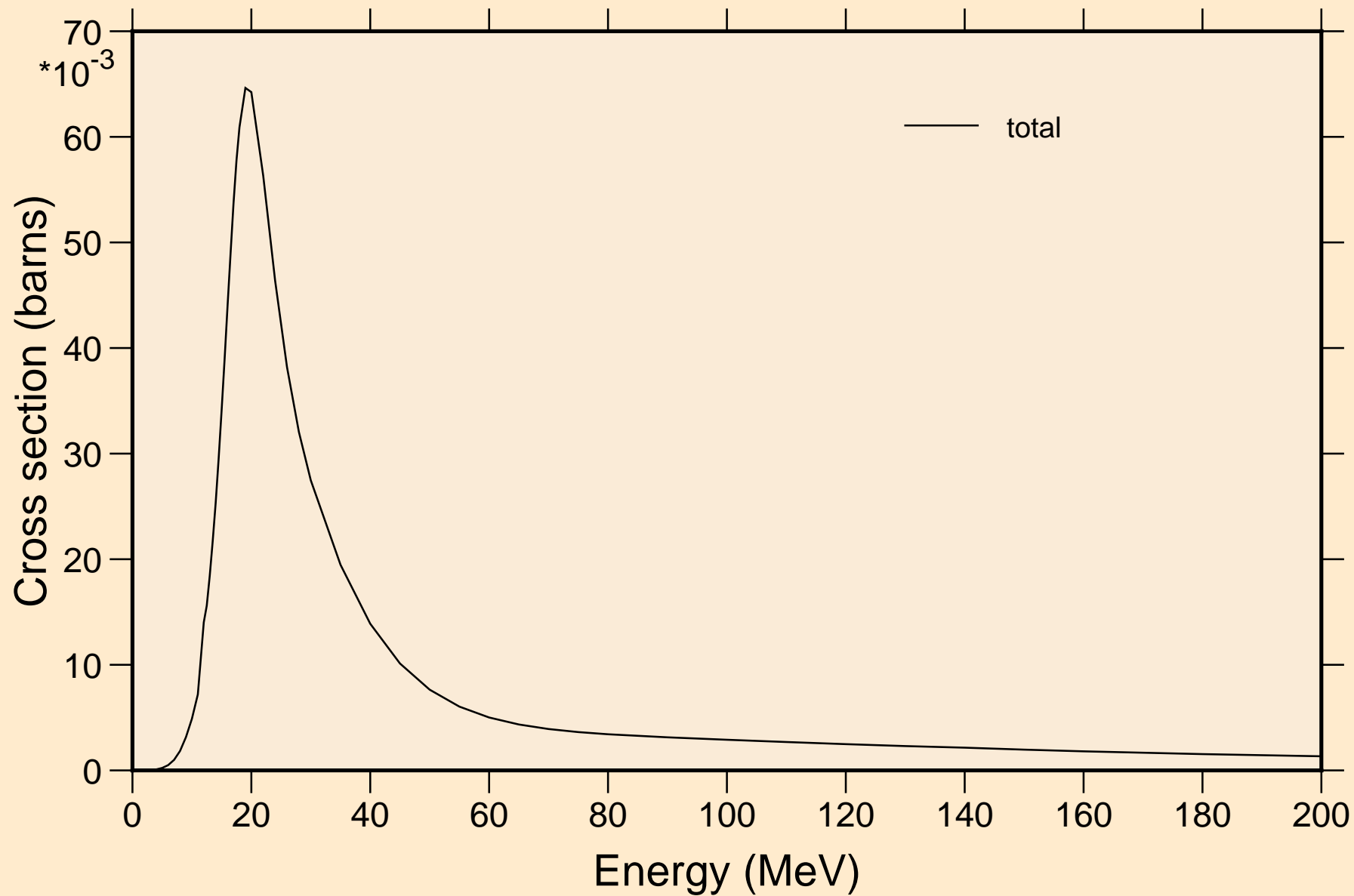

CA044 PHOTON ACER TENDL-2023 LIBRARY; T=0.K

Partial cross sections

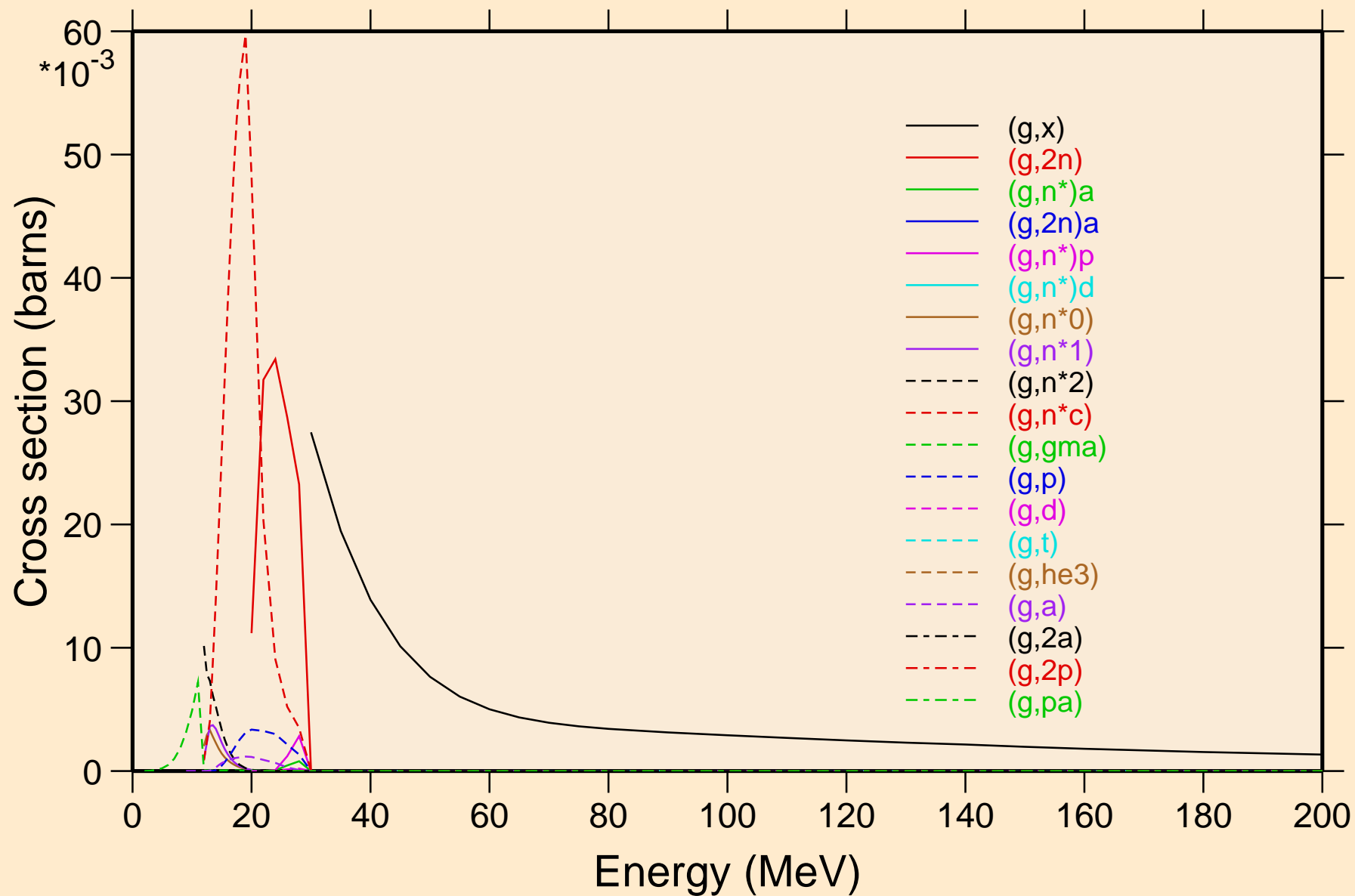

CA044 PHOTON ACER TENDL-2023 LIBRARY; T=0.K

Heating

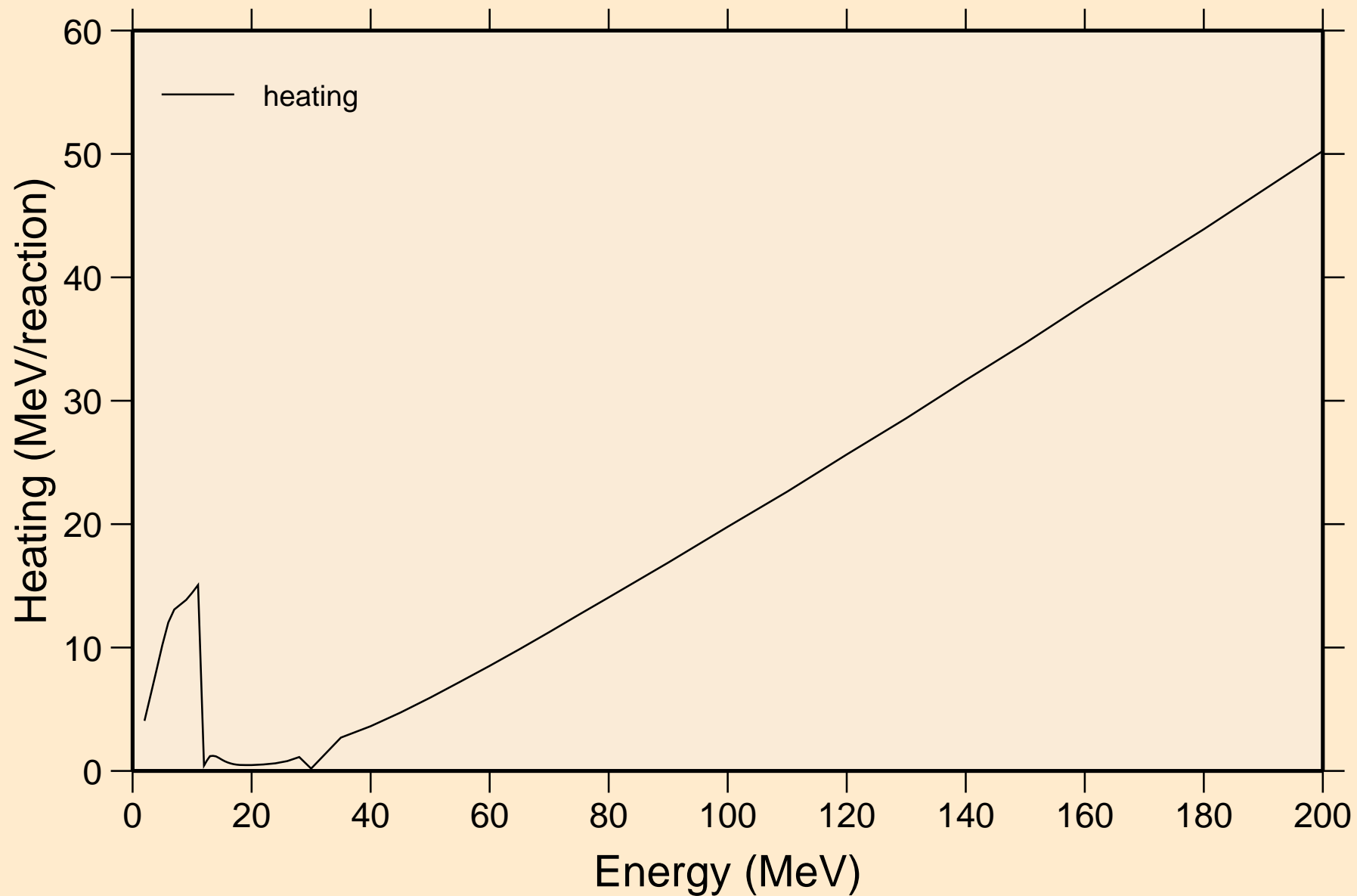

CA044 PHOTON ACER TENDL-2023 LIBRARY; T=0.K

Particle heating contributions

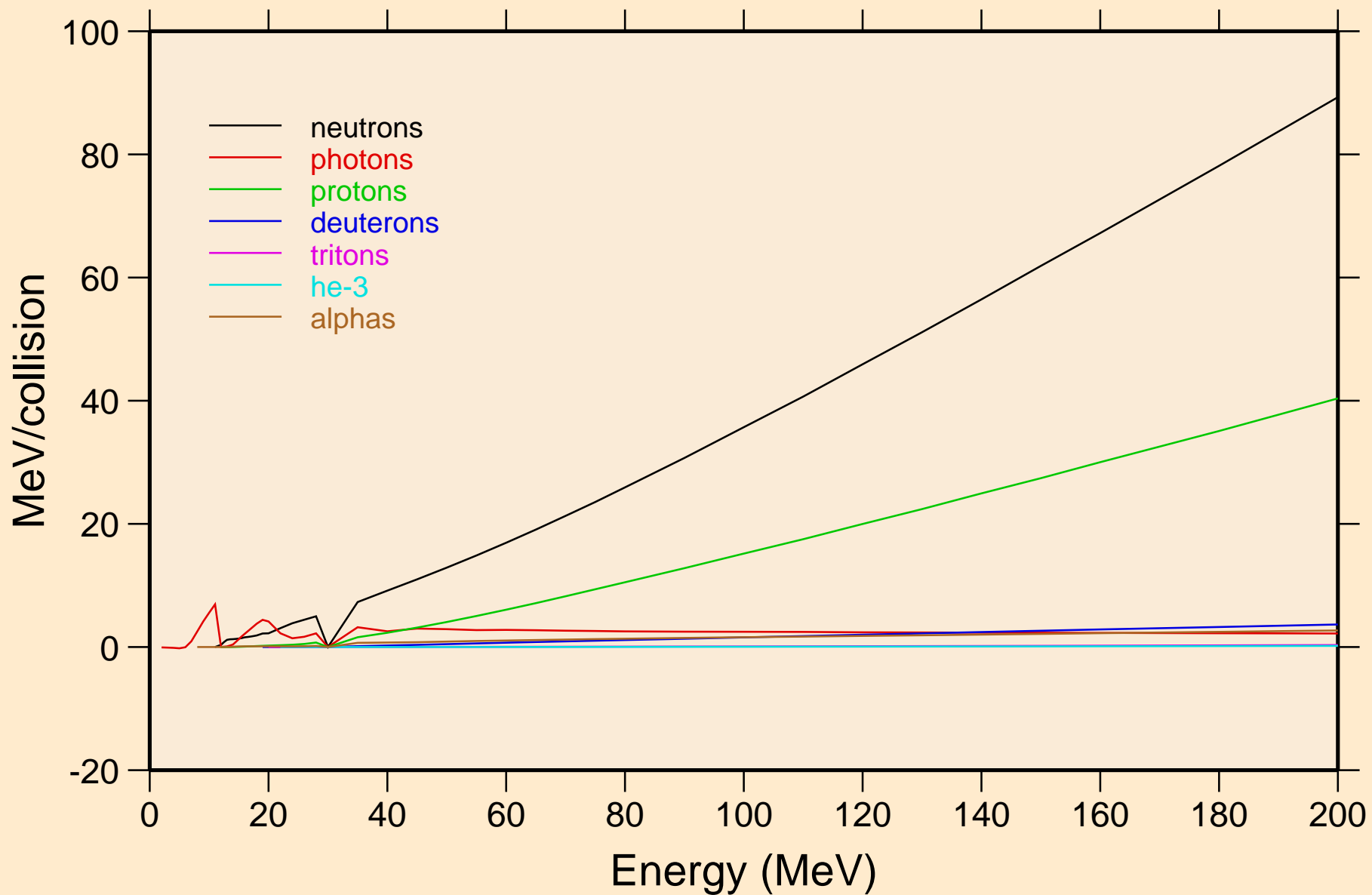

CA044 PHOTON ACER TENDL-2023 LIBRARY; T=0.K

Particle production cross sections

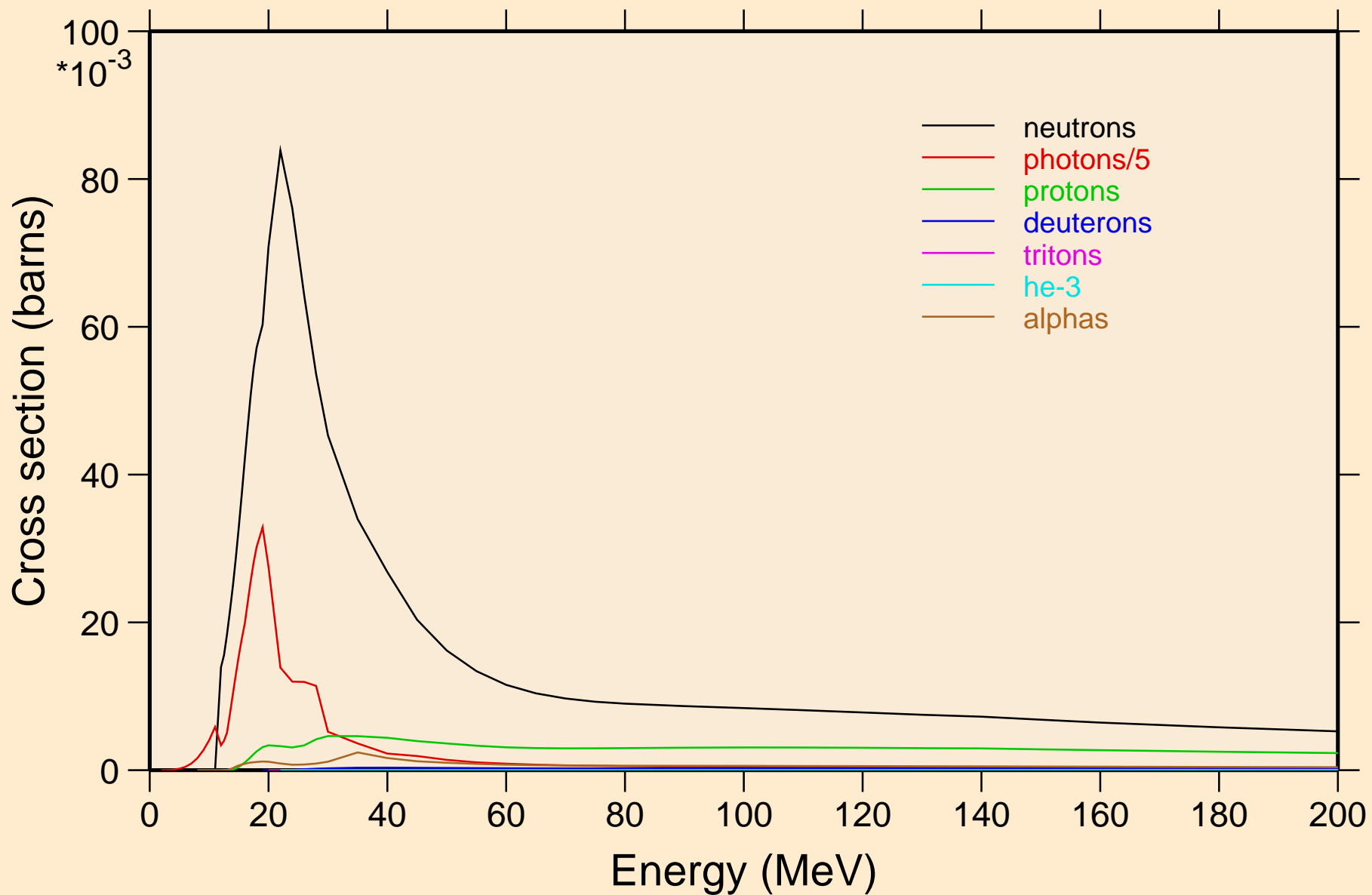

CA044 PHOTON ACER TENDL-2023 LIBRARY; T=0.K
neutrons from (g,x)

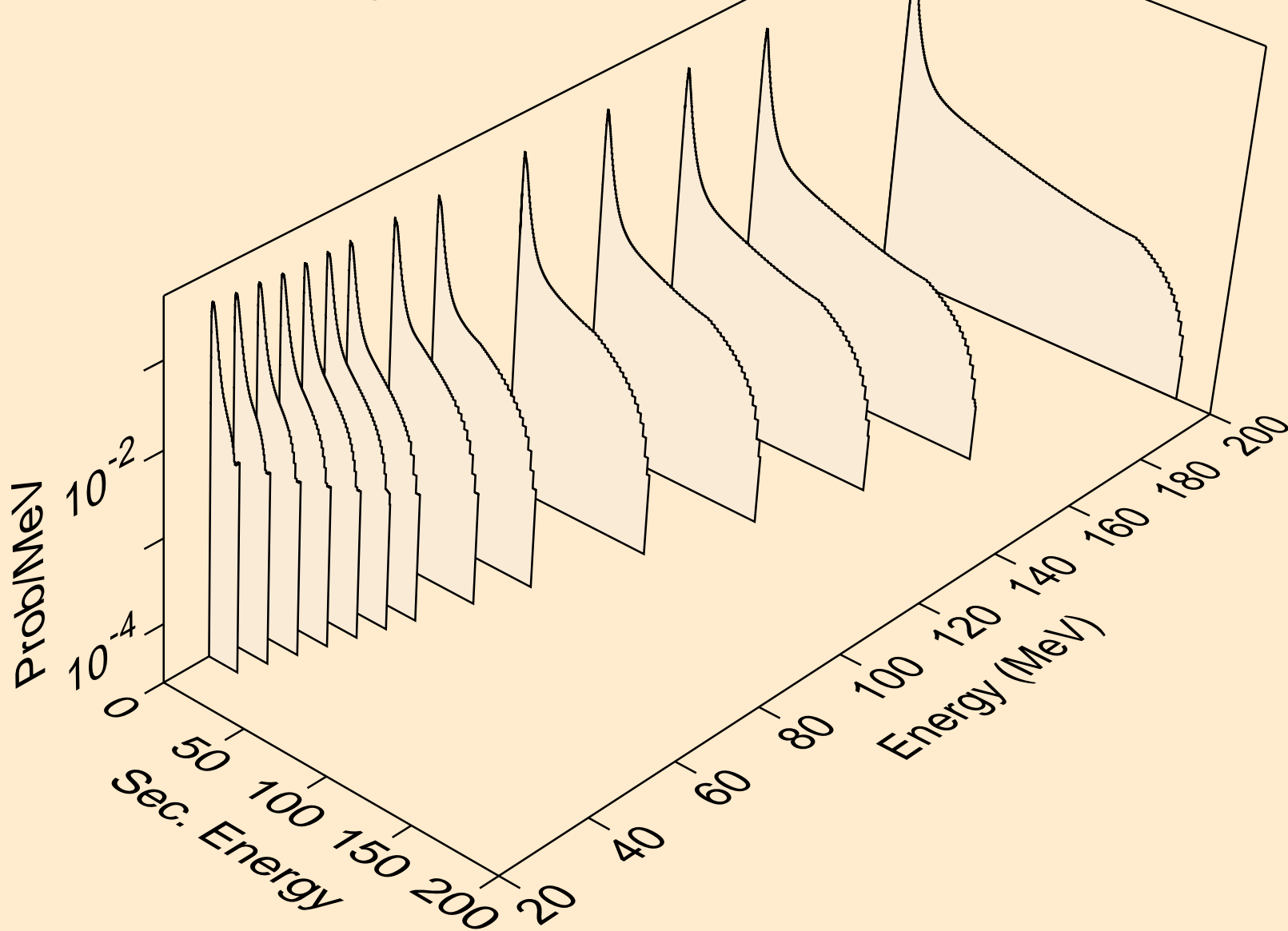

CA044 PHOTON ACER TENDL-2023 LIBRARY; T=0.K
neutrons from (g,2n)

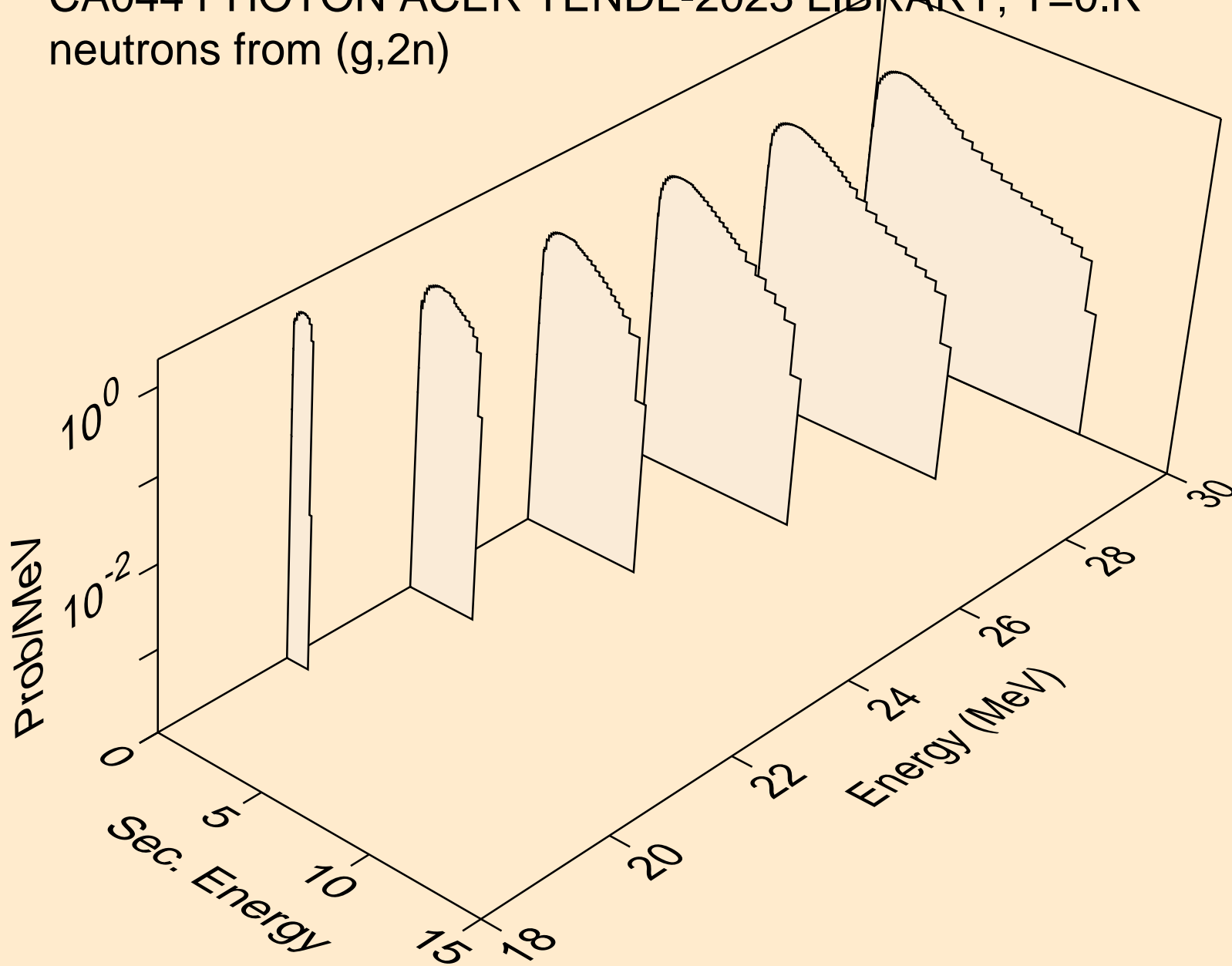

CA044 PHOTON ACER TENDL-2023 LIBRARY; T=0.K
neutrons from (g,n*)a

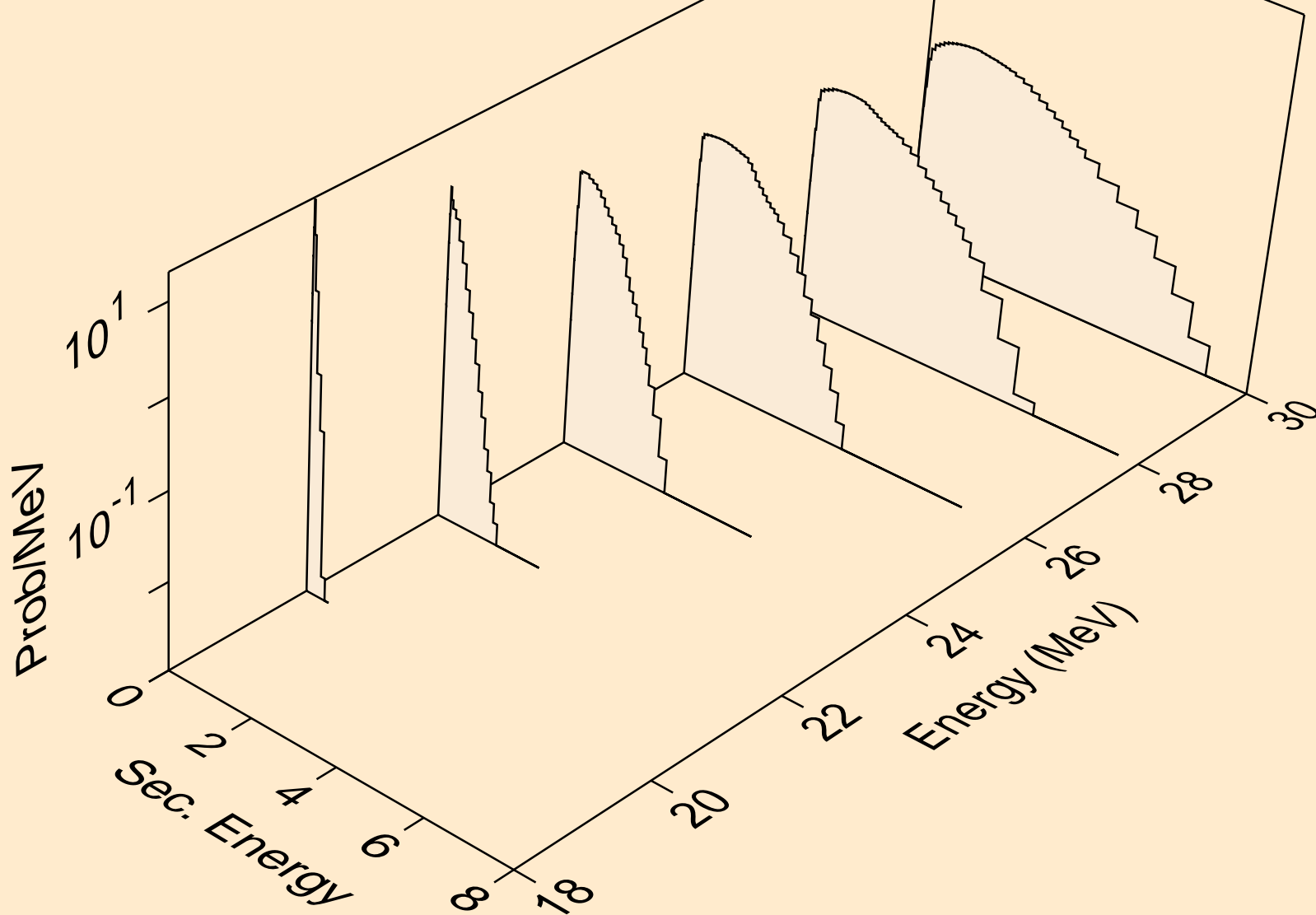

CA044 PHOTON ACER TENDL-2023 LIBRARY; T=0.K
neutrons from (g,2n)a

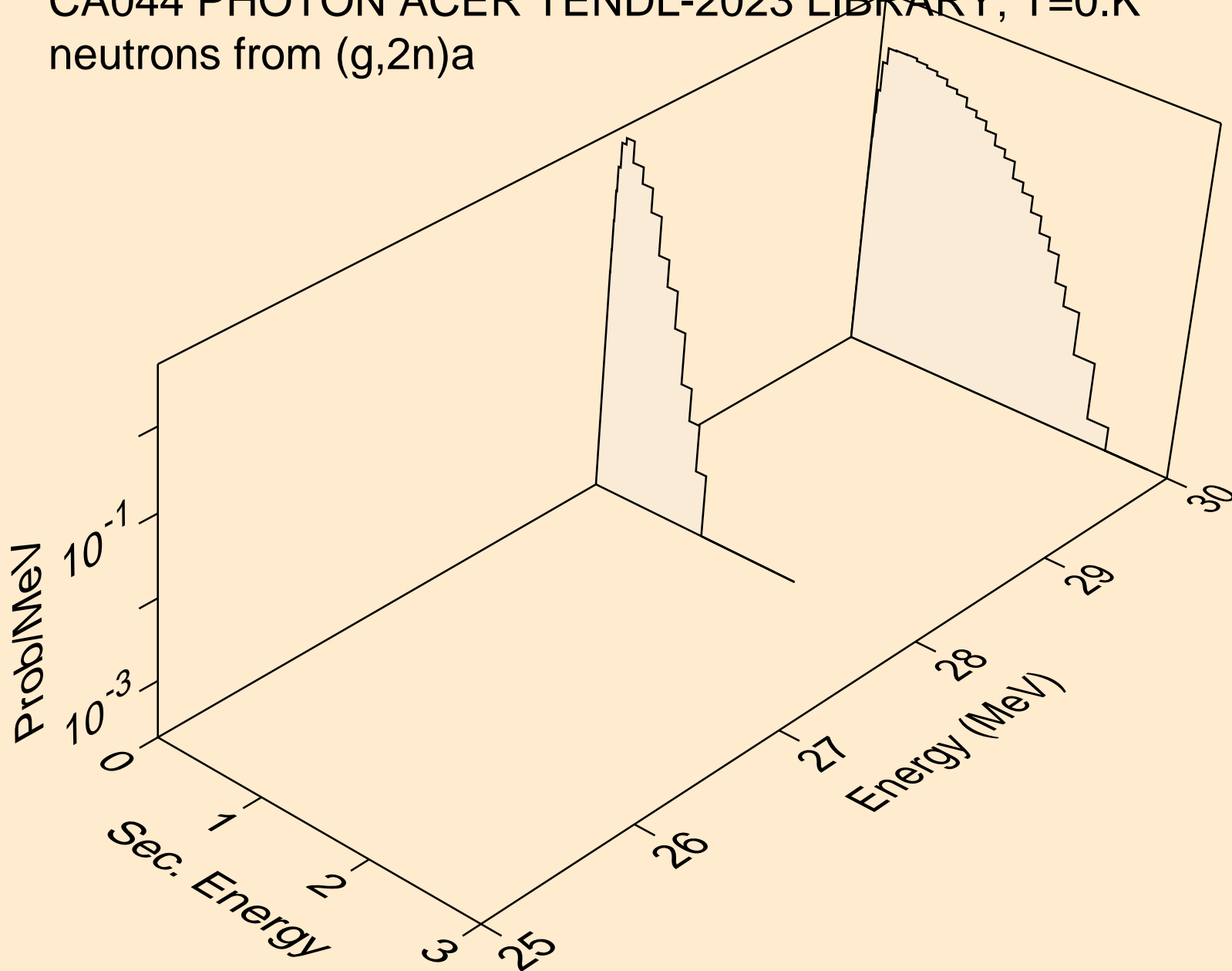

CA044 PHOTON ACER TENDL-2023 LIBRARY; T=0.K
neutrons from (g,n*)p

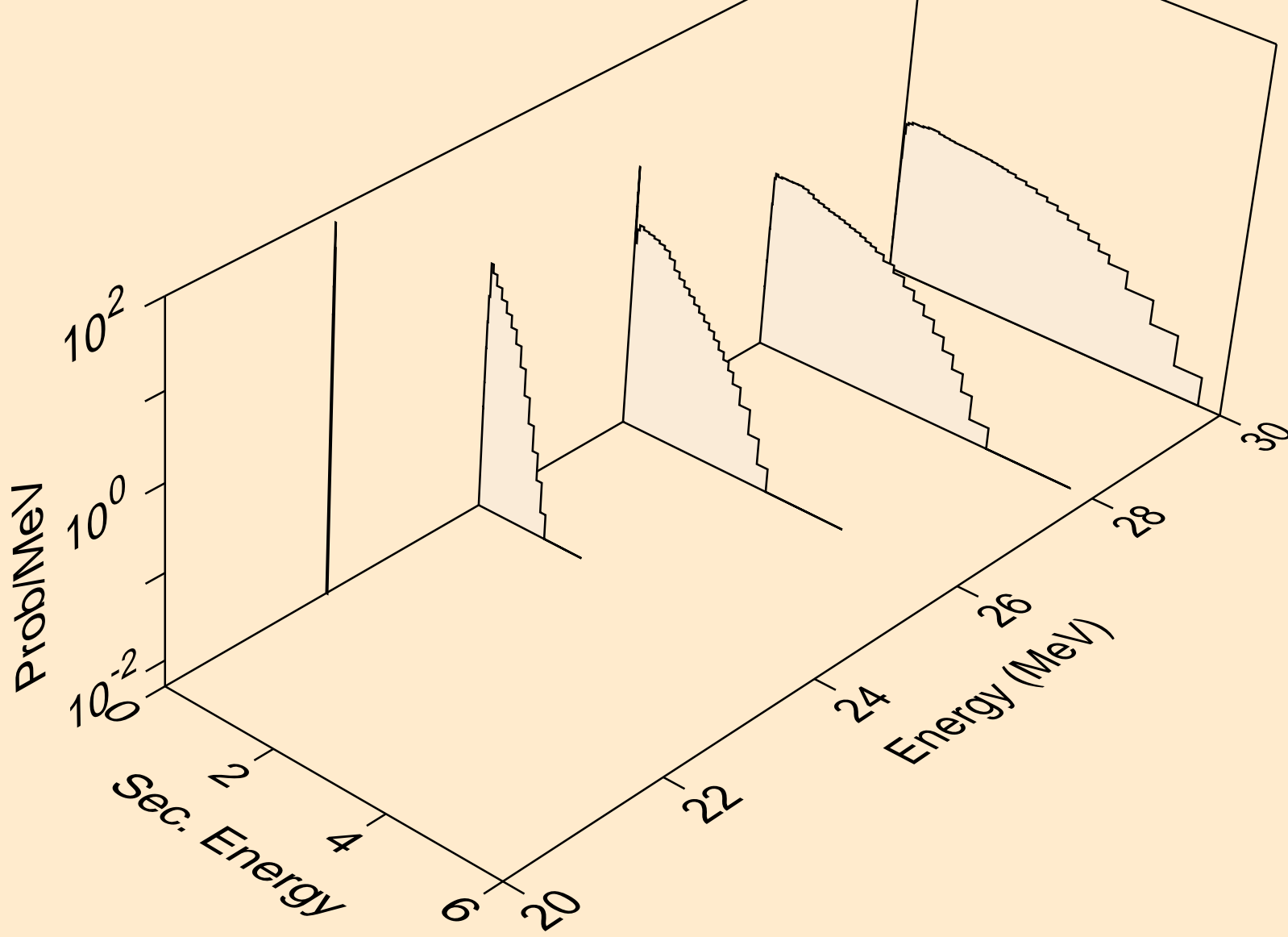

CA044 PHOTON ACER TENDL-2023 LIBRARY; T=0.K
neutrons from (g,n*)d

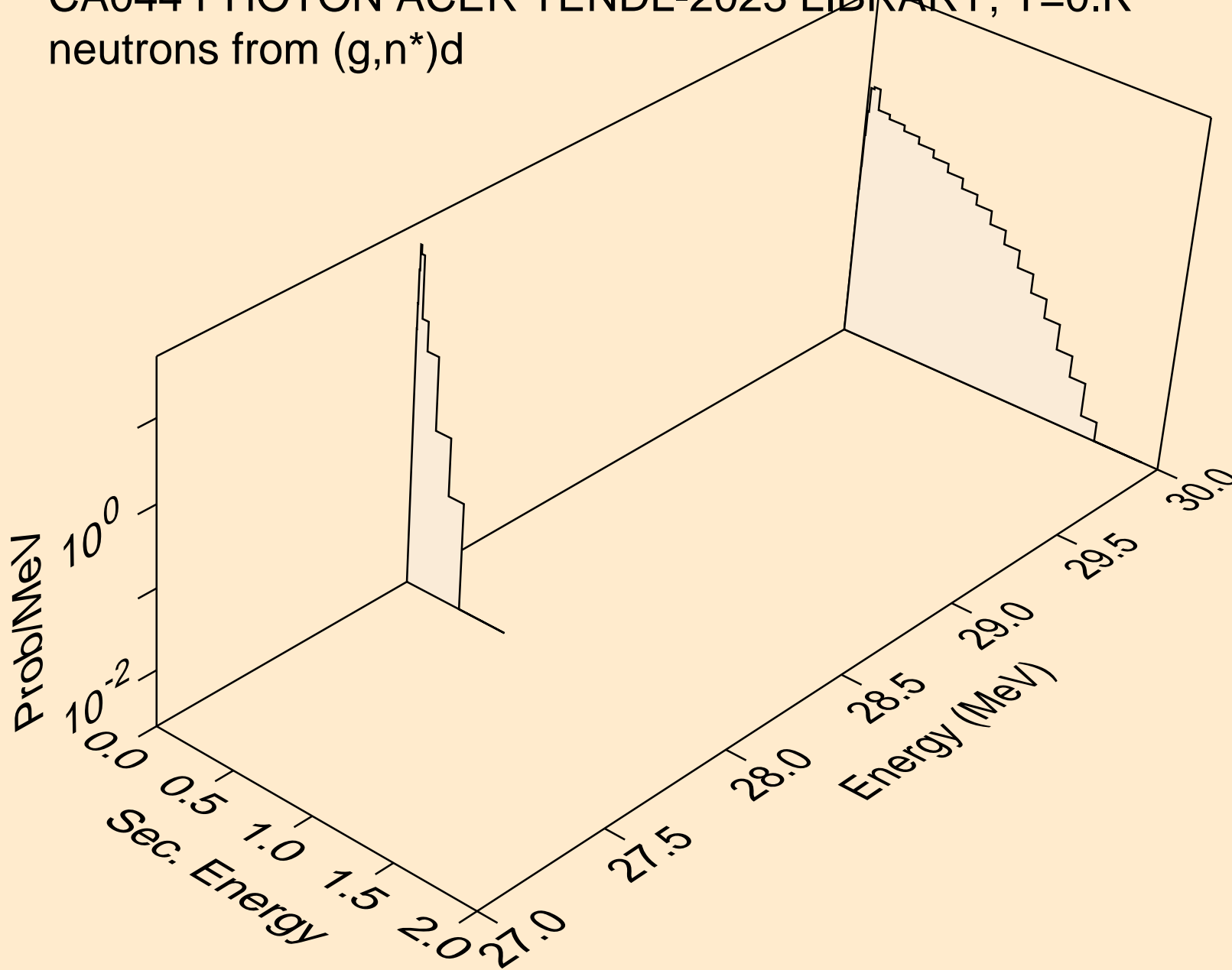

CA044 PHOTON ACER TENDL-2023 LIBRARY; T=0.K
angular distribution for (g,n*0) neutron

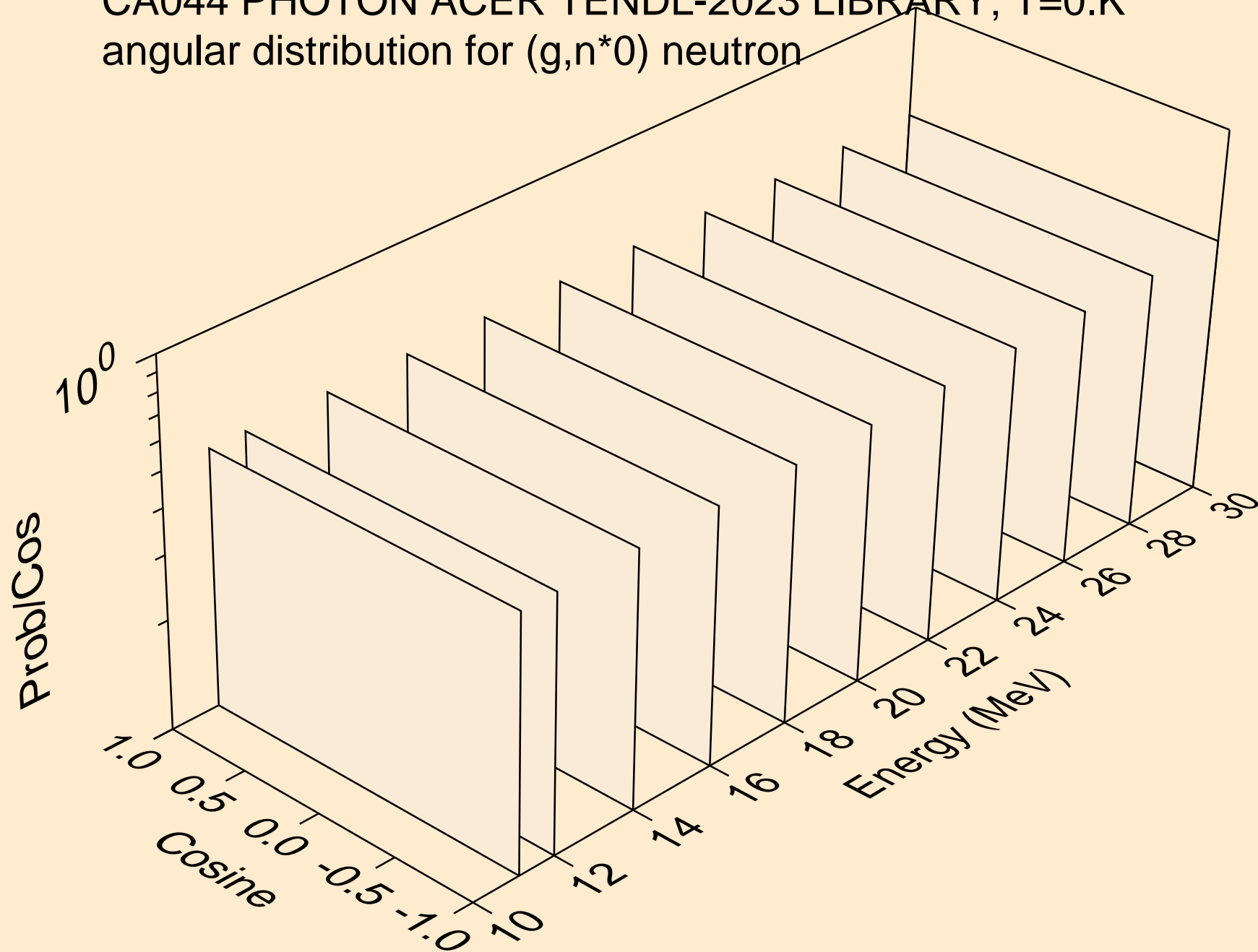

CA044 PHOTON ACER TENDL-2023 LIBRARY; T=0.K
angular distribution for (g,n*1) neutron

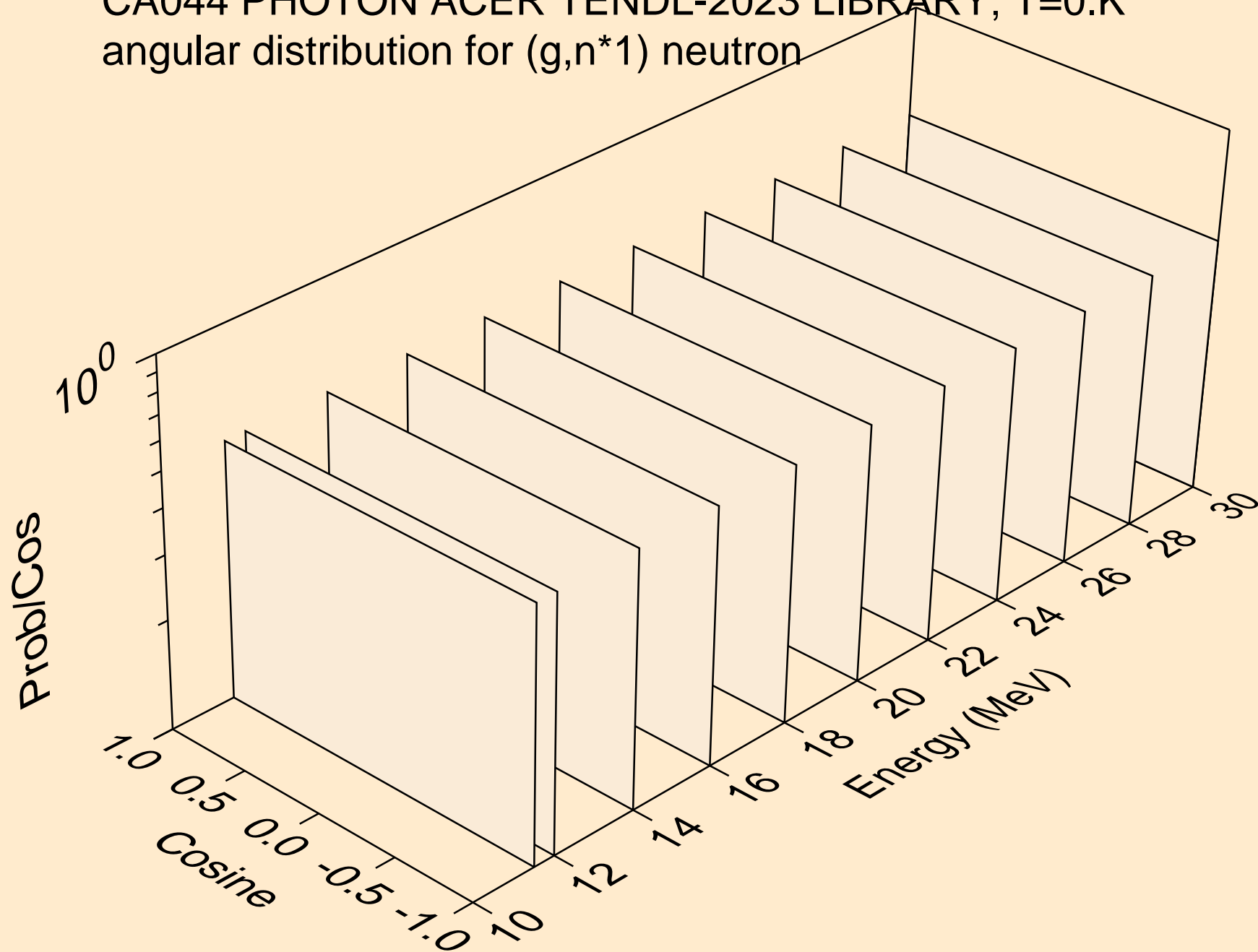

CA044 PHOTON ACER TENDL-2023 LIBRARY; T=0.K
angular distribution for (g,n*2) neutron

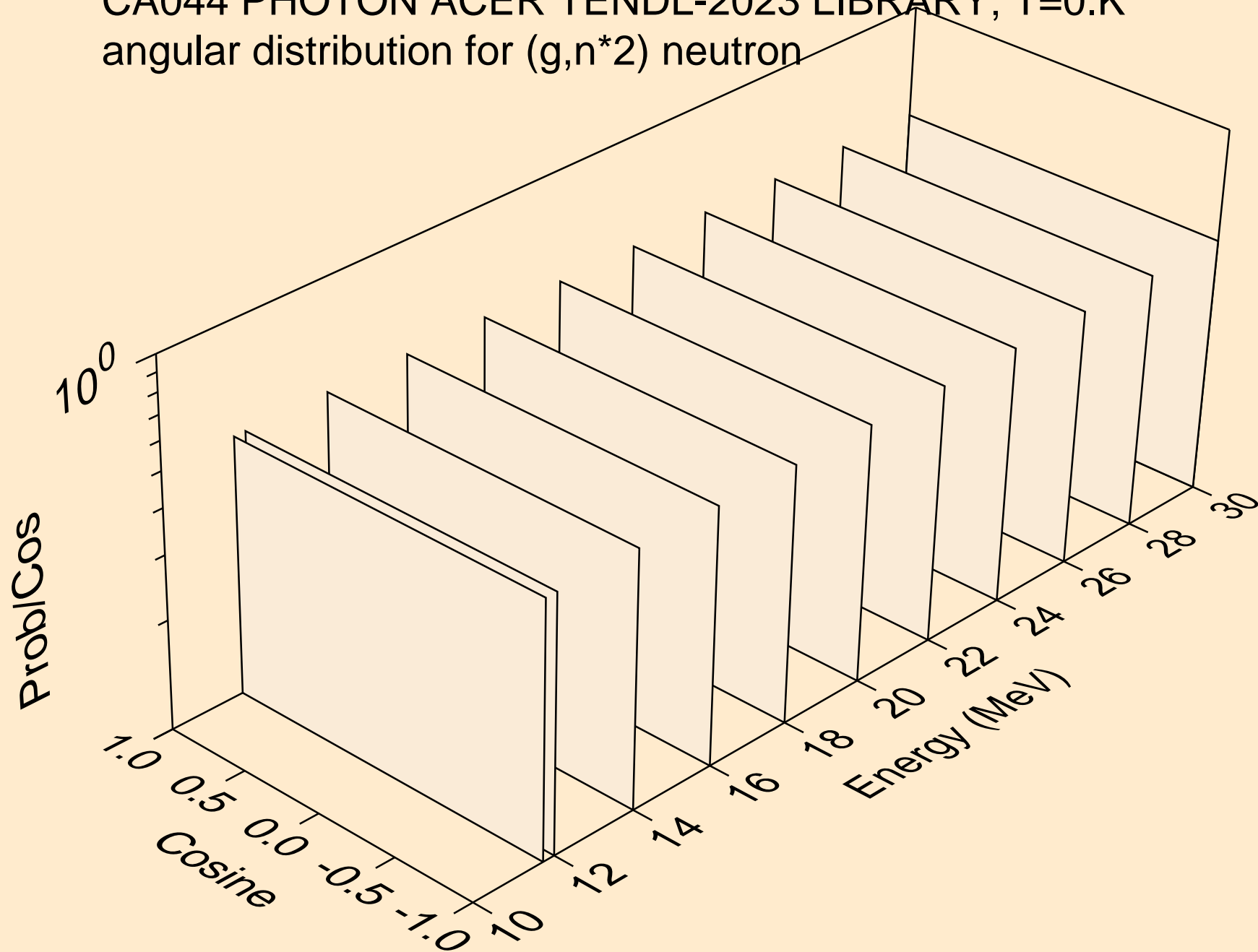

CA044 PHOTON ACER TENDL-2023 LIBRARY; T=0.K
neutrons from (g,n*c)

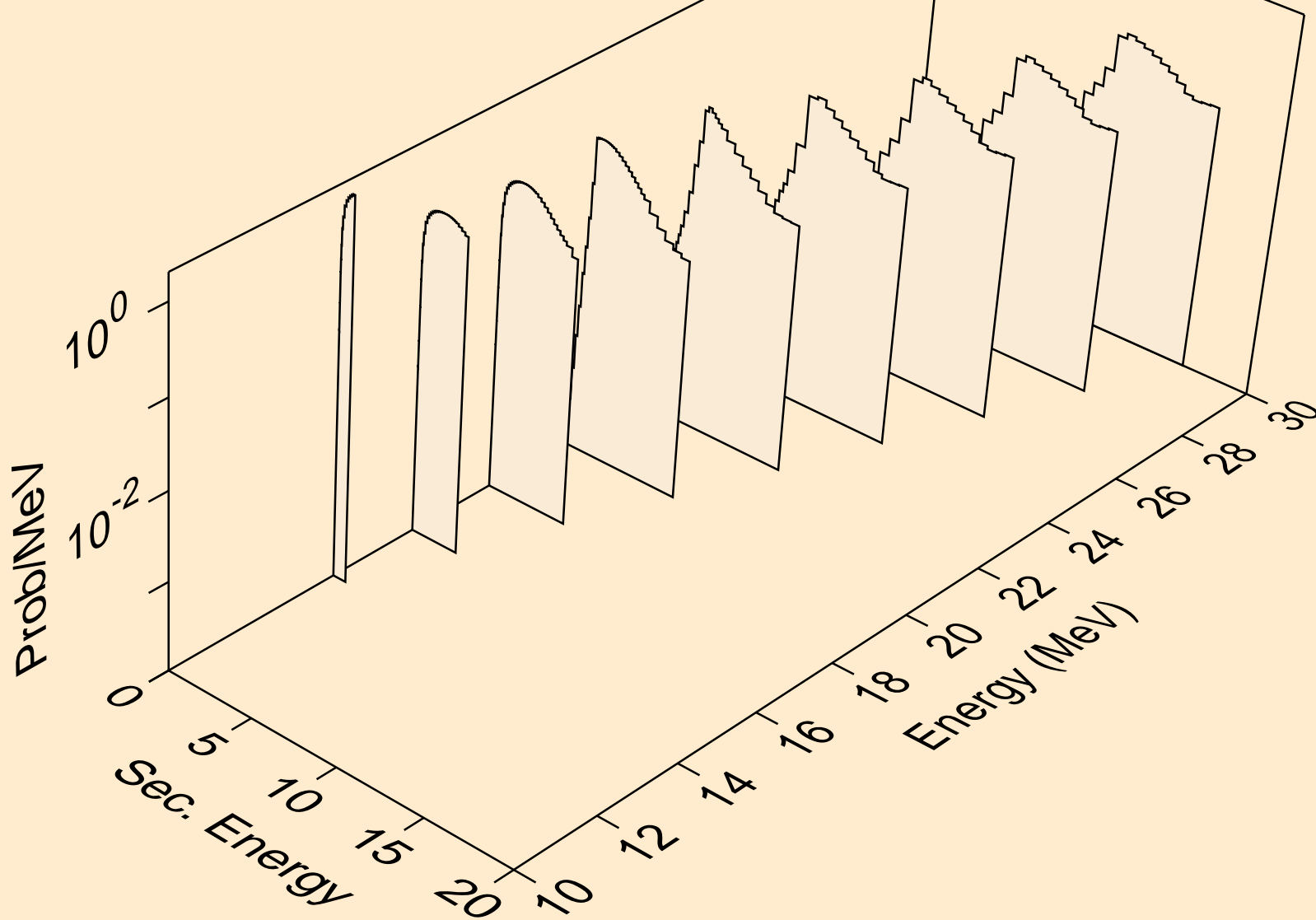

CA044 PHOTON ACER TENDL-2023 LIBRARY; T=0.K
photons from (g,x)

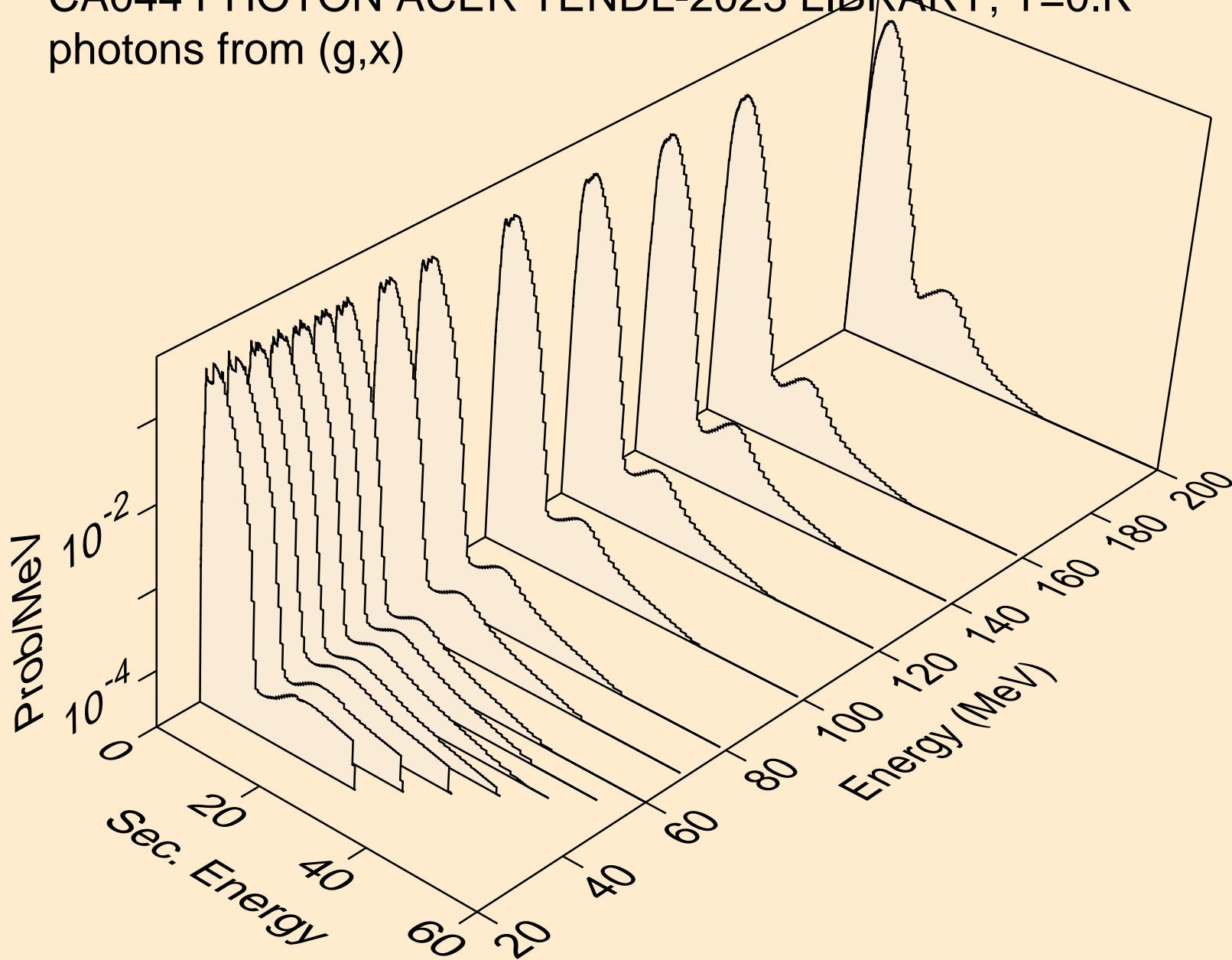

CA044 PHOTON ACER TENDL-2023 LIBRARY; T=0.K
photons from (g,2n)

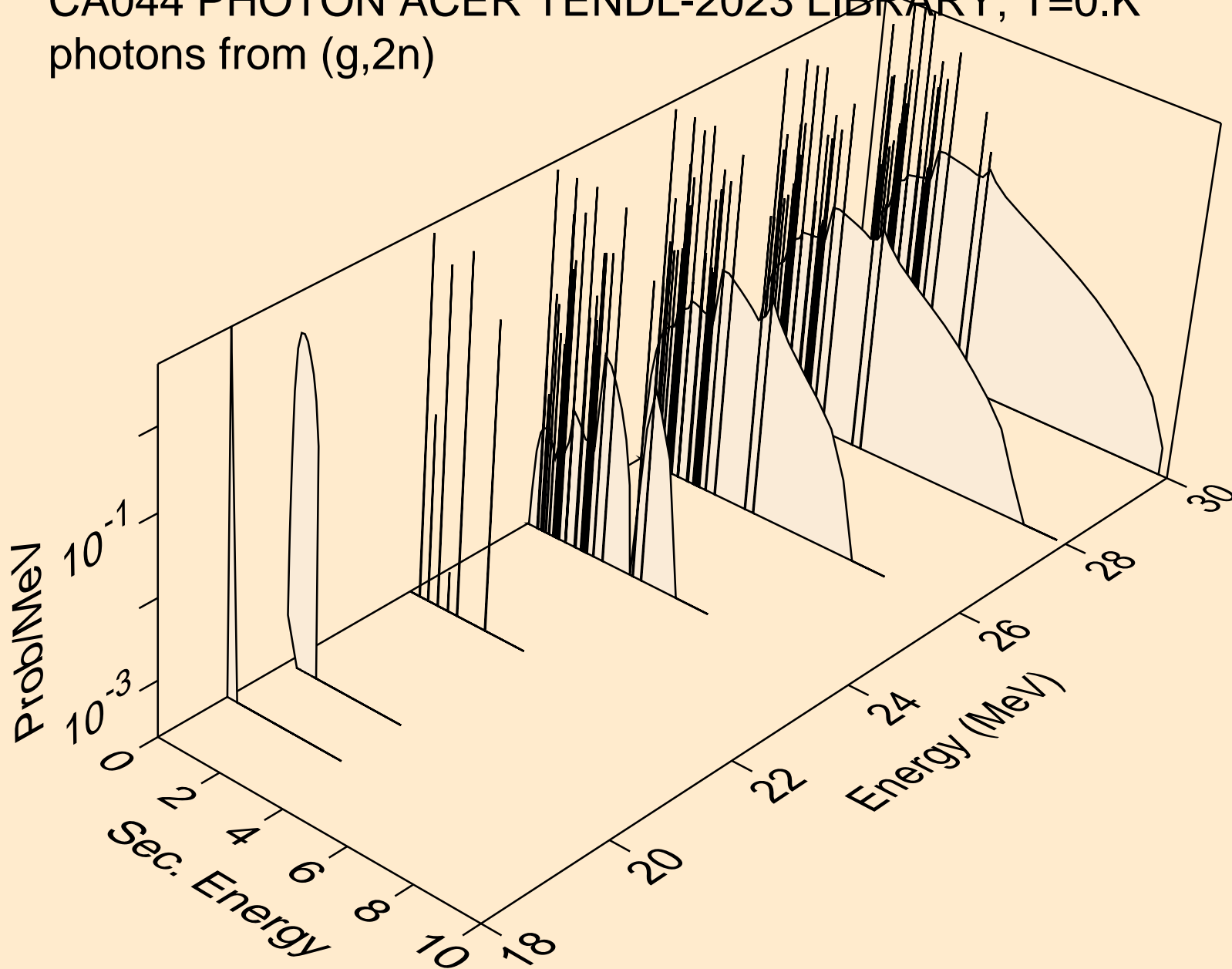

CA044 PHOTON ACER TENDL-2023 LIBRARY; T=0.K
photons from (g,n*)a

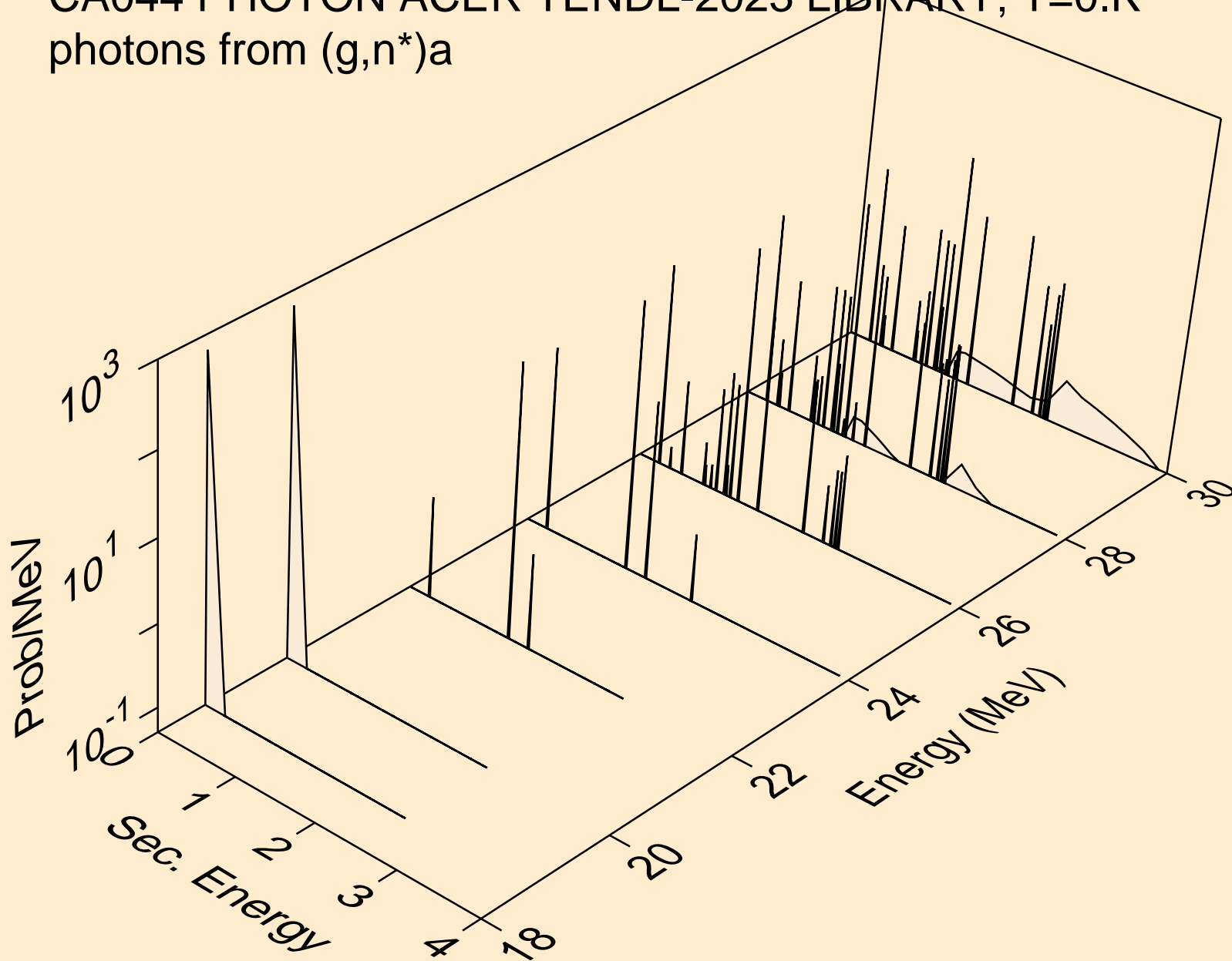

CA044 PHOTON ACER TENDL-2023 LIBRARY; T=0.K
photons from (g,2n)a

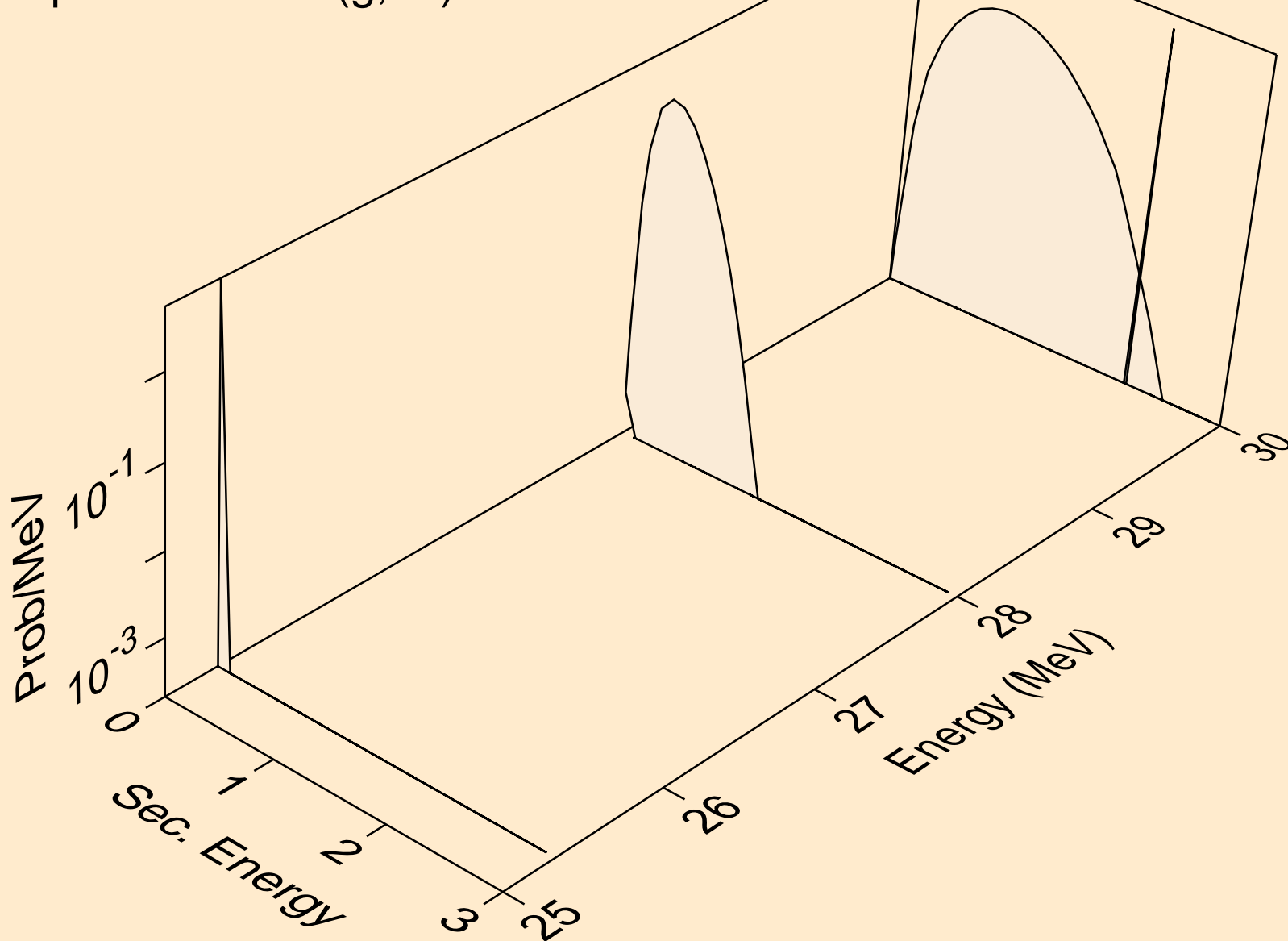

CA044 PHOTON ACER TENDL-2023 LIBRARY; T=0.K
photons from (g,n*)p

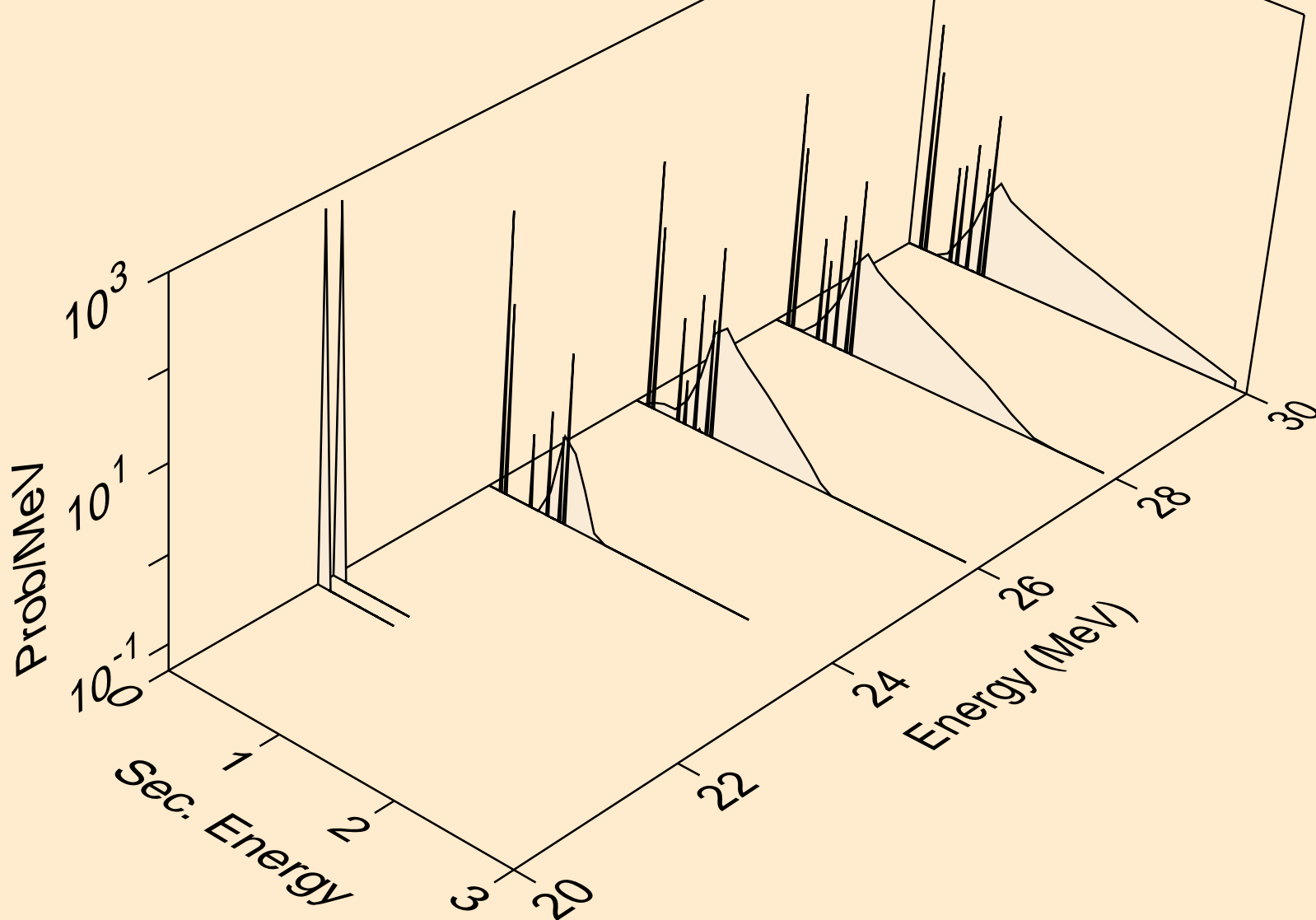

CA044 PHOTON ACER TENDL-2023 LIBRARY; T=0.K
photons from (g,n*)d

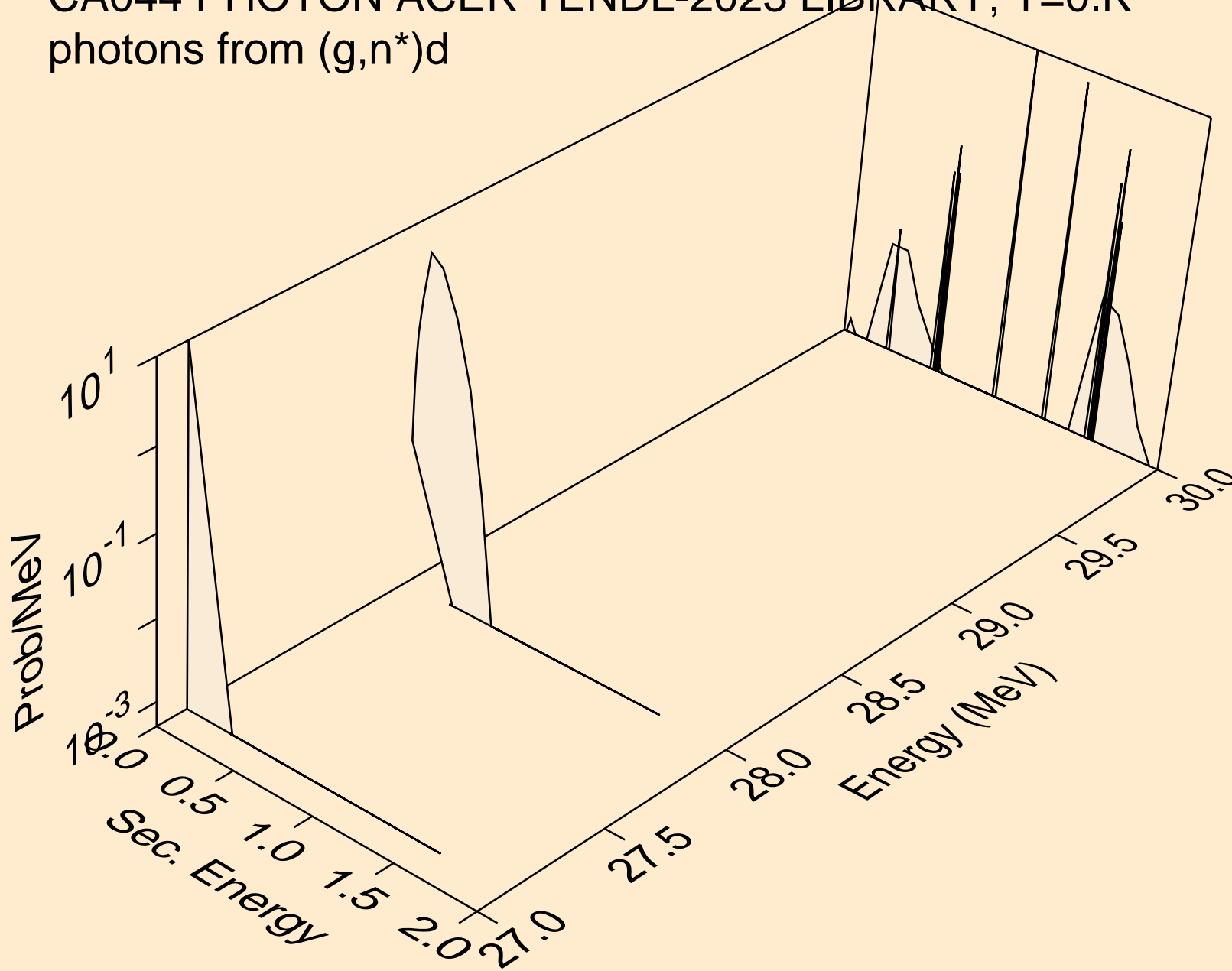

CA044 PHOTON ACER TENDL-2023 LIBRARY; T=0.K
photons from (g,n*c)

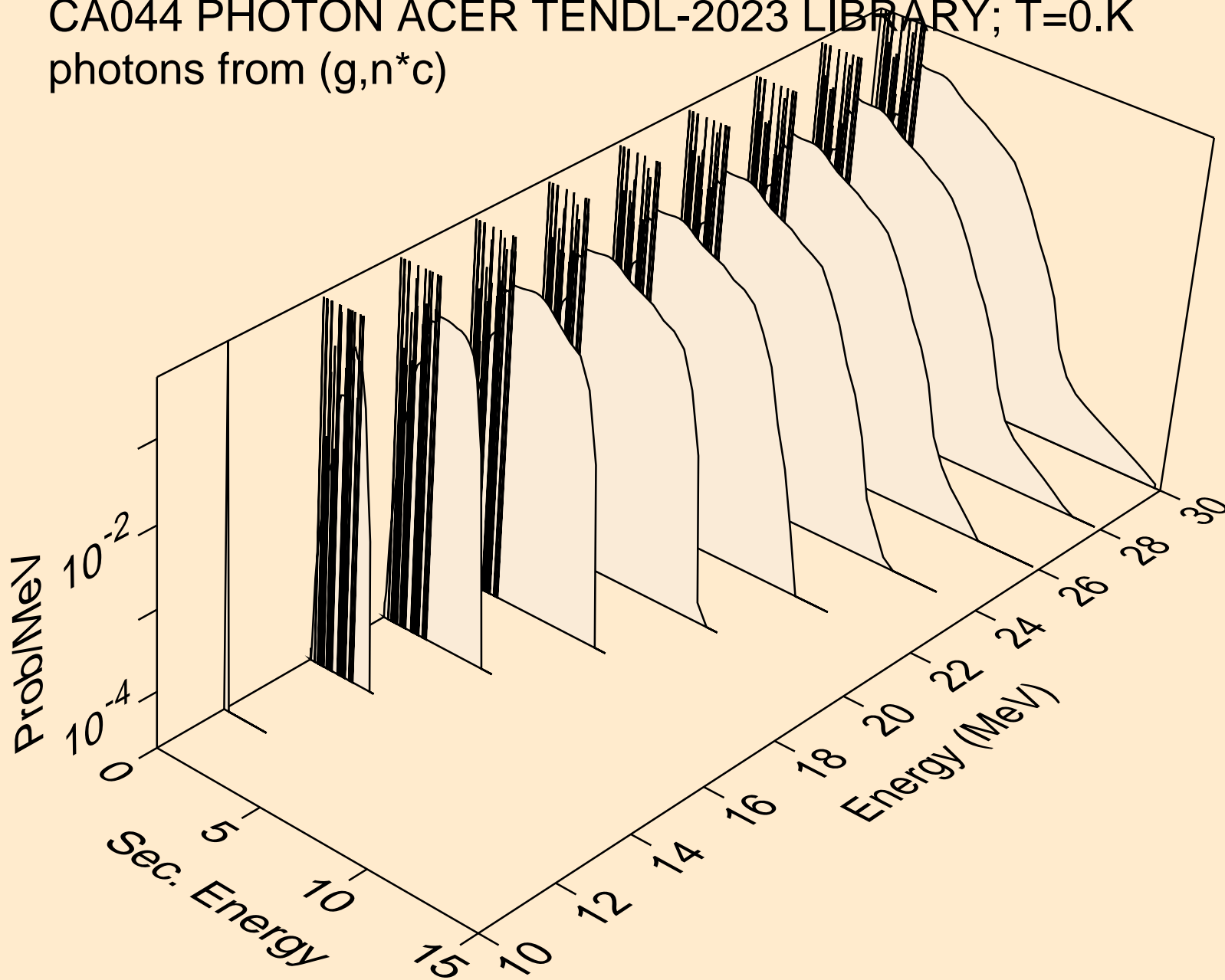

CA044 PHOTON ACER TENDL-2023 LIBRARY; T=0.K
photons from (g,gma)

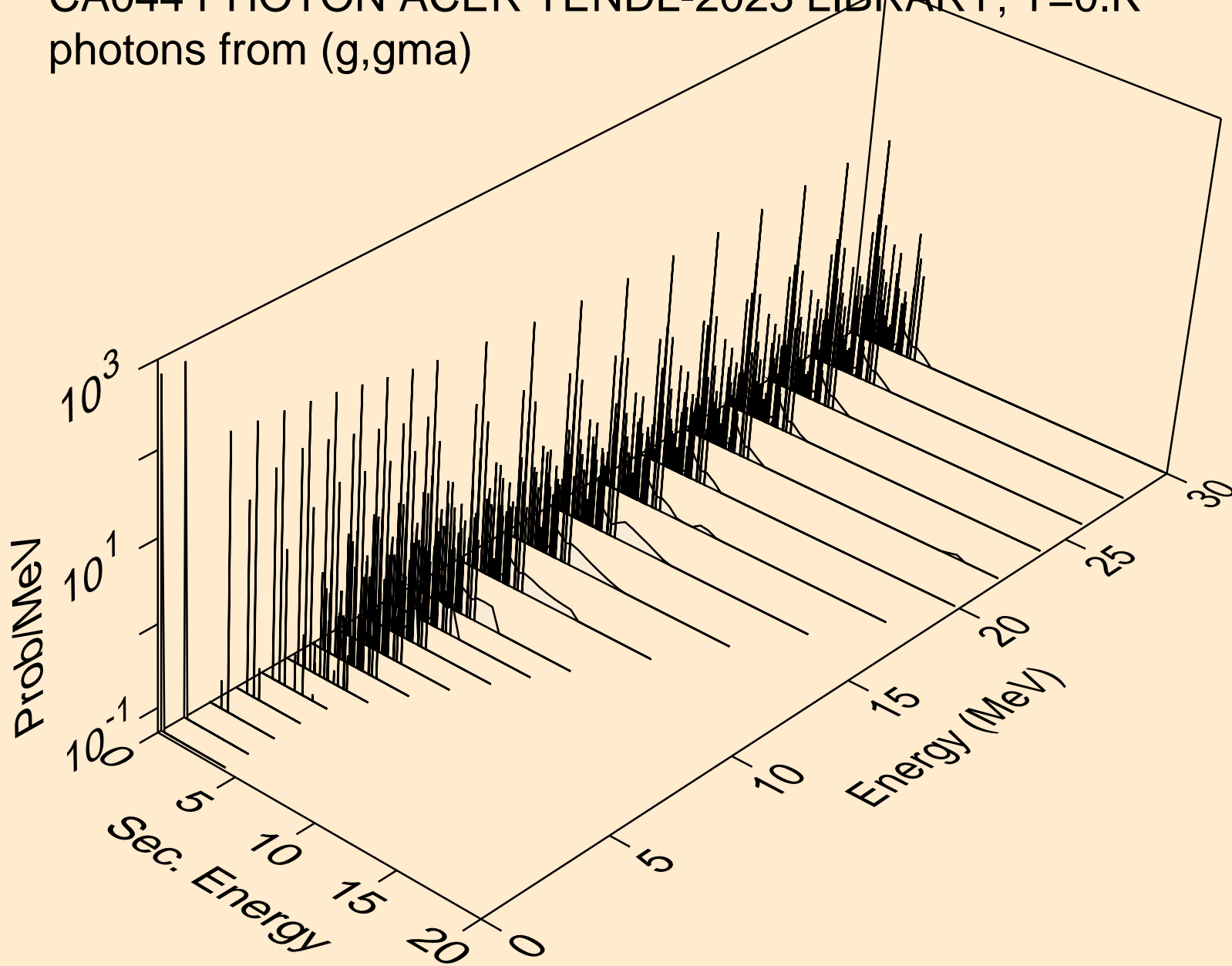

CA044 PHOTON ACER TENDL-2023 LIBRARY; T=0.K
photons from (g,p)

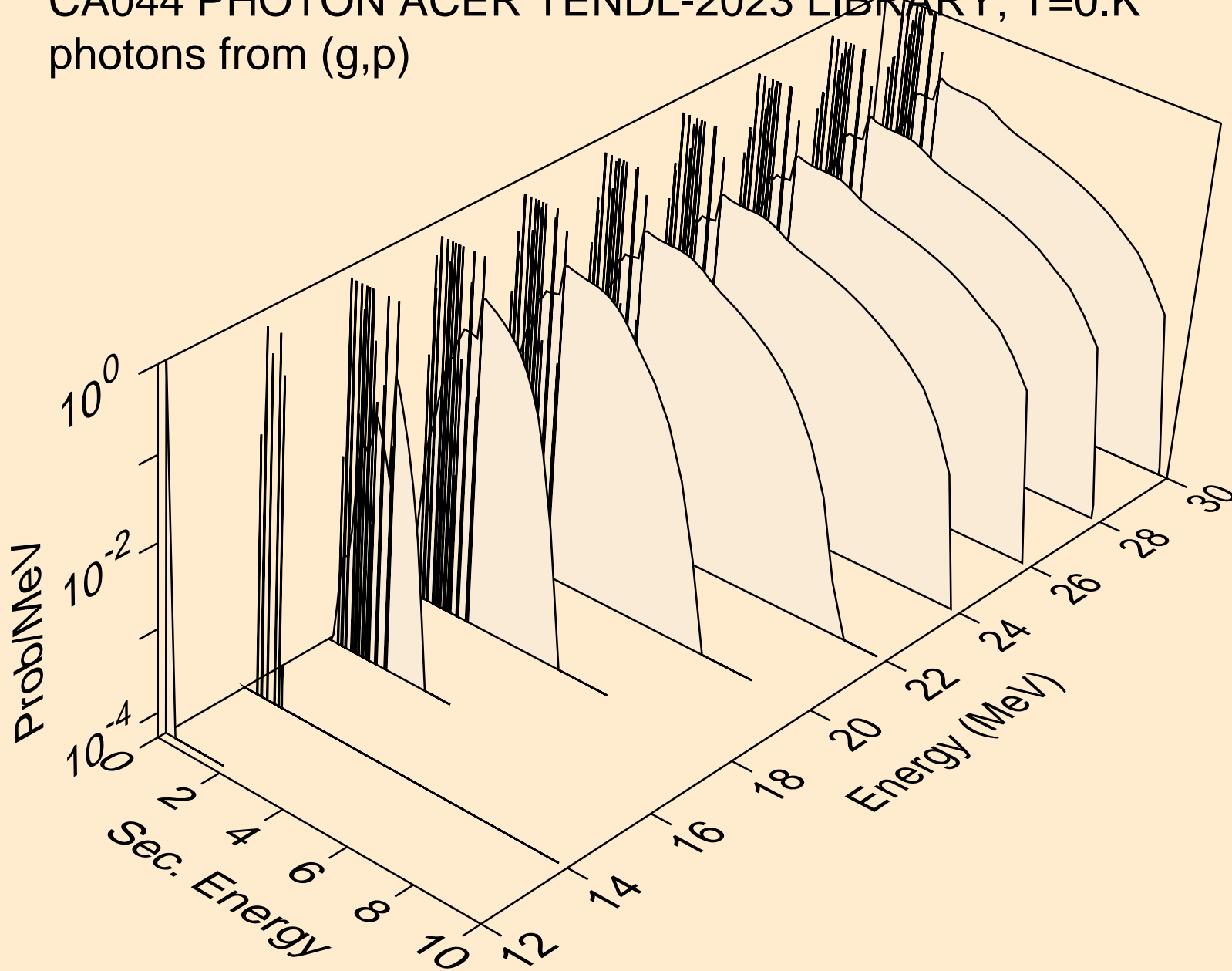

CA044 PHOTON ACER TENDL-2023 LIBRARY; T=0.K
photons from (g,d)

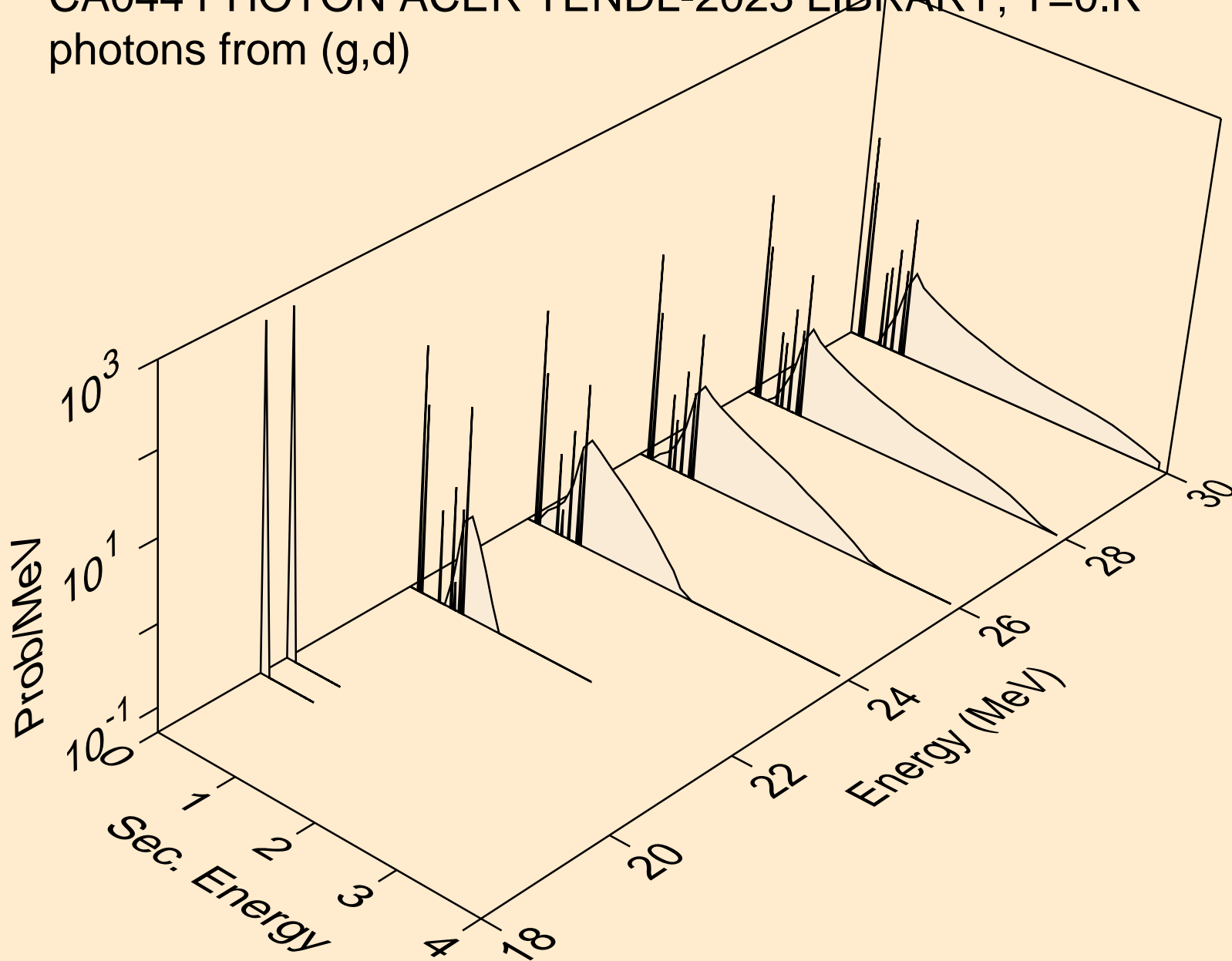

CA044 PHOTON ACER TENDL-2023 LIBRARY; T=0.K
photons from (g,t)

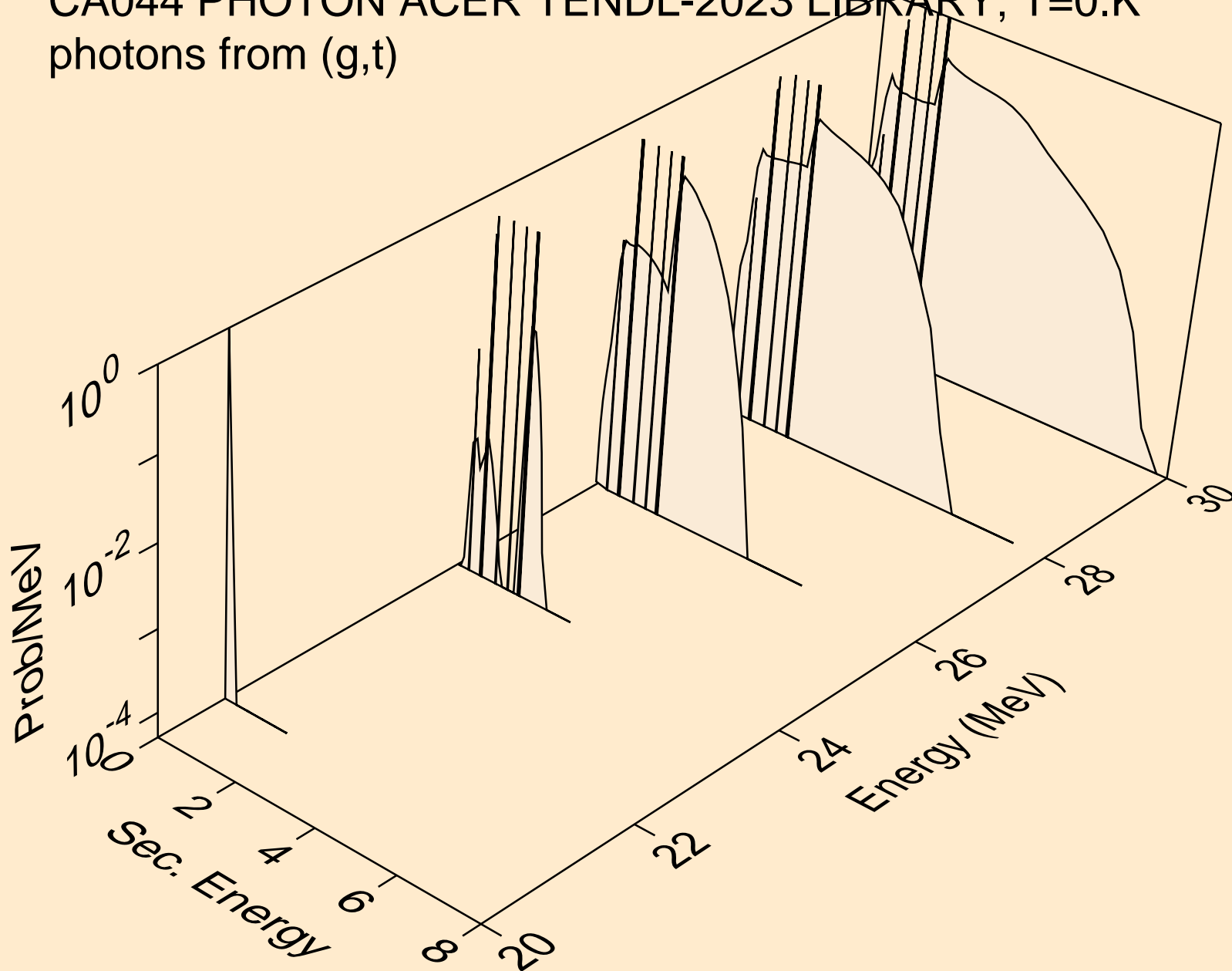

CA044 PHOTON ACER TENDL-2023 LIBRARY; T=0.K
photons from (g,he3)

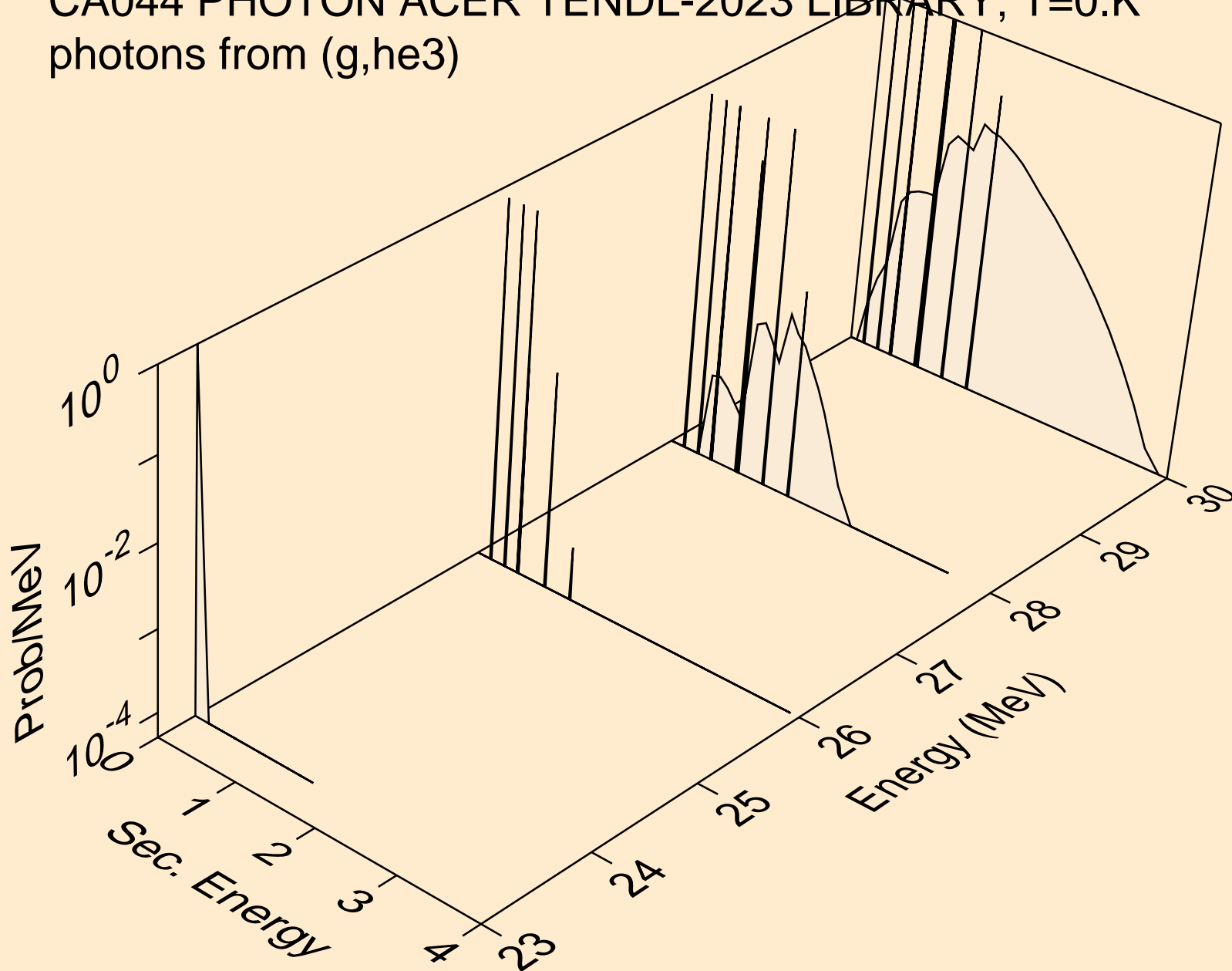

CA044 PHOTON ACER TENDL-2023 LIBRARY; T=0.K
photons from (g,a)

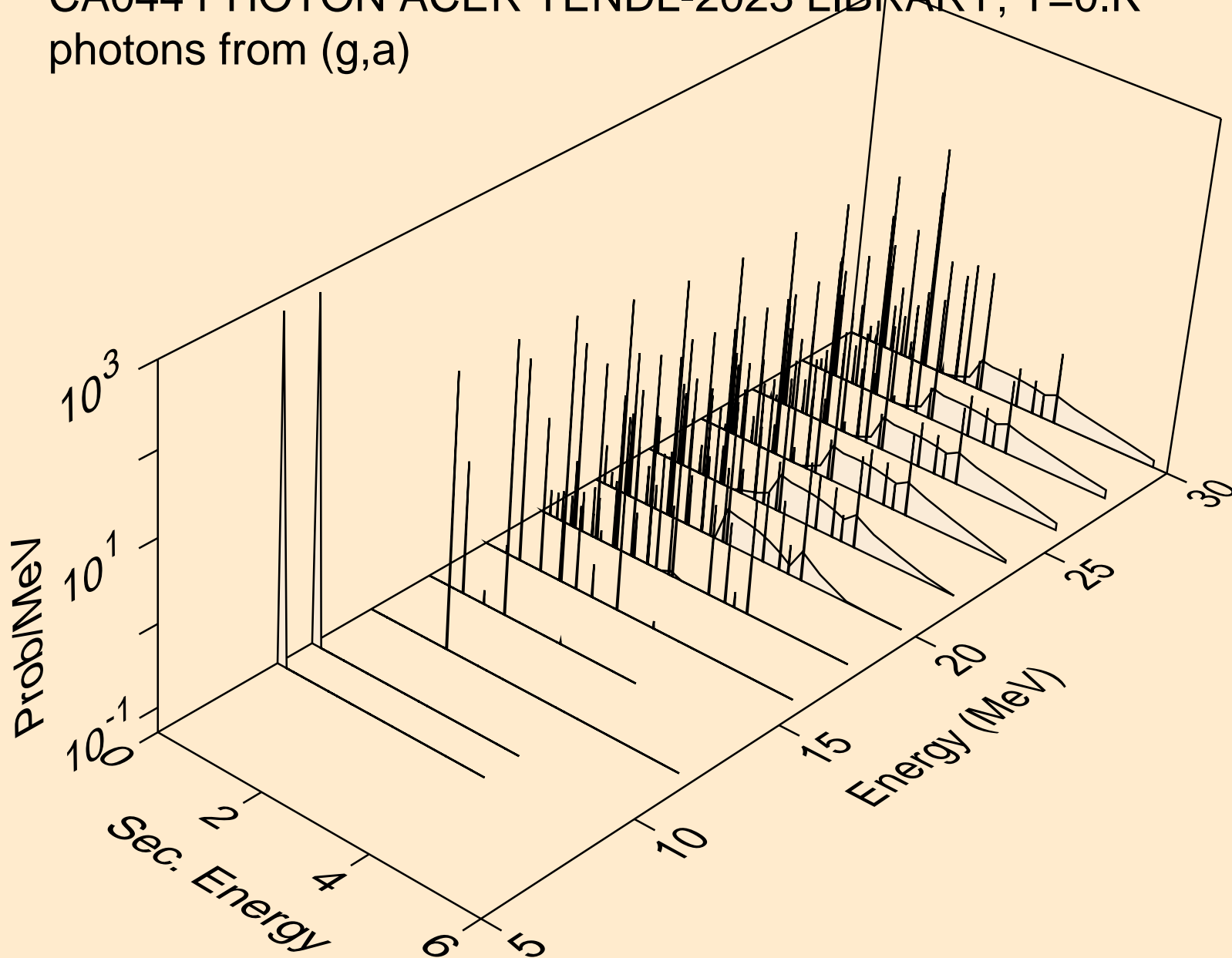

CA044 PHOTON ACER TENDL-2023 LIBRARY; T=0.K
photons from (g,2a)

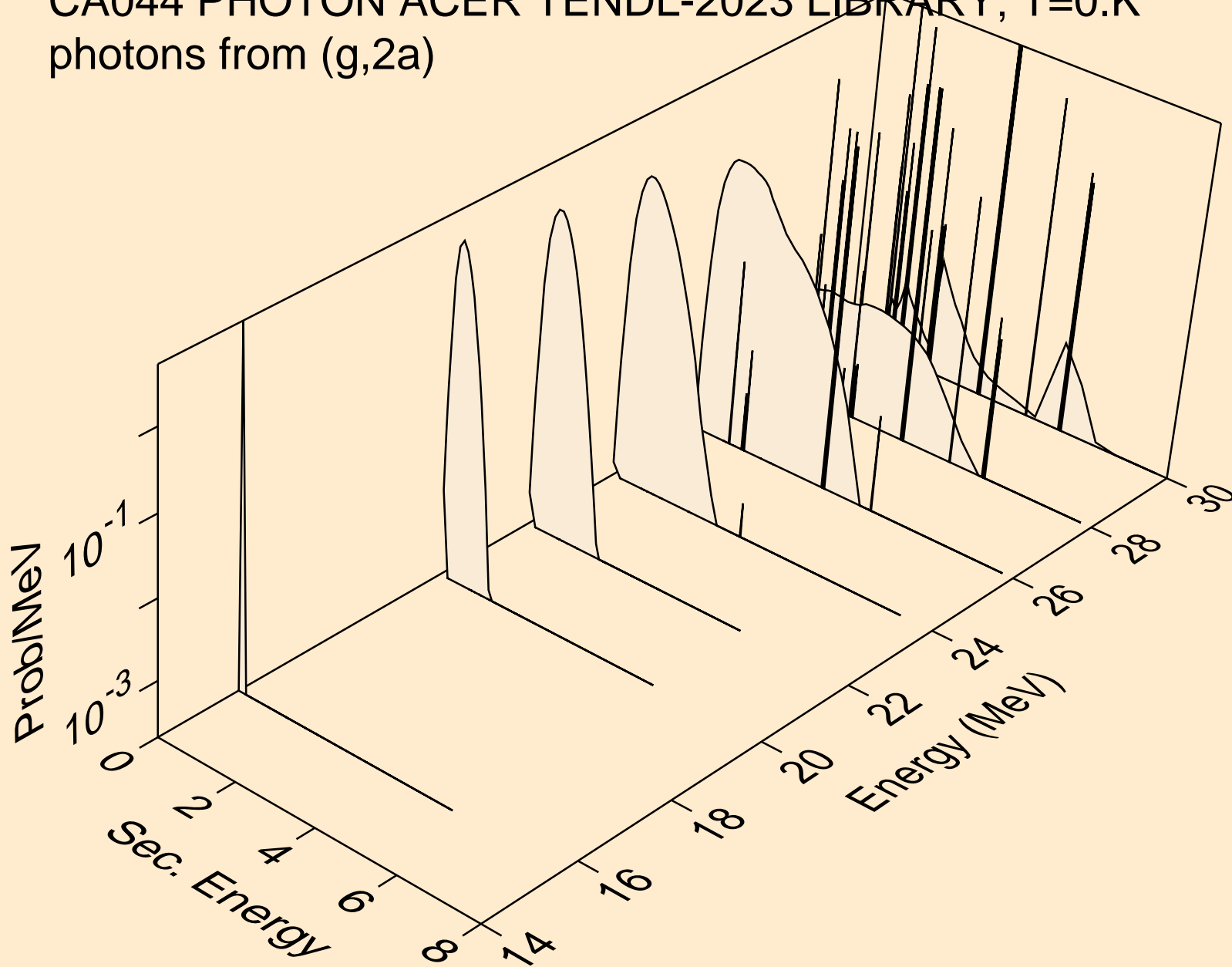

CA044 PHOTON ACER TENDL-2023 LIBRARY; T=0.K
photons from (g,2p)

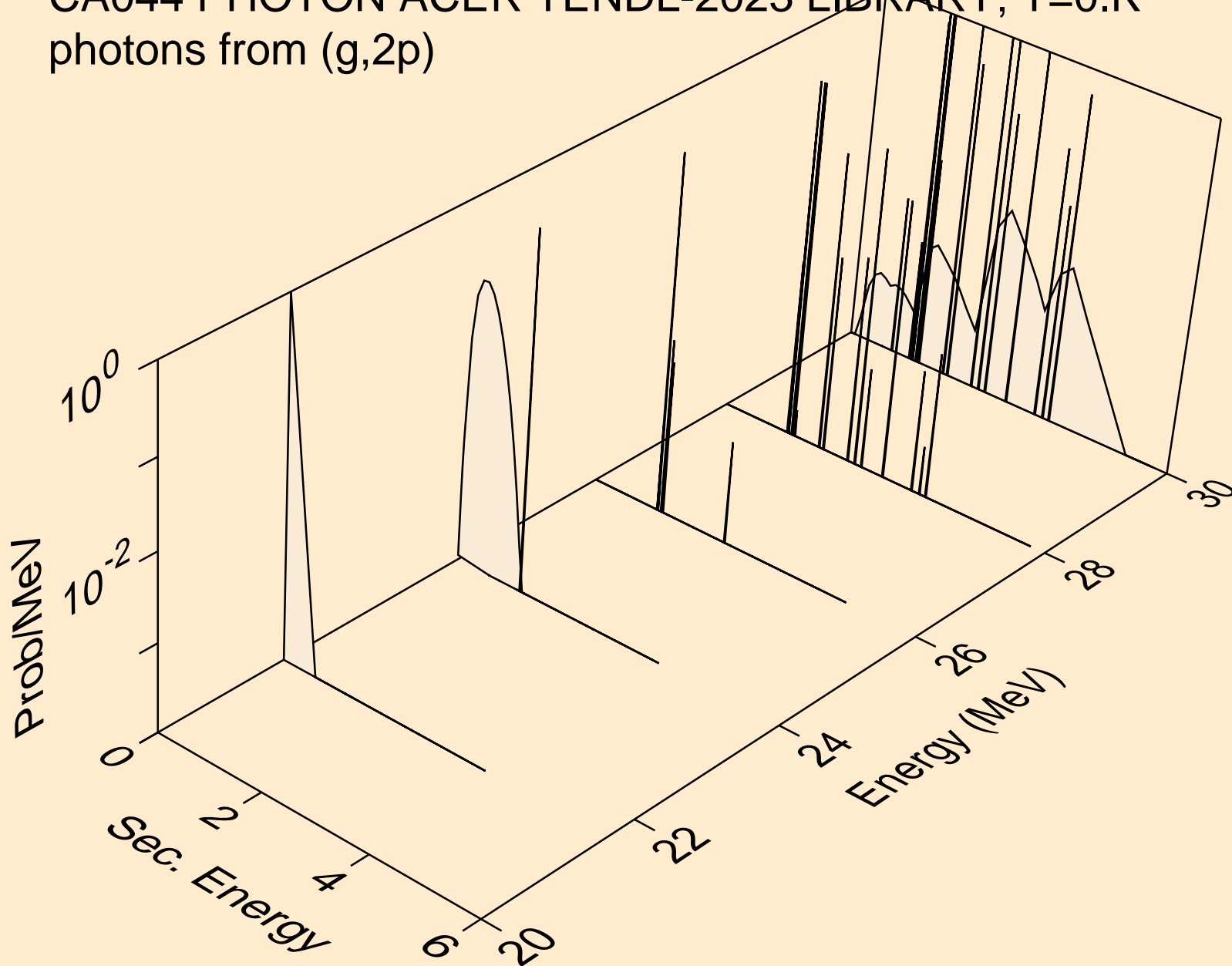

CA044 PHOTON ACER TENDL-2023 LIBRARY; T=0.K
photons from (g,pa)

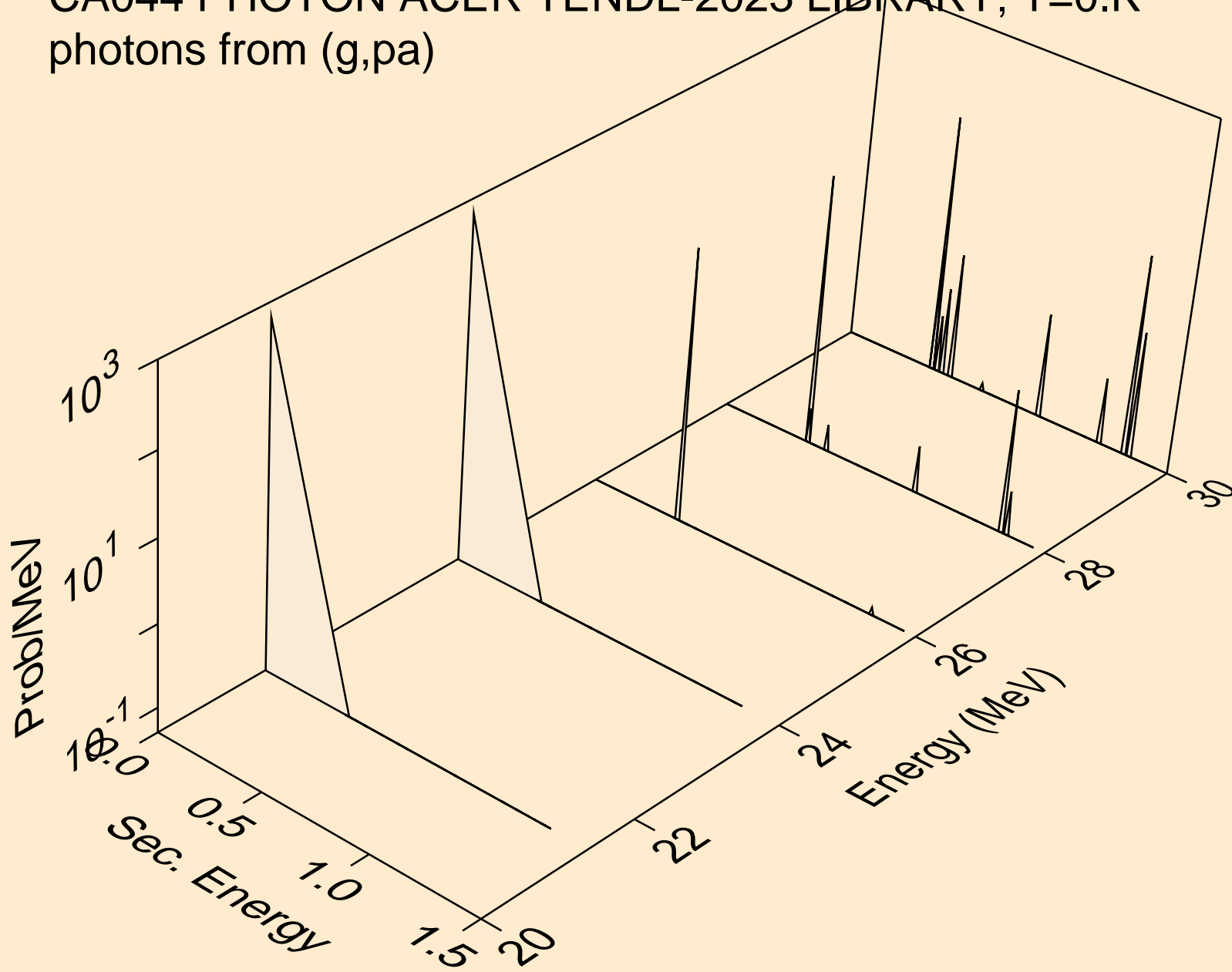

CA044 PHOTON ACER TENDL-2023 LIBRARY; T=0.K
protons from (g,x)

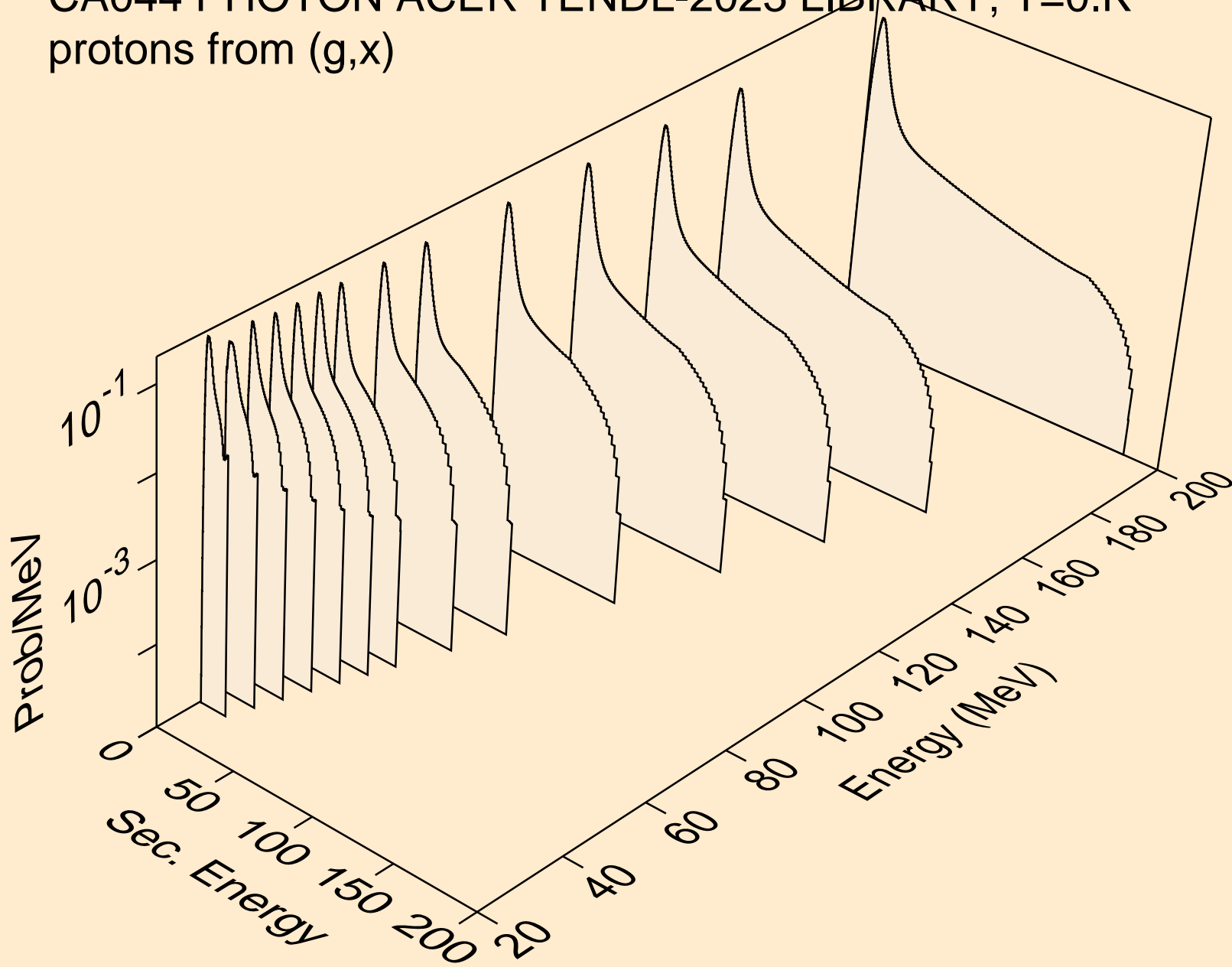

CA044 PHOTON ACER TENDL-2023 LIBRARY; T=0.K
protons from (g,n*)p

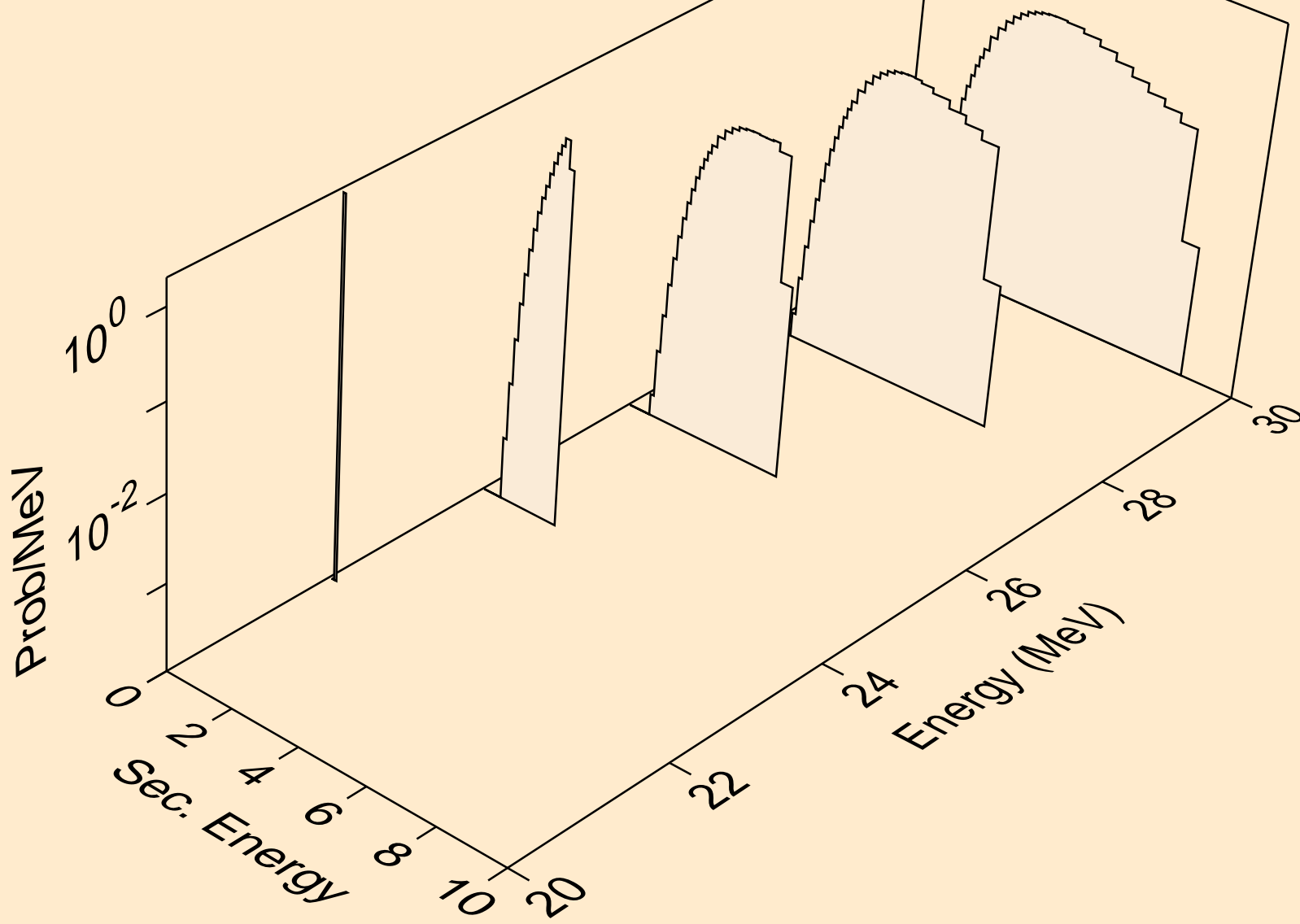

CA044 PHOTON ACER TENDL-2023 LIBRARY; T=0.K
protons from (g,p)

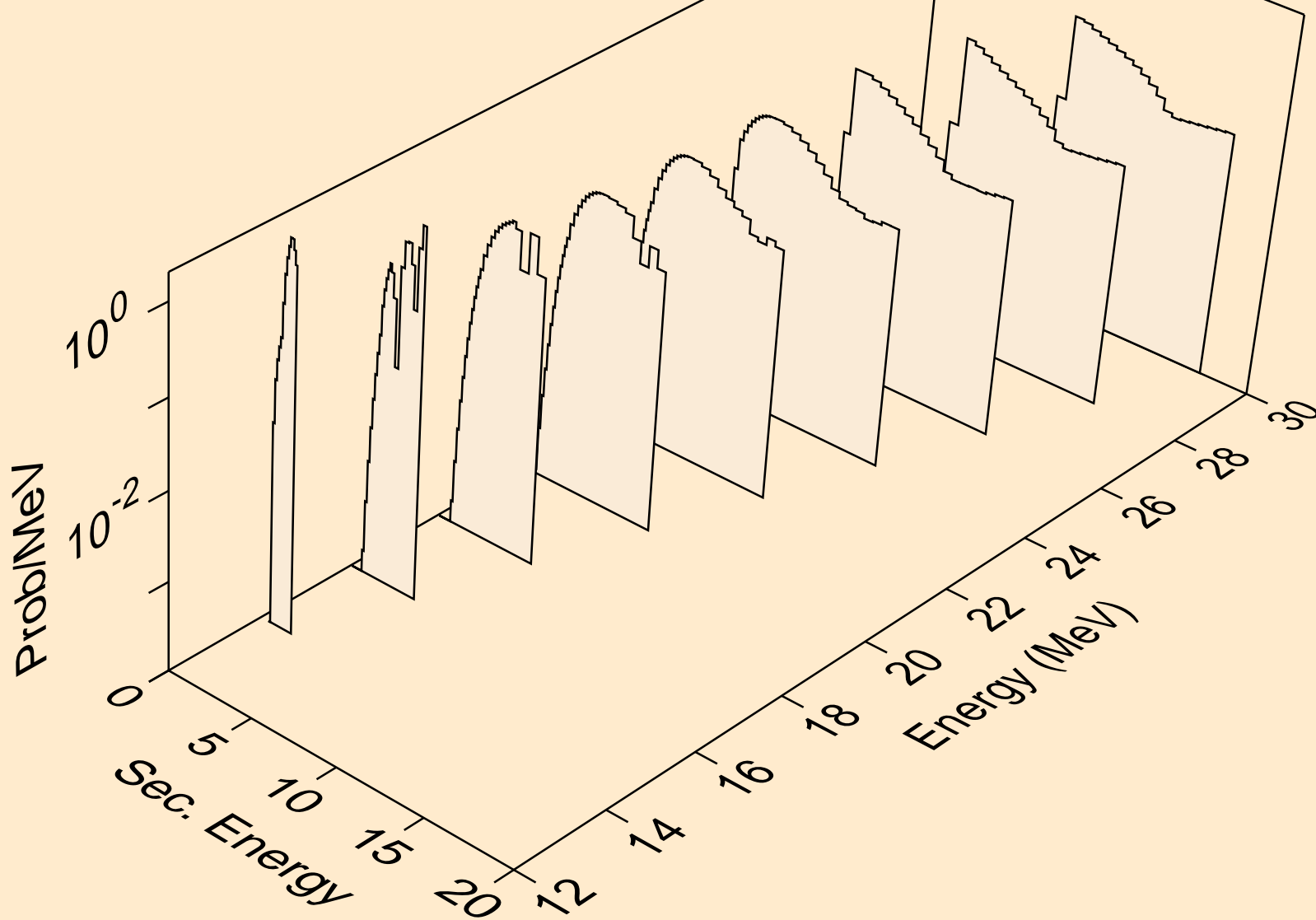

CA044 PHOTON ACER TENDL-2023 LIBRARY; T=0.K
protons from (g,2p)

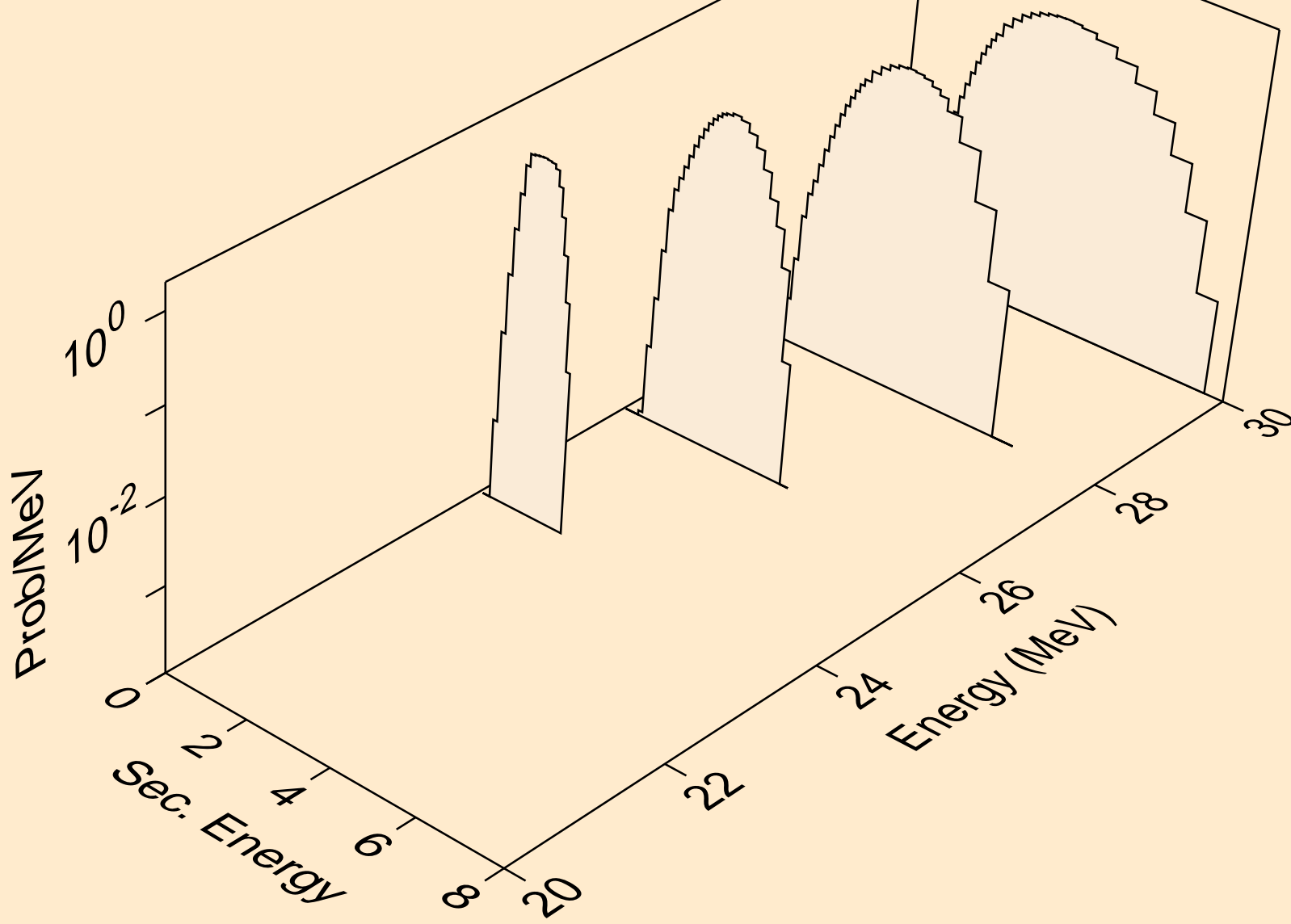

CA044 PHOTON ACER TENDL-2023 LIBRARY; T=0.K
protons from (g,pa)

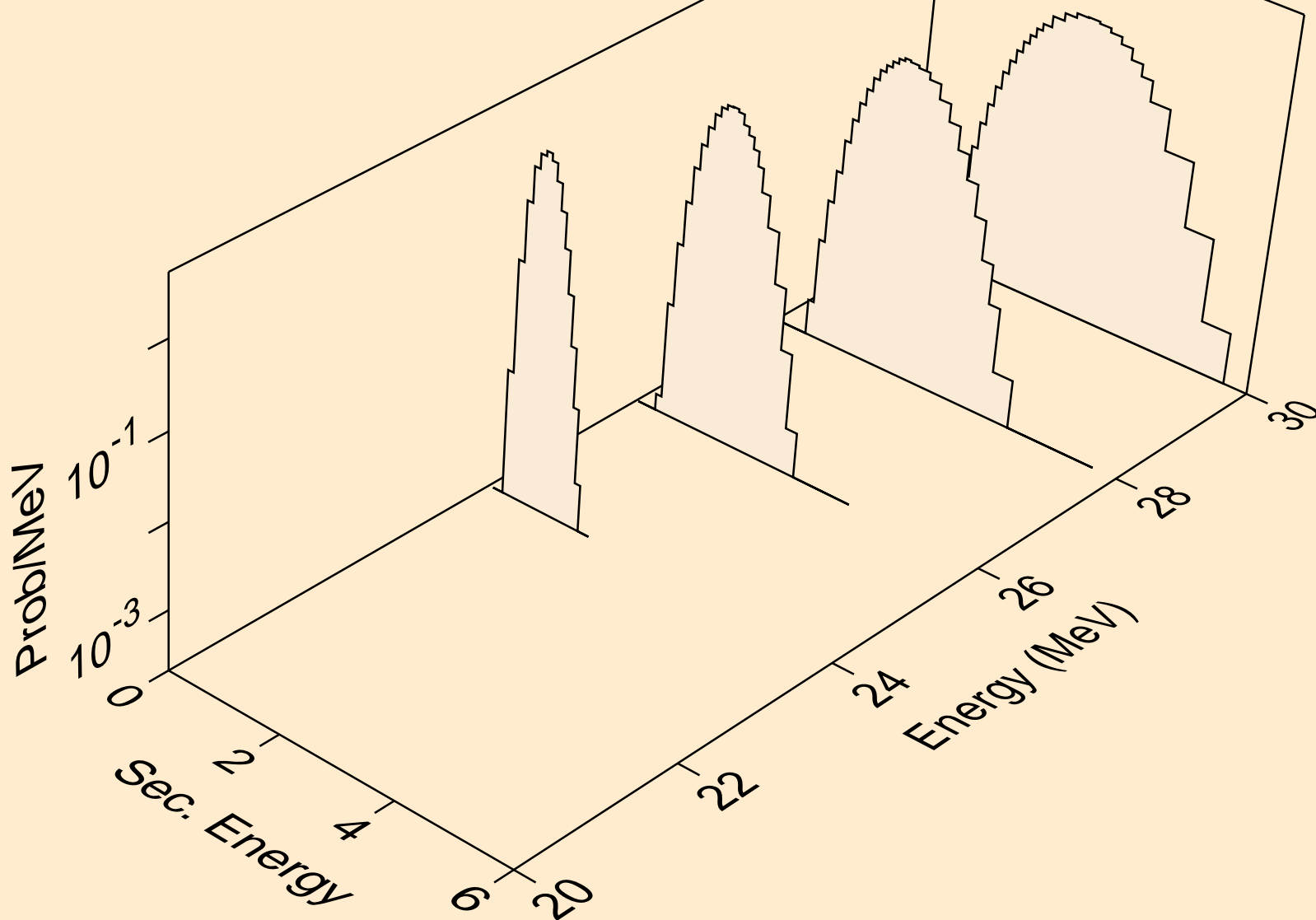

CA044 PHOTON ACER TENDL-2023 LIBRARY; T=0.K
deuterons from (g,x)

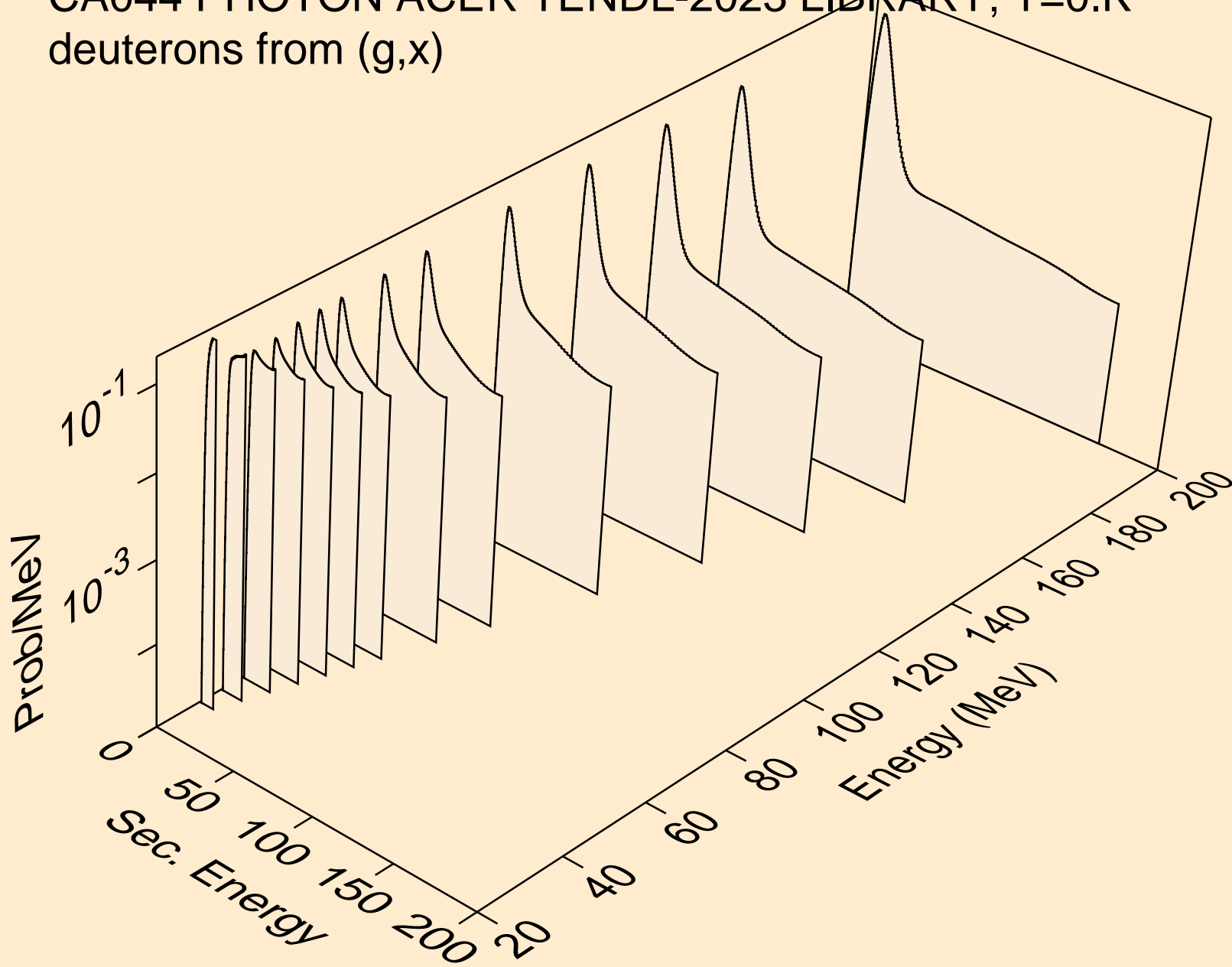

CA044 PHOTON ACER TENDL-2023 LIBRARY; T=0.K
deuterons from (g,n*)d

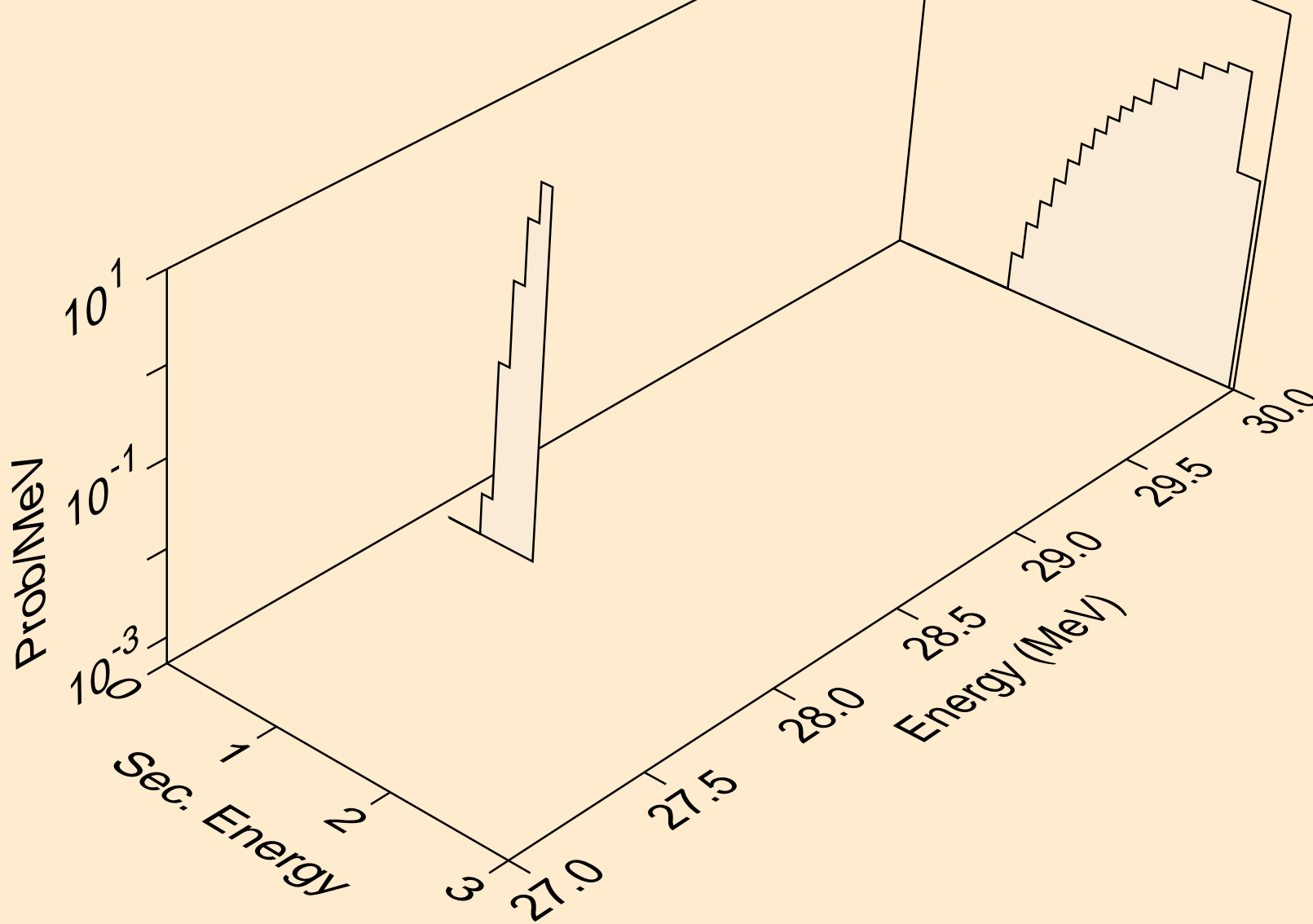

CA044 PHOTON ACER TENDL-2023 LIBRARY; T=0.K
deuterons from (g,d)

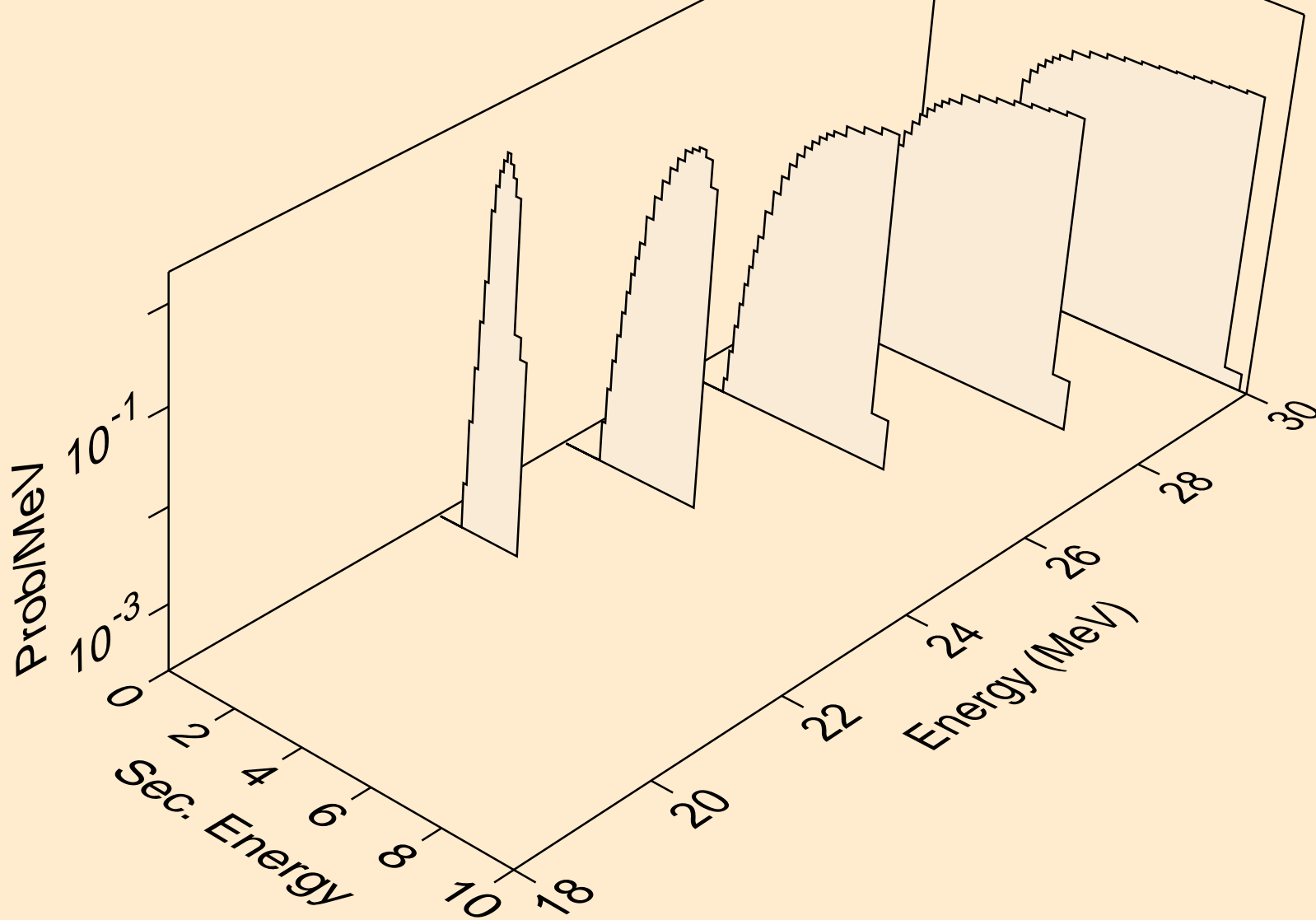

CA044 PHOTON ACER TENDL-2023 LIBRARY; T=0.K
tritons from (g,x)

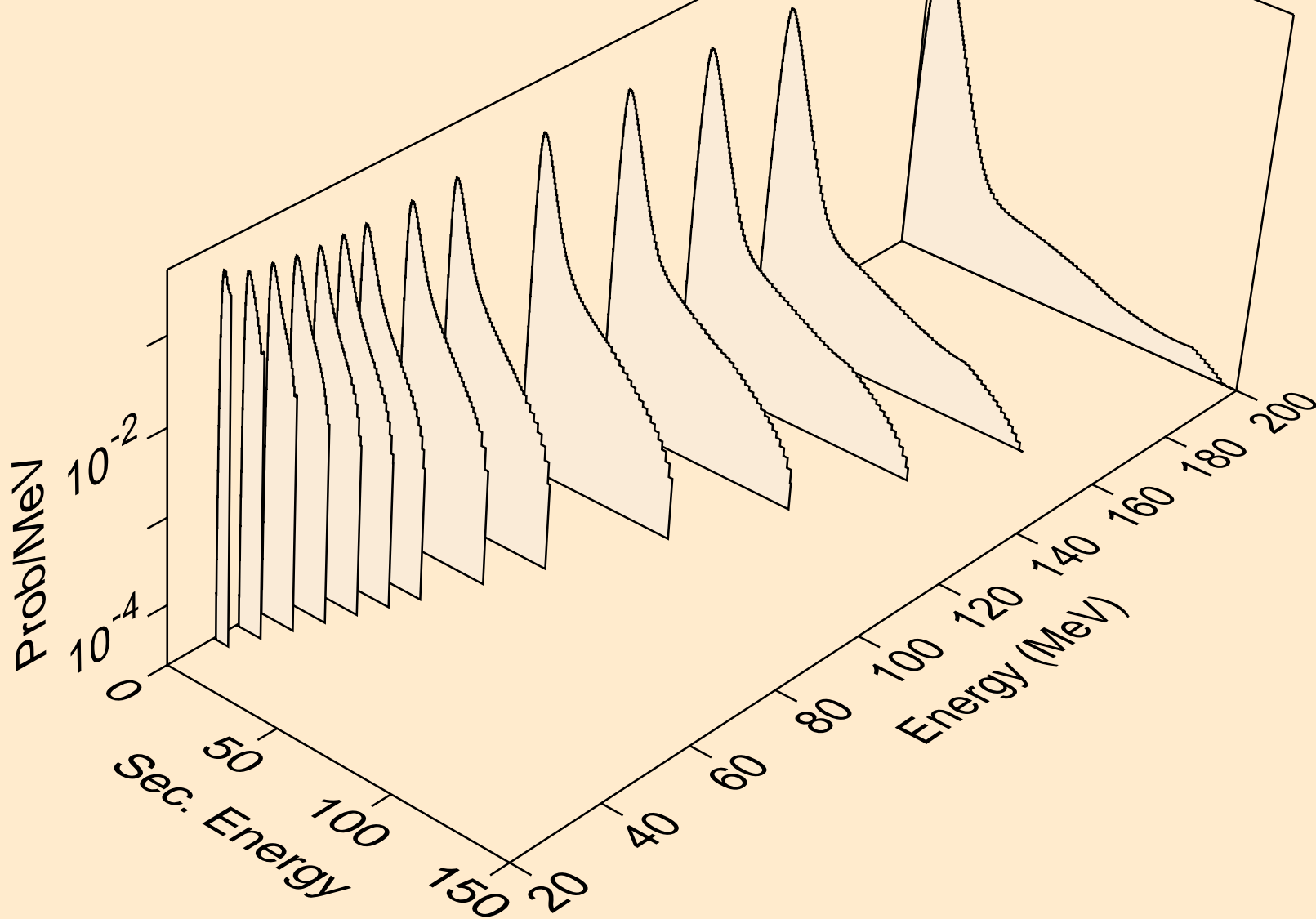

CA044 PHOTON ACER TENDL-2023 LIBRARY; T=0.K
tritons from (g,t)

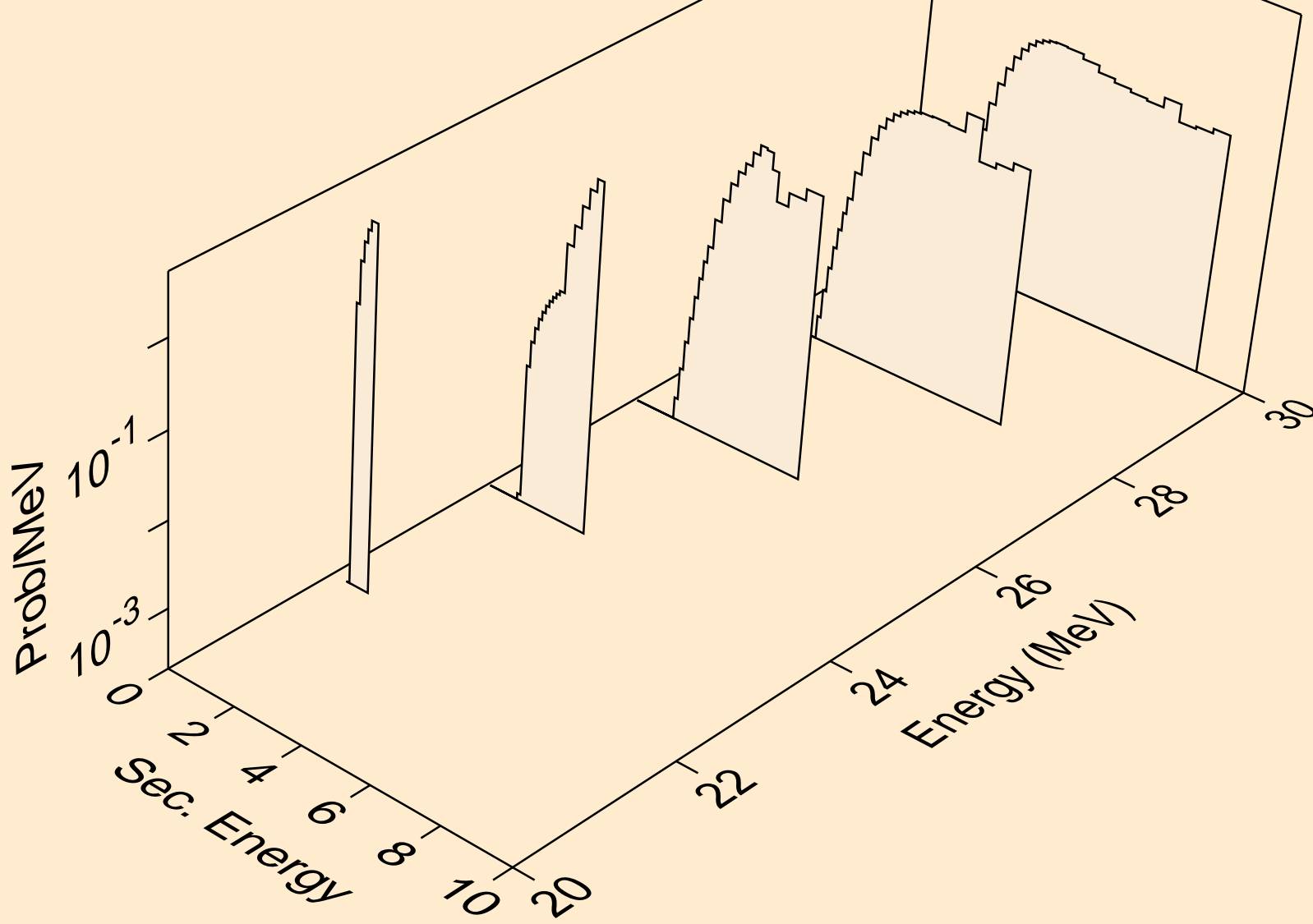

CA044 PHOTON ACER TENDL-2023 LIBRARY; T=0.K
he3s from (g,x)

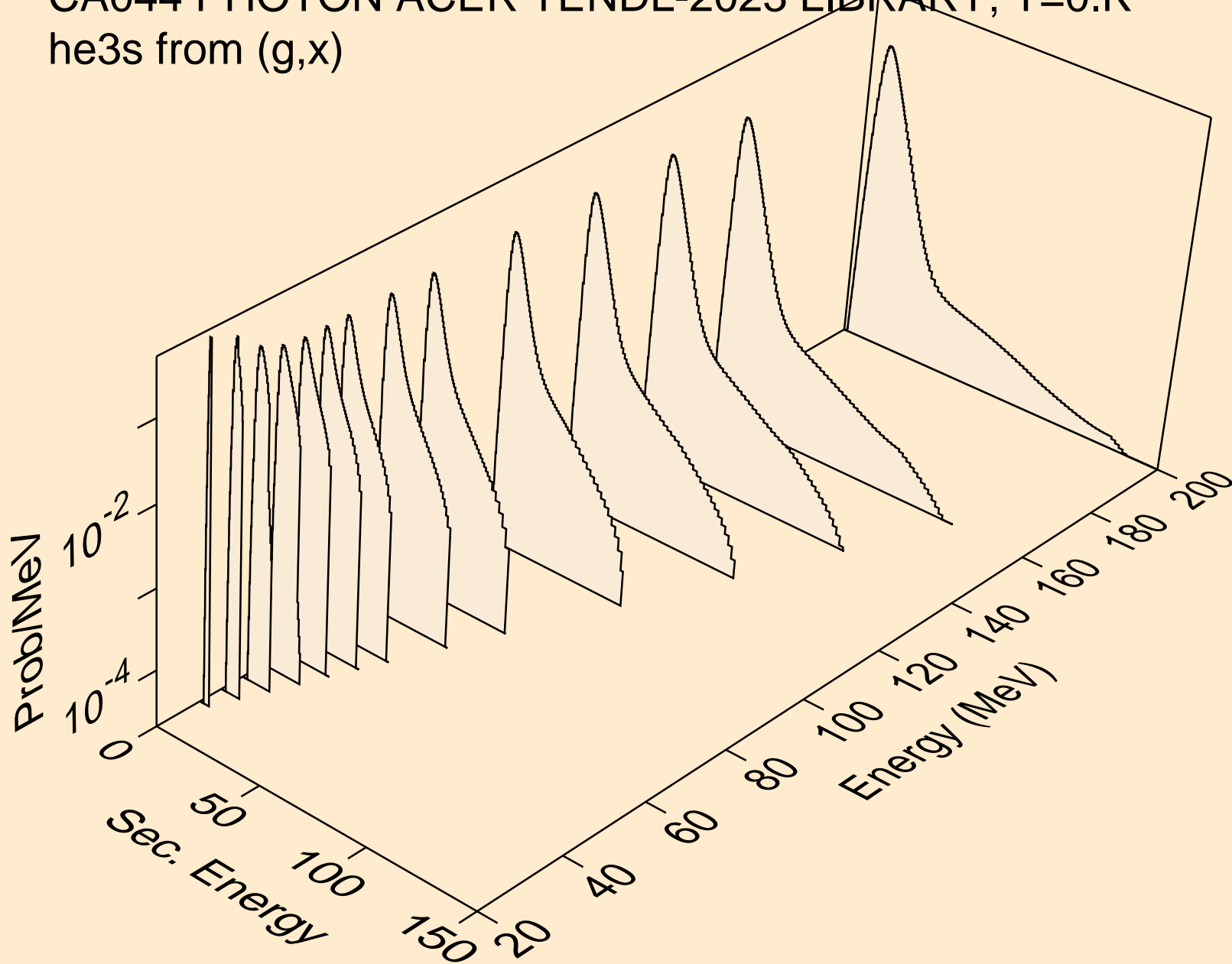

CA044 PHOTON ACER TENDL-2023 LIBRARY; T=0.K
he3s from (g,he3)

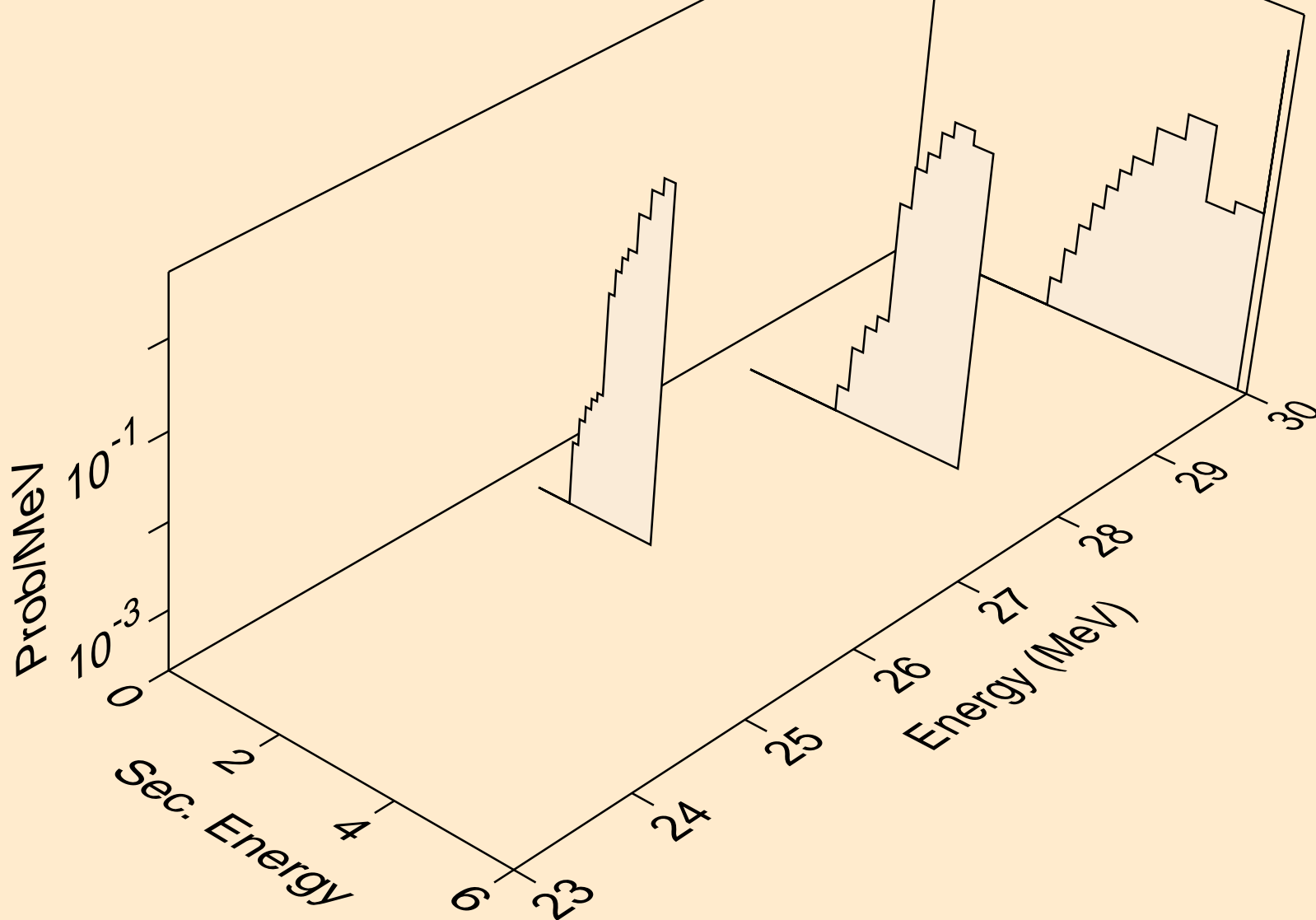

CA044 PHOTON ACER TENDL-2023 LIBRARY; T=0.K
alphas from (g,x)

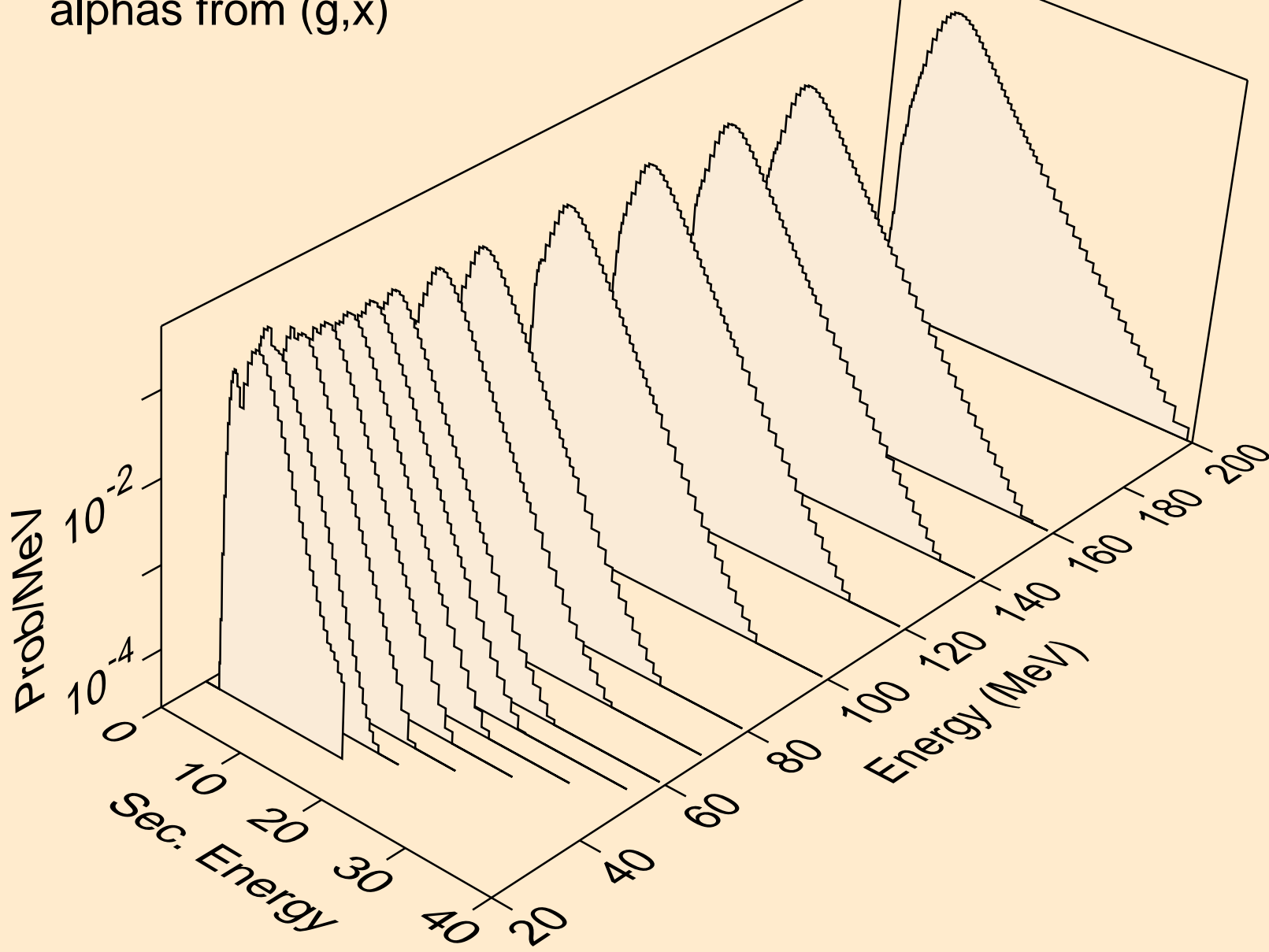

CA044 PHOTON ACER TENDL-2023 LIBRARY; T=0.K
alphas from (g,n*)a

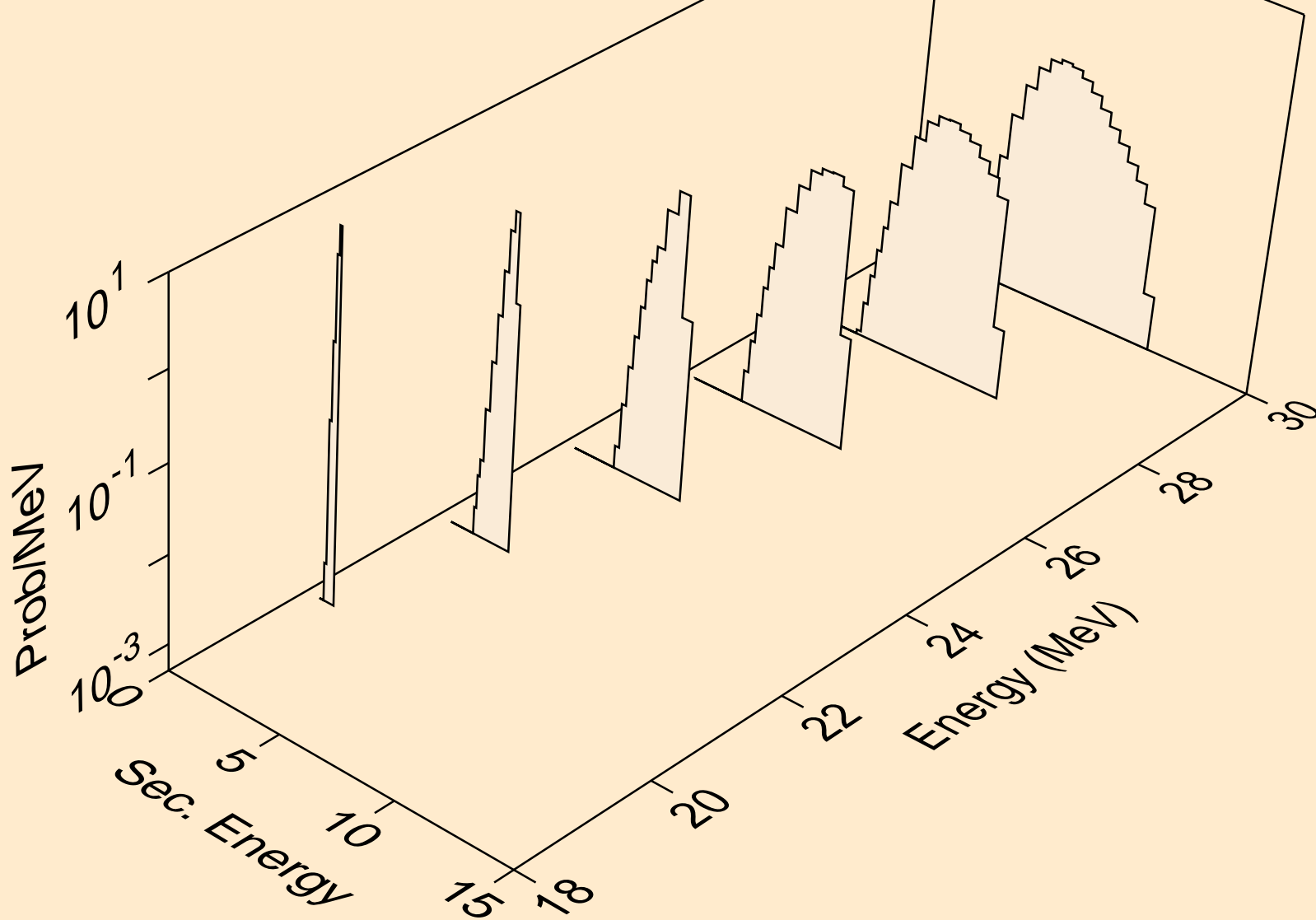

CA044 PHOTON ACER TENDL-2023 LIBRARY; T=0.K
alphas from (g,2n)a

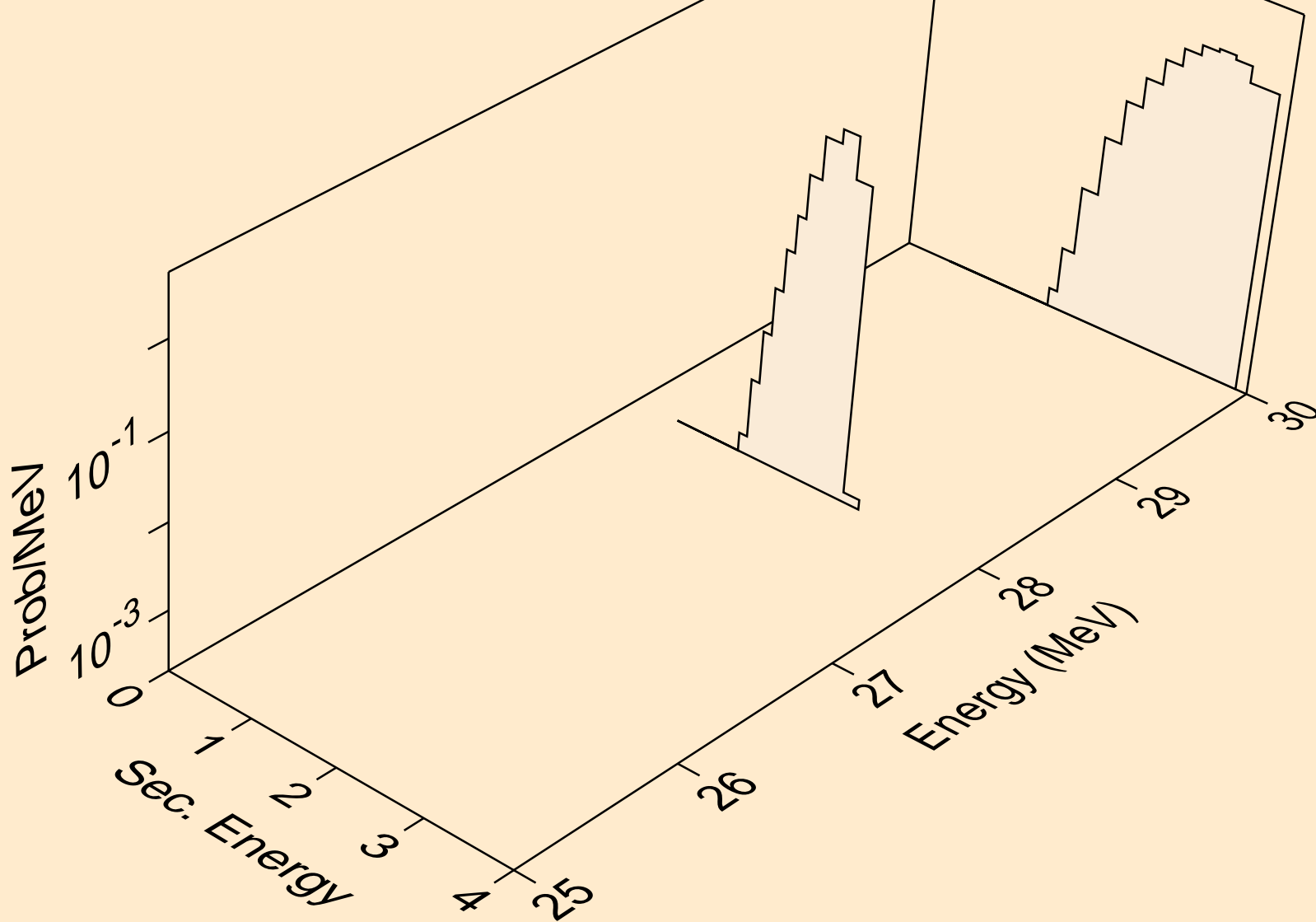

CA044 PHOTON ACER TENDL-2023 LIBRARY; T=0.K
alphas from (g,a)

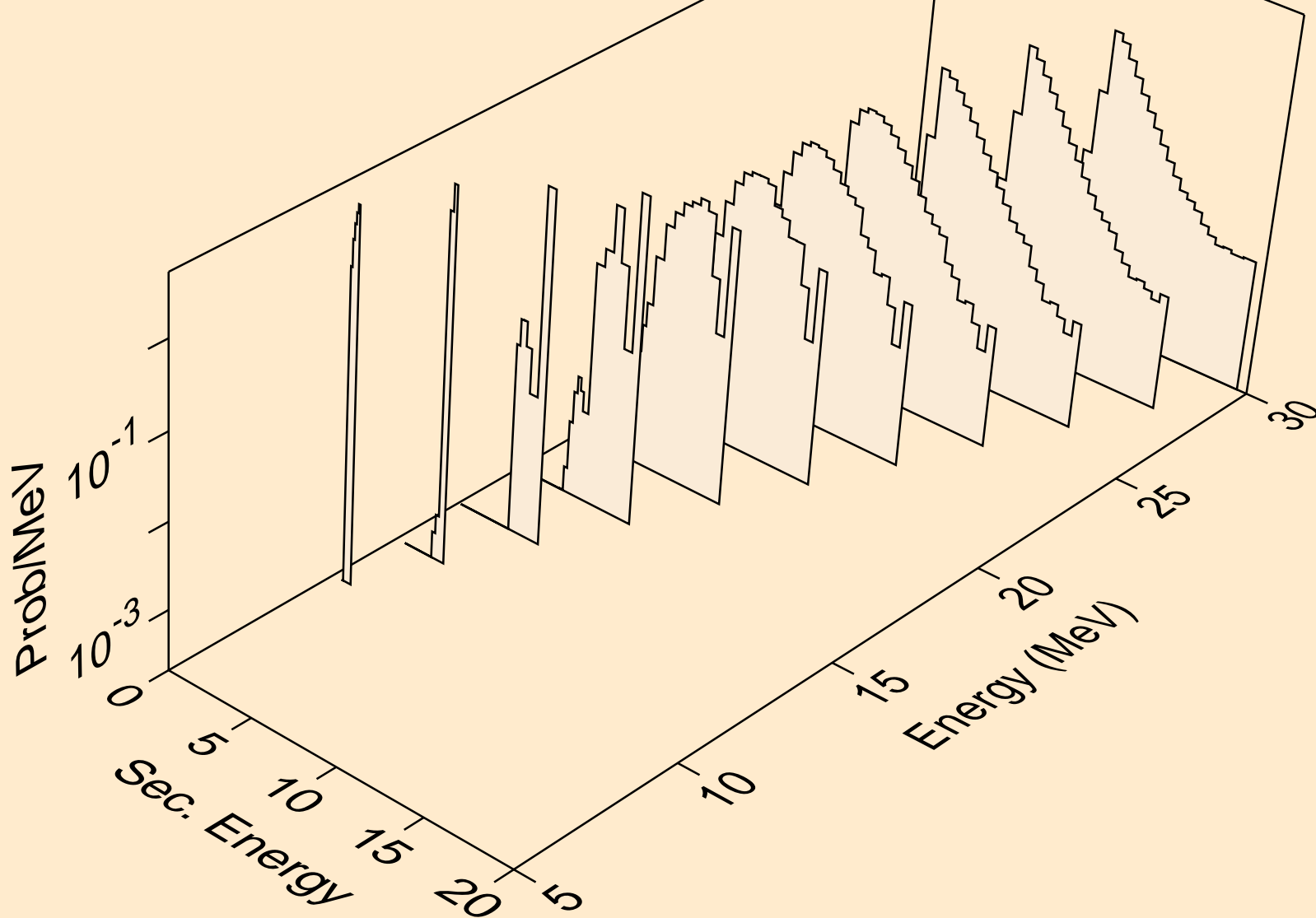

CA044 PHOTON ACER TENDL-2023 LIBRARY; T=0.K
alphas from (g,2a)

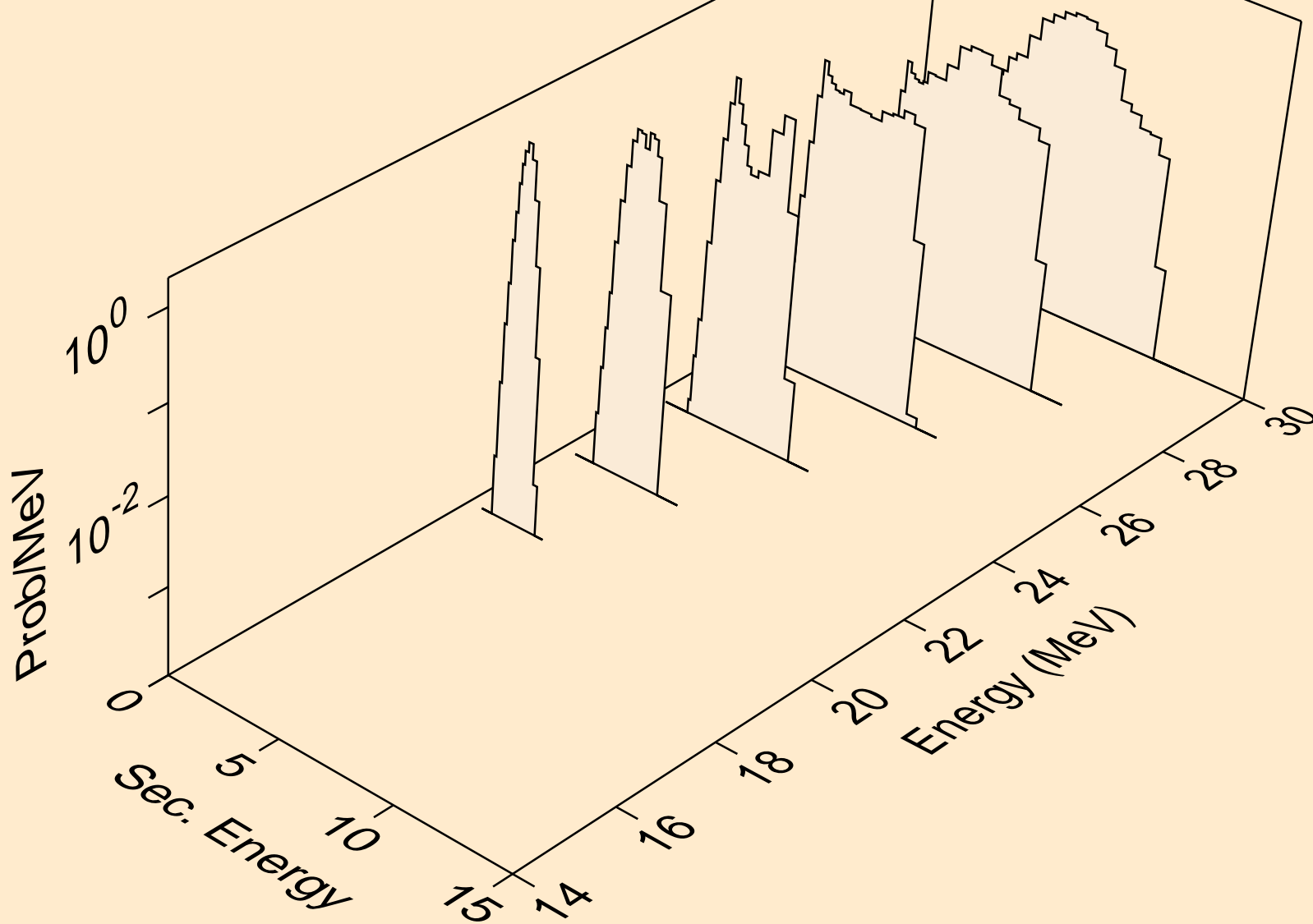

CA044 PHOTON ACER TENDL-2023 LIBRARY; T=0.K
alphas from (g,pa)

