

CD123M PHOTON ACER TENDL-2023 LIBRARY; T=0.K
Principal cross sections

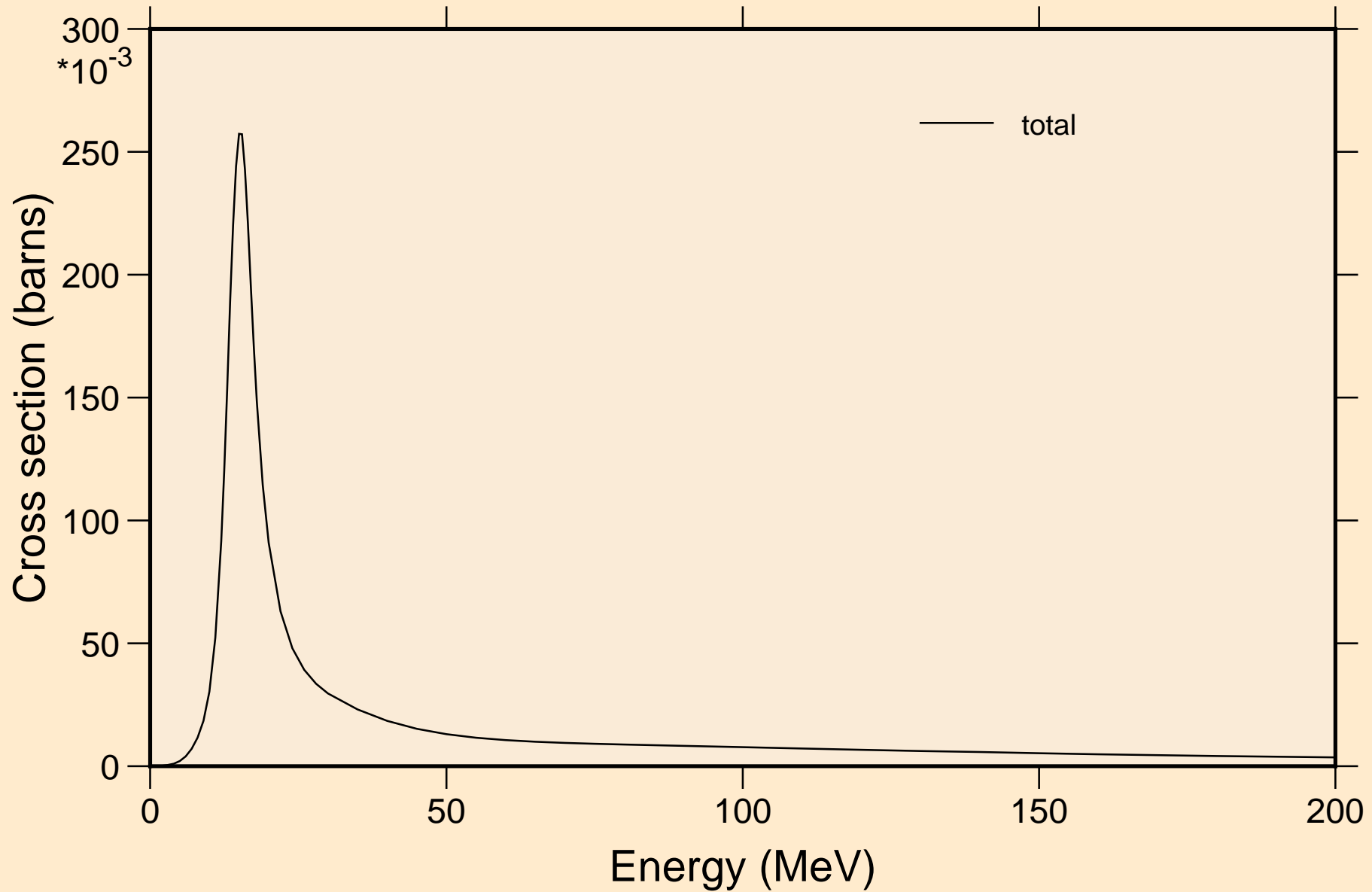

CD123M PHOTON ACER TENDL-2023 LIBRARY; T=0.K

Partial cross sections

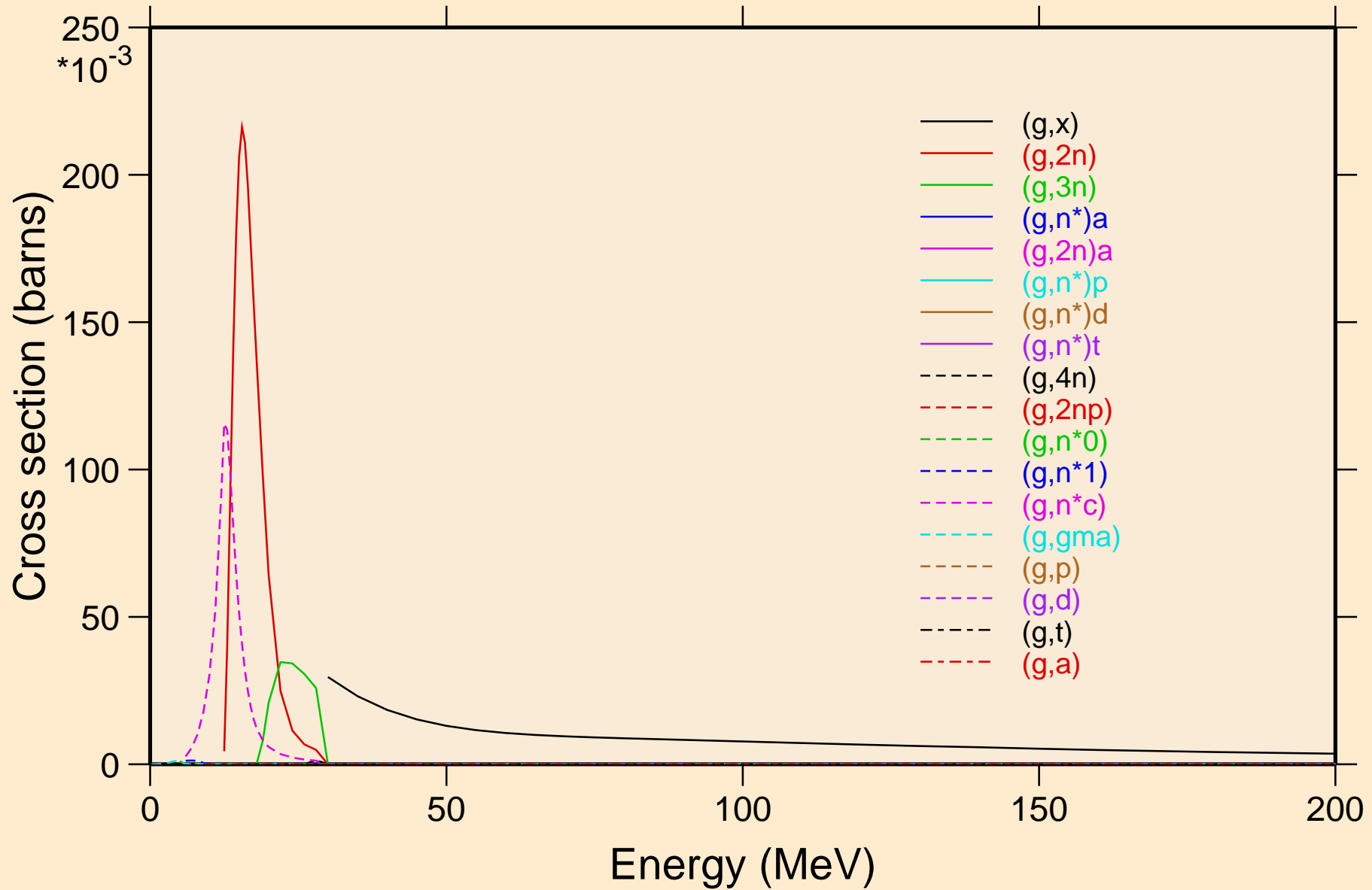

CD123M PHOTON ACER TENDL-2023 LIBRARY; T=0.K

Heating

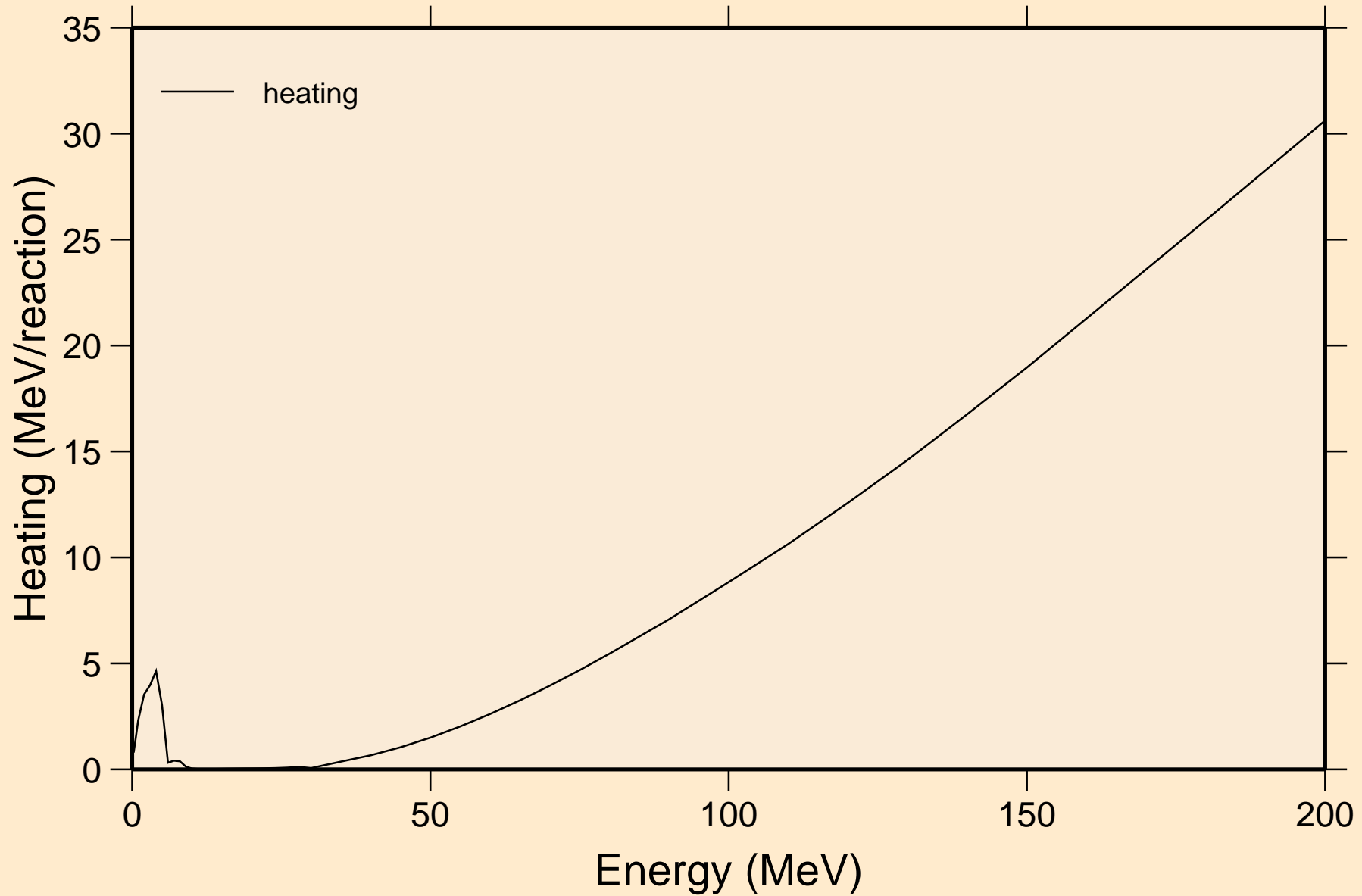

CD123M PHOTON ACER TENDL-2023 LIBRARY; T=0.K

Particle heating contributions

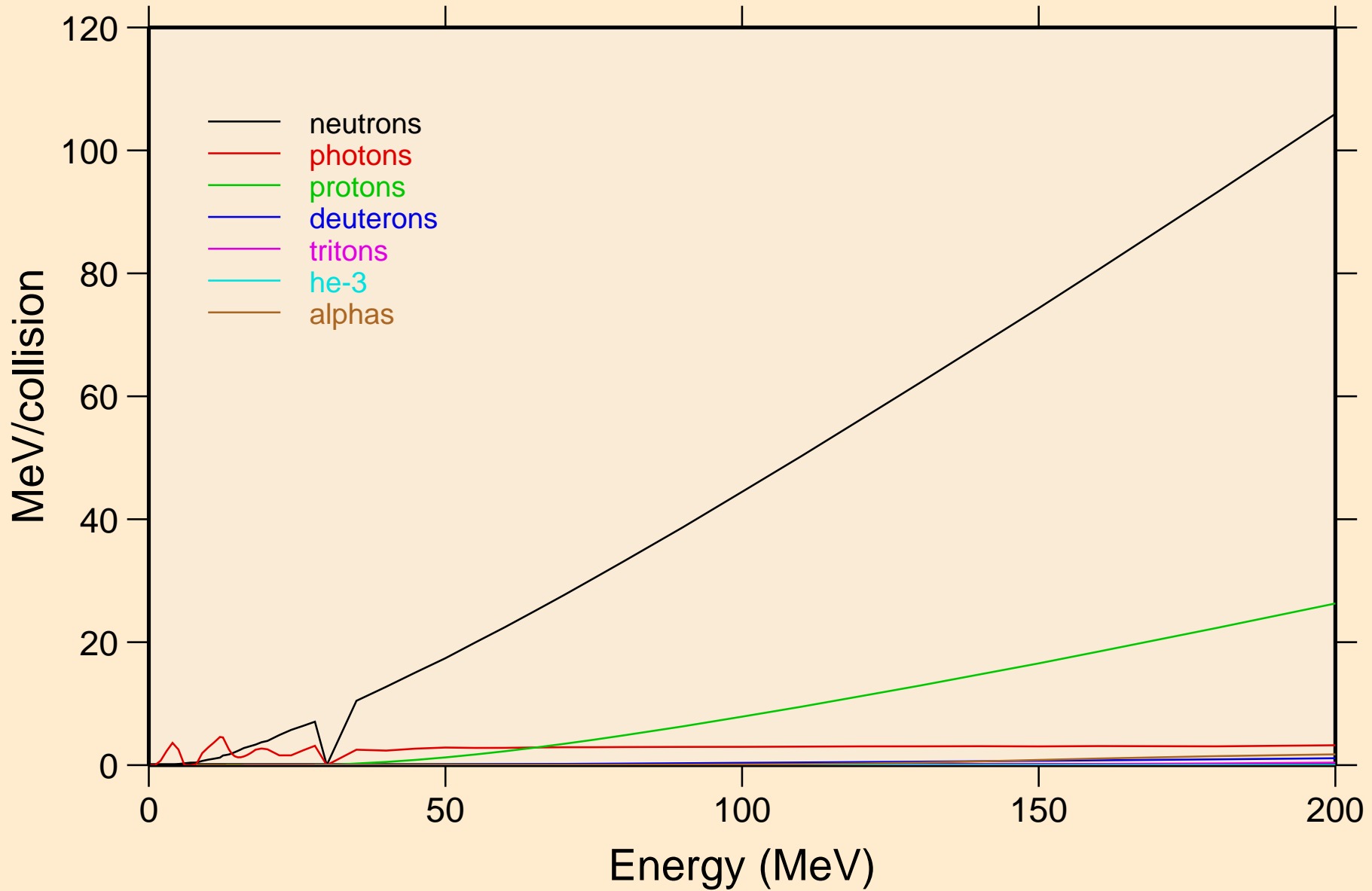

CD123M PHOTON ACER TENDL-2023 LIBRARY; T=0.K

Particle production cross sections

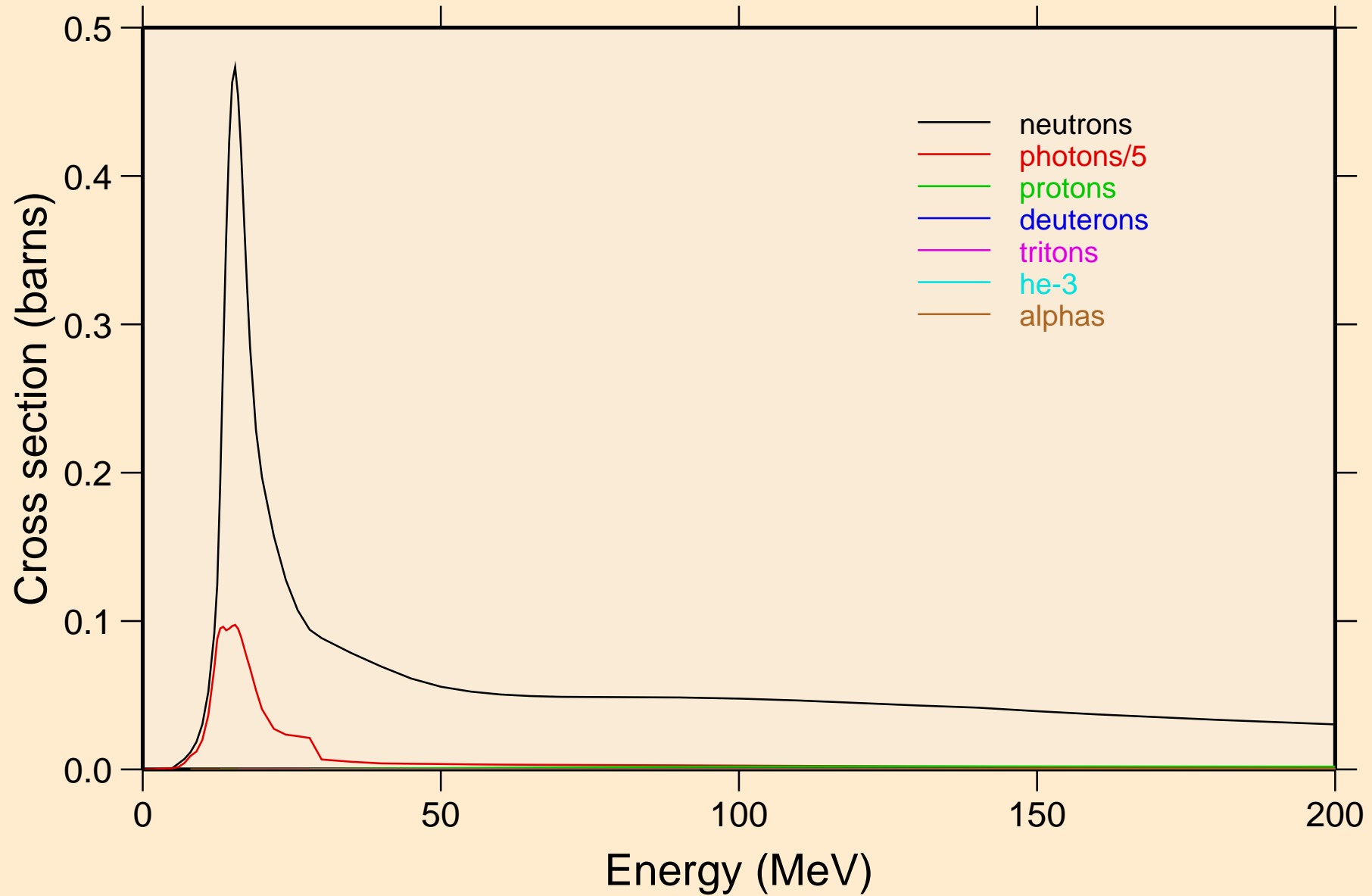

CD123M PHOTON ACER TENDL-2023 LIBRARY; T=0.K
neutrons from (g,x)

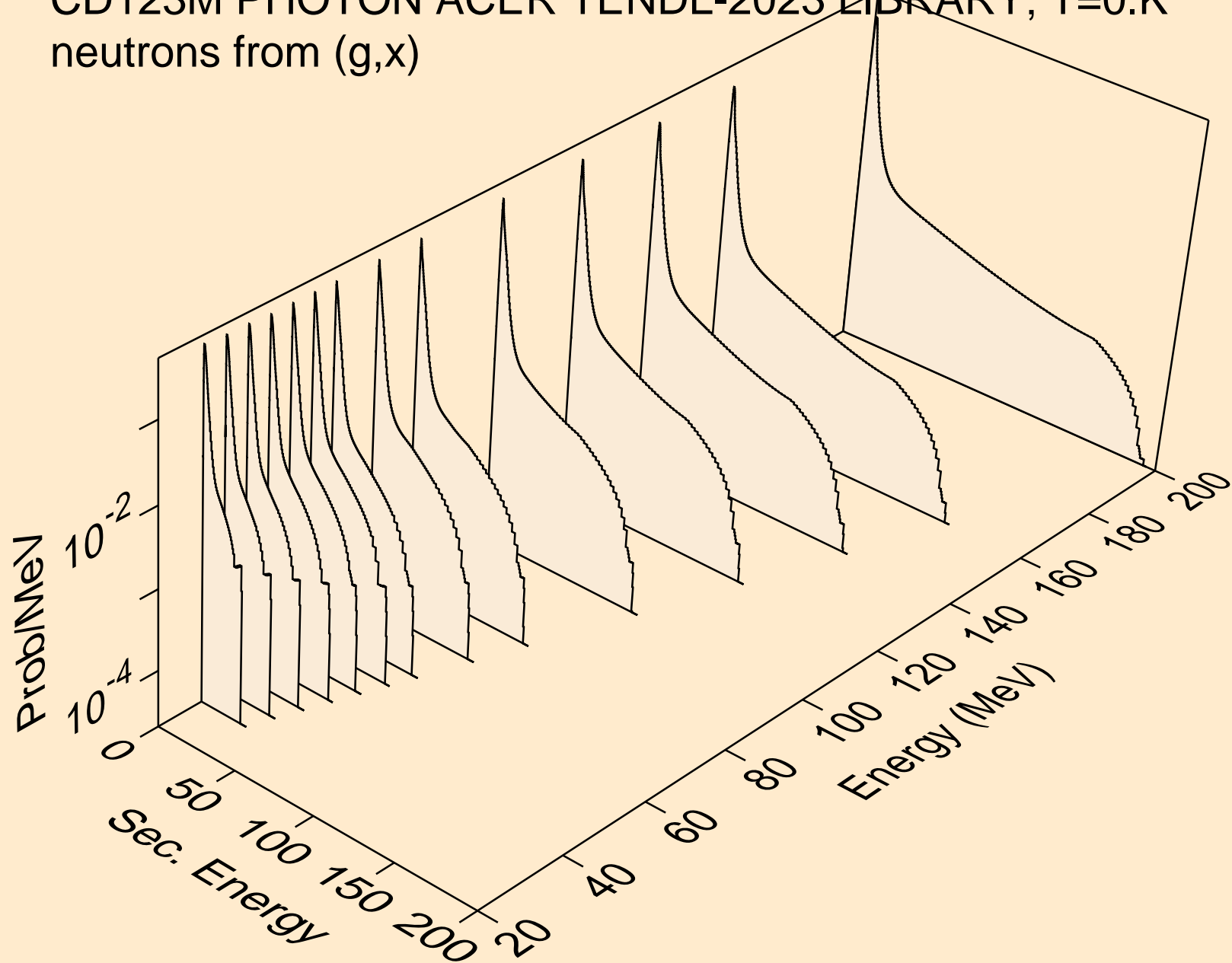

CD123M PHOTON ACER TENDL-2023 LIBRARY; T=0.K
neutrons from (g,2n)

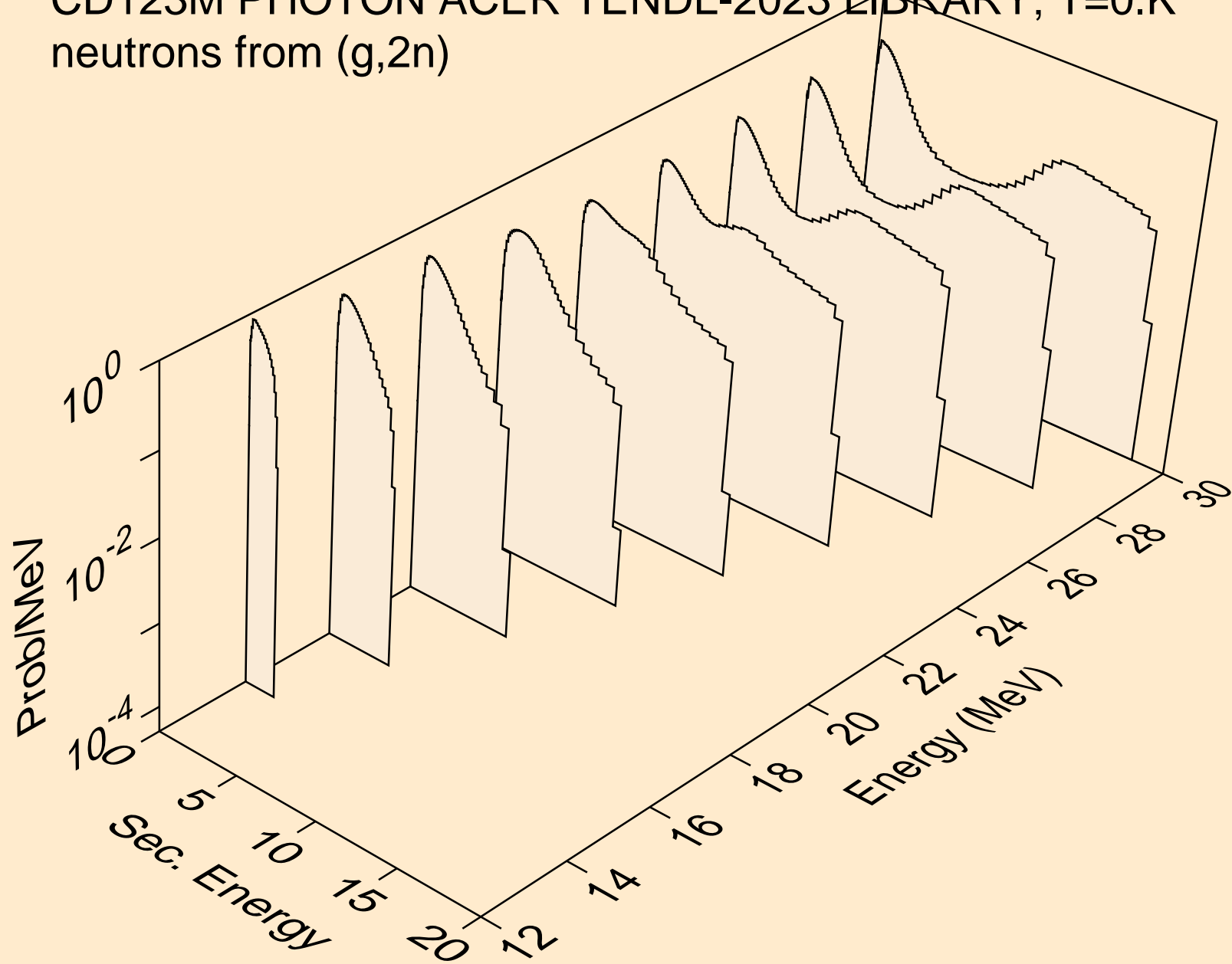

CD123M PHOTON ACER TENDL-2023 LIBRARY; T=0.K
neutrons from (g,3n)

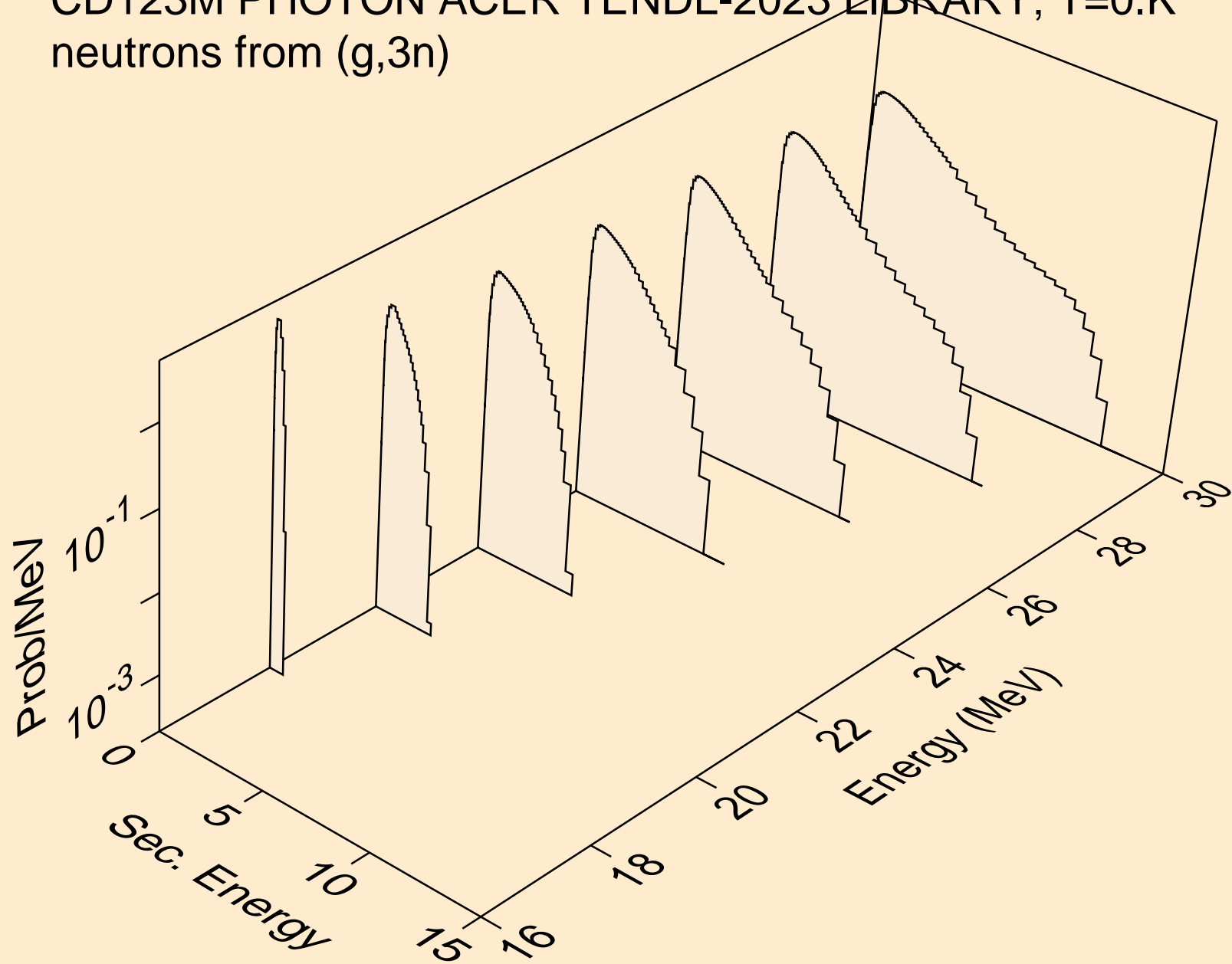

CD123M PHOTON ACER TENDL-2023 LIBRARY; T=0.K
neutrons from (g,n*)a

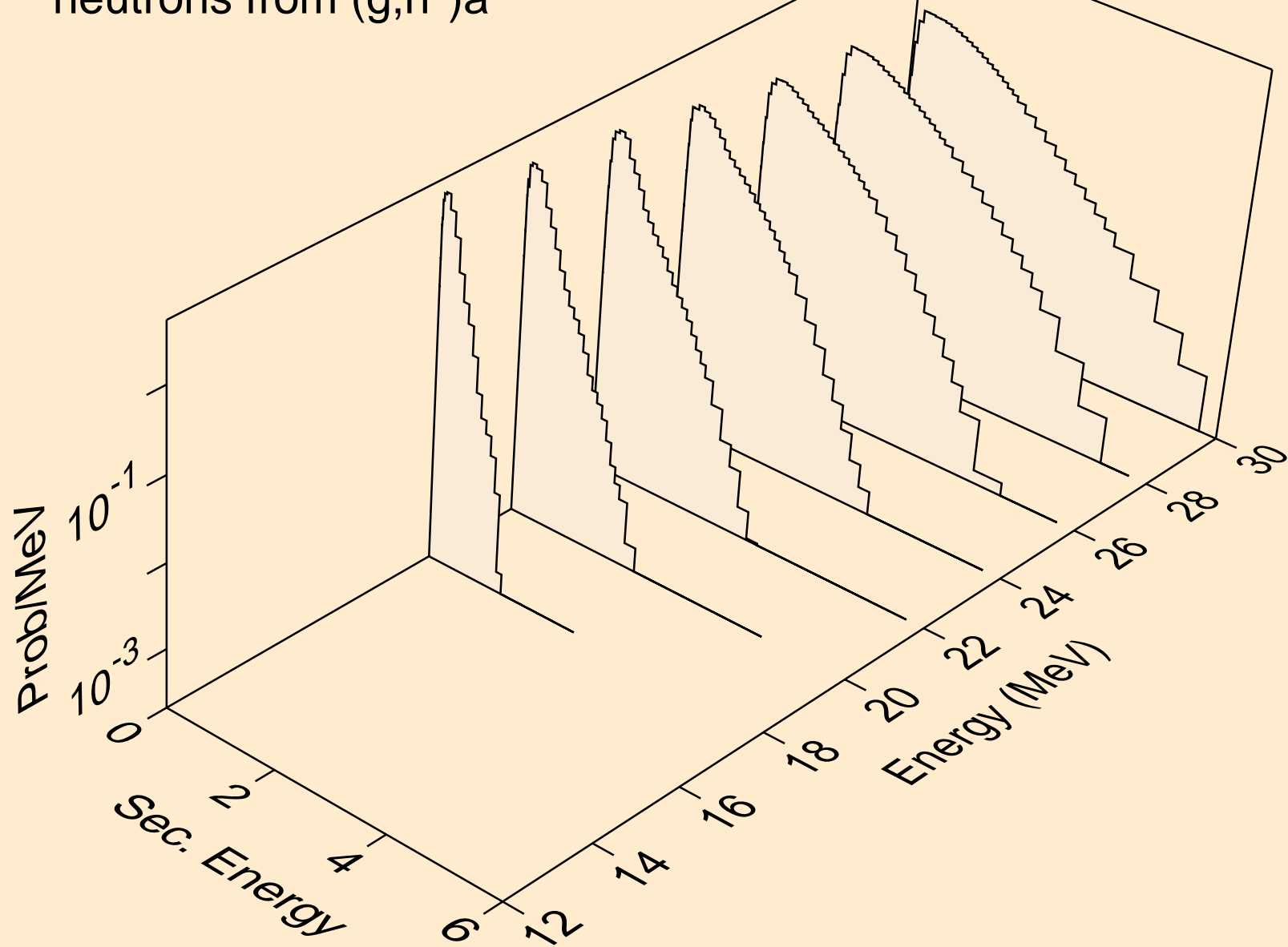

CD123M PHOTON ACER TENDL-2023 LIBRARY; T=0.K
neutrons from (g,2n)a

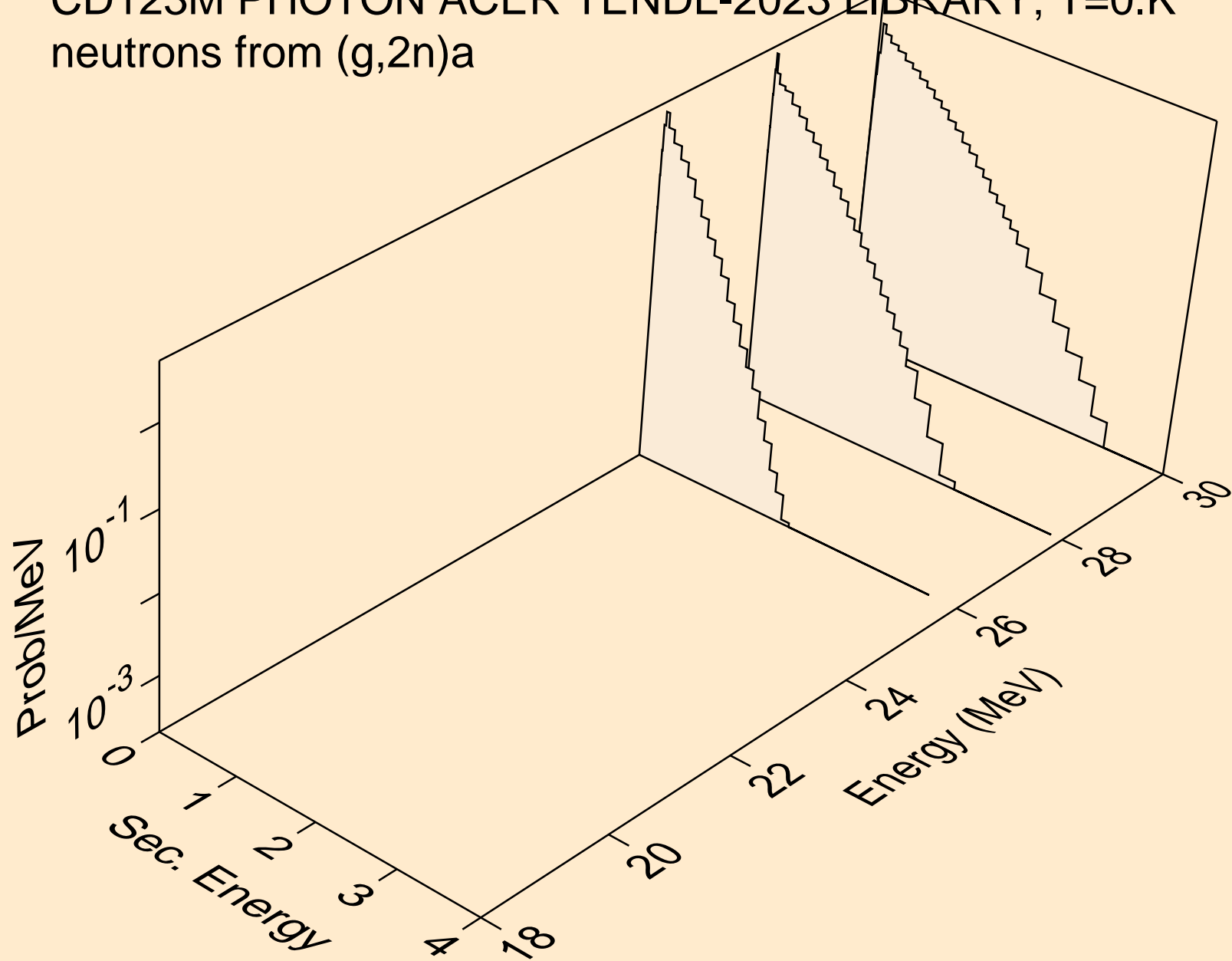

CD123M PHOTON ACER TENDL-2023 LIBRARY; T=0.K
neutrons from (g,n*)p

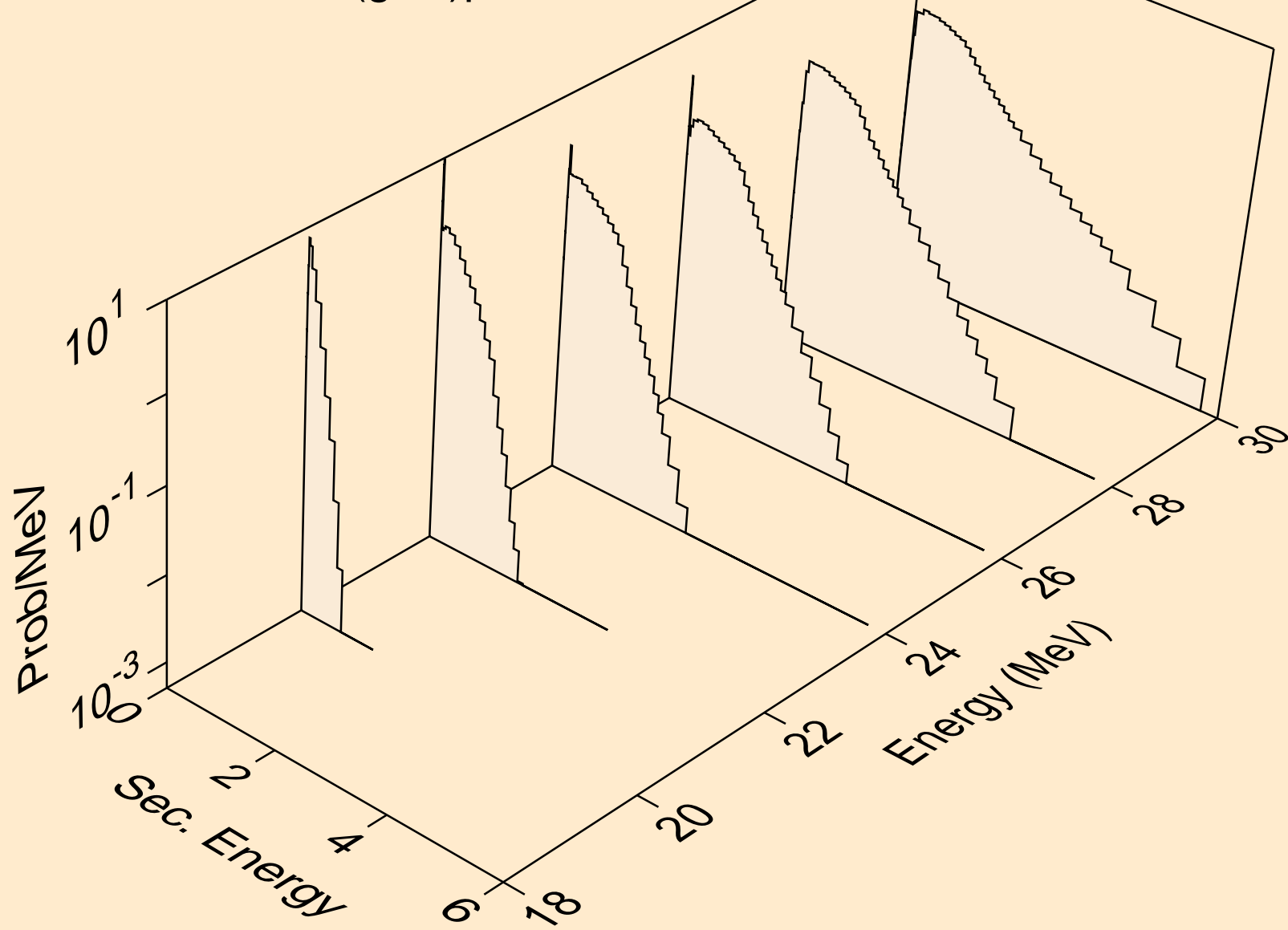

CD123M PHOTON ACER TENDL-2023 LIBRARY; T=0.K
neutrons from (g,n*)d

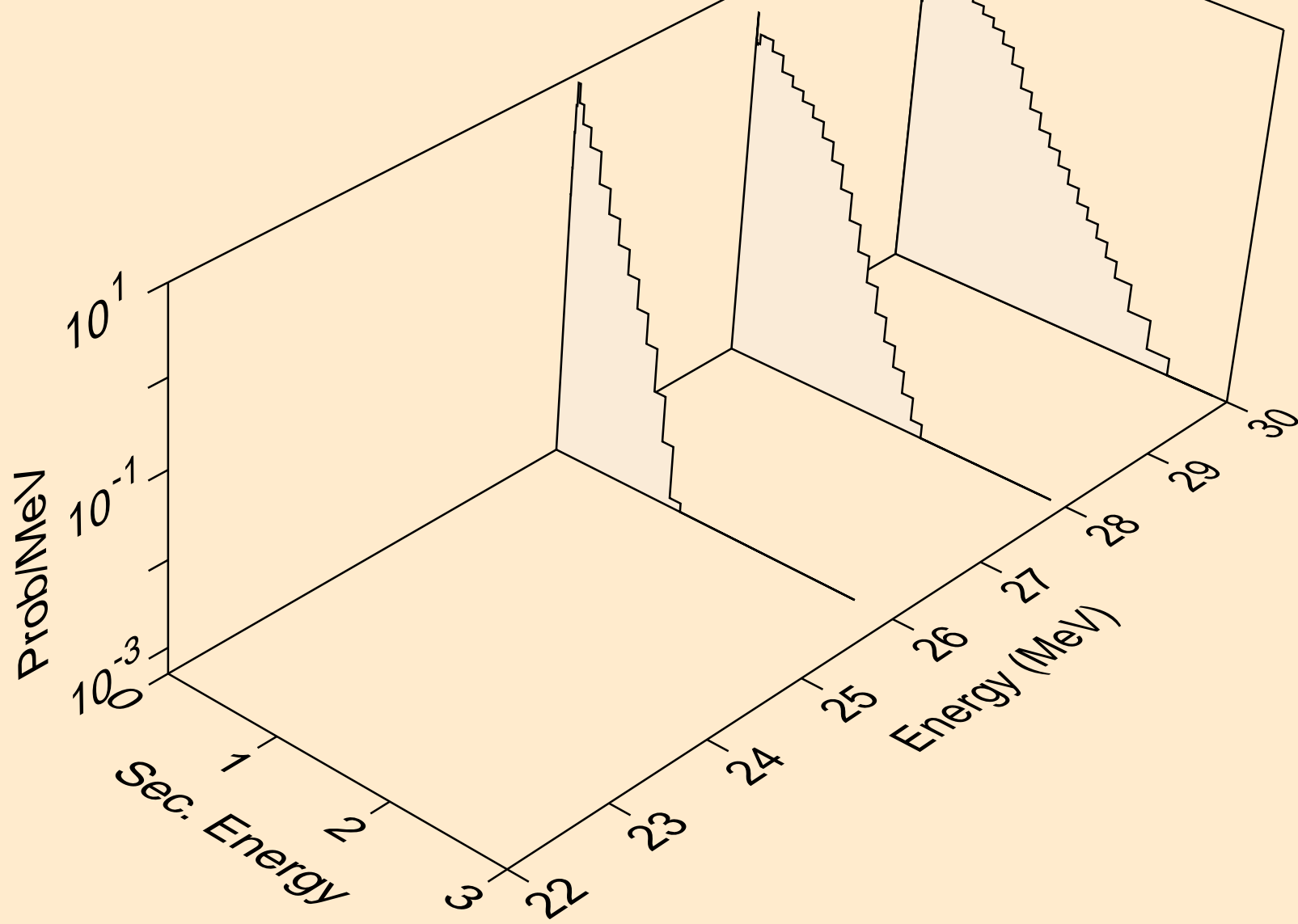

CD123M PHOTON ACER TENDL-2023 LIBRARY; T=0.K
neutrons from (g,n*)t

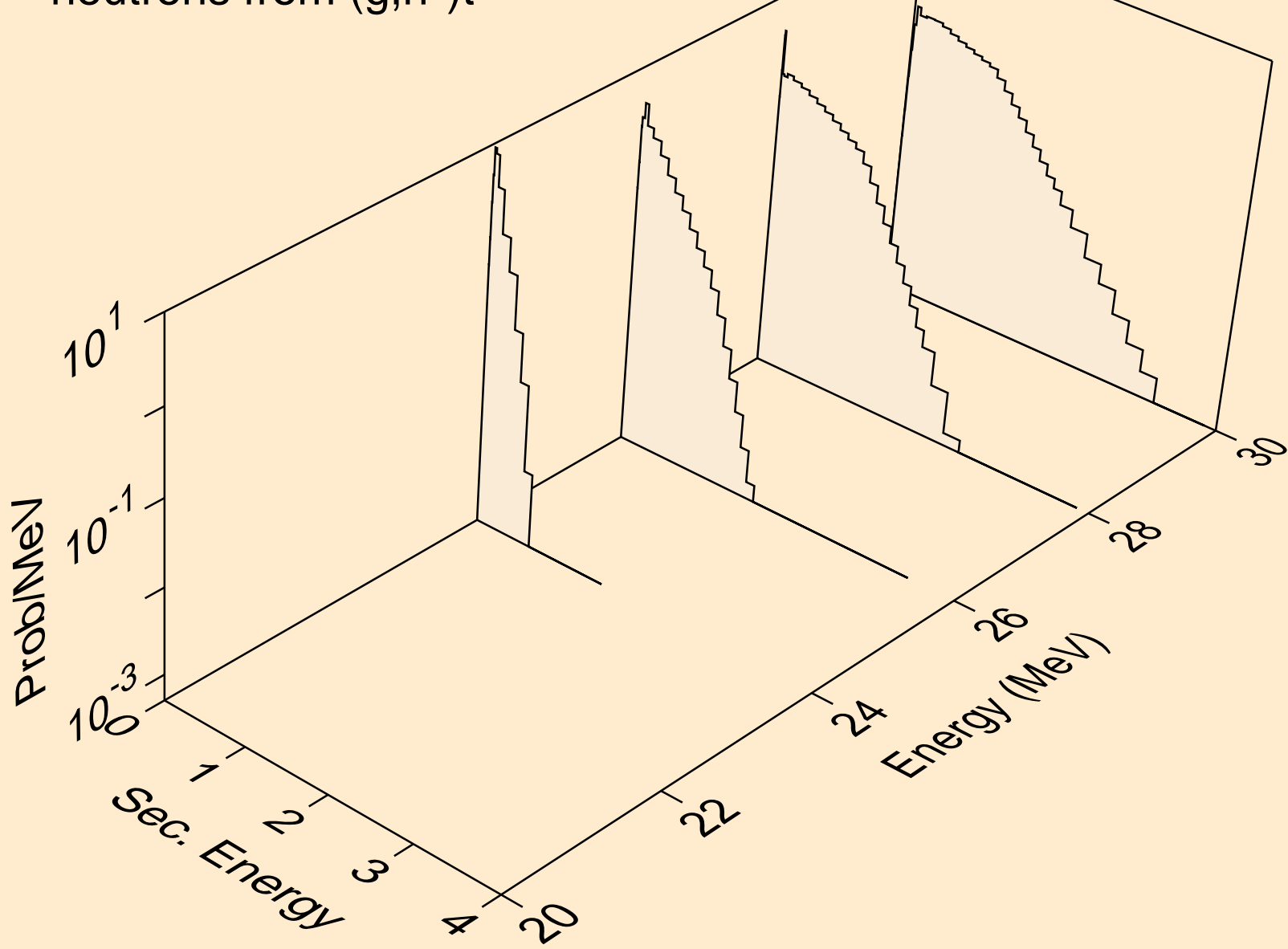

CD123M PHOTON ACER TENDL-2023 LIBRARY; T=0.K
neutrons from (g,4n)

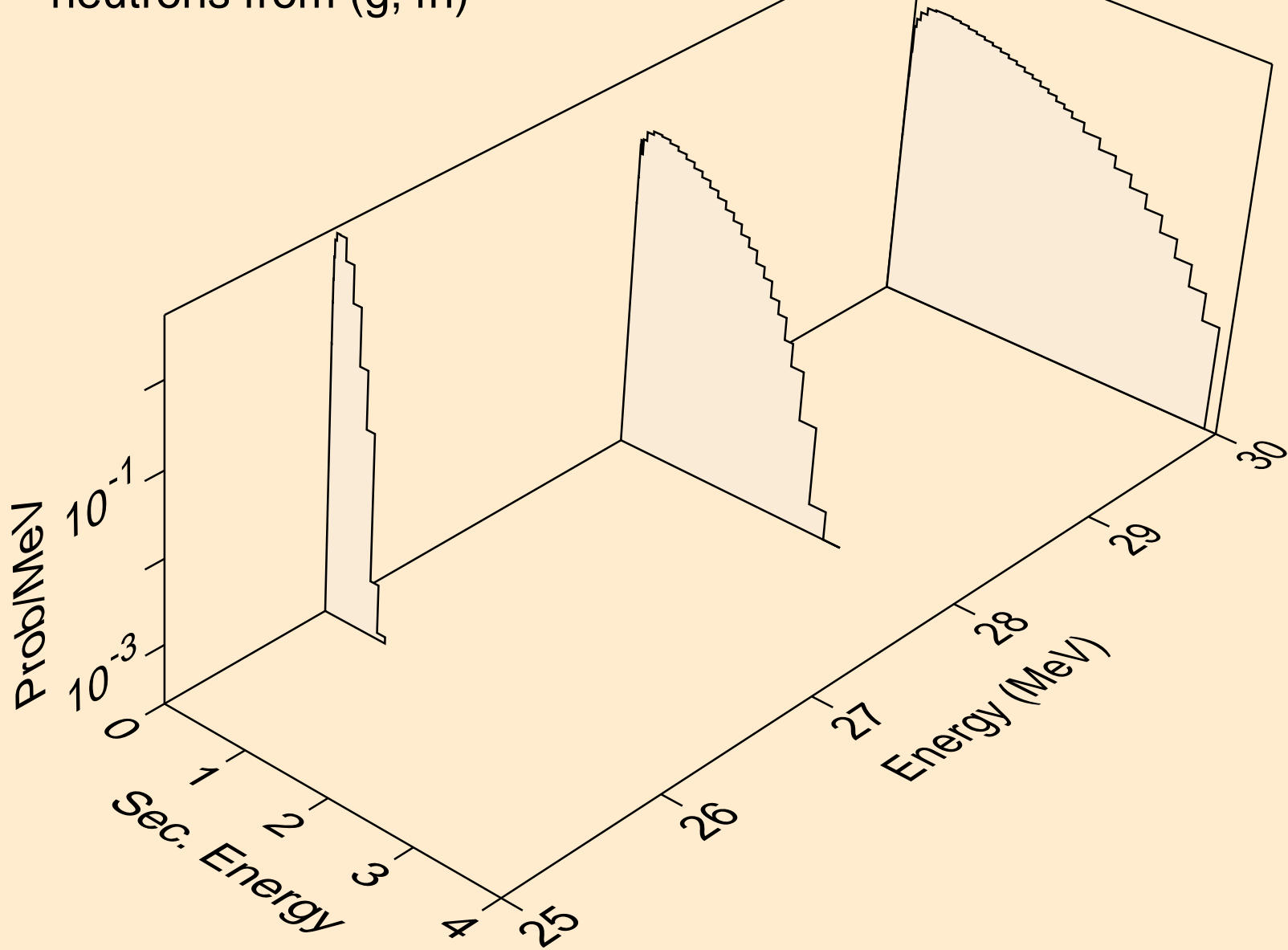

CD123M PHOTON ACER TENDL-2023 LIBRARY; T=0.K
neutrons from (g,2np)

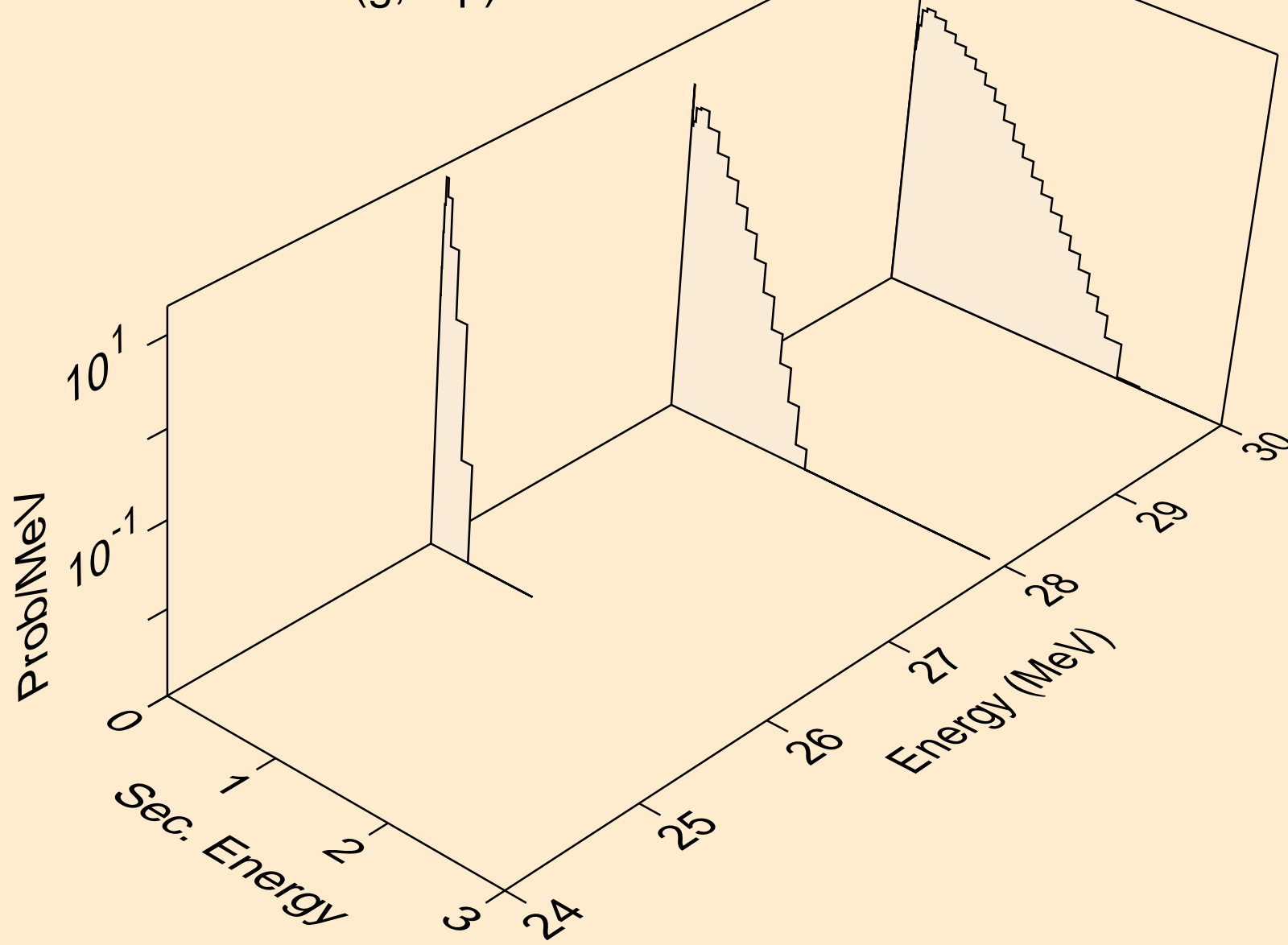

CD123M PHOTON ACER TENDL-2023 LIBRARY; T=0.K
angular distribution for (g,n*0) neutron

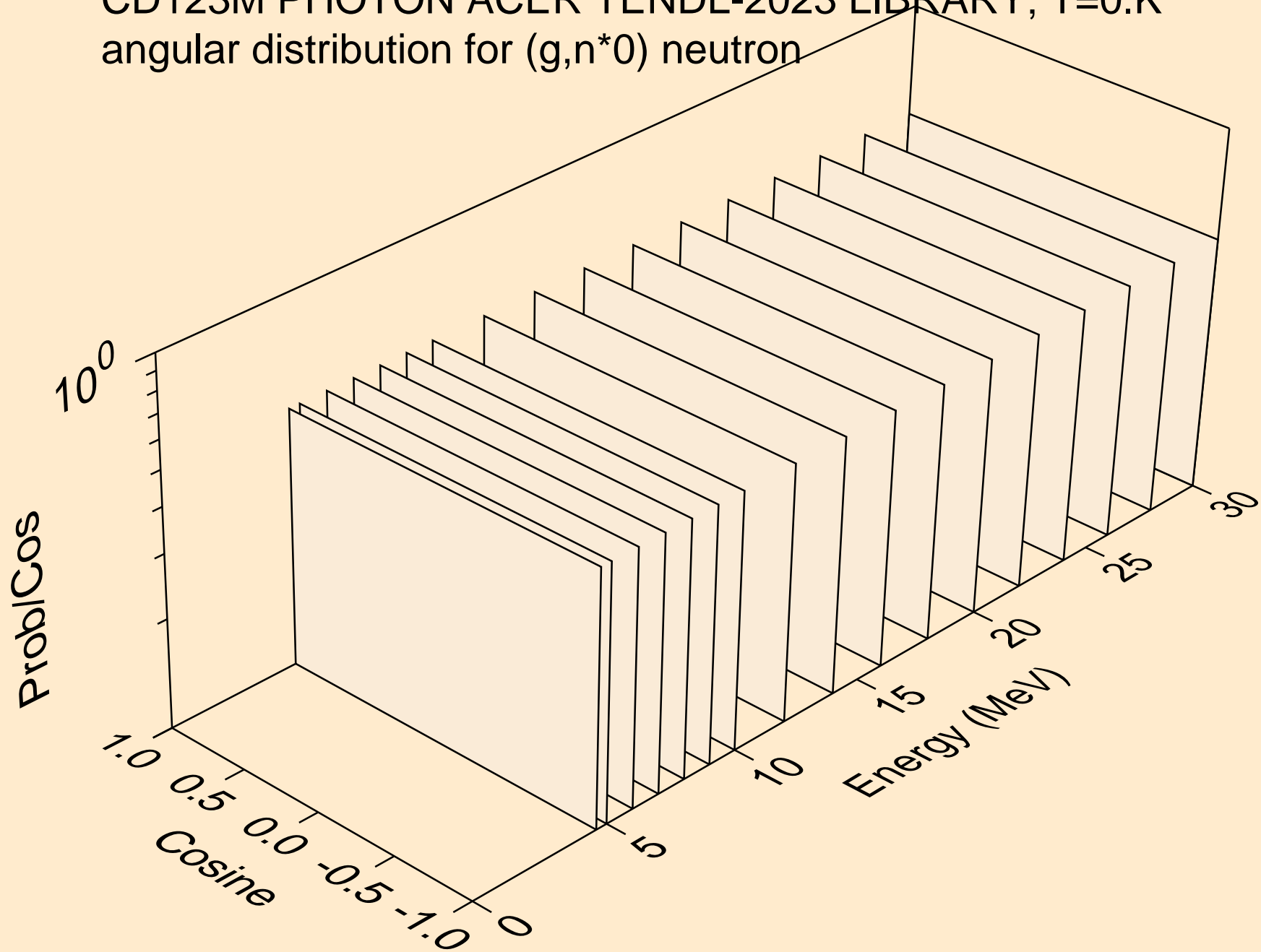

CD123M PHOTON ACER TENDL-2023 LIBRARY; T=0.K
angular distribution for (g,n*1) neutron

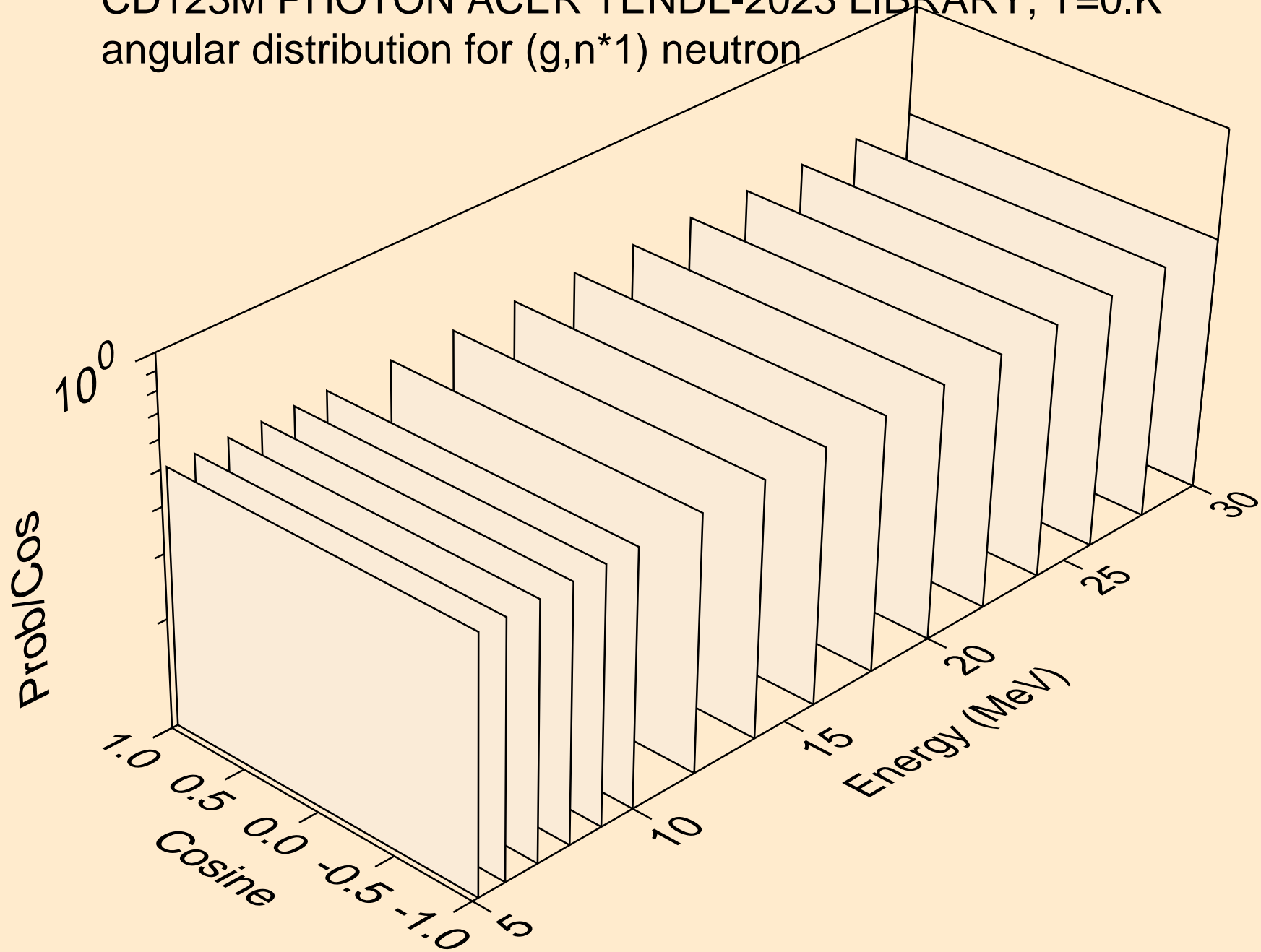

CD123M PHOTON ACER TENDL-2023 LIBRARY; T=0.K
neutrons from (g,n*c)

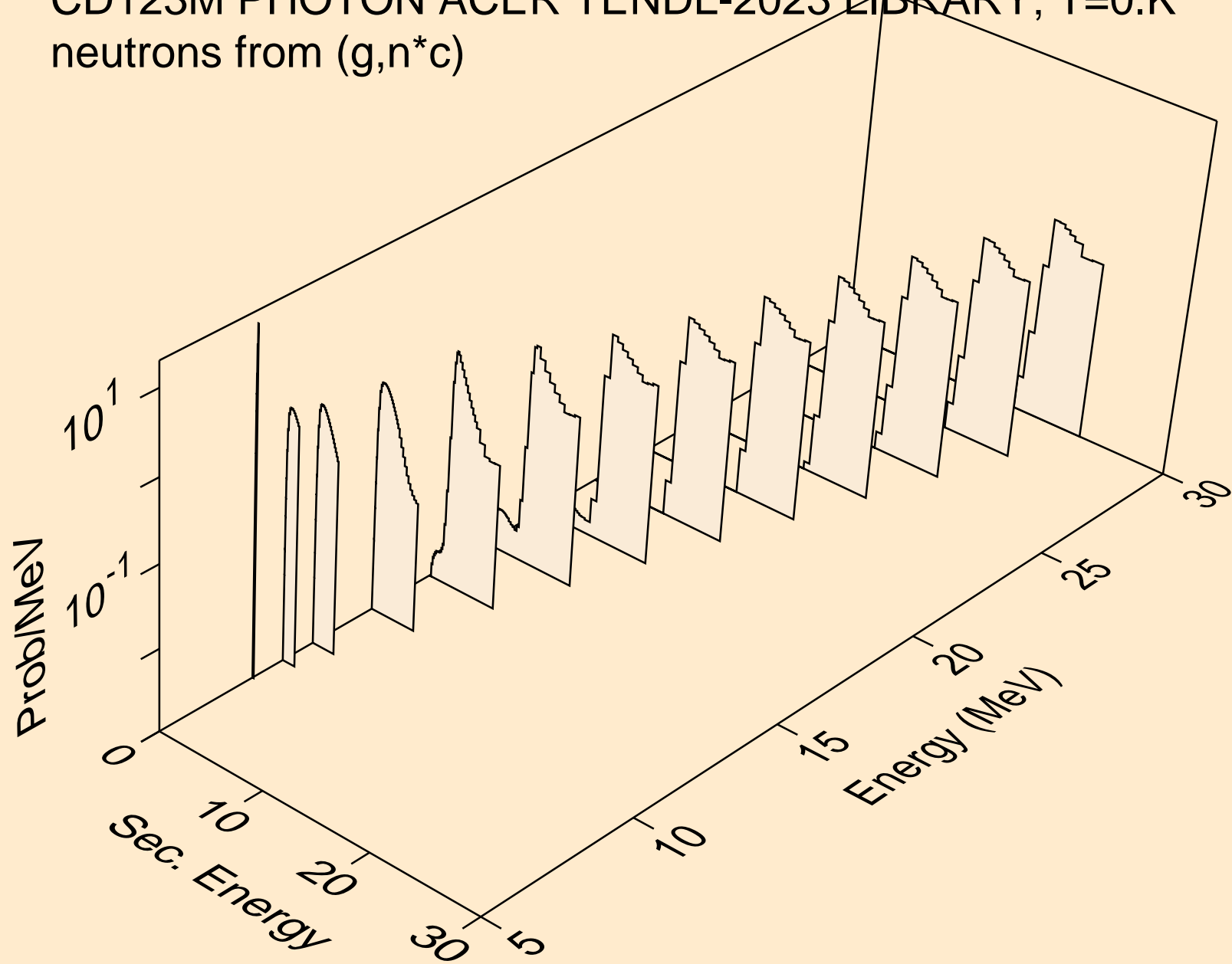

CD123M PHOTON ACER TENDL-2023 LIBRARY; T=0.K
photons from (g,x)

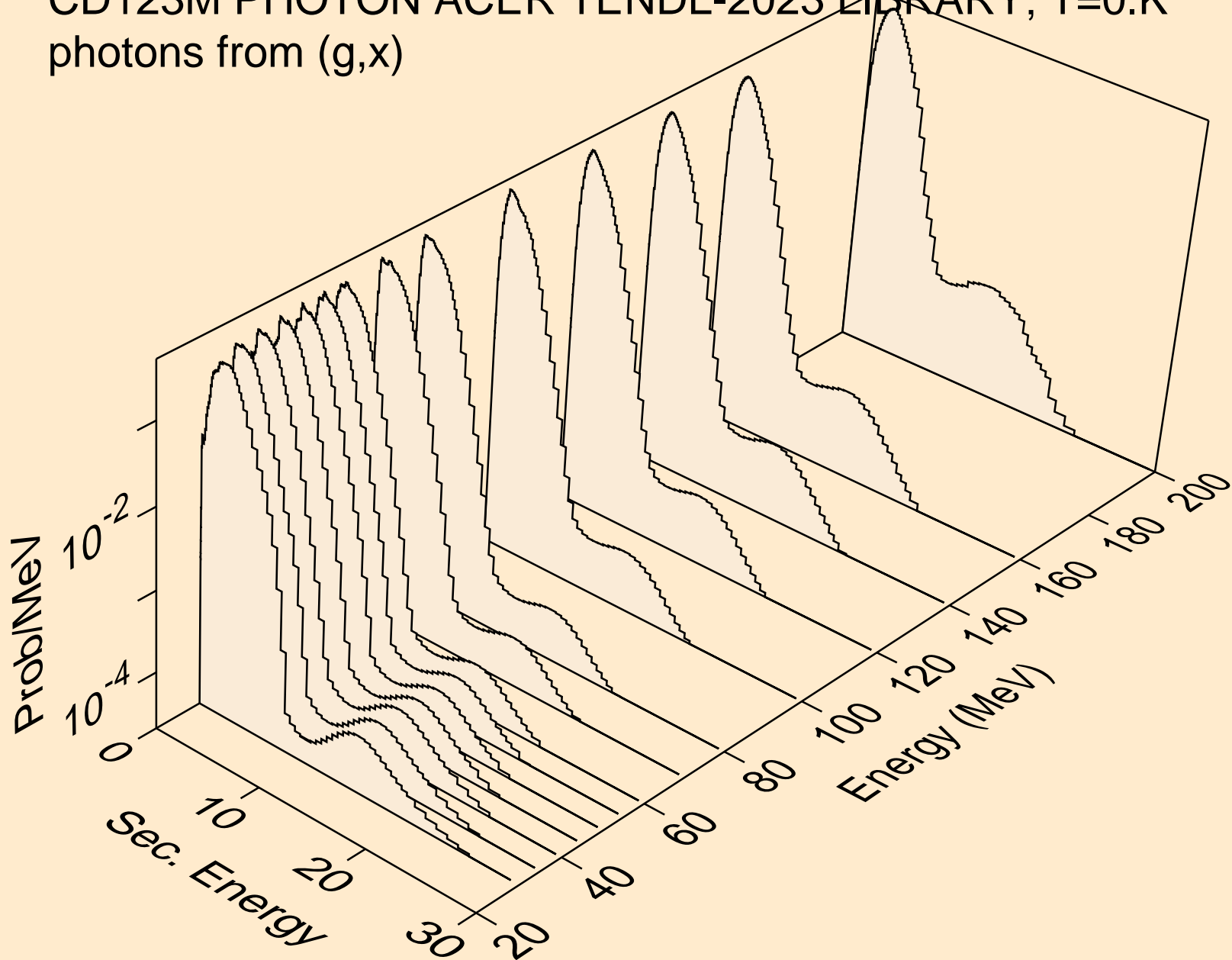

CD123M PHOTON ACER TENDL-2023 LIBRARY; T=0.K
photons from (g,2n)

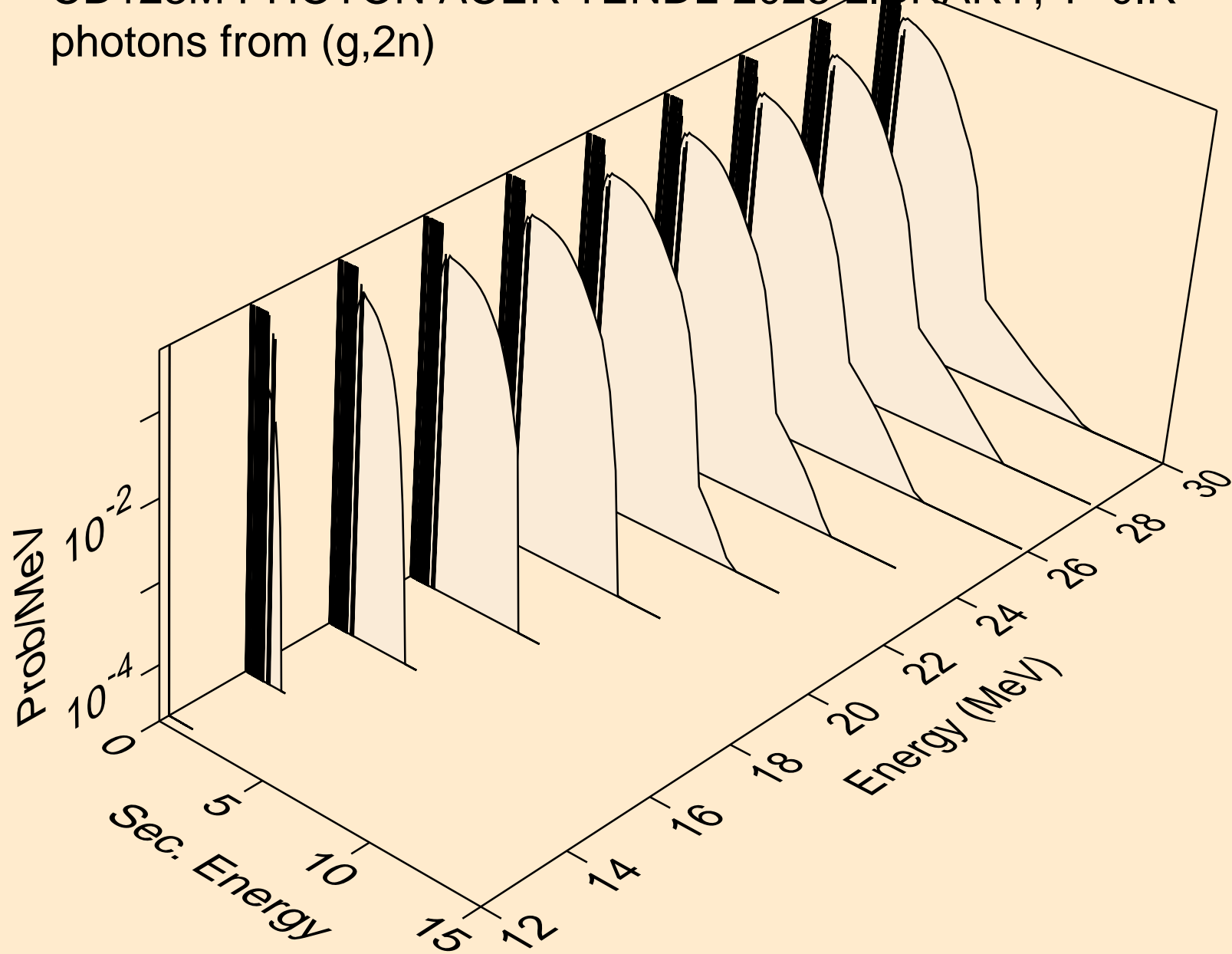

CD123M PHOTON ACER TENDL-2023 LIBRARY; T=0.K
photons from (g,3n)

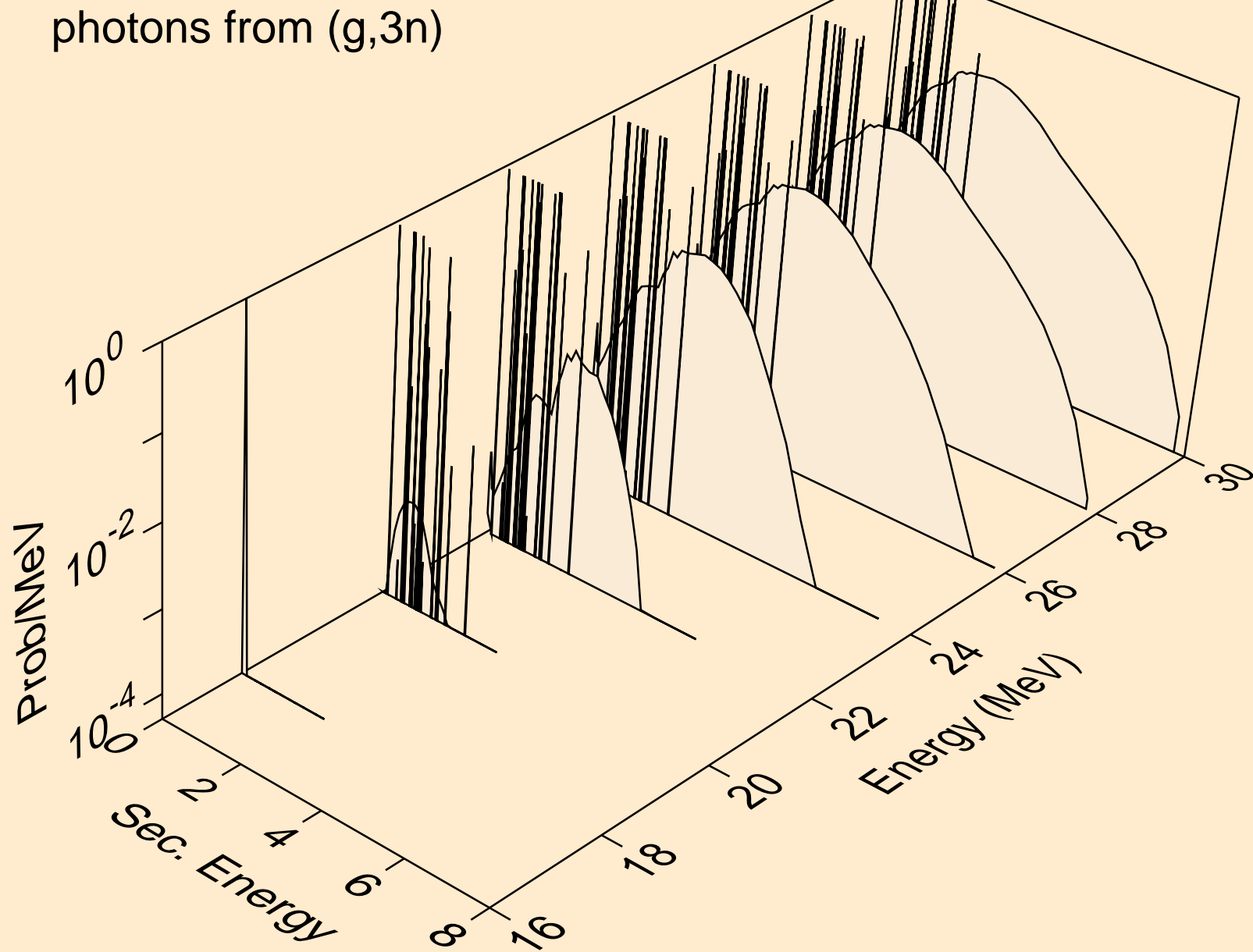

CD123M PHOTON ACER TENDL-2023 LIBRARY; T=0.K
photons from (g,n*)a

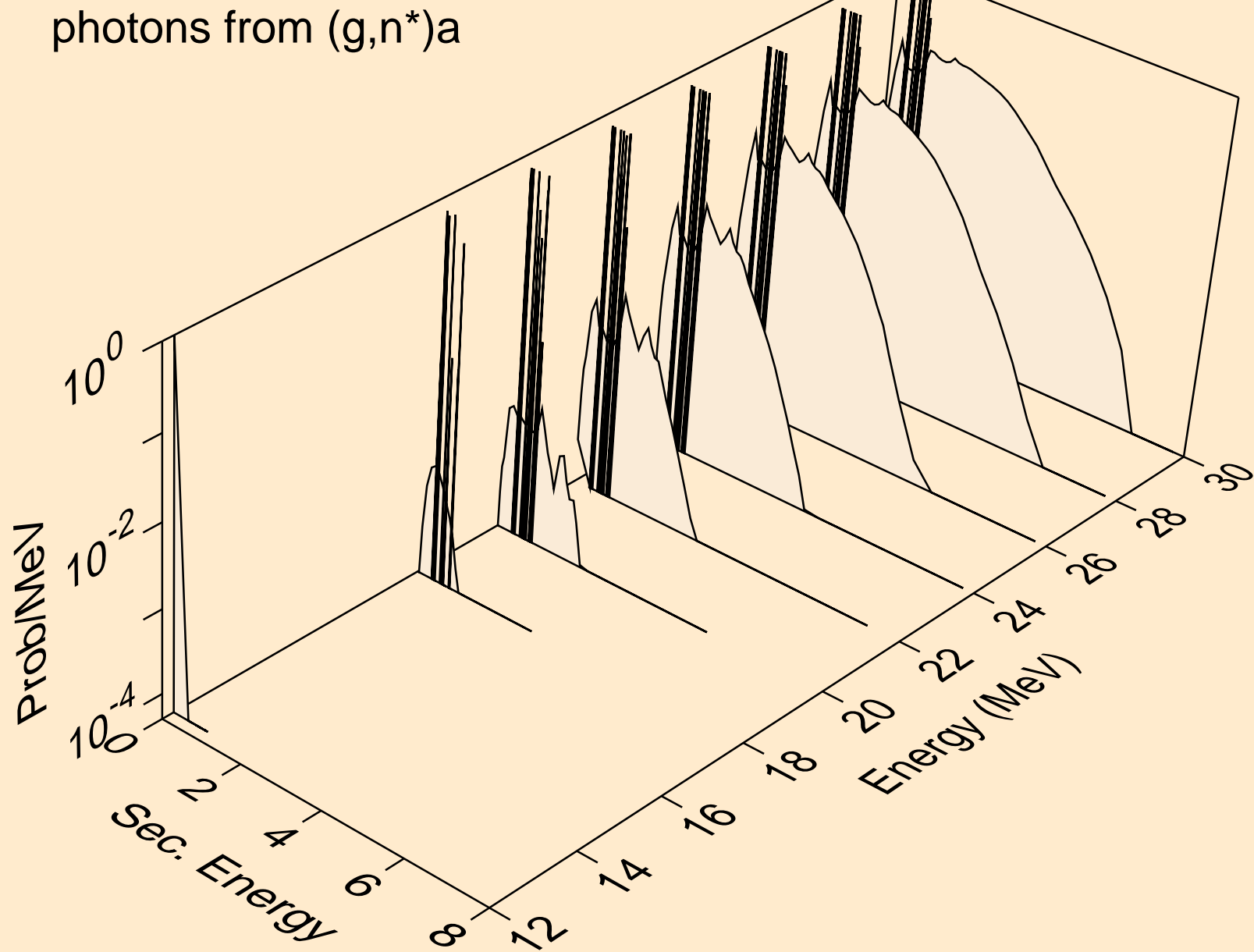

CD123M PHOTON ACER TENDL-2023 LIBRARY; T=0.K
photons from (g,2n)a

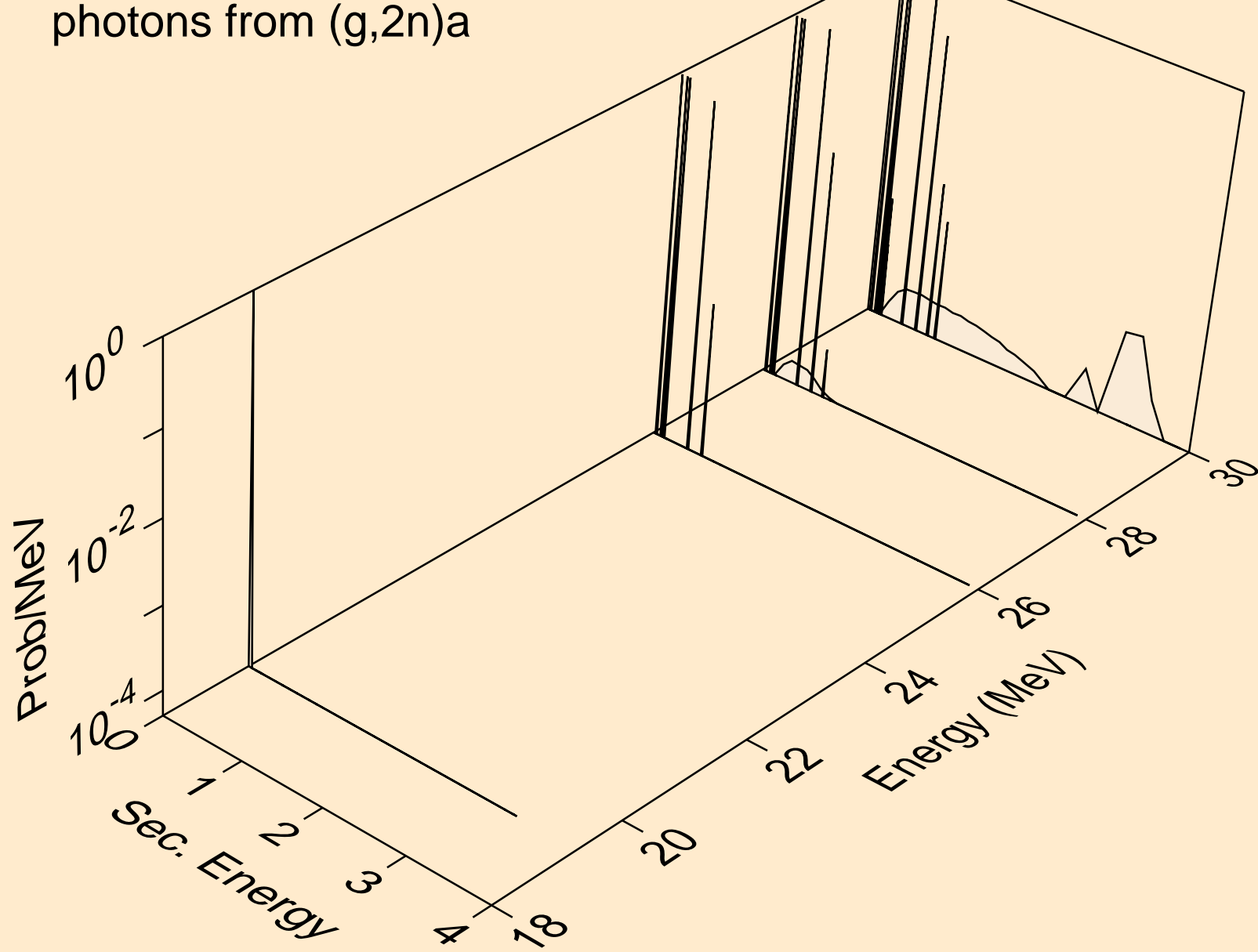

CD123M PHOTON ACER TENDL-2023 LIBRARY; T=0.K
photons from (g,n*)p

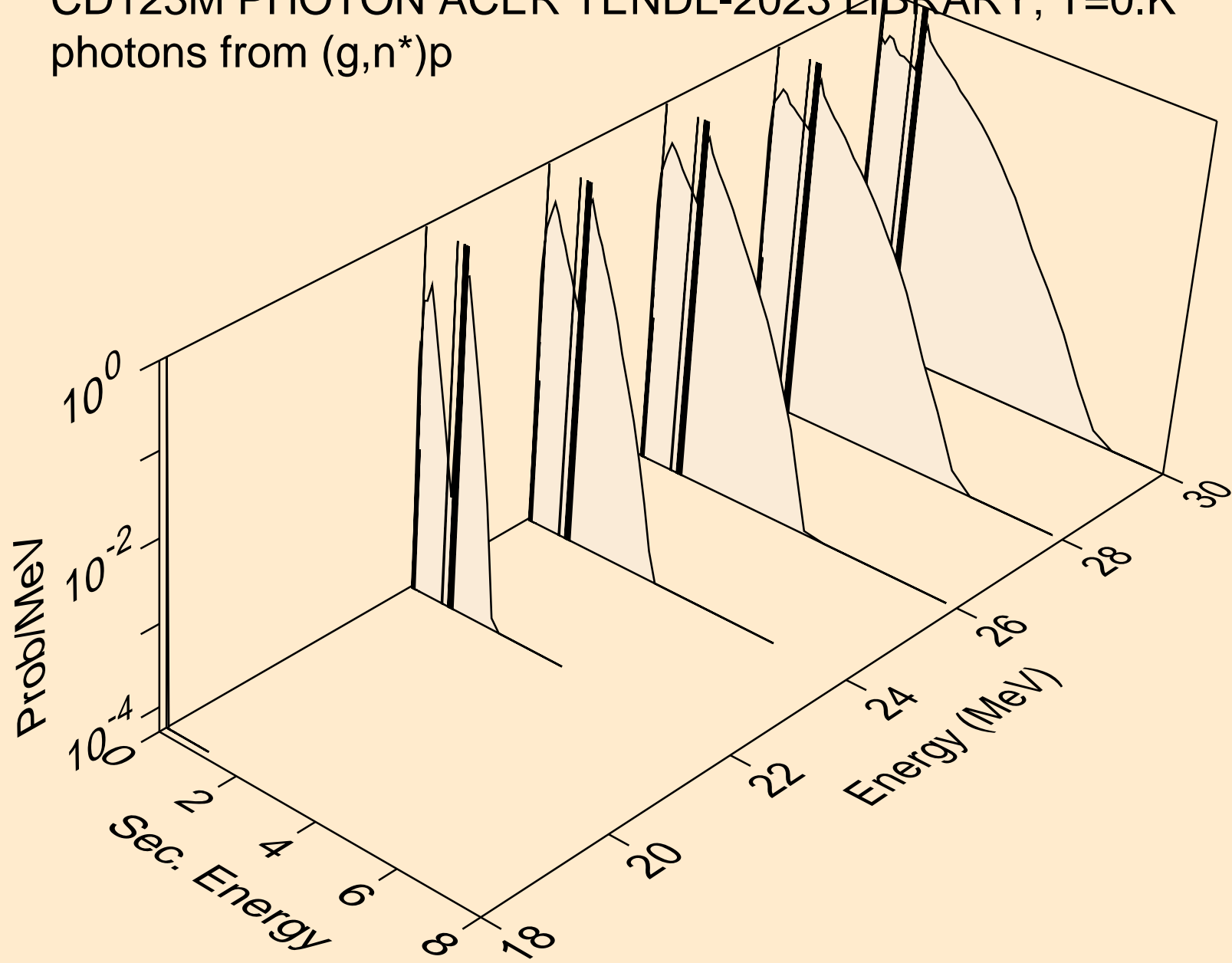

CD123M PHOTON ACER TENDL-2023 LIBRARY; T=0.K
photons from (g,n*)d

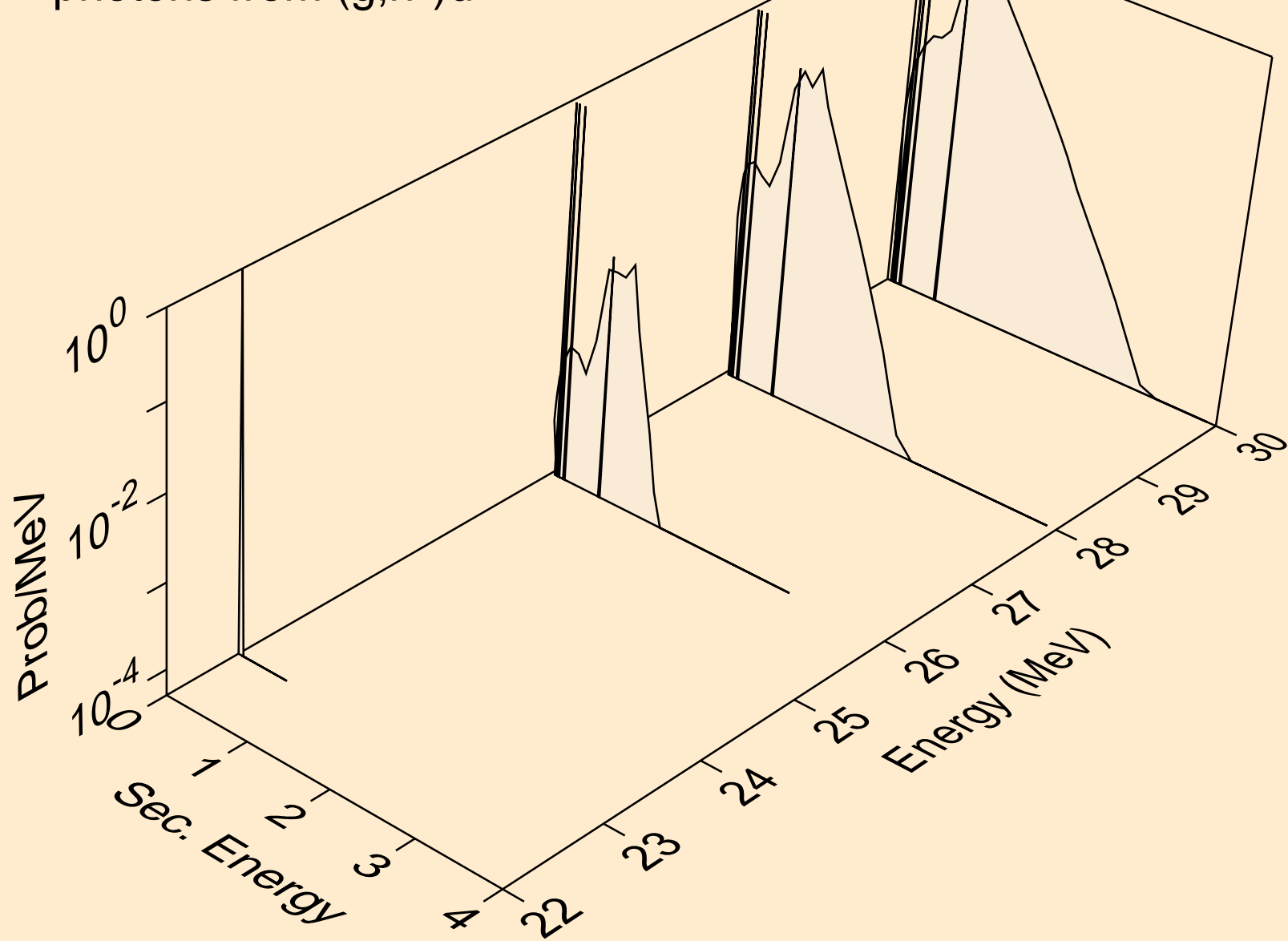

CD123M PHOTON ACER TENDL-2023 LIBRARY; T=0.K
photons from (g,n*)t

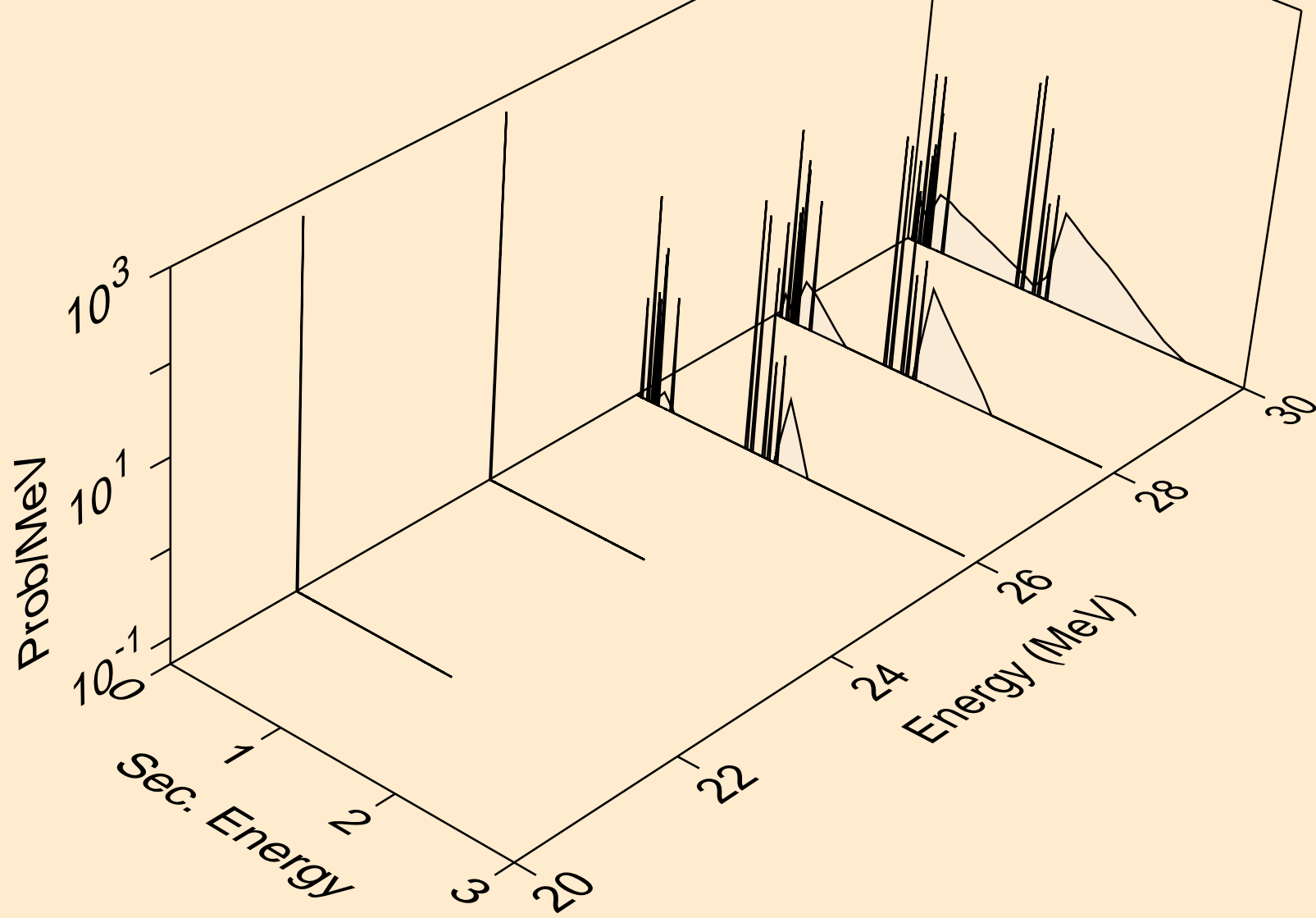

CD123M PHOTON ACER TENDL-2023 LIBRARY; T=0.K
photons from (g,4n)

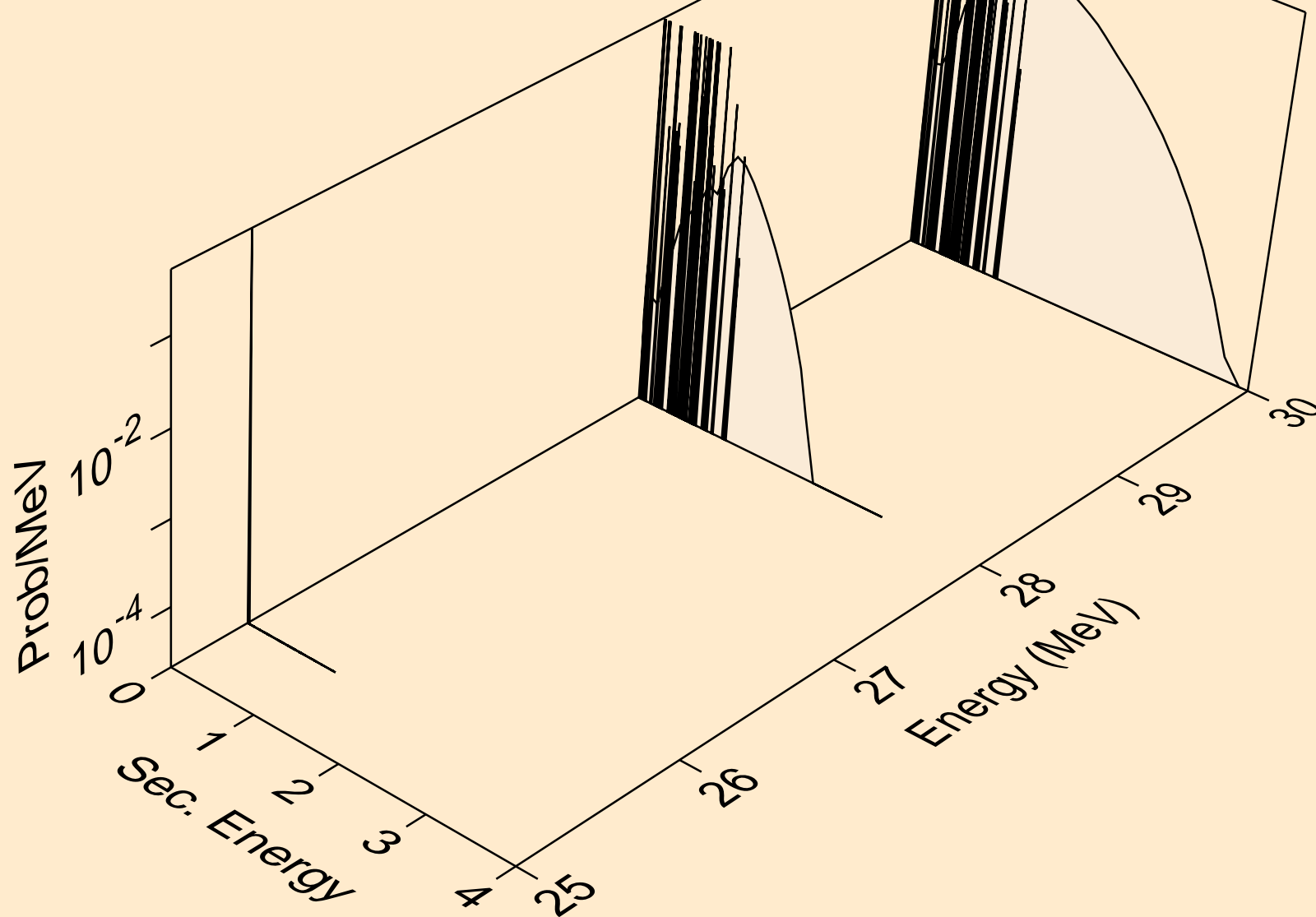

CD123M PHOTON ACER TENDL-2023 LIBRARY; T=0.K
photons from (g,2np)

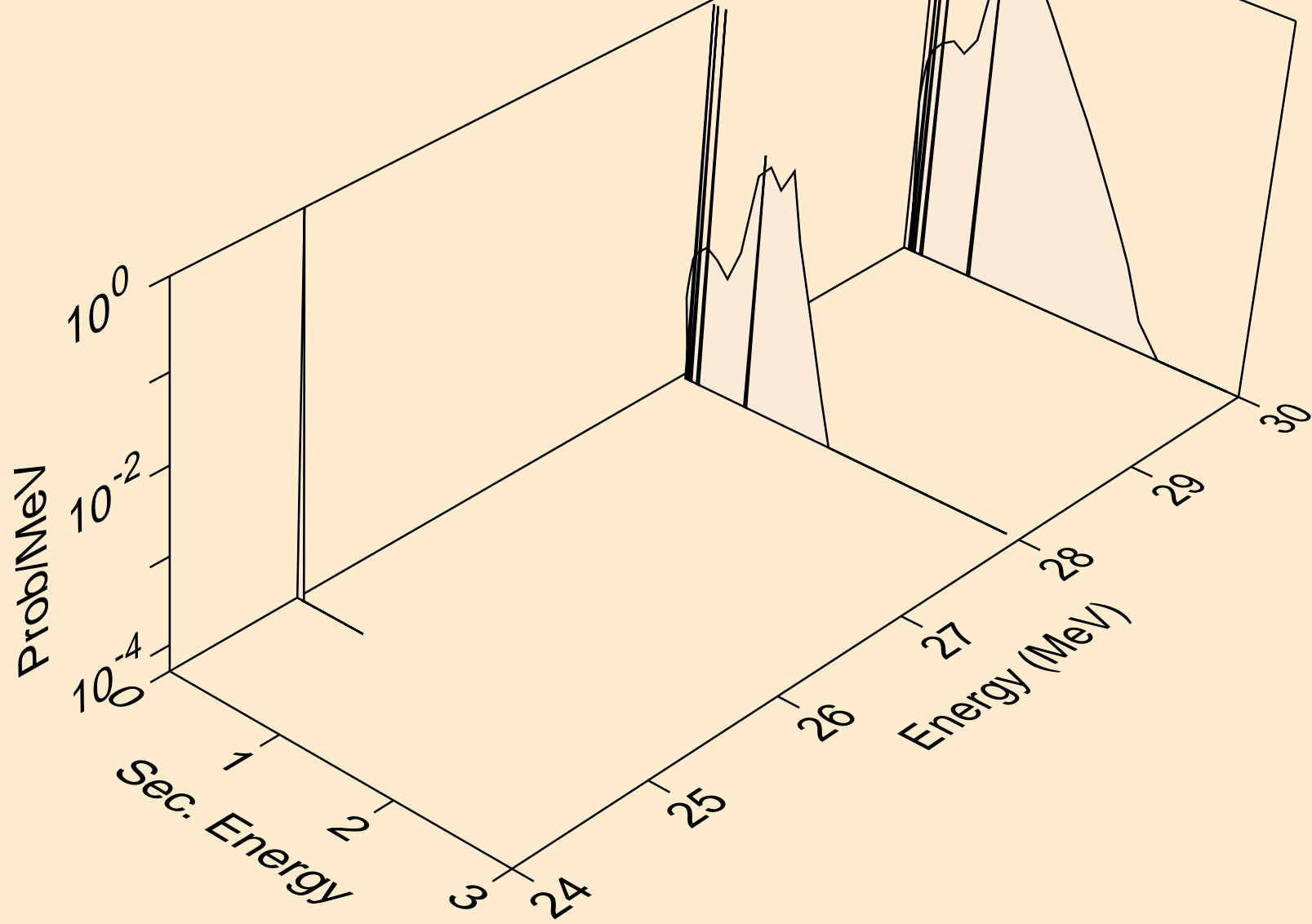

CD123M PHOTON ACER TENDL-2023 LIBRARY; T=0.K
photons from (g,n*c)

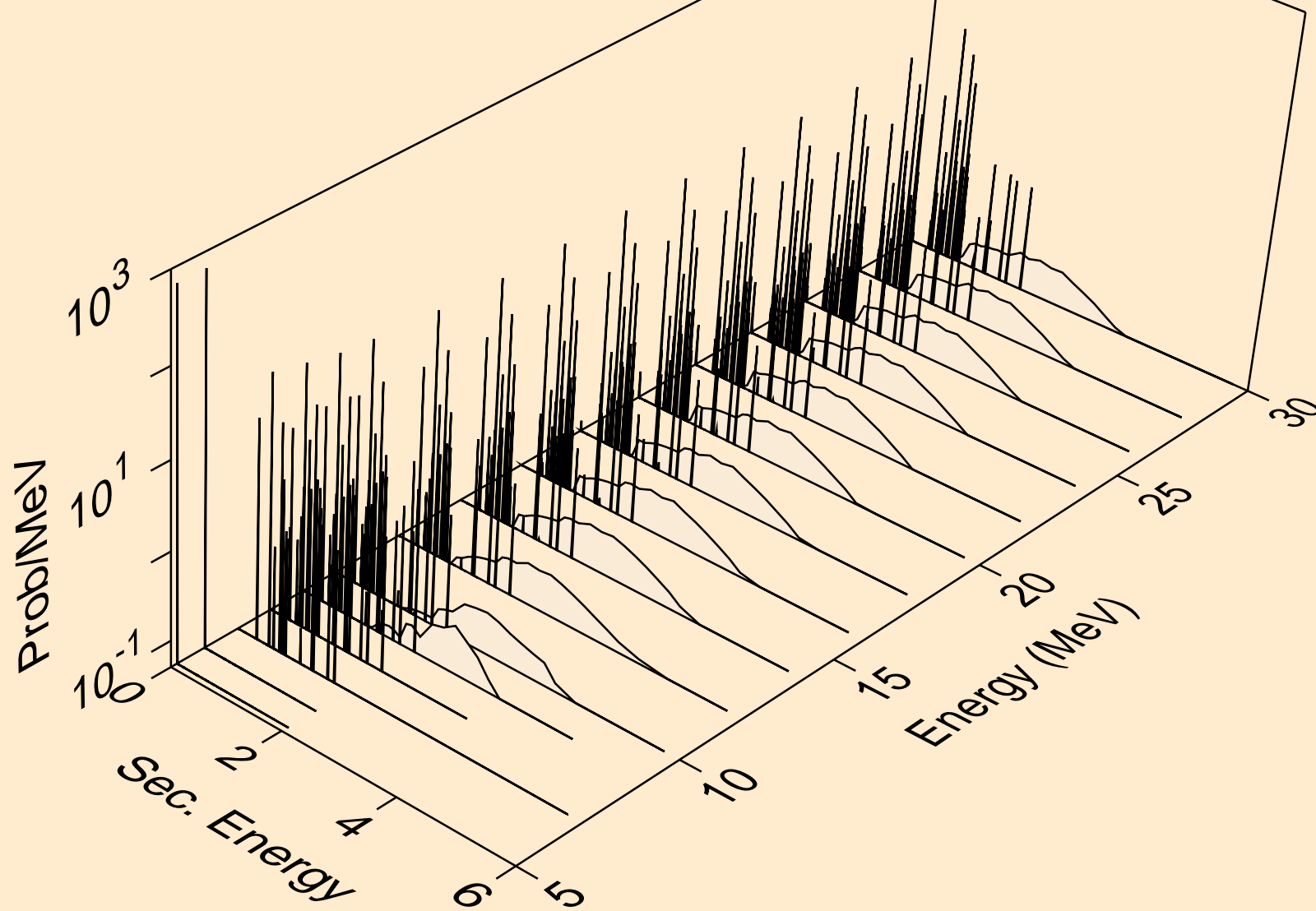

CD123M PHOTON ACER TENDL-2023 LIBRARY; T=0.K
photons from (g,gma)

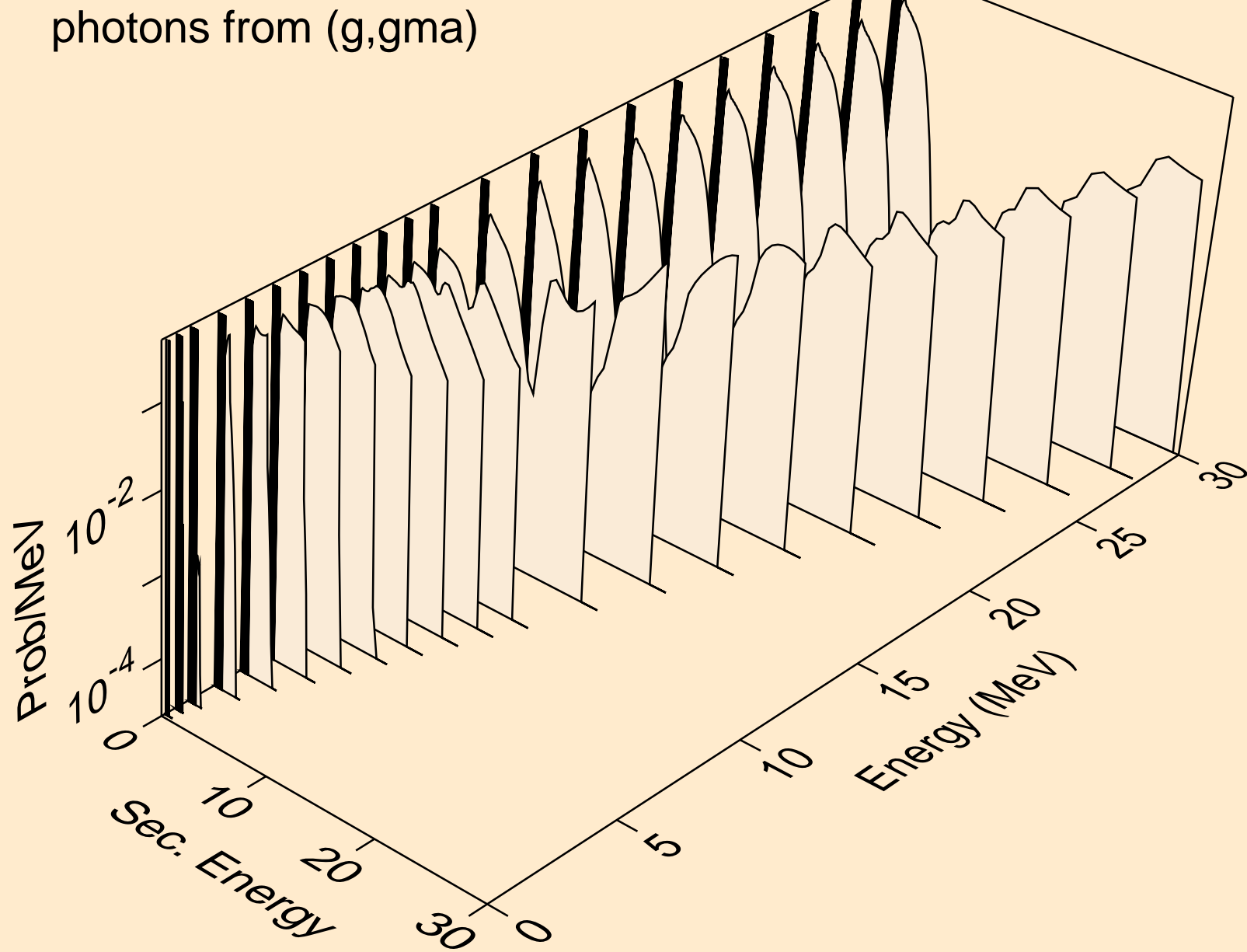

CD123M PHOTON ACER TENDL-2023 LIBRARY; T=0.K
photons from (g,p)

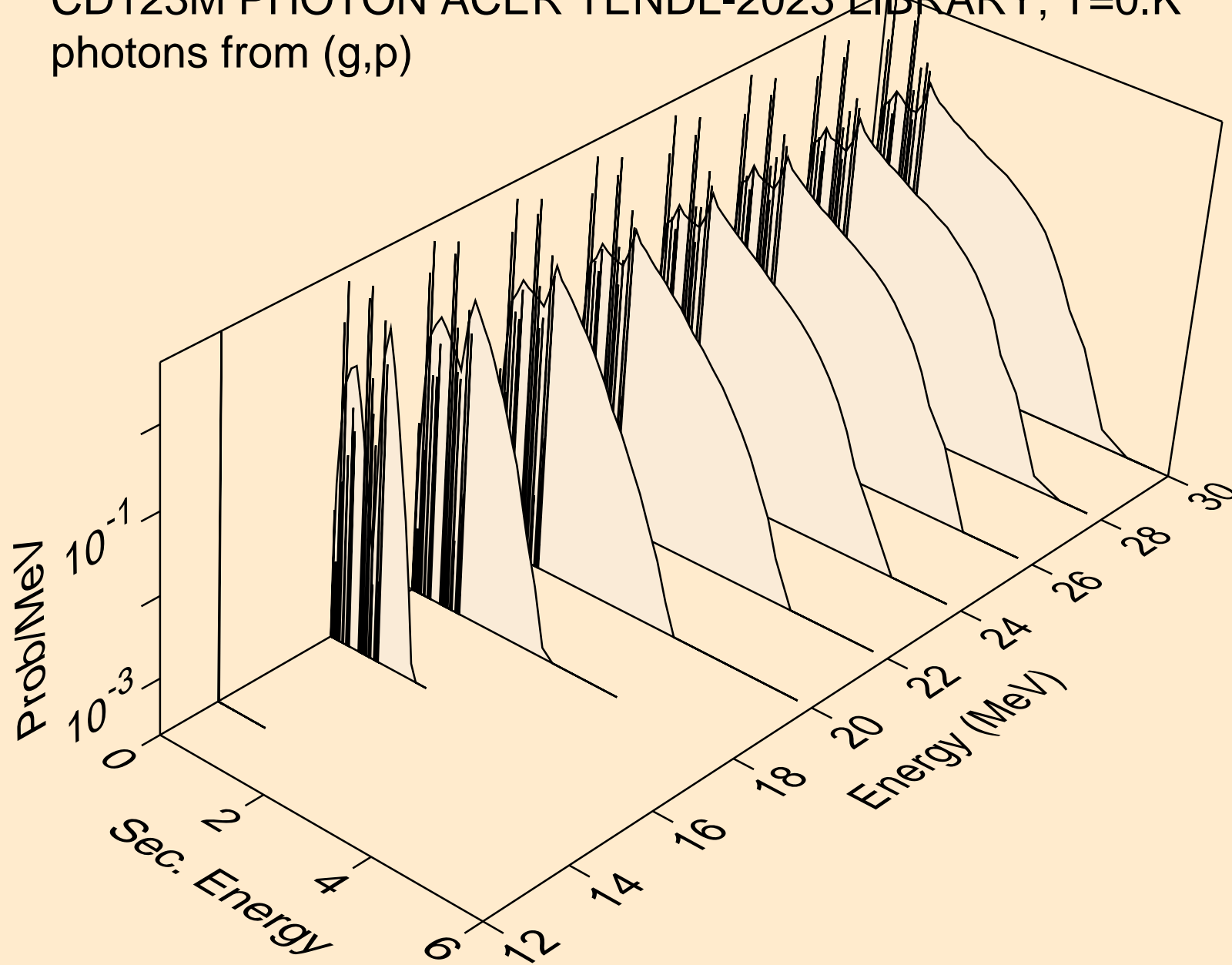

CD123M PHOTON ACER TENDL-2023 LIBRARY; T=0.K
photons from (g,d)

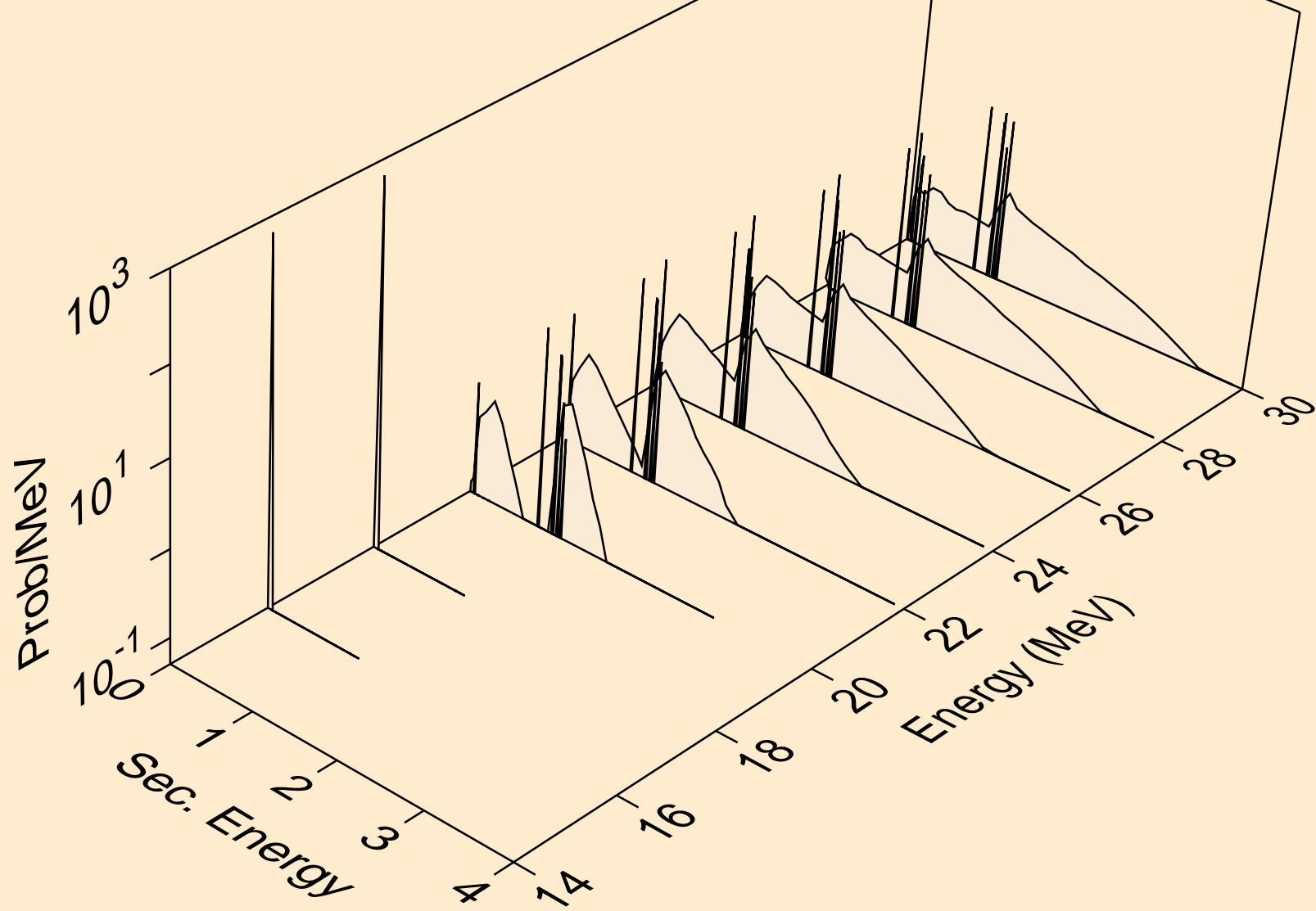

CD123M PHOTON ACER TENDL-2023 LIBRARY; T=0.K
photons from (g,t)

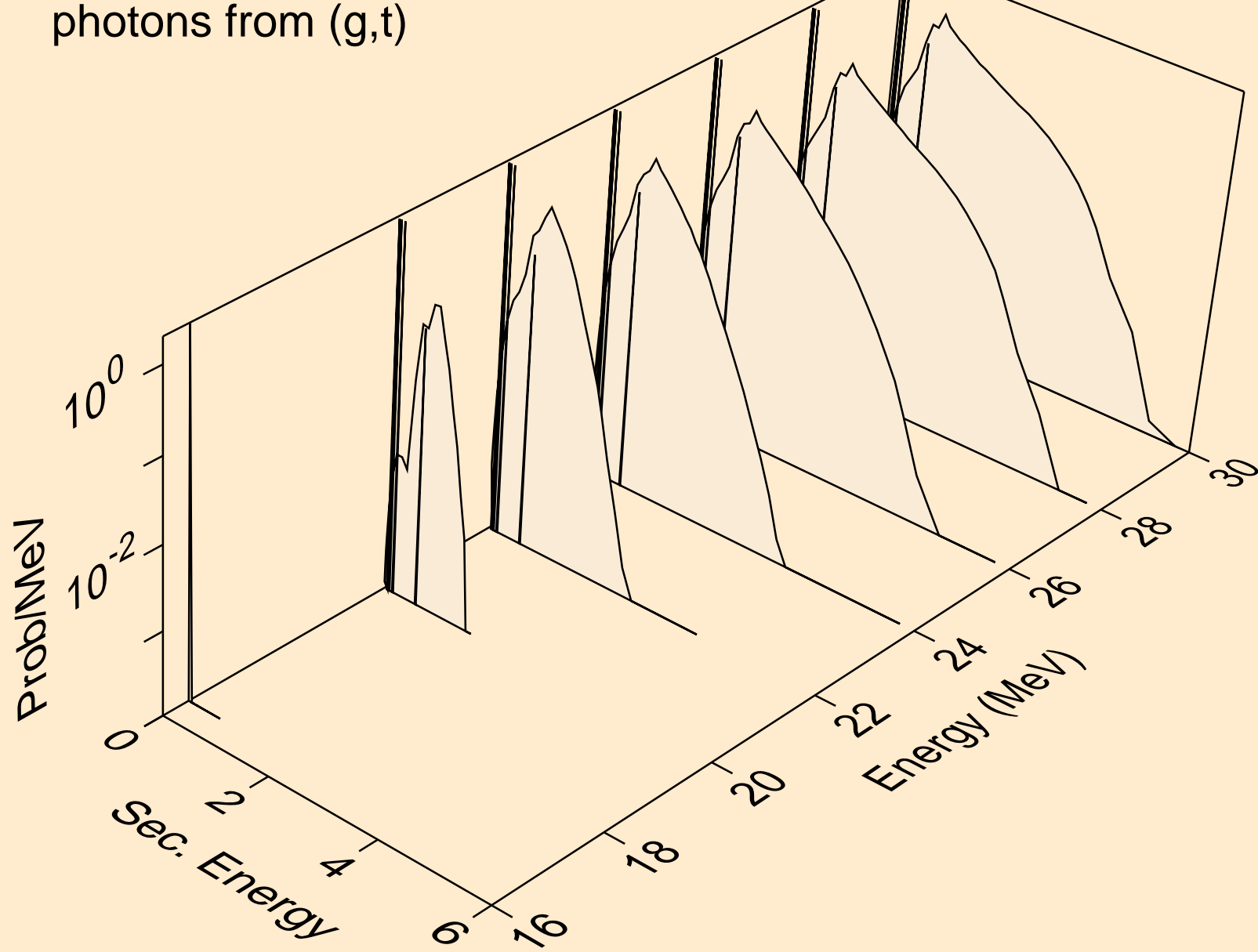

CD123M PHOTON ACER TENDL-2023 LIBRARY; T=0.K
photons from (g,a)

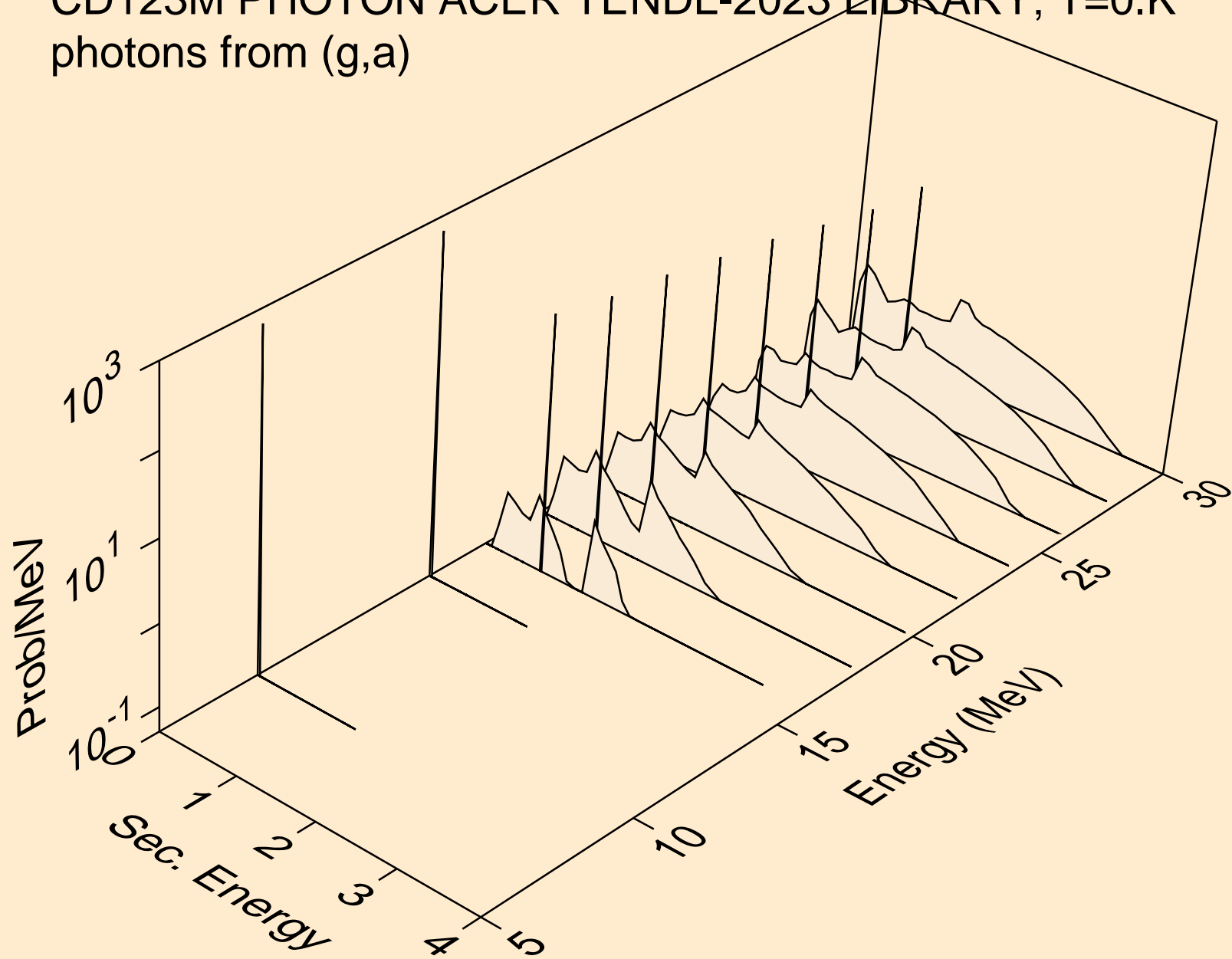

CD123M PHOTON ACER TENDL-2023 LIBRARY; T=0.K
protons from (g,x)

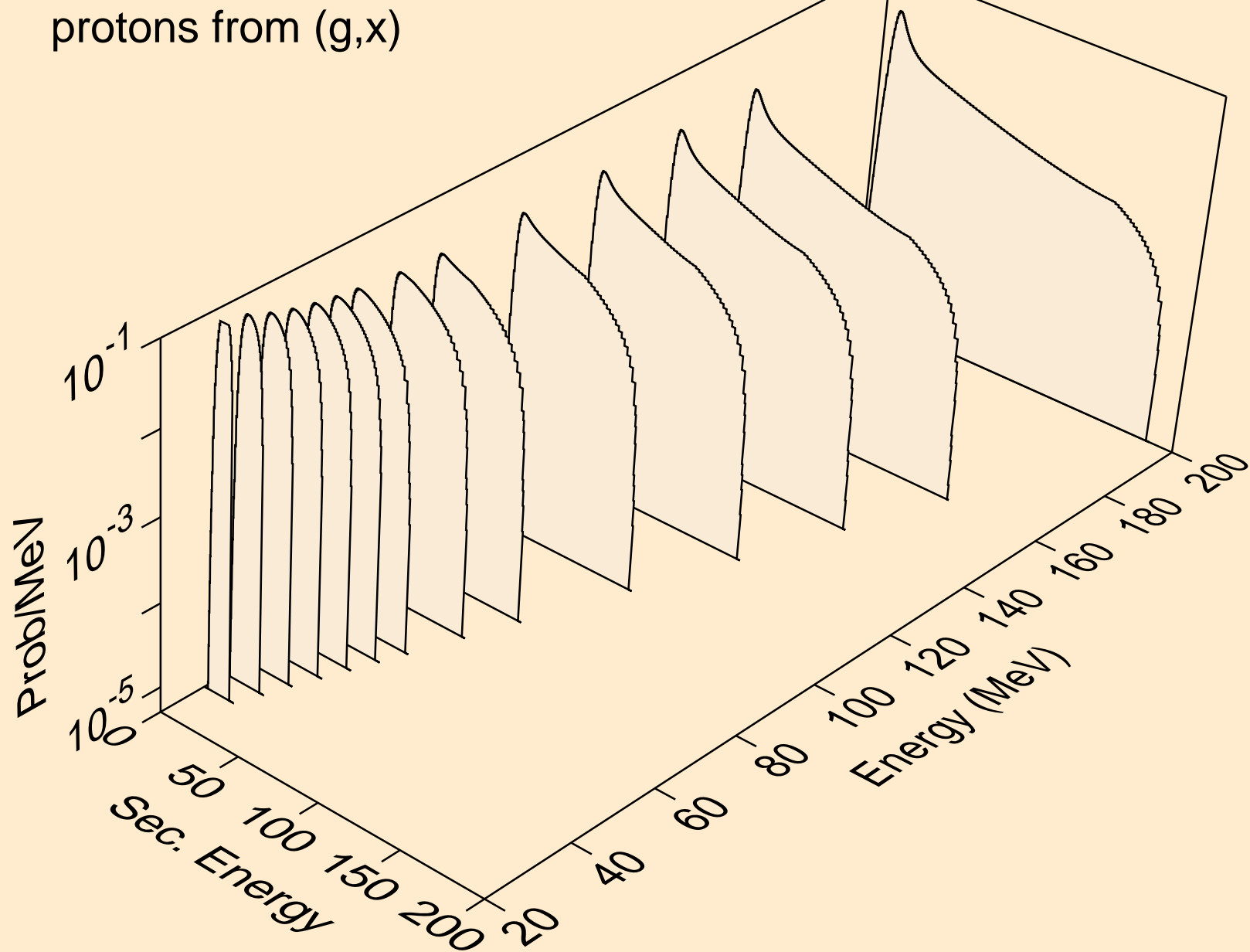

CD123M PHOTON ACER TENDL-2023 LIBRARY; T=0.K
protons from (g,n*)p

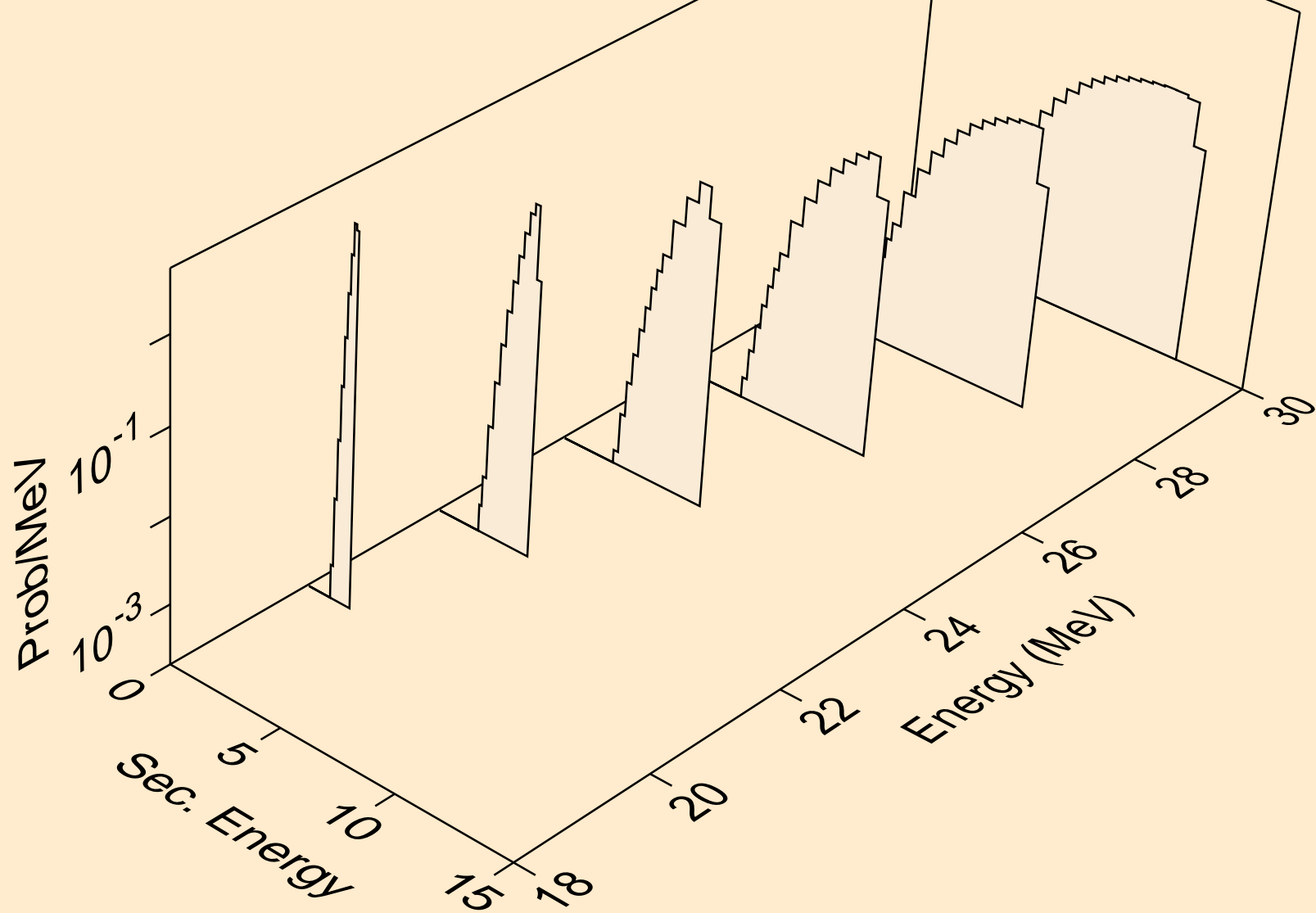

CD123M PHOTON ACER TENDL-2023 LIBRARY; T=0.K
protons from (g,2np)

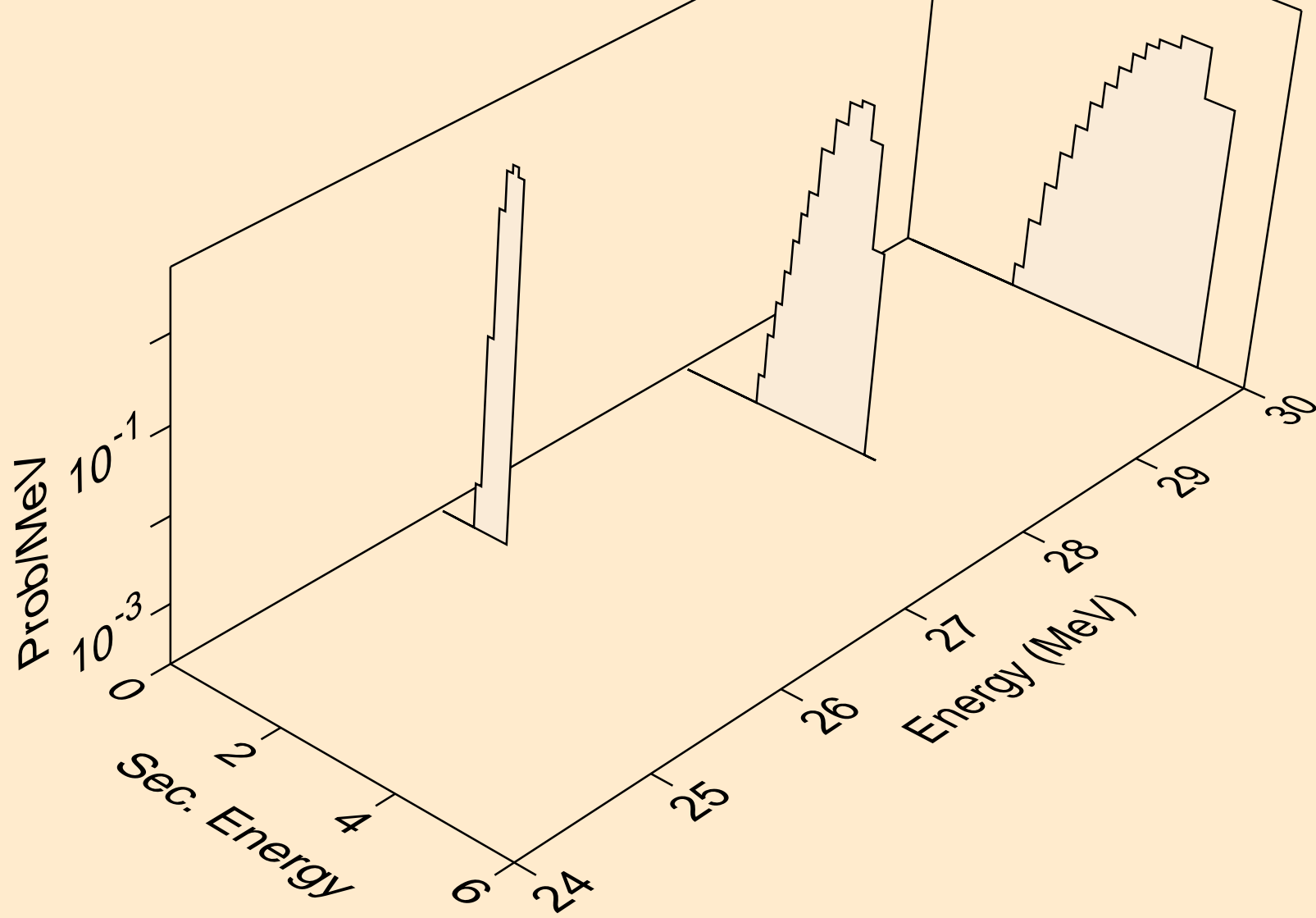

CD123M PHOTON ACER TENDL-2023 LIBRARY; T=0.K
protons from (g,p)

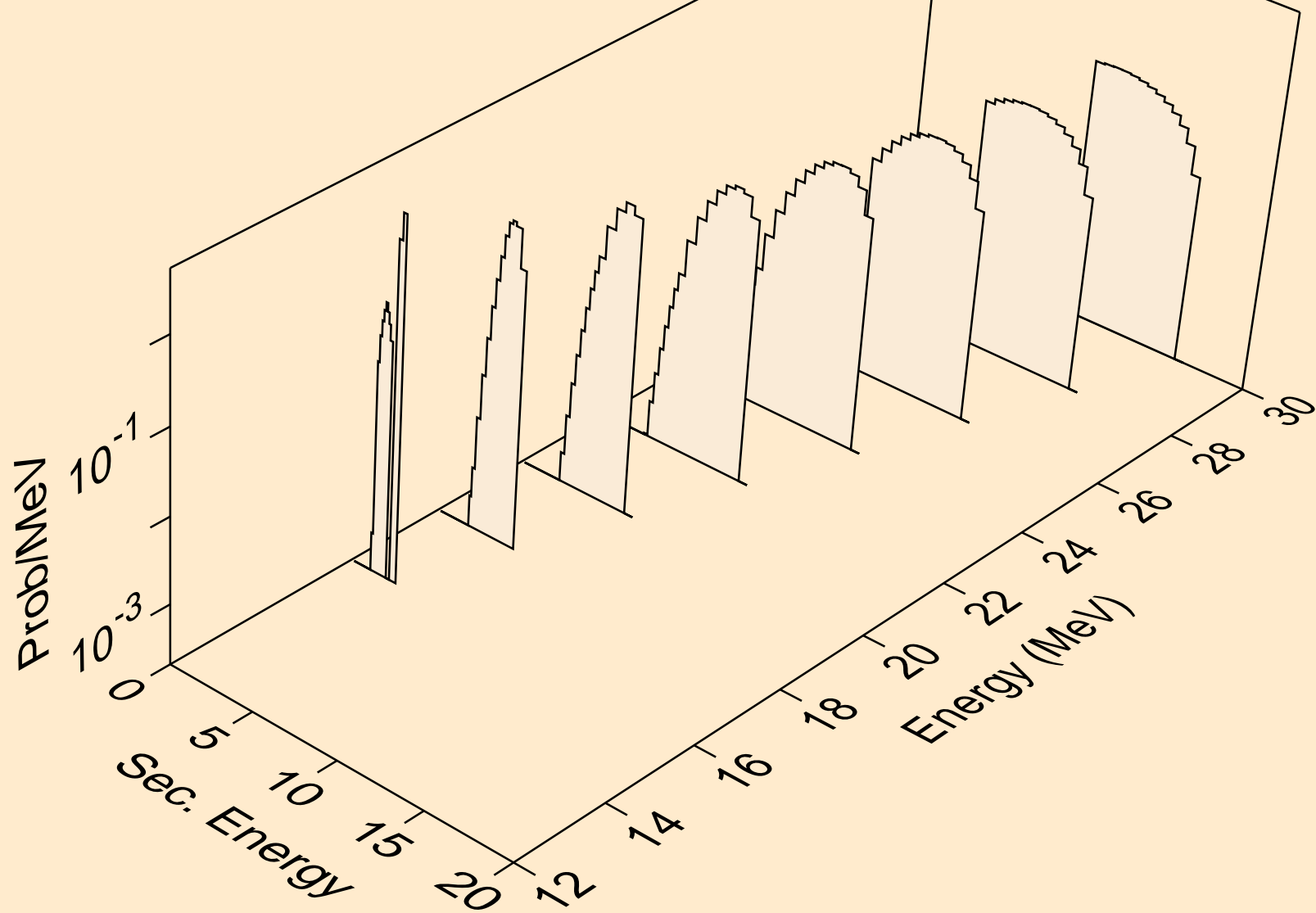

CD123M PHOTON ACER TENDL-2023 LIBRARY; T=0.K
deuterons from (g,x)

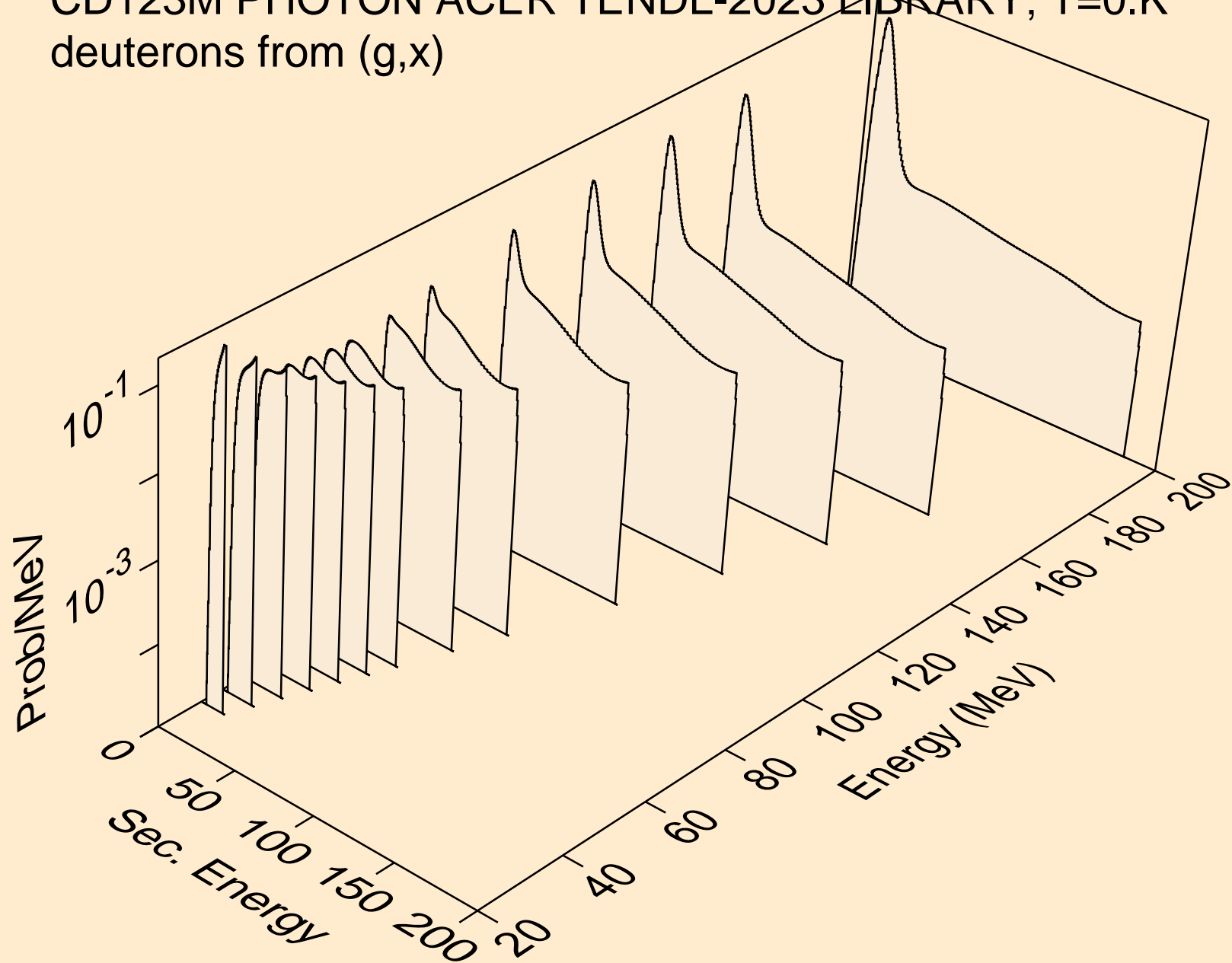

CD123M PHOTON ACER TENDL-2023 LIBRARY; T=0.K
deuterons from (g,n*)d

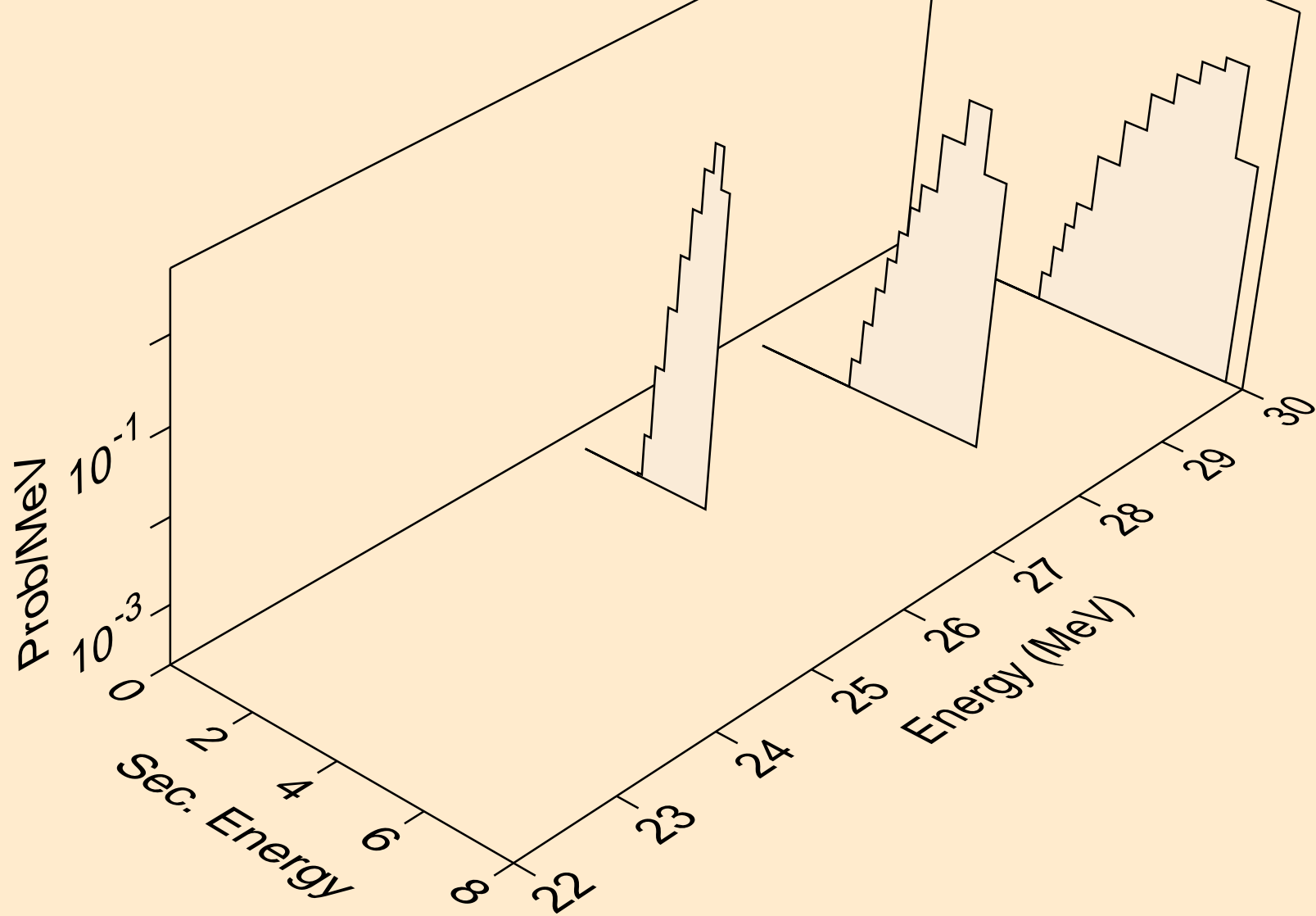

CD123M PHOTON ACER TENDL-2023 LIBRARY; T=0.K
deuterons from (g,d)

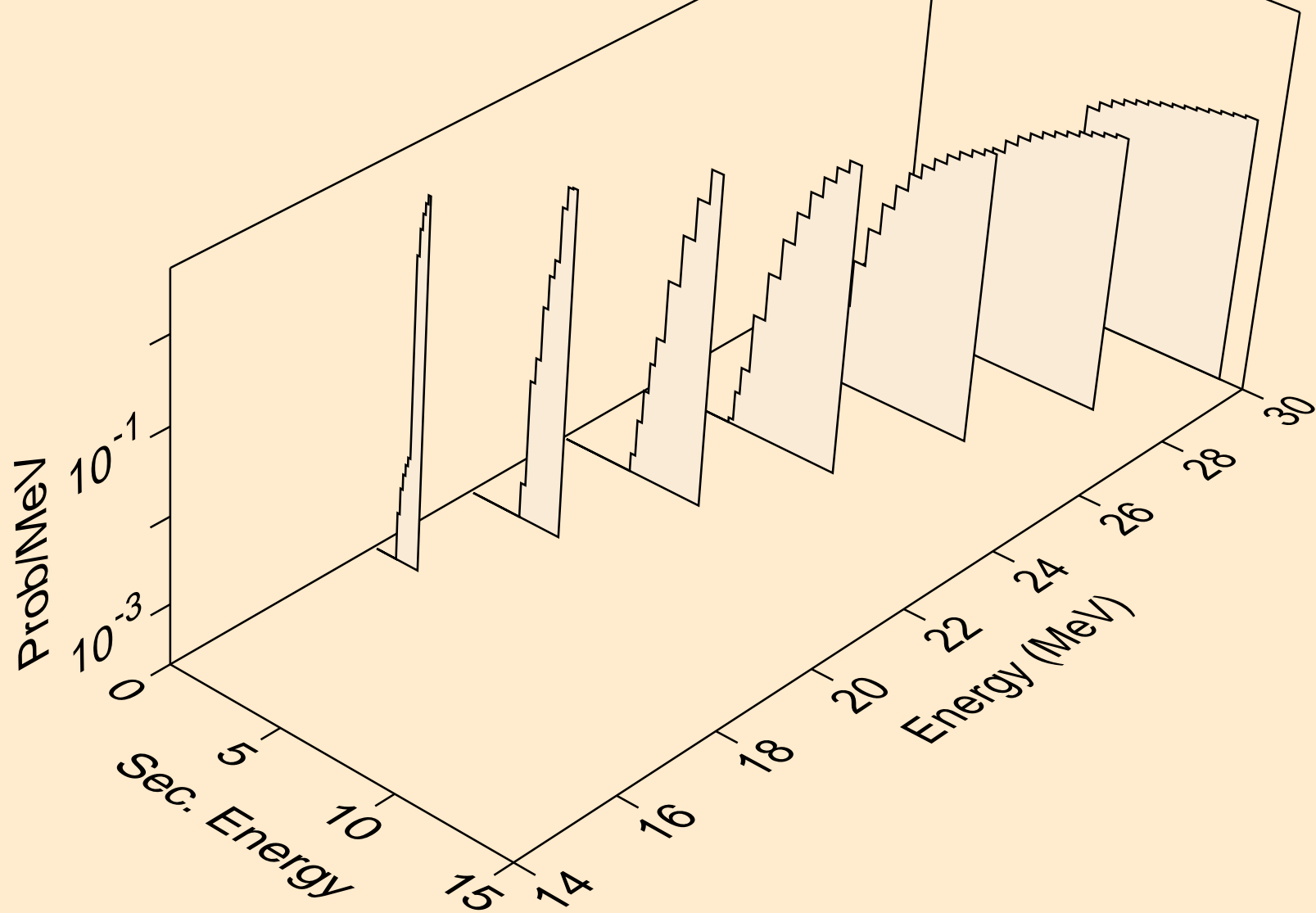

CD123M PHOTON ACER TENDL-2023 LIBRARY; T=0.K
tritons from (g,x)

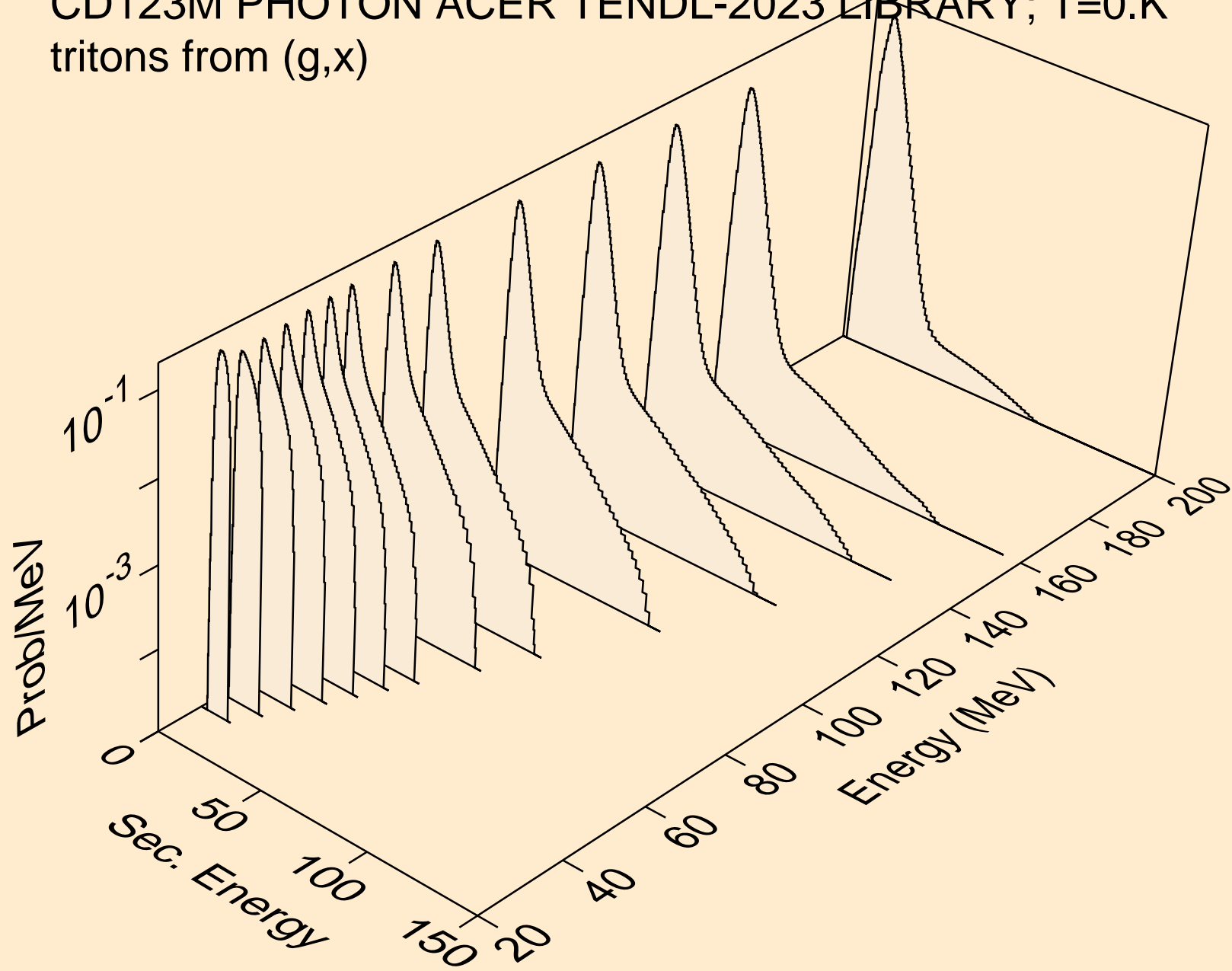

CD123M PHOTON ACER TENDL-2023 LIBRARY; T=0.K
tritons from (g,n*)t

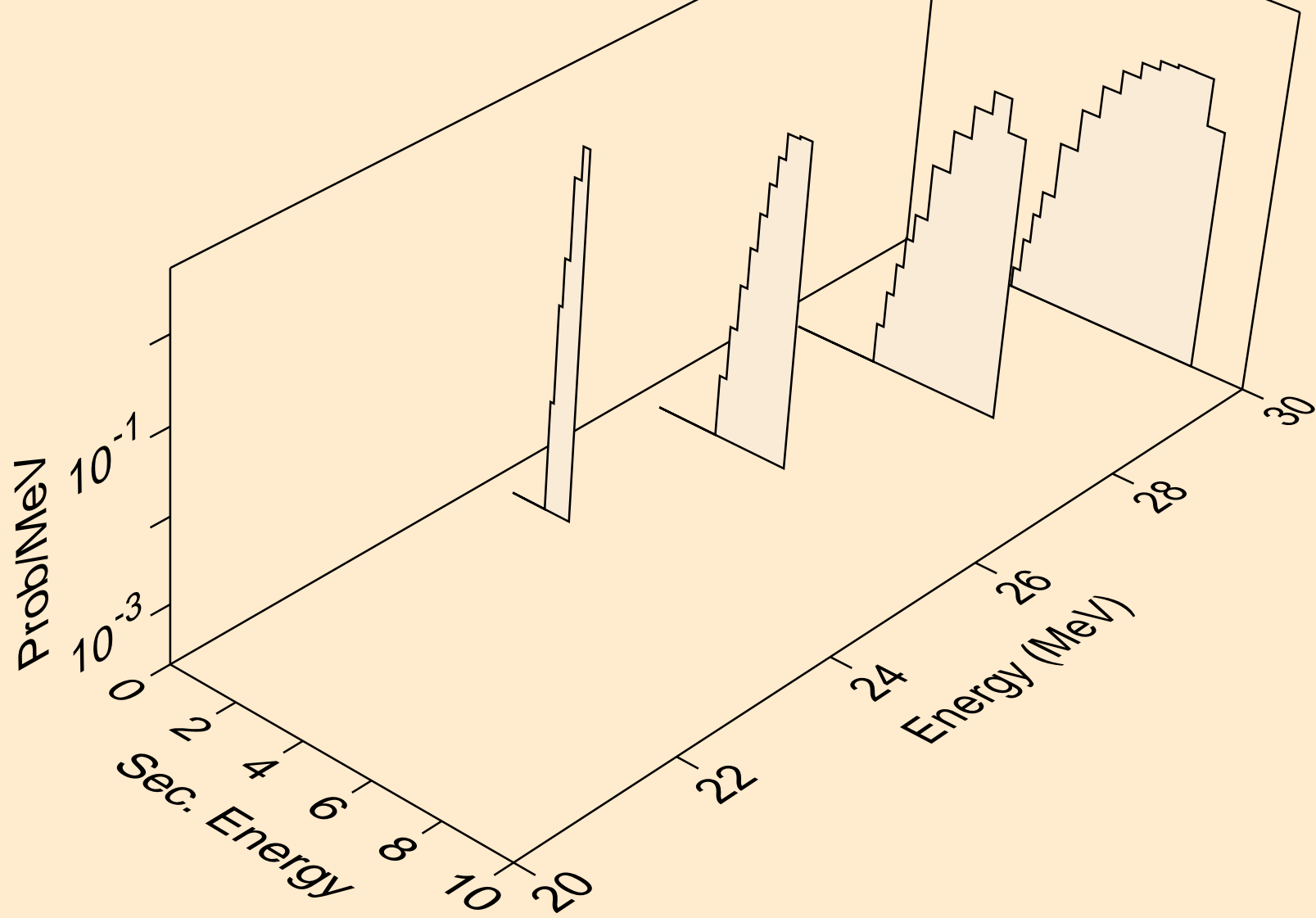

CD123M PHOTON ACER TENDL-2023 LIBRARY; T=0.K
tritons from (g,t)

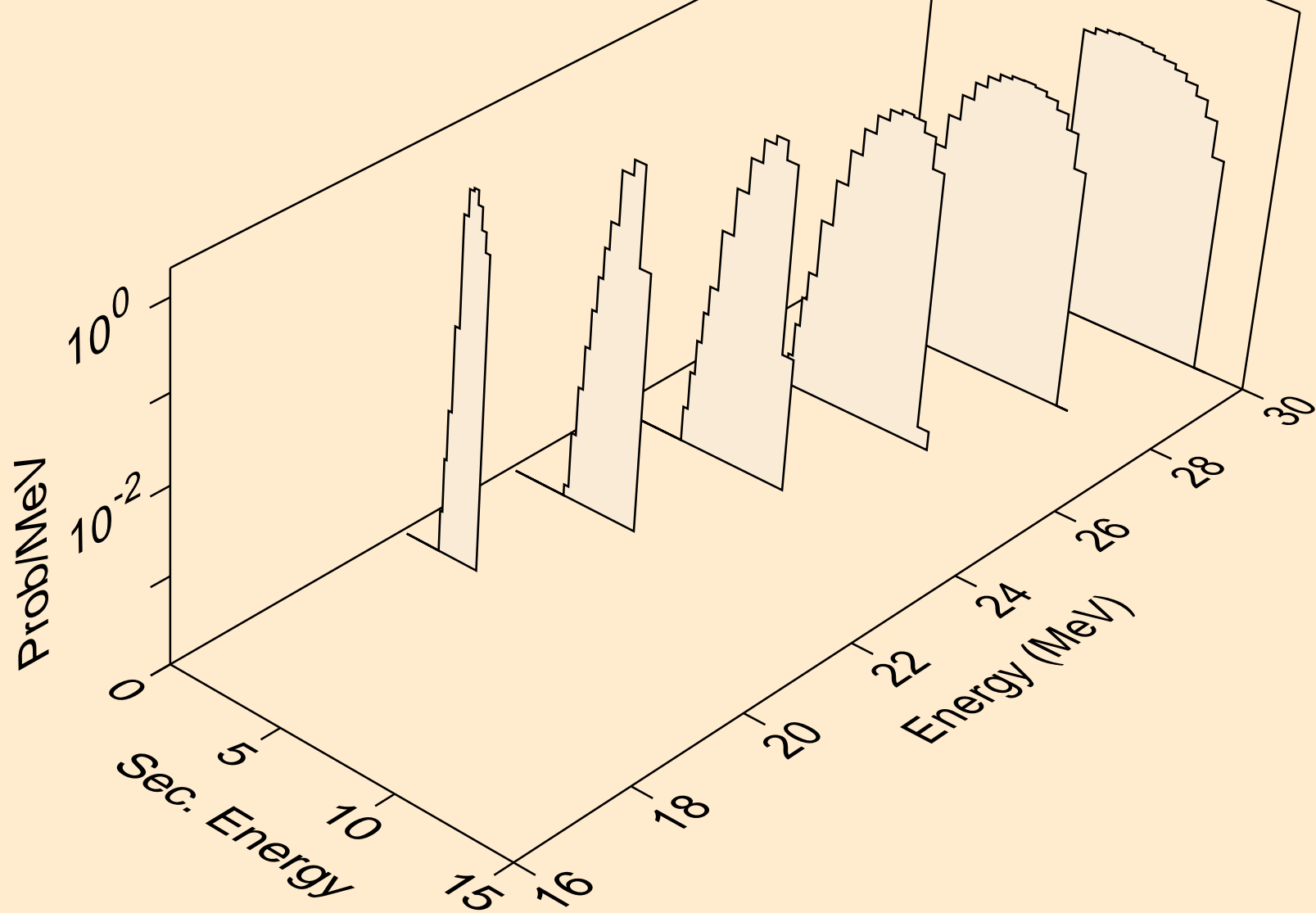

CD123M PHOTON ACER TENDL-2023 LIBRARY; T=0.K
he3s from (g,x)

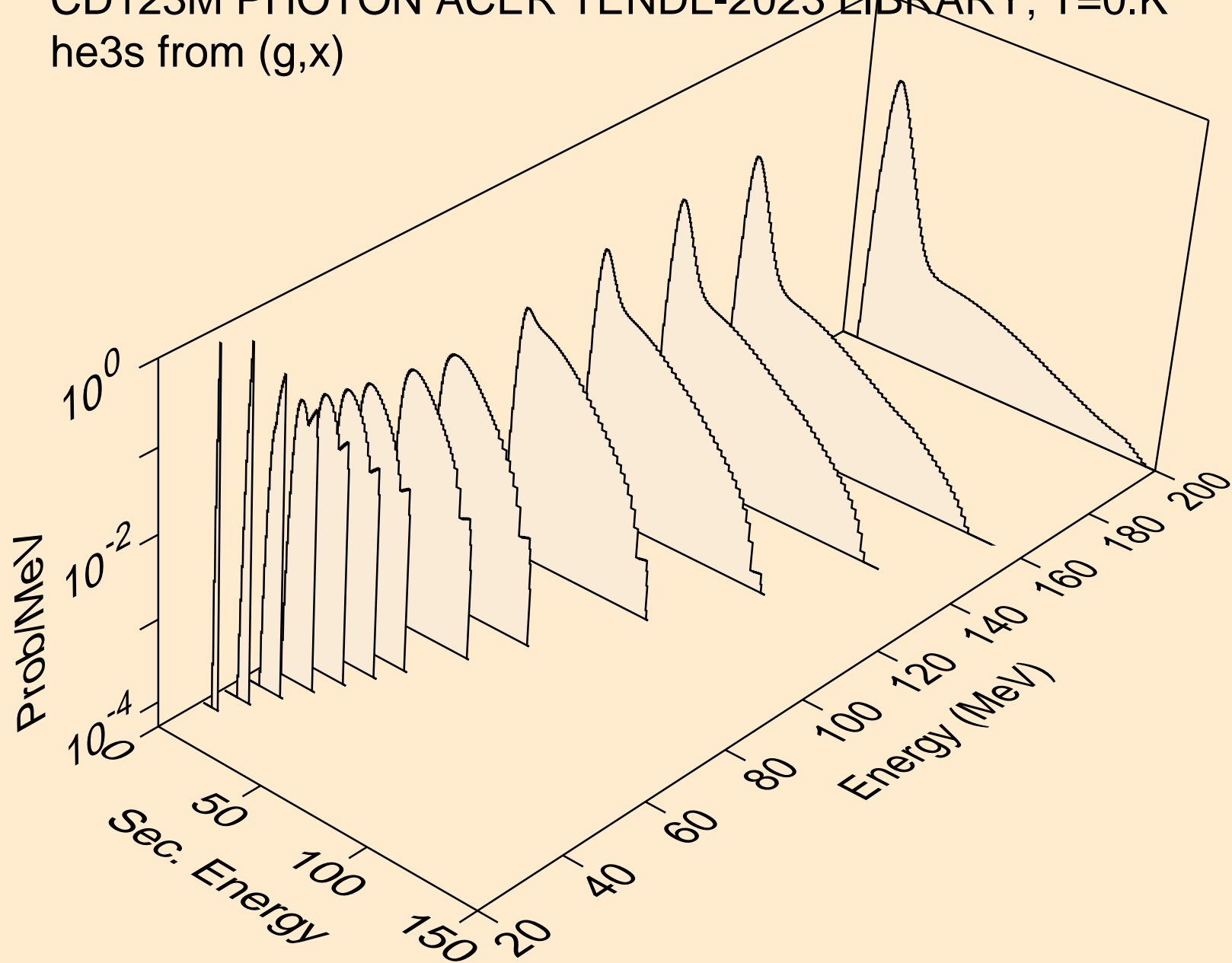

CD123M PHOTON ACER TENDL-2023 LIBRARY; T=0.K
alphas from (g,x)

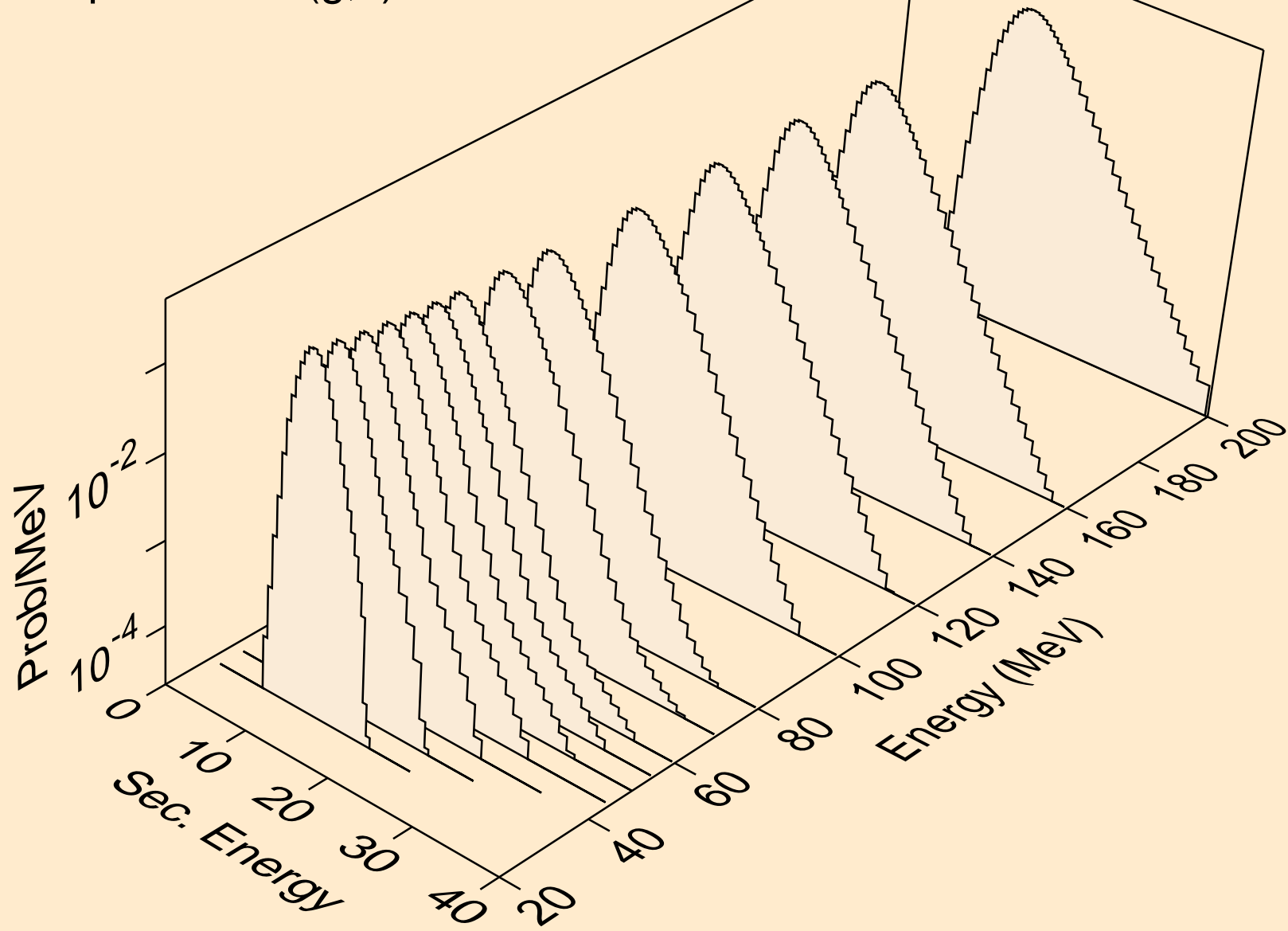

CD123M PHOTON ACER TENDL-2023 LIBRARY; T=0.K
alphas from (g,n*)a

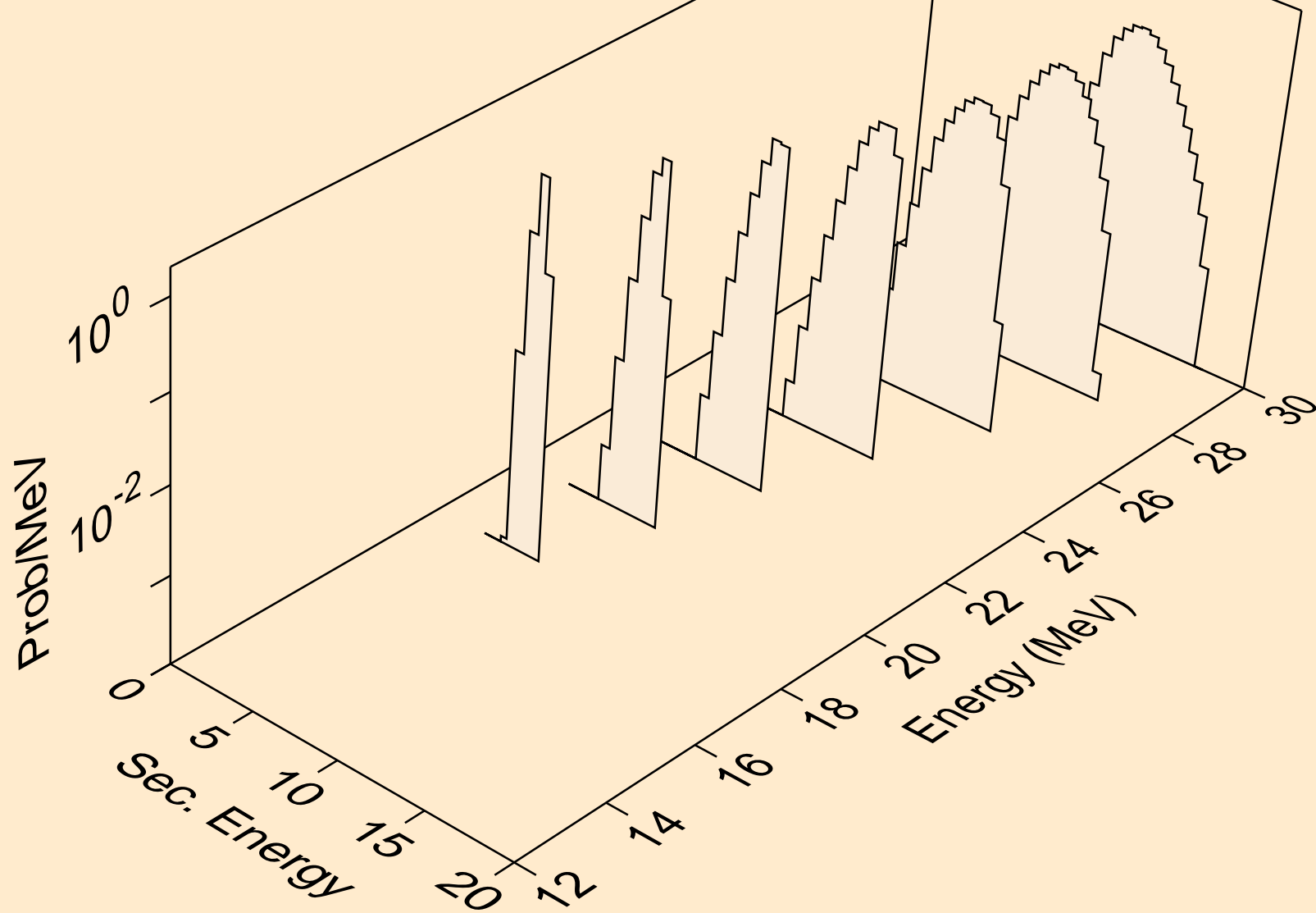

CD123M PHOTON ACER TENDL-2023 LIBRARY; T=0.K
alphas from (g,2n)a

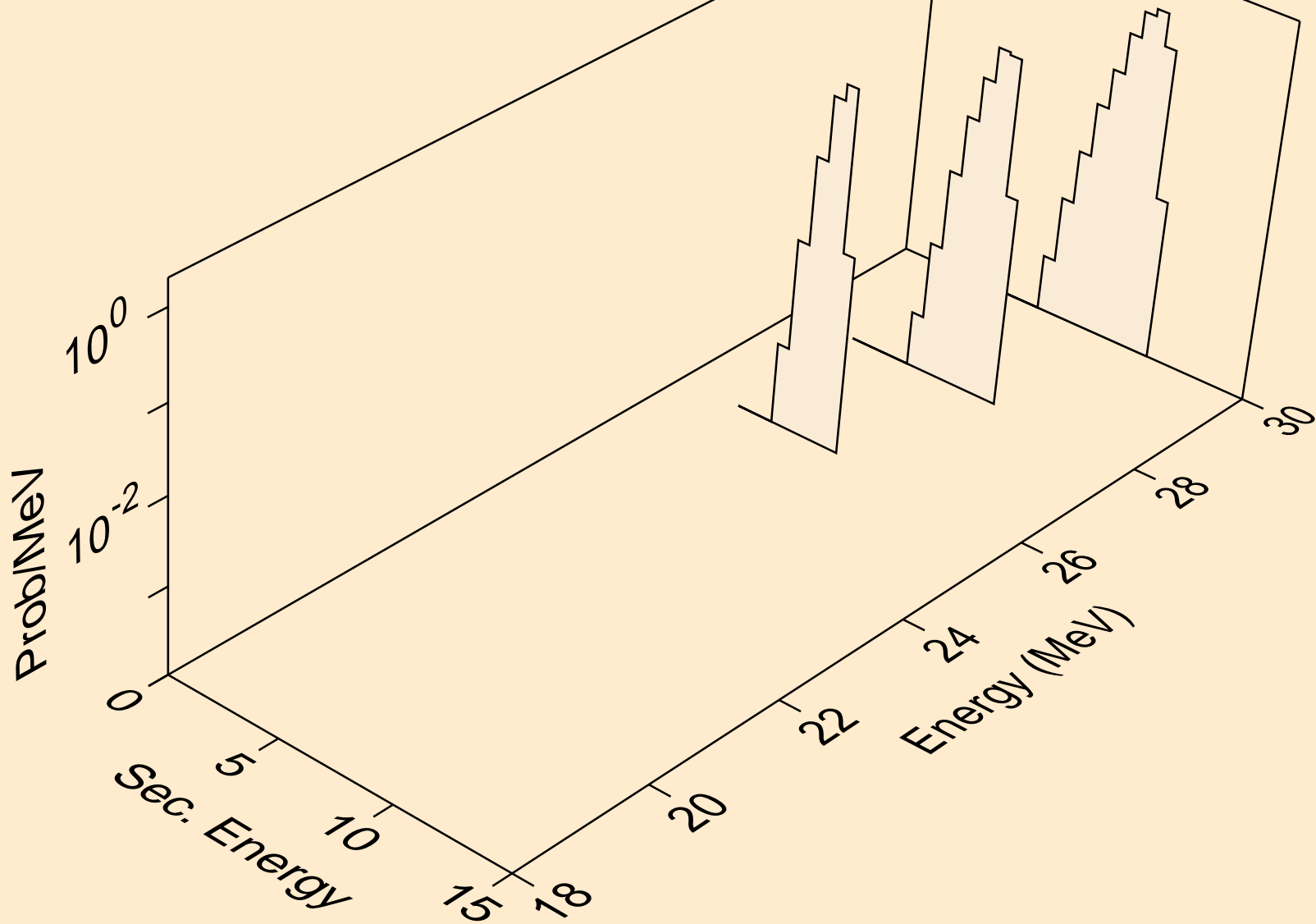

CD123M PHOTON ACER TENDL-2023 LIBRARY; T=0.K
alphas from (g,a)

