

CE122 PHOTON ACER TENDL-2023 LIBRARY; T=0.K
Principal cross sections

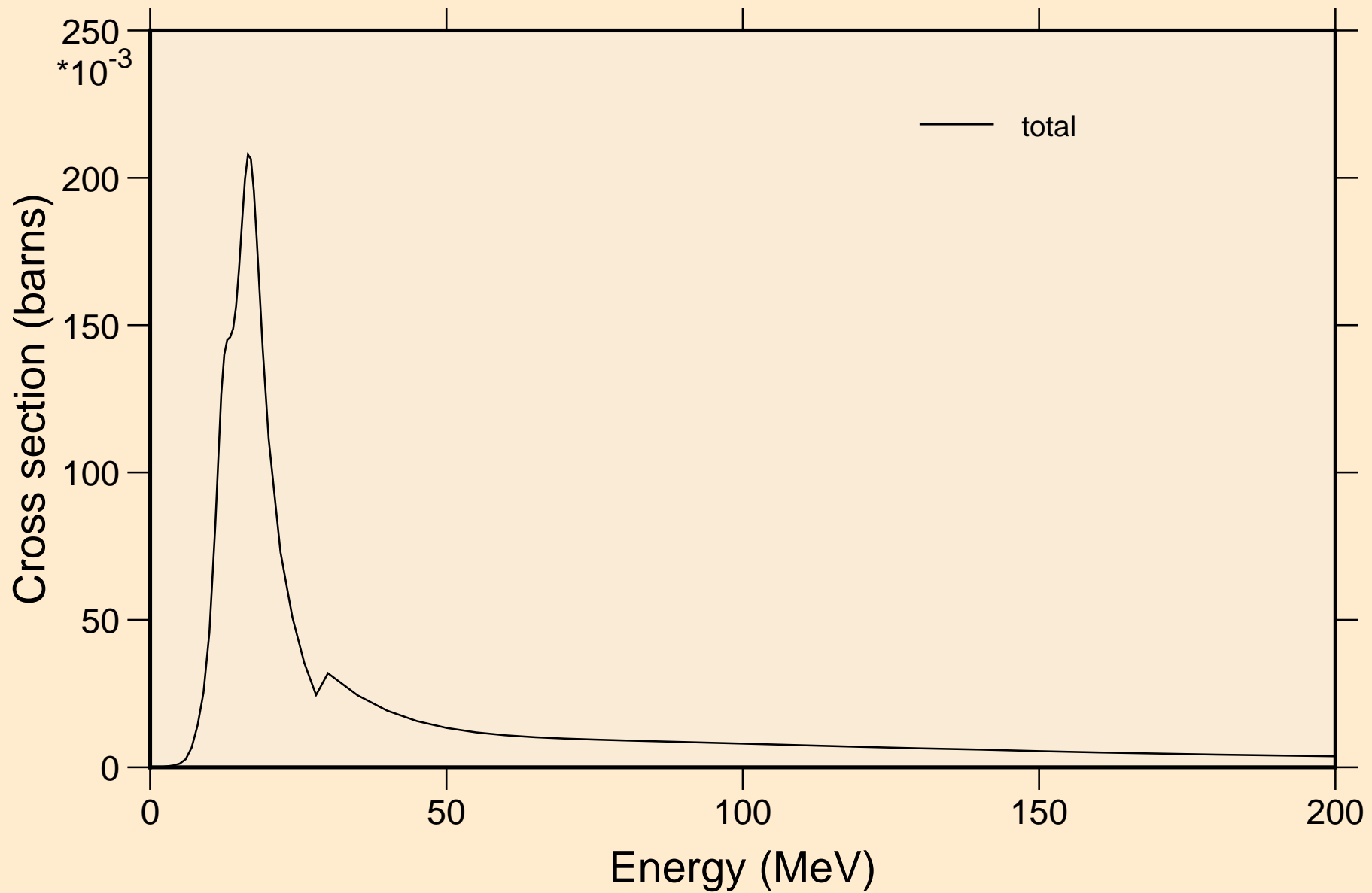

CE122 PHOTON ACER TENDL-2023 LIBRARY; T=0.K

Partial cross sections

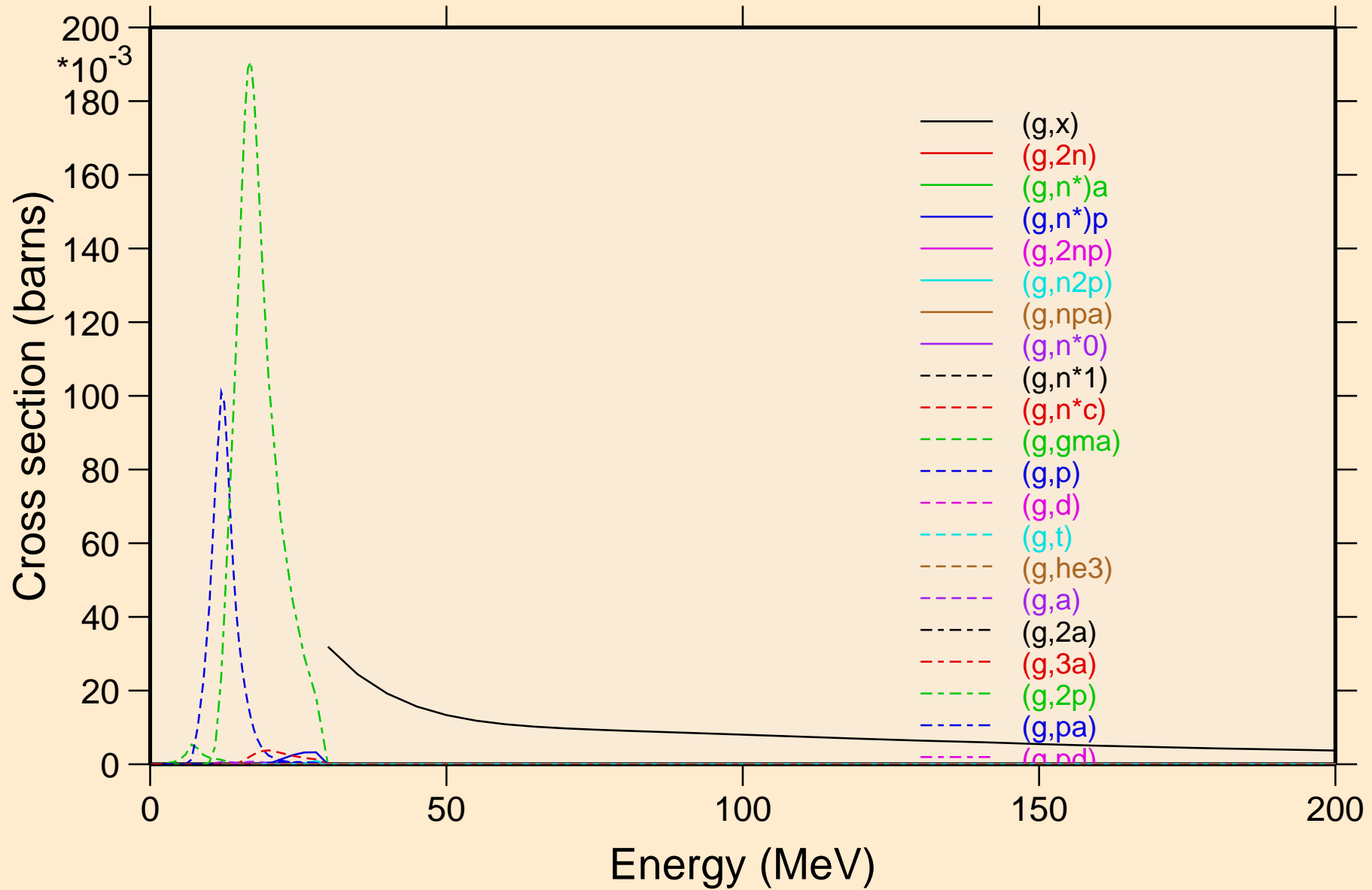

CE122 PHOTON ACER TENDL-2023 LIBRARY; T=0.K

Heating

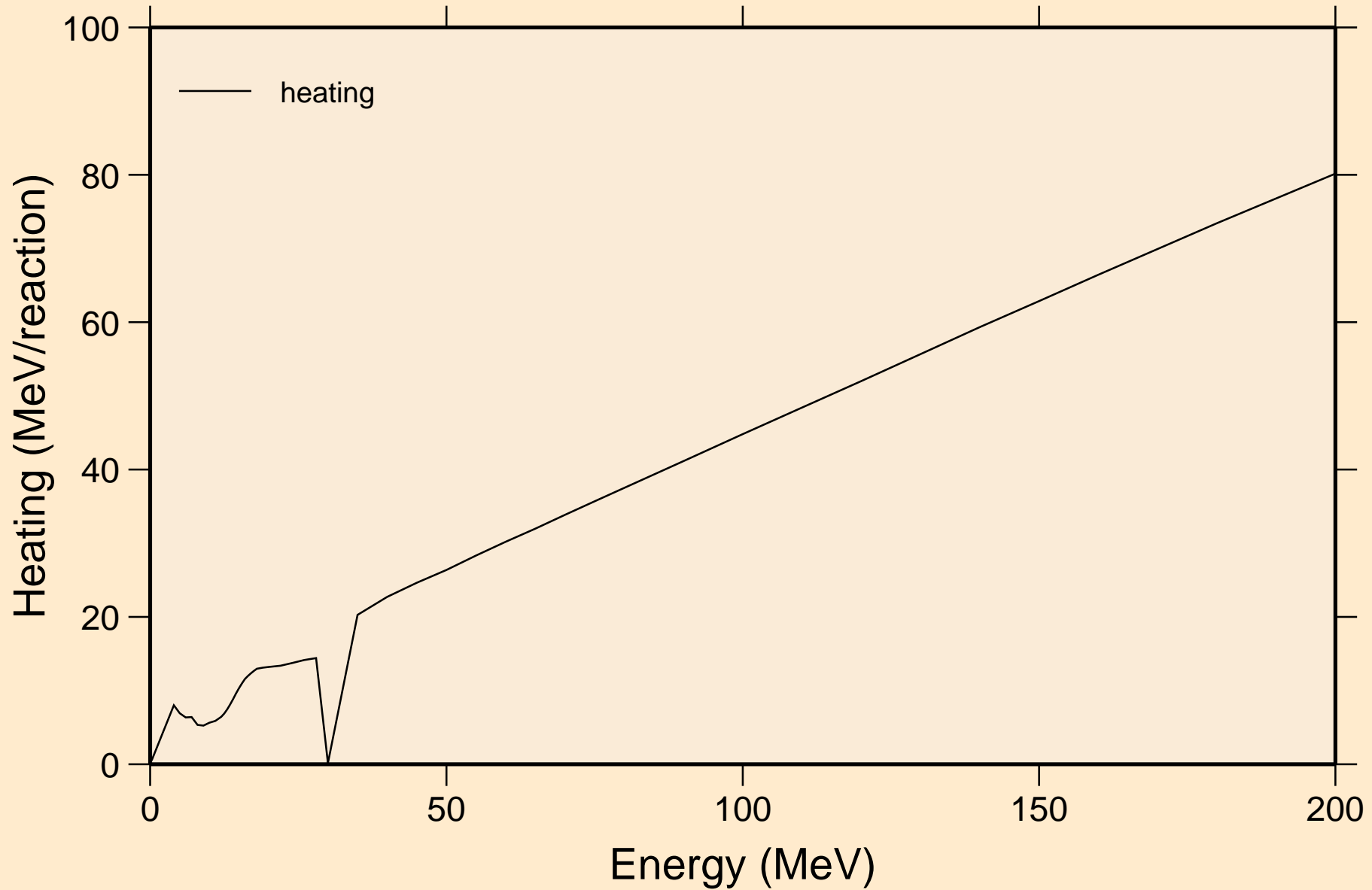

CE122 PHOTON ACER TENDL-2023 LIBRARY; T=0.K

Particle heating contributions

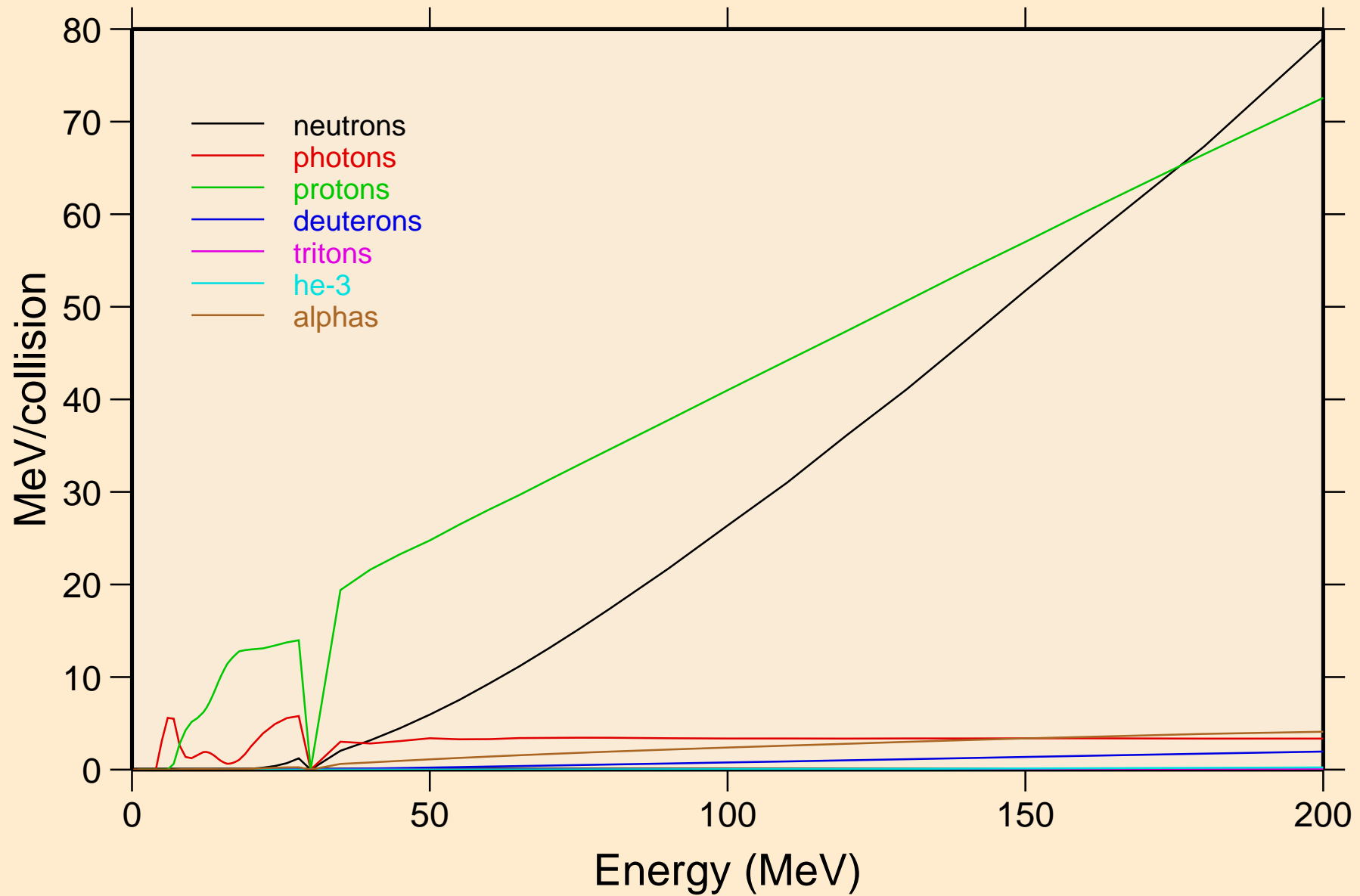

CE122 PHOTON ACER TENDL-2023 LIBRARY; T=0.K

Particle production cross sections

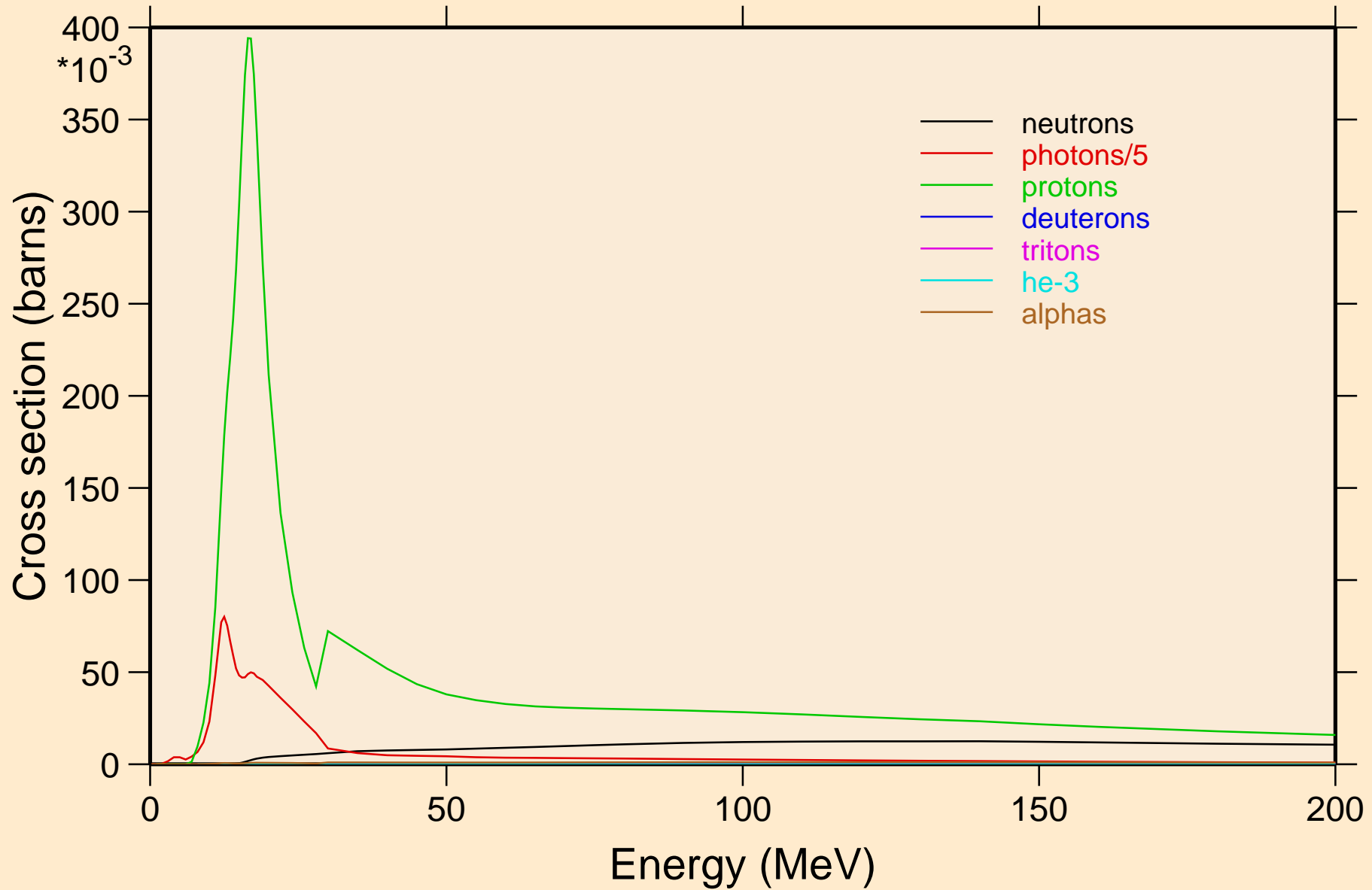

CE122 PHOTON ACER TENDL-2023 LIBRARY; T=0.K
neutrons from (g,x)

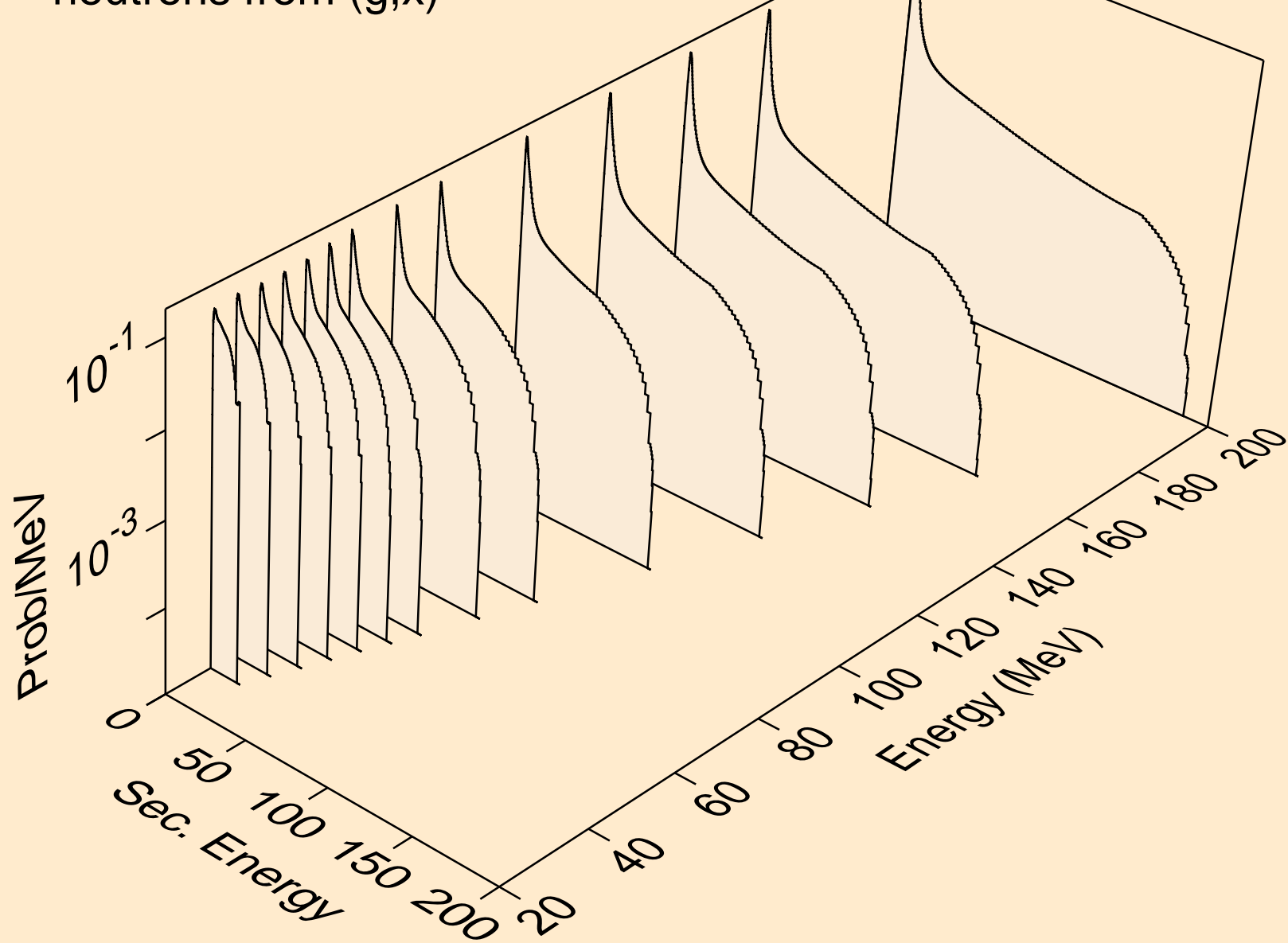

CE122 PHOTON ACER TENDL-2023 LIBRARY; T=0.K
neutrons from (g,2n)

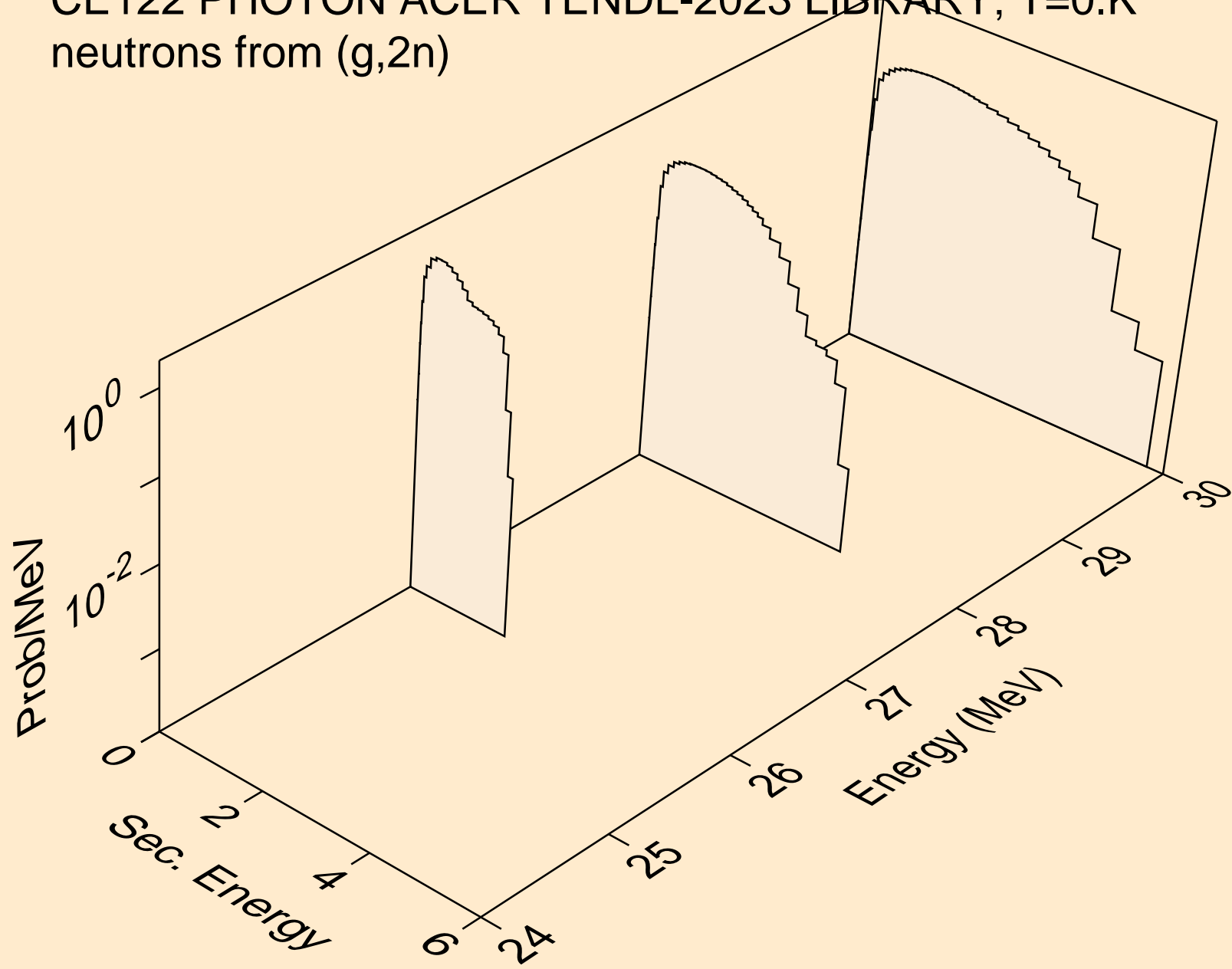

CE122 PHOTON ACER TENDL-2023 LIBRARY; T=0.K
neutrons from (g,n*)a

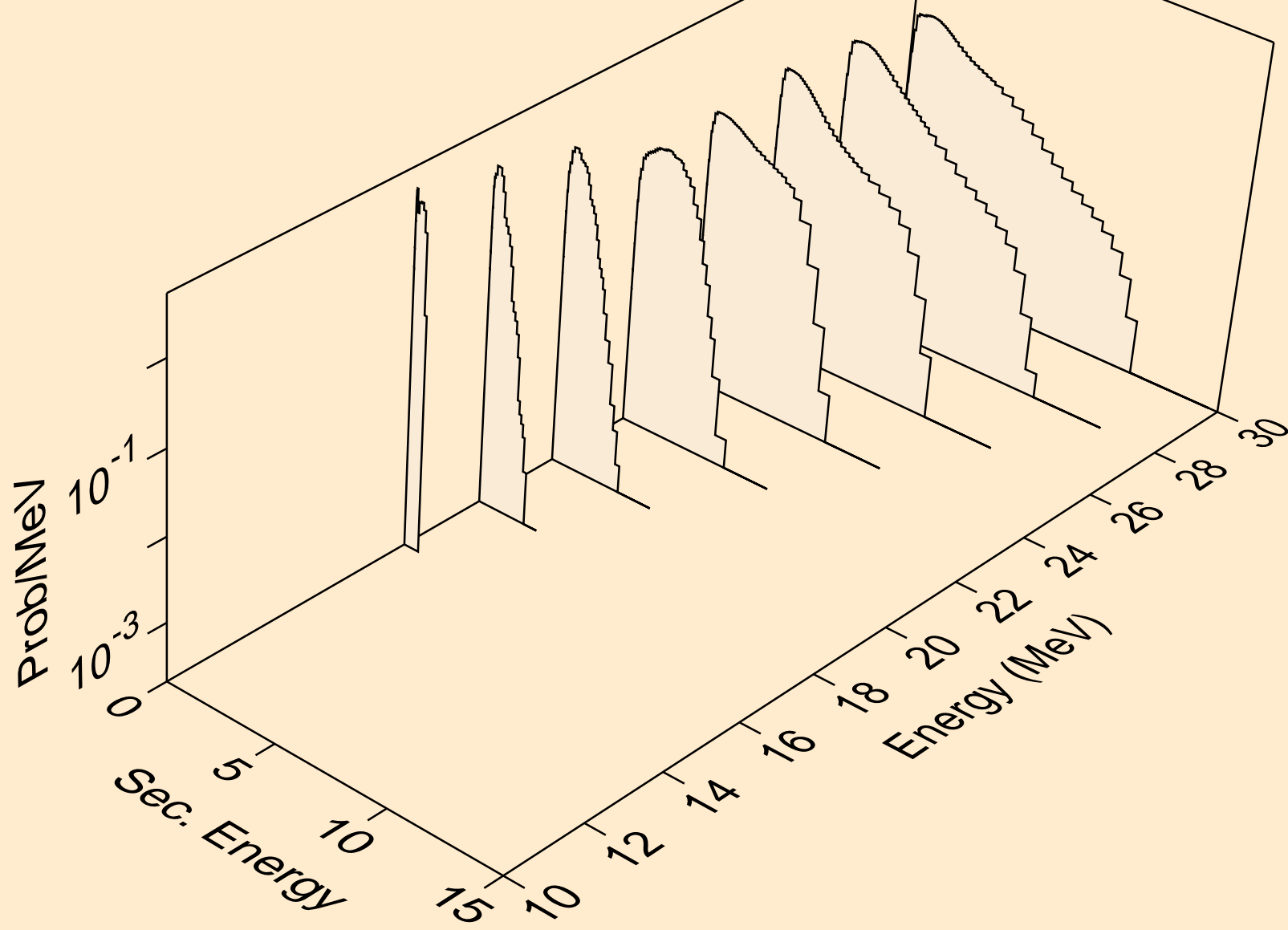

CE122 PHOTON ACER TENDL-2023 LIBRARY; T=0.K
neutrons from (g,n*)p

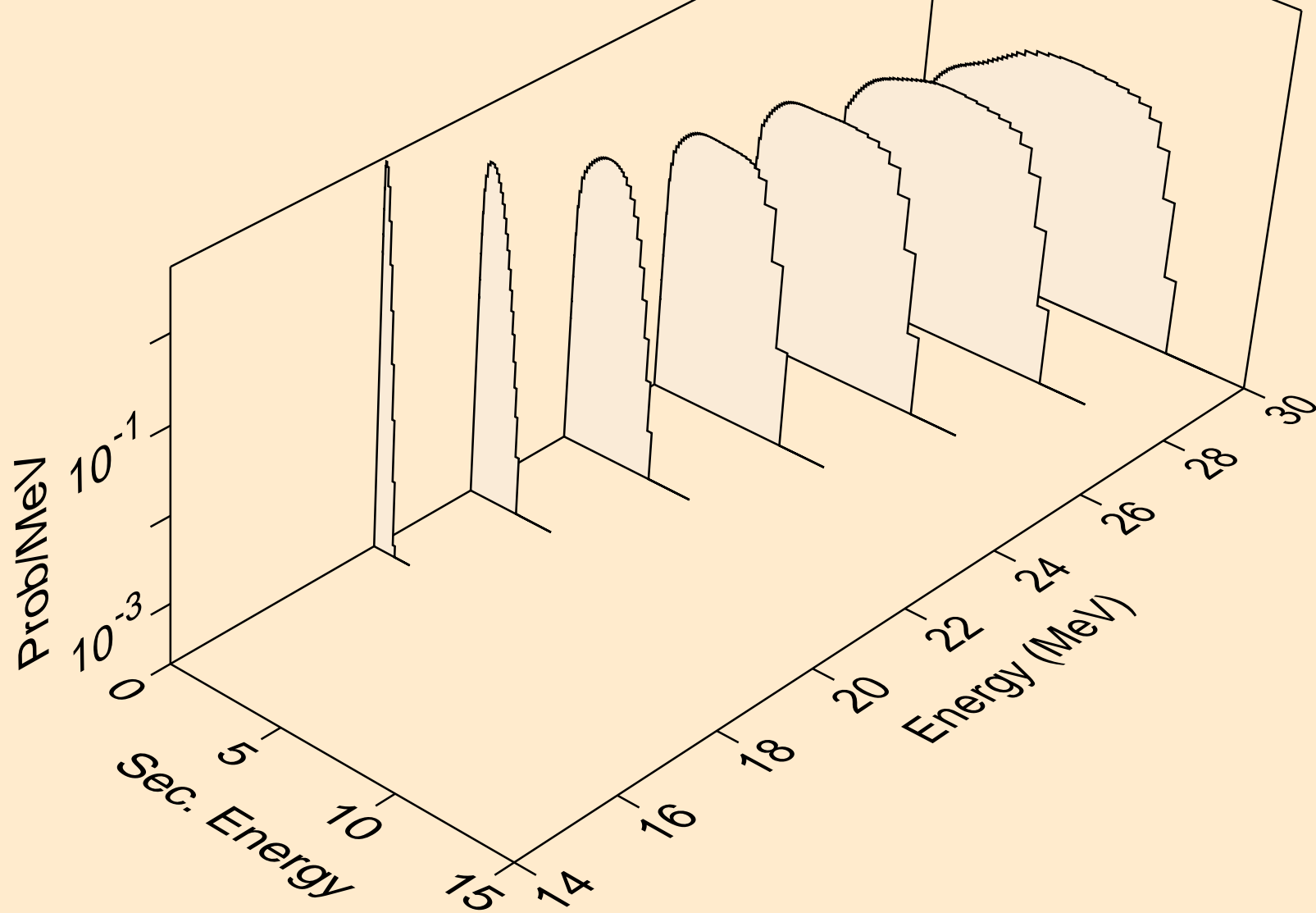

CE122 PHOTON ACER TENDL-2023 LIBRARY; T=0.K
neutrons from (g,2np)

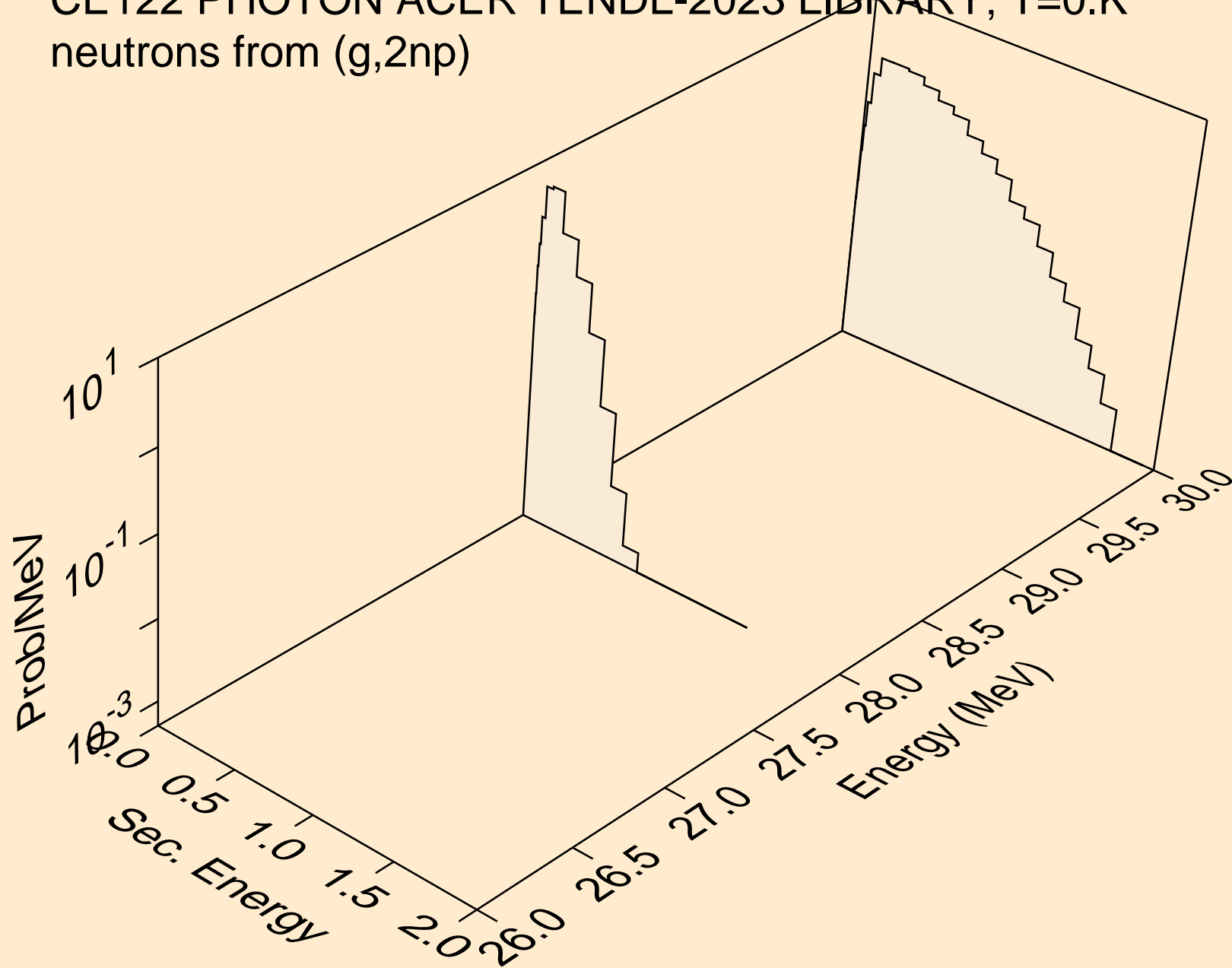

CE122 PHOTON ACER TENDL-2023 LIBRARY; T=0.K
neutrons from (g,n2p)

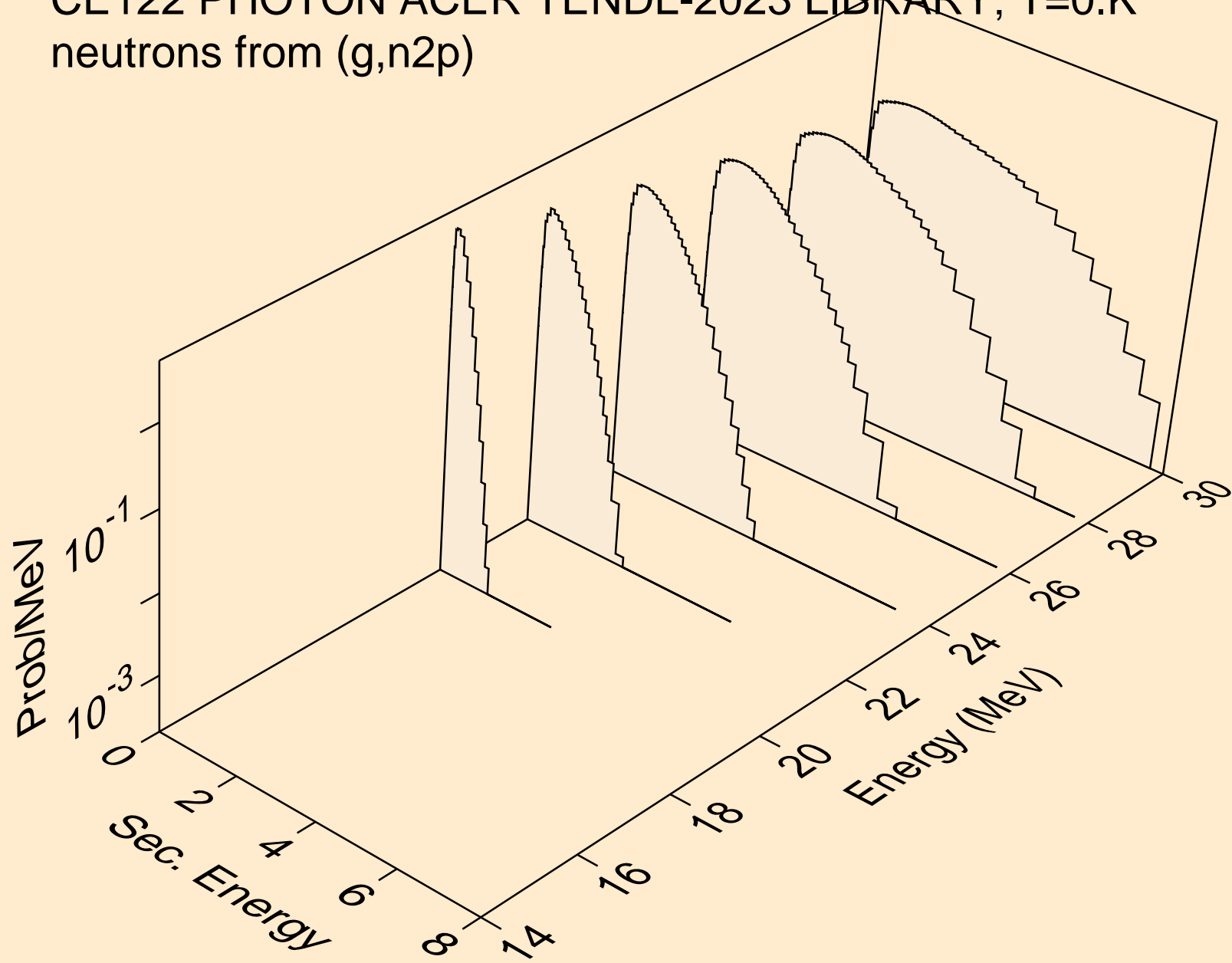

CE122 PHOTON ACER TENDL-2023 LIBRARY; T=0.K
neutrons from (g,npa)

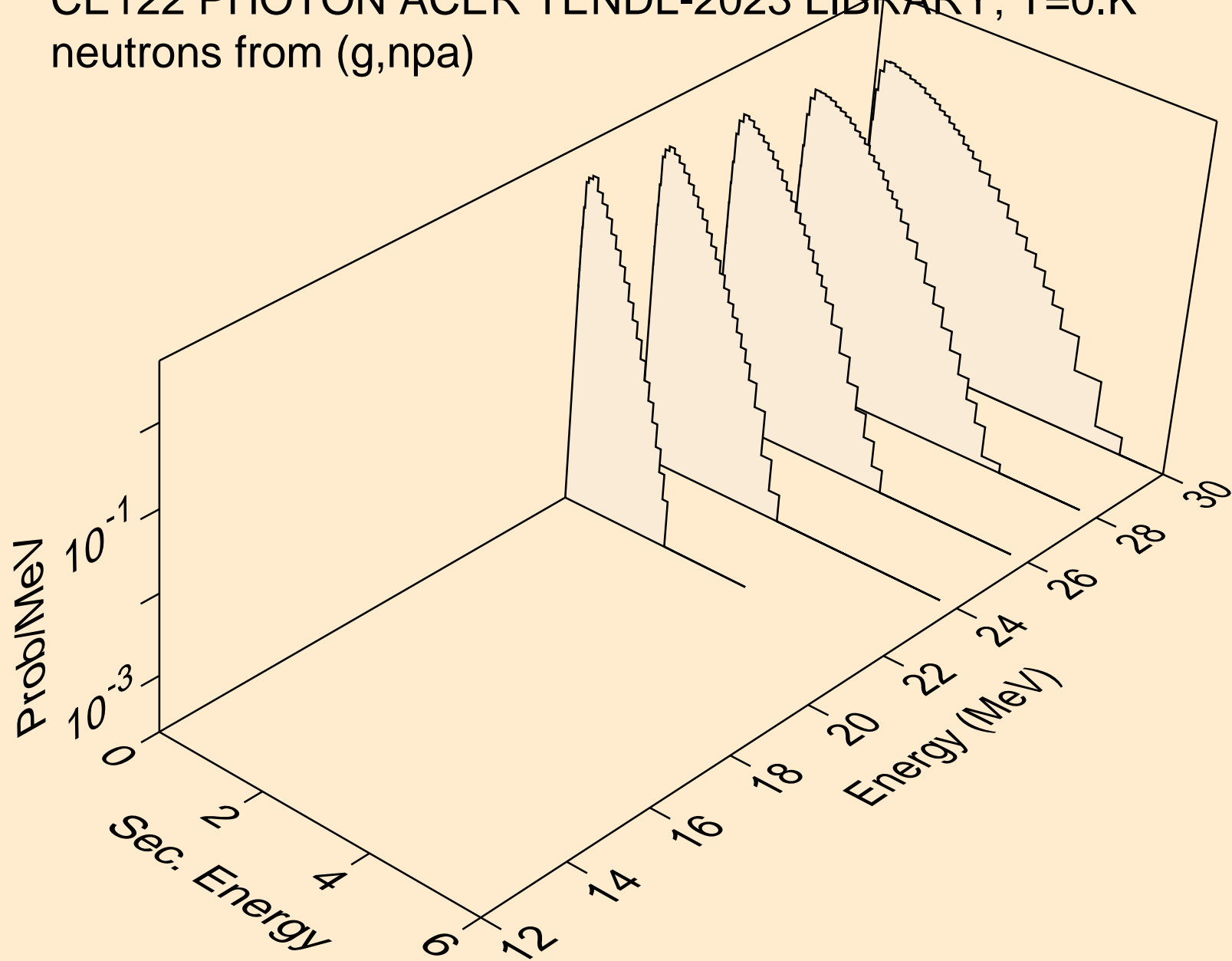

CE122 PHOTON ACER TENDL-2023 LIBRARY; T=0.K
angular distribution for (g,n*0) neutron

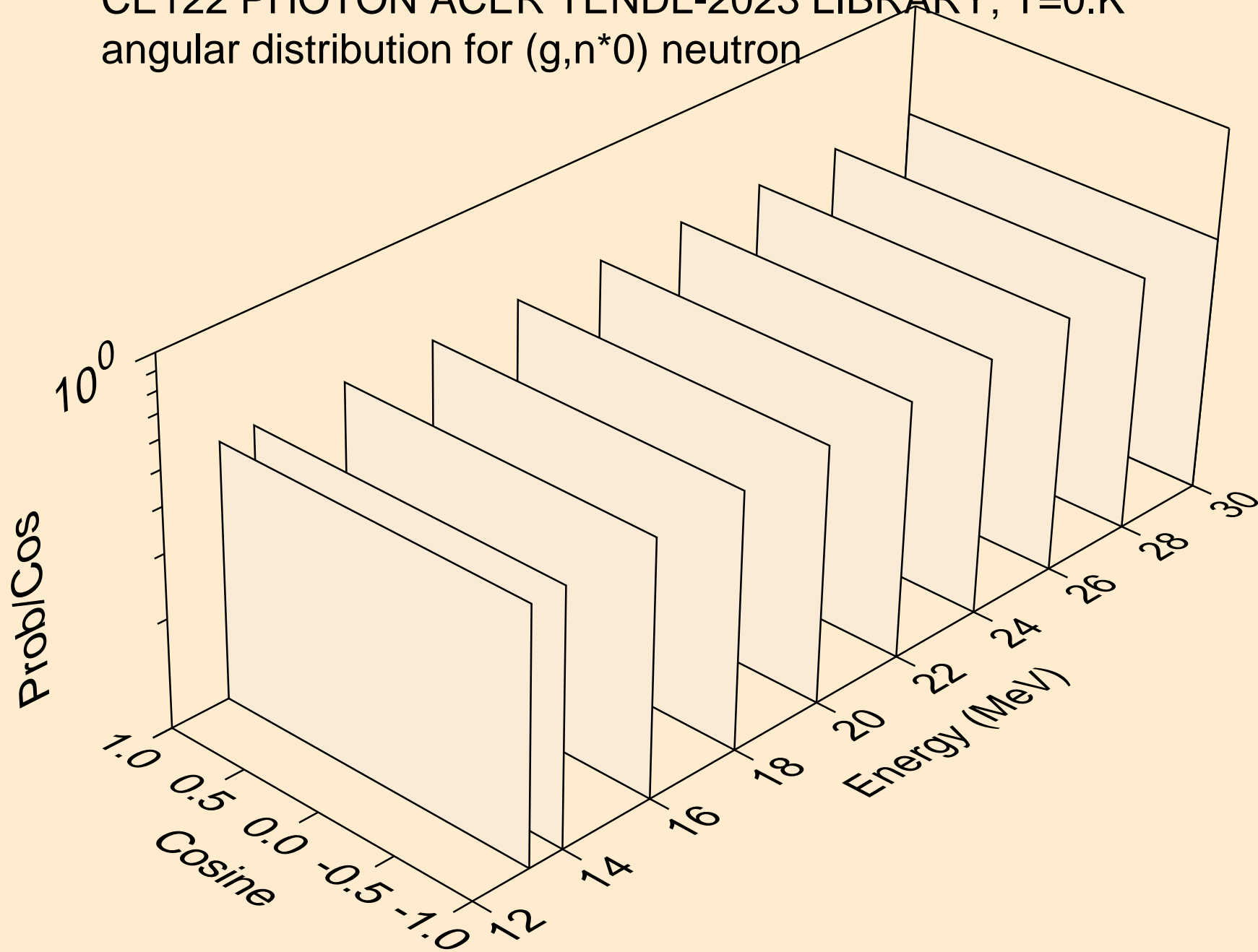

CE122 PHOTON ACER TENDL-2023 LIBRARY; T=0.K
angular distribution for (g,n*1) neutron

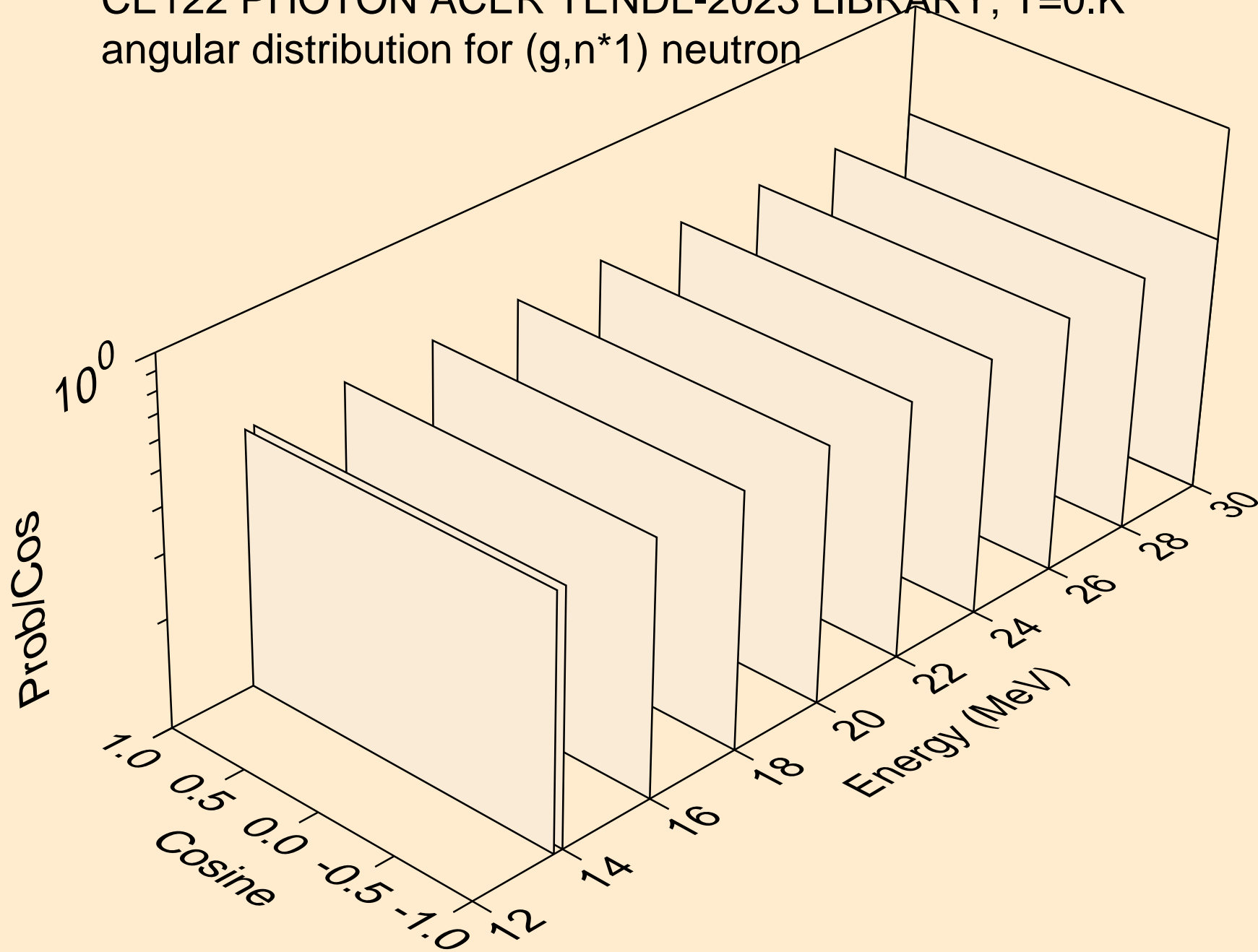

CE122 PHOTON ACER TENDL-2023 LIBRARY; T=0.K
neutrons from (g,n*c)

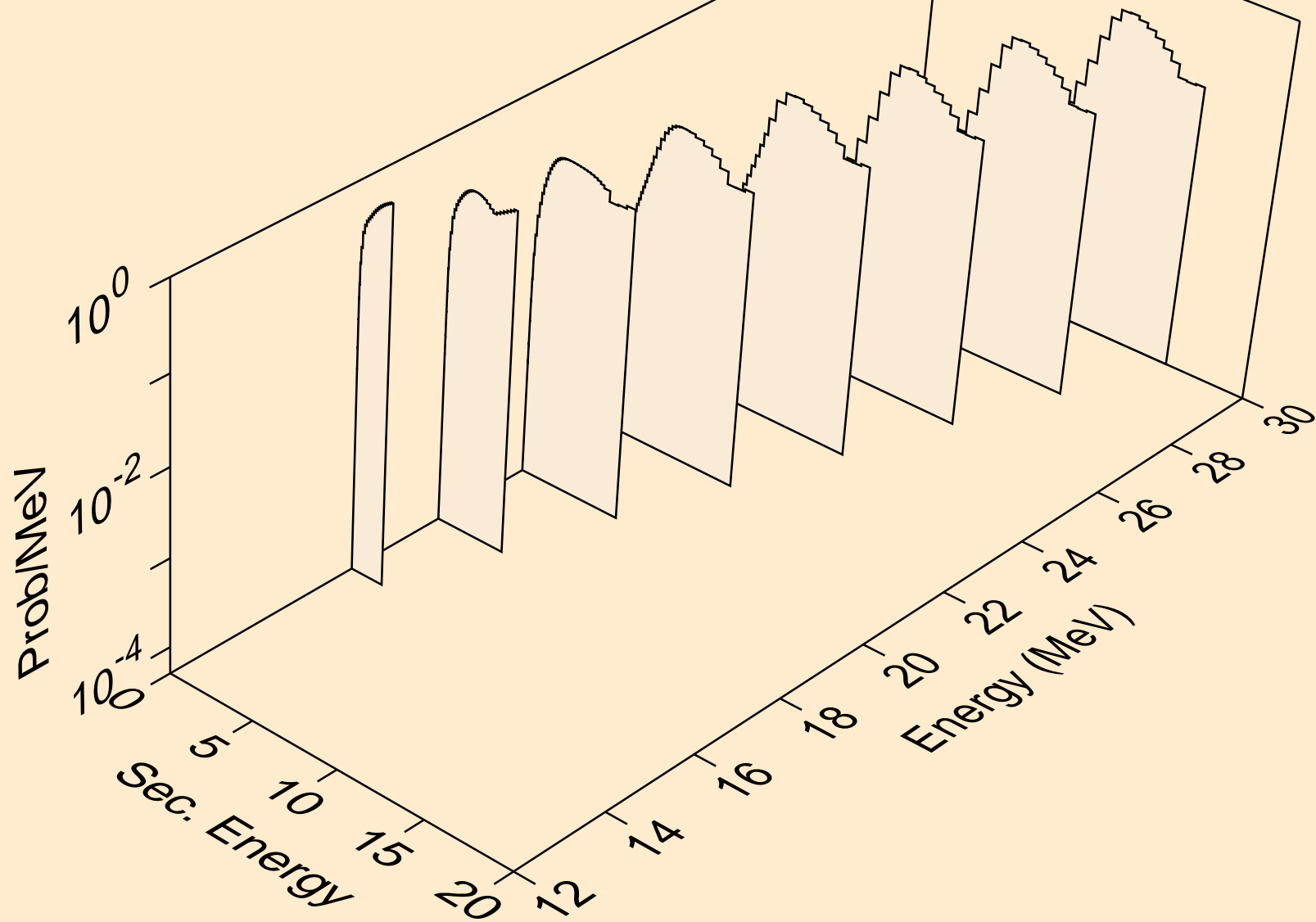

CE122 PHOTON ACER TENDL-2023 LIBRARY; T=0.K
photons from (g,x)

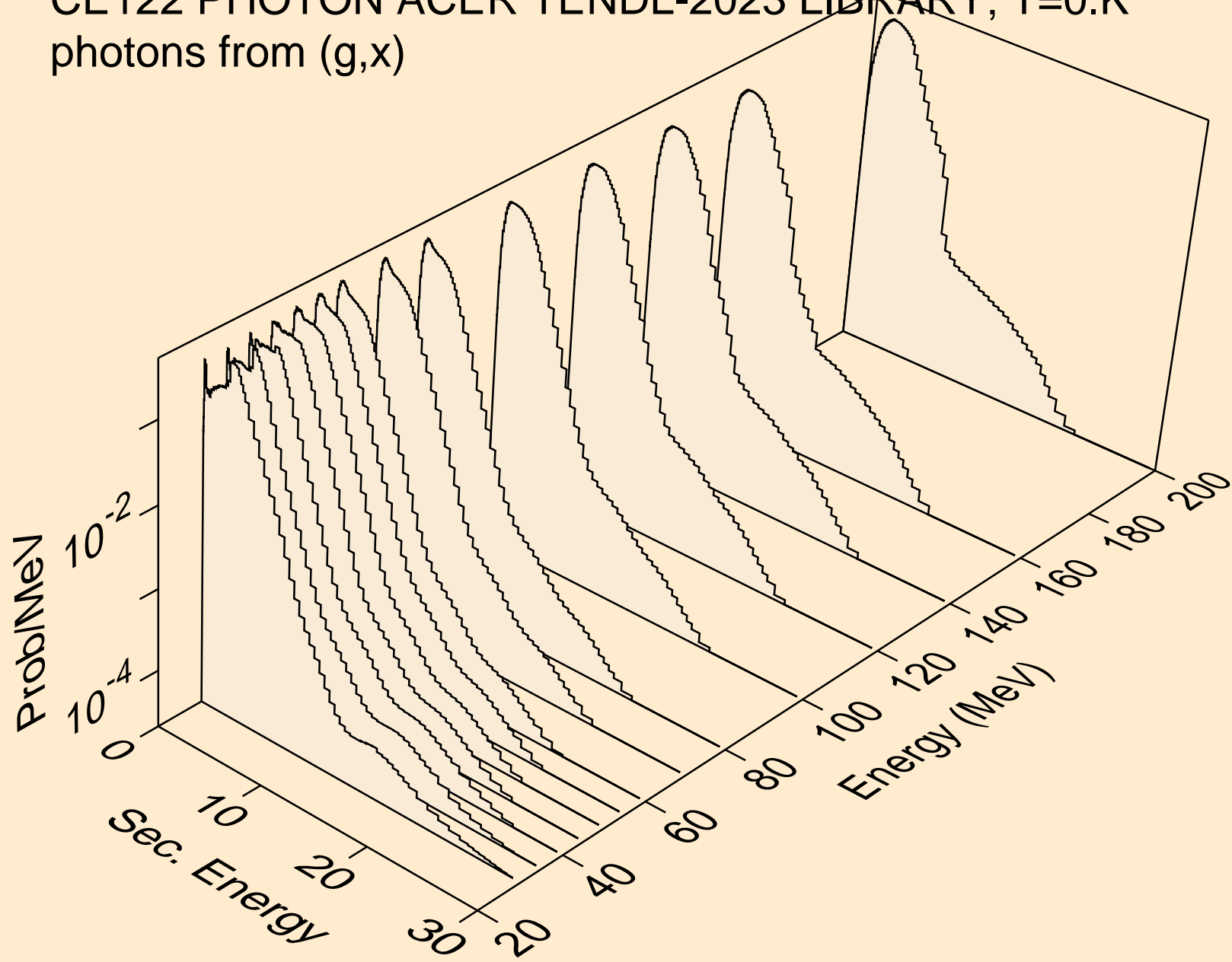

CE122 PHOTON ACER TENDL-2023 LIBRARY; T=0.K
photons from (g,2n)

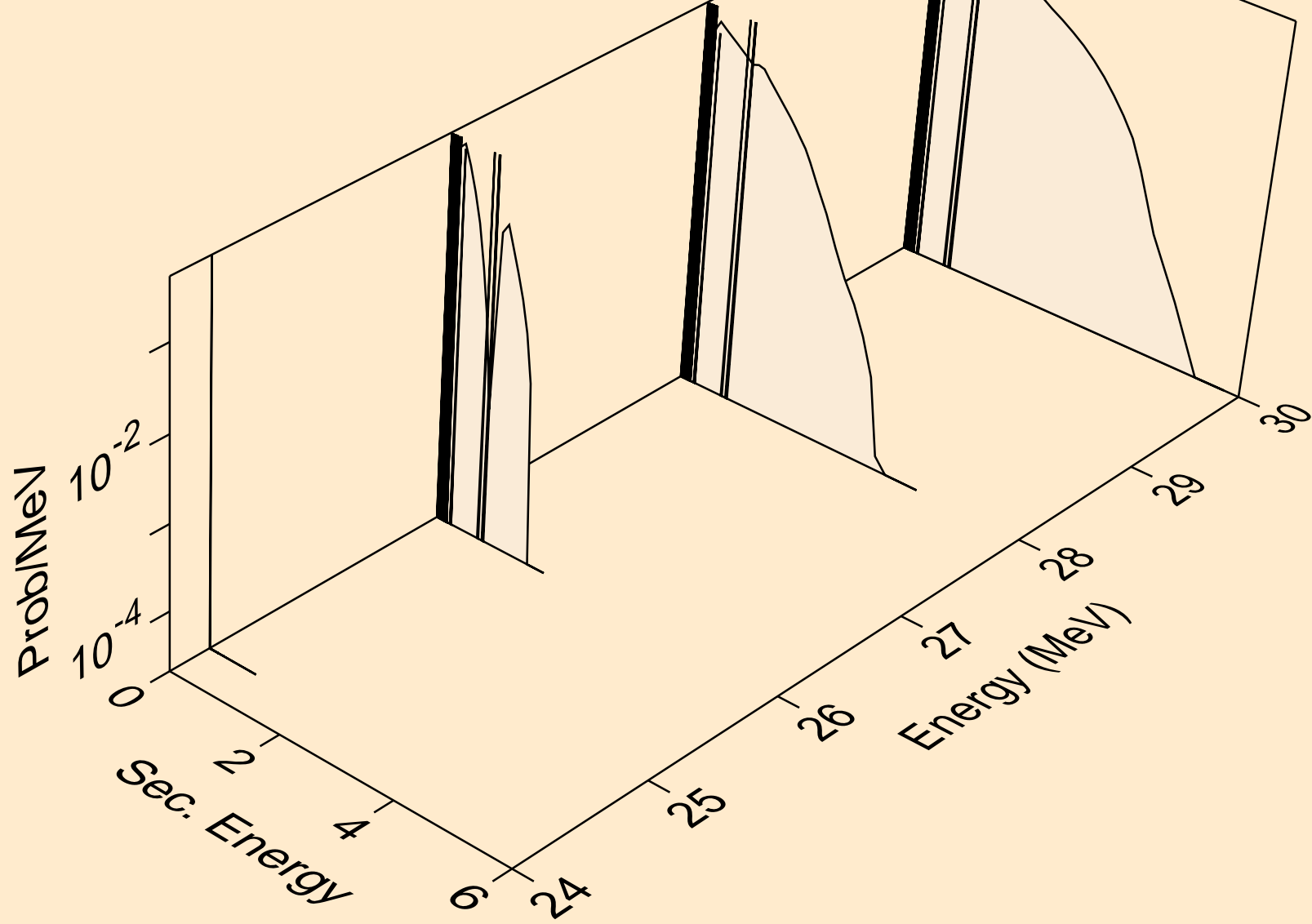

CE122 PHOTON ACER TENDL-2023 LIBRARY; T=0.K
photons from (g,n*)a

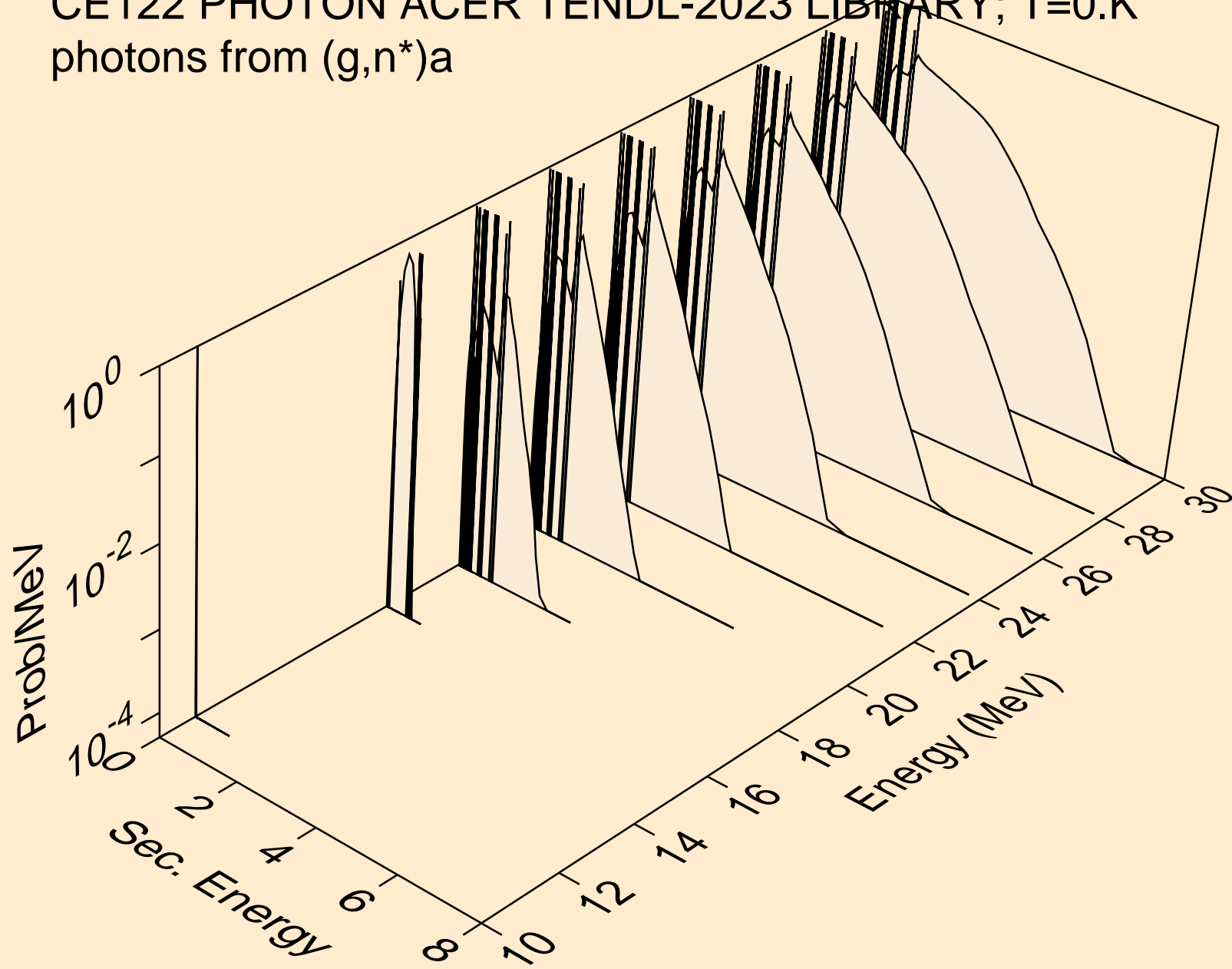

CE122 PHOTON ACER TENDL-2023 LIBRARY; T=0.K
photons from (g,n*)p

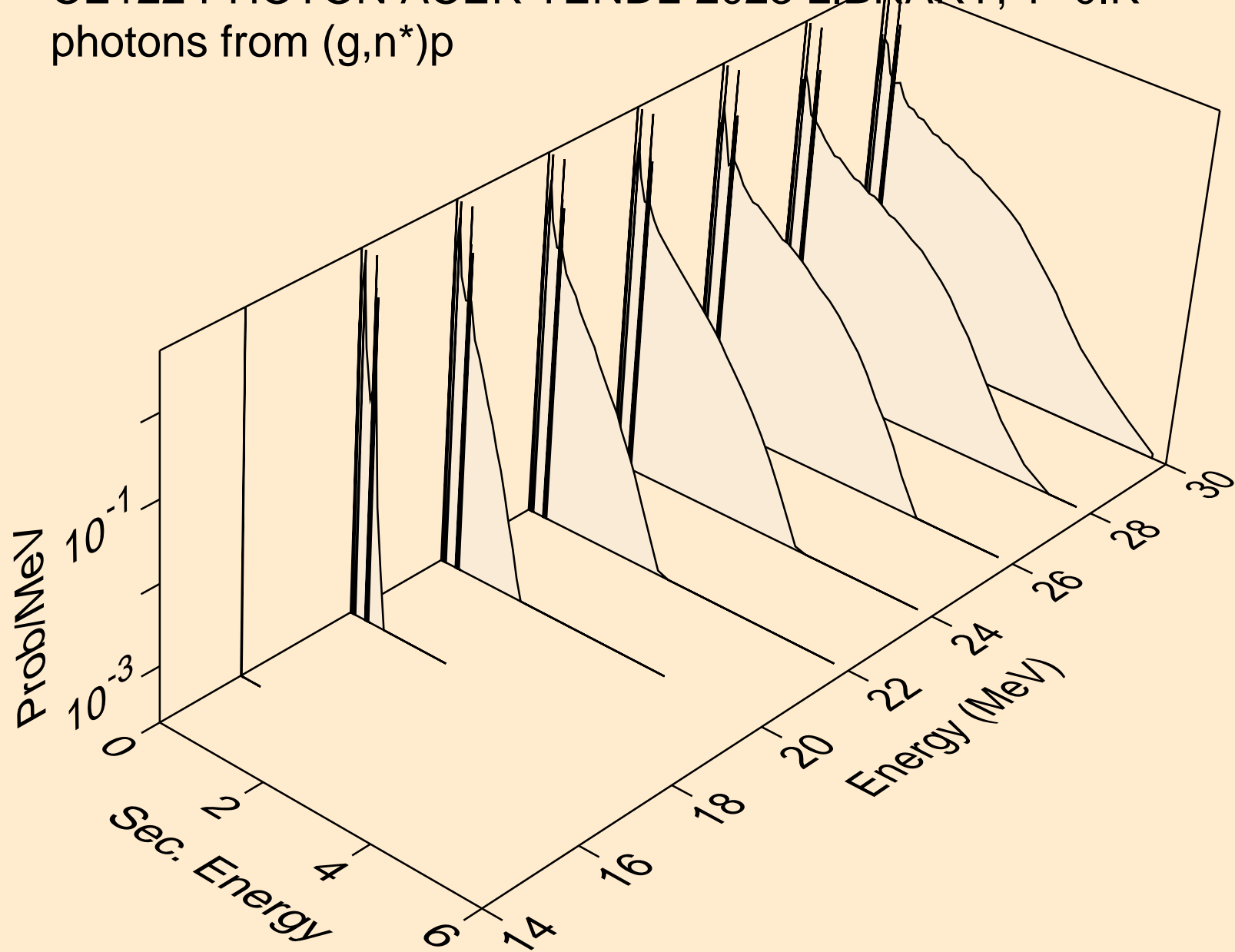

CE122 PHOTON ACER TENDL-2023 LIBRARY; T=0.K
photons from (g,2np)

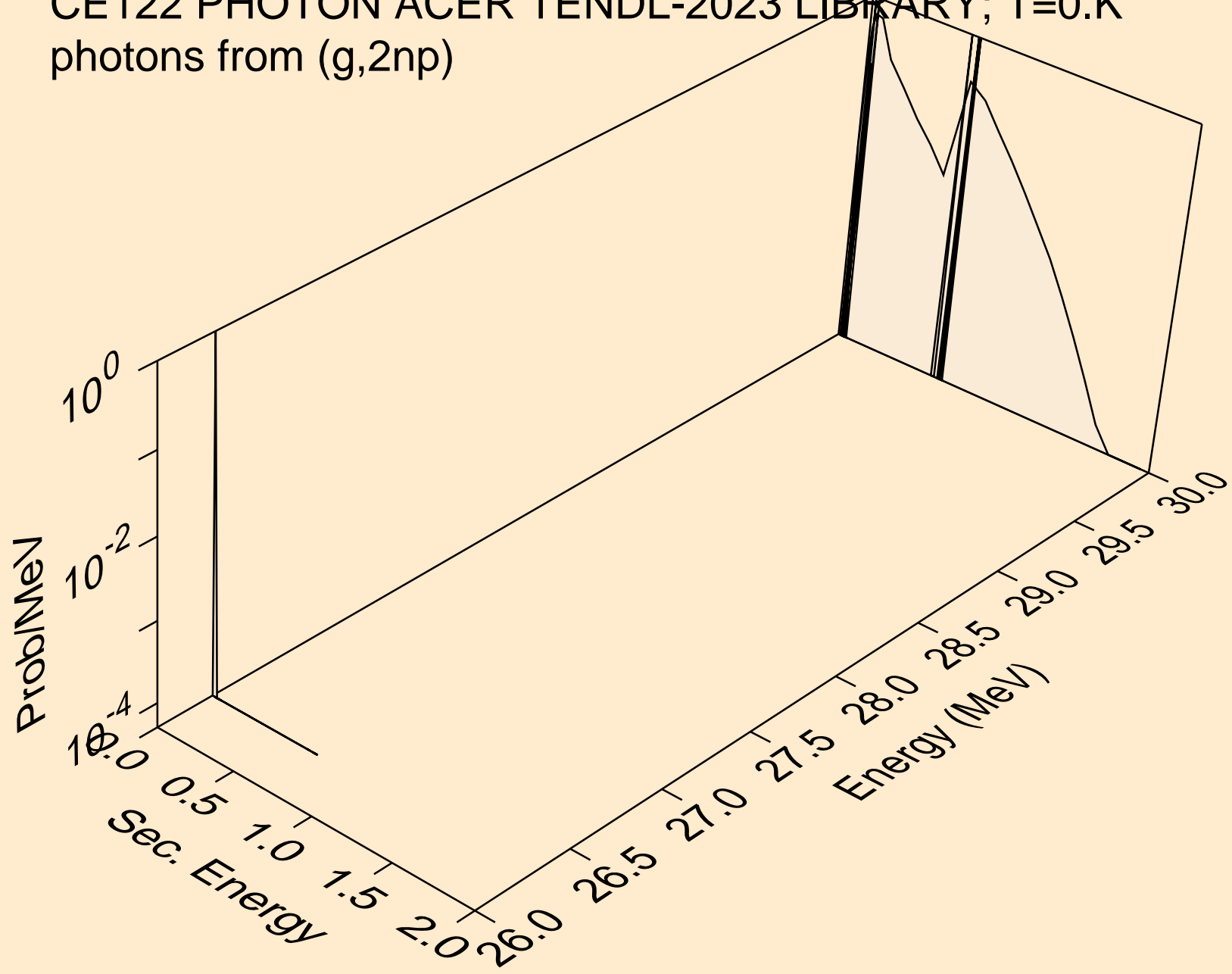

CE122 PHOTON ACER TENDL-2023 LIBRARY; T=0.K
photons from (g,n2p)

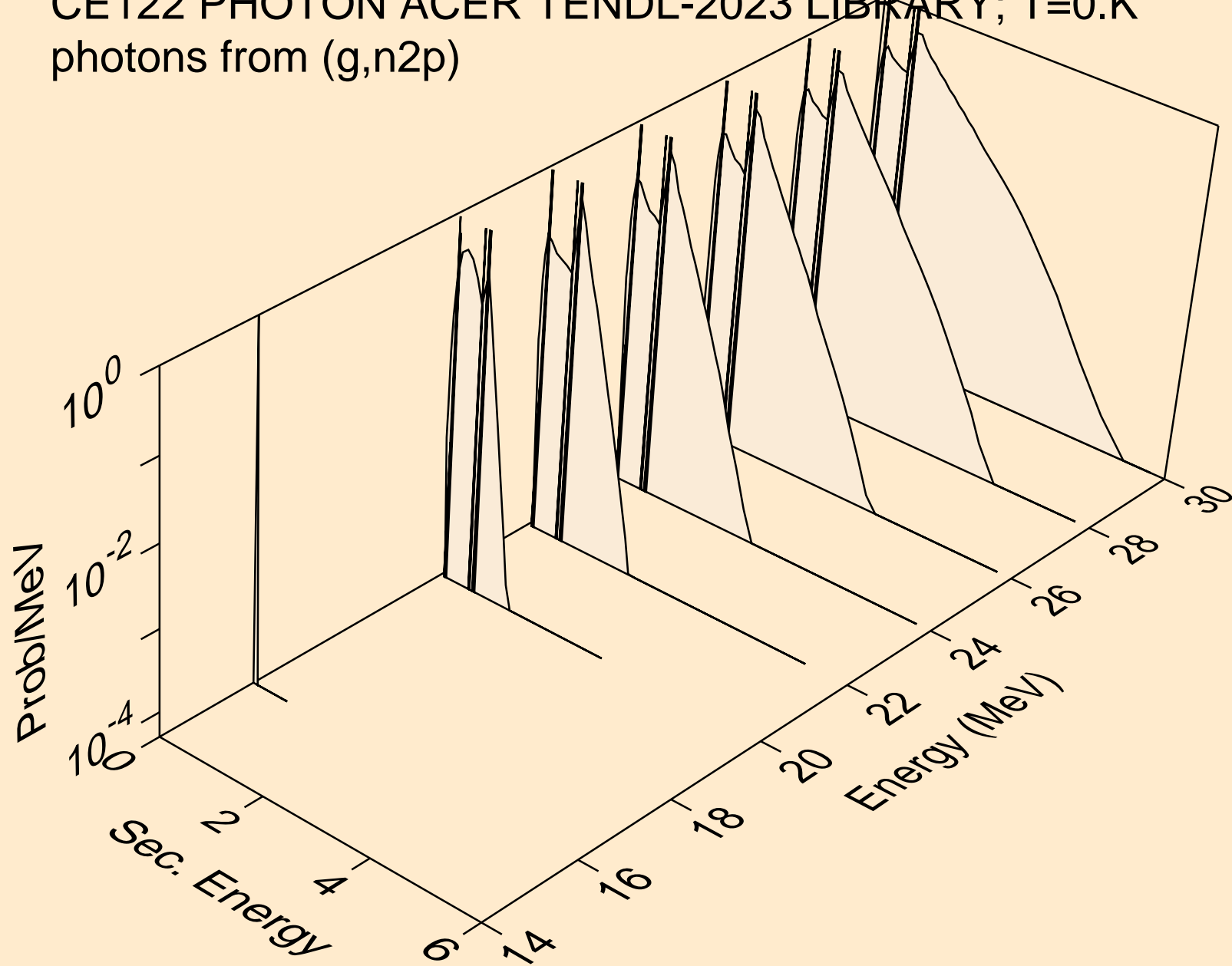

CE122 PHOTON ACER TENDL-2023 LIBRARY; T=0.K
photons from (g,npa)

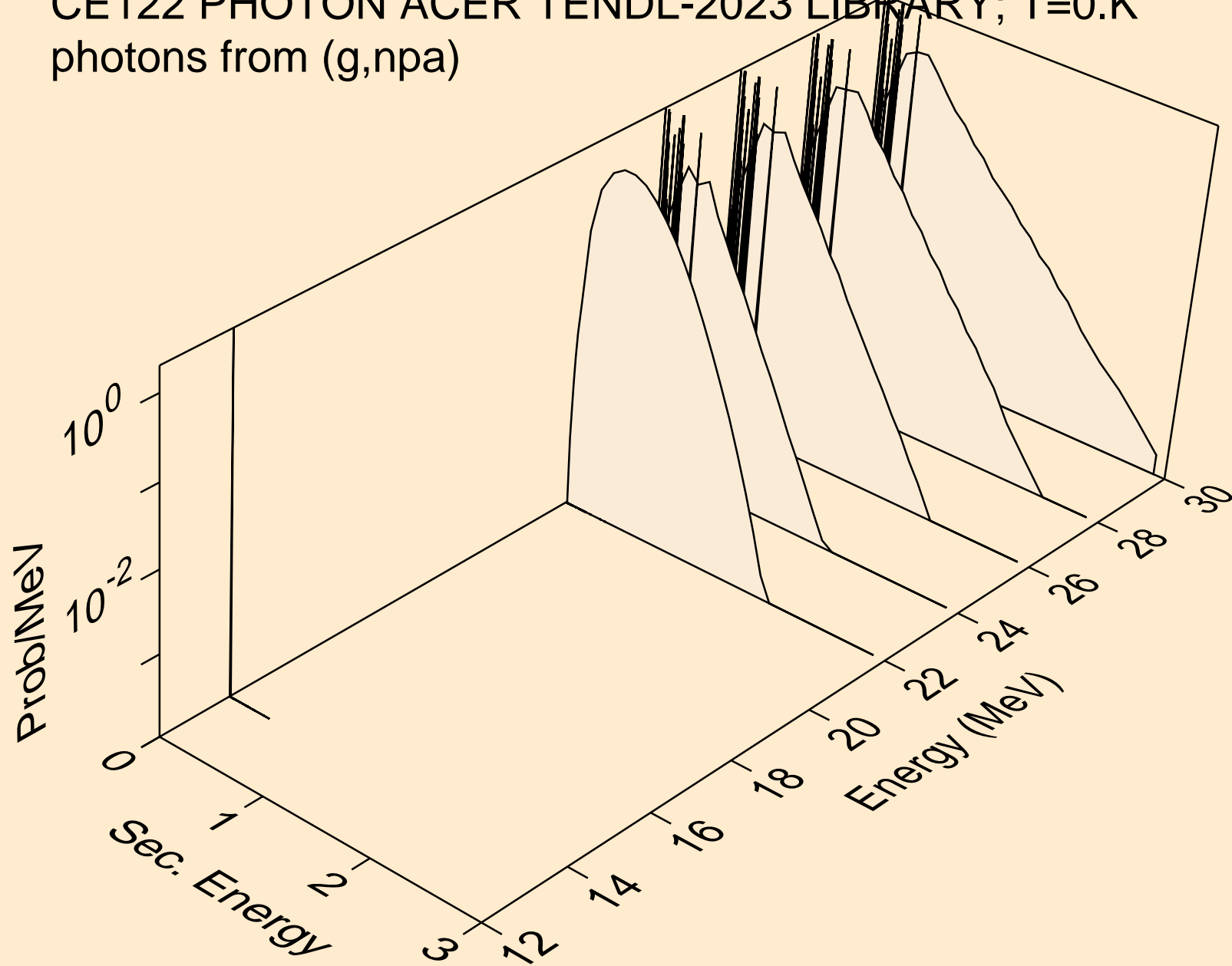

CE122 PHOTON ACER TENDL-2023 LIBRARY; T=0.K
photons from (g,n*c)

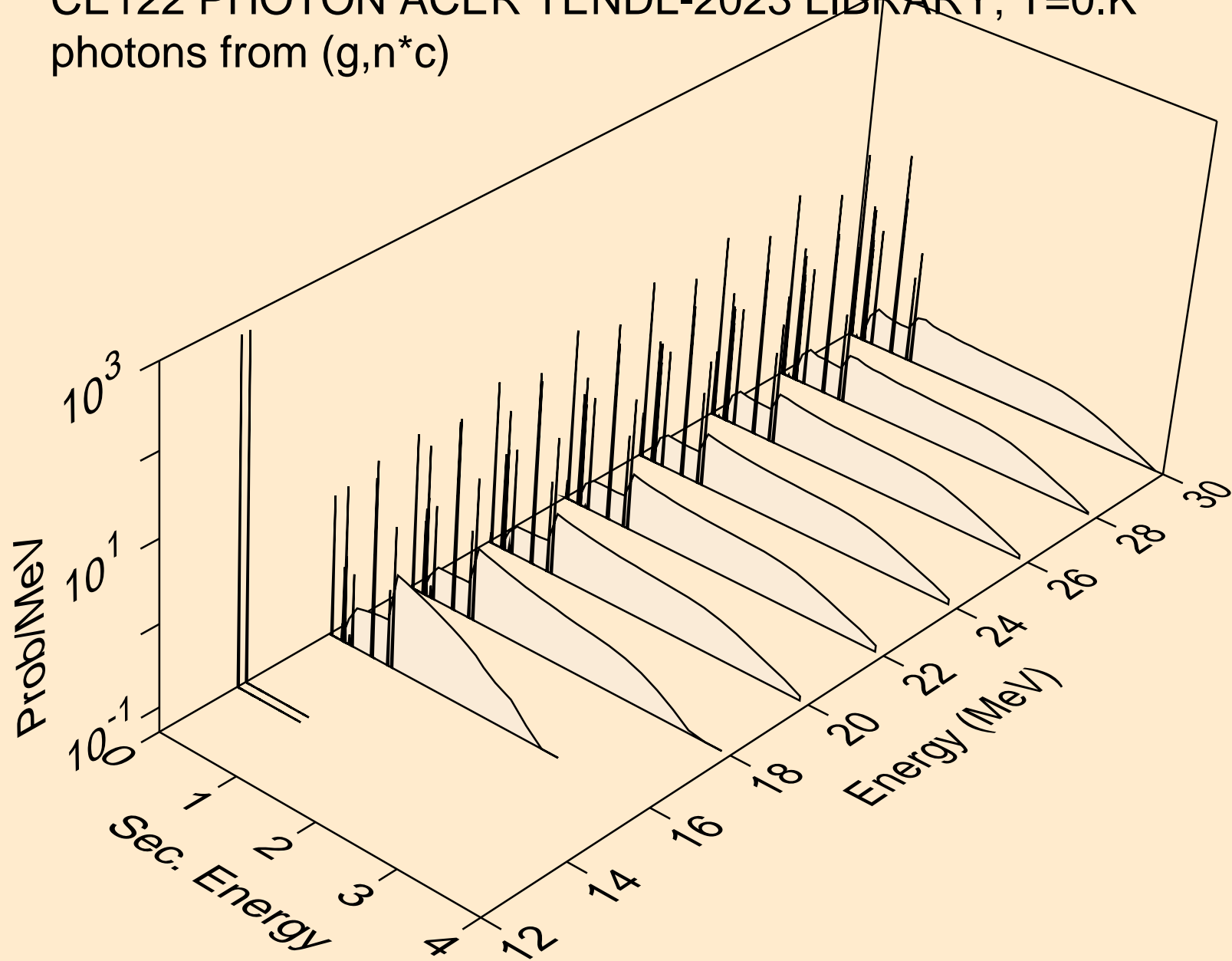

CE122 PHOTON ACER TENDL-2023 LIBRARY; T=0.K
photons from (g,gma)

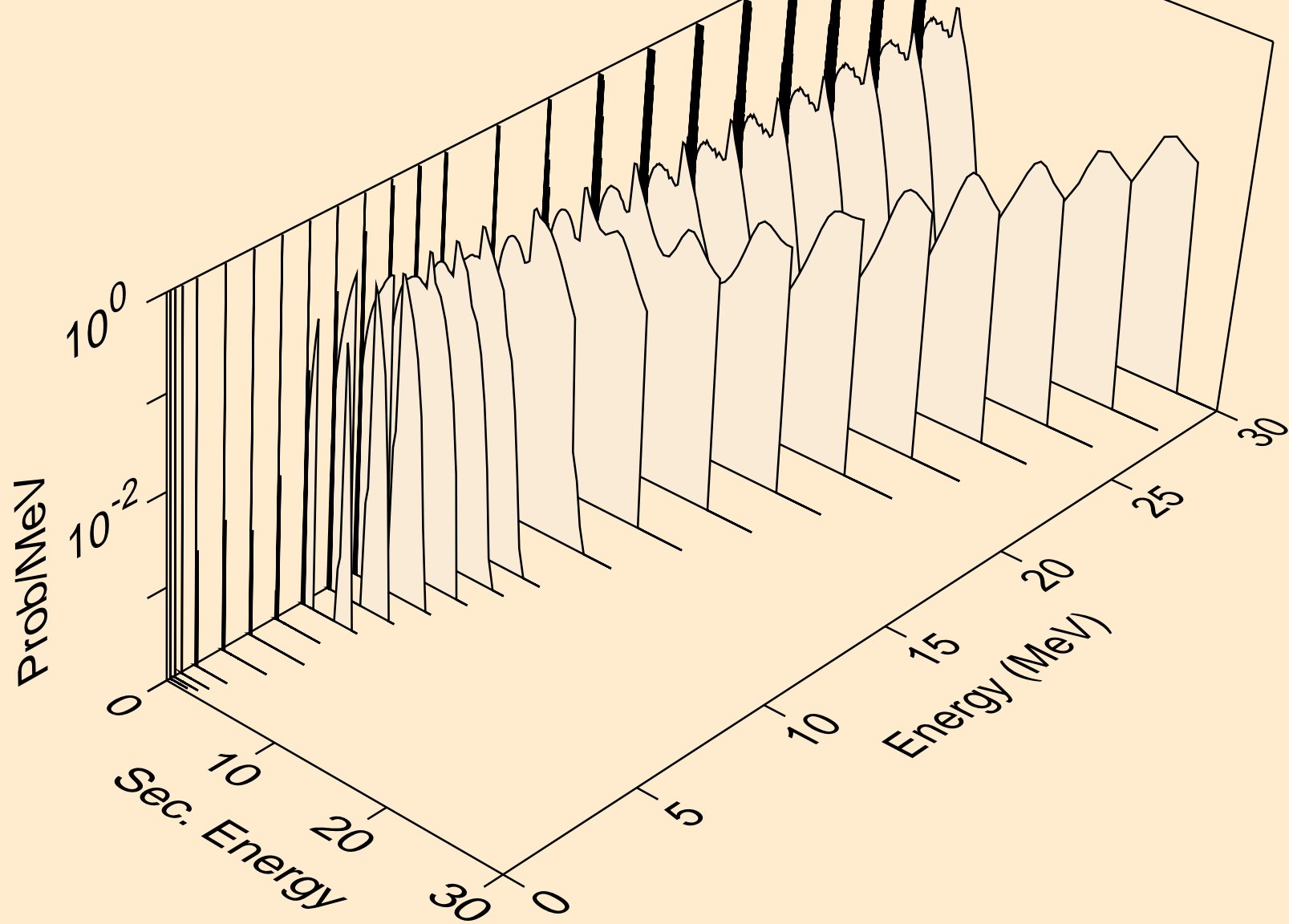

CE122 PHOTON ACER TENDL-2023 LIBRARY; T=0.K
photons from (g,p)

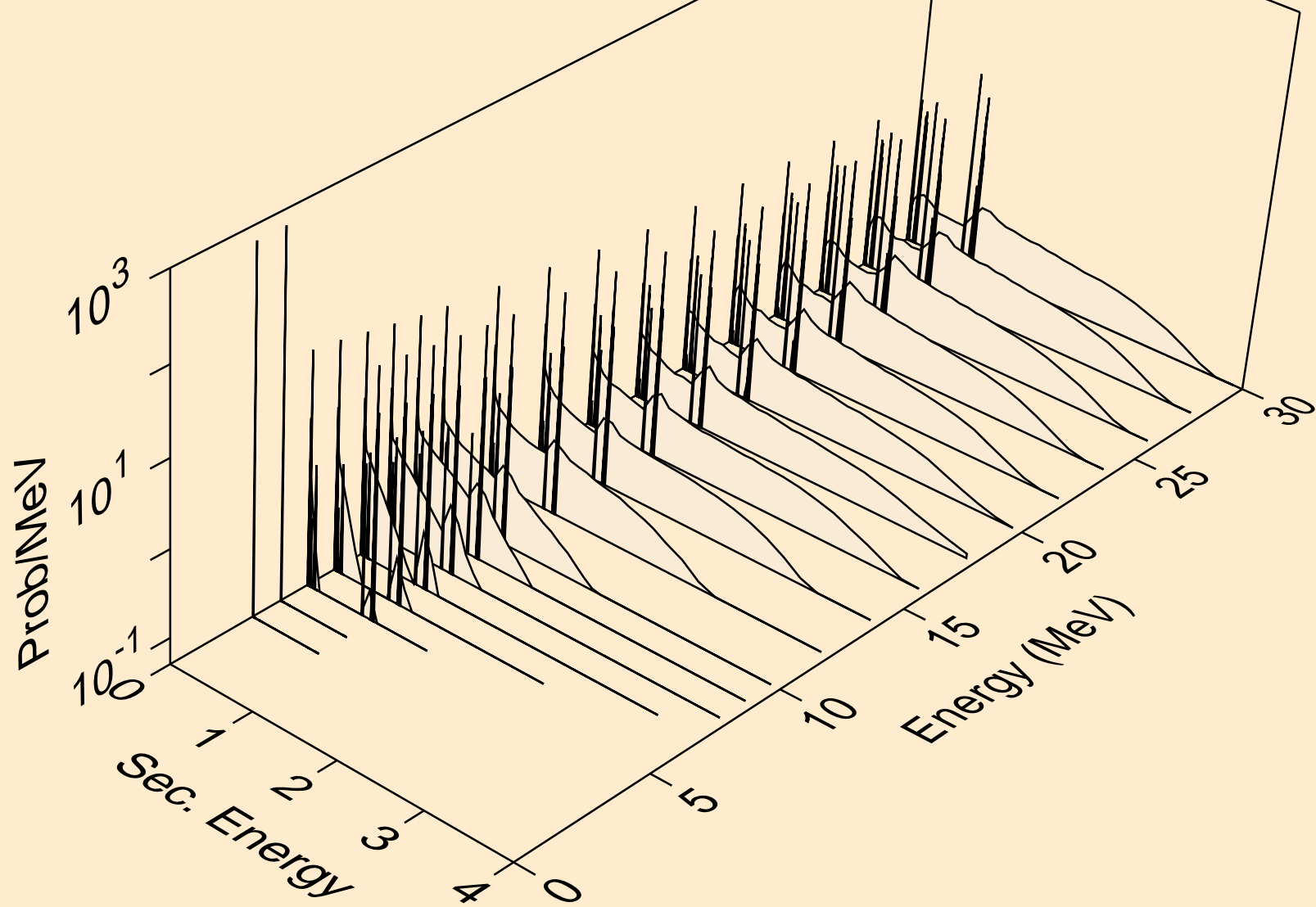

CE122 PHOTON ACER TENDL-2023 LIBRARY; T=0.K
photons from (g,d)

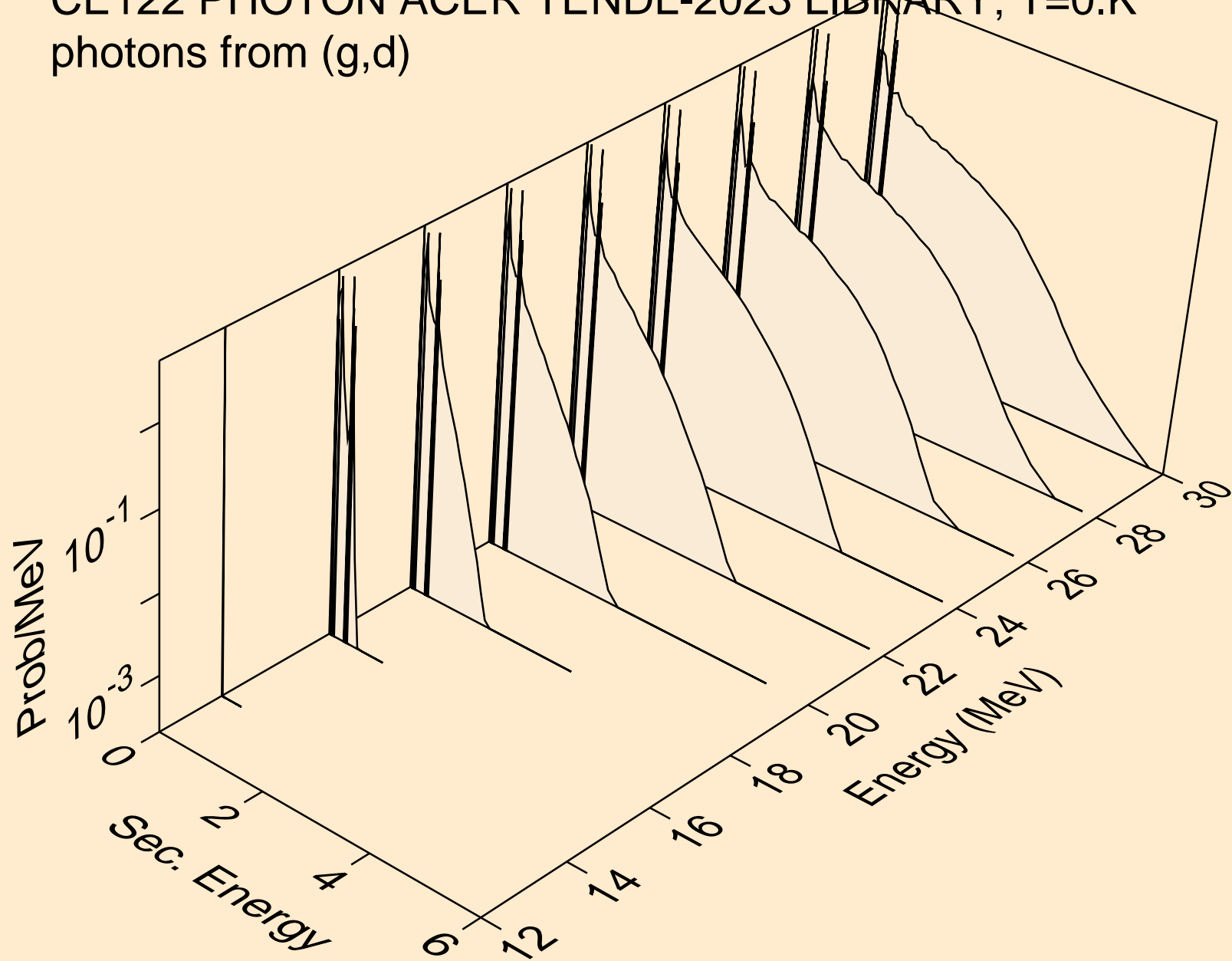

CE122 PHOTON ACER TENDL-2023 LIBRARY; T=0.K
photons from (g,t)

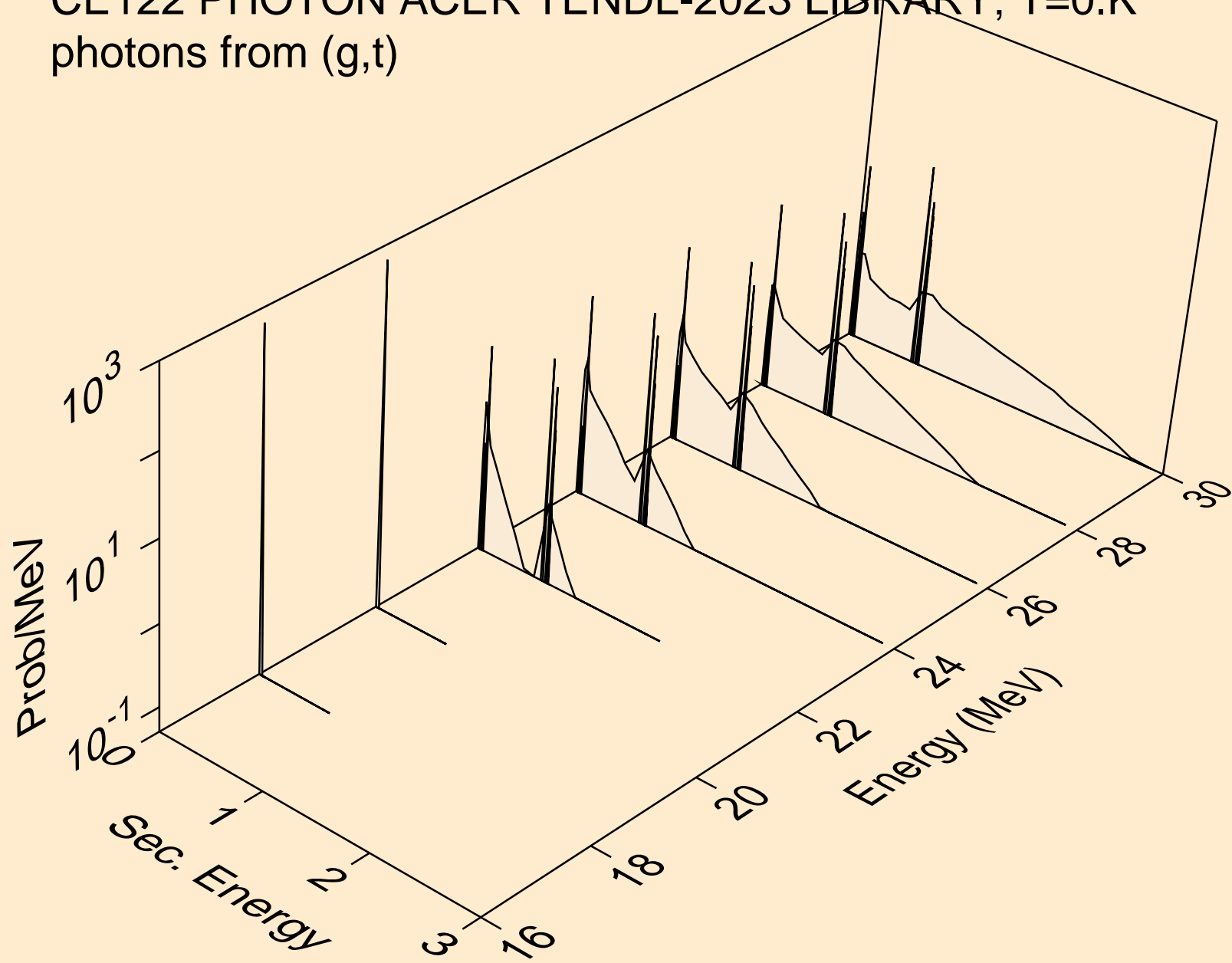

CE122 PHOTON ACER TENDL-2023 LIBRARY; T=0.K
photons from (g,he3)

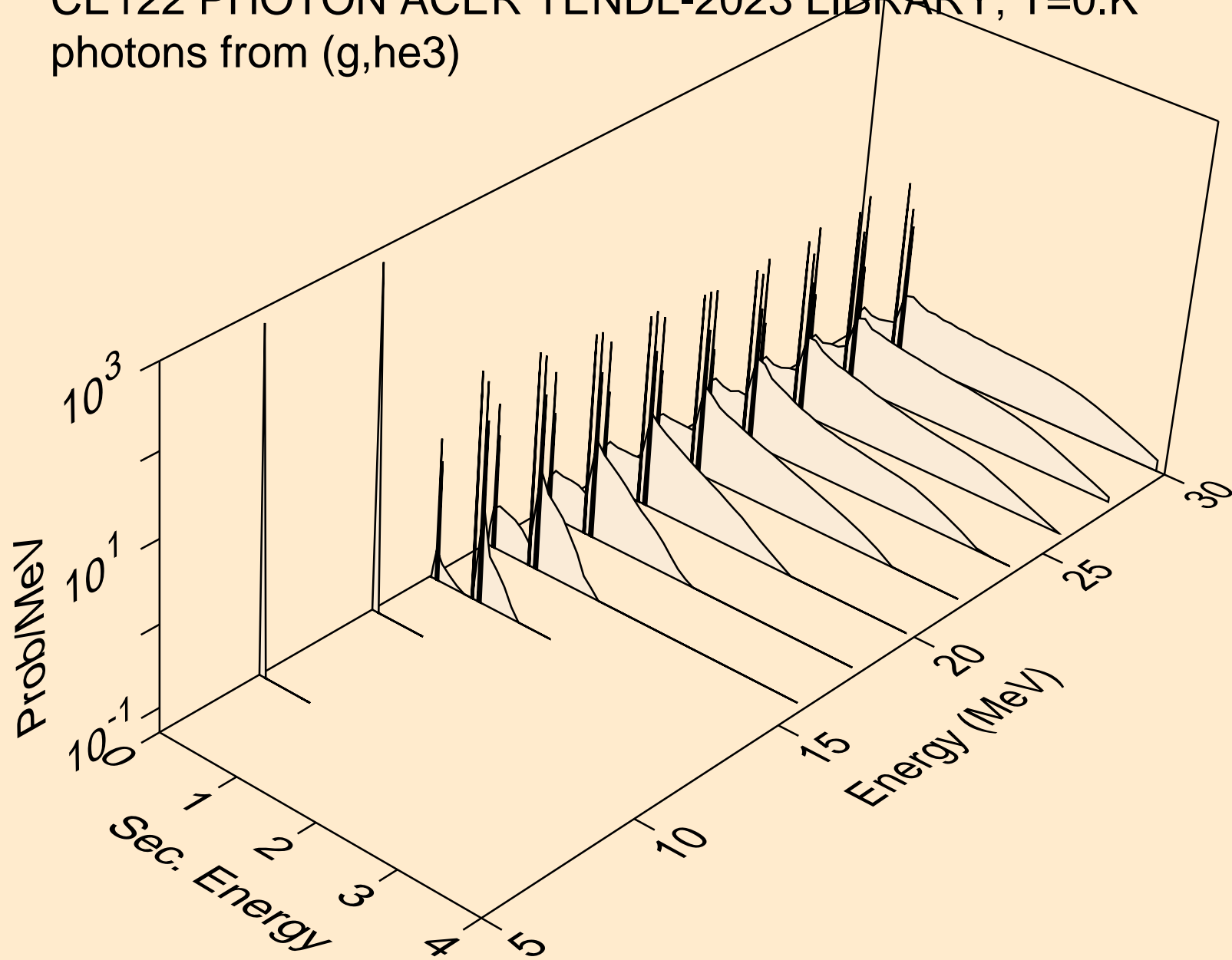

CE122 PHOTON ACER TENDL-2023 LIBRARY; T=0.K
photons from (g,a)

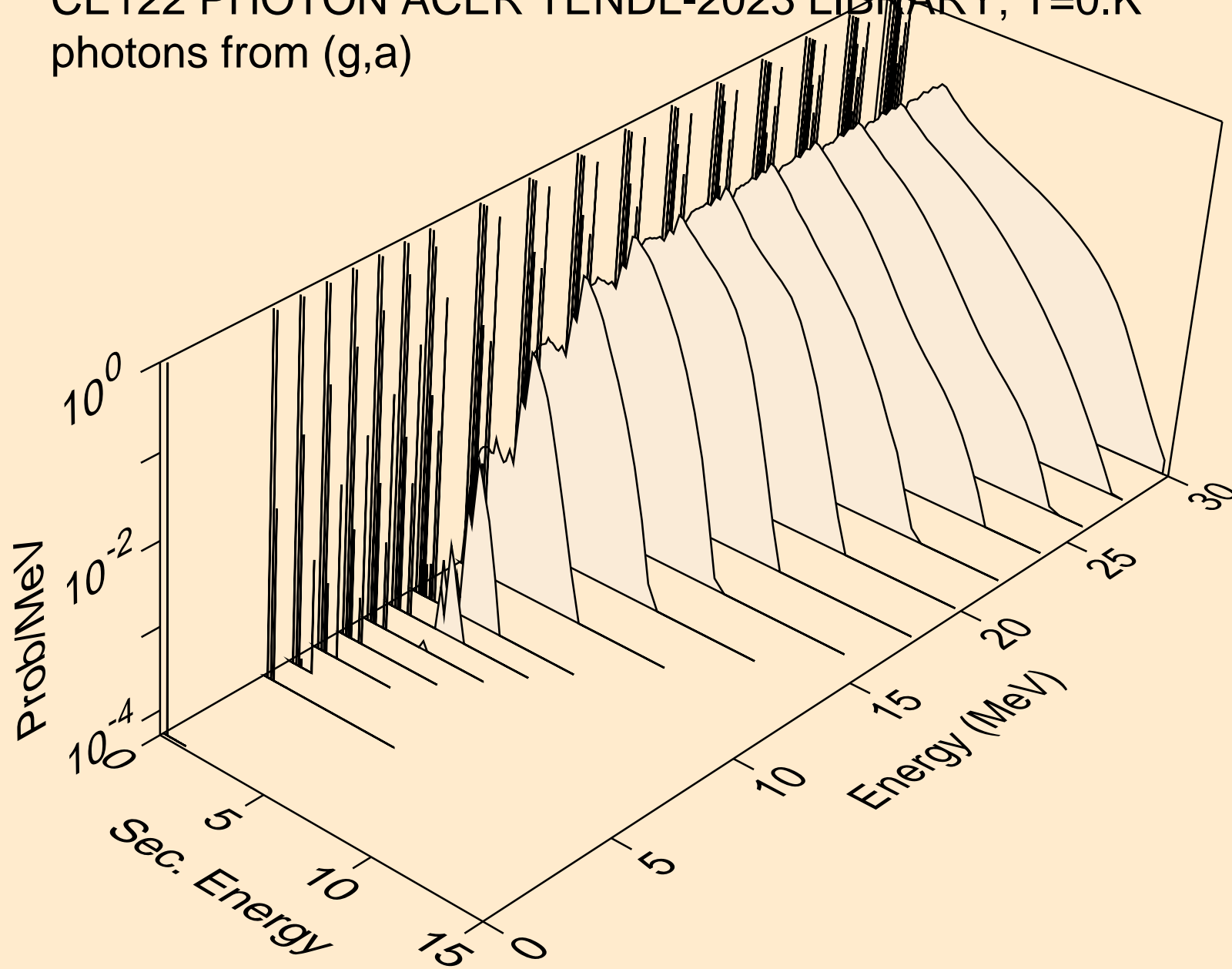

CE122 PHOTON ACER TENDL-2023 LIBRARY; T=0.K
photons from (g,2a)

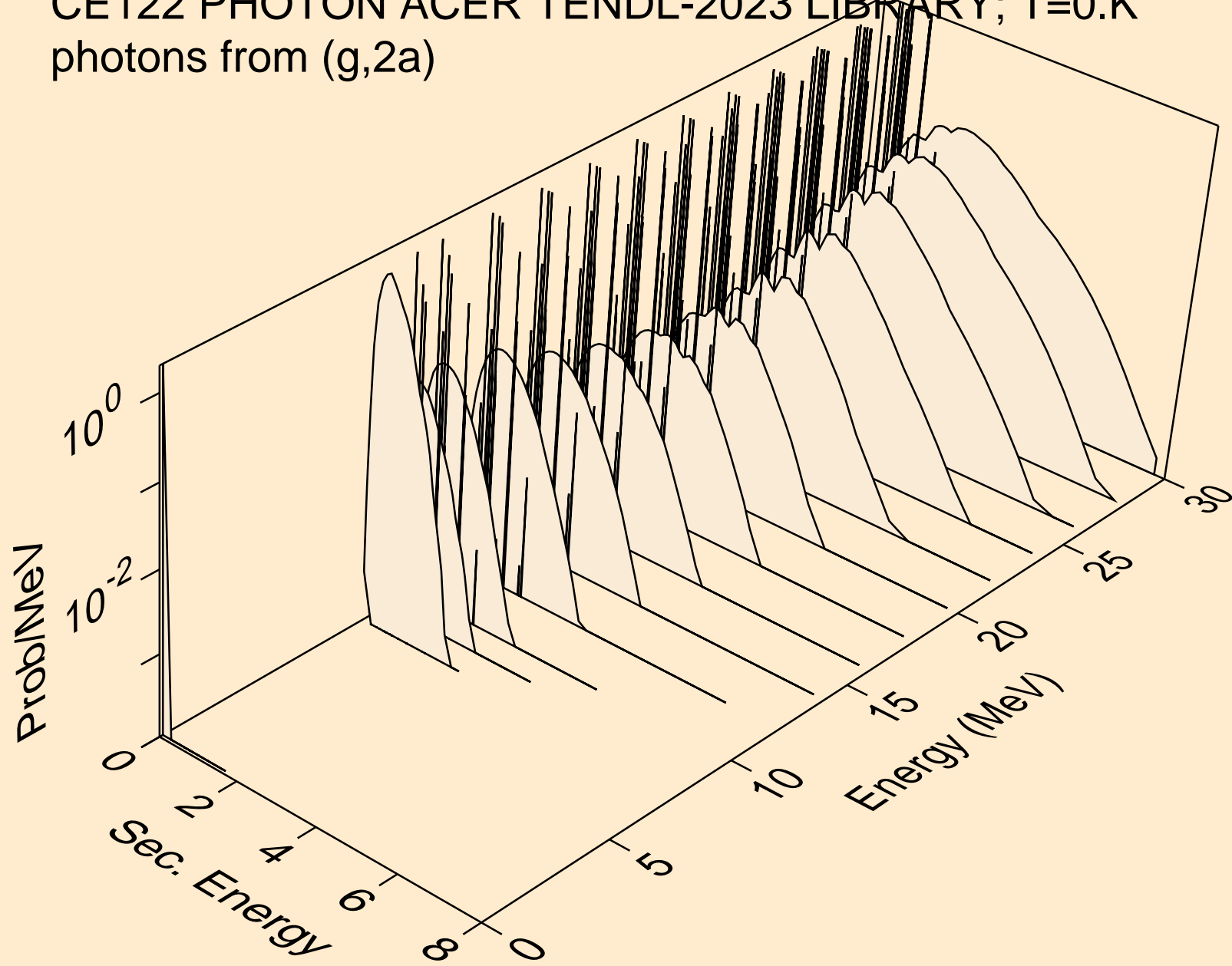

CE122 PHOTON ACER TENDL-2023 LIBRARY; T=0.K
photons from (g,3a)

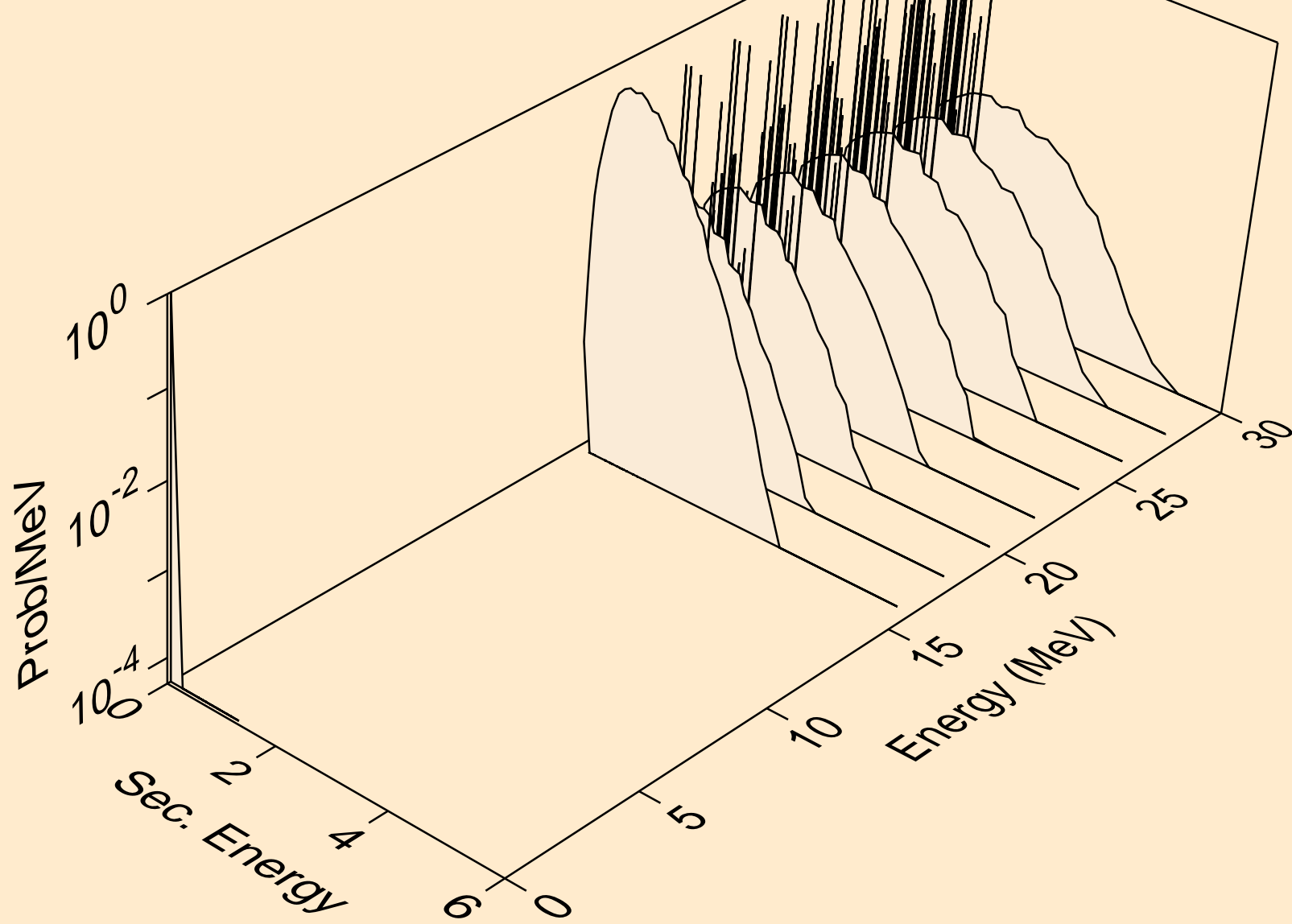

CE122 PHOTON ACER TENDL-2023 LIBRARY; T=0.K
photons from (g,2p)

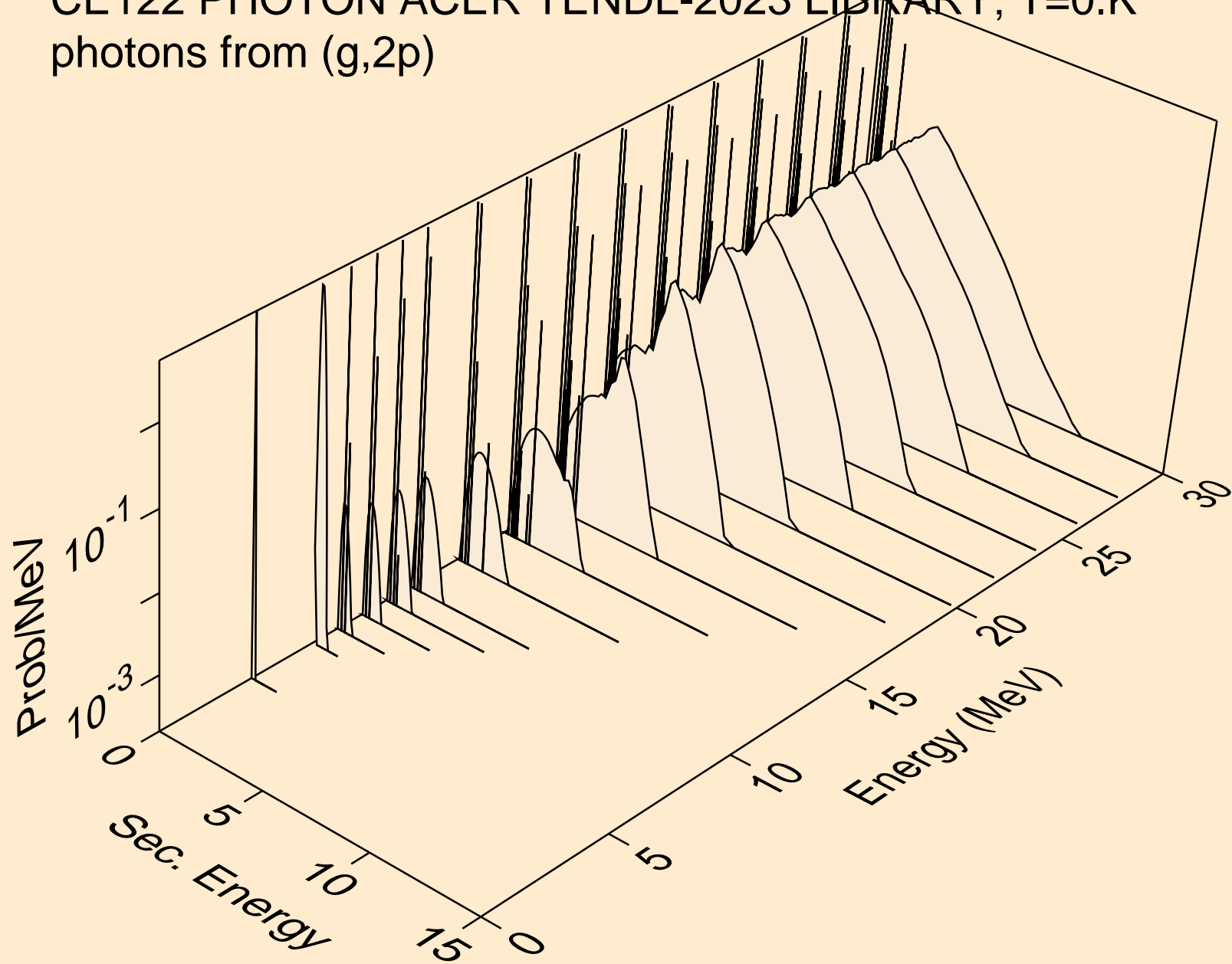

CE122 PHOTON ACER TENDL-2023 LIBRARY; T=0.K
photons from (g,pa)

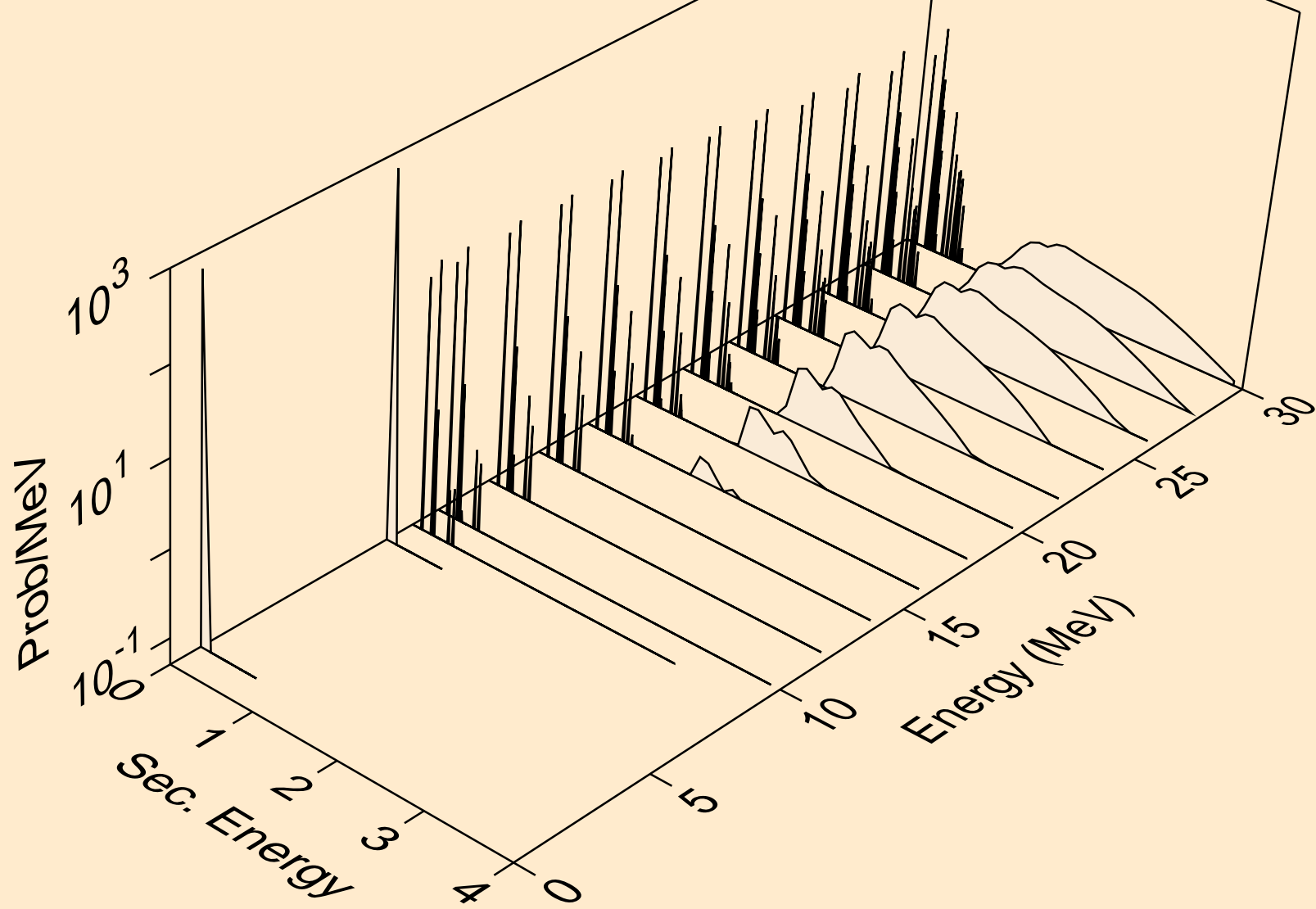

CE122 PHOTON ACER TENDL-2023 LIBRARY; T=0.K
photons from (g,pd)

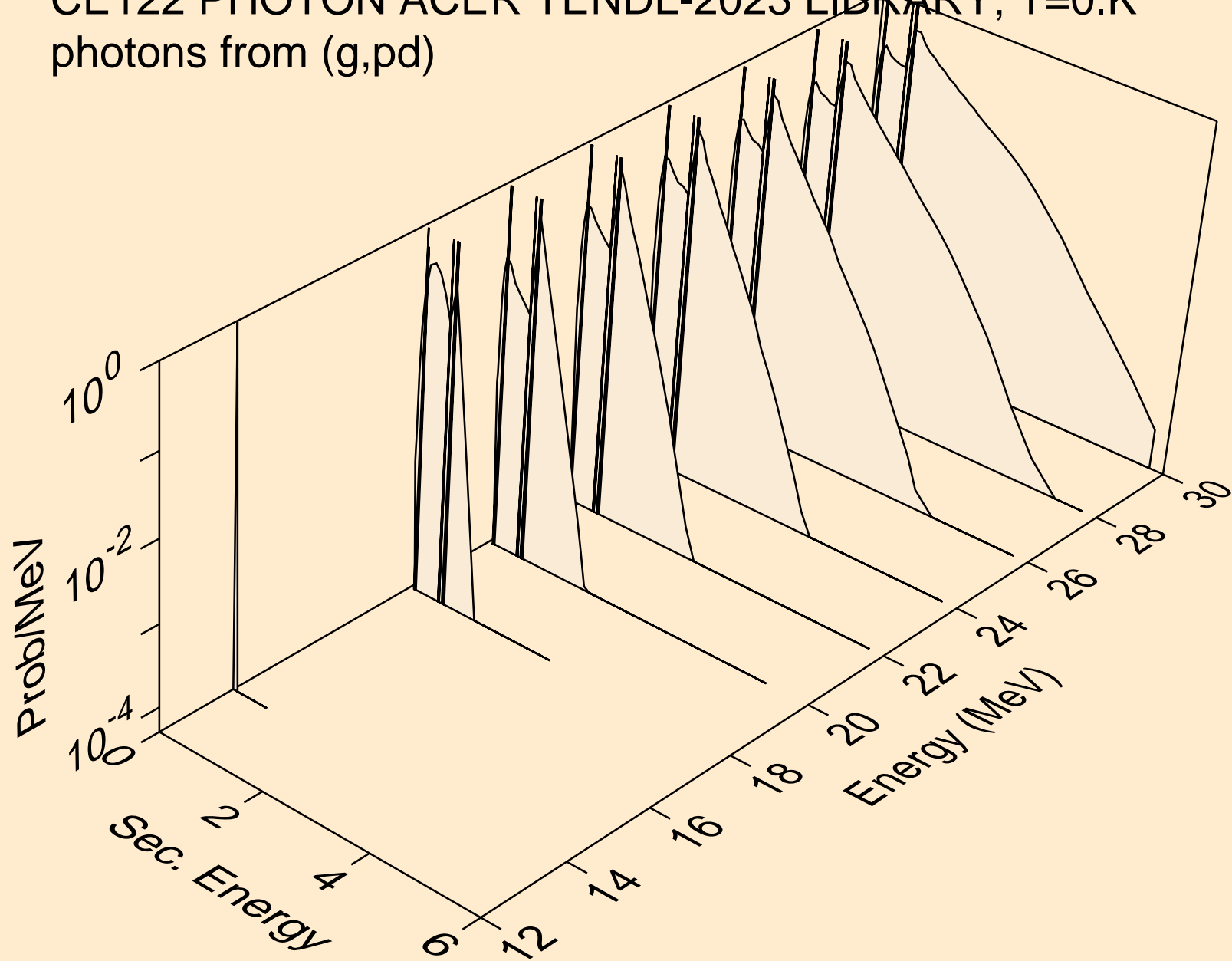

CE122 PHOTON ACER TENDL-2023 LIBRARY; T=0.K
photons from (g,pt)

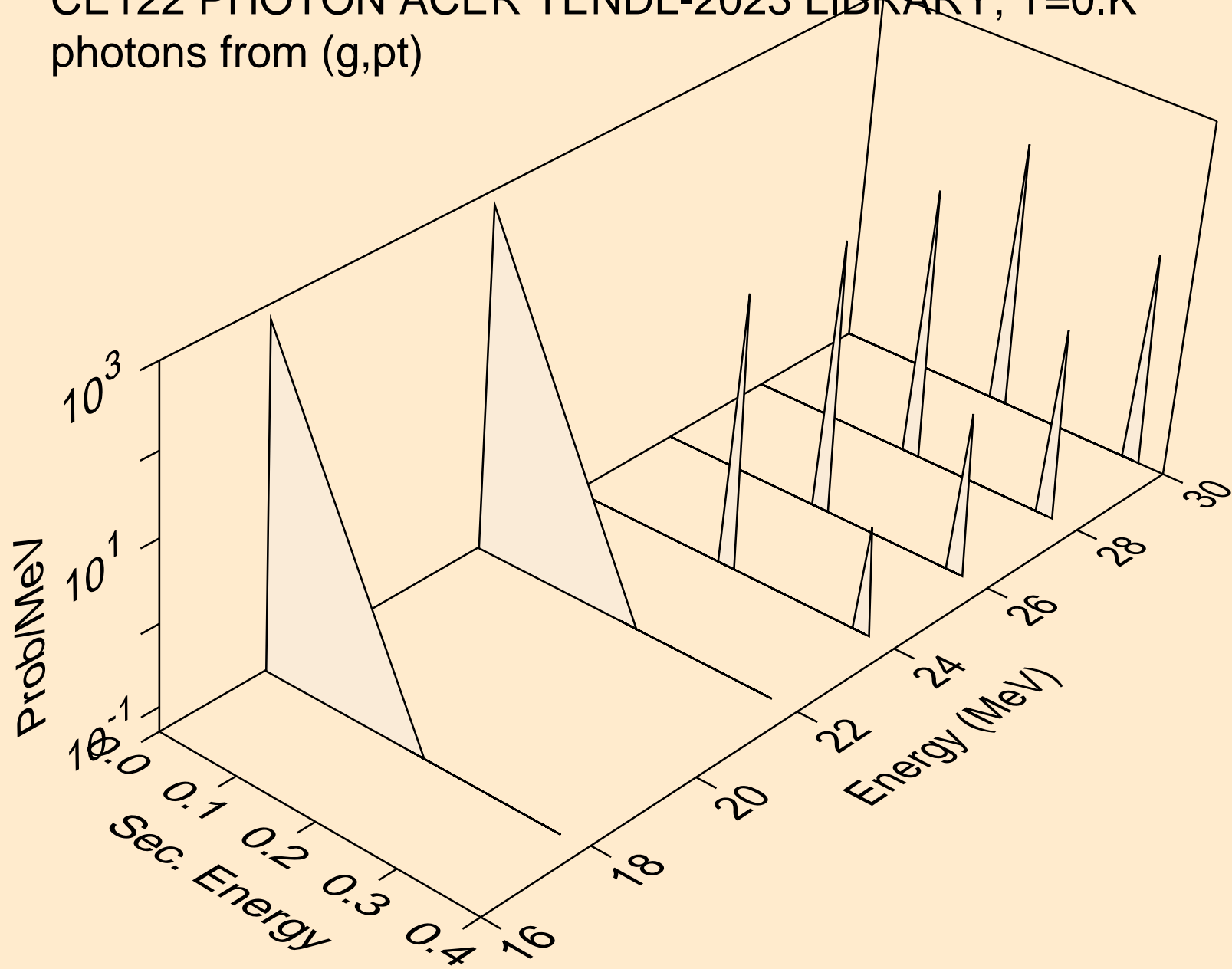

CE122 PHOTON ACER TENDL-2023 LIBRARY; T=0.K
photons from (g,da)

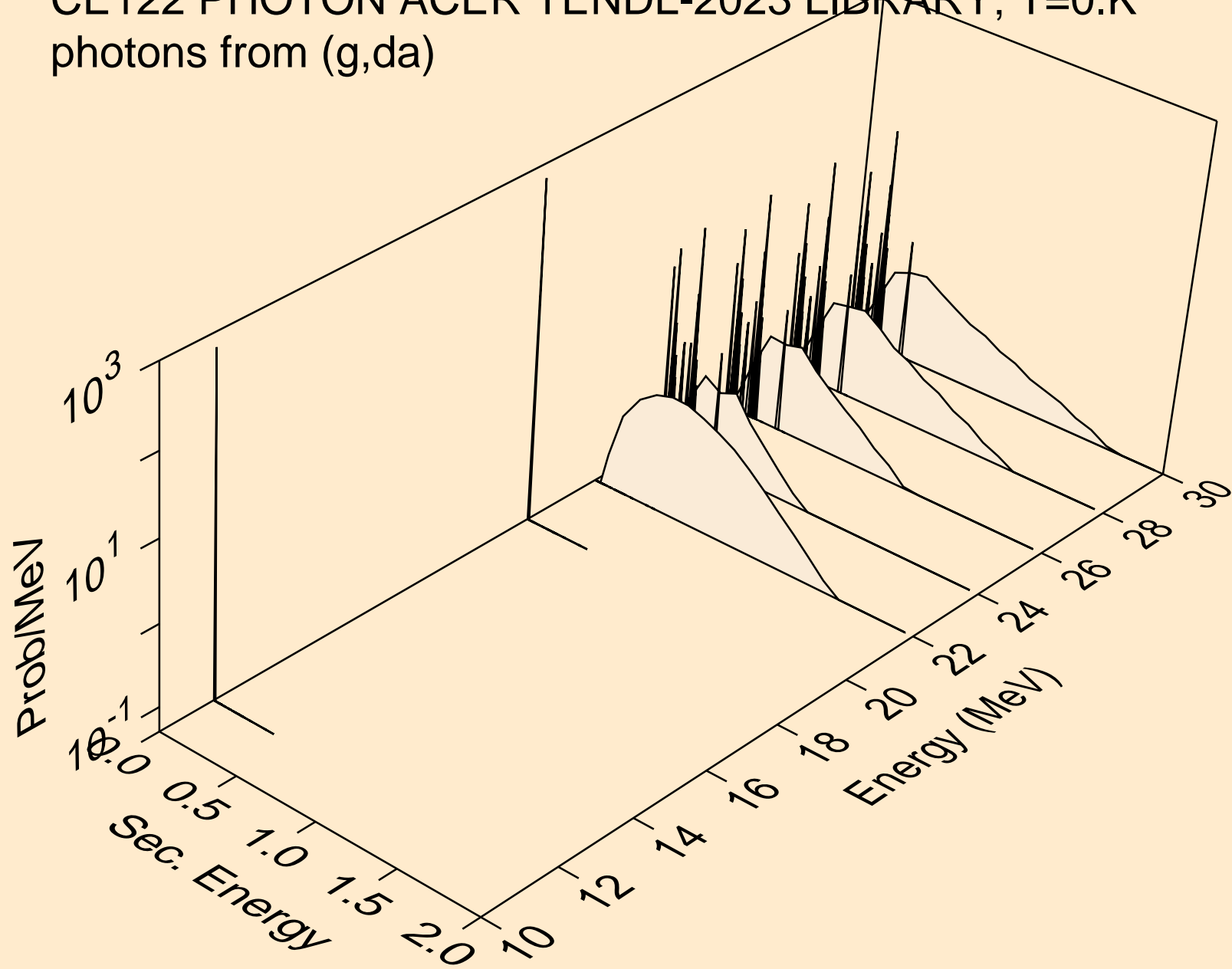

CE122 PHOTON ACER TENDL-2023 LIBRARY; T=0.K
protons from (g,x)

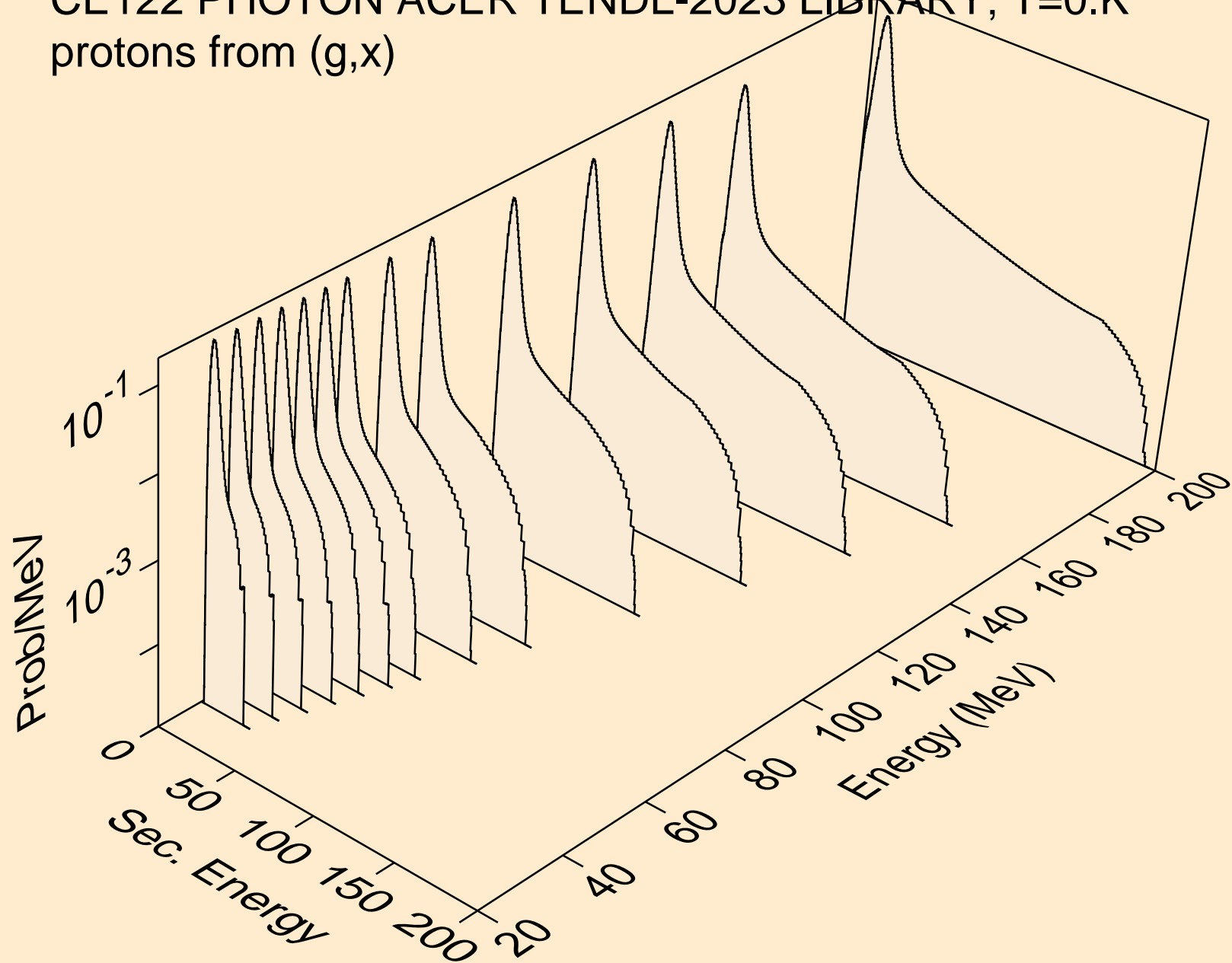

CE122 PHOTON ACER TENDL-2023 LIBRARY; T=0.K
protons from (g,n*)p

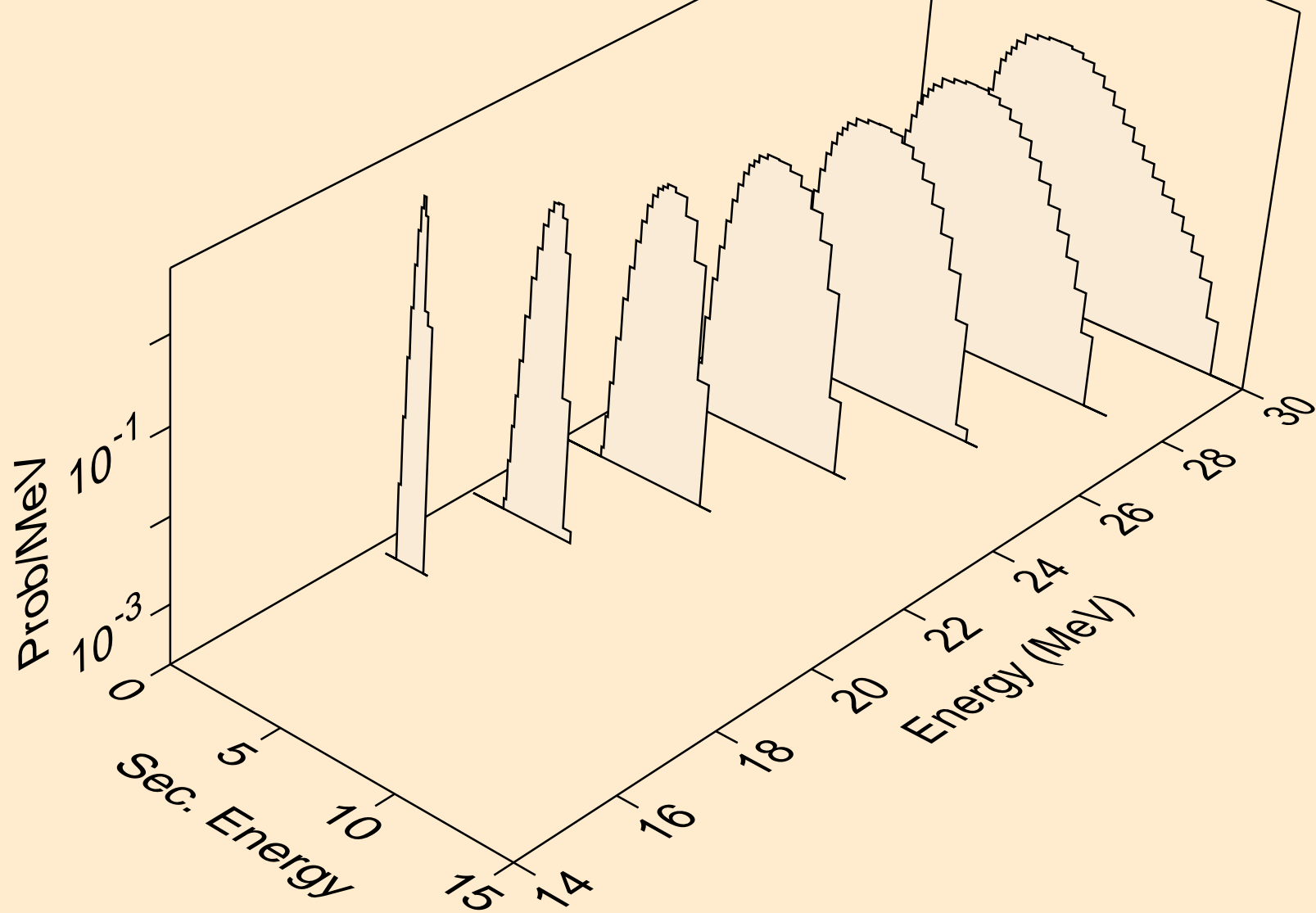

CE122 PHOTON ACER TENDL-2023 LIBRARY; T=0.K
protons from (g,2np)

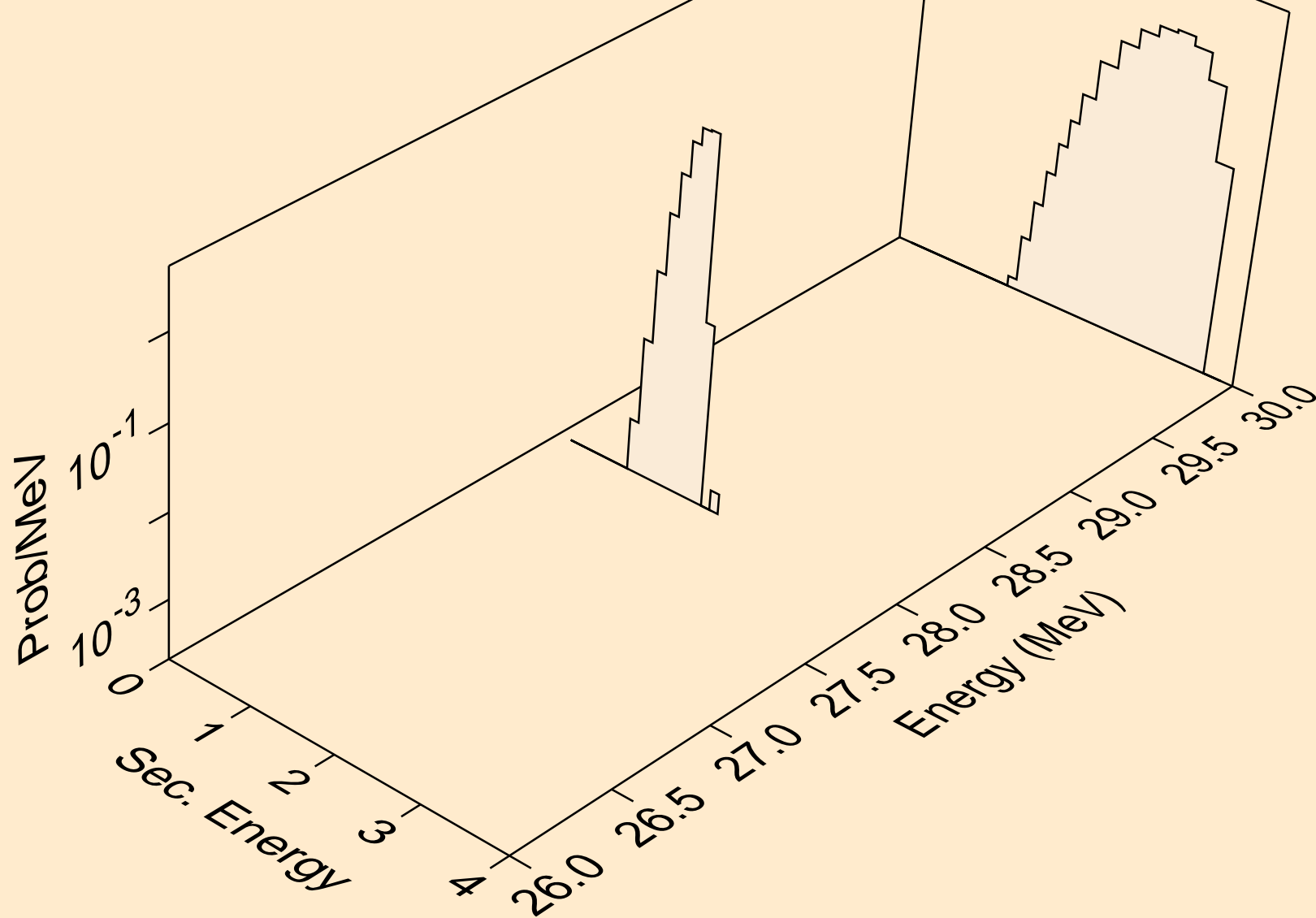

CE122 PHOTON ACER TENDL-2023 LIBRARY; T=0.K
protons from (g,n2p)

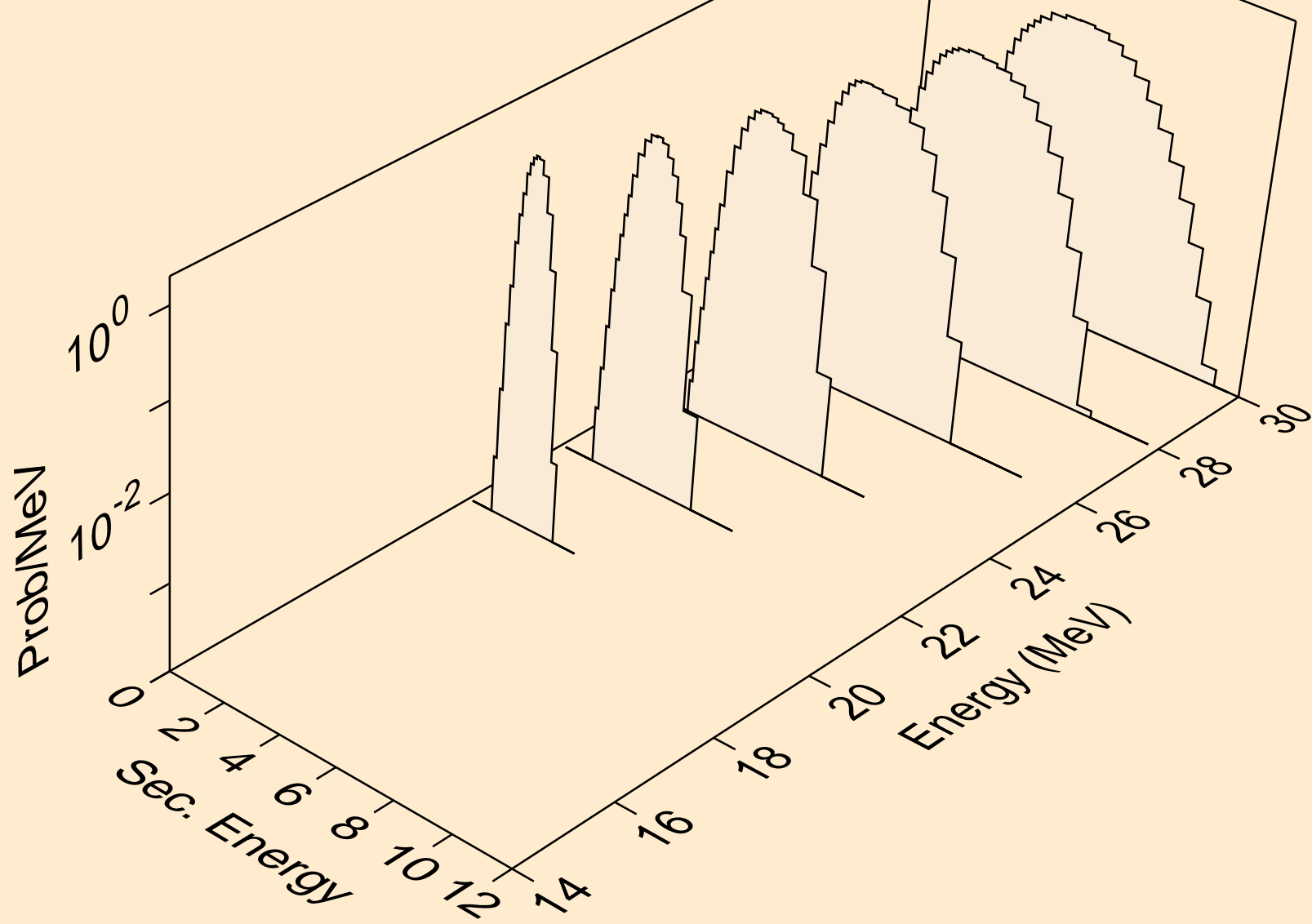

CE122 PHOTON ACER TENDL-2023 LIBRARY; T=0.K
protons from (g,npa)

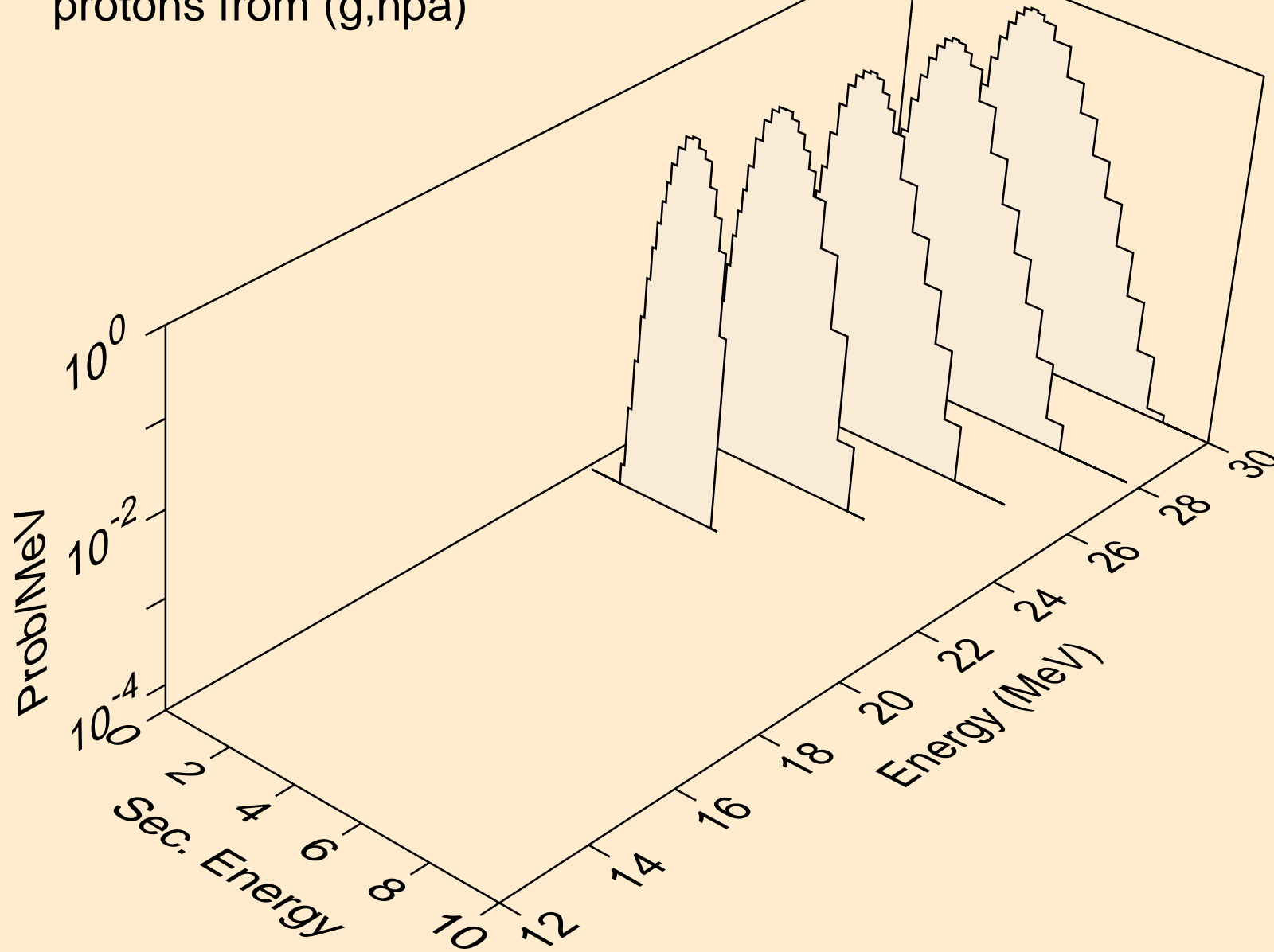

CE122 PHOTON ACER TENDL-2023 LIBRARY; T=0.K
protons from (g,p)

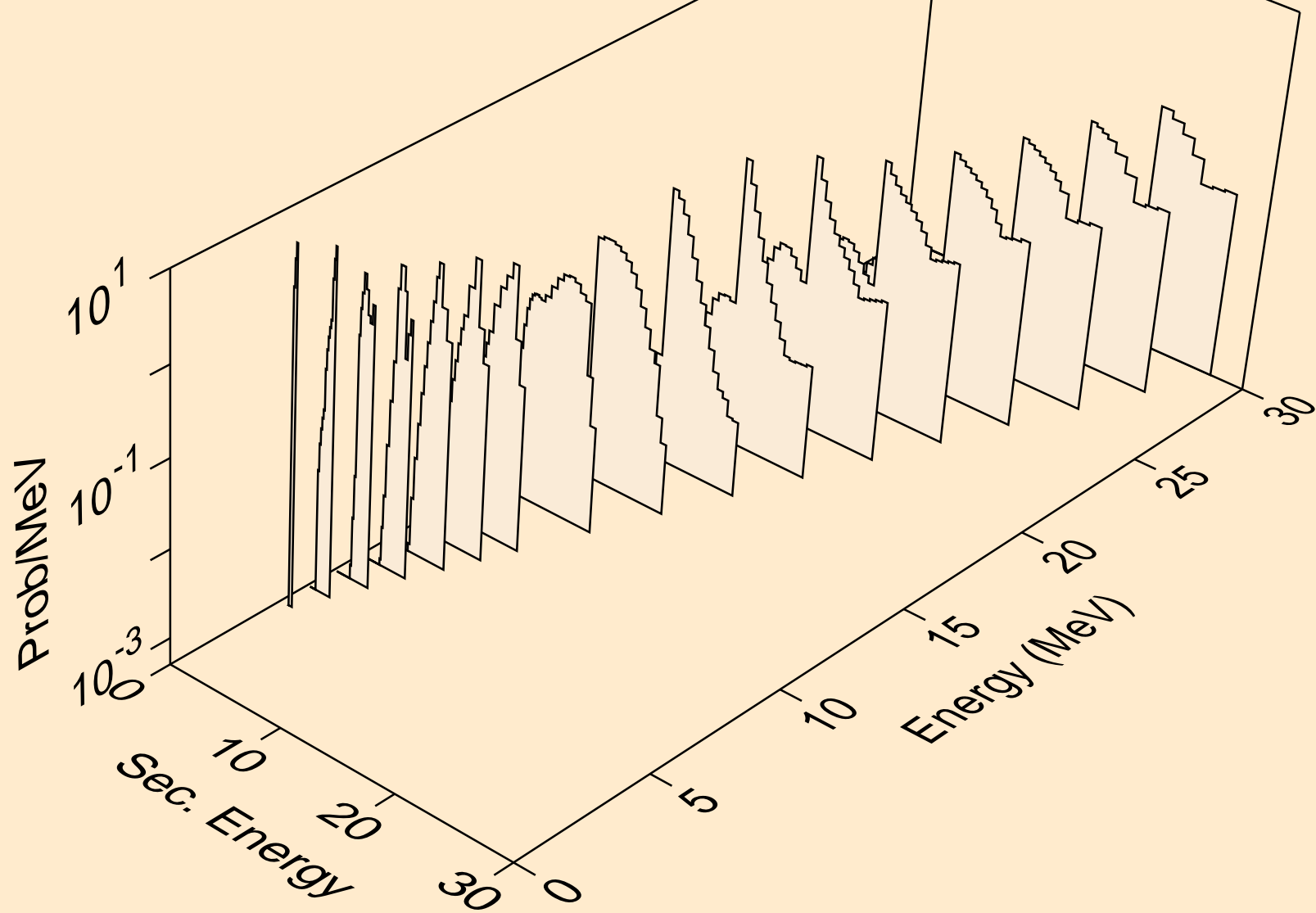

CE122 PHOTON ACER TENDL-2023 LIBRARY; T=0.K
protons from (g,2p)

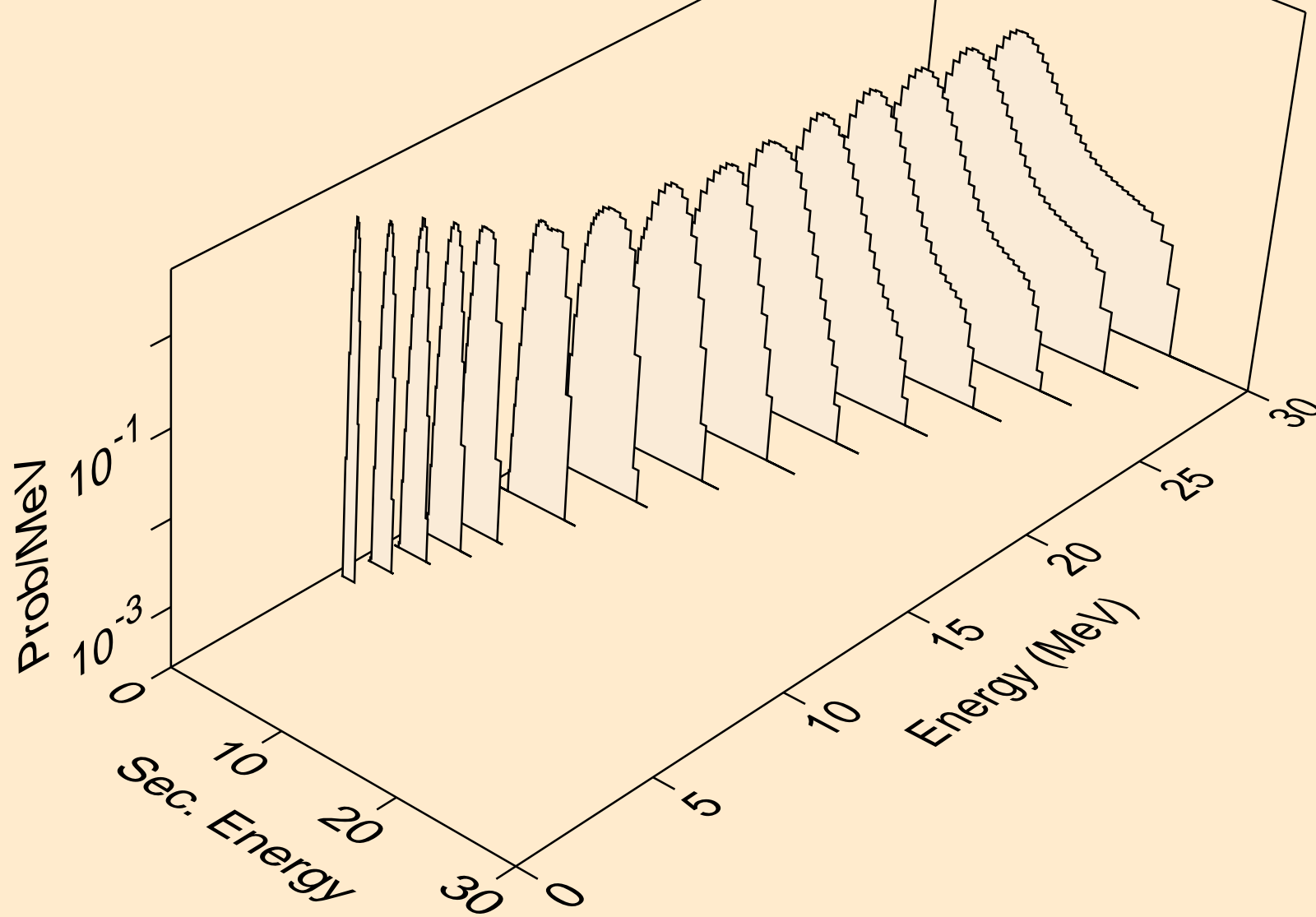

CE122 PHOTON ACER TENDL-2023 LIBRARY; T=0.K
protons from (g,pa)

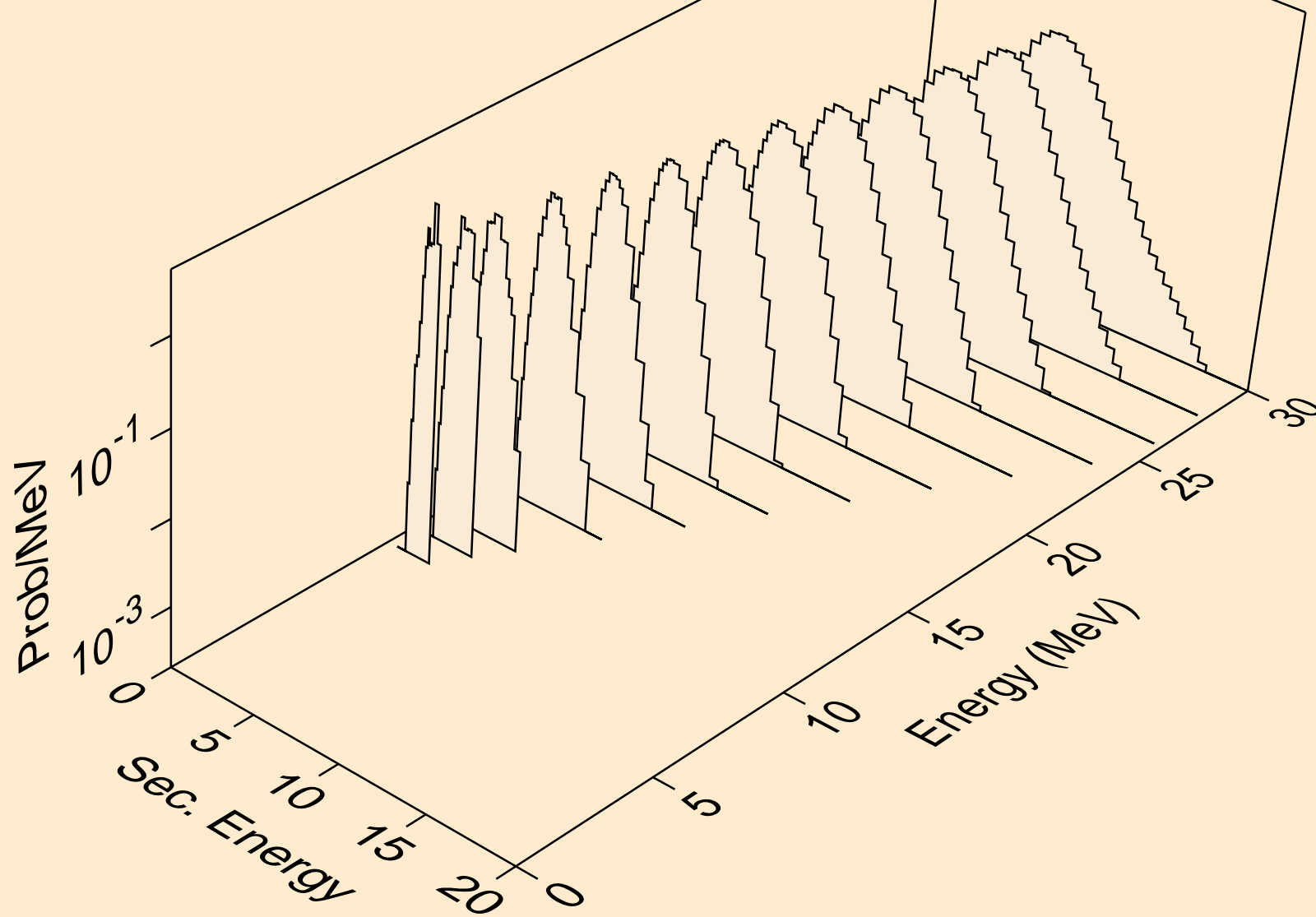

CE122 PHOTON ACER TENDL-2023 LIBRARY; T=0.K
protons from (g,pd)

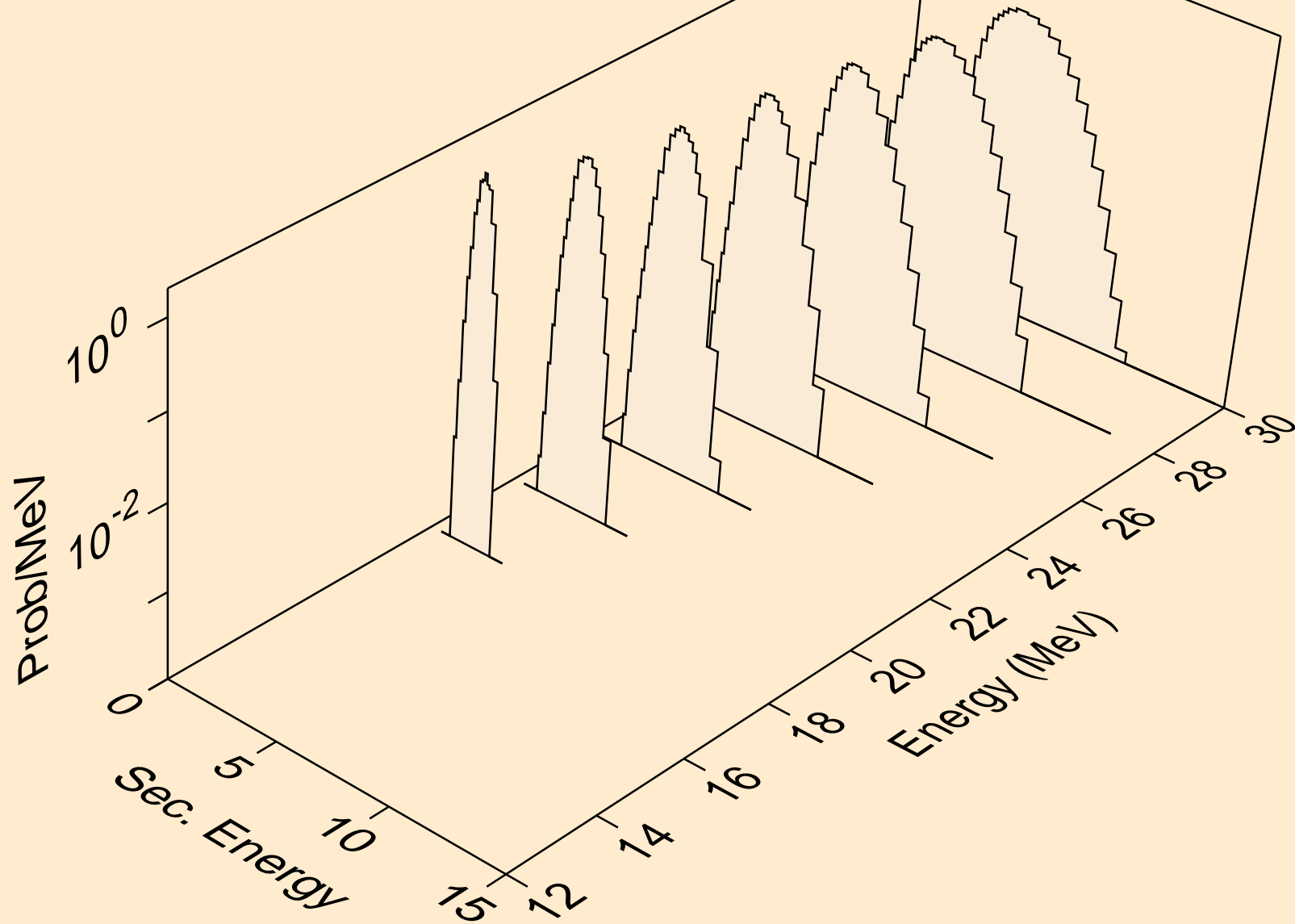

CE122 PHOTON ACER TENDL-2023 LIBRARY; T=0.K
protons from (g,pt)

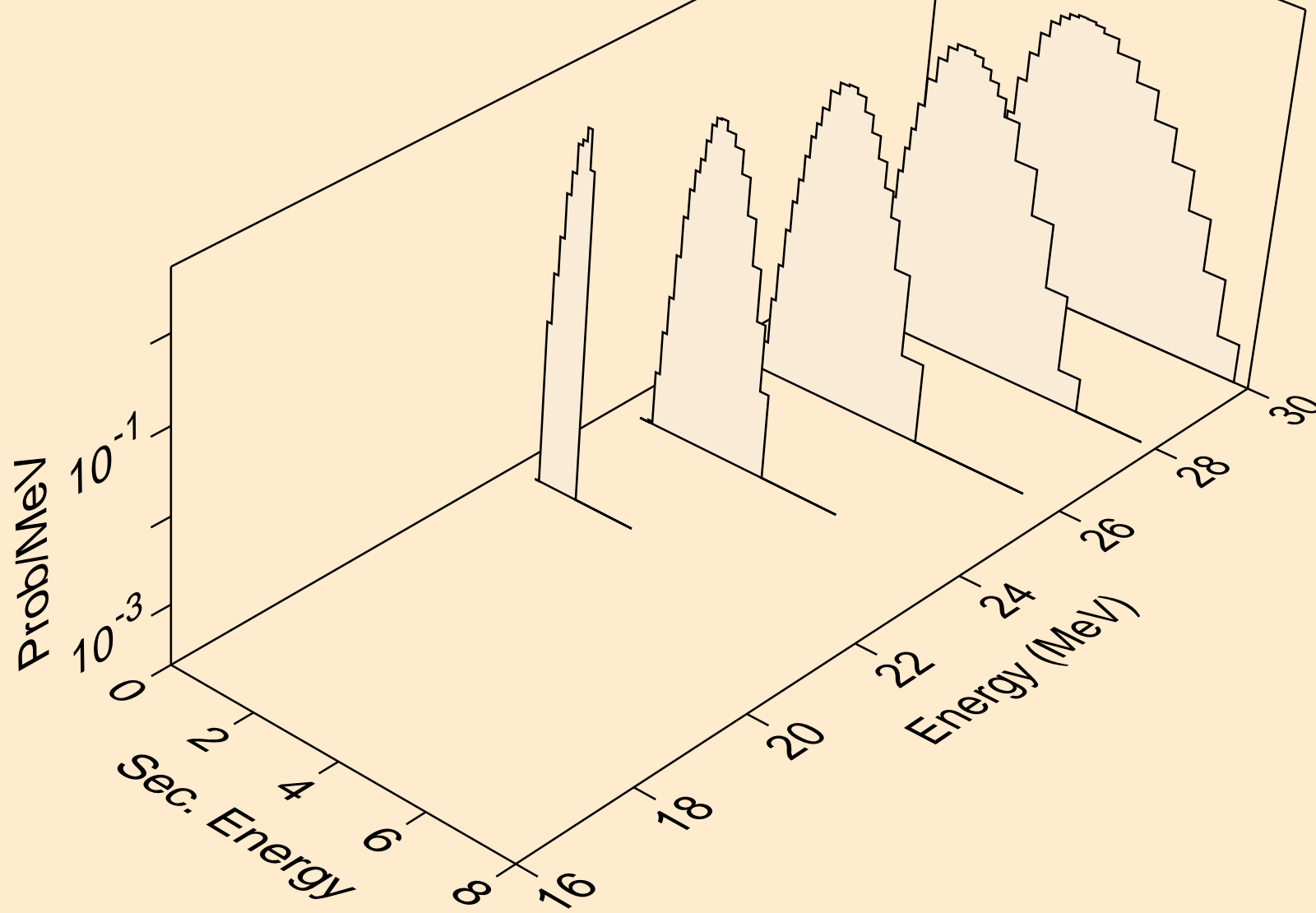

CE122 PHOTON ACER TENDL-2023 LIBRARY; T=0.K
deuterons from (g,x)

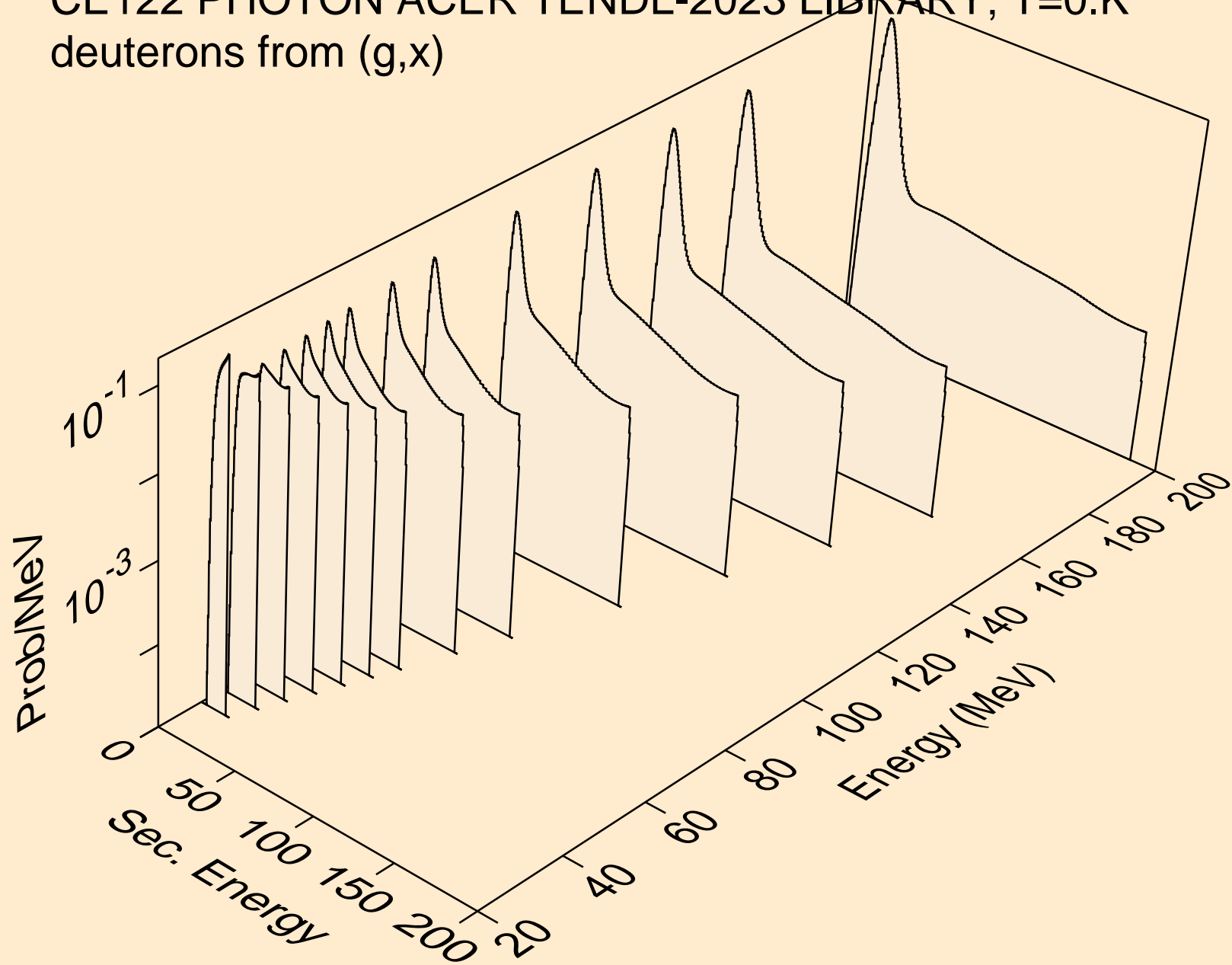

CE122 PHOTON ACER TENDL-2023 LIBRARY; T=0.K
deuterons from (g,d)

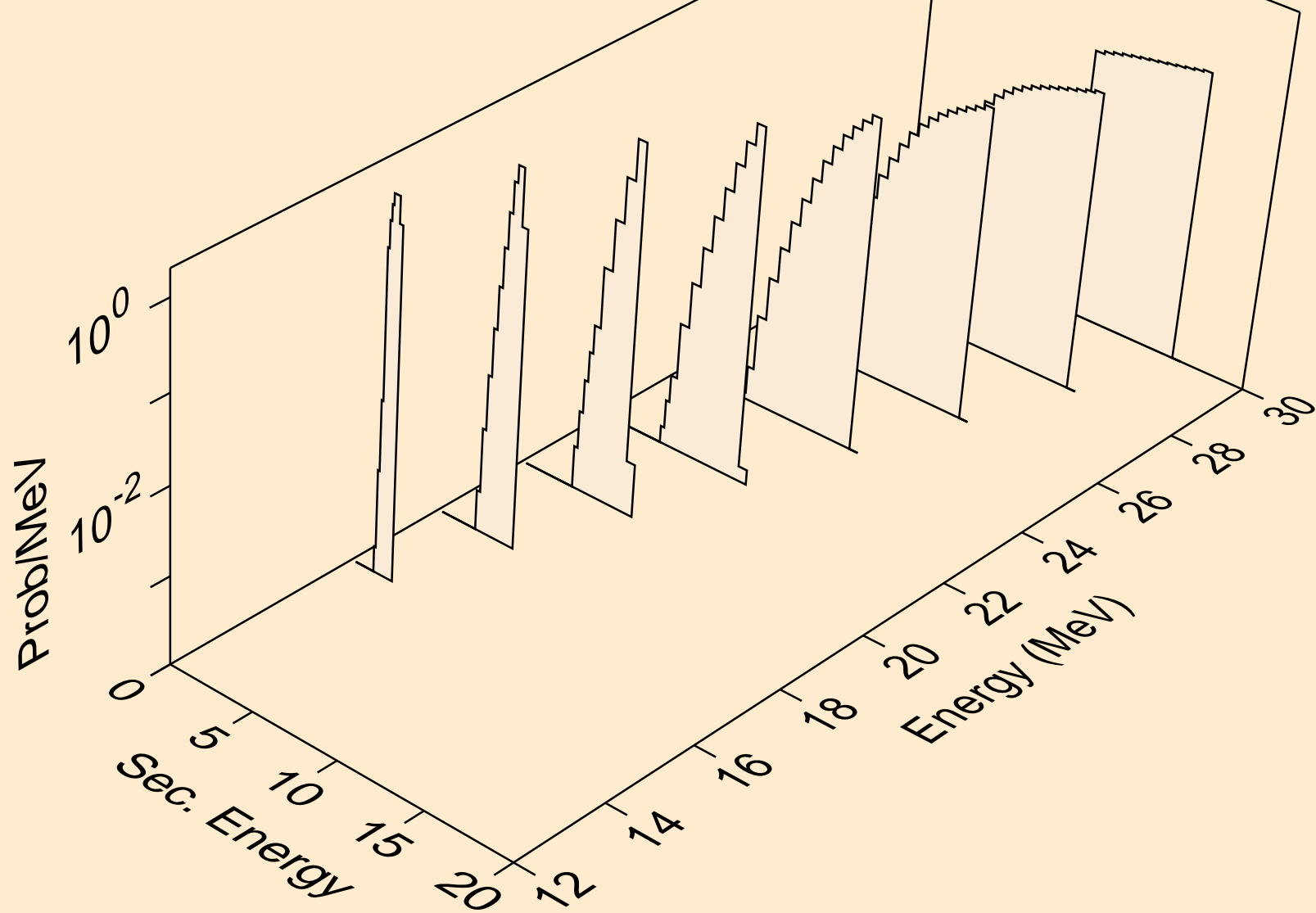

CE122 PHOTON ACER TENDL-2023 LIBRARY; T=0.K
deuterons from (g,pd)

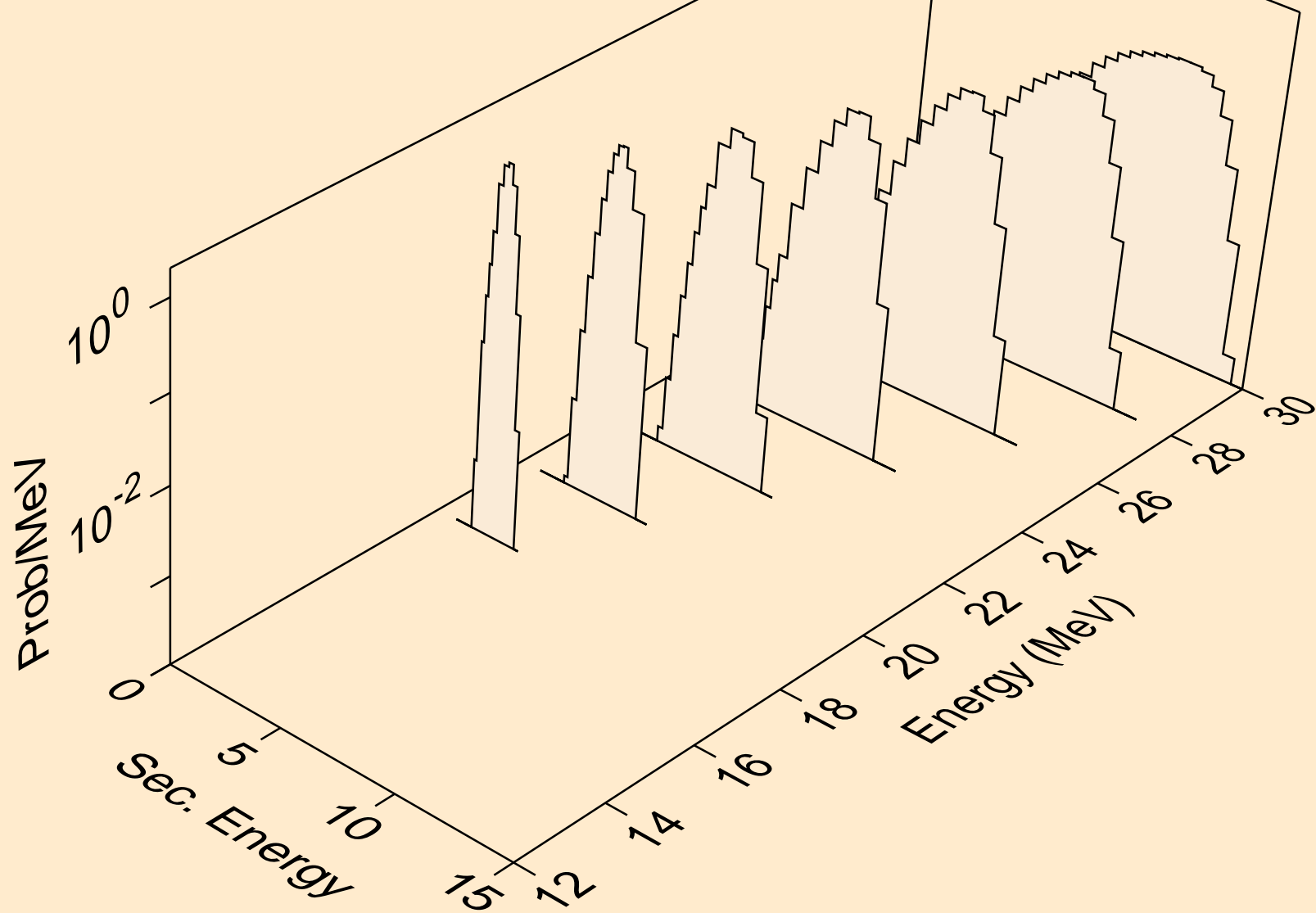

CE122 PHOTON ACER TENDL-2023 LIBRARY; T=0.K
deuterons from (g,da)

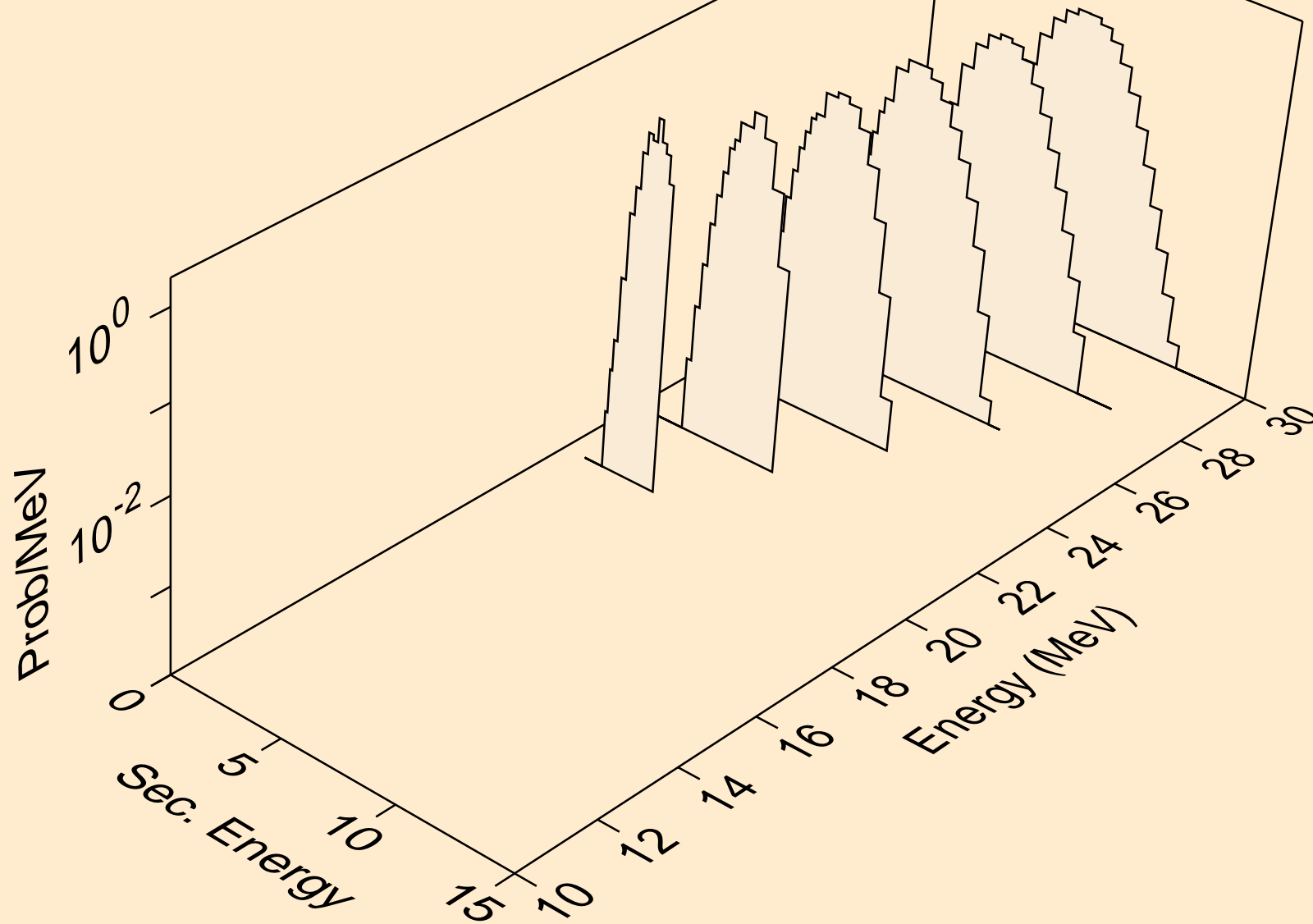

CE122 PHOTON ACER TENDL-2023 LIBRARY; T=0.K
tritons from (g,x)

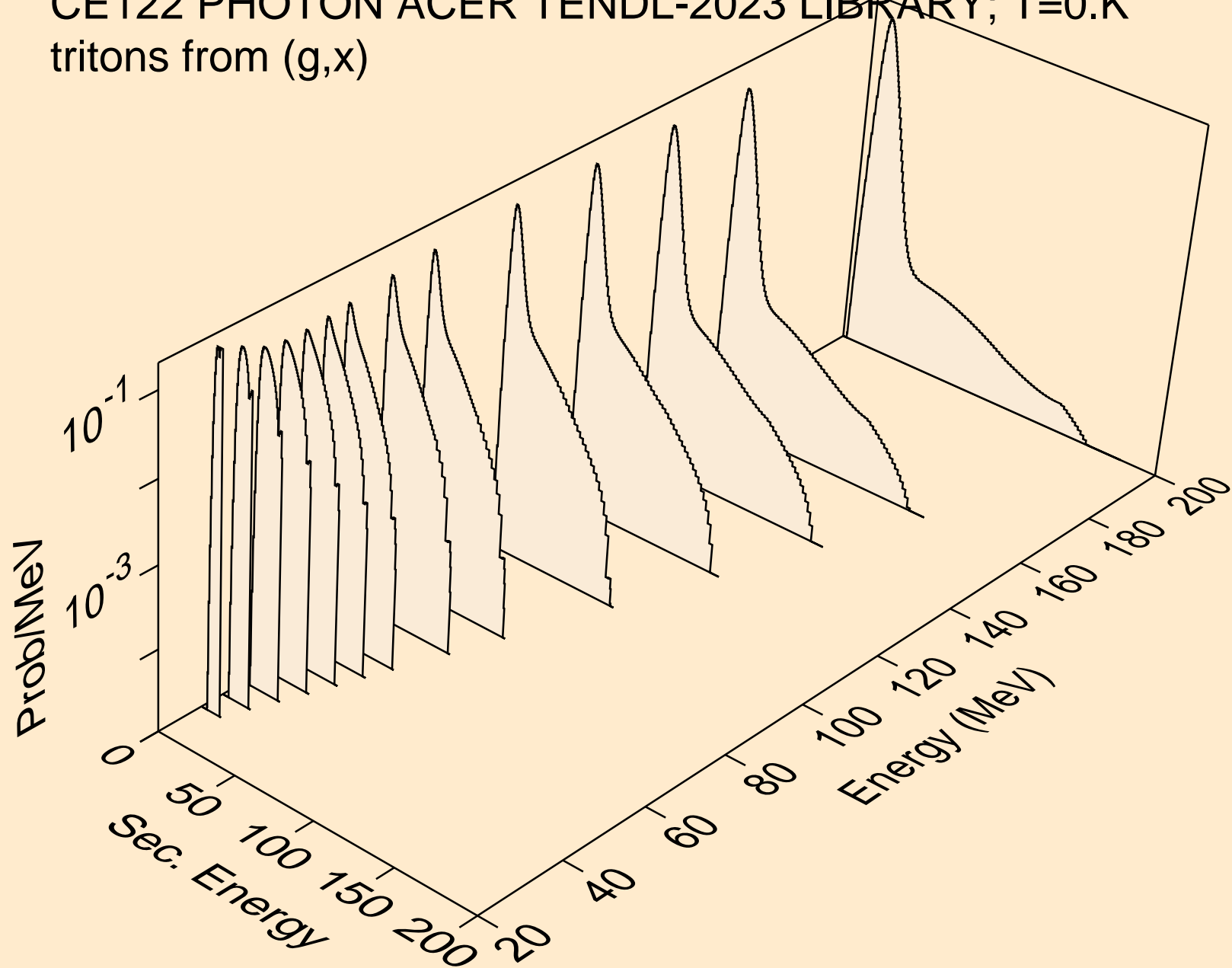

CE122 PHOTON ACER TENDL-2023 LIBRARY; T=0.K
tritons from (g,t)

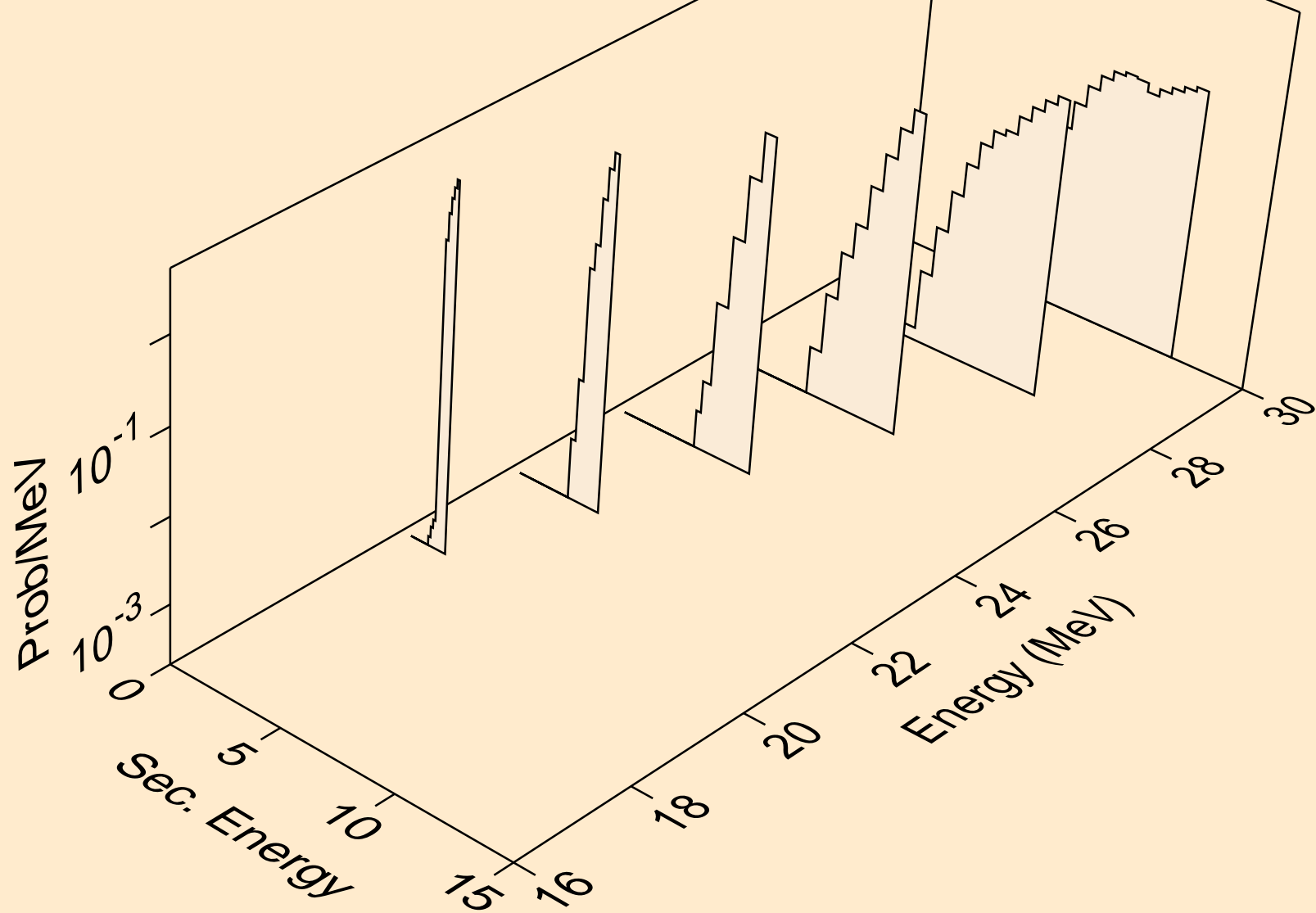

CE122 PHOTON ACER TENDL-2023 LIBRARY; T=0.K
tritons from (g,pt)

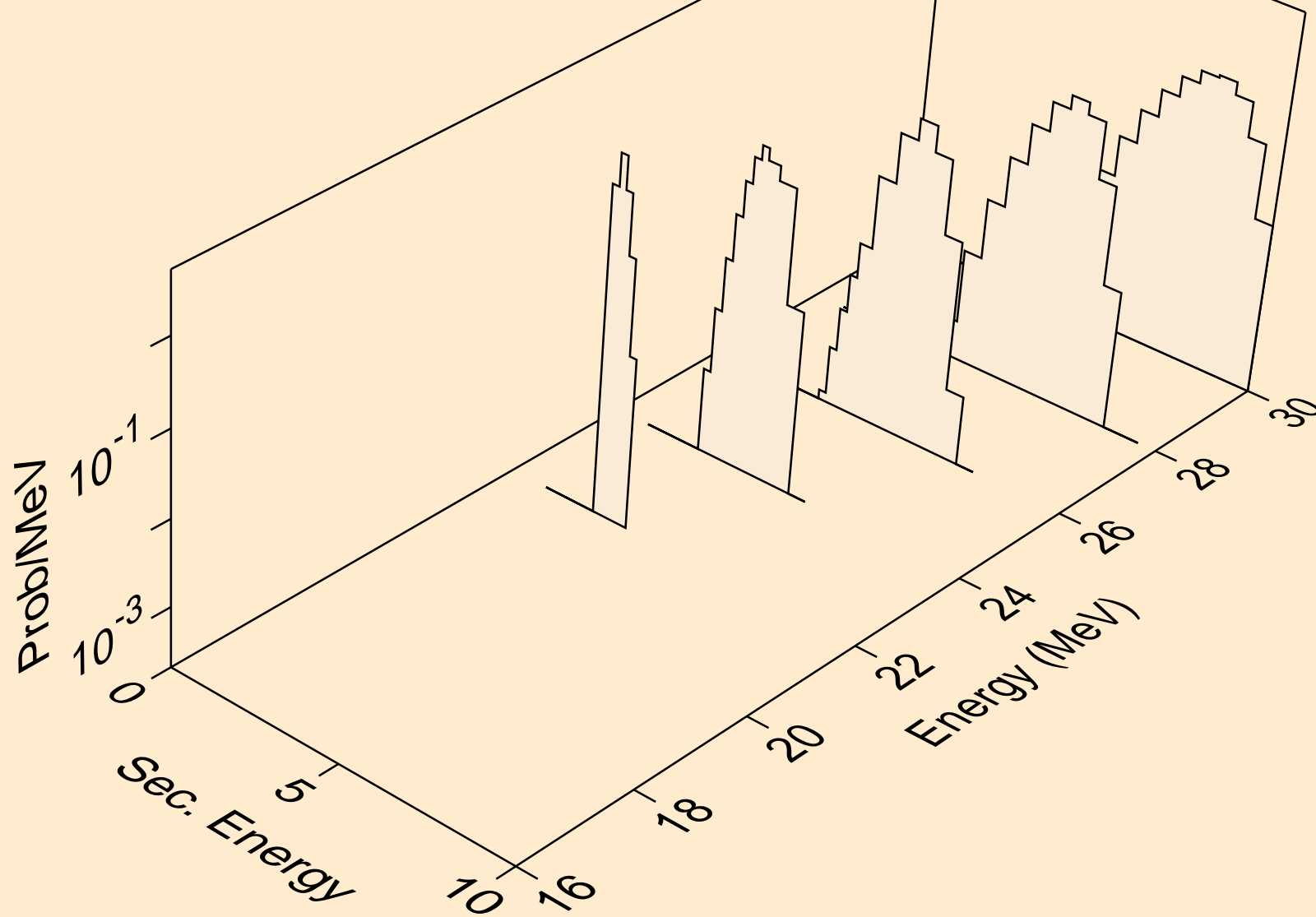

CE122 PHOTON ACER TENDL-2023 LIBRARY; T=0.K
he3s from (g,x)

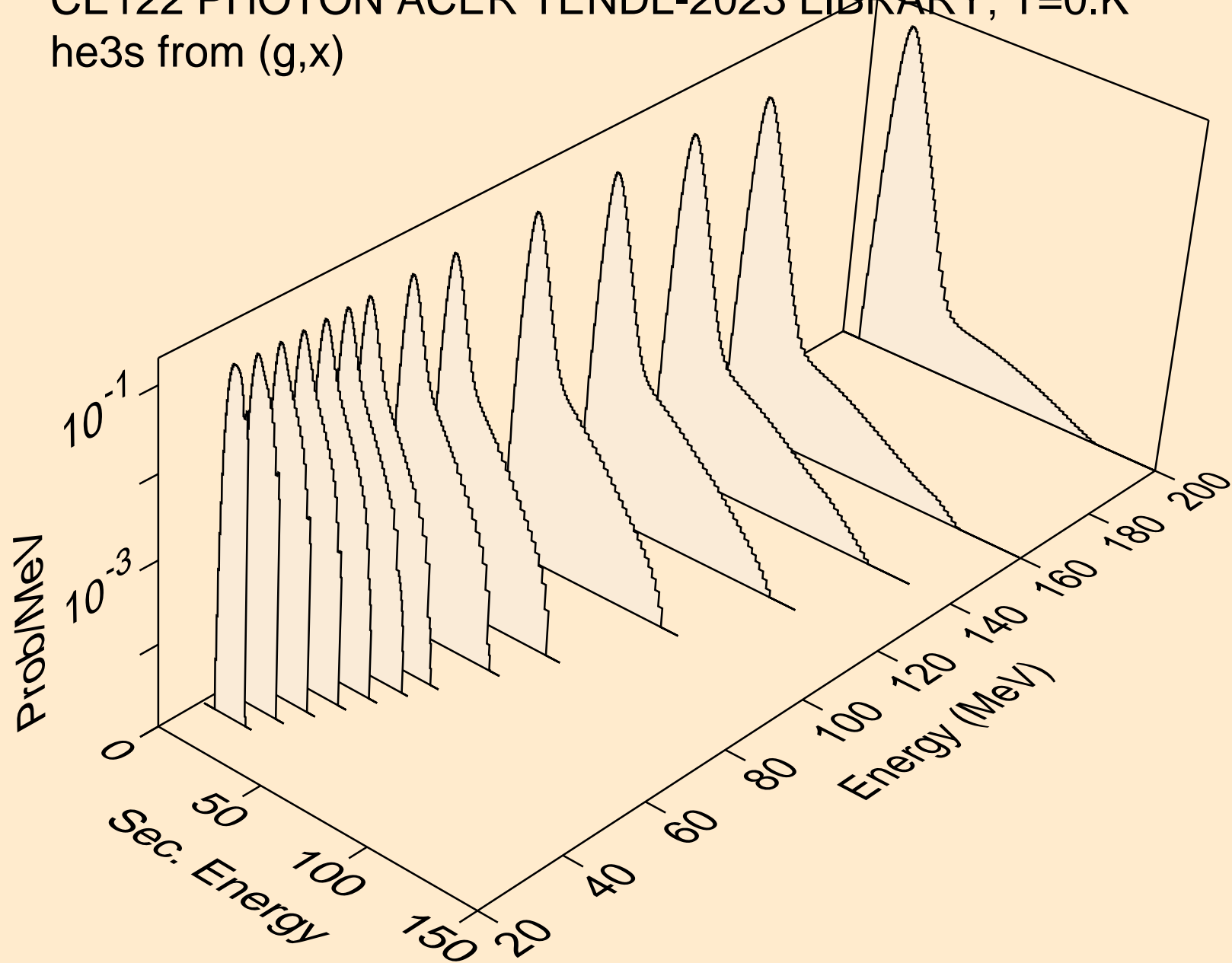

CE122 PHOTON ACER TENDL-2023 LIBRARY; T=0.K
he3s from (g,he3)

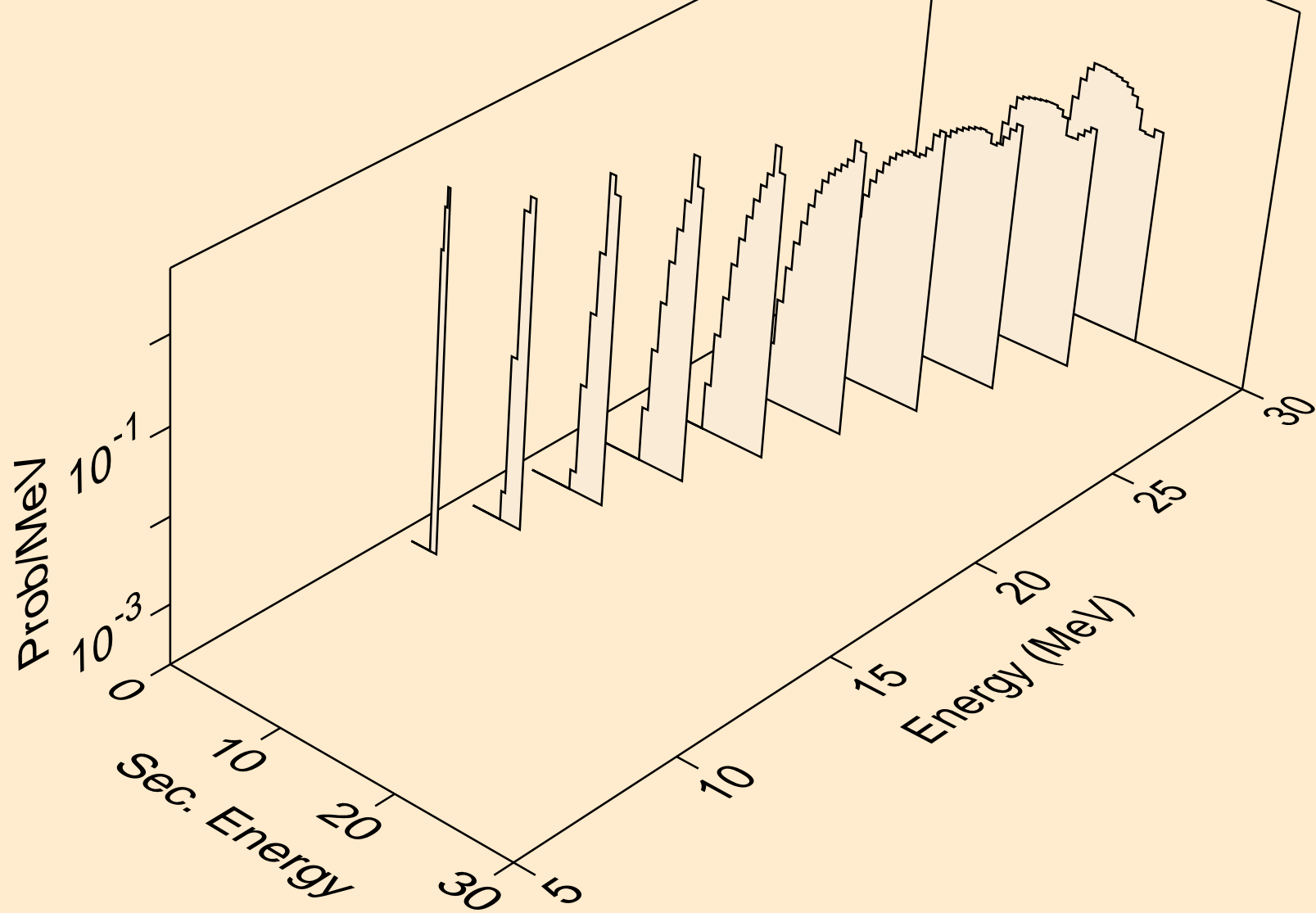

CE122 PHOTON ACER TENDL-2023 LIBRARY; T=0.K
alphas from (g,x)

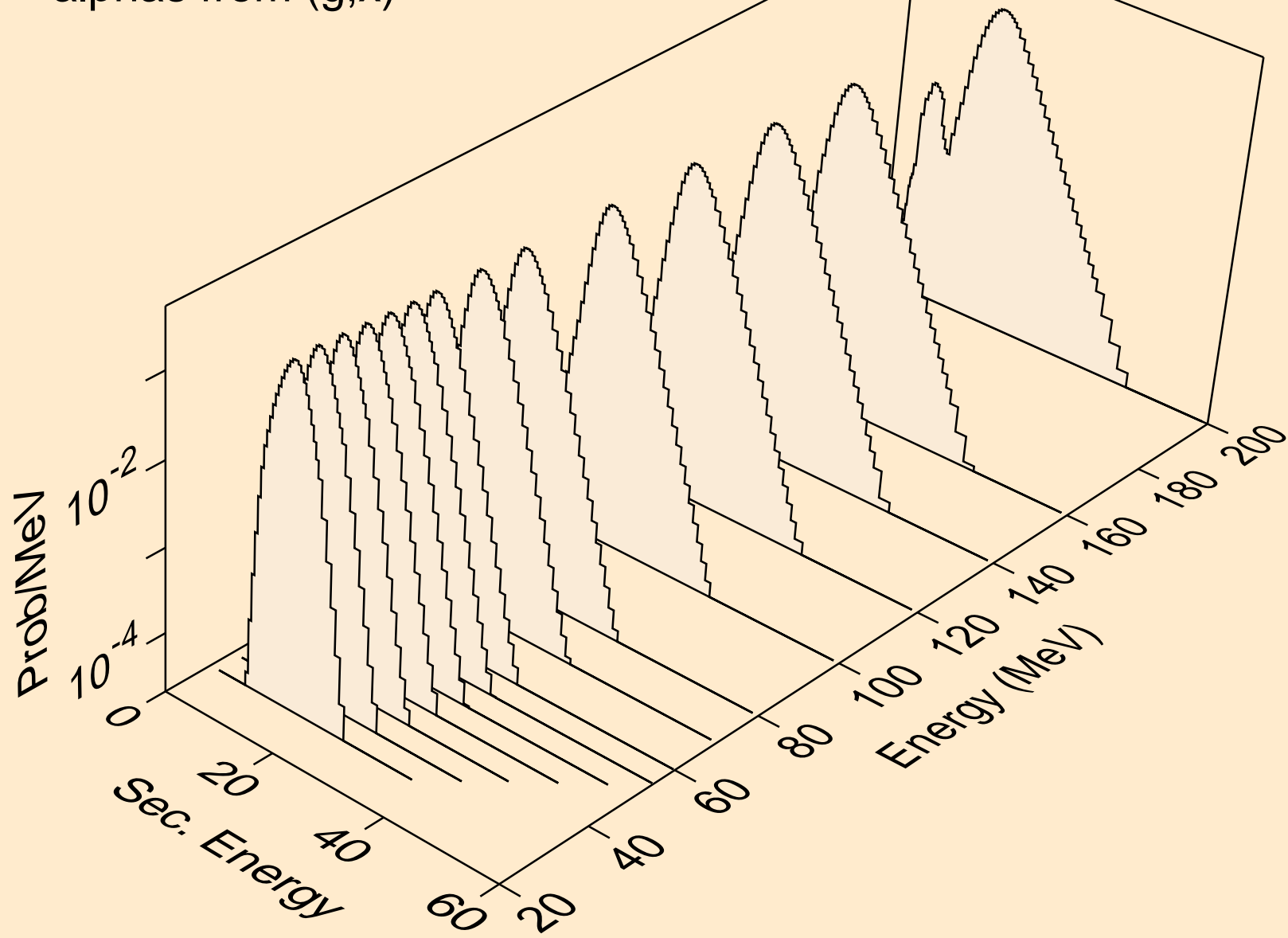

CE122 PHOTON ACER TENDL-2023 LIBRARY; T=0.K
alphas from (g,n*)a

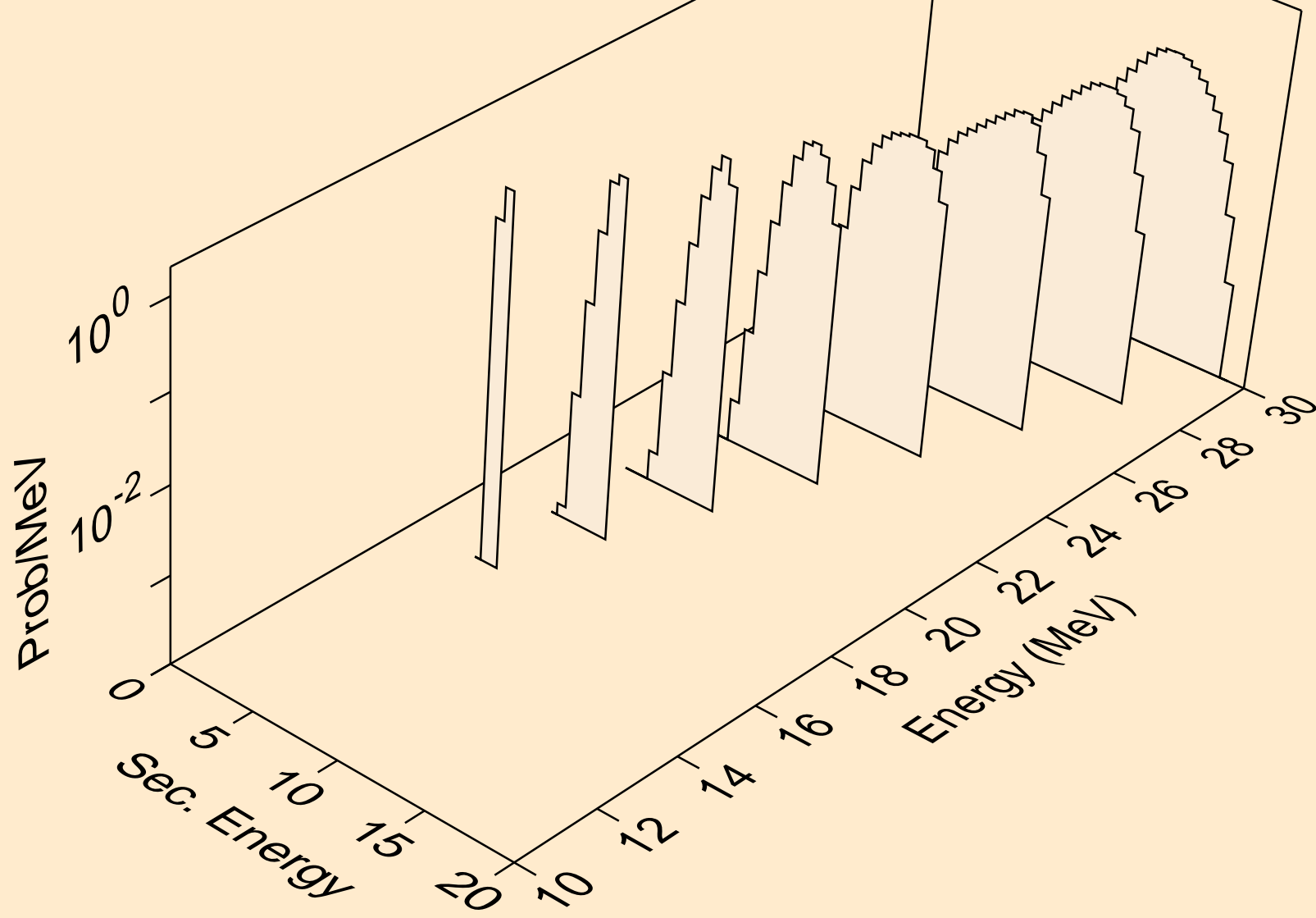

CE122 PHOTON ACER TENDL-2023 LIBRARY; T=0.K
alphas from (g,npa)

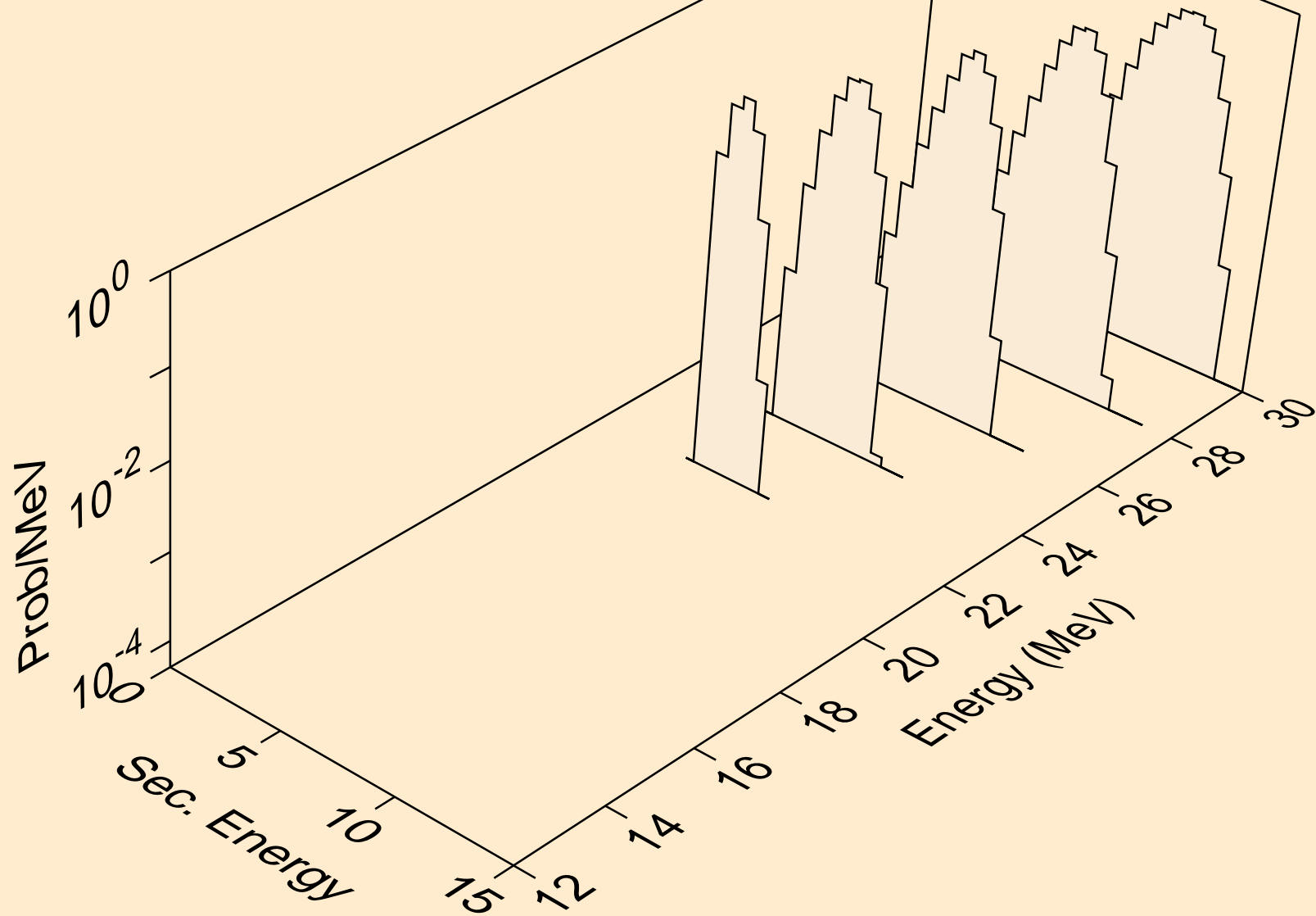

CE122 PHOTON ACER TENDL-2023 LIBRARY; T=0.K
alphas from (g,a)

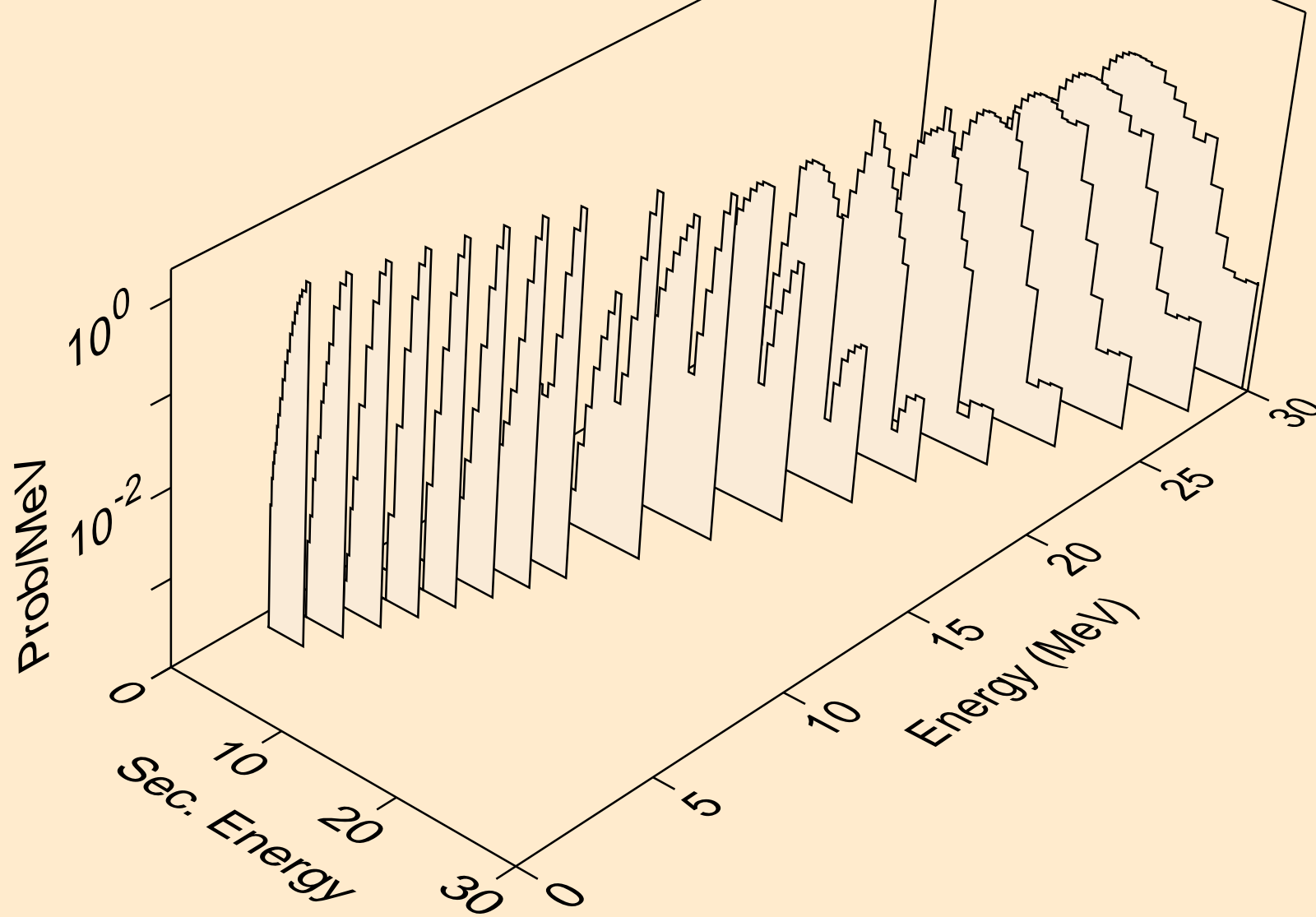

CE122 PHOTON ACER TENDL-2023 LIBRARY; T=0.K
alphas from (g,2a)

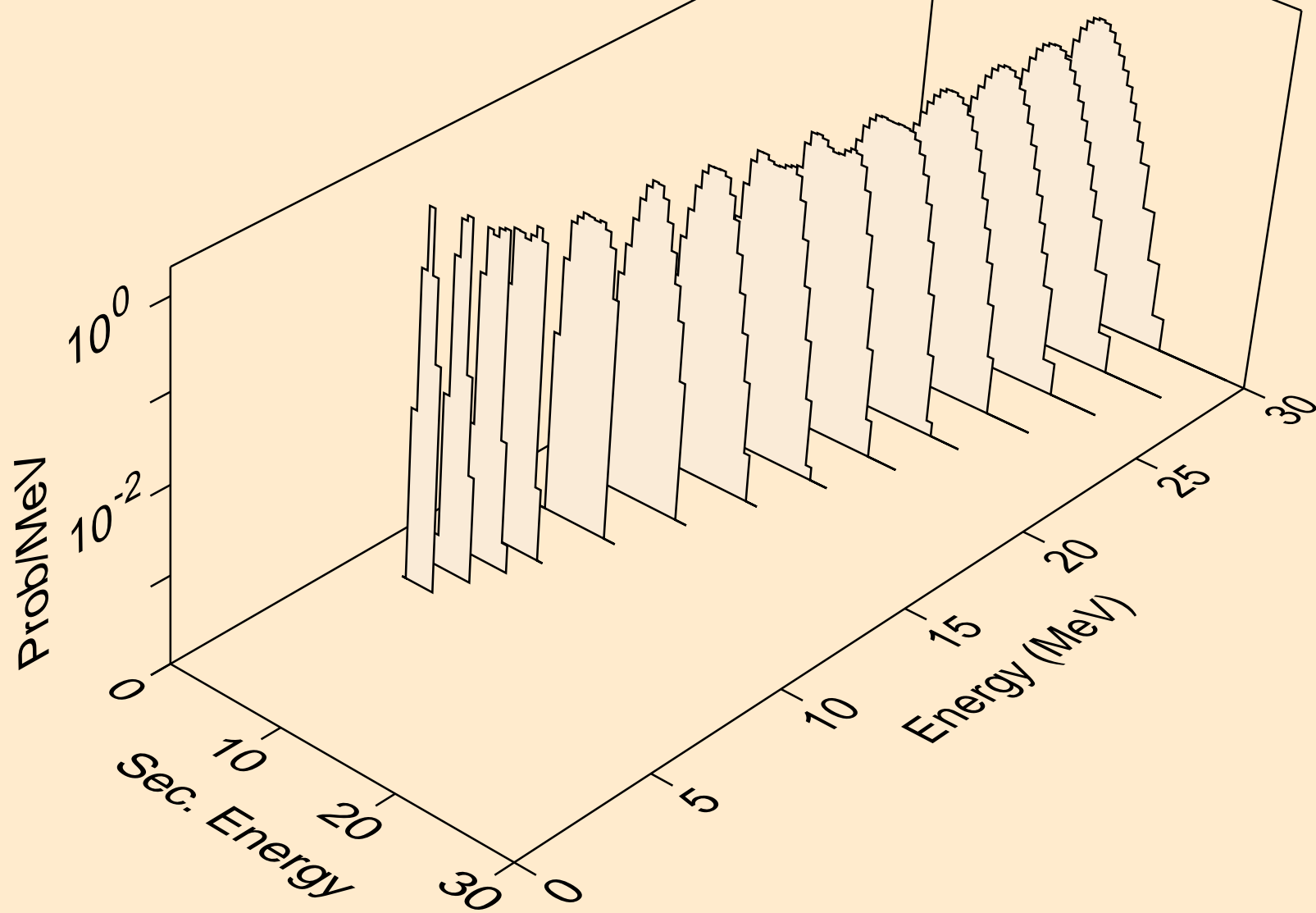

CE122 PHOTON ACER TENDL-2023 LIBRARY; T=0.K
alphas from (g,3a)

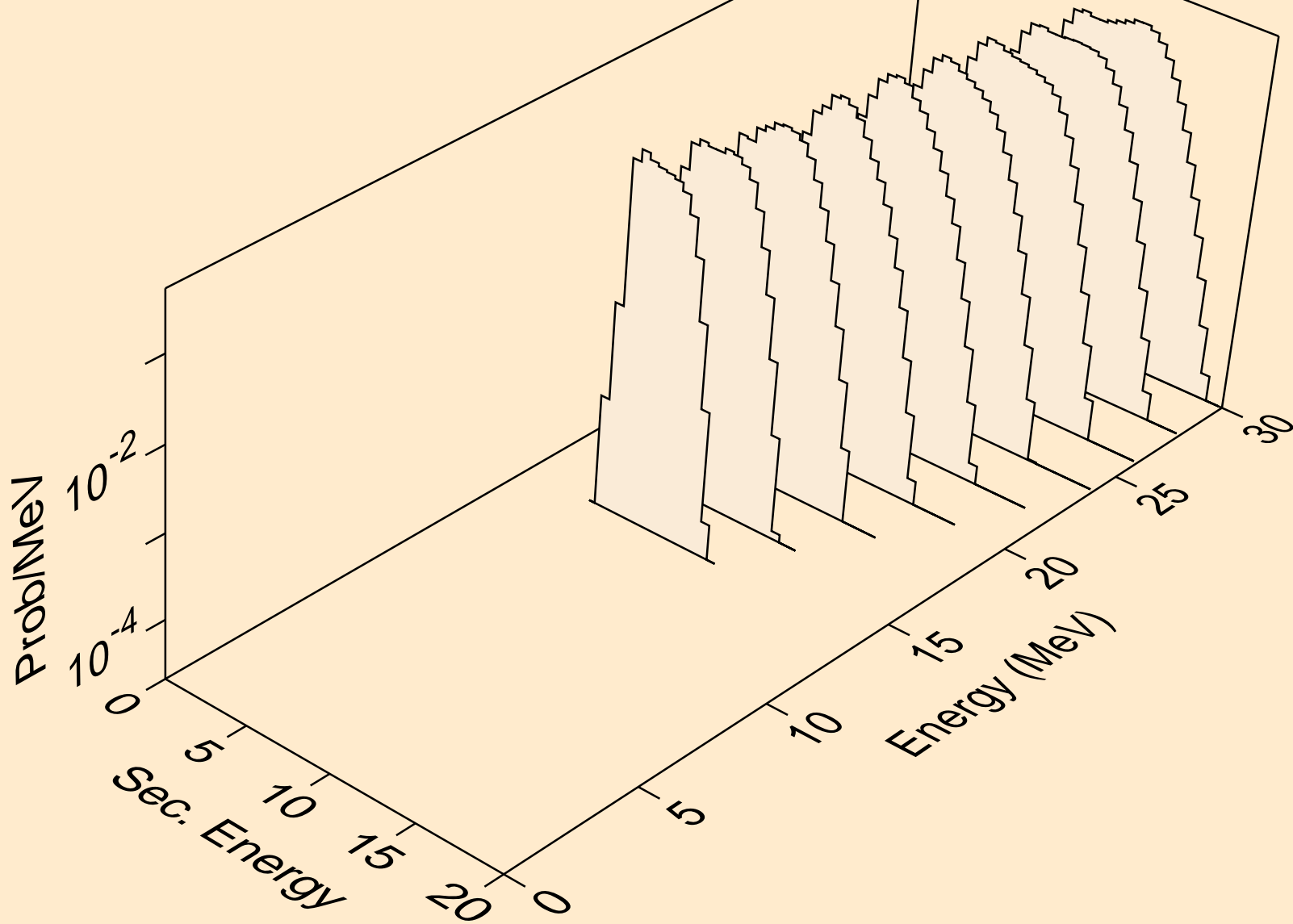

CE122 PHOTON ACER TENDL-2023 LIBRARY; T=0.K
alphas from (g,pa)

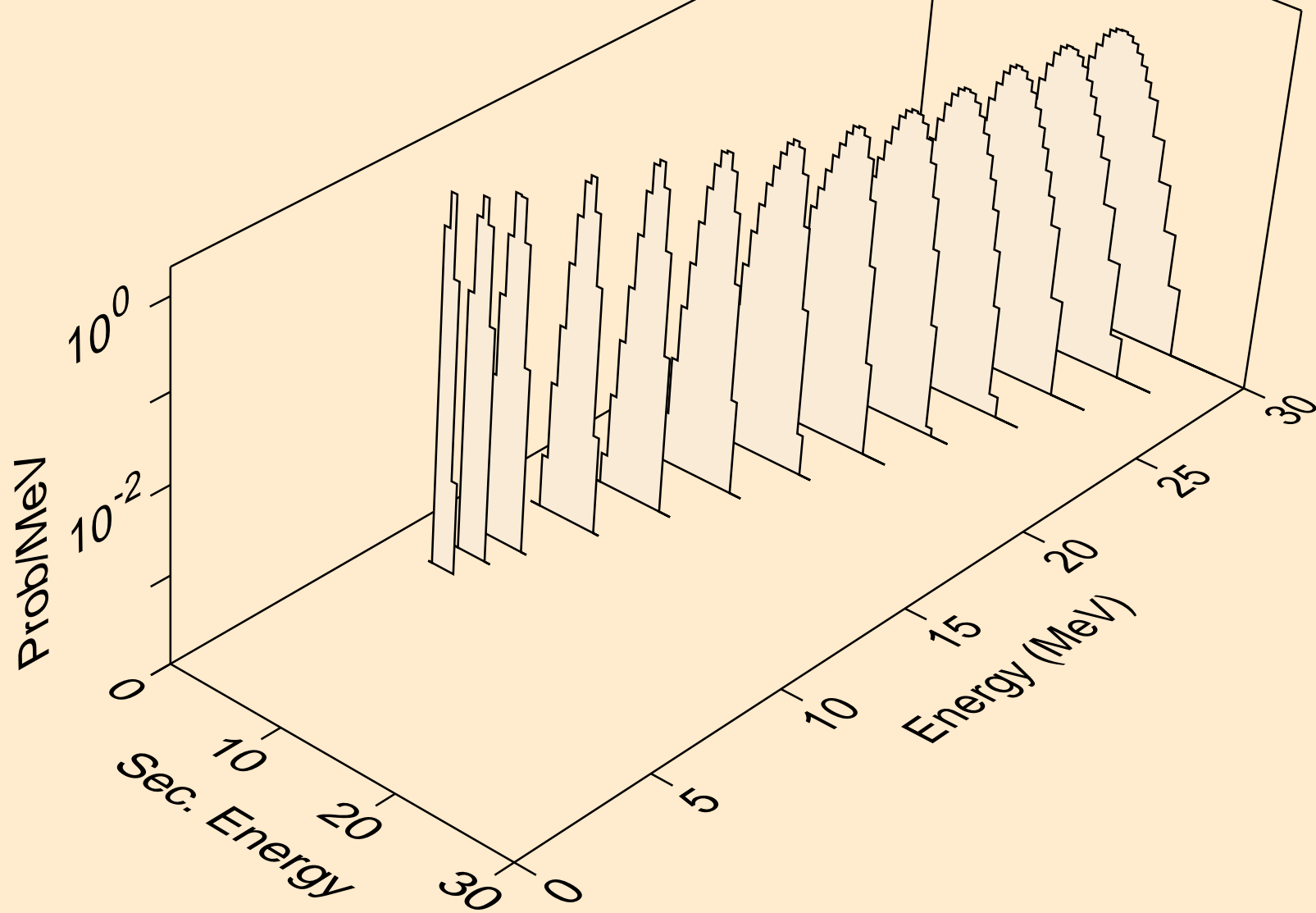

CE122 PHOTON ACER TENDL-2023 LIBRARY; T=0.K
alphas from (g,da)

