

CL035 PHOTON ACER TENDL-2023 LIBRARY; T=0.K

Principal cross sections

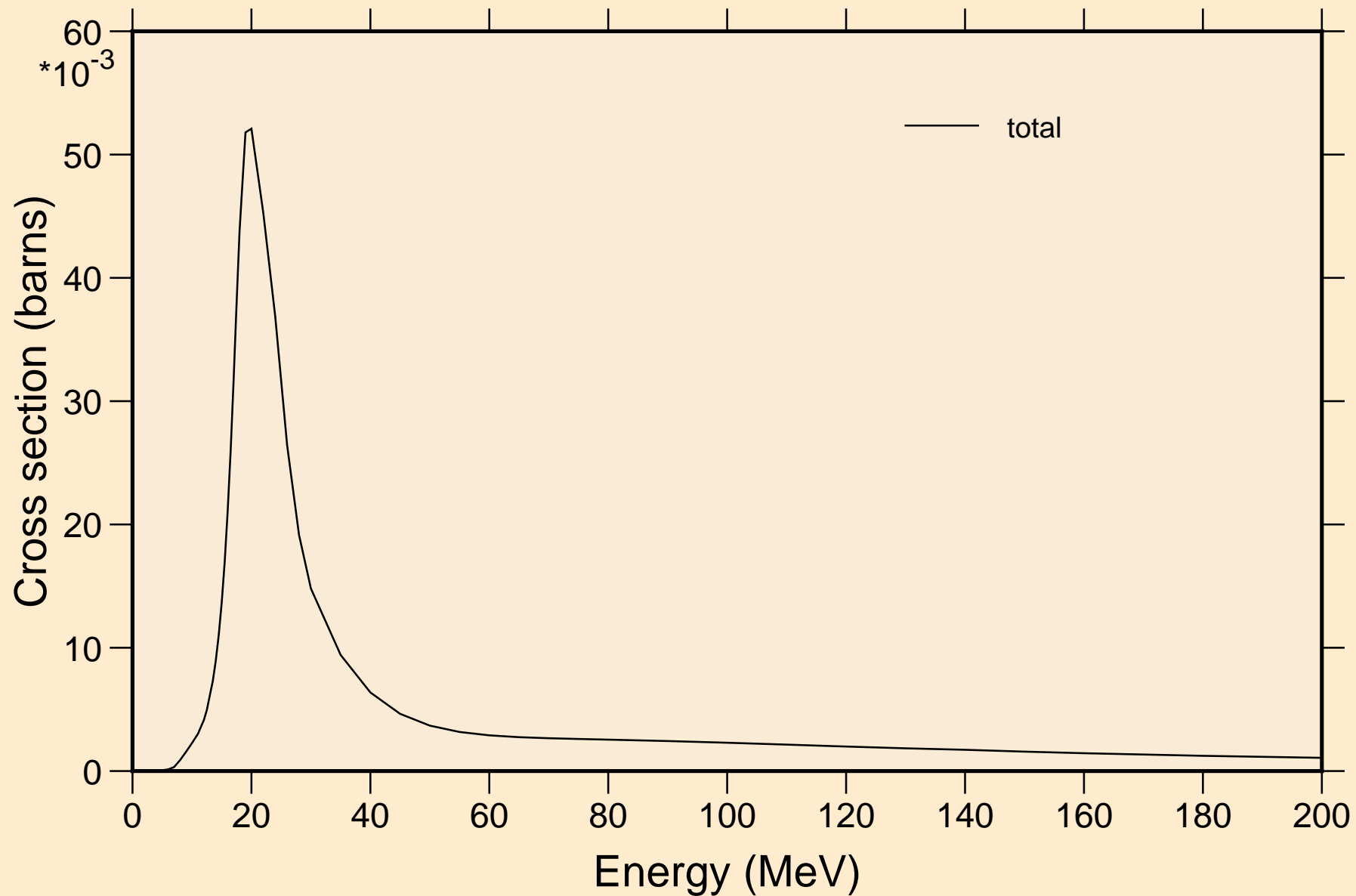

CL035 PHOTON ACER TENDL-2023 LIBRARY; T=0.K

Partial cross sections

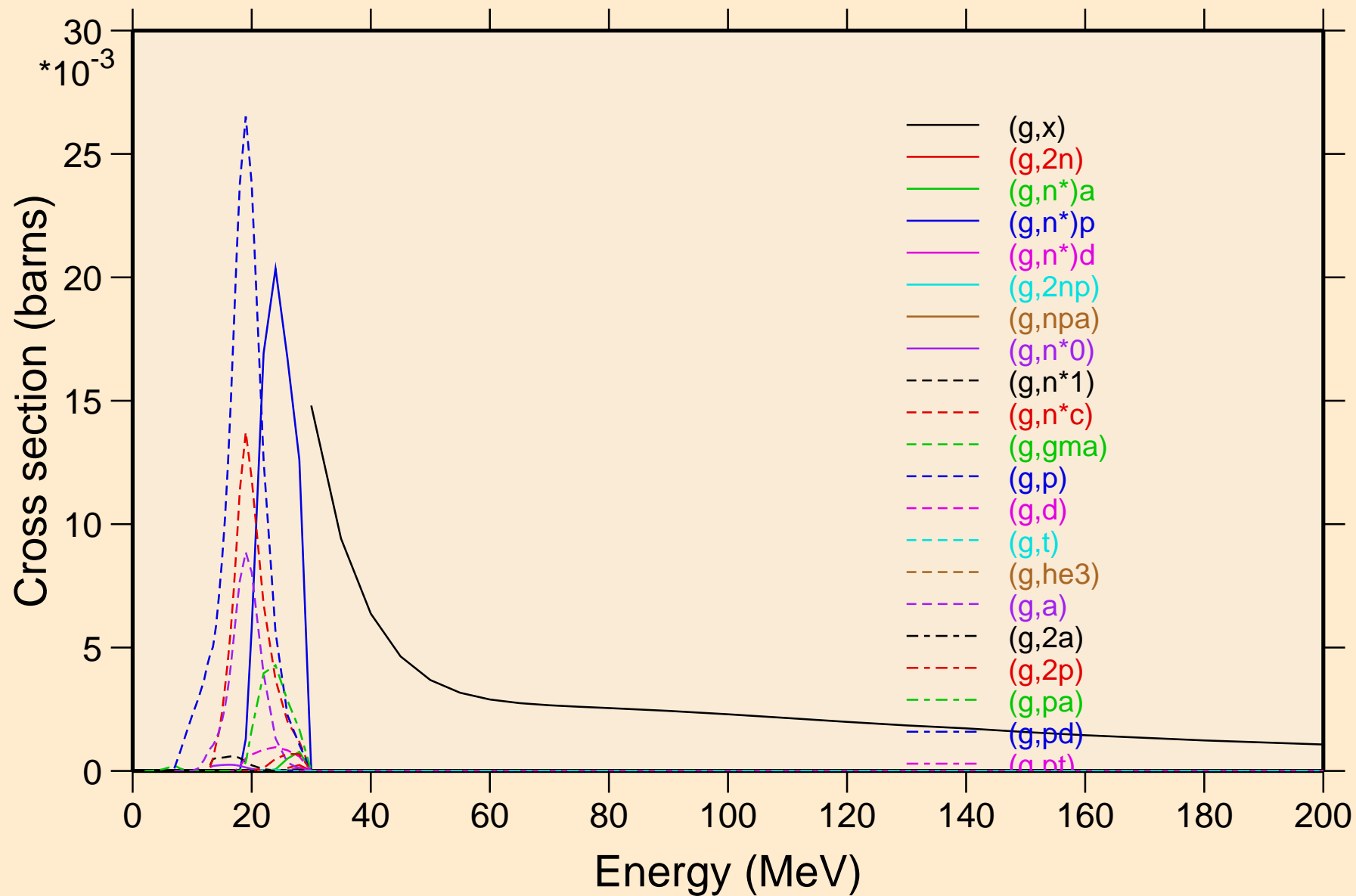

CL035 PHOTON ACER TENDL-2023 LIBRARY; T=0.K

Heating

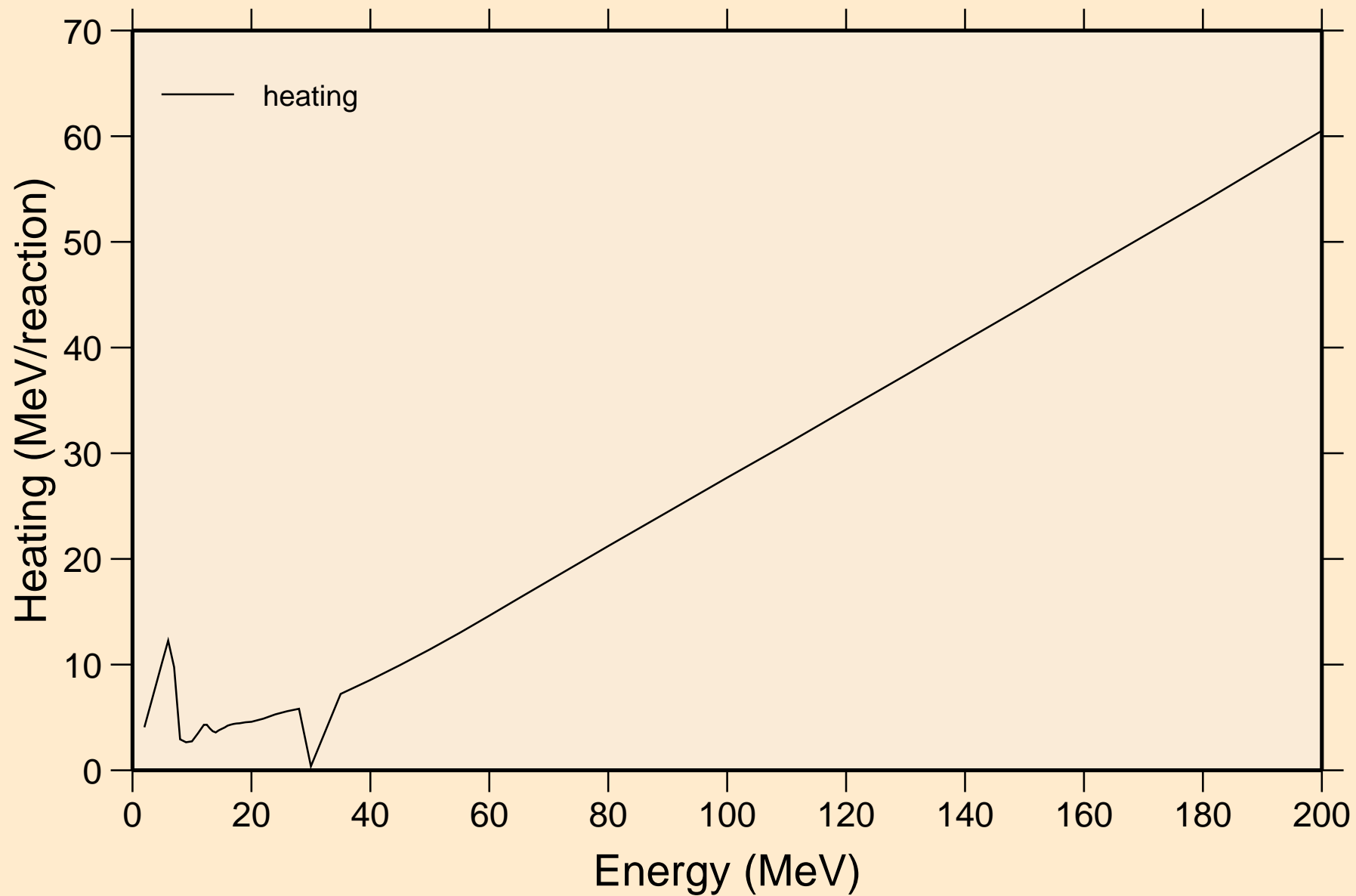

CL035 PHOTON ACER TENDL-2023 LIBRARY; T=0.K

Particle heating contributions

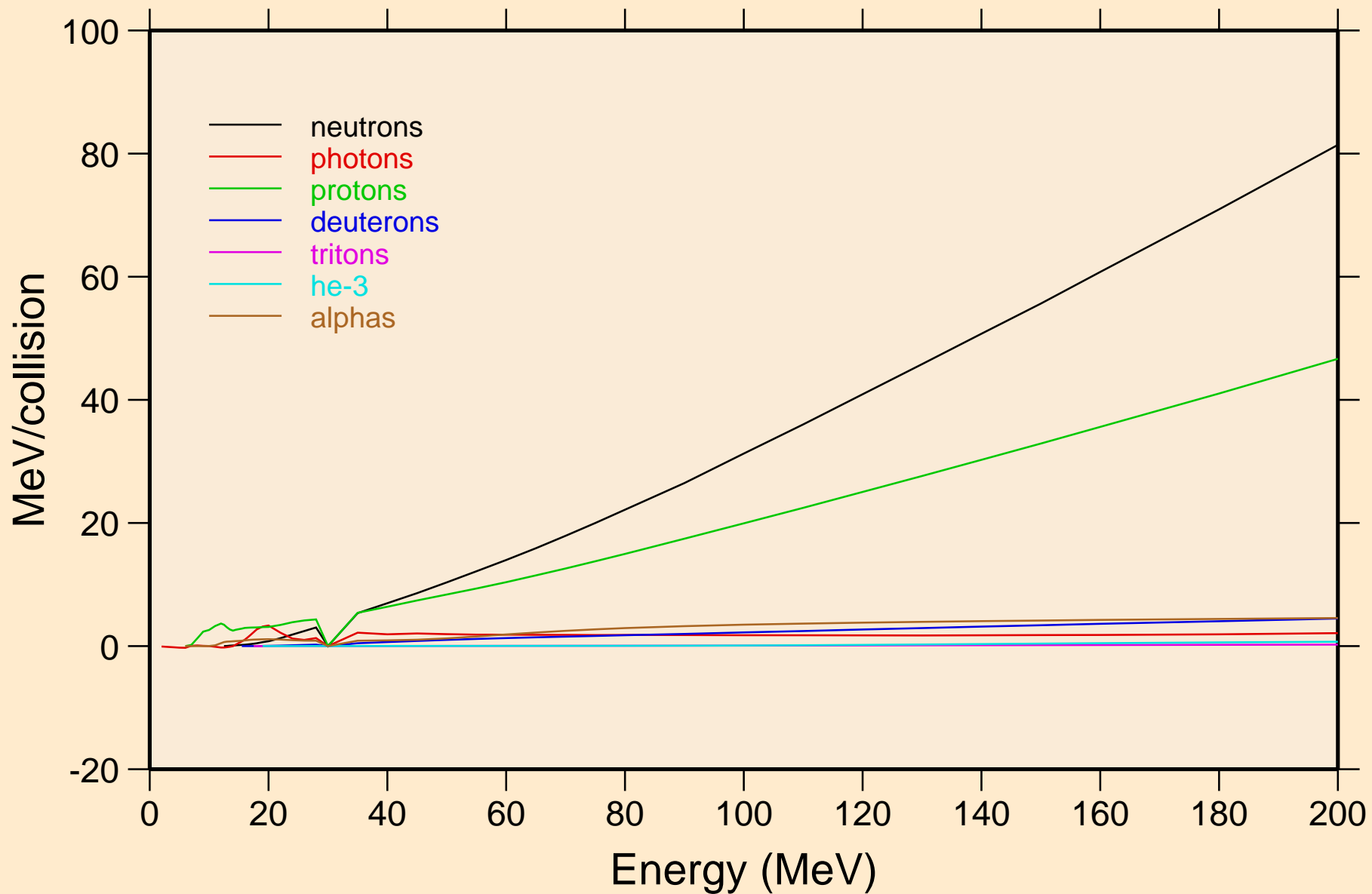

CL035 PHOTON ACER TENDL-2023 LIBRARY; T=0.K

Particle production cross sections

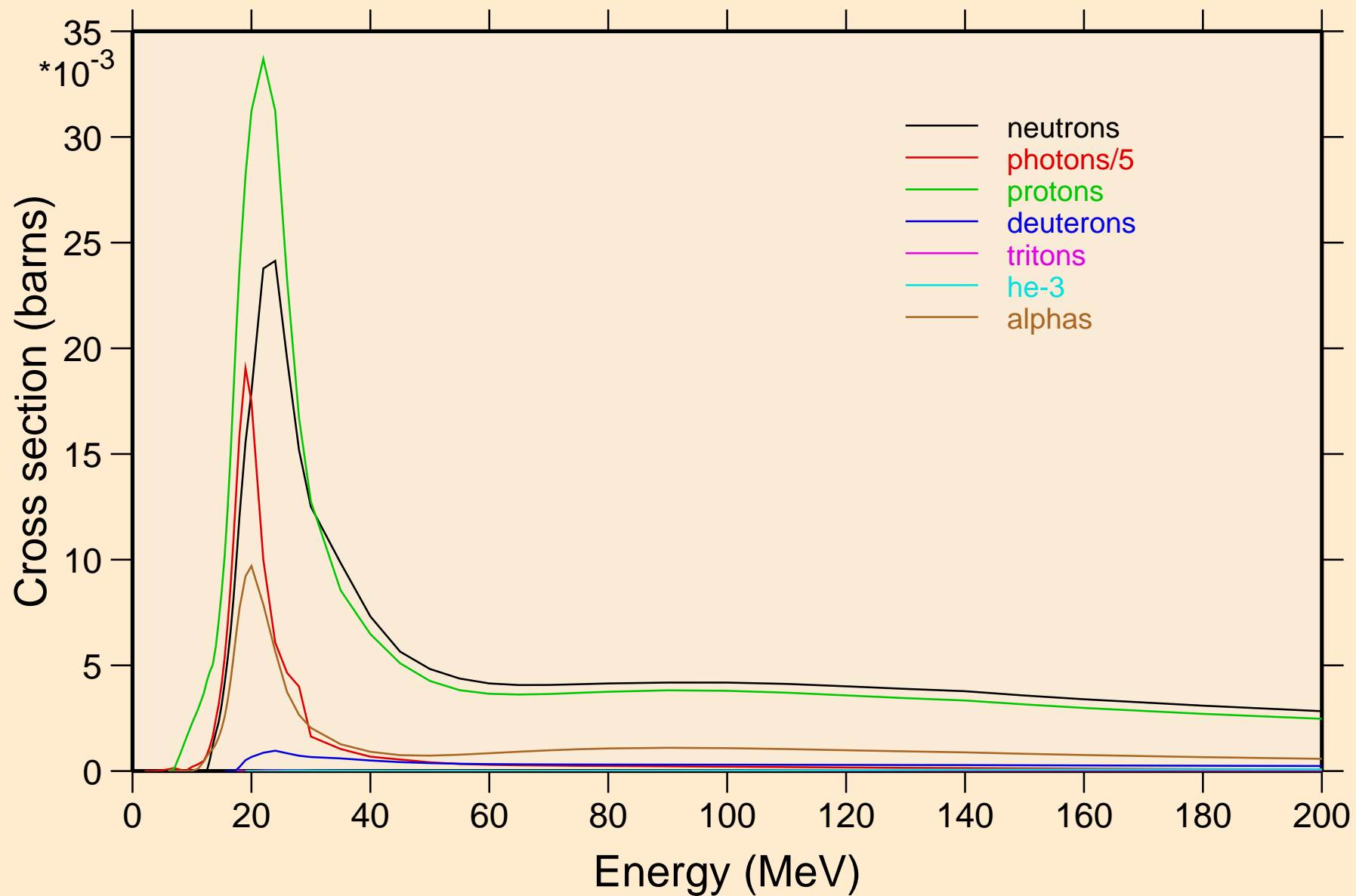

CL035 PHOTON ACER TENDL-2023 LIBRARY; T=0.K
neutrons from (g,x)

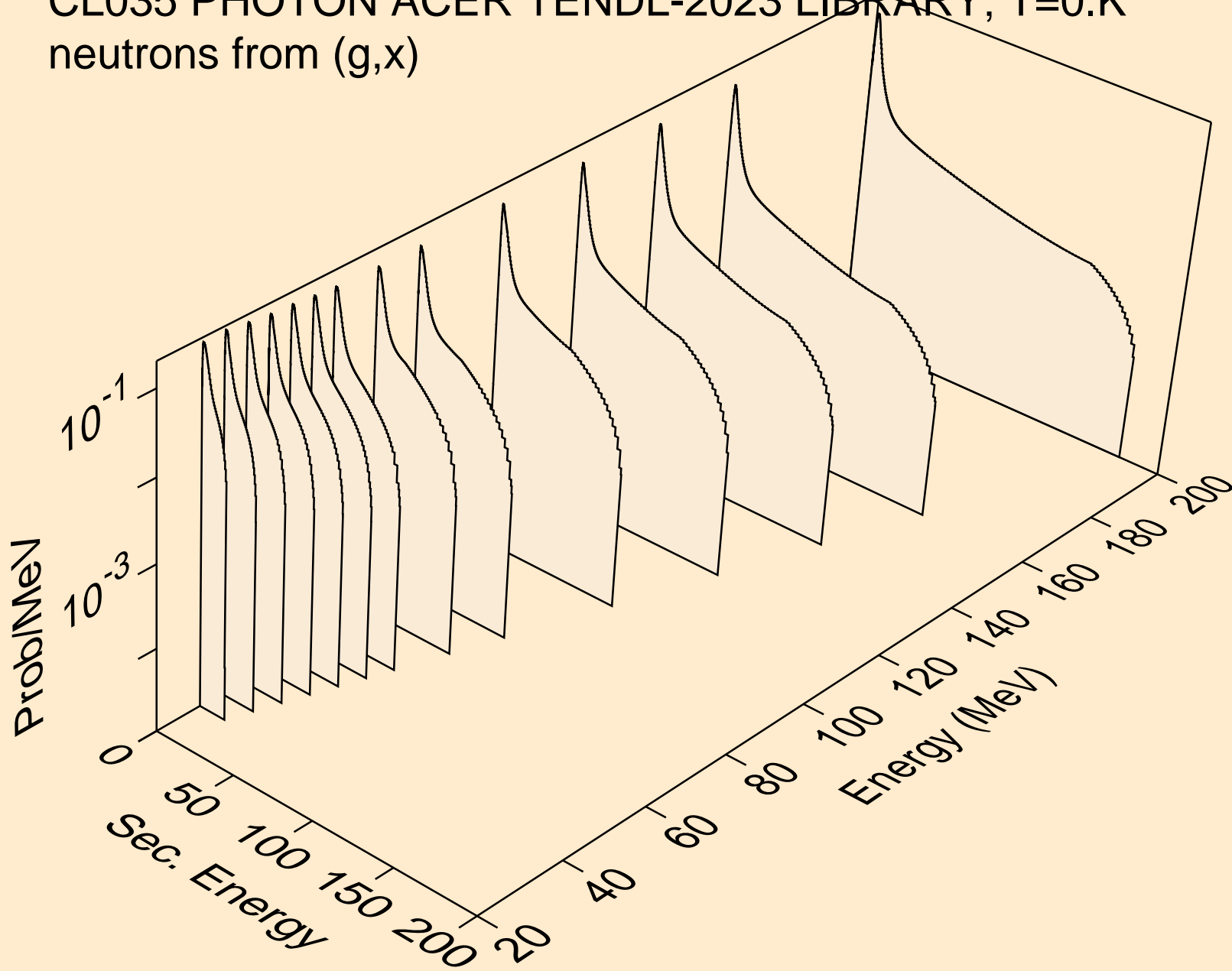

CL035 PHOTON ACER TENDL-2023 LIBRARY; T=0.K
neutrons from (g,2n)

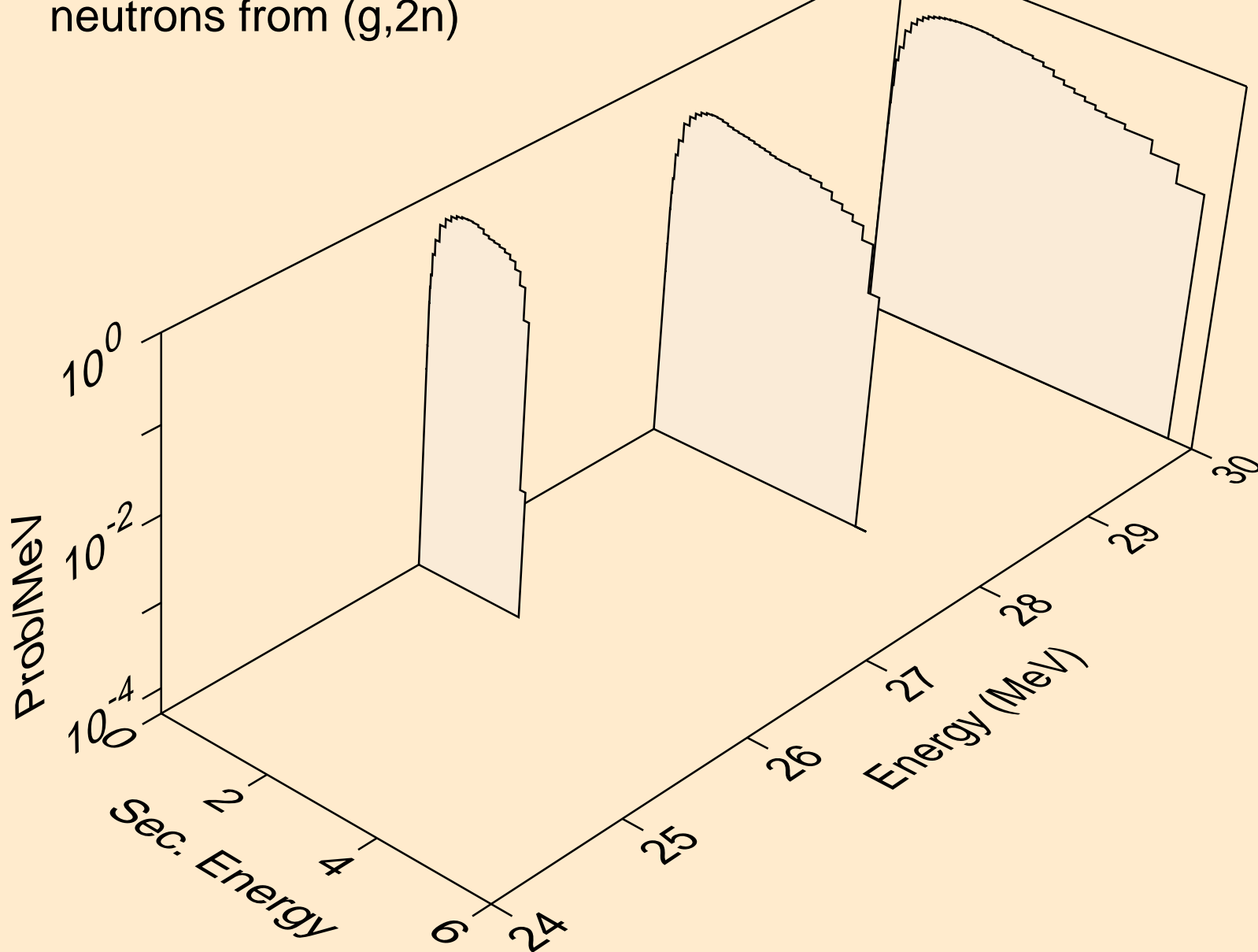

CL035 PHOTON ACER TENDL-2023 LIBRARY; T=0.K
neutrons from (g,n*)a

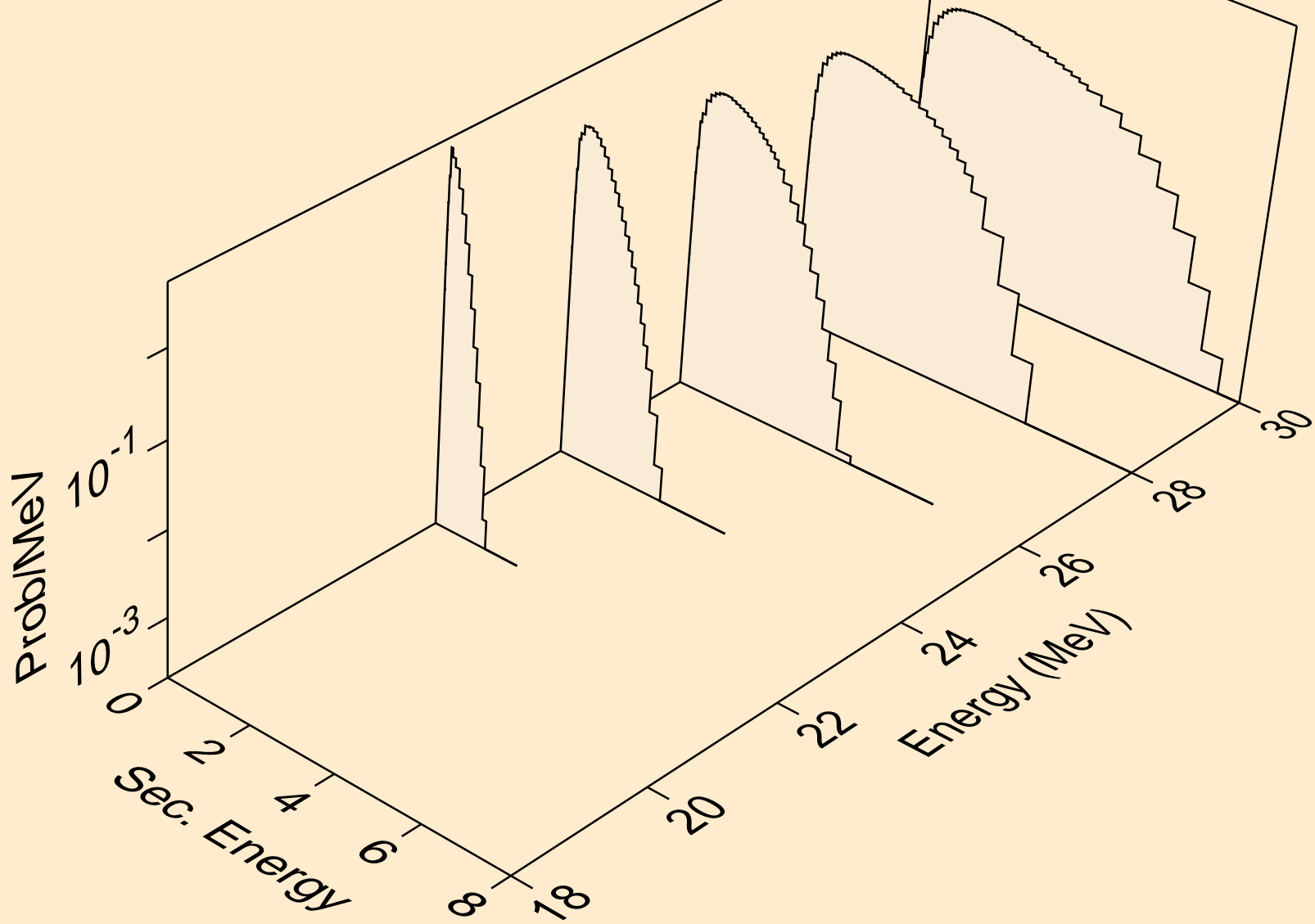

CL035 PHOTON ACER TENDL-2023 LIBRARY; T=0.K
neutrons from (g,n*)p

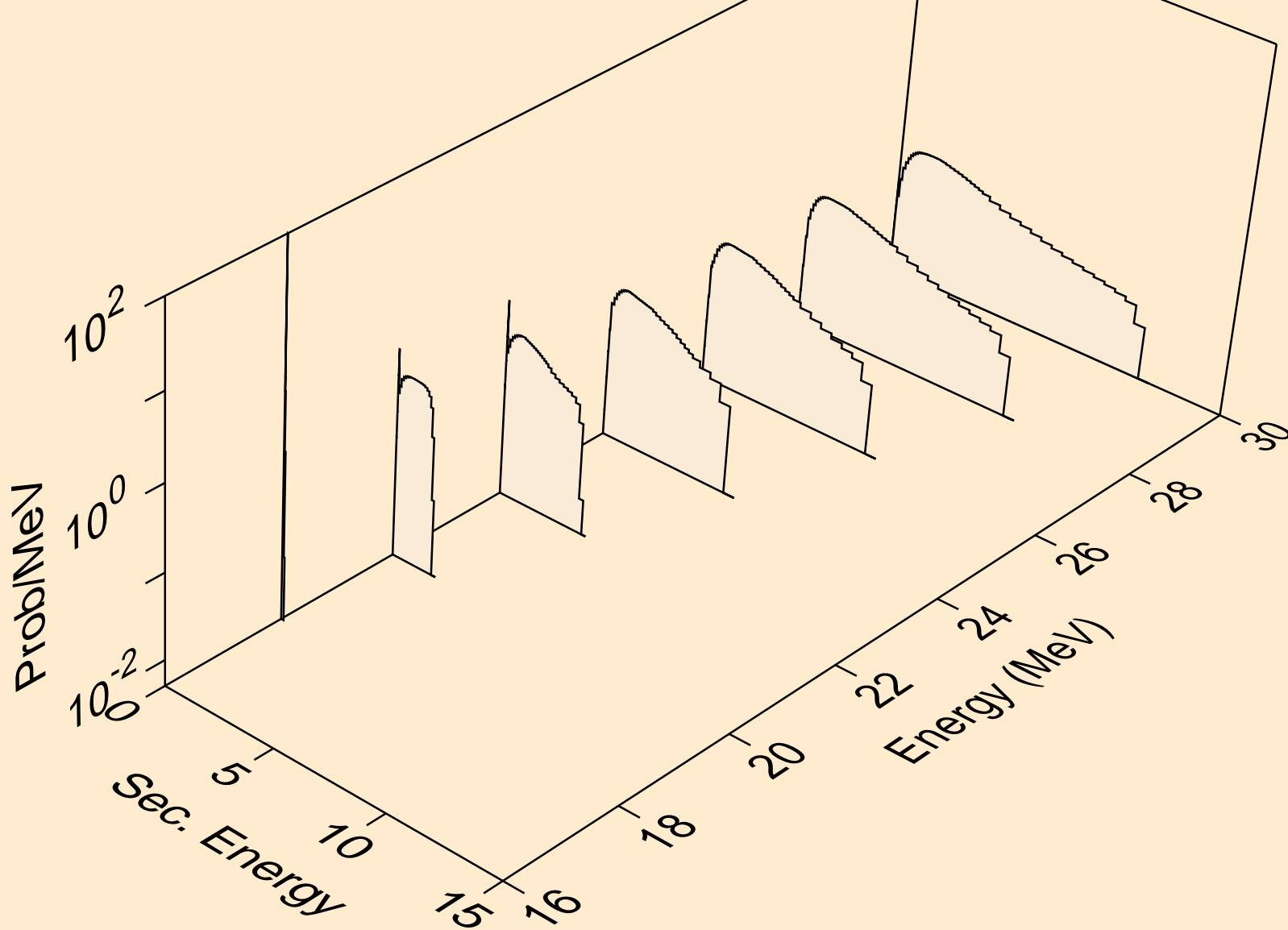

CL035 PHOTON ACER TENDL-2023 LIBRARY; T=0.K
neutrons from (g,n*)d

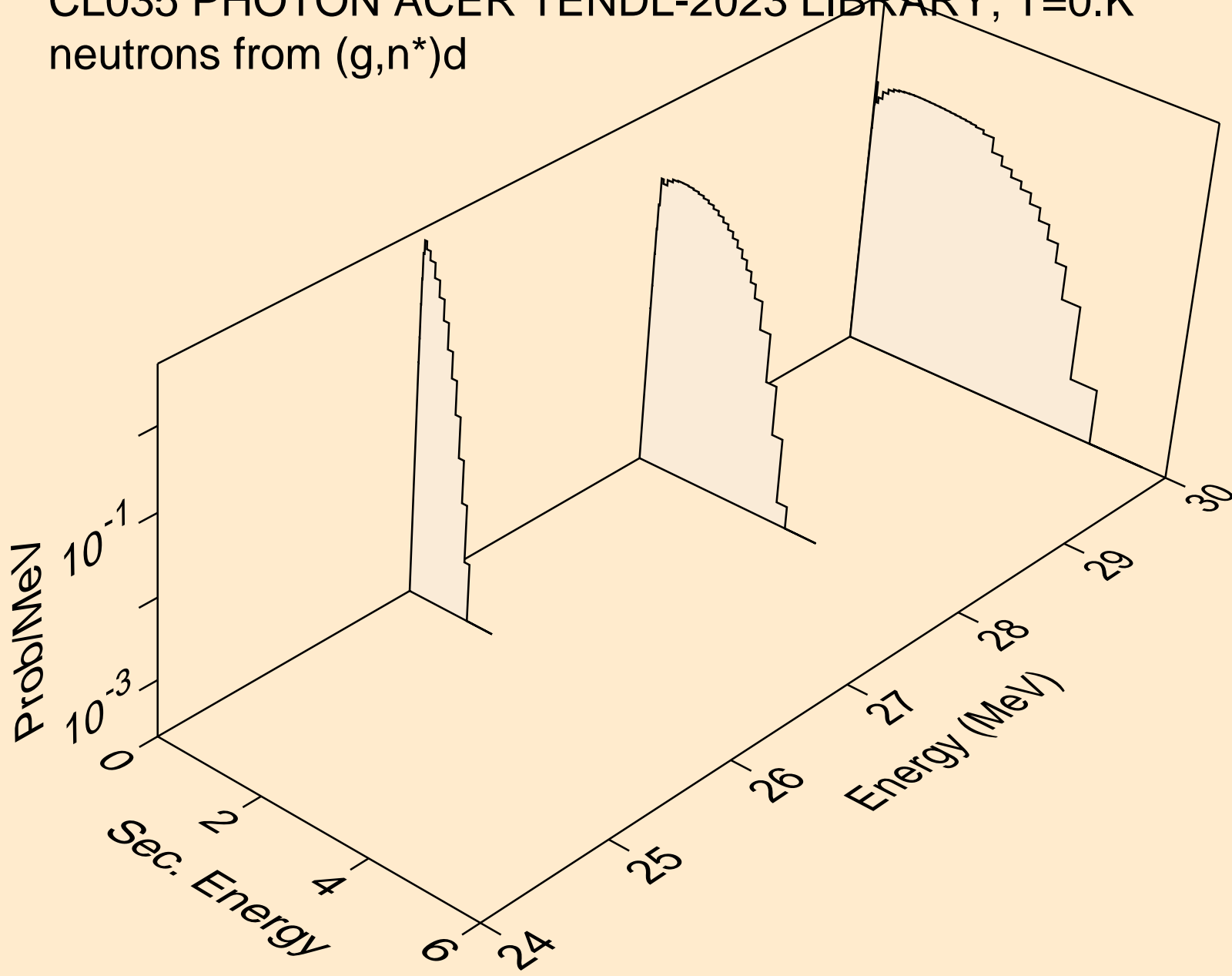

CL035 PHOTON ACER TENDL-2023 LIBRARY; T=0.K
neutrons from (g,2np)

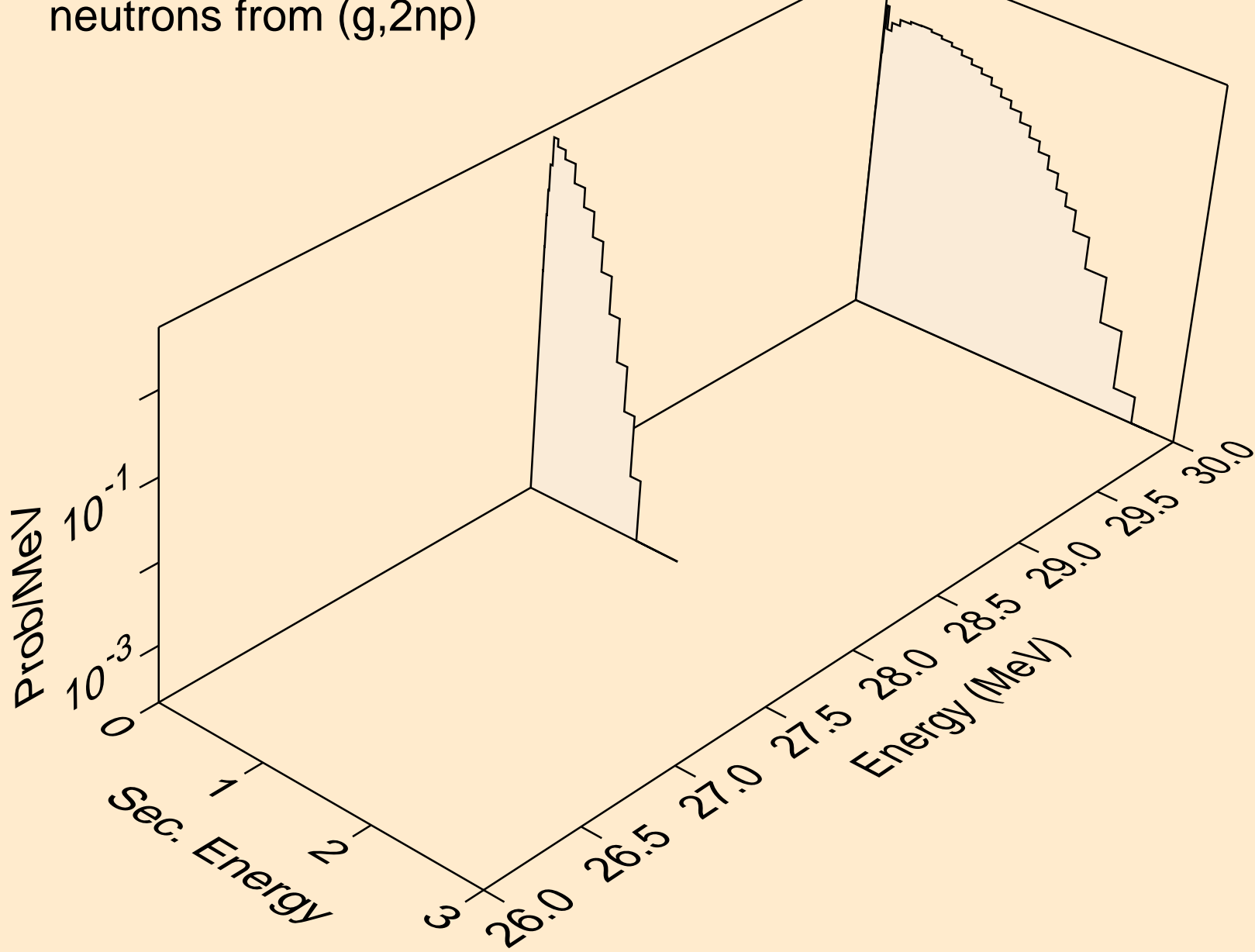

CL035 PHOTON ACER TENDL-2023 LIBRARY; T=0.K
neutrons from (g,npa)

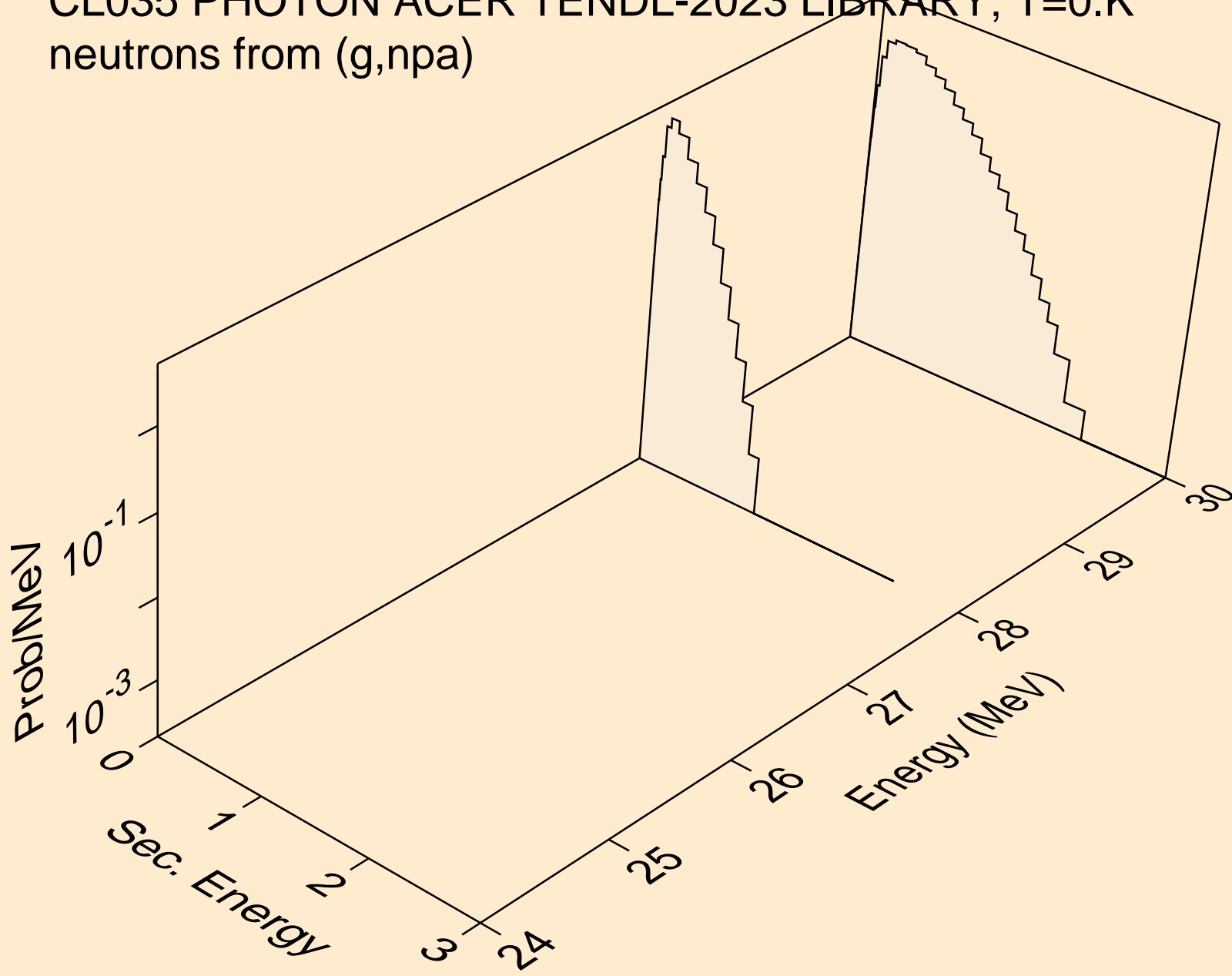

CL035 PHOTON ACER TENDL-2023 LIBRARY; T=0.K
angular distribution for (g,n*0) neutron

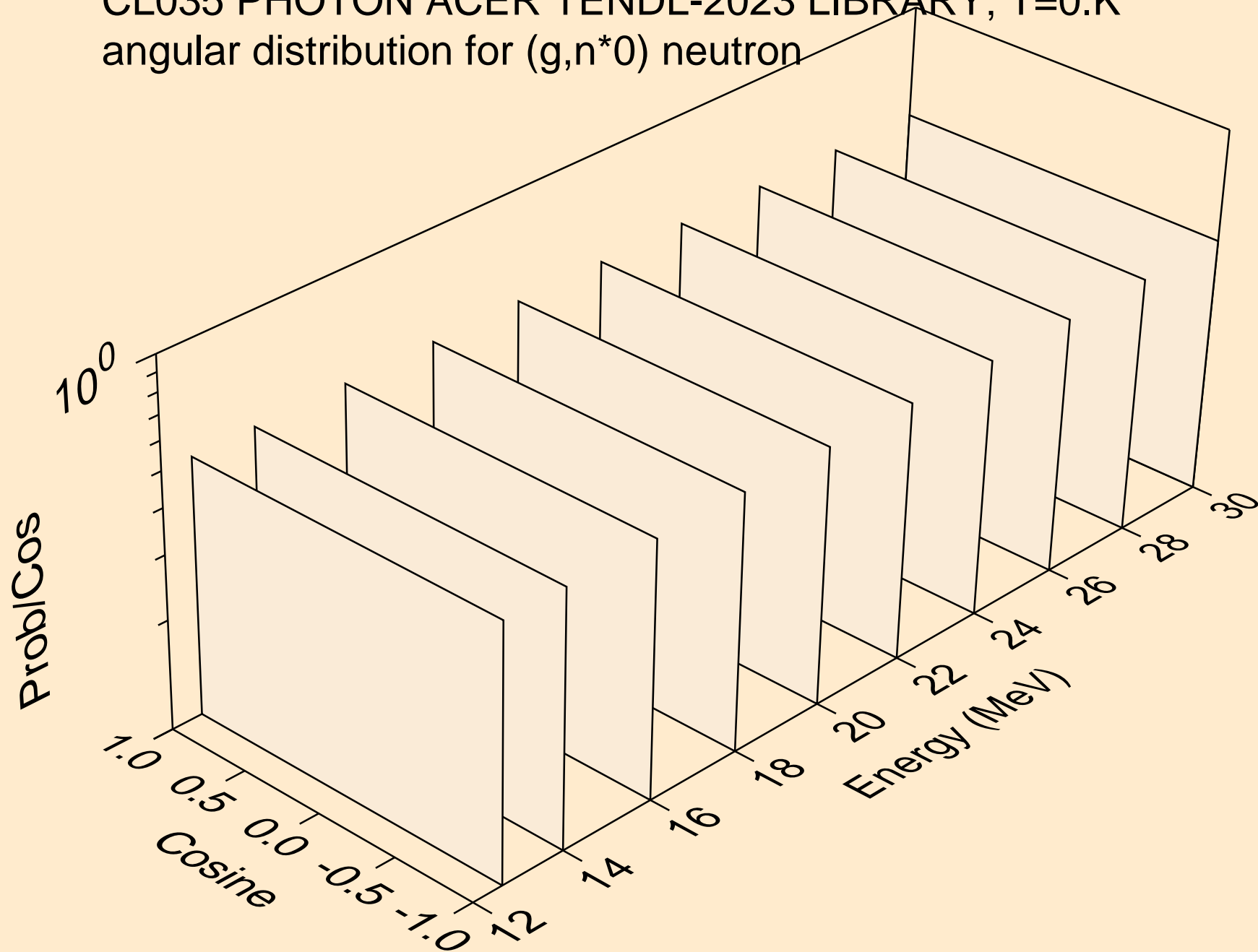

CL035 PHOTON ACER TENDL-2023 LIBRARY; T=0.K
angular distribution for (g,n*1) neutron

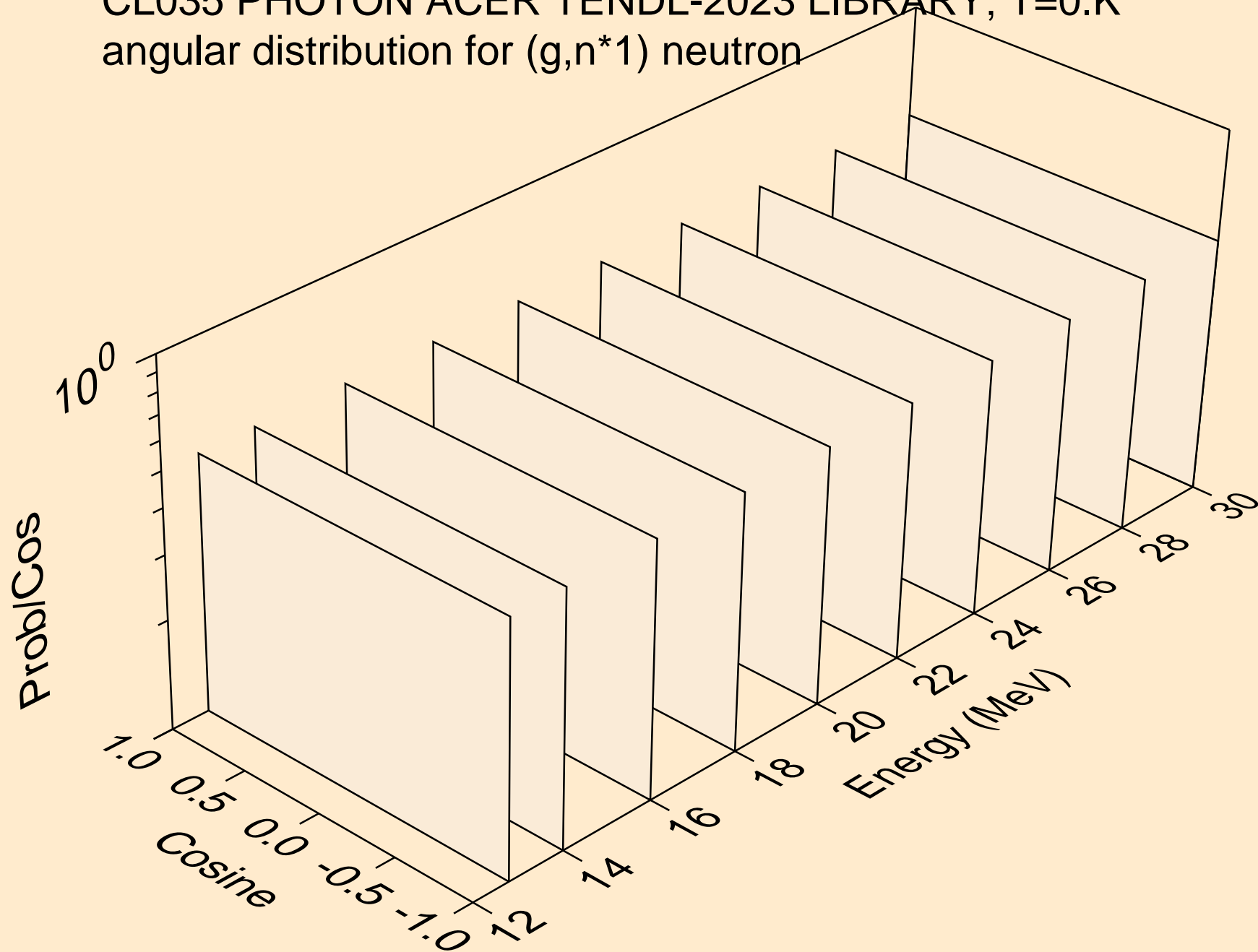

CL035 PHOTON ACER TENDL-2023 LIBRARY; T=0.K
neutrons from (g,n*c)

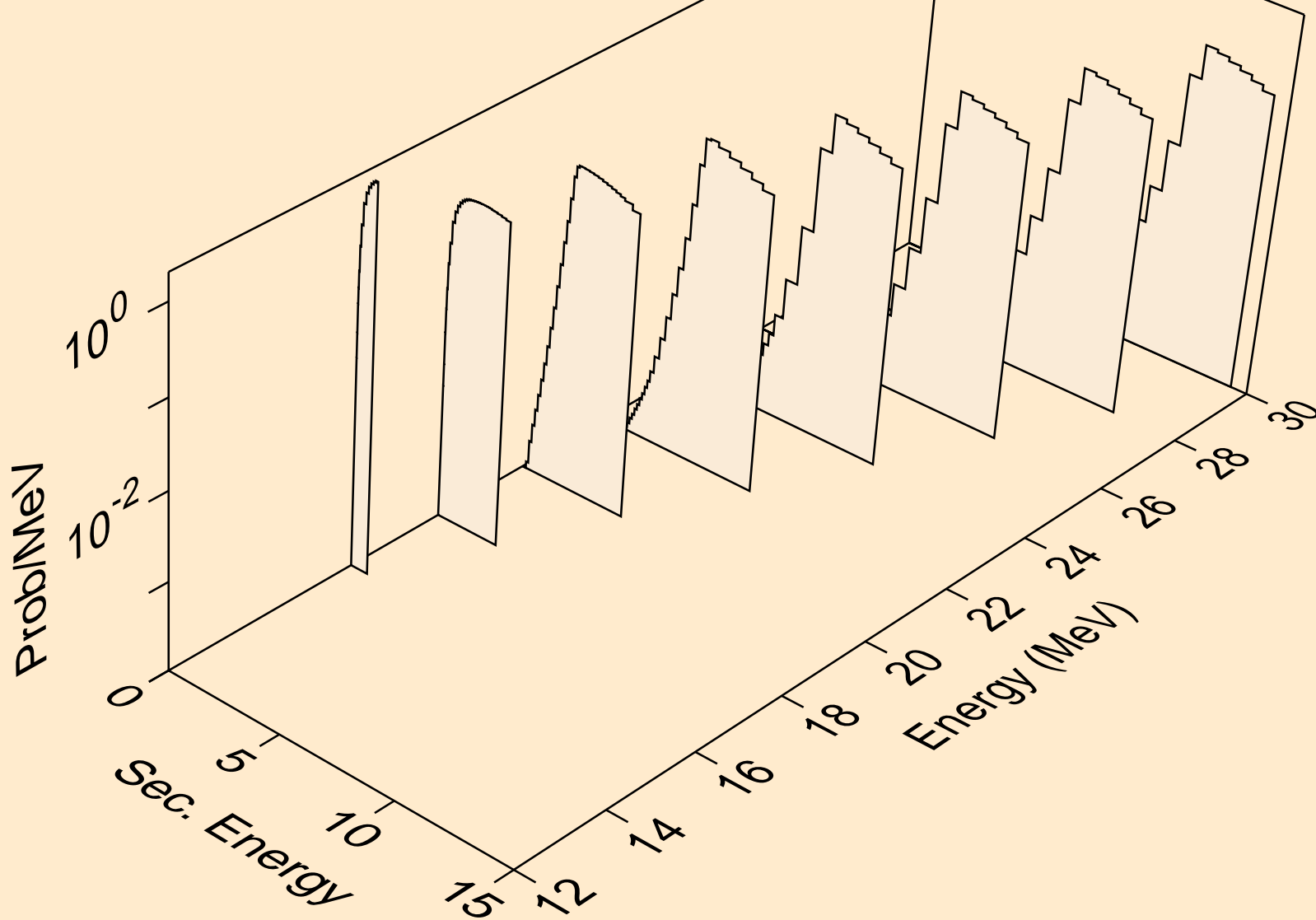

CL035 PHOTON ACER TENDL-2023 LIBRARY; T=0.K
photons from (g,x)

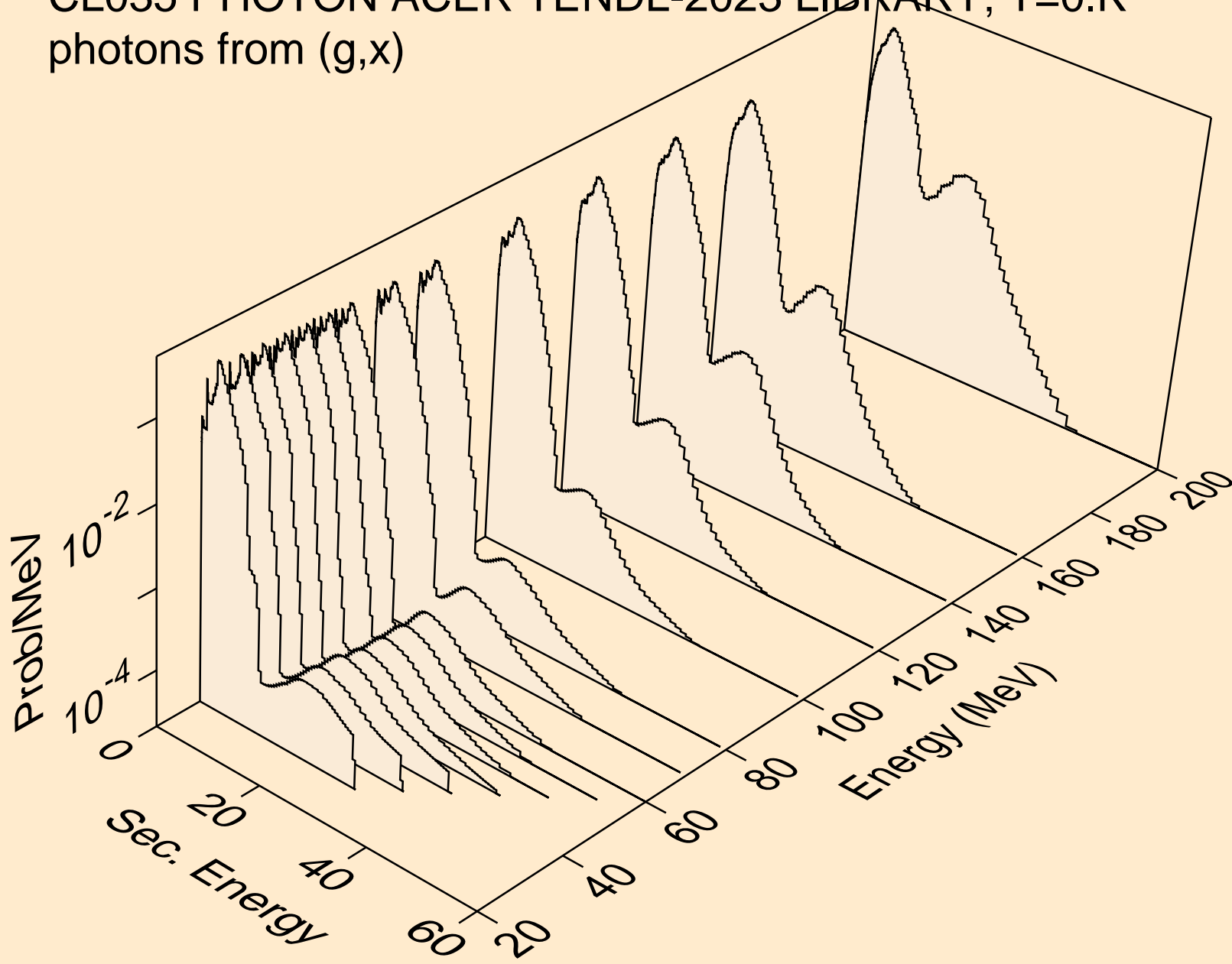

CL035 PHOTON ACER TENDL-2023 LIBRARY; T=0.K
photons from (g,2n)

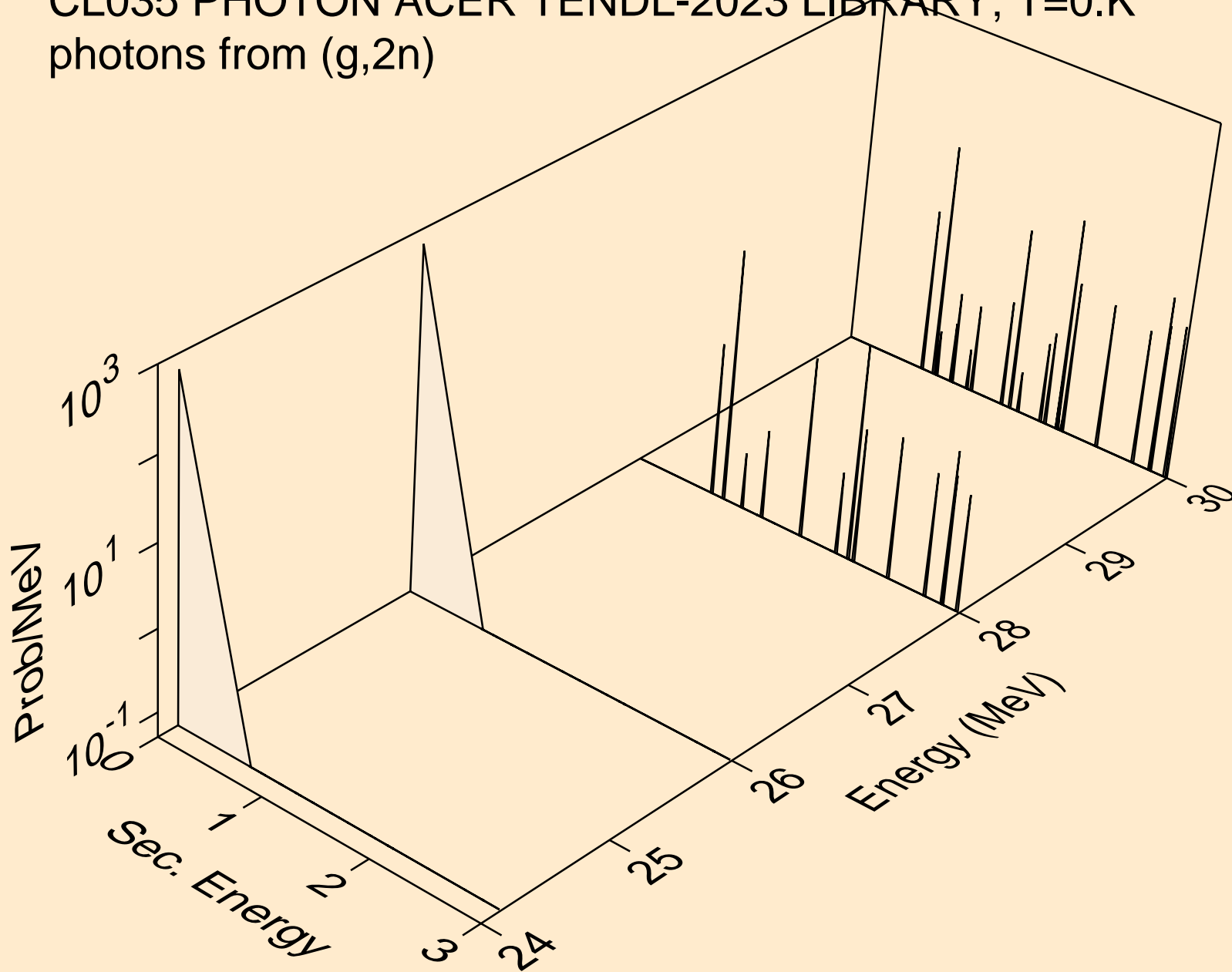

CL035 PHOTON ACER TENDL-2023 LIBRARY; T=0.K
photons from (g,n*)a

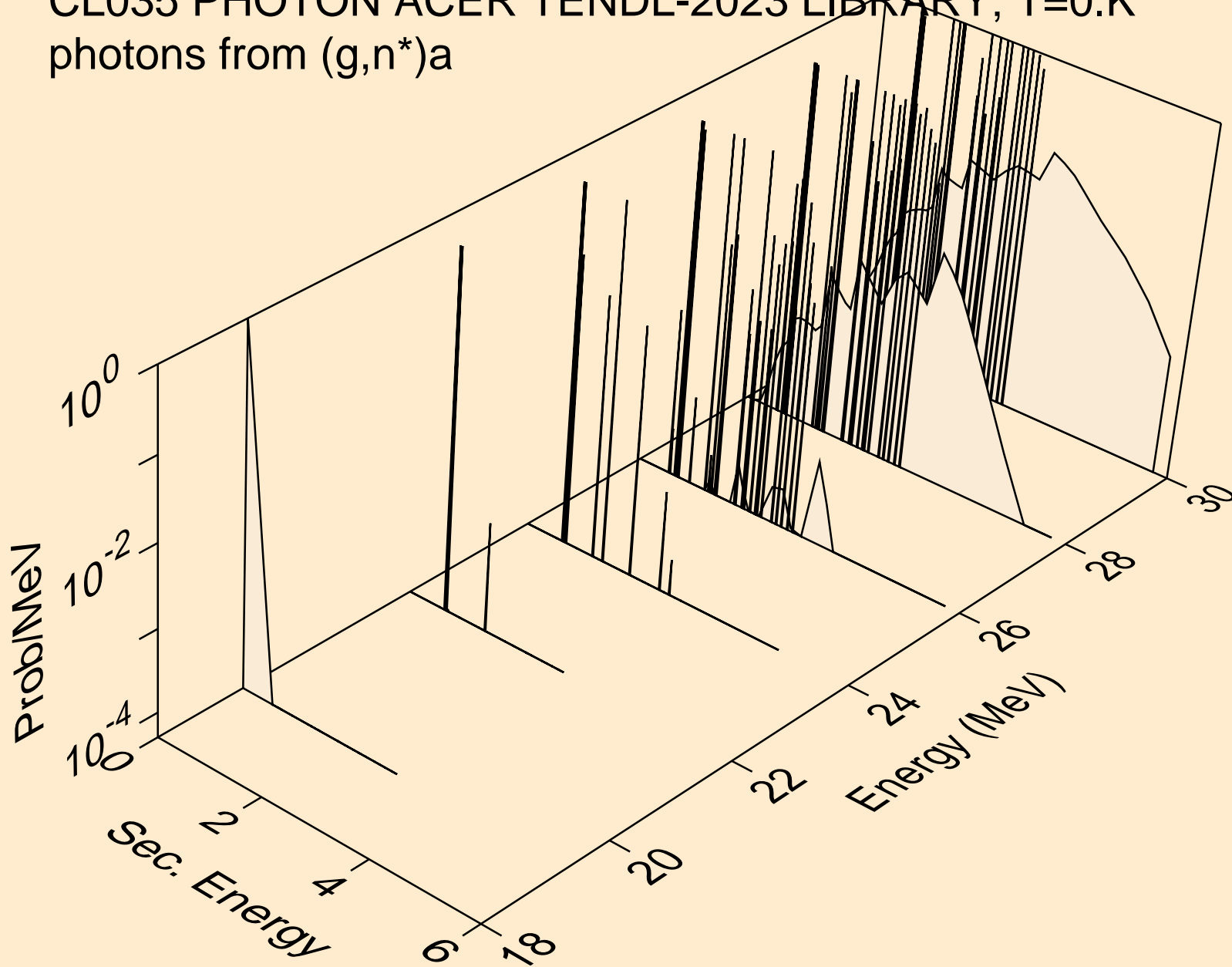

CL035 PHOTON ACER TENDL-2023 LIBRARY; T=0.K
photons from (g,n*)p

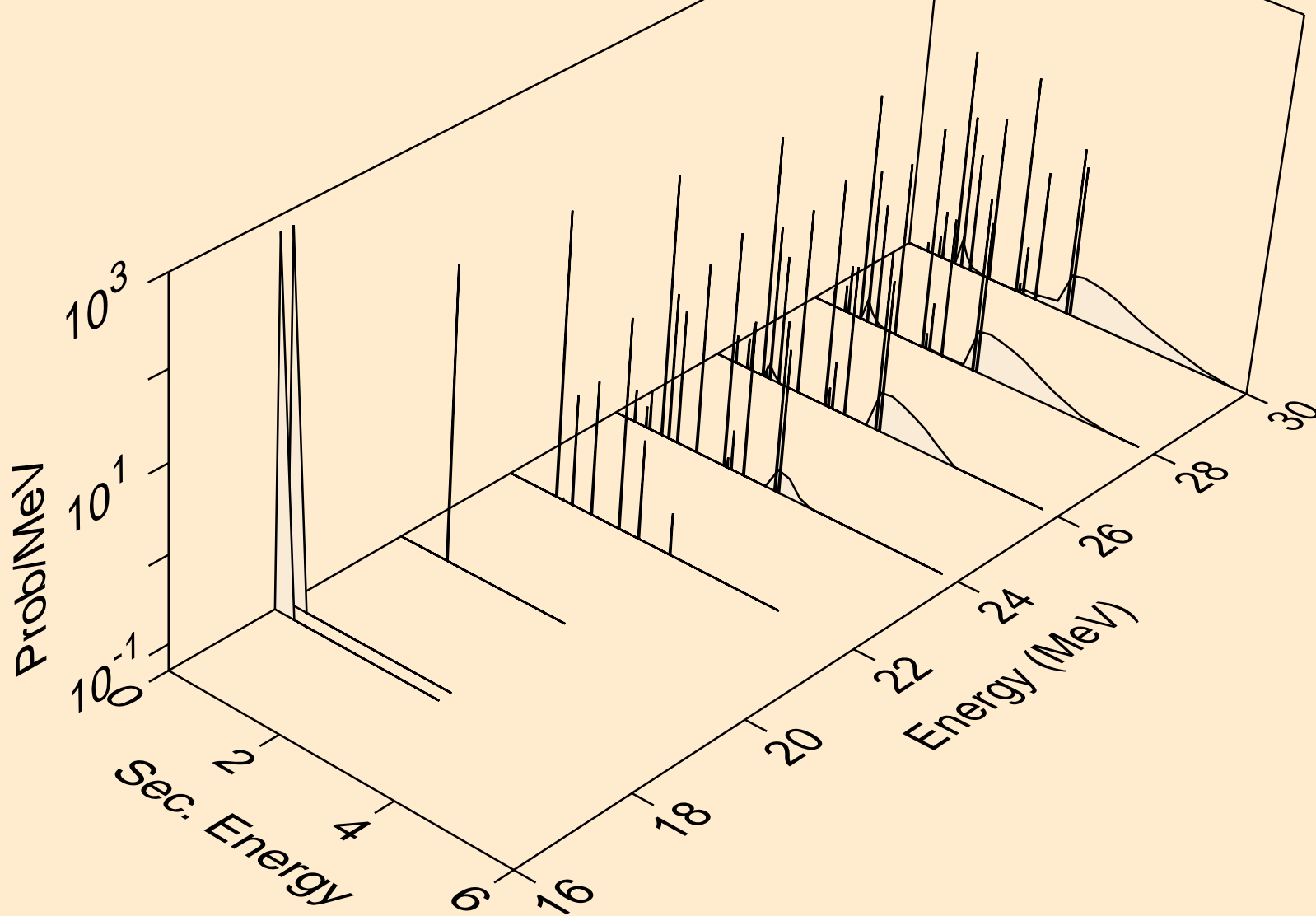

CL035 PHOTON ACER TENDL-2023 LIBRARY; T=0.K
photons from (g,n*)d

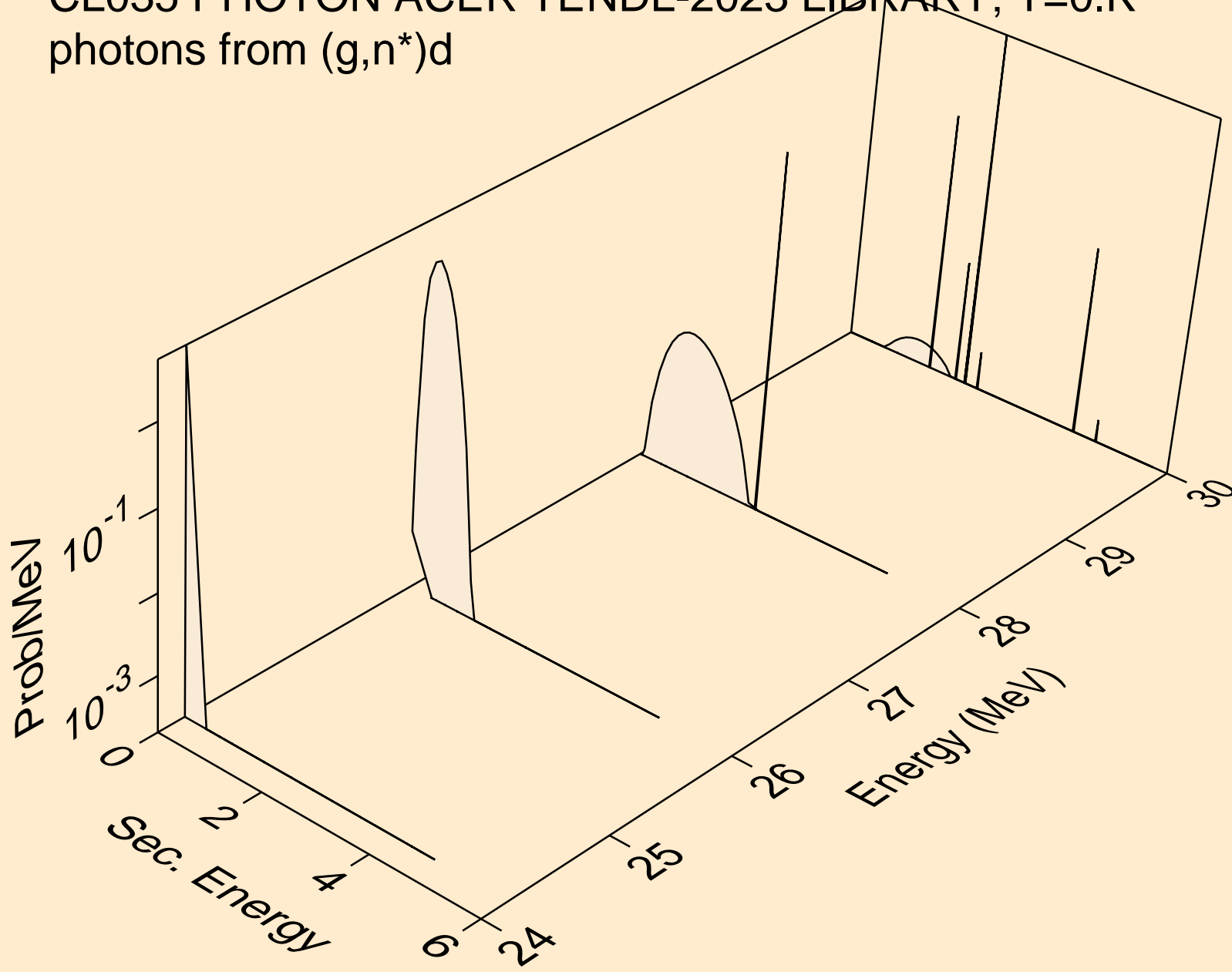

CL035 PHOTON ACER TENDL-2023 LIBRARY; T=0.K
photons from (g,2np)

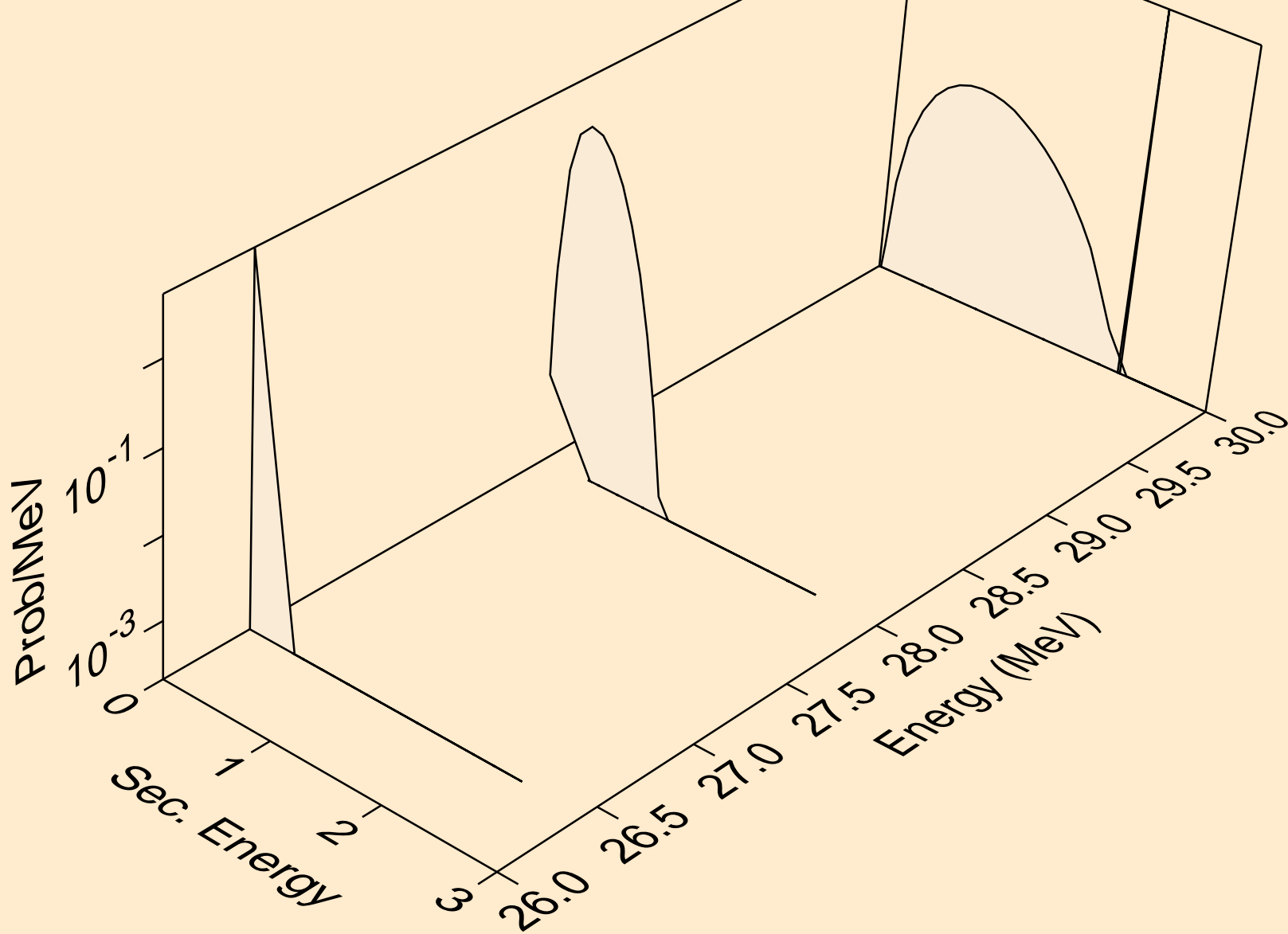

CL035 PHOTON ACER TENDL-2023 LIBRARY; T=0.K
photons from (g,npa)

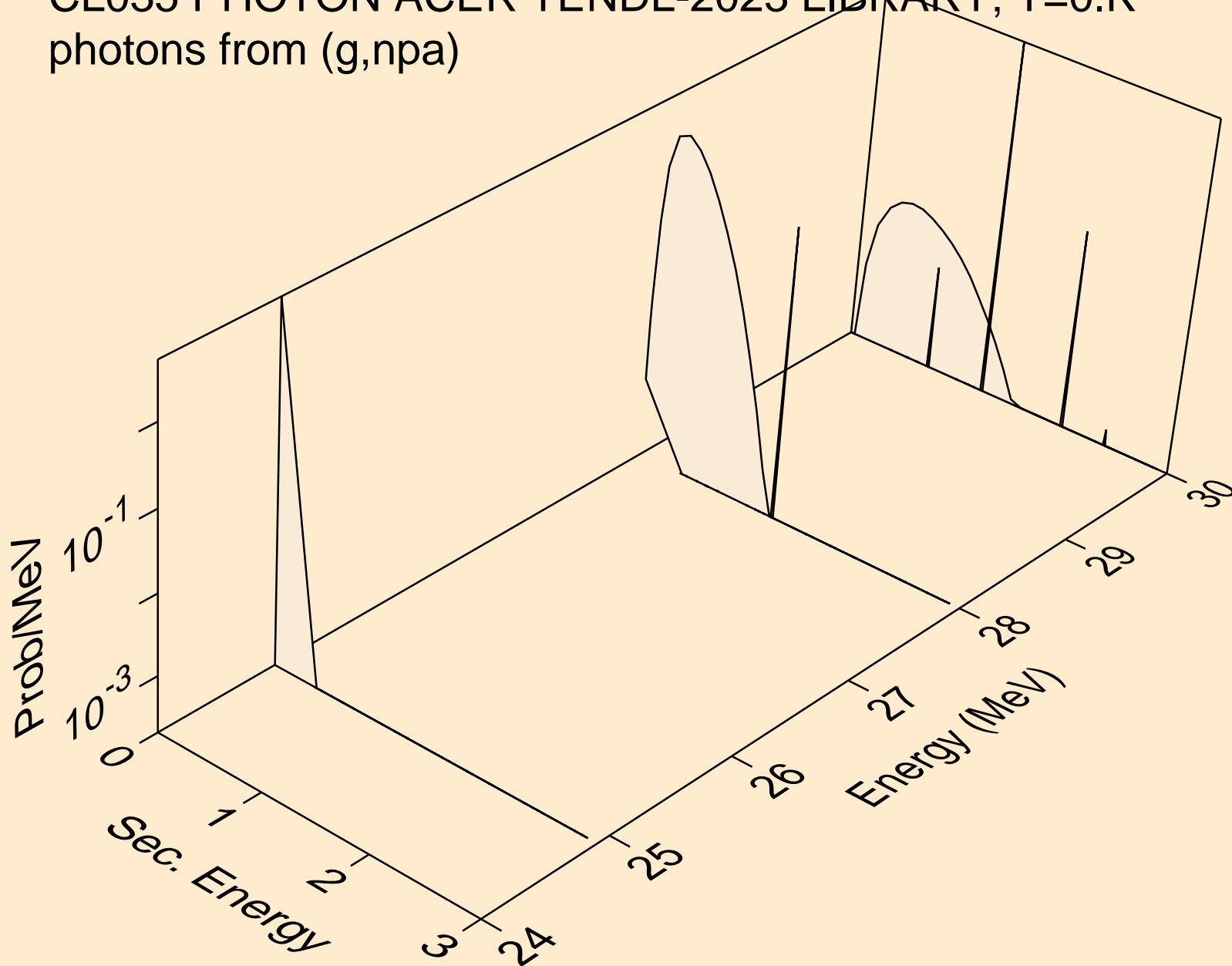

CL035 PHOTON ACER TENDL-2023 LIBRARY; T=0.K
photons from (g,n*c)

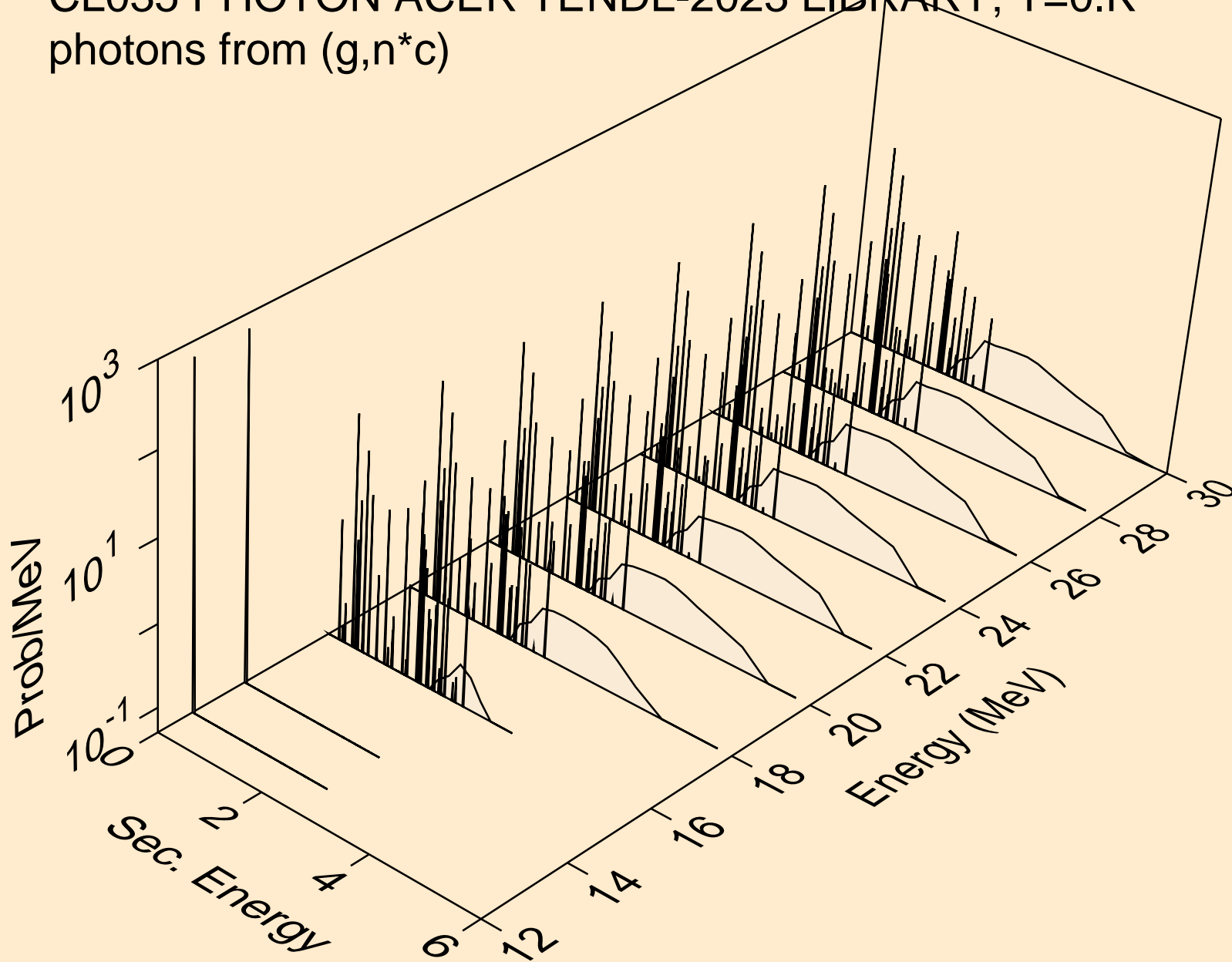

CL035 PHOTON ACER TENDL-2023 LIBRARY; T=0.K
photons from (g,gma)

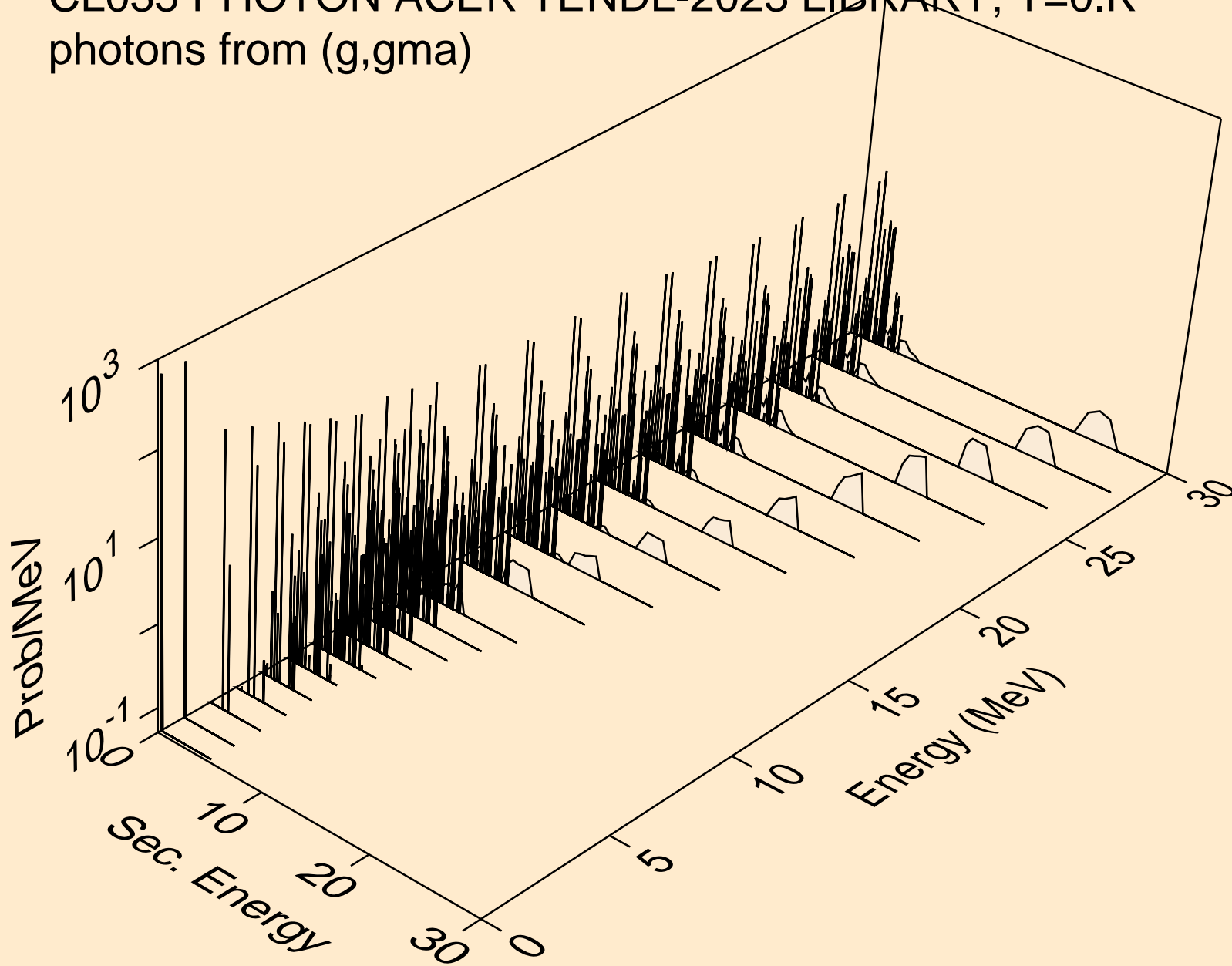

CL035 PHOTON ACER TENDL-2023 LIBRARY; T=0.K
photons from (g,p)

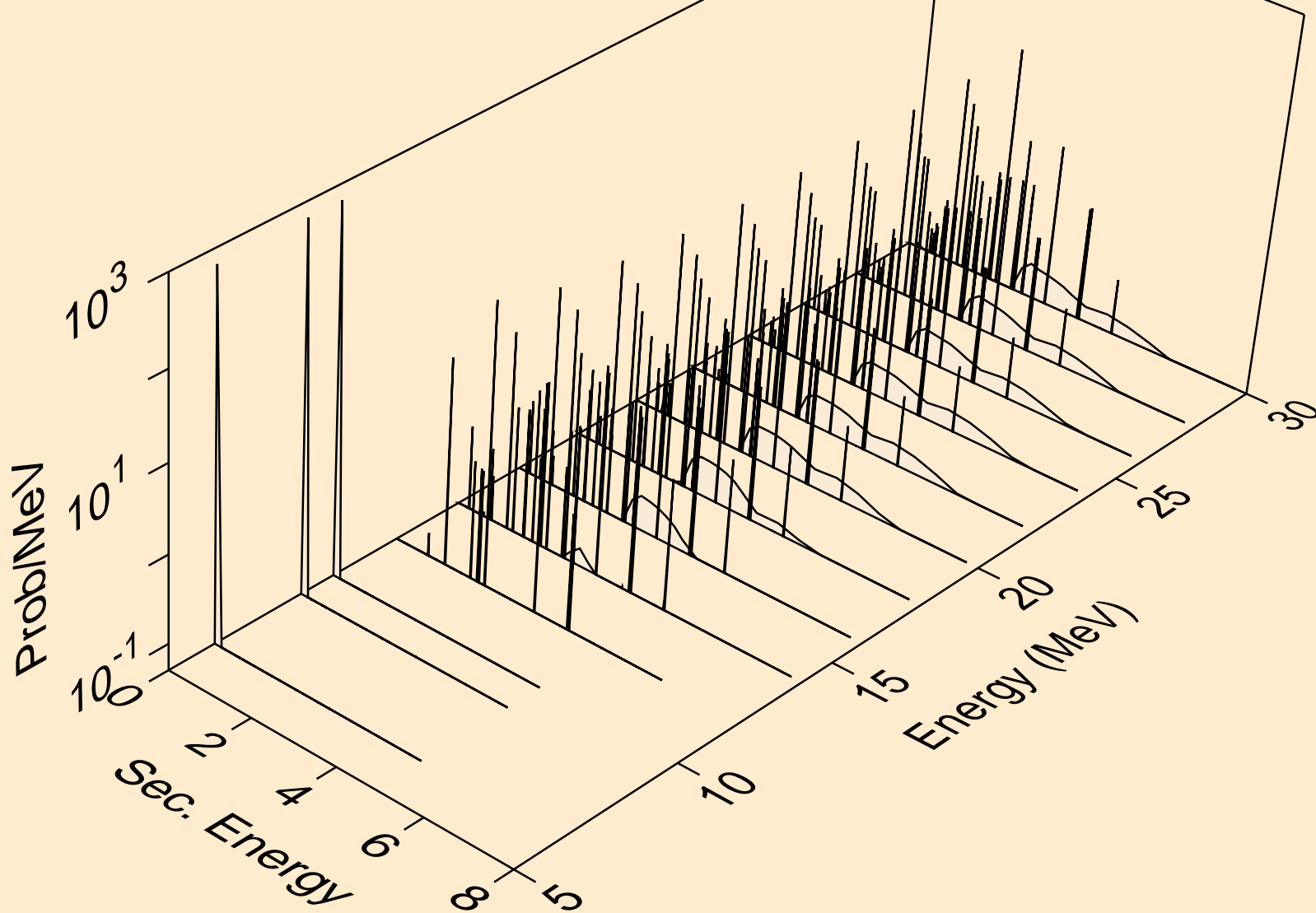

CL035 PHOTON ACER TENDL-2023 LIBRARY; T=0.K
photons from (g,d)

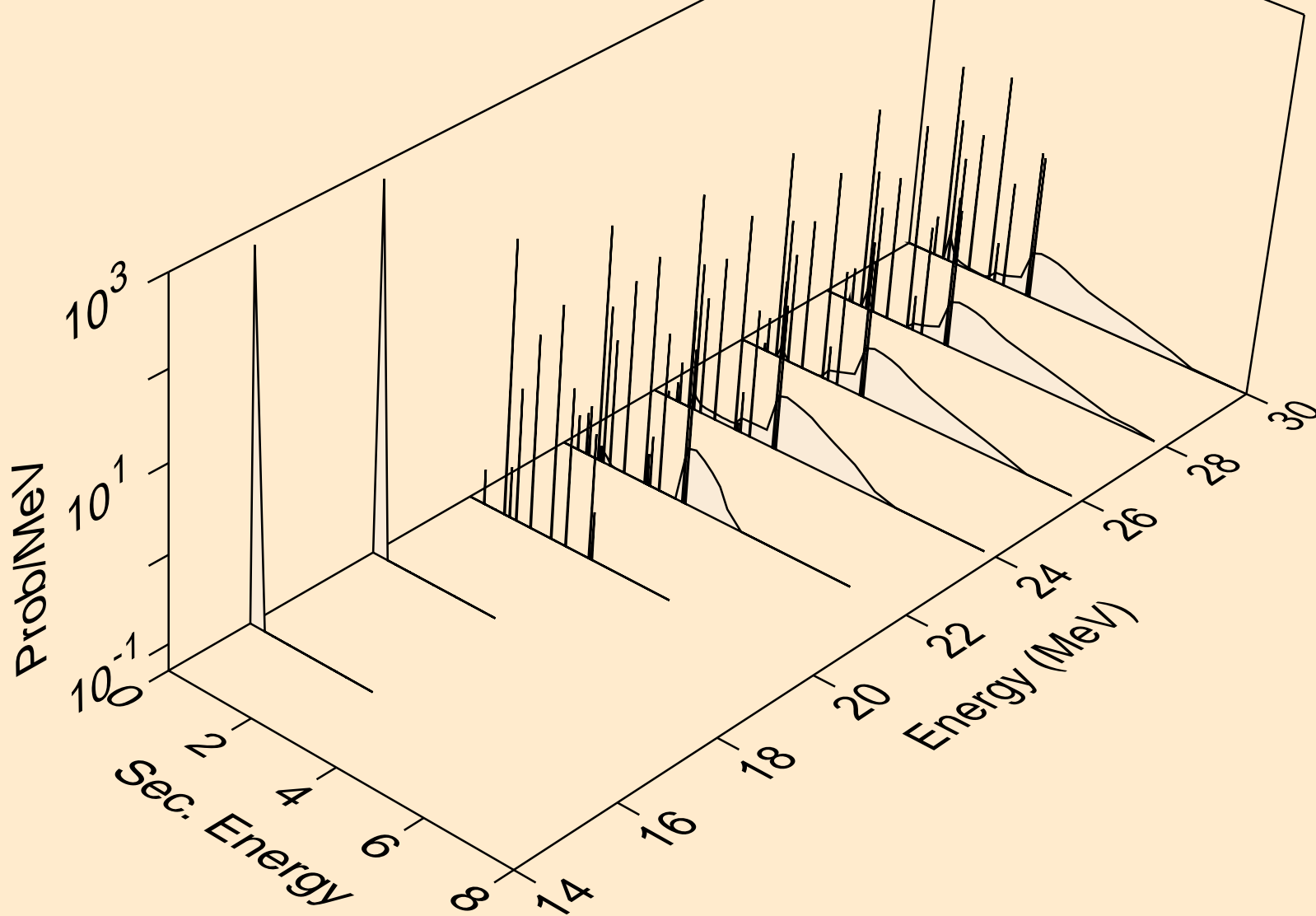

CL035 PHOTON ACER TENDL-2023 LIBRARY; T=0.K
photons from (g,t)

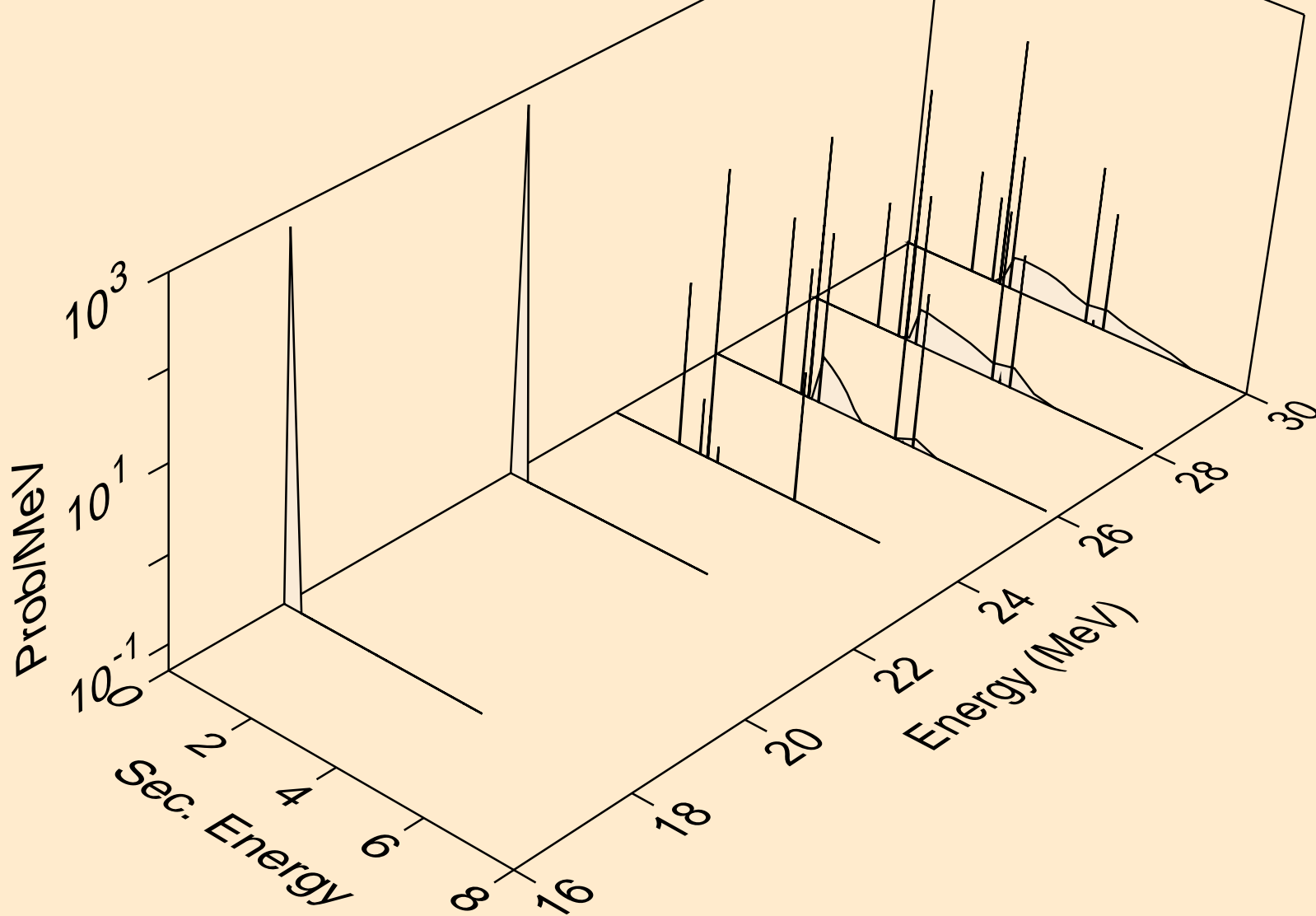

CL035 PHOTON ACER TENDL-2023 LIBRARY; T=0.K
photons from (g,he3)

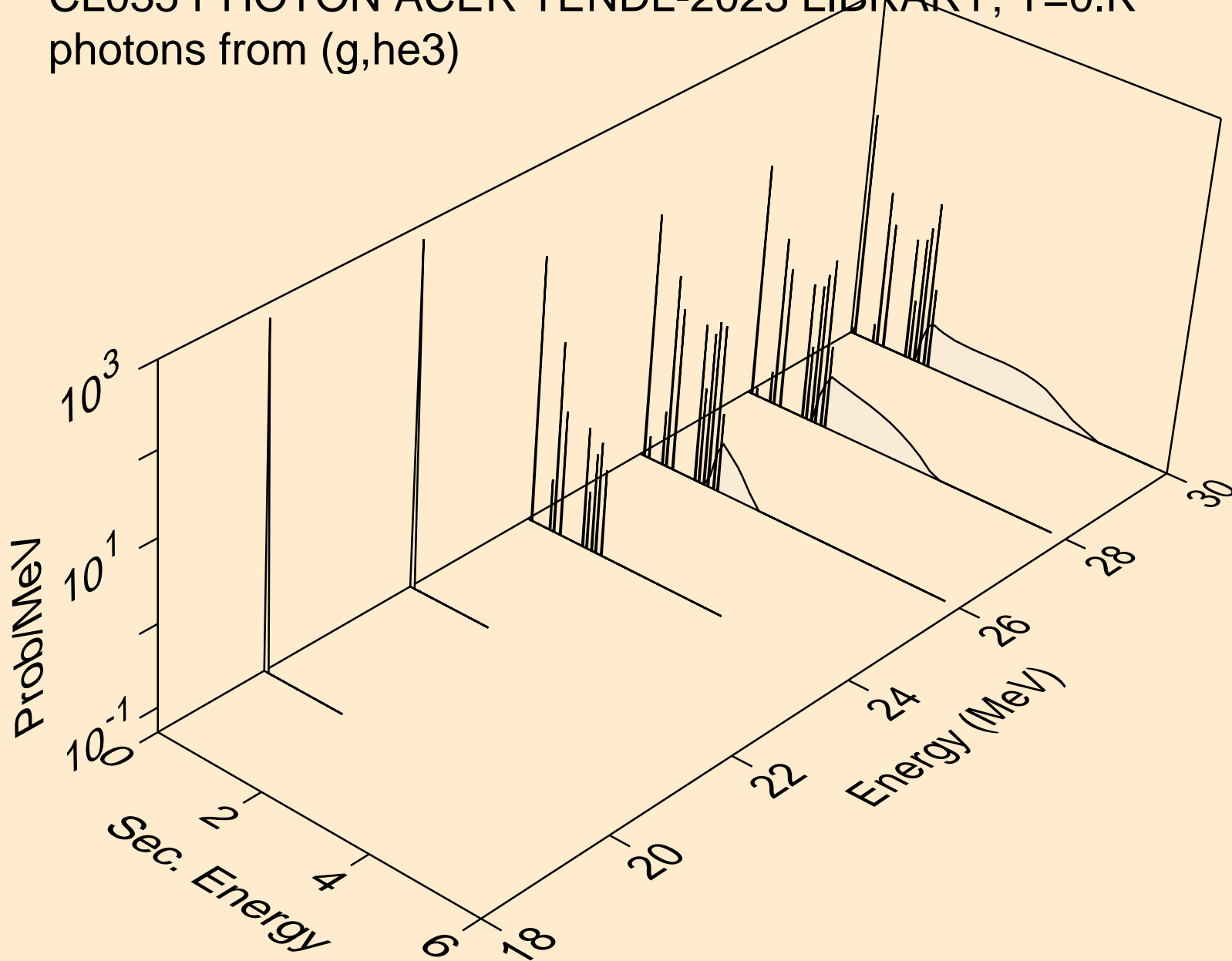

CL035 PHOTON ACER TENDL-2023 LIBRARY; T=0.K
photons from (g,a)

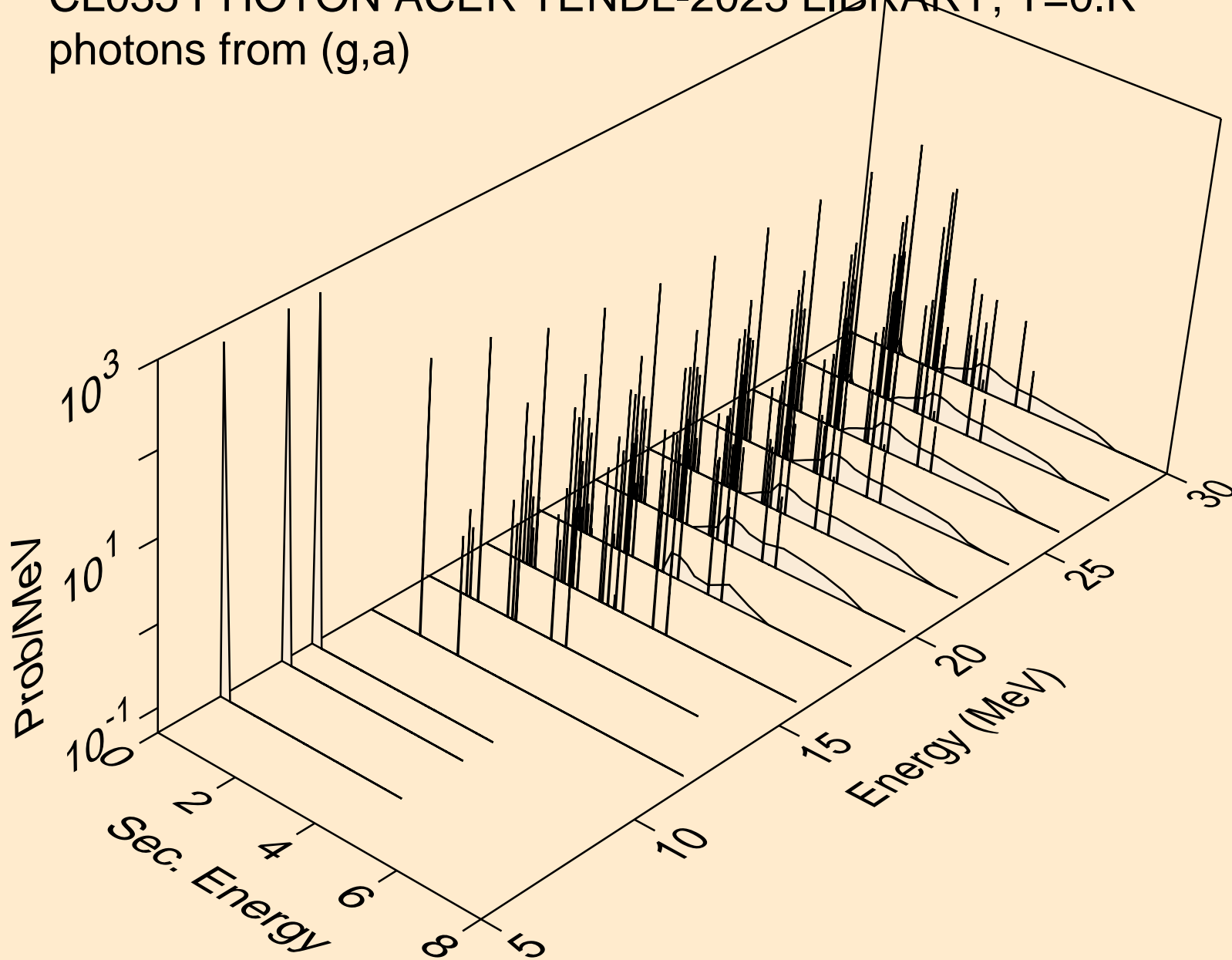

CL035 PHOTON ACER TENDL-2023 LIBRARY; T=0.K
photons from (g,2a)

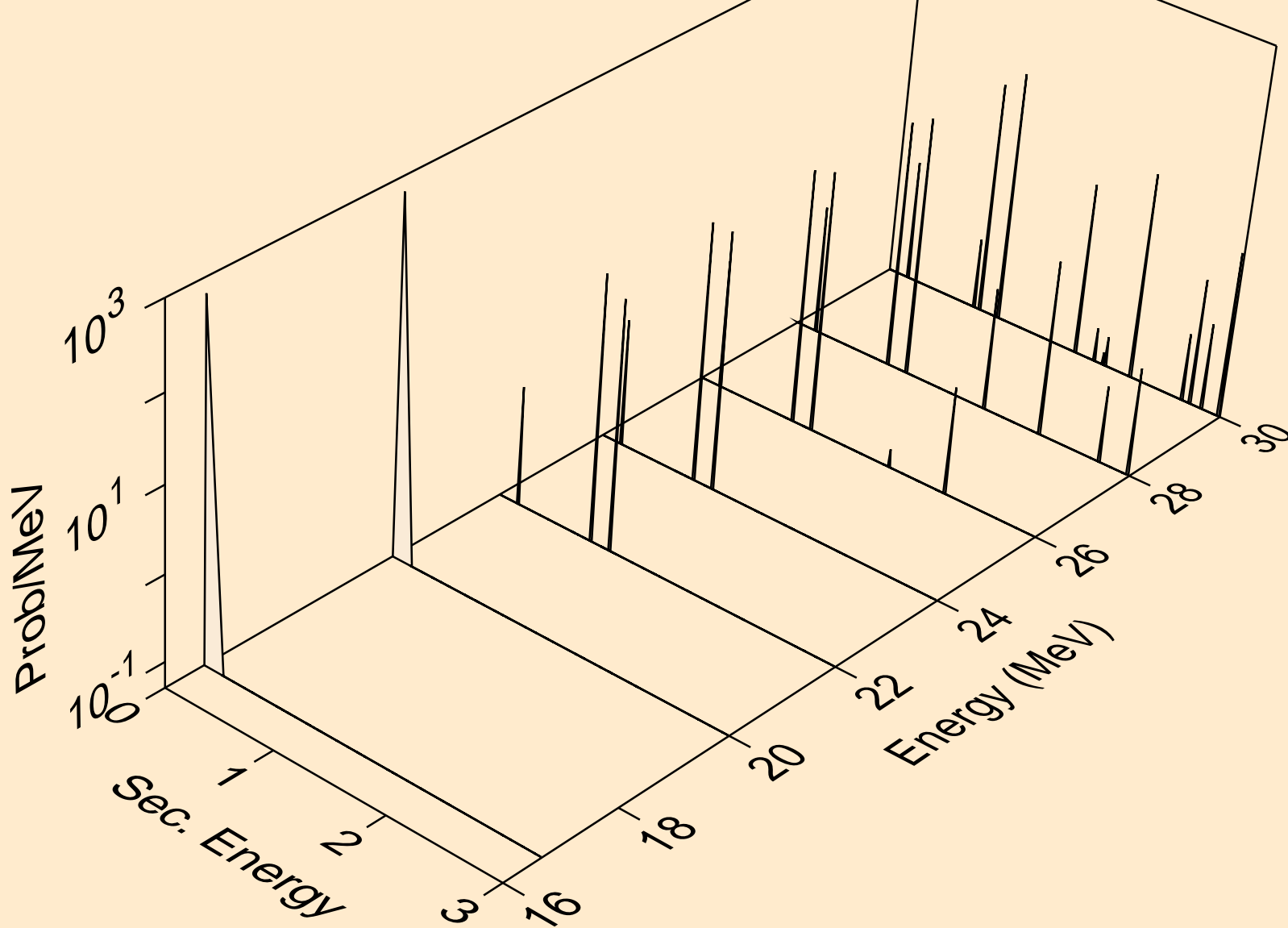

CL035 PHOTON ACER TENDL-2023 LIBRARY; T=0.K
photons from (g,2p)

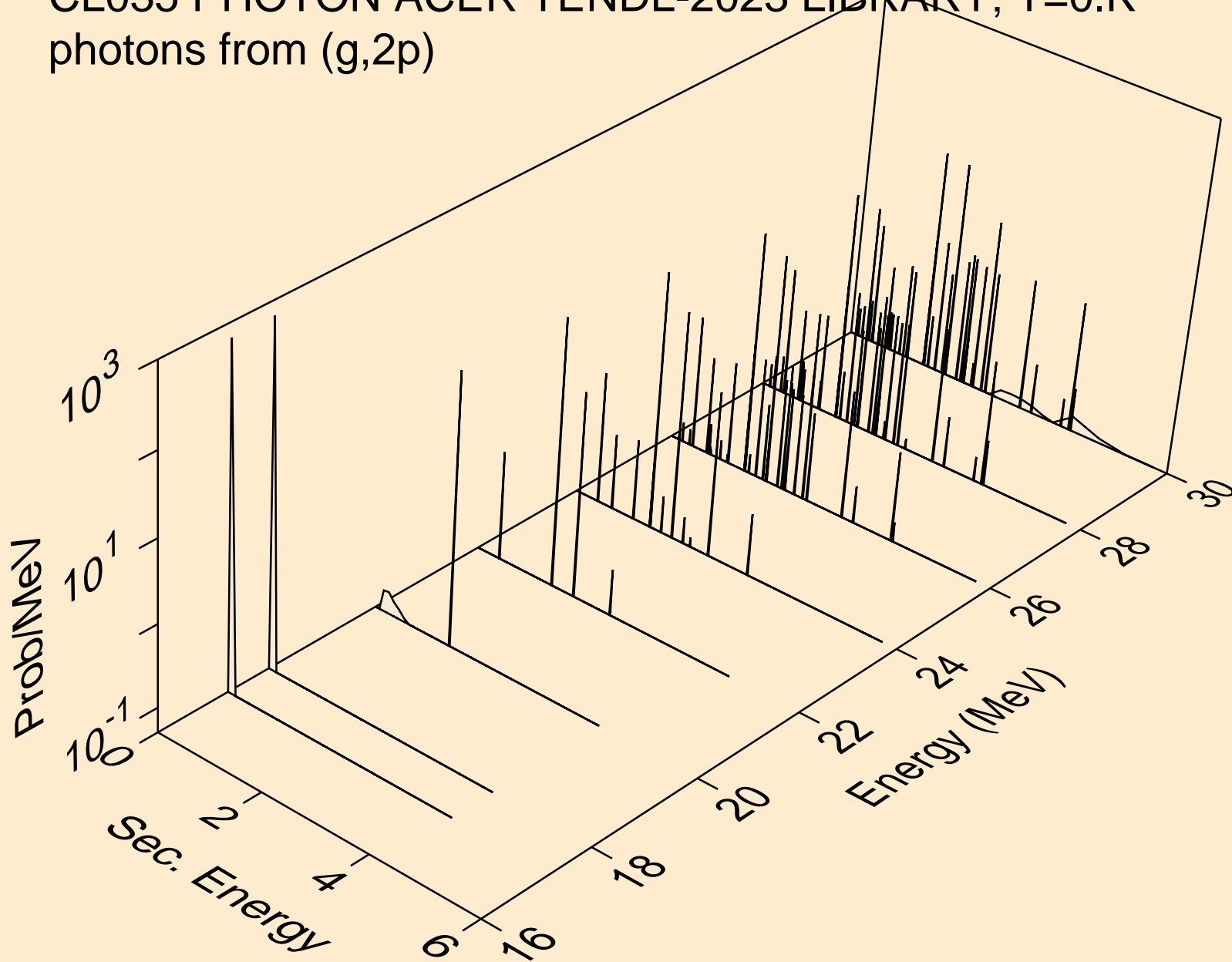

CL035 PHOTON ACER TENDL-2023 LIBRARY; T=0.K
photons from (g,pa)

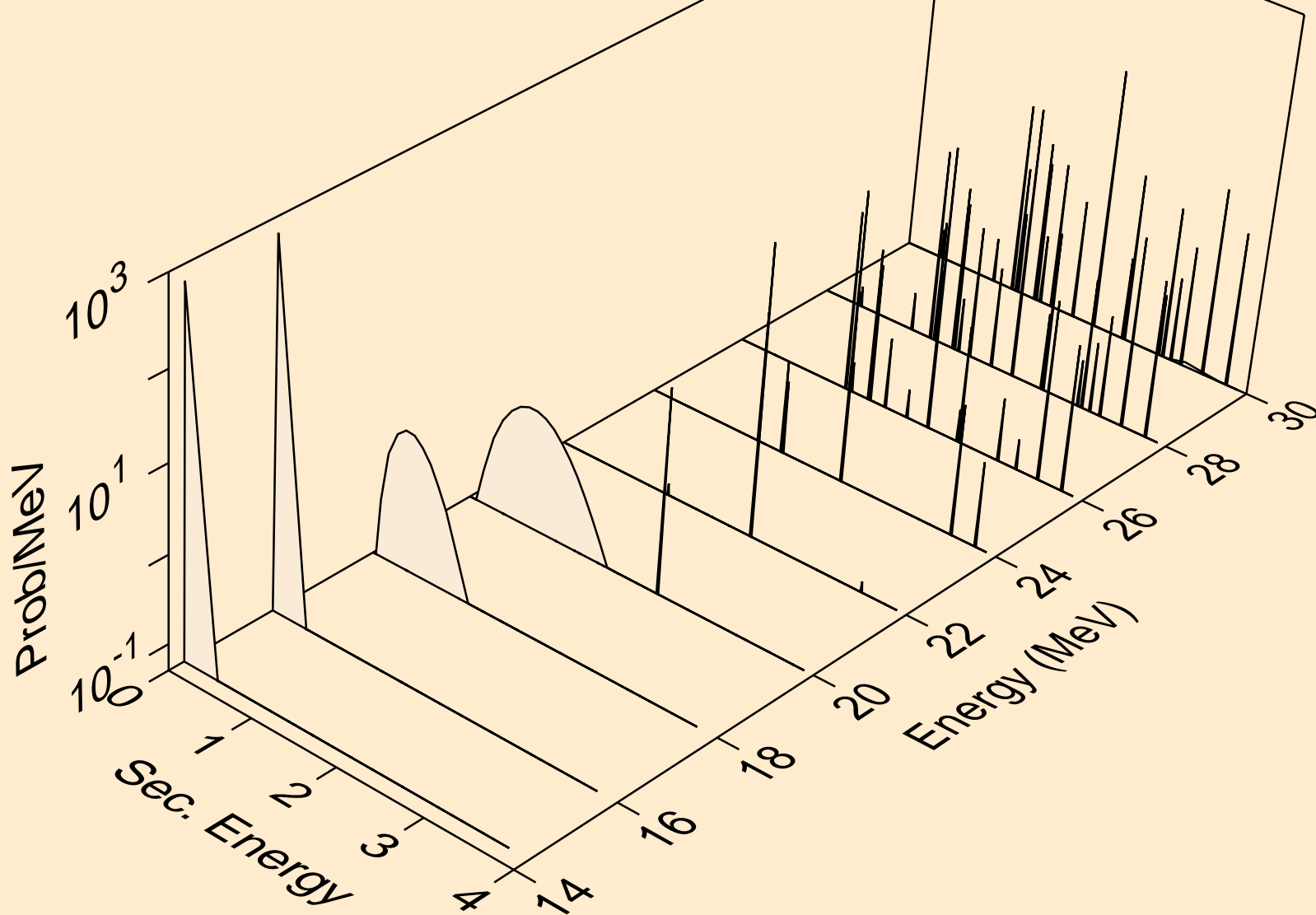

CL035 PHOTON ACER TENDL-2023 LIBRARY; T=0.K
photons from (g,pd)

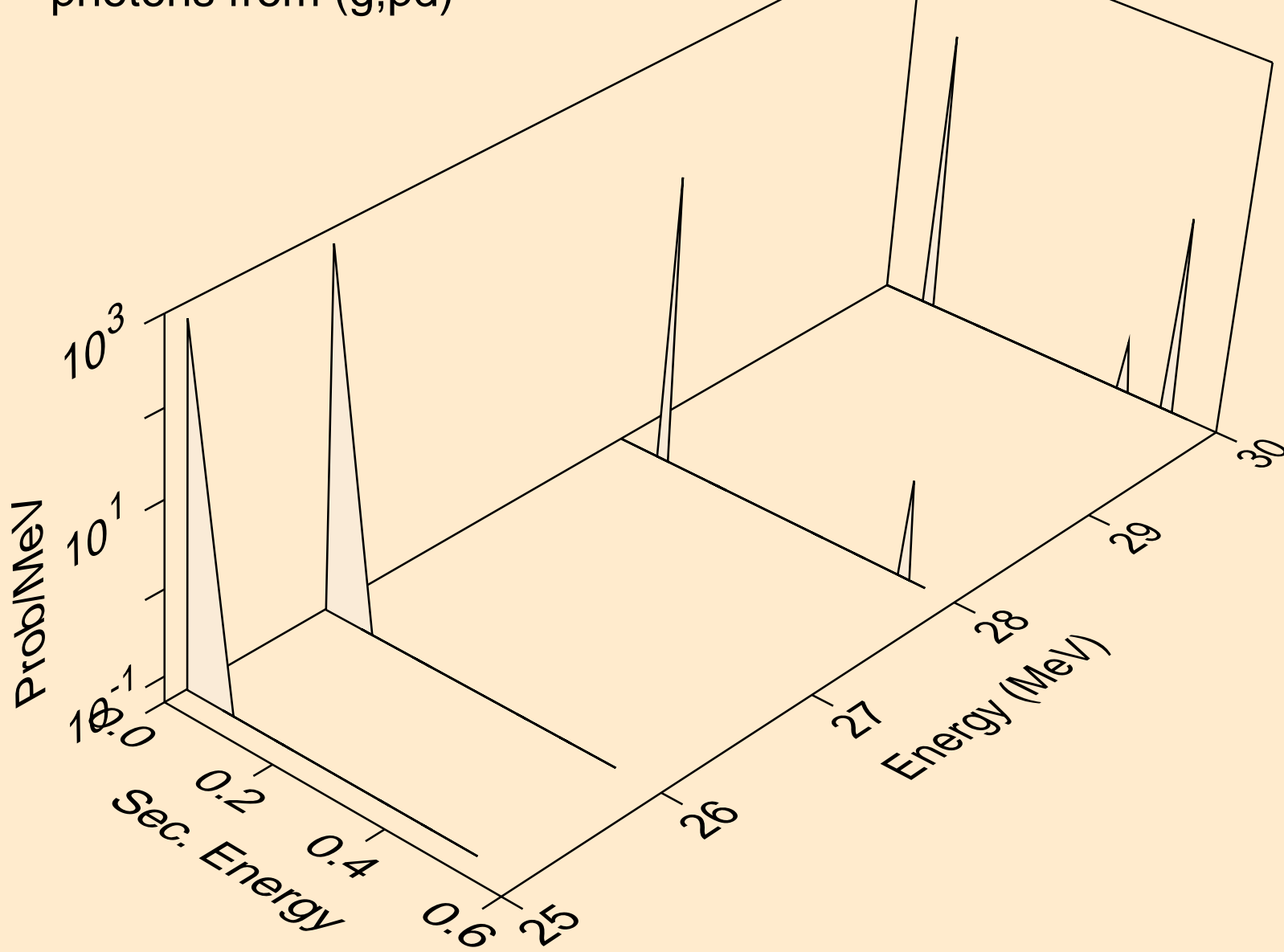

CL035 PHOTON ACER TENDL-2023 LIBRARY; T=0.K
photons from (g,pt)

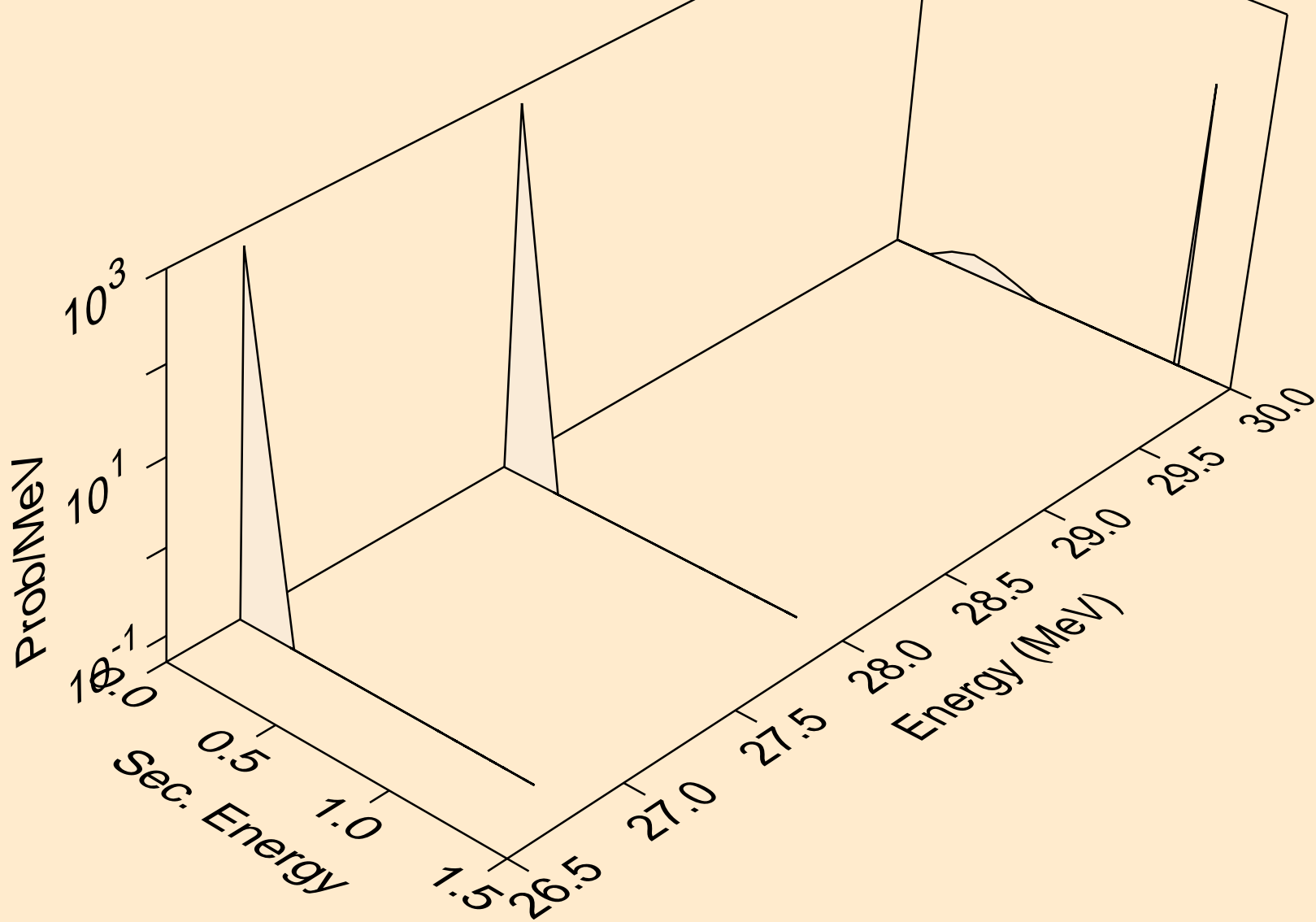

CL035 PHOTON ACER TENDL-2023 LIBRARY; T=0.K
photons from (g,da)

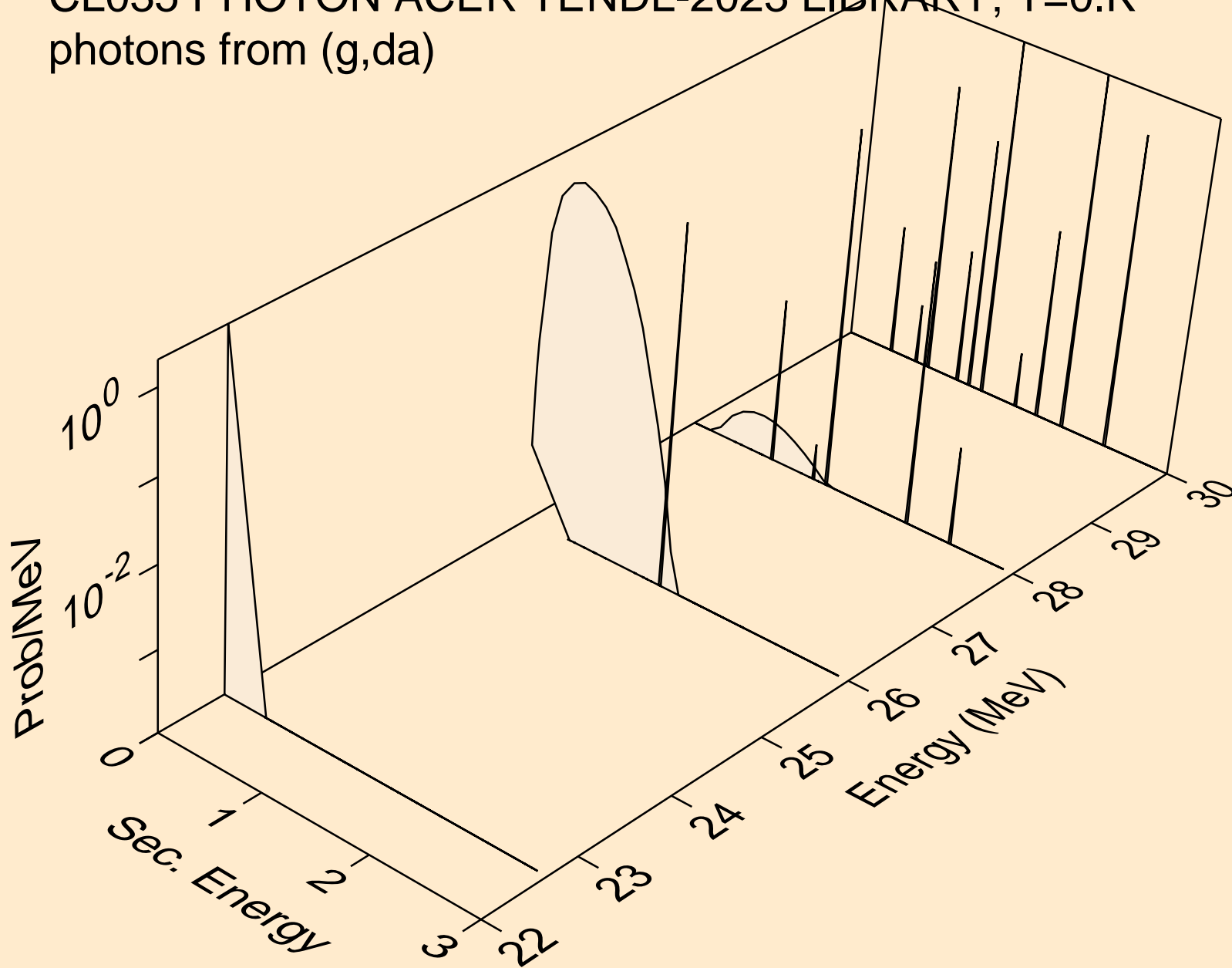

CL035 PHOTON ACER TENDL-2023 LIBRARY; T=0.K
protons from (g,x)

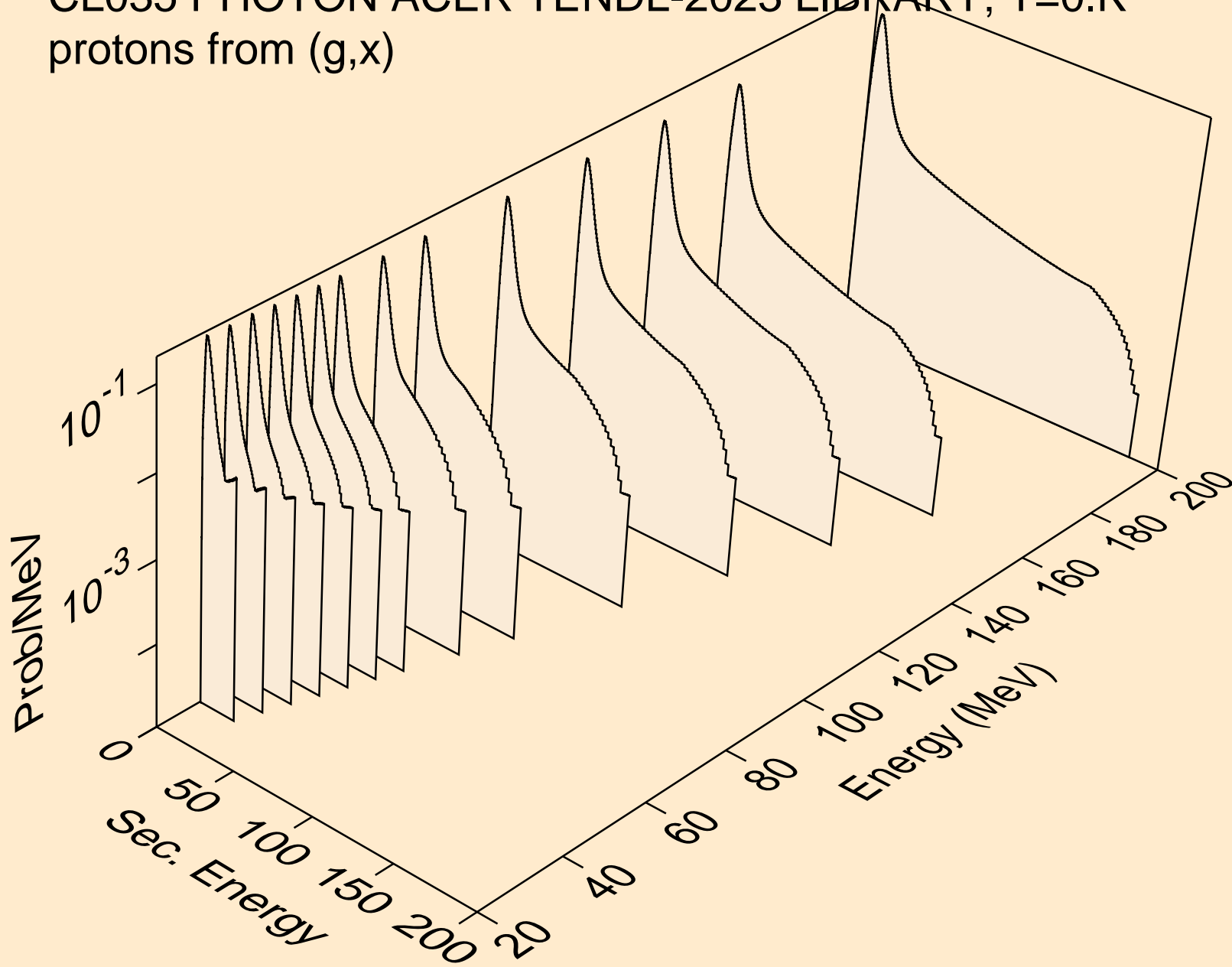

CL035 PHOTON ACER TENDL-2023 LIBRARY; T=0.K
protons from (g,n*)p

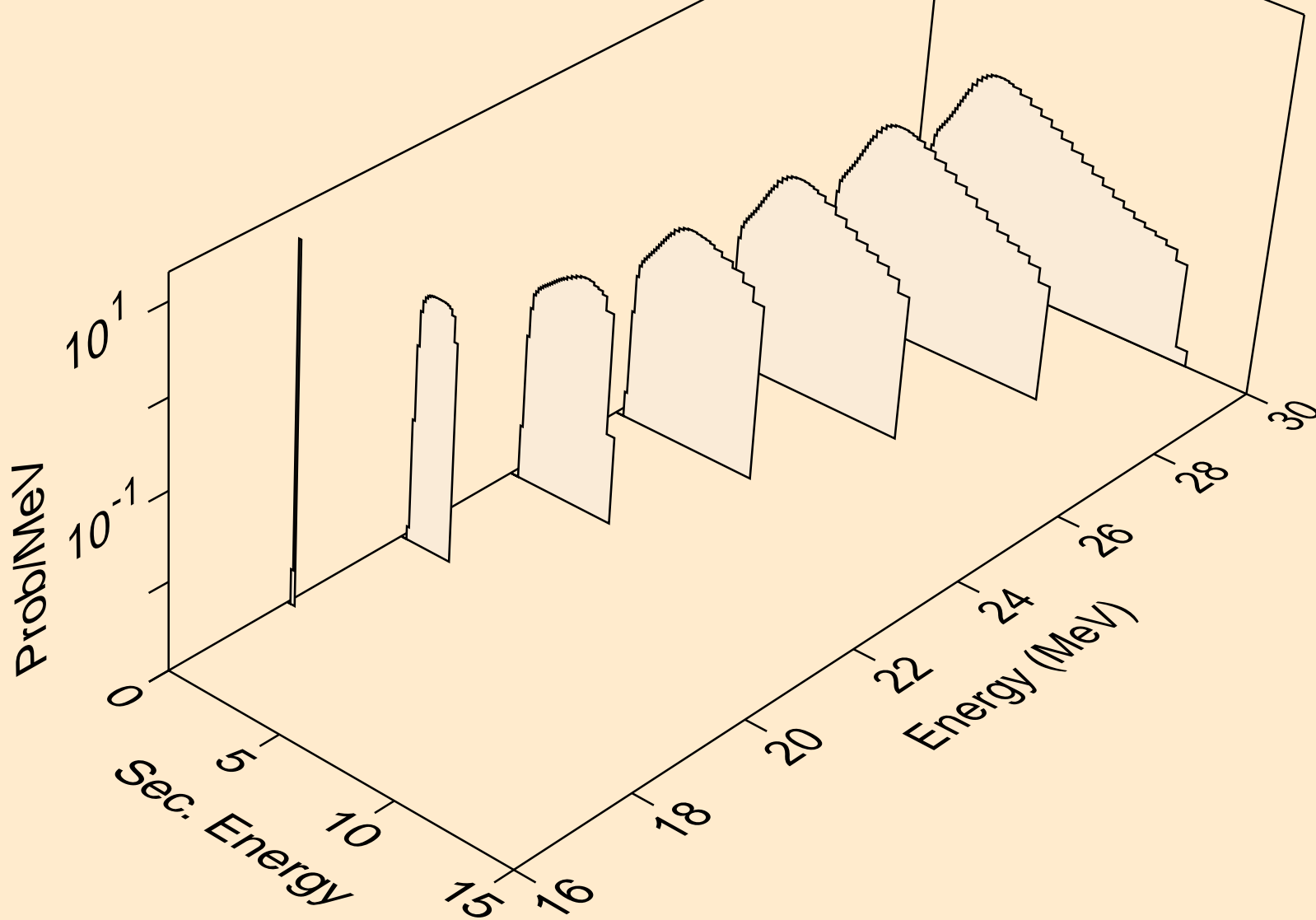

CL035 PHOTON ACER TENDL-2023 LIBRARY; T=0.K
protons from (g,2np)

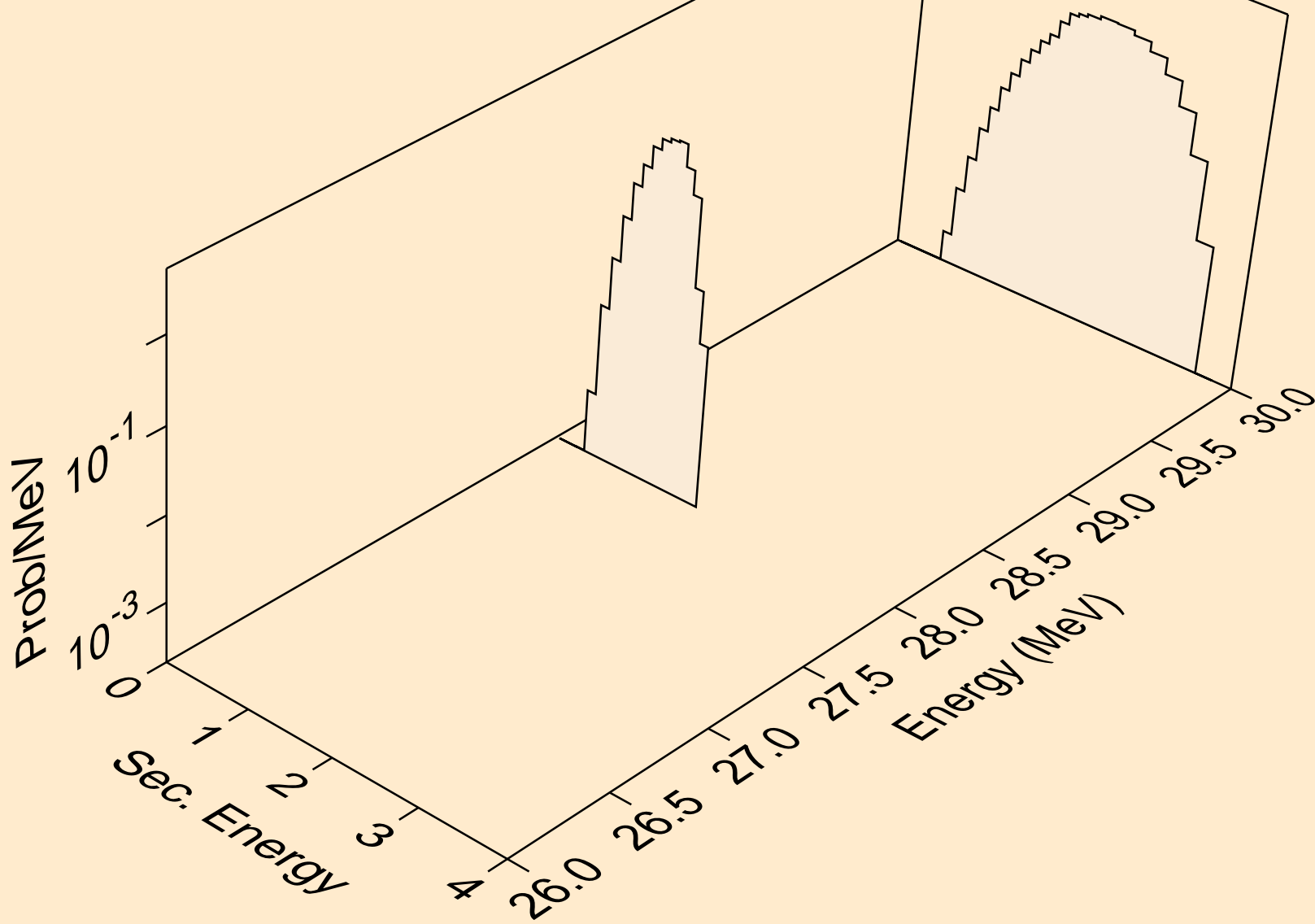

CL035 PHOTON ACER TENDL-2023 LIBRARY; T=0.K
protons from (g,npa)

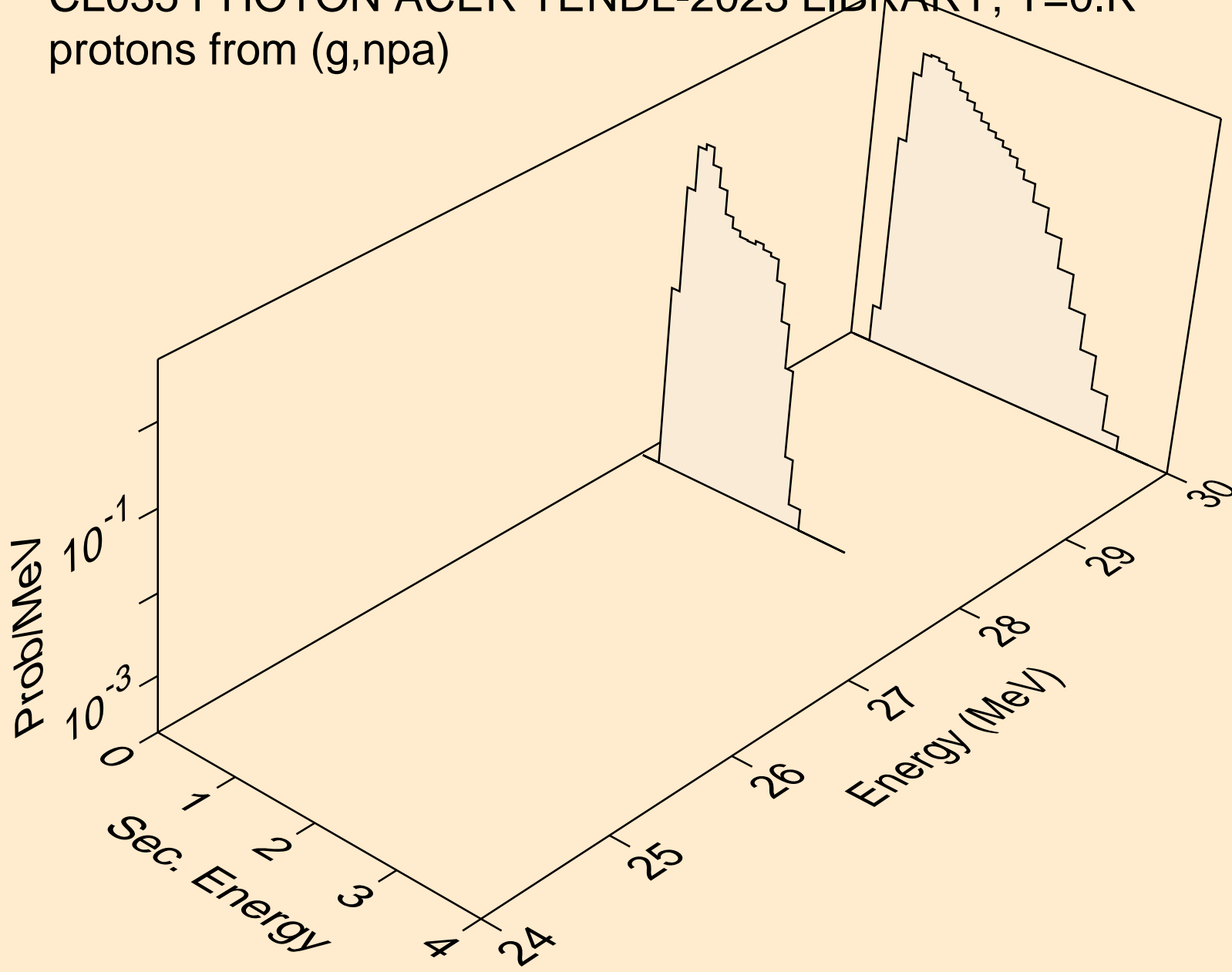

CL035 PHOTON ACER TENDL-2023 LIBRARY; T=0.K
protons from (g,p)

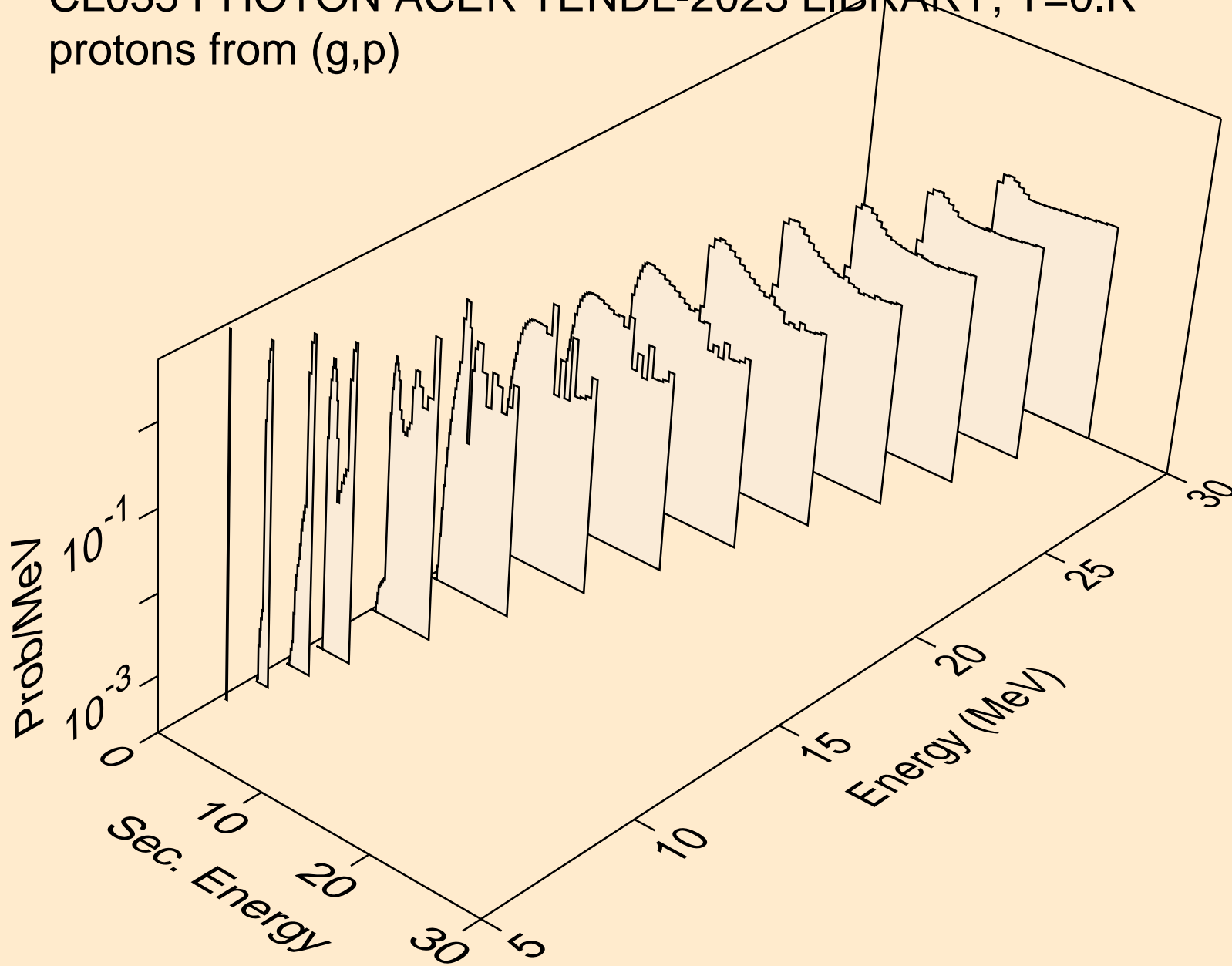

CL035 PHOTON ACER TENDL-2023 LIBRARY; T=0.K
protons from (g,2p)

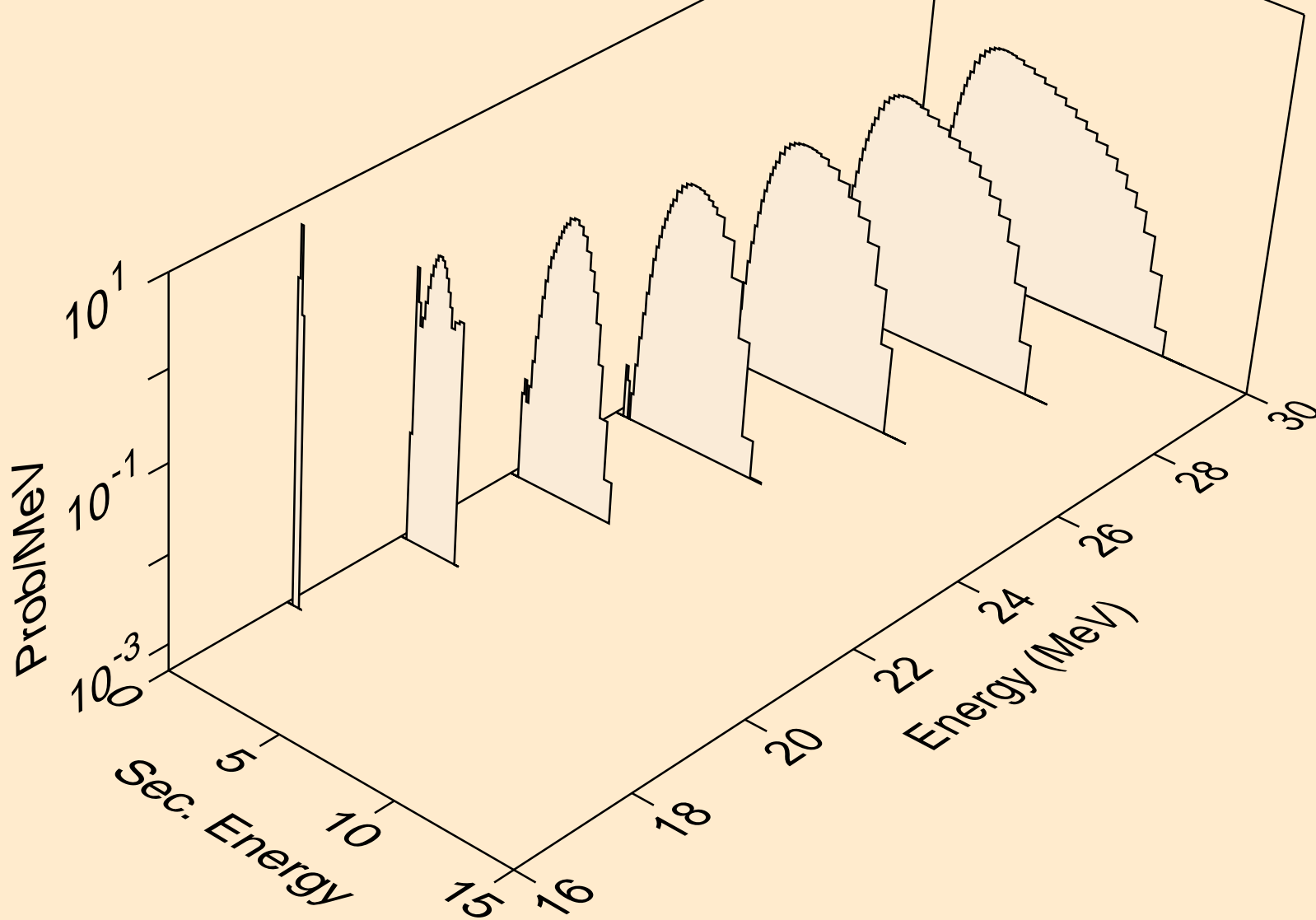

CL035 PHOTON ACER TENDL-2023 LIBRARY; T=0.K
protons from (g,pa)

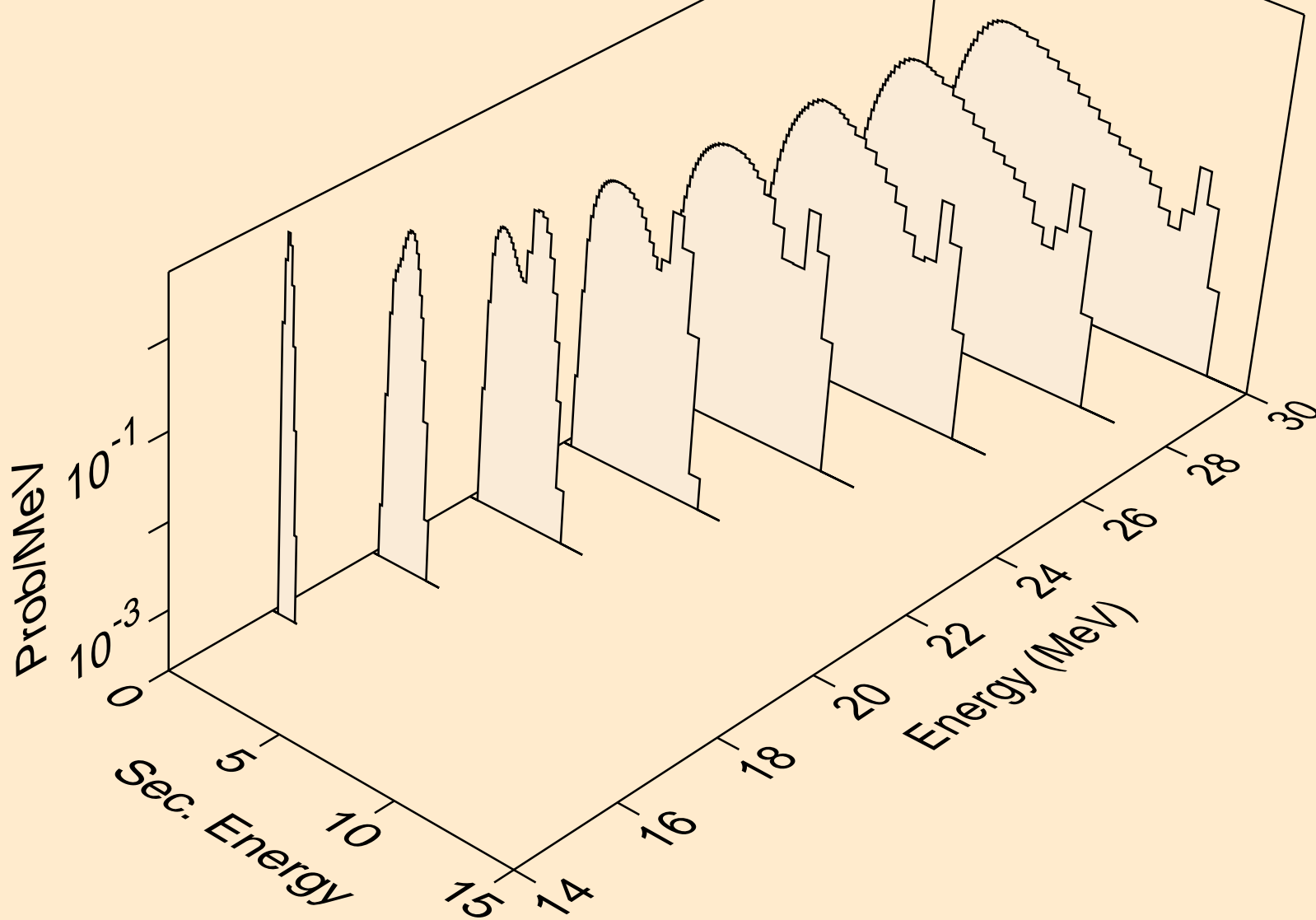

CL035 PHOTON ACER TENDL-2023 LIBRARY; T=0.K
protons from (g,pd)

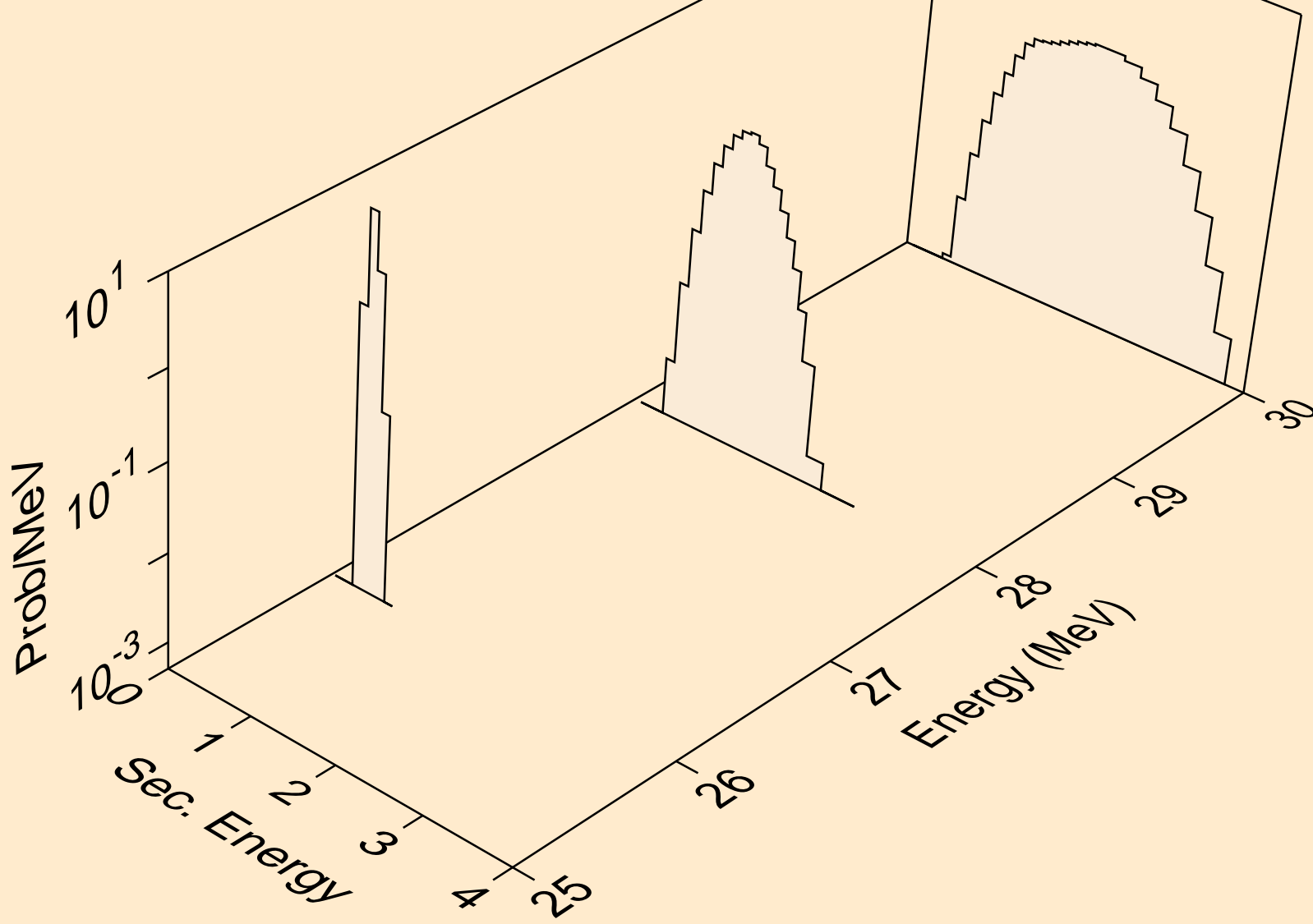

CL035 PHOTON ACER TENDL-2023 LIBRARY; T=0.K
protons from (g,pt)

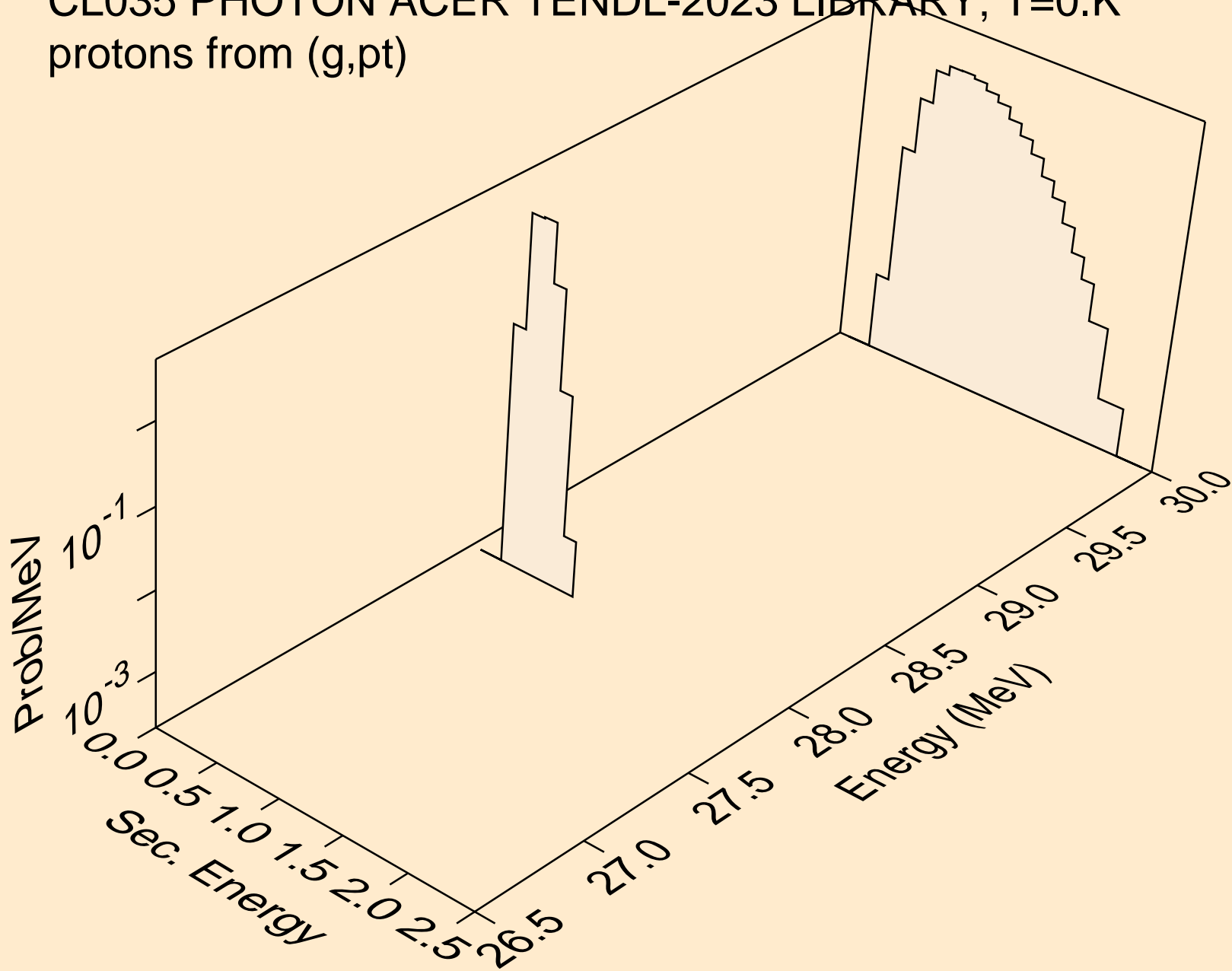

CL035 PHOTON ACER TENDL-2023 LIBRARY; T=0.K
deuterons from (g,x)

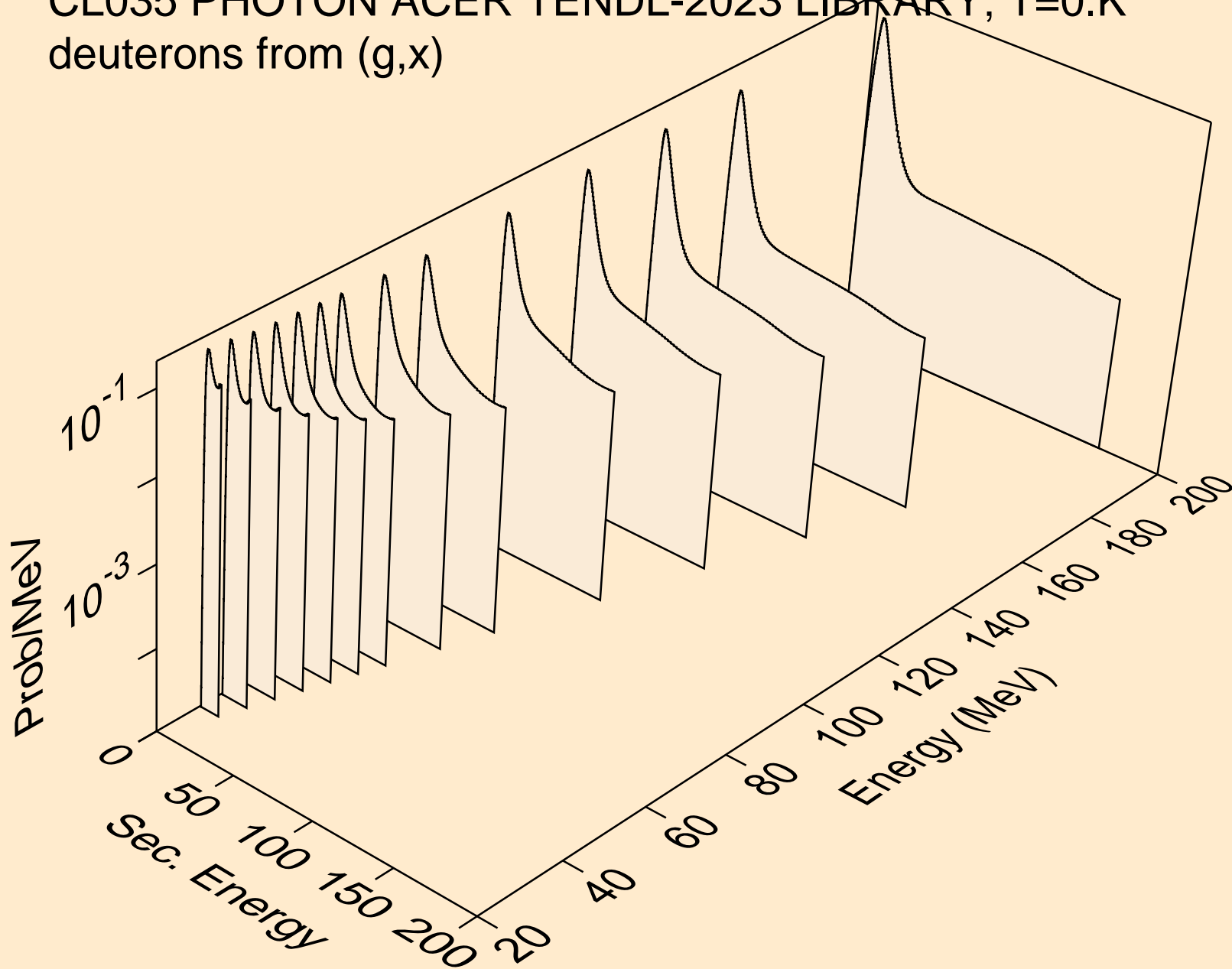

CL035 PHOTON ACER TENDL-2023 LIBRARY; T=0.K
deuterons from (g,n*)d

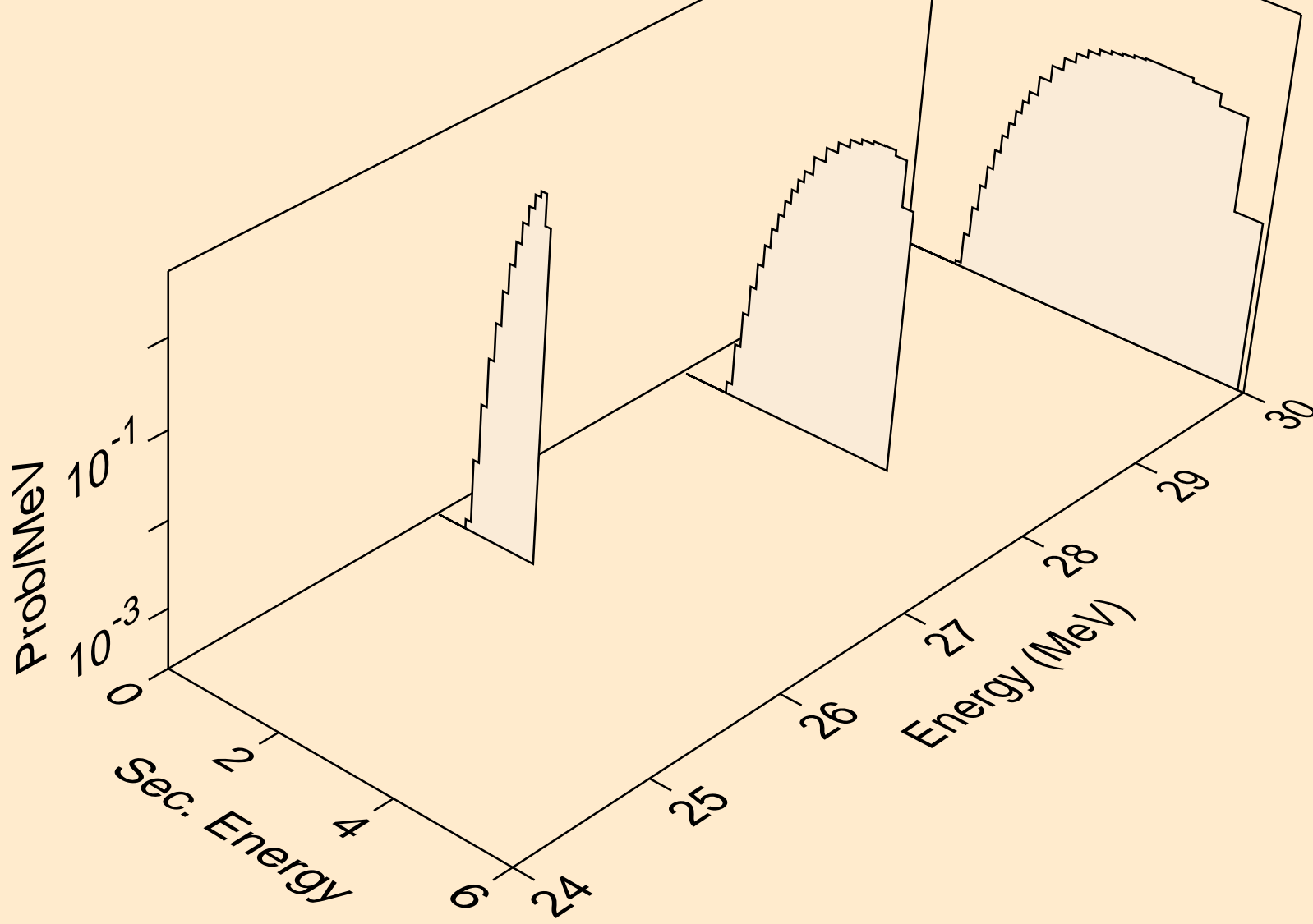

CL035 PHOTON ACER TENDL-2023 LIBRARY; T=0.K
deuterons from (g,d)

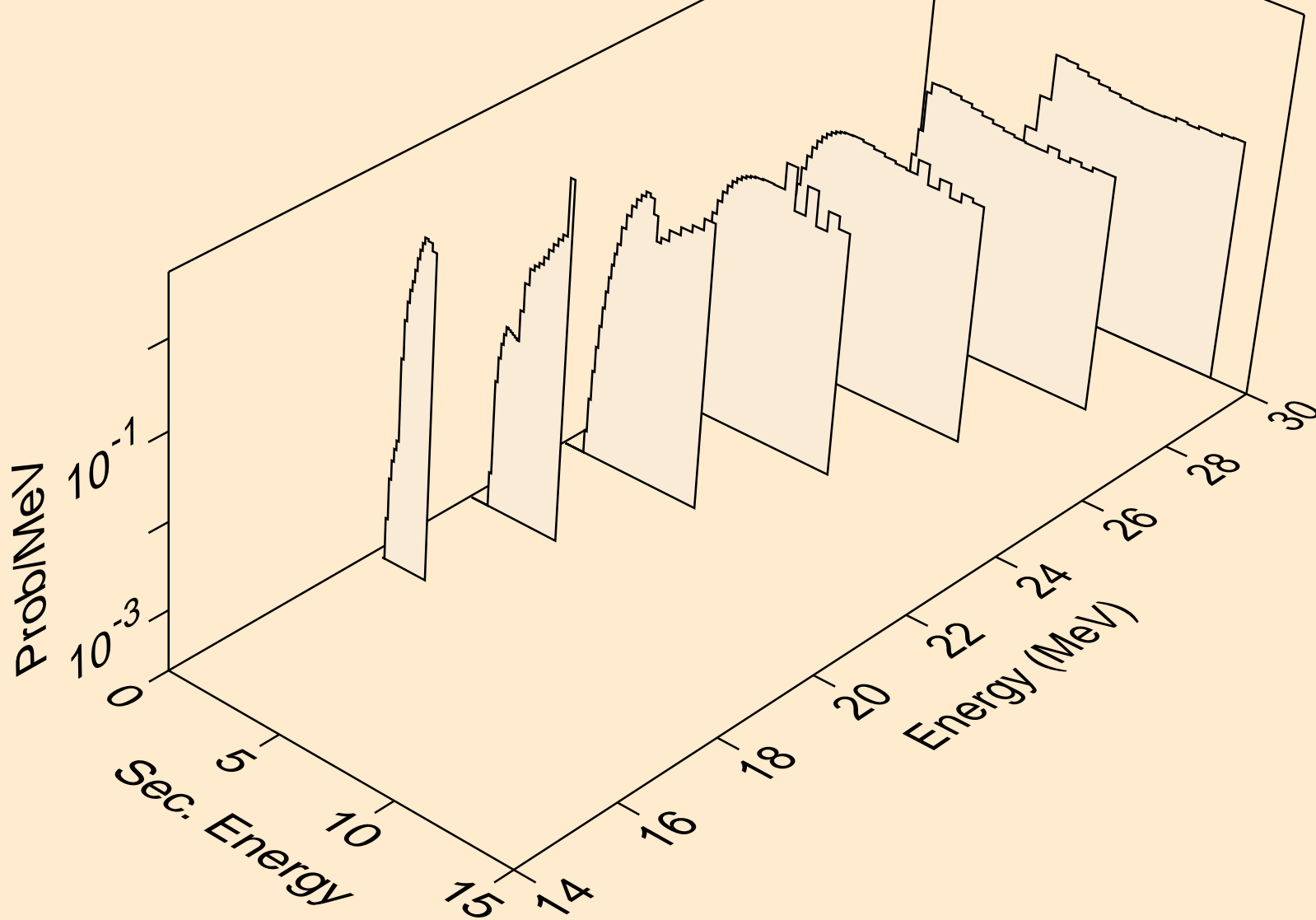

CL035 PHOTON ACER TENDL-2023 LIBRARY; T=0.K
deuterons from (g,pd)

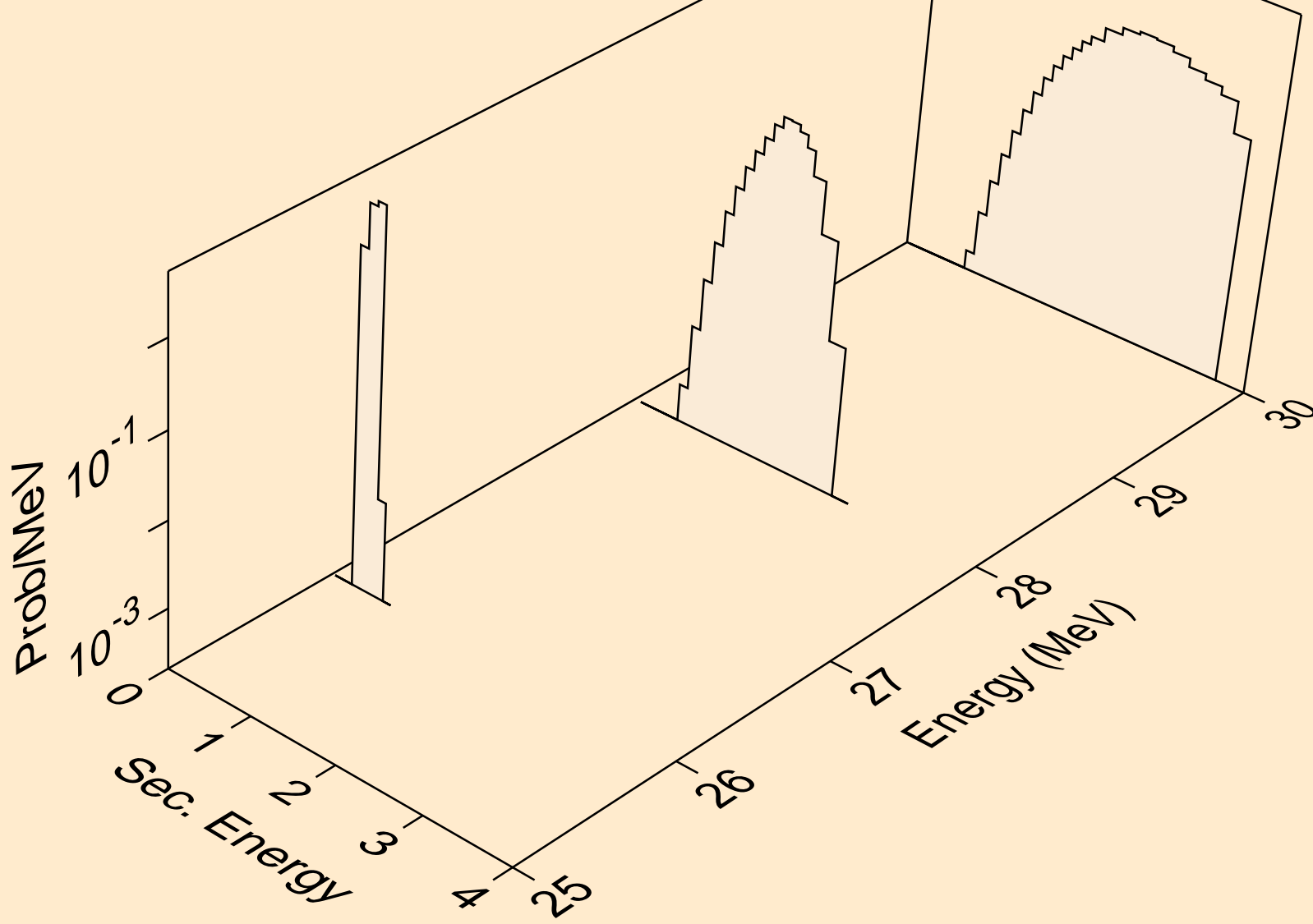

CL035 PHOTON ACER TENDL-2023 LIBRARY; T=0.K
deuterons from (g,da)

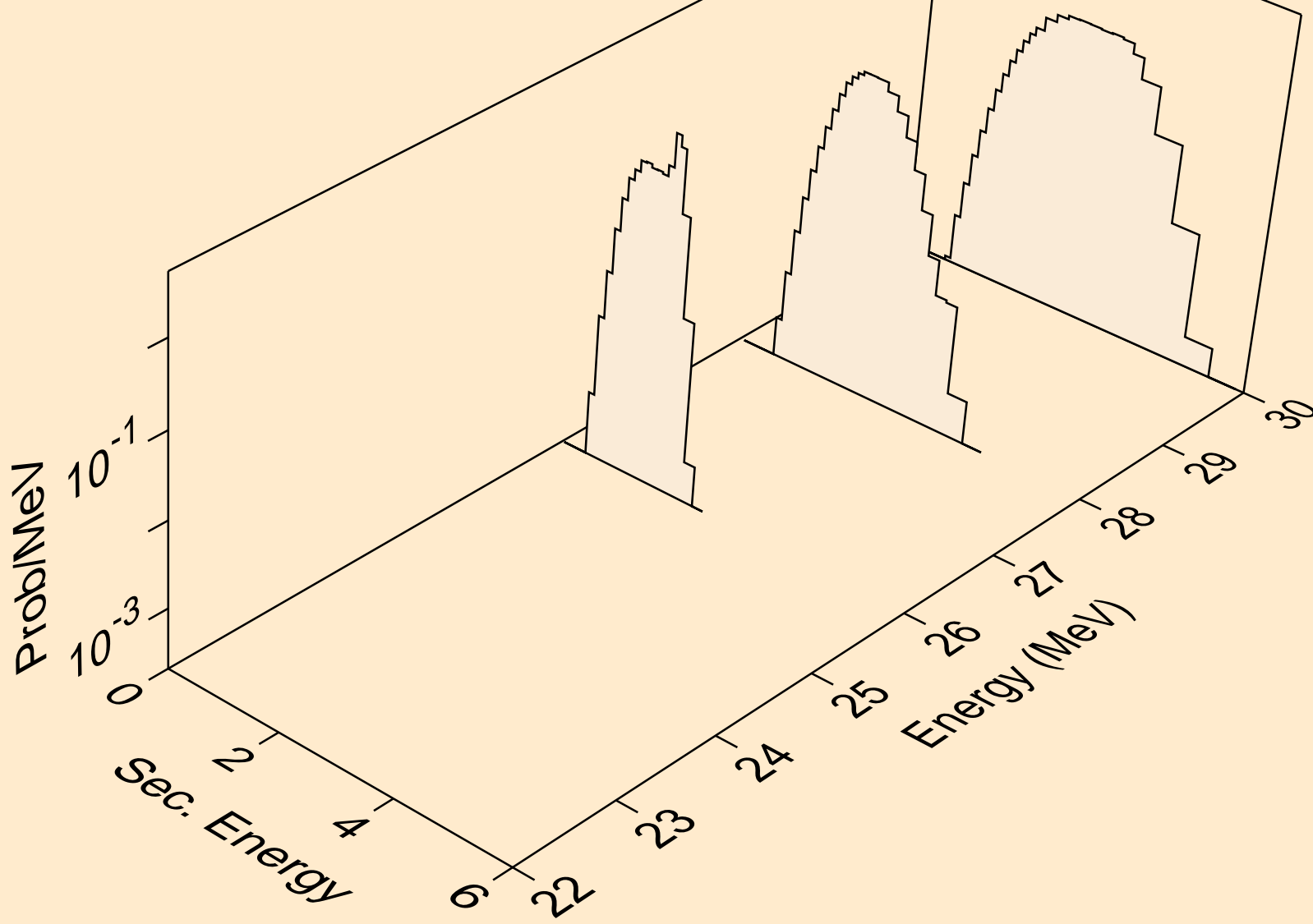

CL035 PHOTON ACER TENDL-2023 LIBRARY; T=0.K
tritons from (g,x)

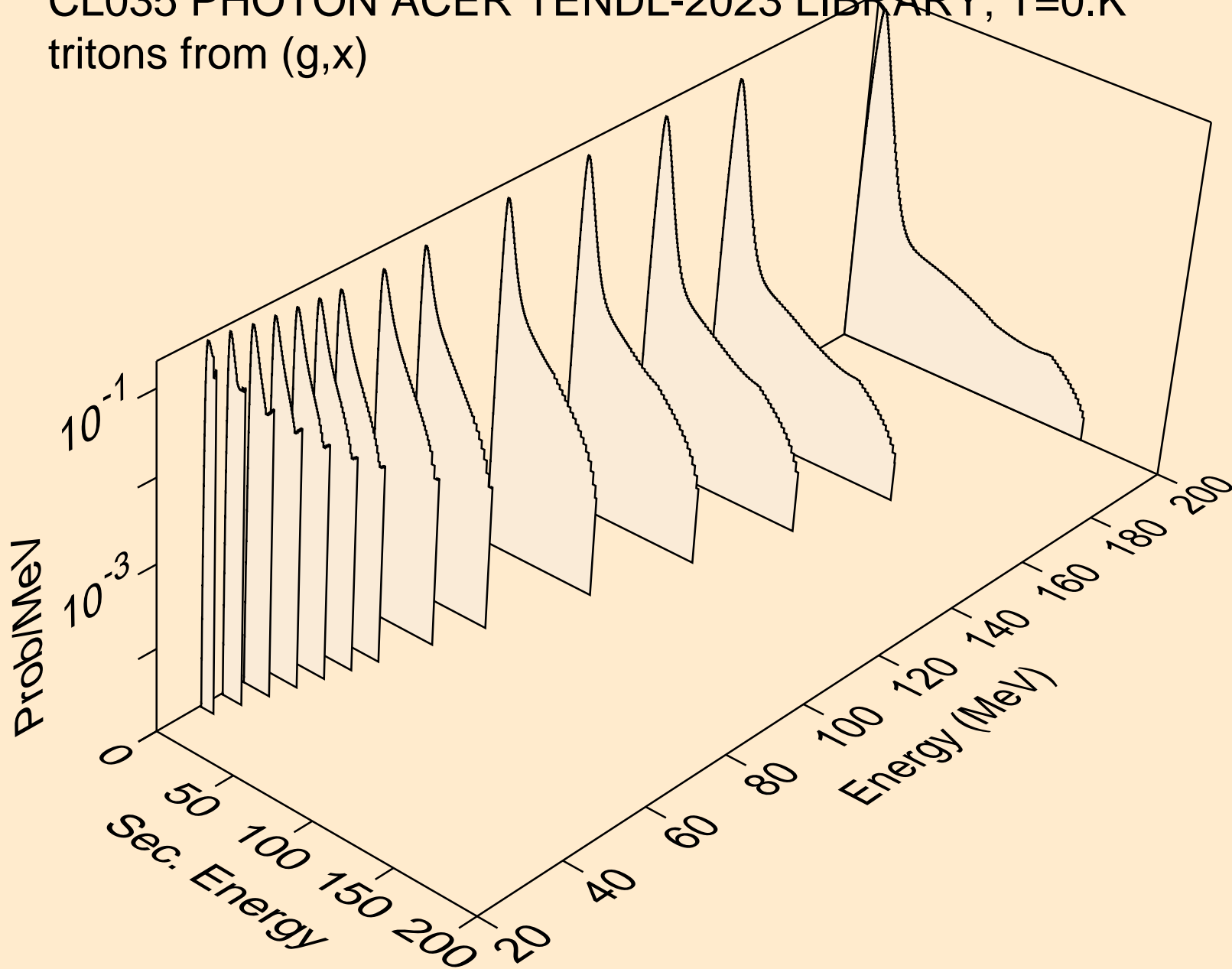

CL035 PHOTON ACER TENDL-2023 LIBRARY; T=0.K
tritons from (g,t)

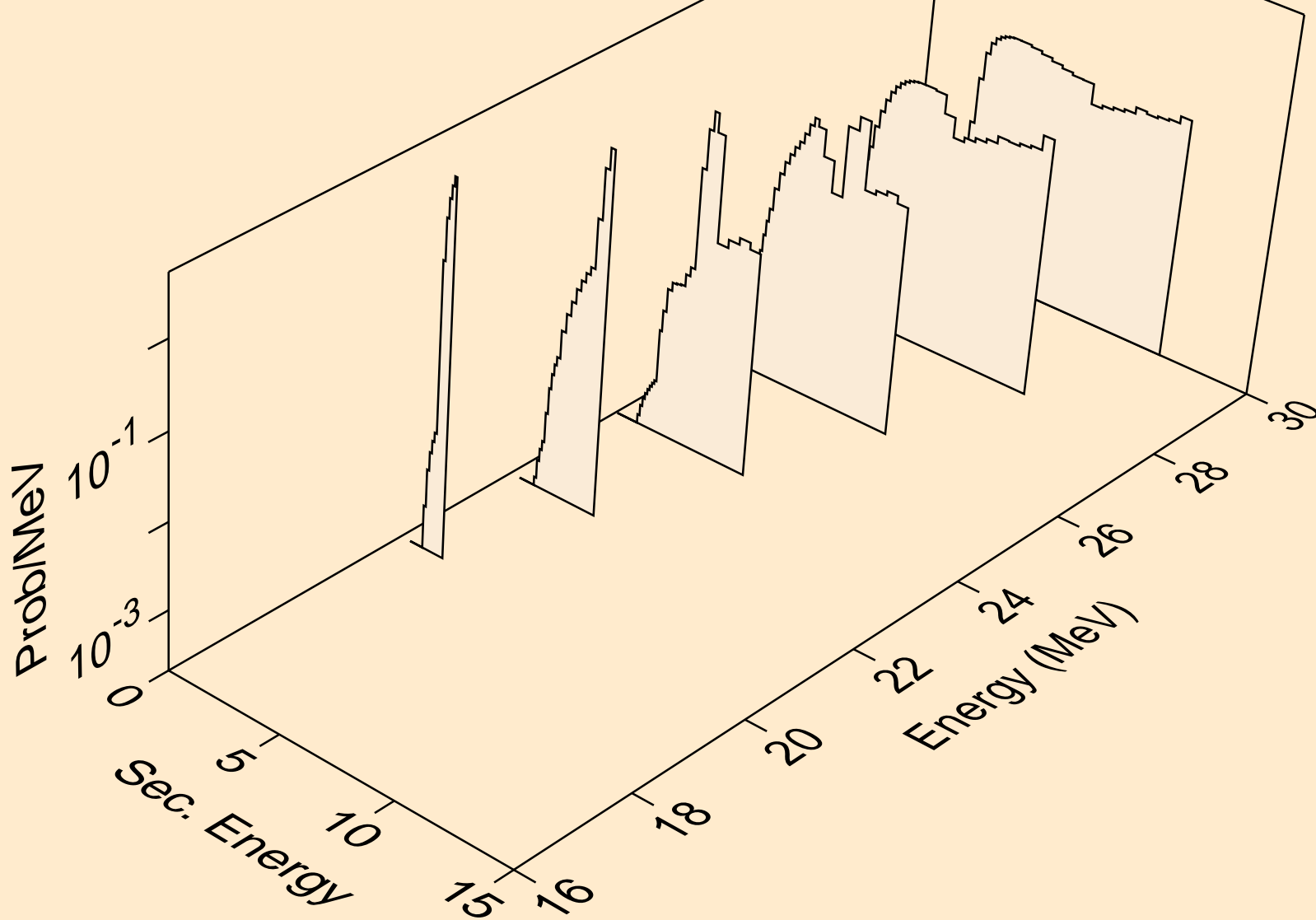

CL035 PHOTON ACER TENDL-2023 LIBRARY; T=0.K
tritons from (g,pt)

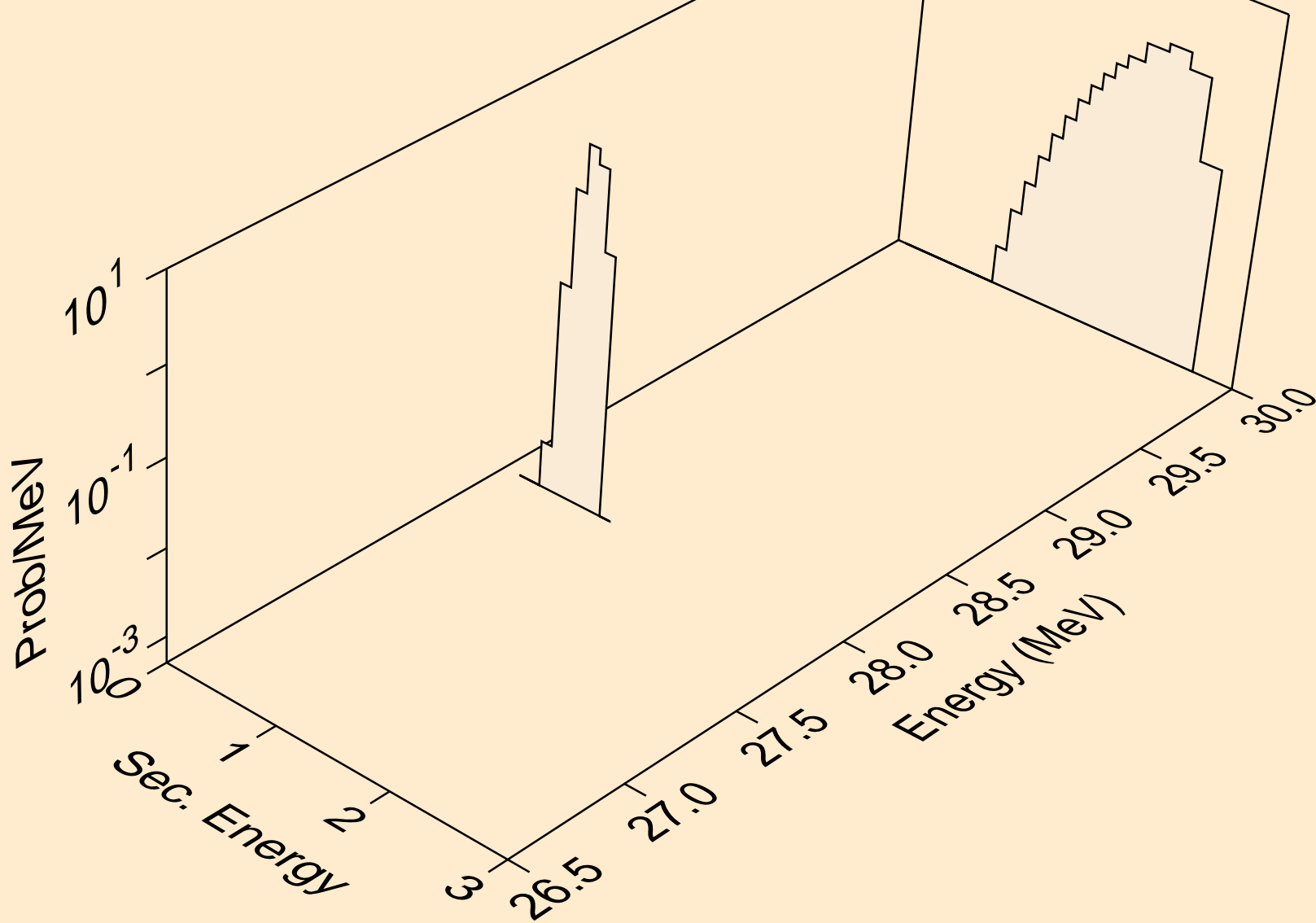

CL035 PHOTON ACER TENDL-2023 LIBRARY; T=0.K
he3s from (g,x)

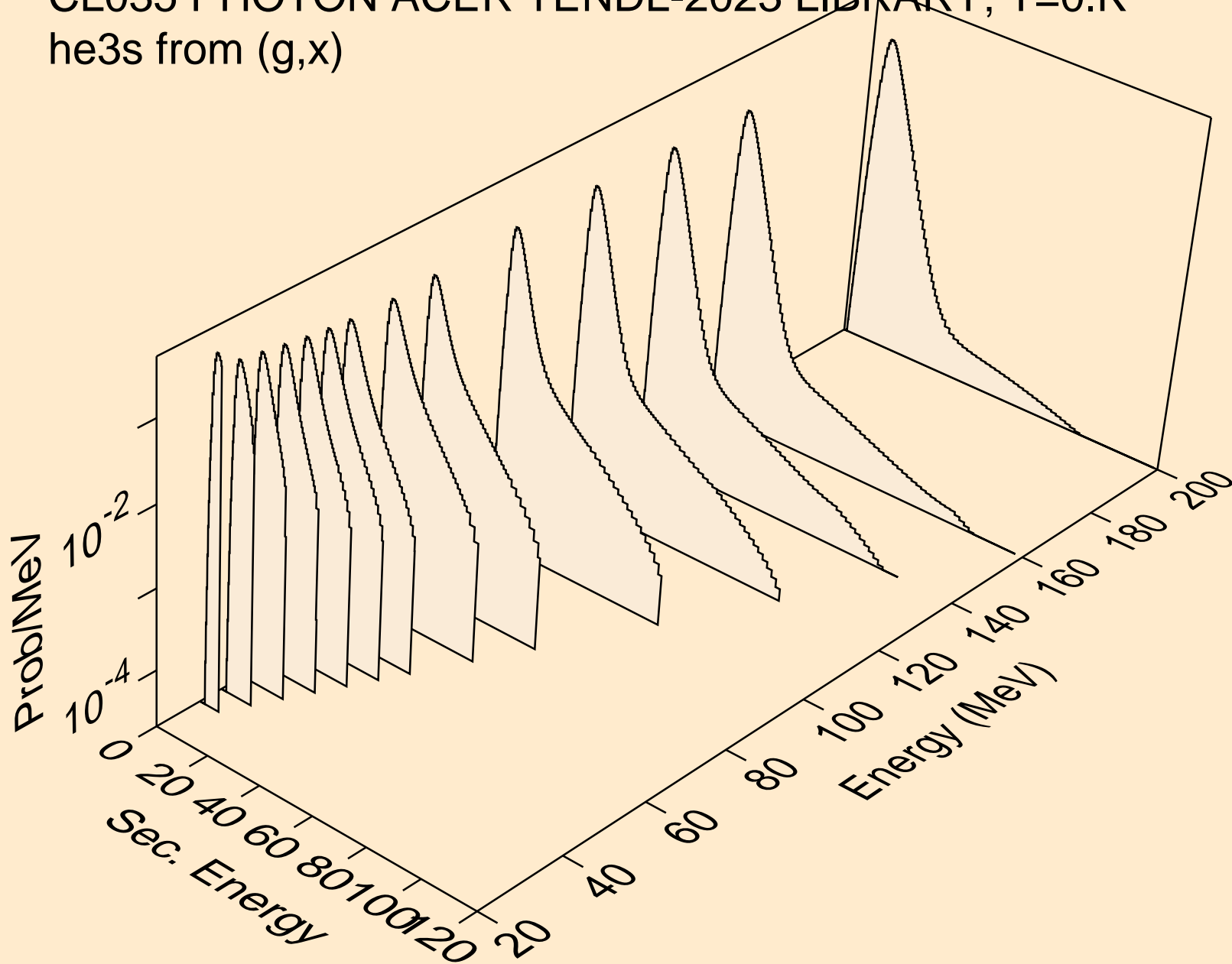

CL035 PHOTON ACER TENDL-2023 LIBRARY; T=0.K
he3s from (g,he3)

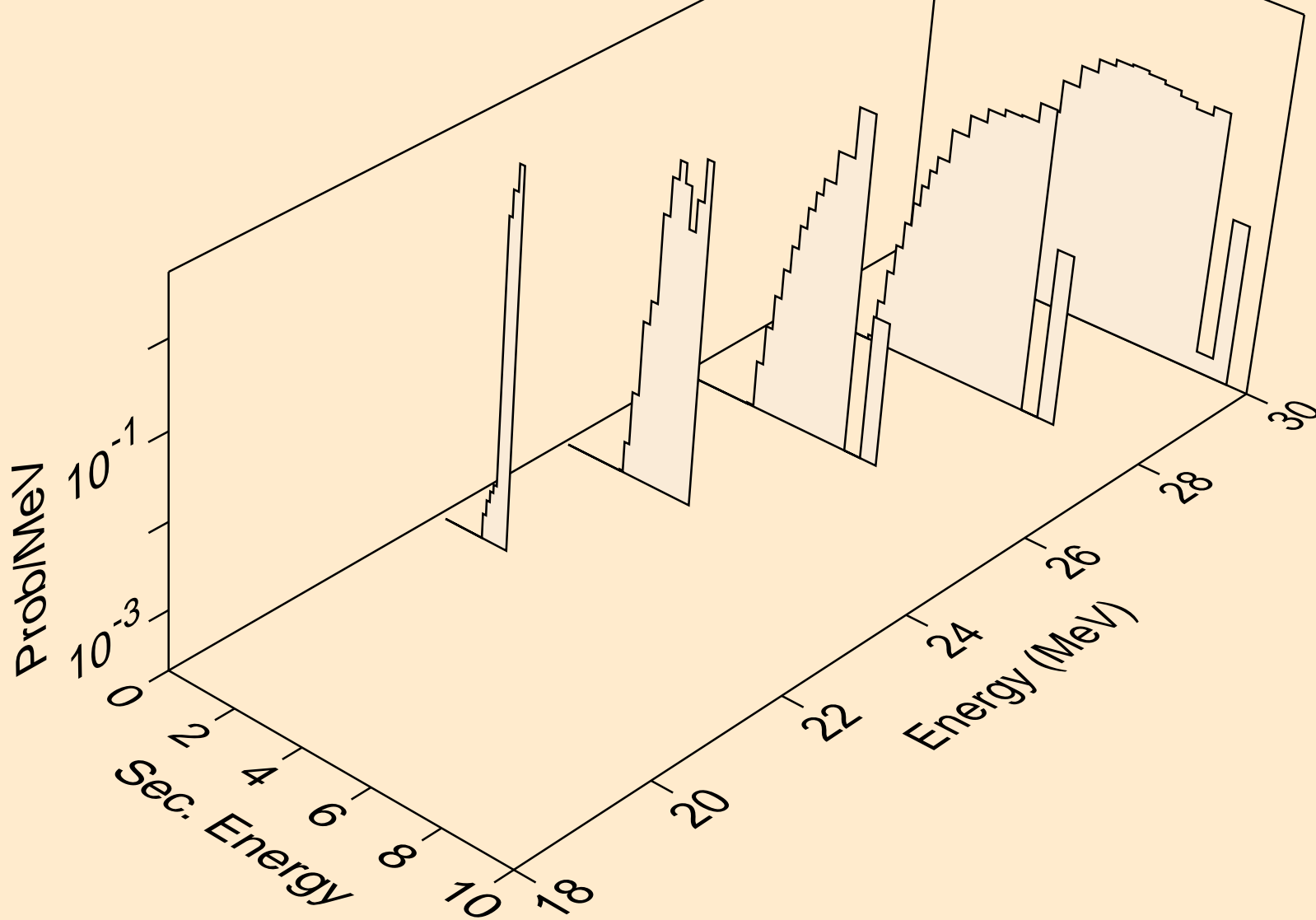

CL035 PHOTON ACER TENDL-2023 LIBRARY; T=0.K
alphas from (g,x)

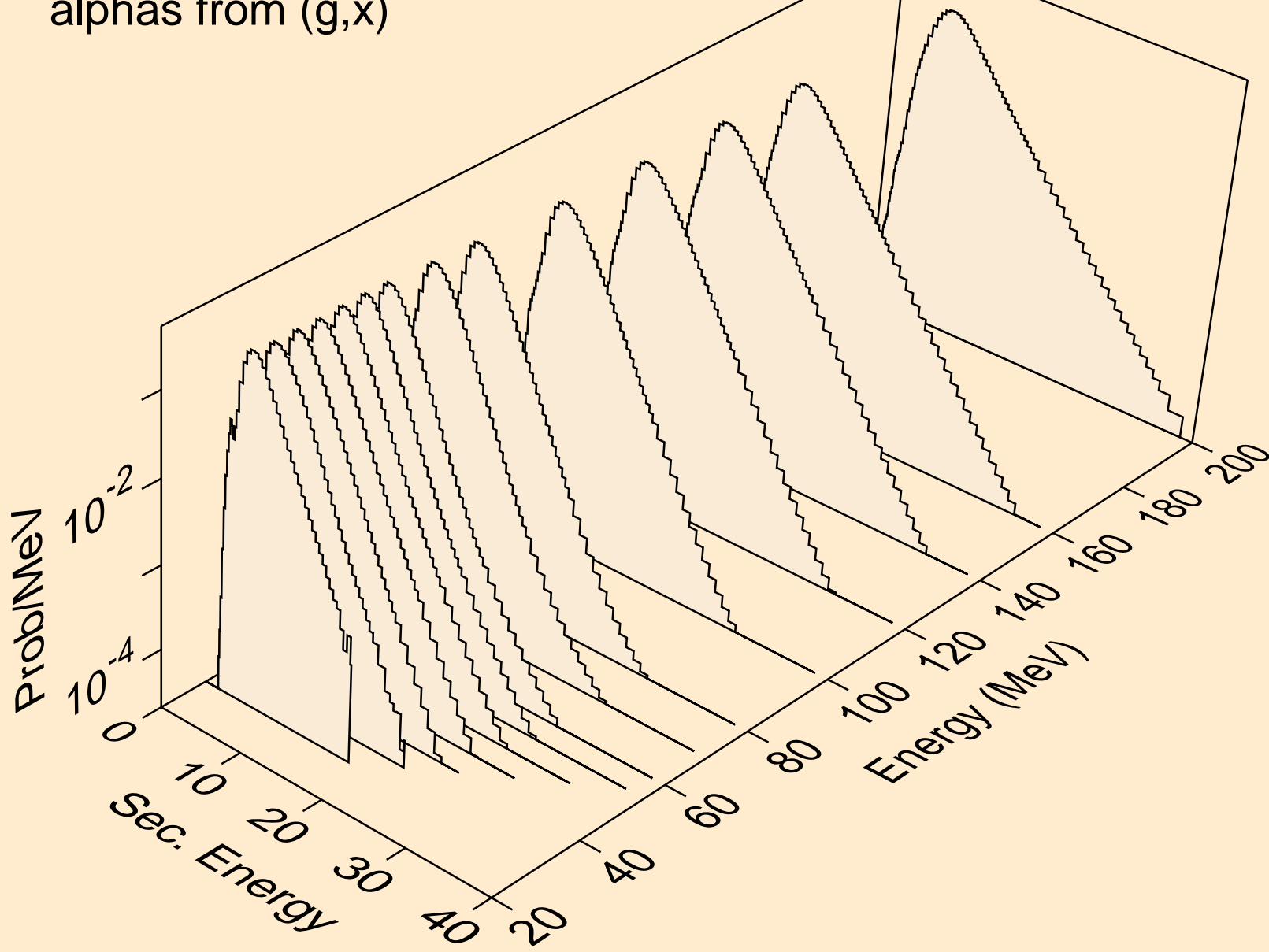

CL035 PHOTON ACER TENDL-2023 LIBRARY; T=0.K
alphas from (g,n*)a

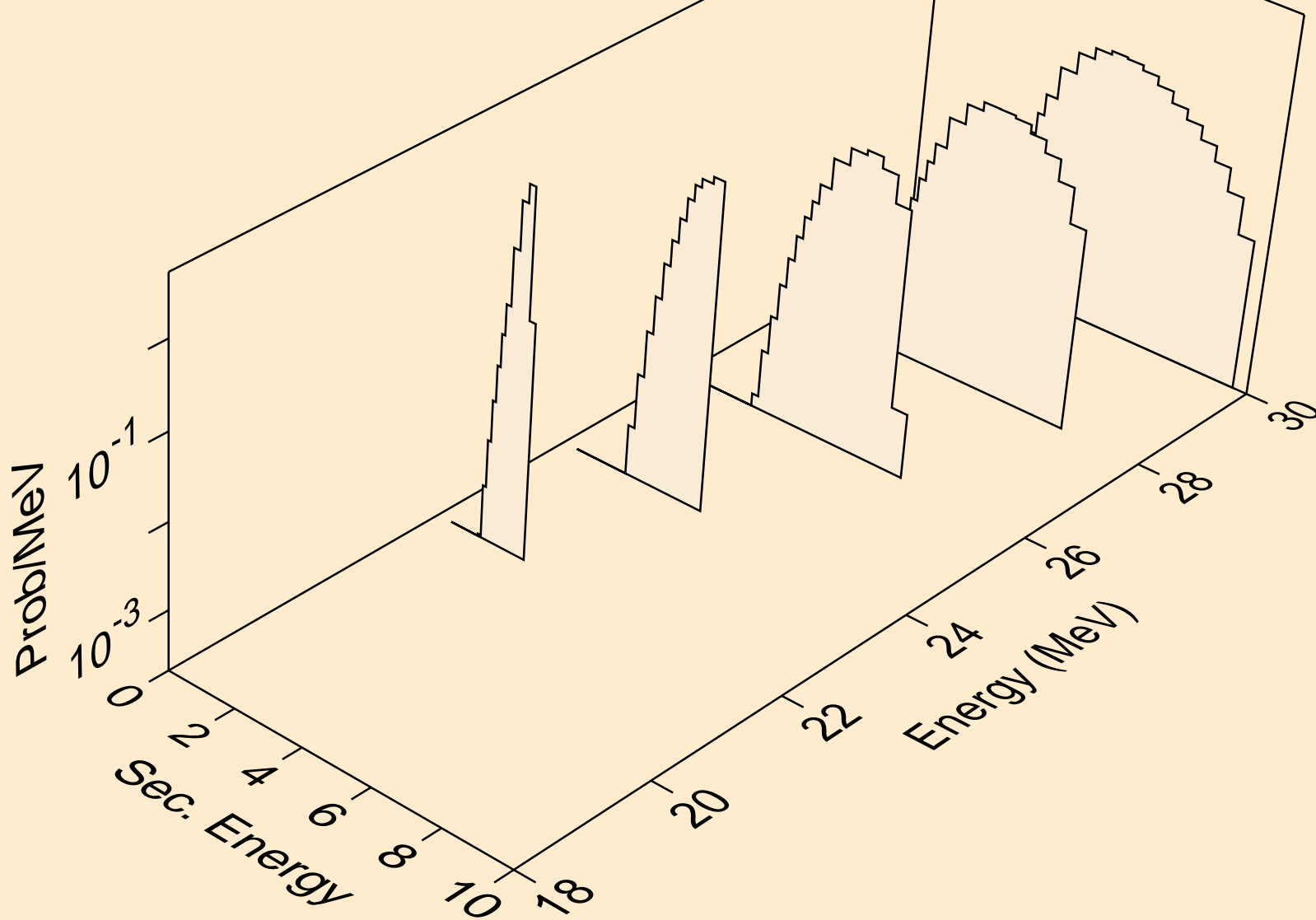

CL035 PHOTON ACER TENDL-2023 LIBRARY; T=0.K
alphas from (g,npa)

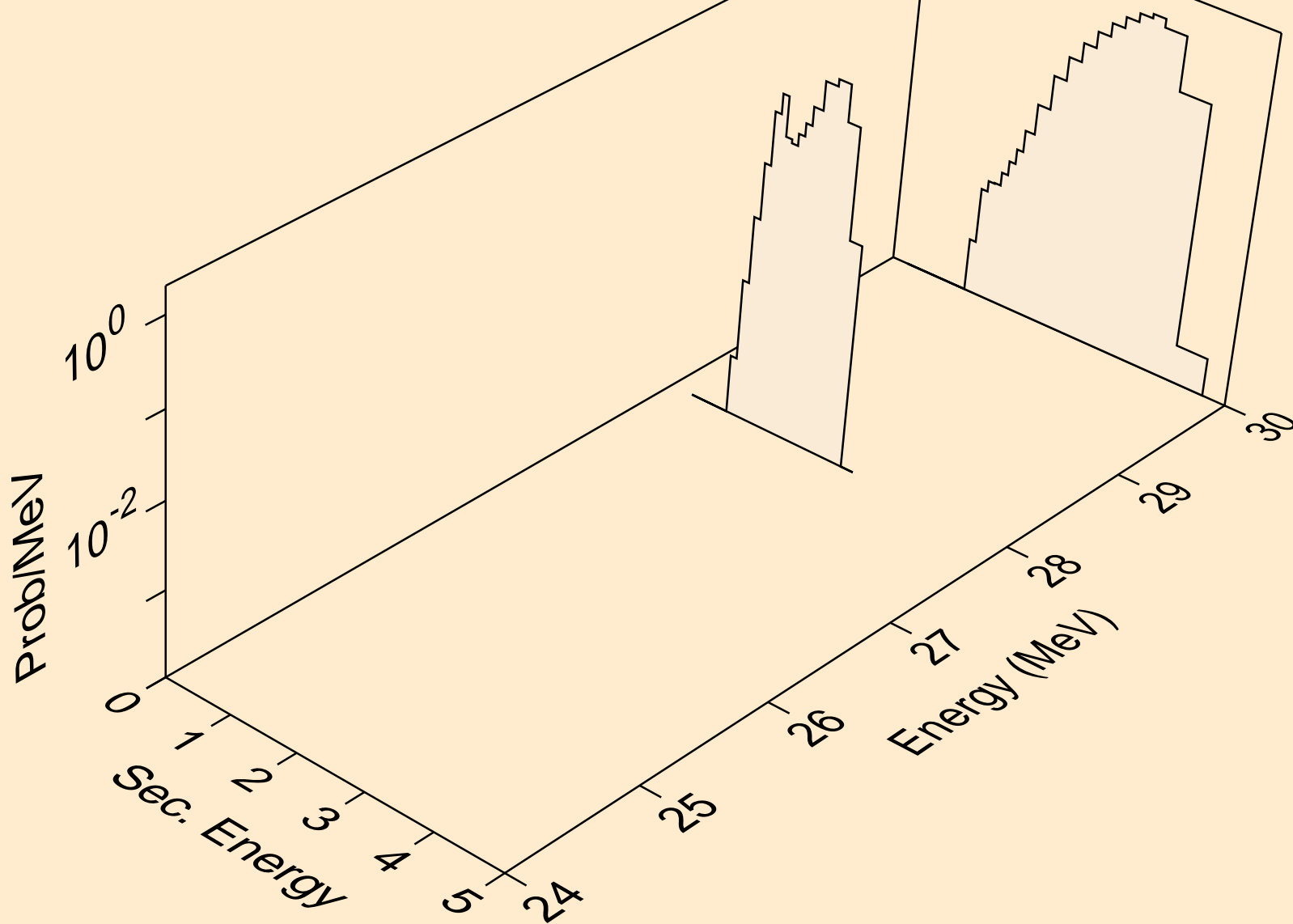

CL035 PHOTON ACER TENDL-2023 LIBRARY; T=0.K
alphas from (g,a)

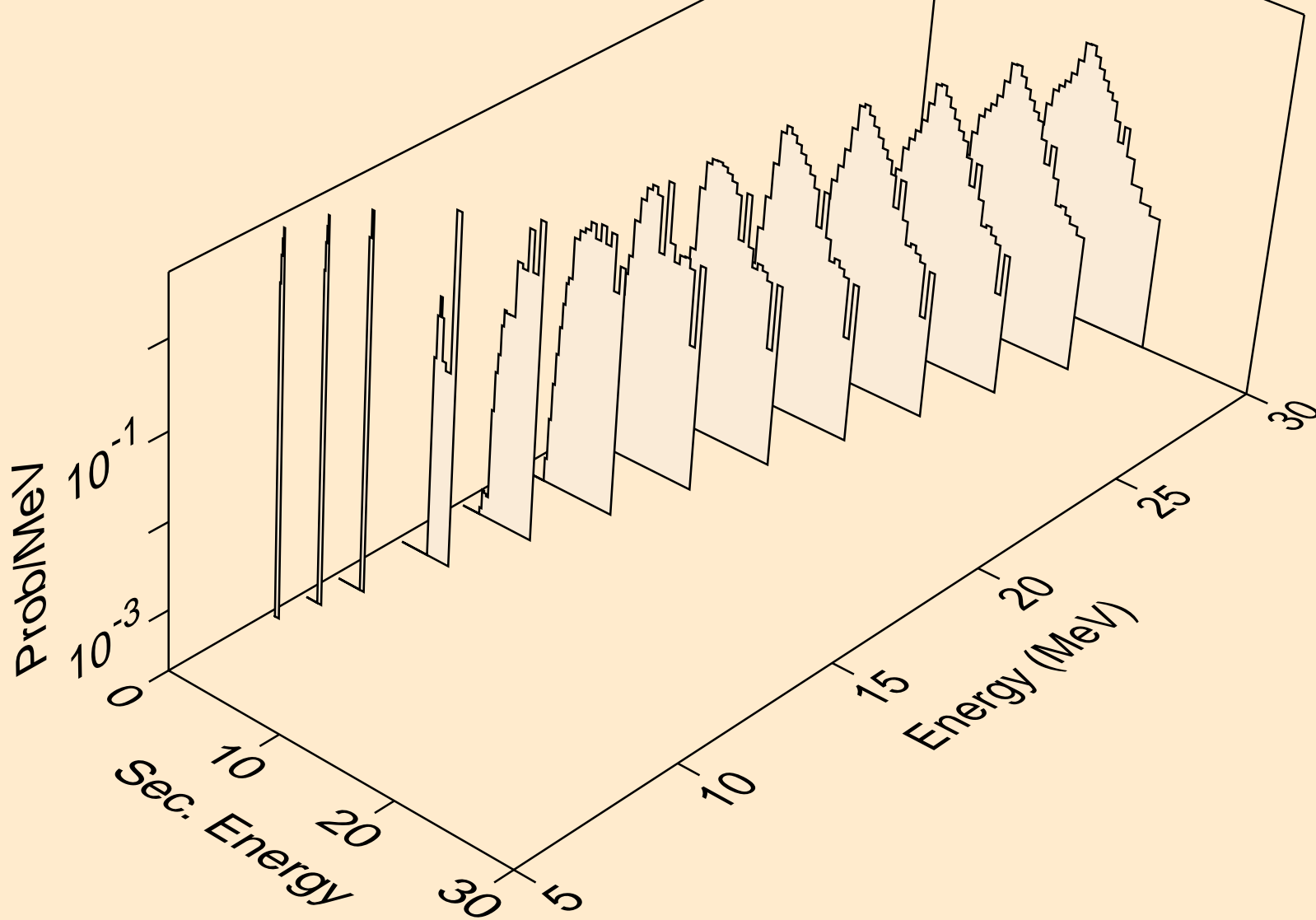

CL035 PHOTON ACER TENDL-2023 LIBRARY; T=0.K
alphas from (g,2a)

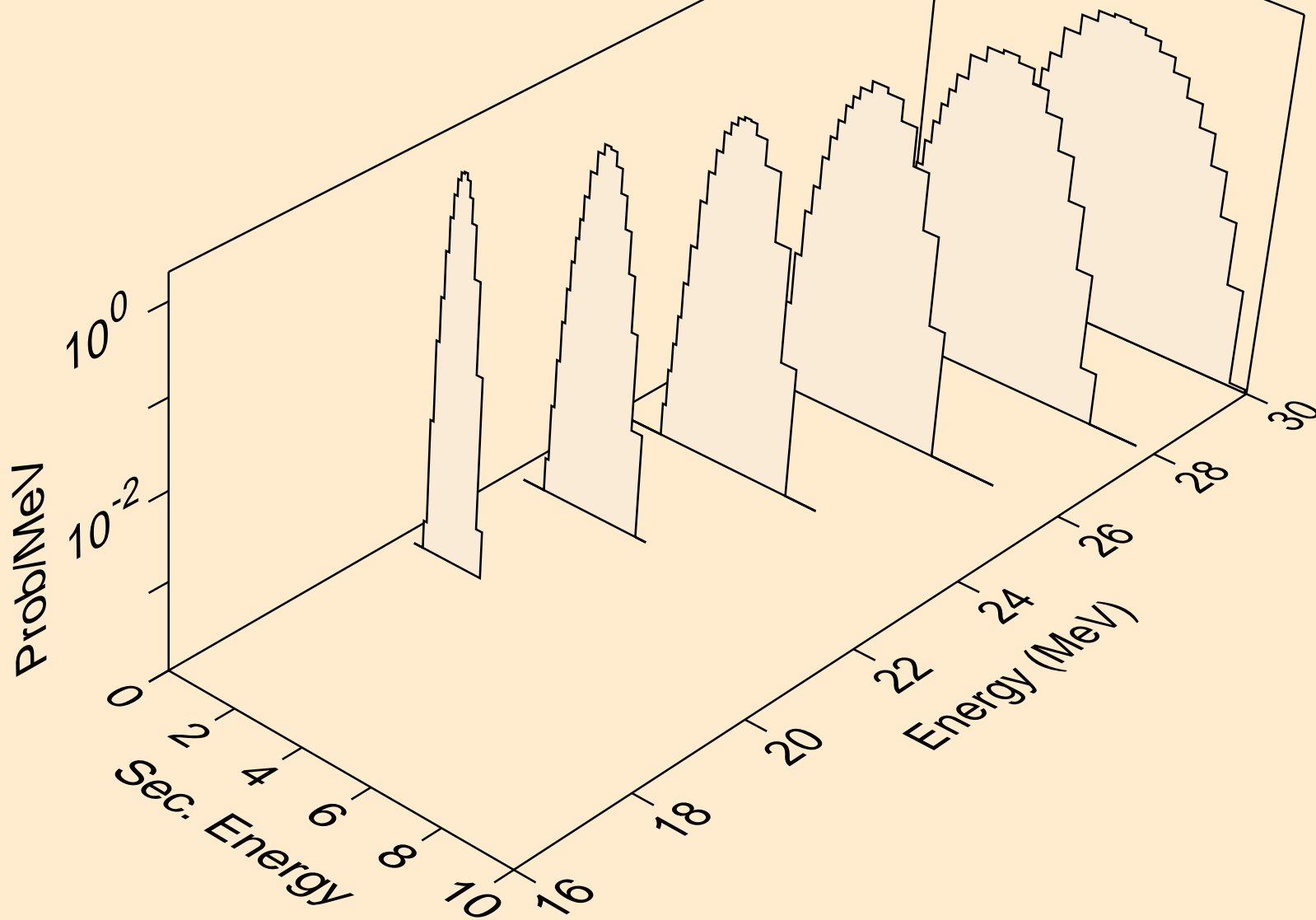

CL035 PHOTON ACER TENDL-2023 LIBRARY; T=0.K
alphas from (g,pa)

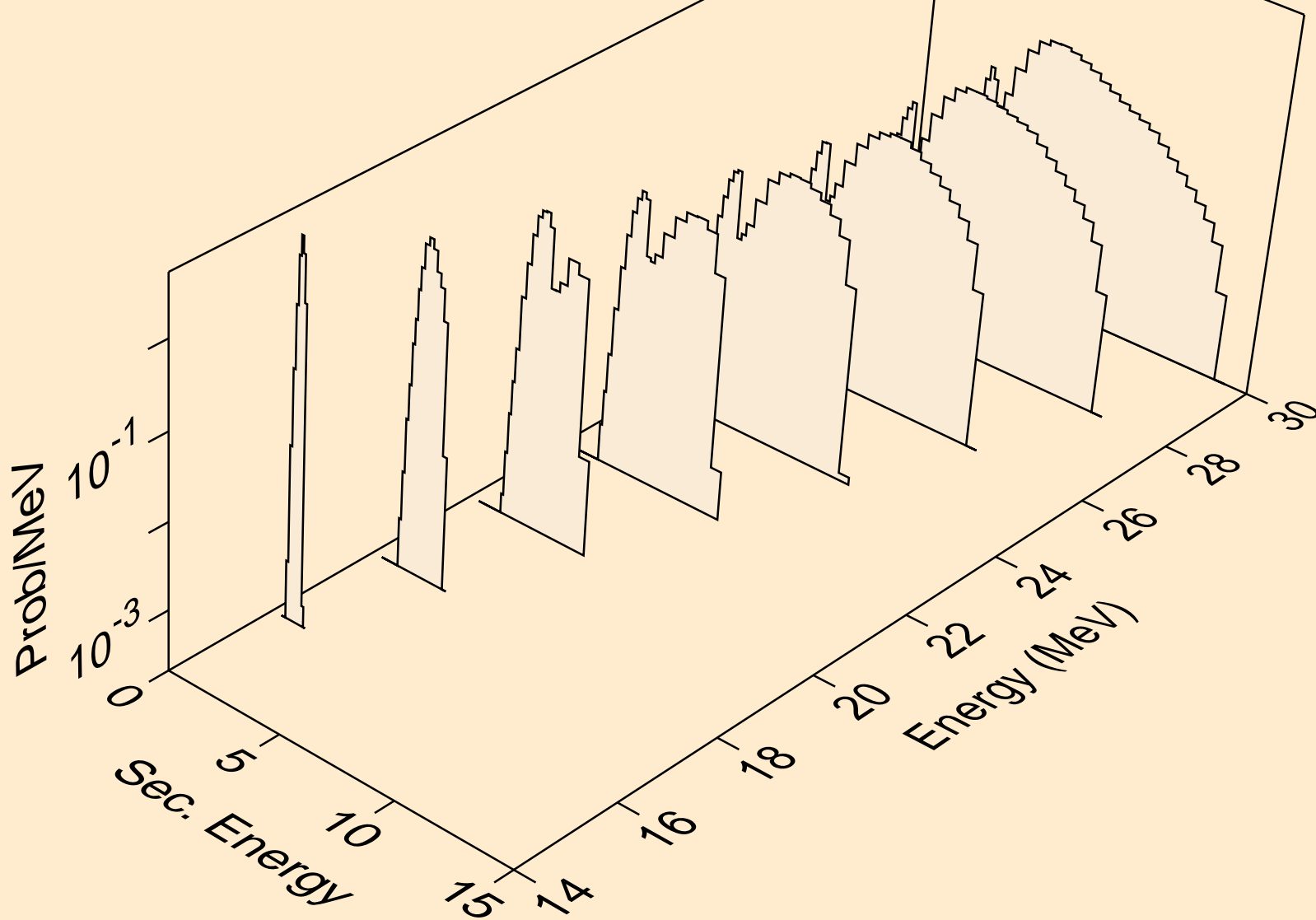

CL035 PHOTON ACER TENDL-2023 LIBRARY; T=0.K
alphas from (g,da)

