

ES239 PHOTON ACER TENDL-2023 LIBRARY; T=0.K
Principal cross sections

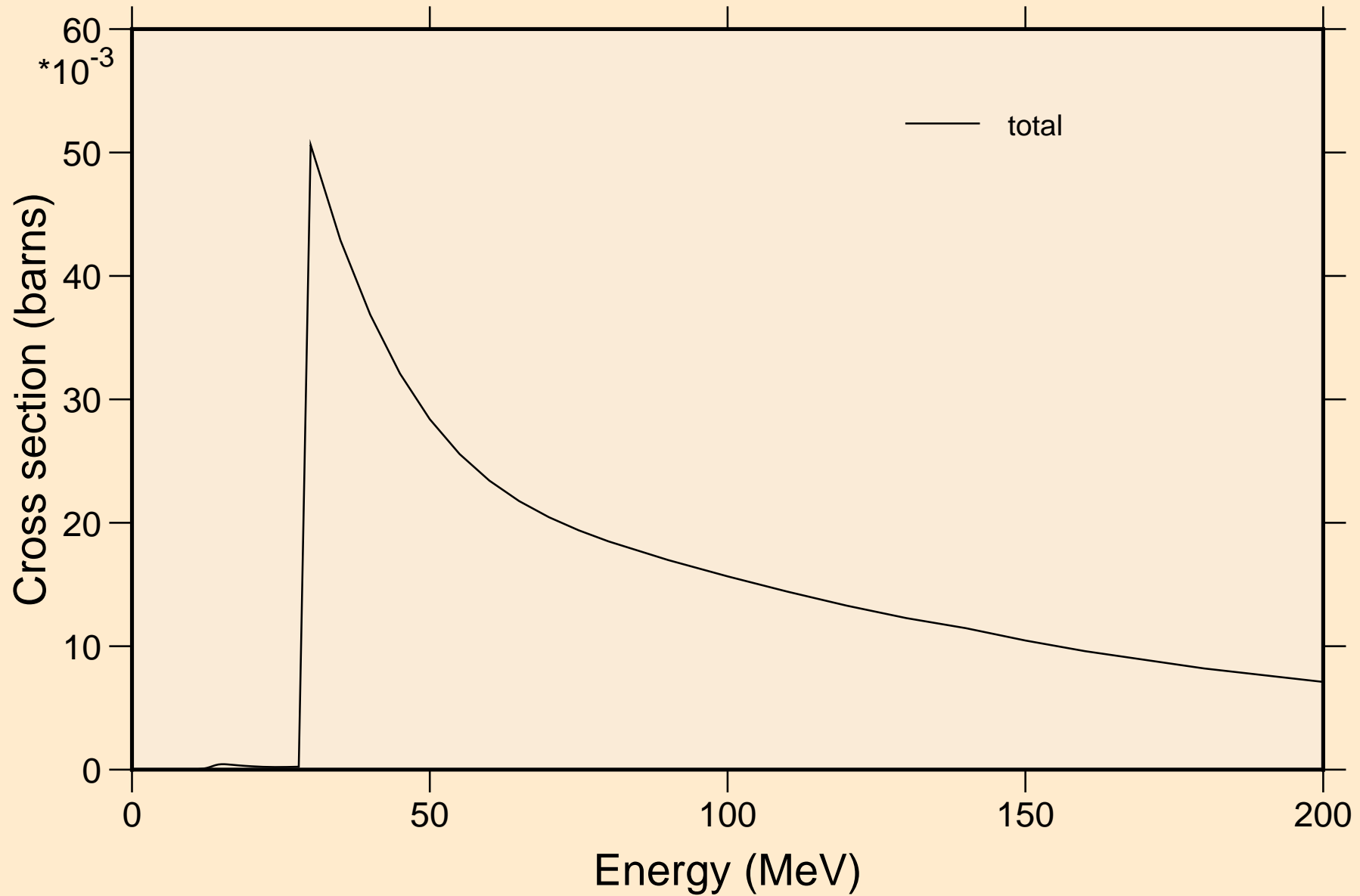

ES239 PHOTON ACER TENDL-2023 LIBRARY; T=0.K

Partial cross sections

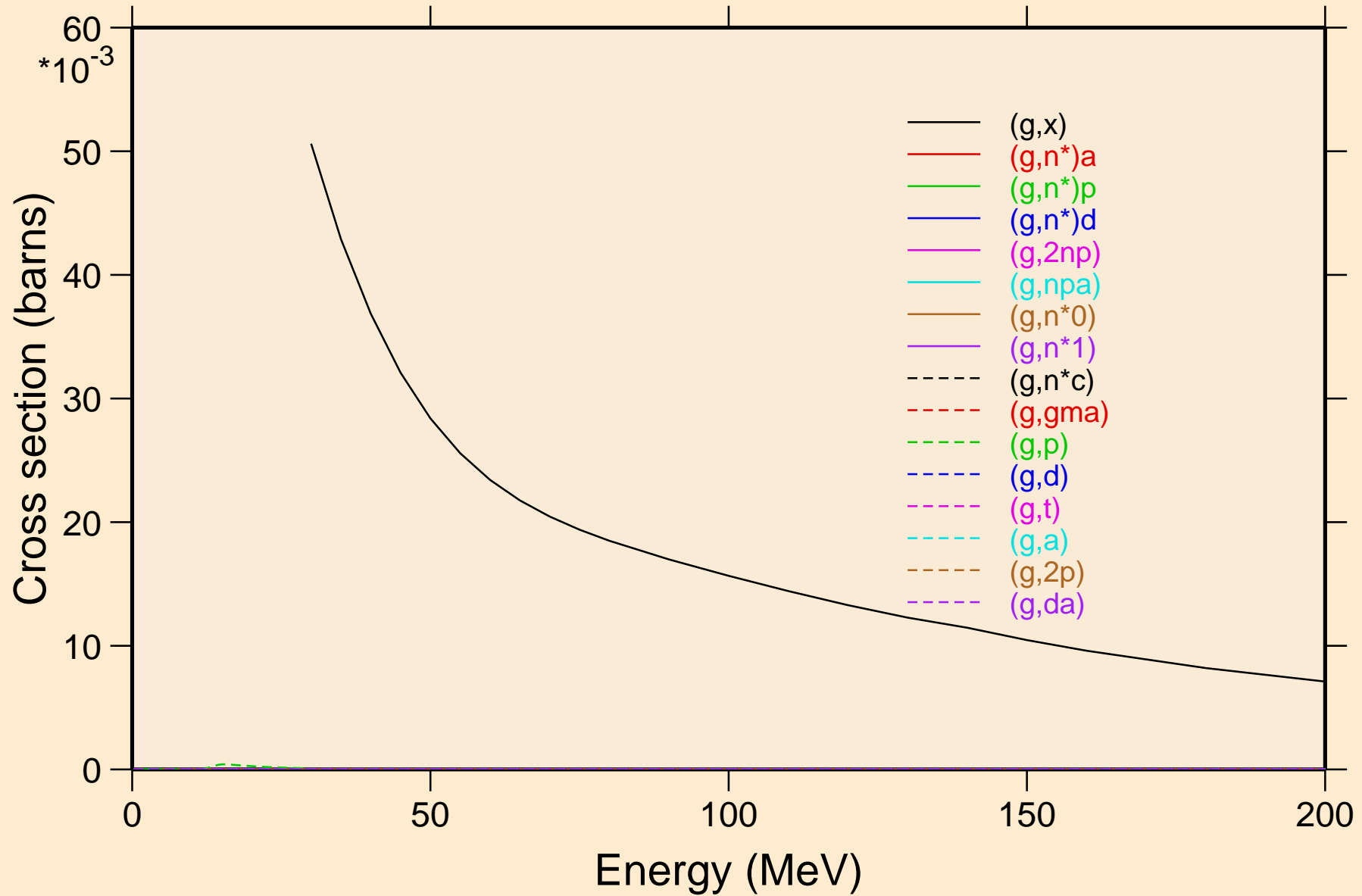

ES239 PHOTON ACER TENDL-2023 LIBRARY; T=0.K

Heating

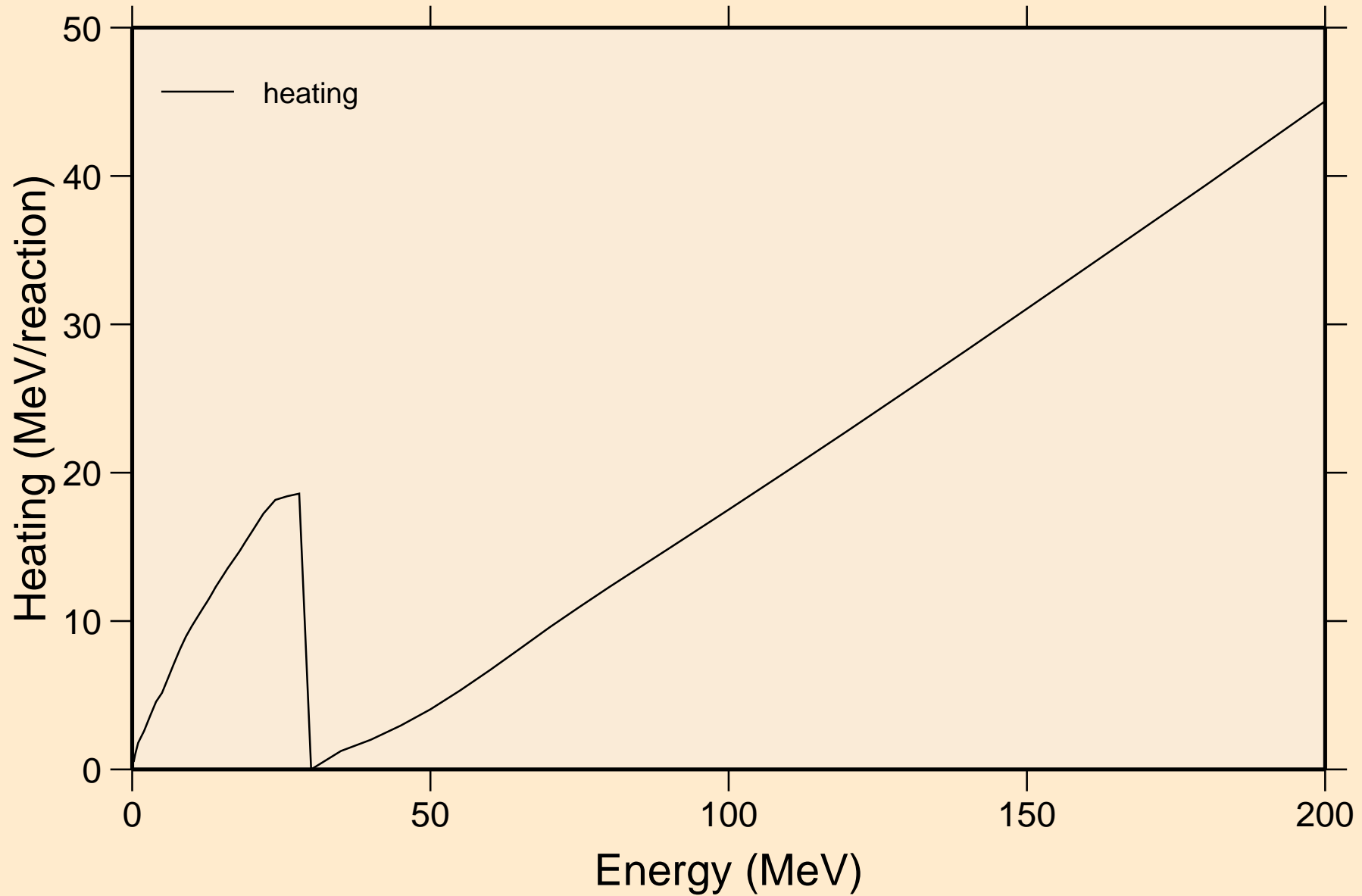

ES239 PHOTON ACER TENDL-2023 LIBRARY; T=0.K

Particle heating contributions

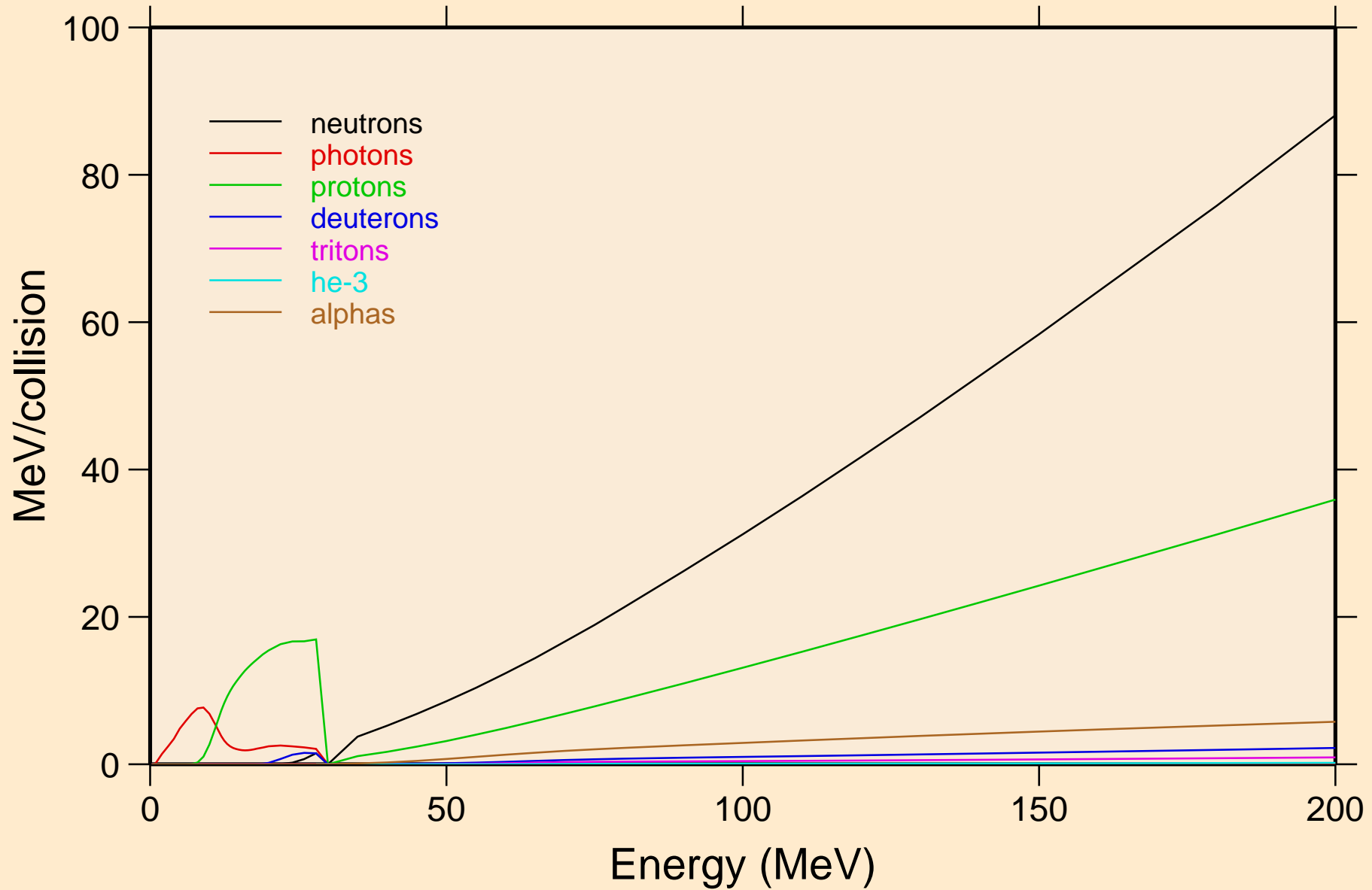

ES239 PHOTON ACER TENDL-2023 LIBRARY; T=0.K

Particle production cross sections

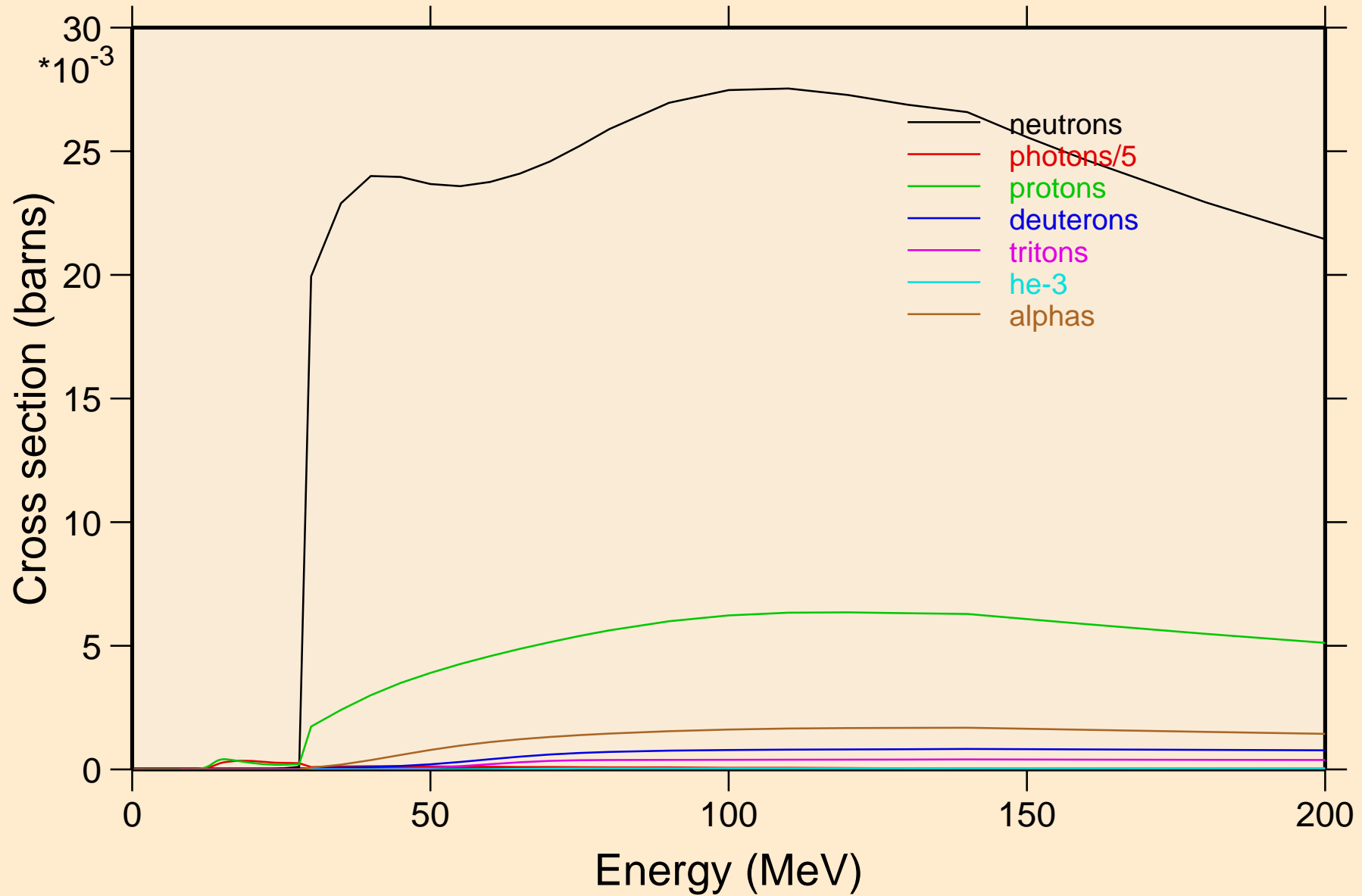

ES239 PHOTON ACER TENDL-2023 LIBRARY; T=0.K
neutrons from (g,x)

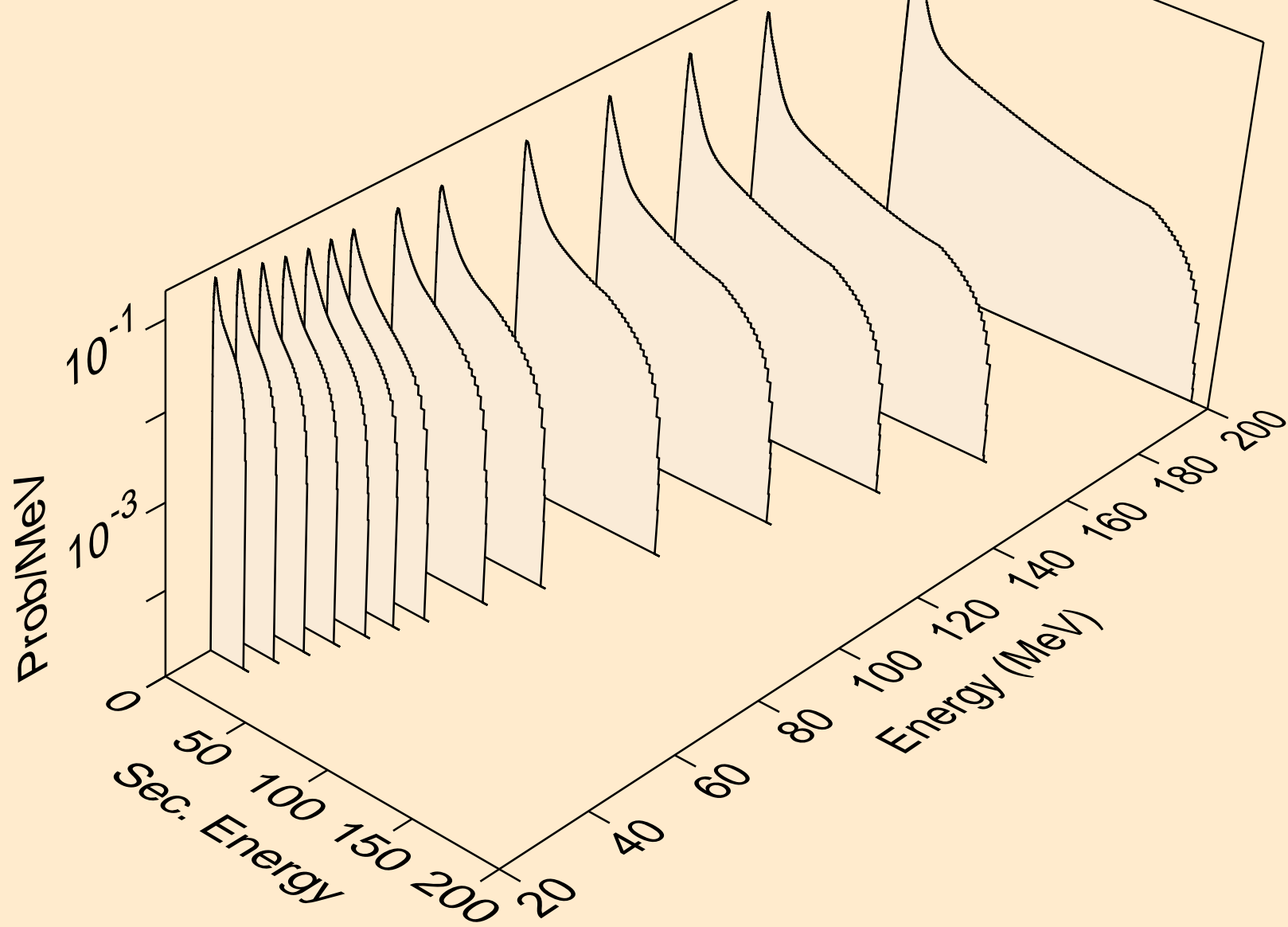

ES239 PHOTON ACER TENDL-2023 LIBRARY; T=0.K
neutrons from (g,n*)a

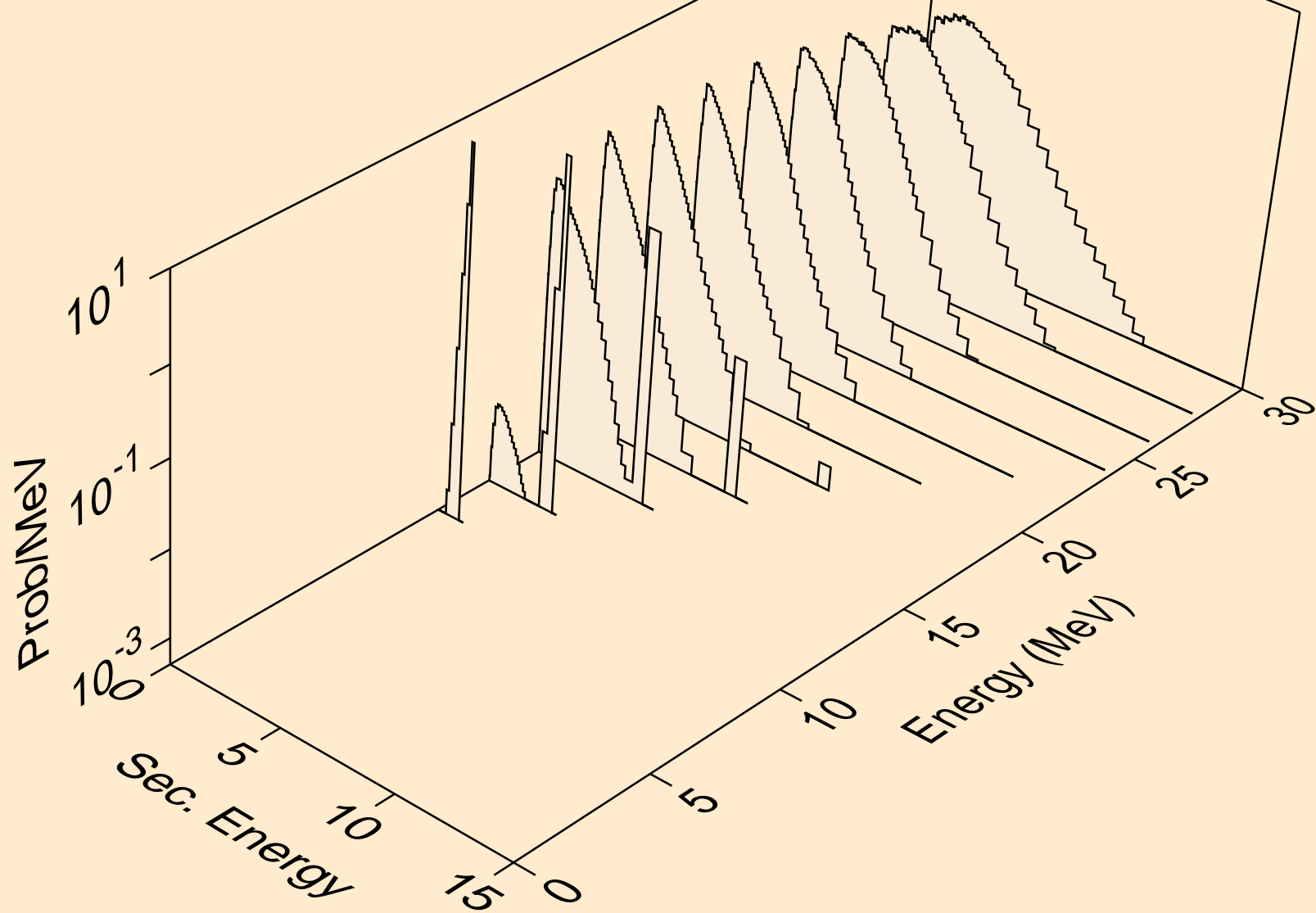

ES239 PHOTON ACER TENDL-2023 LIBRARY; T=0.K
neutrons from (g,n*)p

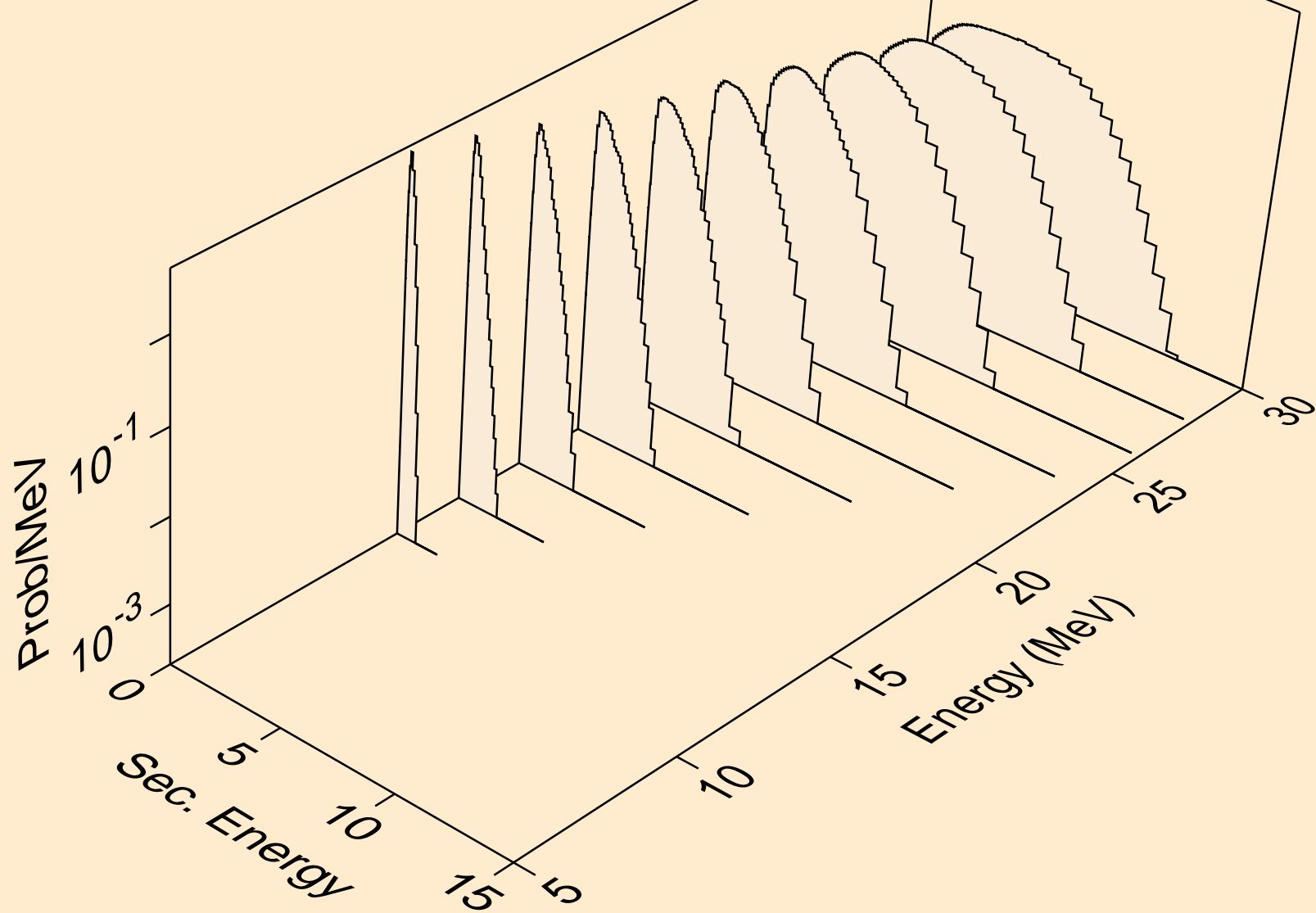

ES239 PHOTON ACER TENDL-2023 LIBRARY; T=0.K
neutrons from (g,n*)d

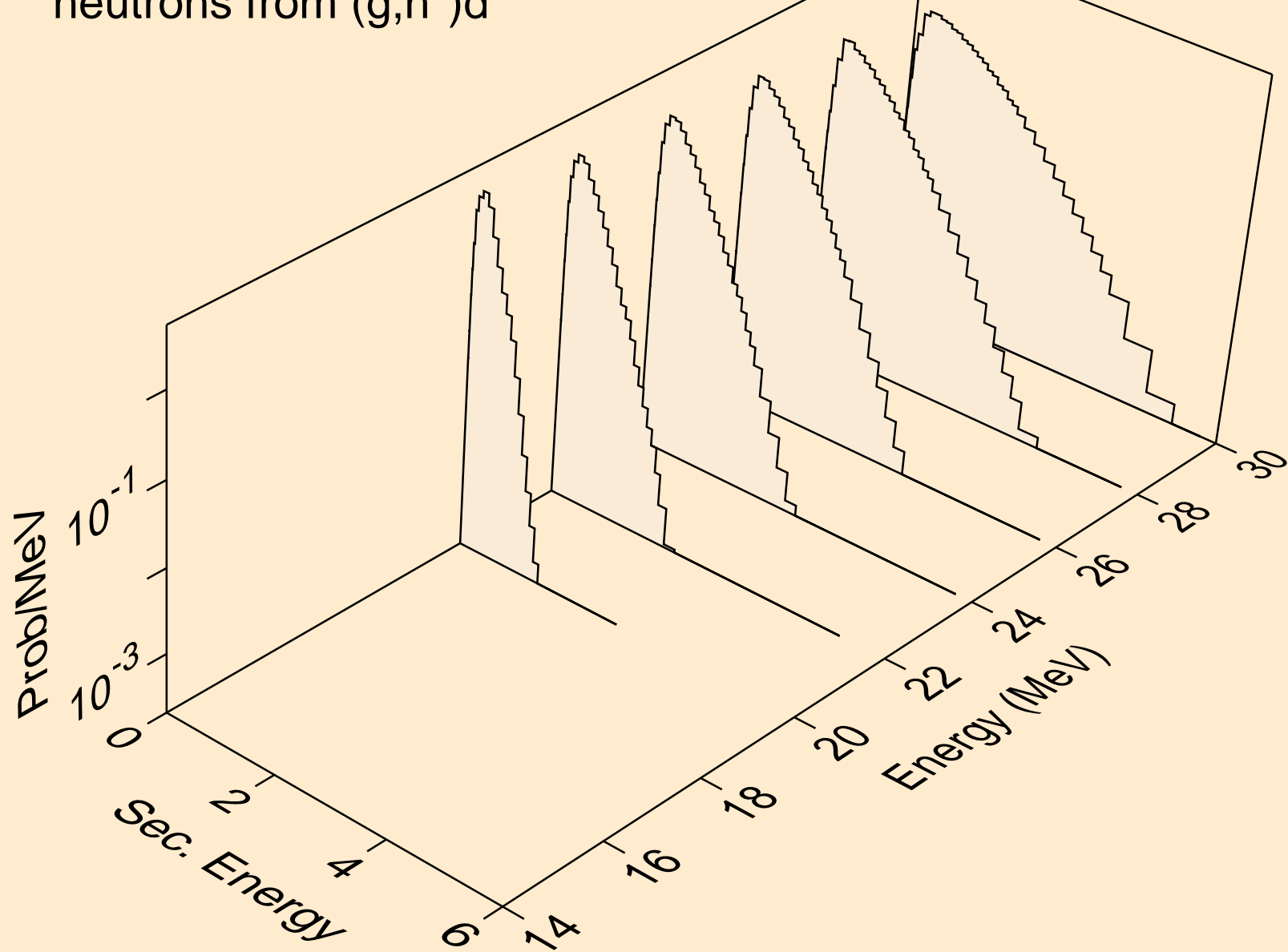

ES239 PHOTON ACER TENDL-2023 LIBRARY; T=0.K
neutrons from (g,2np)

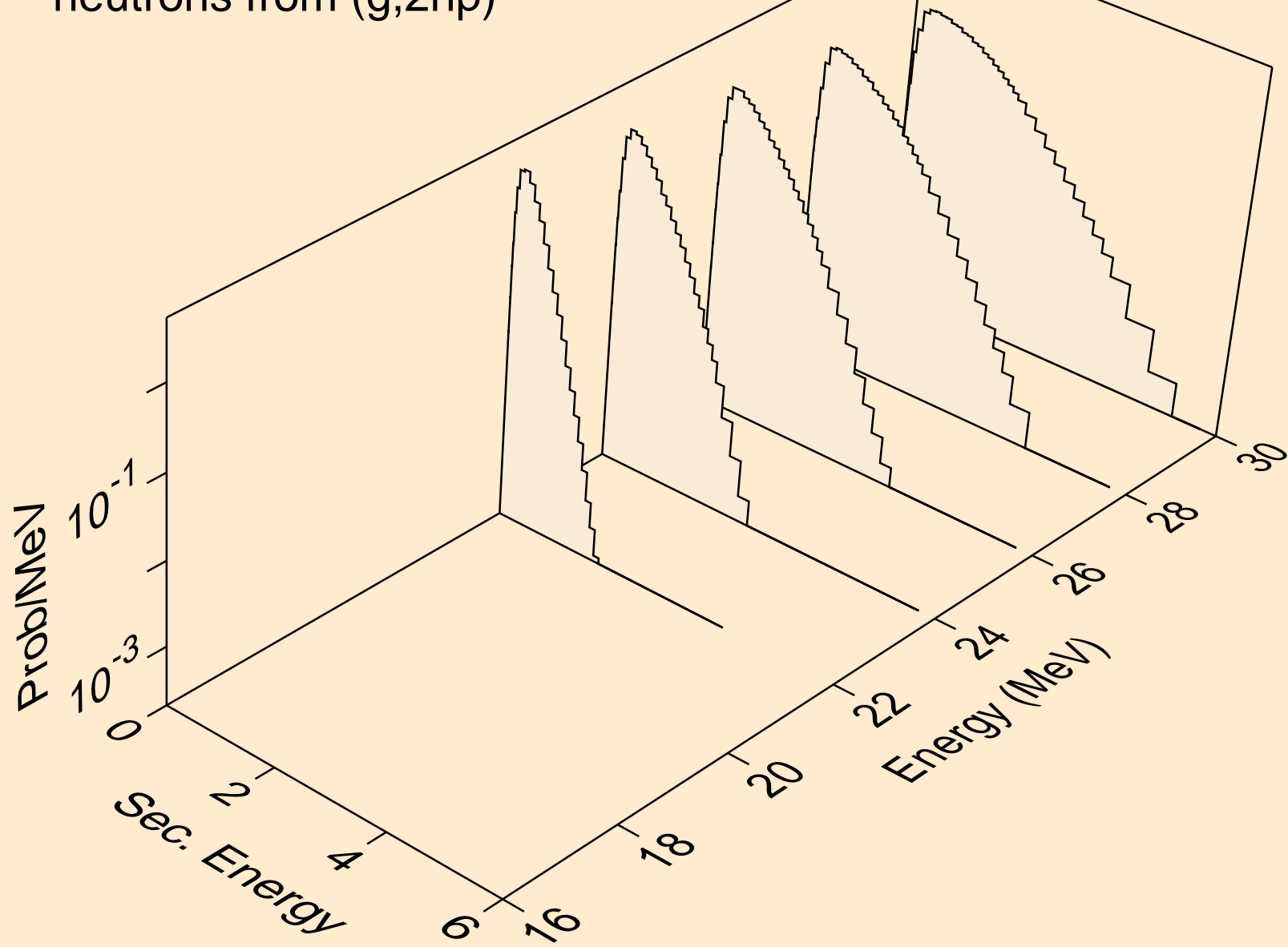

ES239 PHOTON ACER TENDL-2023 LIBRARY; T=0.K
neutrons from (g,npa)

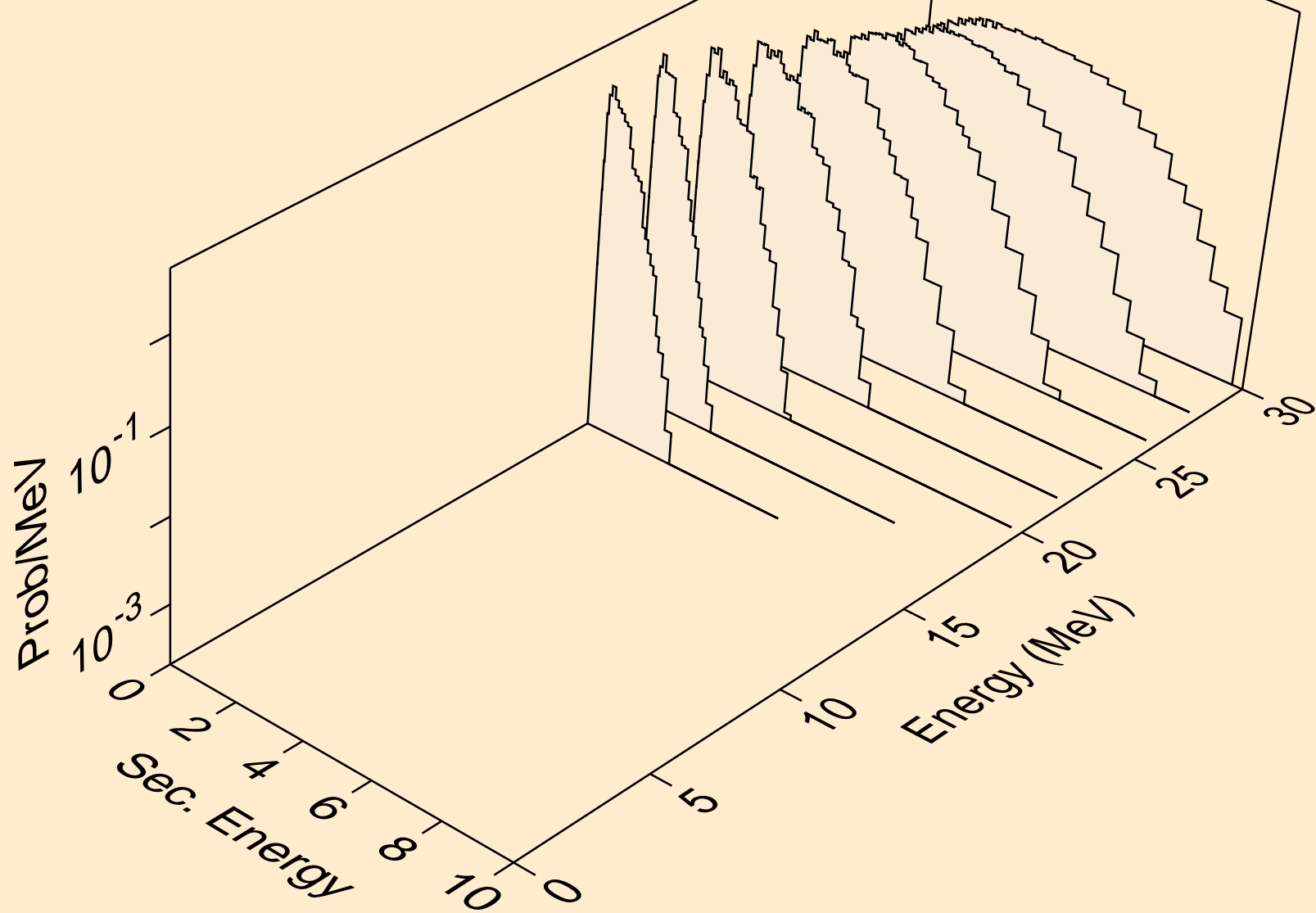

ES239 PHOTON ACER TENDL-2023 LIBRARY; T=0.K
angular distribution for (g,n*0) neutron

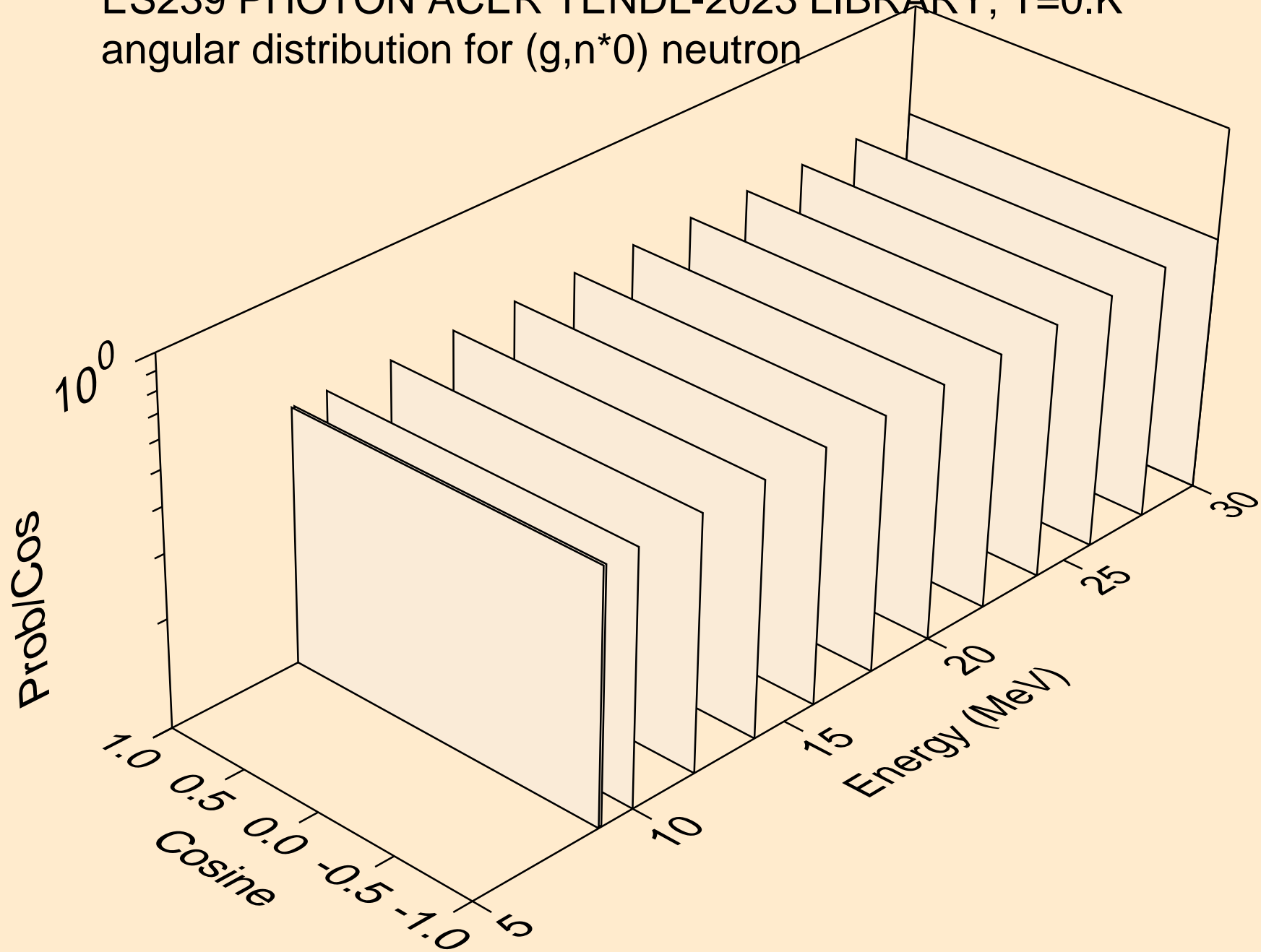

ES239 PHOTON ACER TENDL-2023 LIBRARY; T=0.K
angular distribution for (g,n*1) neutron

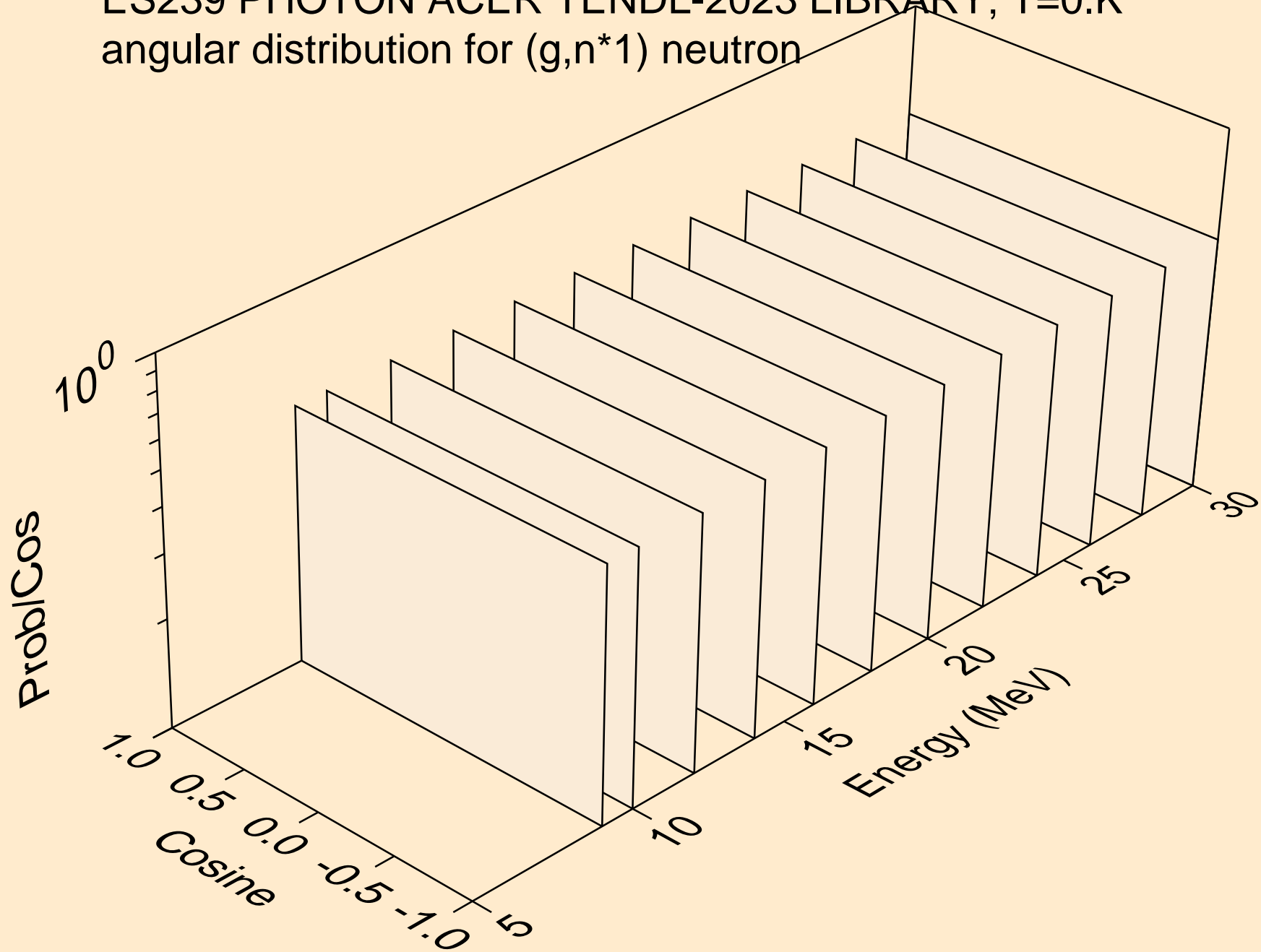

ES239 PHOTON ACER TENDL-2023 LIBRARY; T=0.K
neutrons from (g,n*c)

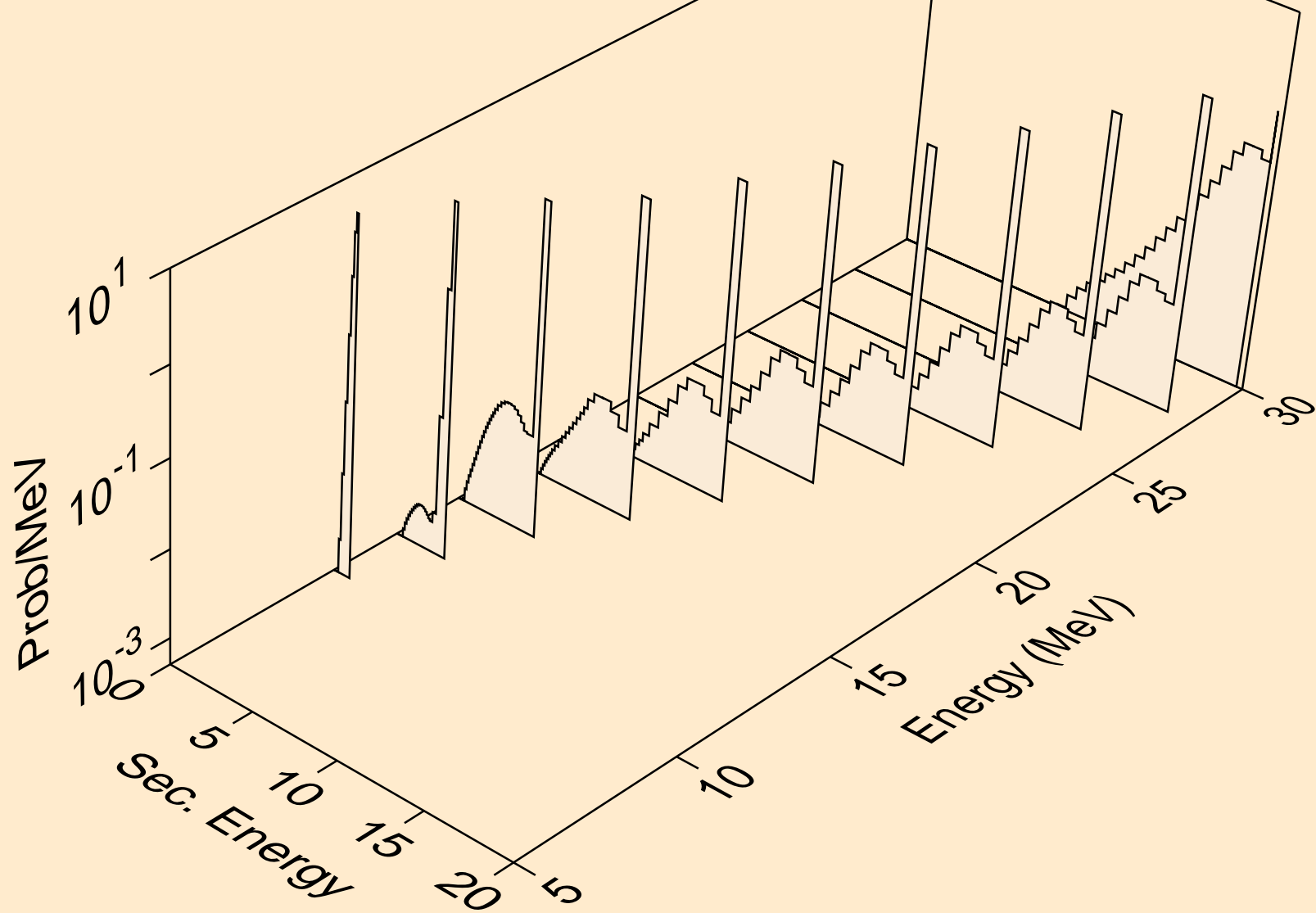

ES239 PHOTON ACER TENDL-2023 LIBRARY; T=0.K
photons from (g,x)

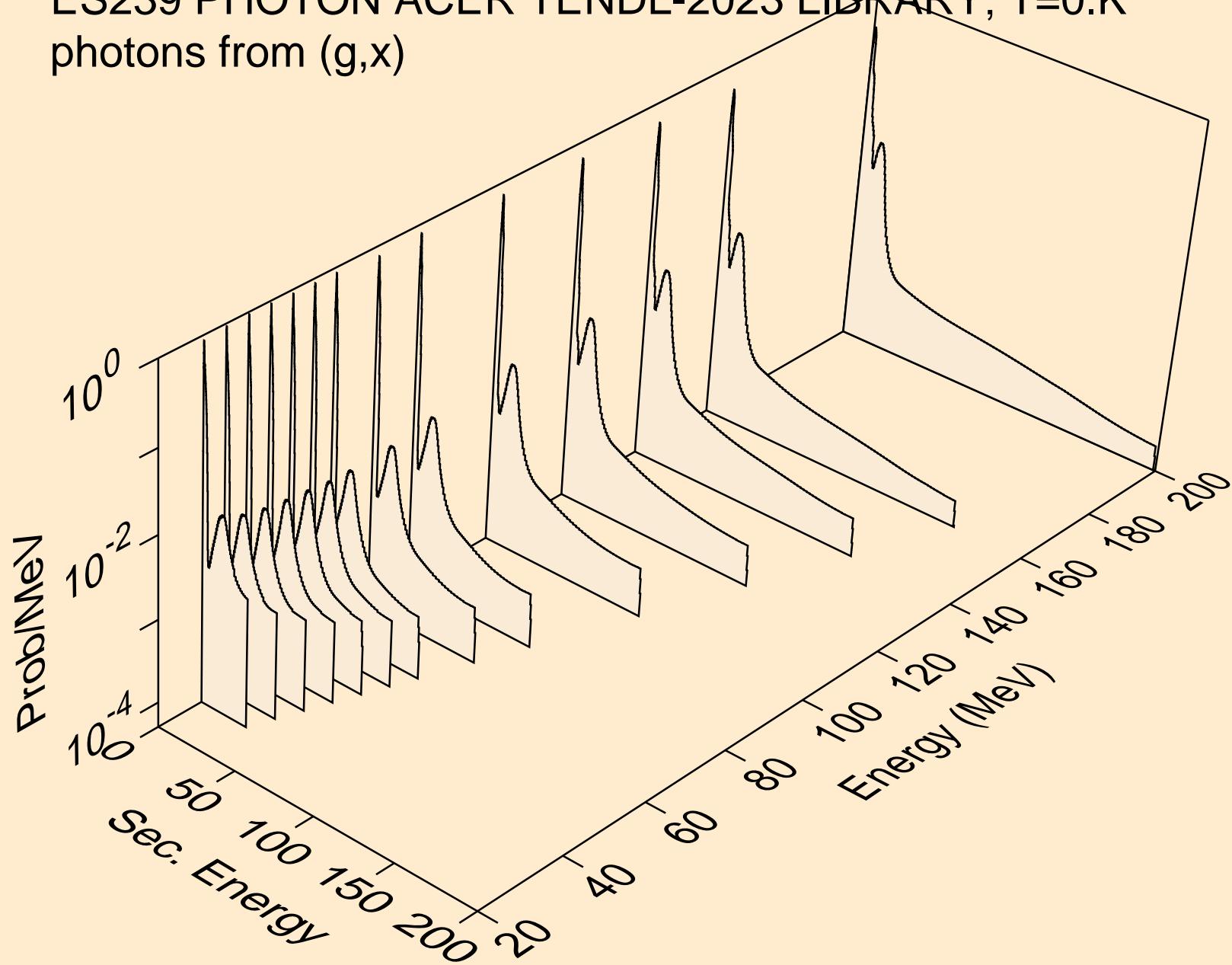

ES239 PHOTON ACER TENDL-2023 LIBRARY; T=0.K
photons from (g,n*)a

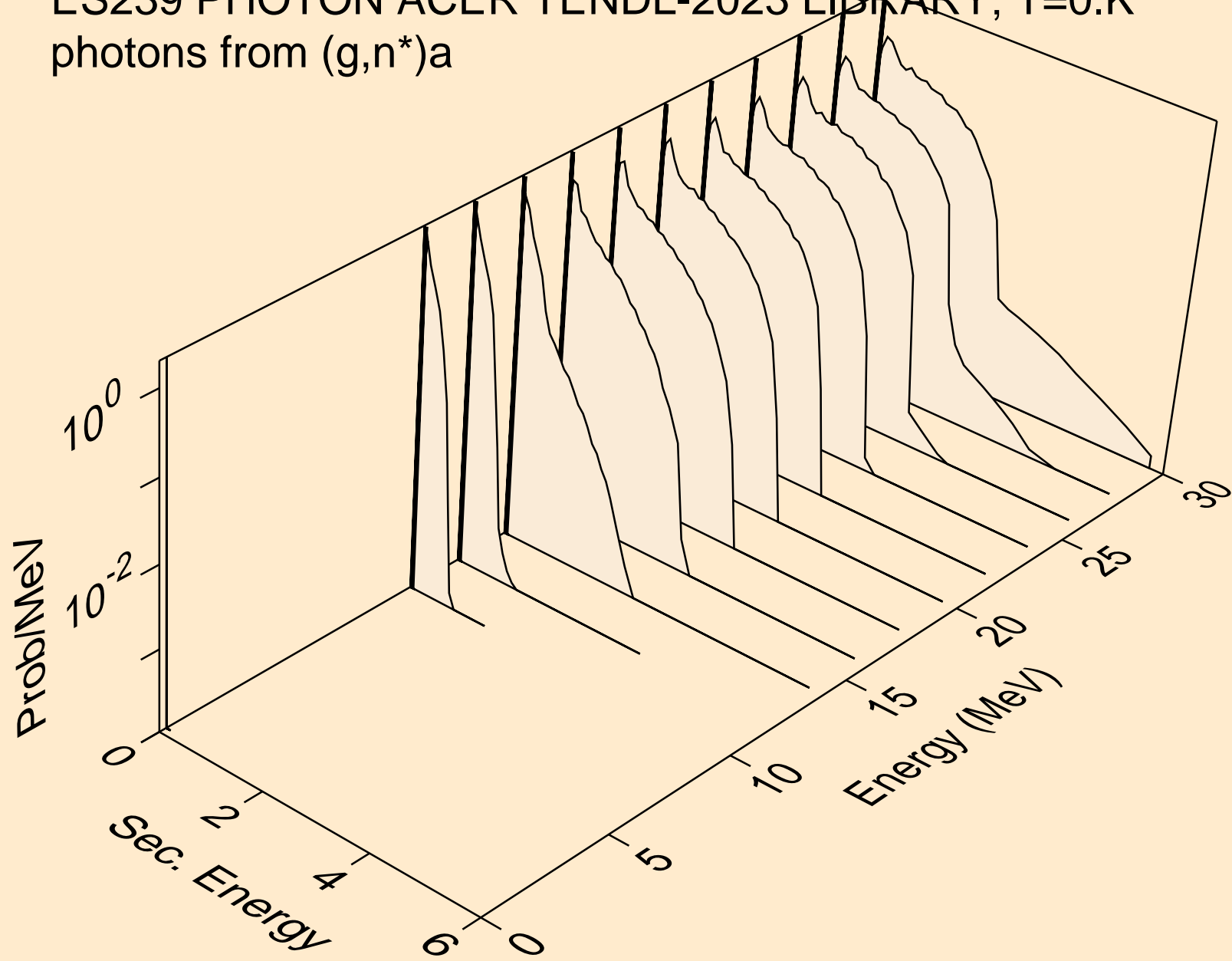

ES239 PHOTON ACER TENDL-2023 LIBRARY; T=0.K
photons from (g,n*)p

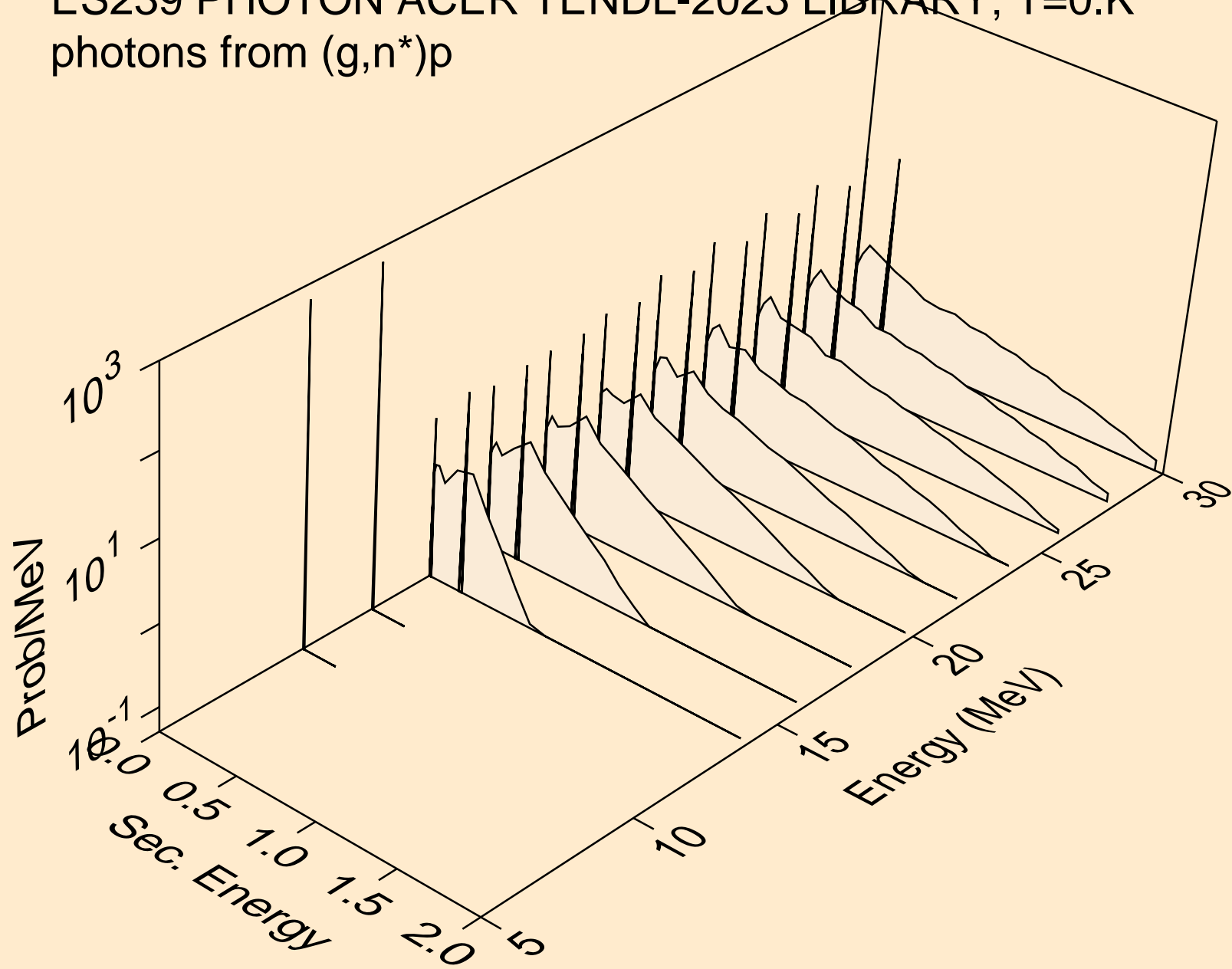

ES239 PHOTON ACER TENDL-2023 LIBRARY; T=0.K
photons from (g,n*)d

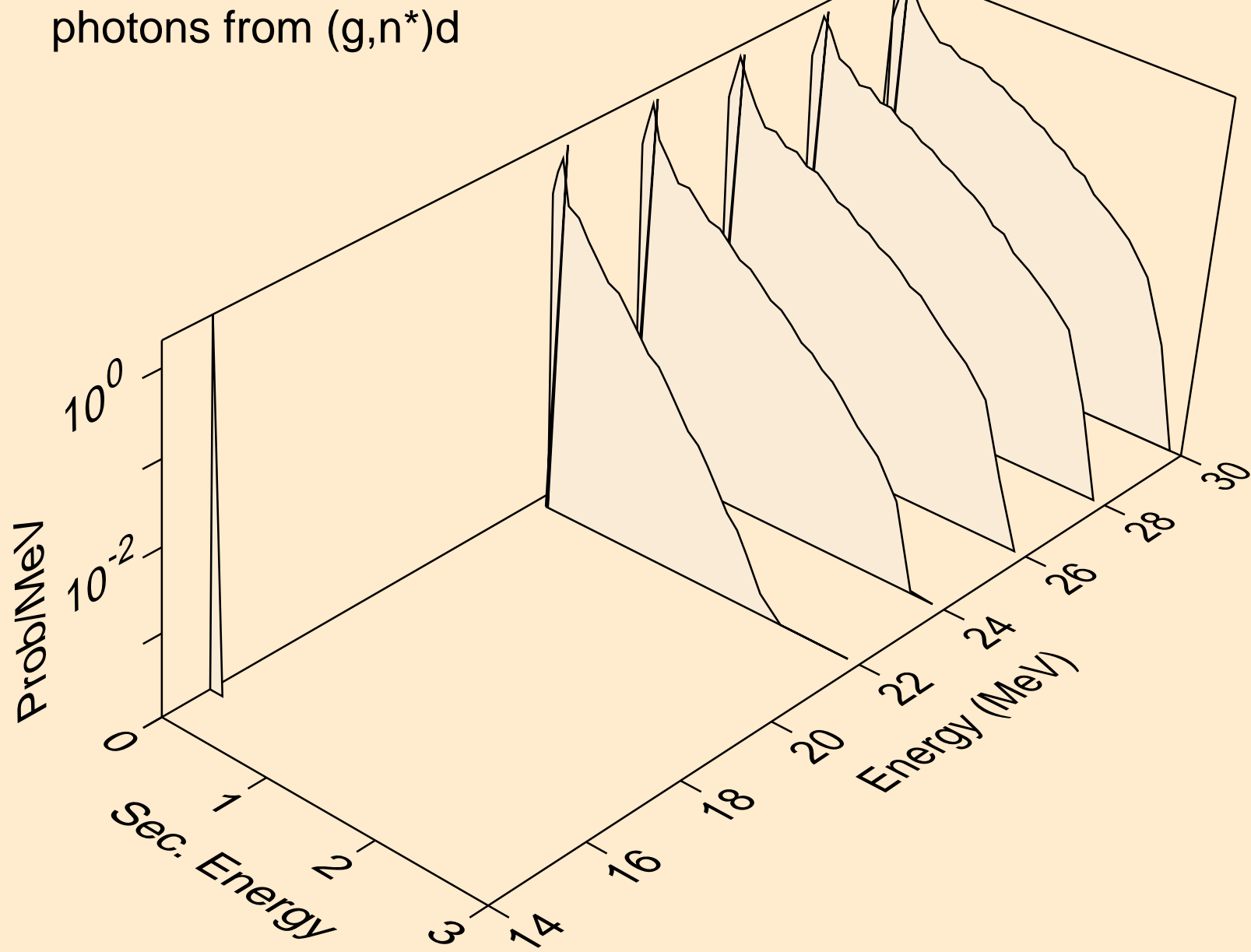

ES239 PHOTON ACER TENDL-2023 LIBRARY; T=0.K
photons from (g,2np)

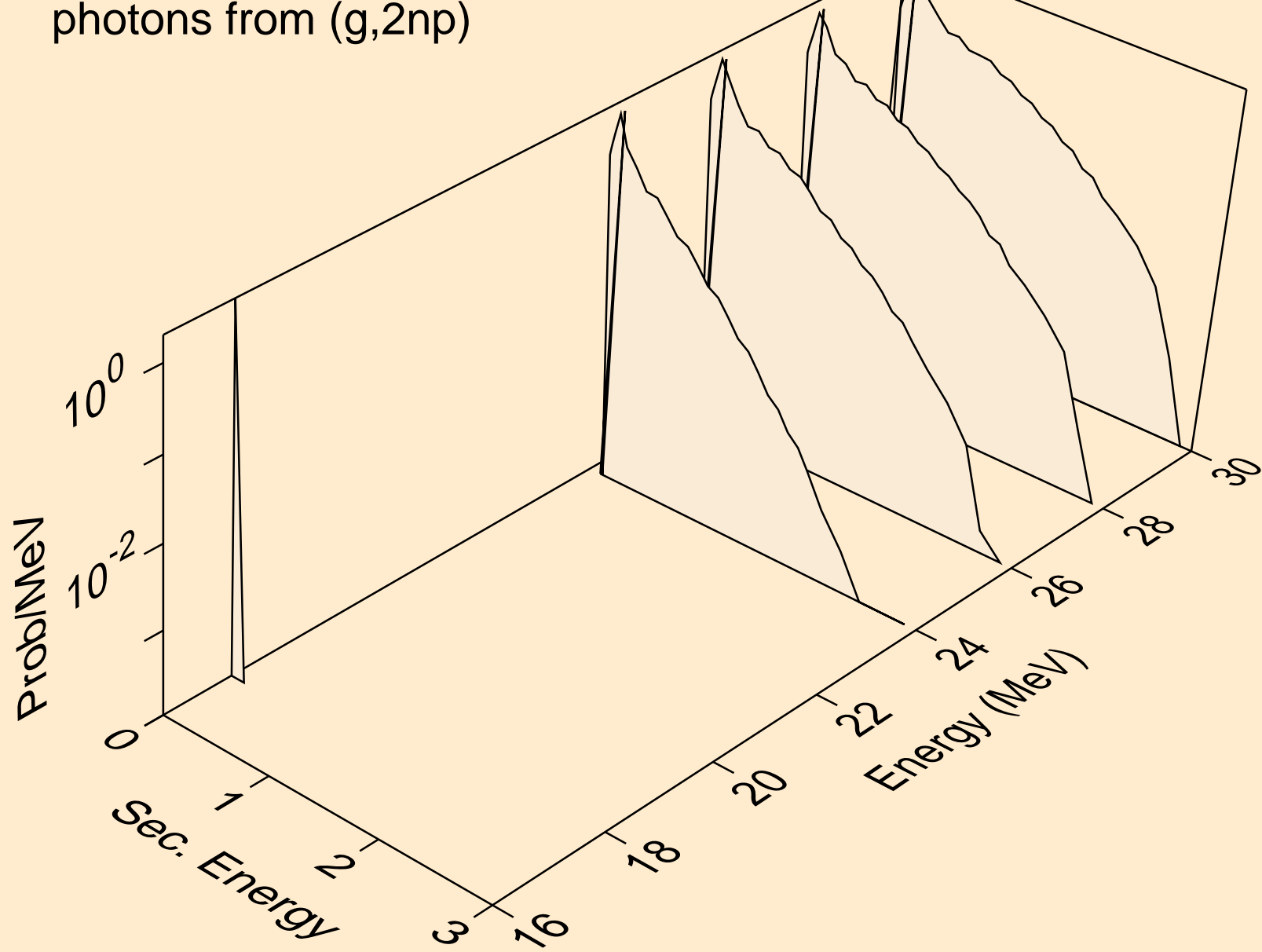

ES239 PHOTON ACER TENDL-2023 LIBRARY; T=0.K
photons from (g,npa)

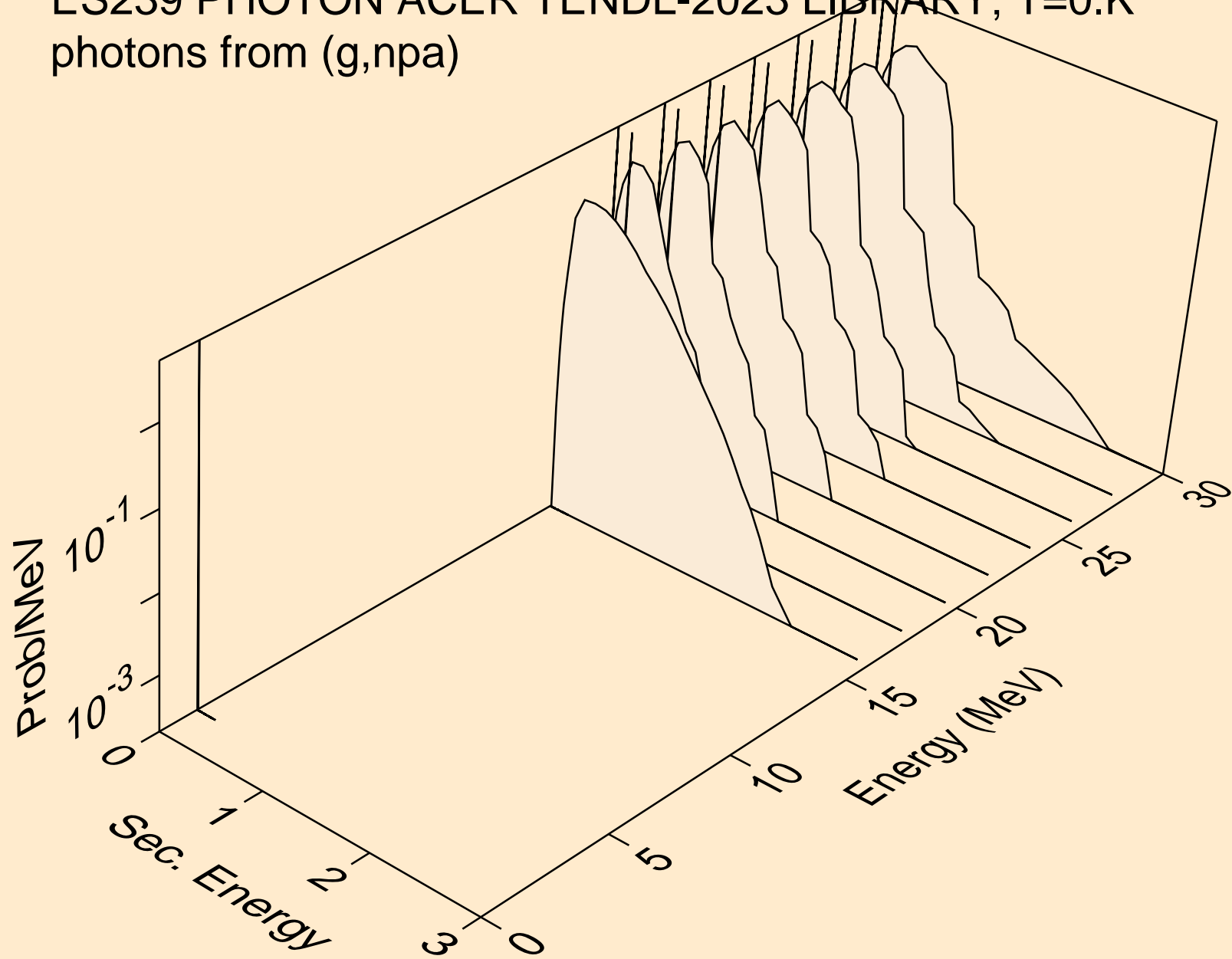

ES239 PHOTON ACER TENDL-2023 LIBRARY; T=0.K
photons from (g,n*c)

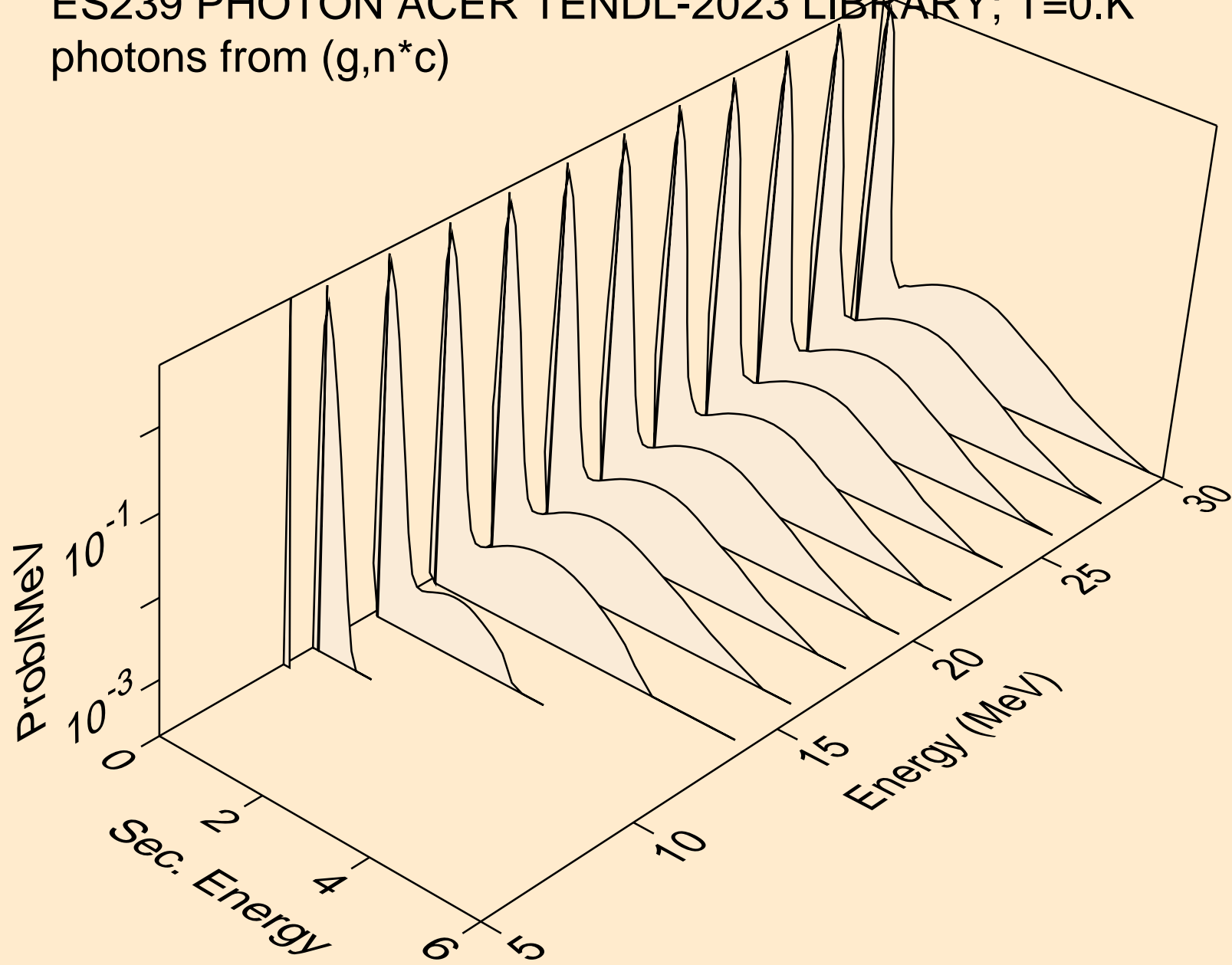

ES239 PHOTON ACER TENDL-2023 LIBRARY; T=0.K
photons from (g,gma)

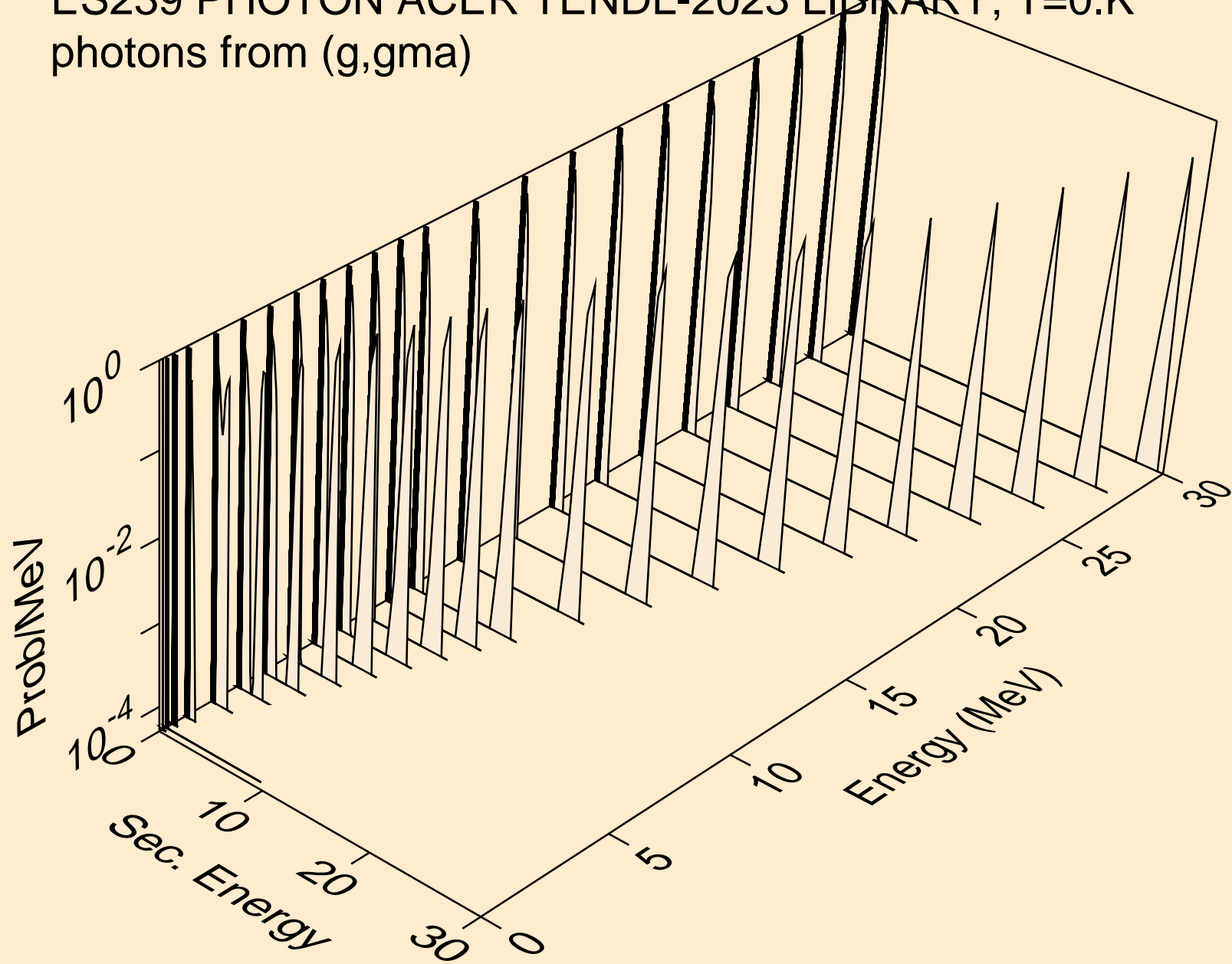

ES239 PHOTON ACER TENDL-2023 LIBRARY; T=0.K
photons from (g,p)

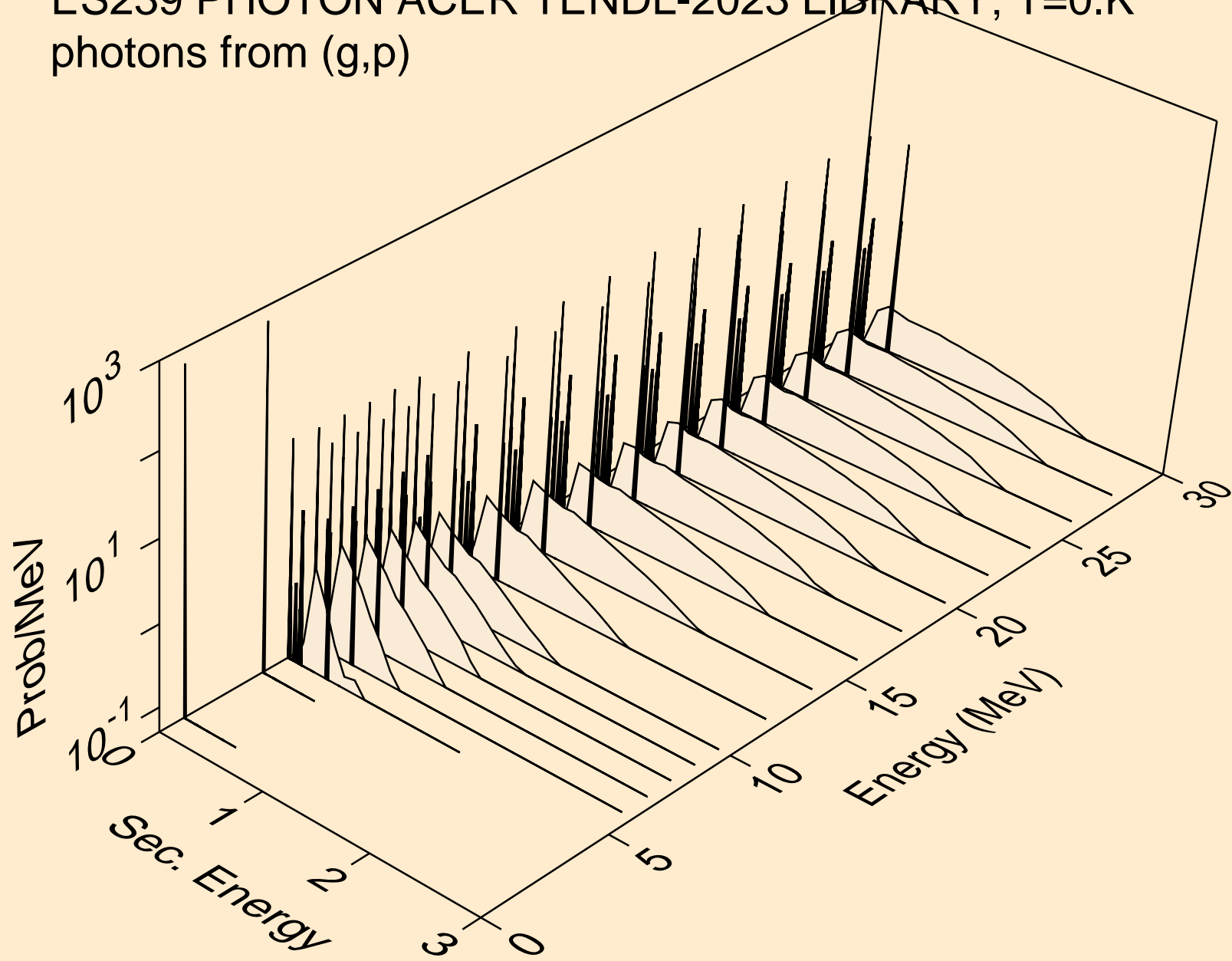

ES239 PHOTON ACER TENDL-2023 LIBRARY; T=0.K
photons from (g,d)

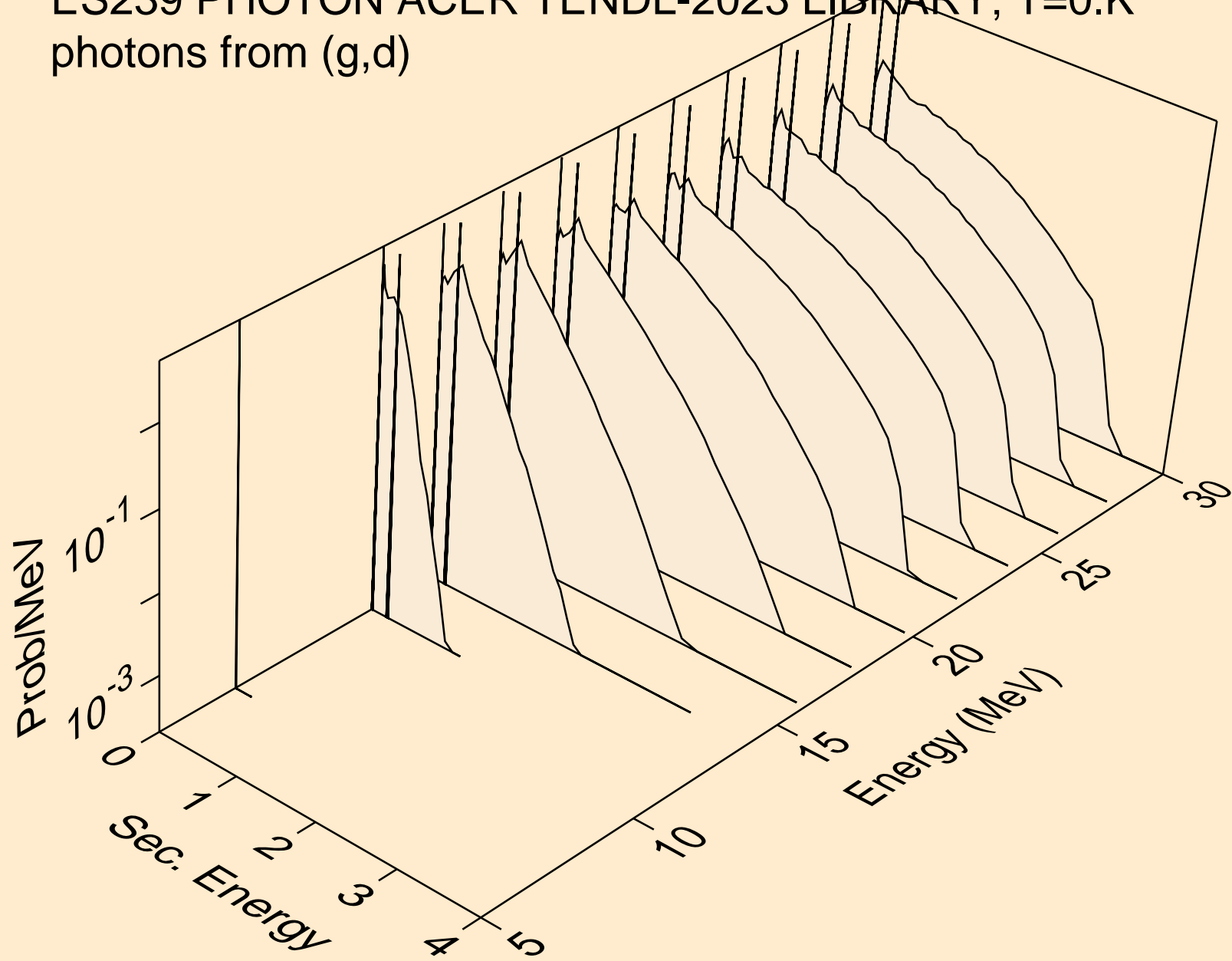

ES239 PHOTON ACER TENDL-2023 LIBRARY; T=0.K
photons from (g,t)

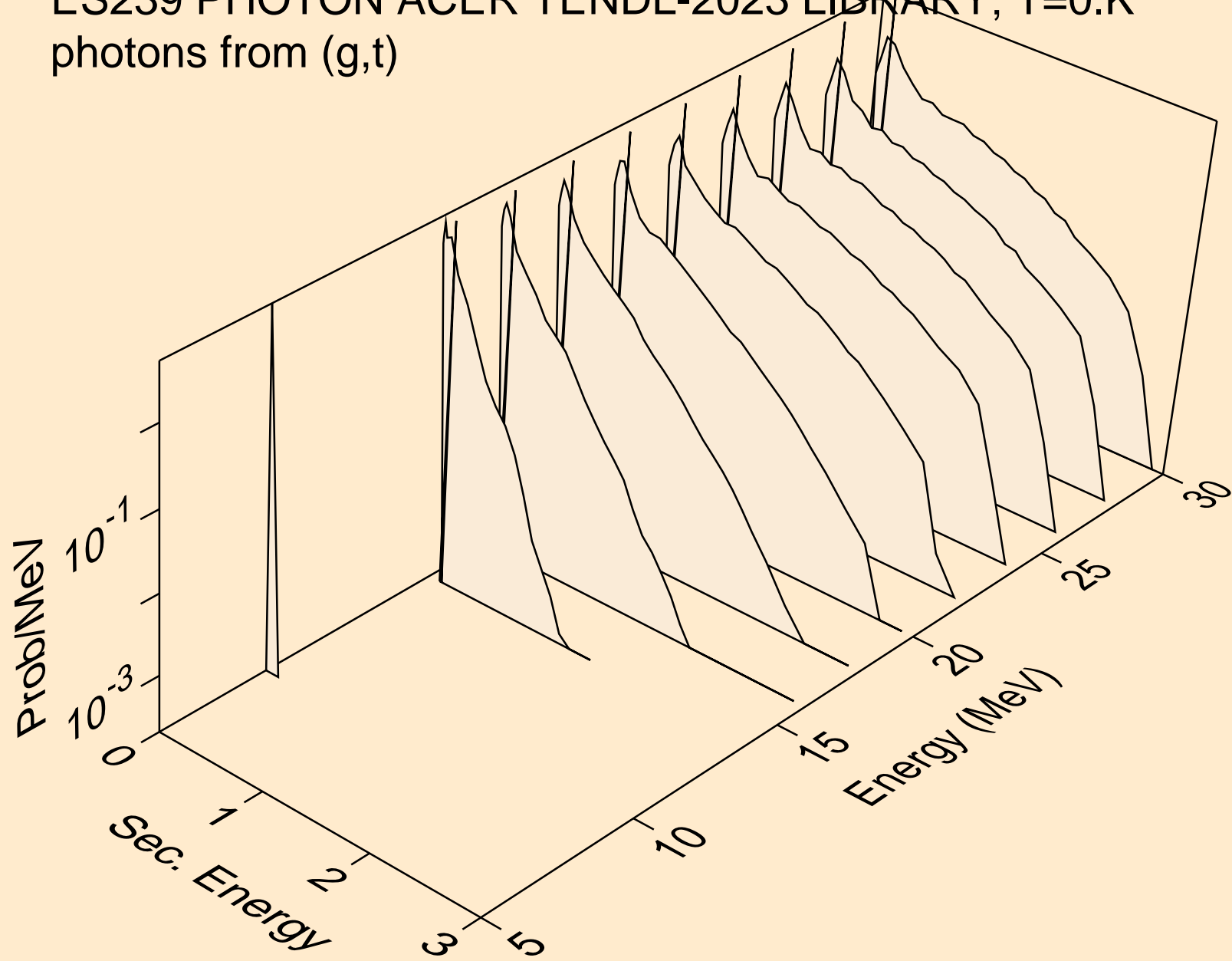

ES239 PHOTON ACER TENDL-2023 LIBRARY; T=0.K
photons from (g,a)

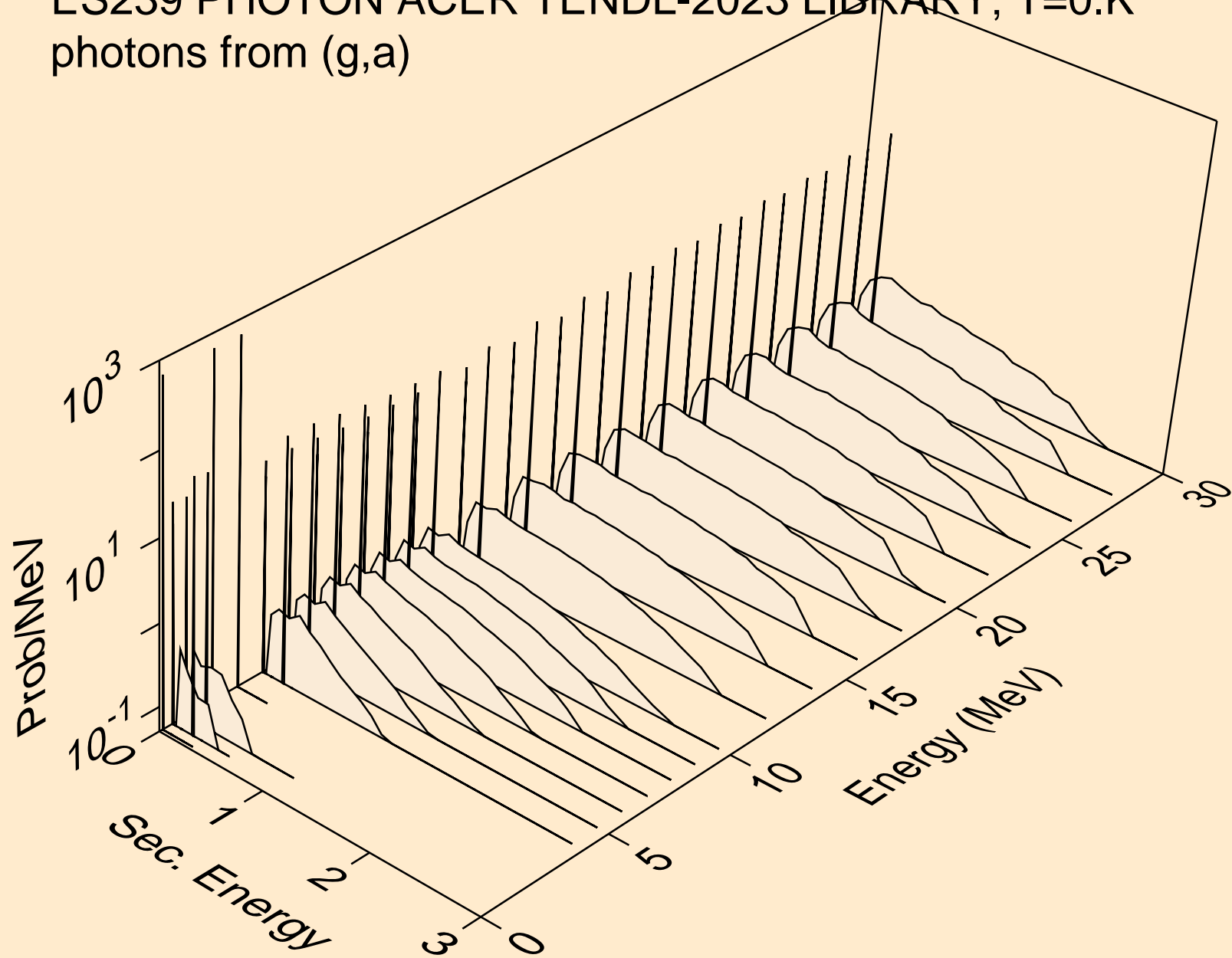

ES239 PHOTON ACER TENDL-2023 LIBRARY; T=0.K
photons from (g,2p)

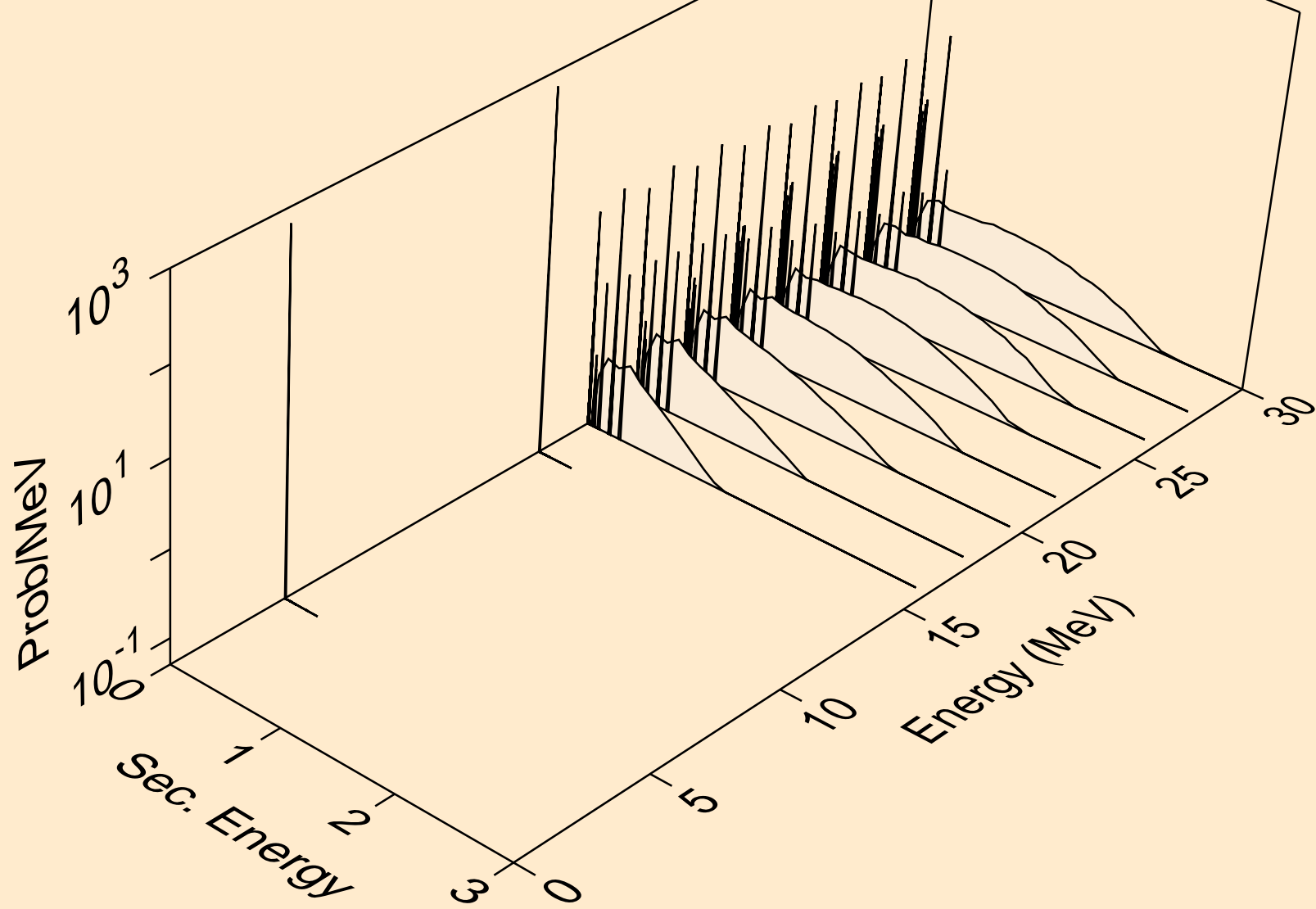

ES239 PHOTON ACER TENDL-2023 LIBRARY; T=0.K
photons from (g,da)

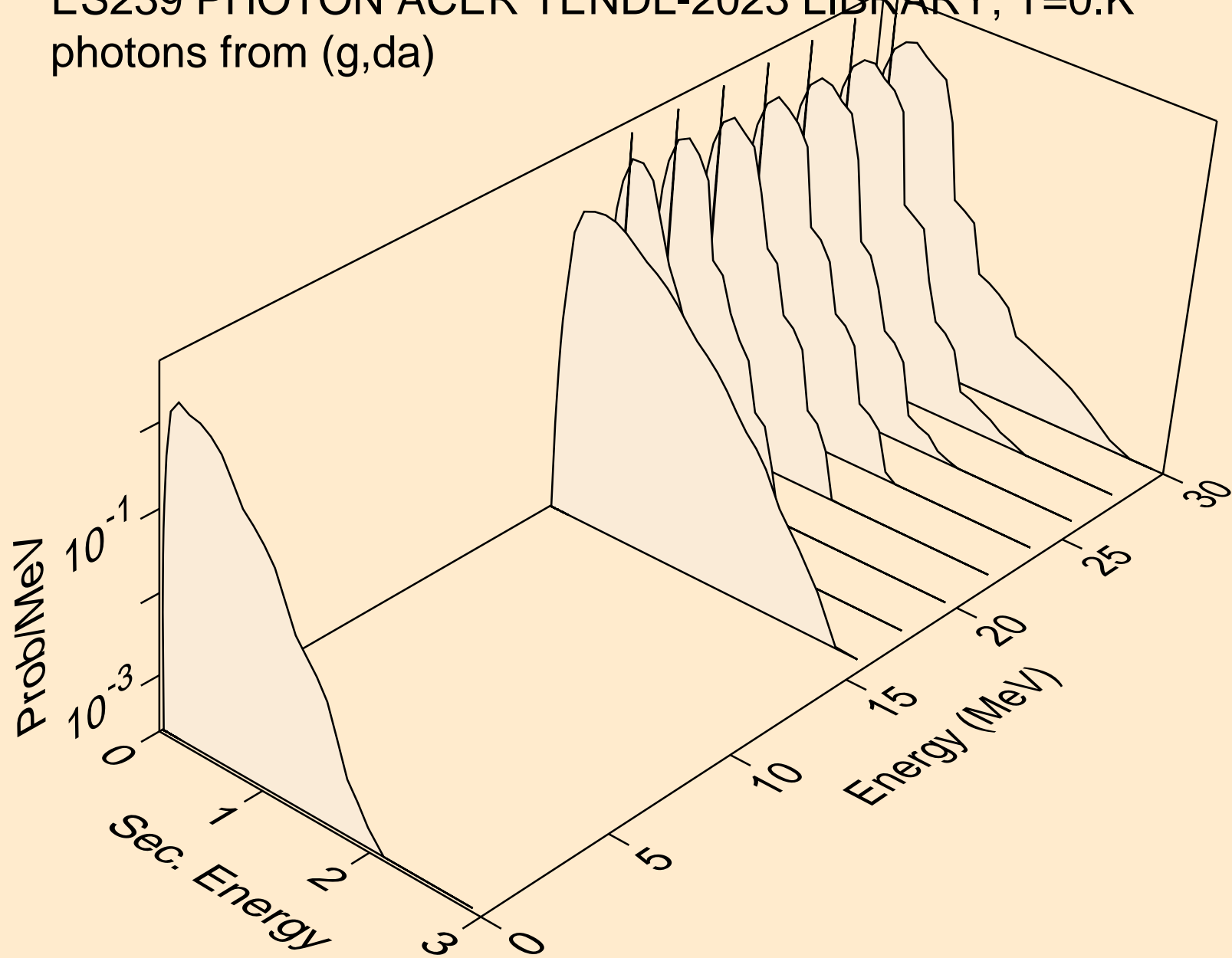

ES239 PHOTON ACER TENDL-2023 LIBRARY; T=0.K
protons from (g,x)

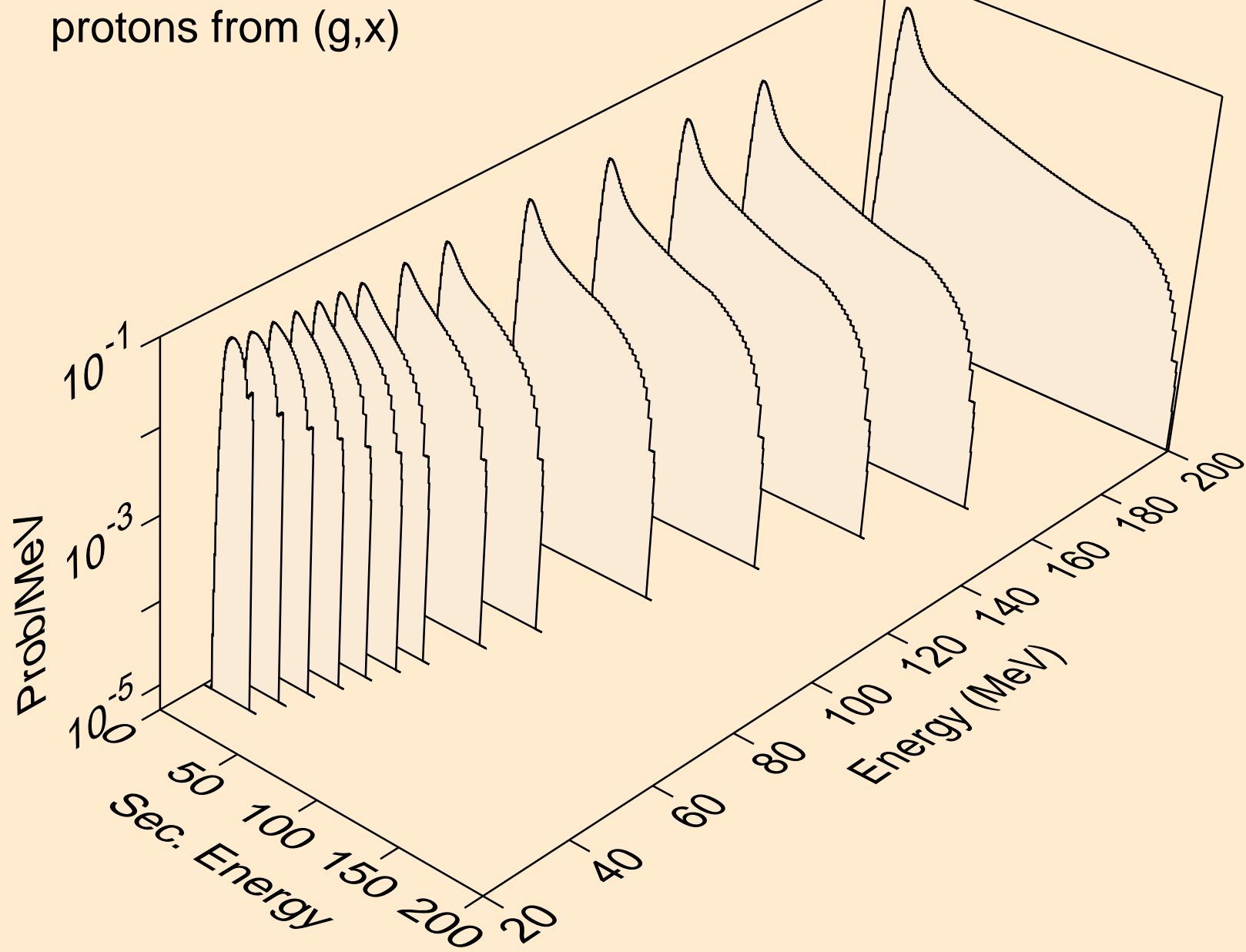

ES239 PHOTON ACER TENDL-2023 LIBRARY; T=0.K
protons from (g,n*)p

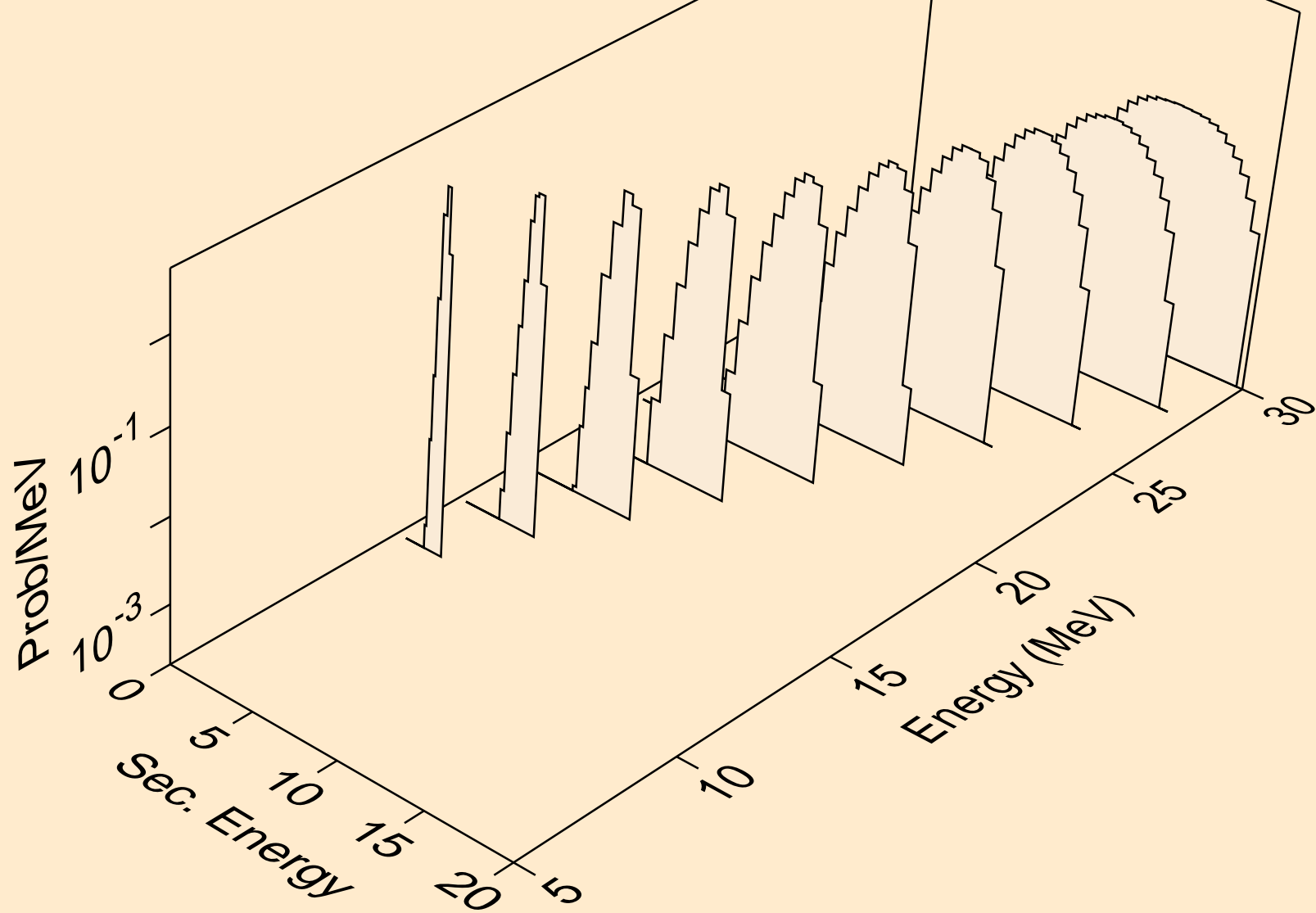

ES239 PHOTON ACER TENDL-2023 LIBRARY; T=0.K
protons from (g,2np)

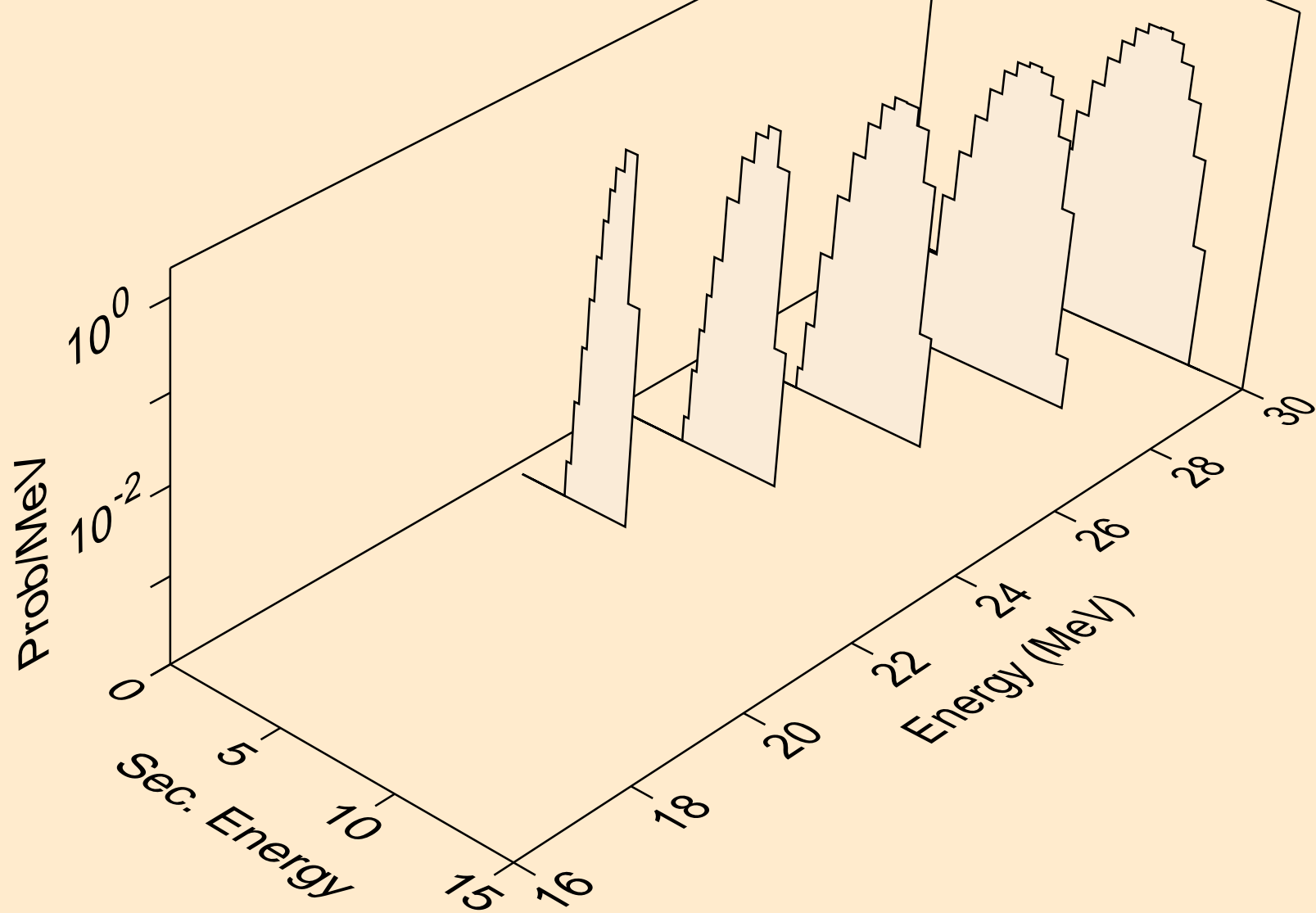

ES239 PHOTON ACER TENDL-2023 LIBRARY; T=0.K
protons from (g,npa)

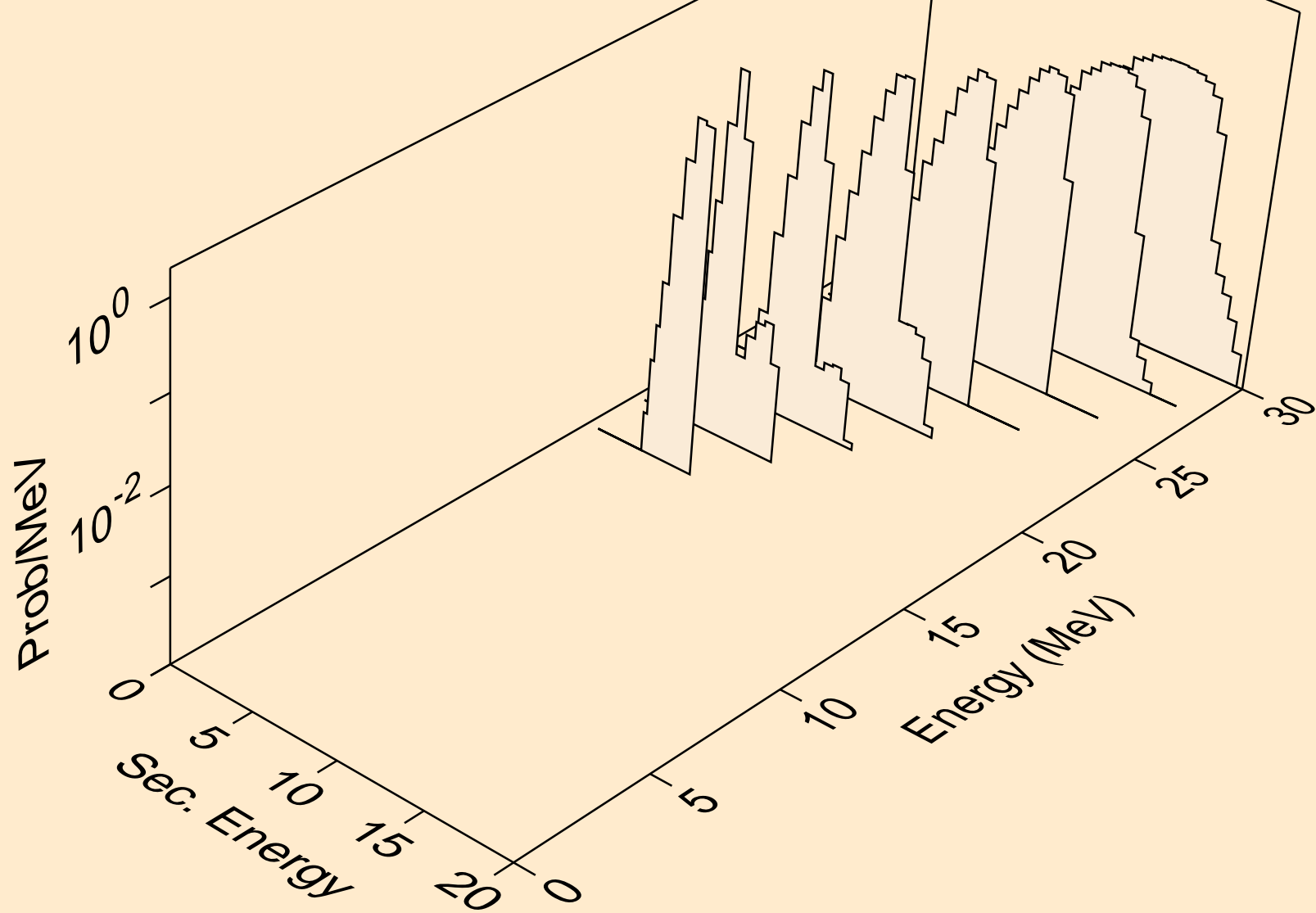

ES239 PHOTON ACER TENDL-2023 LIBRARY; T=0.K
protons from (g,p)

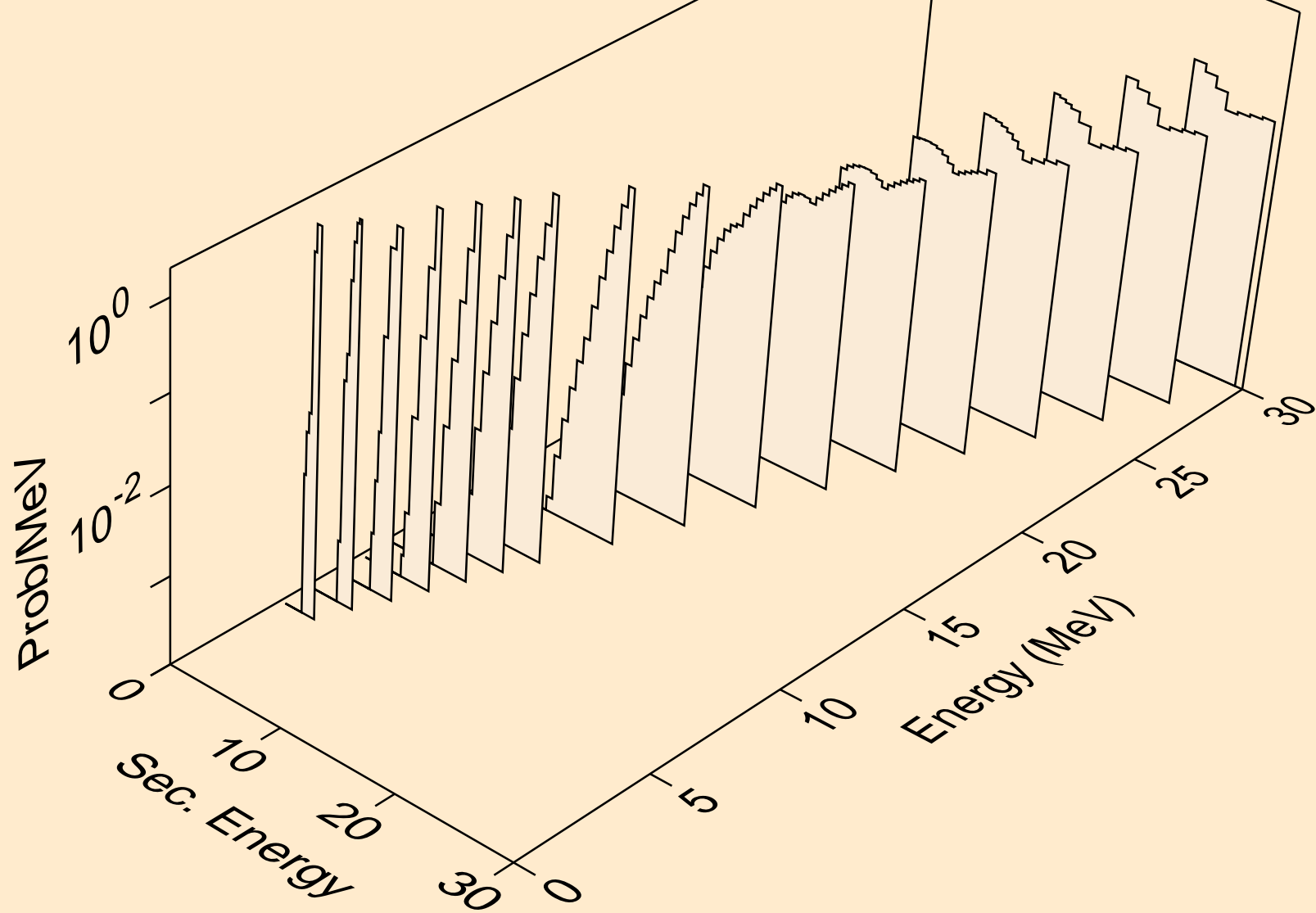

ES239 PHOTON ACER TENDL-2023 LIBRARY; T=0.K
protons from (g,2p)

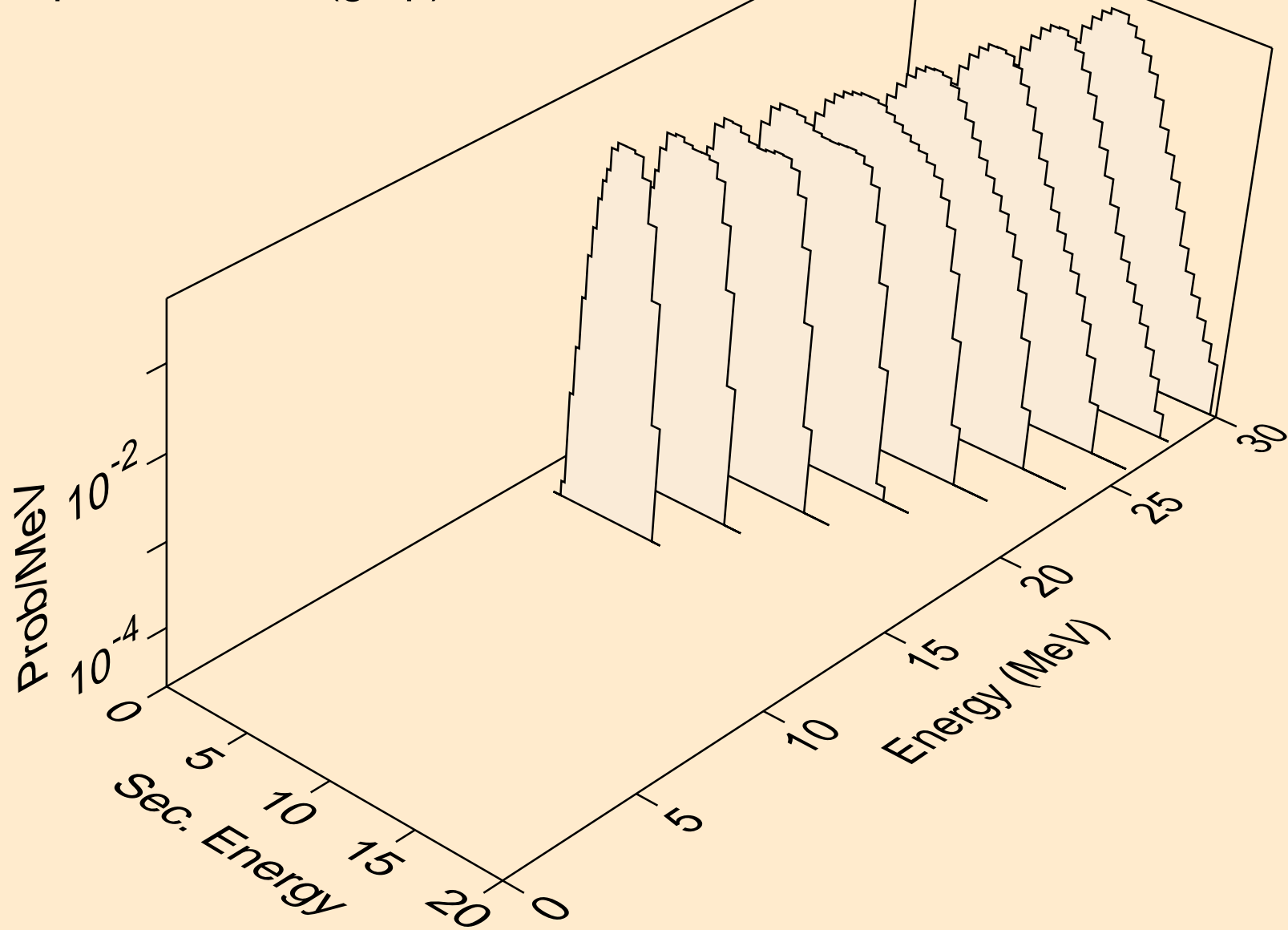

ES239 PHOTON ACER TENDL-2023 LIBRARY; T=0.K
deuterons from (g,x)

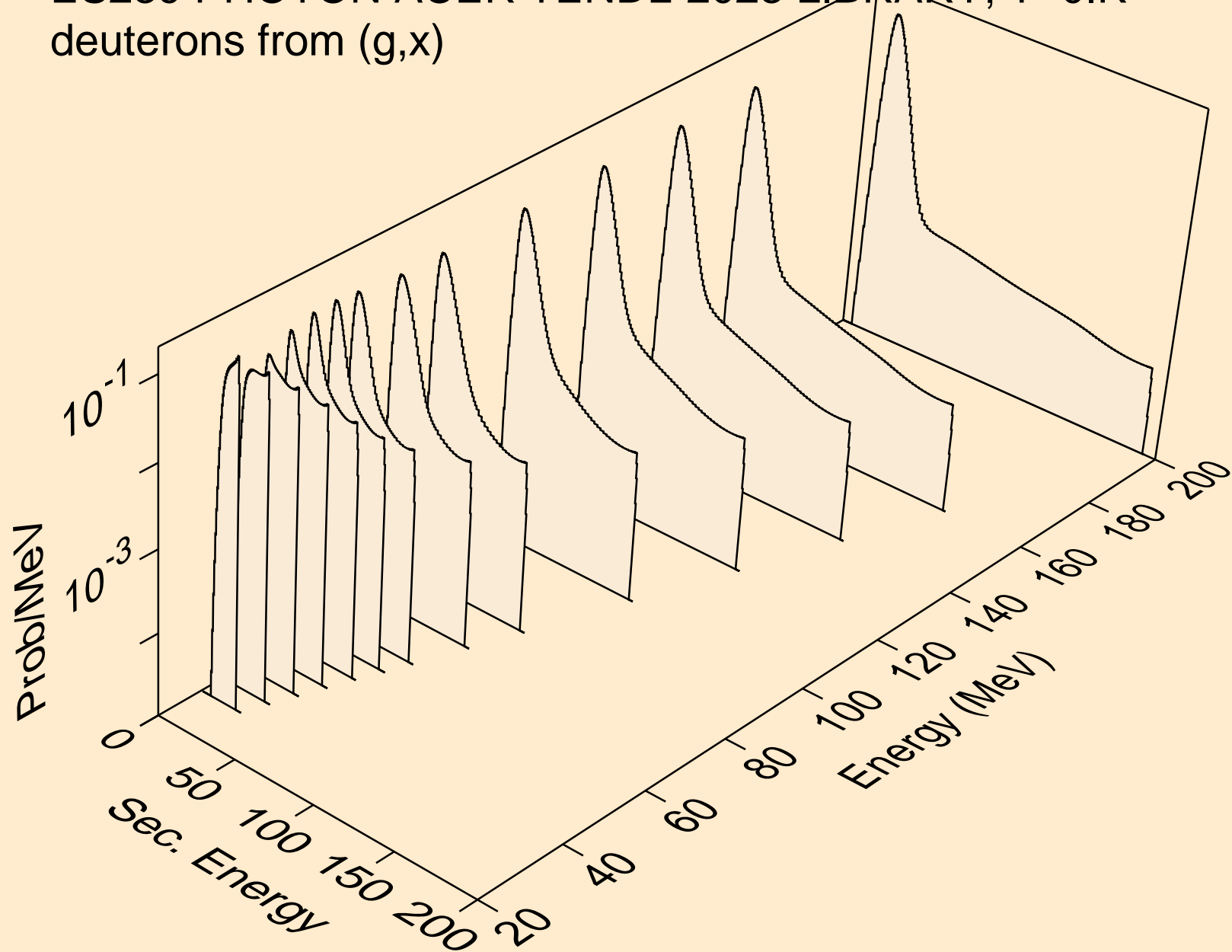

ES239 PHOTON ACER TENDL-2023 LIBRARY; T=0.K
deuterons from (g,n*)d

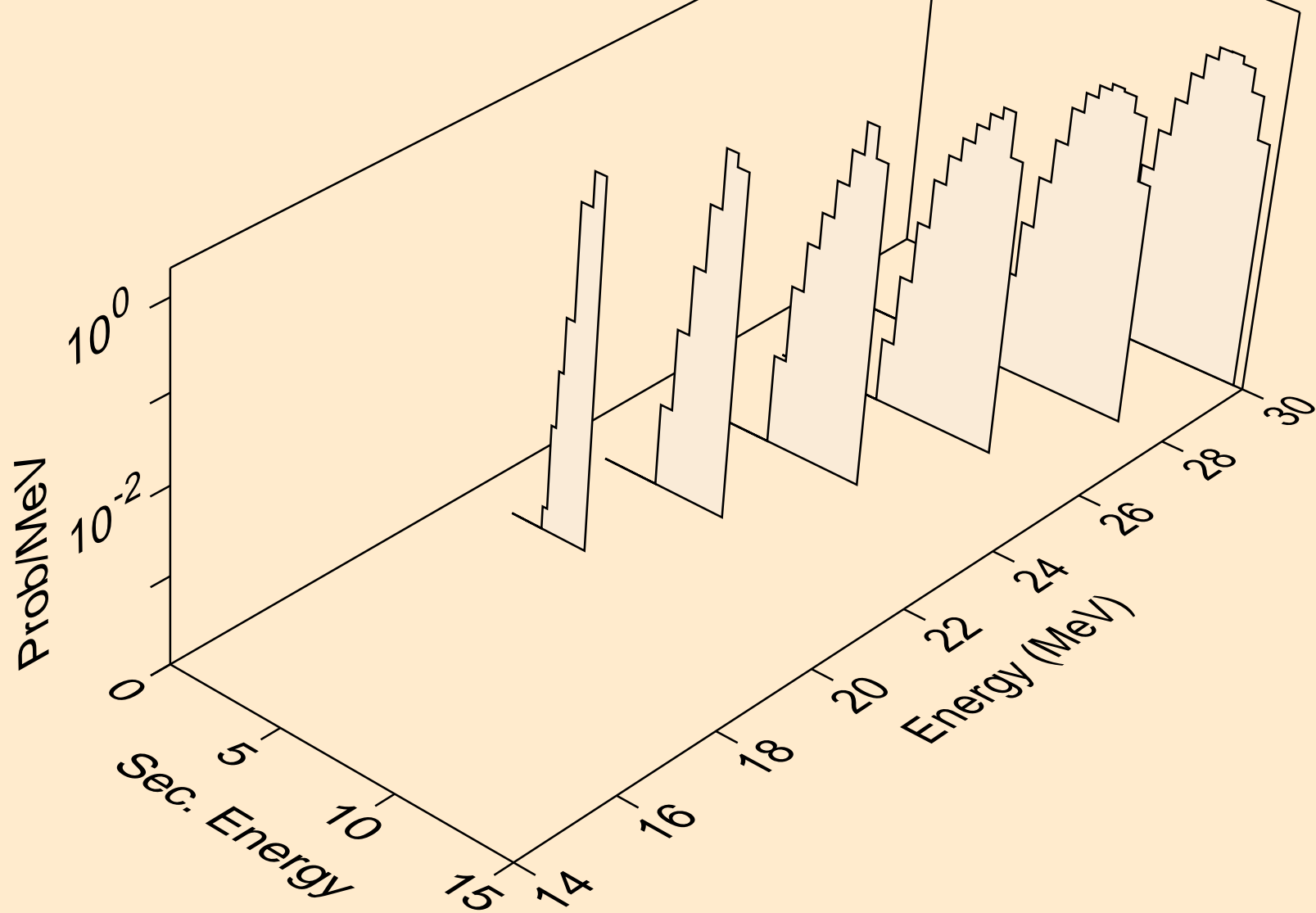

ES239 PHOTON ACER TENDL-2023 LIBRARY; T=0.K
deuterons from (g,d)

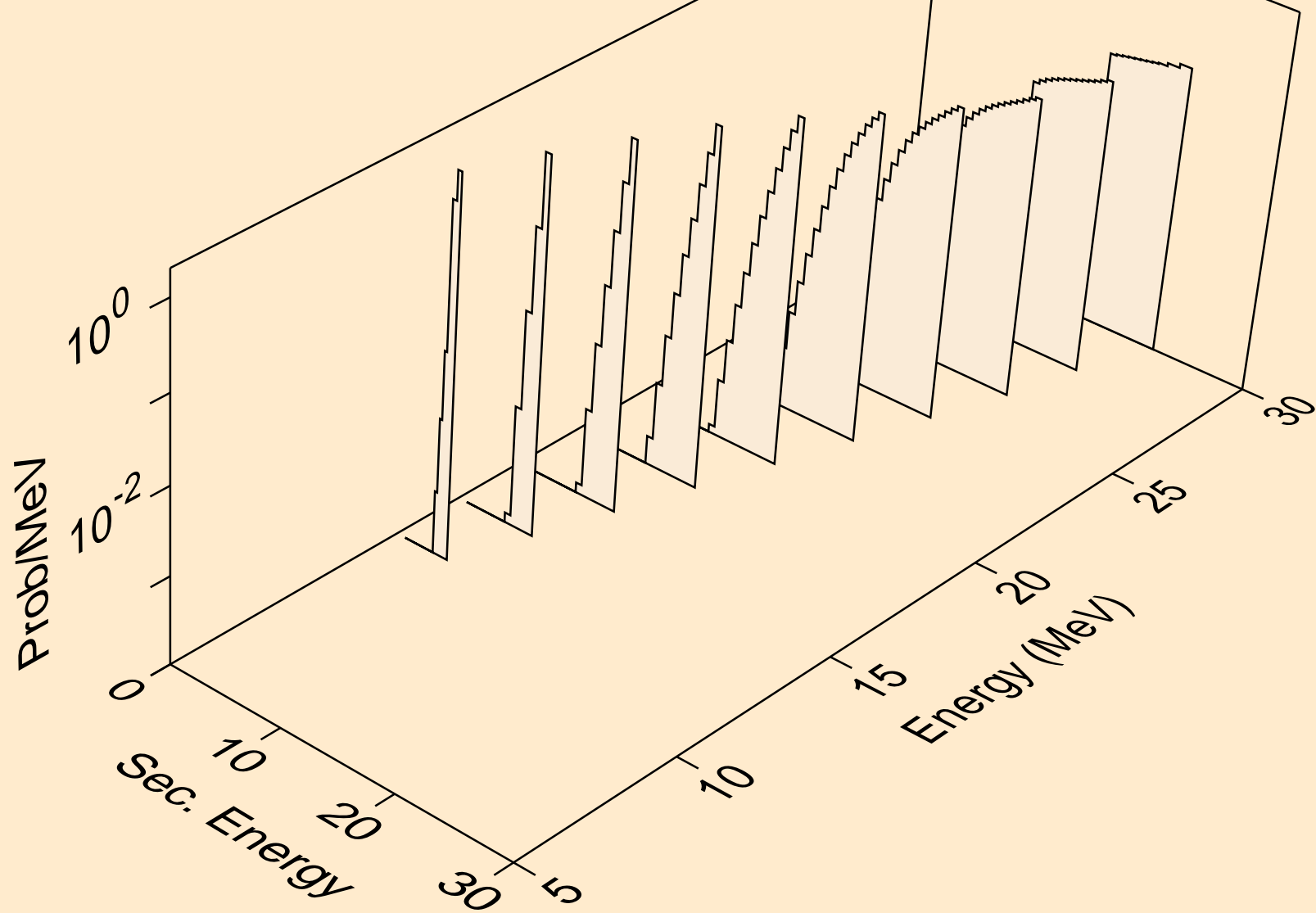

ES239 PHOTON ACER TENDL-2023 LIBRARY; T=0.K
deuterons from (g,da)

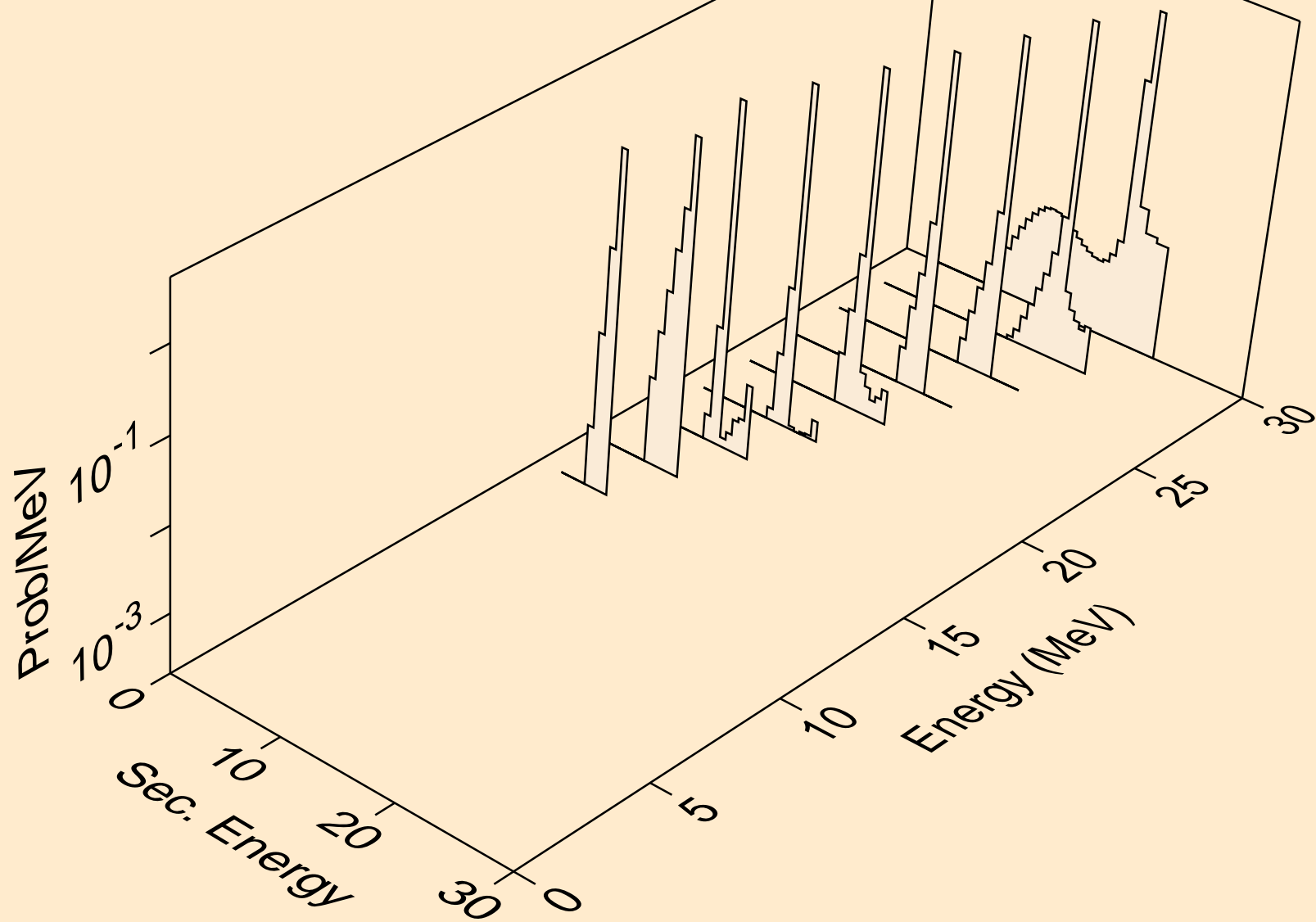

ES239 PHOTON ACER TENDL-2023 LIBRARY; T=0.K
tritons from (g,x)

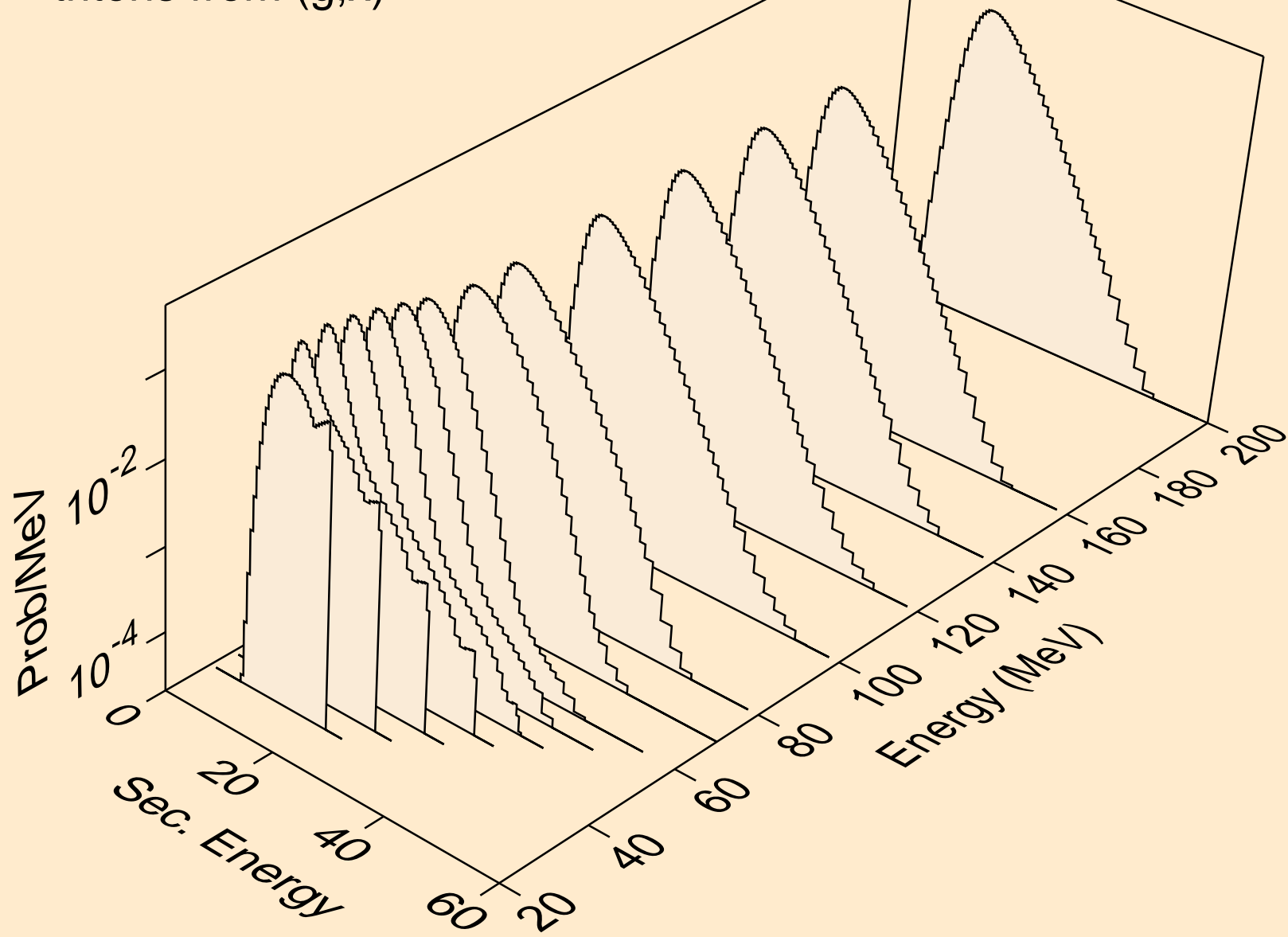

ES239 PHOTON ACER TENDL-2023 LIBRARY; T=0.K
tritons from (g,t)

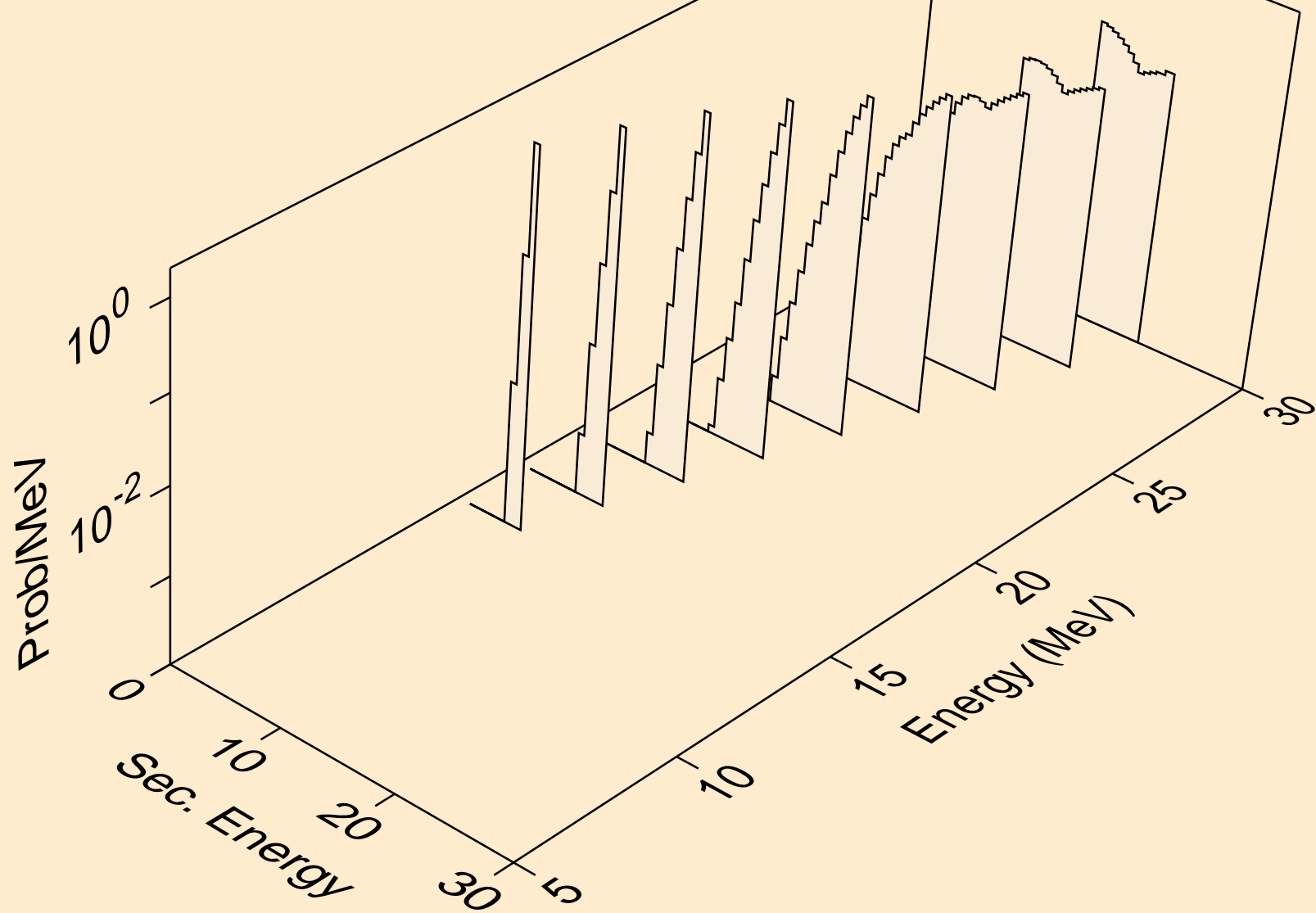

ES239 PHOTON ACER TENDL-2023 LIBRARY; T=0.K
he3s from (g,x)

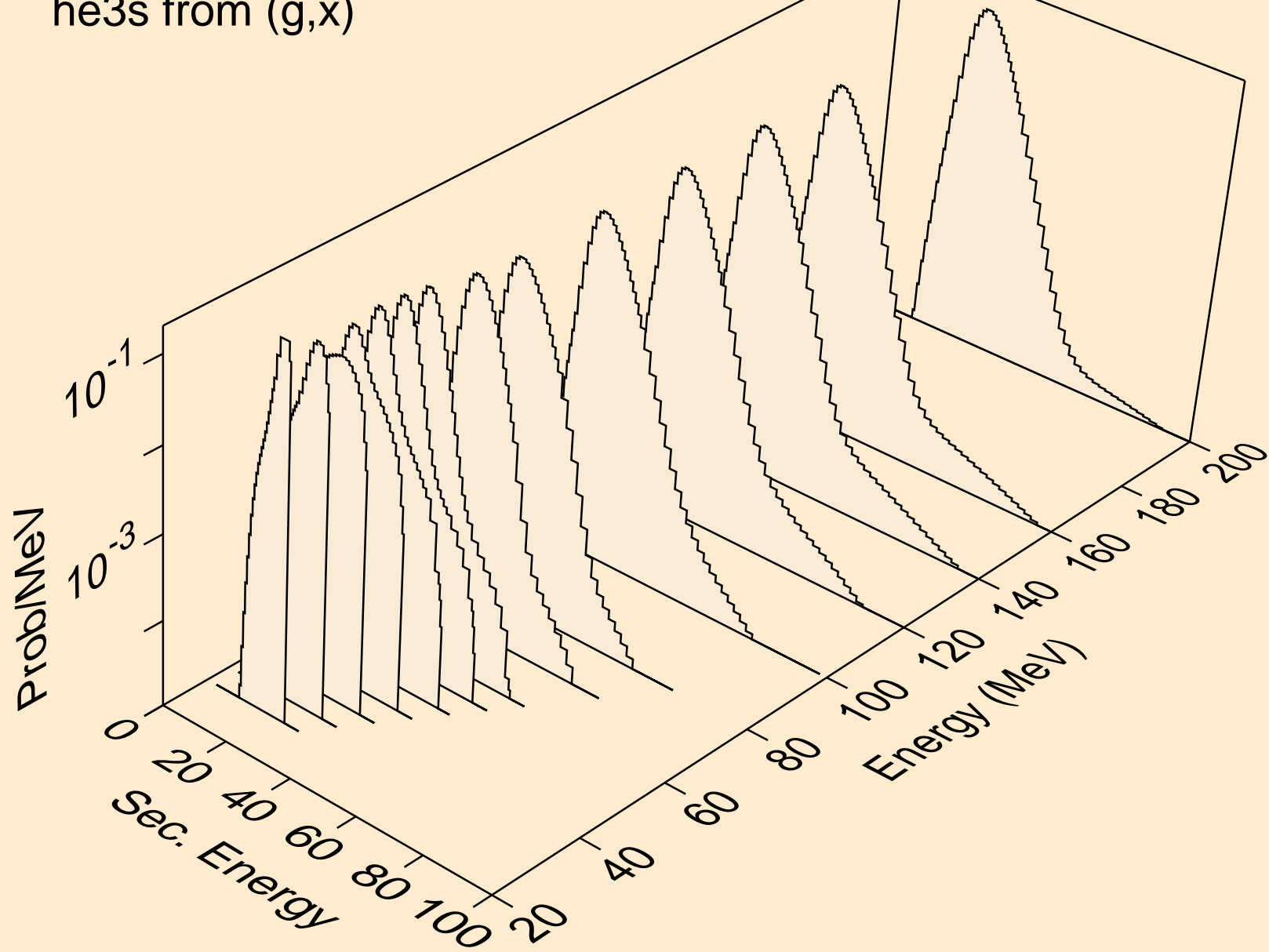

ES239 PHOTON ACER TENDL-2023 LIBRARY; T=0.K
alphas from (g,x)

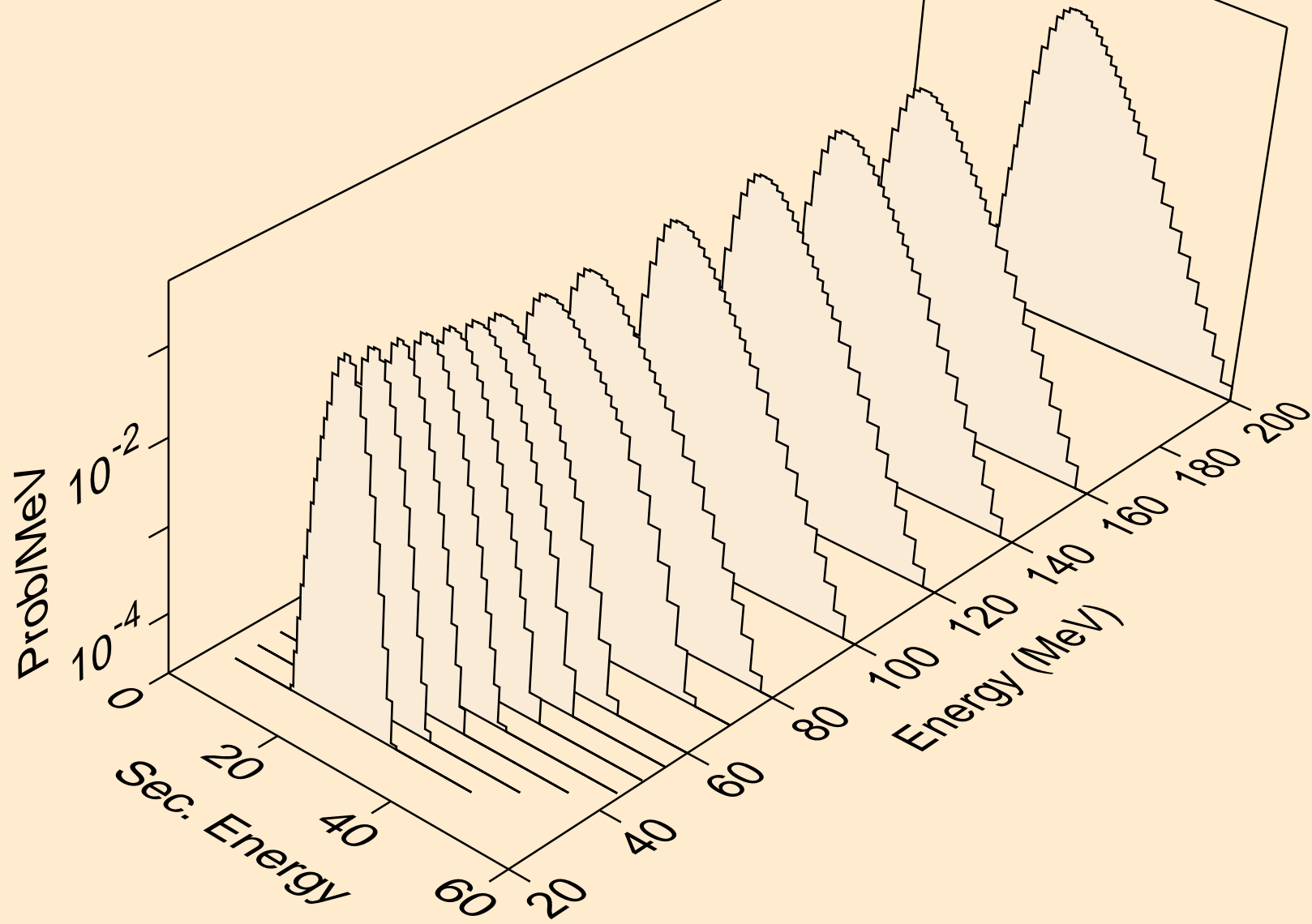

ES239 PHOTON ACER TENDL-2023 LIBRARY; T=0.K
alphas from (g,n*)a

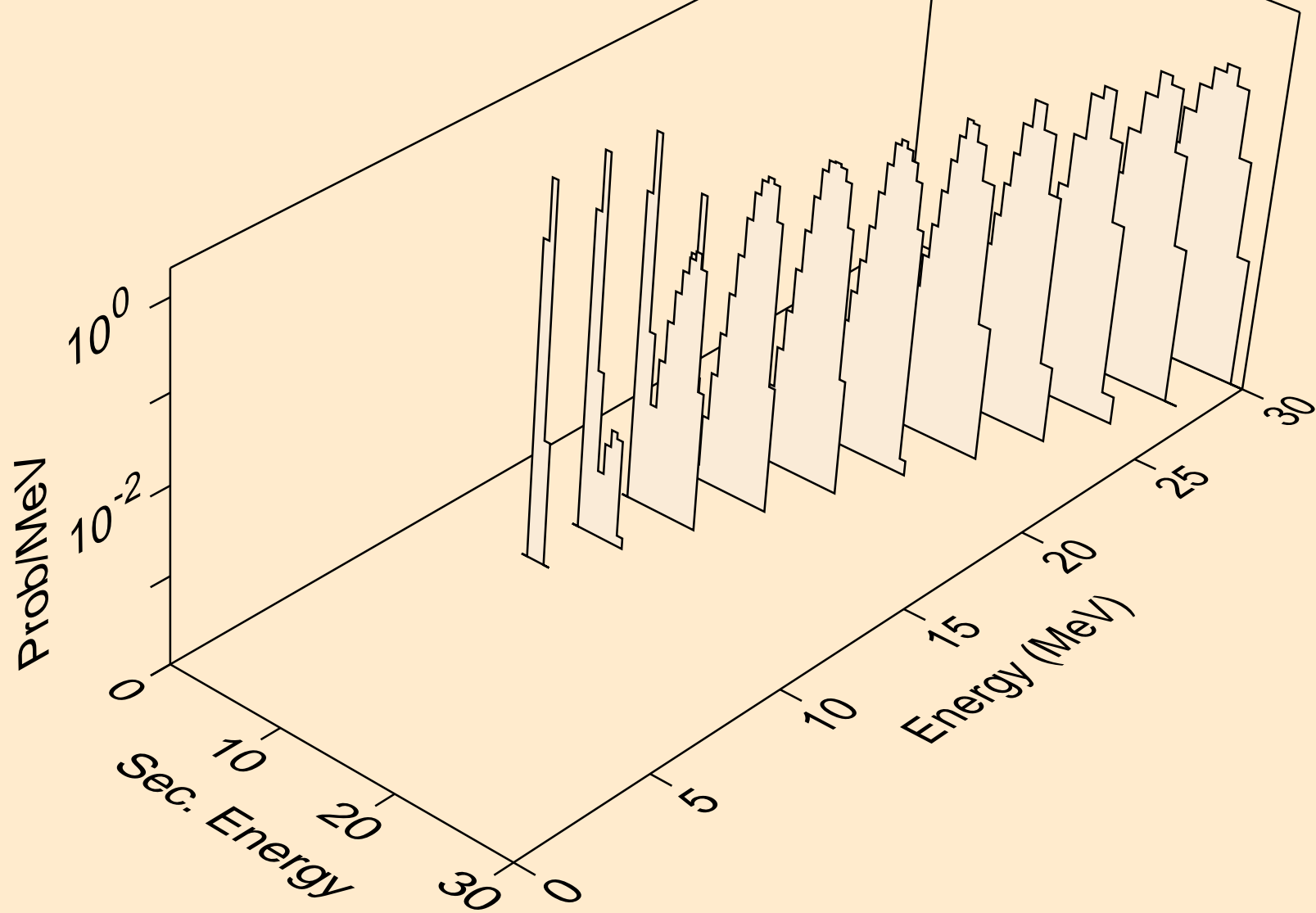

ES239 PHOTON ACER TENDL-2023 LIBRARY; T=0.K
alphas from (g,npa)

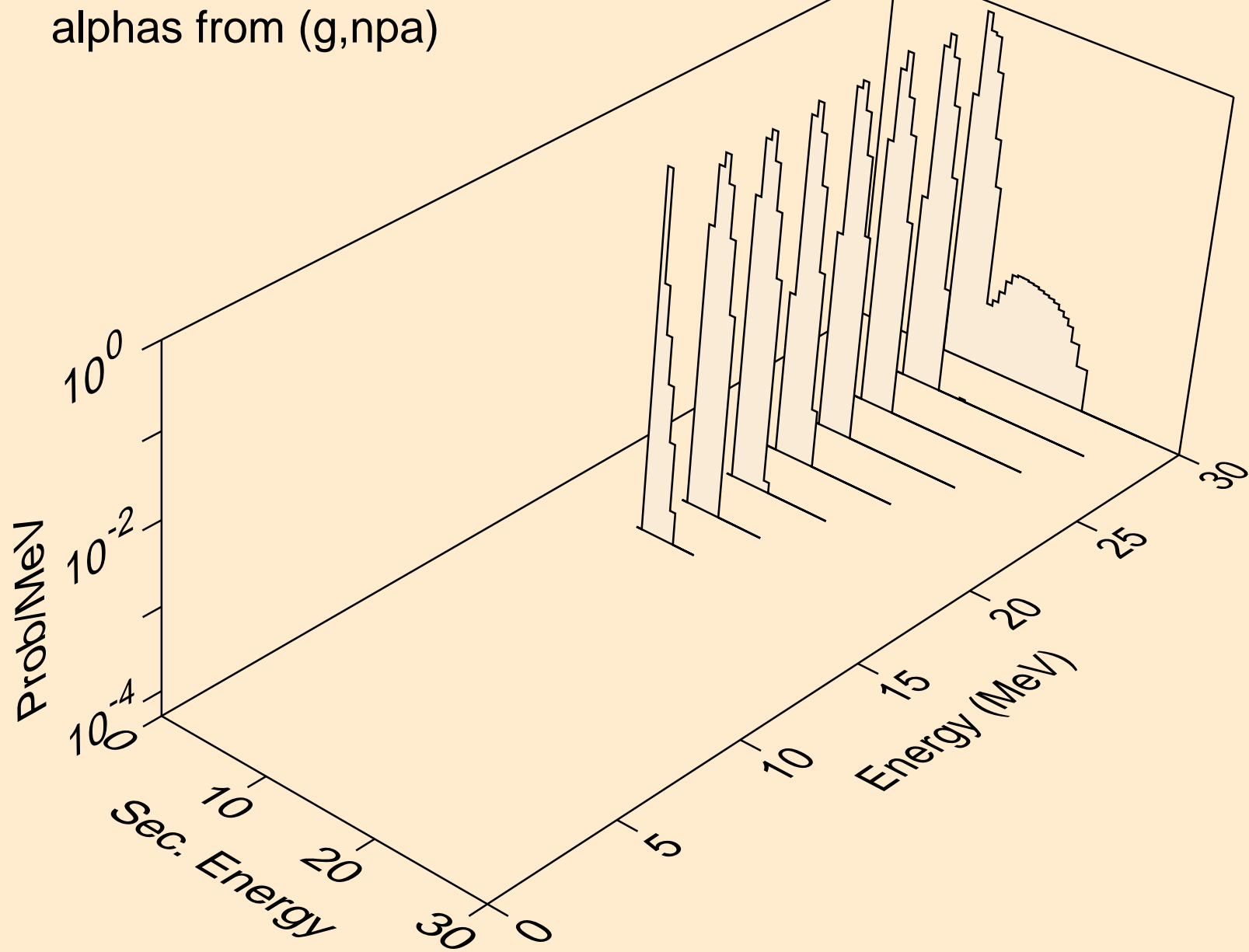

ES239 PHOTON ACER TENDL-2023 LIBRARY; T=0.K
alphas from (g,a)

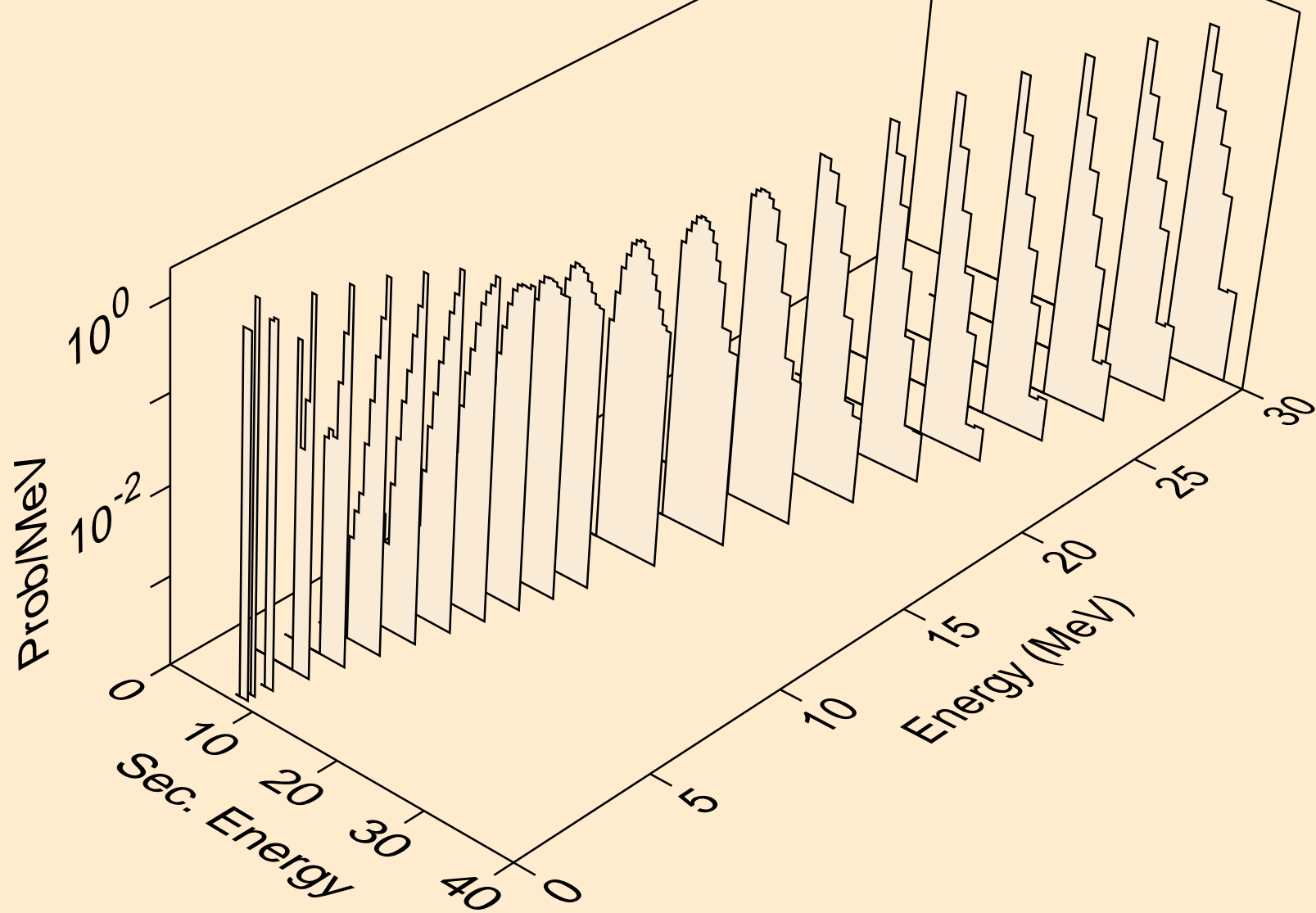

ES239 PHOTON ACER TENDL-2023 LIBRARY; T=0.K
alphas from (g,da)

