

# K047 PHOTON ACER TENDL-2023 LIBRARY; T=0.K

## Principal cross sections

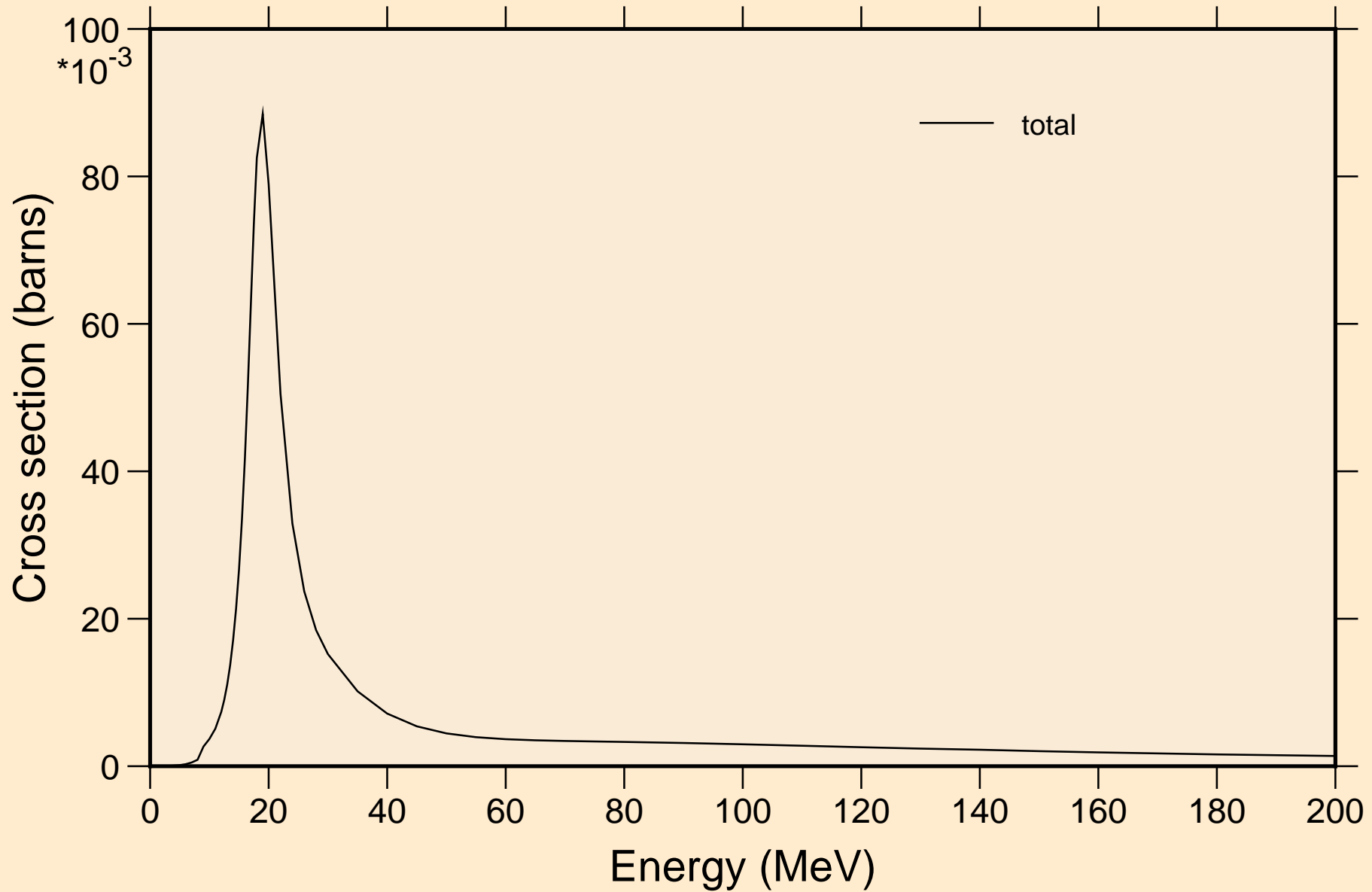

# K047 PHOTON ACER TENDL-2023 LIBRARY; T=0.K

## Partial cross sections

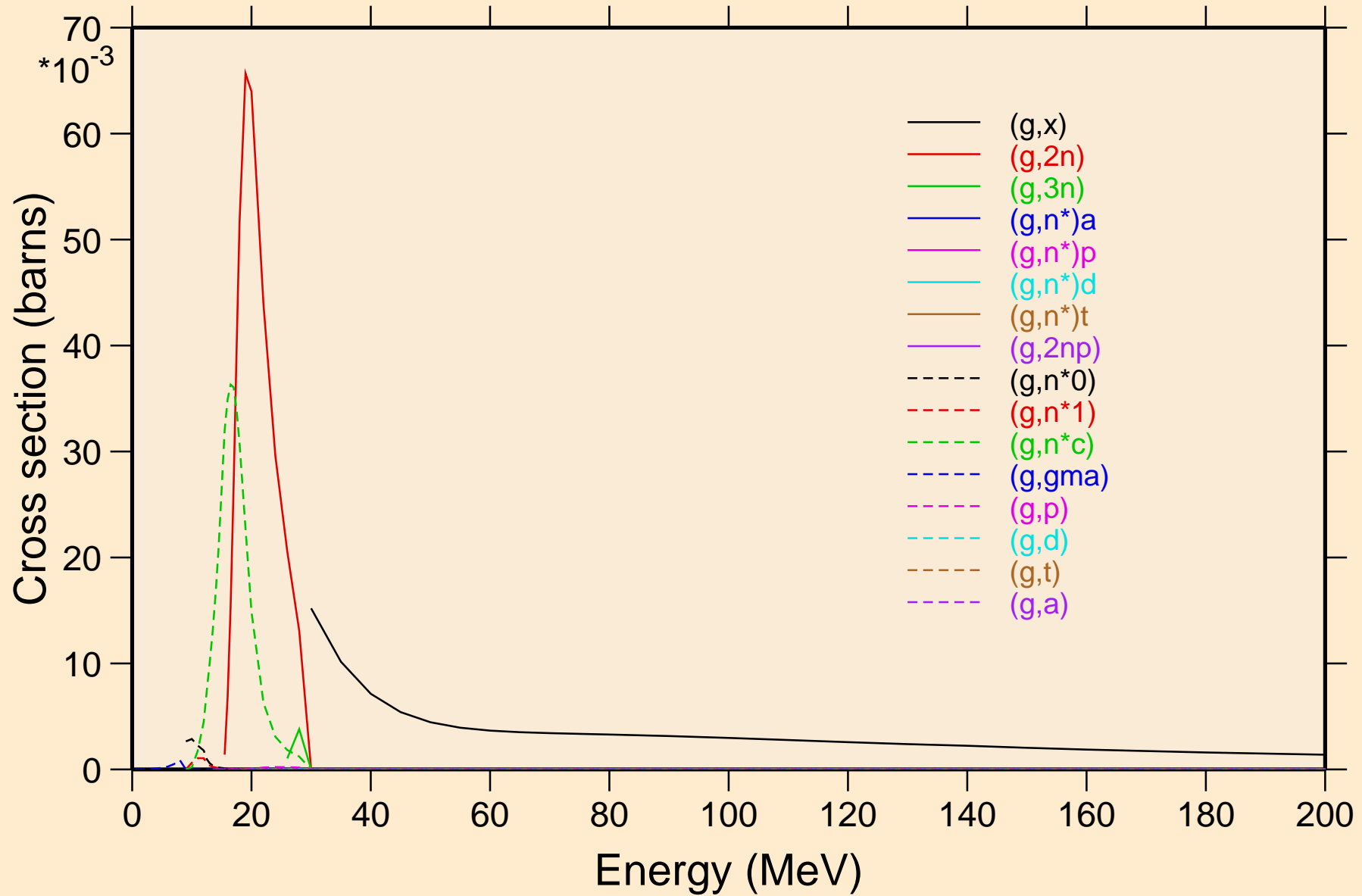

# K047 PHOTON ACER TENDL-2023 LIBRARY; T=0.K

## Heating

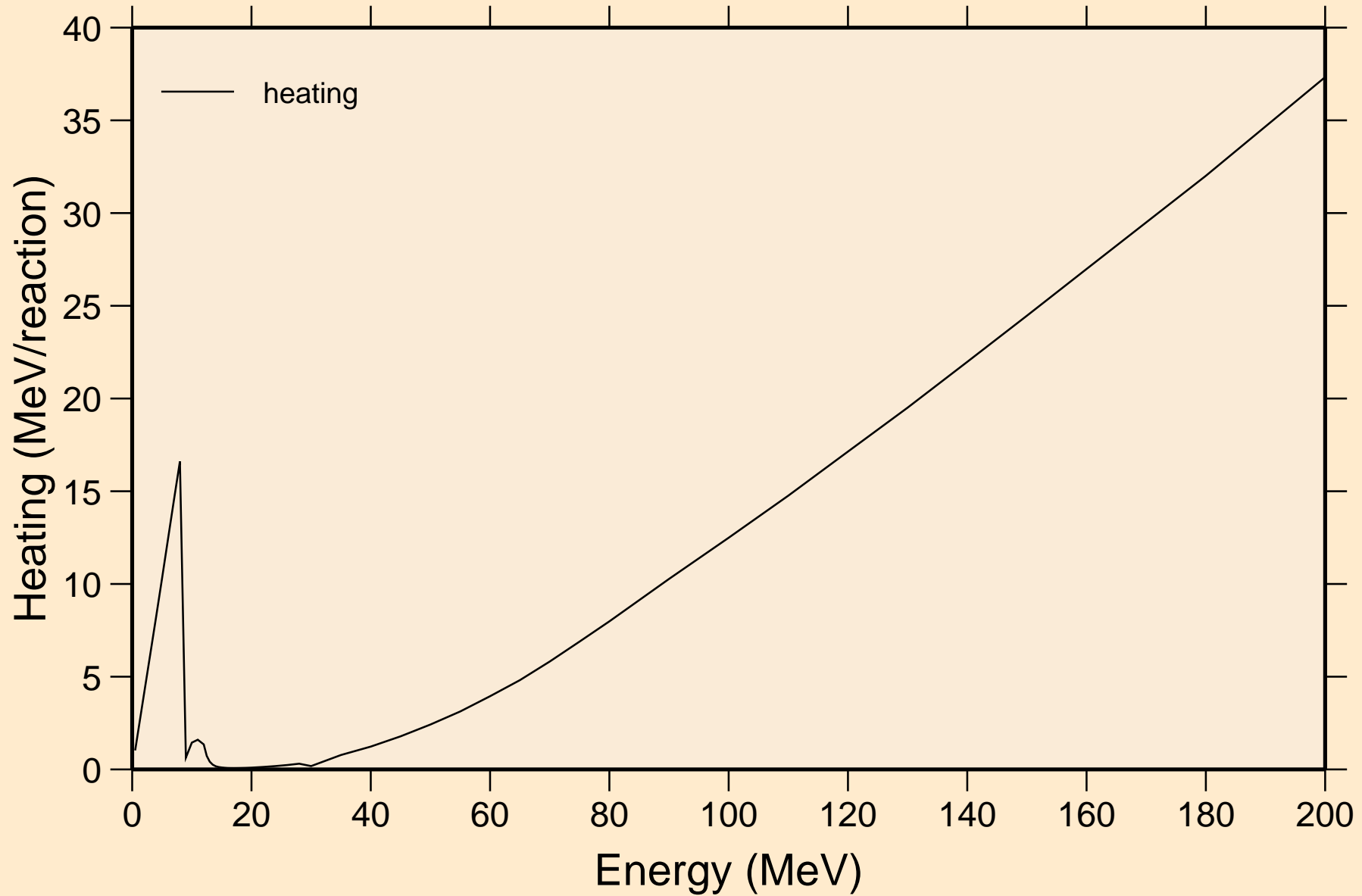

# K047 PHOTON ACER TENDL-2023 LIBRARY; T=0.K

## Particle heating contributions

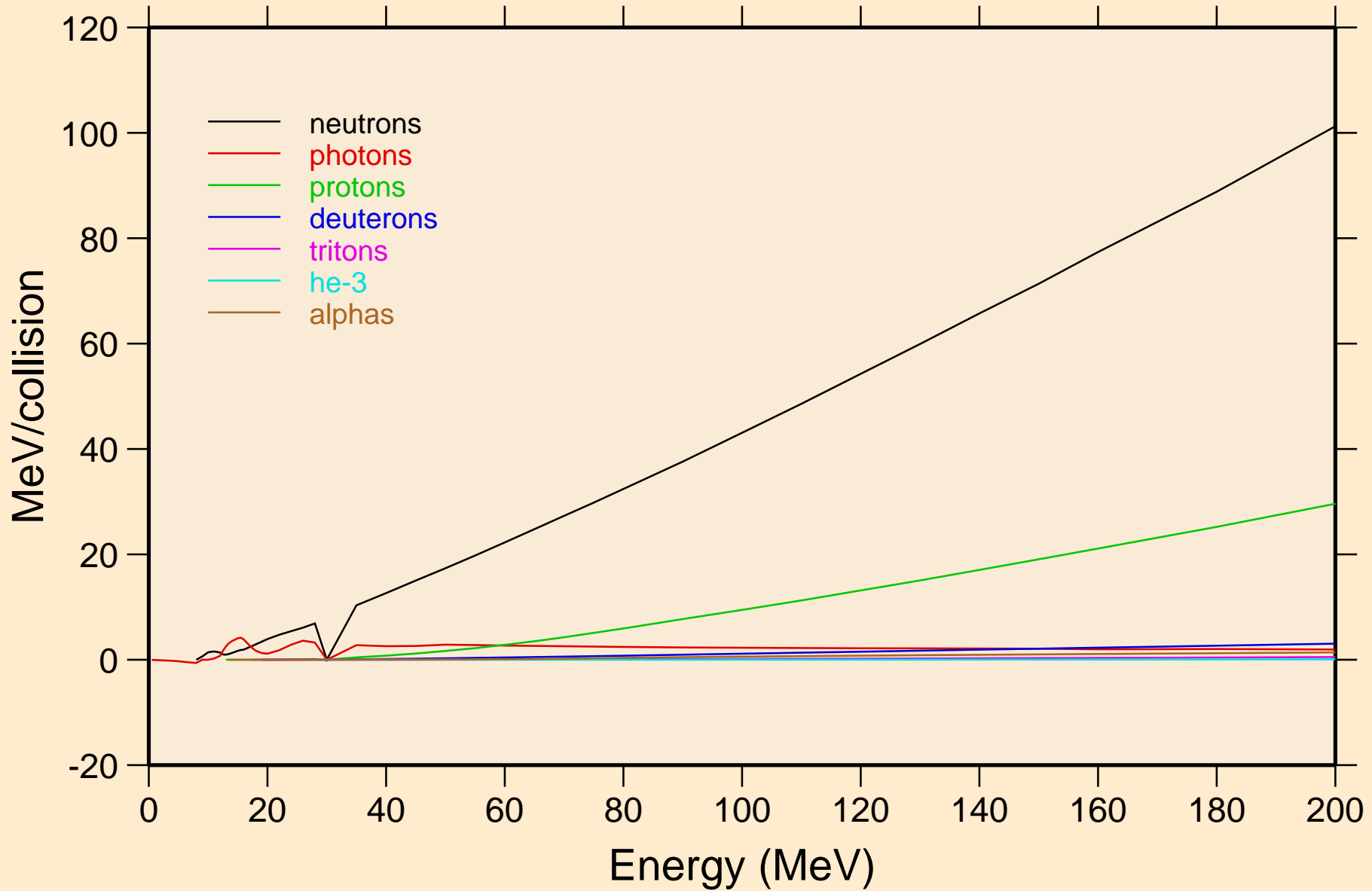

# K047 PHOTON ACER TENDL-2023 LIBRARY; T=0.K

## Particle production cross sections

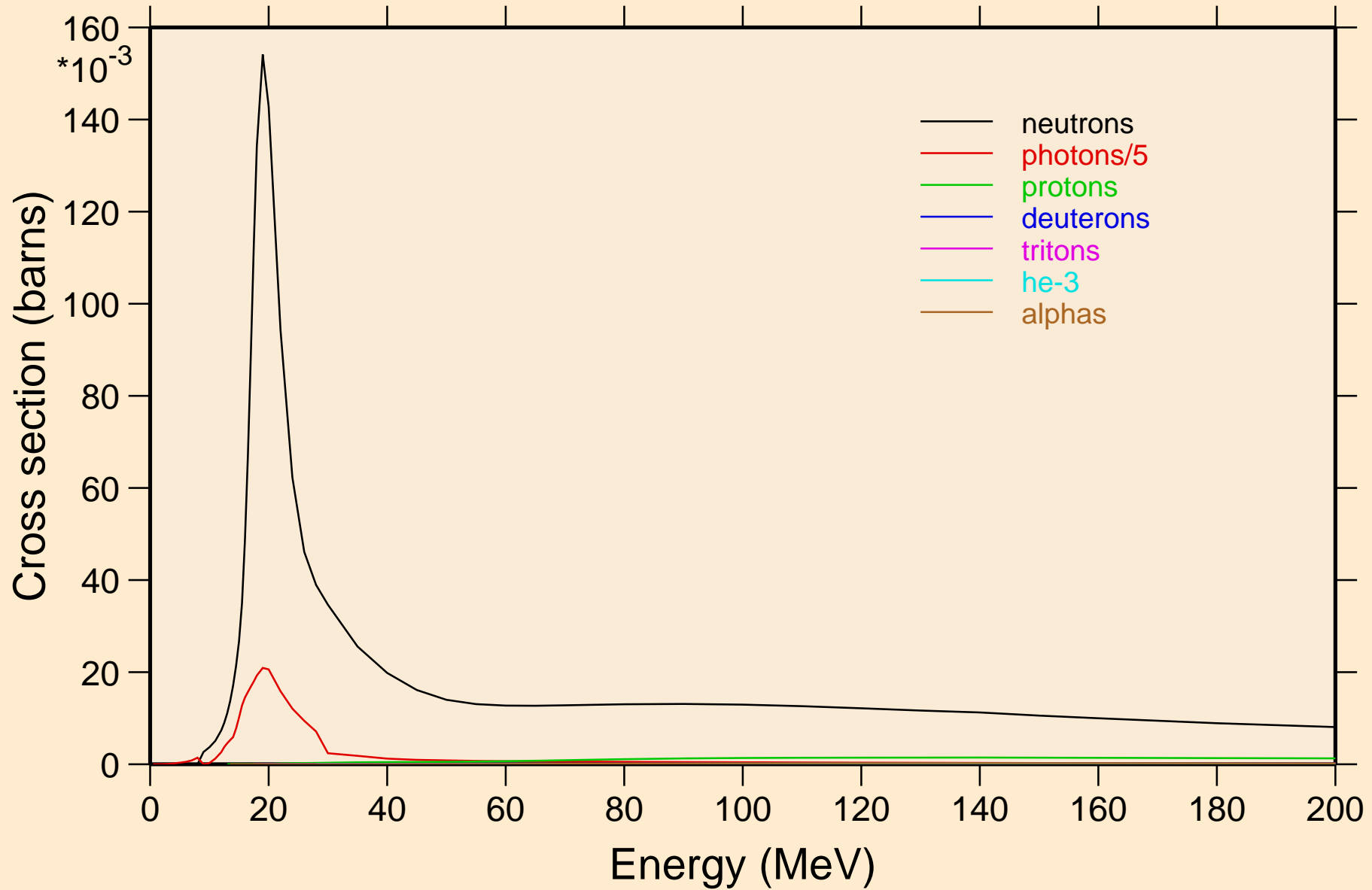

K047 PHOTON ACER TENDL-2023 LIBRARY; T=0.K  
neutrons from (g,x)

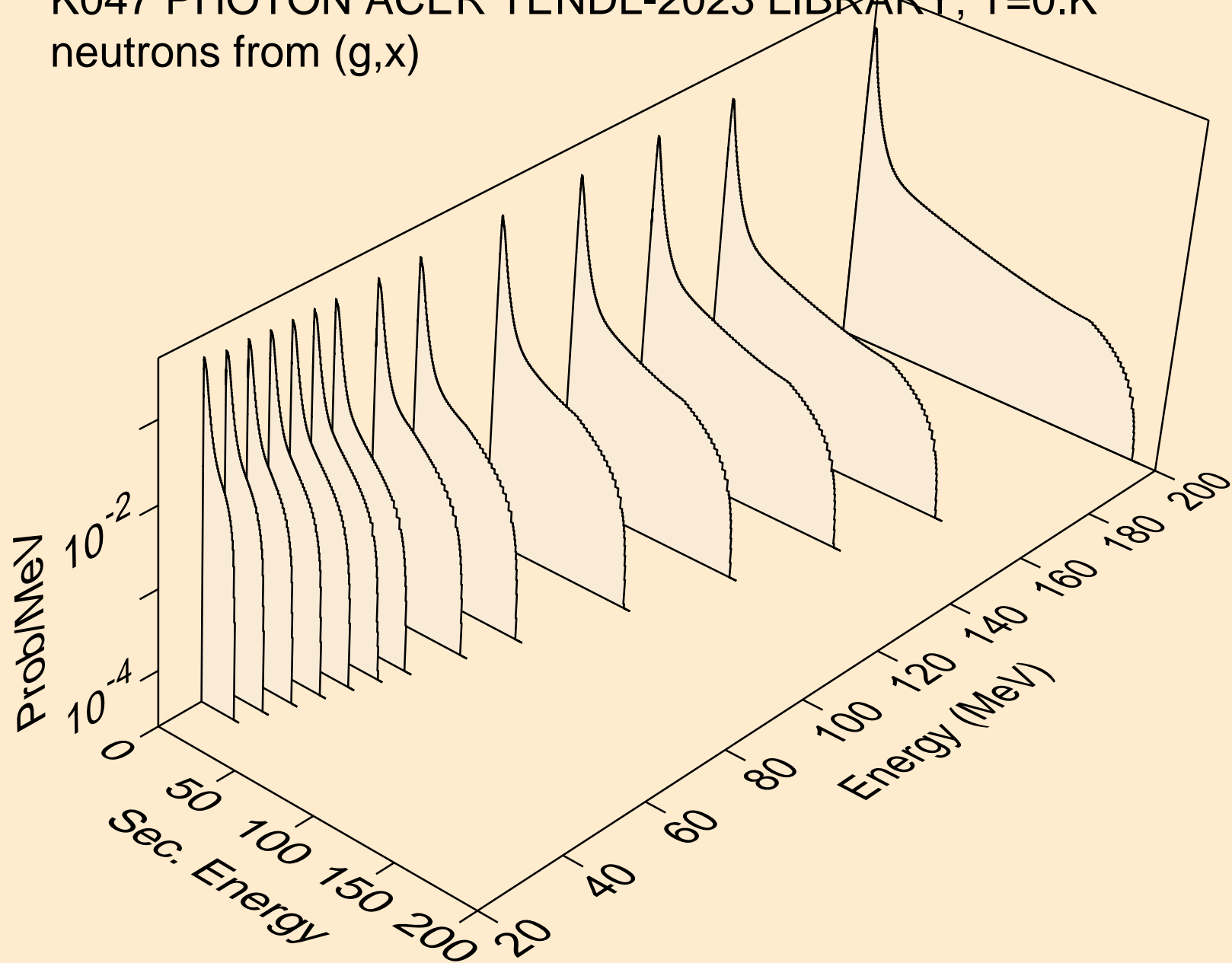

K047 PHOTON ACER TENDL-2023 LIBRARY; T=0.K  
neutrons from (g,2n)

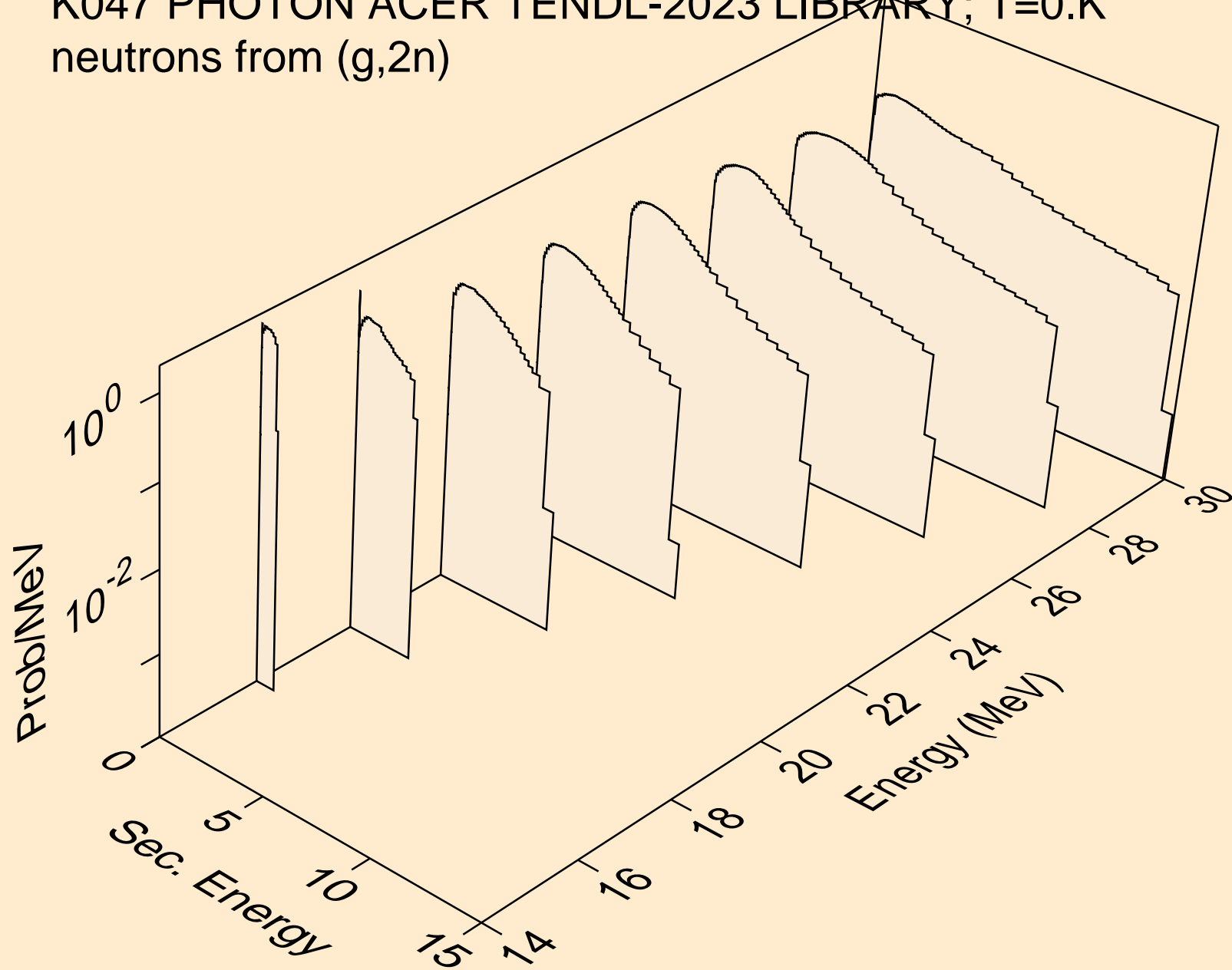

K047 PHOTON ACER TENDL-2023 LIBRARY; T=0.K  
neutrons from (g,3n)

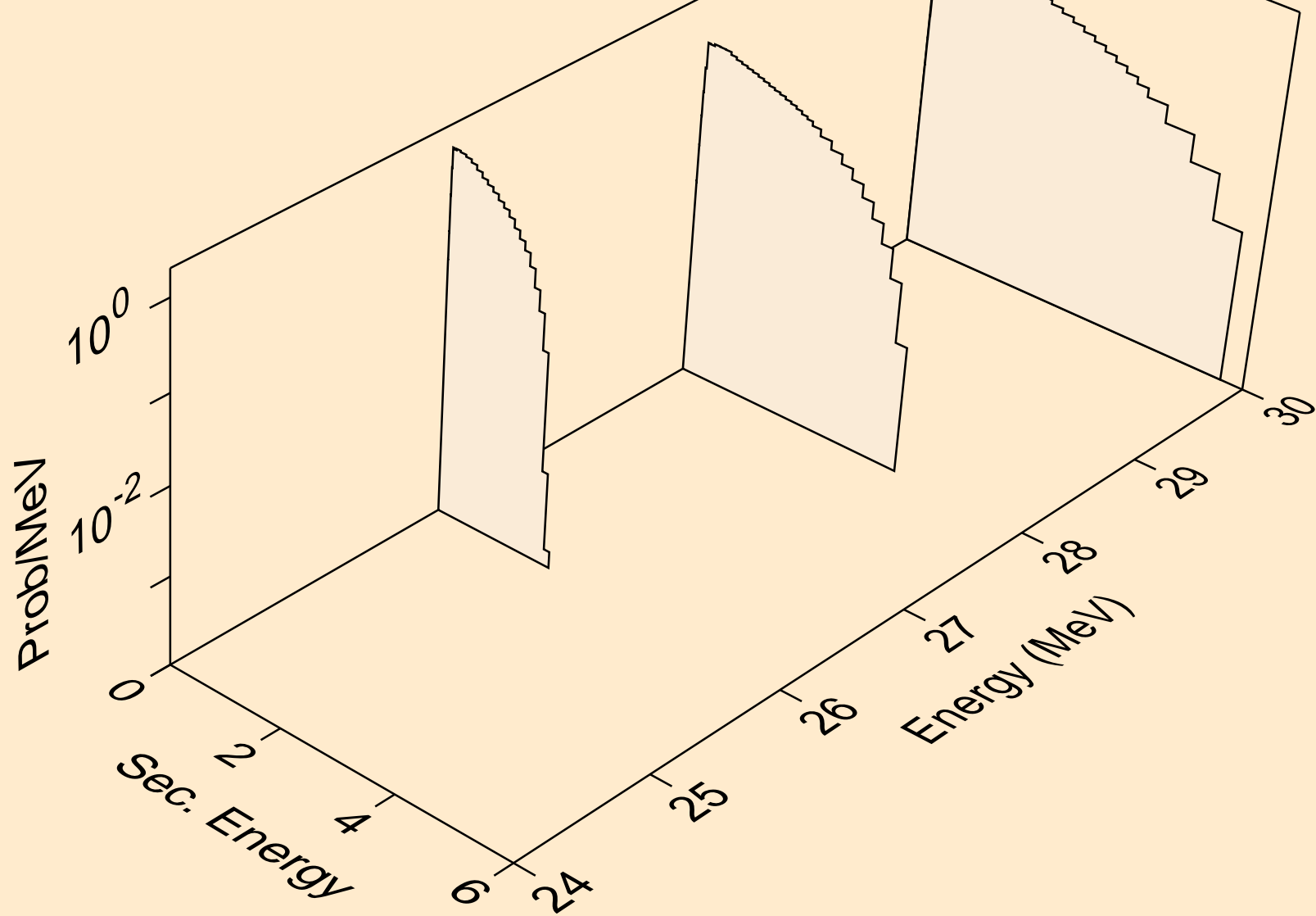



K047 PHOTON ACER TENDL-2023 LIBRARY; T=0.K  
neutrons from (g,n\*)a

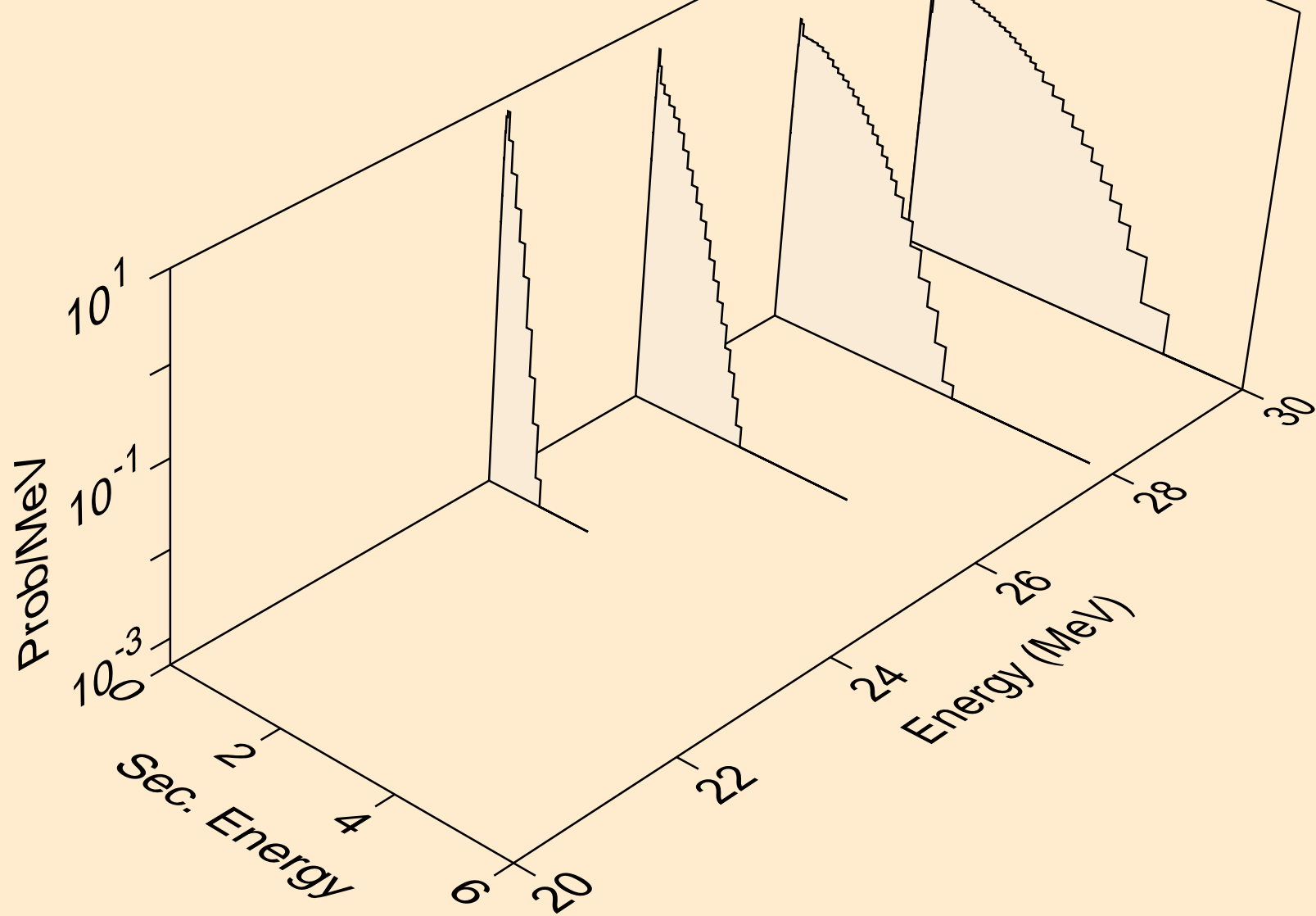

K047 PHOTON ACER TENDL-2023 LIBRARY; T=0.K  
neutrons from (g,n\*)p

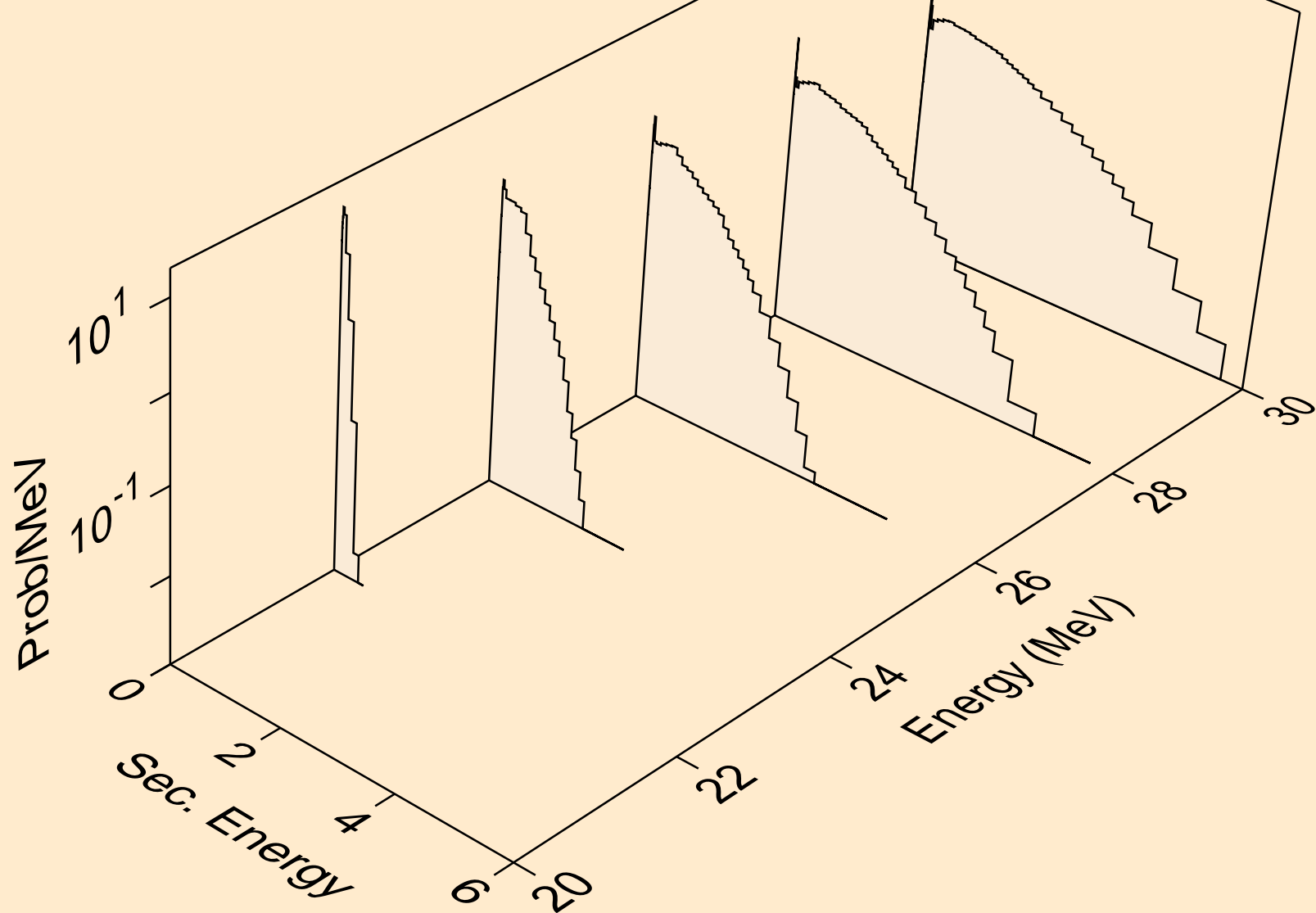

K047 PHOTON ACER TENDL-2023 LIBRARY; T=0.K  
neutrons from (g,n\*)d

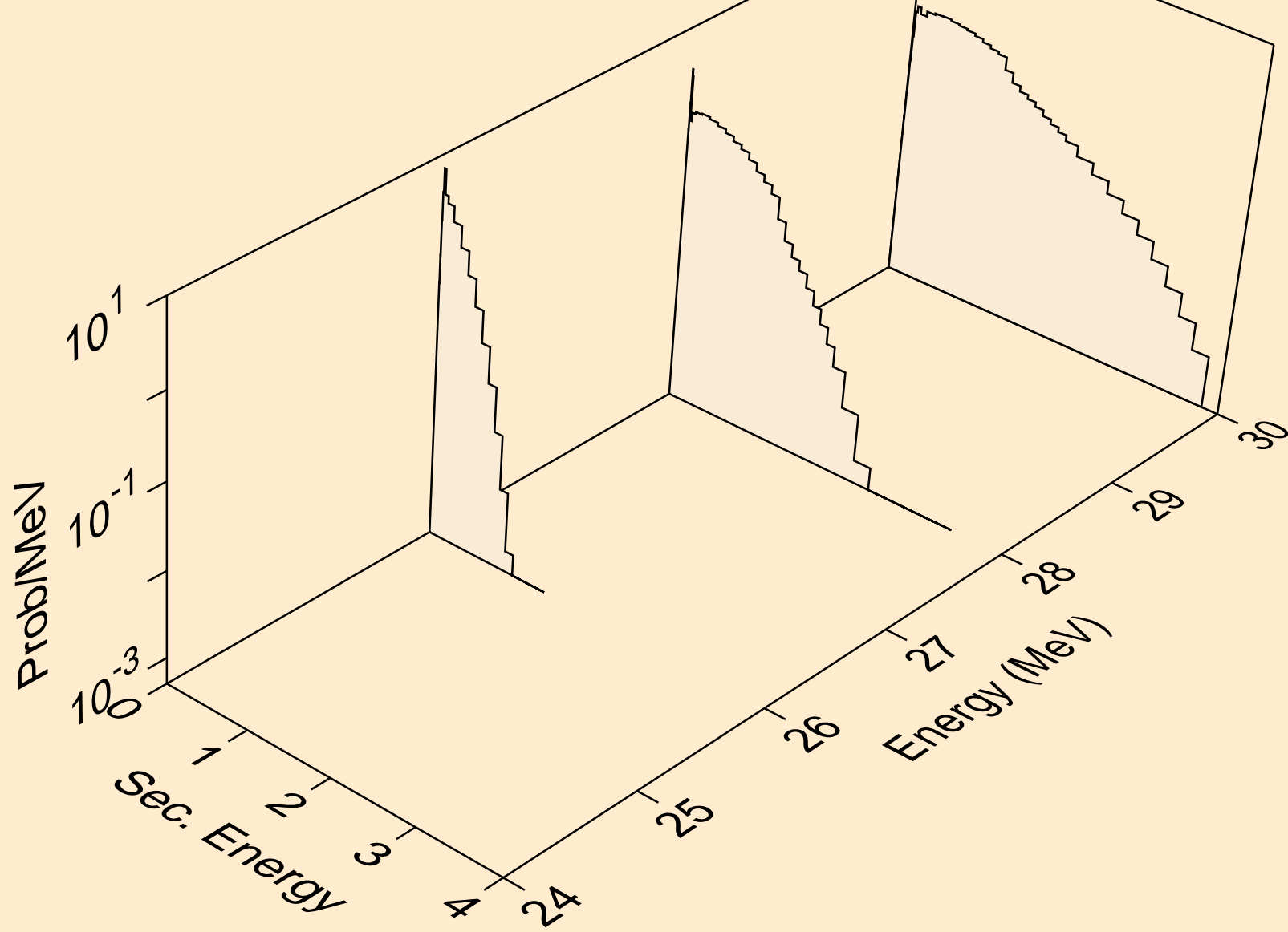

K047 PHOTON ACER TENDL-2023 LIBRARY; T=0.K  
neutrons from (g,n\*)t

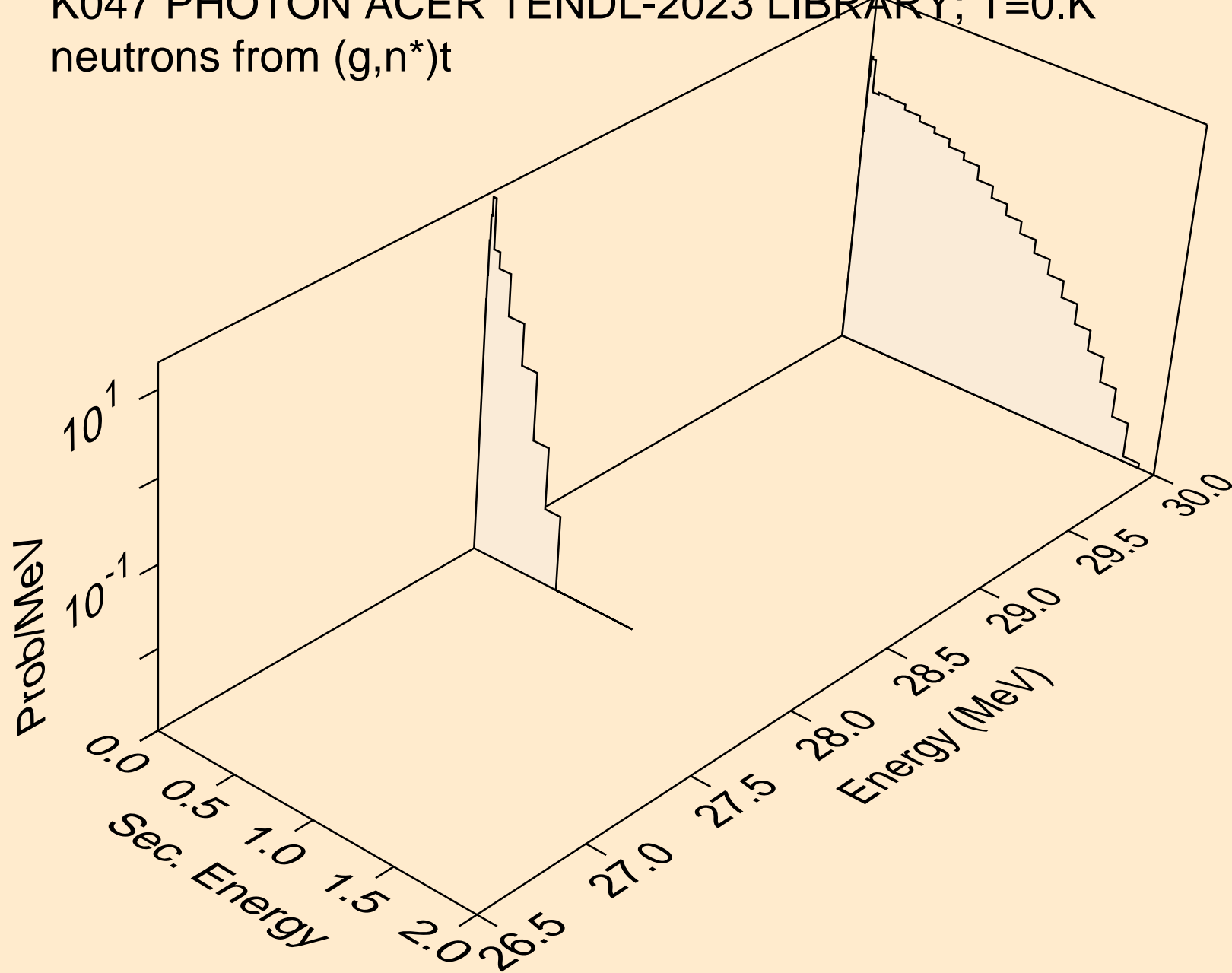

K047 PHOTON ACER TENDL-2023 LIBRARY; T=0.K  
neutrons from (g,2np)

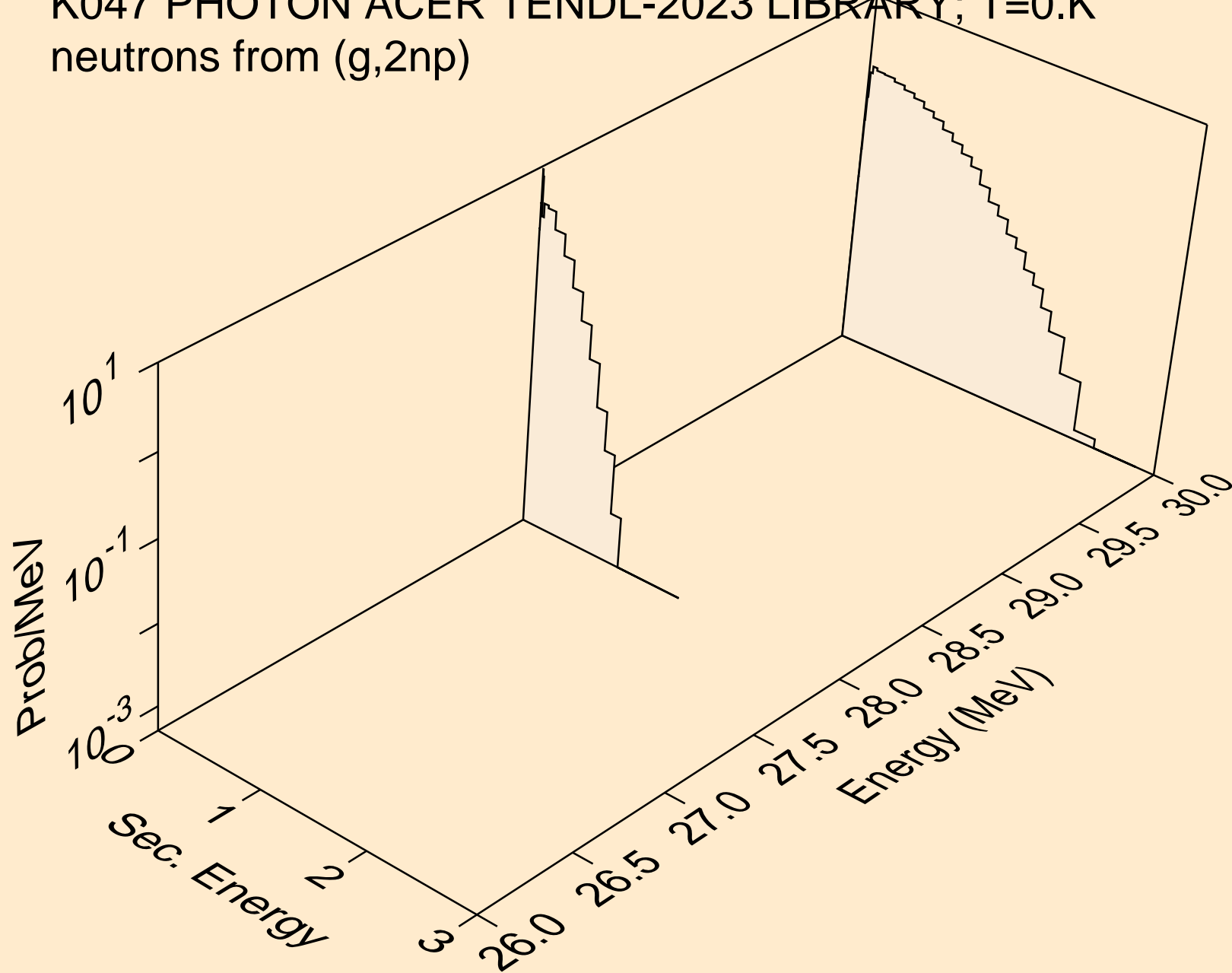

K047 PHOTON ACER TENDL-2023 LIBRARY; T=0.K  
angular distribution for (g,n\*0) neutron

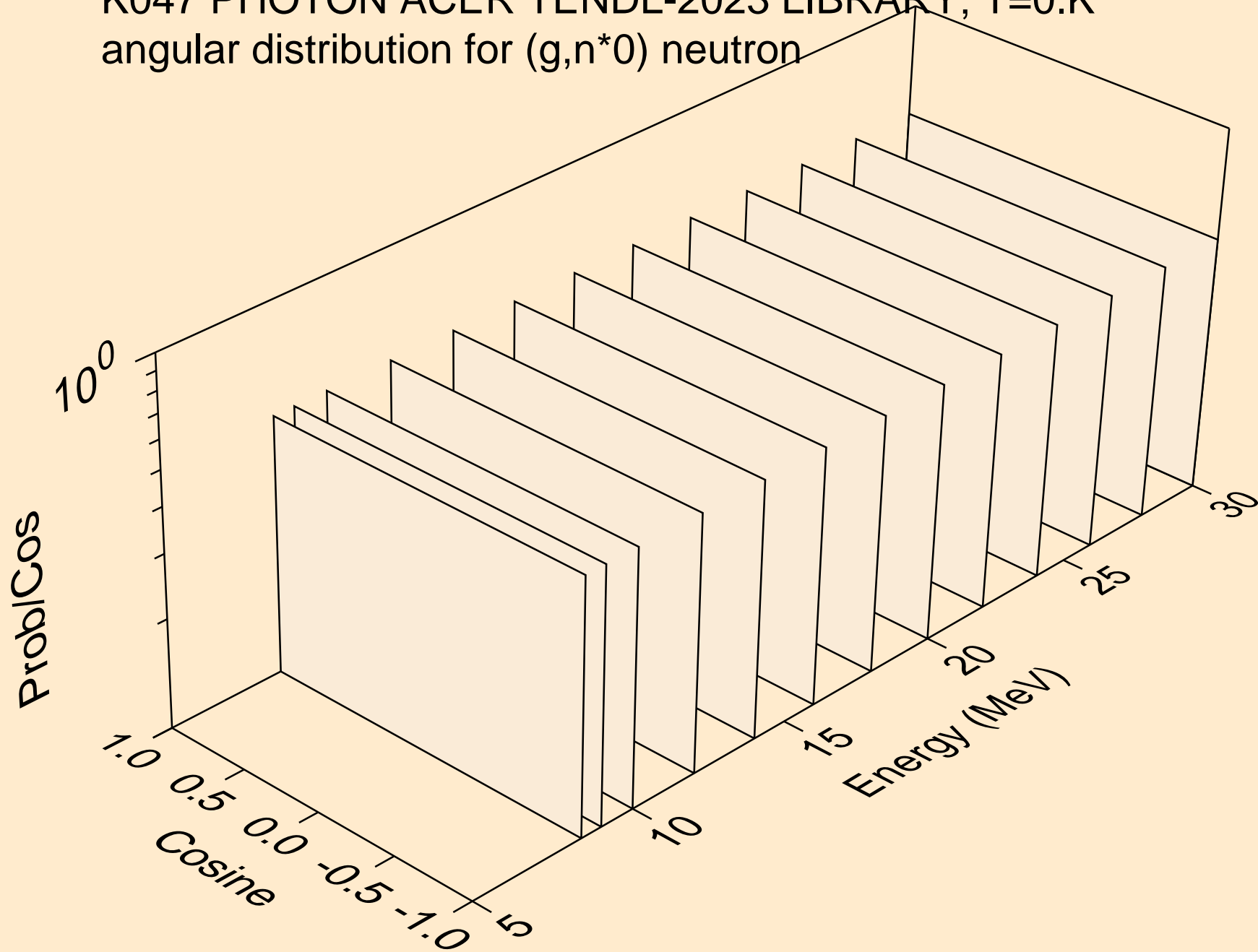

K047 PHOTON ACER TENDL-2023 LIBRARY; T=0.K  
angular distribution for (g,n\*1) neutron

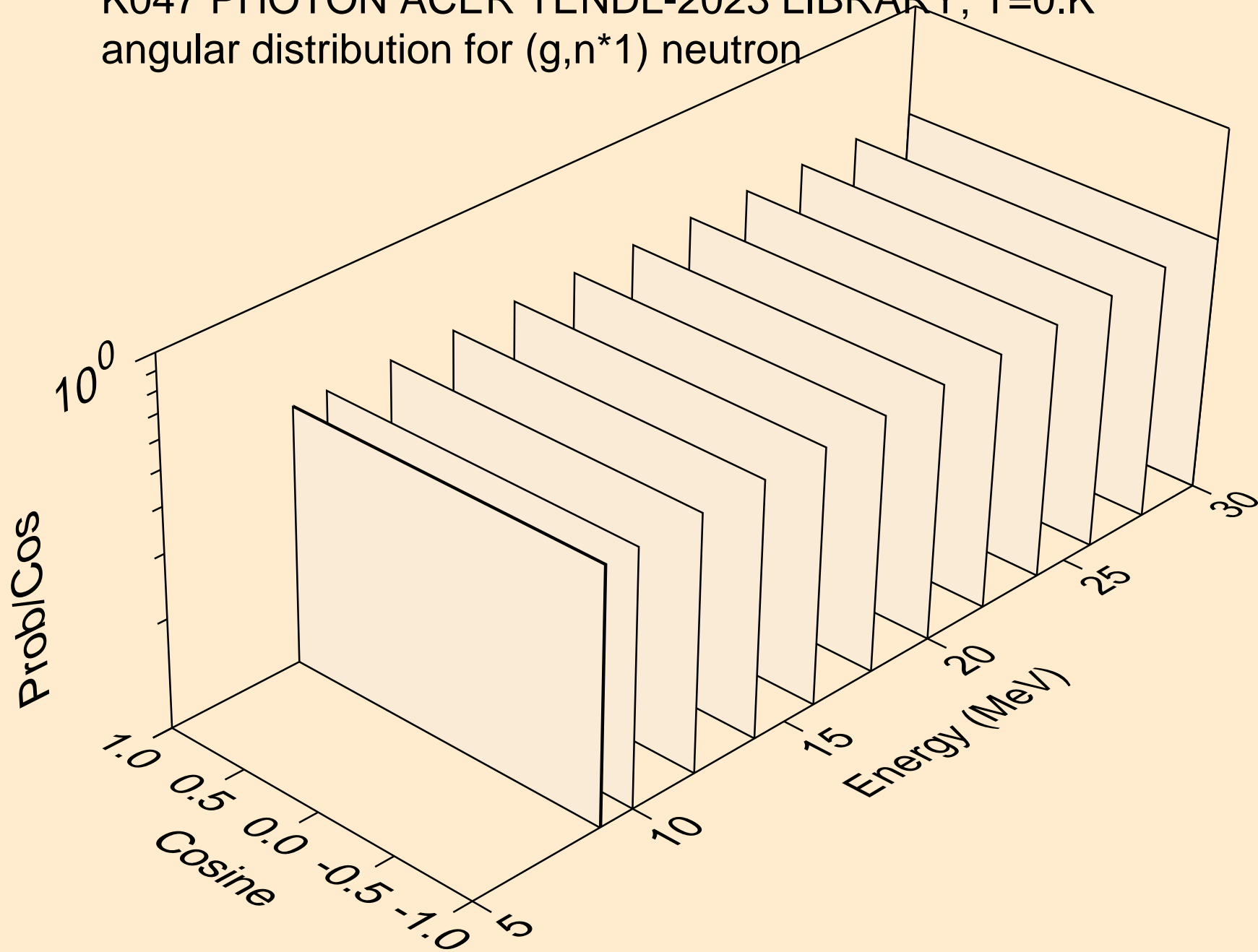

K047 PHOTON ACER TENDL-2023 LIBRARY; T=0.K  
neutrons from (g,n\*c)

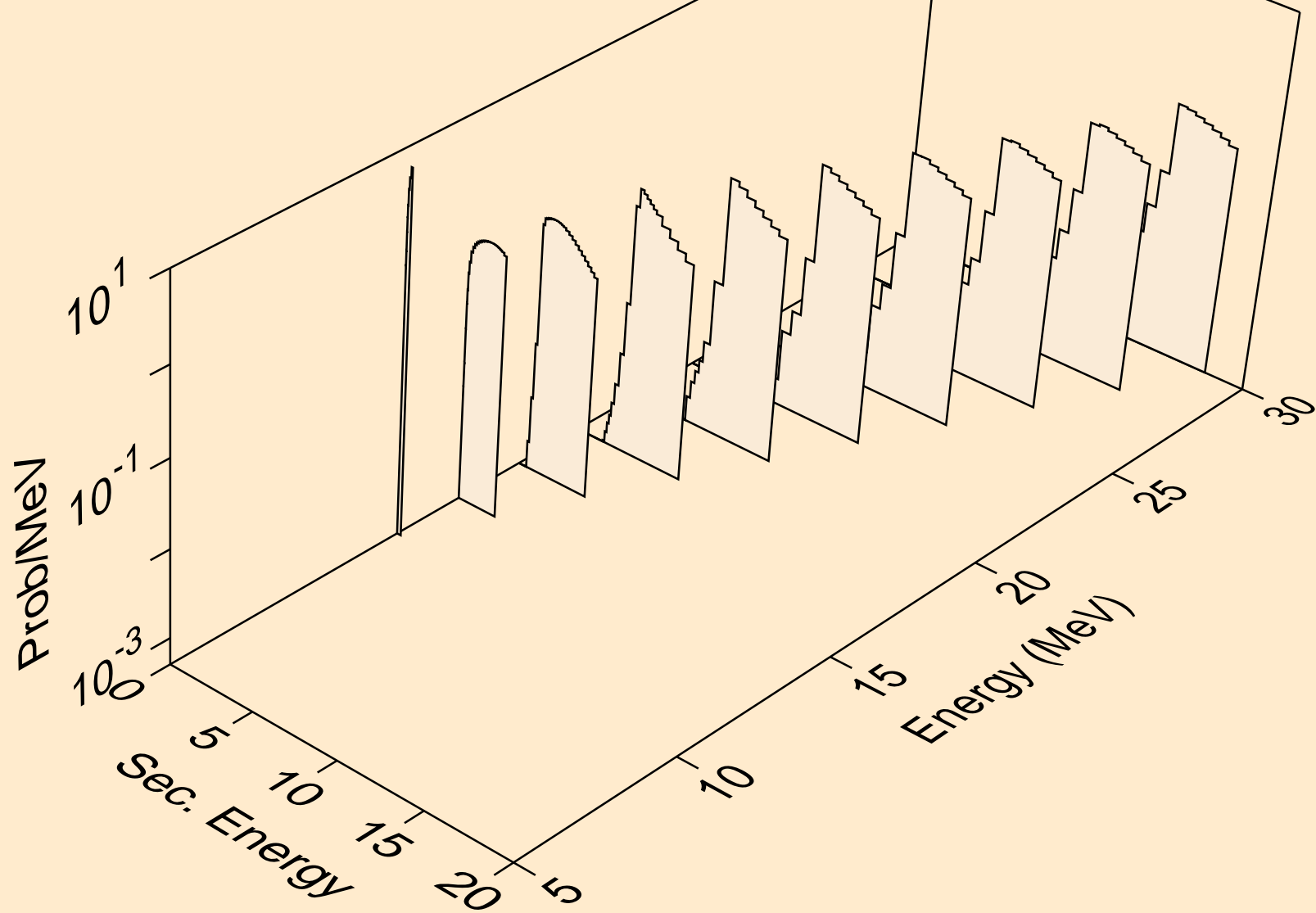



K047 PHOTON ACER TENDL-2023 LIBRARY; T=0.K  
photons from (g,x)

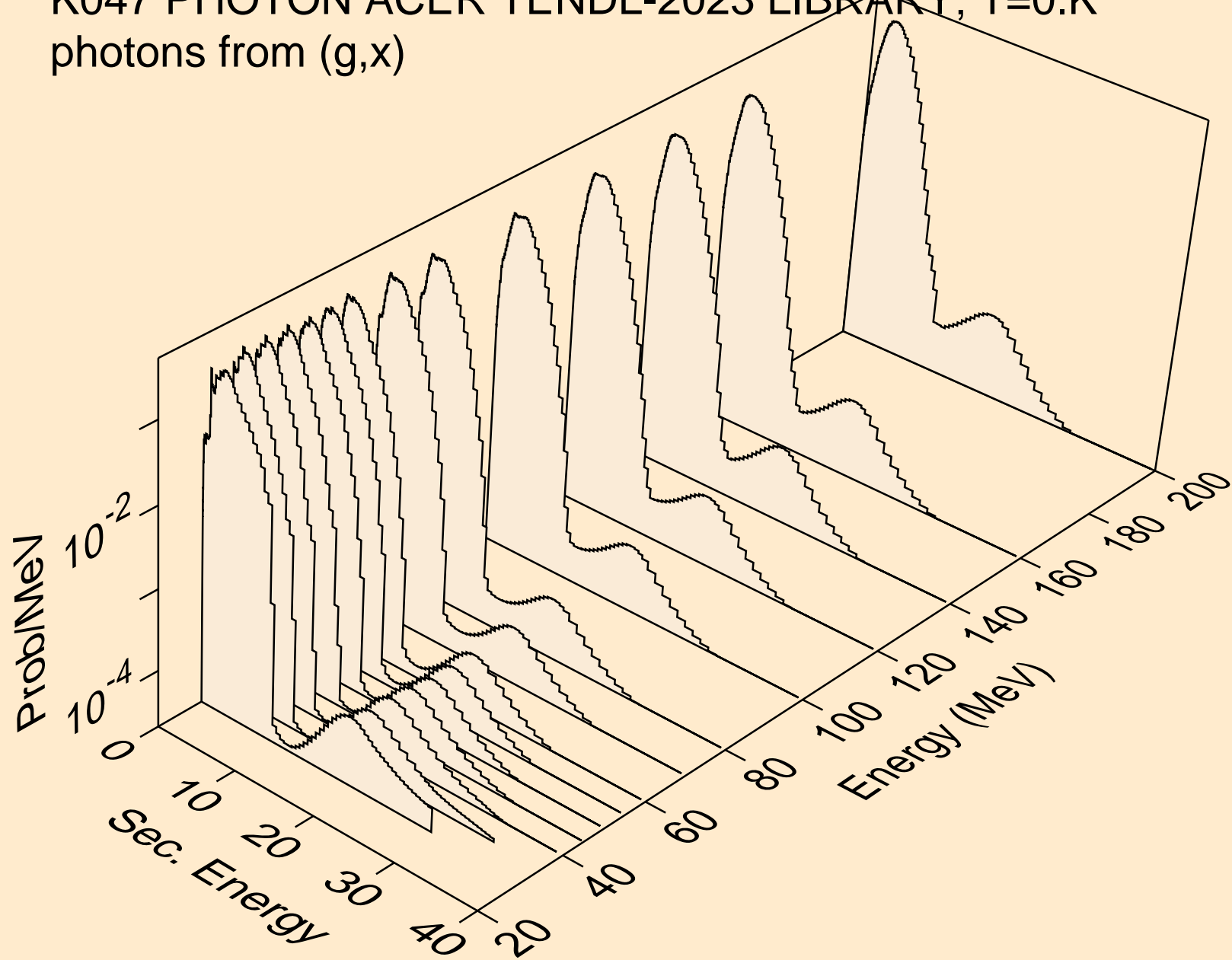

K047 PHOTON ACER TENDL-2023 LIBRARY; T=0.K  
photons from (g,2n)

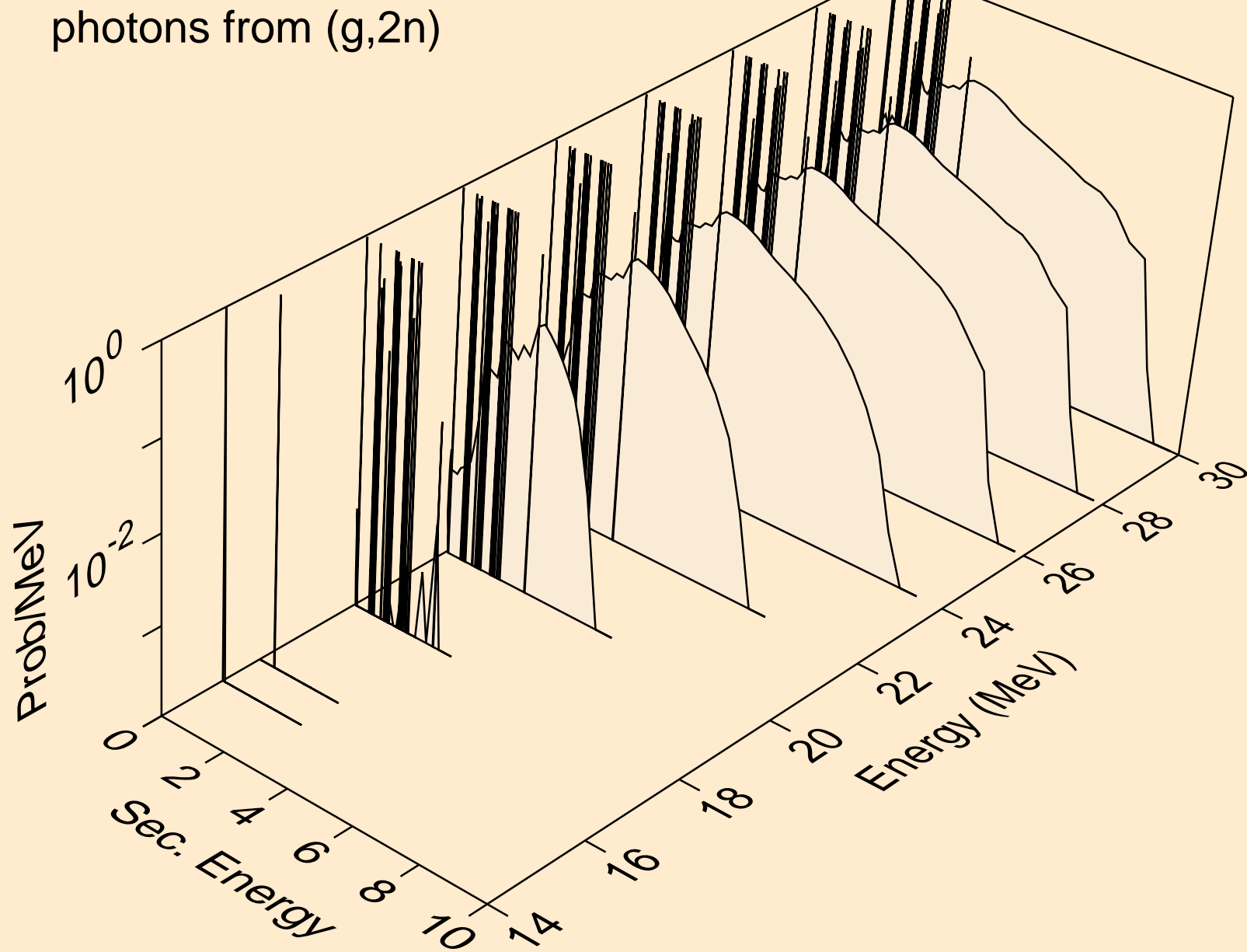

K047 PHOTON ACER TENDL-2023 LIBRARY; T=0.K  
photons from (g,3n)

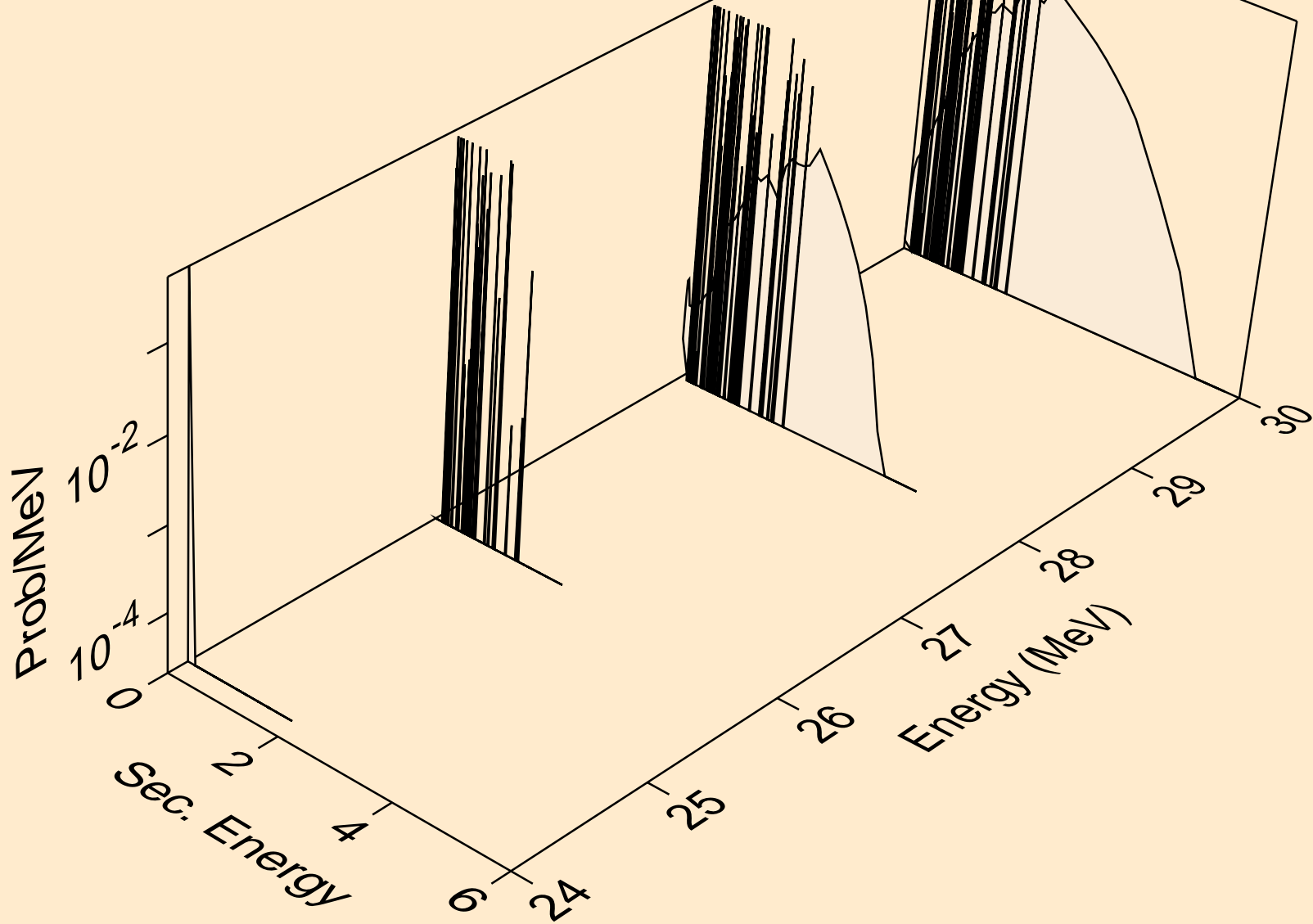

K047 PHOTON ACER TENDL-2023 LIBRARY; T=0.K  
photons from (g,n\*)a

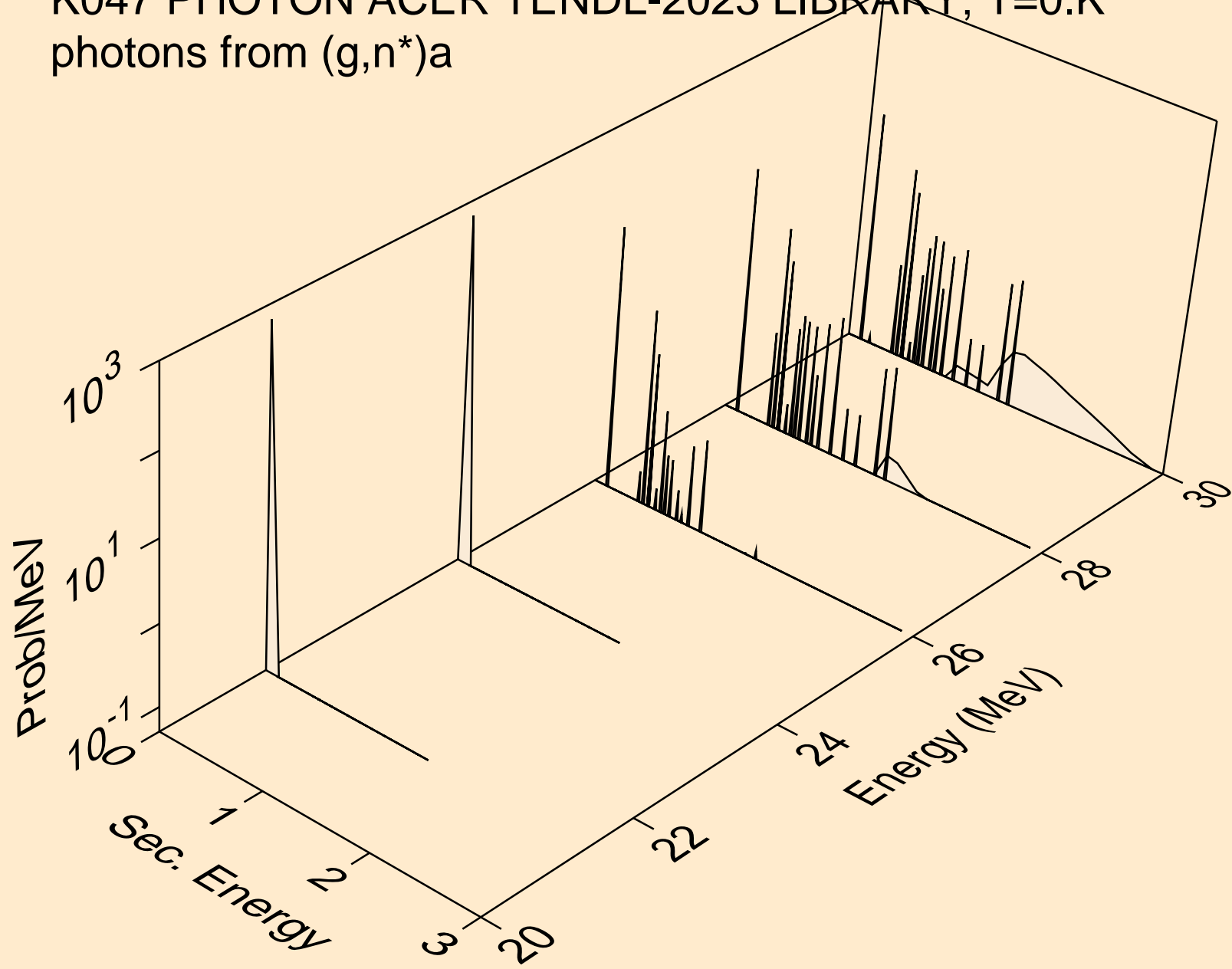

K047 PHOTON ACER TENDL-2023 LIBRARY; T=0.K  
photons from (g,n\*)p

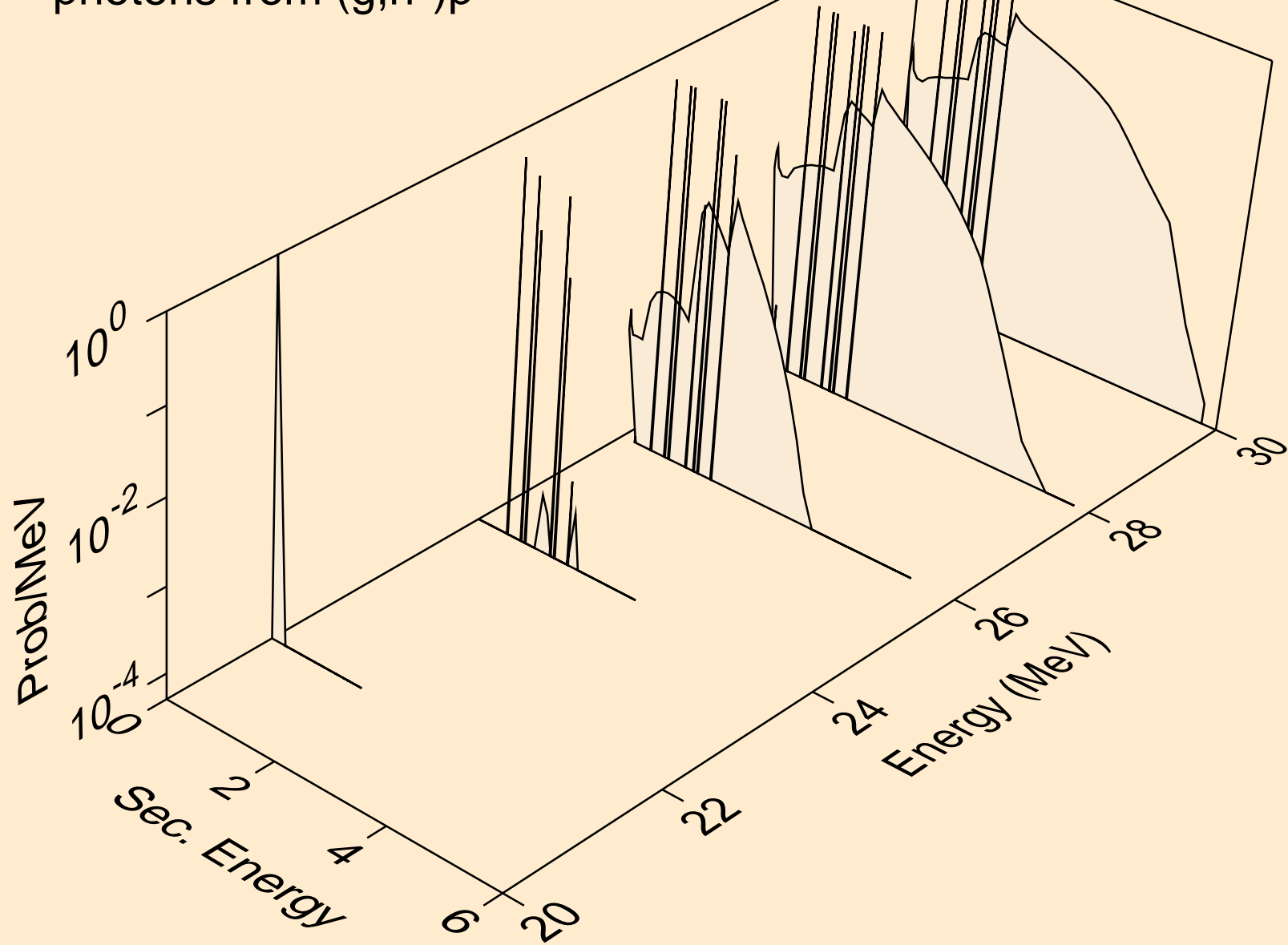

K047 PHOTON ACER TENDL-2023 LIBRARY; T=0.K  
photons from (g,n\*)d

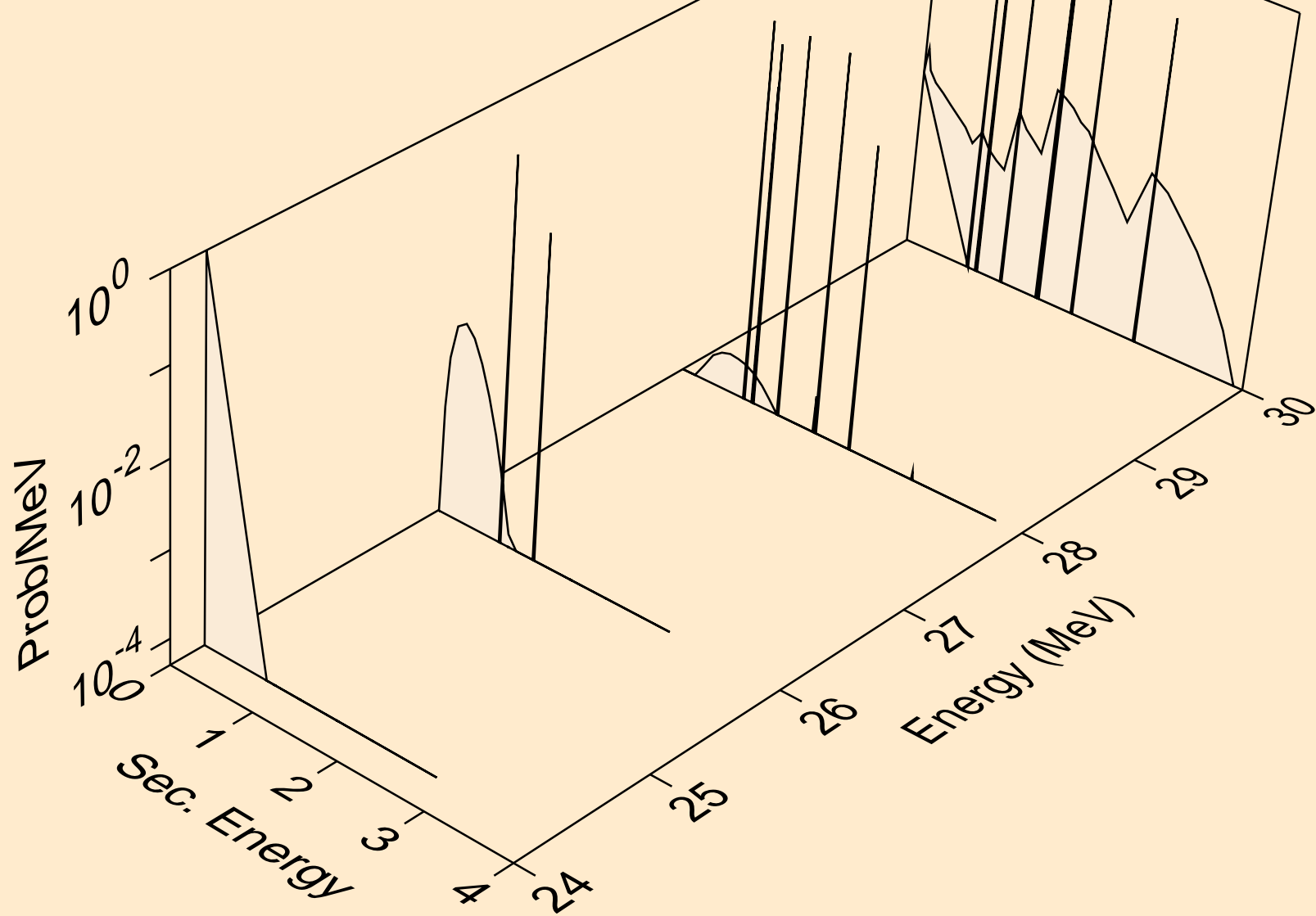

K047 PHOTON ACER TENDL-2023 LIBRARY; T=0.K  
photons from (g,n\*)t

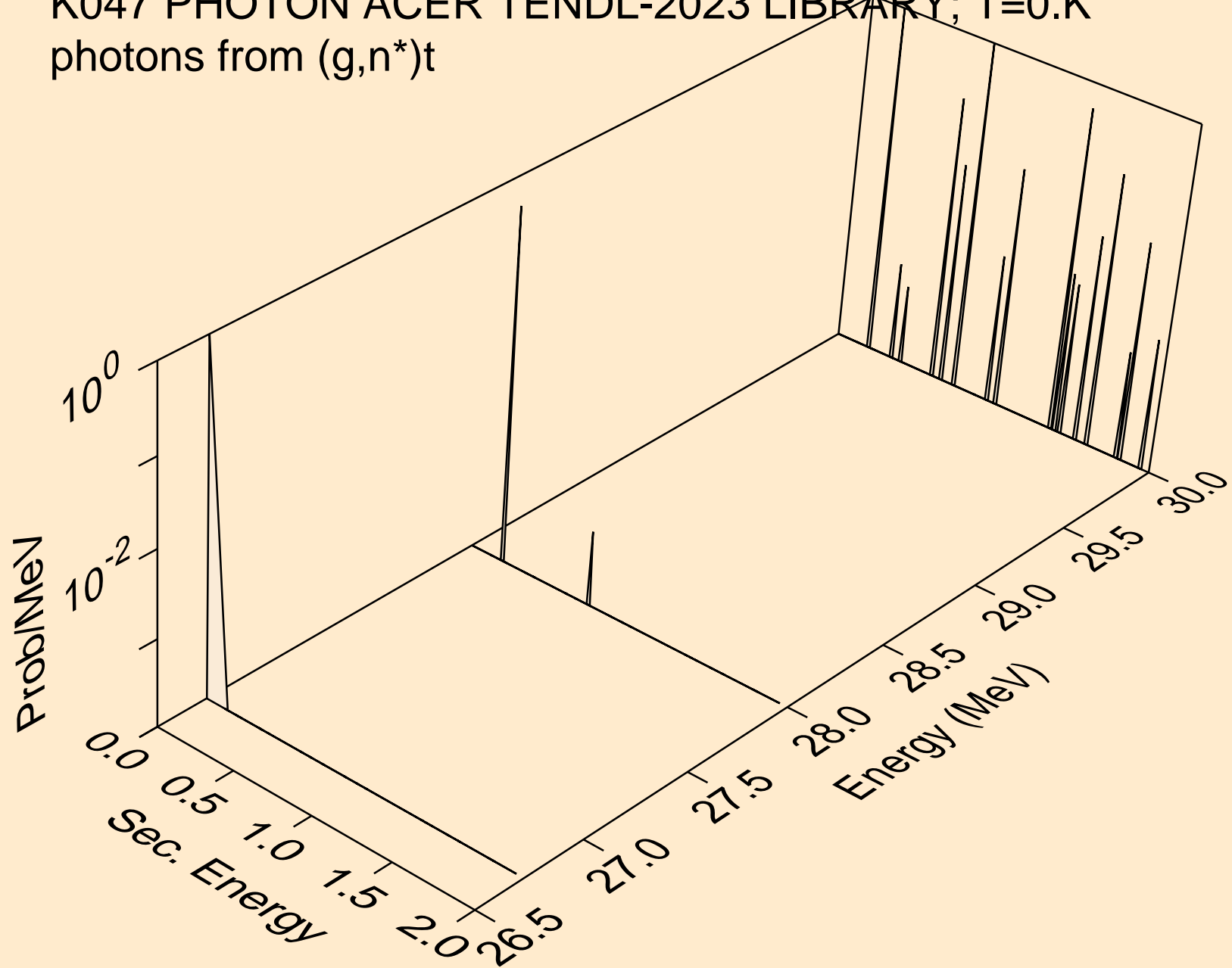

K047 PHOTON ACER TENDL-2023 LIBRARY; T=0.K  
photons from (g,2np)

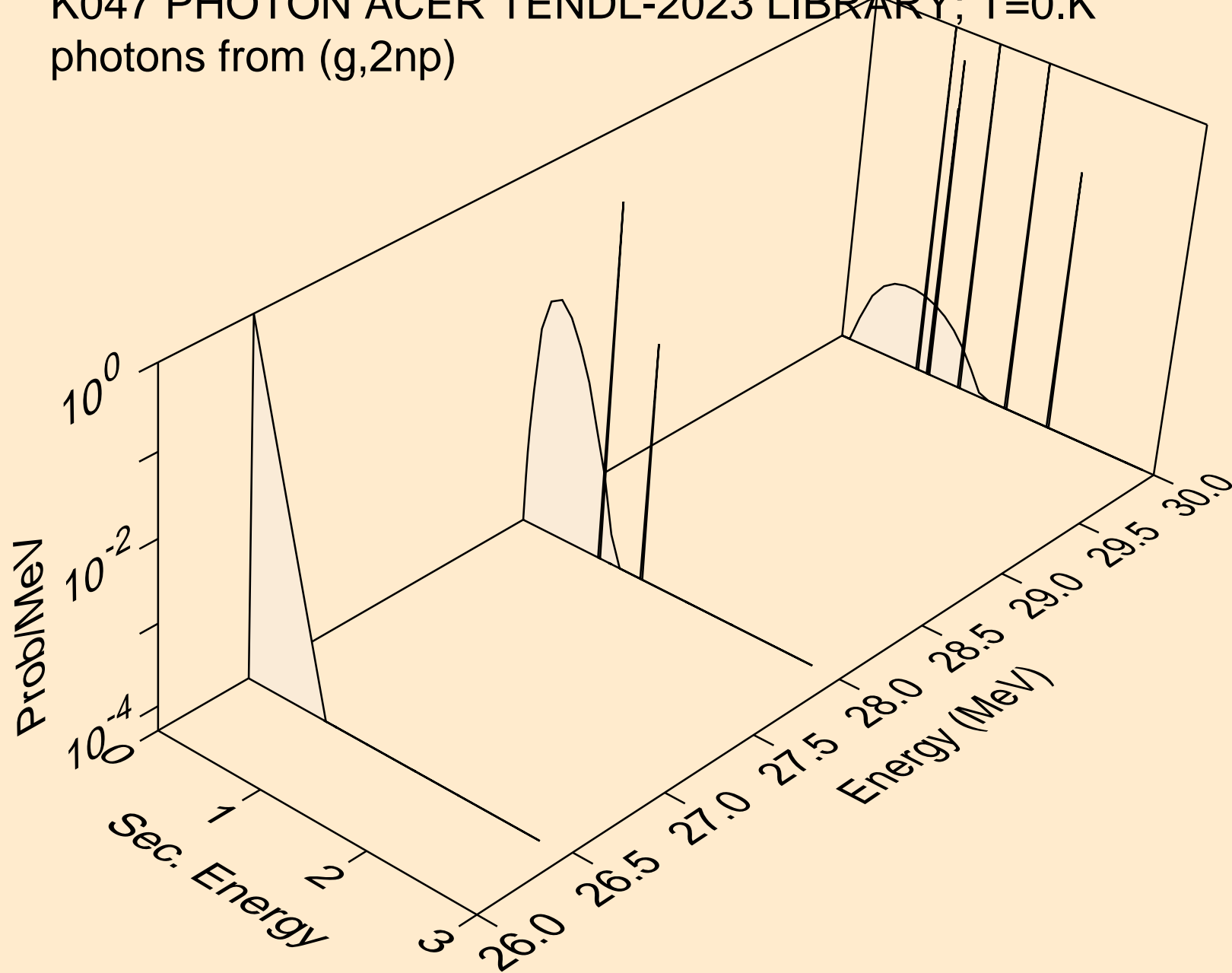



K047 PHOTON ACER TENDL-2023 LIBRARY; T=0.K  
photons from (g,n\*c)

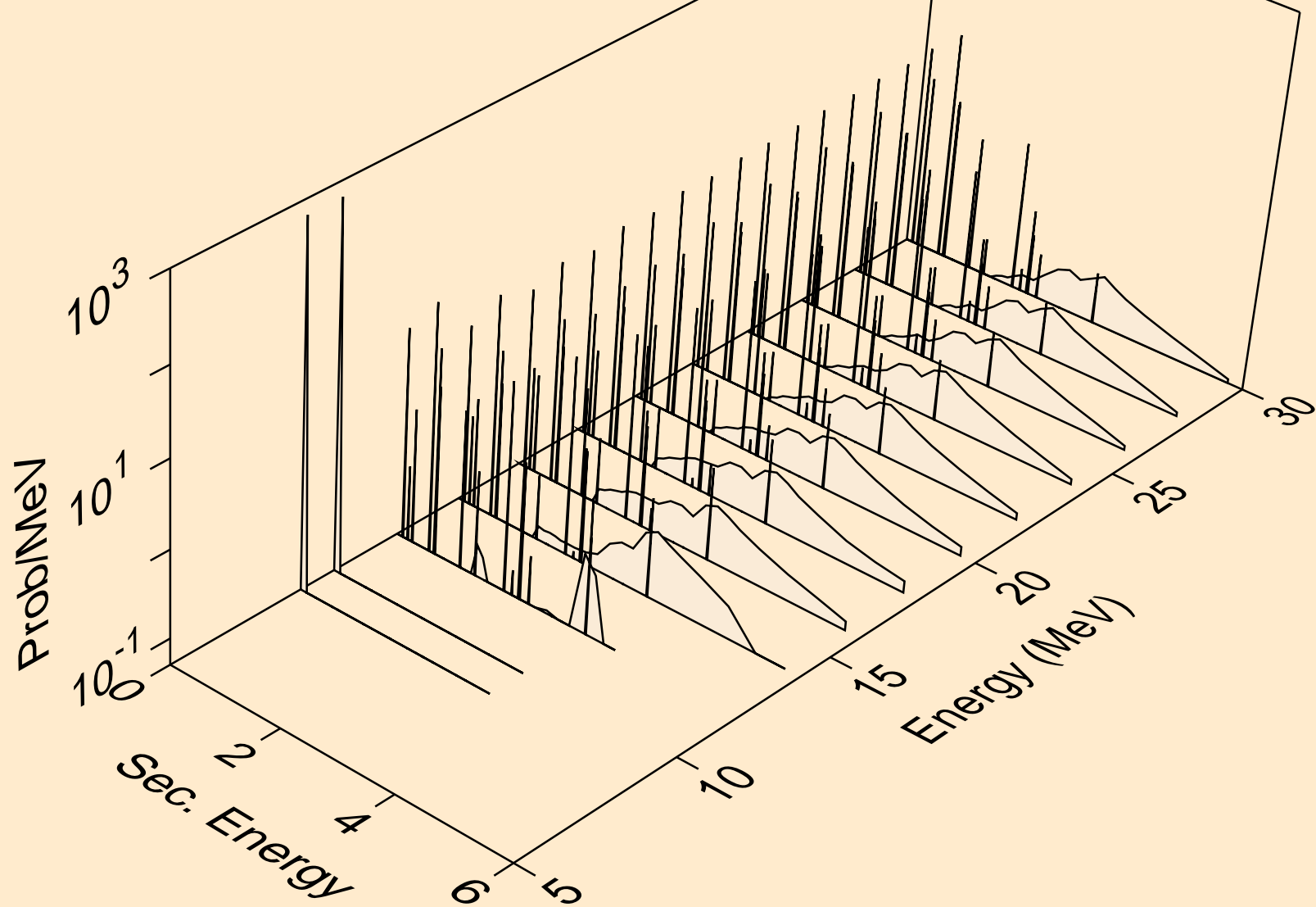

K047 PHOTON ACER TENDL-2023 LIBRARY; T=0.K  
photons from (g,gma)

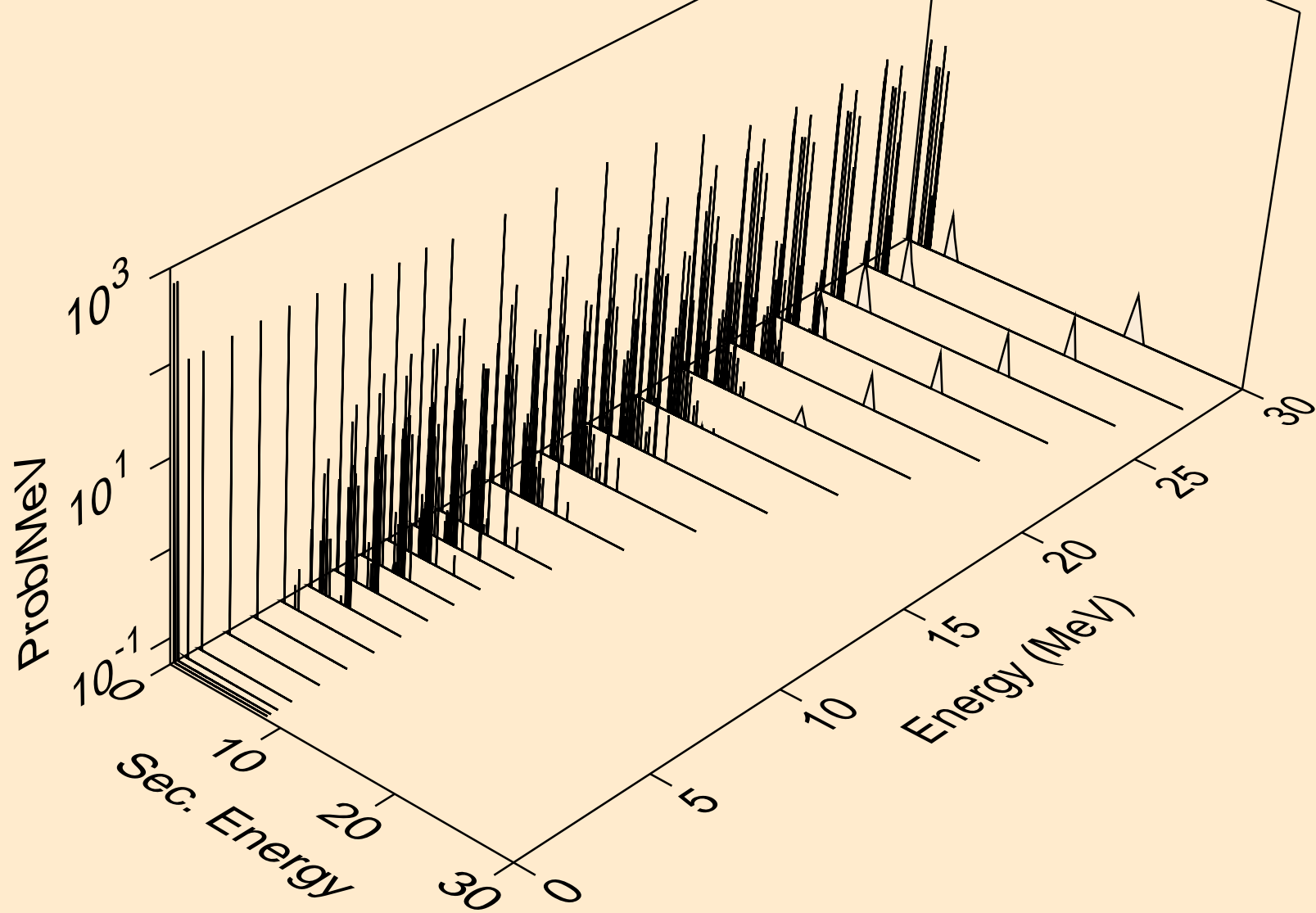

K047 PHOTON ACER TENDL-2023 LIBRARY; T=0.K  
photons from (g,p)

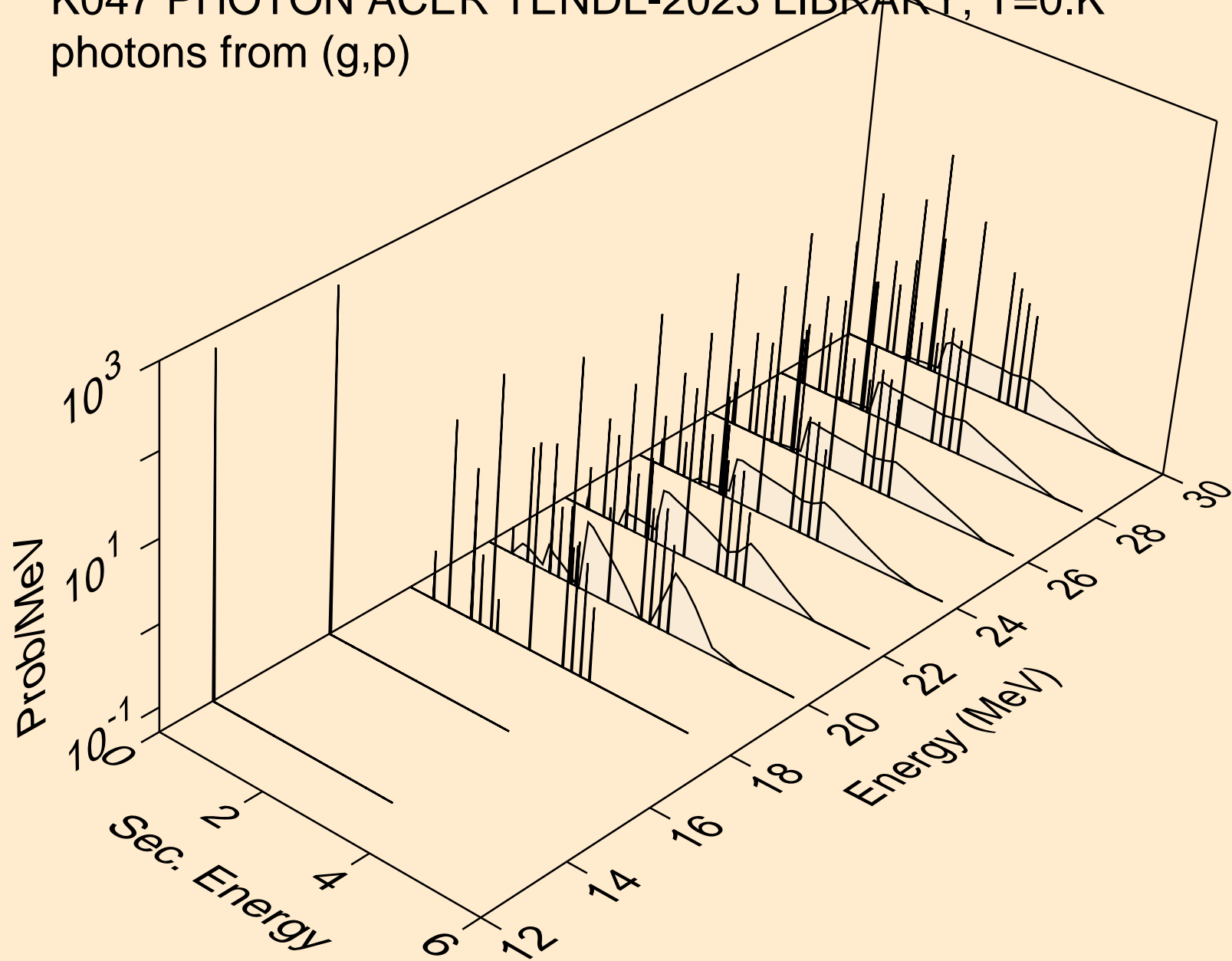

K047 PHOTON ACER TENDL-2023 LIBRARY; T=0.K  
photons from (g,d)

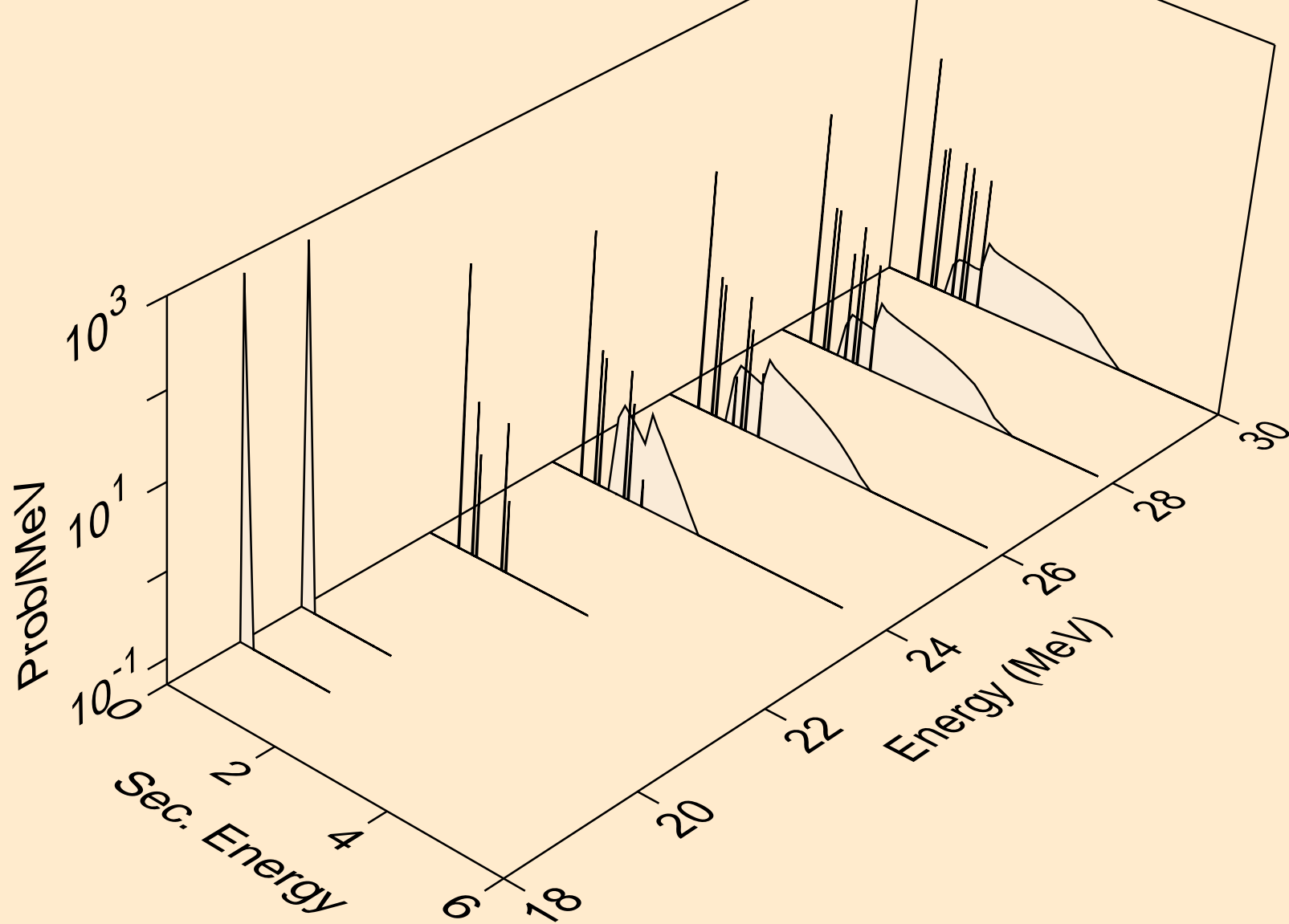

K047 PHOTON ACER TENDL-2023 LIBRARY; T=0.K  
photons from (g,t)

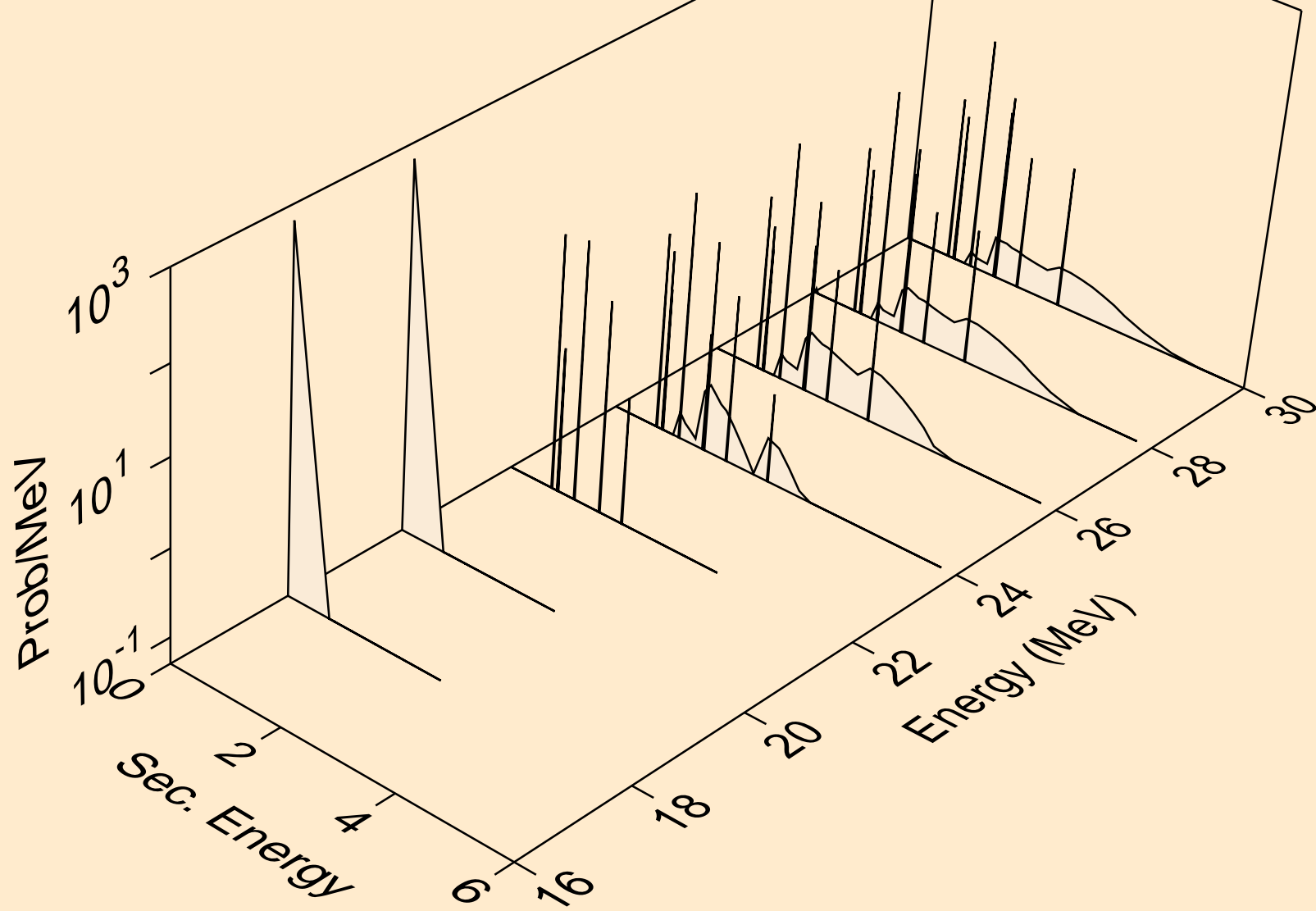

K047 PHOTON ACER TENDL-2023 LIBRARY; T=0.K  
photons from (g,a)

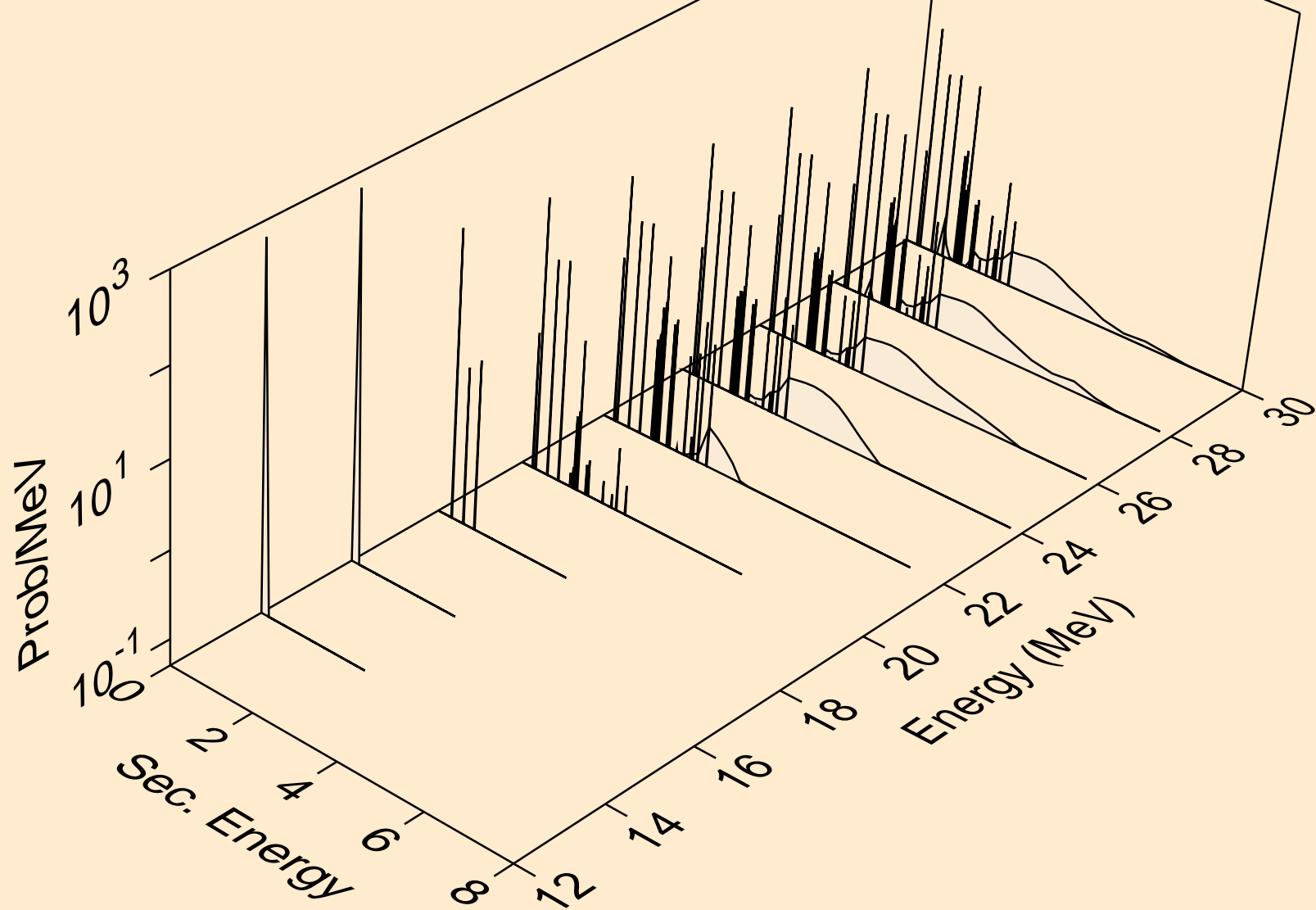

K047 PHOTON ACER TENDL-2023 LIBRARY; T=0.K  
protons from (g,x)

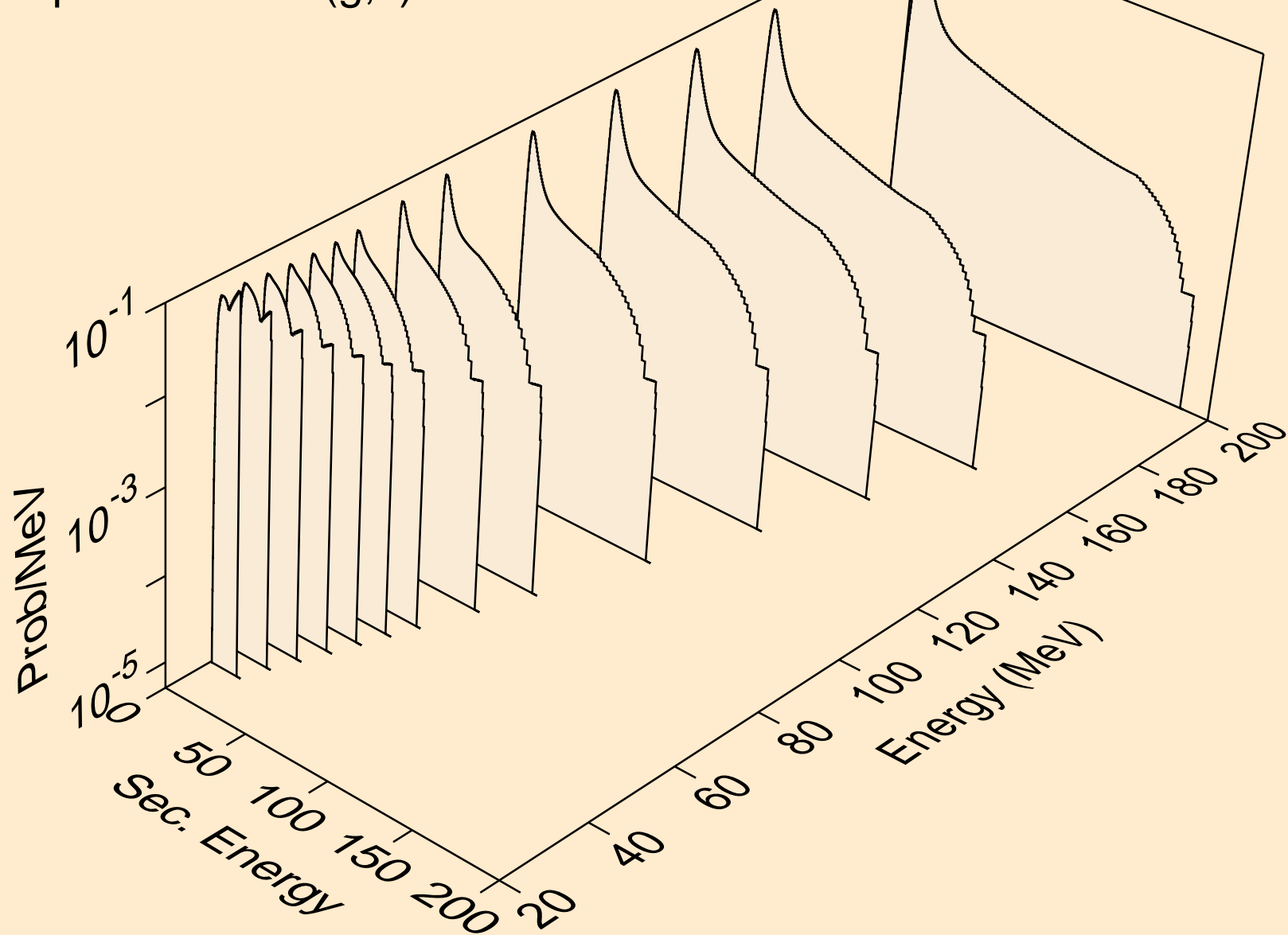

K047 PHOTON ACER TENDL-2023 LIBRARY; T=0.K  
protons from (g,n\*)p

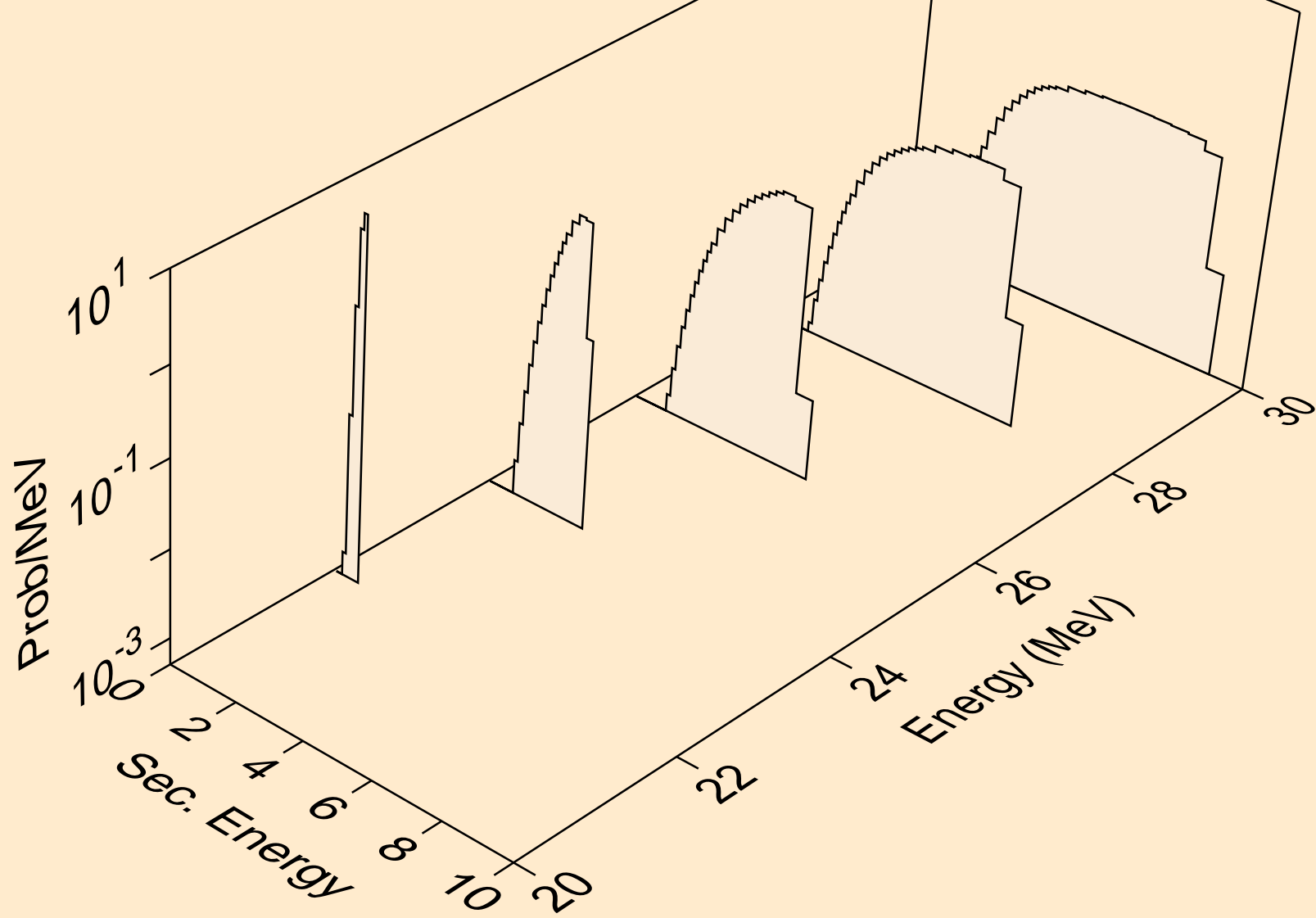



K047 PHOTON ACER TENDL-2023 LIBRARY; T=0.K  
protons from (g,2np)

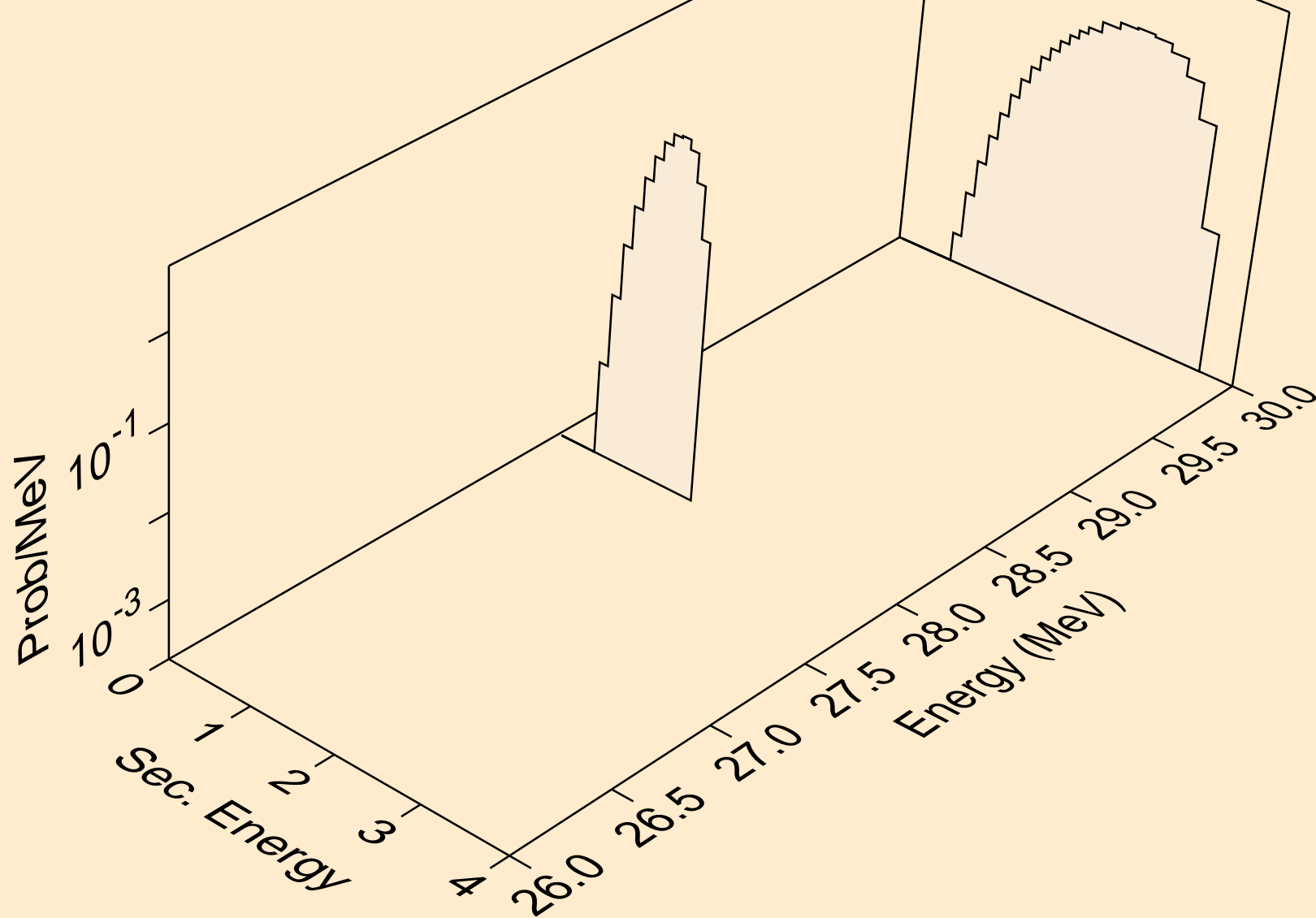

K047 PHOTON ACER TENDL-2023 LIBRARY; T=0.K  
protons from (g,p)

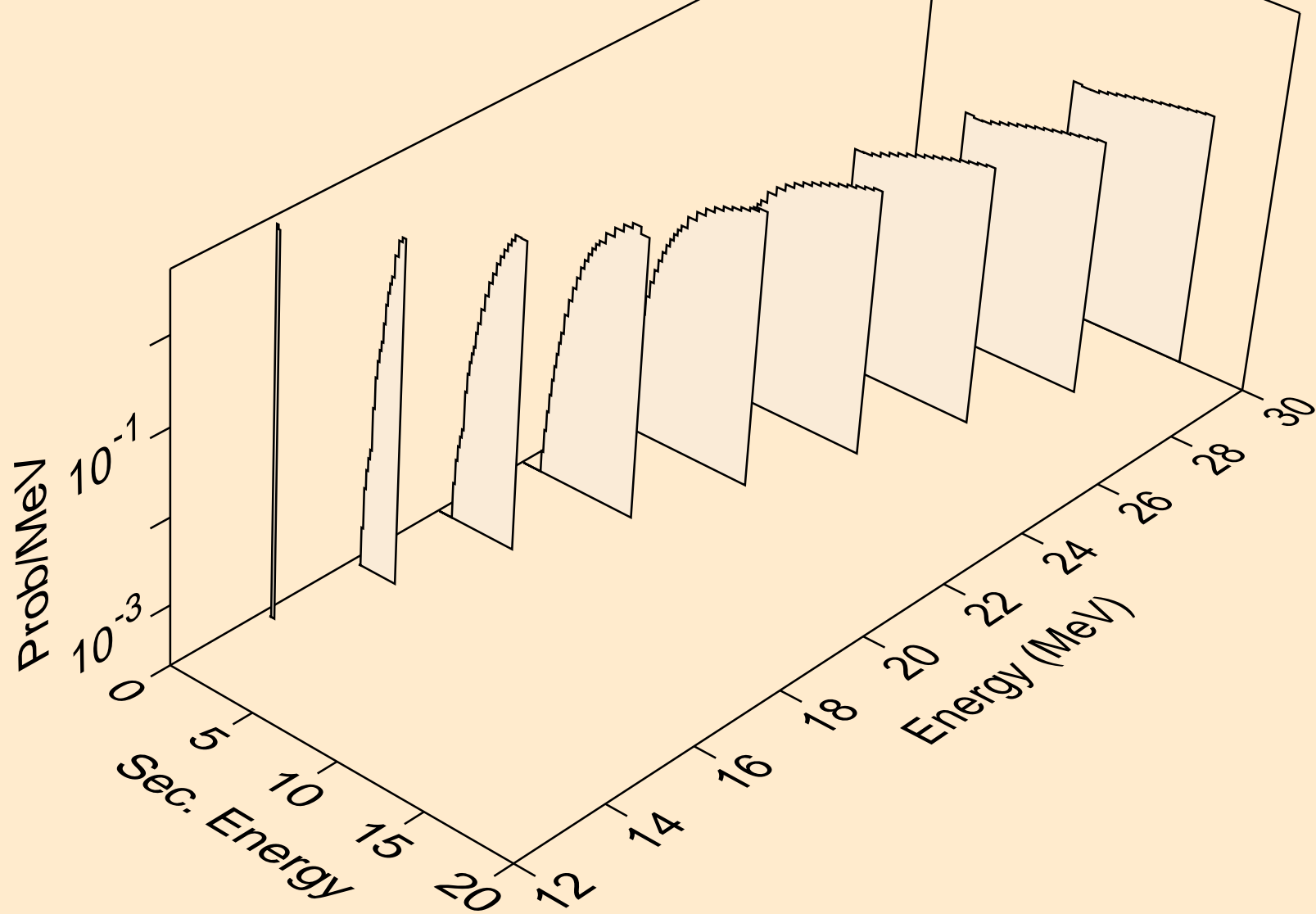

K047 PHOTON ACER TENDL-2023 LIBRARY; T=0.K  
deuterons from (g,x)

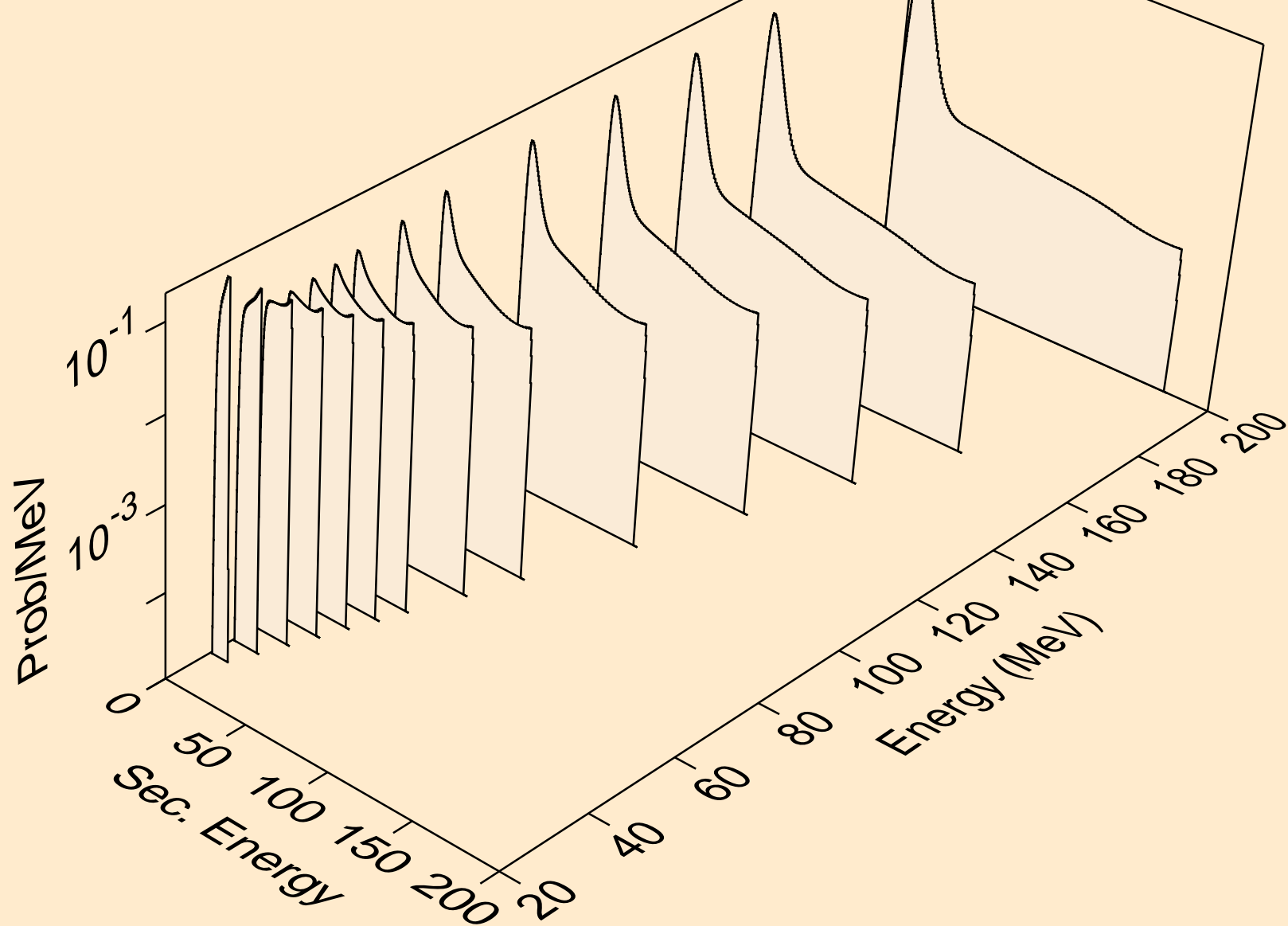

K047 PHOTON ACER TENDL-2023 LIBRARY; T=0.K  
deuterons from (g,n\*)d

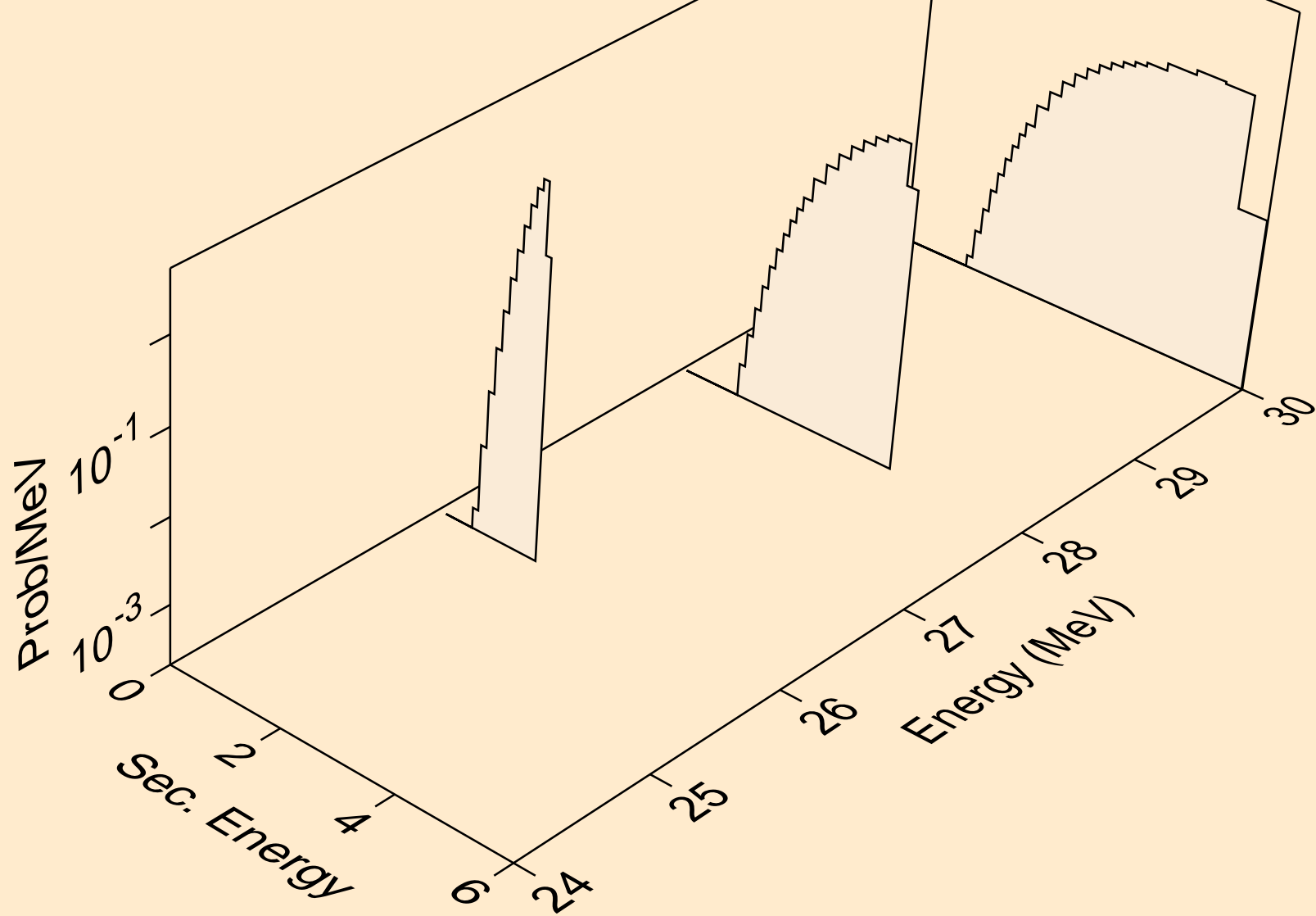

K047 PHOTON ACER TENDL-2023 LIBRARY; T=0.K  
deuterons from (g,d)

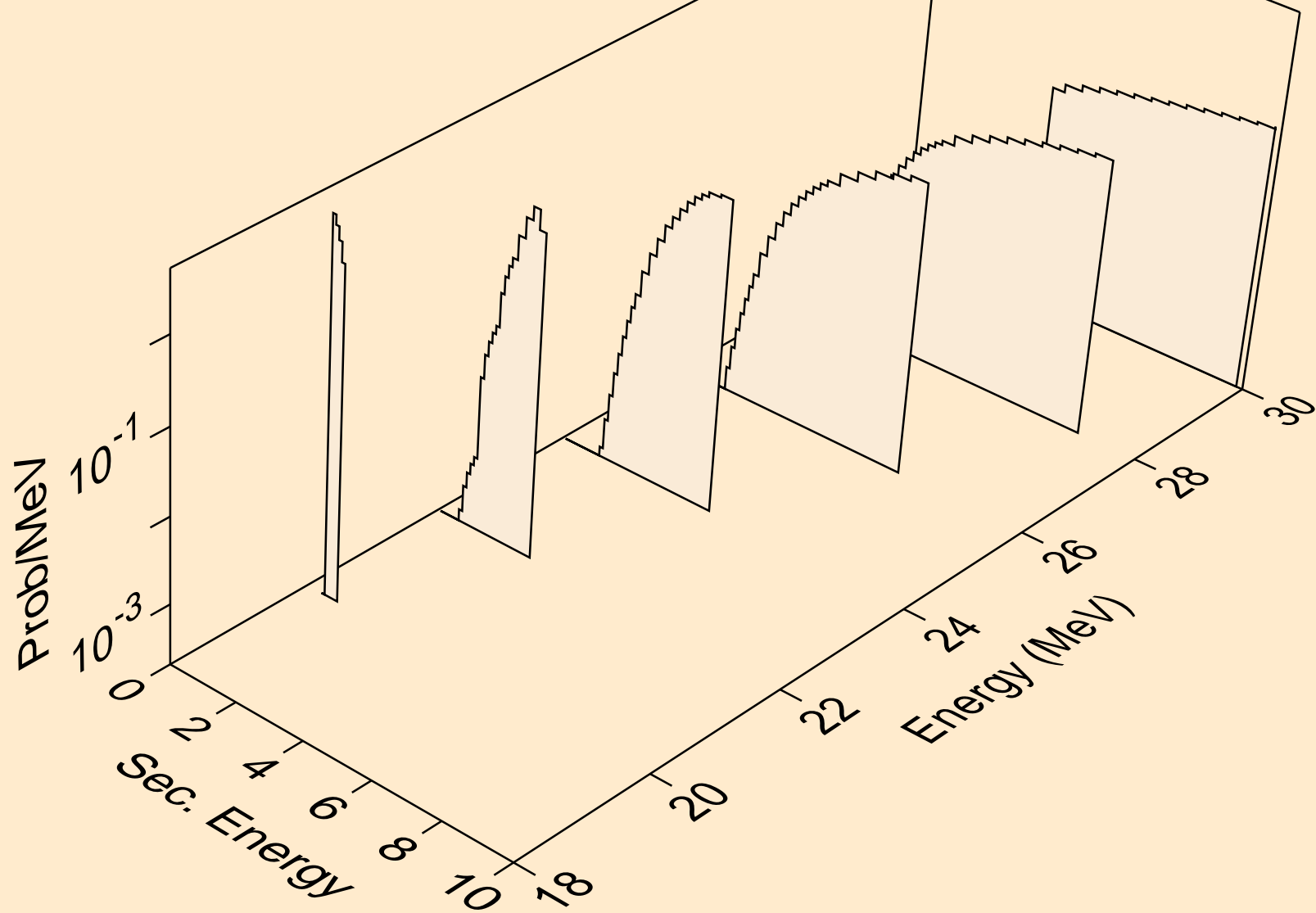

K047 PHOTON ACER TENDL-2023 LIBRARY; T=0.K  
tritons from (g,x)

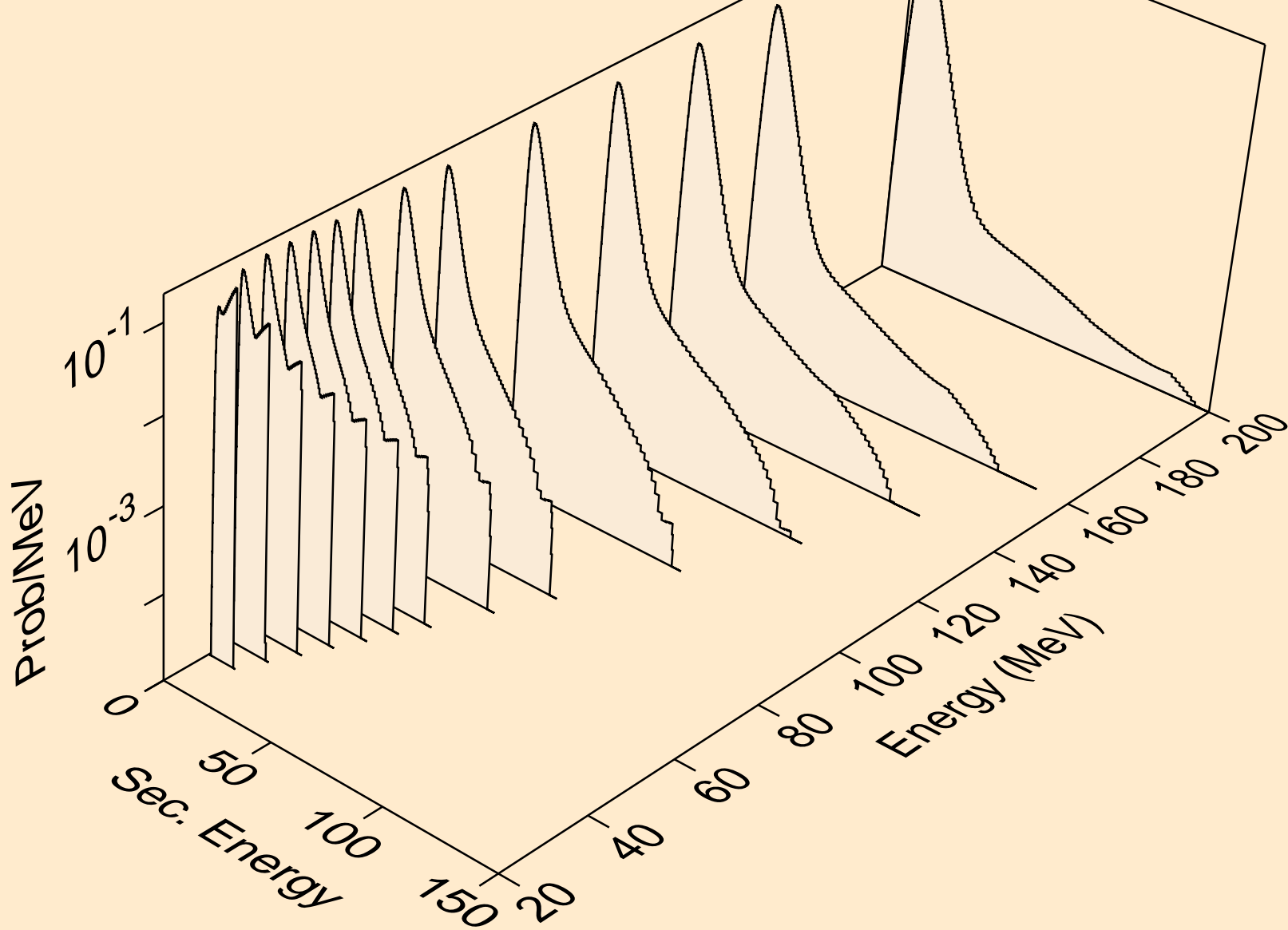

K047 PHOTON ACER TENDL-2023 LIBRARY; T=0.K  
tritons from (g,n\*)t

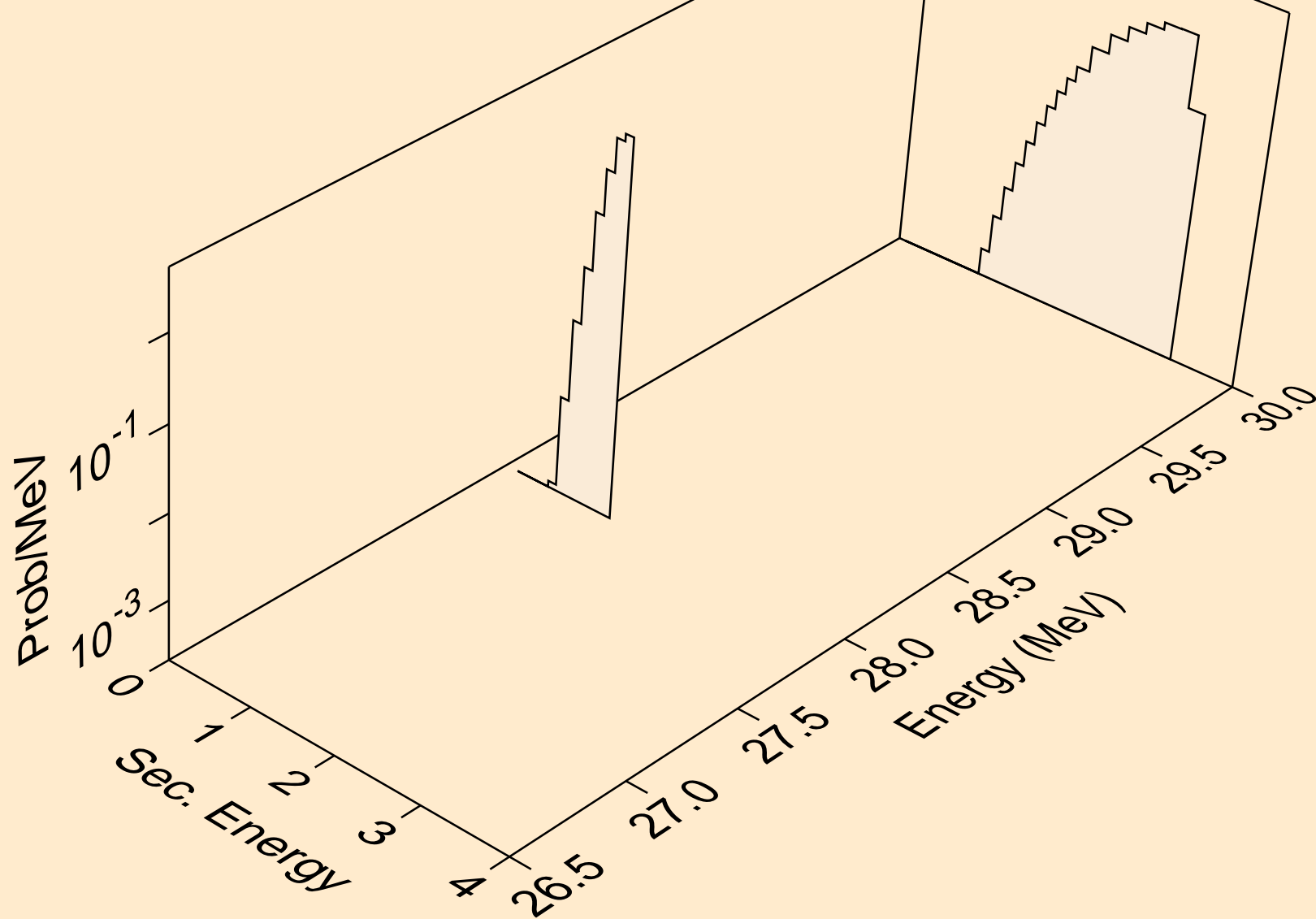

K047 PHOTON ACER TENDL-2023 LIBRARY; T=0.K  
tritons from (g,t)

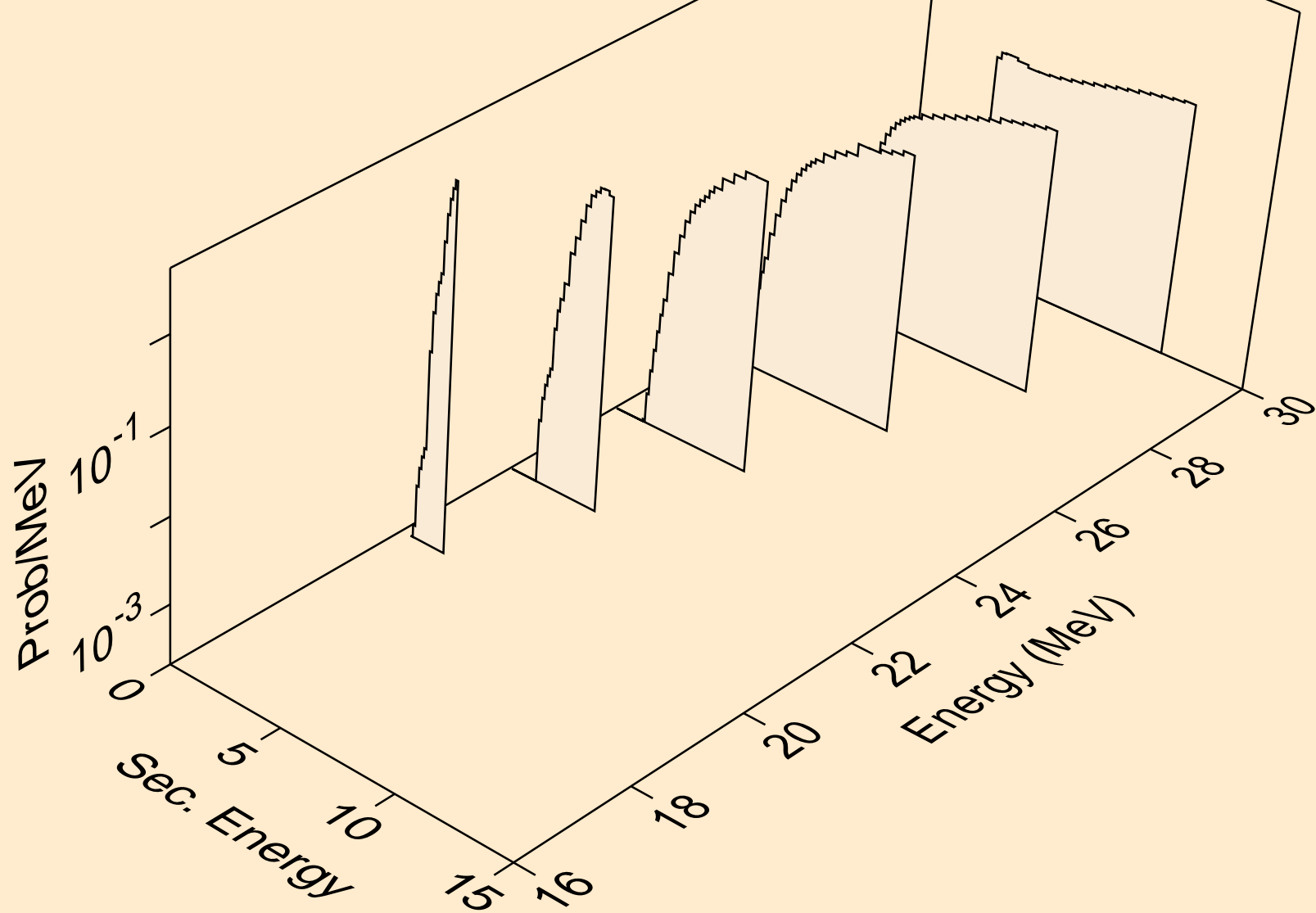



K047 PHOTON ACER TENDL-2023 LIBRARY; T=0.K  
he3s from (g,x)

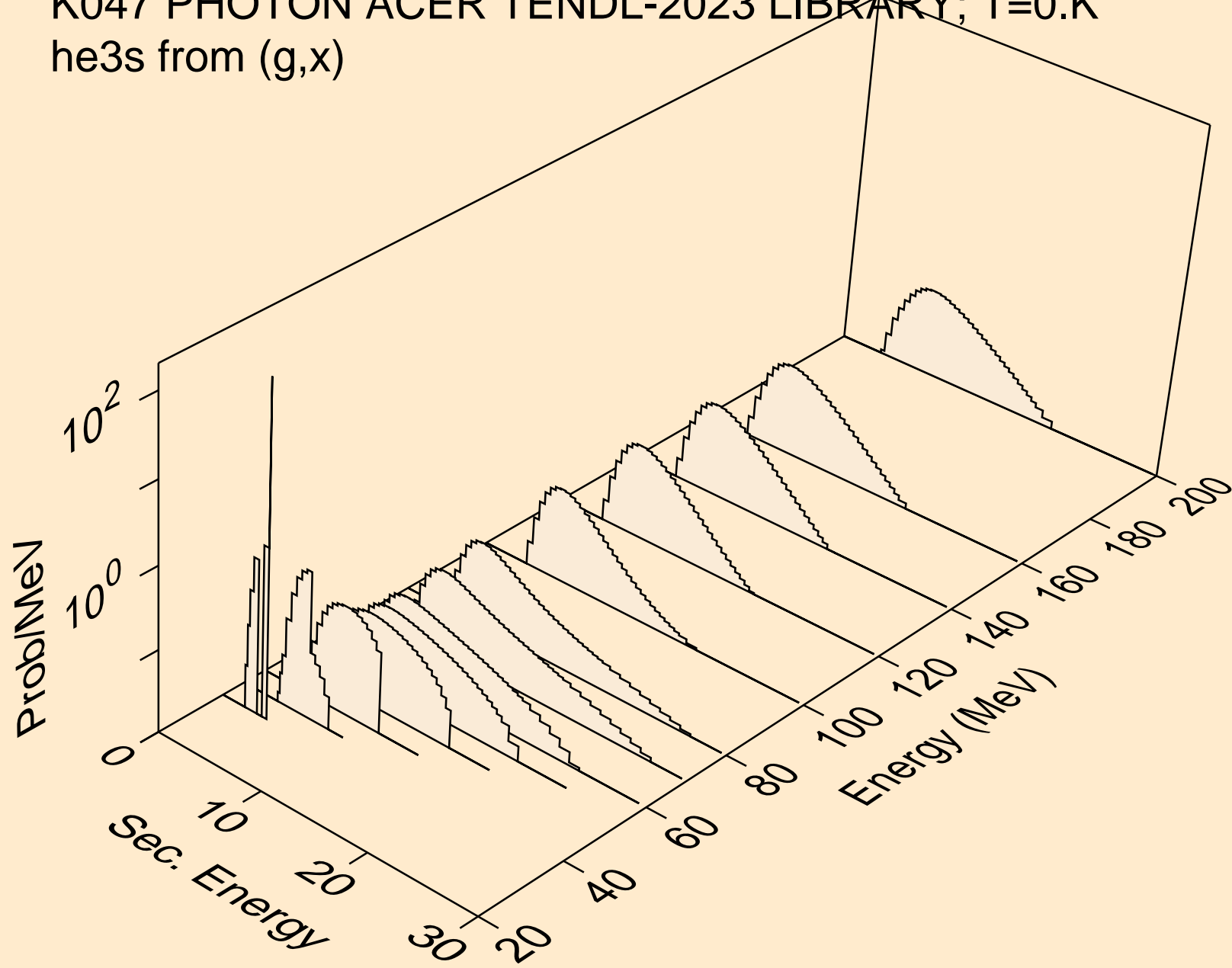

K047 PHOTON ACER TENDL-2023 LIBRARY; T=0.K  
alphas from (g,x)

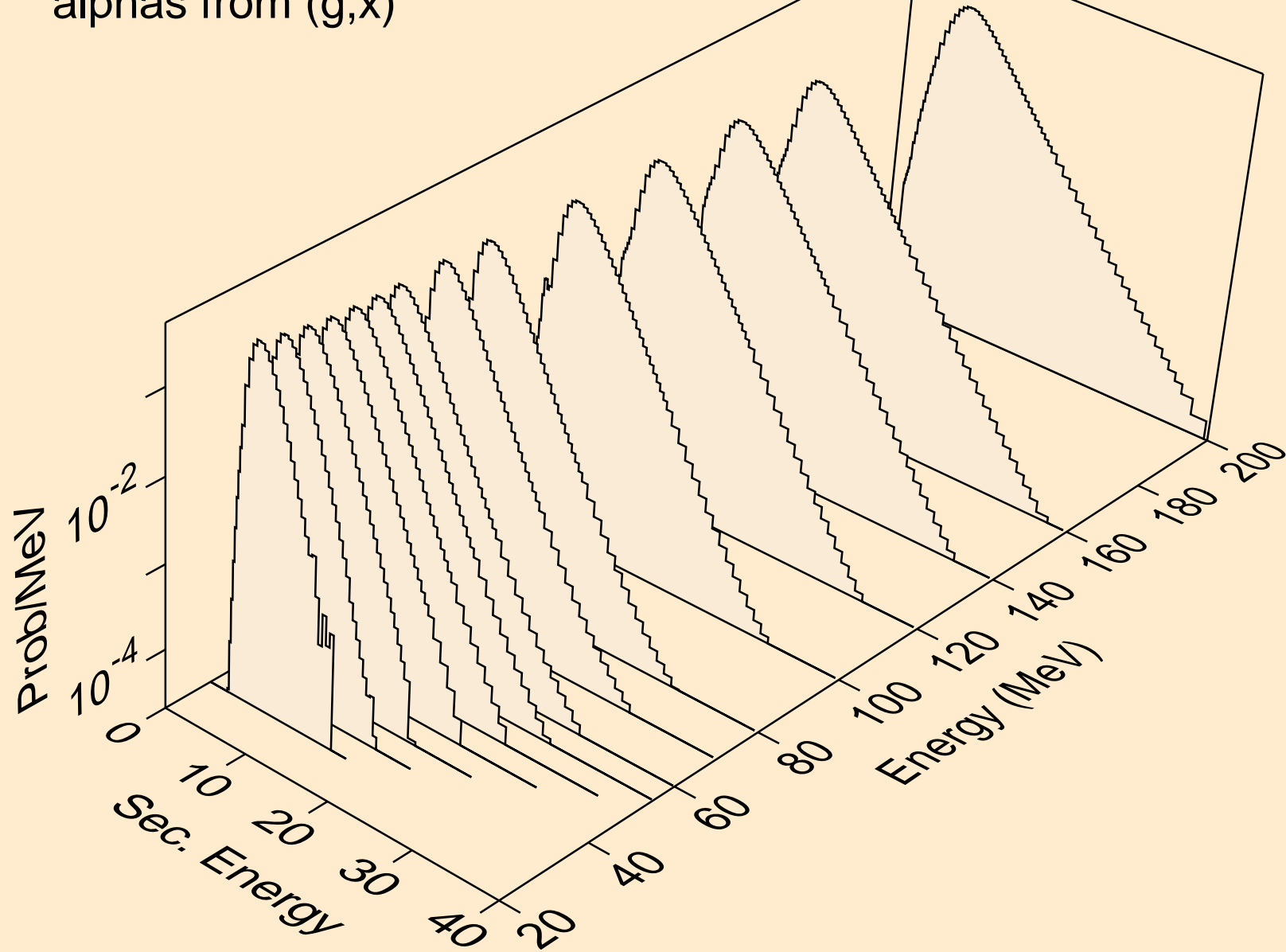

K047 PHOTON ACER TENDL-2023 LIBRARY; T=0.K  
alphas from (g,n\*)a

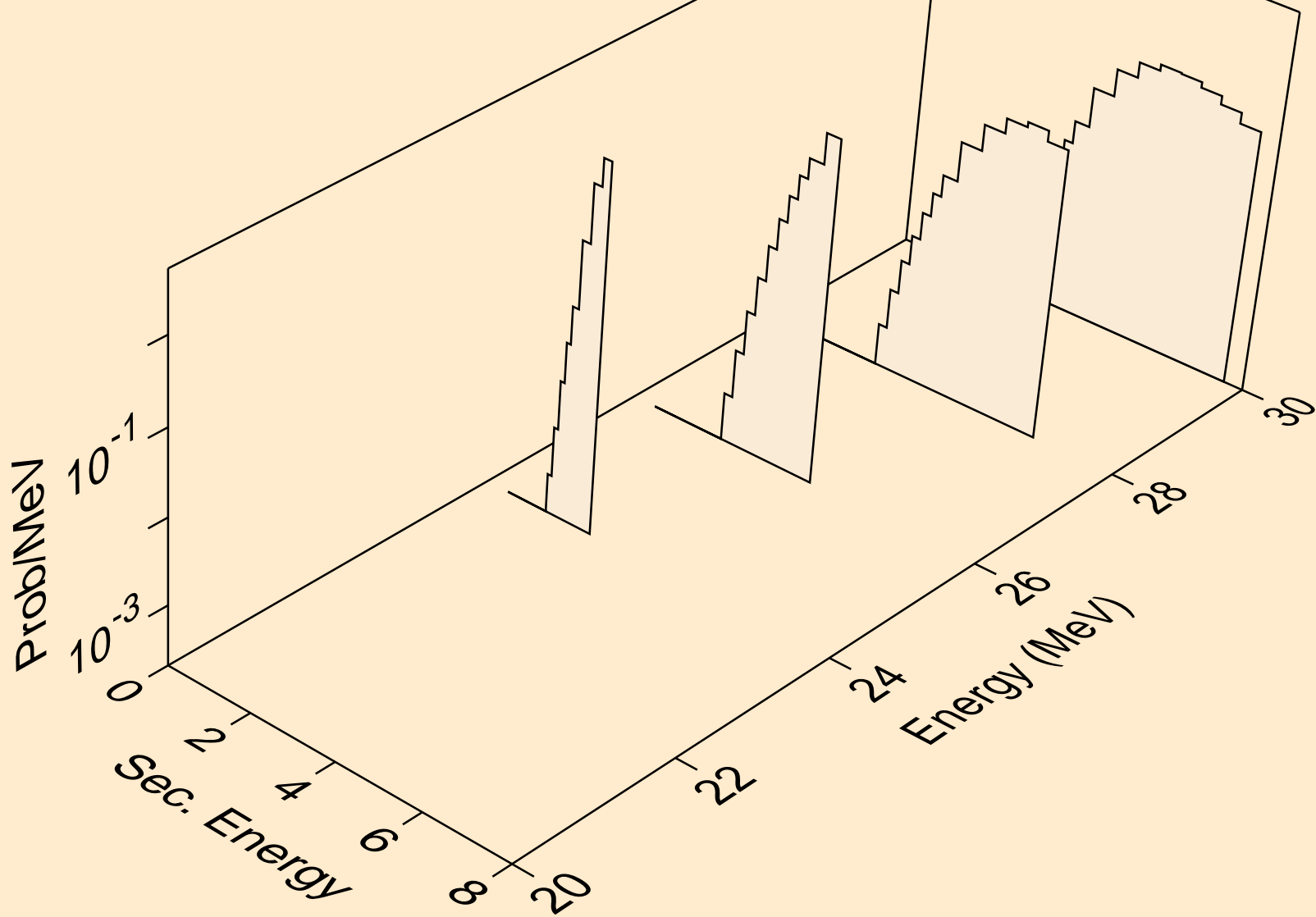

K047 PHOTON ACER TENDL-2023 LIBRARY; T=0.K  
alphas from (g,a)

