

MC291 PHOTON ACER TENDL-2023 LIBRARY; T=0.K

Principal cross sections

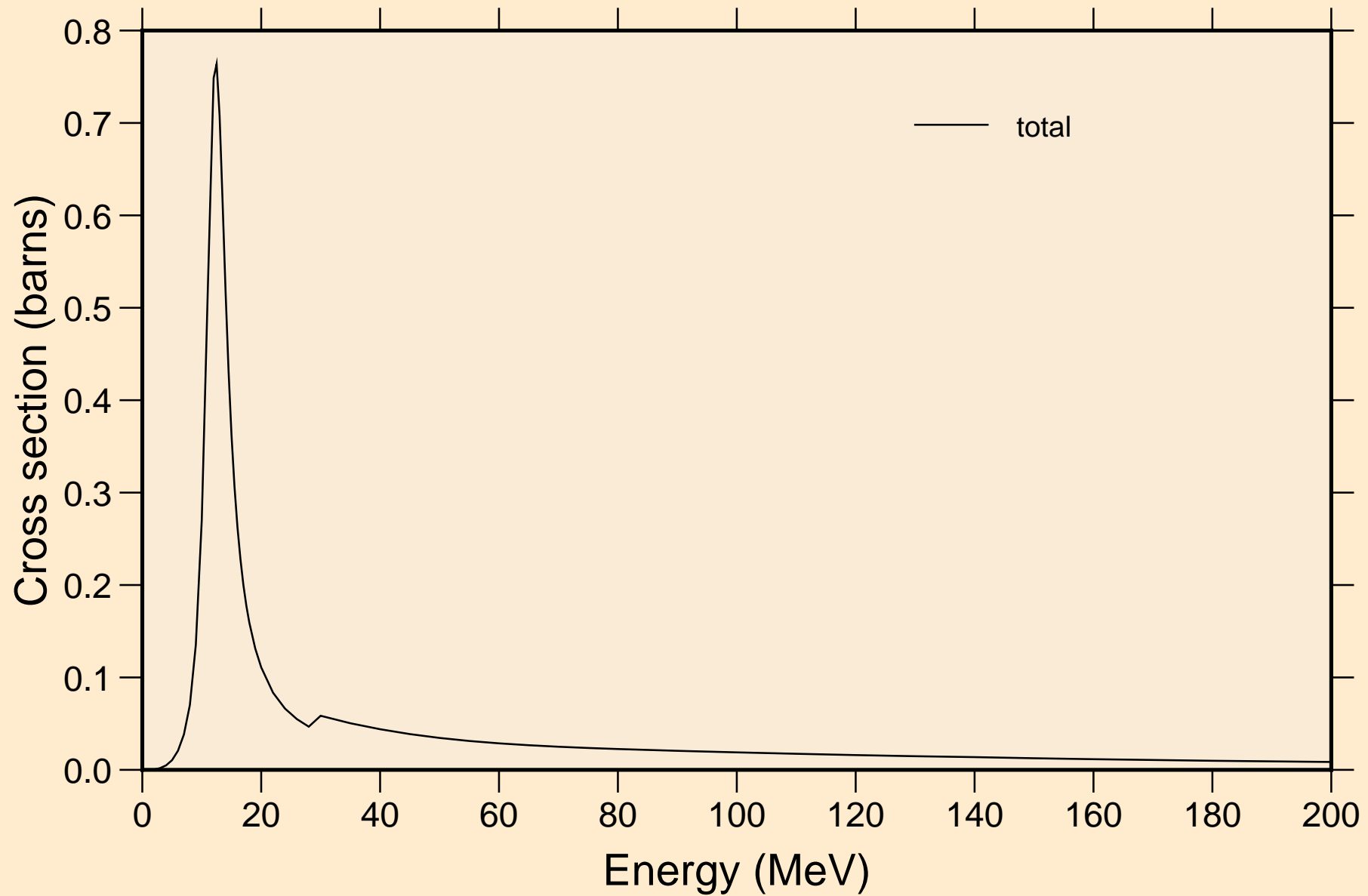

MC291 PHOTON ACER TENDL-2023 LIBRARY; T=0.K

Partial cross sections

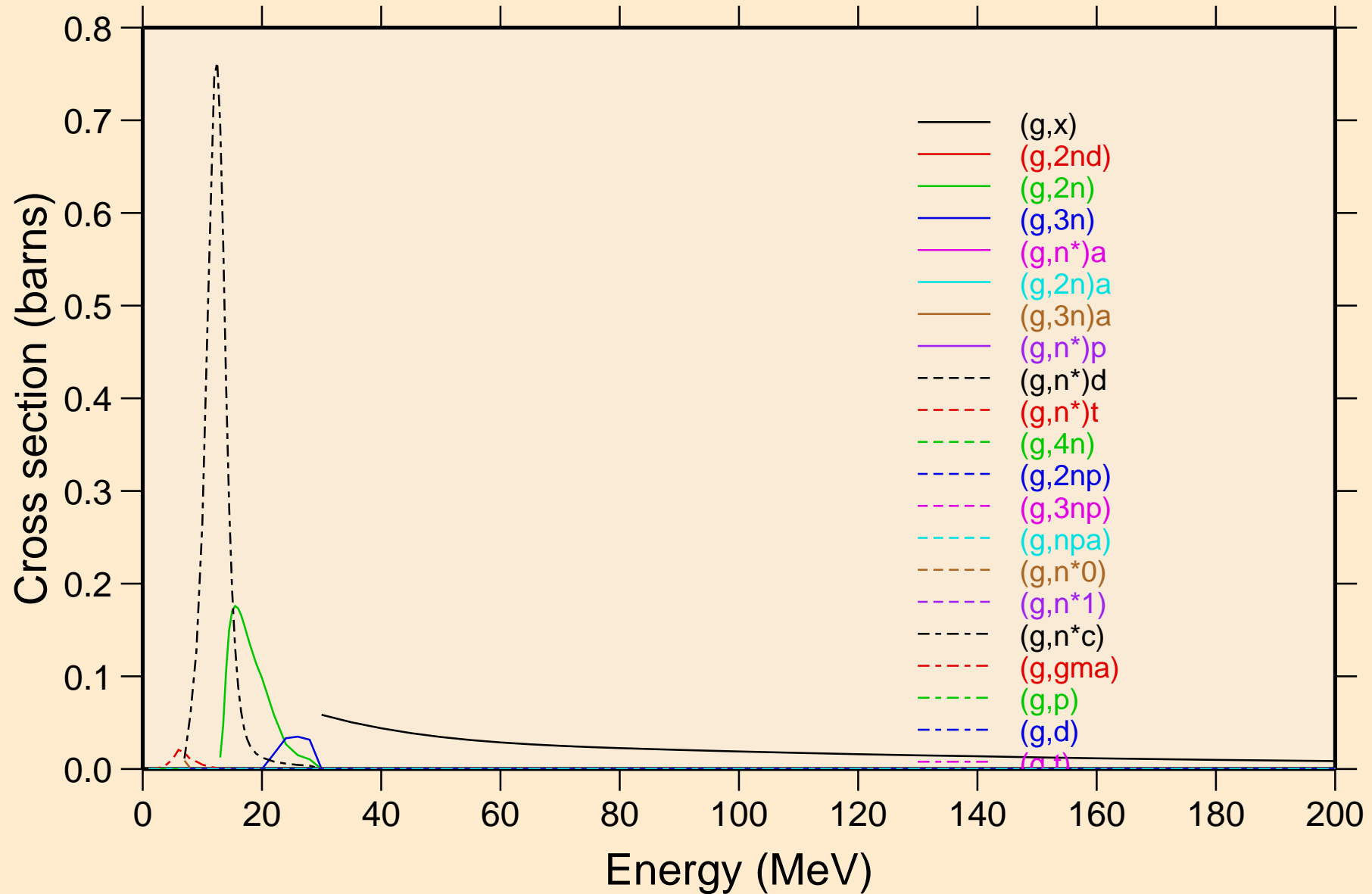

MC291 PHOTON ACER TENDL-2023 LIBRARY; T=0.K

Heating

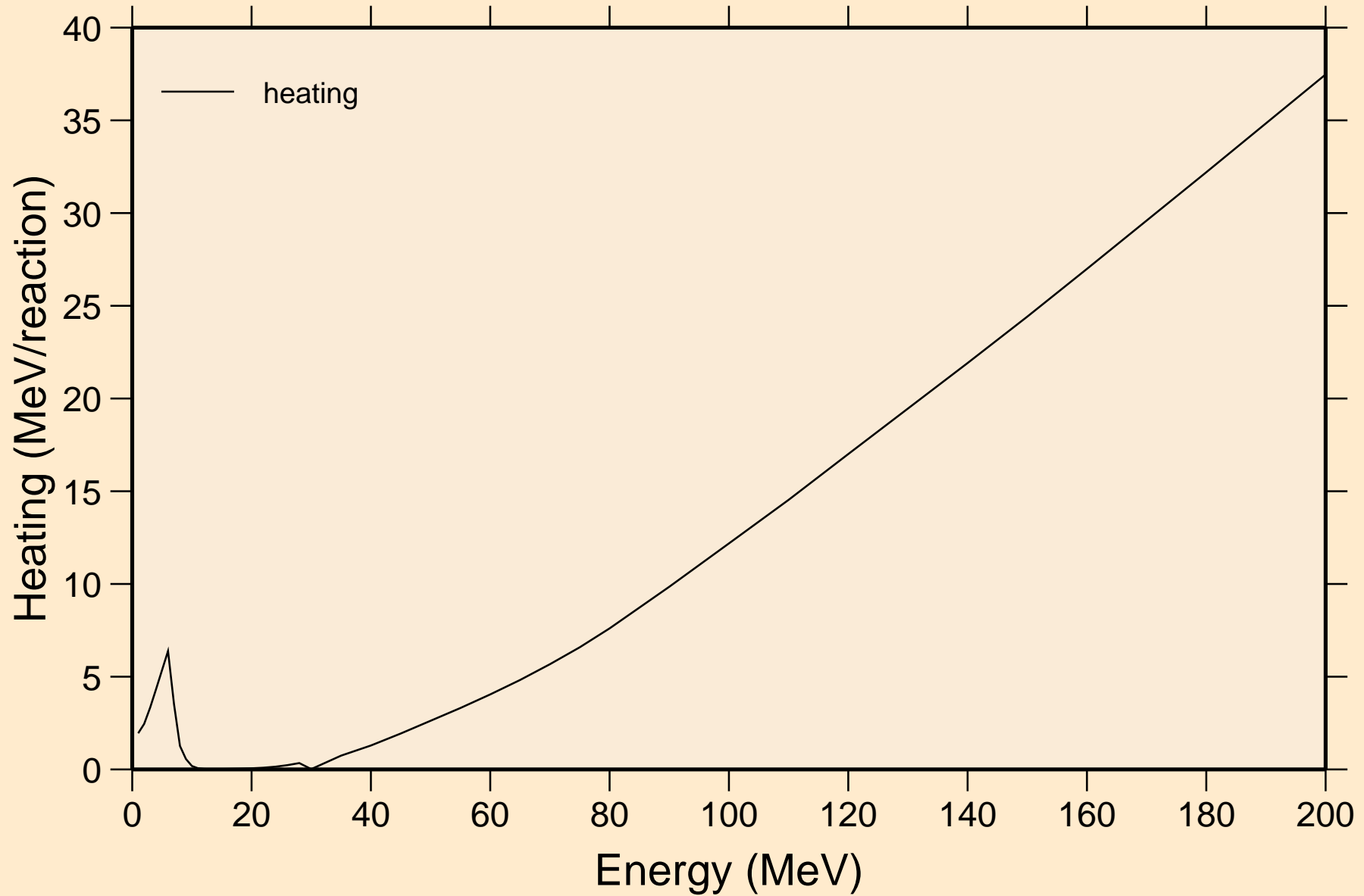

MC291 PHOTON ACER TENDL-2023 LIBRARY; T=0.K

Particle heating contributions

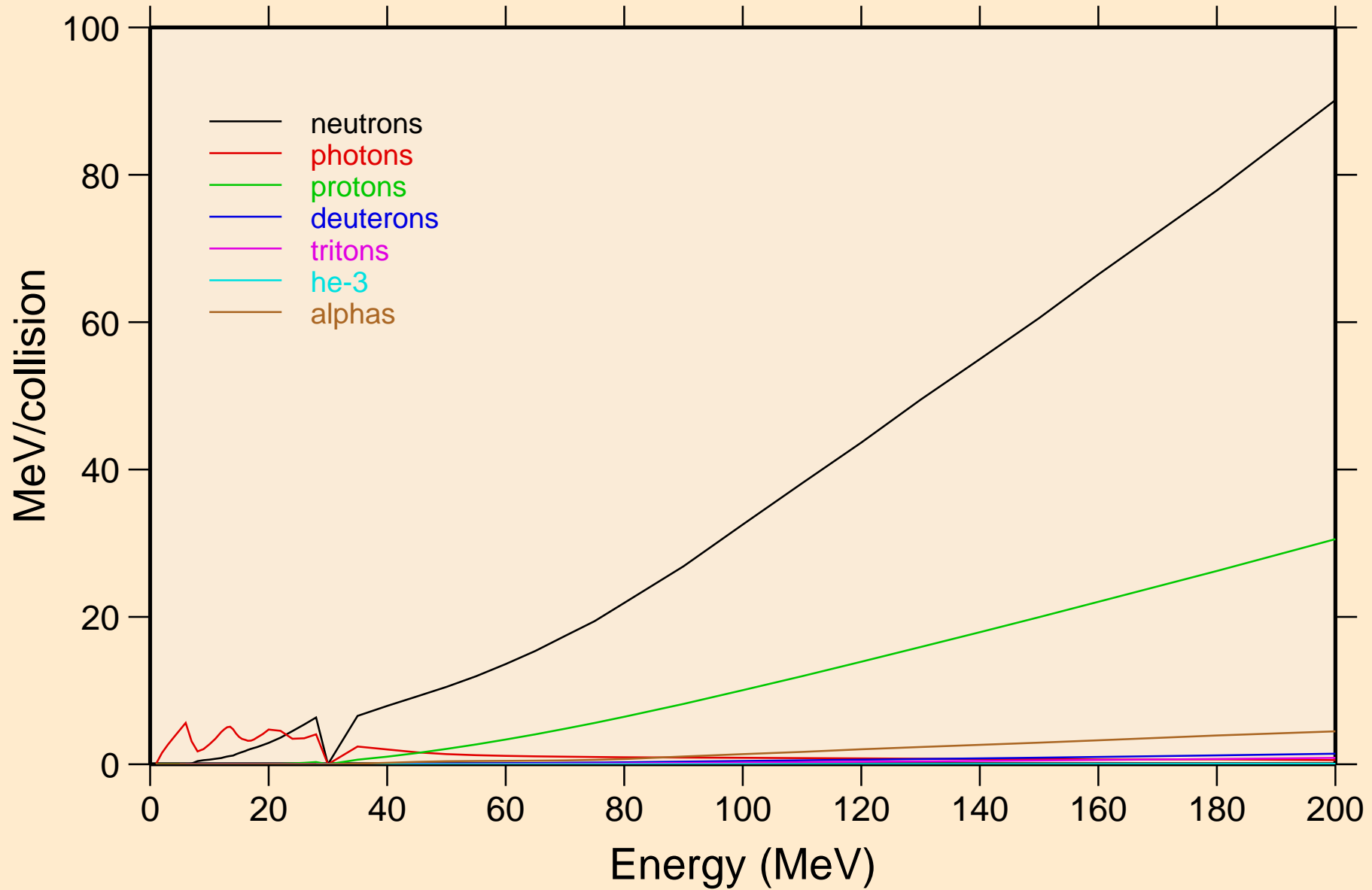

MC291 PHOTON ACER TENDL-2023 LIBRARY; T=0.K
Particle production cross sections

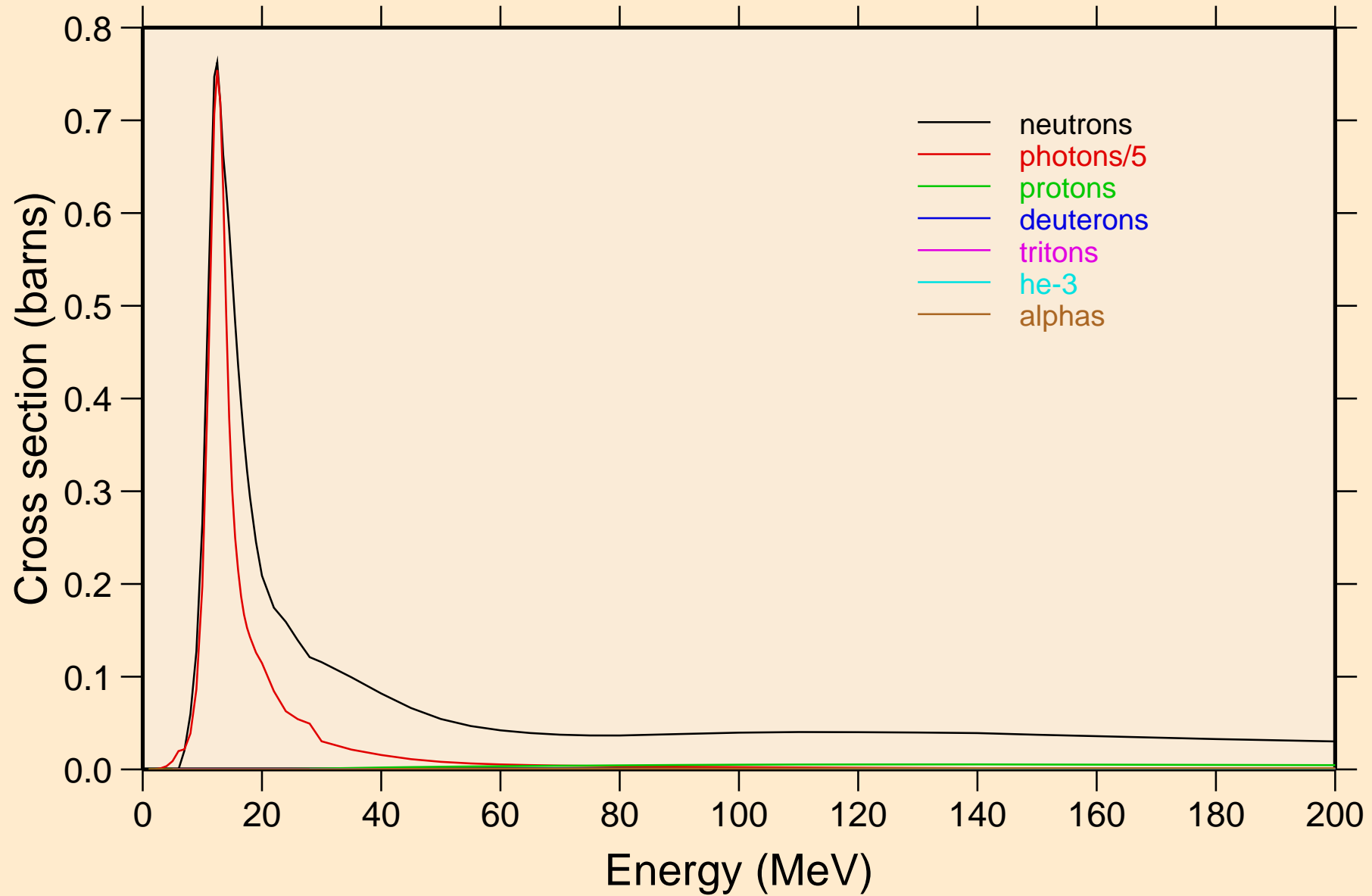

MC291 PHOTON ACER TENDL-2023 LIBRARY; T=0.K
neutrons from (g,x)

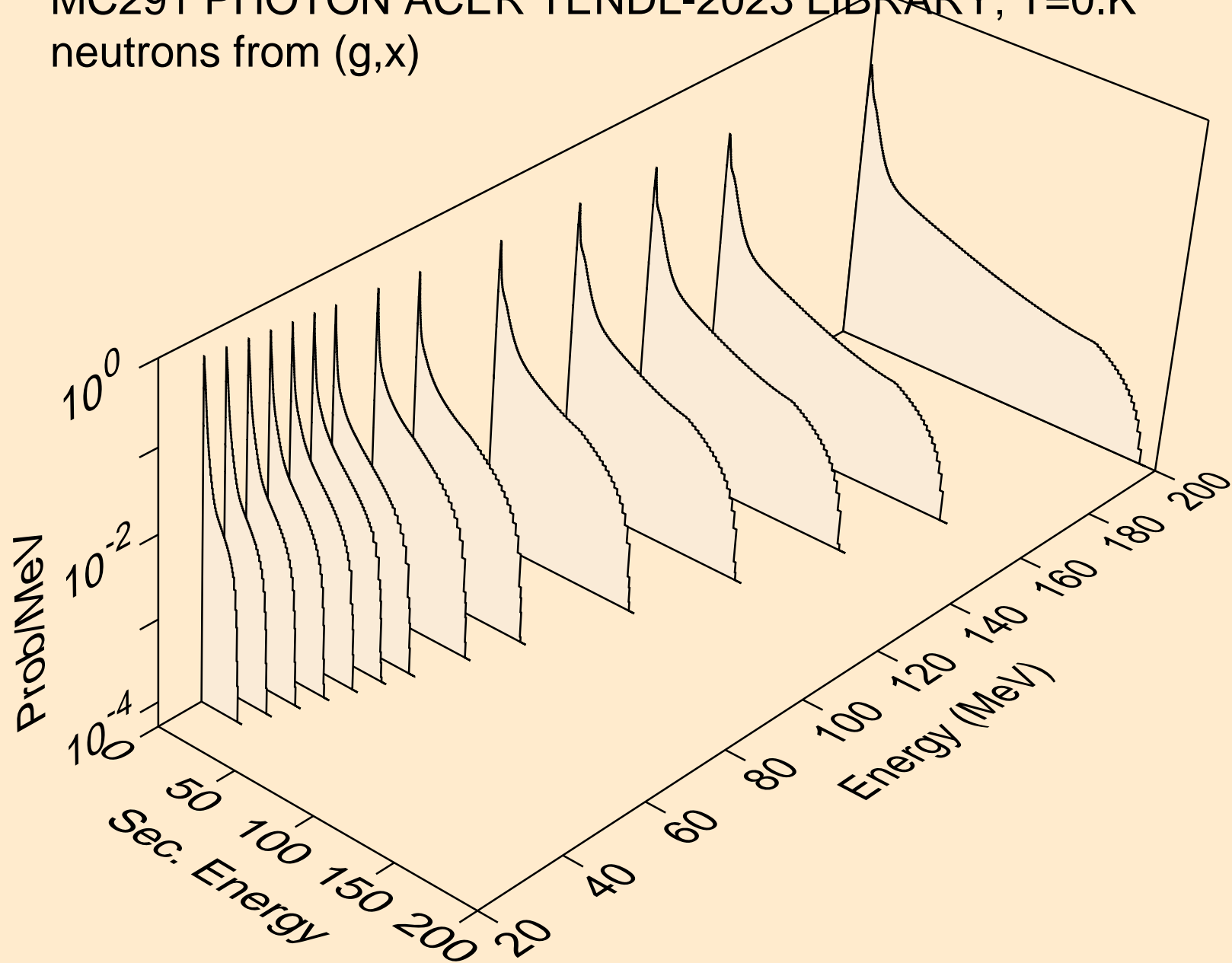

MC291 PHOTON ACER TENDL-2023 LIBRARY; T=0.K
neutrons from (g,2nd)

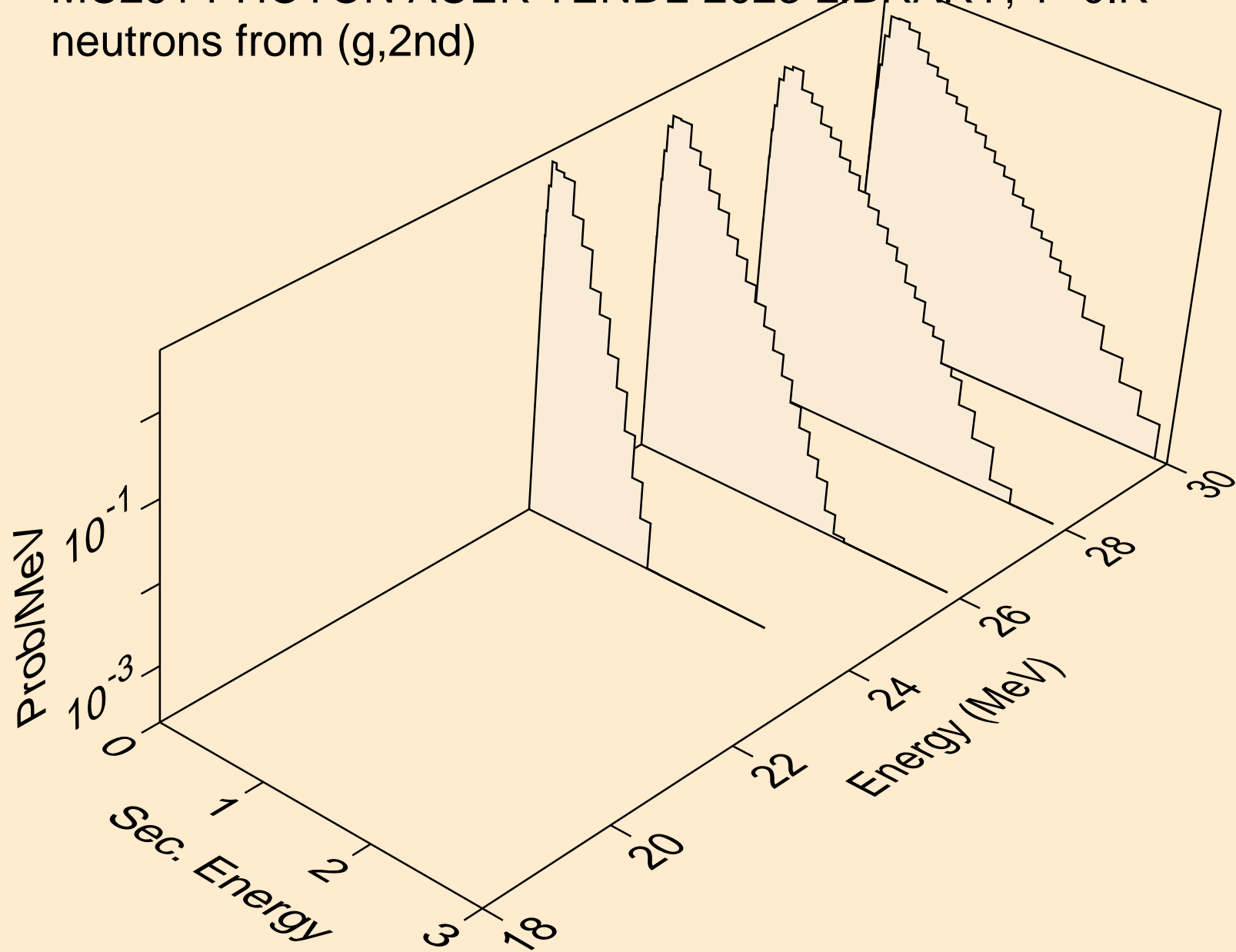

MC291 PHOTON ACER TENDL-2023 LIBRARY; T=0.K
neutrons from (g,2n)

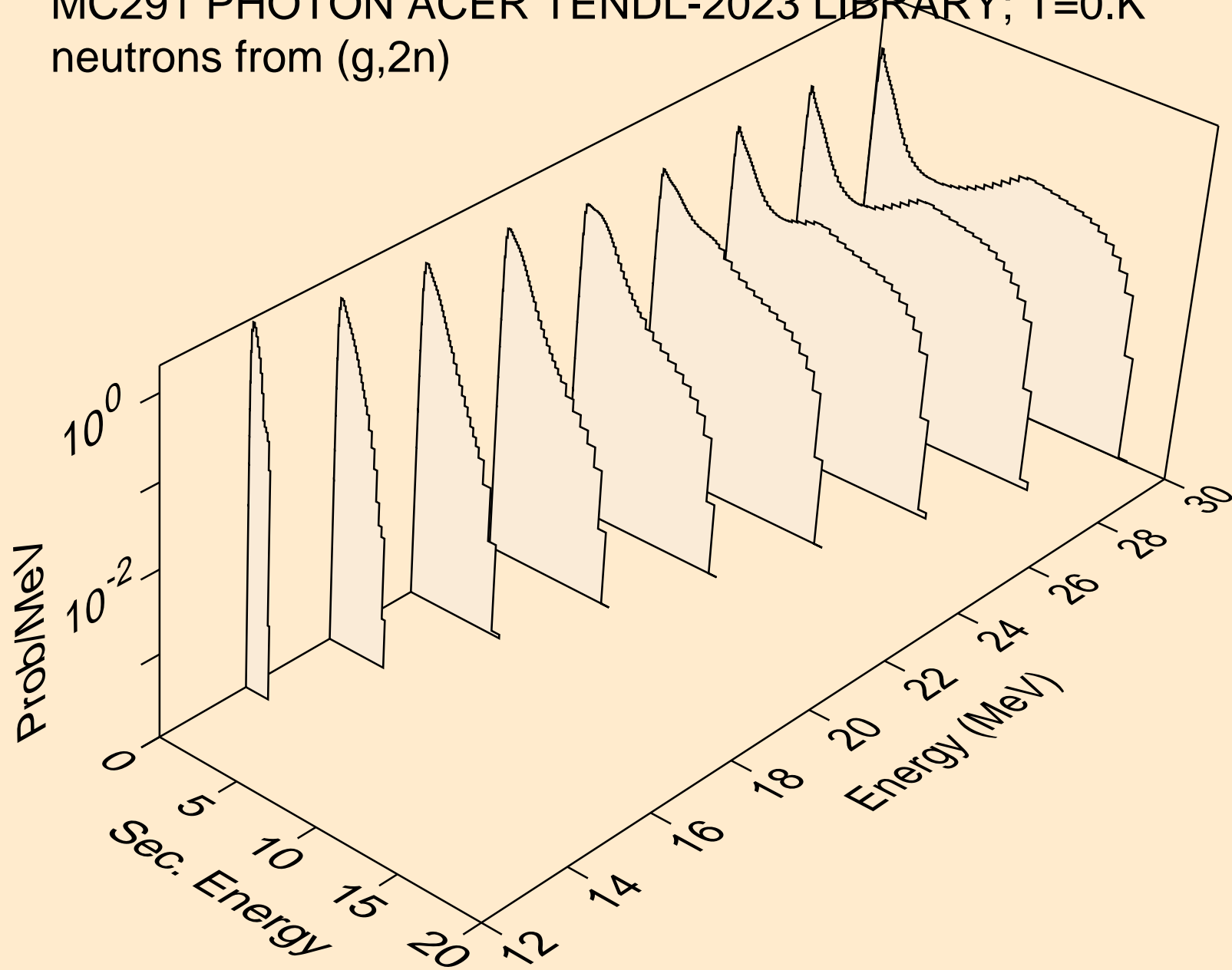

MC291 PHOTON ACER TENDL-2023 LIBRARY; T=0.K
neutrons from (g,3n)

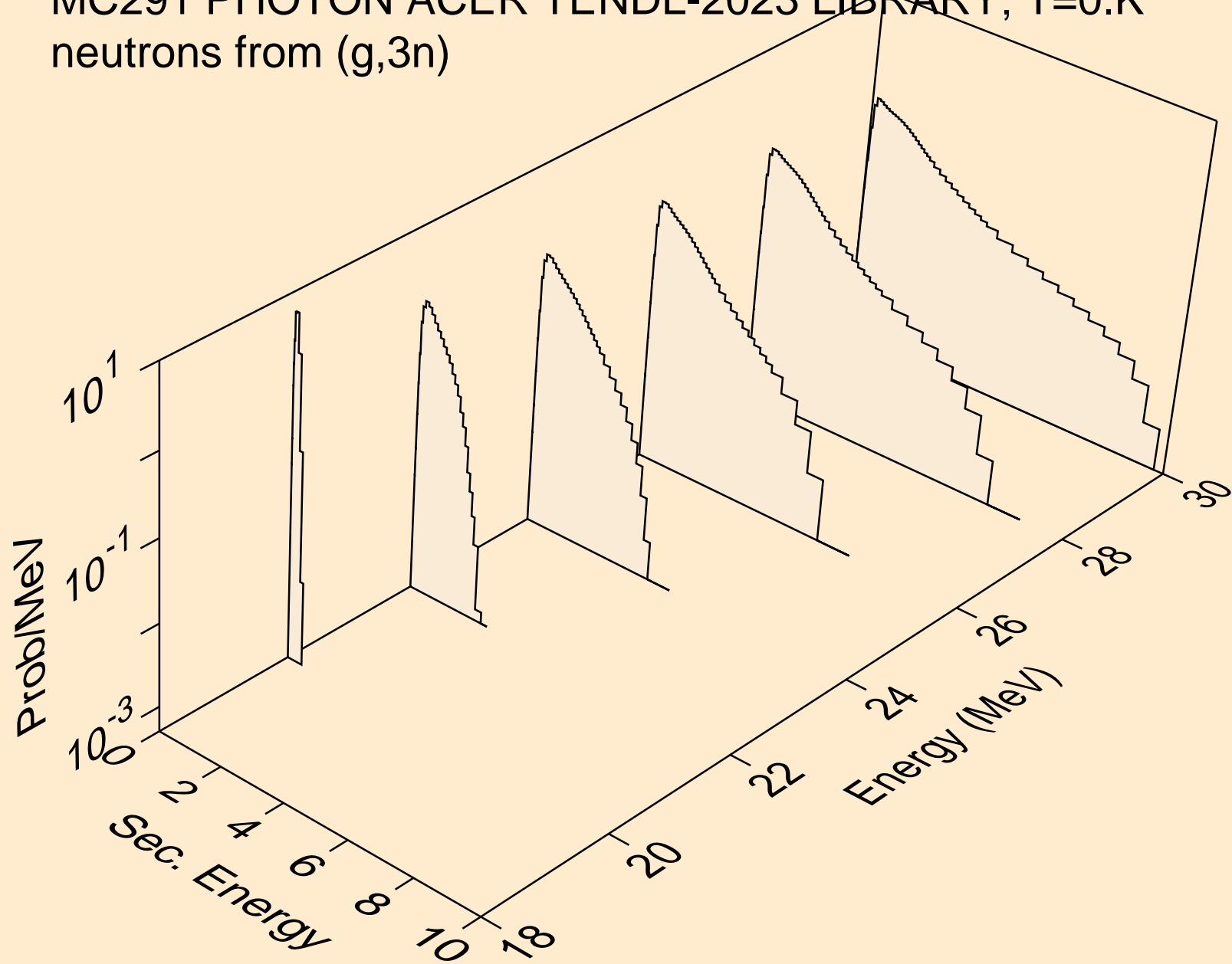

MC291 PHOTON ACER TENDL-2023 LIBRARY; T=0.K
neutrons from (g,n*)a

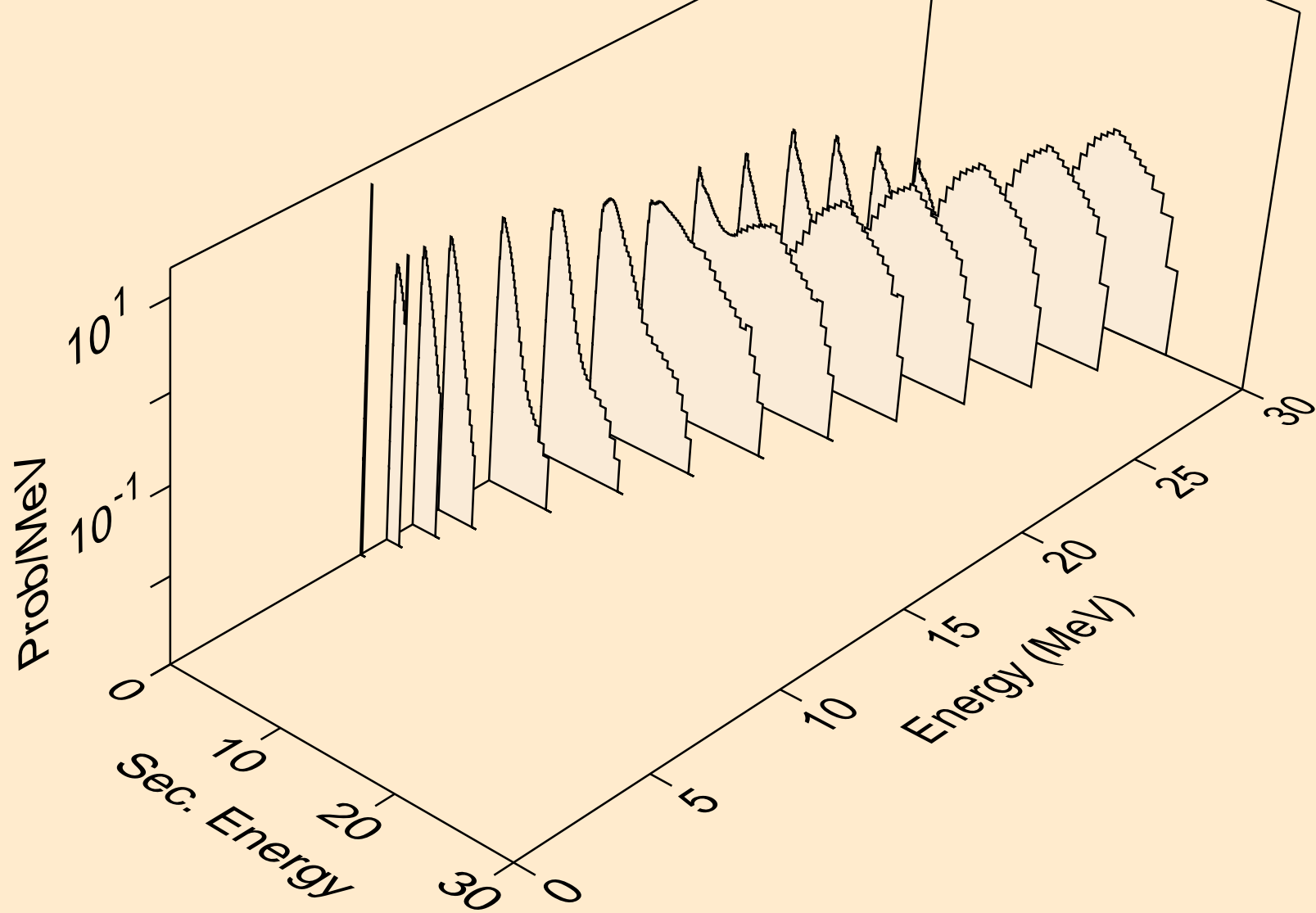

MC291 PHOTON ACER TENDL-2023 LIBRARY; T=0.K
neutrons from (g,2n)a

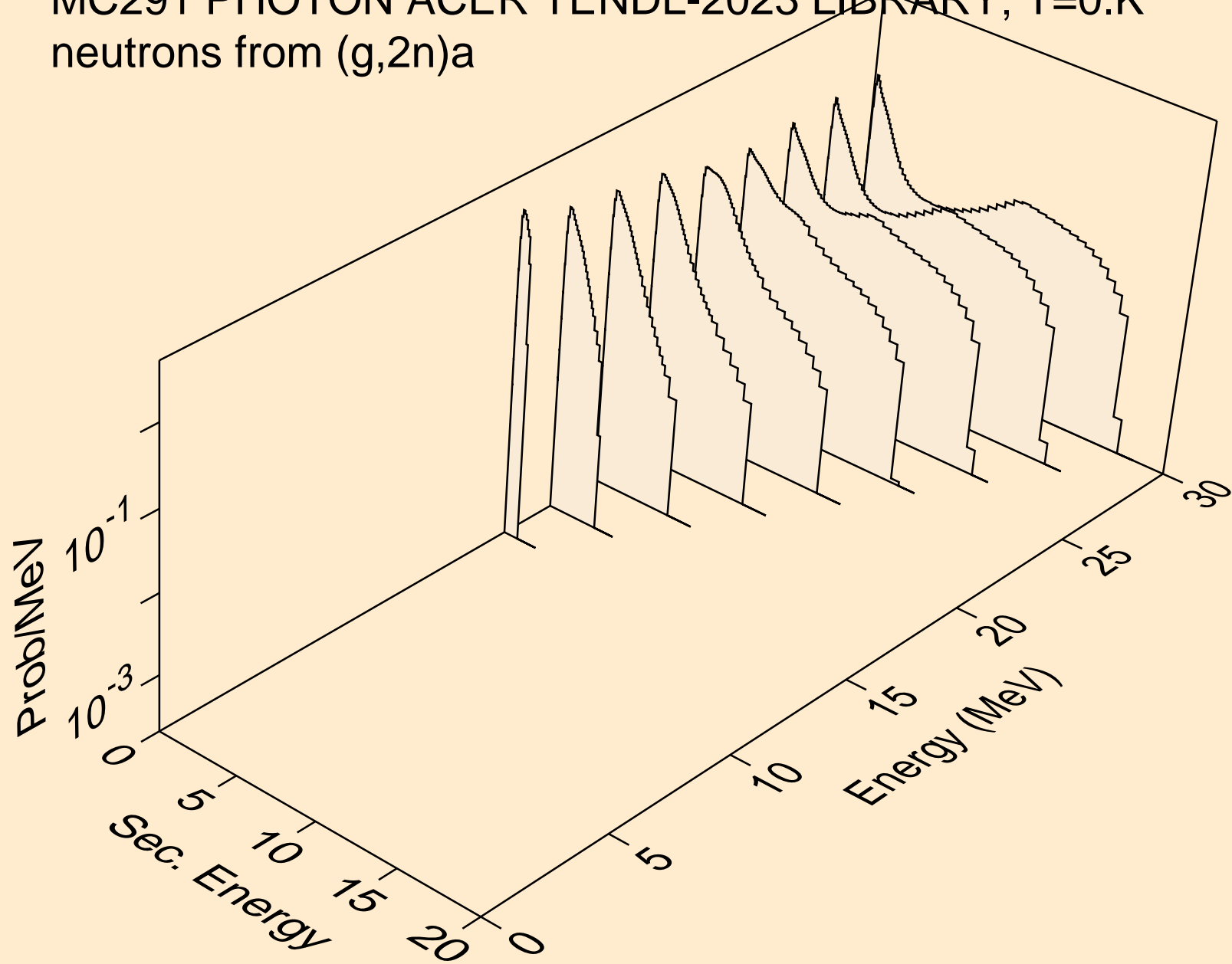

MC291 PHOTON ACER TENDL-2023 LIBRARY; T=0.K
neutrons from (g,3n)a

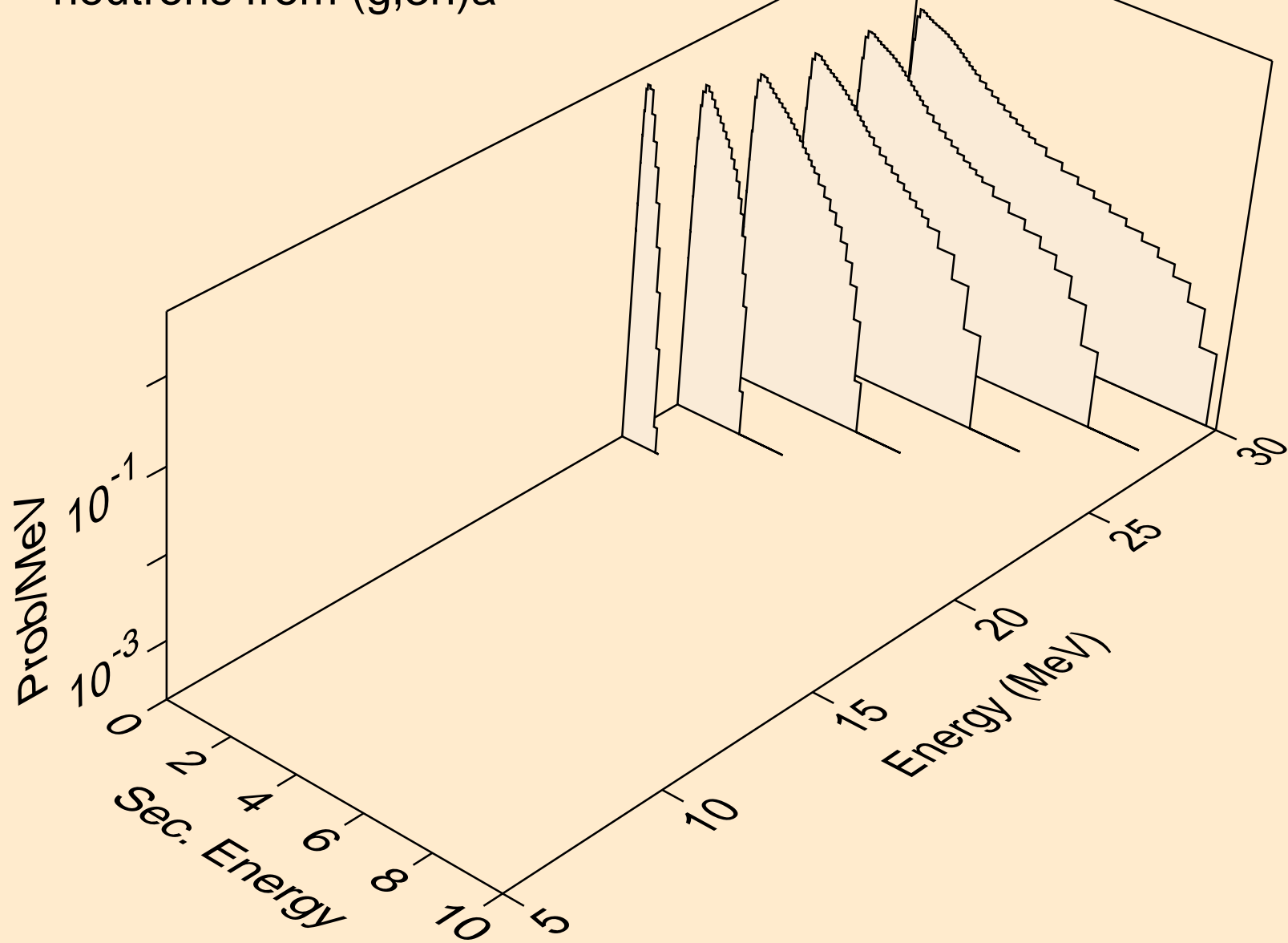

MC291 PHOTON ACER TENDL-2023 LIBRARY; T=0.K
neutrons from (g,n*)p

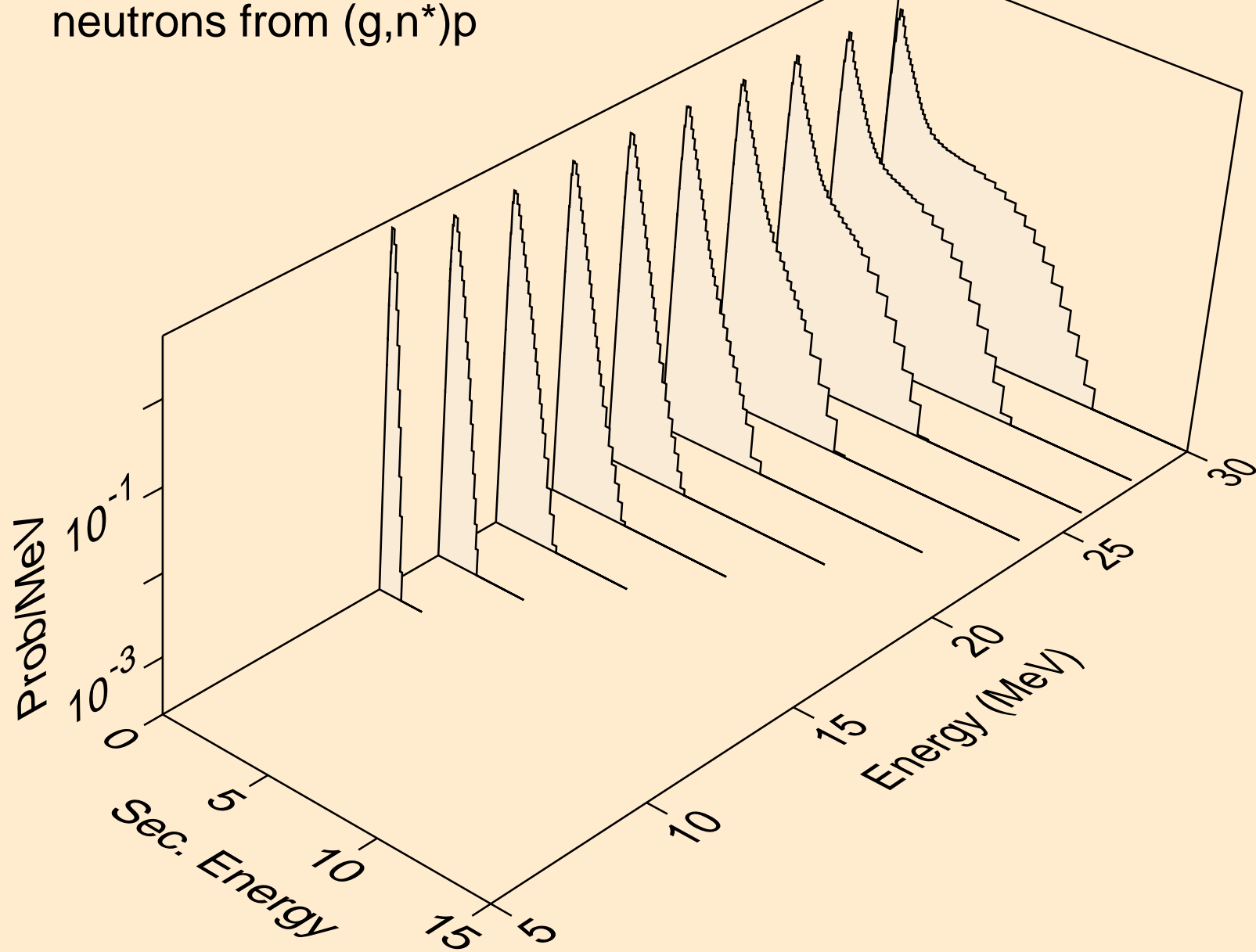

MC291 PHOTON ACER TENDL-2023 LIBRARY; T=0.K
neutrons from (g,n*)d

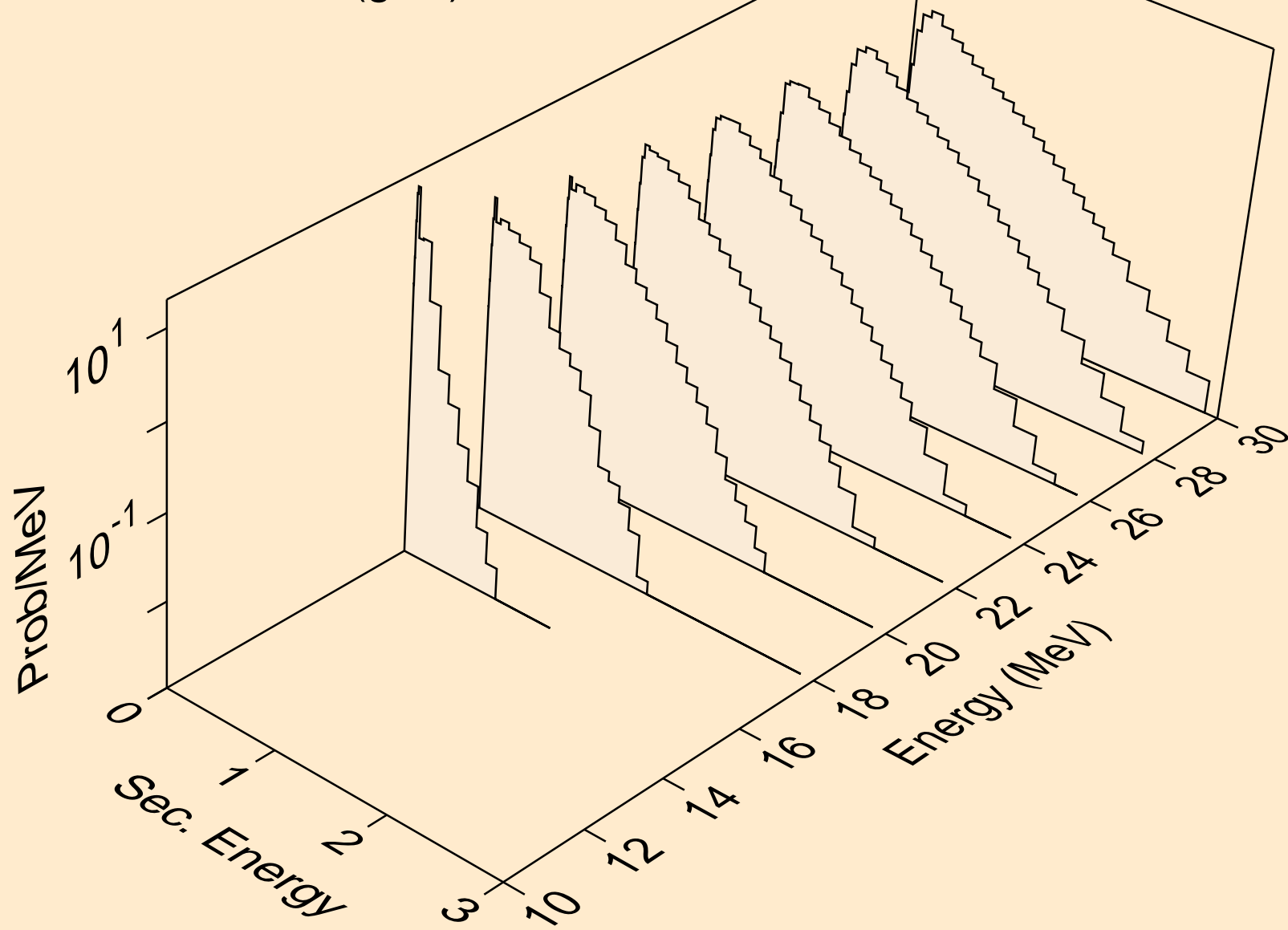

MC291 PHOTON ACER TENDL-2023 LIBRARY; T=0.K
neutrons from (g,n*)t

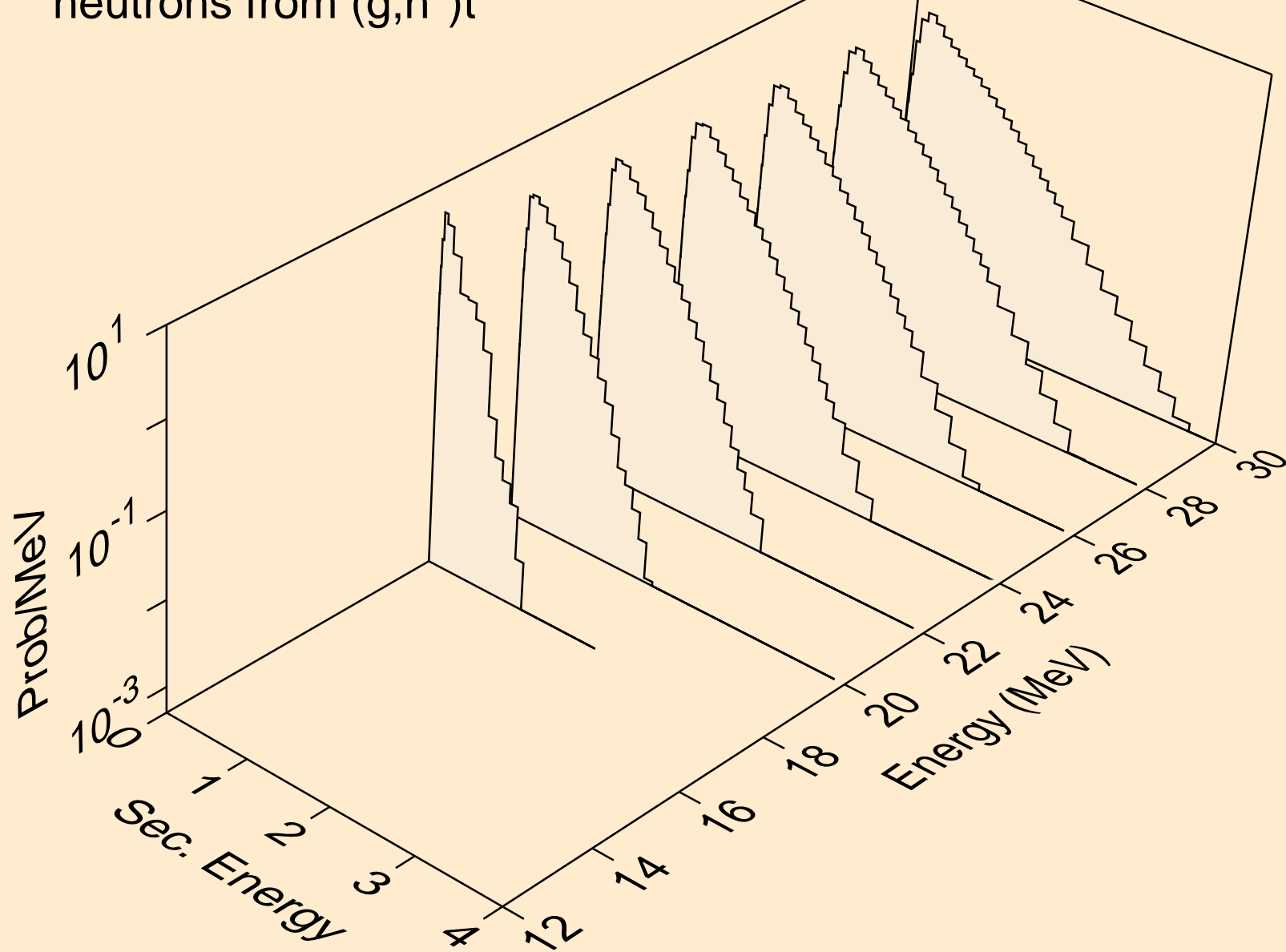

MC291 PHOTON ACER TENDL-2023 LIBRARY; T=0.K
neutrons from (g,4n)

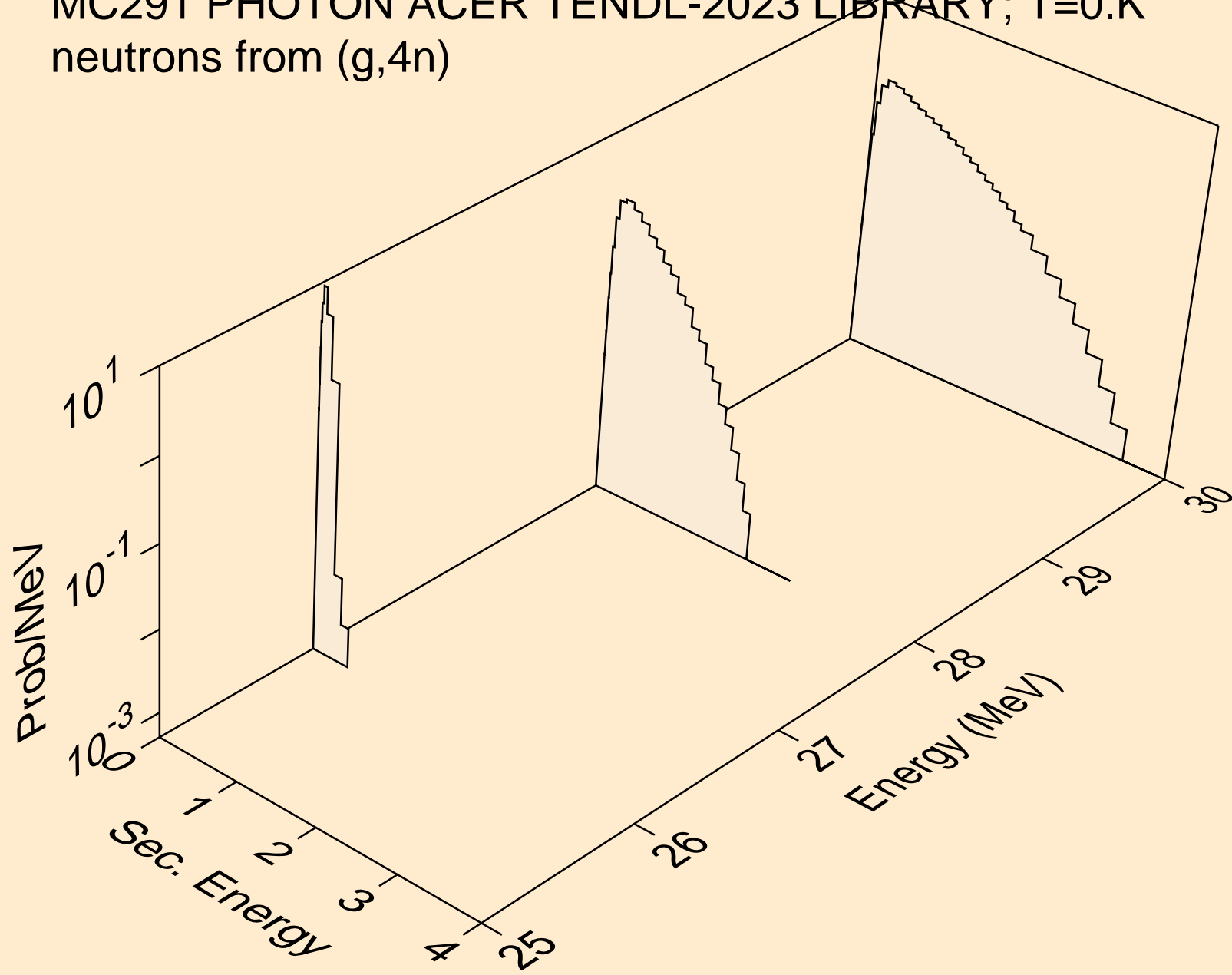

MC291 PHOTON ACER TENDL-2023 LIBRARY; T=0.K
neutrons from (g,2np)

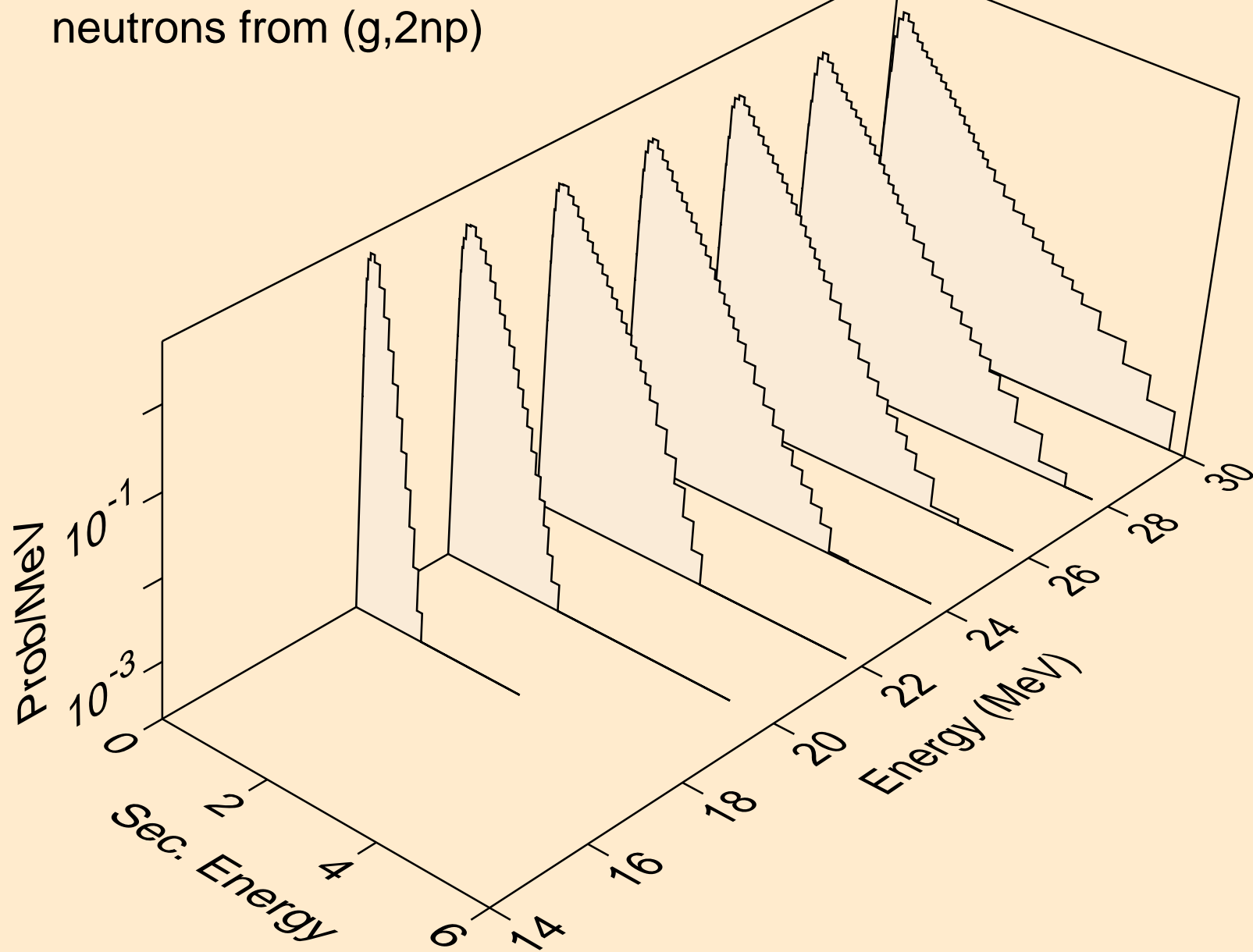

MC291 PHOTON ACER TENDL-2023 LIBRARY; T=0.K
neutrons from (g,3np)

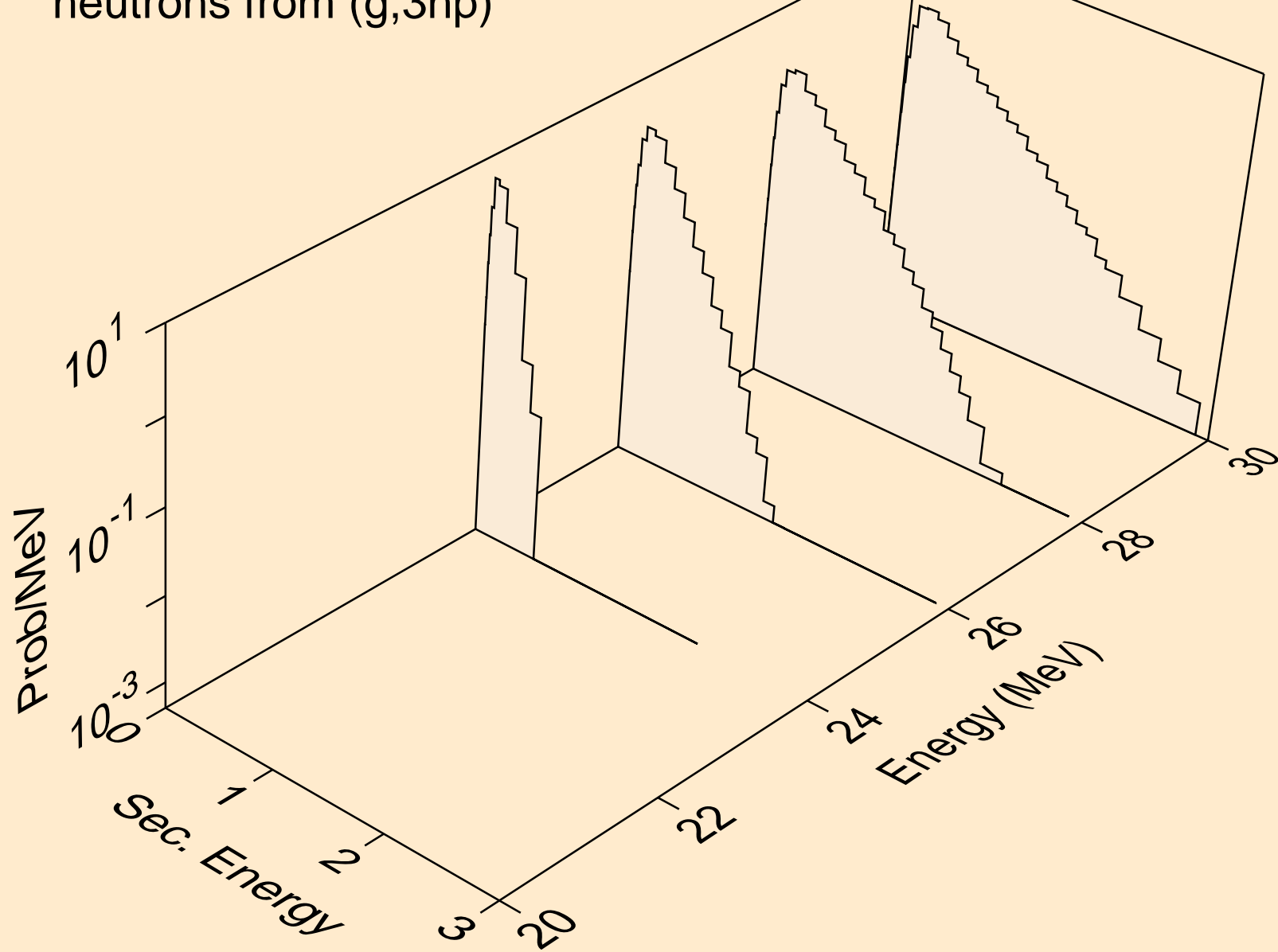

MC291 PHOTON ACER TENDL-2023 LIBRARY; T=0.K
neutrons from (g,npa)

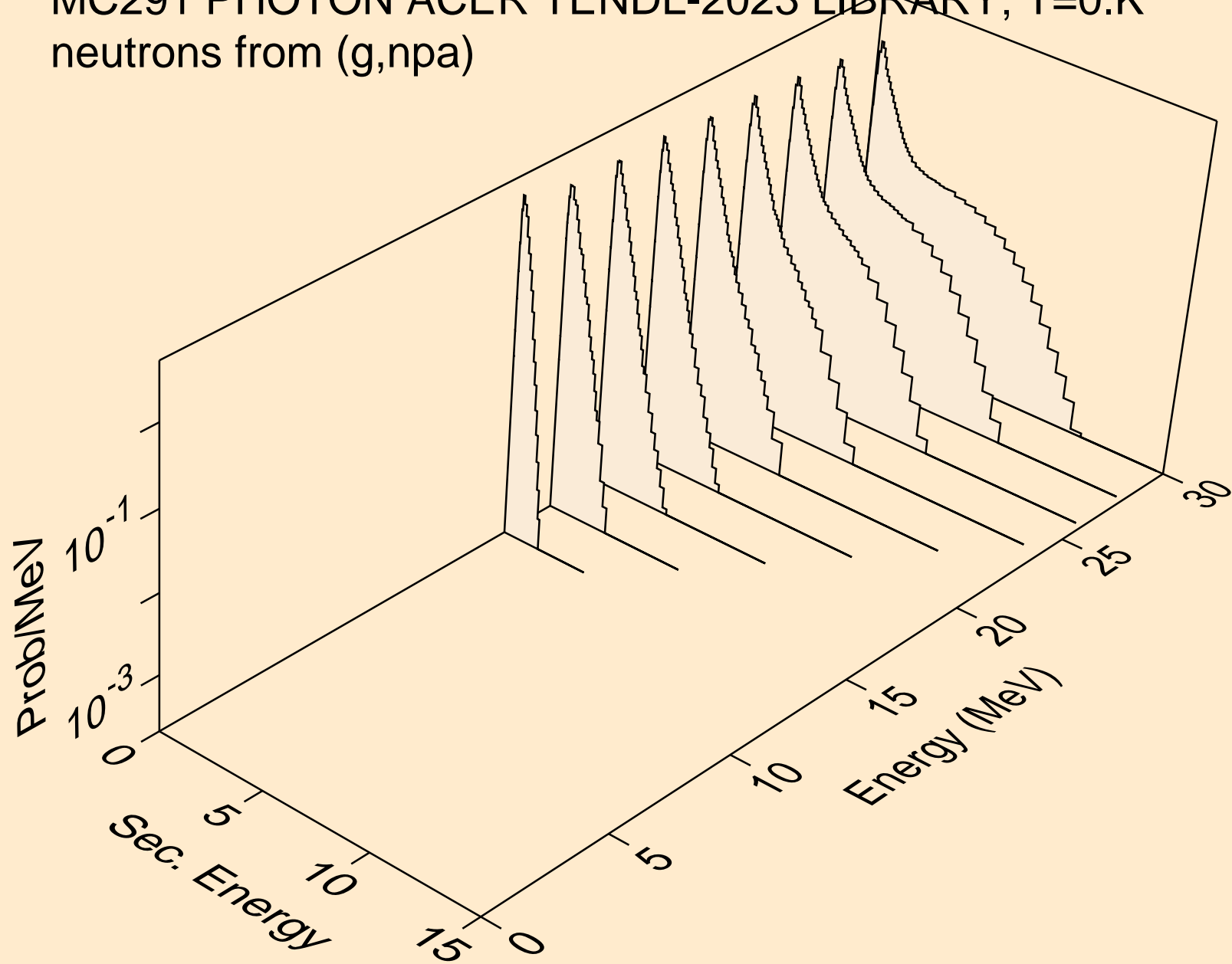

MC291 PHOTON ACER TENDL-2023 LIBRARY; T=0.K
angular distribution for (g,n*0) neutron

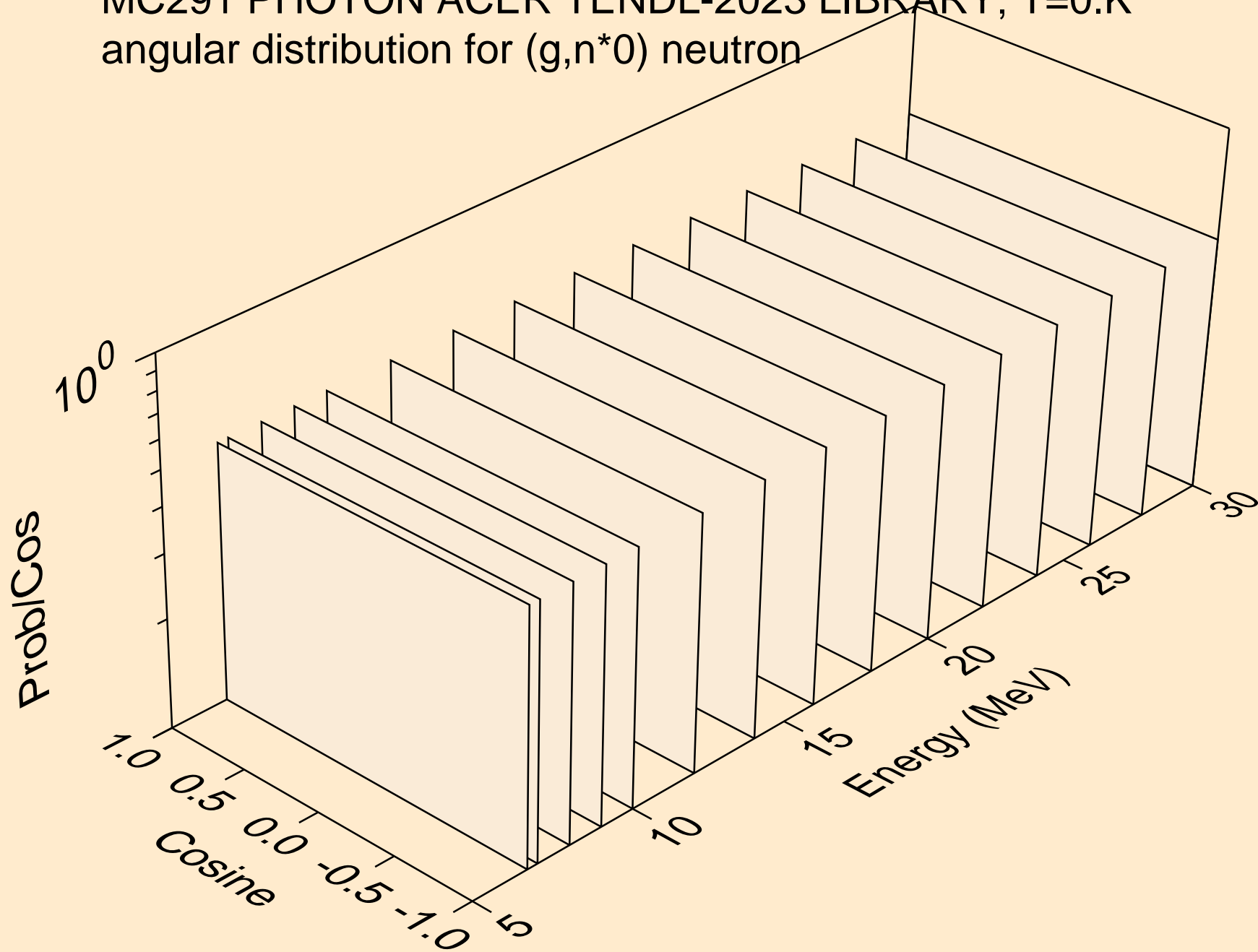

MC291 PHOTON ACER TENDL-2023 LIBRARY; T=0.K
angular distribution for (g,n*1) neutron

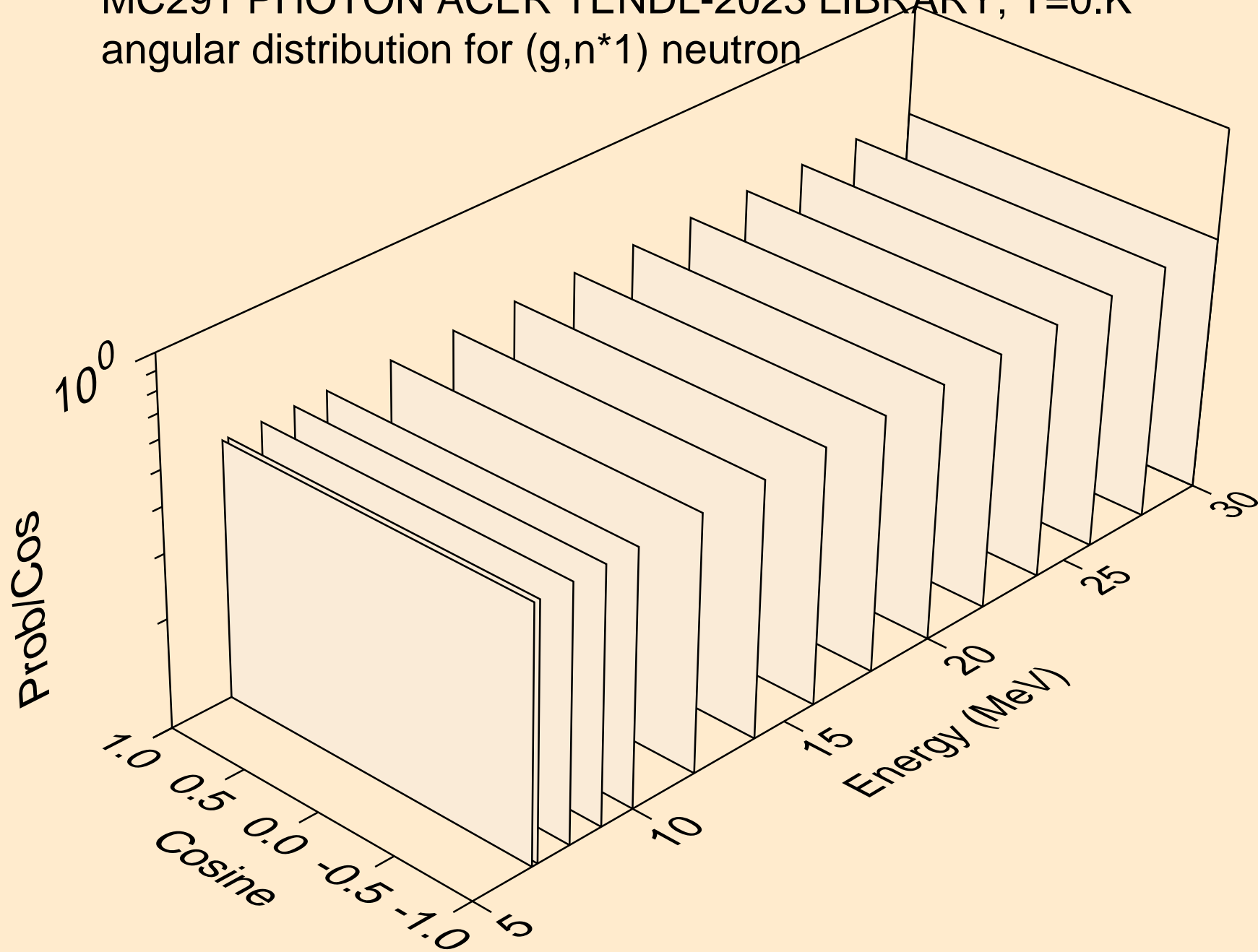

MC291 PHOTON ACER TENDL-2023 LIBRARY; T=0.K
neutrons from (g,n*c)

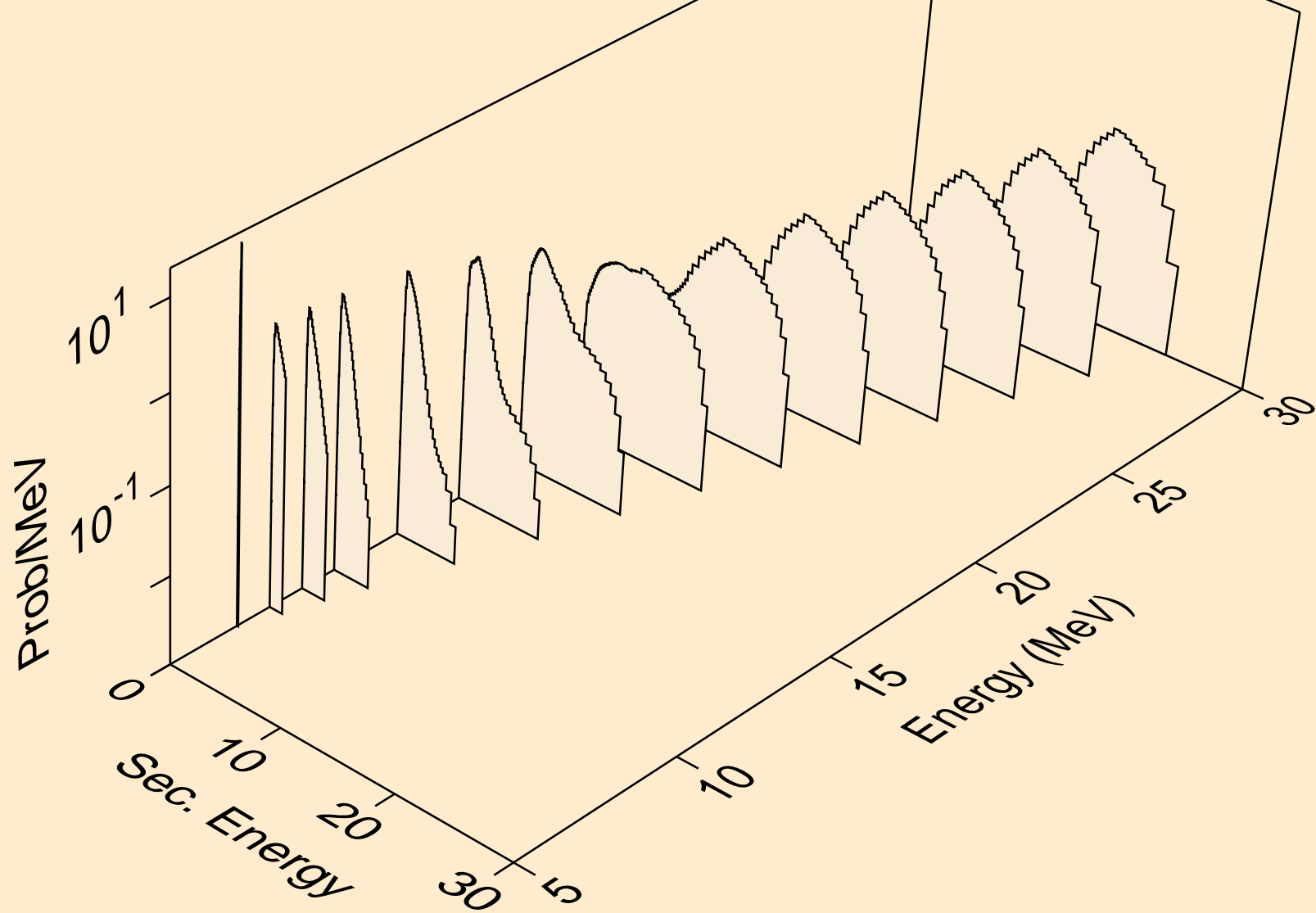

MC291 PHOTON ACER TENDL-2023 LIBRARY; T=0.K
photons from (g,x)

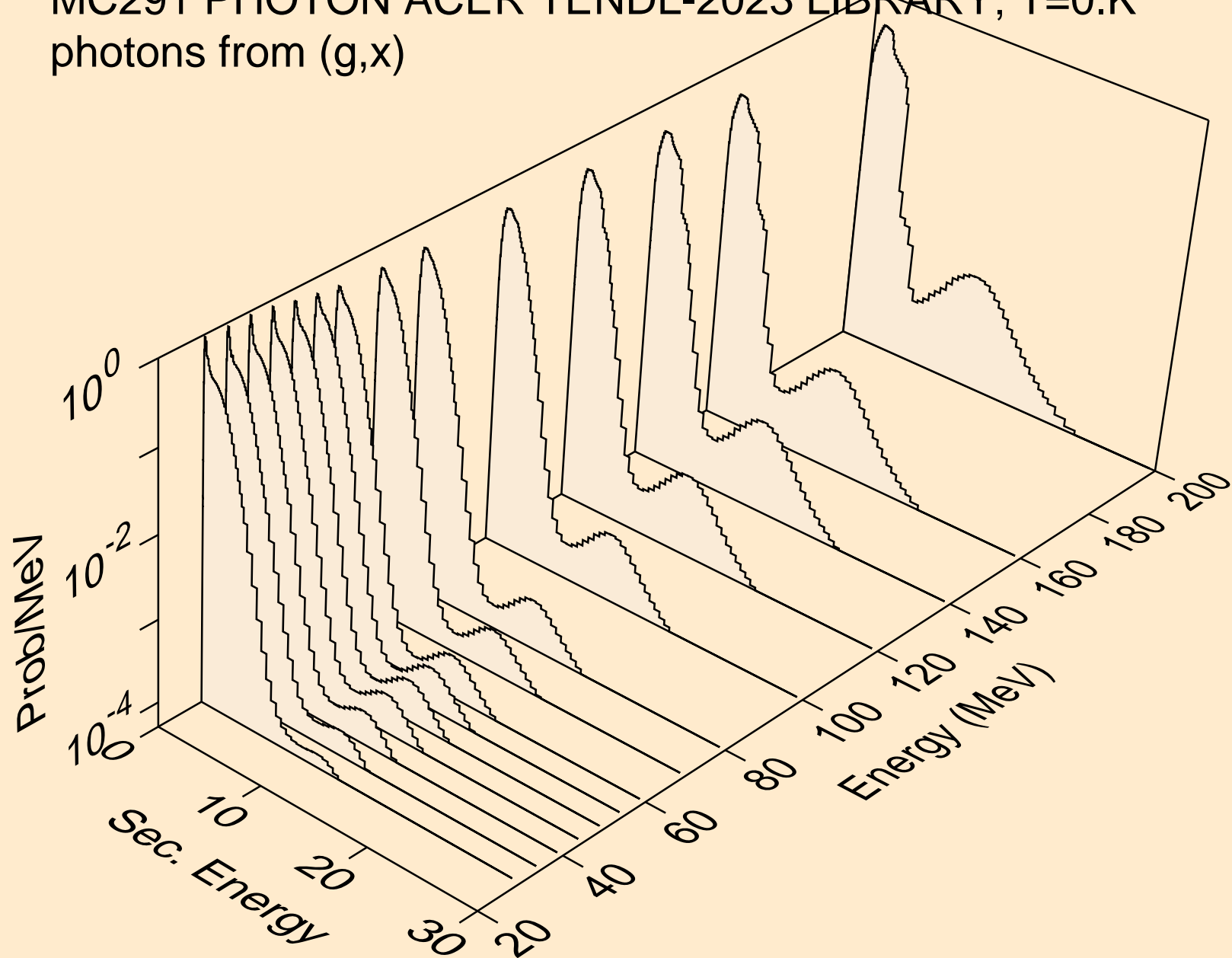

MC291 PHOTON ACER TENDL-2023 LIBRARY; T=0.K
photons from (g,2nd)

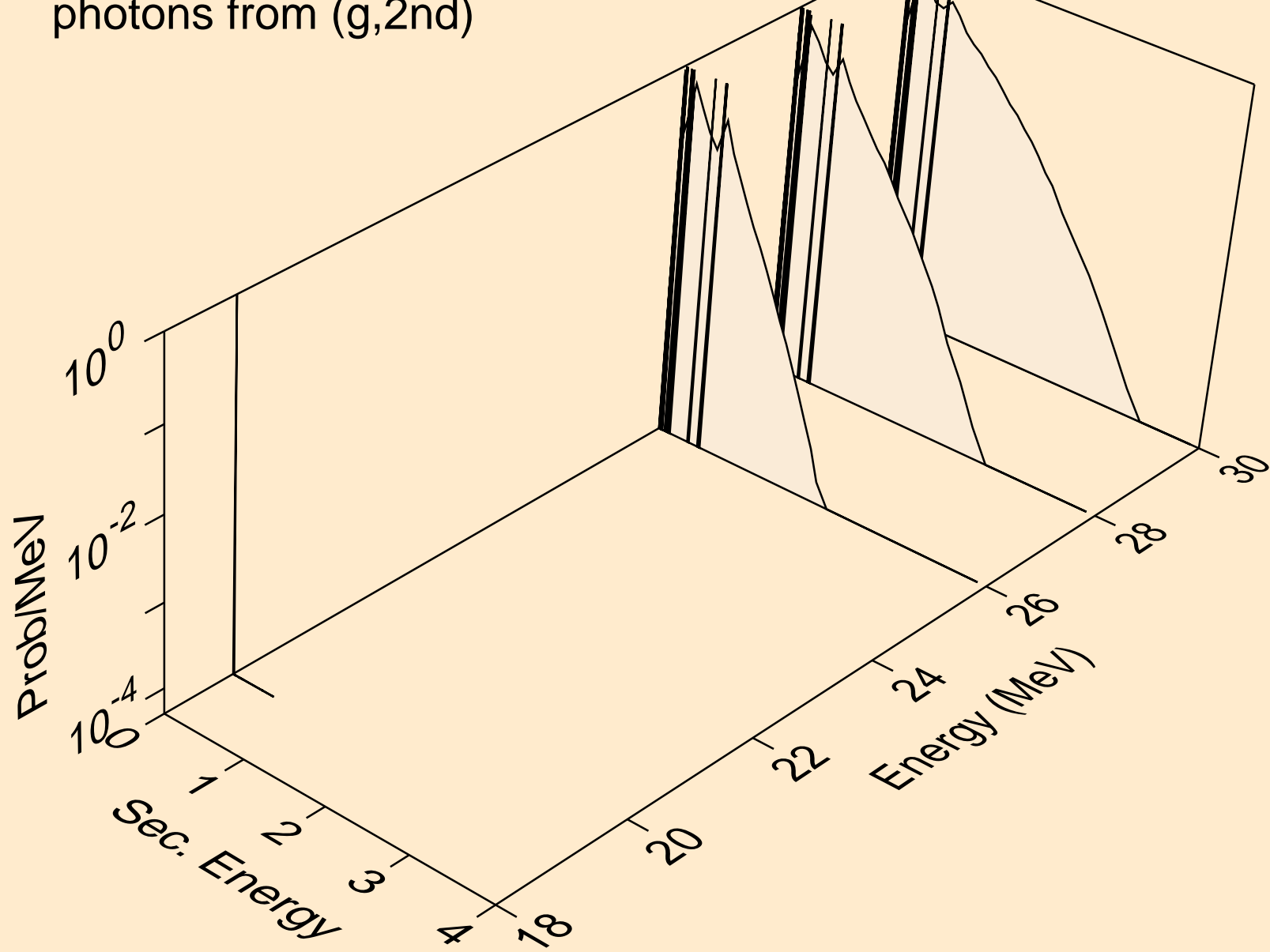

MC291 PHOTON ACER TENDL-2023 LIBRARY; T=0.K
photons from (g,2n)

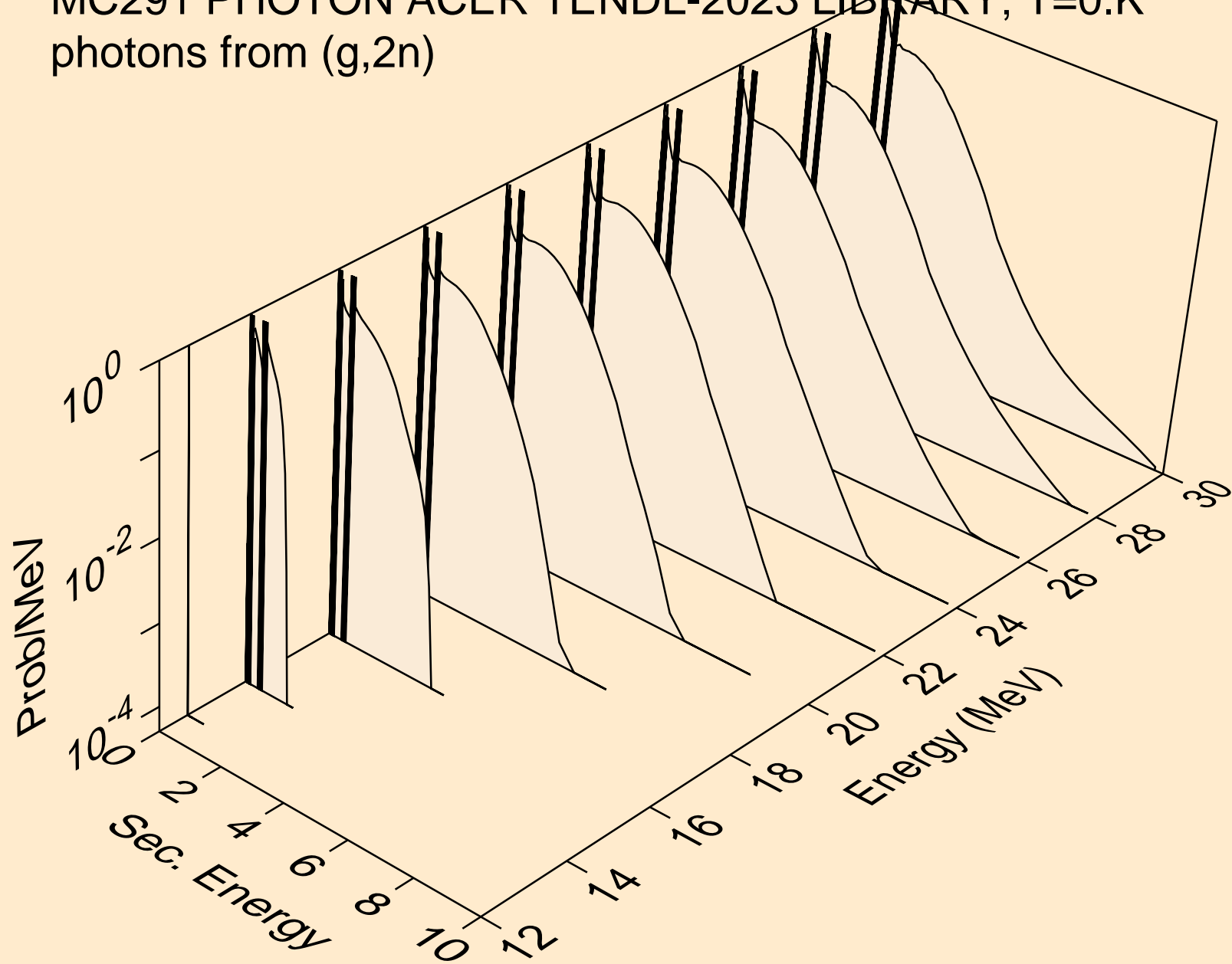

MC291 PHOTON ACER TENDL-2023 LIBRARY; T=0.K
photons from (g,3n)

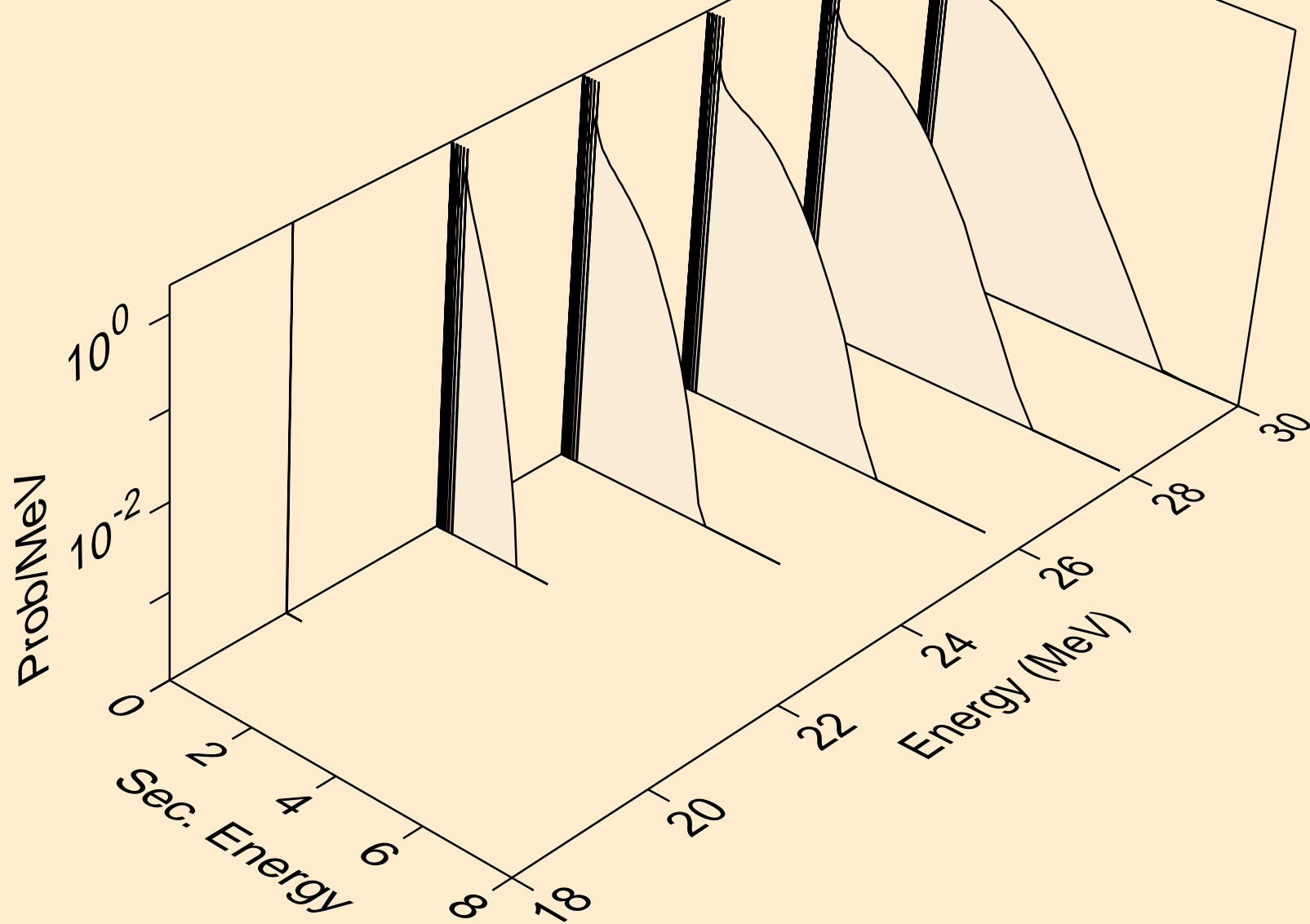

MC291 PHOTON ACER TENDL-2023 LIBRARY; T=0.K
photons from (g,n*)a

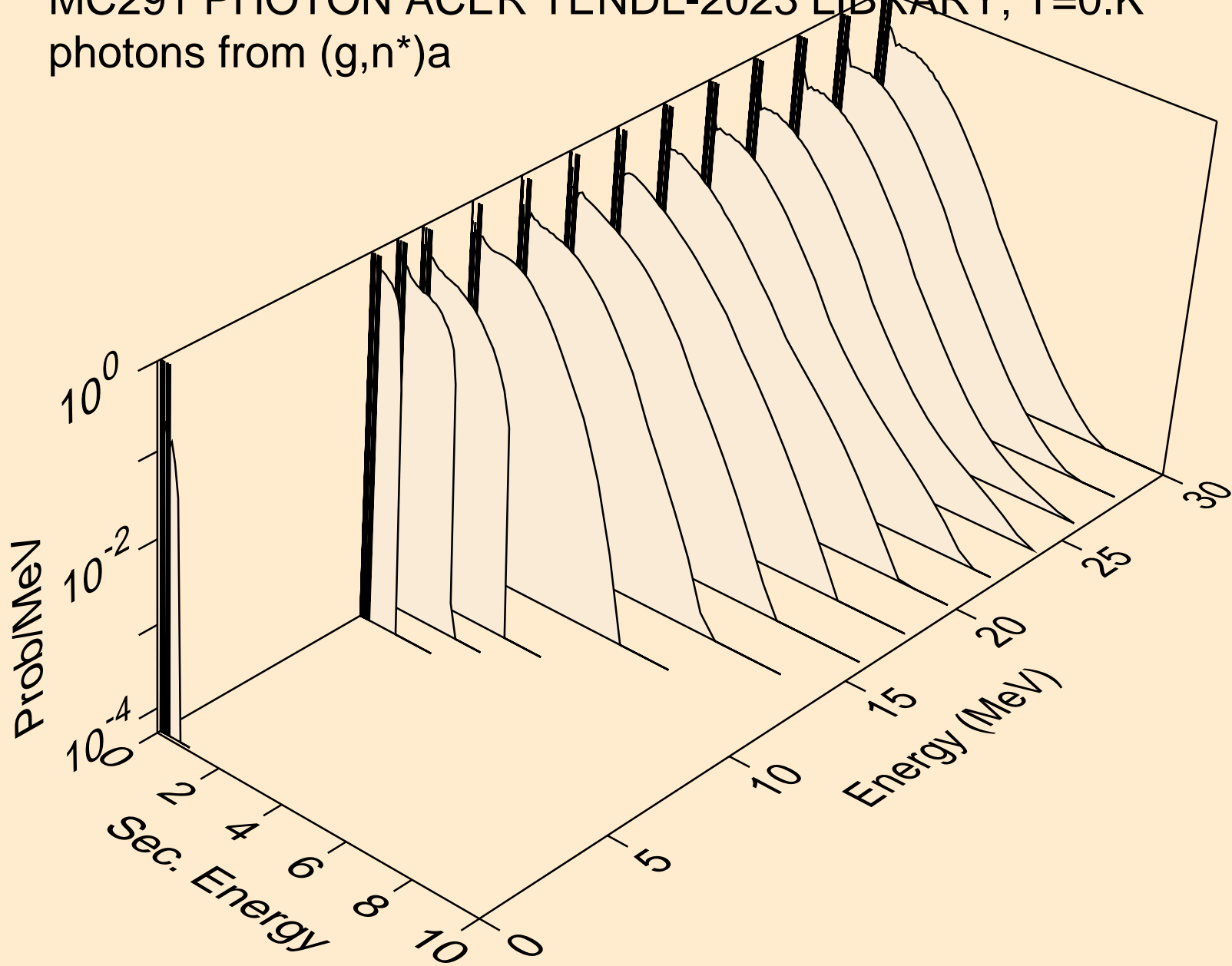

MC291 PHOTON ACER TENDL-2023 LIBRARY; T=0.K
photons from (g,2n)a

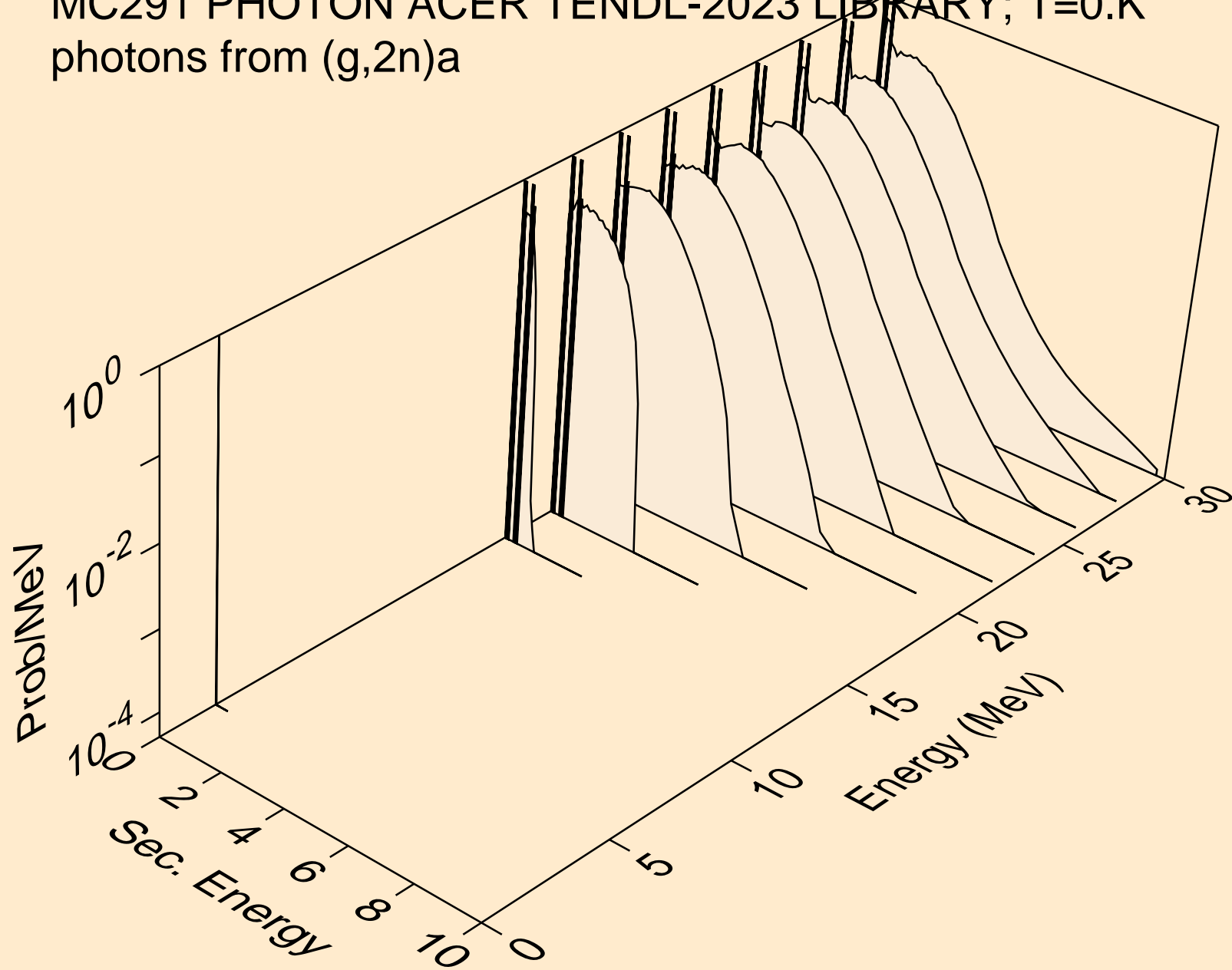

MC291 PHOTON ACER TENDL-2023 LIBRARY; T=0.K
photons from (g,3n)a

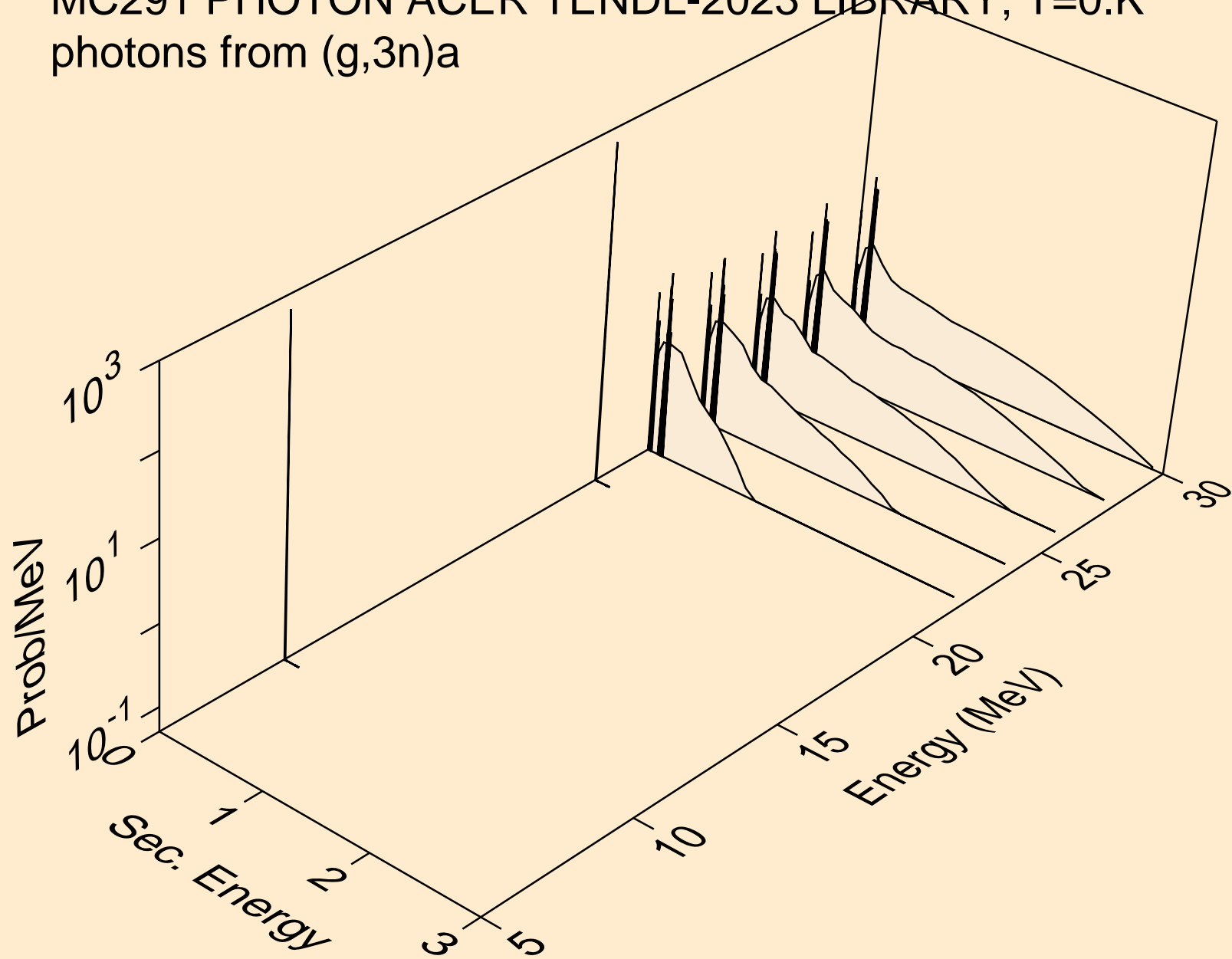

MC291 PHOTON ACER TENDL-2023 LIBRARY; T=0.K
photons from (g,n*)p

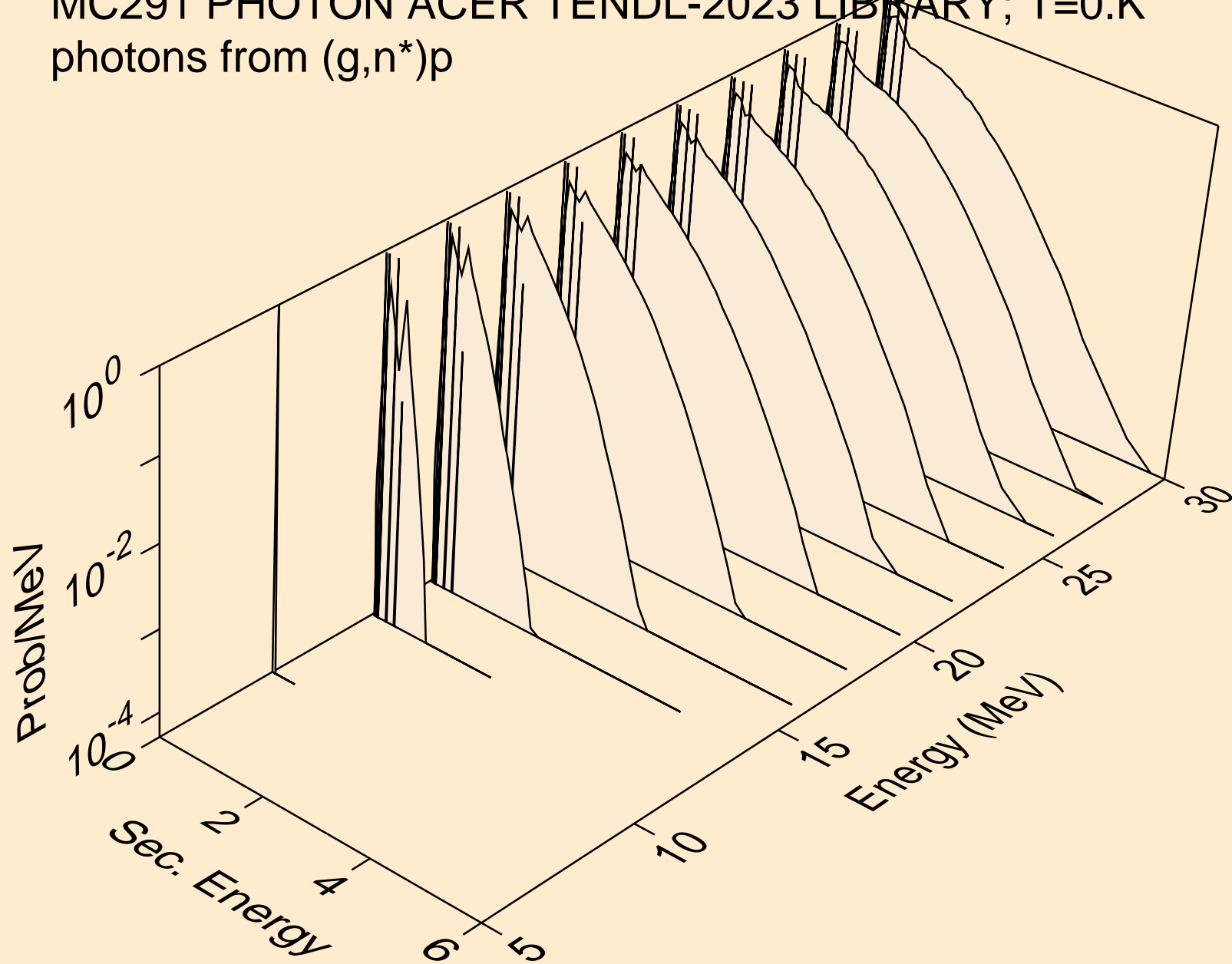

MC291 PHOTON ACER TENDL-2023 LIBRARY; T=0.K
photons from (g,n*)d

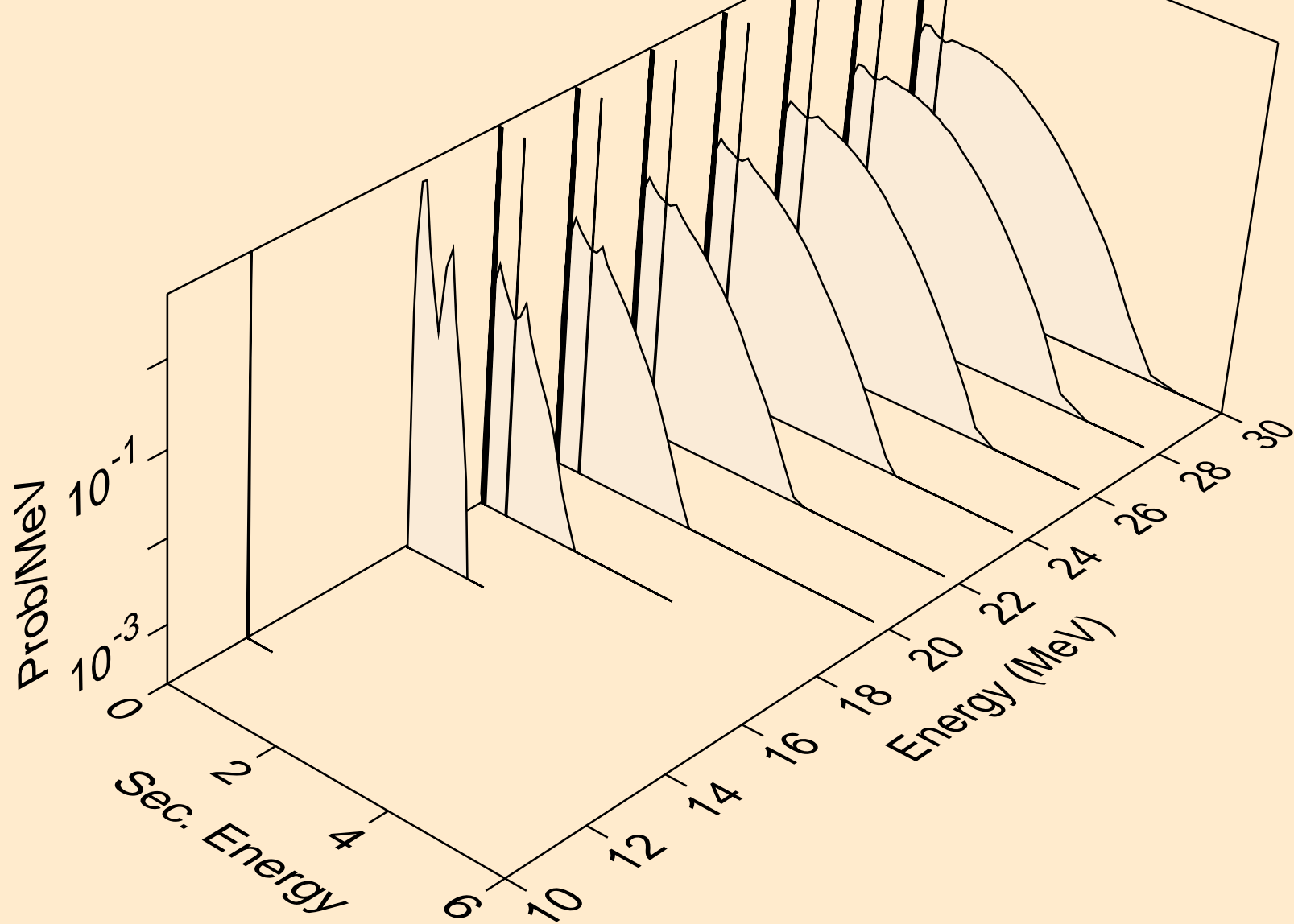

MC291 PHOTON ACER TENDL-2023 LIBRARY; T=0.K
photons from (g,n*)t

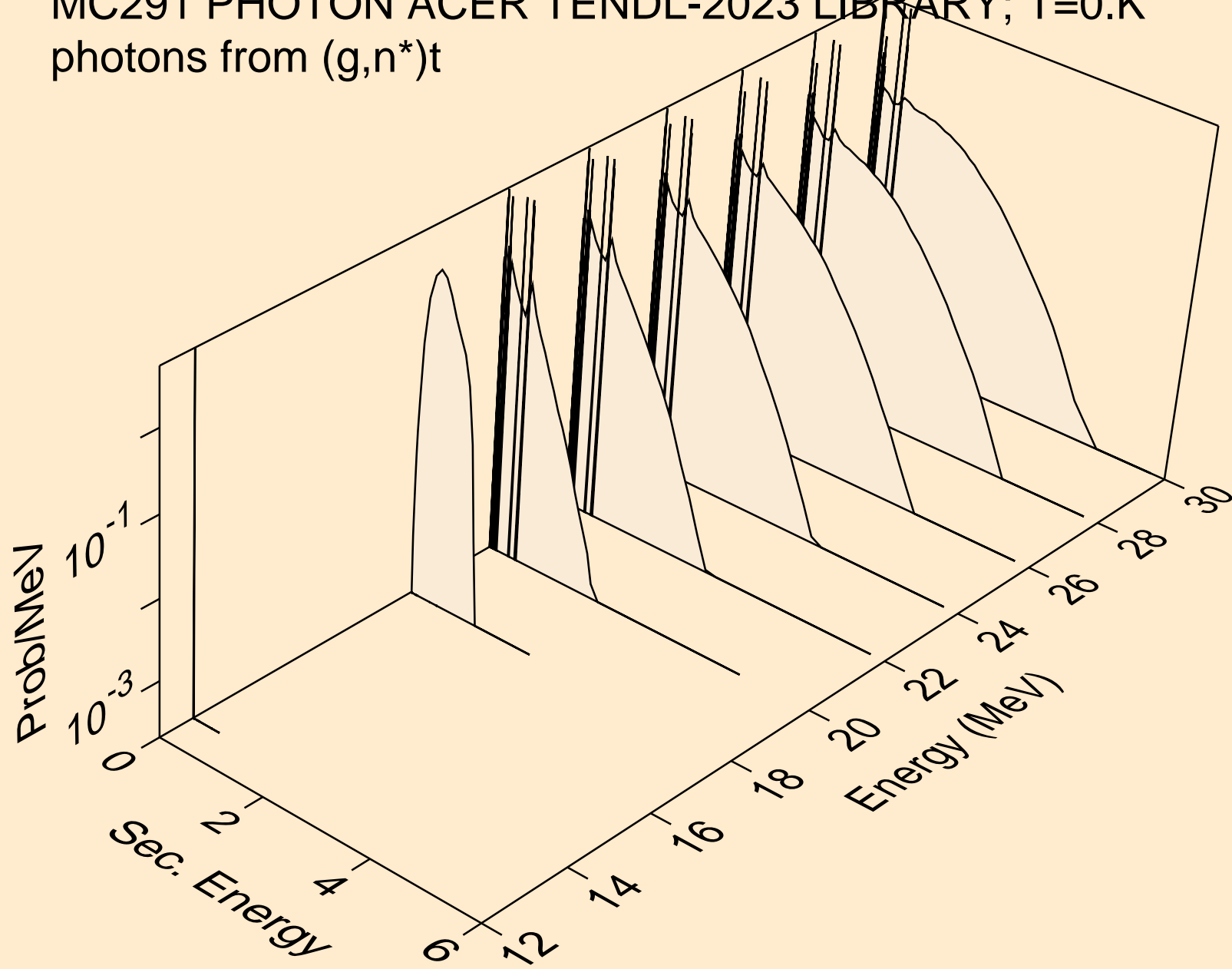

MC291 PHOTON ACER TENDL-2023 LIBRARY; T=0.K
photons from (g,4n)

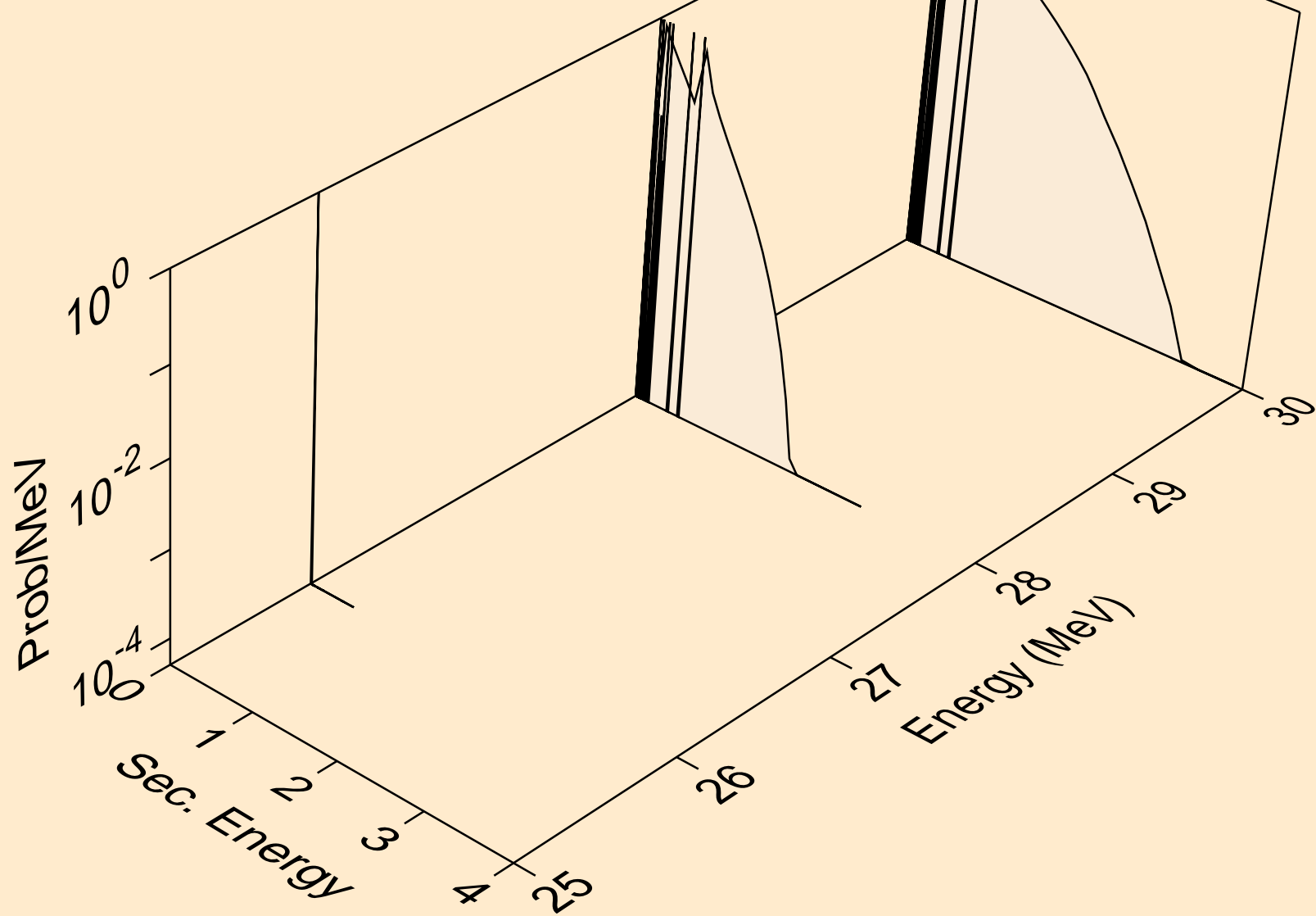

MC291 PHOTON ACER TENDL-2023 LIBRARY; T=0.K
photons from (g,2np)

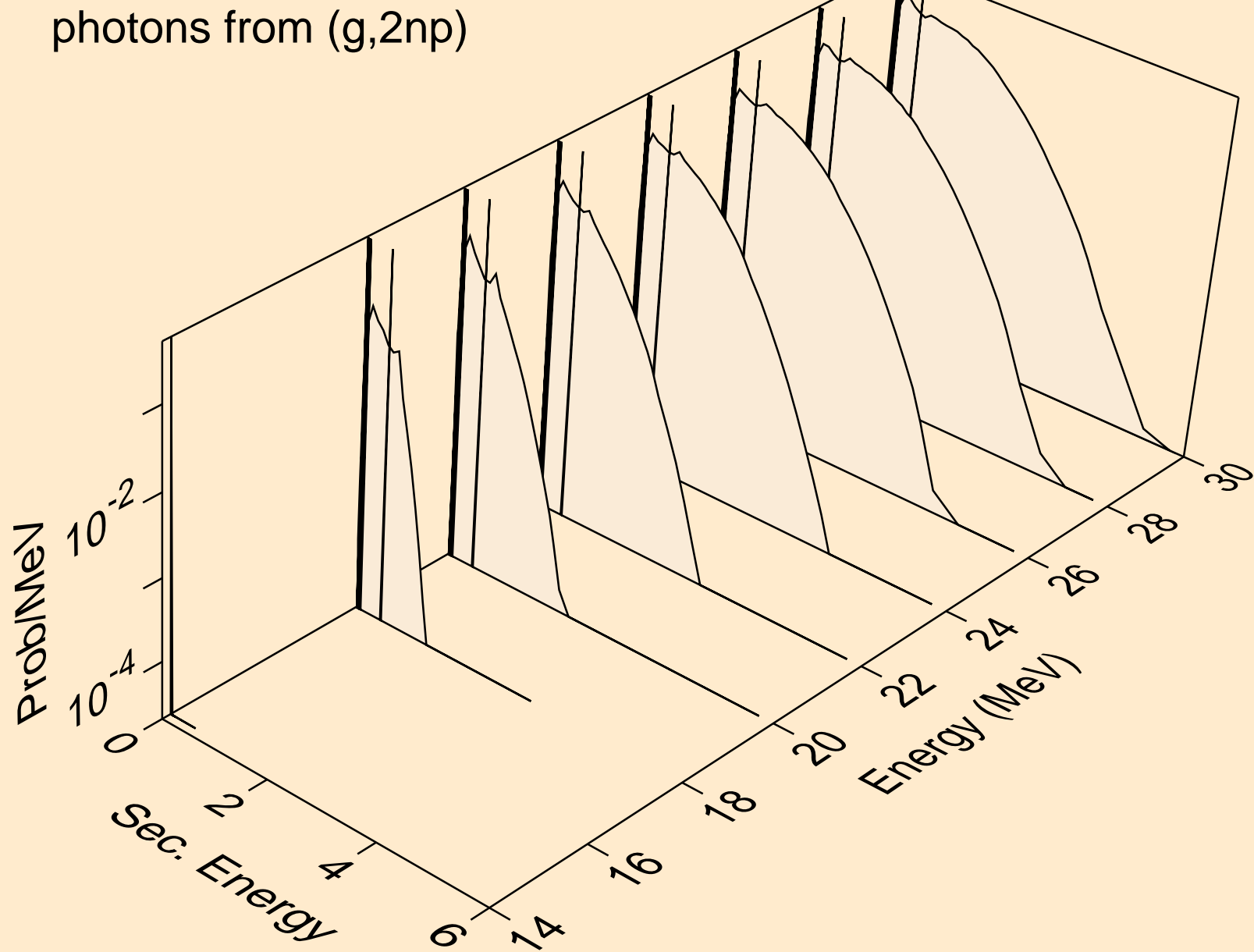

MC291 PHOTON ACER TENDL-2023 LIBRARY; T=0.K
photons from (g,3np)

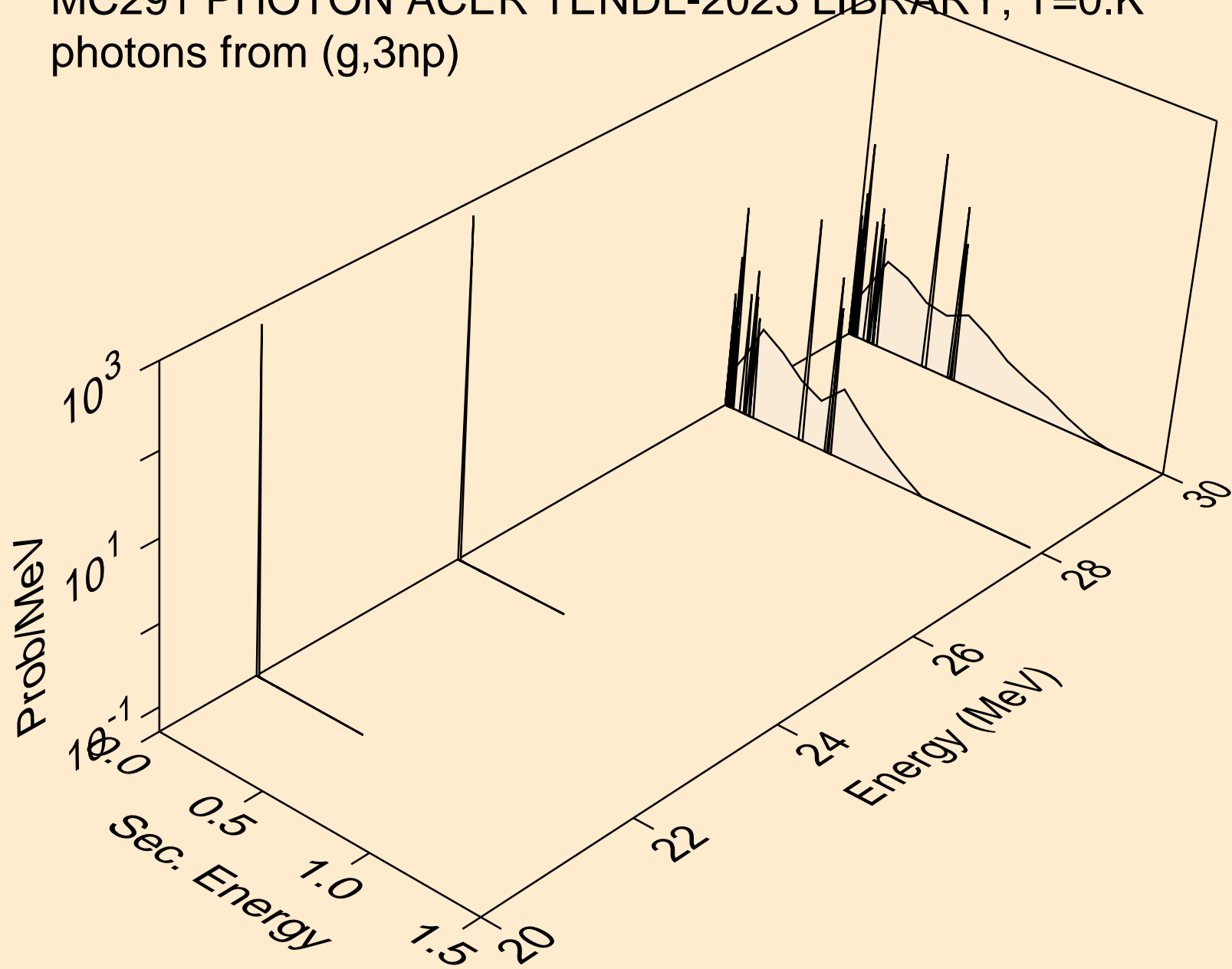

MC291 PHOTON ACER TENDL-2023 LIBRARY; T=0.K
photons from (g,npa)

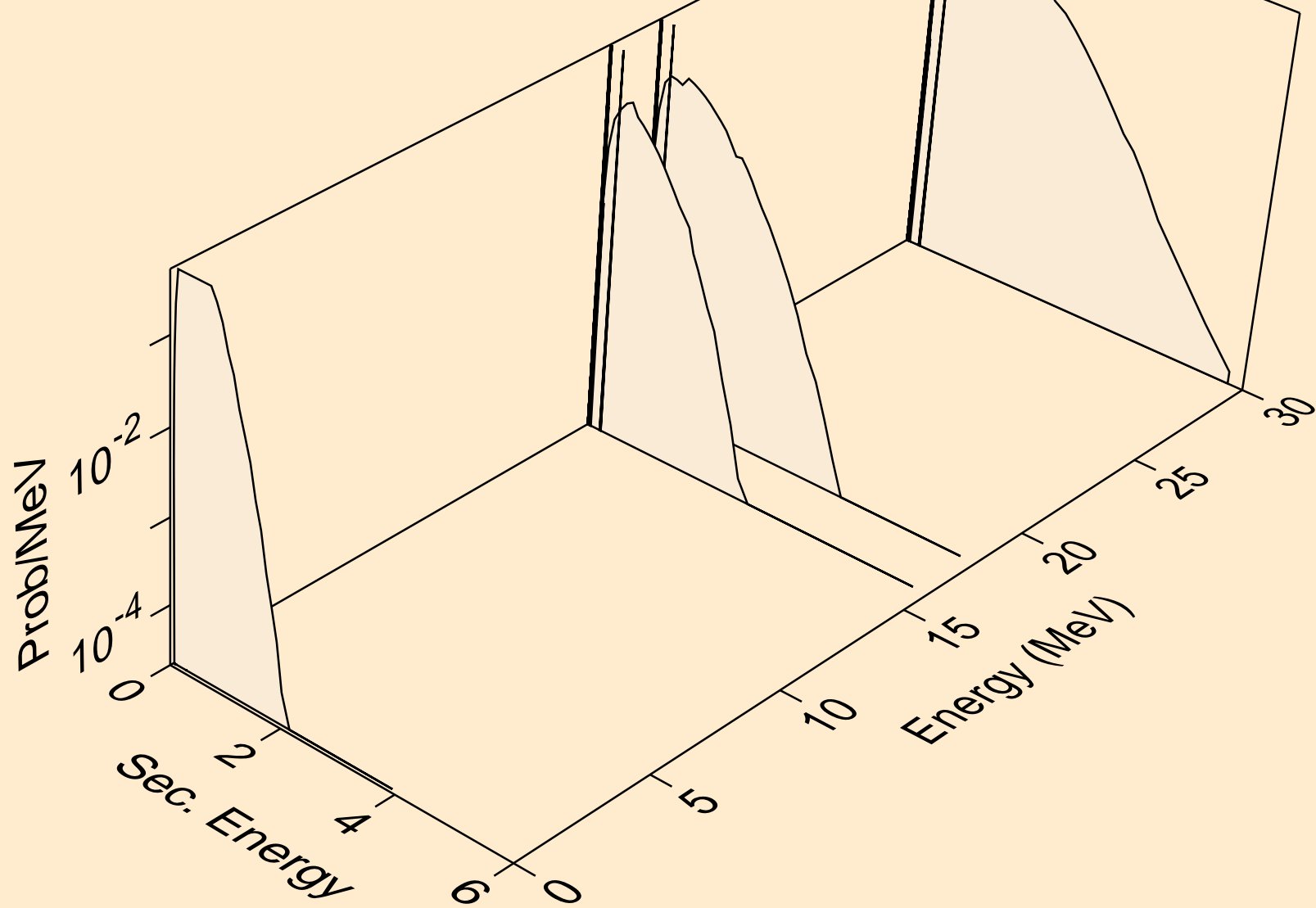

MC291 PHOTON ACER TENDL-2023 LIBRARY; T=0.K
photons from (g,n*c)

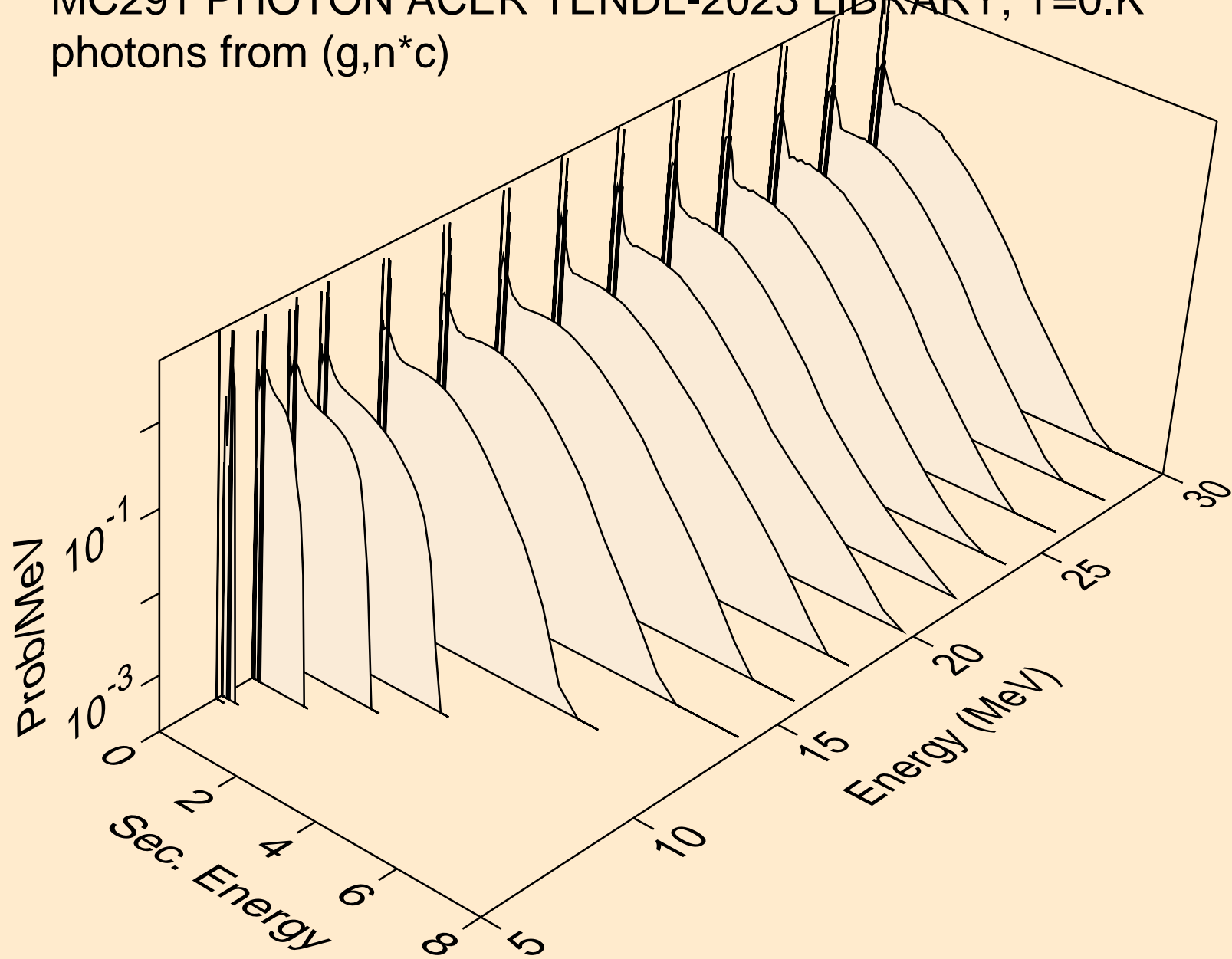

MC291 PHOTON ACER TENDL-2023 LIBRARY; T=0.K
photons from (g,gma)

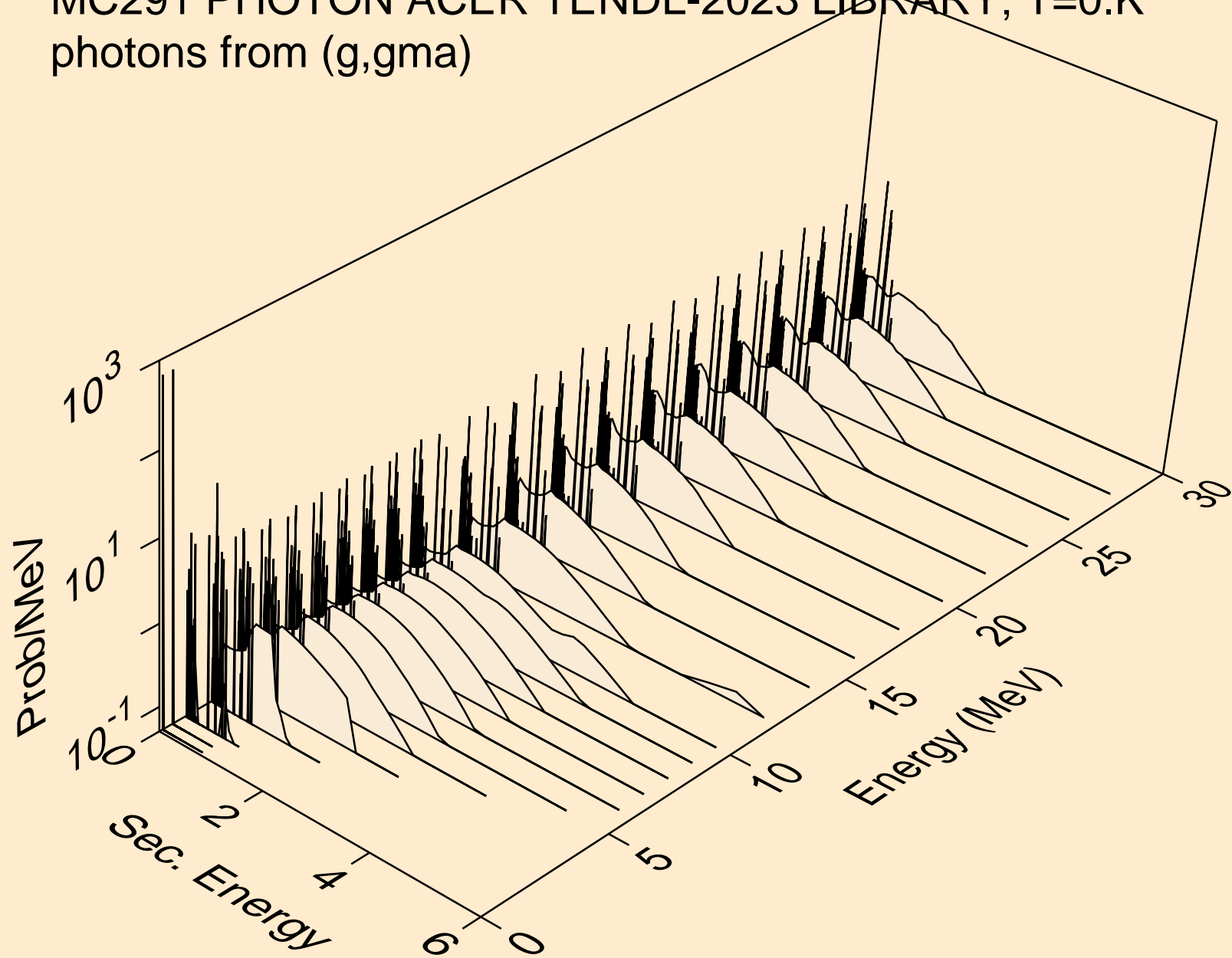

MC291 PHOTON ACER TENDL-2023 LIBRARY; T=0.K
photons from (g,p)

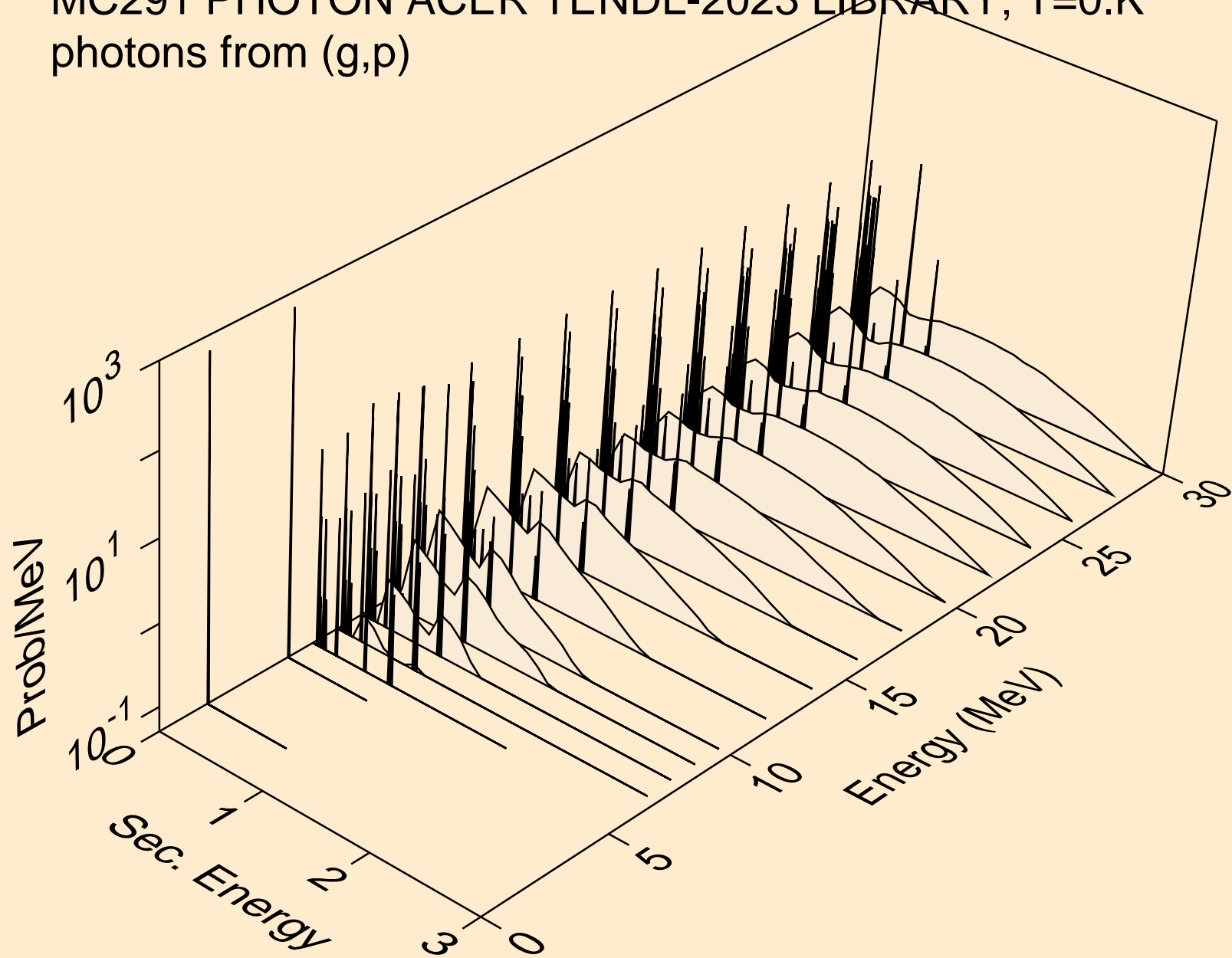

MC291 PHOTON ACER TENDL-2023 LIBRARY; T=0.K
photons from (g,d)

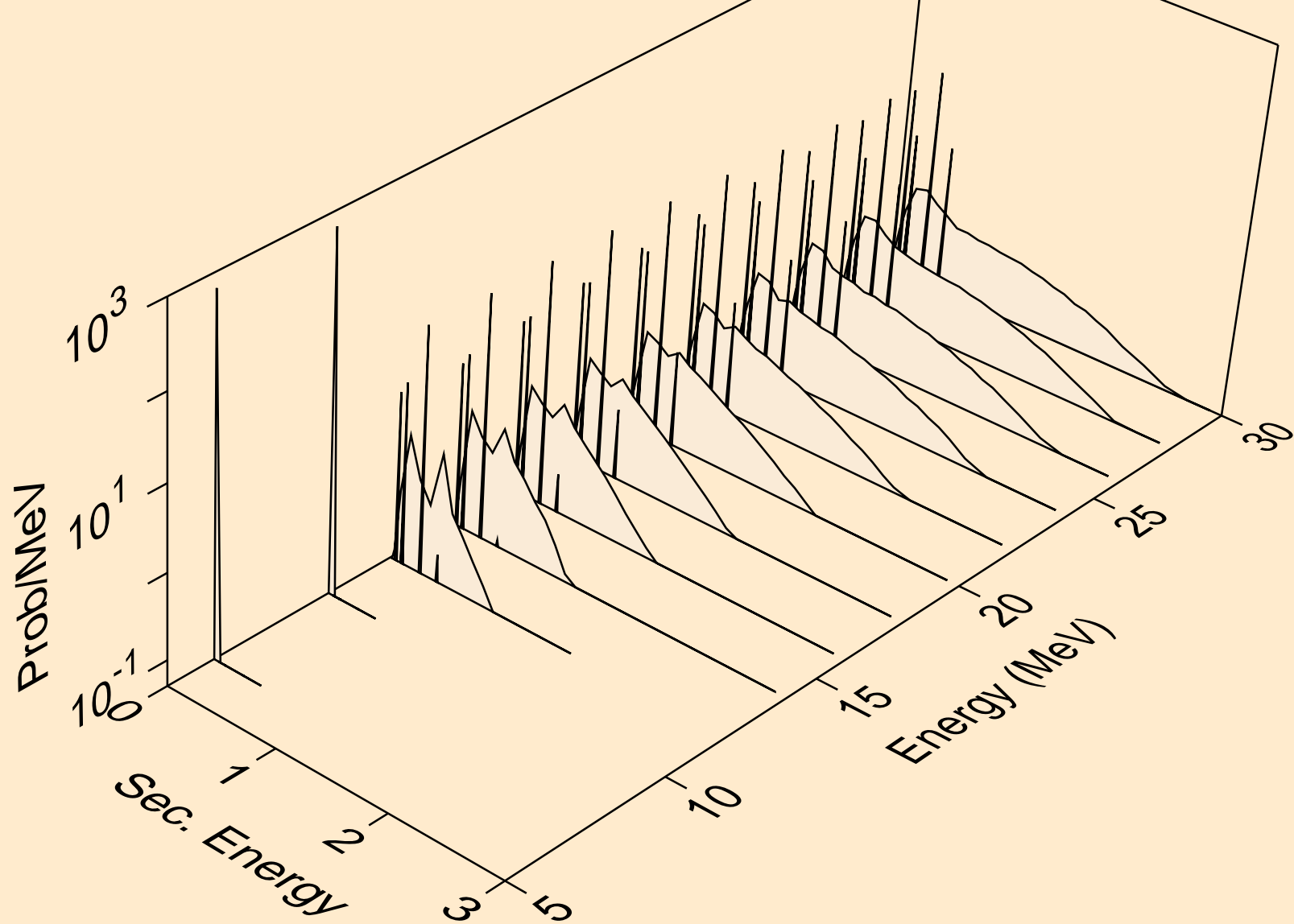

MC291 PHOTON ACER TENDL-2023 LIBRARY; T=0.K
photons from (g,t)

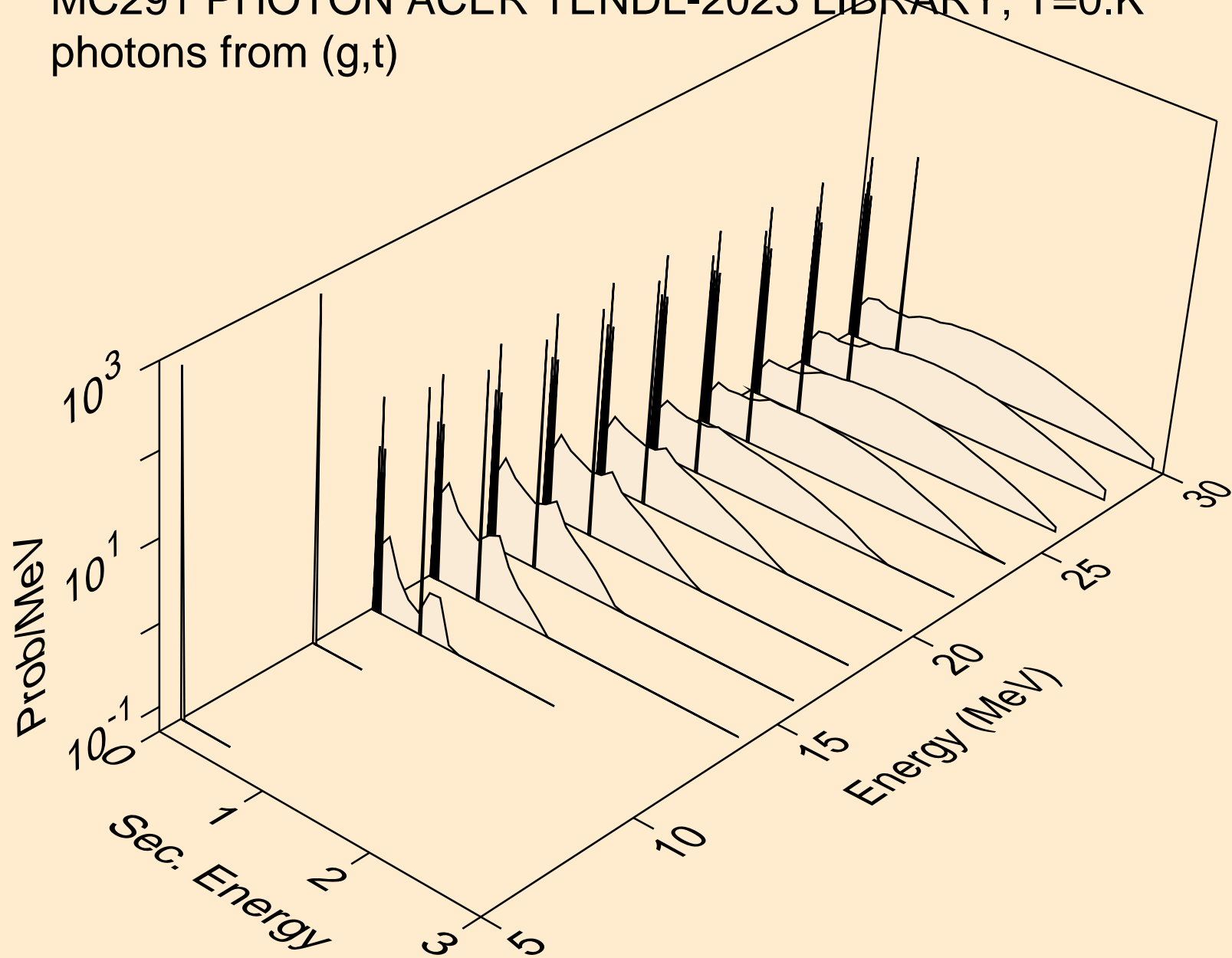

MC291 PHOTON ACER TENDL-2023 LIBRARY; T=0.K
photons from (g,a)

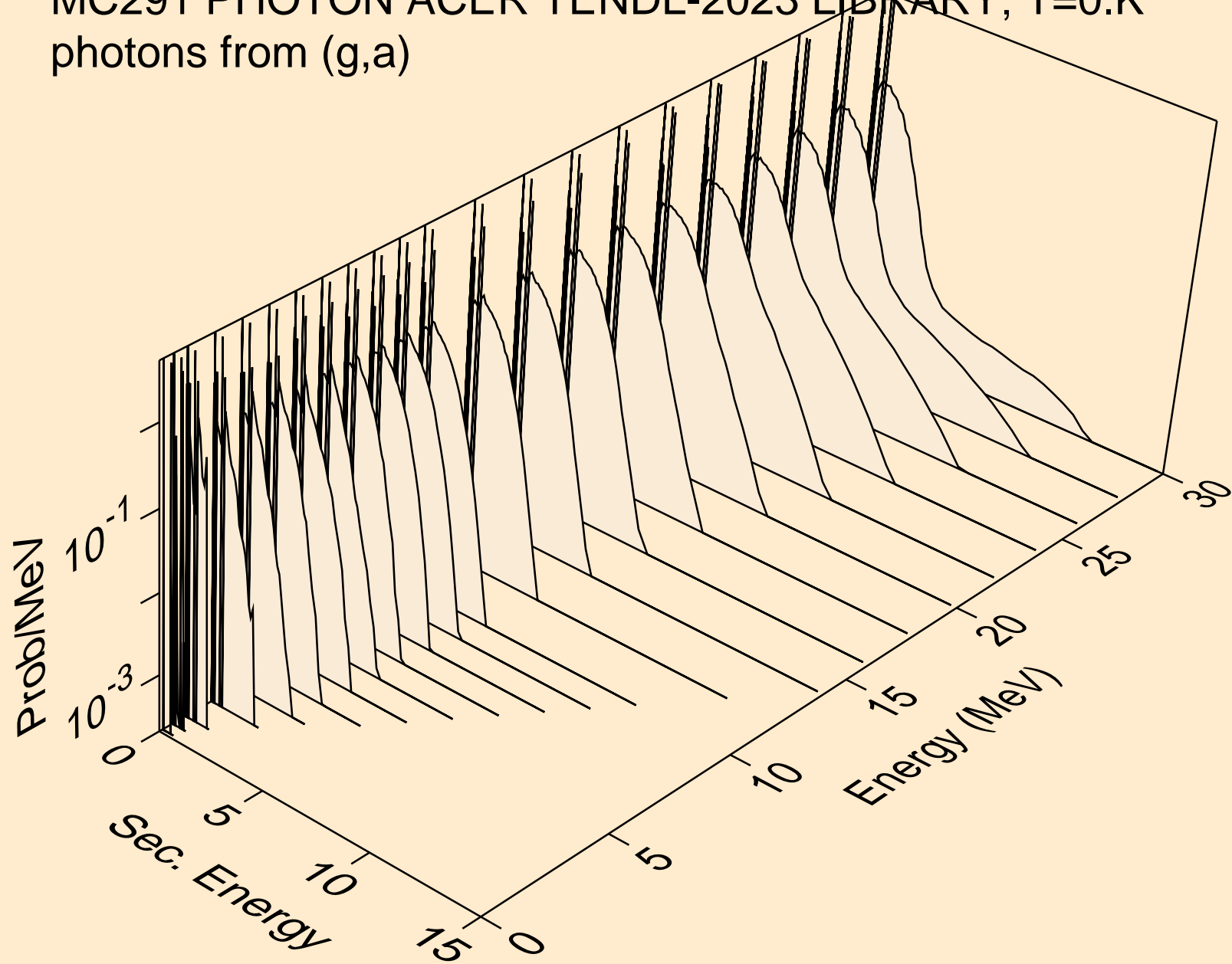

MC291 PHOTON ACER TENDL-2023 LIBRARY; T=0.K
protons from (g,x)

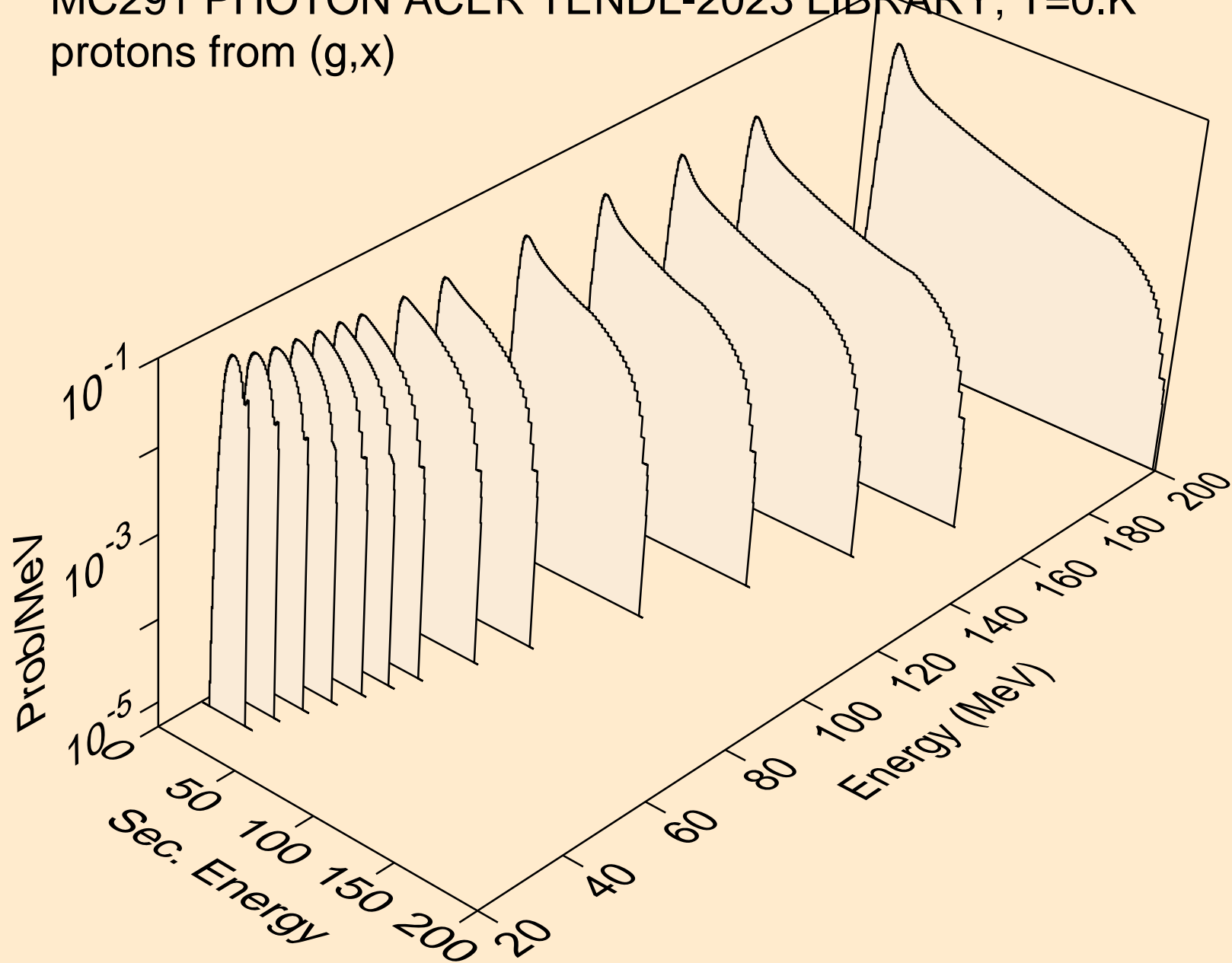

MC291 PHOTON ACER TENDL-2023 LIBRARY; T=0.K
protons from (g,n*)p

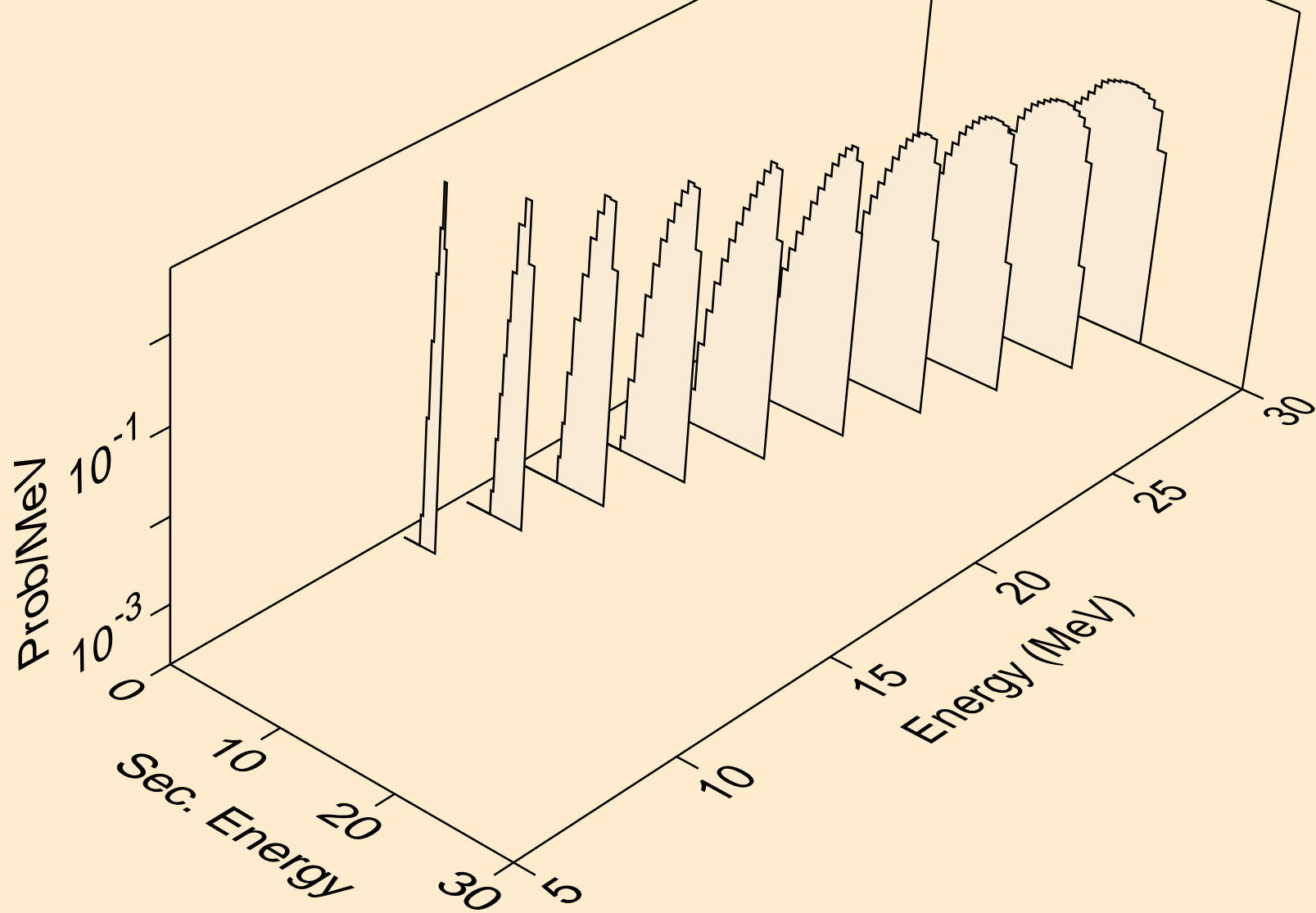

MC291 PHOTON ACER TENDL-2023 LIBRARY; T=0.K
protons from (g,2np)

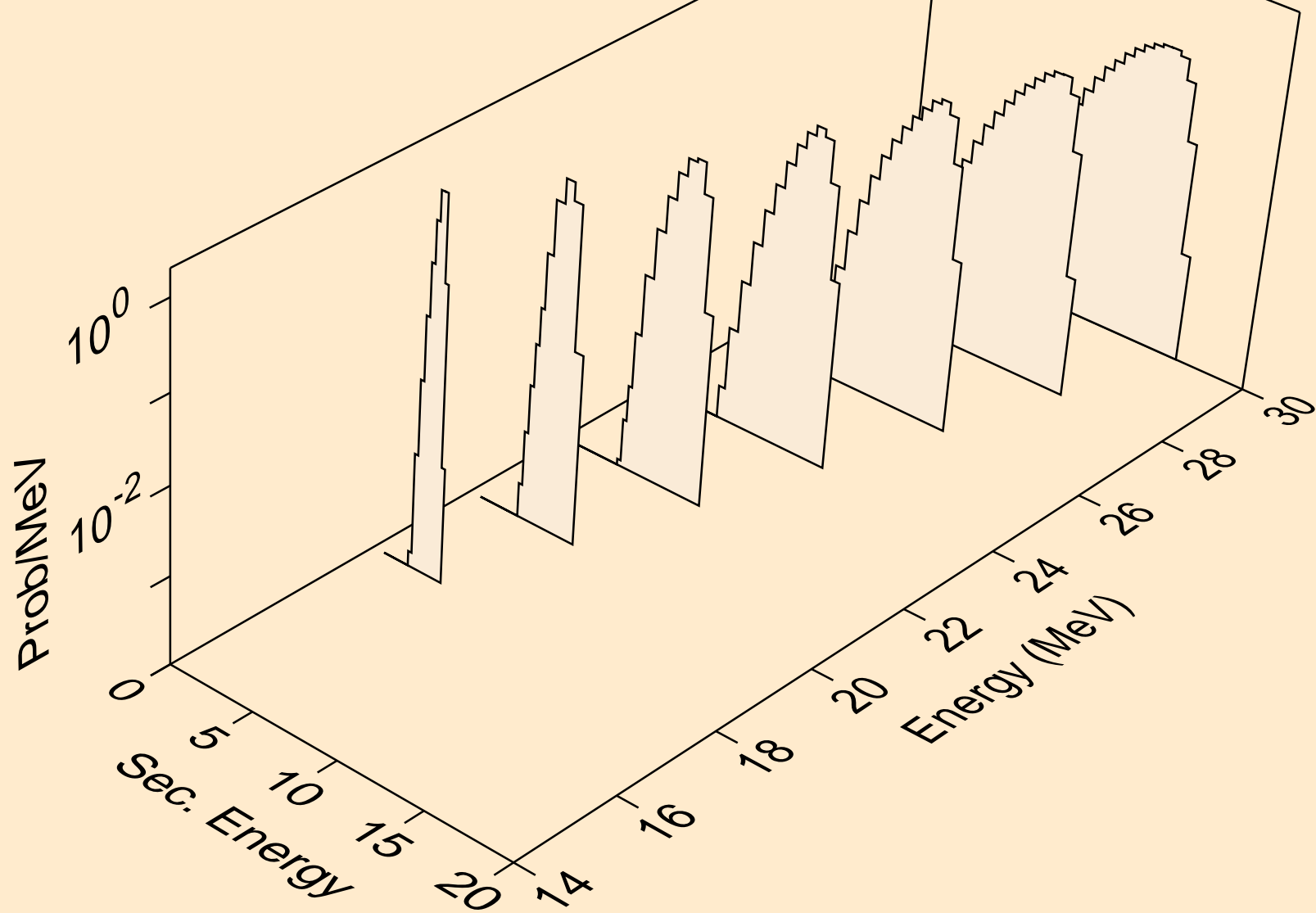

MC291 PHOTON ACER TENDL-2023 LIBRARY; T=0.K
protons from (g,3np)

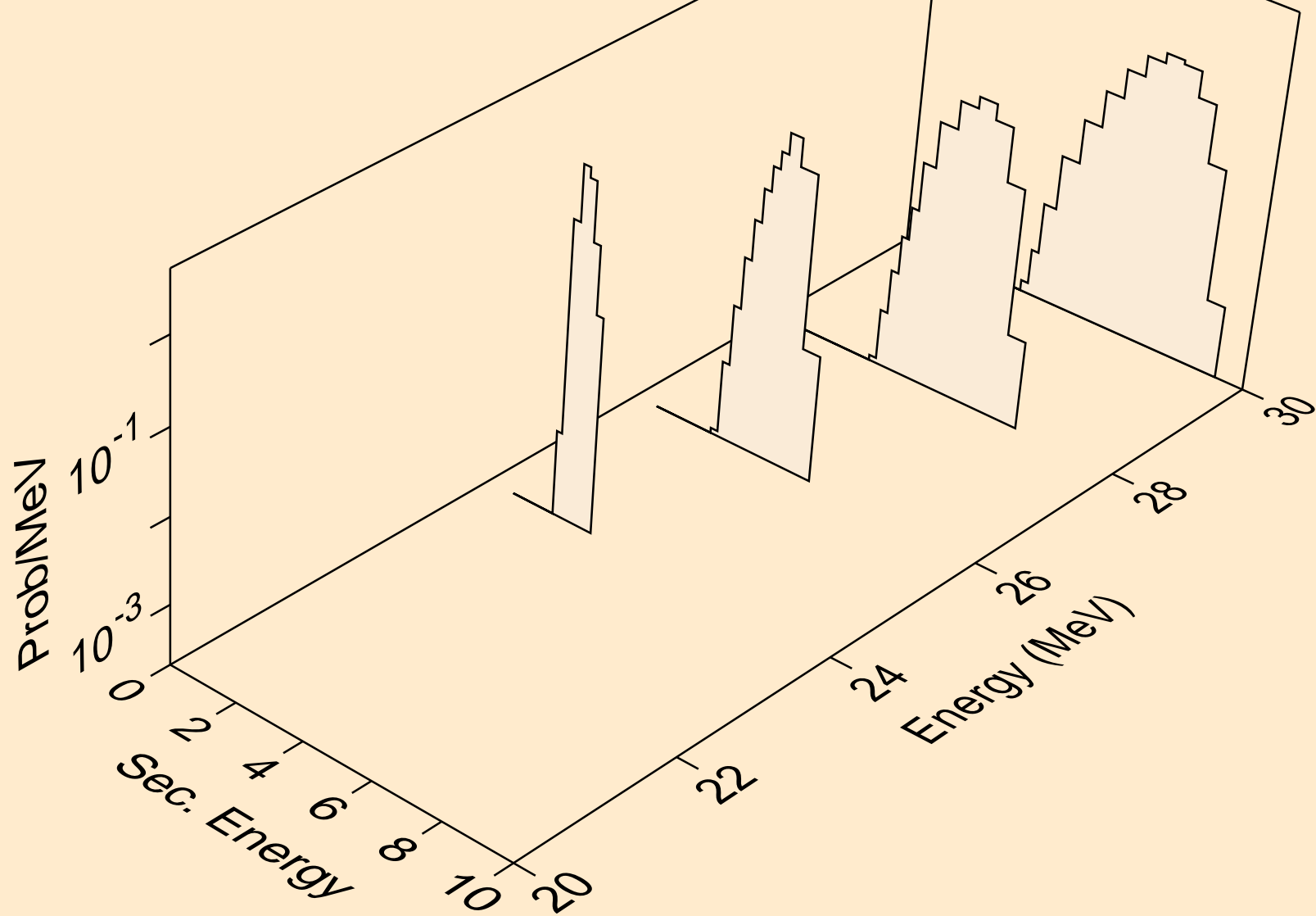

MC291 PHOTON ACER TENDL-2023 LIBRARY; T=0.K
protons from (g,npa)

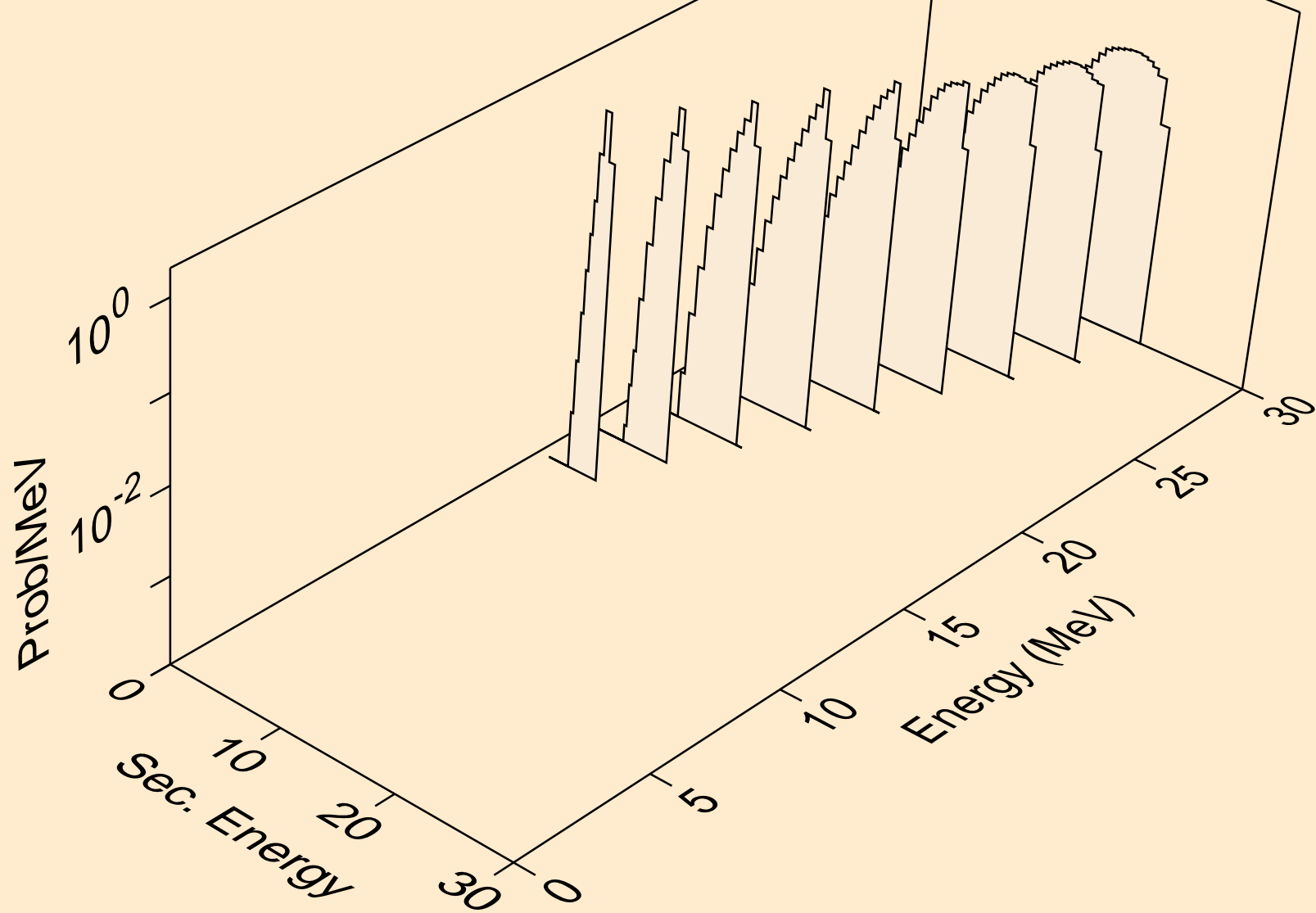

MC291 PHOTON ACER TENDL-2023 LIBRARY; T=0.K
protons from (g,p)

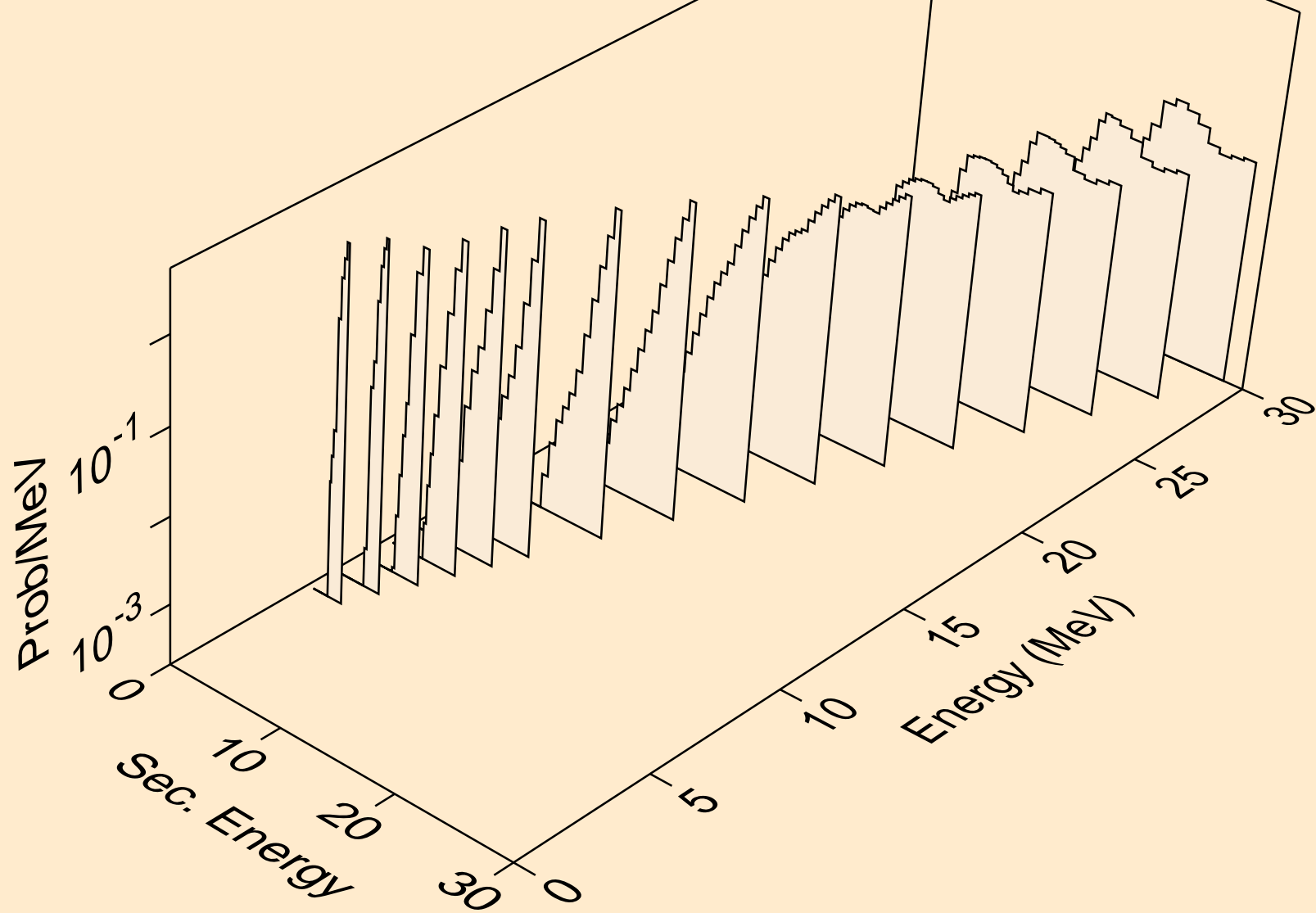

MC291 PHOTON ACER TENDL-2023 LIBRARY; T=0.K
deuterons from (g,x)

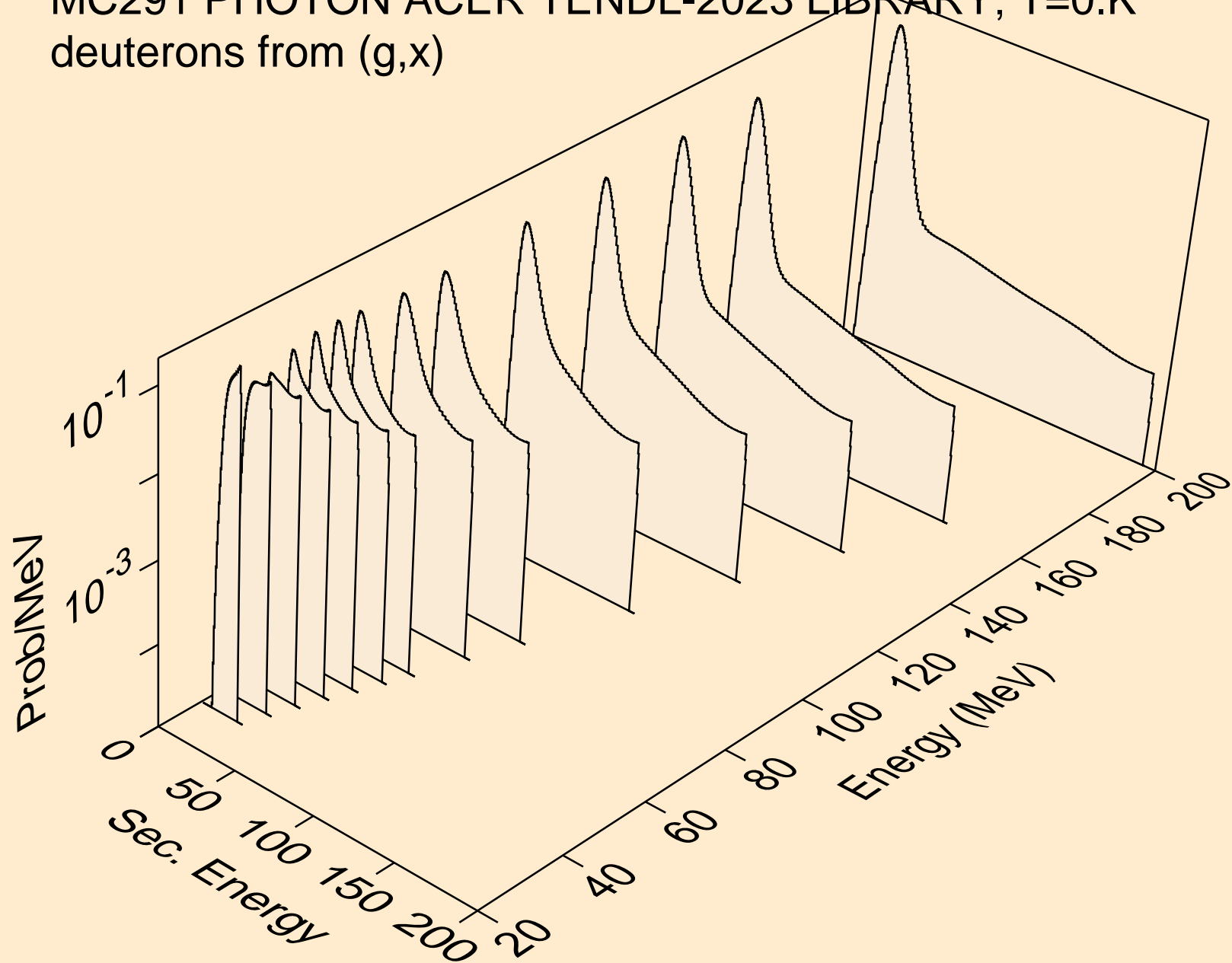

MC291 PHOTON ACER TENDL-2023 LIBRARY; T=0.K
deuterons from (g,2nd)

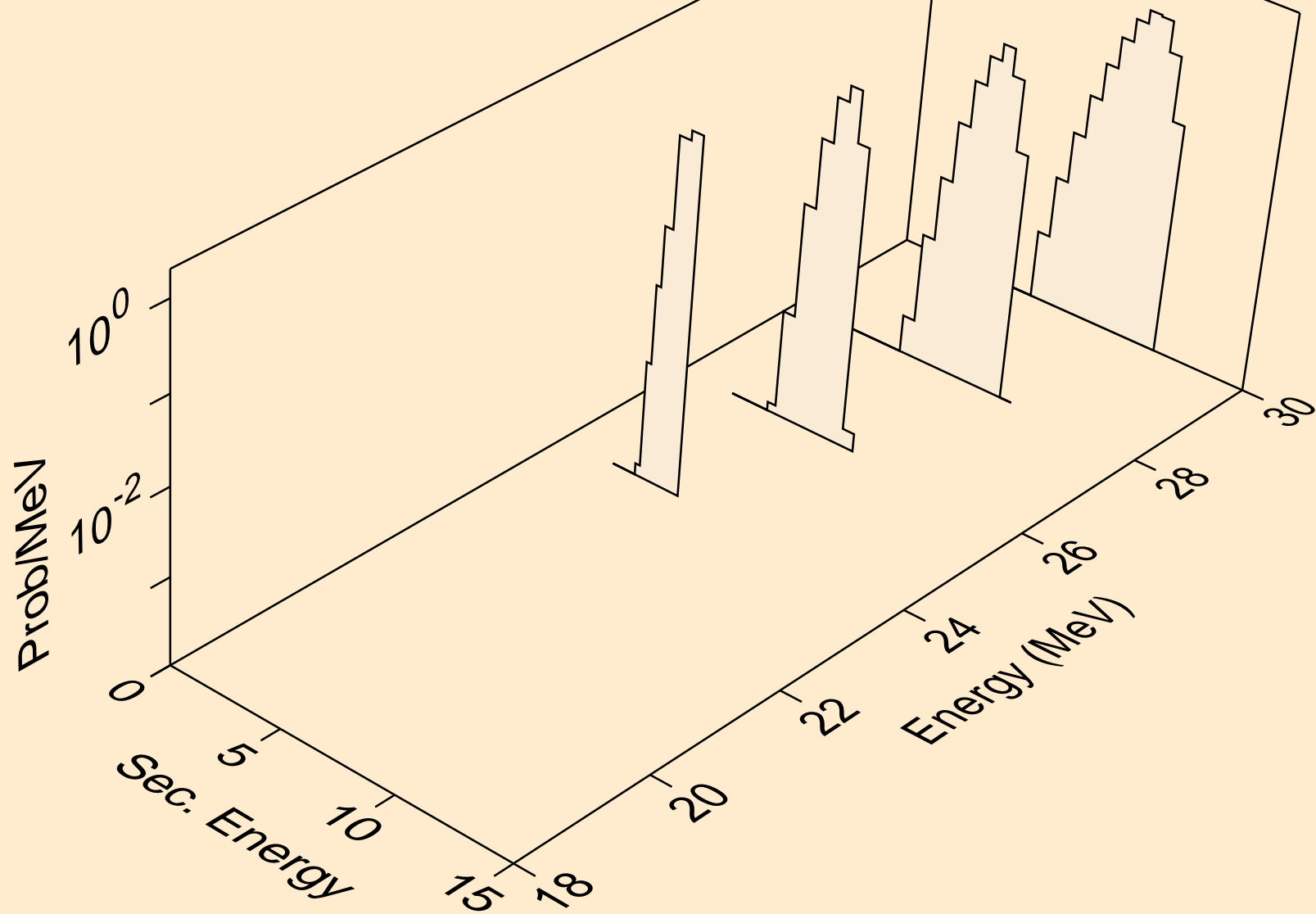

MC291 PHOTON ACER TENDL-2023 LIBRARY; T=0.K
deuterons from (g,n*)d

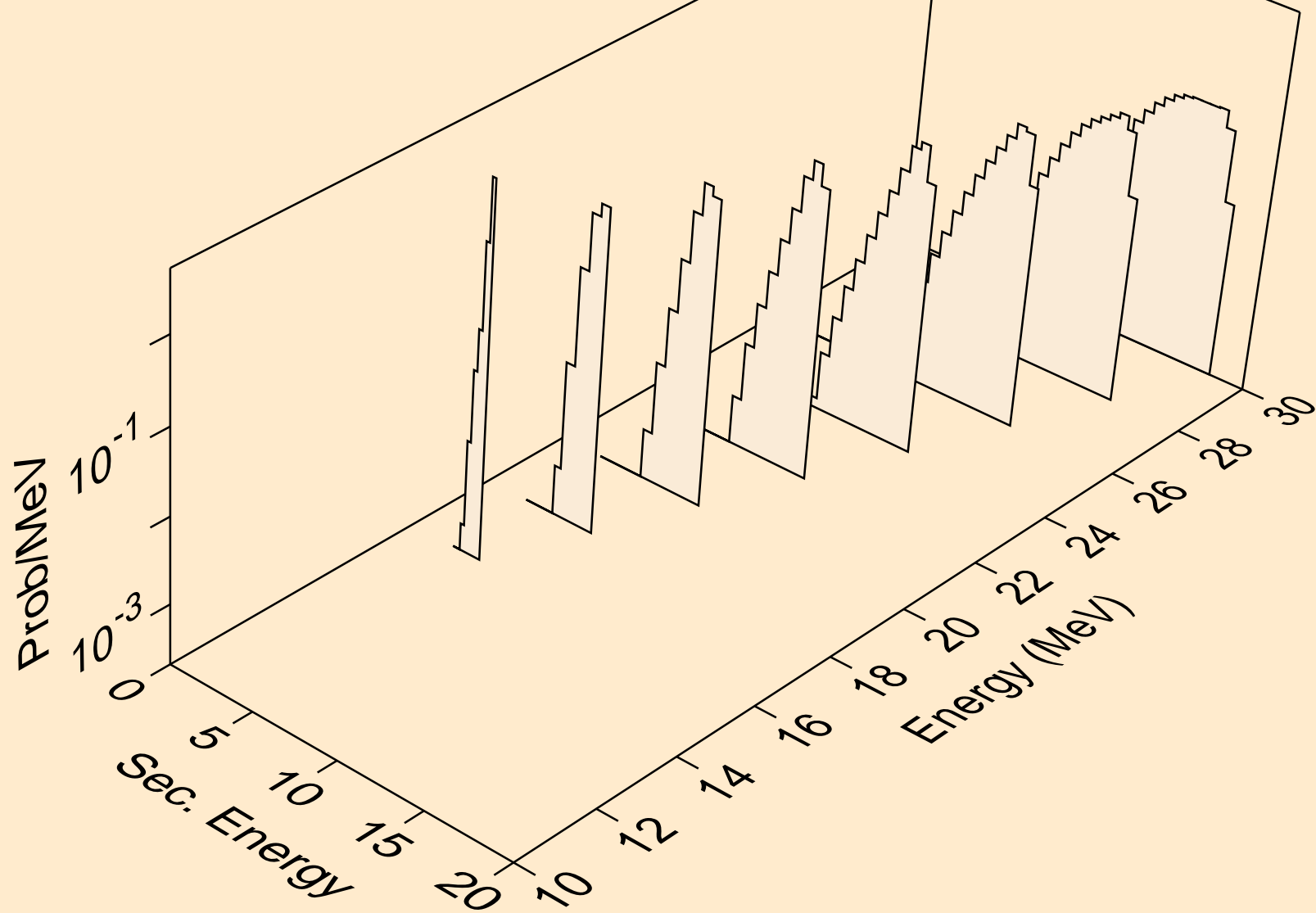

MC291 PHOTON ACER TENDL-2023 LIBRARY; T=0.K
deuterons from (g,d)

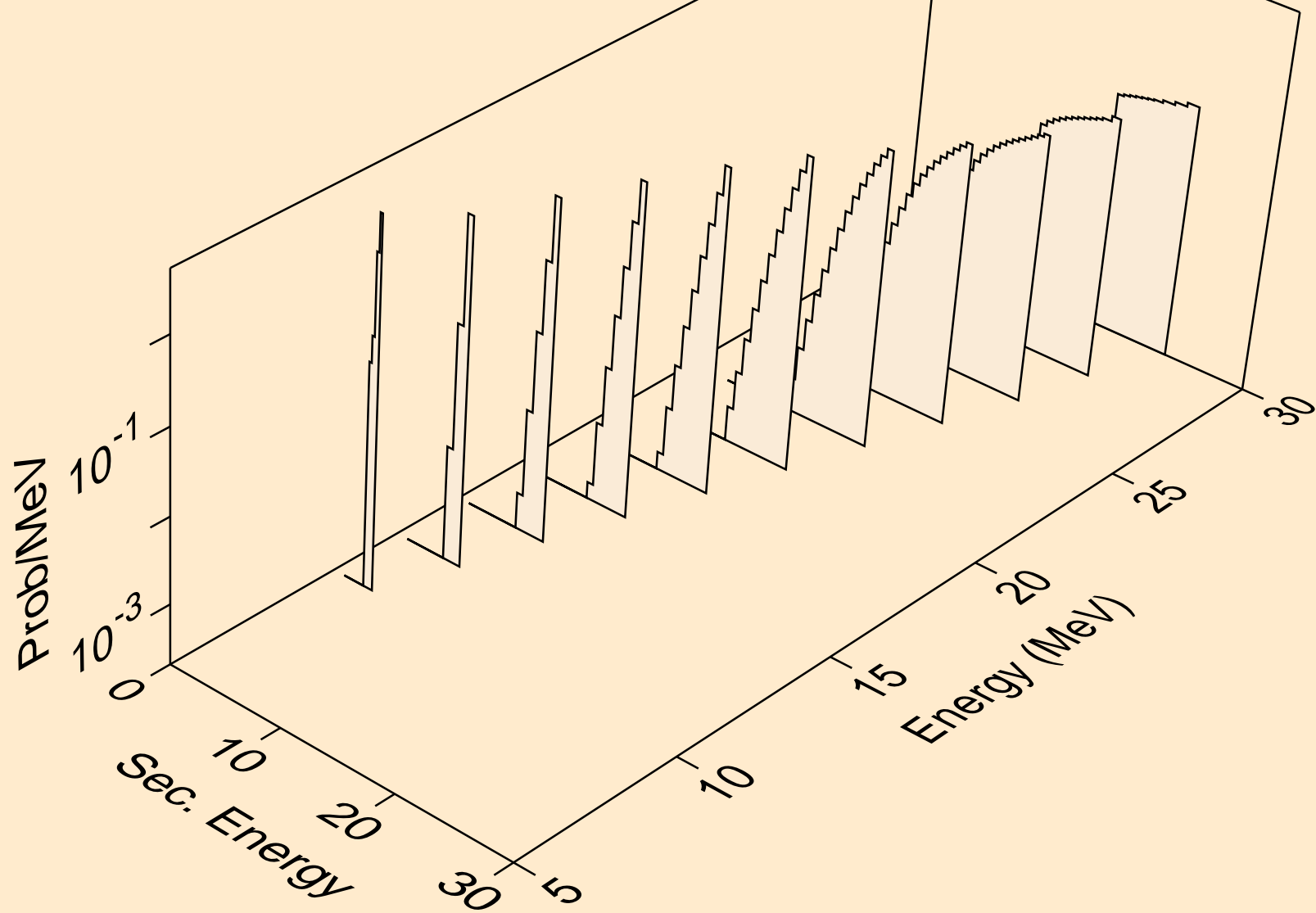

MC291 PHOTON ACER TENDL-2023 LIBRARY; T=0.K
tritons from (g,x)

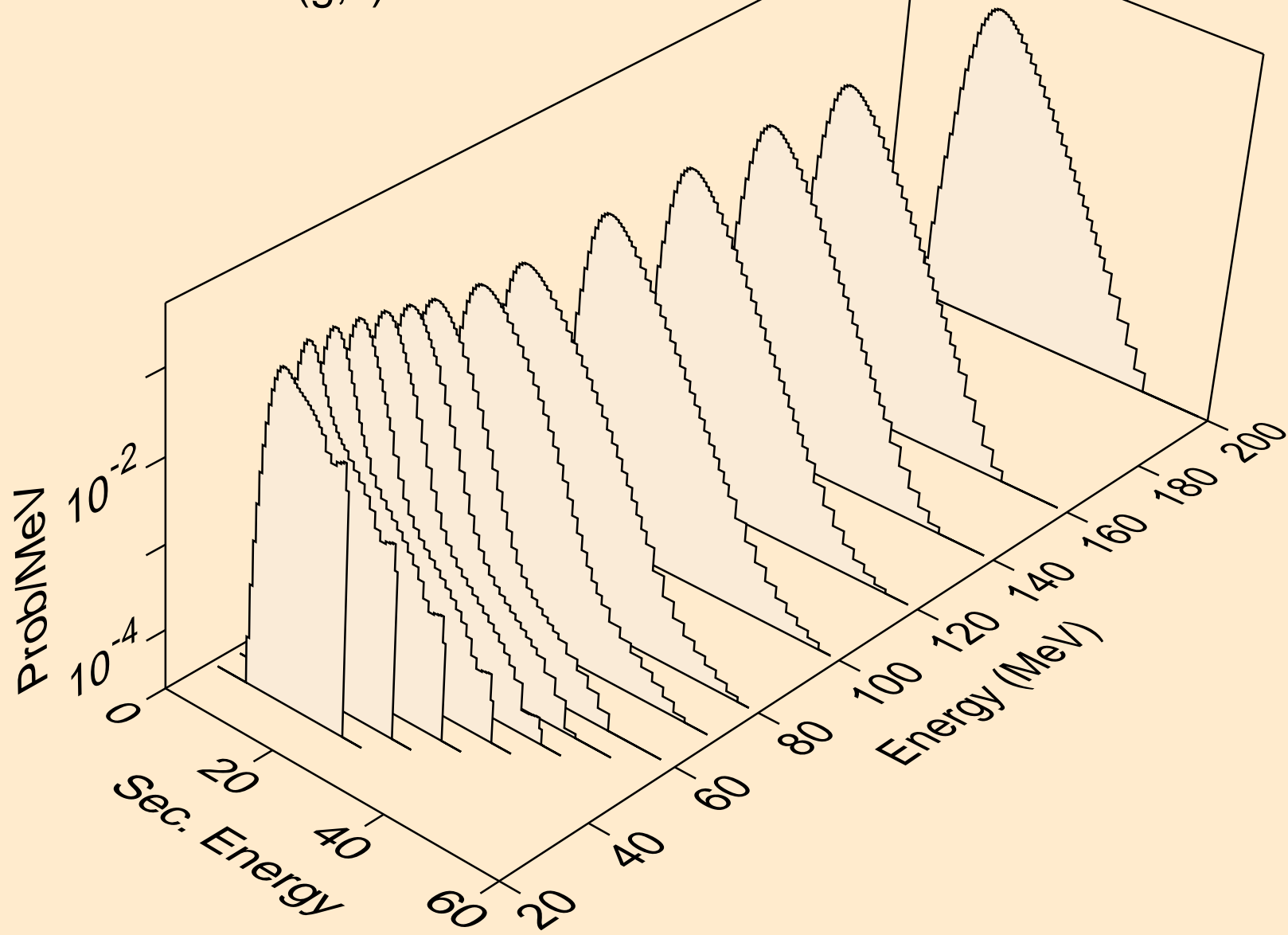

MC291 PHOTON ACER TENDL-2023 LIBRARY; T=0.K
tritons from (g,n*)t

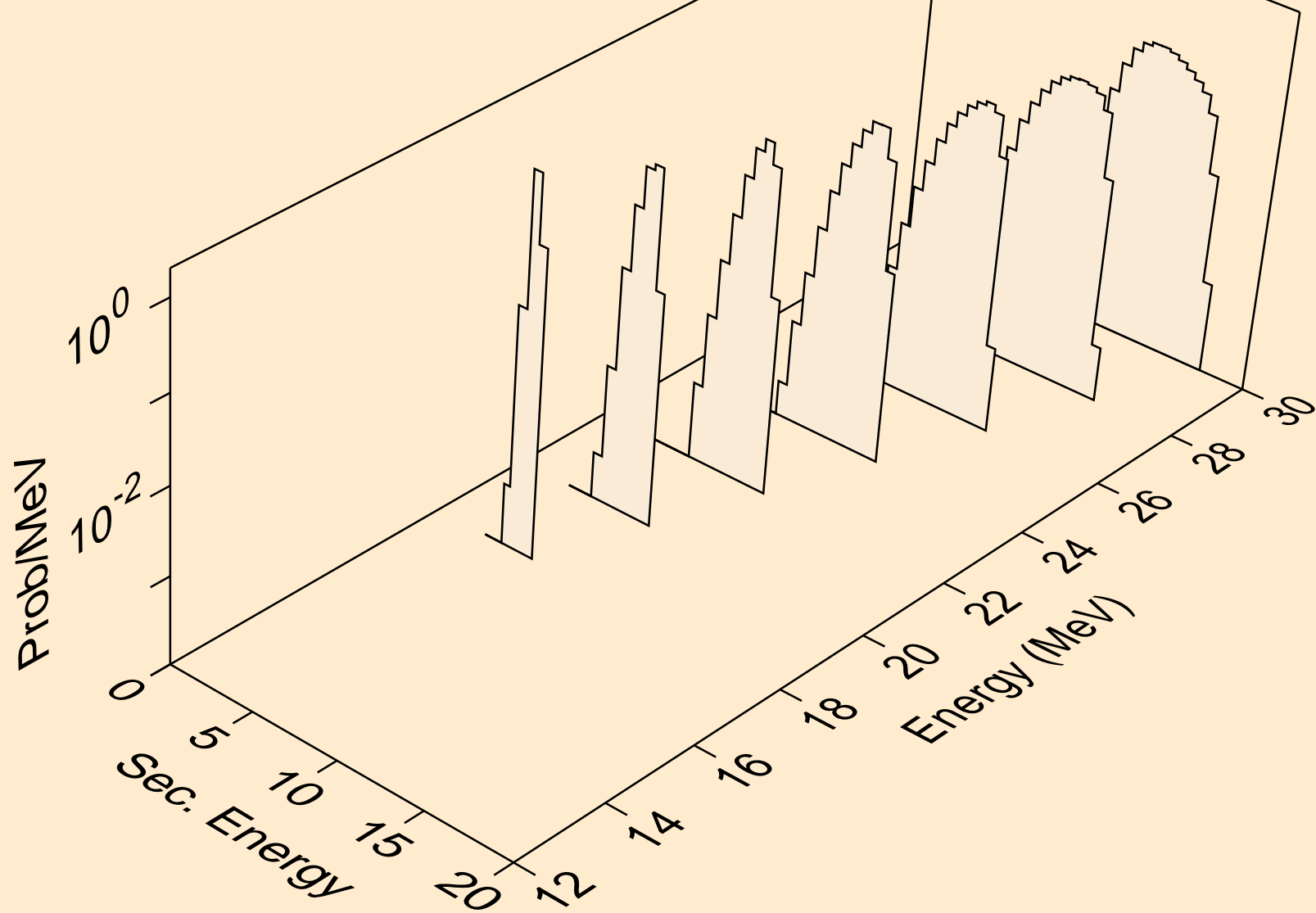

MC291 PHOTON ACER TENDL-2023 LIBRARY; T=0.K
tritons from (g,t)

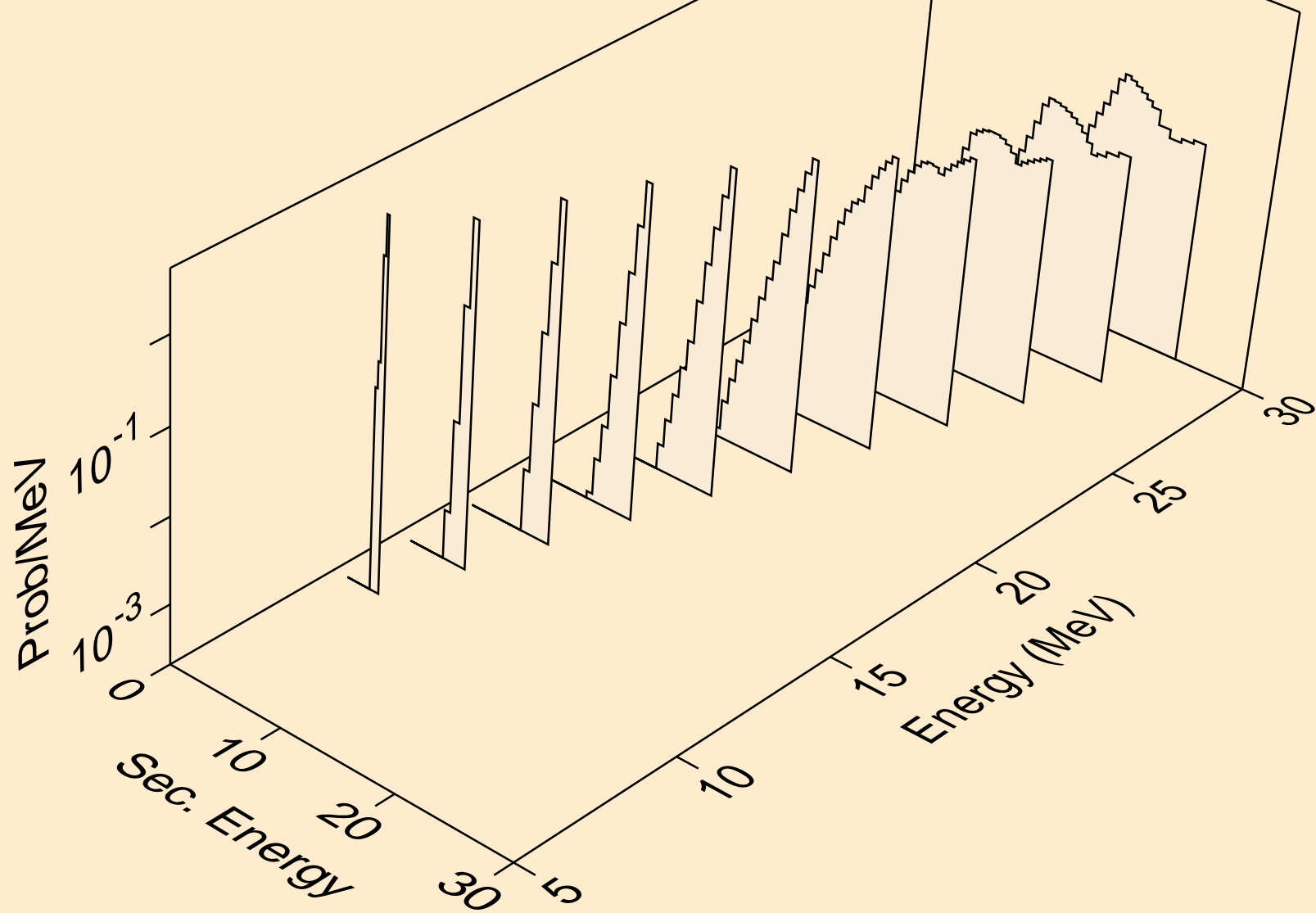

MC291 PHOTON ACER TENDL-2023 LIBRARY; T=0.K
he3s from (g,x)

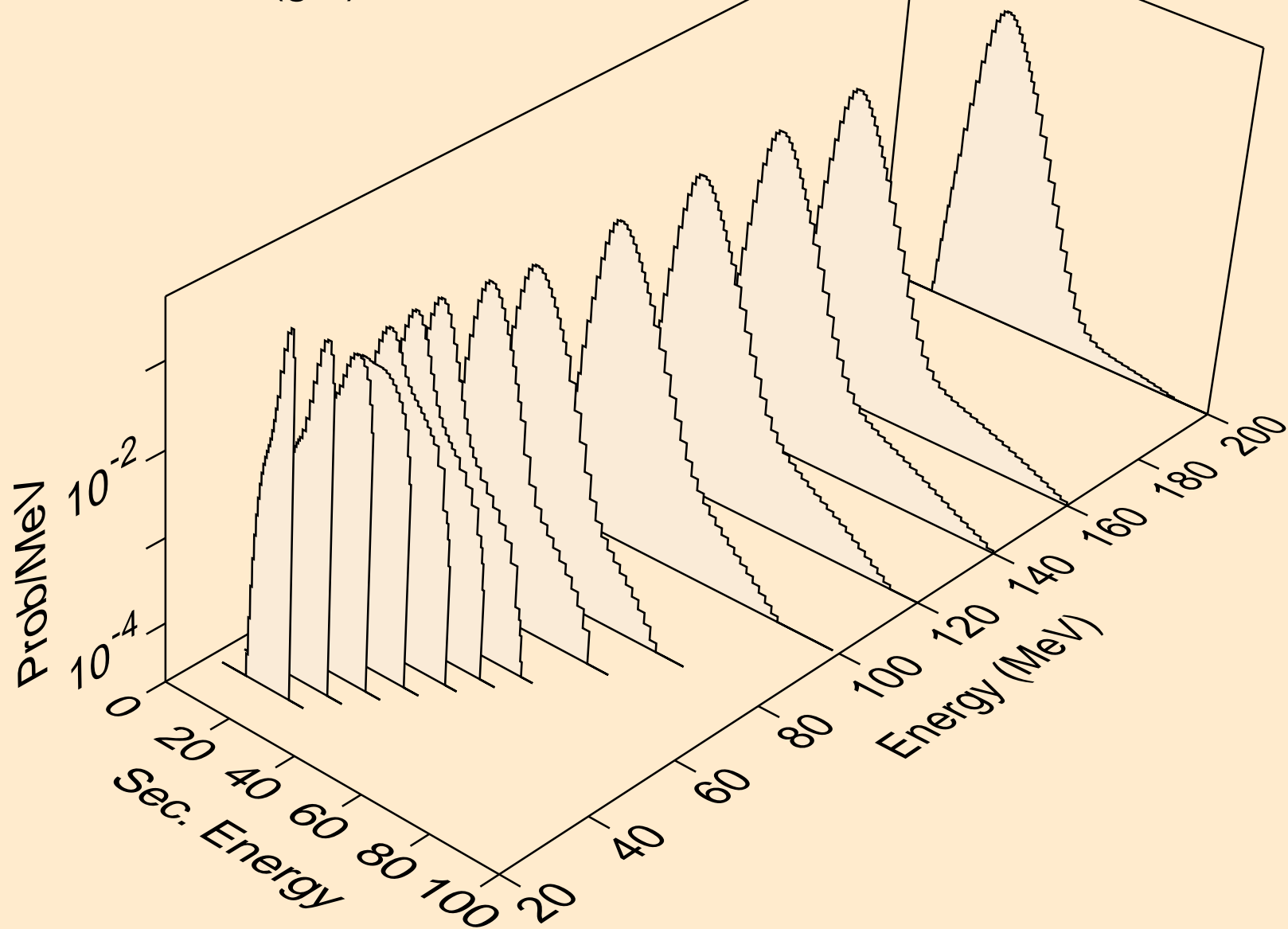

MC291 PHOTON ACER TENDL-2023 LIBRARY; T=0.K
alphas from (g,x)

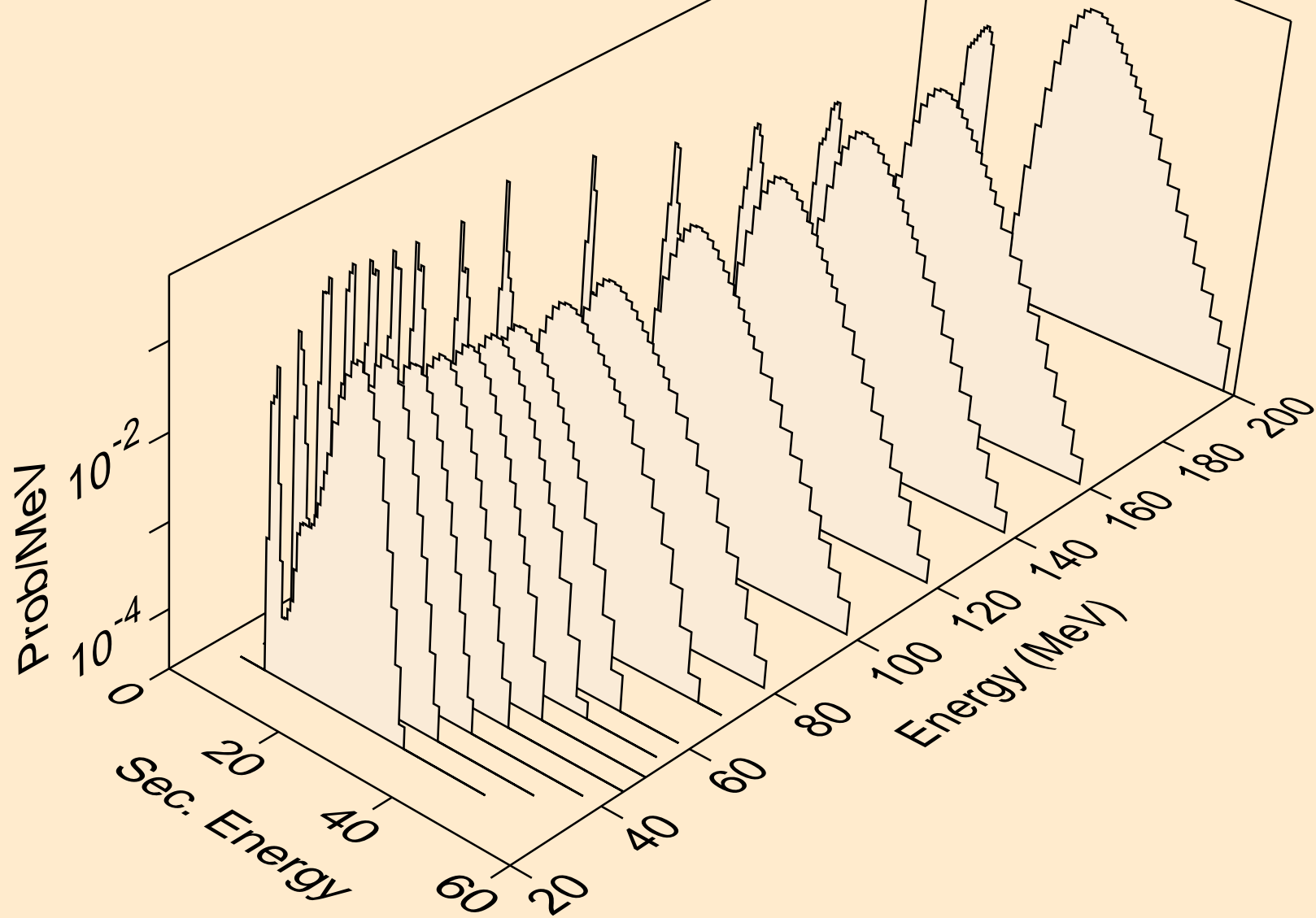

MC291 PHOTON ACER TENDL-2023 LIBRARY; T=0.K
alphas from (g,n*)a

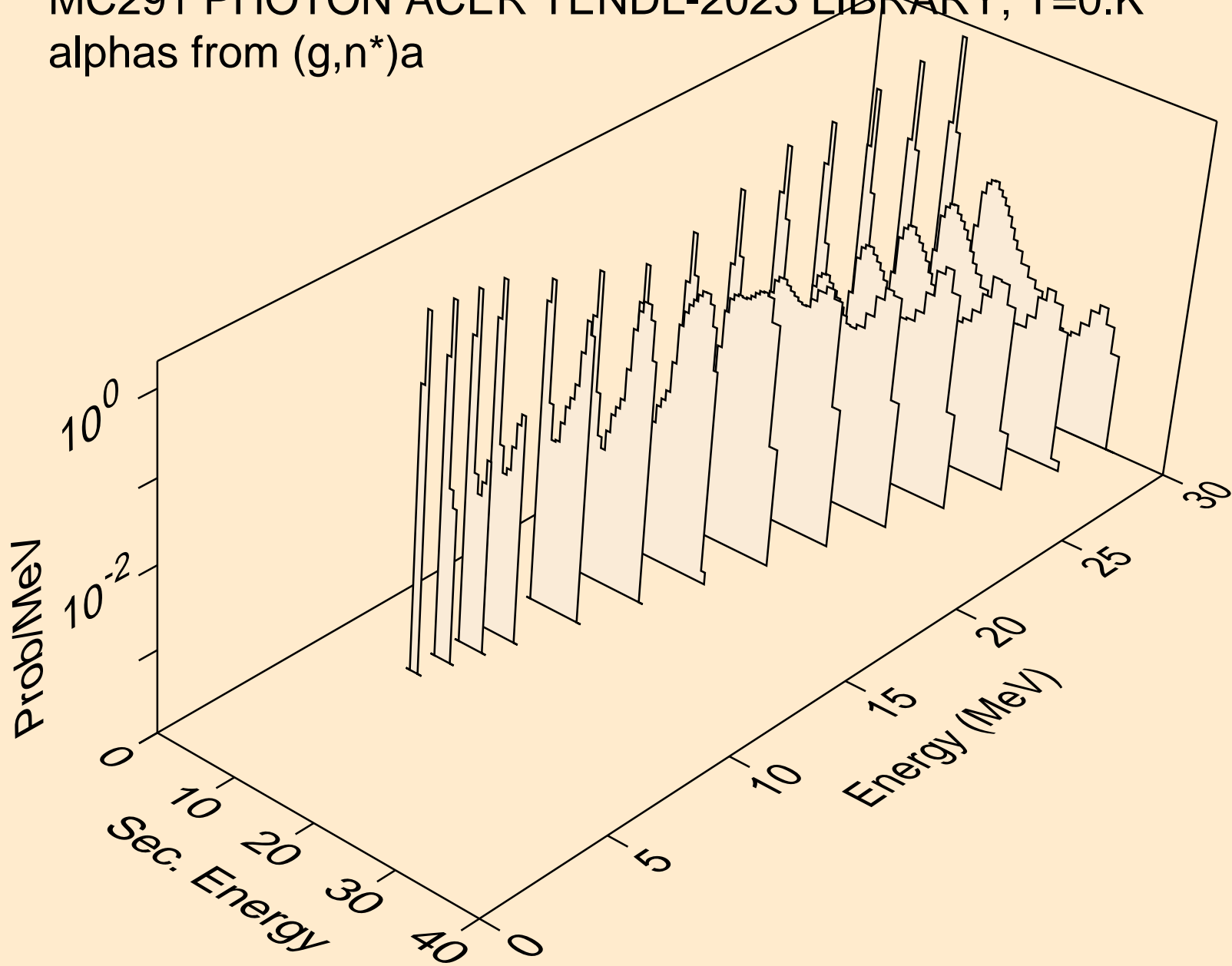

MC291 PHOTON ACER TENDL-2023 LIBRARY; T=0.K
alphas from (g,2n)a

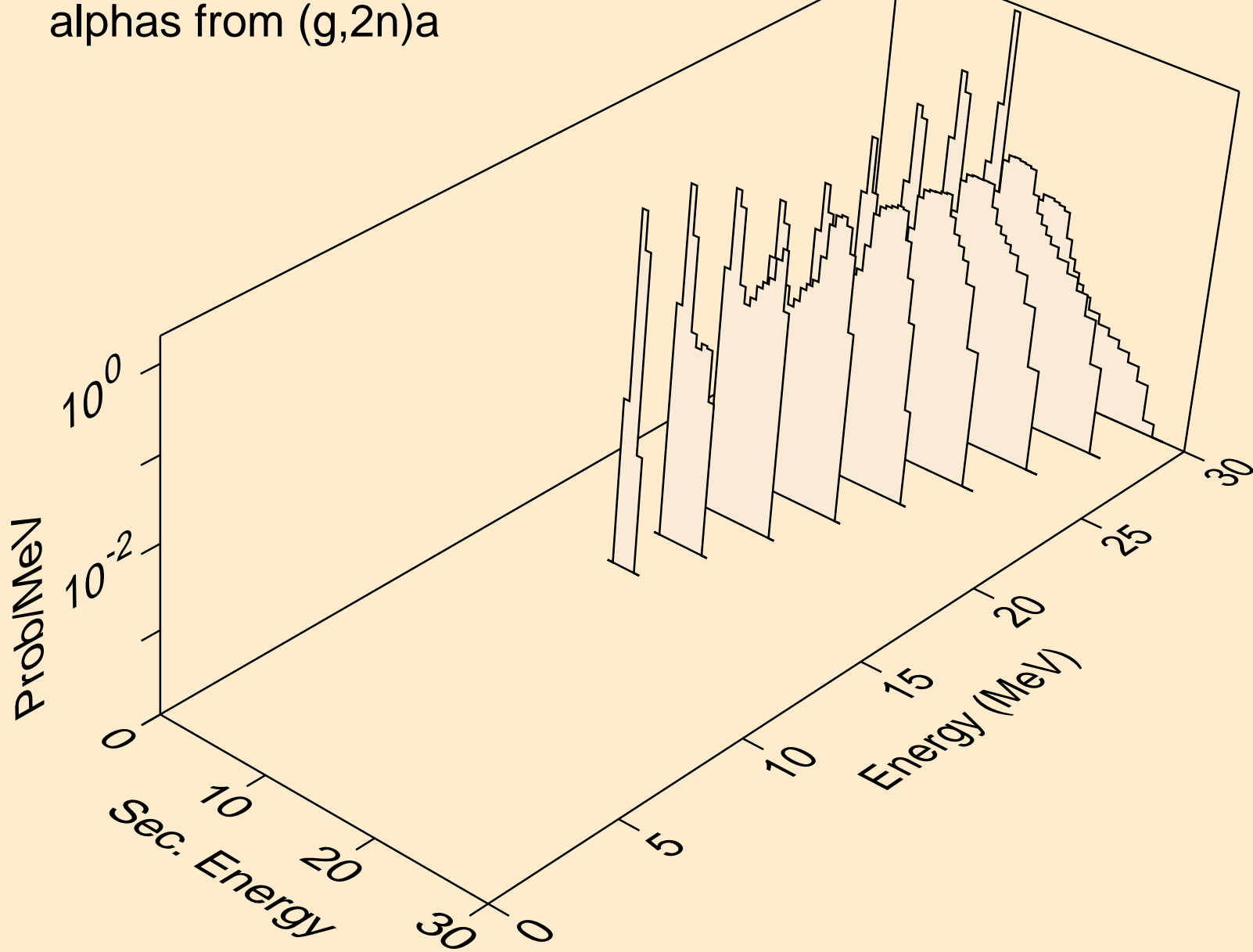

MC291 PHOTON ACER TENDL-2023 LIBRARY; T=0.K
alphas from (g,3n)a

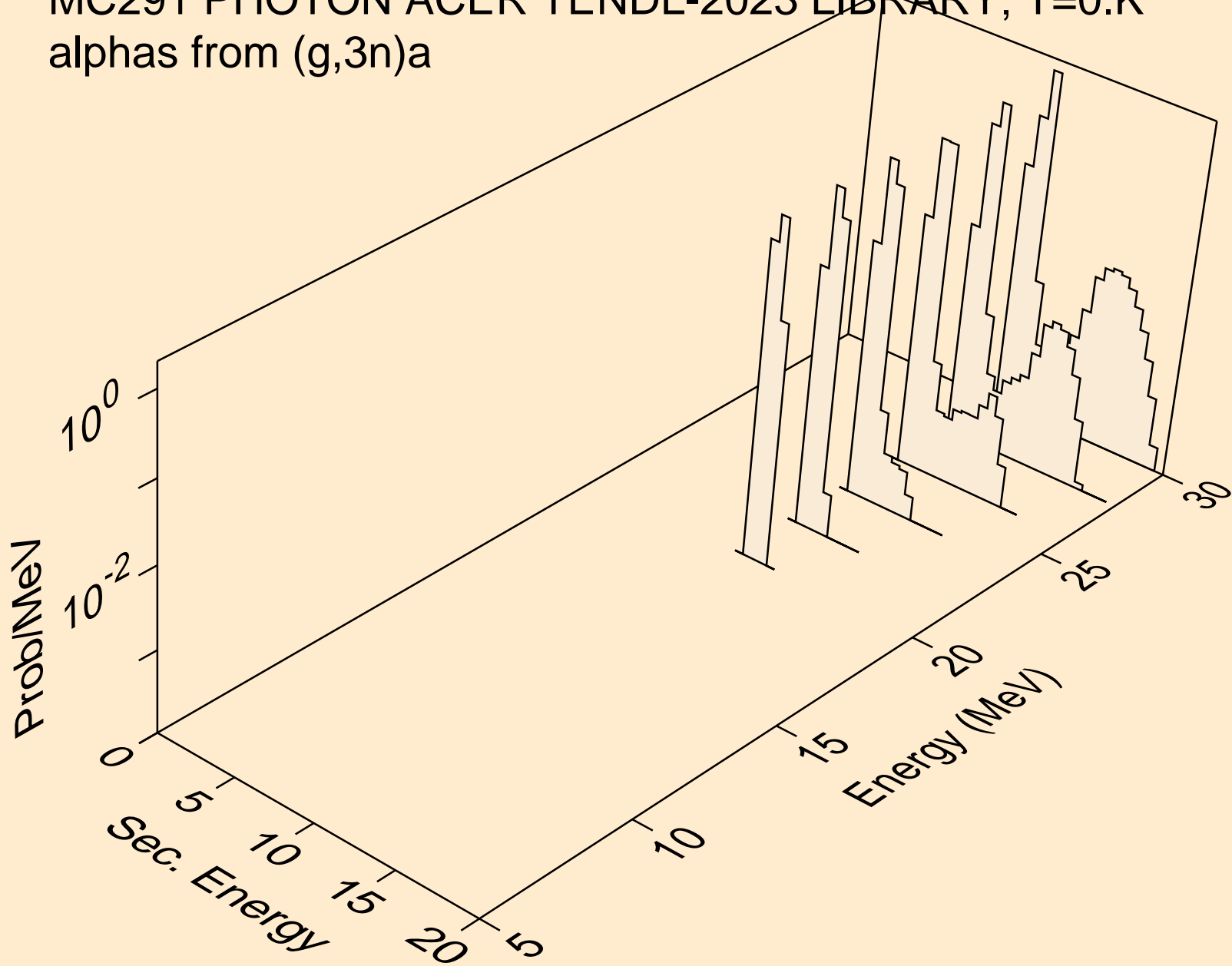

MC291 PHOTON ACER TENDL-2023 LIBRARY; T=0.K
alphas from (g,npa)

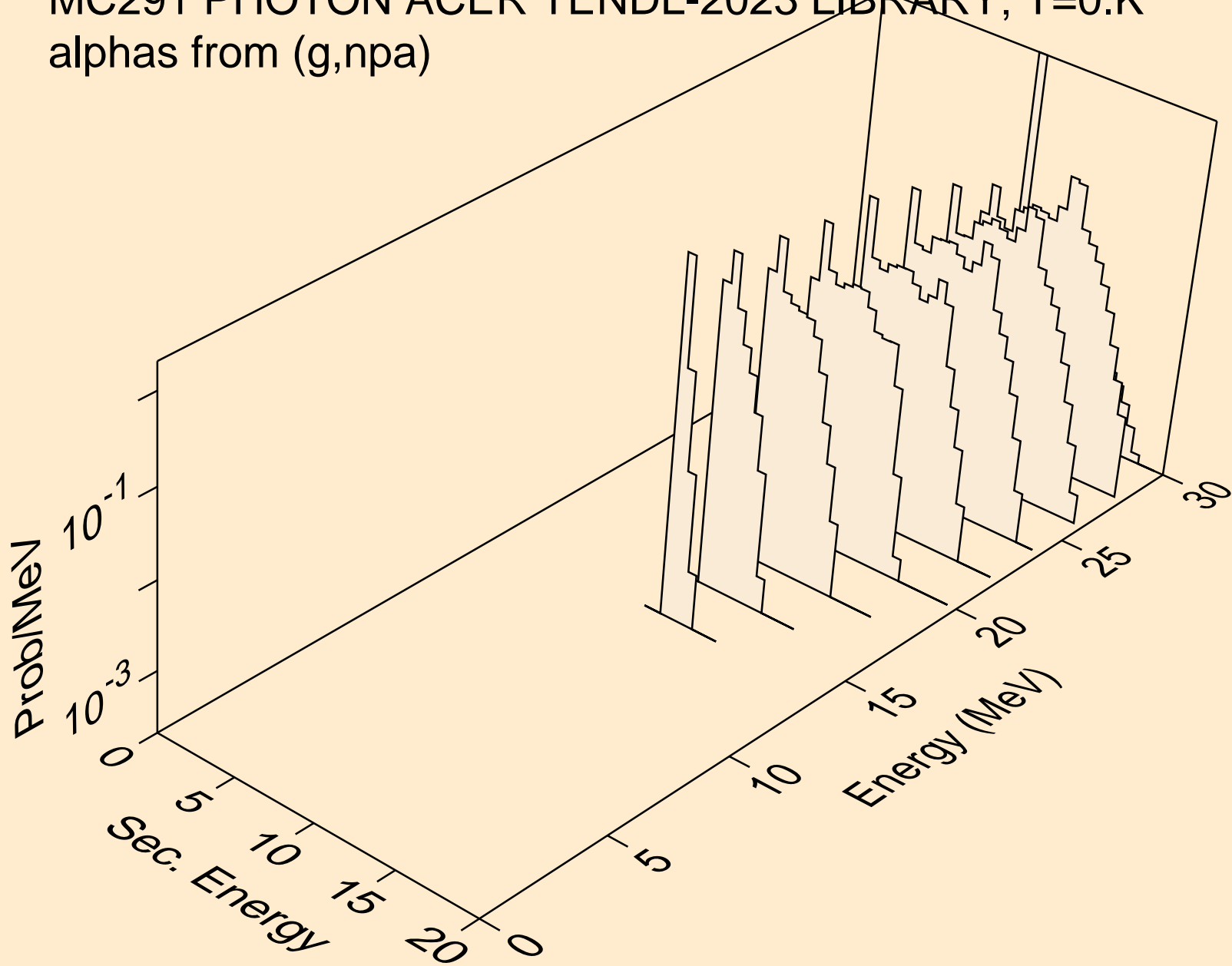

MC291 PHOTON ACER TENDL-2023 LIBRARY; T=0.K
alphas from (g,a)

