

MN054 PHOTON ACER TENDL-2023 LIBRARY; T=0.K
Principal cross sections

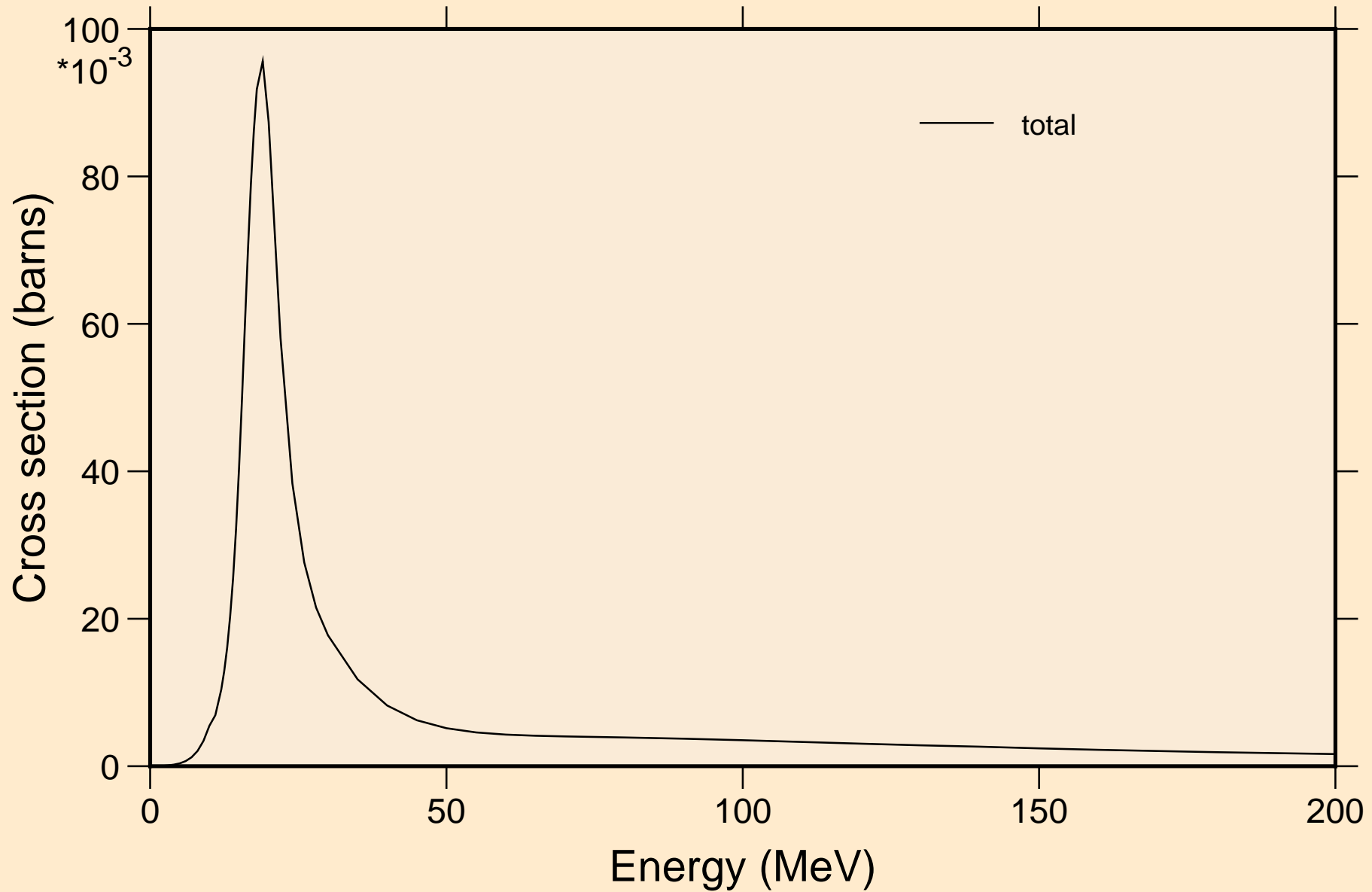

MN054 PHOTON ACER TENDL-2023 LIBRARY; T=0.K

Partial cross sections

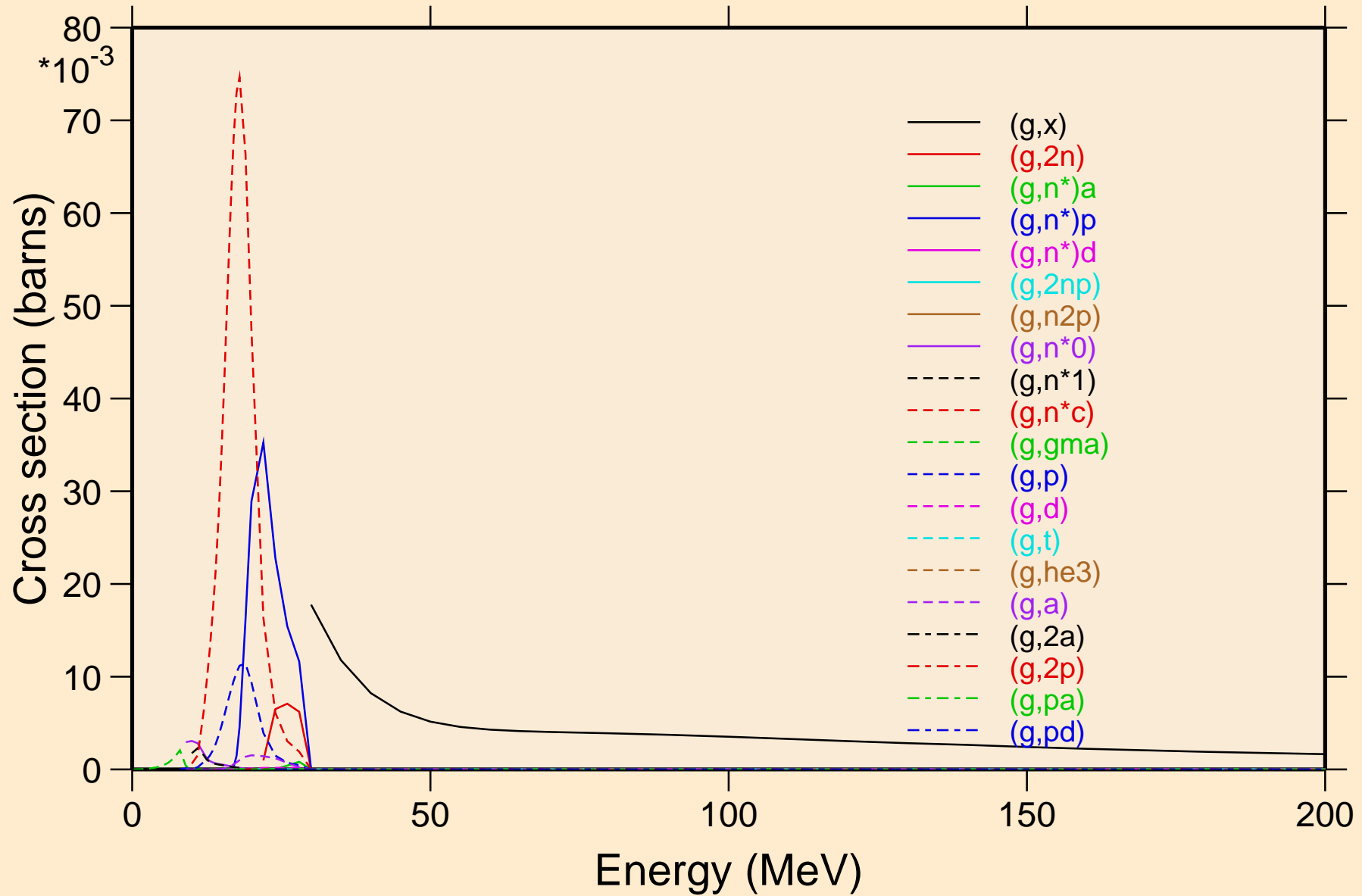

MN054 PHOTON ACER TENDL-2023 LIBRARY; T=0.K

Heating

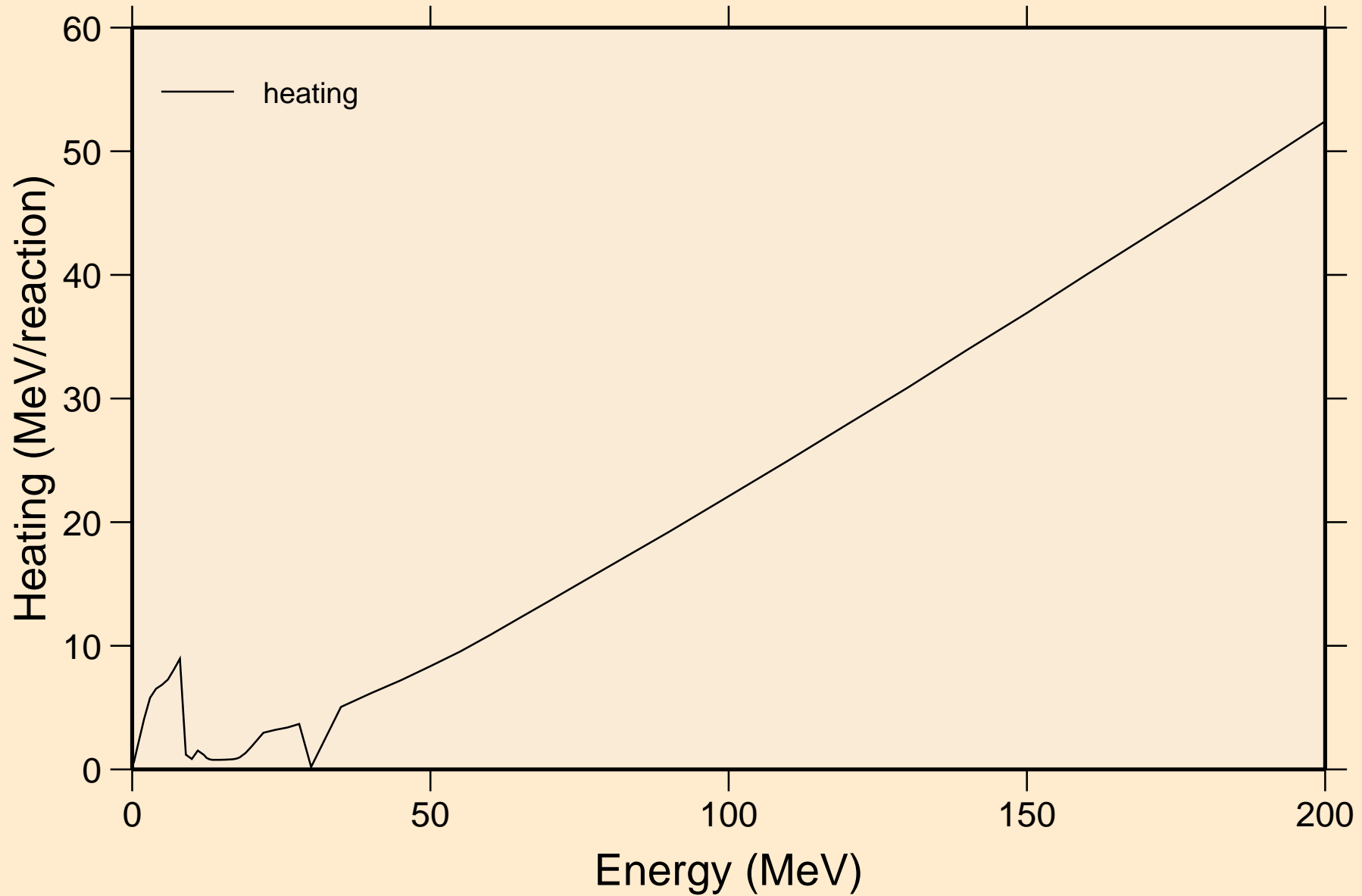

MN054 PHOTON ACER TENDL-2023 LIBRARY; T=0.K

Particle heating contributions

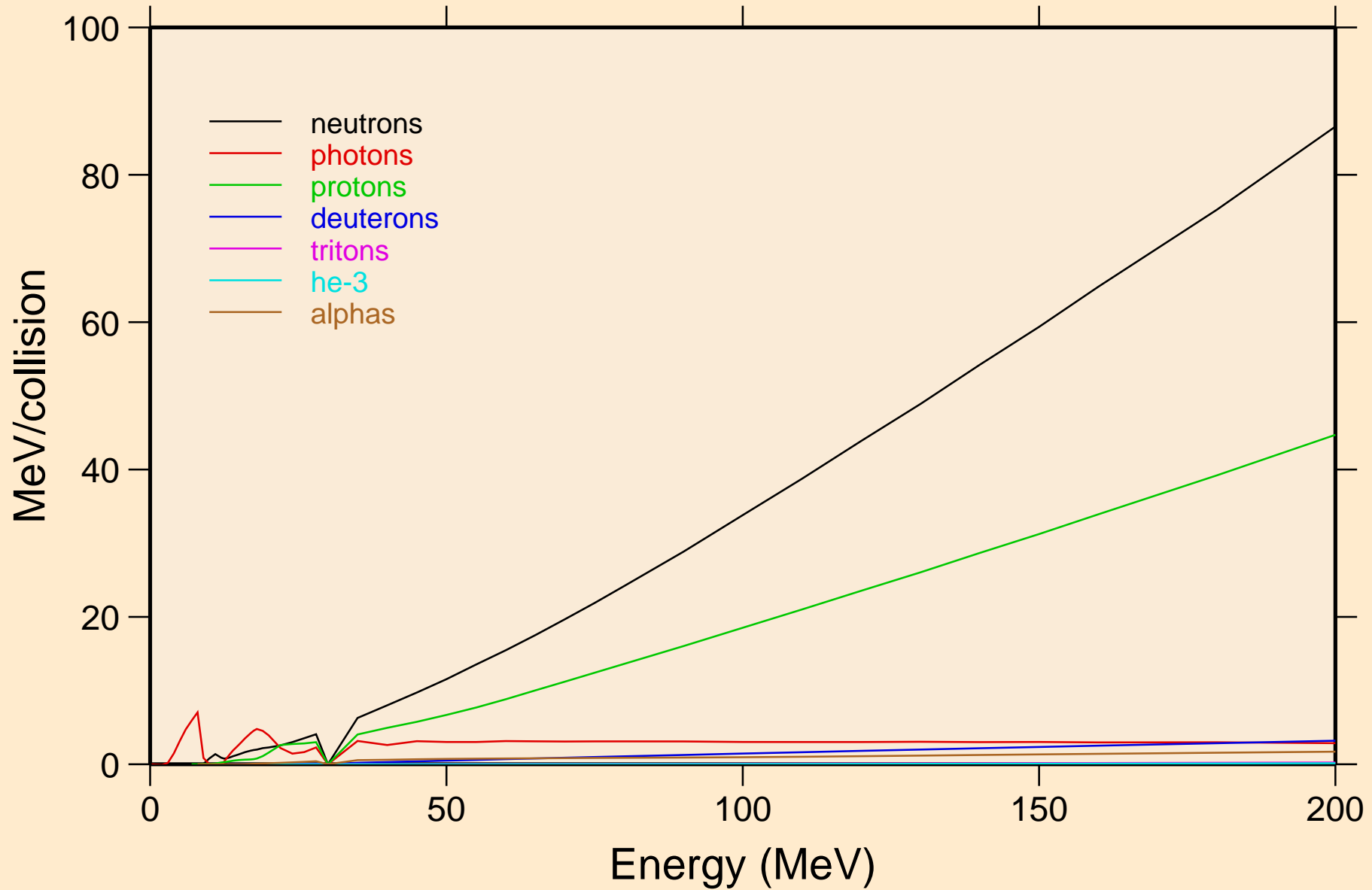

MN054 PHOTON ACER TENDL-2023 LIBRARY; T=0.K

Particle production cross sections

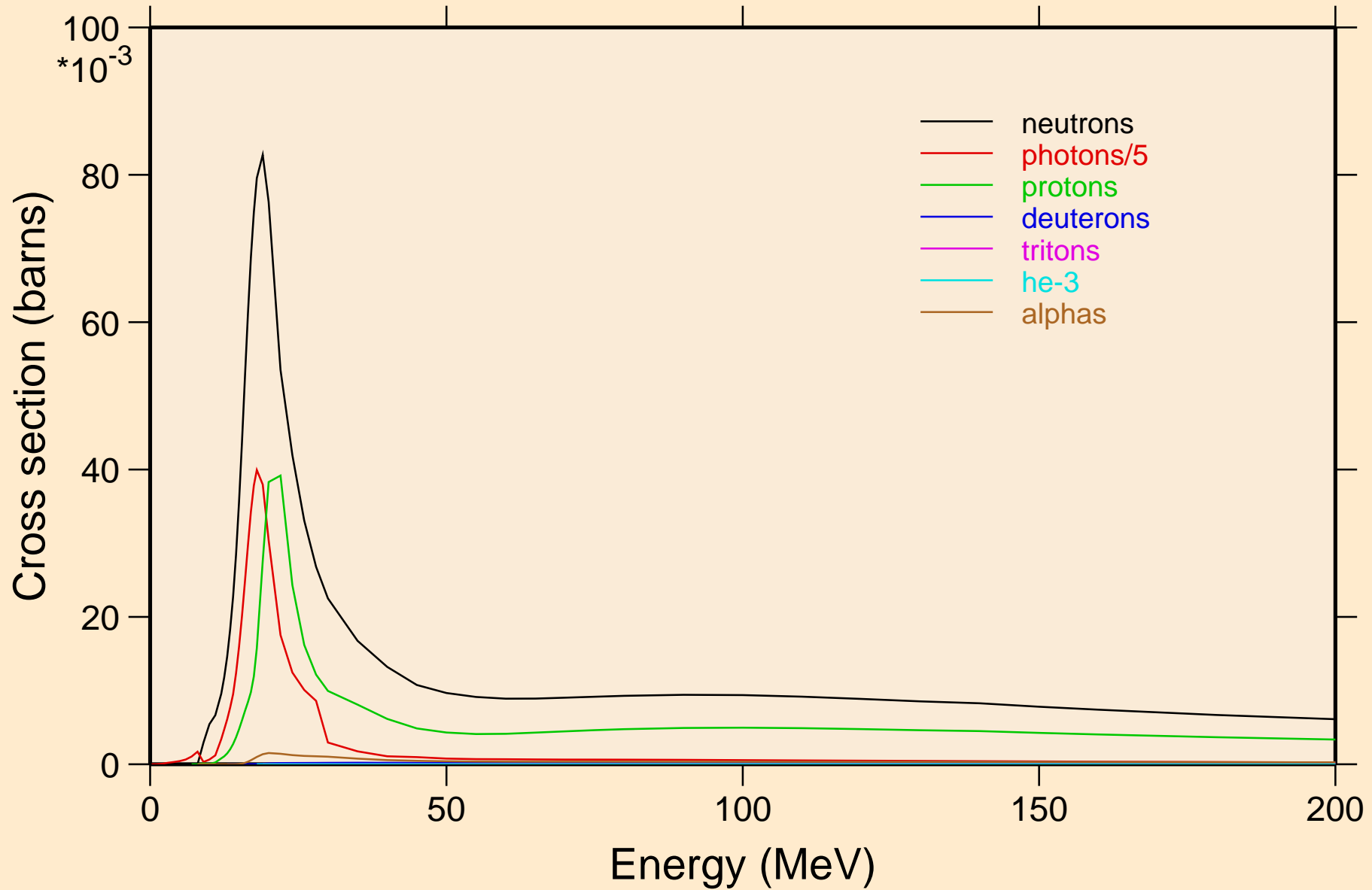

MN054 PHOTON ACER TENDL-2023 LIBRARY; T=0.K
neutrons from (g,x)

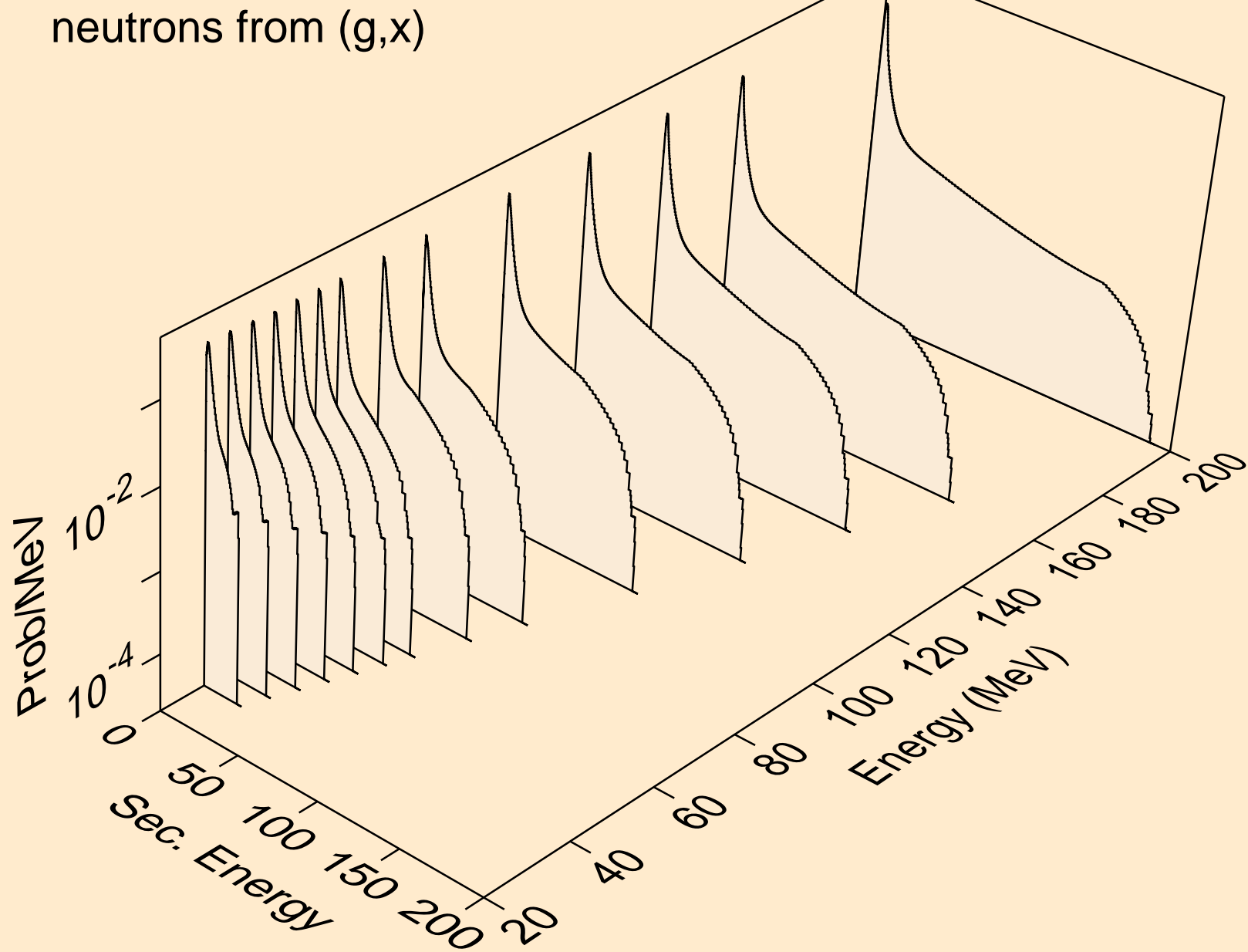

MN054 PHOTON ACER TENDL-2023 LIBRARY; T=0.K
neutrons from (g,2n)

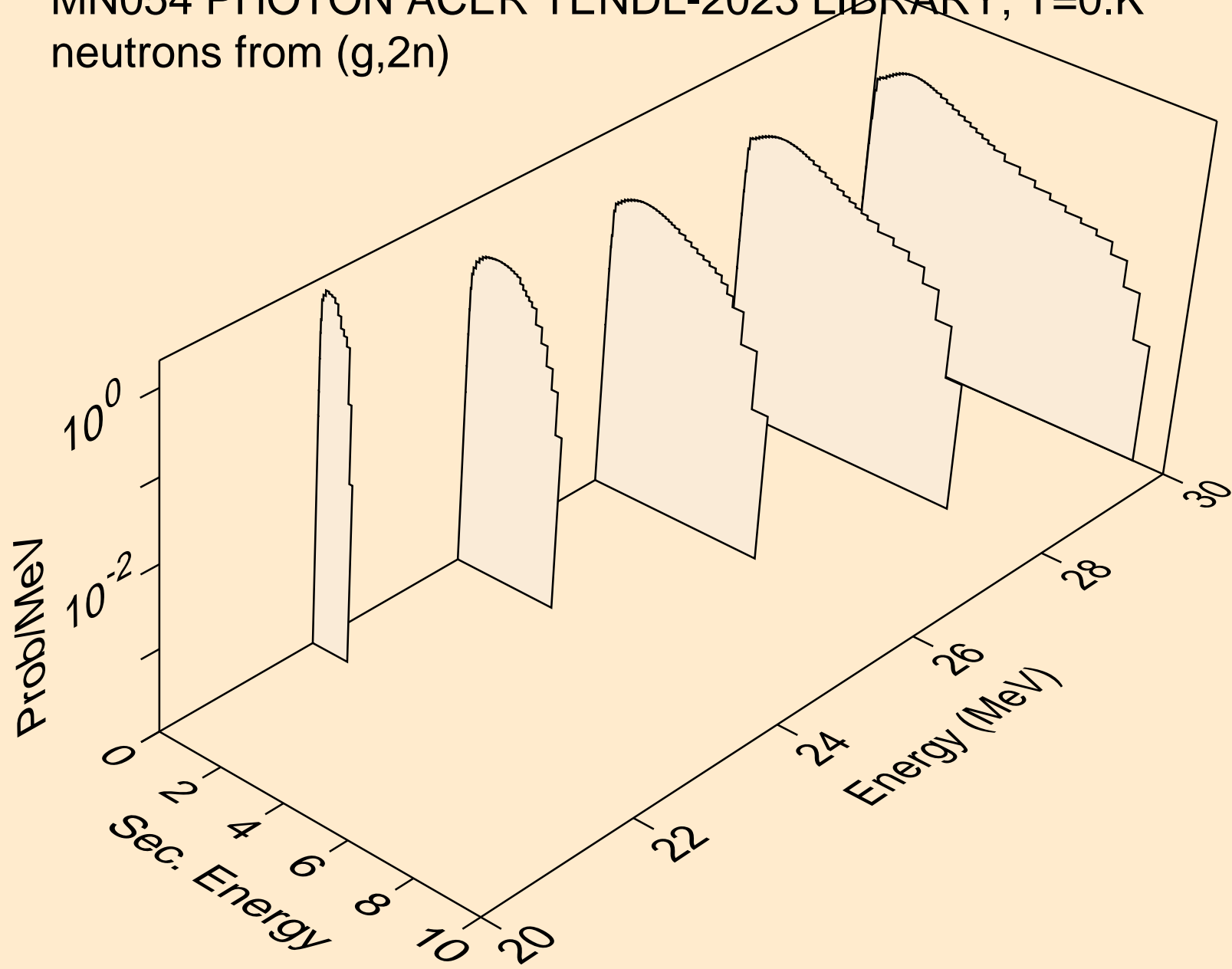

MN054 PHOTON ACER TENDL-2023 LIBRARY; T=0.K
neutrons from (g,n*)a

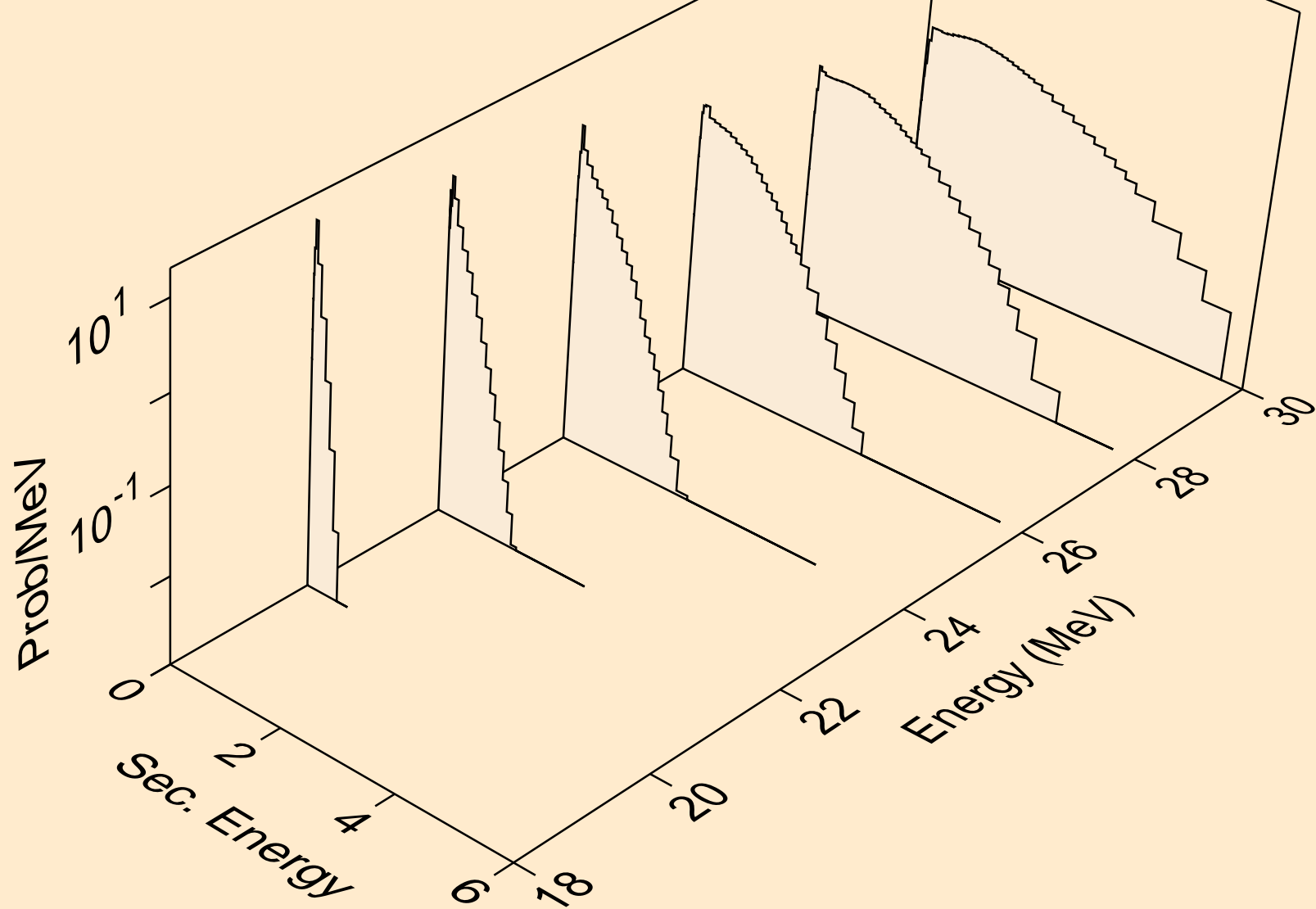

MN054 PHOTON ACER TENDL-2023 LIBRARY; T=0.K
neutrons from (g,n*)p

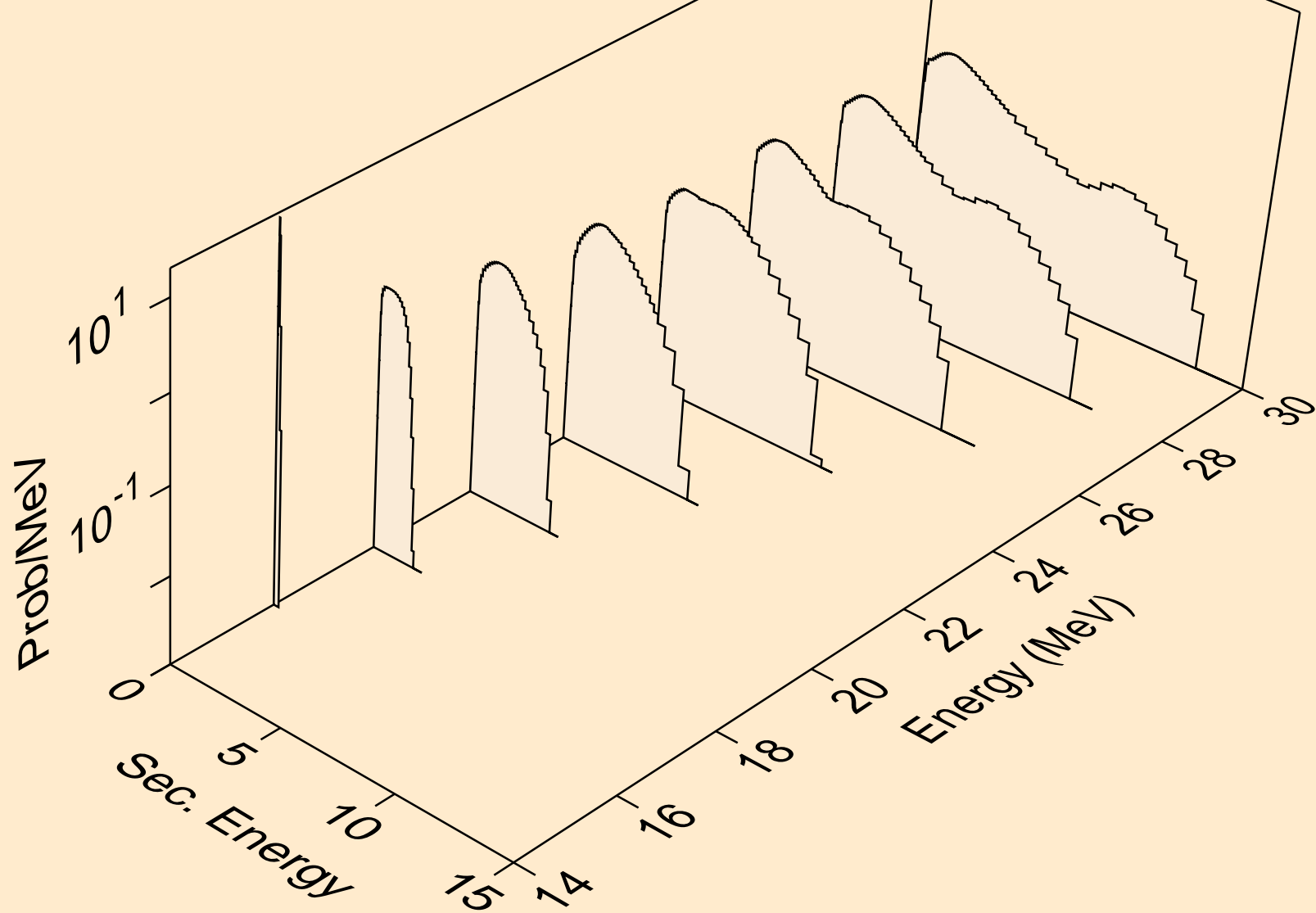

MN054 PHOTON ACER TENDL-2023 LIBRARY; T=0.K
neutrons from (g,n*)d

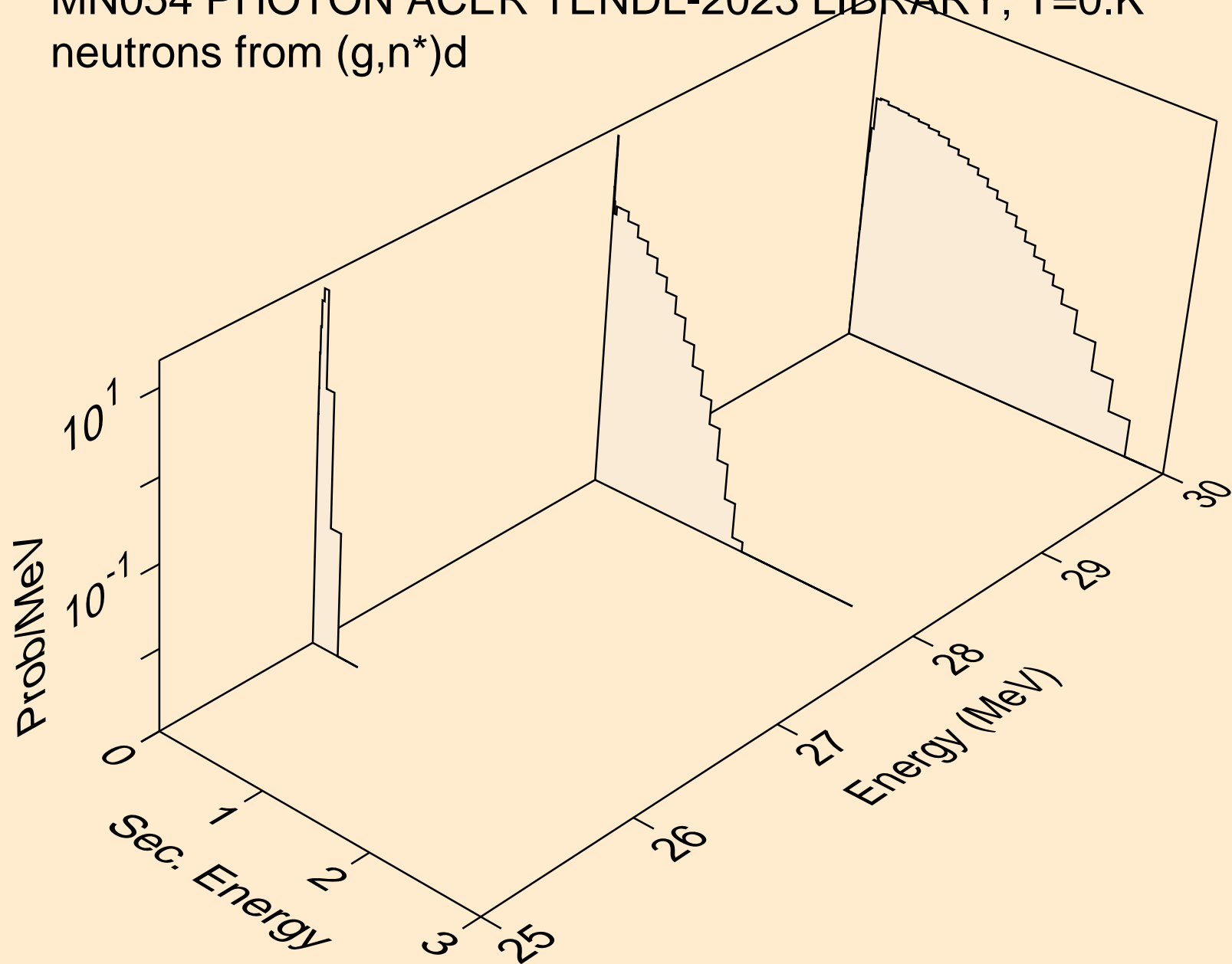

MN054 PHOTON ACER TENDL-2023 LIBRARY; T=0.K
neutrons from (g,2np)

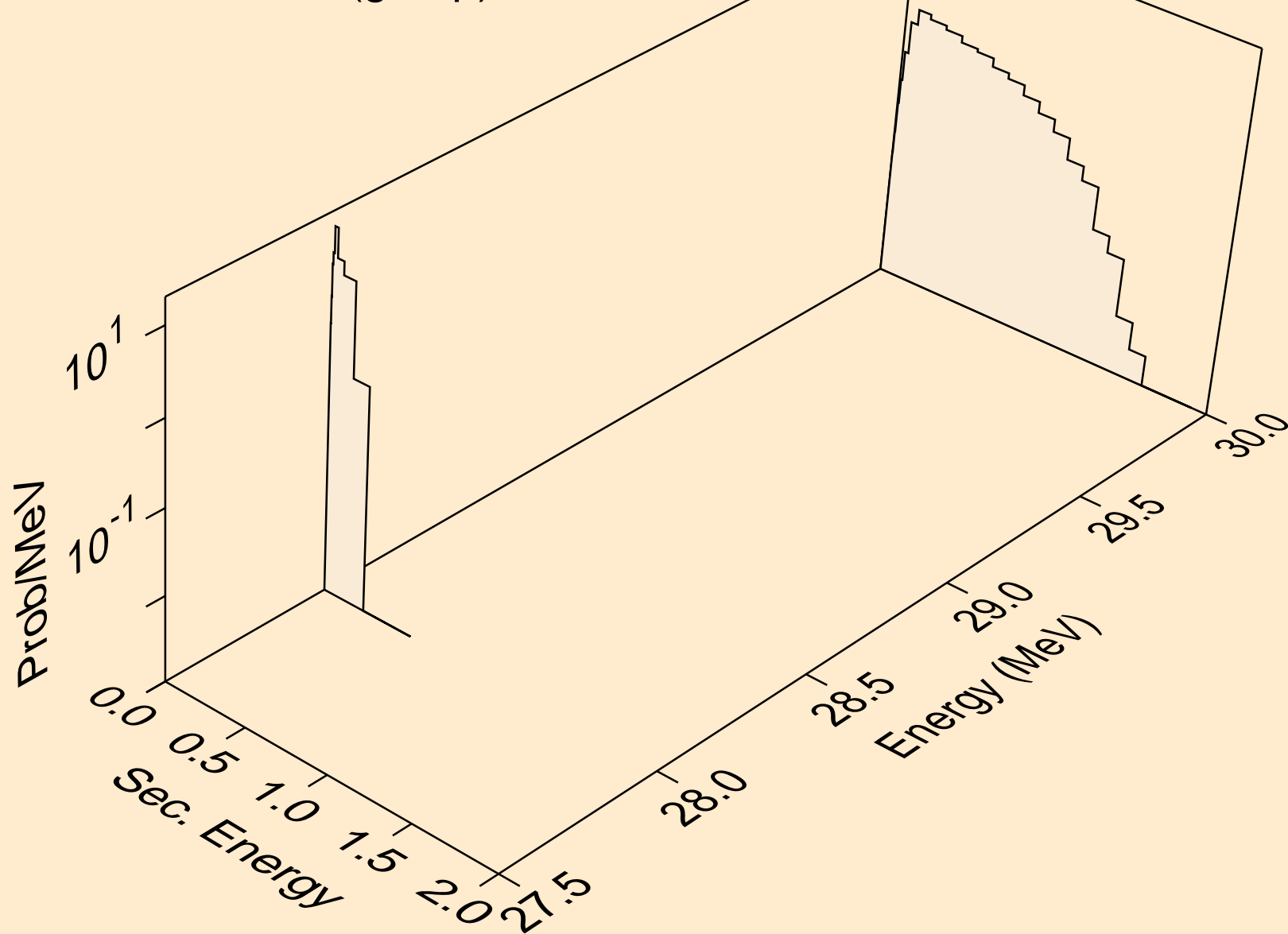

MN054 PHOTON ACER TENDL-2023 LIBRARY; T=0.K
neutrons from (g,n2p)

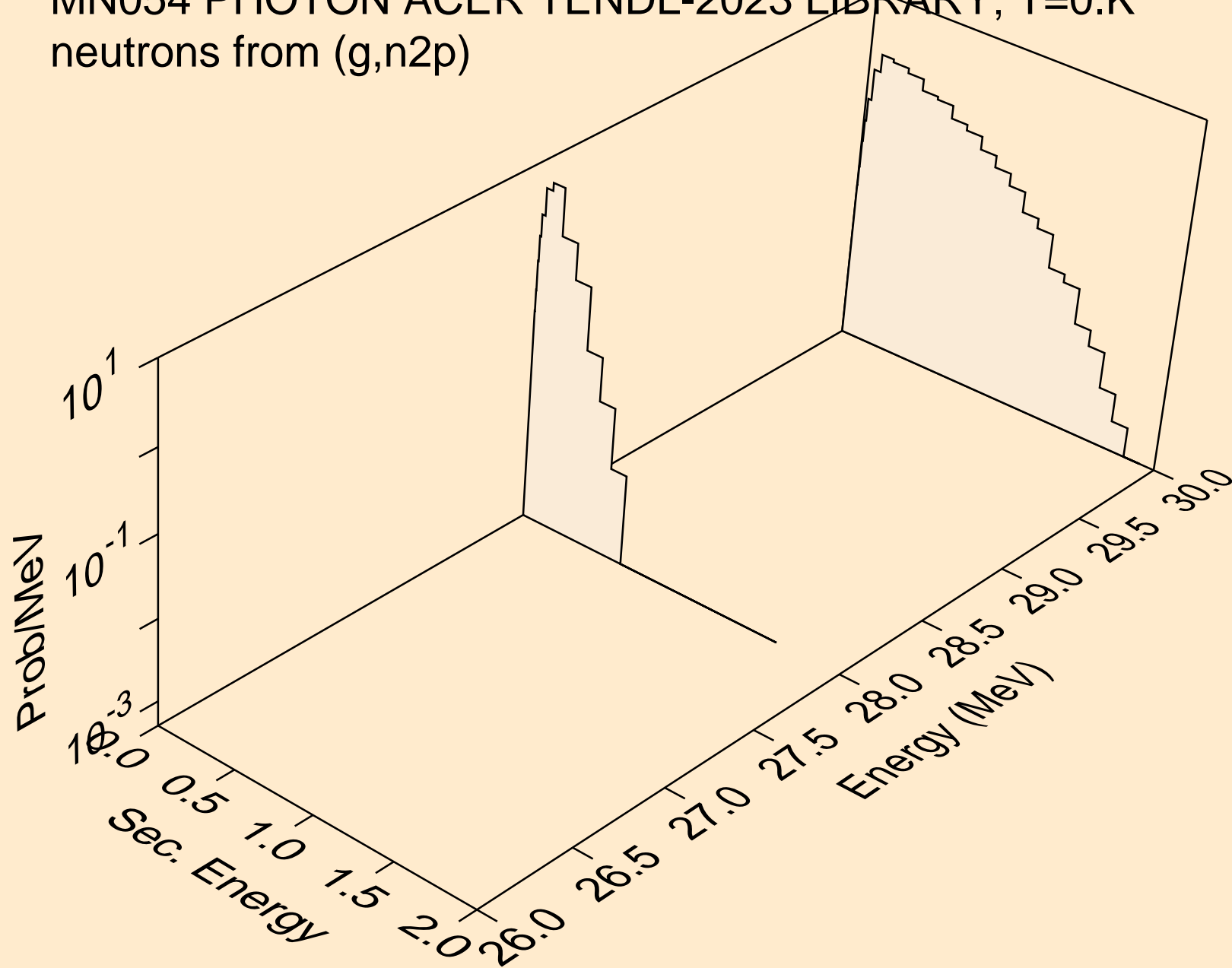

MN054 PHOTON ACER TENDL-2023 LIBRARY; T=0.K
angular distribution for (g,n*0) neutron

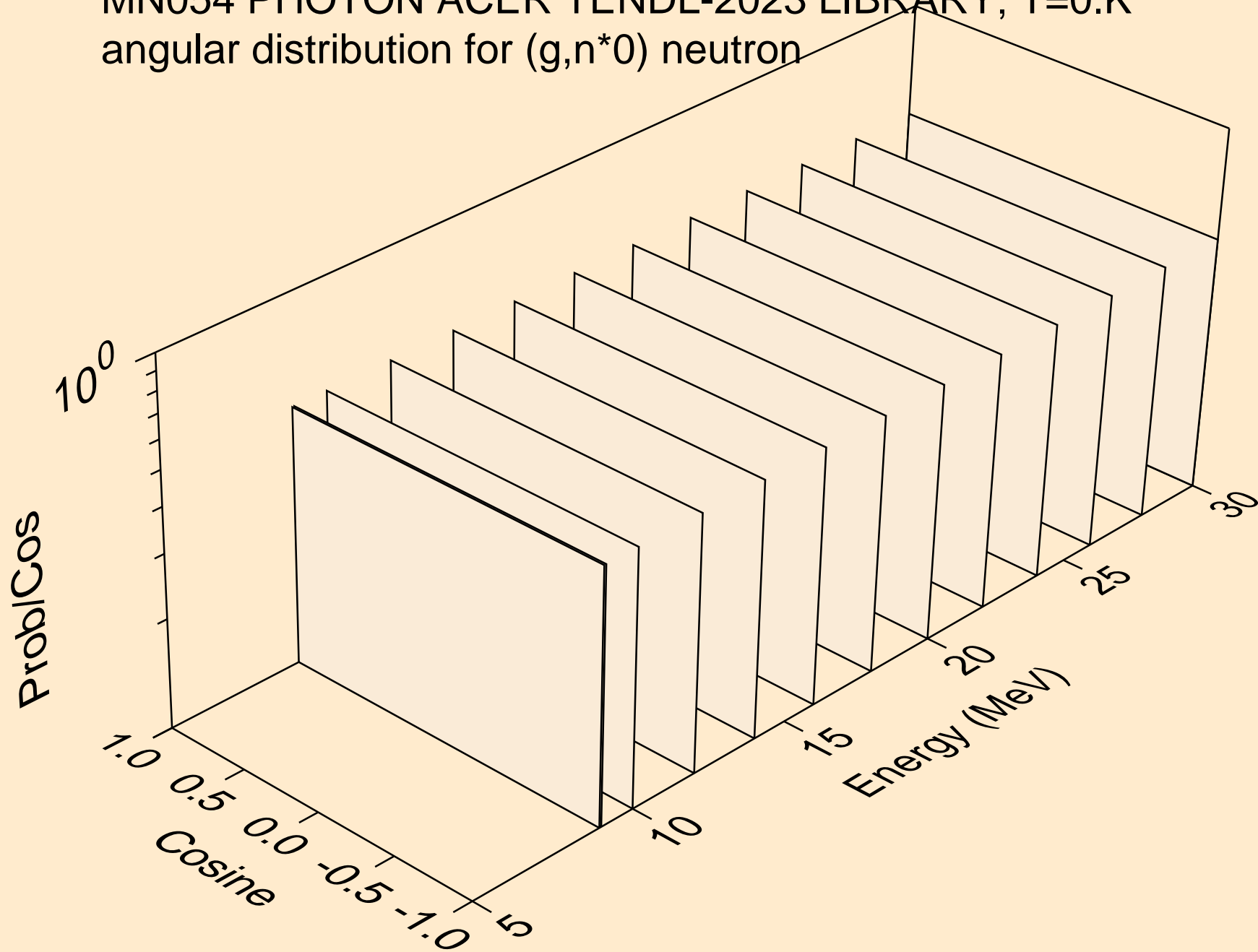

MN054 PHOTON ACER TENDL-2023 LIBRARY; T=0.K
angular distribution for (g,n*1) neutron

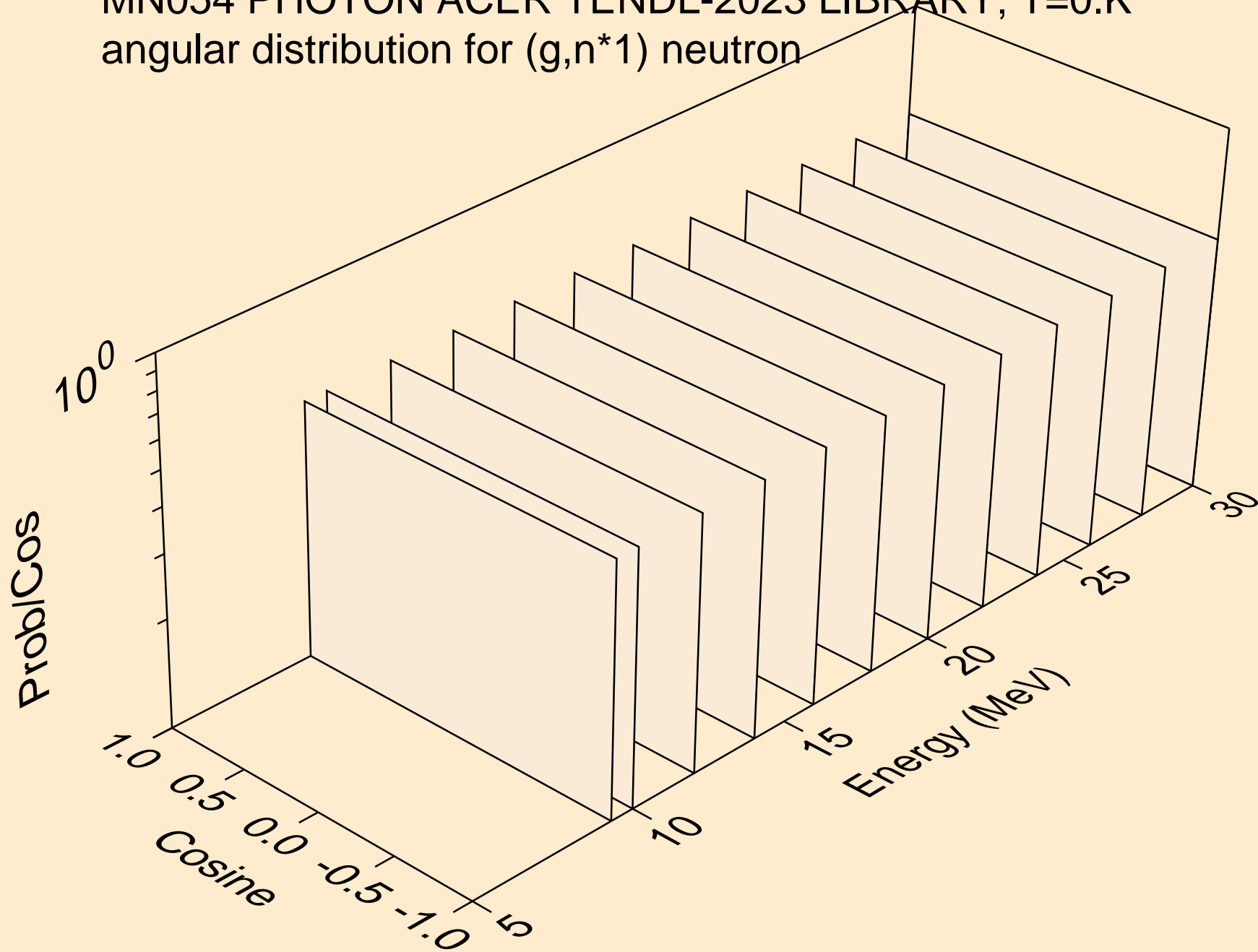

MN054 PHOTON ACER TENDL-2023 LIBRARY; T=0.K
neutrons from (g,n*c)

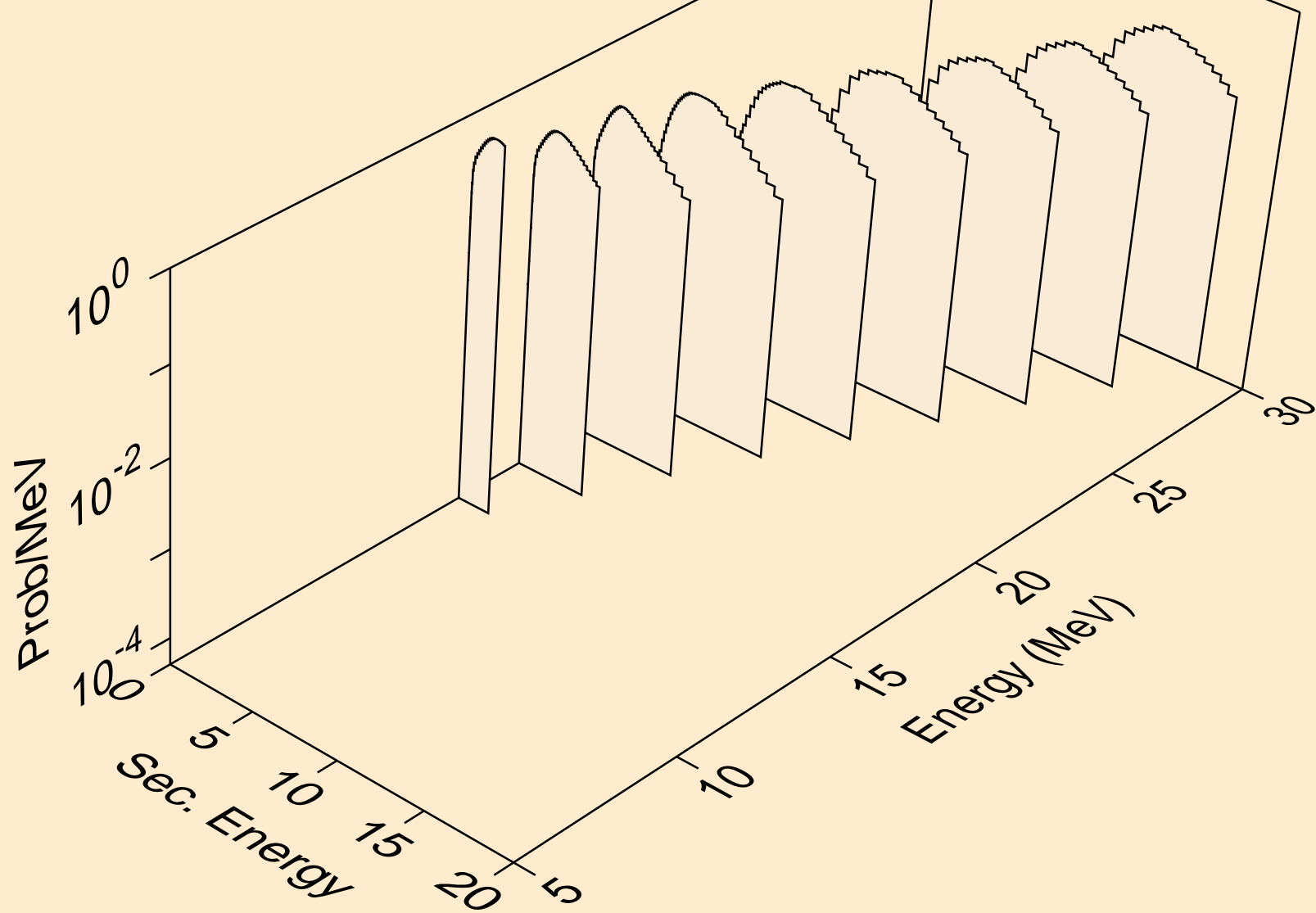

MN054 PHOTON ACER TENDL-2023 LIBRARY; T=0.K
photons from (g,x)

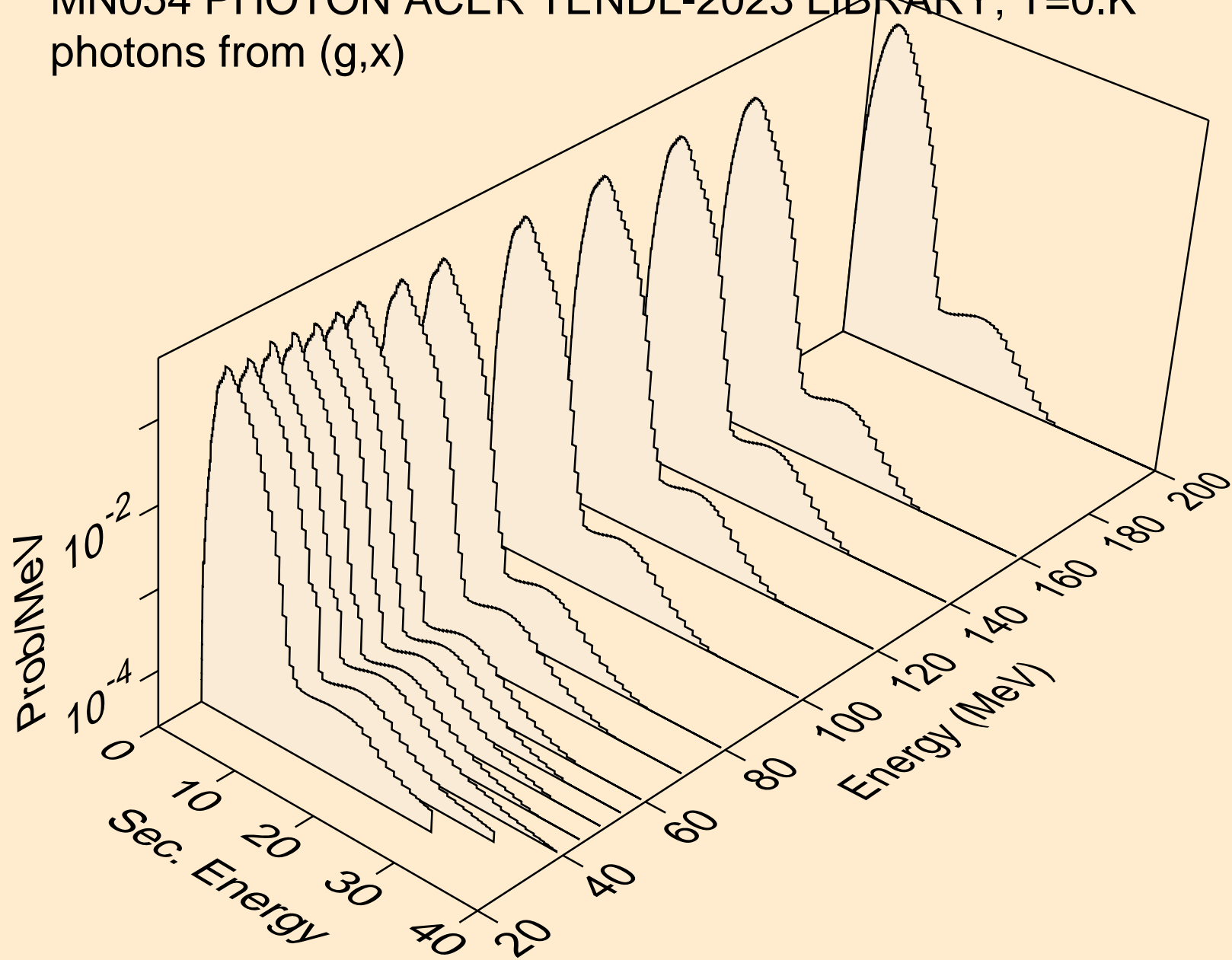

MN054 PHOTON ACER TENDL-2023 LIBRARY; T=0.K
photons from (g,2n)

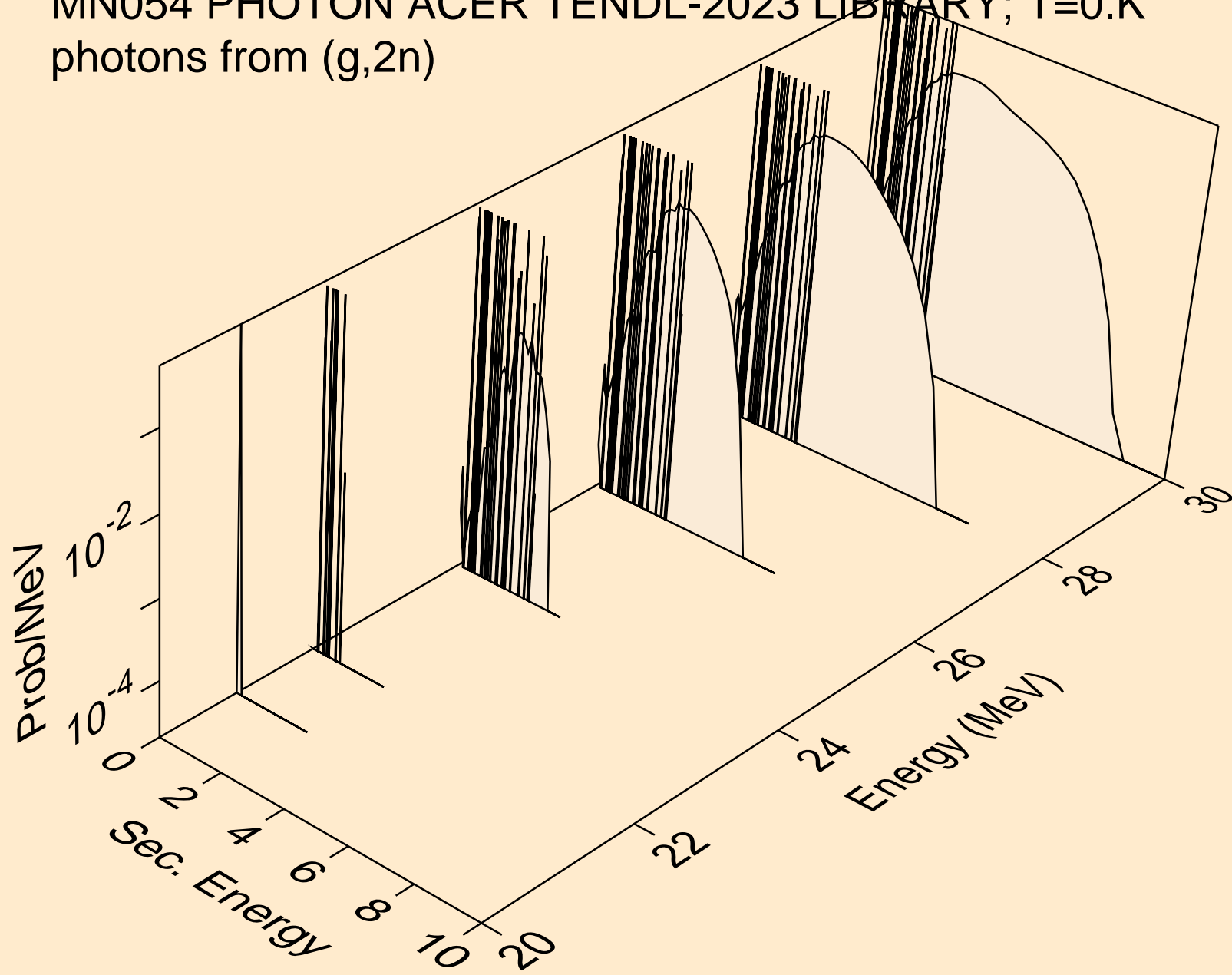

MN054 PHOTON ACER TENDL-2023 LIBRARY; T=0.K
photons from (g,n*)a

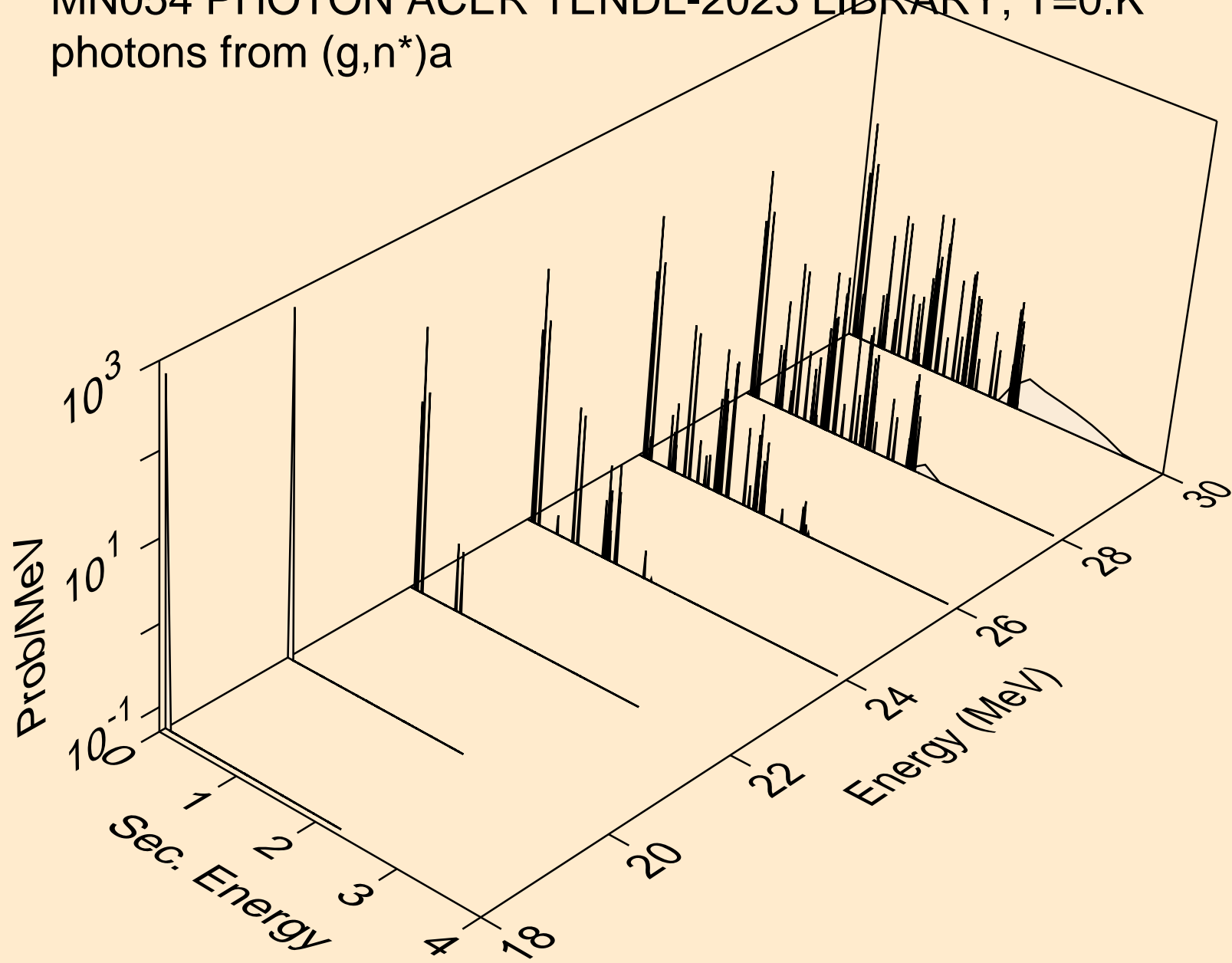

MN054 PHOTON ACER TENDL-2023 LIBRARY; T=0.K
photons from (g,n*)p

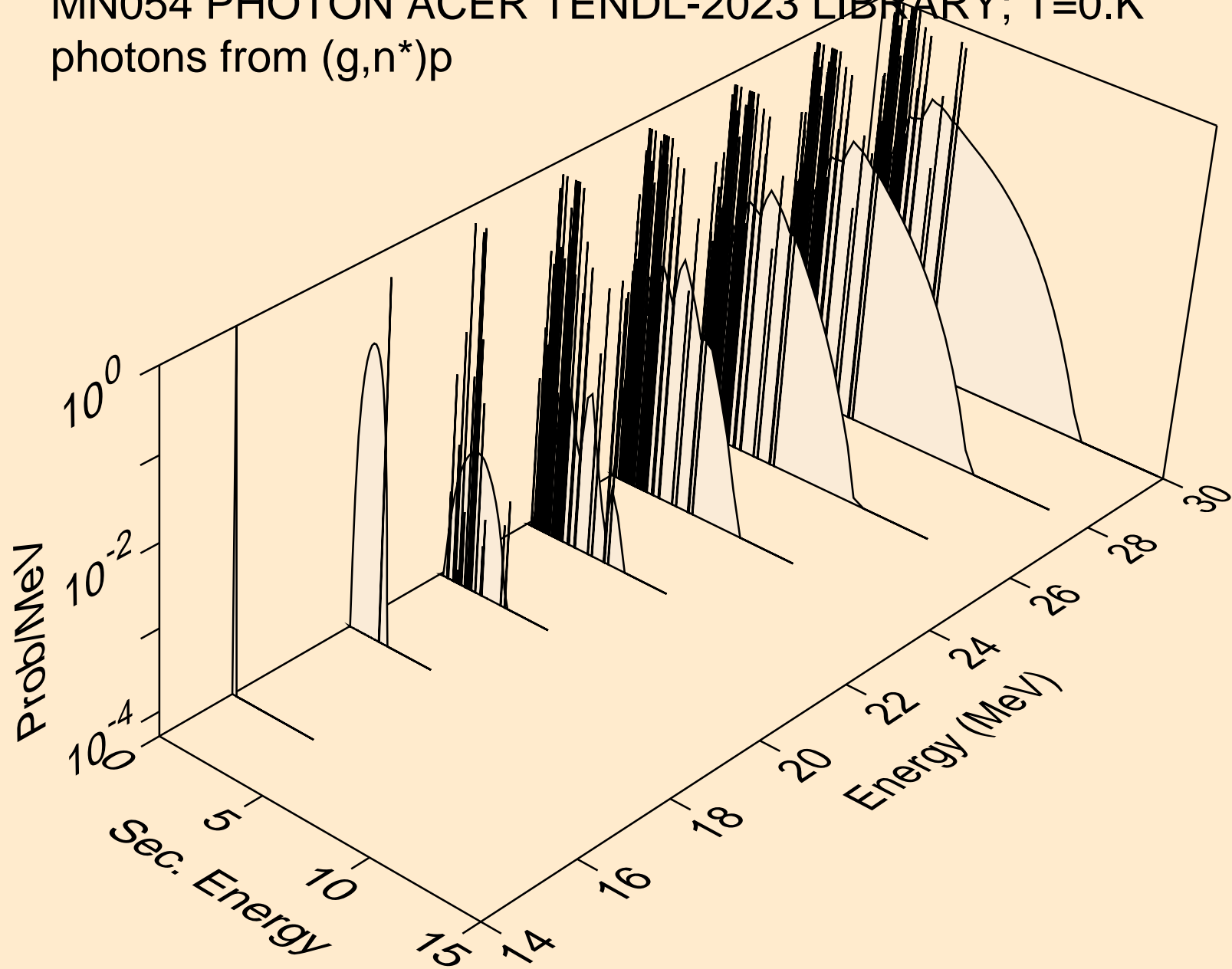

MN054 PHOTON ACER TENDL-2023 LIBRARY; T=0.K
photons from (g,n*)d

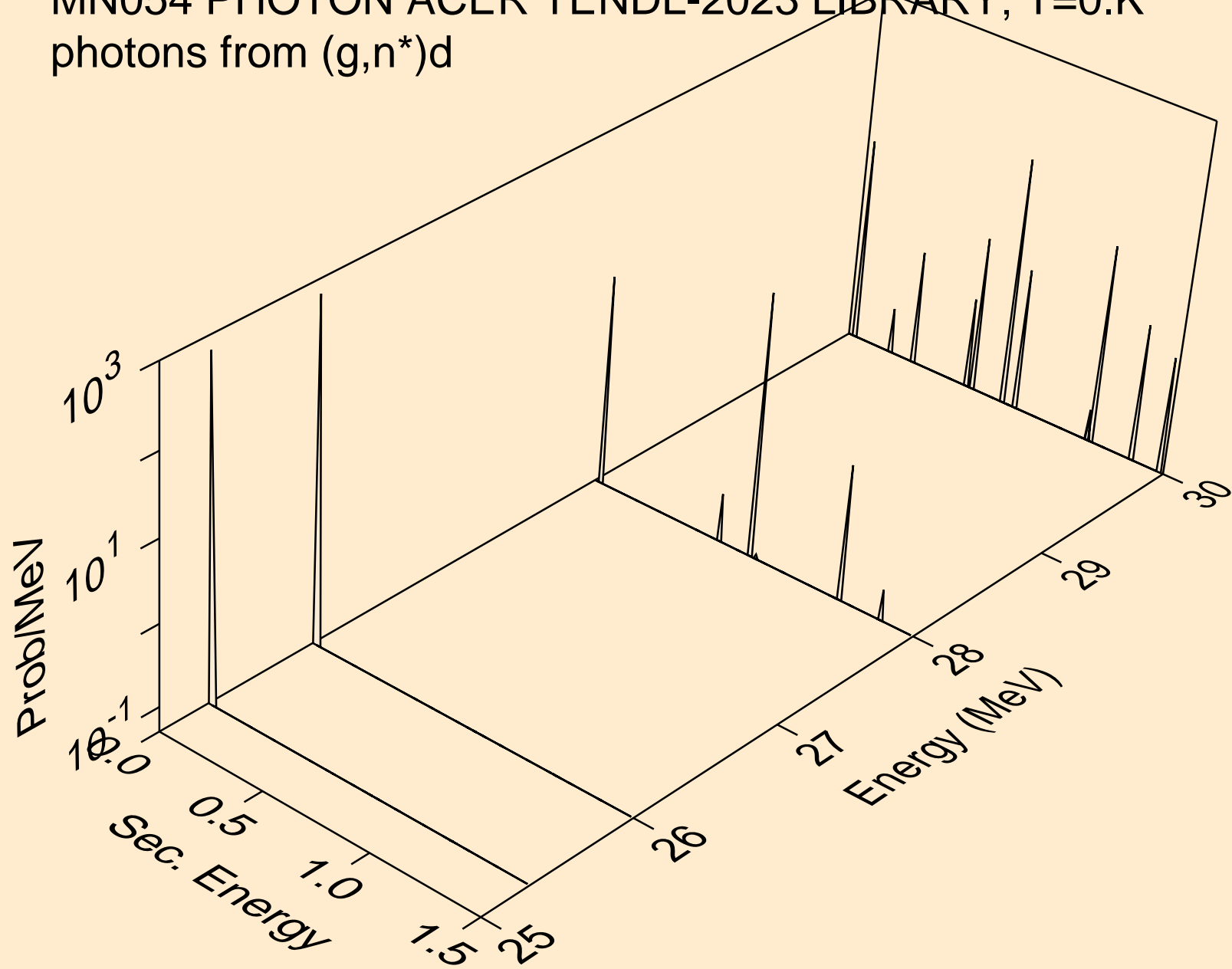

MN054 PHOTON ACER TENDL-2023 LIBRARY; T=0.K
photons from (g,2np)

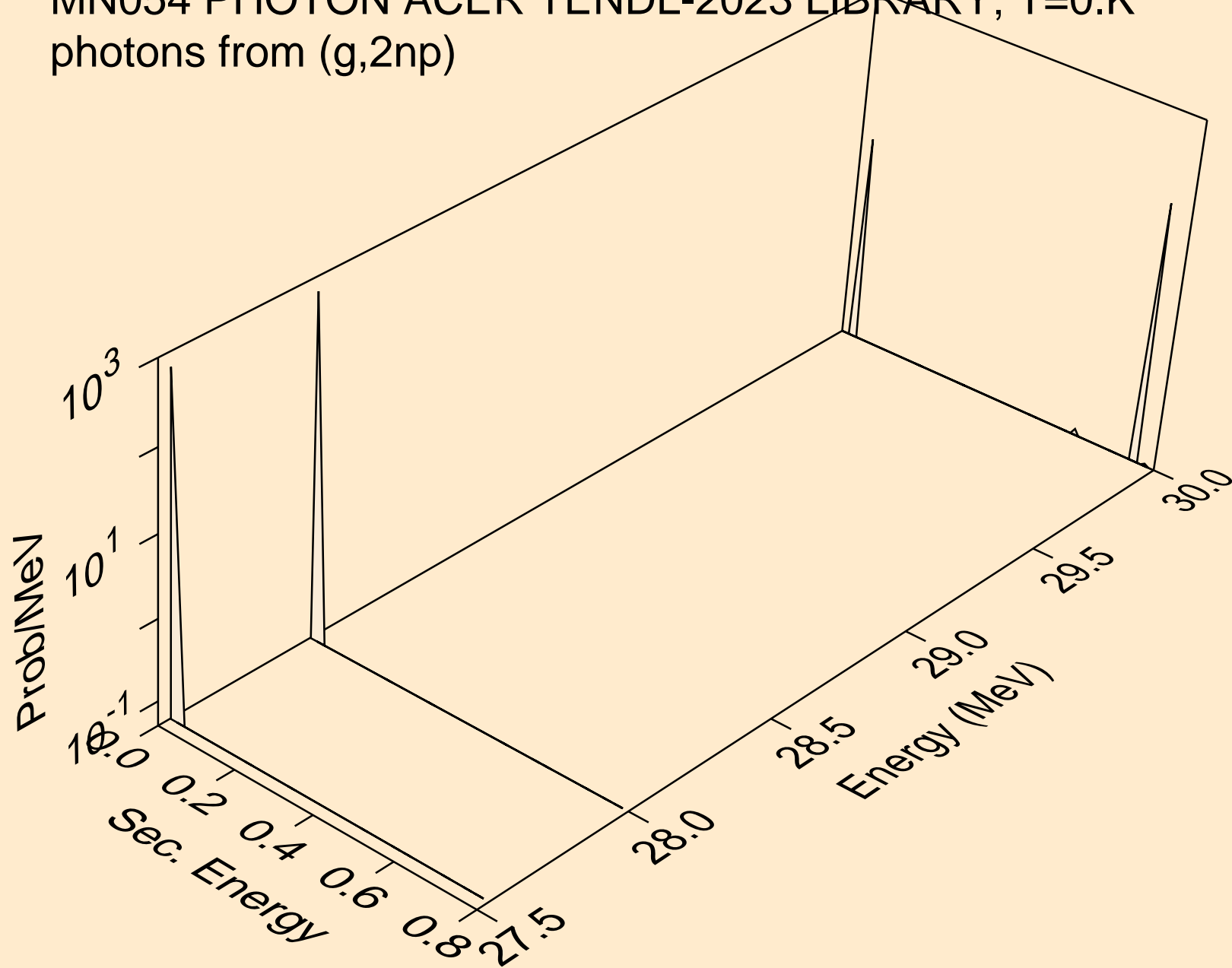

MN054 PHOTON ACER TENDL-2023 LIBRARY; T=0.K
photons from (g,n2p)

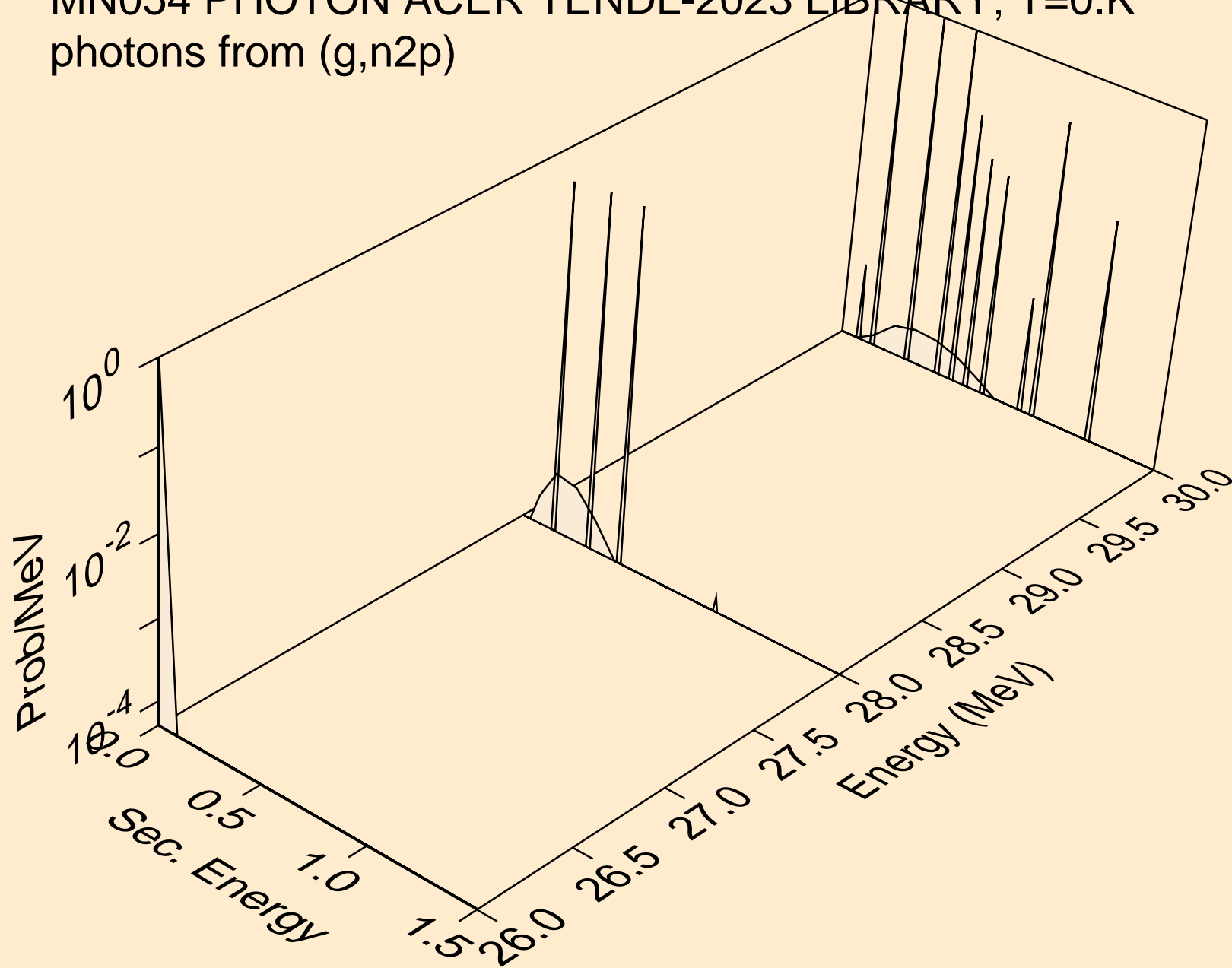

MN054 PHOTON ACER TENDL-2023 LIBRARY; T=0.K
photons from (g,n*c)

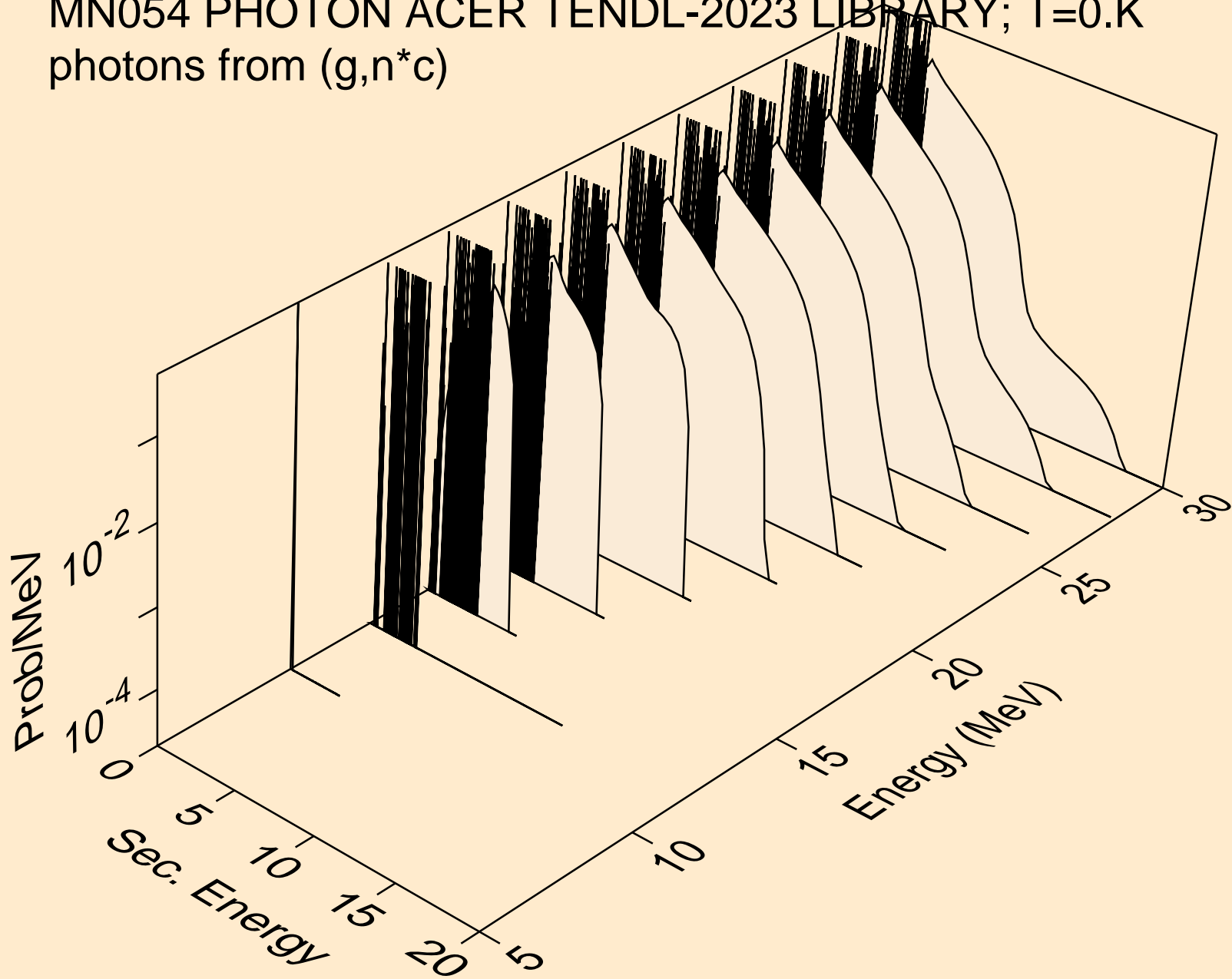

MN054 PHOTON ACER TENDL-2023 LIBRARY; T=0.K
photons from (g,gma)

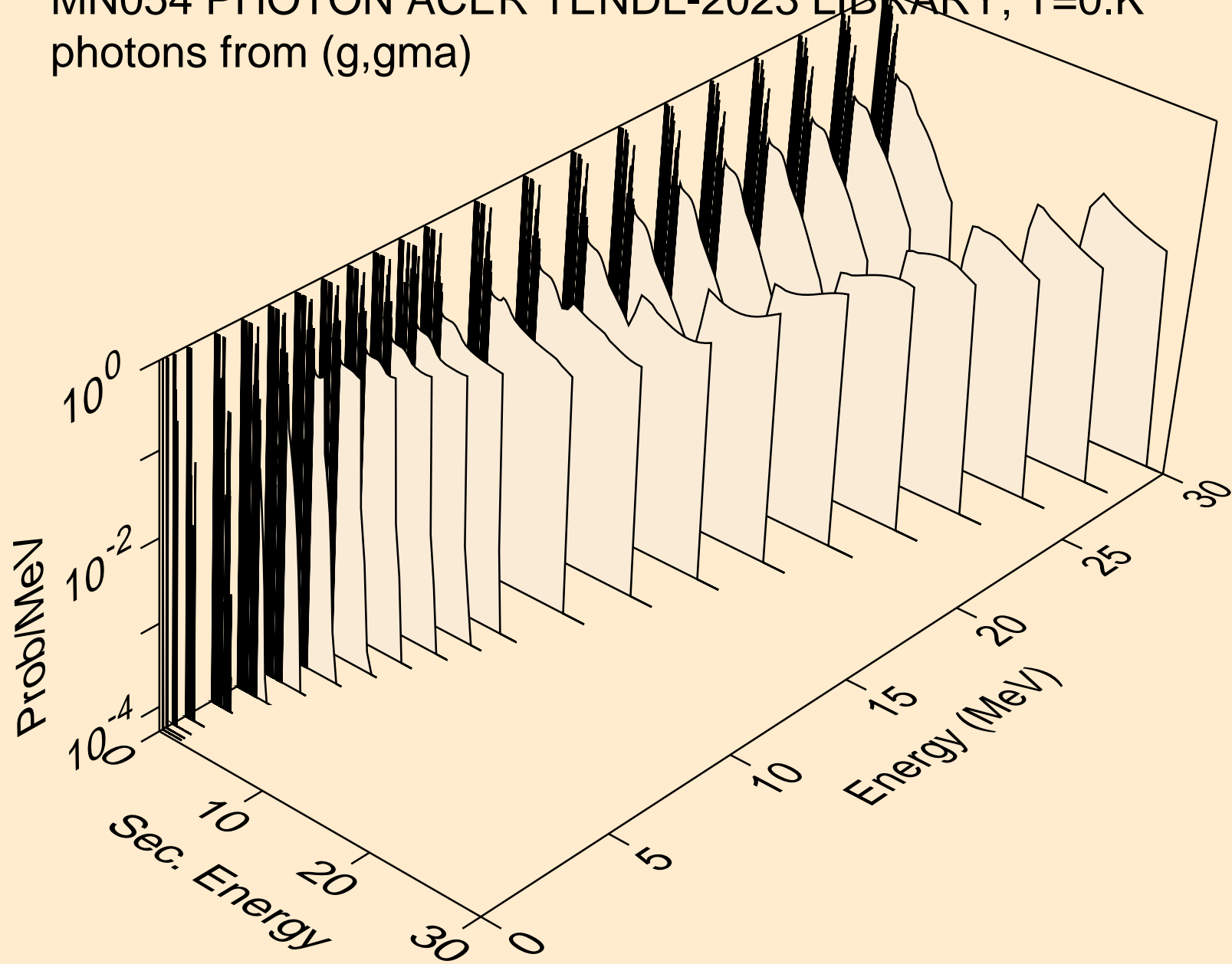

MN054 PHOTON ACER TENDL-2023 LIBRARY; T=0.K
photons from (g,p)

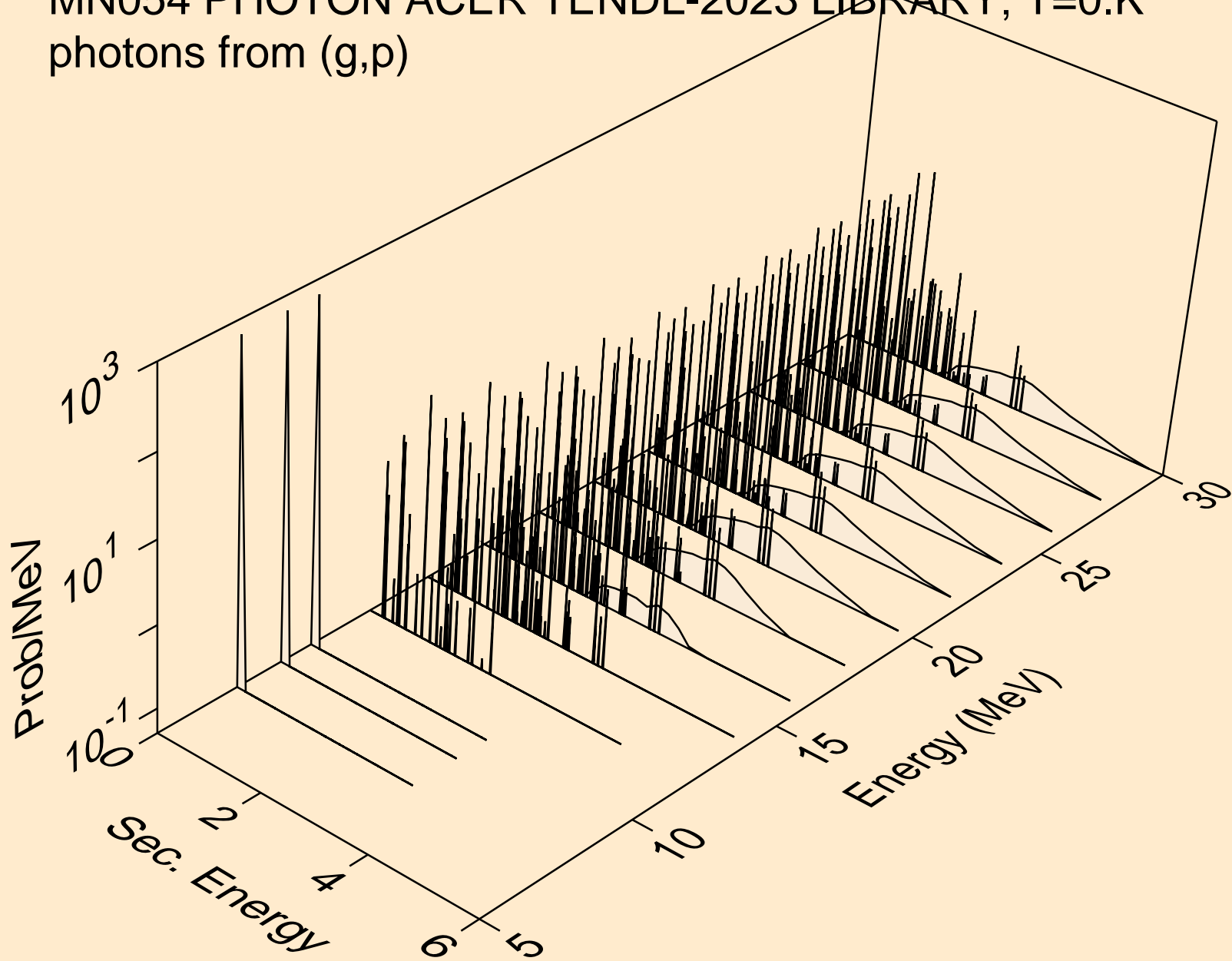

MN054 PHOTON ACER TENDL-2023 LIBRARY; T=0.K
photons from (g,d)

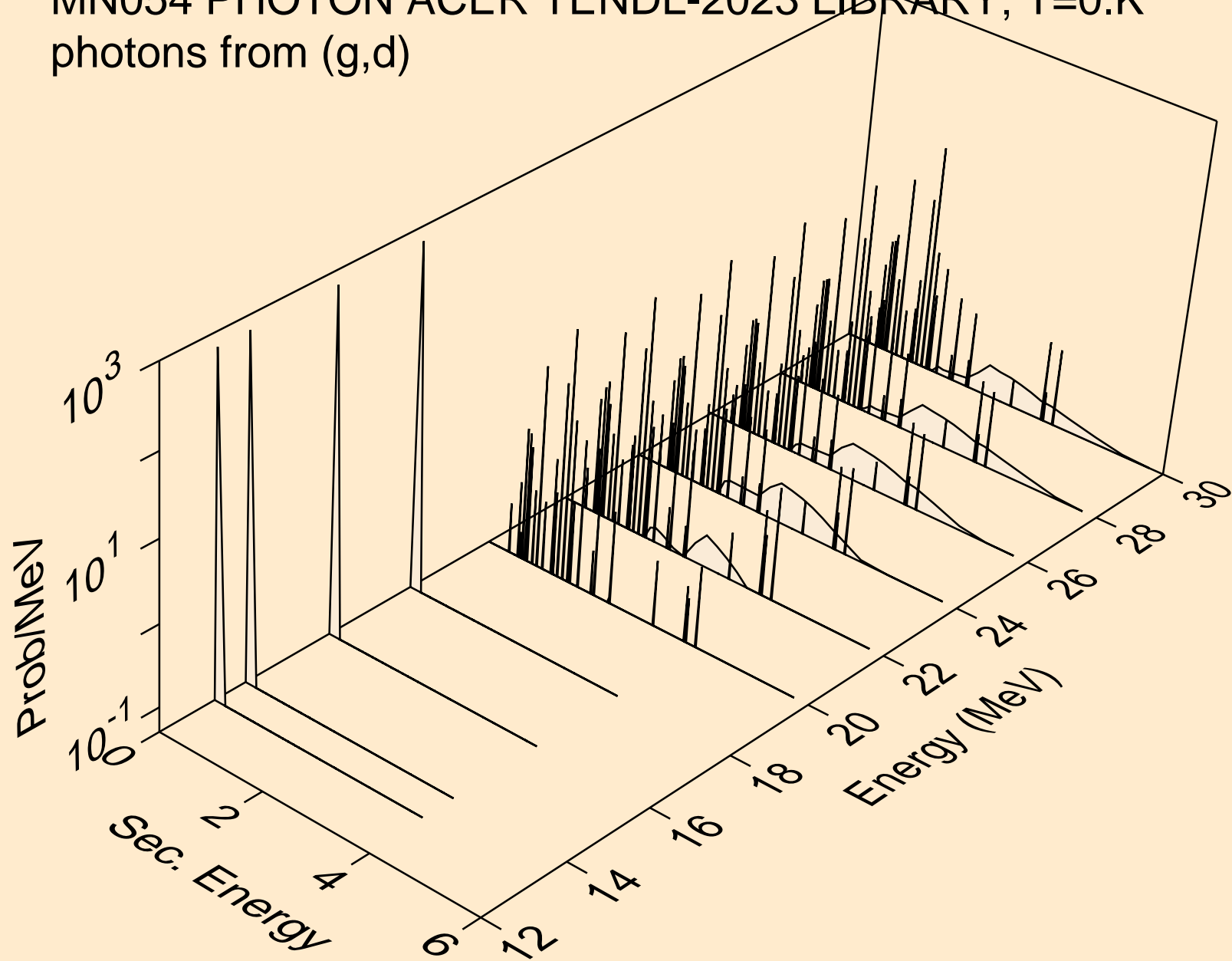

MN054 PHOTON ACER TENDL-2023 LIBRARY; T=0.K
photons from (g,t)

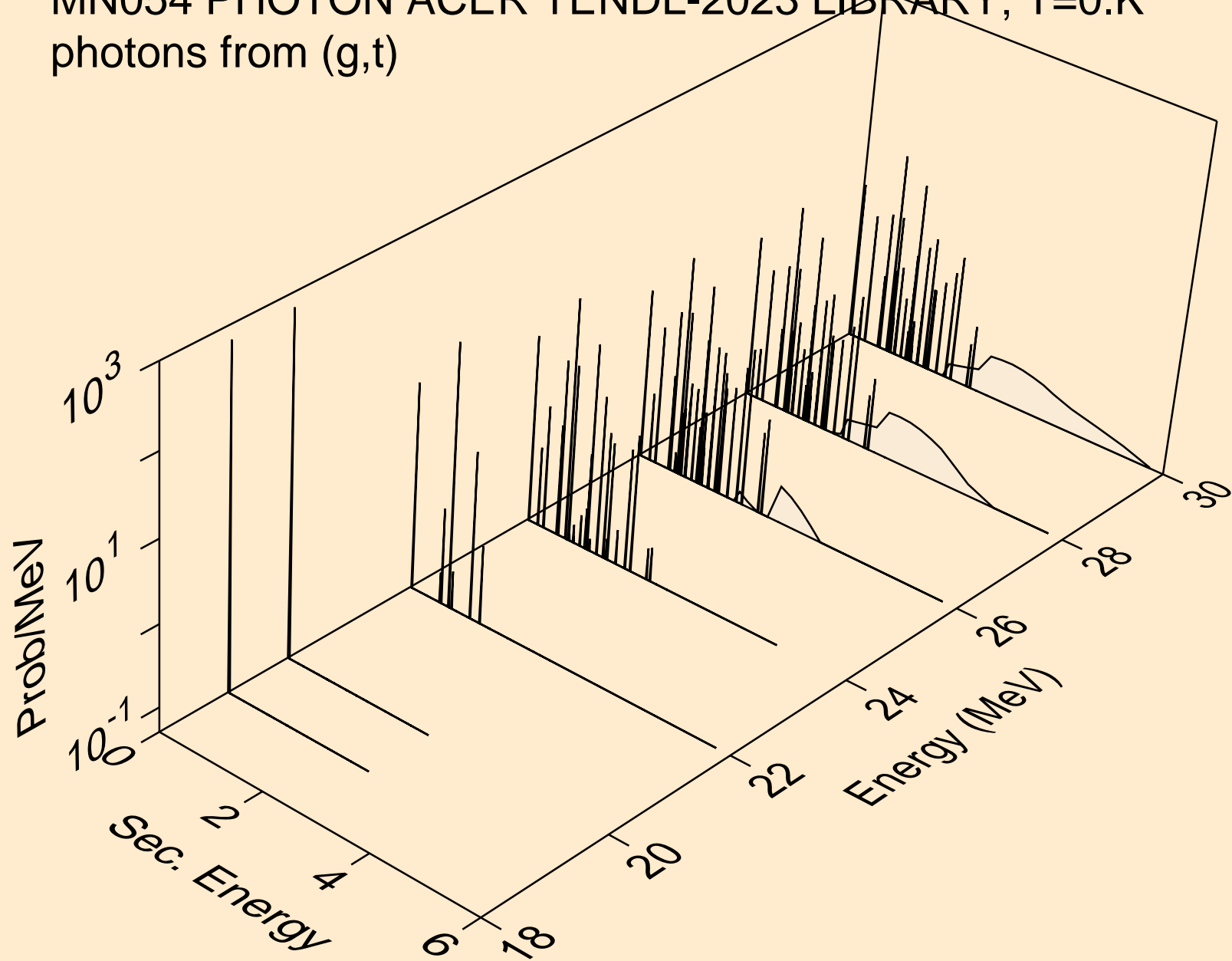

MN054 PHOTON ACER TENDL-2023 LIBRARY; T=0.K
photons from (g,he3)

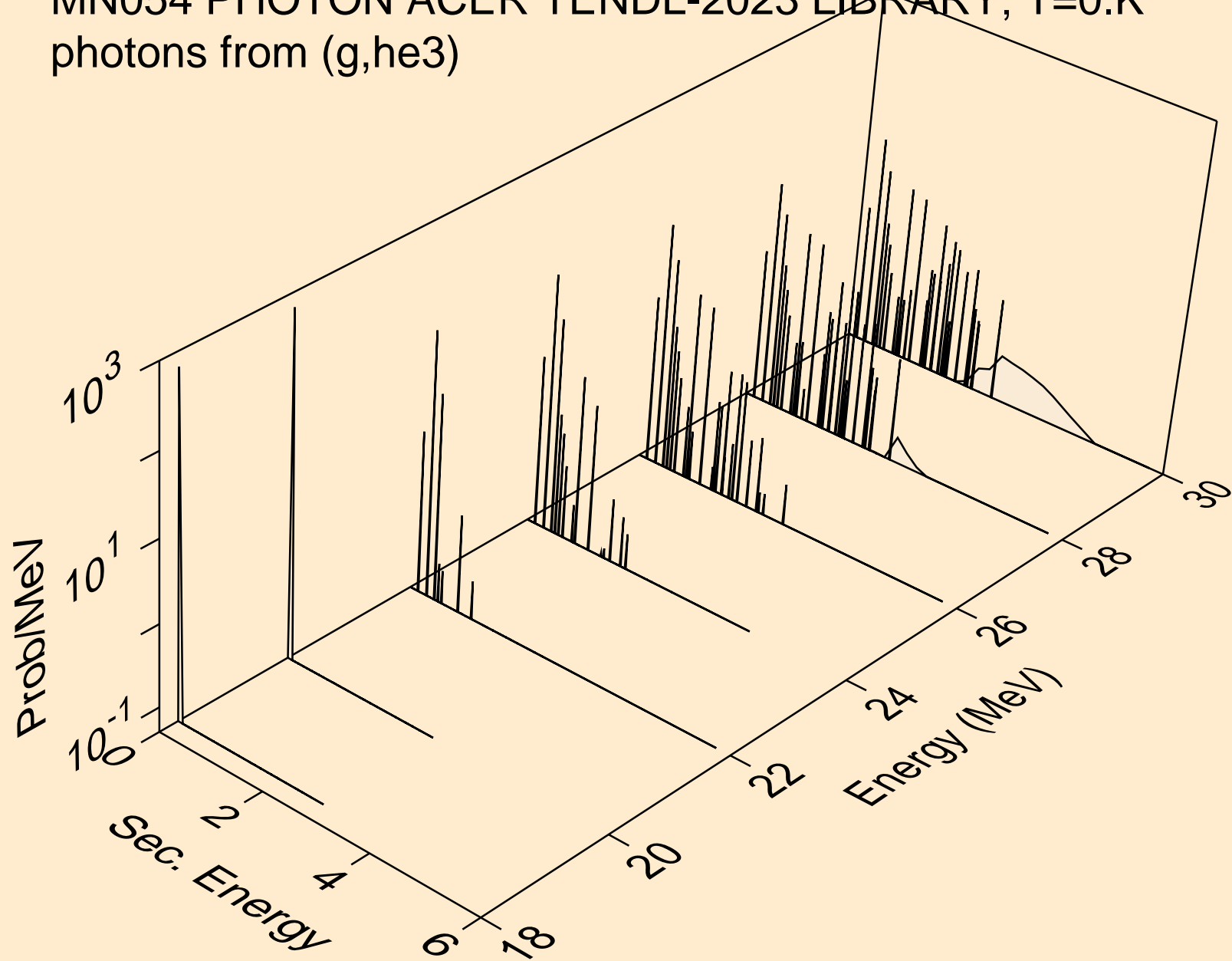

MN054 PHOTON ACER TENDL-2023 LIBRARY; T=0.K
photons from (g,a)

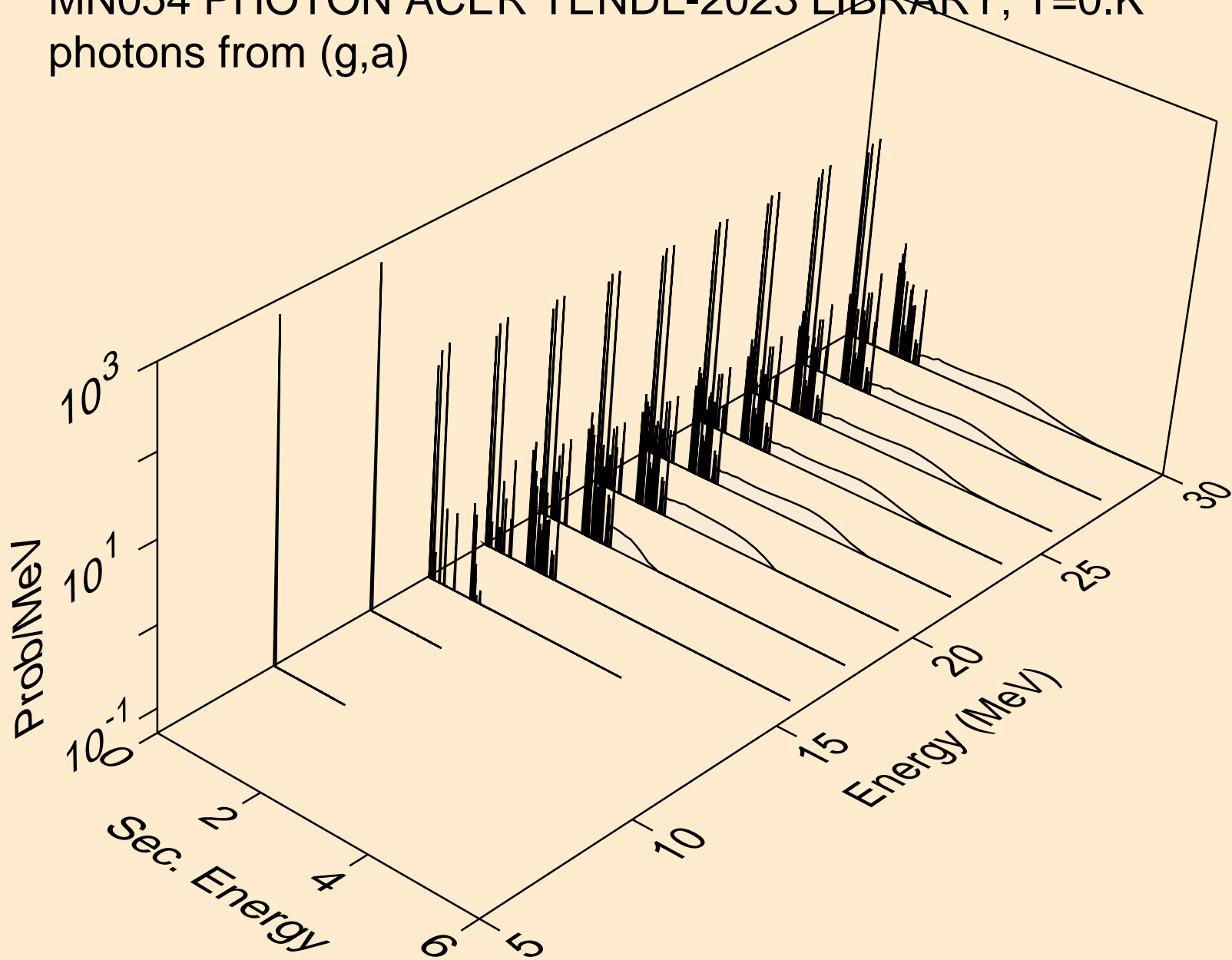

MN054 PHOTON ACER TENDL-2023 LIBRARY; T=0.K
photons from (g,2a)

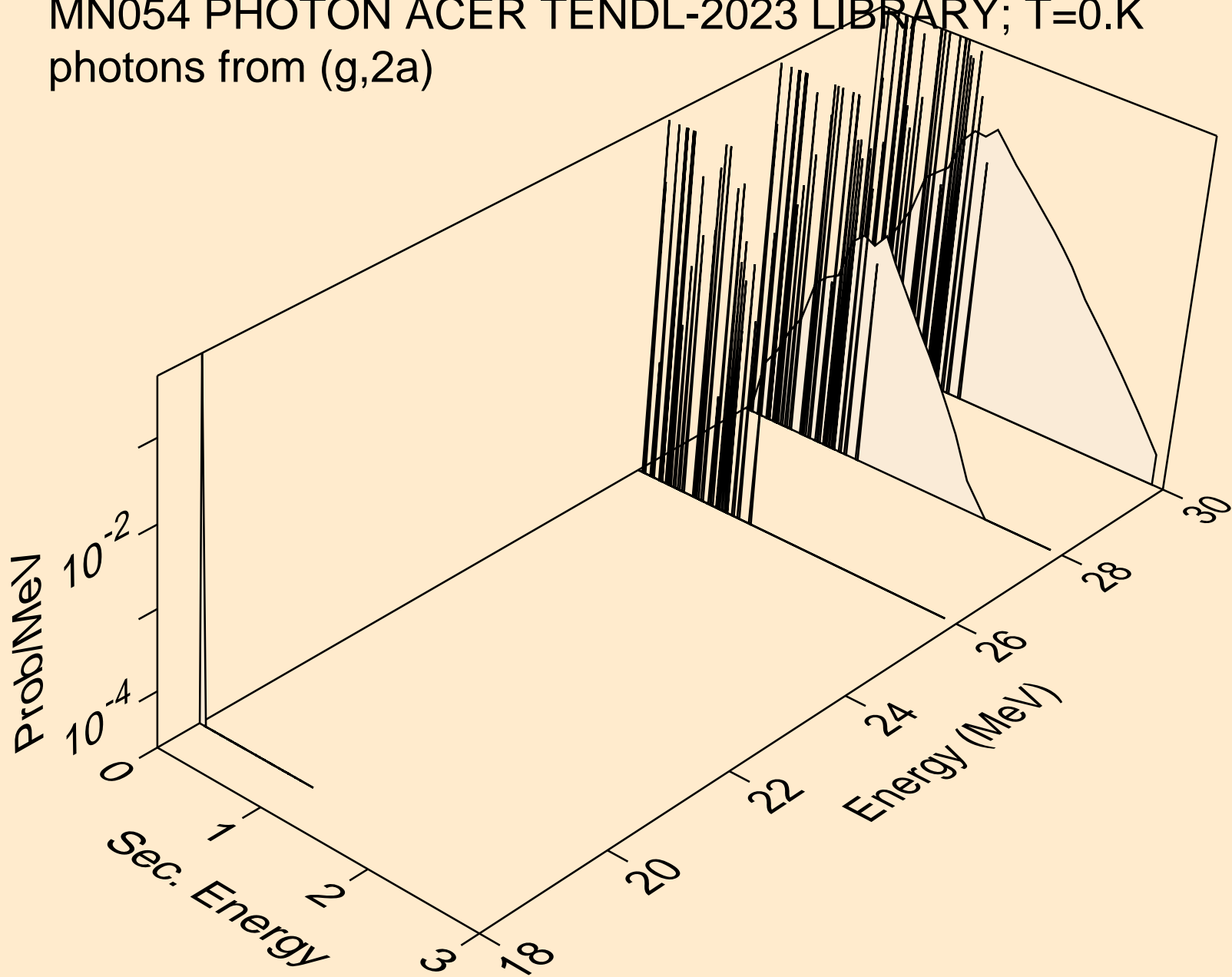

MN054 PHOTON ACER TENDL-2023 LIBRARY; T=0.K
photons from (g,2p)

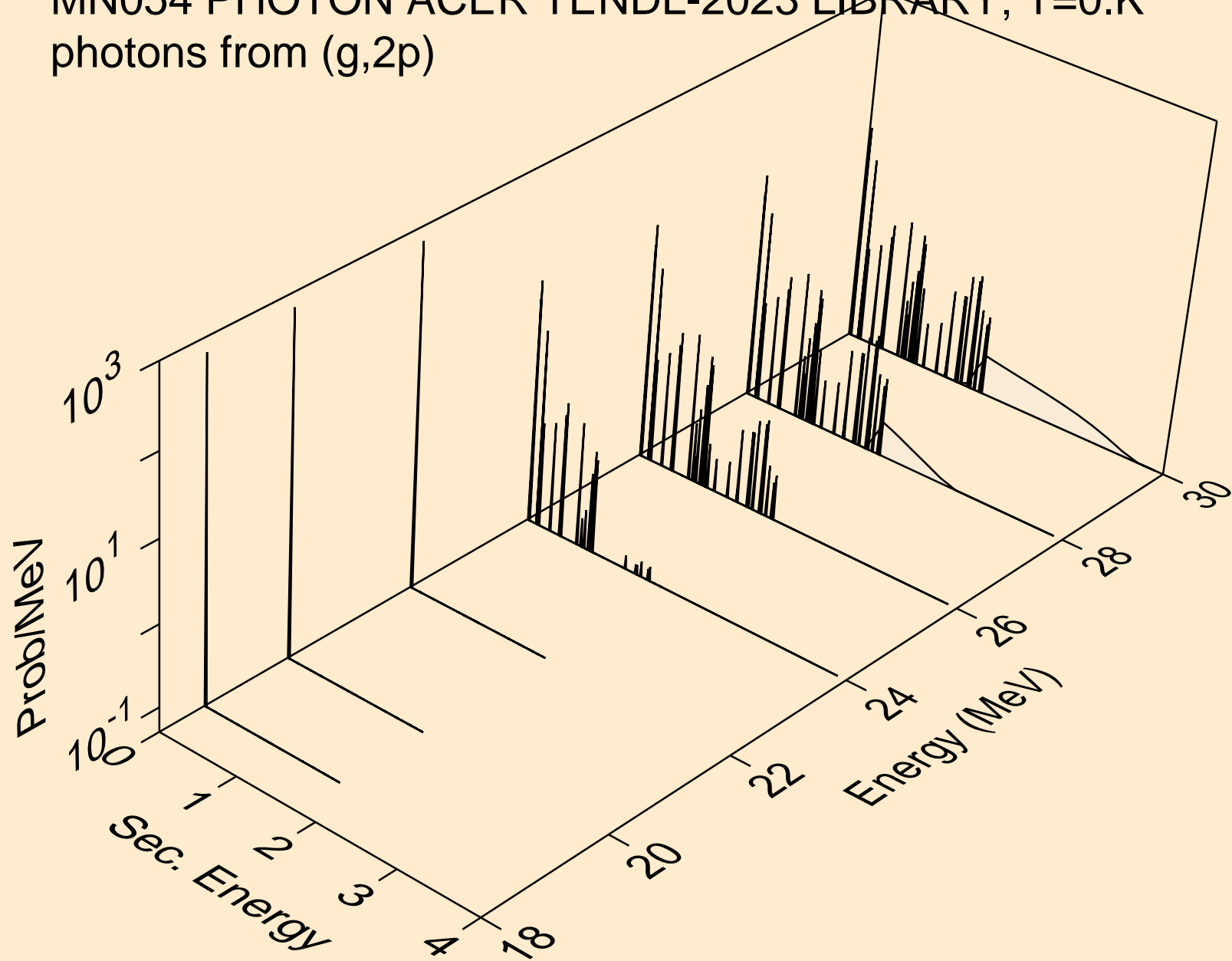

MN054 PHOTON ACER TENDL-2023 LIBRARY; T=0.K
photons from (g,pa)

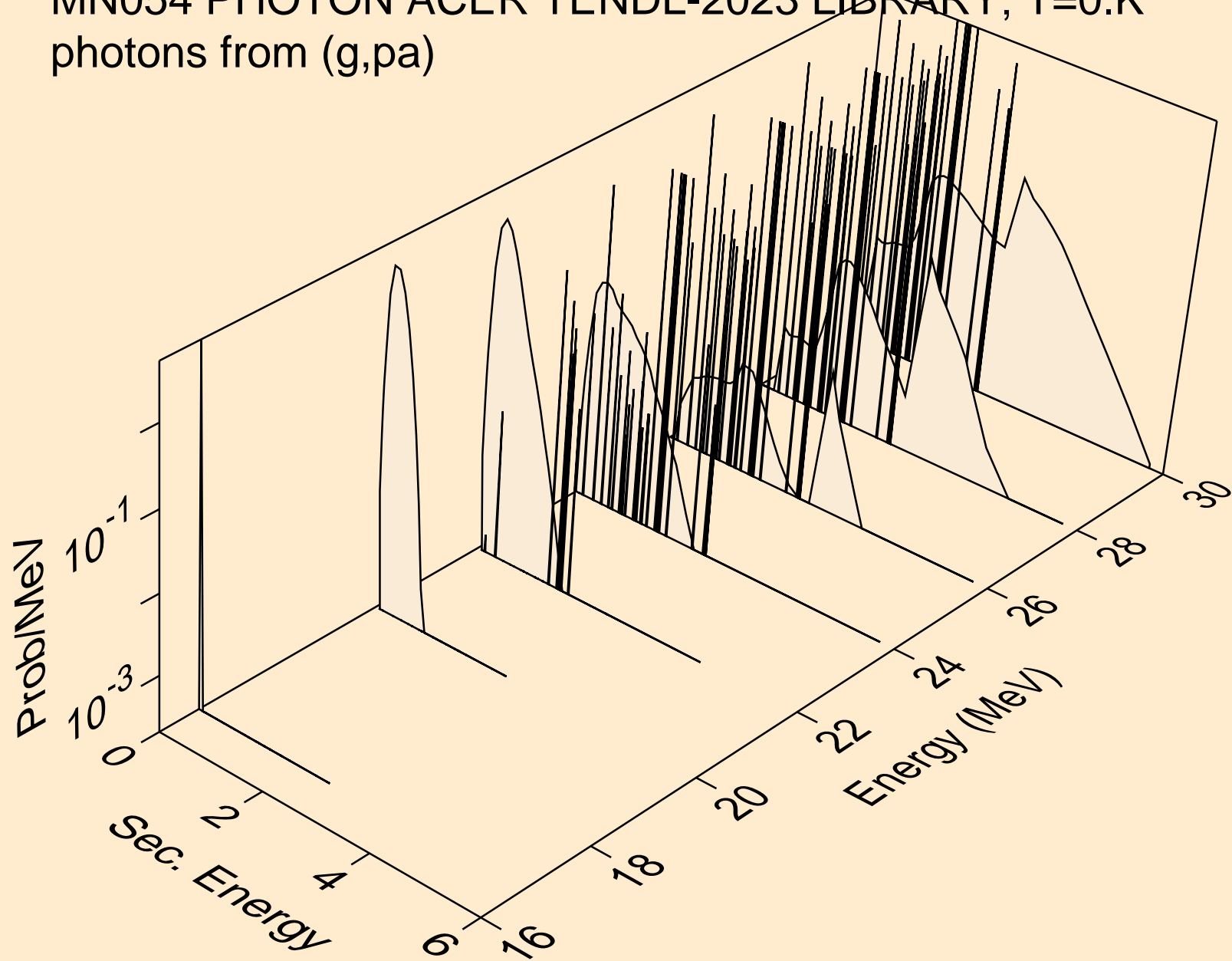

MN054 PHOTON ACER TENDL-2023 LIBRARY; T=0.K
photons from (g,pd)

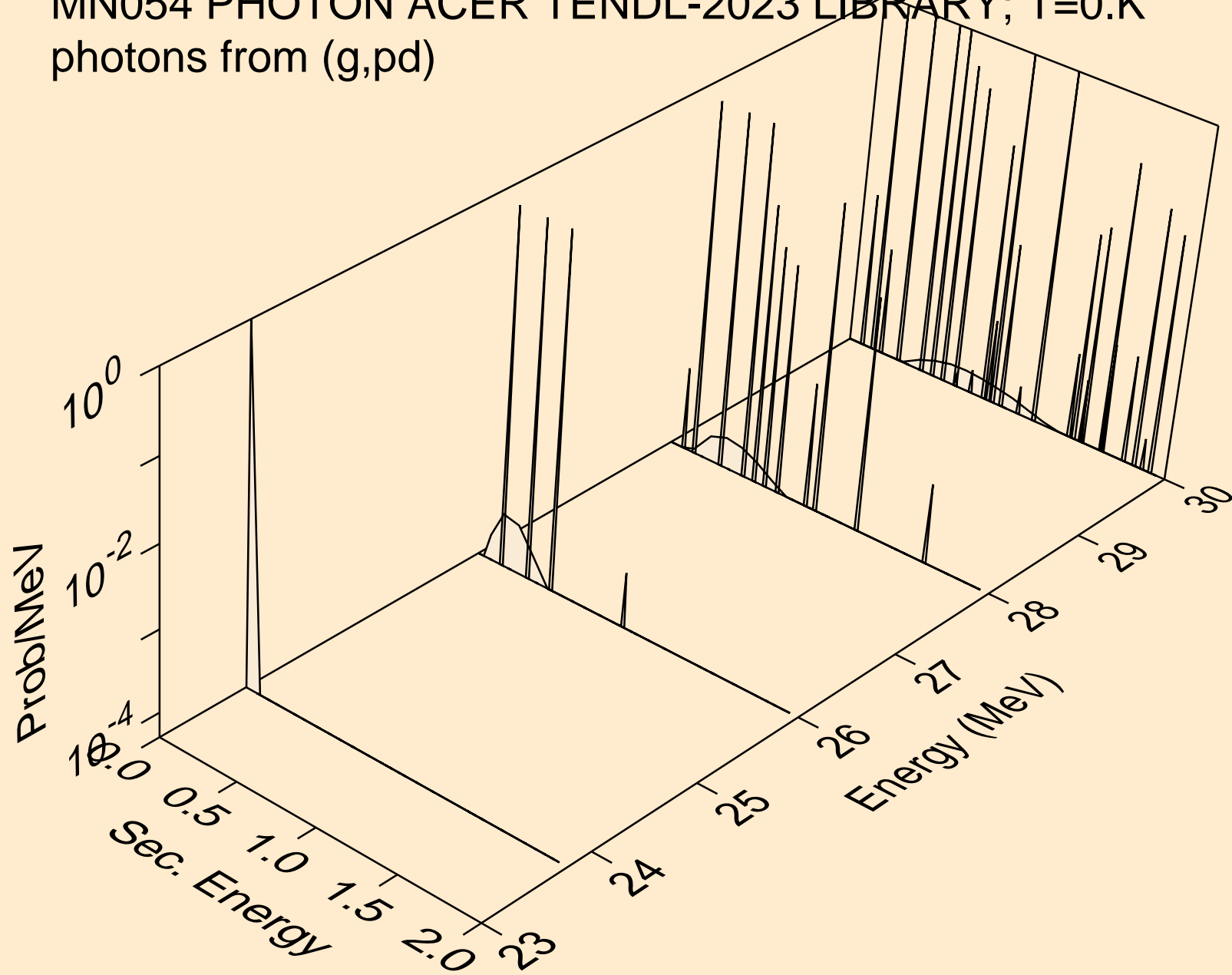

MN054 PHOTON ACER TENDL-2023 LIBRARY; T=0.K
protons from (g,x)

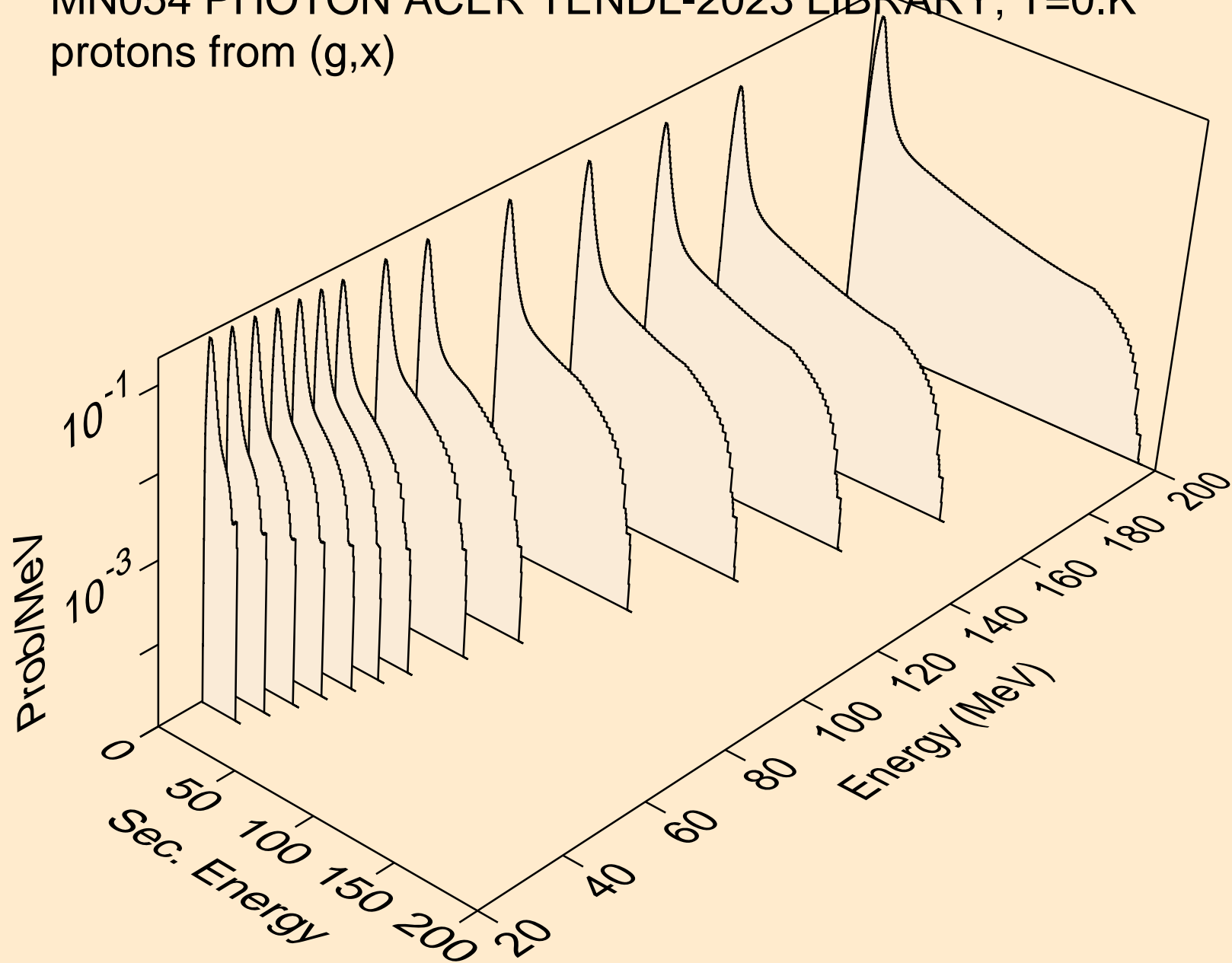

MN054 PHOTON ACER TENDL-2023 LIBRARY; T=0.K
protons from (g,n*)p

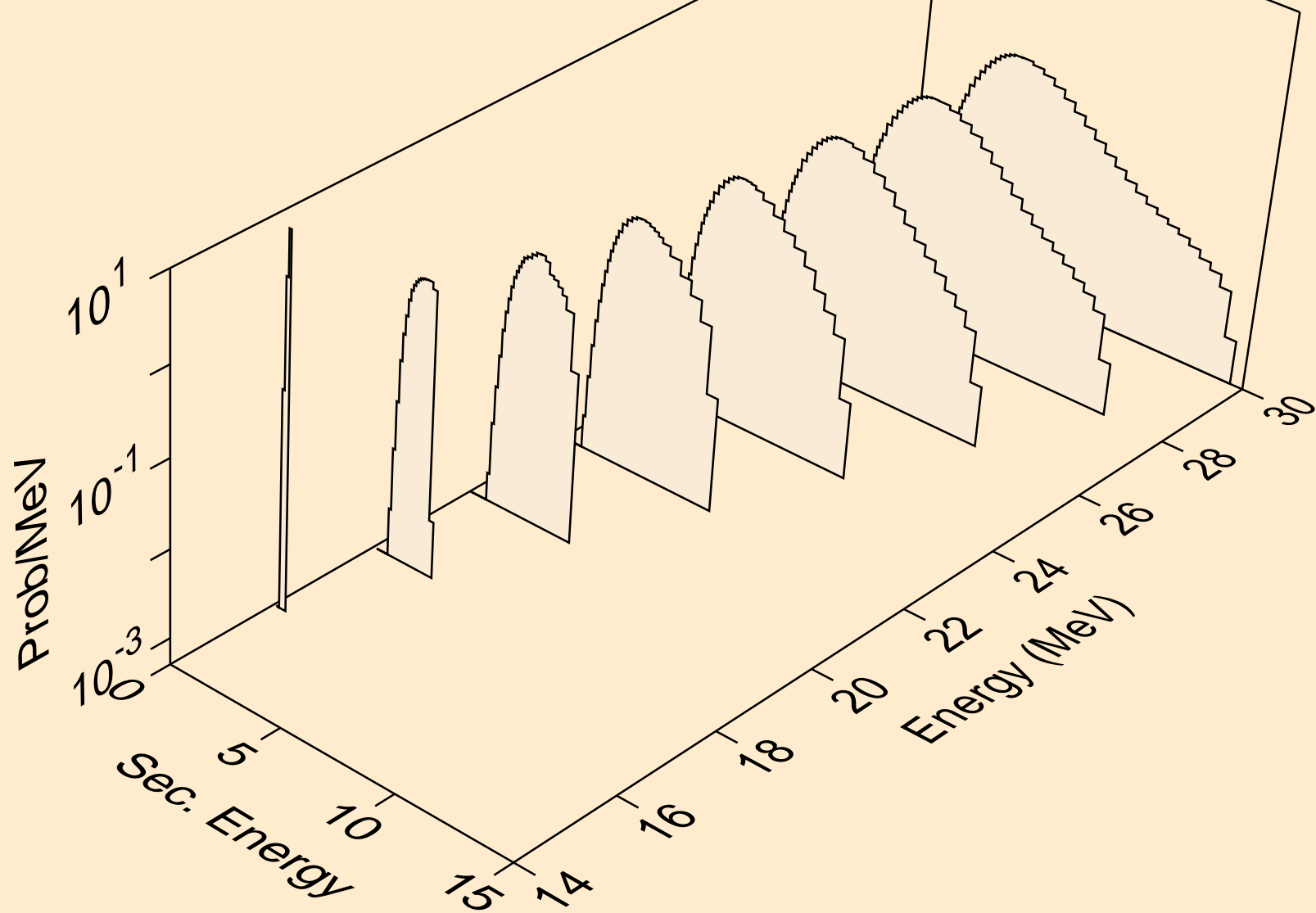

MN054 PHOTON ACER TENDL-2023 LIBRARY; T=0.K
protons from (g,2np)

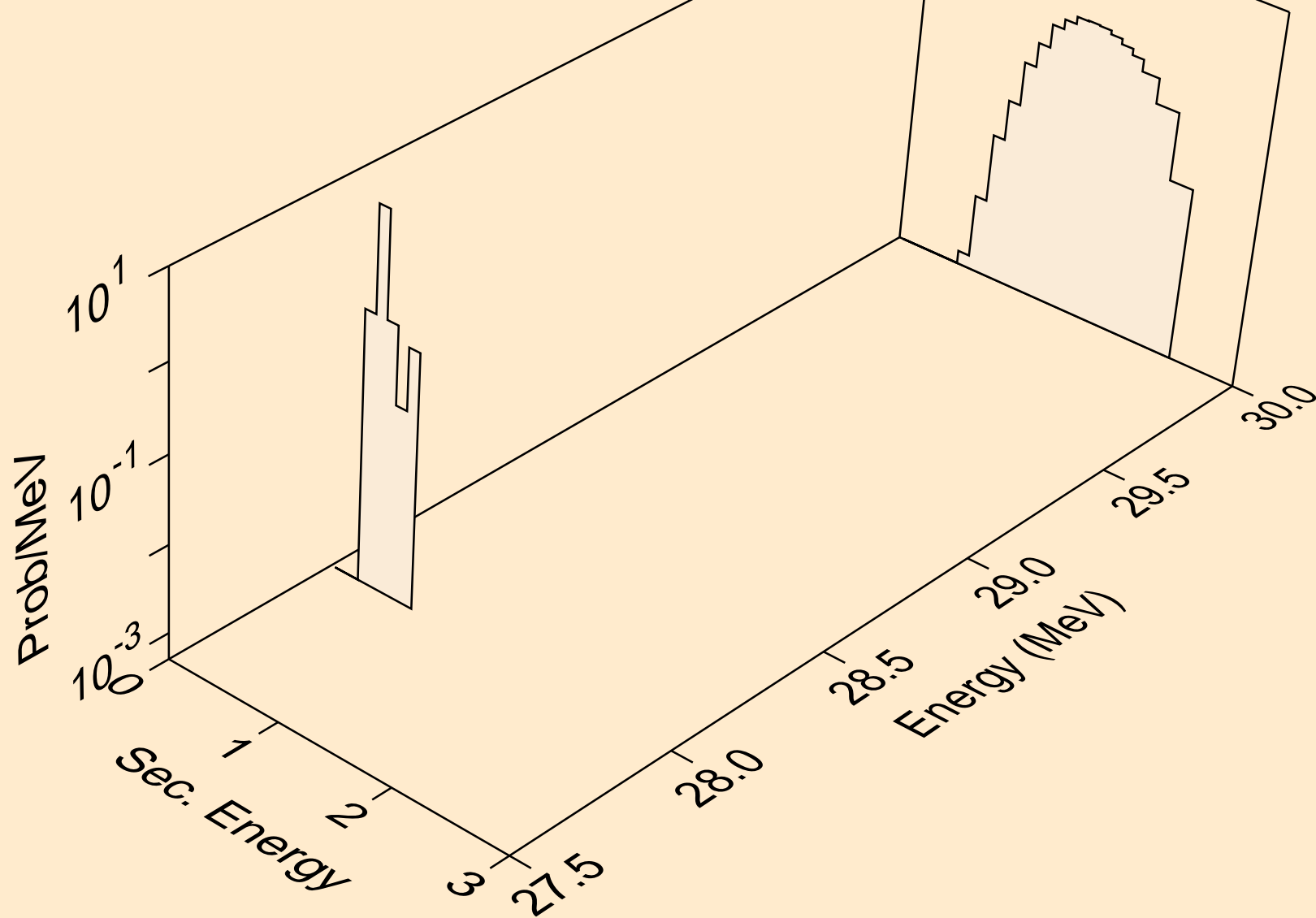

MN054 PHOTON ACER TENDL-2023 LIBRARY; T=0.K
protons from (g,n2p)

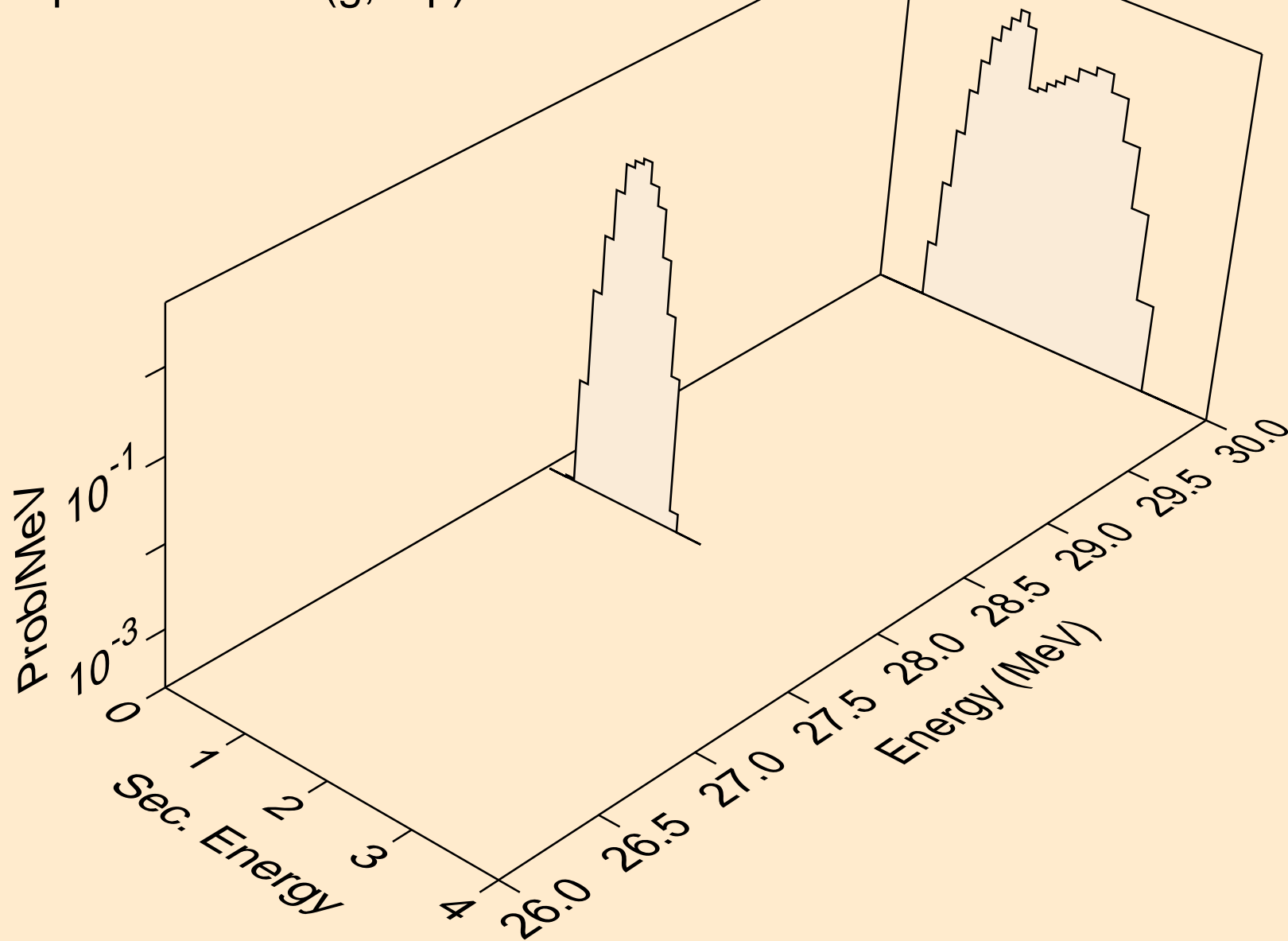

MN054 PHOTON ACER TENDL-2023 LIBRARY; T=0.K
protons from (g,p)

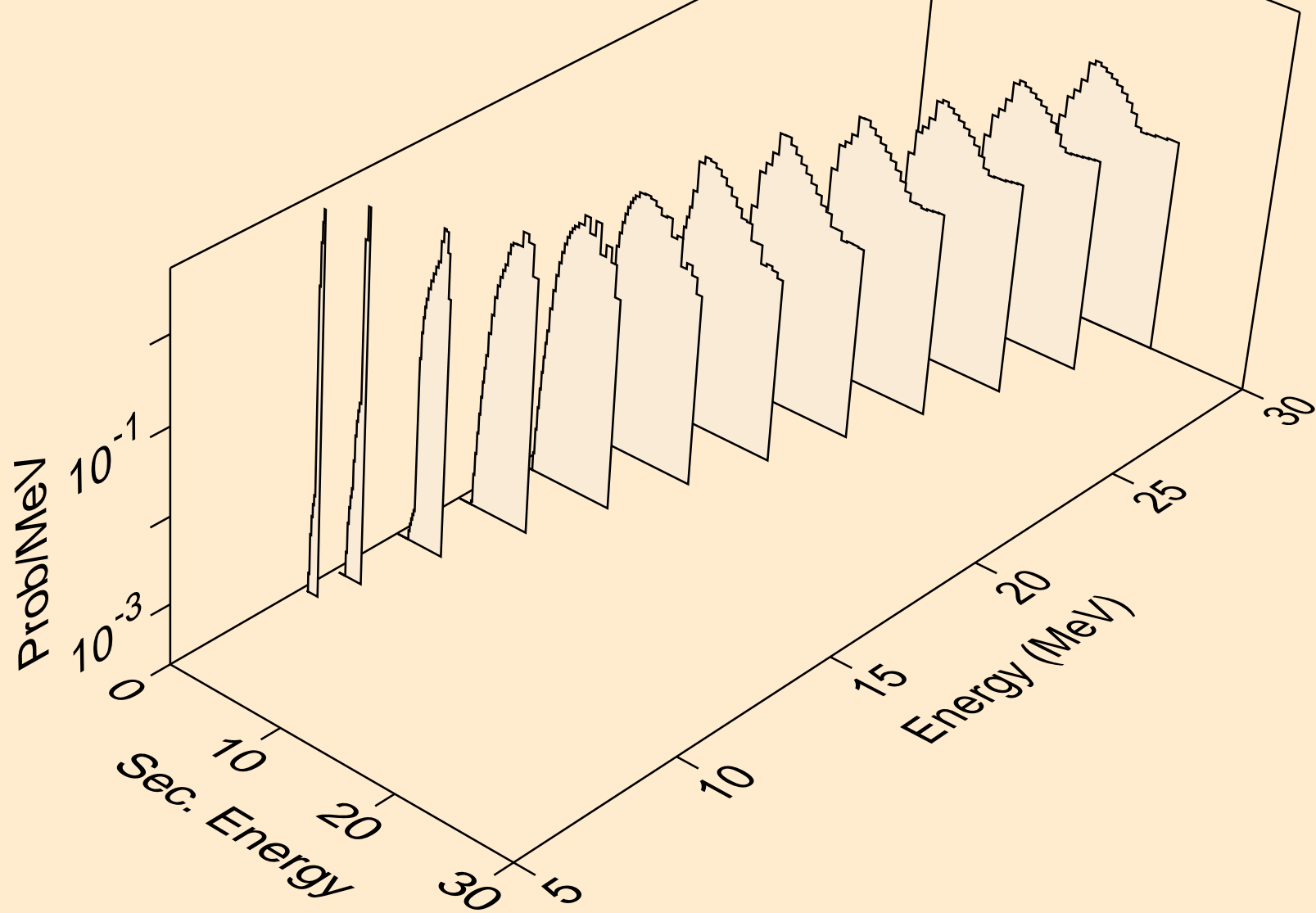

MN054 PHOTON ACER TENDL-2023 LIBRARY; T=0.K
protons from (g,2p)

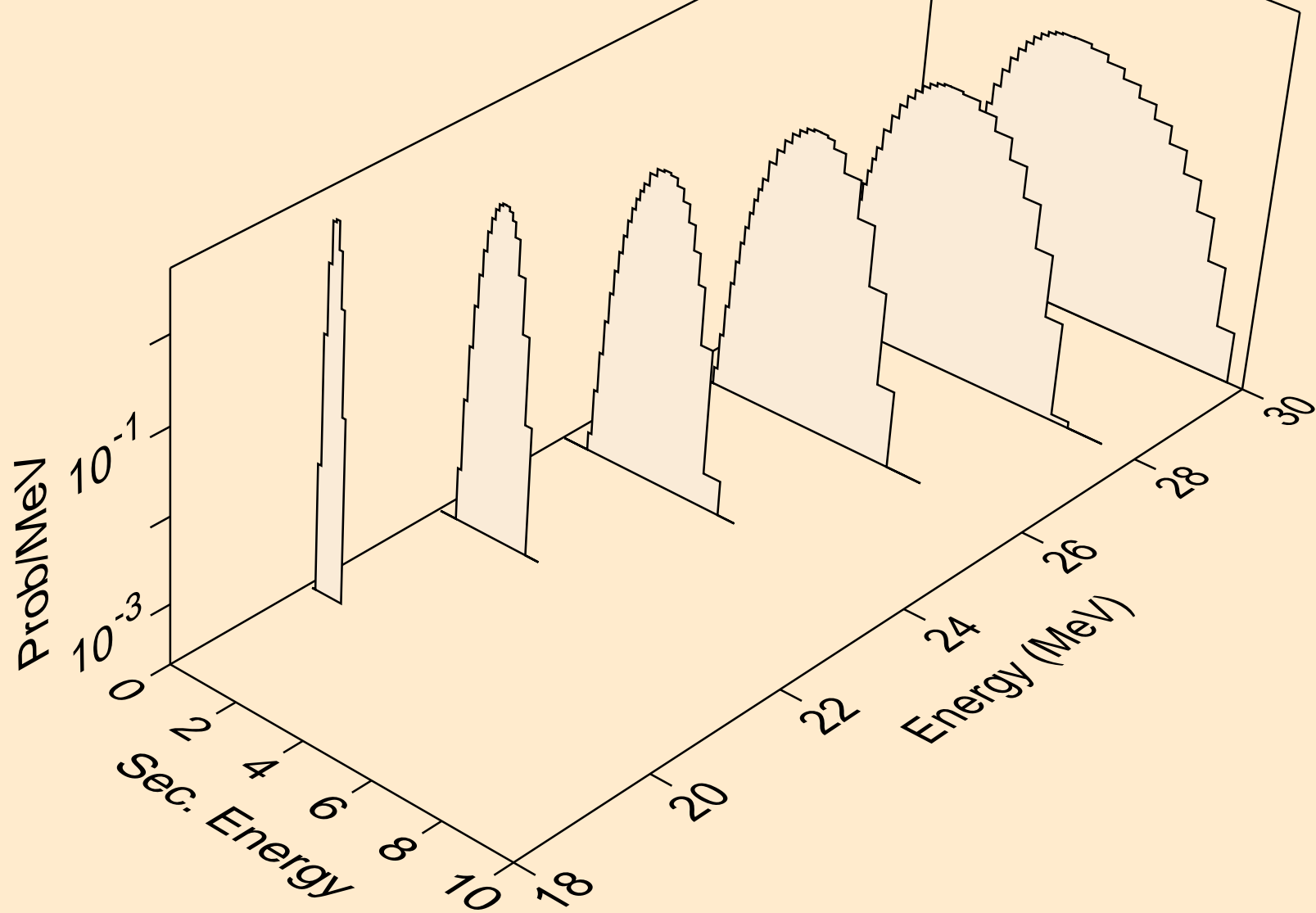

MN054 PHOTON ACER TENDL-2023 LIBRARY; T=0.K
protons from (g,pa)

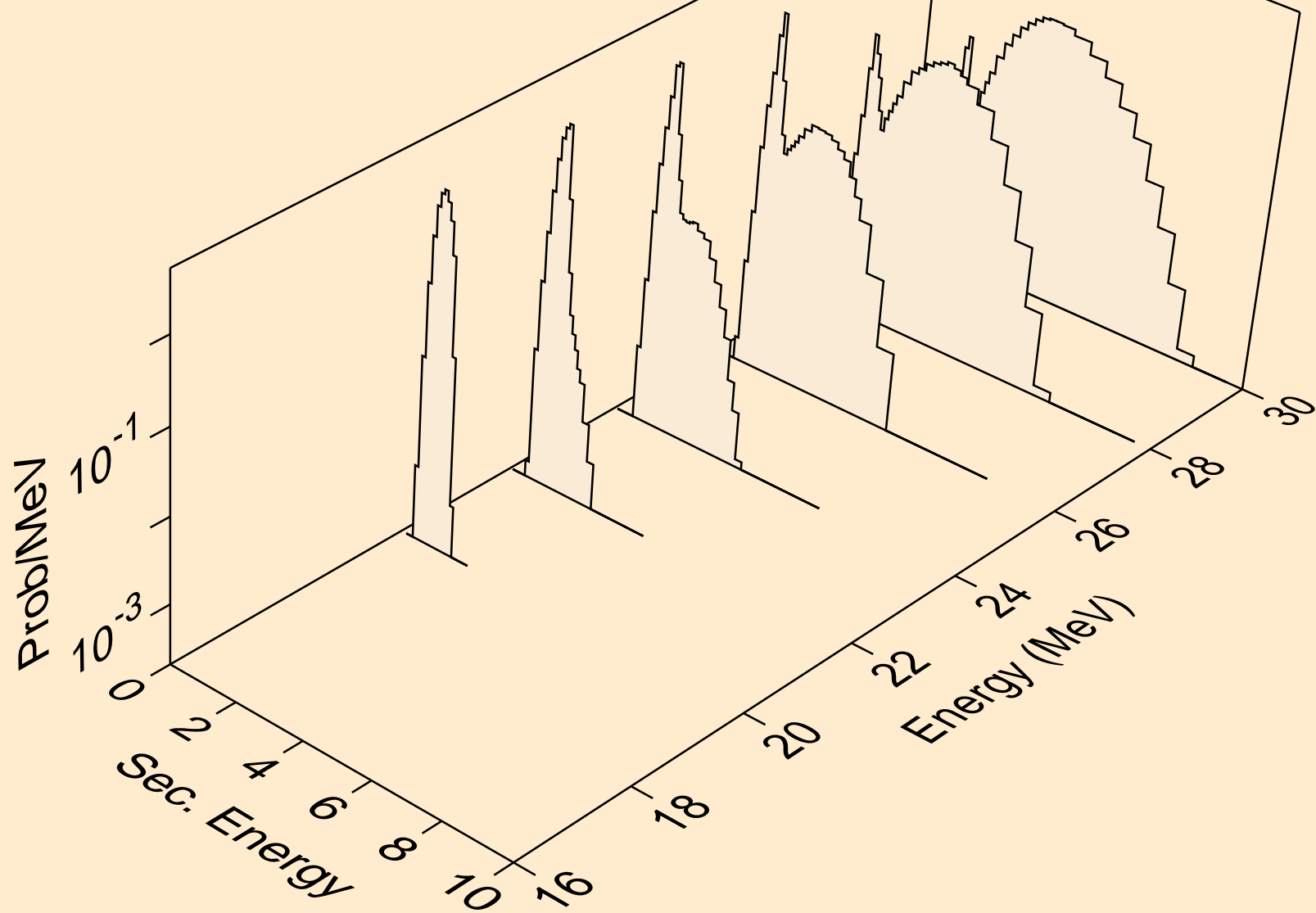

MN054 PHOTON ACER TENDL-2023 LIBRARY; T=0.K
protons from (g,pd)

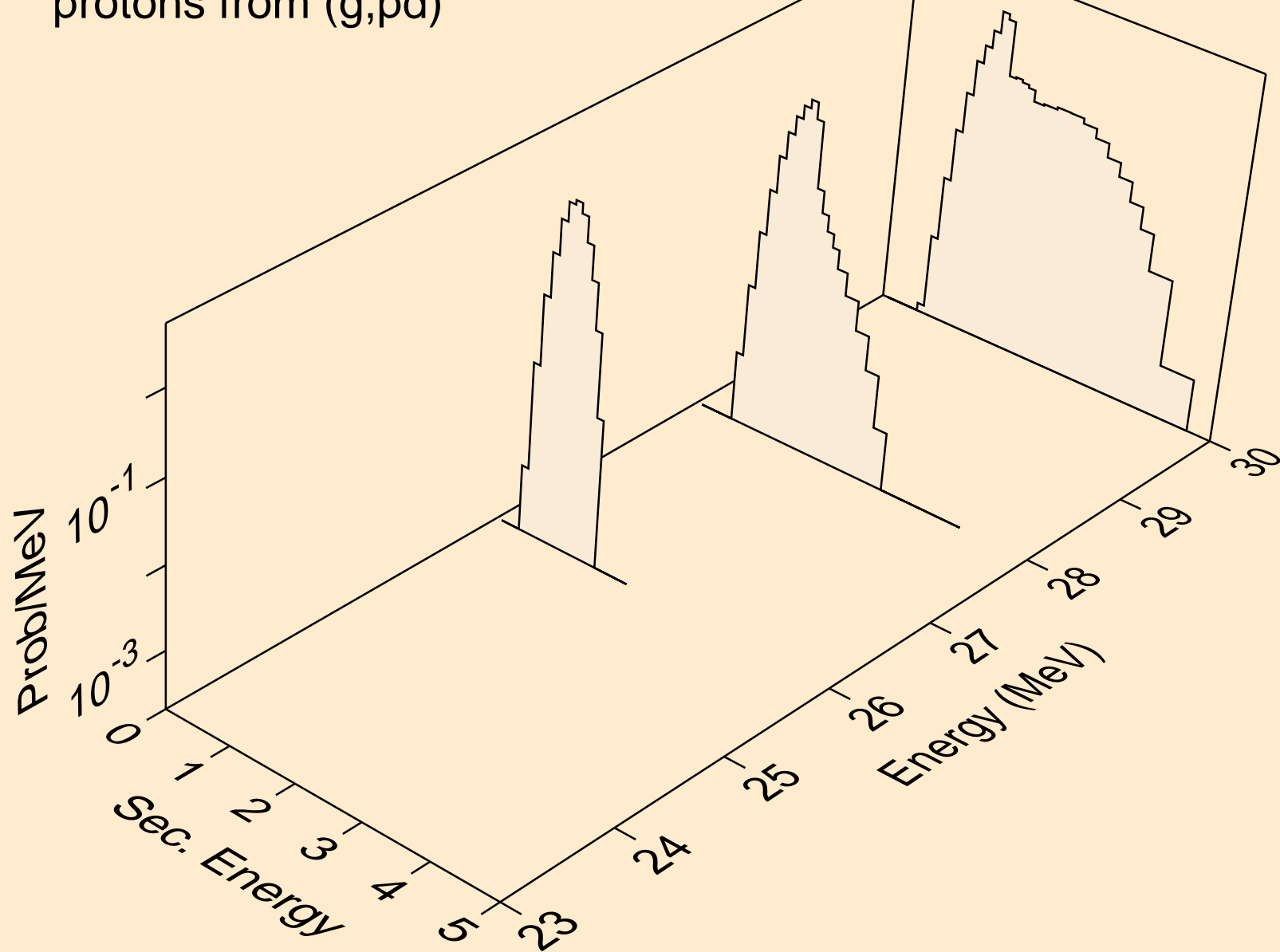

MN054 PHOTON ACER TENDL-2023 LIBRARY; T=0.K
deuterons from (g,x)

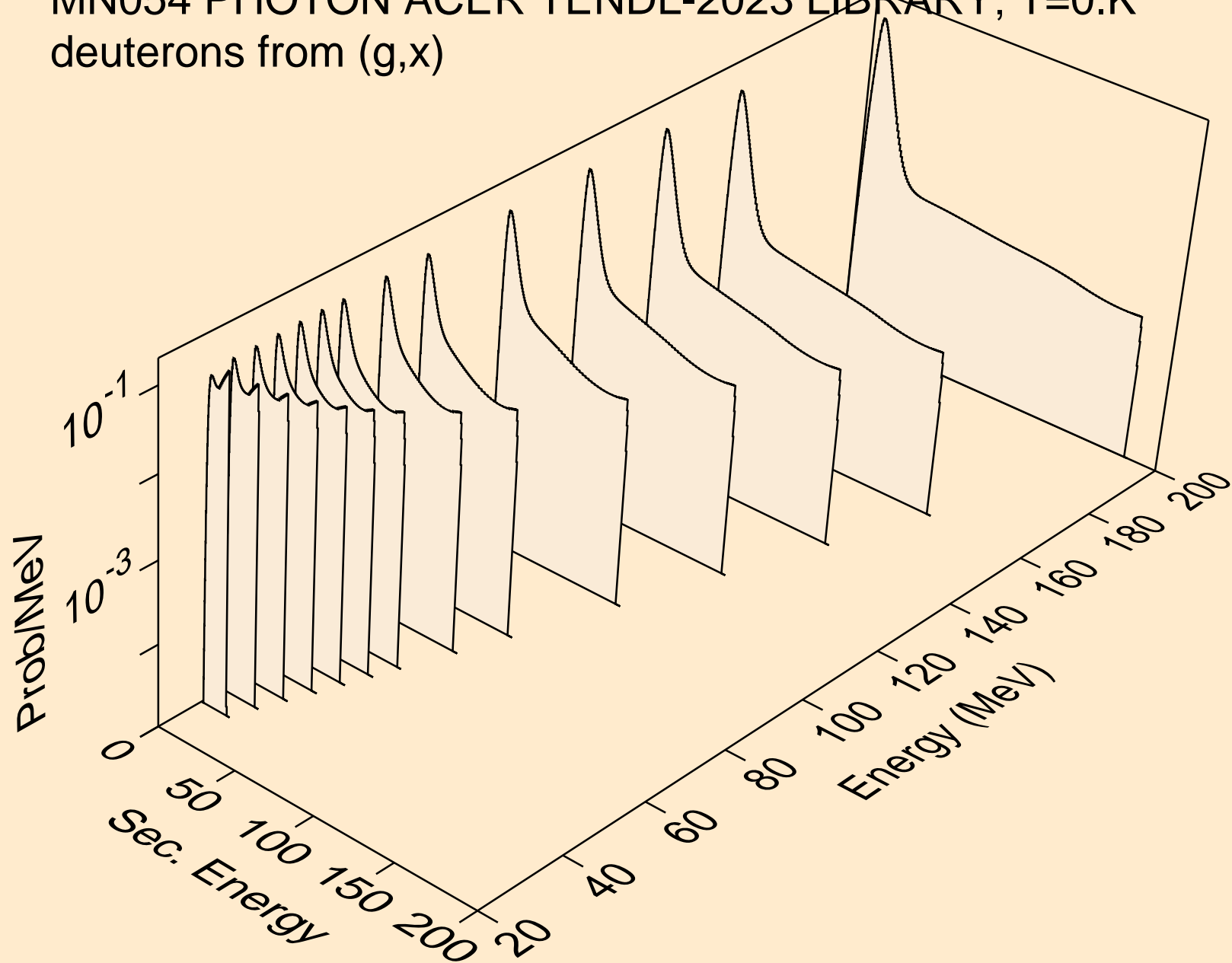

MN054 PHOTON ACER TENDL-2023 LIBRARY; T=0.K
deuterons from (g,n*)d

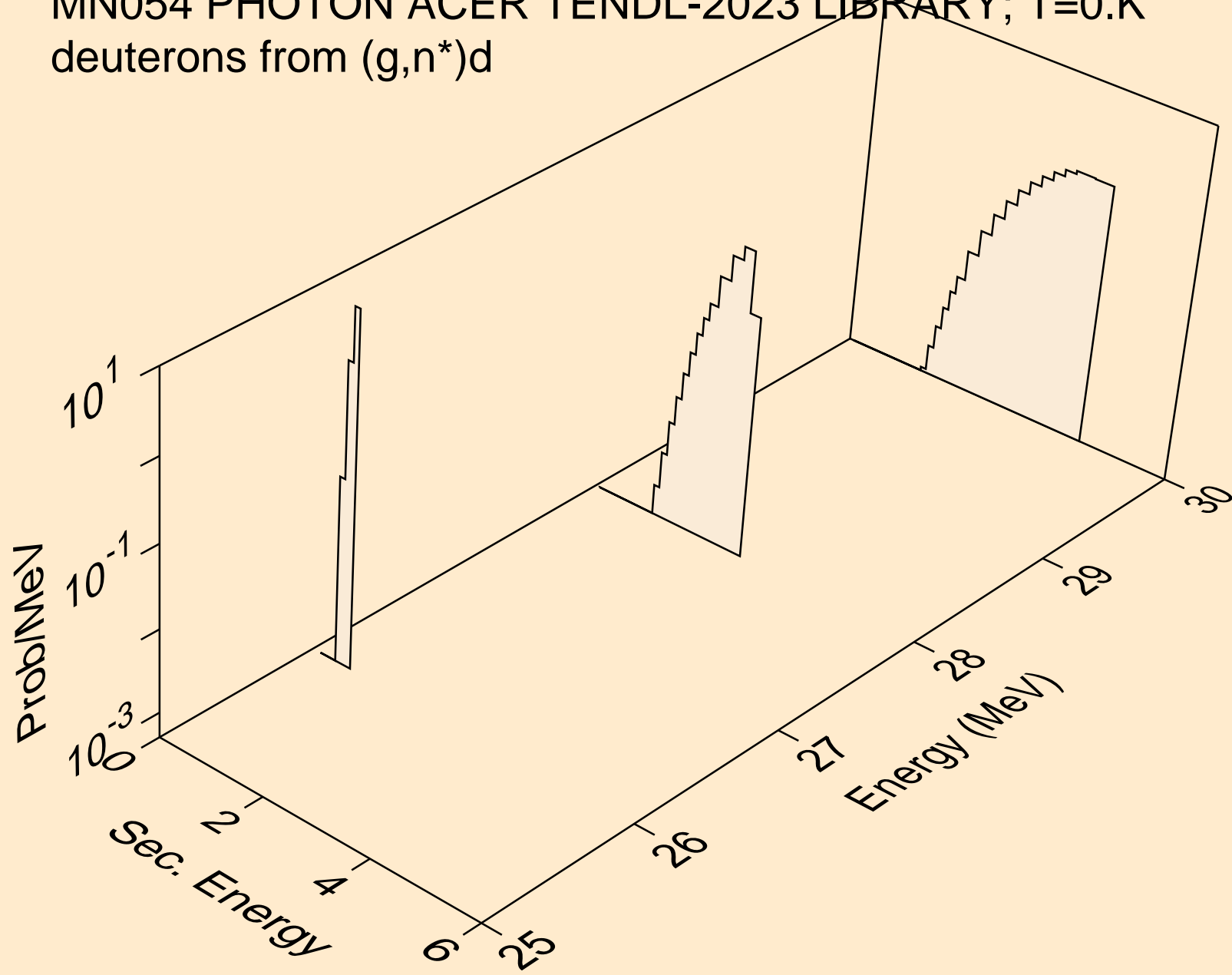

MN054 PHOTON ACER TENDL-2023 LIBRARY; T=0.K
deuterons from (g,d)

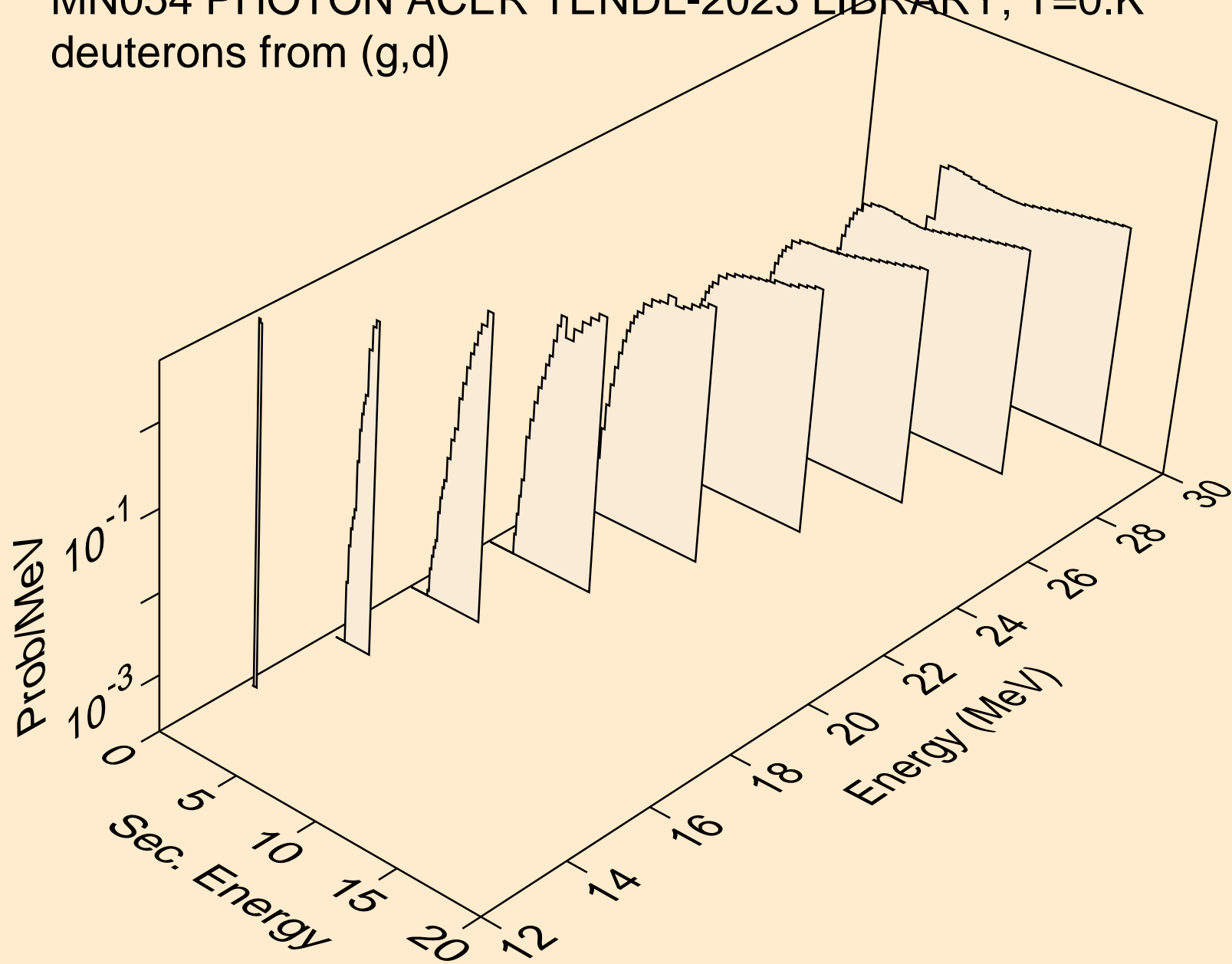

MN054 PHOTON ACER TENDL-2023 LIBRARY; T=0.K
deuterons from (g,pd)

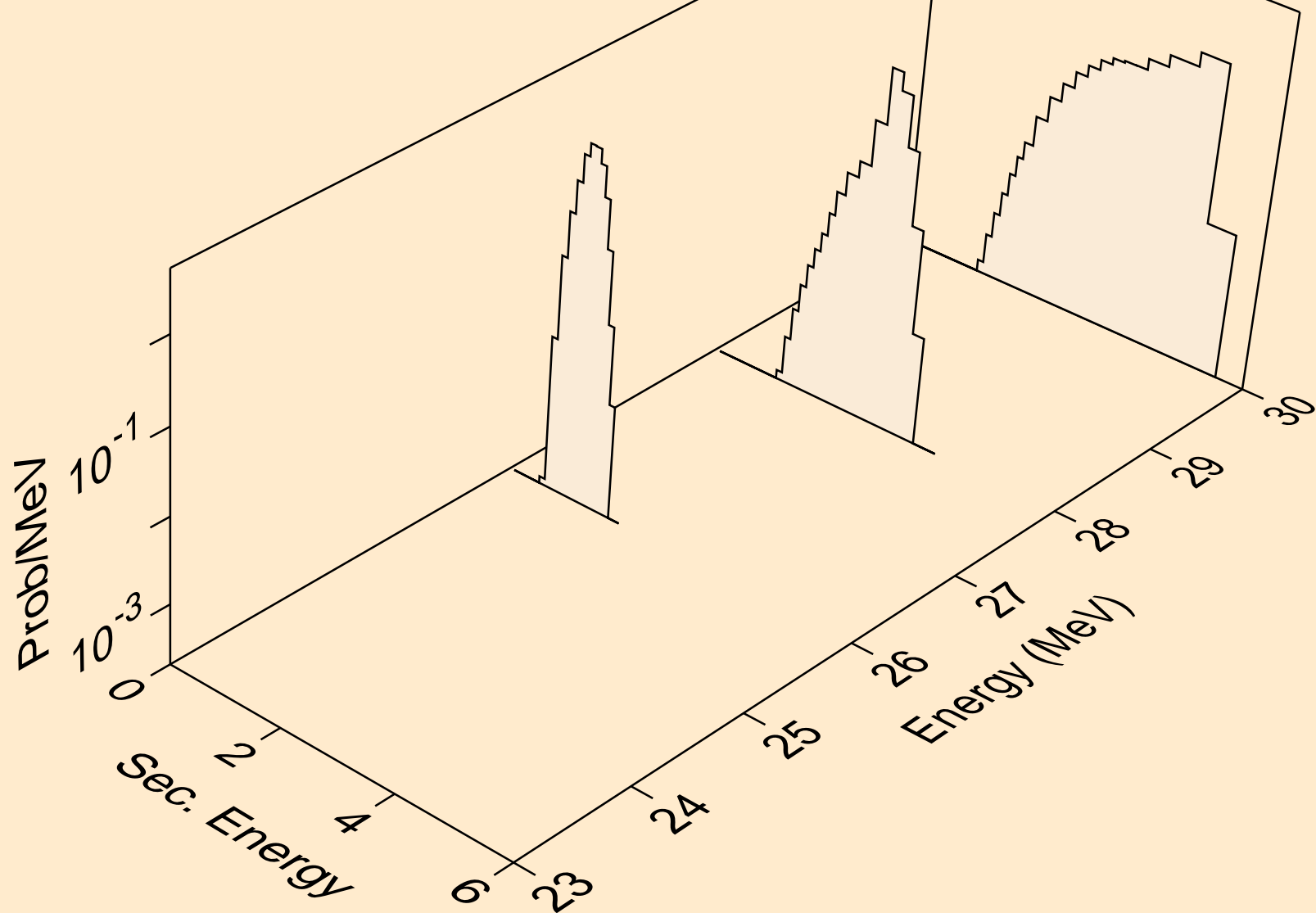

MN054 PHOTON ACER TENDL-2023 LIBRARY; T=0.K
tritons from (g,x)

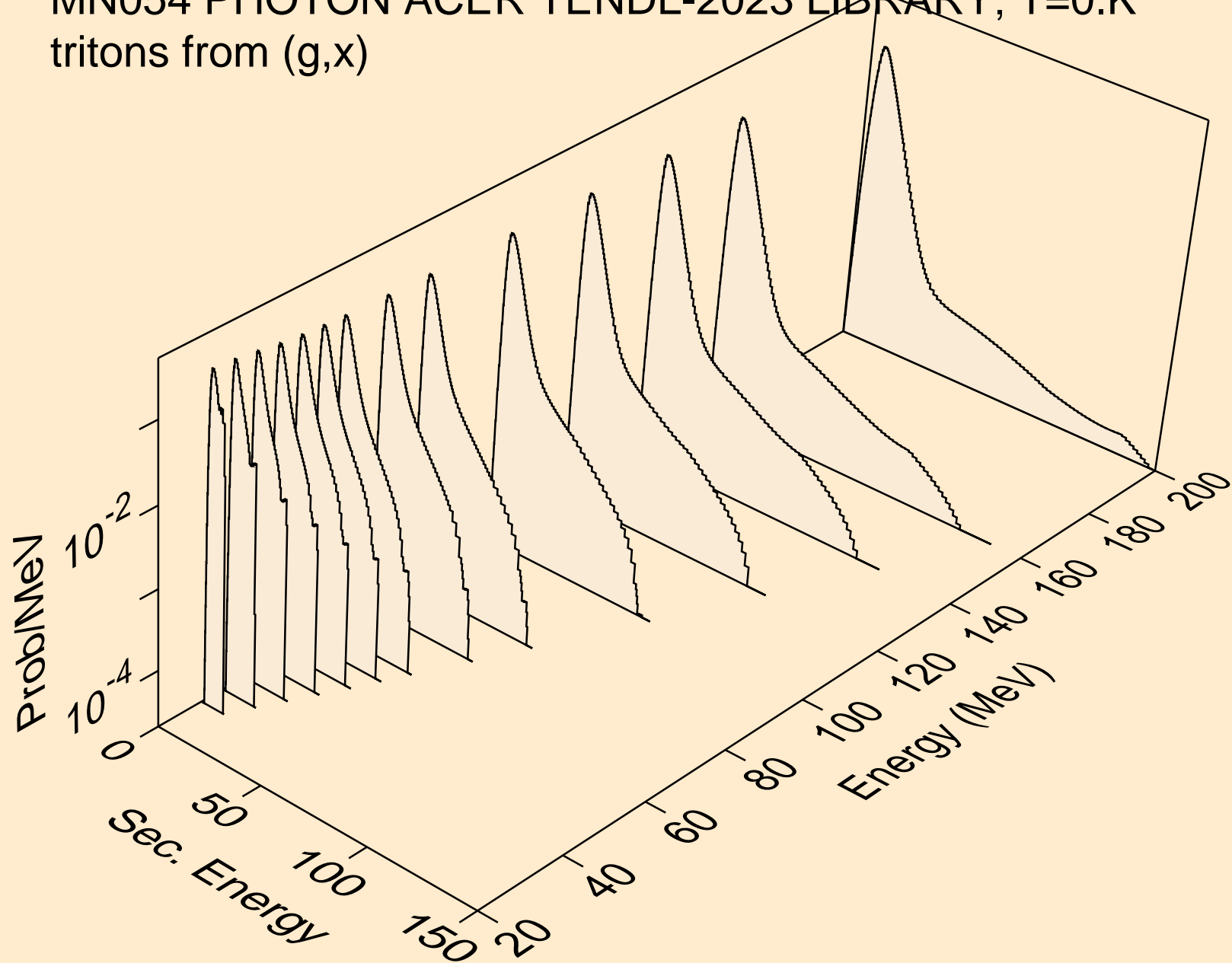

MN054 PHOTON ACER TENDL-2023 LIBRARY; T=0.K
tritons from (g,t)

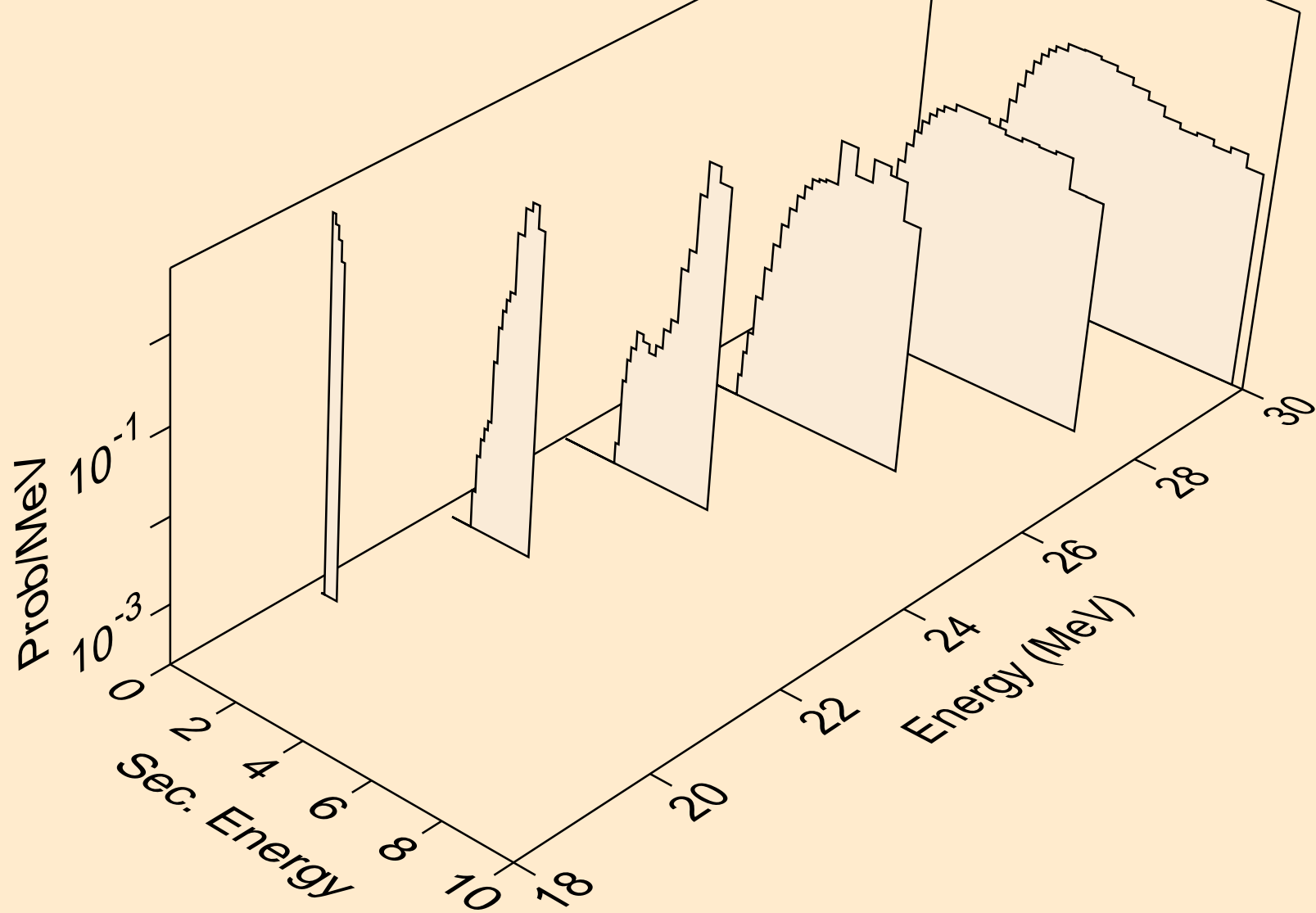

MN054 PHOTON ACER TENDL-2023 LIBRARY; T=0.K
he3s from (g,x)

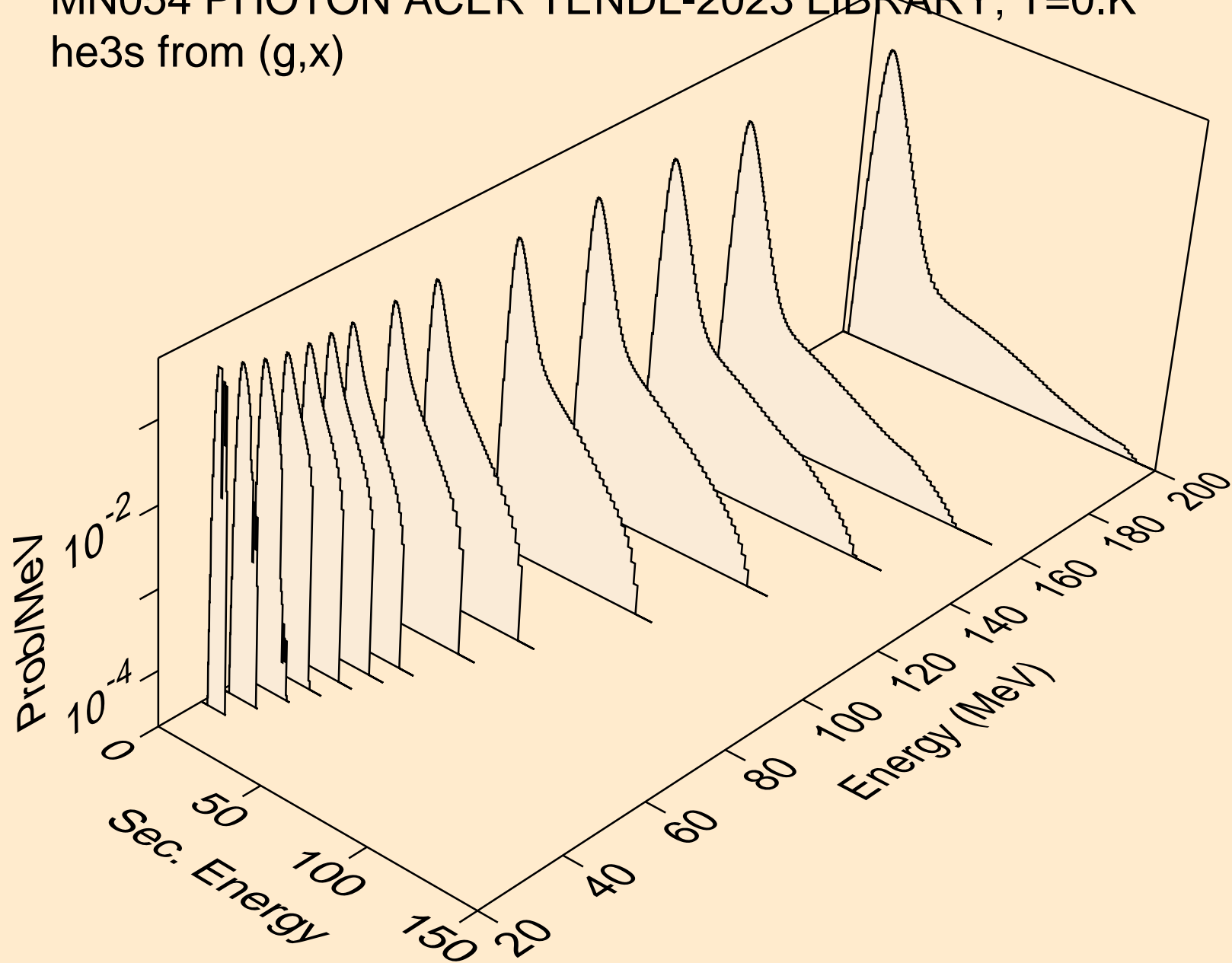

MN054 PHOTON ACER TENDL-2023 LIBRARY; T=0.K
he3s from (g,he3)

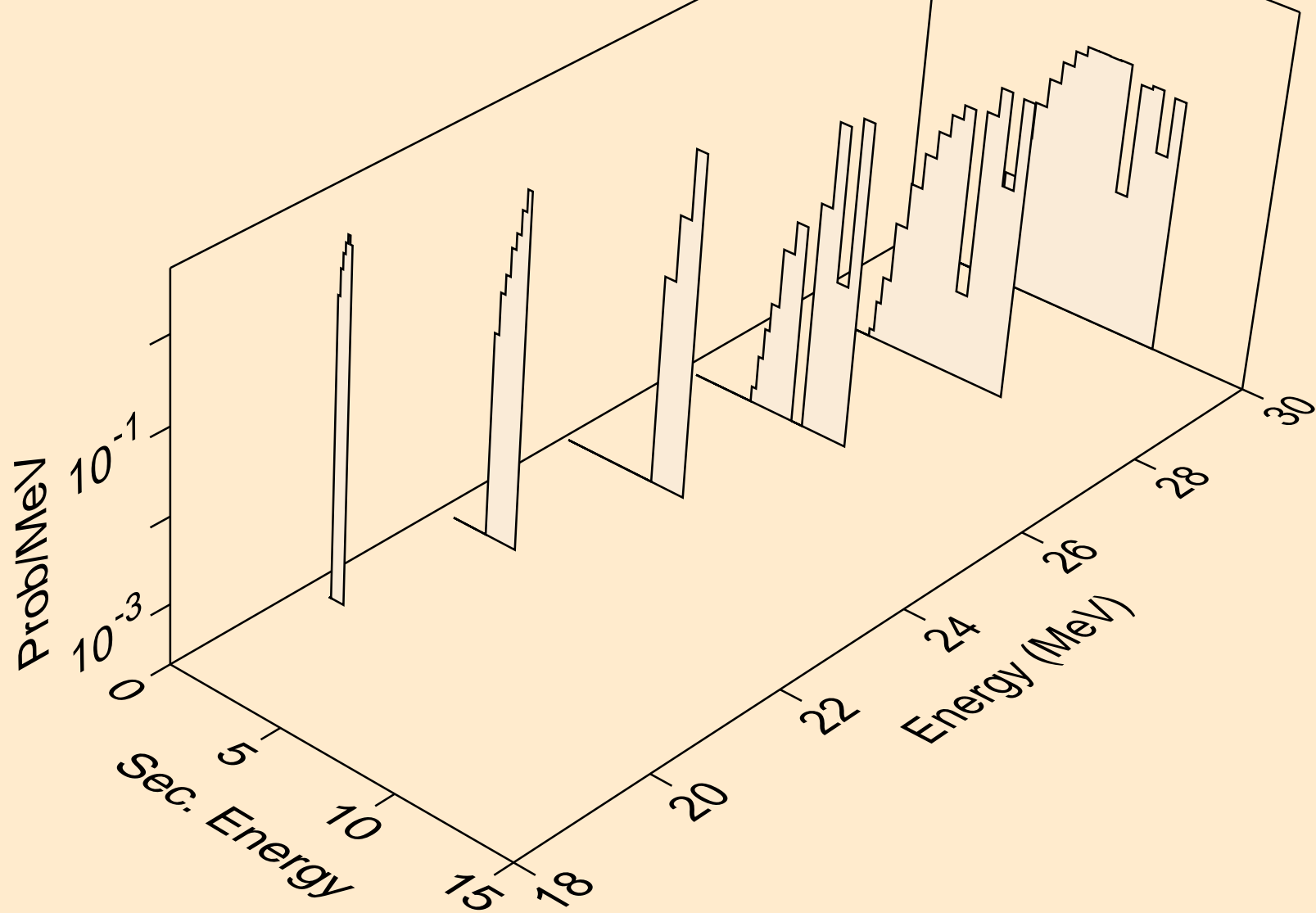

MN054 PHOTON ACER TENDL-2023 LIBRARY; T=0.K
alphas from (g,x)

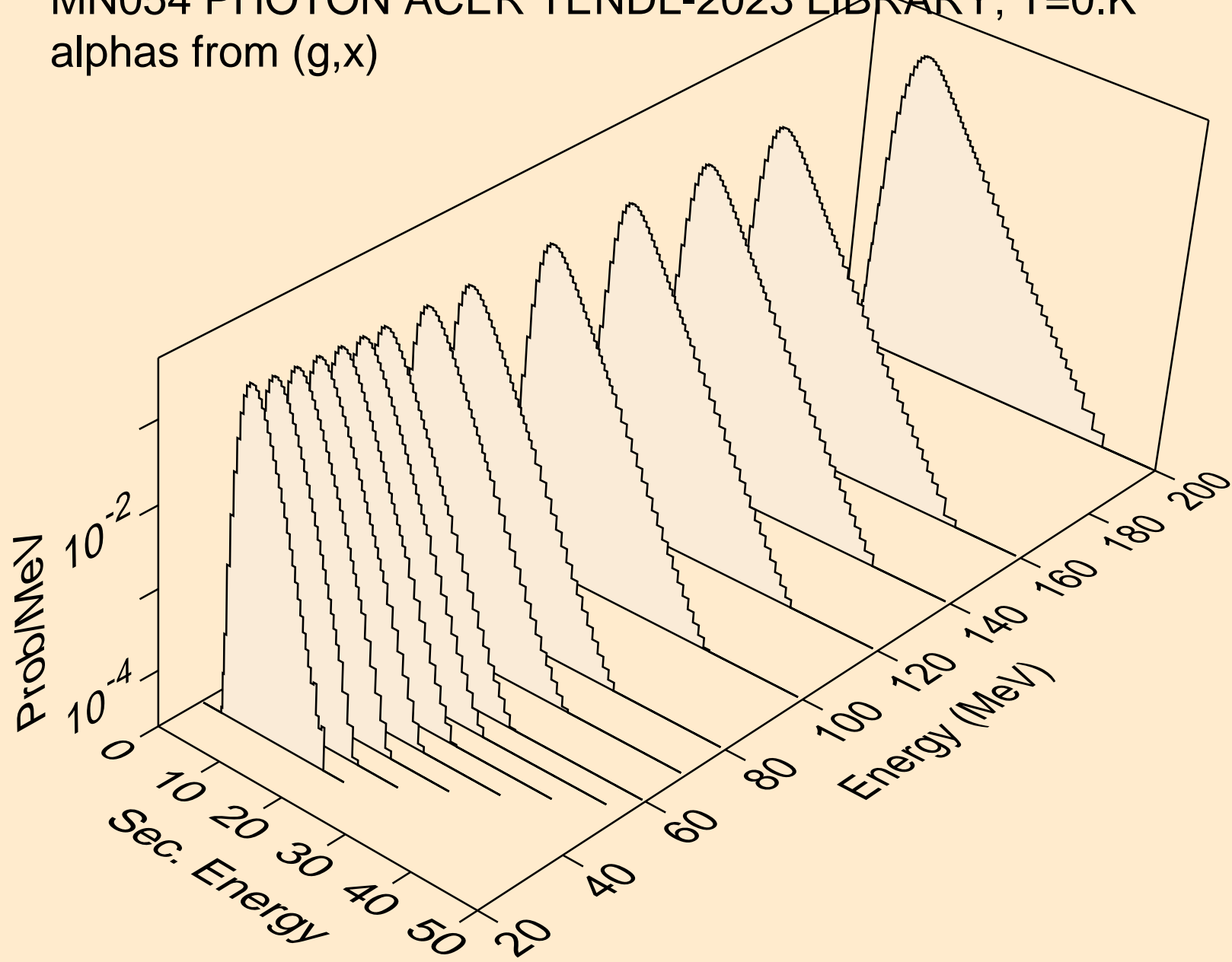

MN054 PHOTON ACER TENDL-2023 LIBRARY; T=0.K
alphas from (g,n*)a

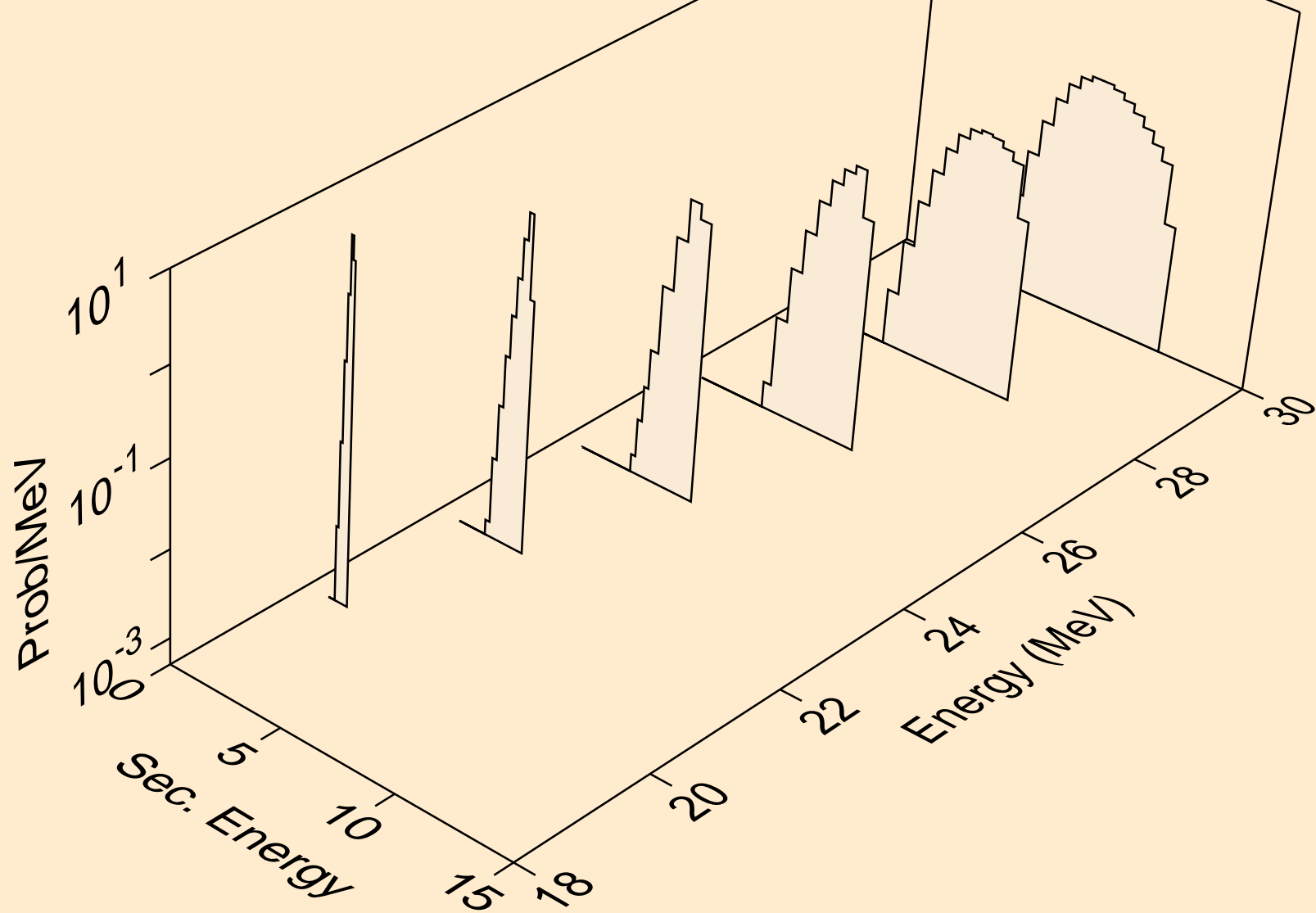

MN054 PHOTON ACER TENDL-2023 LIBRARY; T=0.K
alphas from (g,a)

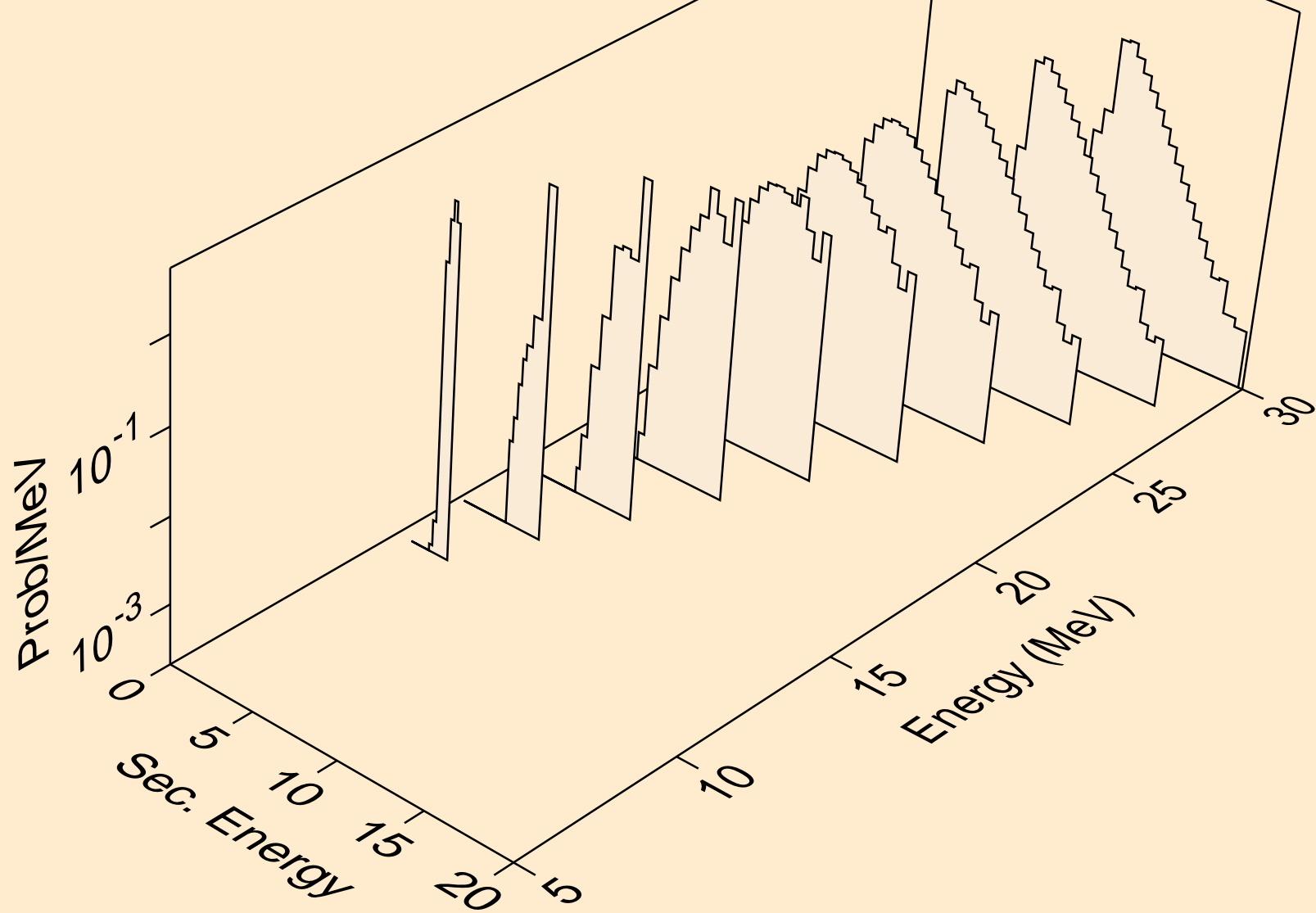

MN054 PHOTON ACER TENDL-2023 LIBRARY; T=0.K
alphas from (g,2a)

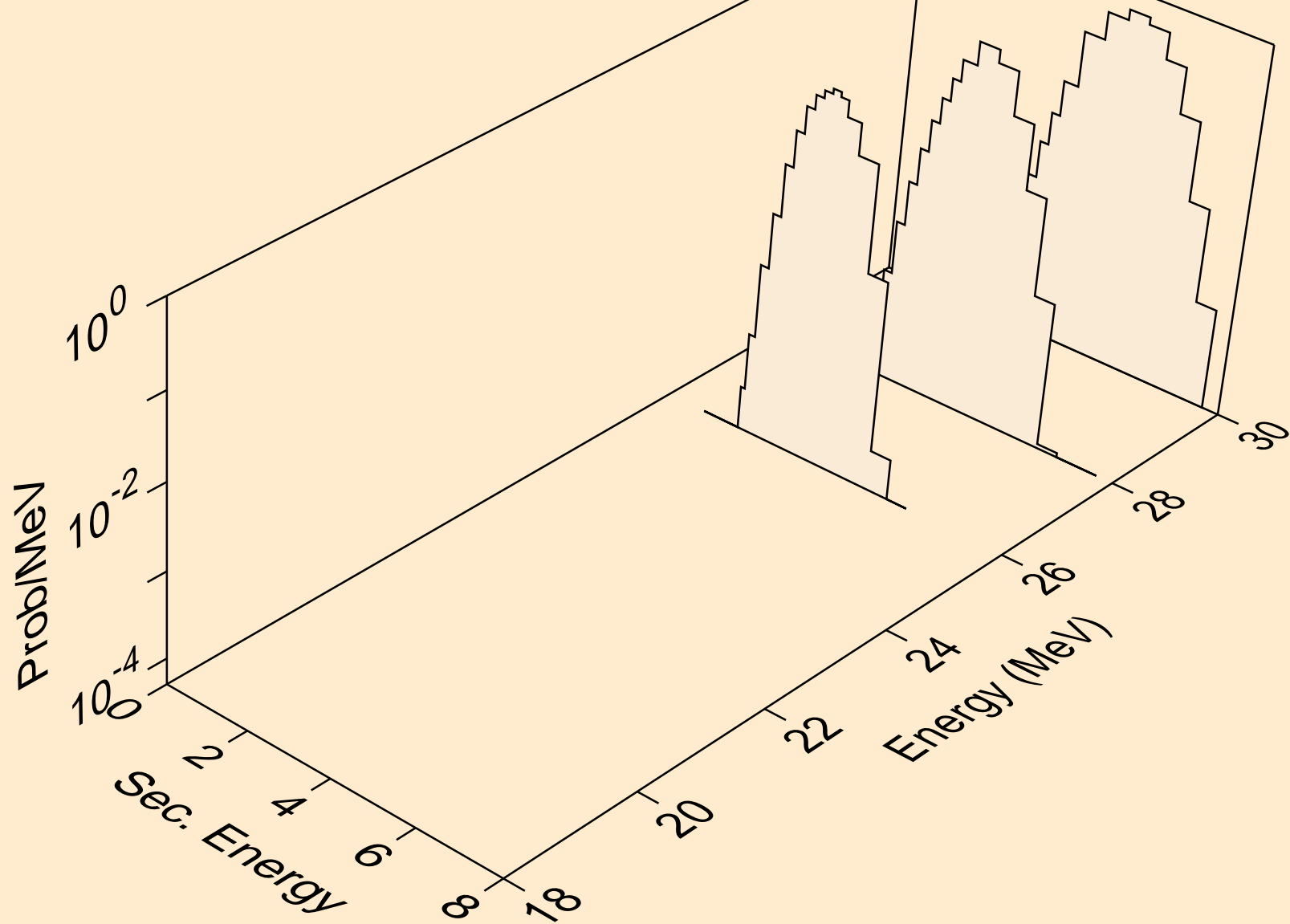

MN054 PHOTON ACER TENDL-2023 LIBRARY; T=0.K
alphas from (g,pa)

