

NB091M PHOTON ACER TENDL-2023 LIBRARY; T=0.K

Principal cross sections

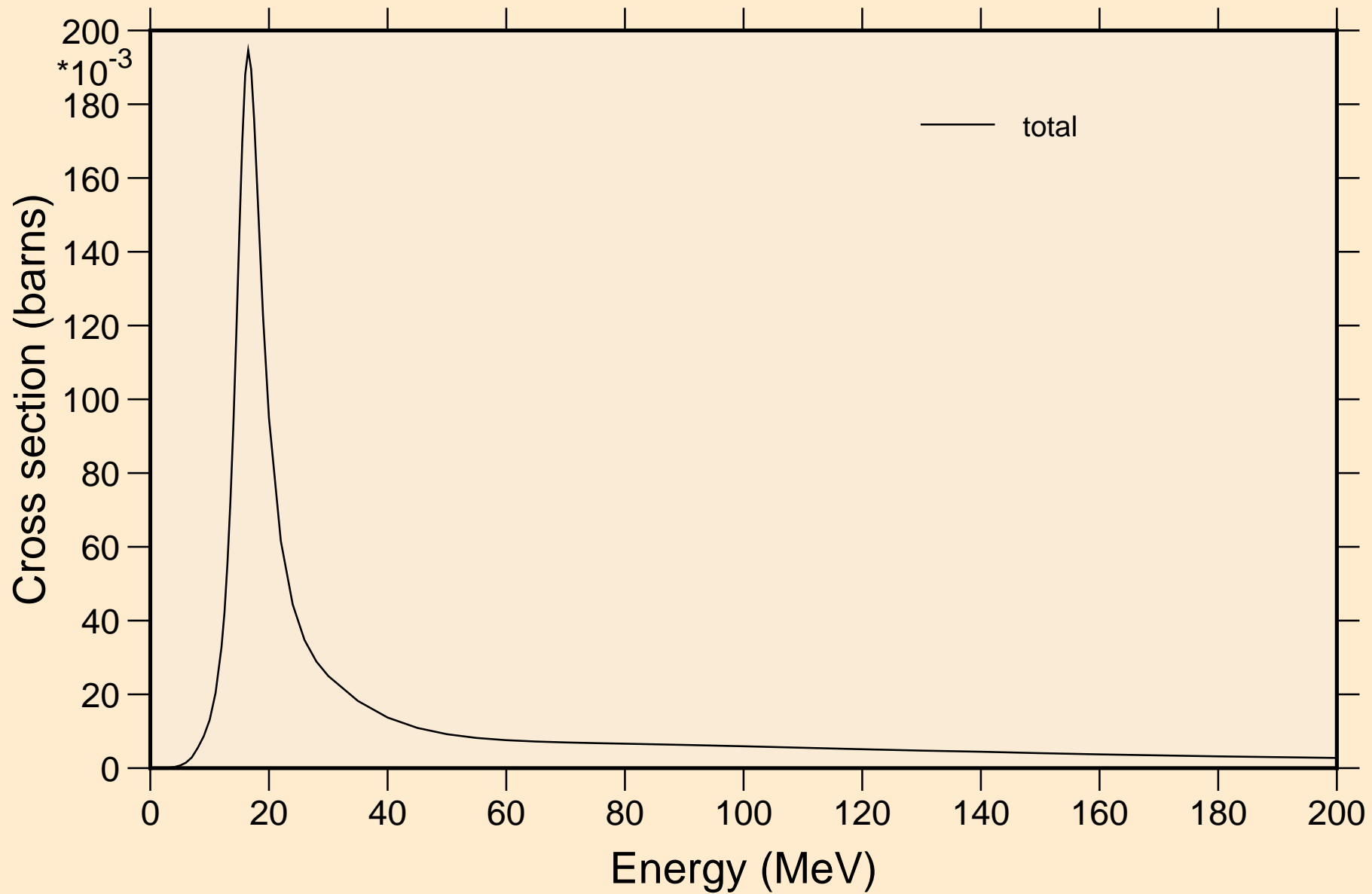

NB091M PHOTON ACER TENDL-2023 LIBRARY; T=0.K

Heating

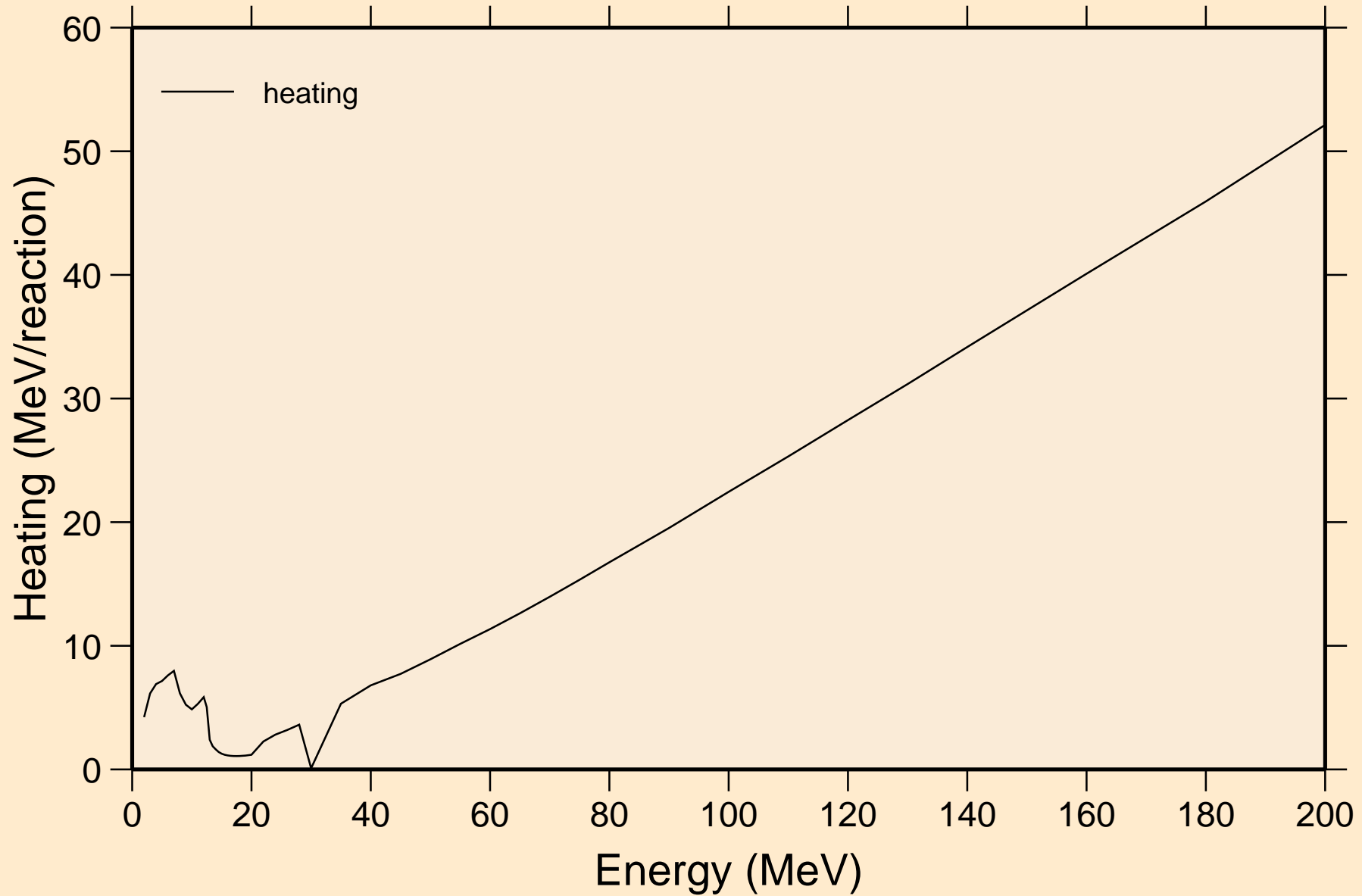

NB091M PHOTON ACER TENDL-2023 LIBRARY; T=0.K

Particle heating contributions

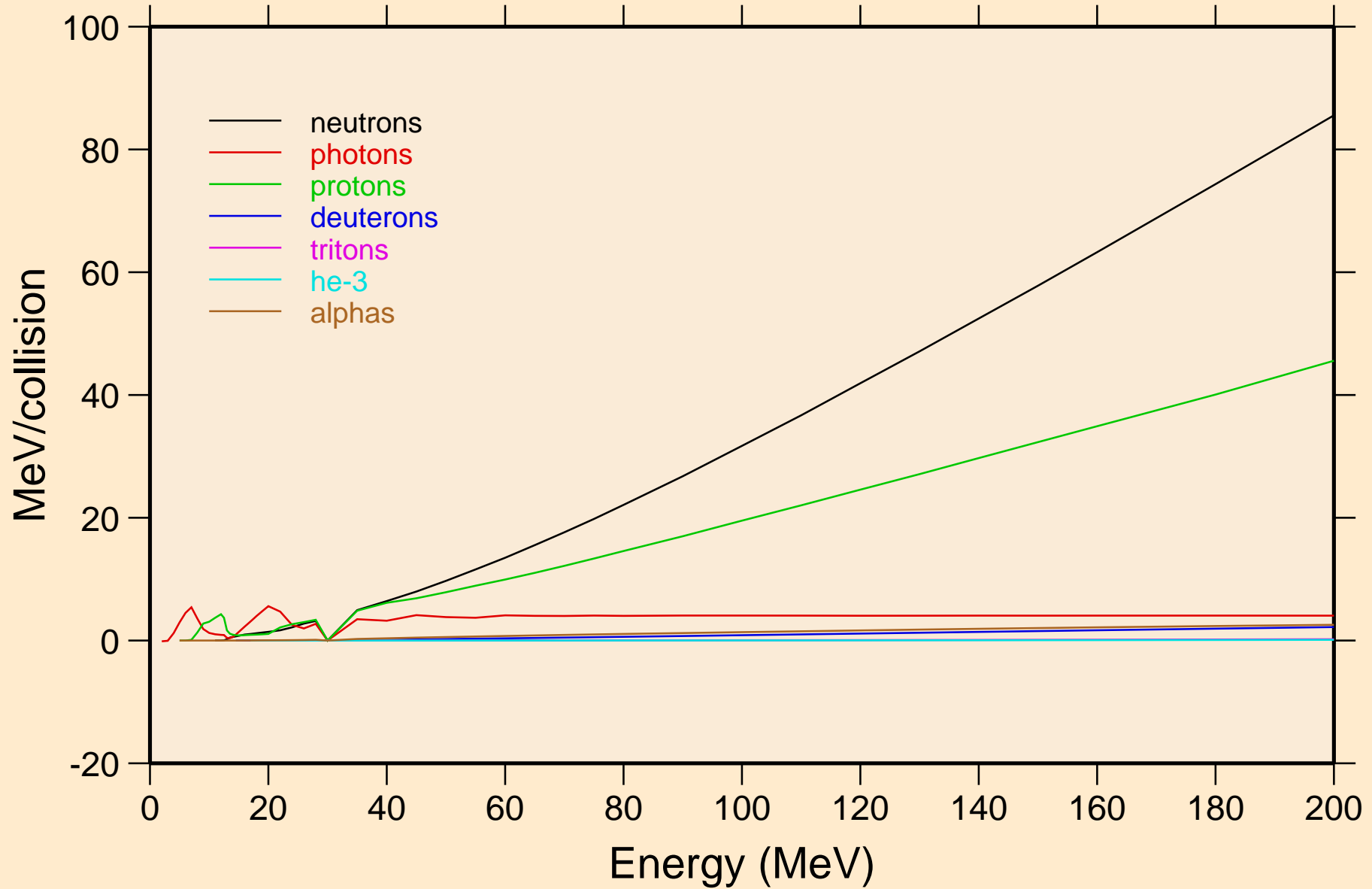

NB091M PHOTON ACER TENDL-2023 LIBRARY; T=0.K

Particle production cross sections

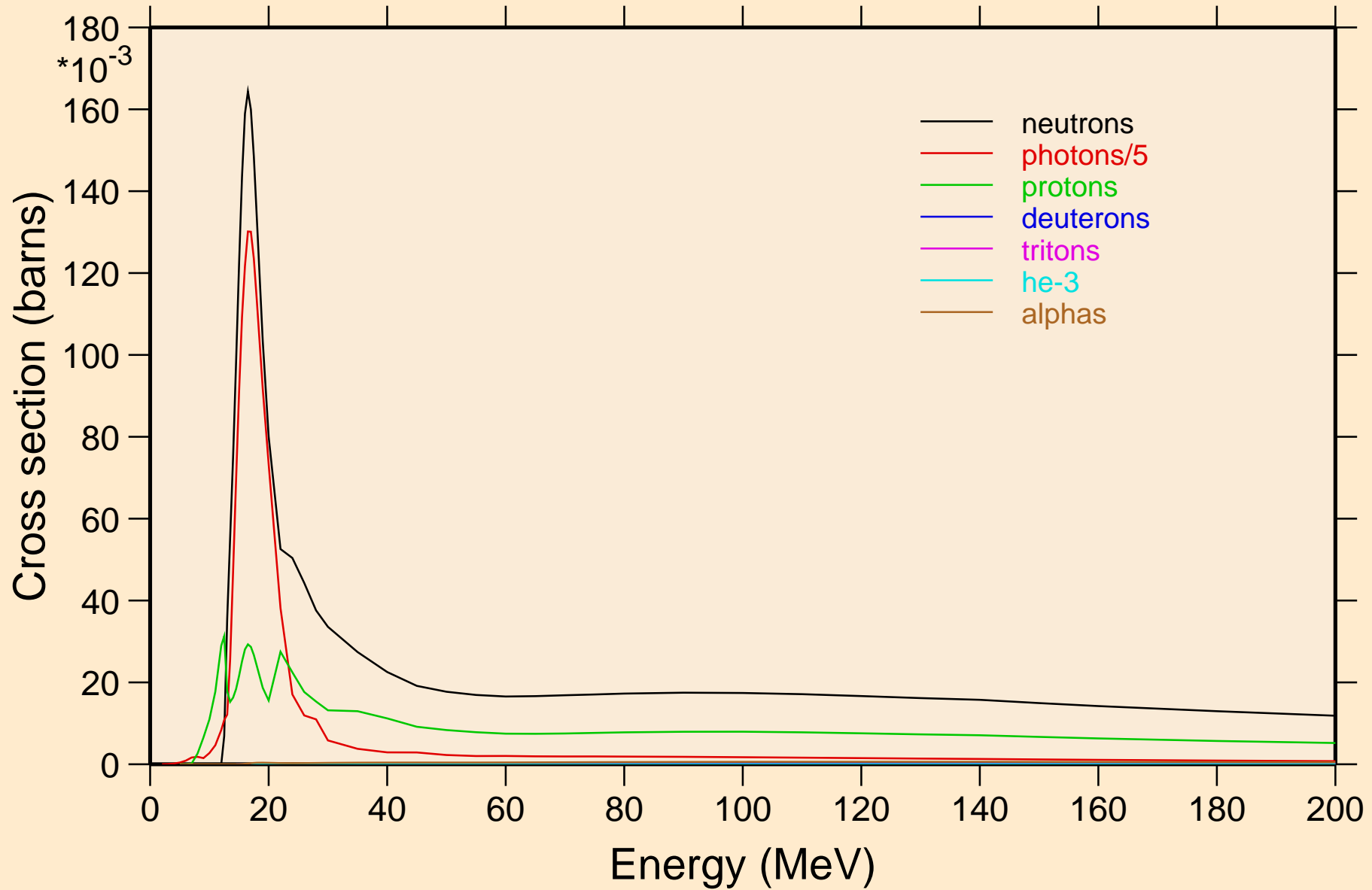

NB091M PHOTON ACER TENDL-2023 LIBRARY; T=0.K
neutrons from (g,x)

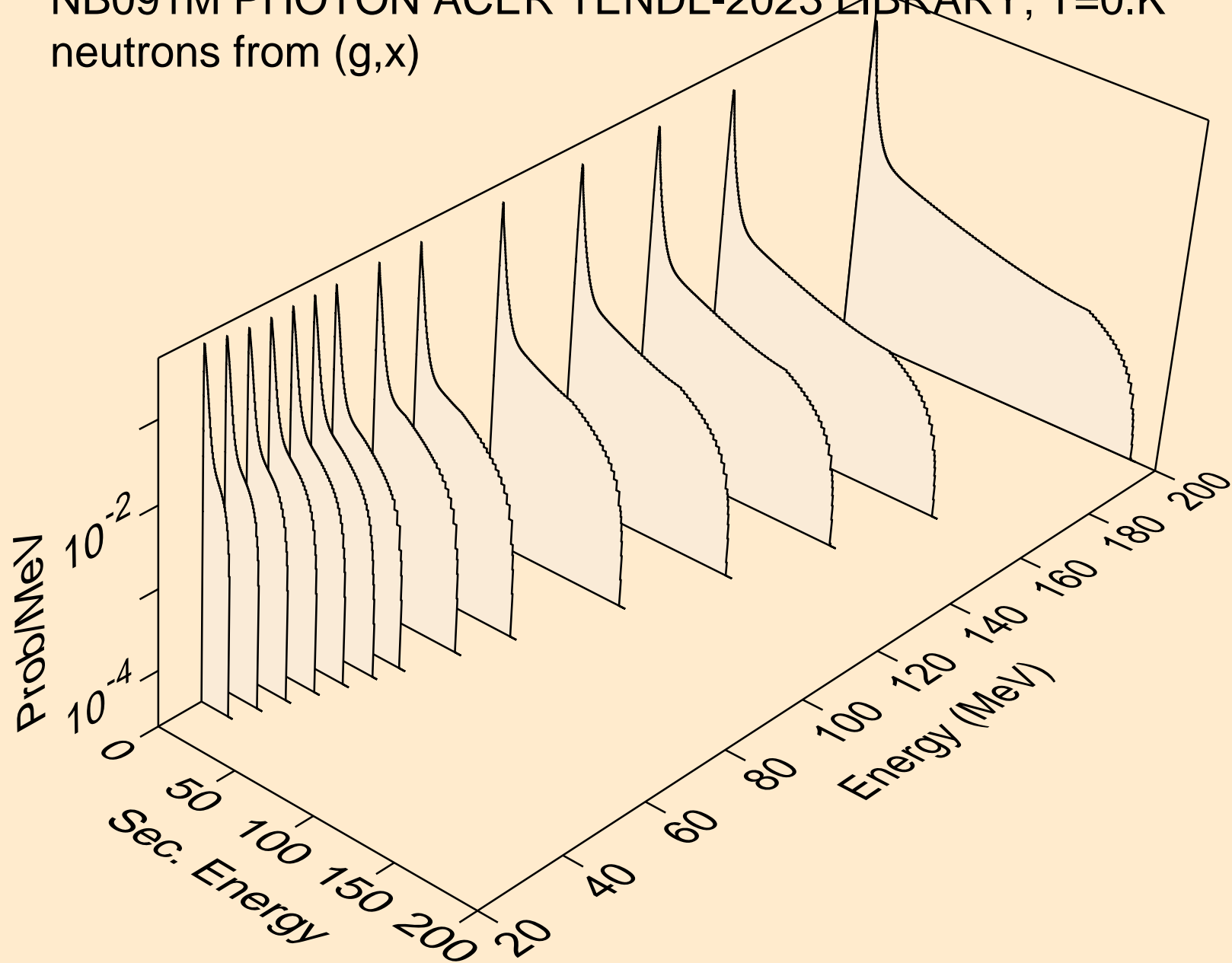

NB091M PHOTON ACER TENDL-2023 LIBRARY; T=0.K
neutrons from (g,2n)

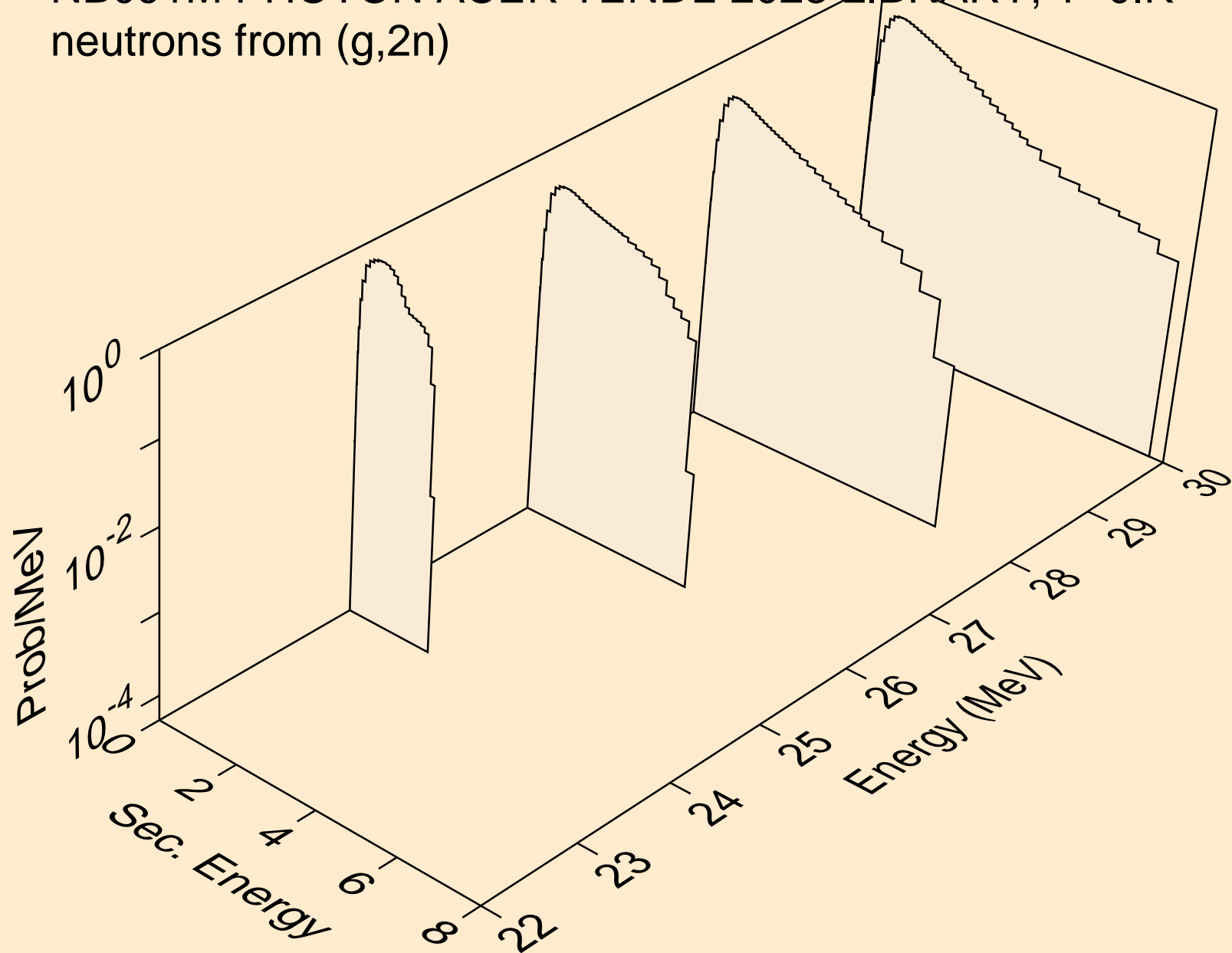

NB091M PHOTON ACER TENDL-2023 LIBRARY; T=0.K
neutrons from (g,n*)a

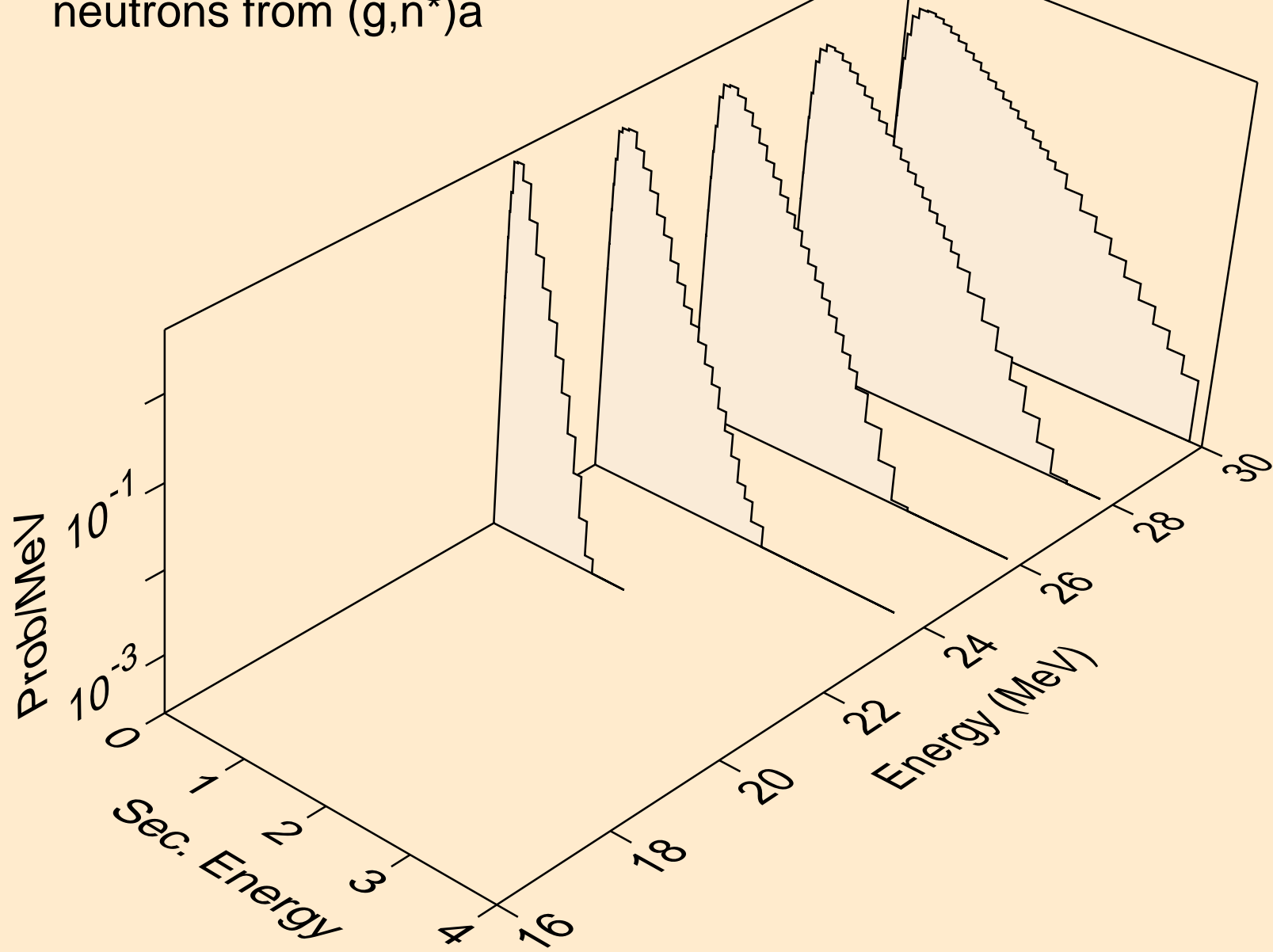

NB091M PHOTON ACER TENDL-2023 LIBRARY; T=0.K
neutrons from (g,n*)p

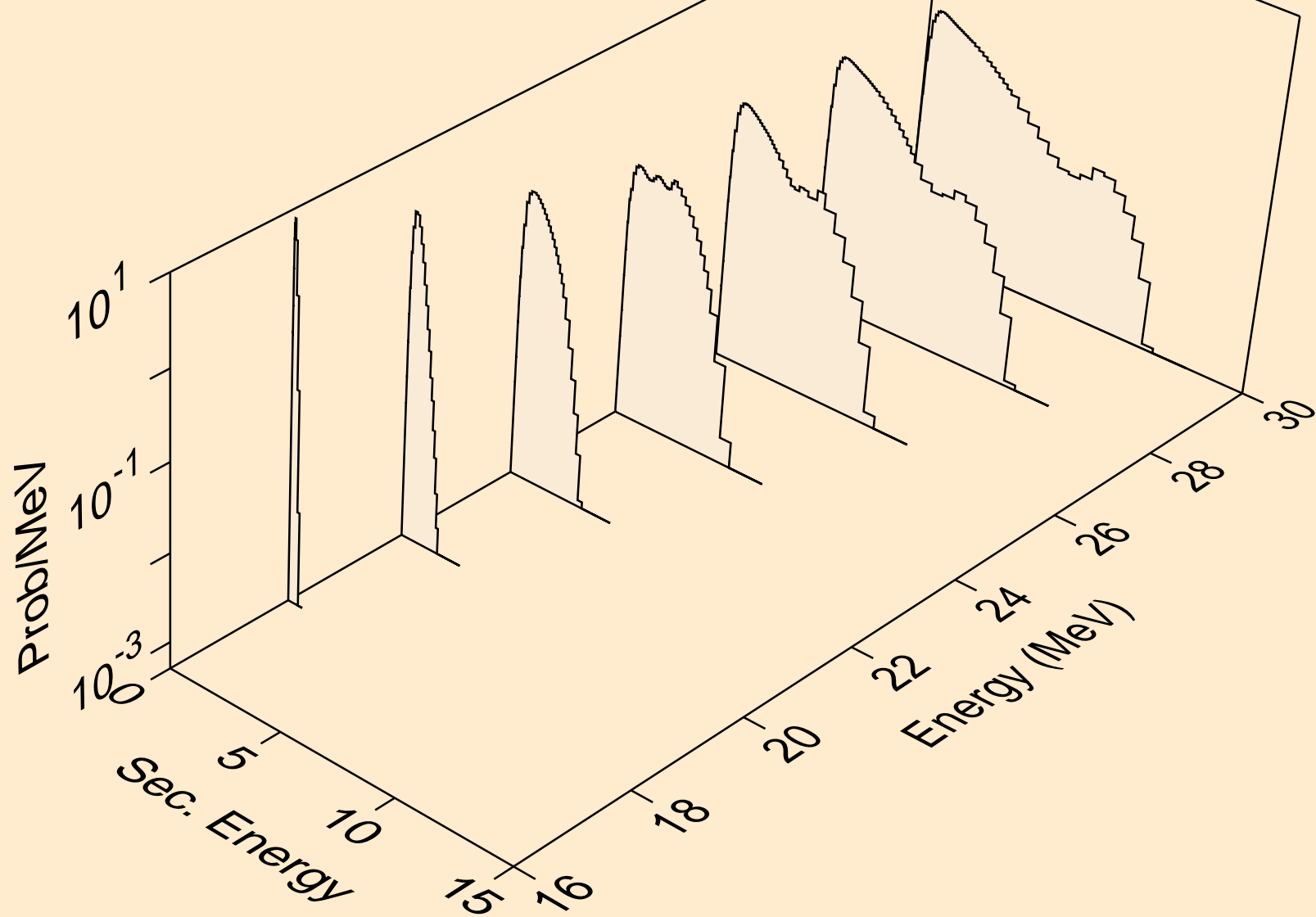

NB091M PHOTON ACER TENDL-2023 LIBRARY; T=0.K
neutrons from (g,n*)d

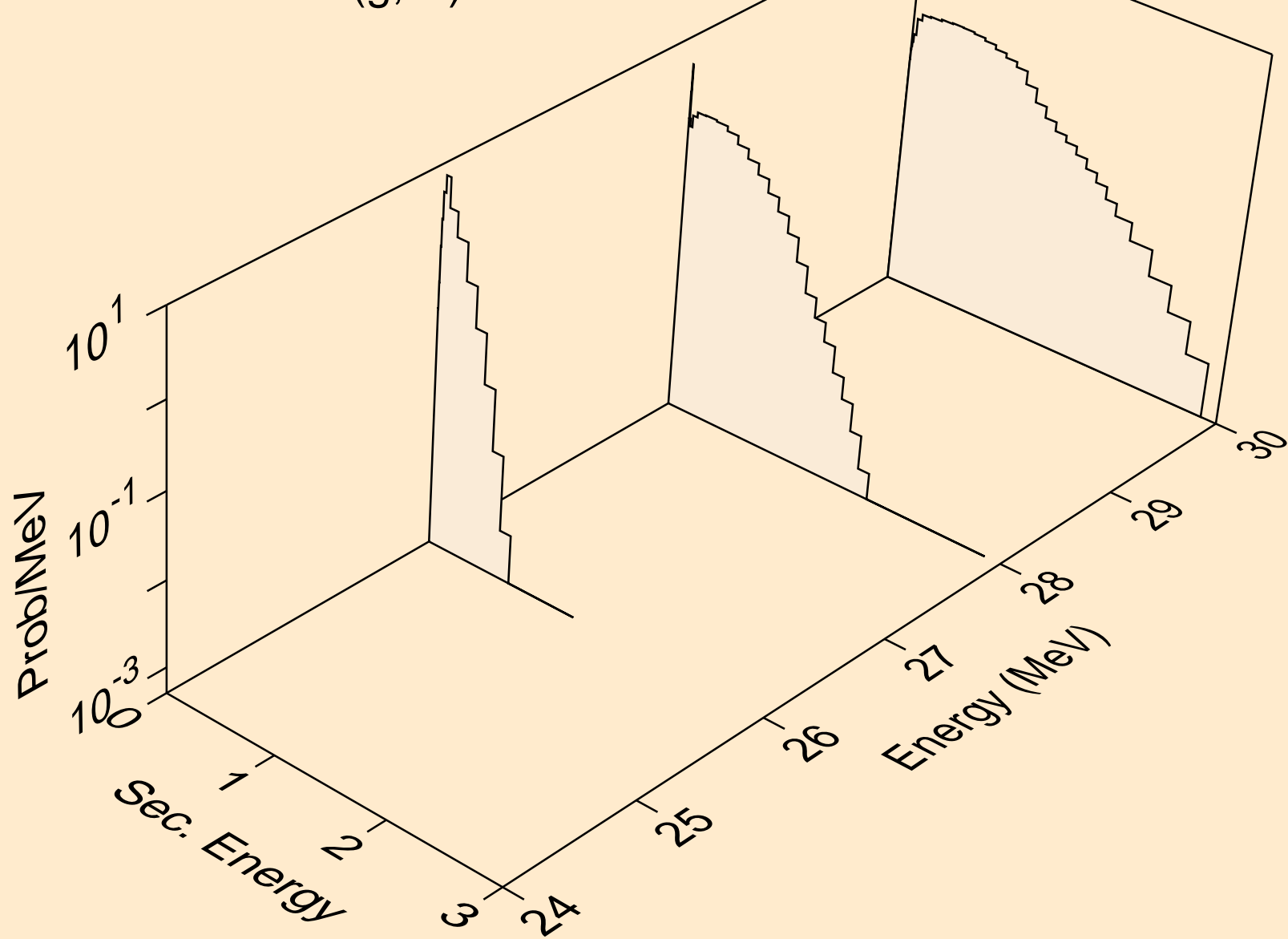

NB091M PHOTON ACER TENDL-2023 LIBRARY; T=0.K
neutrons from (g,2np)

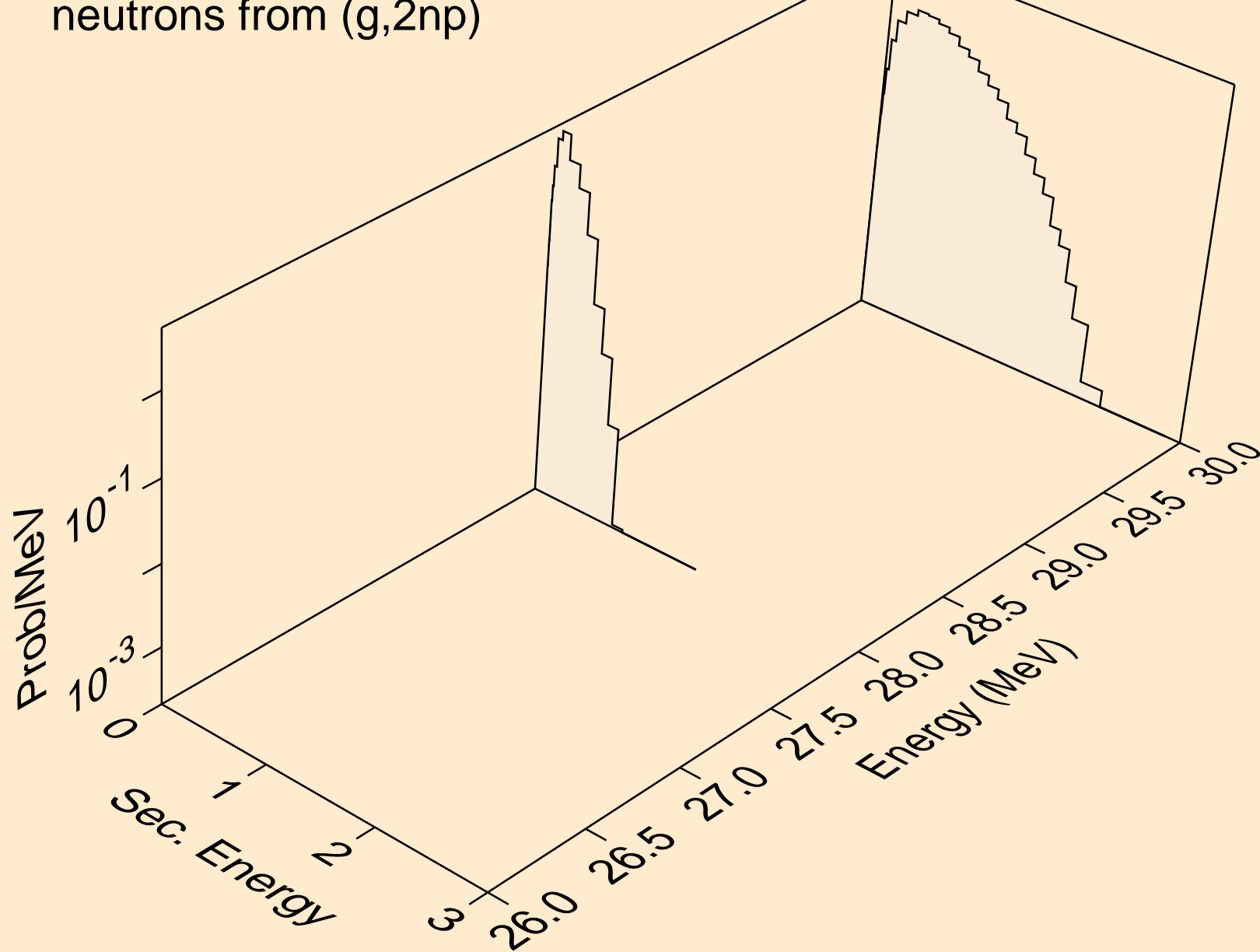

NB091M PHOTON ACER TENDL-2023 LIBRARY; T=0.K
neutrons from (g,n2p)

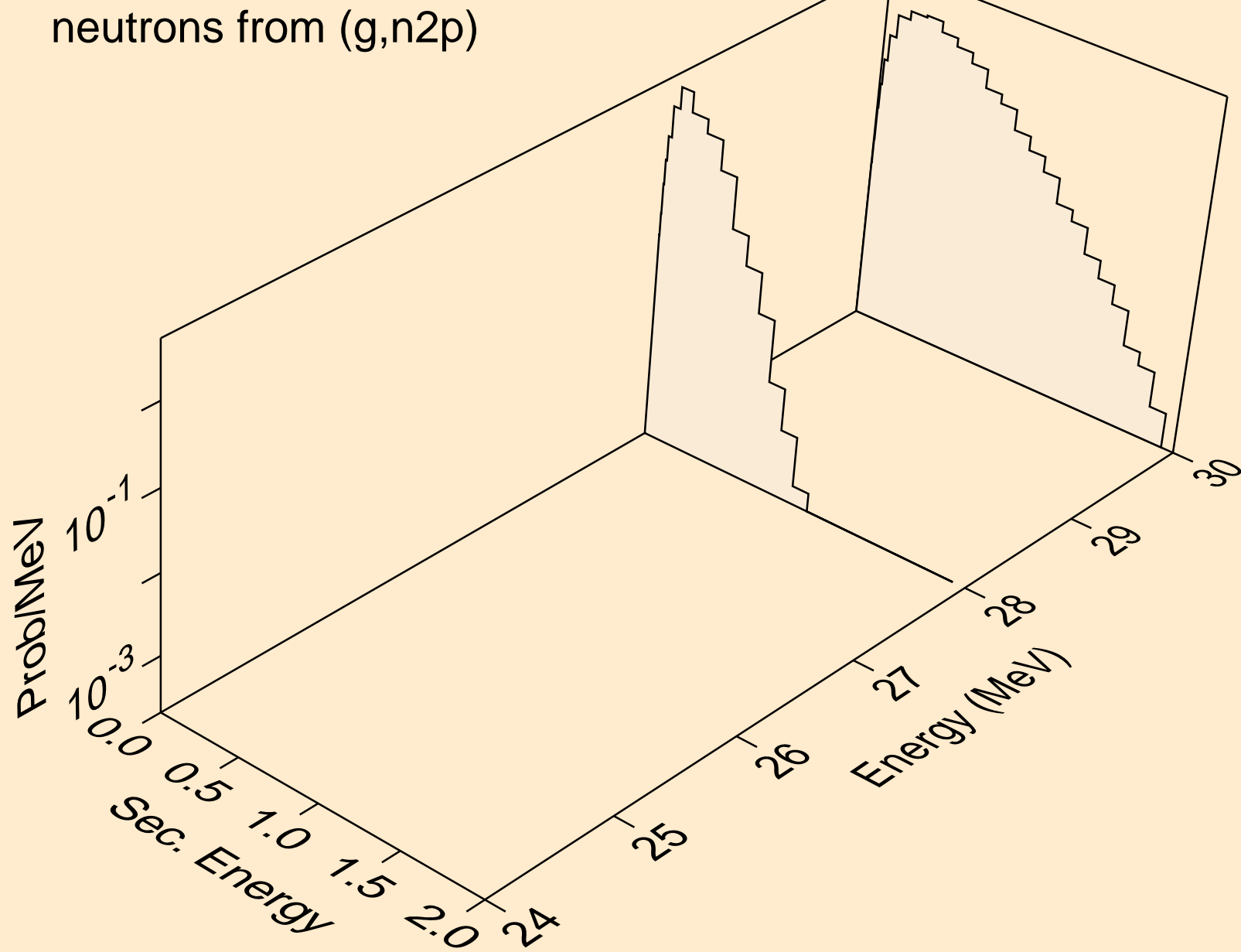

NB091M PHOTON ACER TENDL-2023 LIBRARY; T=0.K
angular distribution for (g,n*0) neutron

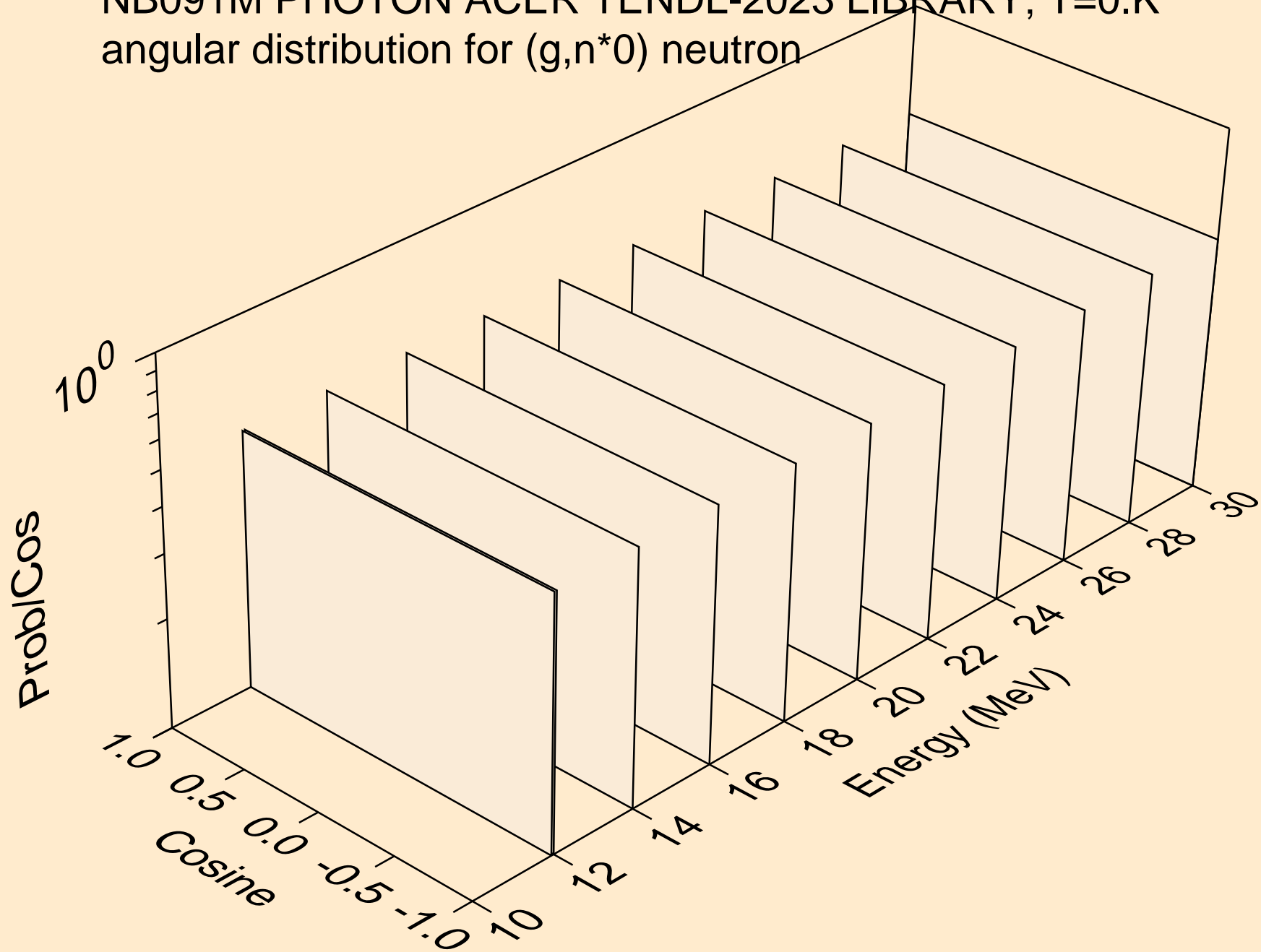

NB091M PHOTON ACER TENDL-2023 LIBRARY; T=0.K
angular distribution for (g,n*1) neutron

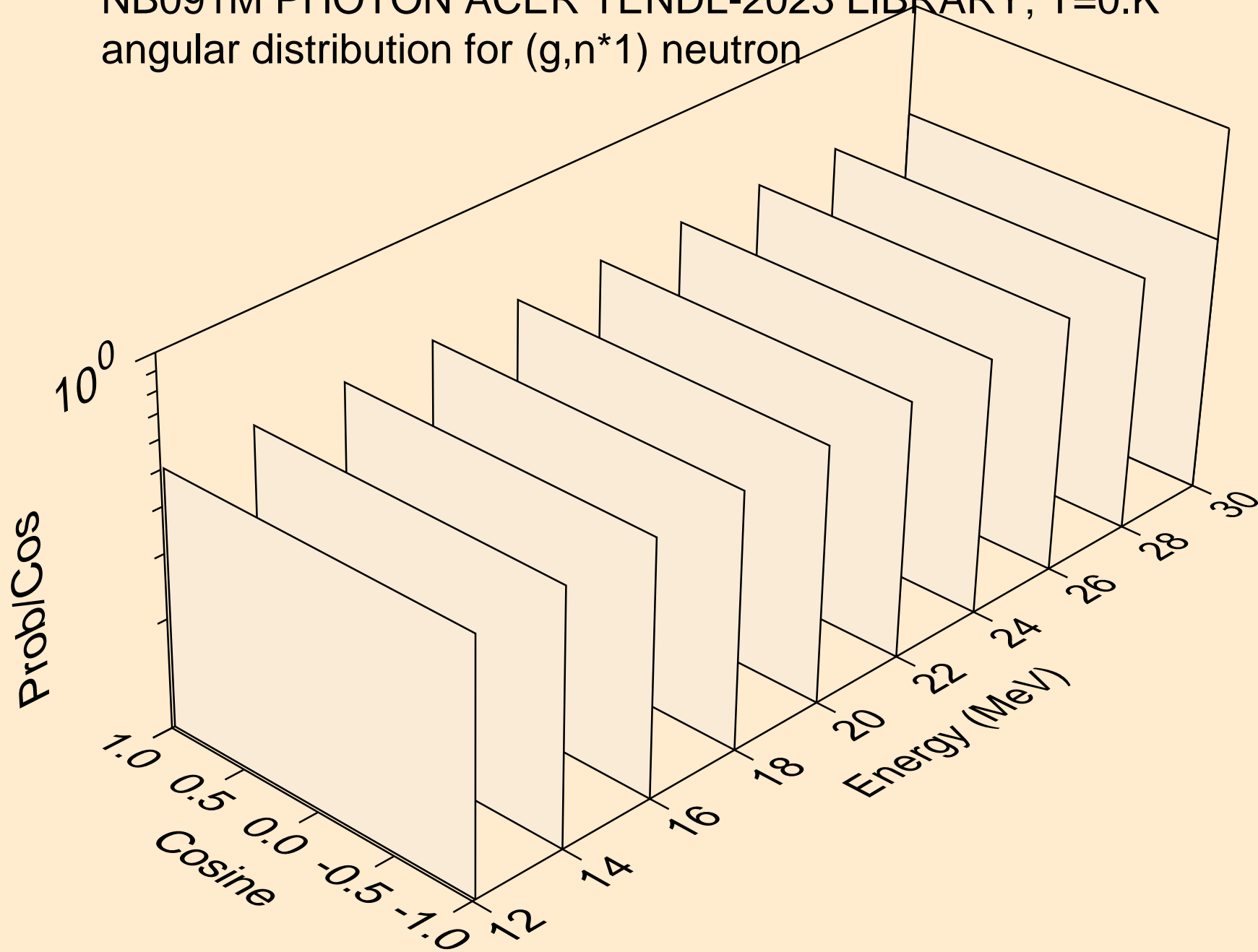

NB091M PHOTON ACER TENDL-2023 LIBRARY; T=0.K
angular distribution for (g,n*2) neutron

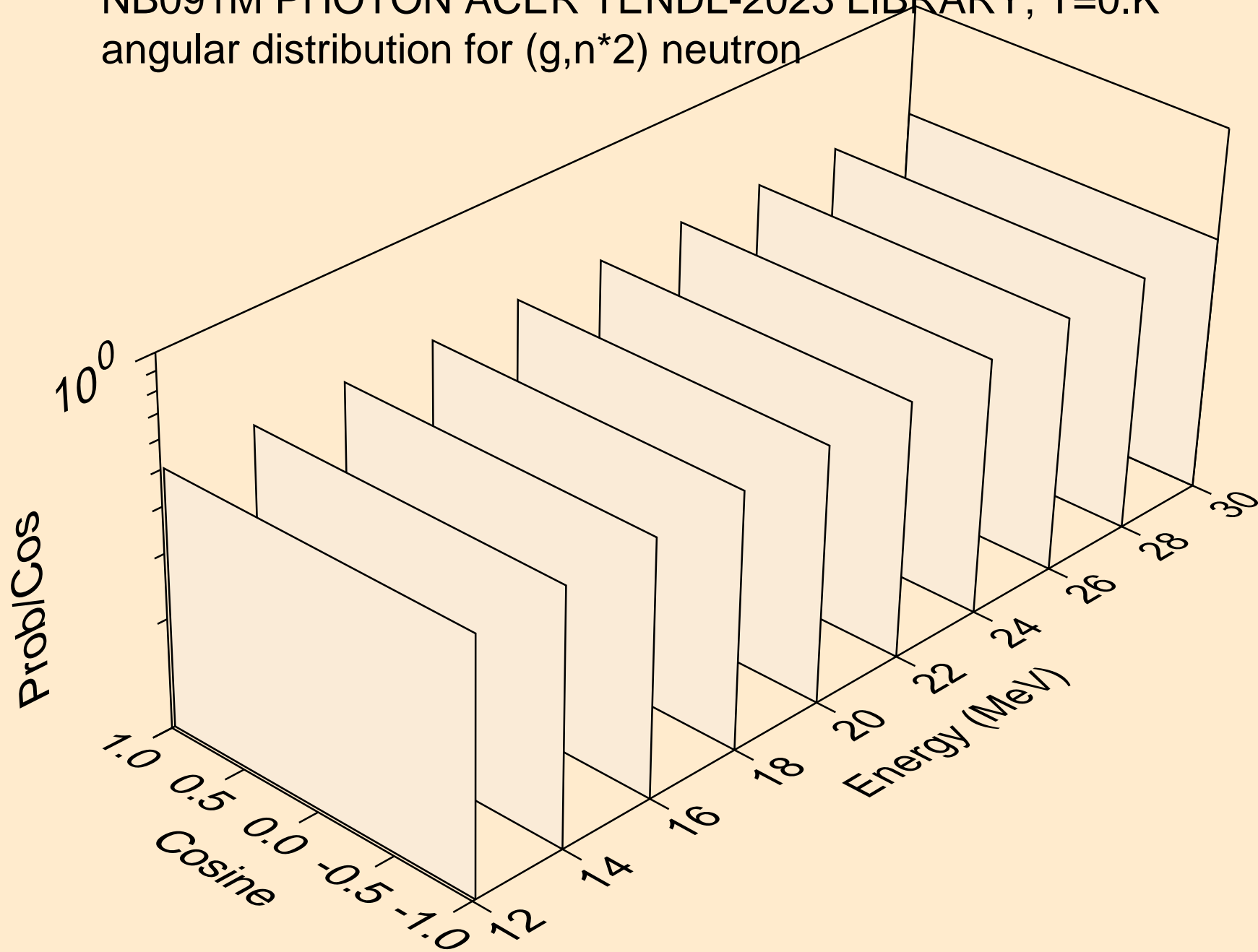

NB091M PHOTON ACER TENDL-2023 LIBRARY; T=0.K
angular distribution for (g,n*3) neutron

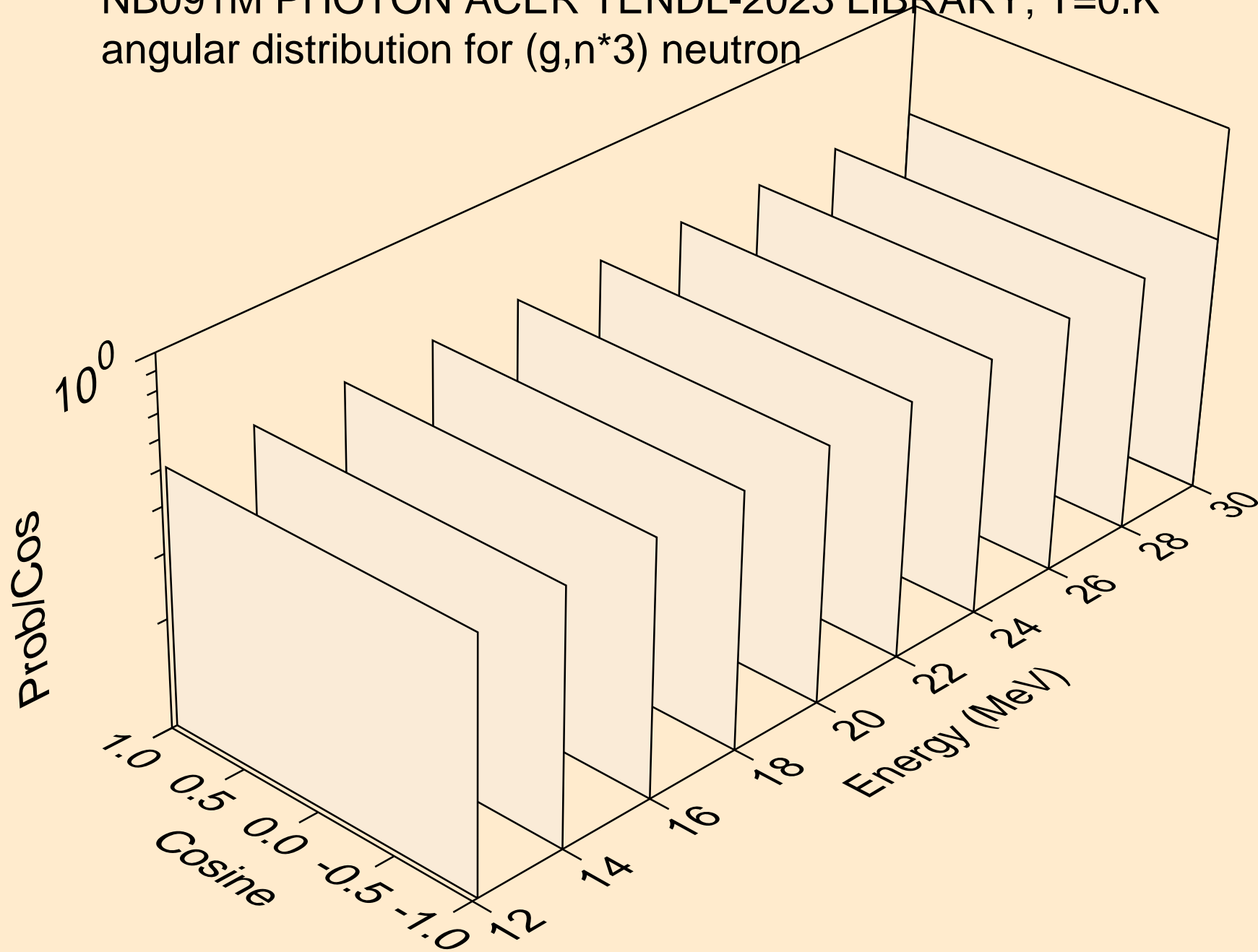

NB091M PHOTON ACER TENDL-2023 LIBRARY; T=0.K
angular distribution for (g,n*4) neutron

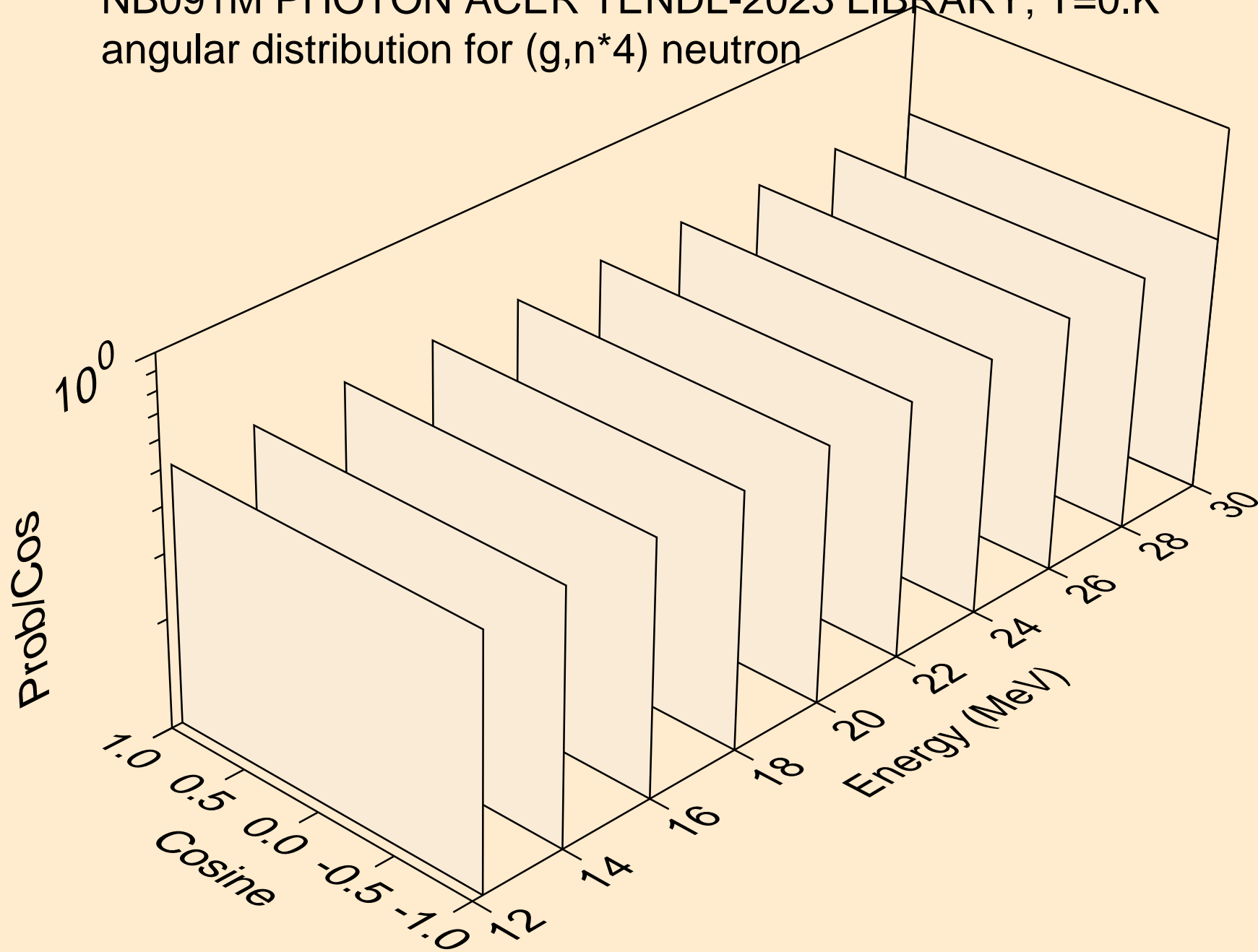

NB091M PHOTON ACER TENDL-2023 LIBRARY; T=0.K
angular distribution for (g,n*5) neutron

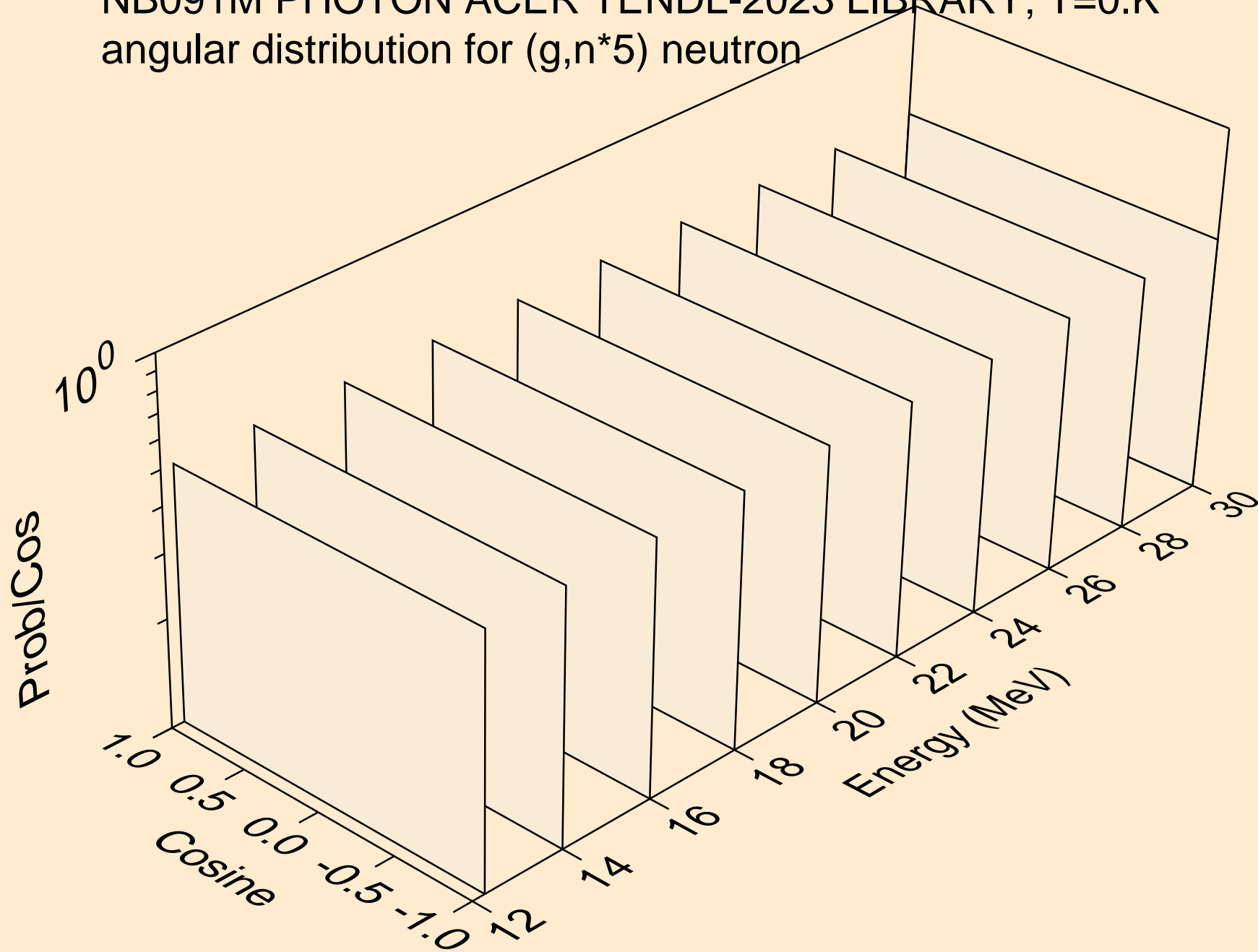

NB091M PHOTON ACER TENDL-2023 LIBRARY; T=0.K
angular distribution for (g,n*6) neutron

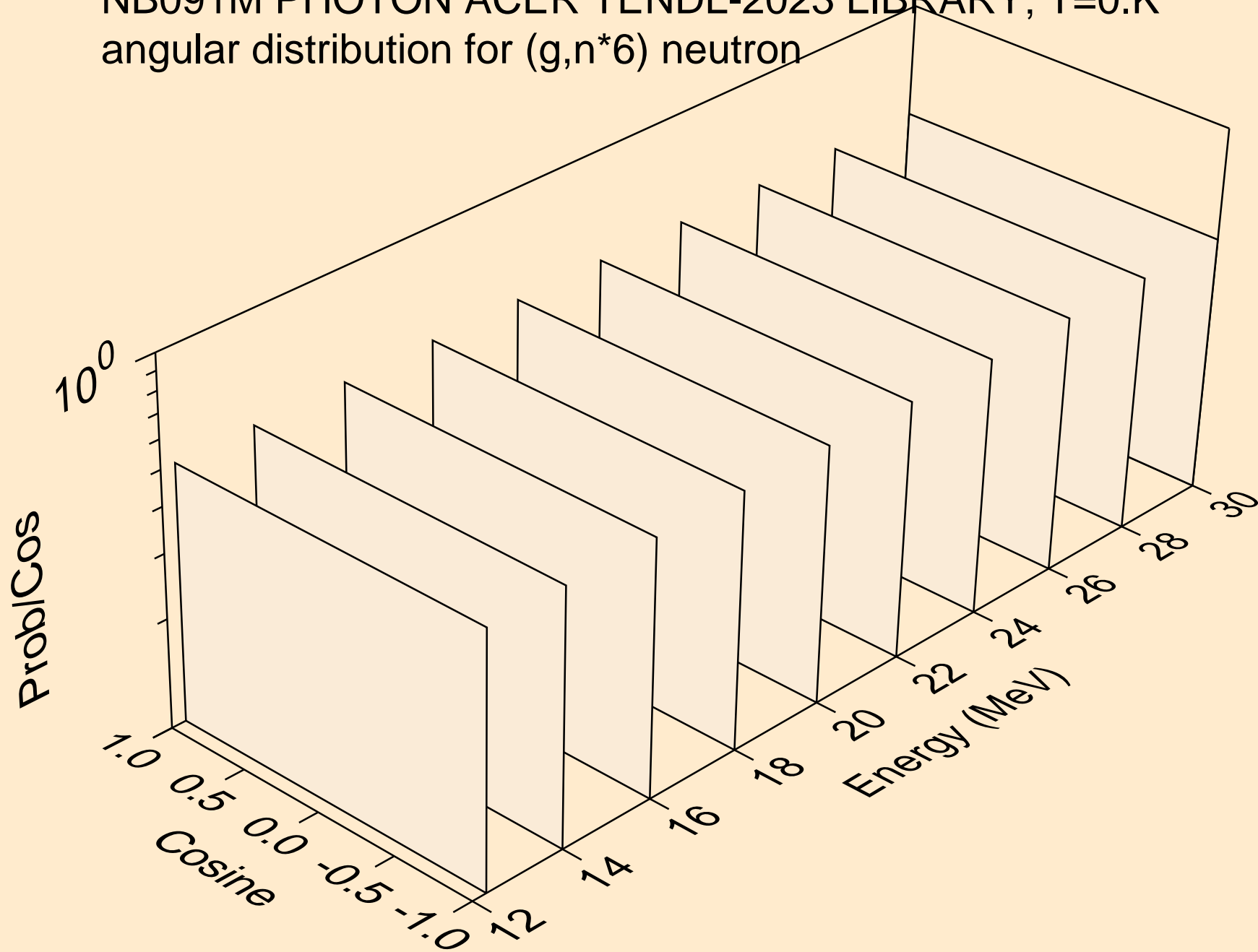

NB091M PHOTON ACER TENDL-2023 LIBRARY; T=0.K
angular distribution for (g,n*7) neutron

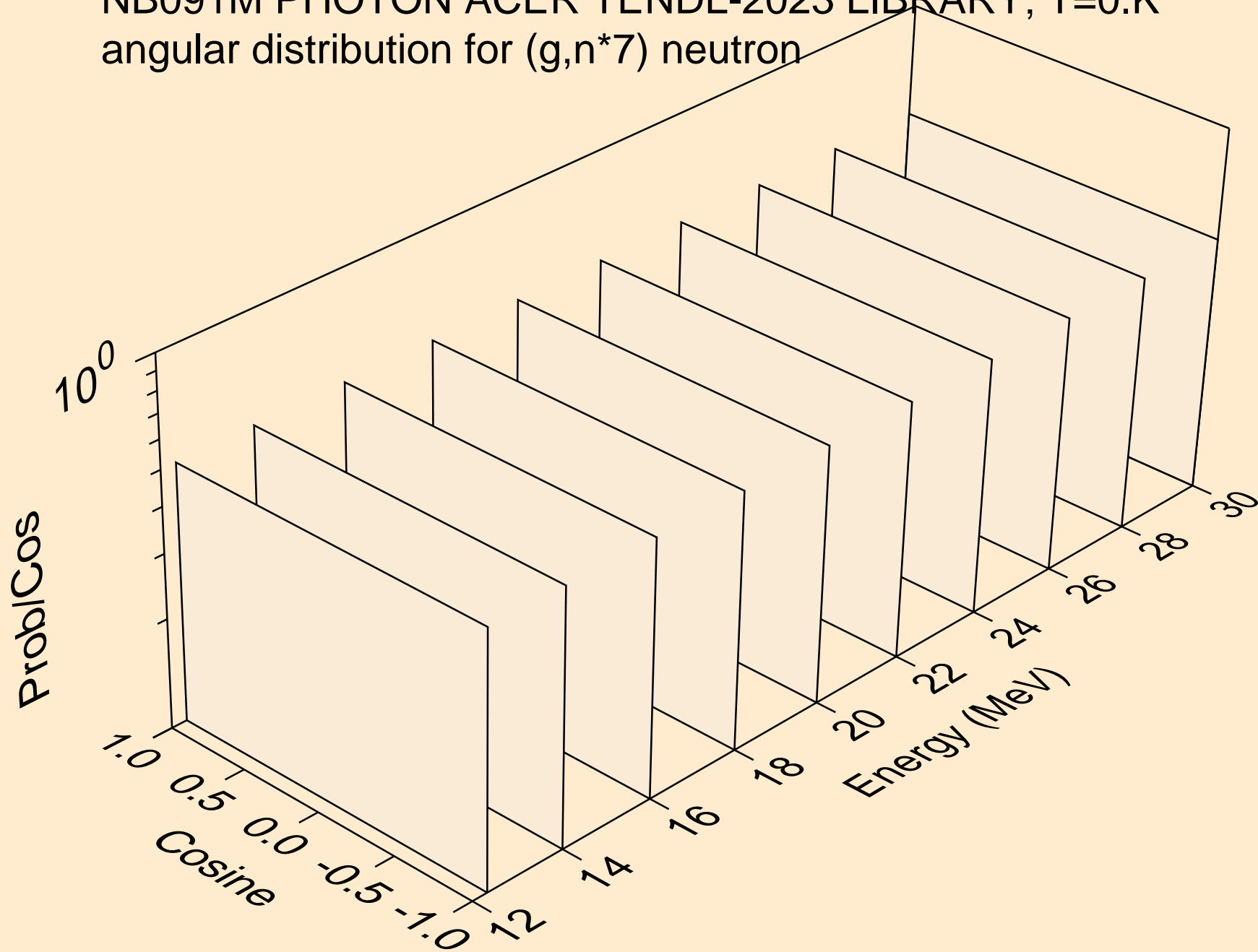

NB091M PHOTON ACER TENDL-2023 LIBRARY; T=0.K
angular distribution for (g,n*8) neutron

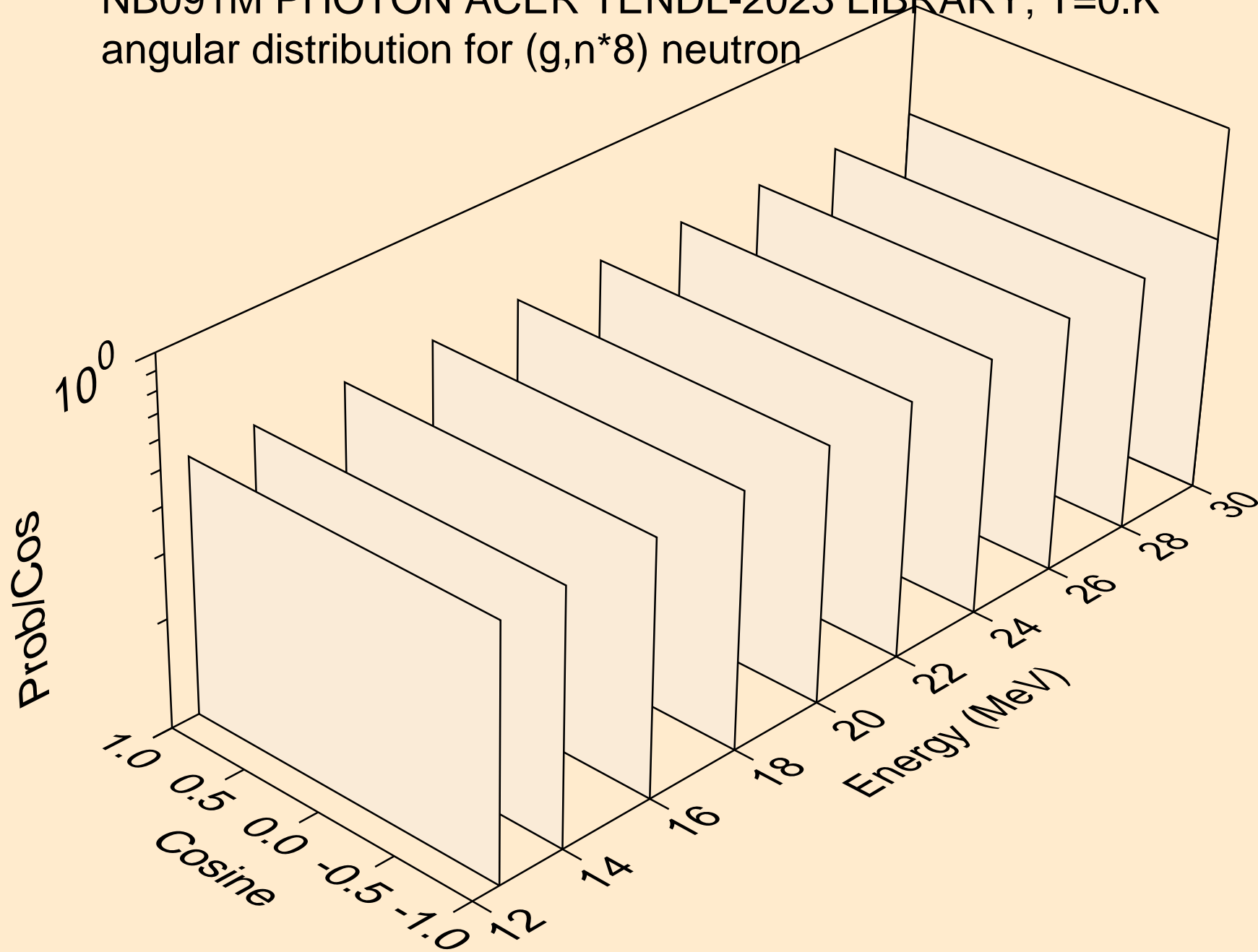

NB091M PHOTON ACER TENDL-2023 LIBRARY; T=0.K
angular distribution for (g,n*9) neutron

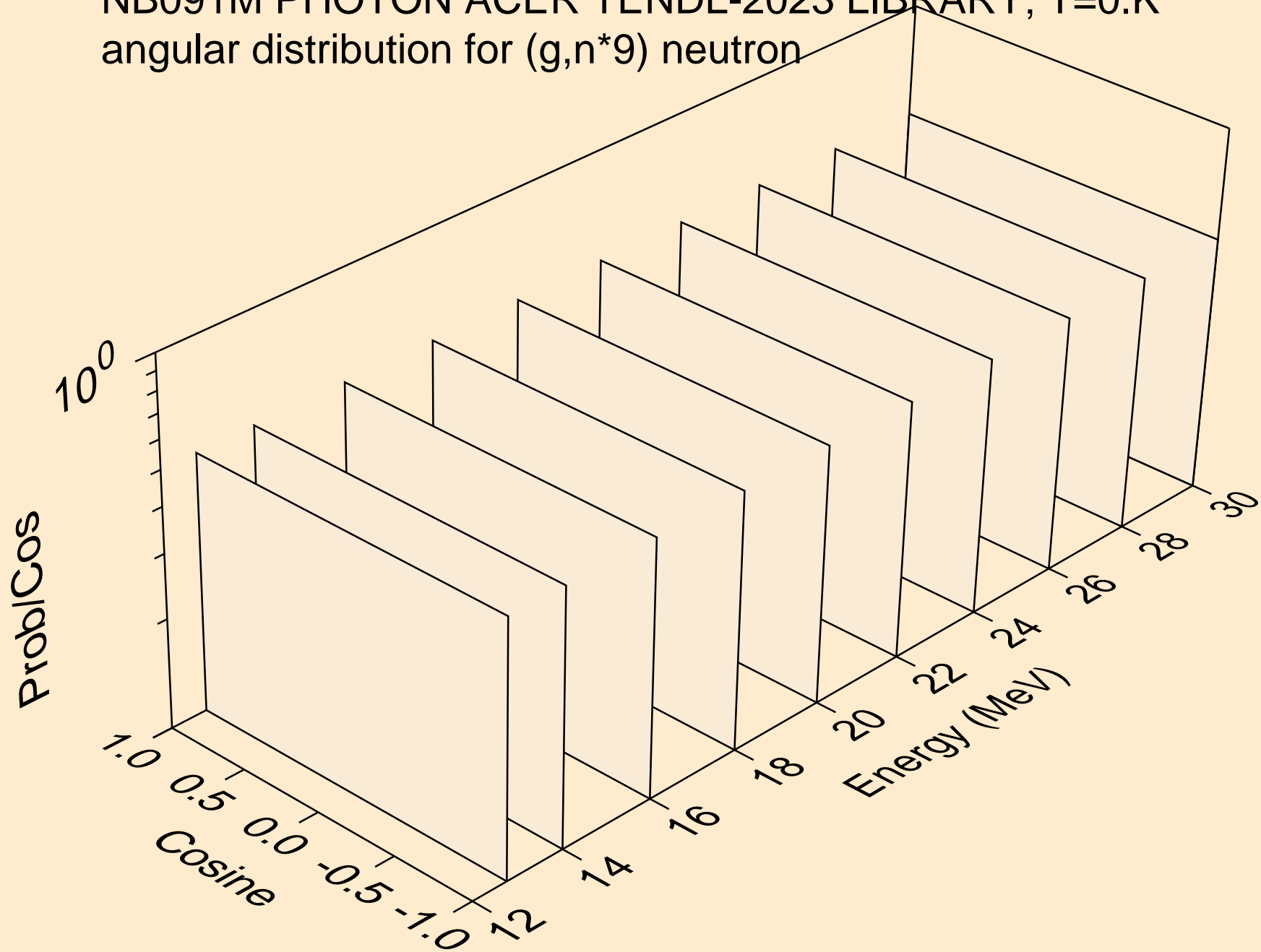

NB091M PHOTON ACER TENDL-2023 LIBRARY; T=0.K
angular distribution for (g,n*10) neutron

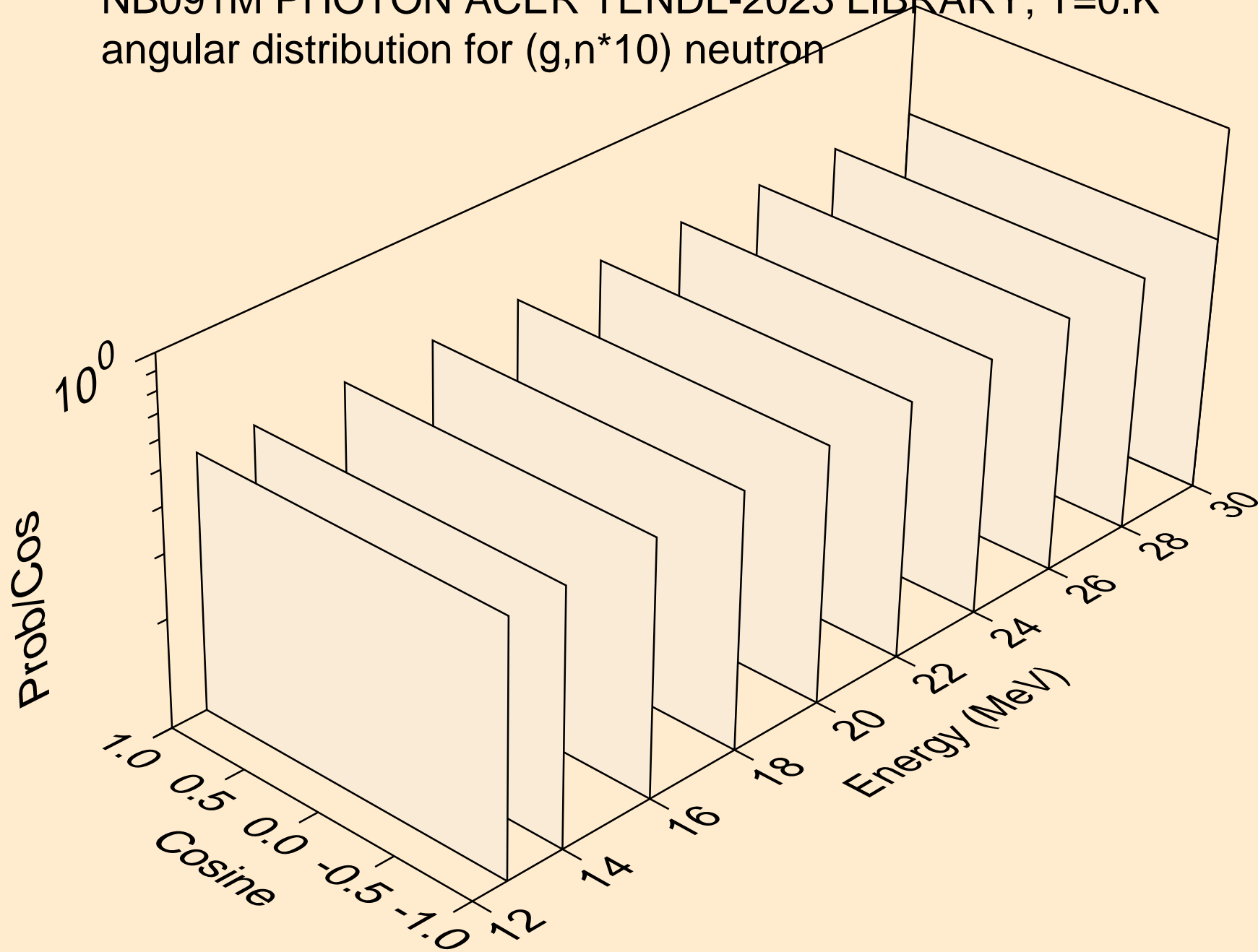

NB091M PHOTON ACER TENDL-2023 LIBRARY; T=0.K
angular distribution for (g,n*11) neutron

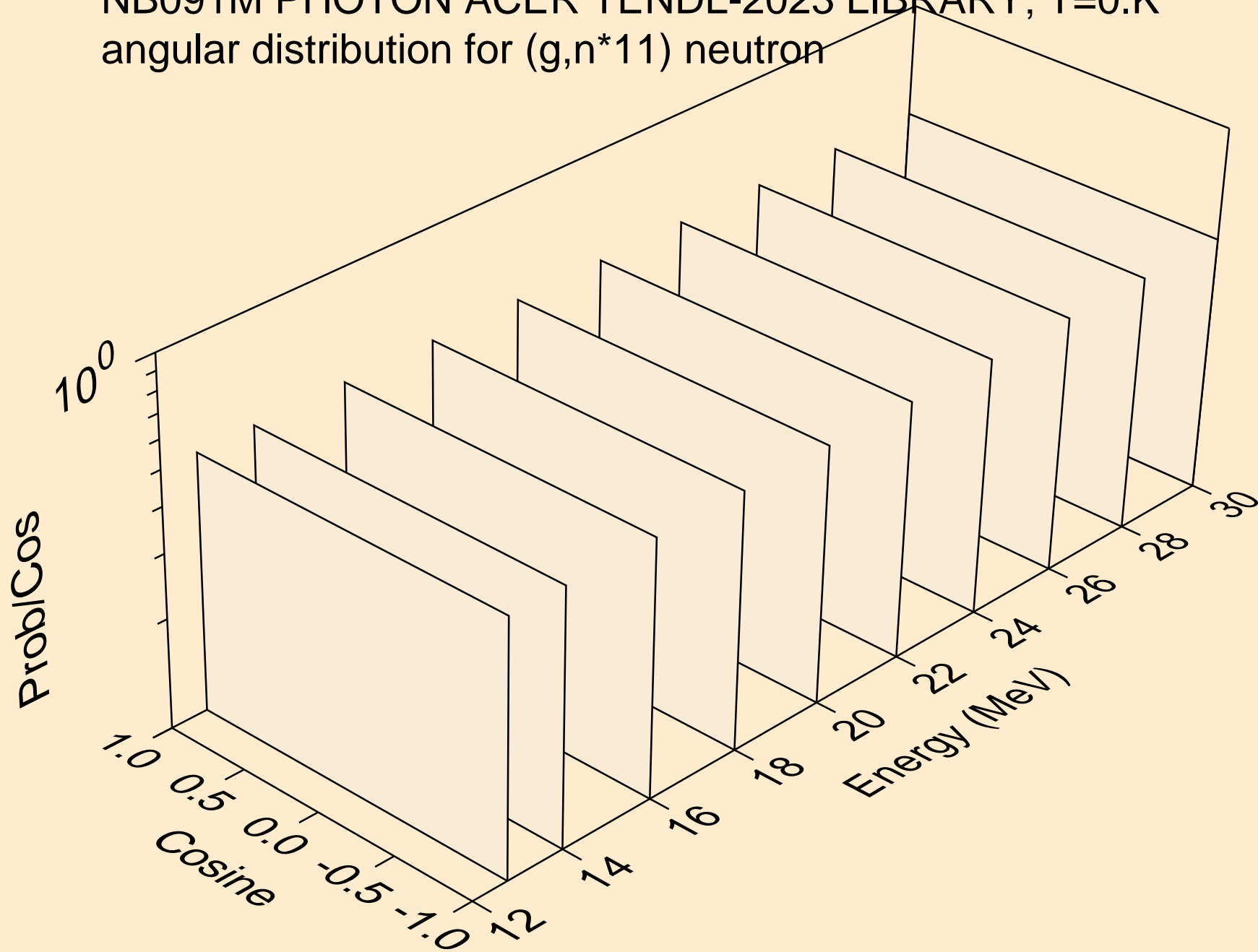

NB091M PHOTON ACER TENDL-2023 LIBRARY; T=0.K
angular distribution for (g,n*12) neutron

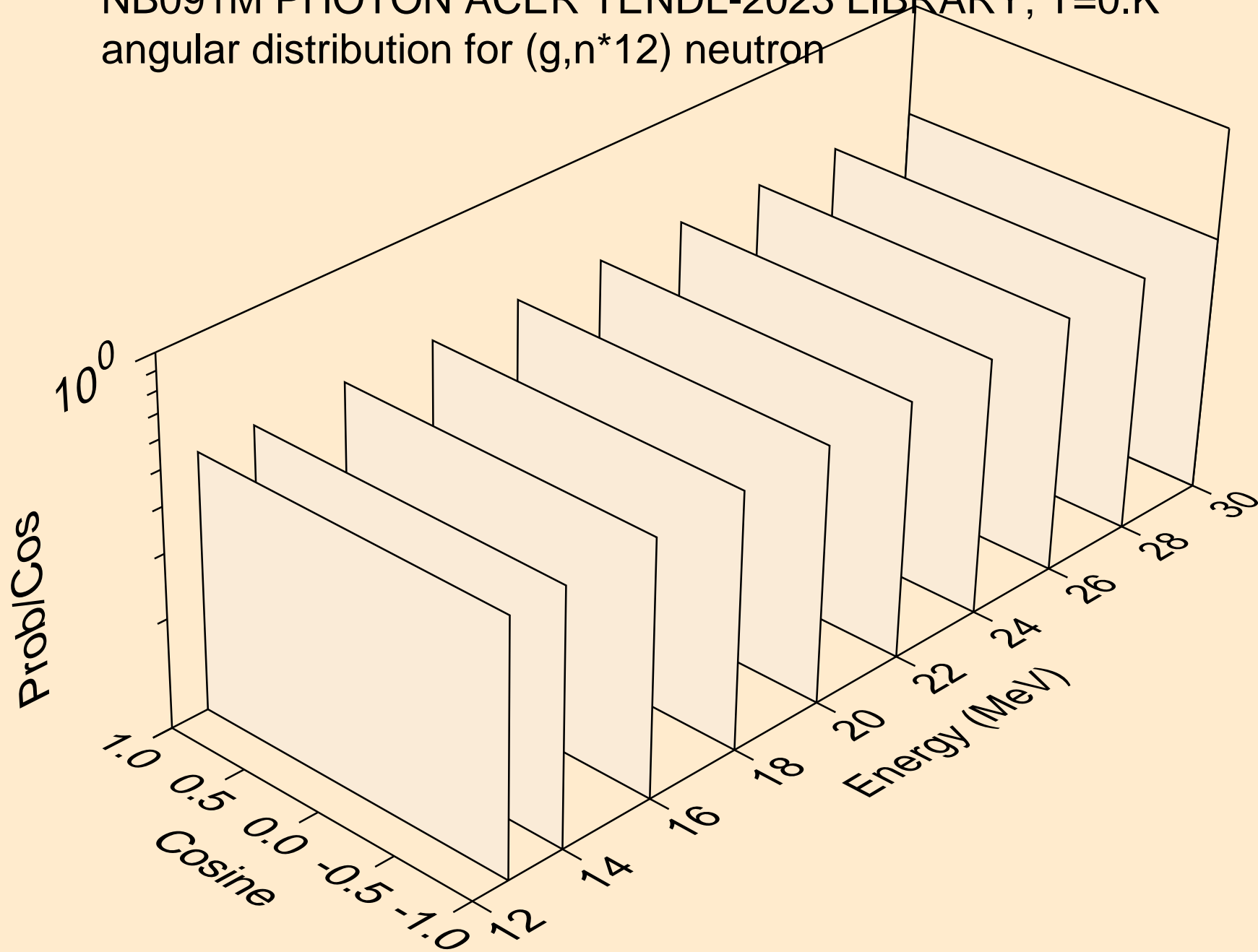

NB091M PHOTON ACER TENDL-2023 LIBRARY; T=0.K
angular distribution for (g,n*13) neutron

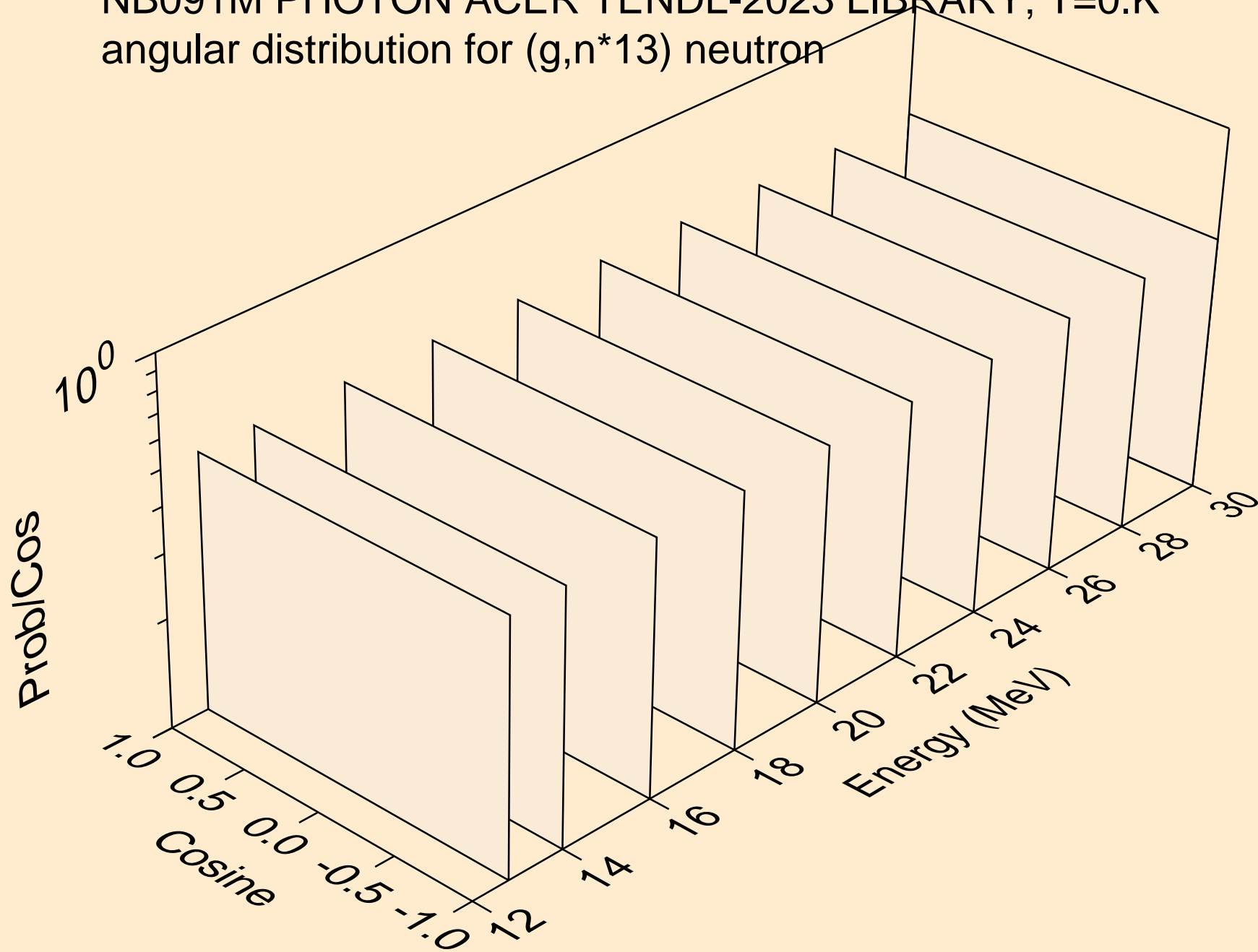

NB091M PHOTON ACER TENDL-2023 LIBRARY; T=0.K
neutrons from (g,n*c)

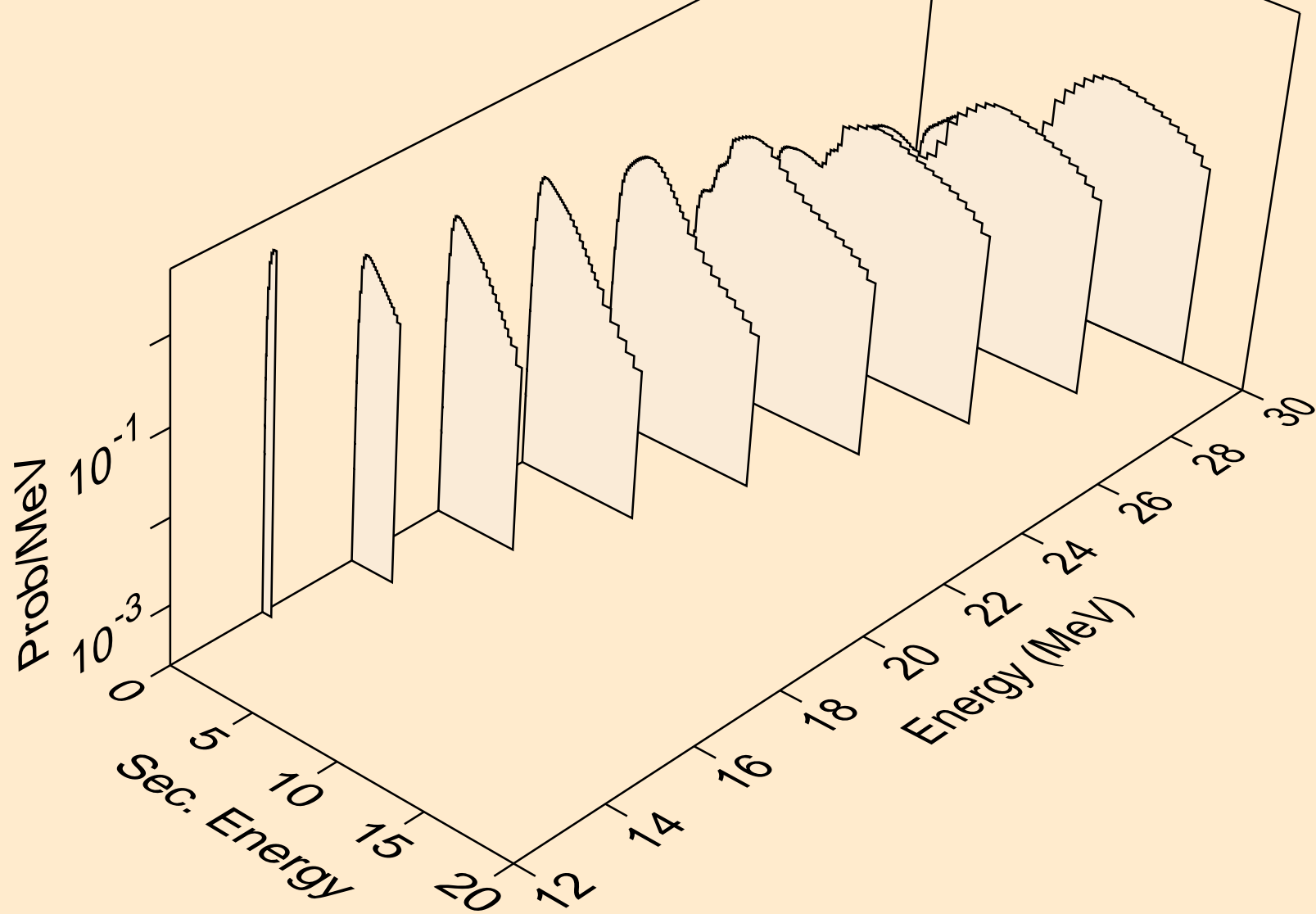

NB091M PHOTON ACER TENDL-2023 LIBRARY; T=0.K
photons from (g,x)

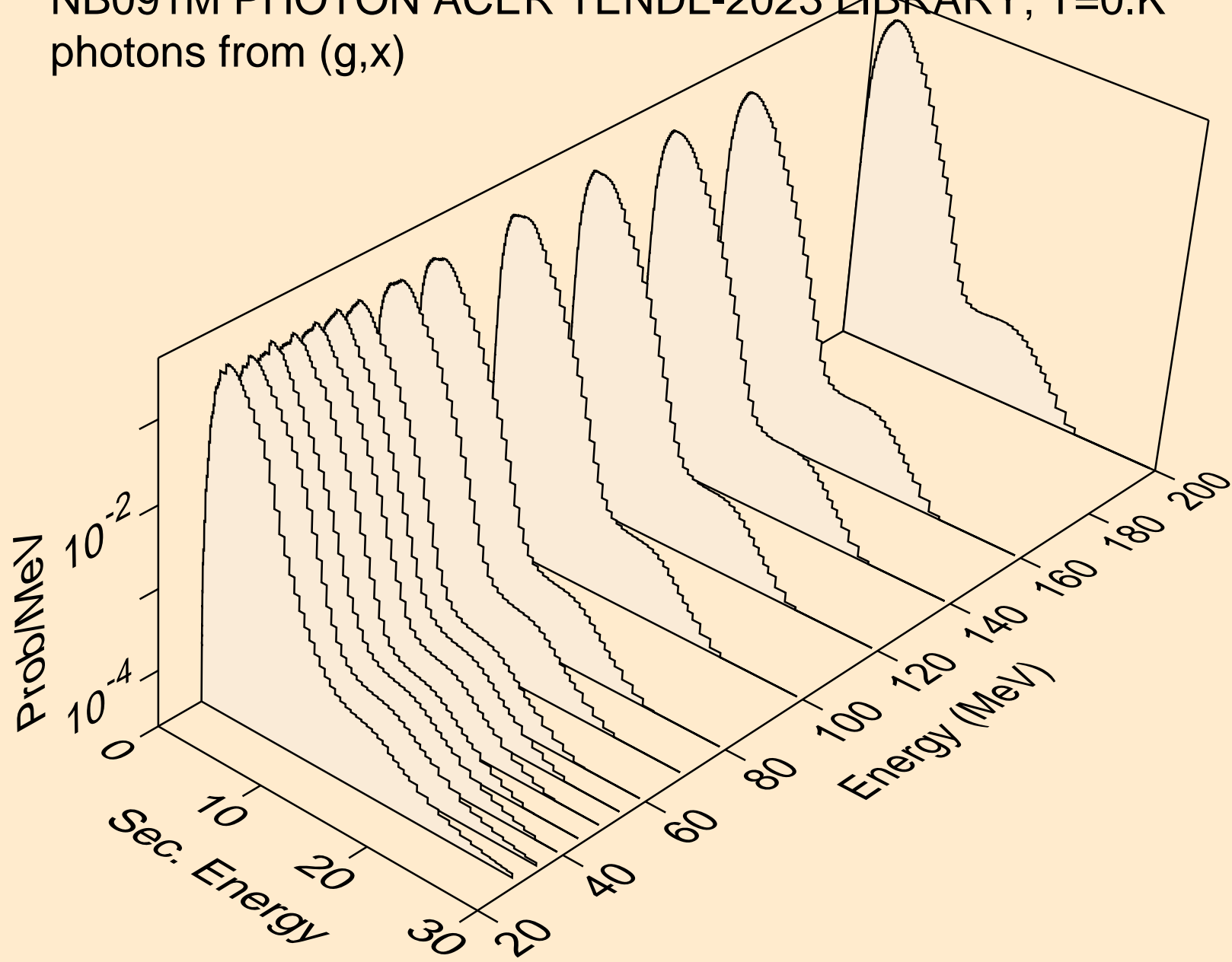

NB091M PHOTON ACER TENDL-2023 LIBRARY; T=0.K
photons from (g,2n)

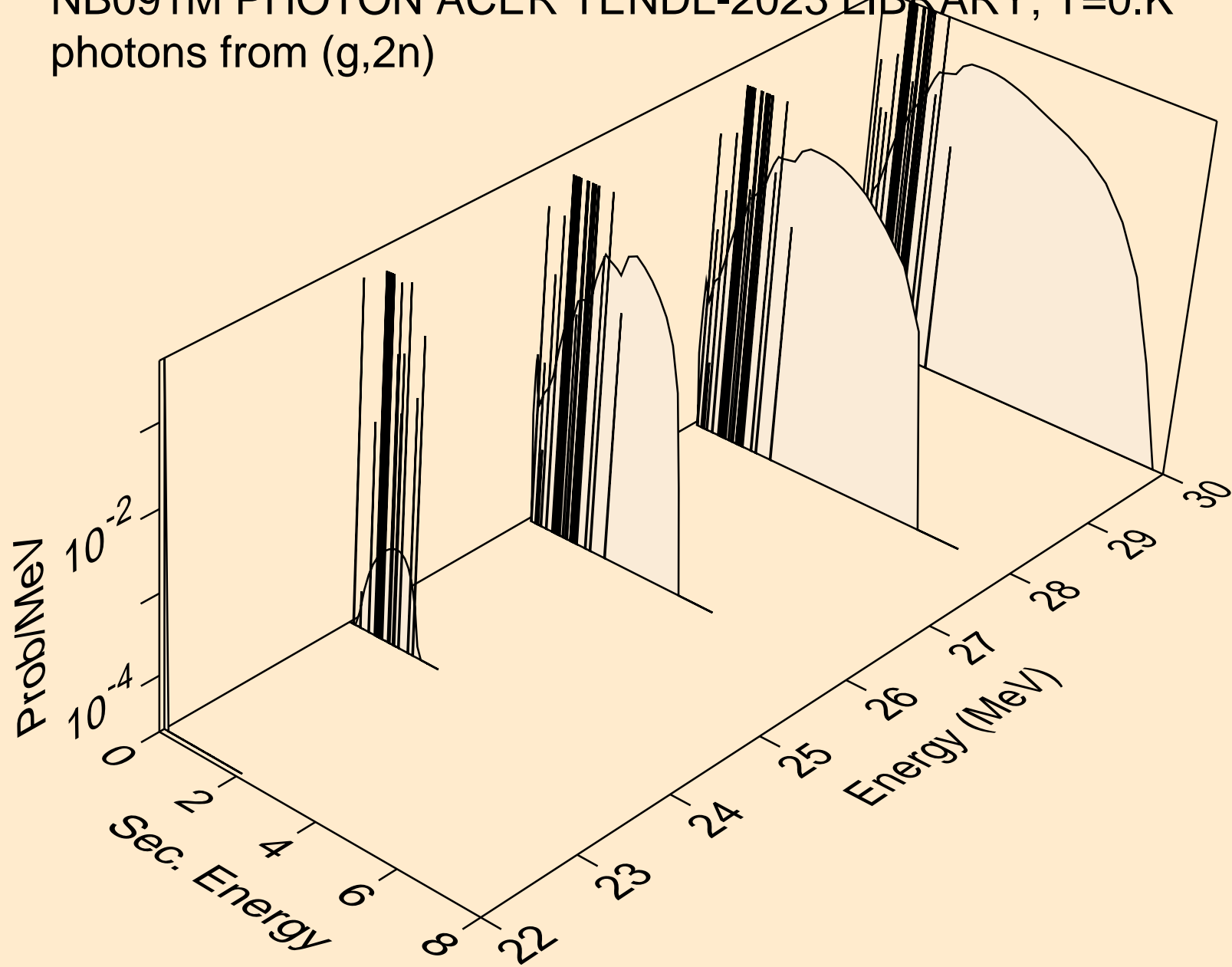

NB091M PHOTON ACER TENDL-2023 LIBRARY; T=0.K
photons from (g,n*)a

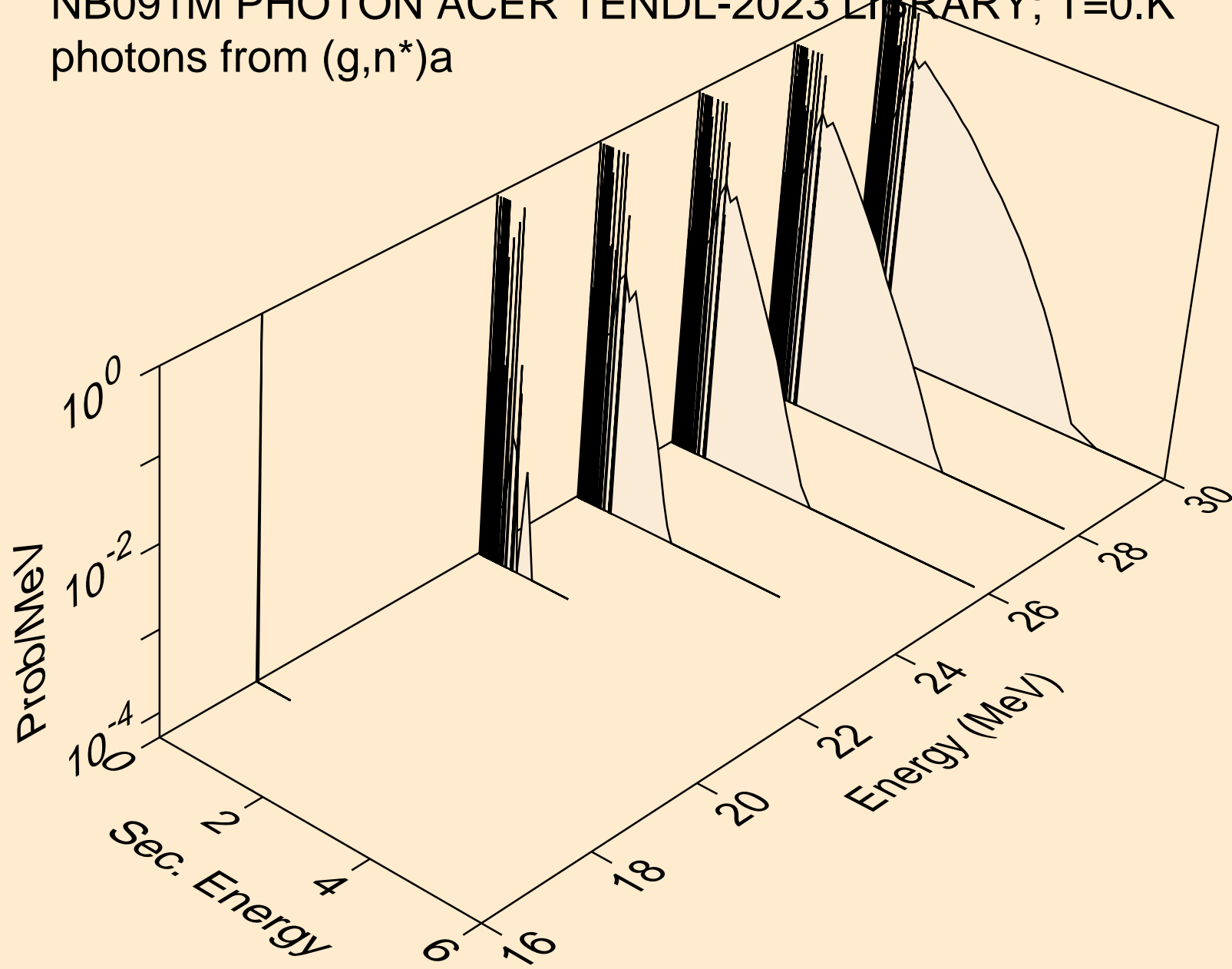

NB091M PHOTON ACER TENDL-2023 LIBRARY; T=0.K
photons from (g,n*)p

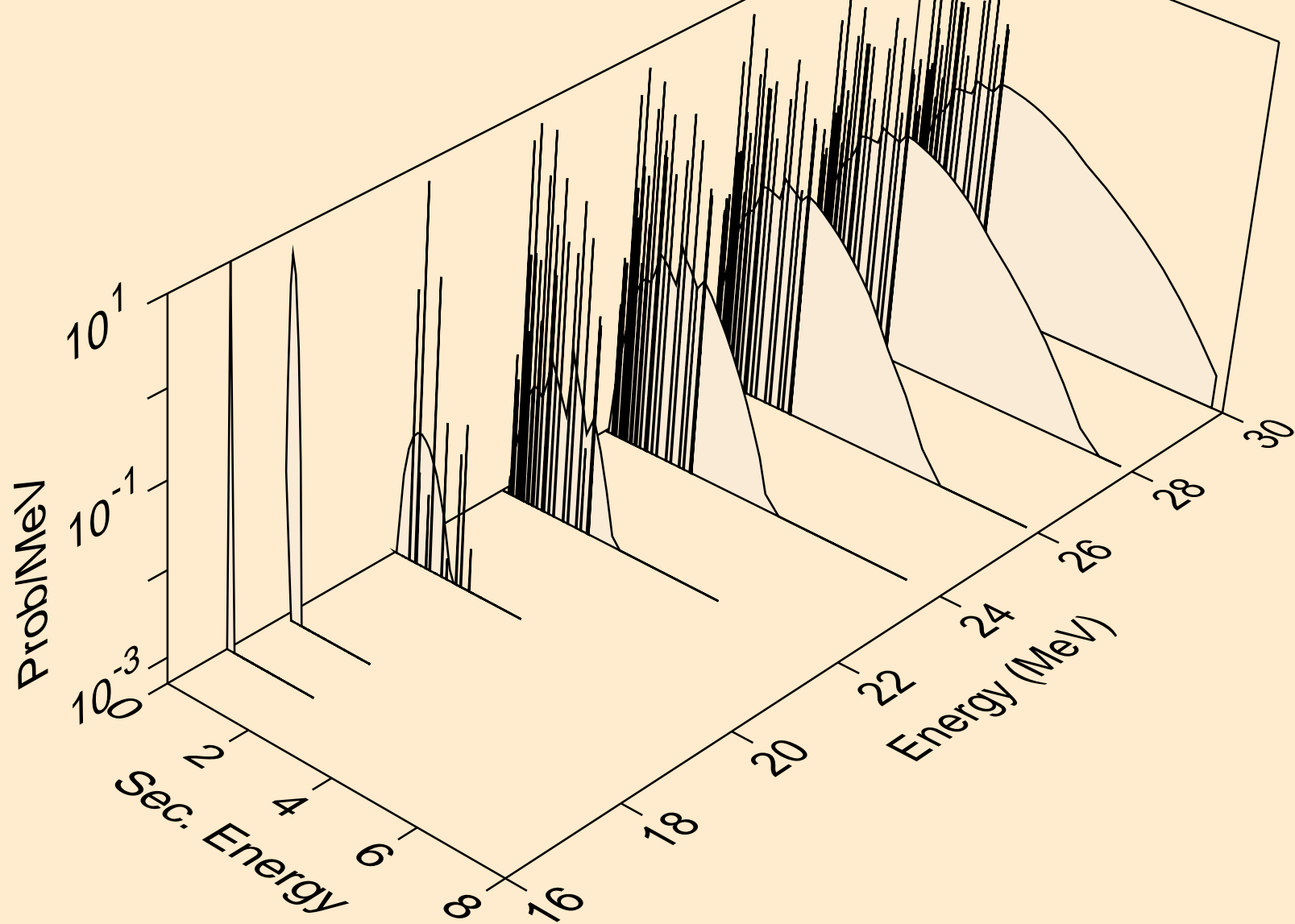

NB091M PHOTON ACER TENDL-2023 LIBRARY; T=0.K
photons from (g,n*)d

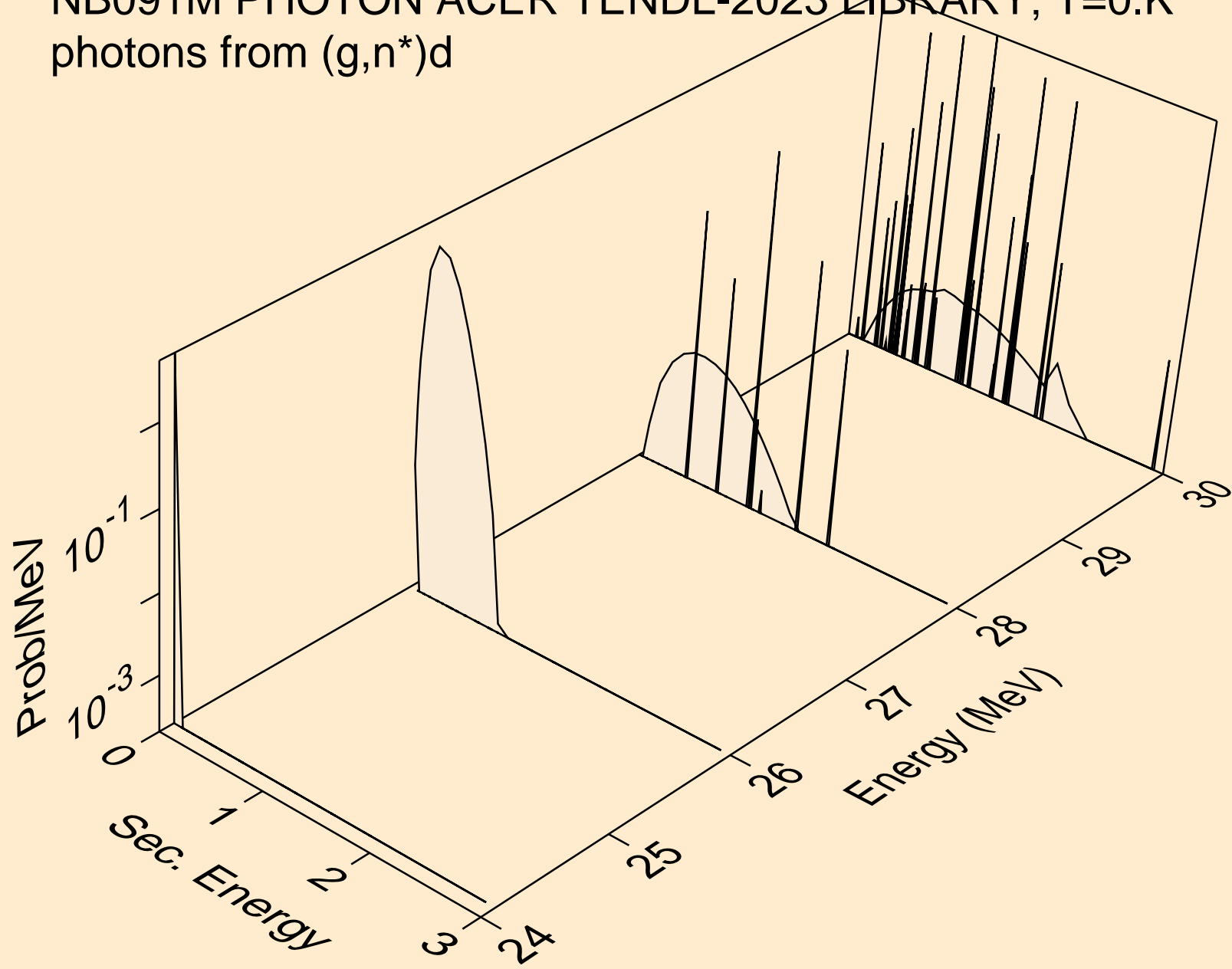

NB091M PHOTON ACER TENDL-2023 LIBRARY; T=0.K
photons from (g,2np)

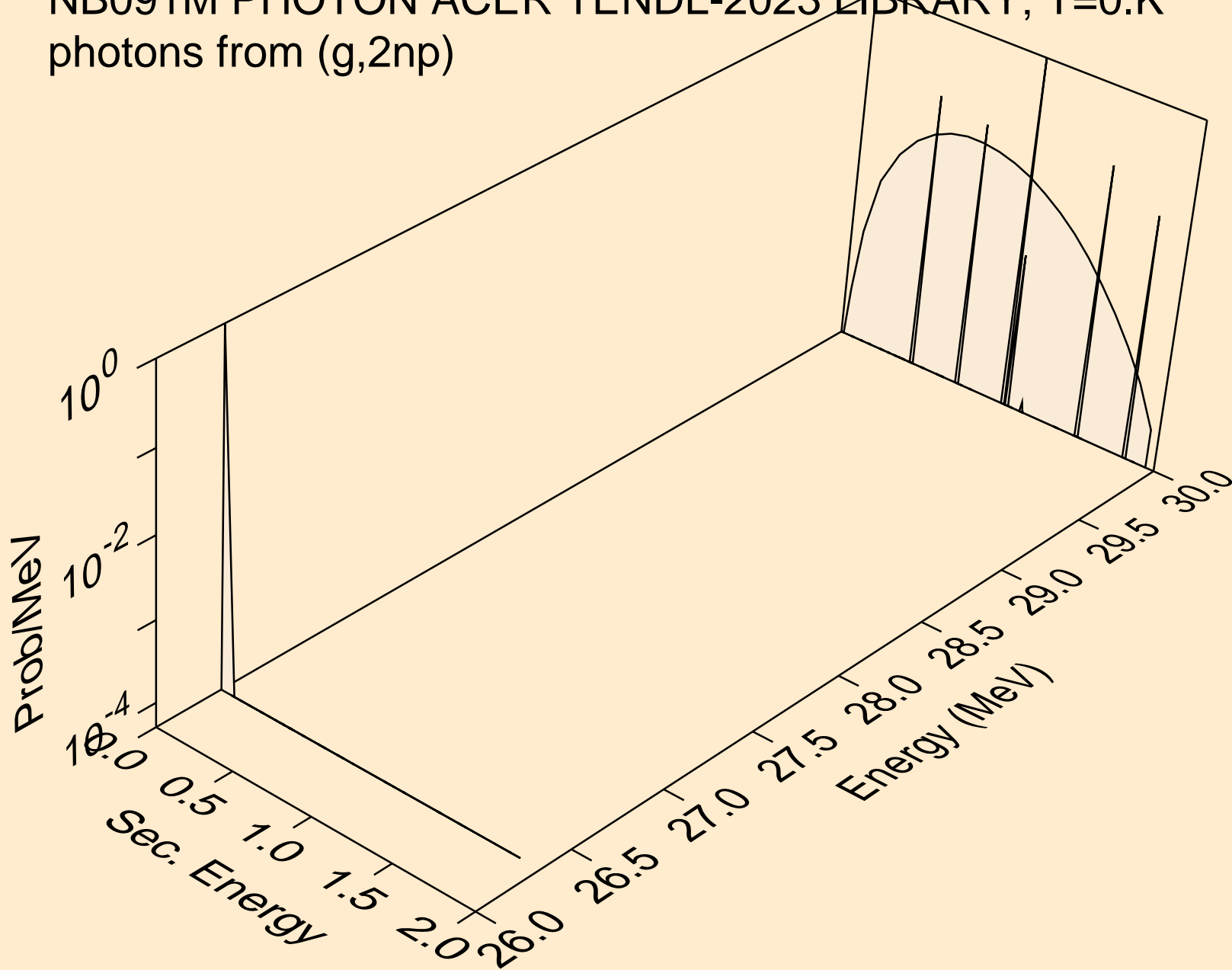

NB091M PHOTON ACER TENDL-2023 LIBRARY; T=0.K
photons from (g,n2p)

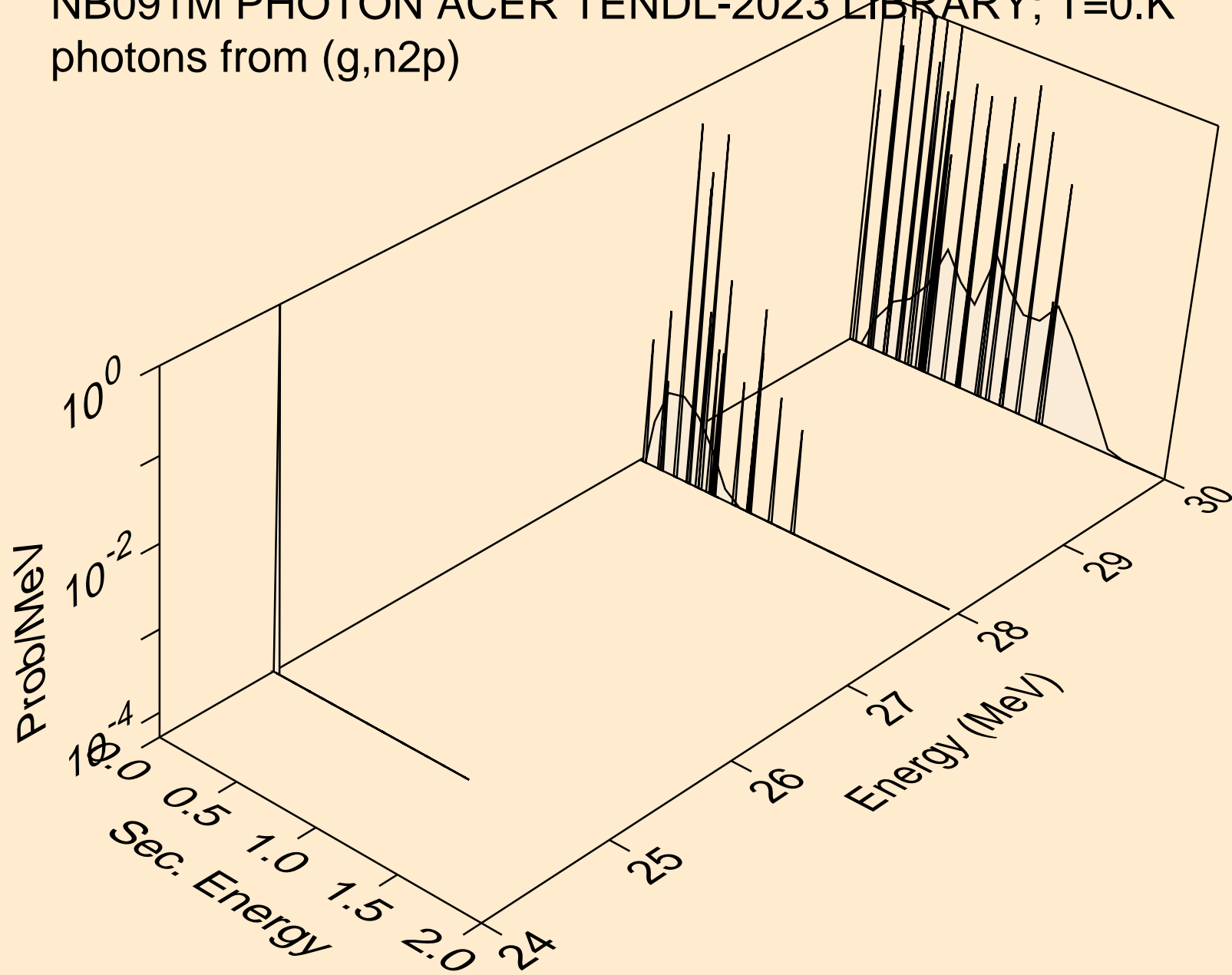

NB091M PHOTON ACER TENDL-2023 LIBRARY; T=0.K
photons from (g,n*c)

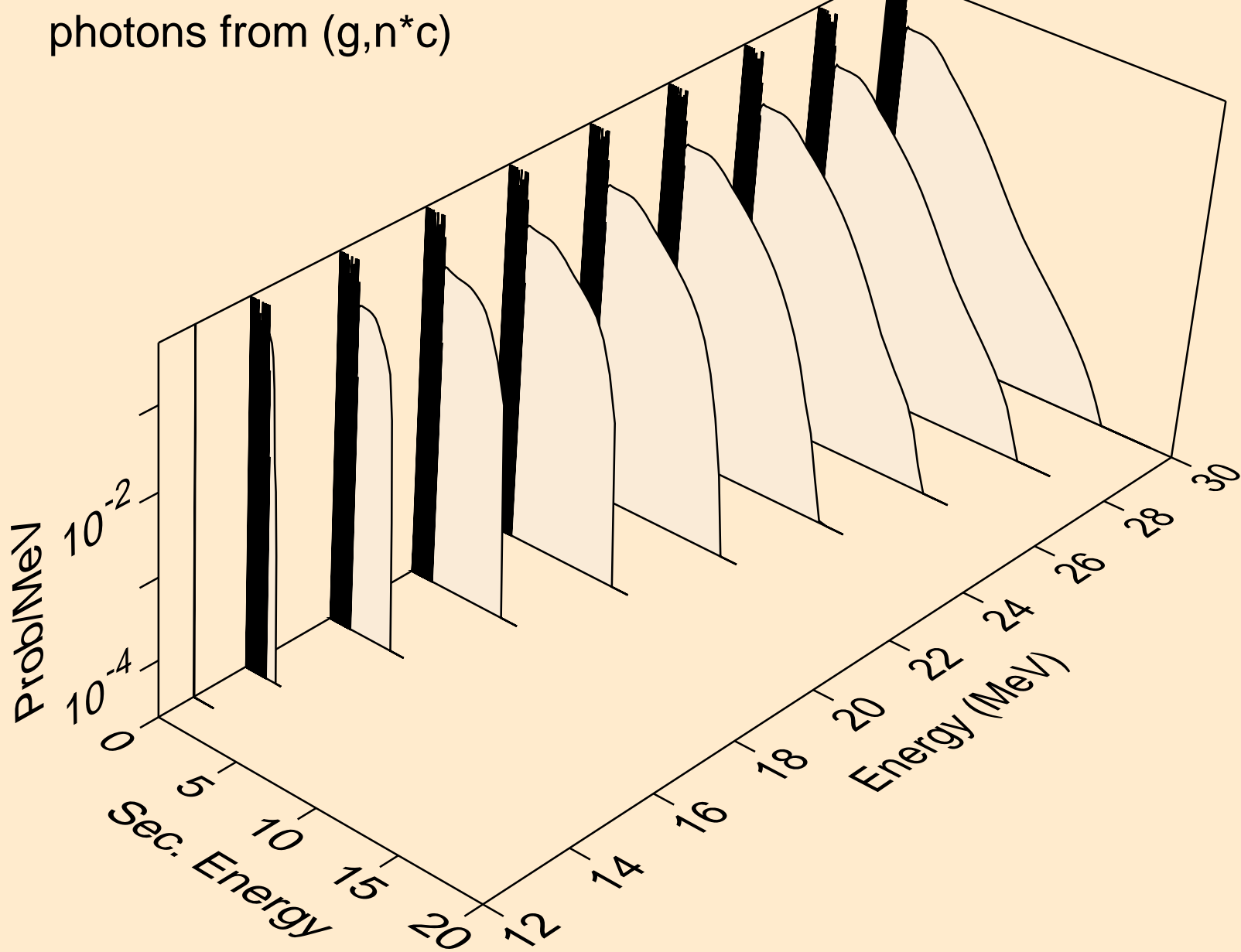

NB091M PHOTON ACER TENDL-2023 LIBRARY; T=0.K
photons from (g,gma)

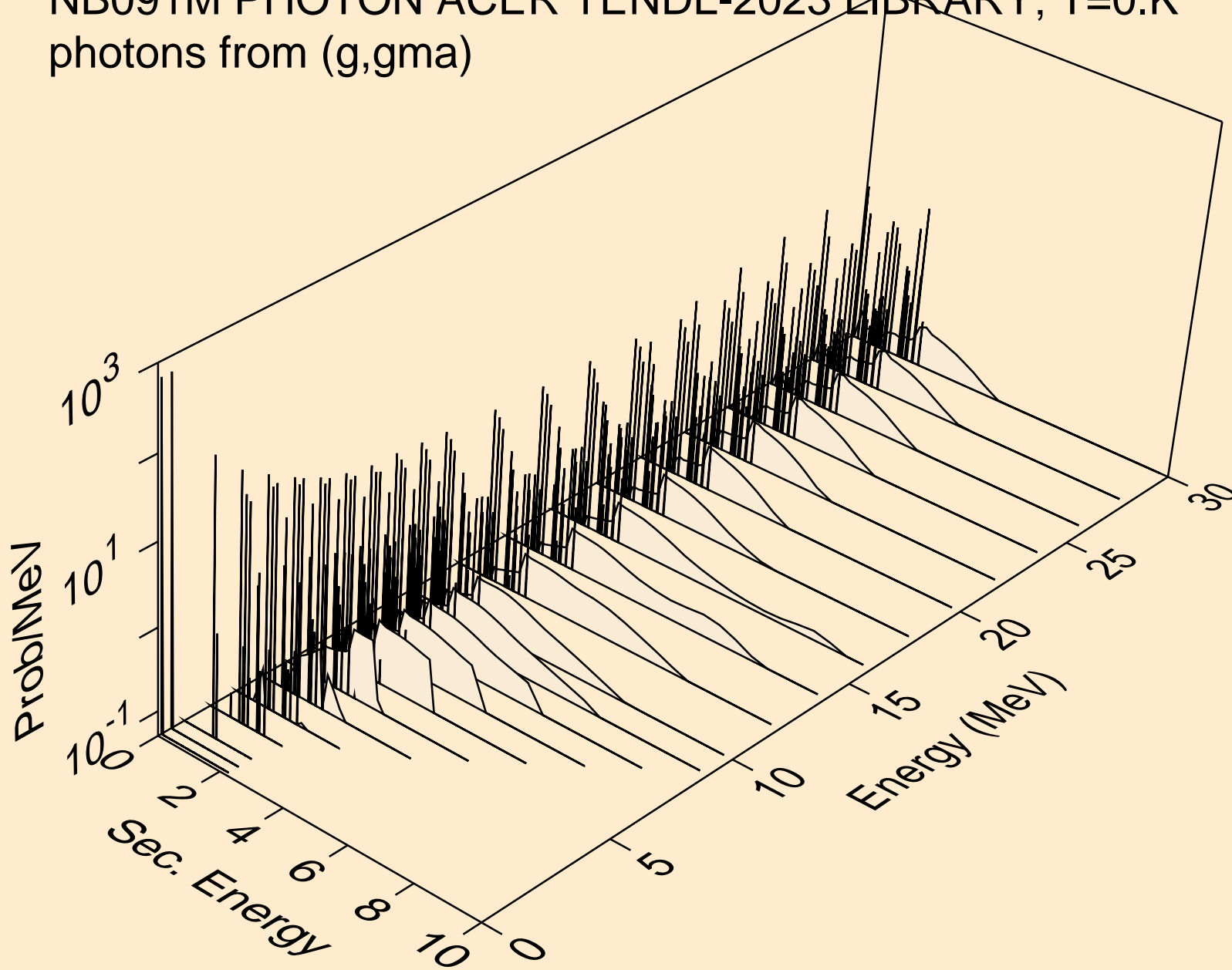

NB091M PHOTON ACER TENDL-2023 LIBRARY; T=0.K
photons from (g,p)

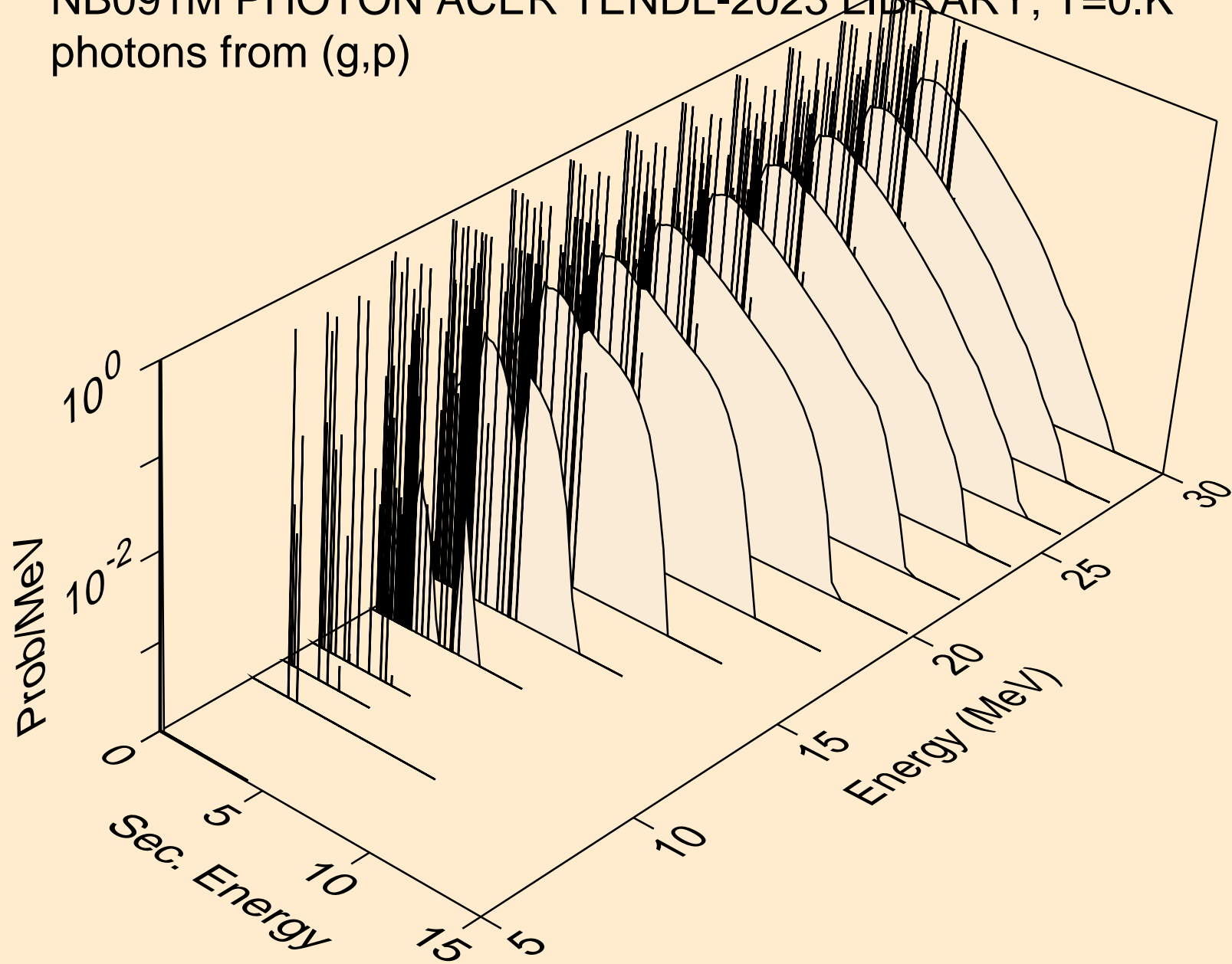

NB091M PHOTON ACER TENDL-2023 LIBRARY; T=0.K
photons from (g,d)

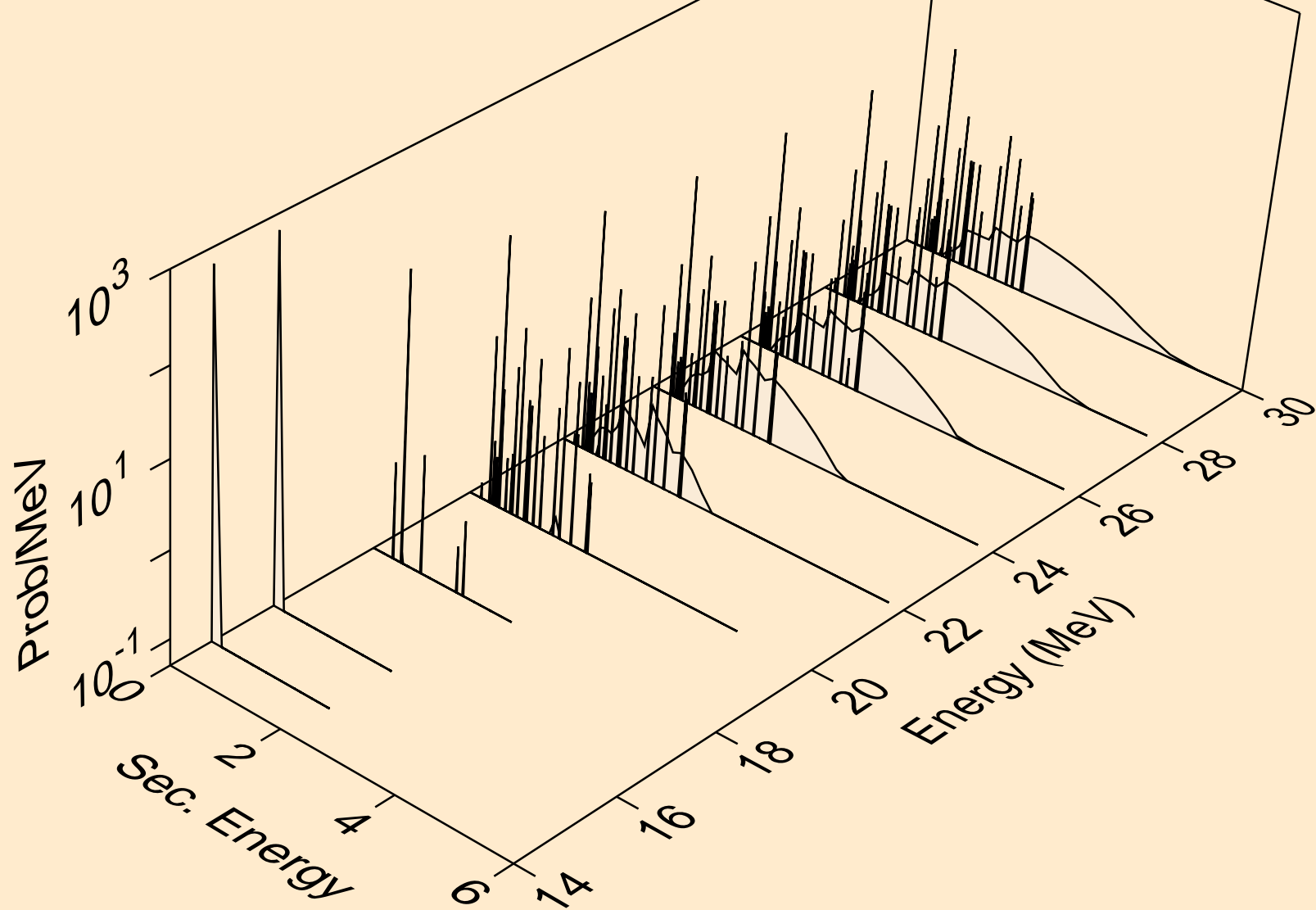

NB091M PHOTON ACER TENDL-2023 LIBRARY; T=0.K
photons from (g,t)

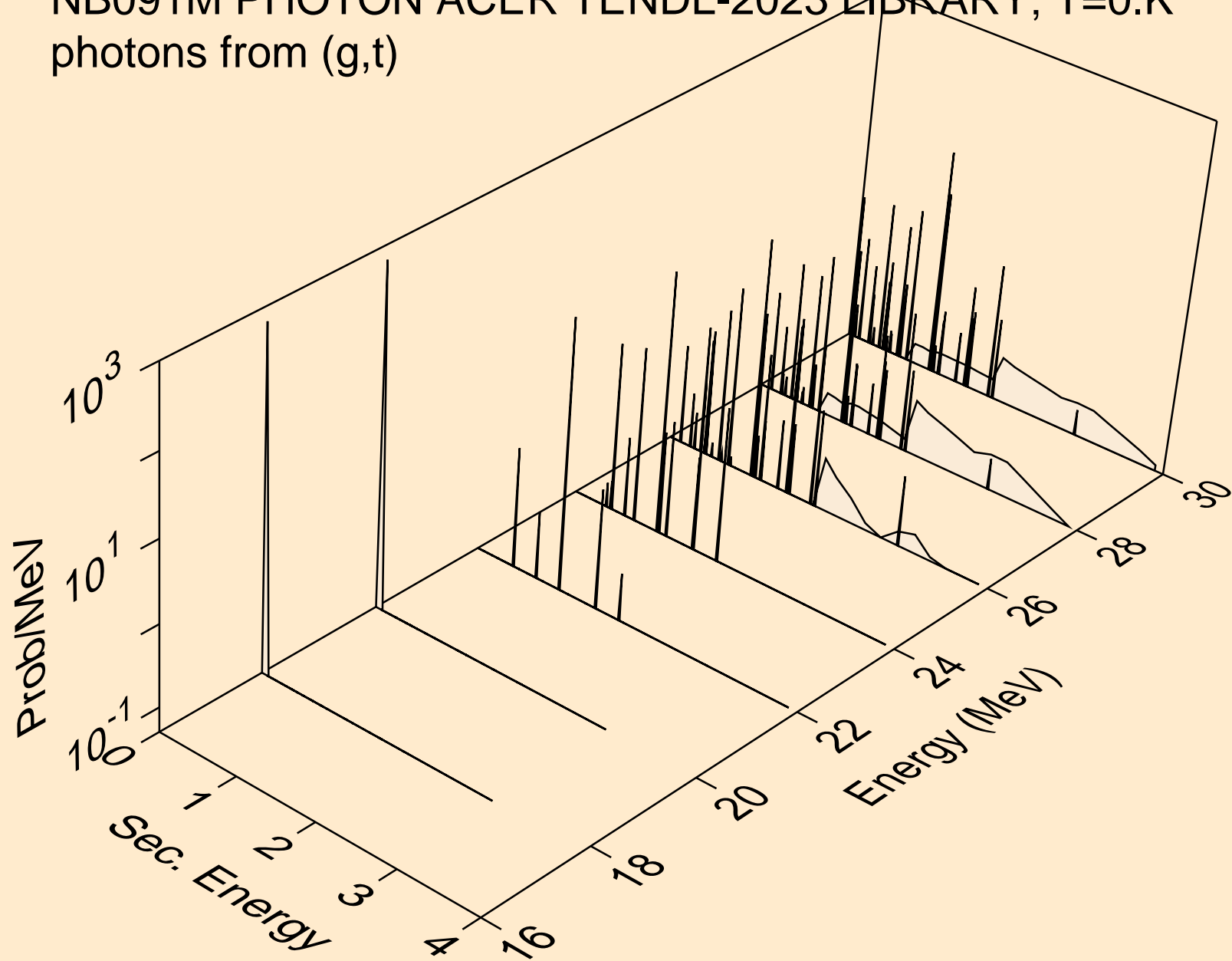

NB091M PHOTON ACER TENDL-2023 LIBRARY; T=0.K
photons from (g,he3)

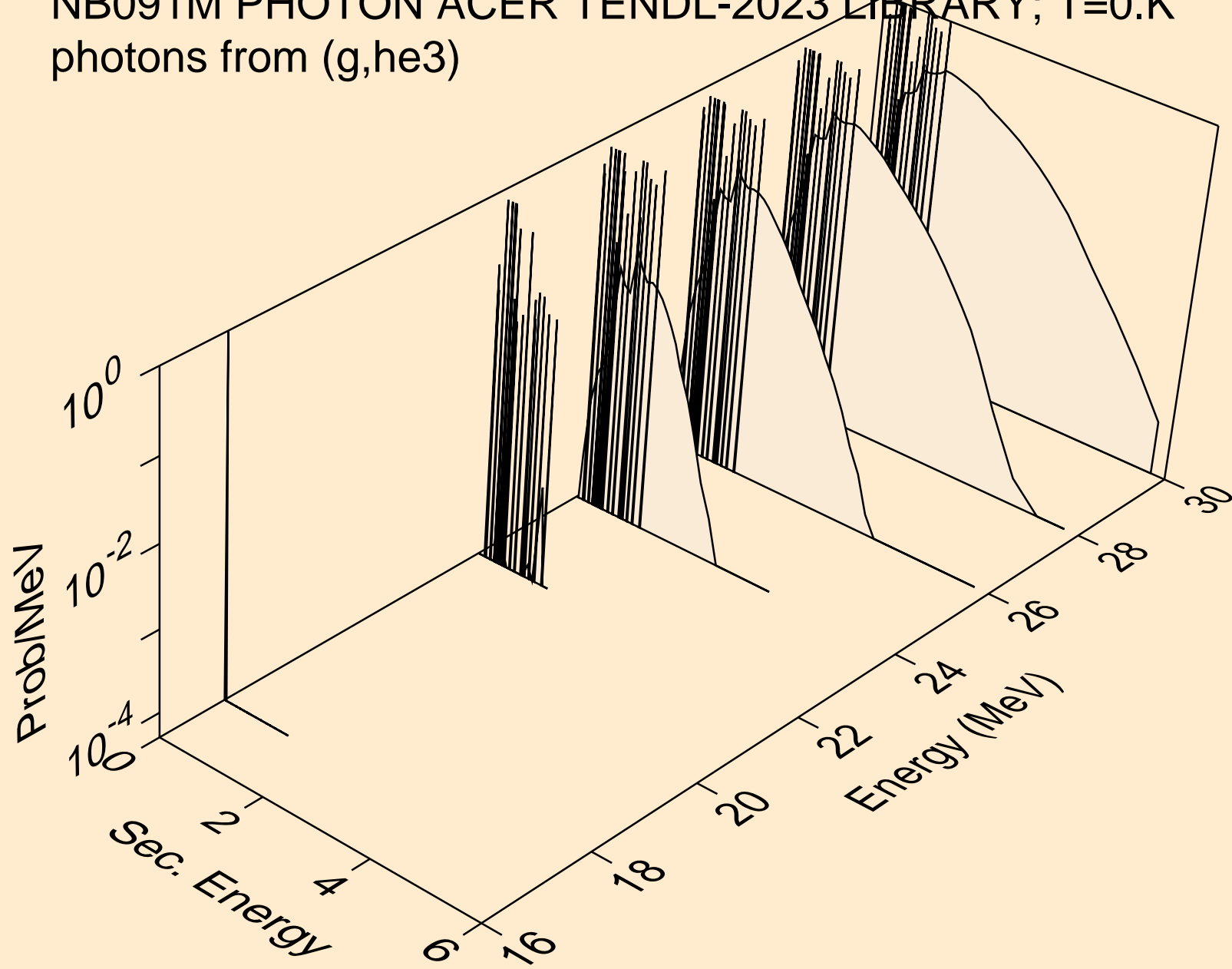

NB091M PHOTON ACER TENDL-2023 LIBRARY; T=0.K
photons from (g,a)

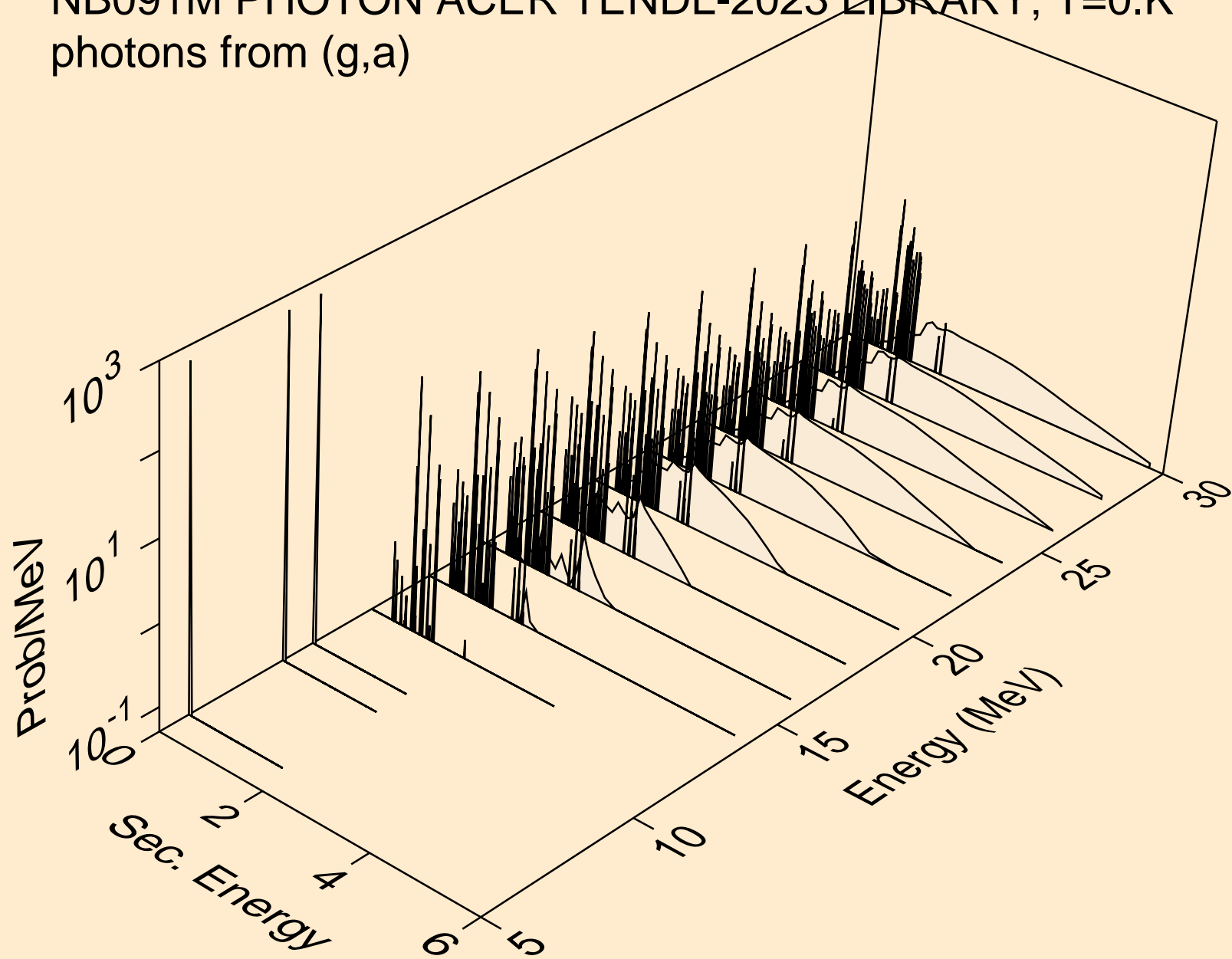

NB091M PHOTON ACER TENDL-2023 LIBRARY; T=0.K
photons from (g,2a)

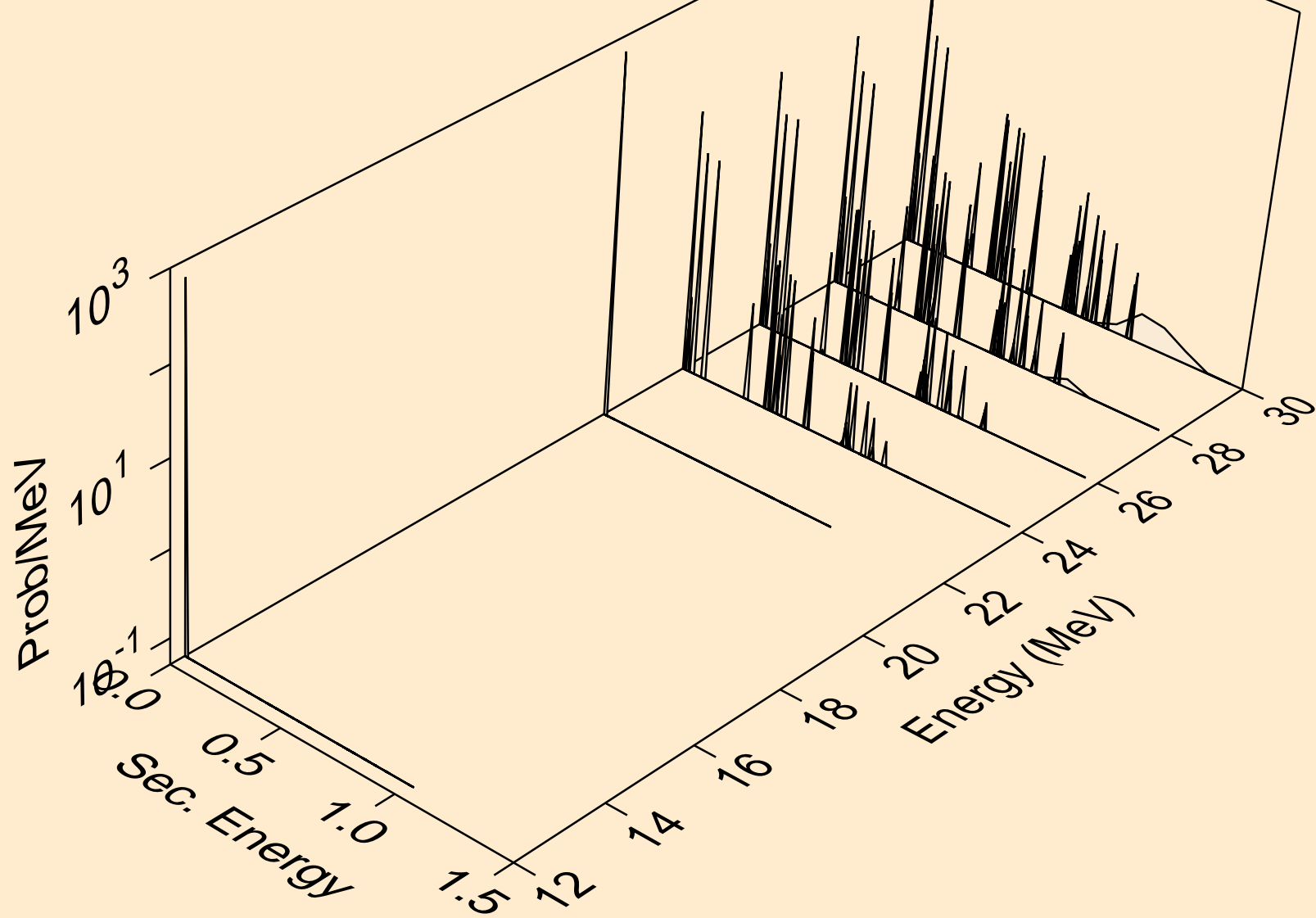

NB091M PHOTON ACER TENDL-2023 LIBRARY; T=0.K
photons from (g,2p)

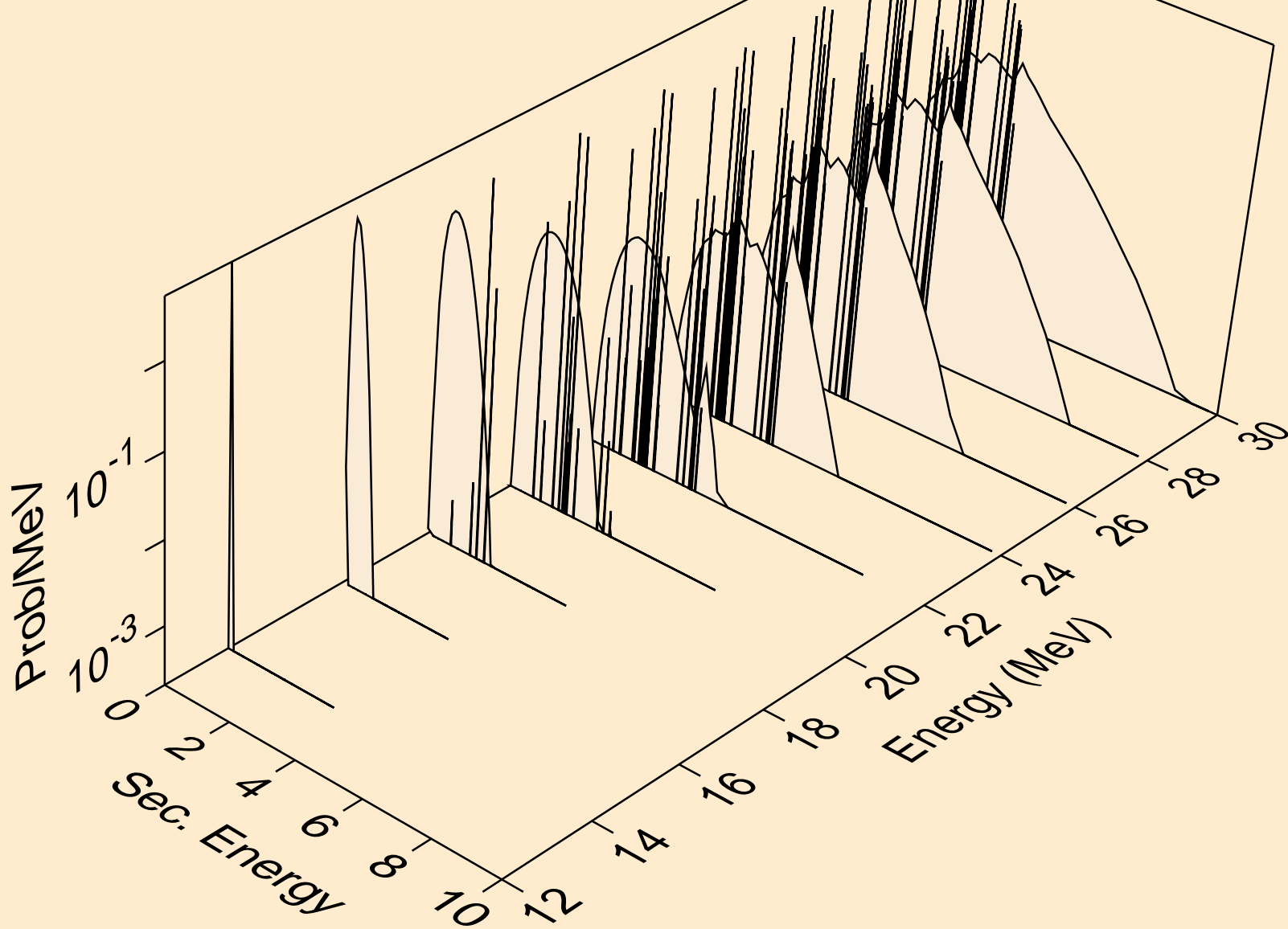

NB091M PHOTON ACER TENDL-2023 LIBRARY; T=0.K
photons from (g,pa)

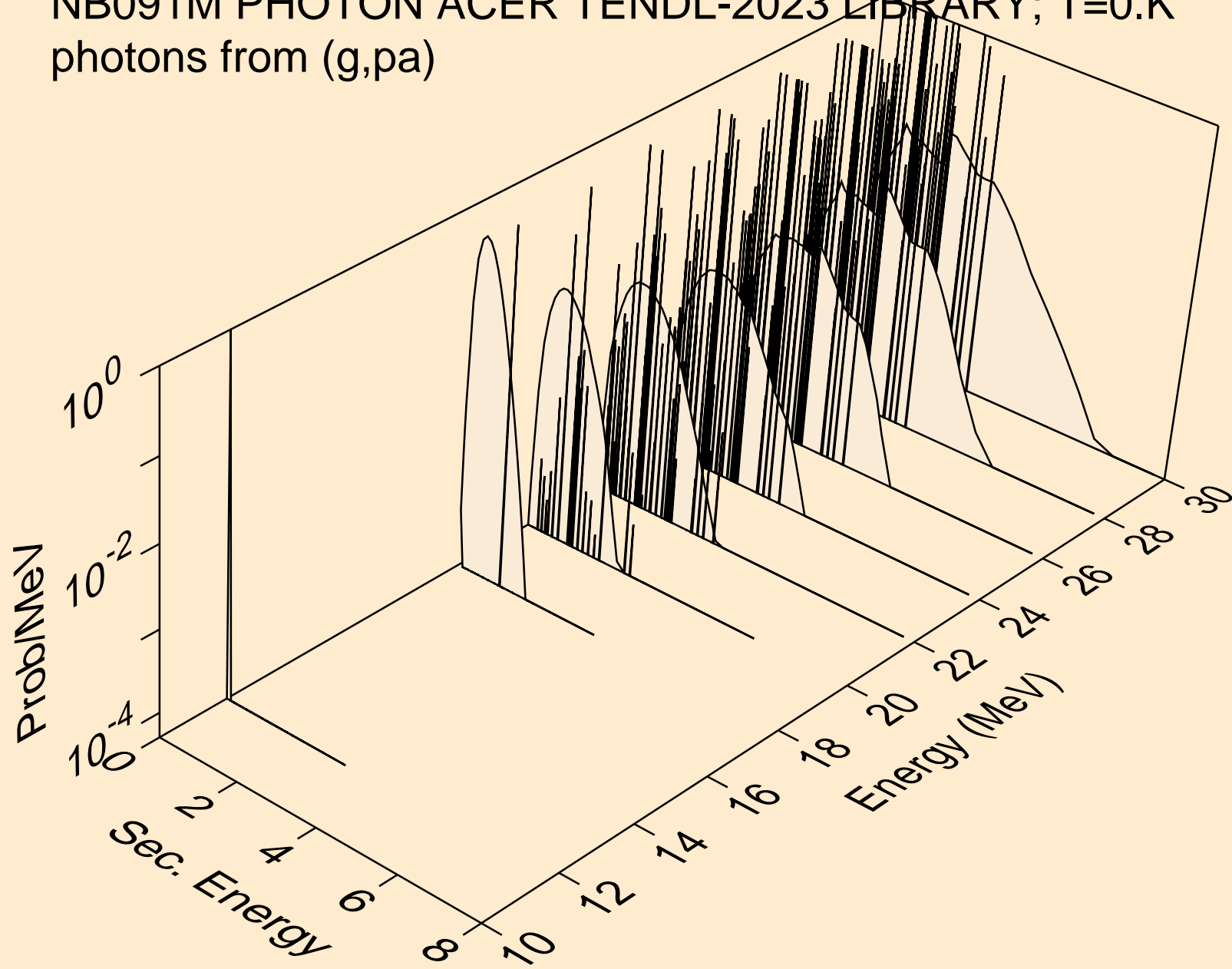

NB091M PHOTON ACER TENDL-2023 LIBRARY; T=0.K
photons from (g,pd)

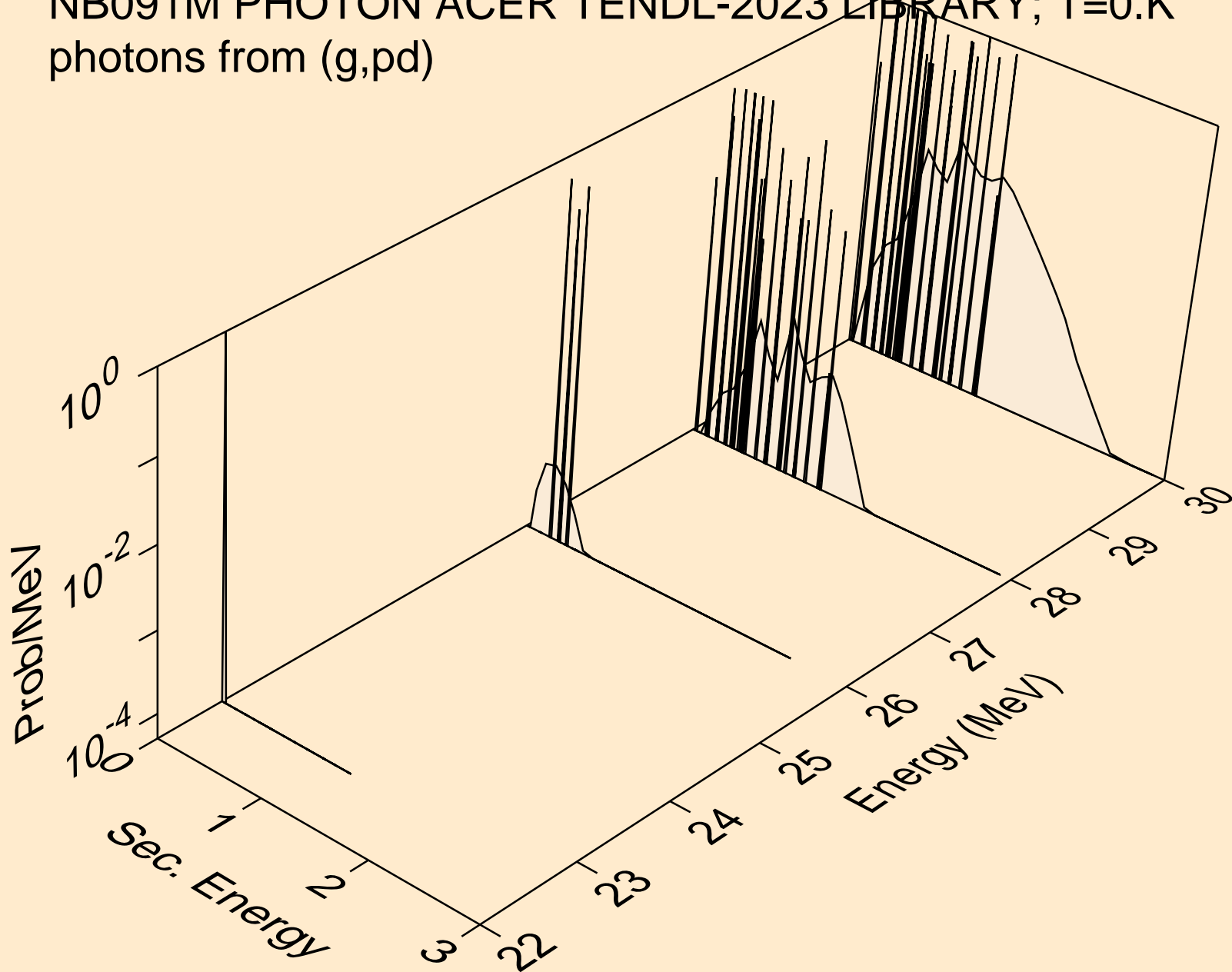

NB091M PHOTON ACER TENDL-2023 LIBRARY; T=0.K
protons from (g,x)

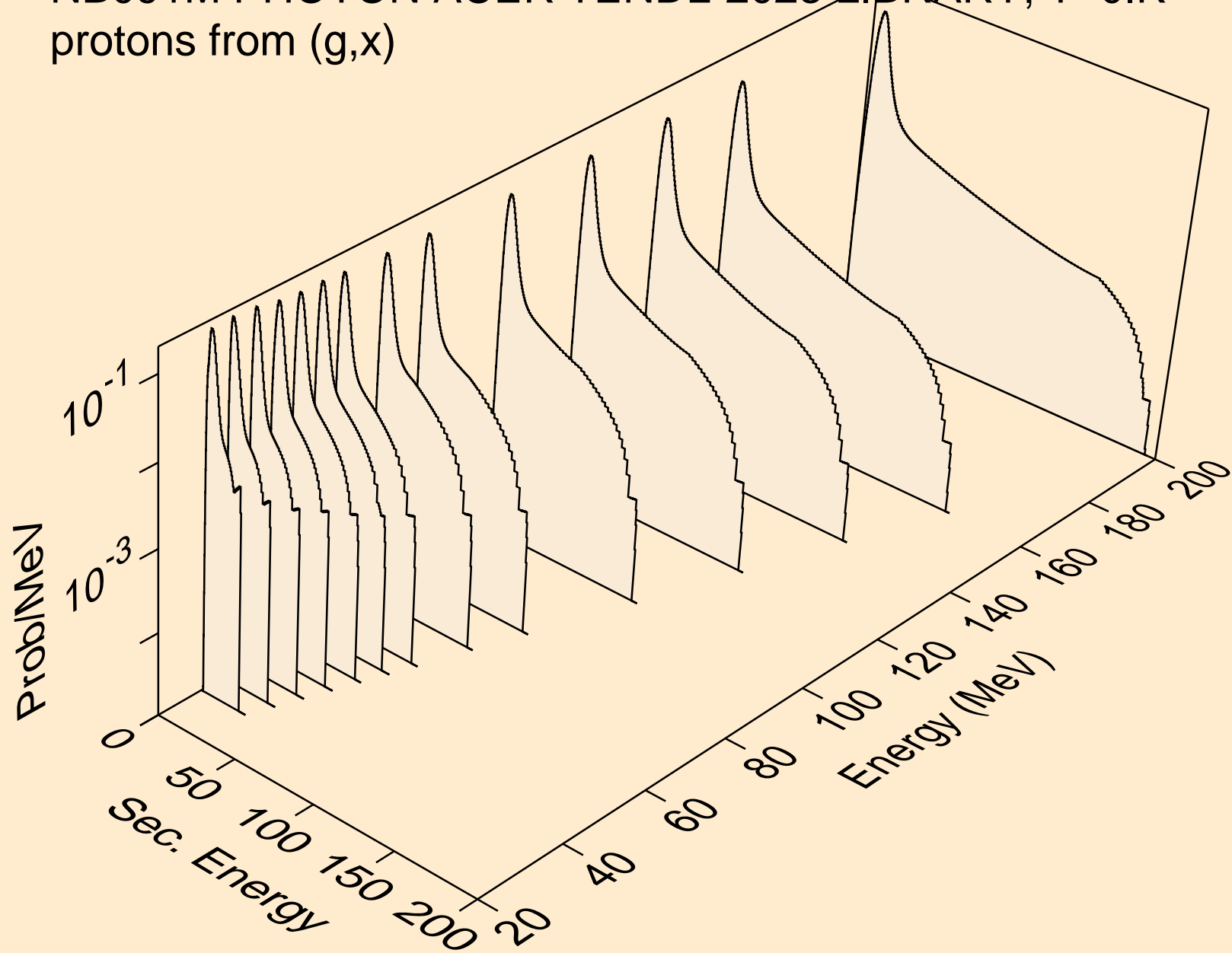

NB091M PHOTON ACER TENDL-2023 LIBRARY; T=0.K
protons from (g,n*)p

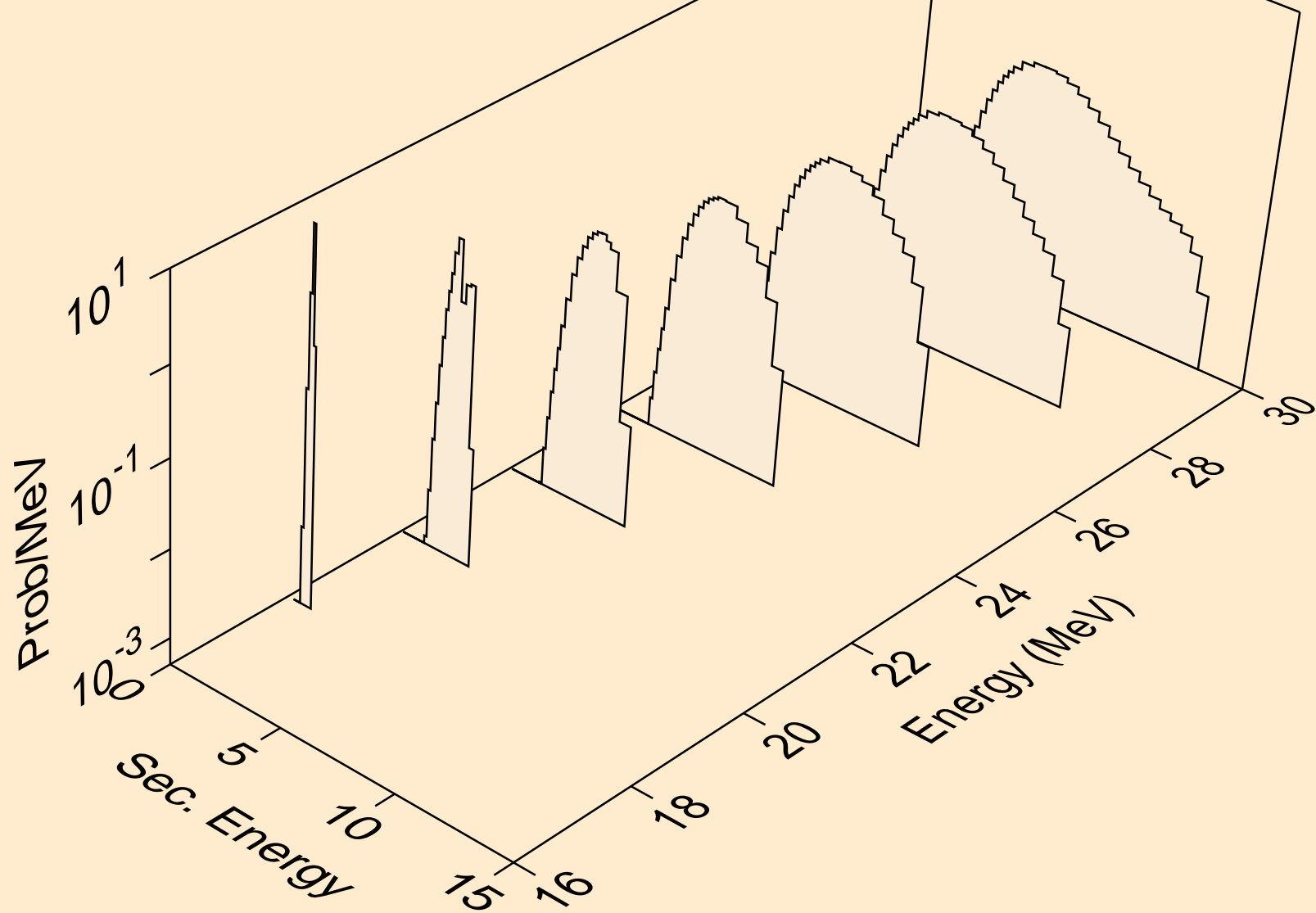

NB091M PHOTON ACER TENDL-2023 LIBRARY; T=0.K
protons from (g,2np)

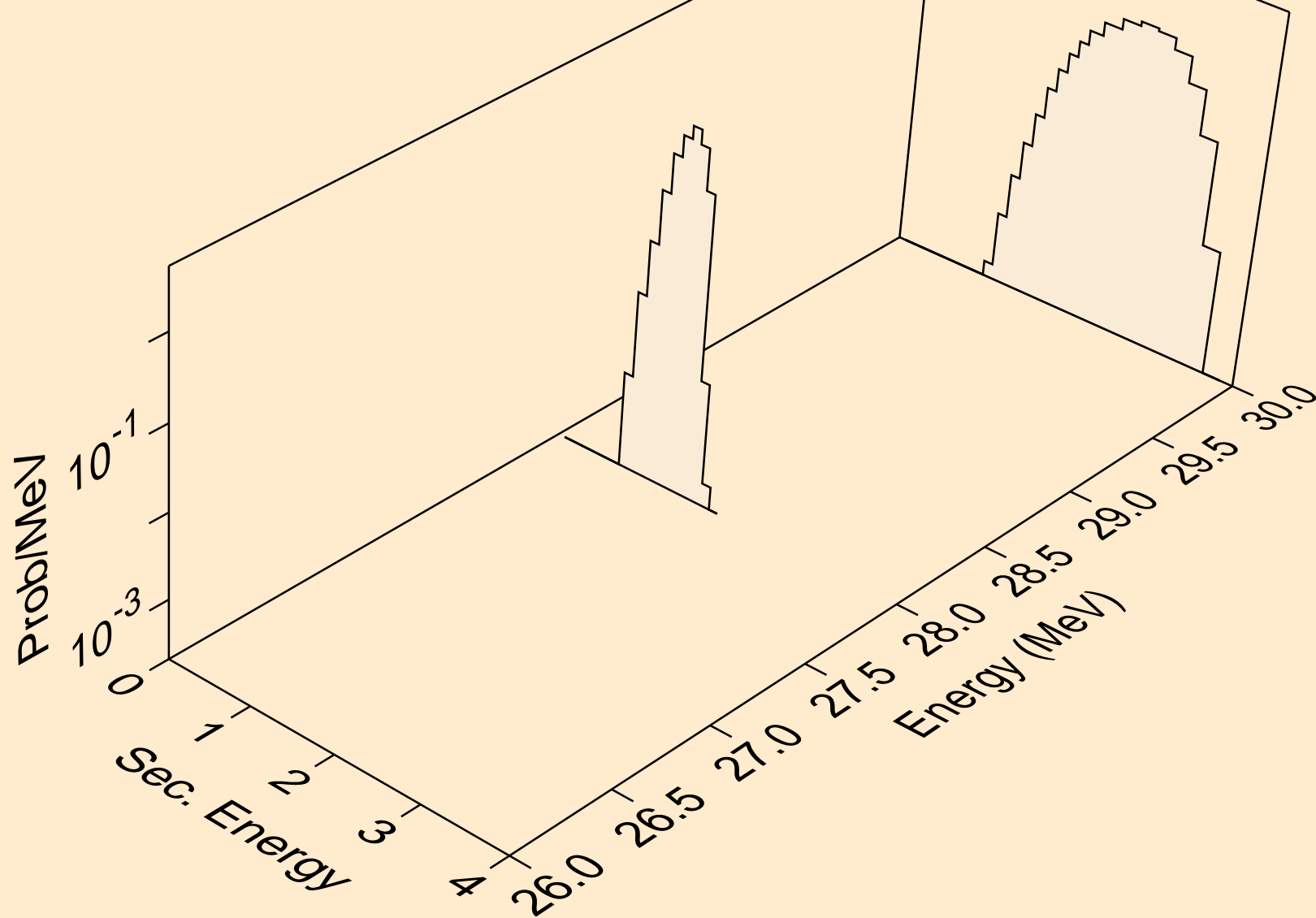

NB091M PHOTON ACER TENDL-2023 LIBRARY; T=0.K
protons from (g,n2p)

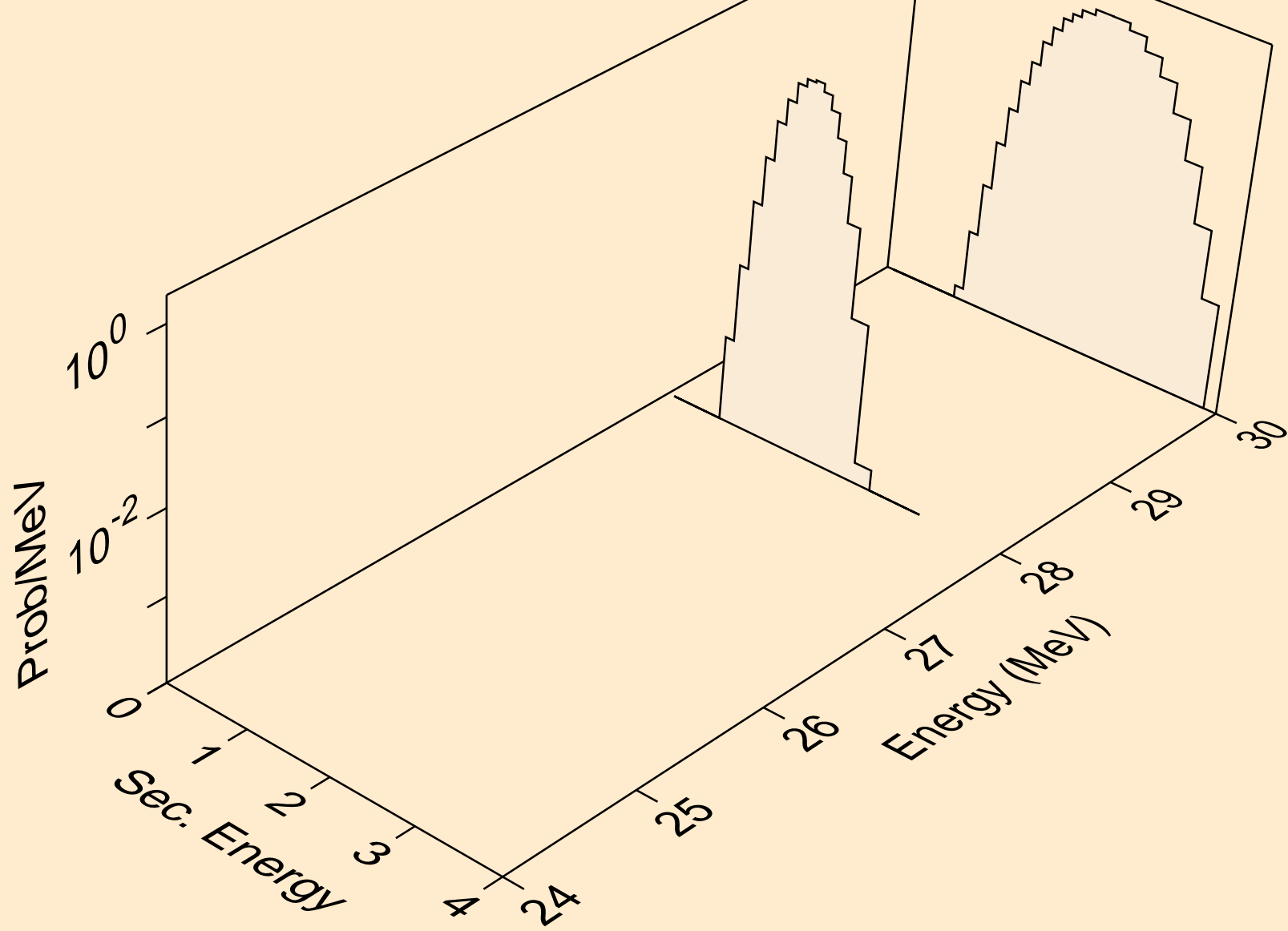

NB091M PHOTON ACER TENDL-2023 LIBRARY; T=0.K
protons from (g,p)

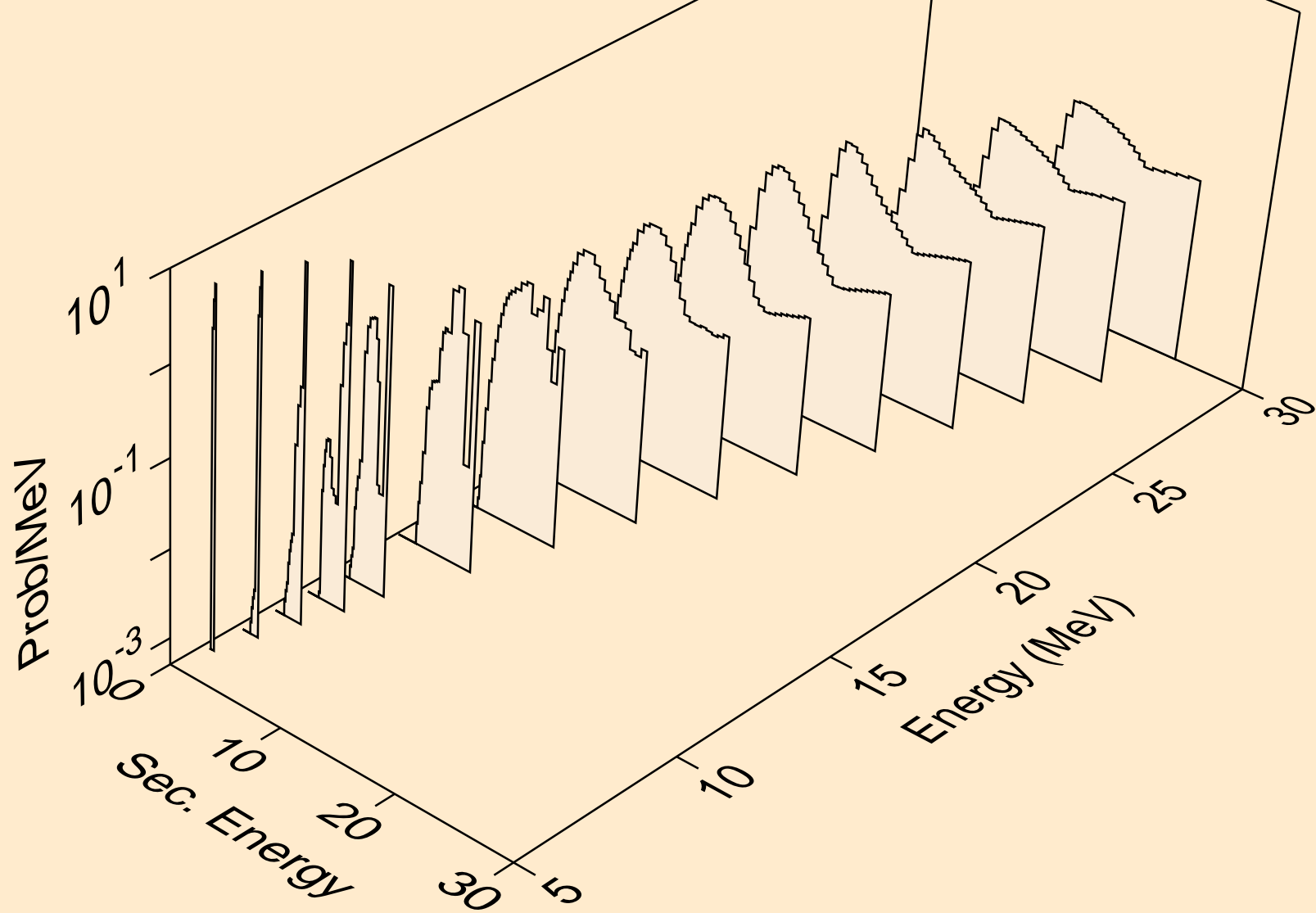

NB091M PHOTON ACER TENDL-2023 LIBRARY; T=0.K
protons from (g,2p)

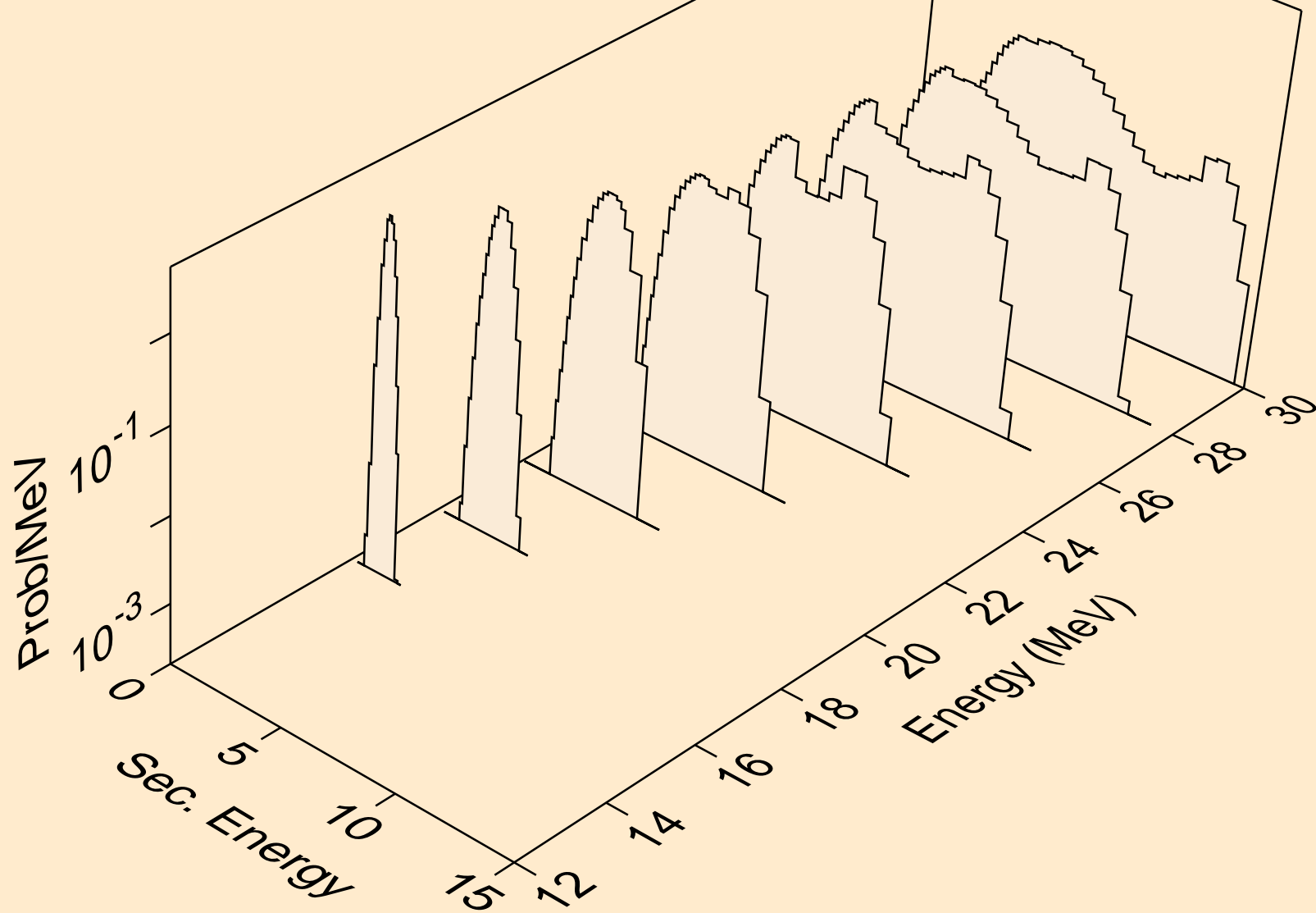

NB091M PHOTON ACER TENDL-2023 LIBRARY; T=0.K
protons from (g,pa)

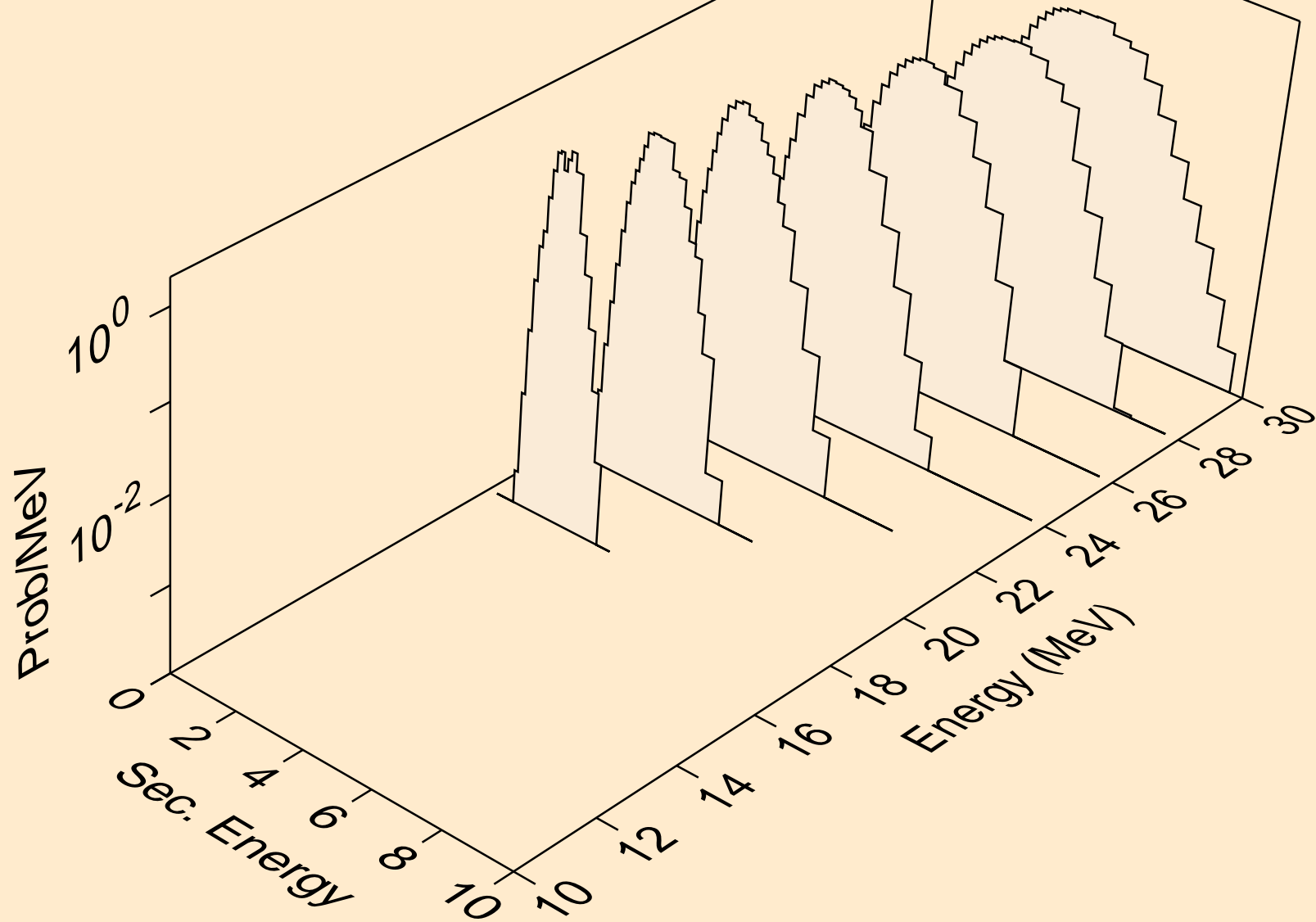

NB091M PHOTON ACER TENDL-2023 LIBRARY; T=0.K
protons from (g,pd)

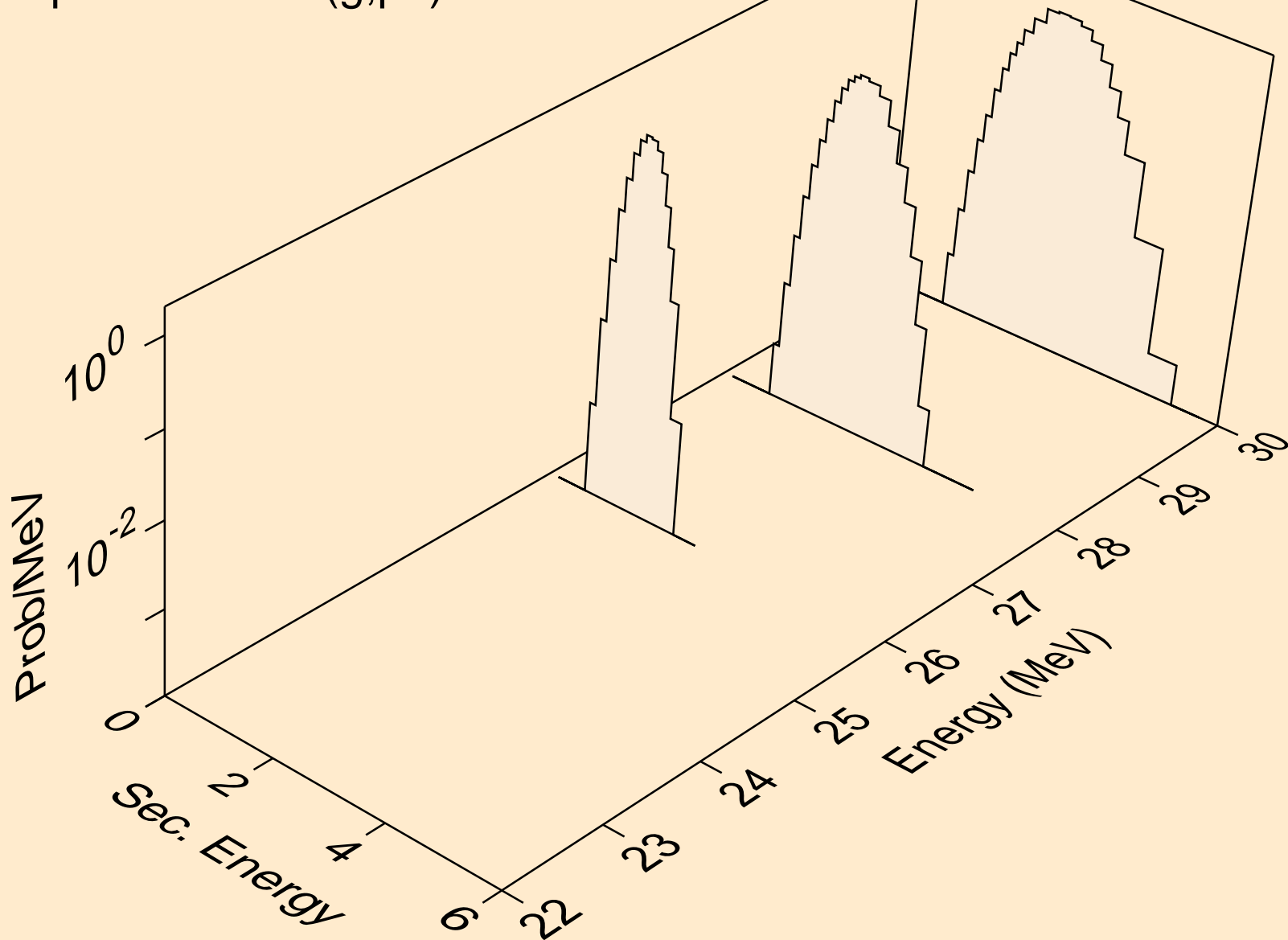

NB091M PHOTON ACER TENDL-2023 LIBRARY; T=0.K
deuterons from (g,x)

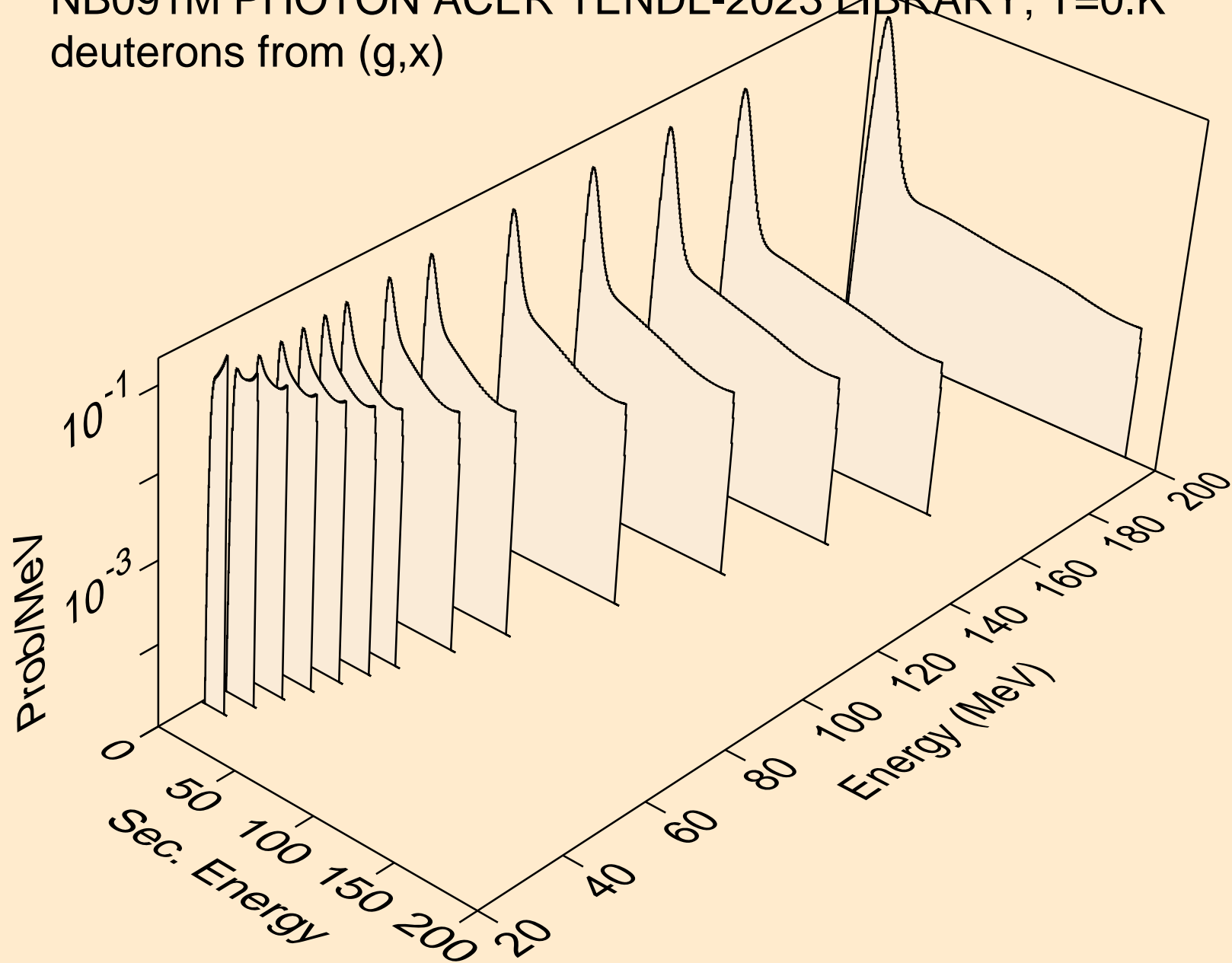

NB091M PHOTON ACER TENDL-2023 LIBRARY; T=0.K
deuterons from (g,n*)d

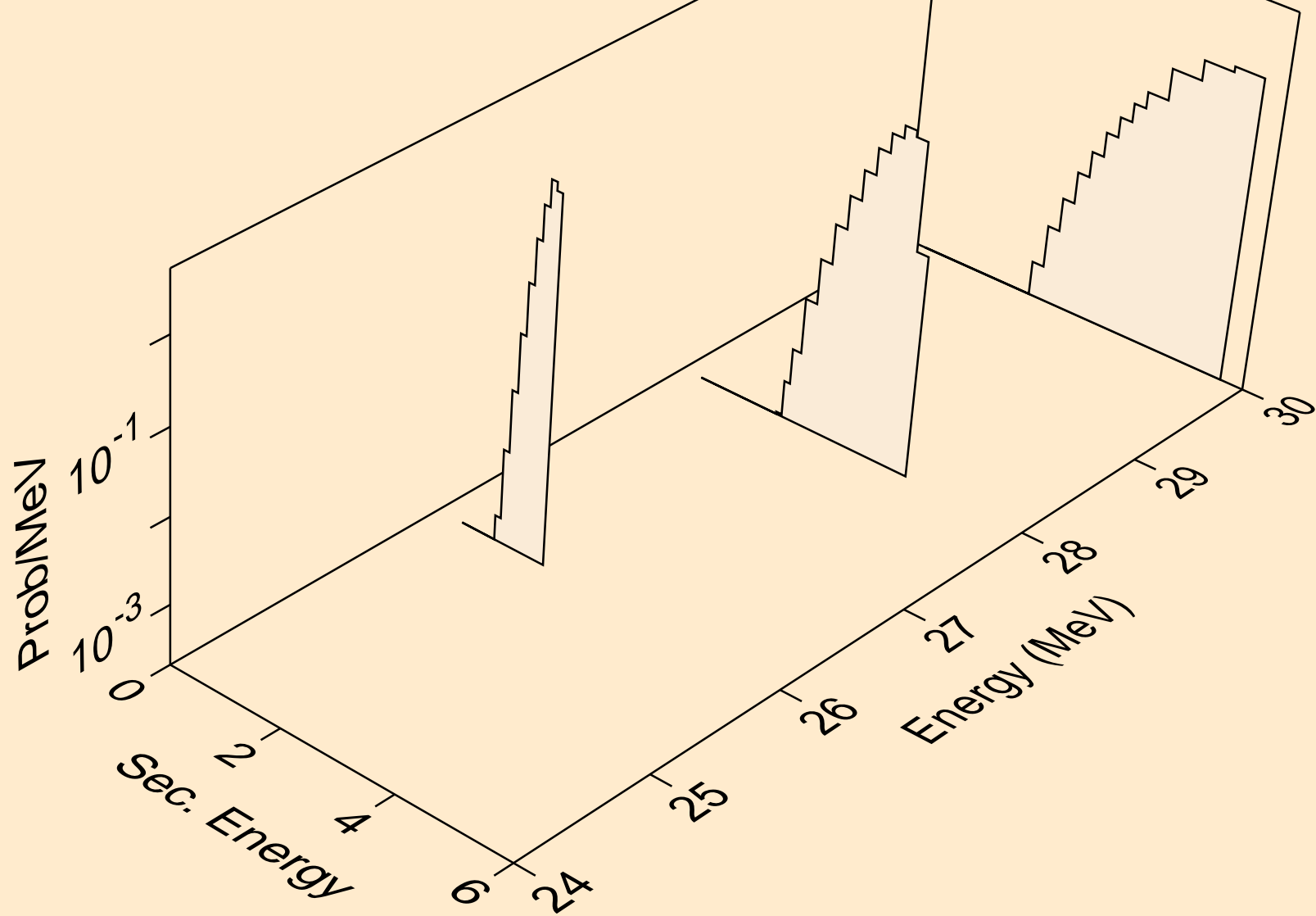

NB091M PHOTON ACER TENDL-2023 LIBRARY; T=0.K
deuterons from (g,d)

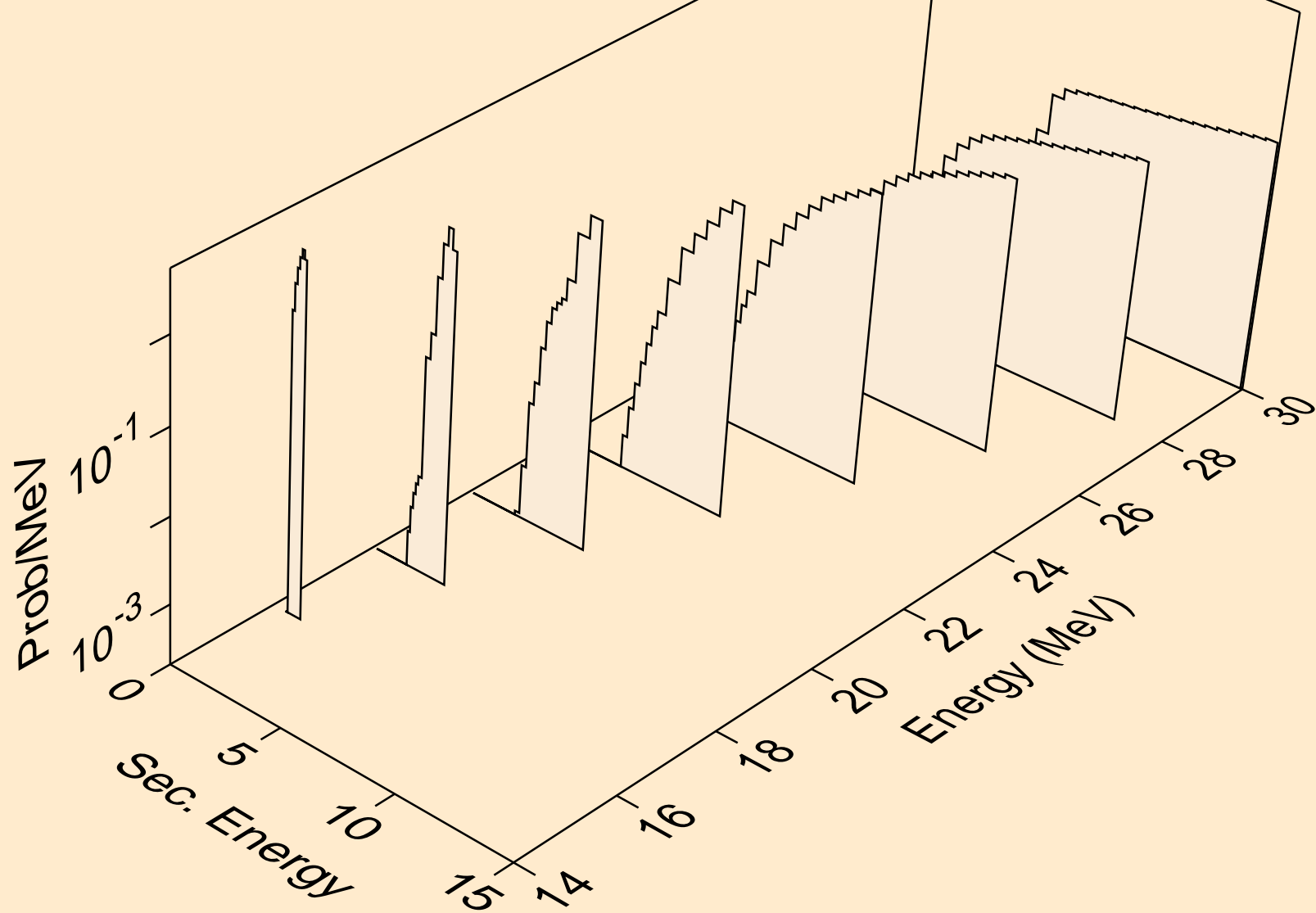

NB091M PHOTON ACER TENDL-2023 LIBRARY; T=0.K
deuterons from (g,pd)

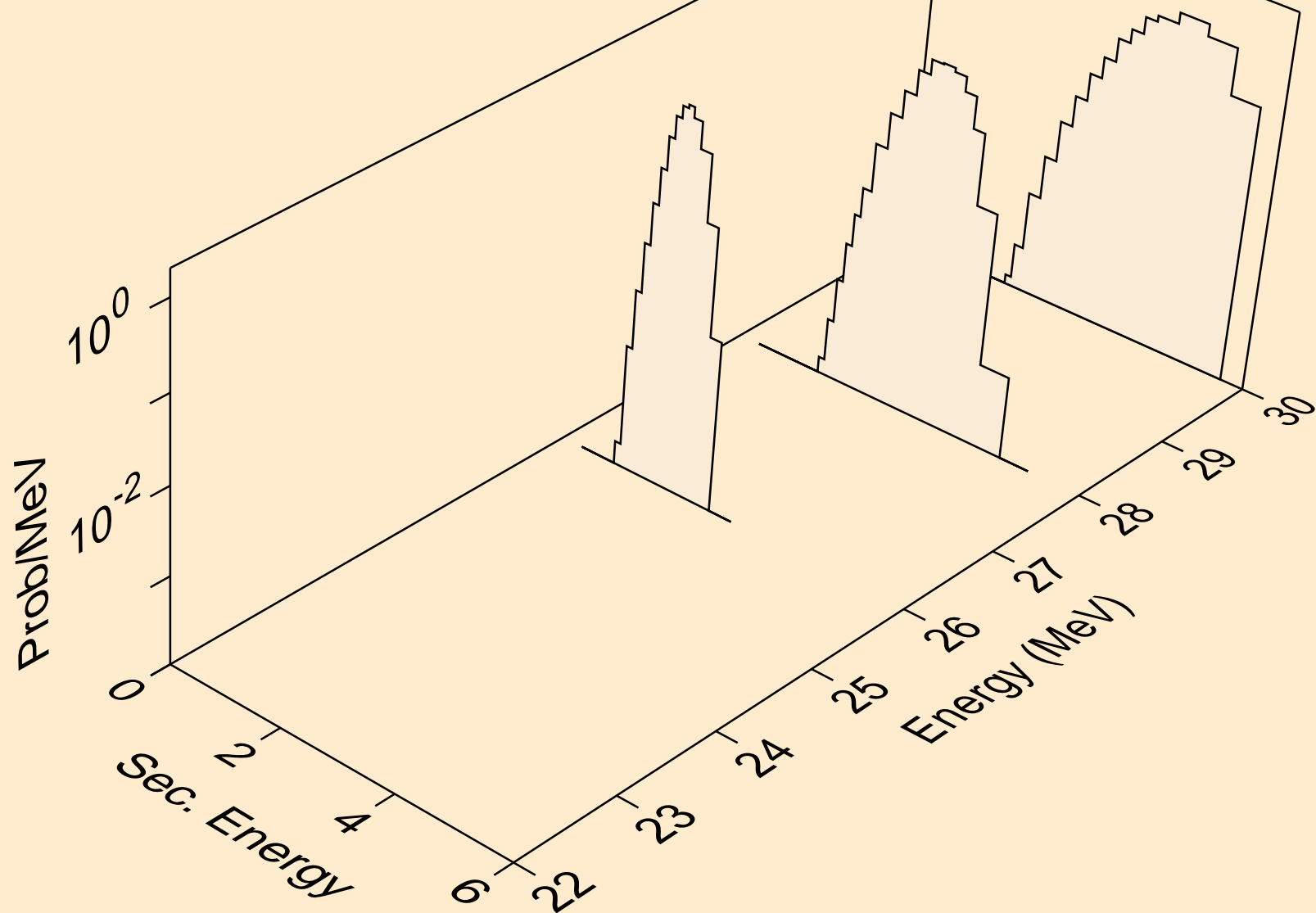

NB091M PHOTON ACER TENDL-2023 LIBRARY; T=0.K
tritons from (g,x)

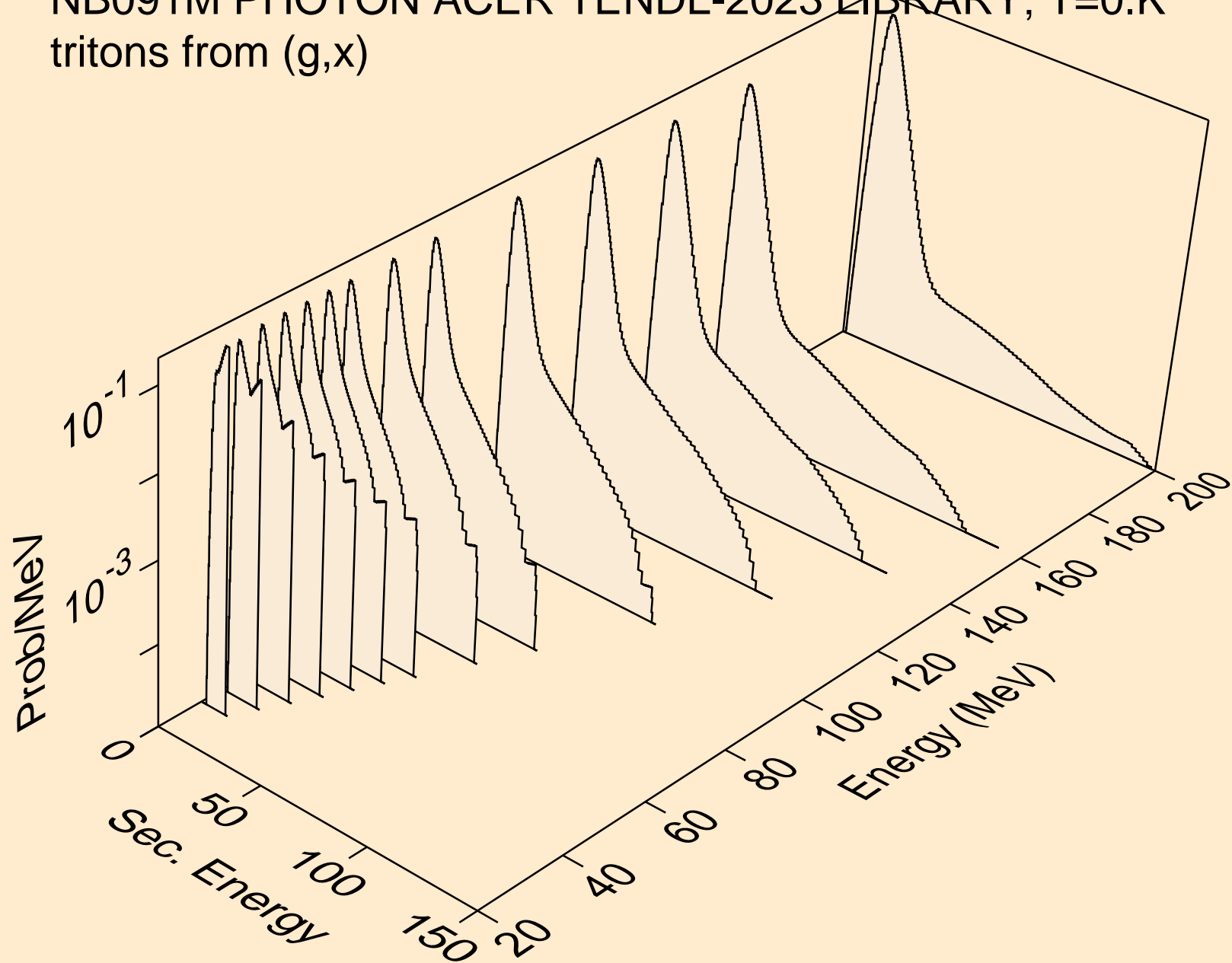

NB091M PHOTON ACER TENDL-2023 LIBRARY; T=0.K
tritons from (g,t)

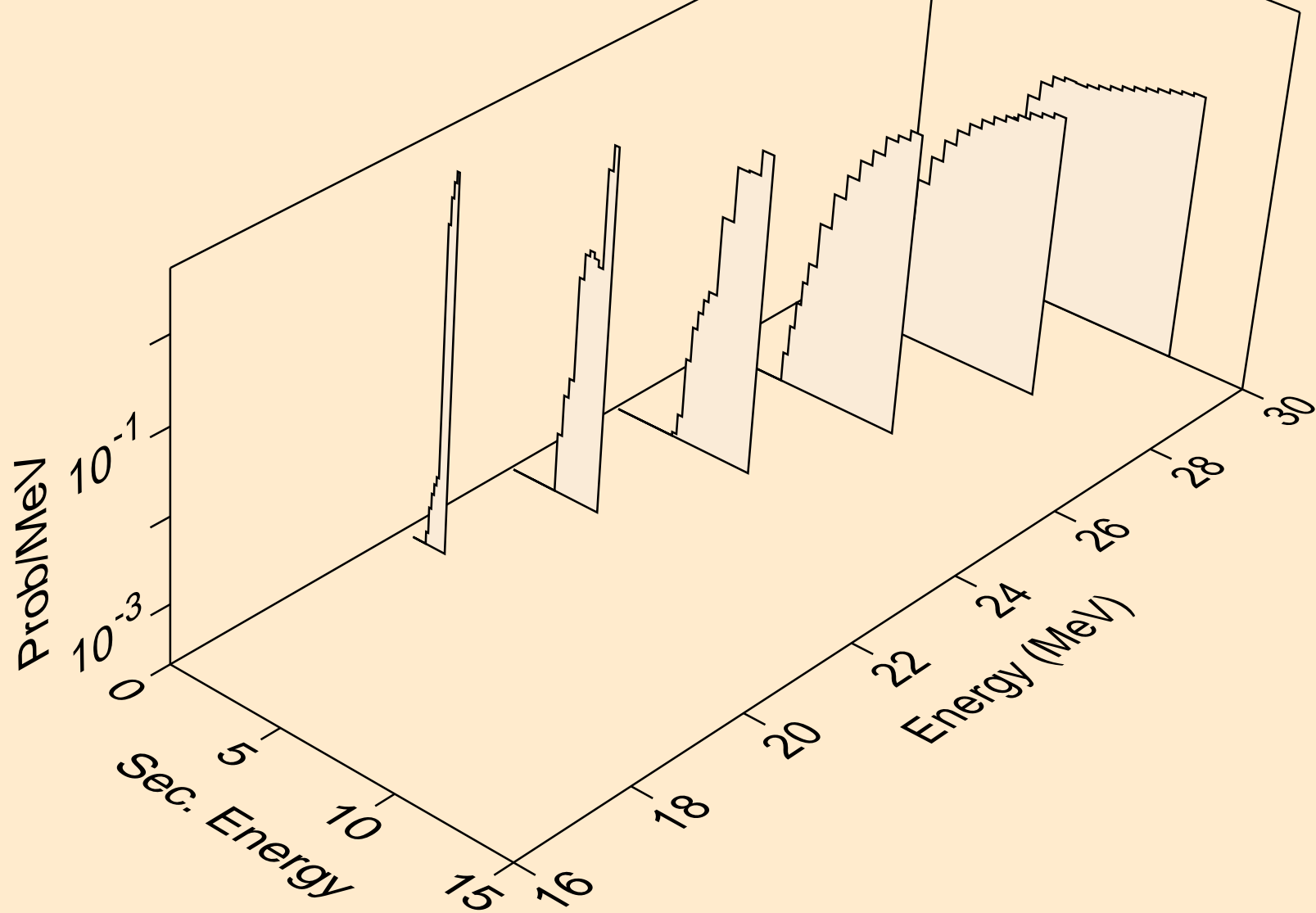

NB091M PHOTON ACER TENDL-2023 LIBRARY; T=0.K
he3s from (g,x)

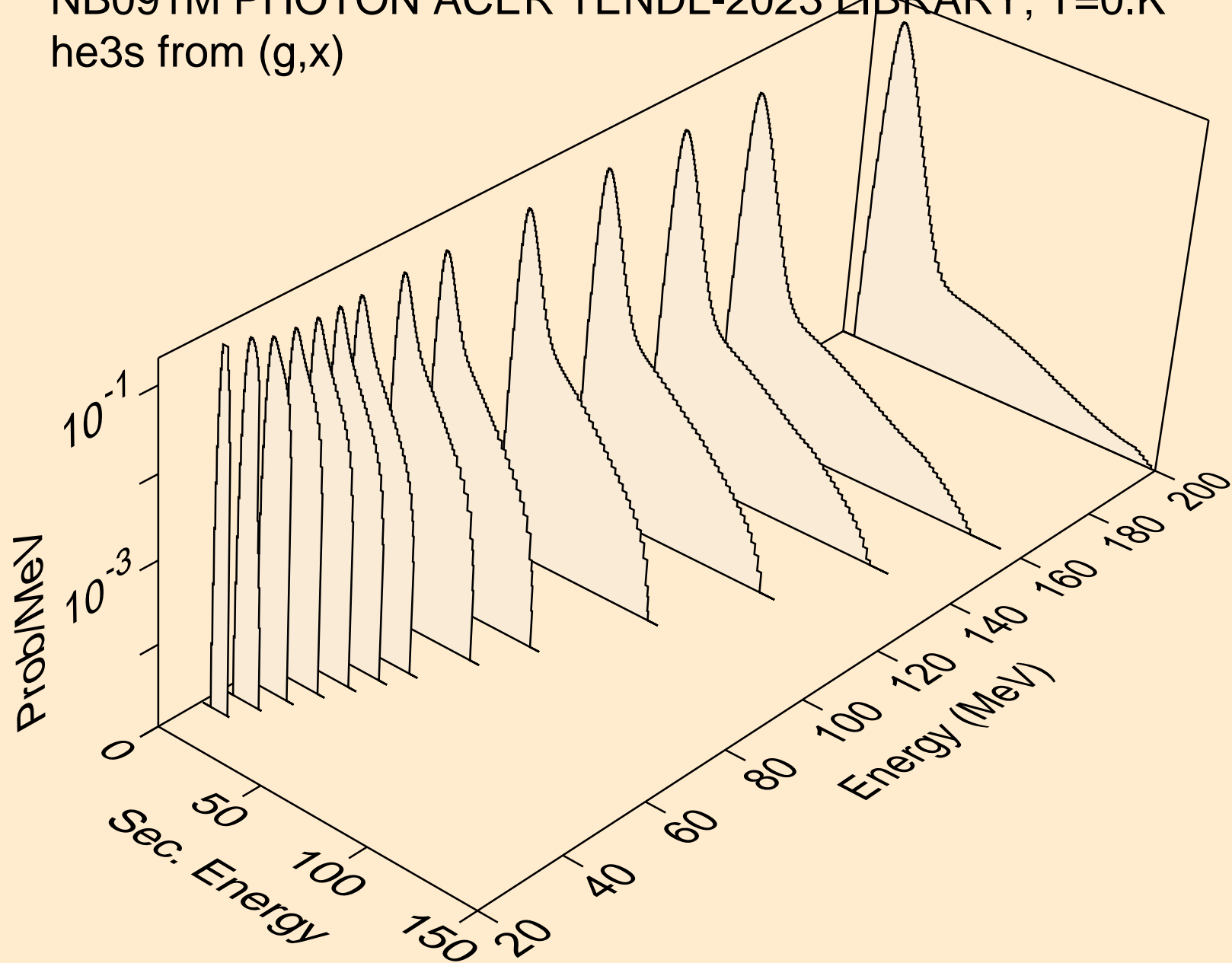

NB091M PHOTON ACER TENDL-2023 LIBRARY; T=0.K
he3s from (g,he3)

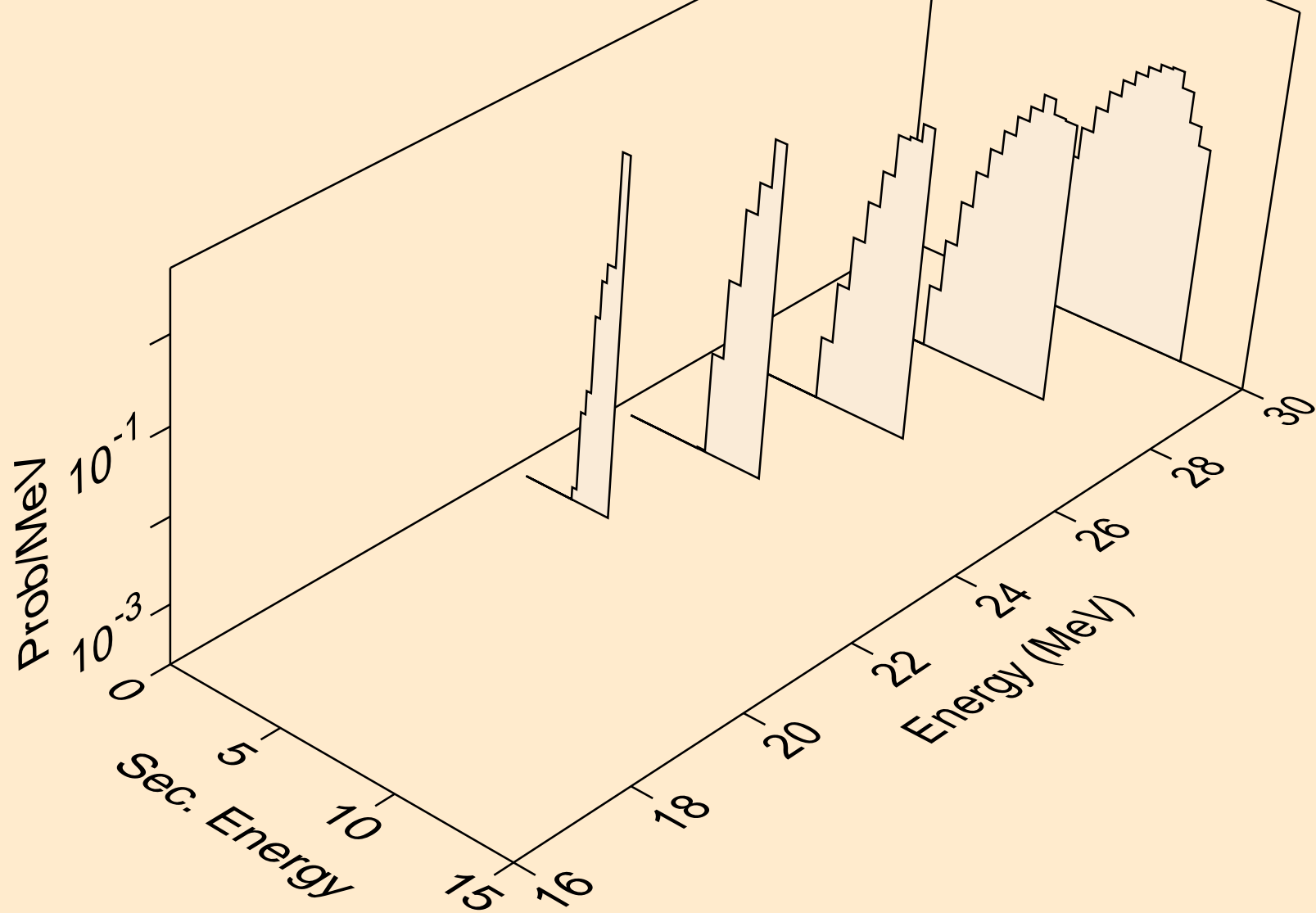

NB091M PHOTON ACER TENDL-2023 LIBRARY; T=0.K
alphas from (g,x)

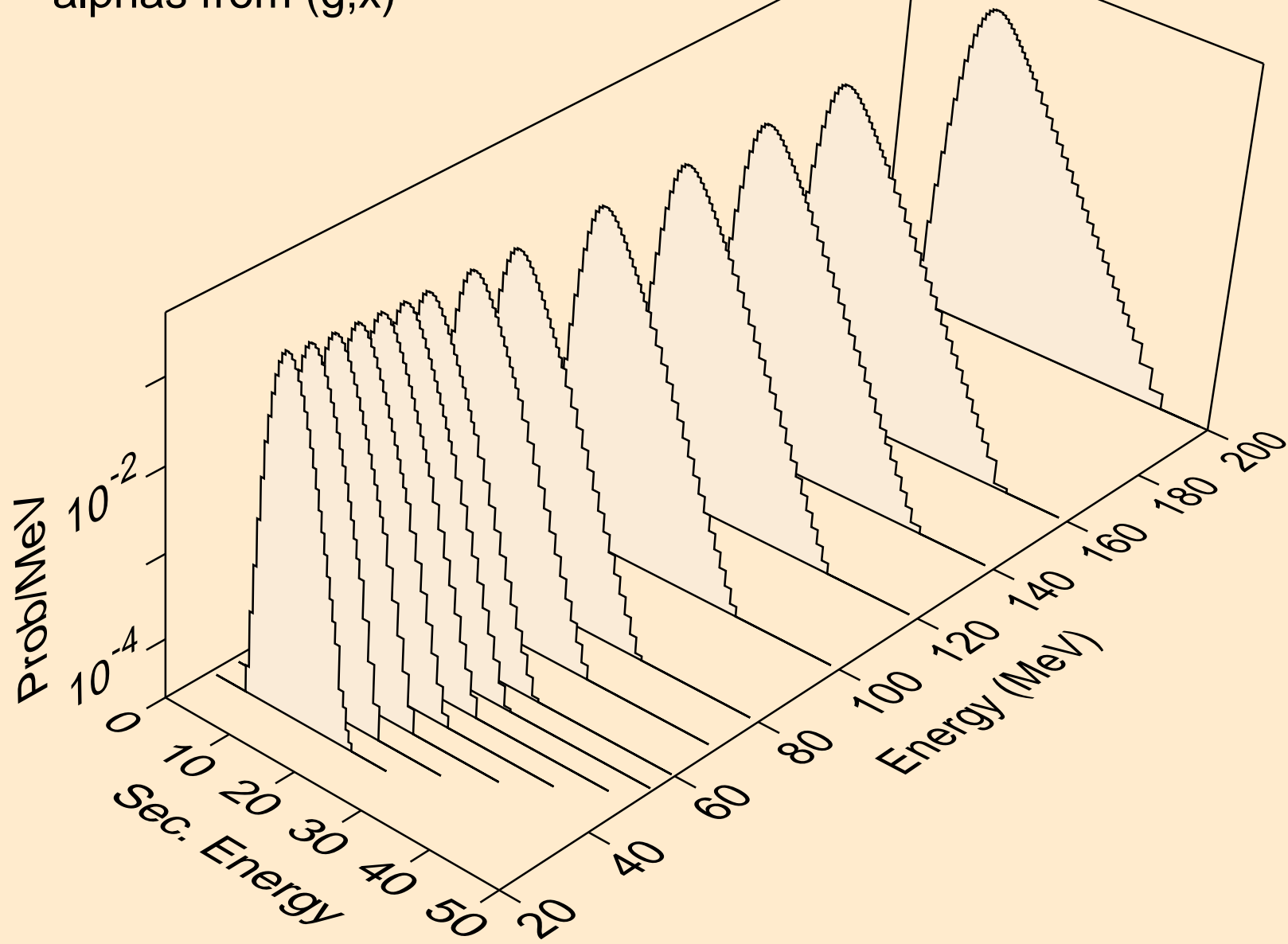

NB091M PHOTON ACER TENDL-2023 LIBRARY; T=0.K
alphas from (g,n*)a

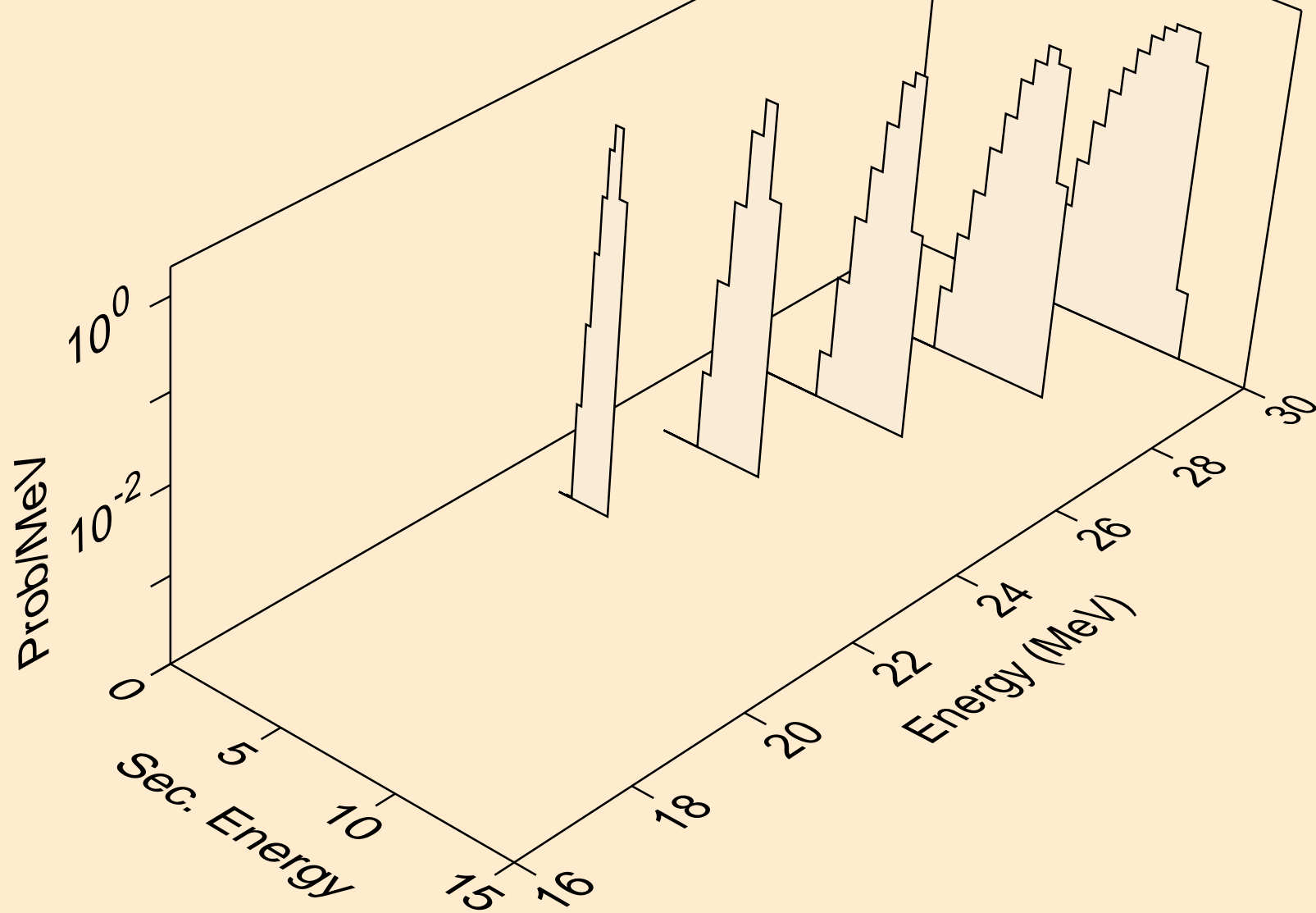

NB091M PHOTON ACER TENDL-2023 LIBRARY; T=0.K
alphas from (g,a)

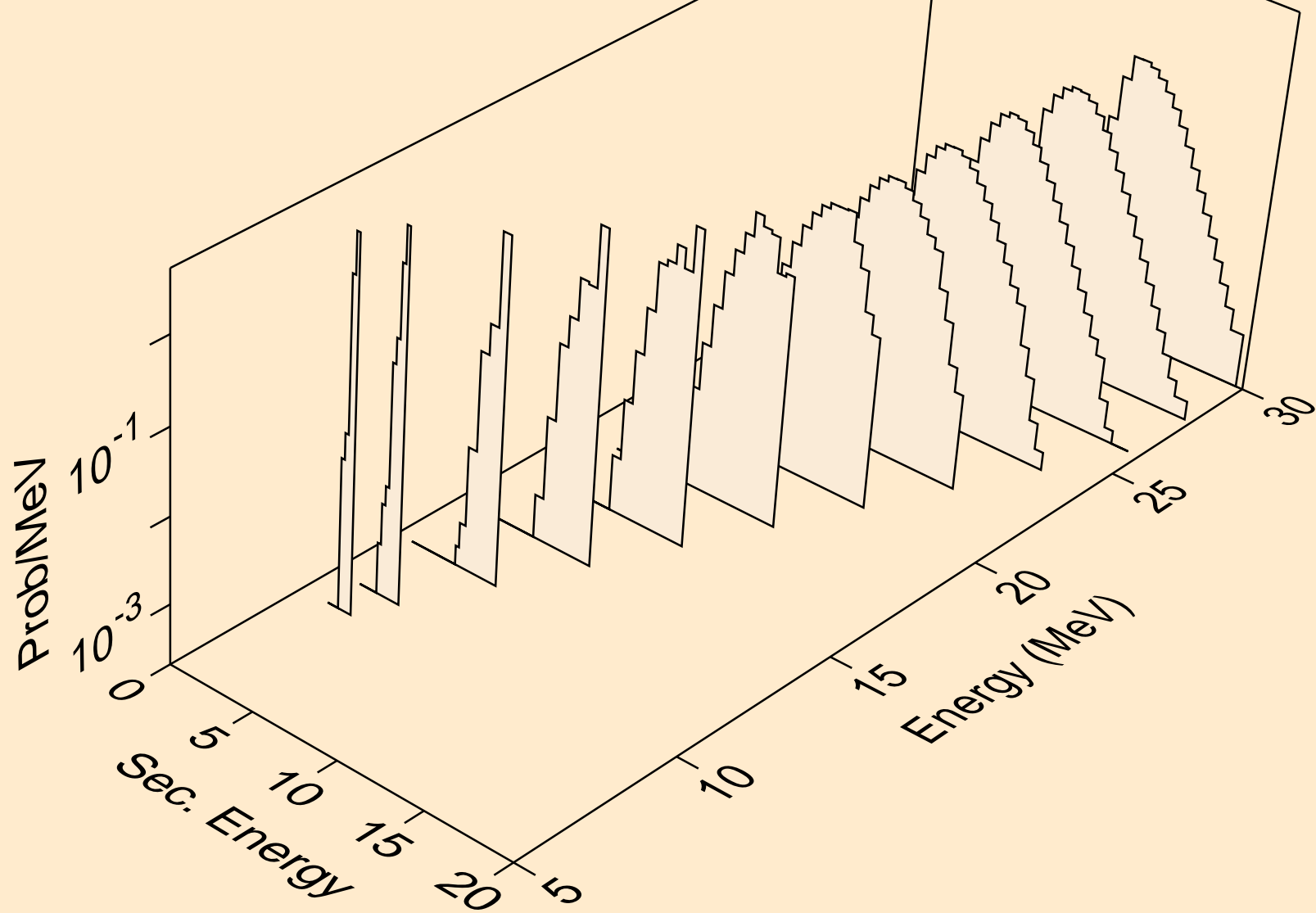

NB091M PHOTON ACER TENDL-2023 LIBRARY; T=0.K
alphas from (g,2a)

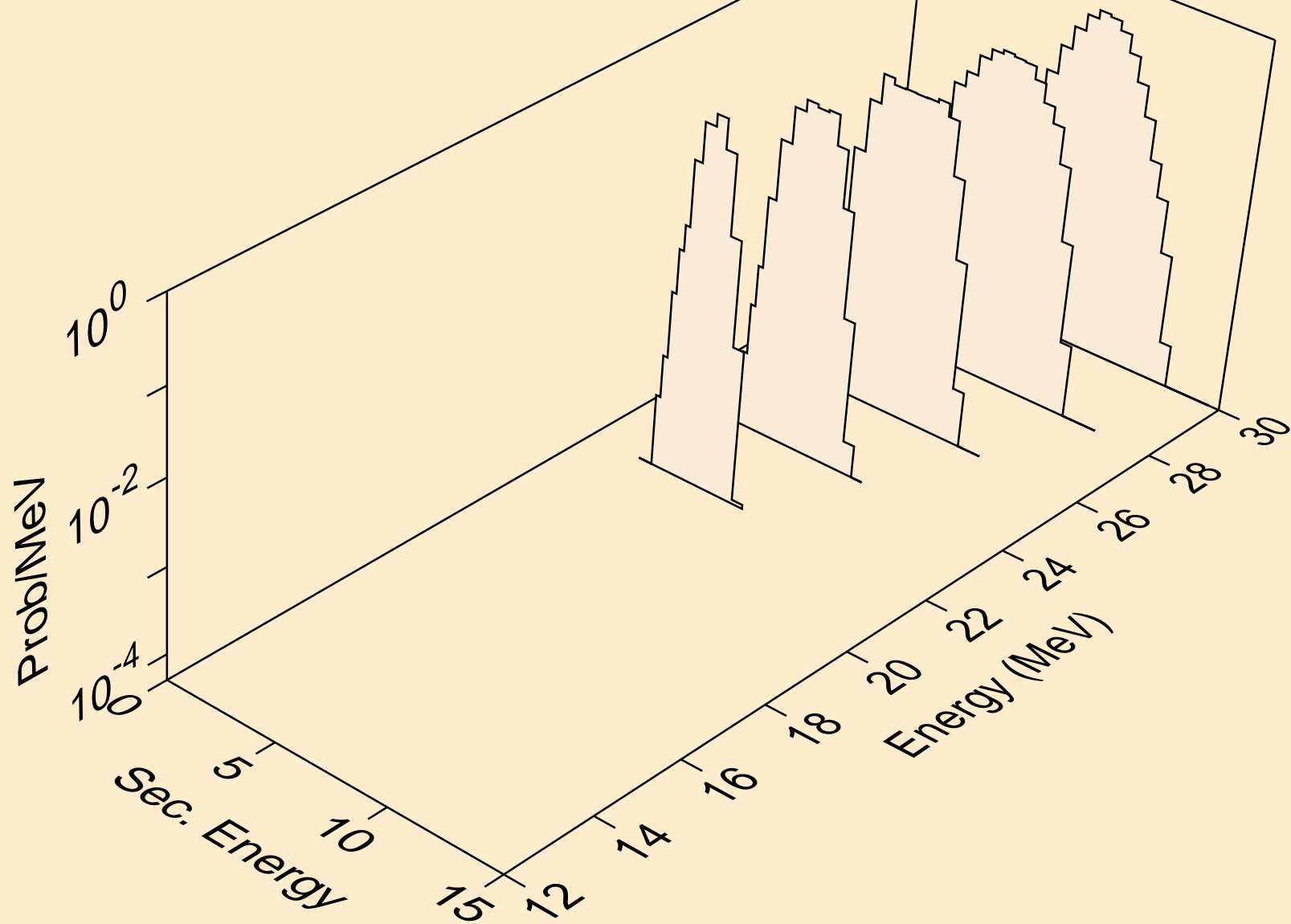

NB091M PHOTON ACER TENDL-2023 LIBRARY; T=0.K
alphas from (g,pa)

