

NB093M PHOTON ACER TENDL-2023 LIBRARY; T=0.K  
Principal cross sections

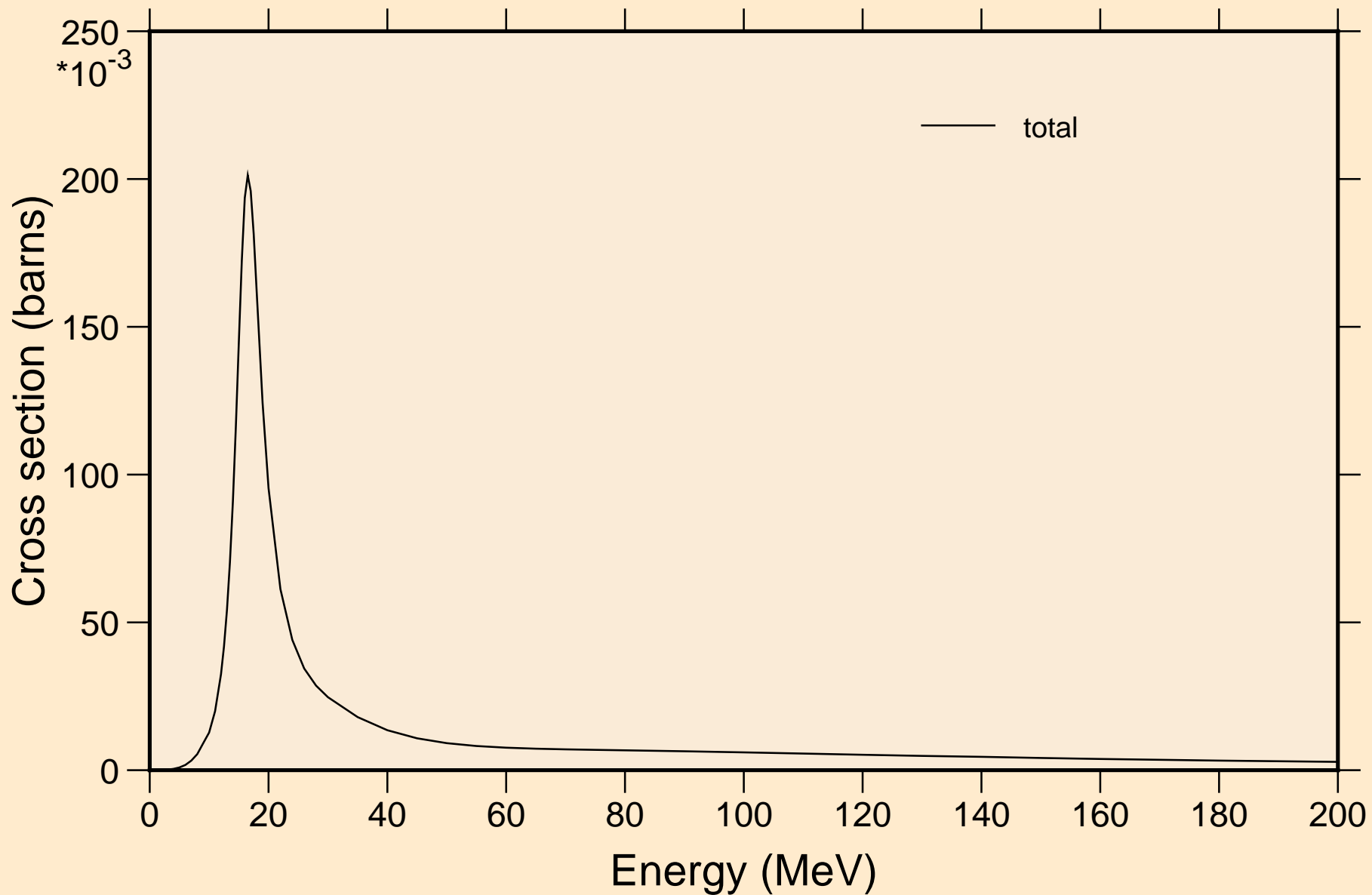

# NB093M PHOTON ACER TENDL-2023 LIBRARY; T=0.K

## Partial cross sections

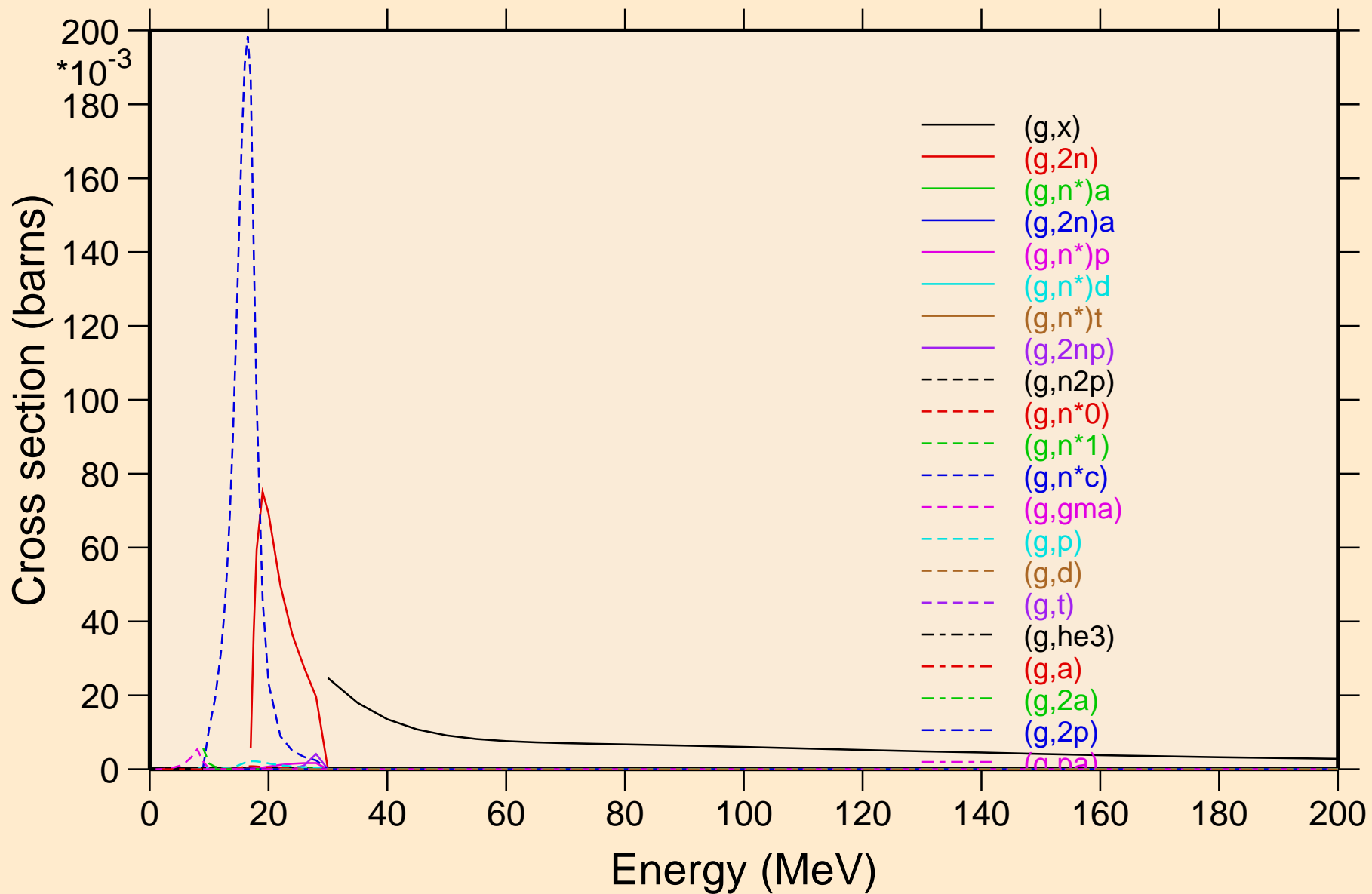

NB093M PHOTON ACER TENDL-2023 LIBRARY; T=0.K  
Heating

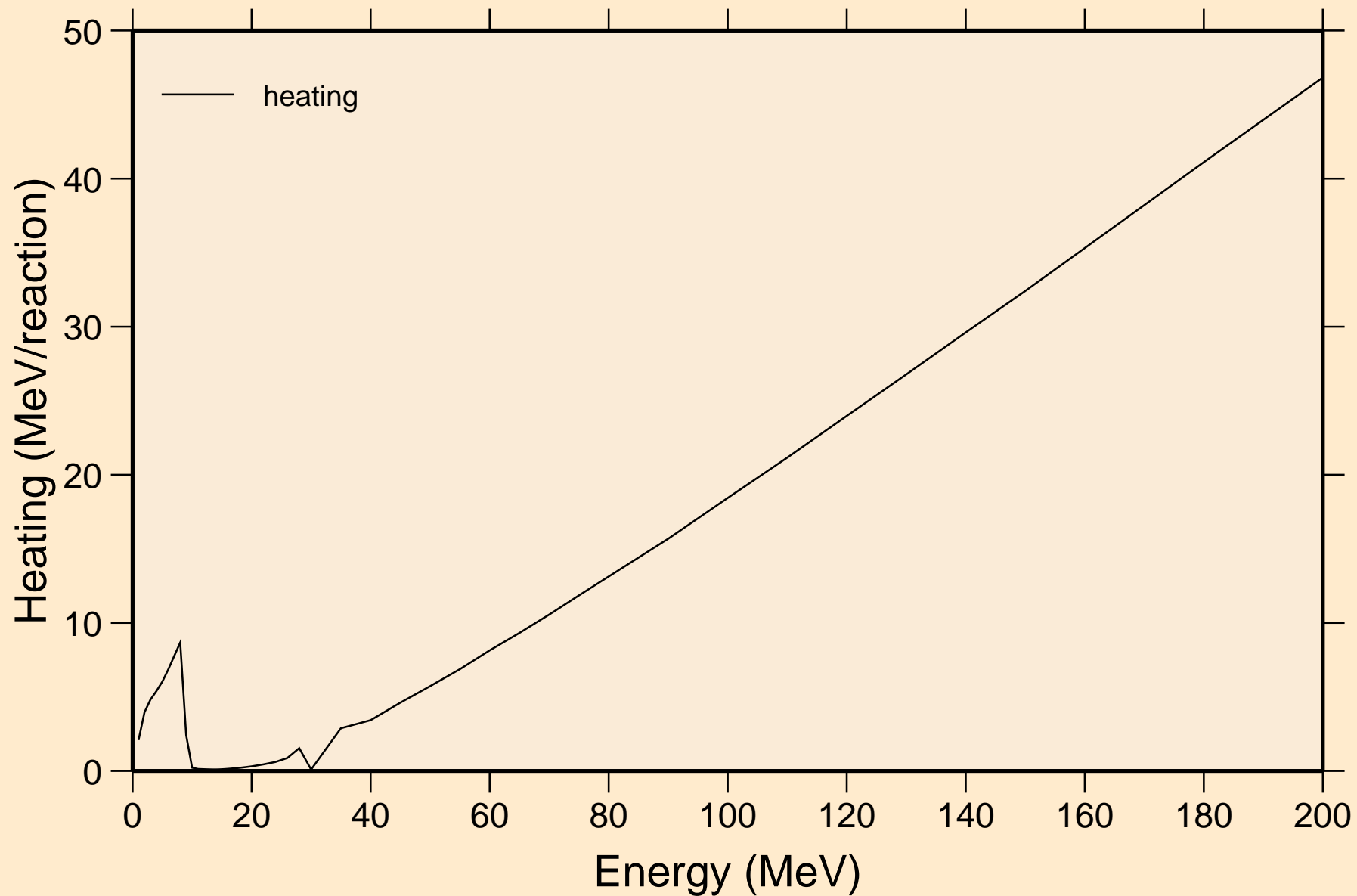

# NB093M PHOTON ACER TENDL-2023 LIBRARY; T=0.K

## Particle heating contributions

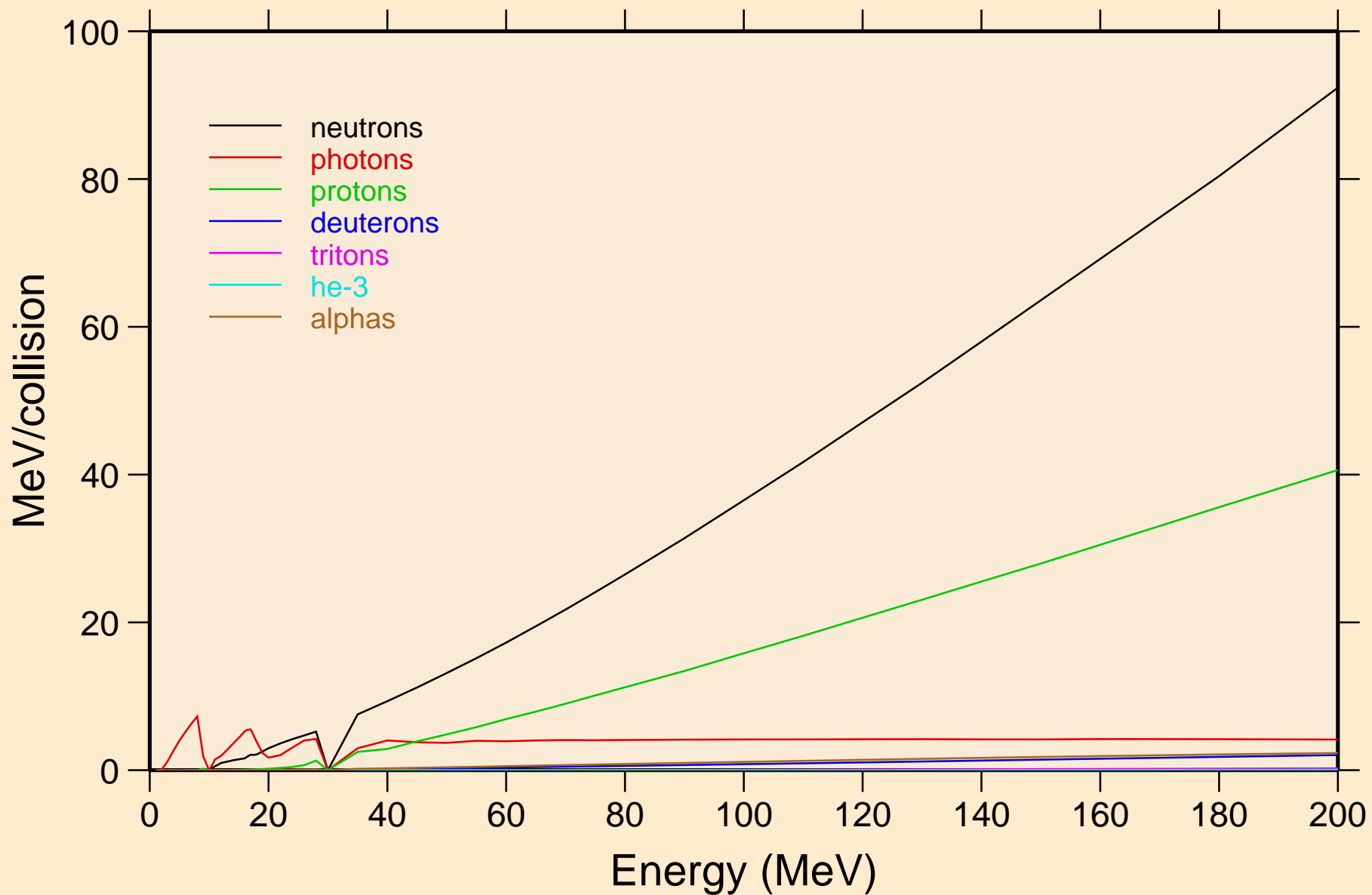

# NB093M PHOTON ACER TENDL-2023 LIBRARY; T=0.K

## Particle production cross sections

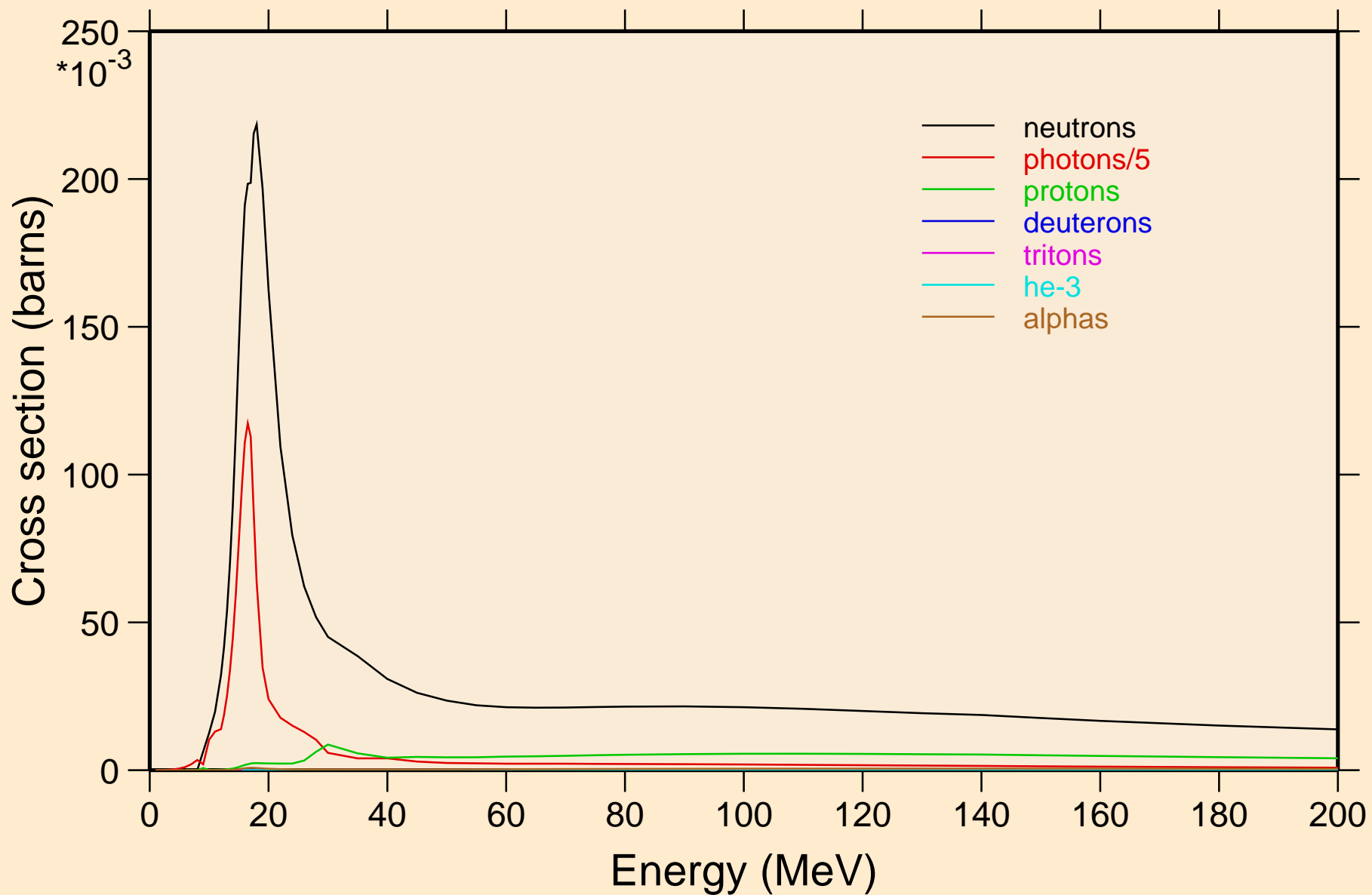

NB093M PHOTON ACER TENDL-2023 LIBRARY; T=0.K  
neutrons from (g,x)

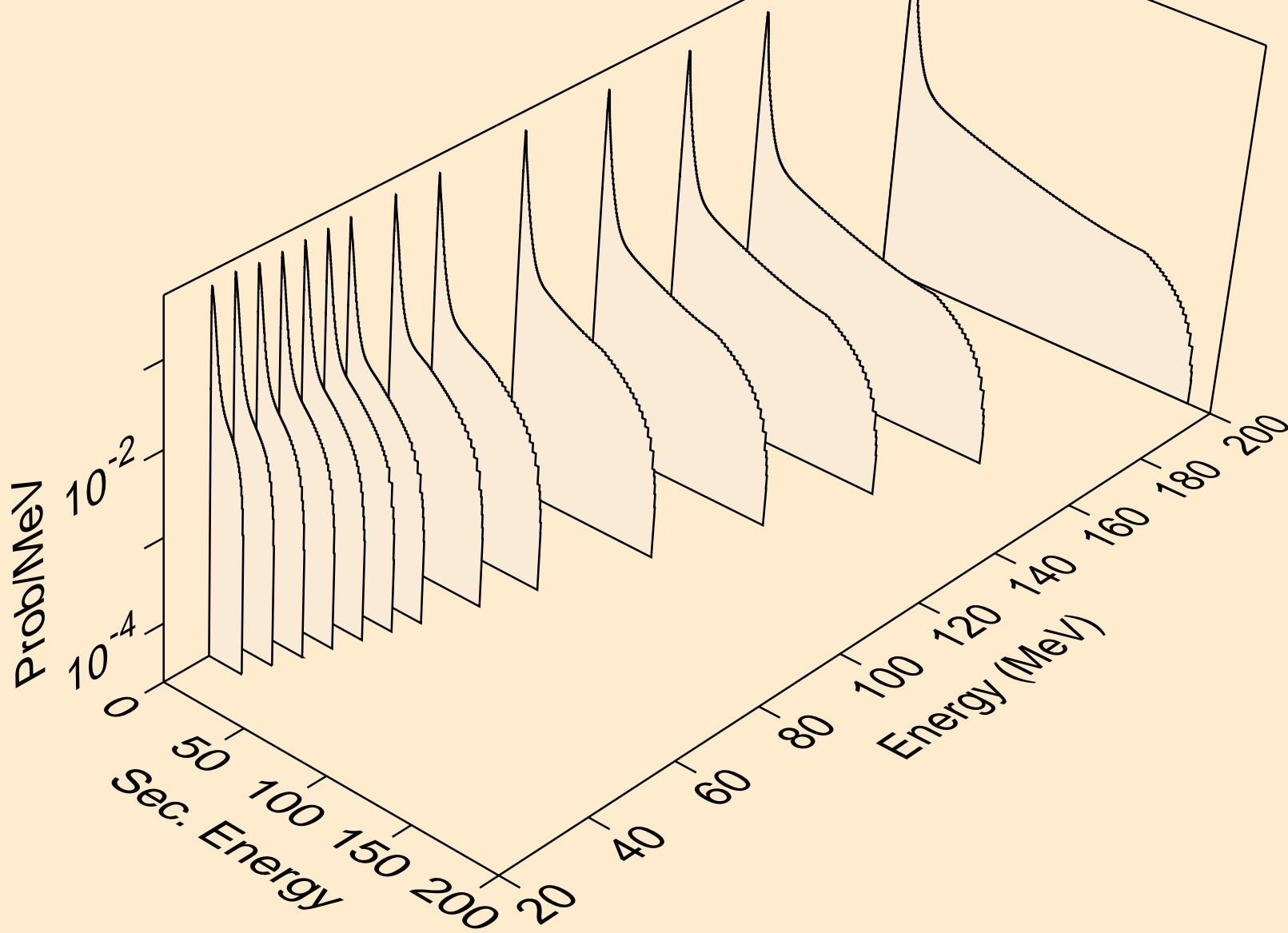

NB093M PHOTON ACER TENDL-2023 LIBRARY; T=0.K  
neutrons from (g,2n)

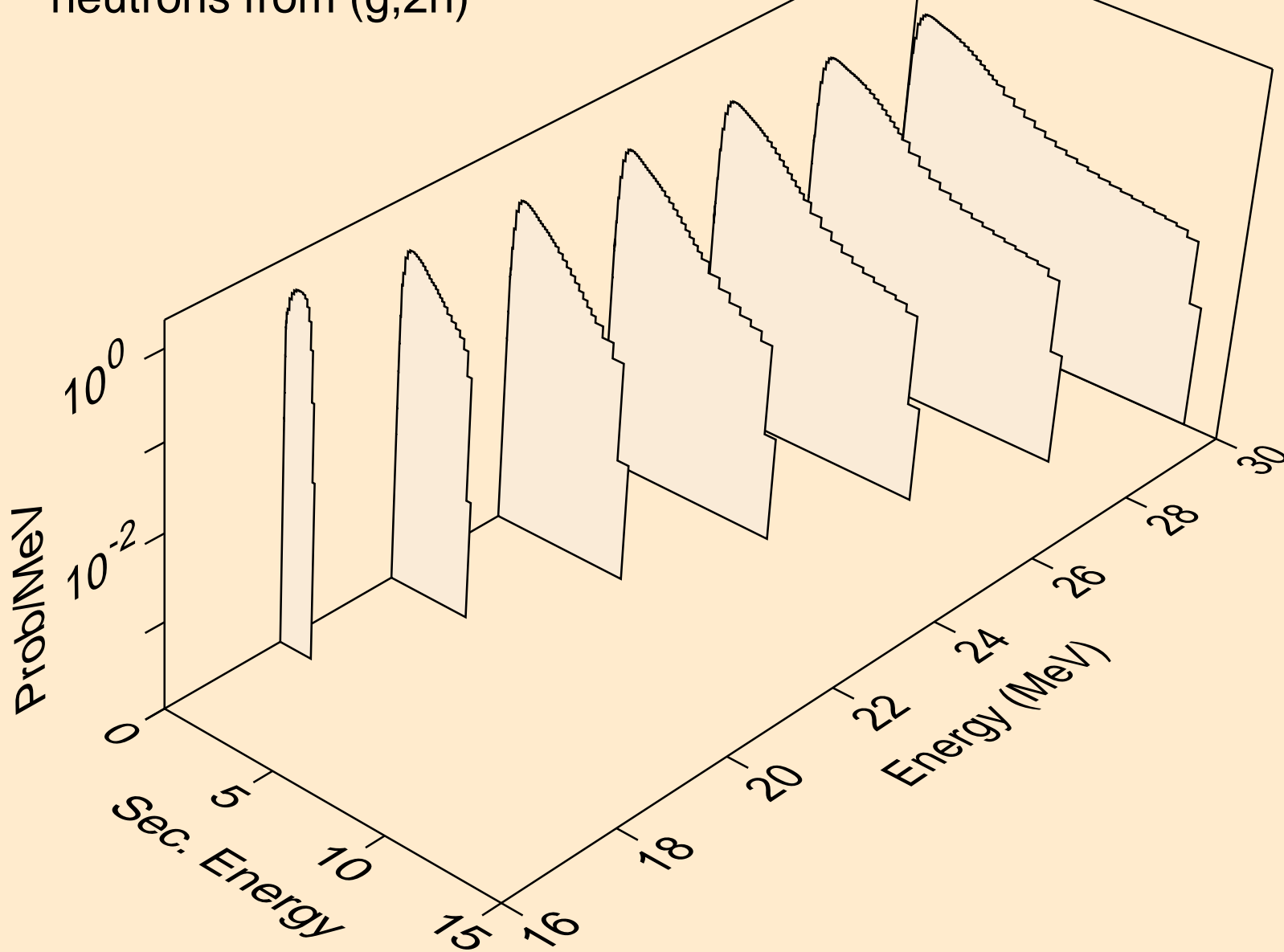

NB093M PHOTON ACER TENDL-2023 LIBRARY; T=0.K  
neutrons from (g,n\*)a

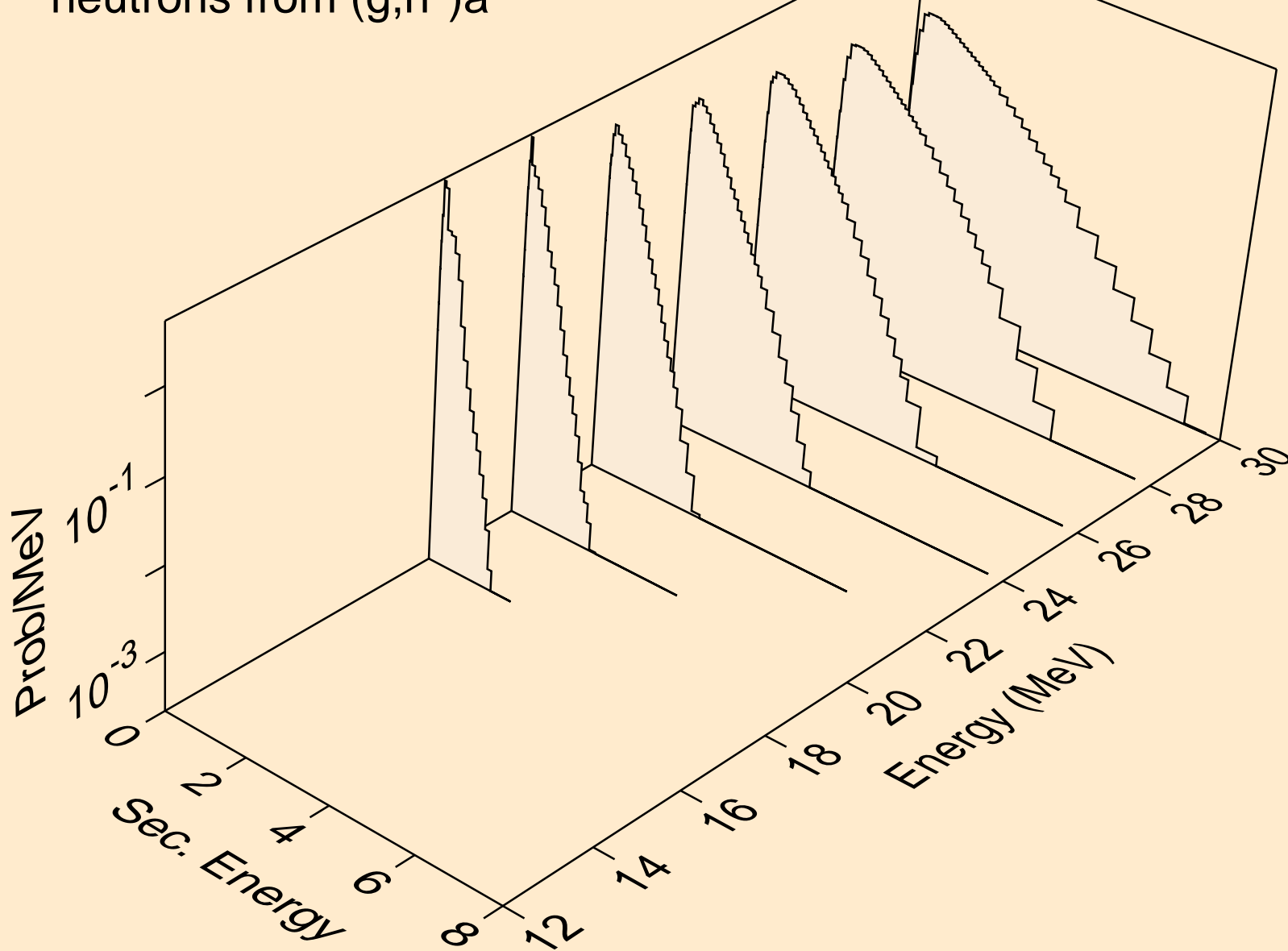



NB093M PHOTON ACER TENDL-2023 LIBRARY; T=0.K  
neutrons from (g,2n)a

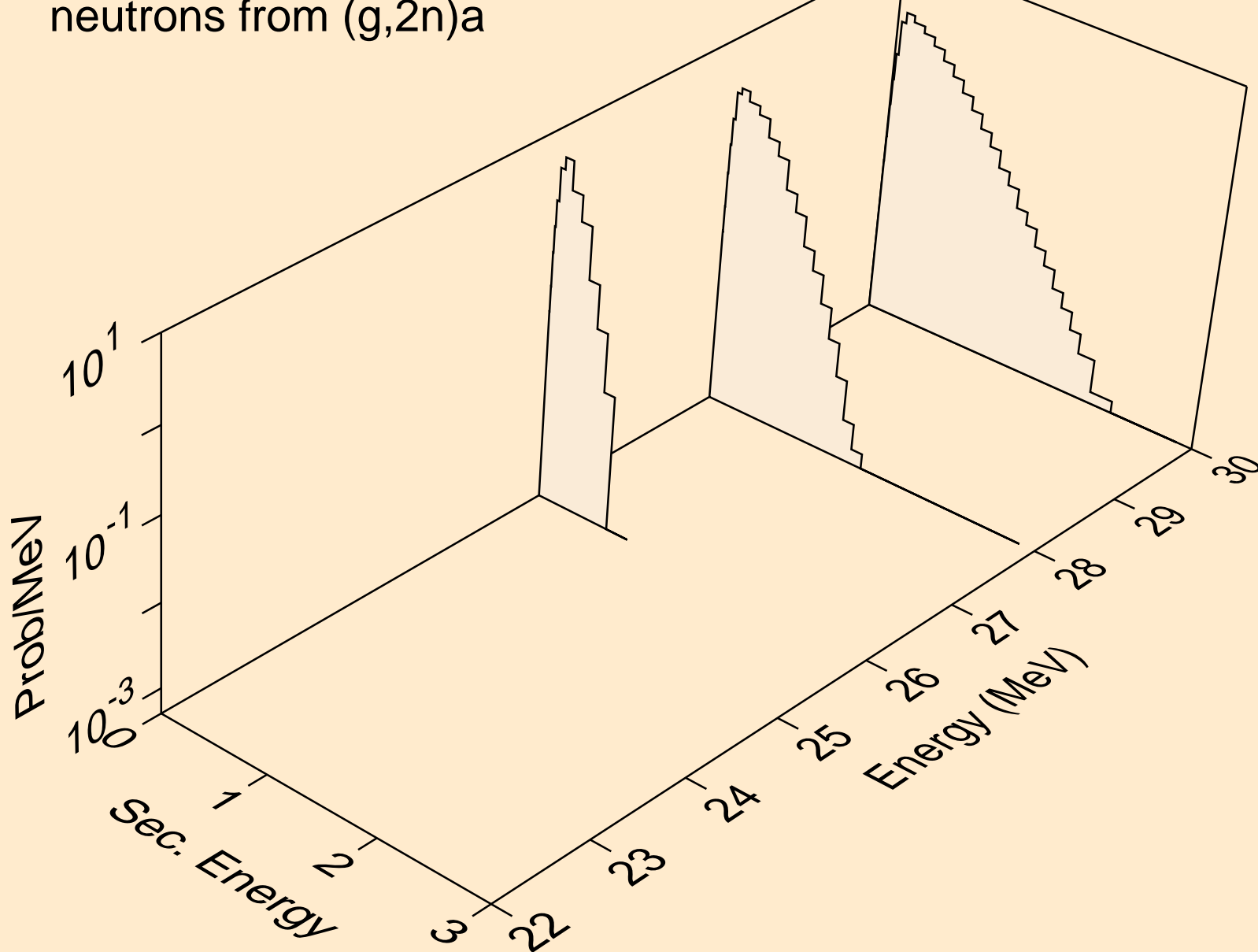

NB093M PHOTON ACER TENDL-2023 LIBRARY; T=0.K  
neutrons from (g,n\*)p

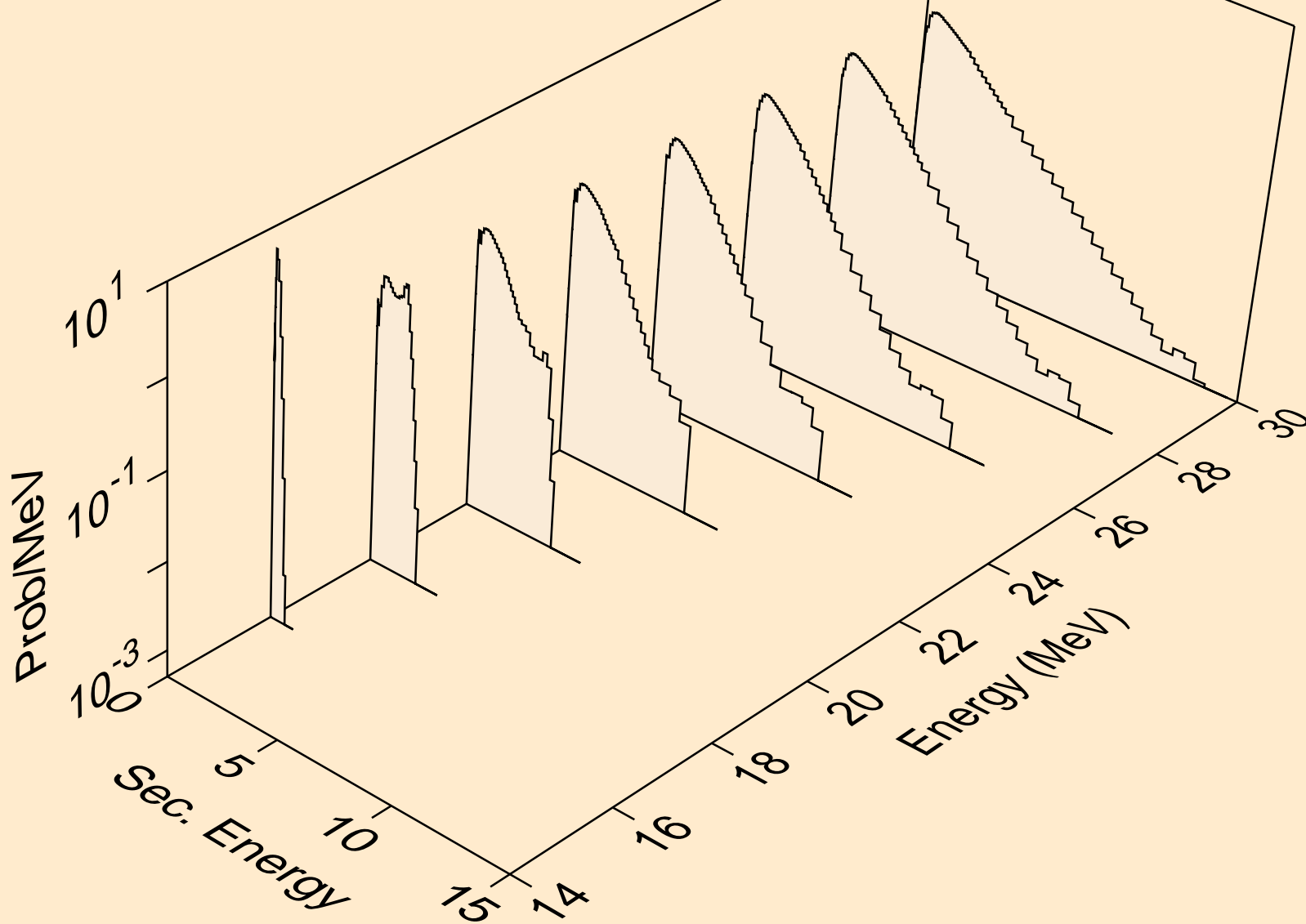

NB093M PHOTON ACER TENDL-2023 LIBRARY; T=0.K  
neutrons from (g,n\*)d

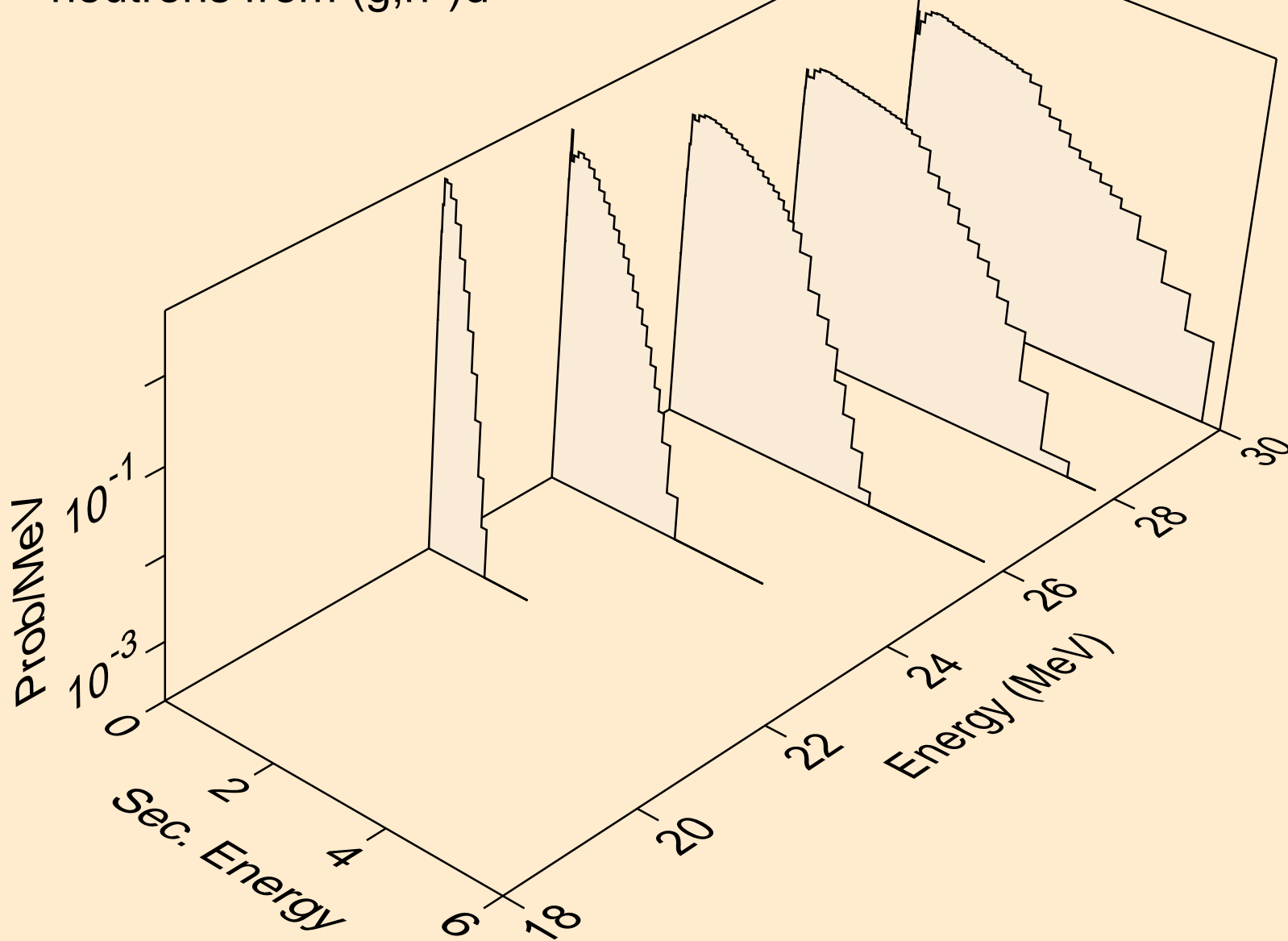

NB093M PHOTON ACER TENDL-2023 LIBRARY; T=0.K  
neutrons from (g,n\*)t

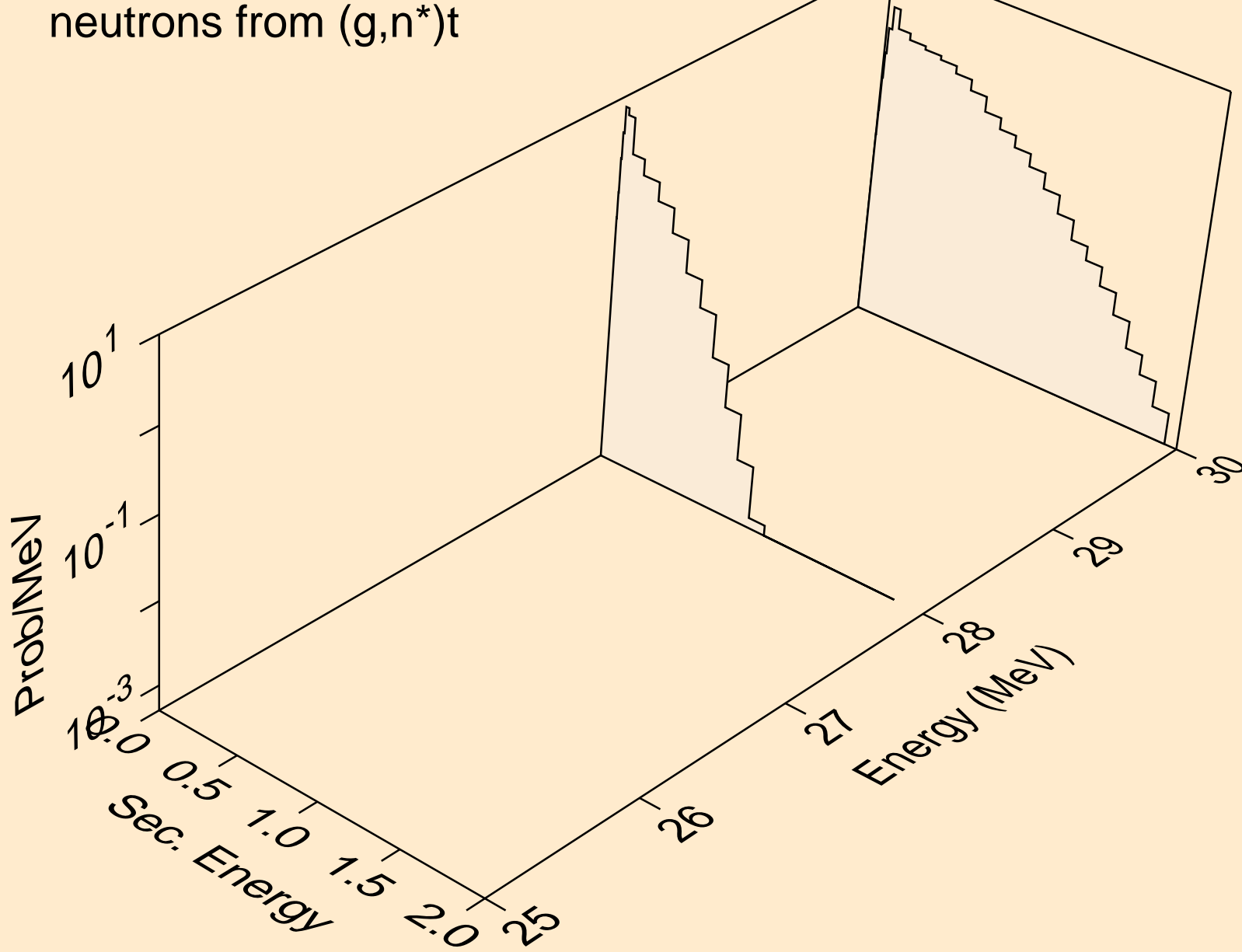

NB093M PHOTON ACER TENDL-2023 LIBRARY; T=0.K  
neutrons from (g,2np)

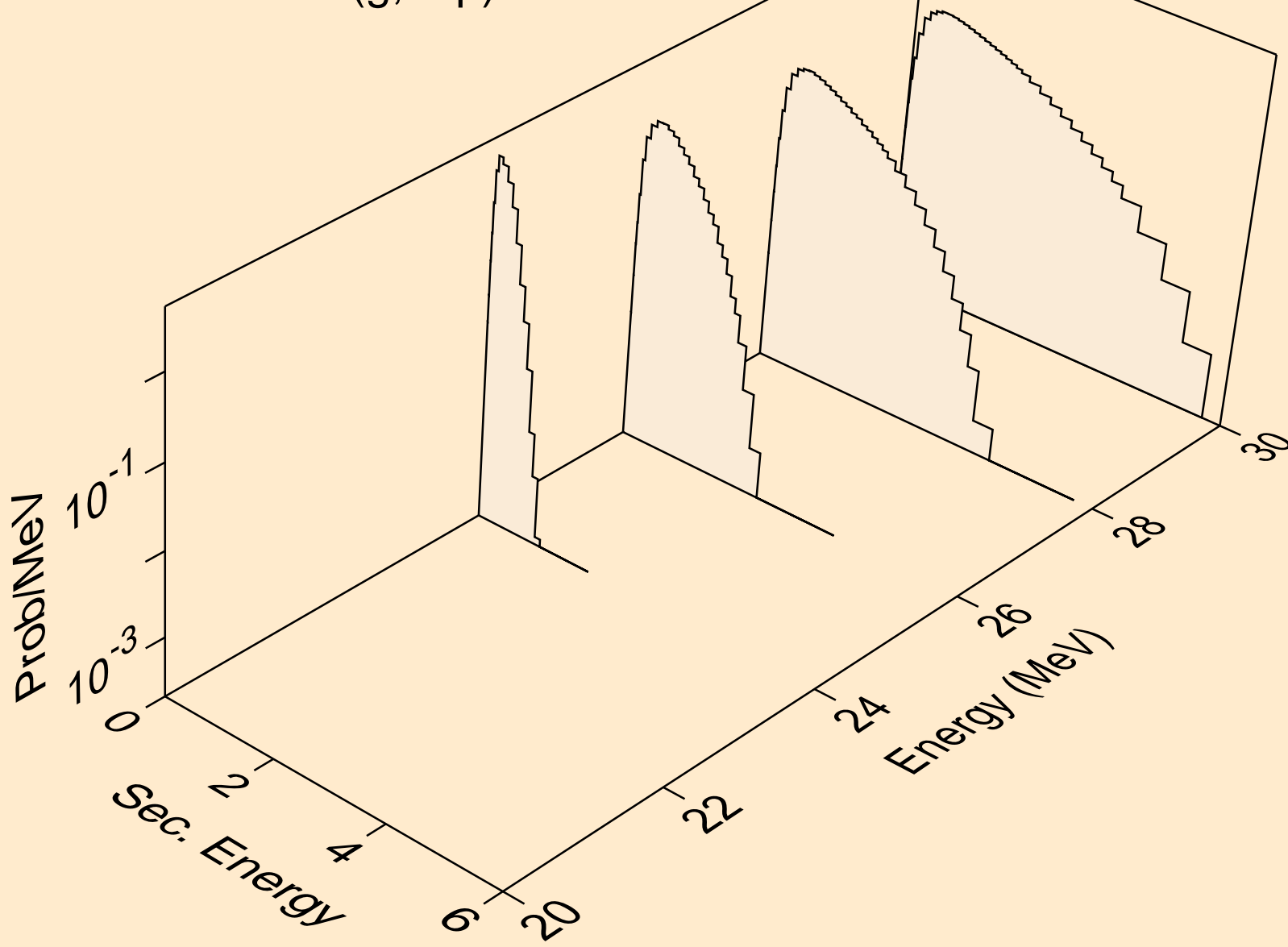

NB093M PHOTON ACER TENDL-2023 LIBRARY; T=0.K  
neutrons from (g,n2p)

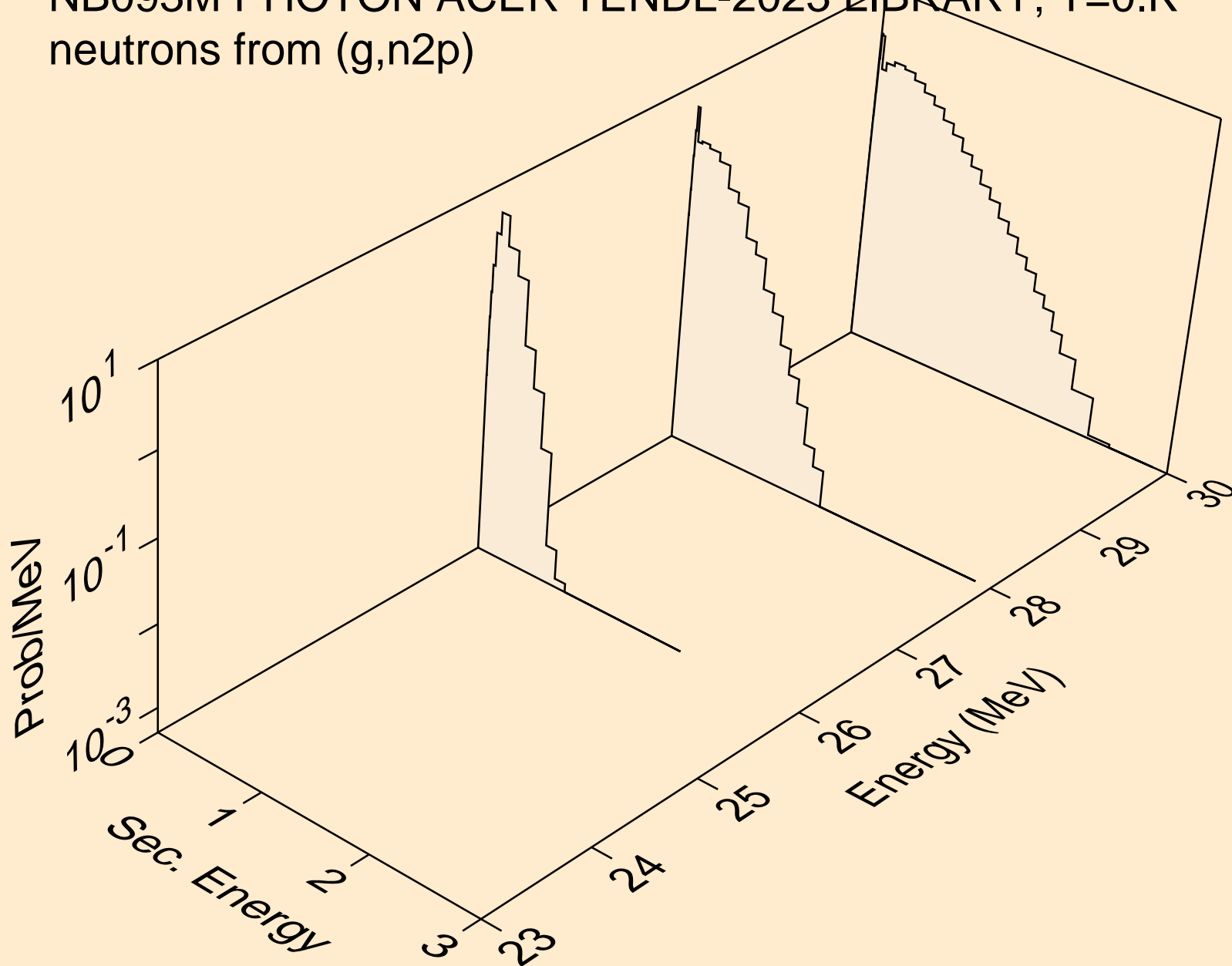

NB093M PHOTON ACER TENDL-2023 LIBRARY; T=0.K  
angular distribution for (g,n\*0) neutron

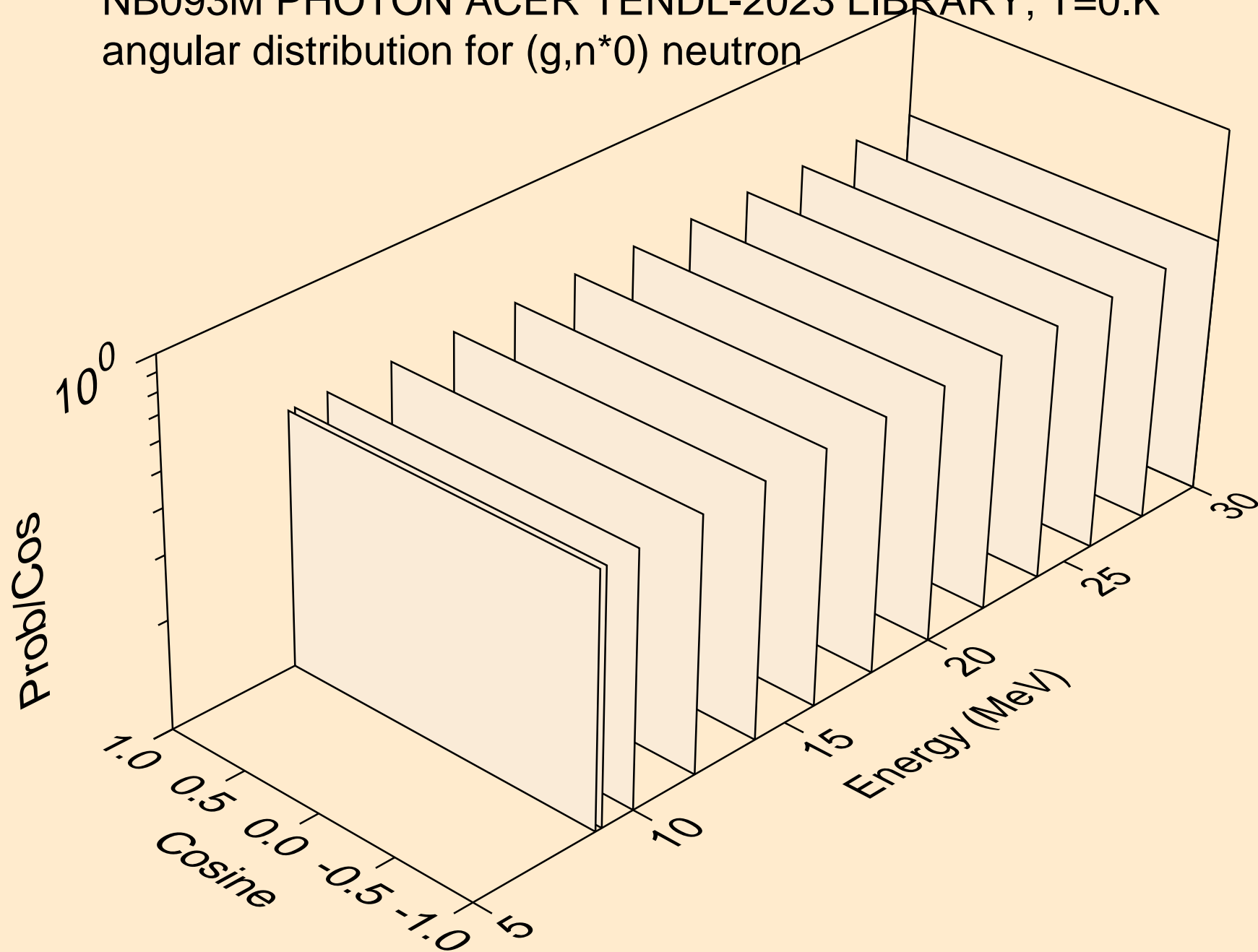

NB093M PHOTON ACER TENDL-2023 LIBRARY; T=0.K  
angular distribution for (g,n\*1) neutron

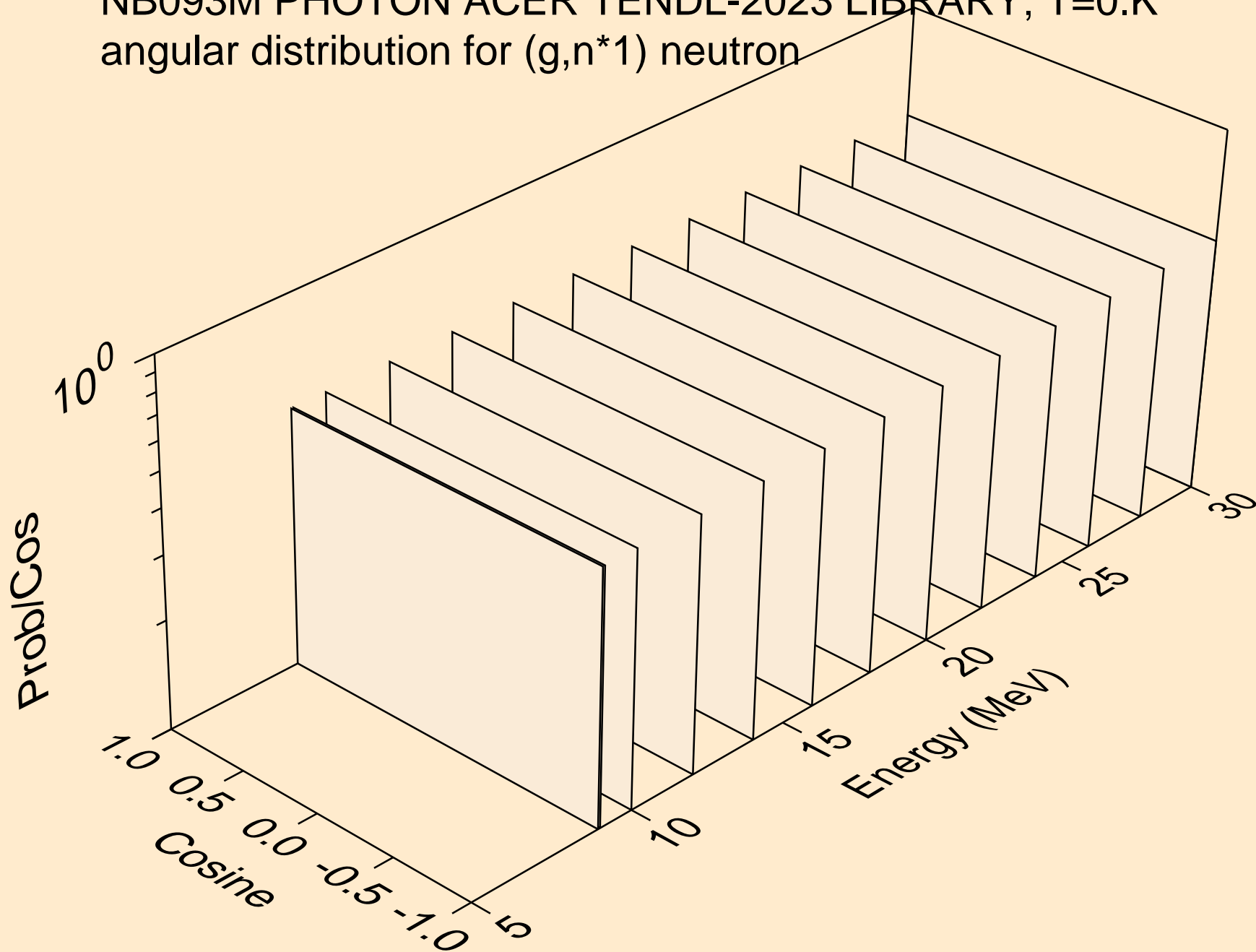



NB093M PHOTON ACER TENDL-2023 LIBRARY; T=0.K  
neutrons from (g,n\*c)

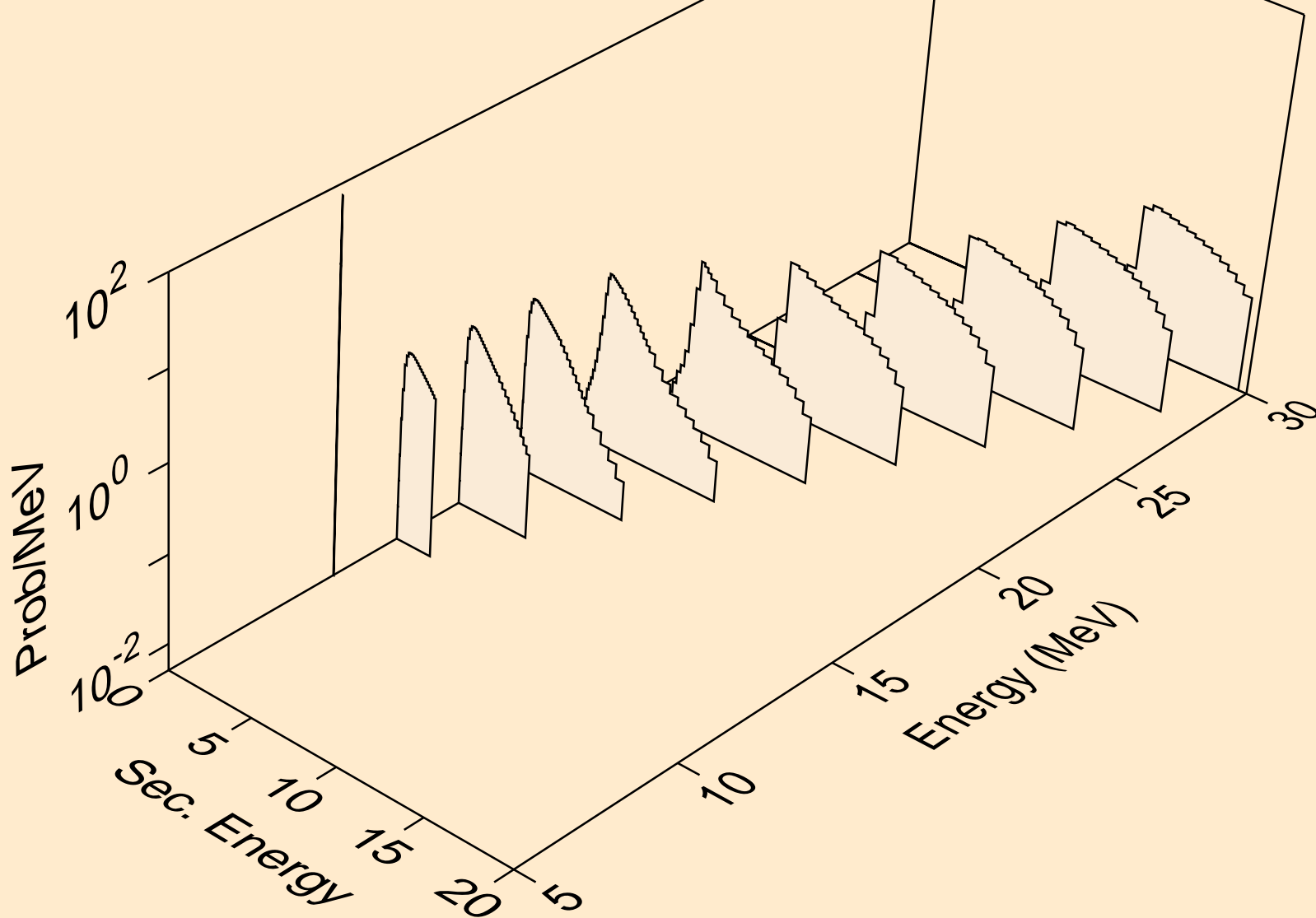

NB093M PHOTON ACER TENDL-2023 LIBRARY; T=0.K  
photons from (g,x)

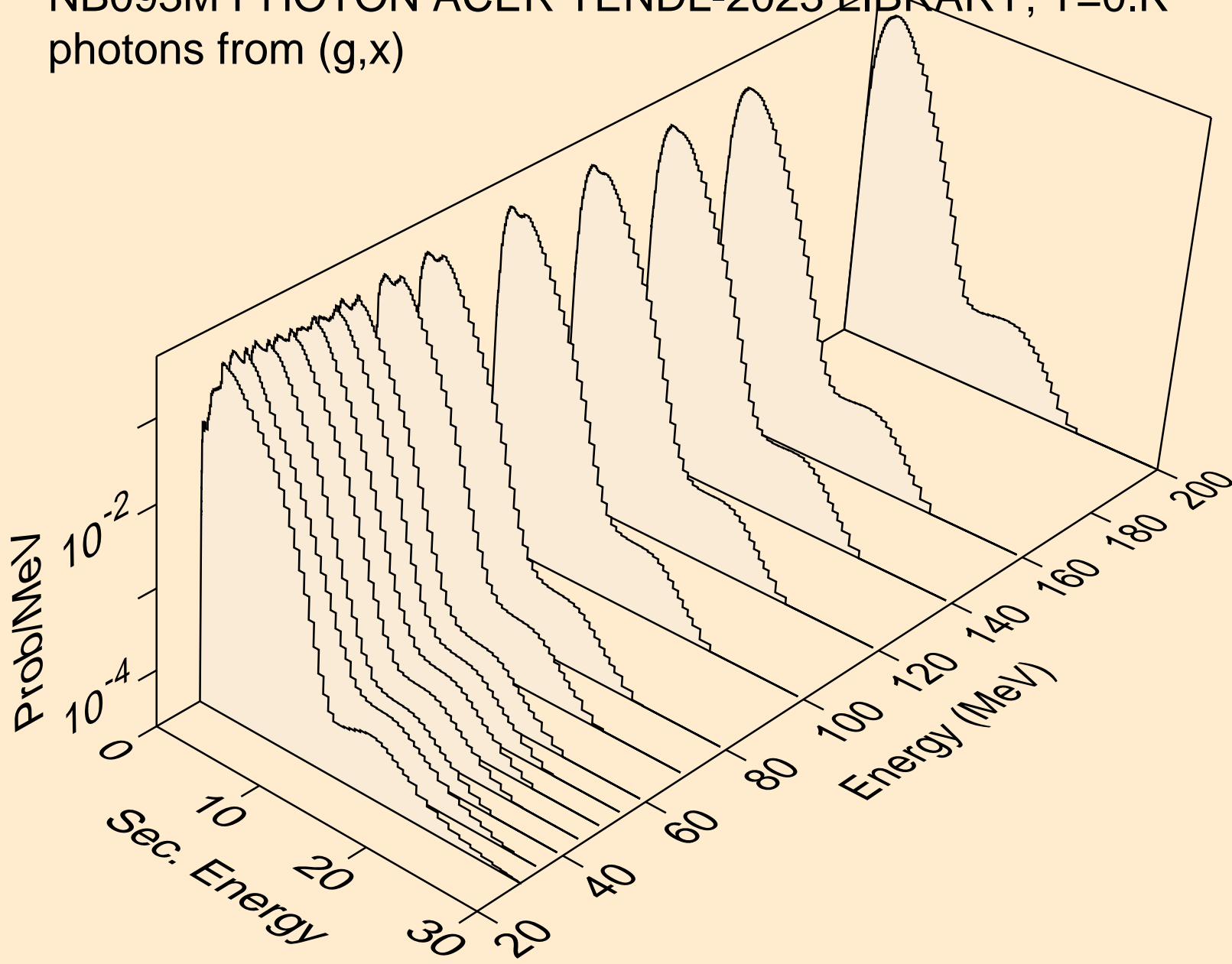

NB093M PHOTON ACER TENDL-2023 LIBRARY; T=0.K  
photons from (g,2n)

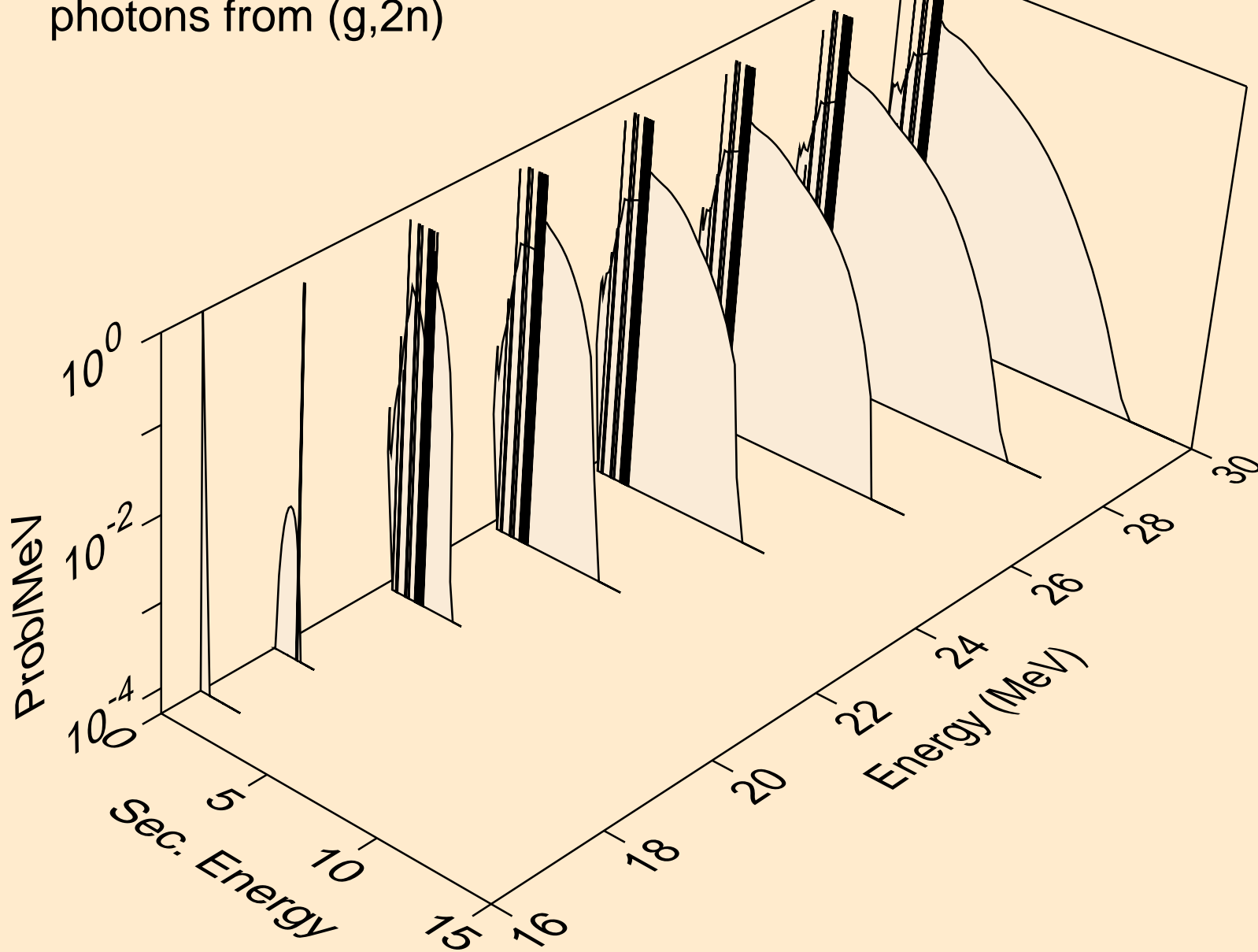

NB093M PHOTON ACER TENDL-2023 LIBRARY; T=0.K  
photons from (g,n\*)a

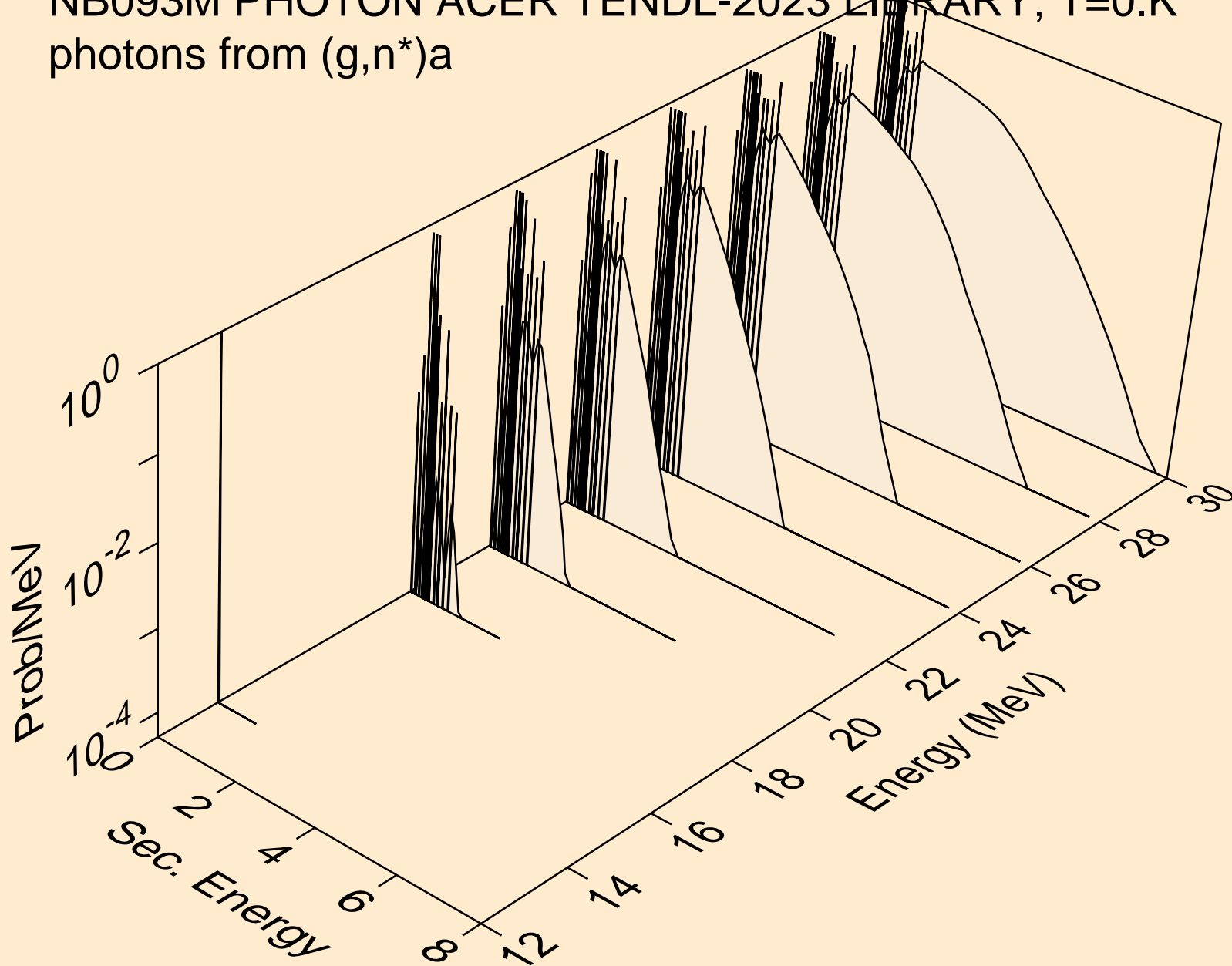

NB093M PHOTON ACER TENDL-2023 LIBRARY; T=0.K  
photons from (g,2n)a

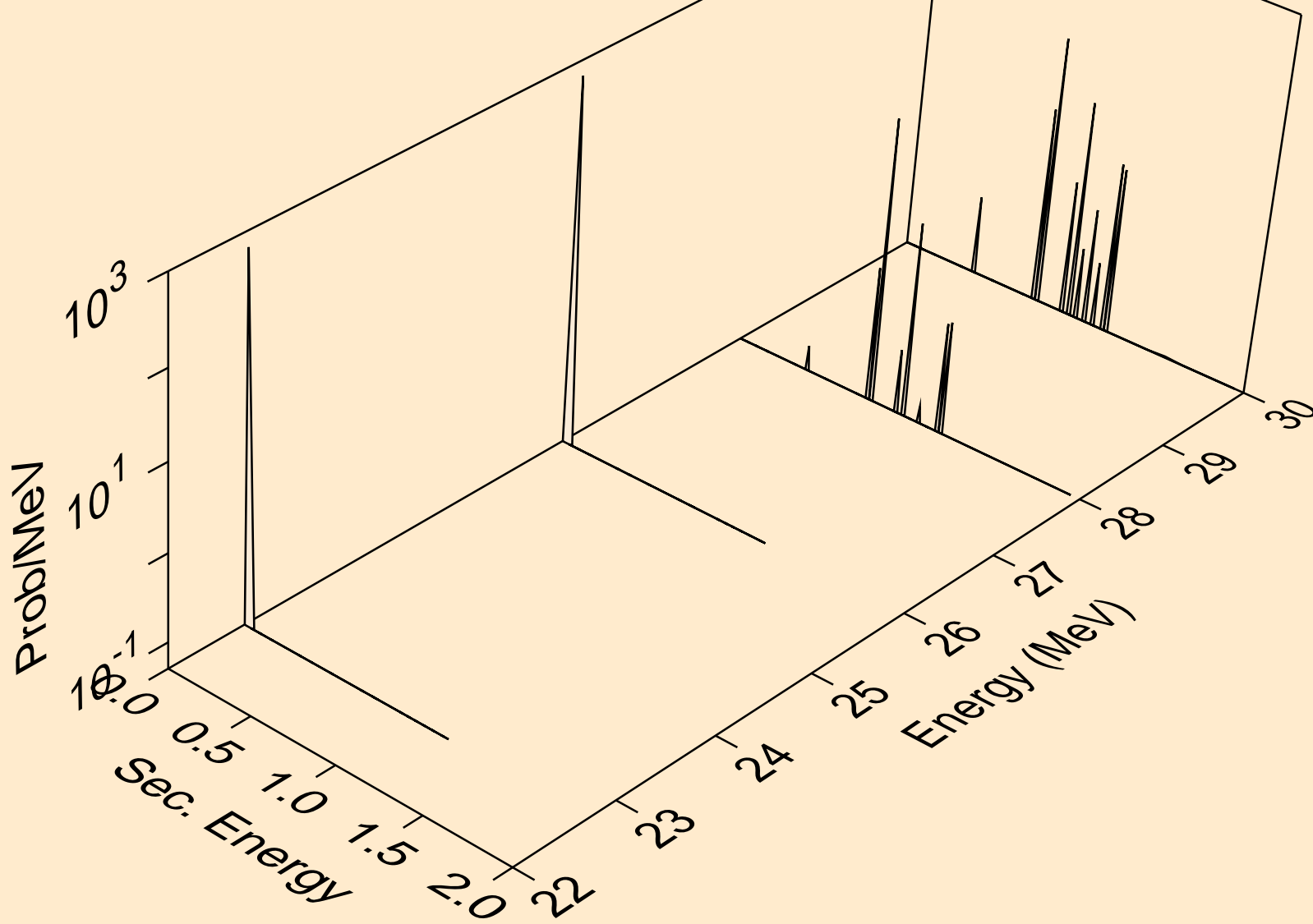

NB093M PHOTON ACER TENDL-2023 LIBRARY; T=0.K  
photons from (g,n\*)p

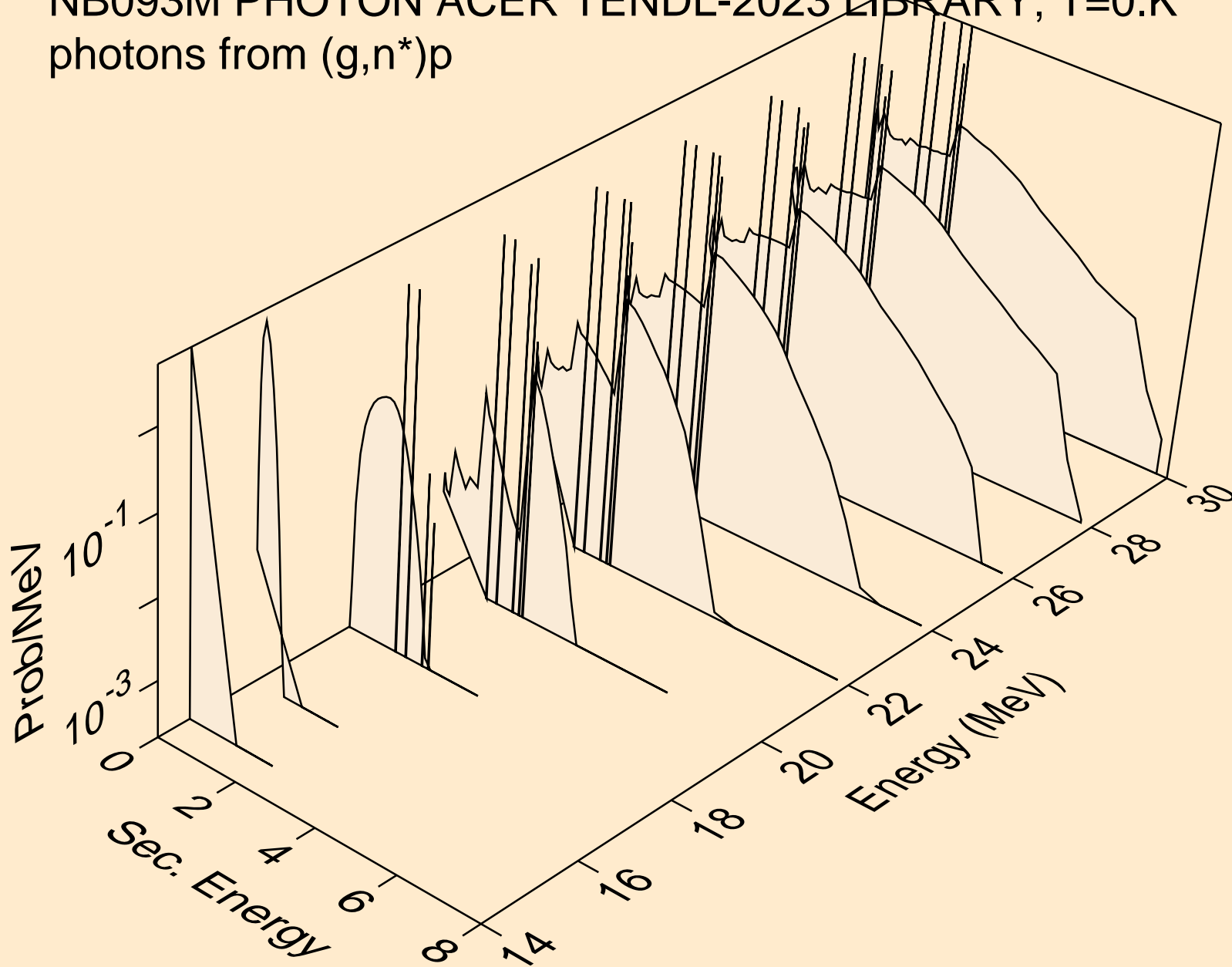

NB093M PHOTON ACER TENDL-2023 LIBRARY; T=0.K  
photons from (g,n\*)d

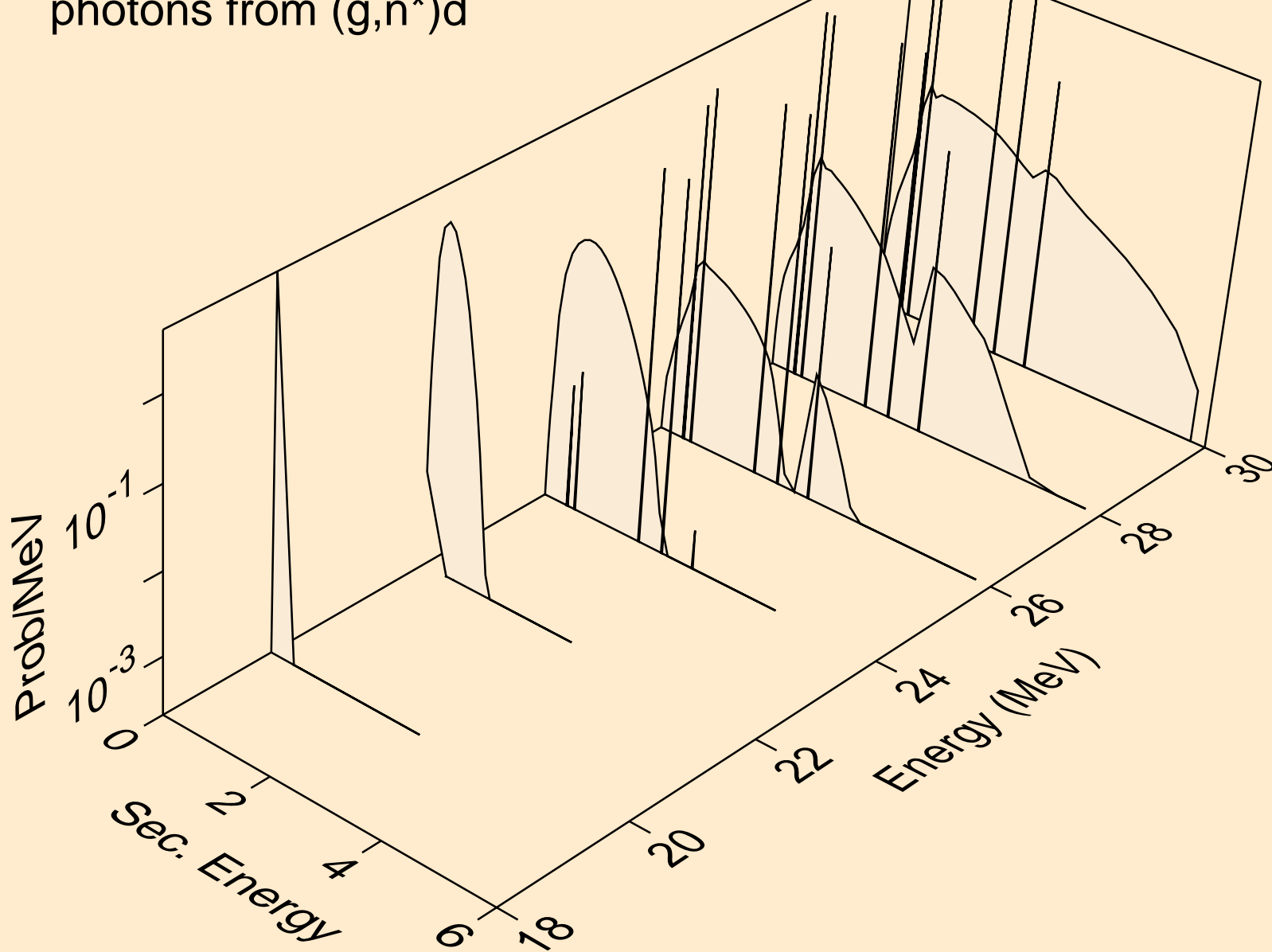

NB093M PHOTON ACER TENDL-2023 LIBRARY; T=0.K  
photons from (g,n\*)t

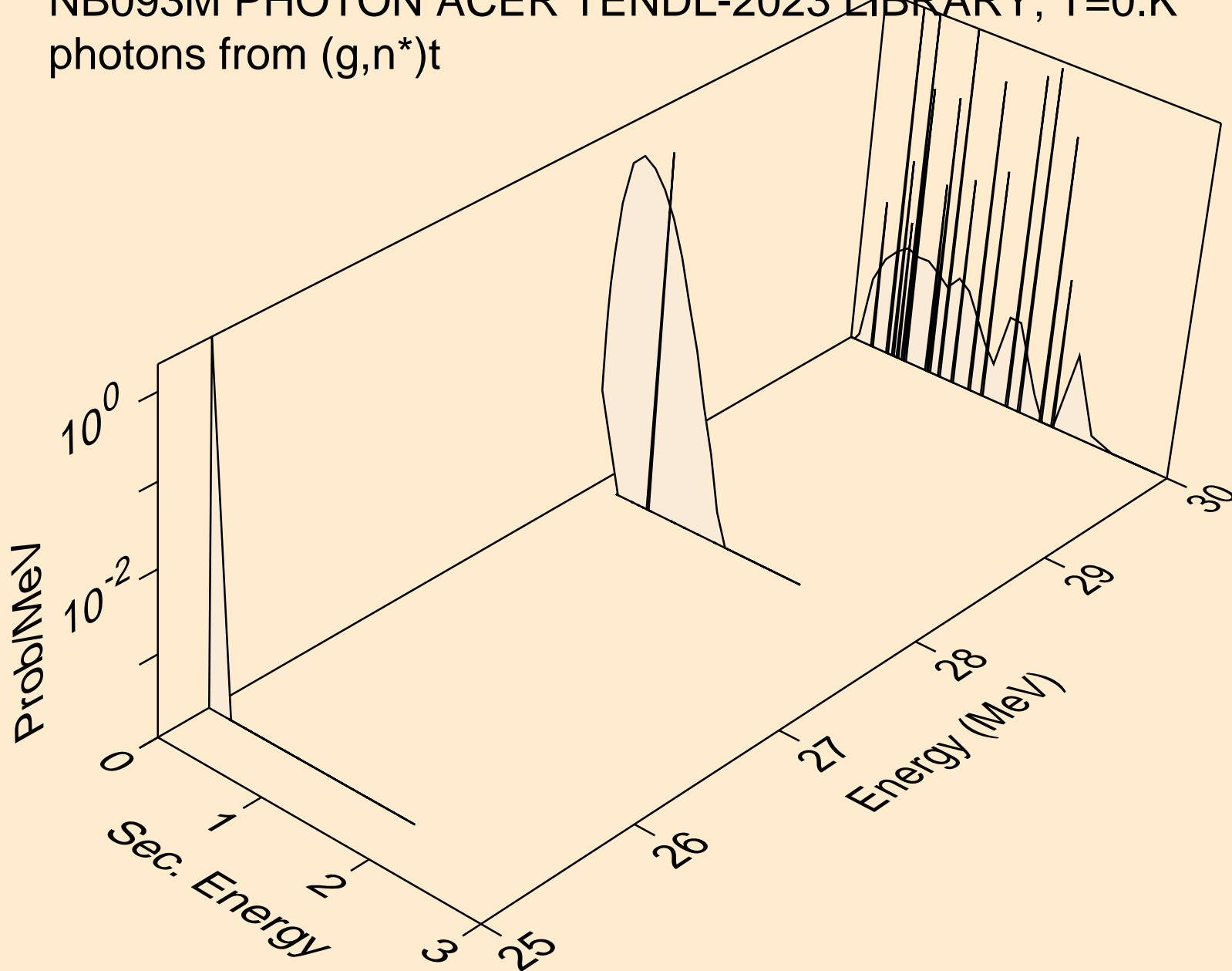



NB093M PHOTON ACER TENDL-2023 LIBRARY; T=0.K  
photons from (g,2np)

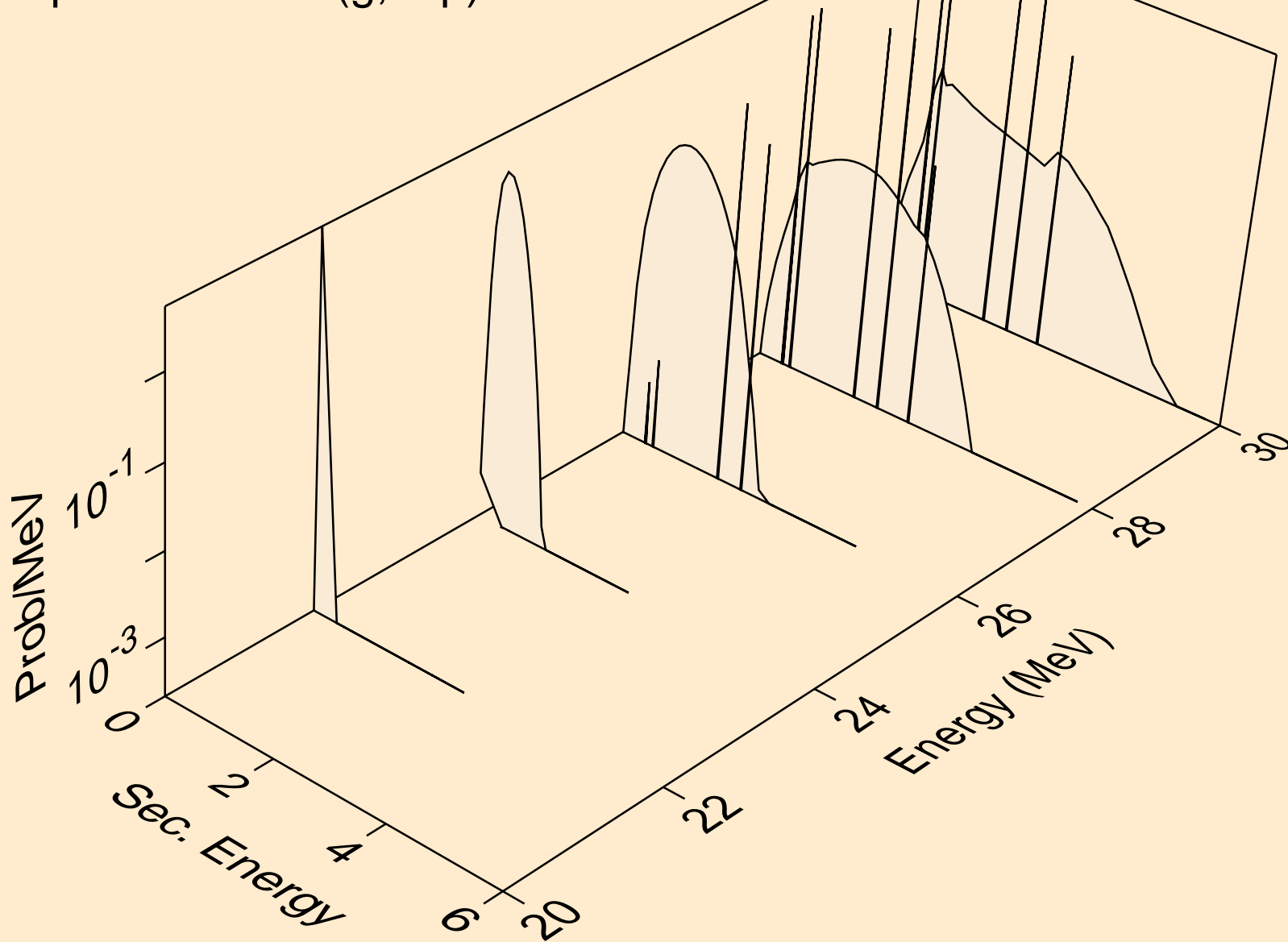

NB093M PHOTON ACER TENDL-2023 LIBRARY; T=0.K  
photons from (g,n2p)

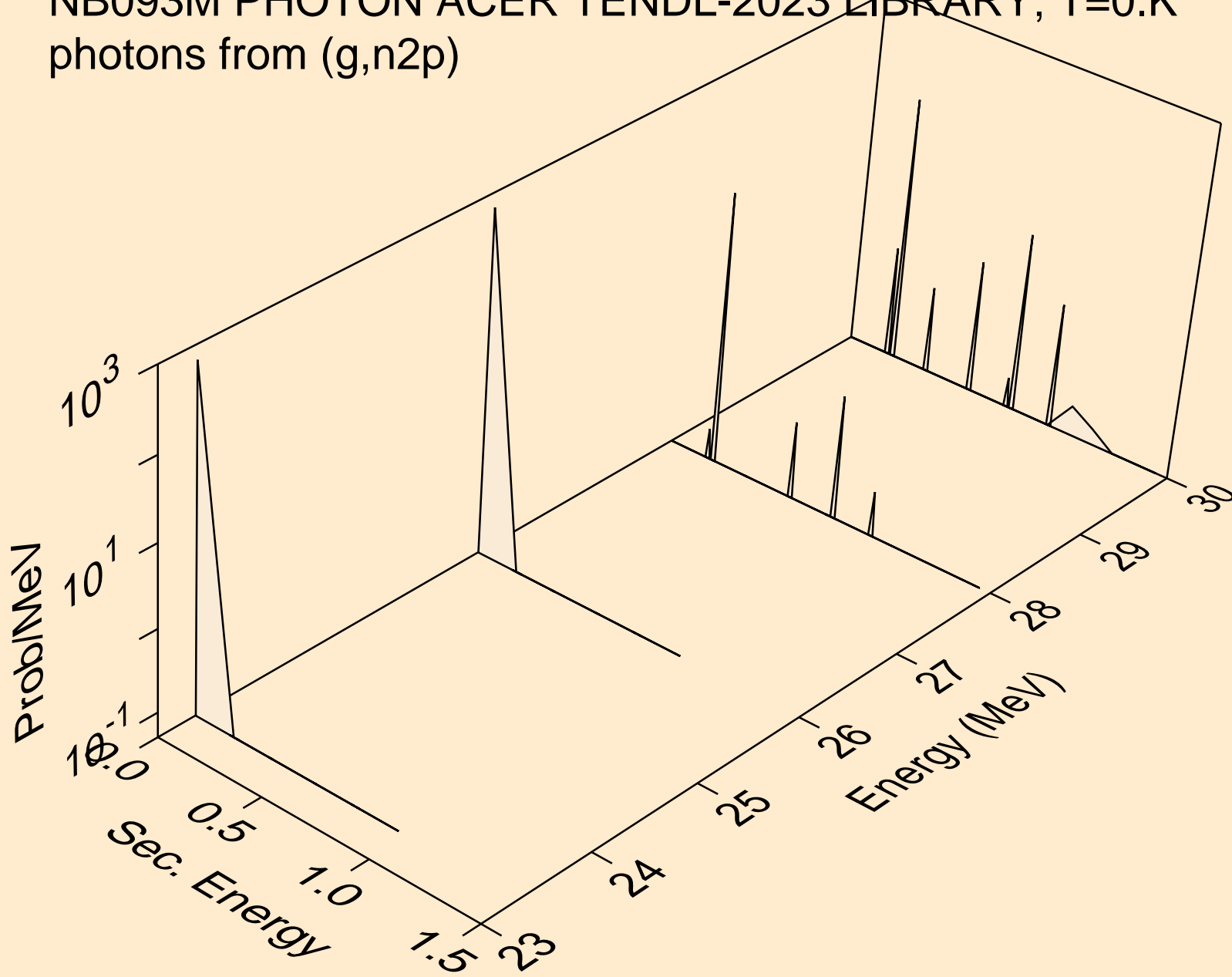

NB093M PHOTON ACER TENDL-2023 LIBRARY; T=0.K  
photons from (g,n\*c)

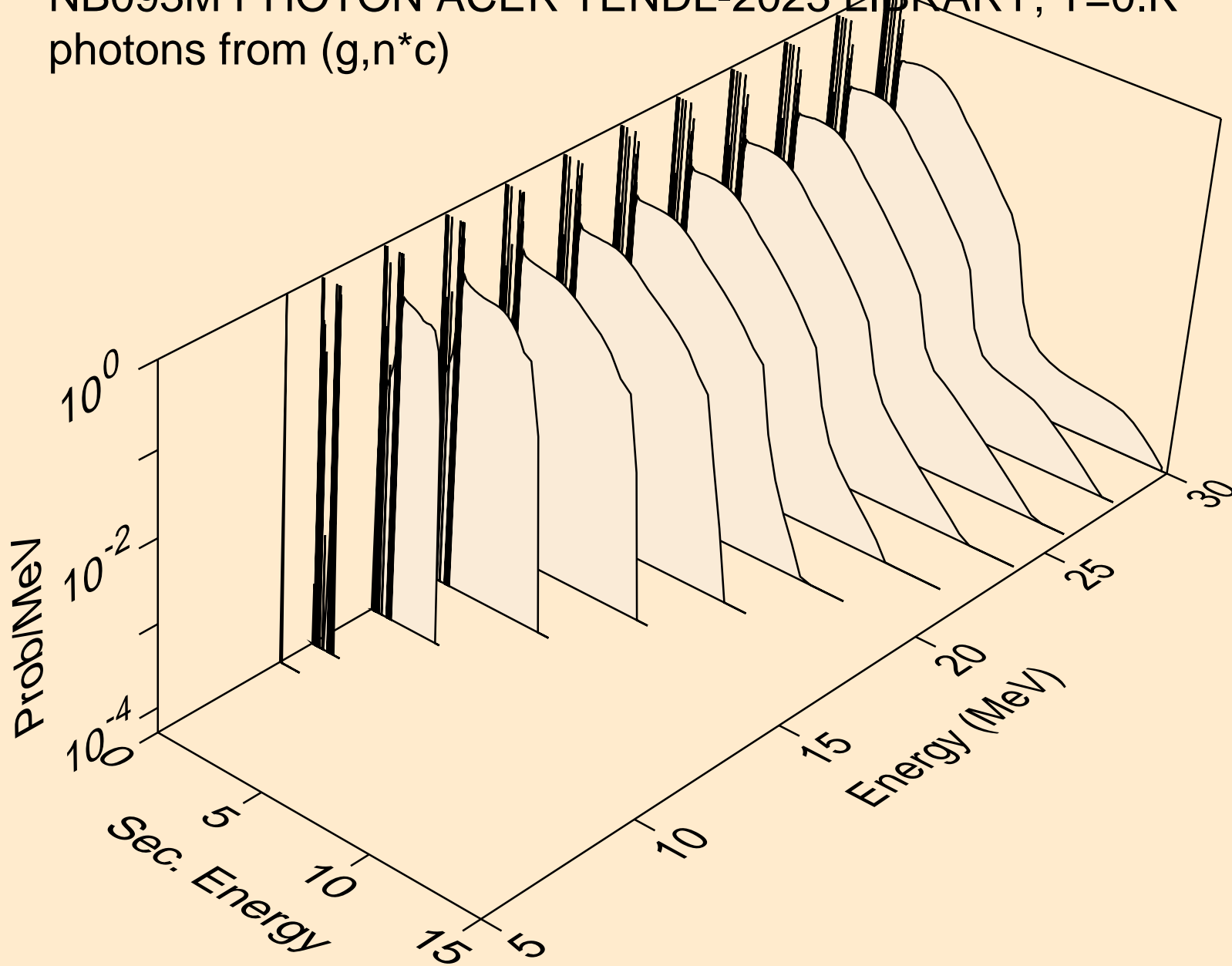

NB093M PHOTON ACER TENDL-2023 LIBRARY; T=0.K  
photons from (g,gma)

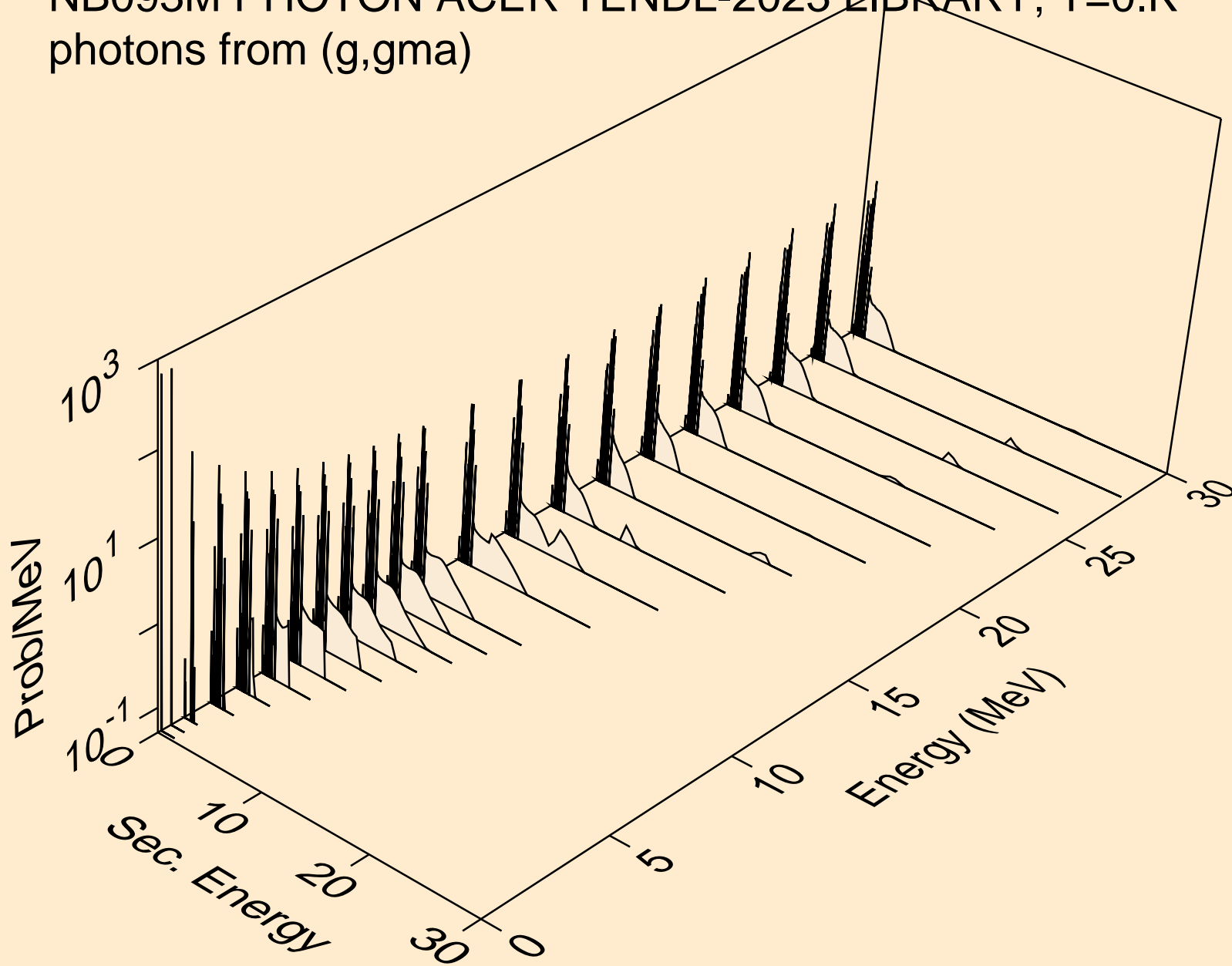

NB093M PHOTON ACER TENDL-2023 LIBRARY; T=0.K  
photons from (g,p)

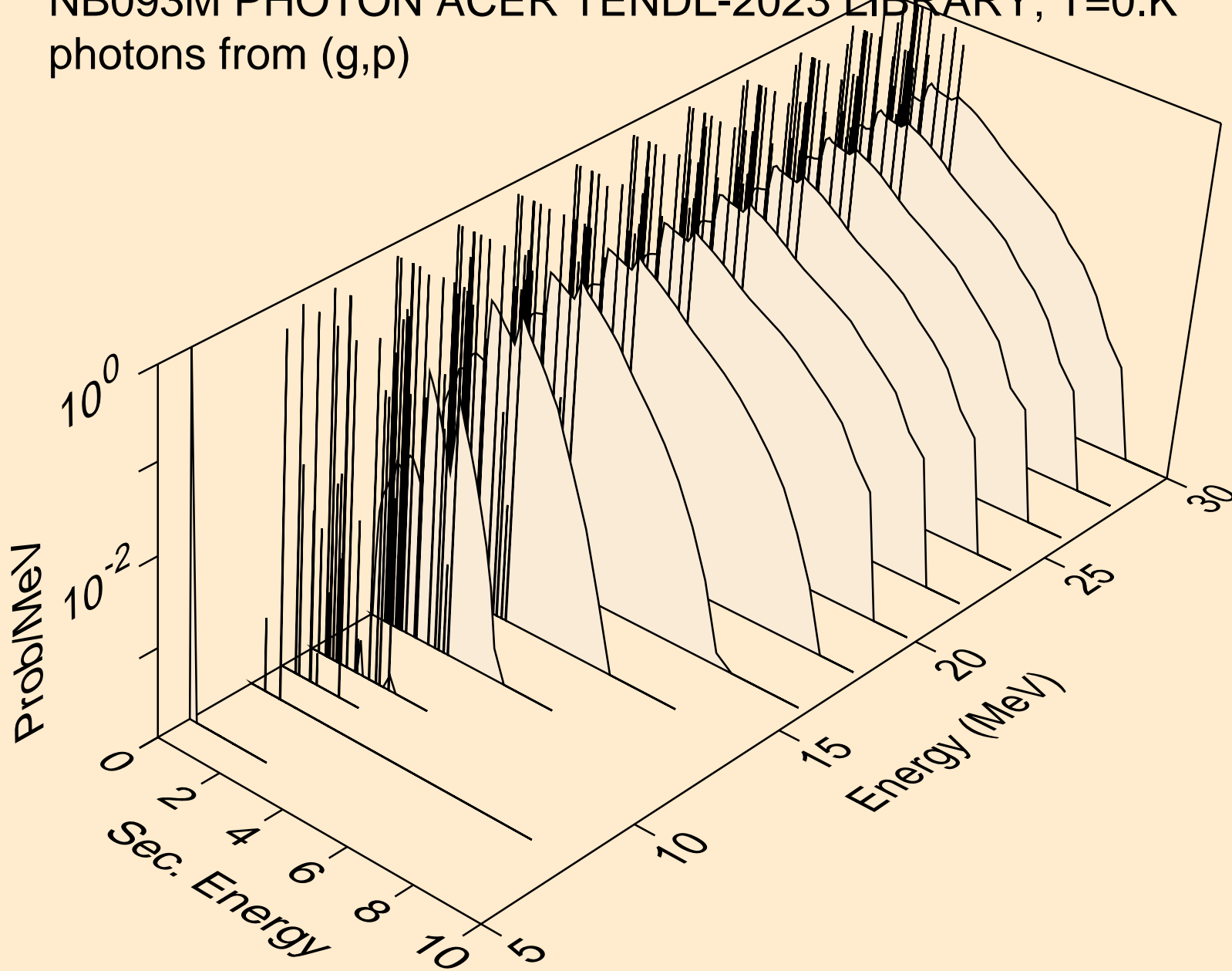

NB093M PHOTON ACER TENDL-2023 LIBRARY; T=0.K  
photons from (g,d)

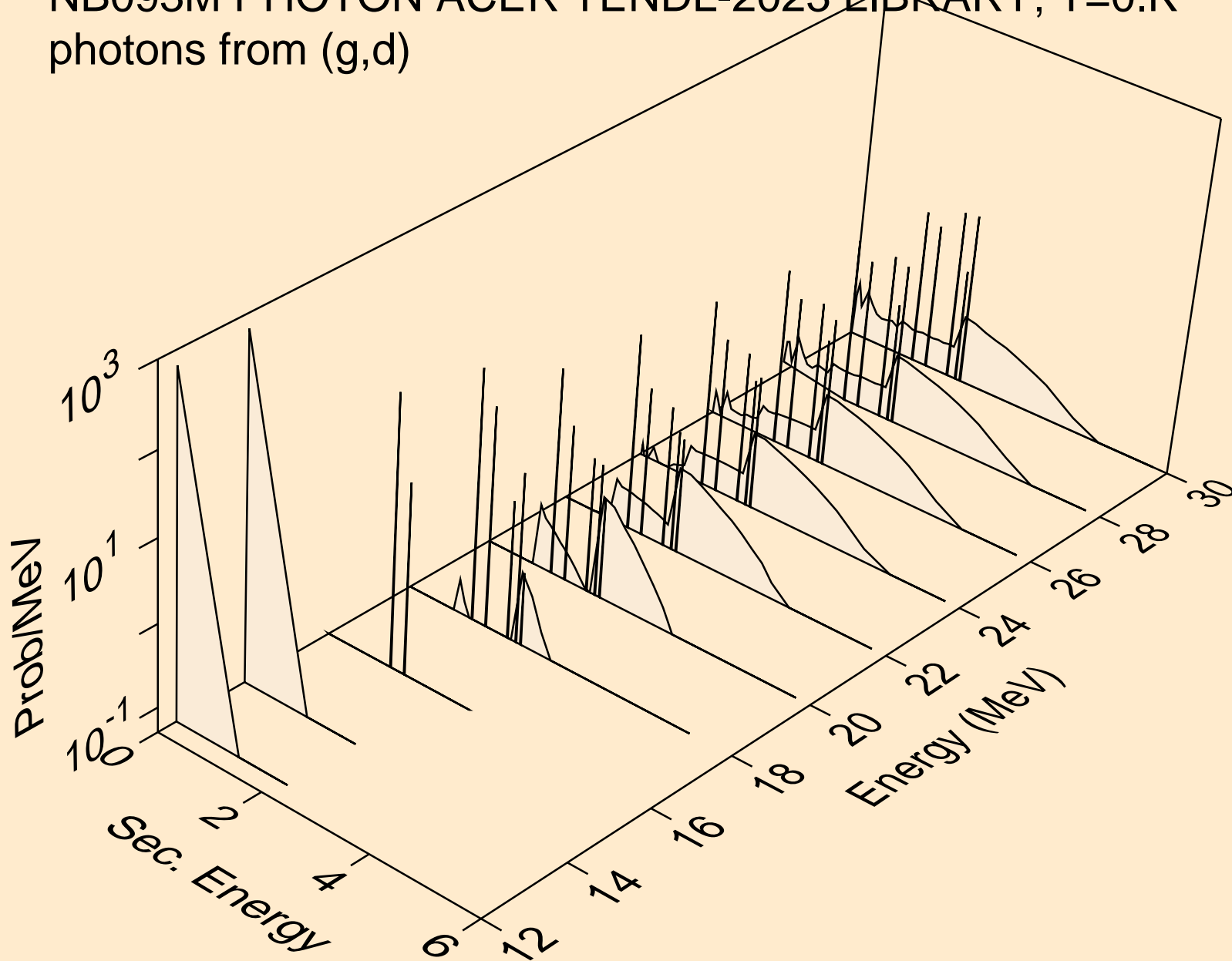

NB093M PHOTON ACER TENDL-2023 LIBRARY; T=0.K  
photons from (g,t)

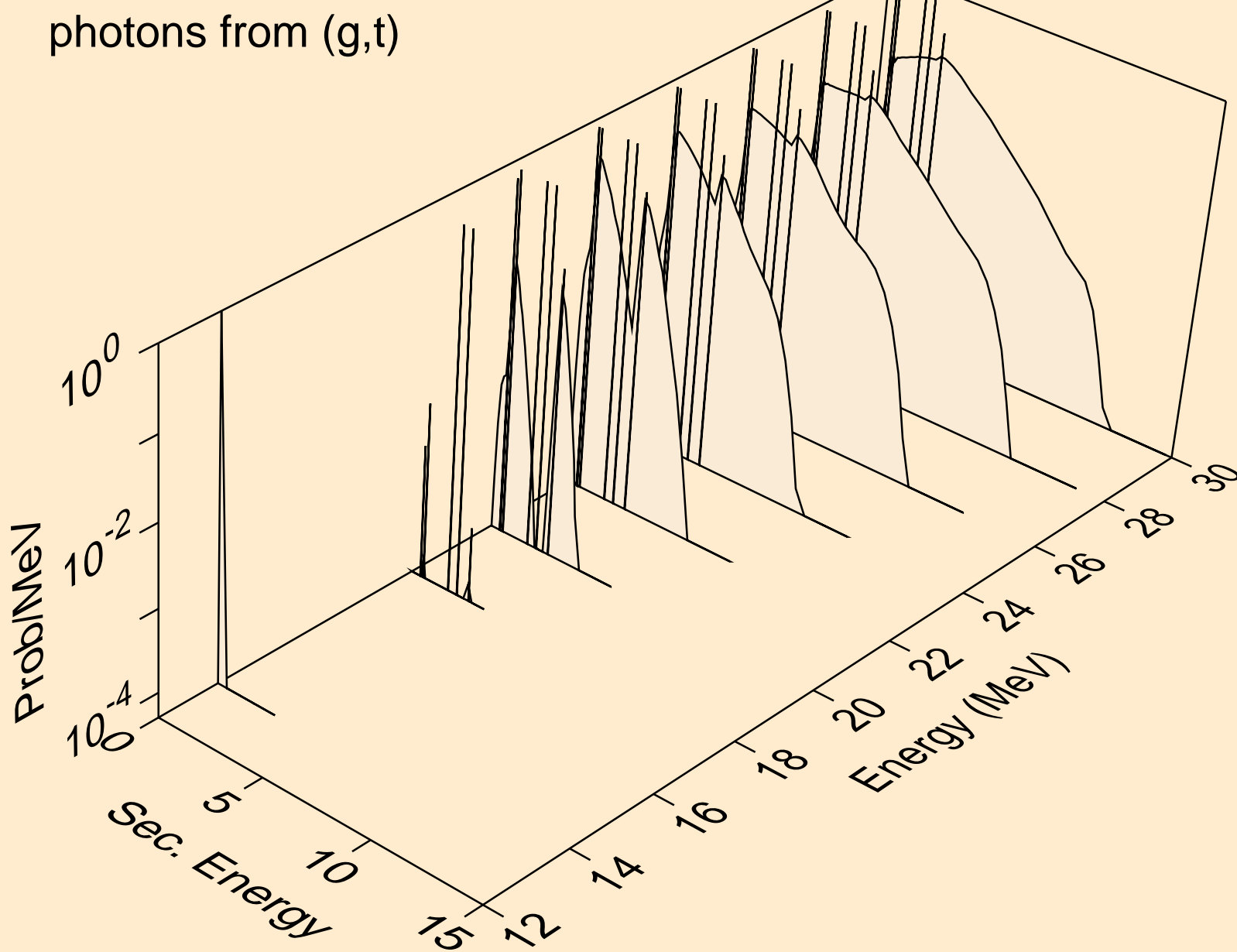

NB093M PHOTON ACER TENDL-2023 LIBRARY; T=0.K  
photons from (g,he3)

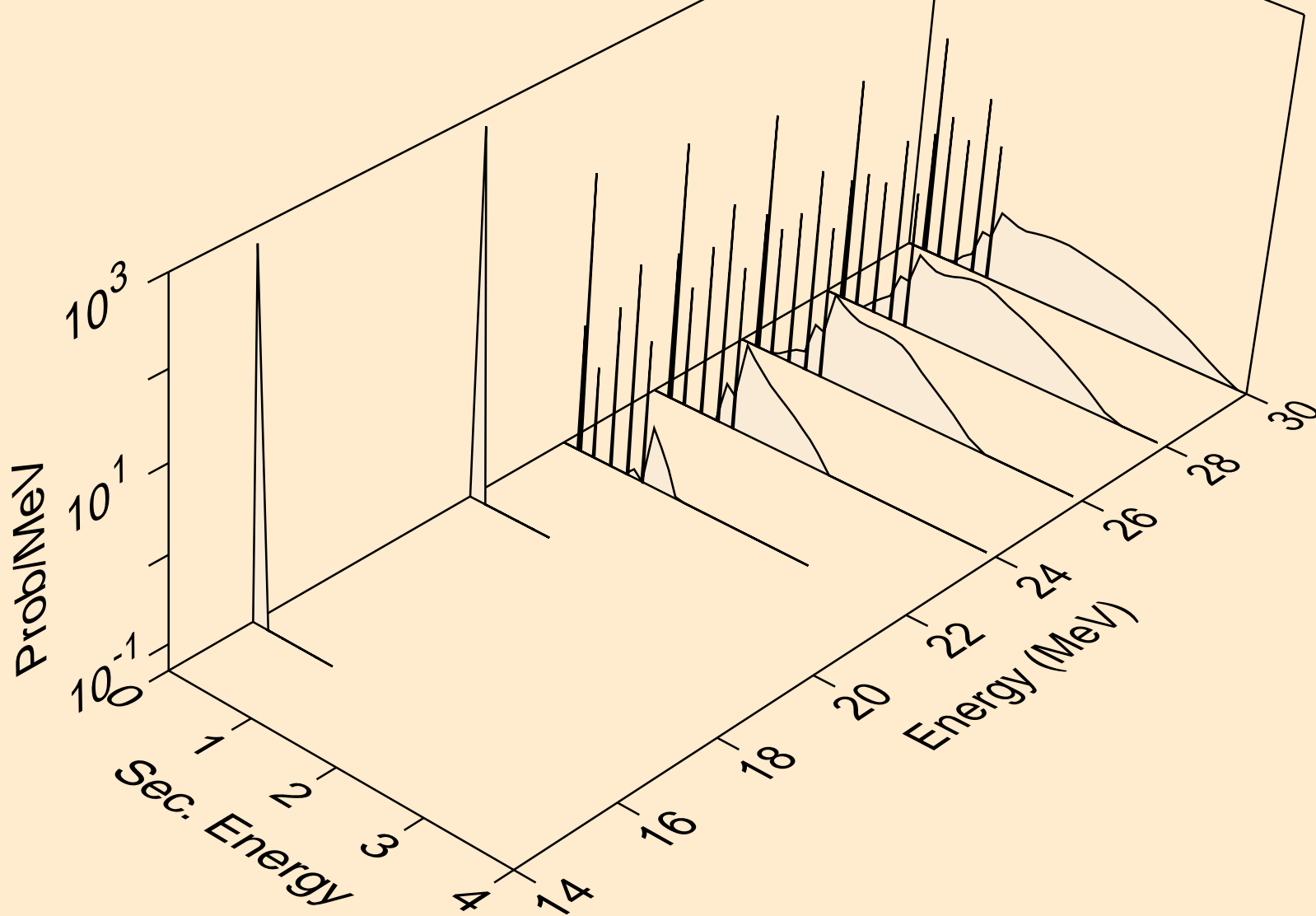



NB093M PHOTON ACER TENDL-2023 LIBRARY; T=0.K  
photons from (g,a)

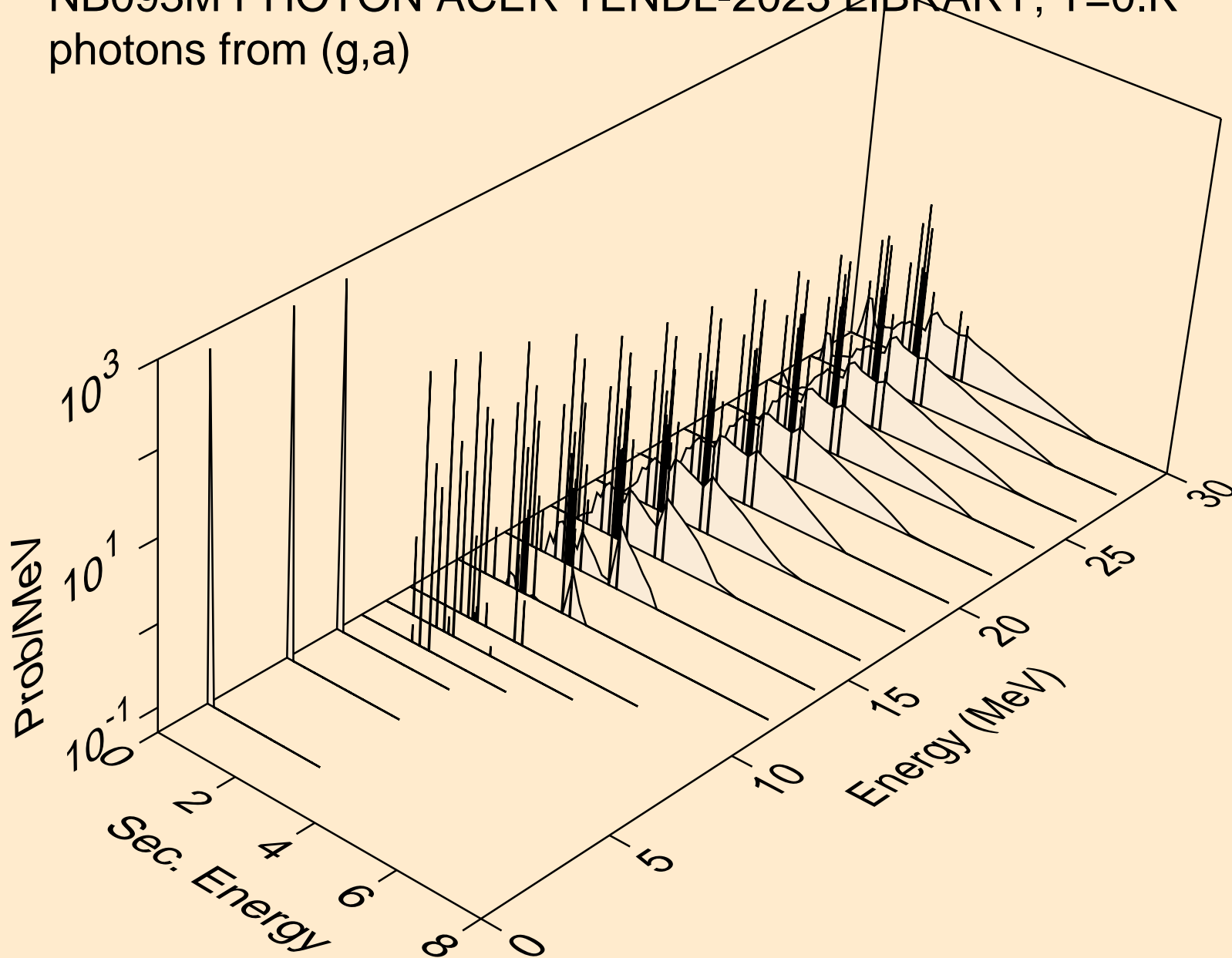

NB093M PHOTON ACER TENDL-2023 LIBRARY; T=0.K  
photons from (g,2a)

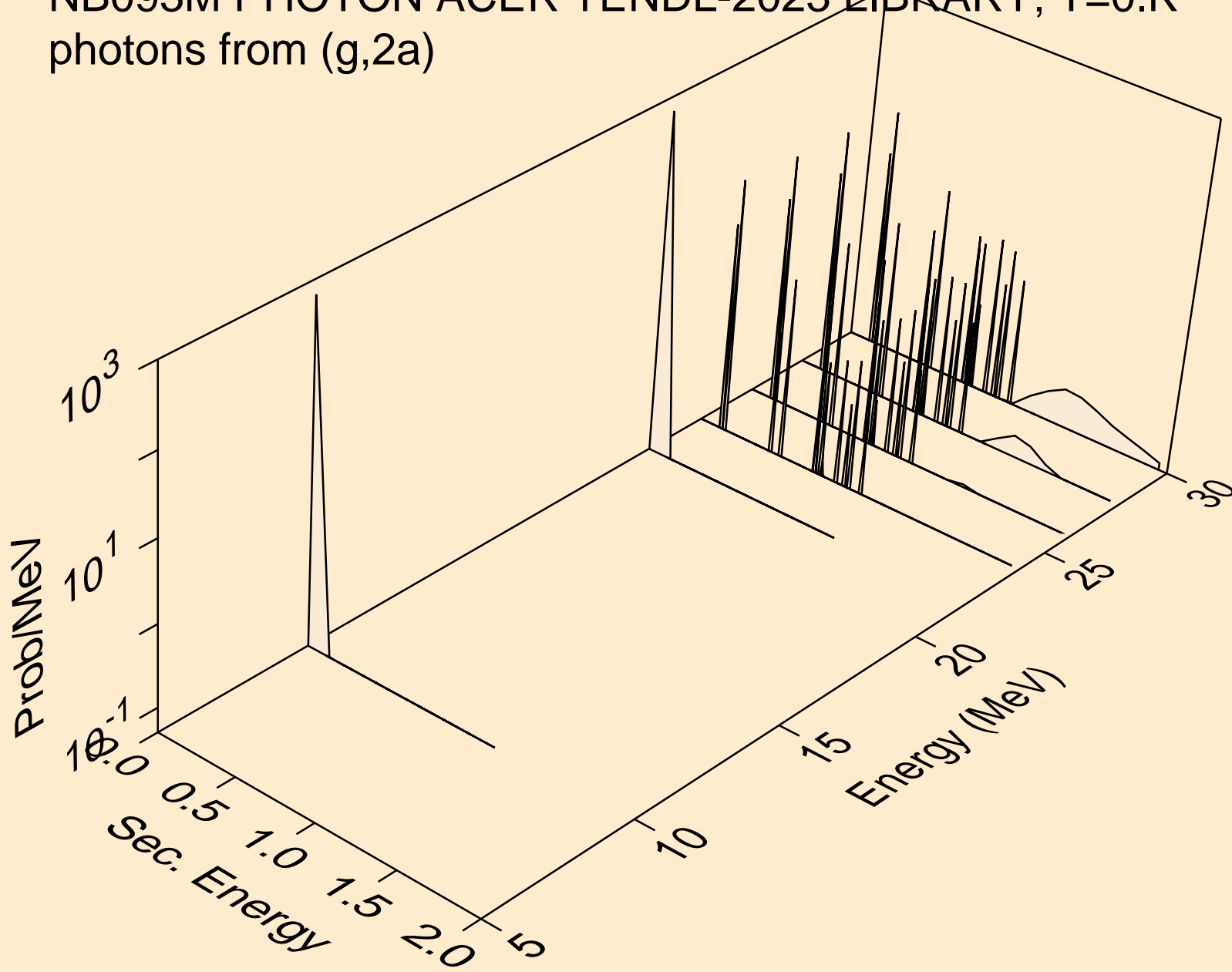

NB093M PHOTON ACER TENDL-2023 LIBRARY; T=0.K  
photons from (g,2p)

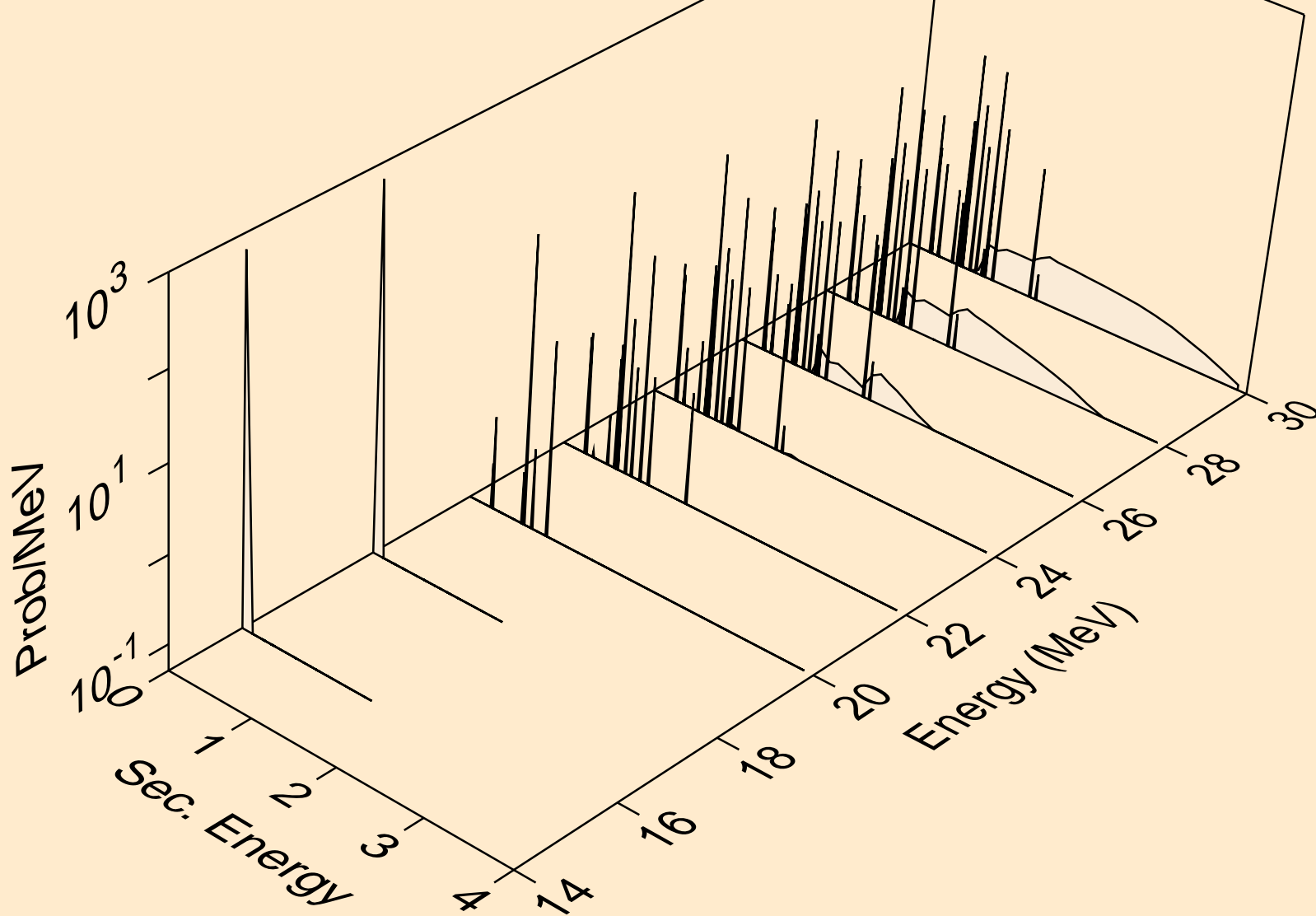

NB093M PHOTON ACER TENDL-2023 LIBRARY; T=0.K  
photons from (g,pa)

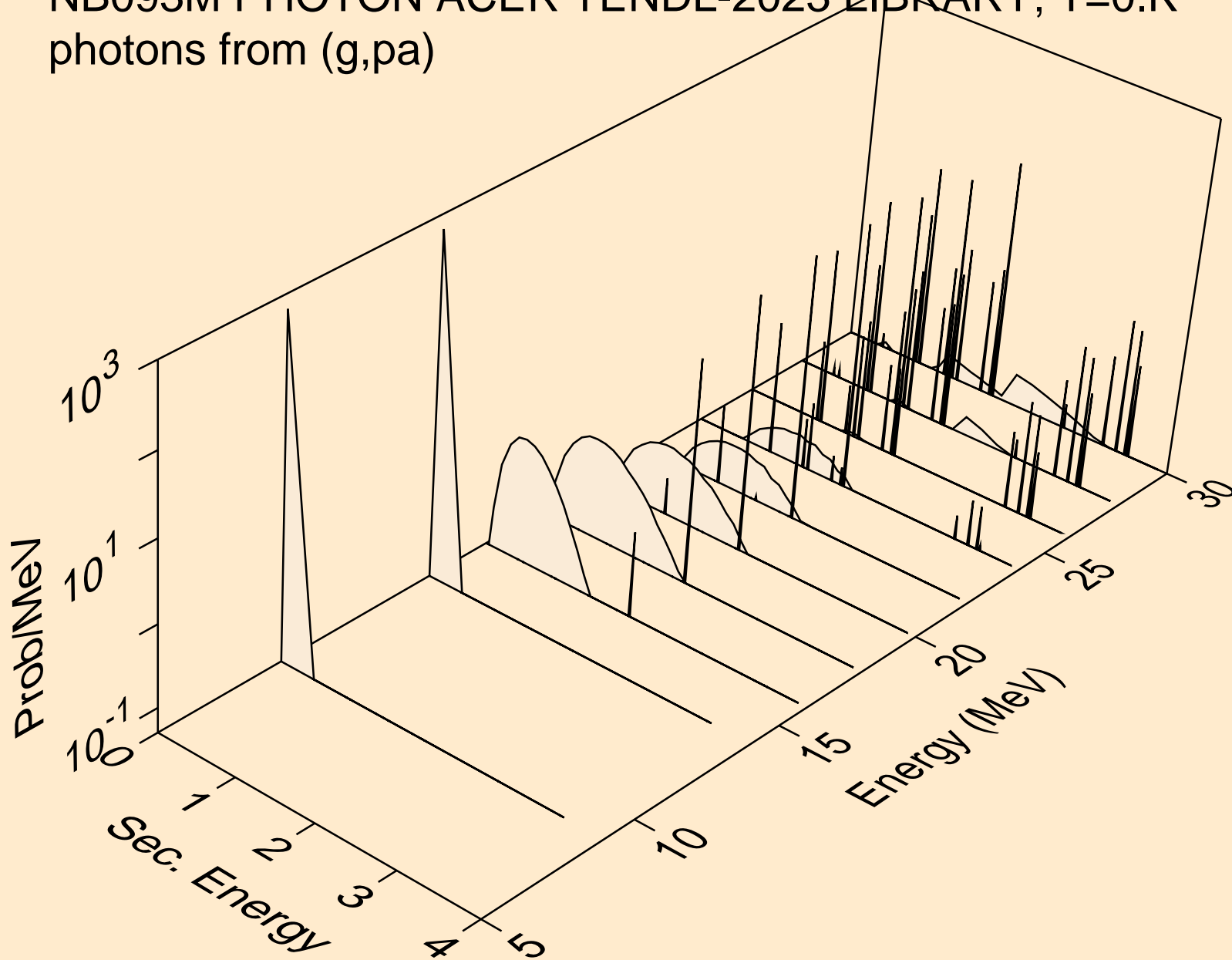

NB093M PHOTON ACER TENDL-2023 LIBRARY; T=0.K  
photons from (g,pd)

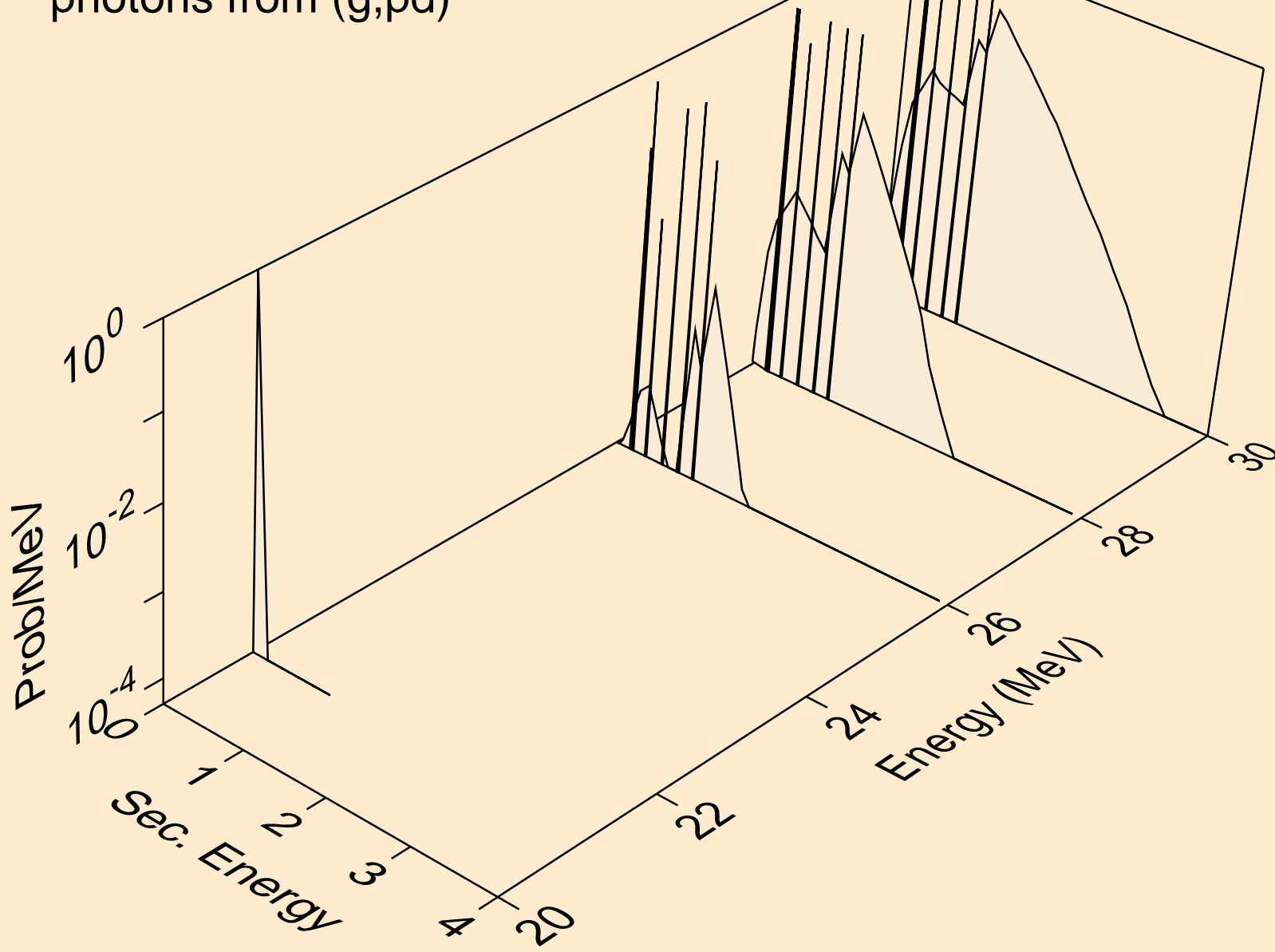

NB093M PHOTON ACER TENDL-2023 LIBRARY; T=0.K  
photons from (g,pt)

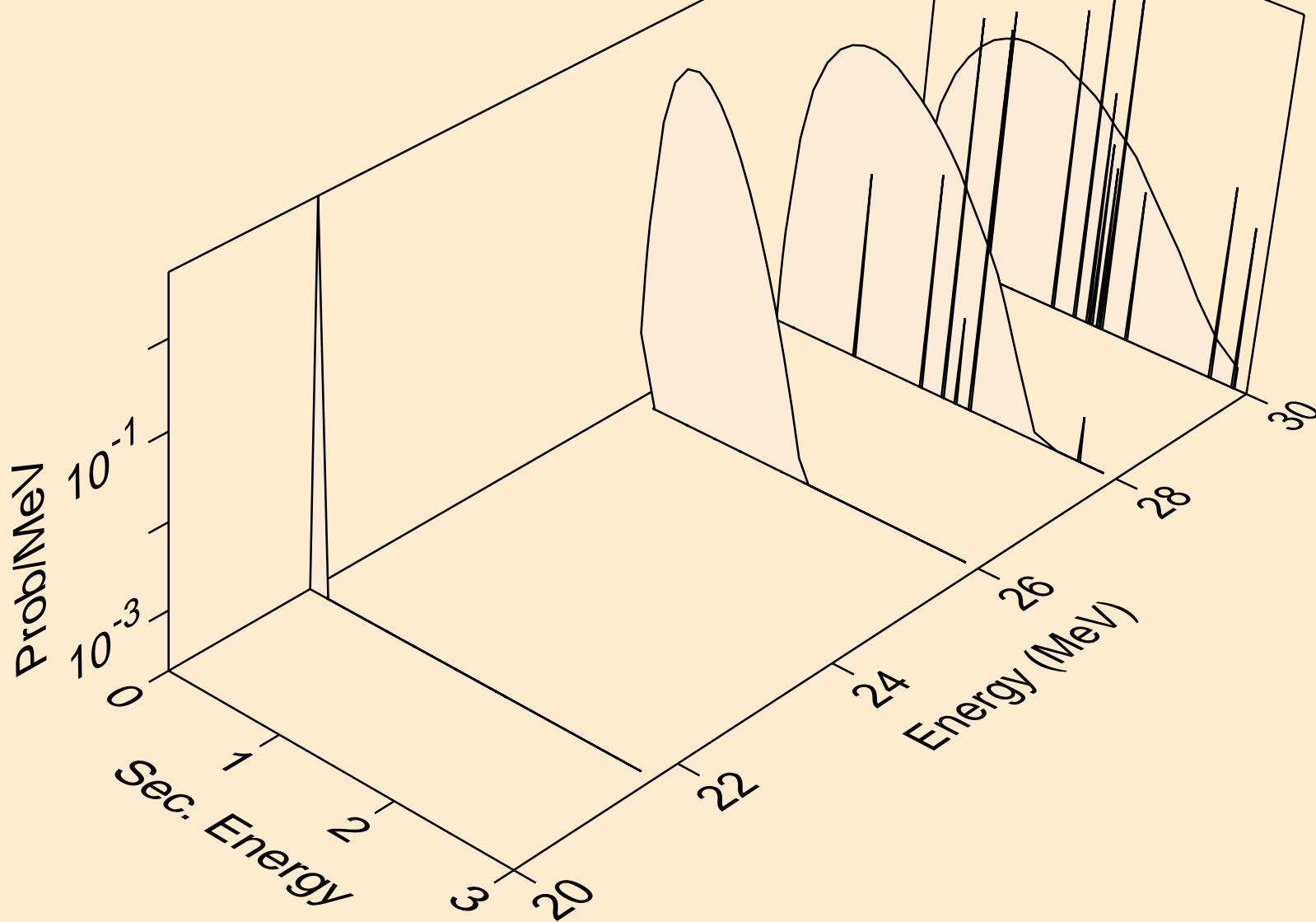

NB093M PHOTON ACER TENDL-2023 LIBRARY; T=0.K  
protons from (g,x)

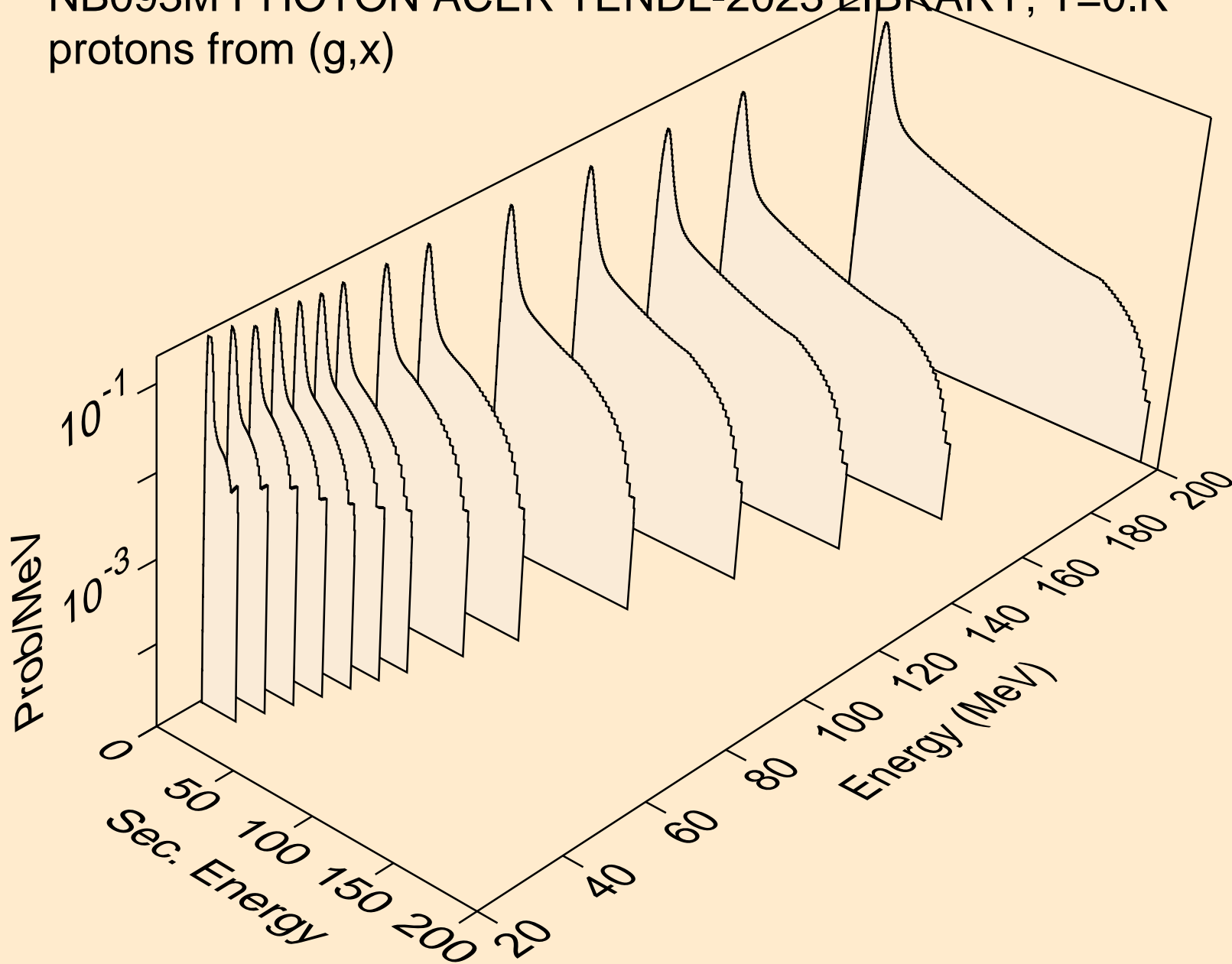

NB093M PHOTON ACER TENDL-2023 LIBRARY; T=0.K  
protons from (g,n\*)p

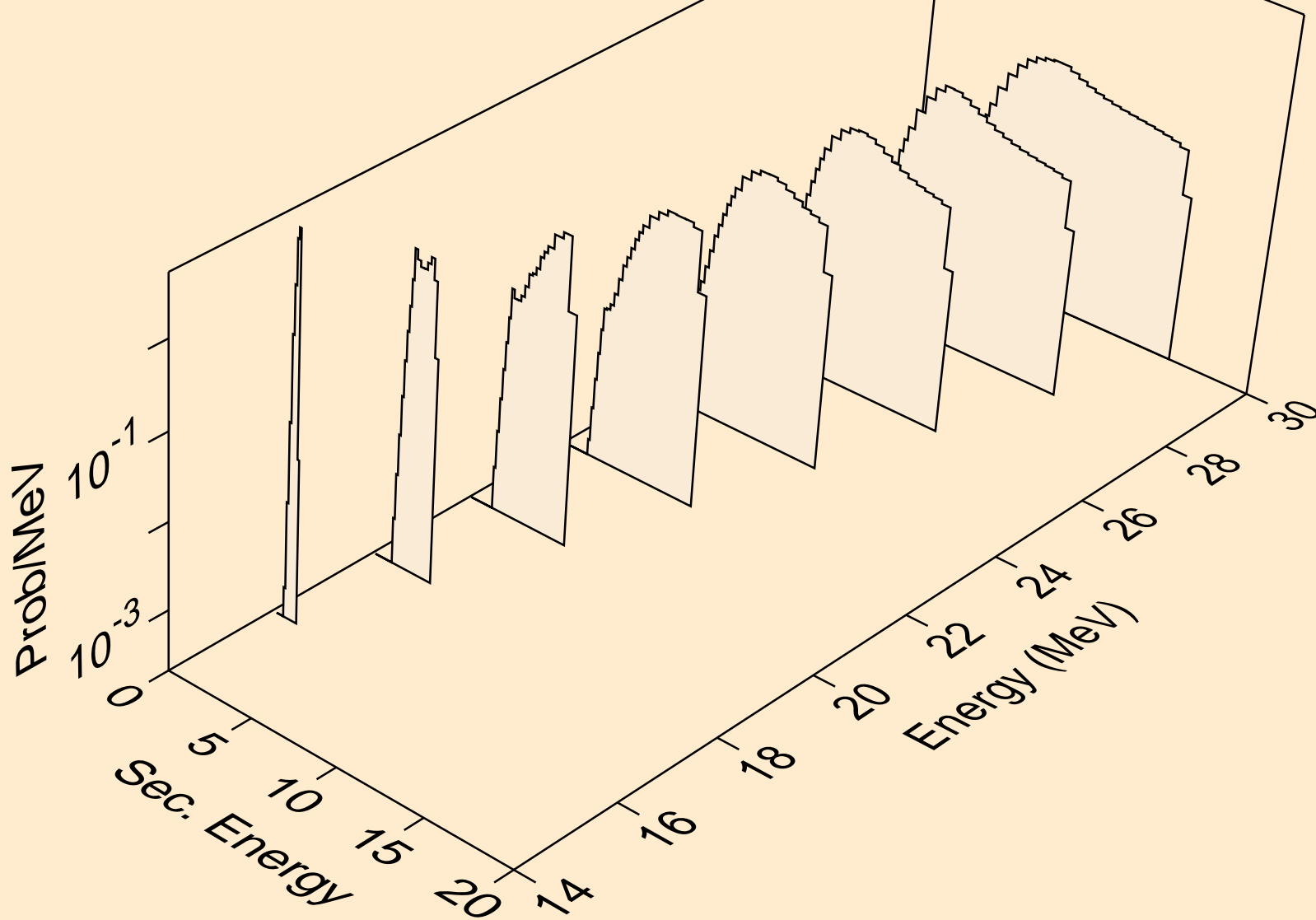



NB093M PHOTON ACER TENDL-2023 LIBRARY; T=0.K  
protons from (g,2np)

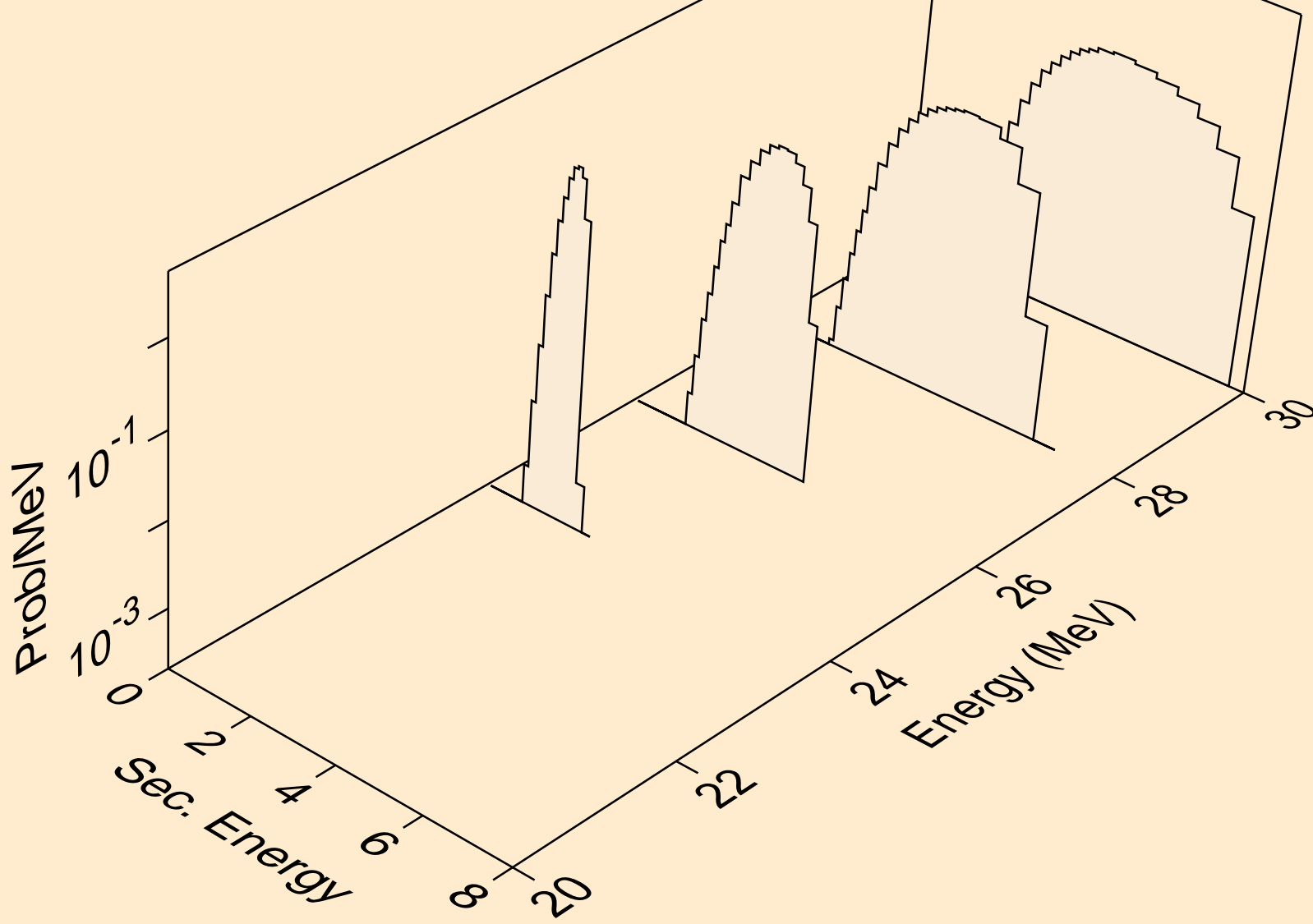

NB093M PHOTON ACER TENDL-2023 LIBRARY; T=0.K  
protons from (g,n2p)

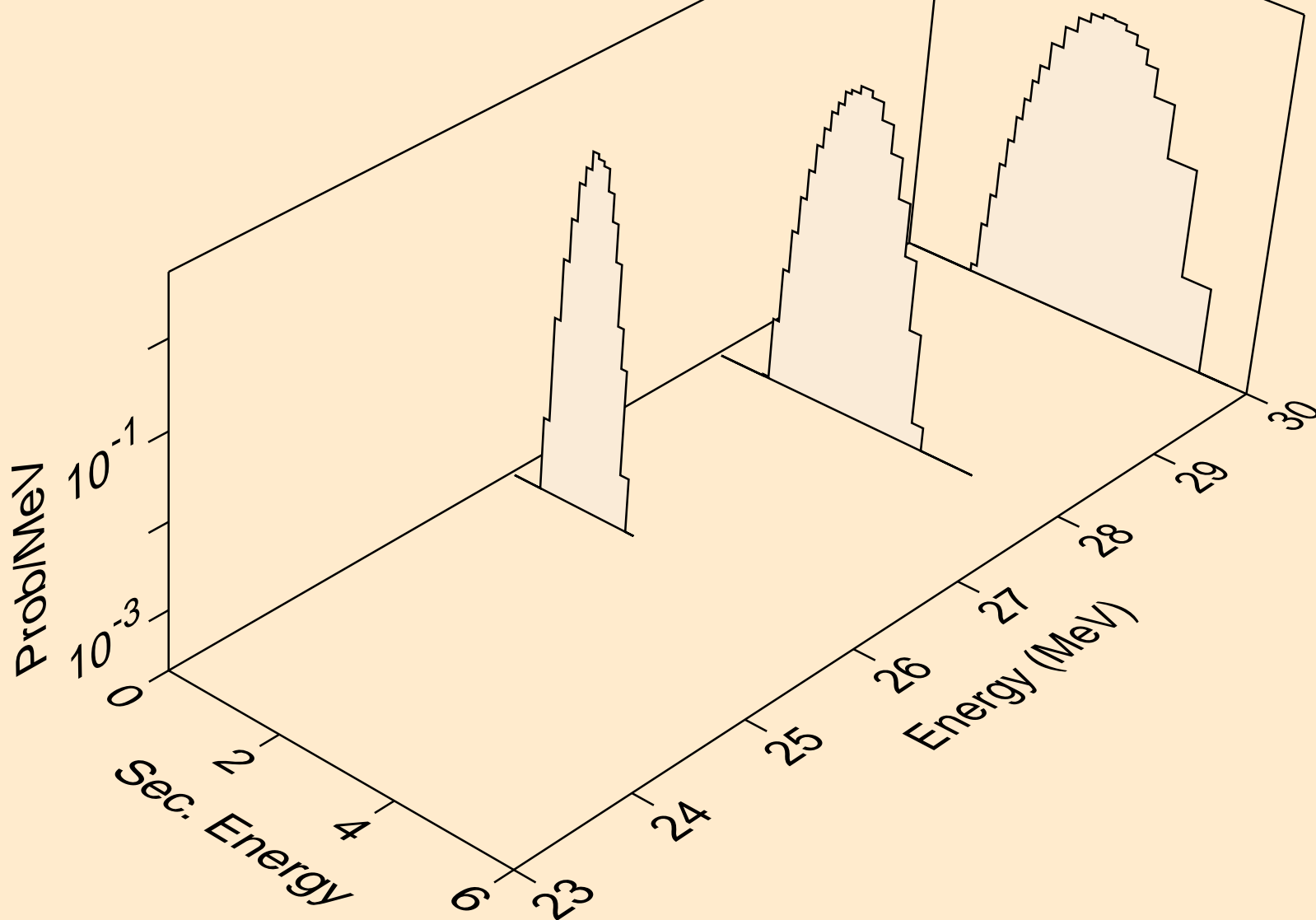

NB093M PHOTON ACER TENDL-2023 LIBRARY; T=0.K  
protons from (g,p)

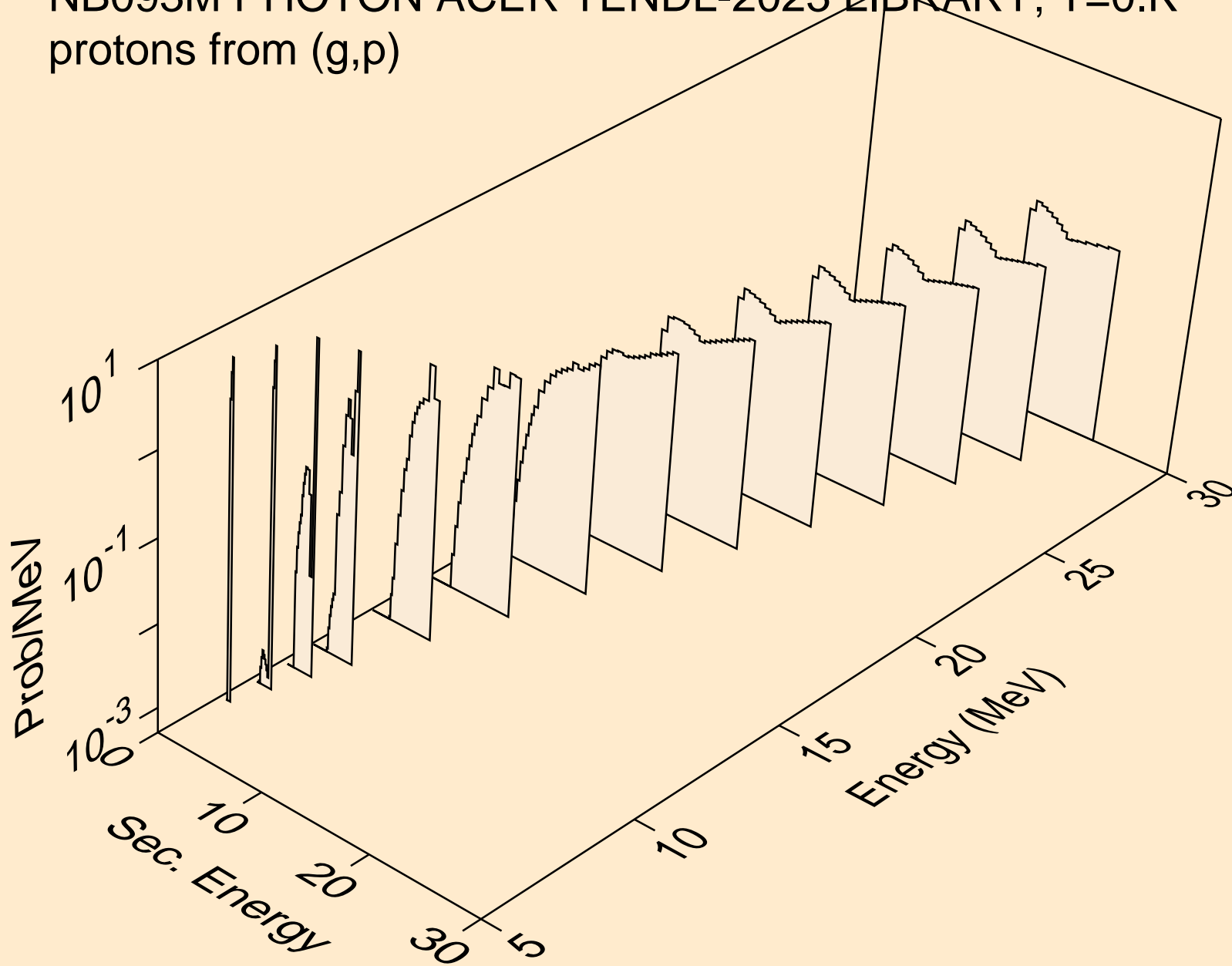

NB093M PHOTON ACER TENDL-2023 LIBRARY; T=0.K  
protons from (g,2p)

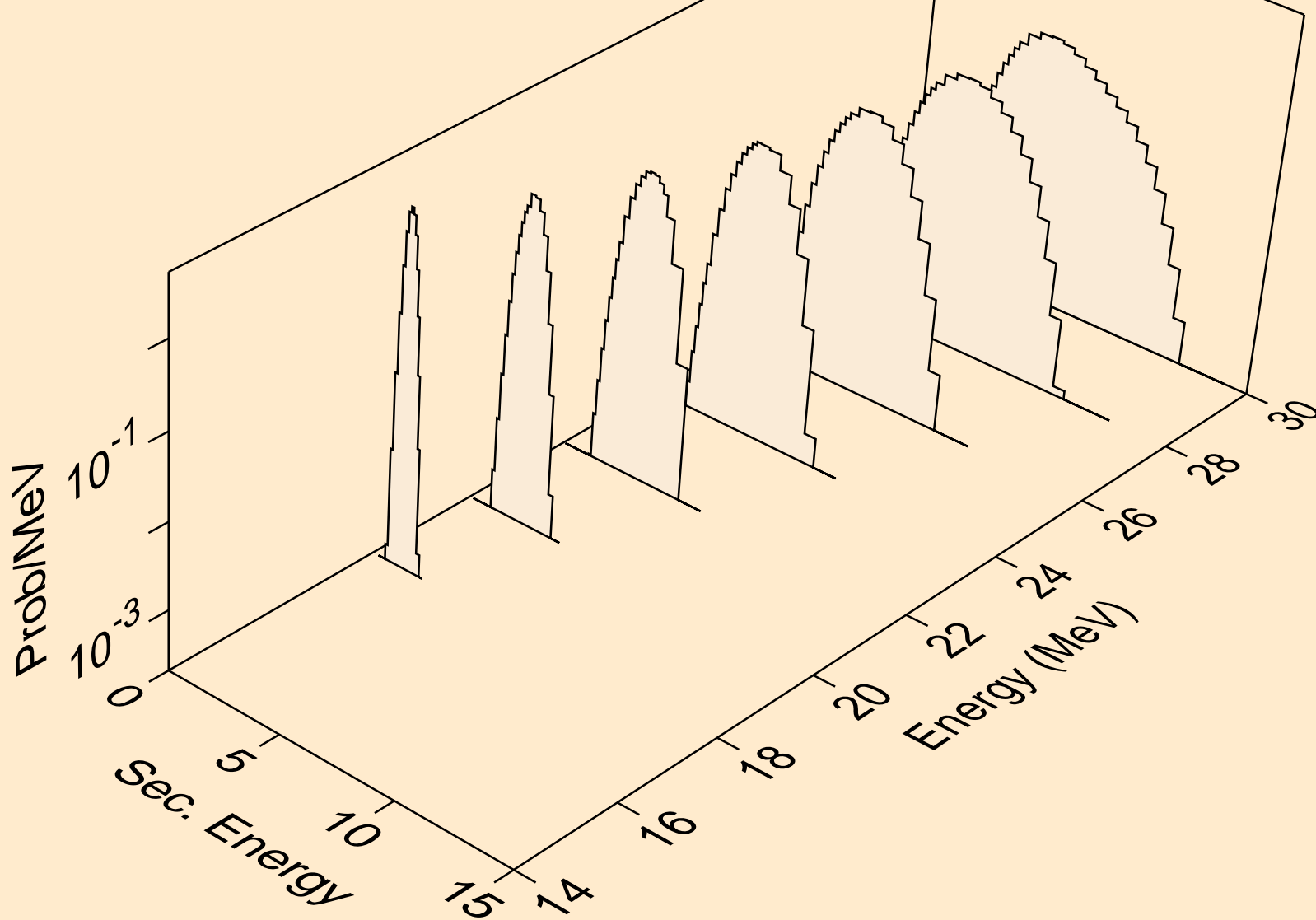

NB093M PHOTON ACER TENDL-2023 LIBRARY; T=0.K  
protons from (g,pa)

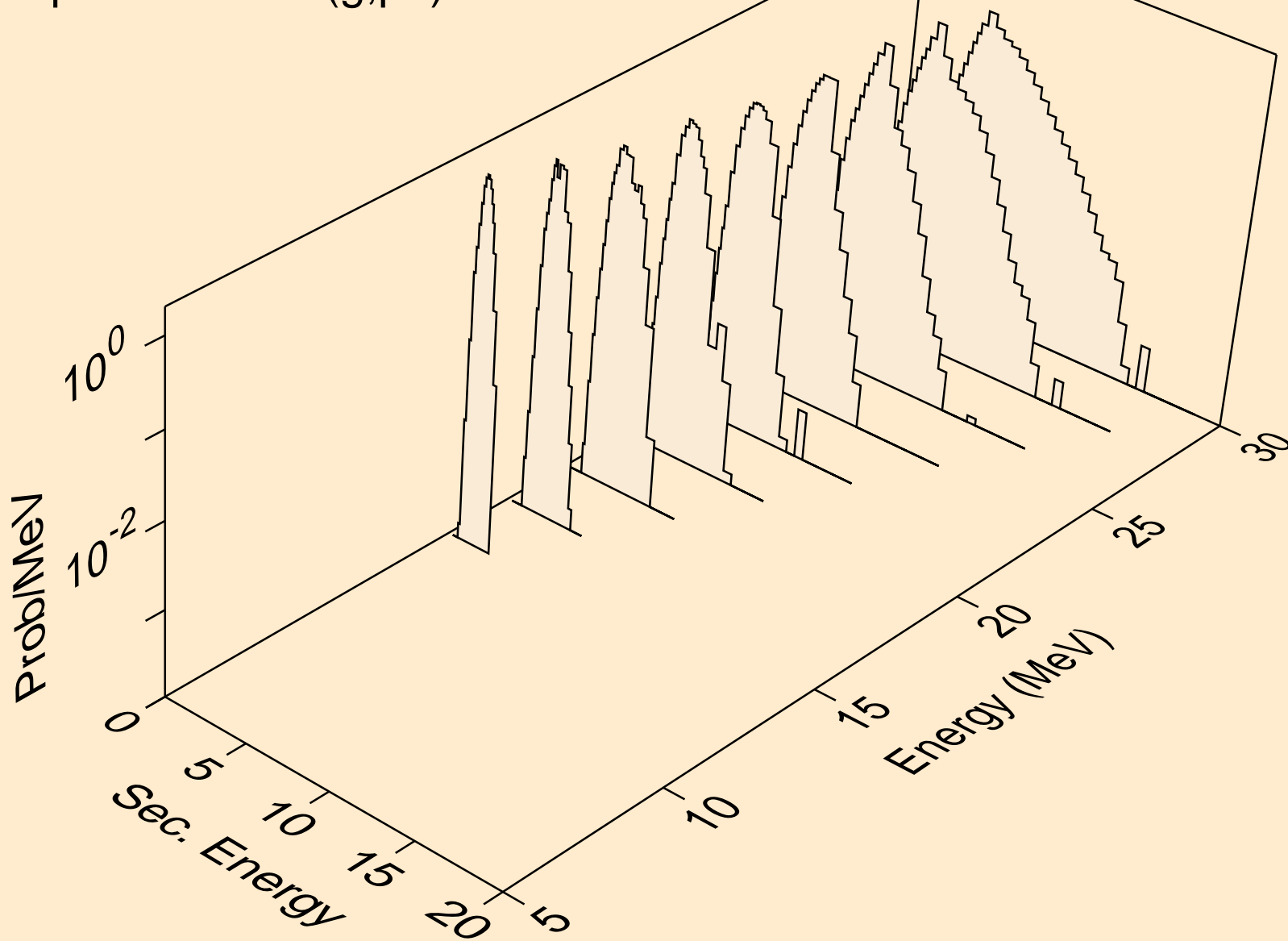

NB093M PHOTON ACER TENDL-2023 LIBRARY; T=0.K  
protons from (g,pd)

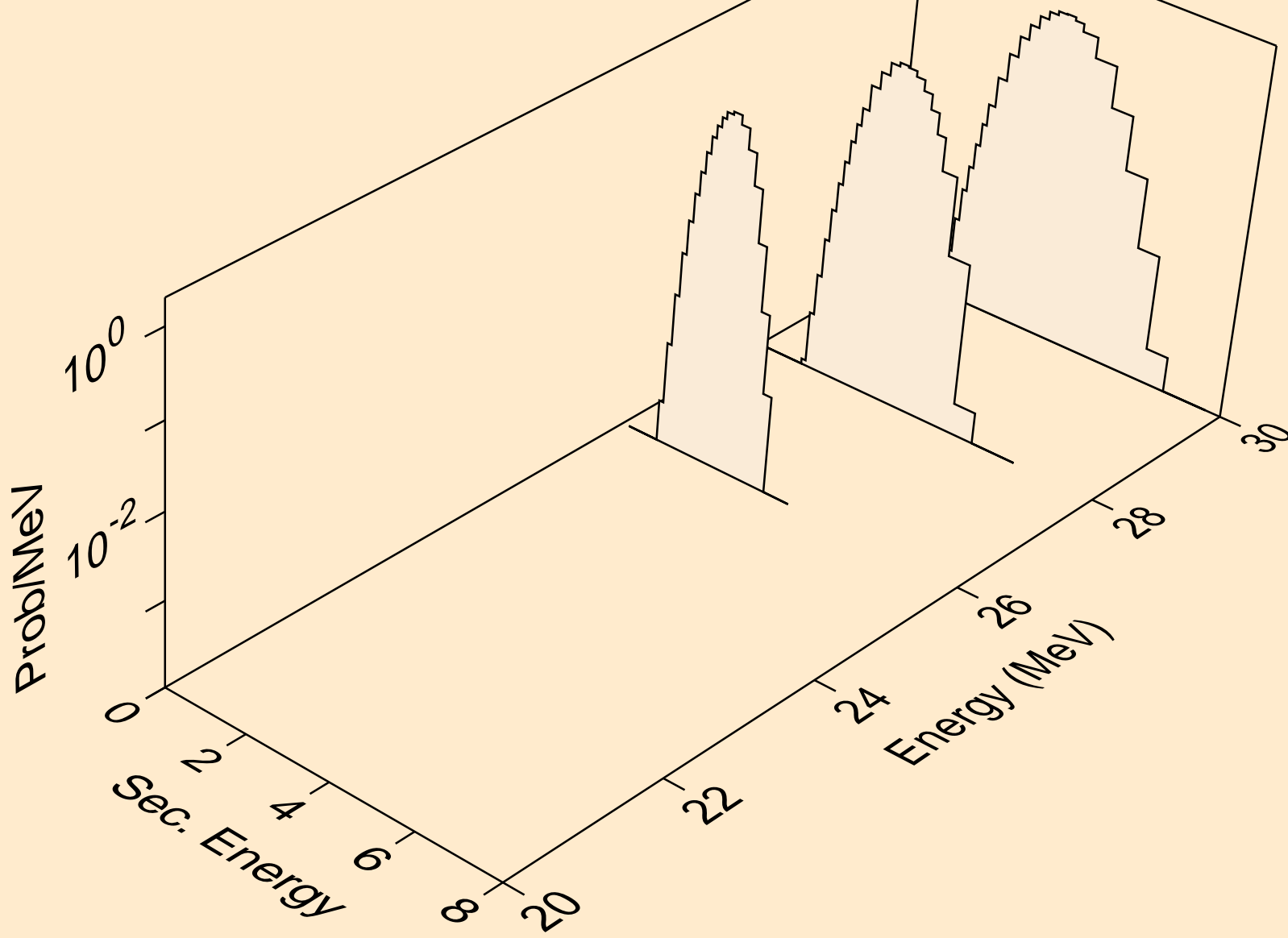

NB093M PHOTON ACER TENDL-2023 LIBRARY; T=0.K  
protons from (g,pt)

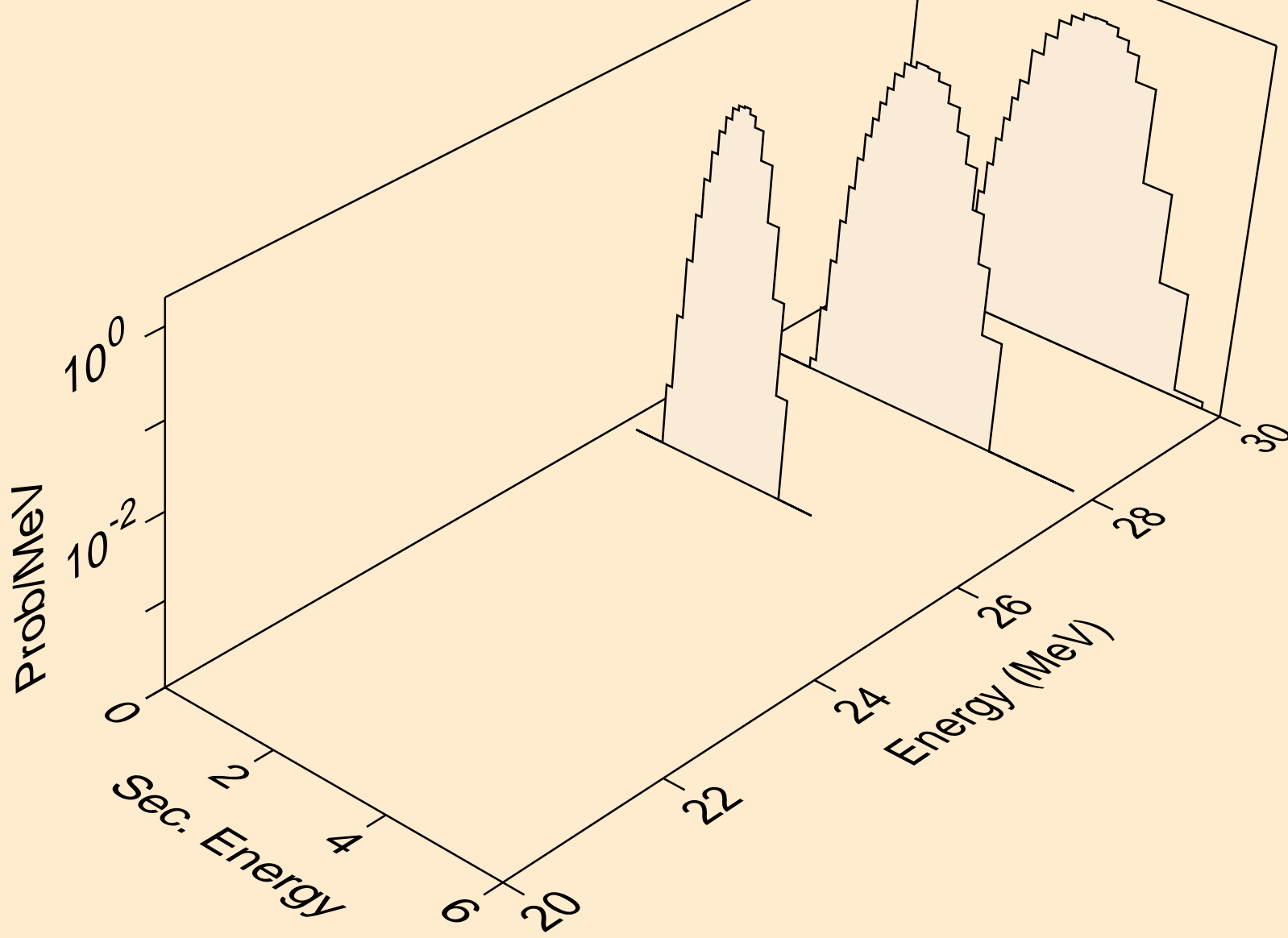

NB093M PHOTON ACER TENDL-2023 LIBRARY; T=0.K  
deuterons from (g,x)

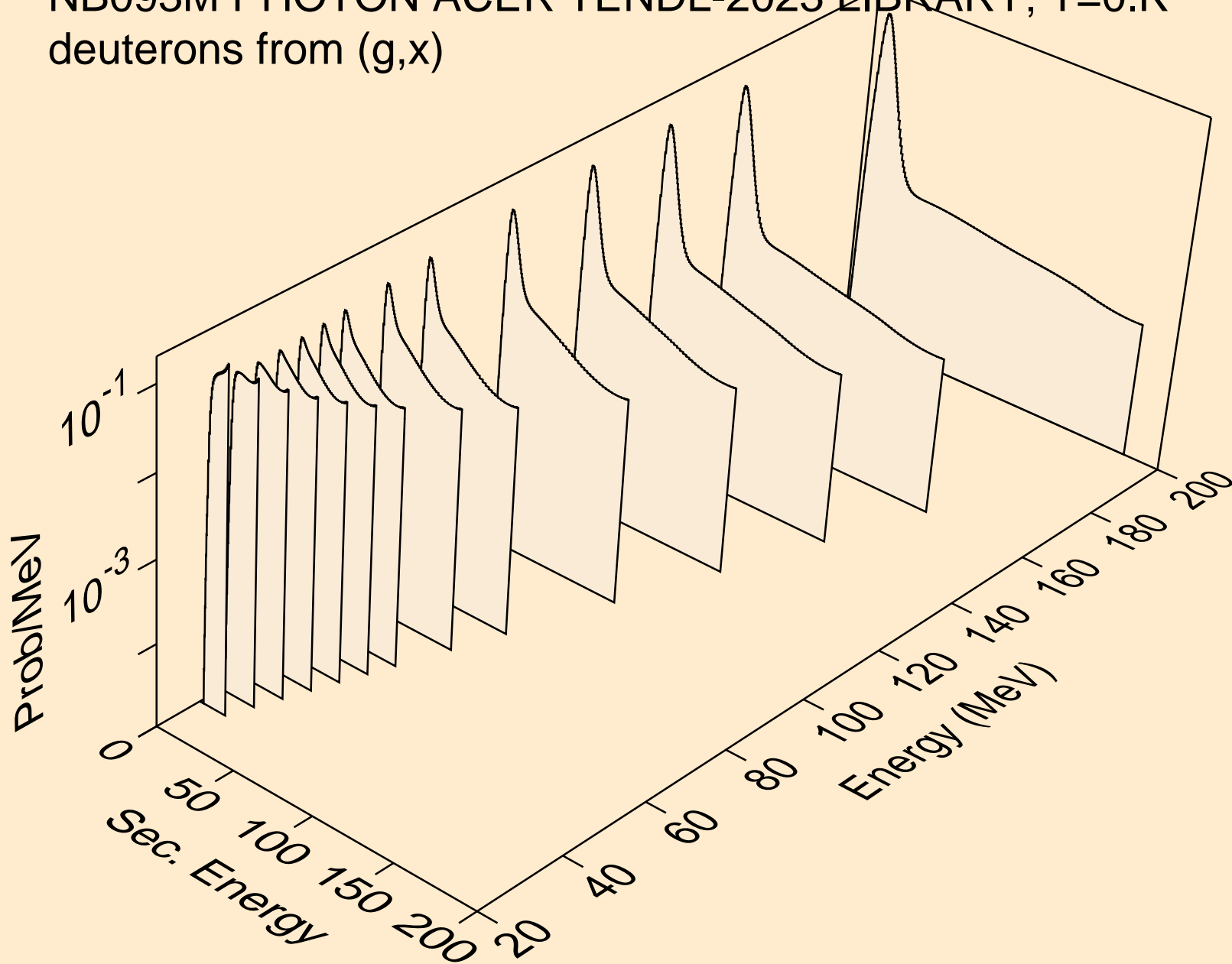



NB093M PHOTON ACER TENDL-2023 LIBRARY; T=0.K  
deuterons from (g,n\*)d

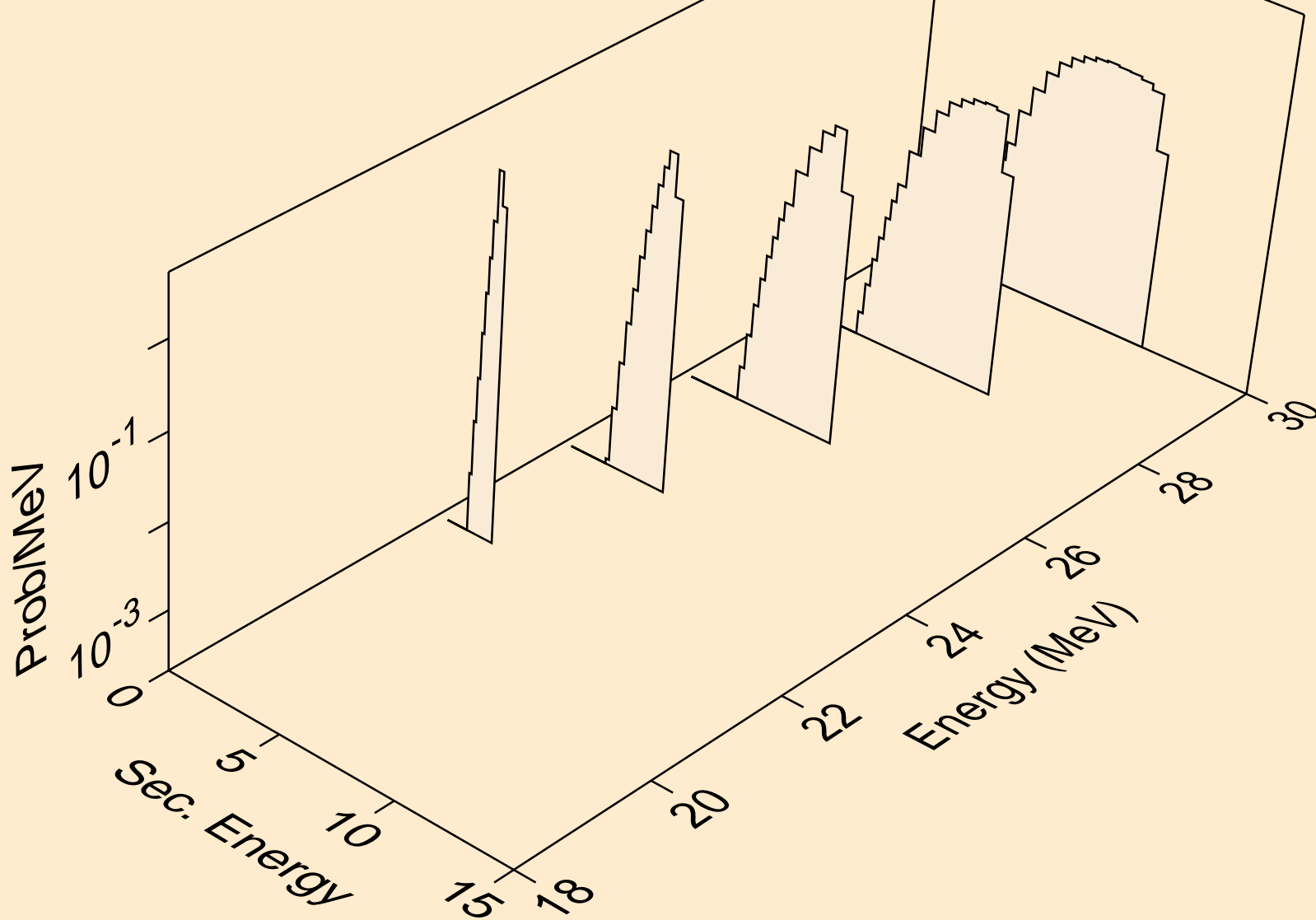

NB093M PHOTON ACER TENDL-2023 LIBRARY; T=0.K  
deuterons from (g,d)

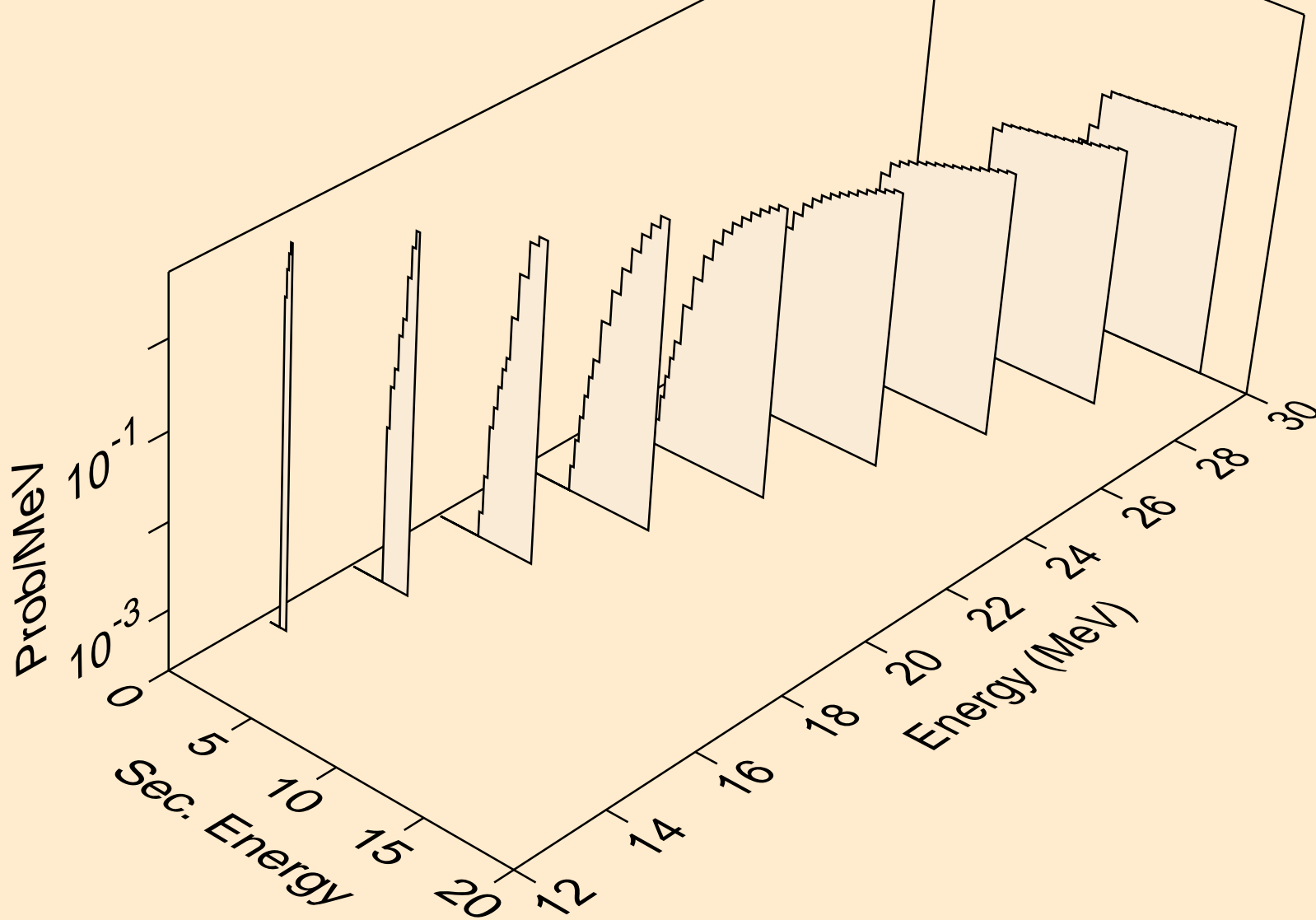

NB093M PHOTON ACER TENDL-2023 LIBRARY; T=0.K  
deuterons from (g,pd)

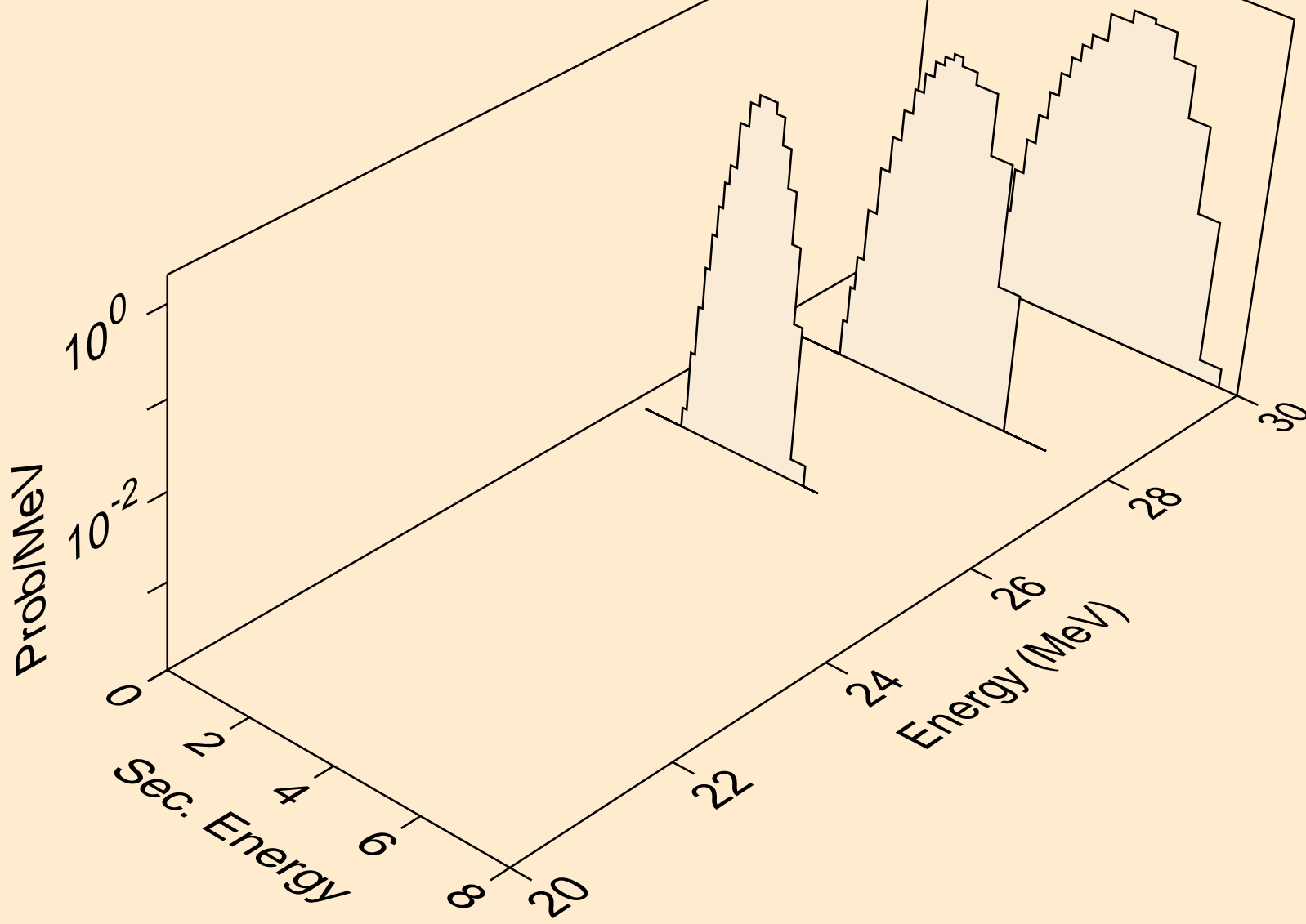

NB093M PHOTON ACER TENDL-2023 LIBRARY; T=0.K  
tritons from (g,x)

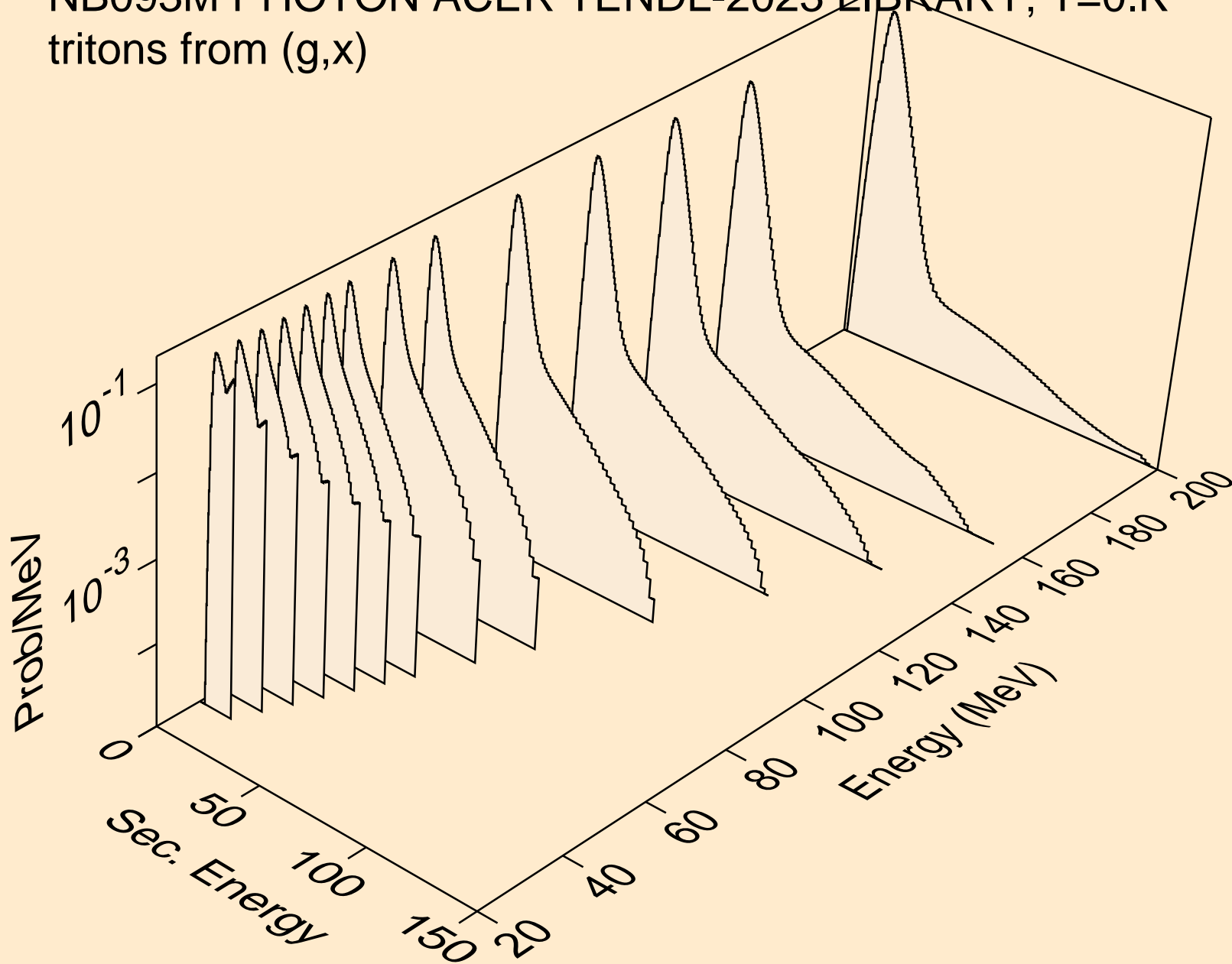

NB093M PHOTON ACER TENDL-2023 LIBRARY; T=0.K  
tritons from (g,n\*)t

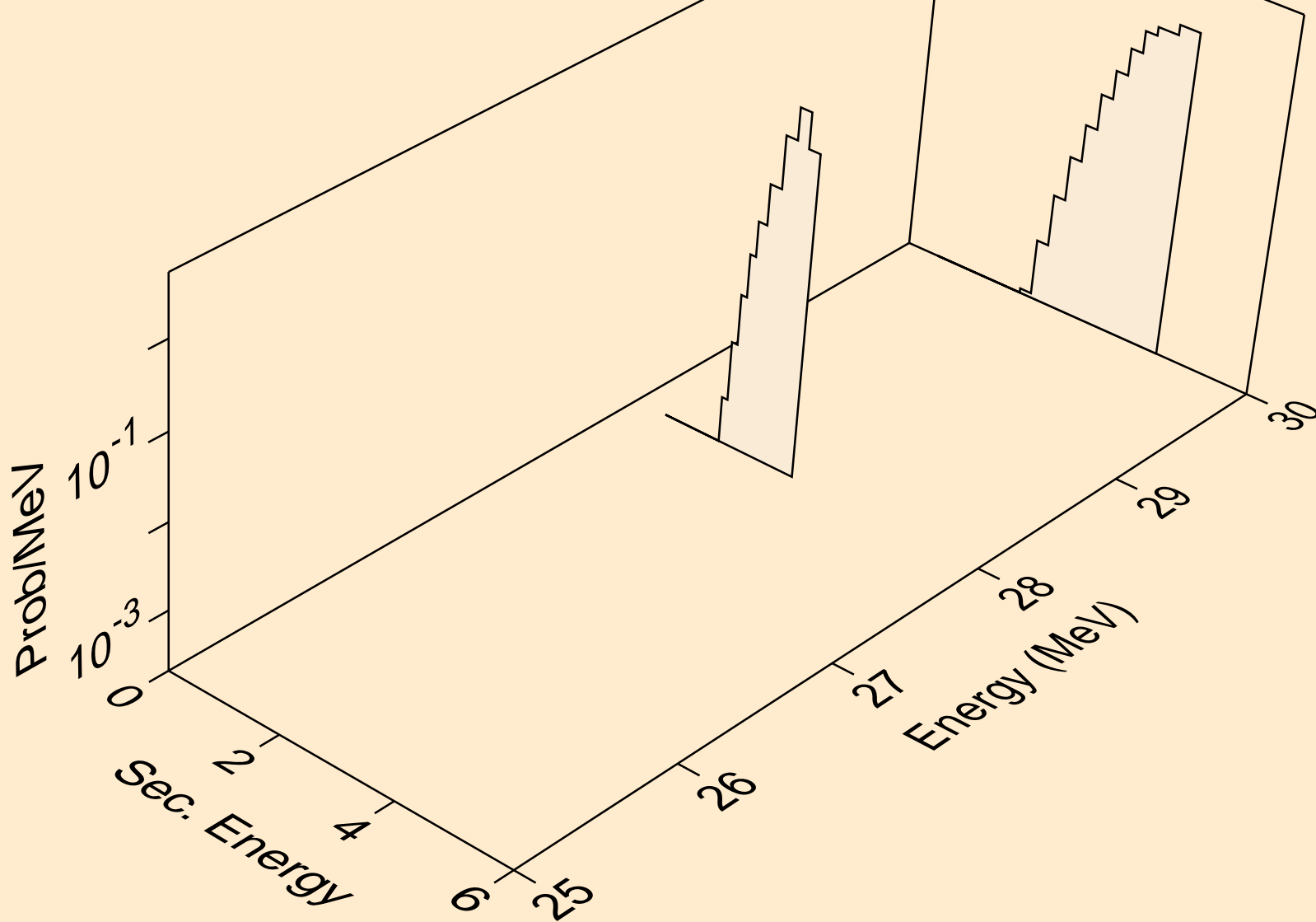

NB093M PHOTON ACER TENDL-2023 LIBRARY; T=0.K  
tritons from (g,t)

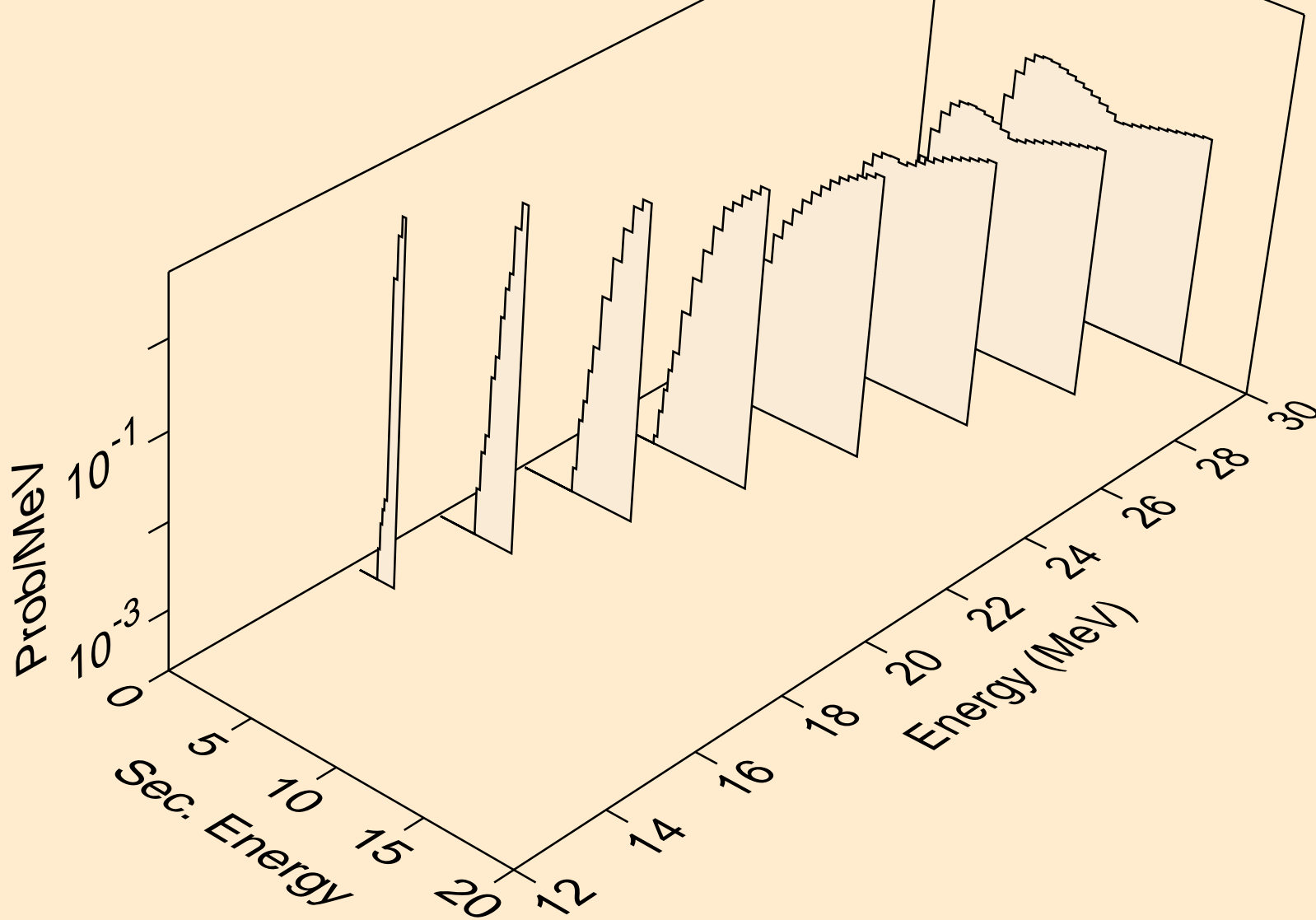

NB093M PHOTON ACER TENDL-2023 LIBRARY; T=0.K  
tritons from (g,pt)

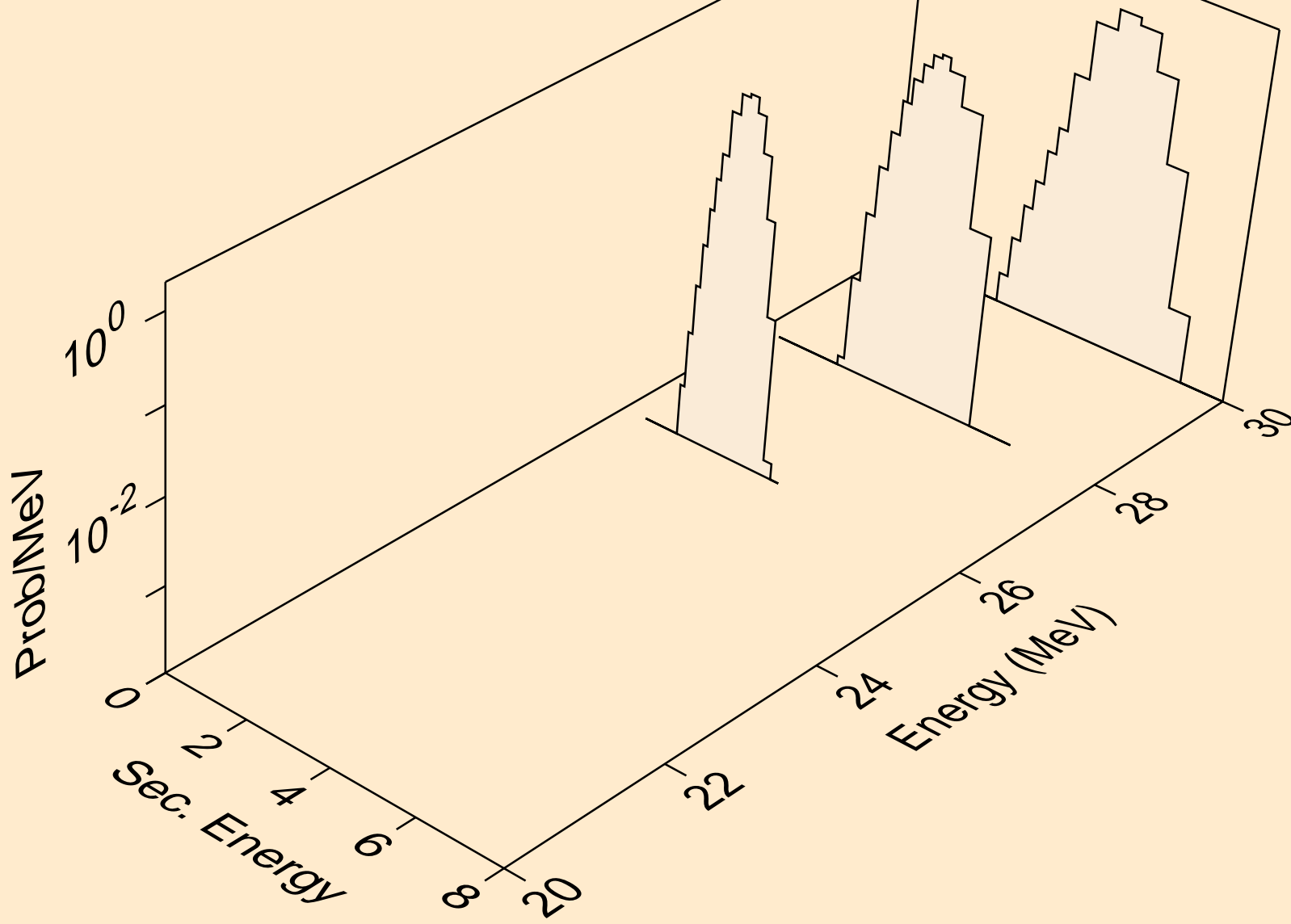

NB093M PHOTON ACER TENDL-2023 LIBRARY; T=0.K  
he3s from (g,x)

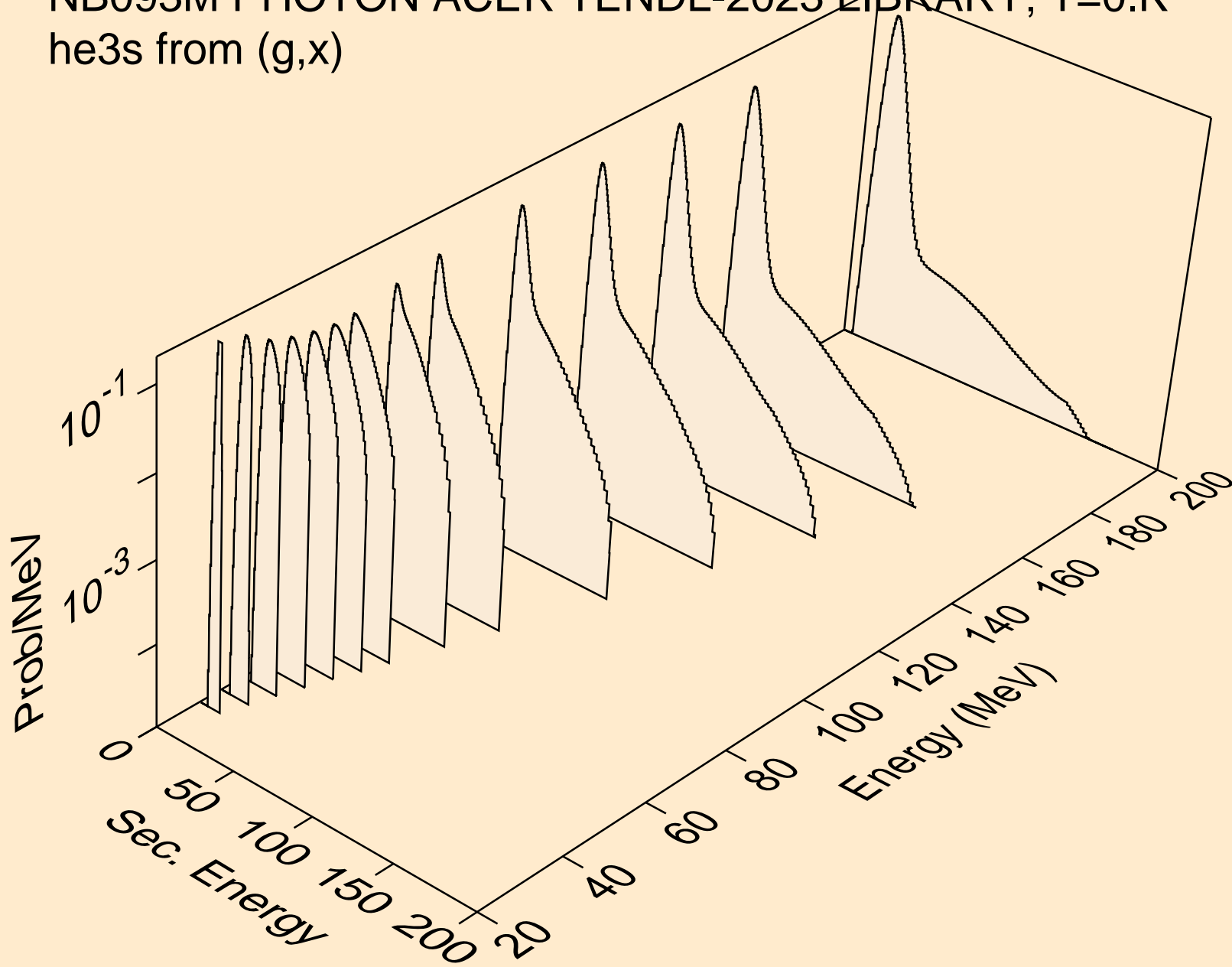



NB093M PHOTON ACER TENDL-2023 LIBRARY; T=0.K  
he3s from (g,he3)

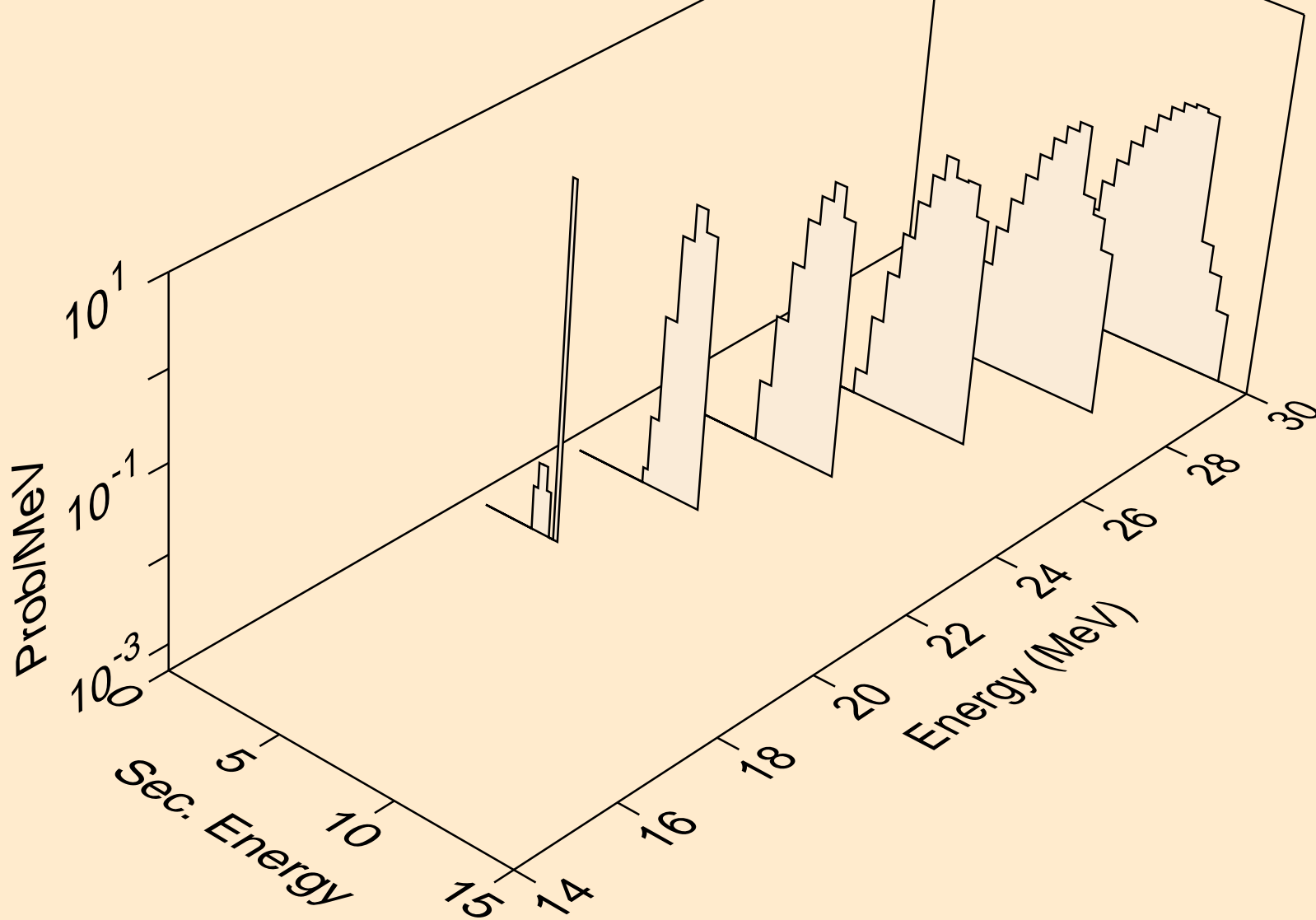

NB093M PHOTON ACER TENDL-2023 LIBRARY; T=0.K  
alphas from (g,x)

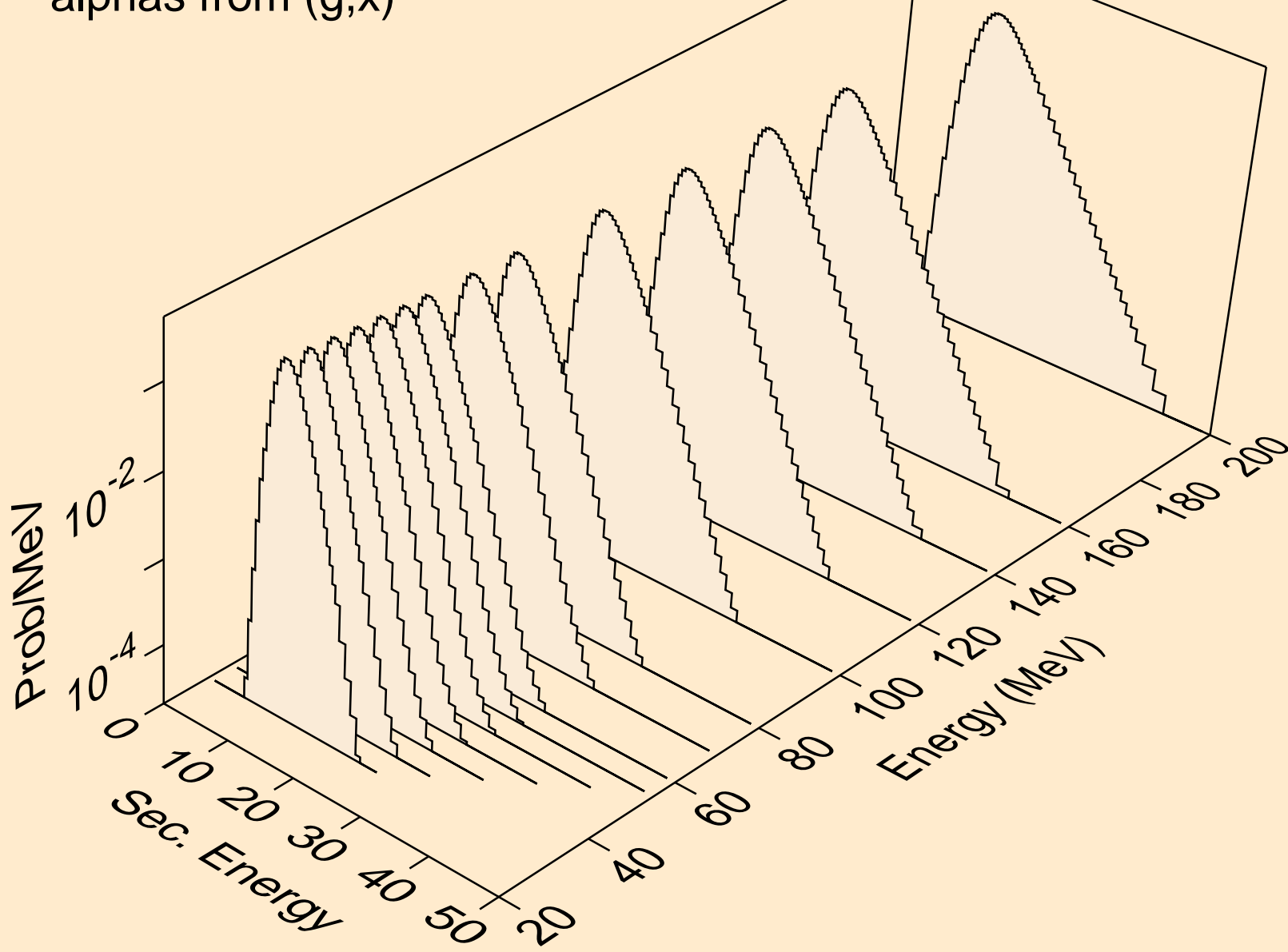

NB093M PHOTON ACER TENDL-2023 LIBRARY; T=0.K  
alphas from (g,n\*)a

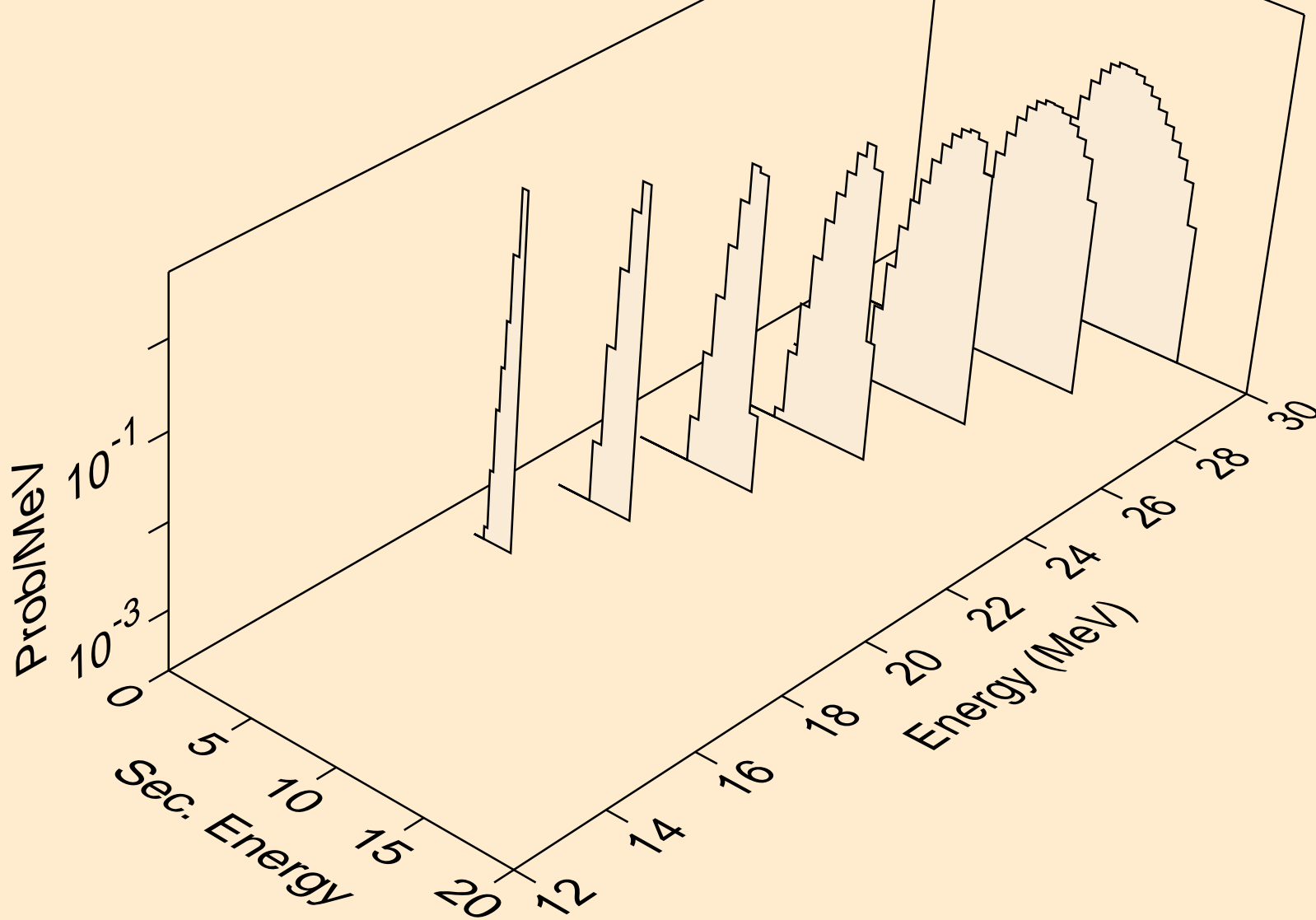

NB093M PHOTON ACER TENDL-2023 LIBRARY; T=0.K  
alphas from (g,2n)a

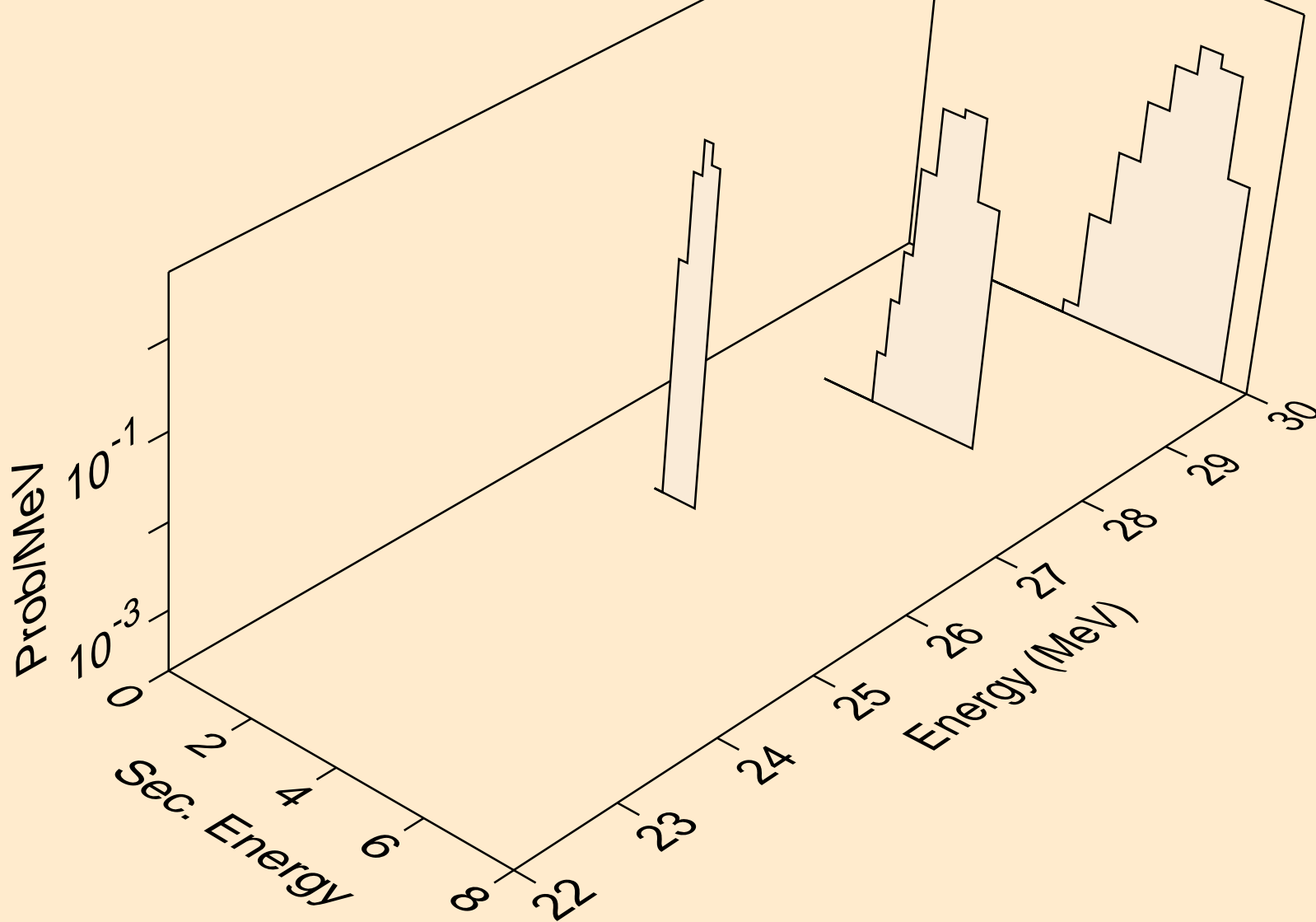

NB093M PHOTON ACER TENDL-2023 LIBRARY; T=0.K  
alphas from (g,a)

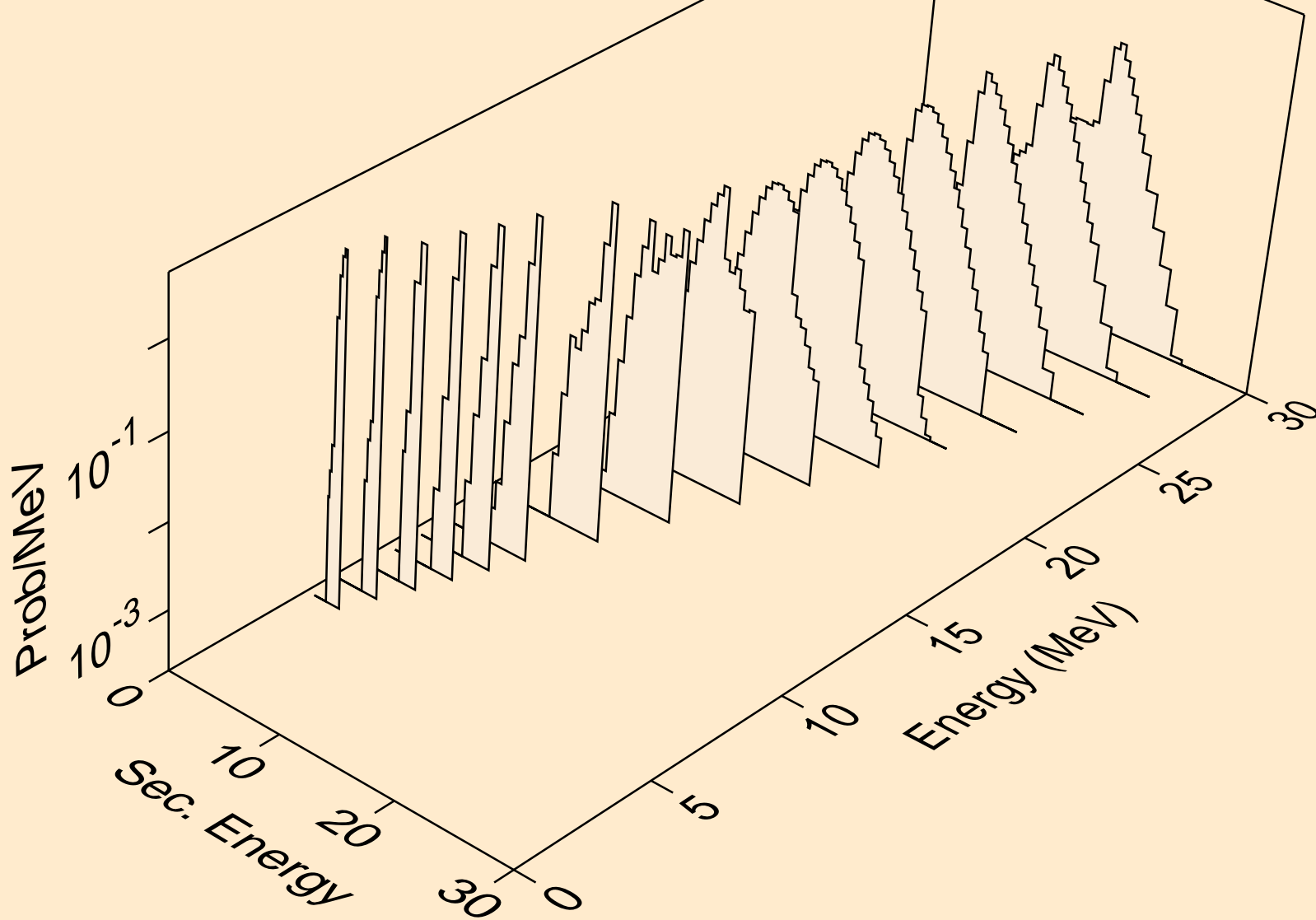

NB093M PHOTON ACER TENDL-2023 LIBRARY; T=0.K  
alphas from (g,2a)

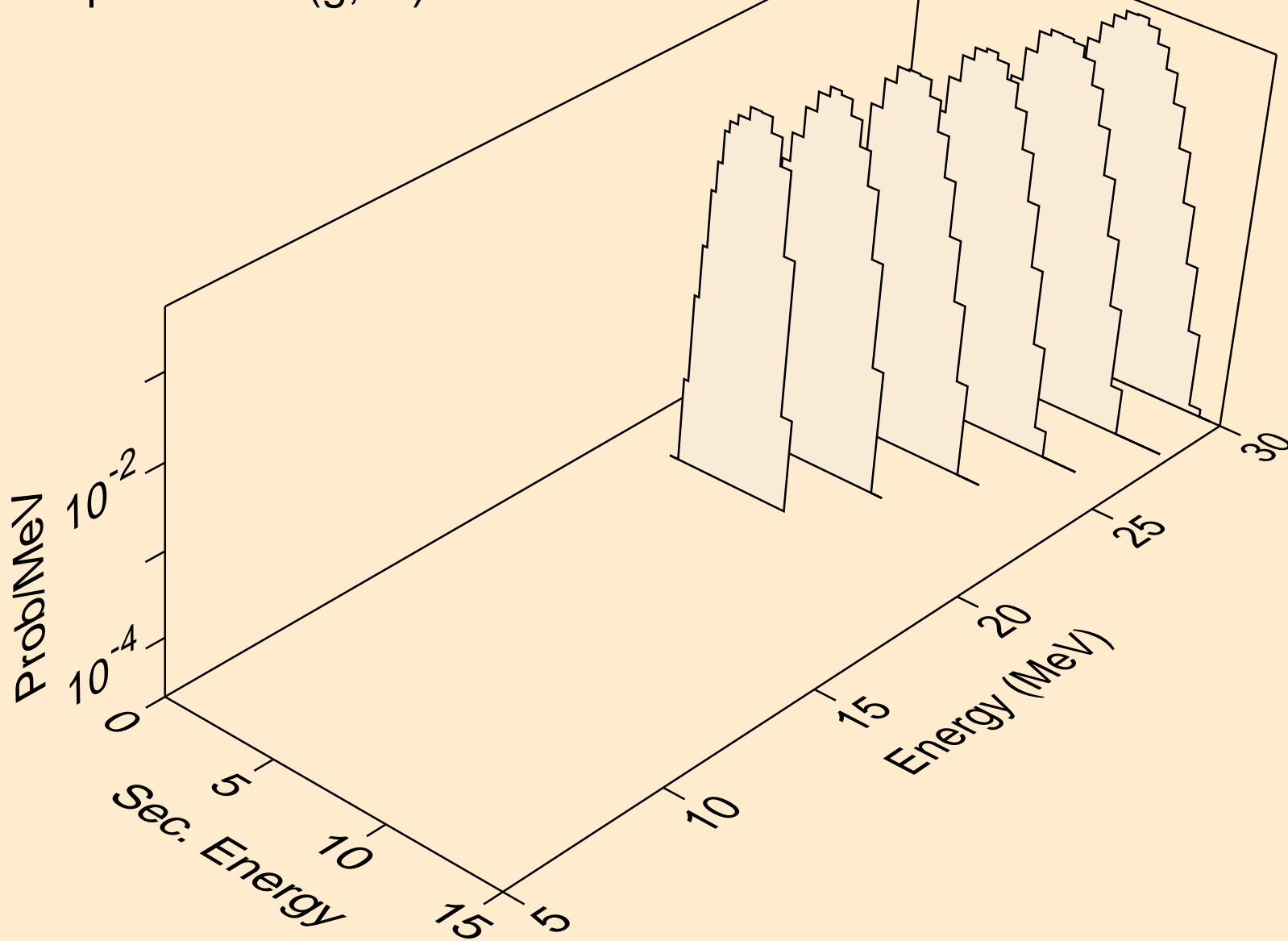

NB093M PHOTON ACER TENDL-2023 LIBRARY; T=0.K  
alphas from (g,pa)

