

S036 PHOTON ACER TENDL-2023 LIBRARY; T=0.K

Principal cross sections

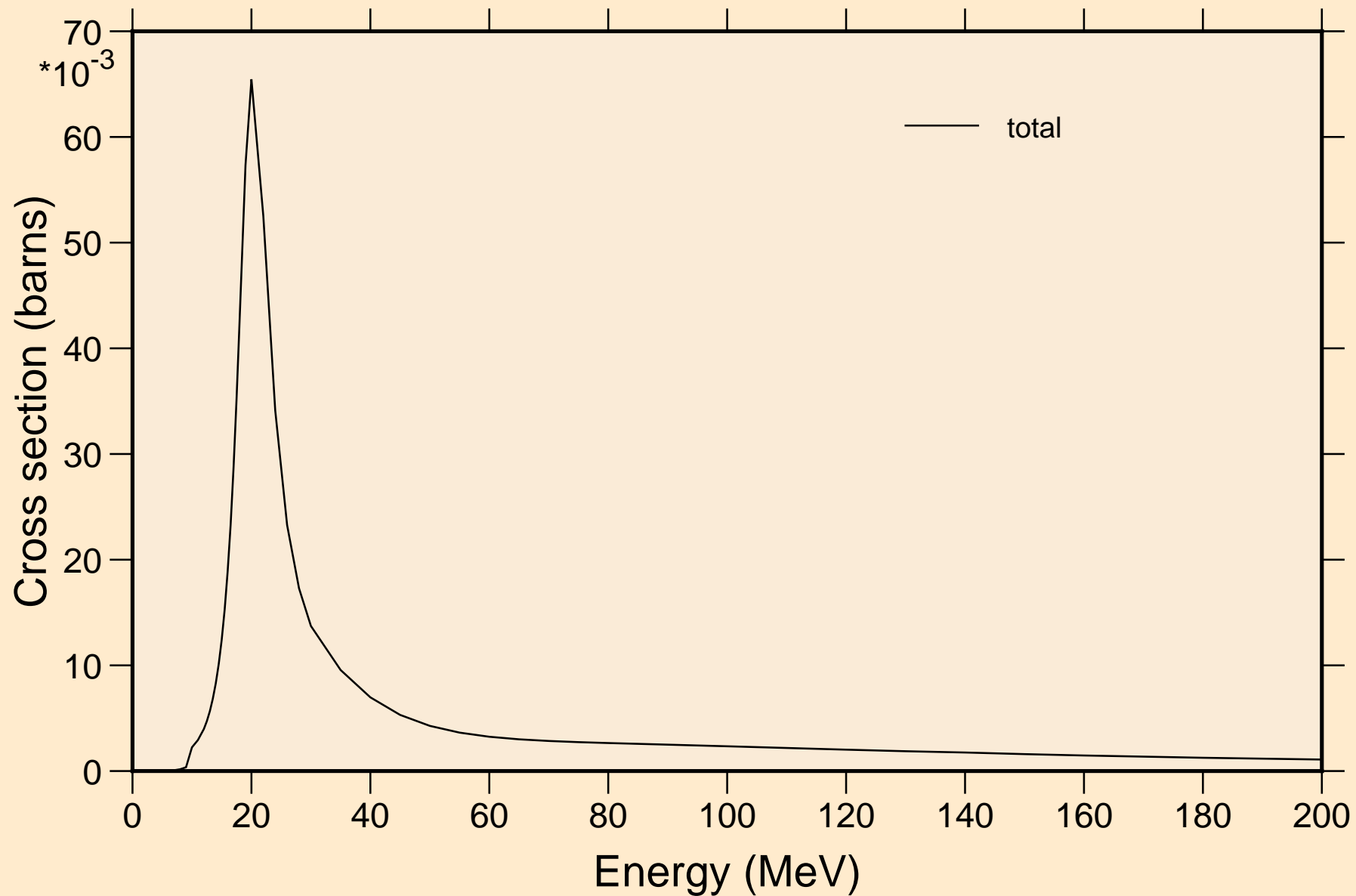

S036 PHOTON ACER TENDL-2023 LIBRARY; T=0.K

Partial cross sections

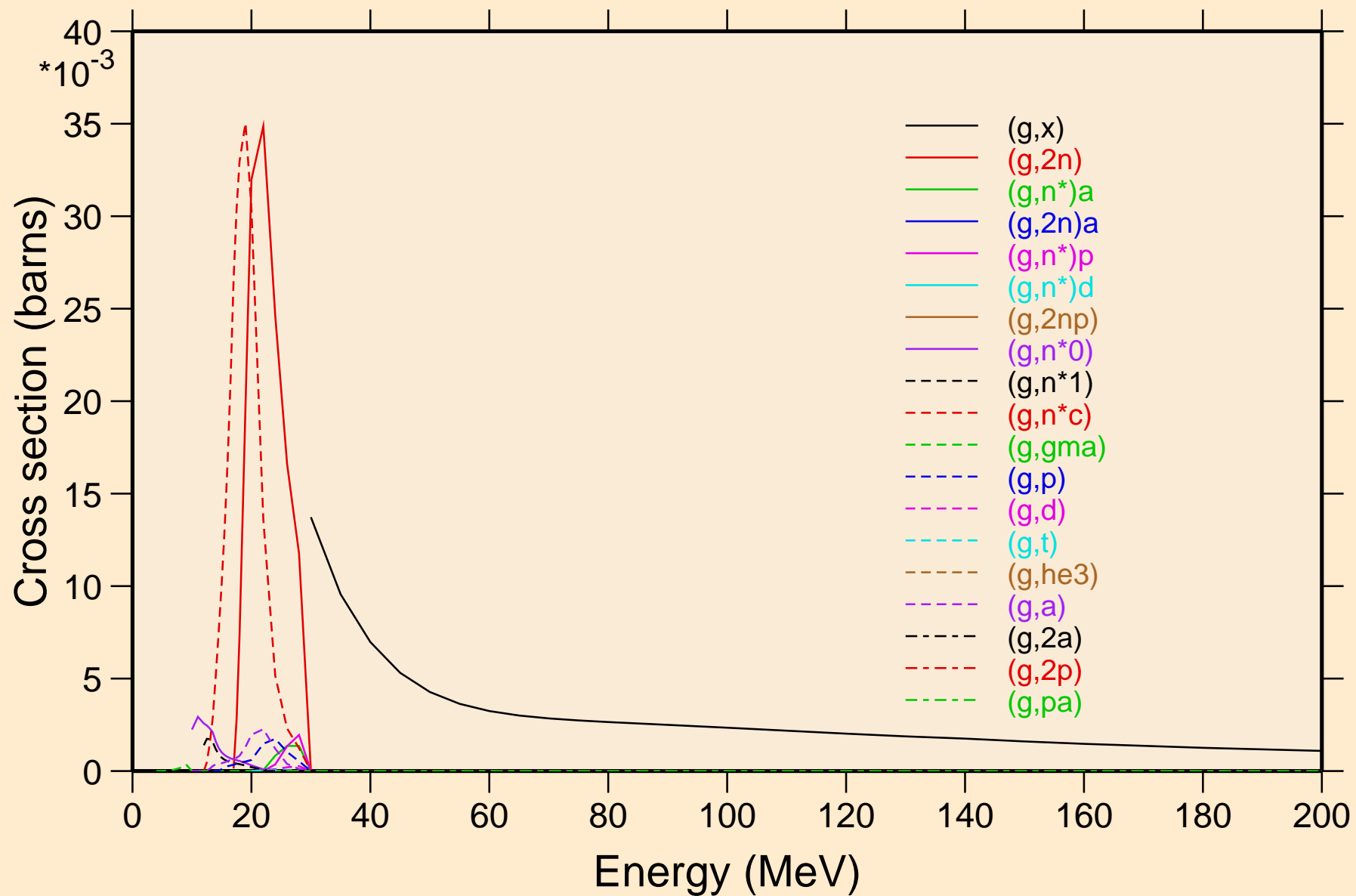

S036 PHOTON ACER TENDL-2023 LIBRARY; T=0.K

Heating

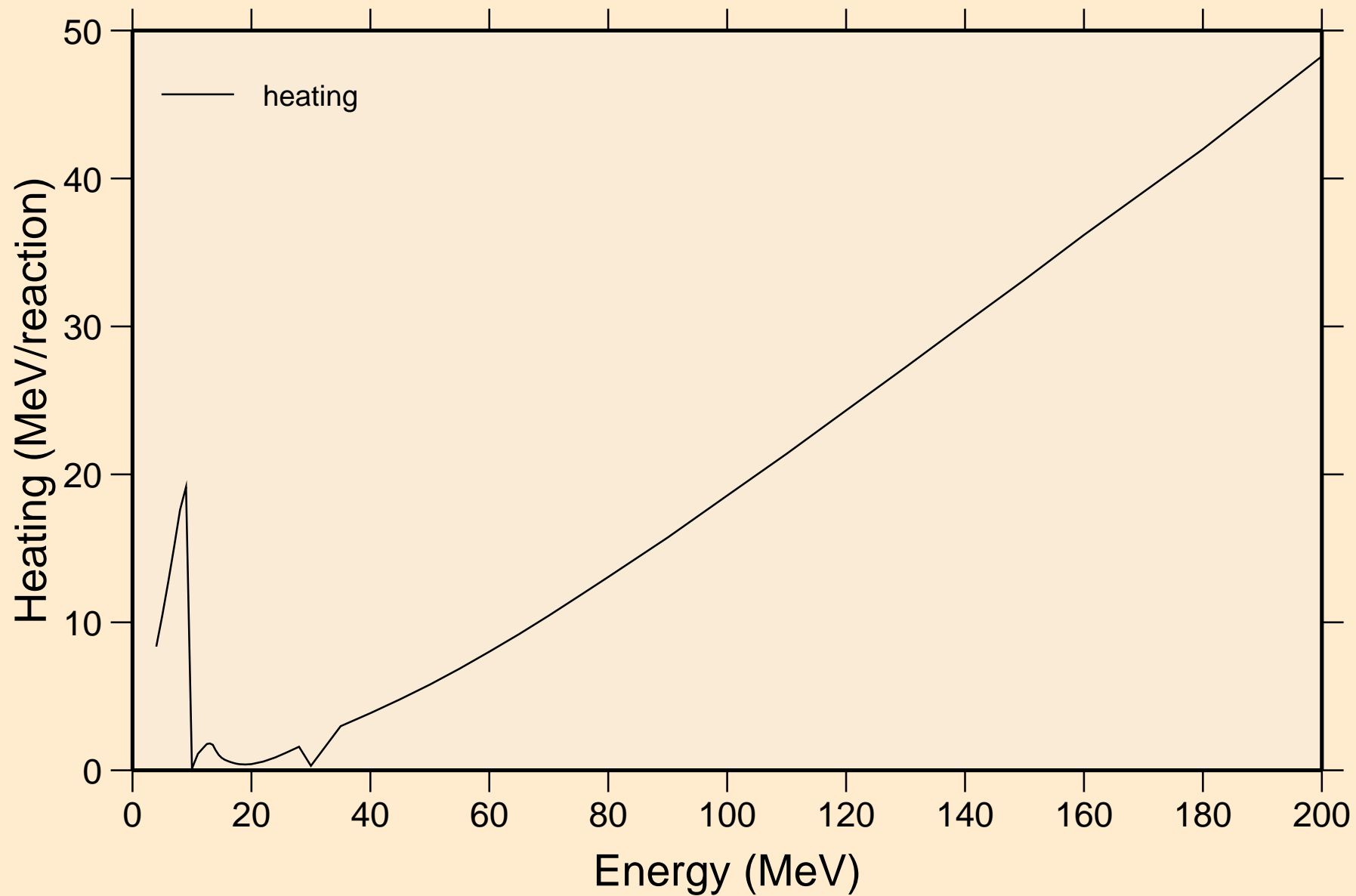

S036 PHOTON ACER TENDL-2023 LIBRARY; T=0.K

Particle heating contributions

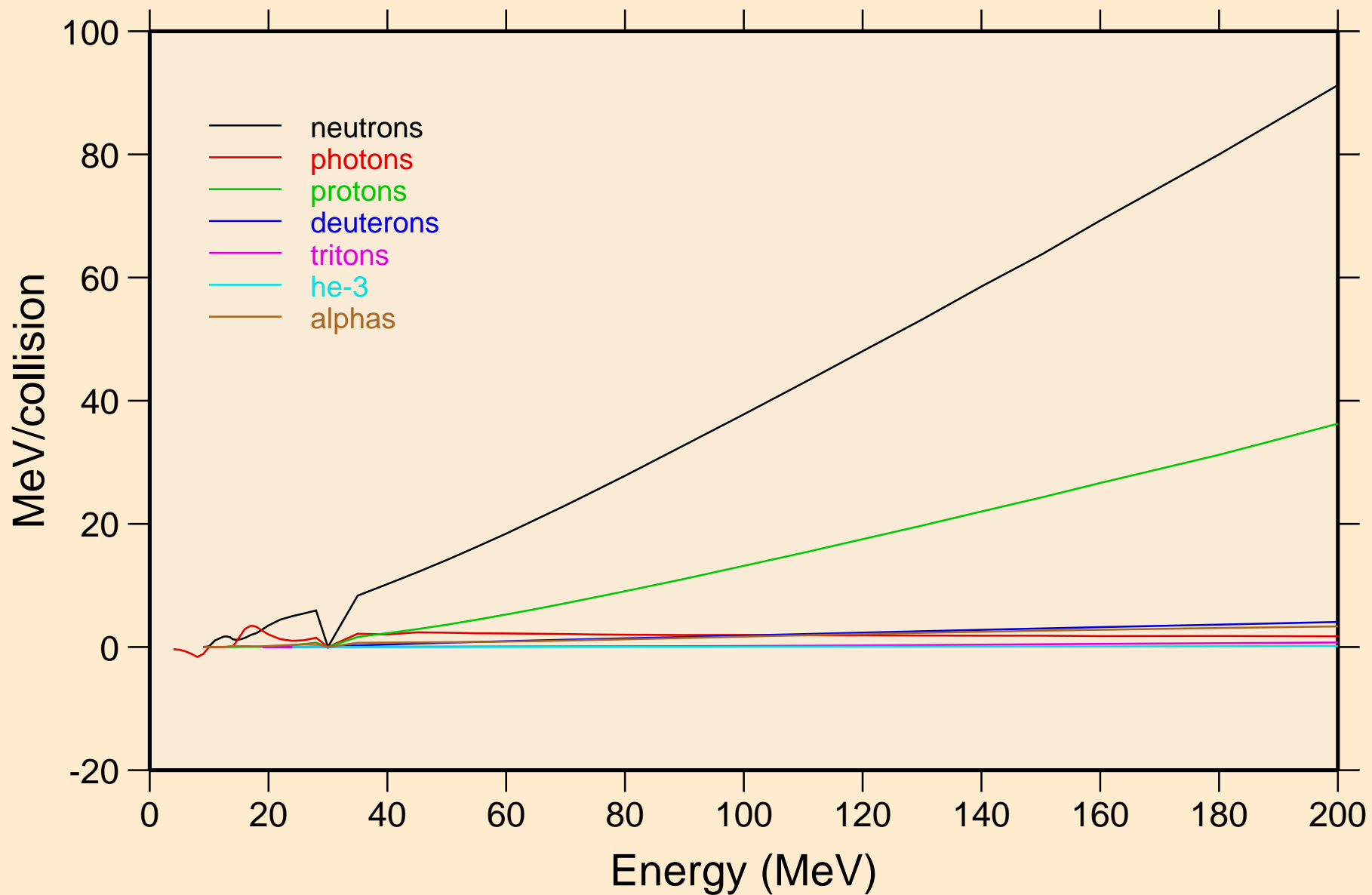

S036 PHOTON ACER TENDL-2023 LIBRARY; T=0.K

Particle production cross sections

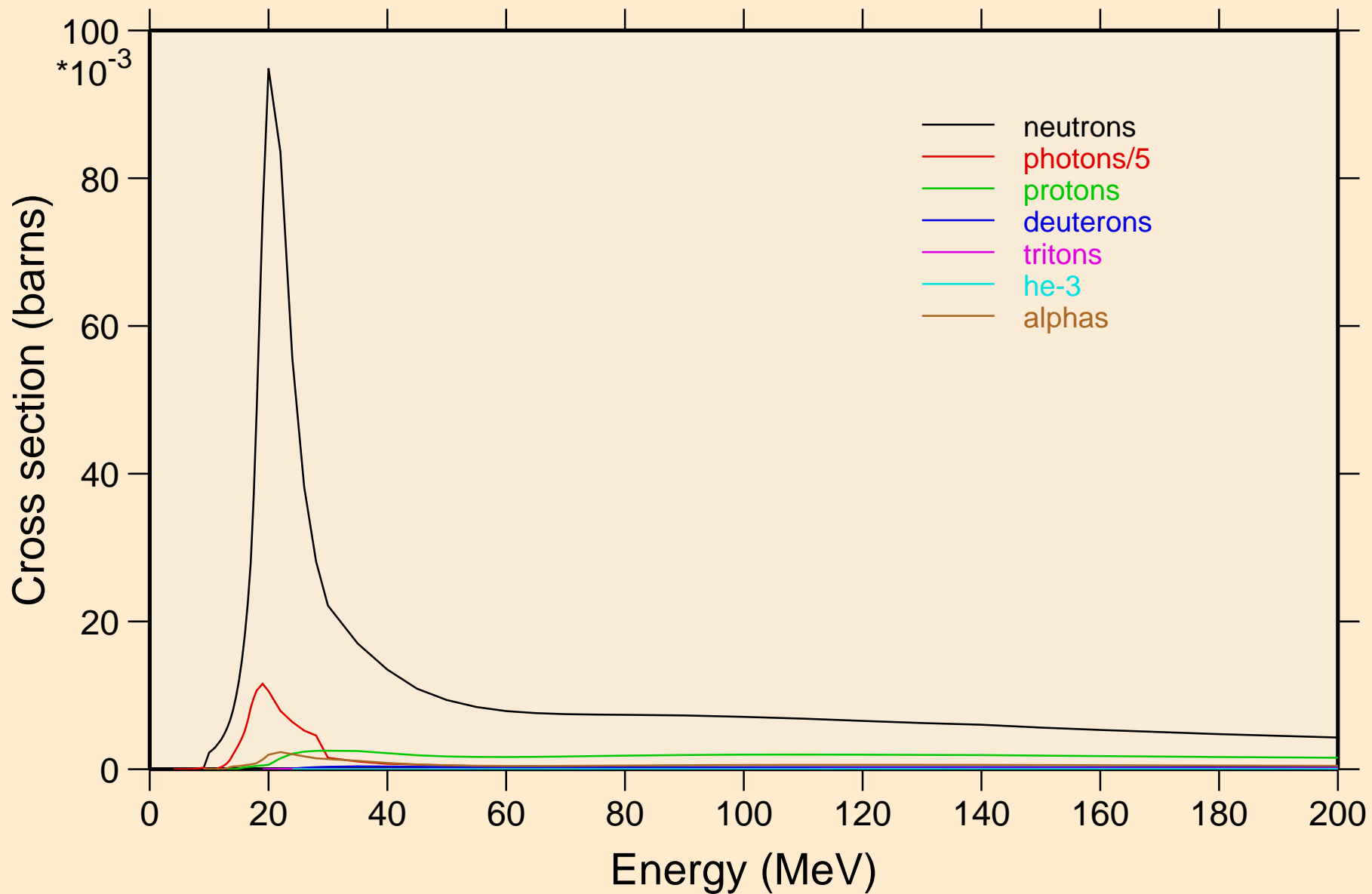

S036 PHOTON ACER TENDL-2023 LIBRARY; T=0.K
neutrons from (g,x)

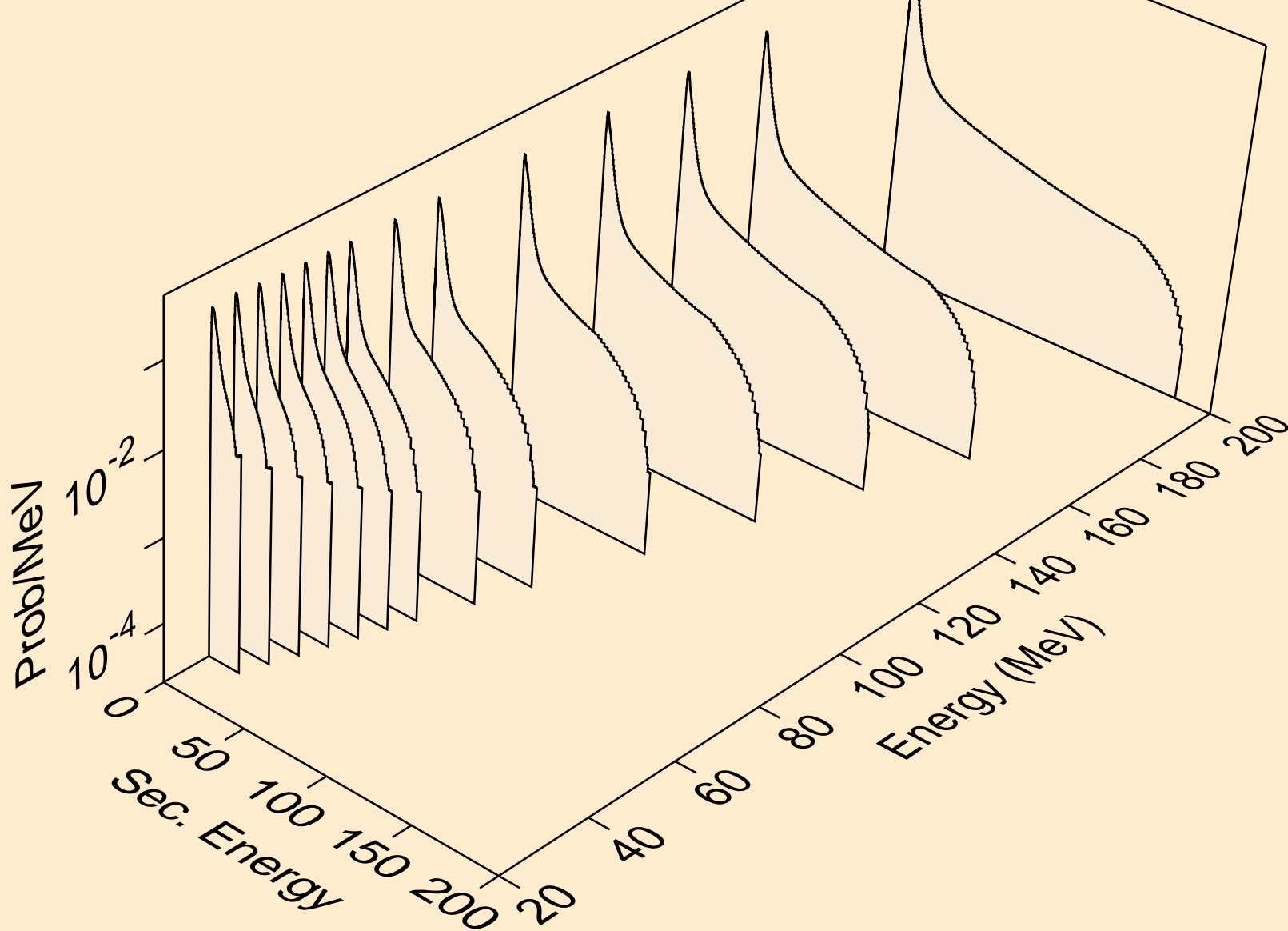

S036 PHOTON ACER TENDL-2023 LIBRARY; T=0.K
neutrons from (g,2n)

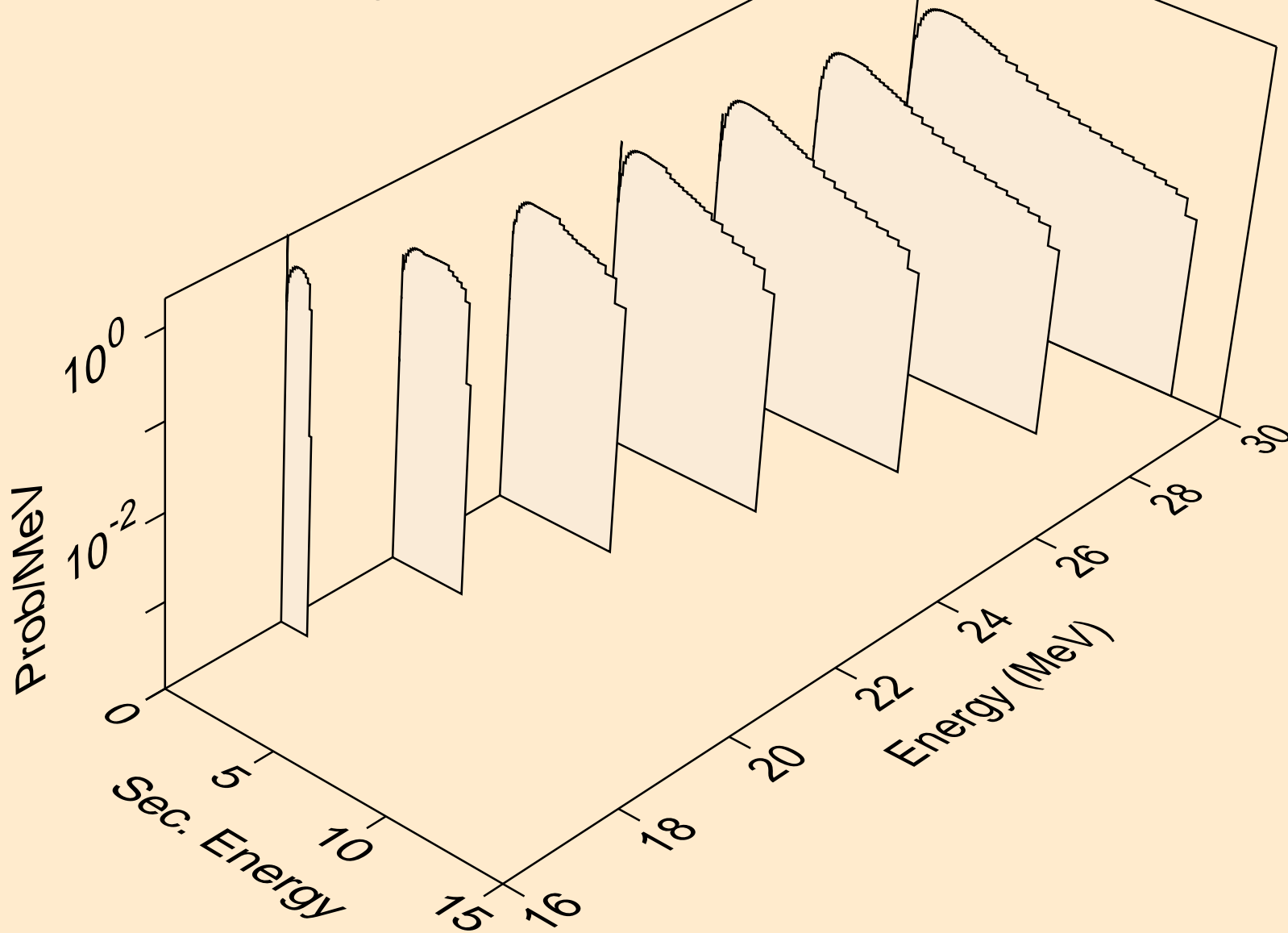

S036 PHOTON ACER TENDL-2023 LIBRARY; T=0.K
neutrons from (g,n*)a

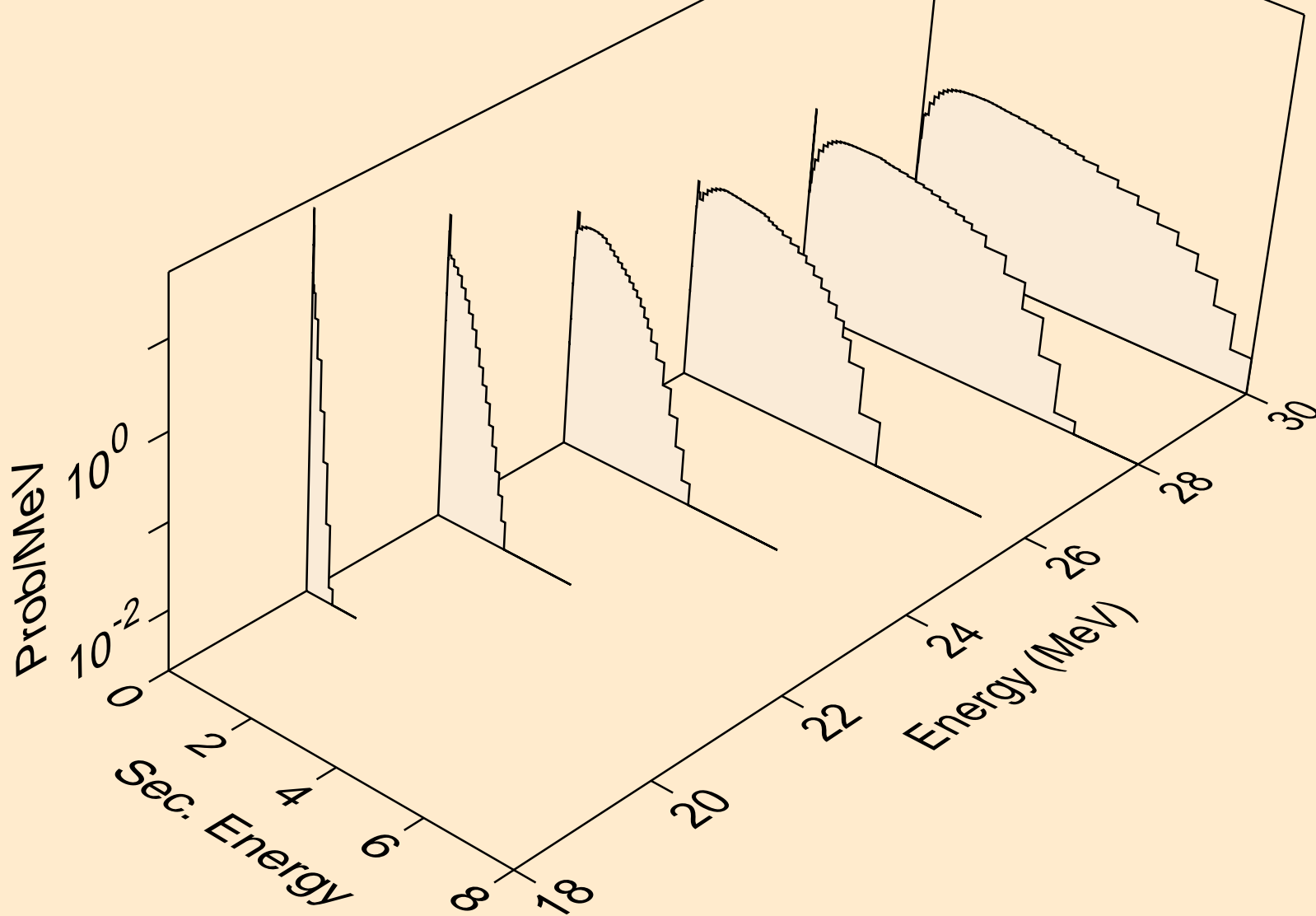

S036 PHOTON ACER TENDL-2023 LIBRARY; T=0.K
neutrons from (g,2n)a

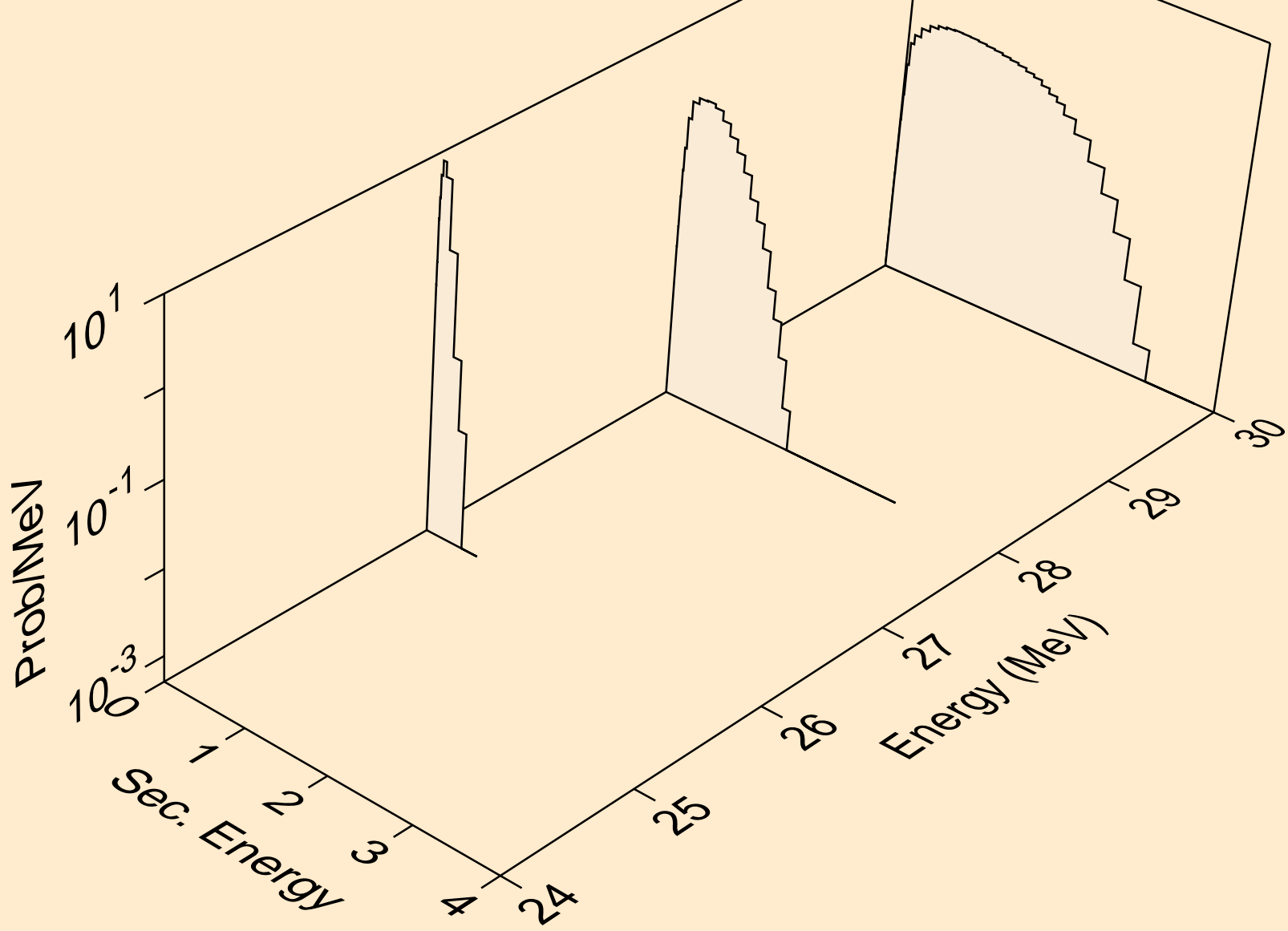

S036 PHOTON ACER TENDL-2023 LIBRARY; T=0.K
neutrons from (g,n*)p

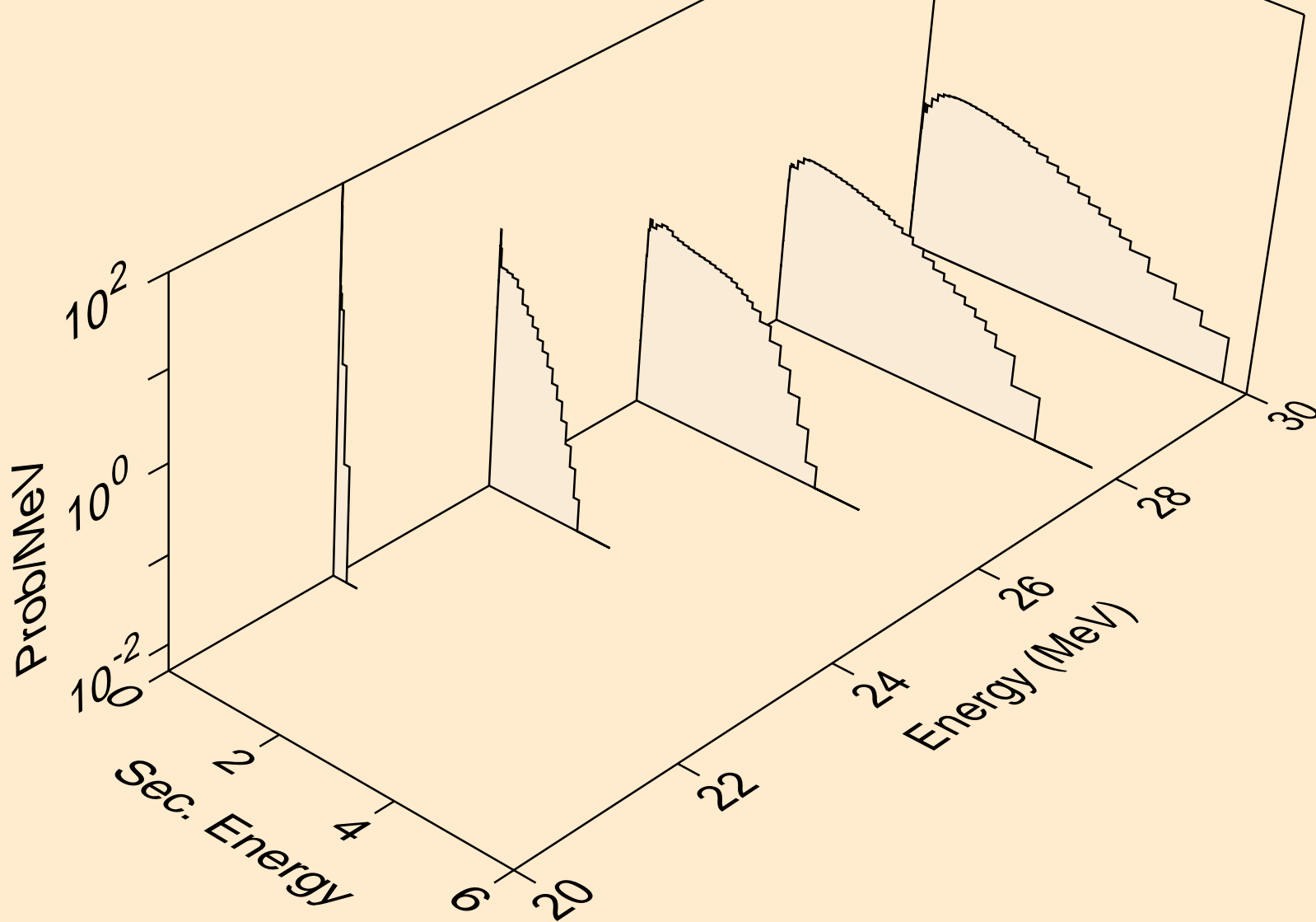

S036 PHOTON ACER TENDL-2023 LIBRARY; T=0.K
neutrons from (g,n*)d

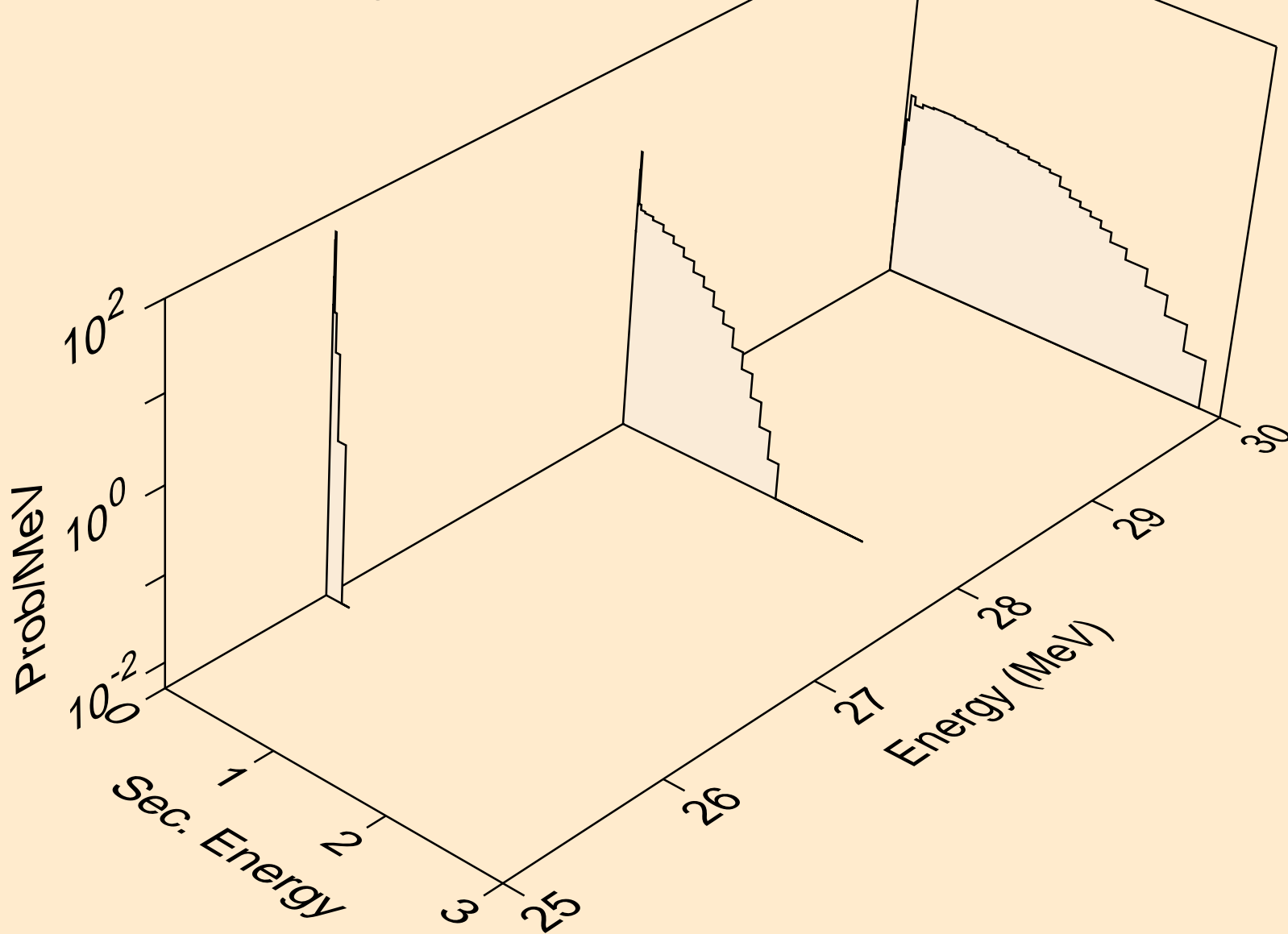

S036 PHOTON ACER TENDL-2023 LIBRARY; T=0.K
neutrons from (g,2np)

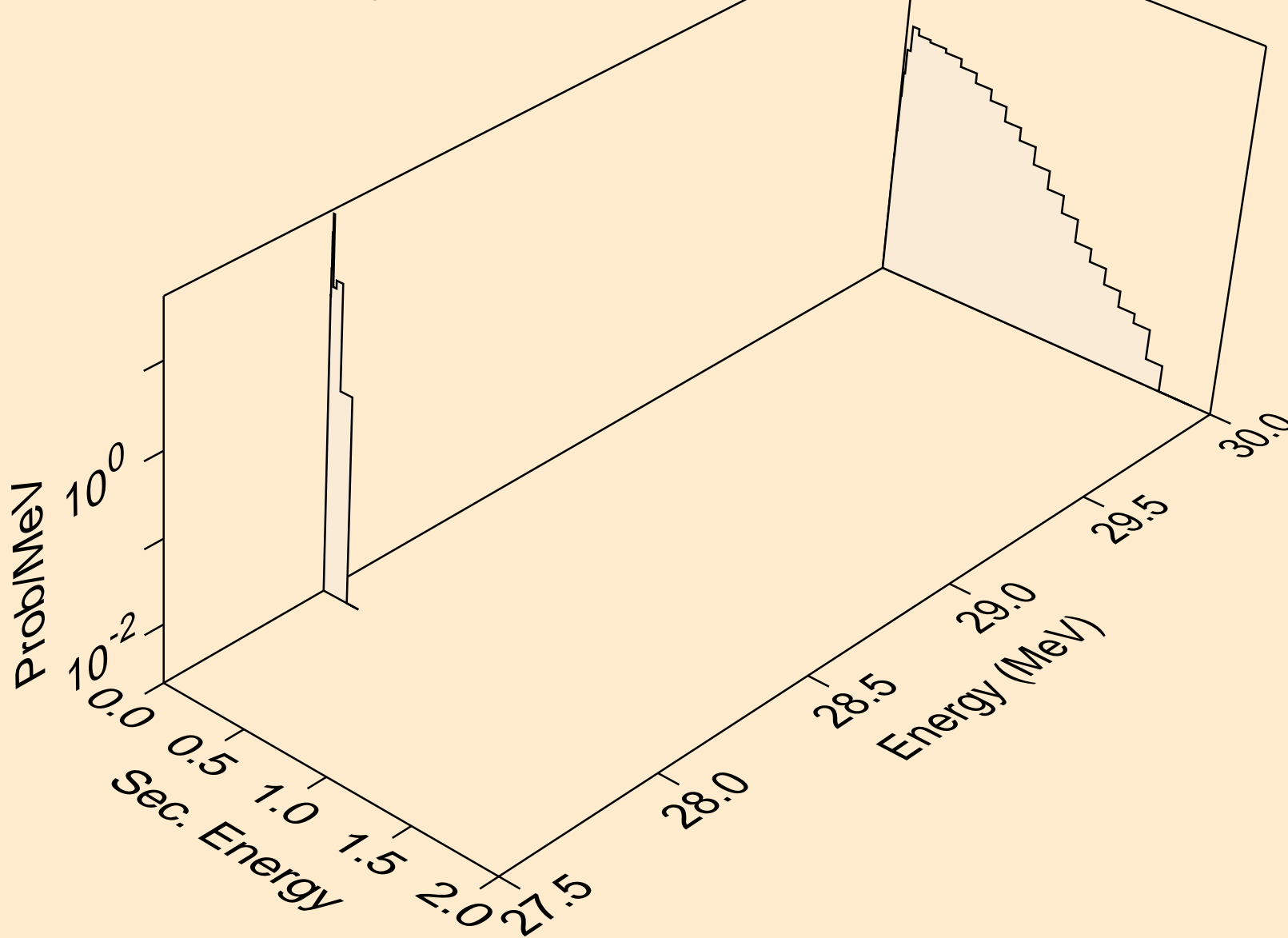

S036 PHOTON ACER TENDL-2023 LIBRARY; T=0.K
angular distribution for (g,n*0) neutron

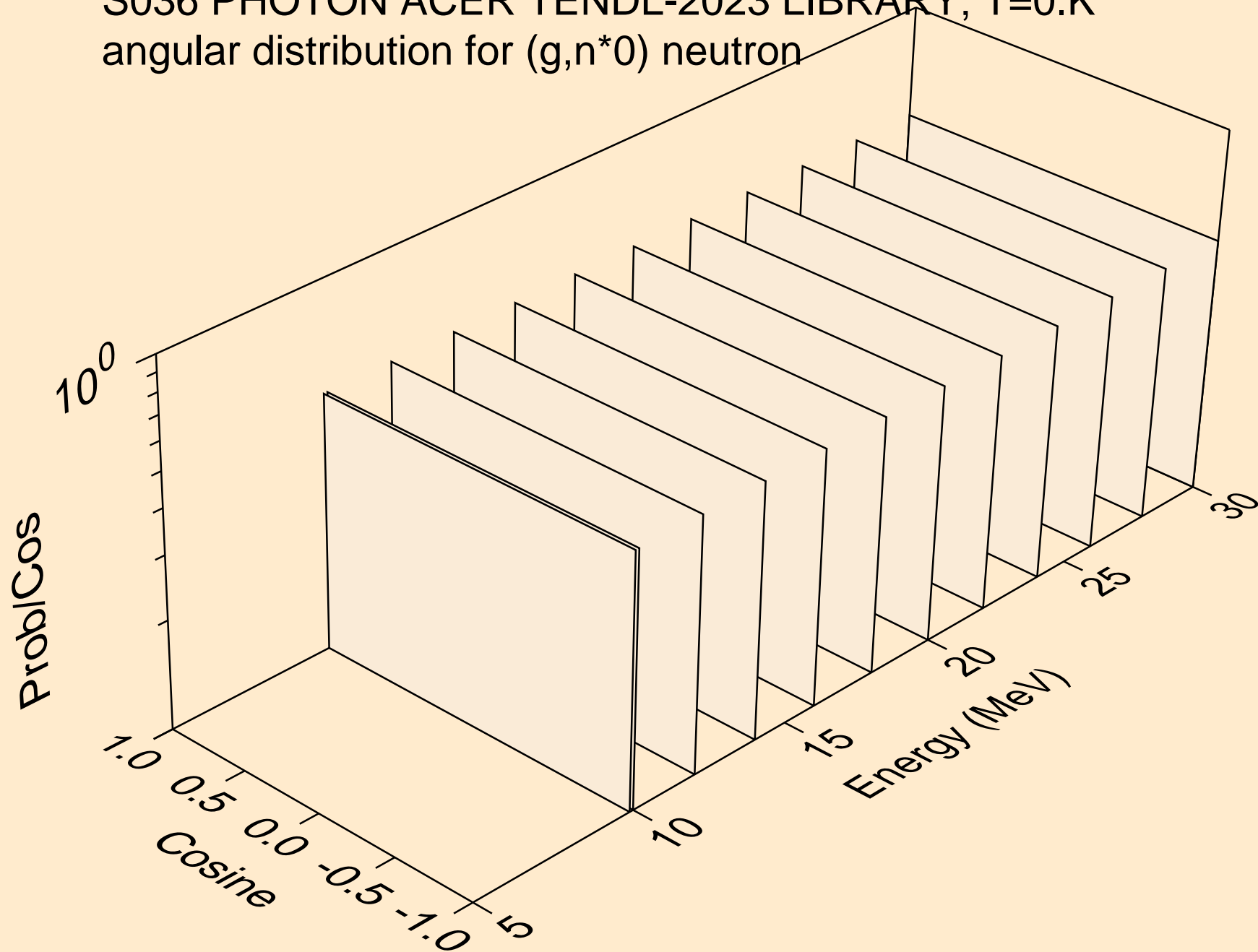

S036 PHOTON ACER TENDL-2023 LIBRARY; T=0.K
angular distribution for (g,n*1) neutron

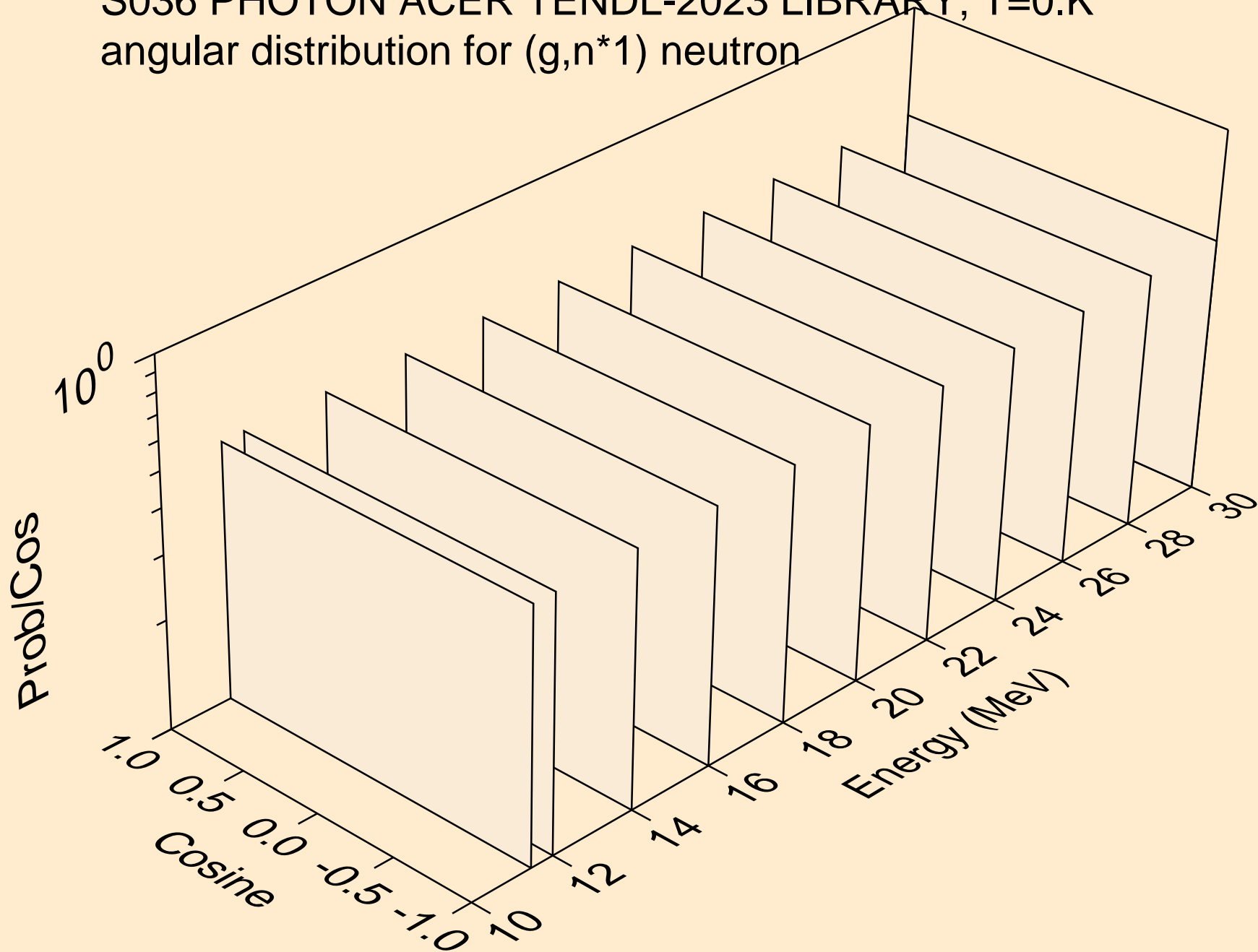

S036 PHOTON ACER TENDL-2023 LIBRARY; T=0.K
neutrons from (g,n*c)

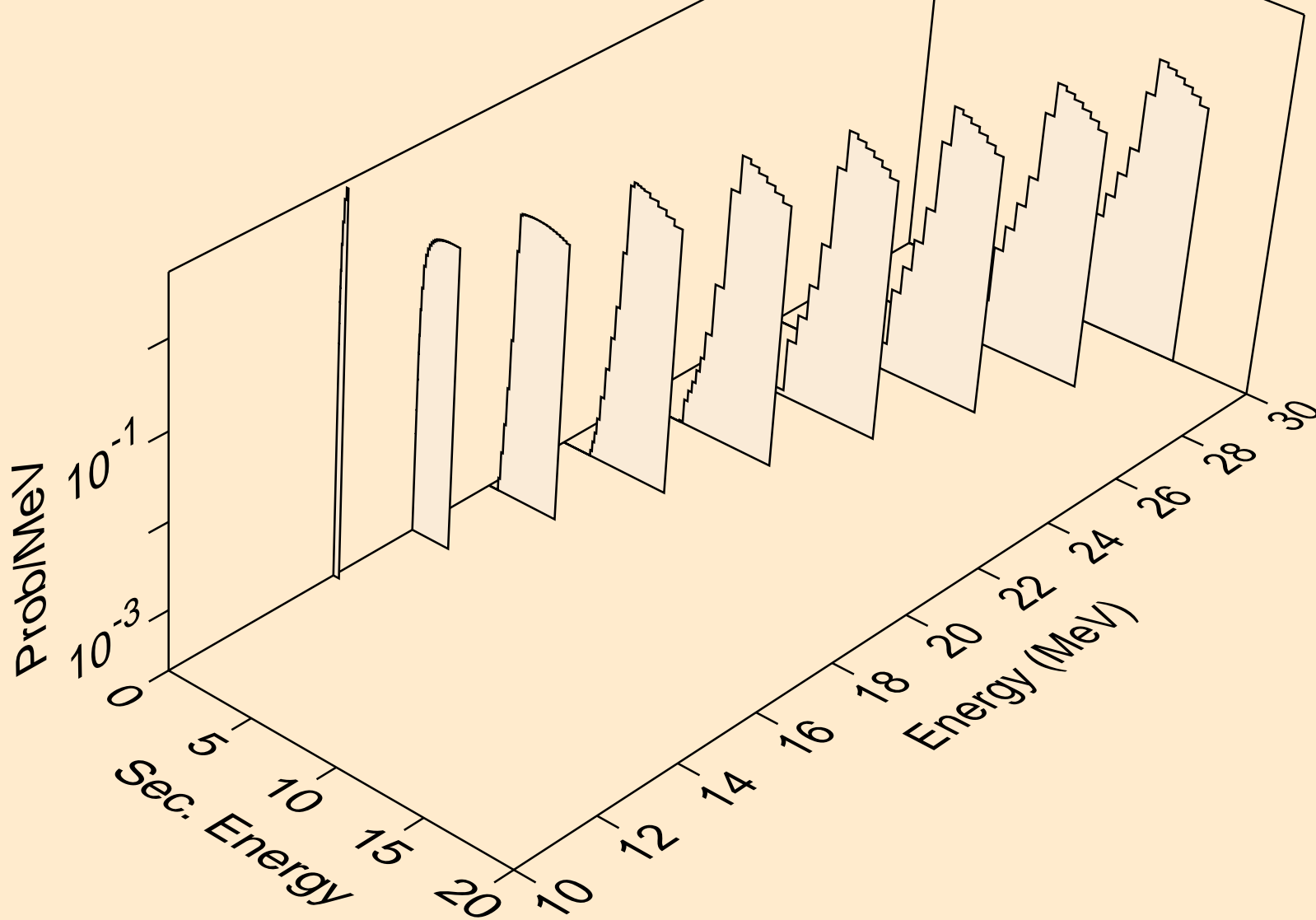

S036 PHOTON ACER TENDL-2023 LIBRARY; T=0.K
photons from (g,x)

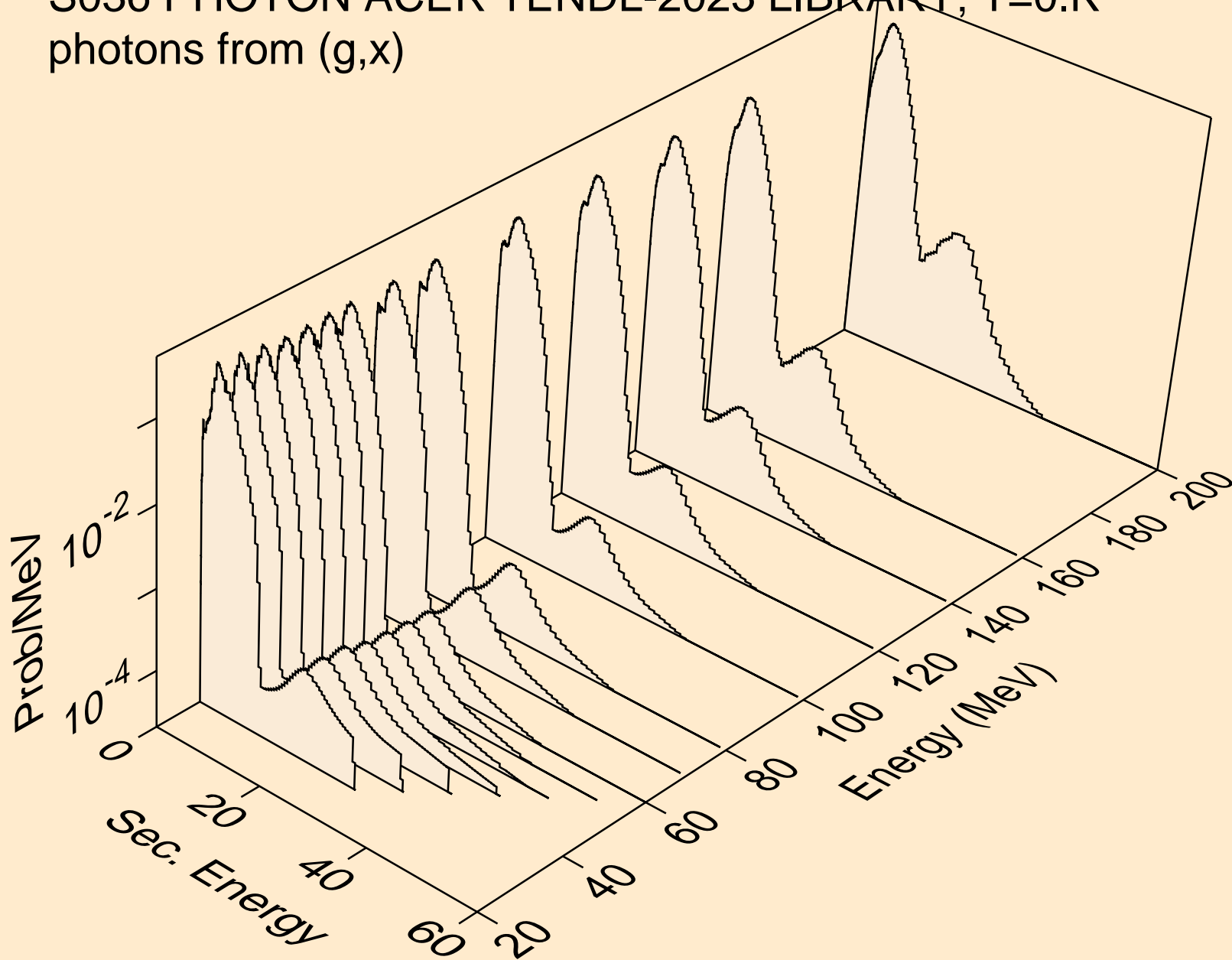

S036 PHOTON ACER TENDL-2023 LIBRARY; T=0.K
photons from (g,2n)

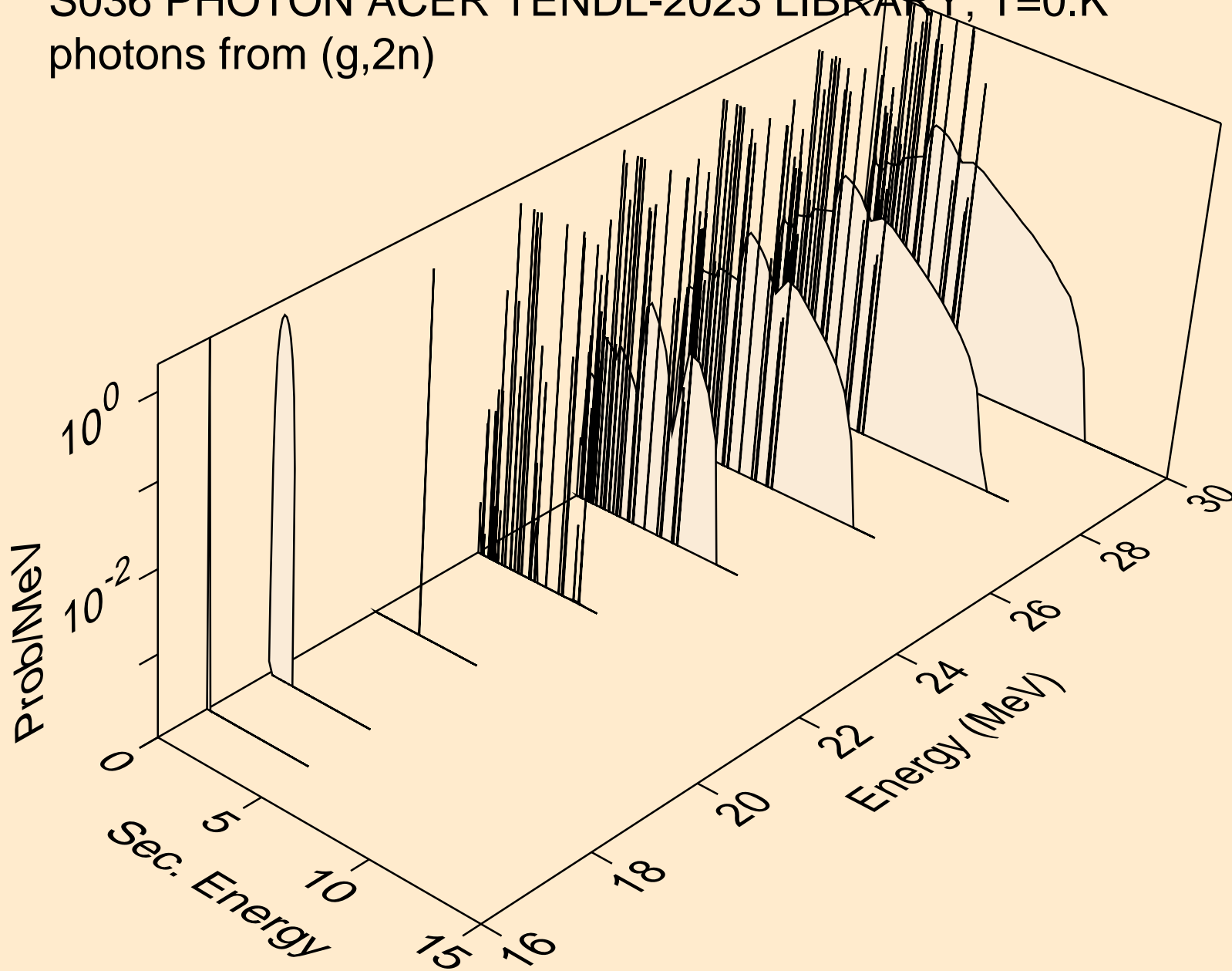

S036 PHOTON ACER TENDL-2023 LIBRARY; T=0.K
photons from (g,n*)a

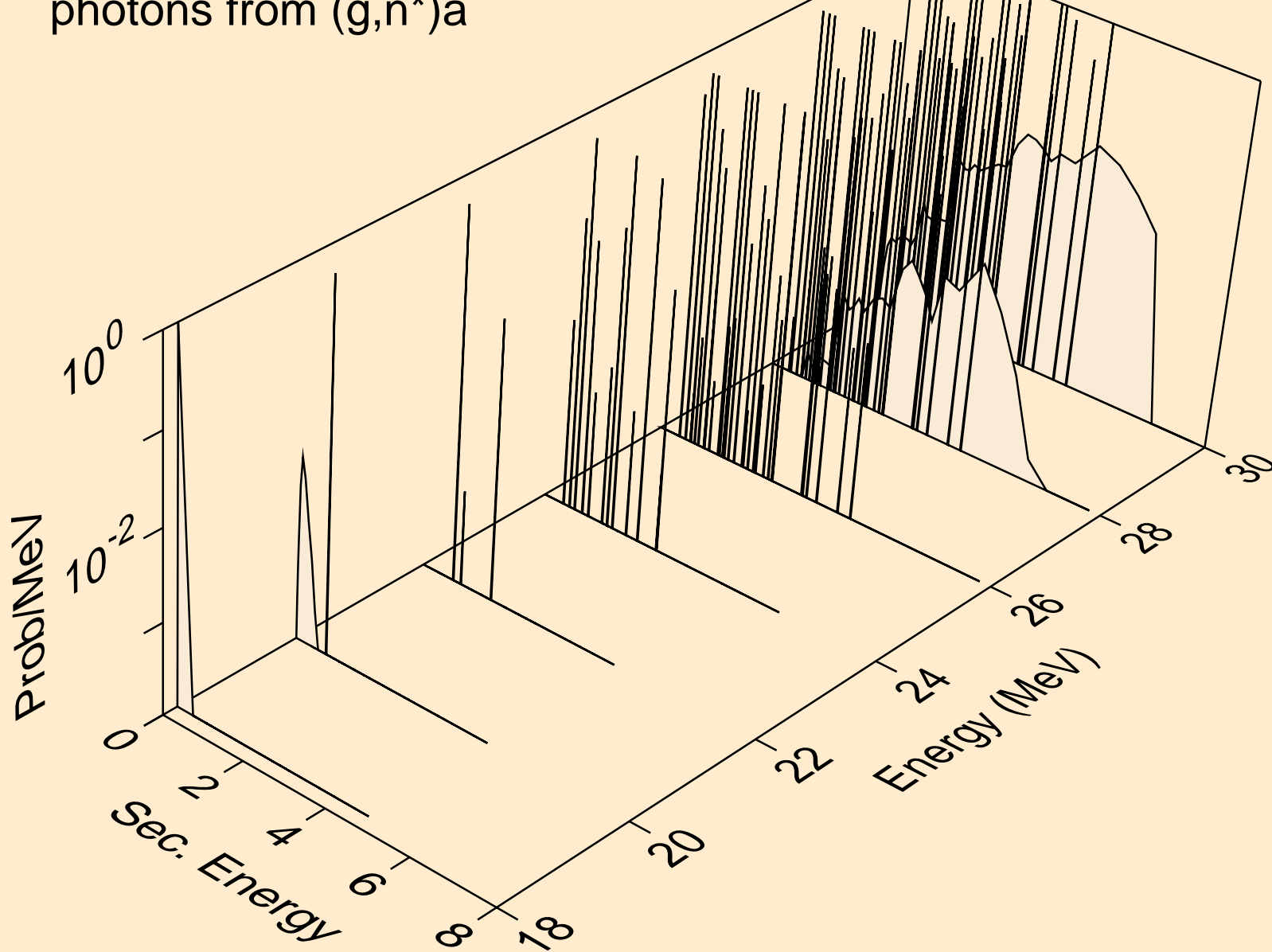

S036 PHOTON ACER TENDL-2023 LIBRARY; T=0.K
photons from (g,2n)a

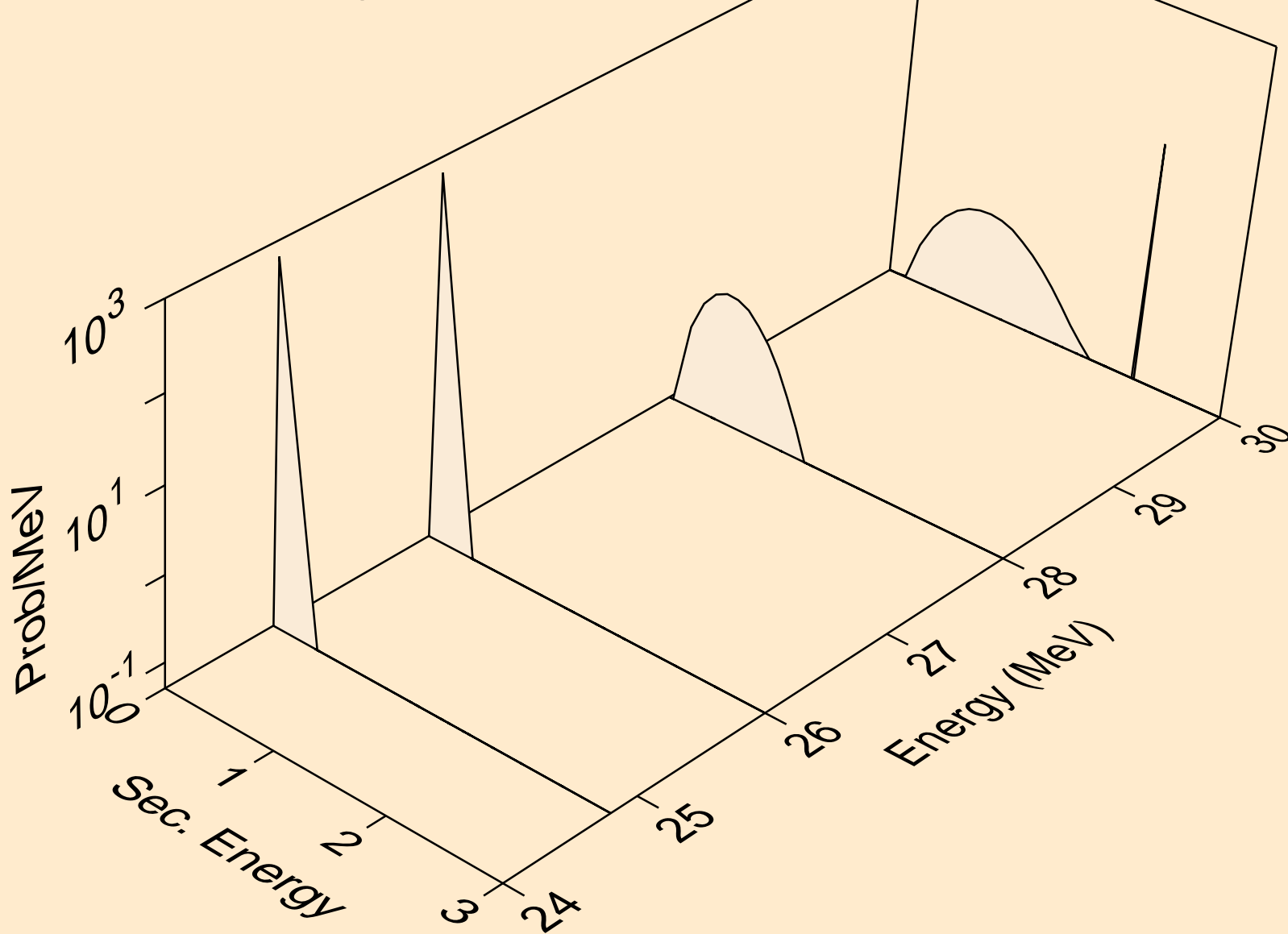

S036 PHOTON ACER TENDL-2023 LIBRARY; T=0.K
photons from (g,n*)p

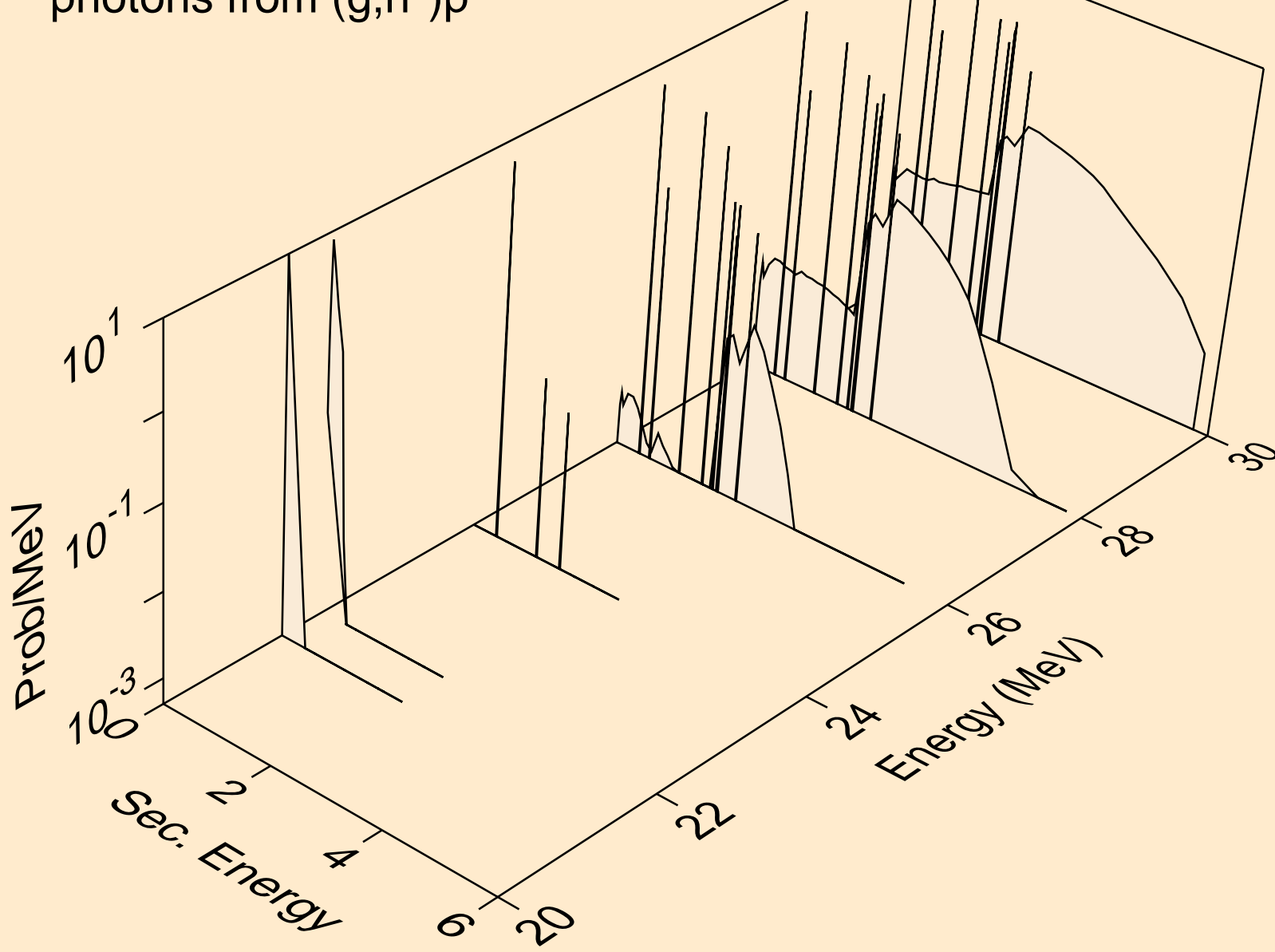

S036 PHOTON ACER TENDL-2023 LIBRARY; T=0.K
photons from (g,n*)d

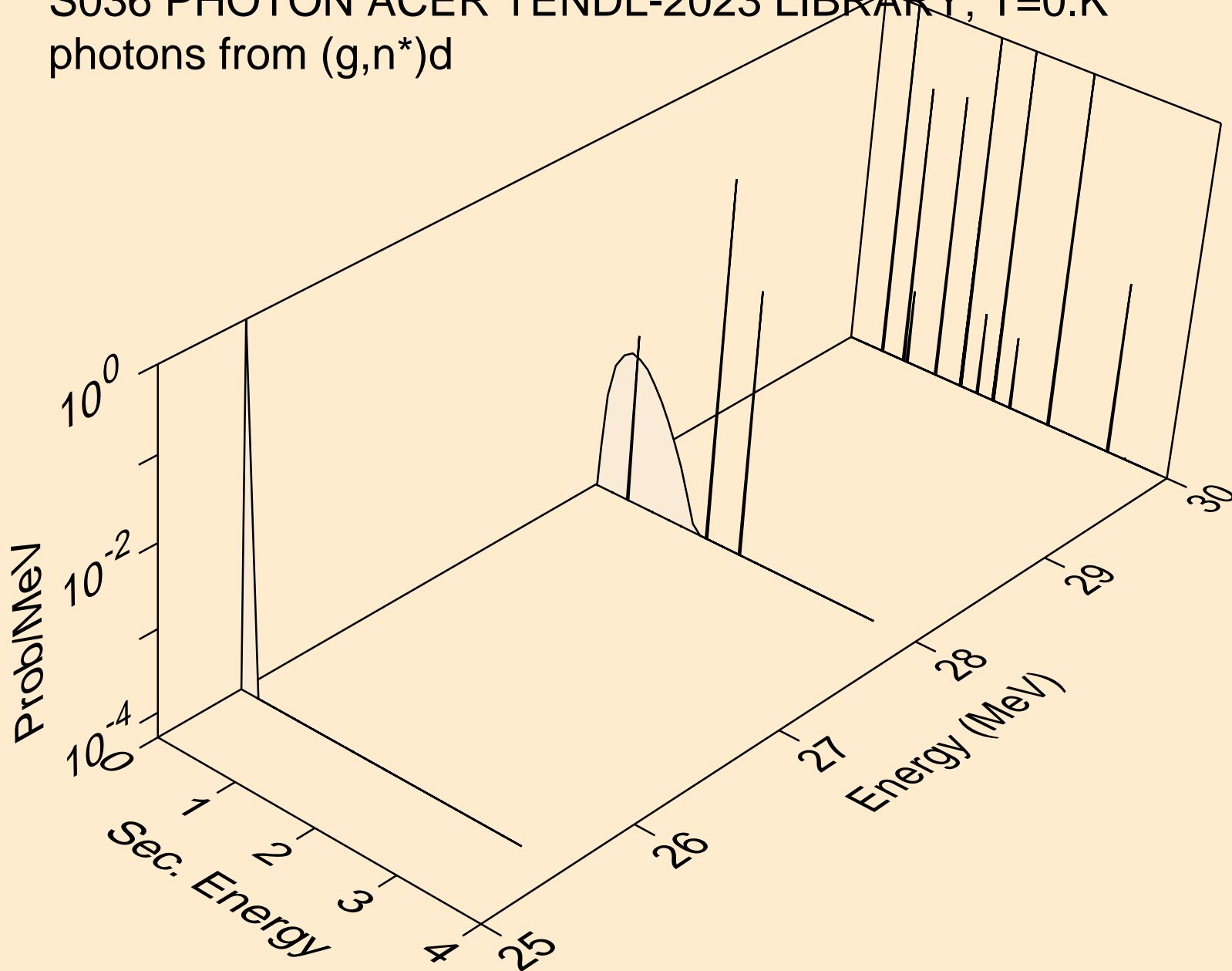

S036 PHOTON ACER TENDL-2023 LIBRARY; T=0.K
photons from (g,2np)

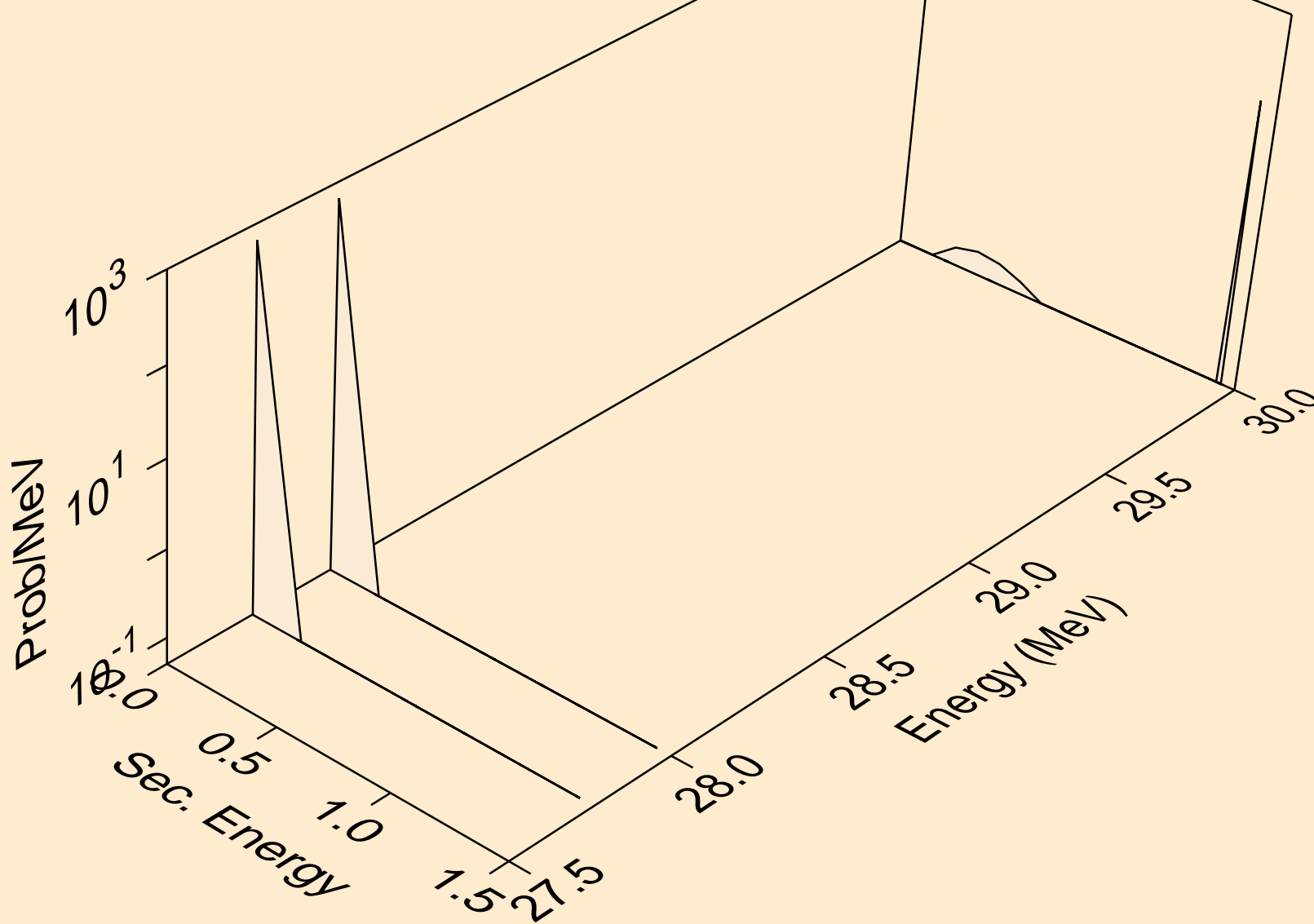

S036 PHOTON ACER TENDL-2023 LIBRARY; T=0.K
photons from (g,n*c)

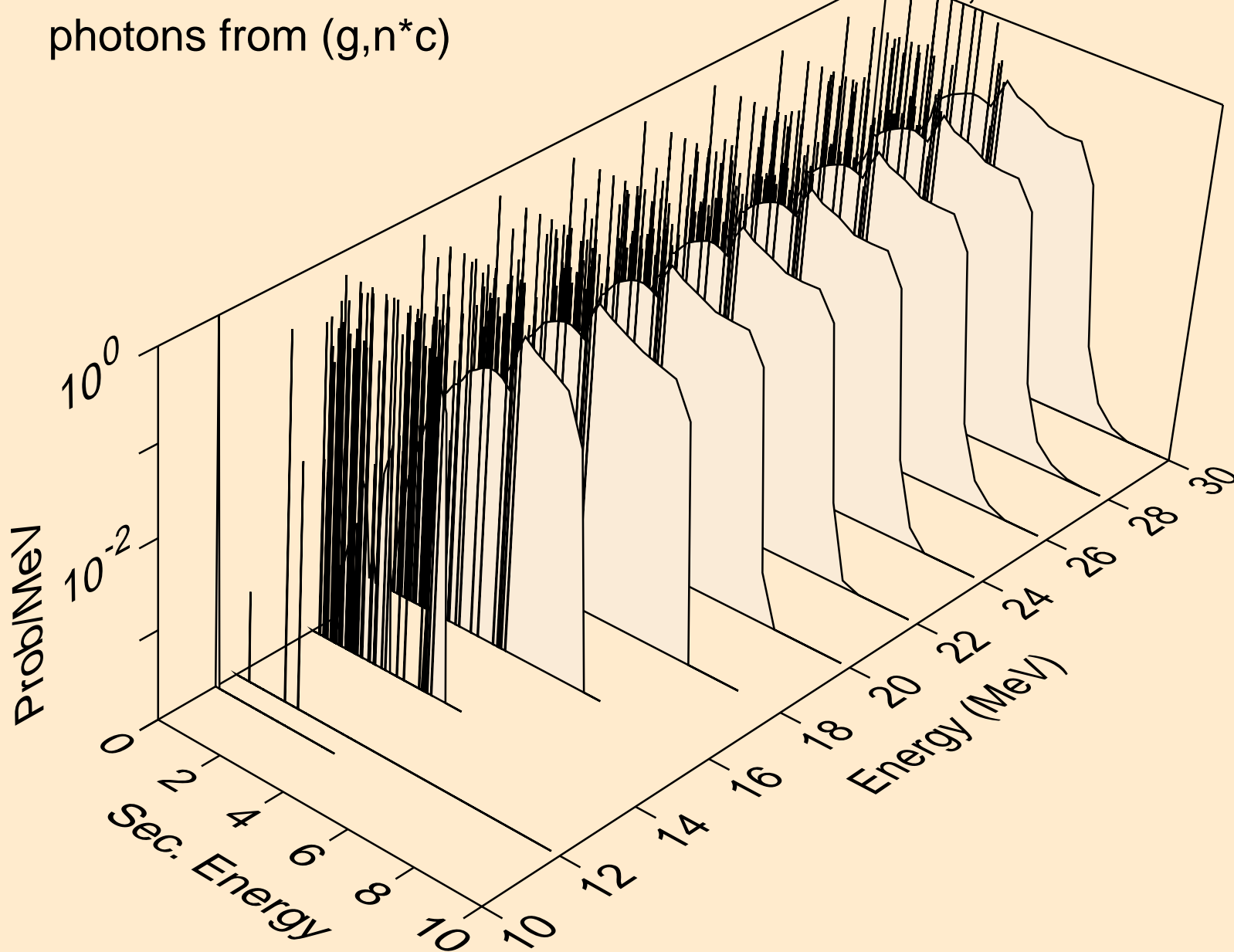

S036 PHOTON ACER TENDL-2023 LIBRARY; T=0.K
photons from (g,gma)

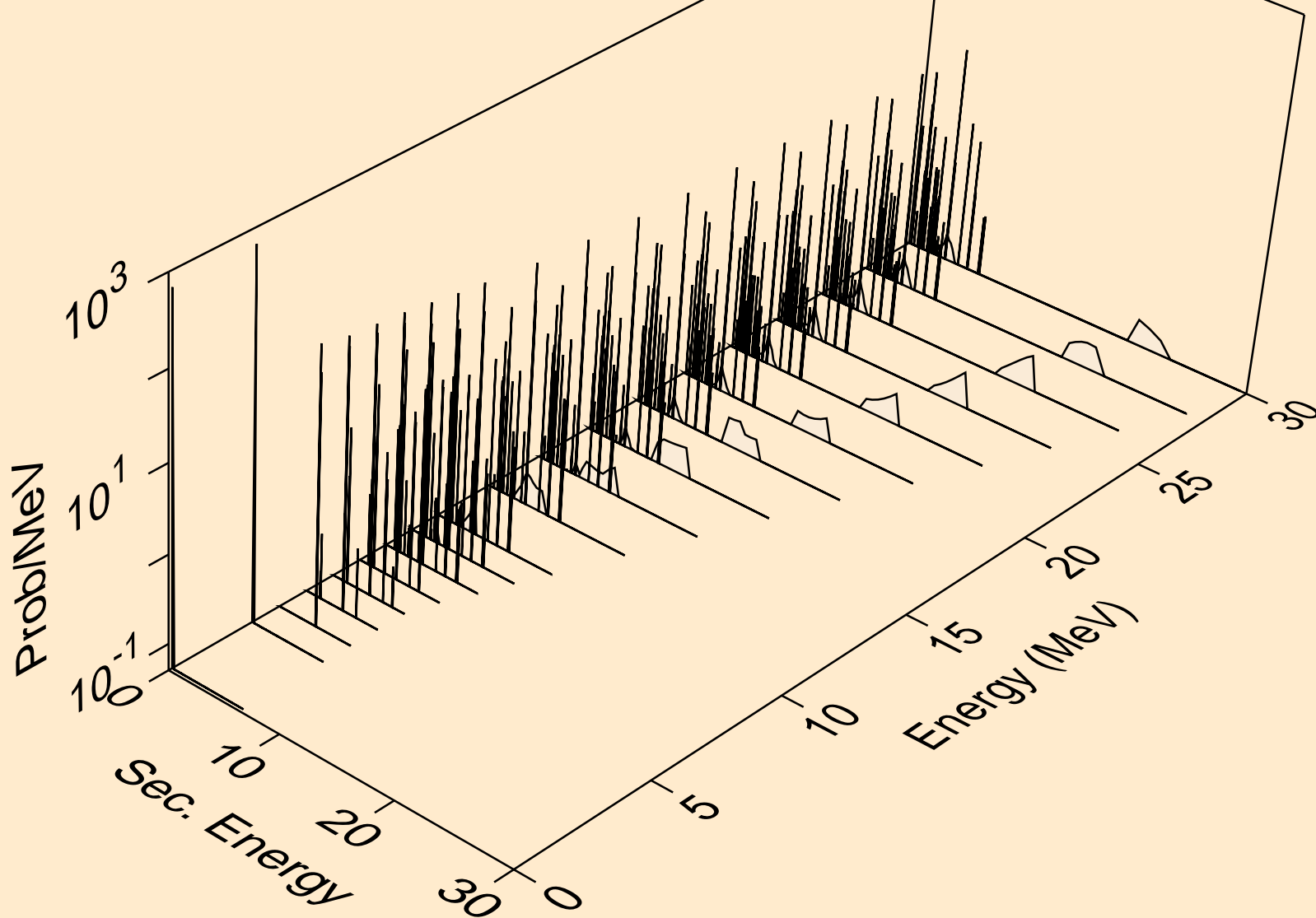

S036 PHOTON ACER TENDL-2023 LIBRARY; T=0.K
photons from (g,p)

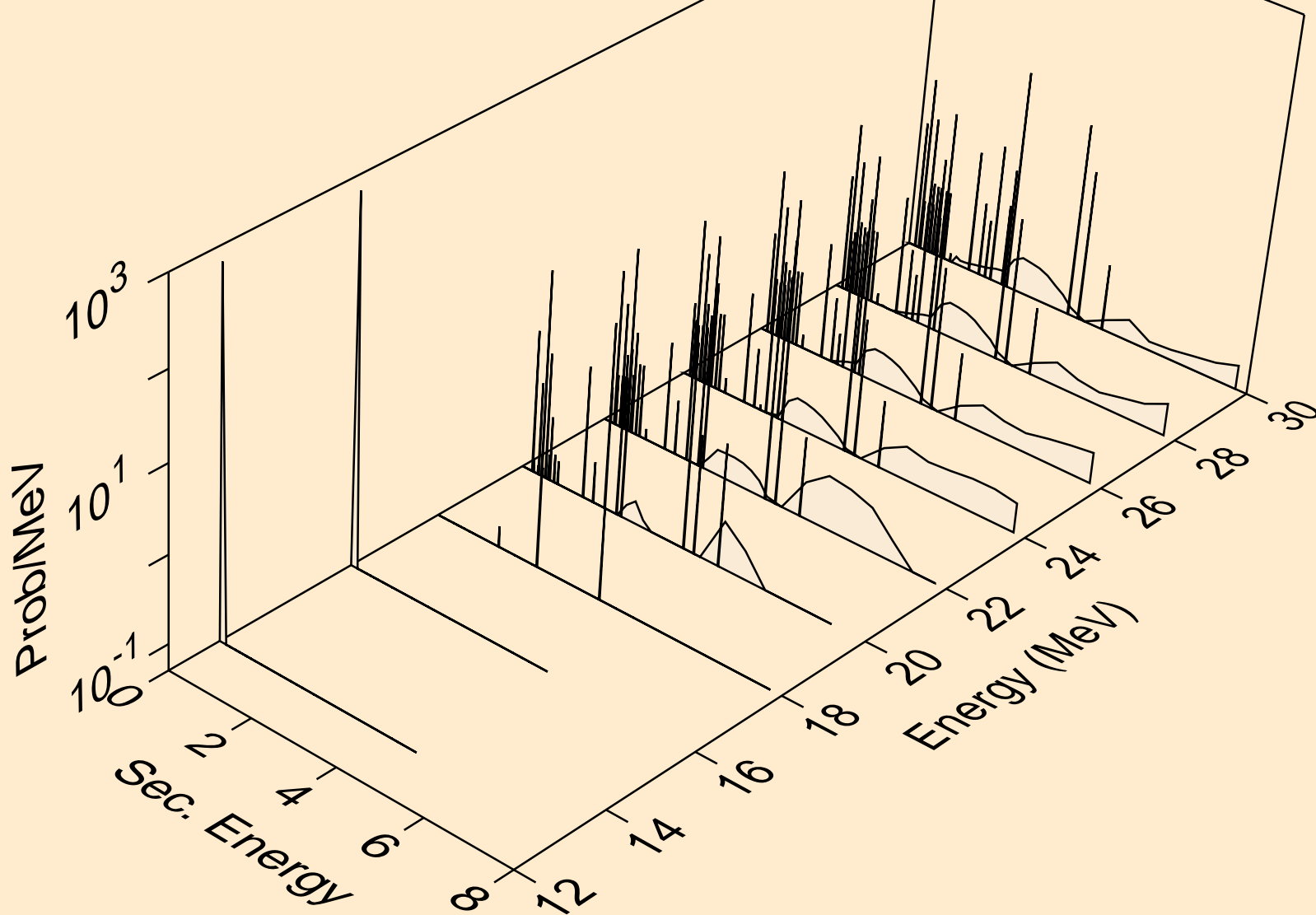

S036 PHOTON ACER TENDL-2023 LIBRARY; T=0.K
photons from (g,d)

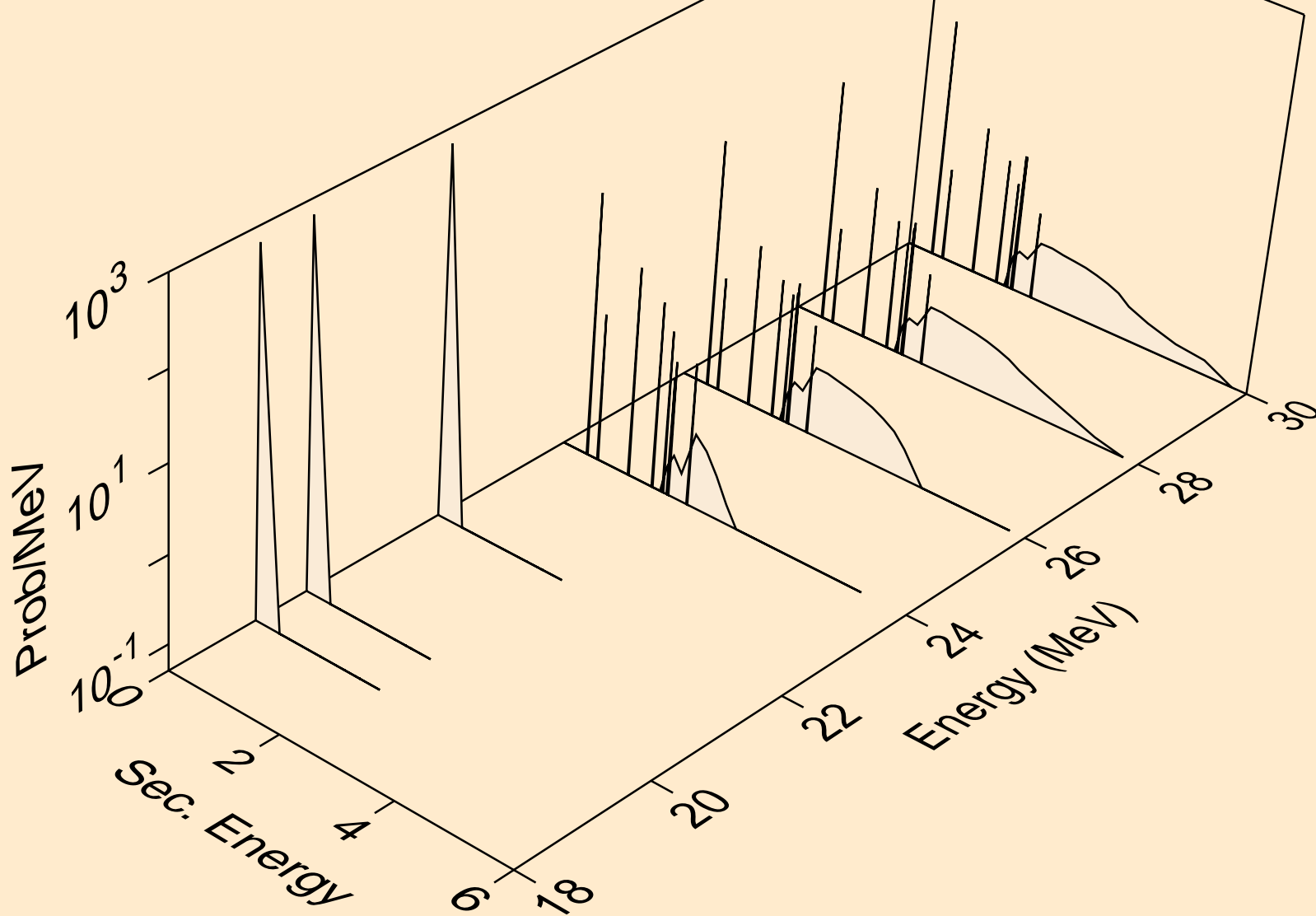

S036 PHOTON ACER TENDL-2023 LIBRARY; T=0.K
photons from (g,t)

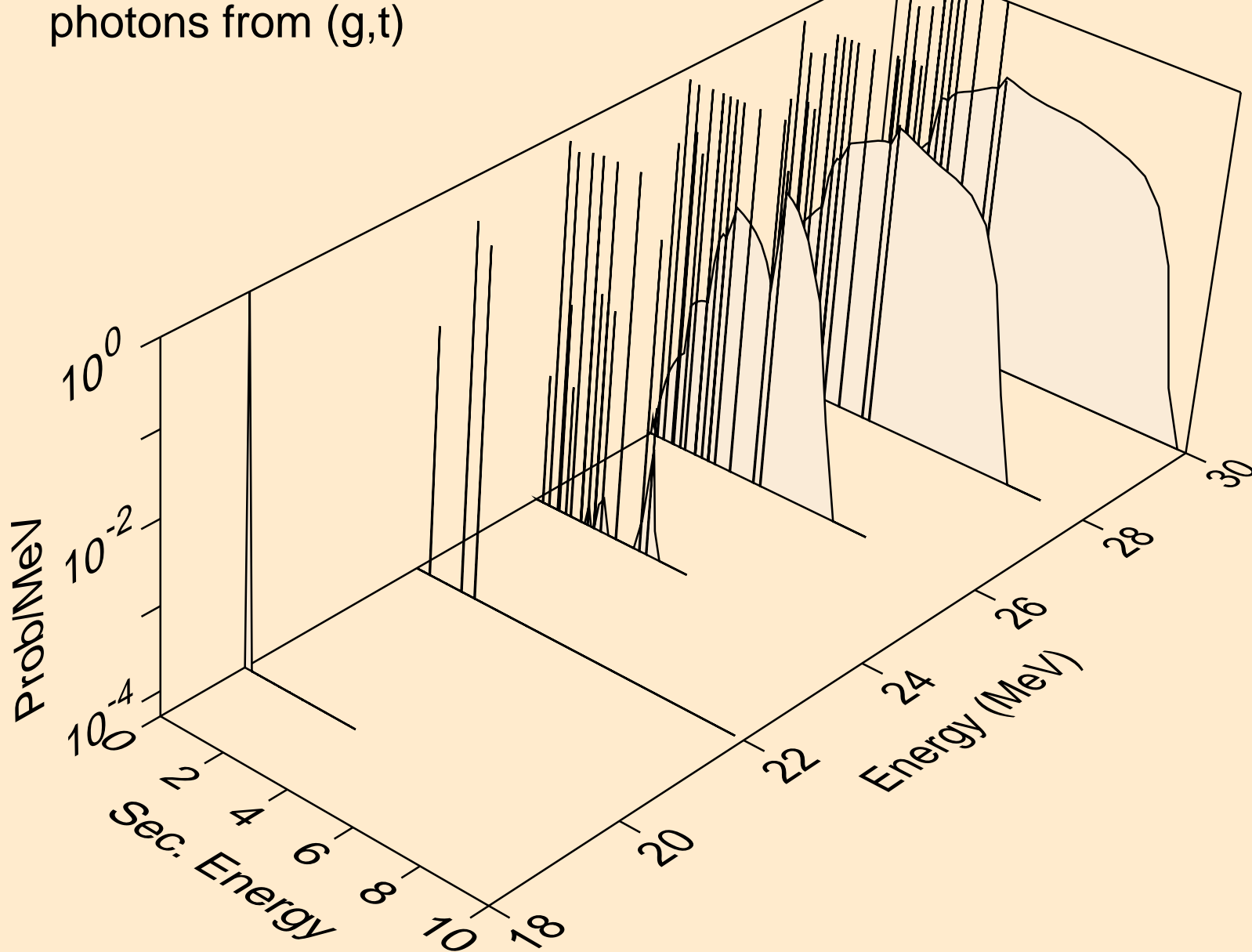

S036 PHOTON ACER TENDL-2023 LIBRARY; T=0.K
photons from (g,he3)

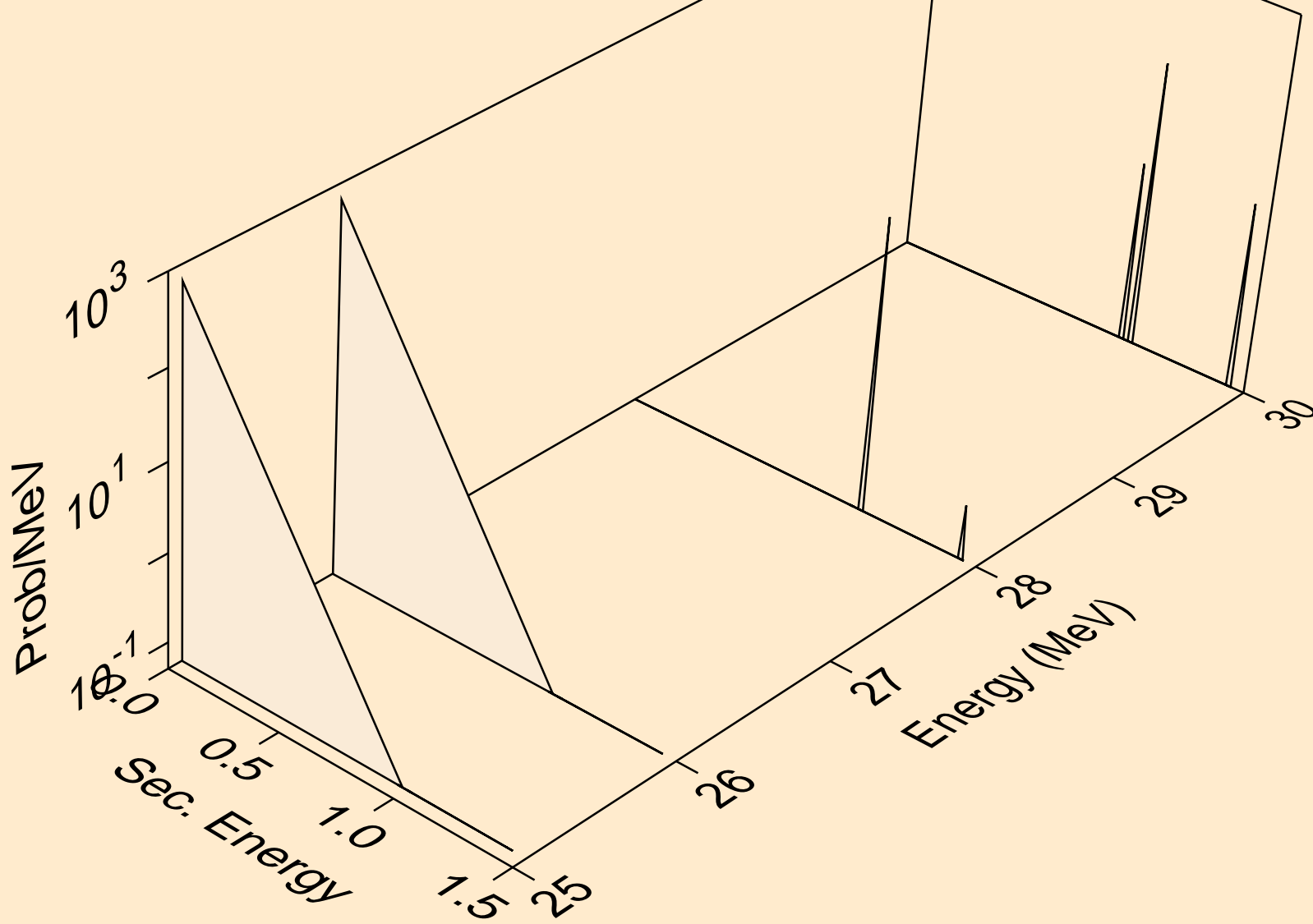

S036 PHOTON ACER TENDL-2023 LIBRARY; T=0.K
photons from (g,a)

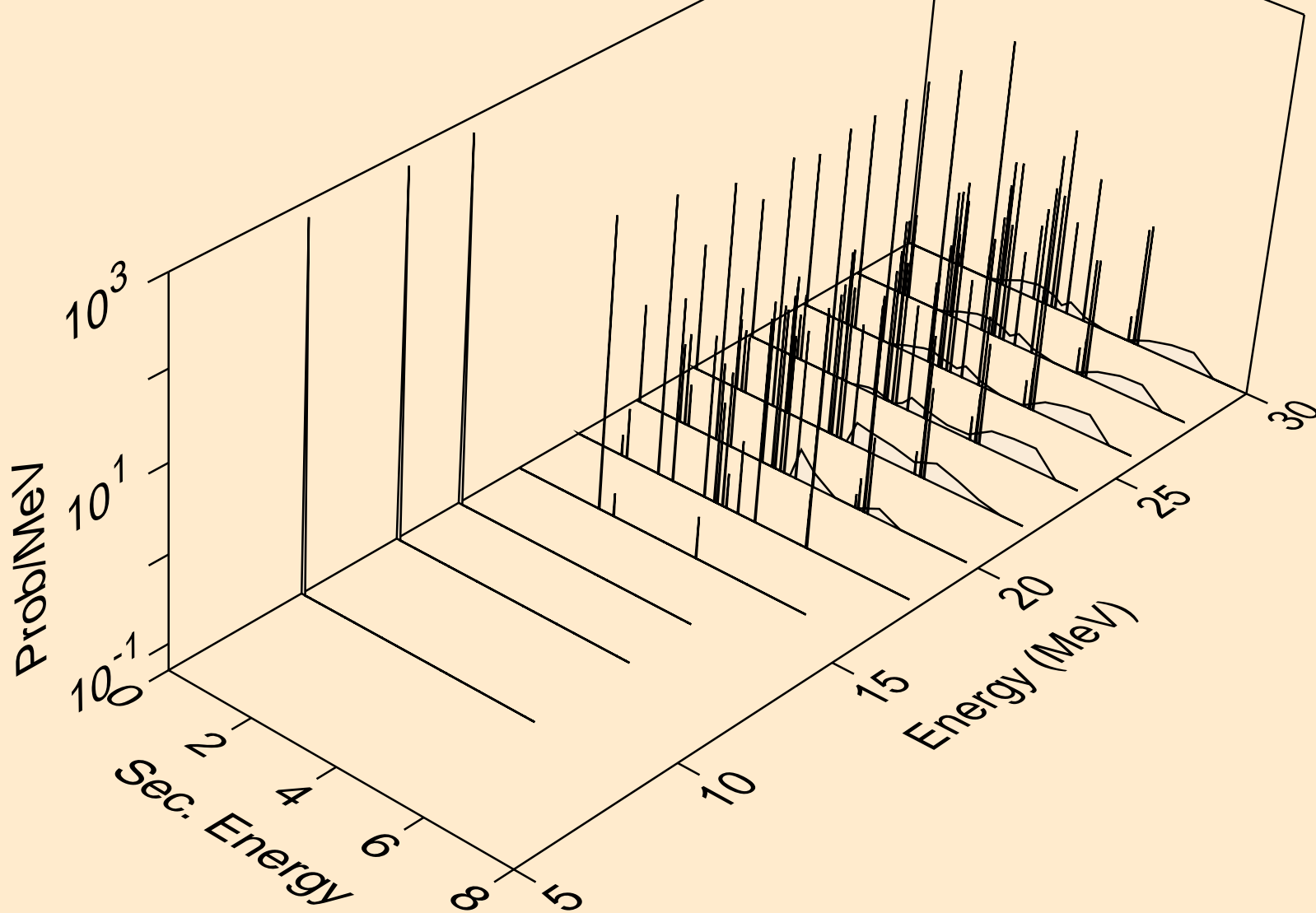

S036 PHOTON ACER TENDL-2023 LIBRARY; T=0.K
photons from (g,2a)

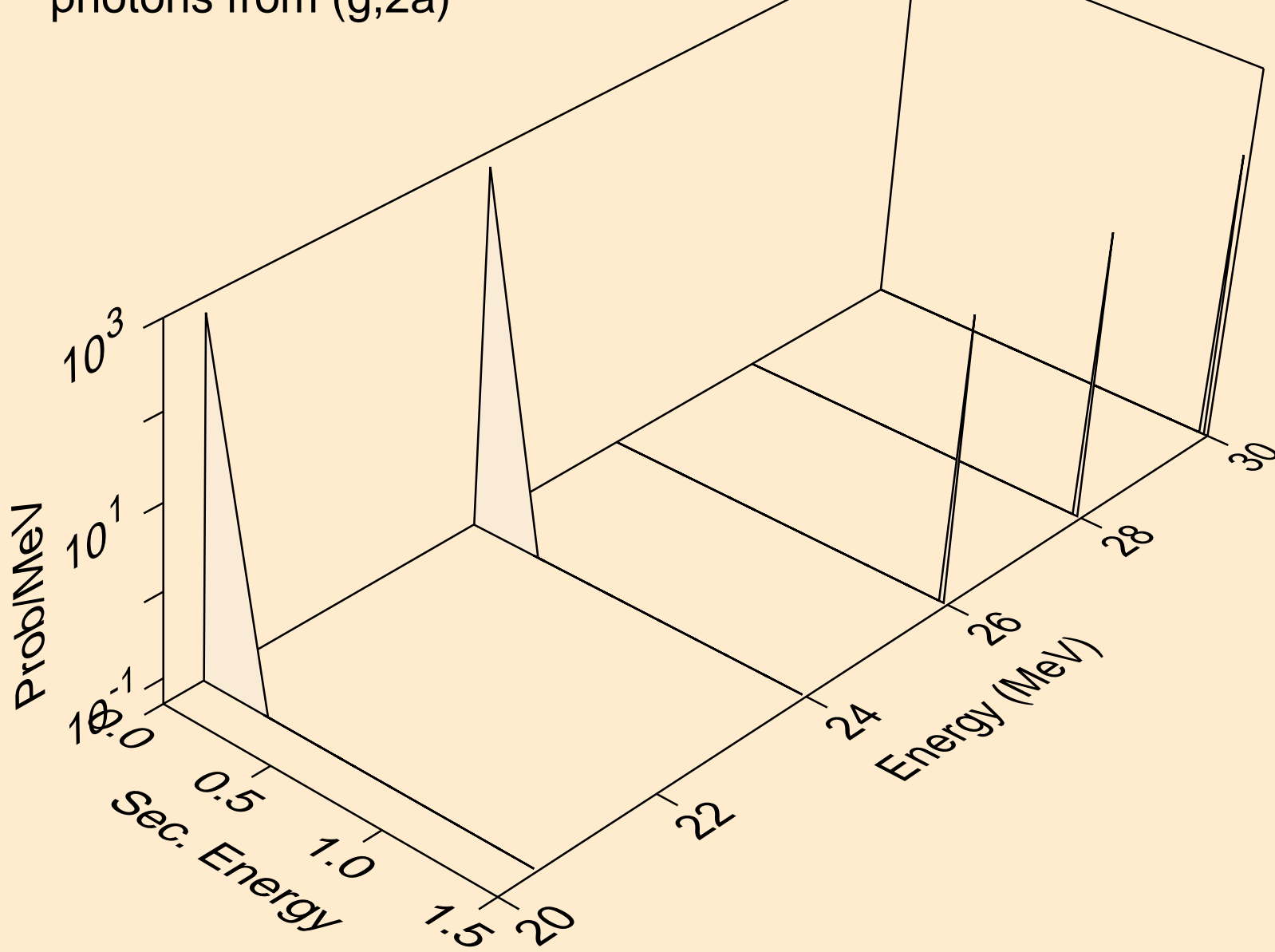

S036 PHOTON ACER TENDL-2023 LIBRARY; T=0.K
photons from (g,2p)

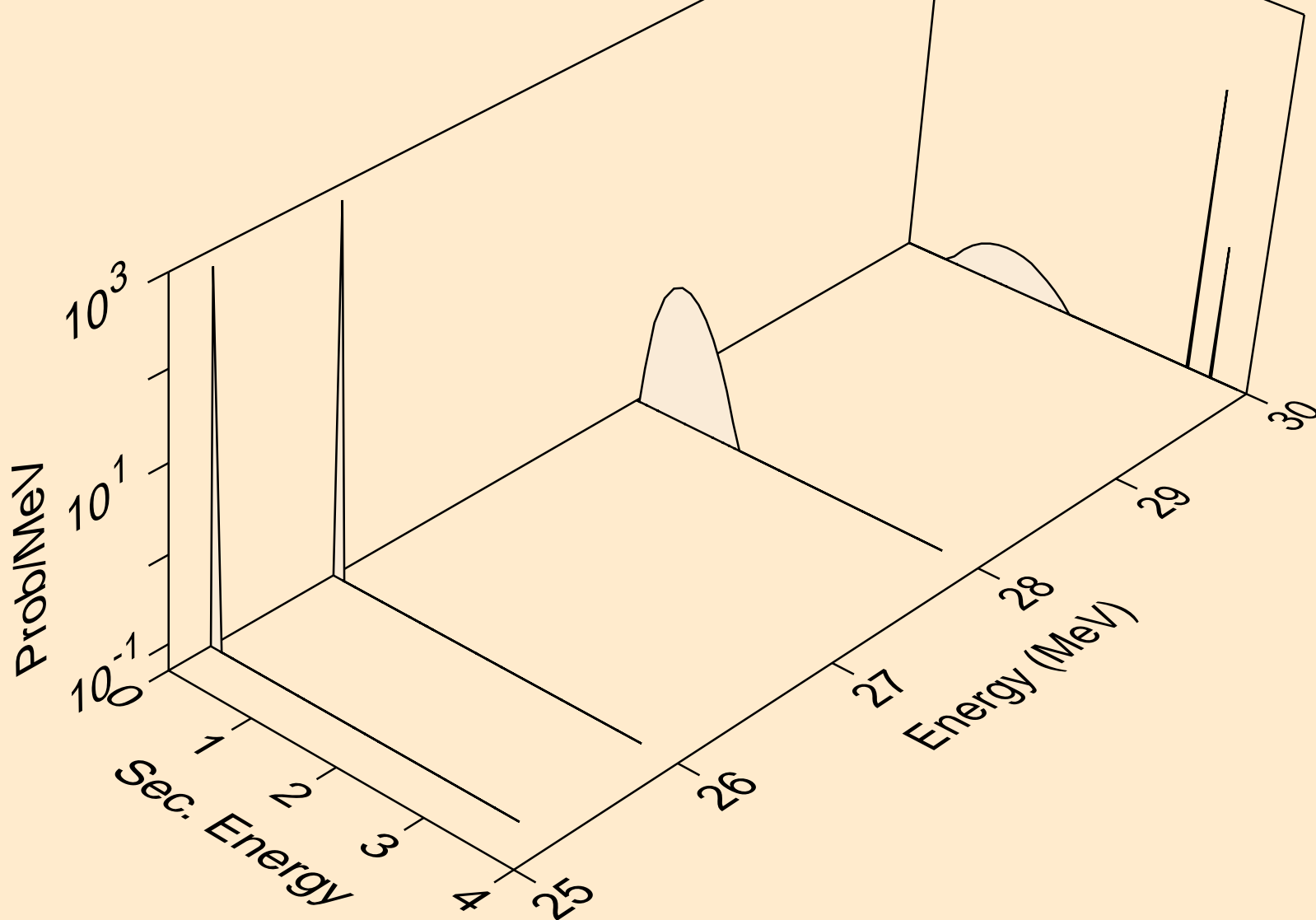

S036 PHOTON ACER TENDL-2023 LIBRARY; T=0.K
photons from (g,pa)

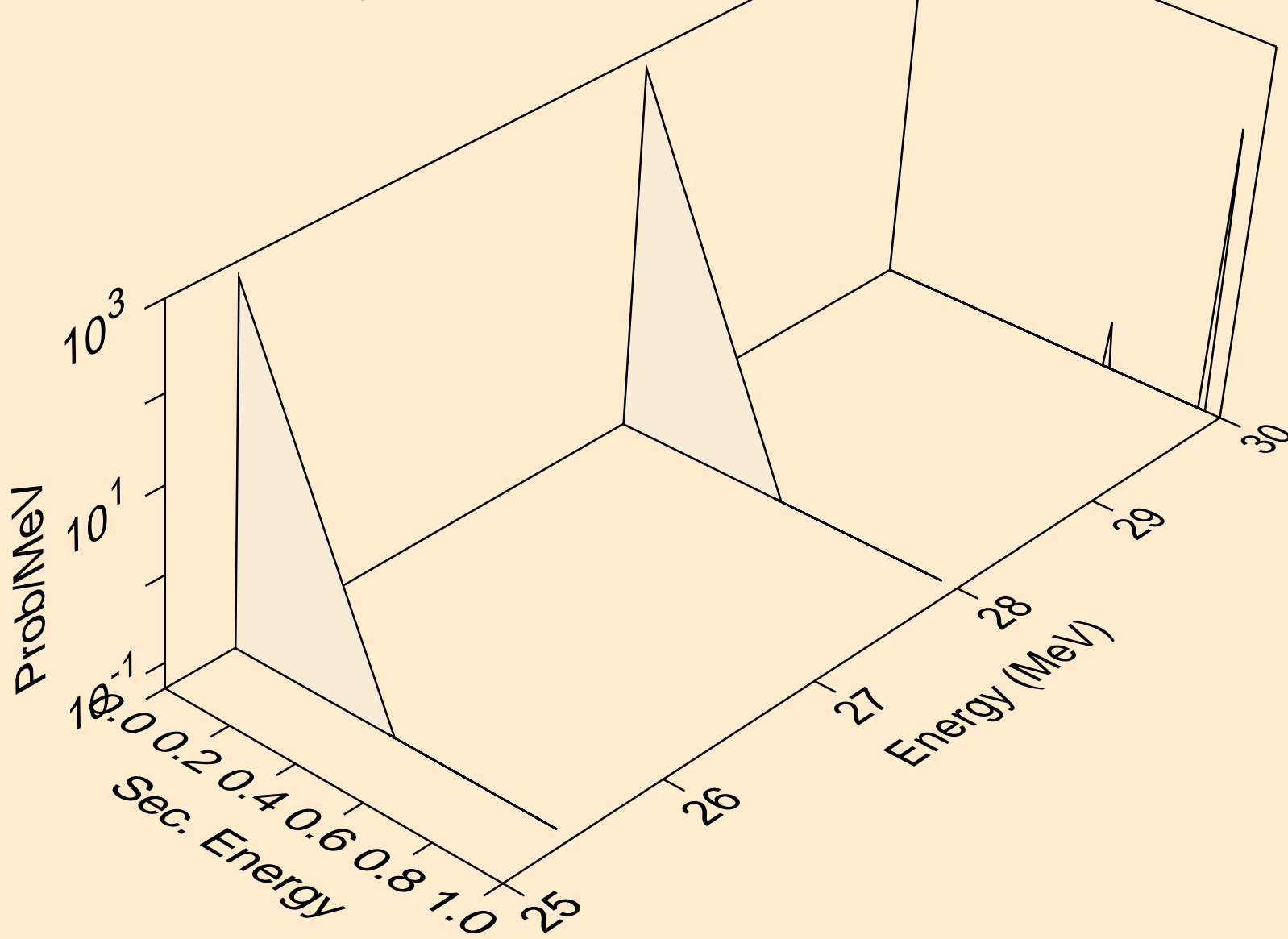

S036 PHOTON ACER TENDL-2023 LIBRARY; T=0.K
protons from (g,x)

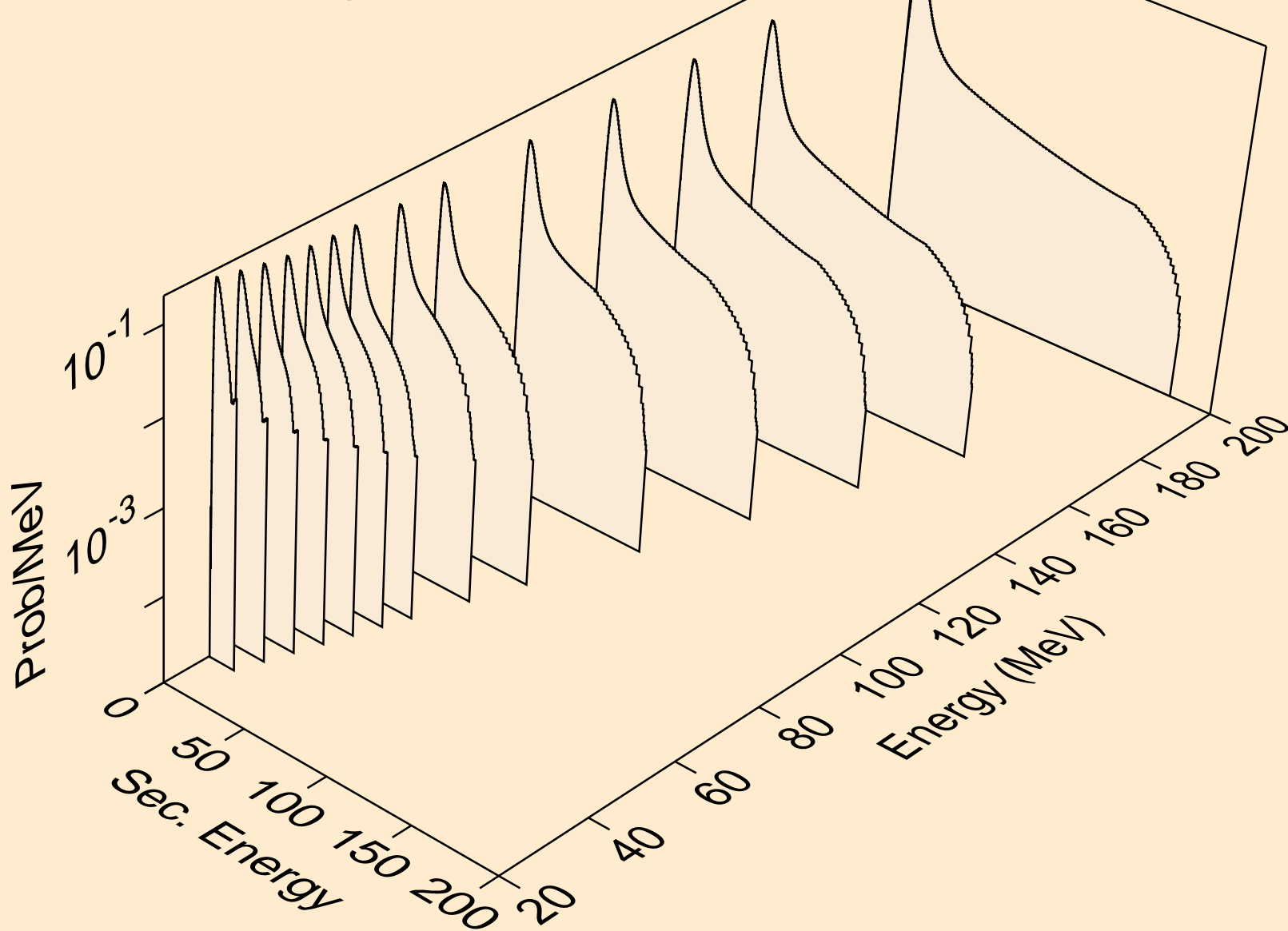

S036 PHOTON ACER TENDL-2023 LIBRARY; T=0.K
protons from (g,n*)p

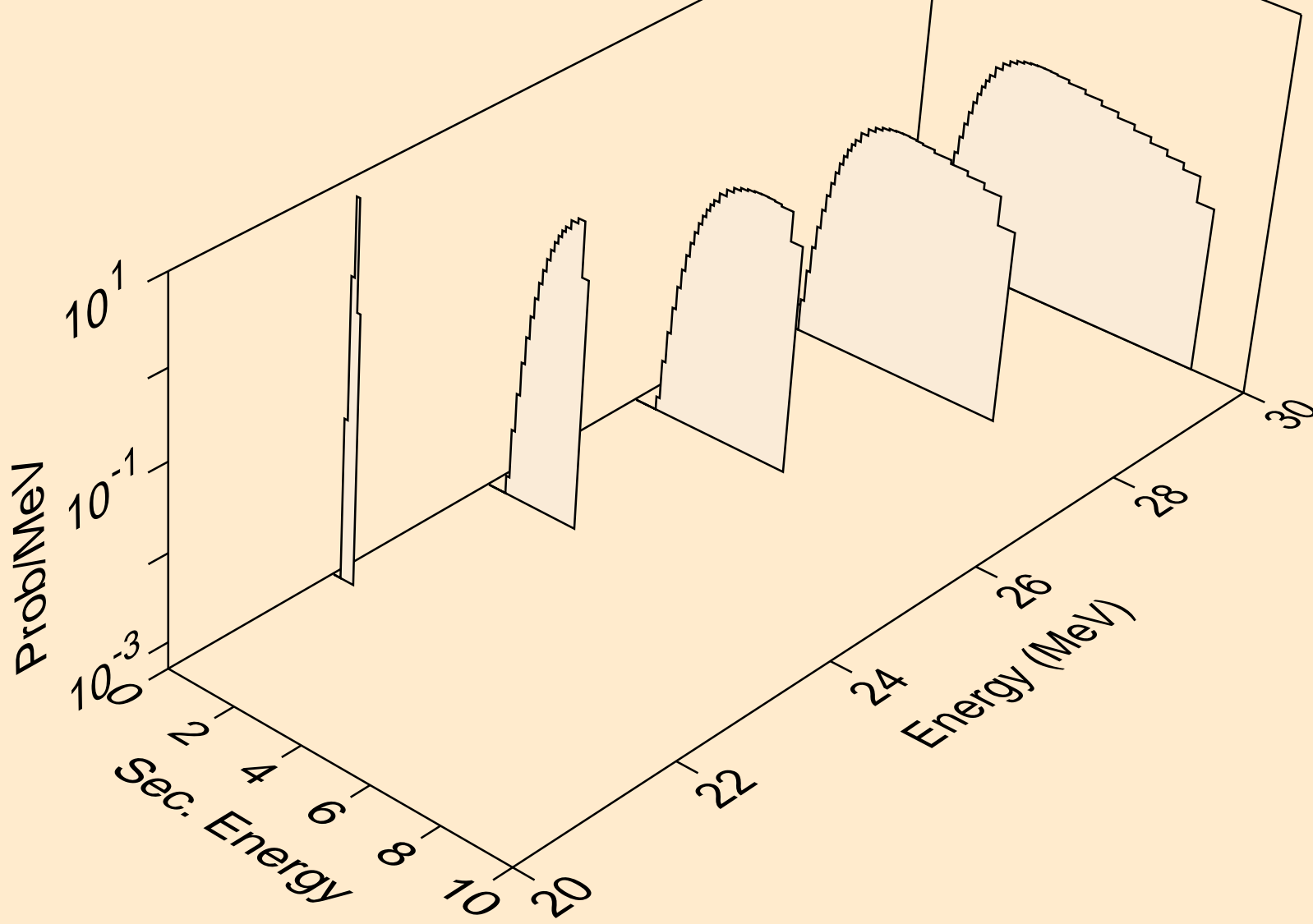

S036 PHOTON ACER TENDL-2023 LIBRARY; T=0.K
protons from (g,2np)

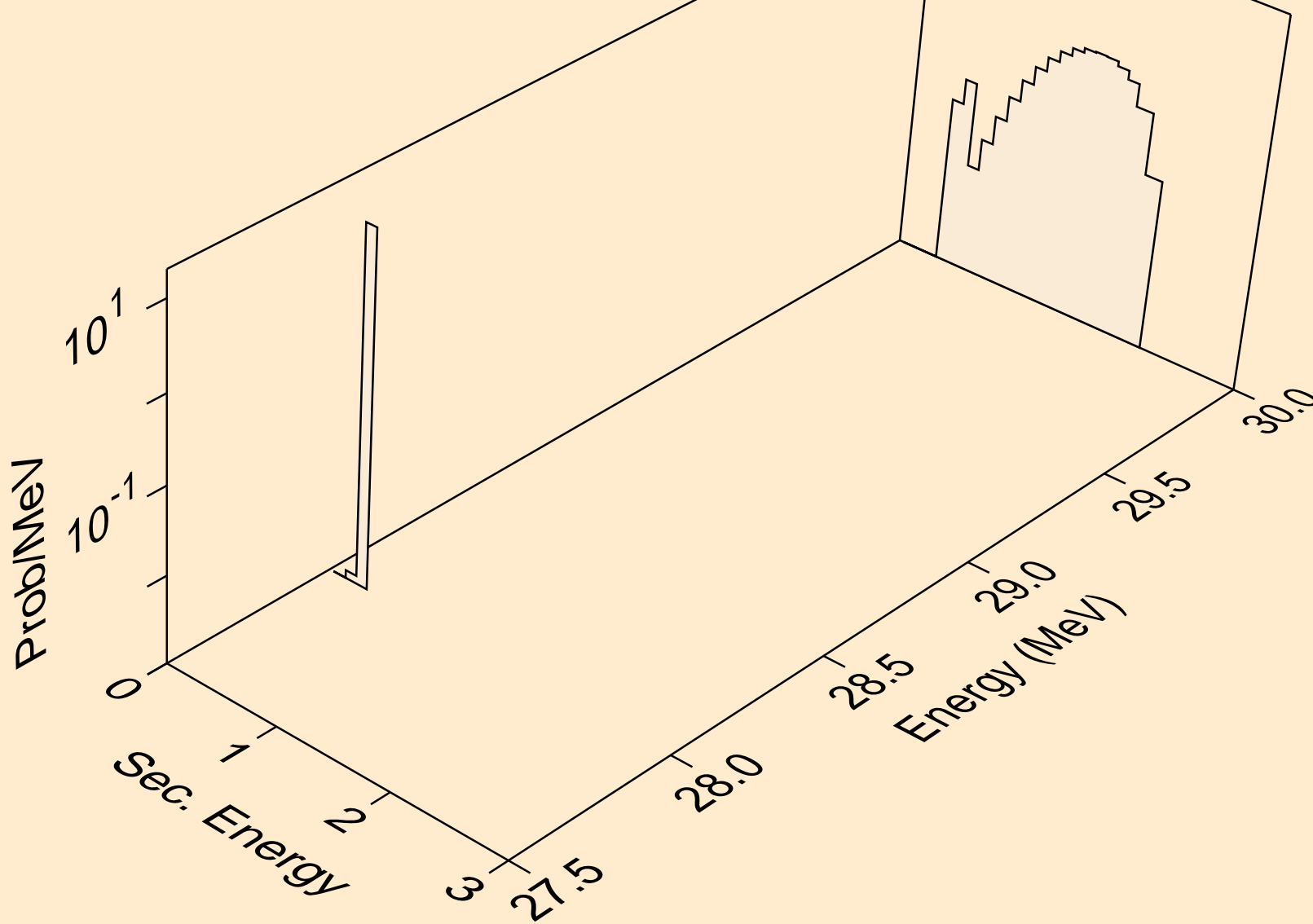

S036 PHOTON ACER TENDL-2023 LIBRARY; T=0.K
protons from (g,p)

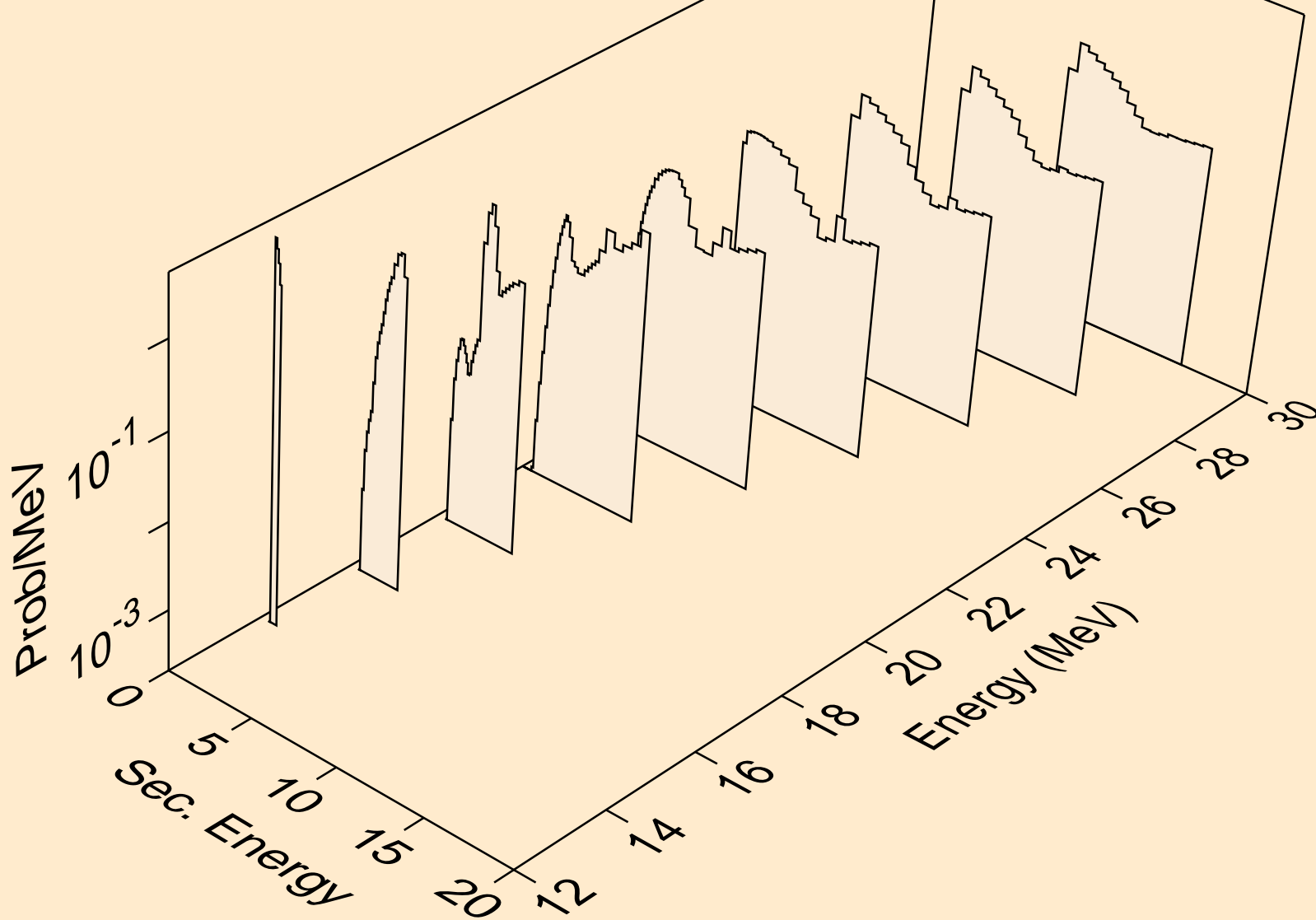

S036 PHOTON ACER TENDL-2023 LIBRARY; T=0.K
protons from (g,2p)

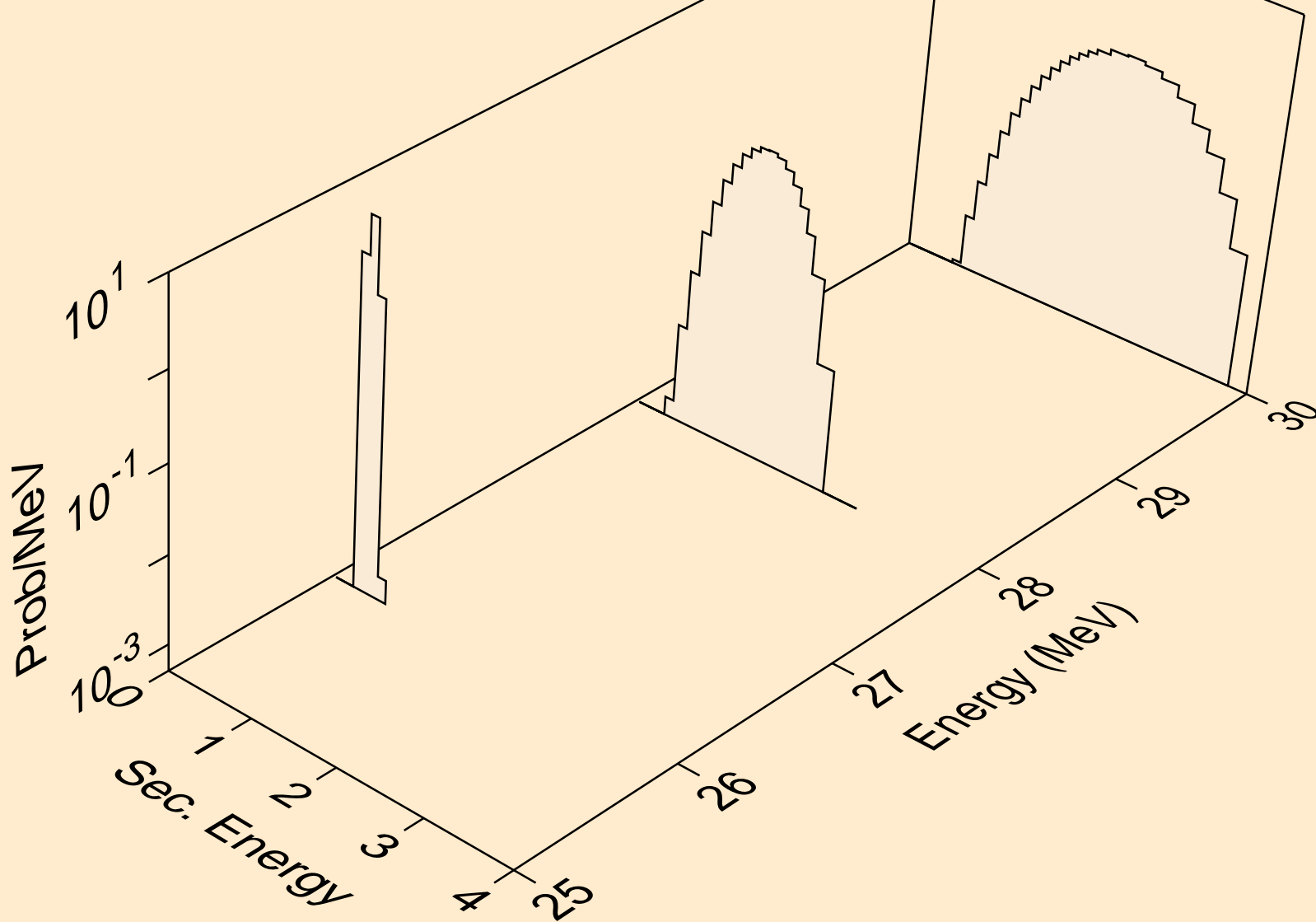

S036 PHOTON ACER TENDL-2023 LIBRARY; T=0.K
protons from (g,pa)

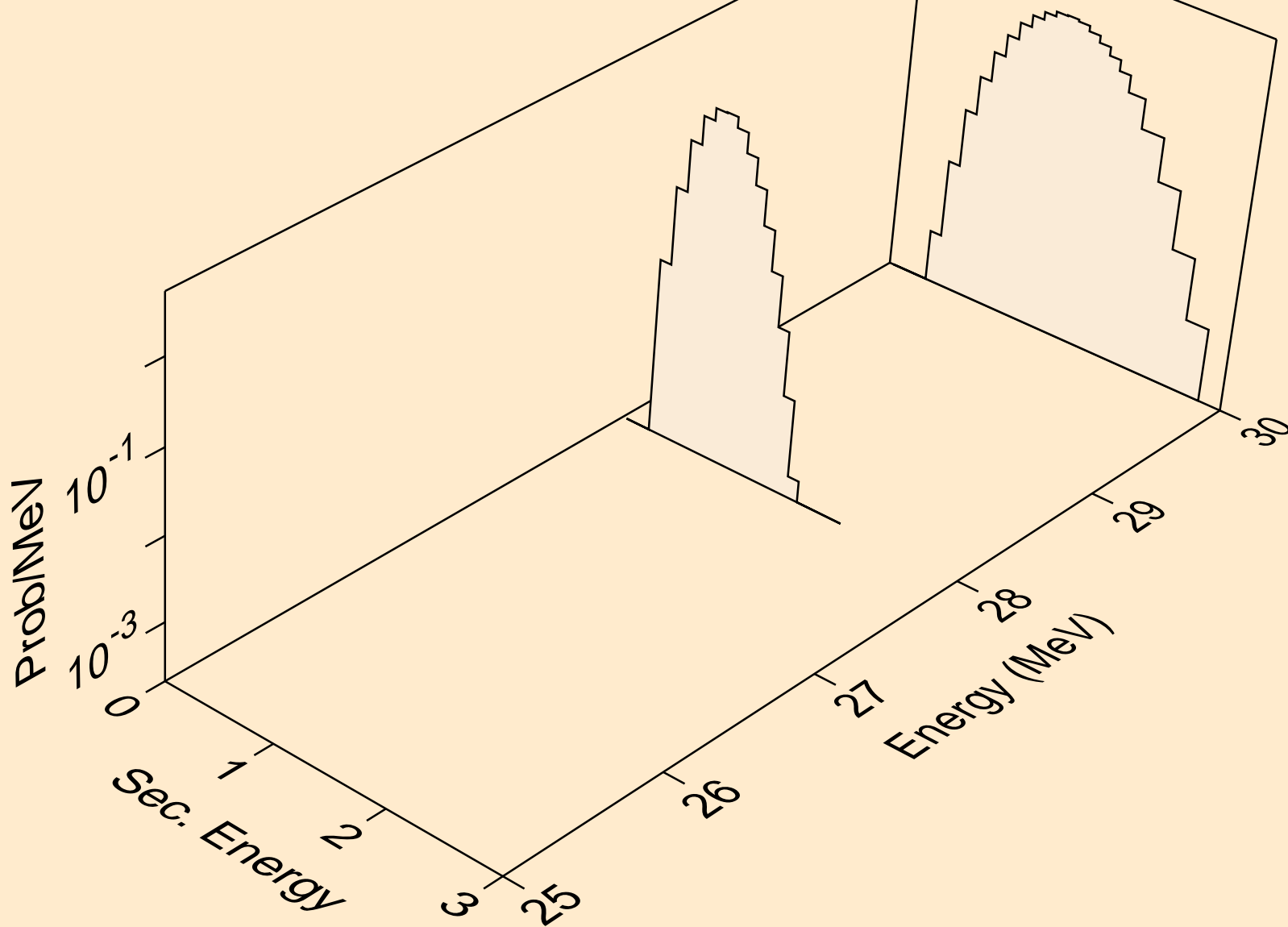

S036 PHOTON ACER TENDL-2023 LIBRARY; T=0.K
deuterons from (g,x)

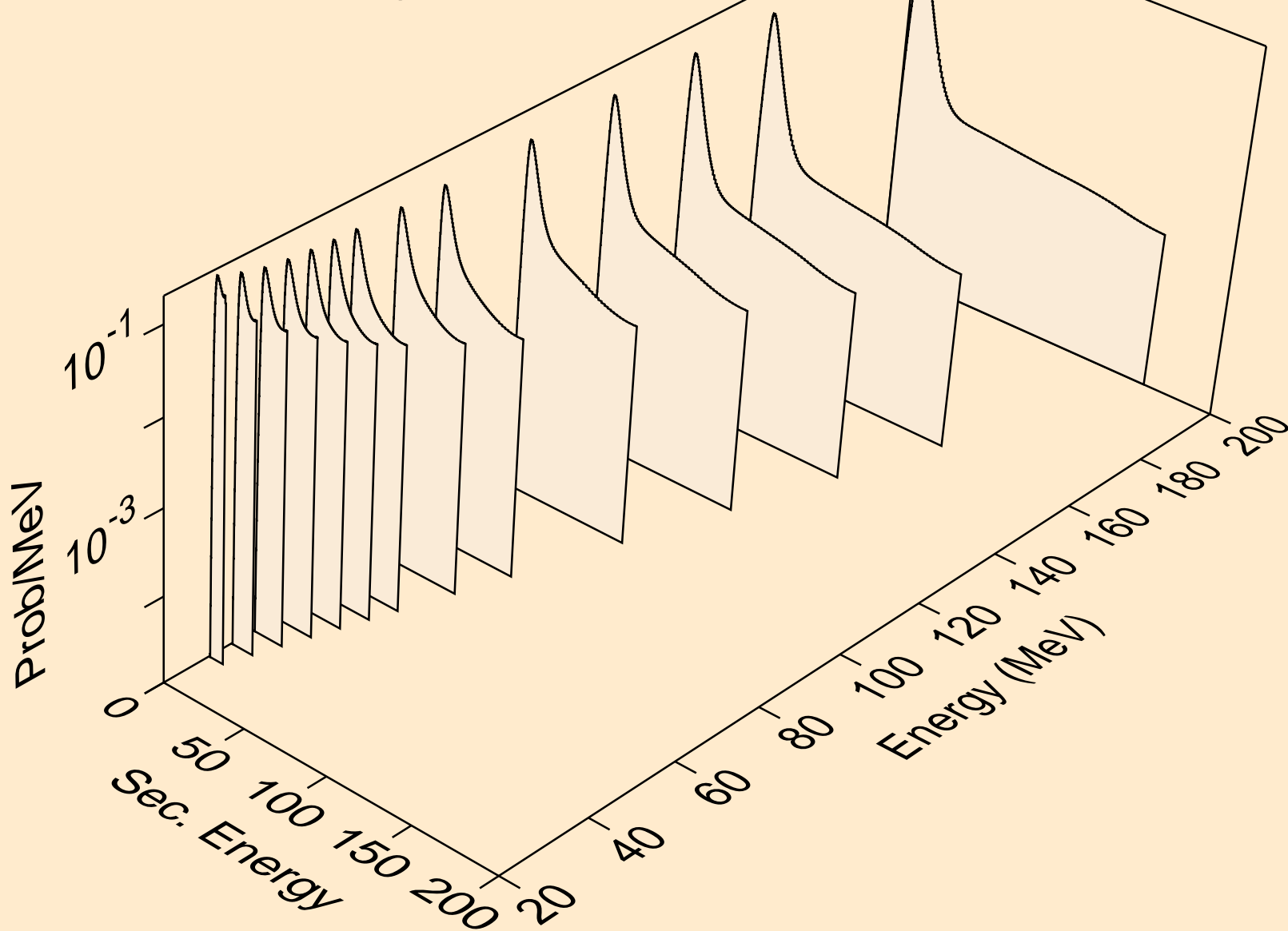

S036 PHOTON ACER TENDL-2023 LIBRARY; T=0.K
deuterons from (g,n*)d

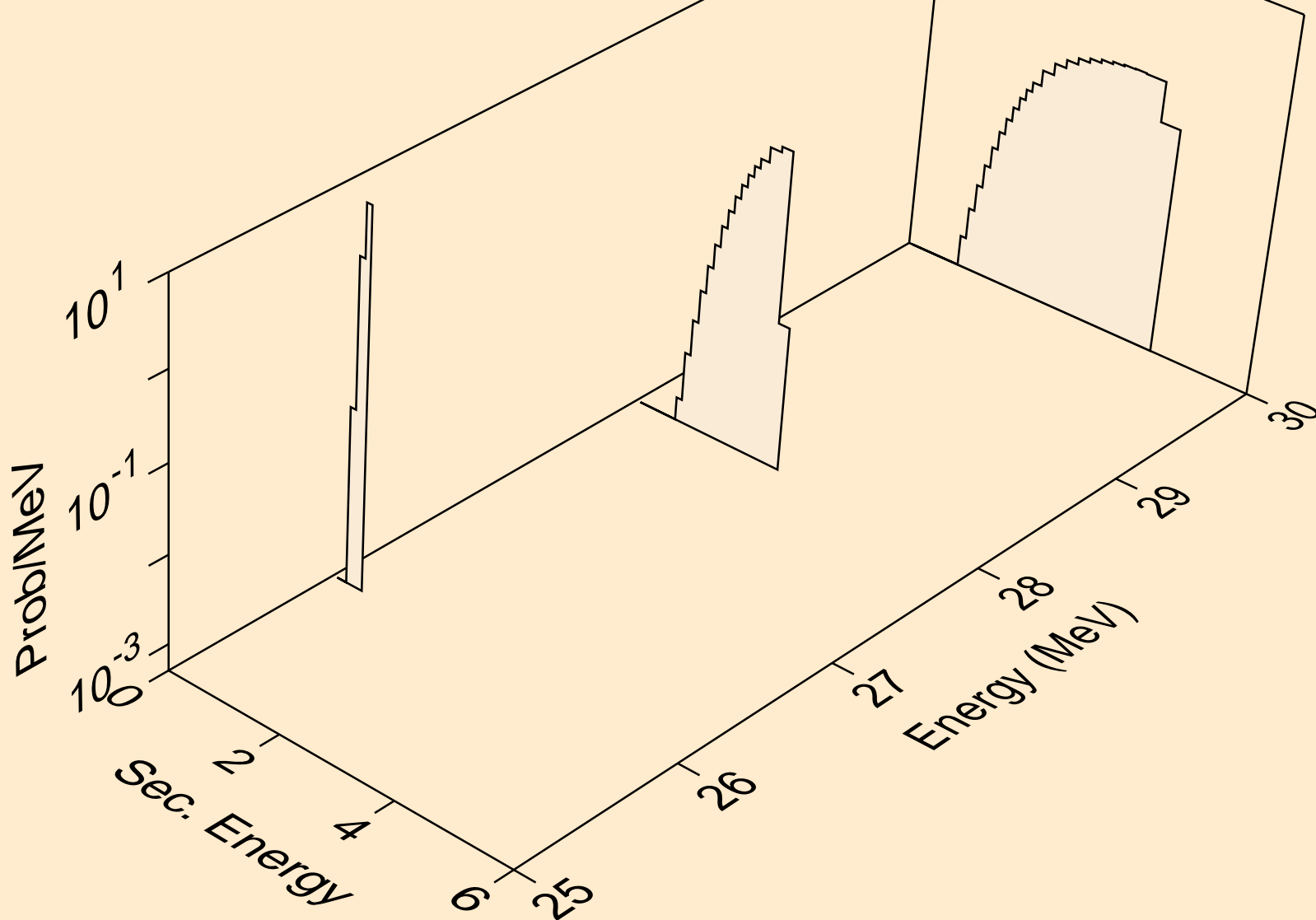

S036 PHOTON ACER TENDL-2023 LIBRARY; T=0.K
deuterons from (g,d)

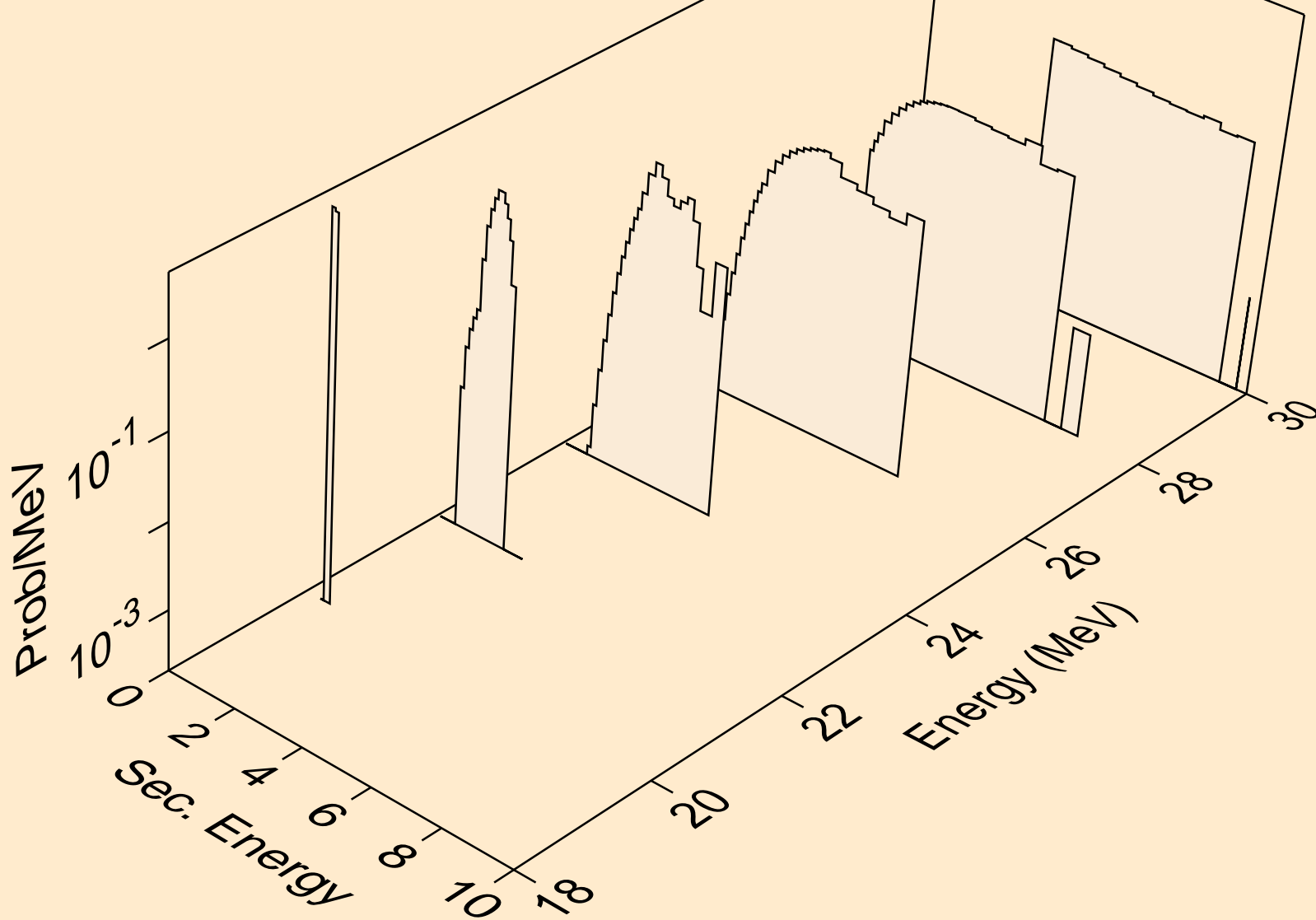

S036 PHOTON ACER TENDL-2023 LIBRARY; T=0.K
tritons from (g,x)

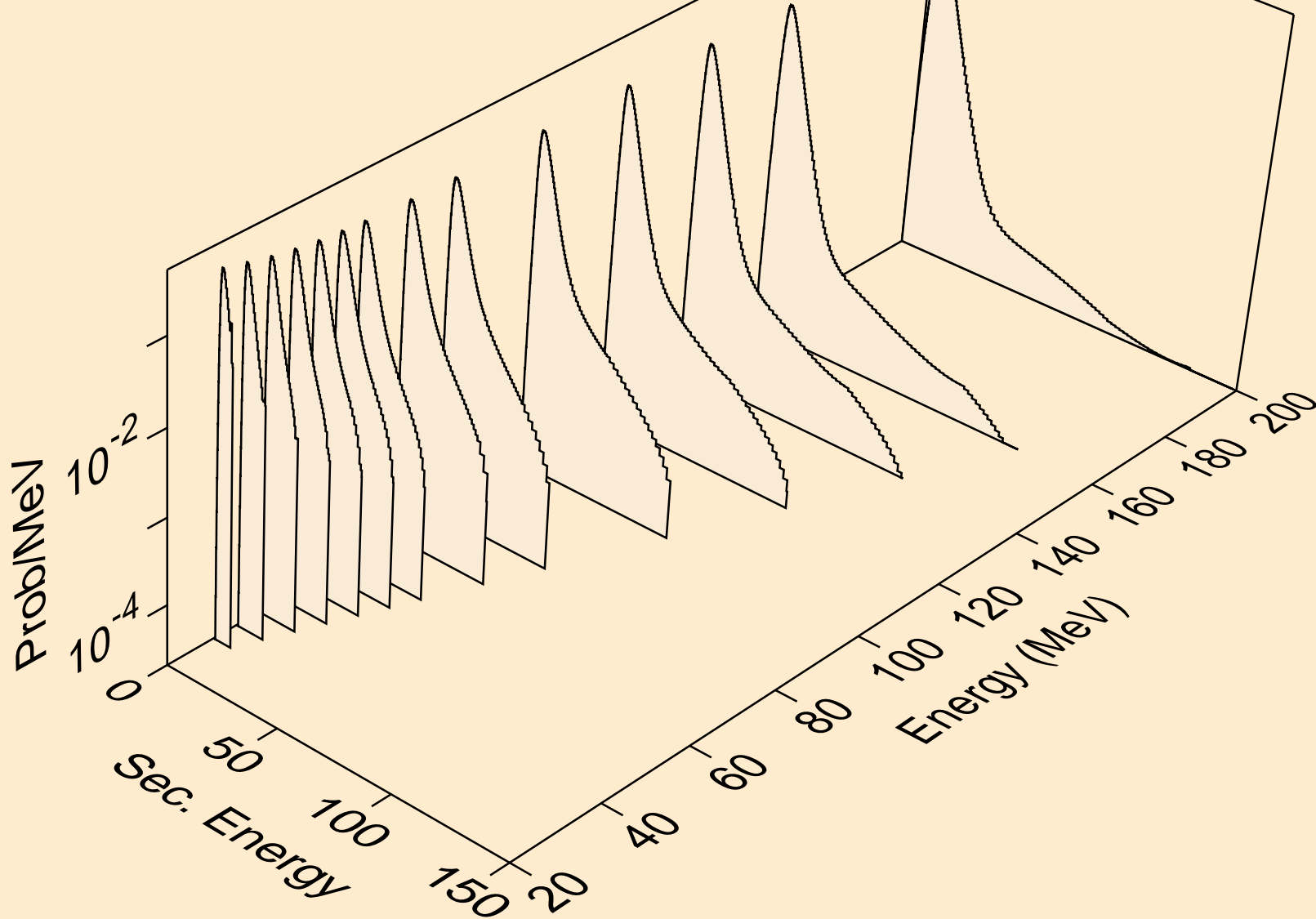

S036 PHOTON ACER TENDL-2023 LIBRARY; T=0.K
tritons from (g,t)

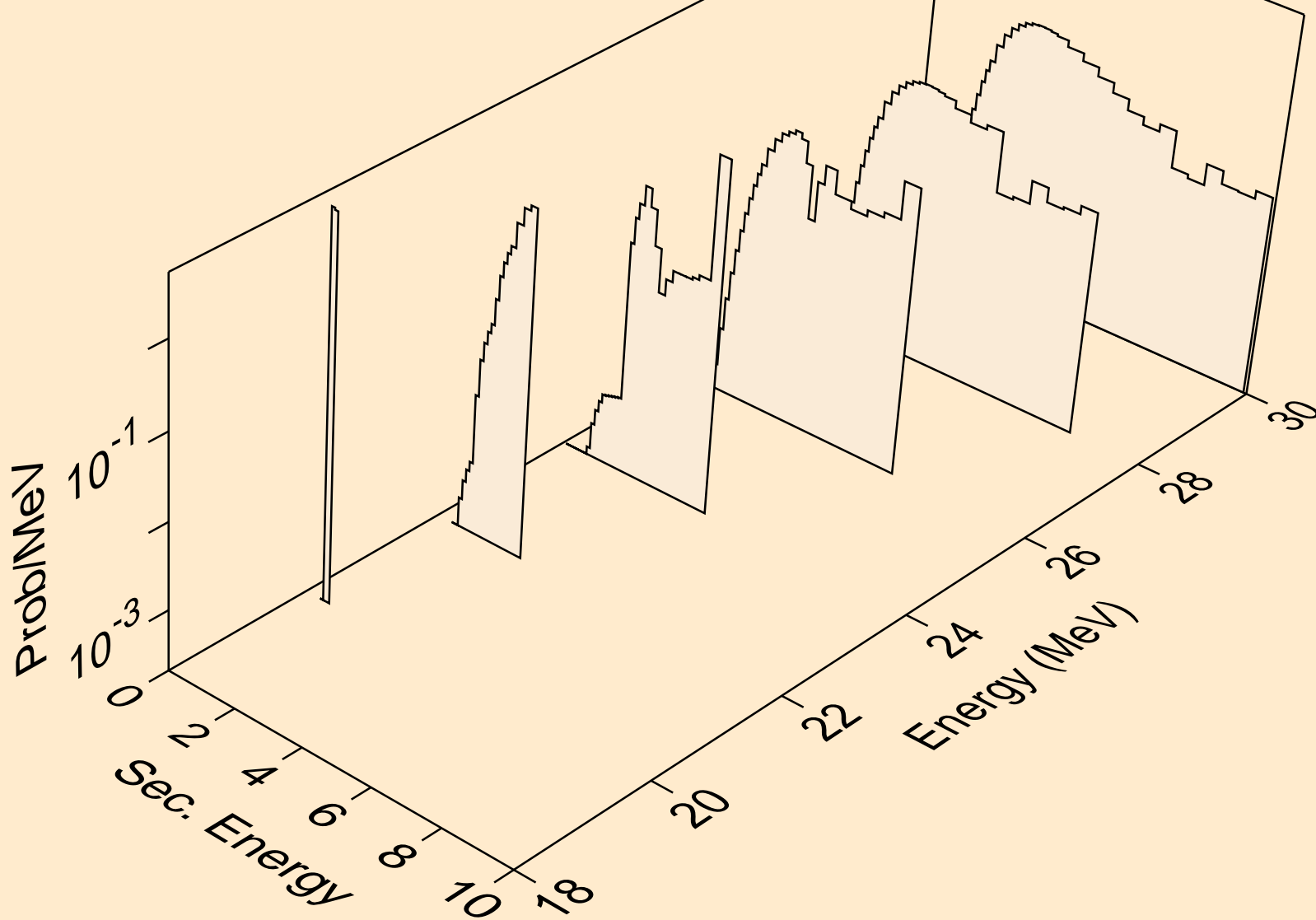

S036 PHOTON ACER TENDL-2023 LIBRARY; T=0.K
he3s from (g,x)

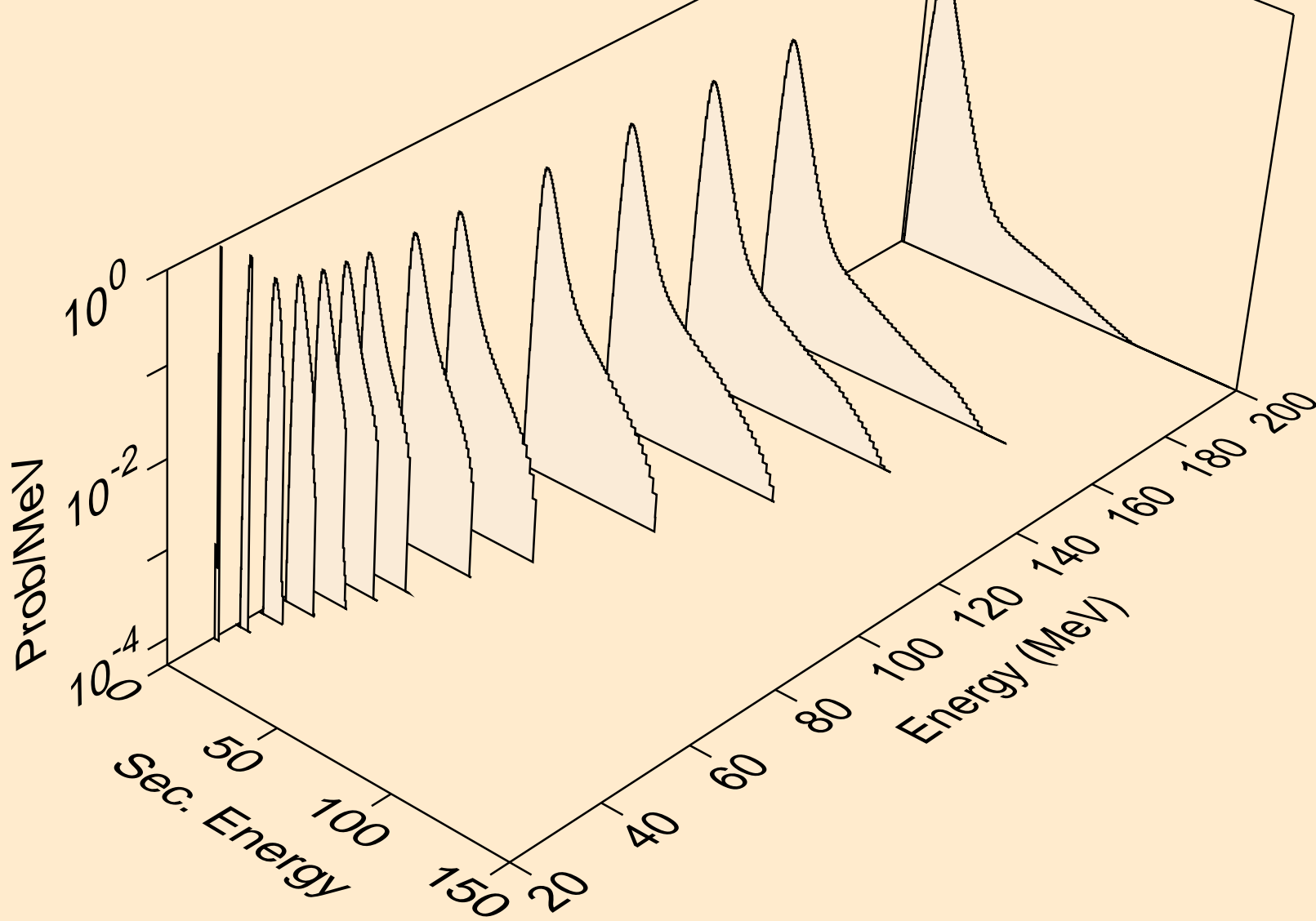

S036 PHOTON ACER TENDL-2023 LIBRARY; T=0.K
he3s from (g,he3)

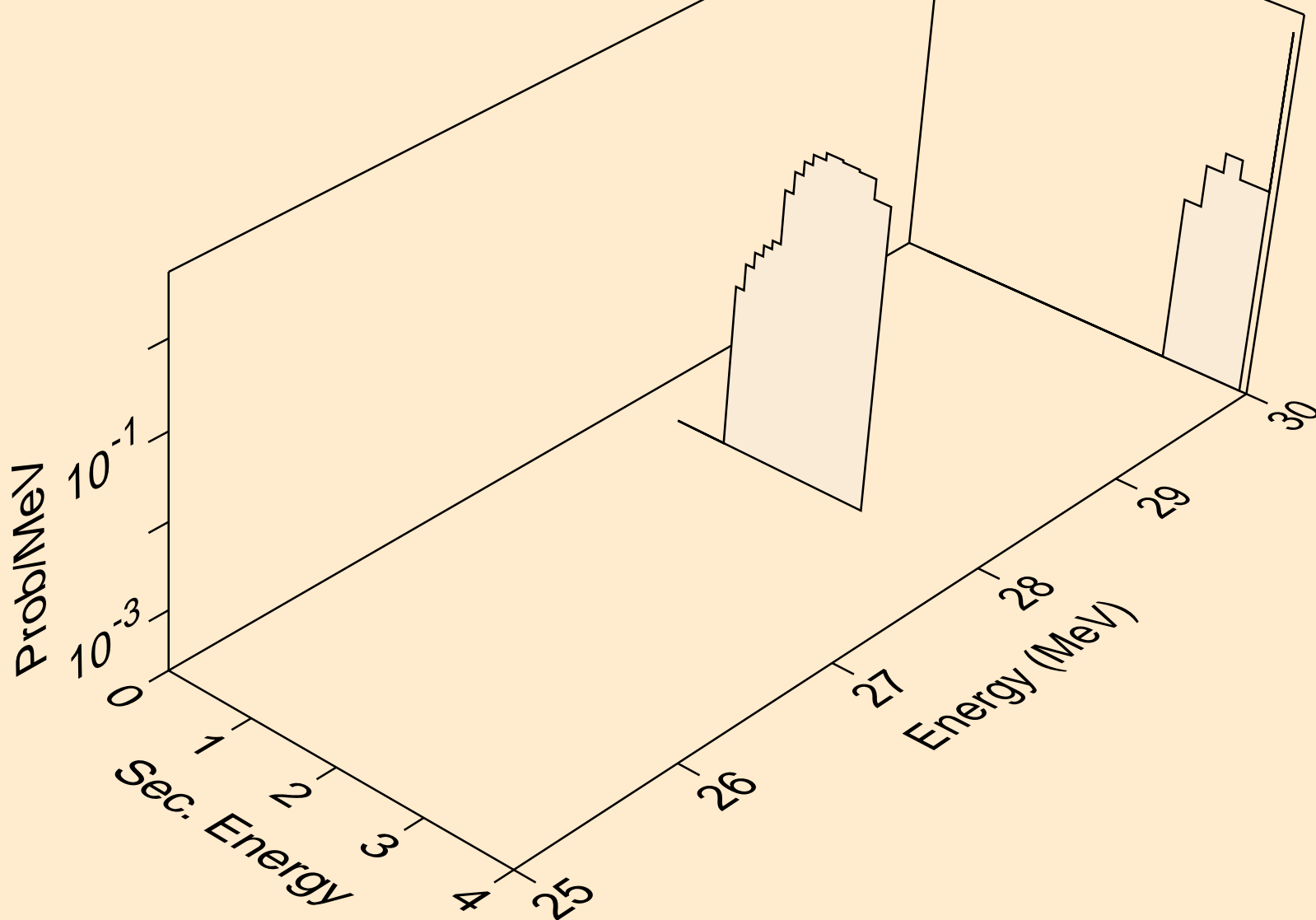

S036 PHOTON ACER TENDL-2023 LIBRARY; T=0.K
alphas from (g,x)

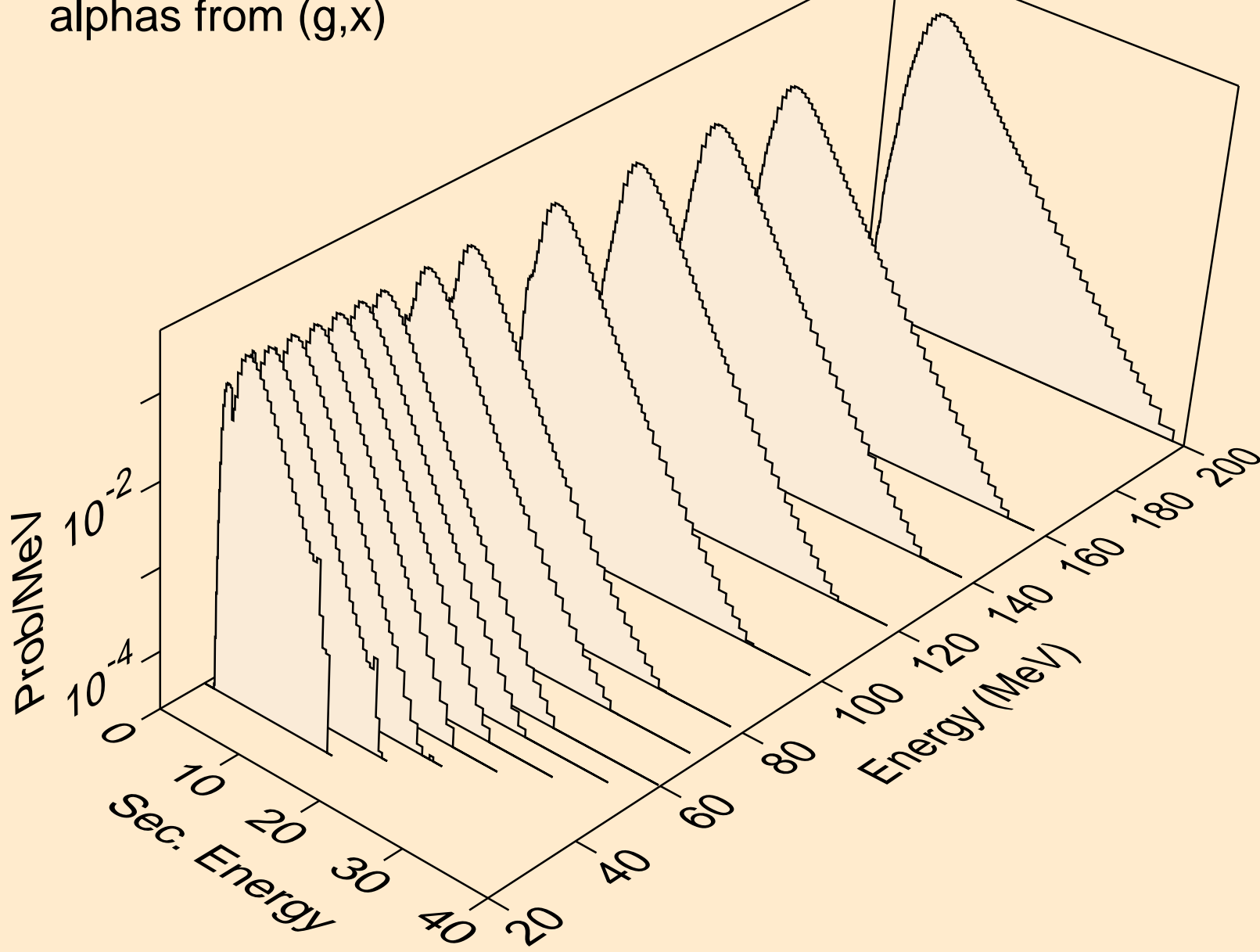

S036 PHOTON ACER TENDL-2023 LIBRARY; T=0.K
alphas from (g,n*)a

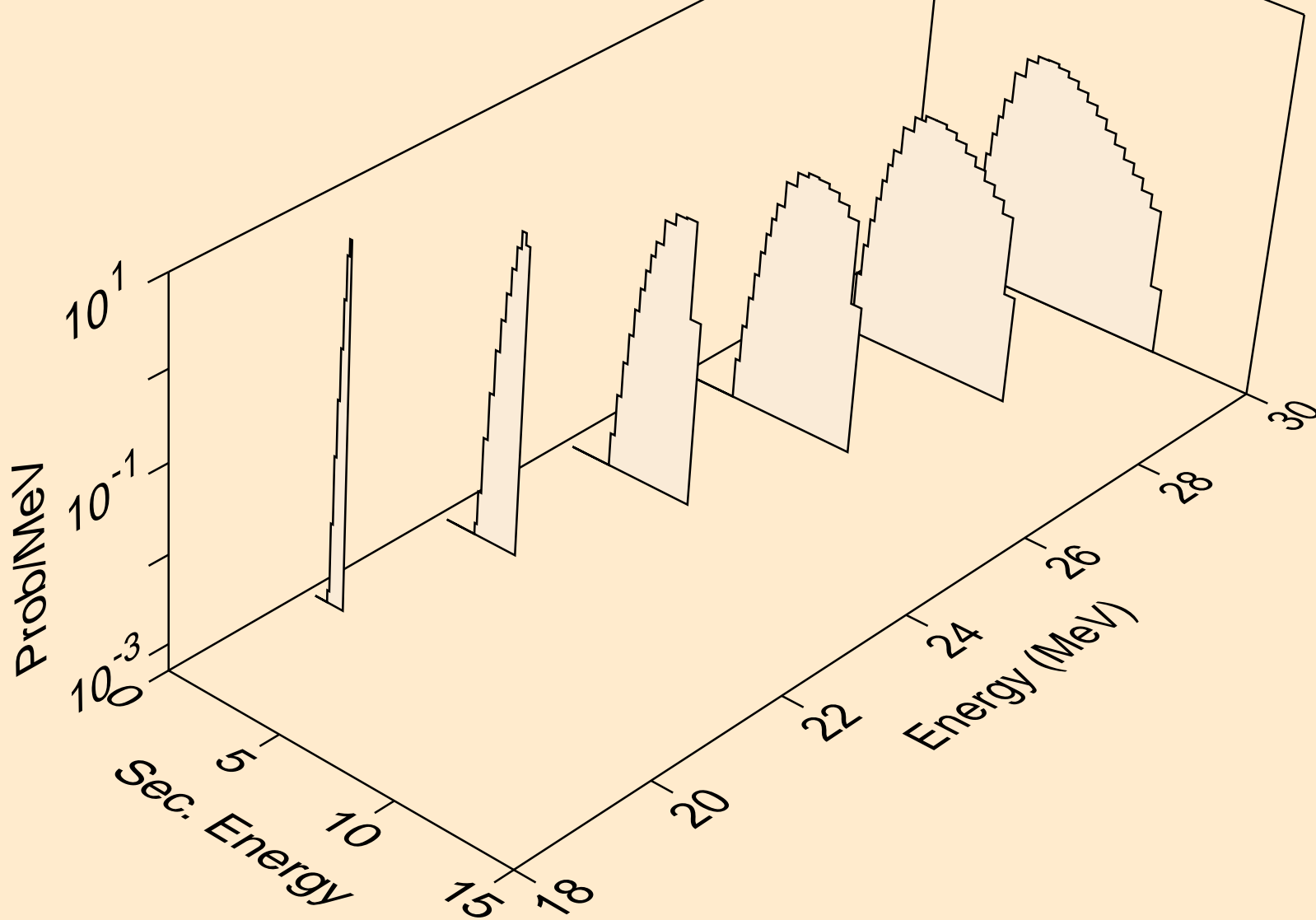

S036 PHOTON ACER TENDL-2023 LIBRARY; T=0.K
alphas from (g,2n)a

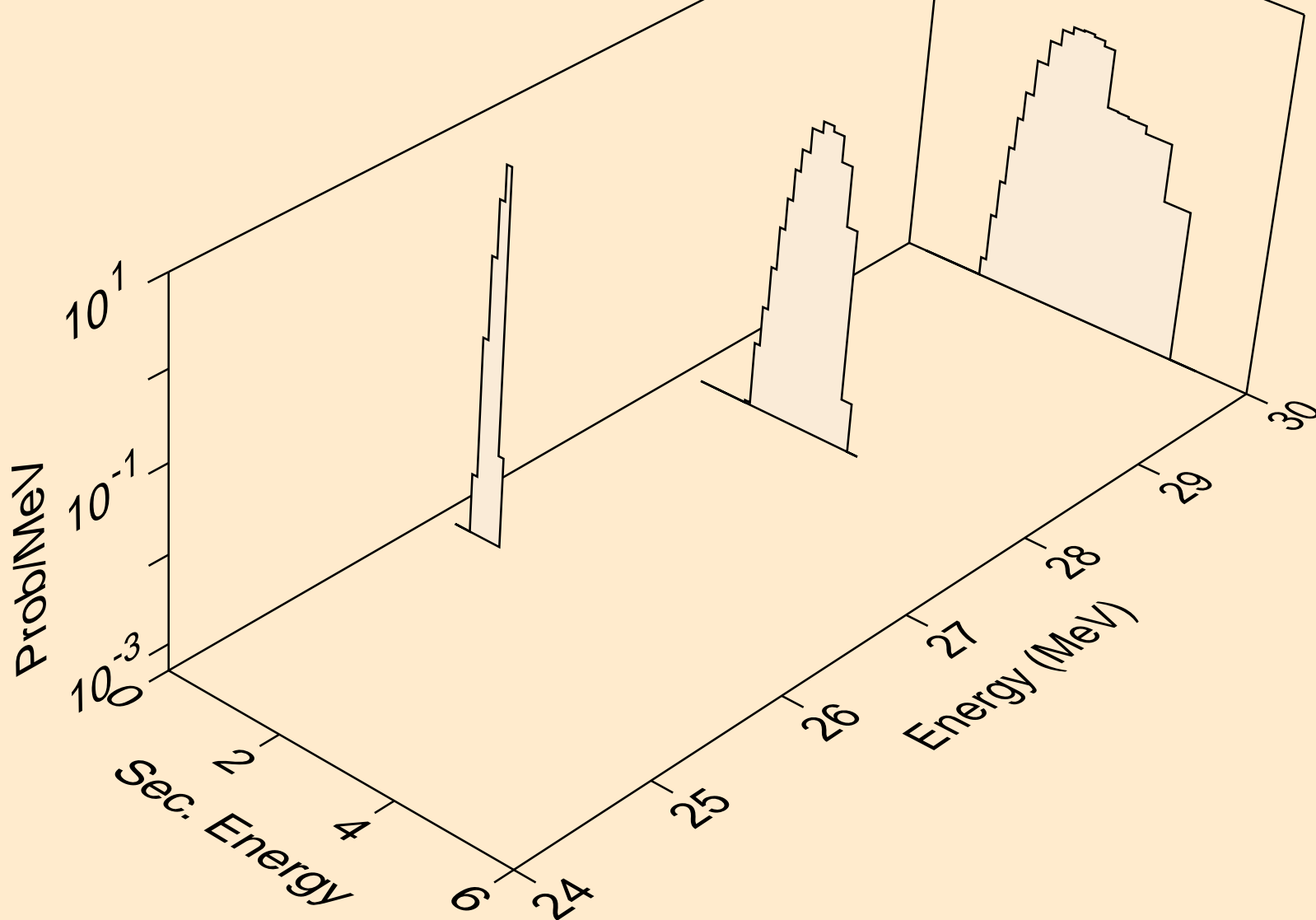

S036 PHOTON ACER TENDL-2023 LIBRARY; T=0.K
alphas from (g,a)

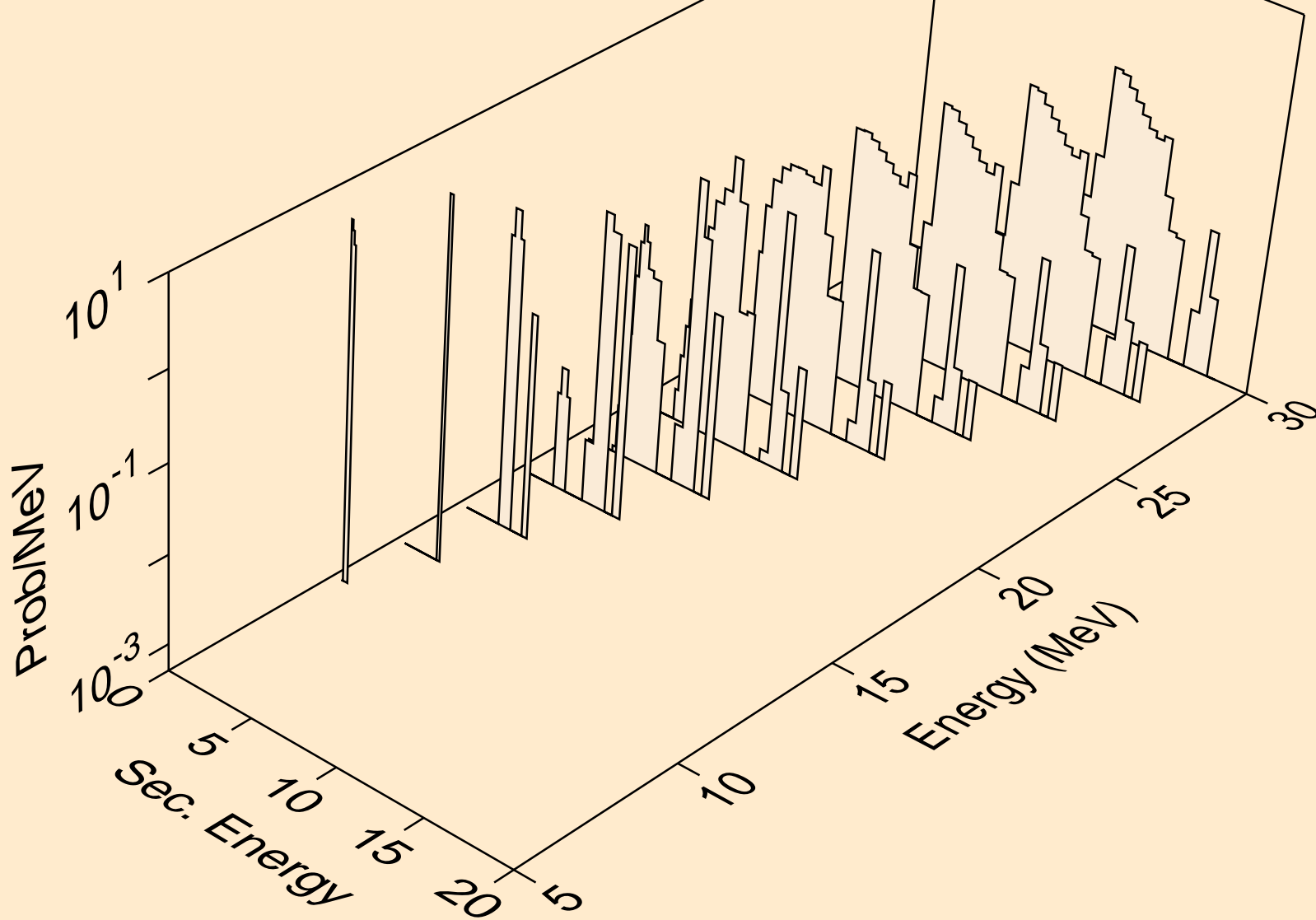

S036 PHOTON ACER TENDL-2023 LIBRARY; T=0.K
alphas from (g,2a)

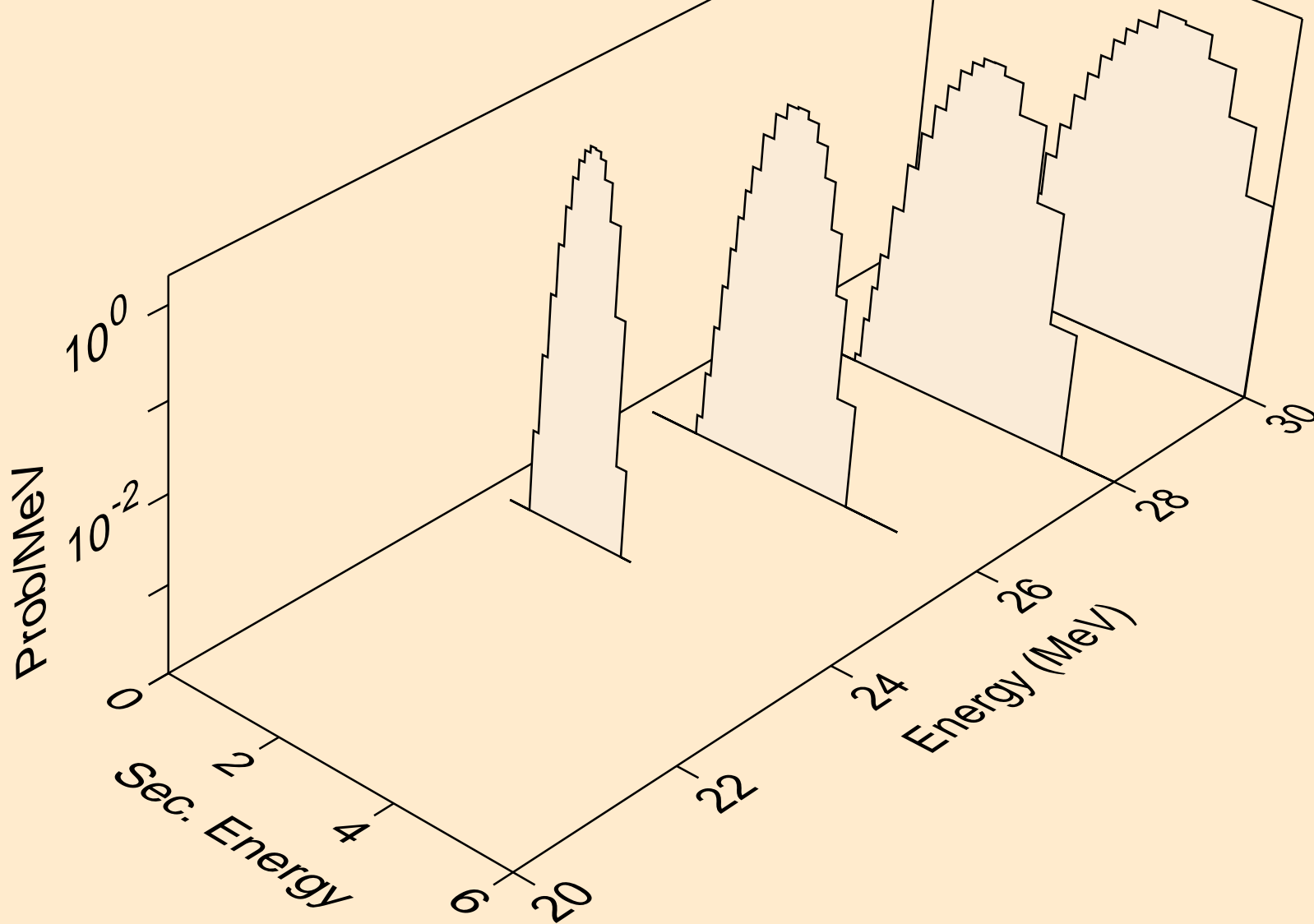

S036 PHOTON ACER TENDL-2023 LIBRARY; T=0.K
alphas from (g,pa)

