

TI052 PHOTON ACER TENDL-2023 LIBRARY; T=0.K

Principal cross sections

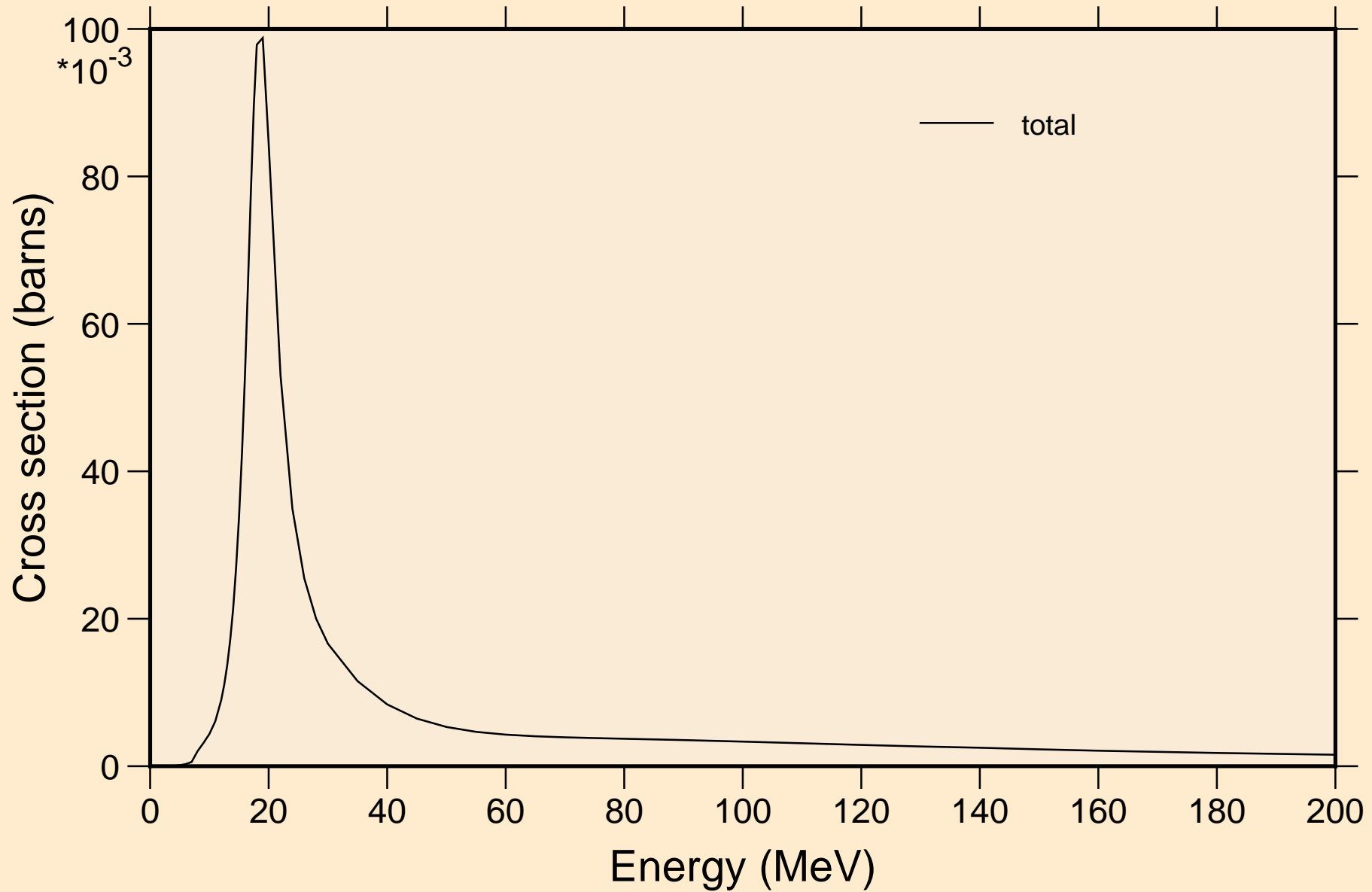

TI052 PHOTON ACER TENDL-2023 LIBRARY; T=0.K

Heating

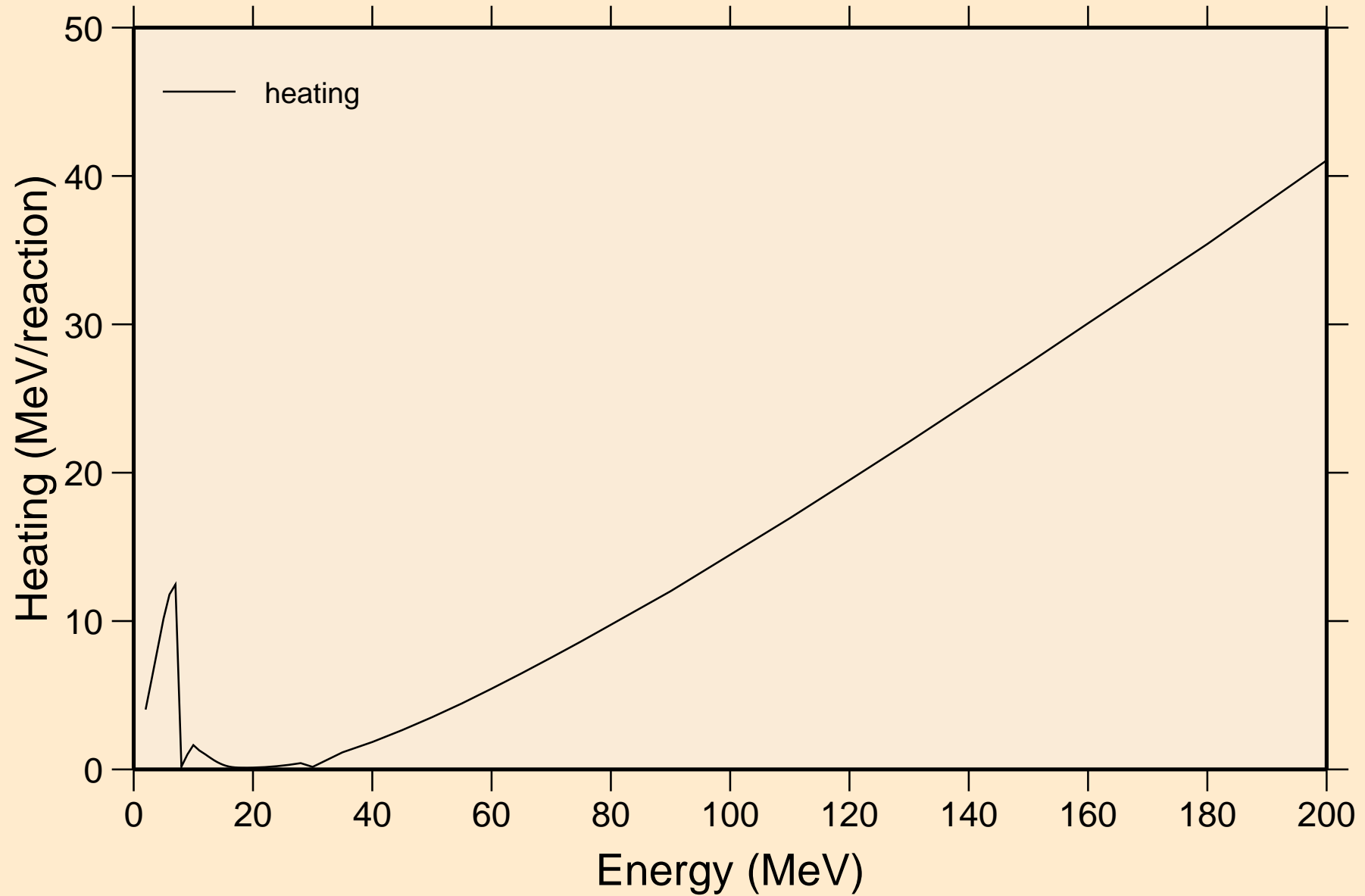

TI052 PHOTON ACER TENDL-2023 LIBRARY; T=0.K

Particle heating contributions

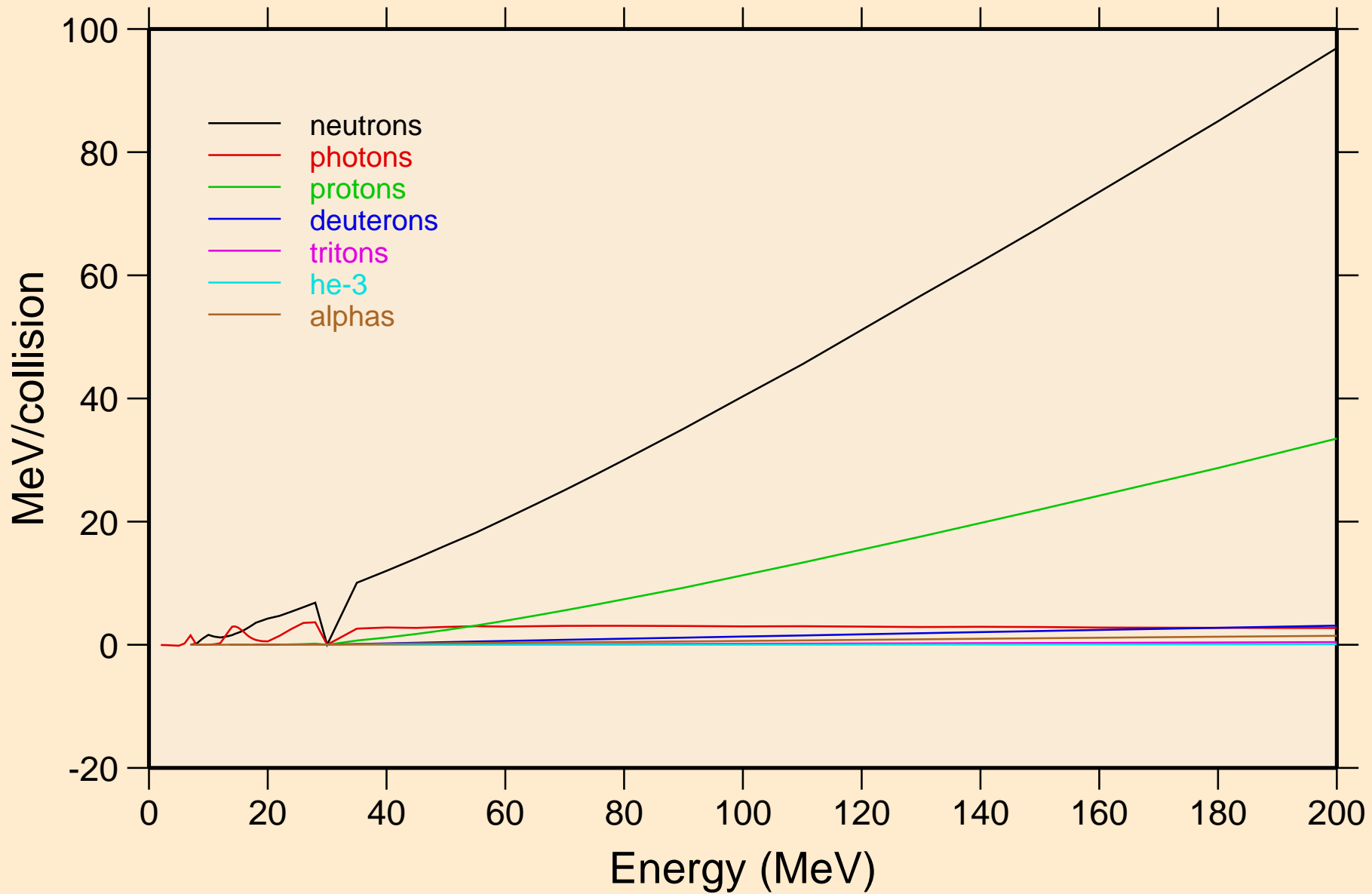

TI052 PHOTON ACER TENDL-2023 LIBRARY; T=0.K
Particle production cross sections

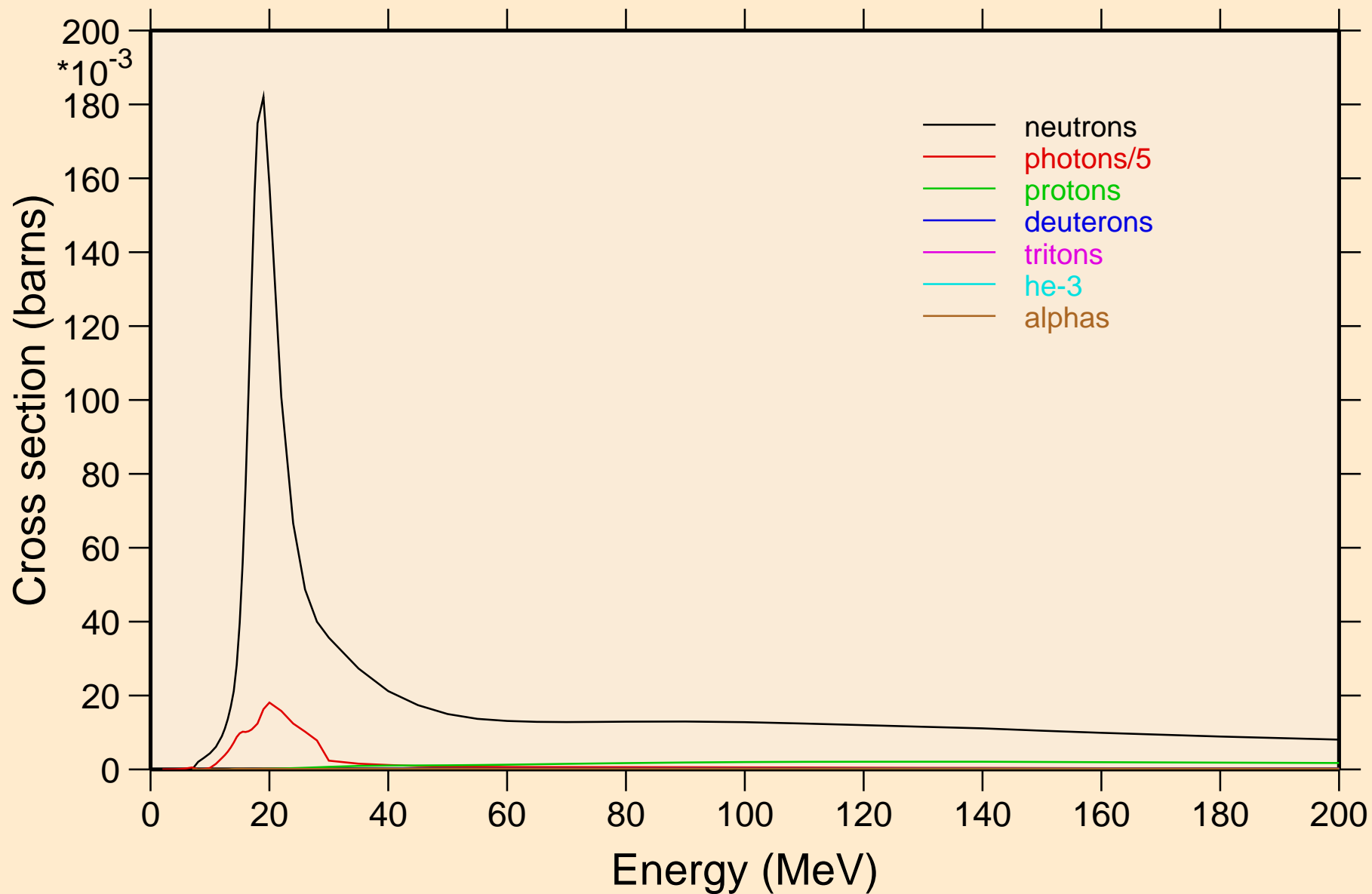

TI052 PHOTON ACER TENDL-2023 LIBRARY; T=0.K
neutrons from (g,x)

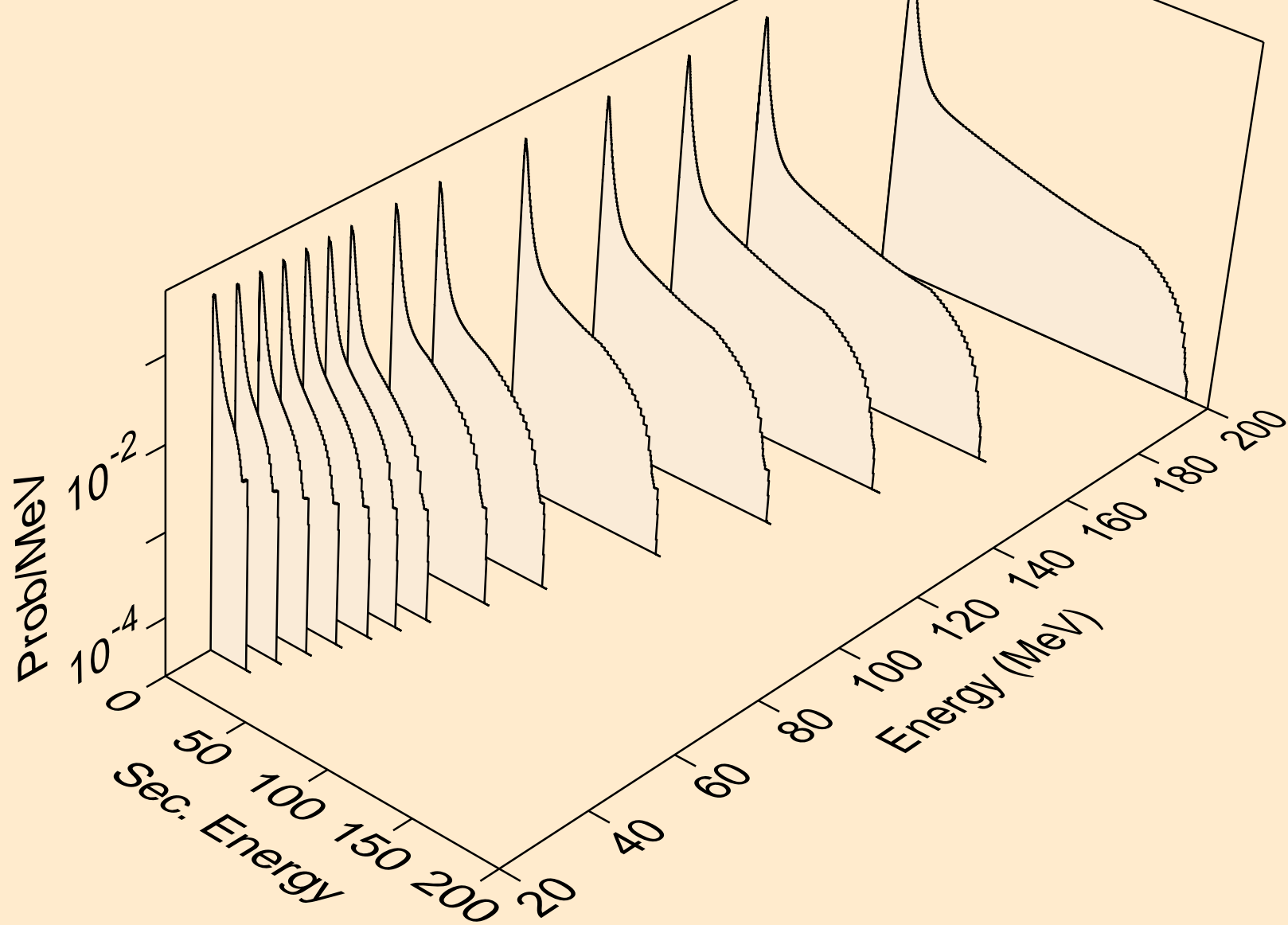

TI052 PHOTON ACER TENDL-2023 LIBRARY; T=0.K
neutrons from (g,2n)

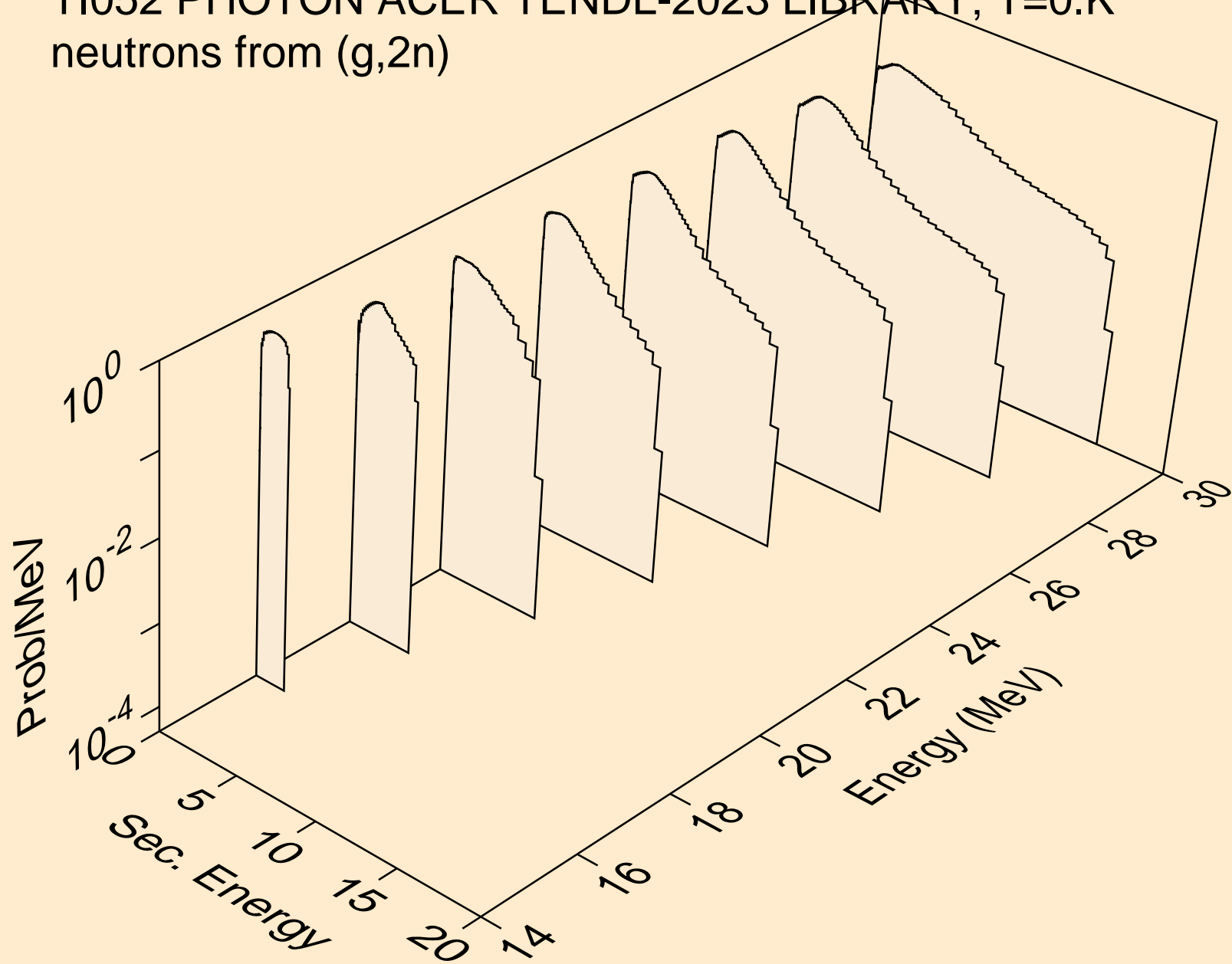

TI052 PHOTON ACER TENDL-2023 LIBRARY; T=0.K
neutrons from (g,3n)

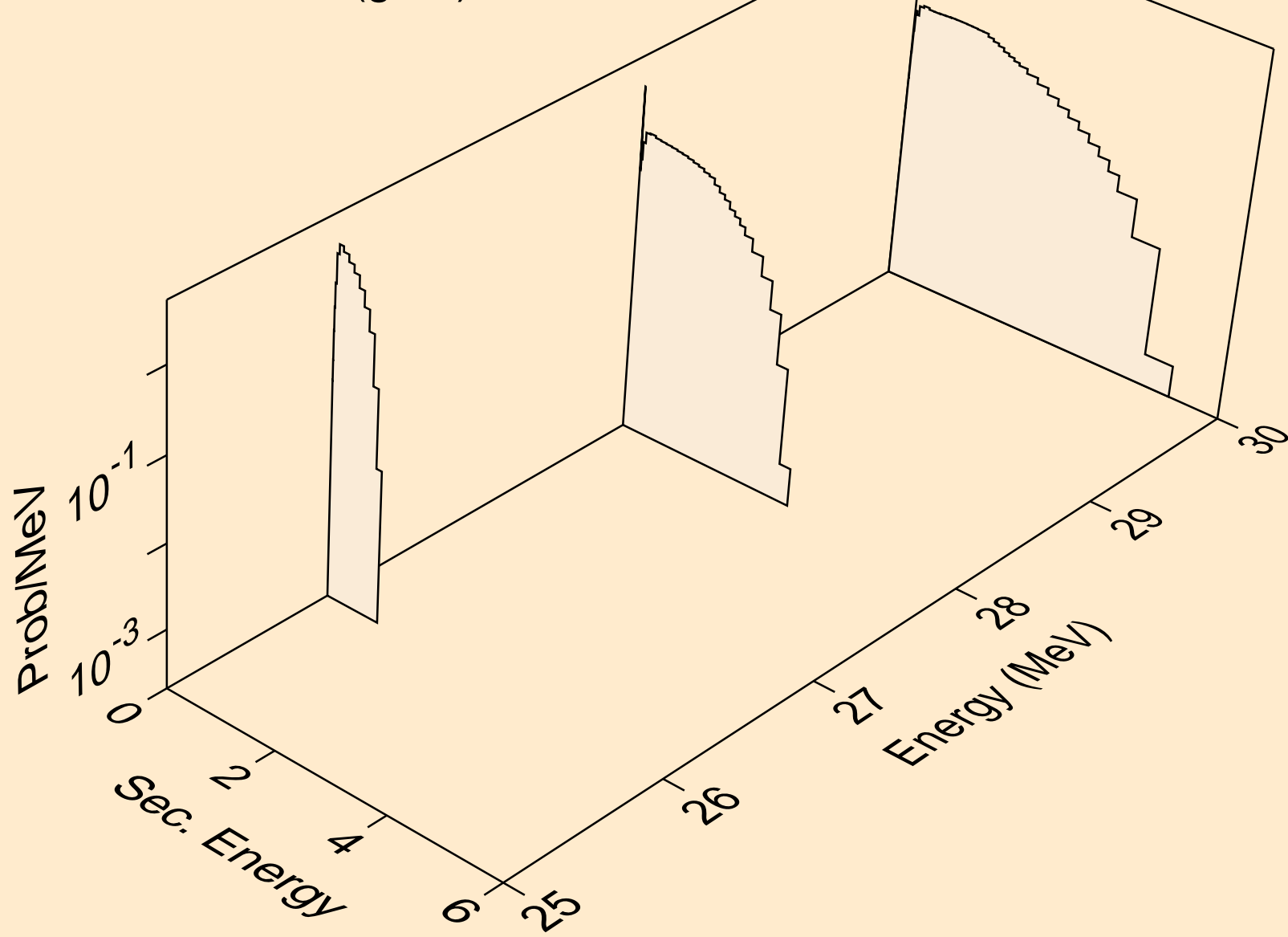

TI052 PHOTON ACER TENDL-2023 LIBRARY; T=0.K
neutrons from (g,n*)a

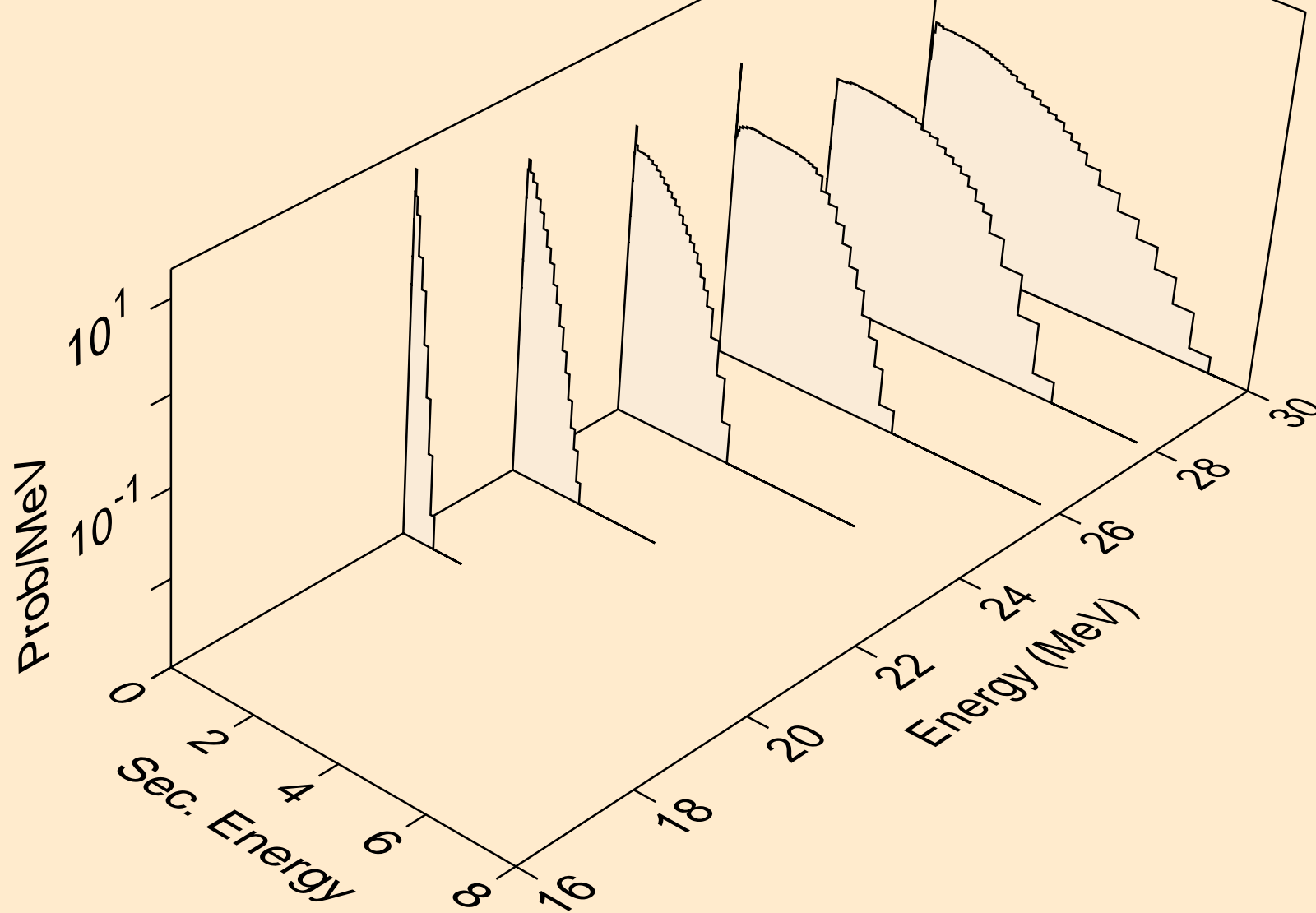

TI052 PHOTON ACER TENDL-2023 LIBRARY; T=0.K
neutrons from (g,2n)a

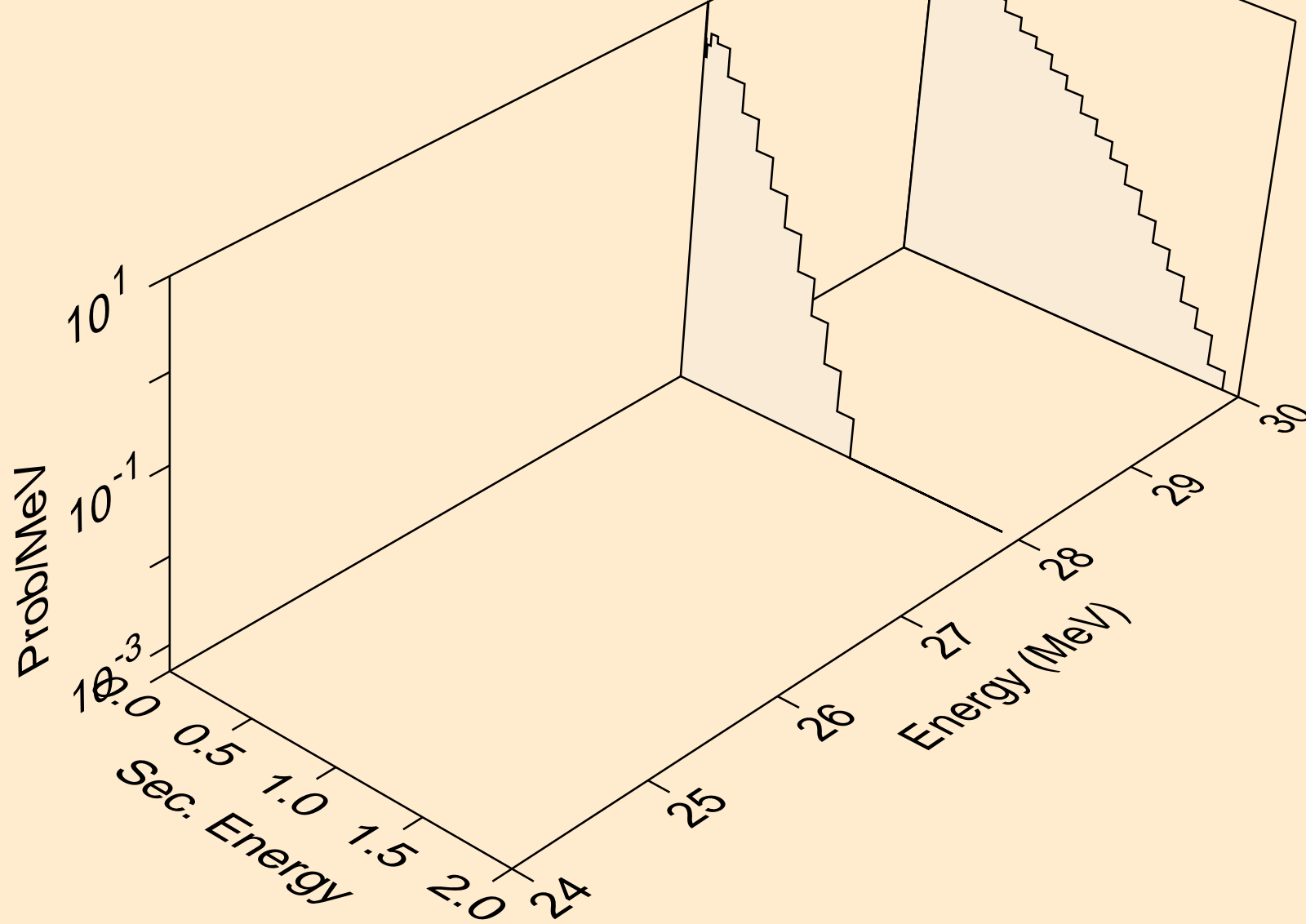

TI052 PHOTON ACER TENDL-2023 LIBRARY; T=0.K
neutrons from (g,n*)p

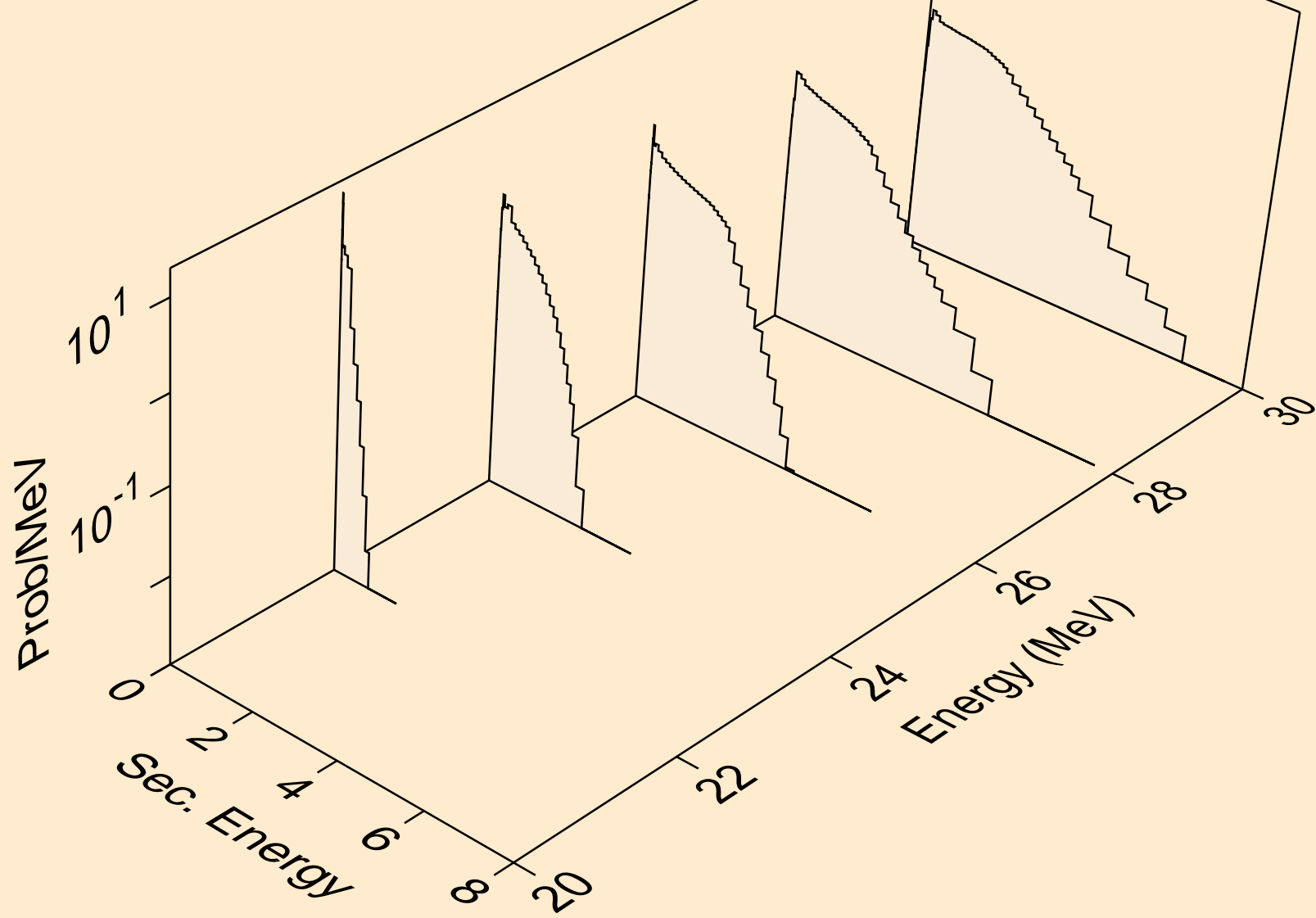

TI052 PHOTON ACER TENDL-2023 LIBRARY; T=0.K
neutrons from (g,n*)d

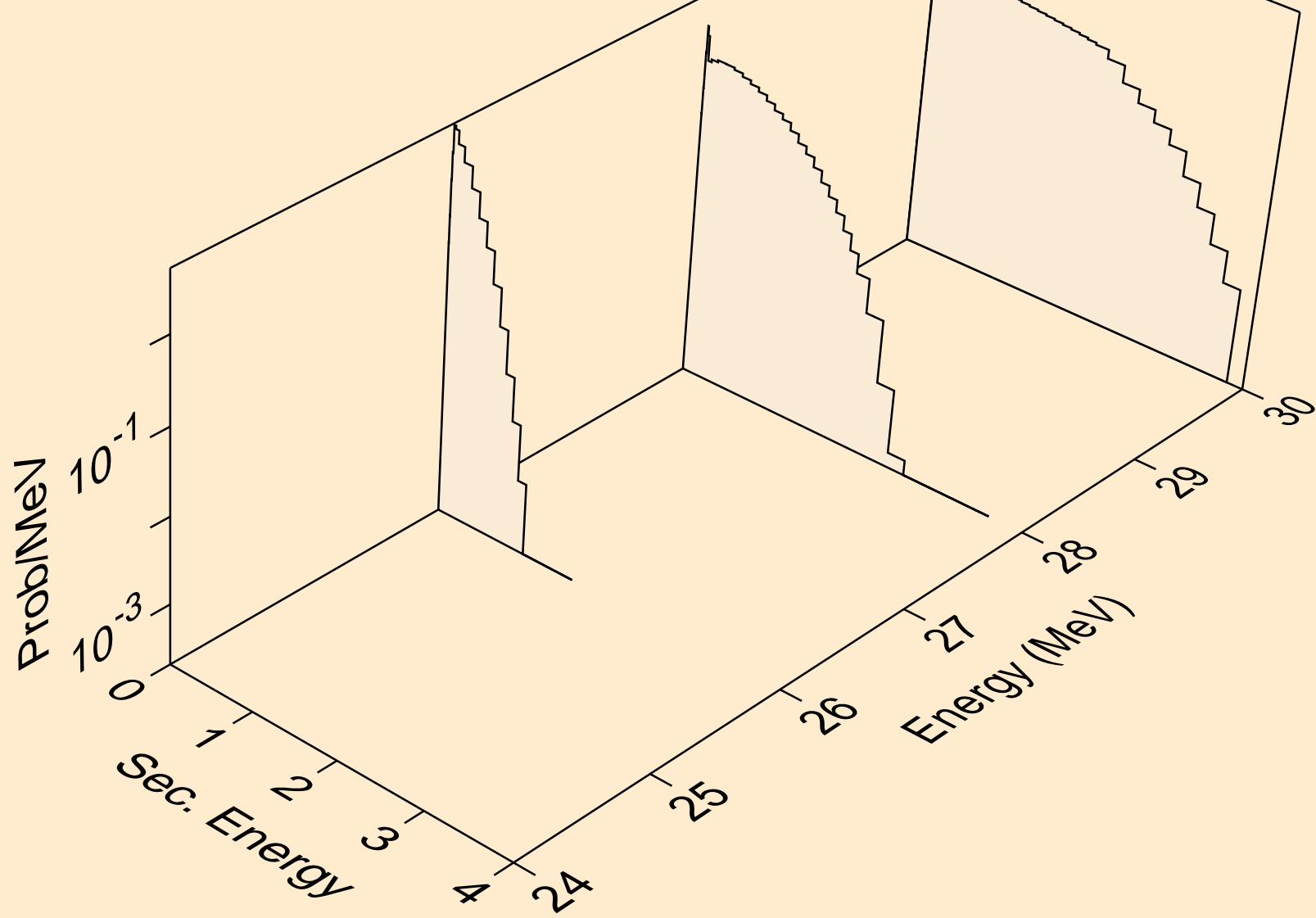

TI052 PHOTON ACER TENDL-2023 LIBRARY; T=0.K
neutrons from (g,2np)

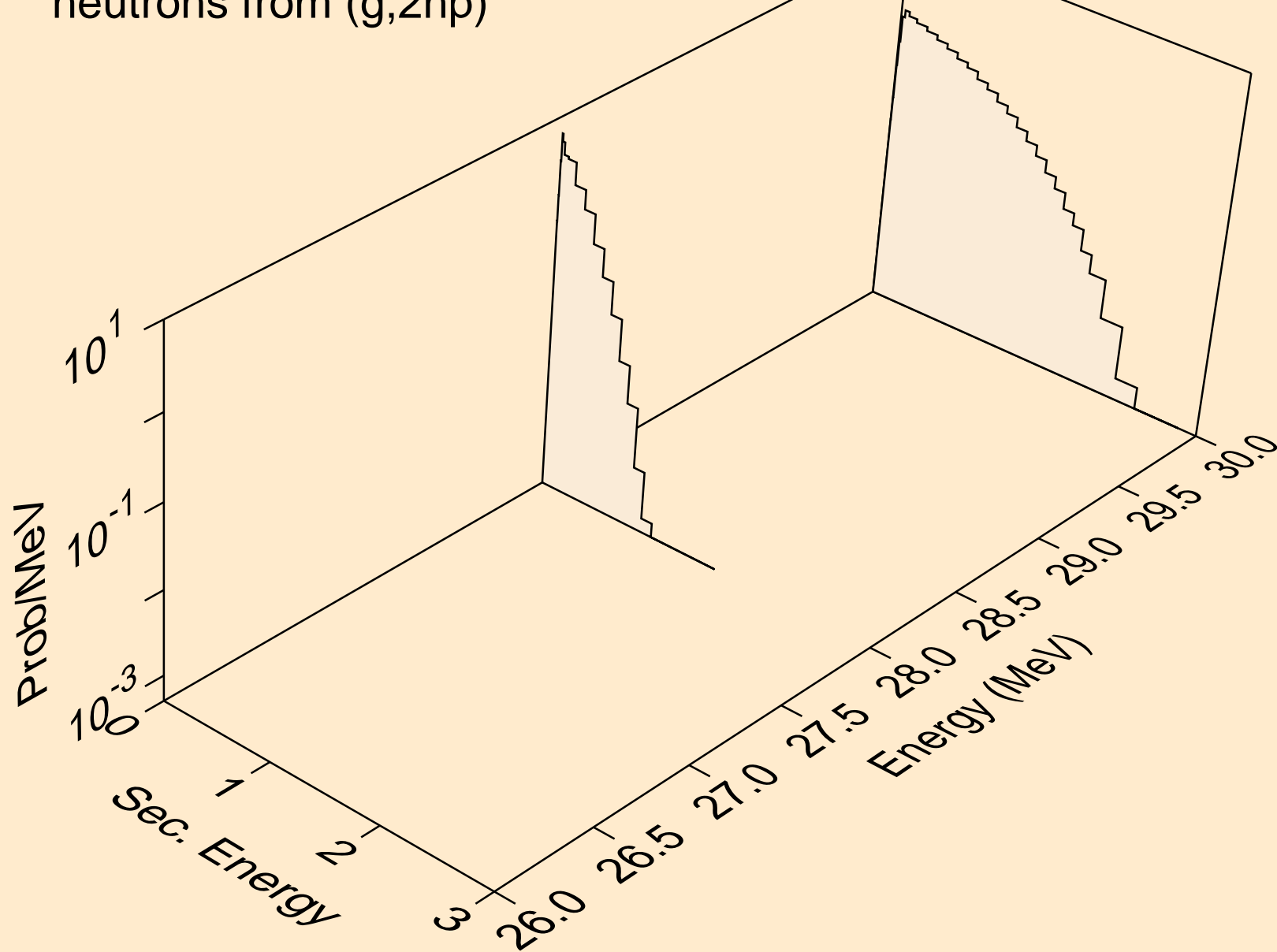

TI052 PHOTON ACER TENDL-2023 LIBRARY; T=0.K
angular distribution for (g,n*0) neutron

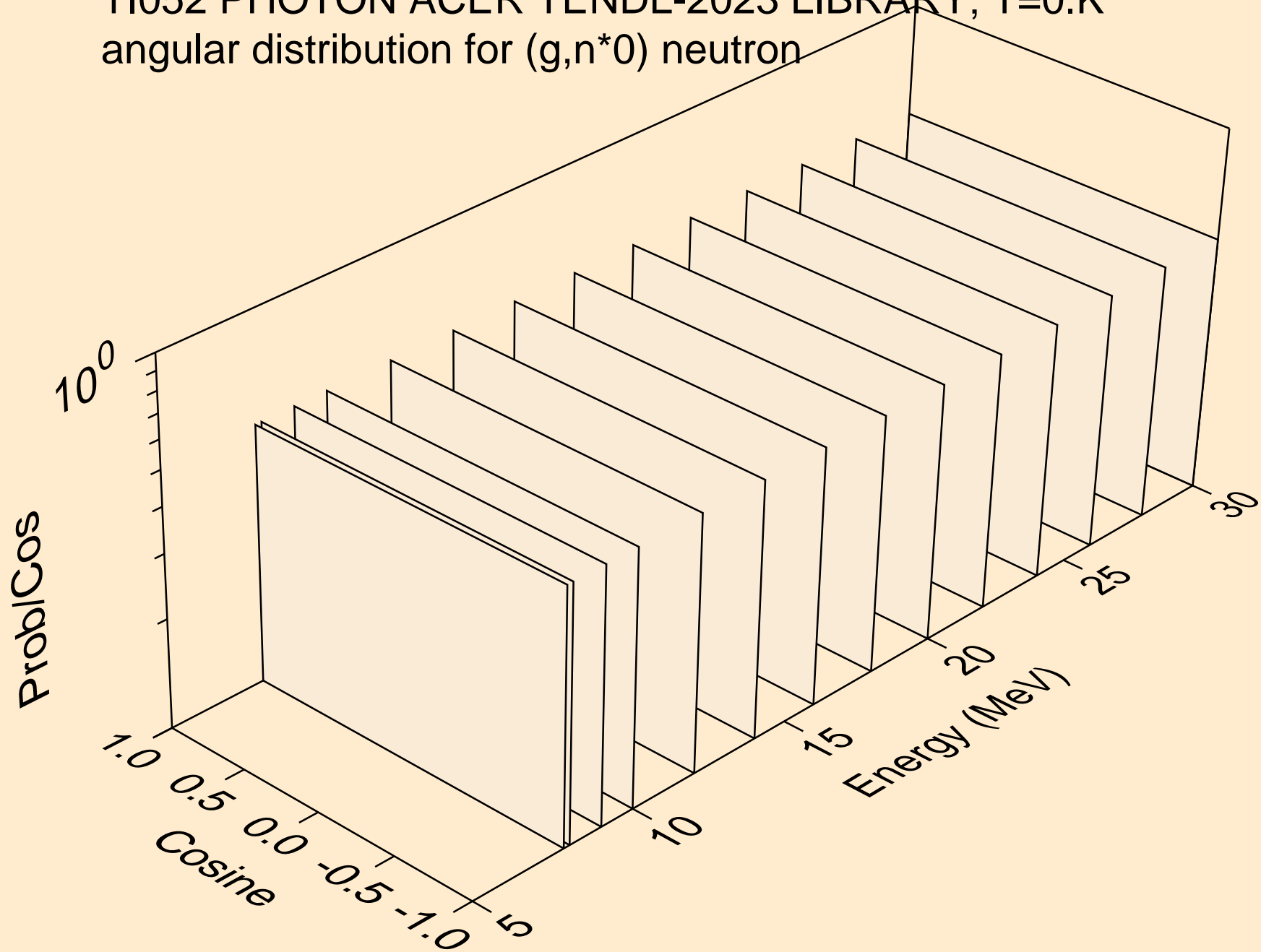

TI052 PHOTON ACER TENDL-2023 LIBRARY; T=0.K
angular distribution for (g,n*1) neutron

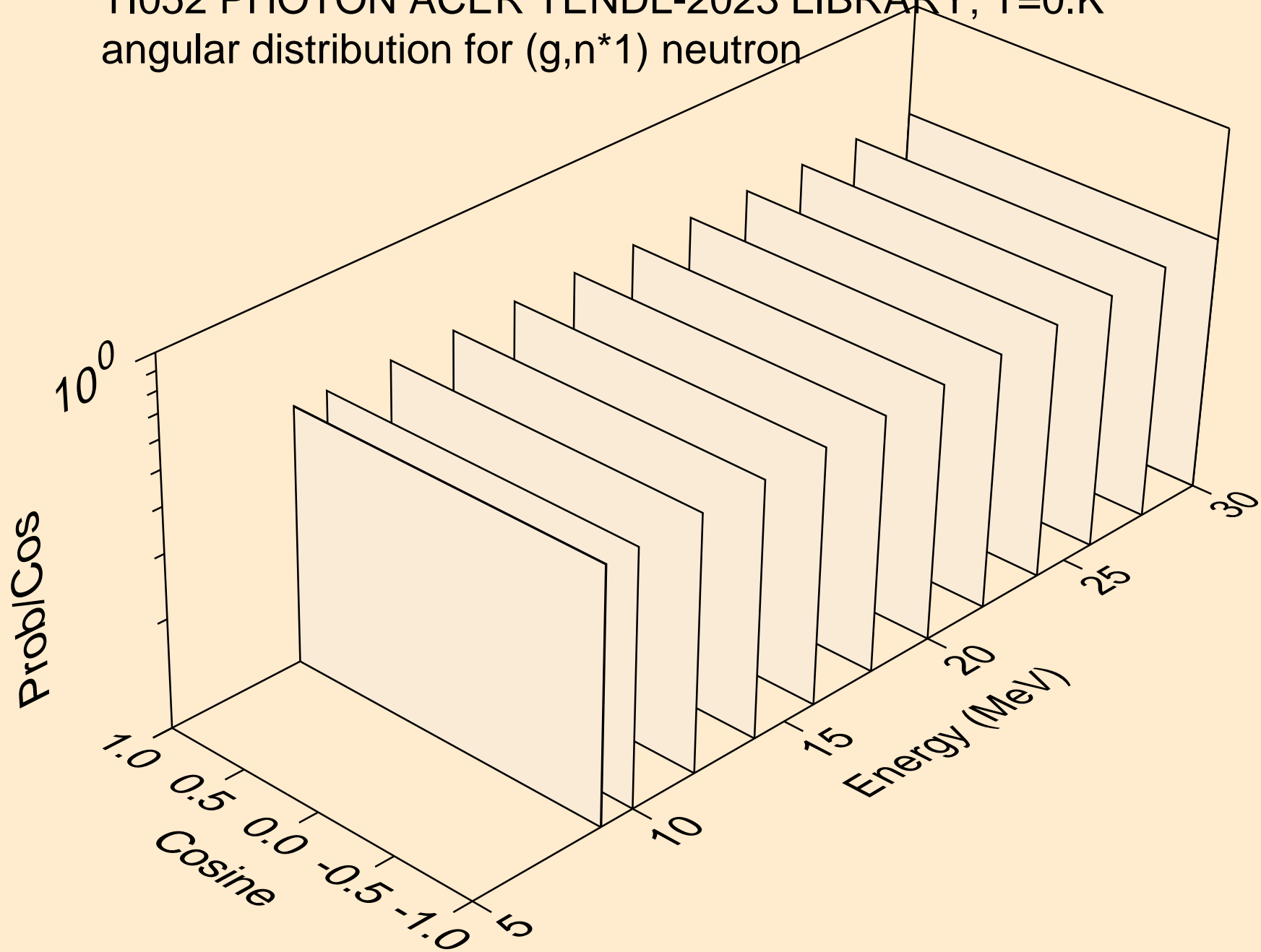

TI052 PHOTON ACER TENDL-2023 LIBRARY; T=0.K
neutrons from (g,n*c)

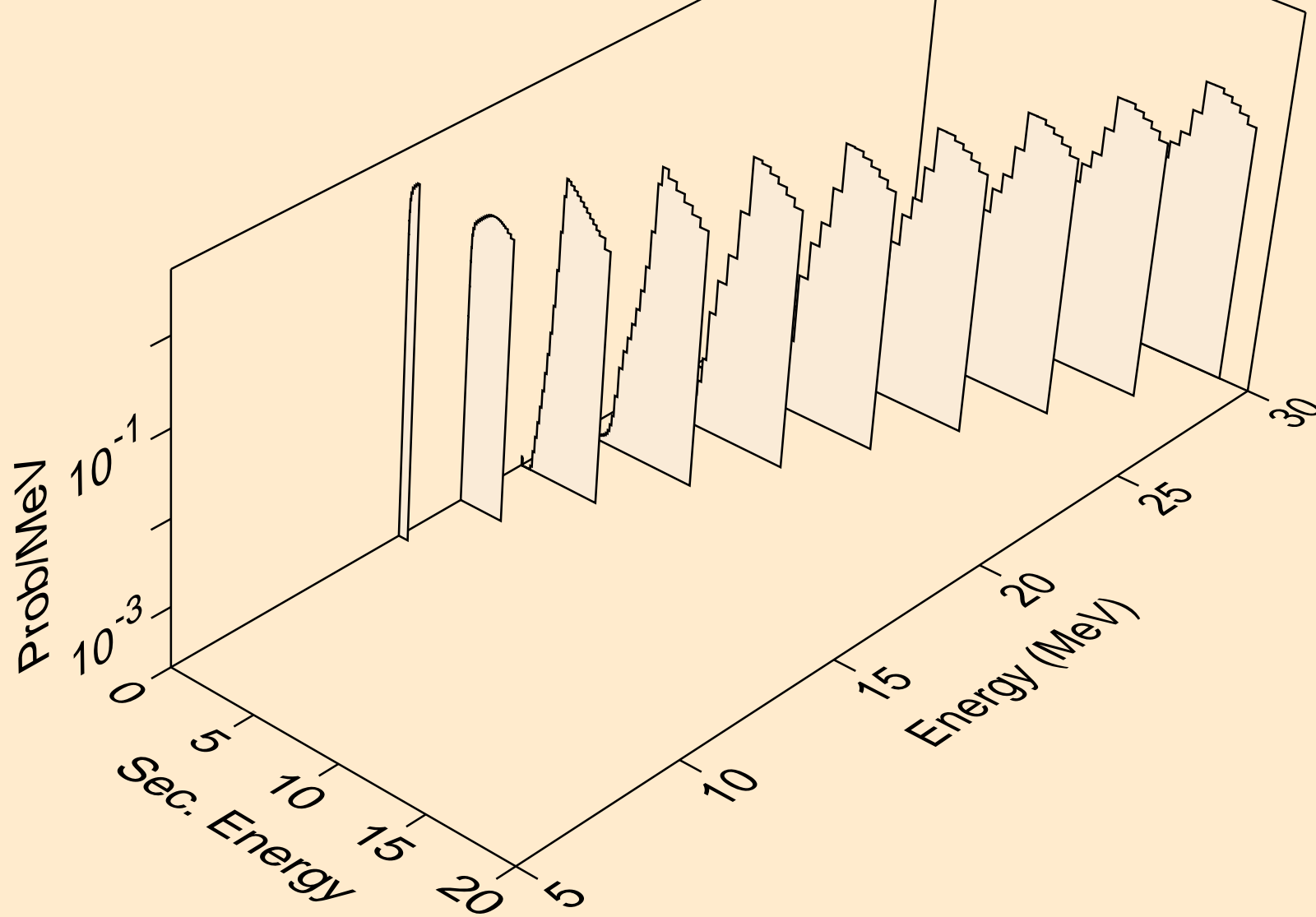

TI052 PHOTON ACER TENDL-2023 LIBRARY; T=0.K
photons from (g,x)

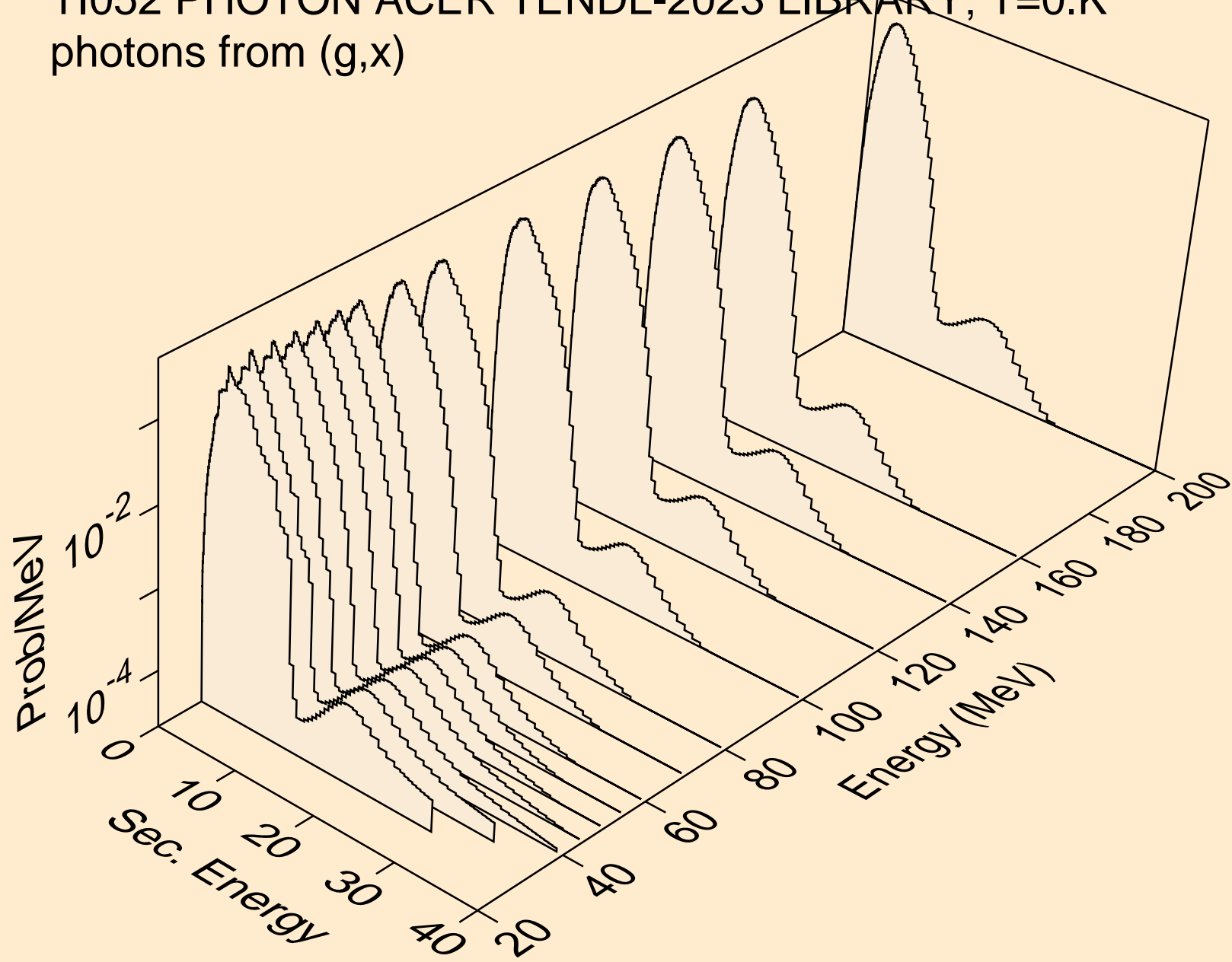

TI052 PHOTON ACER TENDL-2023 LIBRARY; T=0.K
photons from (g,2n)

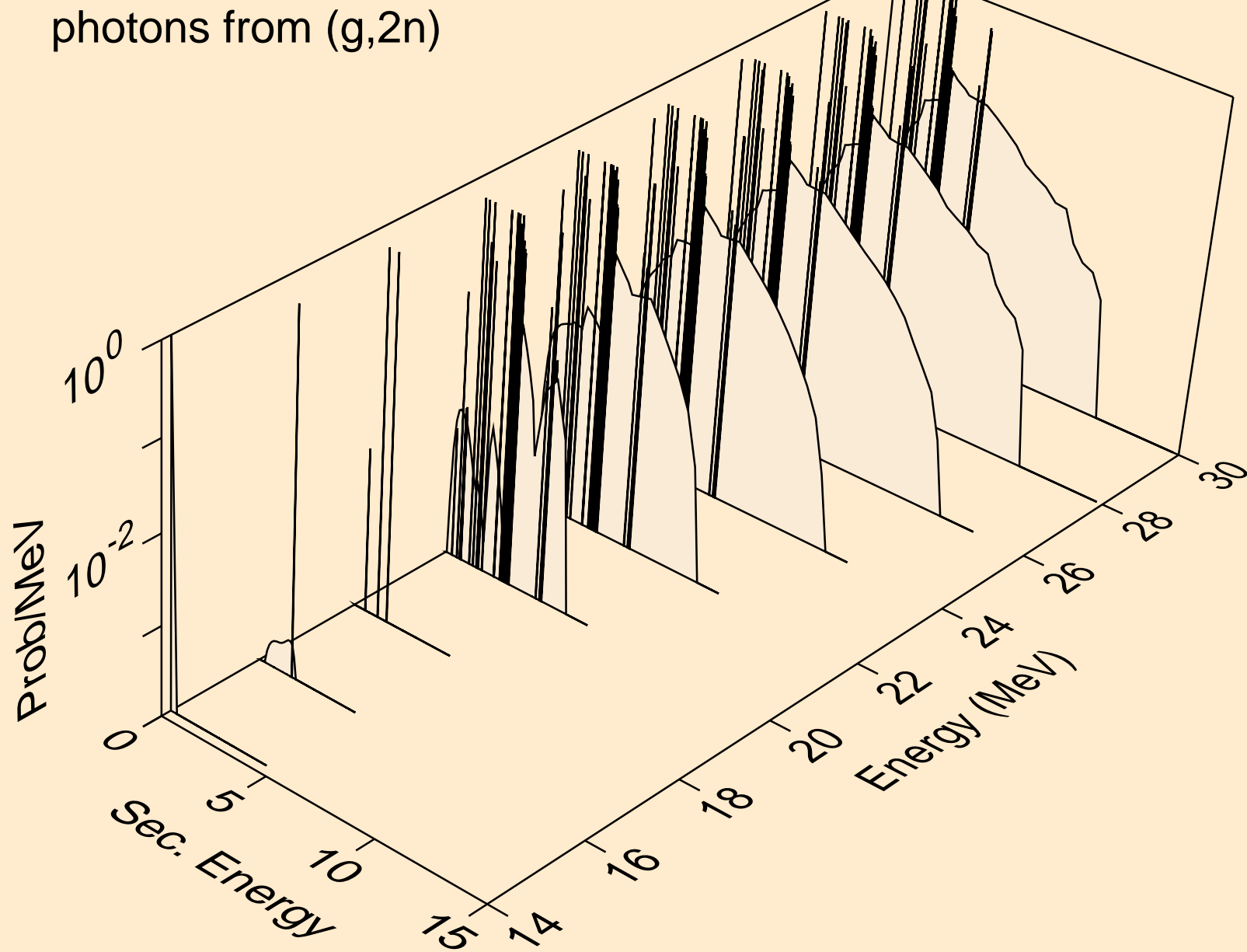

TI052 PHOTON ACER TENDL-2023 LIBRARY; T=0.K
photons from (g,3n)

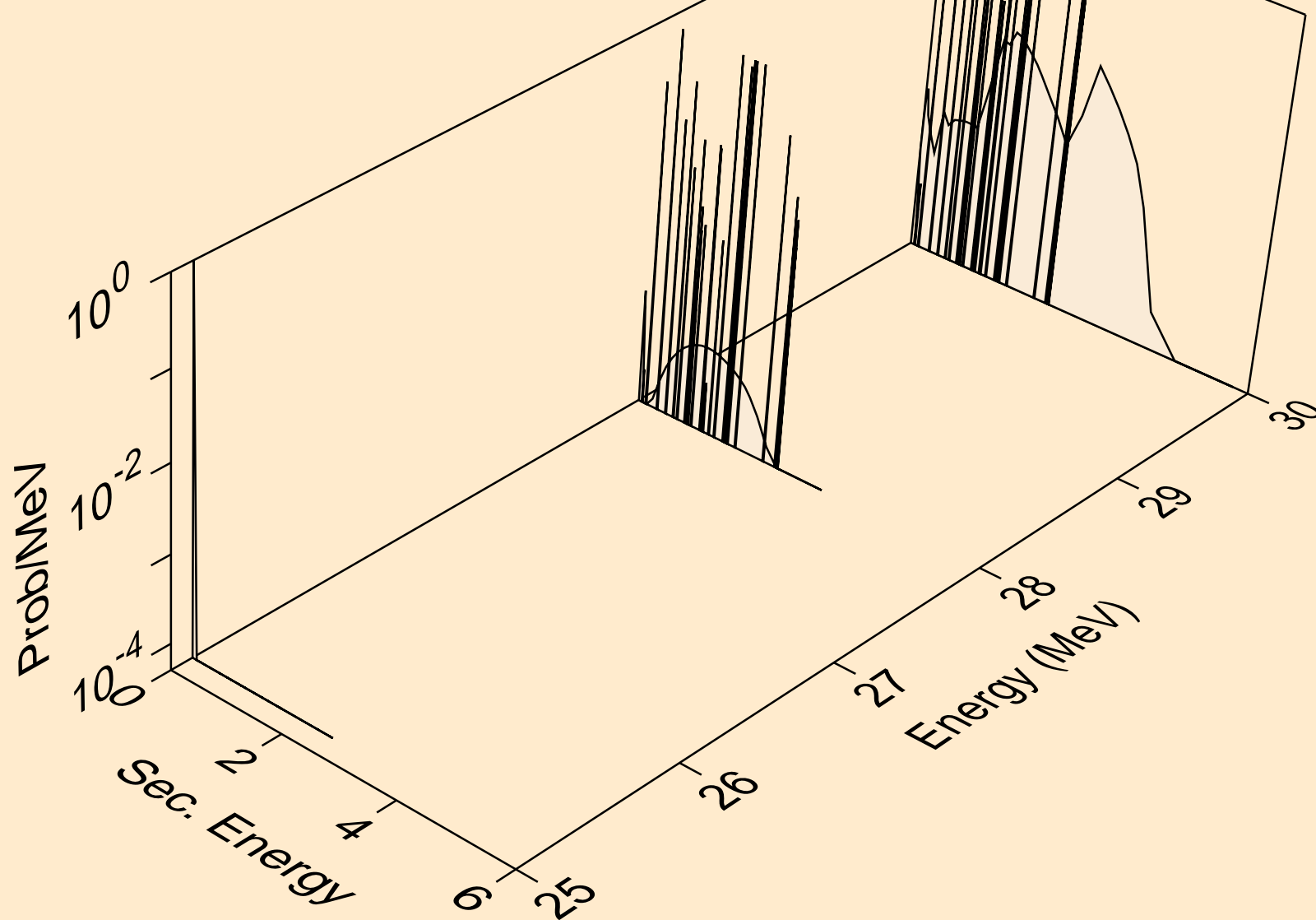

TI052 PHOTON ACER TENDL-2023 LIBRARY; T=0.K
photons from (g,n*)a

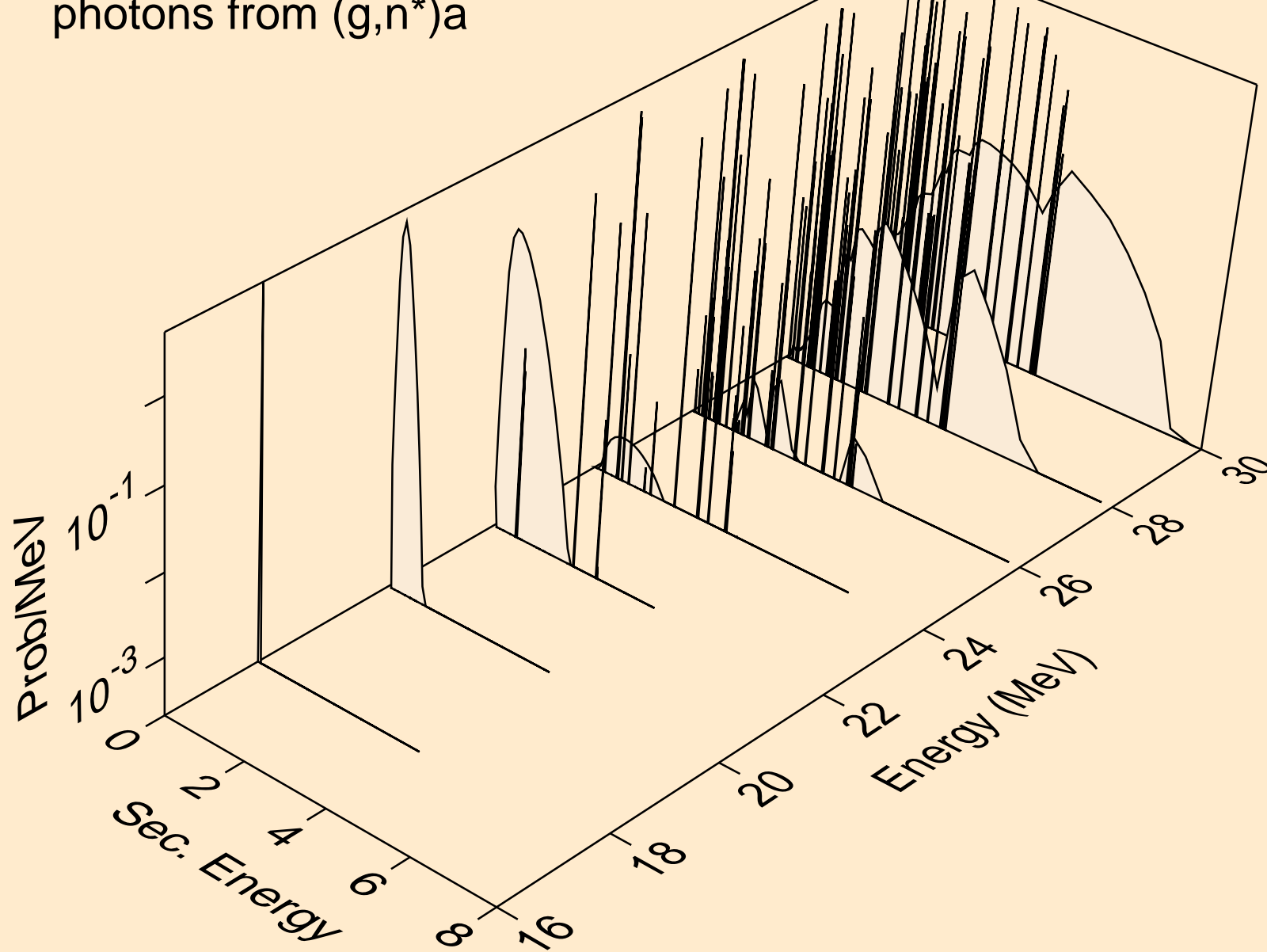

TI052 PHOTON ACER TENDL-2023 LIBRARY; T=0.K
photons from (g,2n)a

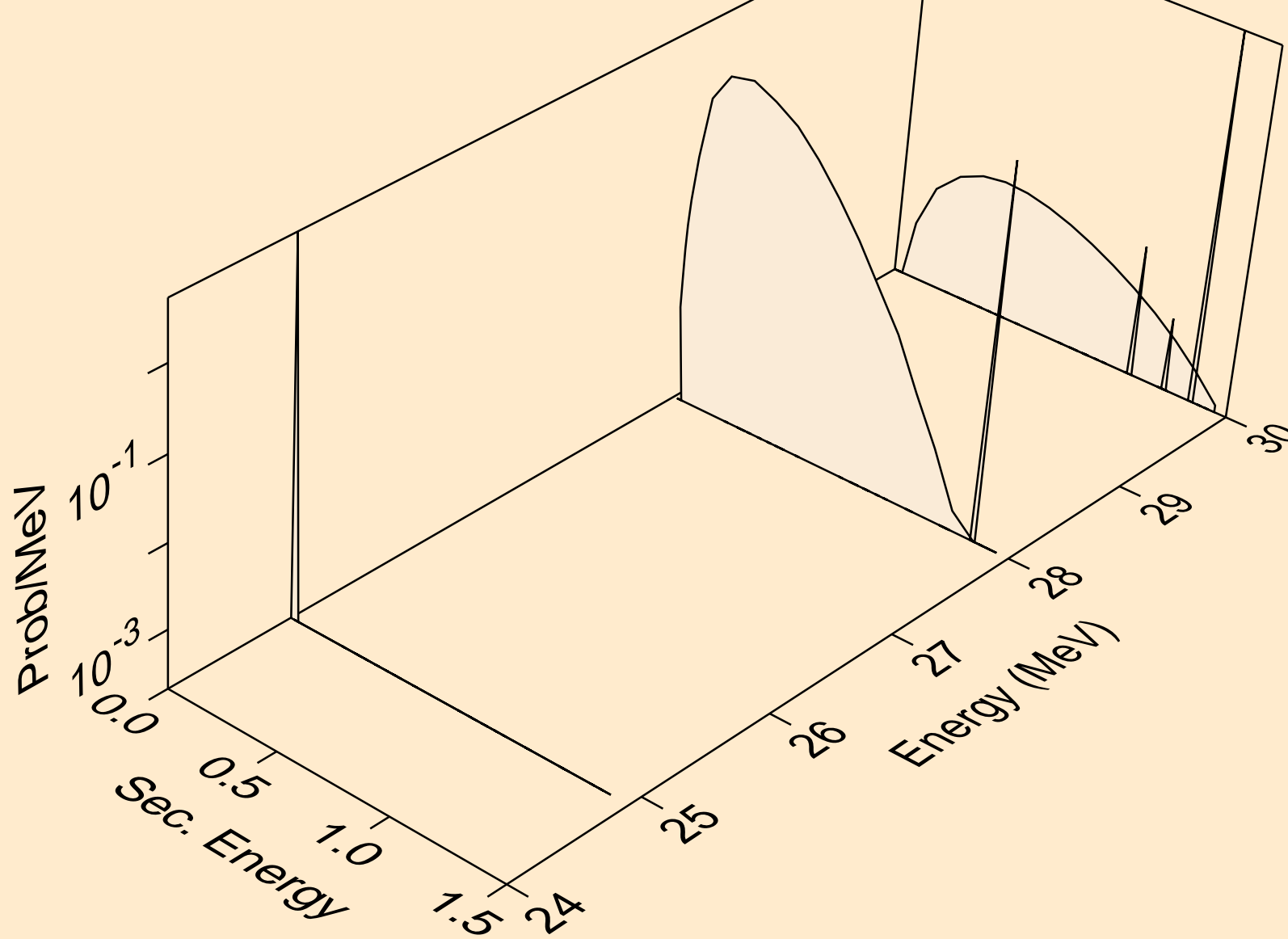

TI052 PHOTON ACER TENDL-2023 LIBRARY; T=0.K
photons from (g,n*)p

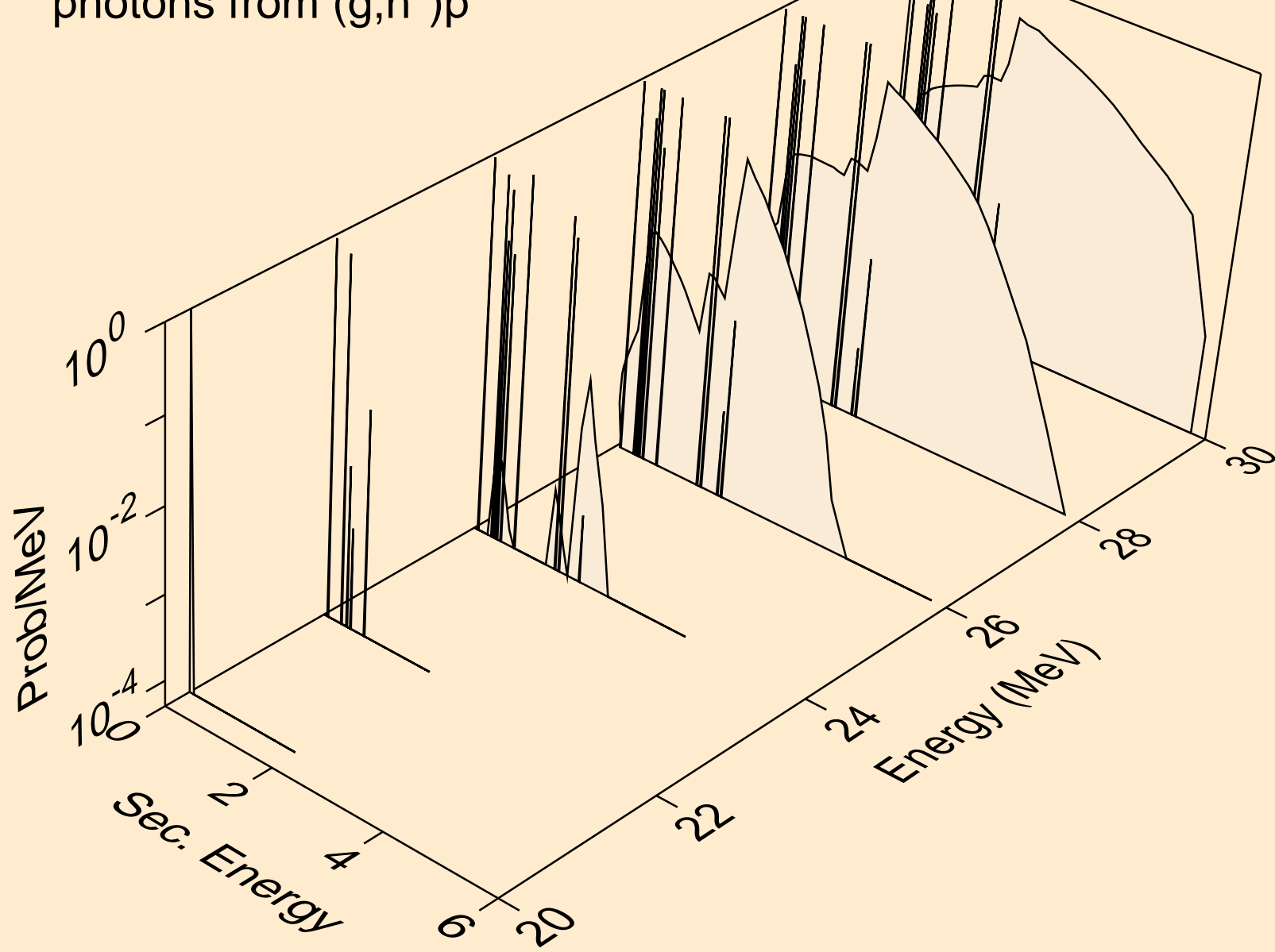

TI052 PHOTON ACER TENDL-2023 LIBRARY; T=0.K
photons from (g,n*)d

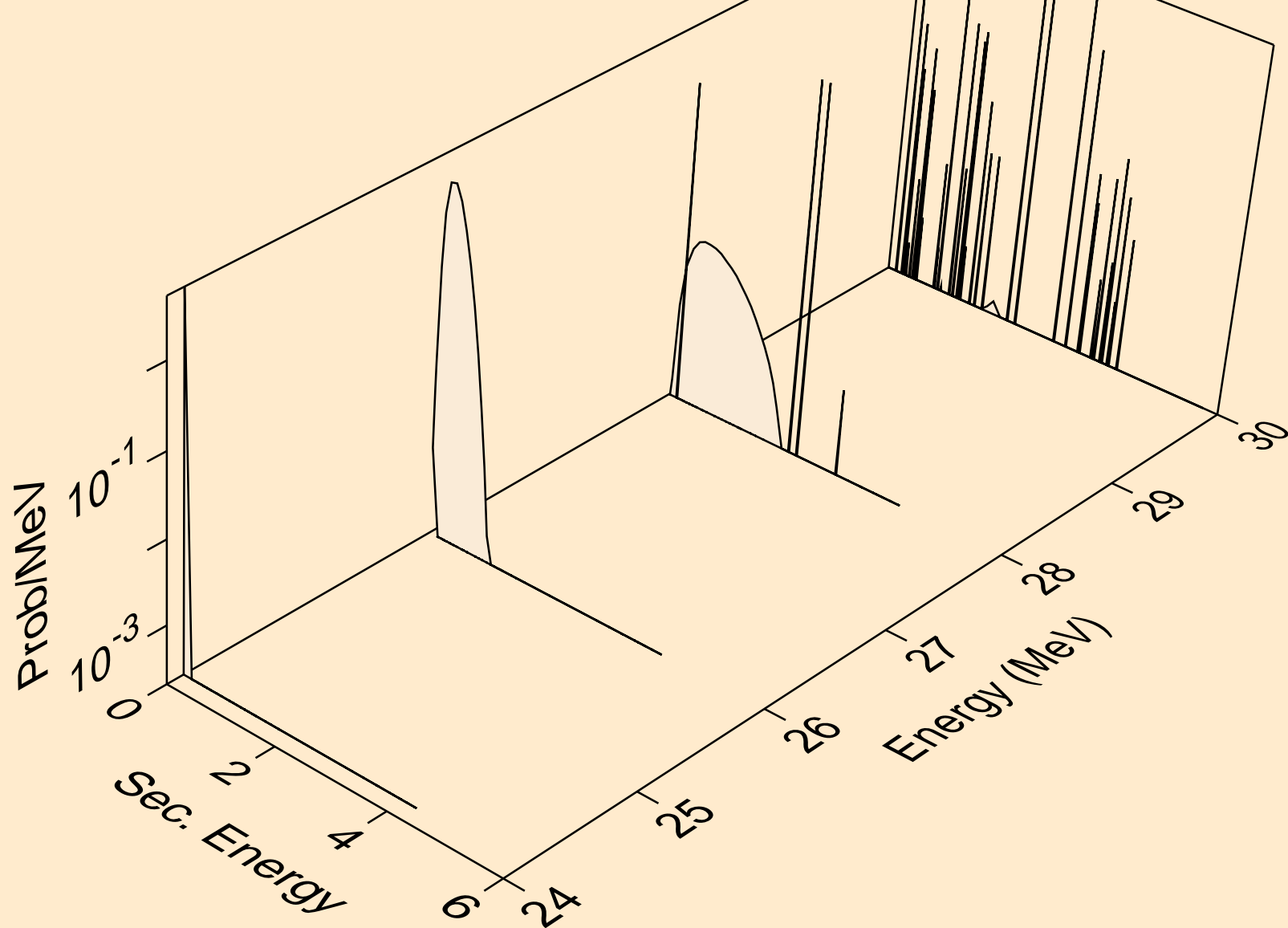

TI052 PHOTON ACER TENDL-2023 LIBRARY; T=0.K
photons from (g,2np)

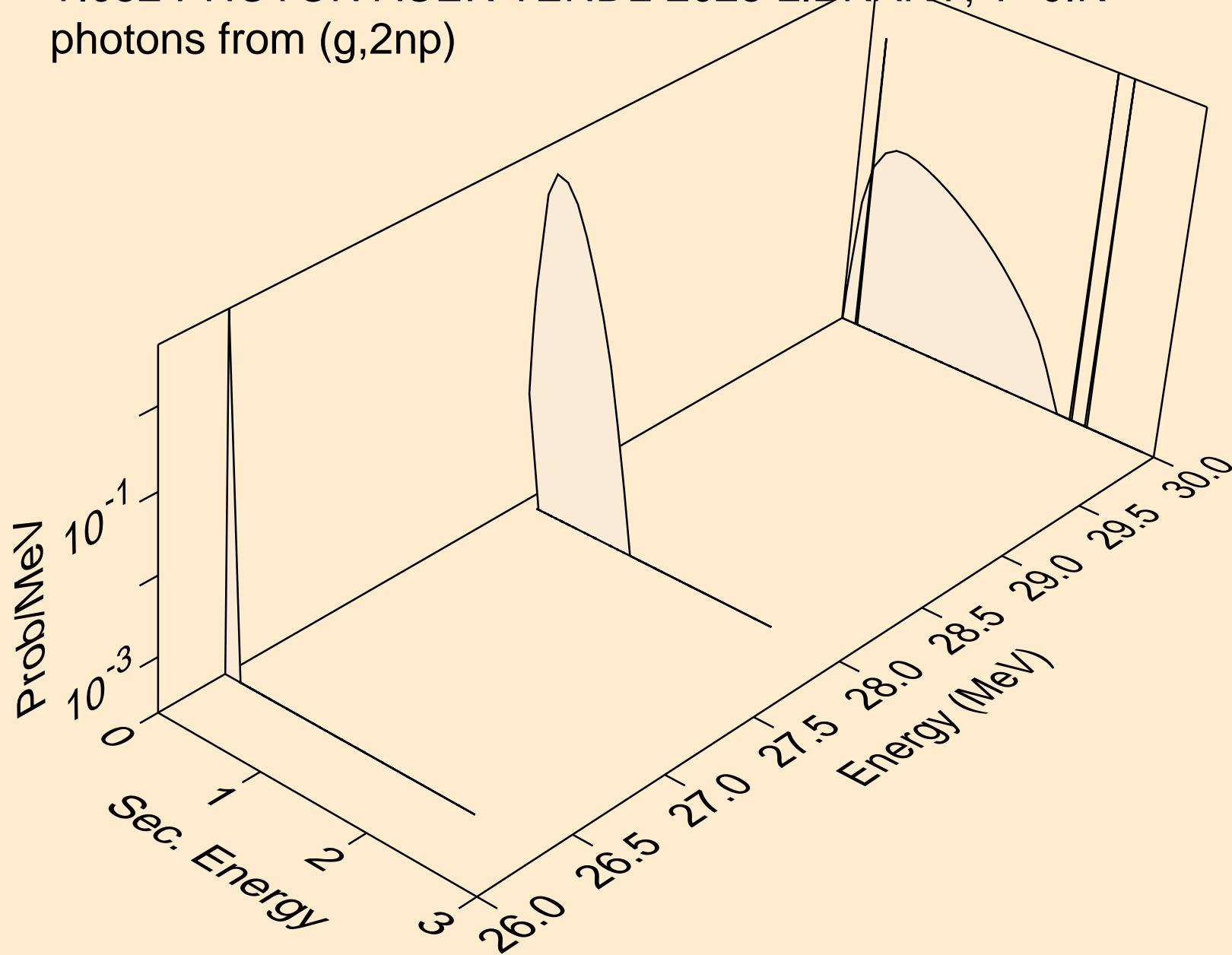

TI052 PHOTON ACER TENDL-2023 LIBRARY; T=0.K
photons from (g,n*c)

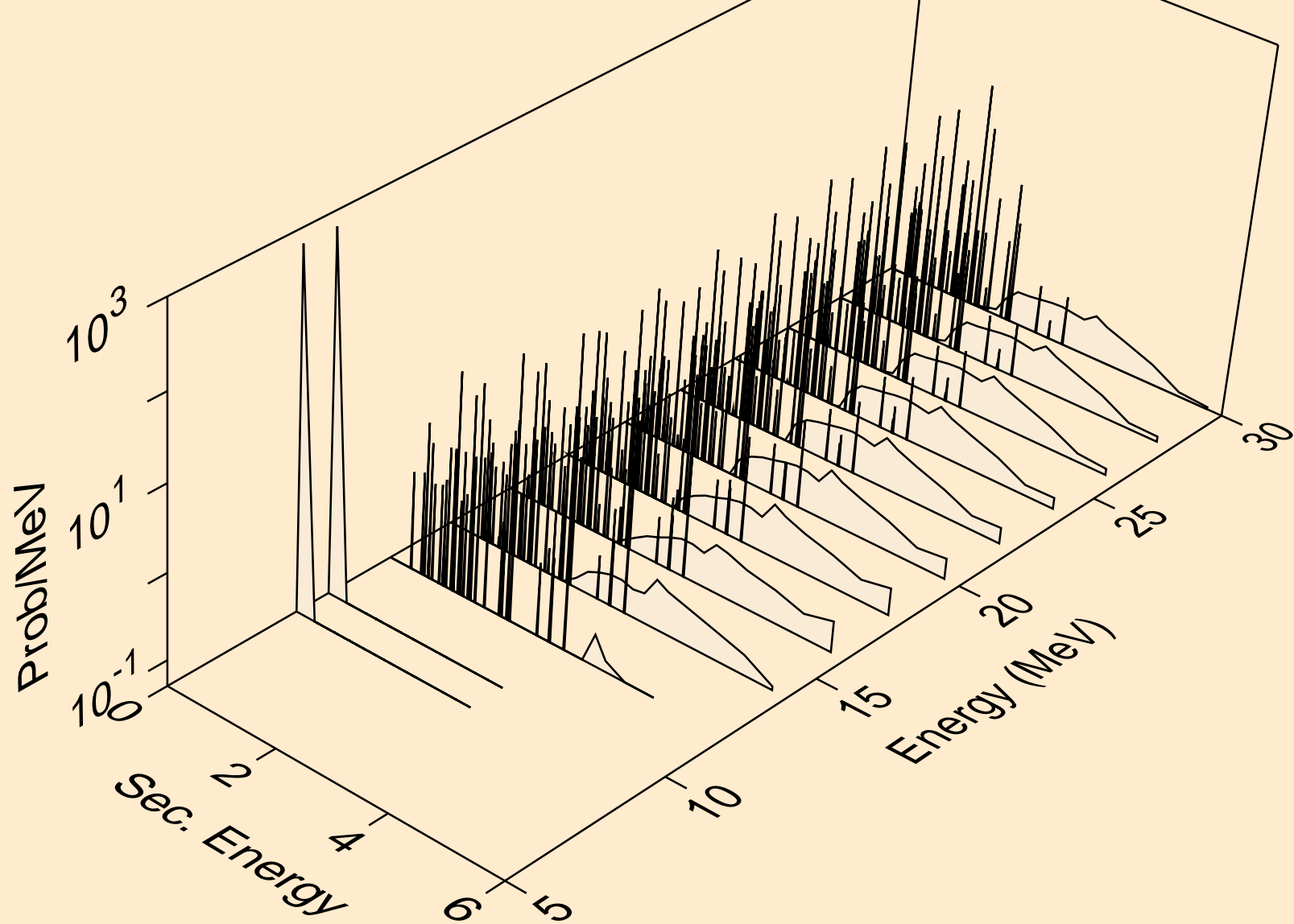

TI052 PHOTON ACER TENDL-2023 LIBRARY; T=0.K
photons from (g,gma)

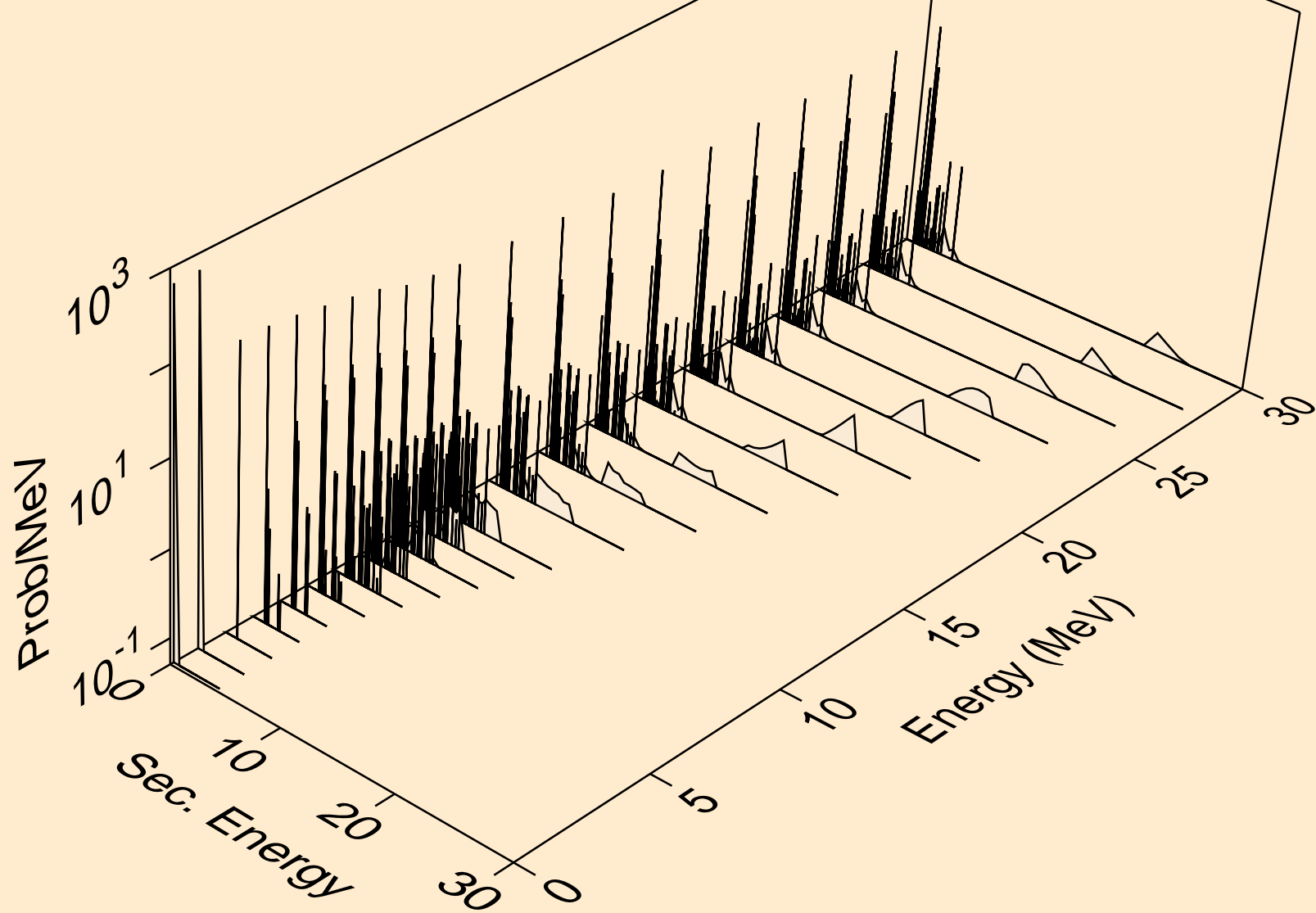

TI052 PHOTON ACER TENDL-2023 LIBRARY; T=0.K
photons from (g,p)

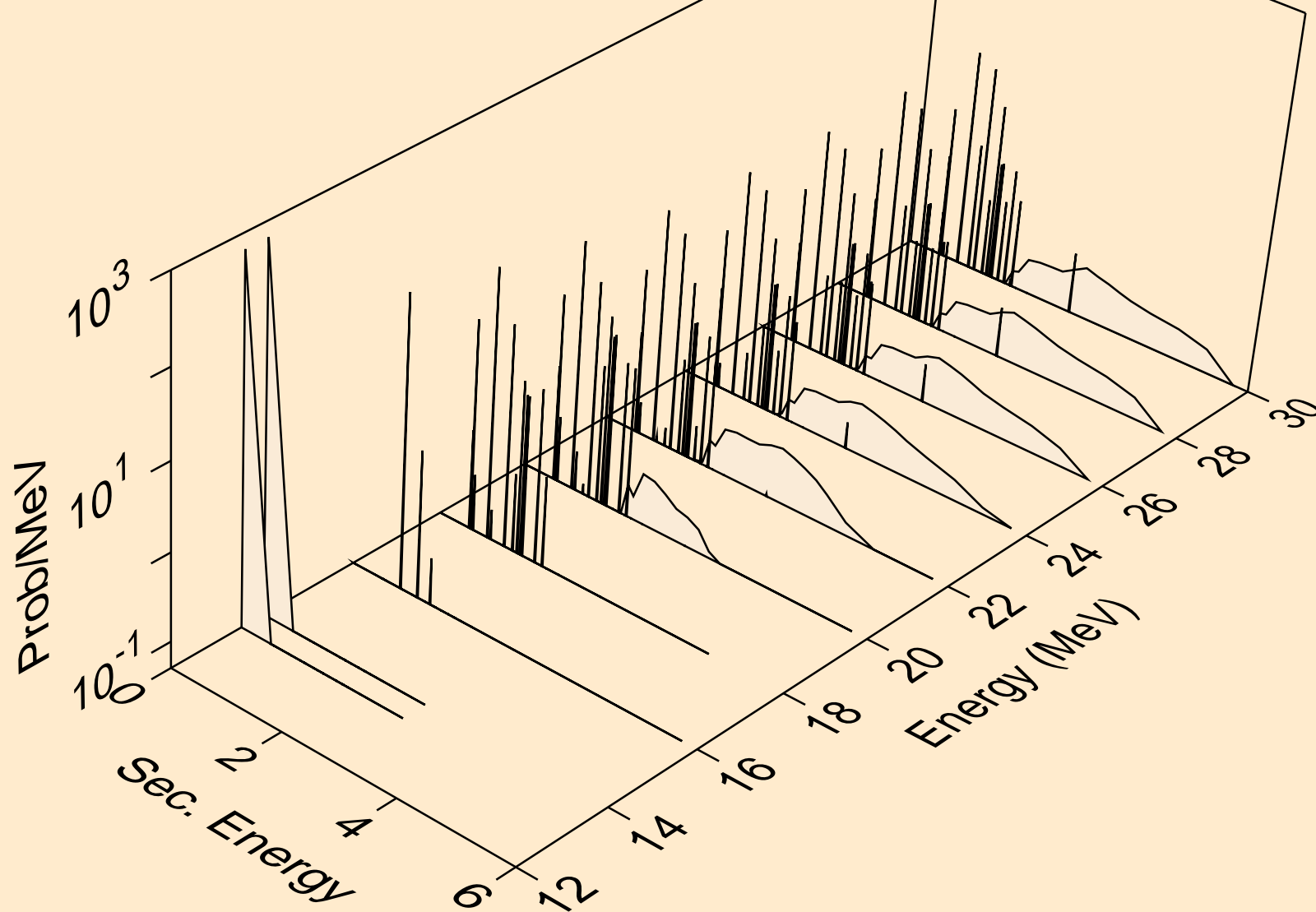

TI052 PHOTON ACER TENDL-2023 LIBRARY; T=0.K
photons from (g,d)

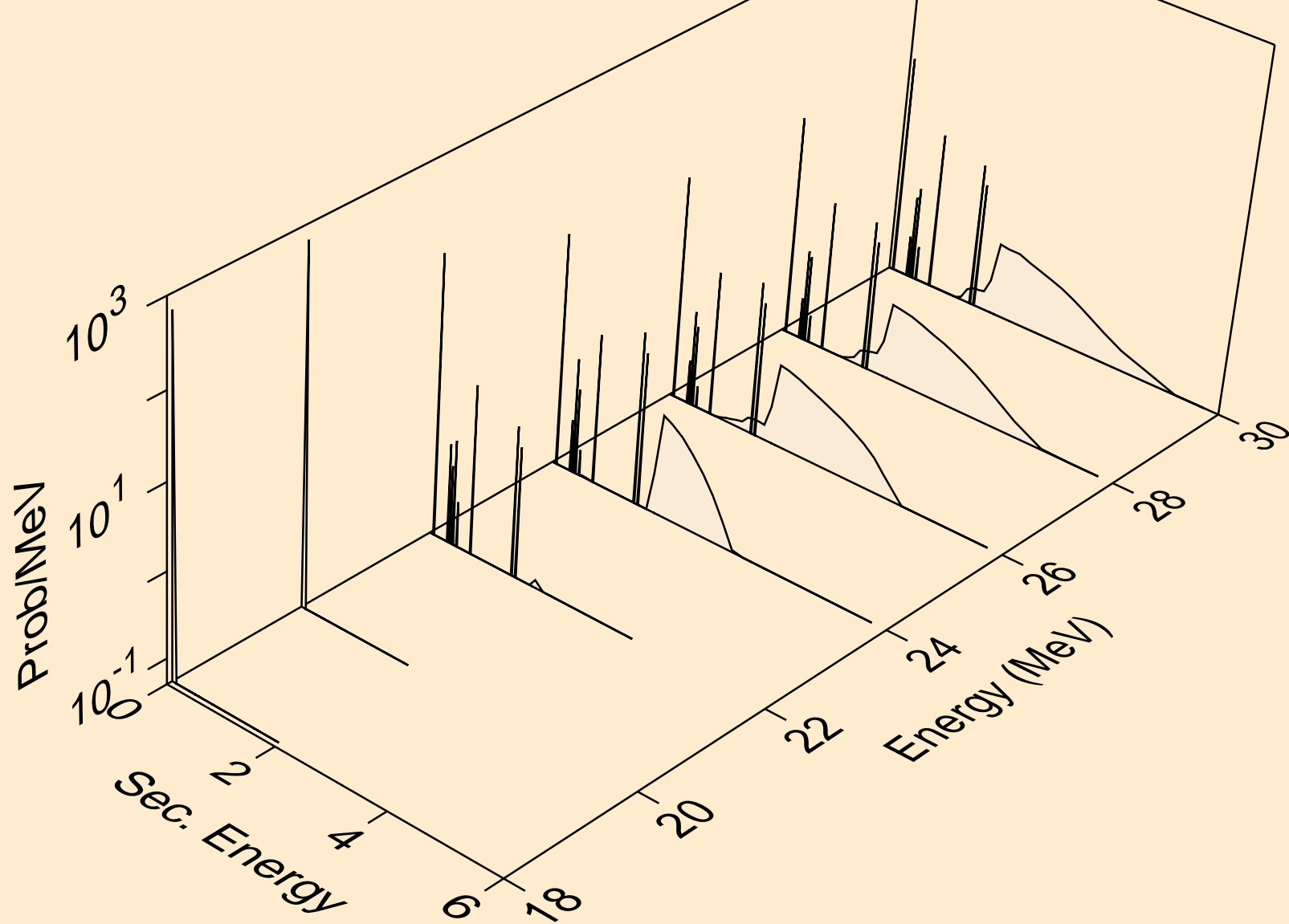

TI052 PHOTON ACER TENDL-2023 LIBRARY; T=0.K
photons from (g,t)

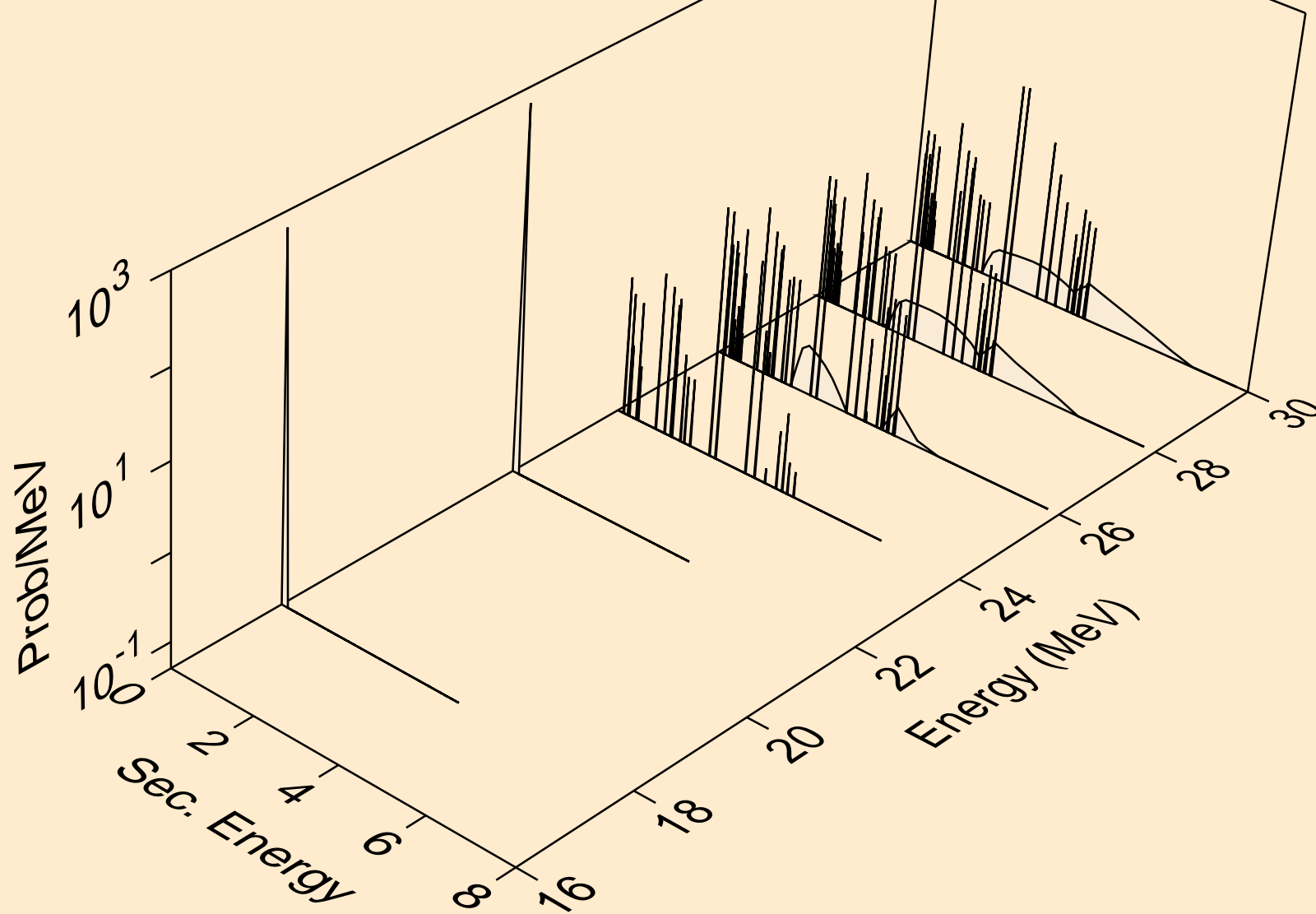

TI052 PHOTON ACER TENDL-2023 LIBRARY; T=0.K
photons from (g,a)

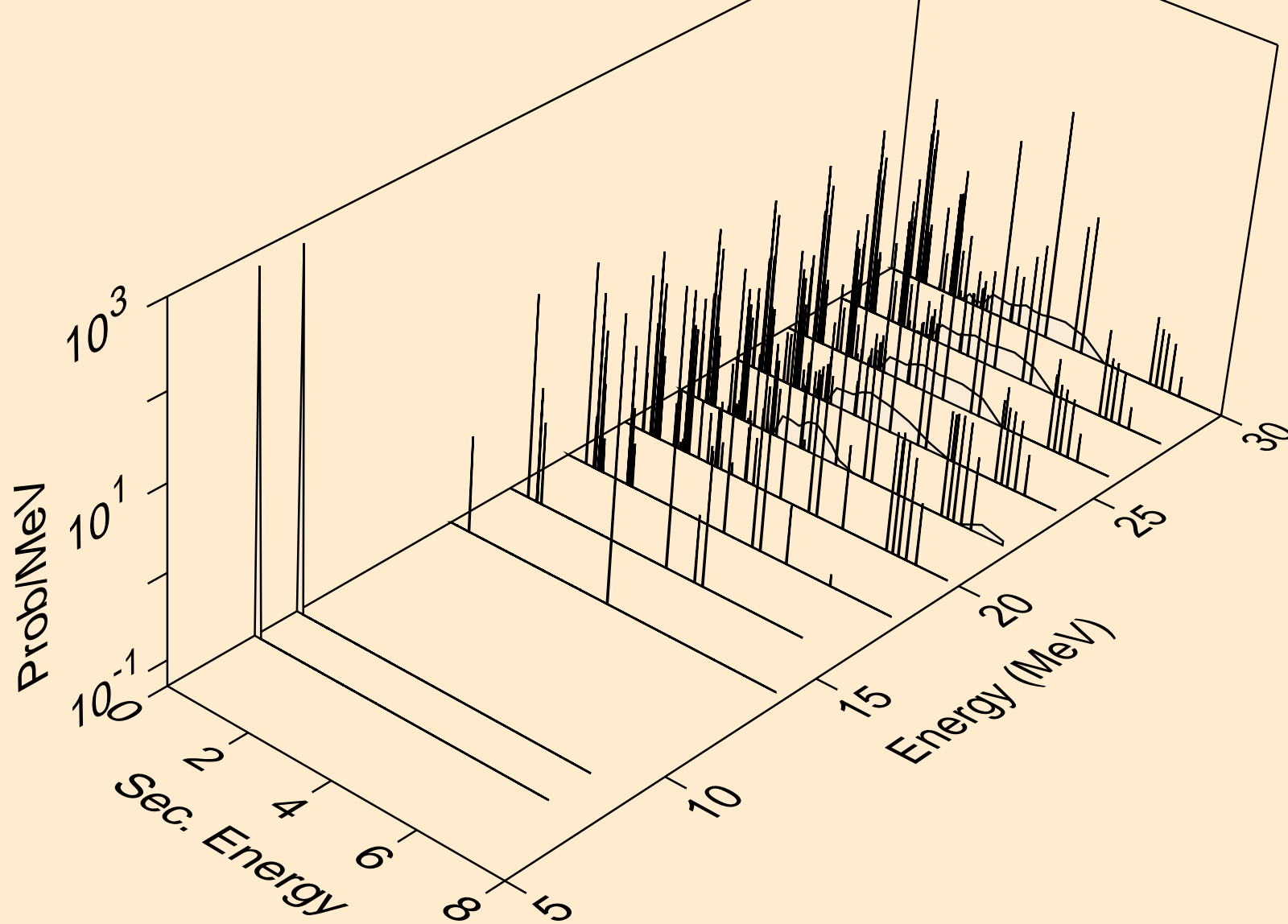

TI052 PHOTON ACER TENDL-2023 LIBRARY; T=0.K
photons from (g,2p)

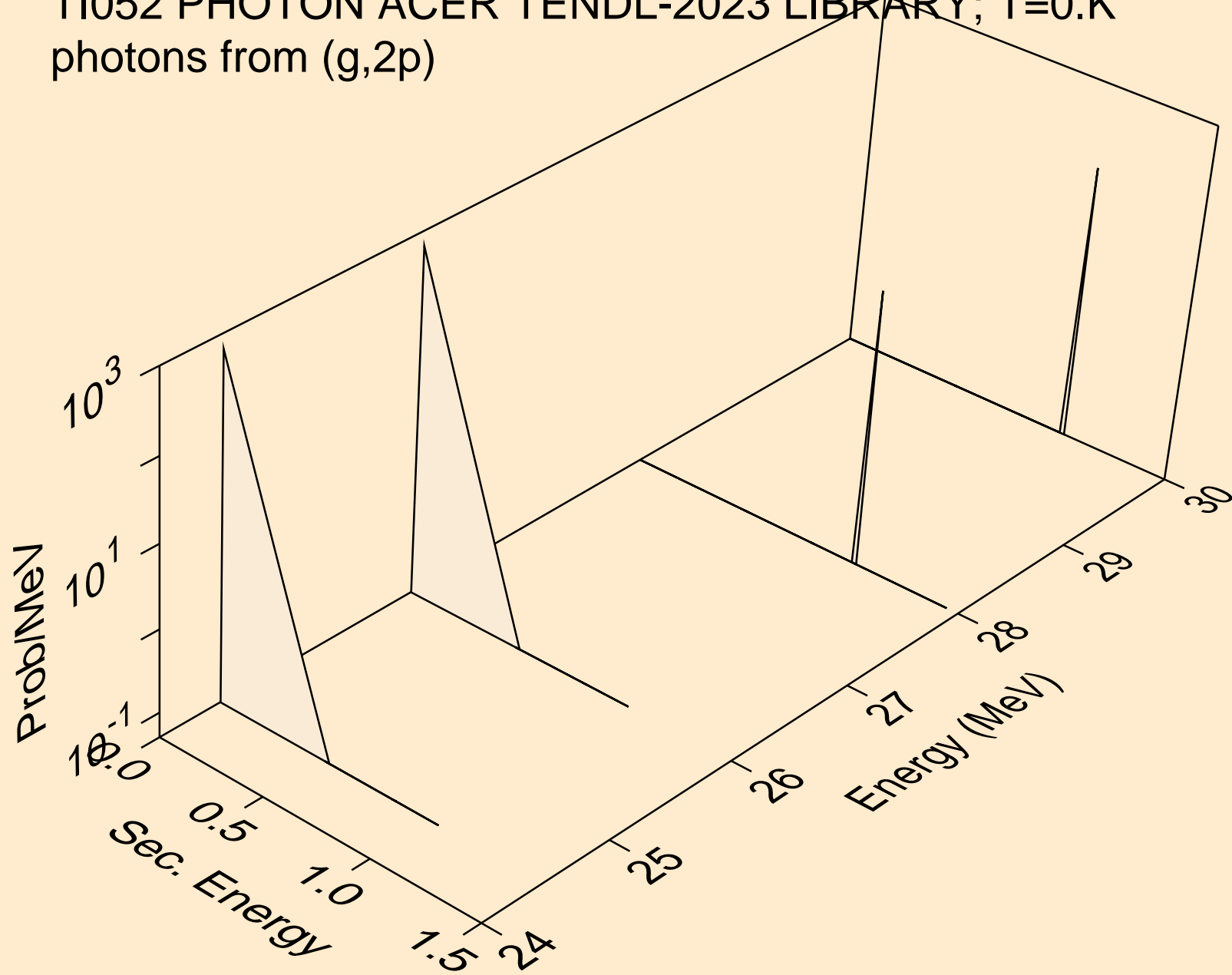

TI052 PHOTON ACER TENDL-2023 LIBRARY; T=0.K
protons from (g,x)

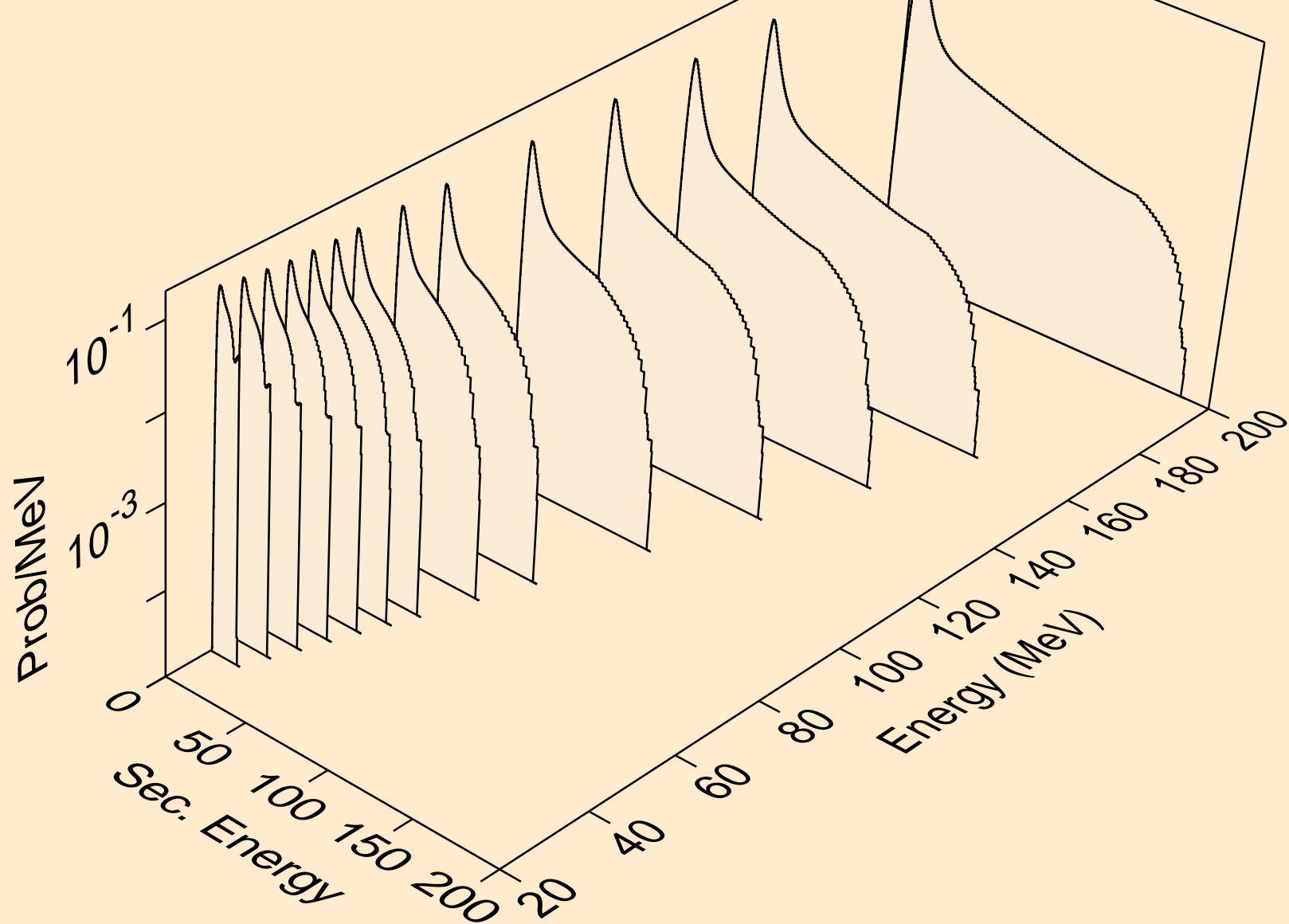

TI052 PHOTON ACER TENDL-2023 LIBRARY; T=0.K
protons from (g,n*)p

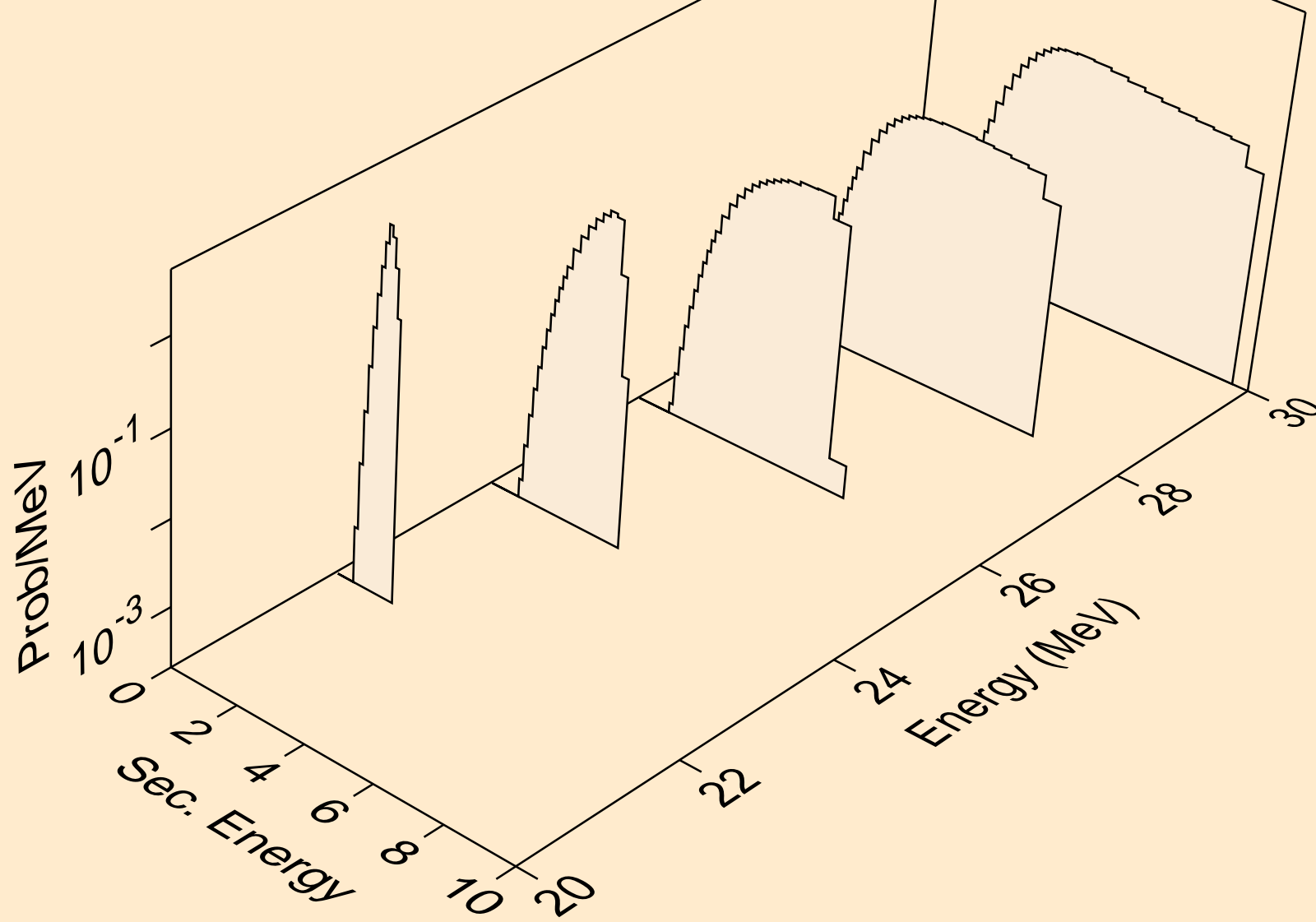

TI052 PHOTON ACER TENDL-2023 LIBRARY; T=0.K
protons from (g,2np)

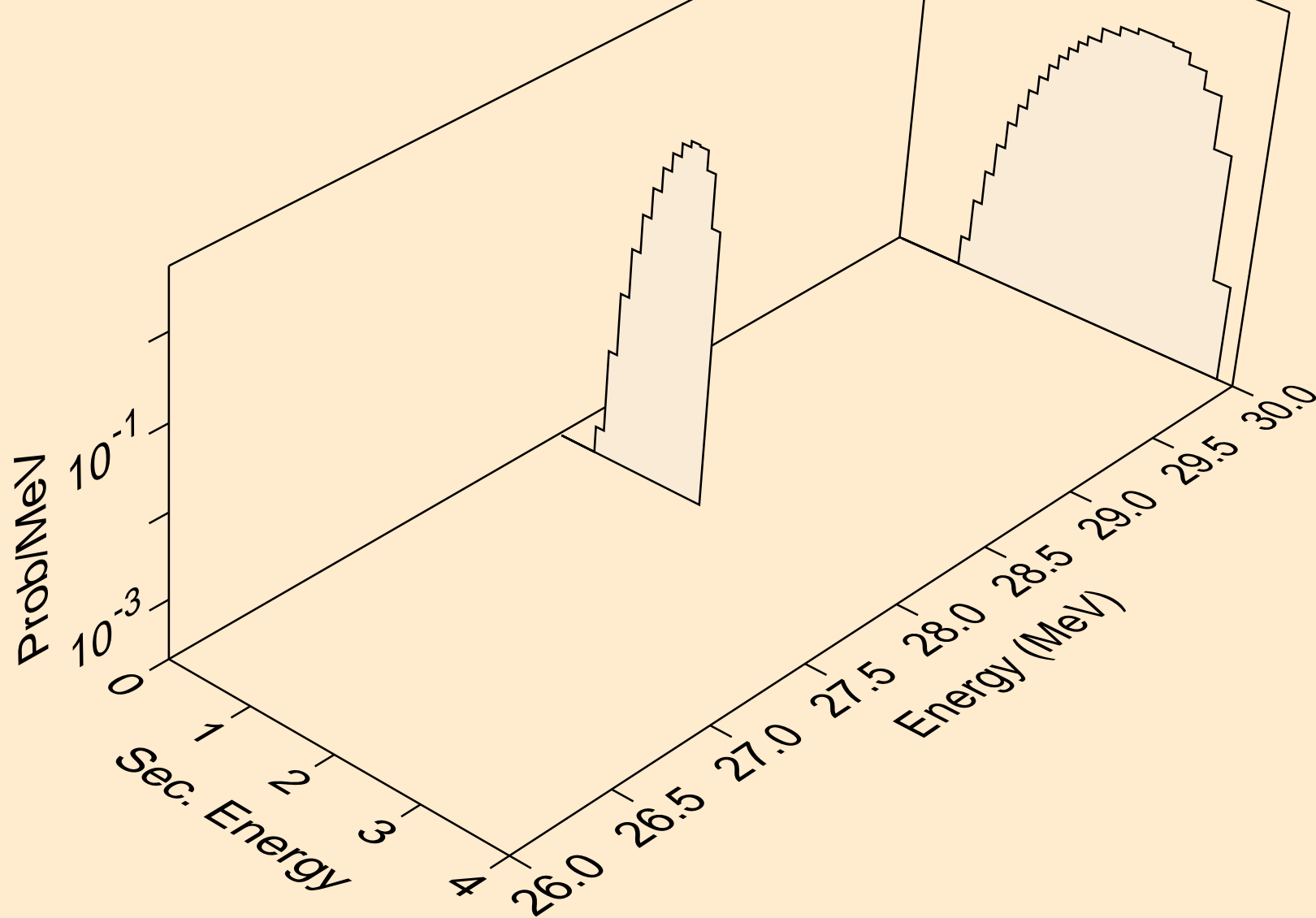

TI052 PHOTON ACER TENDL-2023 LIBRARY; T=0.K
protons from (g,p)

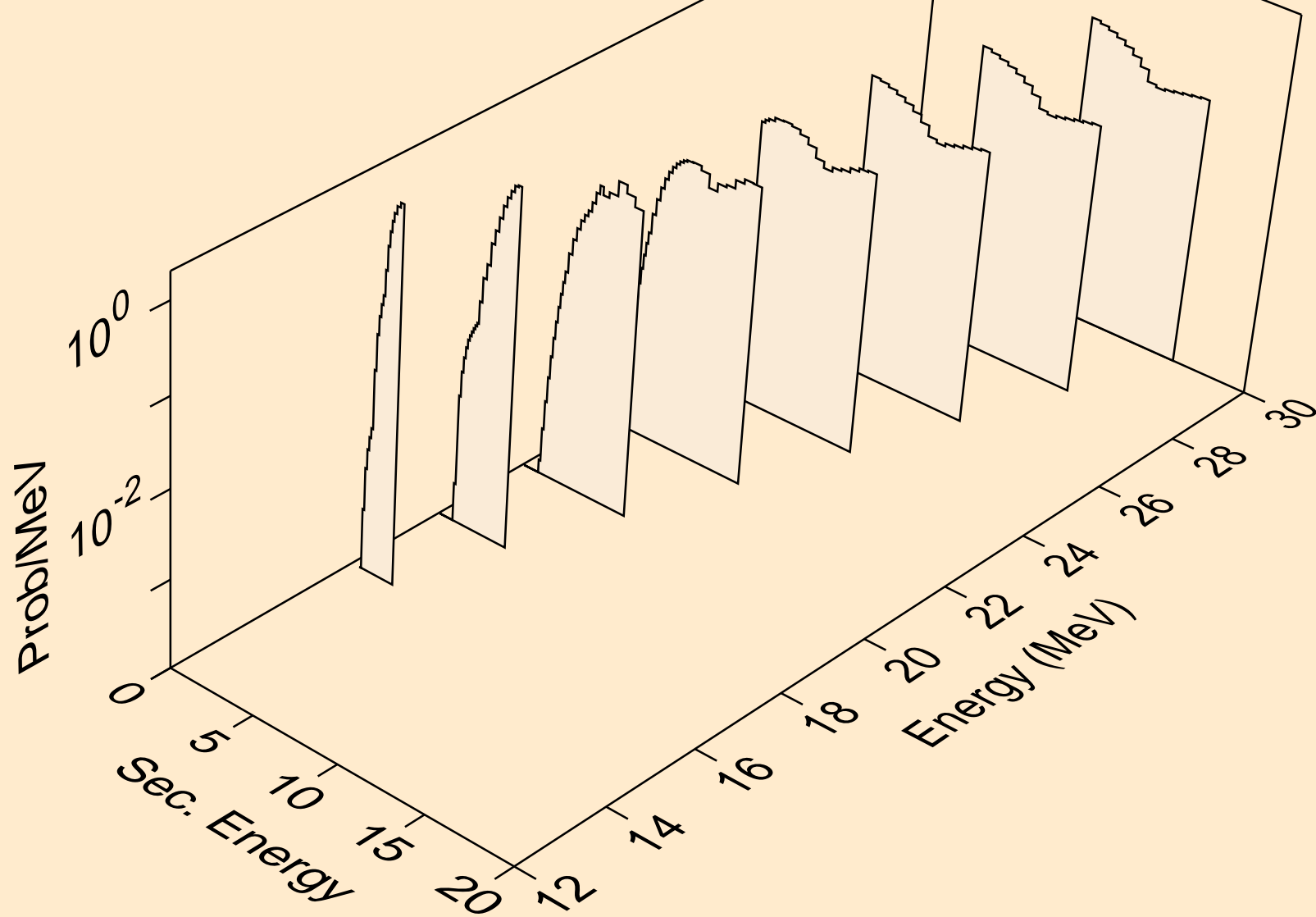

TI052 PHOTON ACER TENDL-2023 LIBRARY; T=0.K
protons from (g,2p)

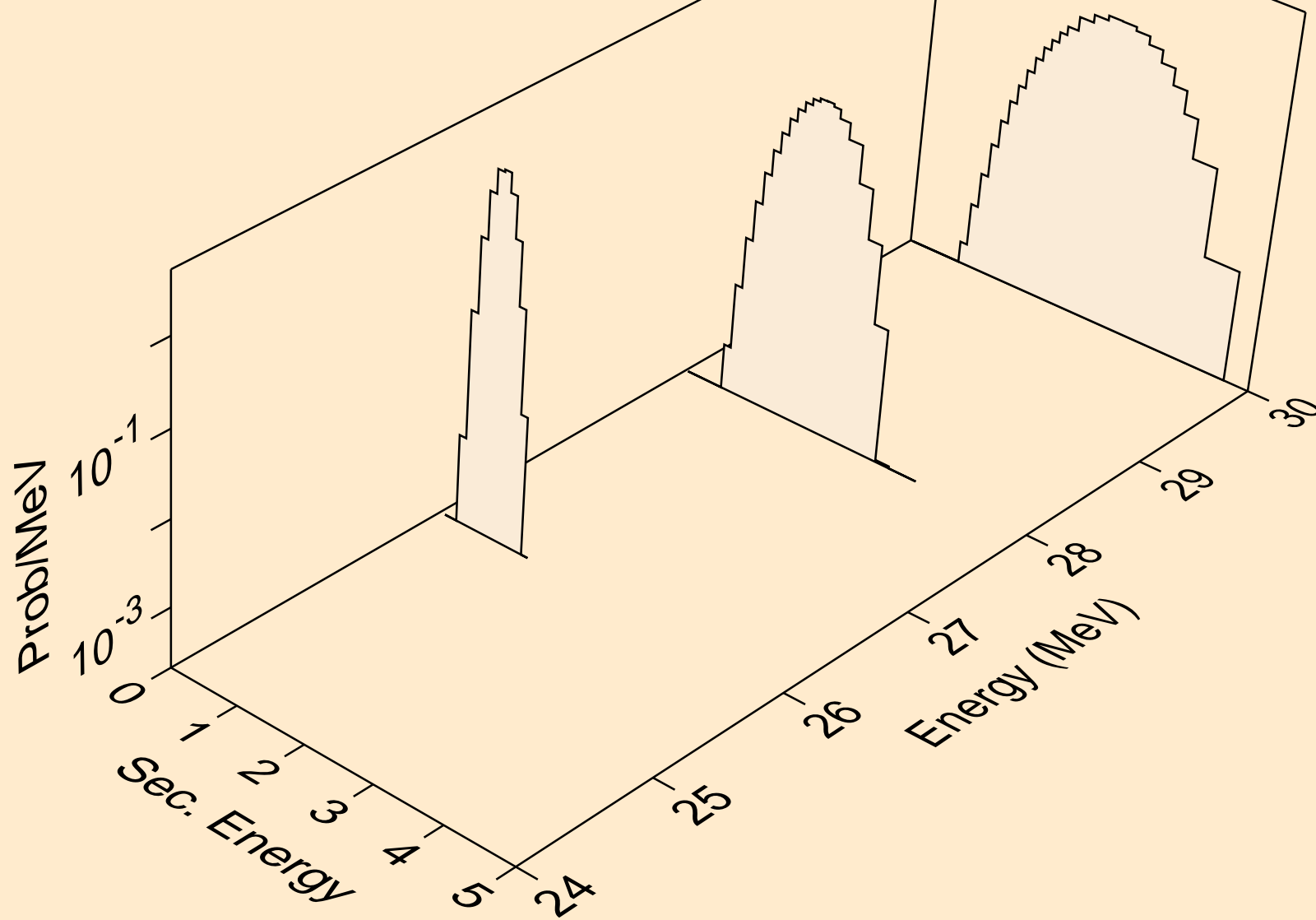

TI052 PHOTON ACER TENDL-2023 LIBRARY; T=0.K
deuterons from (g,x)

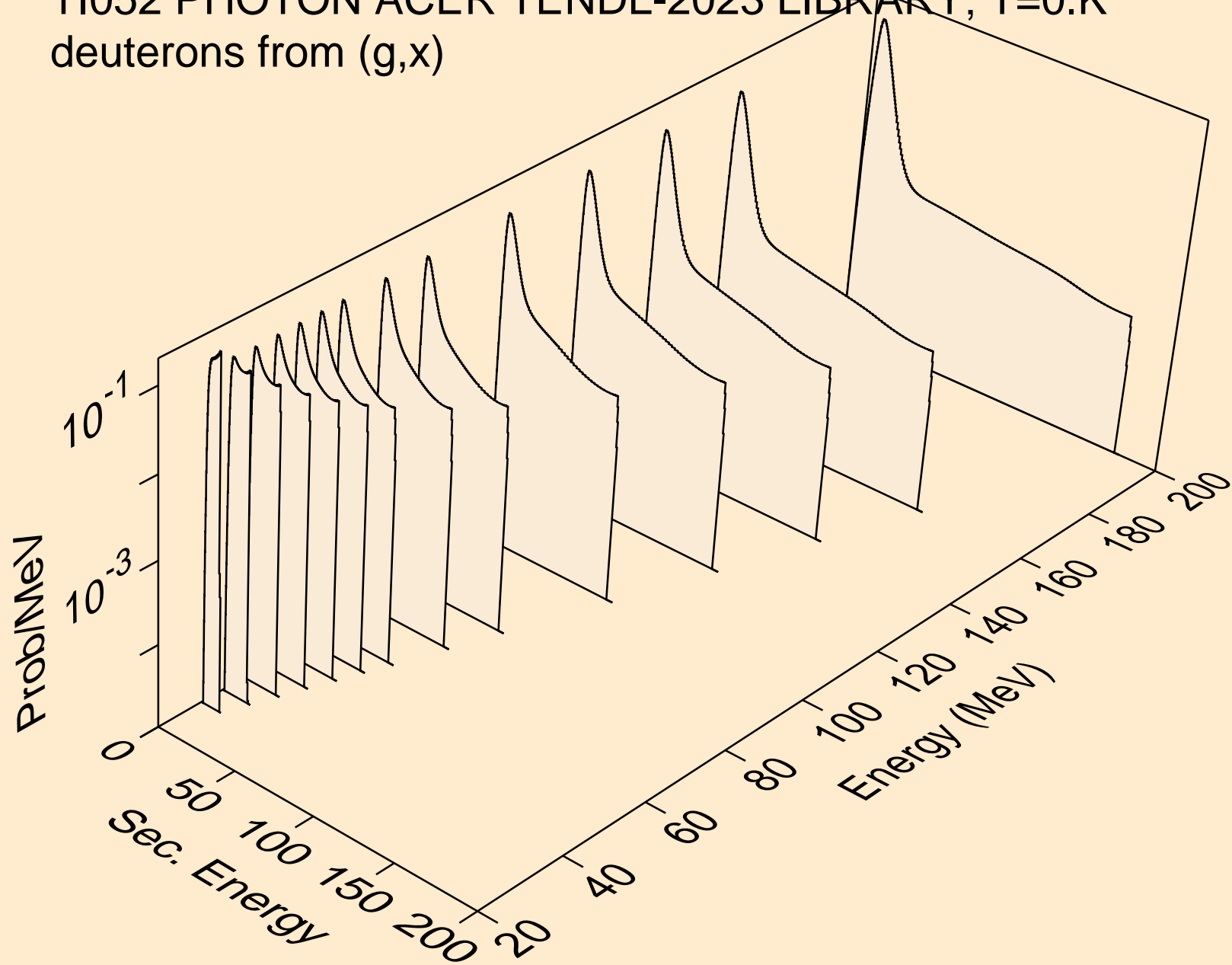

TI052 PHOTON ACER TENDL-2023 LIBRARY; T=0.K
deuterons from (g,n*)d

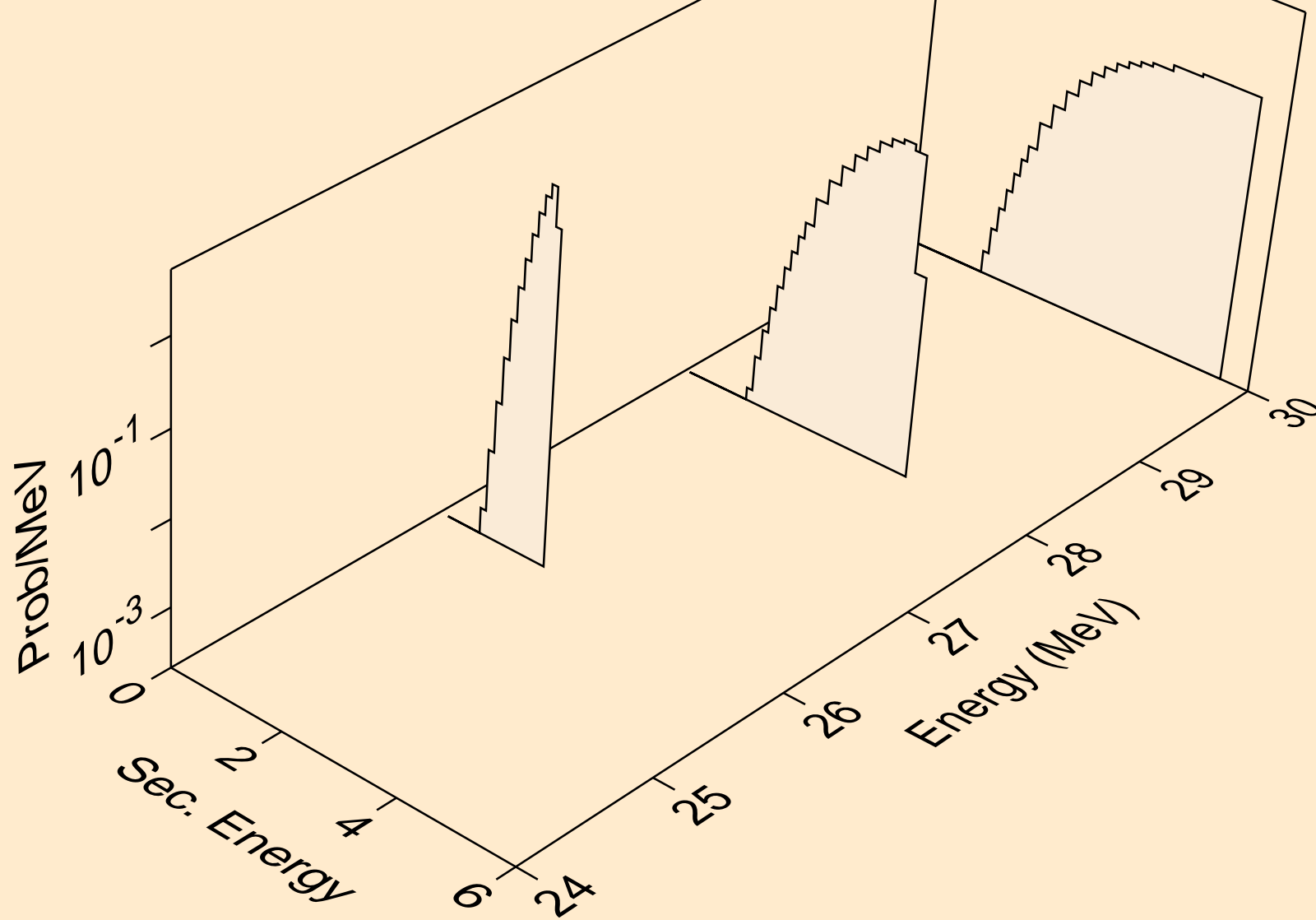

TI052 PHOTON ACER TENDL-2023 LIBRARY; T=0.K
deuterons from (g,d)

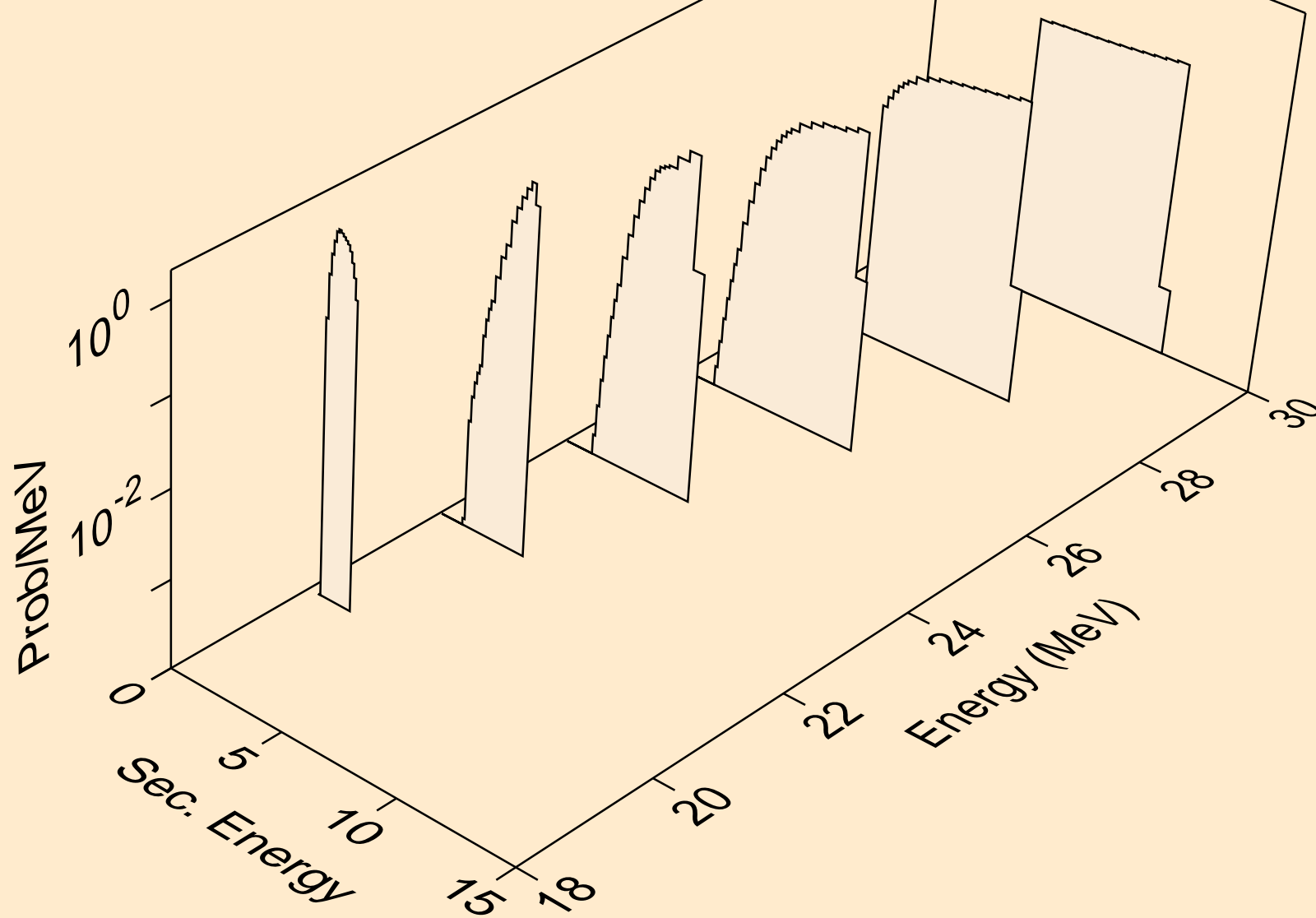

TI052 PHOTON ACER TENDL-2023 LIBRARY; T=0.K
tritons from (g,x)

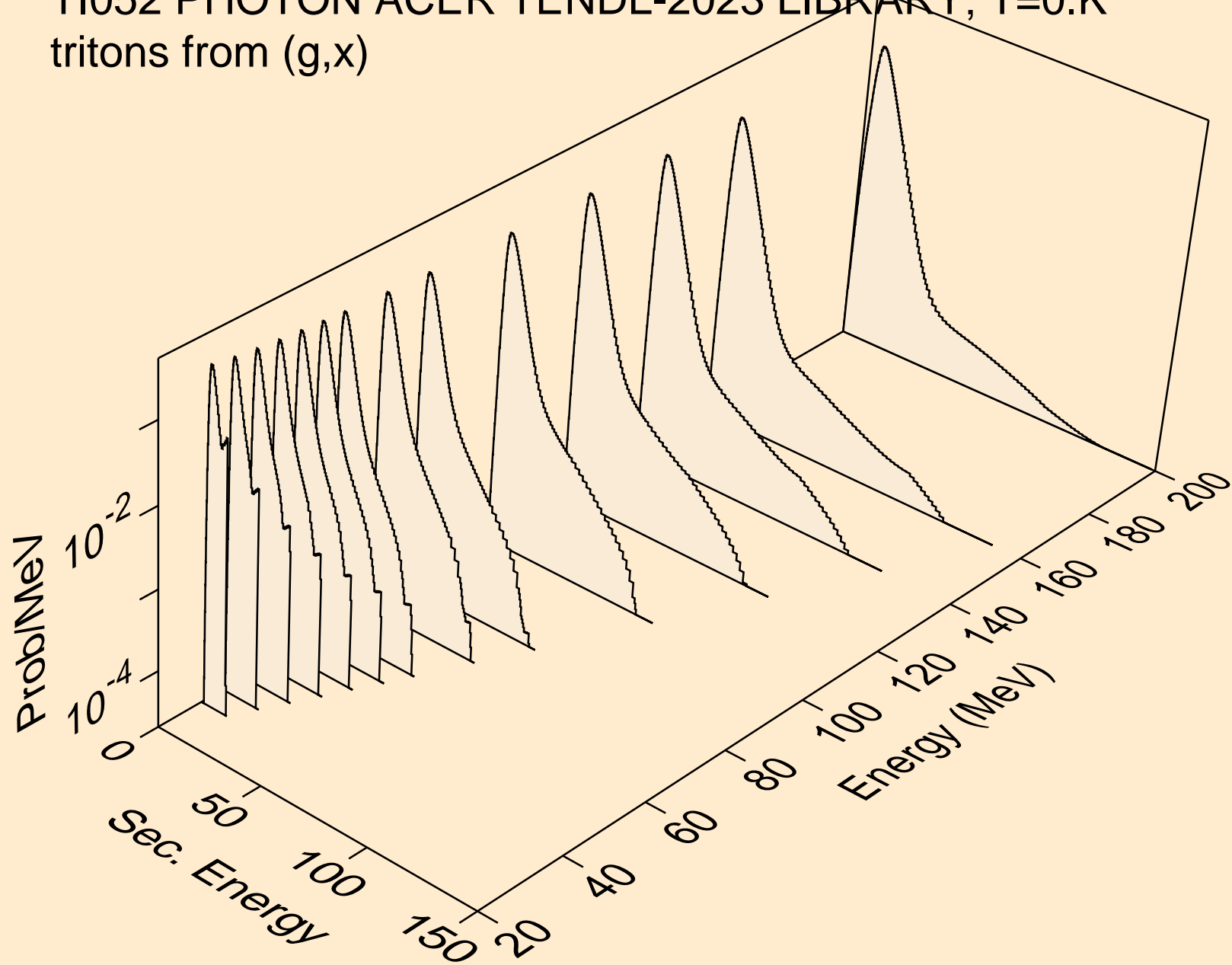

TI052 PHOTON ACER TENDL-2023 LIBRARY; T=0.K
tritons from (g,t)

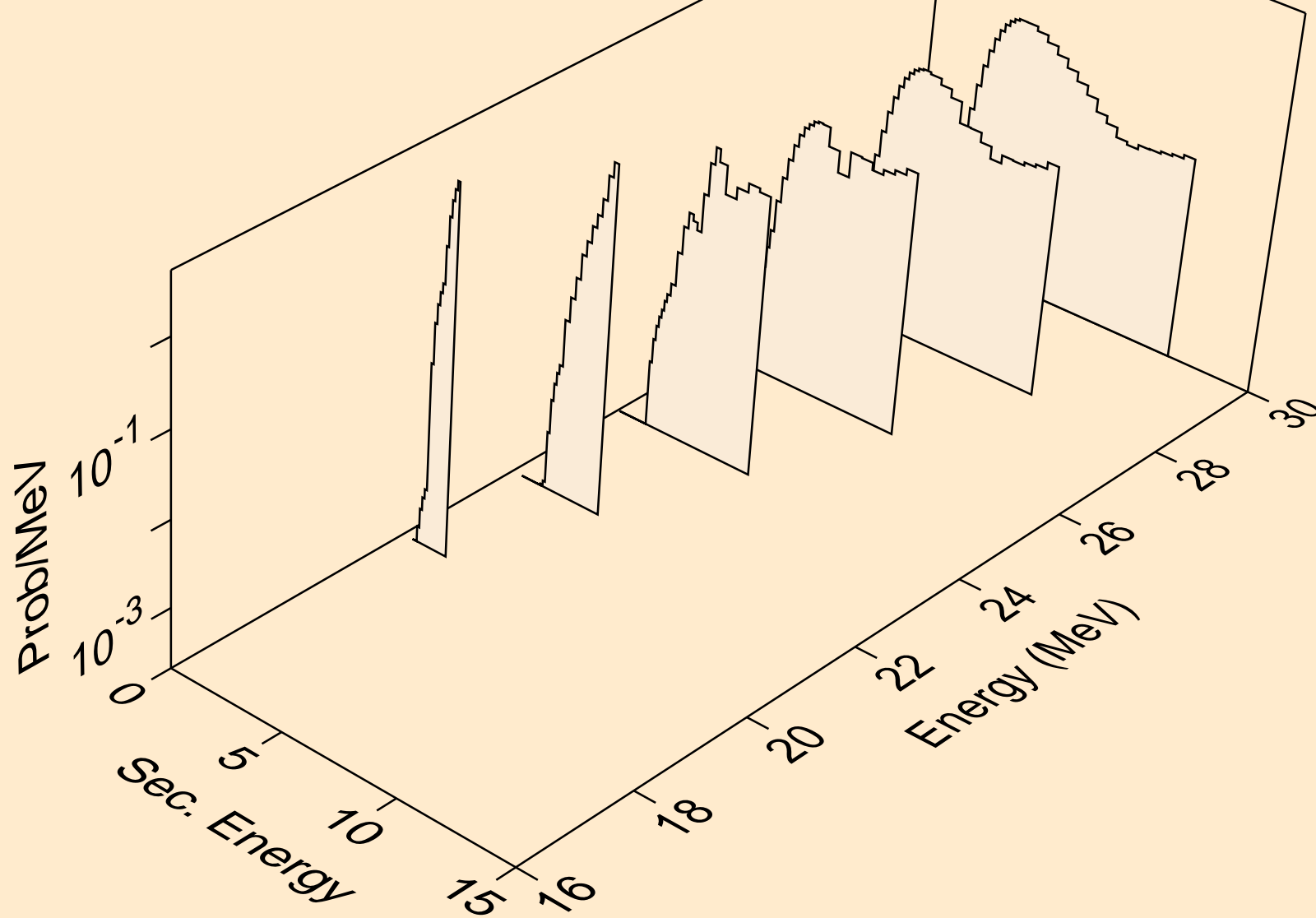

TI052 PHOTON ACER TENDL-2023 LIBRARY; T=0.K
he3s from (g,x)

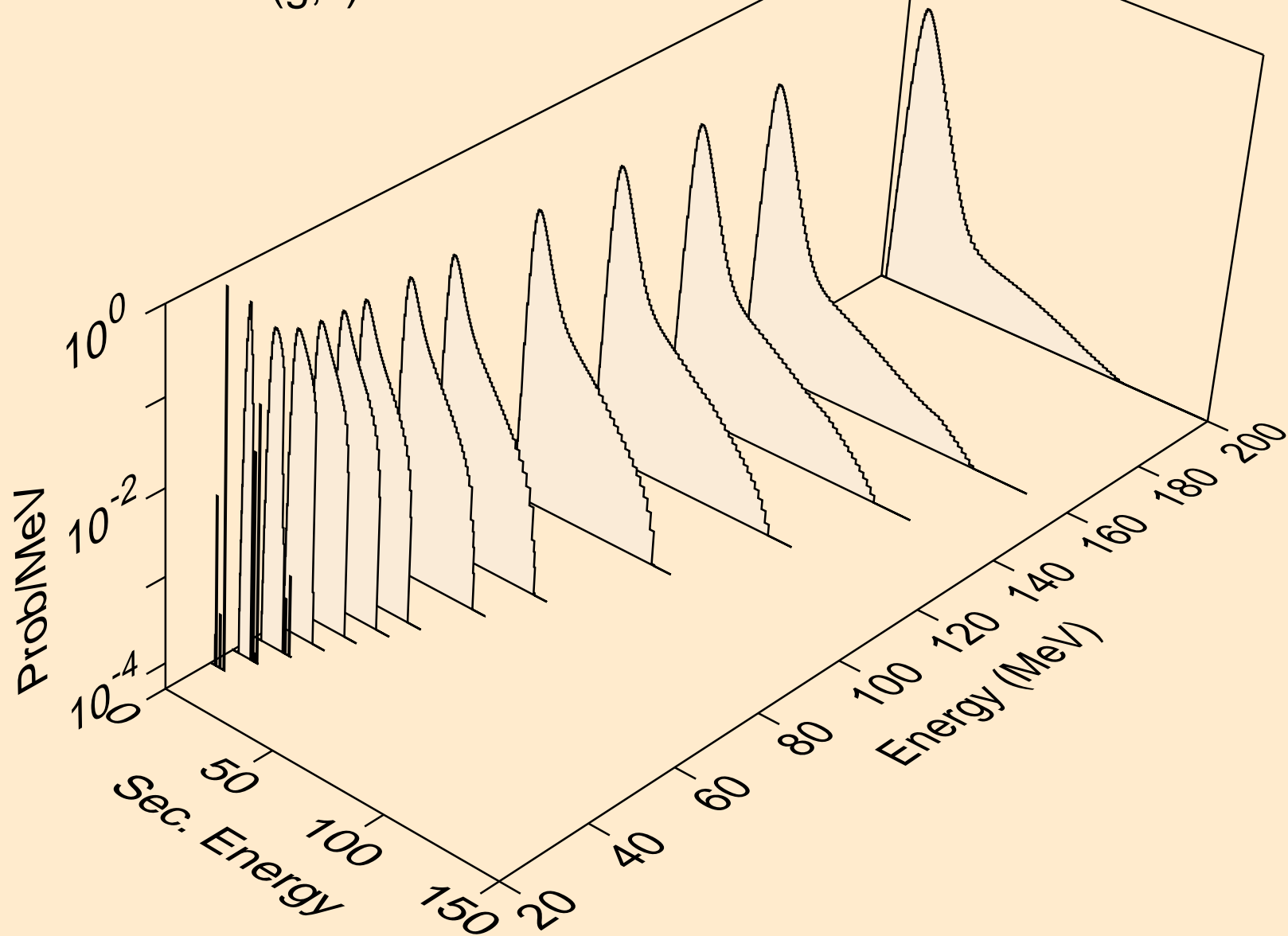

TI052 PHOTON ACER TENDL-2023 LIBRARY; T=0.K
he3s from (g,he3)

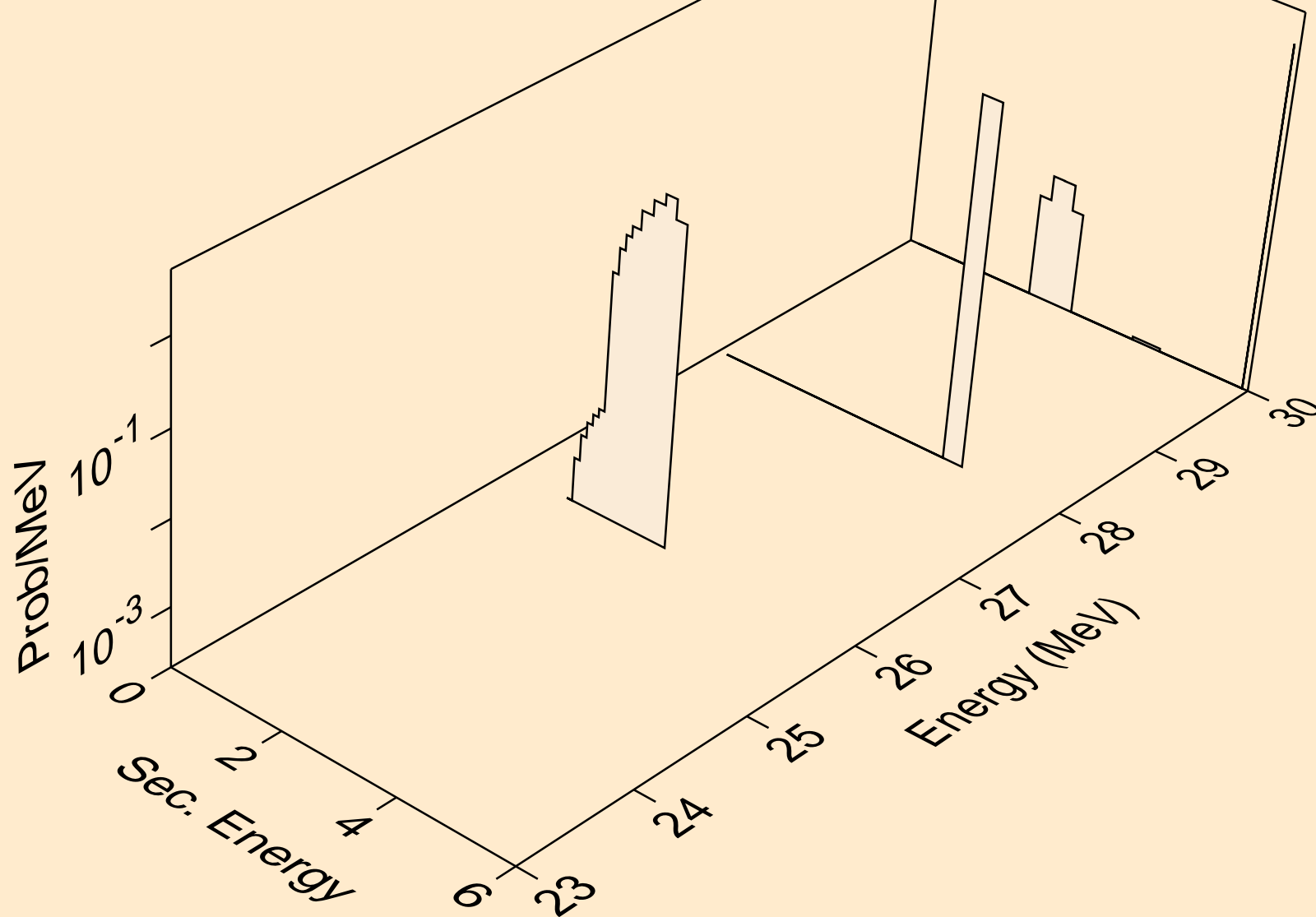

TI052 PHOTON ACER TENDL-2023 LIBRARY; T=0.K
alphas from (g,x)

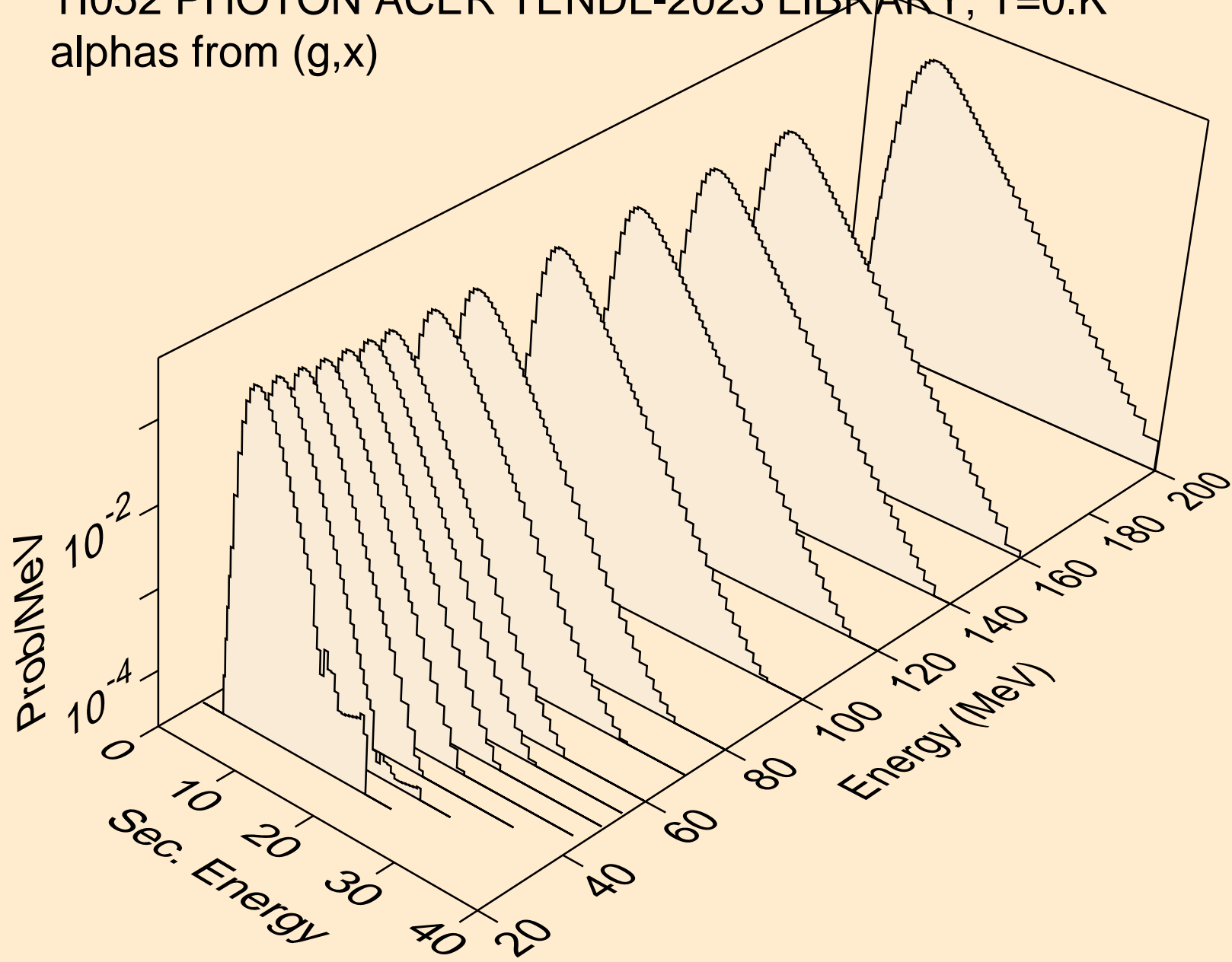

TI052 PHOTON ACER TENDL-2023 LIBRARY; T=0.K
alphas from (g,n*)a

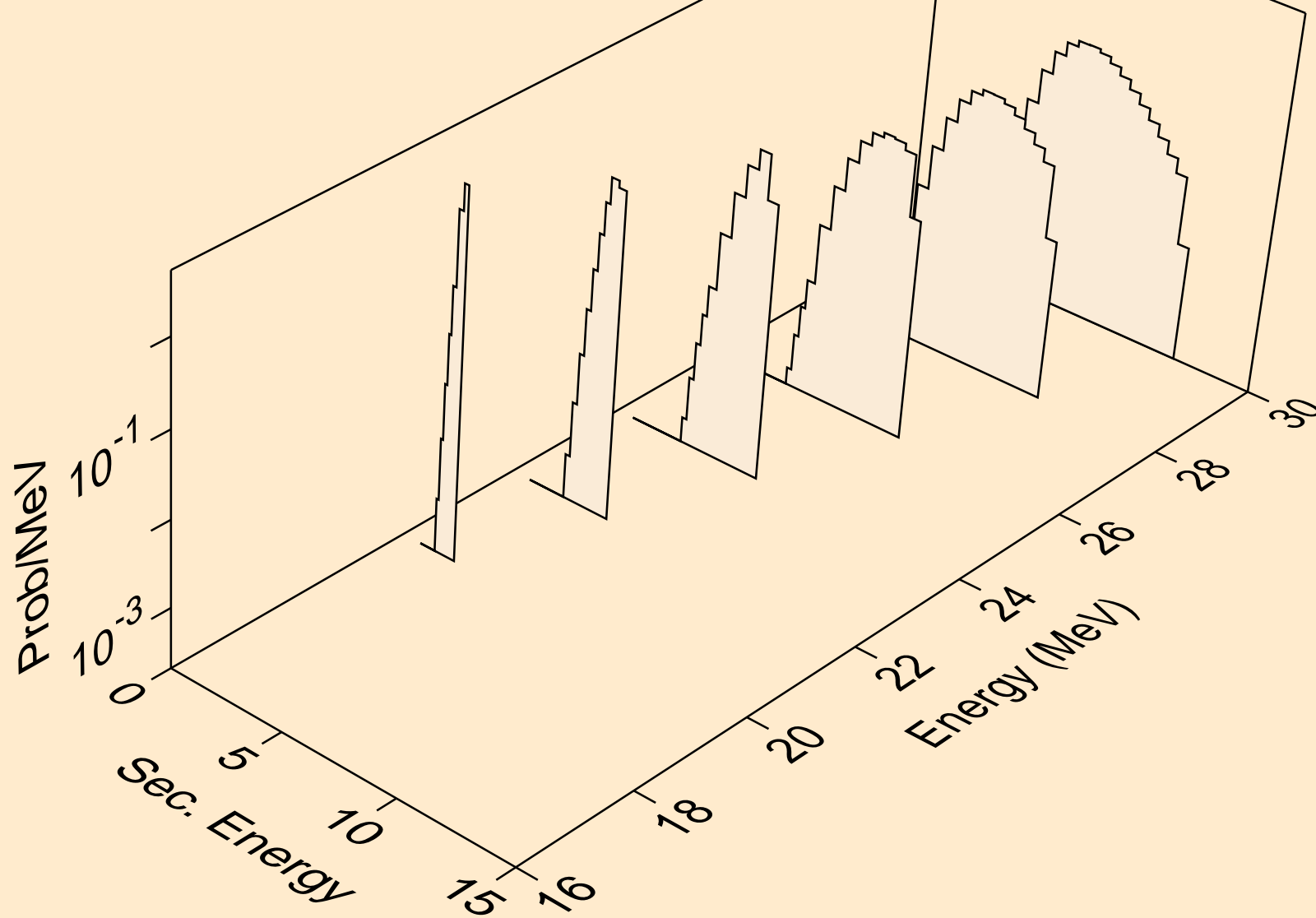

TI052 PHOTON ACER TENDL-2023 LIBRARY; T=0.K
alphas from (g,2n)a

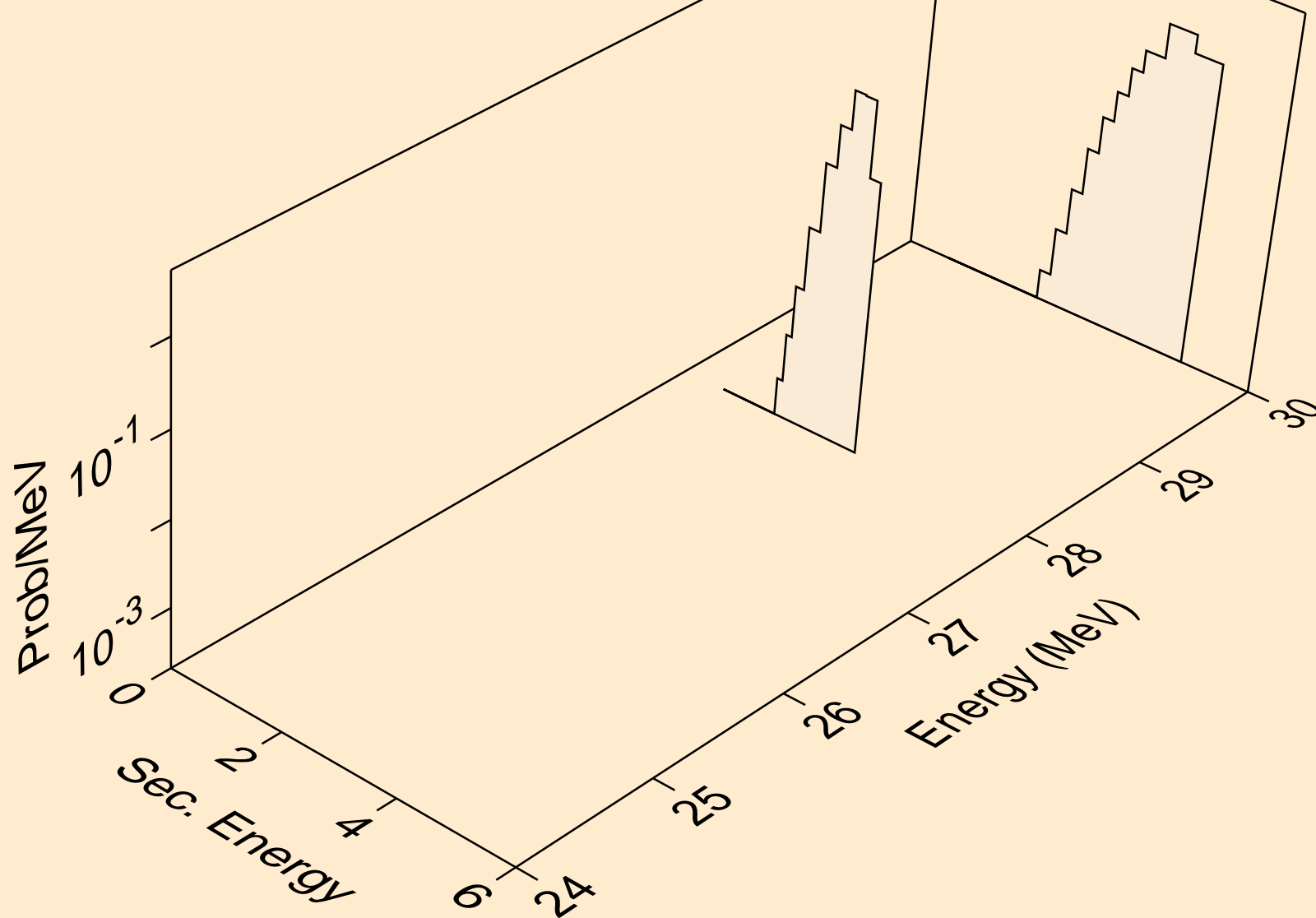

TI052 PHOTON ACER TENDL-2023 LIBRARY; T=0.K
alphas from (g,a)

