

U227 PHOTON ACER TENDL-2023 LIBRARY; T=0.K
Principal cross sections

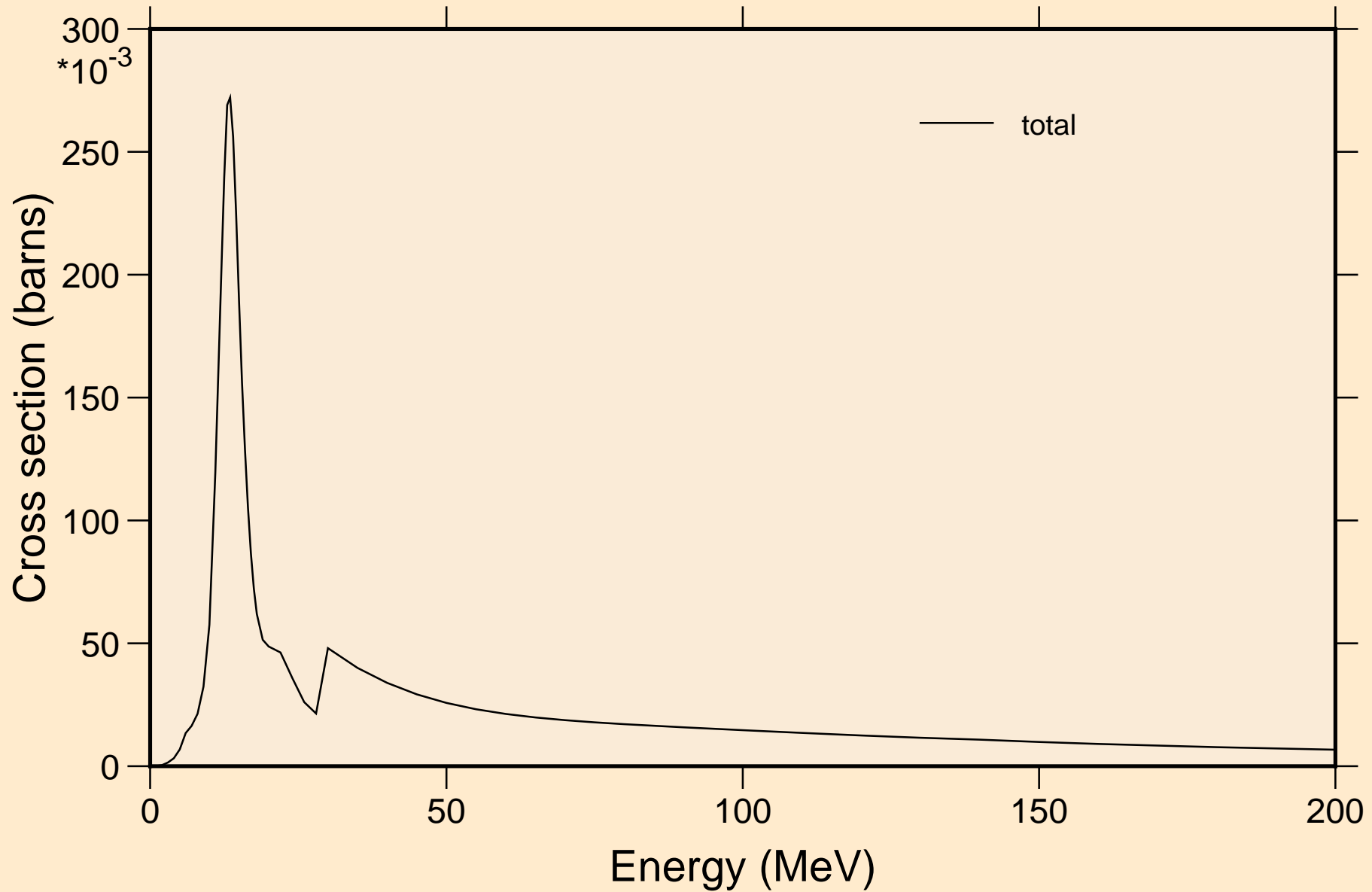

U227 PHOTON ACER TENDL-2023 LIBRARY; T=0.K

Partial cross sections

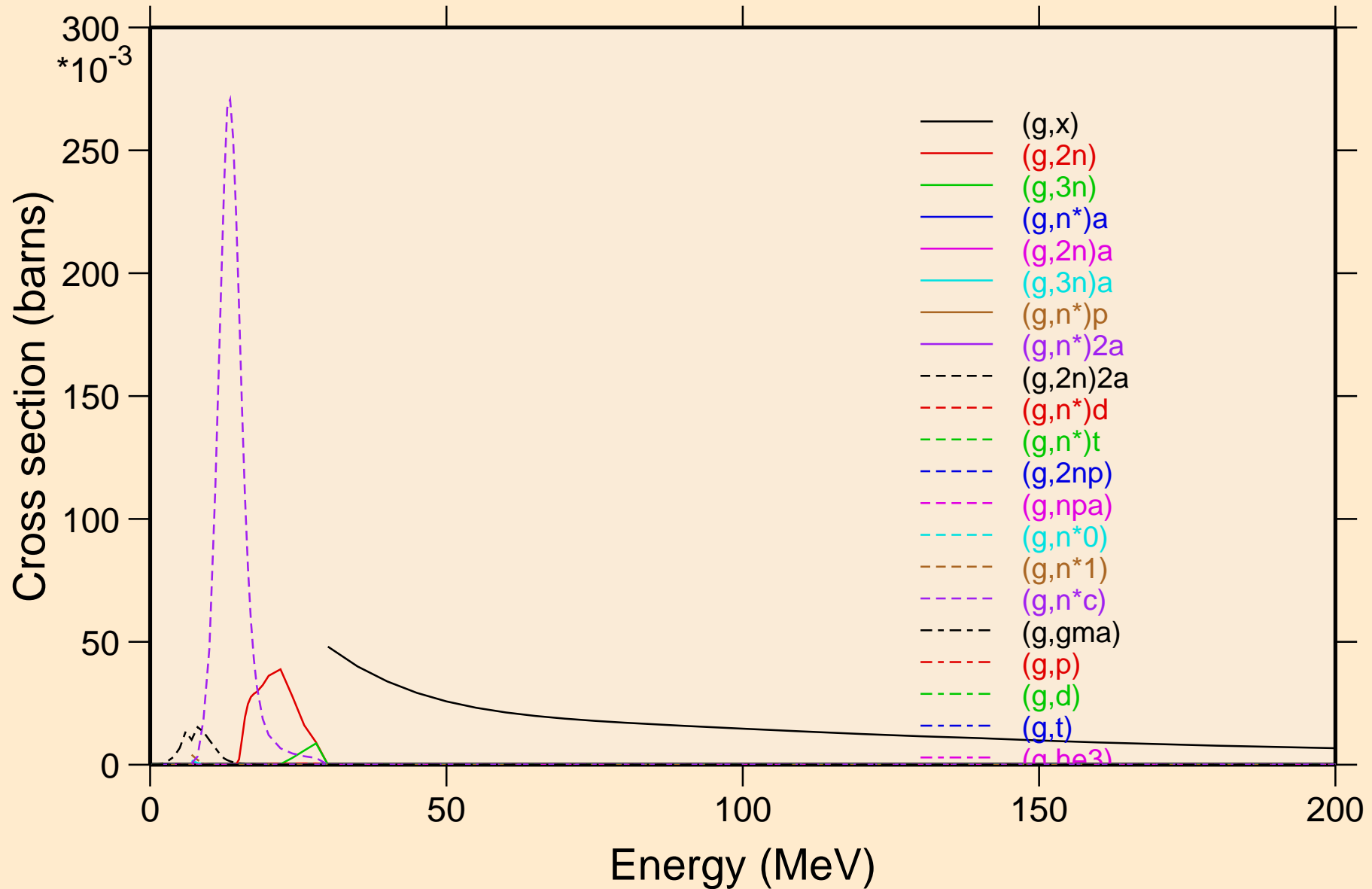

U227 PHOTON ACER TENDL-2023 LIBRARY; T=0.K

Heating

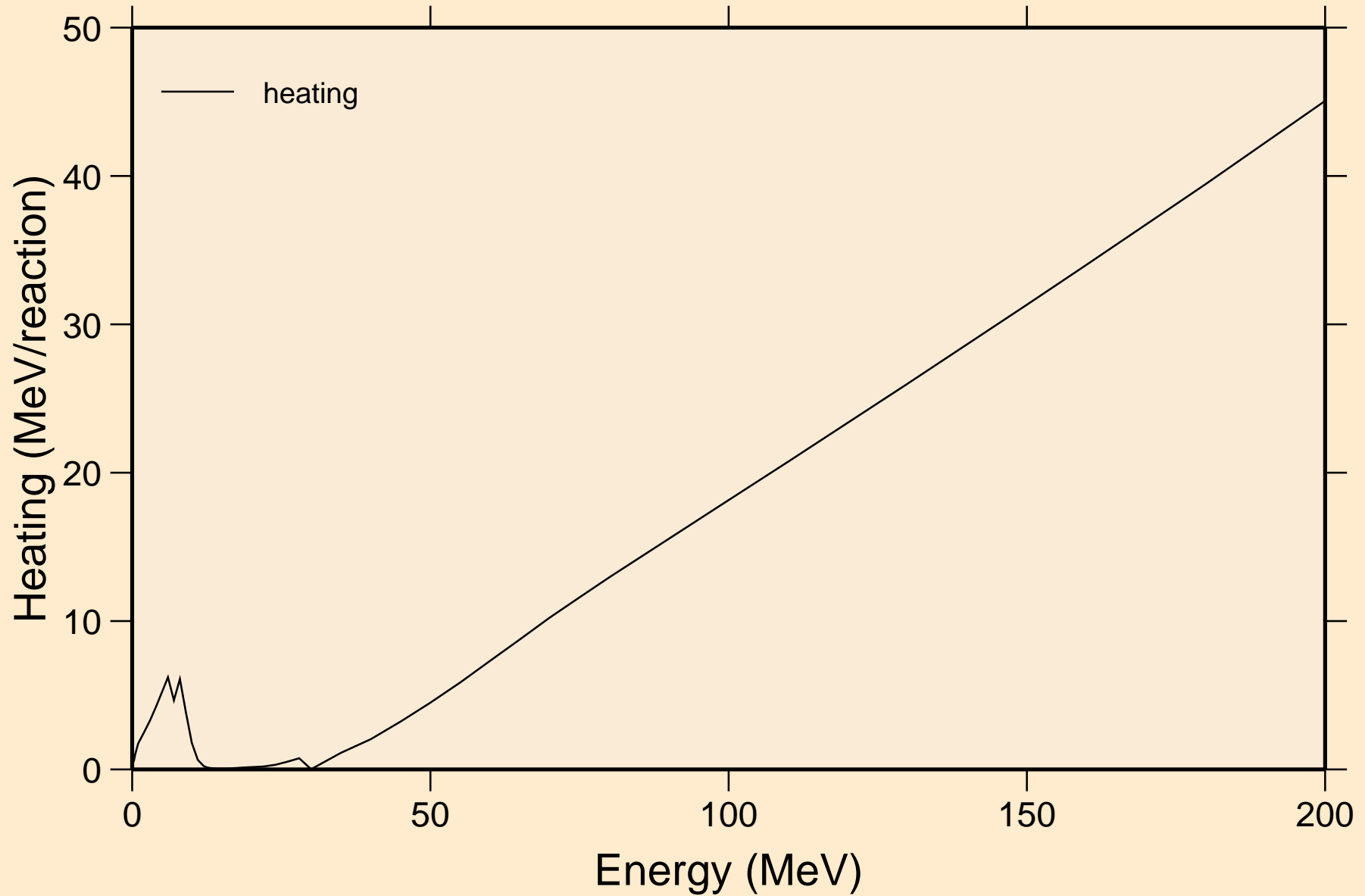

U227 PHOTON ACER TENDL-2023 LIBRARY; T=0.K

Particle heating contributions

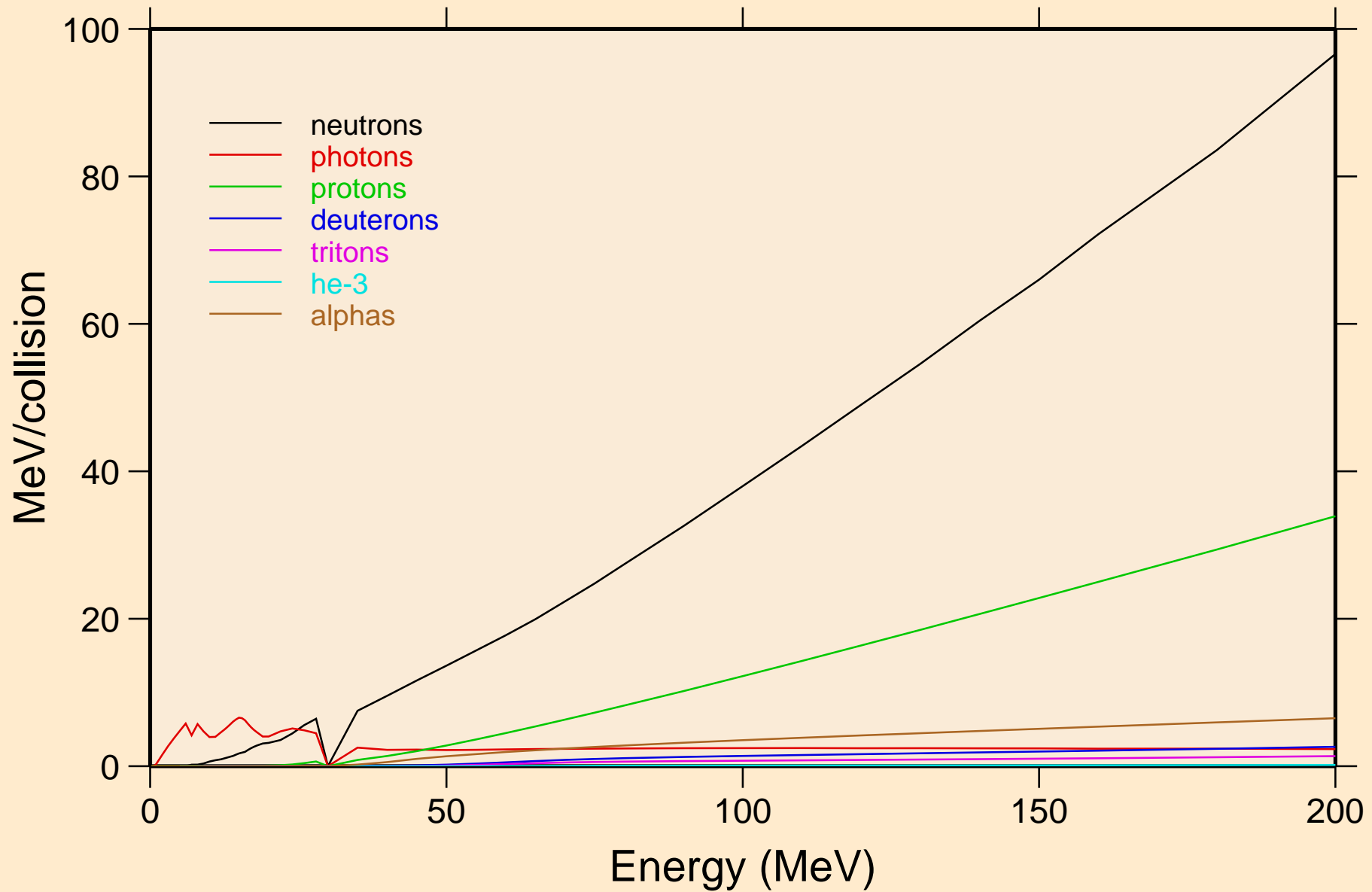

U227 PHOTON ACER TENDL-2023 LIBRARY; T=0.K

Particle production cross sections

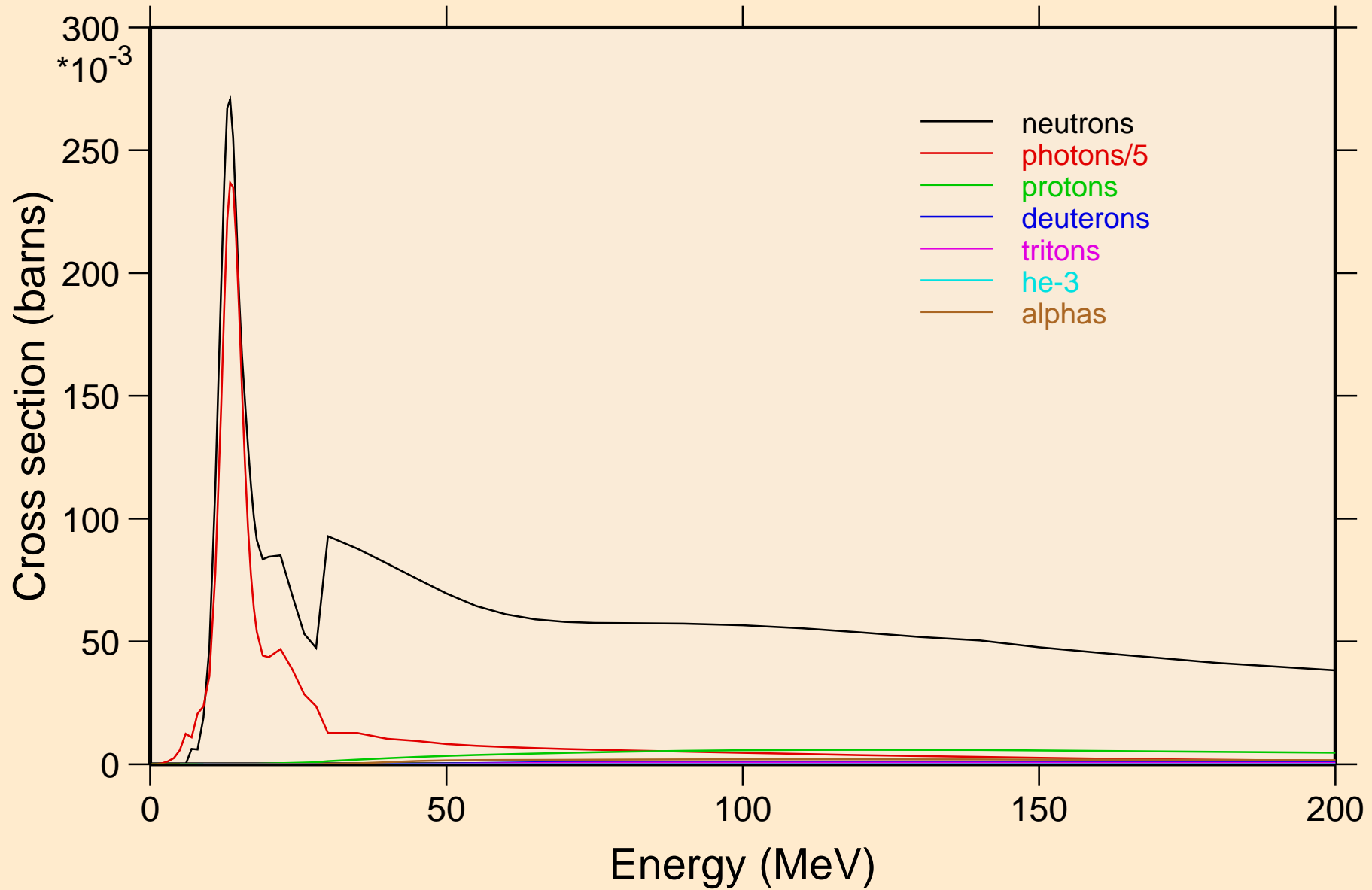

U227 PHOTON ACER TENDL-2023 LIBRARY; T=0.K
neutrons from (g,x)

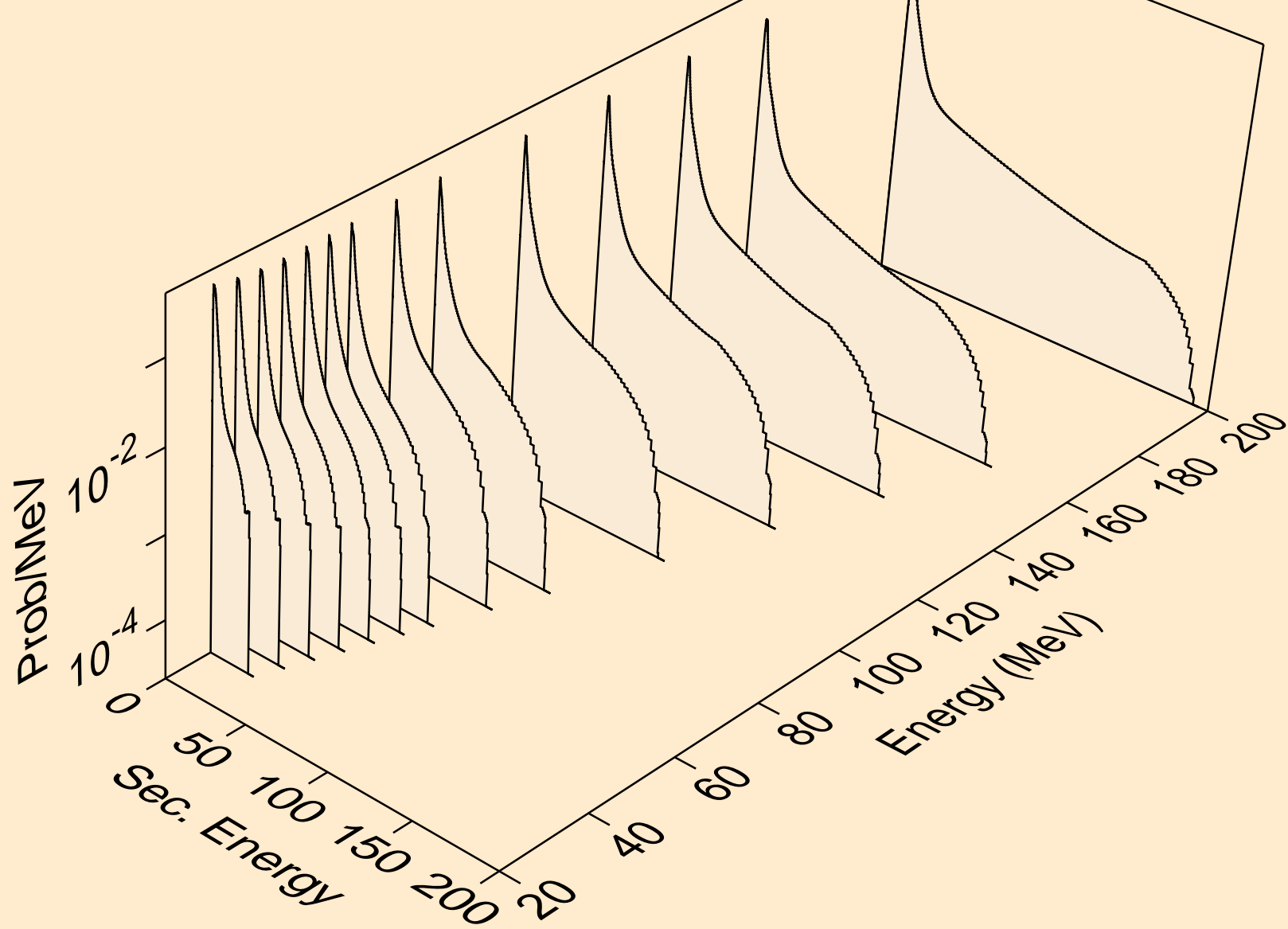

U227 PHOTON ACER TENDL-2023 LIBRARY; T=0.K
neutrons from (g,2n)

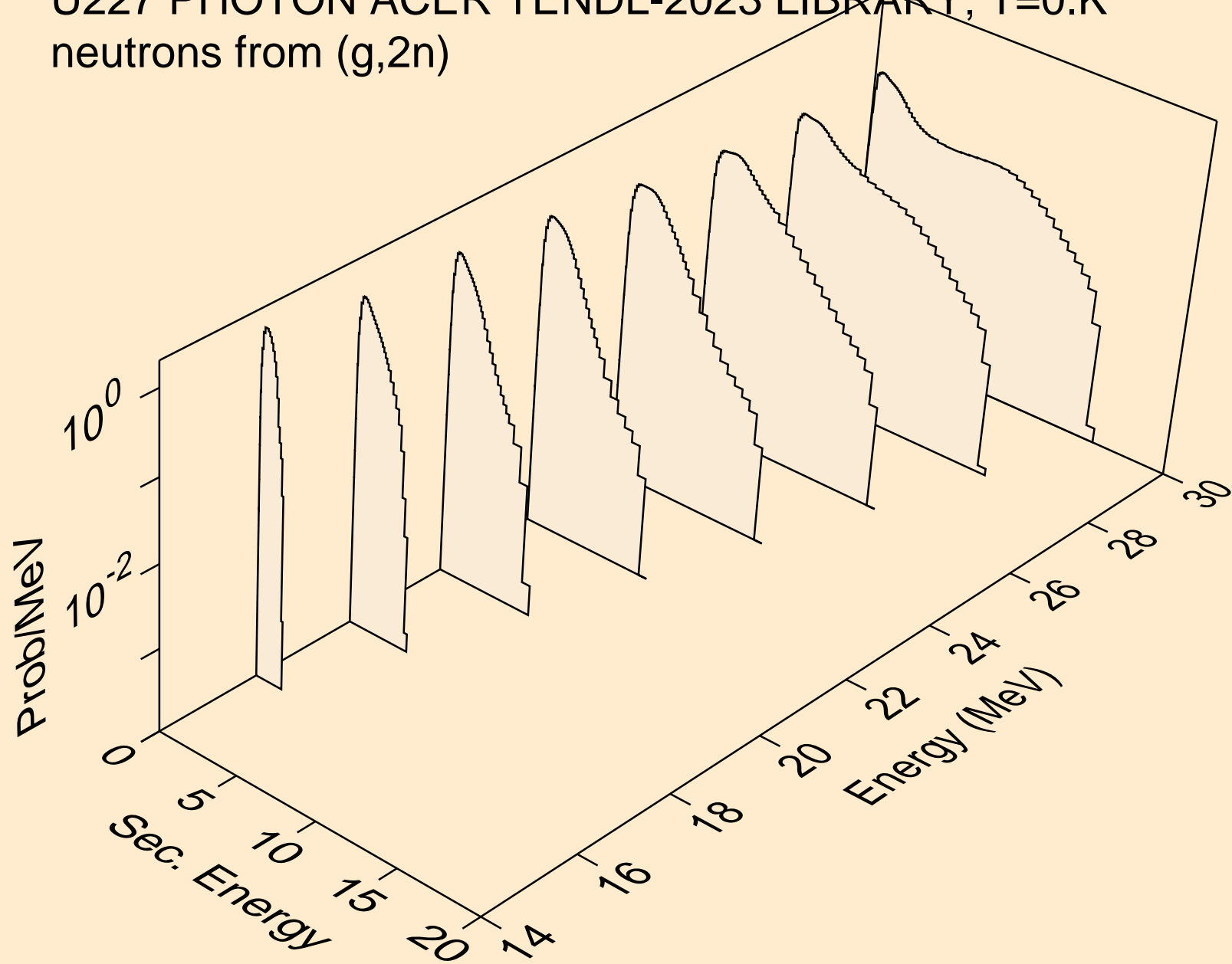

U227 PHOTON ACER TENDL-2023 LIBRARY; T=0.K
neutrons from (g,3n)

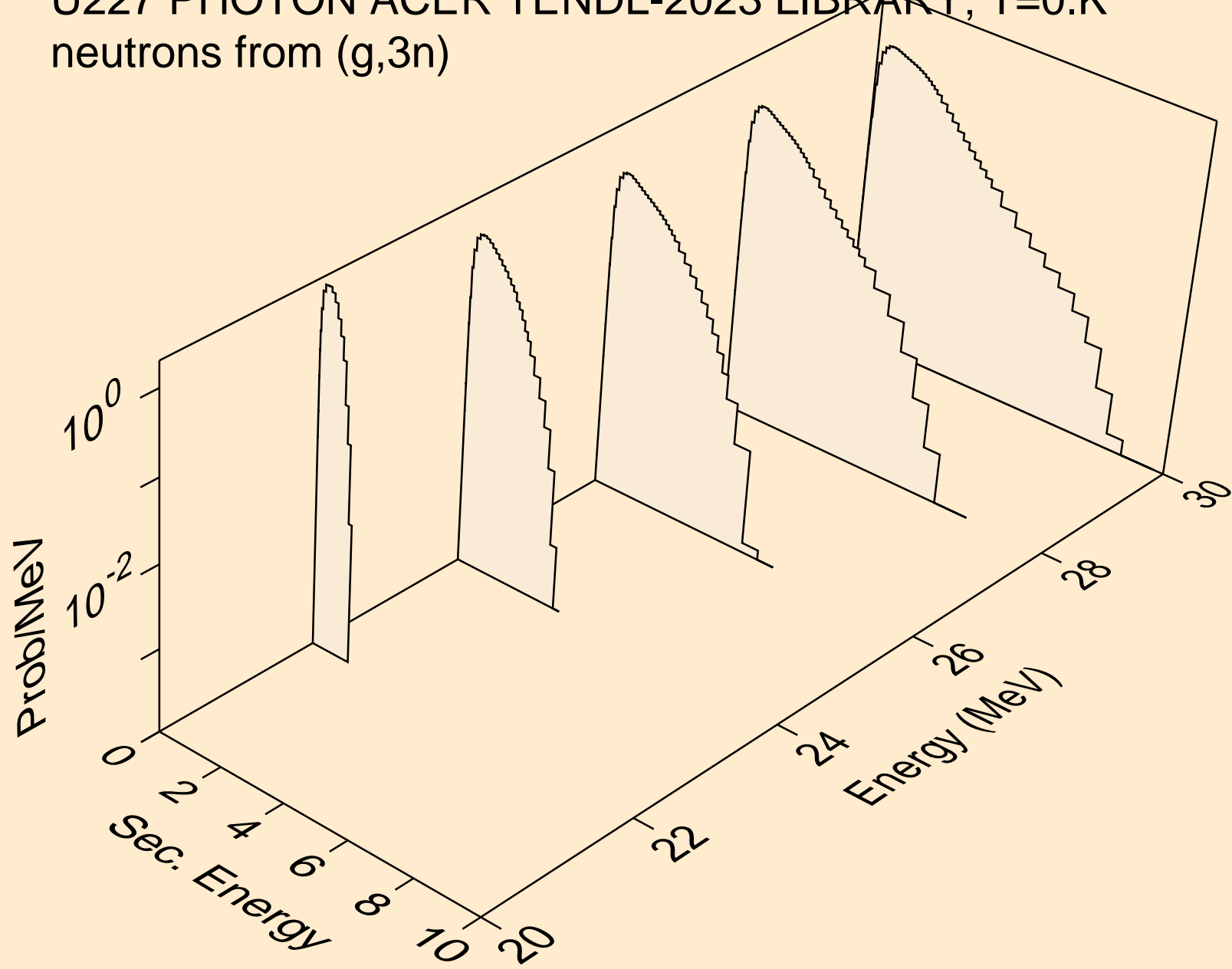

U227 PHOTON ACER TENDL-2023 LIBRARY; T=0.K
neutrons from (g,n*)a

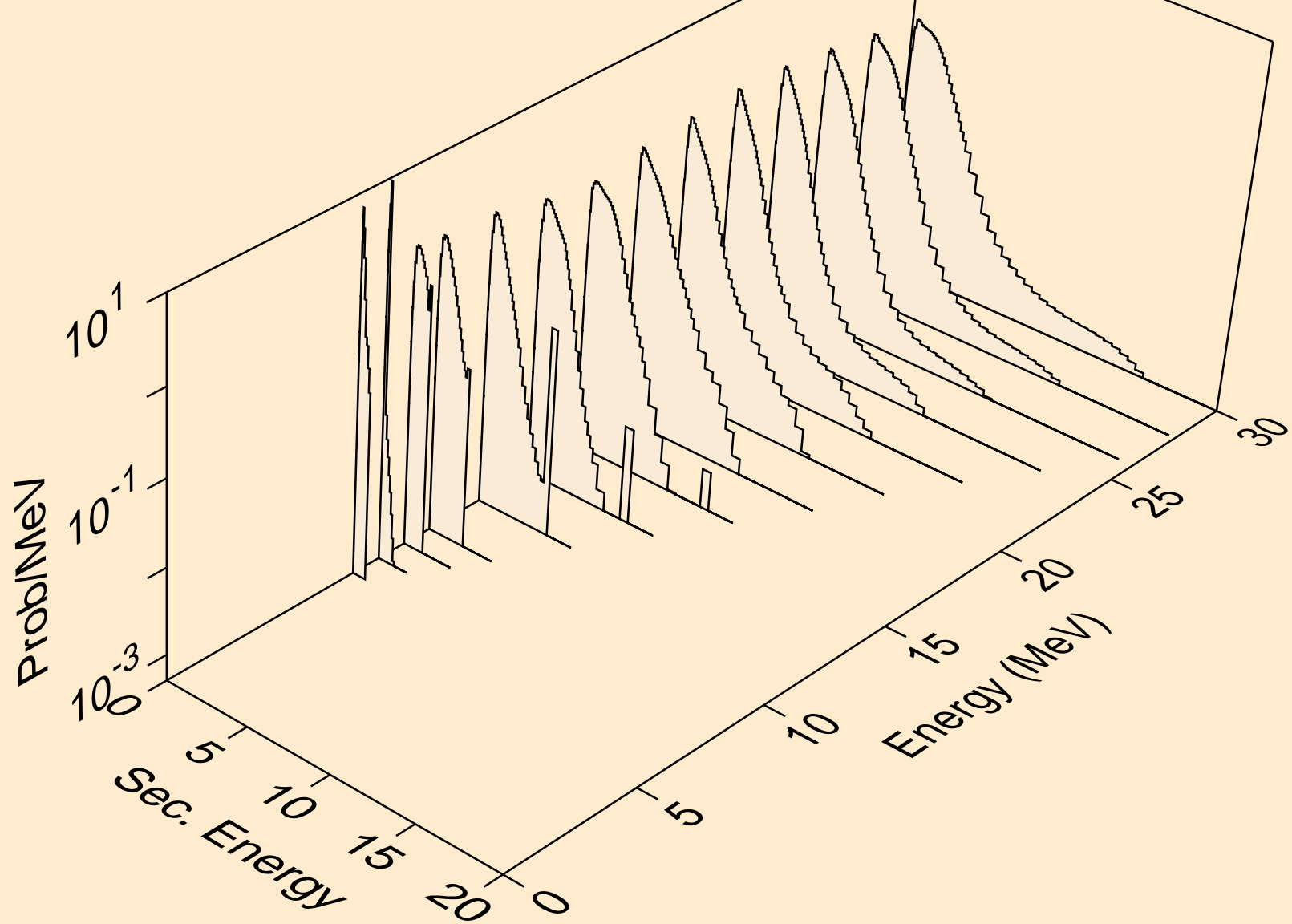

U227 PHOTON ACER TENDL-2023 LIBRARY; T=0.K
neutrons from (g,2n)a

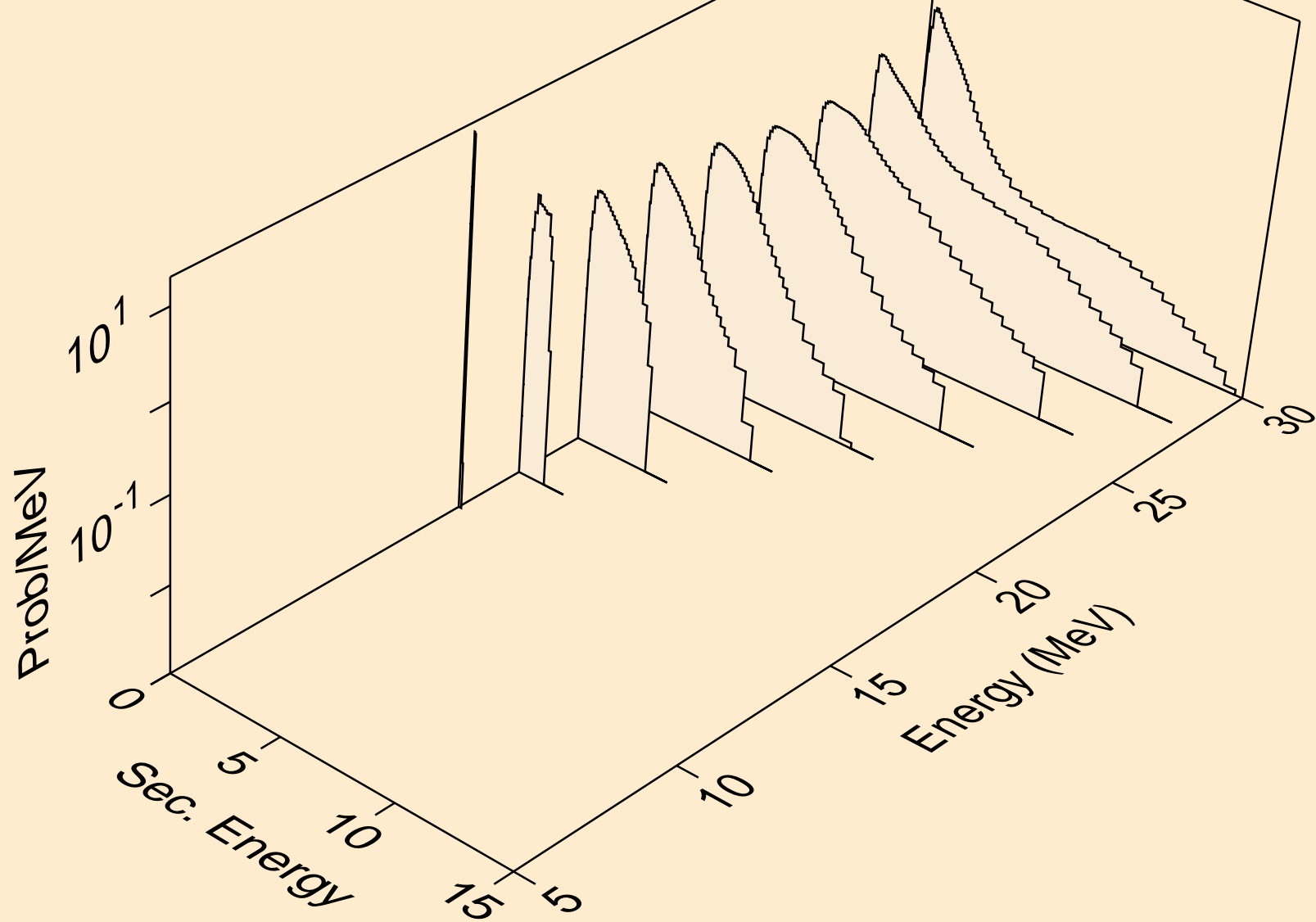

U227 PHOTON ACER TENDL-2023 LIBRARY; T=0.K
neutrons from (g,3n)a

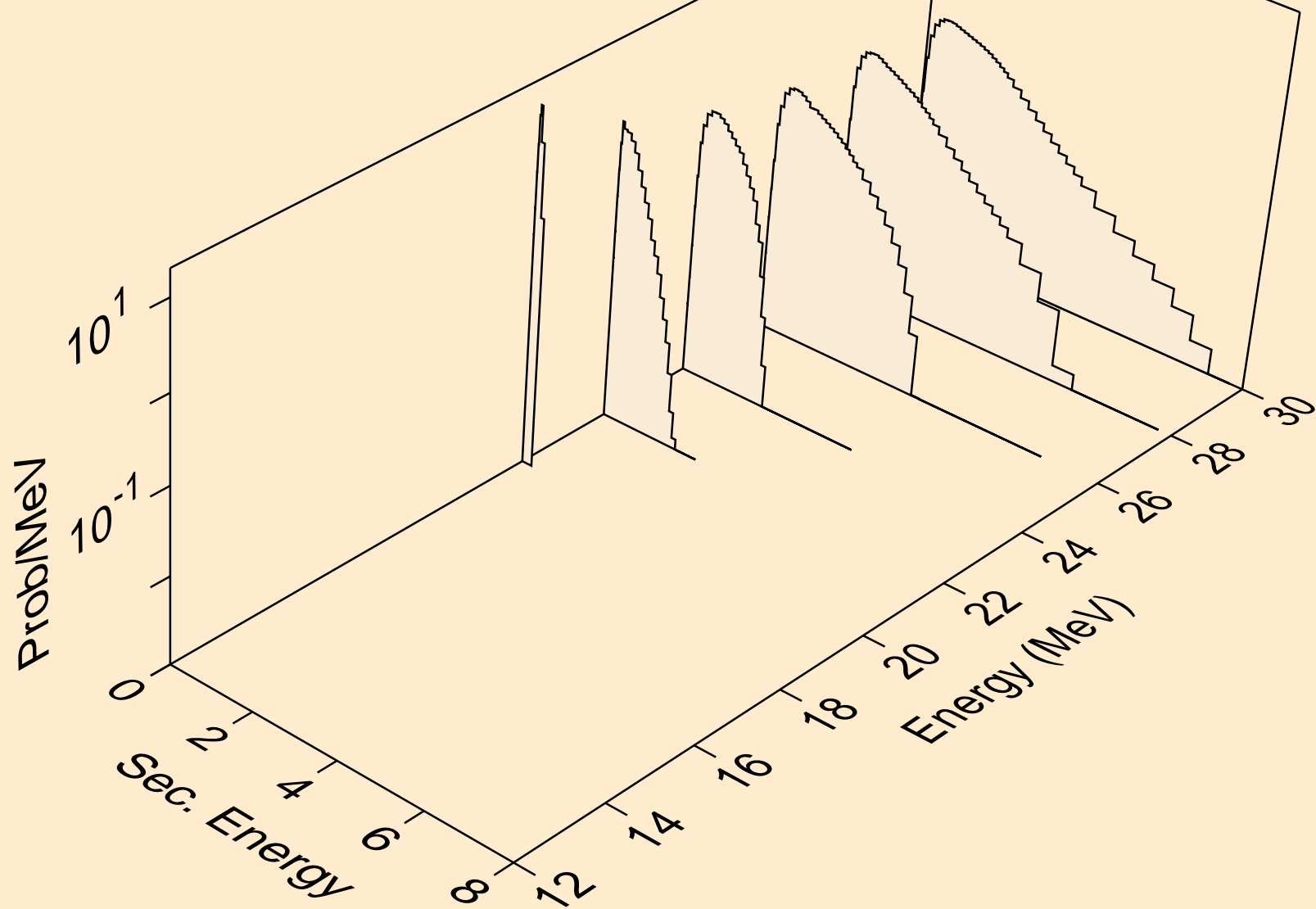

U227 PHOTON ACER TENDL-2023 LIBRARY; T=0.K
neutrons from (g,n*)p

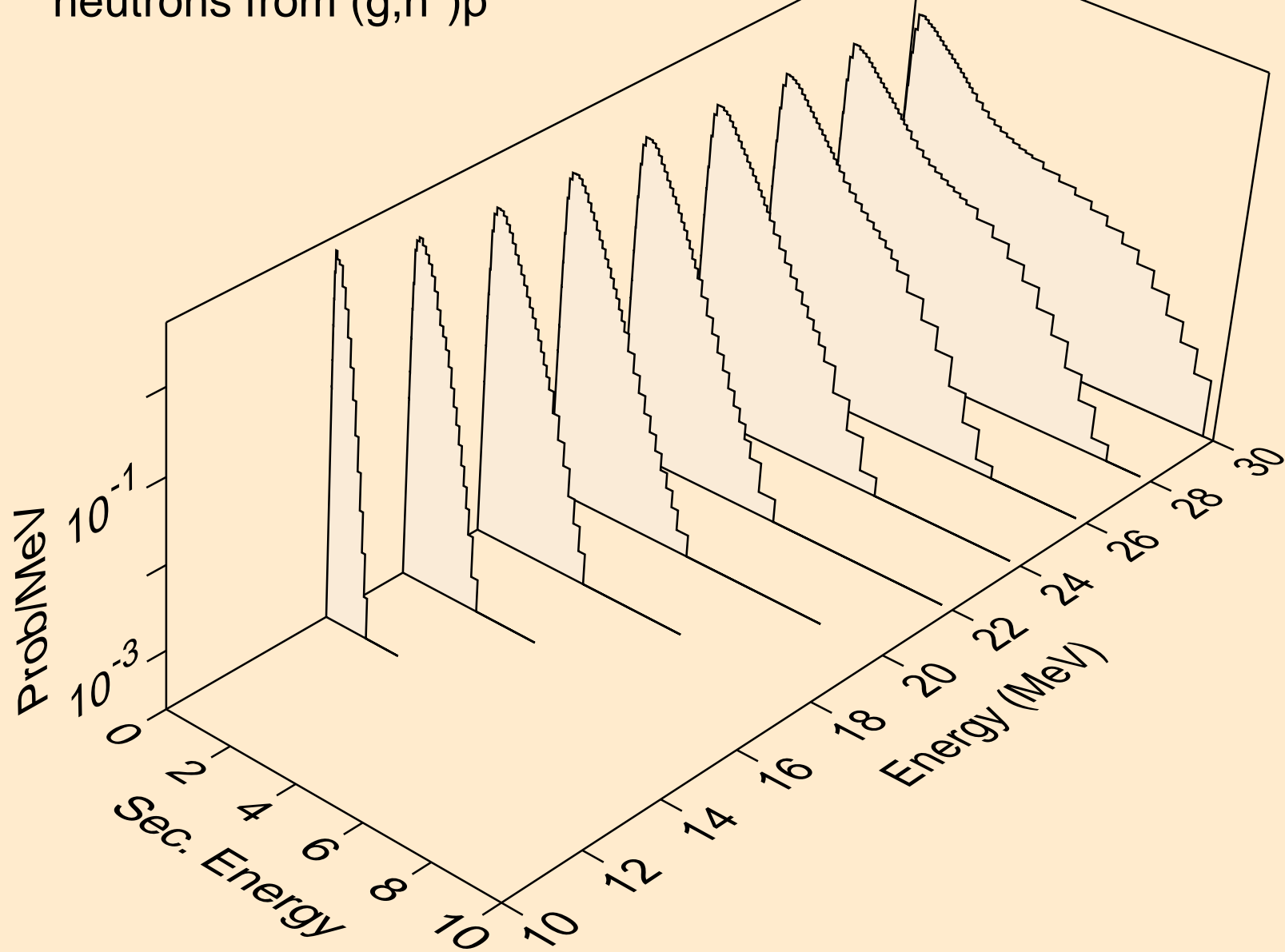

U227 PHOTON ACER TENDL-2023 LIBRARY; T=0.K
neutrons from (g,n*)2a

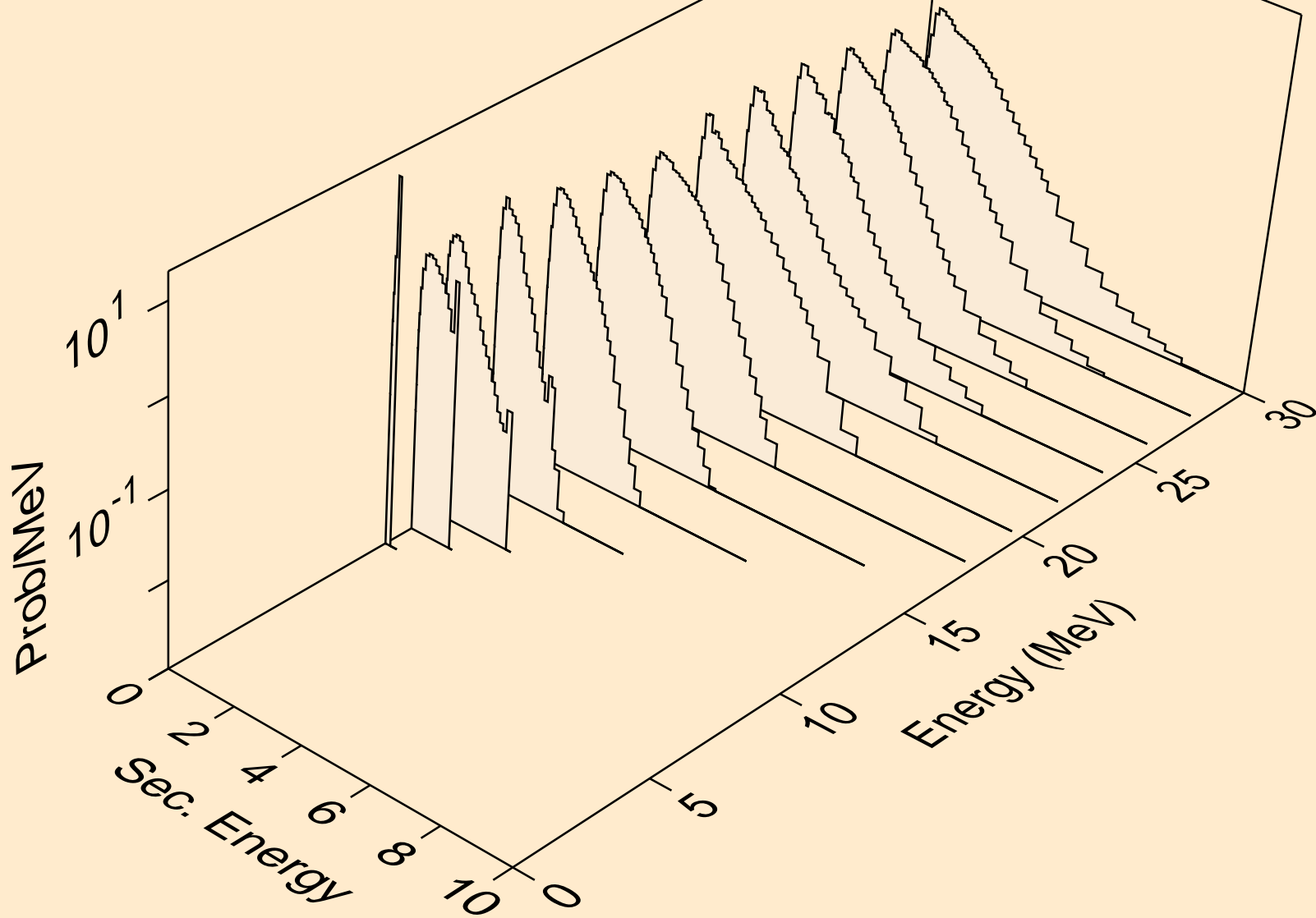

U227 PHOTON ACER TENDL-2023 LIBRARY; T=0.K
neutrons from (g,2n)2a

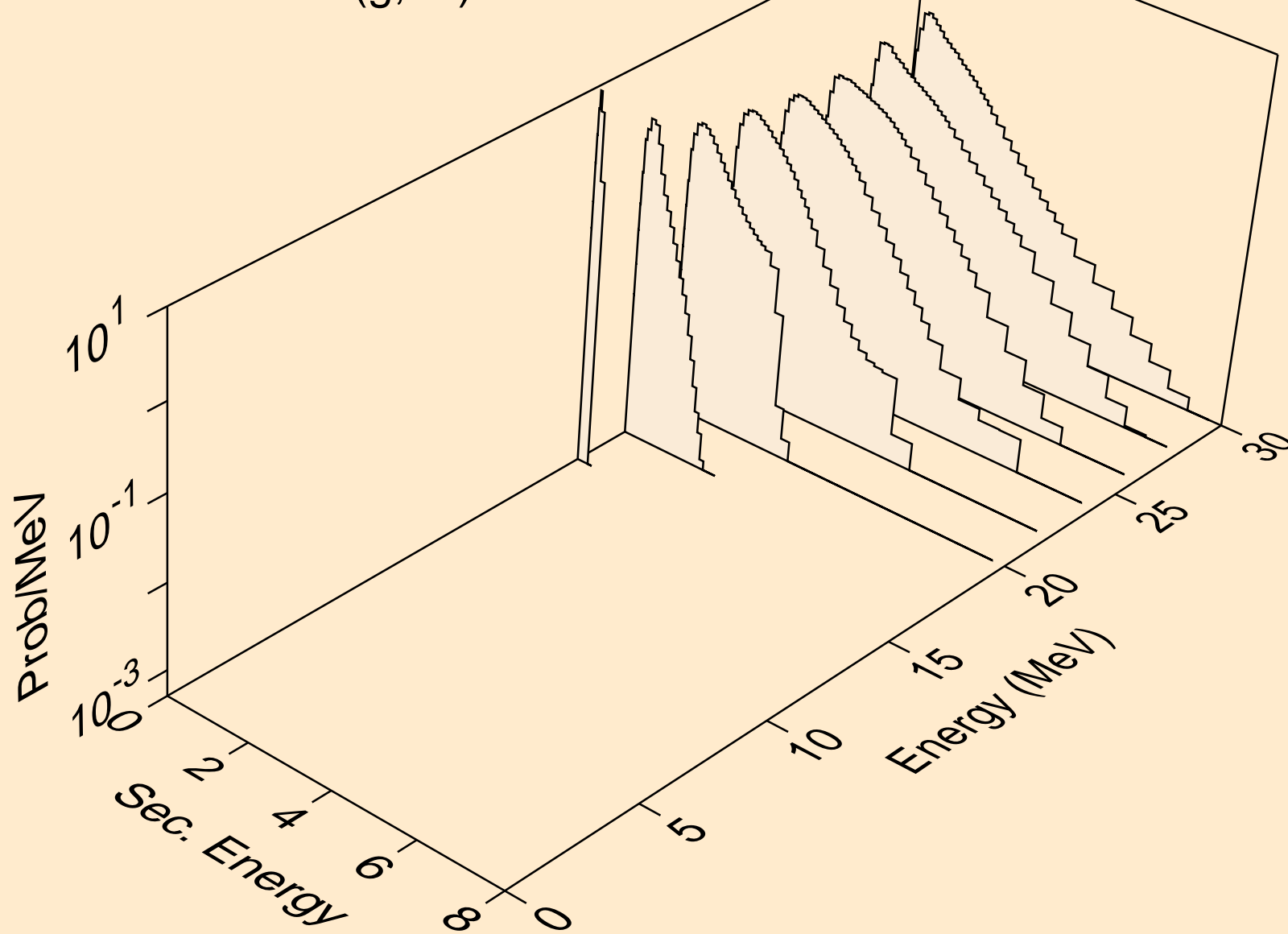

U227 PHOTON ACER TENDL-2023 LIBRARY; T=0.K
neutrons from (g,n*)d

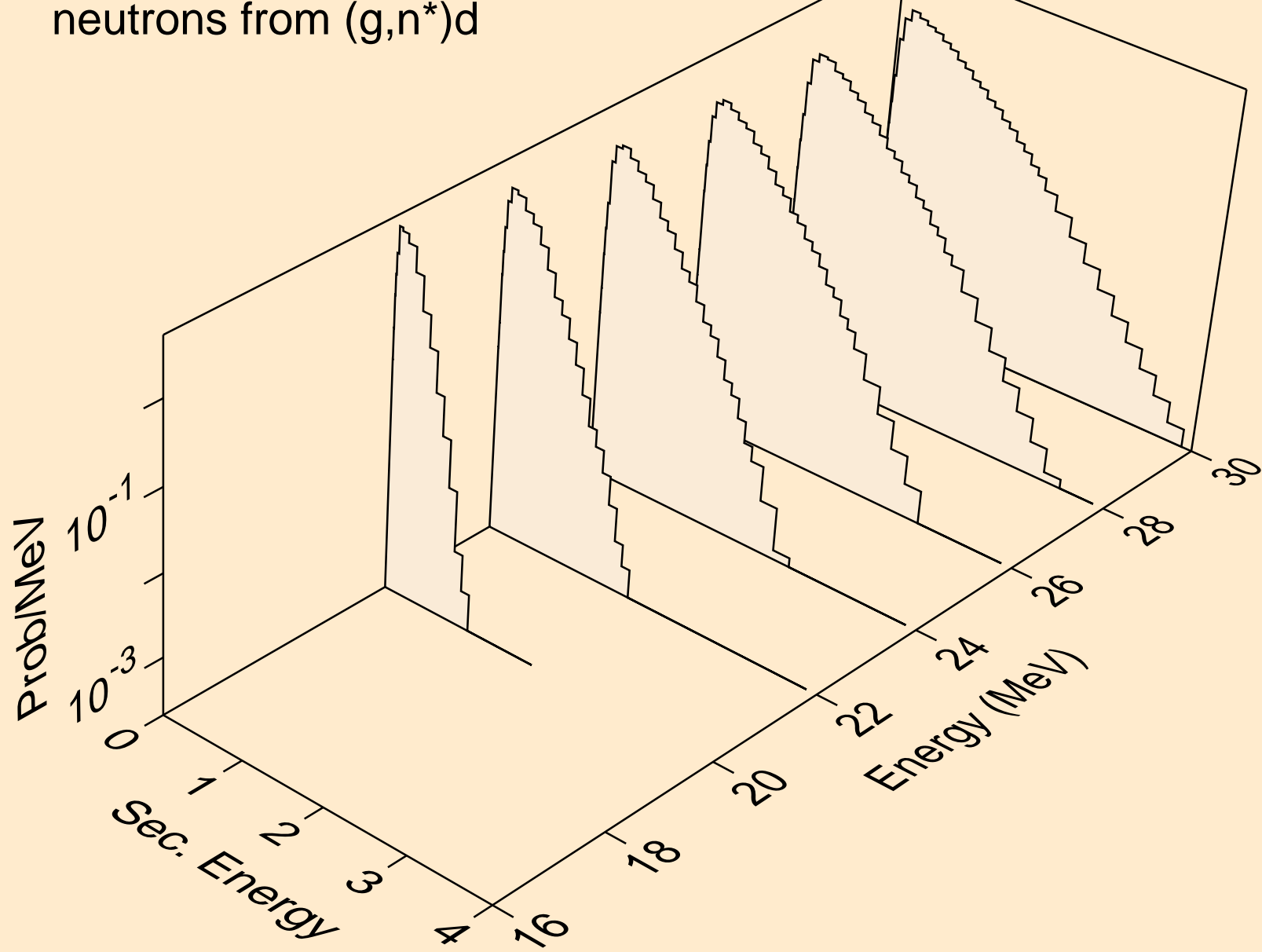

U227 PHOTON ACER TENDL-2023 LIBRARY; T=0.K
neutrons from (g,n*)t

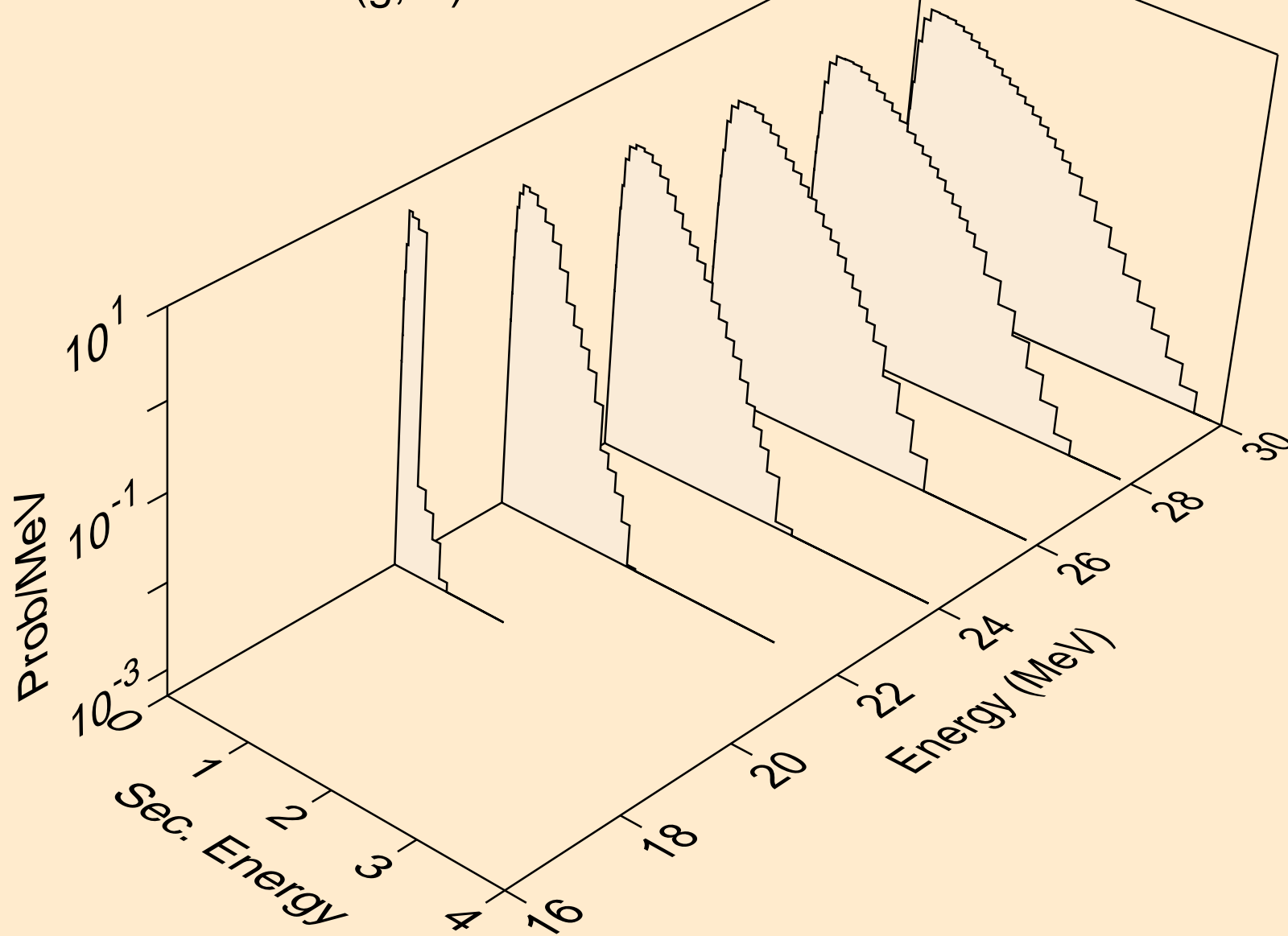

U227 PHOTON ACER TENDL-2023 LIBRARY; T=0.K
neutrons from (g,2np)

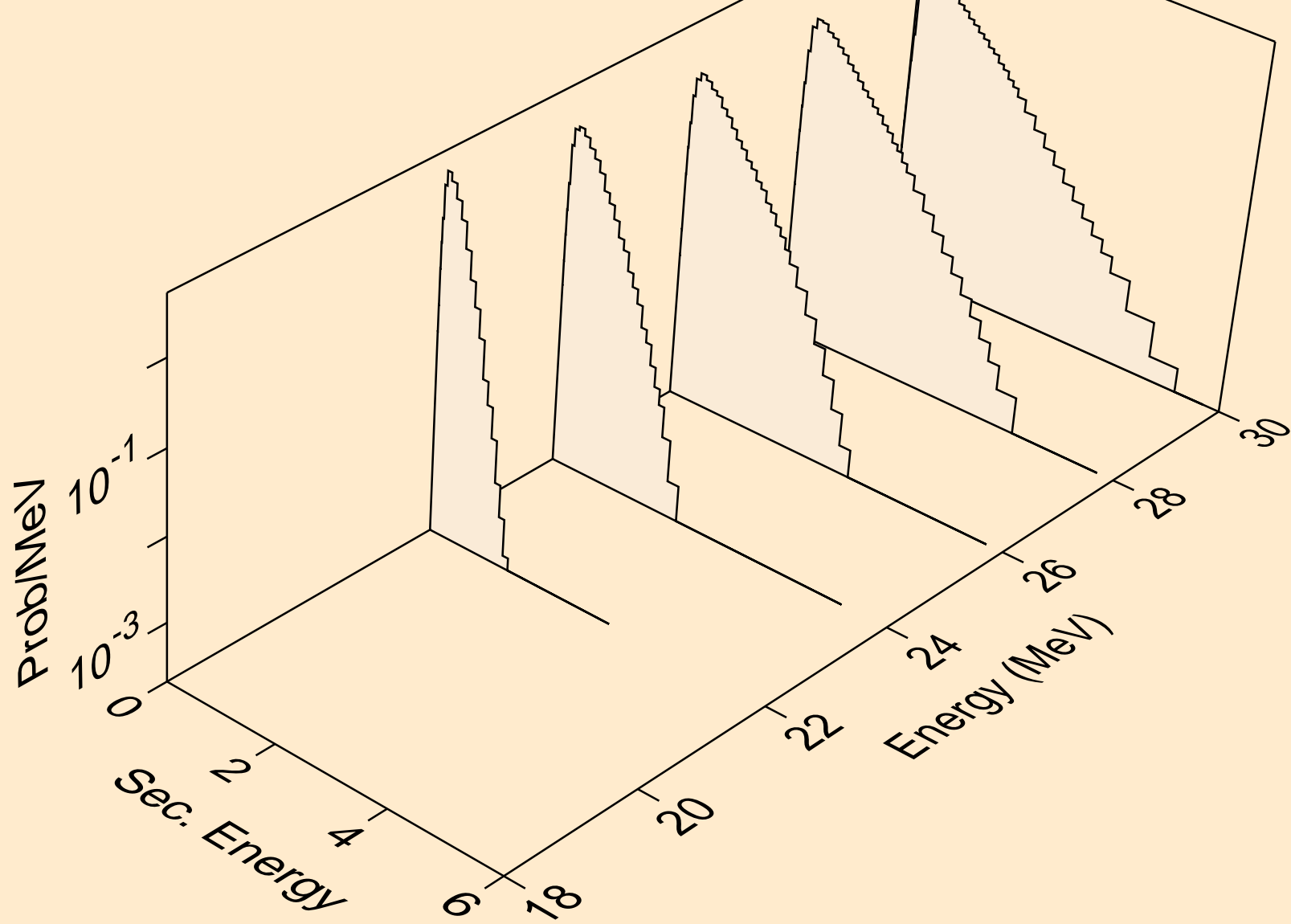

U227 PHOTON ACER TENDL-2023 LIBRARY; T=0.K
neutrons from (g,npa)

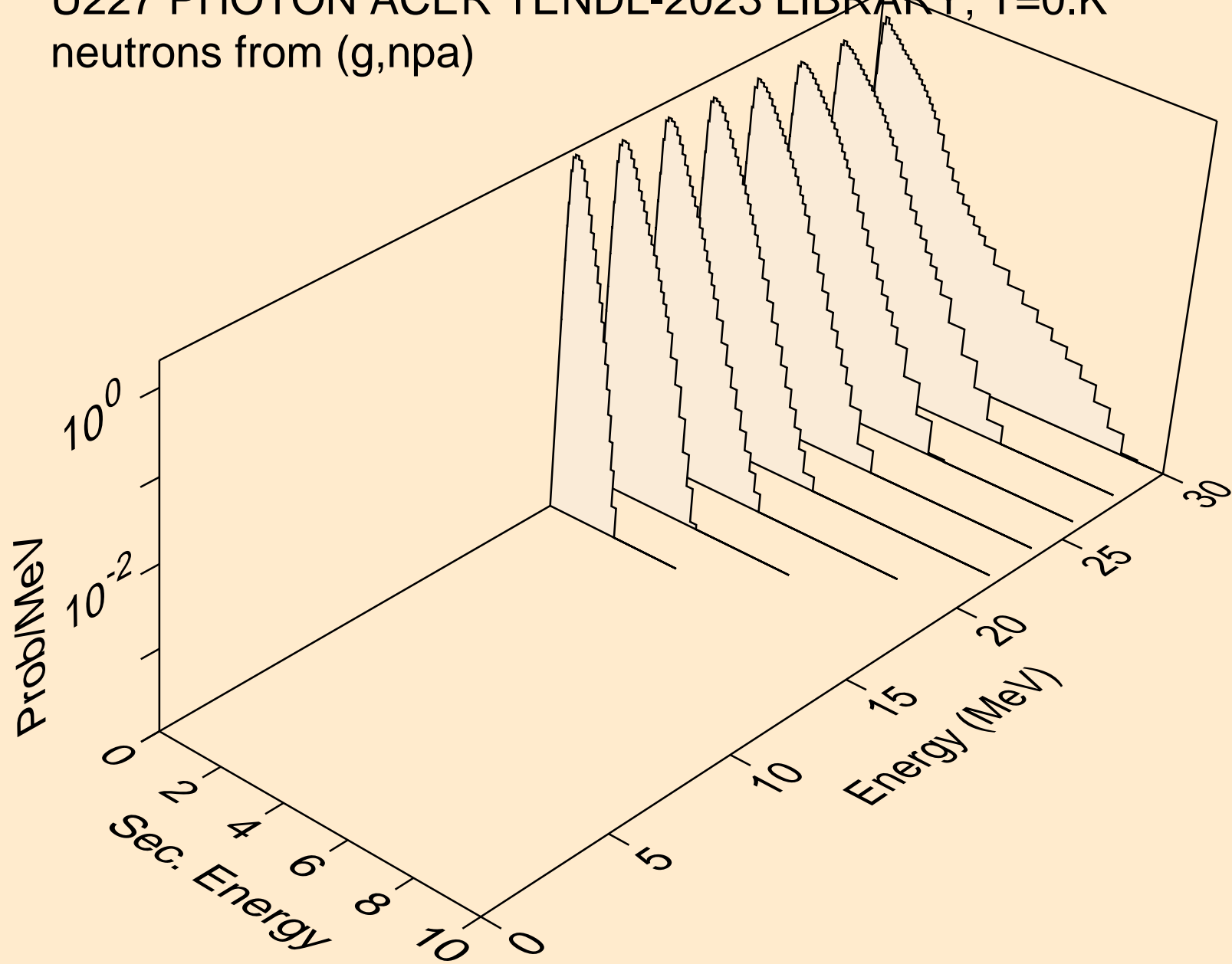

U227 PHOTON ACER TENDL-2023 LIBRARY; T=0.K
angular distribution for (g,n*0) neutron

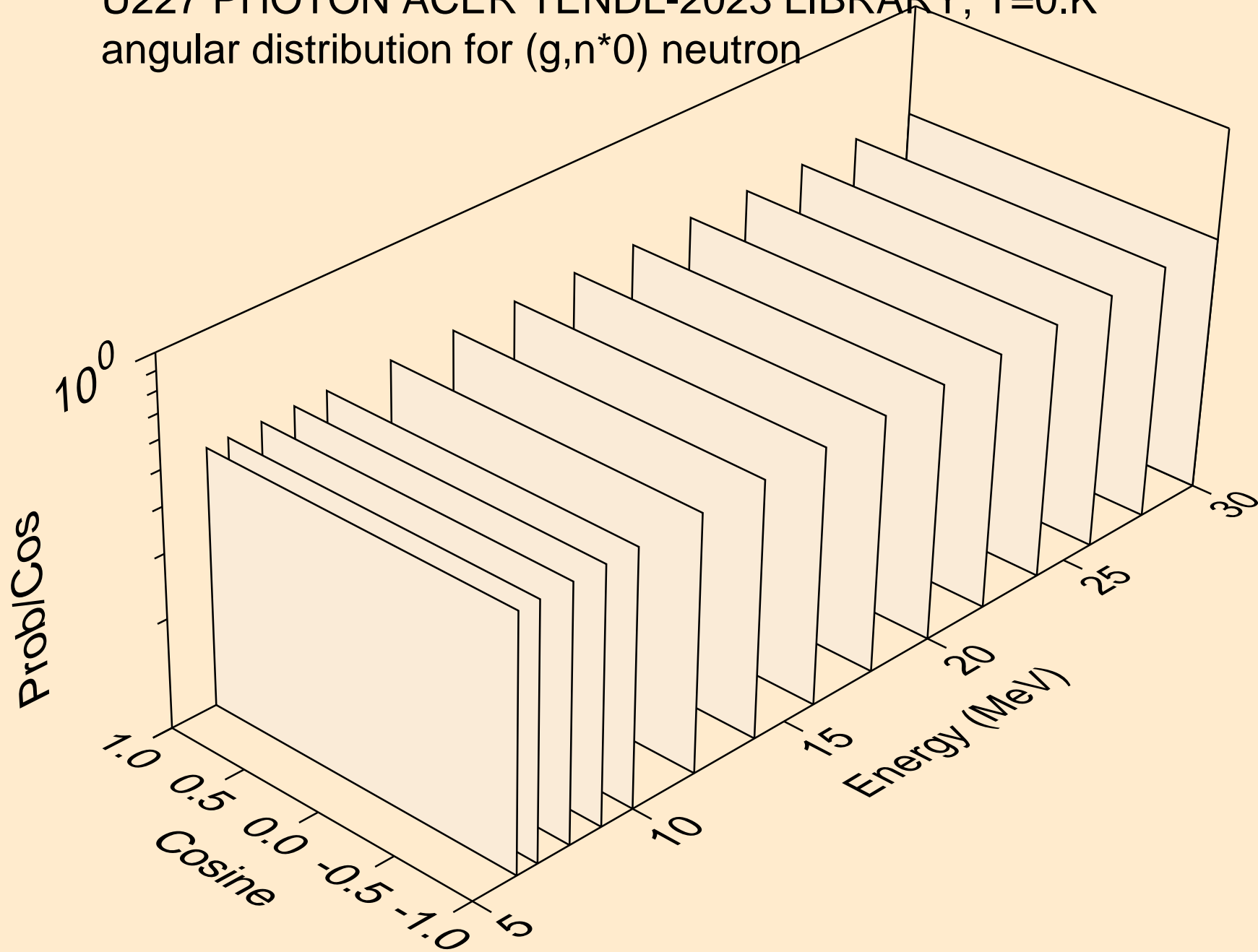

U227 PHOTON ACER TENDL-2023 LIBRARY; T=0.K
angular distribution for (g,n*1) neutron

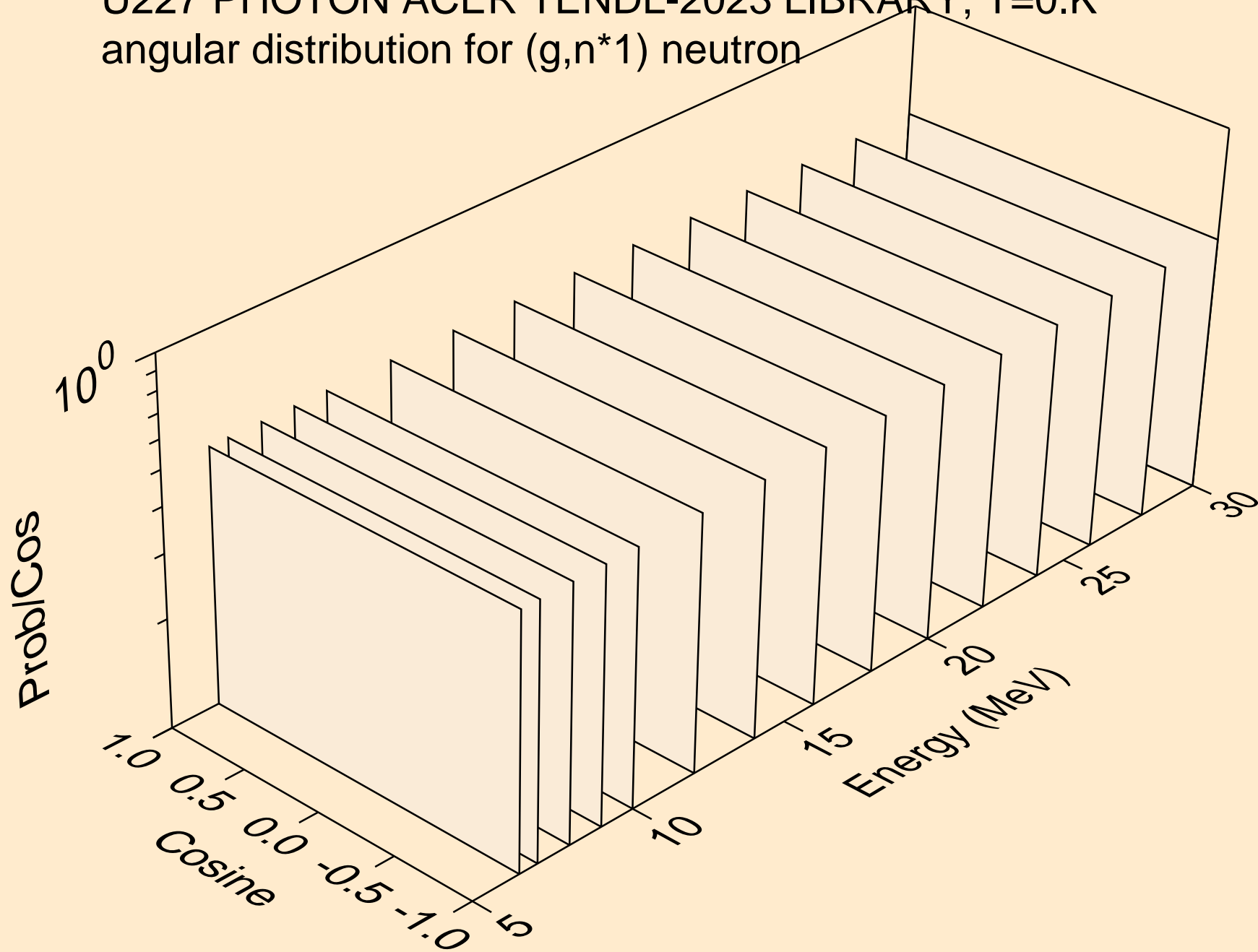

U227 PHOTON ACER TENDL-2023 LIBRARY; T=0.K
neutrons from (g,n*c)

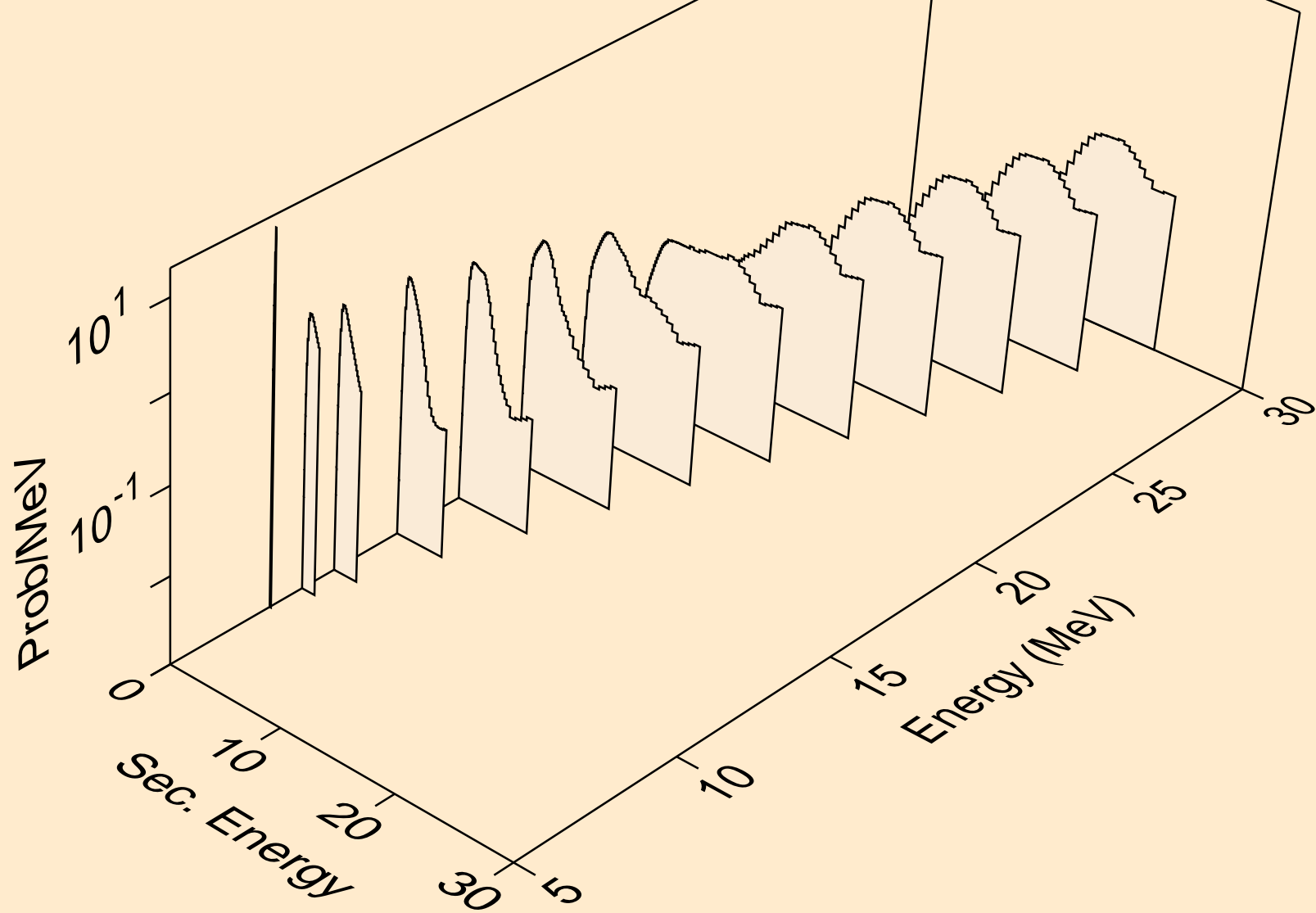

U227 PHOTON ACER TENDL-2023 LIBRARY; T=0.K
photons from (g,x)

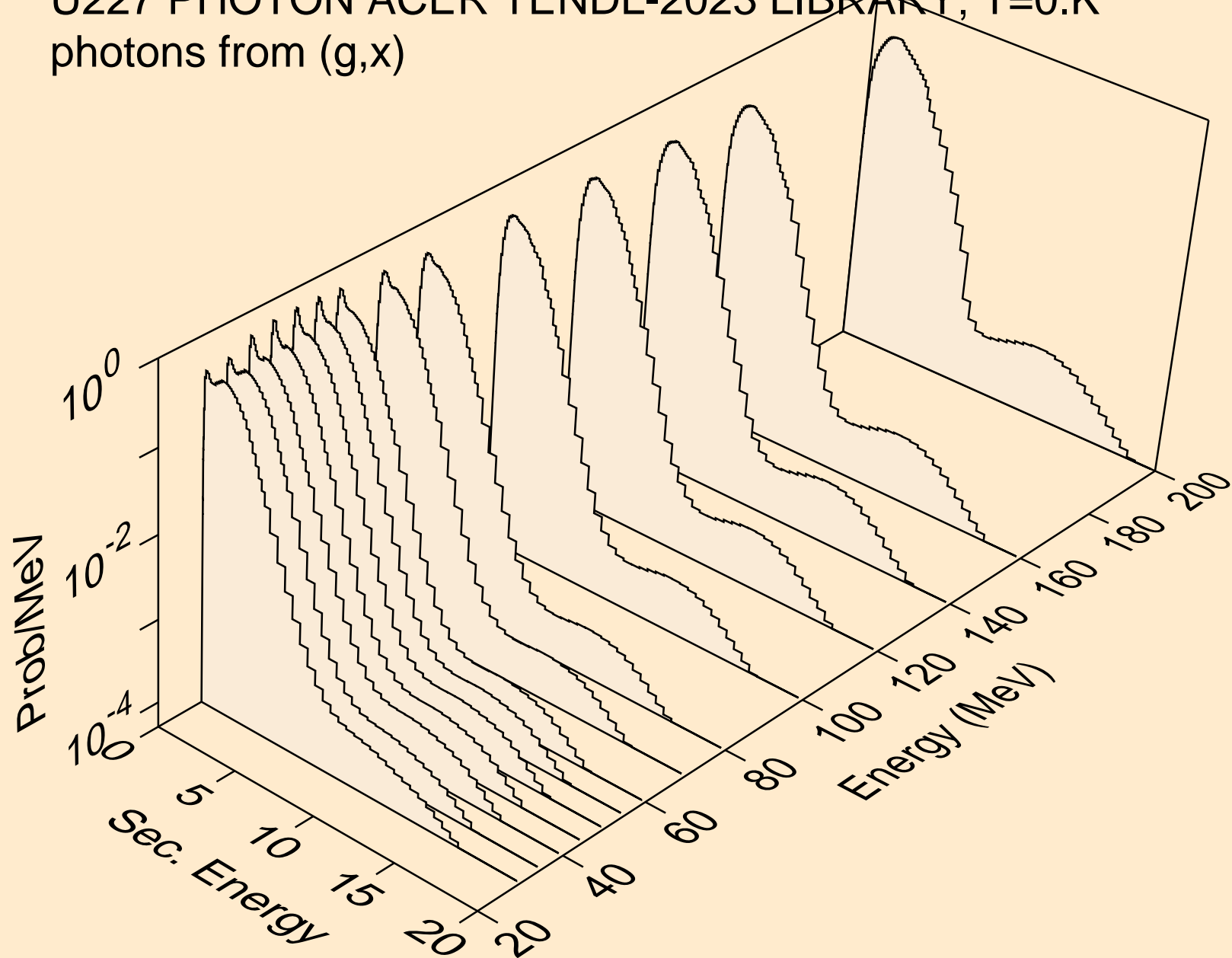

U227 PHOTON ACER TENDL-2023 LIBRARY; T=0.K
photons from (g,2n)

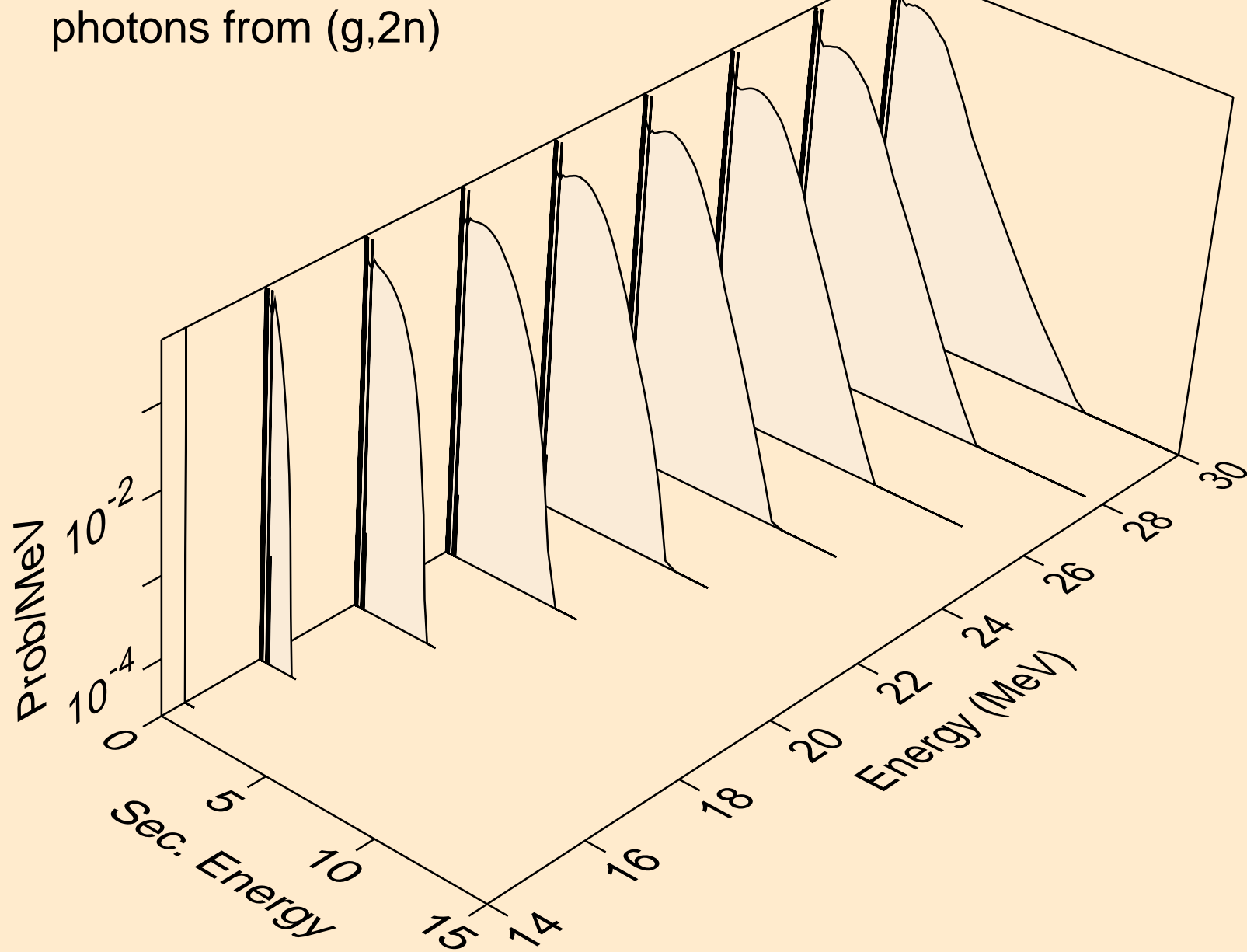

U227 PHOTON ACER TENDL-2023 LIBRARY; T=0.K
photons from (g,3n)

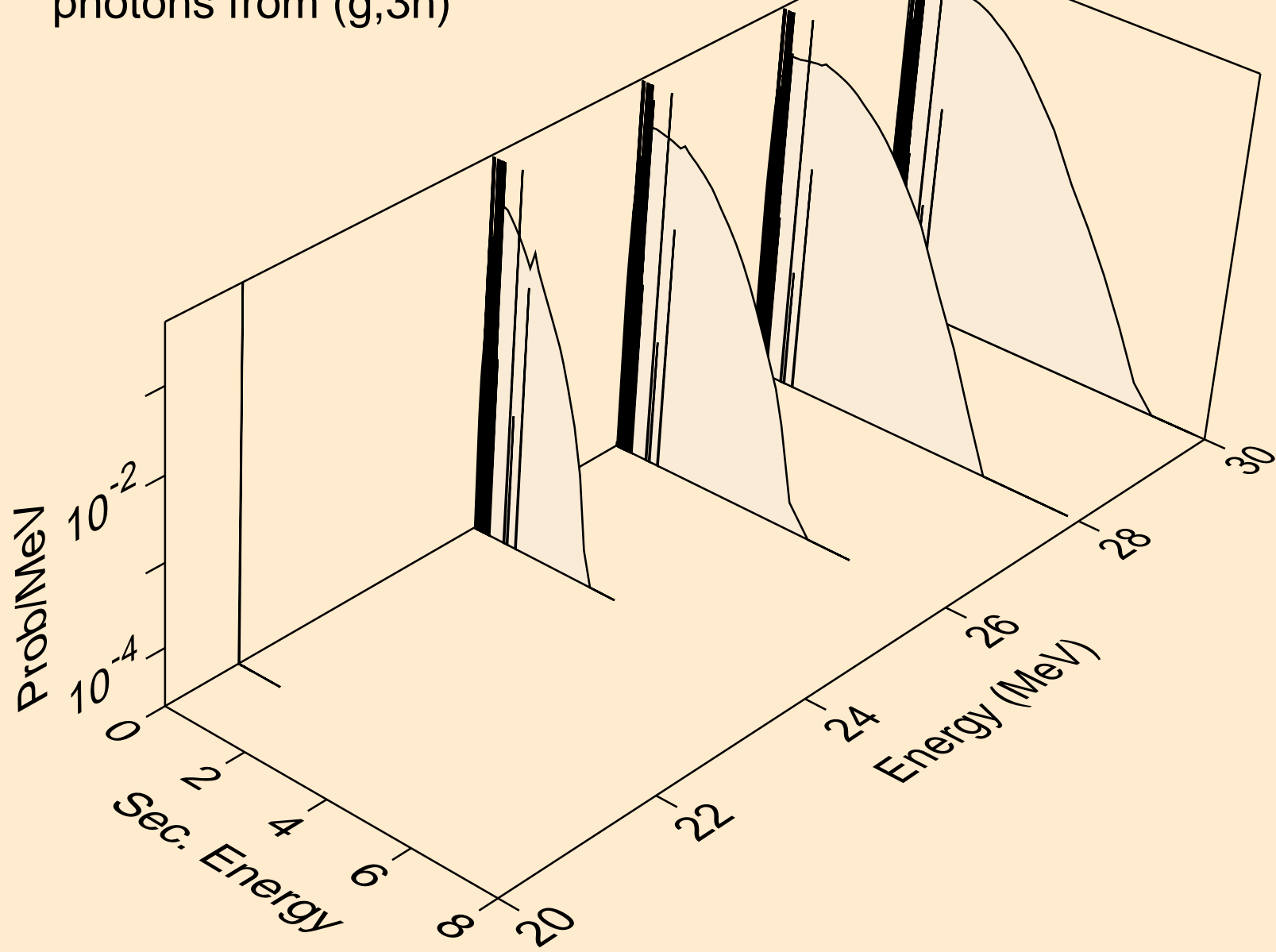

U227 PHOTON ACER TENDL-2023 LIBRARY; T=0.K
photons from (g,n*)a

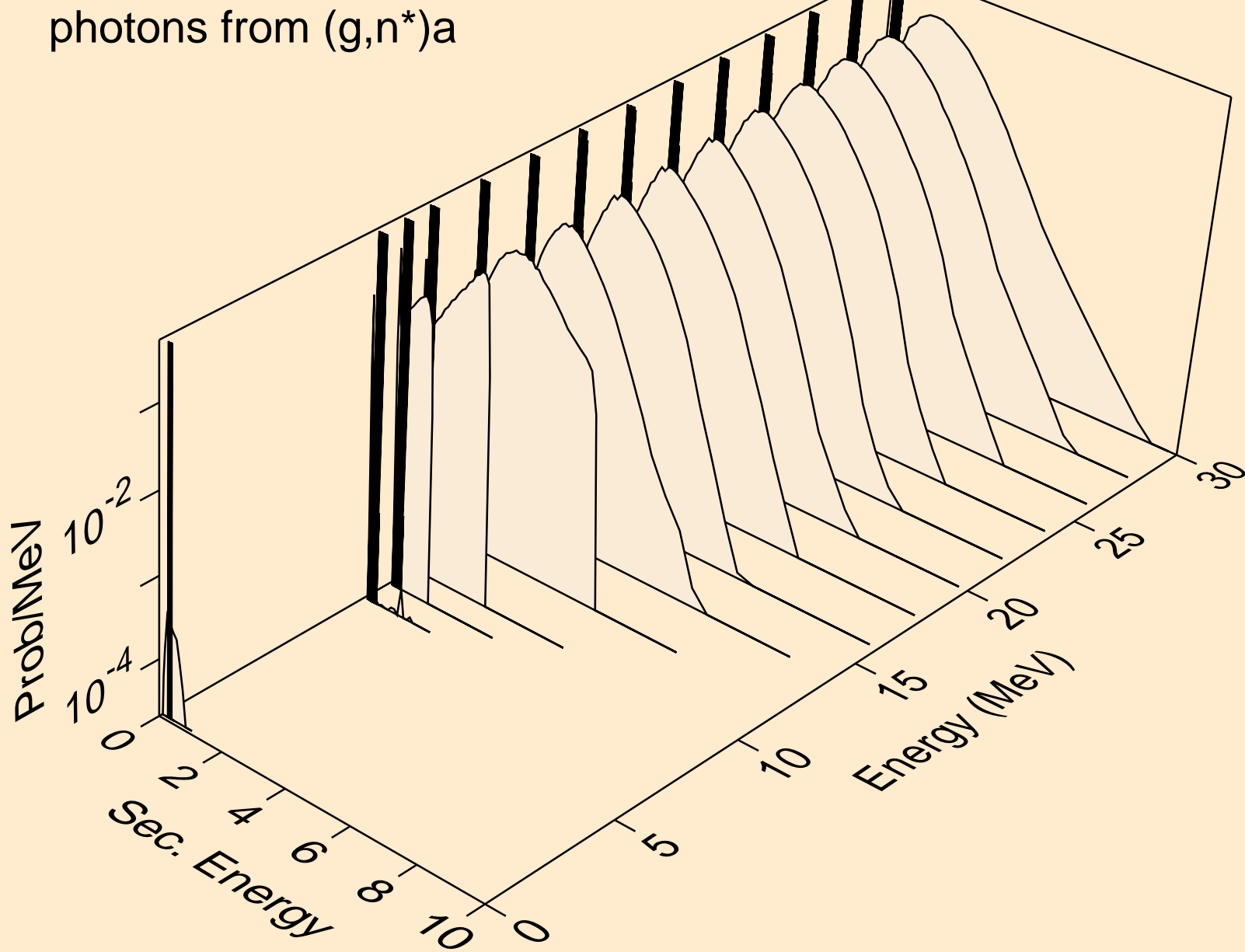

U227 PHOTON ACER TENDL-2023 LIBRARY; T=0.K
photons from (g,2n)a

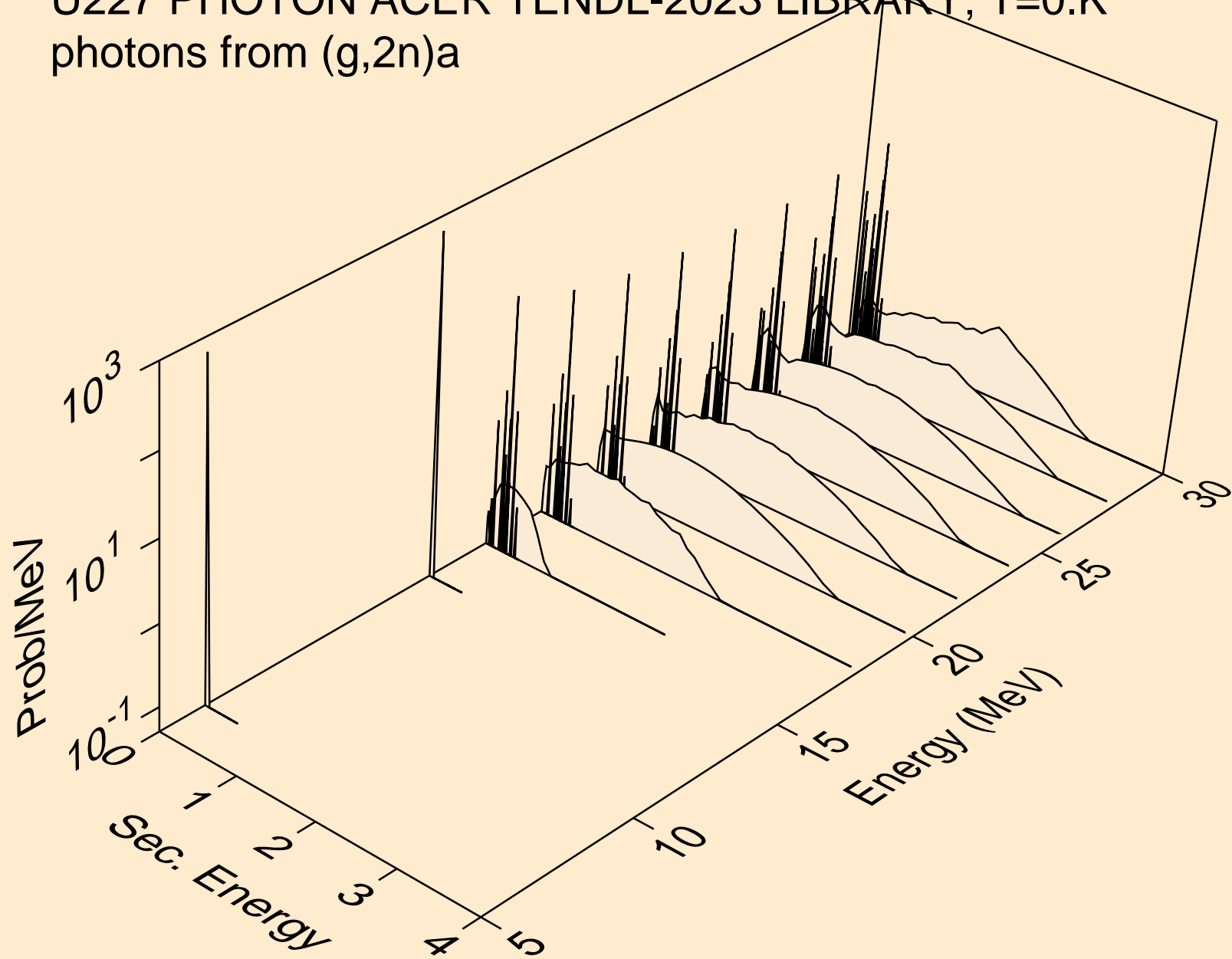

U227 PHOTON ACER TENDL-2023 LIBRARY; T=0.K
photons from (g,3n)a

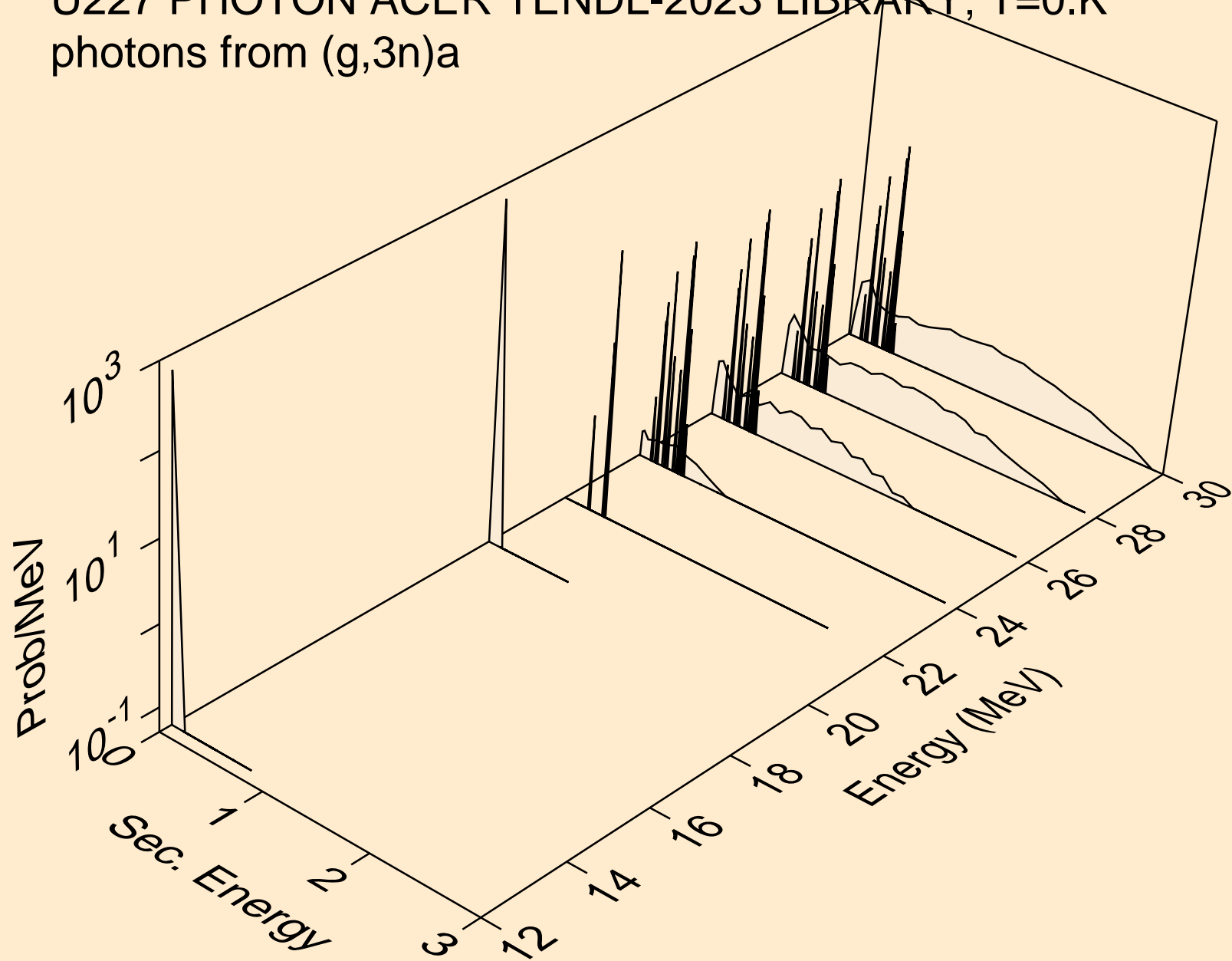

U227 PHOTON ACER TENDL-2023 LIBRARY; T=0.K
photons from (g,n*)p

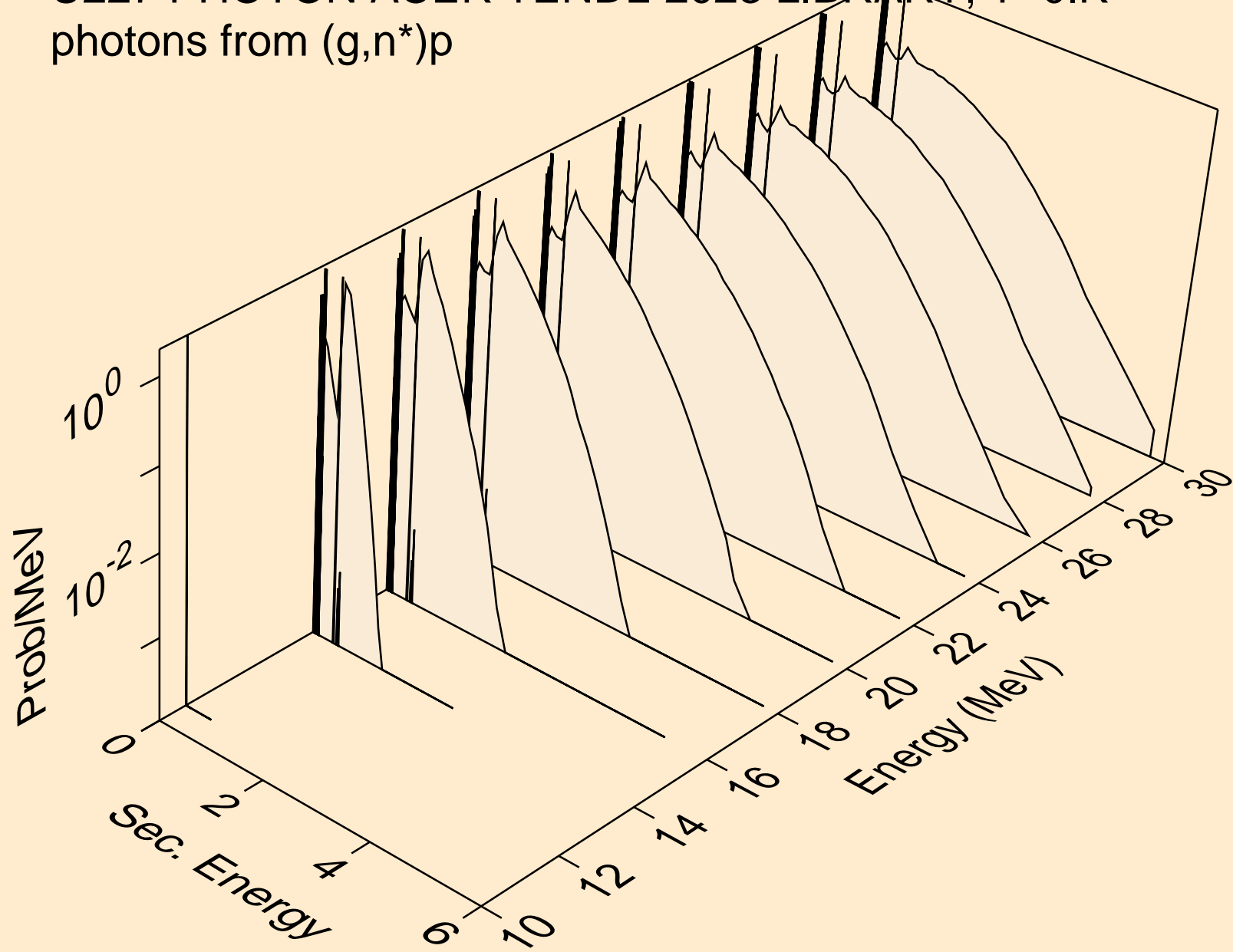

U227 PHOTON ACER TENDL-2023 LIBRARY; T=0.K
photons from (g,n*)2a

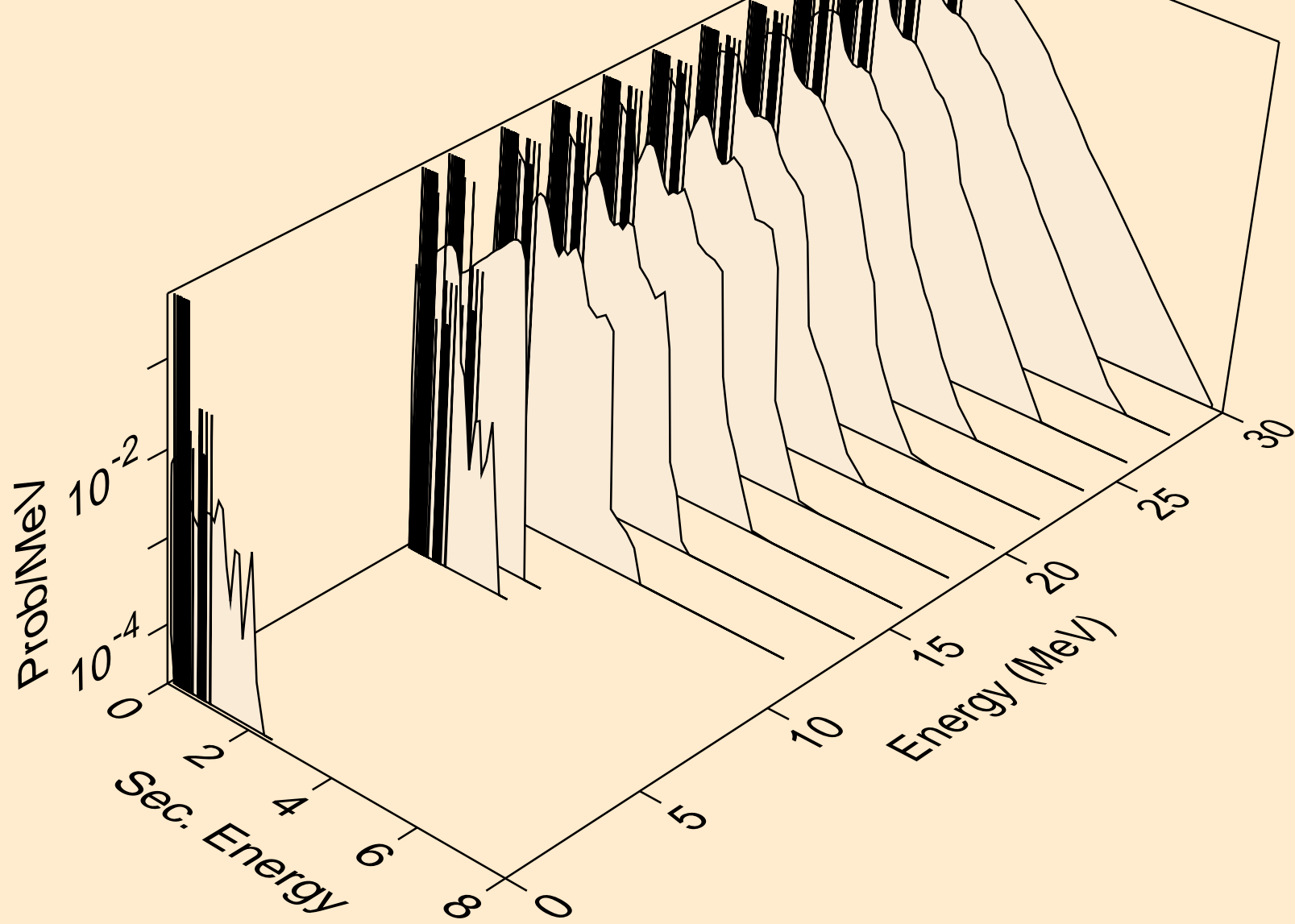

U227 PHOTON ACER TENDL-2023 LIBRARY; T=0.K
photons from (g,2n)2a

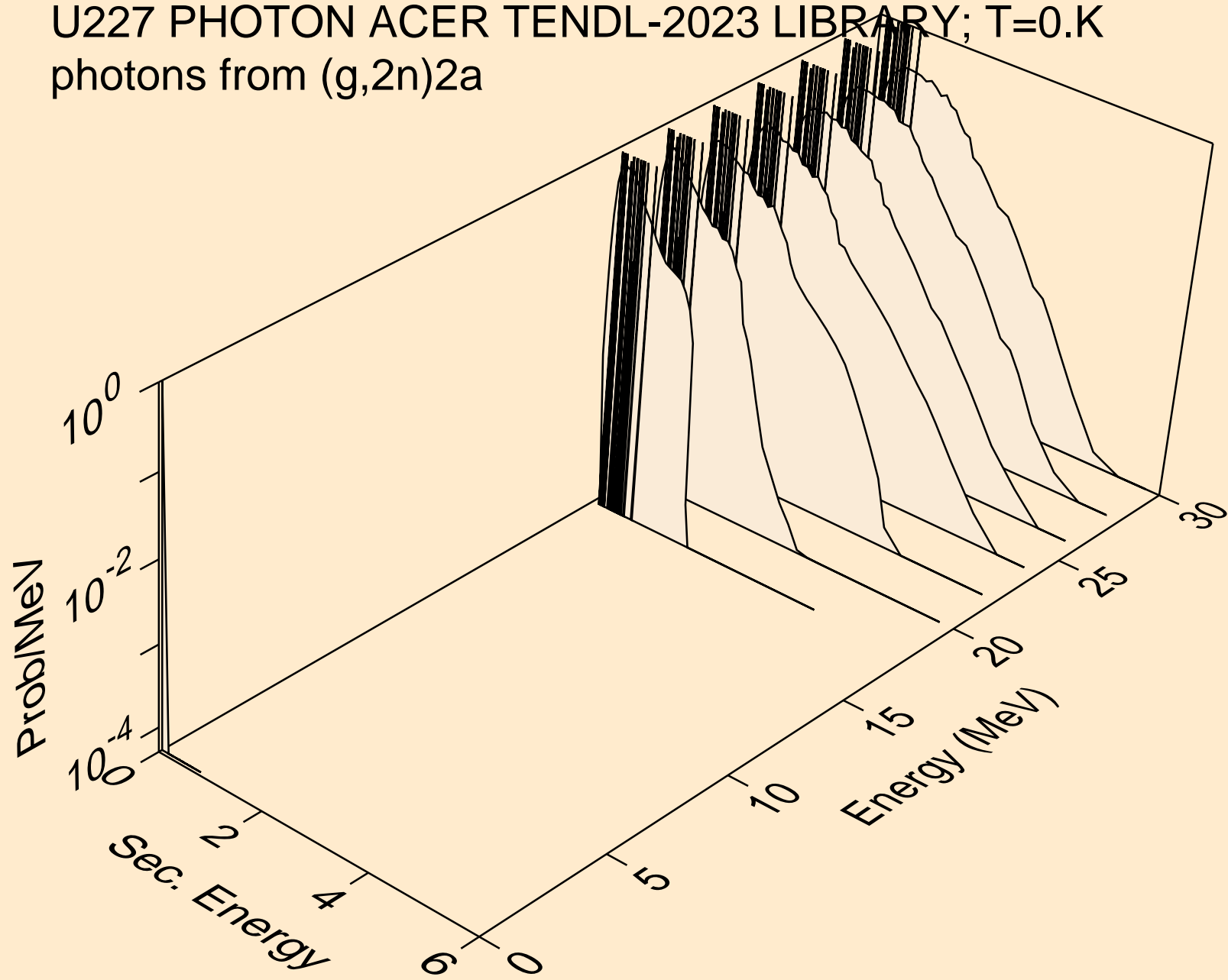

U227 PHOTON ACER TENDL-2023 LIBRARY; T=0.K
photons from (g,n*)d

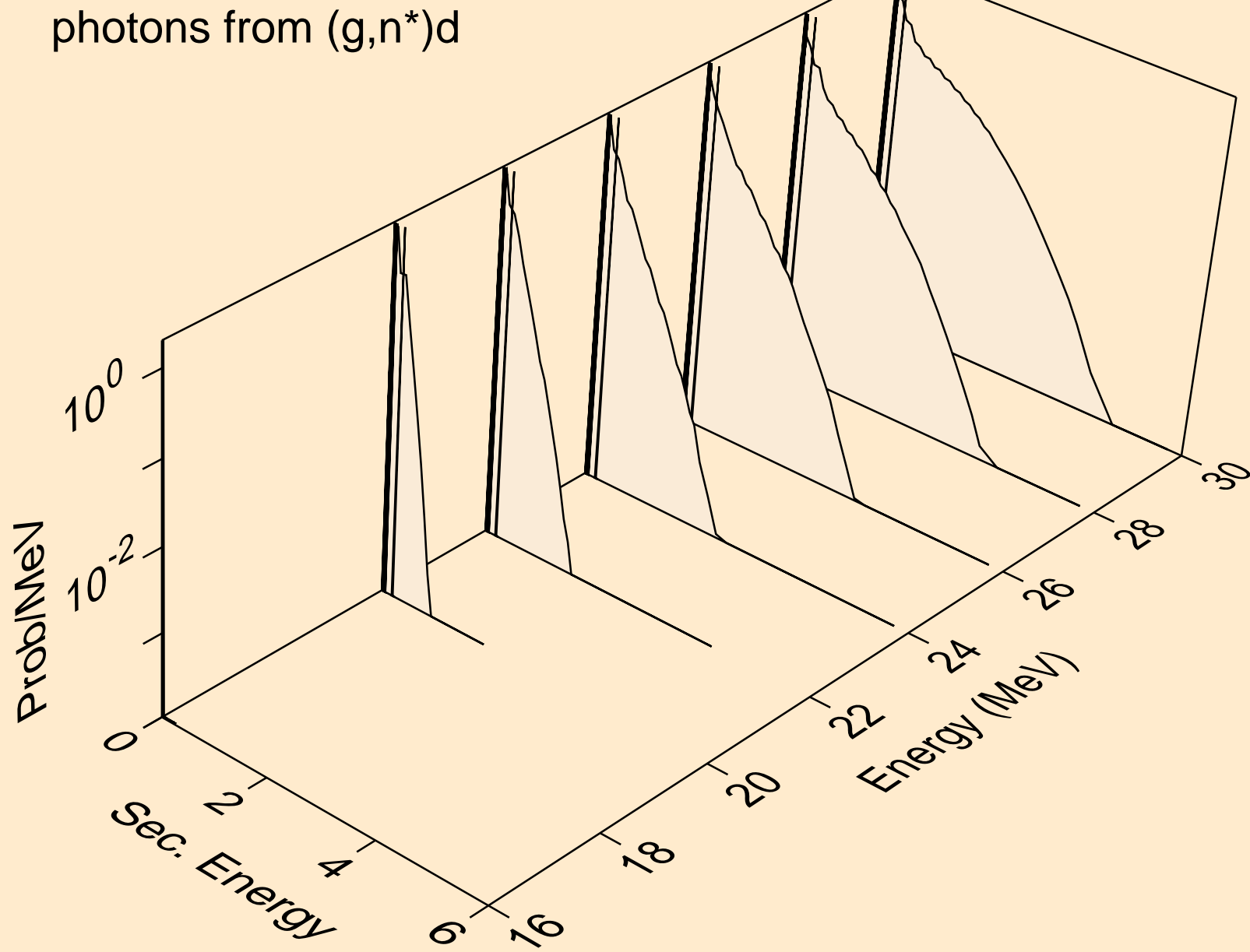

U227 PHOTON ACER TENDL-2023 LIBRARY; T=0.K
photons from (g,n*)t

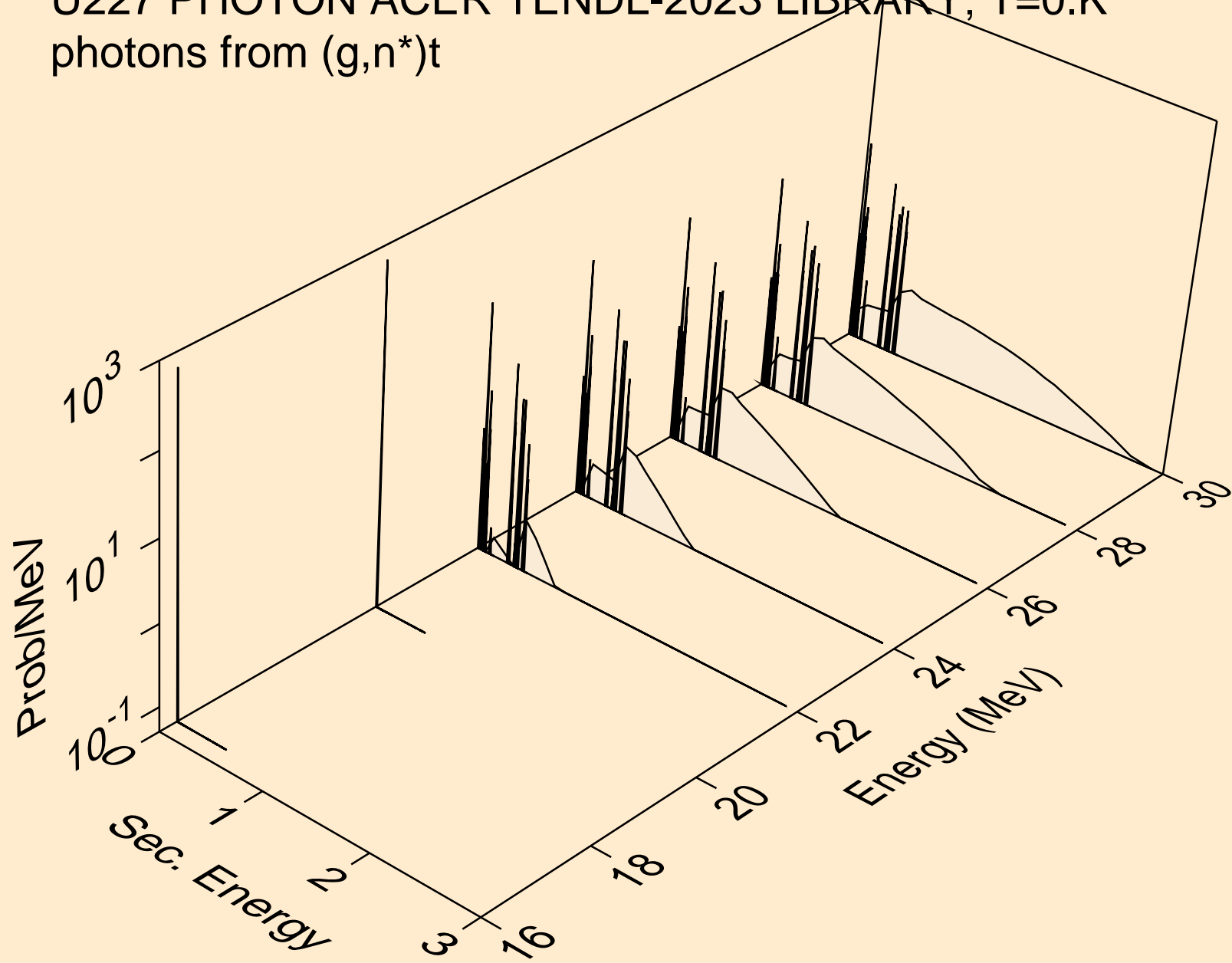

U227 PHOTON ACER TENDL-2023 LIBRARY; T=0.K
photons from (g,2np)

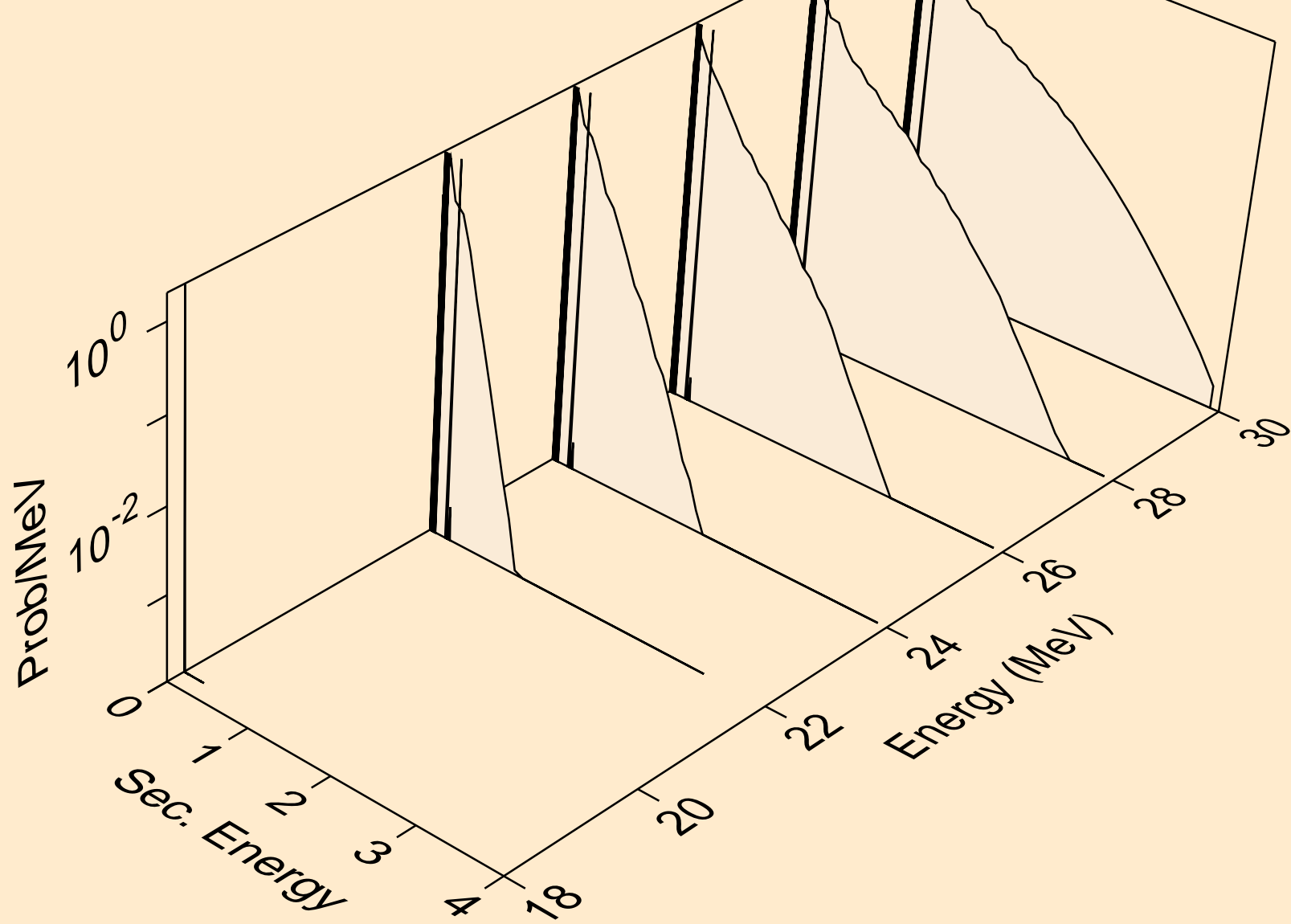

U227 PHOTON ACER TENDL-2023 LIBRARY; T=0.K
photons from (g,npa)

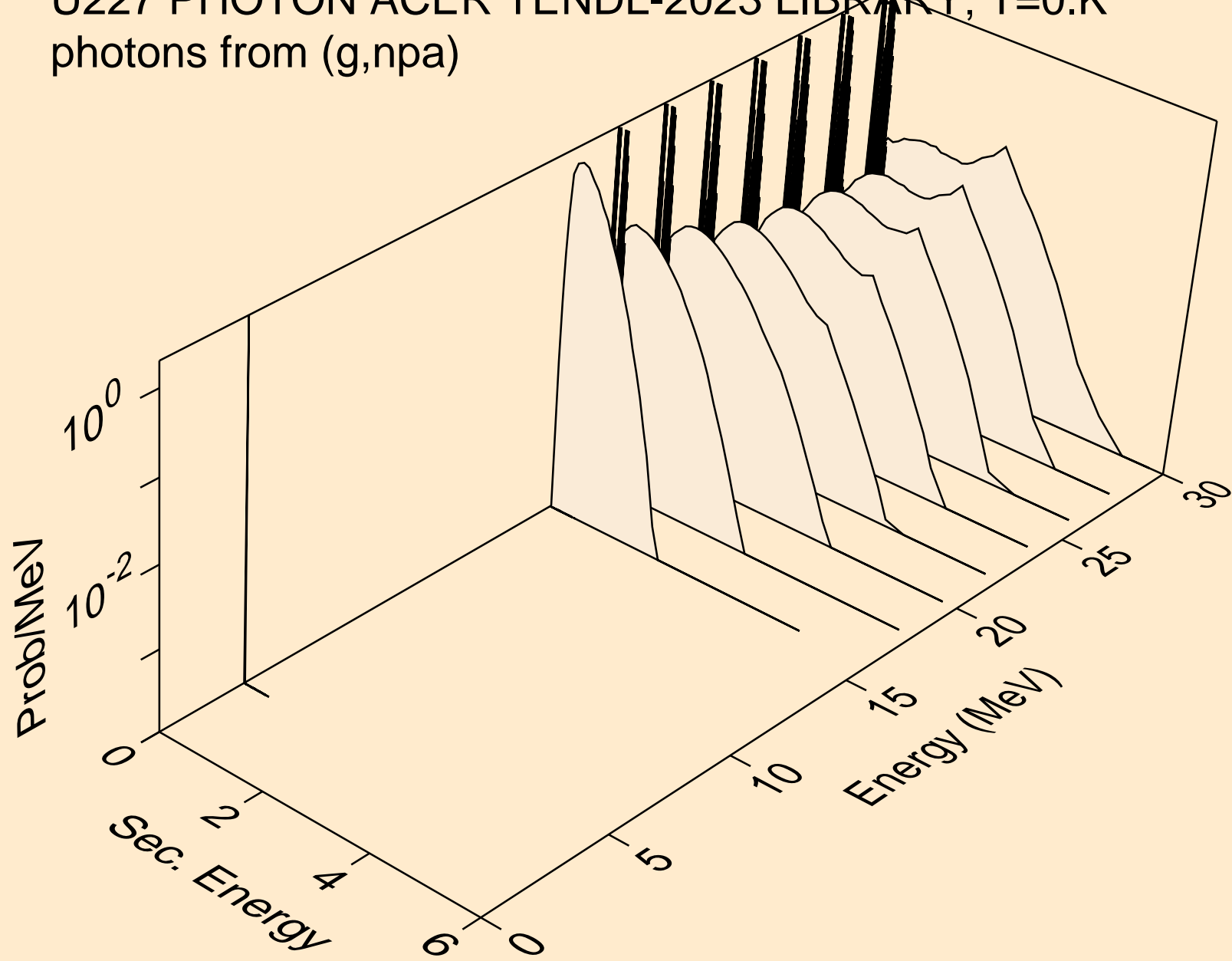

U227 PHOTON ACER TENDL-2023 LIBRARY; T=0.K
photons from (g,n*c)

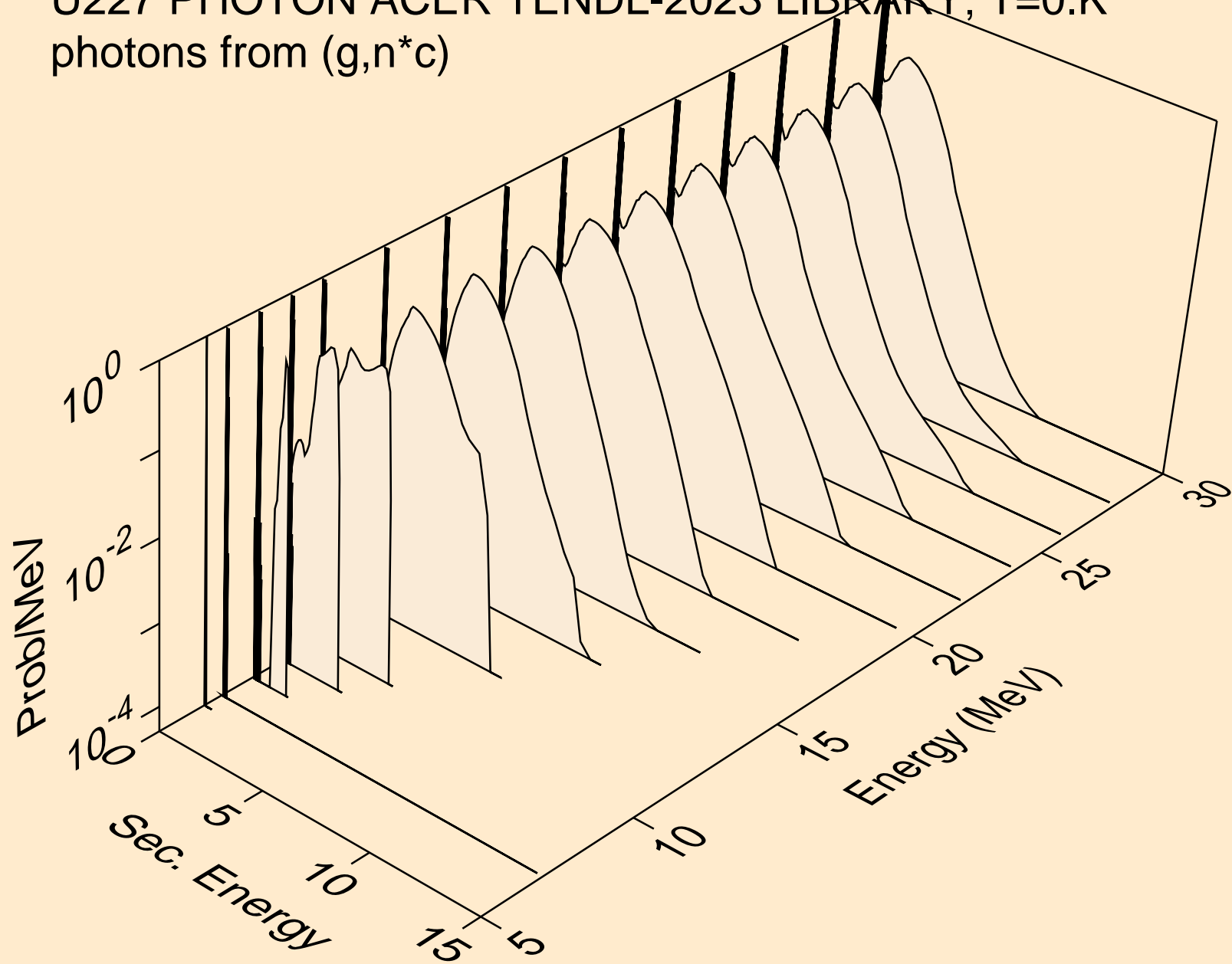

U227 PHOTON ACER TENDL-2023 LIBRARY; T=0.K
photons from (g,gma)

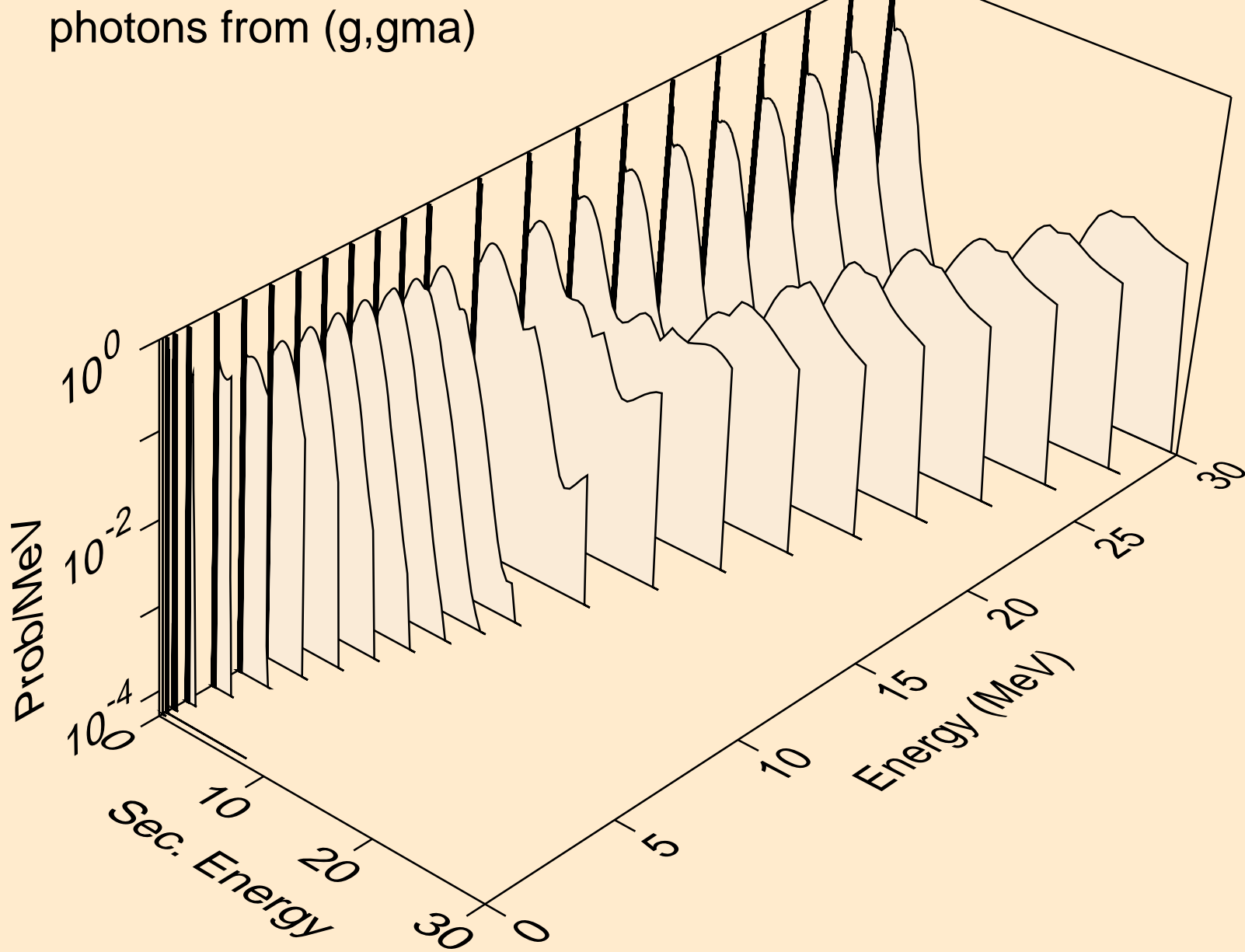

U227 PHOTON ACER TENDL-2023 LIBRARY; T=0.K
photons from (g,p)

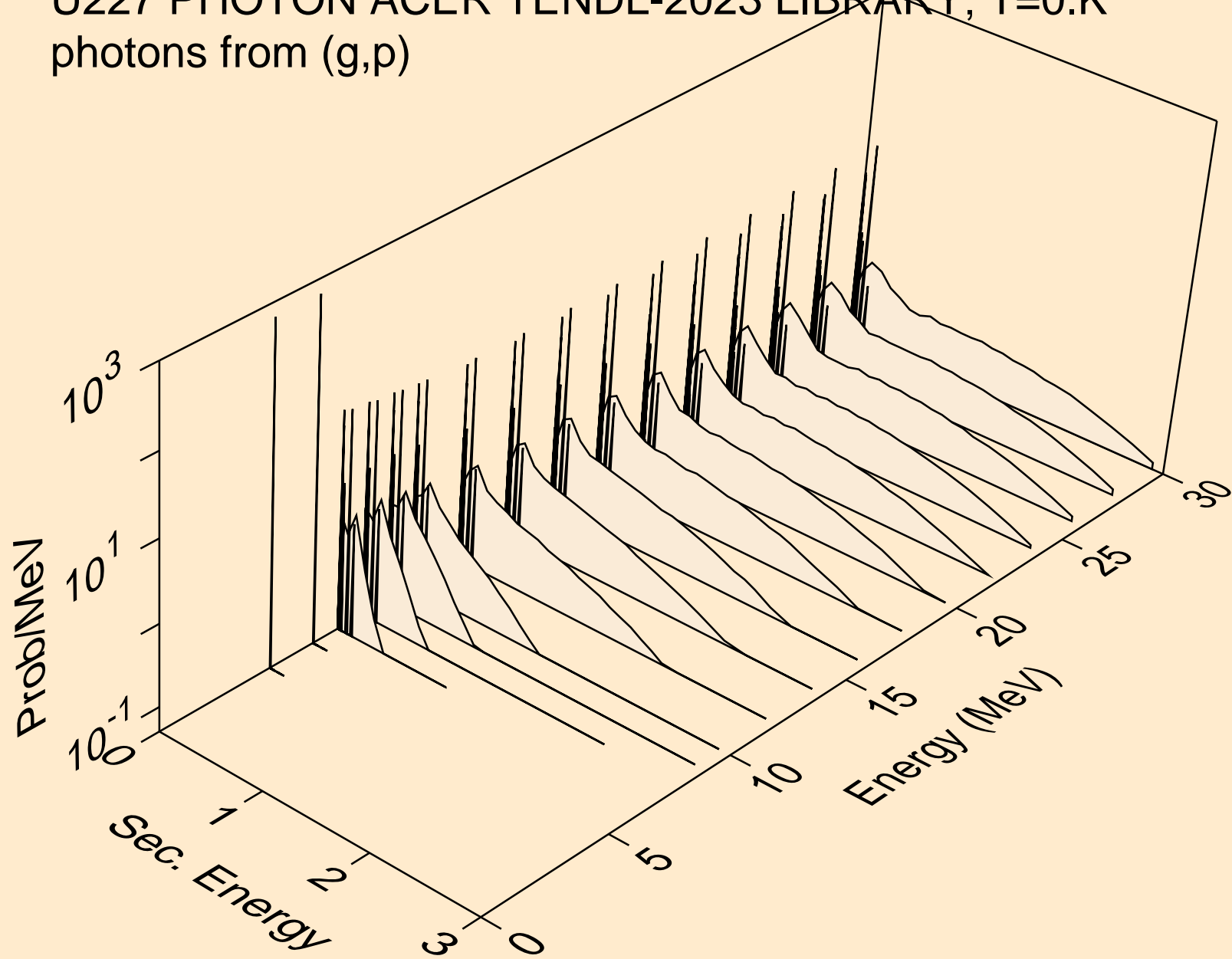

U227 PHOTON ACER TENDL-2023 LIBRARY; T=0.K
photons from (g,d)

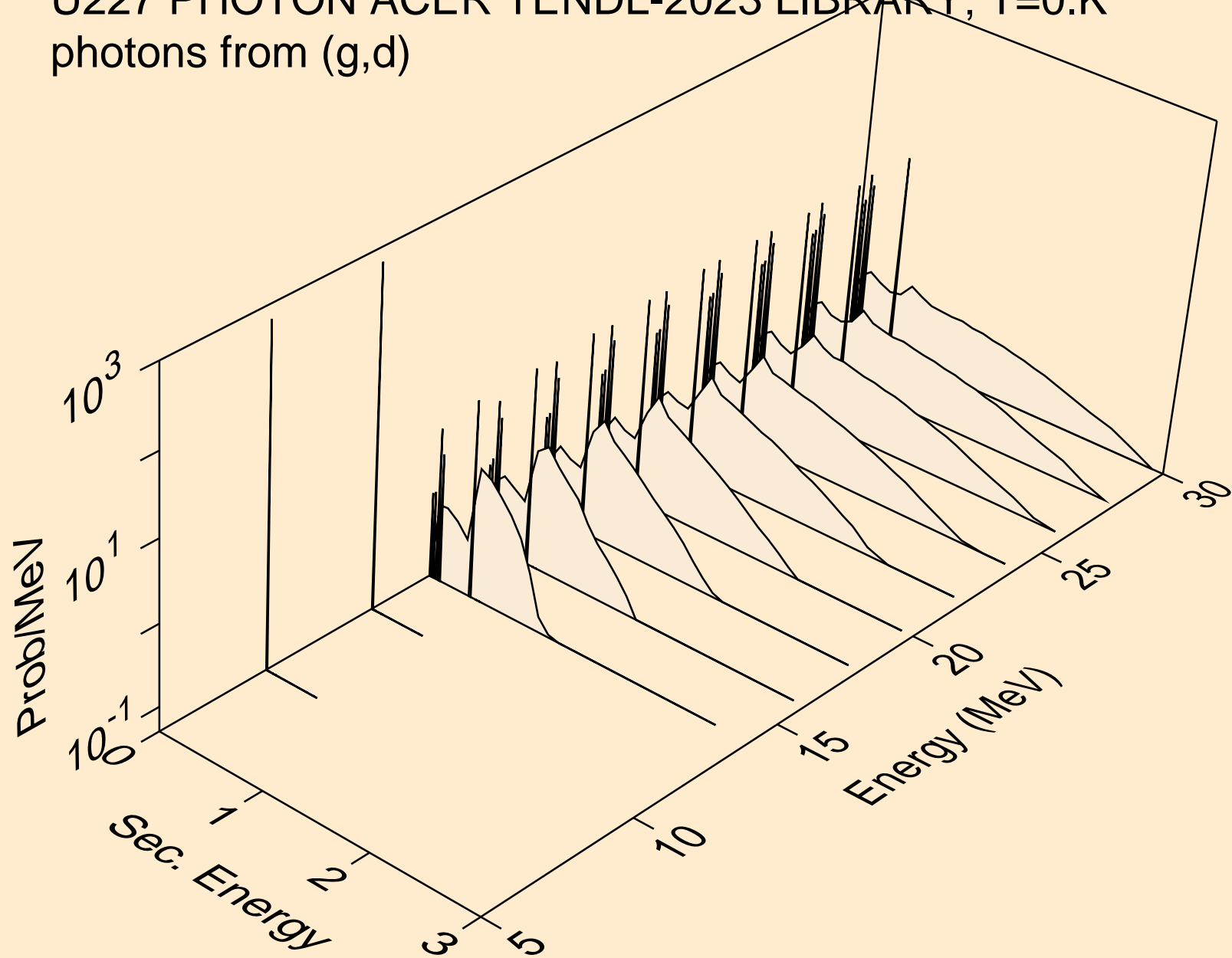

U227 PHOTON ACER TENDL-2023 LIBRARY; T=0.K
photons from (g,t)

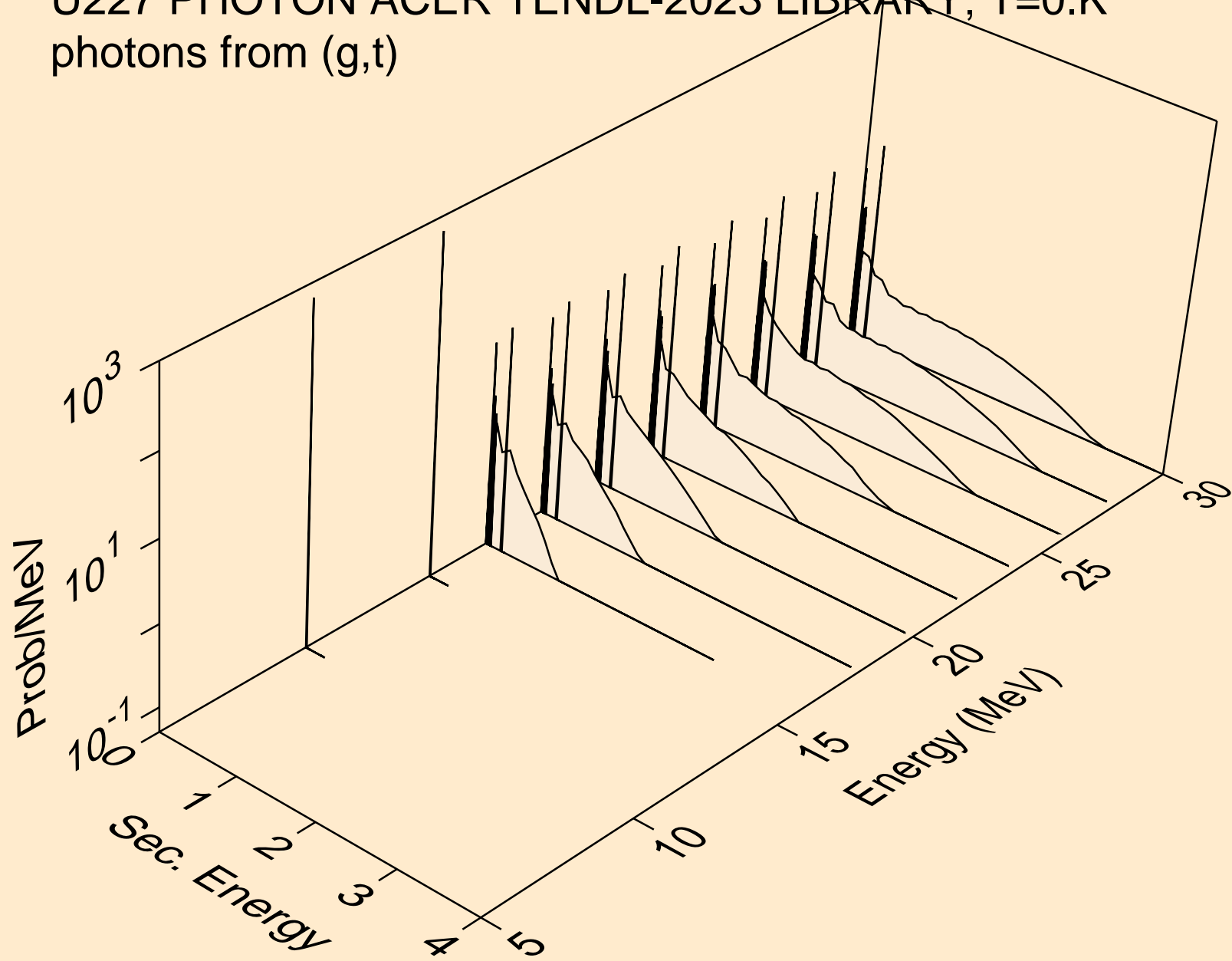

U227 PHOTON ACER TENDL-2023 LIBRARY; T=0.K
photons from (g,he3)

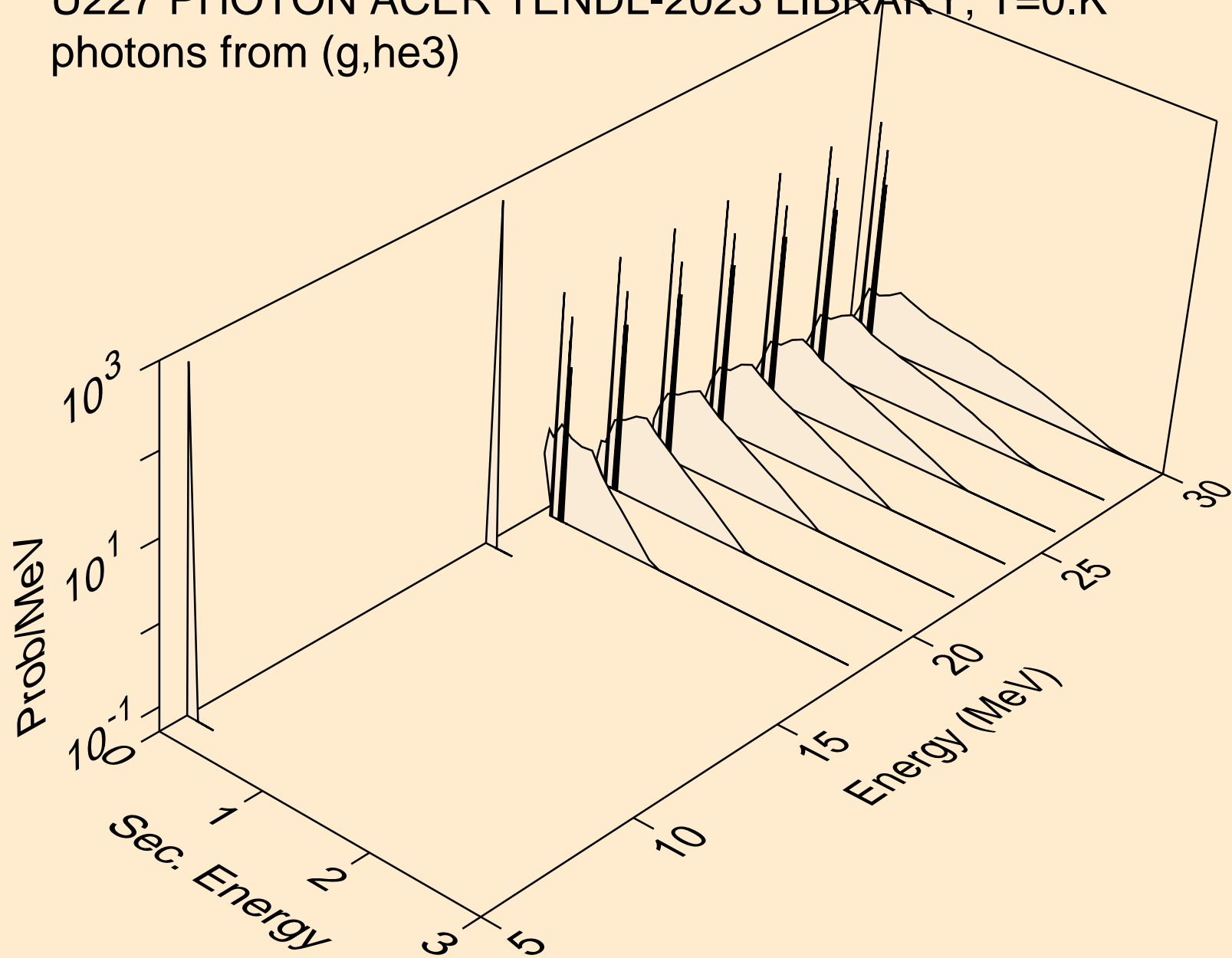

U227 PHOTON ACER TENDL-2023 LIBRARY; T=0.K
photons from (g,a)

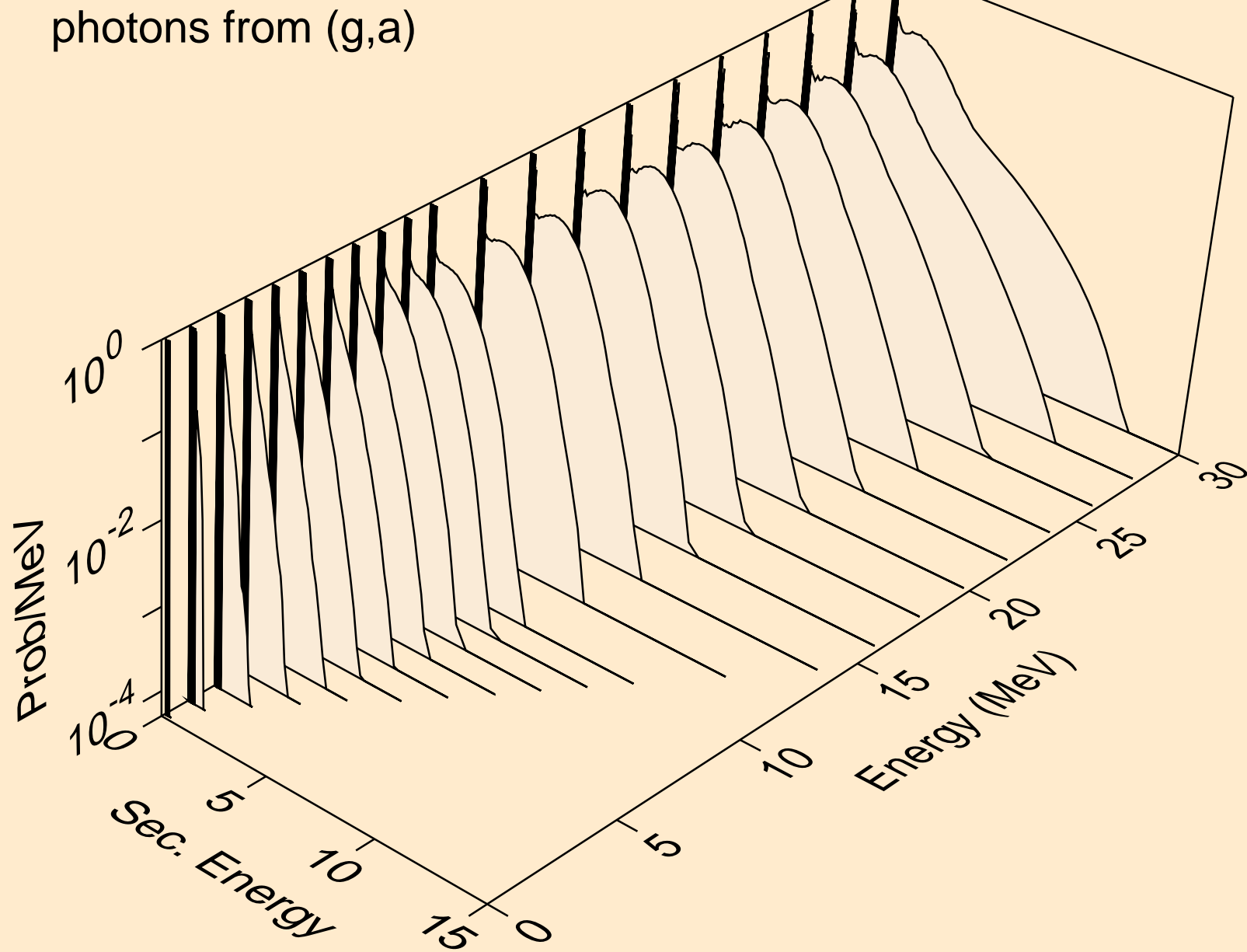

U227 PHOTON ACER TENDL-2023 LIBRARY; T=0.K
photons from (g,2a)

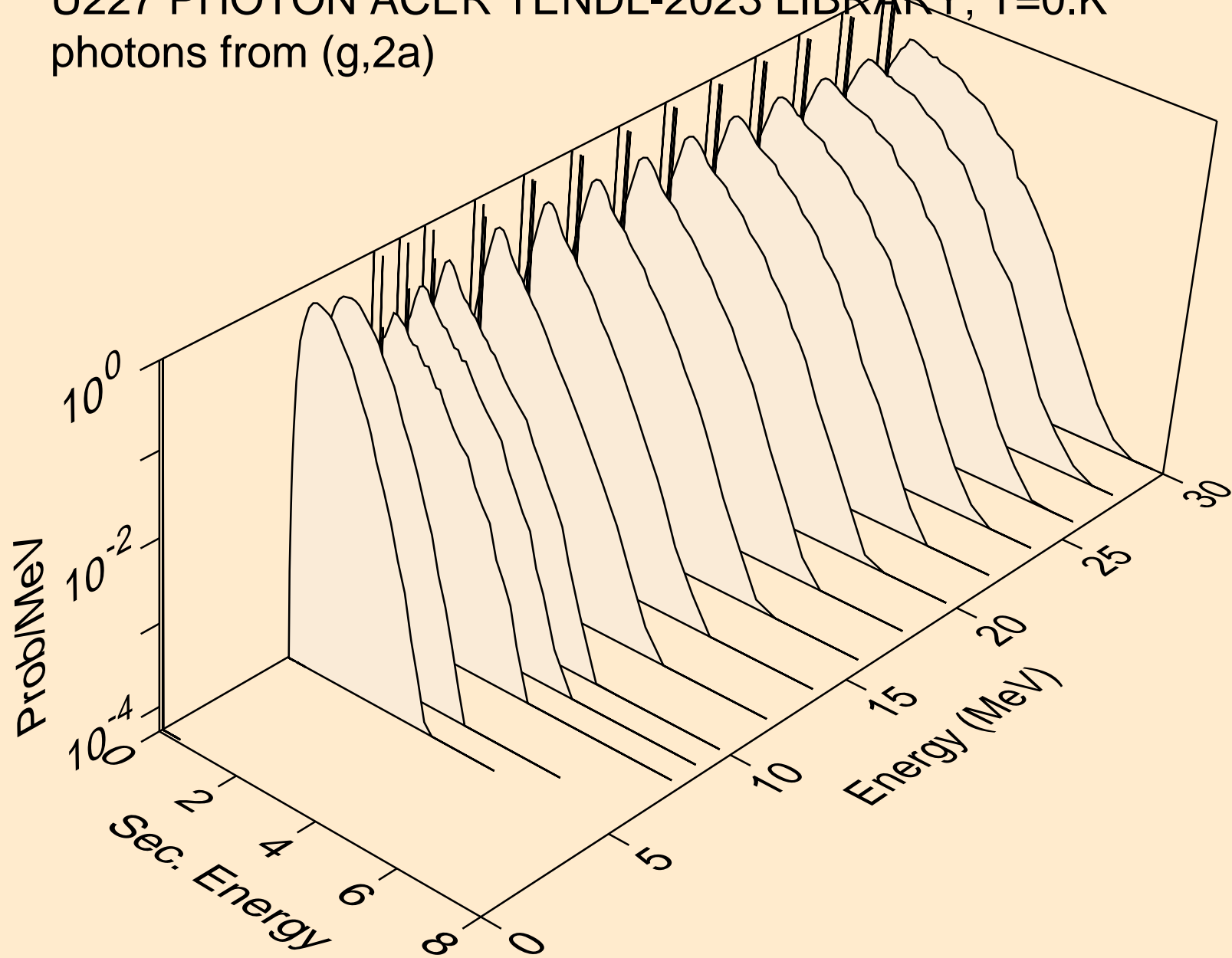

U227 PHOTON ACER TENDL-2023 LIBRARY; T=0.K
photons from (g,2p)

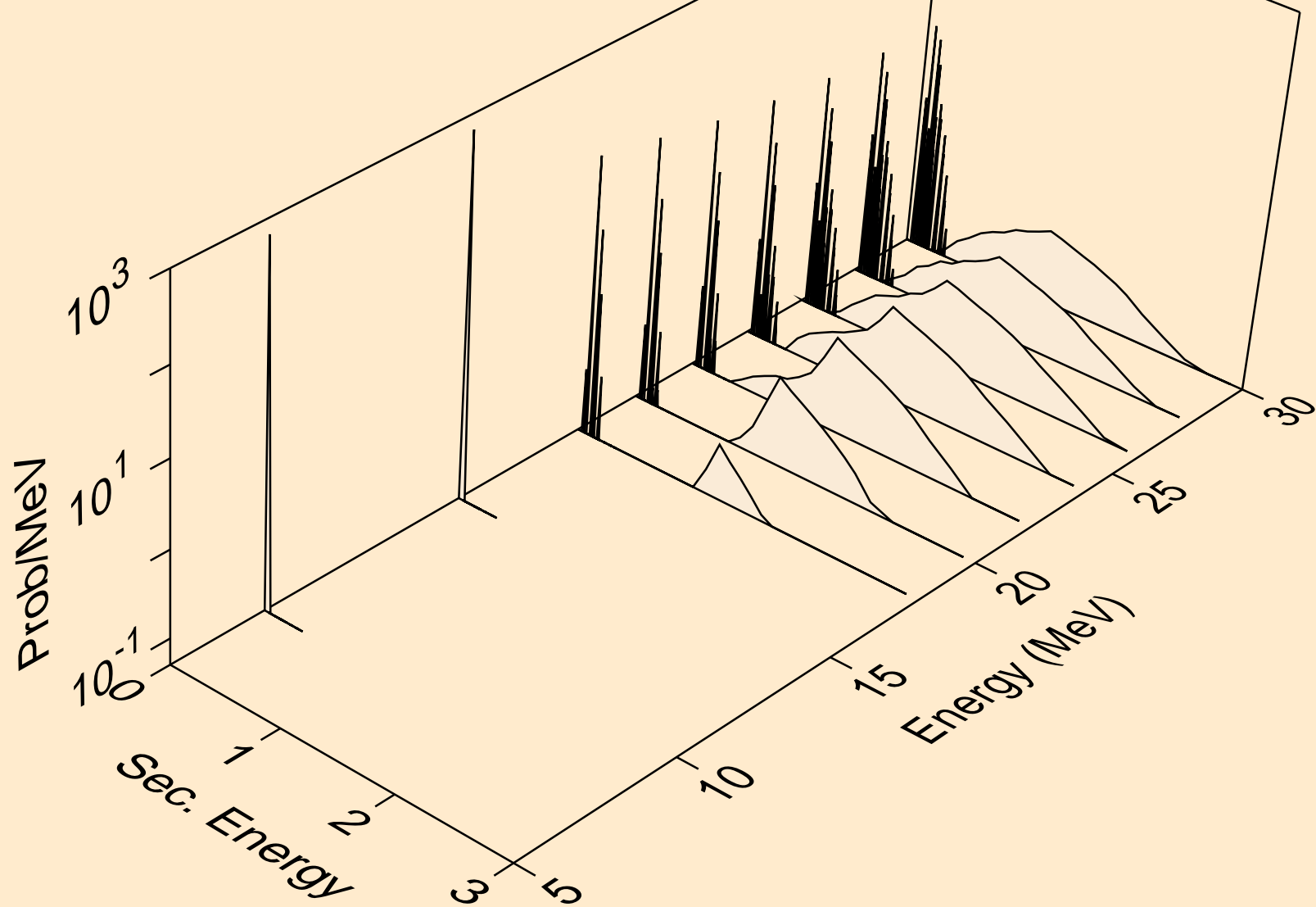

U227 PHOTON ACER TENDL-2023 LIBRARY; T=0.K
photons from (g,pa)

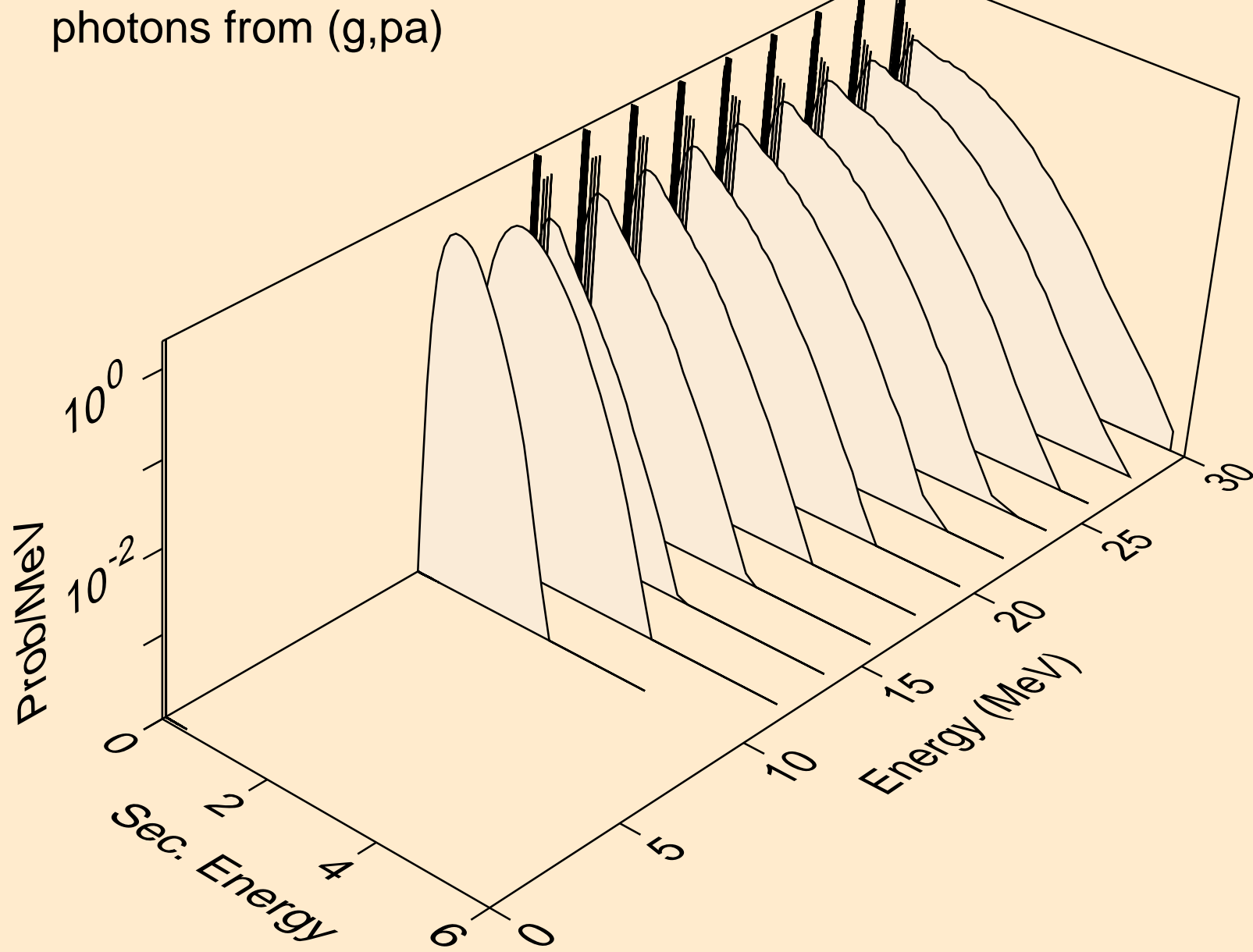

U227 PHOTON ACER TENDL-2023 LIBRARY; T=0.K
protons from (g,x)

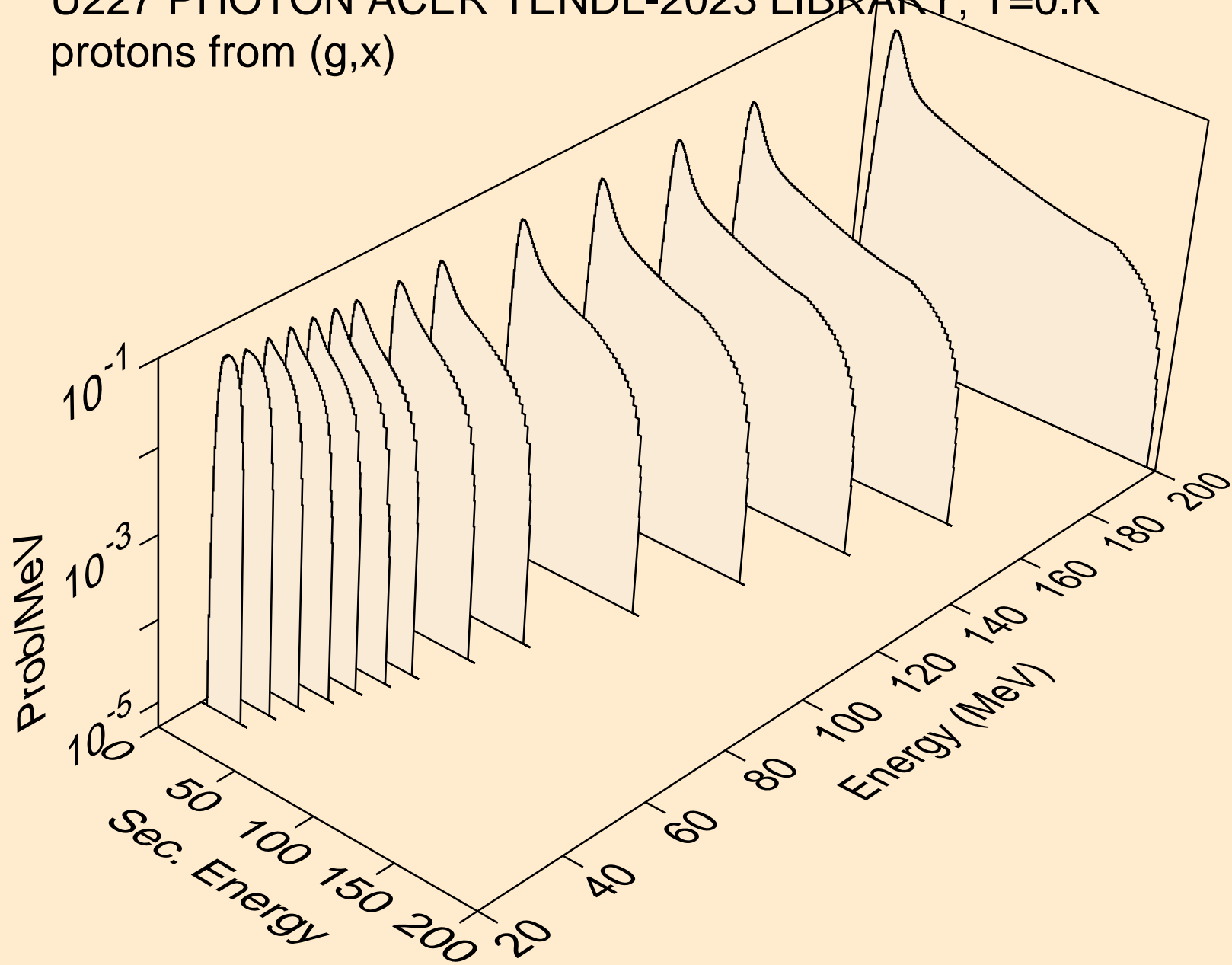

U227 PHOTON ACER TENDL-2023 LIBRARY; T=0.K
protons from (g,n*)p

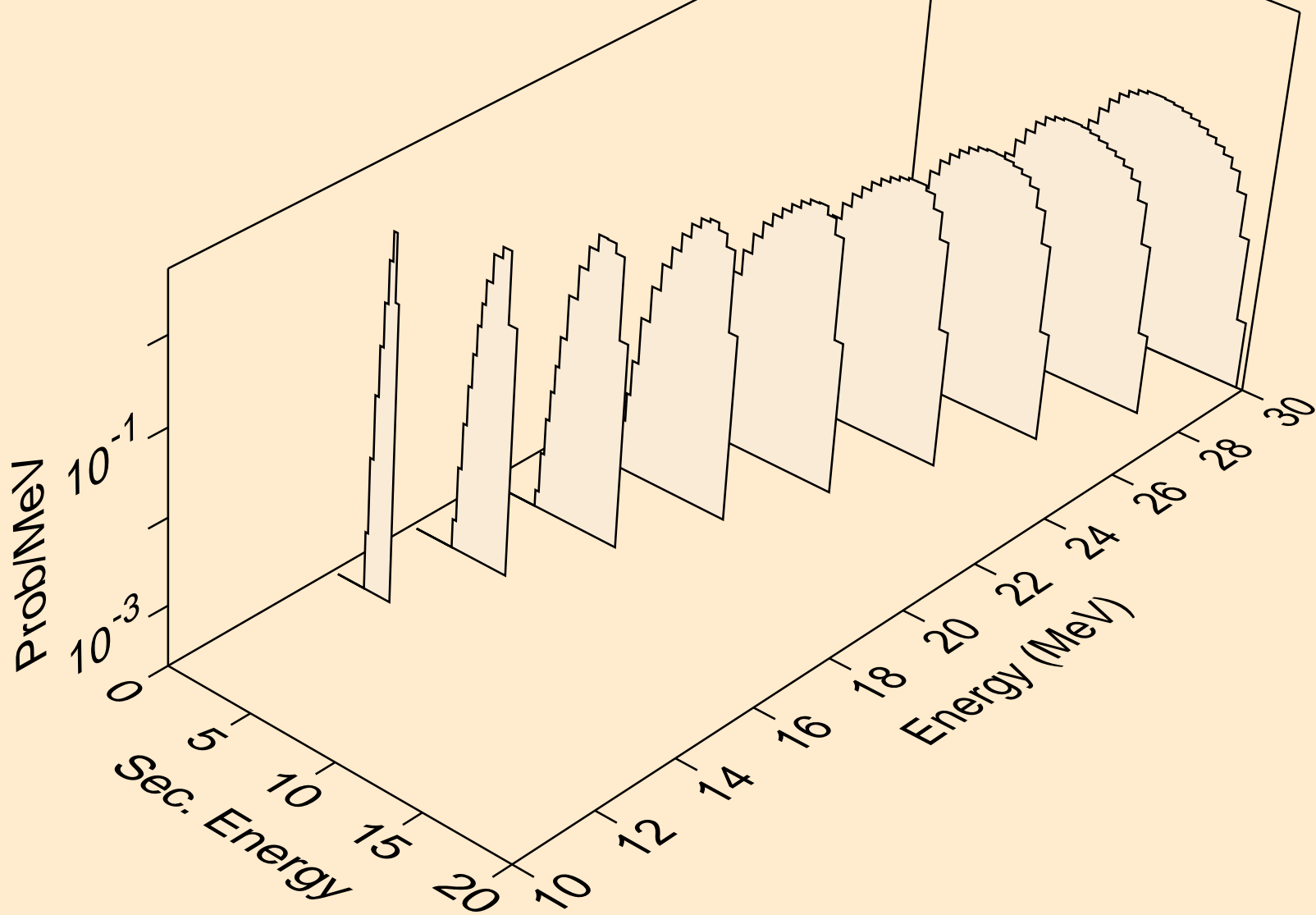

U227 PHOTON ACER TENDL-2023 LIBRARY; T=0.K
protons from (g,2np)

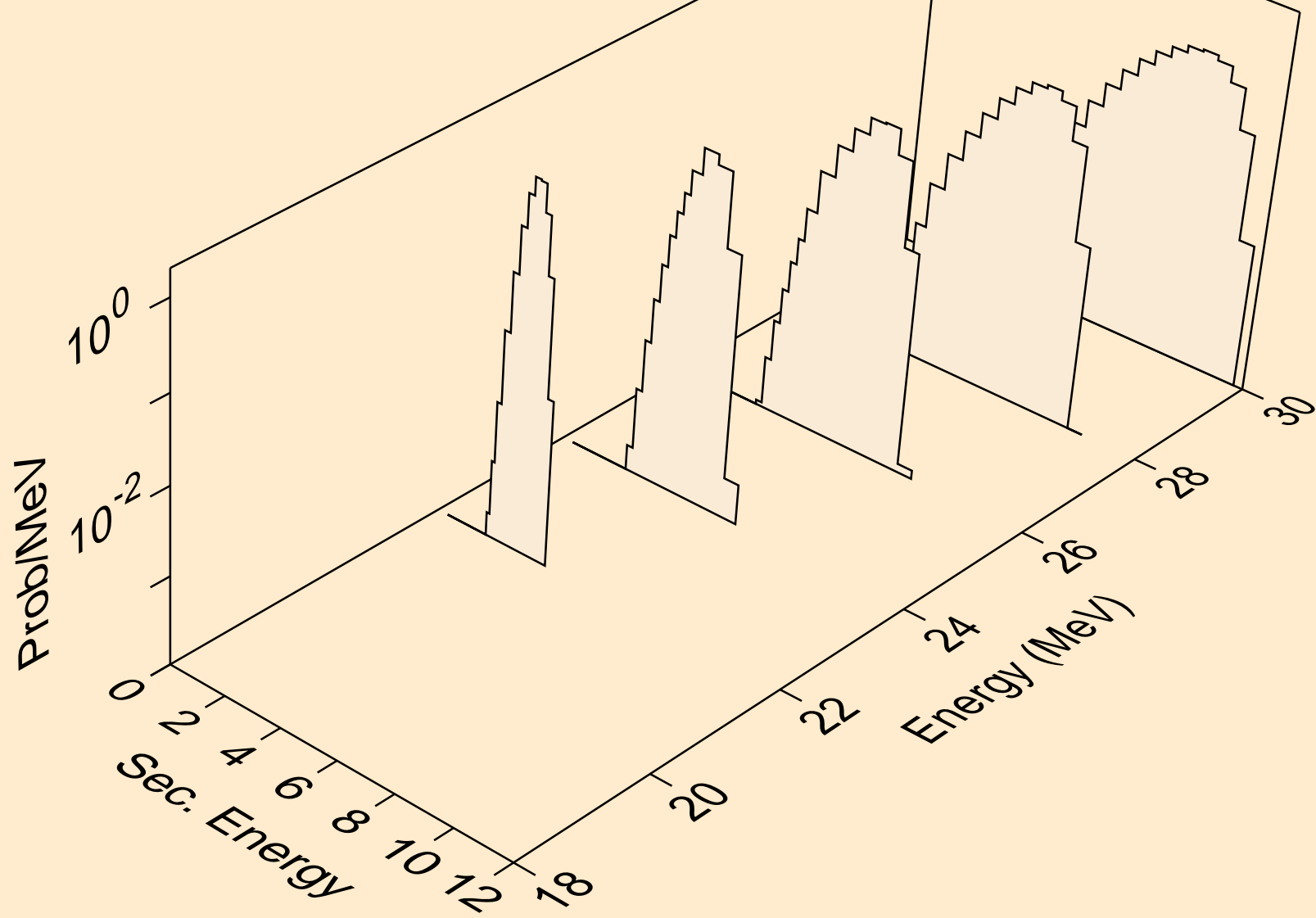

U227 PHOTON ACER TENDL-2023 LIBRARY; T=0.K
protons from (g,npa)

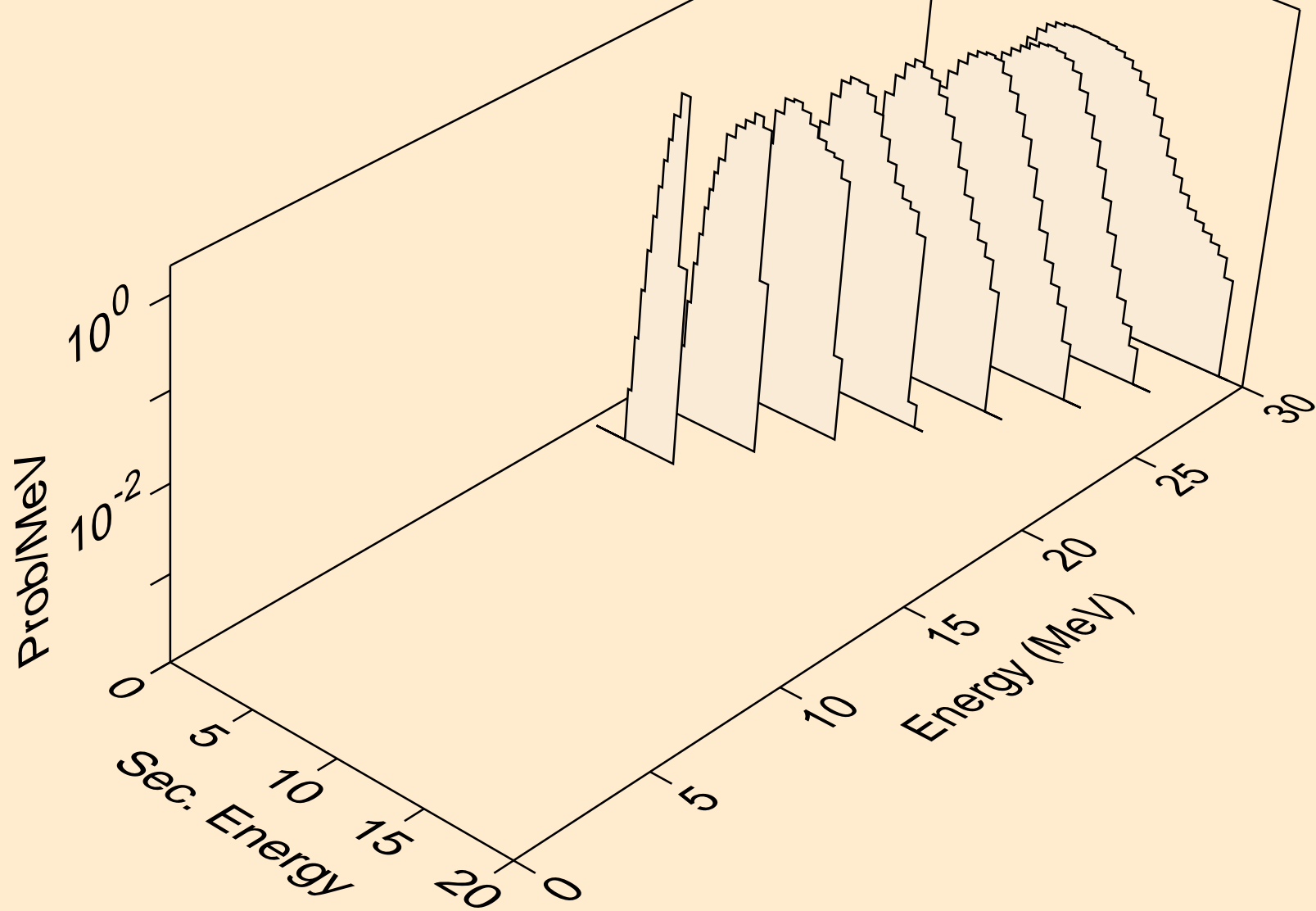

U227 PHOTON ACER TENDL-2023 LIBRARY; T=0.K
protons from (g,p)

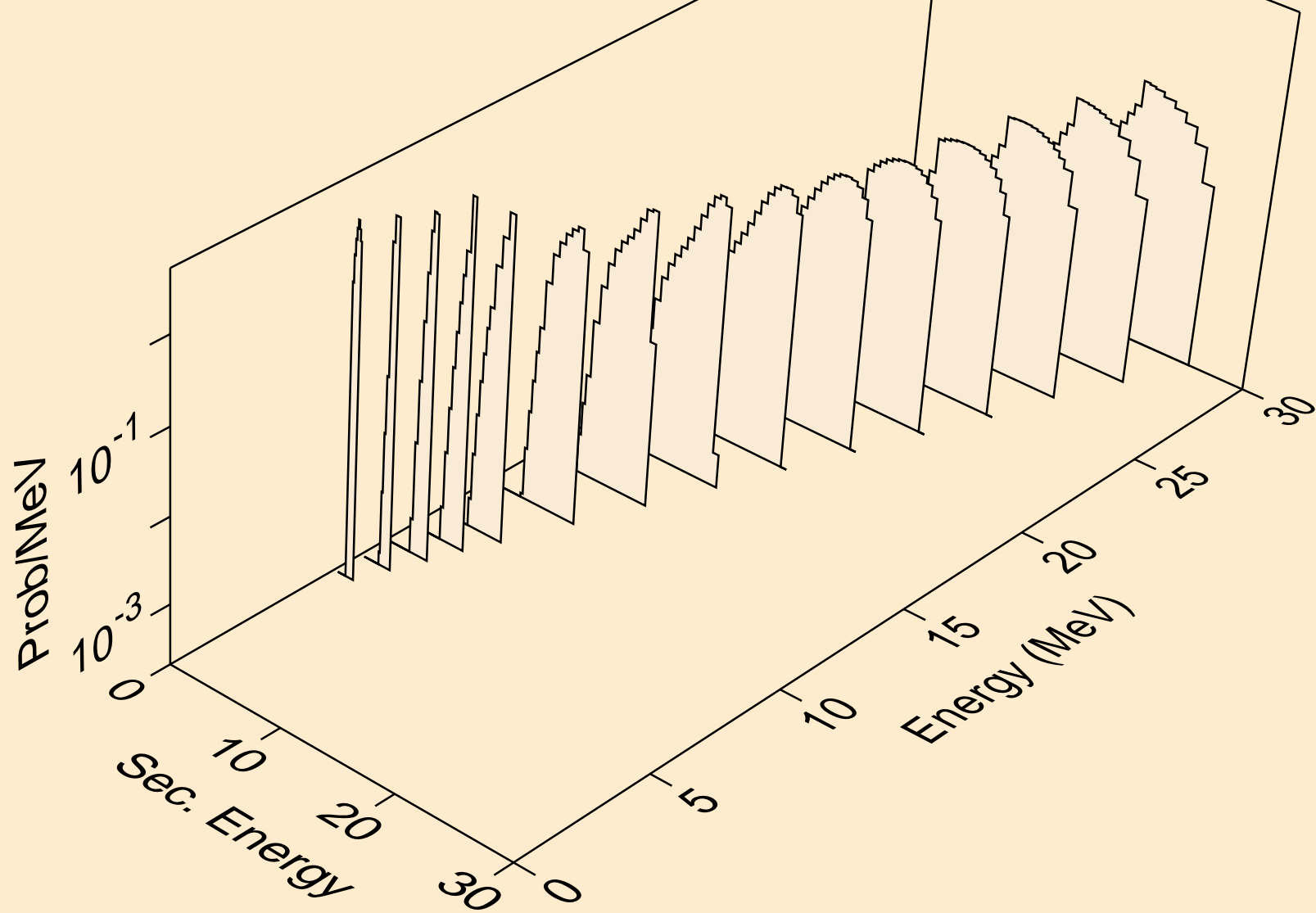

U227 PHOTON ACER TENDL-2023 LIBRARY; T=0.K
protons from (g,2p)

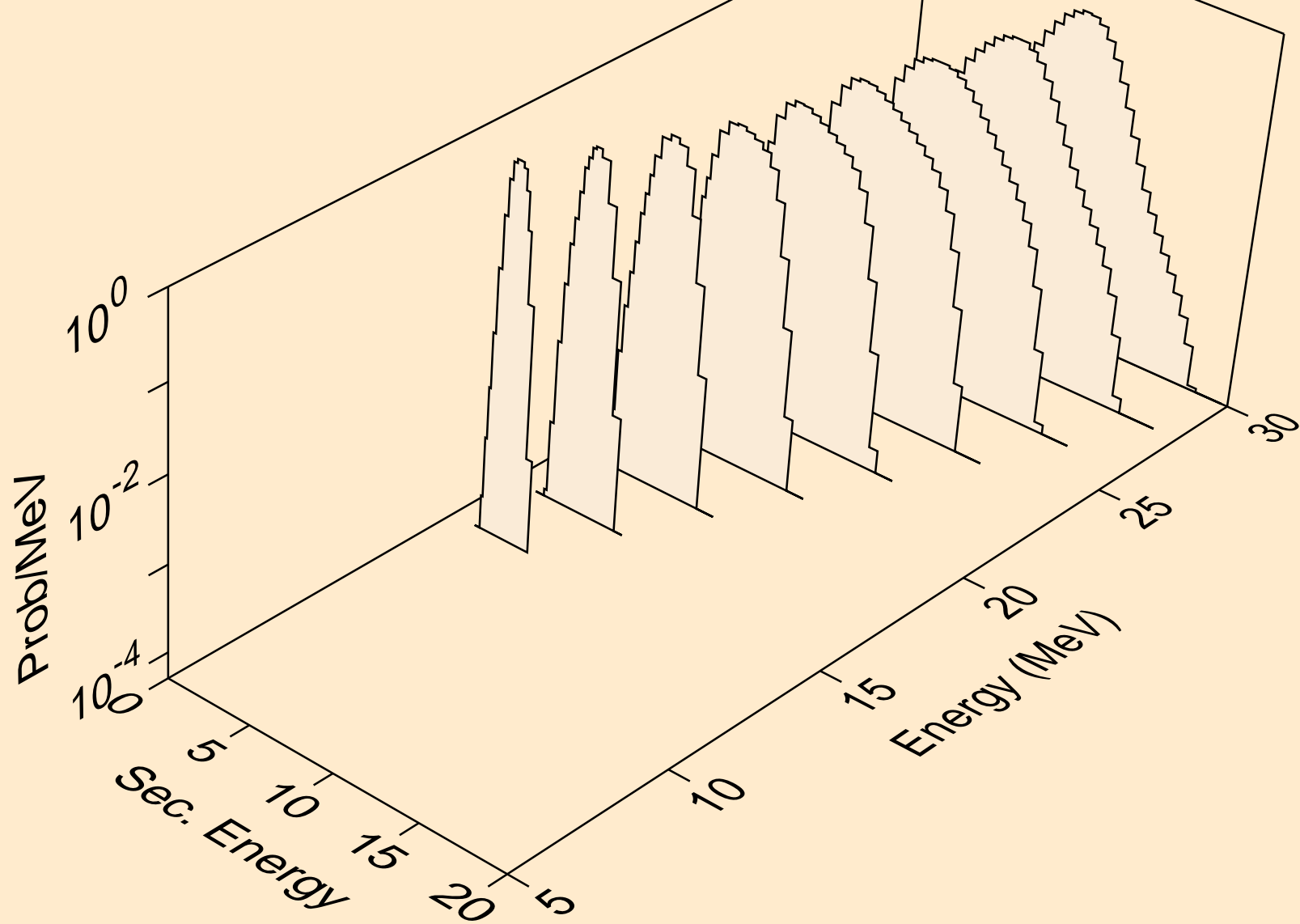

U227 PHOTON ACER TENDL-2023 LIBRARY; T=0.K
protons from (g,pa)

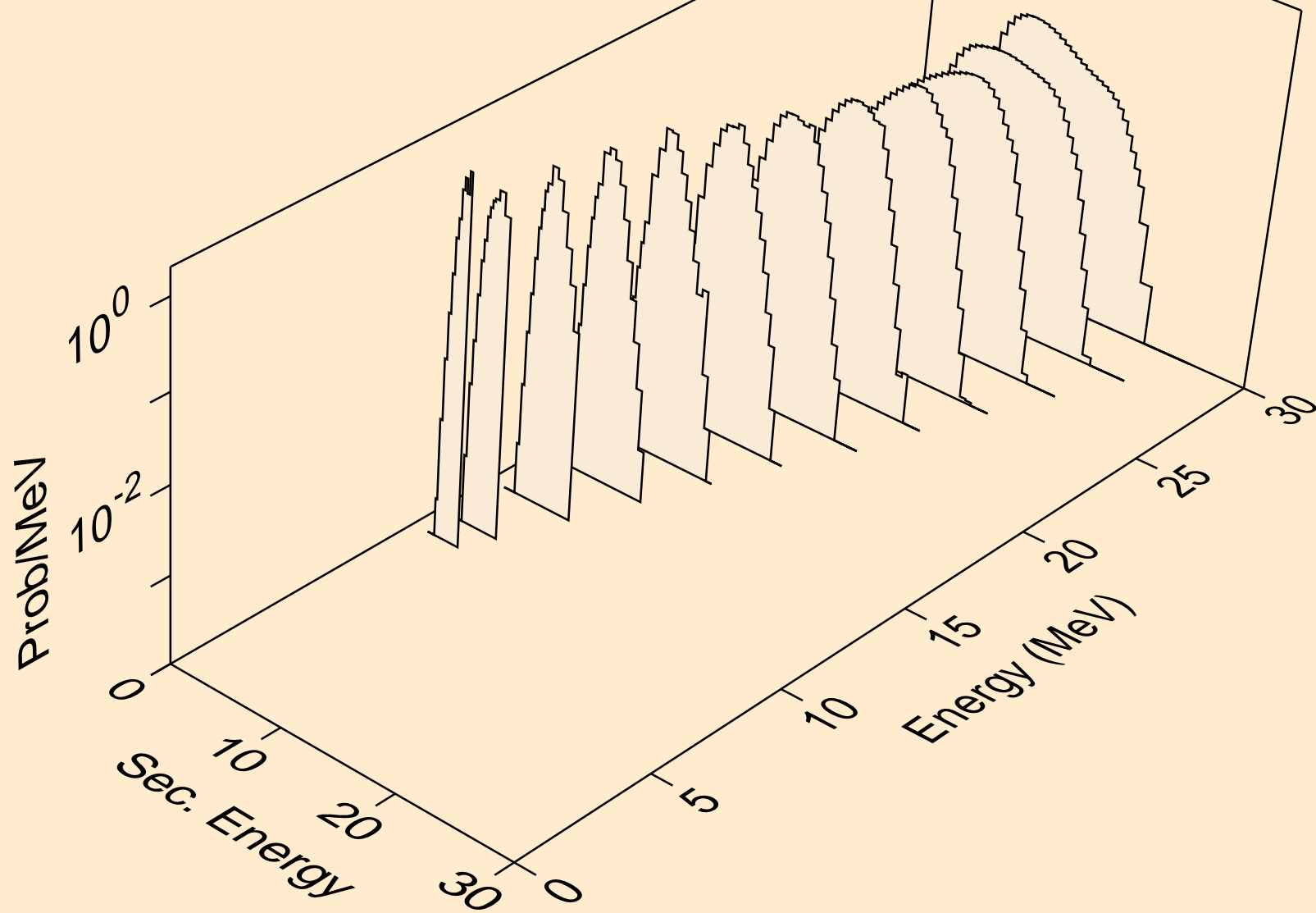

U227 PHOTON ACER TENDL-2023 LIBRARY; T=0.K
deuterons from (g,x)

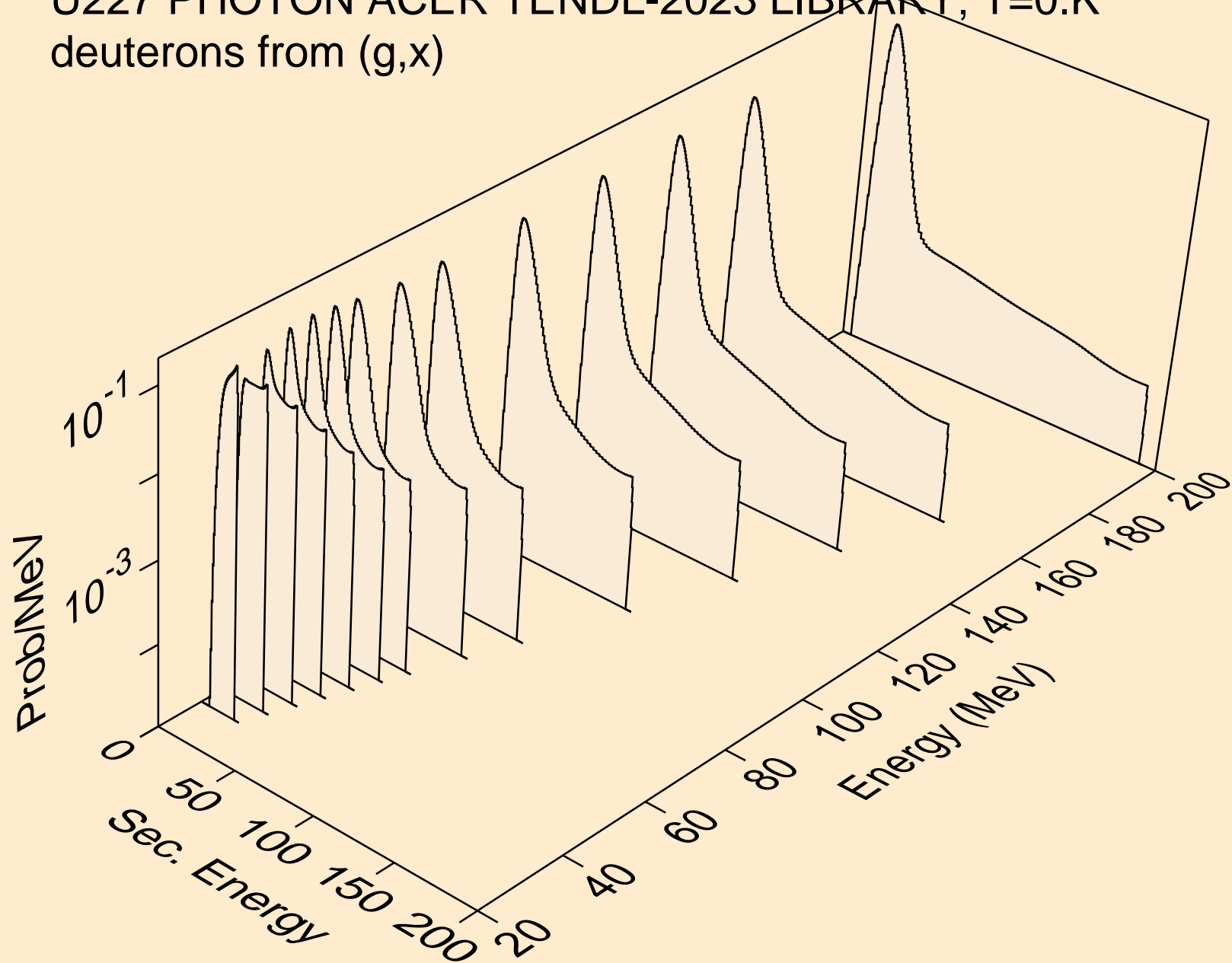

U227 PHOTON ACER TENDL-2023 LIBRARY; T=0.K
deuterons from (g,n*)d

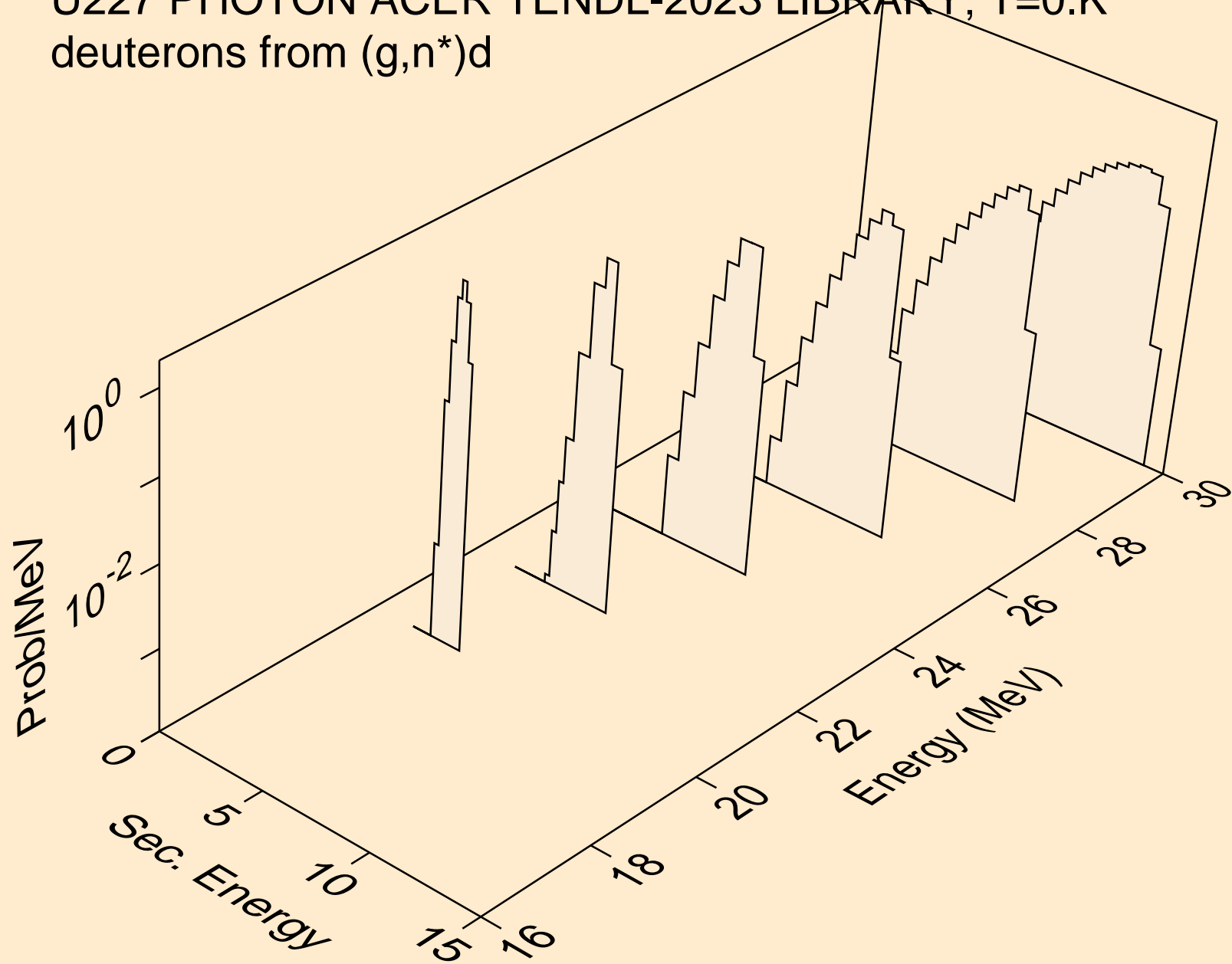

U227 PHOTON ACER TENDL-2023 LIBRARY; T=0.K
deuterons from (g,d)

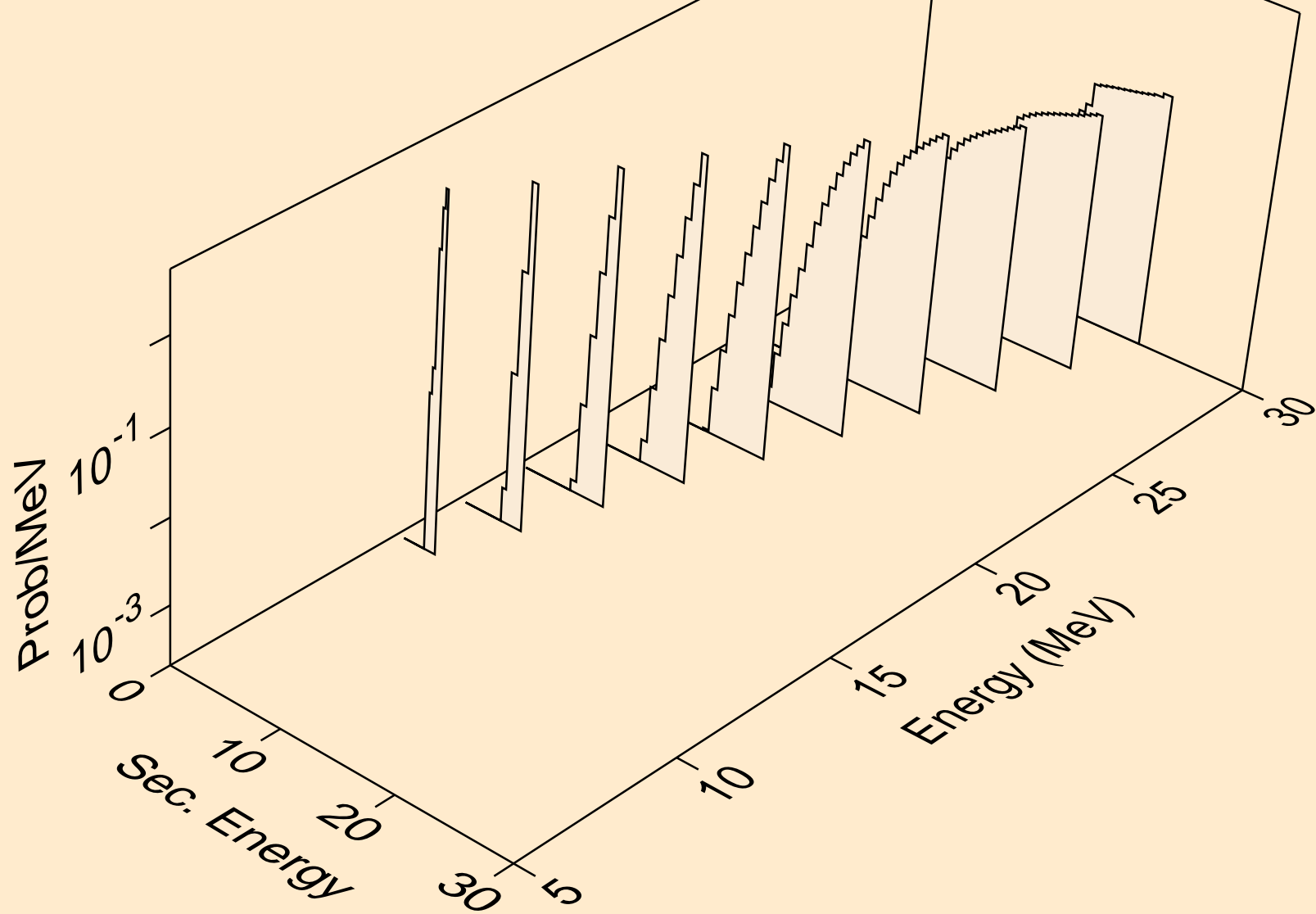

U227 PHOTON ACER TENDL-2023 LIBRARY; T=0.K
tritons from (g,x)

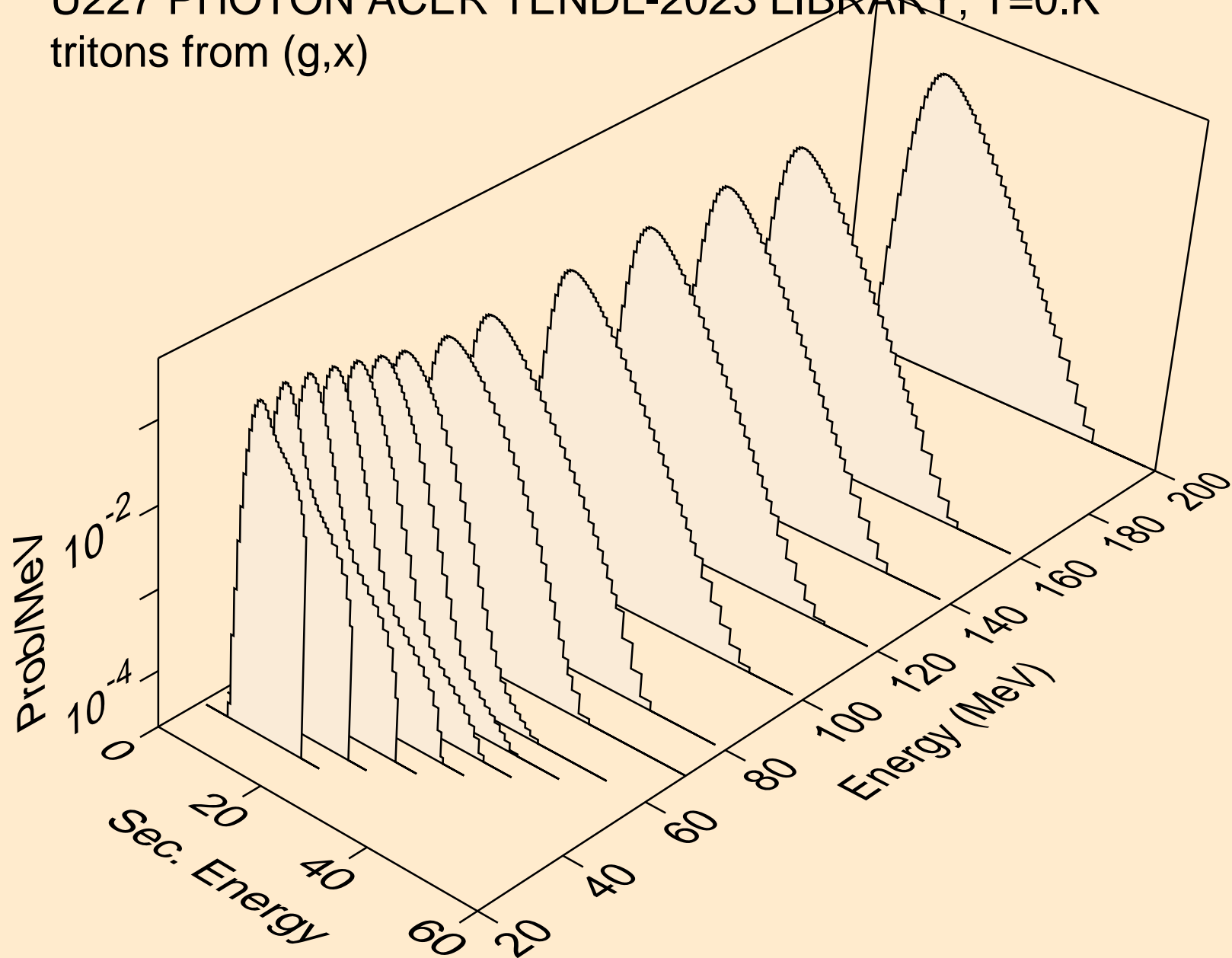

U227 PHOTON ACER TENDL-2023 LIBRARY; T=0.K
tritons from (g,n*)t

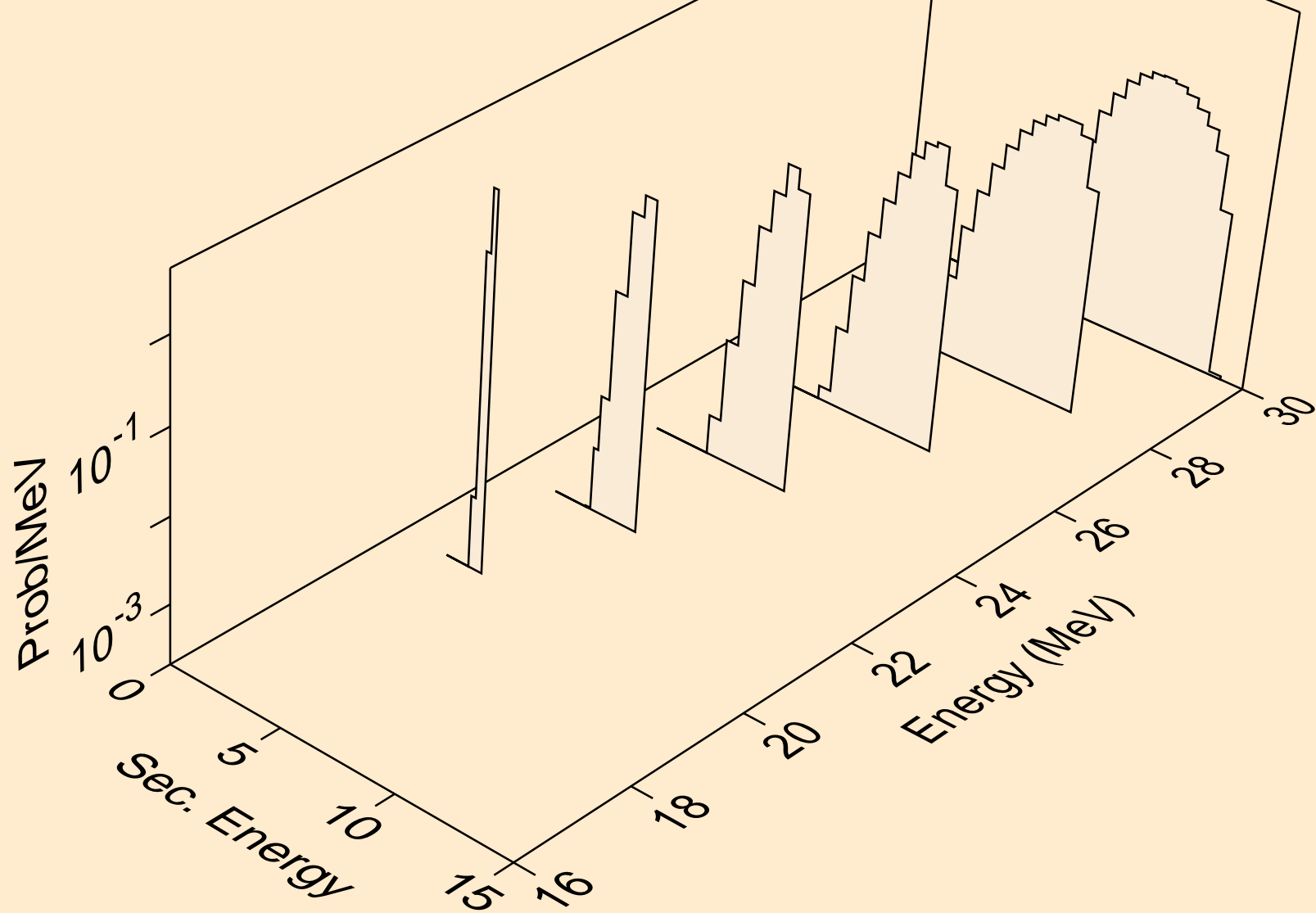

U227 PHOTON ACER TENDL-2023 LIBRARY; T=0.K
tritons from (g,t)

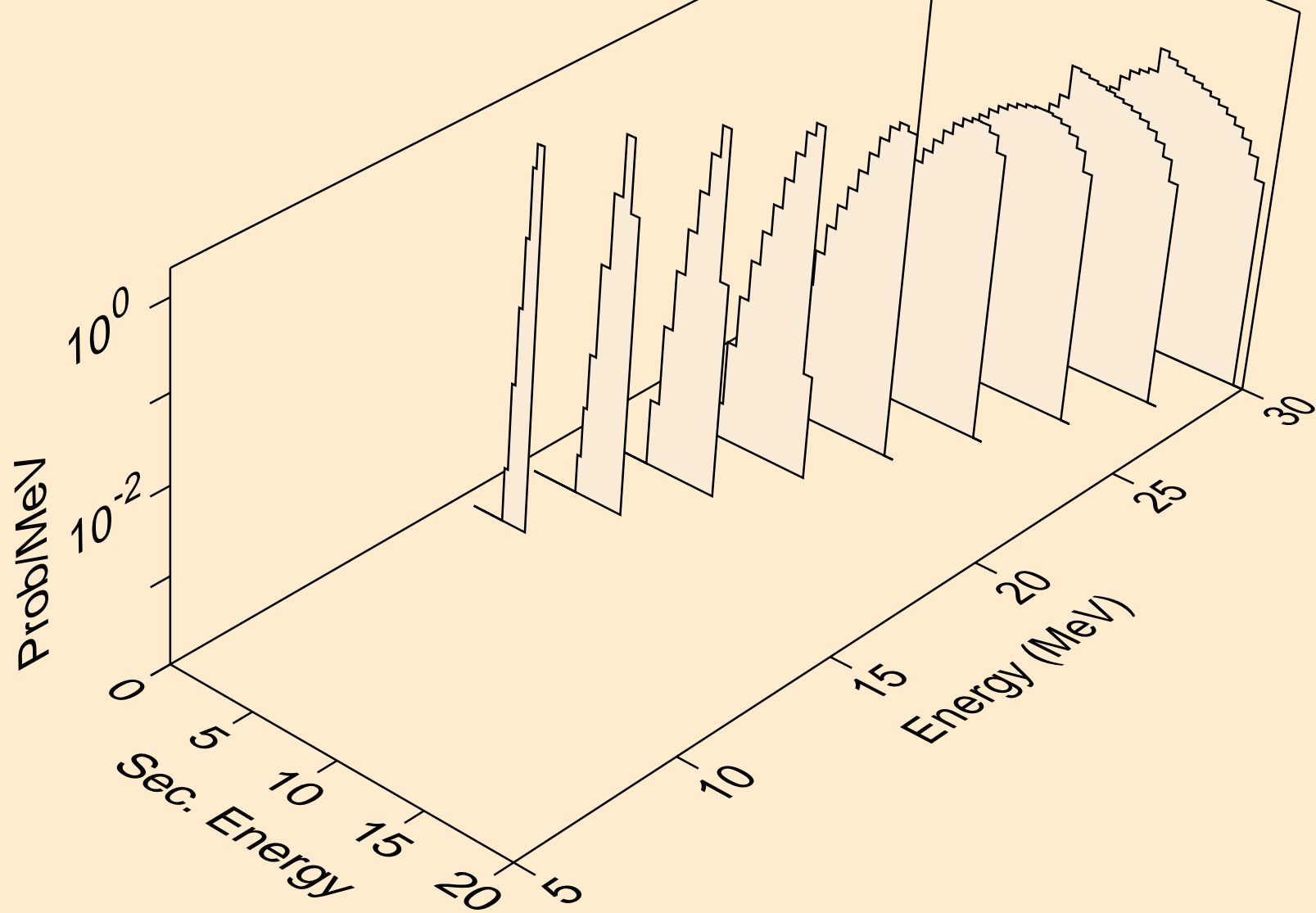

U227 PHOTON ACER TENDL-2023 LIBRARY; T=0.K
he3s from (g,x)

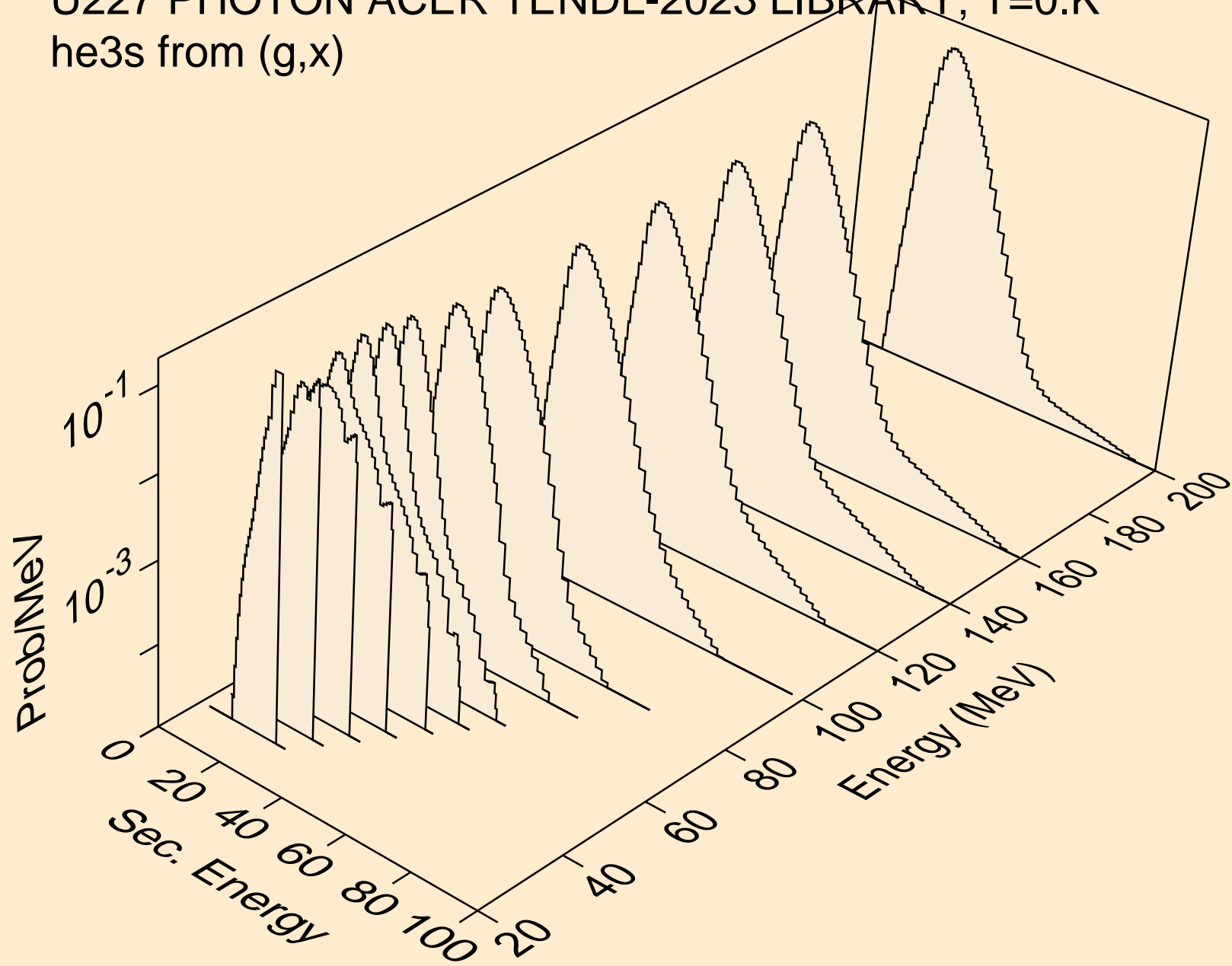

U227 PHOTON ACER TENDL-2023 LIBRARY; T=0.K
he3s from (g,he3)

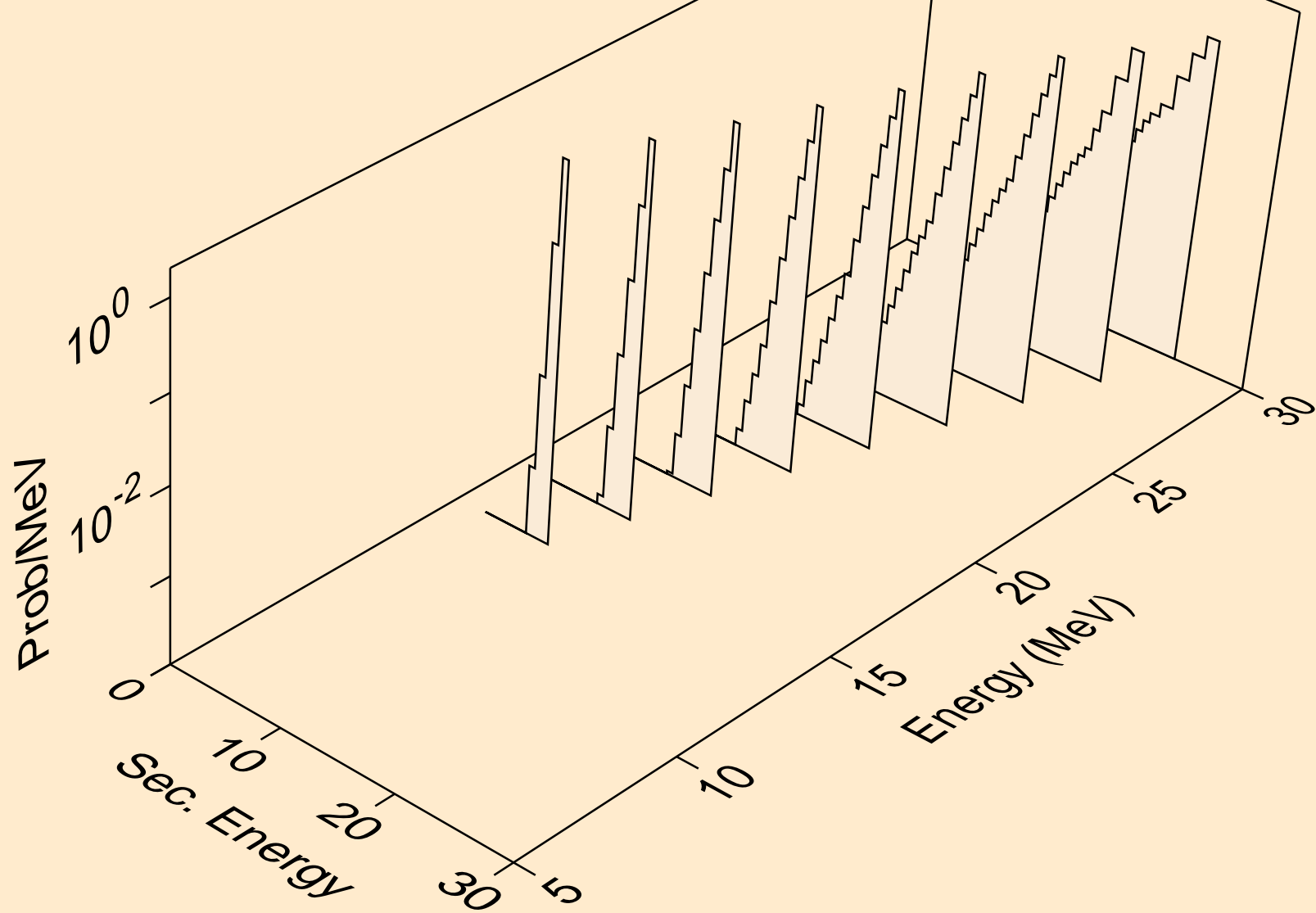

U227 PHOTON ACER TENDL-2023 LIBRARY; T=0.K
alphas from (g,x)

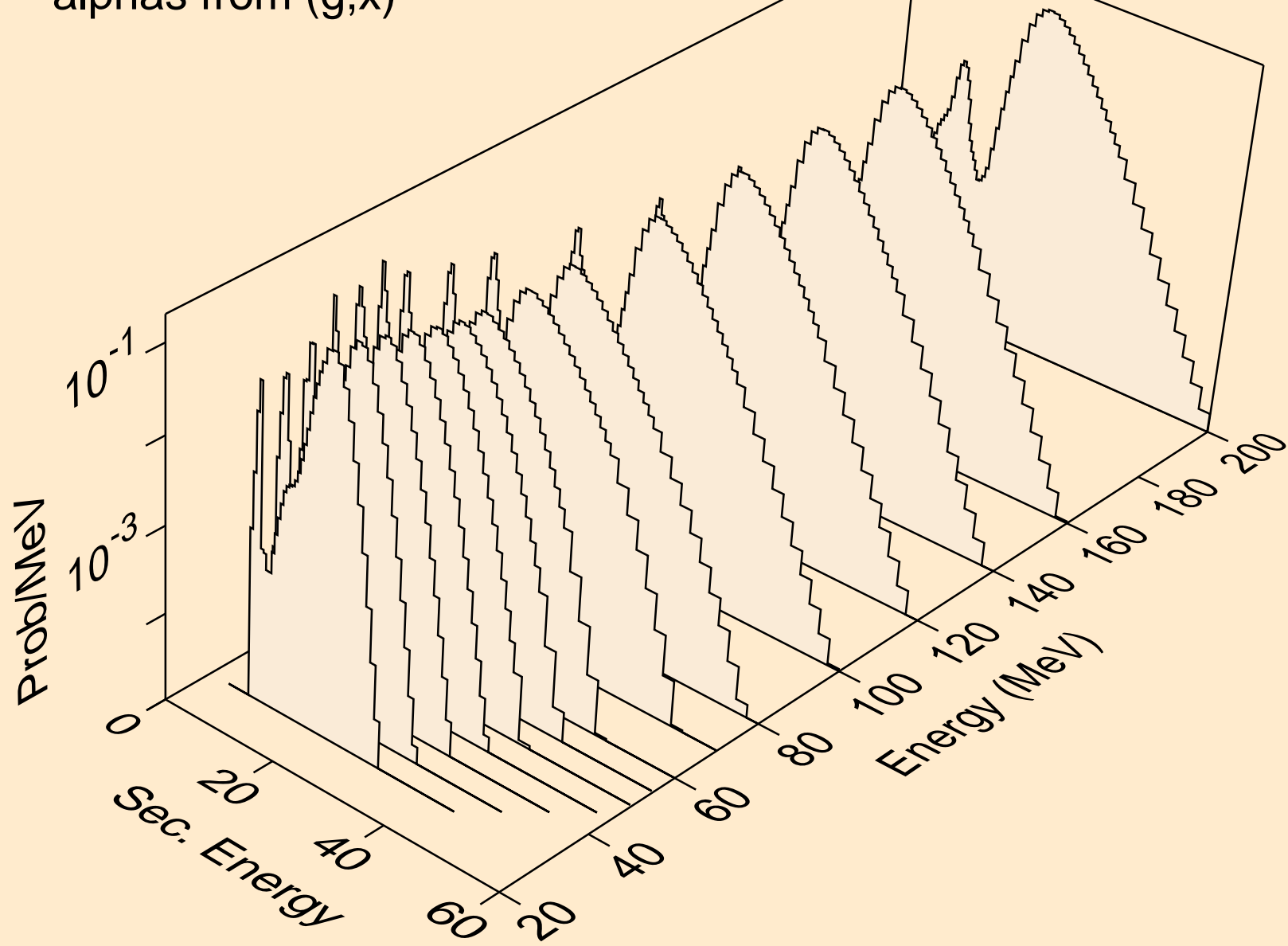

U227 PHOTON ACER TENDL-2023 LIBRARY; T=0.K
alphas from (g,n*)a

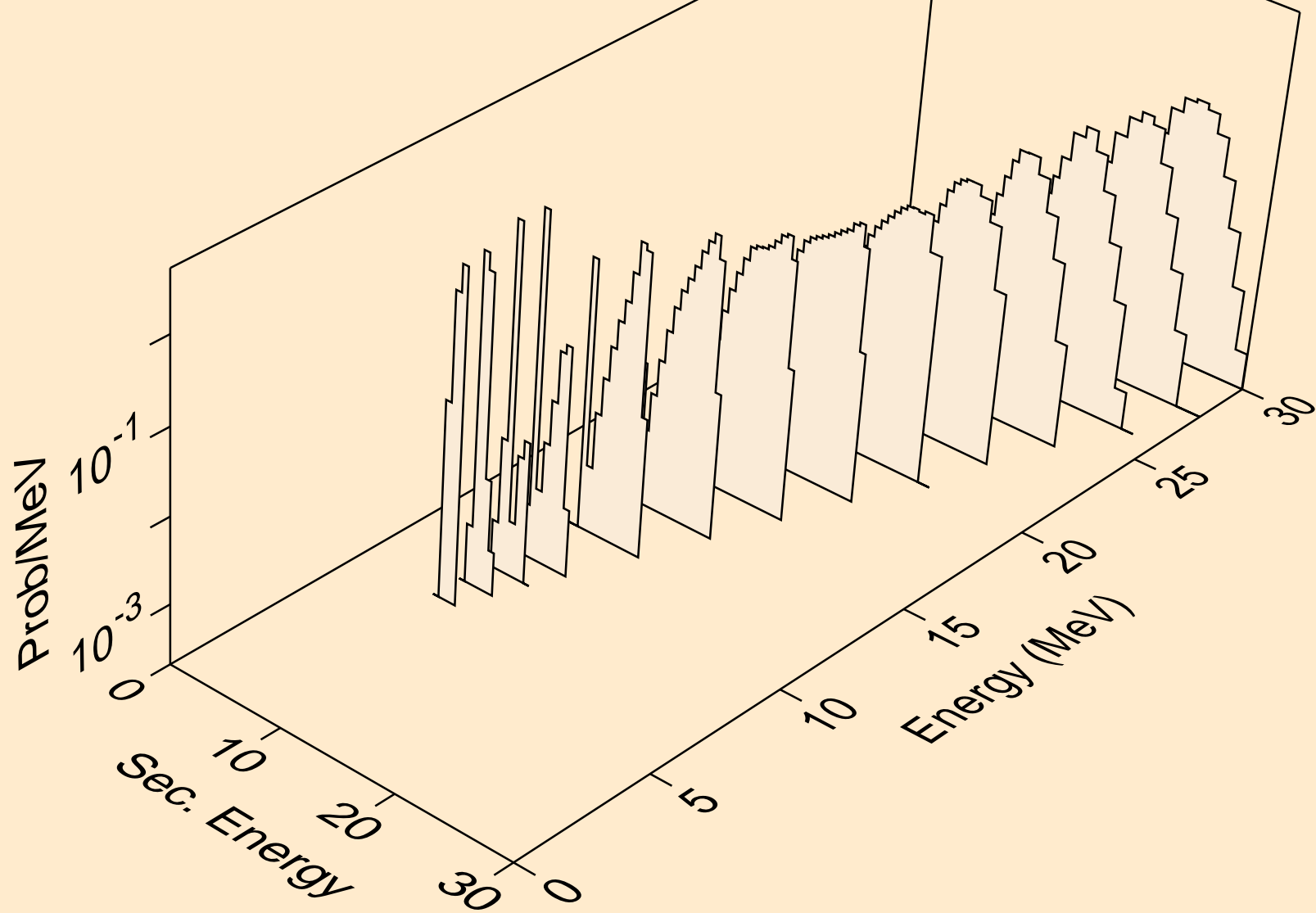

U227 PHOTON ACER TENDL-2023 LIBRARY; T=0.K
alphas from (g,2n)a

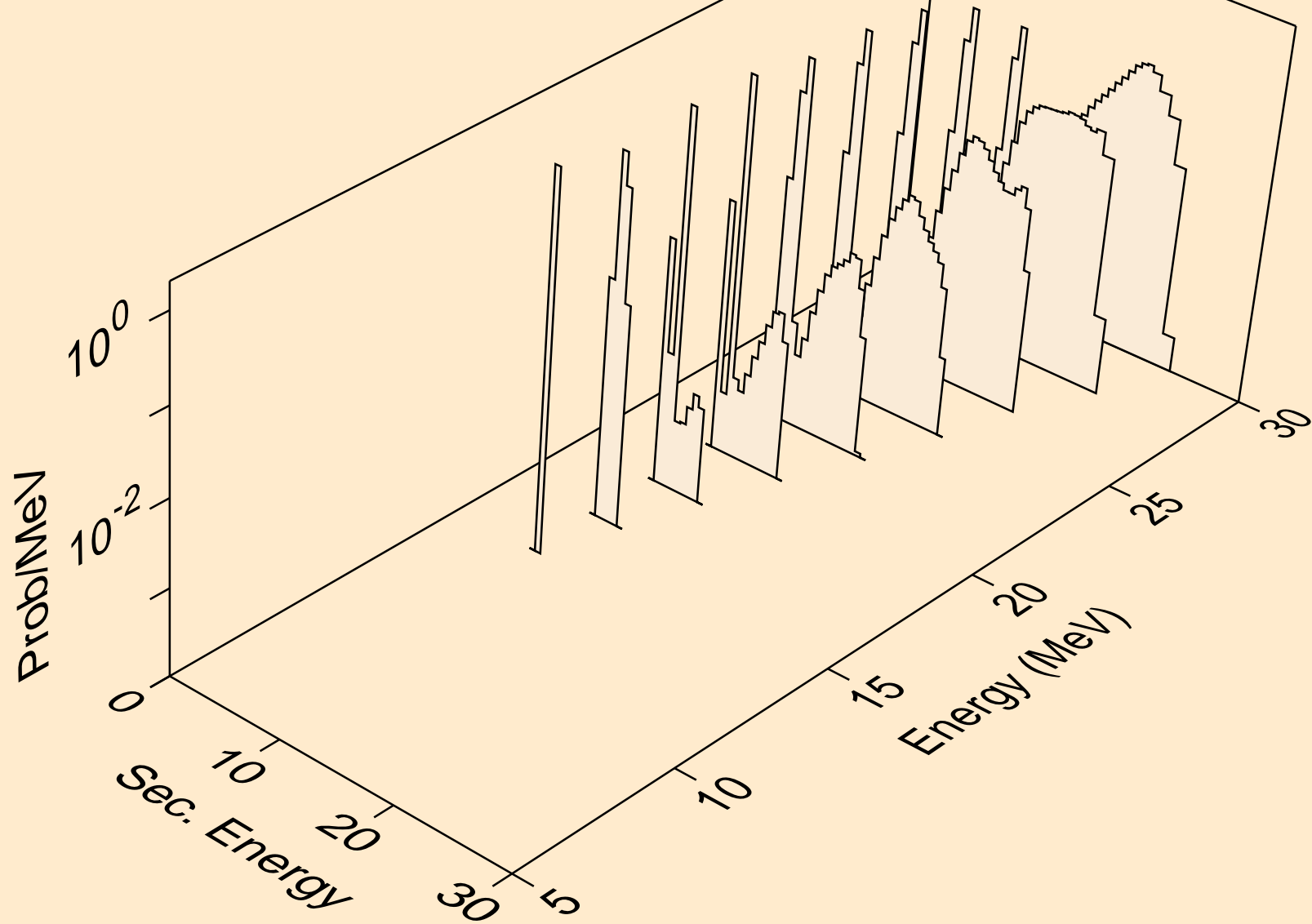

U227 PHOTON ACER TENDL-2023 LIBRARY; T=0.K
alphas from (g,3n)a

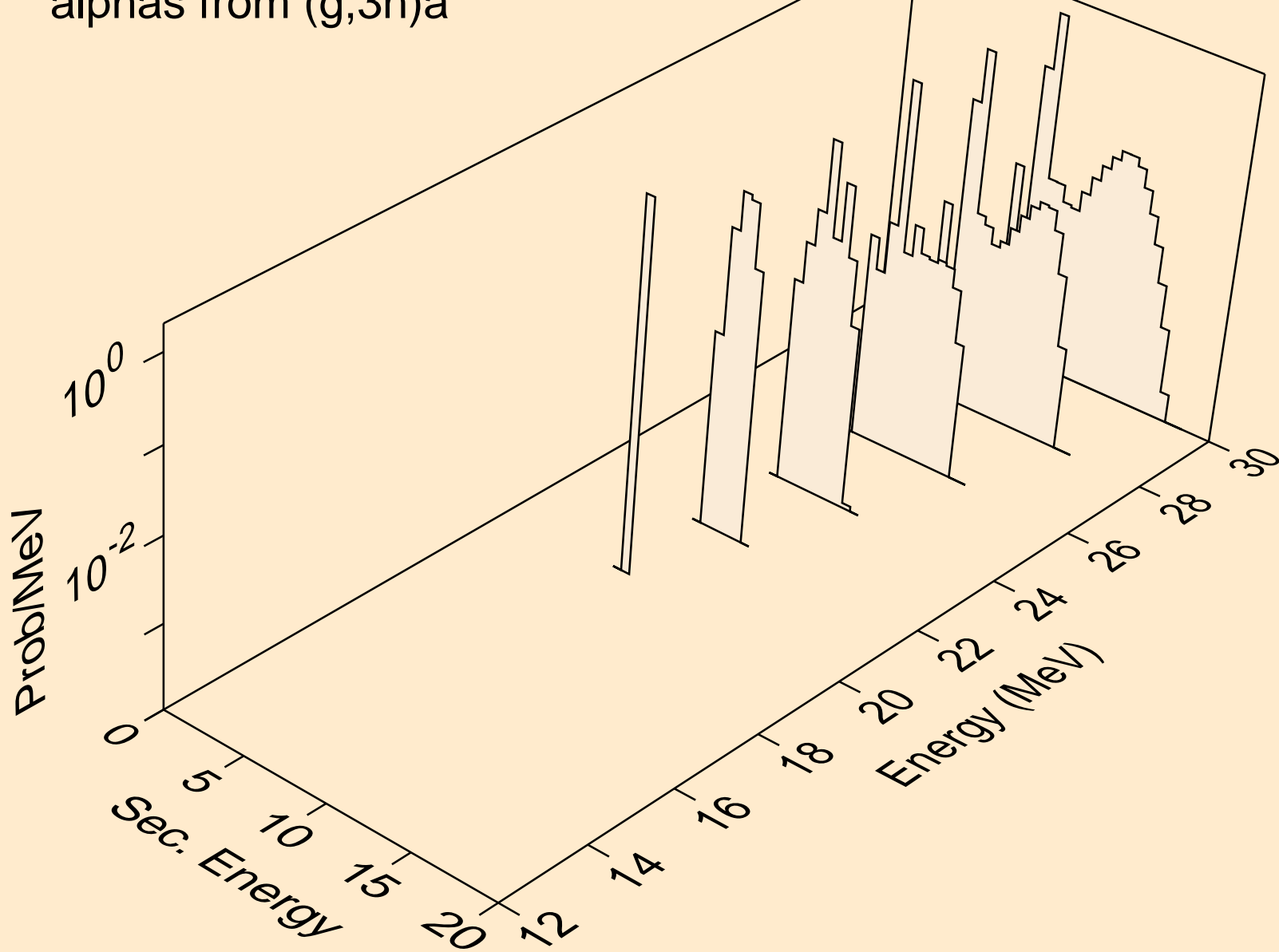

U227 PHOTON ACER TENDL-2023 LIBRARY; T=0.K
alphas from (g,n*)2a

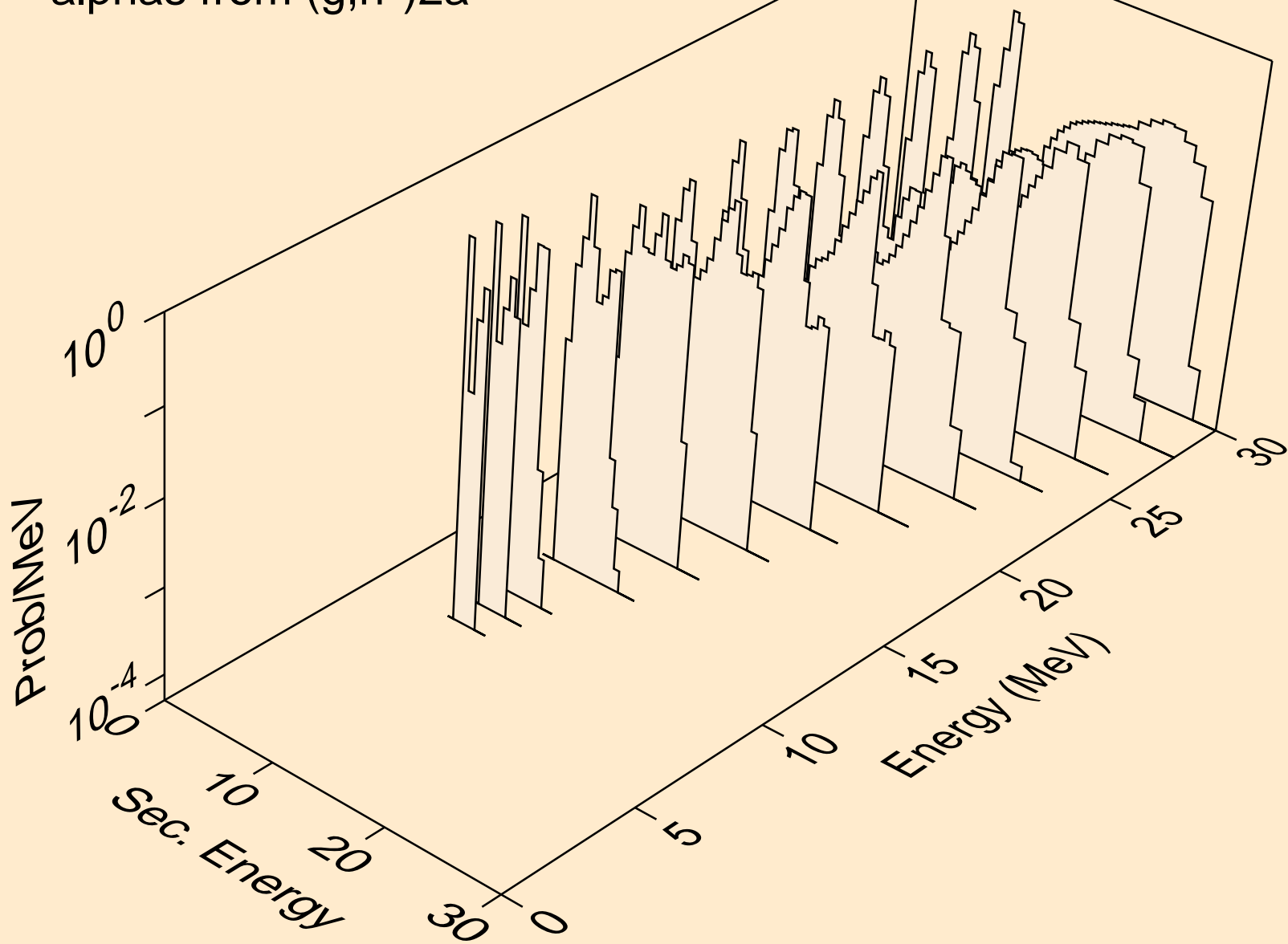

U227 PHOTON ACER TENDL-2023 LIBRARY; T=0.K
alphas from (g,2n)2a

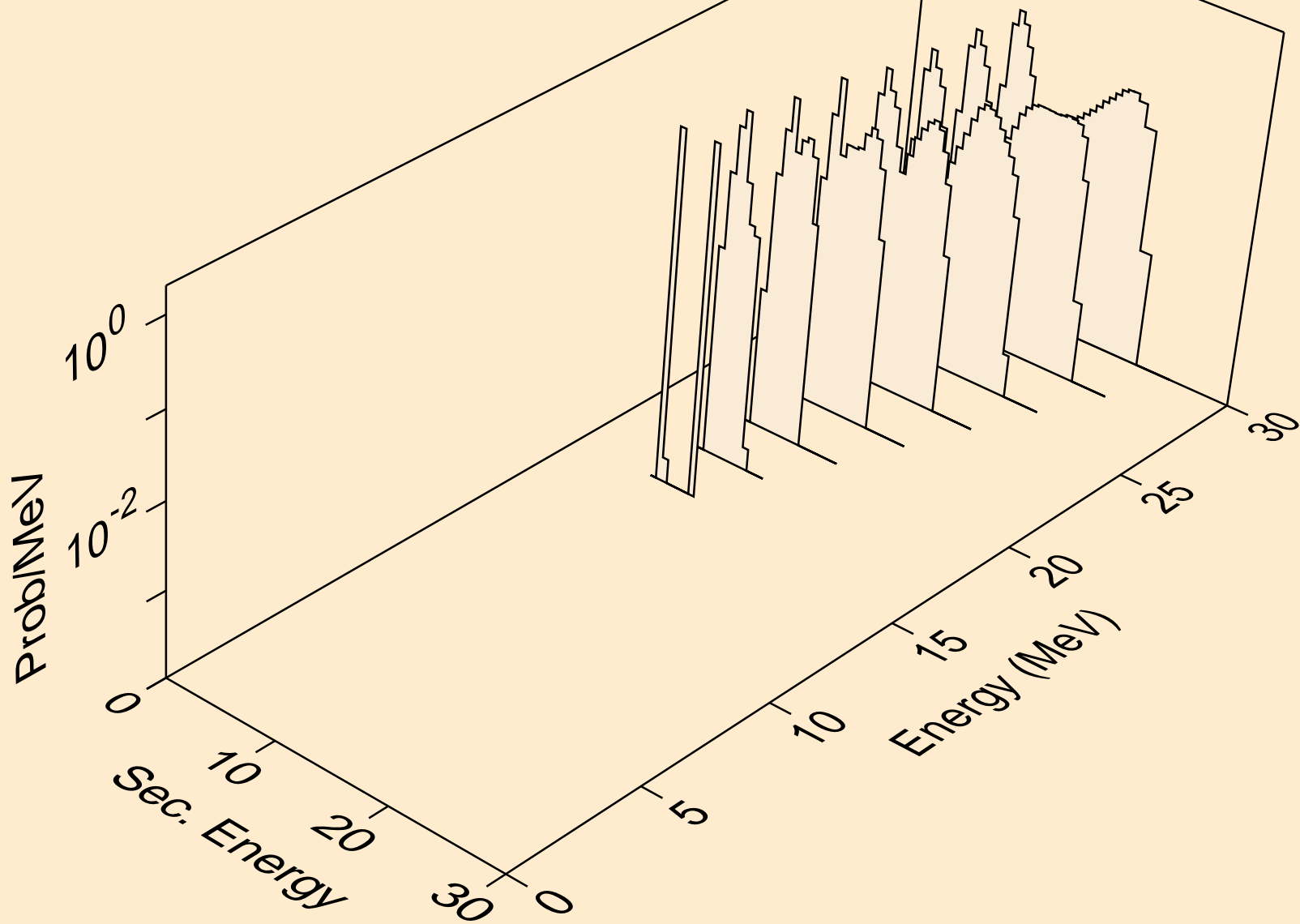

U227 PHOTON ACER TENDL-2023 LIBRARY; T=0.K
alphas from (g,npa)

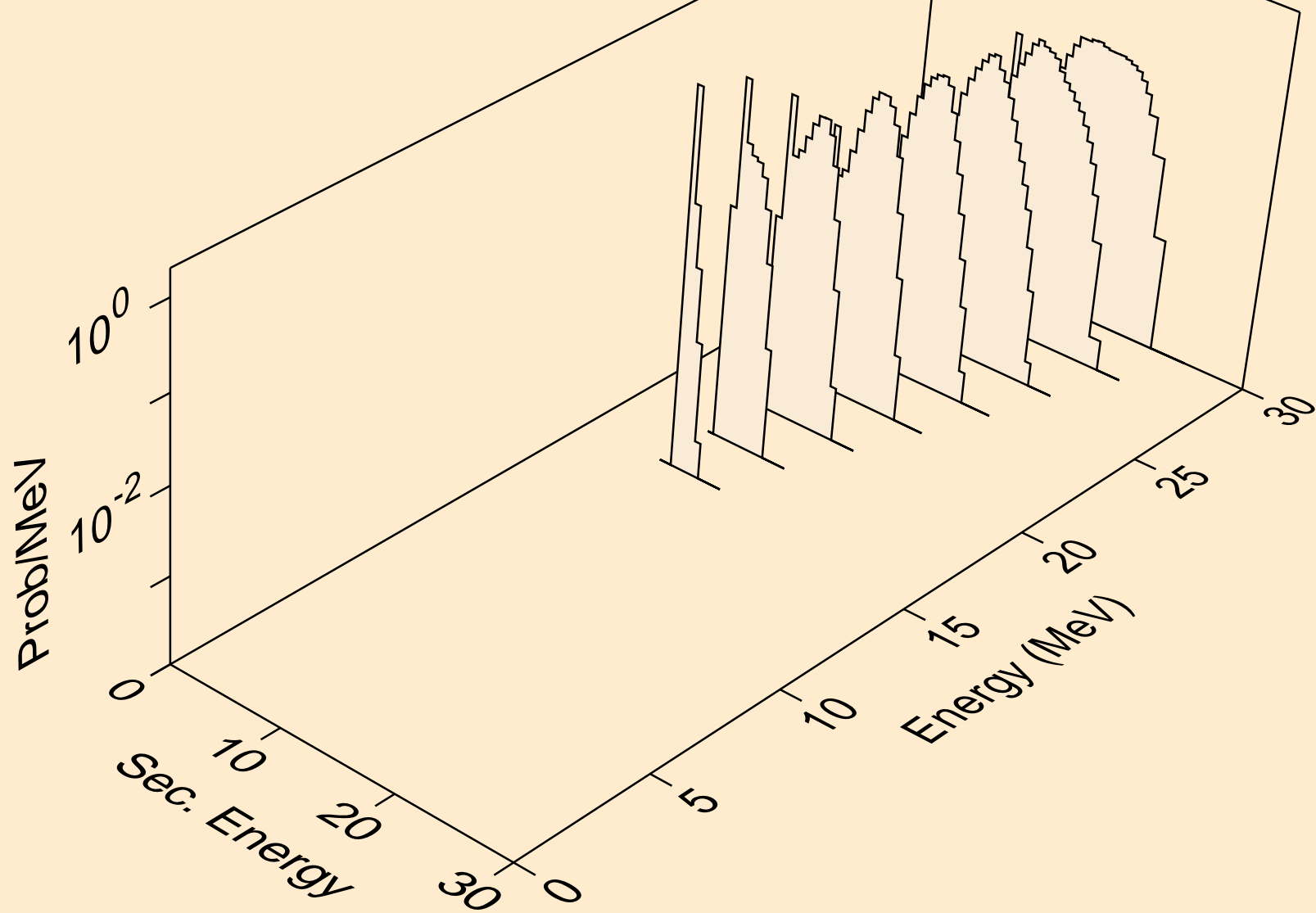

U227 PHOTON ACER TENDL-2023 LIBRARY; T=0.K
alphas from (g,a)

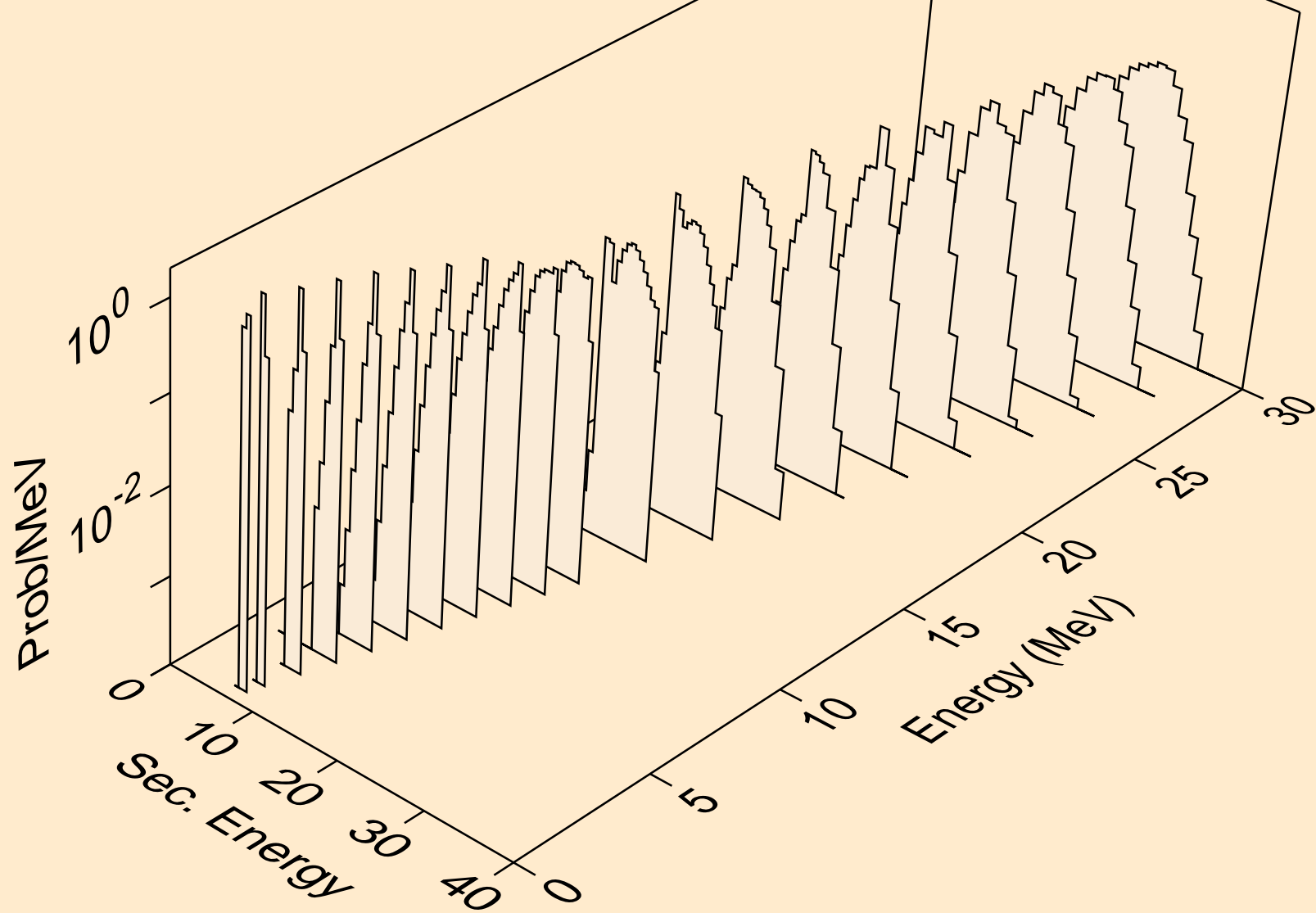

U227 PHOTON ACER TENDL-2023 LIBRARY; T=0.K
alphas from (g,2a)

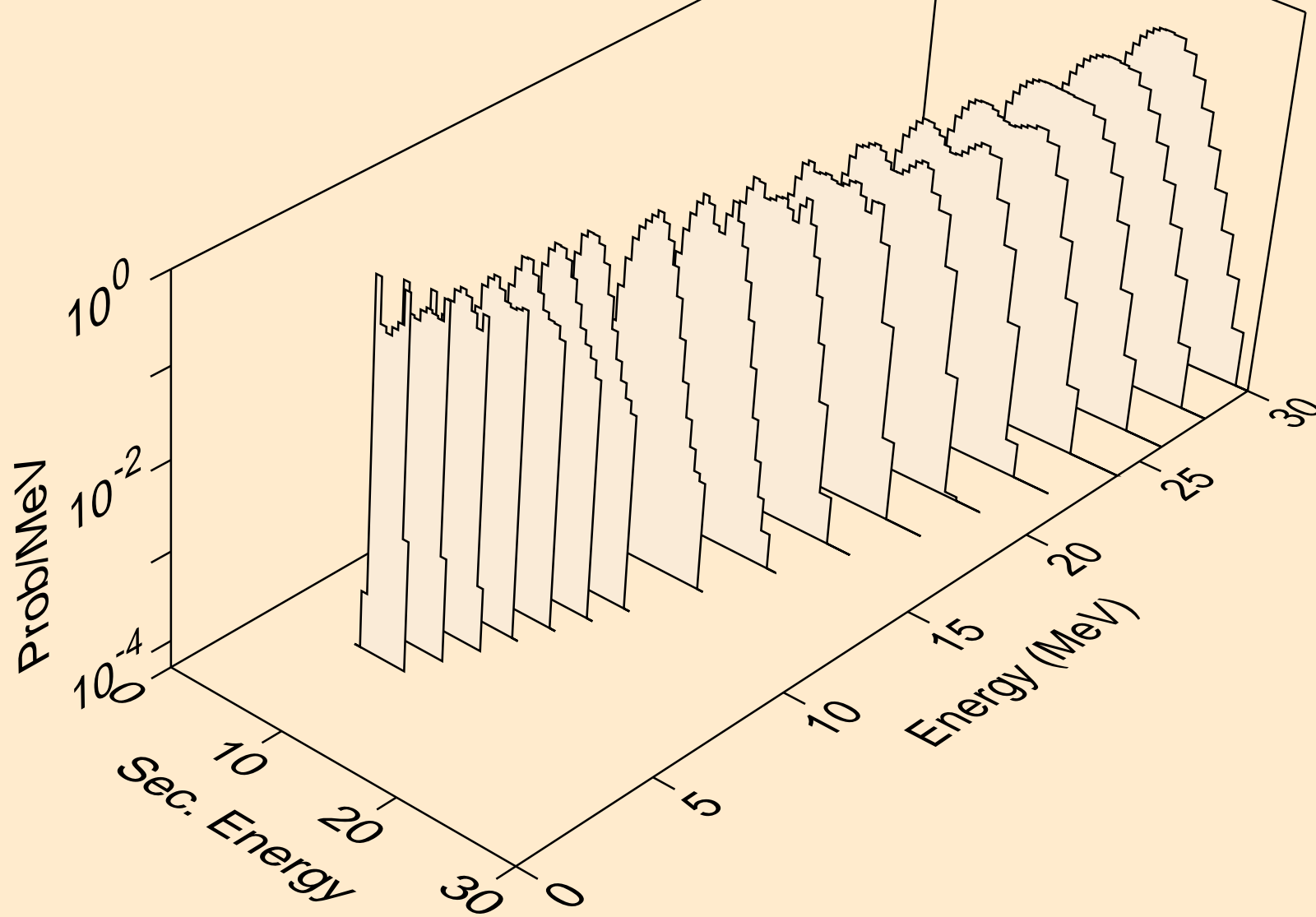

U227 PHOTON ACER TENDL-2023 LIBRARY; T=0.K
alphas from (g,pa)

