

# V049 PHOTON ACER TENDL-2023 LIBRARY; T=0.K

## Principal cross sections

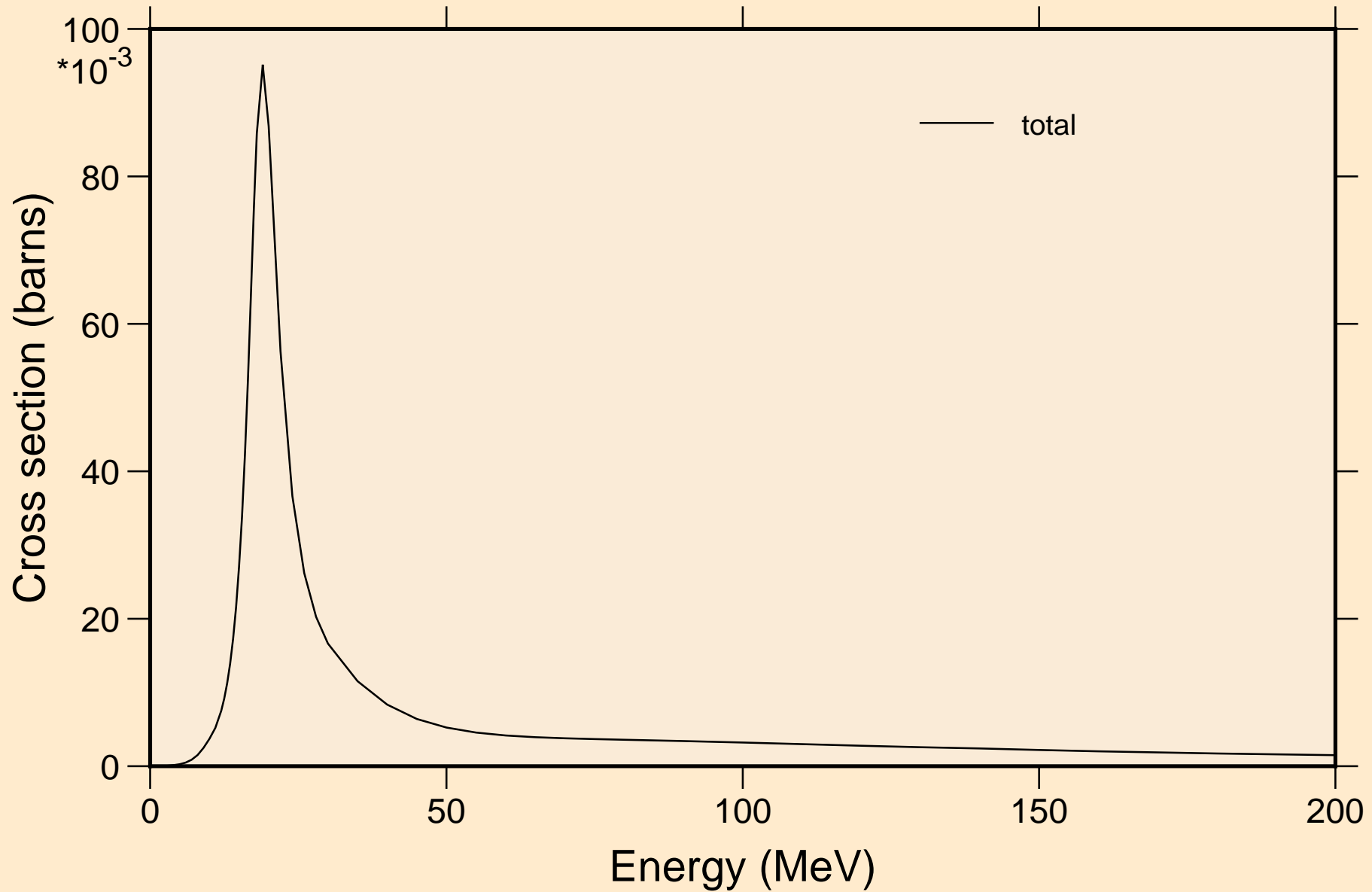

# V049 PHOTON ACER TENDL-2023 LIBRARY; T=0.K

## Partial cross sections

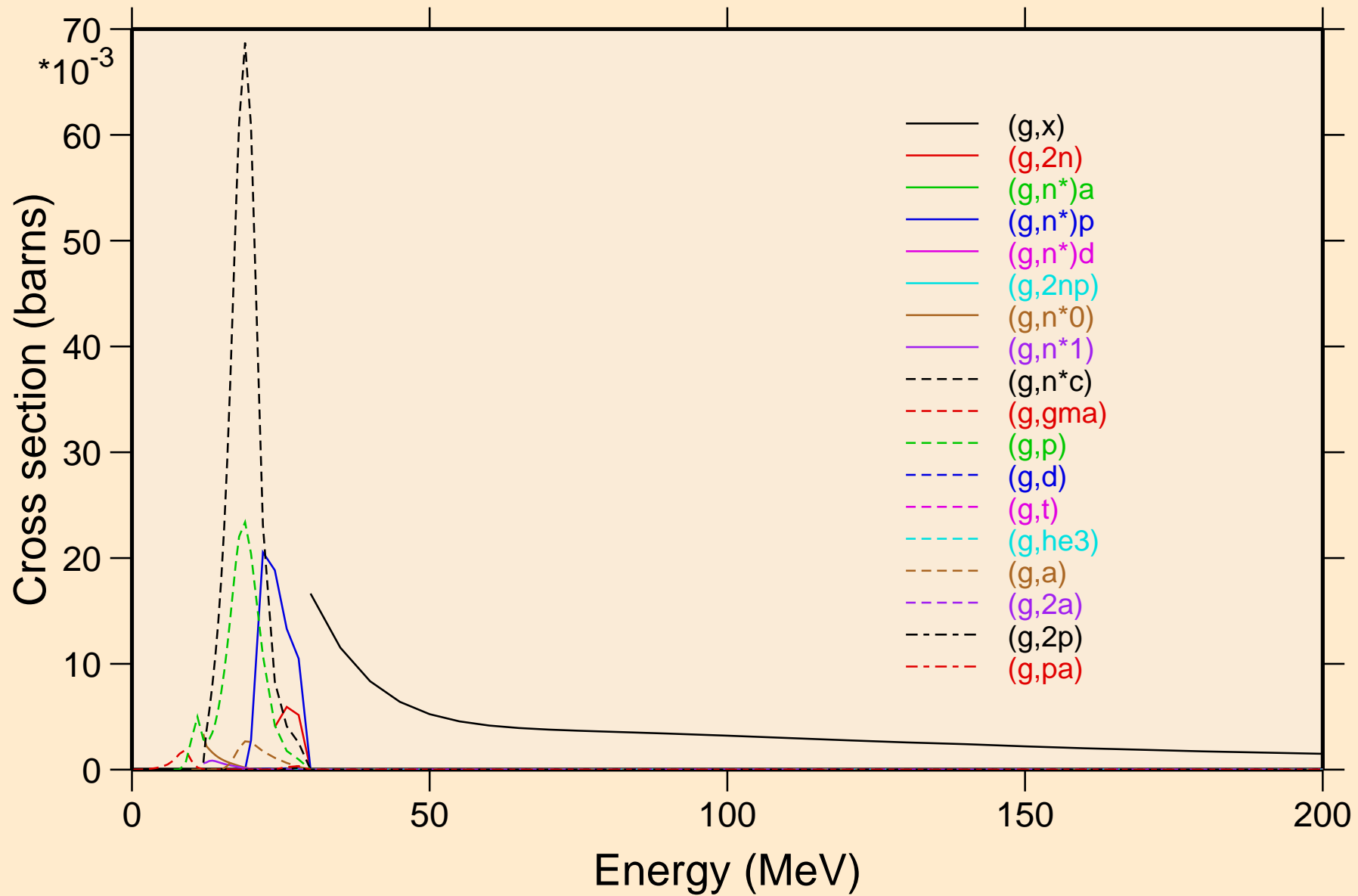

V049 PHOTON ACER TENDL-2023 LIBRARY; T=0.K

Heating

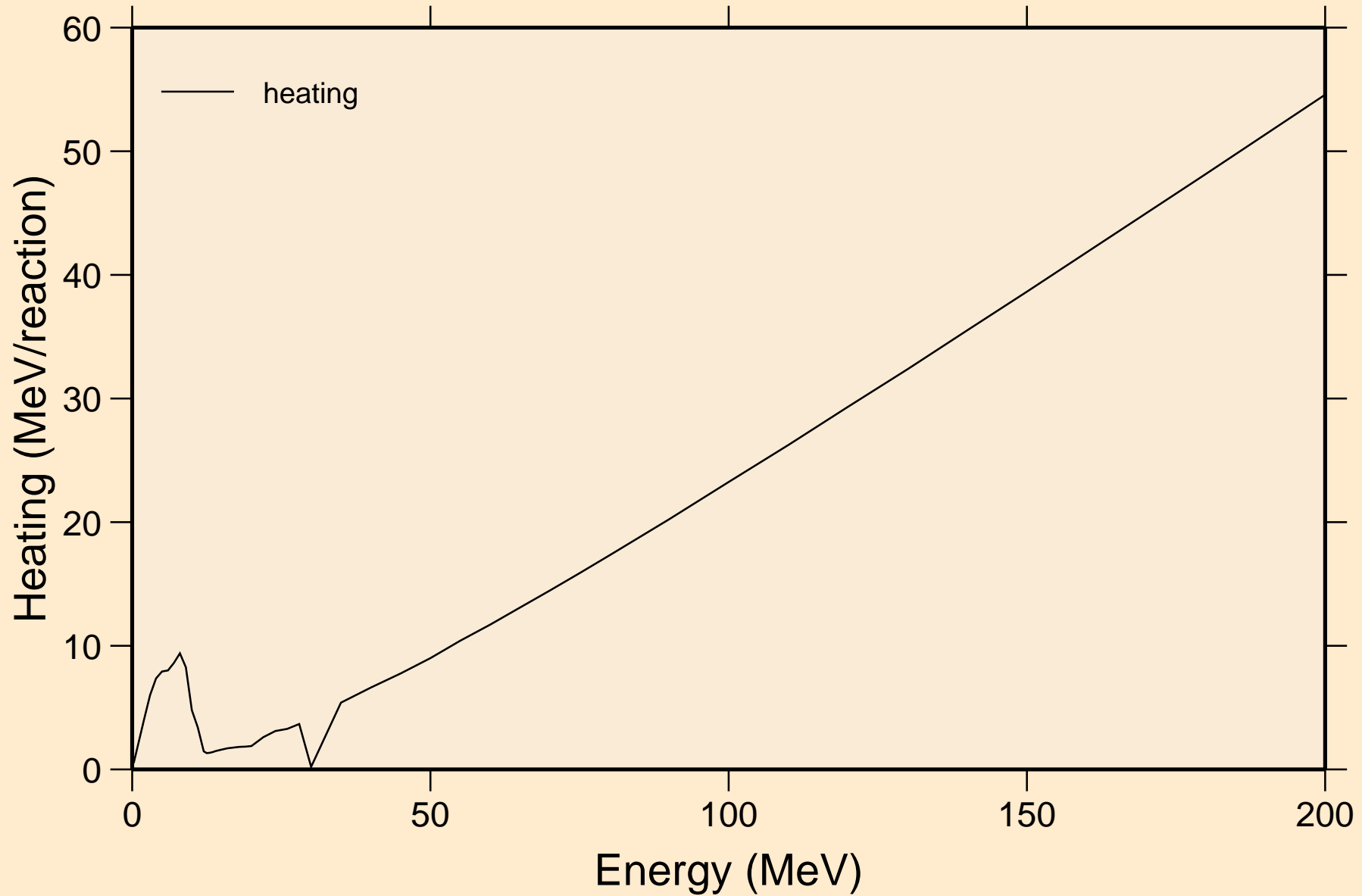

V049 PHOTON ACER TENDL-2023 LIBRARY; T=0.K  
Particle heating contributions

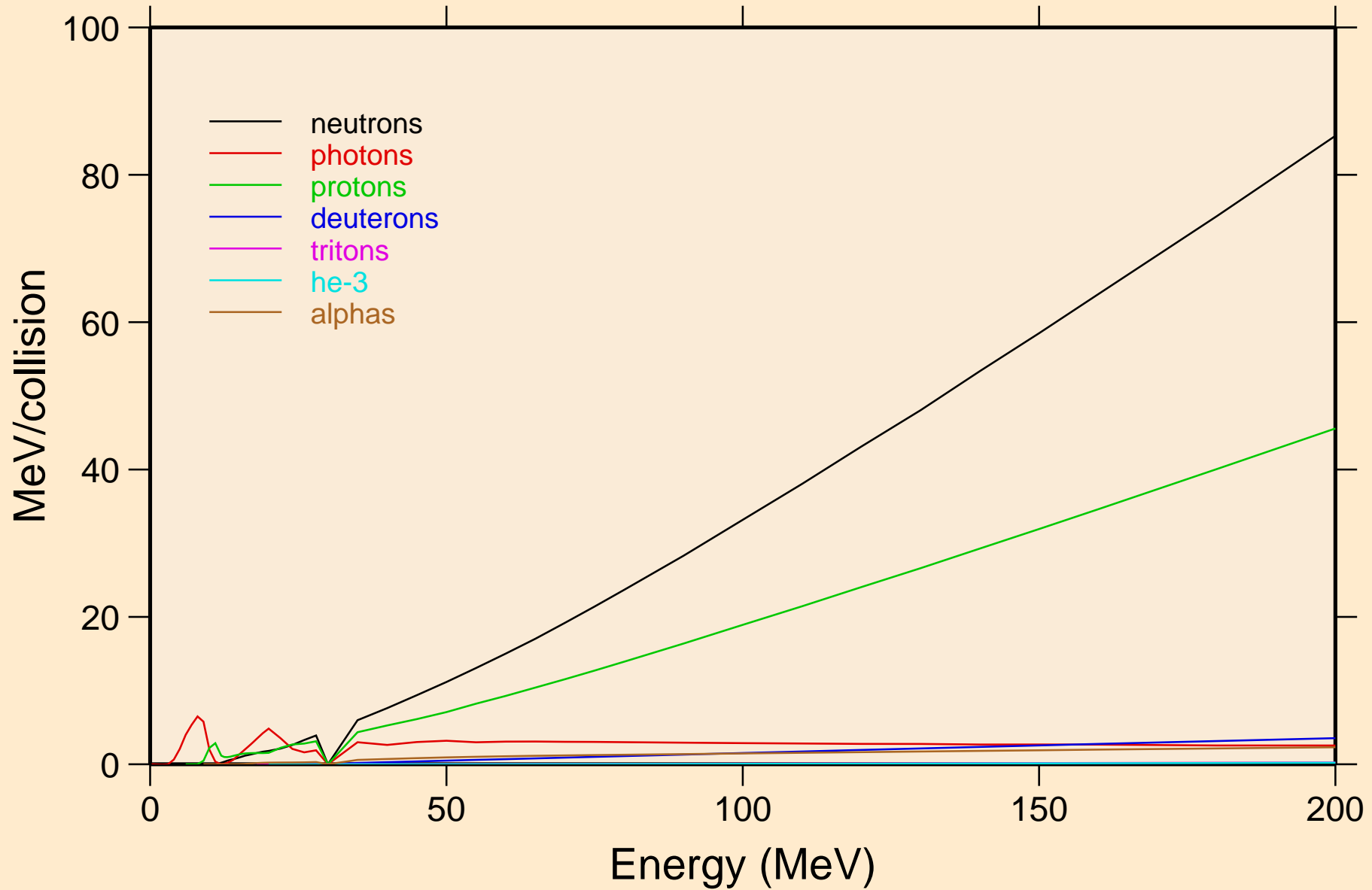

V049 PHOTON ACER TENDL-2023 LIBRARY; T=0.K  
Particle production cross sections

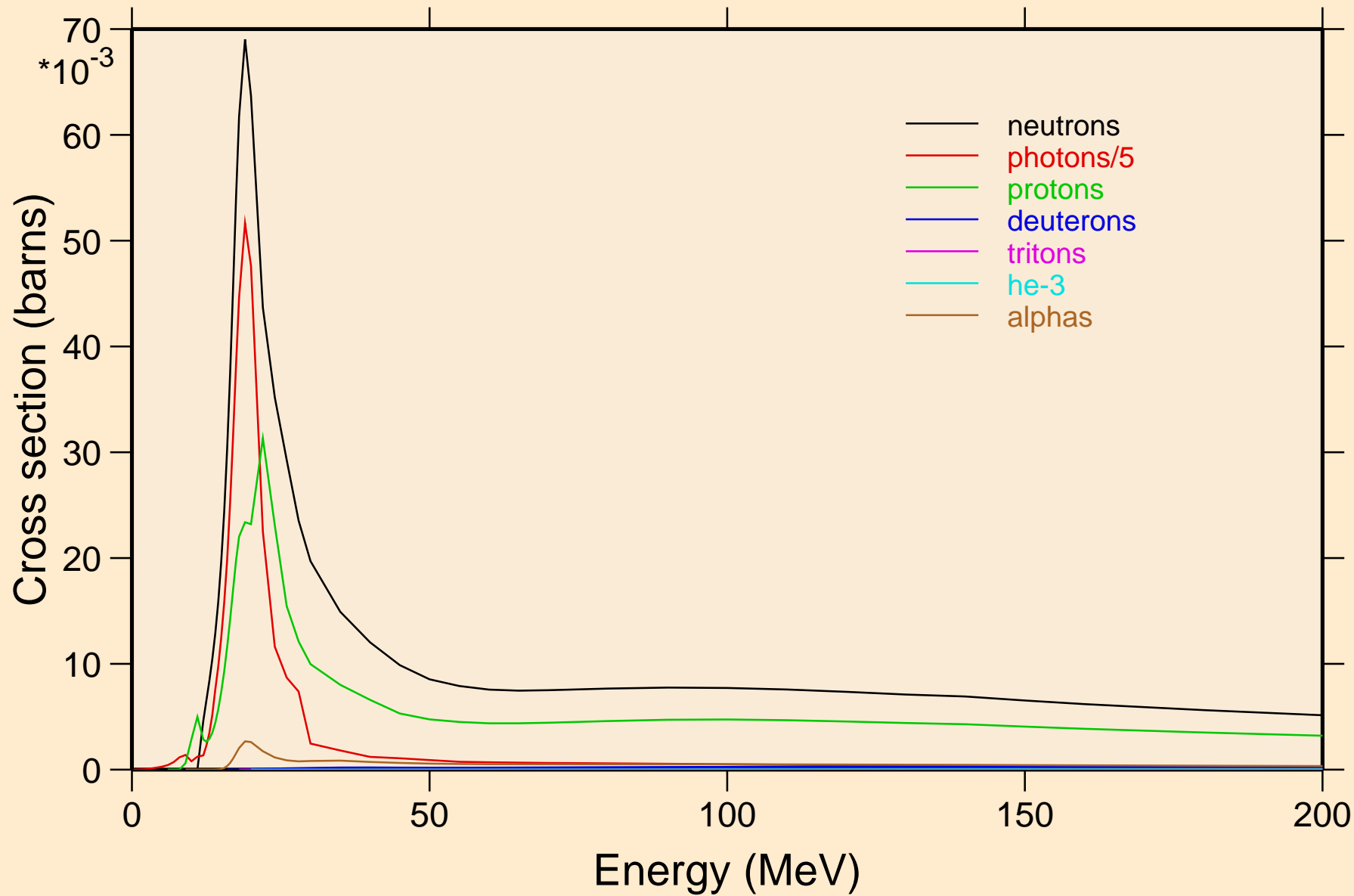

V049 PHOTON ACER TENDL-2023 LIBRARY; T=0.K  
neutrons from (g,x)

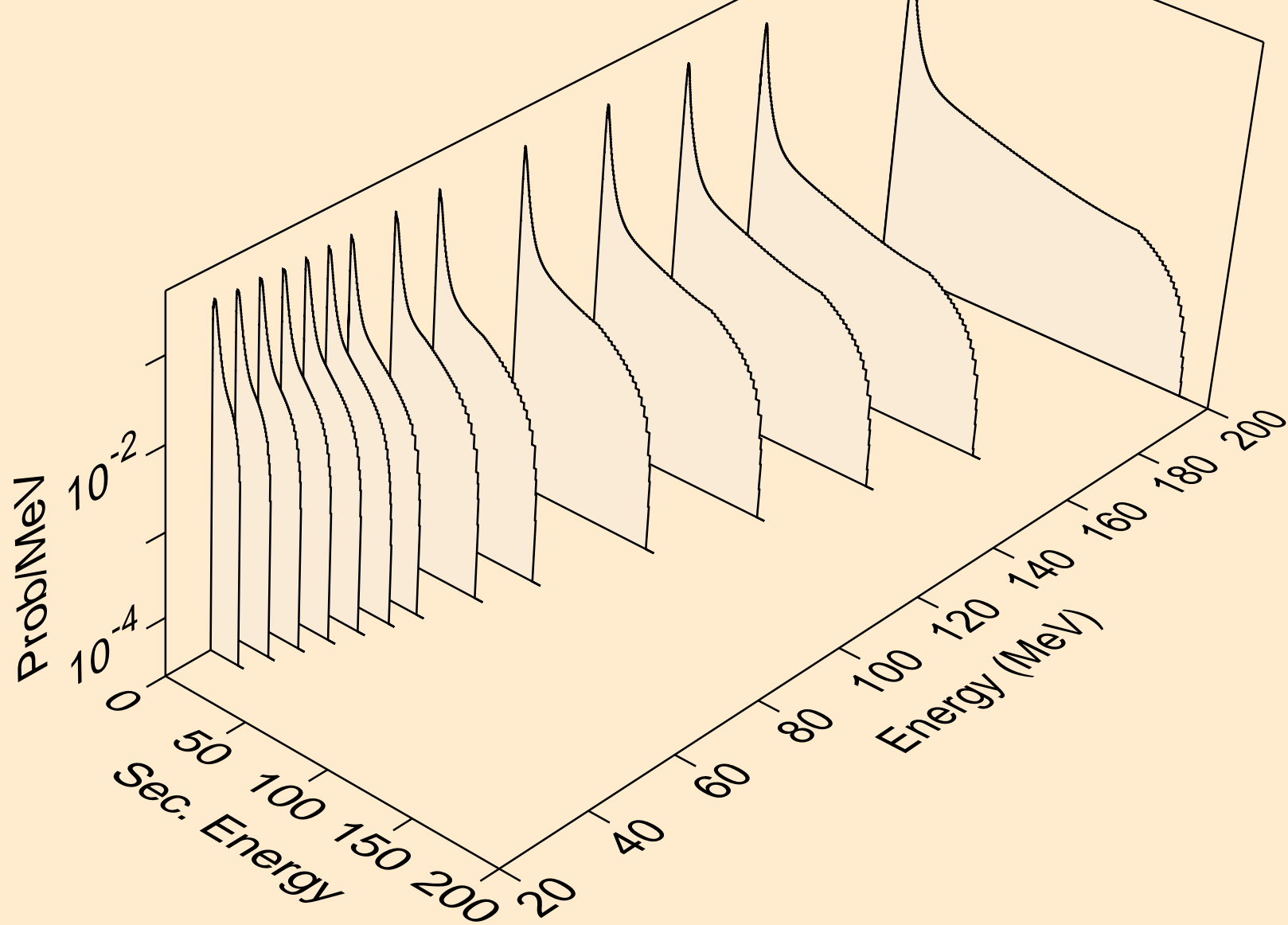

V049 PHOTON ACER TENDL-2023 LIBRARY; T=0.K  
neutrons from (g,2n)

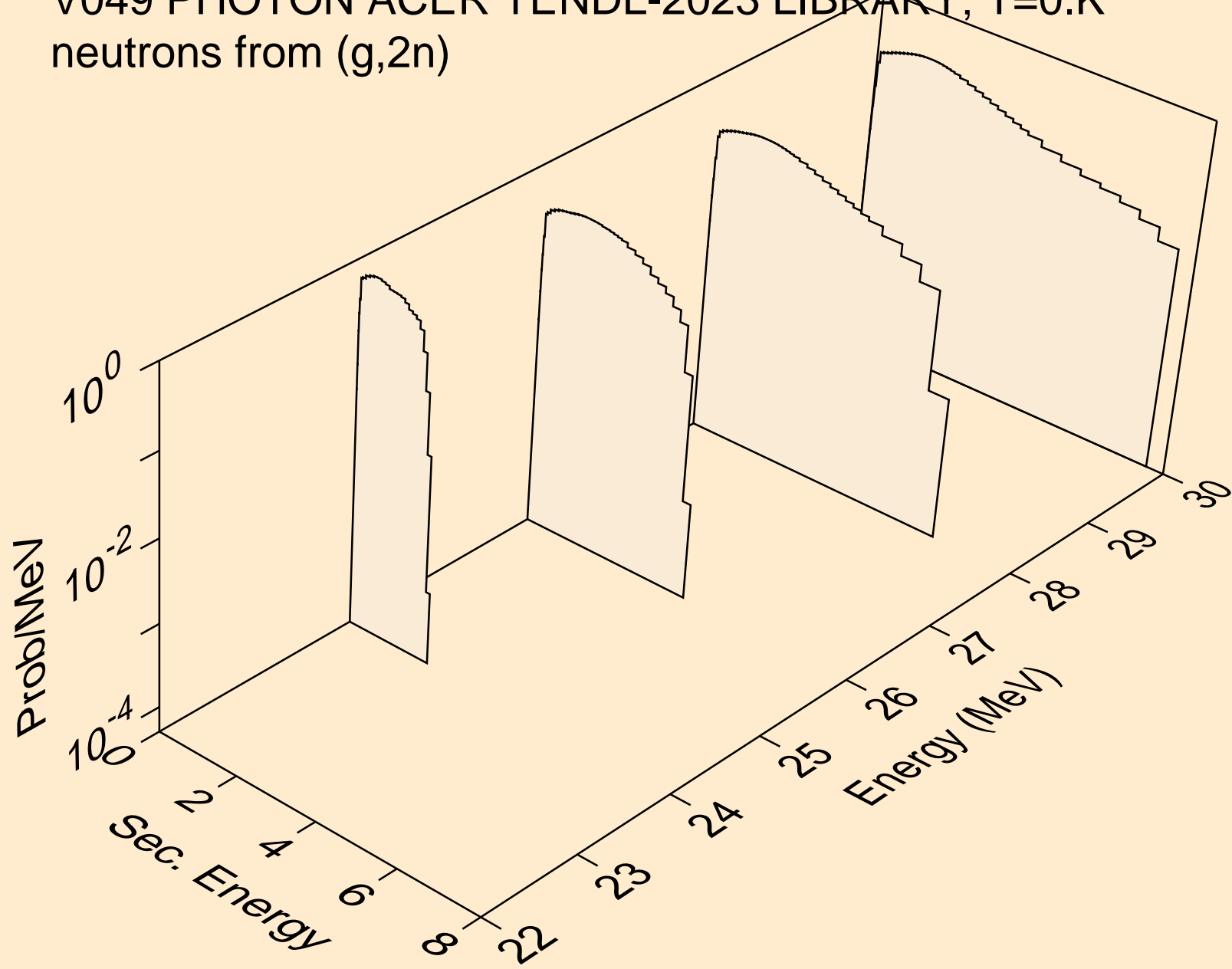

V049 PHOTON ACER TENDL-2023 LIBRARY; T=0.K  
neutrons from (g,n\*)a

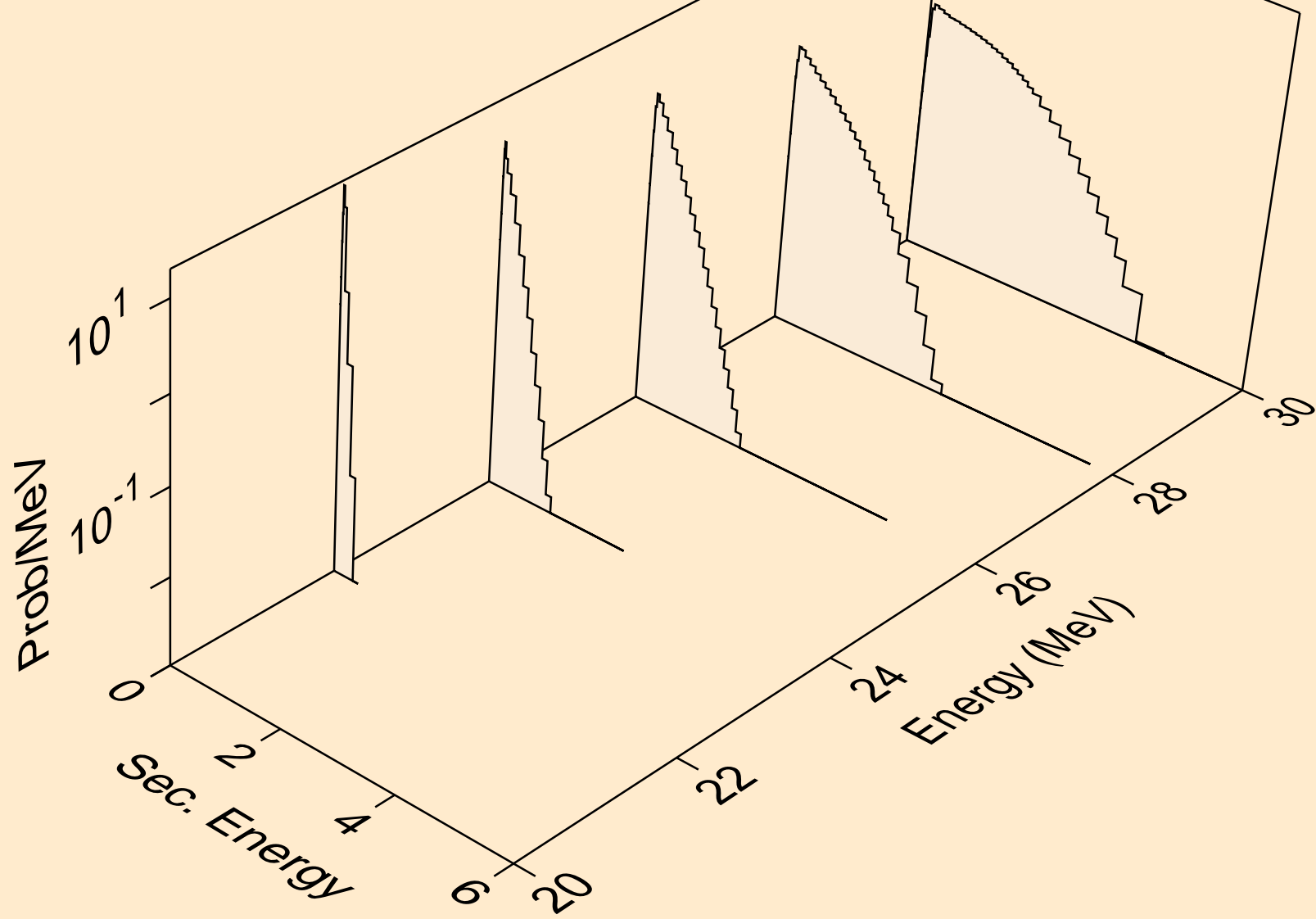



V049 PHOTON ACER TENDL-2023 LIBRARY; T=0.K  
neutrons from (g,n\*)p

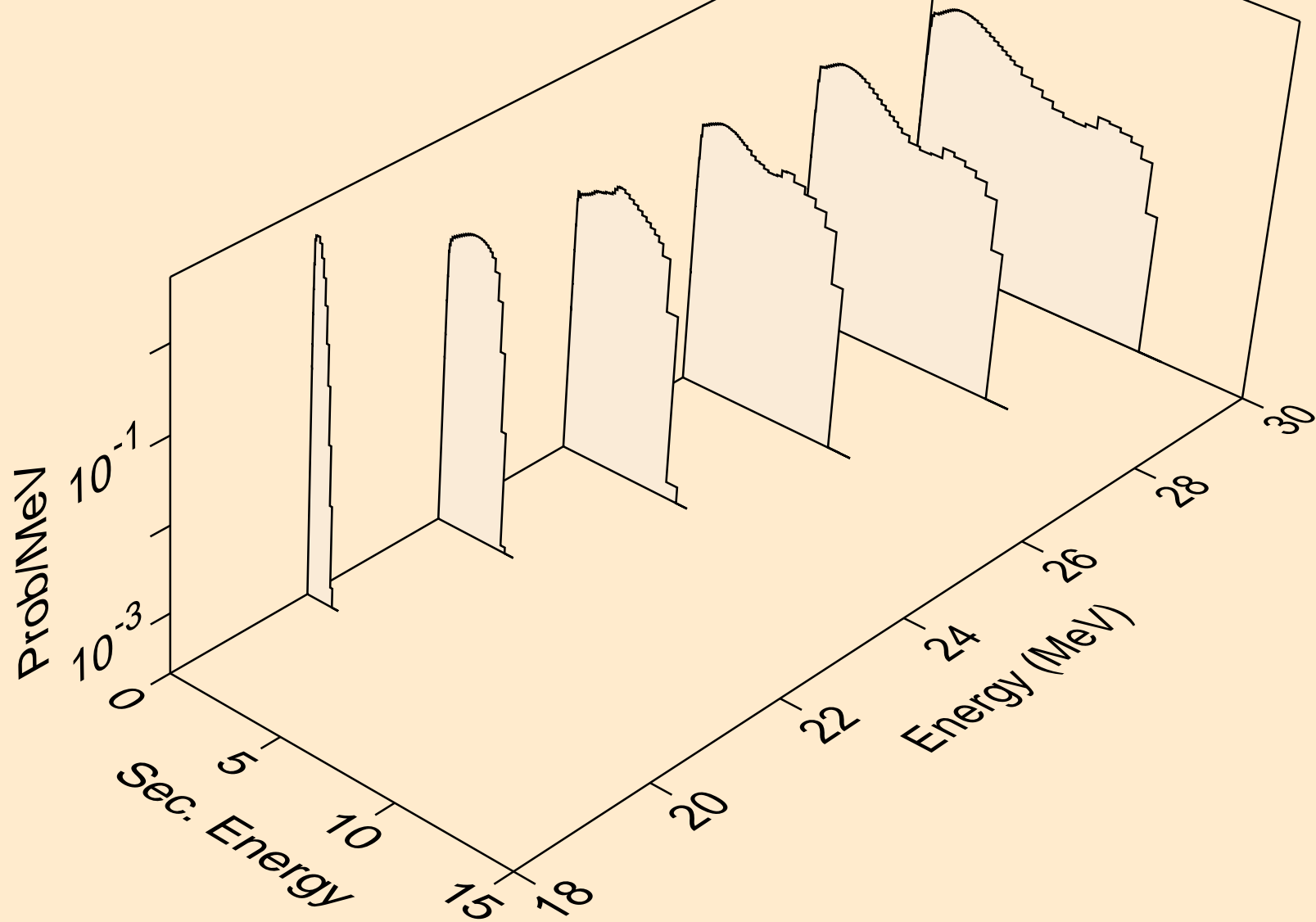

V049 PHOTON ACER TENDL-2023 LIBRARY; T=0.K  
neutrons from (g,n\*)d

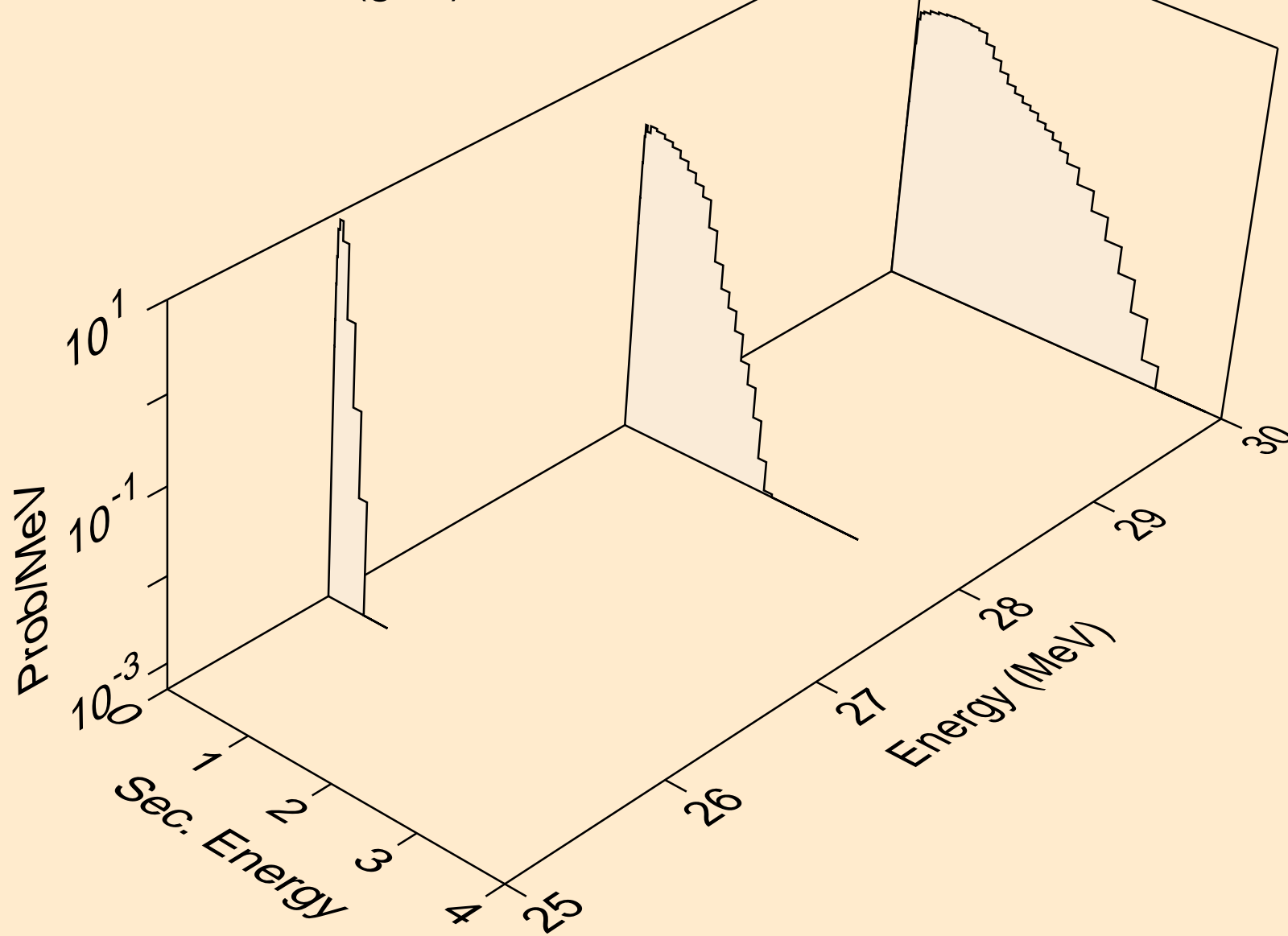

V049 PHOTON ACER TENDL-2023 LIBRARY; T=0.K  
neutrons from (g,2np)

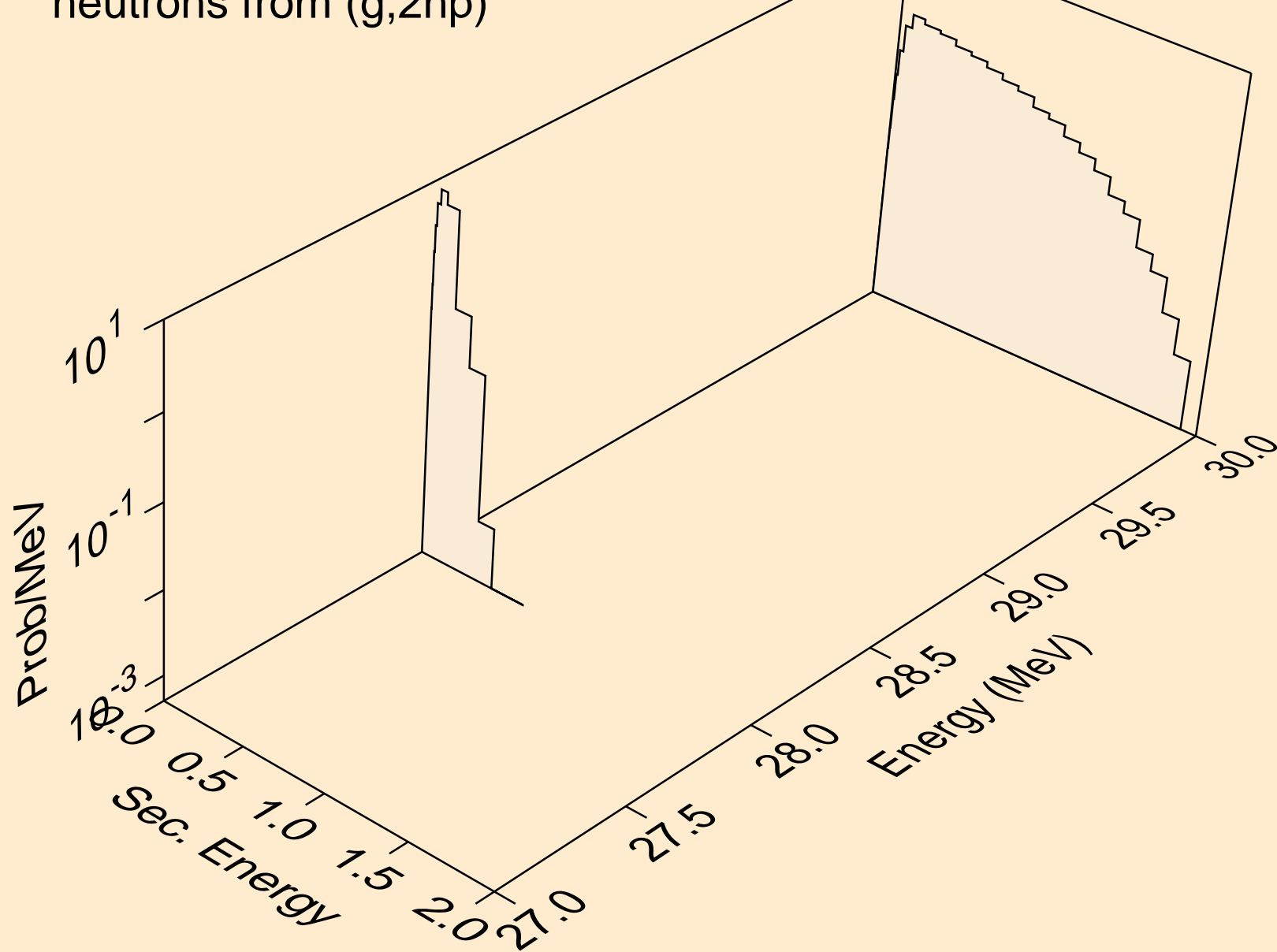

V049 PHOTON ACER TENDL-2023 LIBRARY; T=0.K  
angular distribution for (g,n\*0) neutron

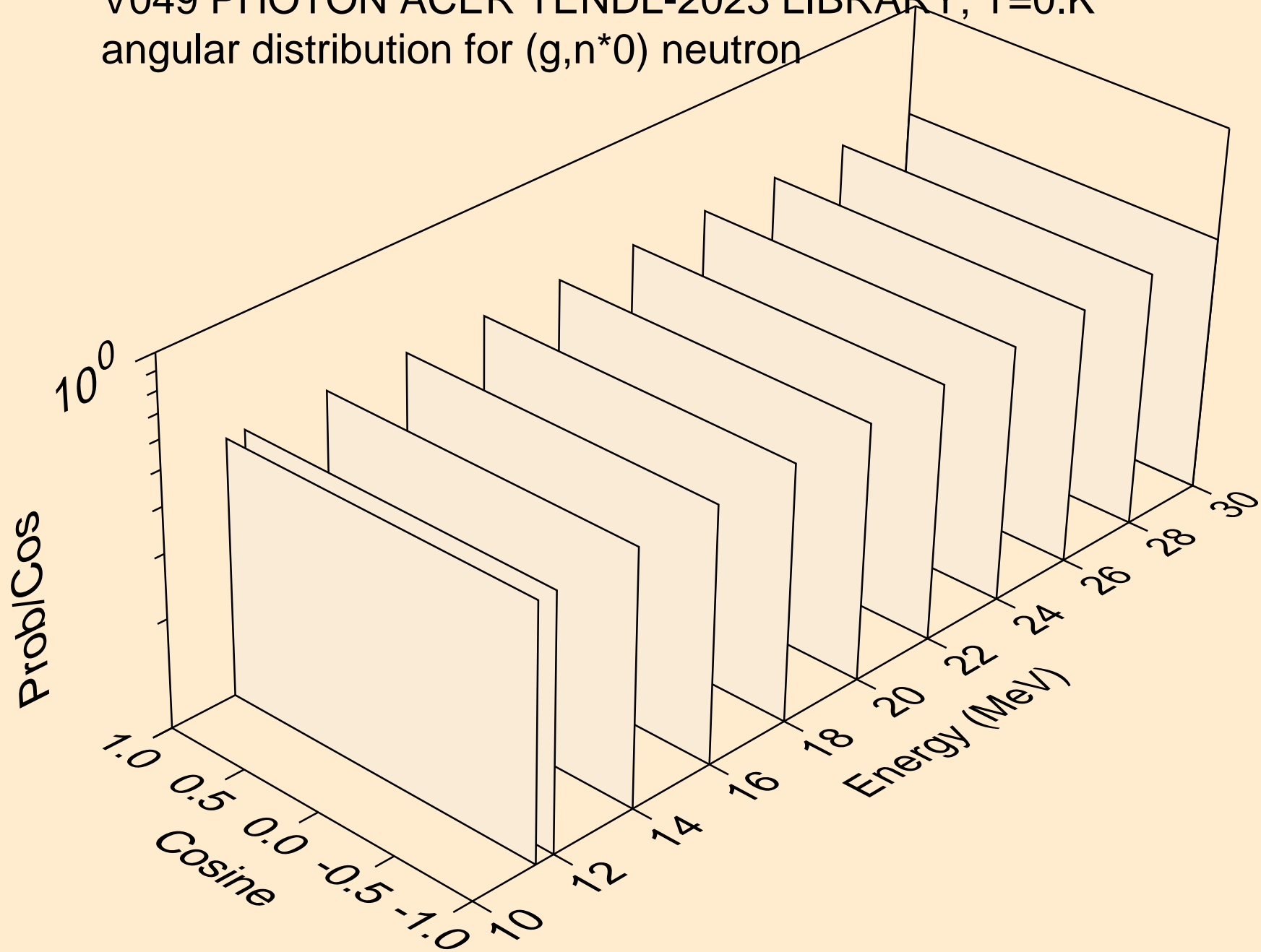

V049 PHOTON ACER TENDL-2023 LIBRARY; T=0.K  
angular distribution for (g,n\*1) neutron

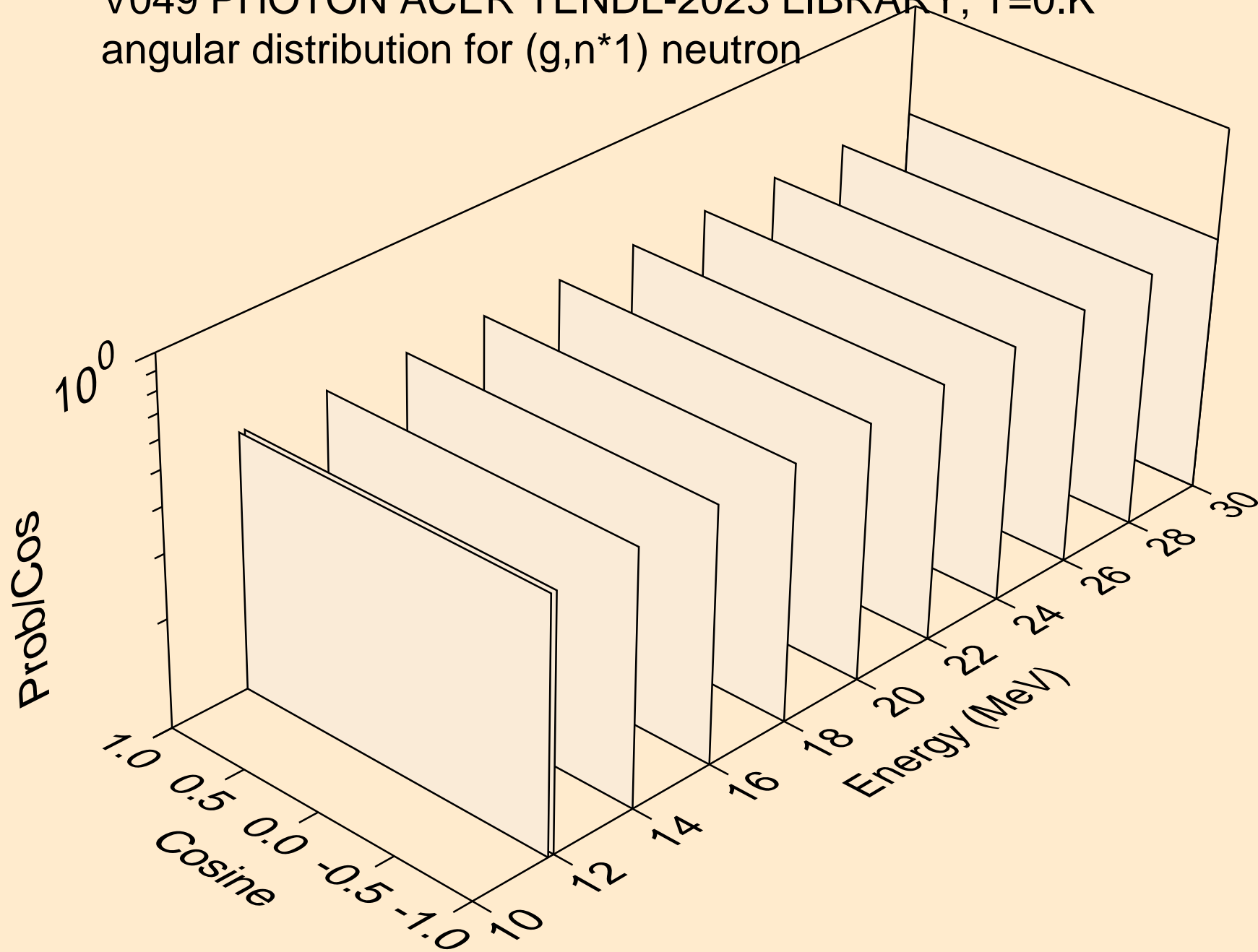

V049 PHOTON ACER TENDL-2023 LIBRARY; T=0.K  
neutrons from (g,n\*c)

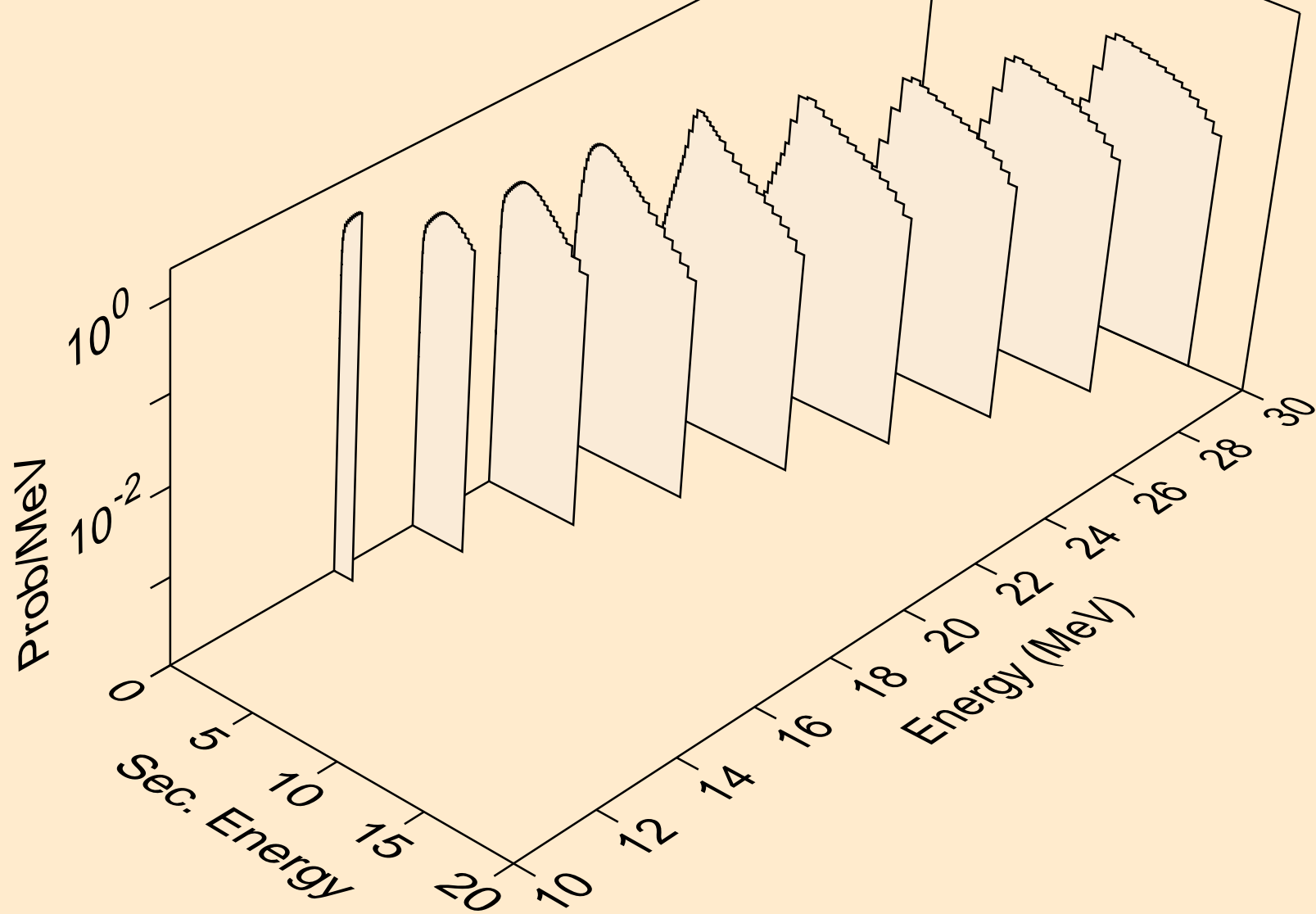

V049 PHOTON ACER TENDL-2023 LIBRARY; T=0.K  
photons from (g,x)

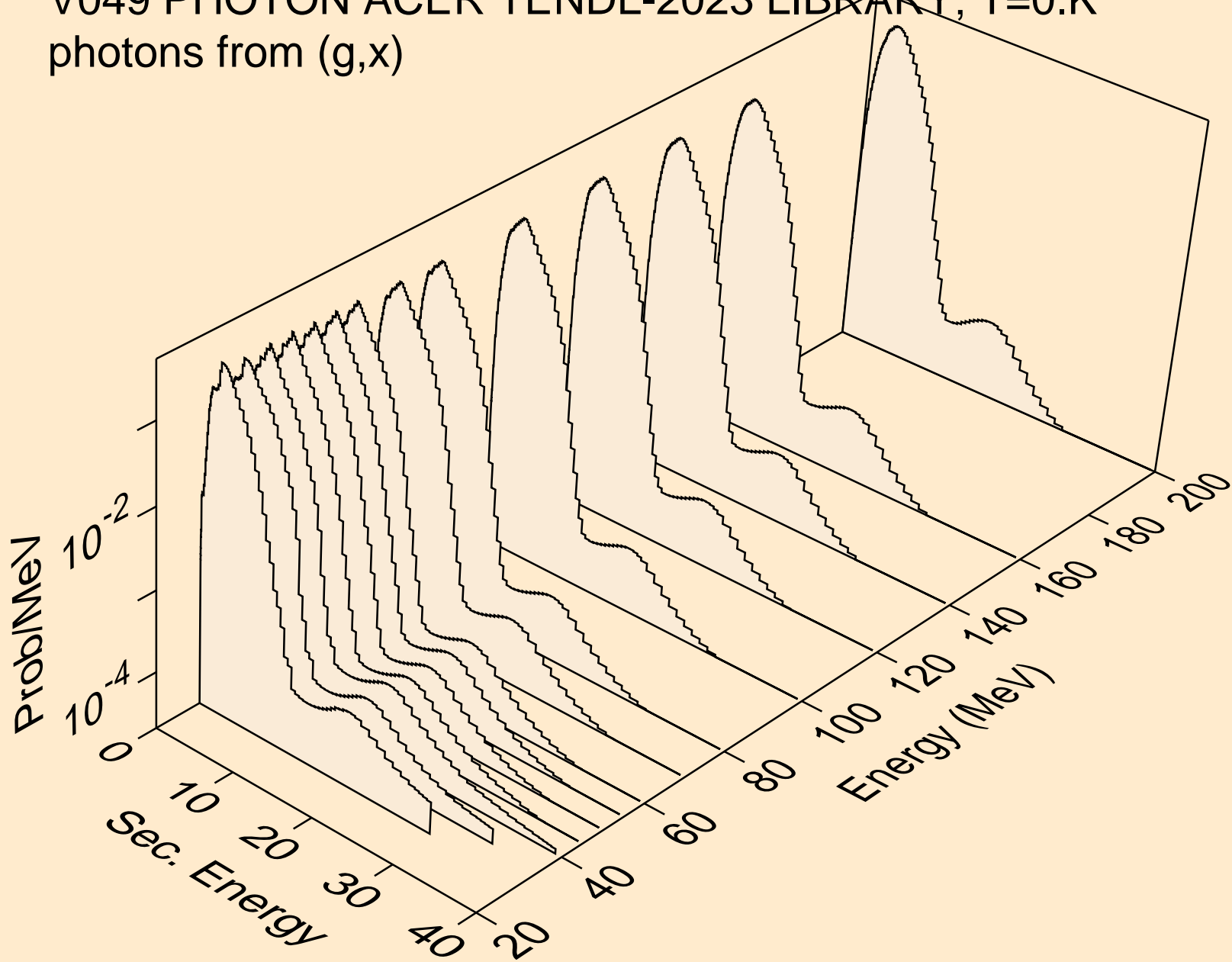

V049 PHOTON ACER TENDL-2023 LIBRARY; T=0.K  
photons from (g,2n)

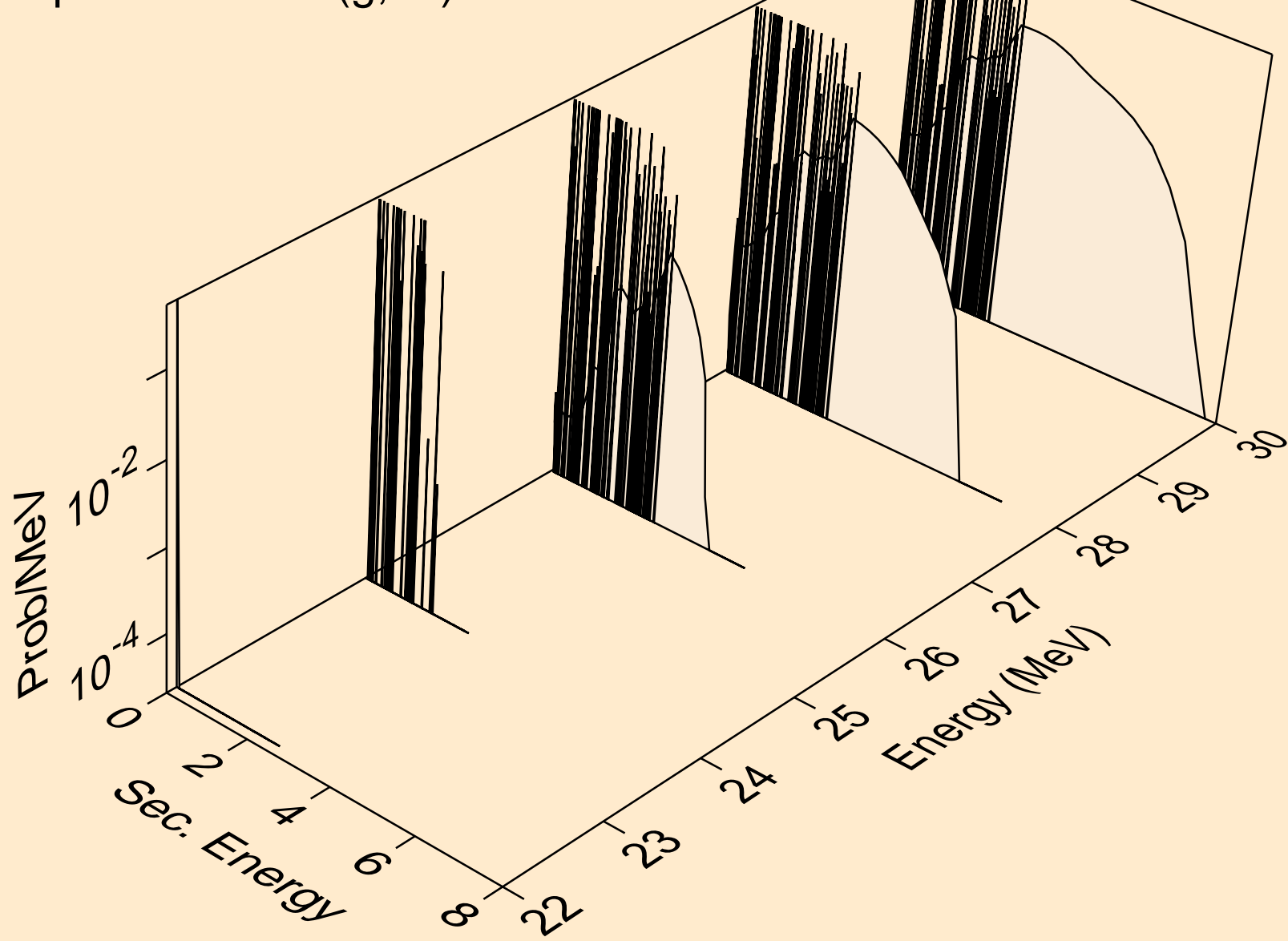



V049 PHOTON ACER TENDL-2023 LIBRARY; T=0.K  
photons from (g,n\*)a

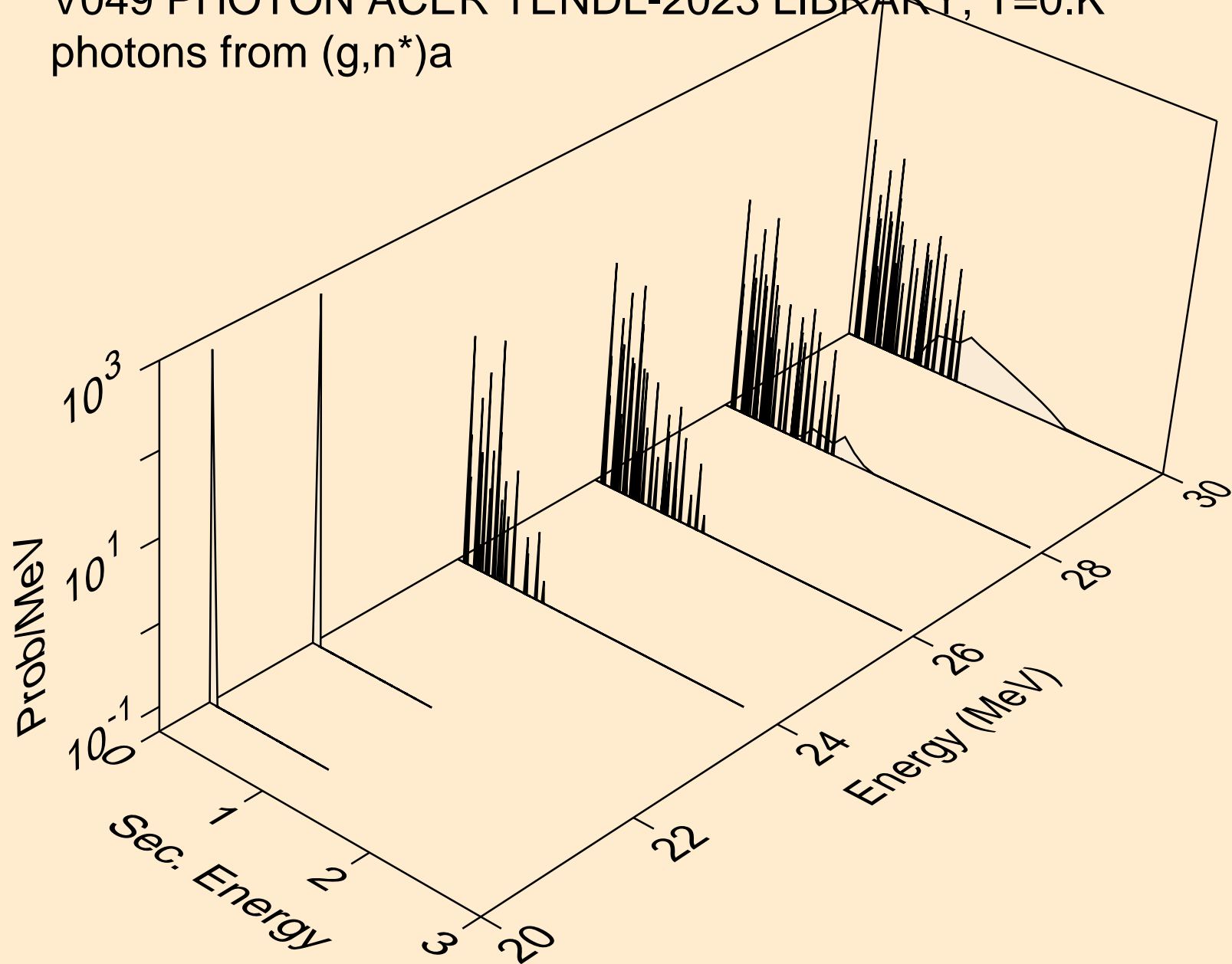

V049 PHOTON ACER TENDL-2023 LIBRARY; T=0.K  
photons from (g,n\*)p

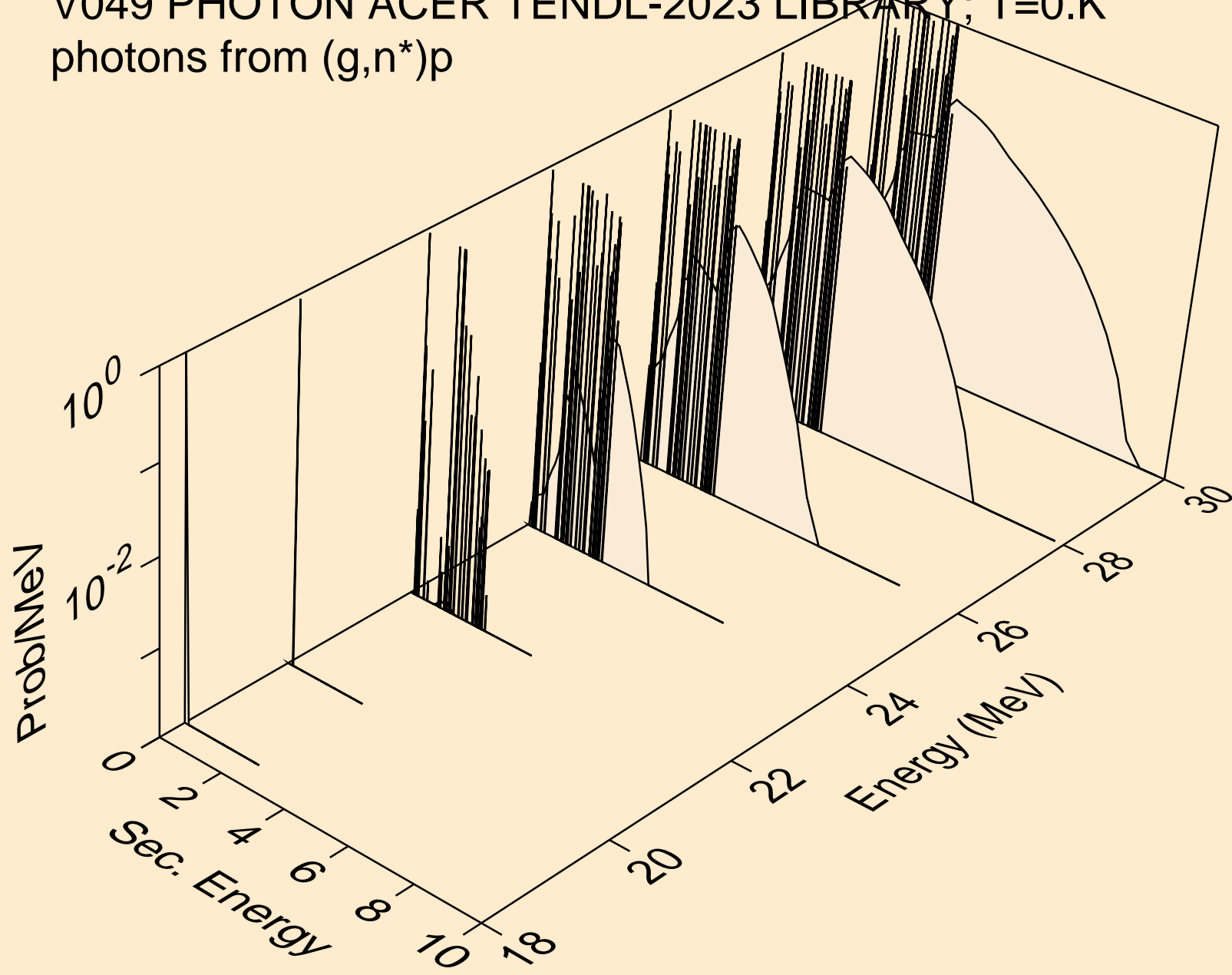

V049 PHOTON ACER TENDL-2023 LIBRARY; T=0.K  
photons from (g,n\*)d

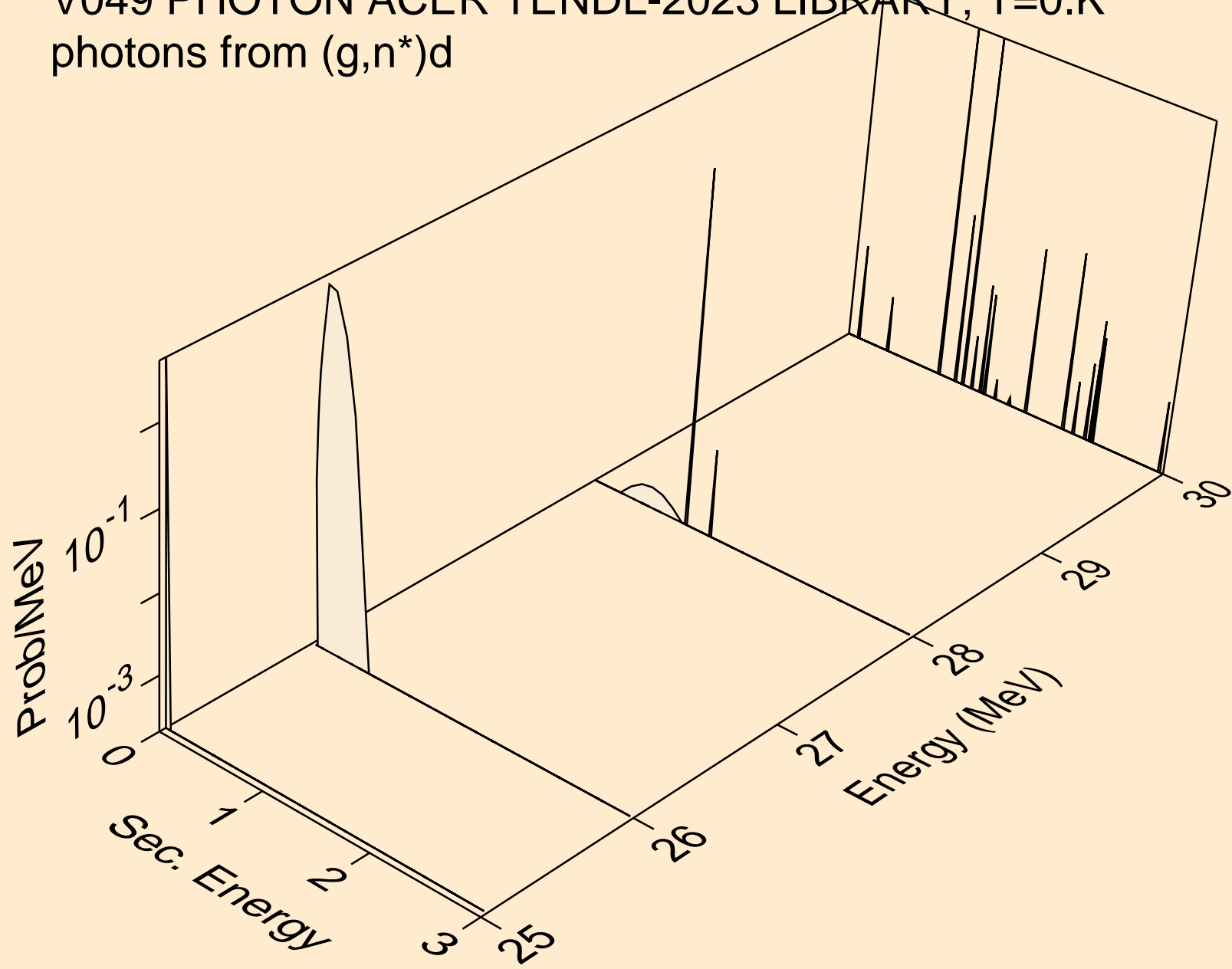

V049 PHOTON ACER TENDL-2023 LIBRARY; T=0.K  
photons from (g,2np)

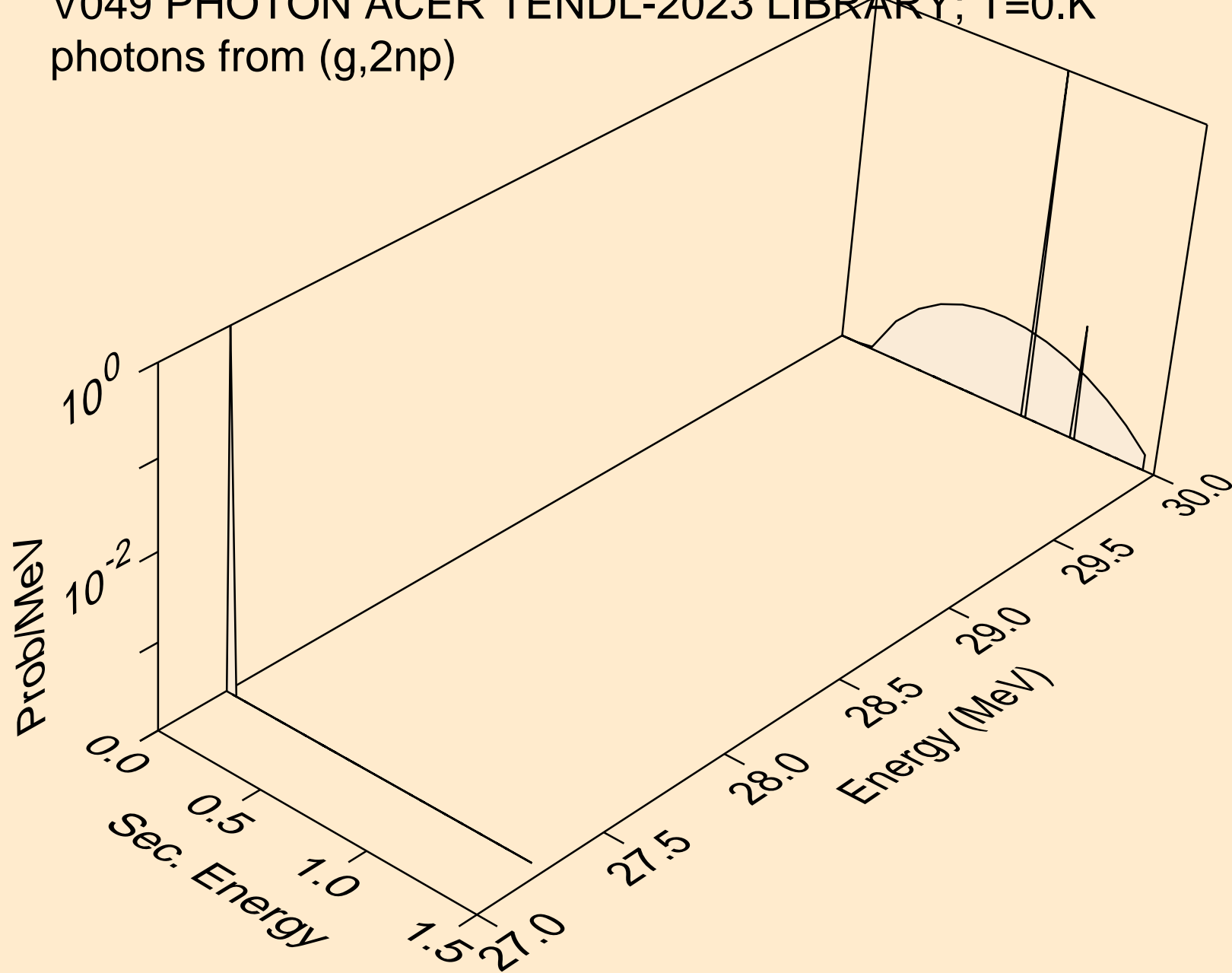

V049 PHOTON ACER TENDL-2023 LIBRARY; T=0.K  
photons from (g,n\*c)

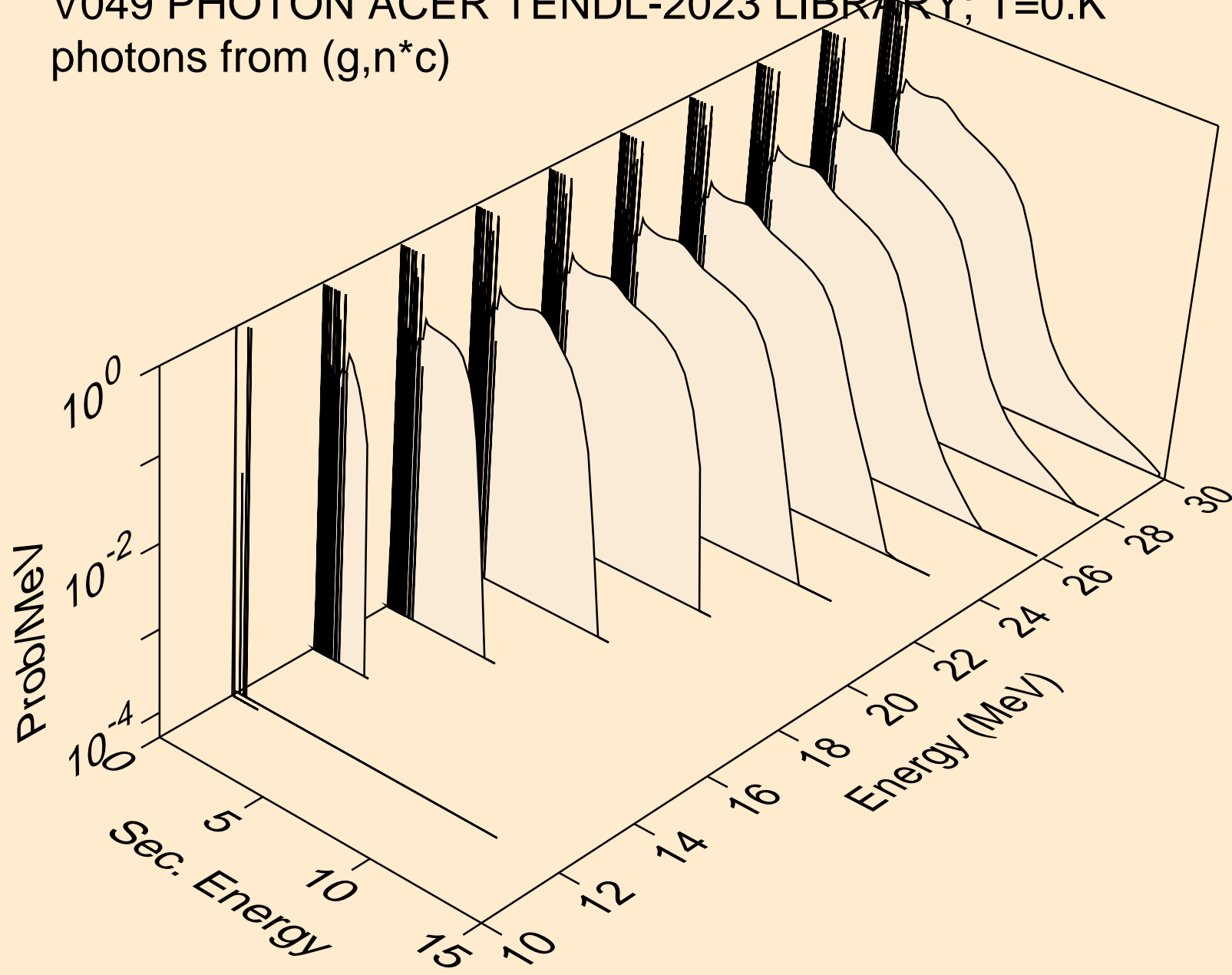

V049 PHOTON ACER TENDL-2023 LIBRARY; T=0.K  
photons from (g,gma)

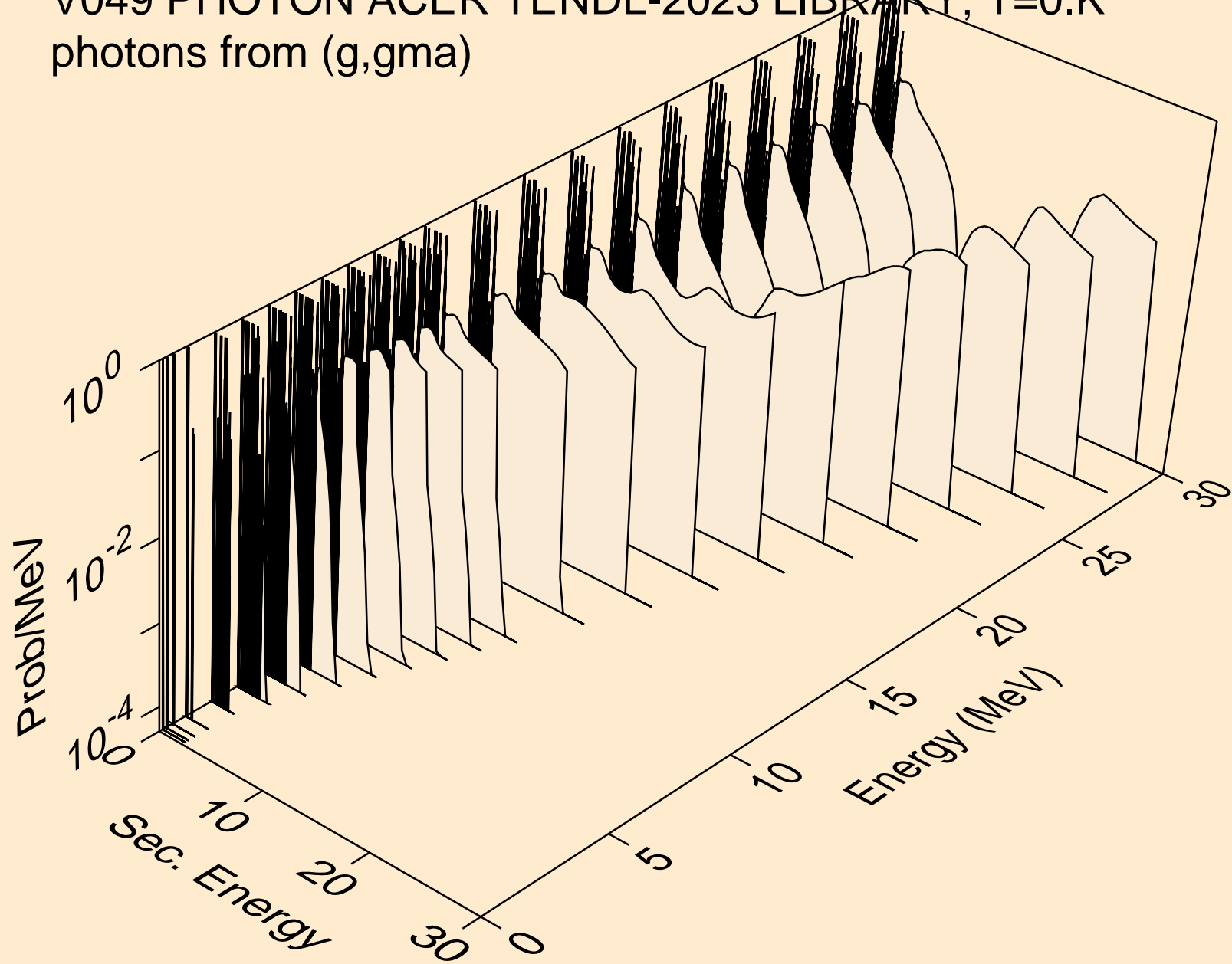

V049 PHOTON ACER TENDL-2023 LIBRARY; T=0.K  
photons from (g,p)

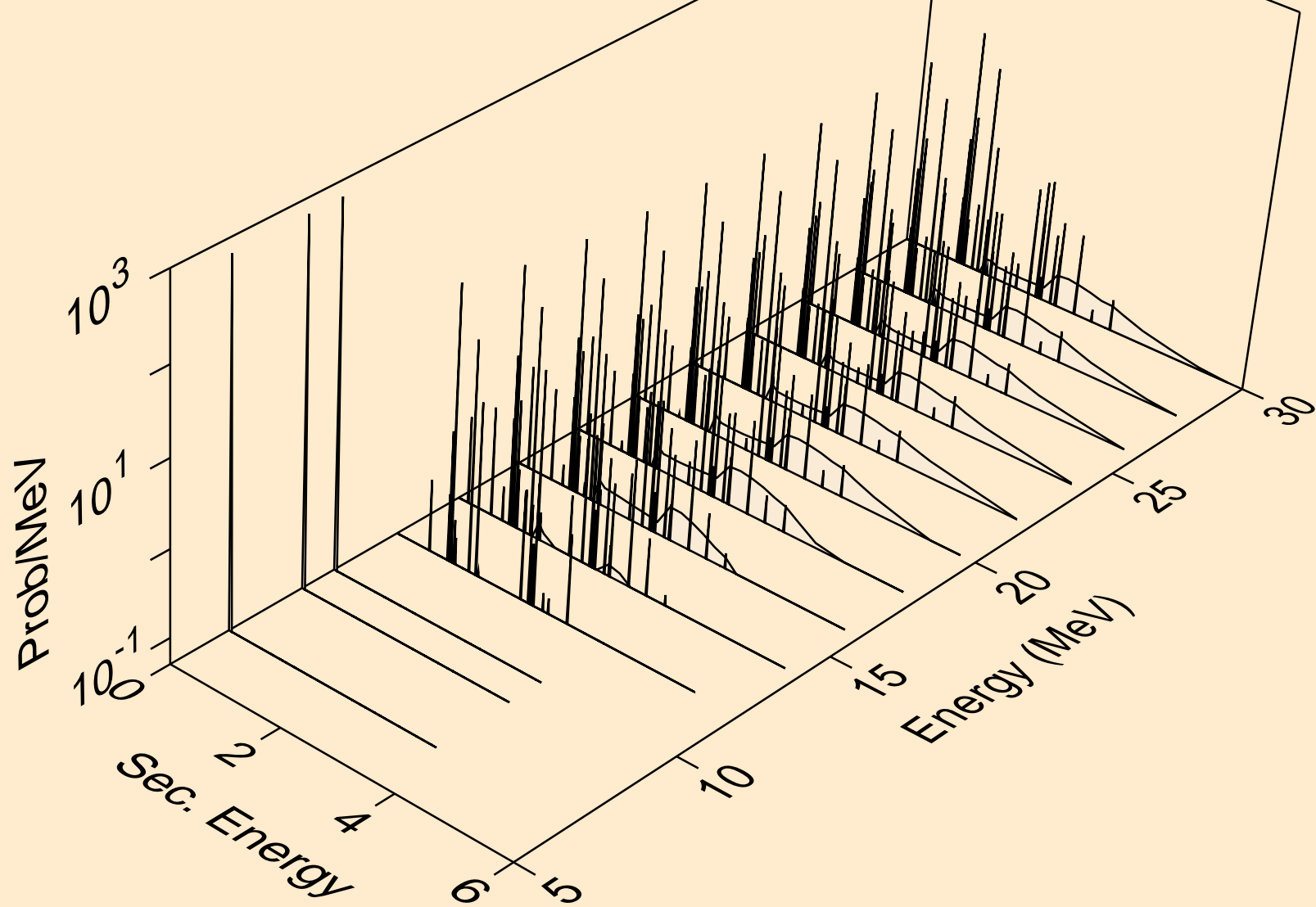

V049 PHOTON ACER TENDL-2023 LIBRARY; T=0.K  
photons from (g,d)

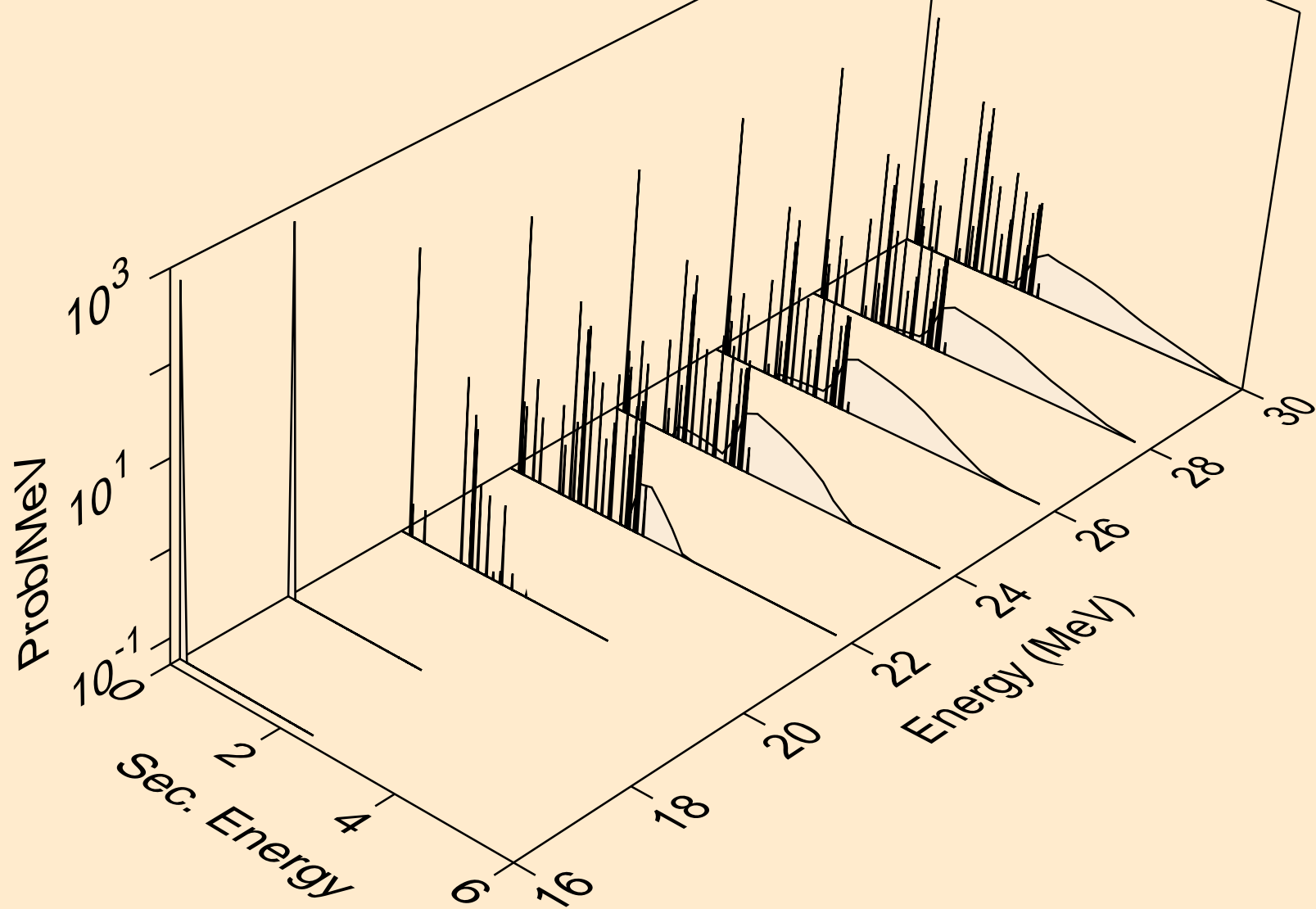



V049 PHOTON ACER TENDL-2023 LIBRARY; T=0.K  
photons from (g,t)

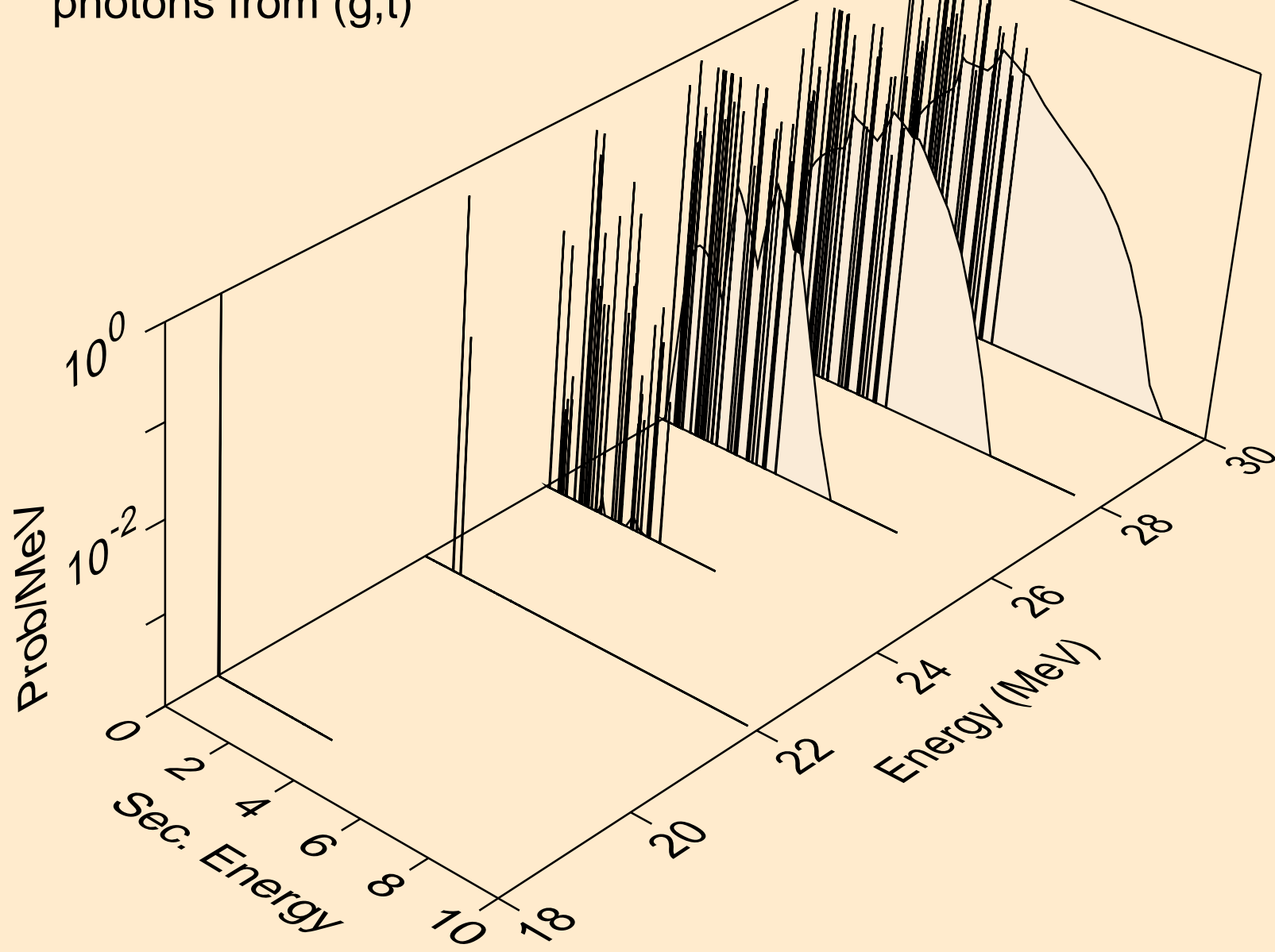

V049 PHOTON ACER TENDL-2023 LIBRARY; T=0.K  
photons from (g,he3)

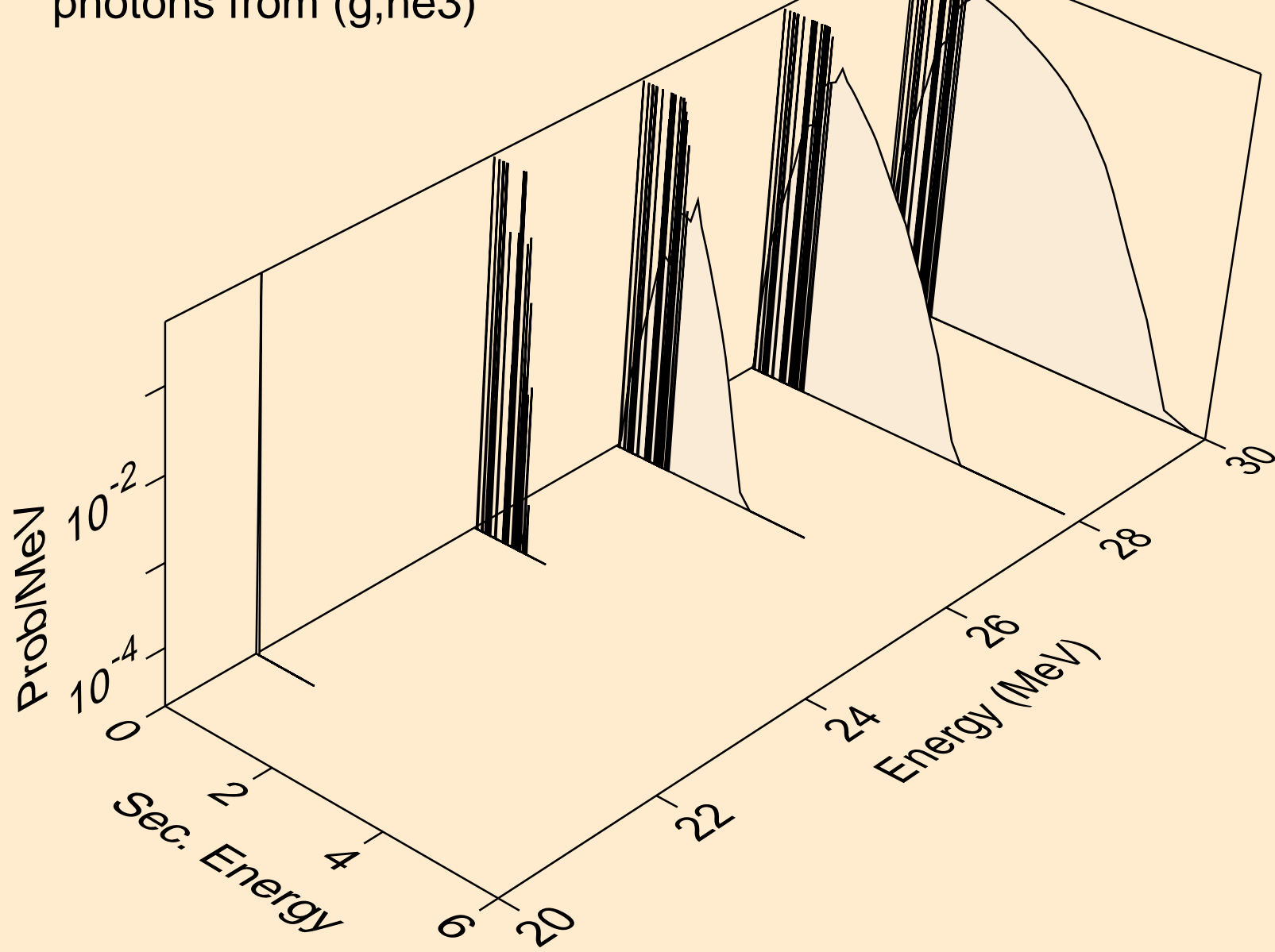

V049 PHOTON ACER TENDL-2023 LIBRARY; T=0.K  
photons from (g,a)

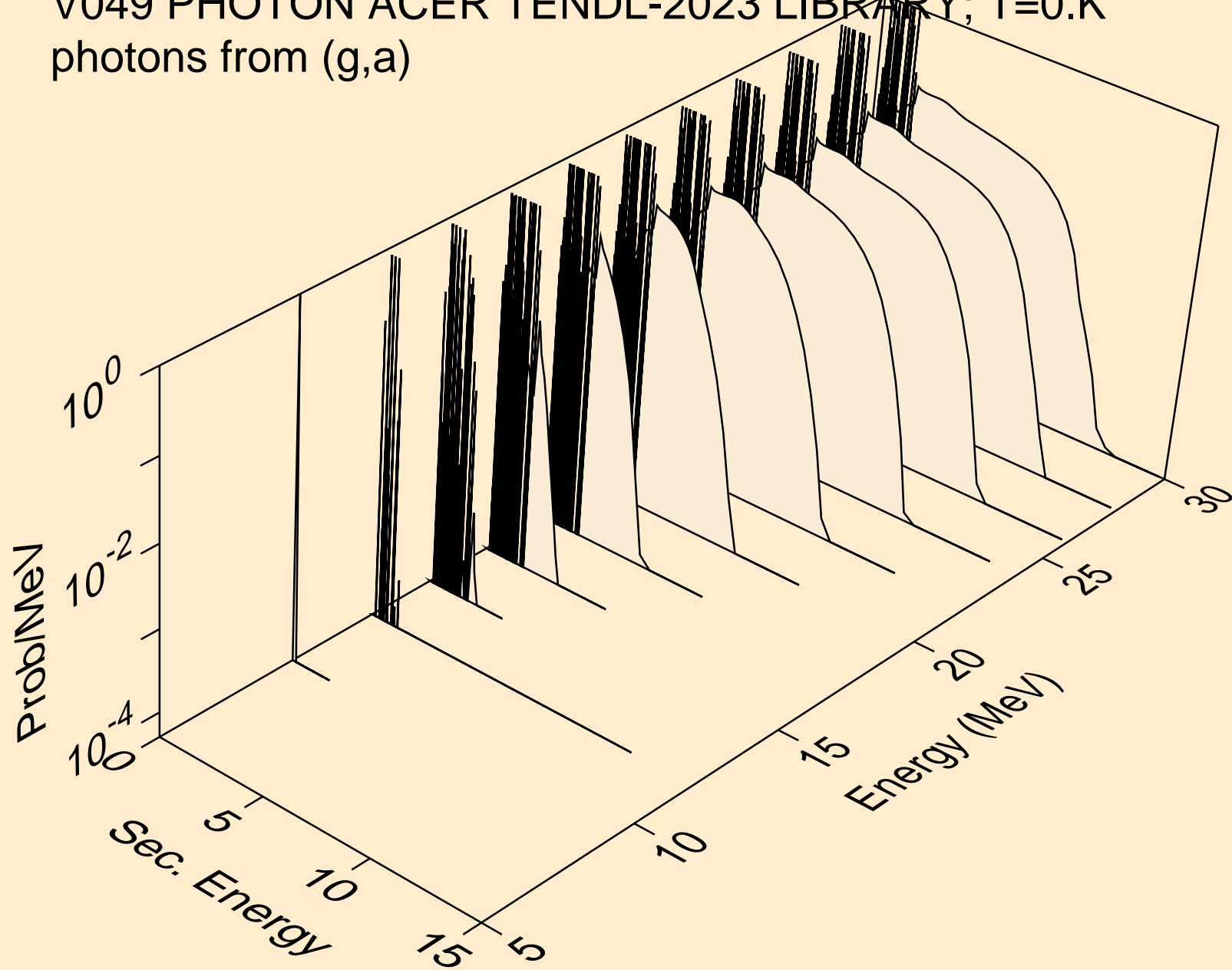

V049 PHOTON ACER TENDL-2023 LIBRARY; T=0.K  
photons from (g,2a)

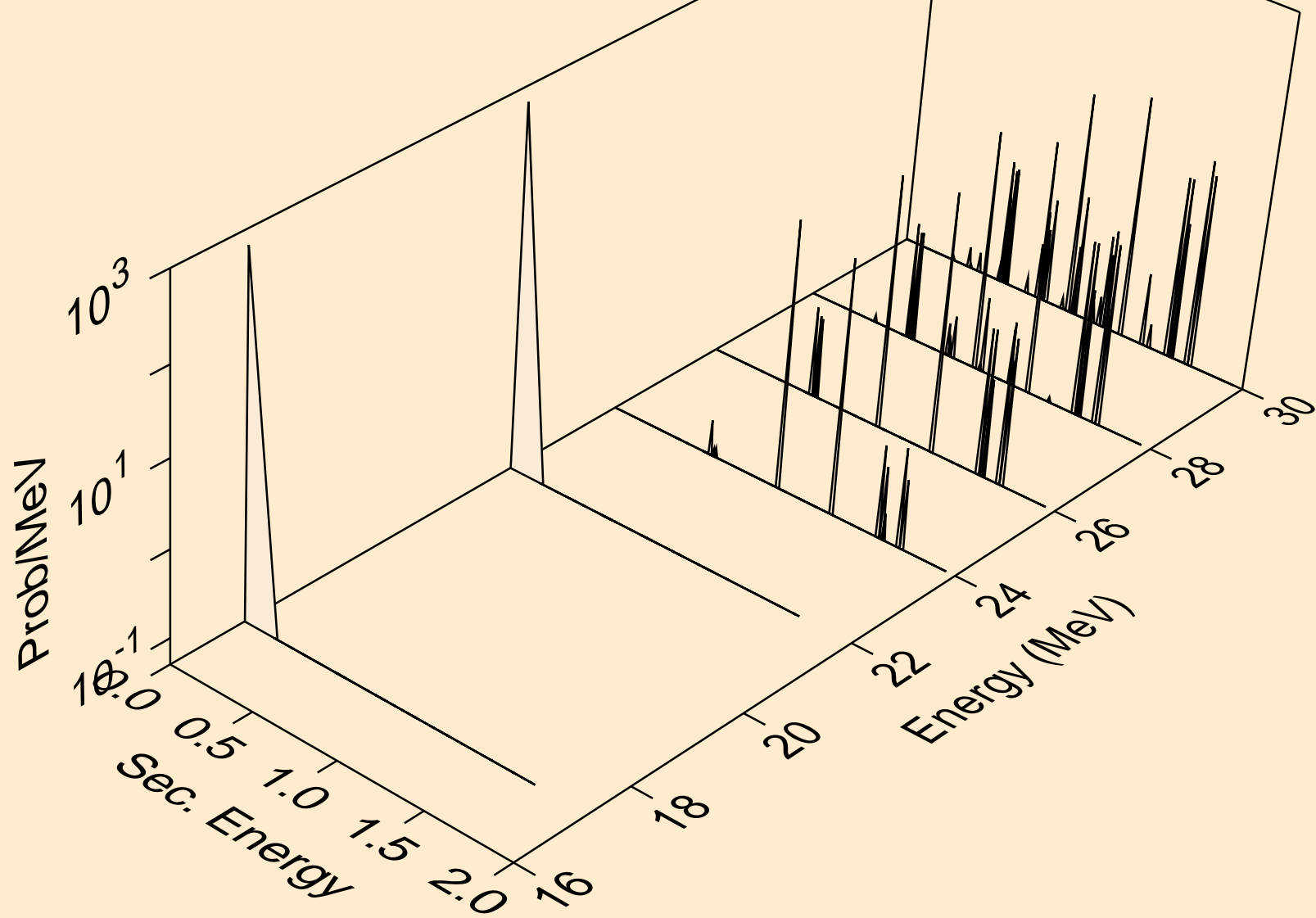

V049 PHOTON ACER TENDL-2023 LIBRARY; T=0.K  
photons from (g,2p)

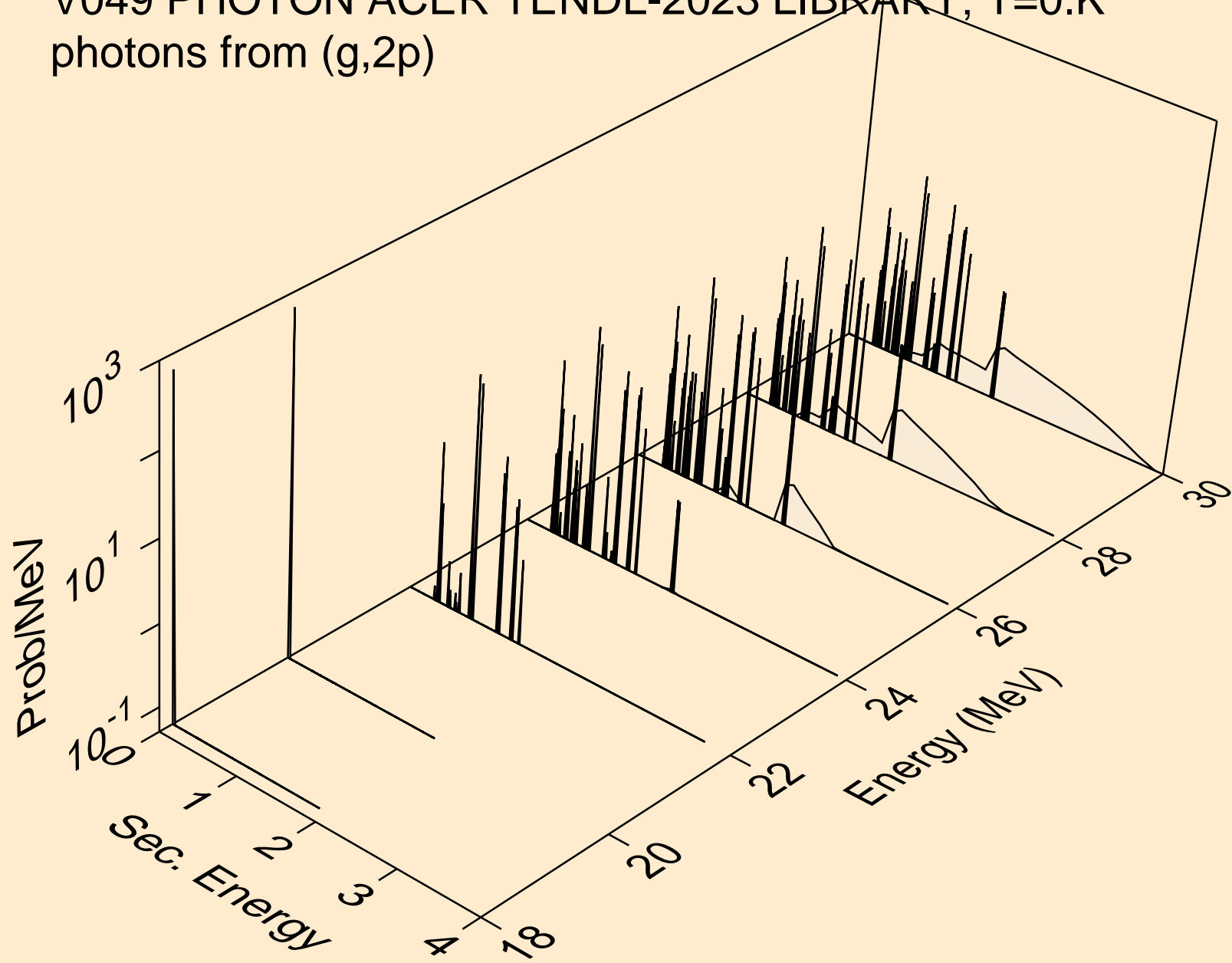

V049 PHOTON ACER TENDL-2023 LIBRARY; T=0.K  
photons from (g,pa)

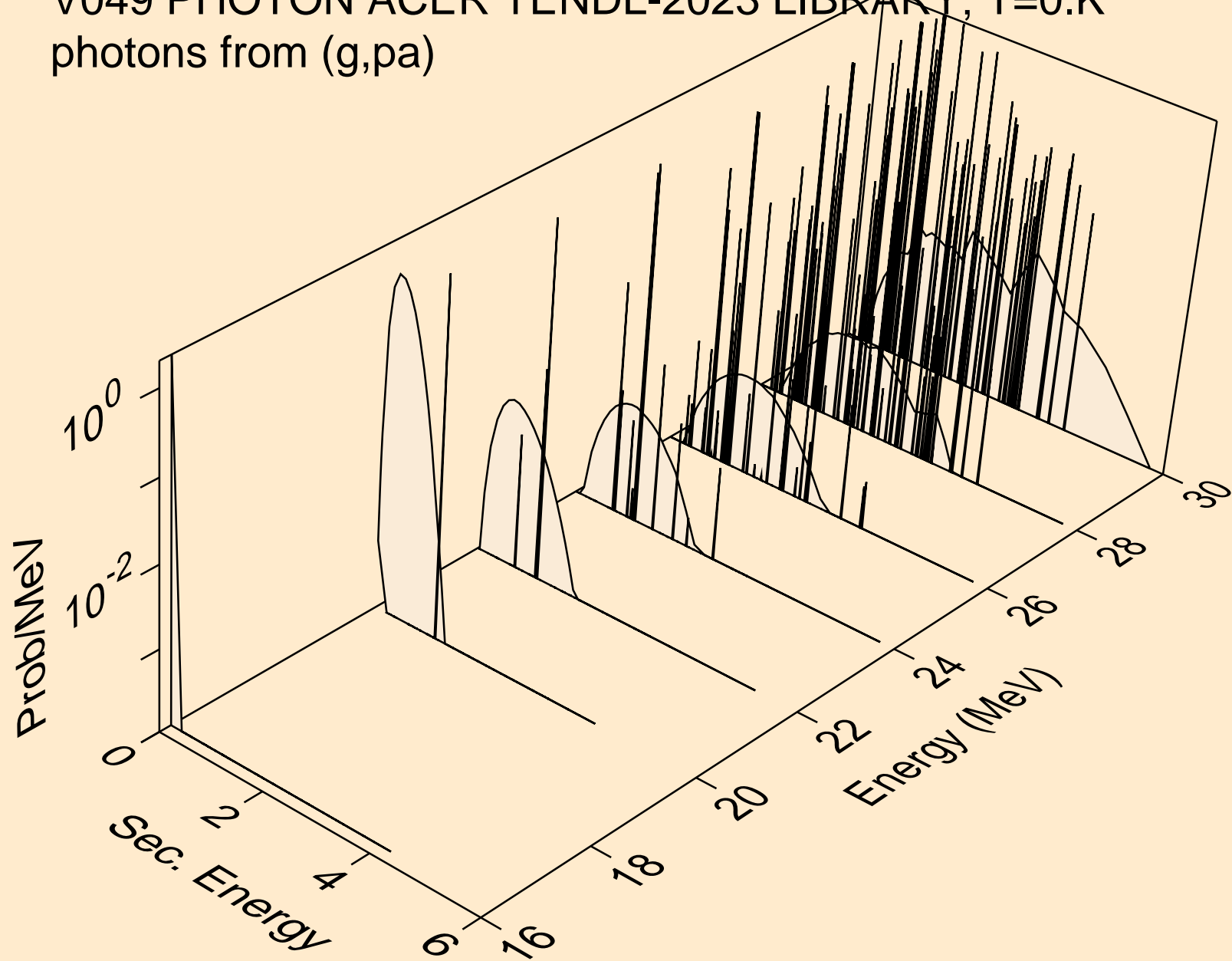

V049 PHOTON ACER TENDL-2023 LIBRARY; T=0.K  
protons from (g,x)

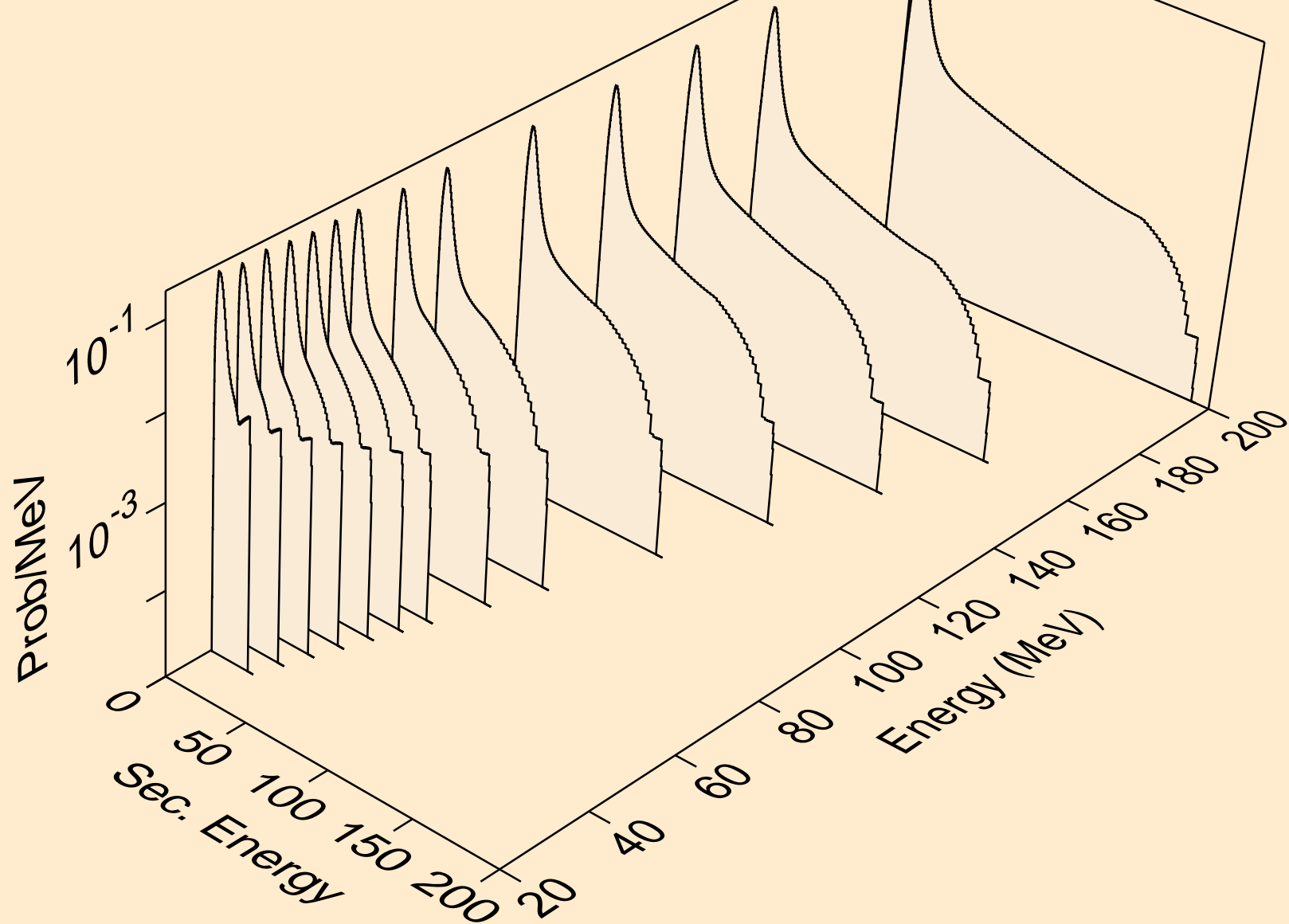

V049 PHOTON ACER TENDL-2023 LIBRARY; T=0.K  
protons from (g,n\*)p

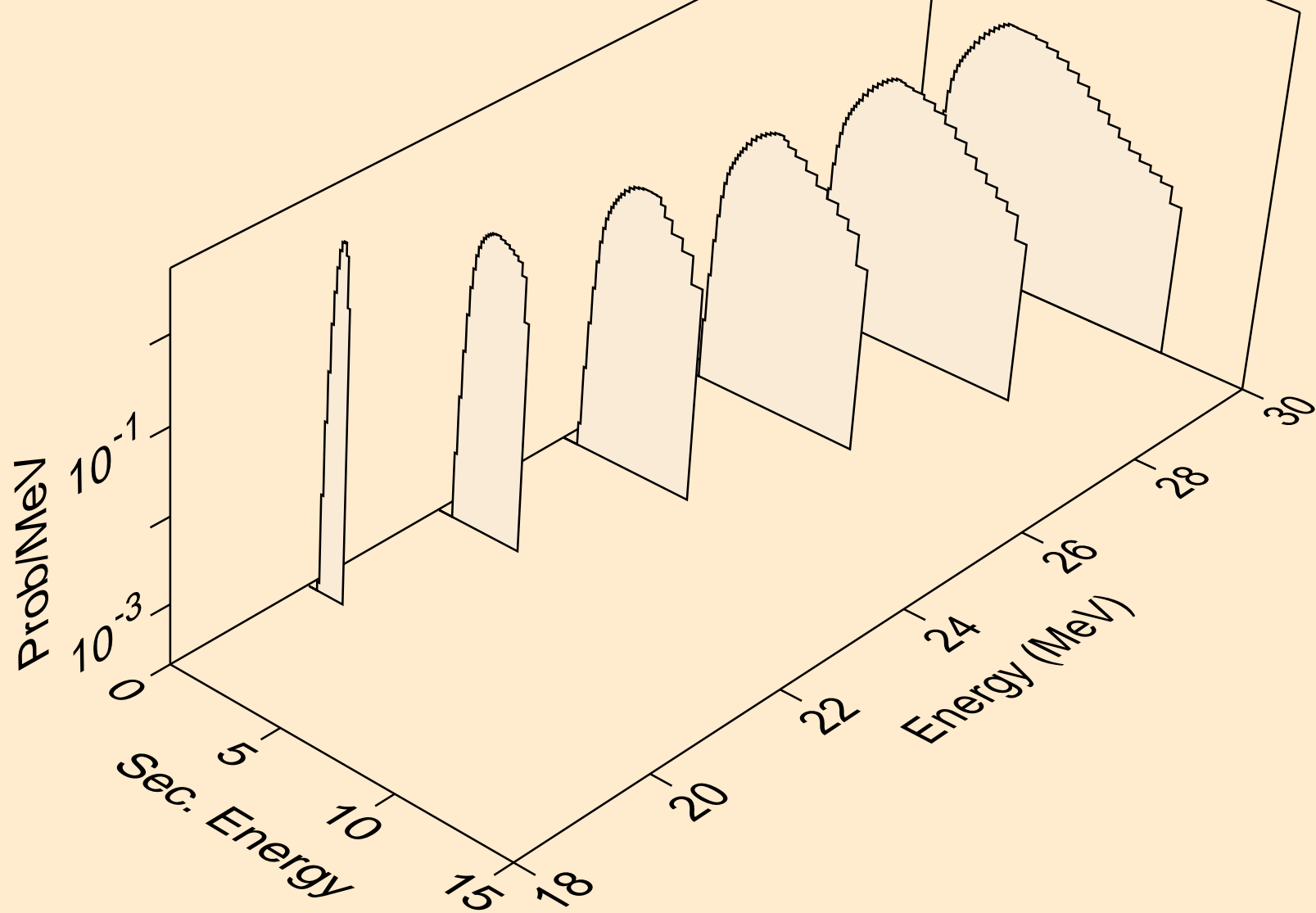



V049 PHOTON ACER TENDL-2023 LIBRARY; T=0.K  
protons from (g,2np)

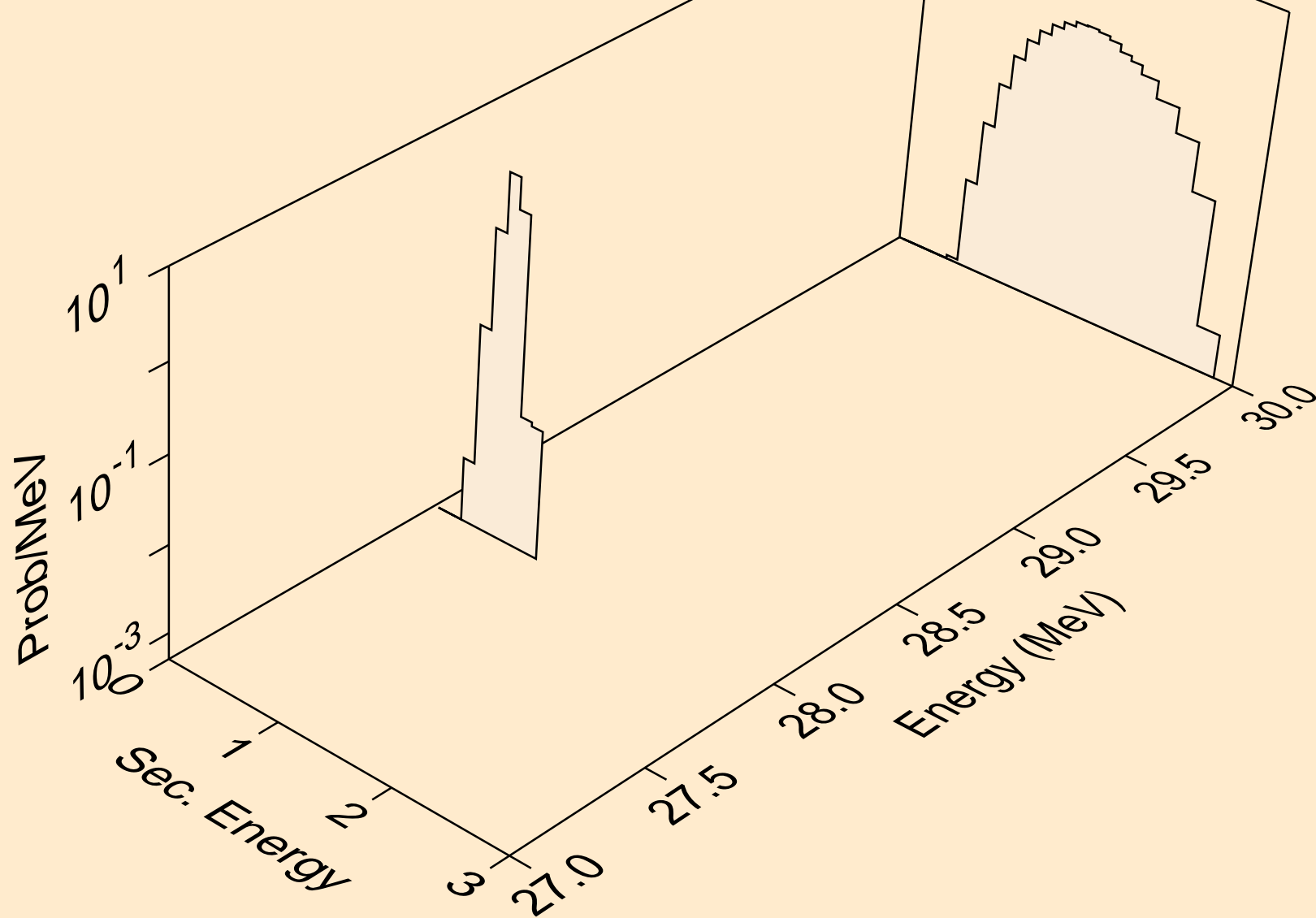

V049 PHOTON ACER TENDL-2023 LIBRARY; T=0.K  
protons from (g,p)

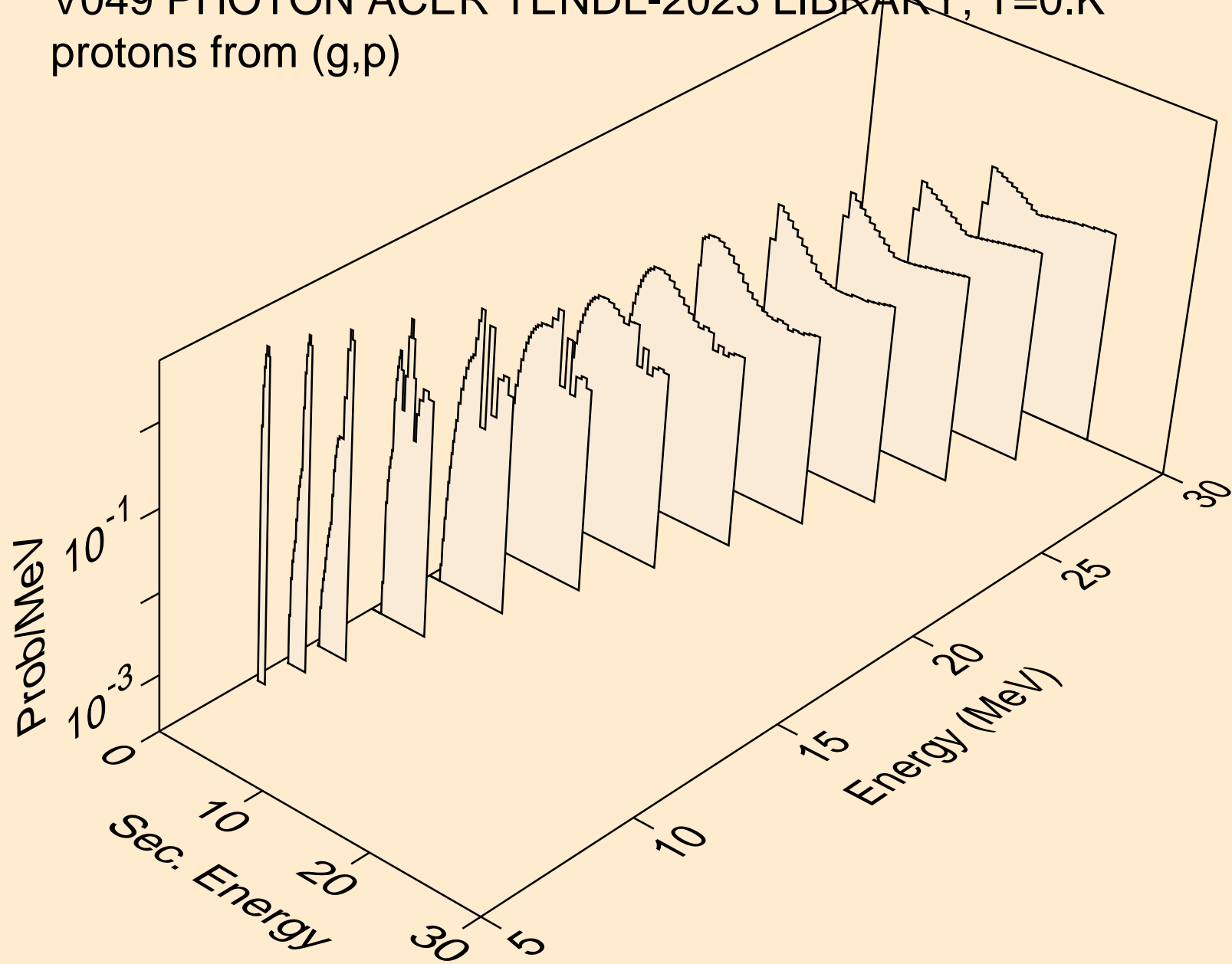

V049 PHOTON ACER TENDL-2023 LIBRARY; T=0.K  
protons from (g,2p)

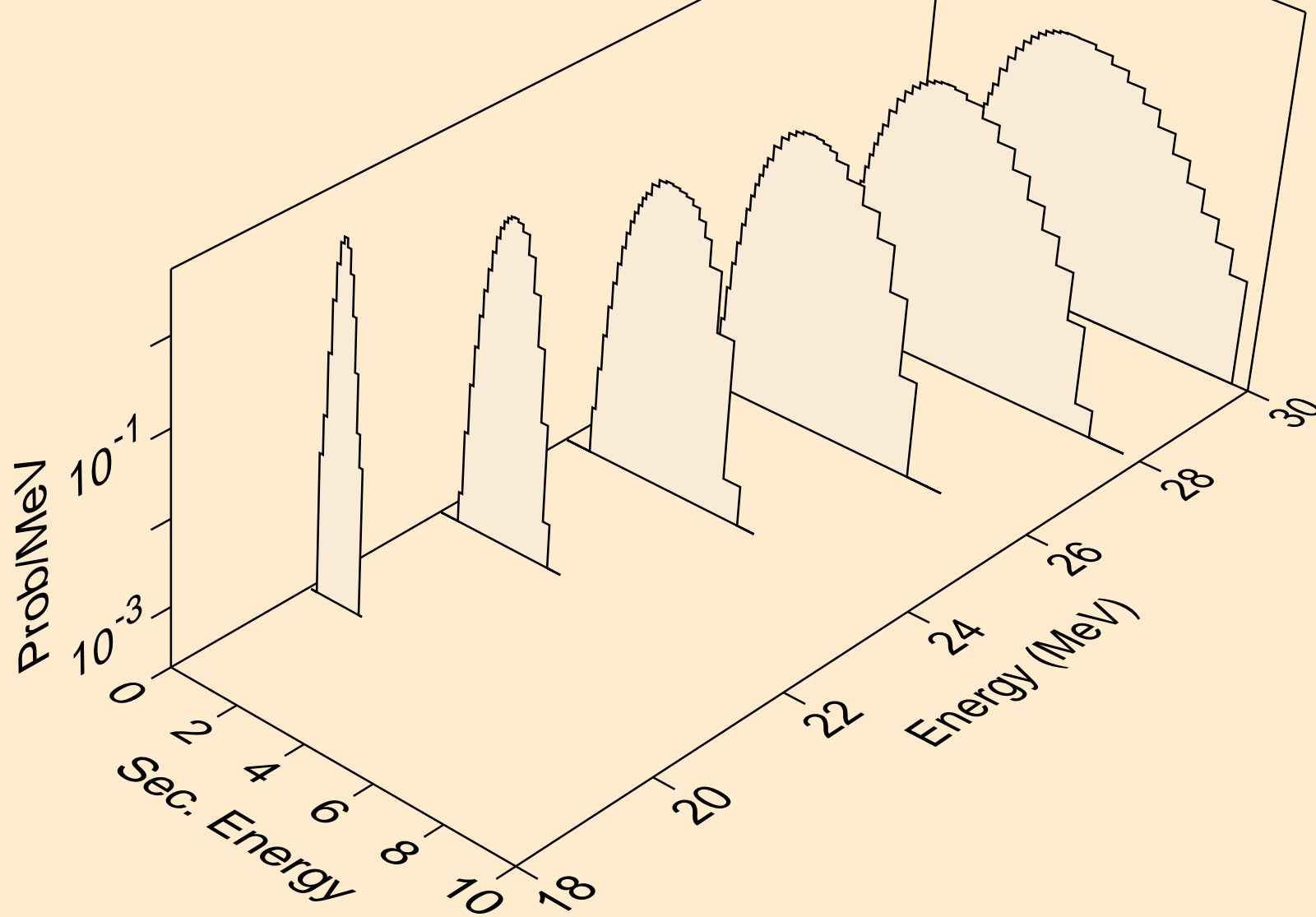

V049 PHOTON ACER TENDL-2023 LIBRARY; T=0.K  
protons from (g,pa)

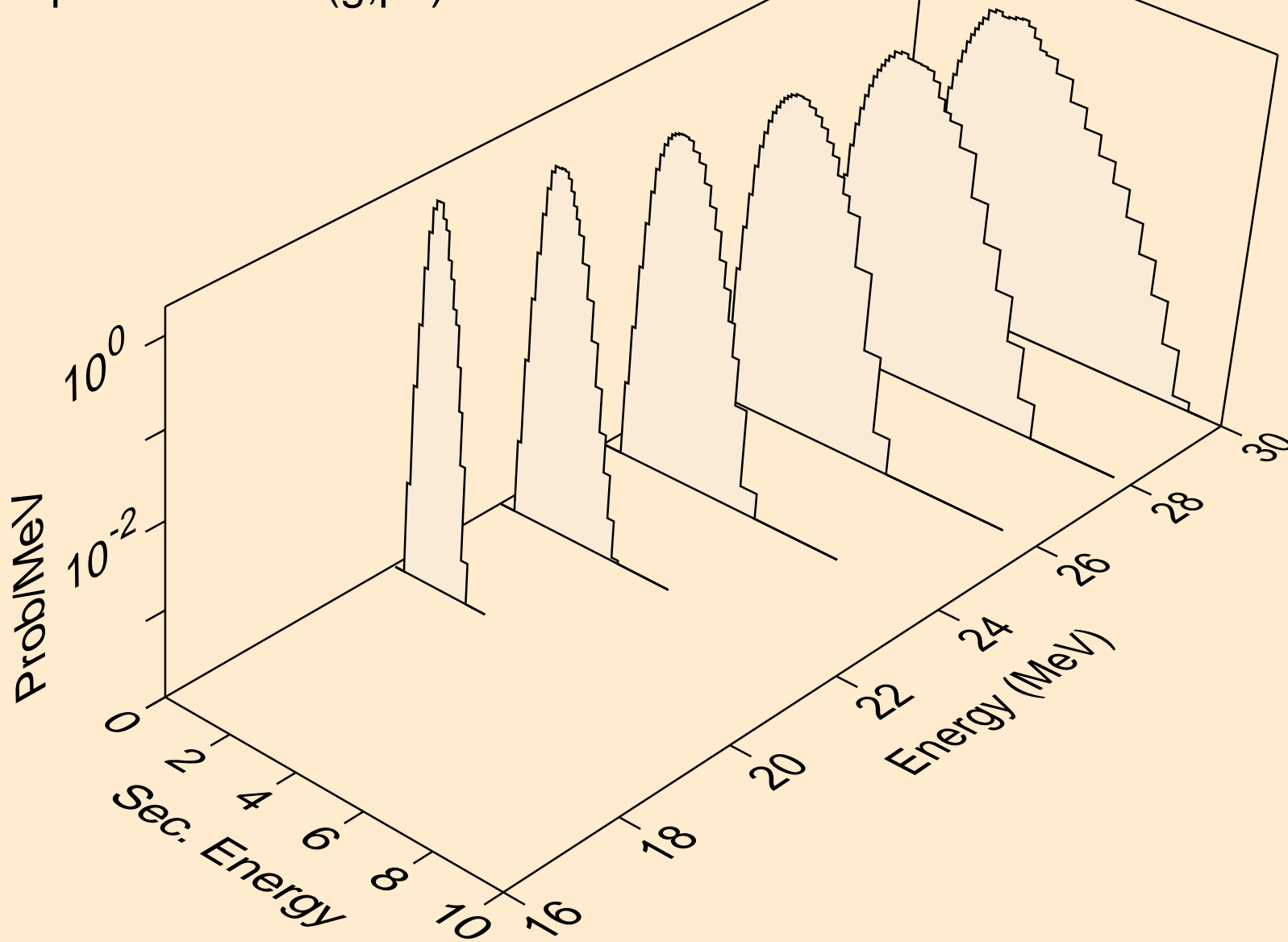

V049 PHOTON ACER TENDL-2023 LIBRARY; T=0.K  
deuterons from (g,x)

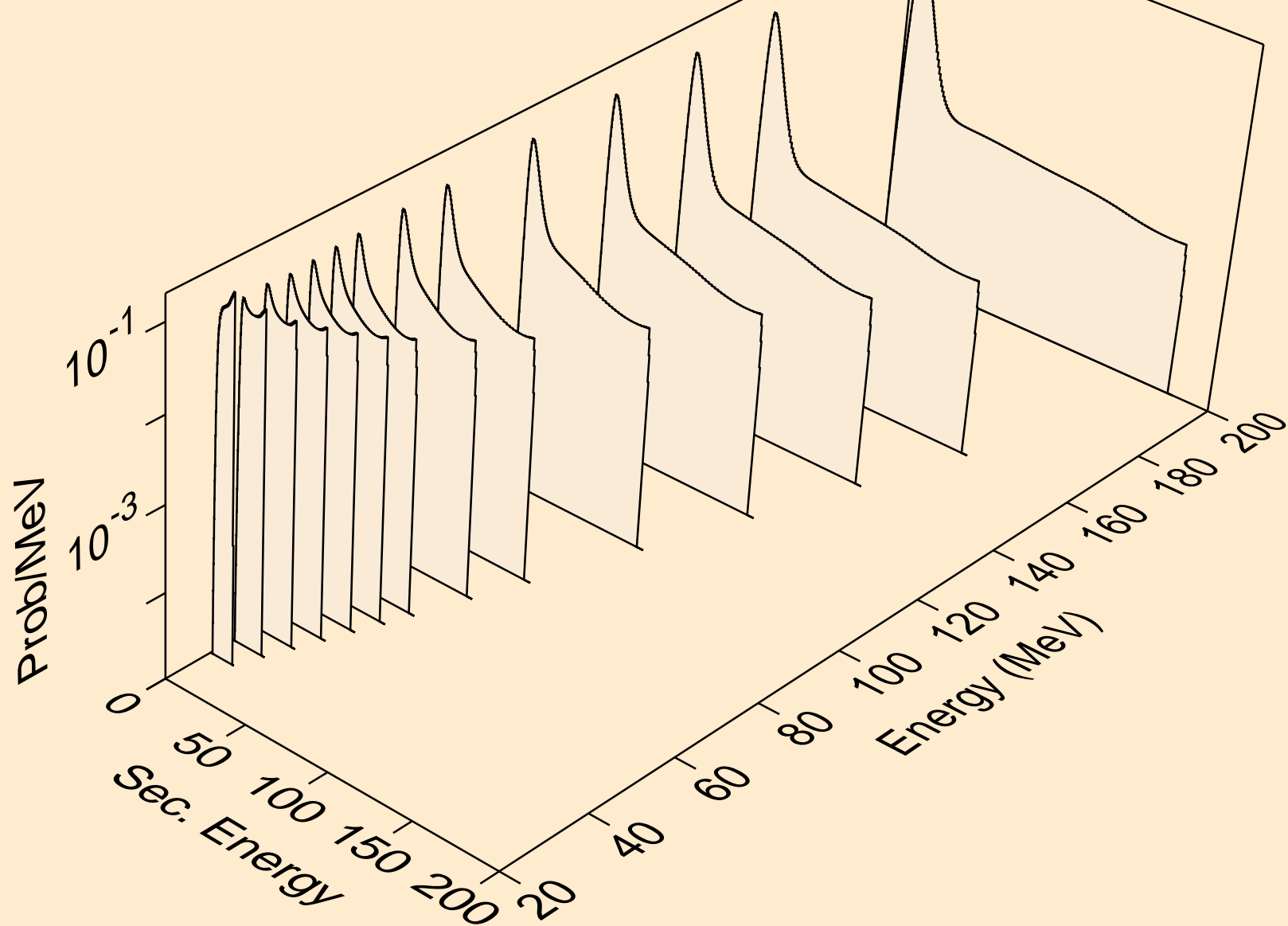

V049 PHOTON ACER TENDL-2023 LIBRARY; T=0.K  
deuterons from (g,n\*)d

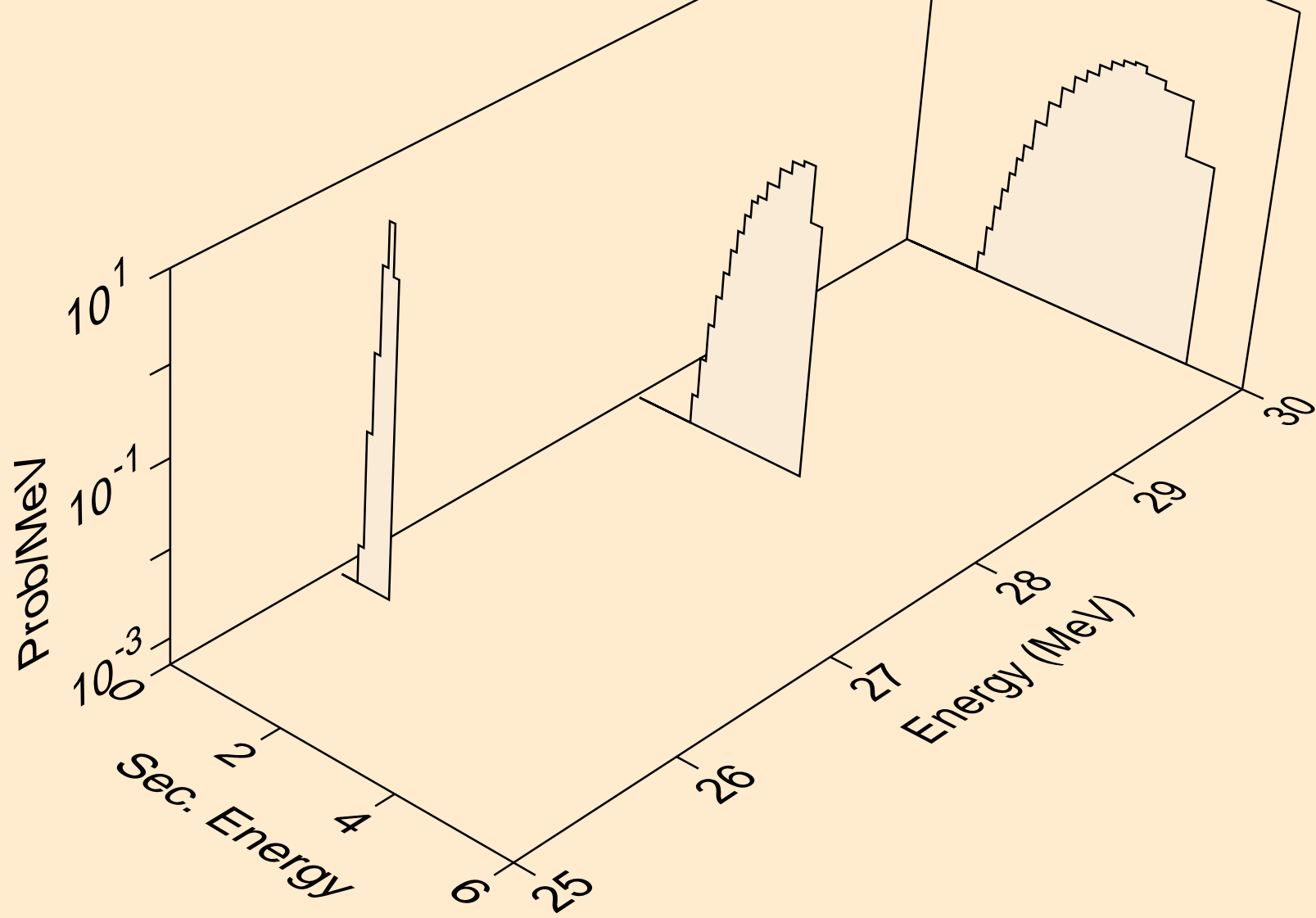

V049 PHOTON ACER TENDL-2023 LIBRARY; T=0.K  
deuterons from (g,d)

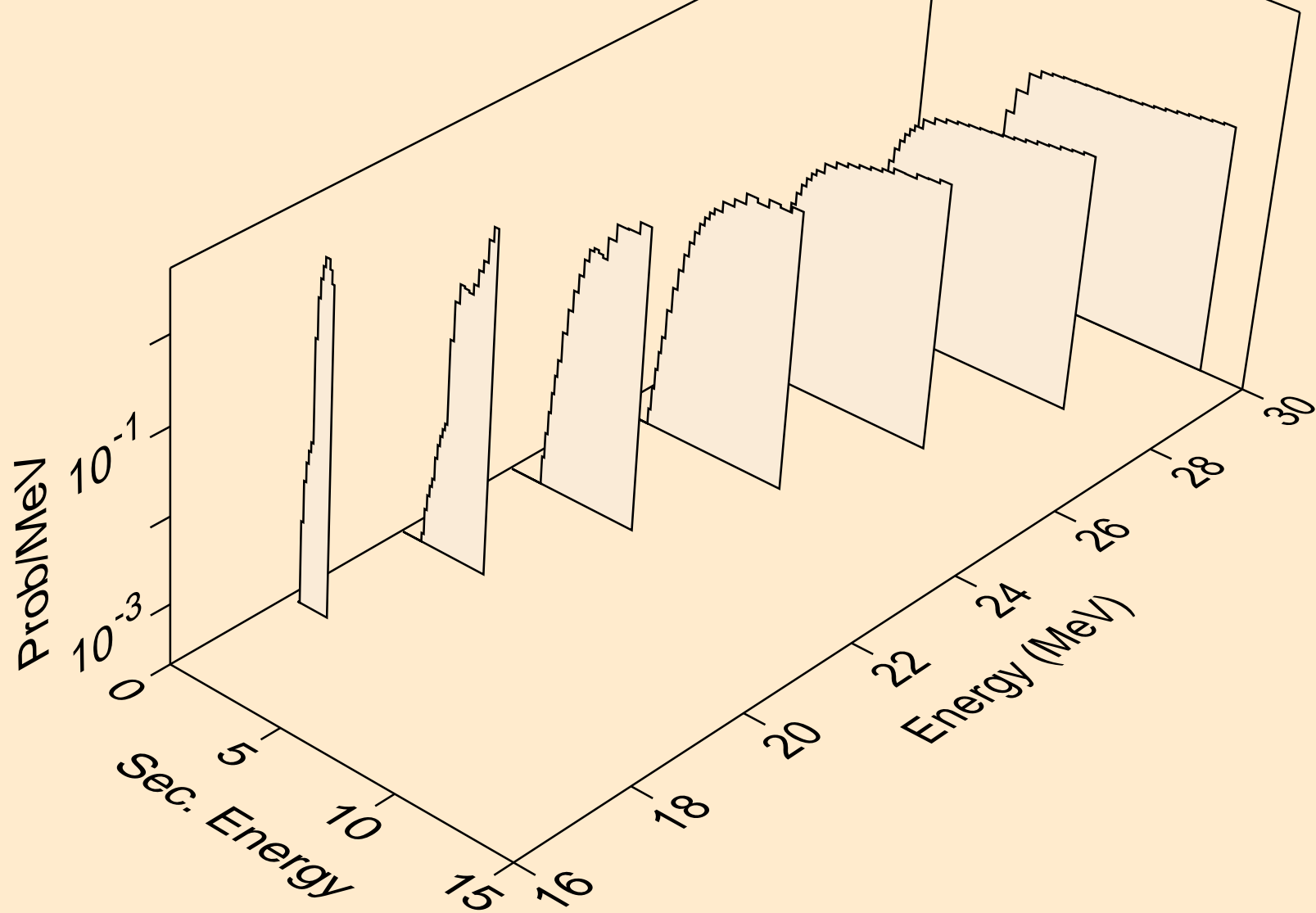

V049 PHOTON ACER TENDL-2023 LIBRARY; T=0.K  
tritons from (g,x)

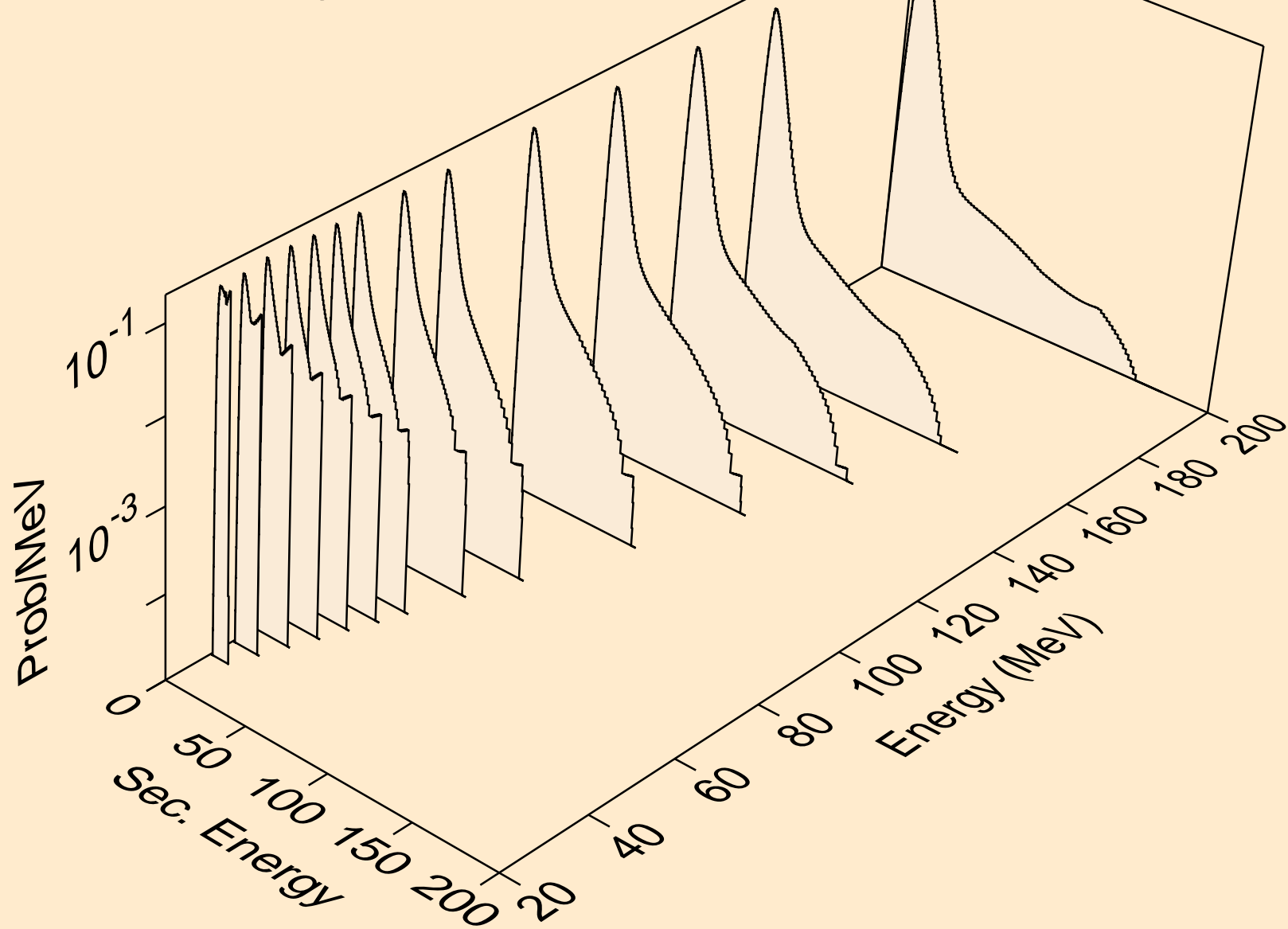



V049 PHOTON ACER TENDL-2023 LIBRARY; T=0.K  
tritons from (g,t)

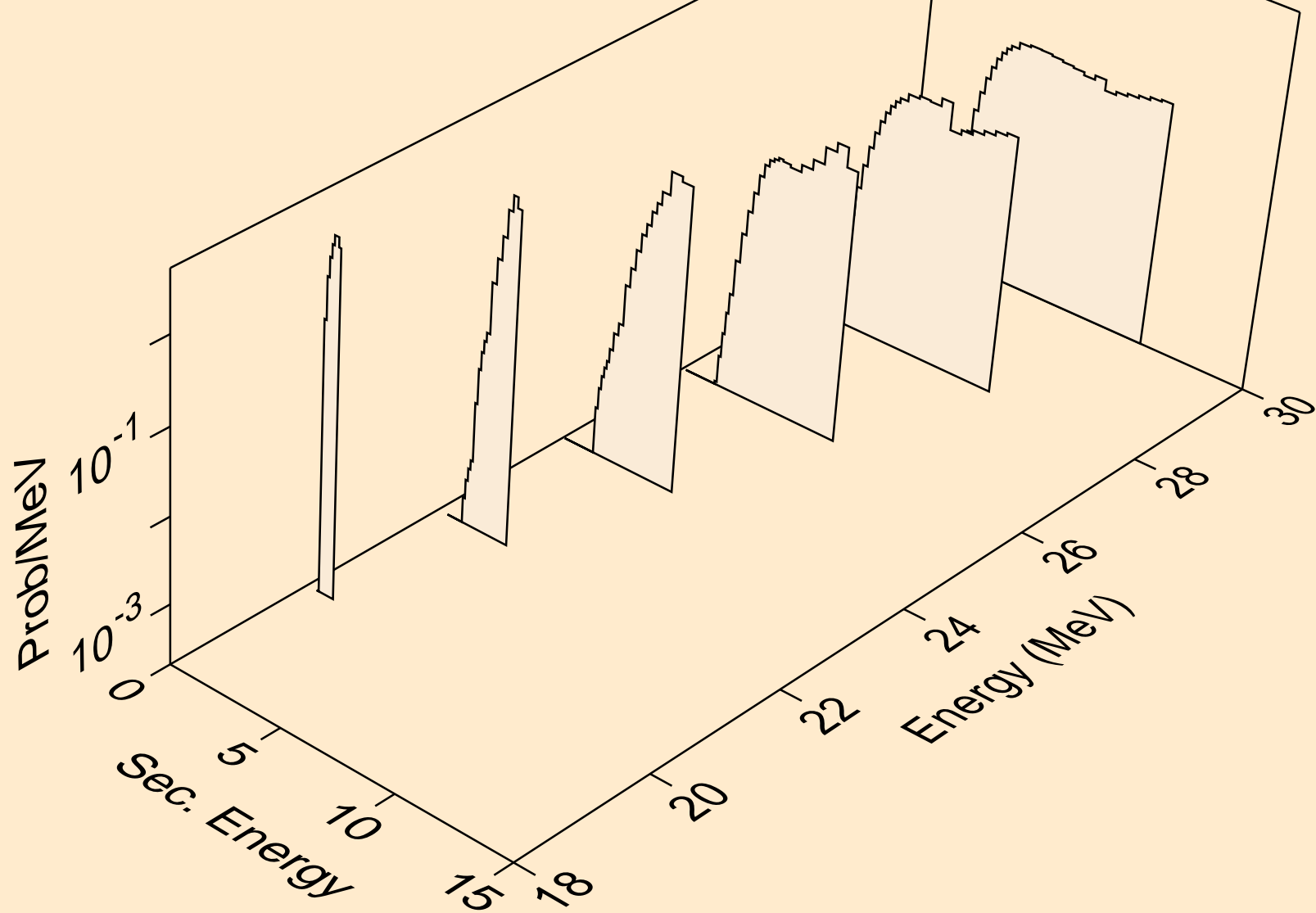

V049 PHOTON ACER TENDL-2023 LIBRARY; T=0.K  
he3s from (g,x)

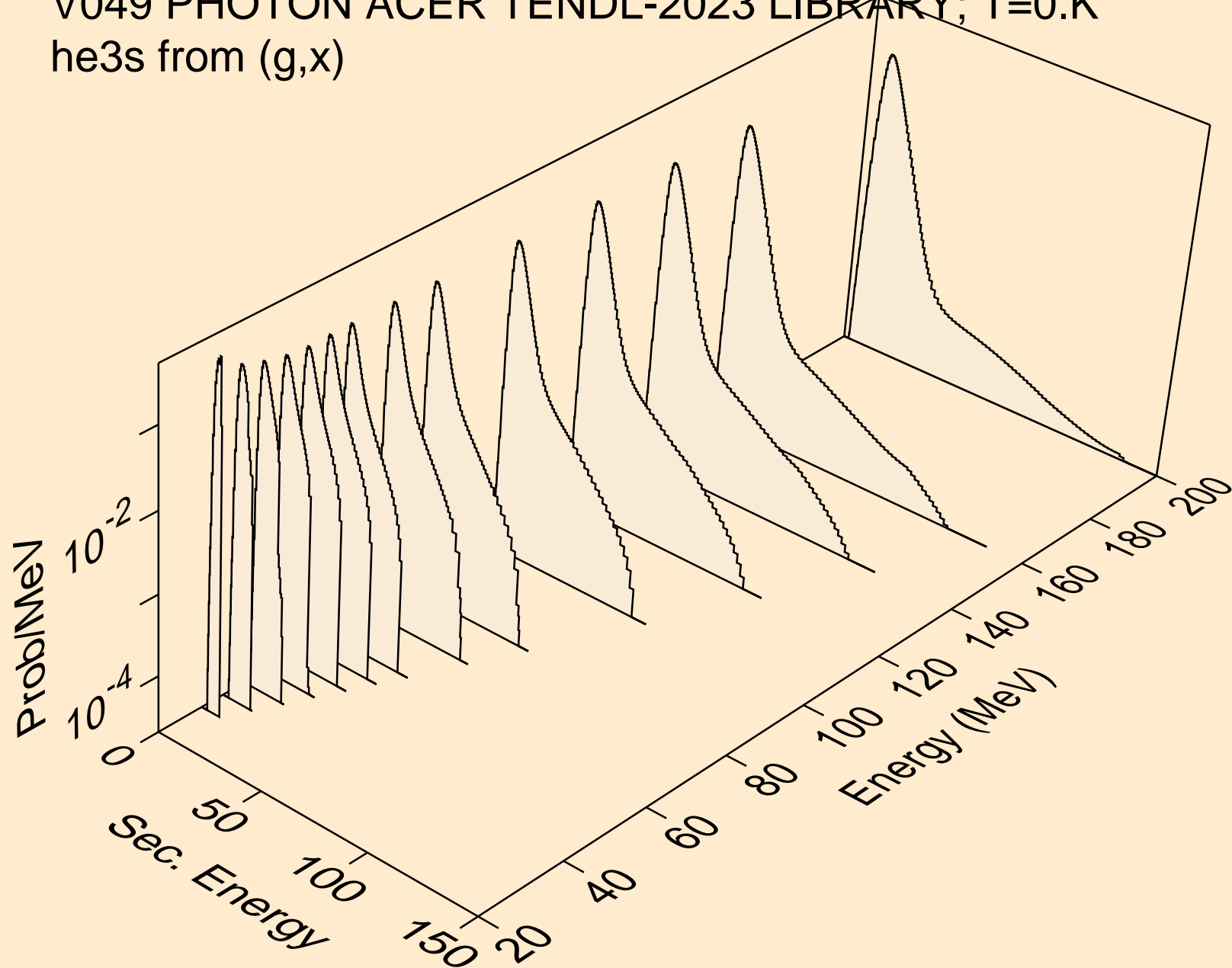

V049 PHOTON ACER TENDL-2023 LIBRARY; T=0.K  
he3s from (g,he3)

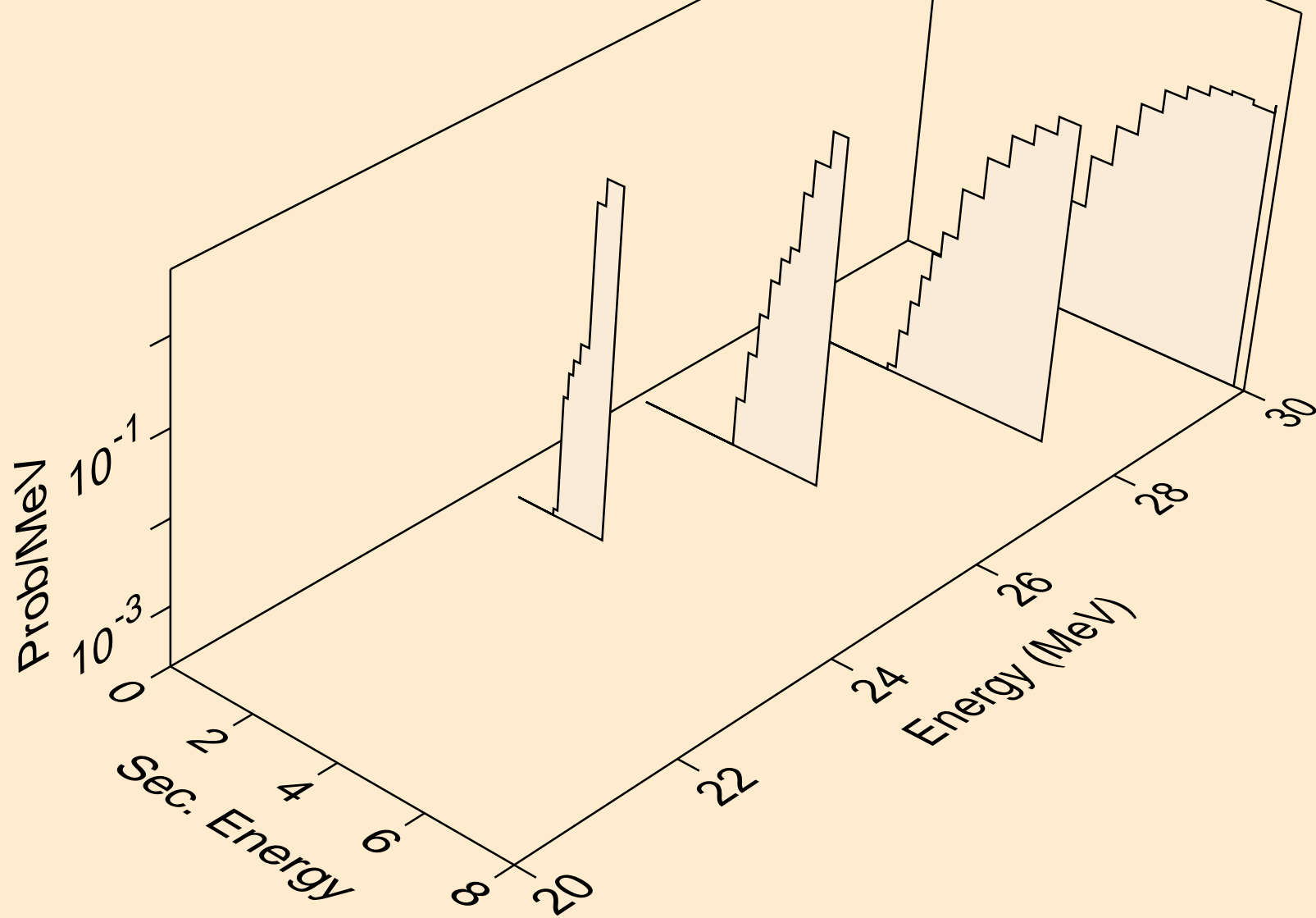

V049 PHOTON ACER TENDL-2023 LIBRARY; T=0.K  
alphas from (g,x)

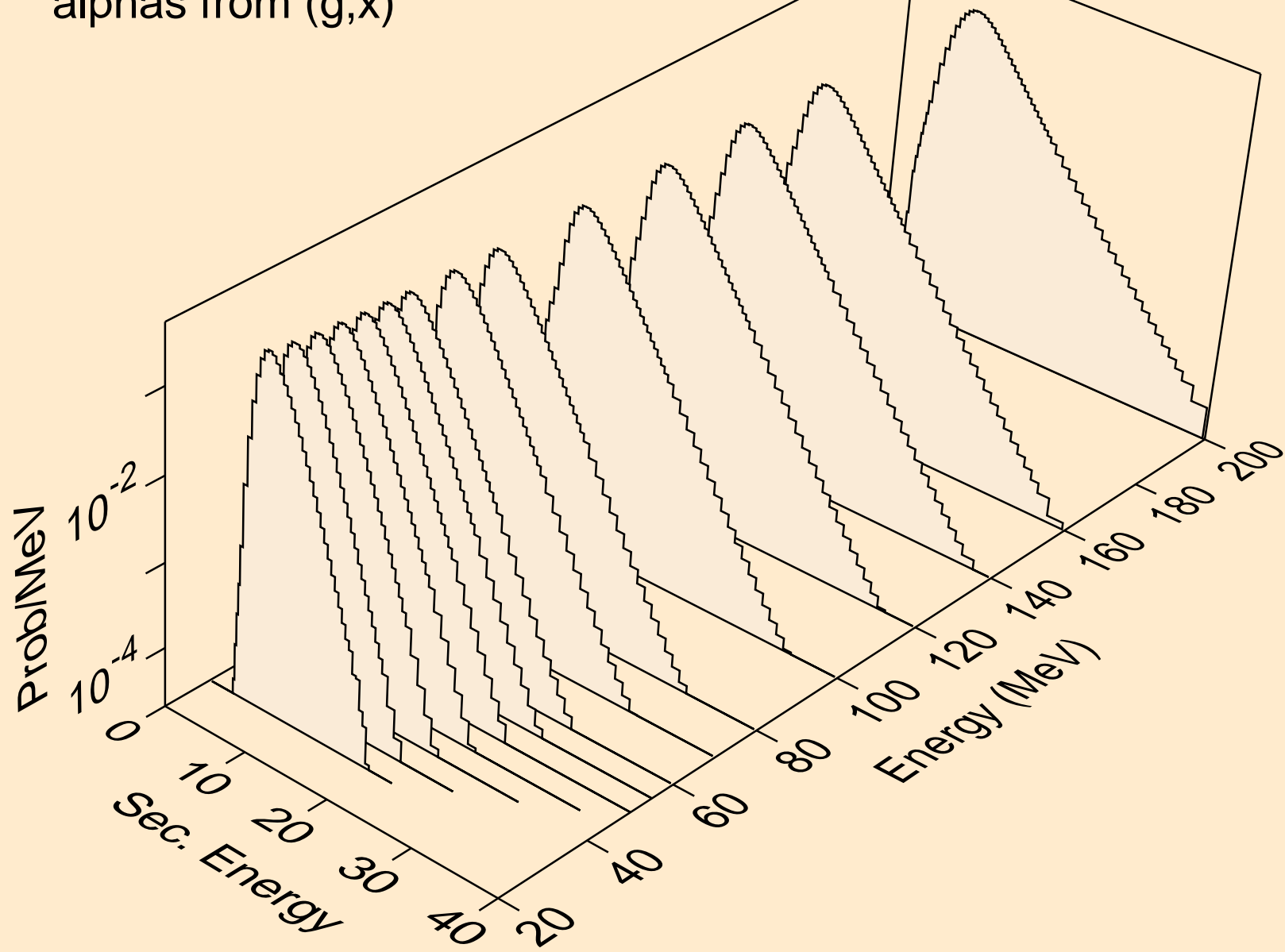

V049 PHOTON ACER TENDL-2023 LIBRARY; T=0.K  
alphas from (g,n\*)a

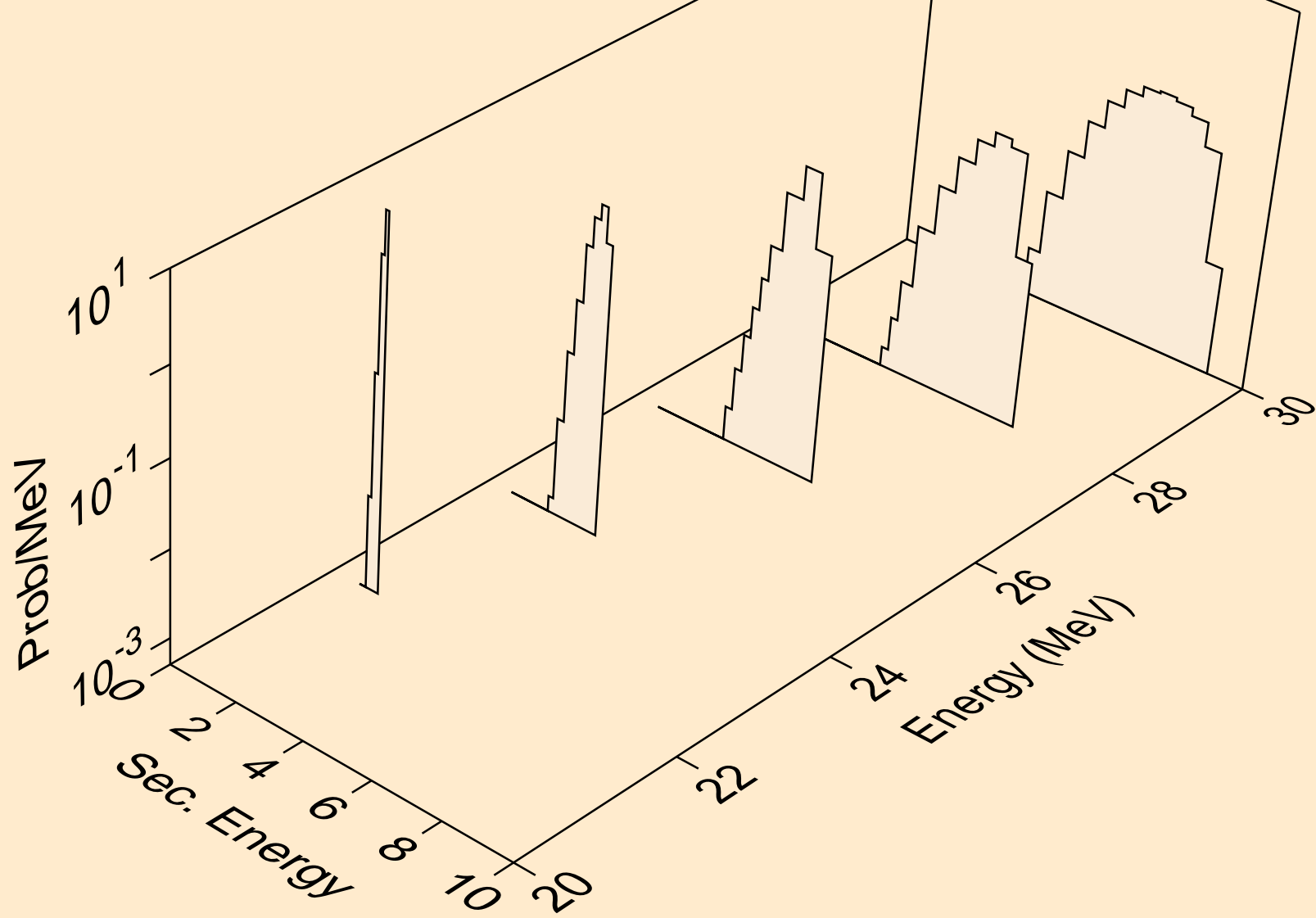

V049 PHOTON ACER TENDL-2023 LIBRARY; T=0.K  
alphas from (g,a)

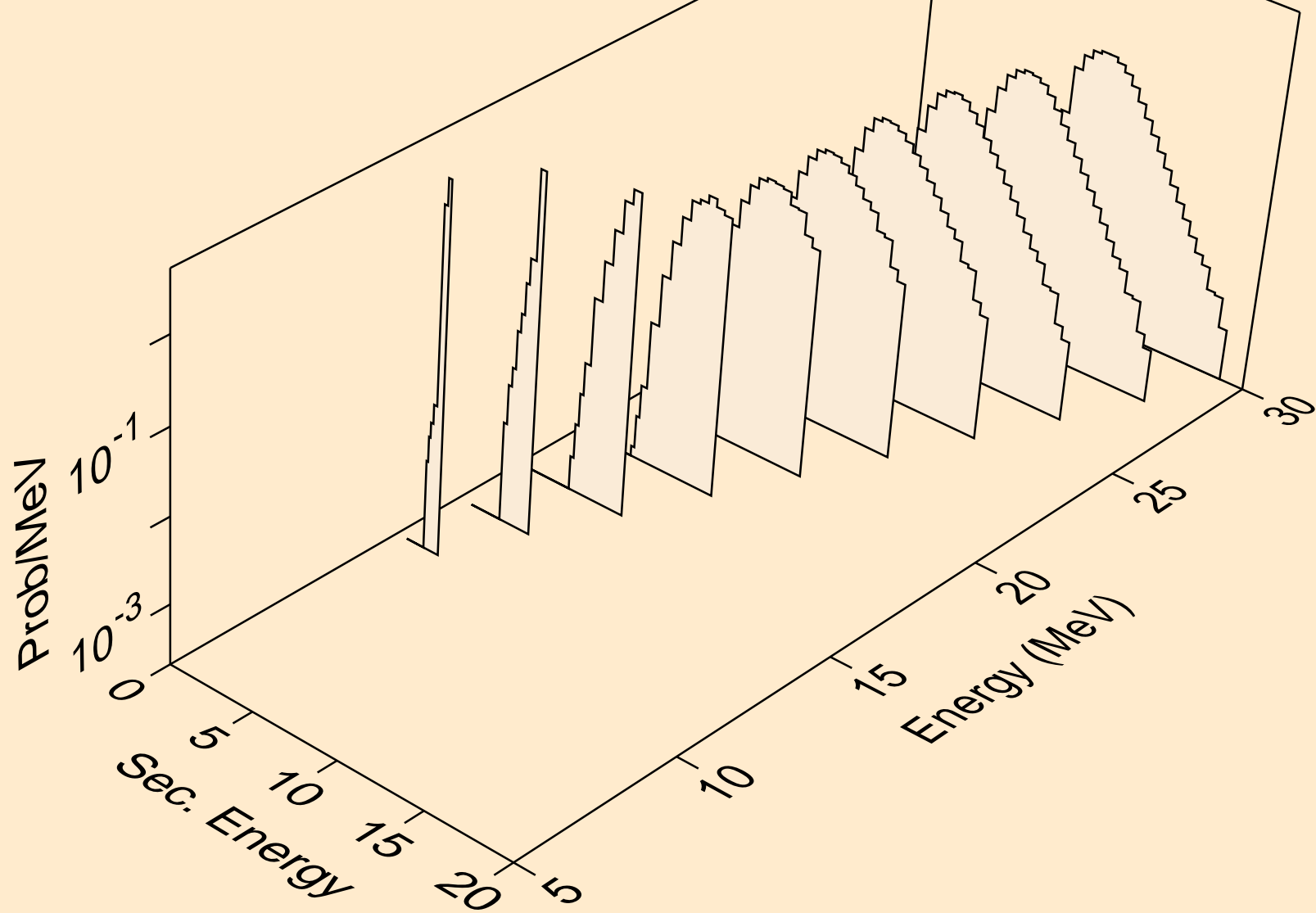

V049 PHOTON ACER TENDL-2023 LIBRARY; T=0.K  
alphas from (g,2a)

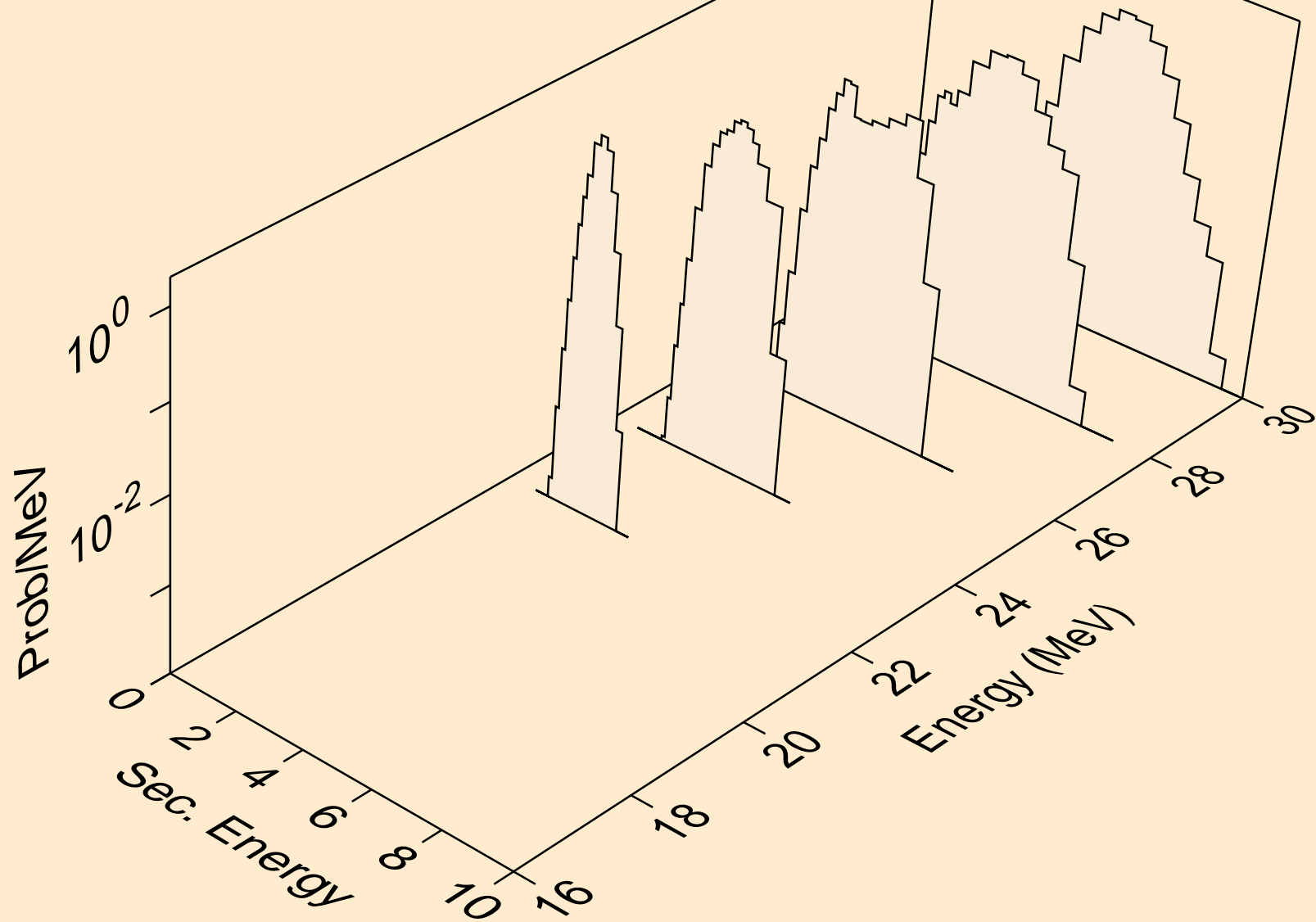

V049 PHOTON ACER TENDL-2023 LIBRARY; T=0.K  
alphas from (g,pa)

