

# Y080M PHOTON ACER TENDL-2023 LIBRARY; T=0.K

## Principal cross sections

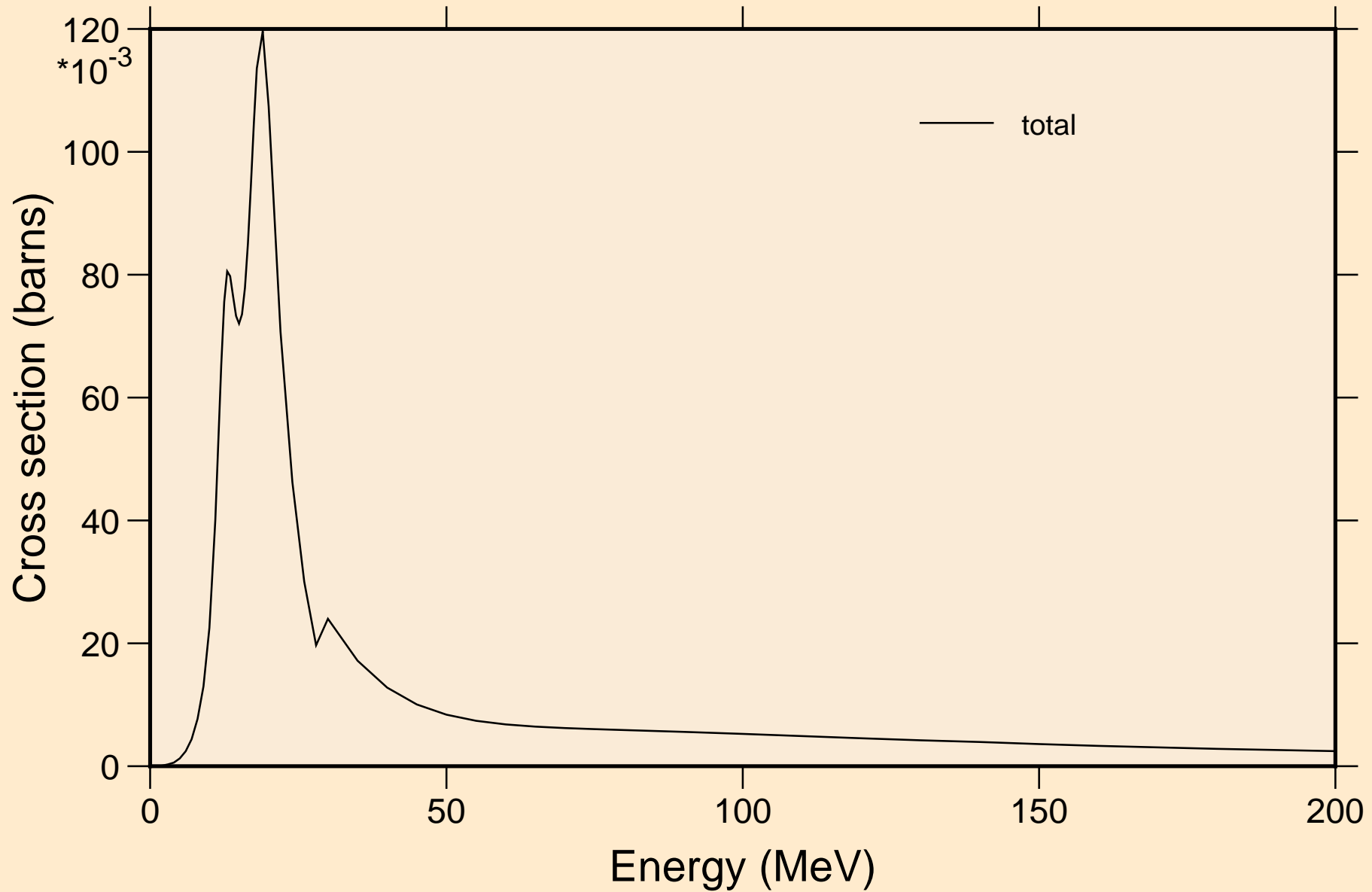

# Y080M PHOTON ACER TENDL-2023 LIBRARY; T=0.K

## Partial cross sections

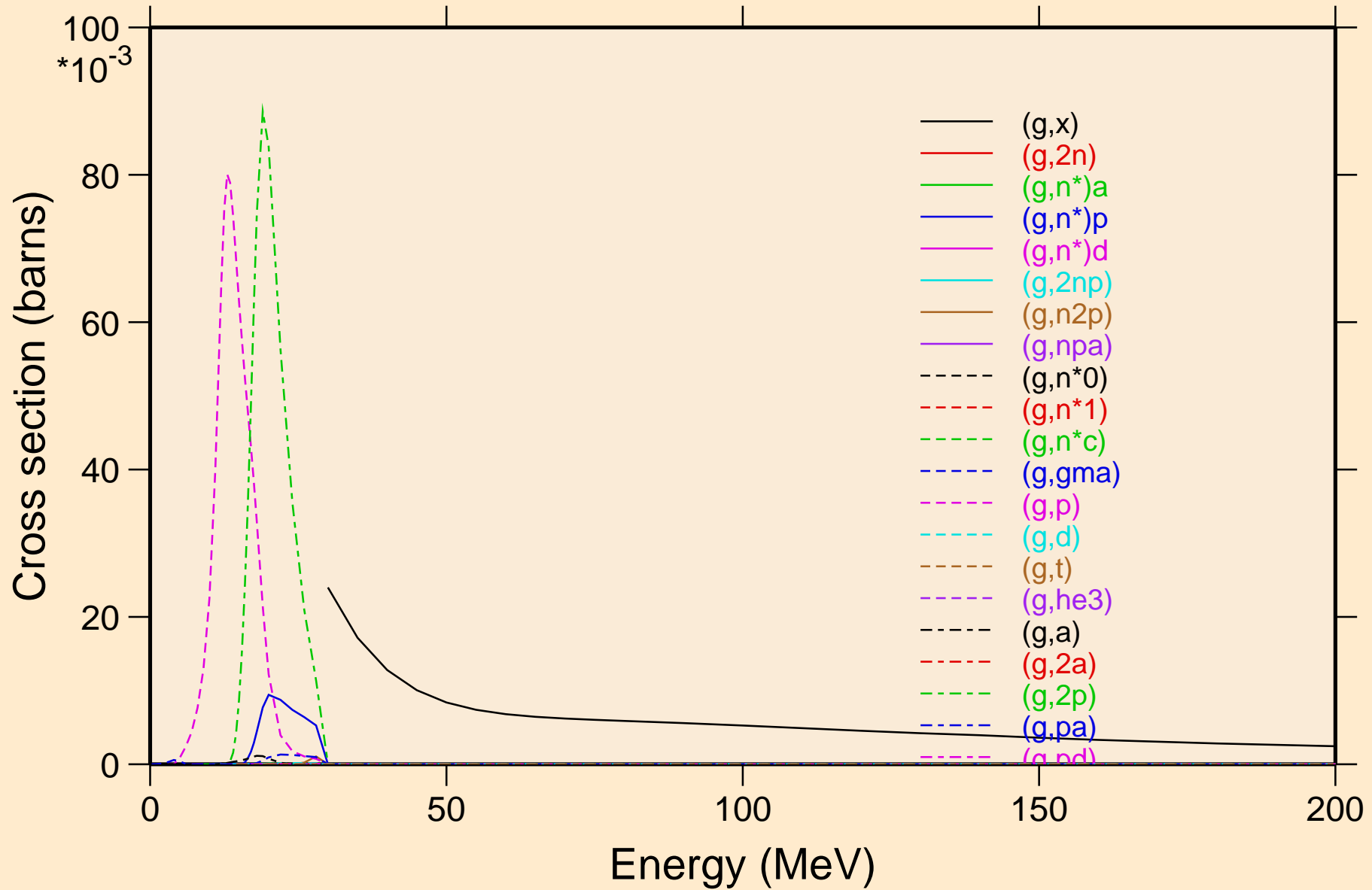

# Y080M PHOTON ACER TENDL-2023 LIBRARY; T=0.K

## Heating

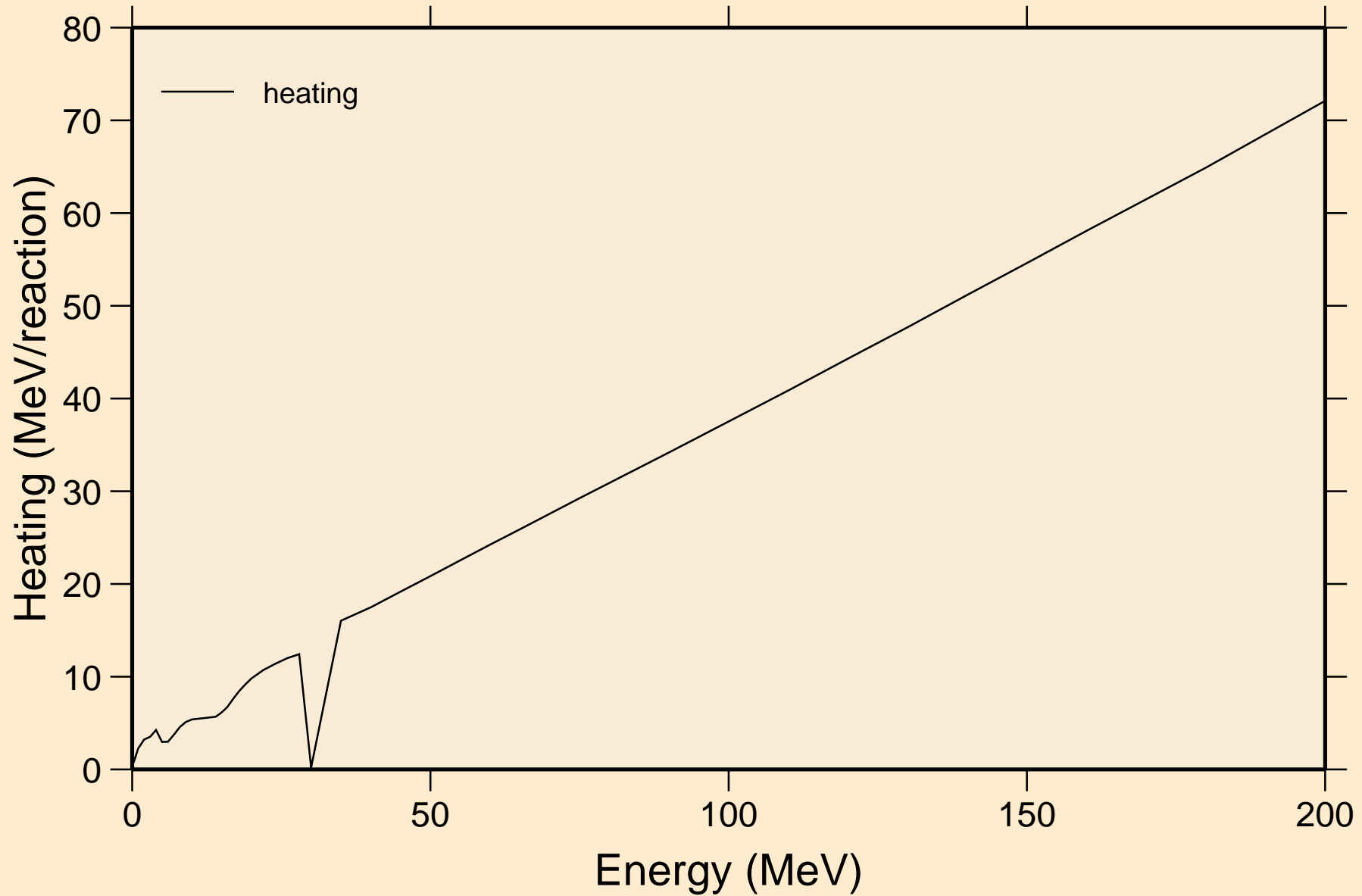

# Y080M PHOTON ACER TENDL-2023 LIBRARY; T=0.K

## Particle heating contributions

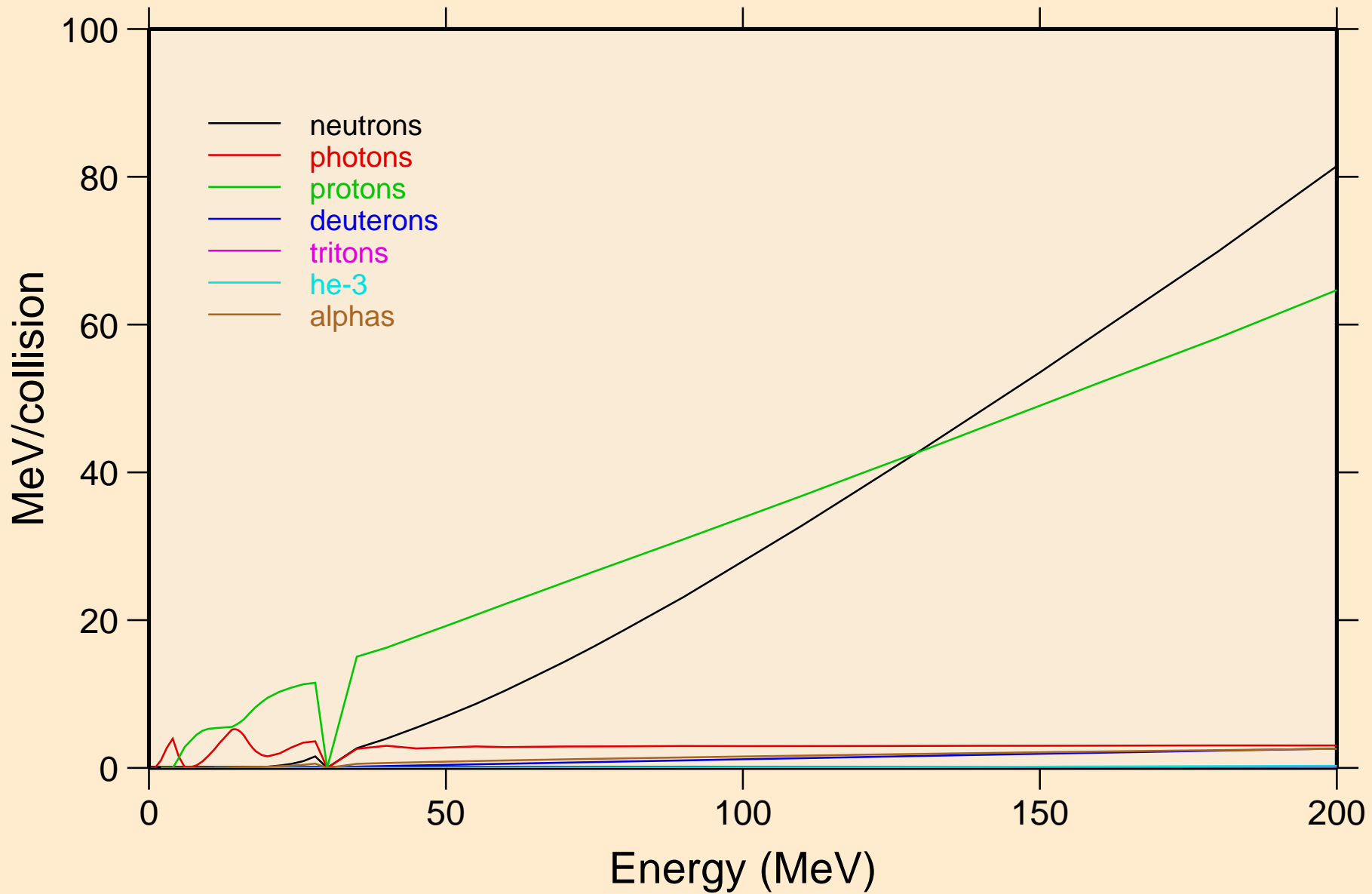

Y080M PHOTON ACER TENDL-2023 LIBRARY; T=0.K  
Particle production cross sections

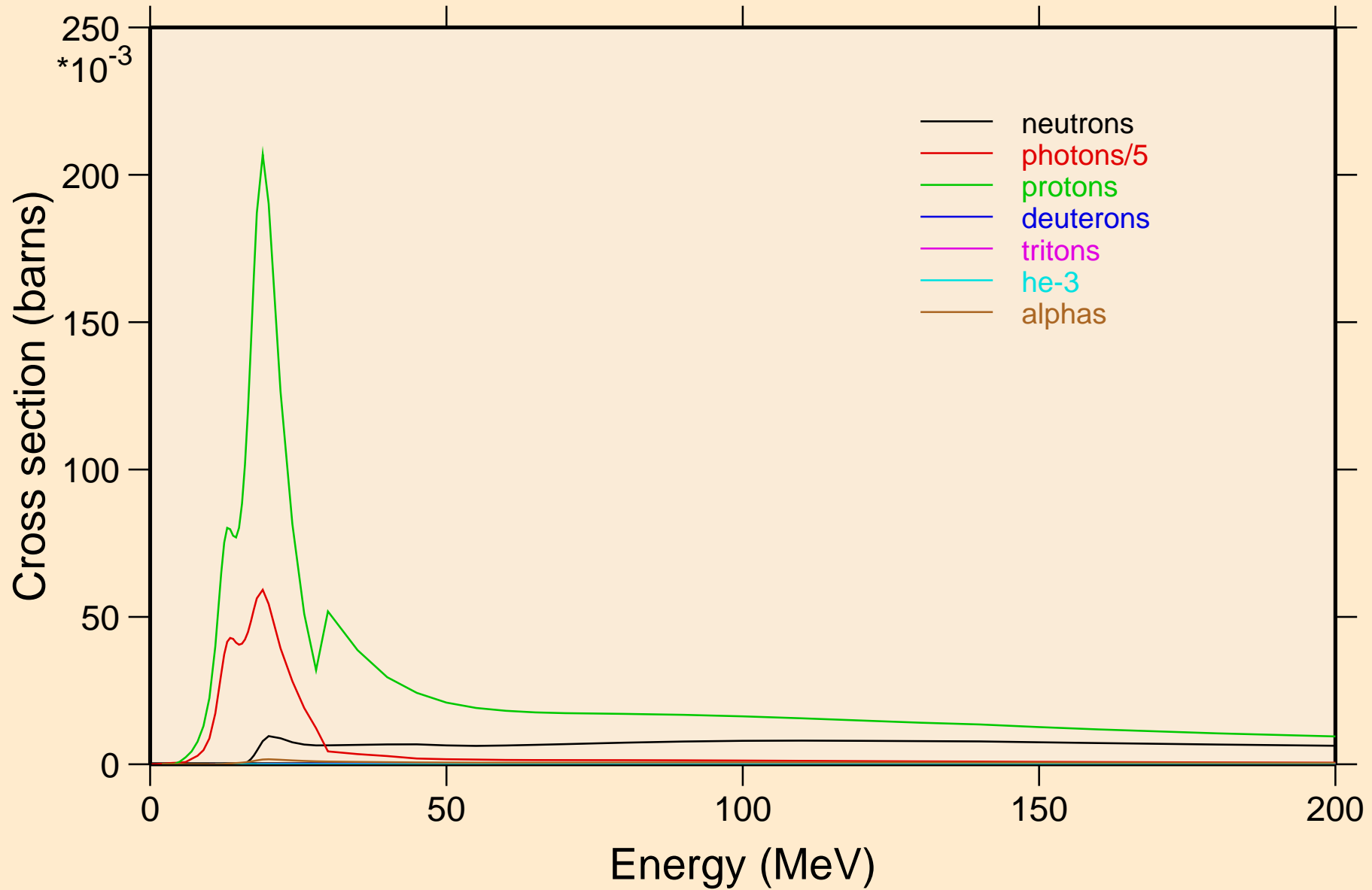

Y080M PHOTON ACER TENDL-2023 LIBRARY; T=0.K  
neutrons from (g,x)

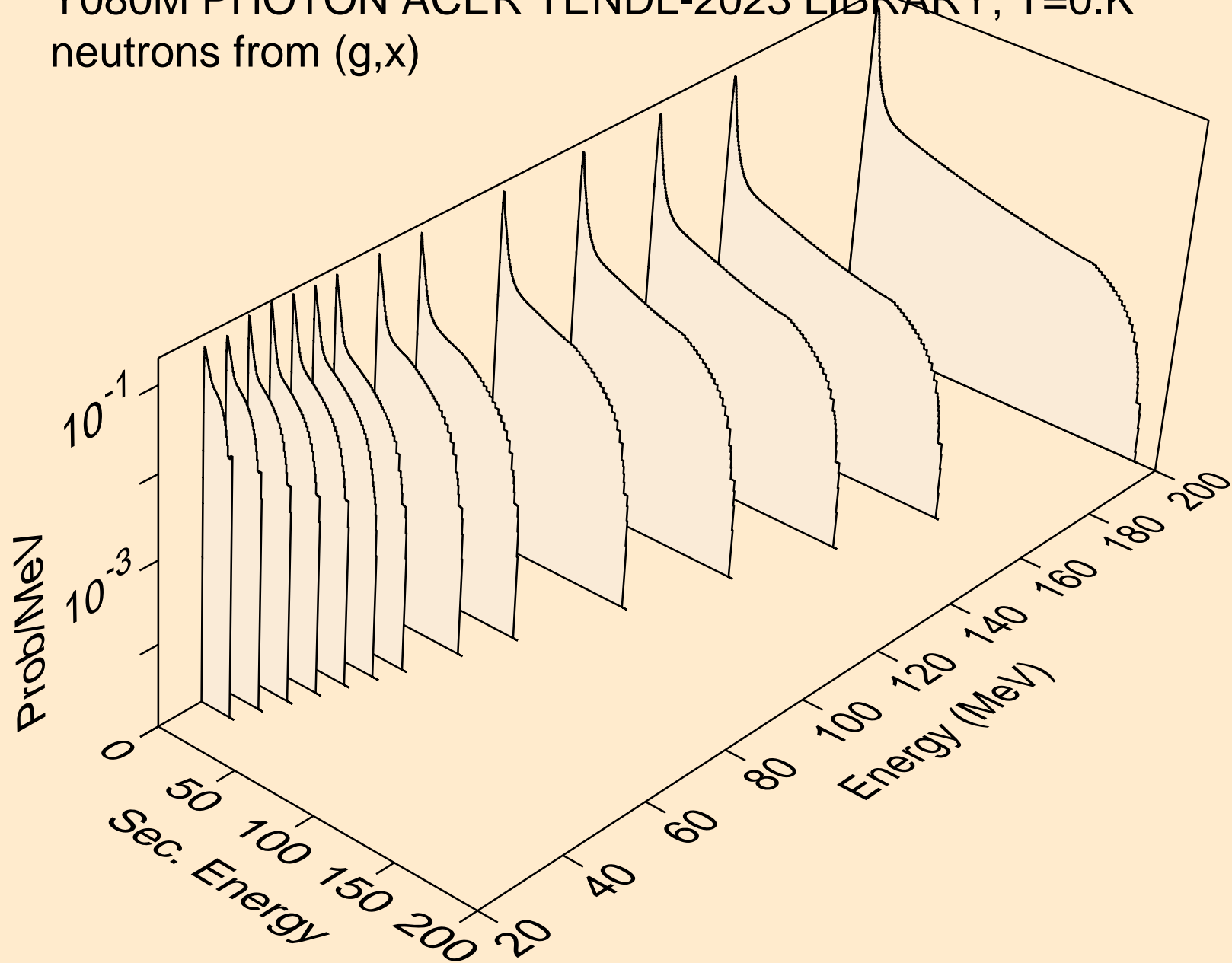

Y080M PHOTON ACER TENDL-2023 LIBRARY; T=0.K  
neutrons from (g,2n)

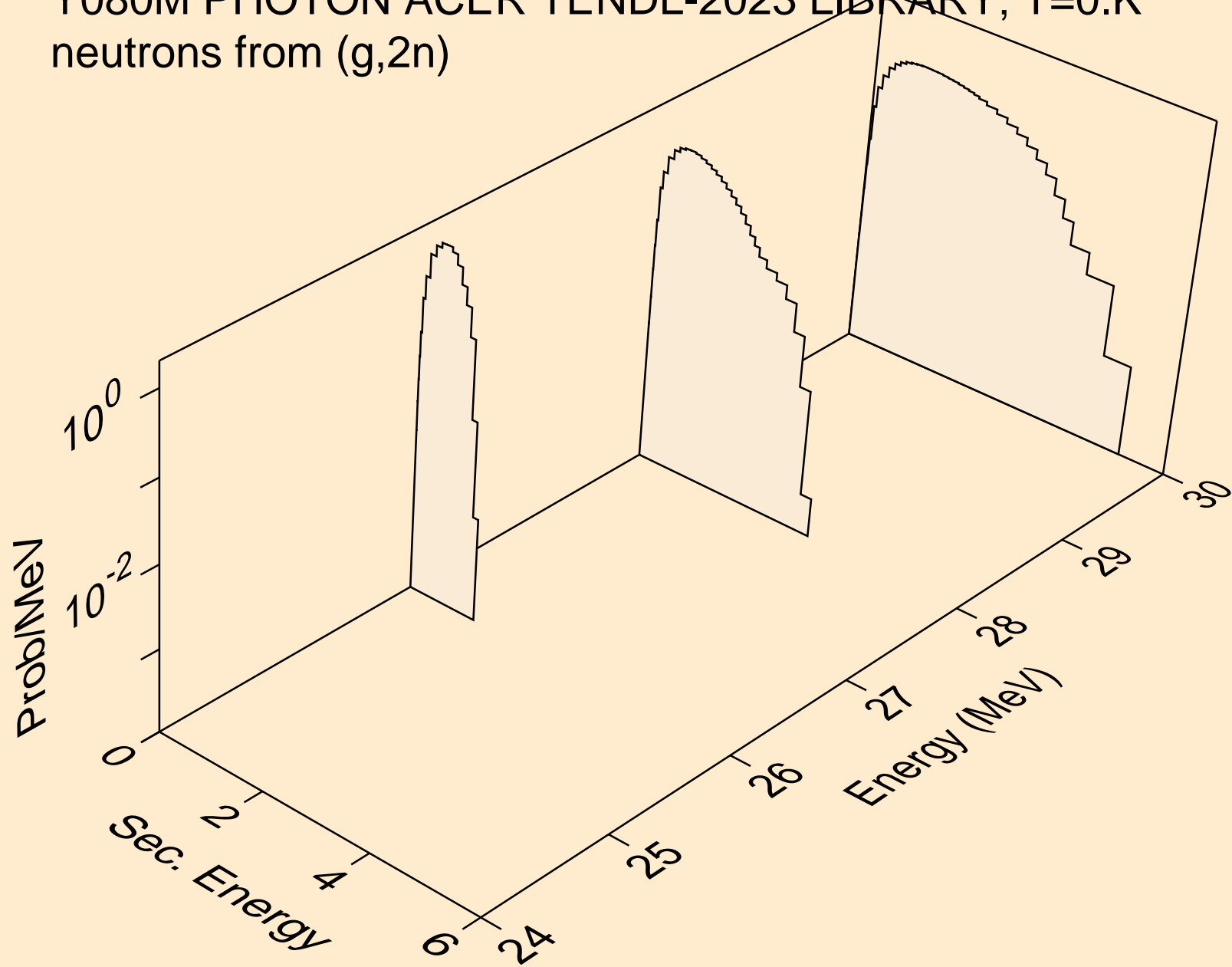

Y080M PHOTON ACER TENDL-2023 LIBRARY; T=0.K  
neutrons from (g,n\*)a

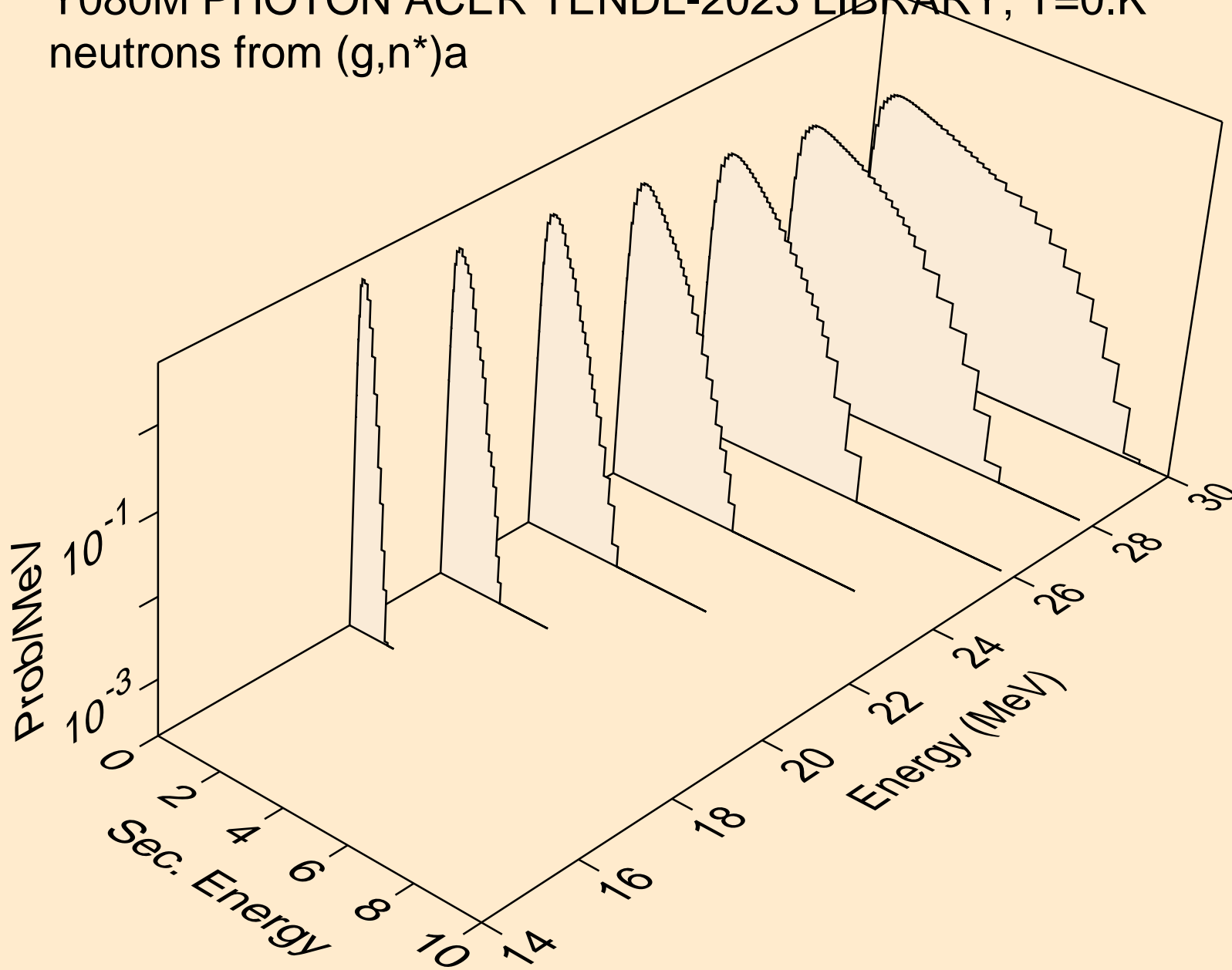



Y080M PHOTON ACER TENDL-2023 LIBRARY; T=0.K  
neutrons from (g,n\*)p

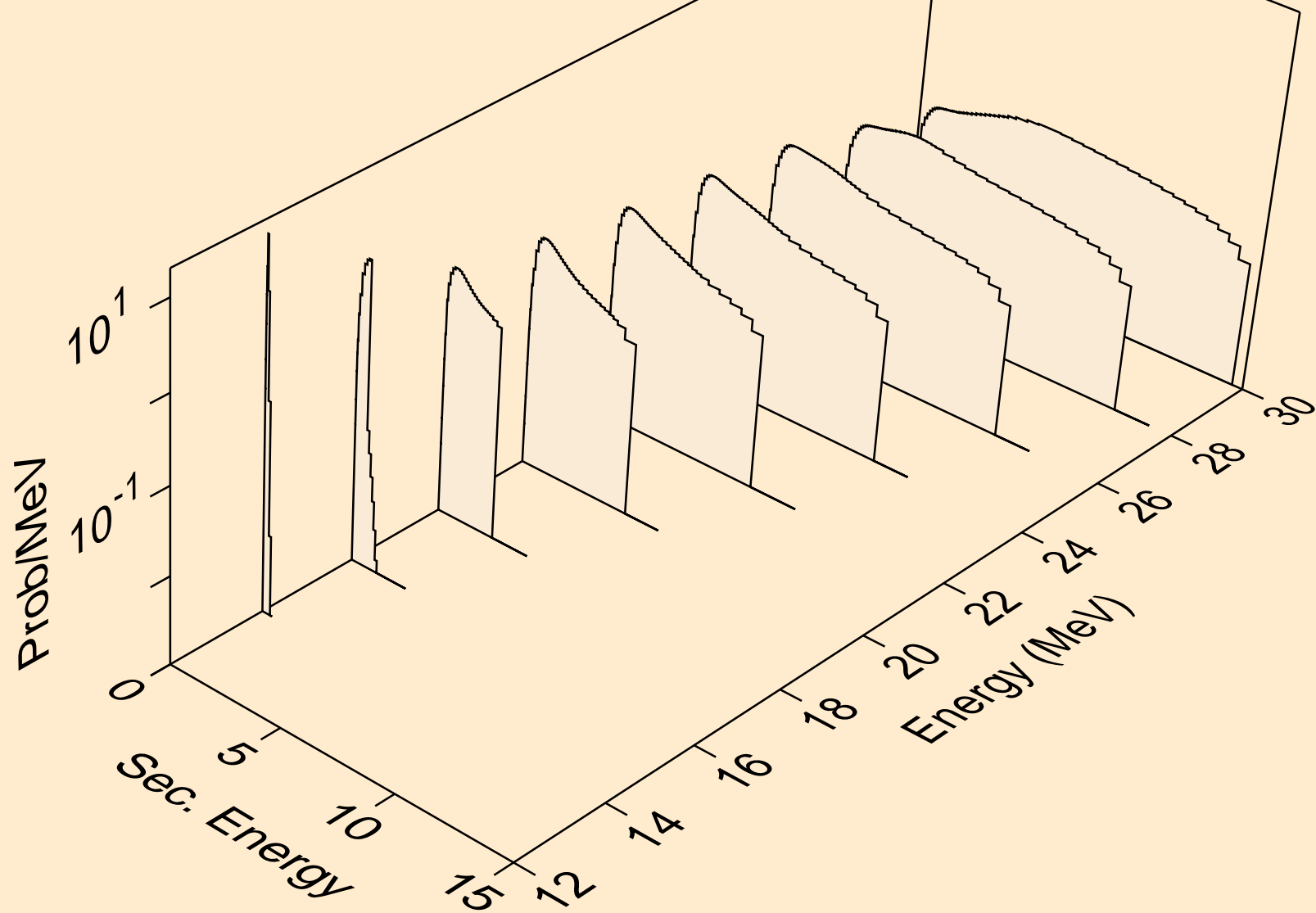

Y080M PHOTON ACER TENDL-2023 LIBRARY; T=0.K  
neutrons from (g,n\*)d

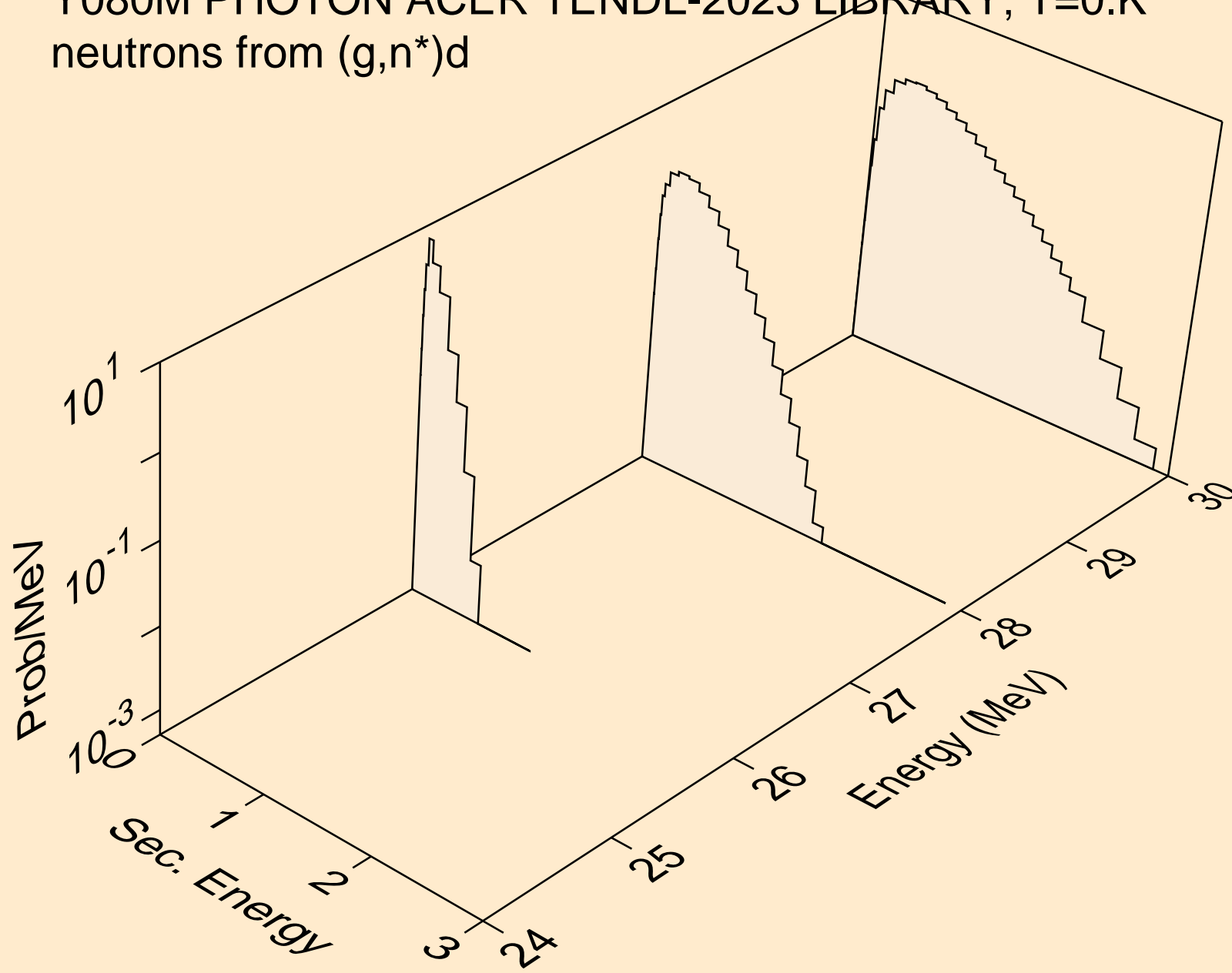

Y080M PHOTON ACER TENDL-2023 LIBRARY; T=0.K  
neutrons from (g,2np)

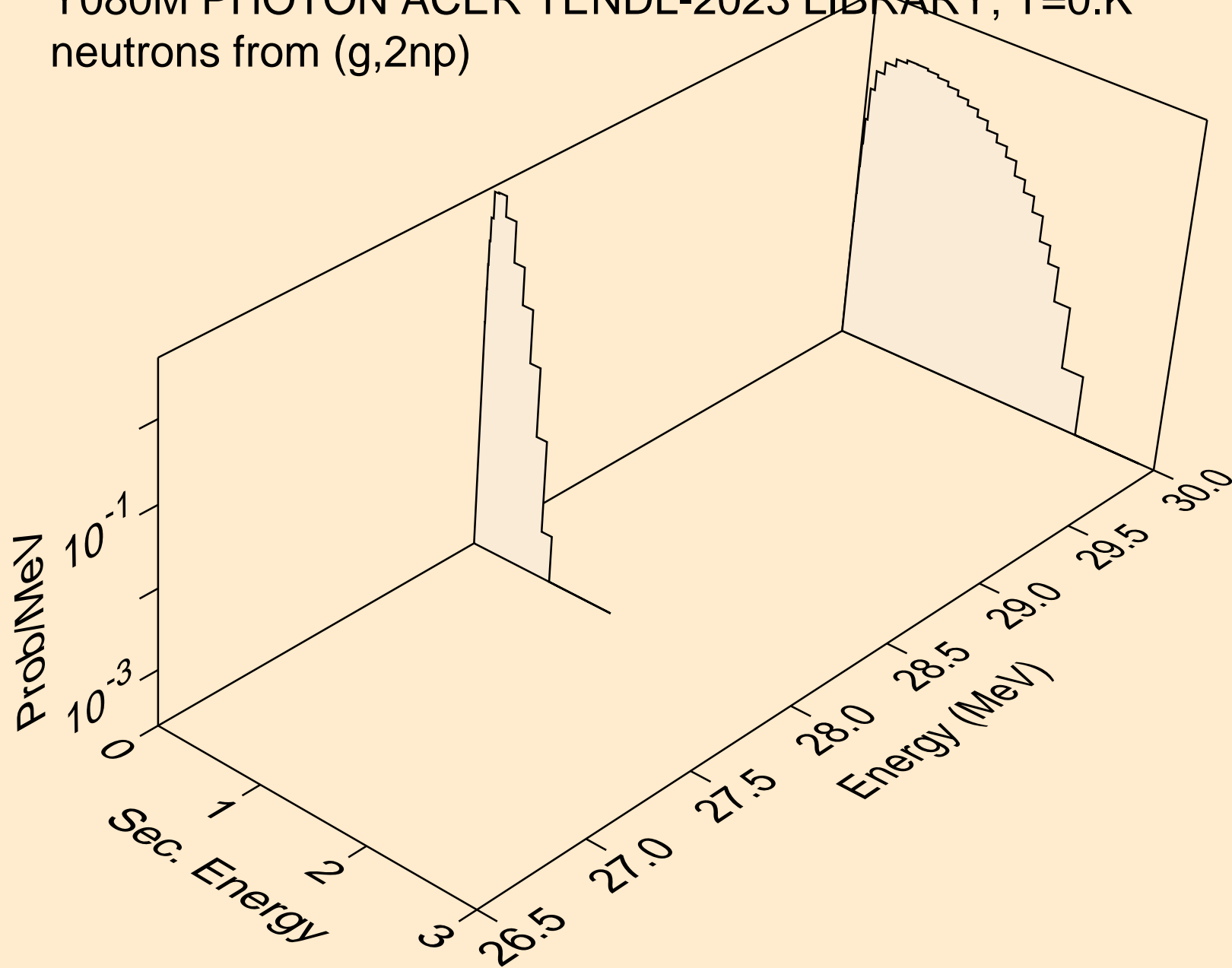

Y080M PHOTON ACER TENDL-2023 LIBRARY; T=0.K  
neutrons from (g,n2p)

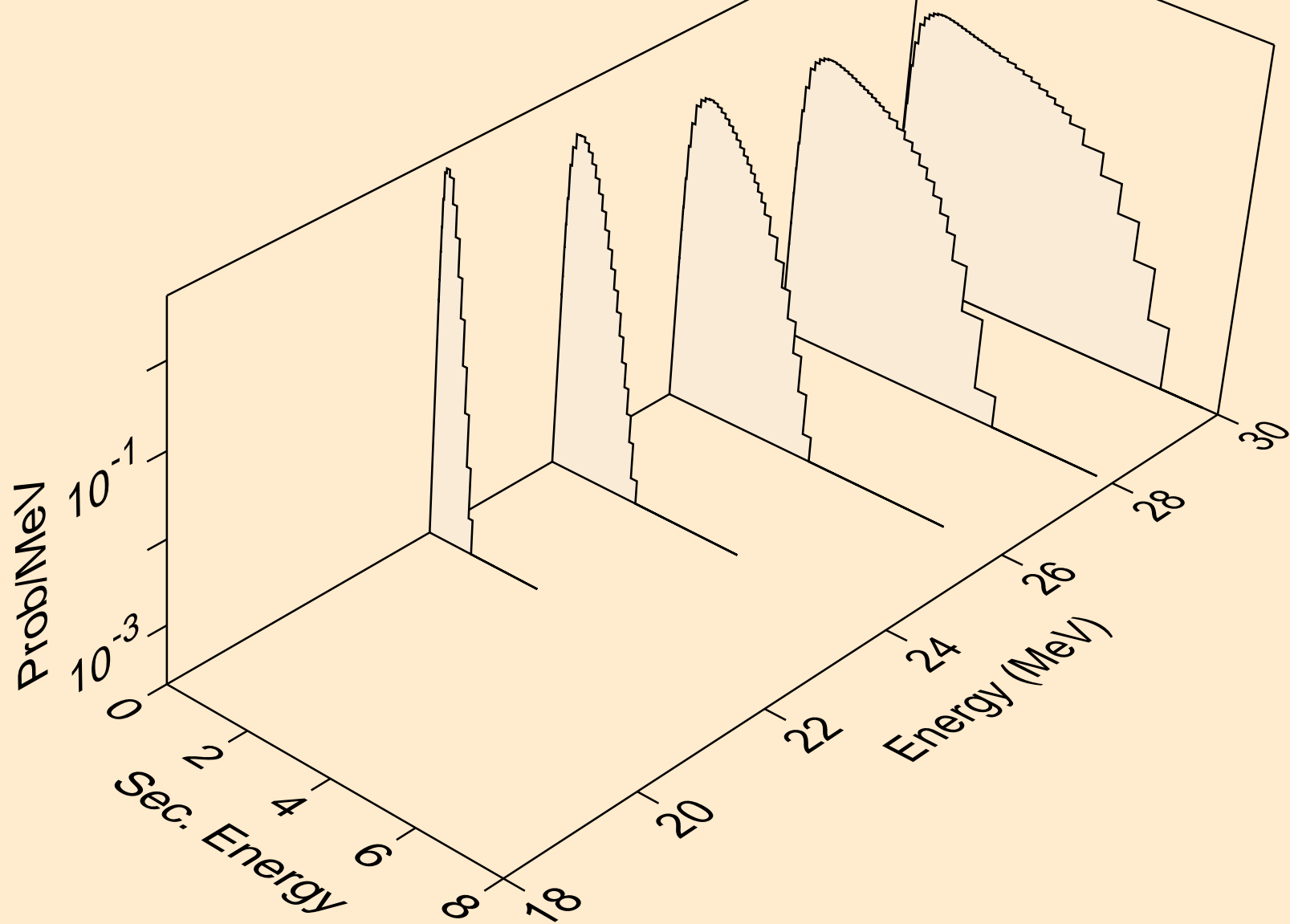

Y080M PHOTON ACER TENDL-2023 LIBRARY; T=0.K  
neutrons from (g,npa)

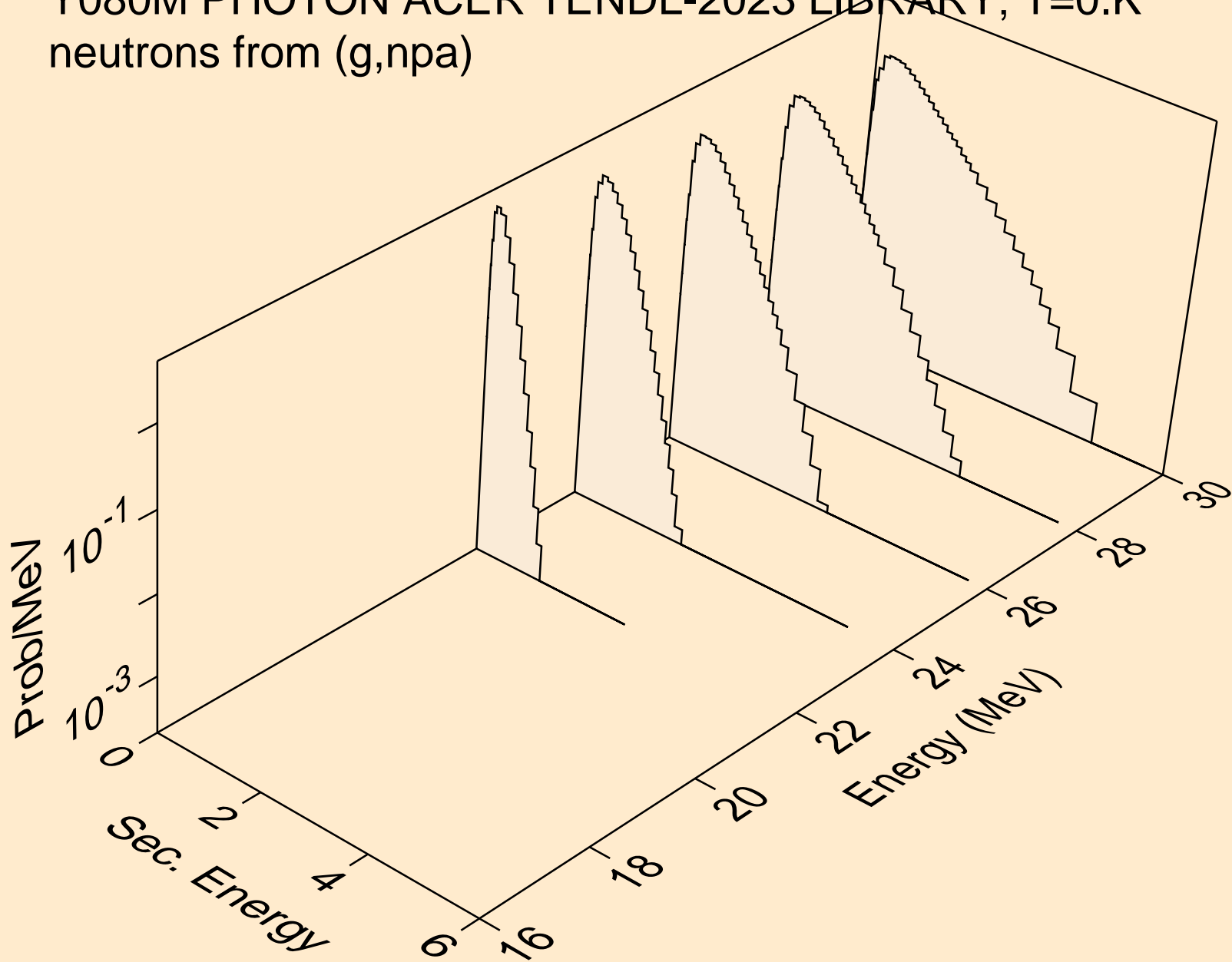

Y080M PHOTON ACER TENDL-2023 LIBRARY; T=0.K  
angular distribution for (g,n\*0) neutron

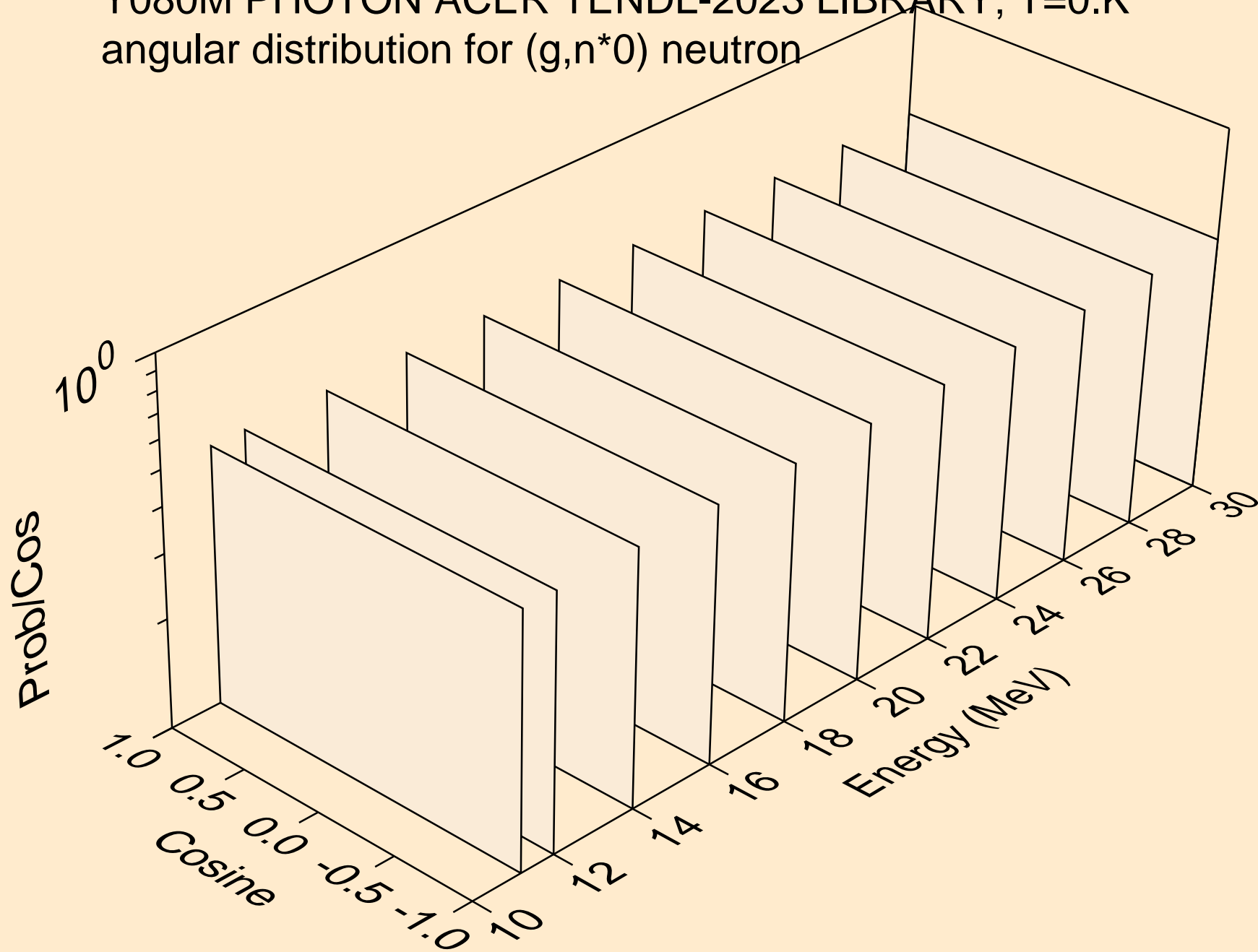

Y080M PHOTON ACER TENDL-2023 LIBRARY; T=0.K  
angular distribution for (g,n\*1) neutron

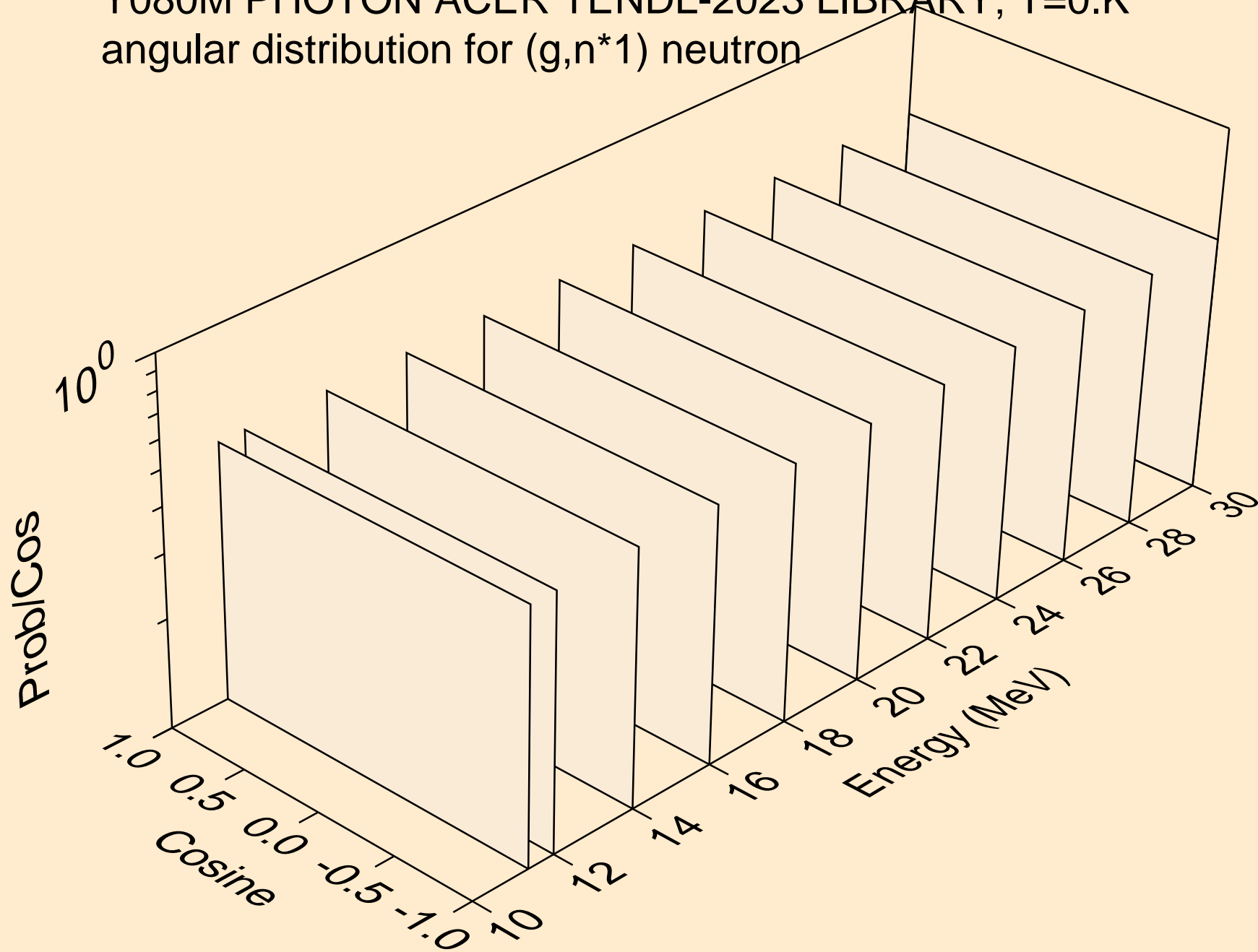

Y080M PHOTON ACER TENDL-2023 LIBRARY; T=0.K  
neutrons from (g,n\*c)

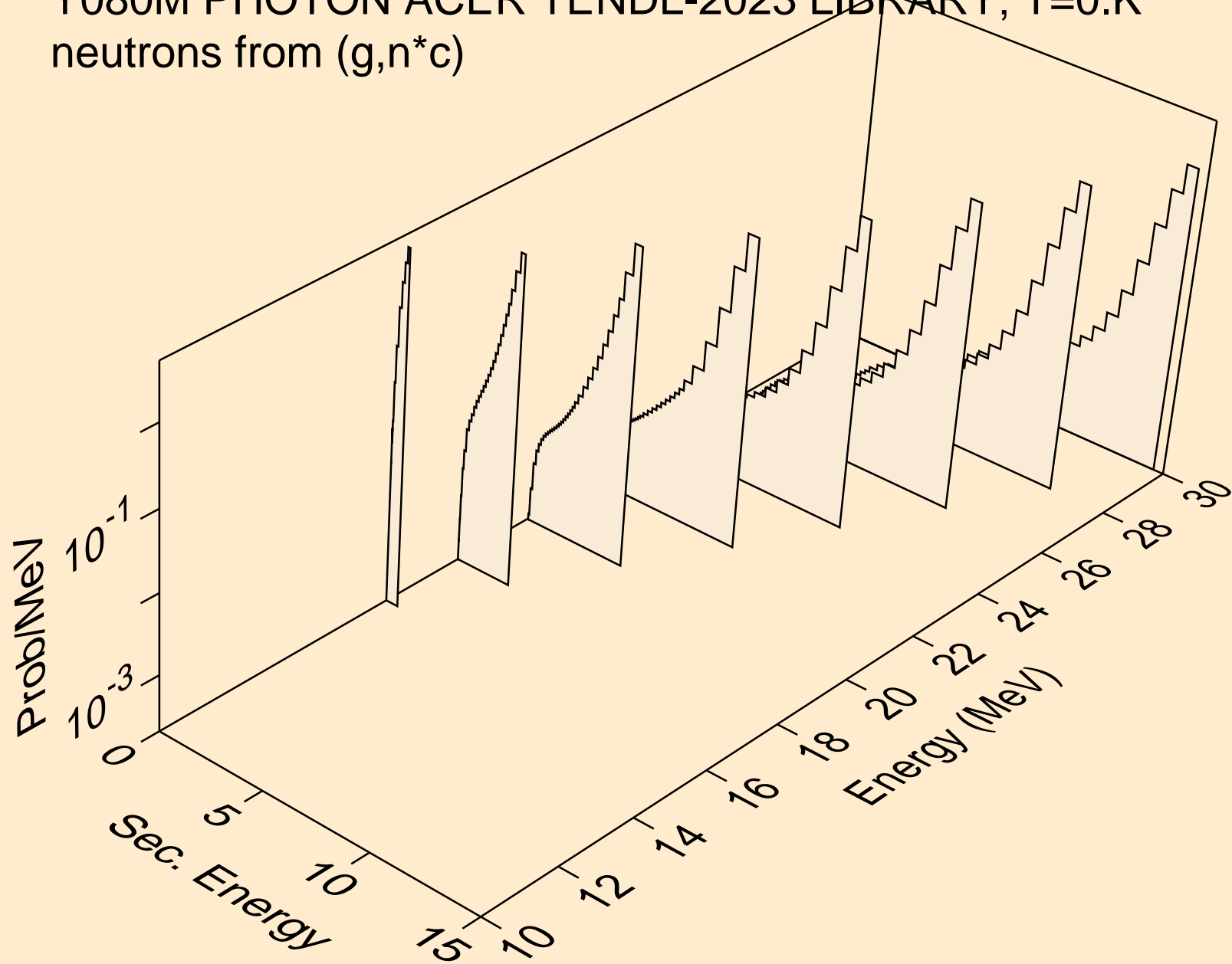



Y080M PHOTON ACER TENDL-2023 LIBRARY; T=0.K  
photons from (g,x)

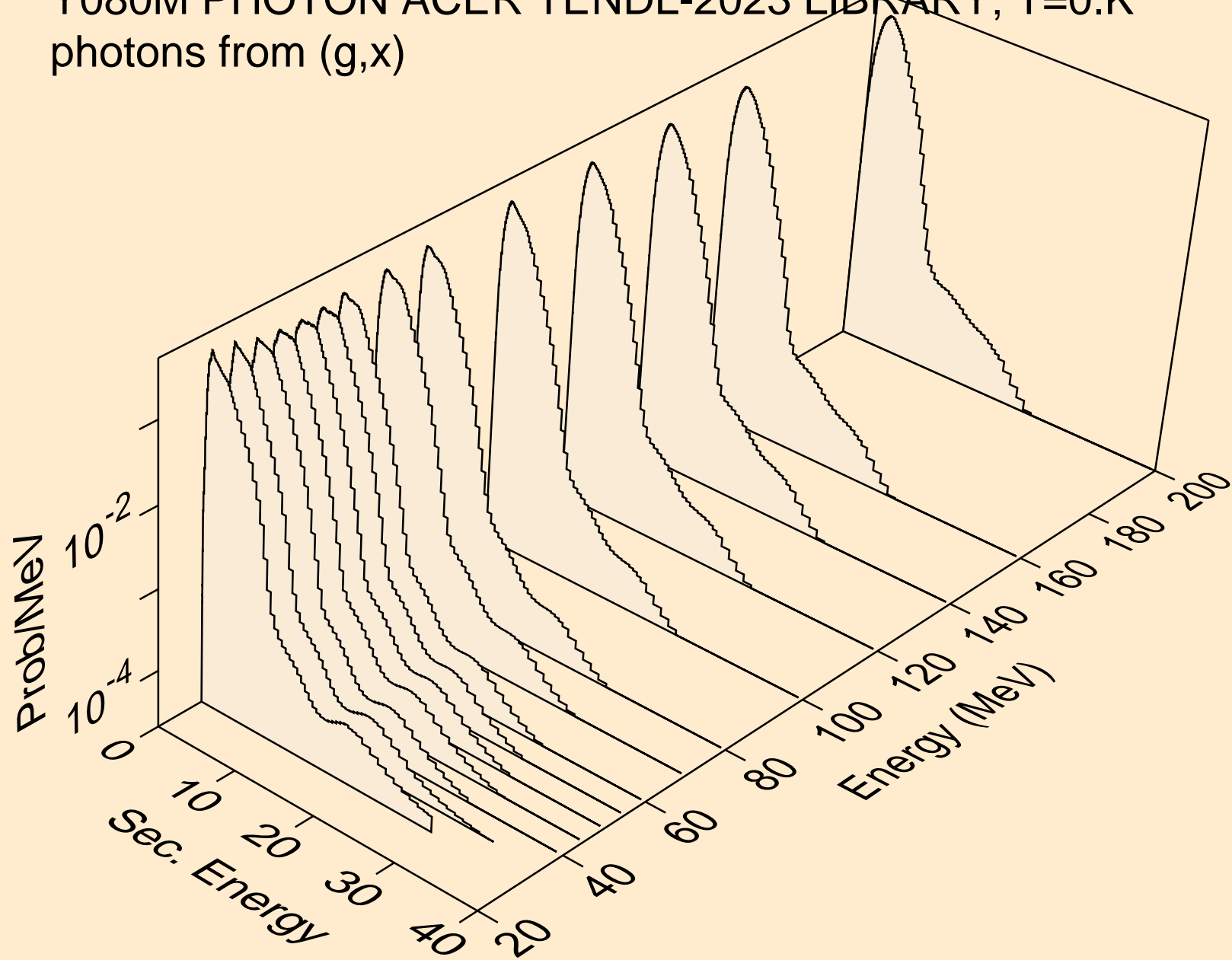

Y080M PHOTON ACER TENDL-2023 LIBRARY; T=0.K  
photons from (g,2n)

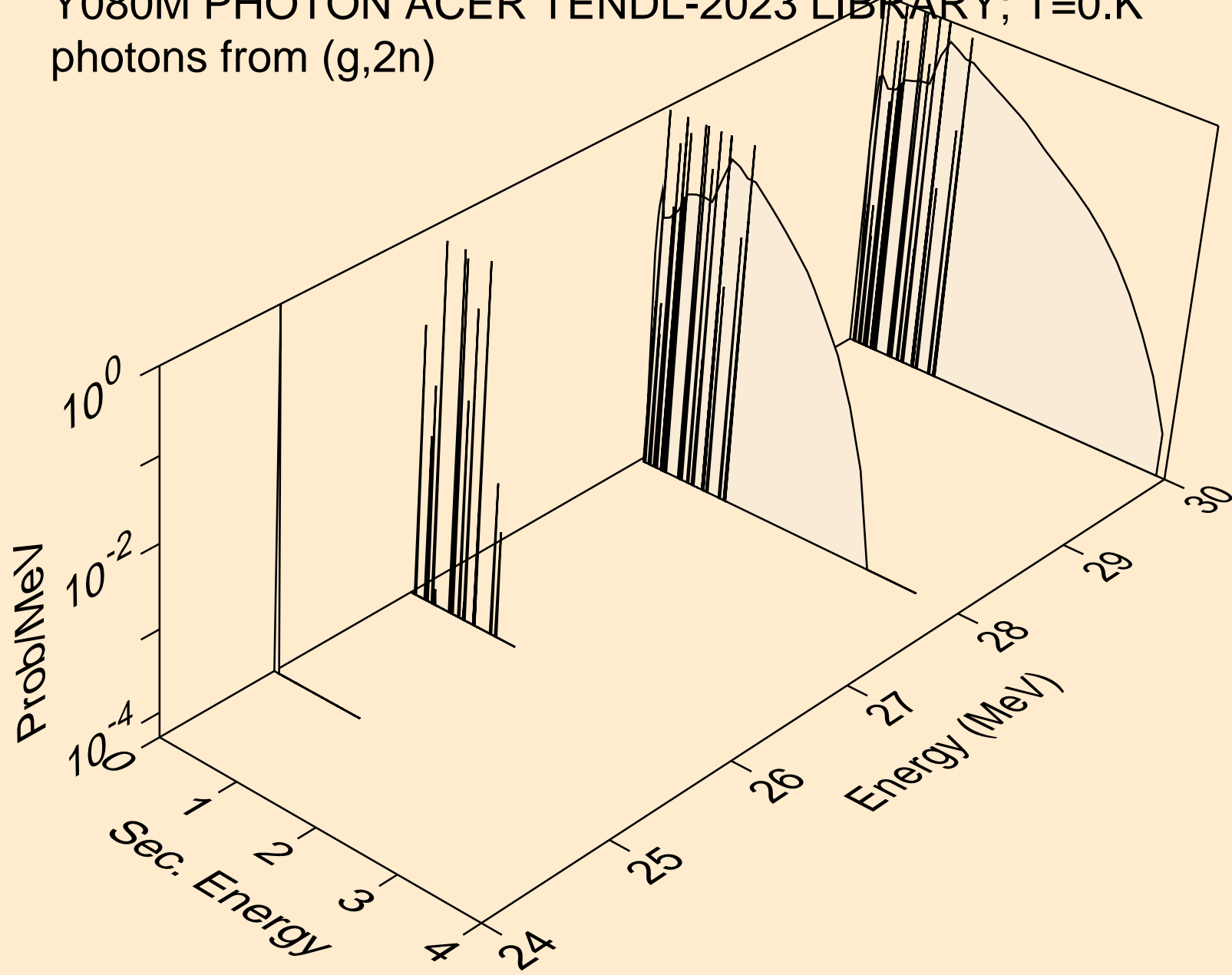

Y080M PHOTON ACER TENDL-2023 LIBRARY; T=0.K  
photons from (g,n\*)a

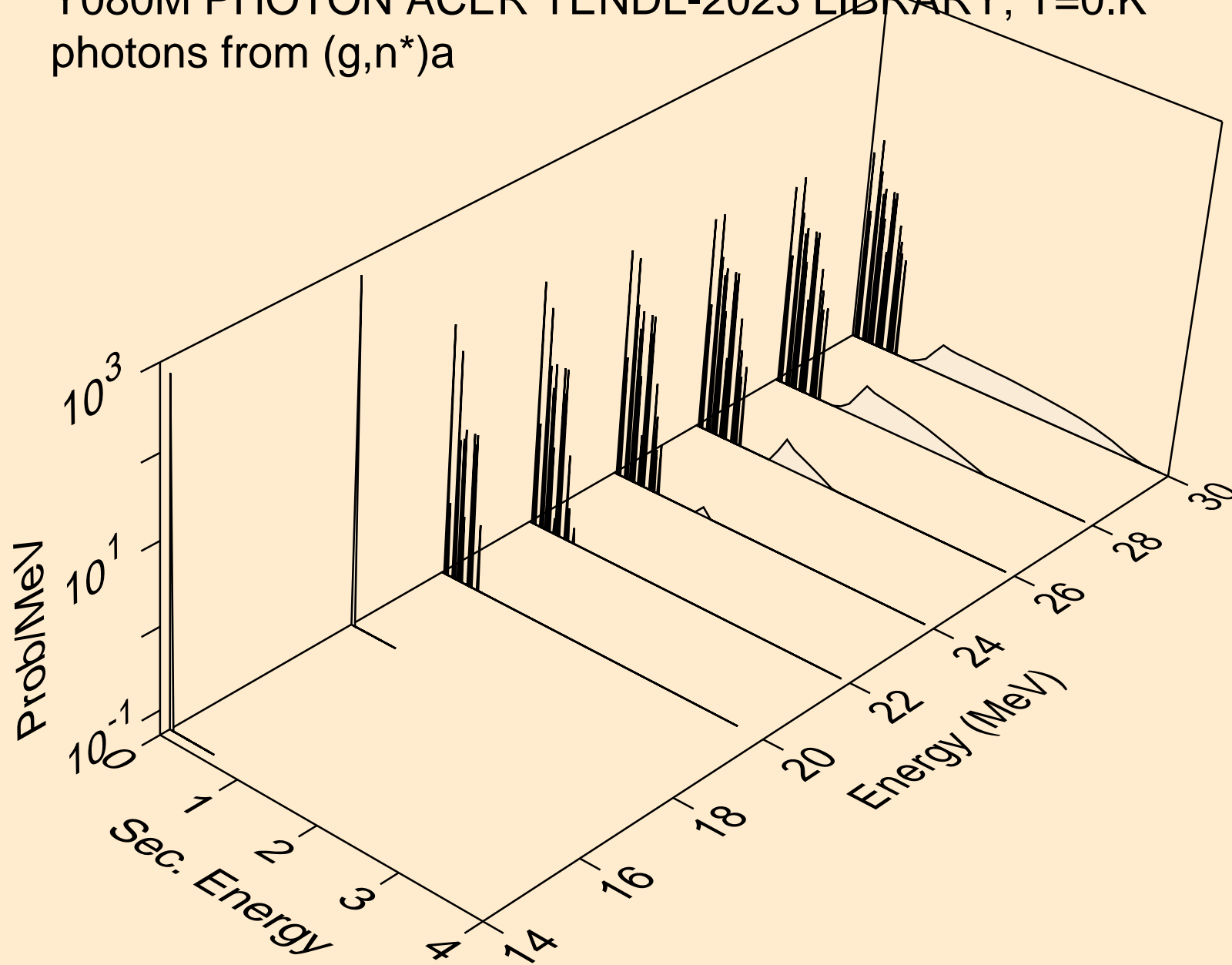

Y080M PHOTON ACER TENDL-2023 LIBRARY; T=0.K  
photons from (g,n\*)p

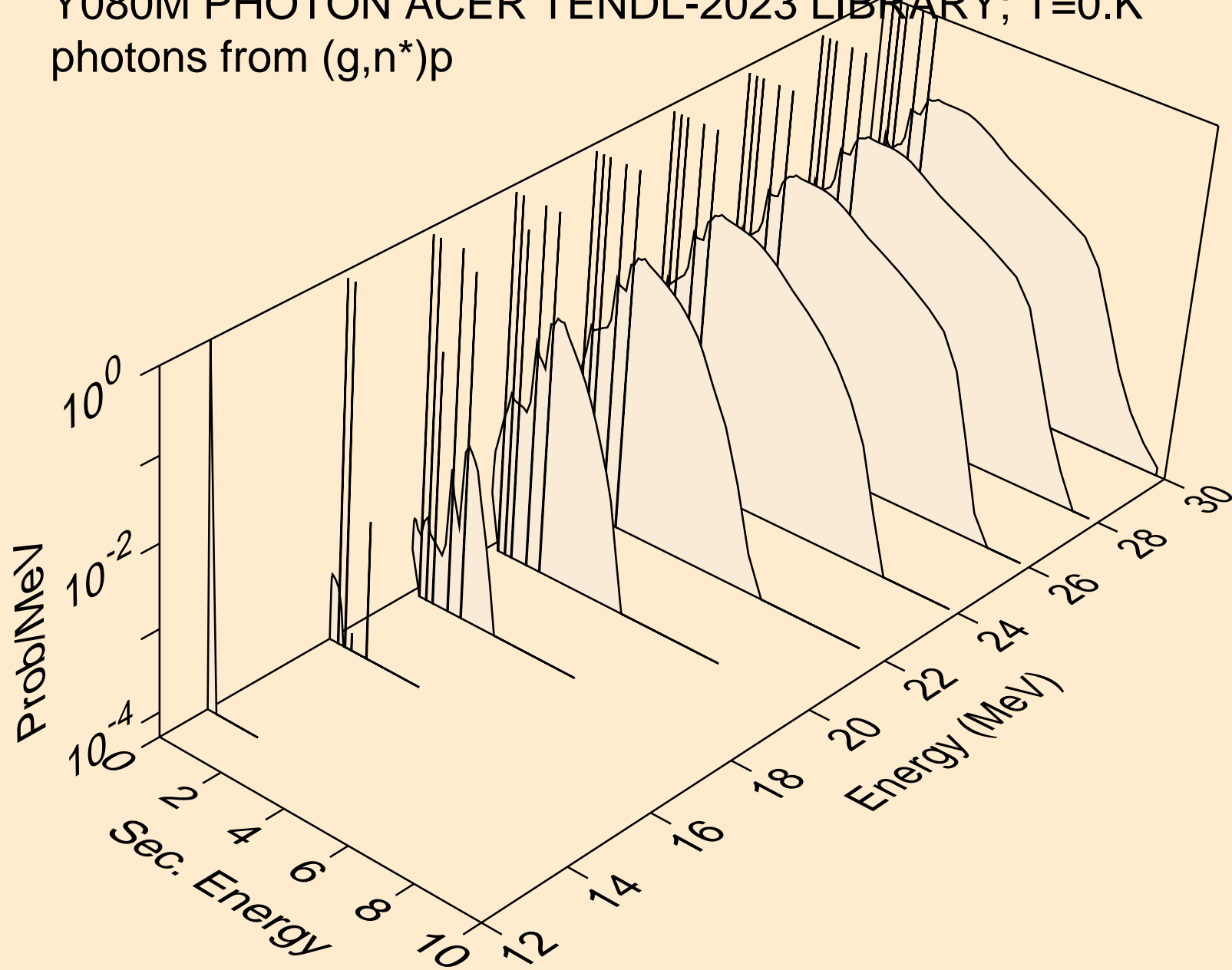

Y080M PHOTON ACER TENDL-2023 LIBRARY; T=0.K  
photons from (g,n\*)d

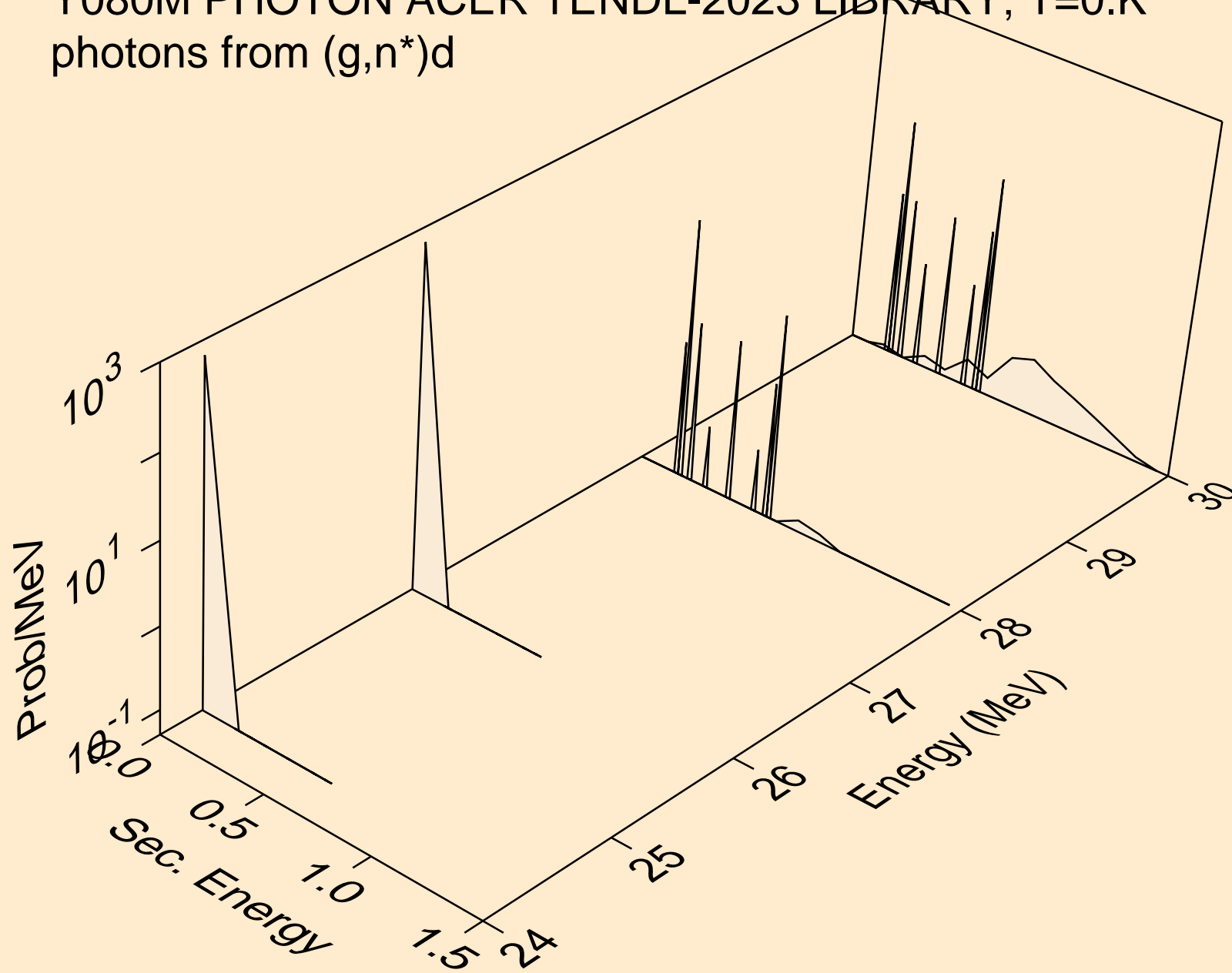

Y080M PHOTON ACER TENDL-2023 LIBRARY; T=0.K  
photons from (g,2np)

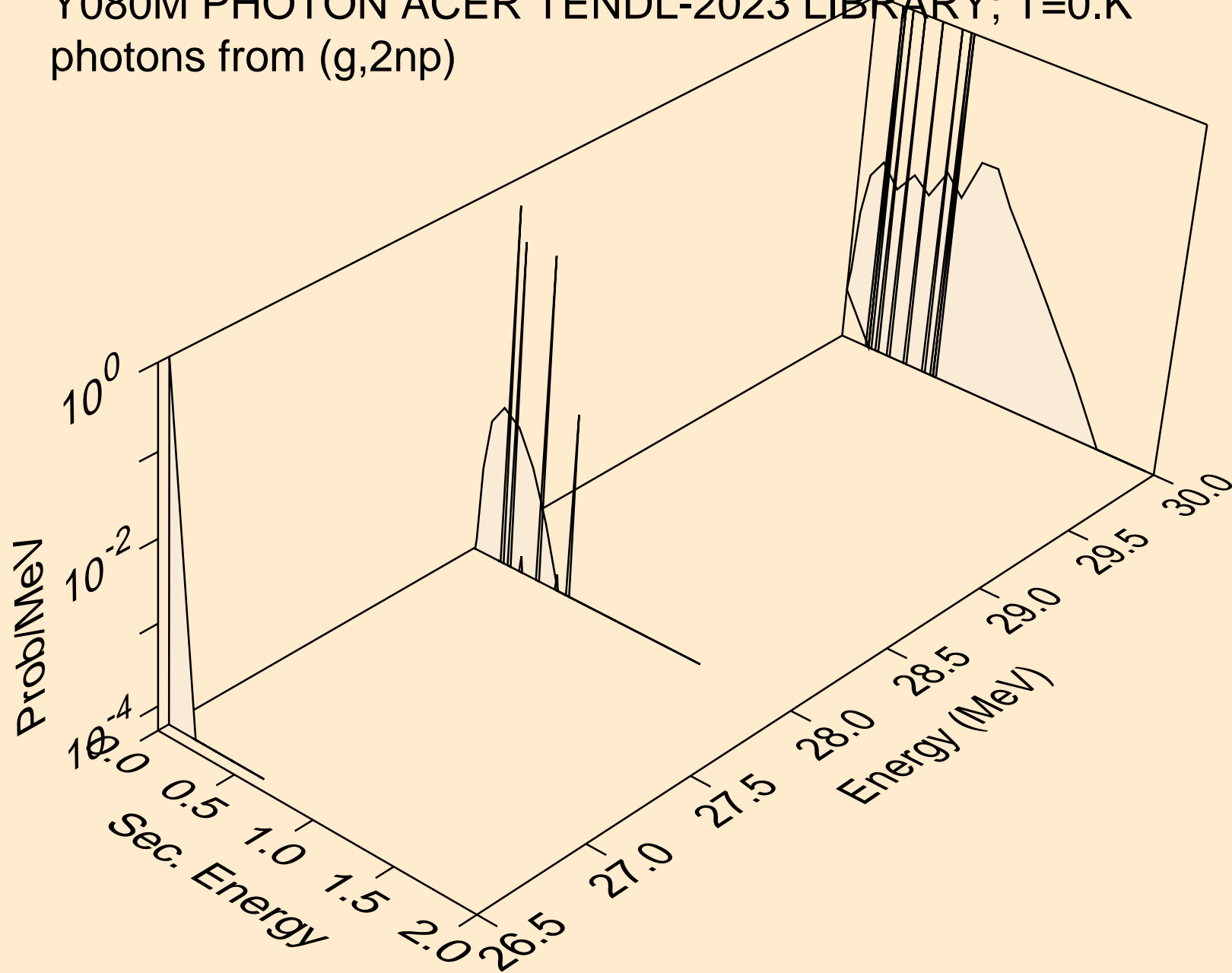

Y080M PHOTON ACER TENDL-2023 LIBRARY; T=0.K  
photons from (g,n2p)

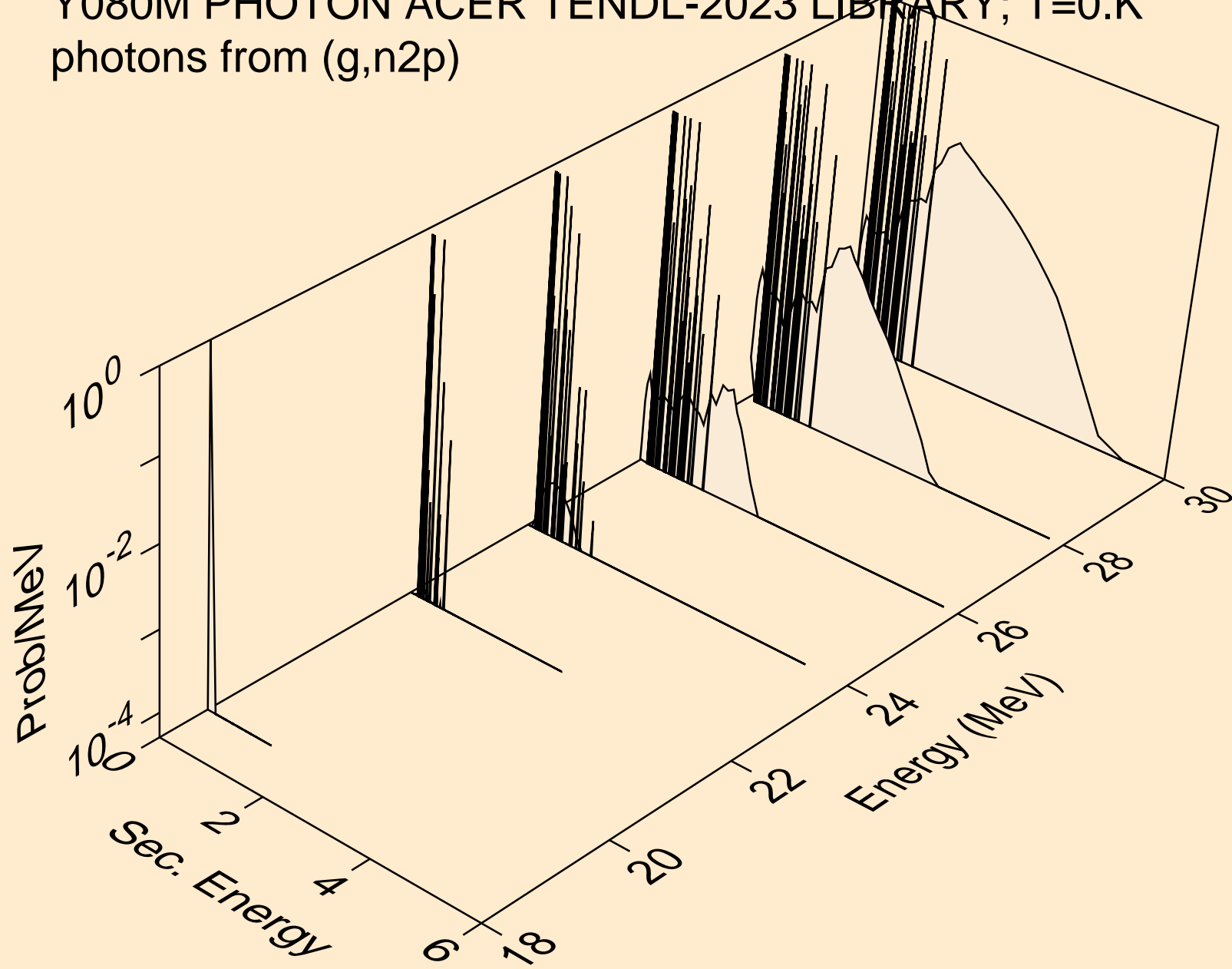

Y080M PHOTON ACER TENDL-2023 LIBRARY; T=0.K  
photons from (g,npa)

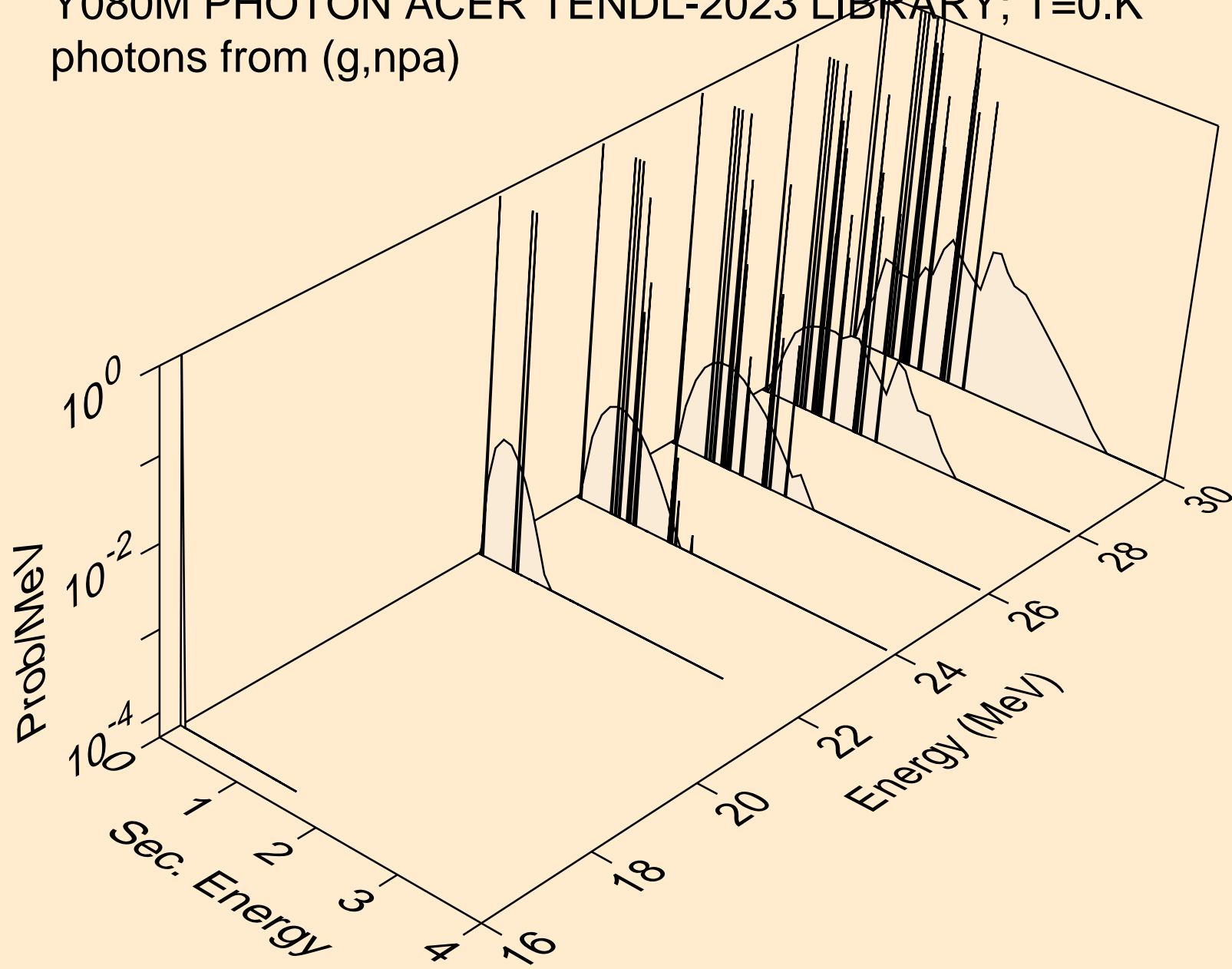



Y080M PHOTON ACER TENDL-2023 LIBRARY; T=0.K  
photons from (g,n\*c)

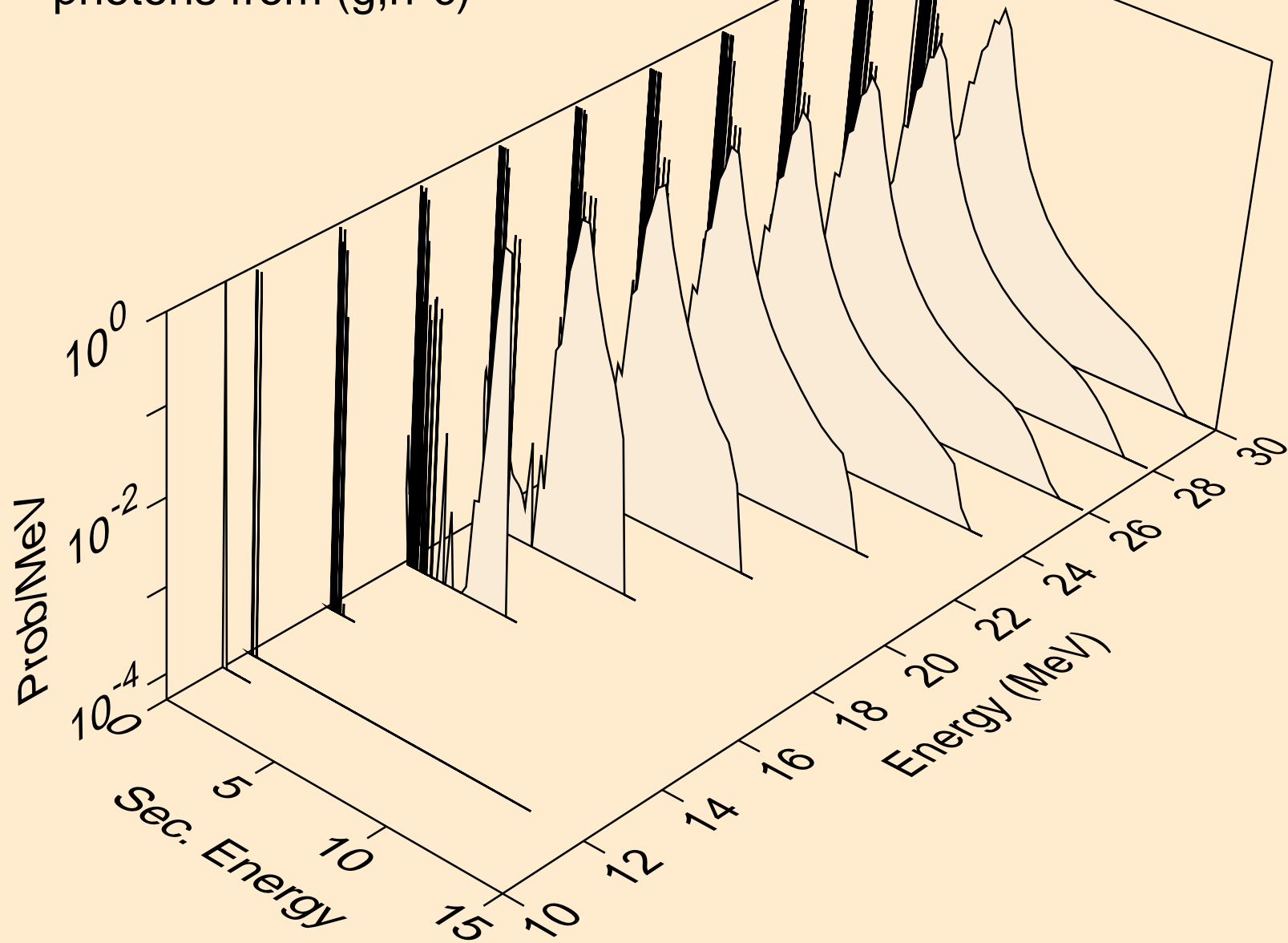

Y080M PHOTON ACER TENDL-2023 LIBRARY; T=0.K  
photons from (g,gma)

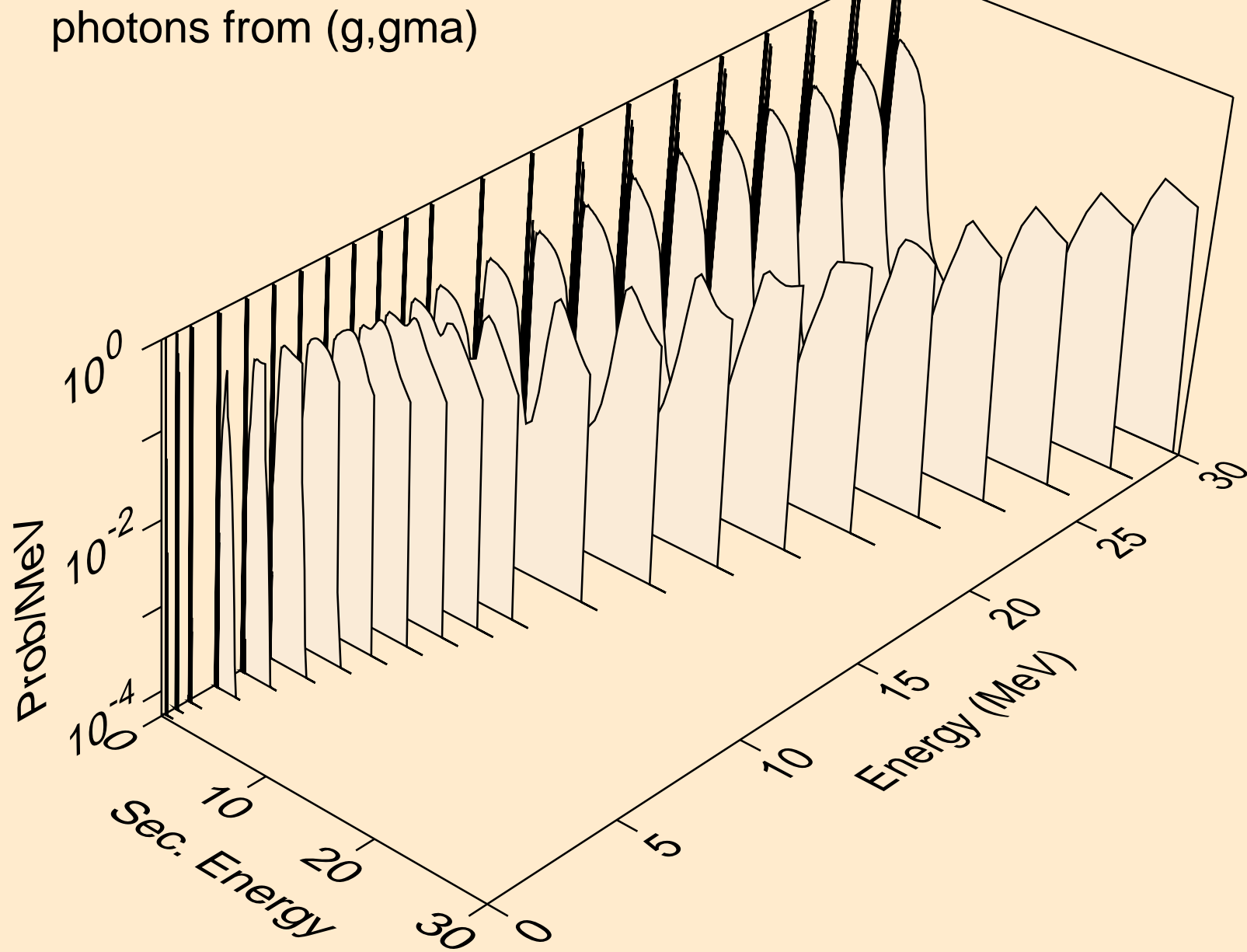

Y080M PHOTON ACER TENDL-2023 LIBRARY; T=0.K  
photons from (g,p)

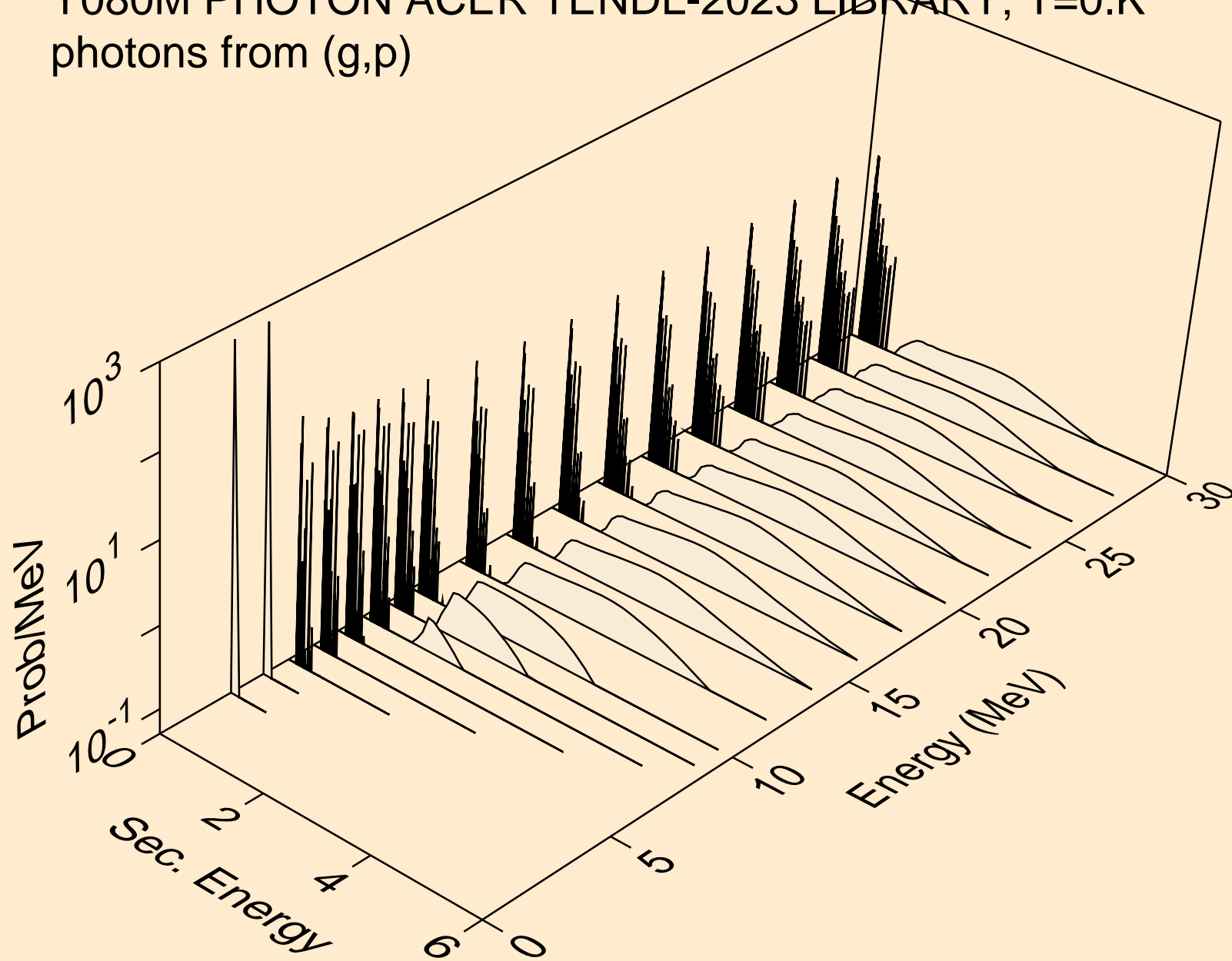

Y080M PHOTON ACER TENDL-2023 LIBRARY; T=0.K  
photons from (g,d)

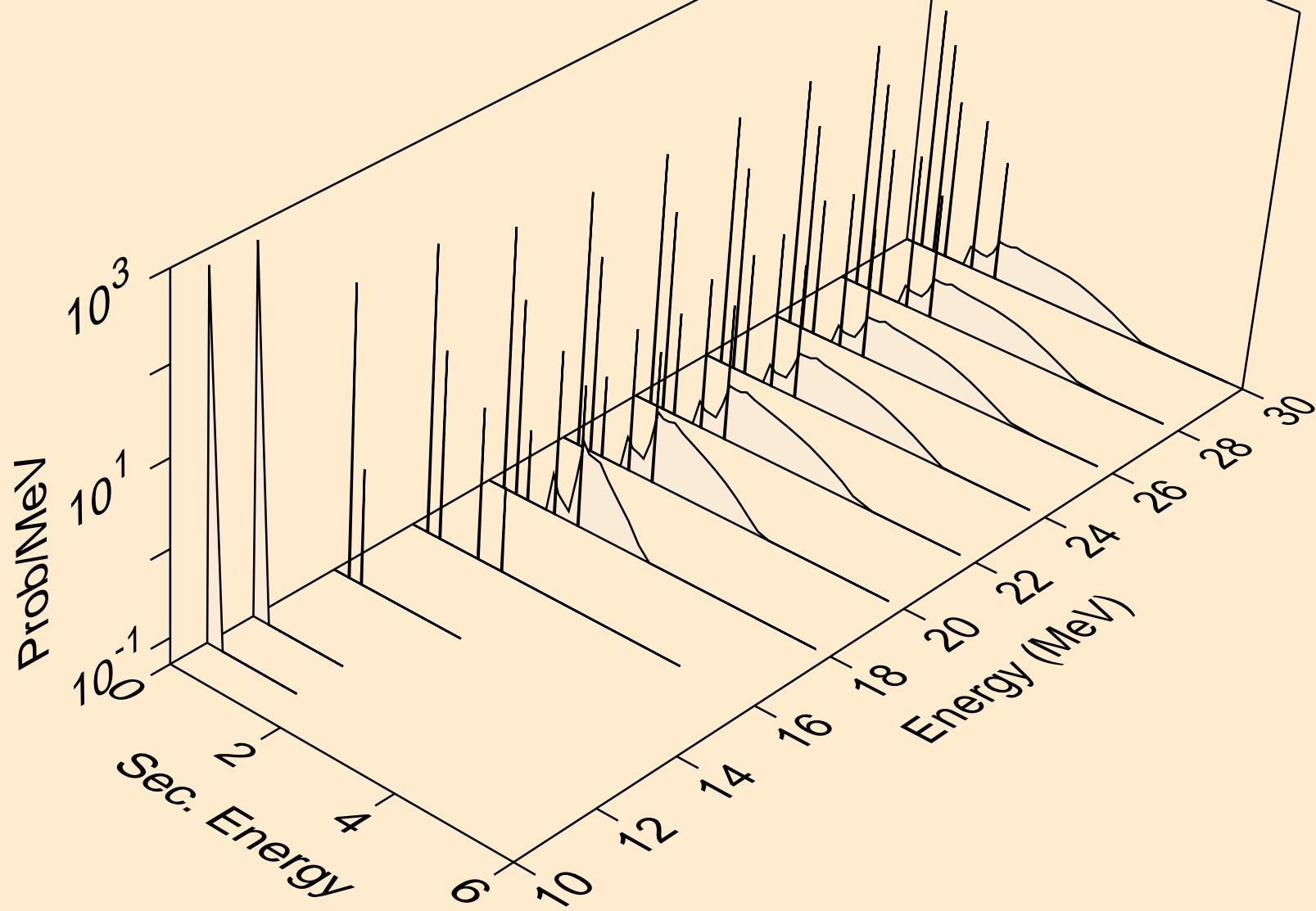

Y080M PHOTON ACER TENDL-2023 LIBRARY; T=0.K  
photons from (g,t)

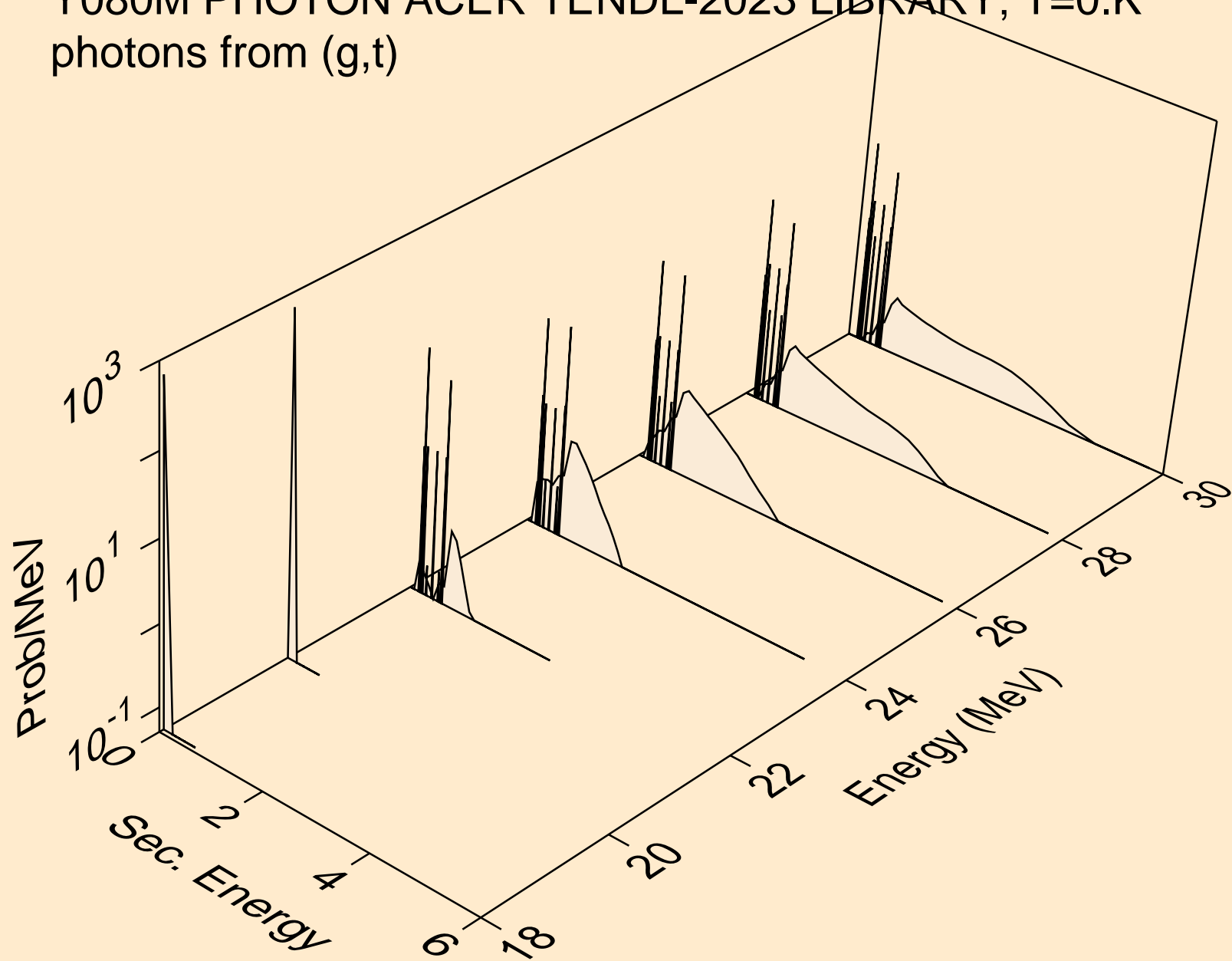

Y080M PHOTON ACER TENDL-2023 LIBRARY; T=0.K  
photons from (g,he3)

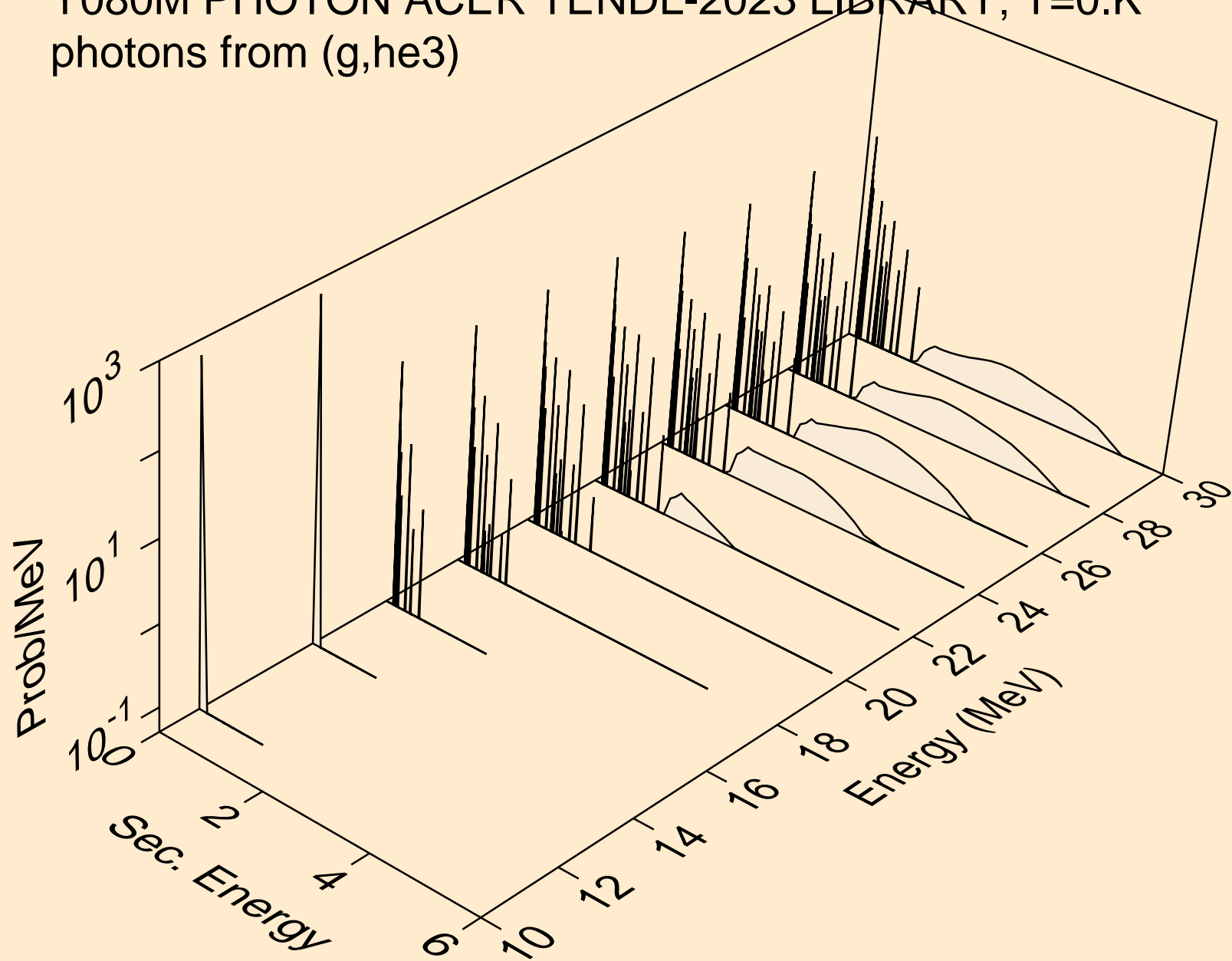

Y080M PHOTON ACER TENDL-2023 LIBRARY; T=0.K  
photons from (g,a)

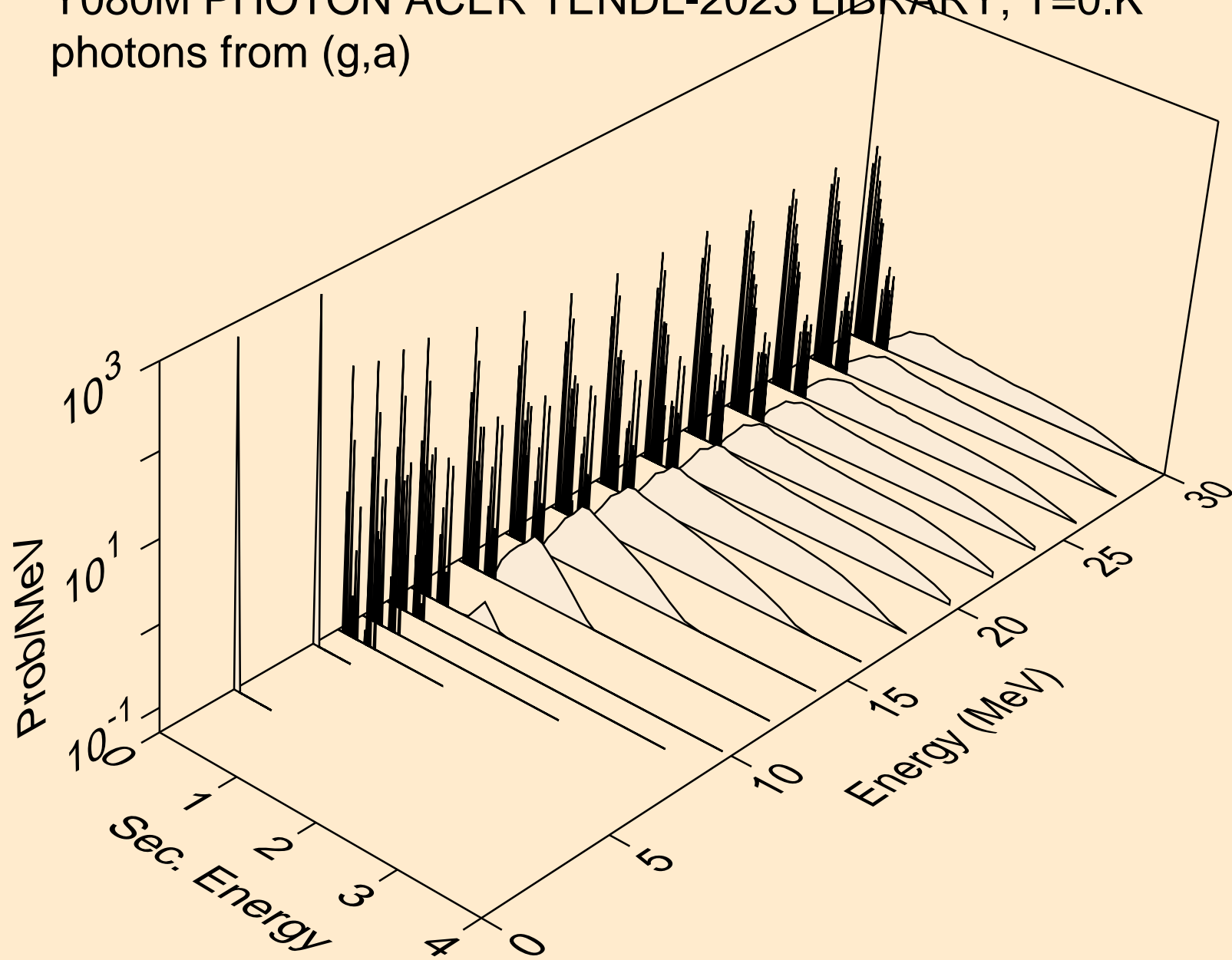

Y080M PHOTON ACER TENDL-2023 LIBRARY; T=0.K  
photons from (g,2a)

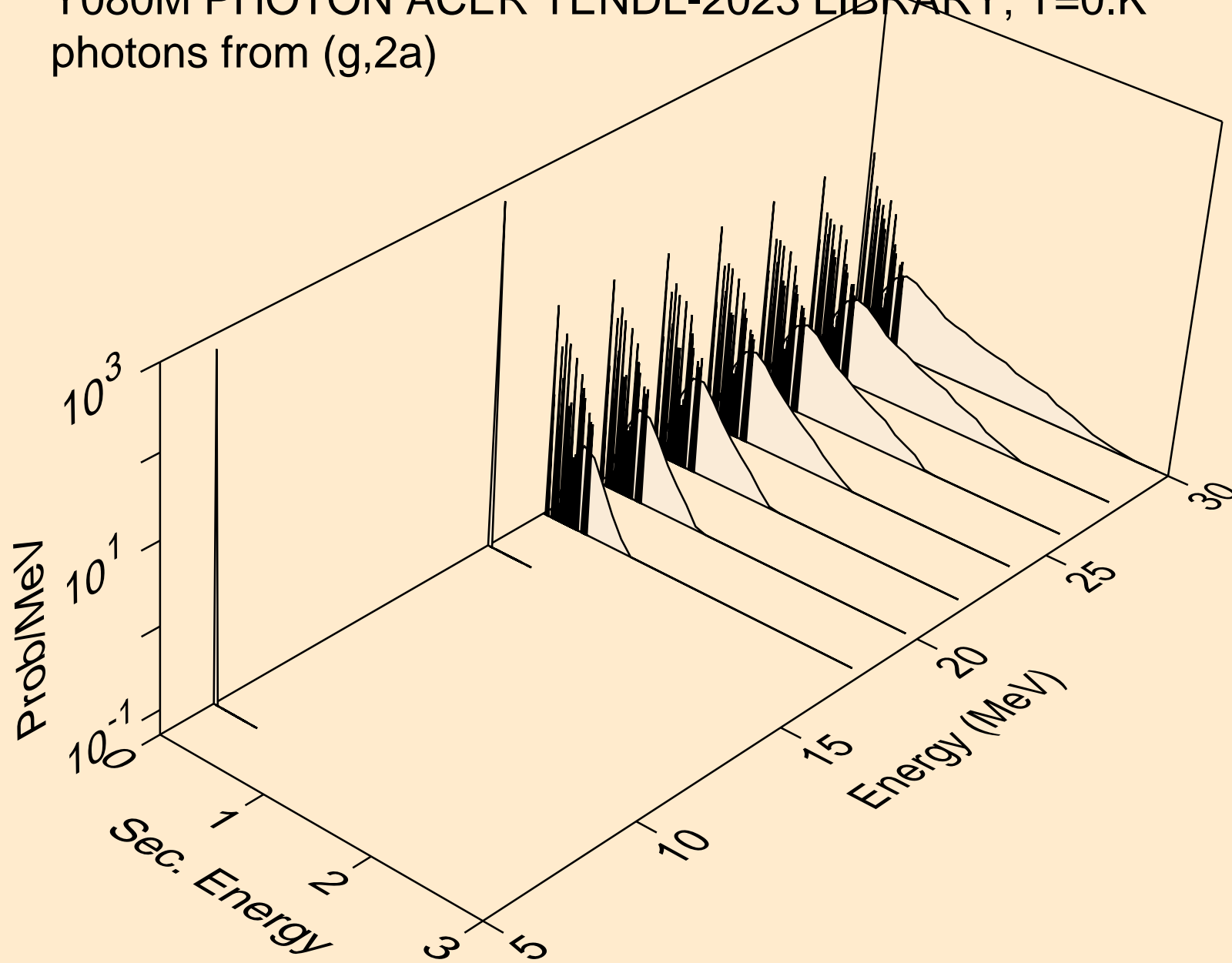



Y080M PHOTON ACER TENDL-2023 LIBRARY; T=0.K  
photons from (g,2p)

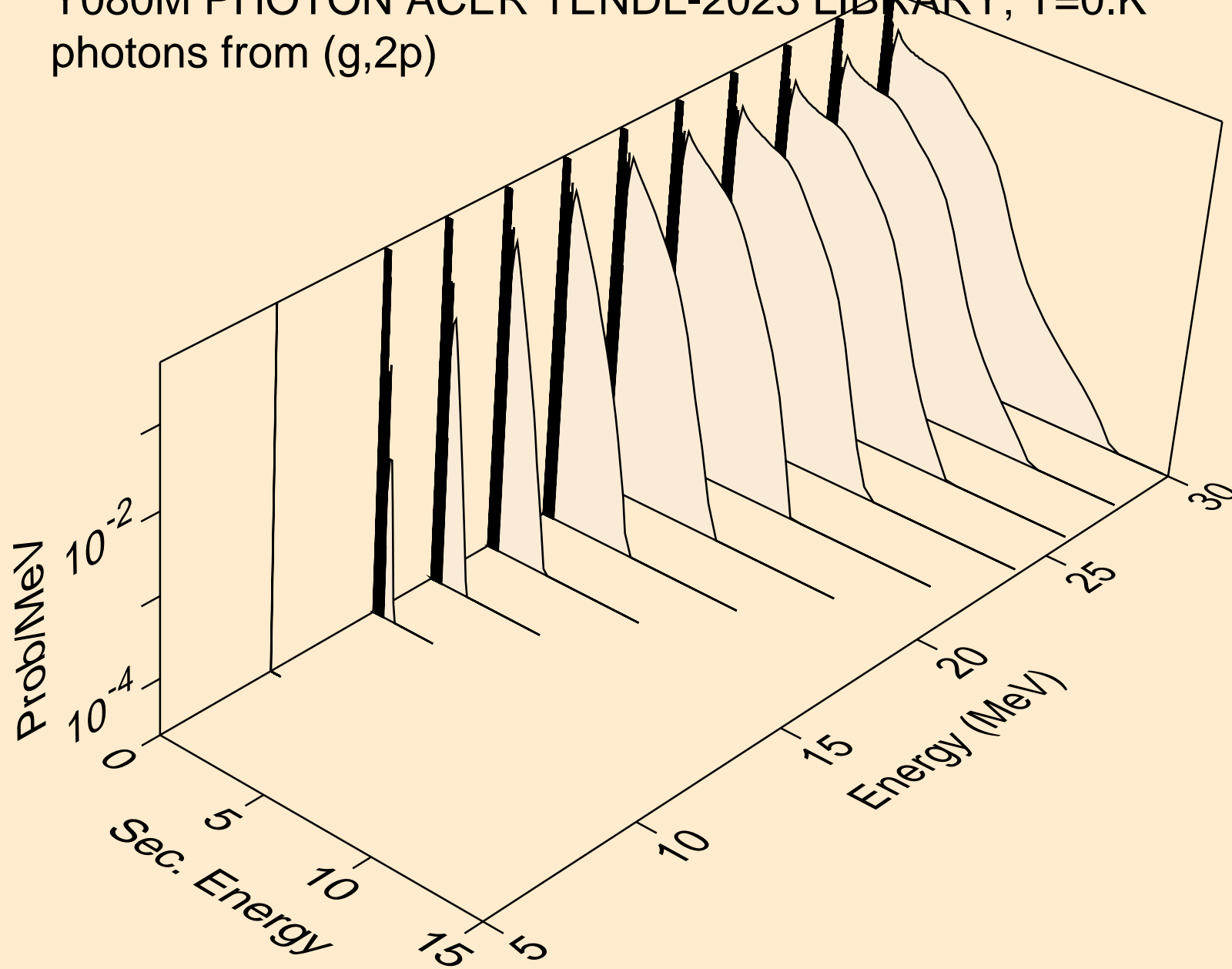

Y080M PHOTON ACER TENDL-2023 LIBRARY; T=0.K  
photons from (g,pa)

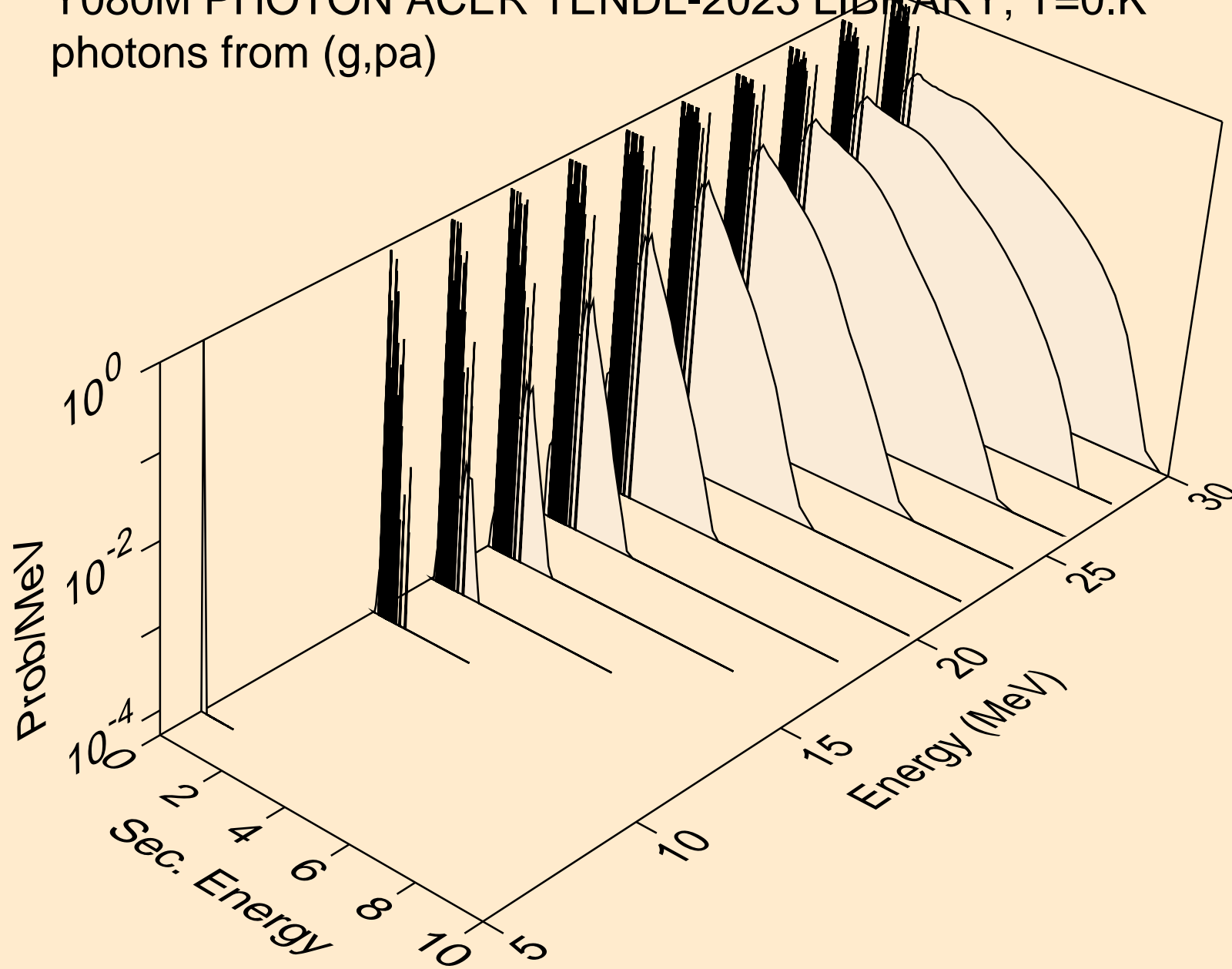

Y080M PHOTON ACER TENDL-2023 LIBRARY; T=0.K  
photons from (g,pd)

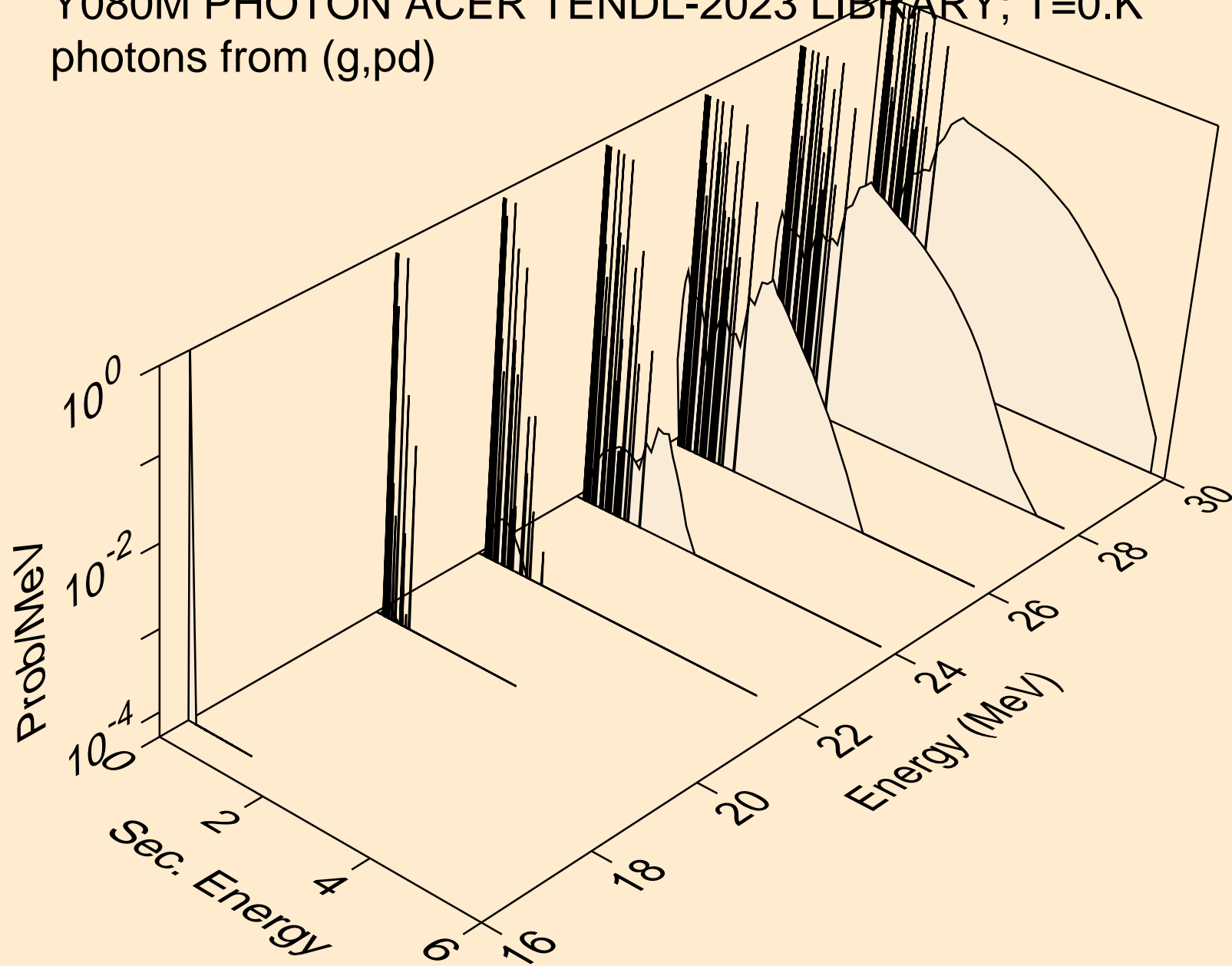

Y080M PHOTON ACER TENDL-2023 LIBRARY; T=0.K  
photons from (g,pt)

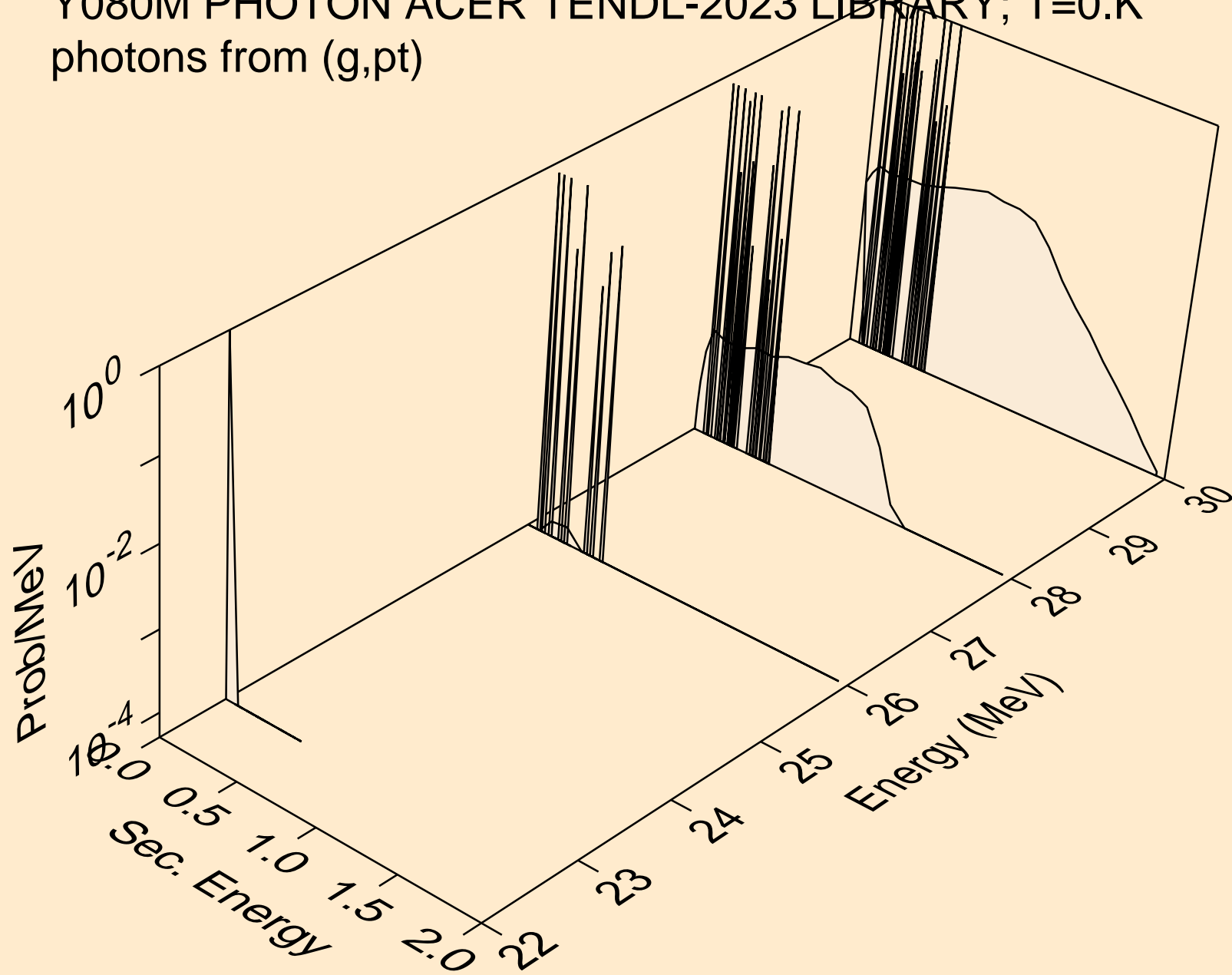

Y080M PHOTON ACER TENDL-2023 LIBRARY; T=0.K  
photons from (g,da)

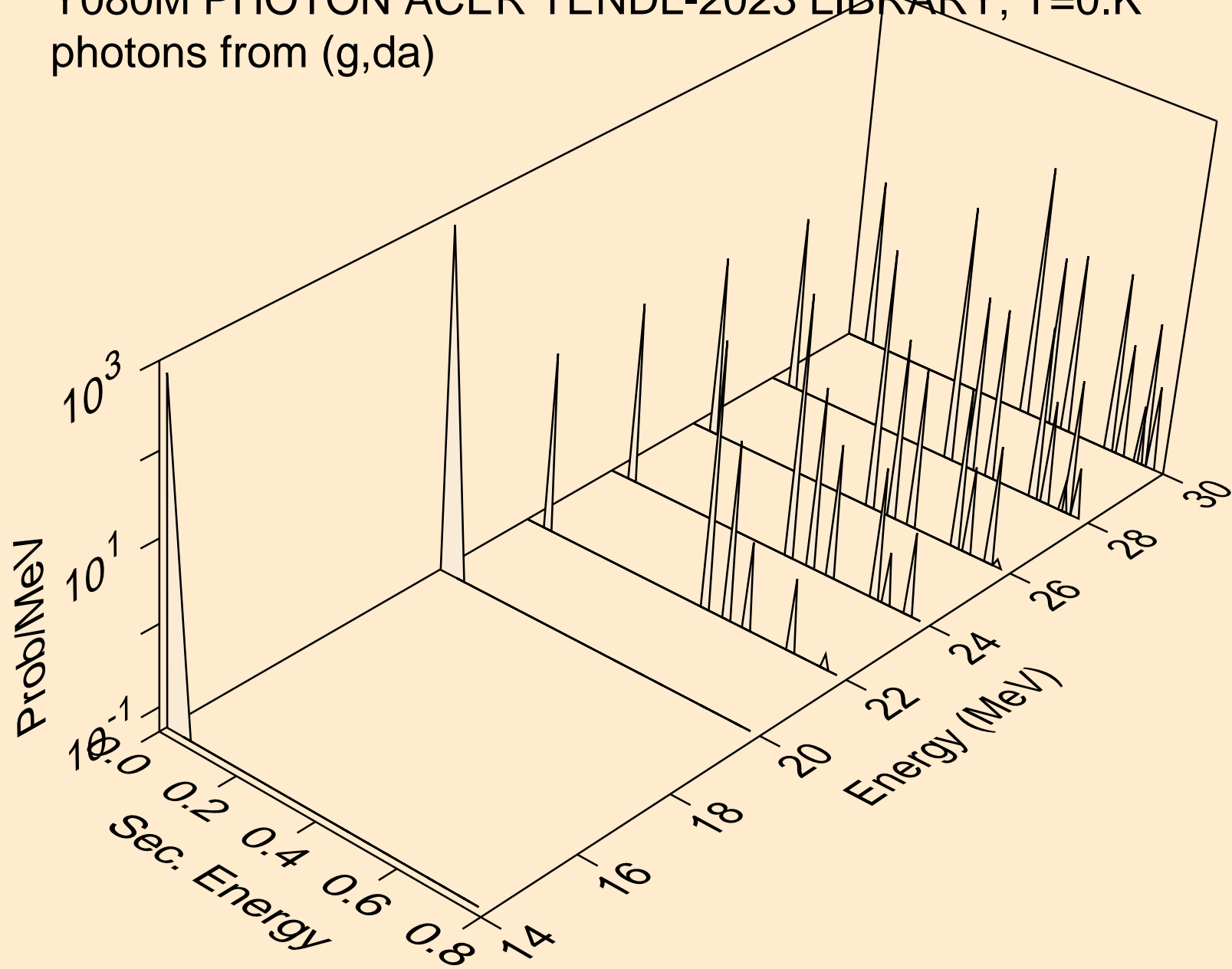

Y080M PHOTON ACER TENDL-2023 LIBRARY; T=0.K  
protons from (g,x)

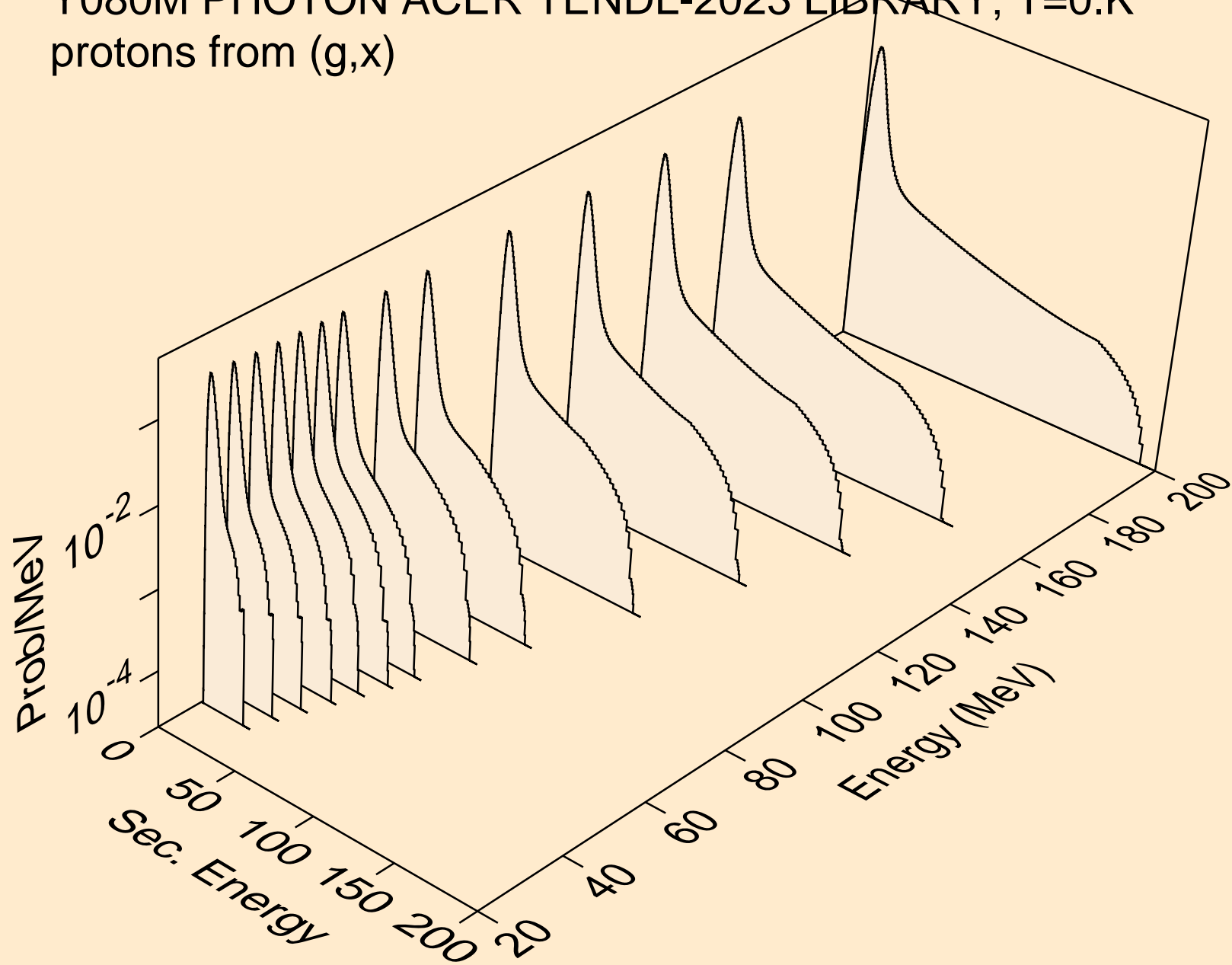

Y080M PHOTON ACER TENDL-2023 LIBRARY; T=0.K  
protons from (g,n\*)p

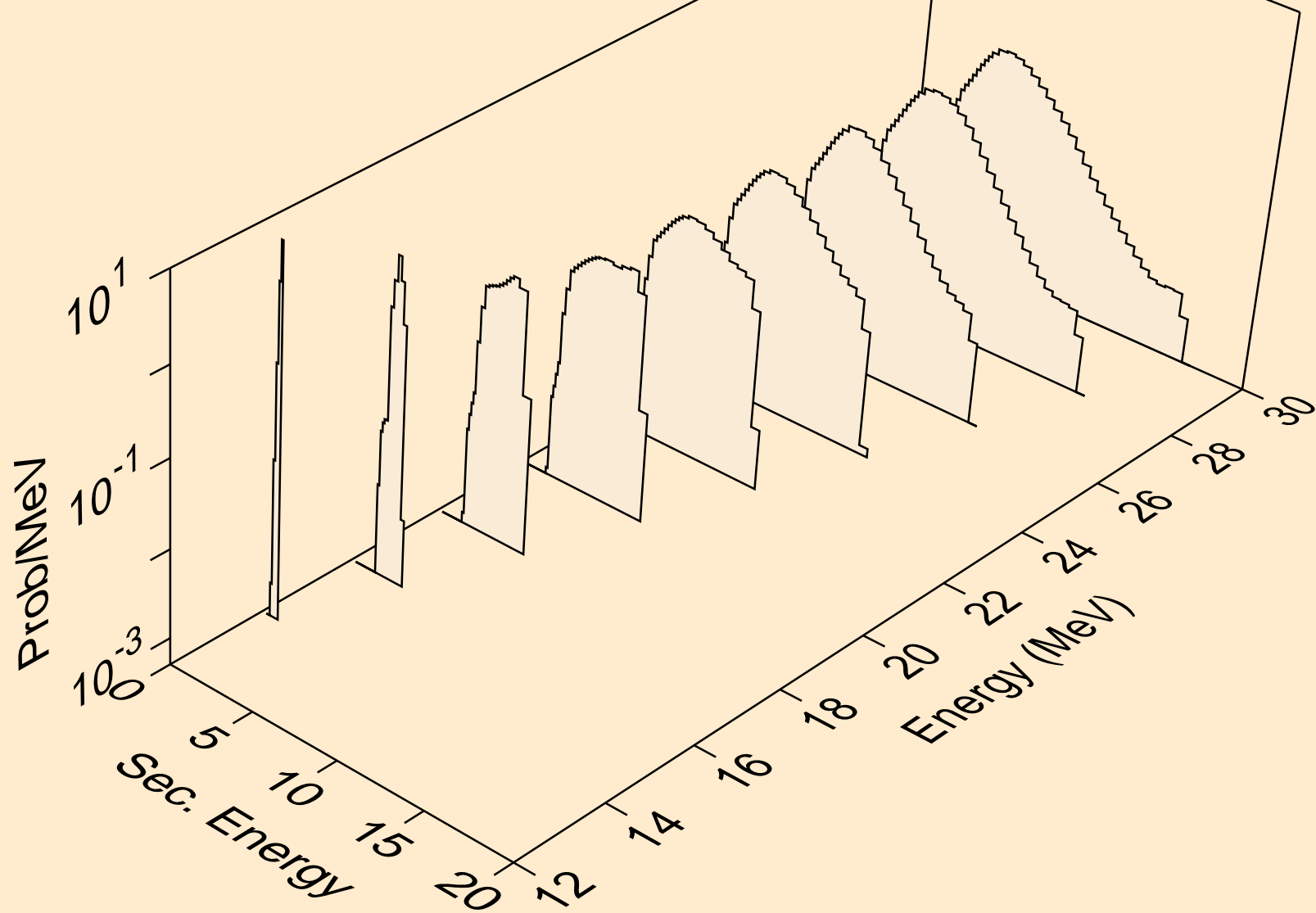

Y080M PHOTON ACER TENDL-2023 LIBRARY; T=0.K  
protons from (g,2np)

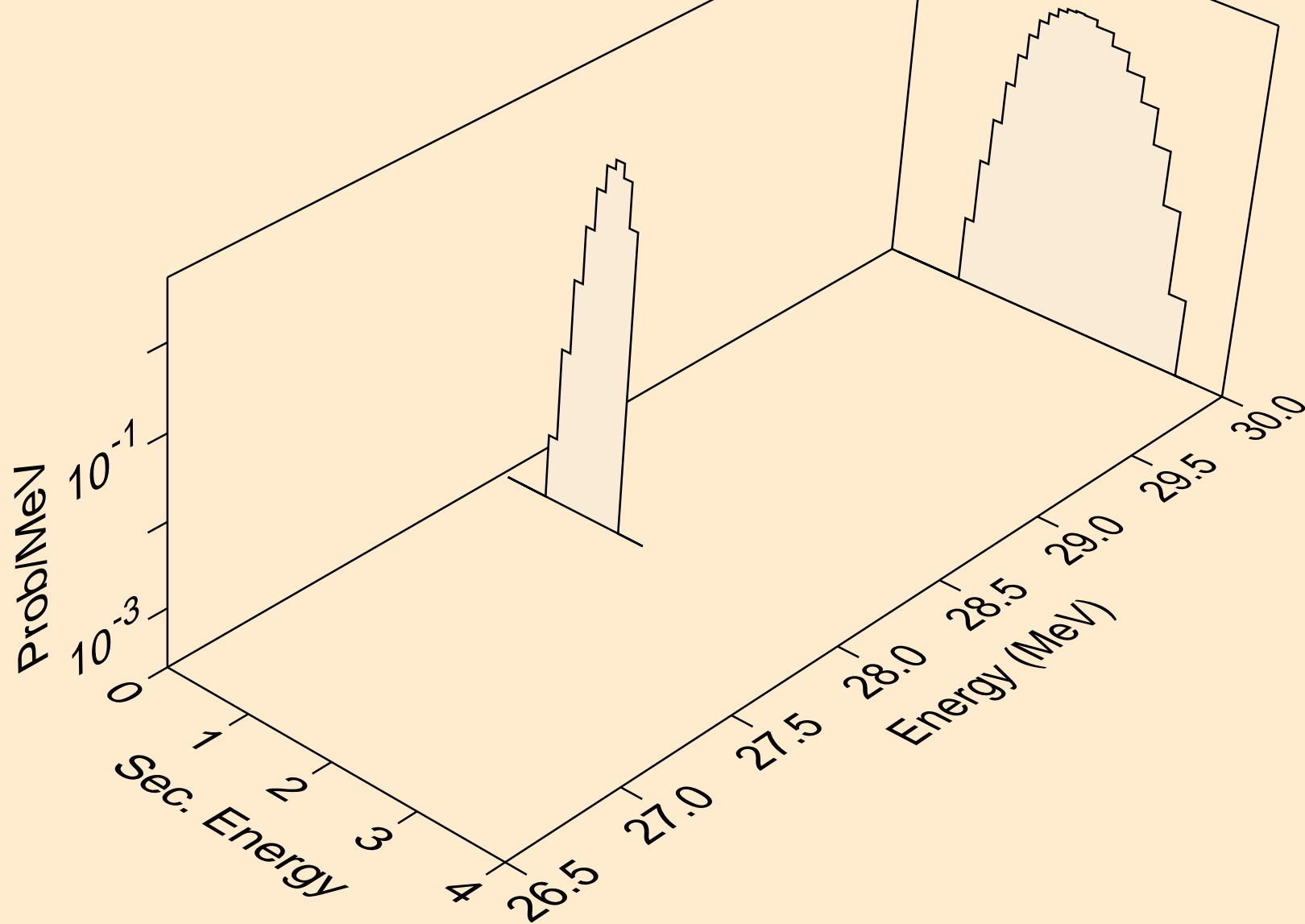



Y080M PHOTON ACER TENDL-2023 LIBRARY; T=0.K  
protons from (g,n2p)

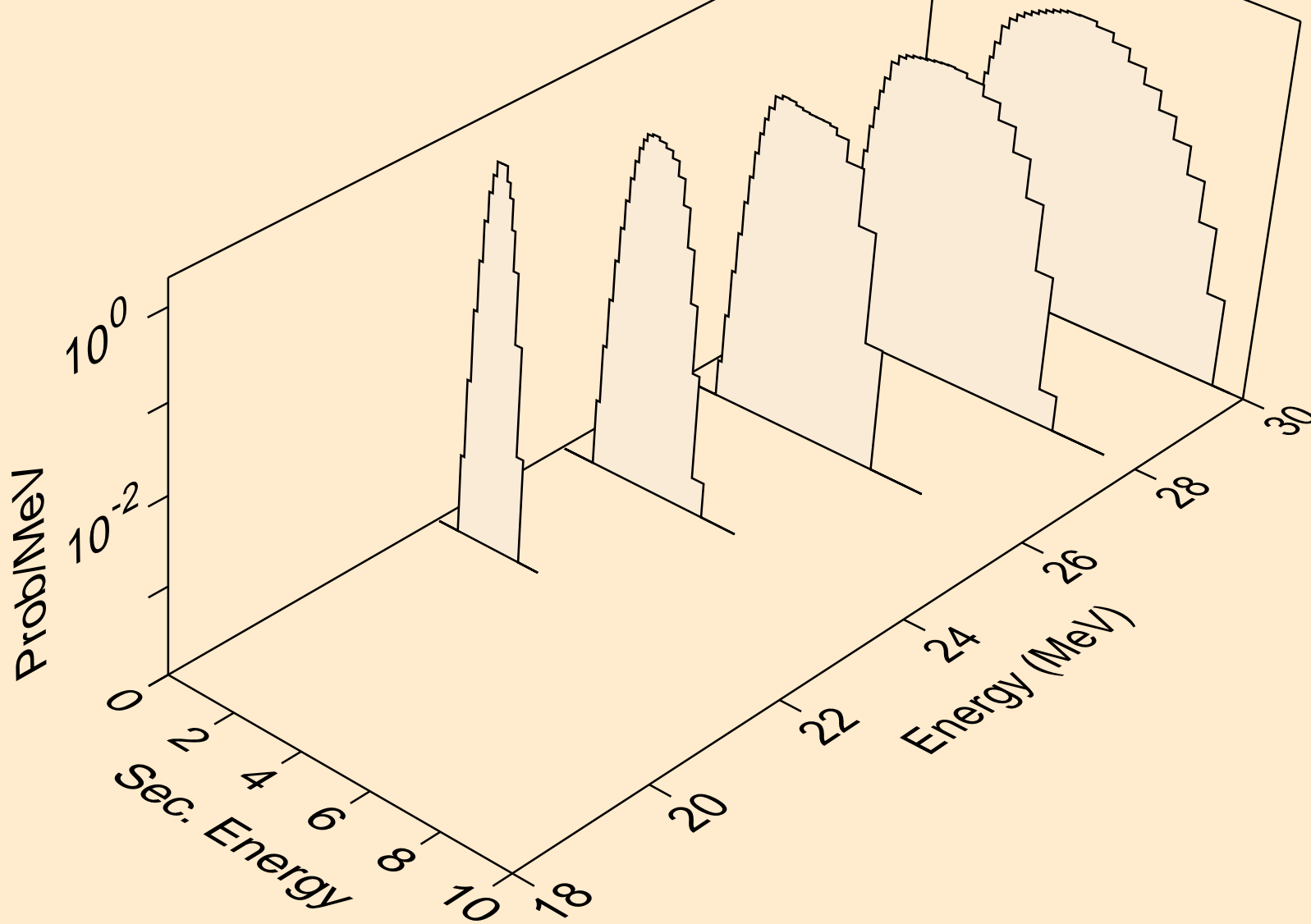

Y080M PHOTON ACER TENDL-2023 LIBRARY; T=0.K  
protons from (g,npa)

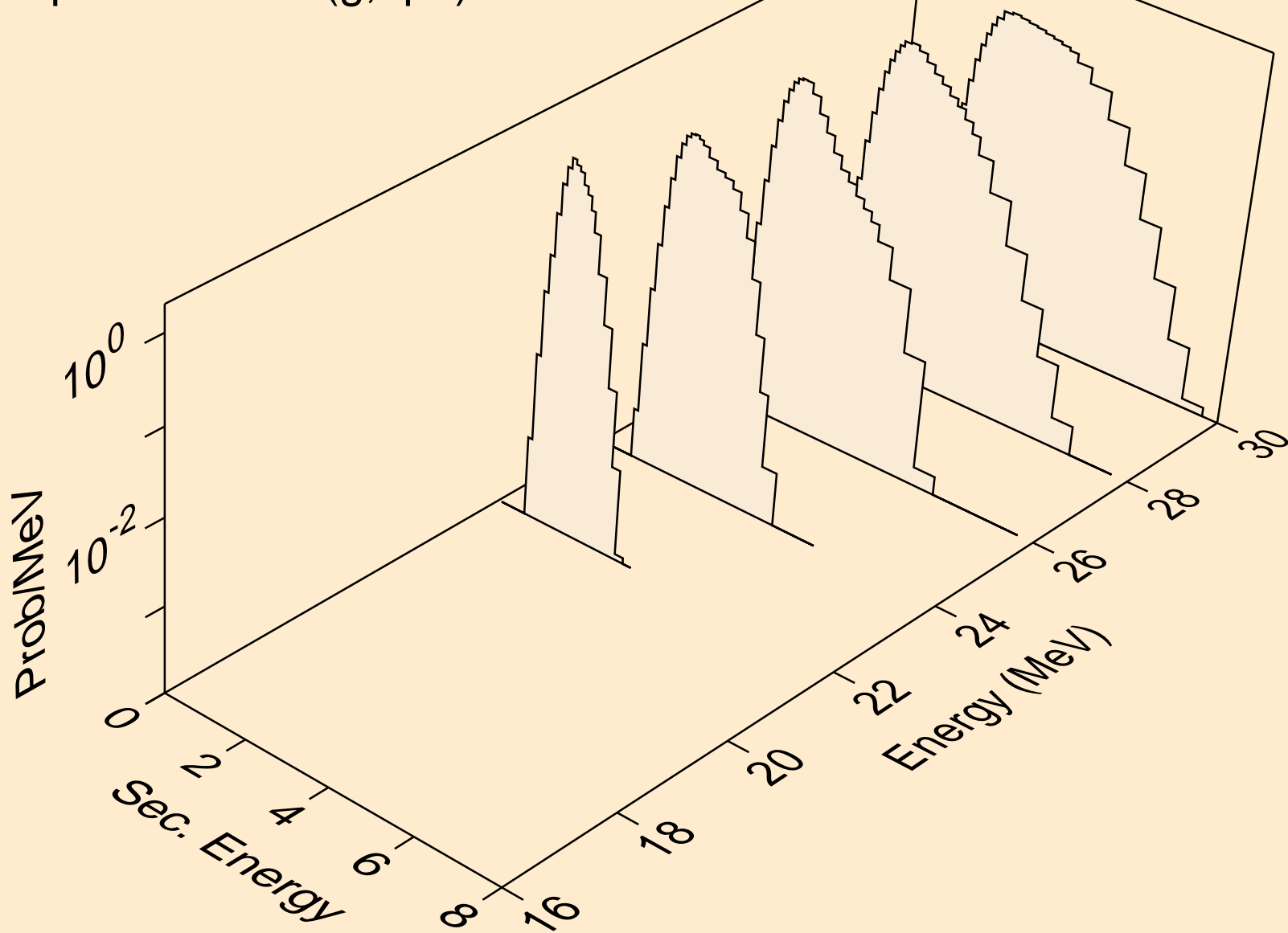

Y080M PHOTON ACER TENDL-2023 LIBRARY; T=0.K  
protons from (g,p)

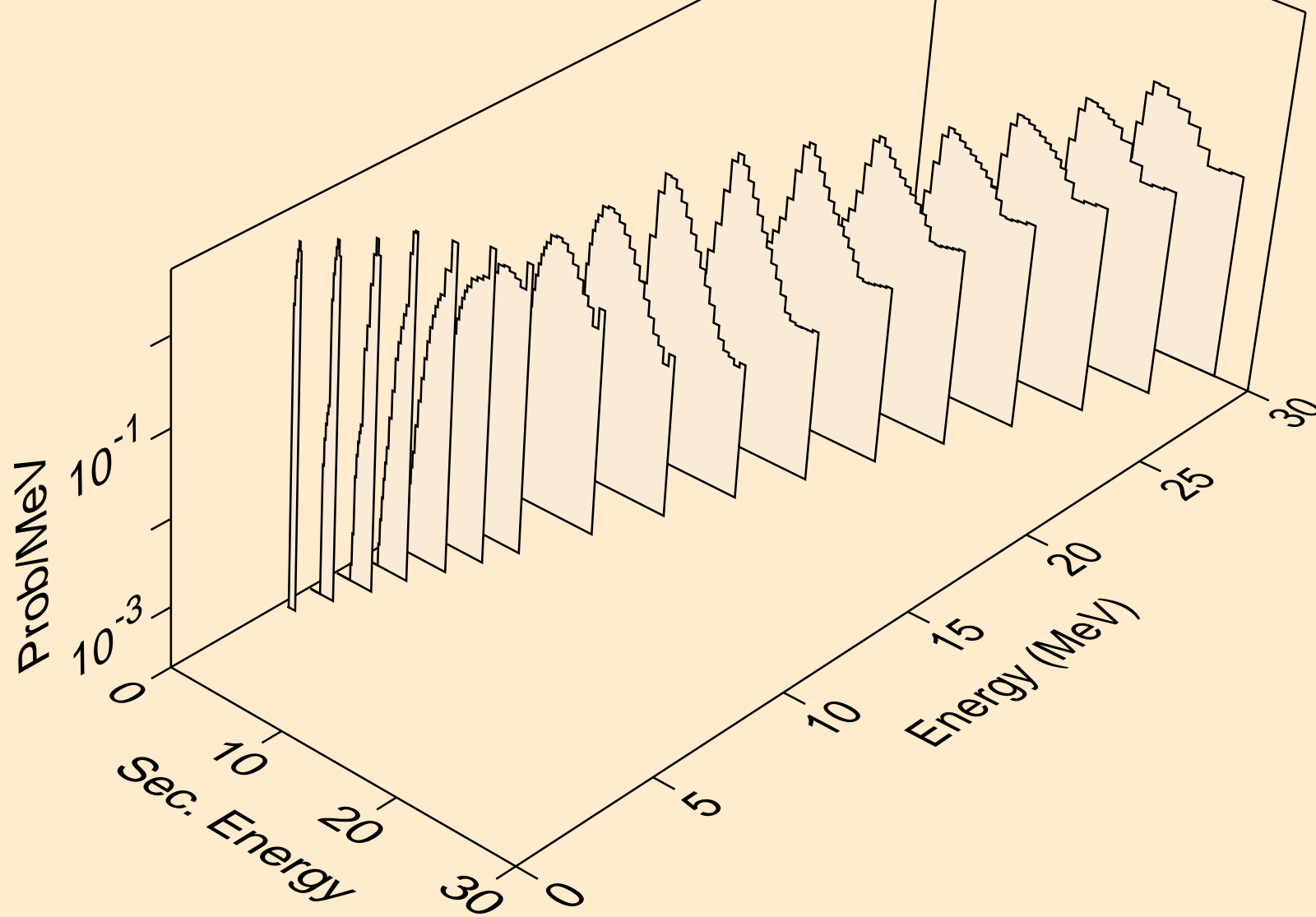

Y080M PHOTON ACER TENDL-2023 LIBRARY; T=0.K  
protons from (g,2p)

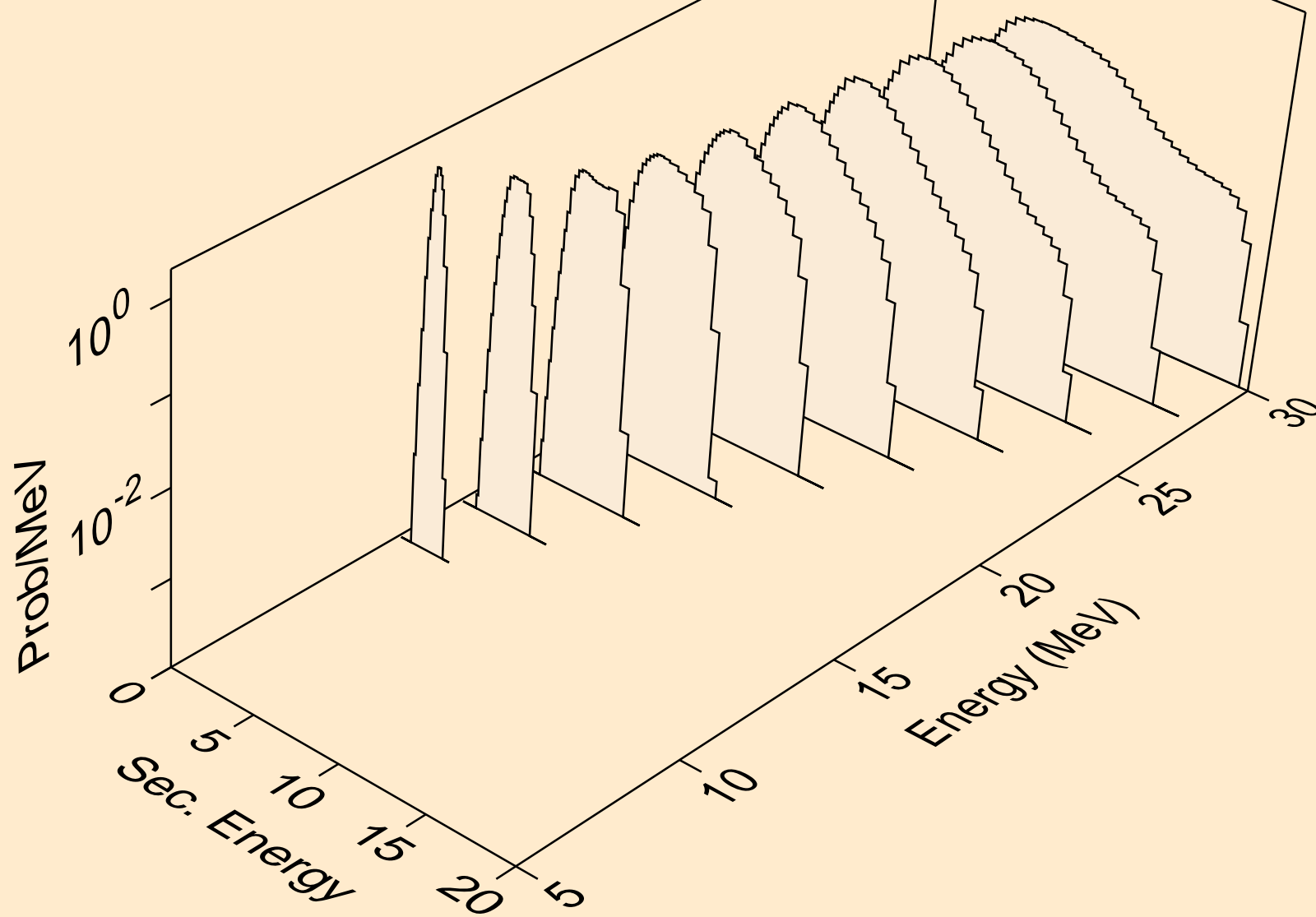

Y080M PHOTON ACER TENDL-2023 LIBRARY; T=0.K  
protons from (g,pa)

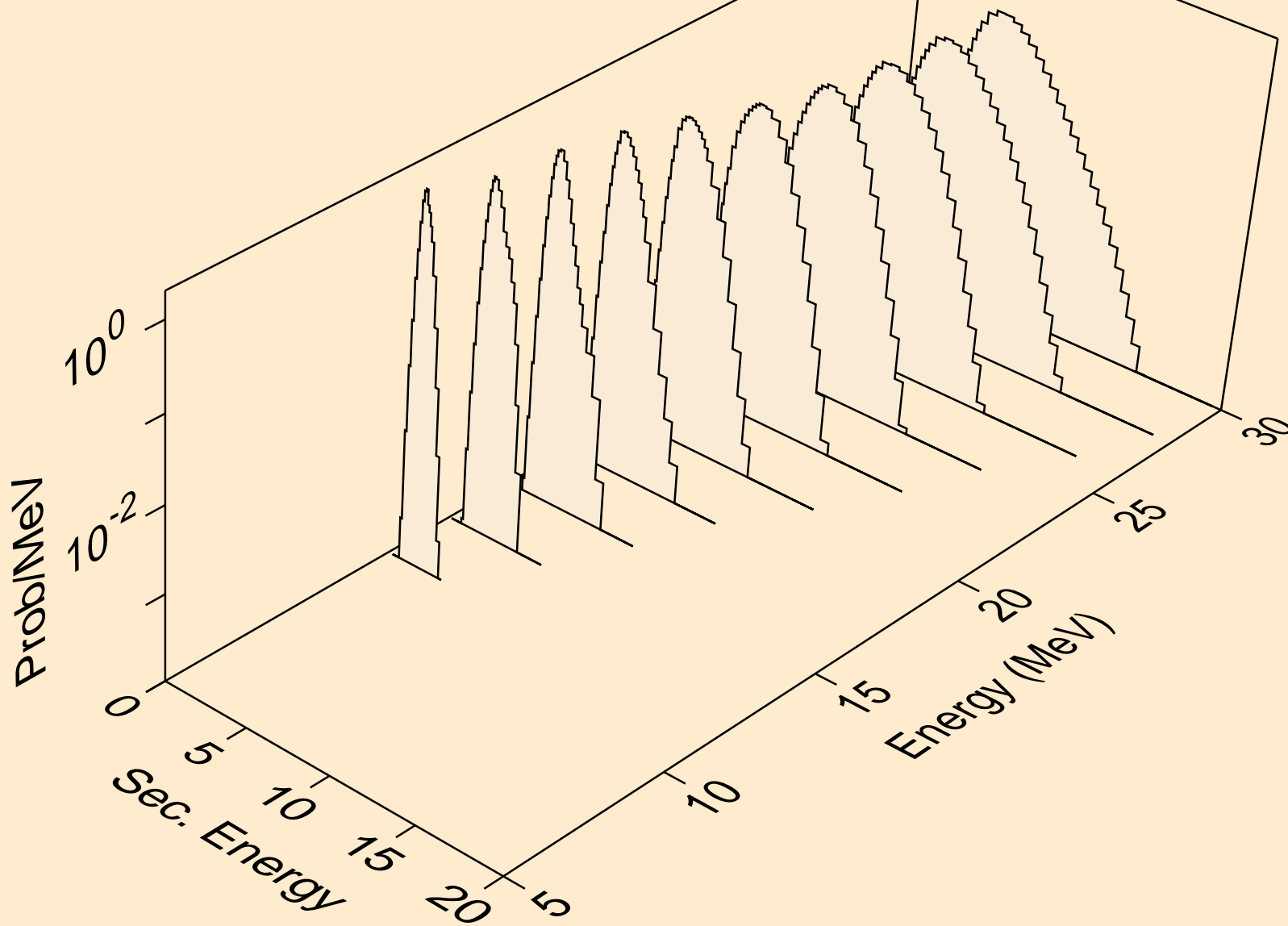

Y080M PHOTON ACER TENDL-2023 LIBRARY; T=0.K  
protons from (g,pd)

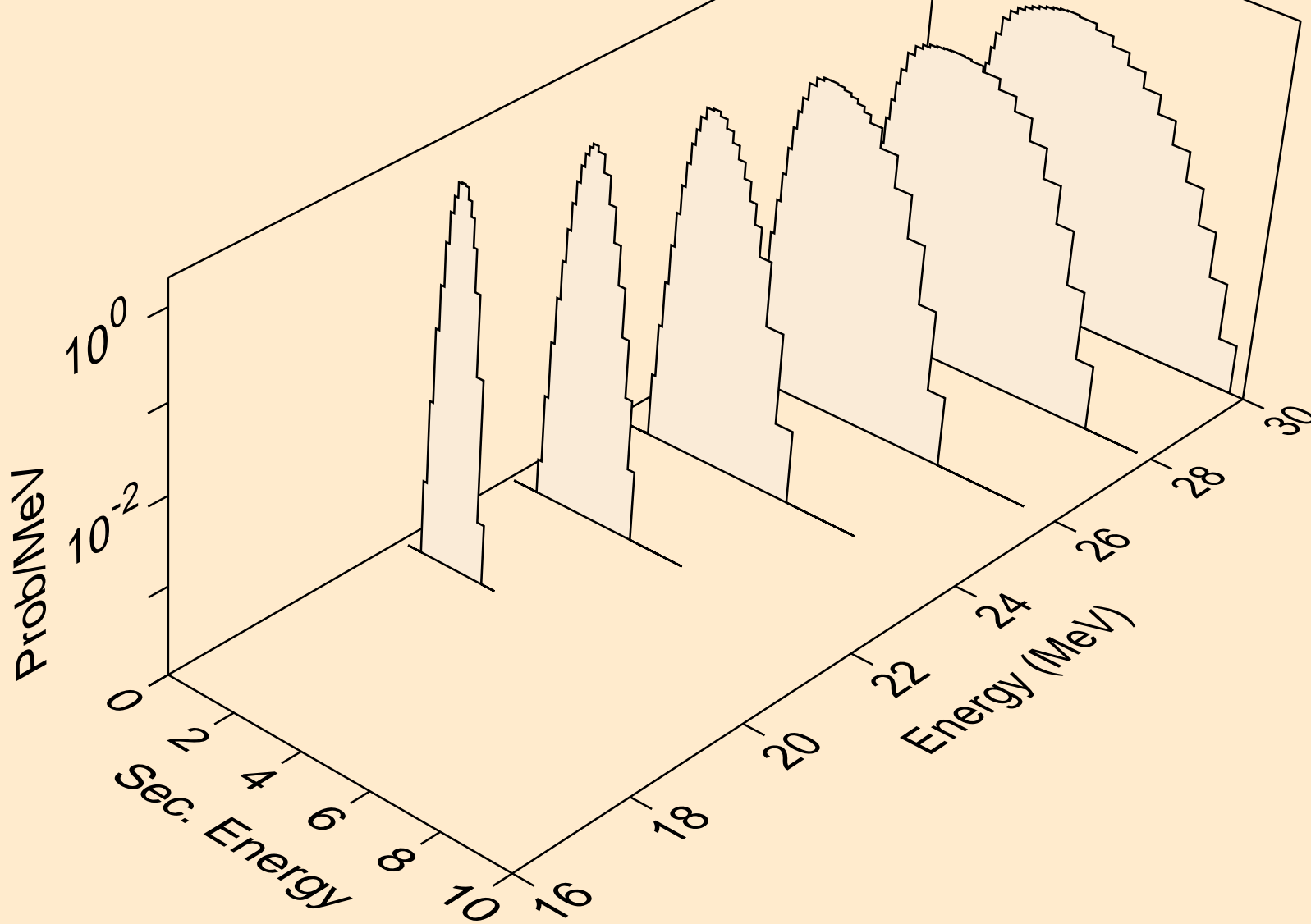

Y080M PHOTON ACER TENDL-2023 LIBRARY; T=0.K  
protons from (g,pt)

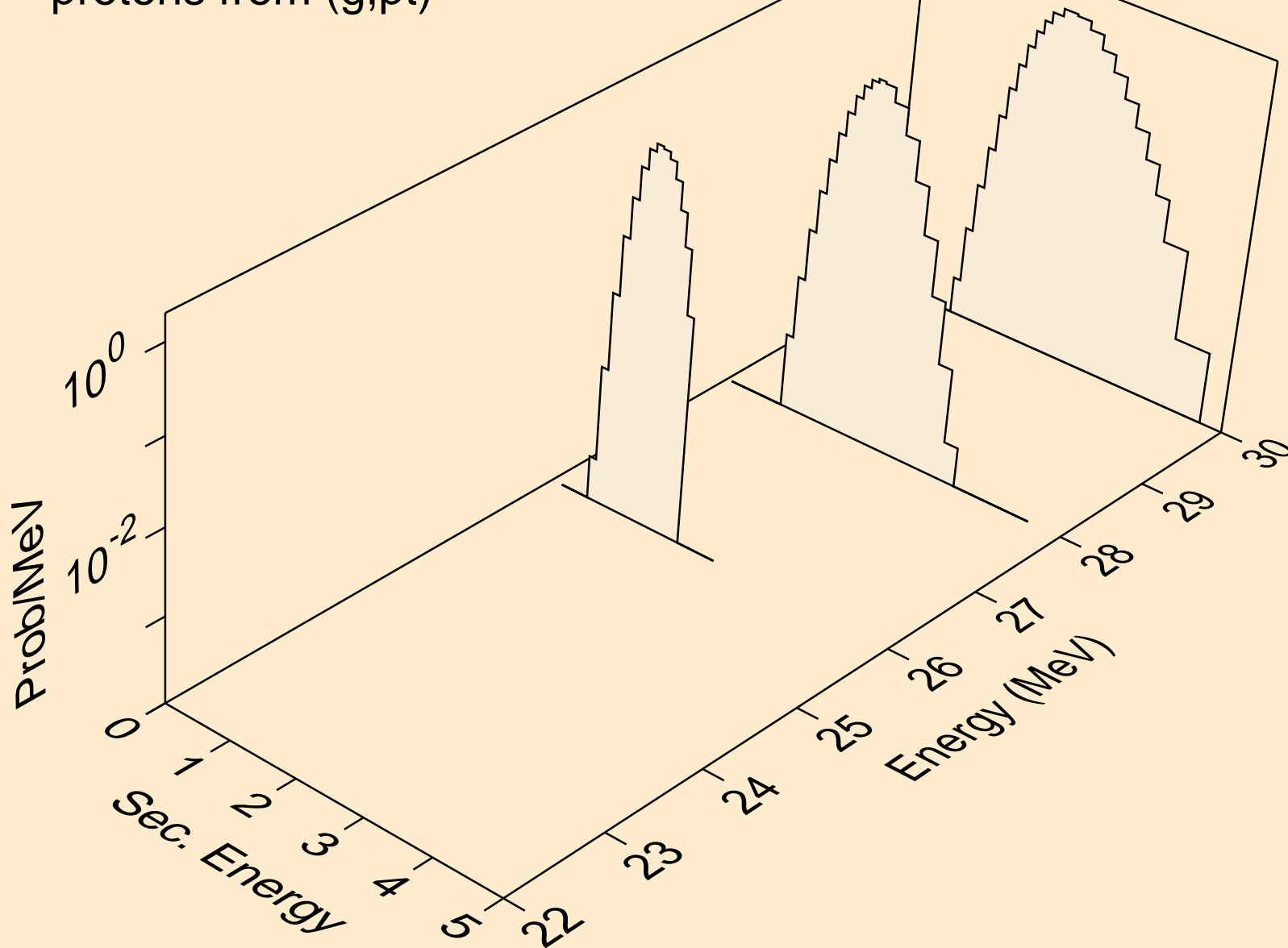

Y080M PHOTON ACER TENDL-2023 LIBRARY; T=0.K  
deuterons from (g,x)

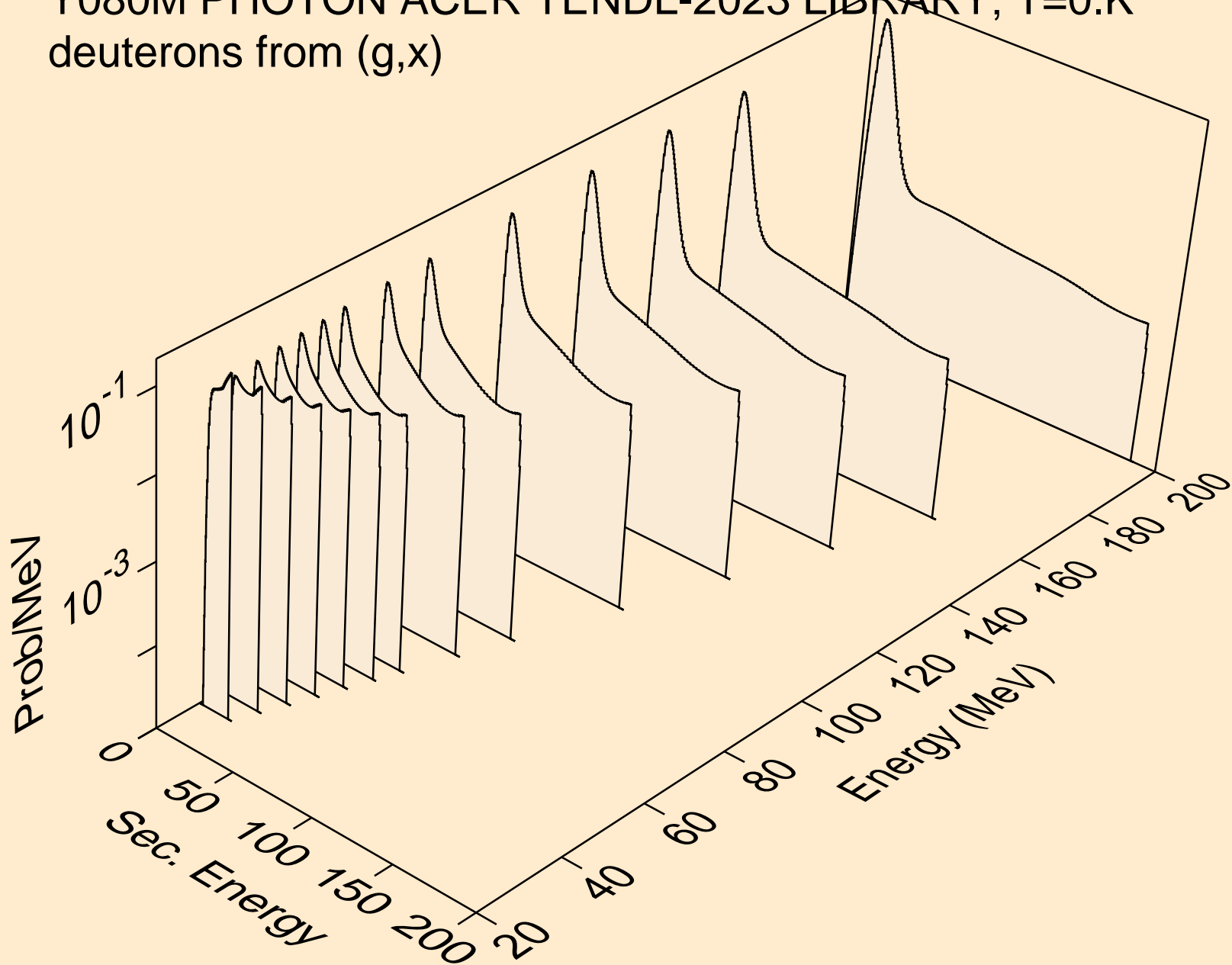



Y080M PHOTON ACER TENDL-2023 LIBRARY; T=0.K  
deuterons from (g,n\*)d

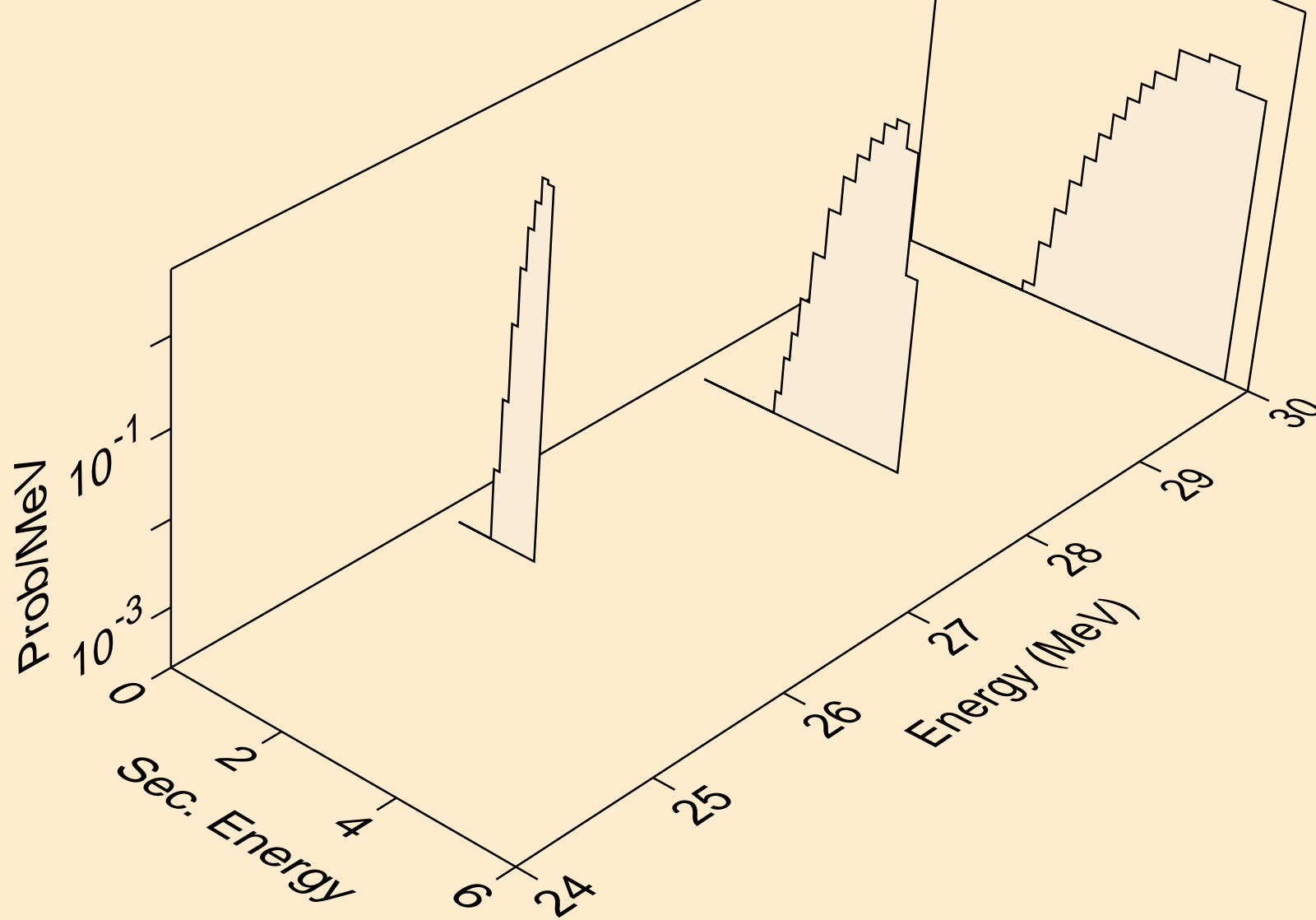

Y080M PHOTON ACER TENDL-2023 LIBRARY; T=0.K  
deuterons from (g,d)

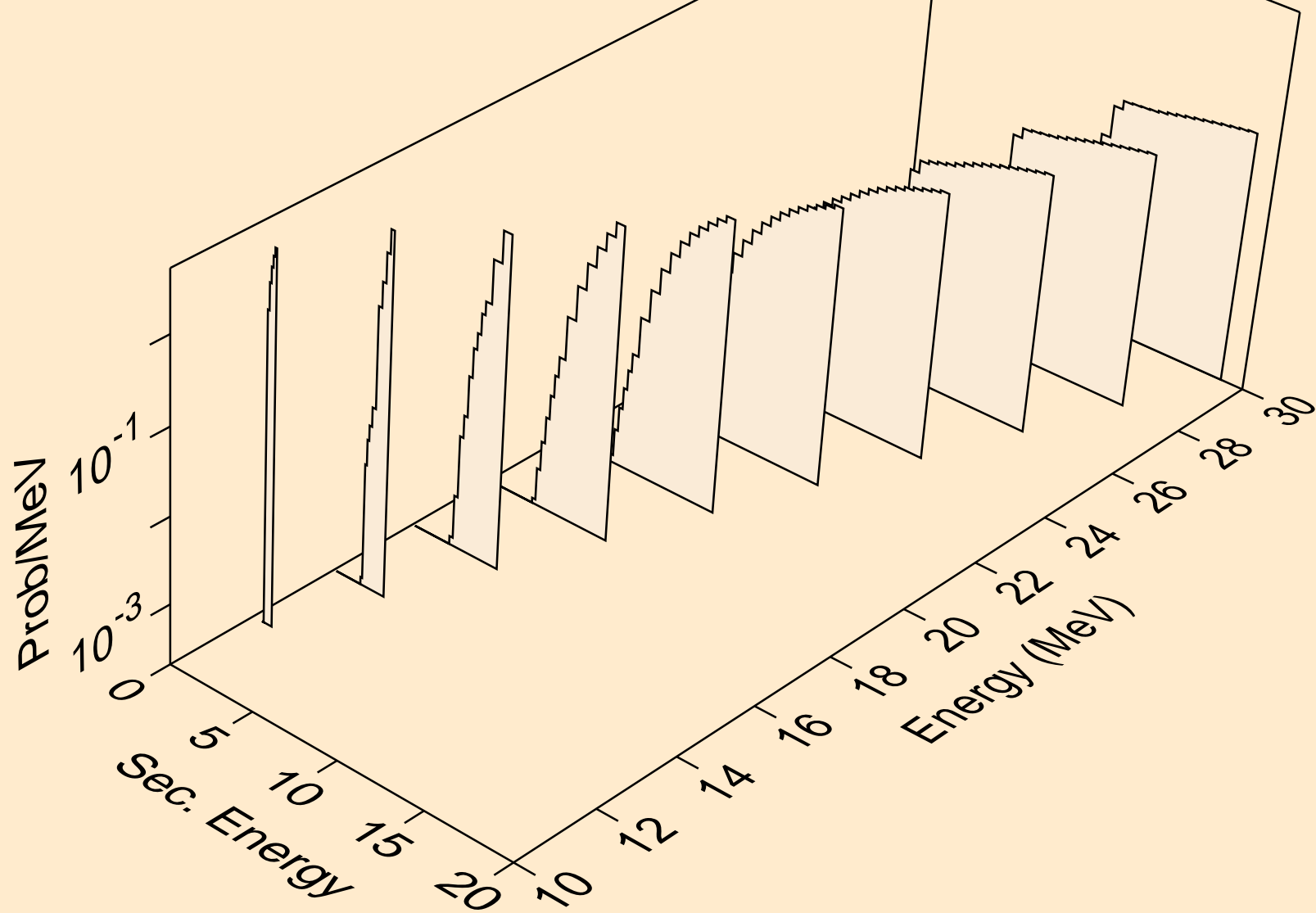

Y080M PHOTON ACER TENDL-2023 LIBRARY; T=0.K  
deuterons from (g,pd)

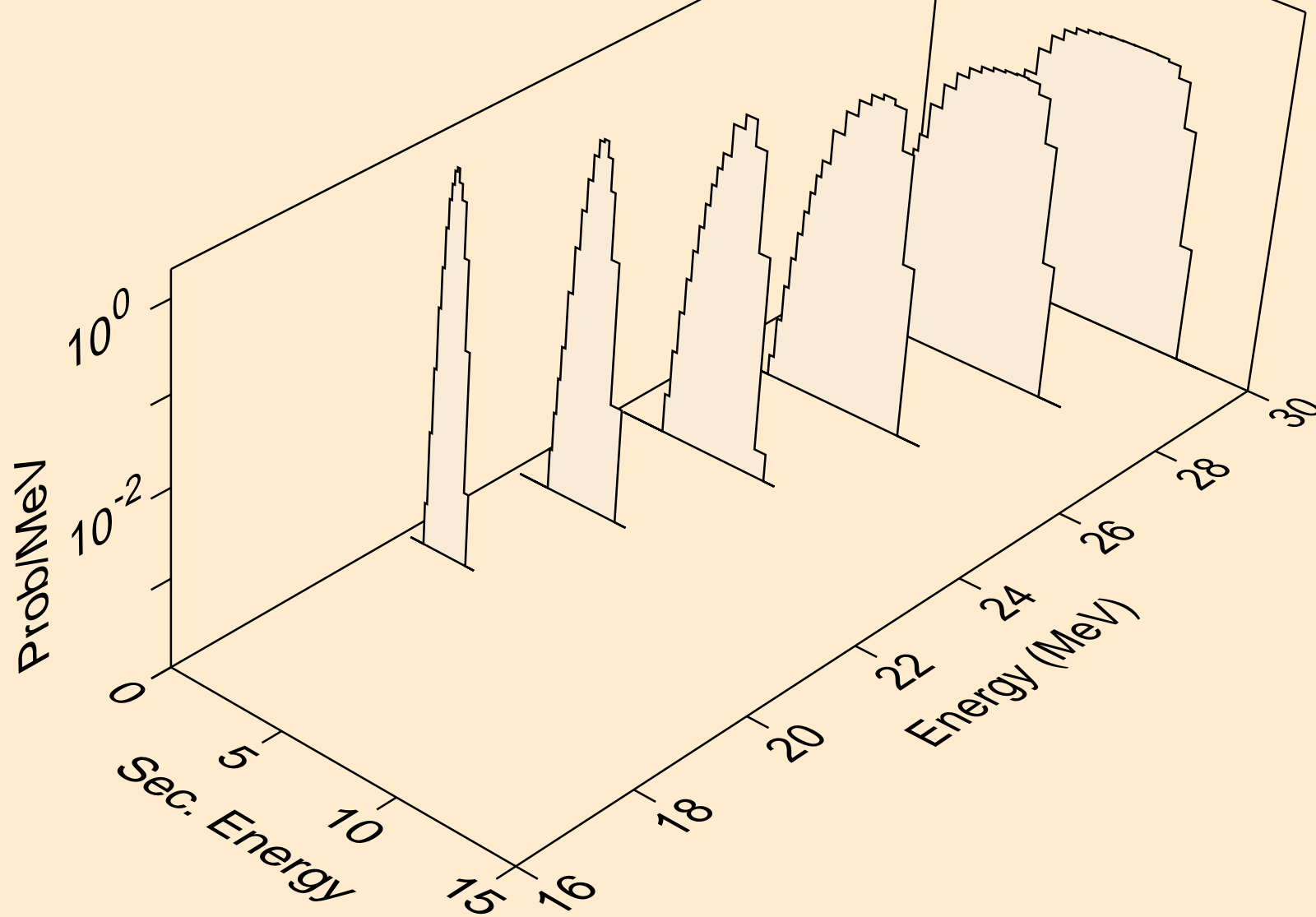

Y080M PHOTON ACER TENDL-2023 LIBRARY; T=0.K  
deuterons from (g,da)

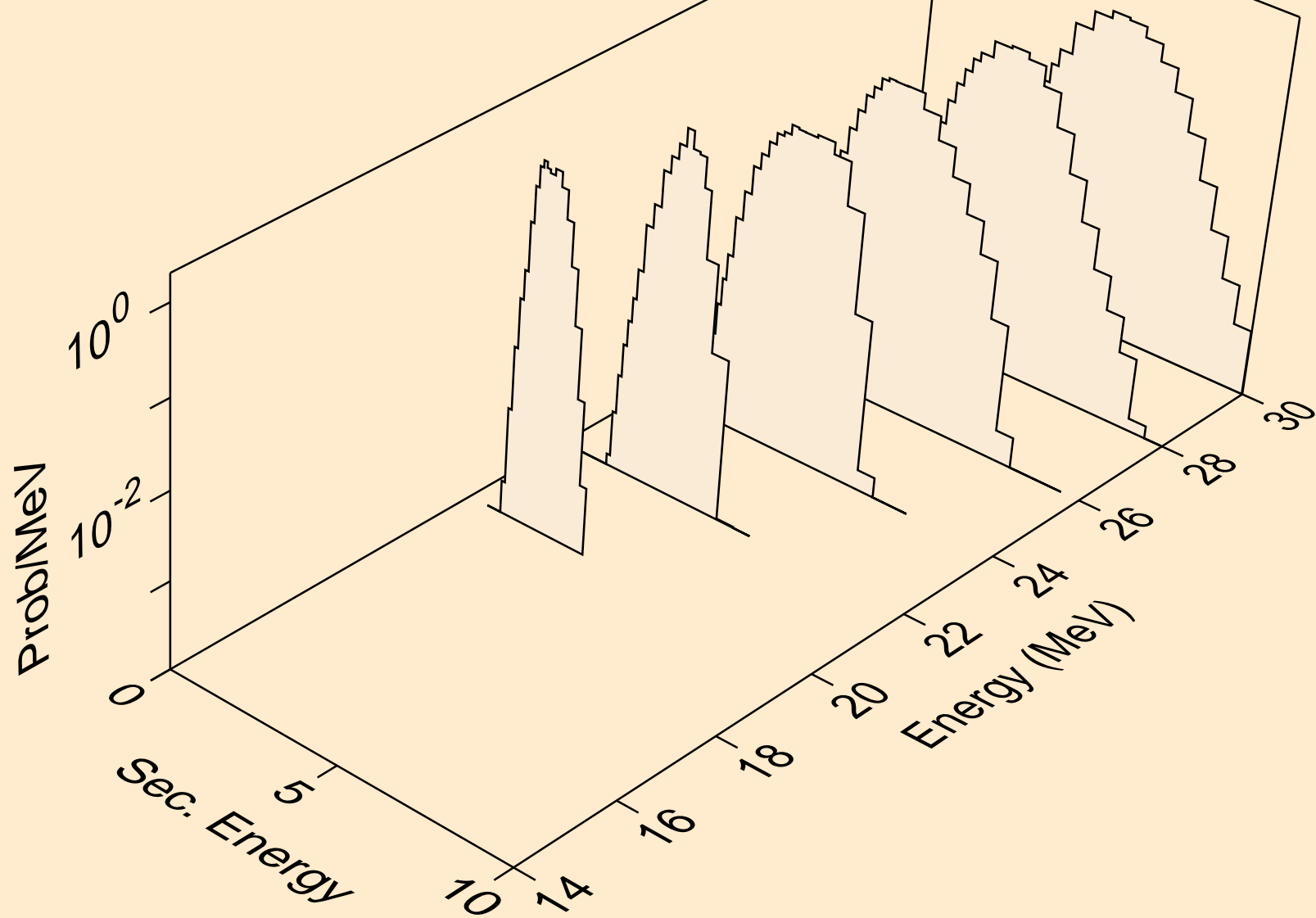

Y080M PHOTON ACER TENDL-2023 LIBRARY; T=0.K  
tritons from (g,x)

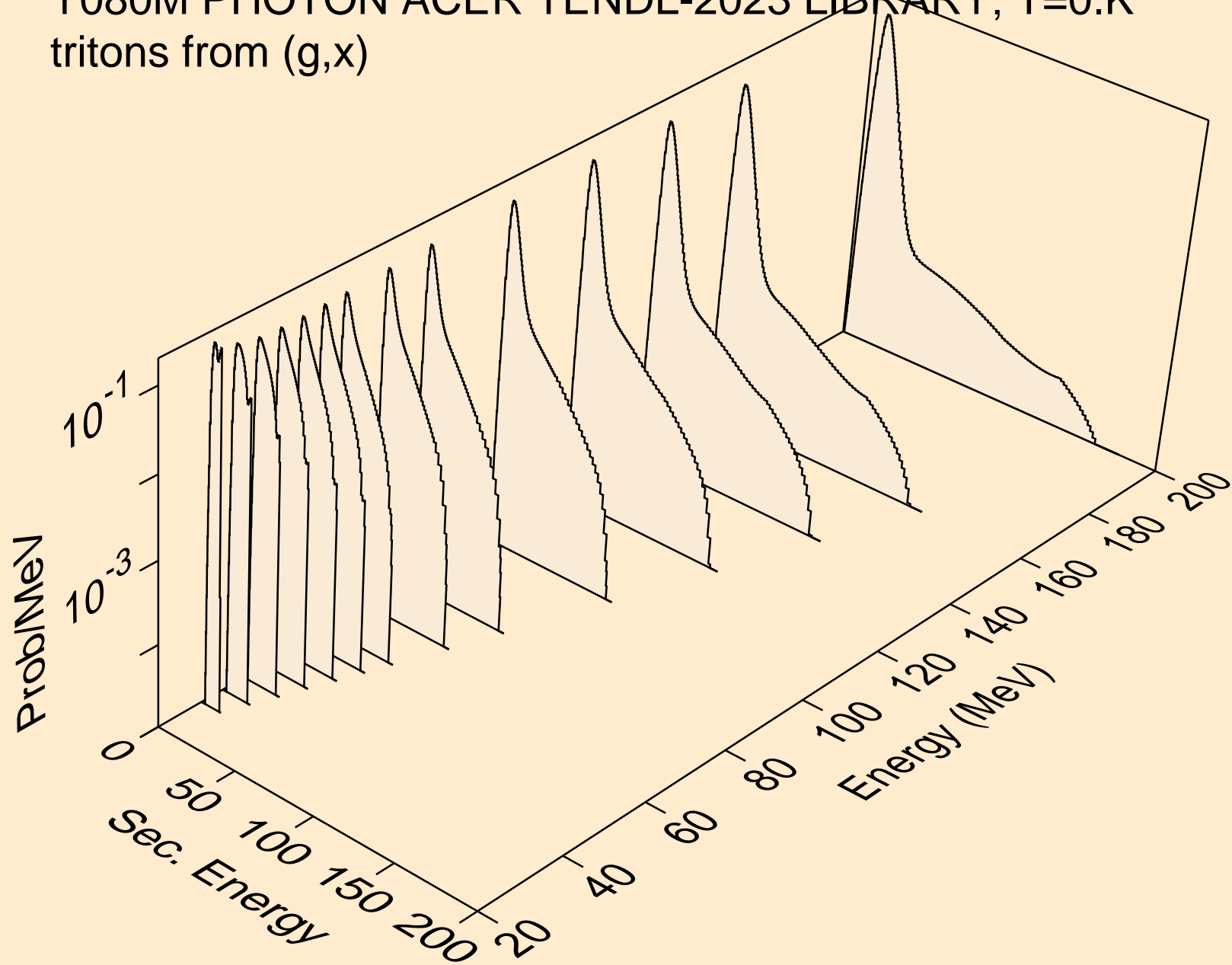

Y080M PHOTON ACER TENDL-2023 LIBRARY; T=0.K  
tritons from (g,t)

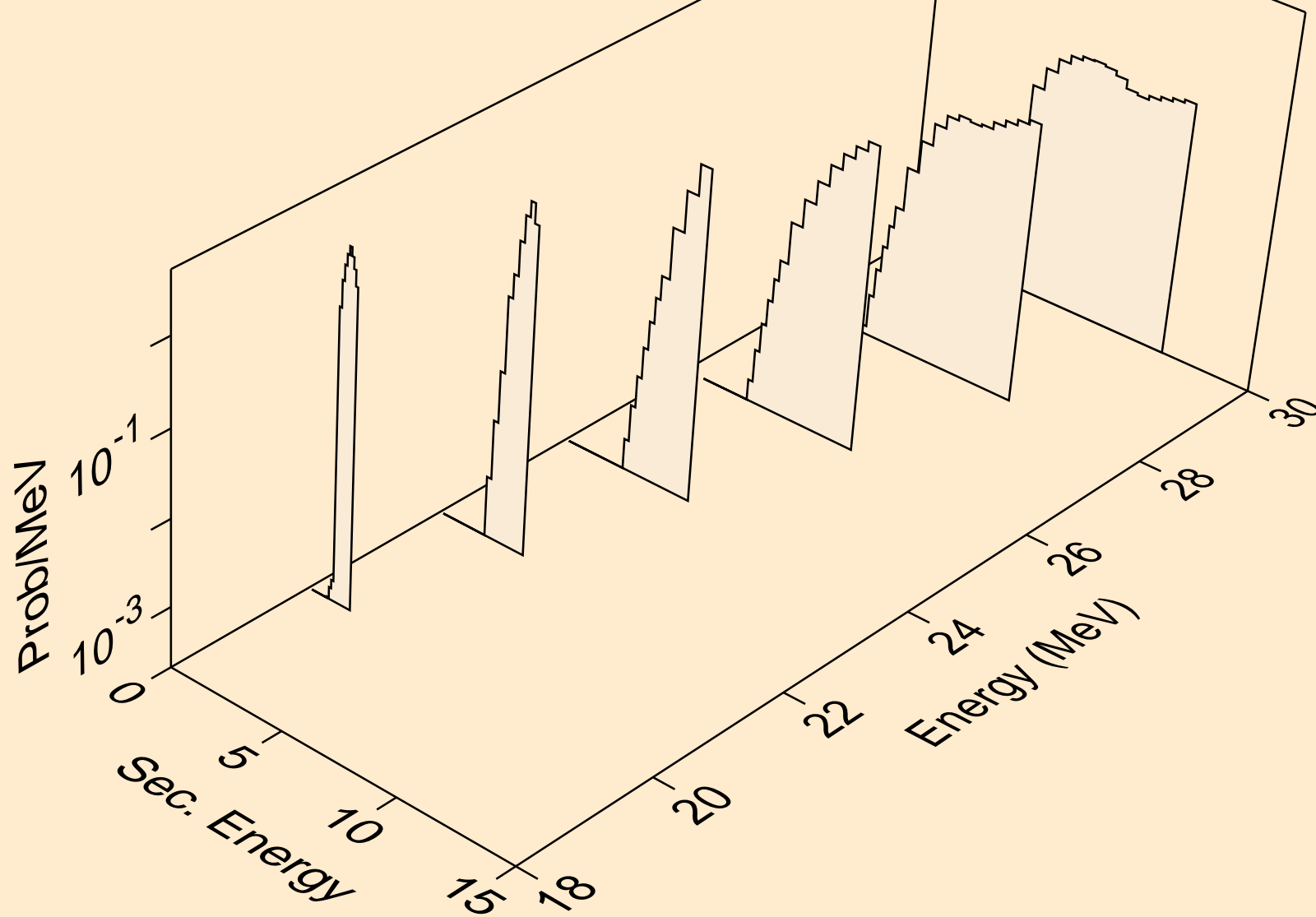

Y080M PHOTON ACER TENDL-2023 LIBRARY; T=0.K  
tritons from (g,pt)

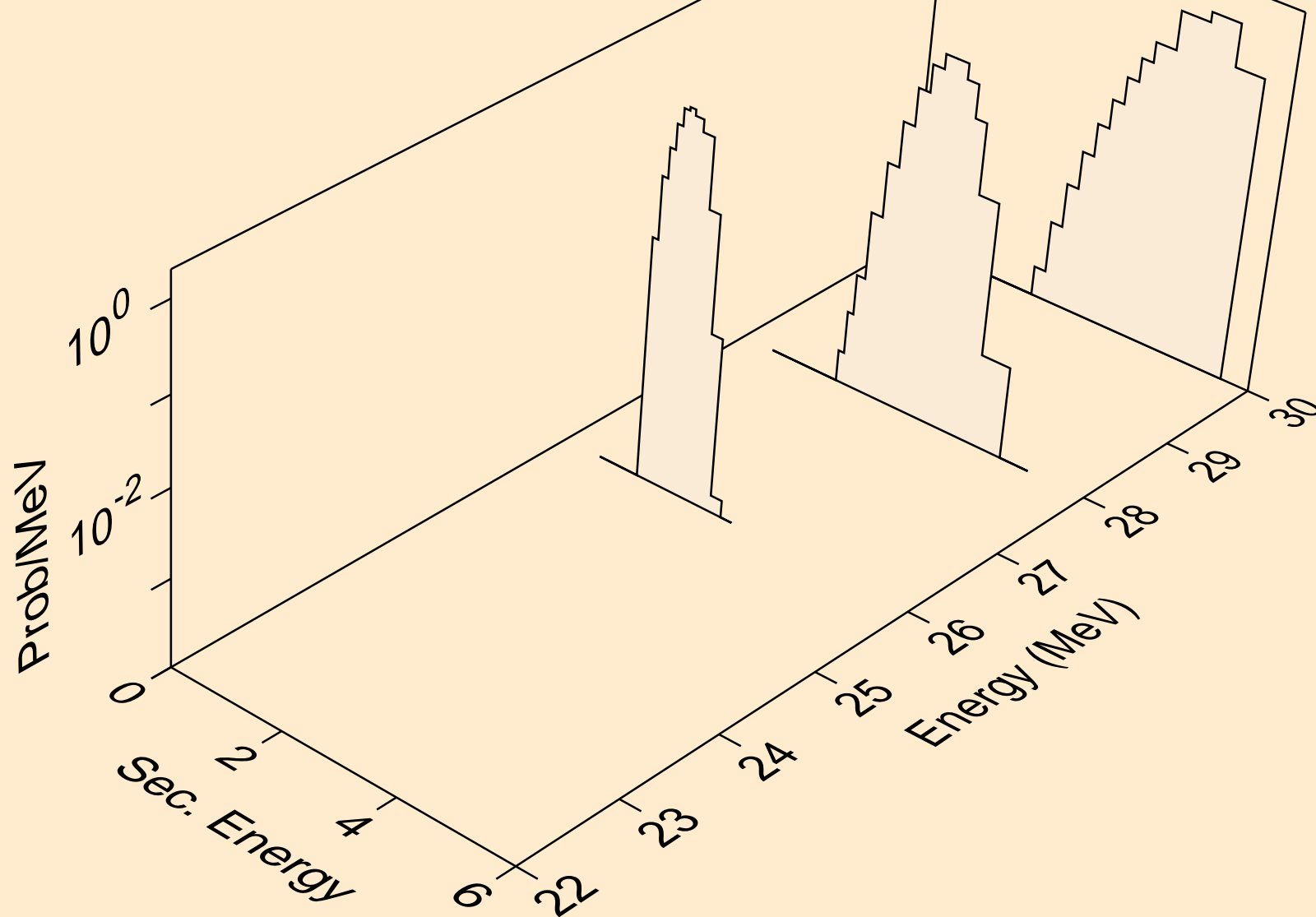

Y080M PHOTON ACER TENDL-2023 LIBRARY; T=0.K  
he3s from (g,x)

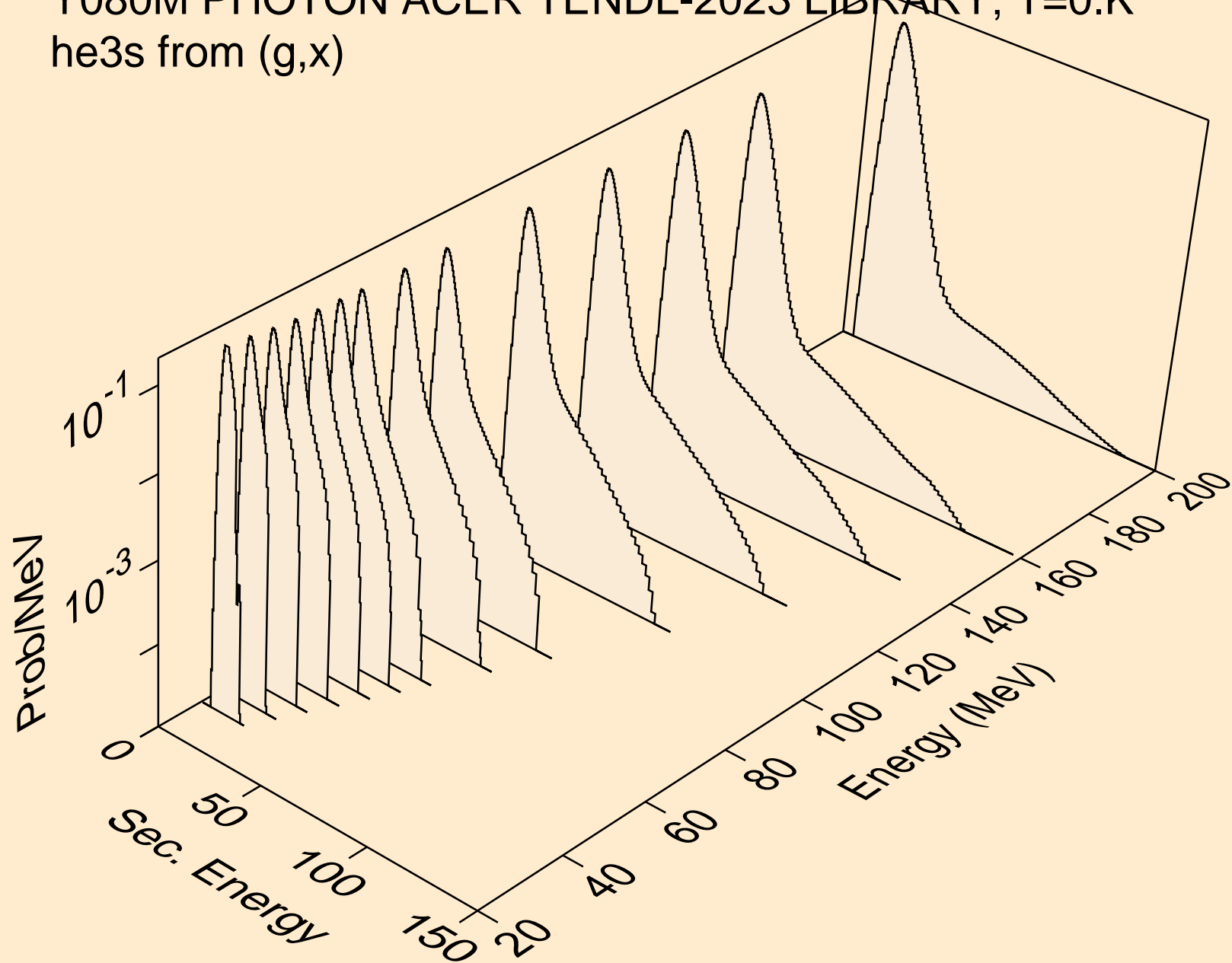



Y080M PHOTON ACER TENDL-2023 LIBRARY; T=0.K  
he3s from (g,he3)

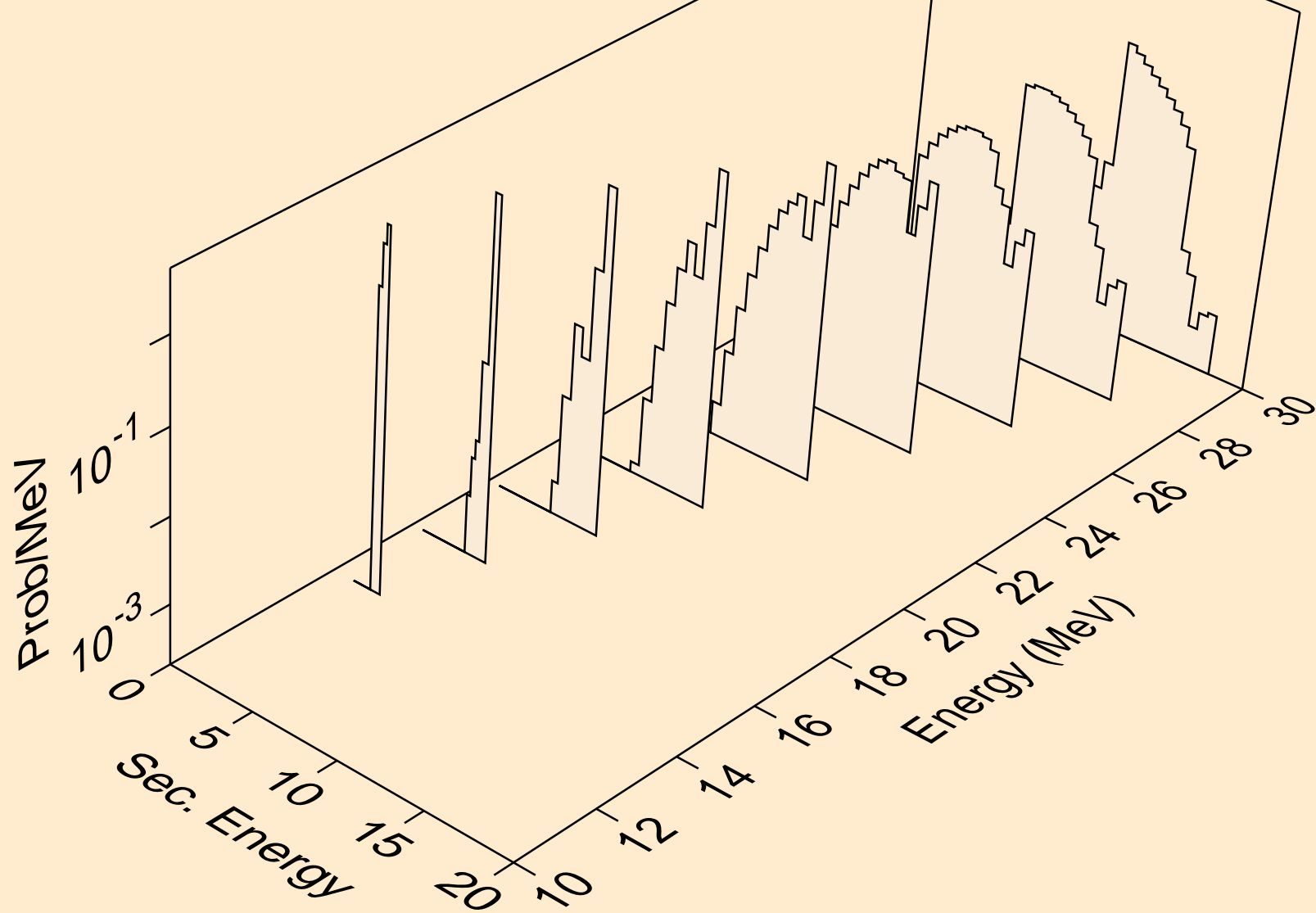

Y080M PHOTON ACER TENDL-2023 LIBRARY; T=0.K  
alphas from (g,x)

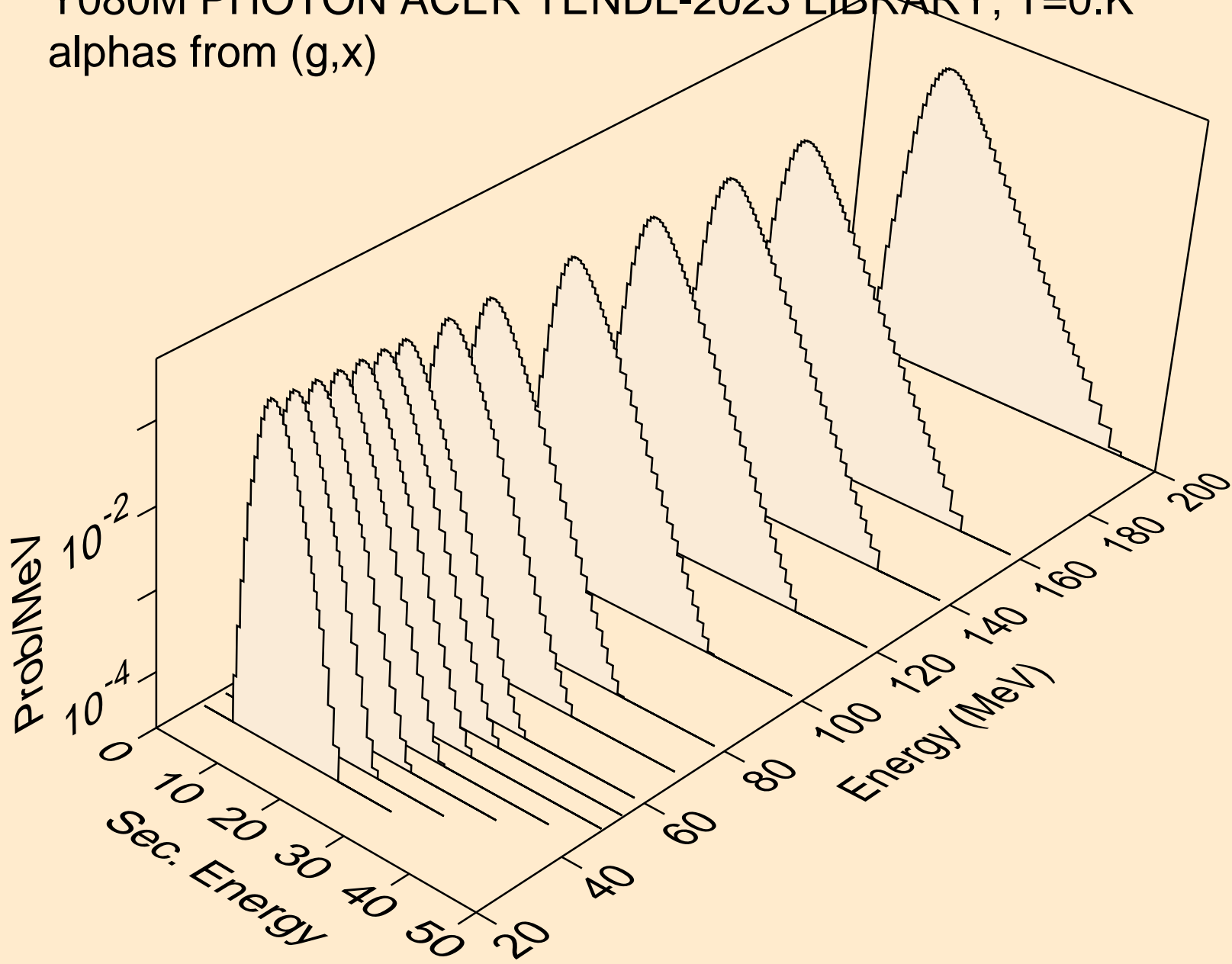

Y080M PHOTON ACER TENDL-2023 LIBRARY; T=0.K  
alphas from (g,n\*)a

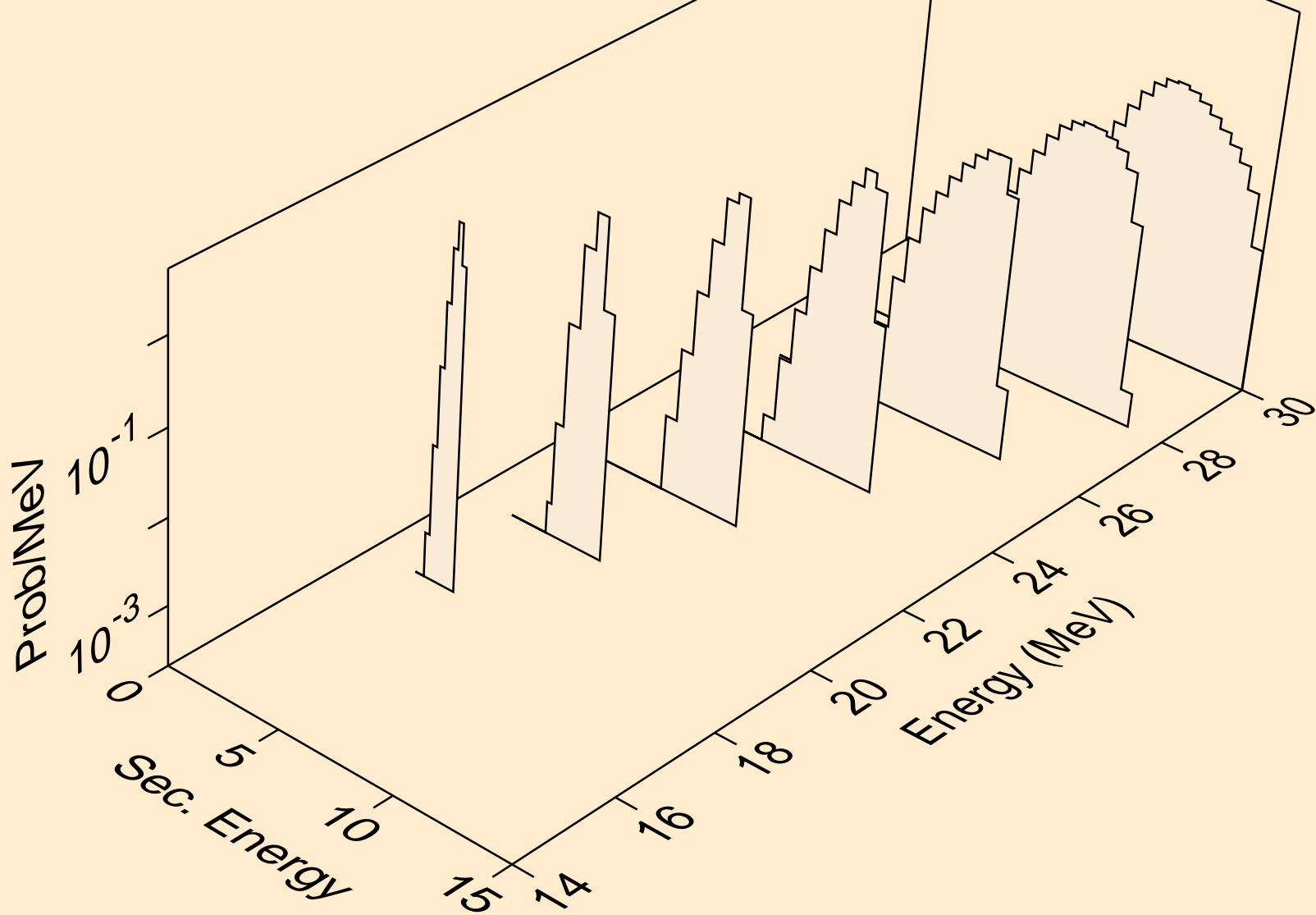

Y080M PHOTON ACER TENDL-2023 LIBRARY; T=0.K  
alphas from (g,npa)

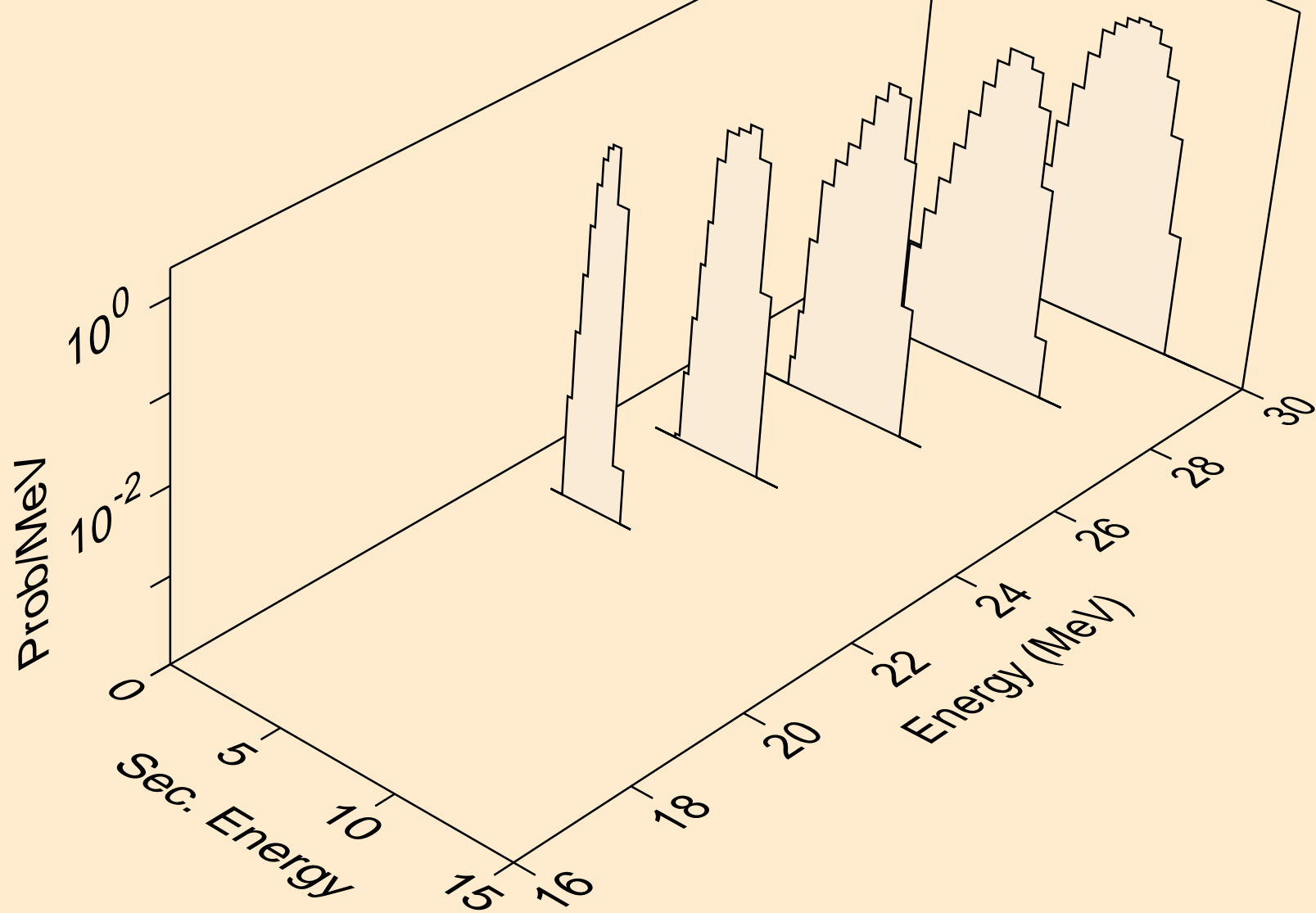

Y080M PHOTON ACER TENDL-2023 LIBRARY; T=0.K  
alphas from (g,a)

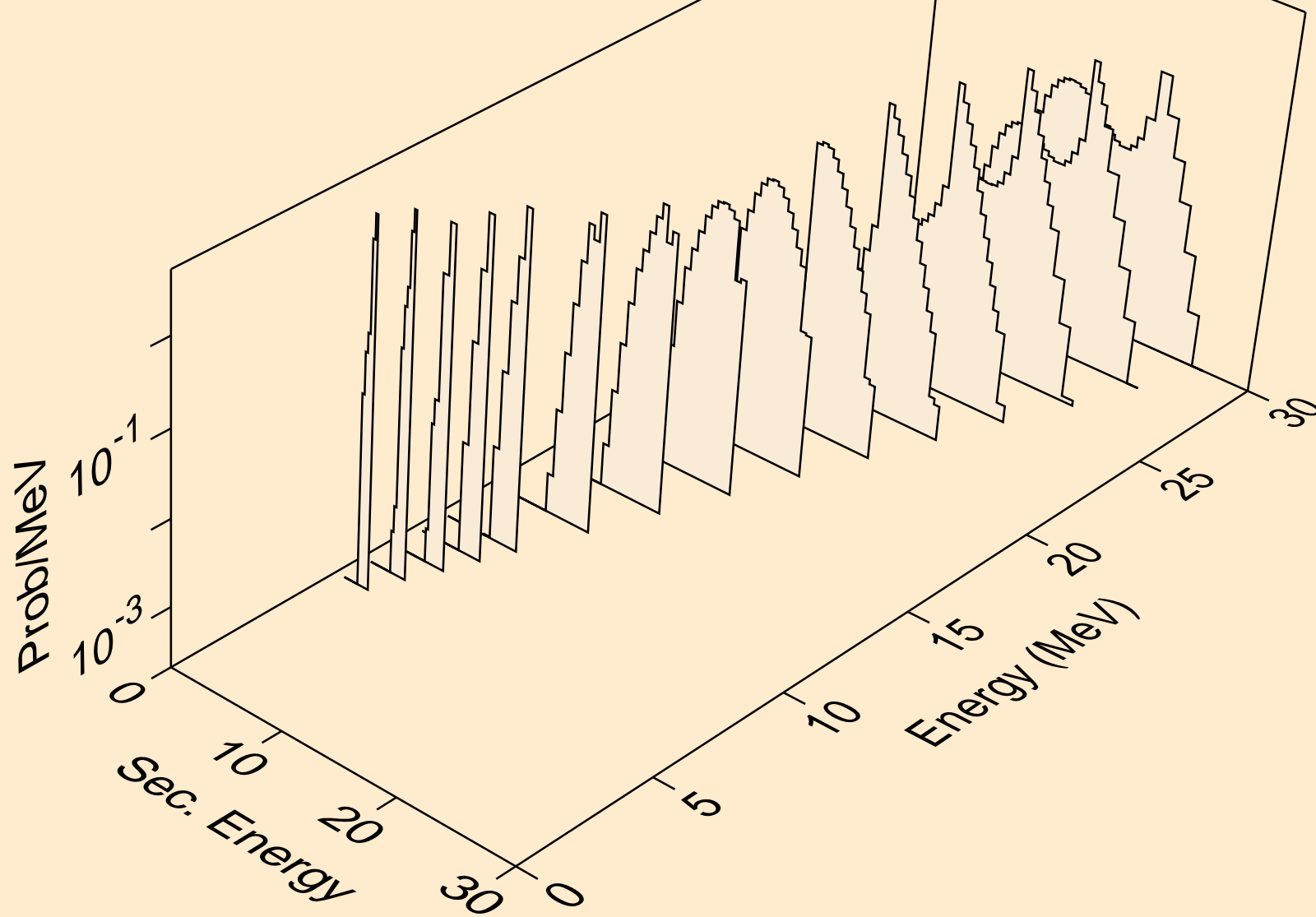

Y080M PHOTON ACER TENDL-2023 LIBRARY; T=0.K  
alphas from (g,2a)

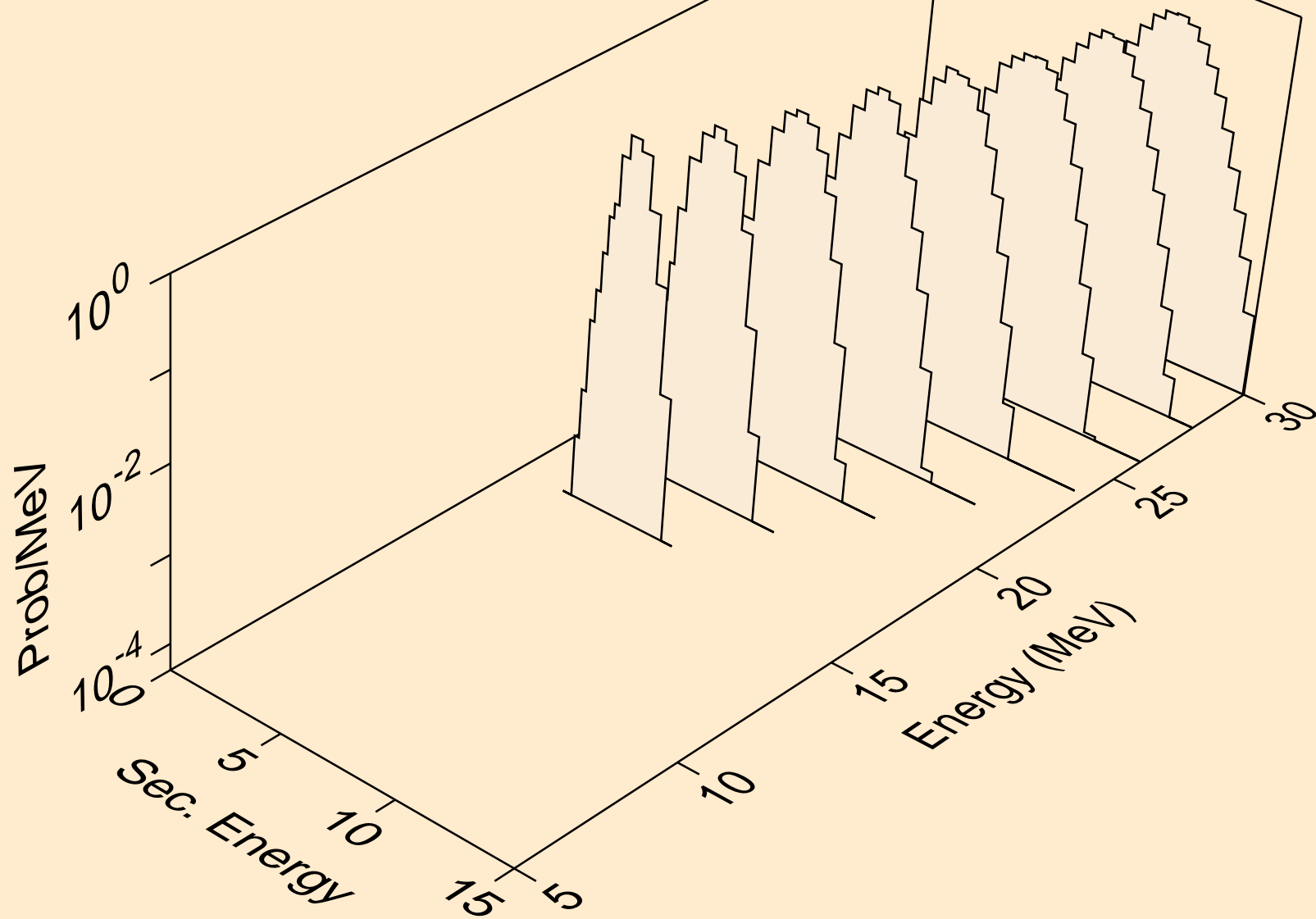

Y080M PHOTON ACER TENDL-2023 LIBRARY; T=0.K  
alphas from (g,pa)

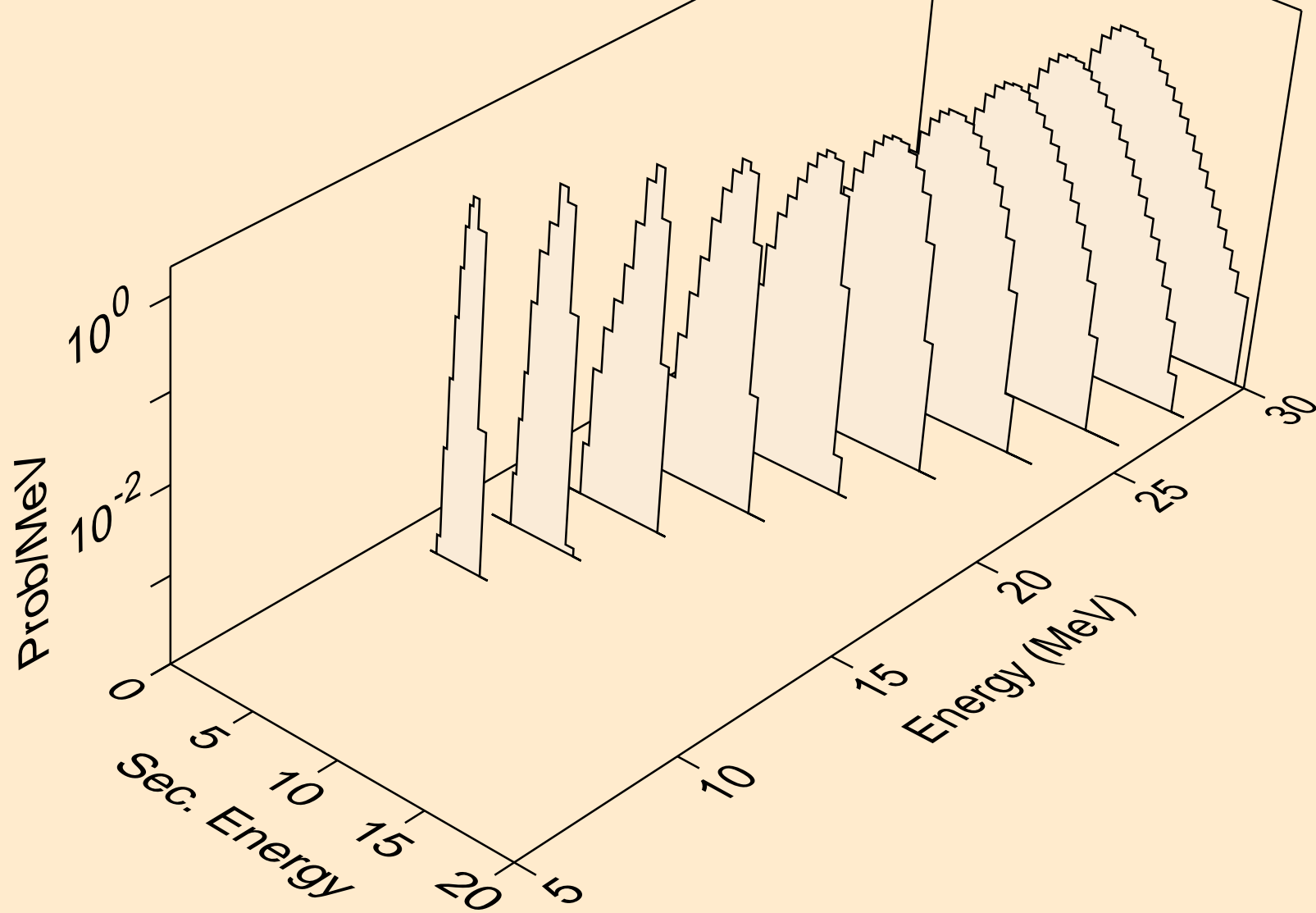

Y080M PHOTON ACER TENDL-2023 LIBRARY; T=0.K  
alphas from (g,da)

