

AC222 NEUTRON ACER TENDL-2023 LIBRARY; T=0.K

Principal cross sections

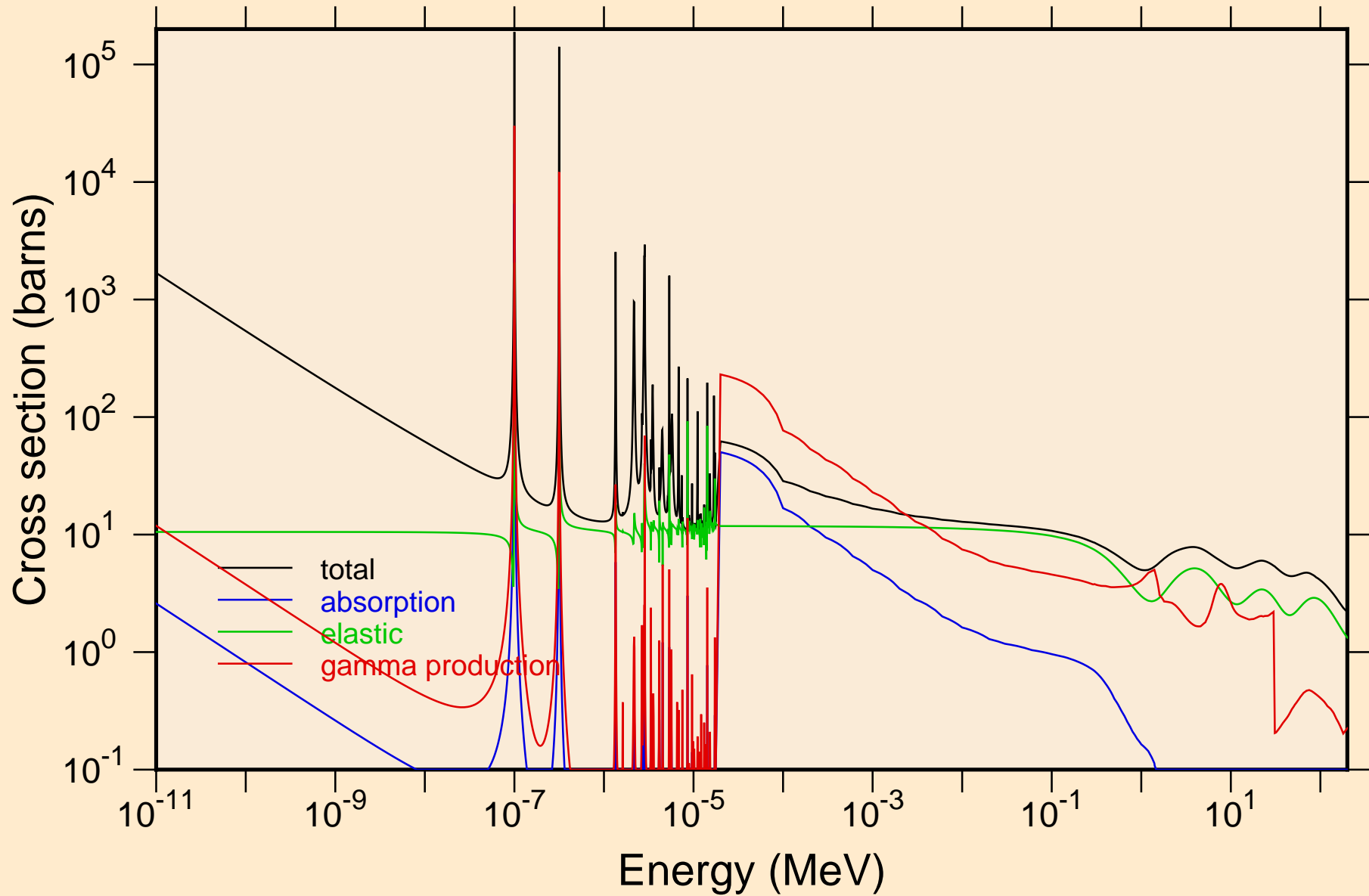

AC222 NEUTRON ACER TENDL-2023 LIBRARY; T=0.K
resonance total cross section

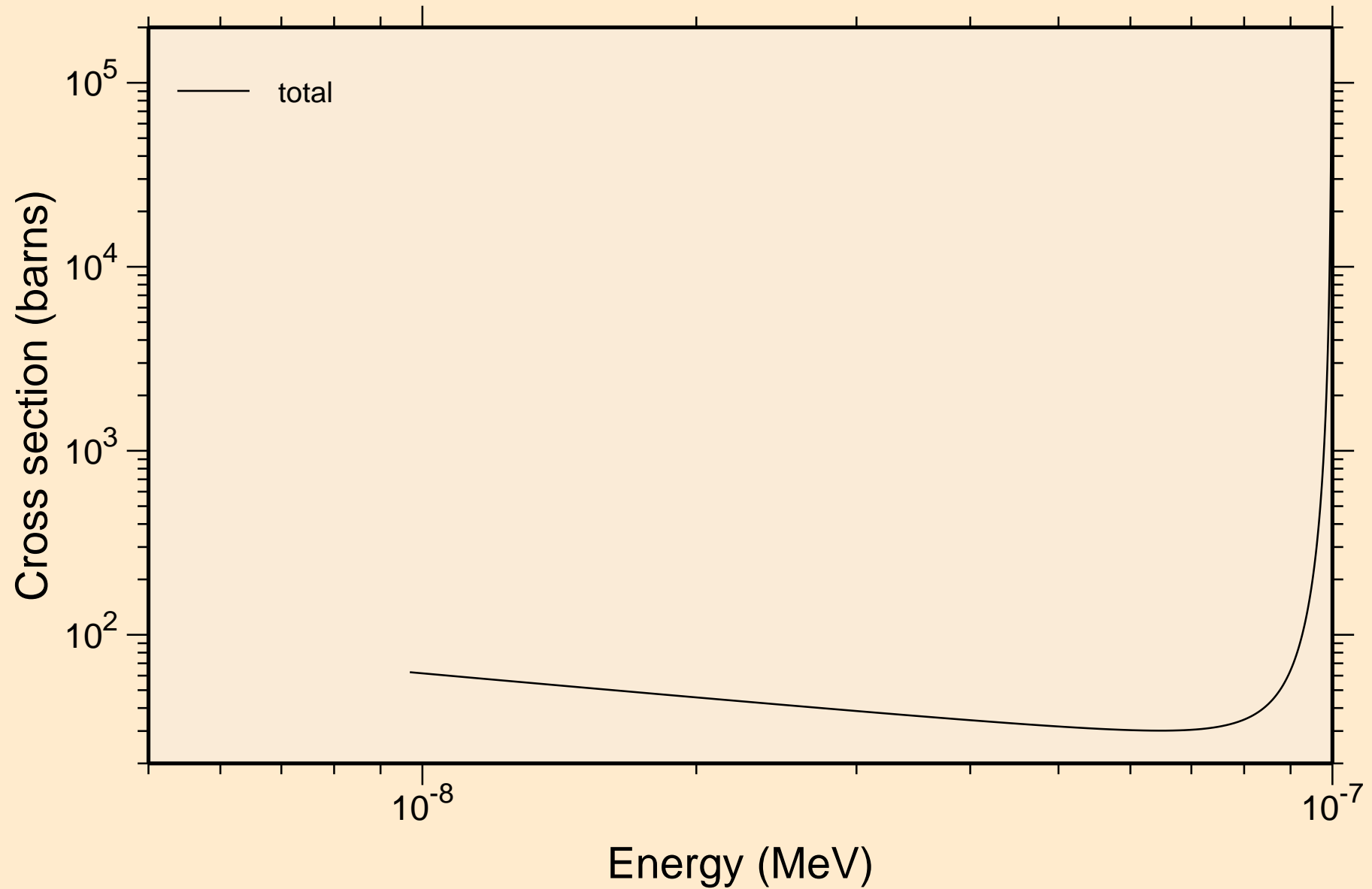

AC222 NEUTRON ACER TENDL-2023 LIBRARY; T=0.K
resonance total cross section

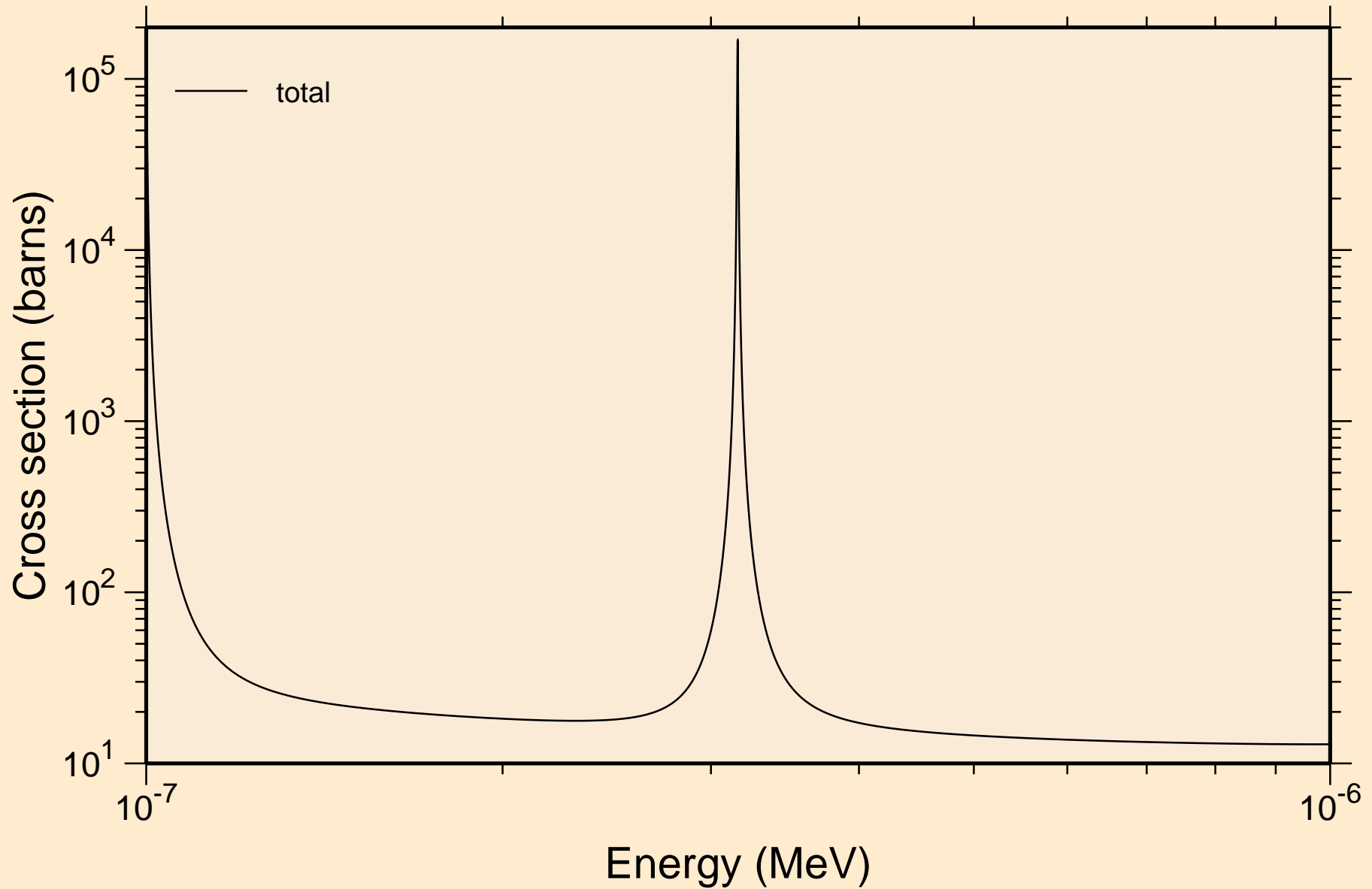

AC222 NEUTRON ACER TENDL-2023 LIBRARY; T=0.K
resonance total cross section

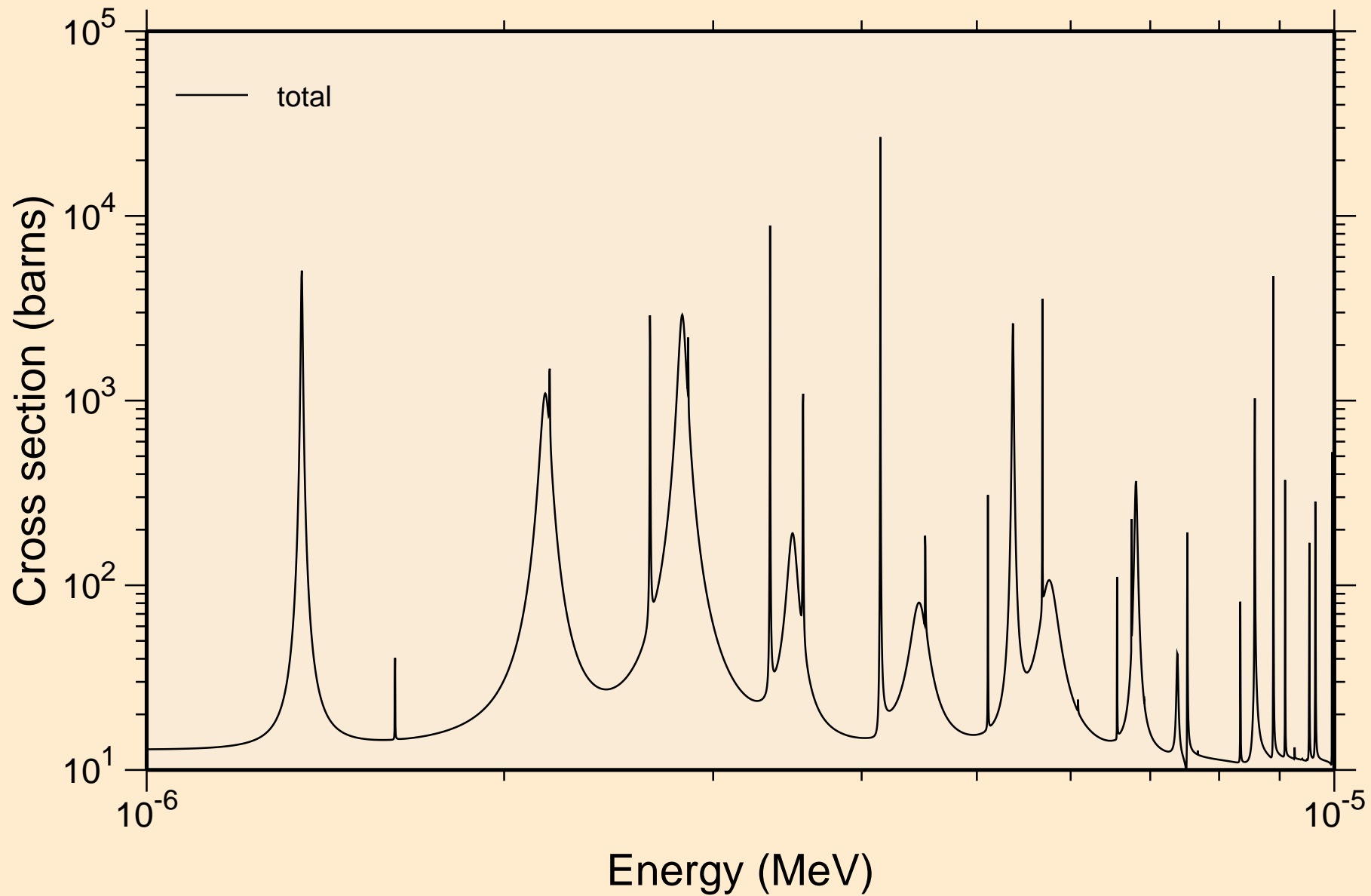

AC222 NEUTRON ACER TENDL-2023 LIBRARY; T=0.K
resonance total cross section

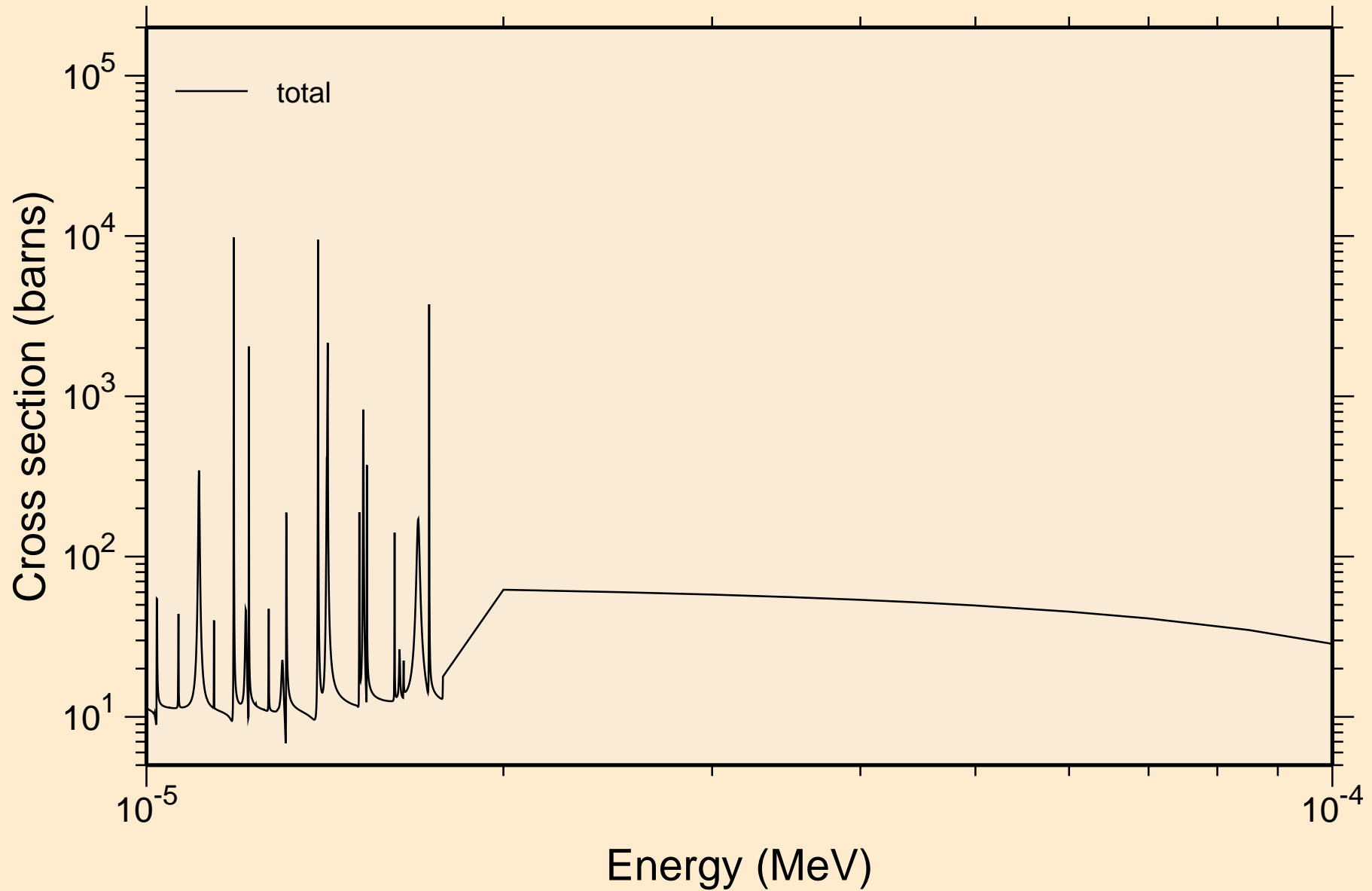

AC222 NEUTRON ACER TENDL-2023 LIBRARY; T=0.K
resonance total cross section

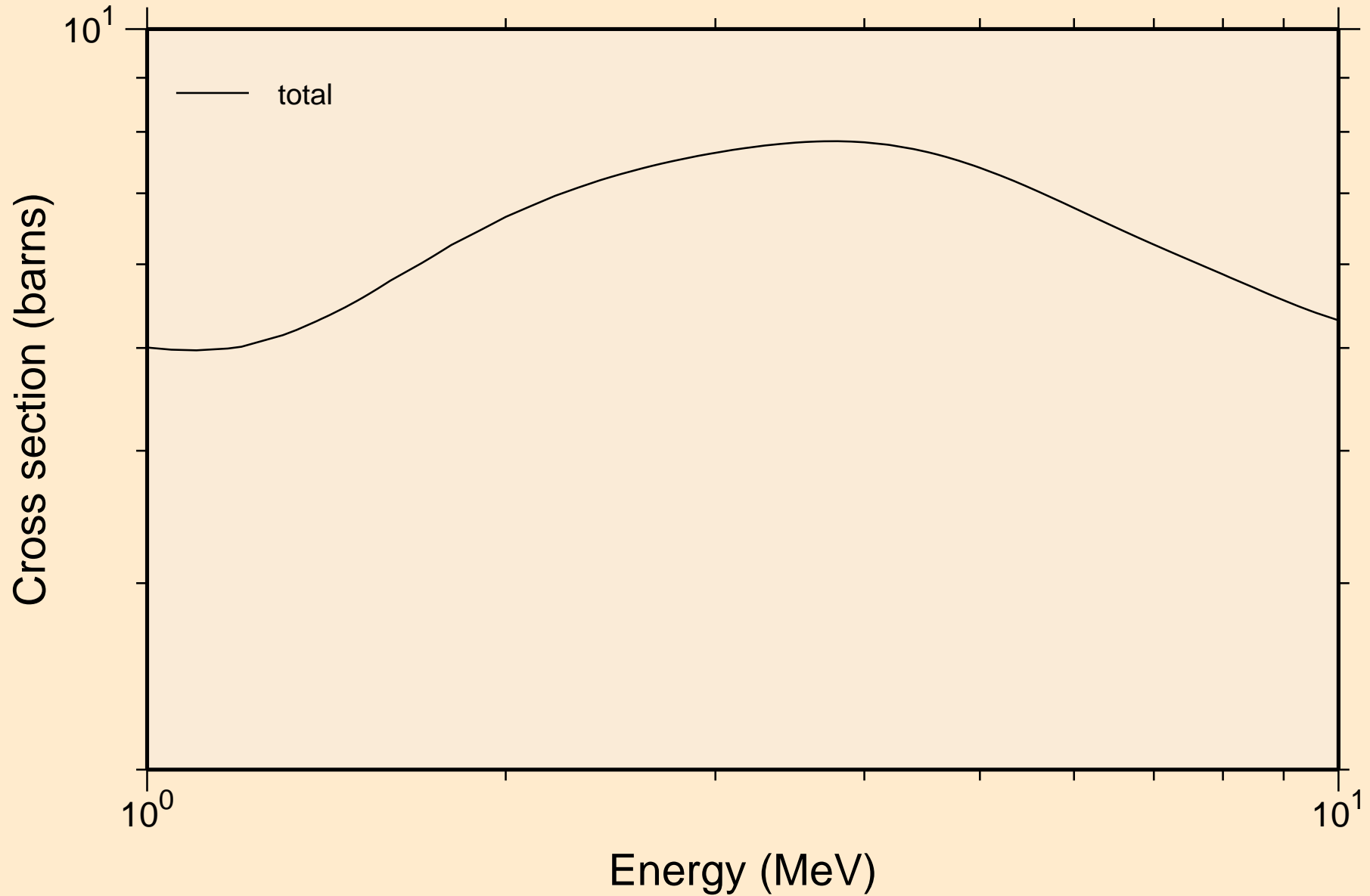

AC222 NEUTRON ACER TENDL-2023 LIBRARY; T=0.K
resonance absorption cross sections

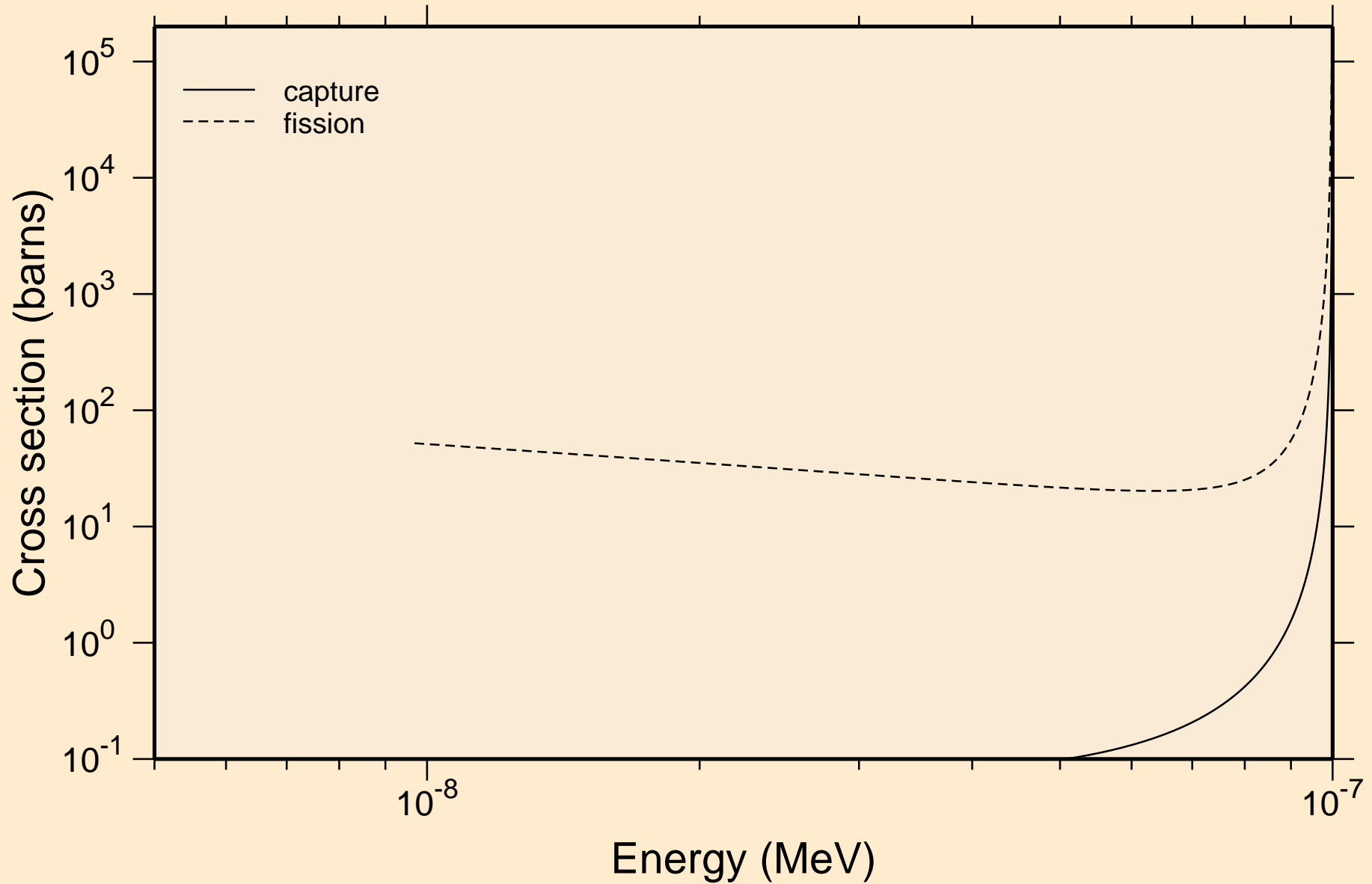

AC222 NEUTRON ACER TENDL-2023 LIBRARY; T=0.K
resonance absorption cross sections

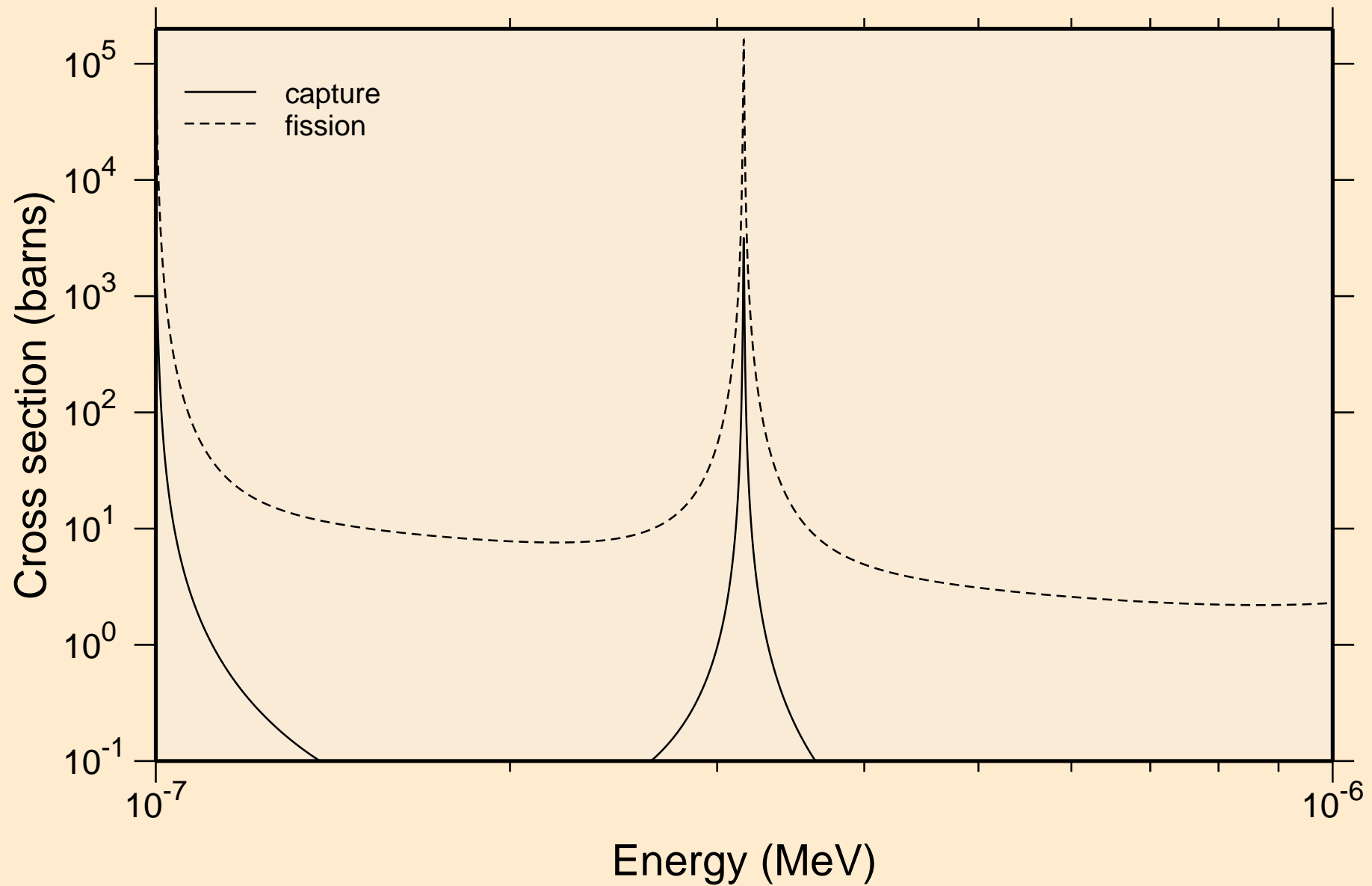

AC222 NEUTRON ACER TENDL-2023 LIBRARY; T=0.K

resonance absorption cross sections

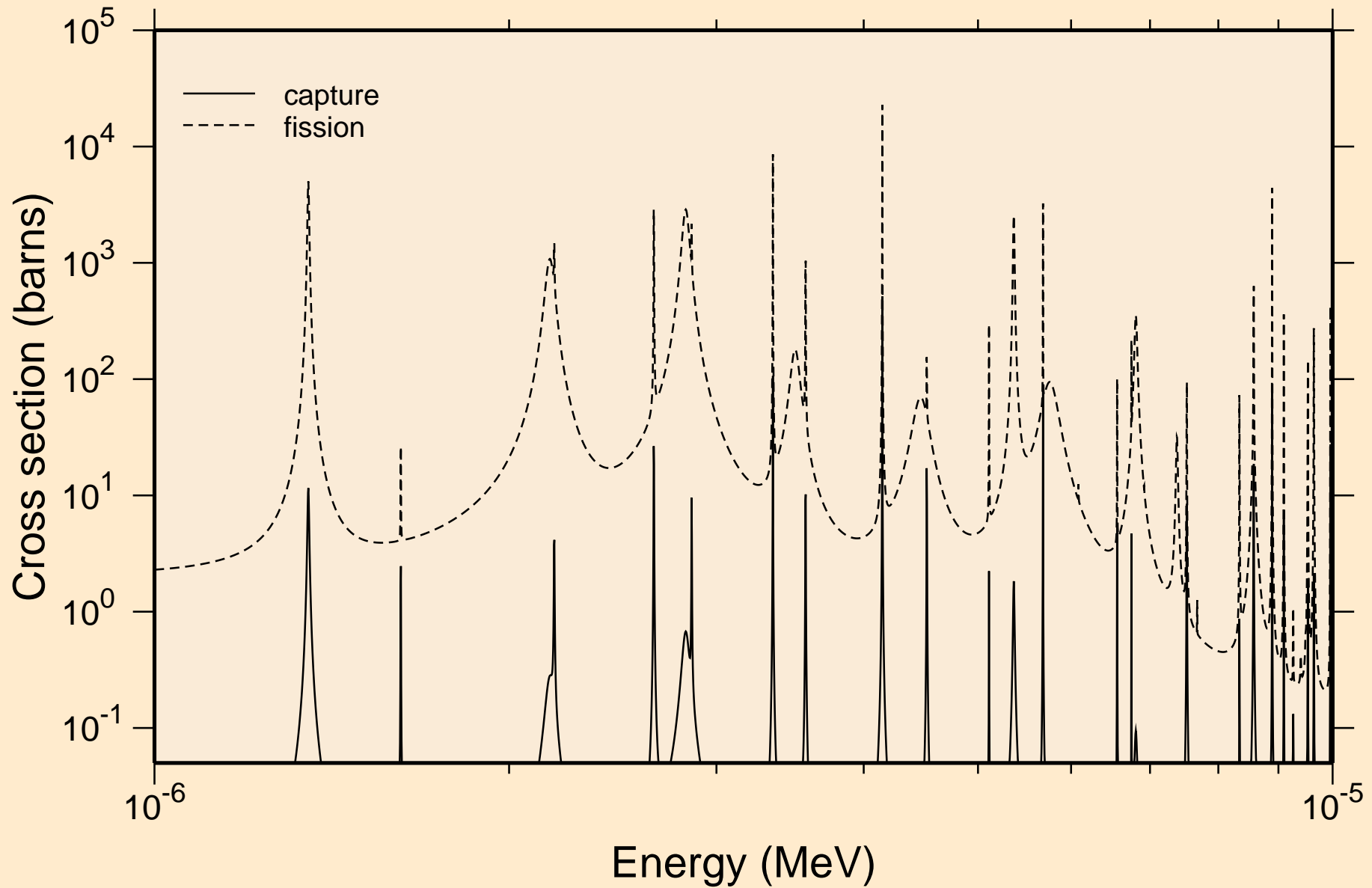

AC222 NEUTRON ACER TENDL-2023 LIBRARY; T=0.K
resonance absorption cross sections

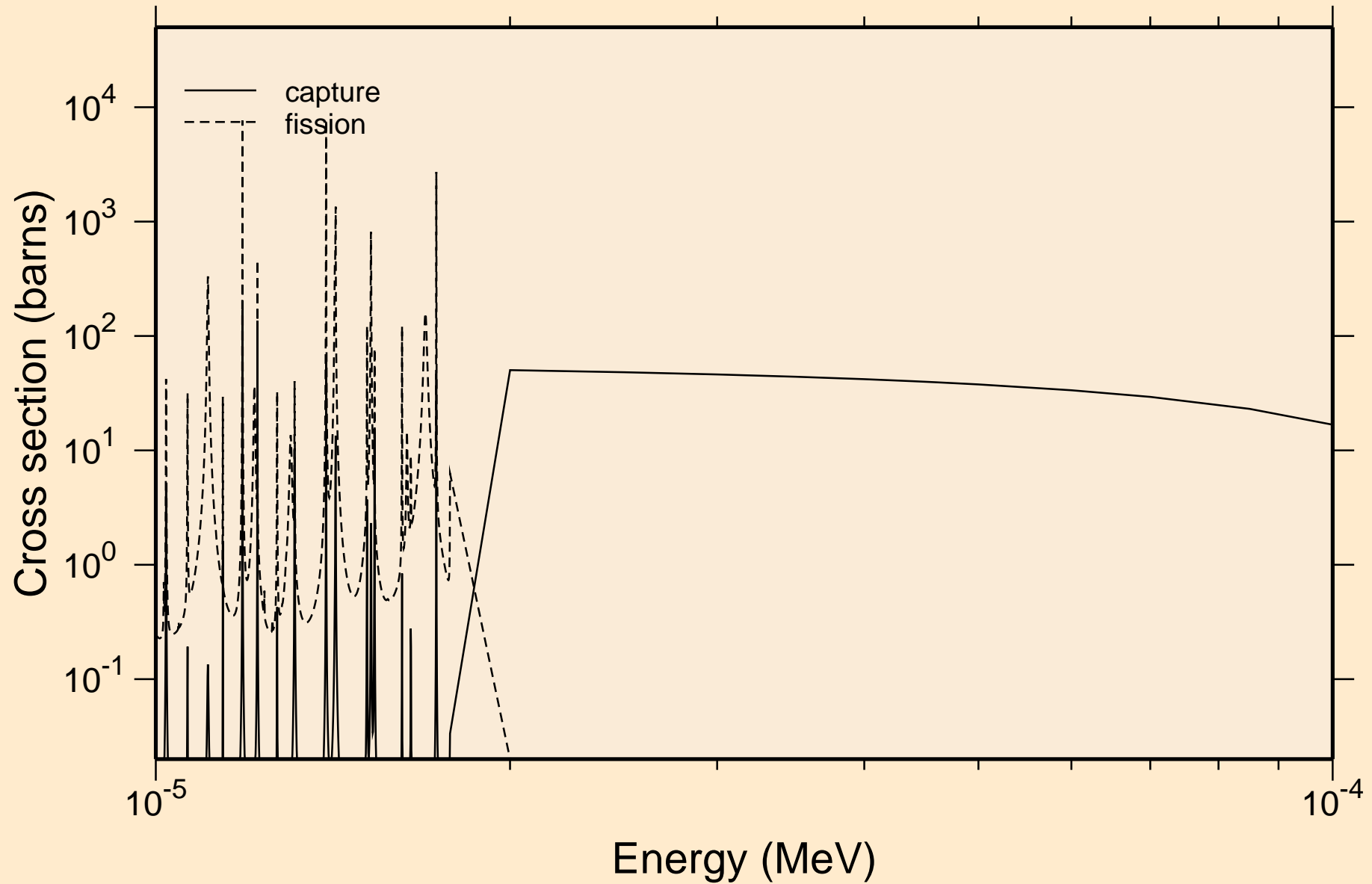

AC222 NEUTRON ACER TENDL-2023 LIBRARY; T=0.K
resonance absorption cross sections

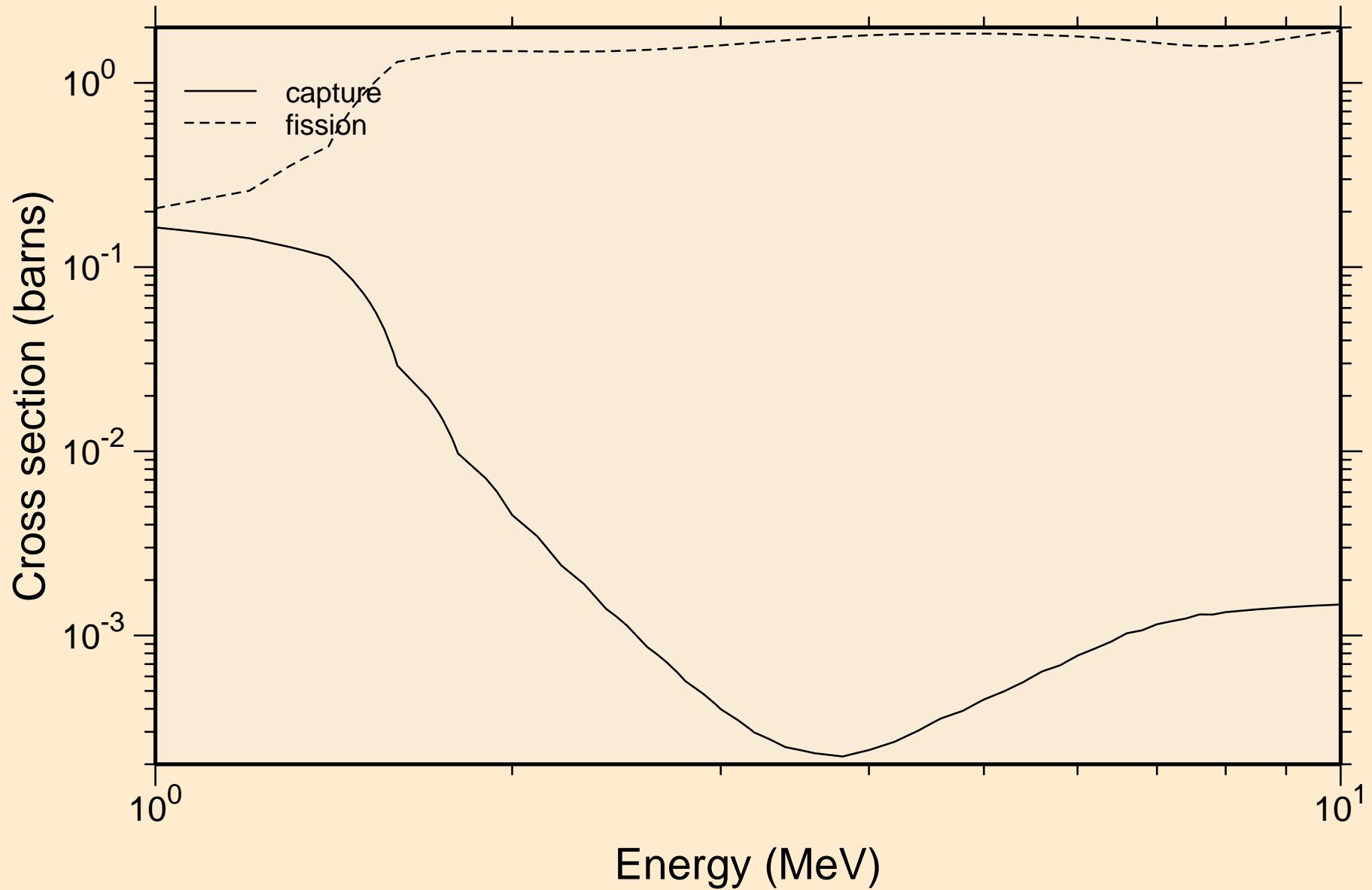

AC222 NEUTRON ACER TENDL-2023 LIBRARY; T=0.K

Heating

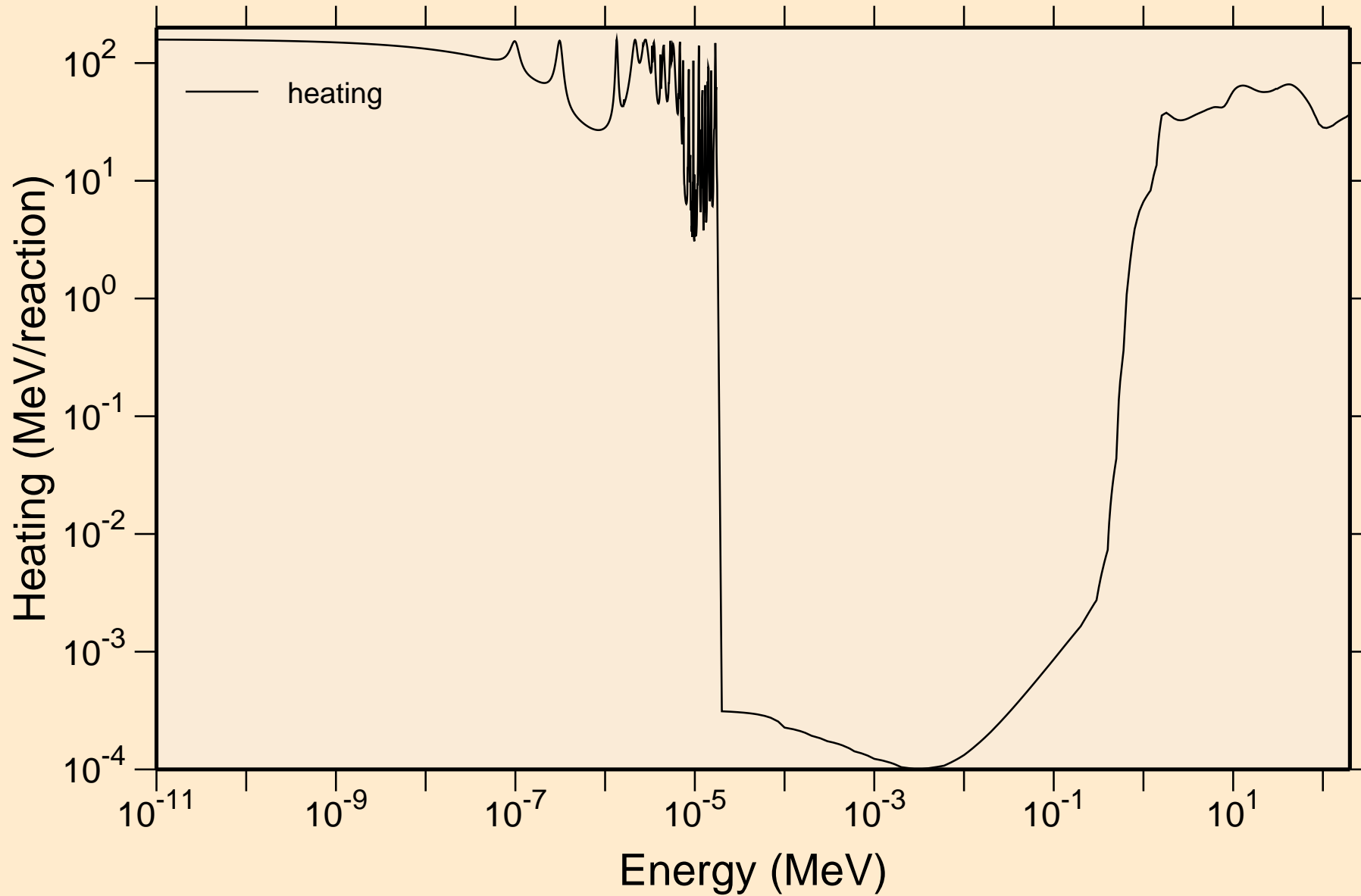

AC222 NEUTRON ACER TENDL-2023 LIBRARY; T=0.K
Damage

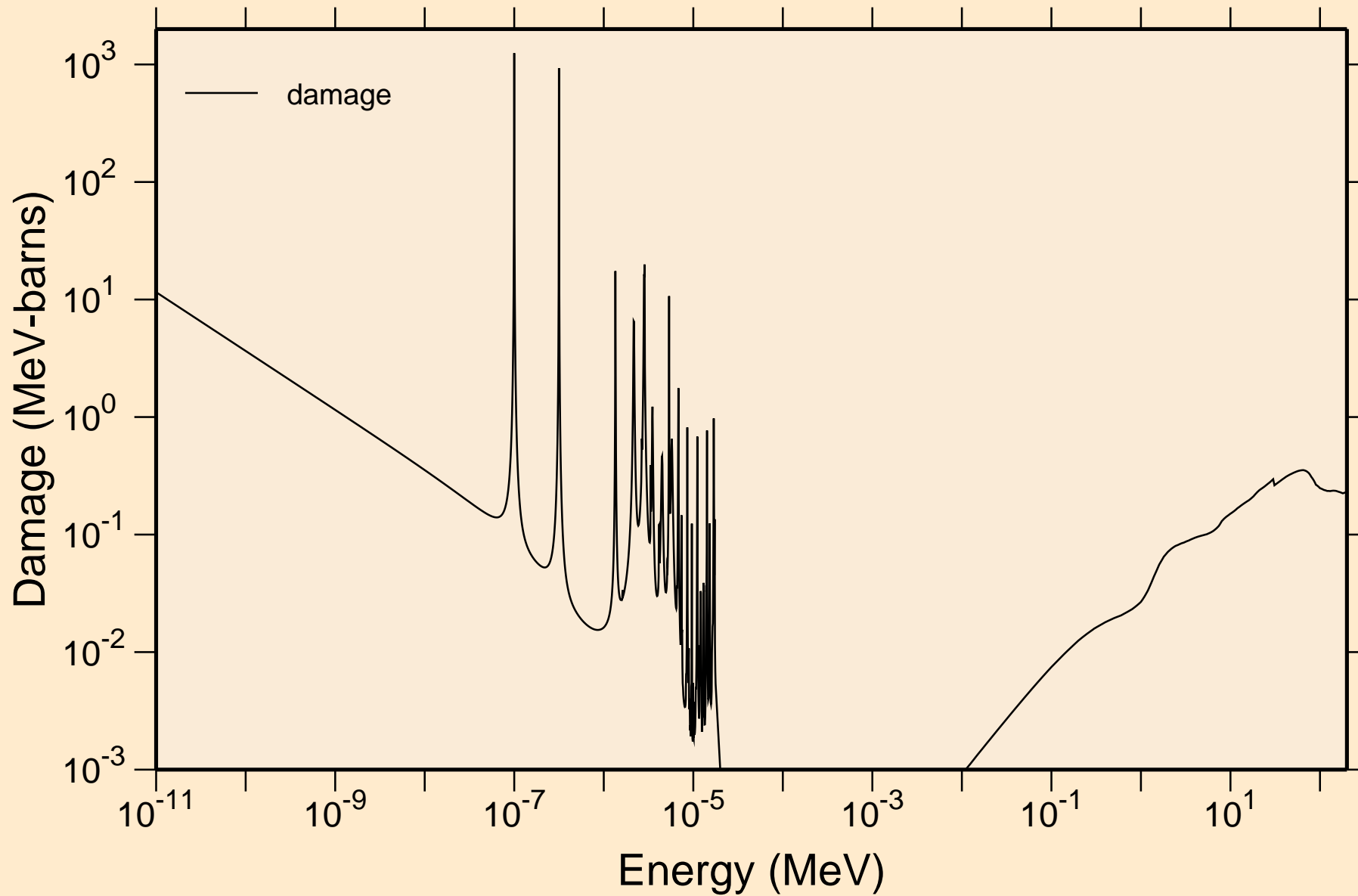

AC222 NEUTRON ACER TENDL-2023 LIBRARY; T=0.K

Non-threshold reactions

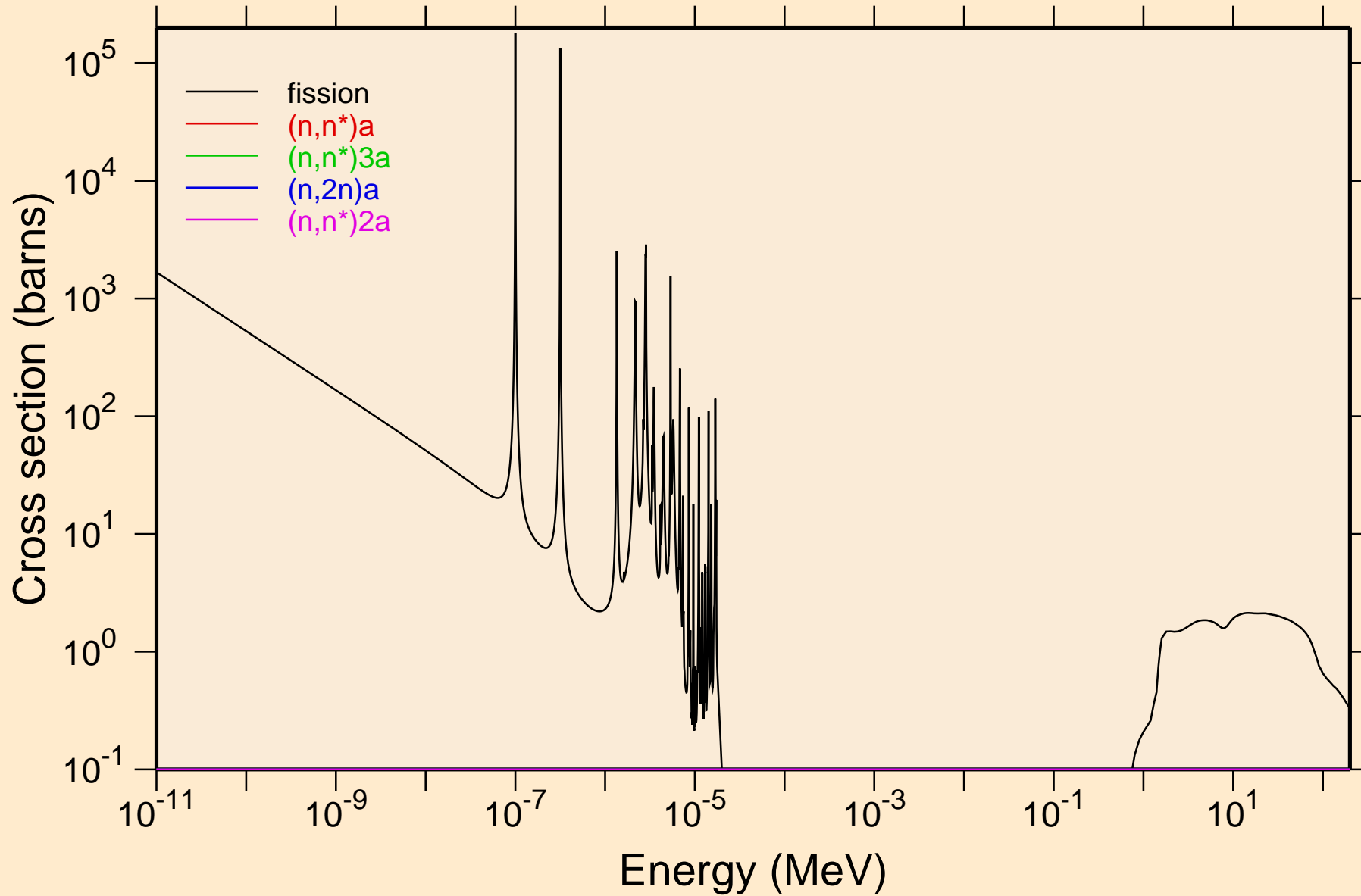

AC222 NEUTRON ACER TENDL-2023 LIBRARY; T=0.K
Non-threshold reactions

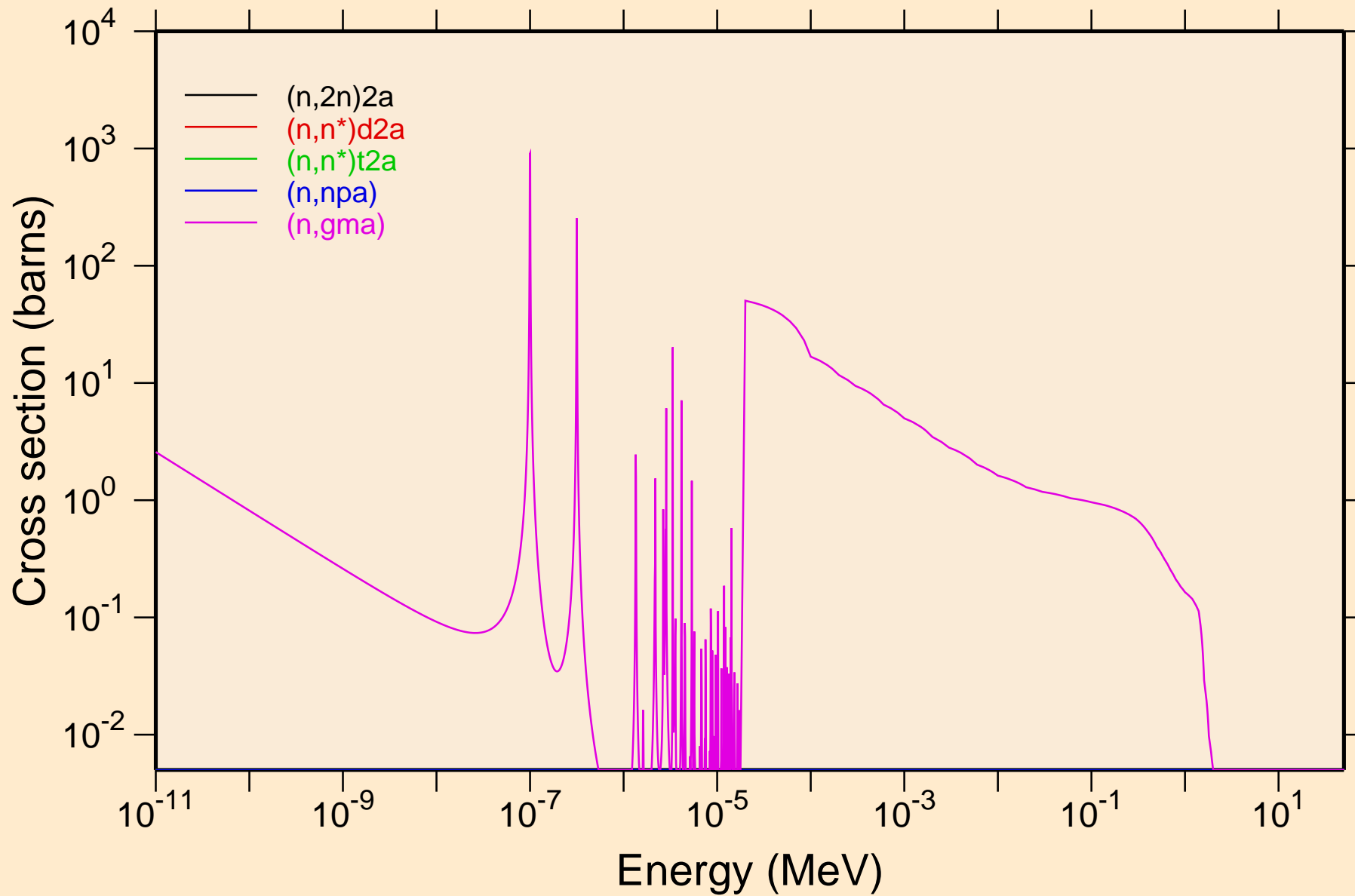

AC222 NEUTRON ACER TENDL-2023 LIBRARY; T=0.K
Non-threshold reactions

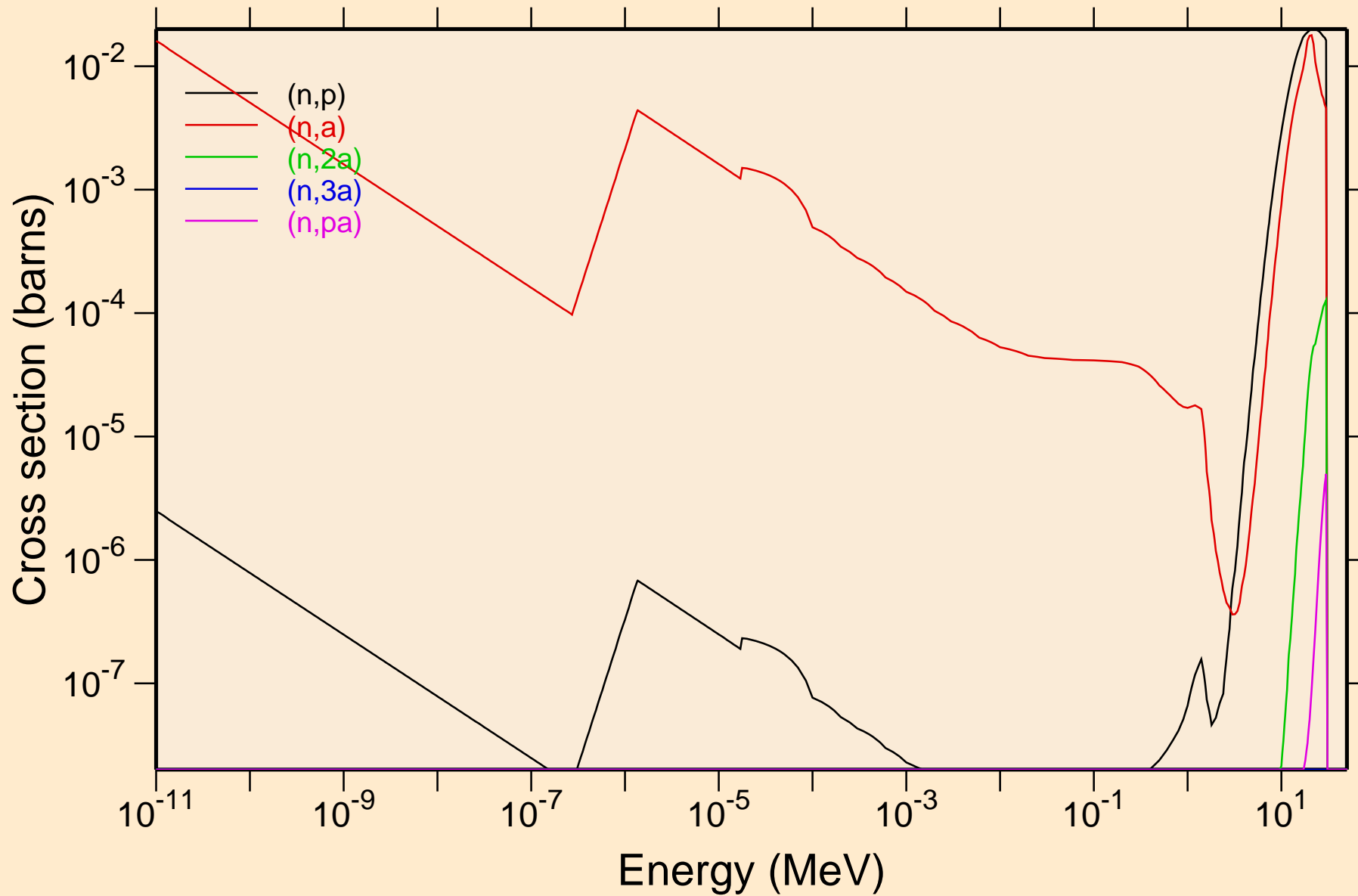

AC222 NEUTRON ACER TENDL-2023 LIBRARY; T=0.K
Non-threshold reactions

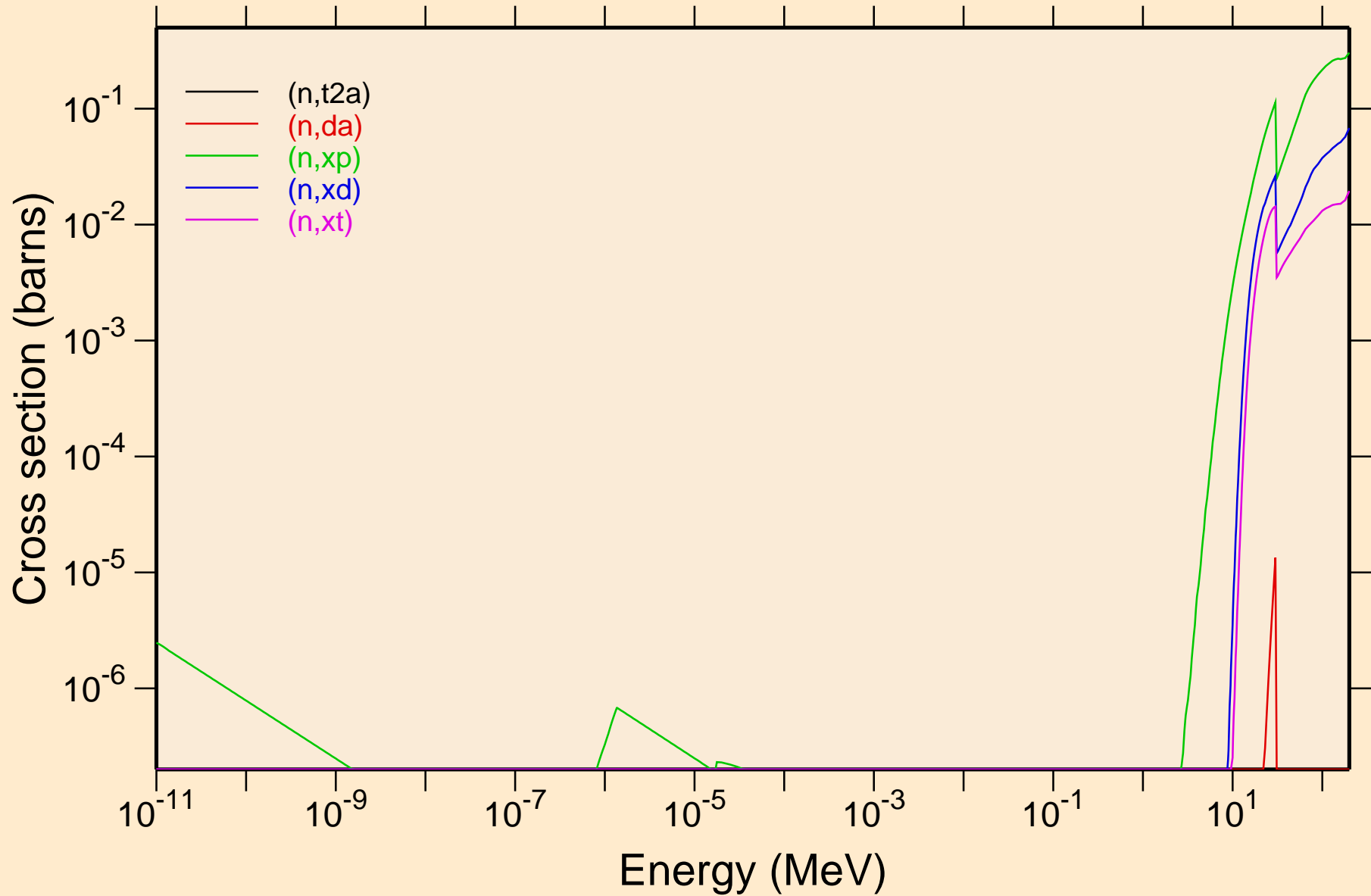

AC222 NEUTRON ACER TENDL-2023 LIBRARY; T=0.K
Non-threshold reactions

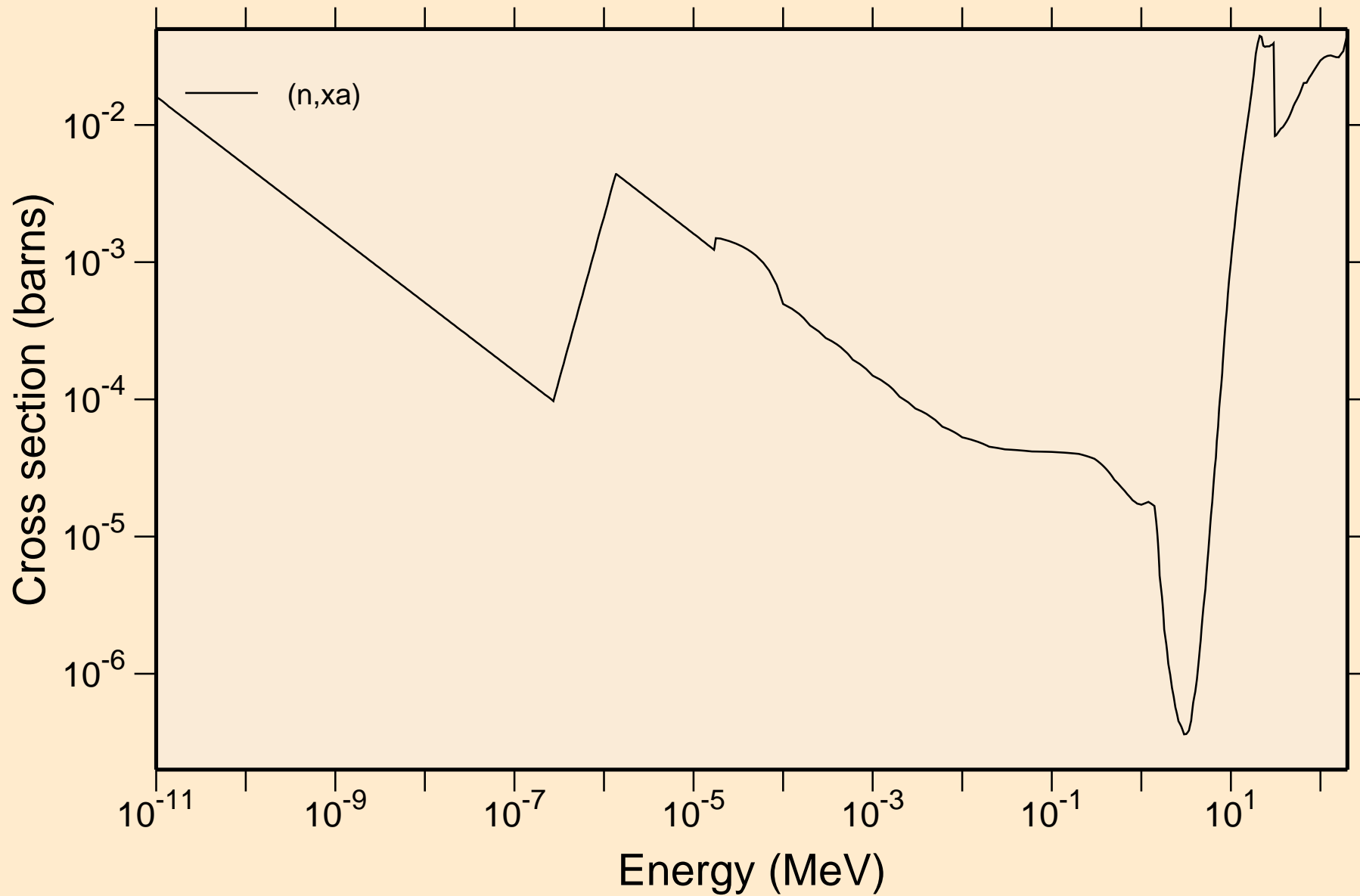

AC222 NEUTRON ACER TENDL-2023 LIBRARY; T=0.K

Principal cross sections

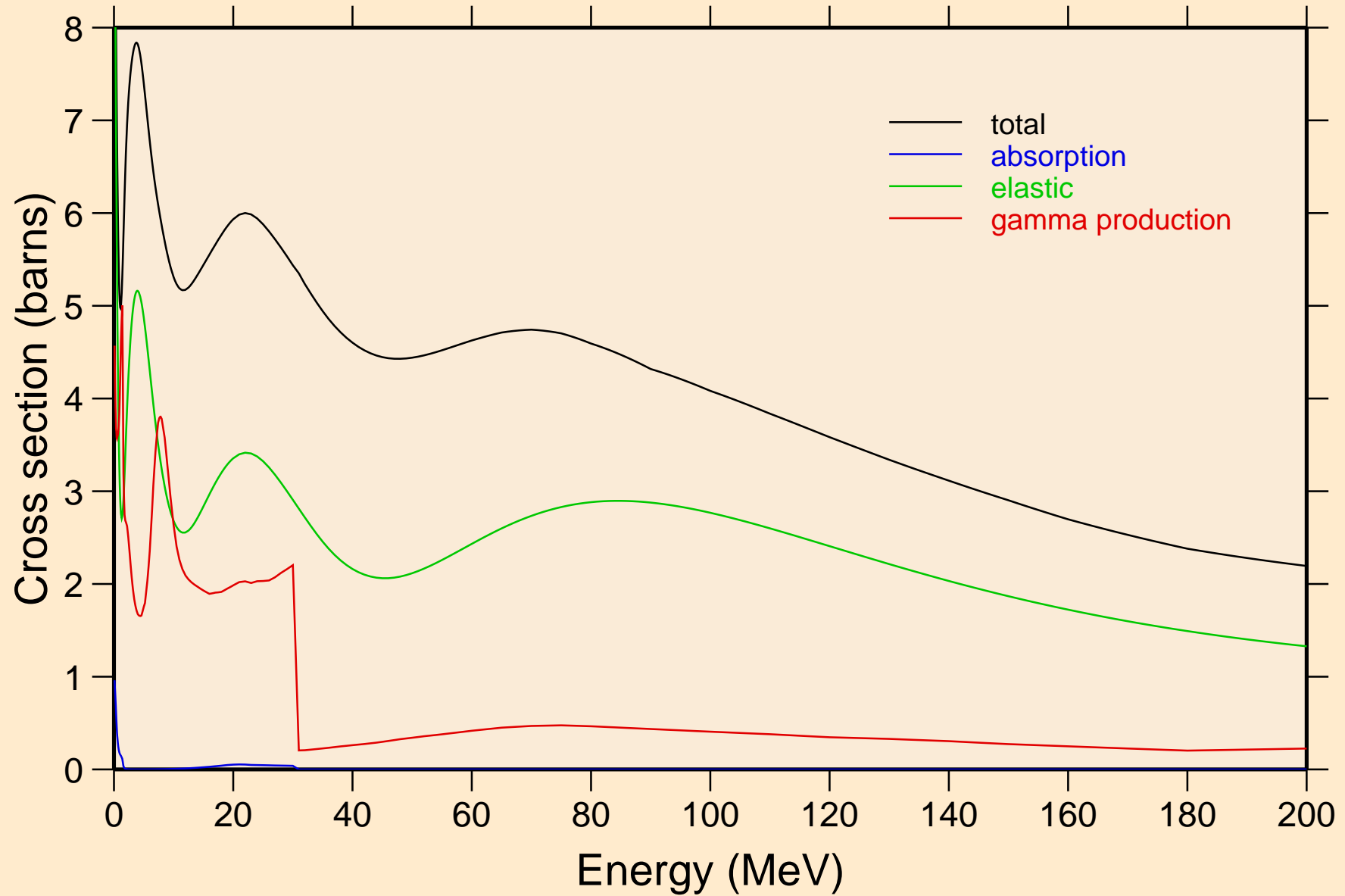

AC222 NEUTRON ACER TENDL-2023 LIBRARY; T=0.K

Heating

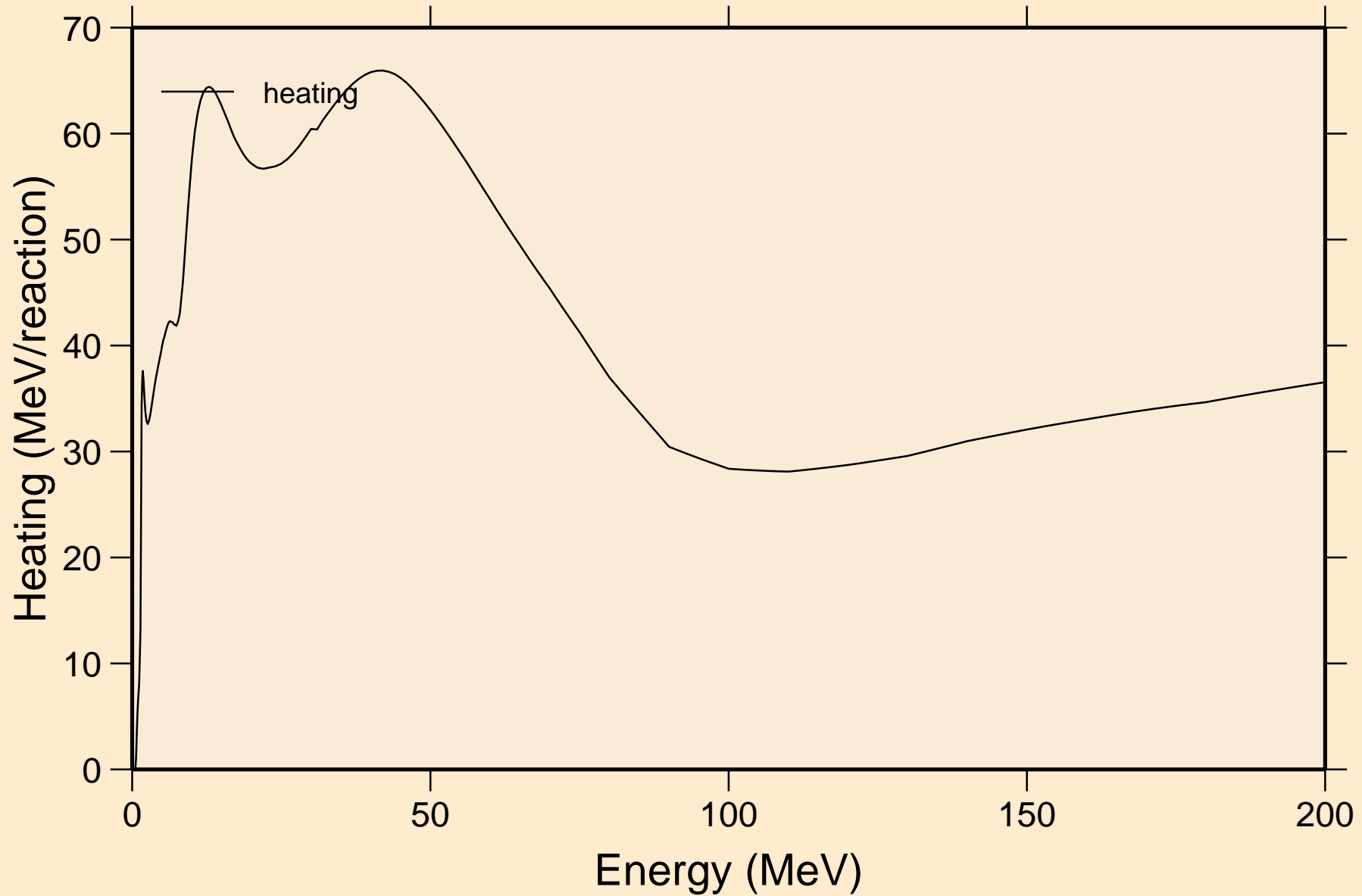

AC222 NEUTRON ACER TENDL-2023 LIBRARY; T=0.K

Damage

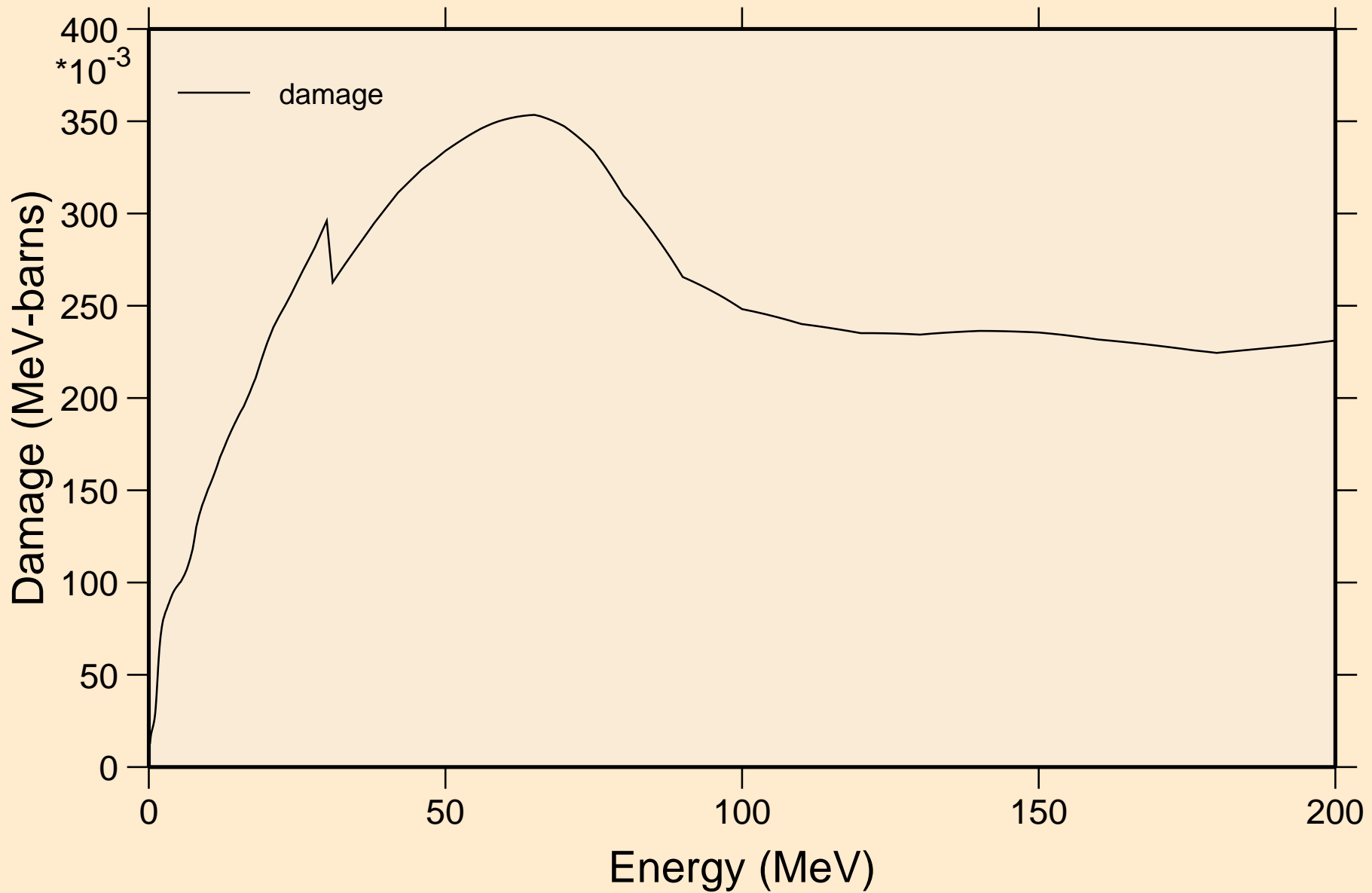

AC222 NEUTRON ACER TENDL-2023 LIBRARY; T=0.K

Non-threshold reactions

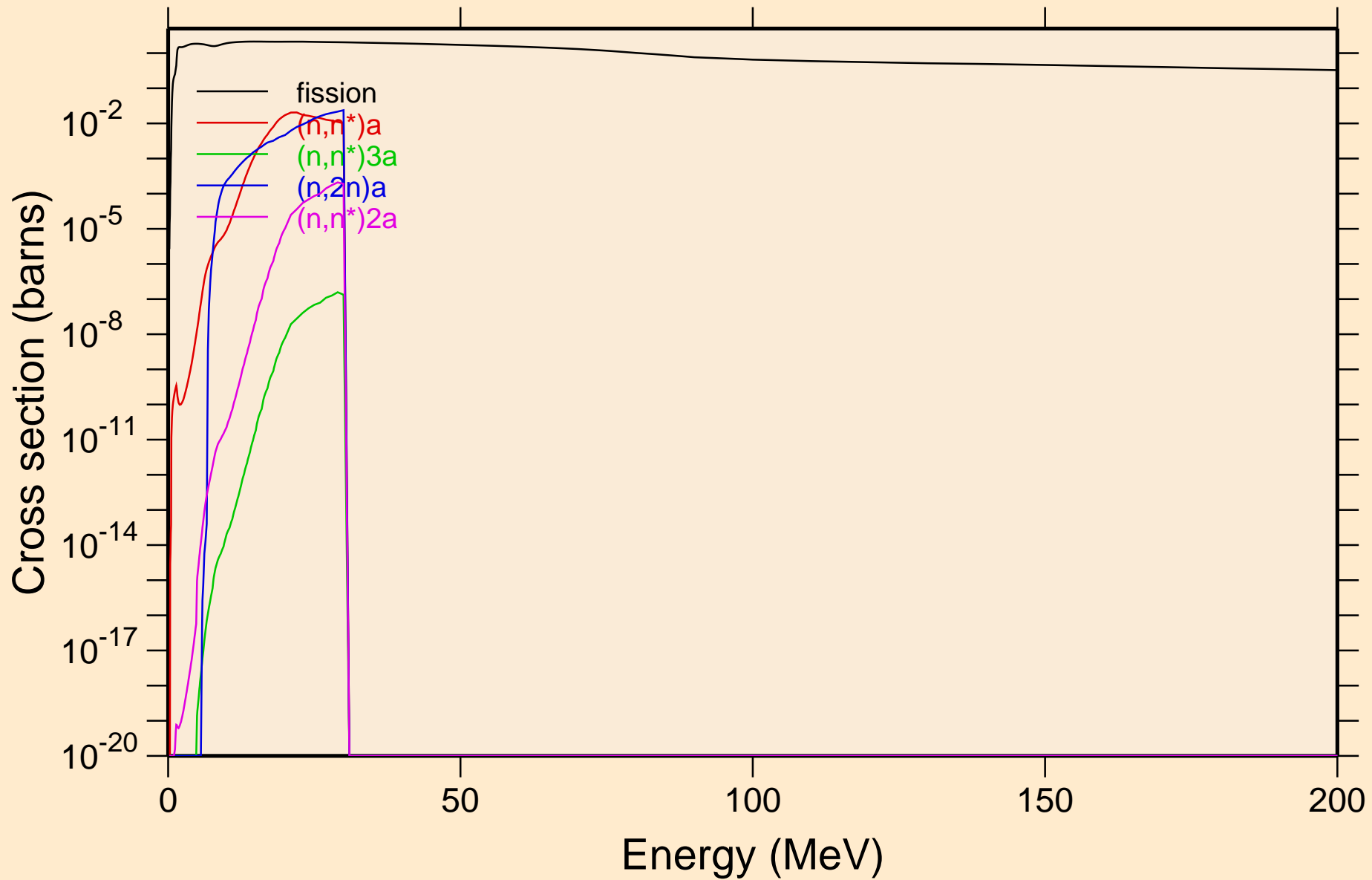

AC222 NEUTRON ACER TENDL-2023 LIBRARY; T=0.K

Non-threshold reactions

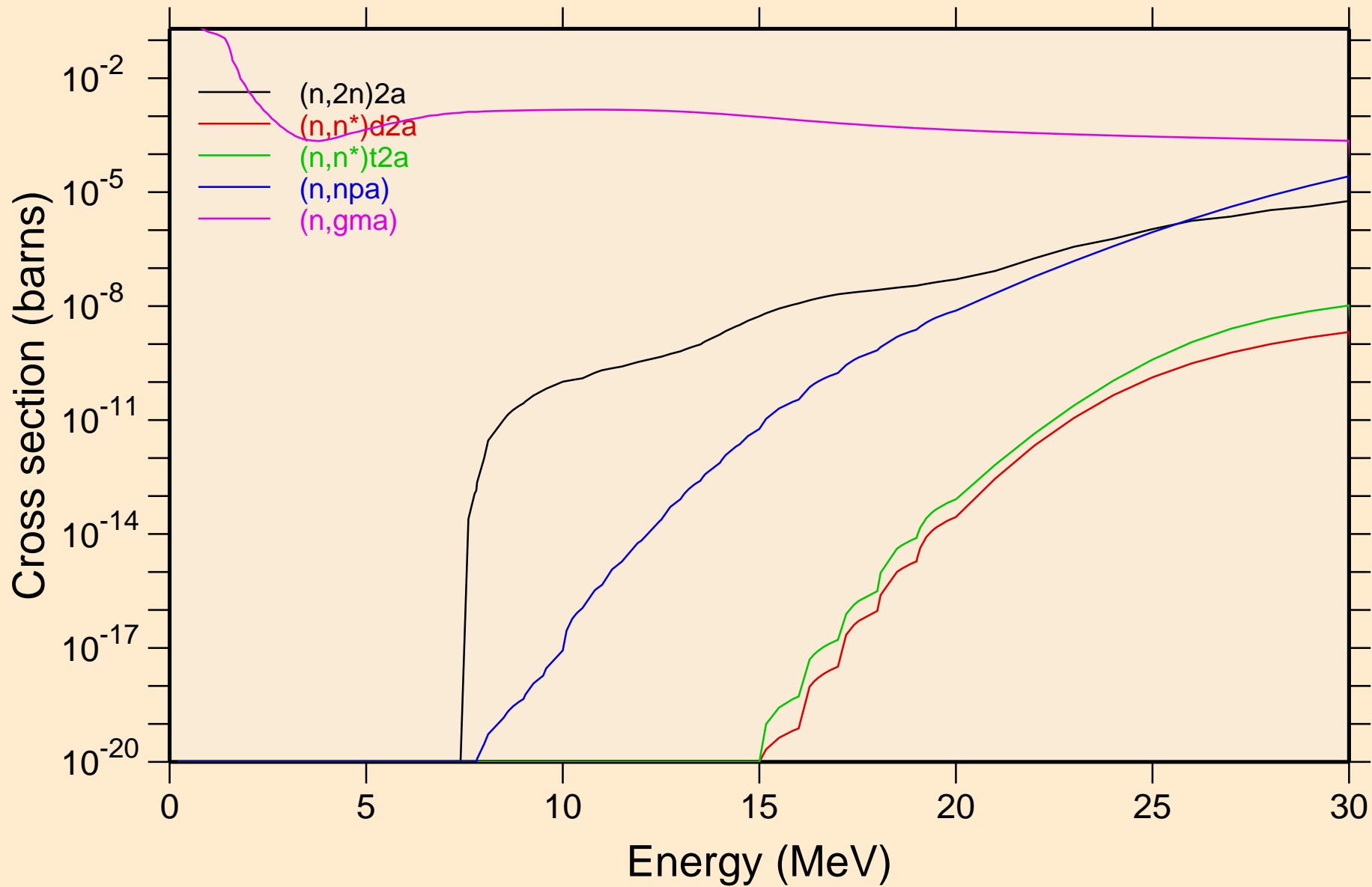

AC222 NEUTRON ACER TENDL-2023 LIBRARY; T=0.K
Non-threshold reactions

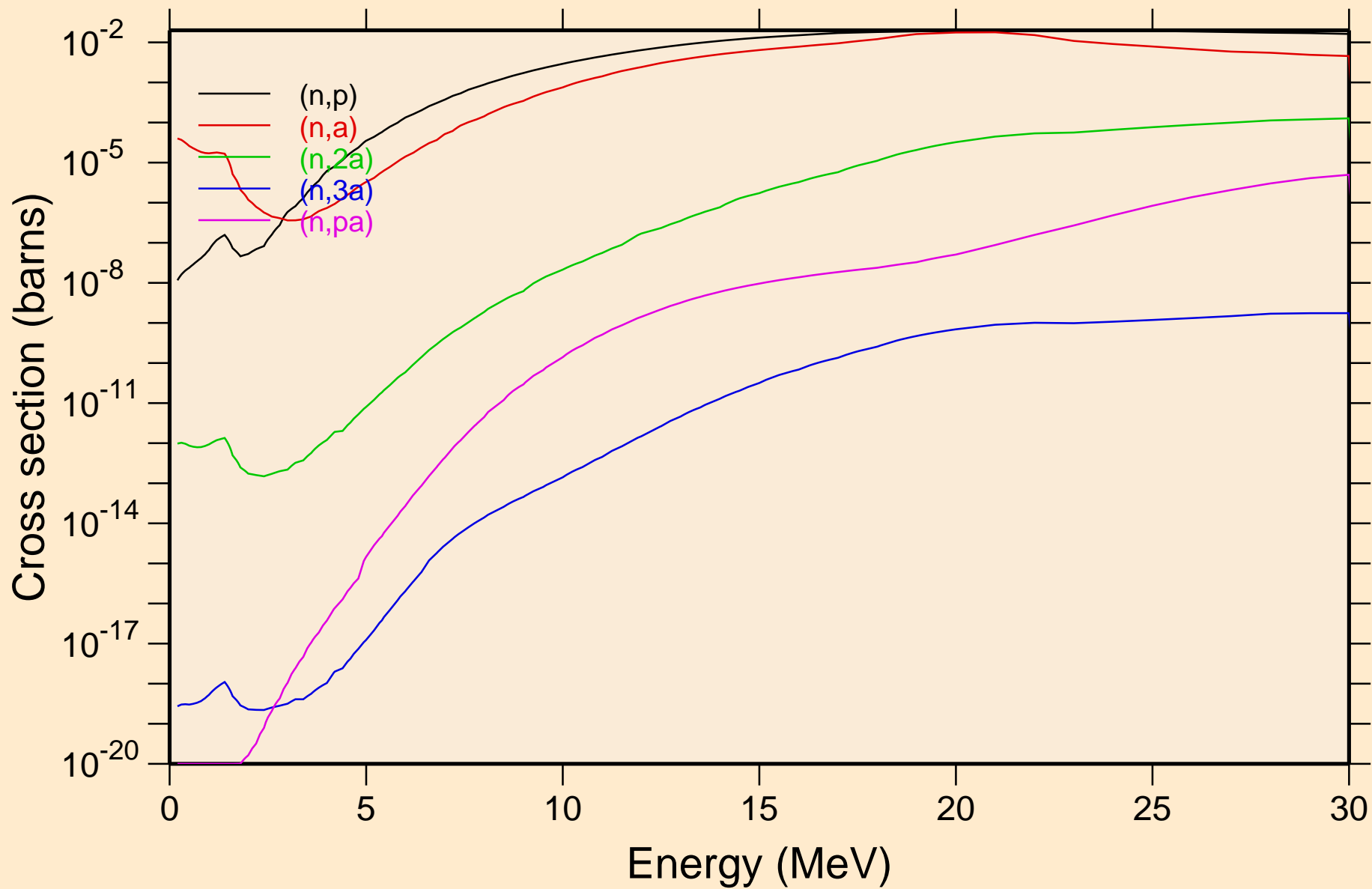

AC222 NEUTRON ACER TENDL-2023 LIBRARY; T=0.K
Non-threshold reactions

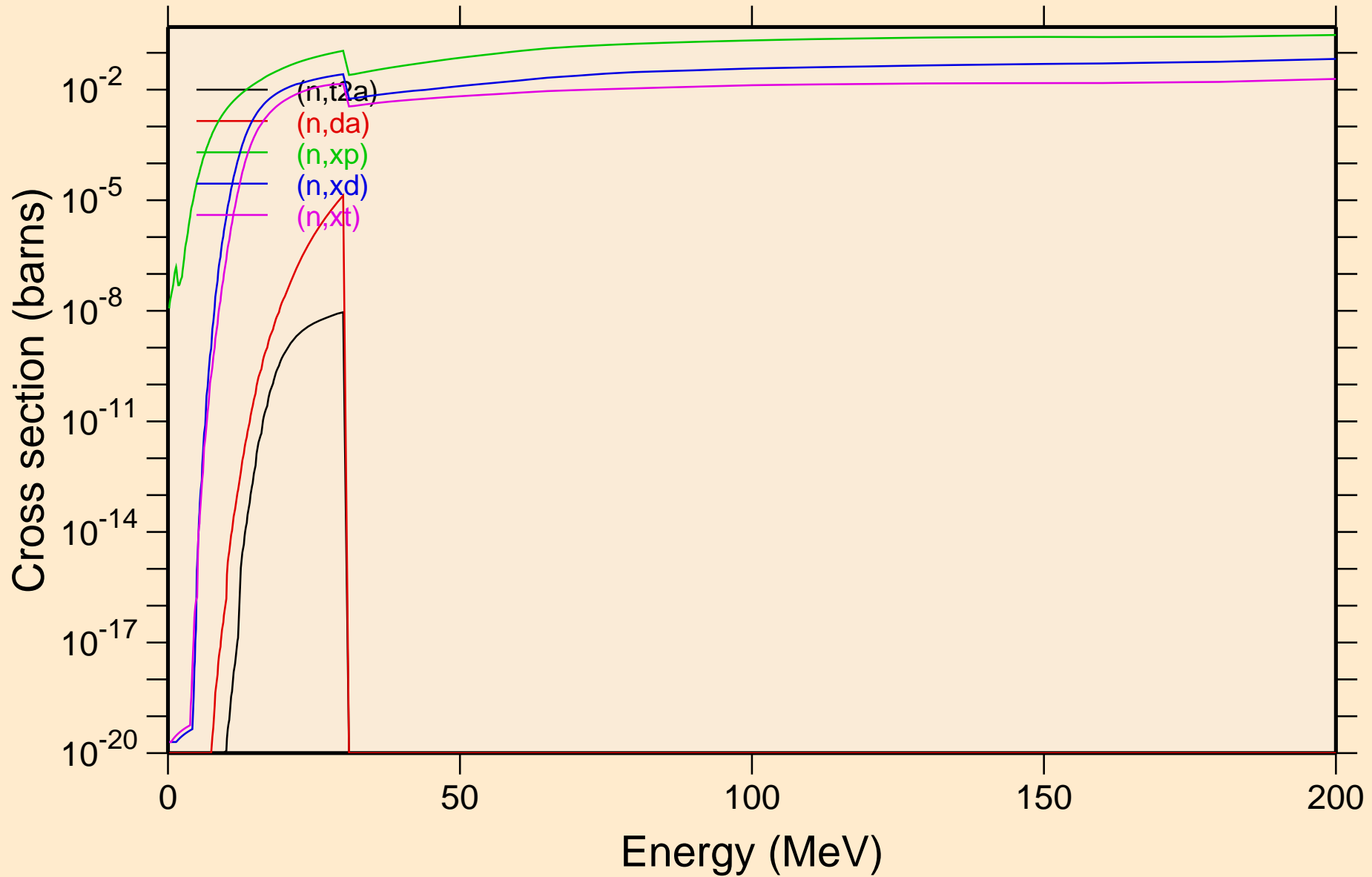

AC222 NEUTRON ACER TENDL-2023 LIBRARY; T=0.K
Non-threshold reactions

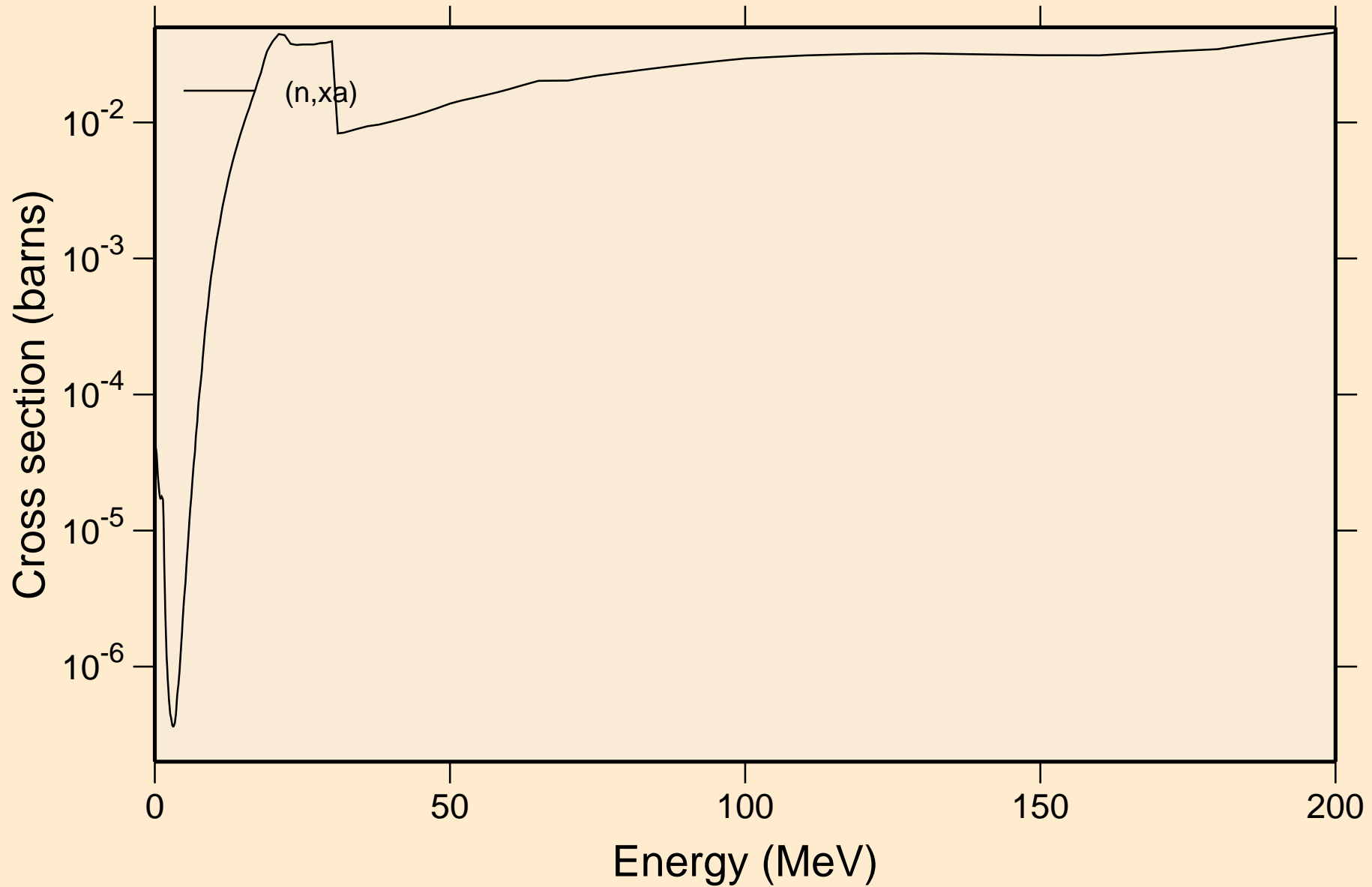

AC222 NEUTRON ACER TENDL-2023 LIBRARY; T=0.K
Inelastic levels

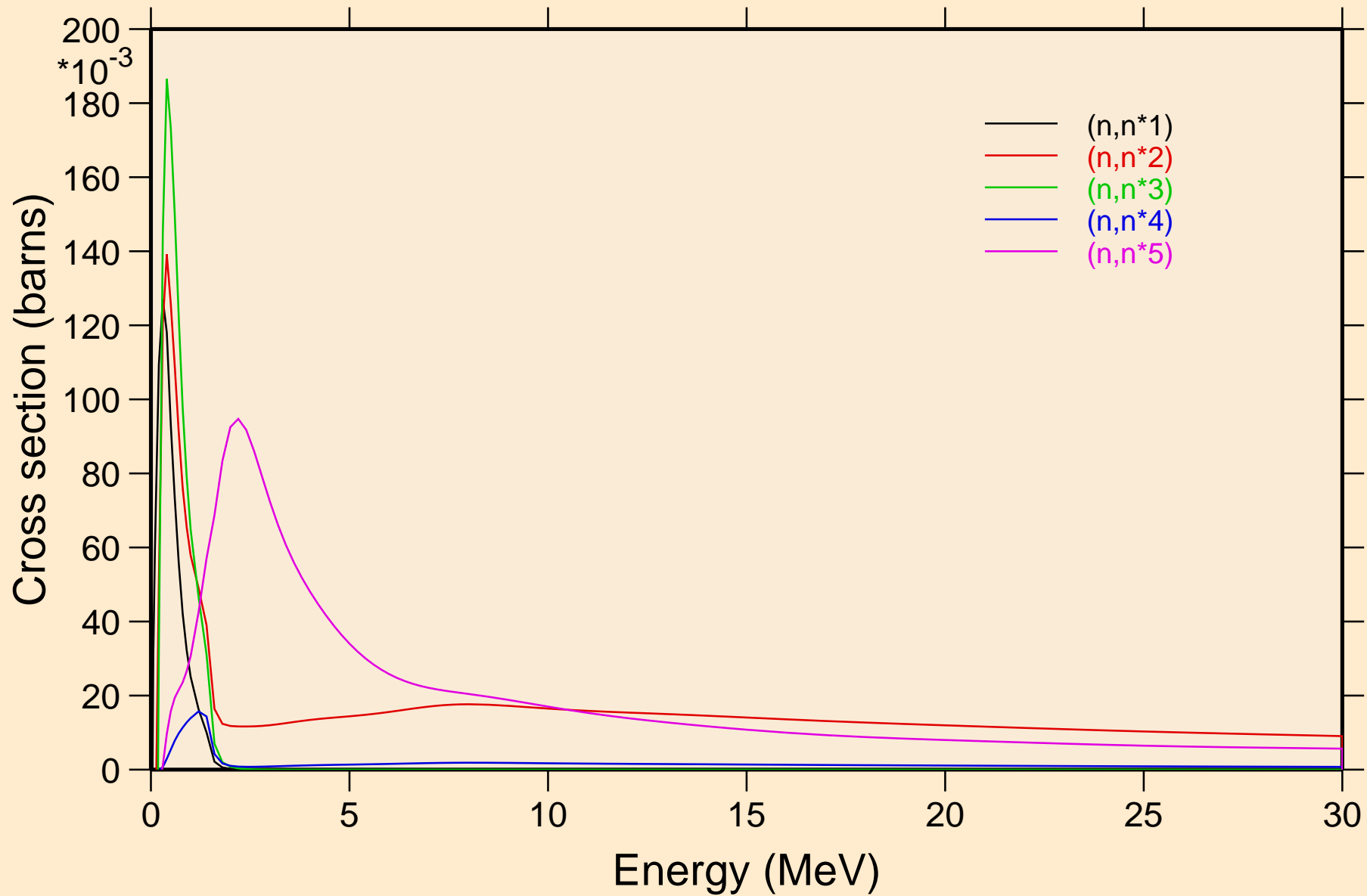

AC222 NEUTRON ACER TENDL-2023 LIBRARY; T=0.K
Inelastic levels

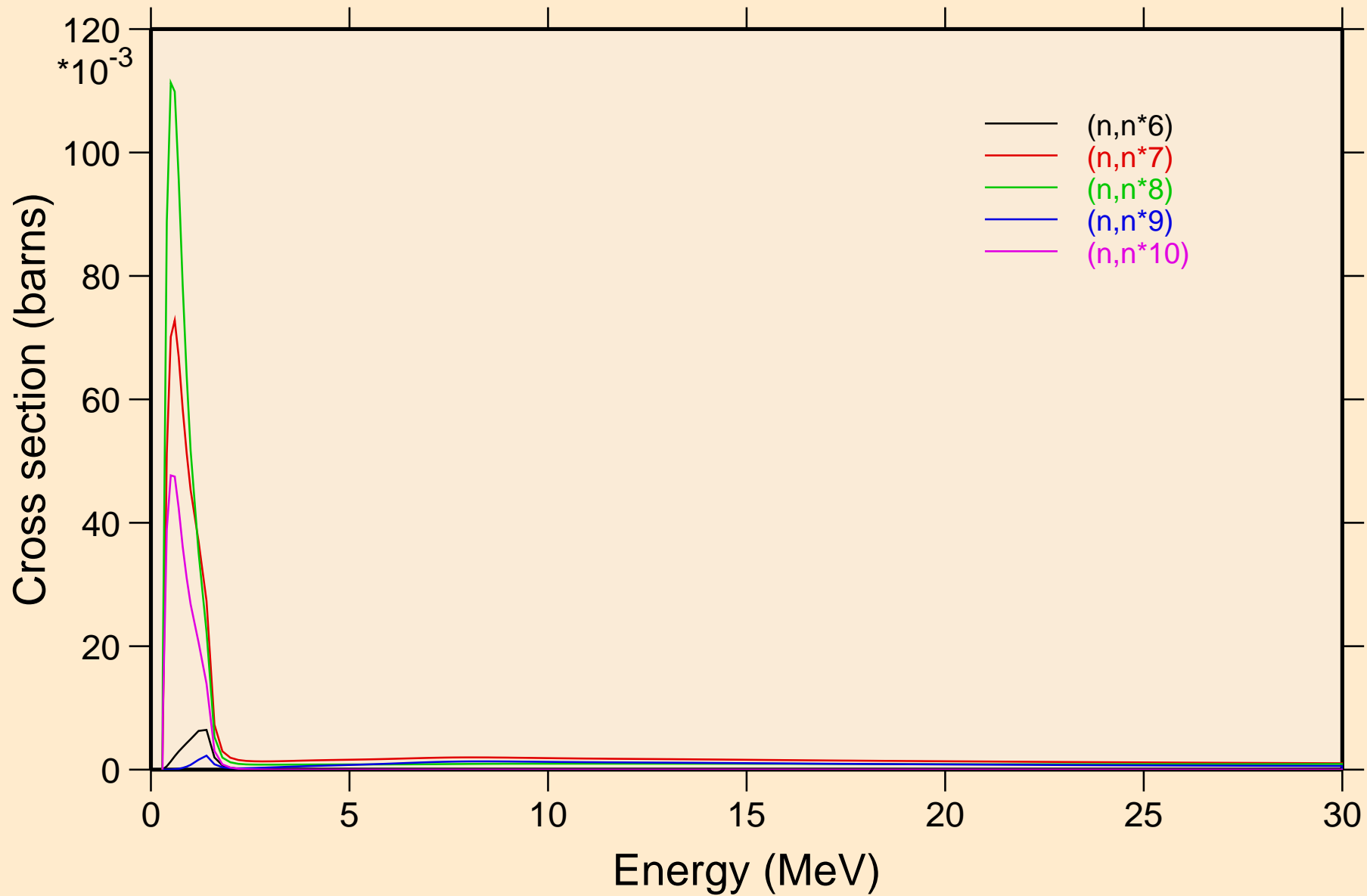

AC222 NEUTRON ACER TENDL-2023 LIBRARY; T=0.K
Inelastic levels

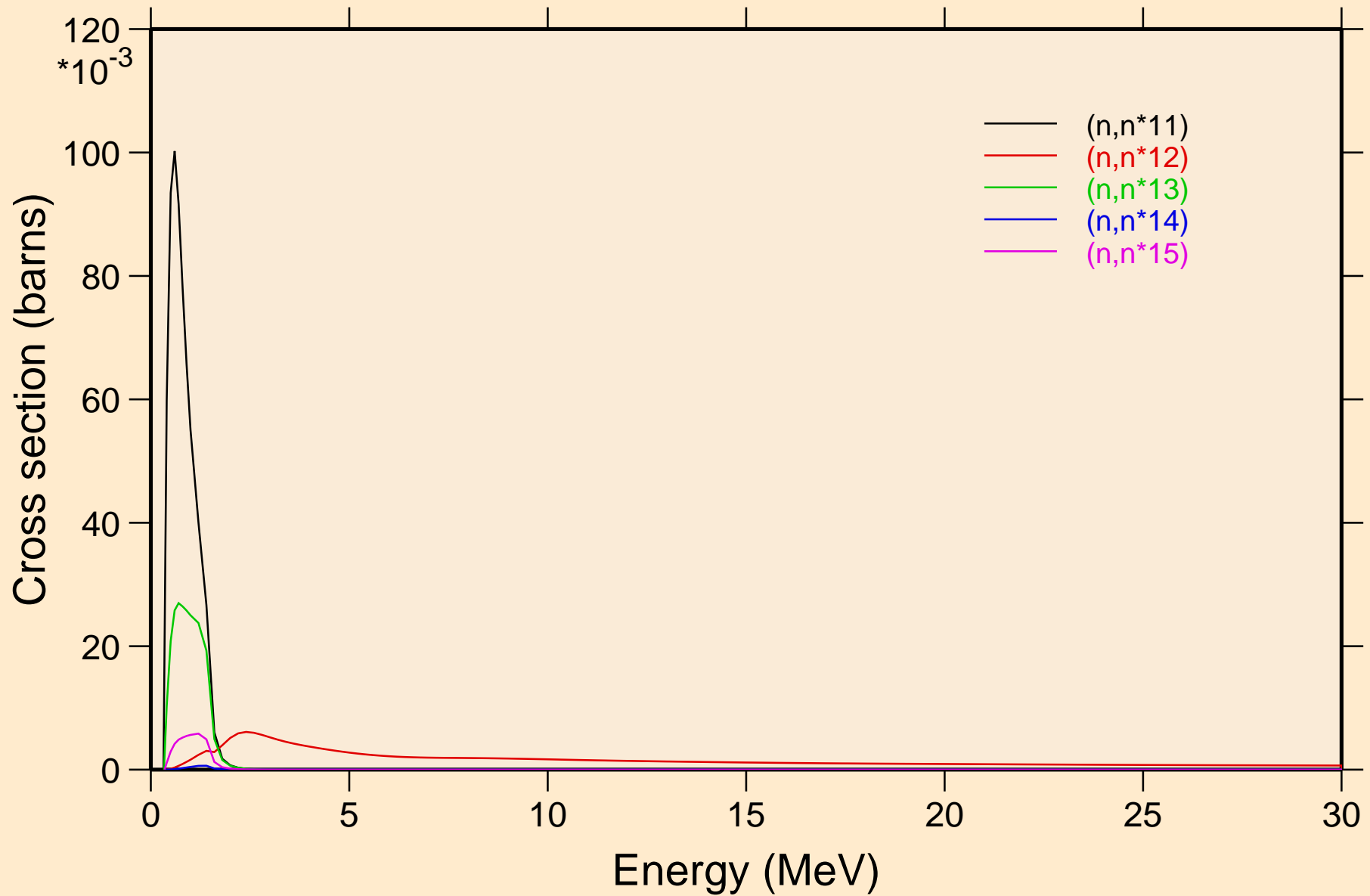

AC222 NEUTRON ACER TENDL-2023 LIBRARY; T=0.K
Inelastic levels

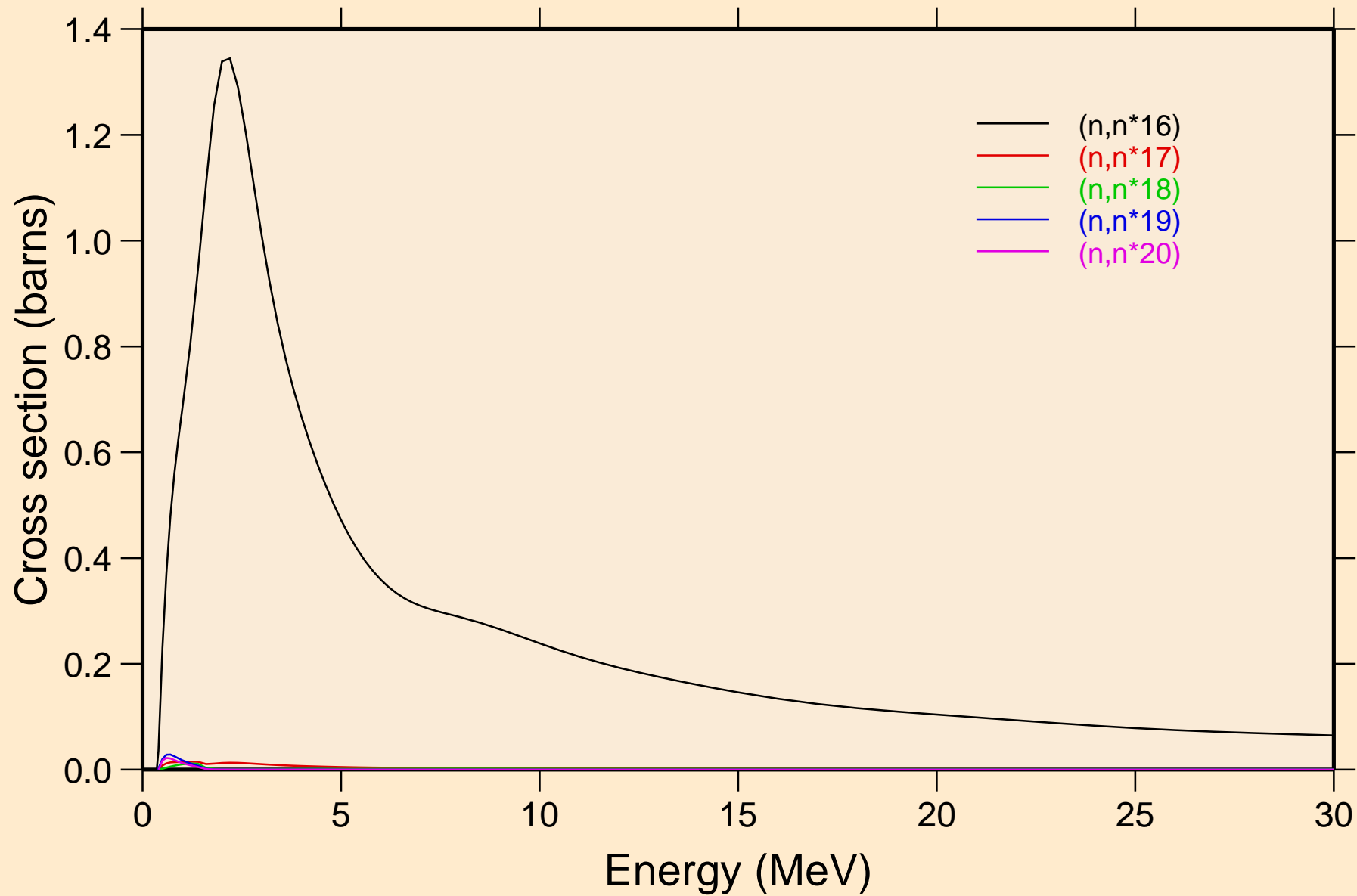

AC222 NEUTRON ACER TENDL-2023 LIBRARY; T=0.K
Inelastic levels

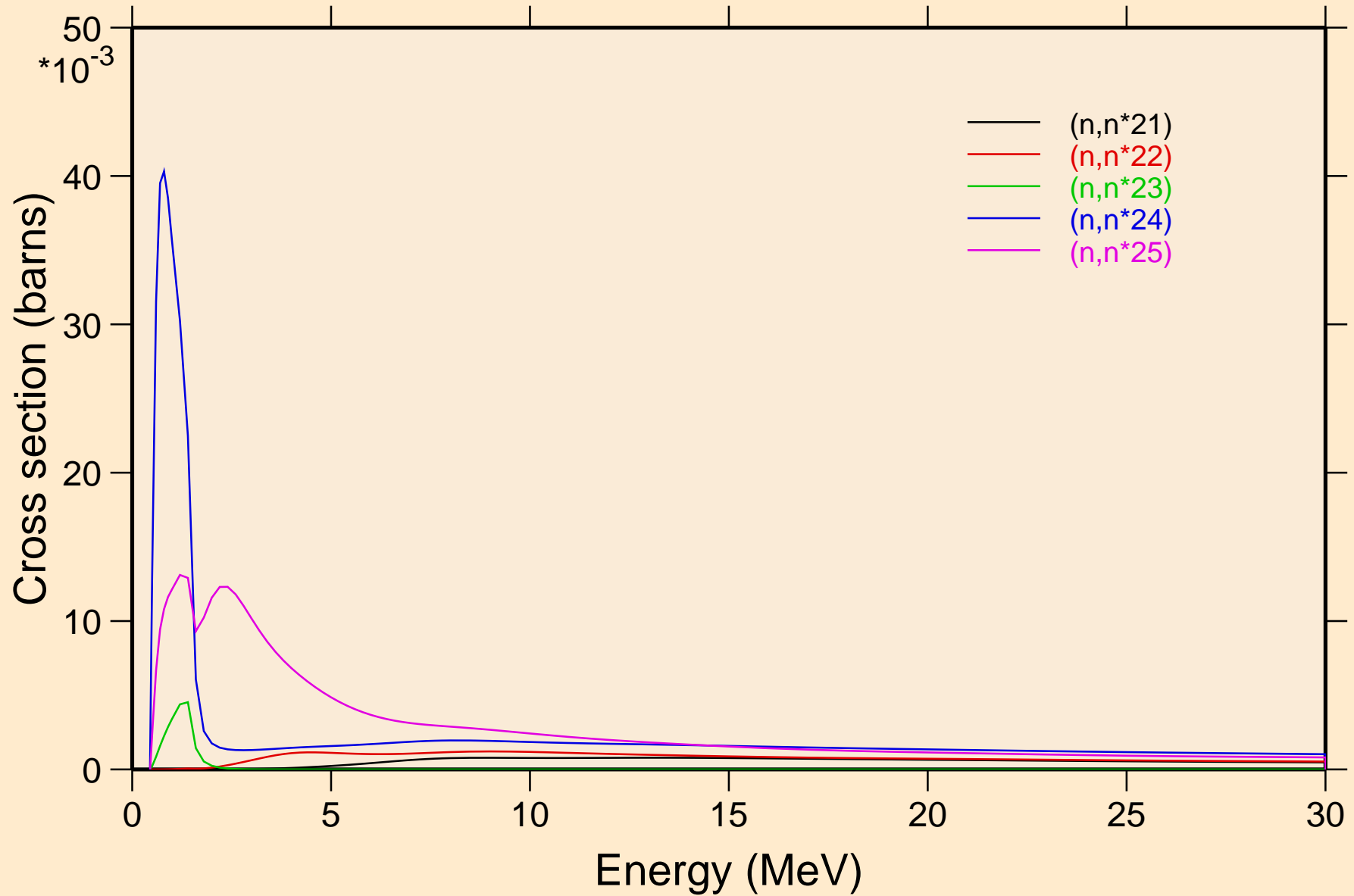

AC222 NEUTRON ACER TENDL-2023 LIBRARY; T=0.K
Inelastic levels

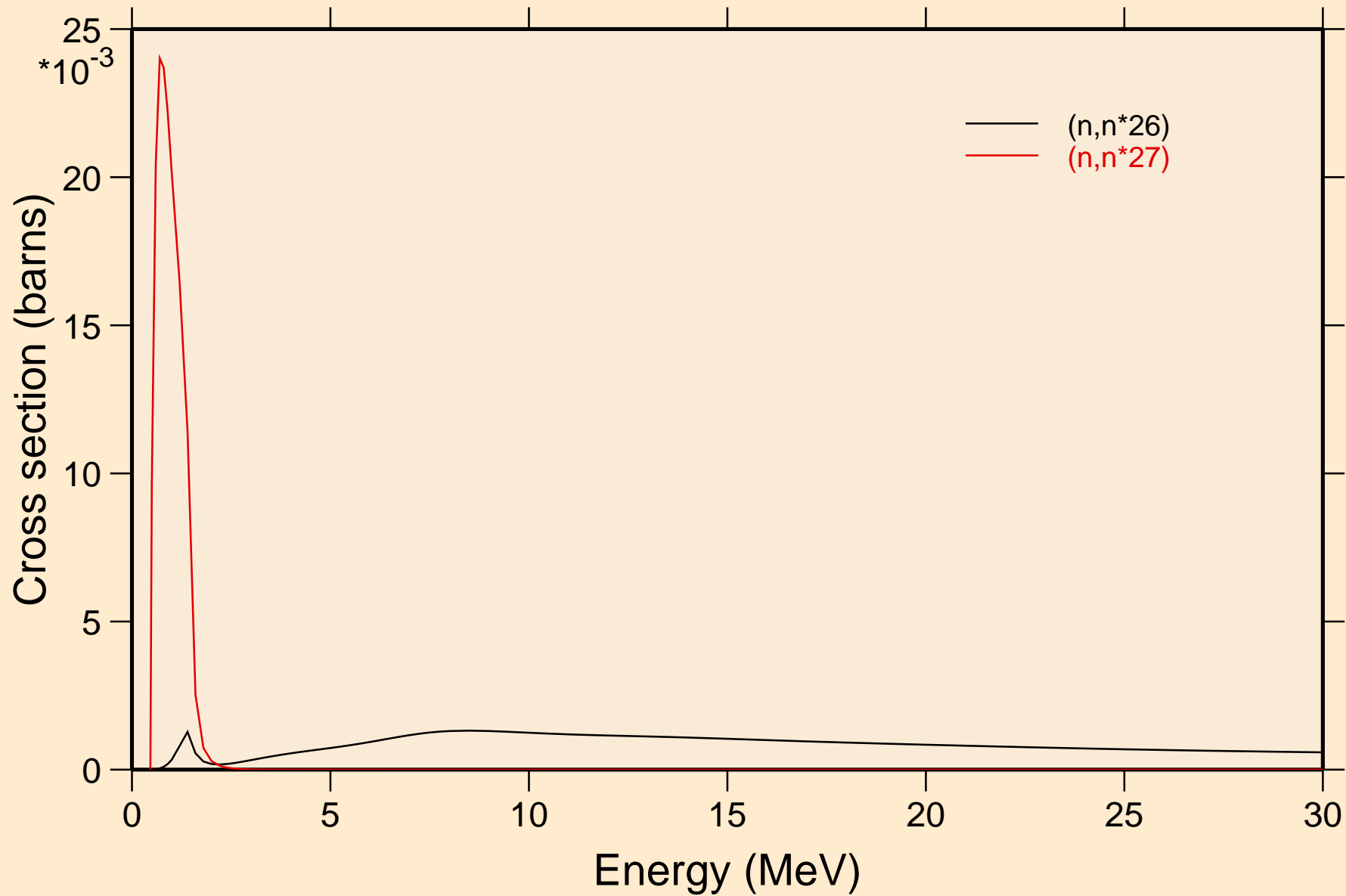

AC222 NEUTRON ACER TENDL-2023 LIBRARY; T=0.K

Threshold reactions

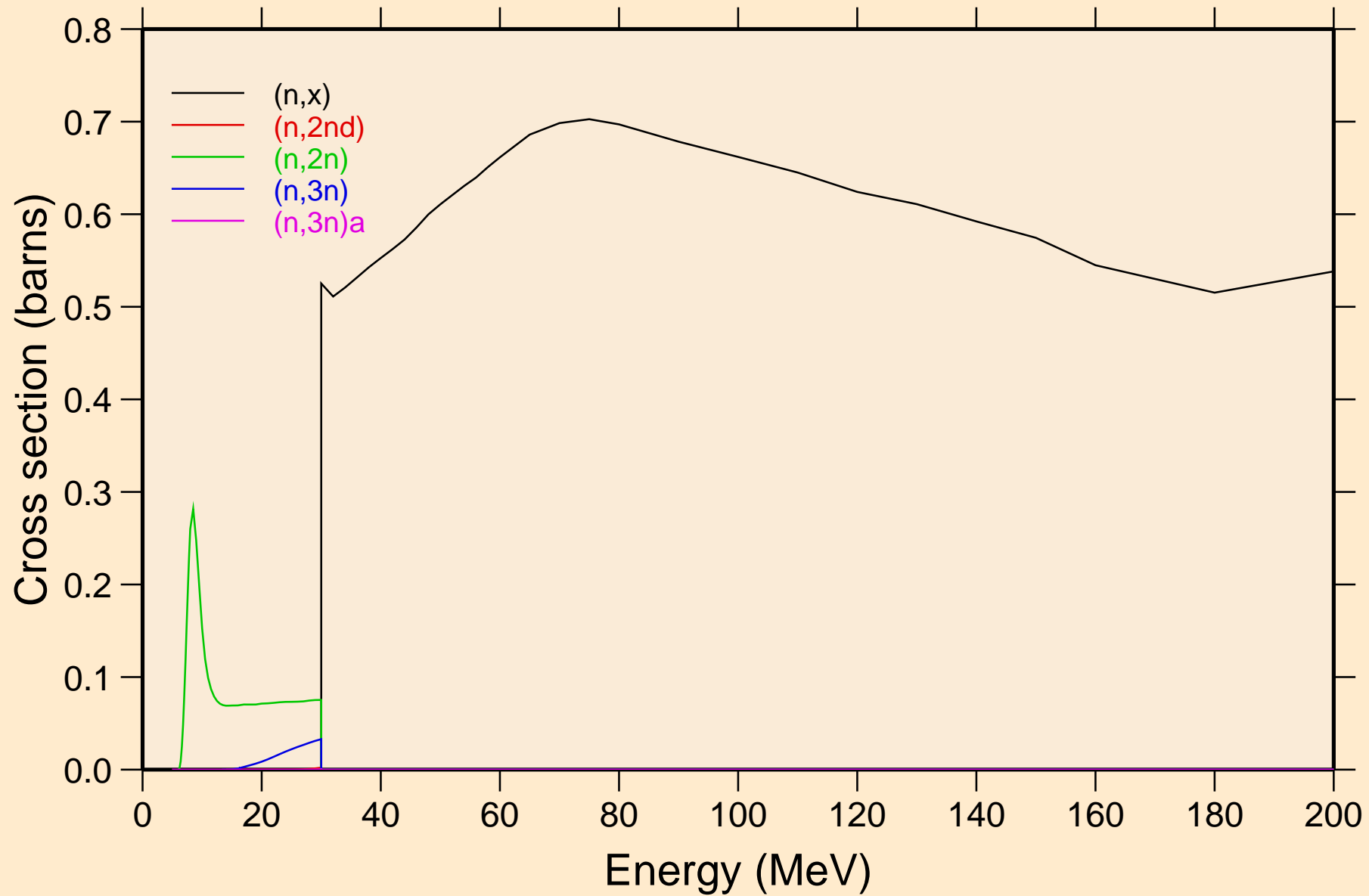

AC222 NEUTRON ACER TENDL-2023 LIBRARY; T=0.K
Threshold reactions

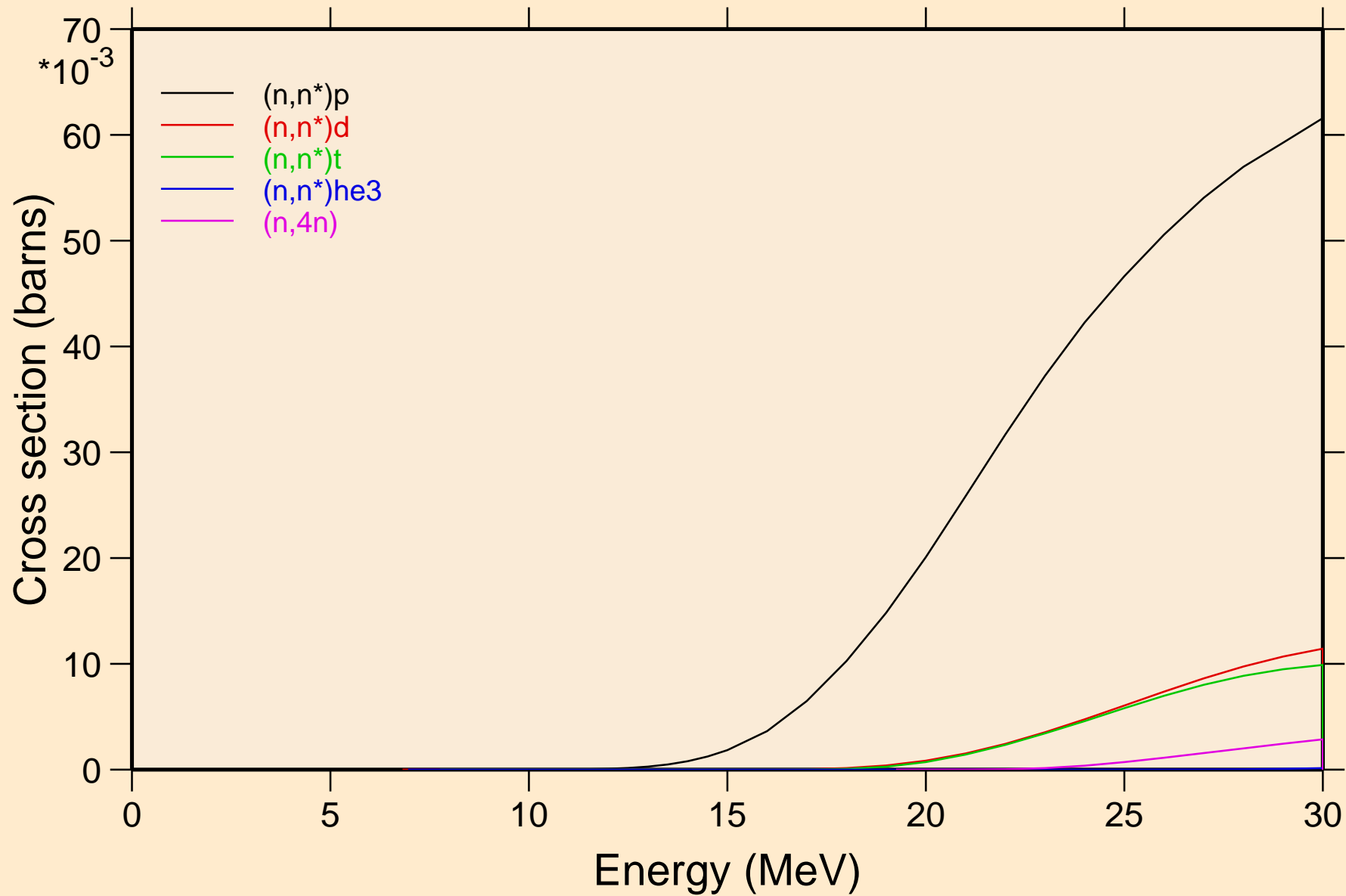

AC222 NEUTRON ACER TENDL-2023 LIBRARY; T=0.K

Threshold reactions

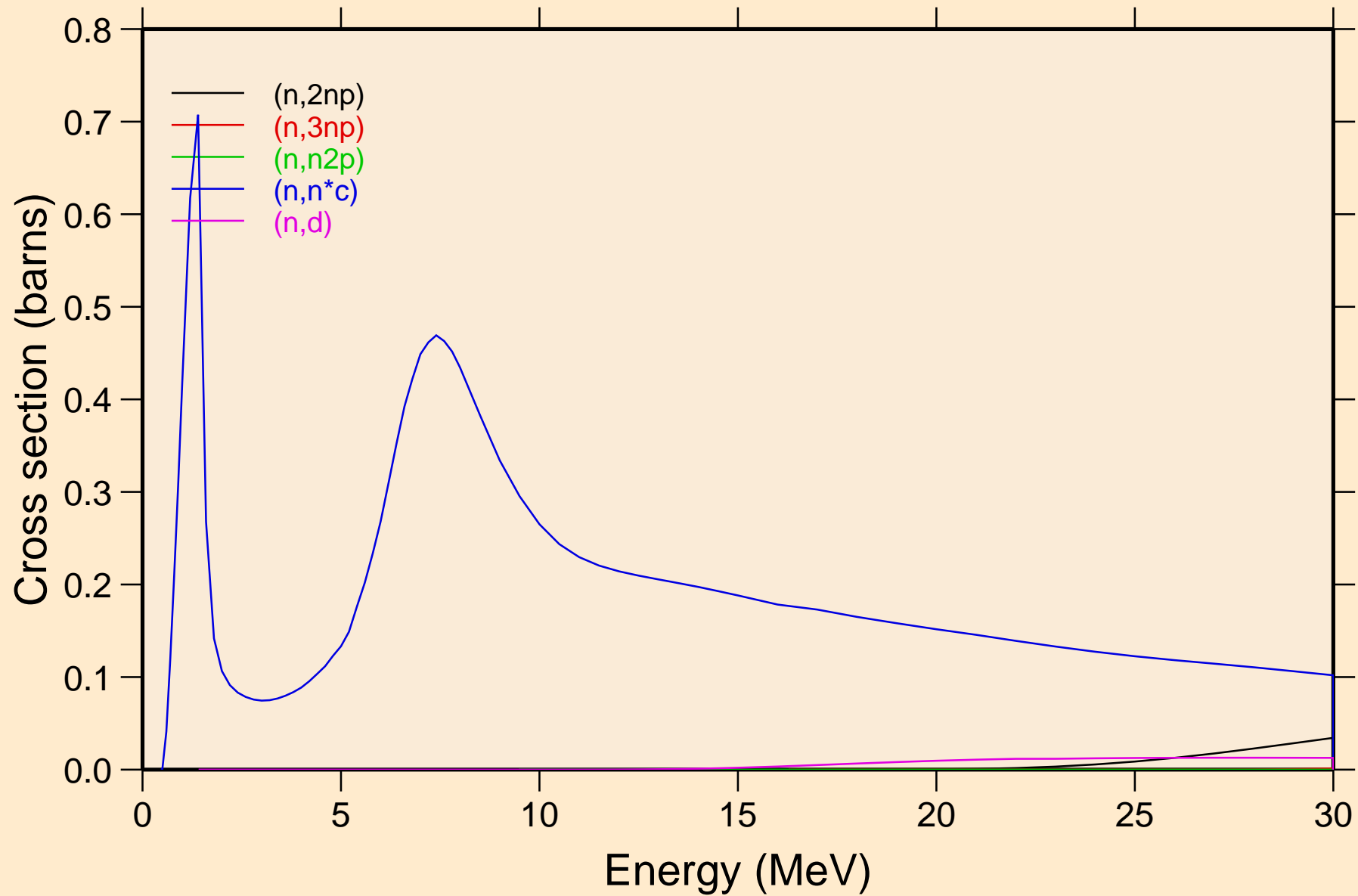

AC222 NEUTRON ACER TENDL-2023 LIBRARY; T=0.K
Threshold reactions

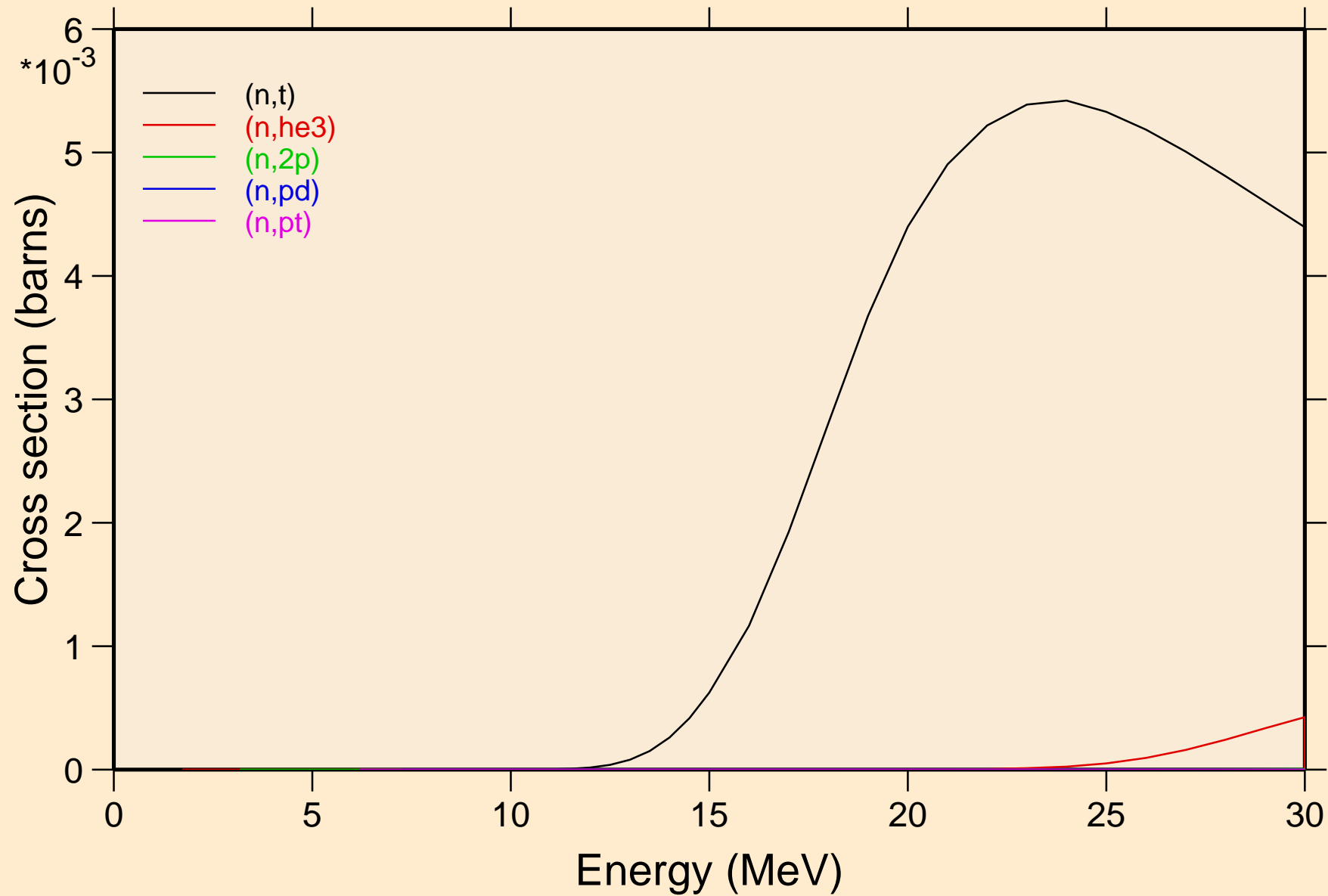

AC222 NEUTRON ACER TENDL-2023 LIBRARY; T=0.K
Threshold reactions

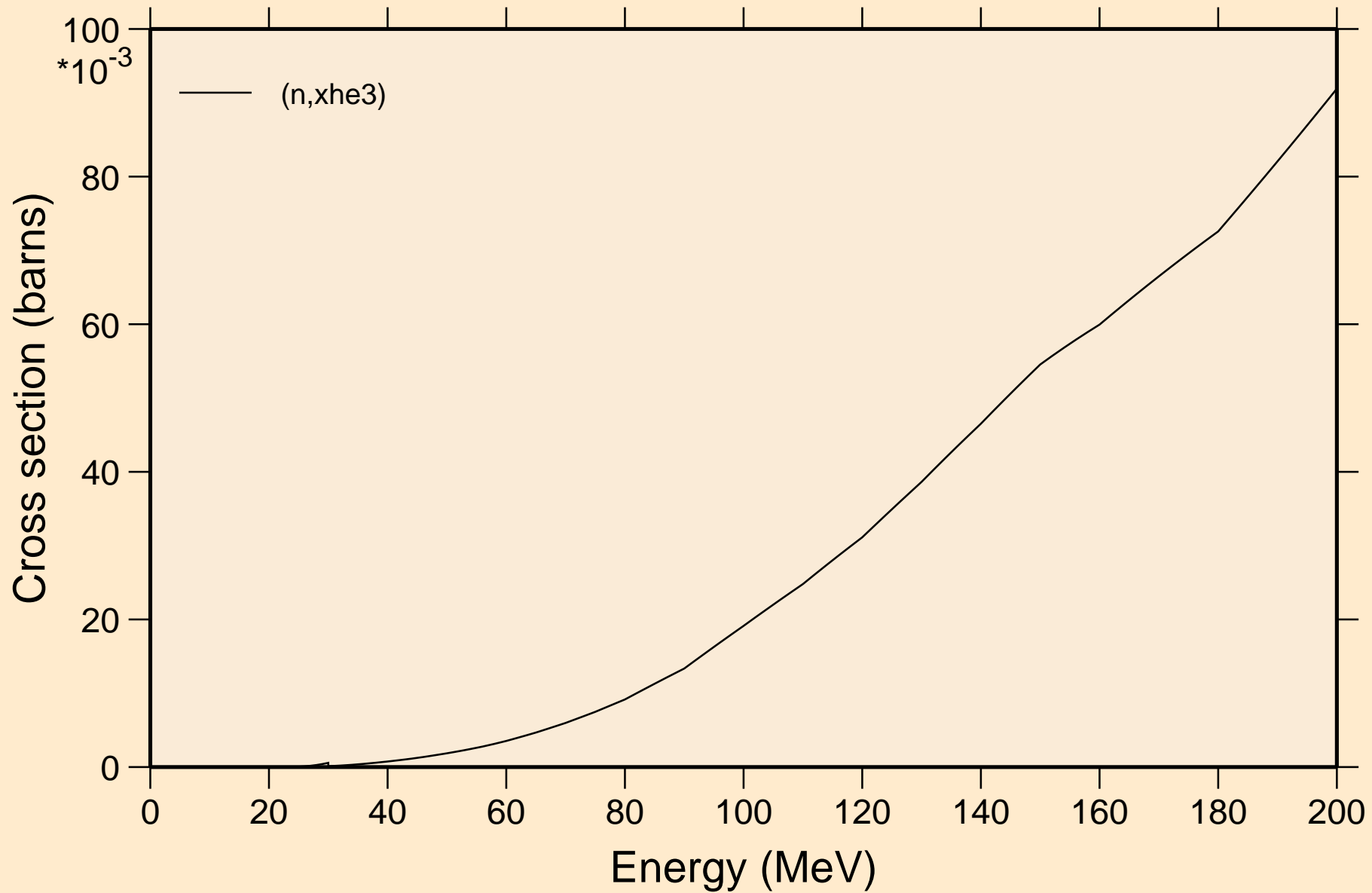

AC222 NEUTRON ACER TENDL-2023 LIBRARY; T=0.K
angular distribution for elastic

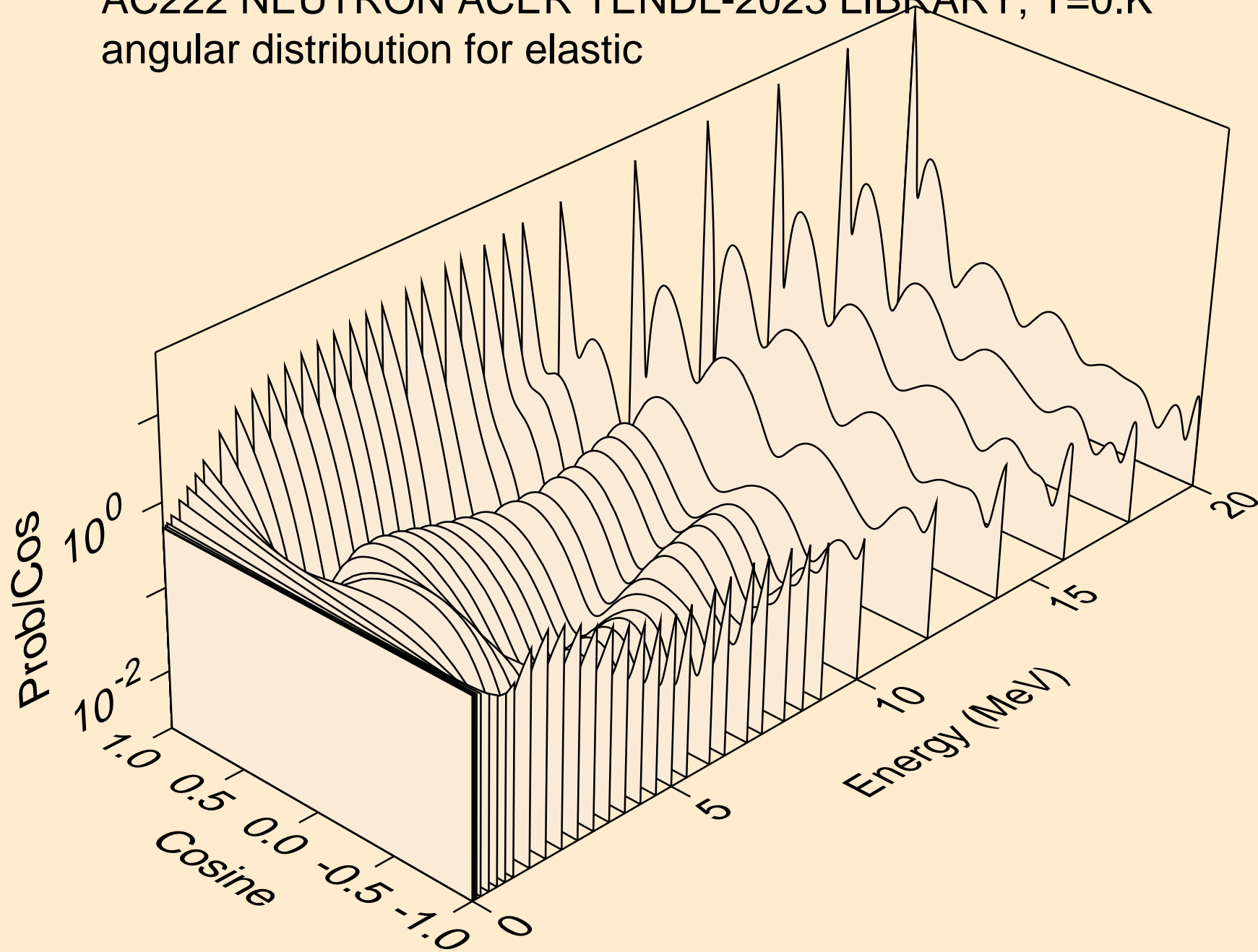

AC222 NEUTRON ACER TENDL-2023 LIBRARY; T=0.K
angular distribution for elastic

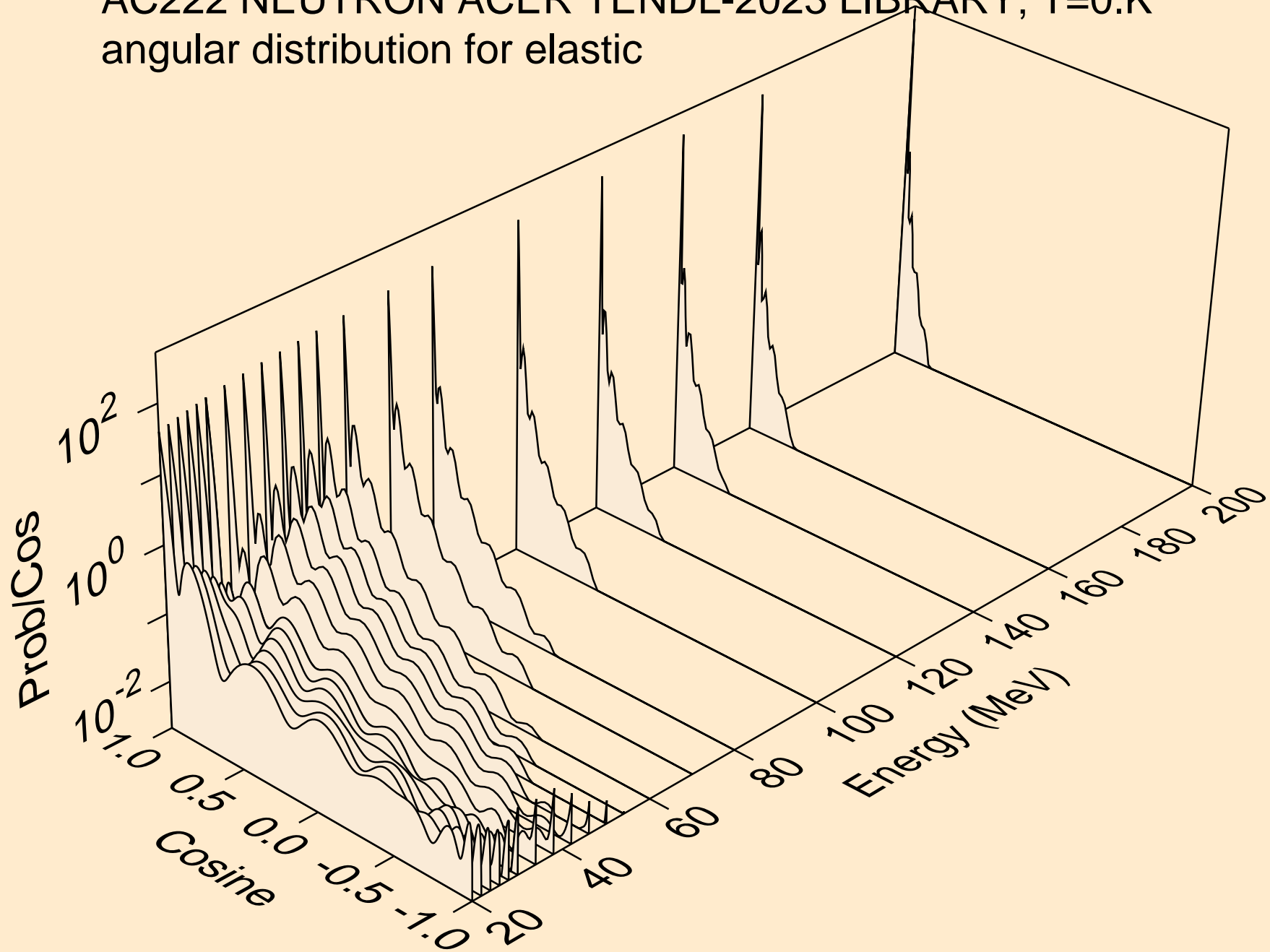

AC222 NEUTRON ACER TENDL-2023 LIBRARY; T=0.K
angular distribution for (n,n*1)

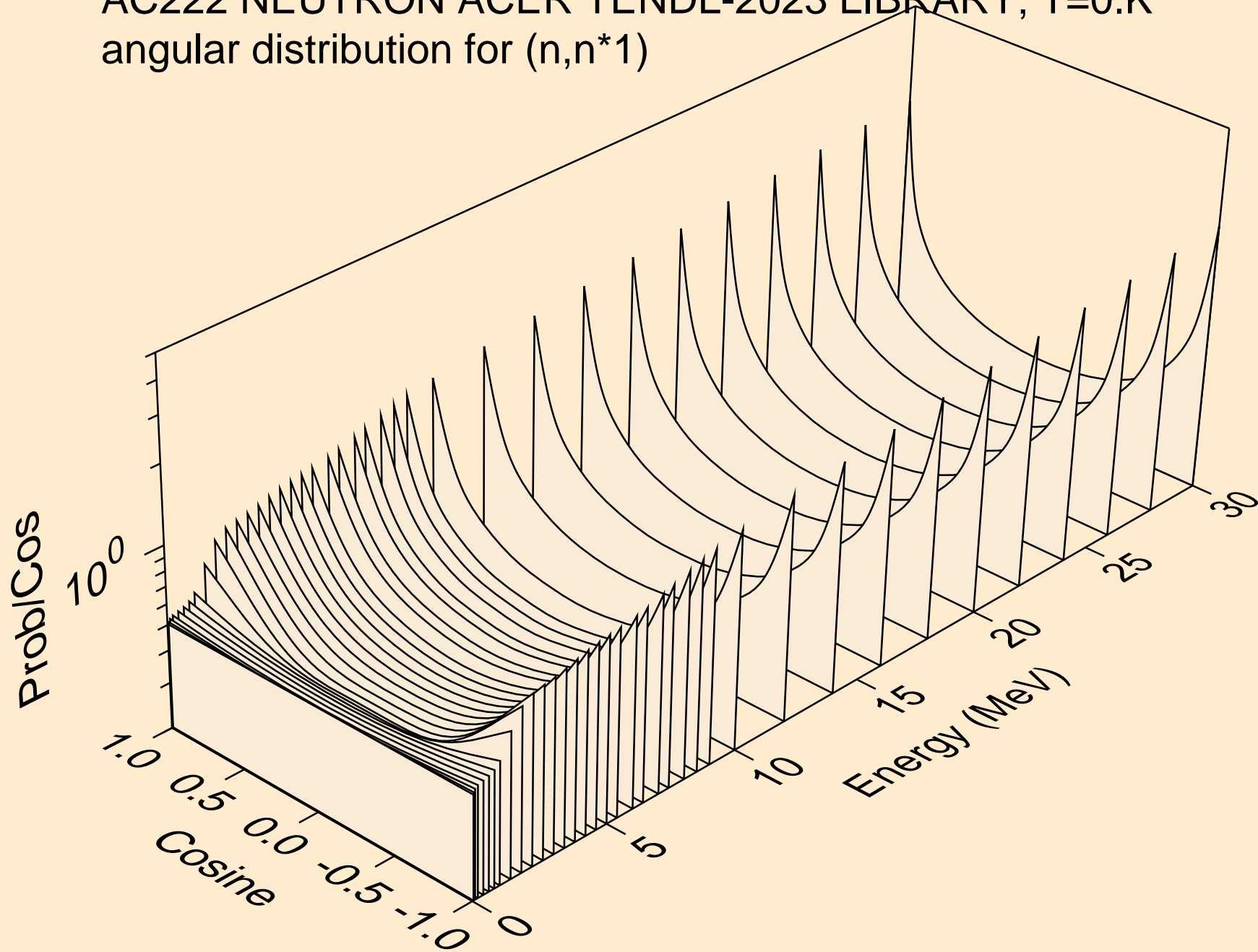

AC222 NEUTRON ACER TENDL-2023 LIBRARY; T=0.K
angular distribution for (n,n*2)

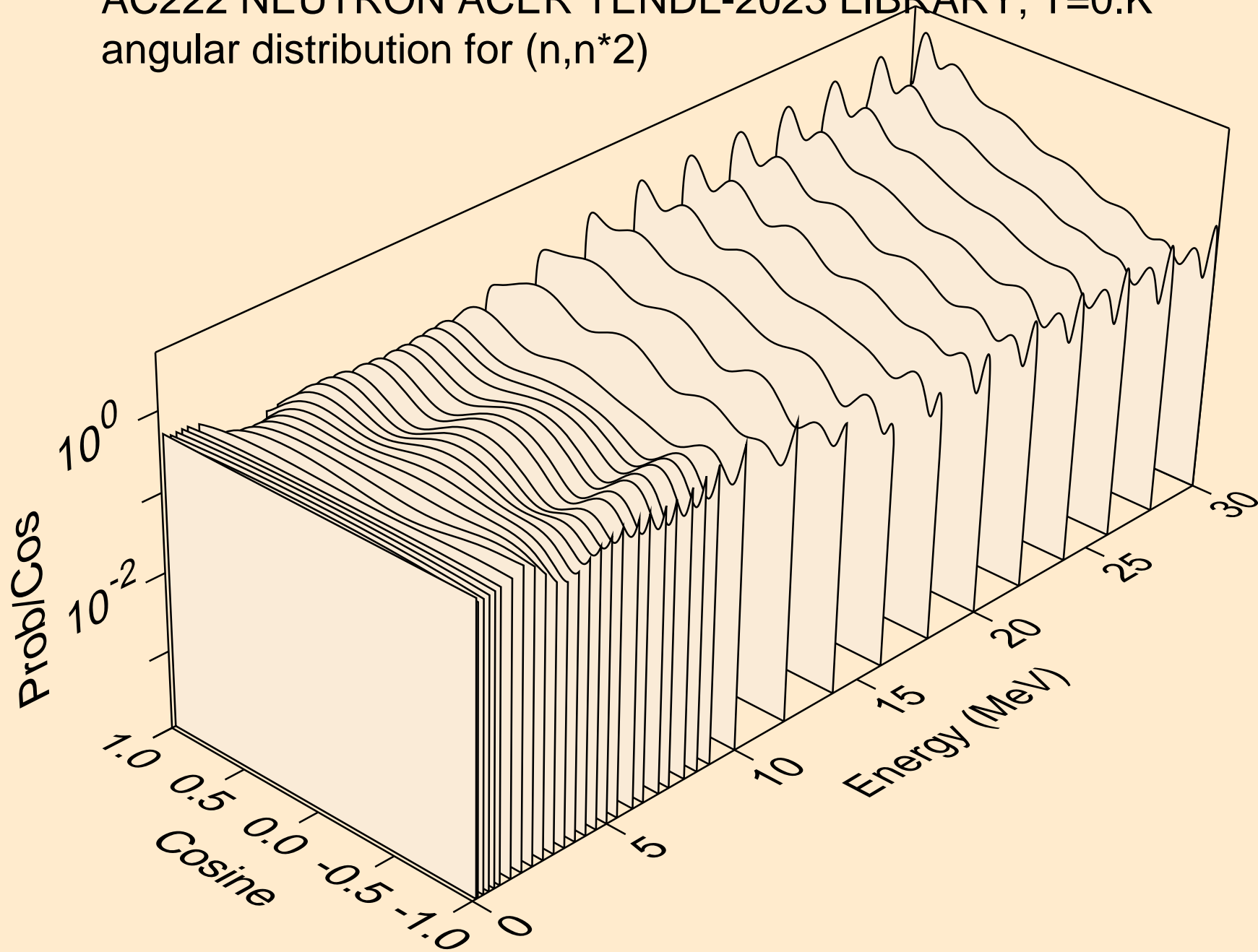

AC222 NEUTRON ACER TENDL-2023 LIBRARY; T=0.K
angular distribution for (n,n*3)

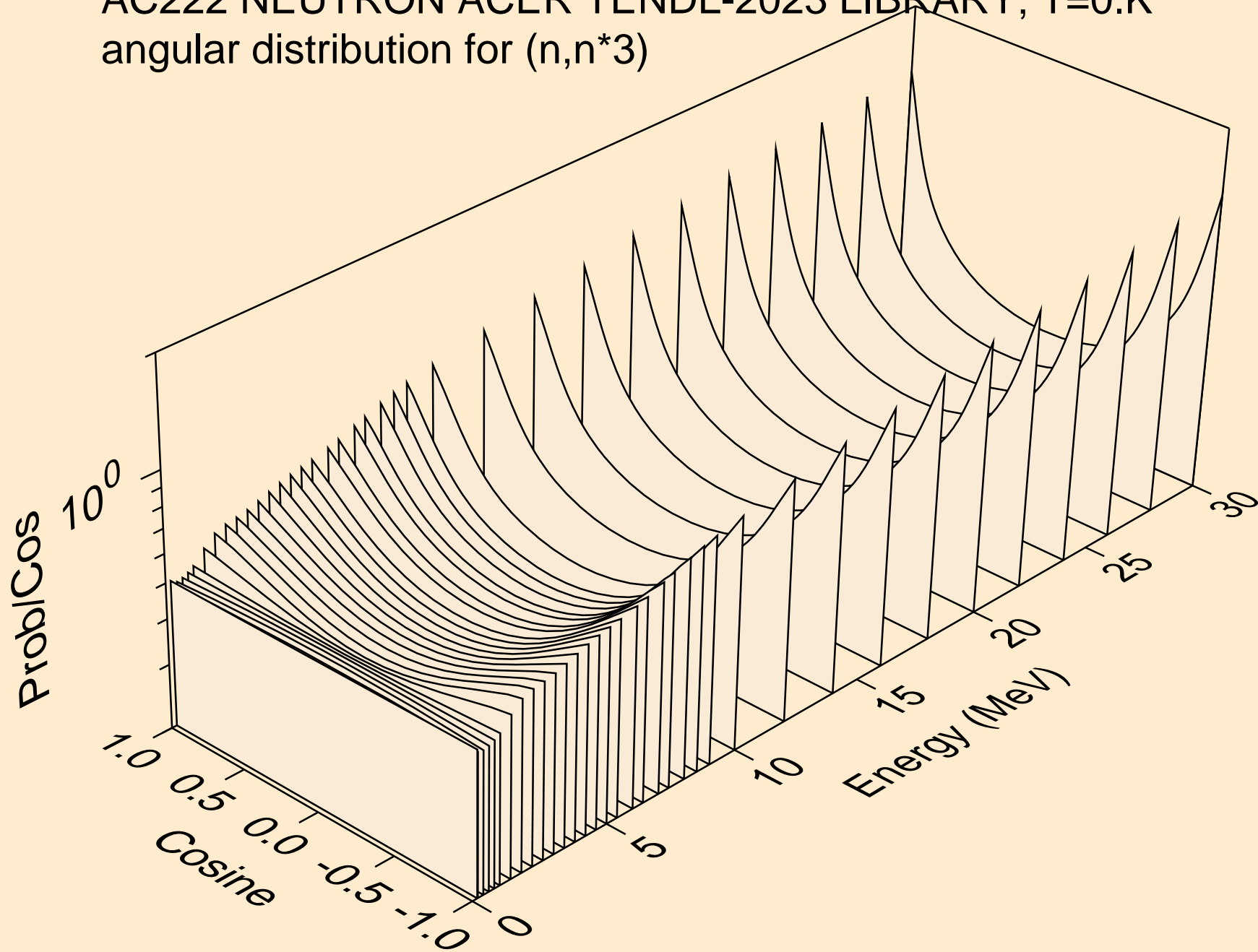

AC222 NEUTRON ACER TENDL-2023 LIBRARY; T=0.K
angular distribution for (n,n*4)

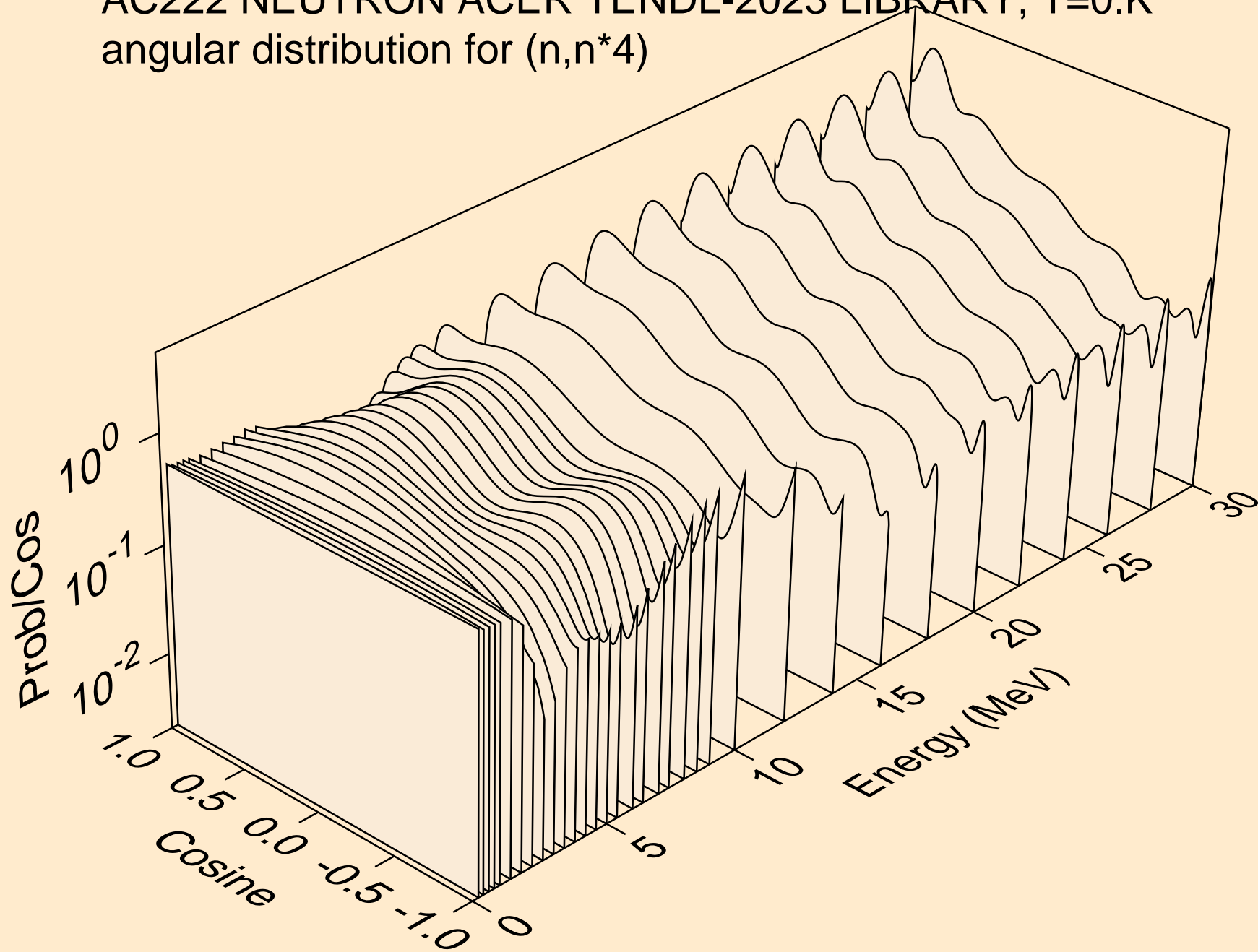

AC222 NEUTRON ACER TENDL-2023 LIBRARY; T=0.K
angular distribution for (n,n*5)

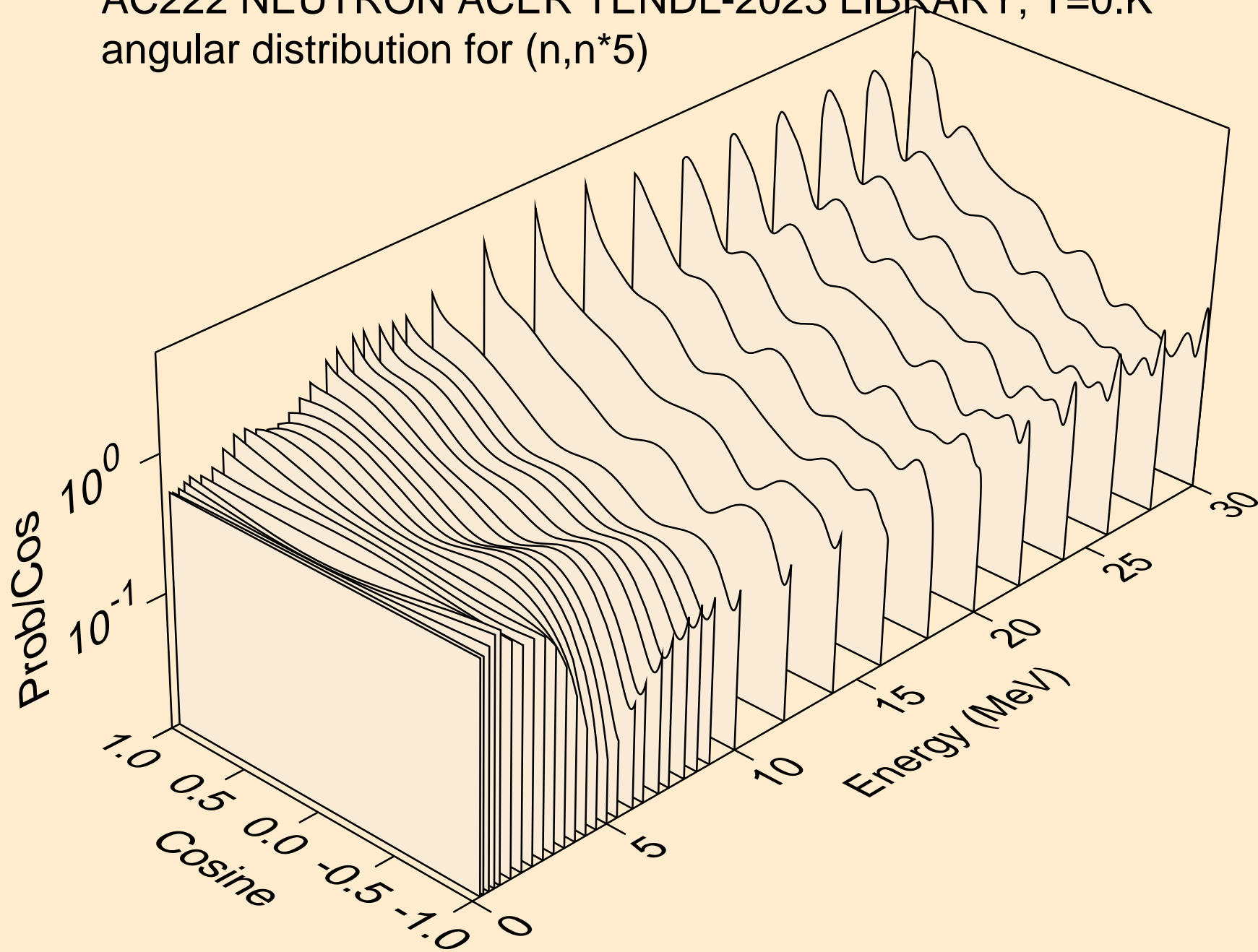

AC222 NEUTRON ACER TENDL-2023 LIBRARY; T=0.K
angular distribution for (n,n*6)

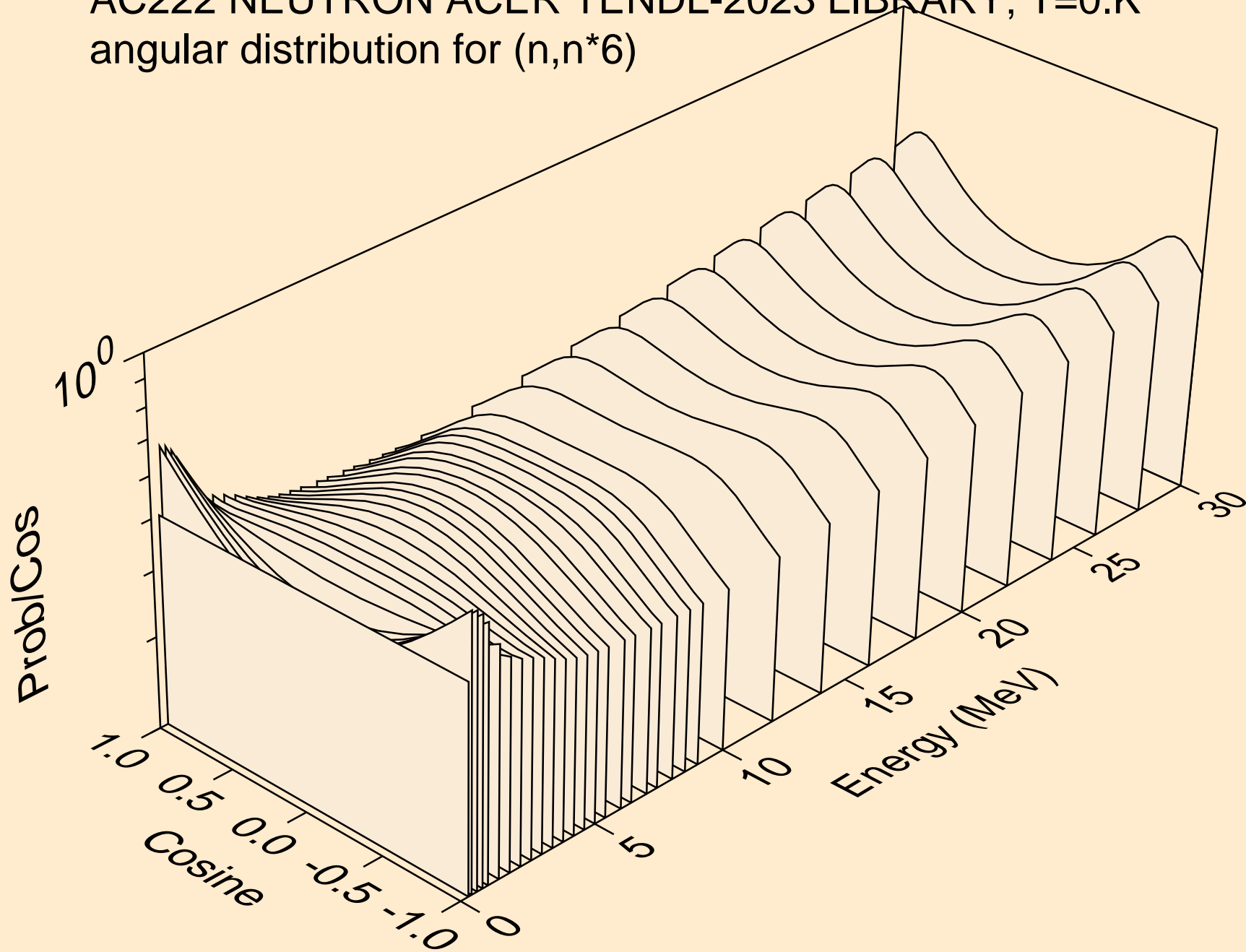

AC222 NEUTRON ACER TENDL-2023 LIBRARY; T=0.K
angular distribution for (n,n*7)

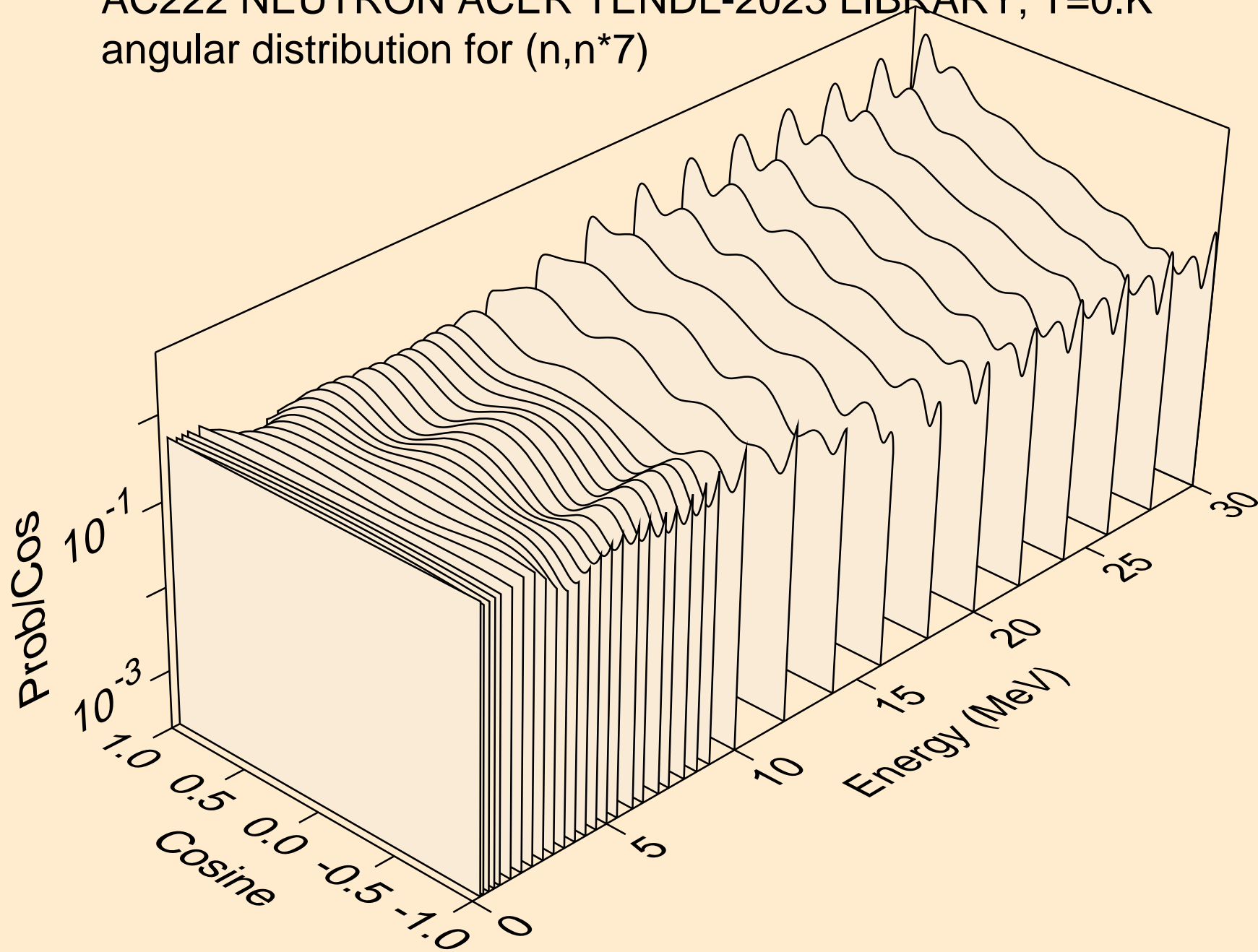

AC222 NEUTRON ACER TENDL-2023 LIBRARY; T=0.K
angular distribution for (n,n*8)

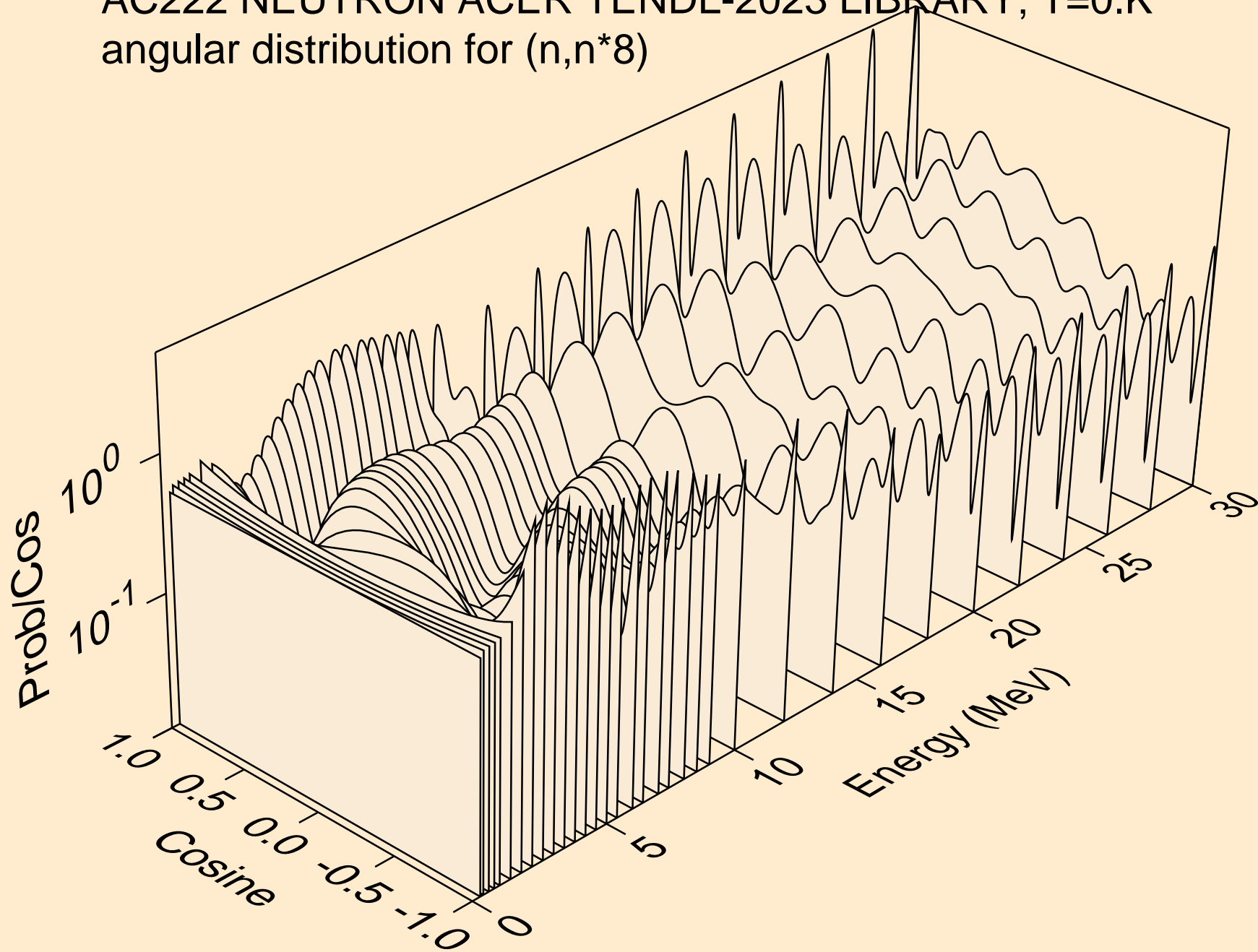

AC222 NEUTRON ACER TENDL-2023 LIBRARY; T=0.K
angular distribution for (n,n*9)

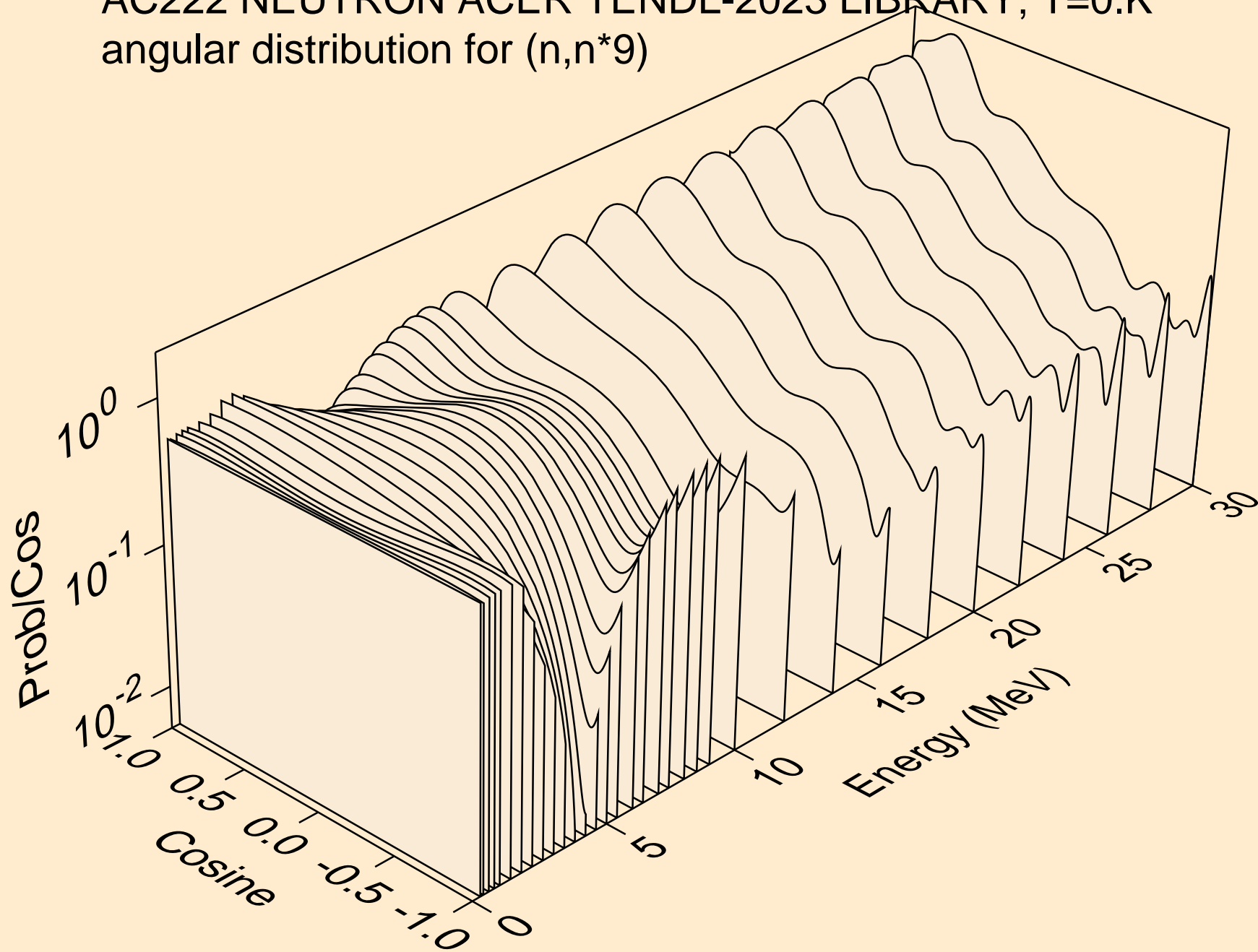

AC222 NEUTRON ACER TENDL-2023 LIBRARY; T=0.K
angular distribution for (n,n*10)

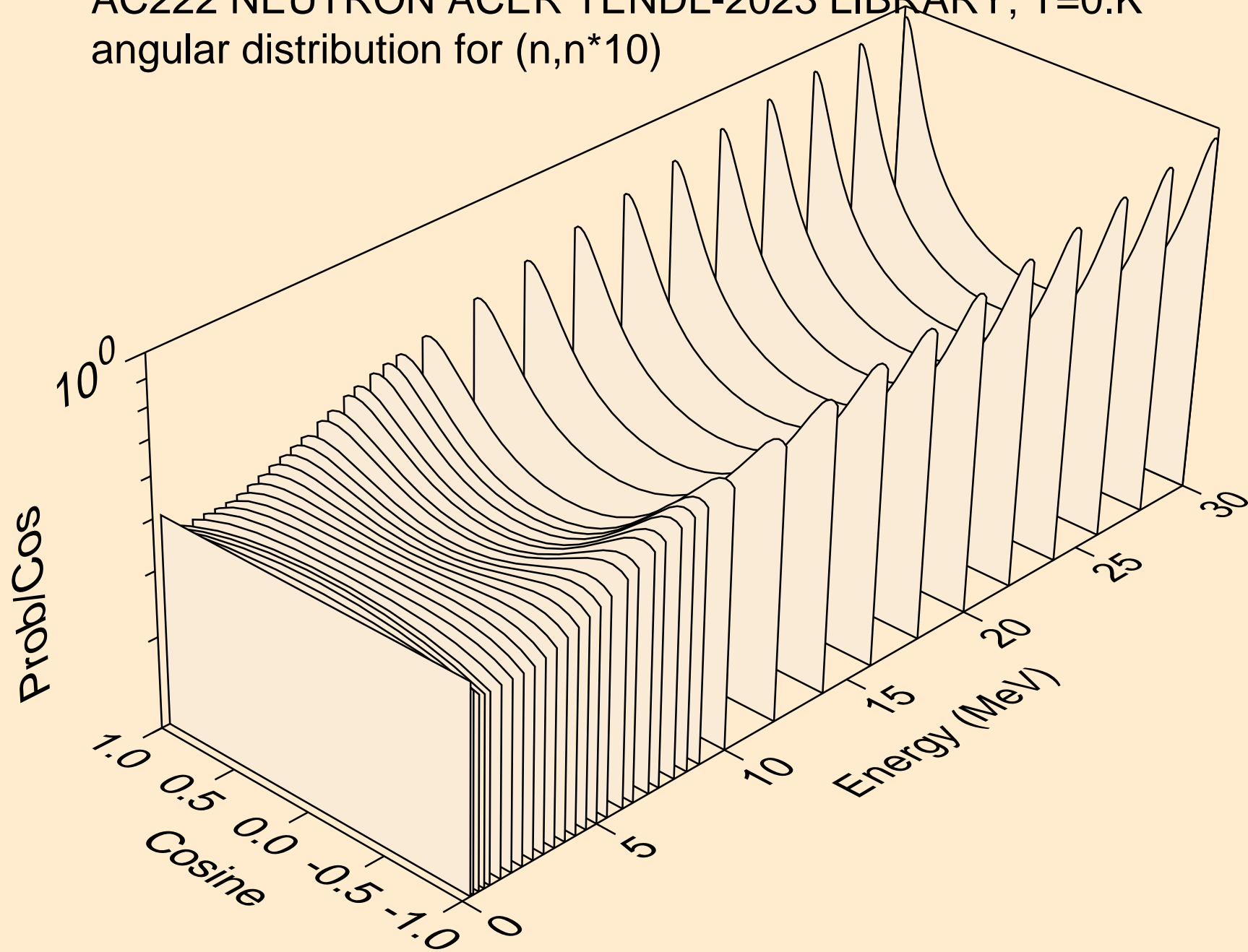

AC222 NEUTRON ACER TENDL-2023 LIBRARY; T=0.K
angular distribution for (n,n*11)

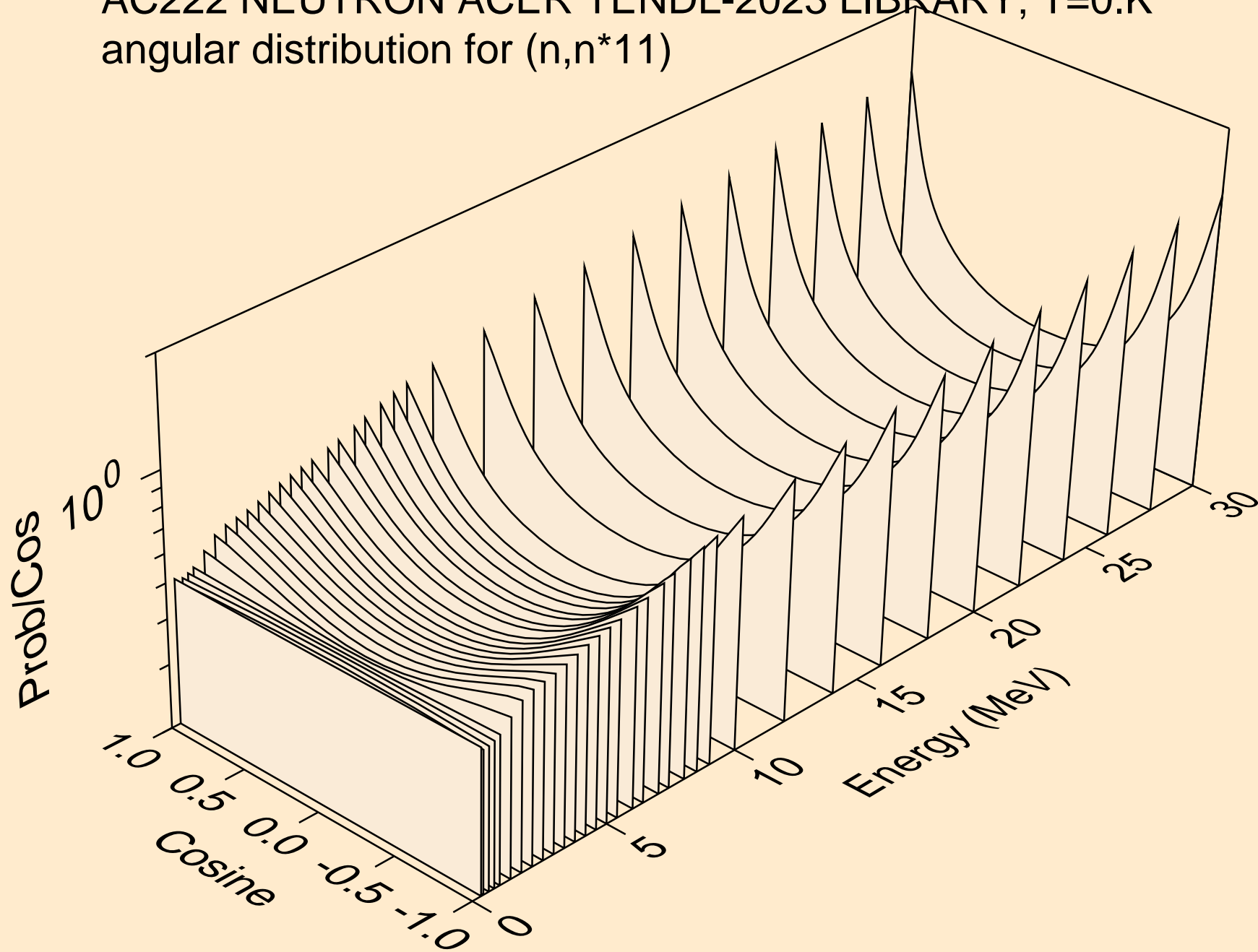

AC222 NEUTRON ACER TENDL-2023 LIBRARY; T=0.K
angular distribution for (n,n*12)

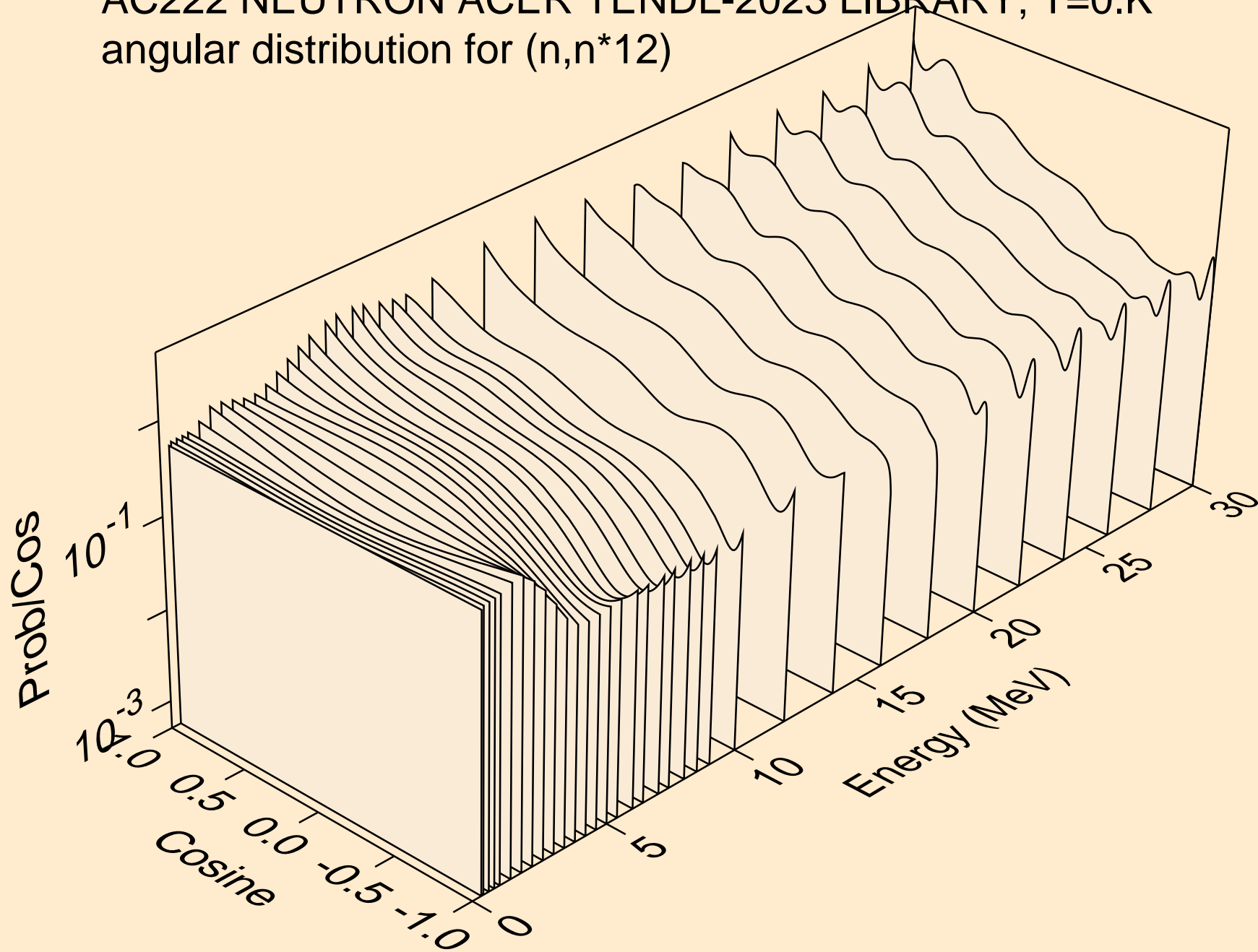

AC222 NEUTRON ACER TENDL-2023 LIBRARY; T=0.K
angular distribution for (n,n*13)

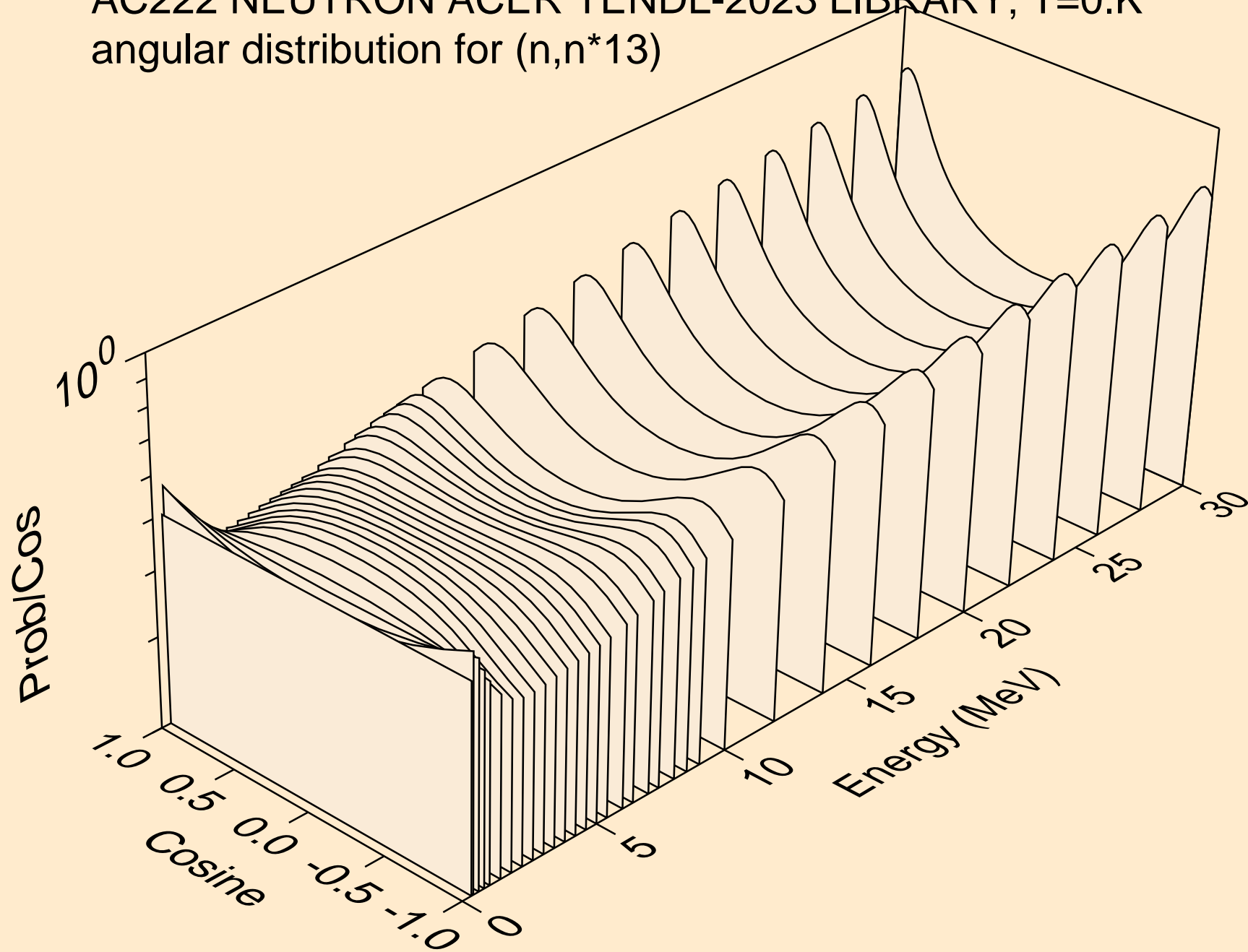

AC222 NEUTRON ACER TENDL-2023 LIBRARY; T=0.K
angular distribution for (n,n*14)

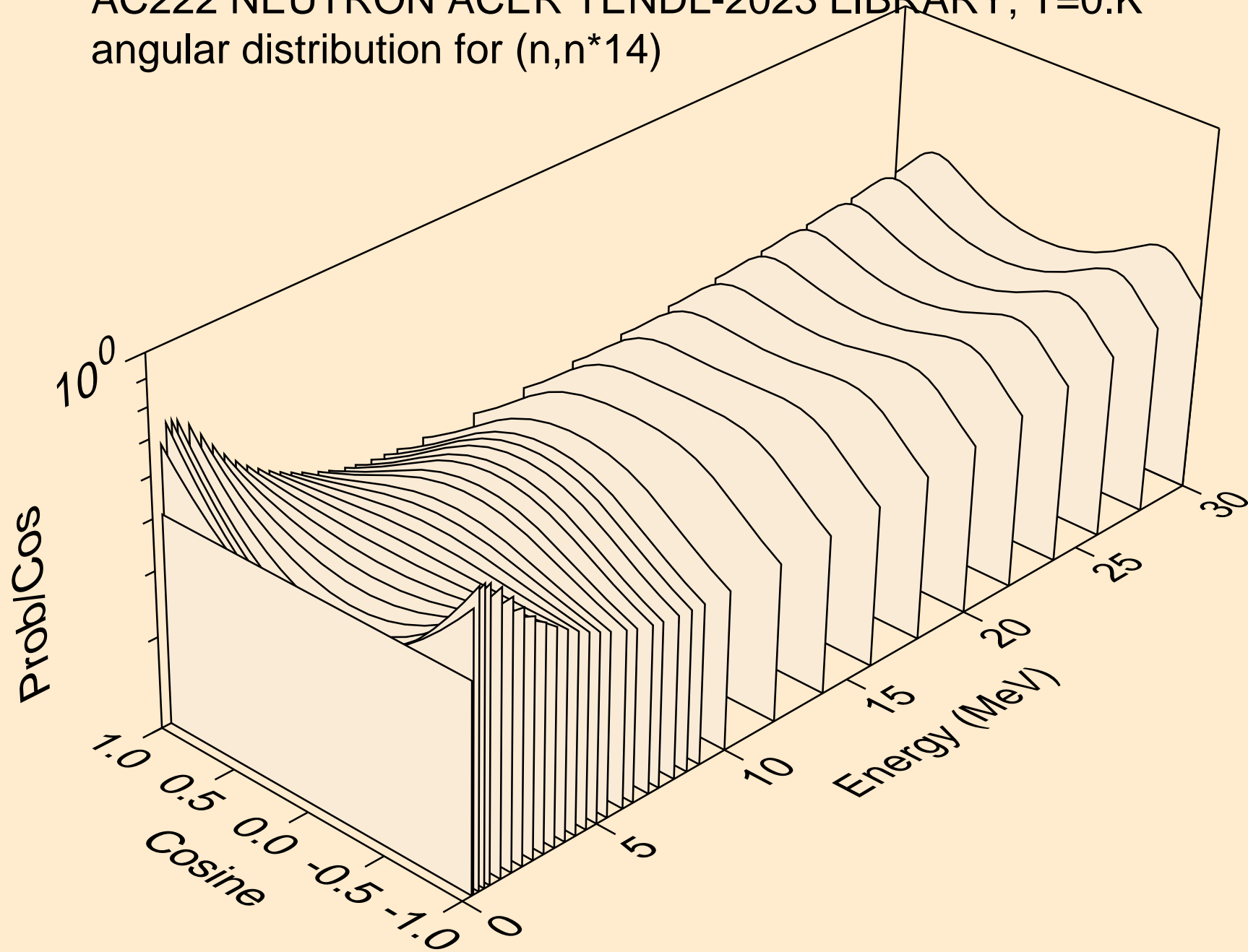

AC222 NEUTRON ACER TENDL-2023 LIBRARY; T=0.K
angular distribution for (n,n*15)

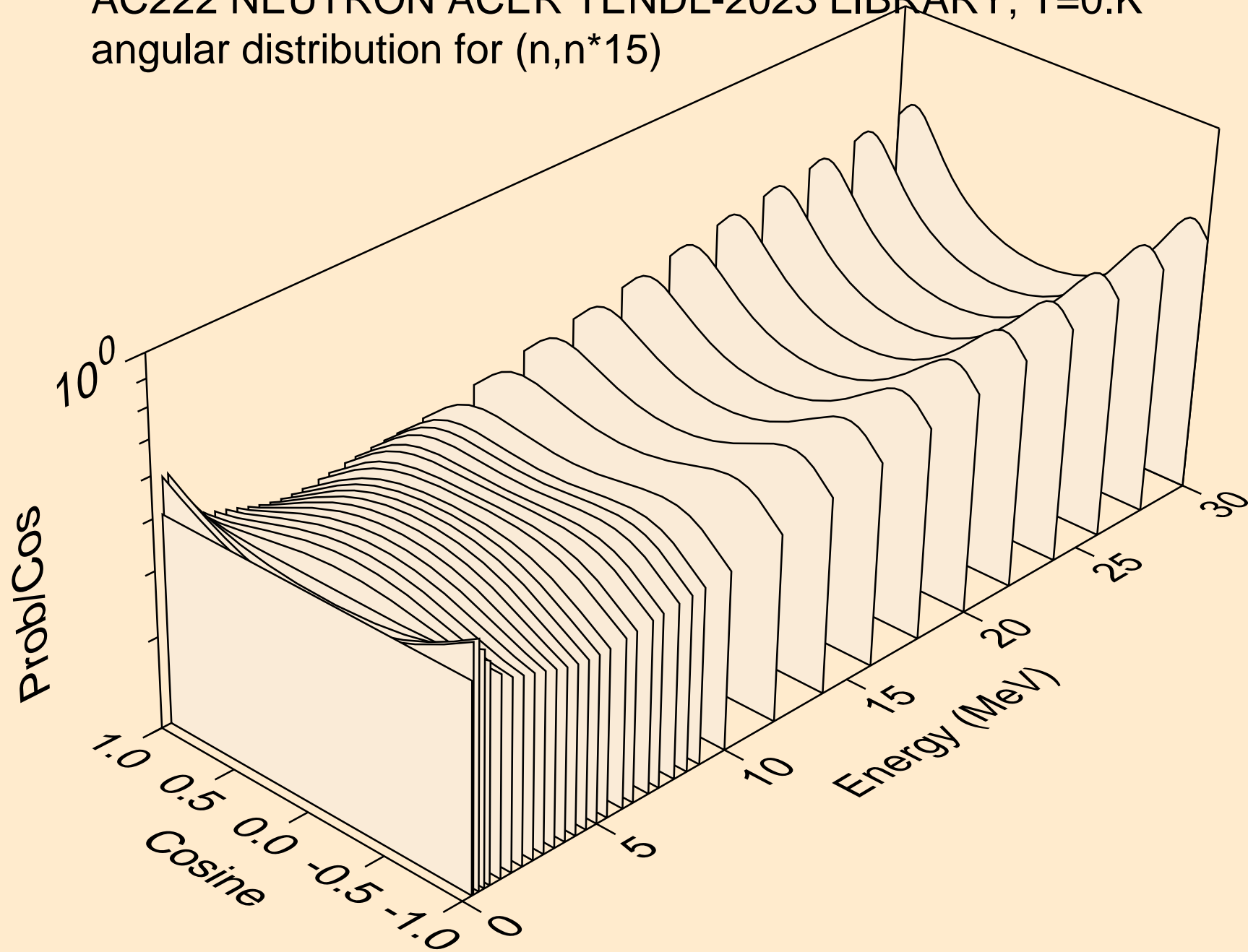

AC222 NEUTRON ACER TENDL-2023 LIBRARY; T=0.K
angular distribution for (n,n*16)

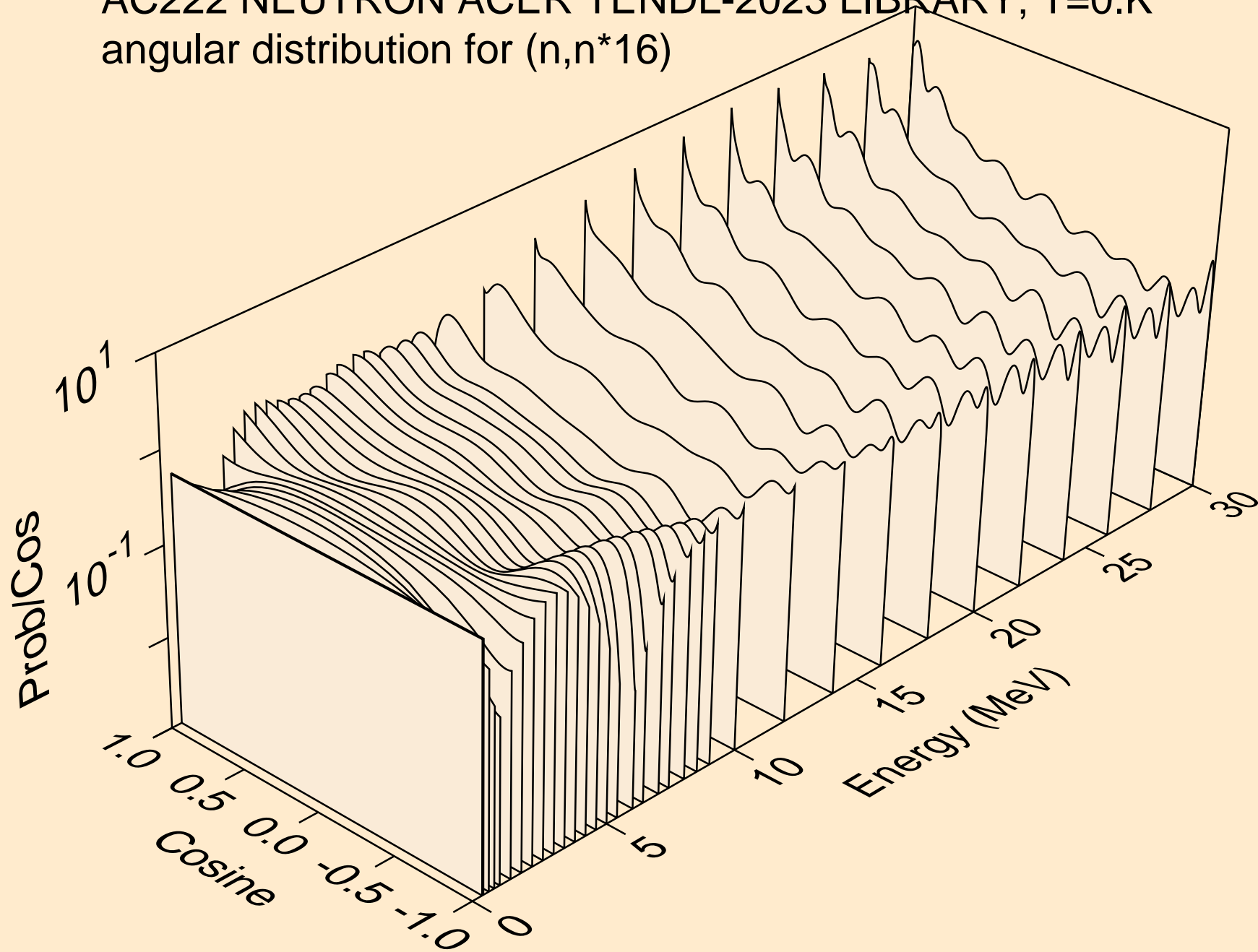

AC222 NEUTRON ACER TENDL-2023 LIBRARY; T=0.K
angular distribution for (n,n*17)

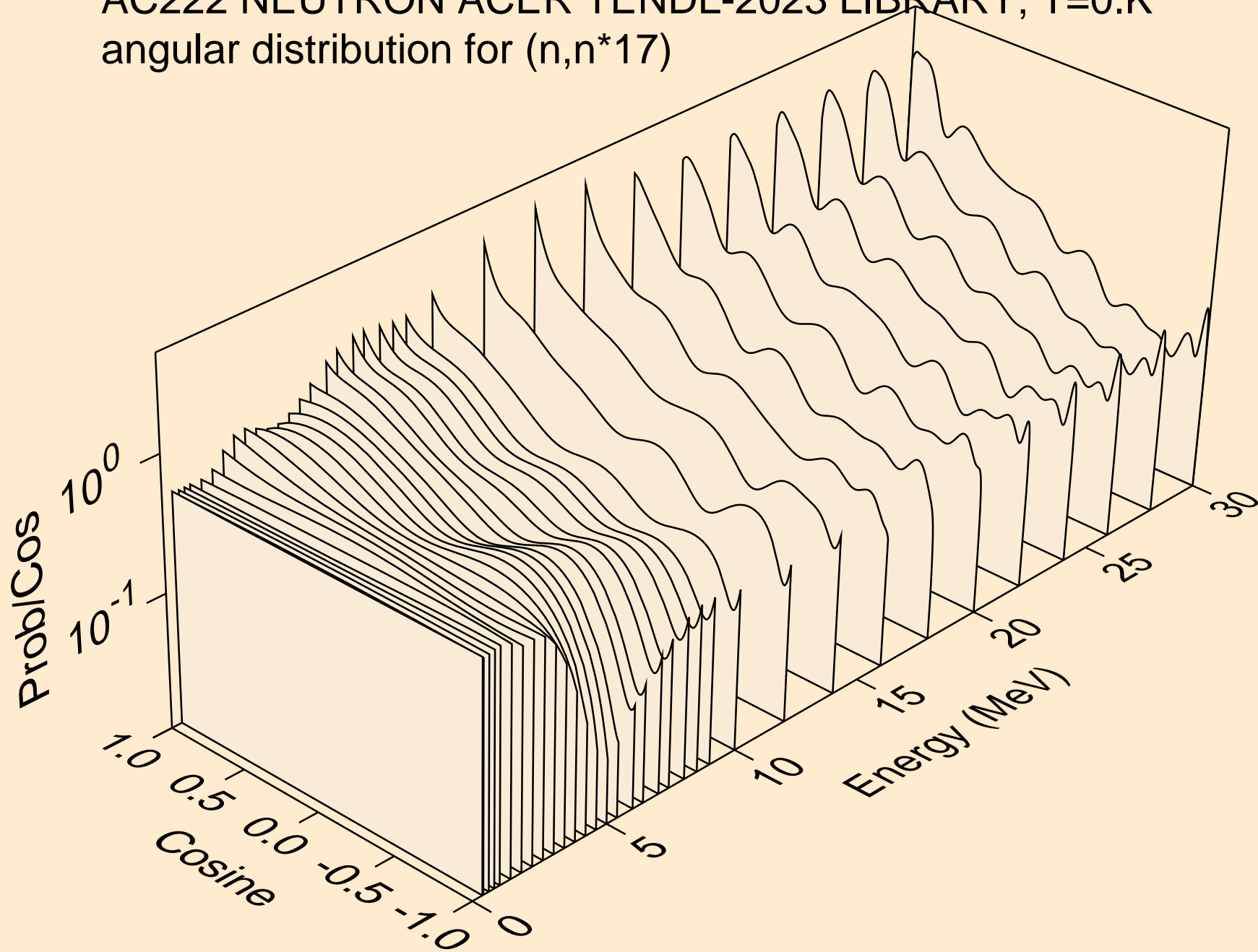

AC222 NEUTRON ACER TENDL-2023 LIBRARY; T=0.K
angular distribution for (n,n*18)

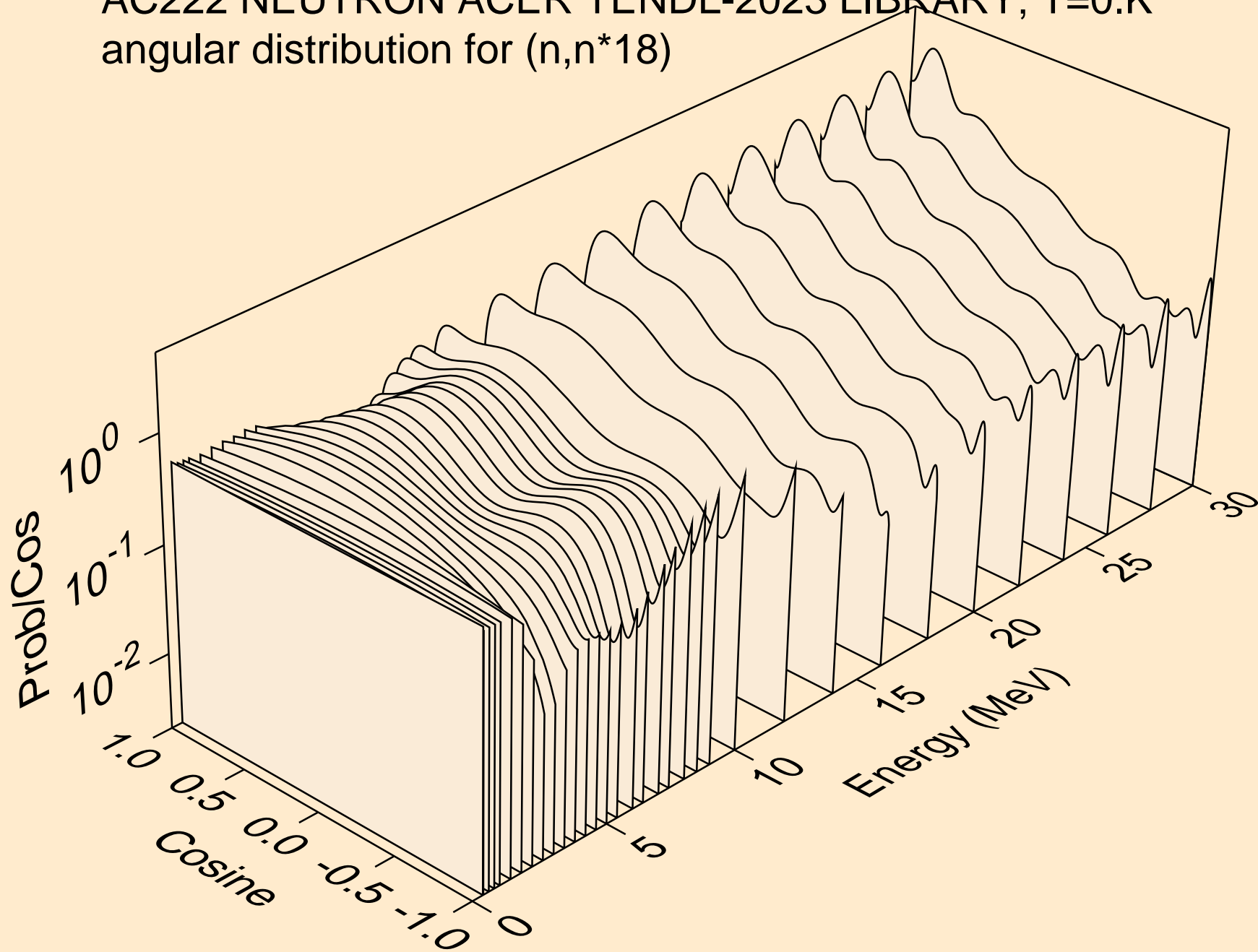

AC222 NEUTRON ACER TENDL-2023 LIBRARY; T=0.K
angular distribution for (n,n*19)

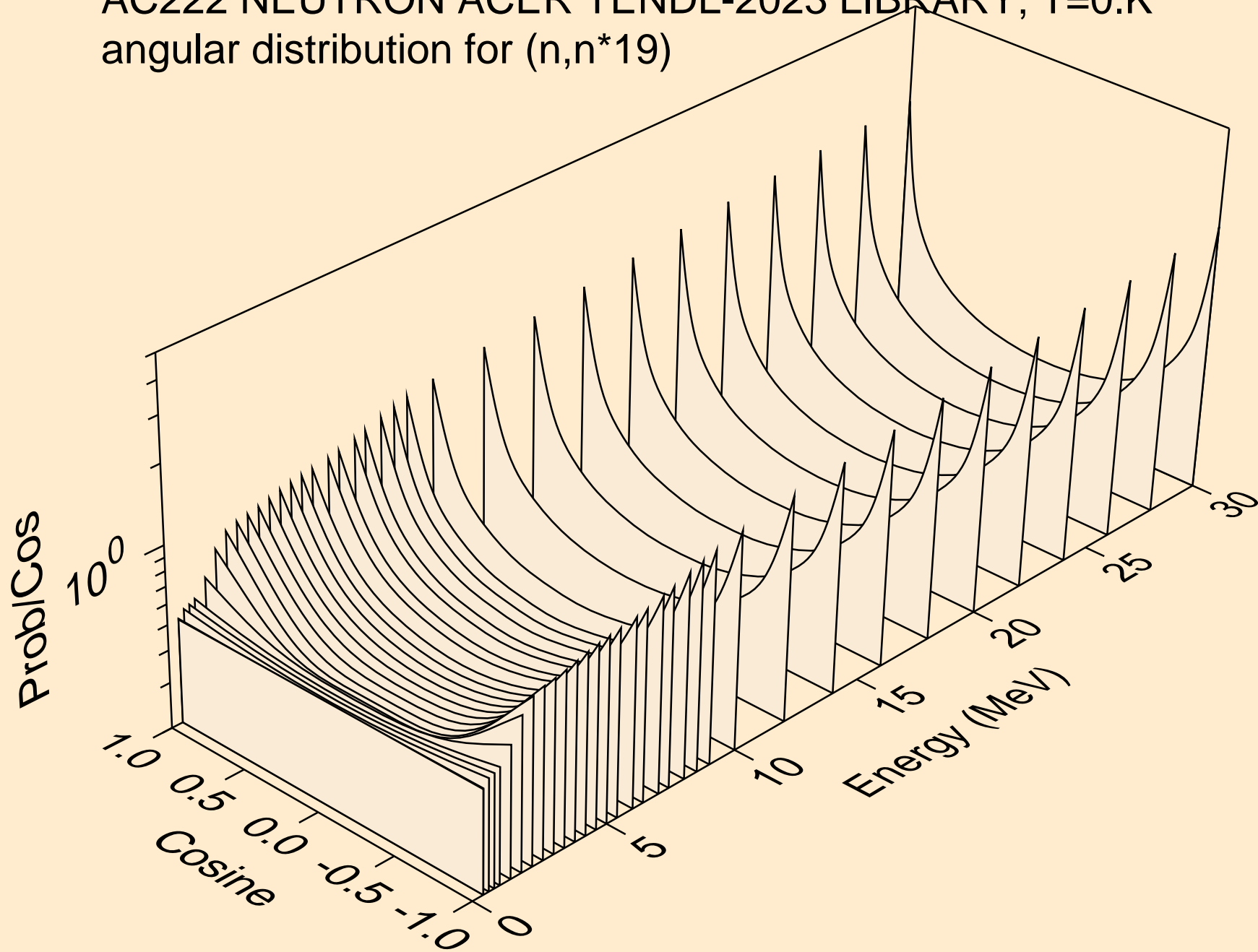

AC222 NEUTRON ACER TENDL-2023 LIBRARY; T=0.K
angular distribution for (n,n*20)

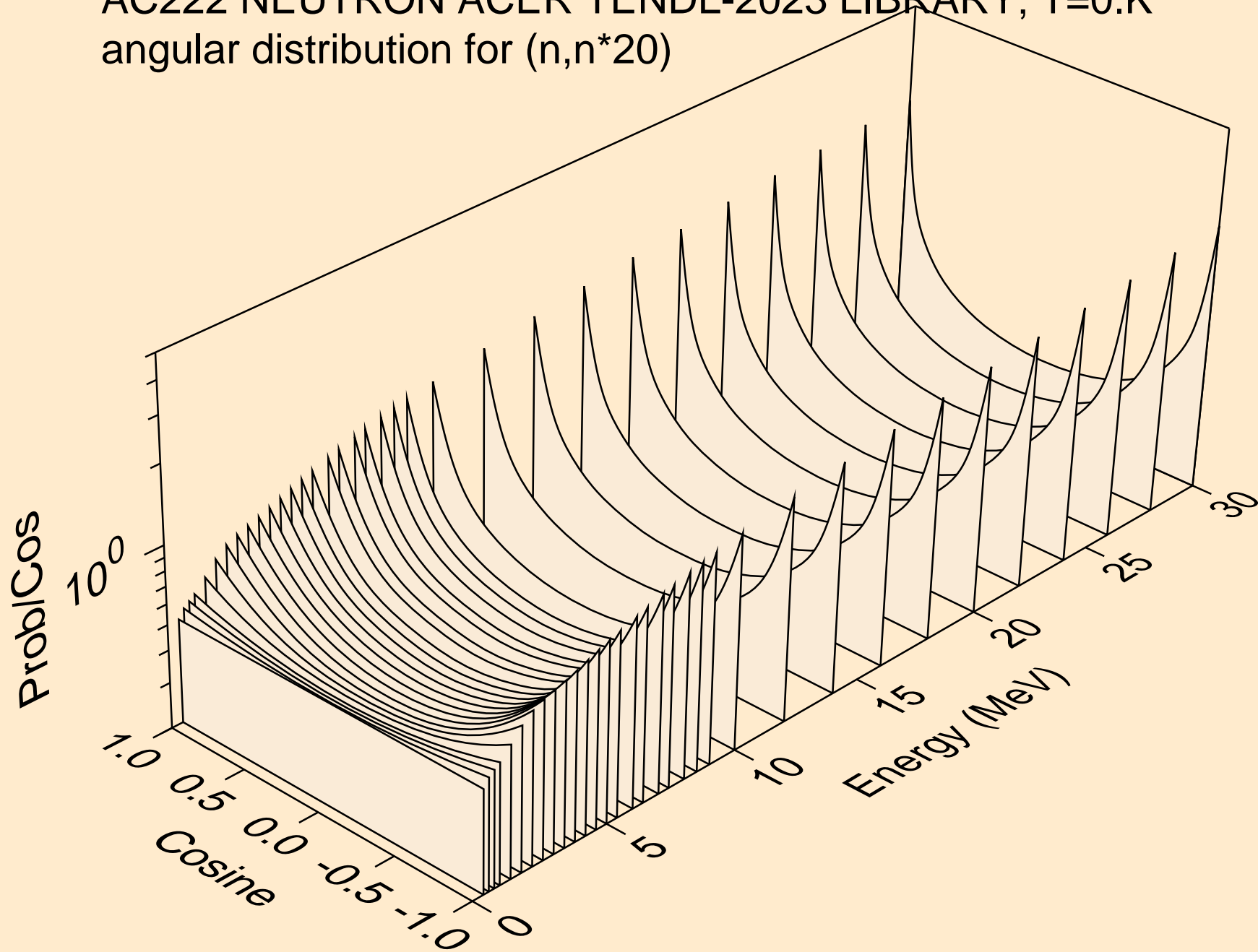

AC222 NEUTRON ACER TENDL-2023 LIBRARY; T=0.K
angular distribution for (n,n*21)

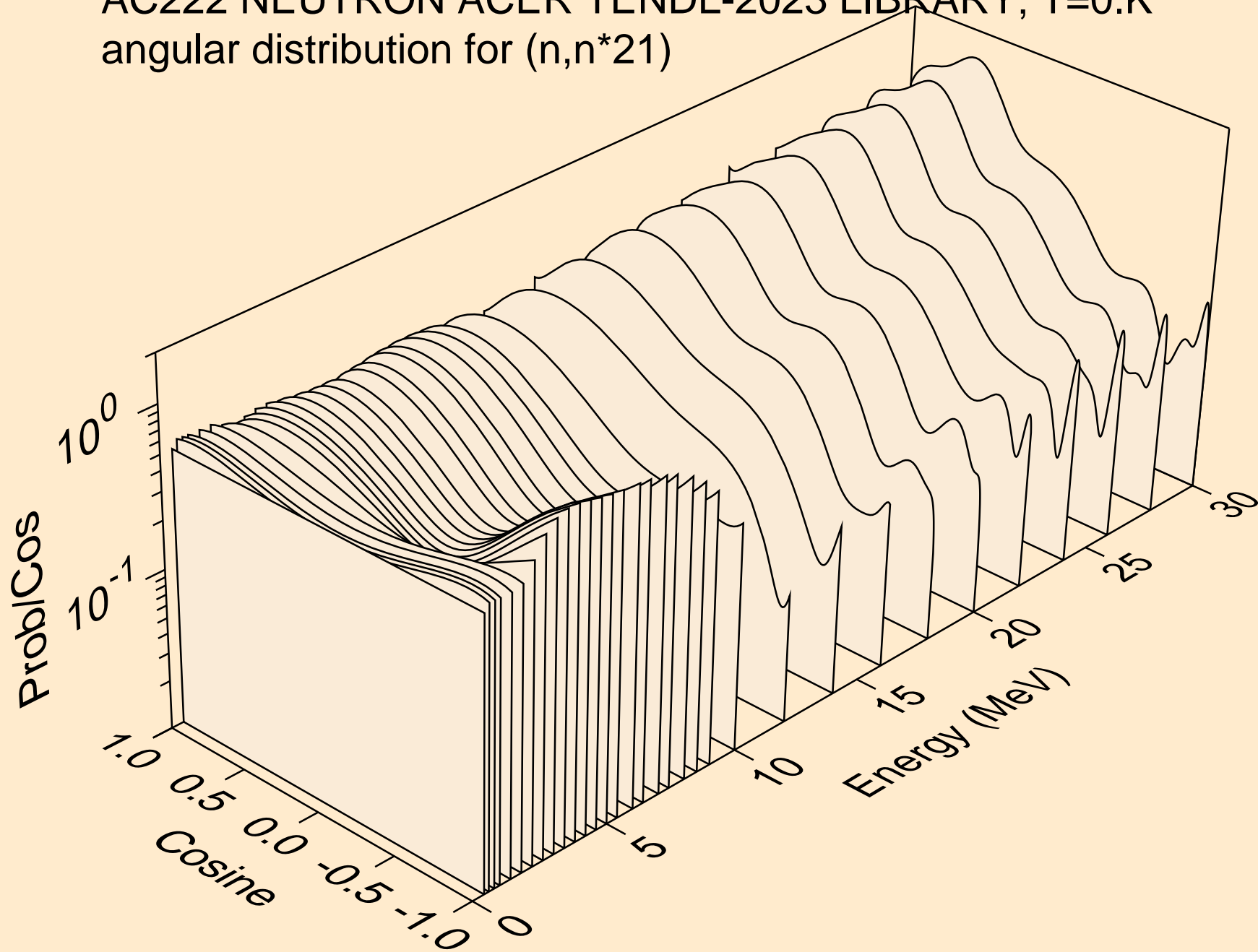

AC222 NEUTRON ACER TENDL-2023 LIBRARY; T=0.K
angular distribution for (n,n*22)

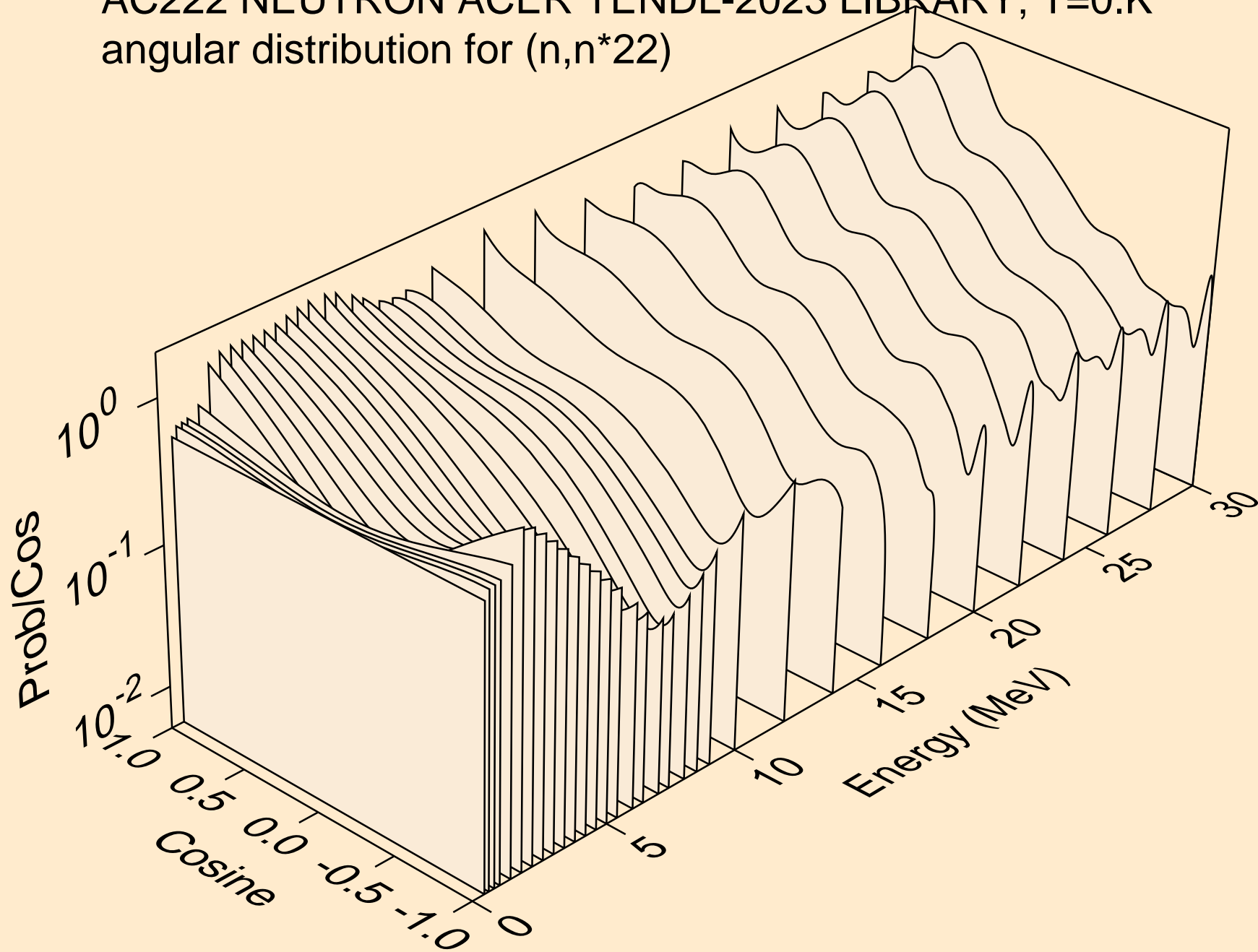

AC222 NEUTRON ACER TENDL-2023 LIBRARY; T=0.K
angular distribution for (n,n*23)

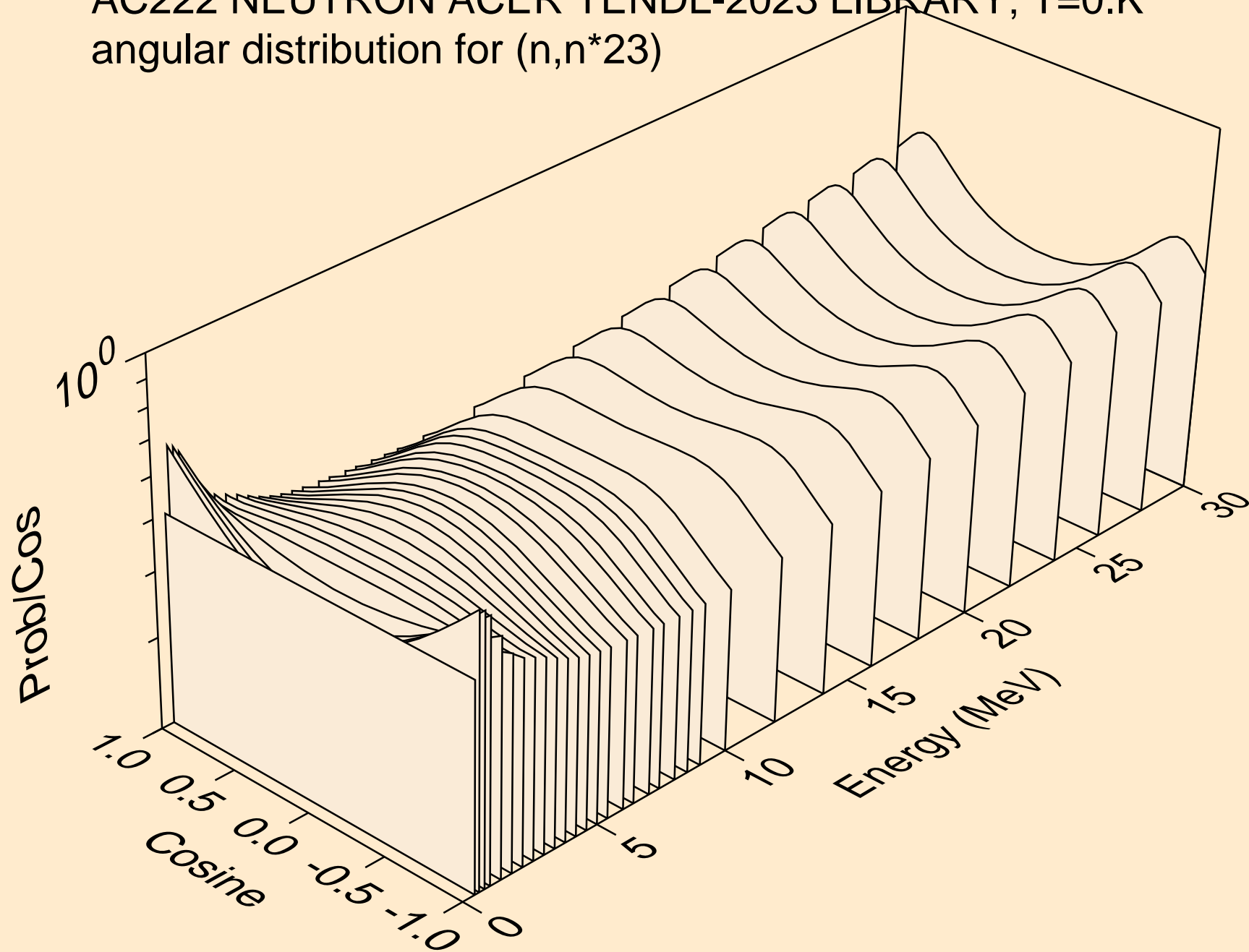

AC222 NEUTRON ACER TENDL-2023 LIBRARY; T=0.K
angular distribution for (n,n*24)

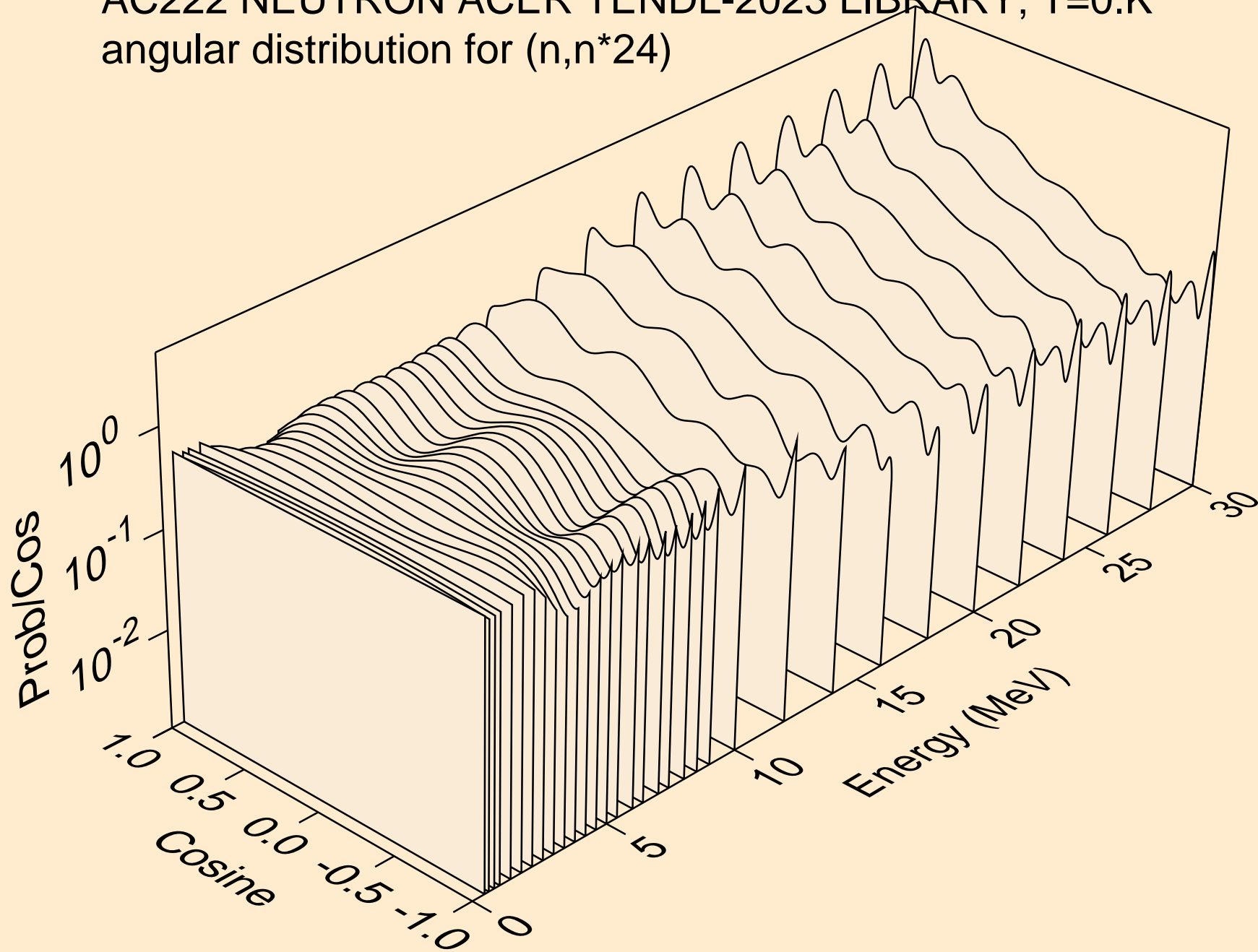

AC222 NEUTRON ACER TENDL-2023 LIBRARY; T=0.K
angular distribution for (n,n*25)

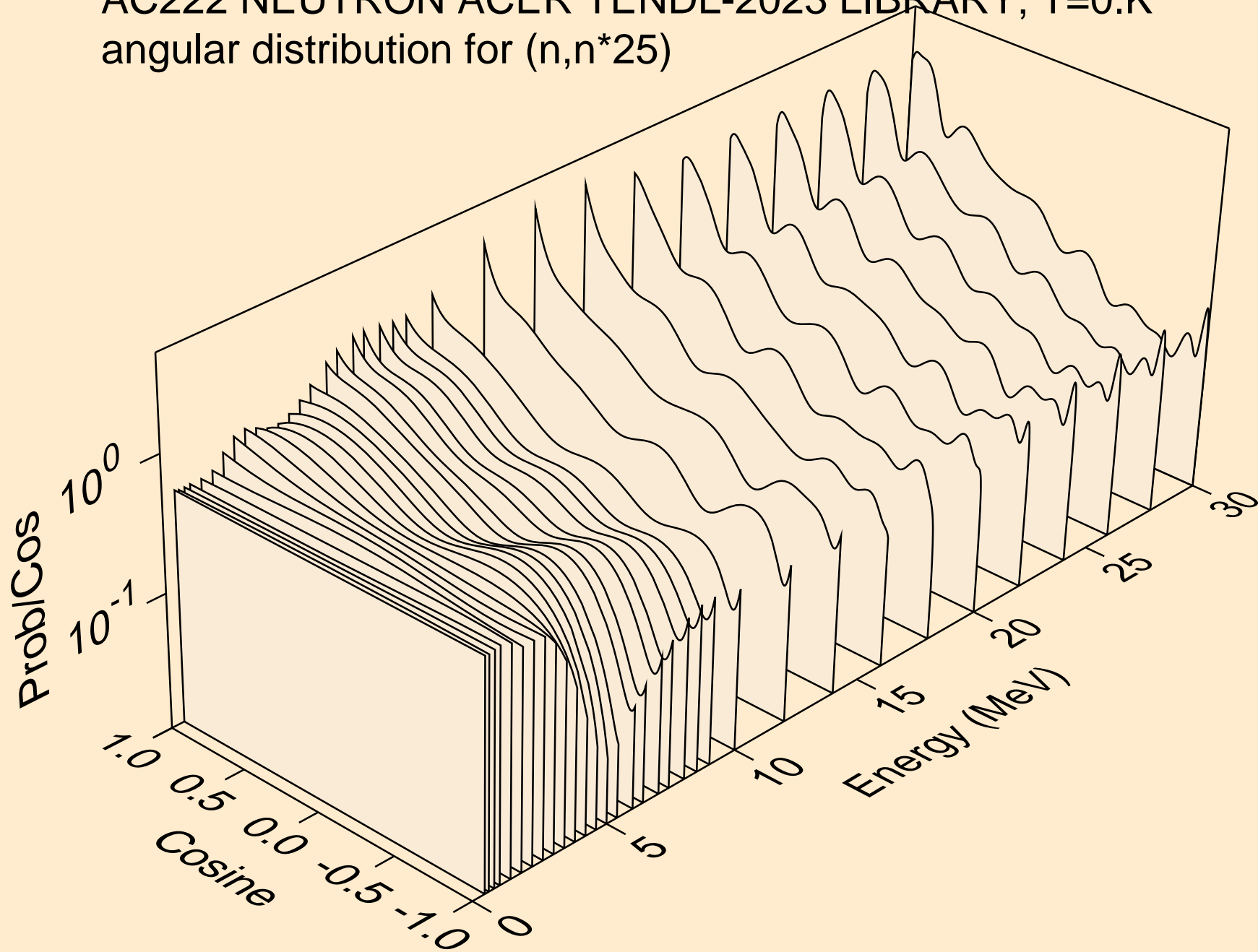

AC222 NEUTRON ACER TENDL-2023 LIBRARY; T=0.K
angular distribution for (n,n*26)

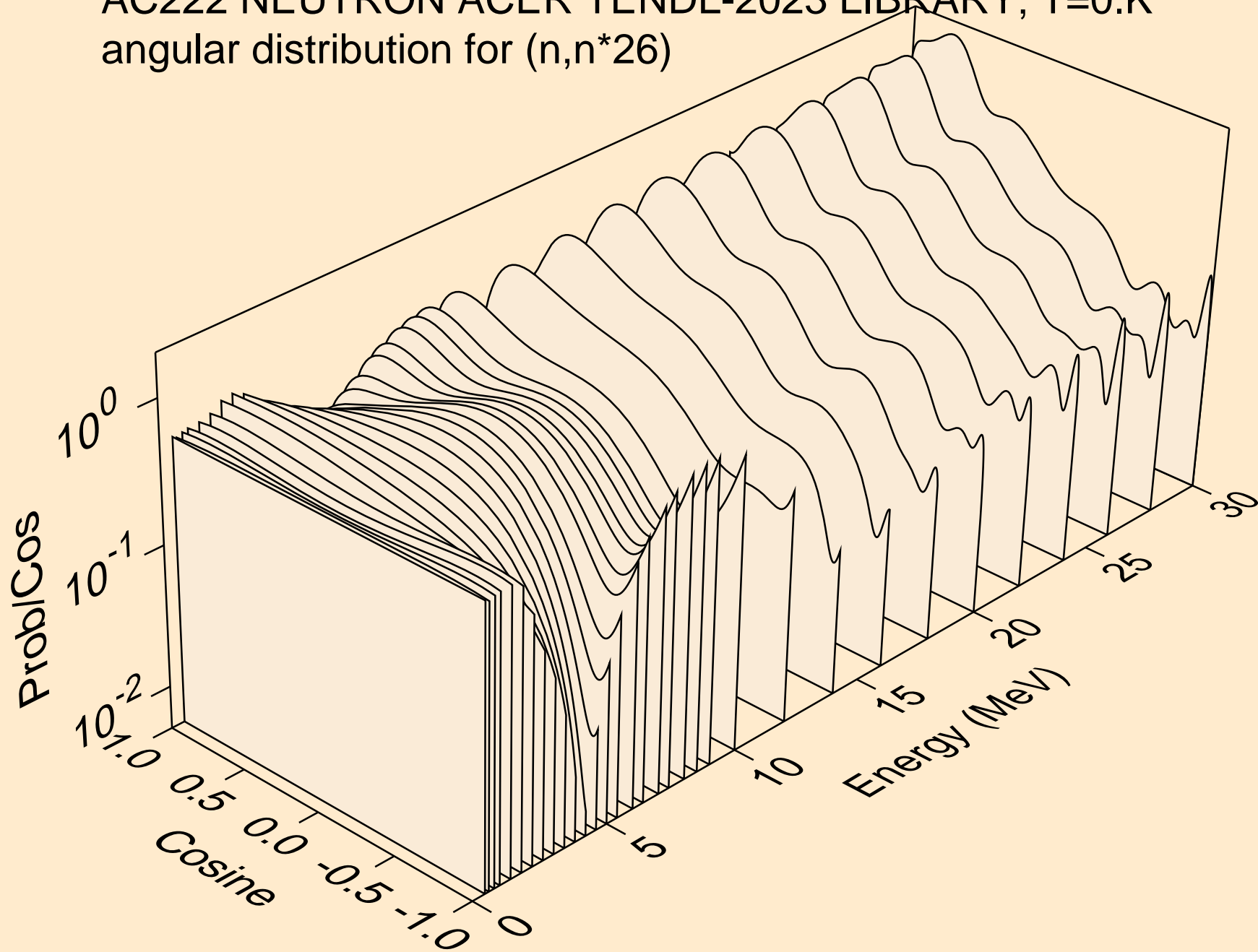

AC222 NEUTRON ACER TENDL-2023 LIBRARY; T=0.K
angular distribution for (n,n*27)

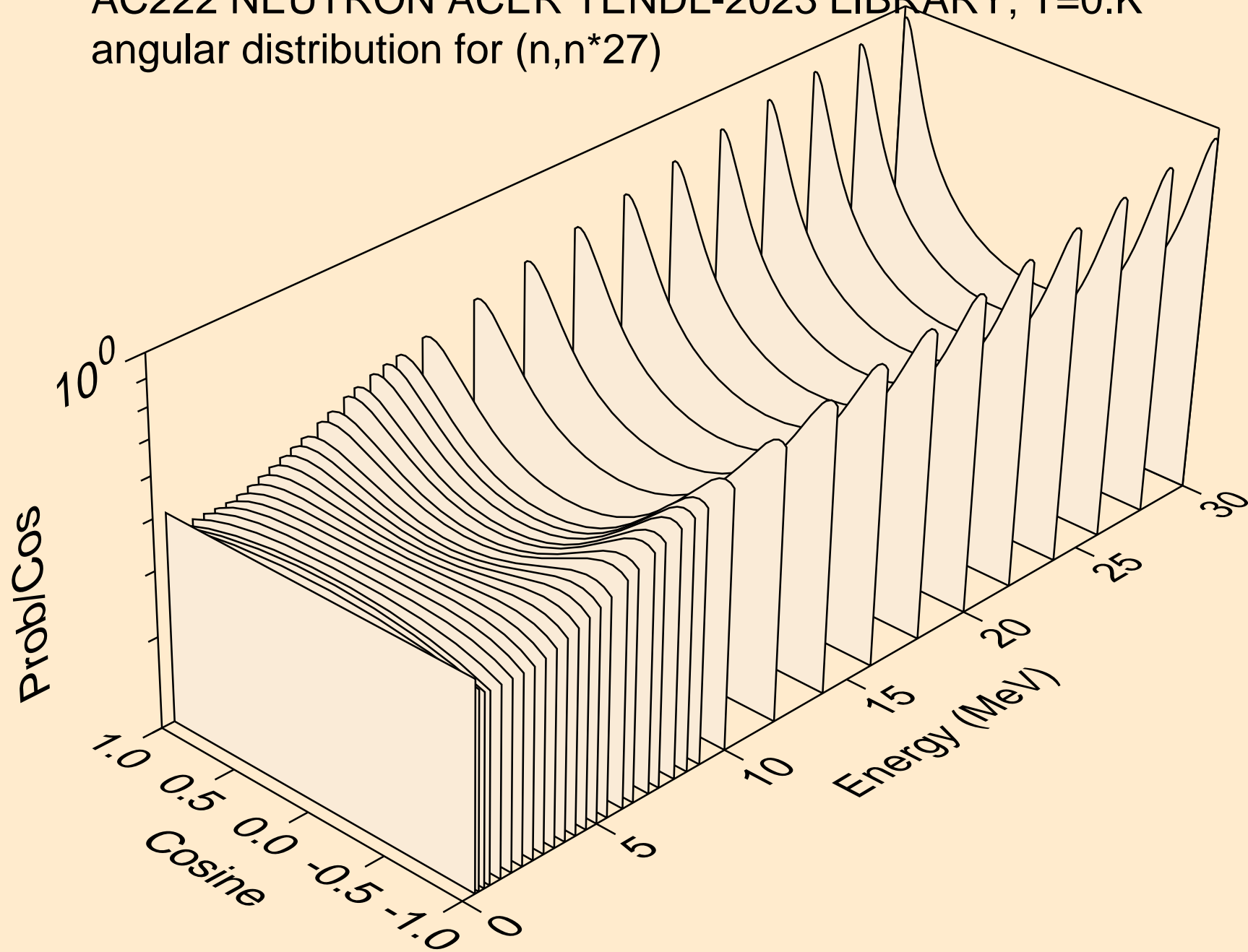

AC222 NEUTRON ACER TENDL-2023 LIBRARY; T=0.K

Total fission nubar

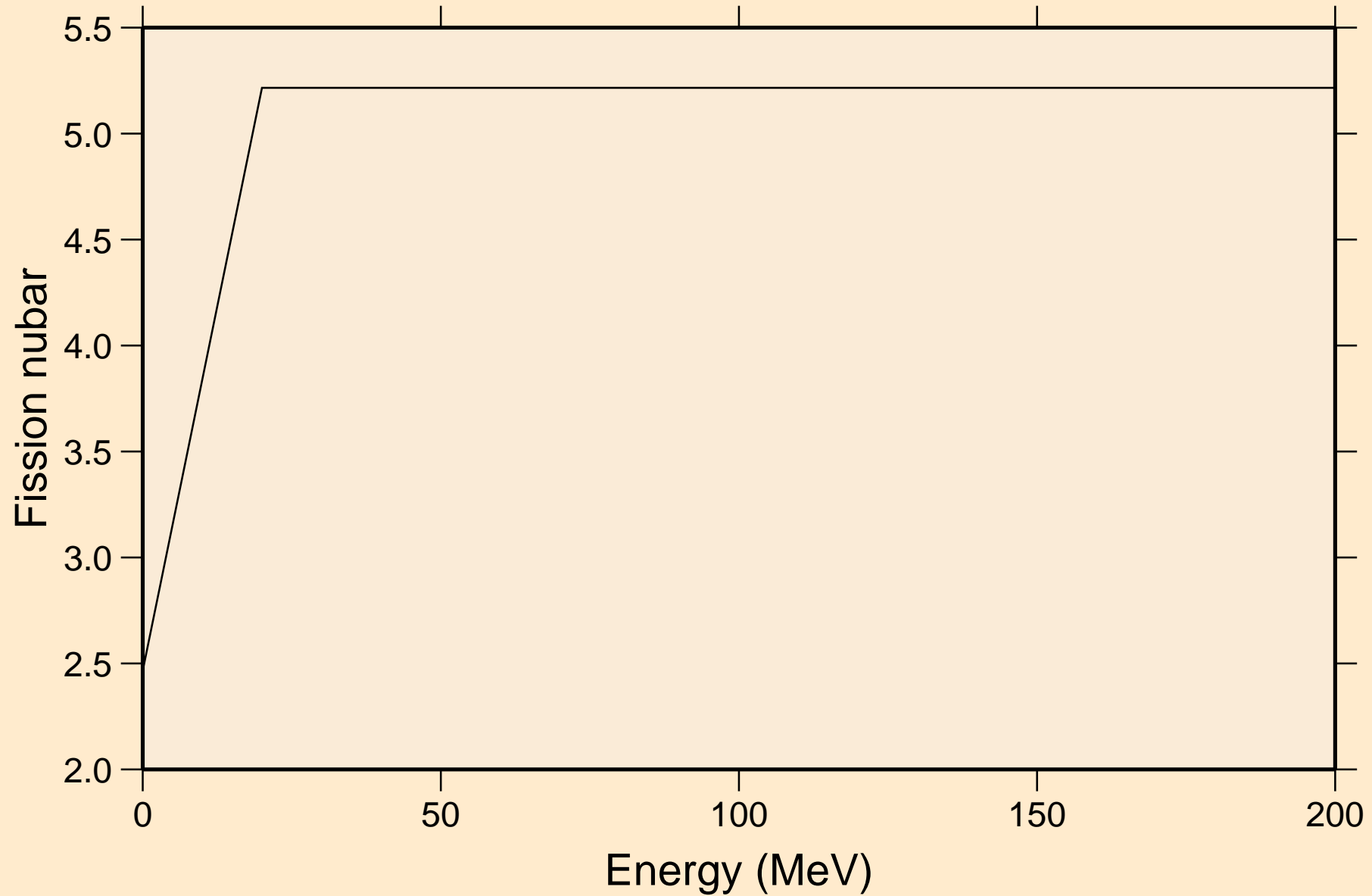

AC222 NEUTRON ACER TENDL-2023 LIBRARY; T=0.K
Neutron emission for (n,x)

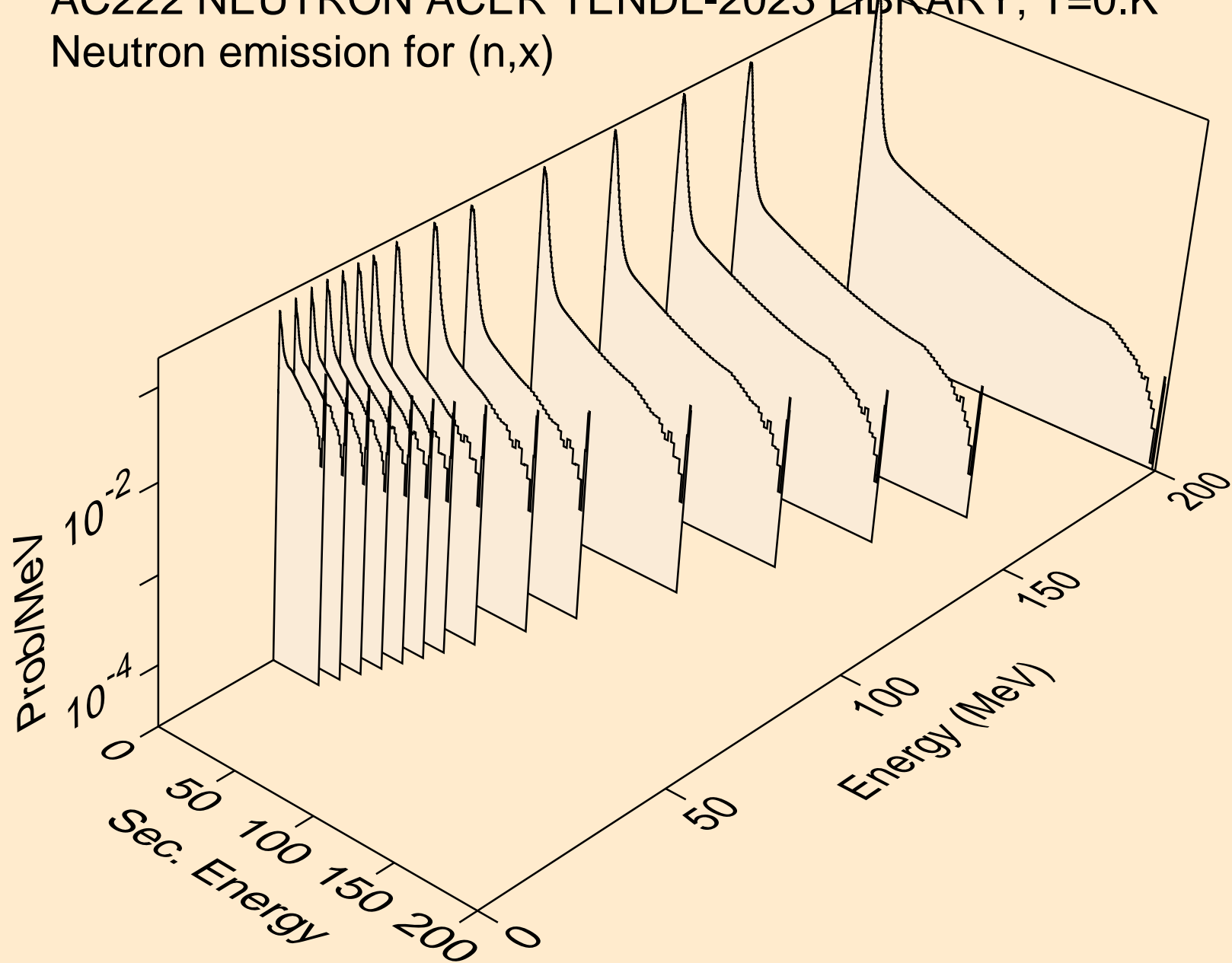

AC222 NEUTRON ACER TENDL-2023 LIBRARY; T=0.K
Neutron emission for (n,2nd)

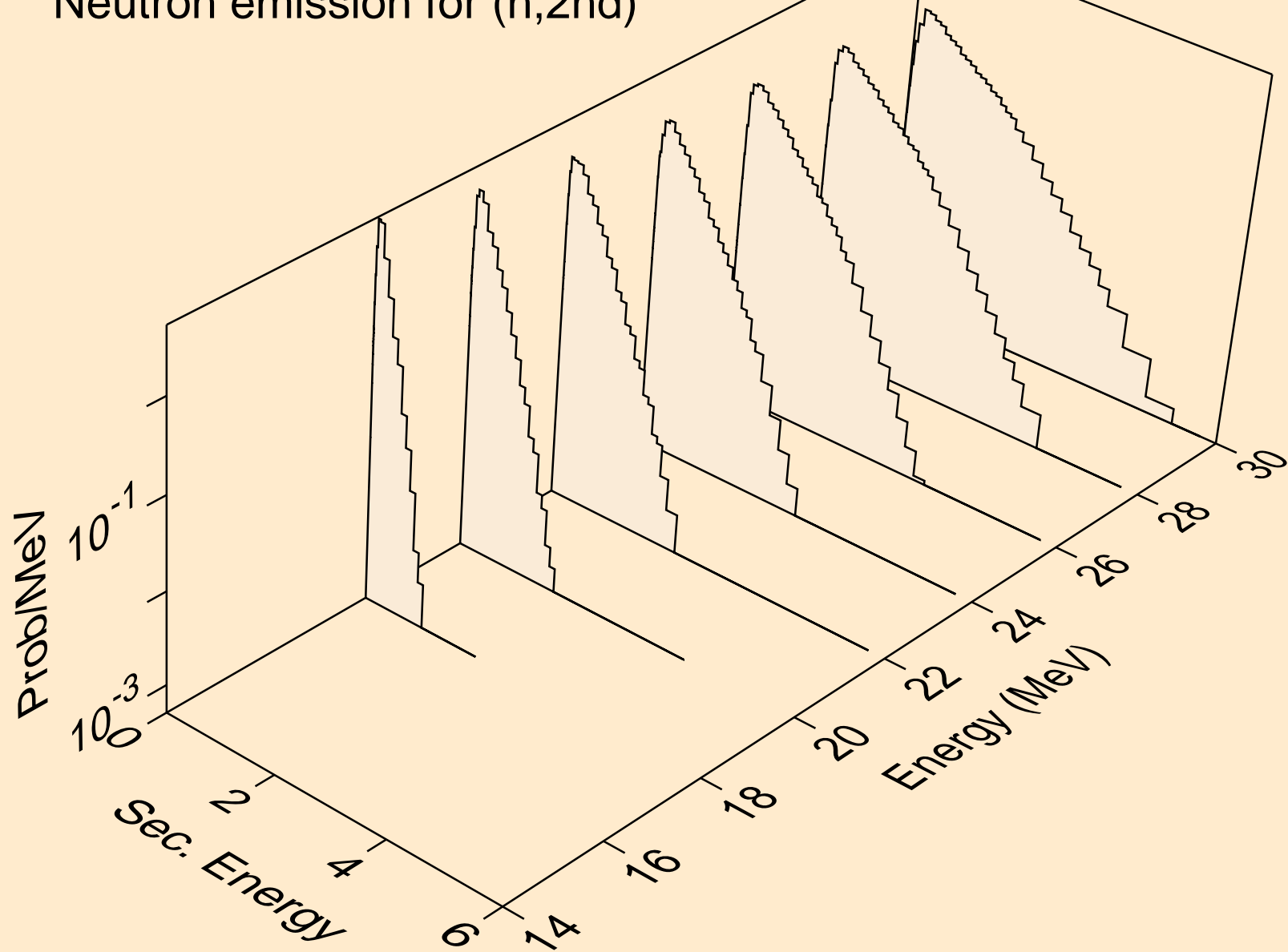

AC222 NEUTRON ACER TENDL-2023 LIBRARY; T=0.K
Neutron emission for (n,2n)

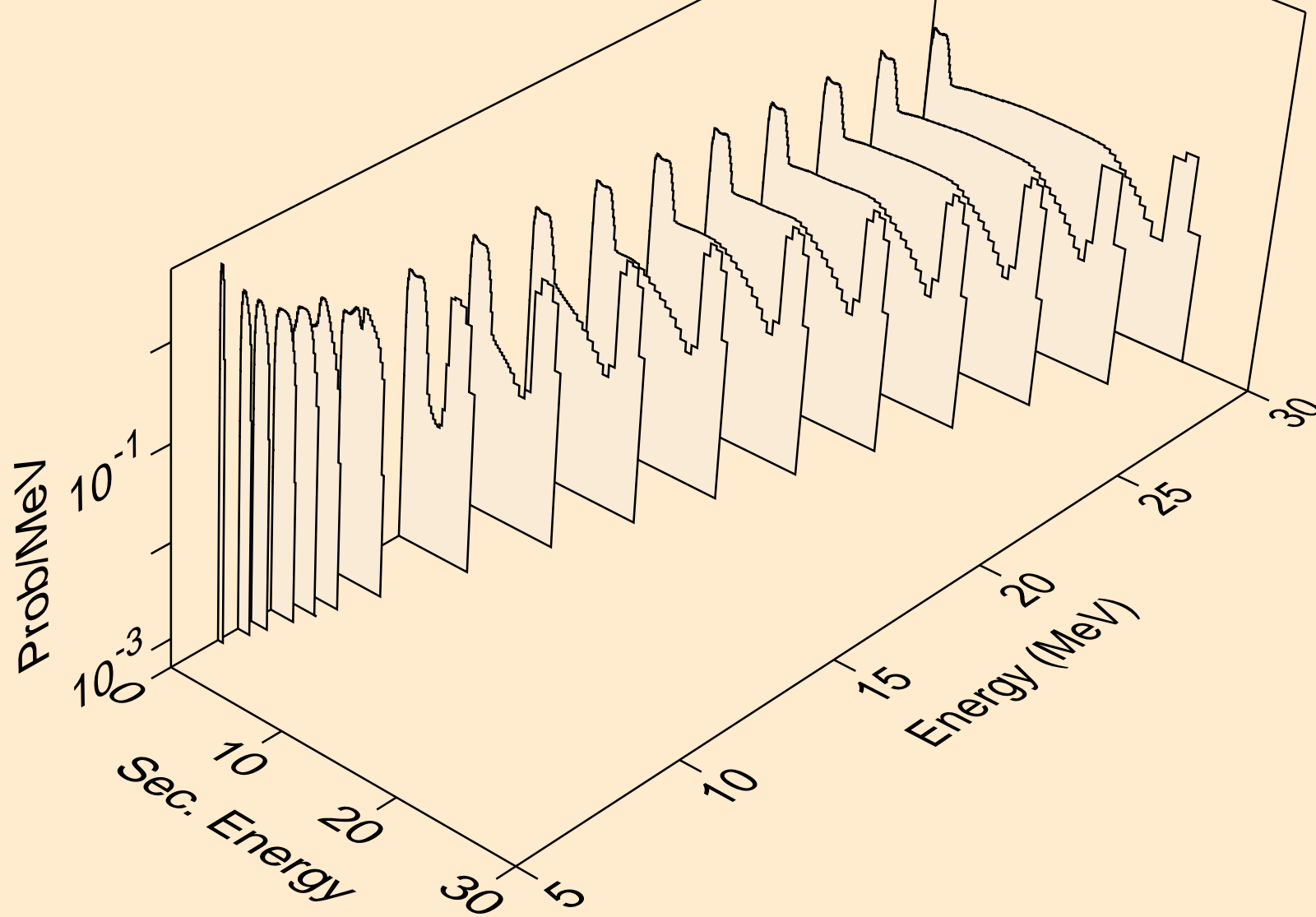

AC222 NEUTRON ACER TENDL-2023 LIBRARY; T=0.K
Neutron emission for (n,3n)

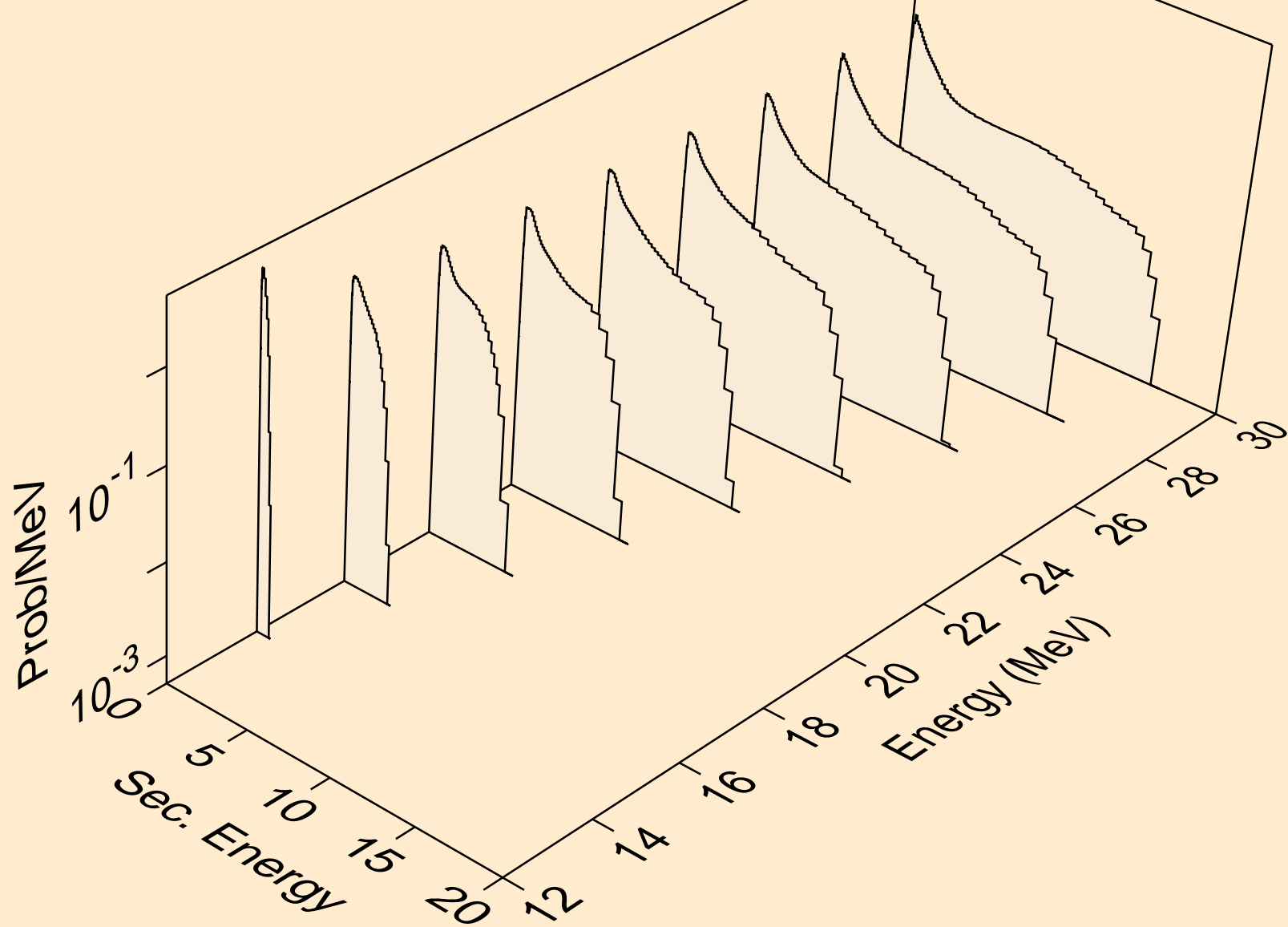

AC222 NEUTRON ACER TENDL-2023 LIBRARY; T=0.K
Neutron emission for fission

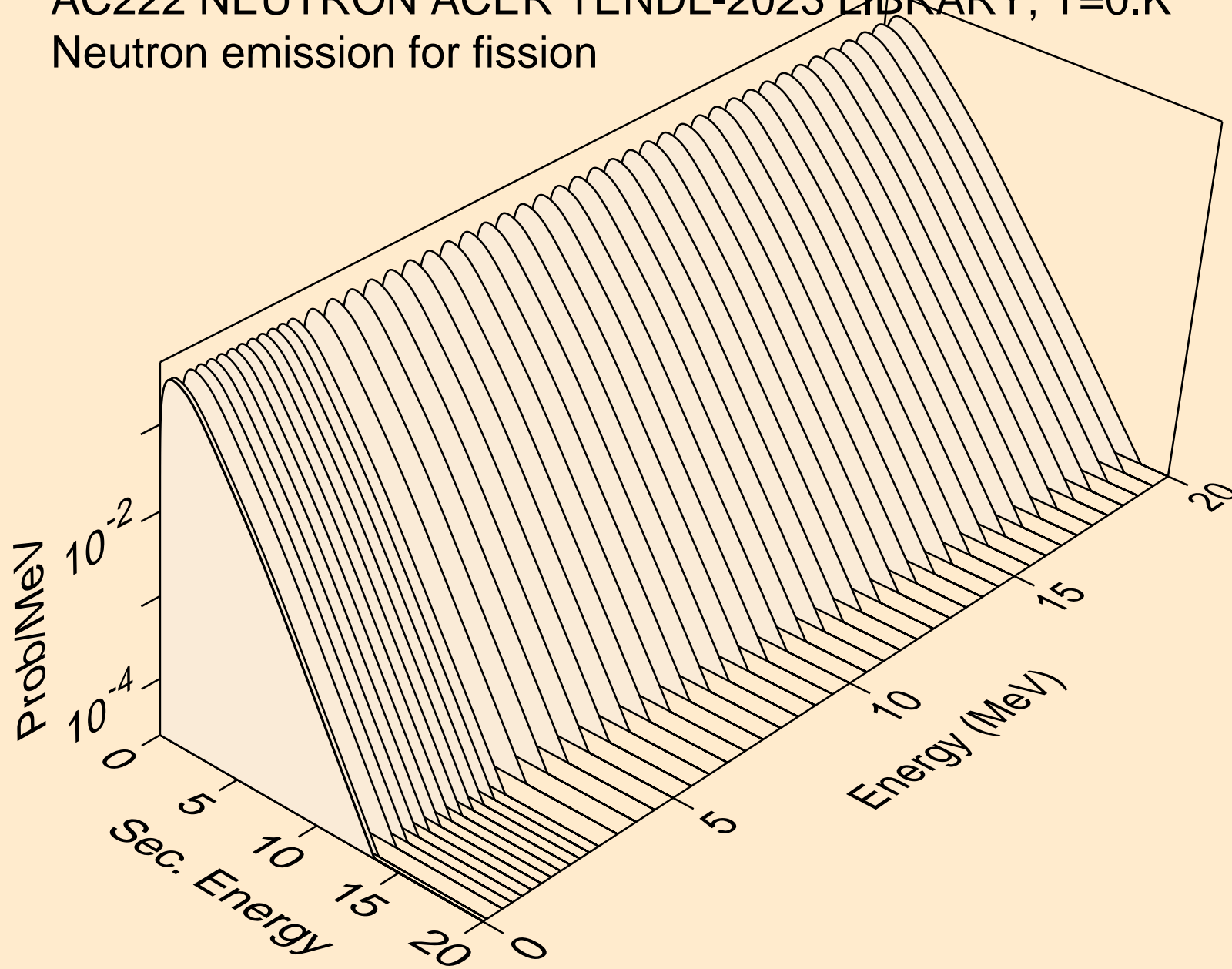

AC222 NEUTRON ACER TENDL-2023 LIBRARY; T=0.K
Neutron emission for (n,n*)a

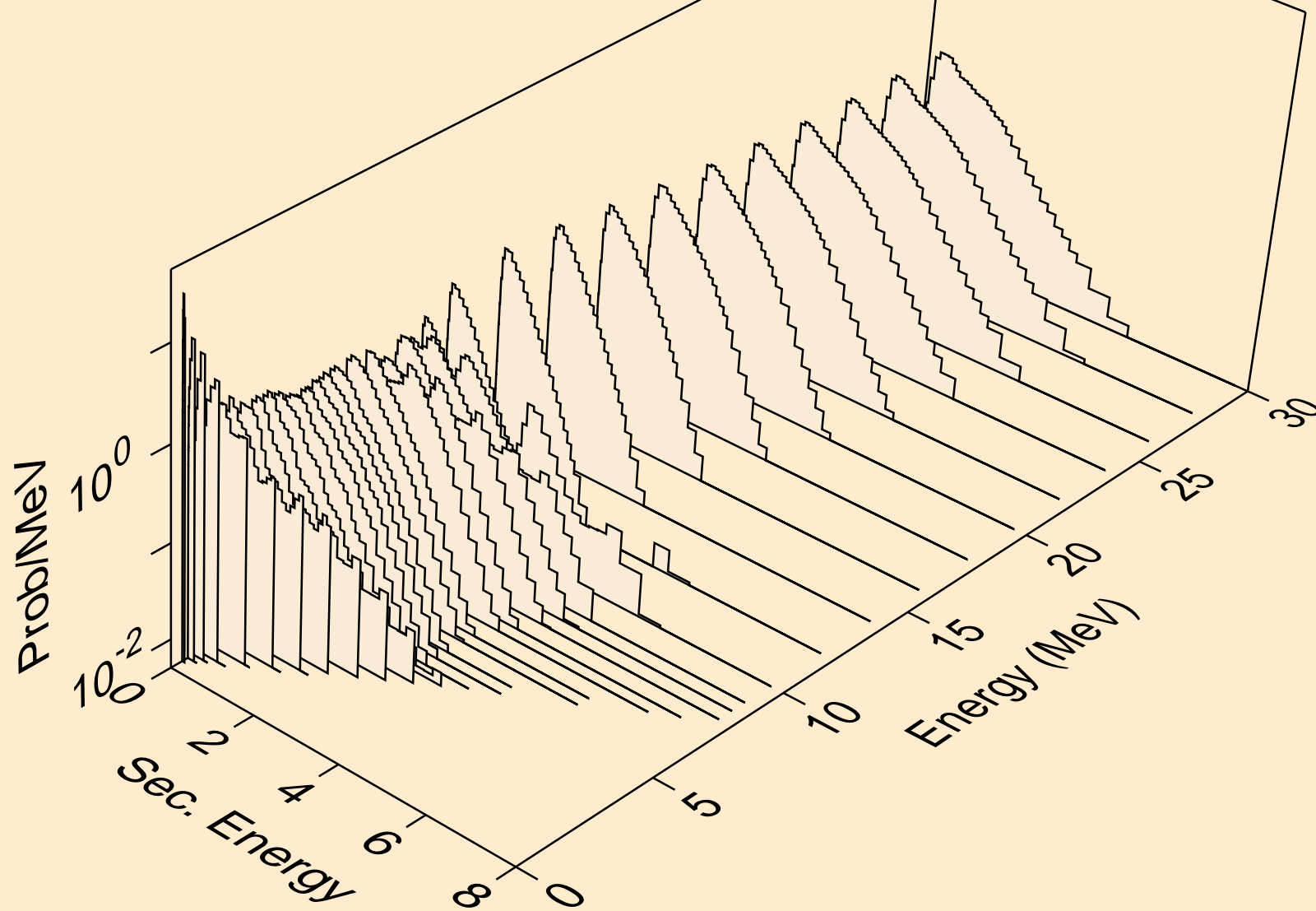

AC222 NEUTRON ACER TENDL-2023 LIBRARY; T=0.K
Neutron emission for (n,n*)3a

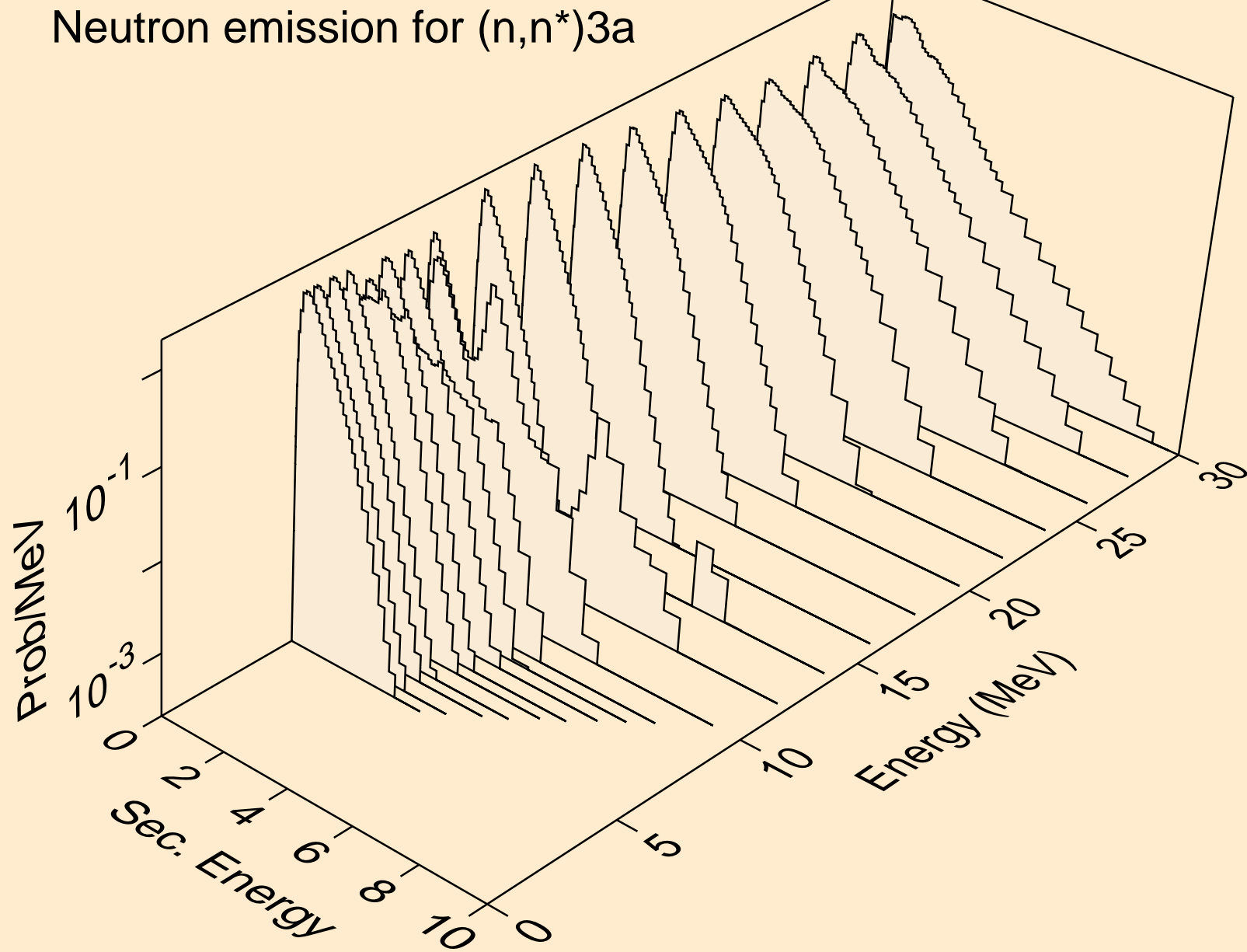

AC222 NEUTRON ACER TENDL-2023 LIBRARY; T=0.K
Neutron emission for (n,2n)a

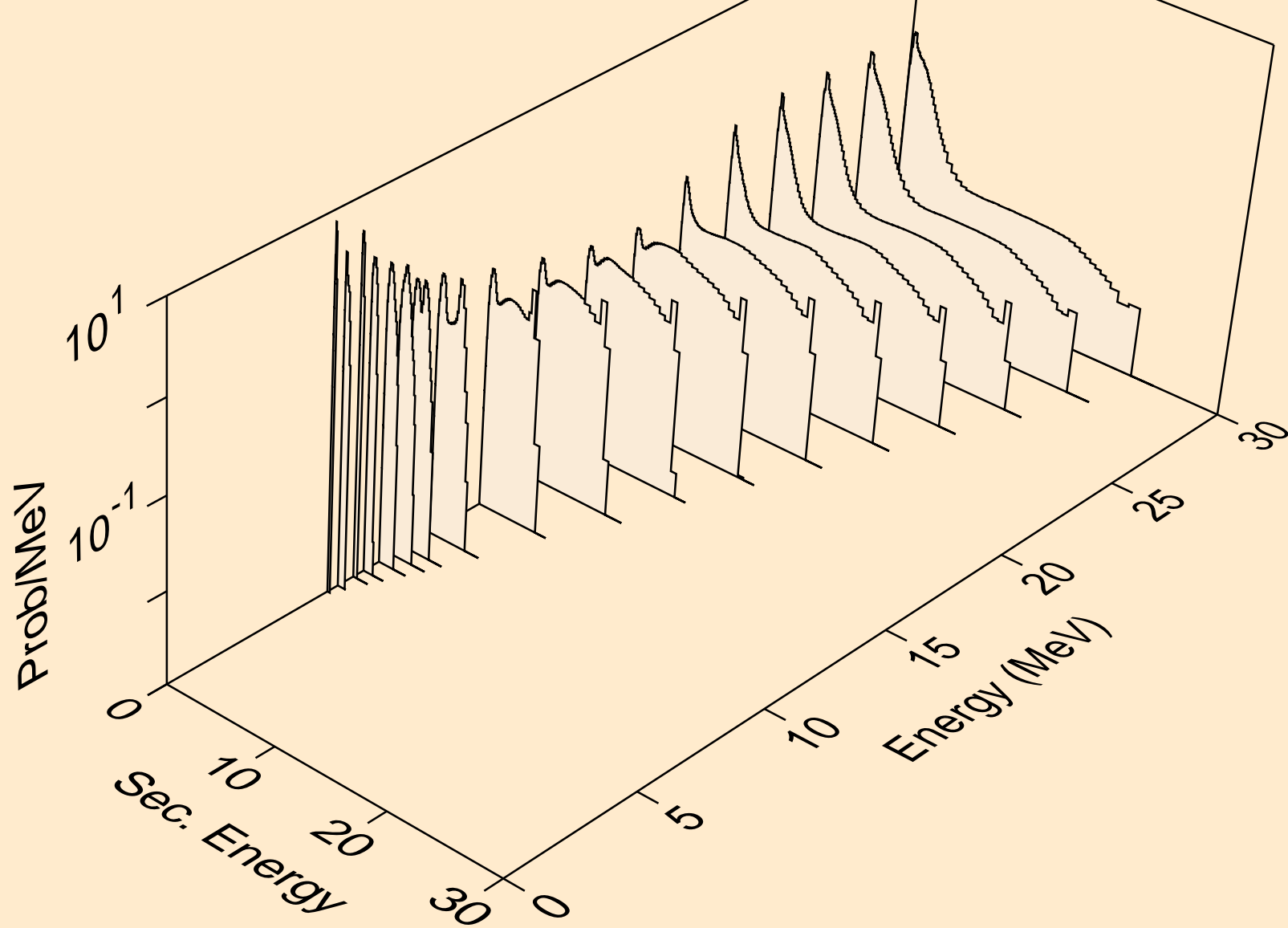

AC222 NEUTRON ACER TENDL-2023 LIBRARY; T=0.K
Neutron emission for (n,3n)a

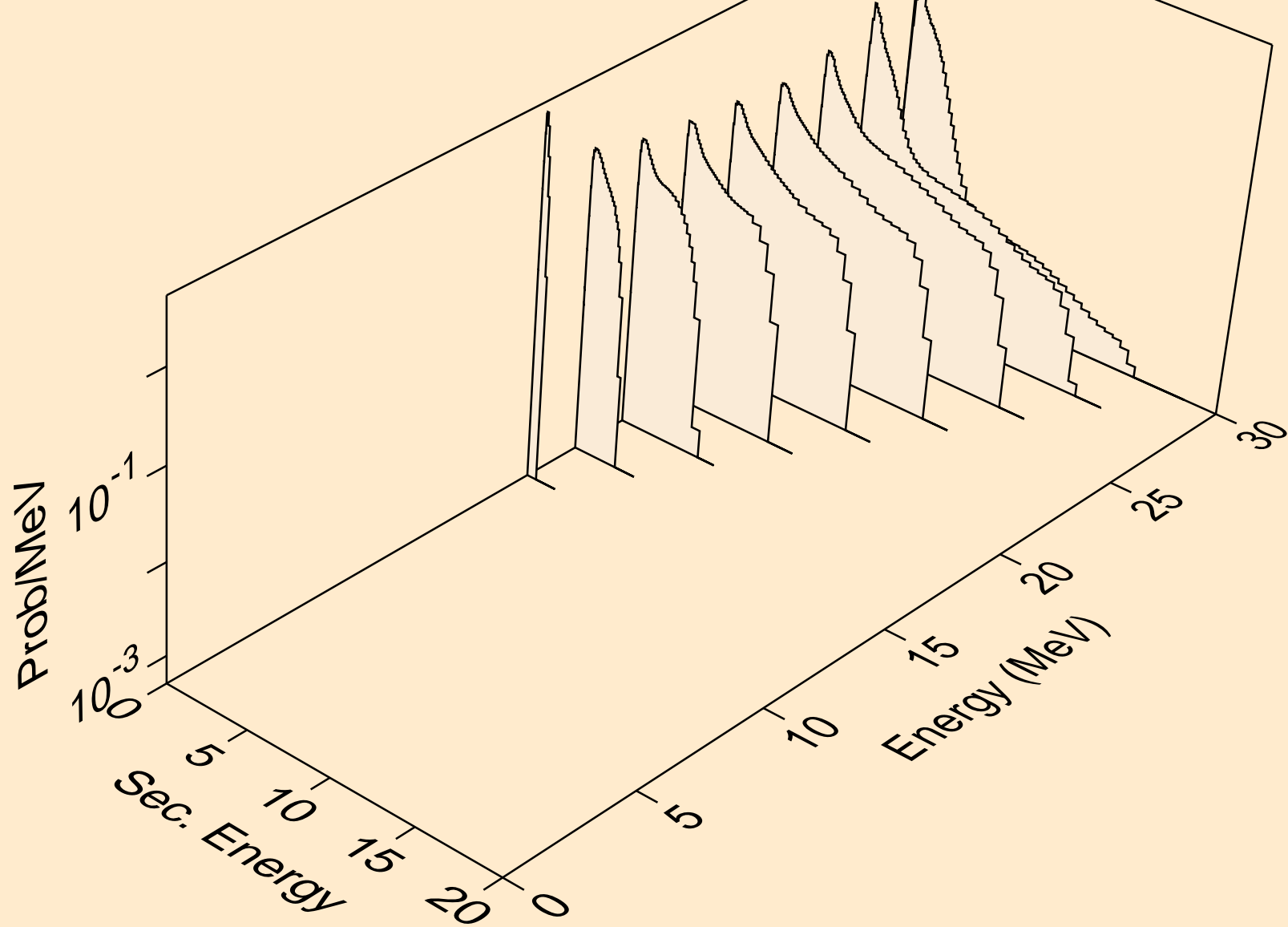

AC222 NEUTRON ACER TENDL-2023 LIBRARY; T=0.K
Neutron emission for (n,n*)p

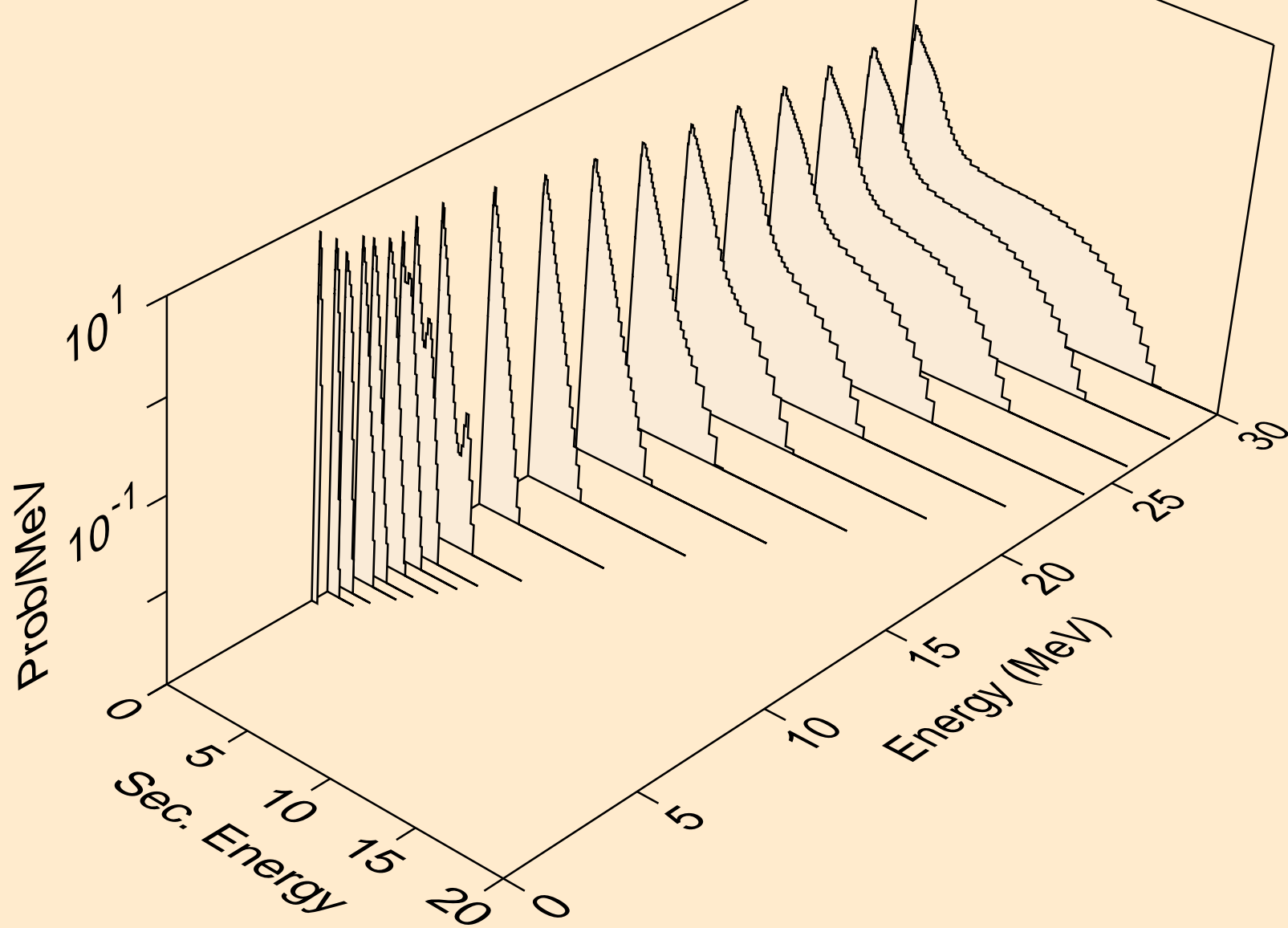

AC222 NEUTRON ACER TENDL-2023 LIBRARY; T=0.K
Neutron emission for (n,n*)2a

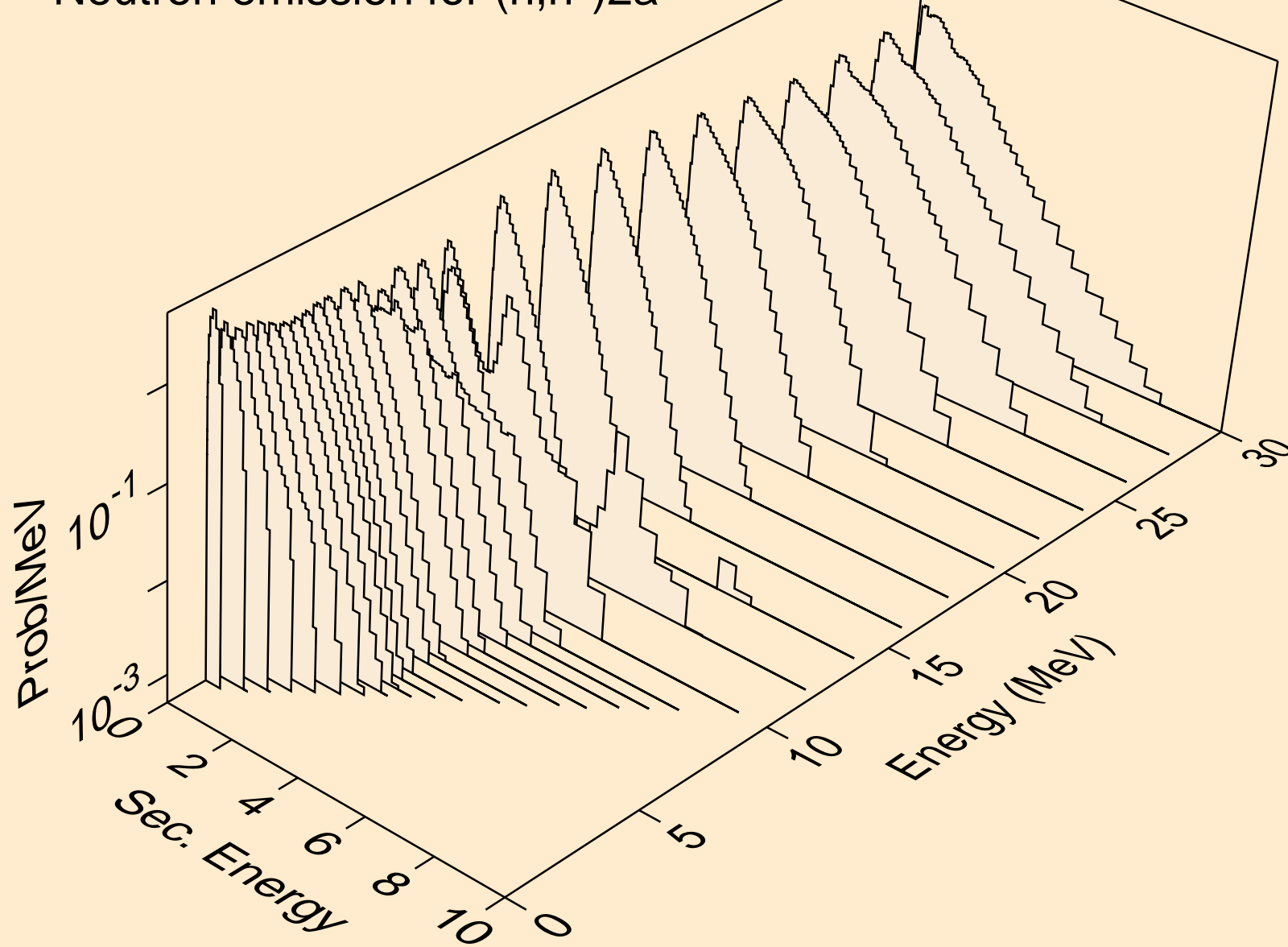

AC222 NEUTRON ACER TENDL-2023 LIBRARY; T=0.K
Neutron emission for (n,2n)2a

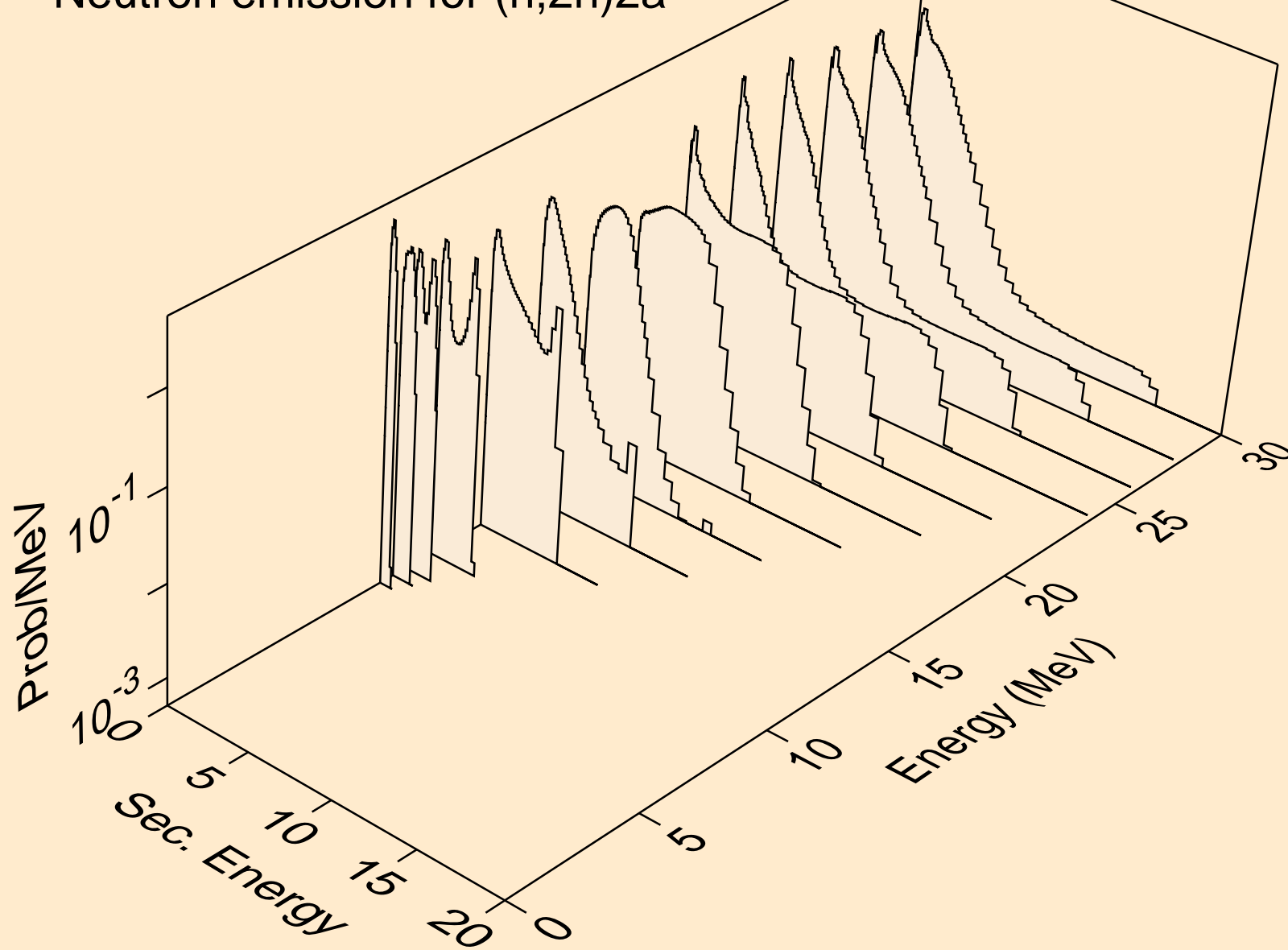

AC222 NEUTRON ACER TENDL-2023 LIBRARY; T=0.K
Neutron emission for (n,n*)d

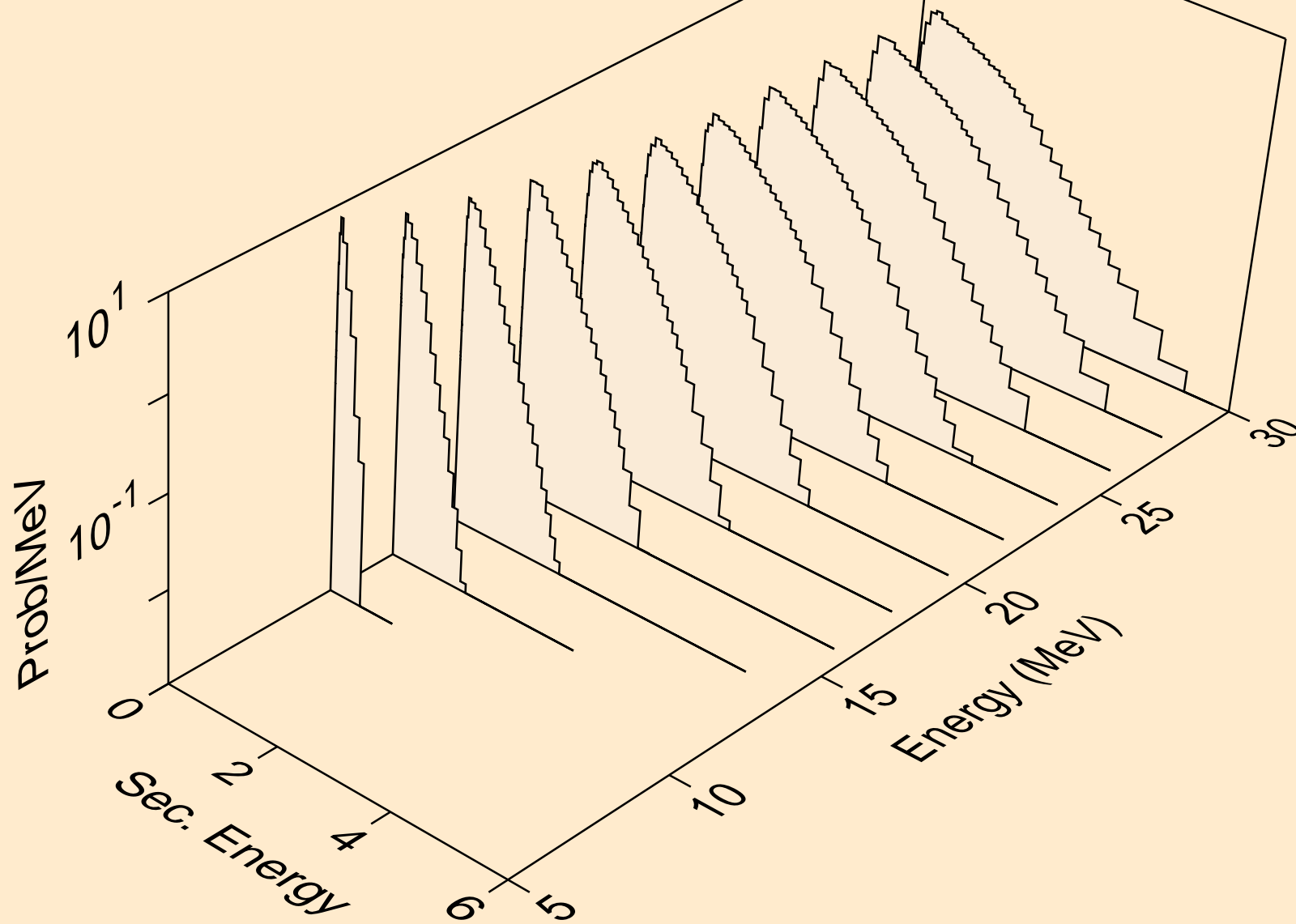

AC222 NEUTRON ACER TENDL-2023 LIBRARY; T=0.K
Neutron emission for (n,n*)t

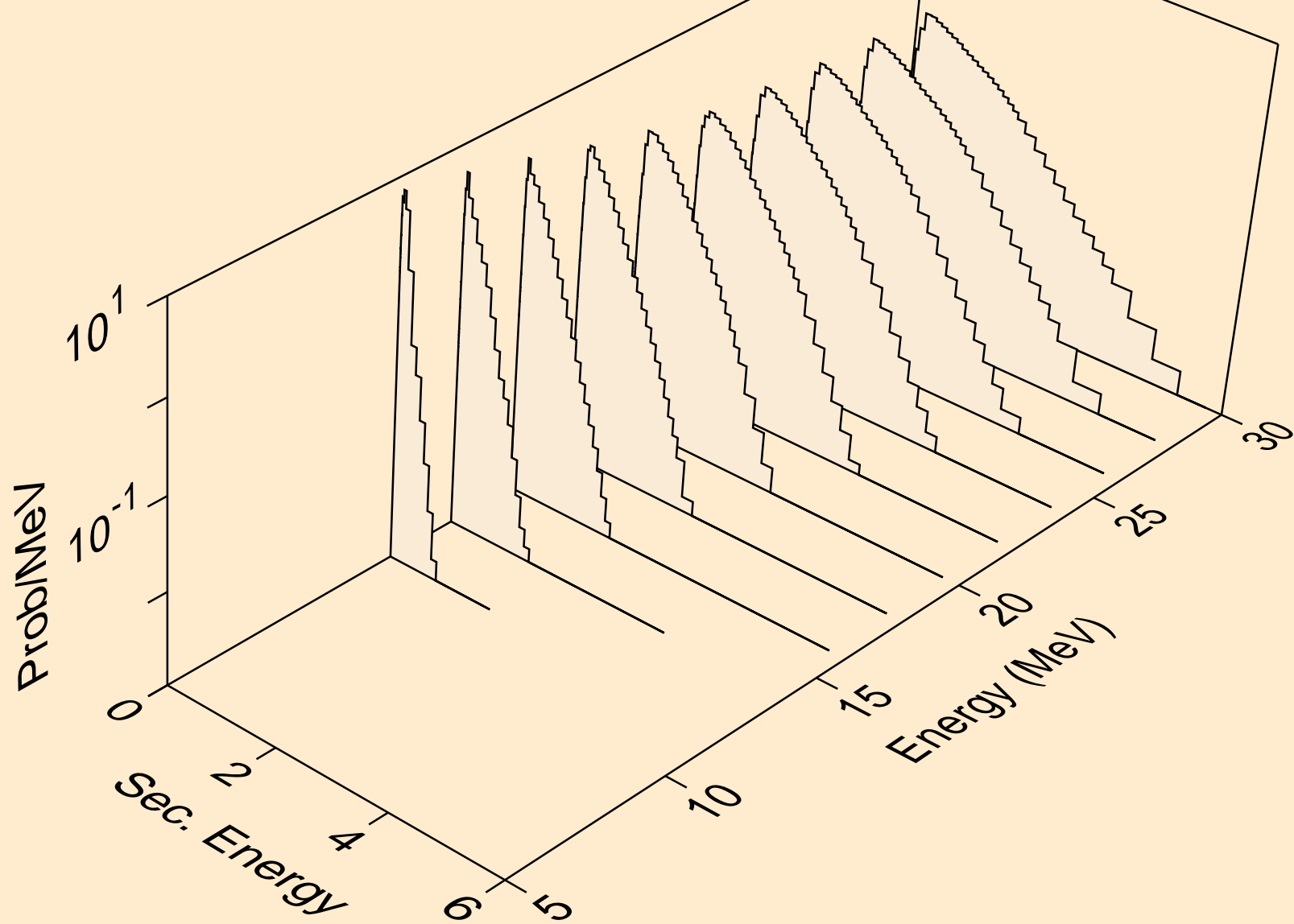

AC222 NEUTRON ACER TENDL-2023 LIBRARY; T=0.K
Neutron emission for (n,n*)he3

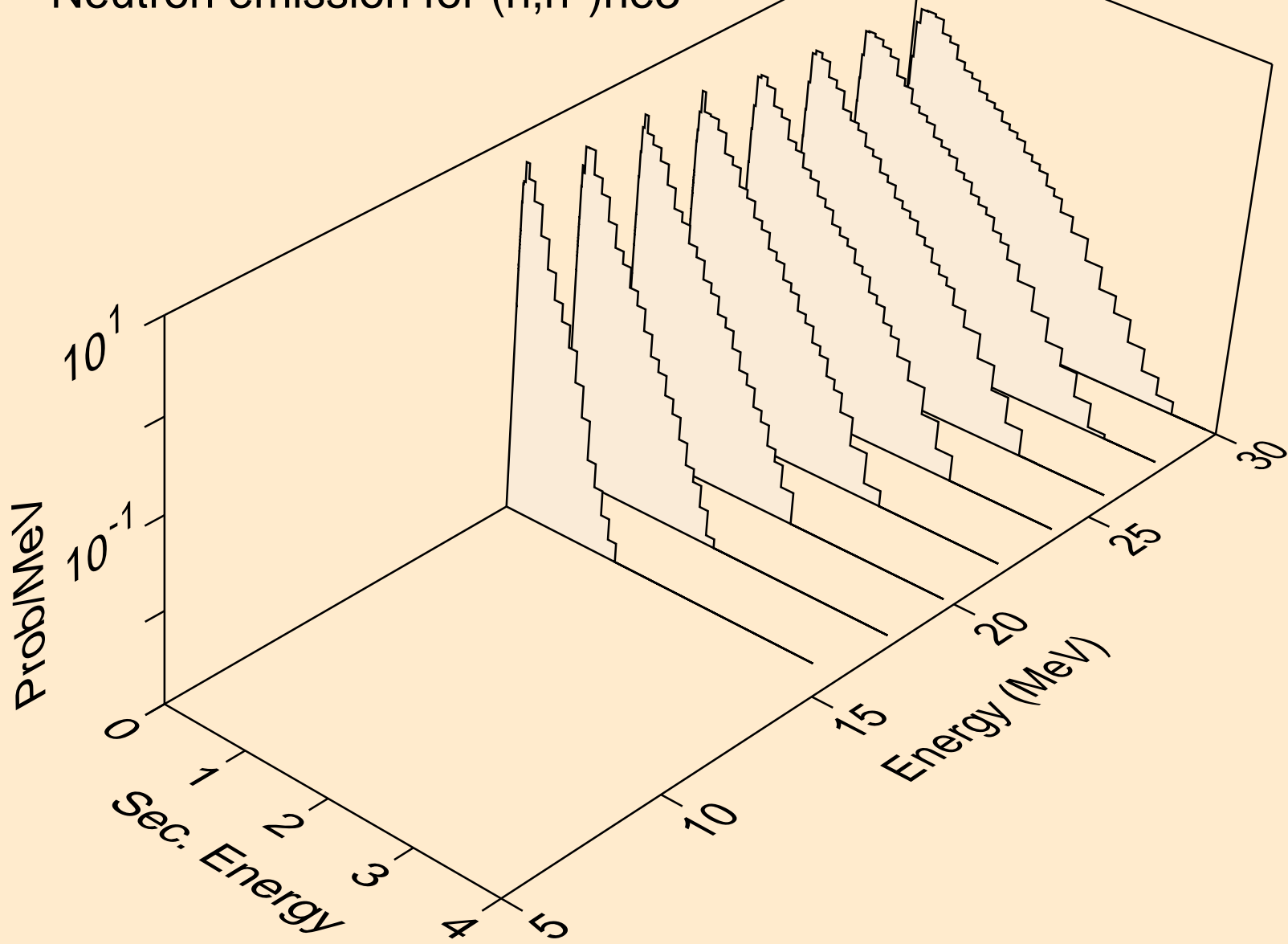

AC222 NEUTRON ACER TENDL-2023 LIBRARY; T=0.K
Neutron emission for (n,n*)d2a

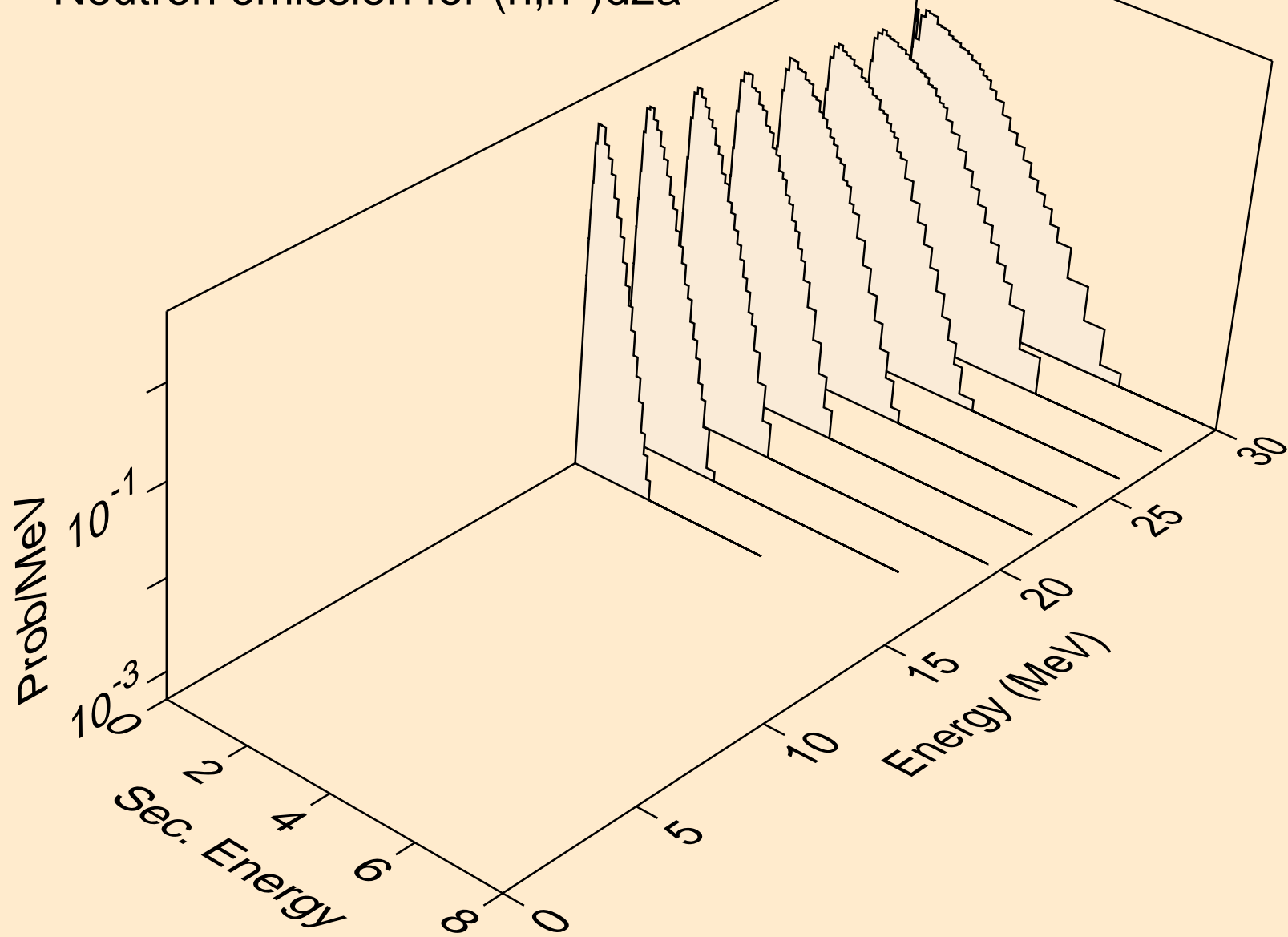

AC222 NEUTRON ACER TENDL-2023 LIBRARY; T=0.K
Neutron emission for (n,n*)t2a

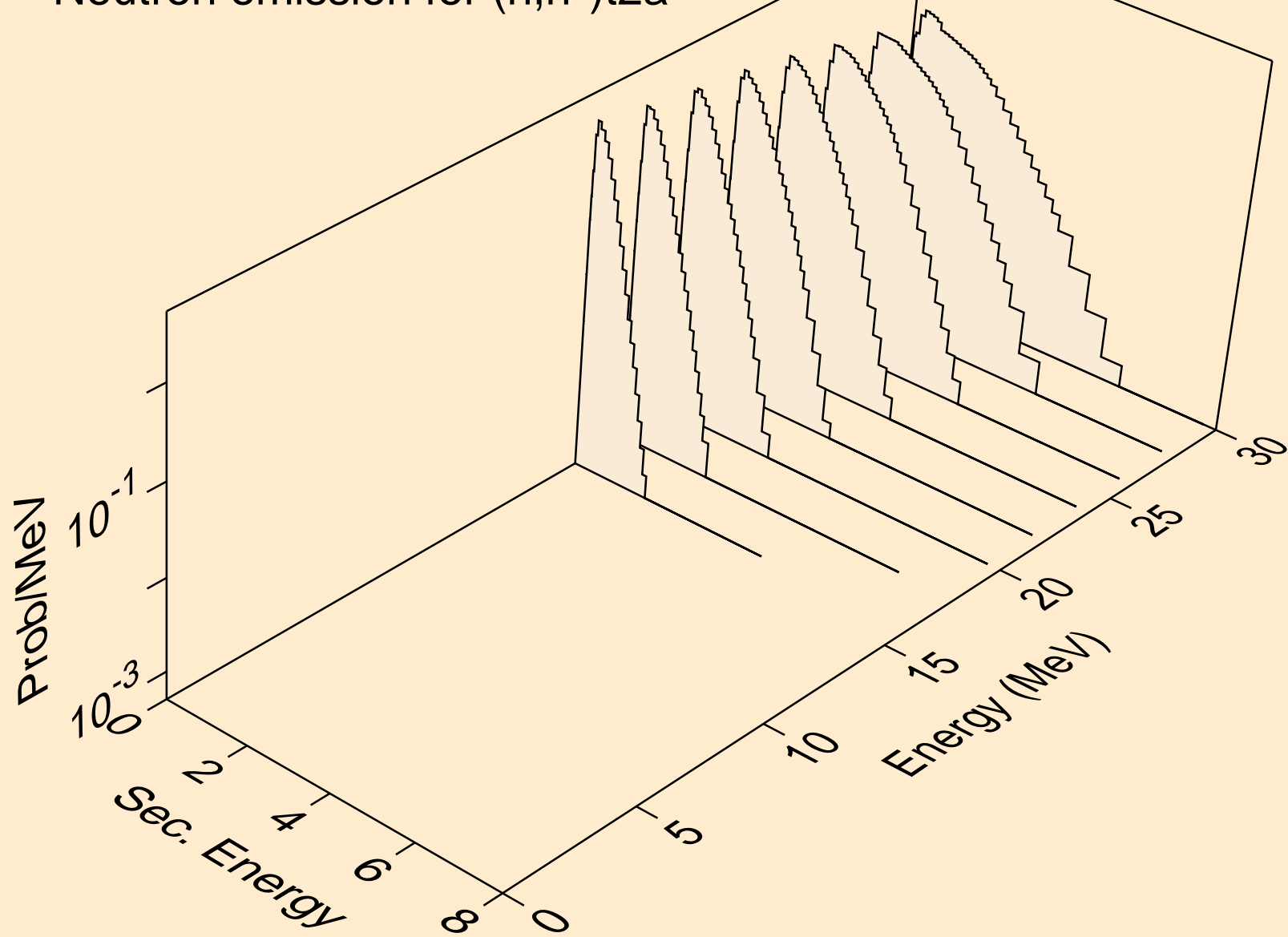

AC222 NEUTRON ACER TENDL-2023 LIBRARY; T=0.K
Neutron emission for (n,4n)

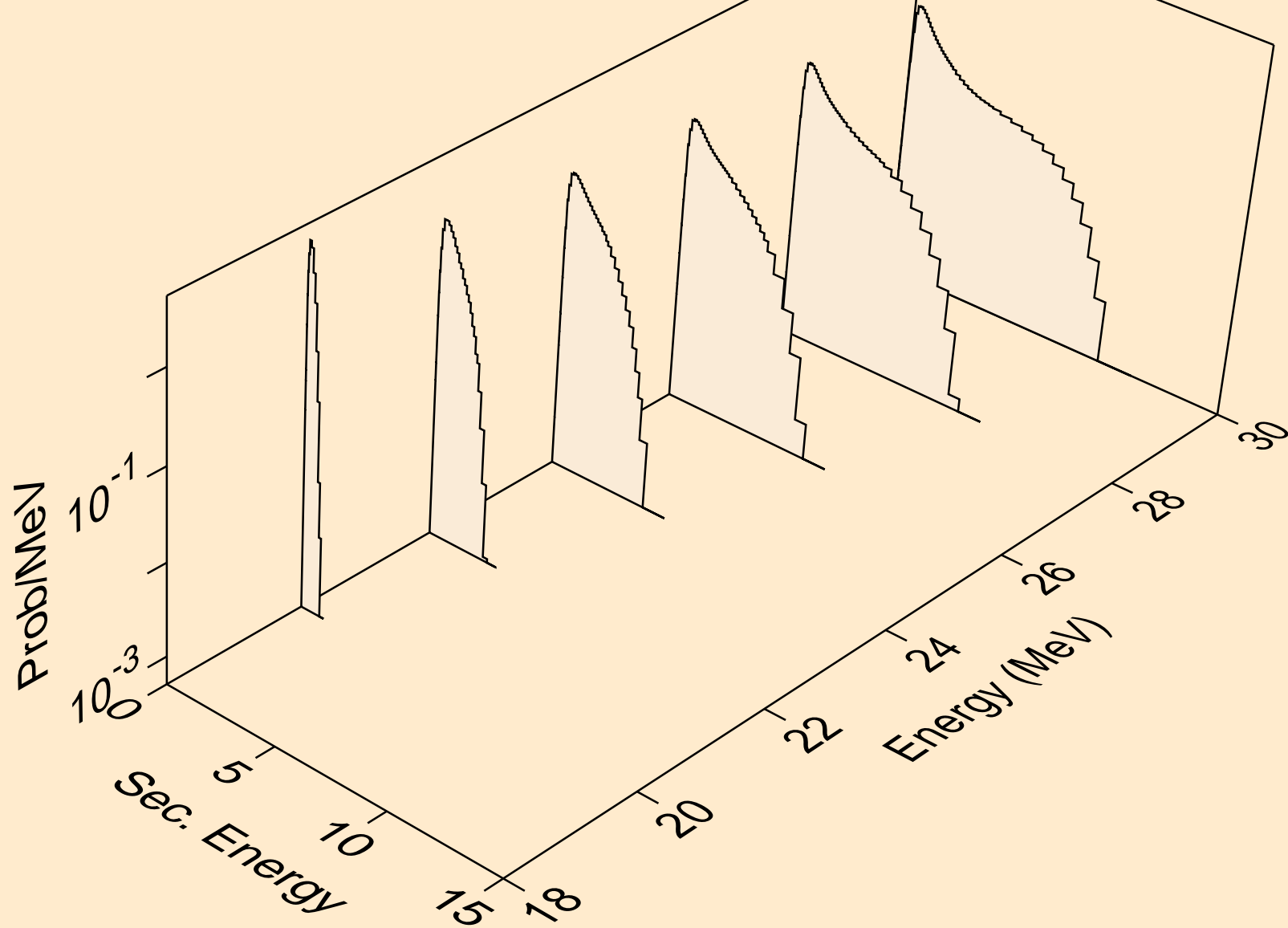

AC222 NEUTRON ACER TENDL-2023 LIBRARY; T=0.K
Neutron emission for (n,2np)

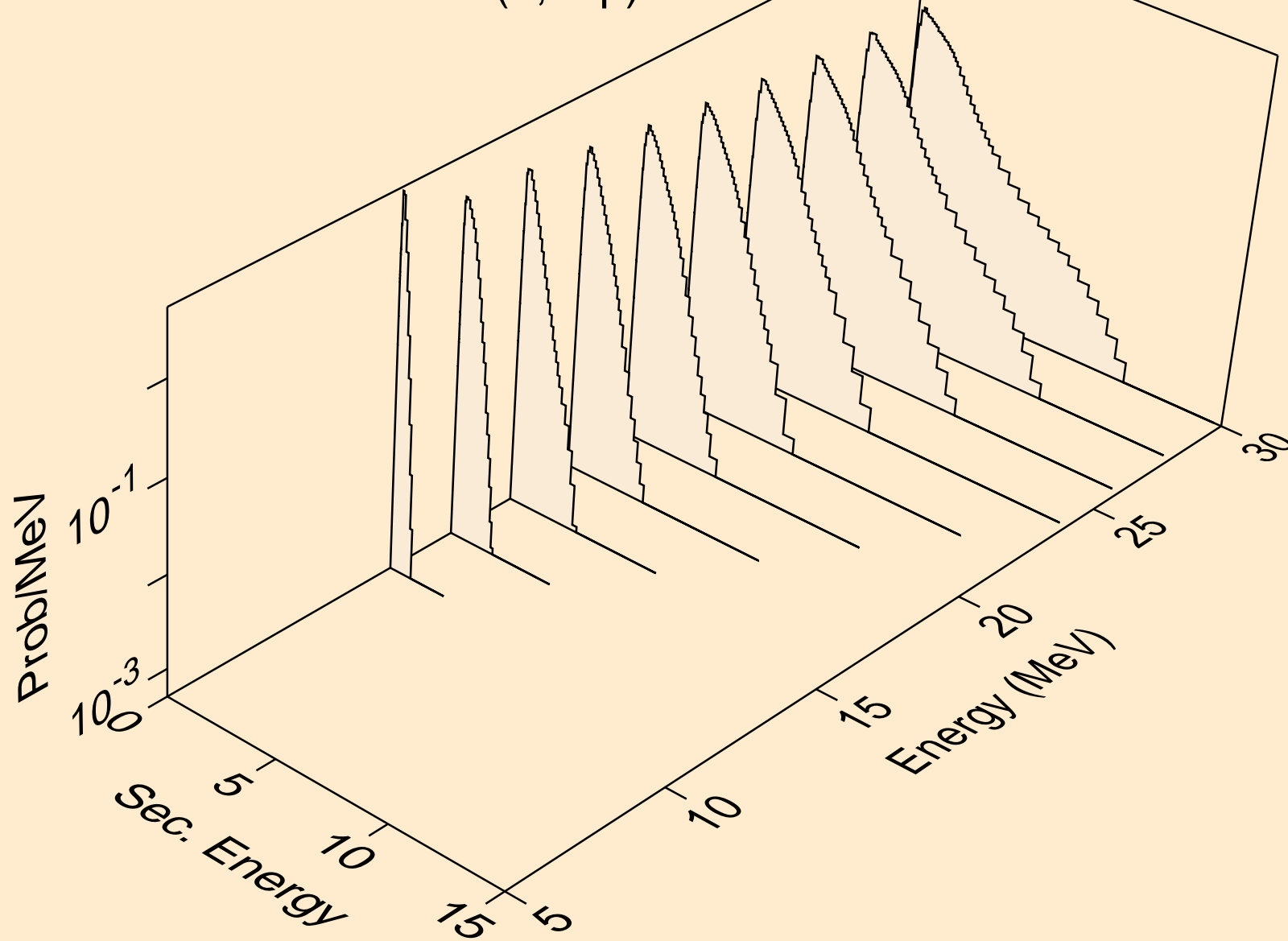

AC222 NEUTRON ACER TENDL-2023 LIBRARY; T=0.K
Neutron emission for (n,3np)

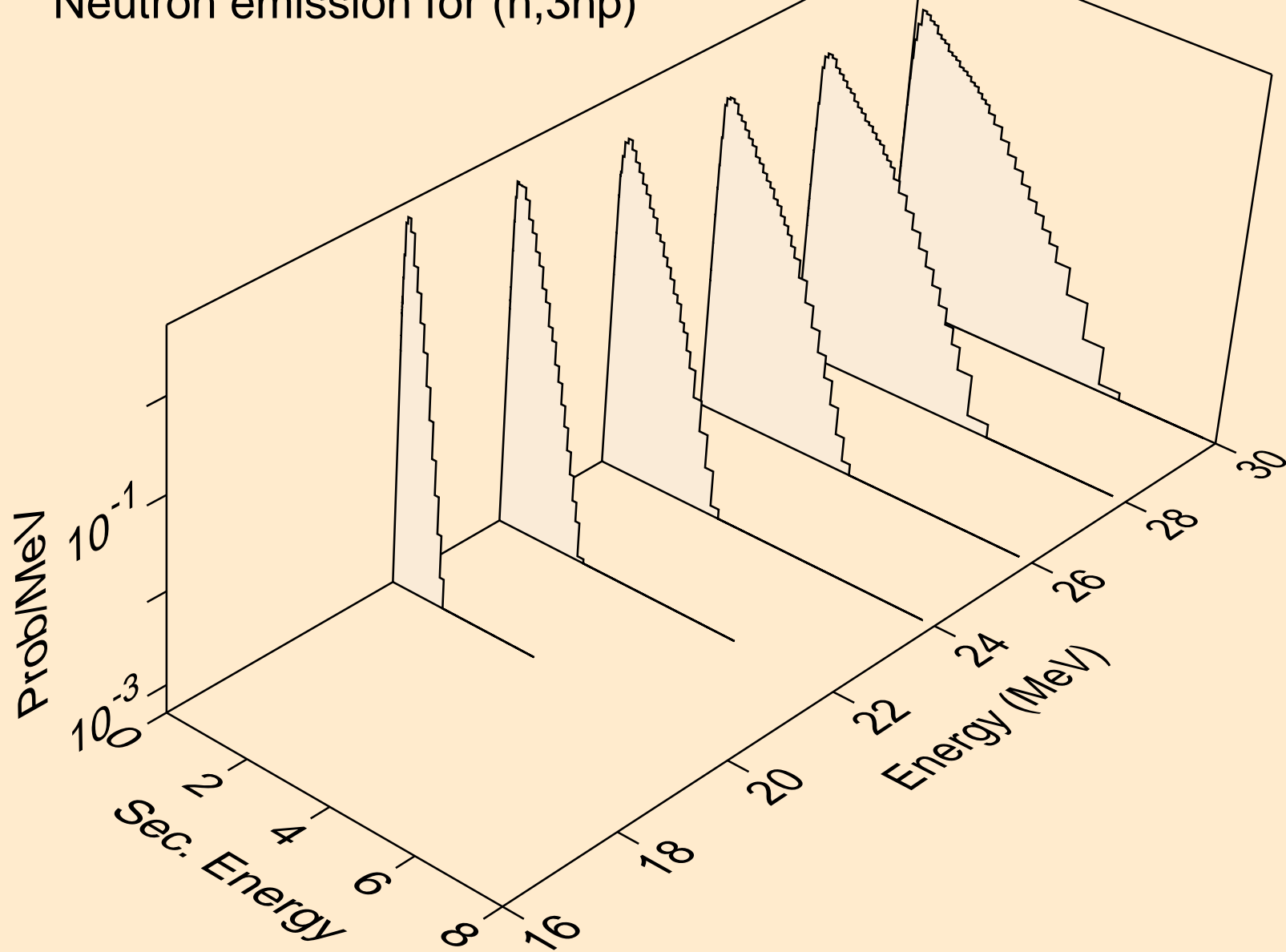

AC222 NEUTRON ACER TENDL-2023 LIBRARY; T=0.K
Neutron emission for (n,n2p)

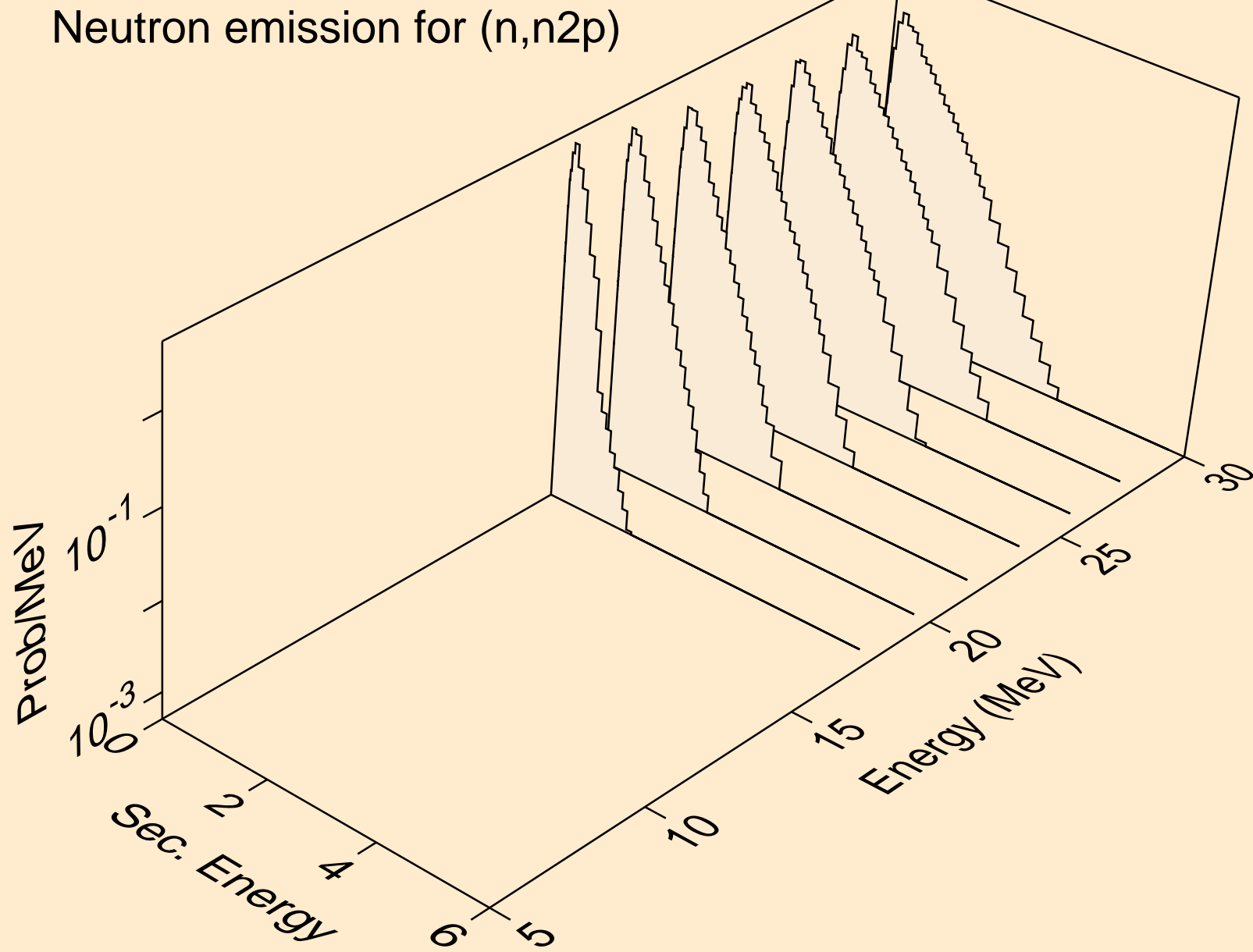

AC222 NEUTRON ACER TENDL-2023 LIBRARY; T=0.K
Neutron emission for (n,npa)

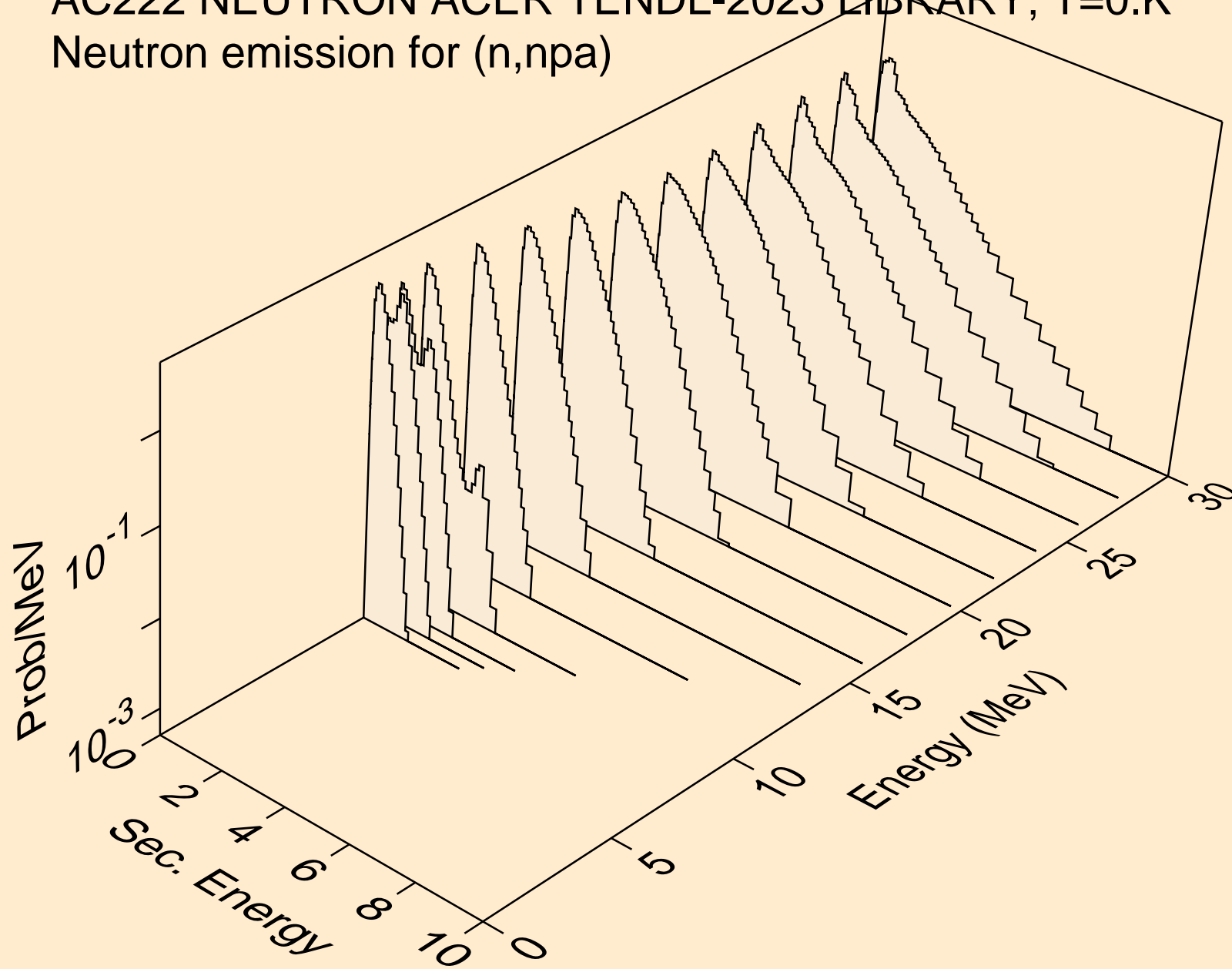

AC222 NEUTRON ACER TENDL-2023 LIBRARY; T=0.K
Neutron emission for (n,n*c)

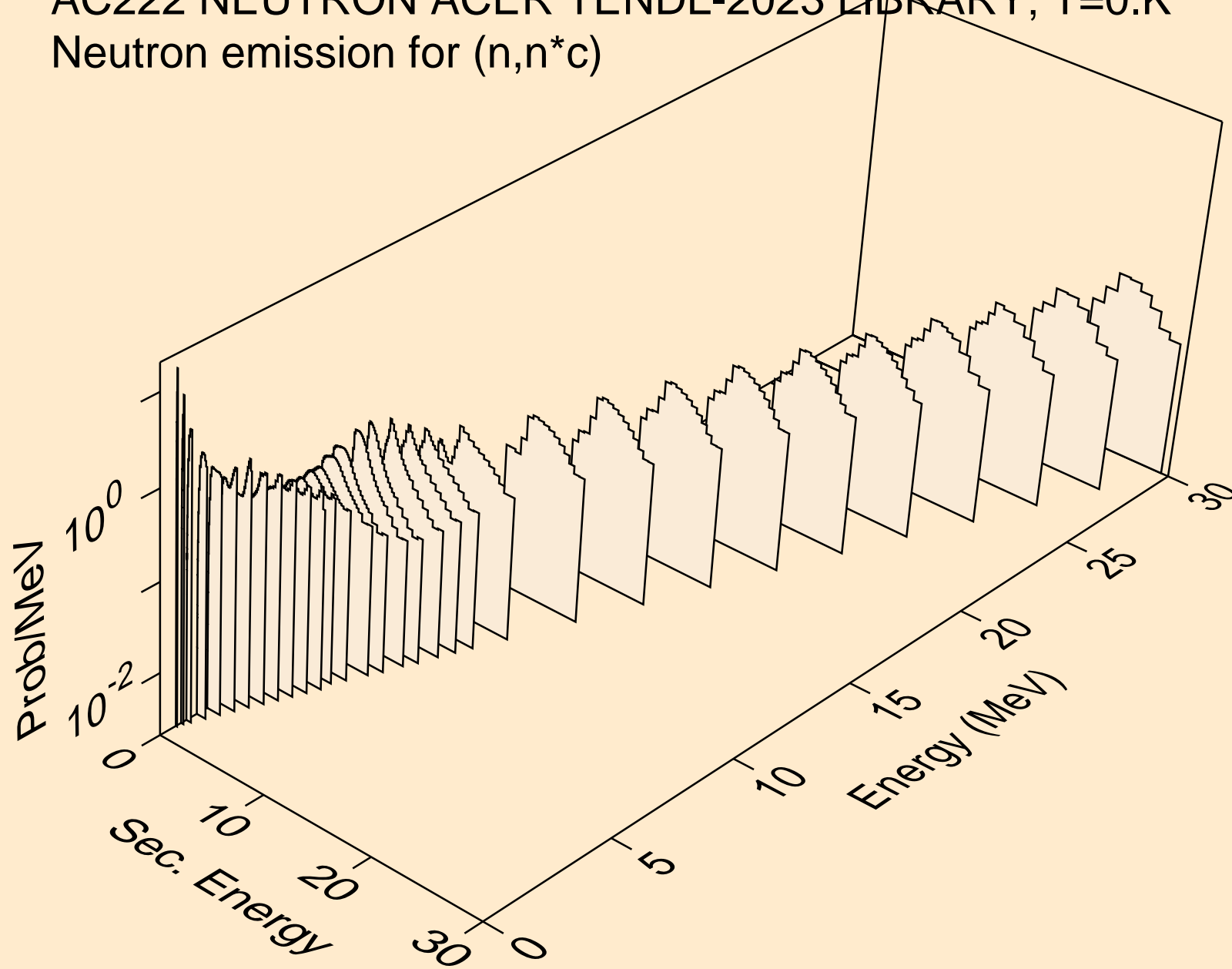

AC222 NEUTRON ACER TENDL-2023 LIBRARY; T=0.K

Delayed nubar

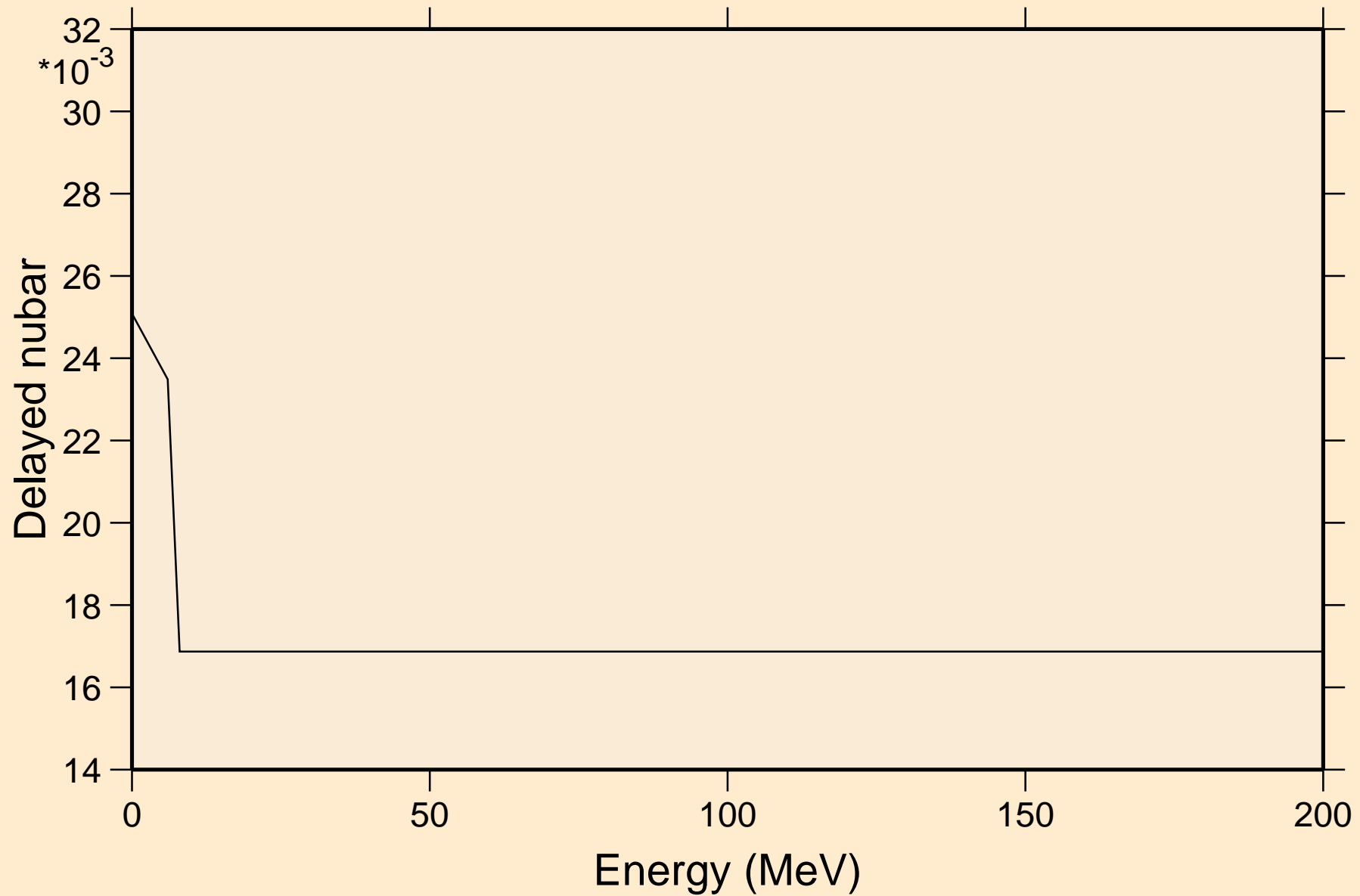

AC222 NEUTRON ACER TENDL-2023 LIBRARY; T=0.K

Delayed neutron spectra

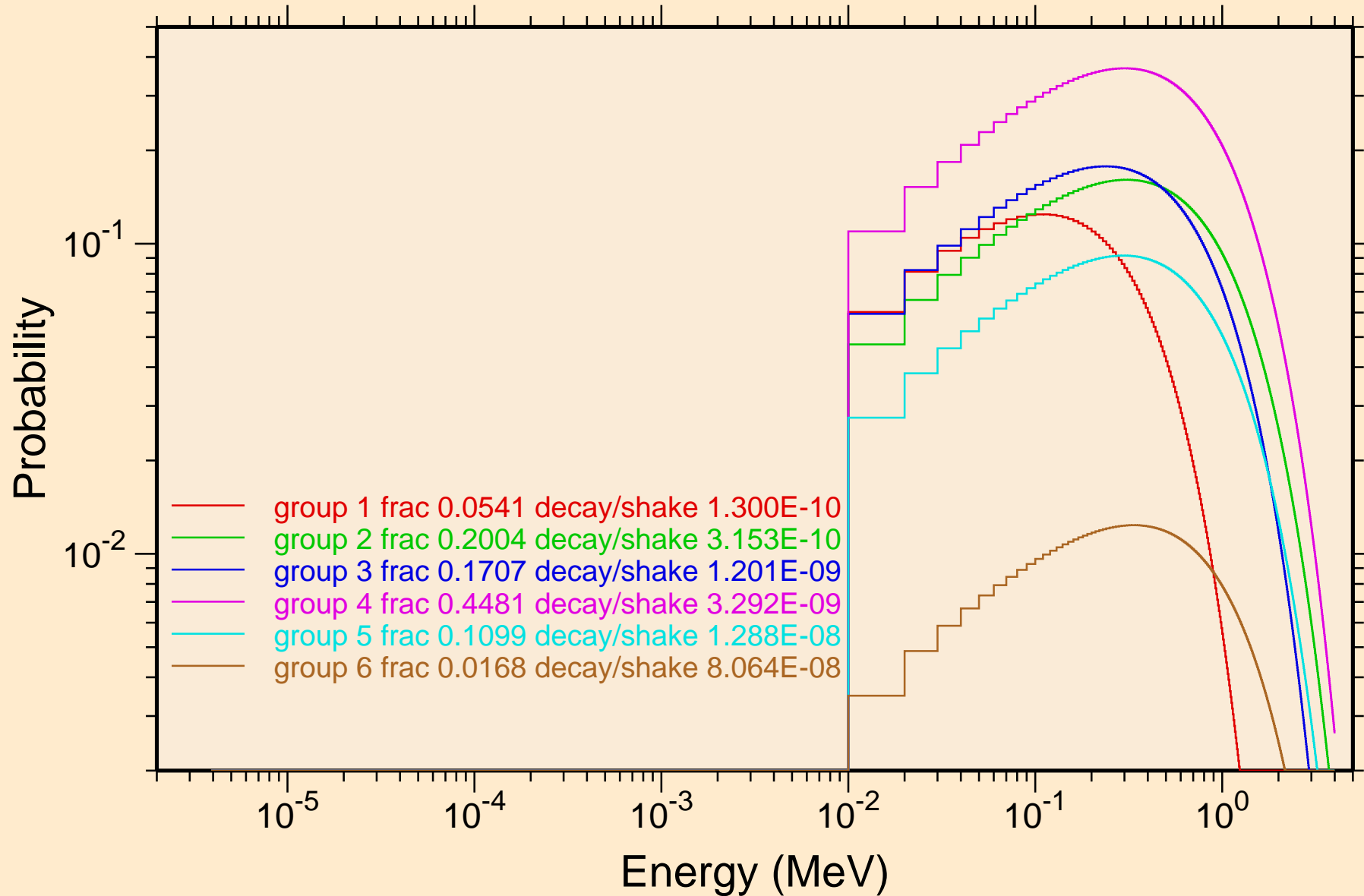

AC222 NEUTRON ACER TENDL-2023 LIBRARY; T=0.K
Photon emission for (n,x)

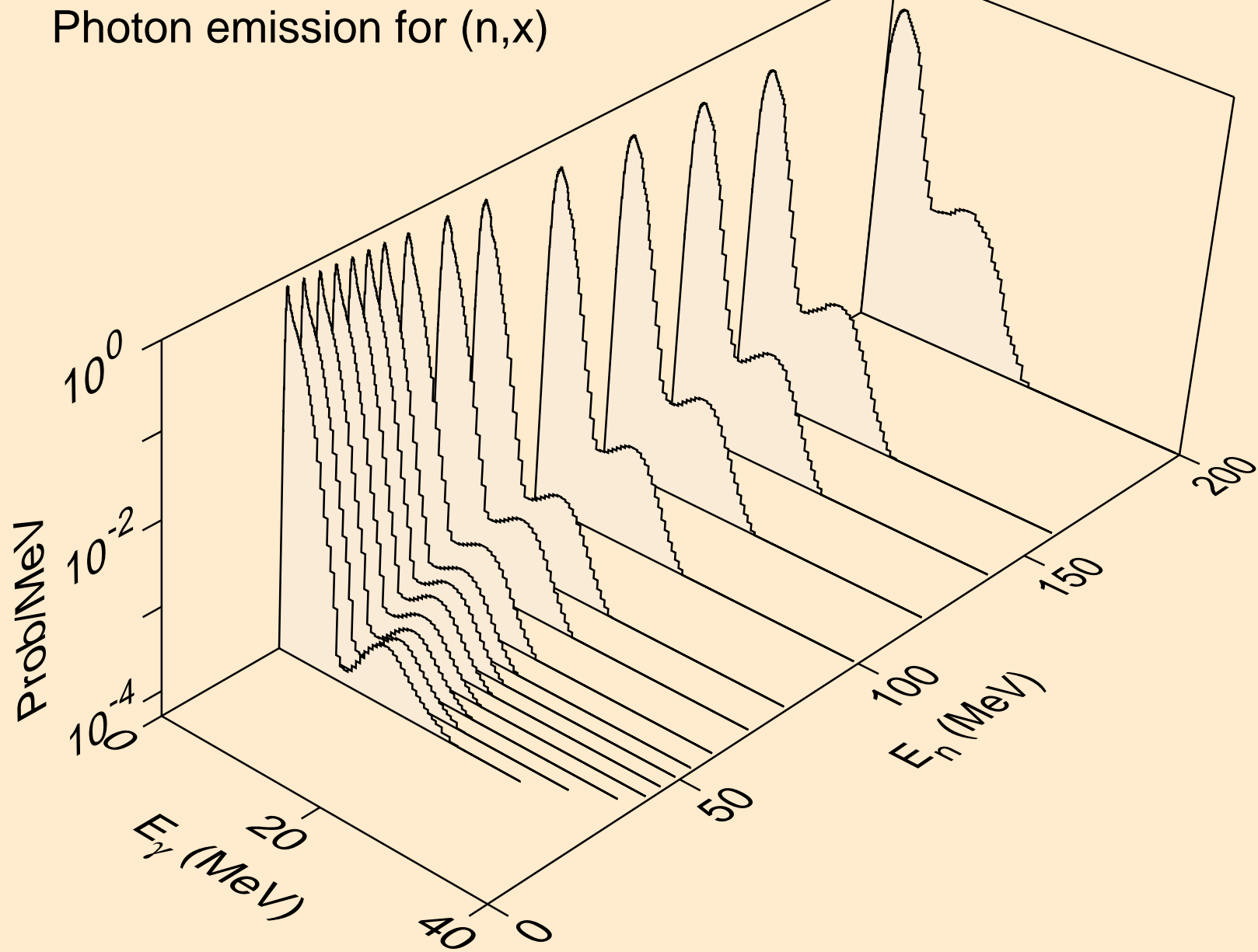

AC222 NEUTRON ACER TENDL-2023 LIBRARY; T=0.K
Photon emission for (n,2nd)

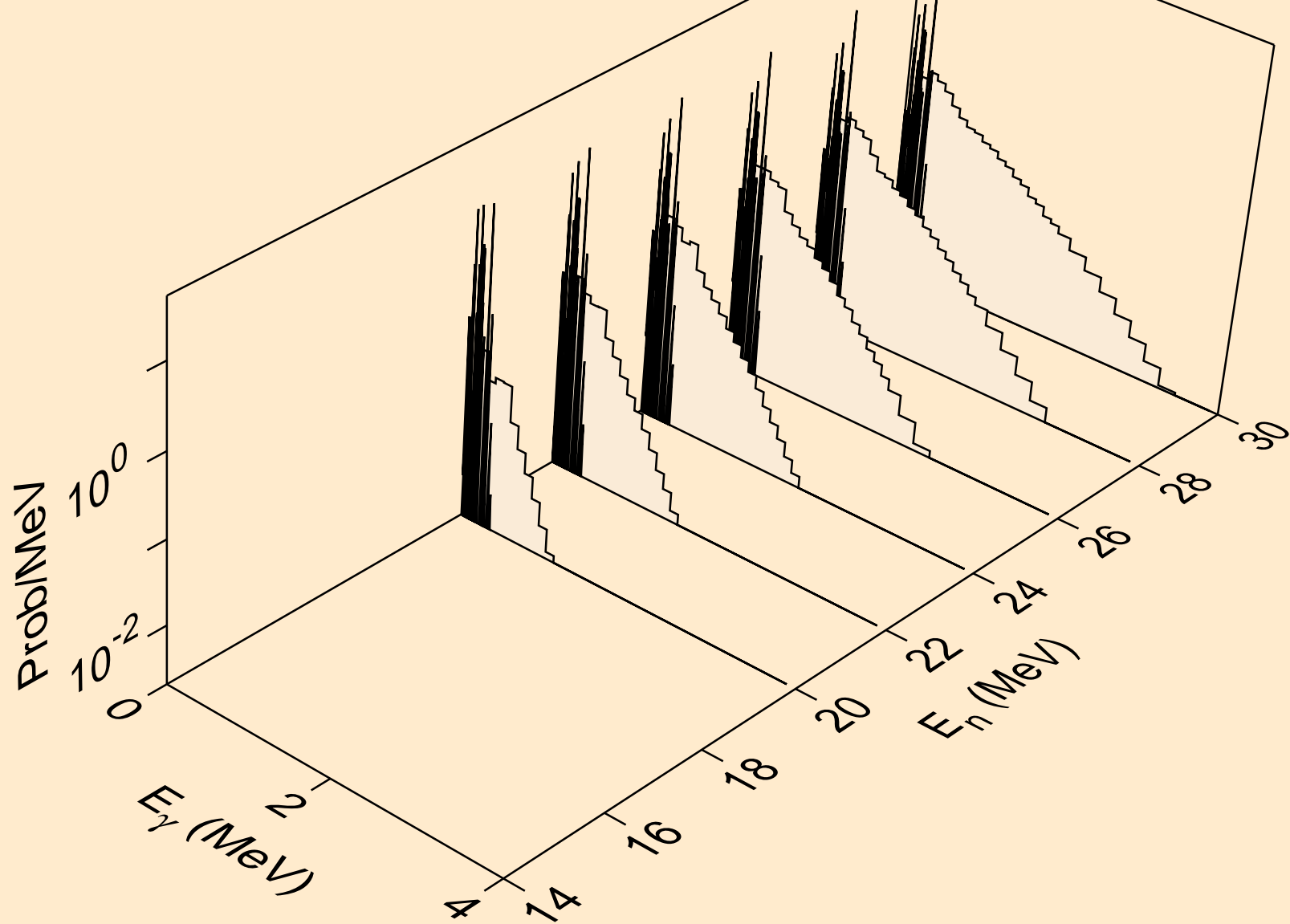

AC222 NEUTRON ACER TENDL-2023 LIBRARY; T=0.K
Photon emission for (n,2n)

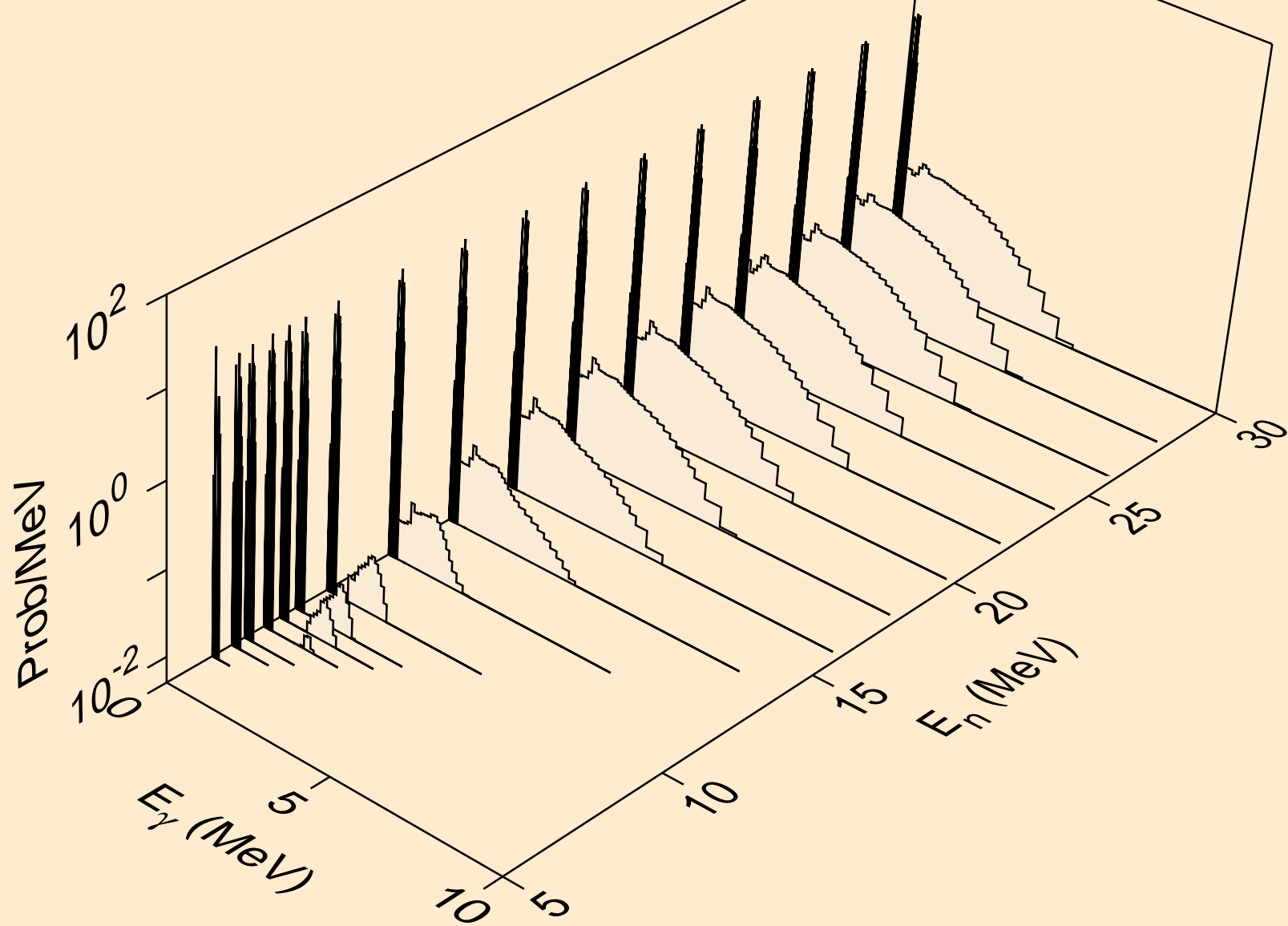

AC222 NEUTRON ACER TENDL-2023 LIBRARY; T=0.K
Photon emission for (n,3n)

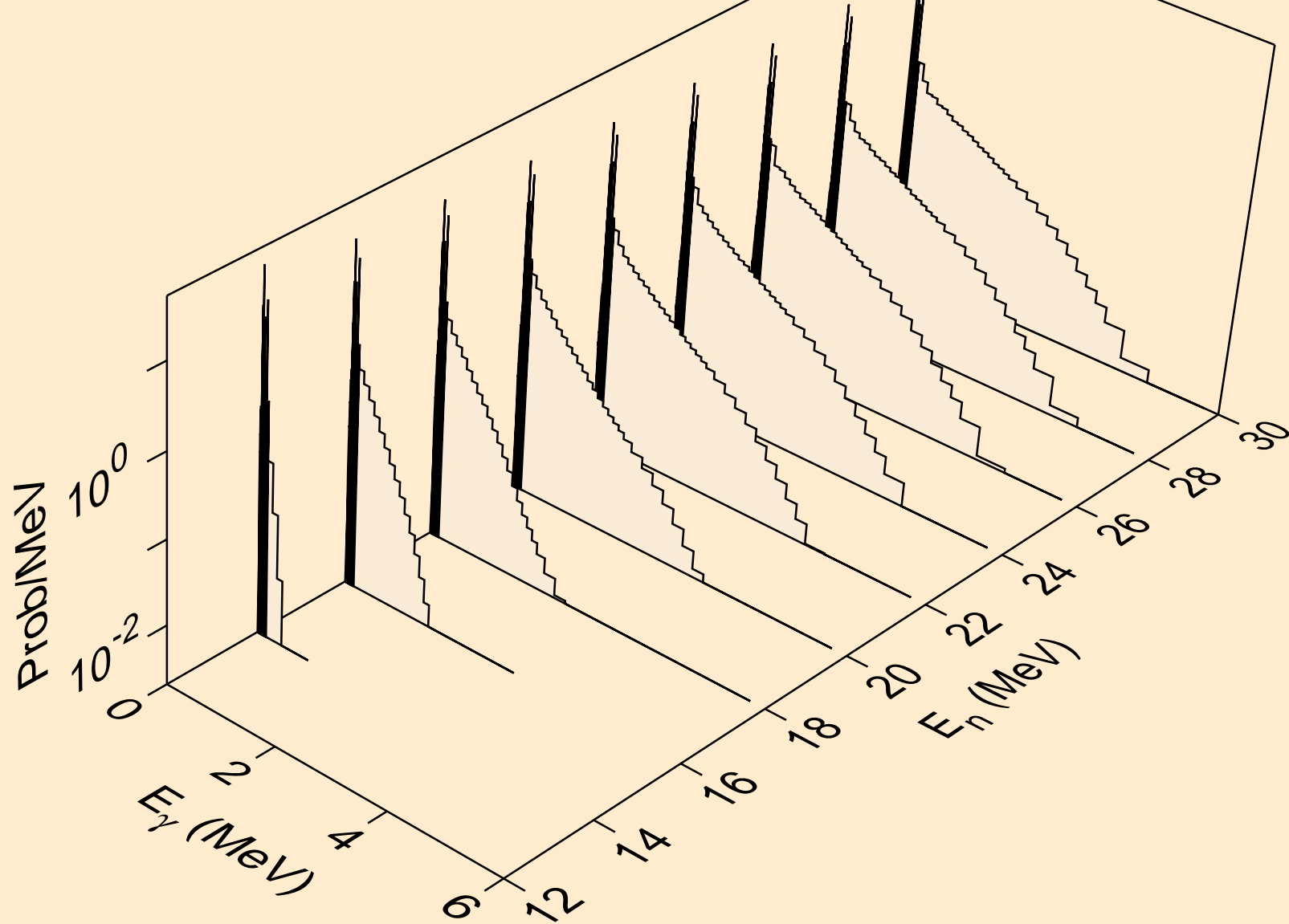

AC222 NEUTRON ACER TENDL-2023 LIBRARY; T=0.K
Photon emission for (n,n*)a

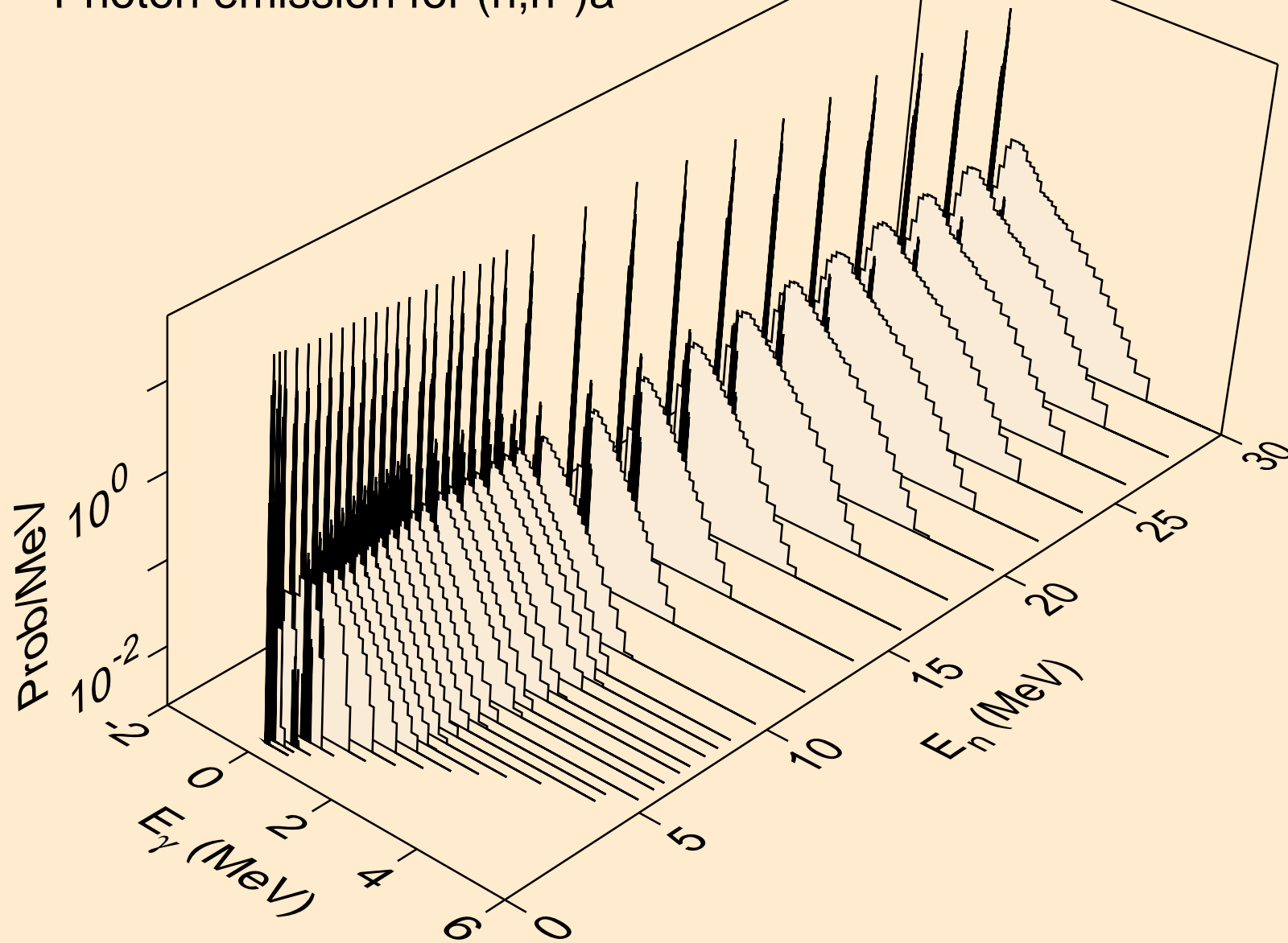

AC222 NEUTRON ACER TENDL-2023 LIBRARY; T=0.K
Photon emission for (n,n*)3a

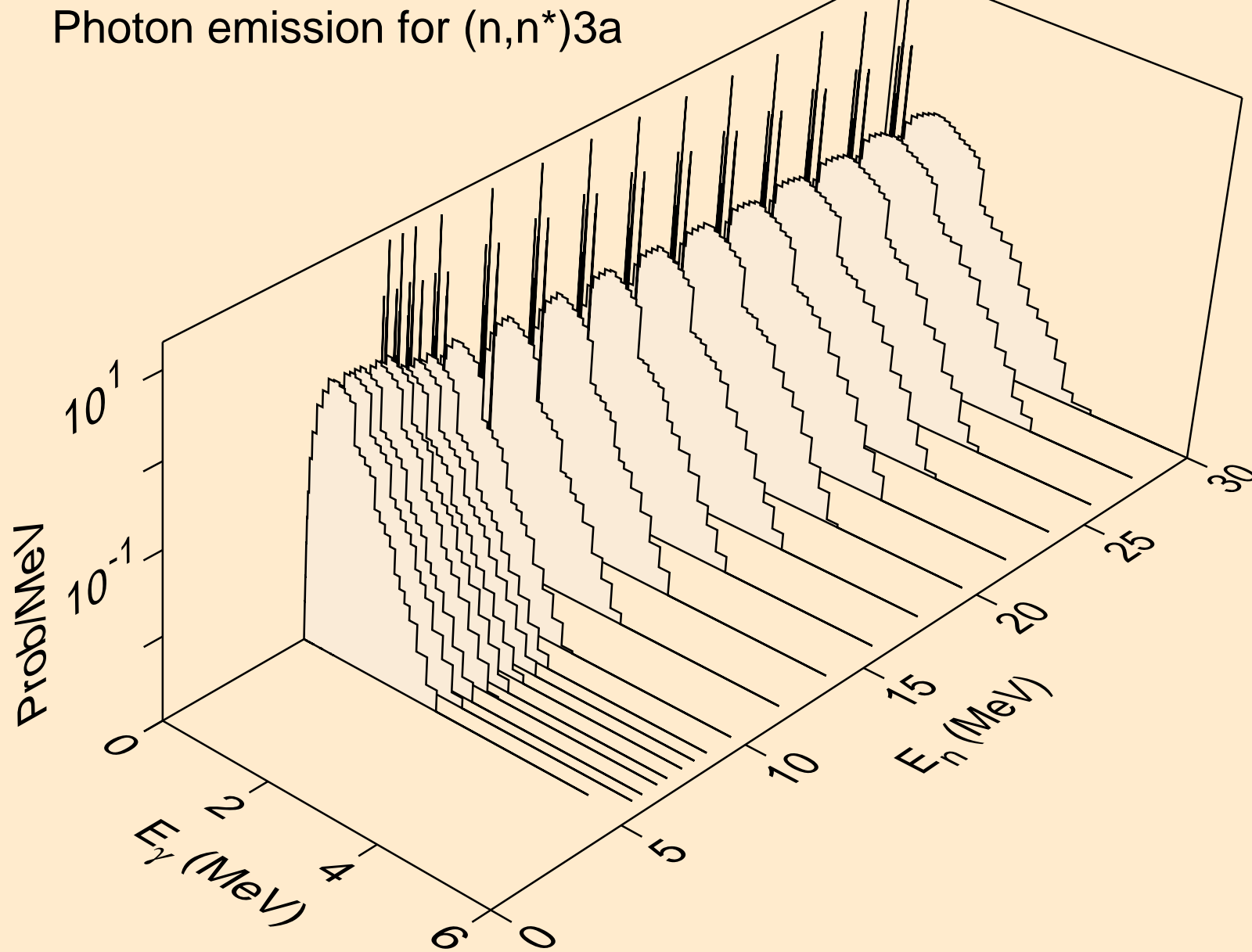

AC222 NEUTRON ACER TENDL-2023 LIBRARY; T=0.K
Photon emission for (n,2n)a

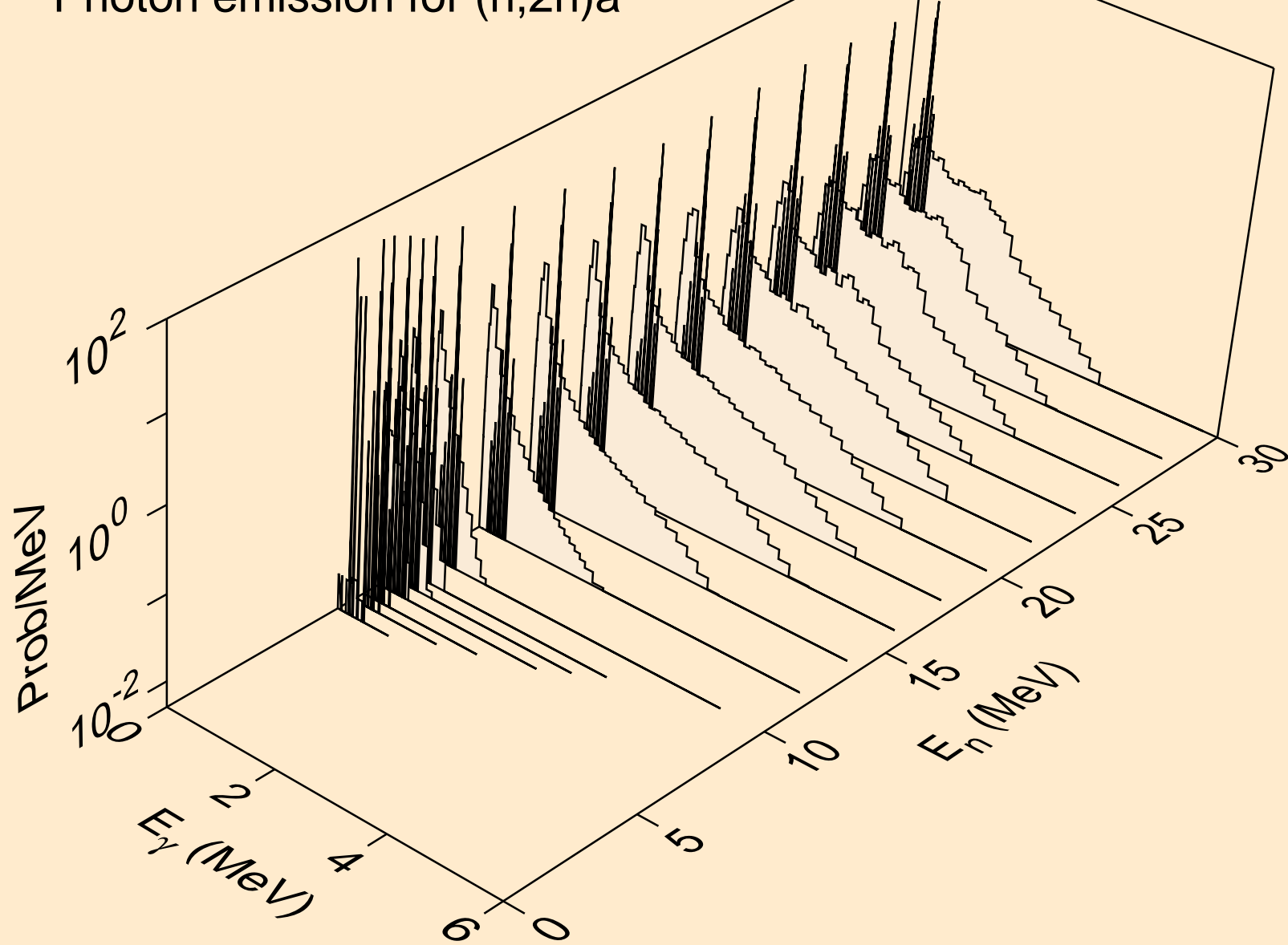

AC222 NEUTRON ACER TENDL-2023 LIBRARY; T=0.K
Photon emission for (n,3n)a

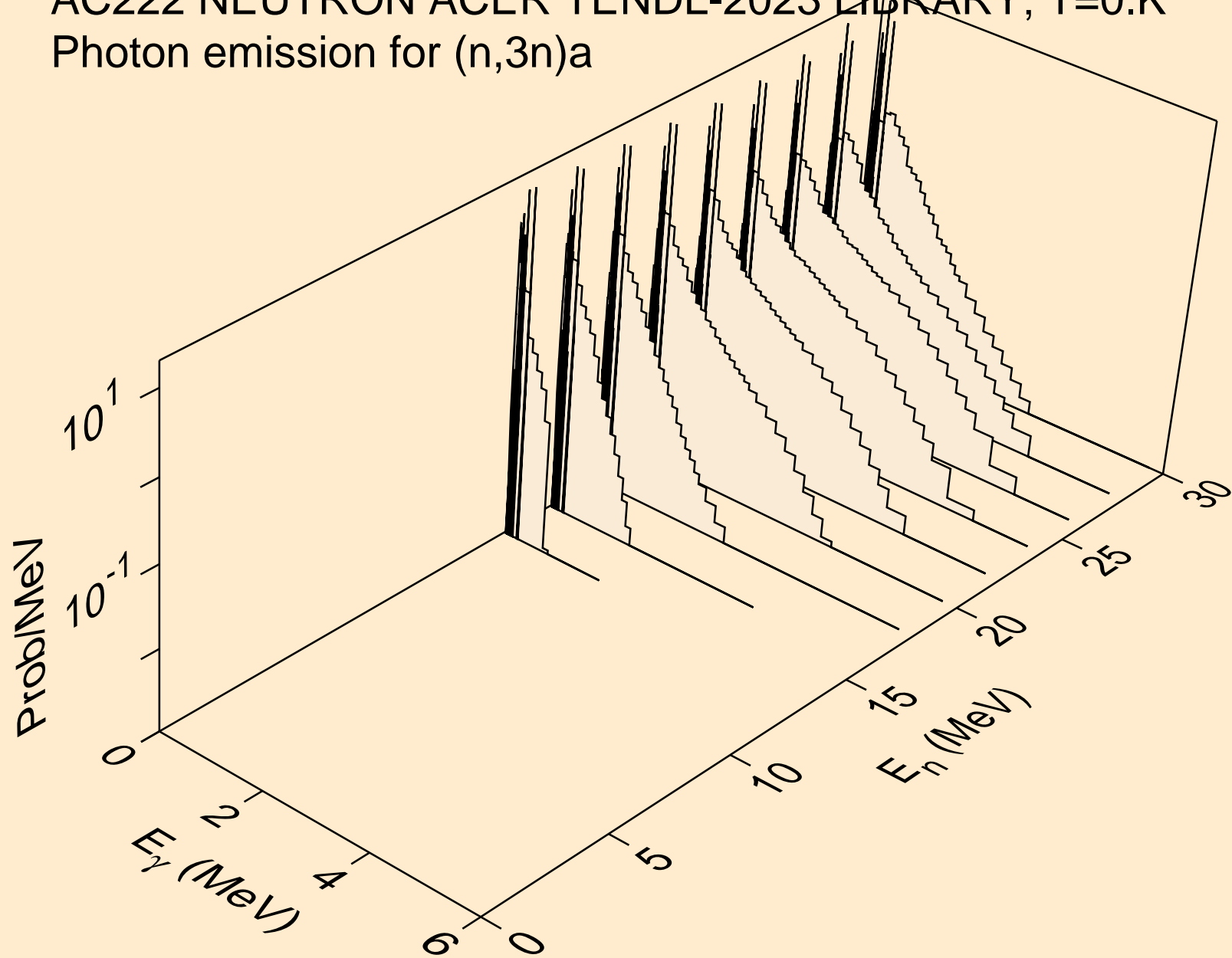

AC222 NEUTRON ACER TENDL-2023 LIBRARY; T=0.K
Photon emission for (n,n*)p

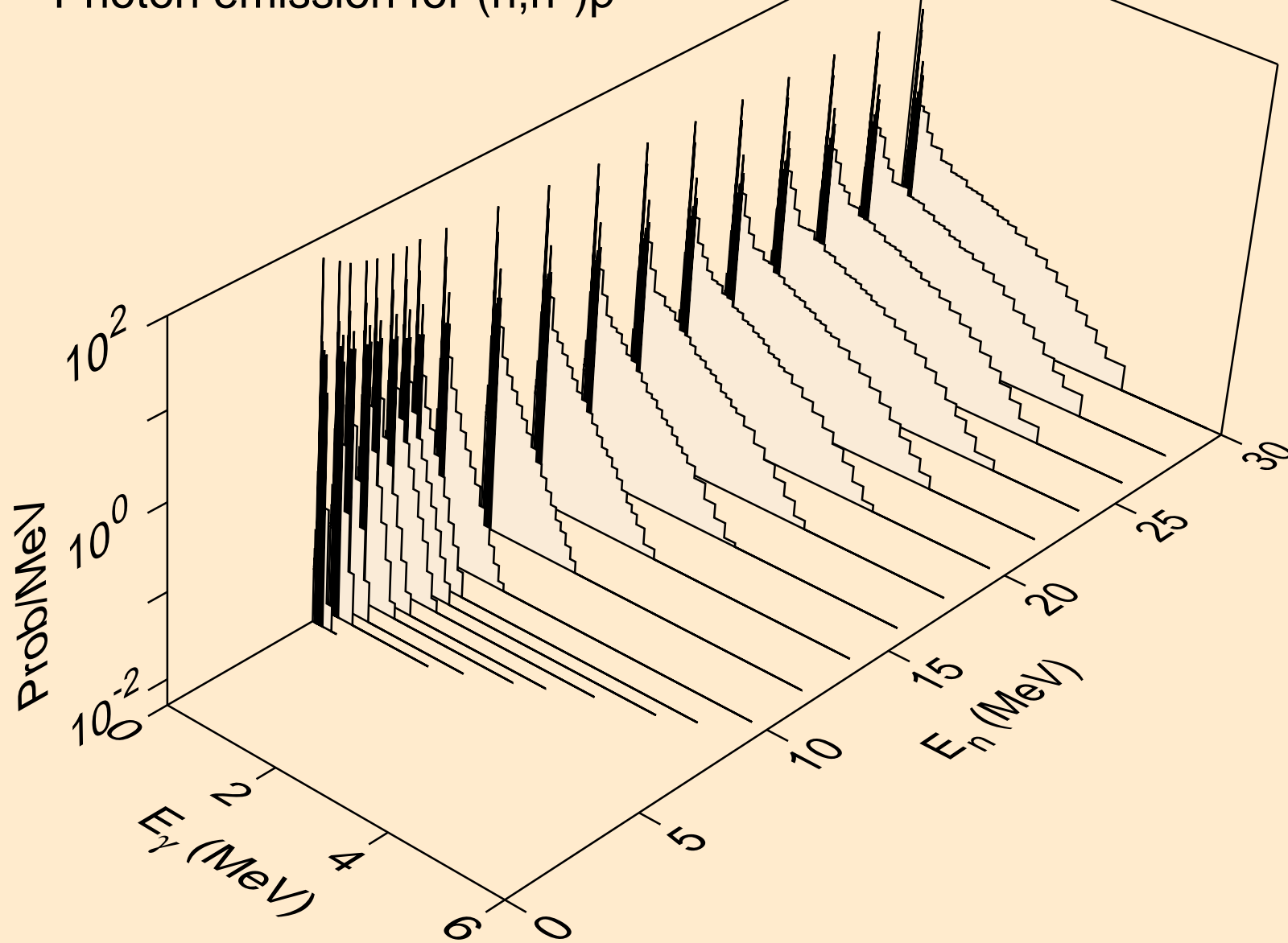

AC222 NEUTRON ACER TENDL-2023 LIBRARY; T=0.K
Photon emission for (n,n*)2a

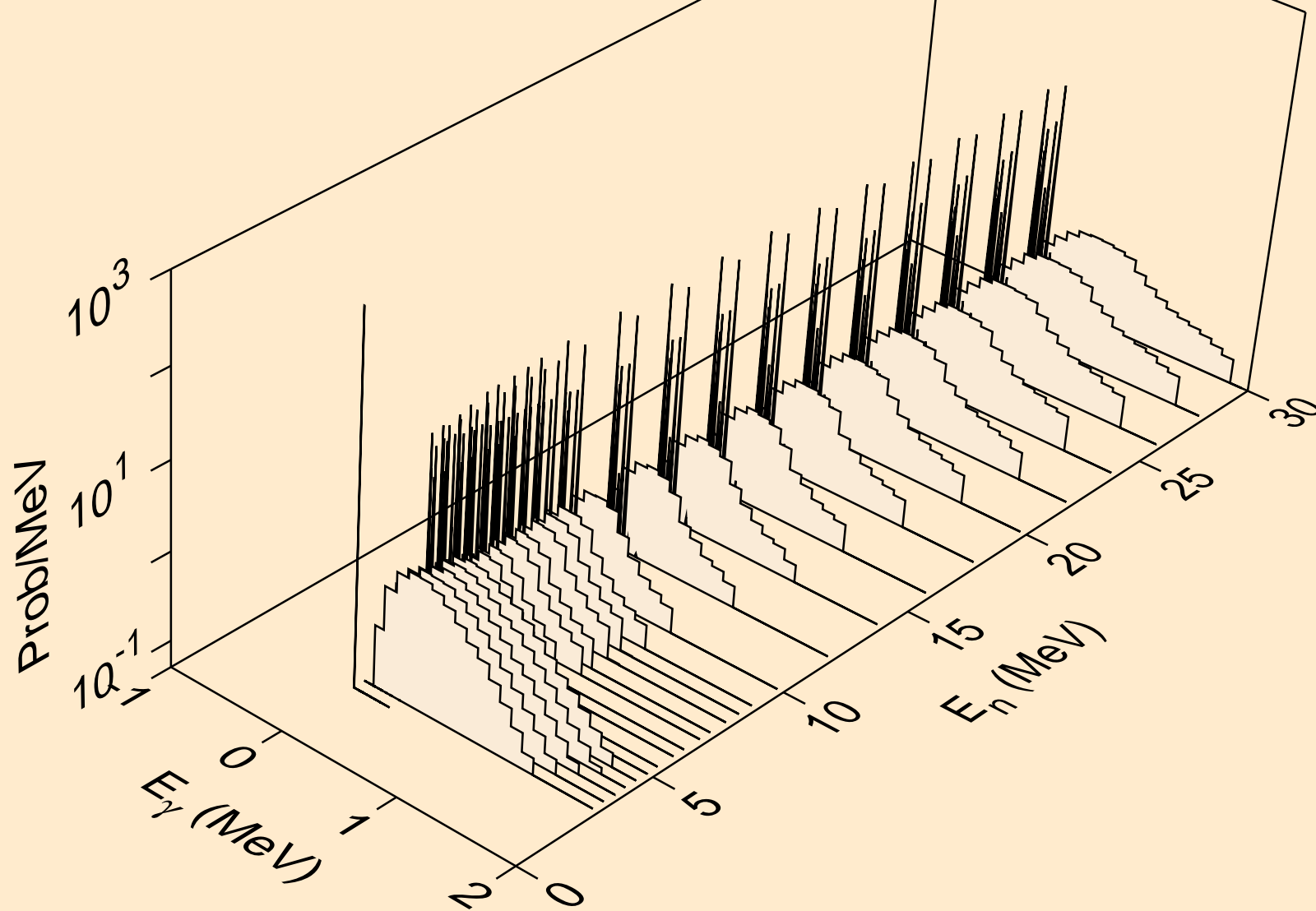

AC222 NEUTRON ACER TENDL-2023 LIBRARY; T=0.K
Photon emission for (n,2n)2a

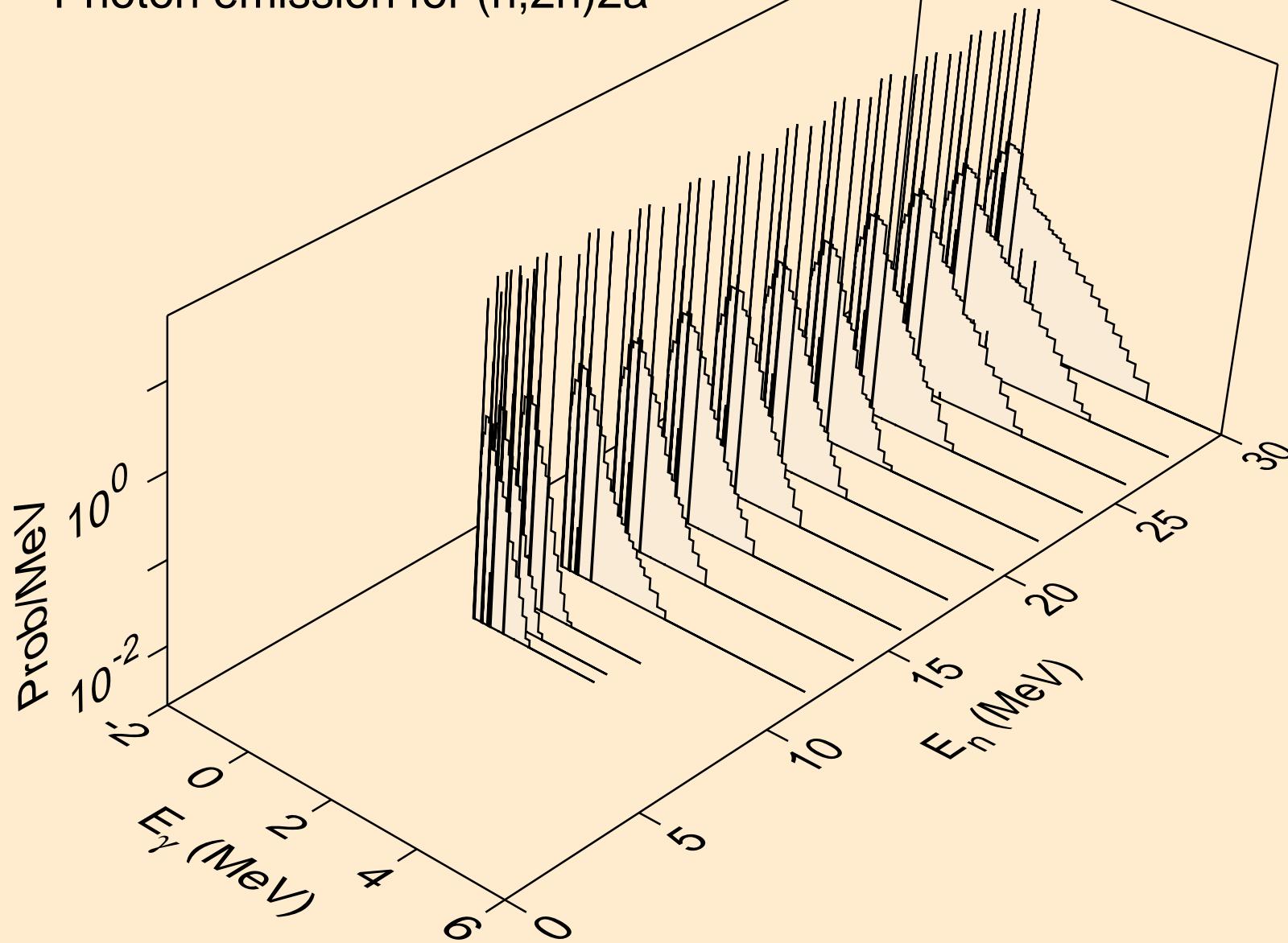

AC222 NEUTRON ACER TENDL-2023 LIBRARY; T=0.K
Photon emission for (n,n*)d

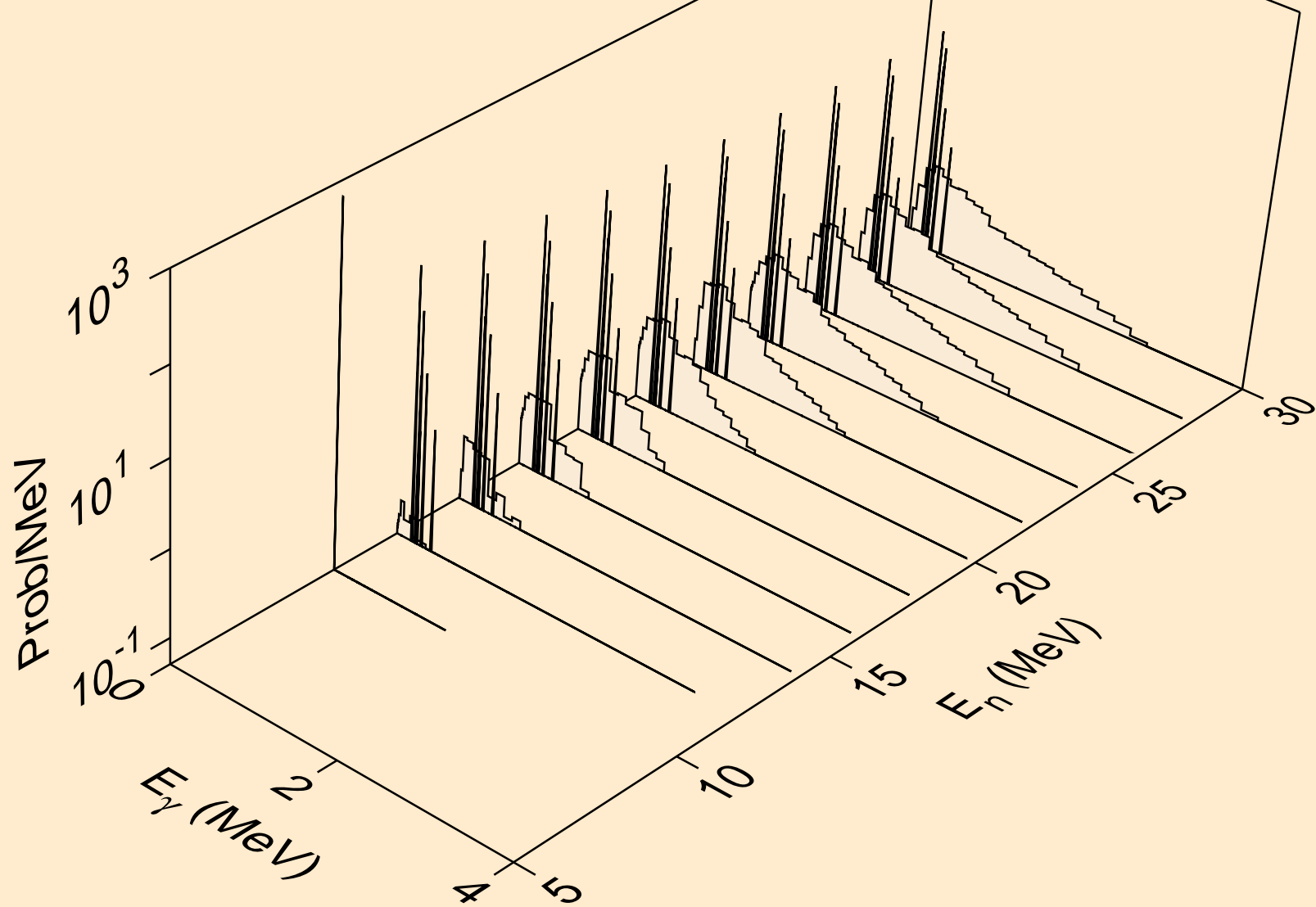

AC222 NEUTRON ACER TENDL-2023 LIBRARY; T=0.K
Photon emission for (n,n*)t

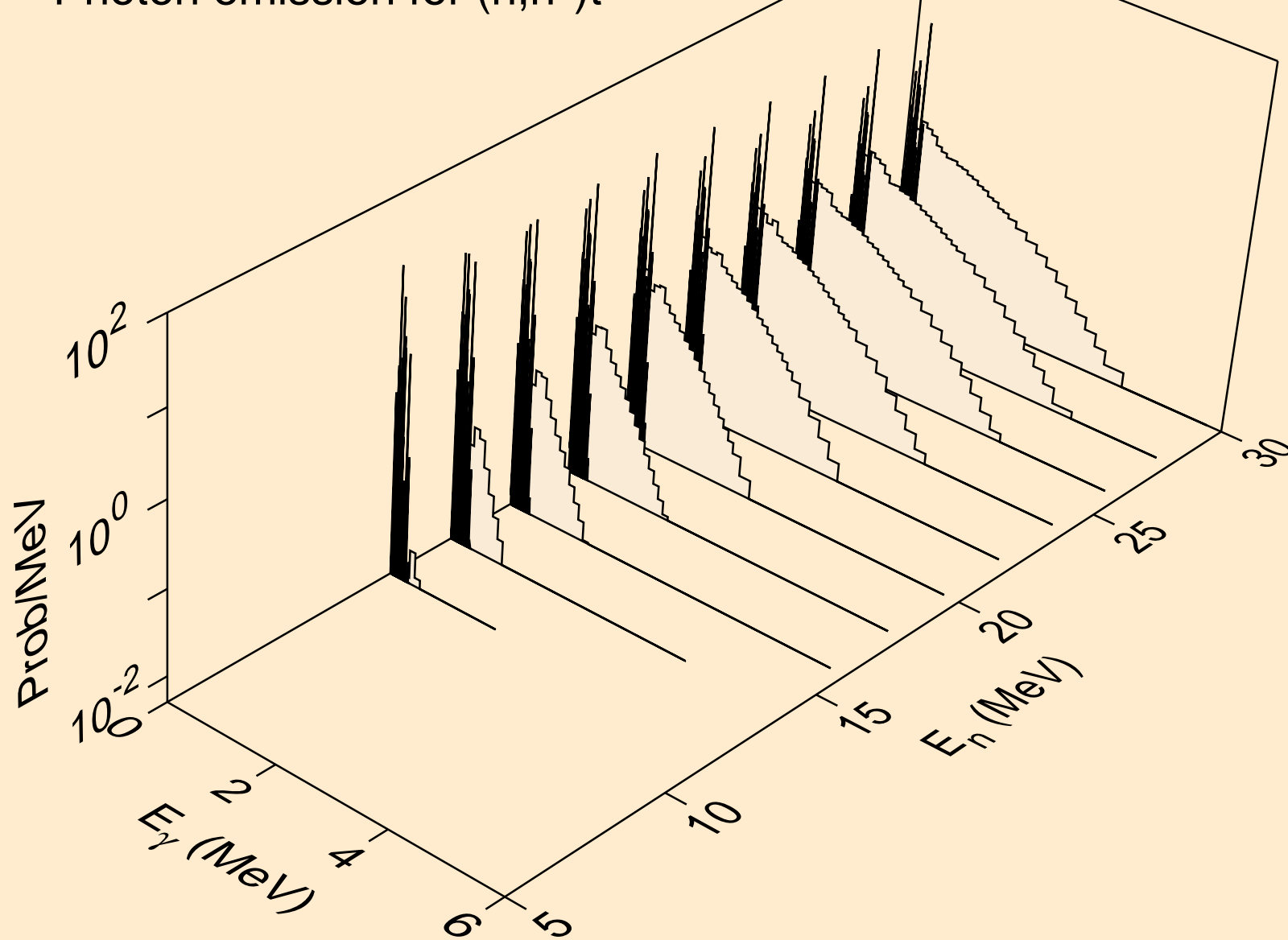

AC222 NEUTRON ACER TENDL-2023 LIBRARY; T=0.K
Photon emission for (n,n*)he3

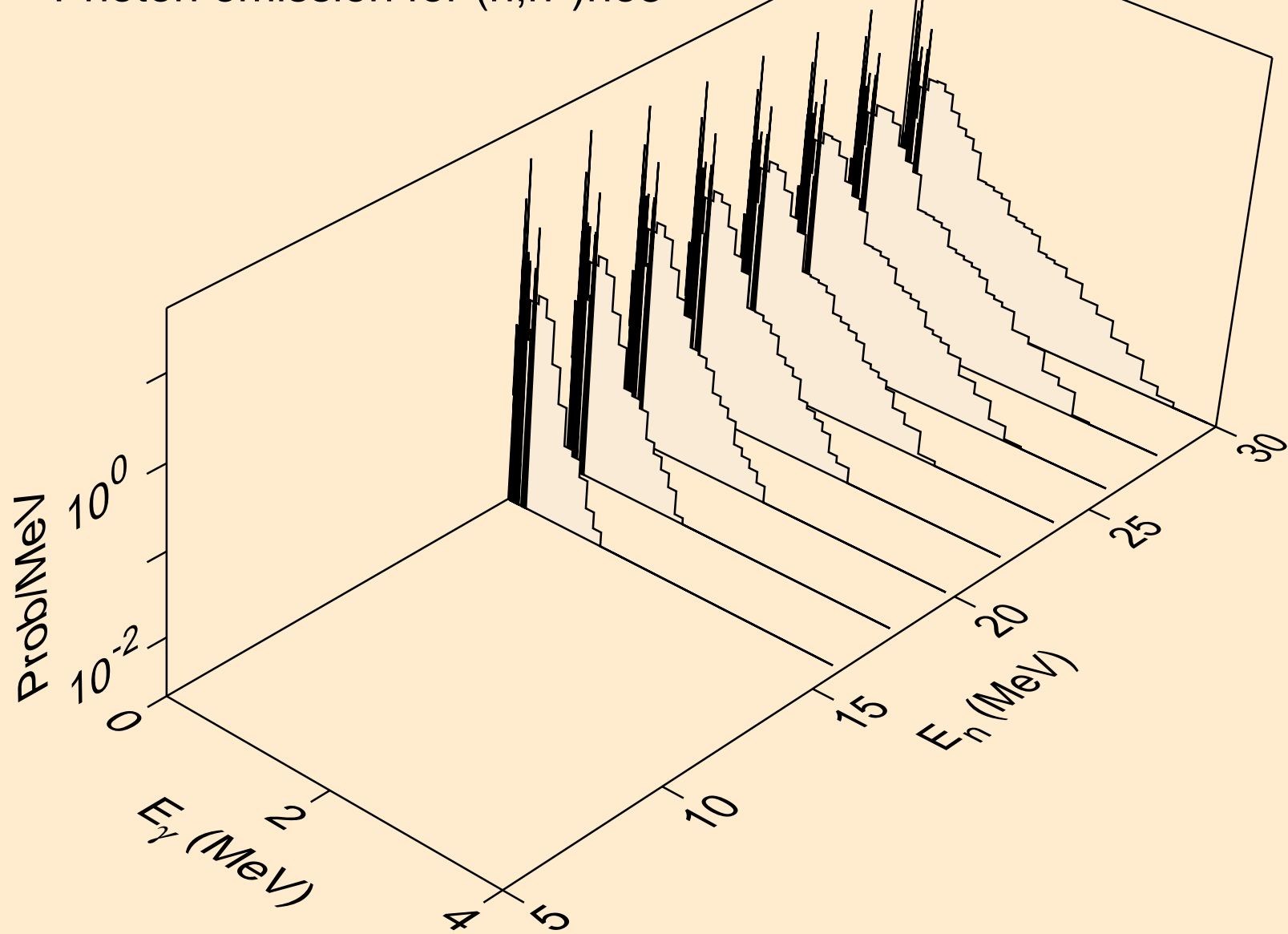

AC222 NEUTRON ACER TENDL-2023 LIBRARY; T=0.K
Photon emission for (n,n*)d2a

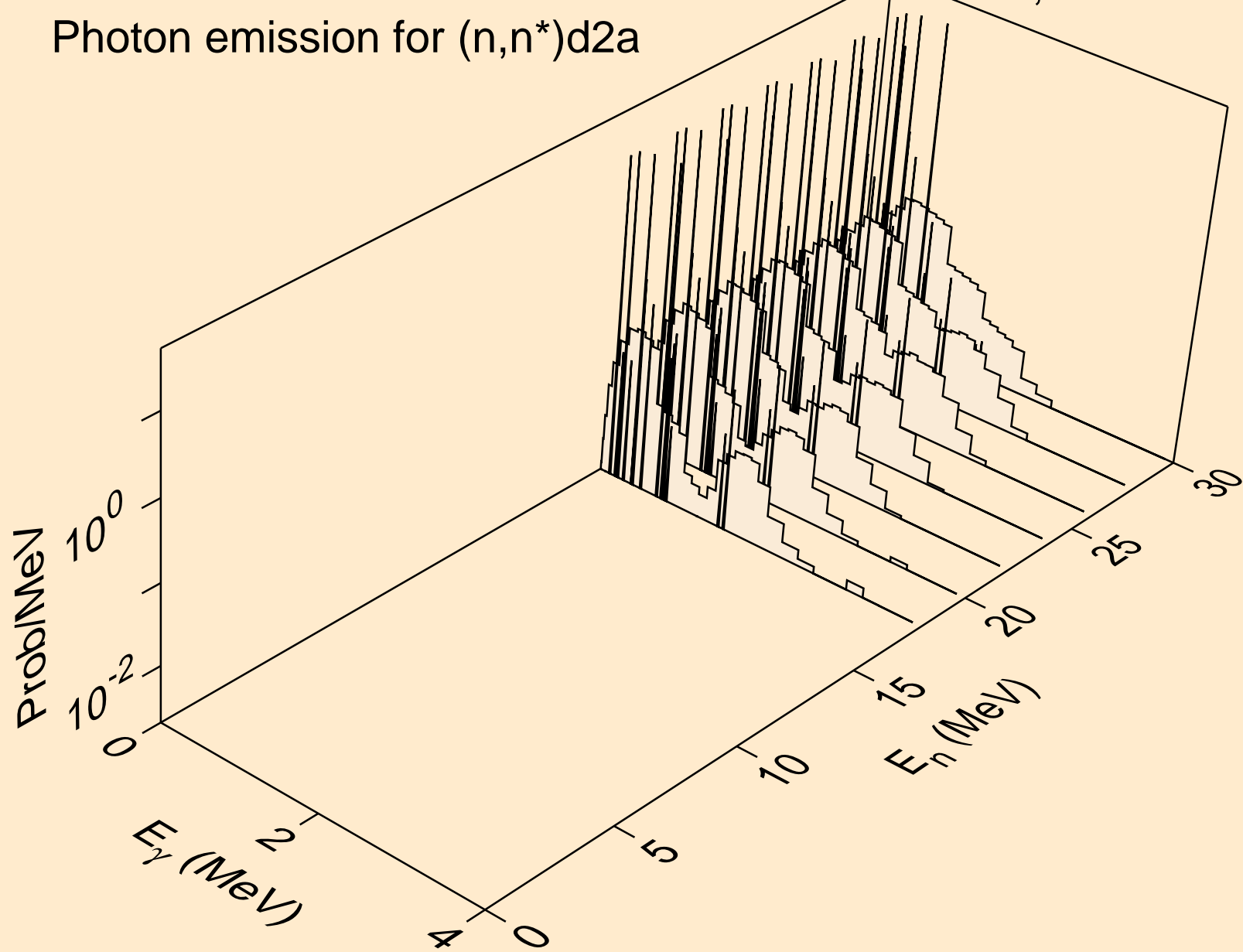

AC222 NEUTRON ACER TENDL-2023 LIBRARY; T=0.K
Photon emission for (n,n*)t2a

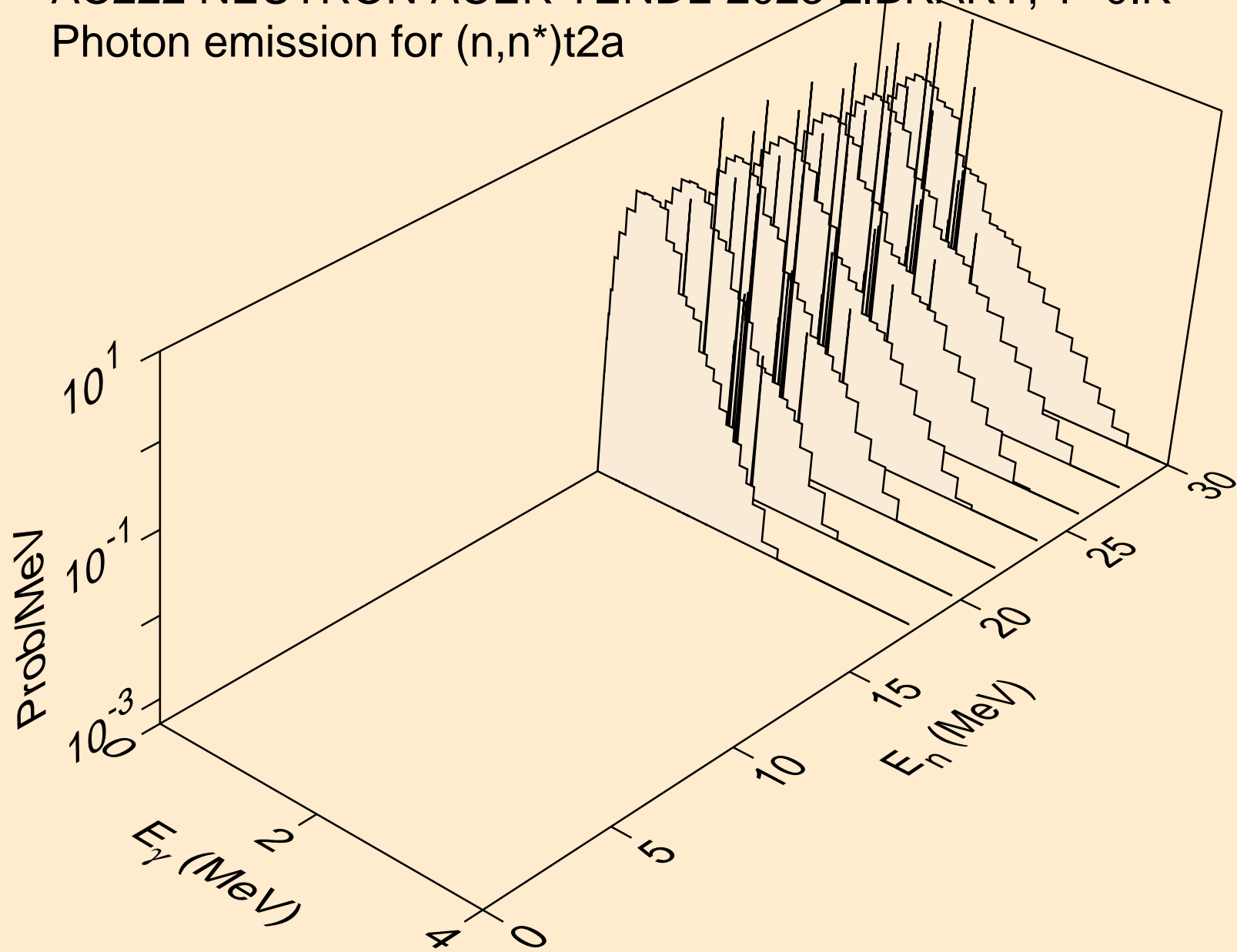

AC222 NEUTRON ACER TENDL-2023 LIBRARY; T=0.K
Photon emission for (n,4n)

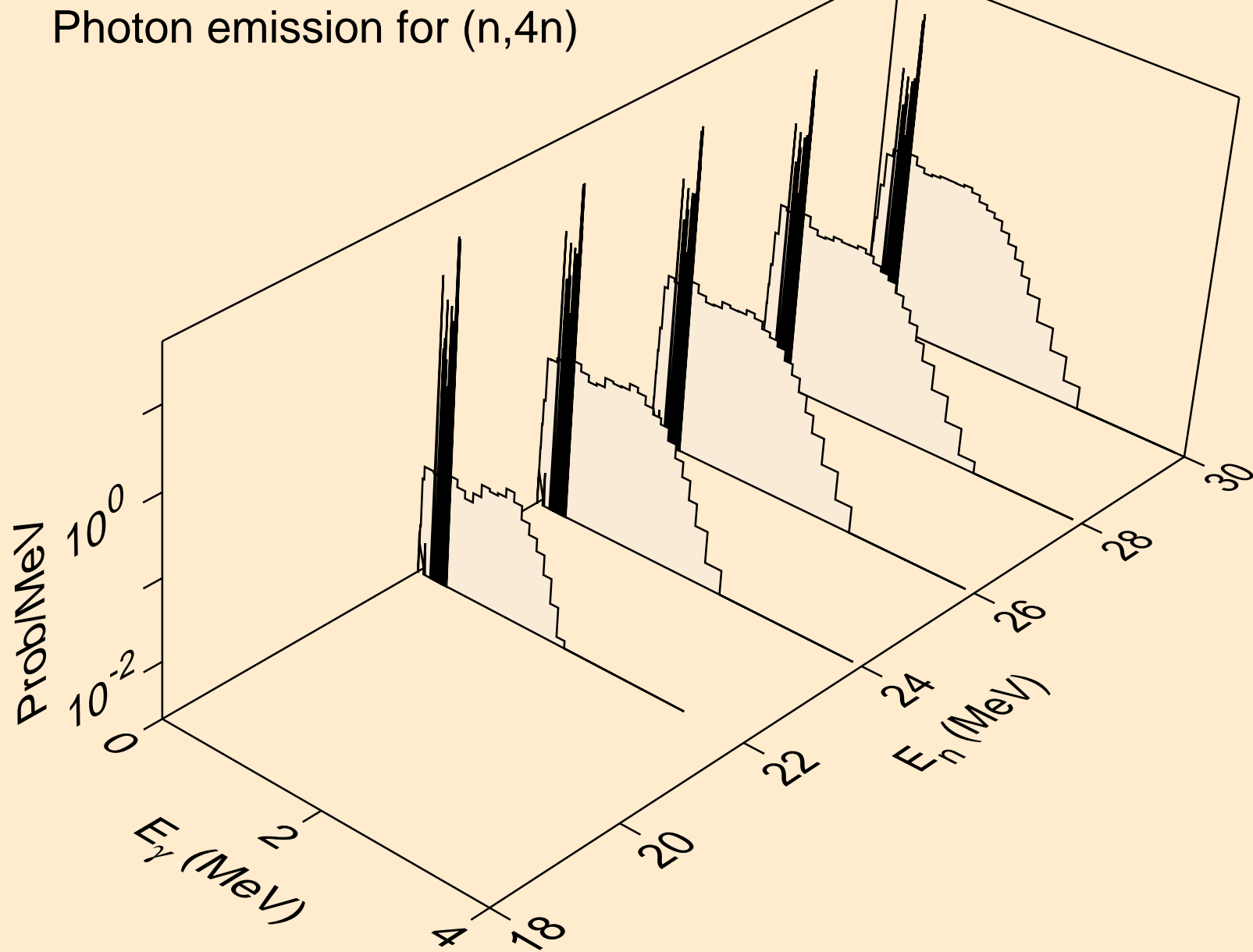

AC222 NEUTRON ACER TENDL-2023 LIBRARY; T=0.K
Photon emission for (n,2np)

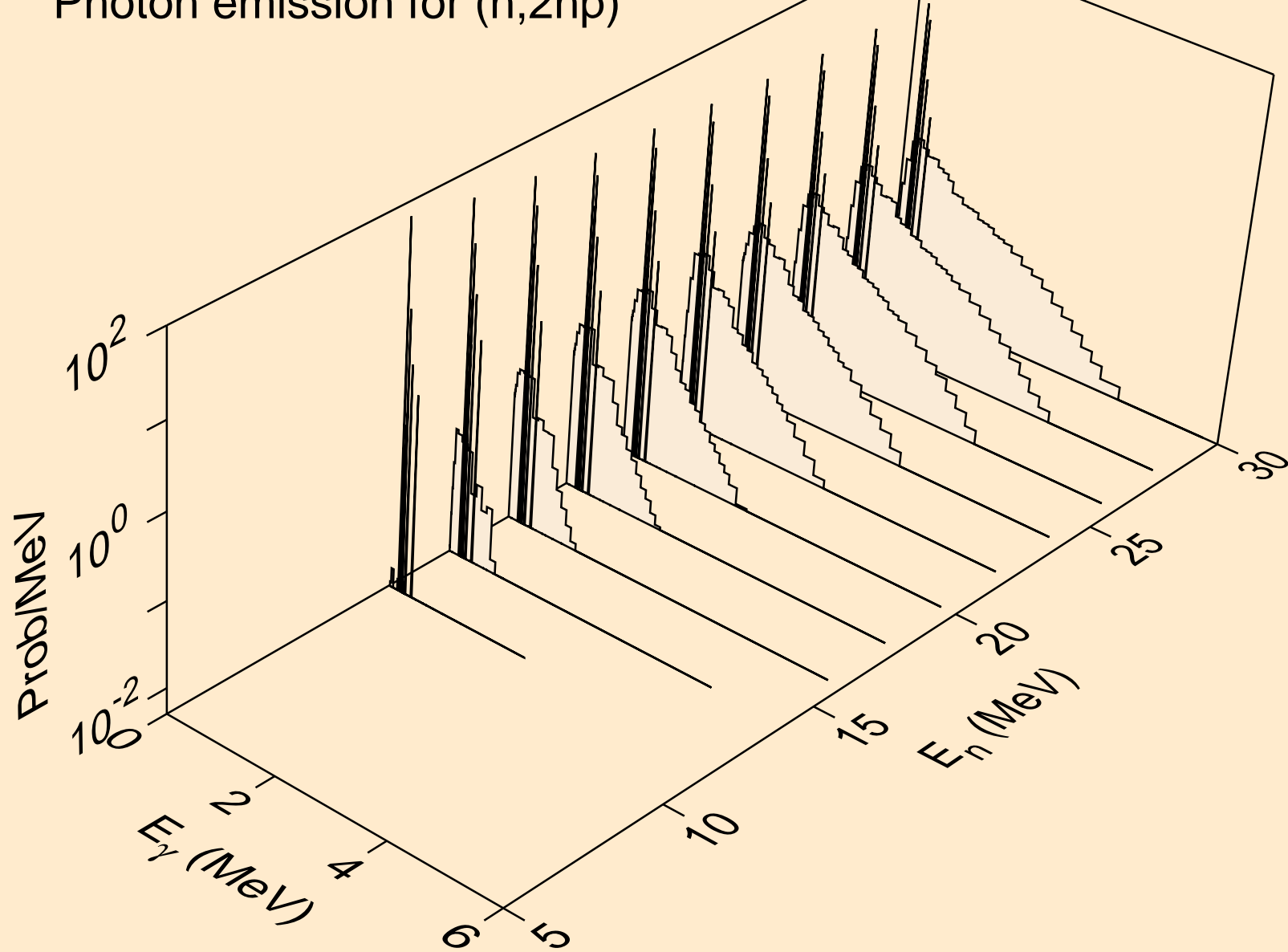

AC222 NEUTRON ACER TENDL-2023 LIBRARY; T=0.K
Photon emission for (n,3np)

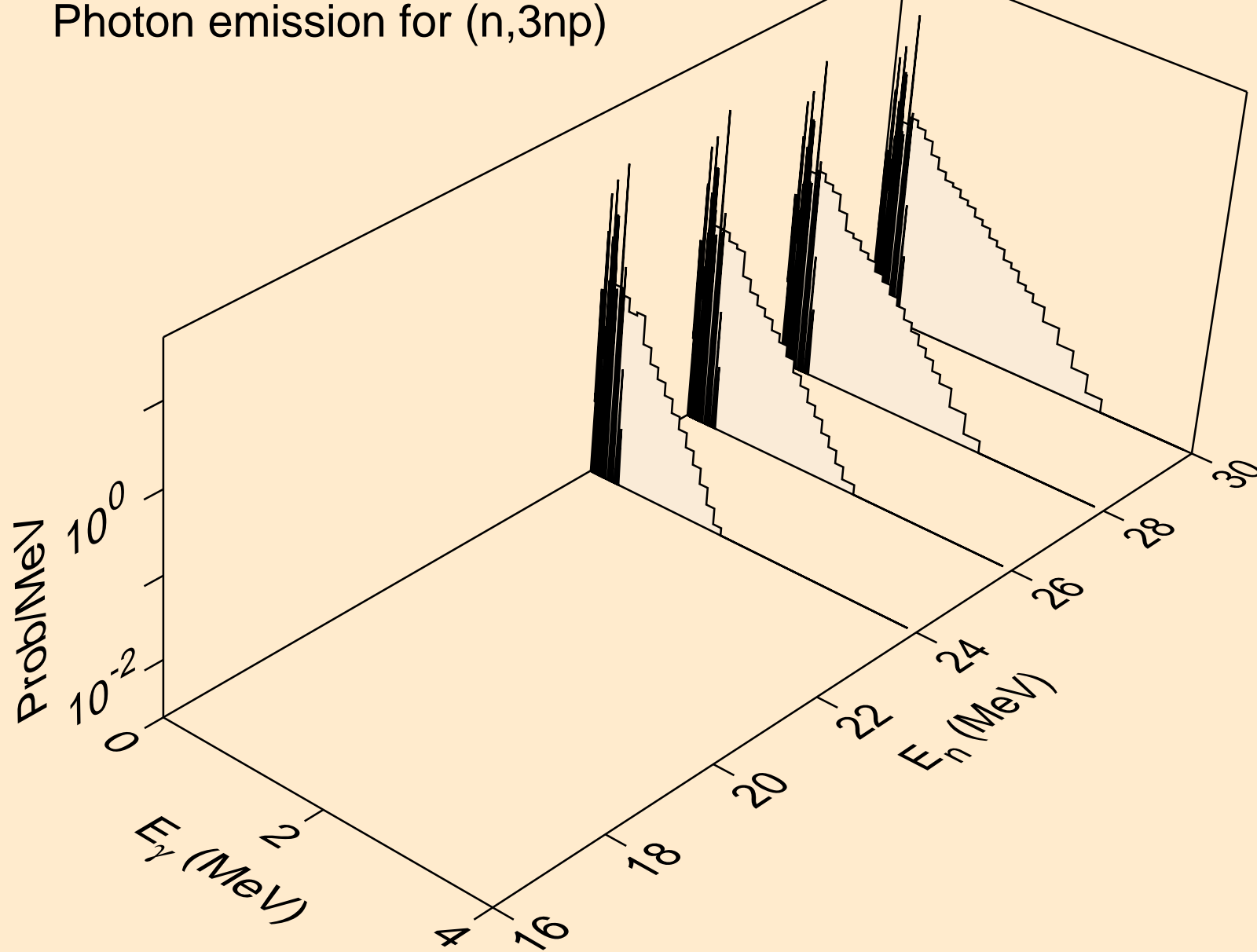

AC222 NEUTRON ACER TENDL-2023 LIBRARY; T=0.K
Photon emission for (n,n2p)

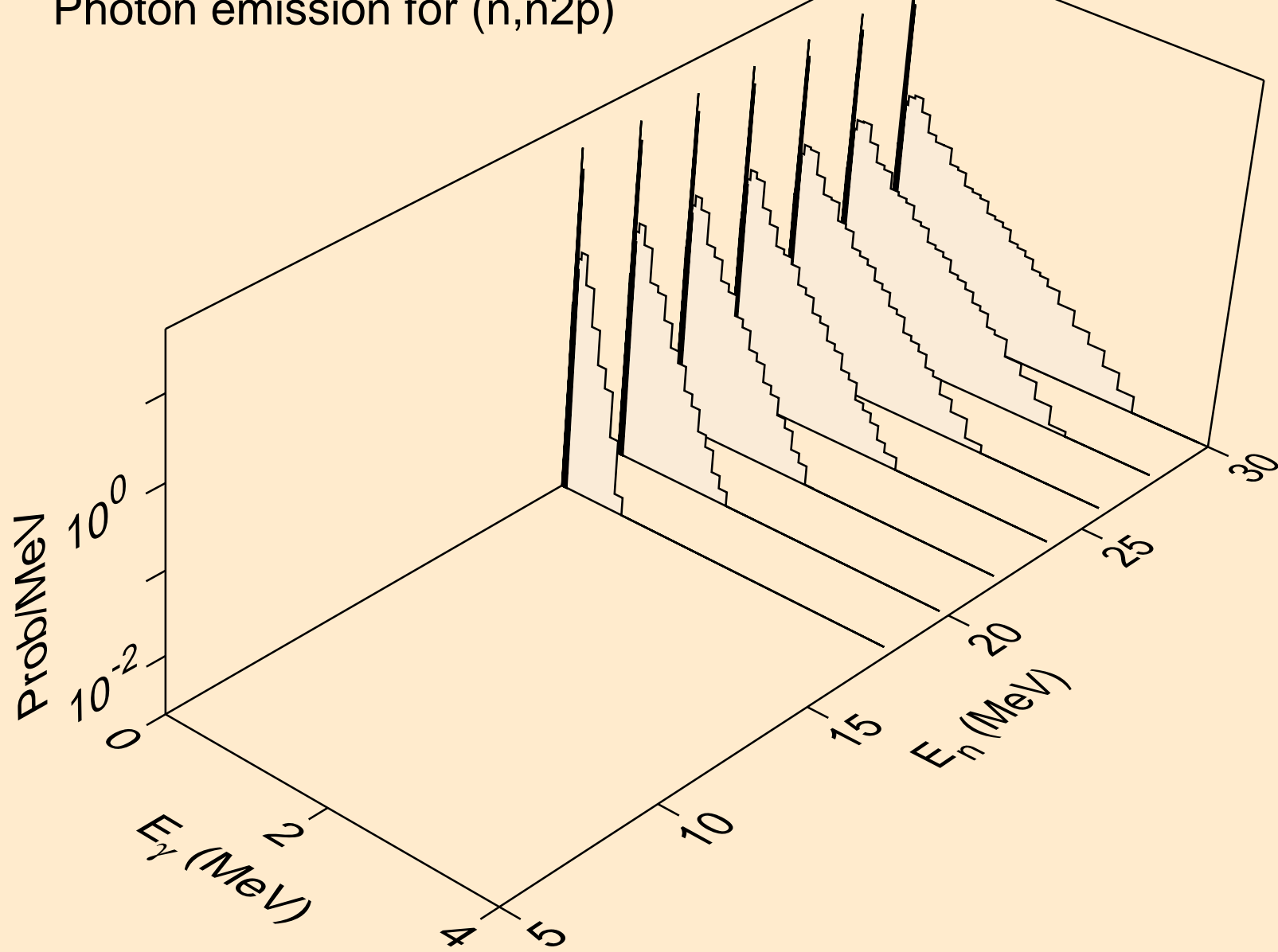

AC222 NEUTRON ACER TENDL-2023 LIBRARY; T=0.K
Photon emission for (n,npa)

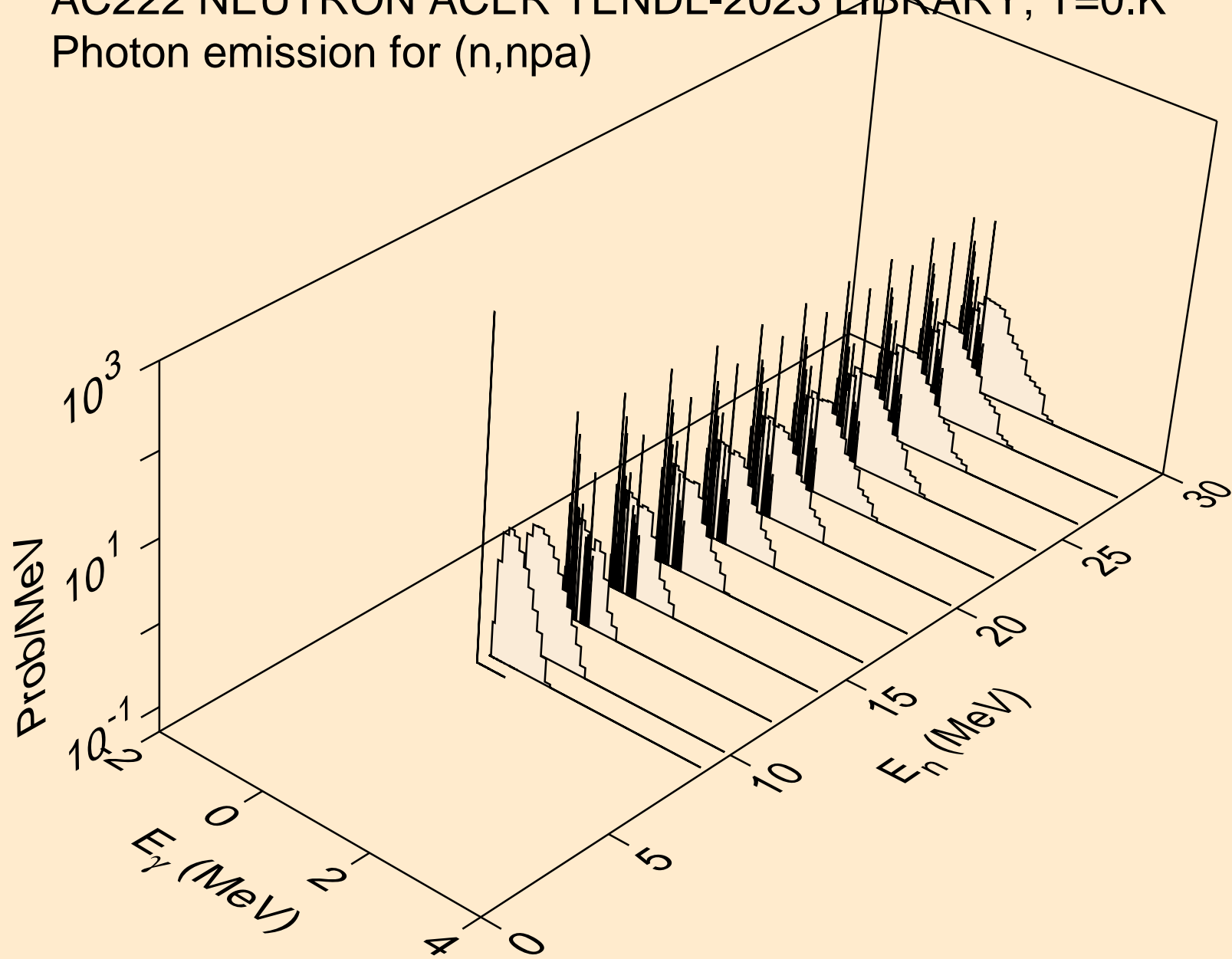

AC222 NEUTRON ACER TENDL-2023 LIBRARY; T=0.K
Photon emission for (n,n*c)

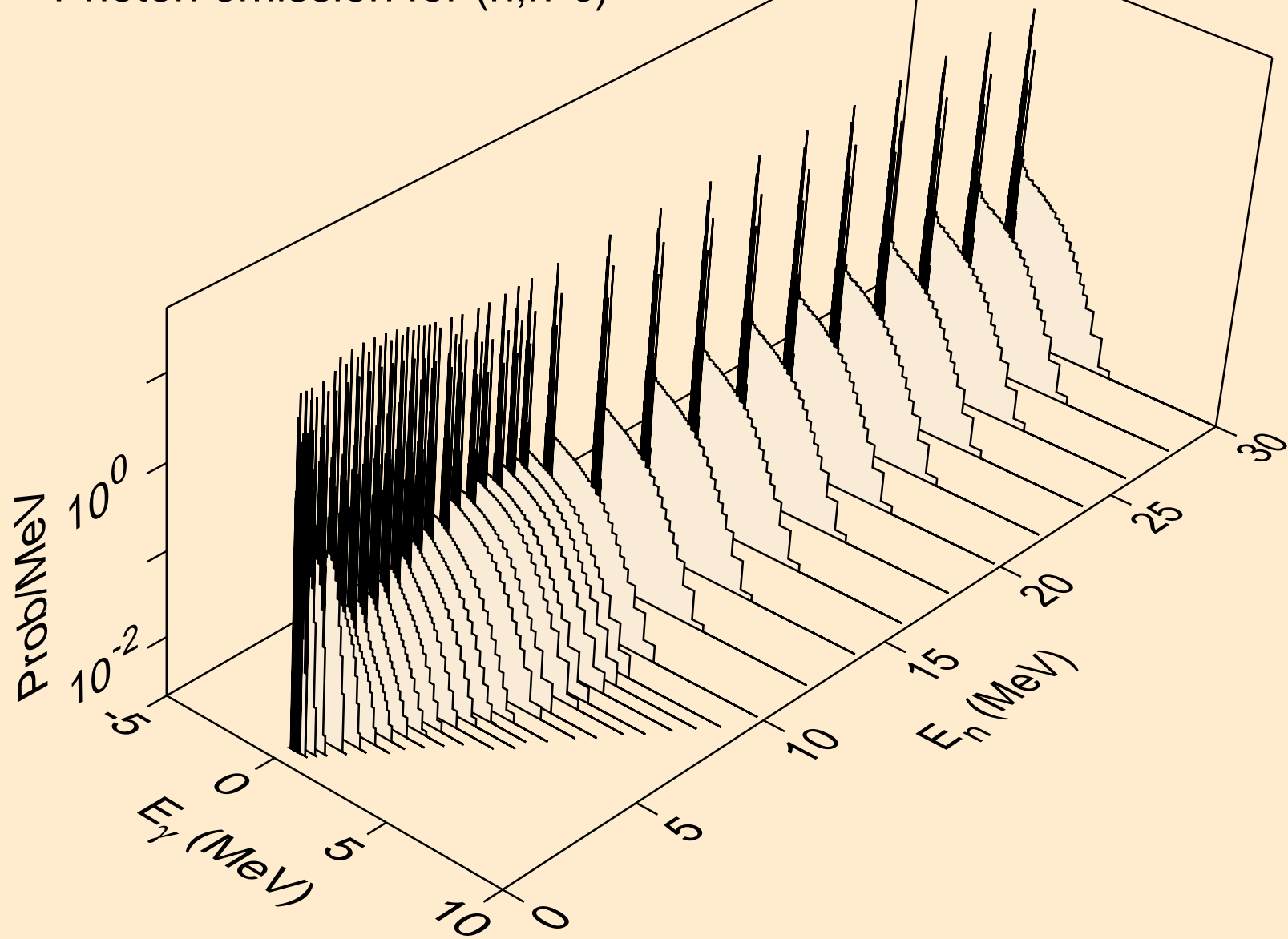

AC222 NEUTRON ACER TENDL-2023 LIBRARY; T=0.K
Photon emission for (n,gma)

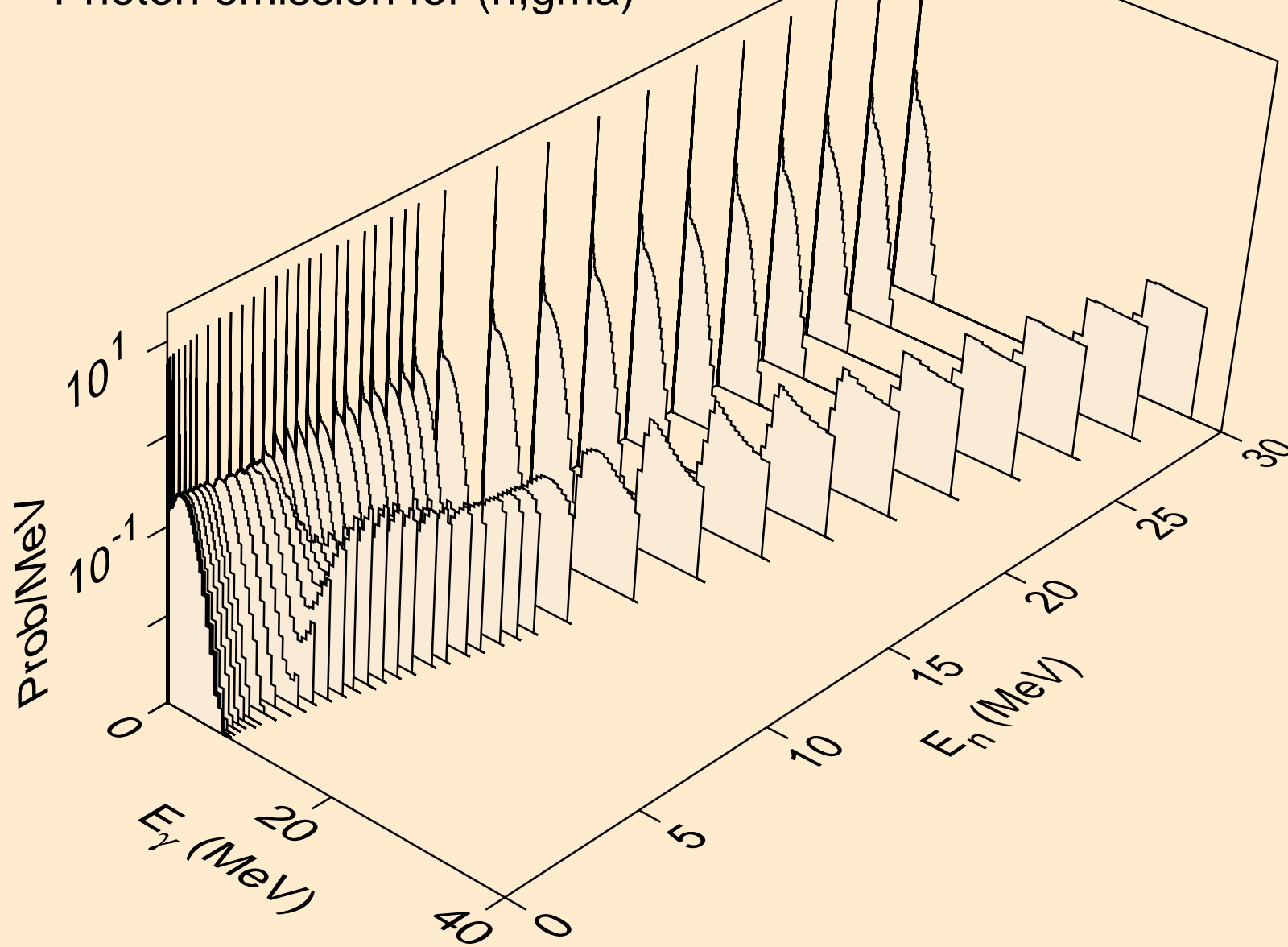

AC222 NEUTRON ACER TENDL-2023 LIBRARY; T=0.K
Photon emission for (n,p)

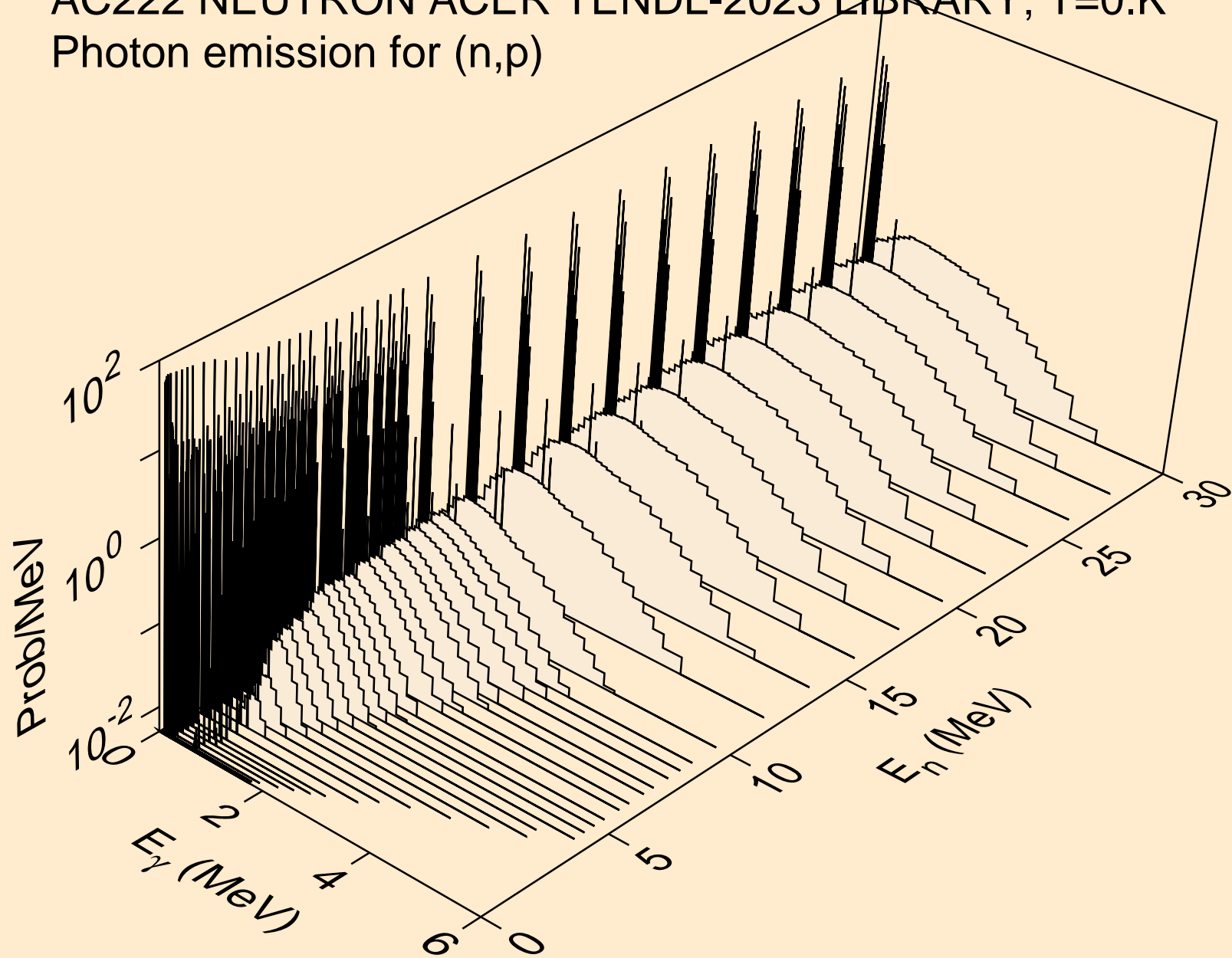

AC222 NEUTRON ACER TENDL-2023 LIBRARY; T=0.K
Photon emission for (n,d)

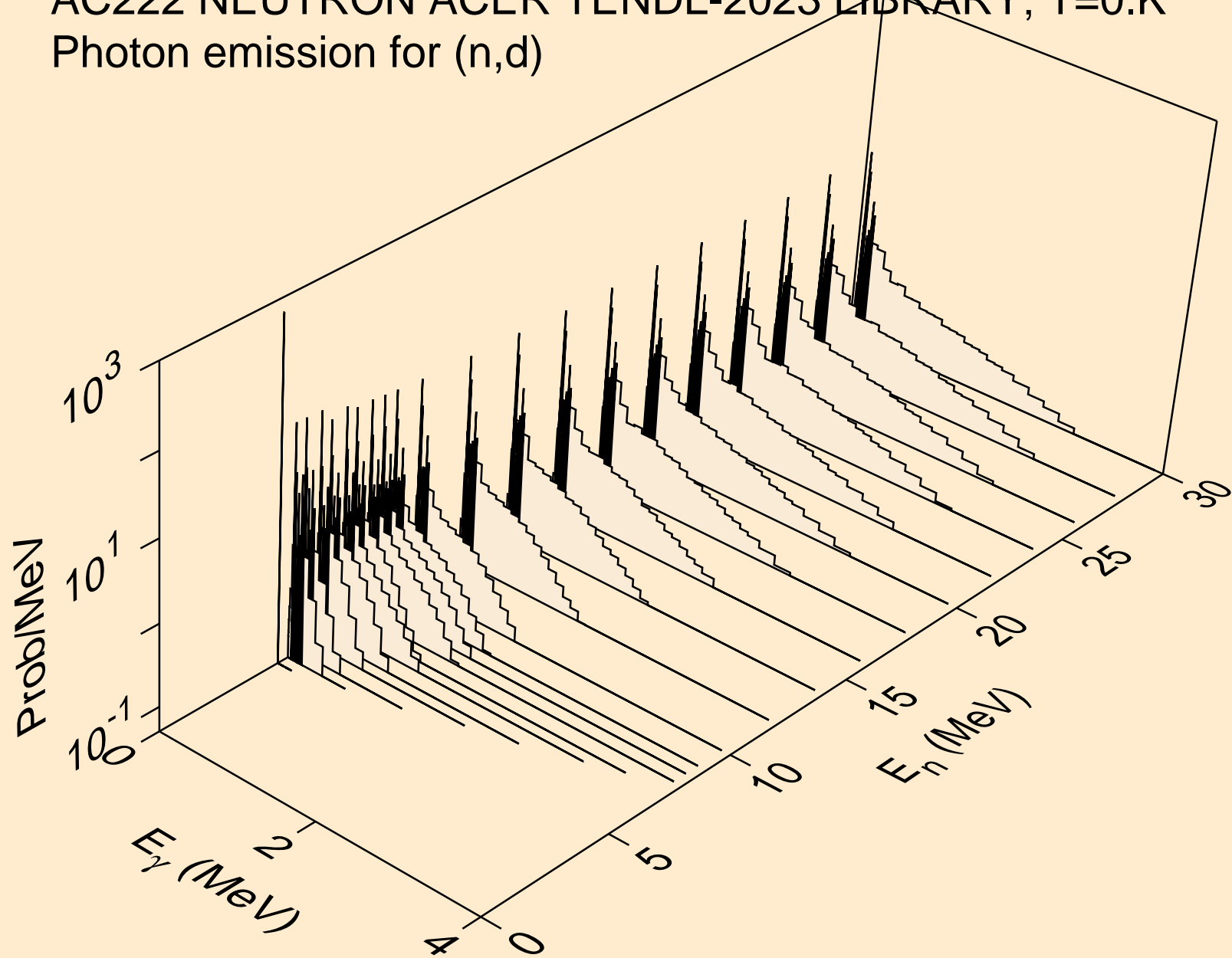

AC222 NEUTRON ACER TENDL-2023 LIBRARY; T=0.K
Photon emission for (n,t)

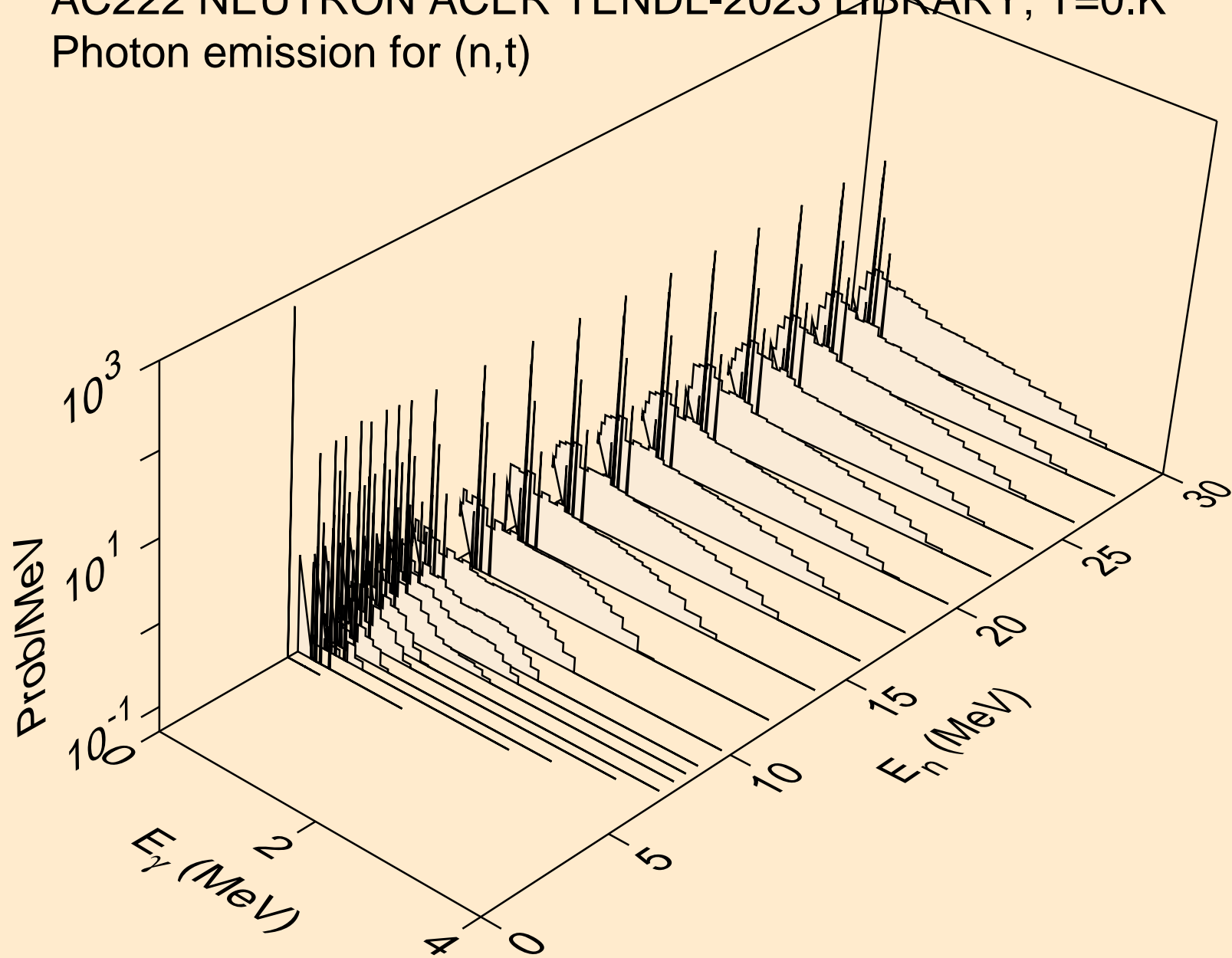

AC222 NEUTRON ACER TENDL-2023 LIBRARY; T=0.K
Photon emission for (n,he3)

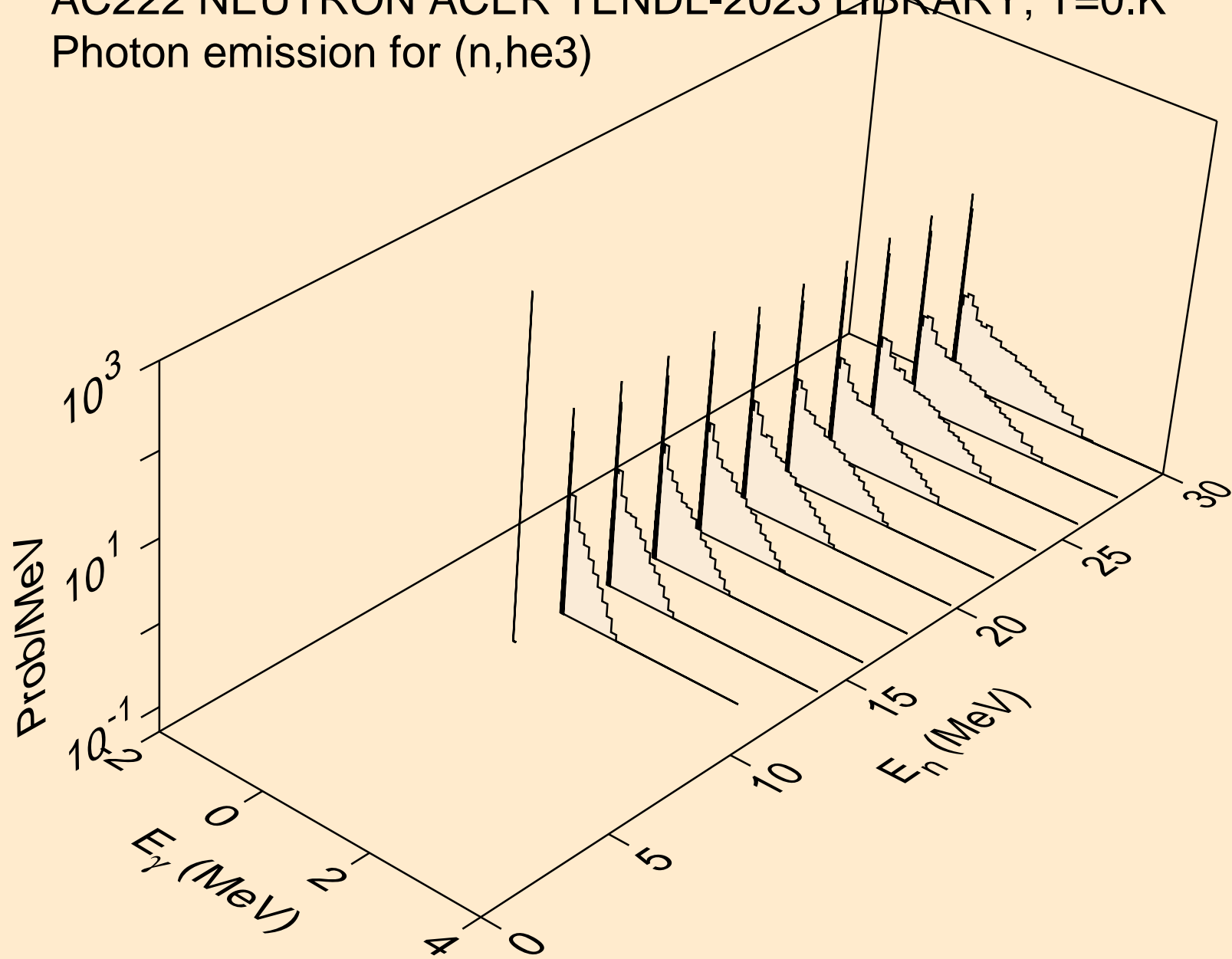

AC222 NEUTRON ACER TENDL-2023 LIBRARY; T=0.K
Photon emission for (n,a)

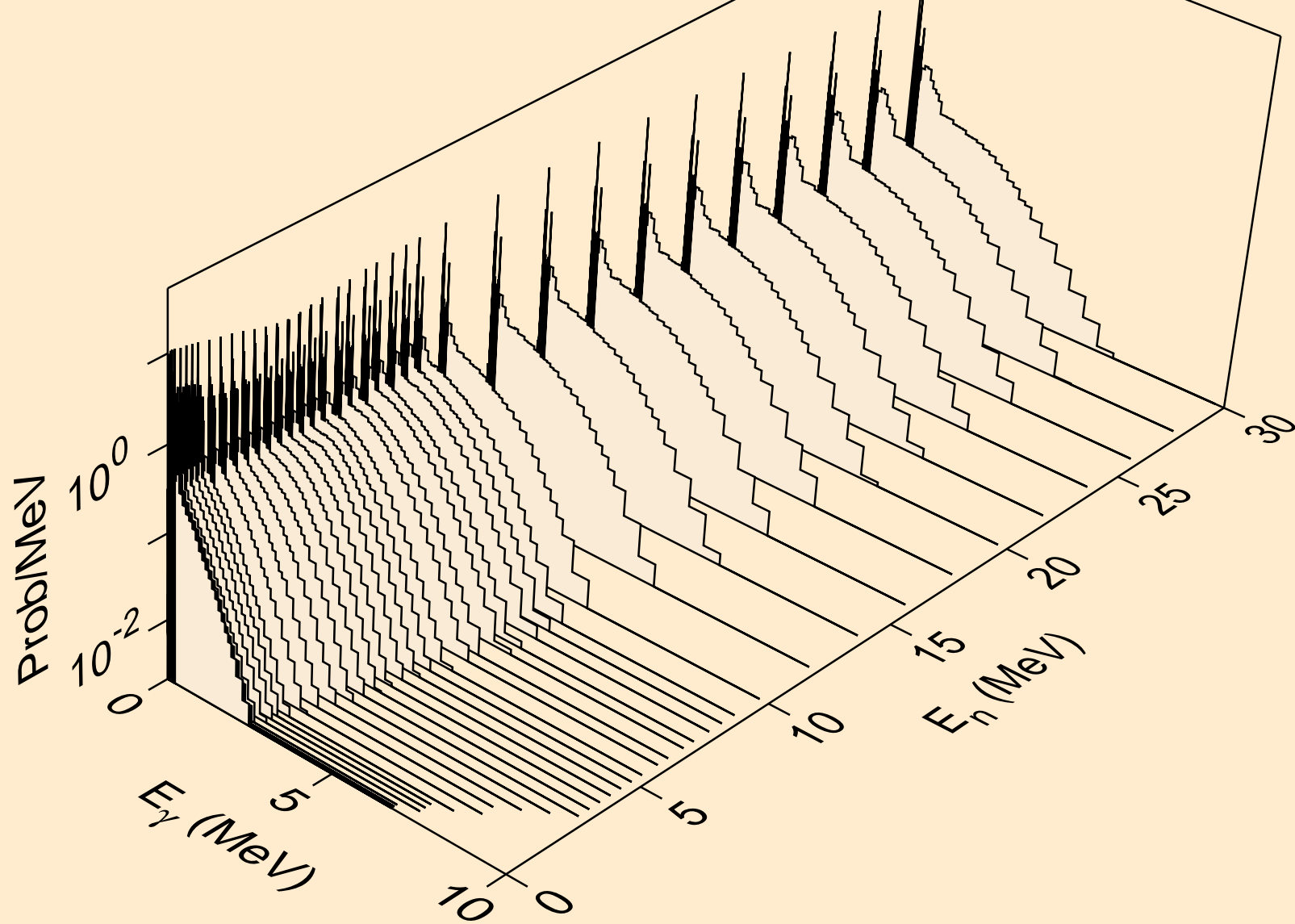

AC222 NEUTRON ACER TENDL-2023 LIBRARY; T=0.K
Photon emission for (n,2a)

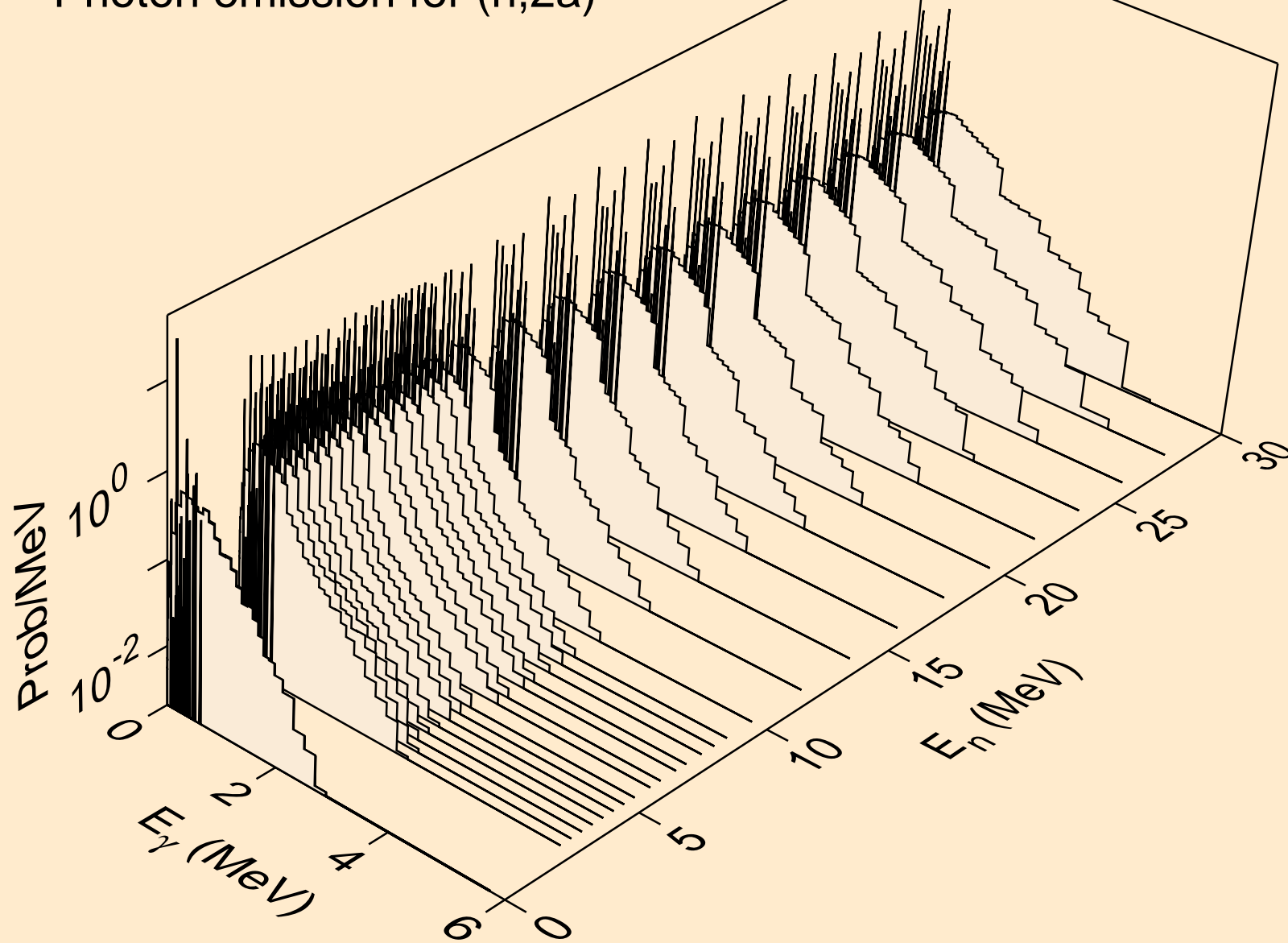

AC222 NEUTRON ACER TENDL-2023 LIBRARY; T=0.K
Photon emission for (n,3a)

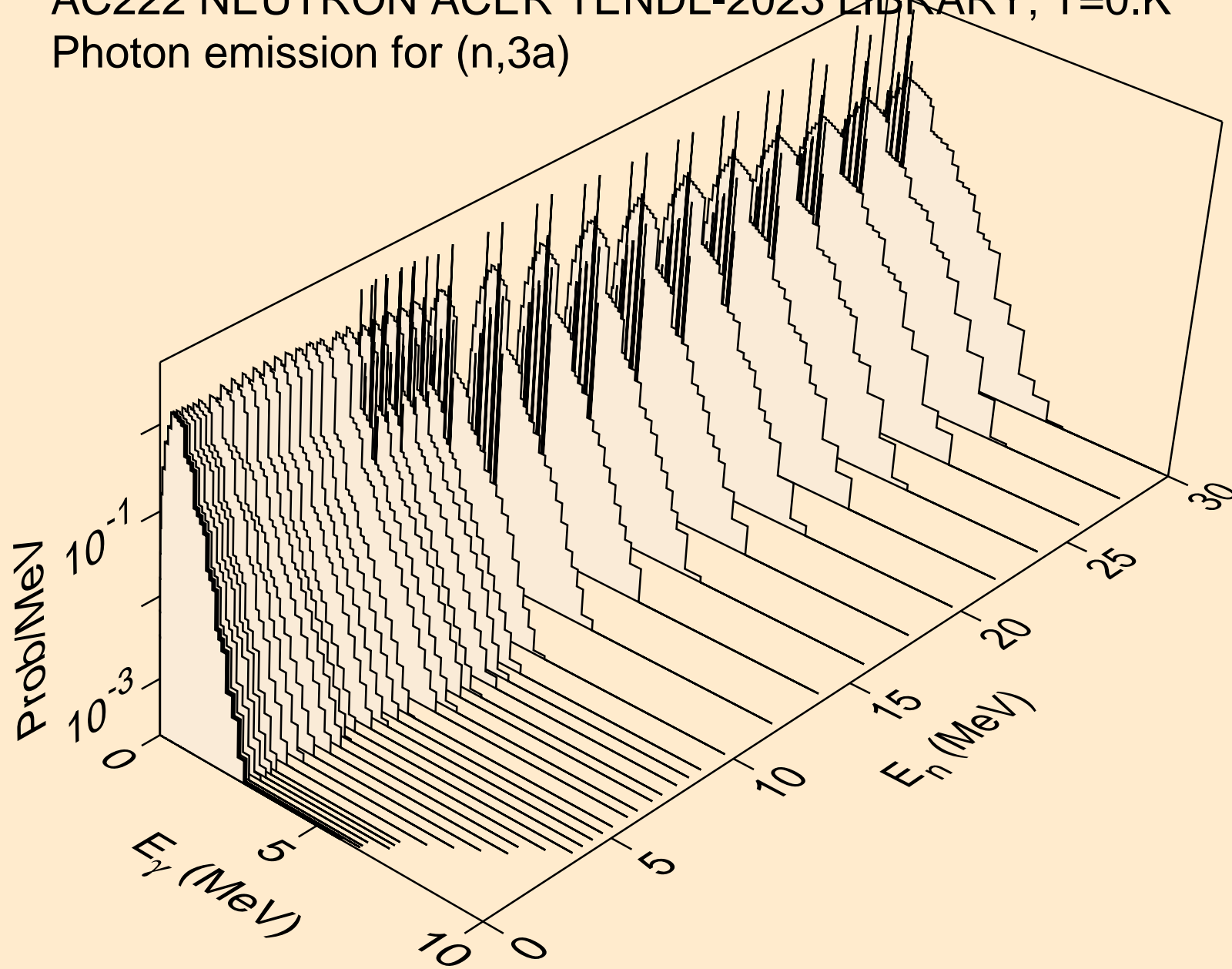

AC222 NEUTRON ACER TENDL-2023 LIBRARY; T=0.K
Photon emission for (n,2p)

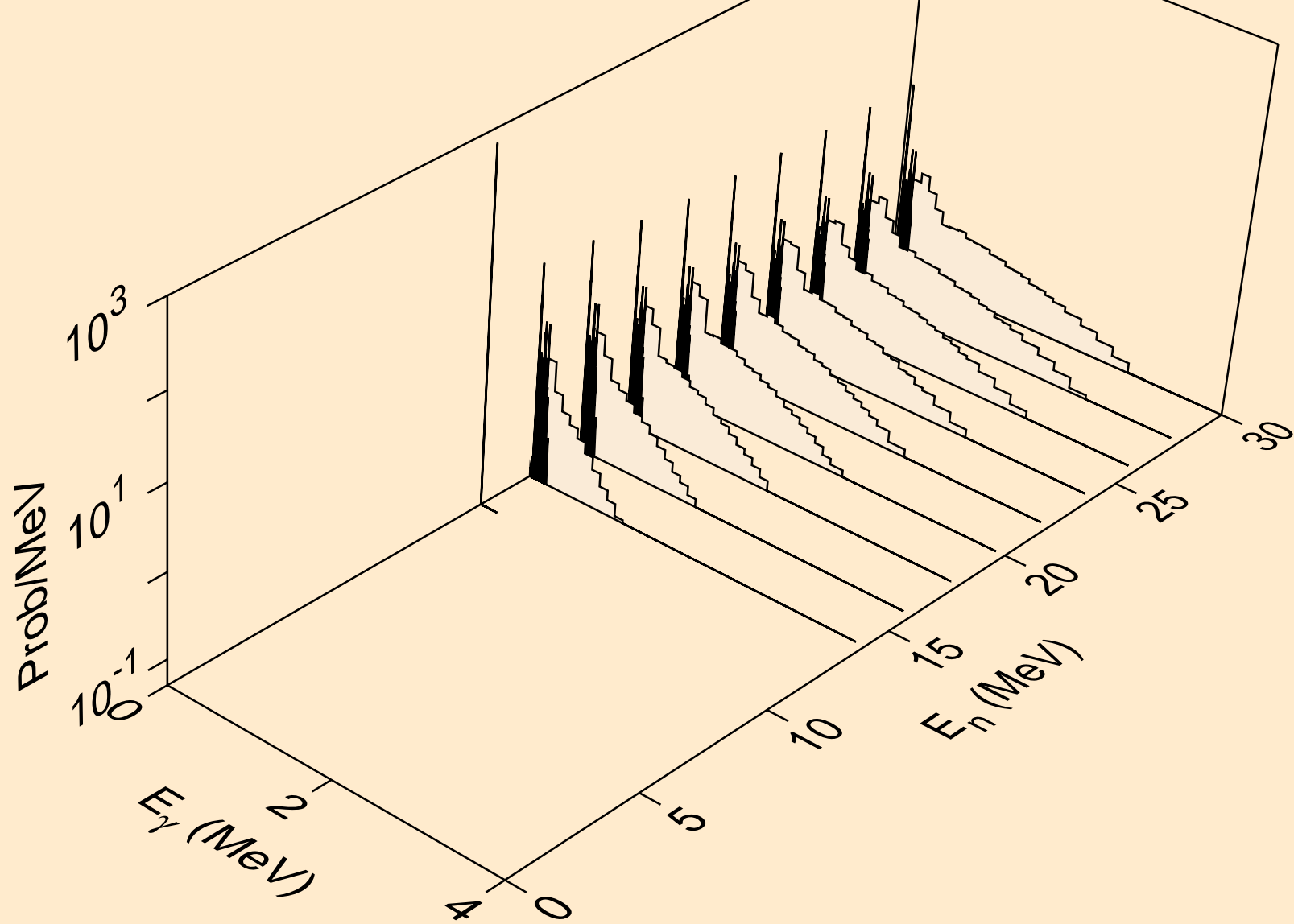

AC222 NEUTRON ACER TENDL-2023 LIBRARY; T=0.K
Photon emission for (n,p α)

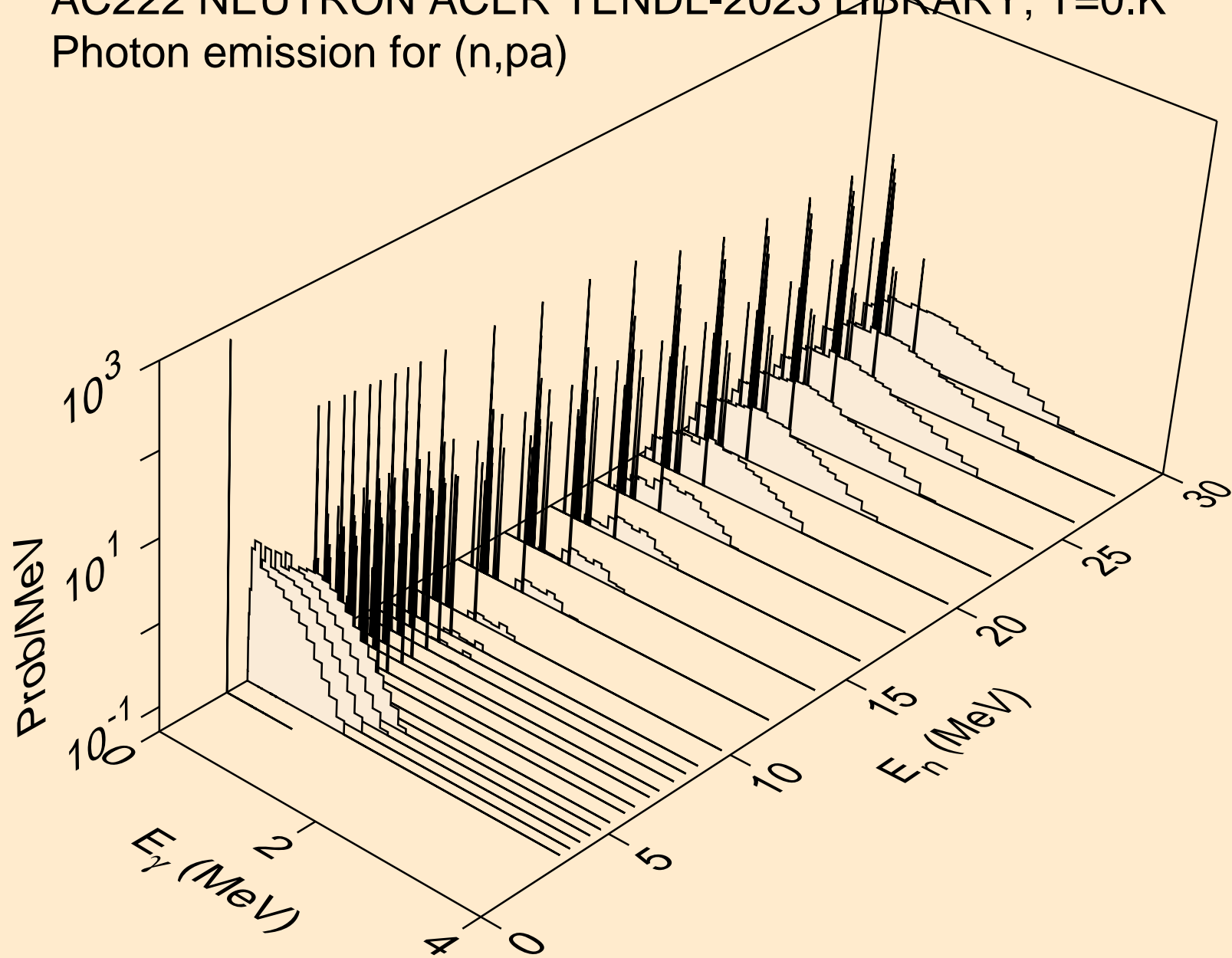

AC222 NEUTRON ACER TENDL-2023 LIBRARY; T=0.K
Photon emission for (n,t2a)

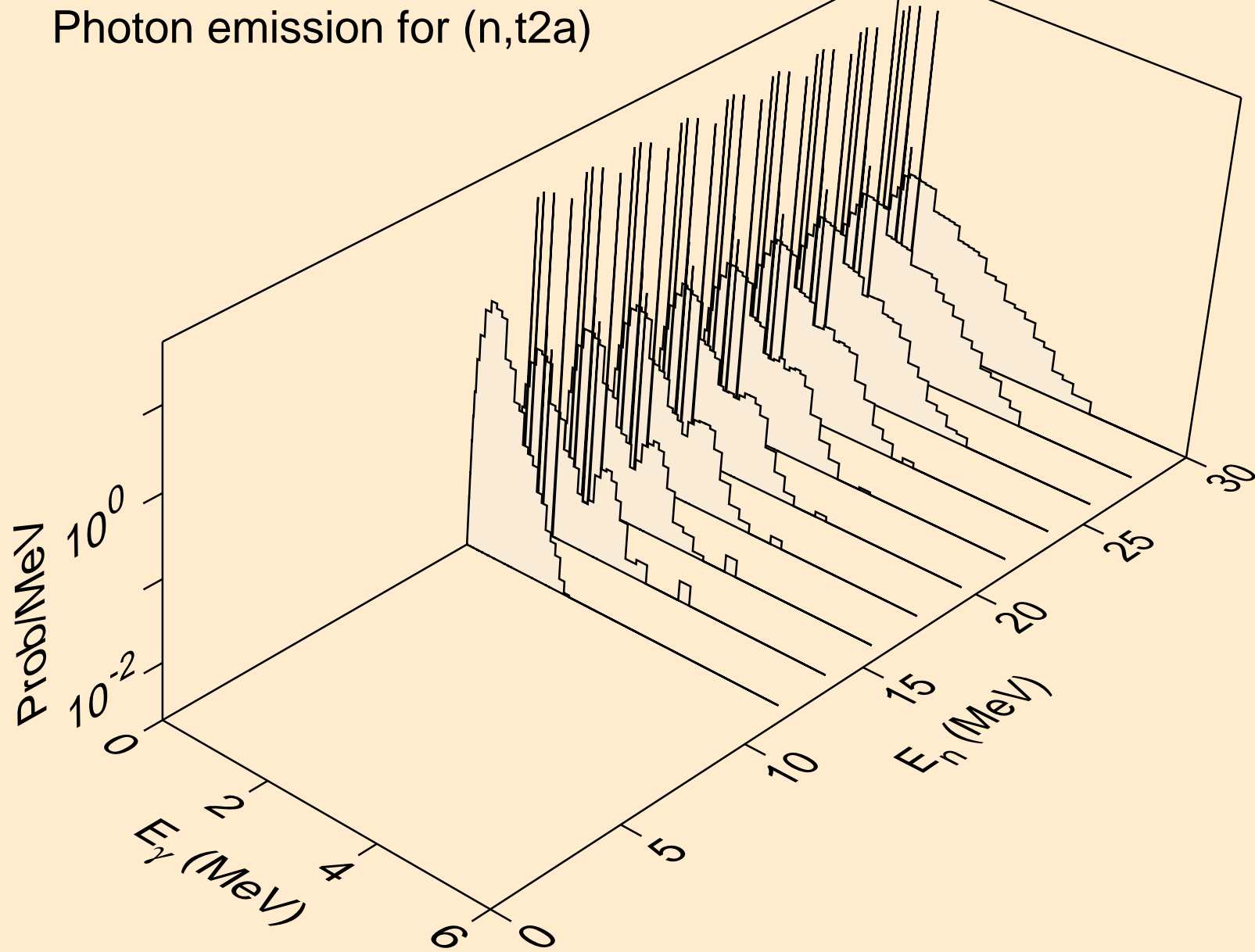

AC222 NEUTRON ACER TENDL-2023 LIBRARY; T=0.K
Photon emission for (n,pd)

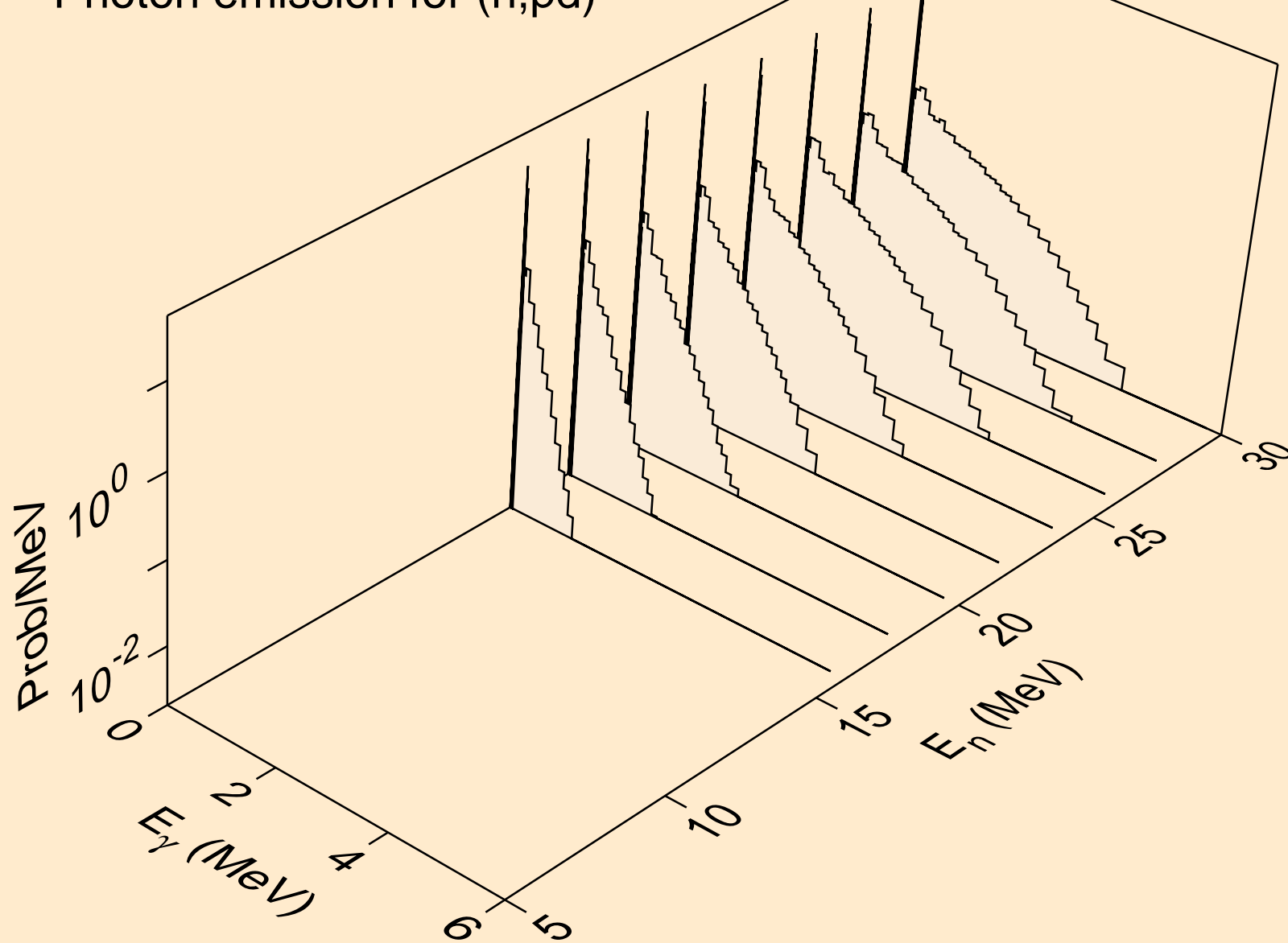

AC222 NEUTRON ACER TENDL-2023 LIBRARY; T=0.K
Photon emission for (n,pt)

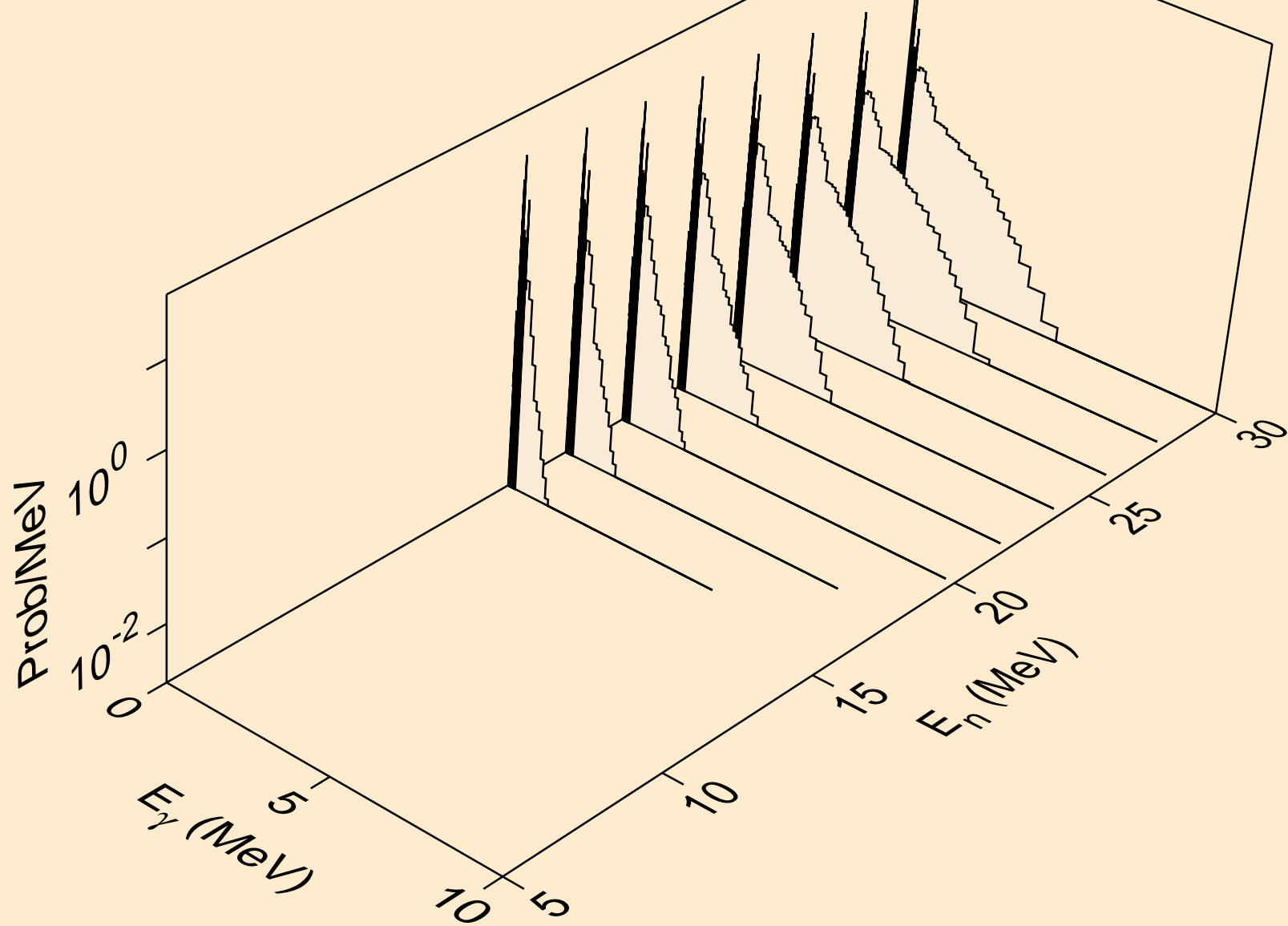

AC222 NEUTRON ACER TENDL-2023 LIBRARY; T=0.K
Photon emission for (n,da)

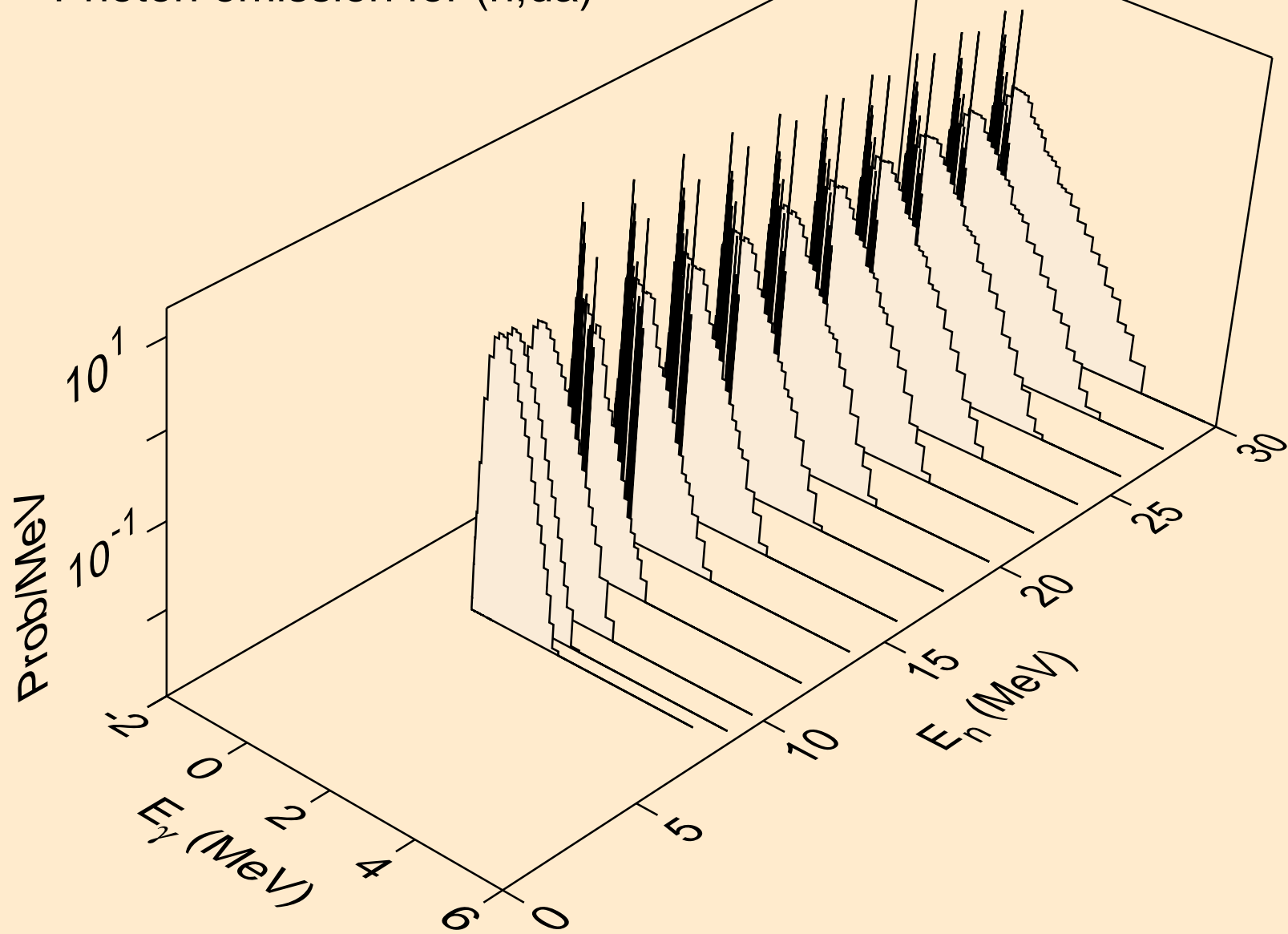

AC222 NEUTRON ACER TENDL-2023 LIBRARY; T=0.K
thermal capture photon spectrum

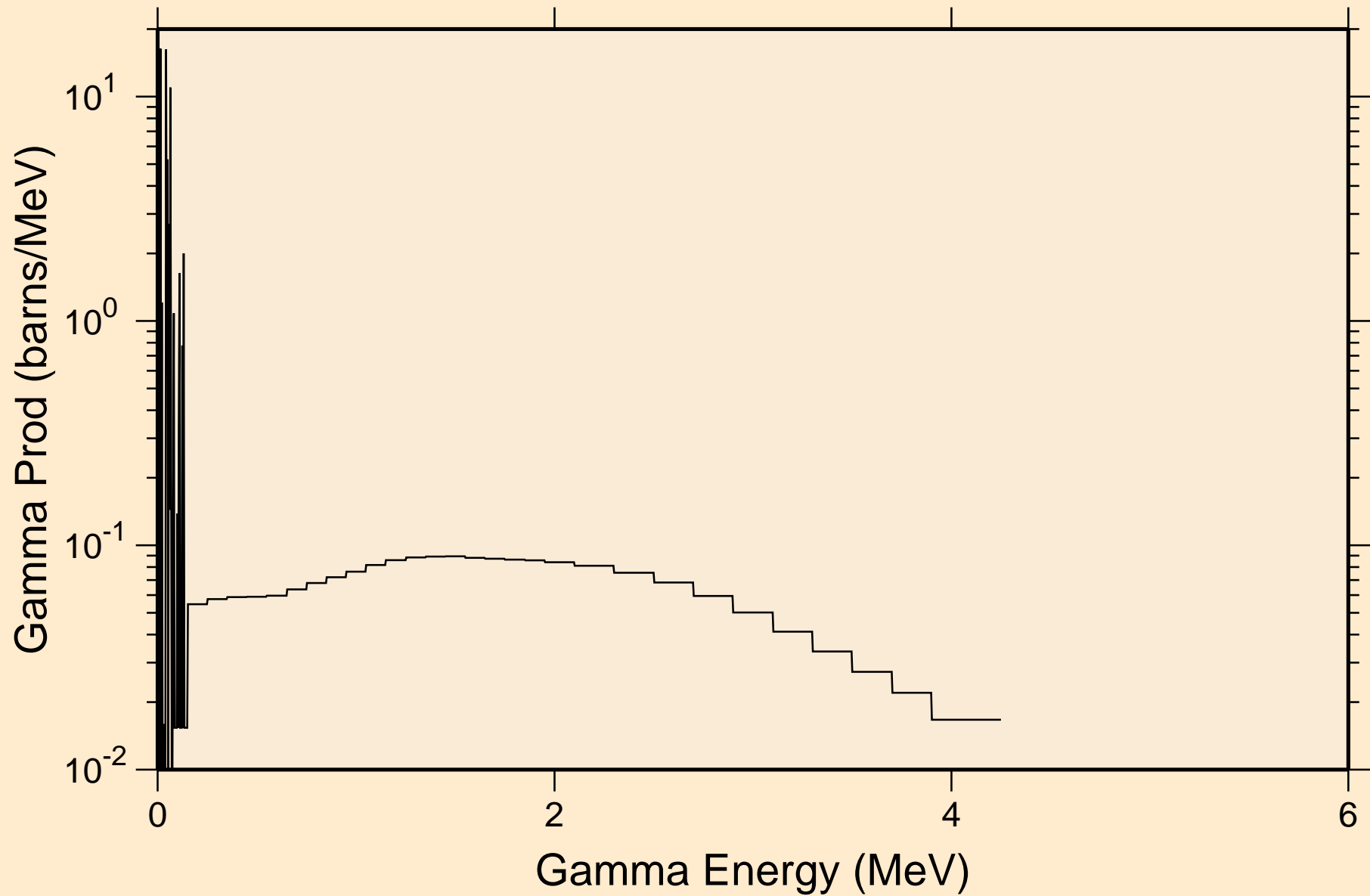

AC222 NEUTRON ACER TENDL-2023 LIBRARY; T=0.K
14 MeV photon spectrum

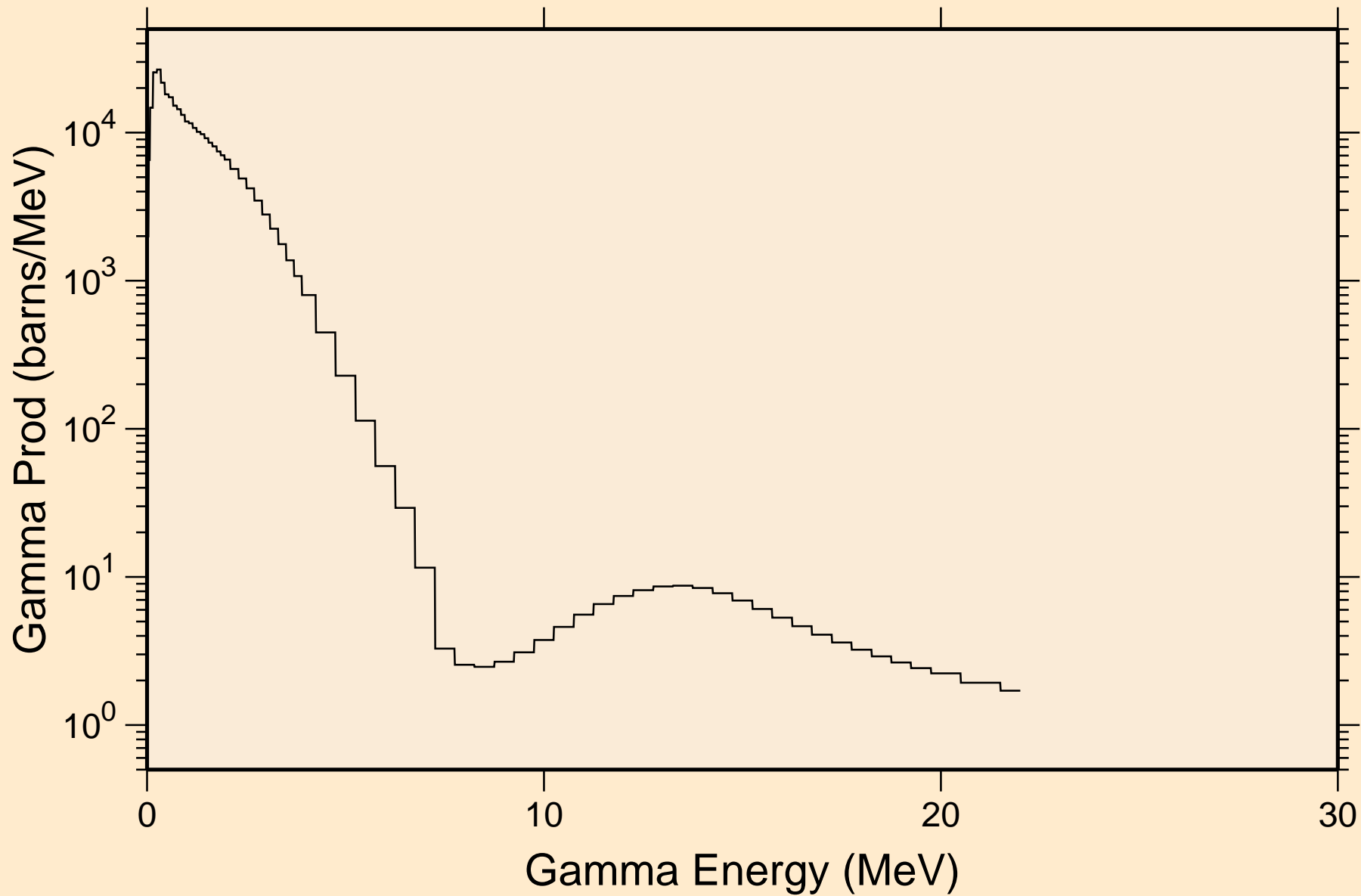

AC222 NEUTRON ACER TENDL-2023 LIBRARY; T=0.K
Particle heating contributions

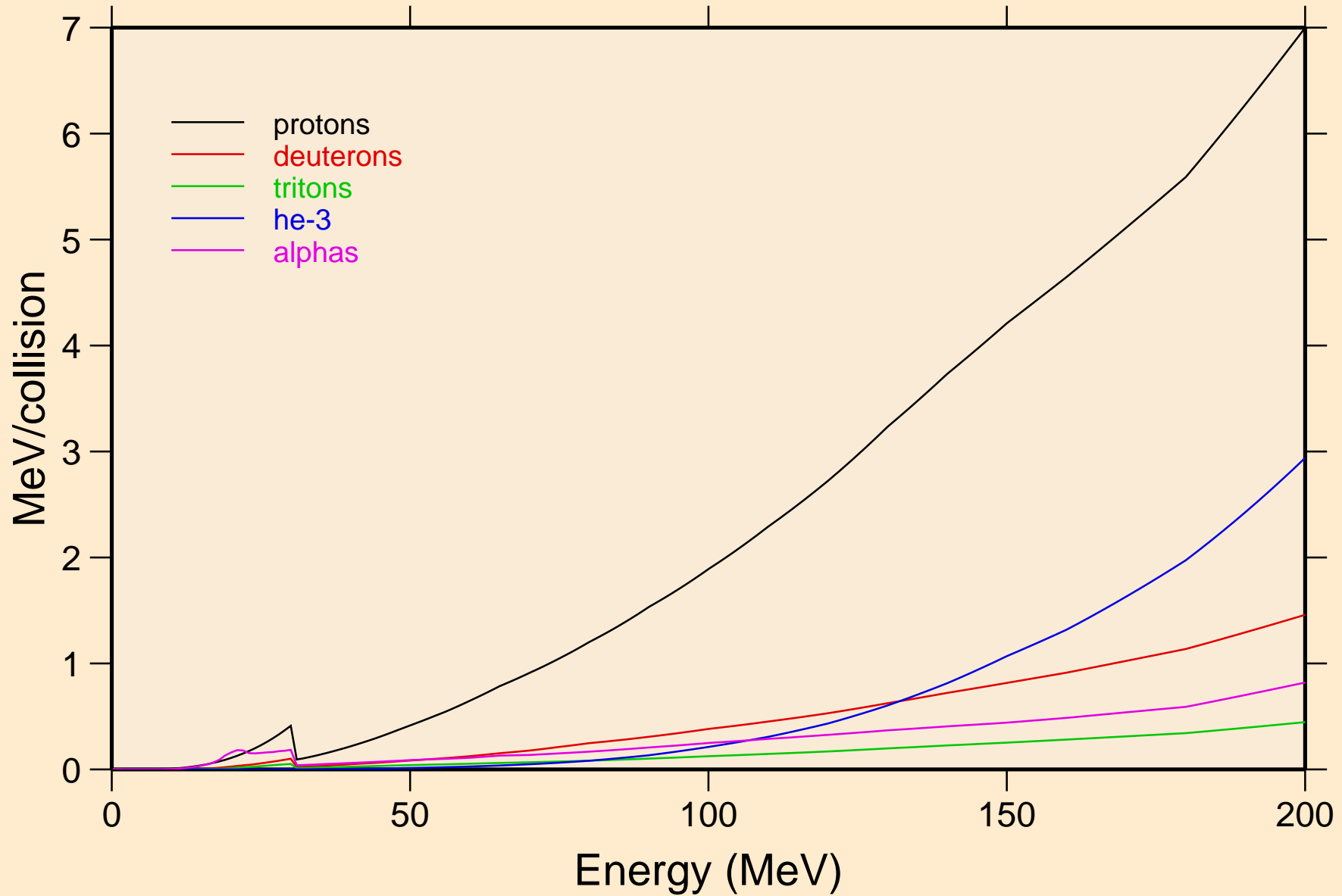

AC222 NEUTRON ACER TENDL-2023 LIBRARY; T=0.K
Recoil Heating

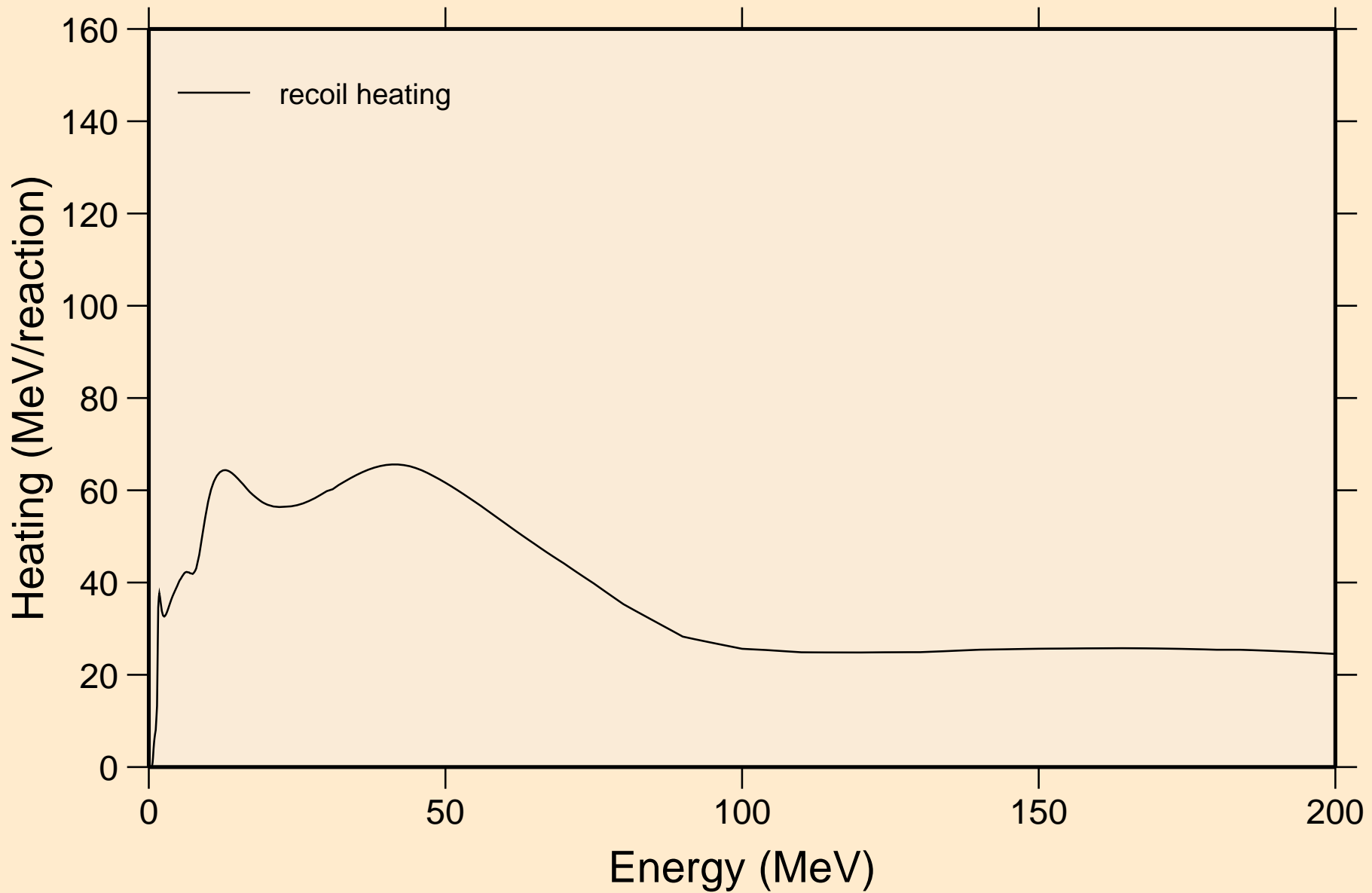

AC222 NEUTRON ACER TENDL-2023 LIBRARY; T=0.K
Particle production cross sections

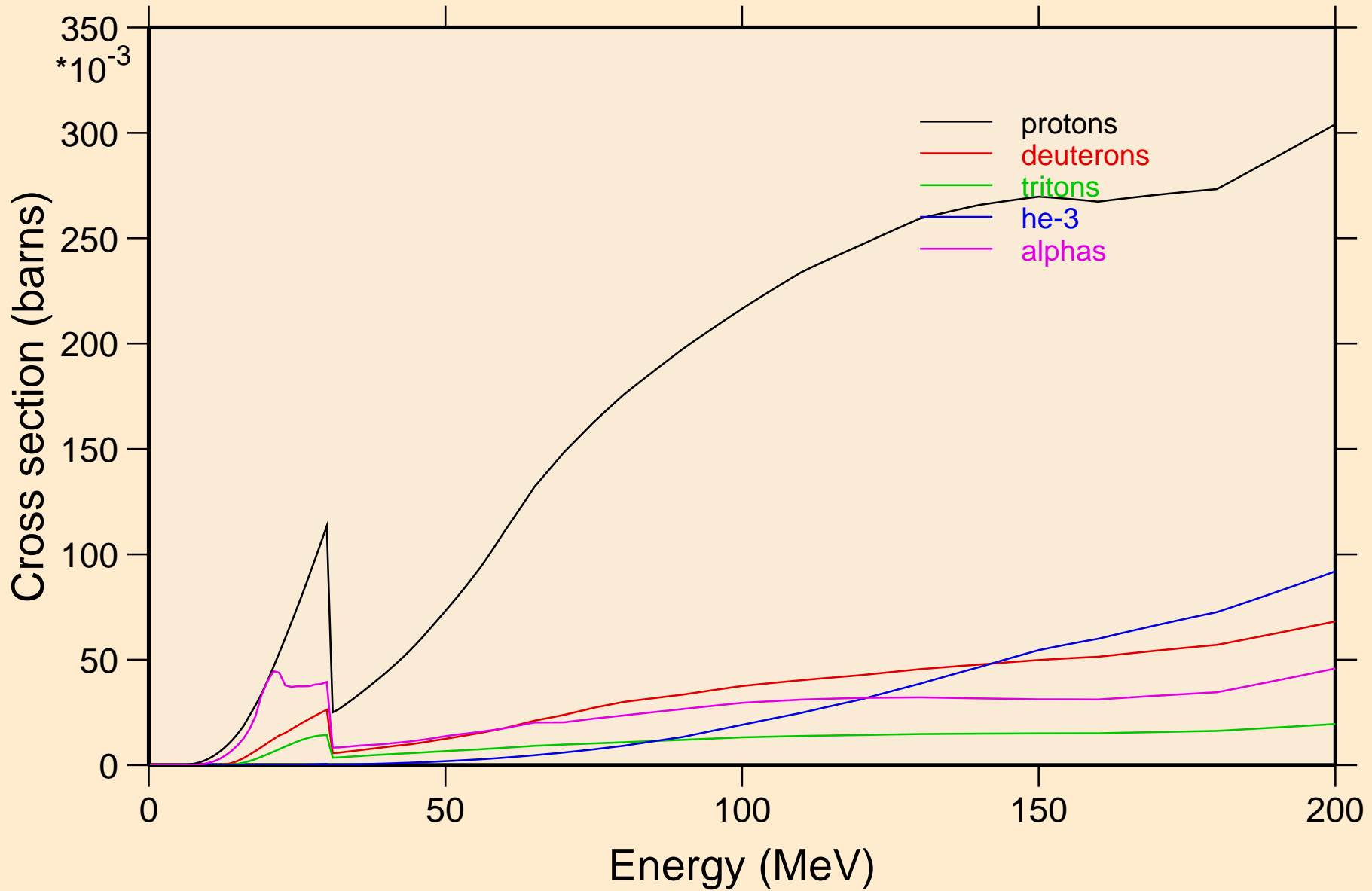

AC222 NEUTRON ACER TENDL-2023 LIBRARY; T=0.K
protons from (n,x)

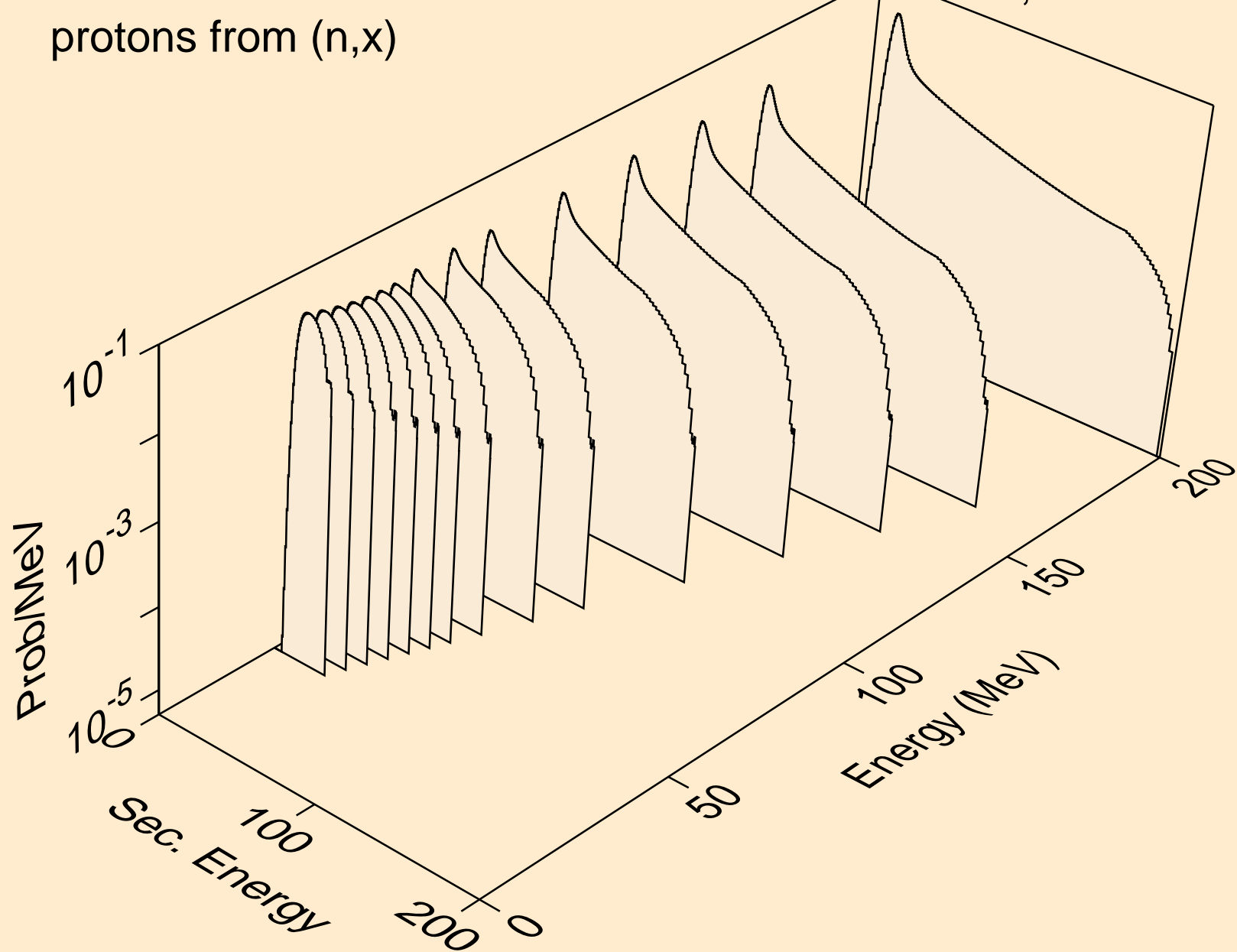

AC222 NEUTRON ACER TENDL-2023 LIBRARY; T=0.K
protons from (n,n*)p

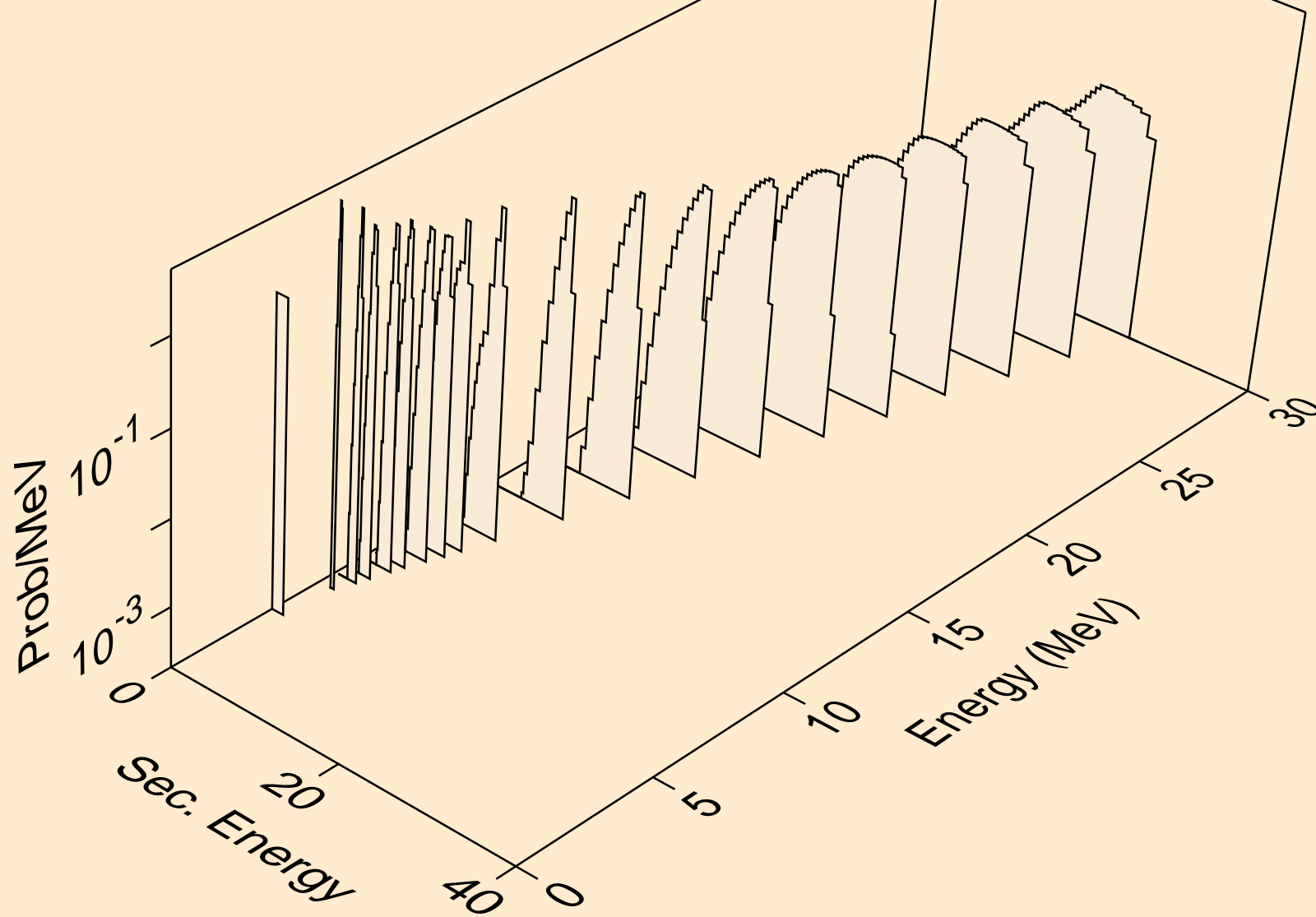

AC222 NEUTRON ACER TENDL-2023 LIBRARY; T=0.K
protons from (n,2np)

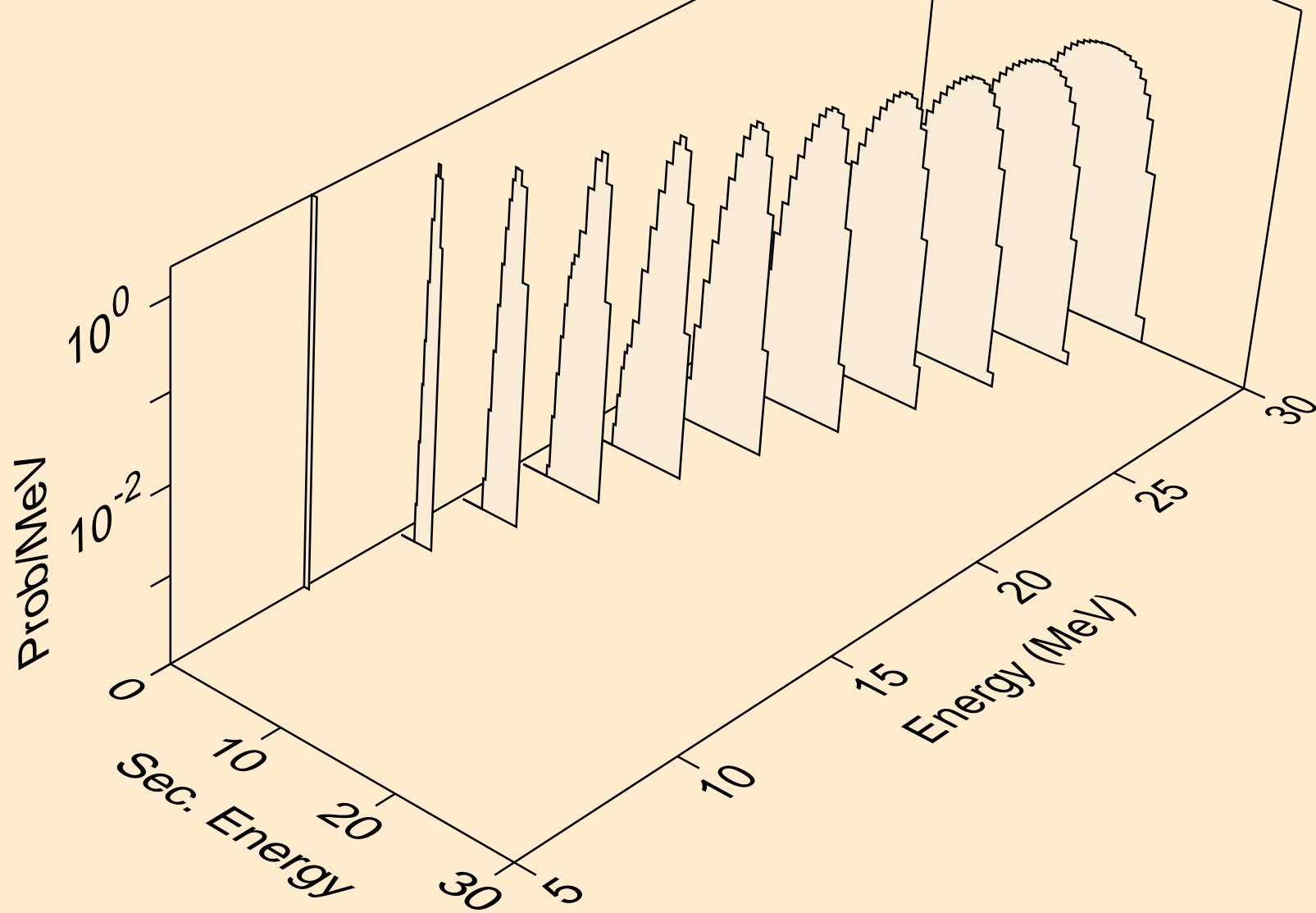

AC222 NEUTRON ACER TENDL-2023 LIBRARY; T=0.K
protons from (n,3np)

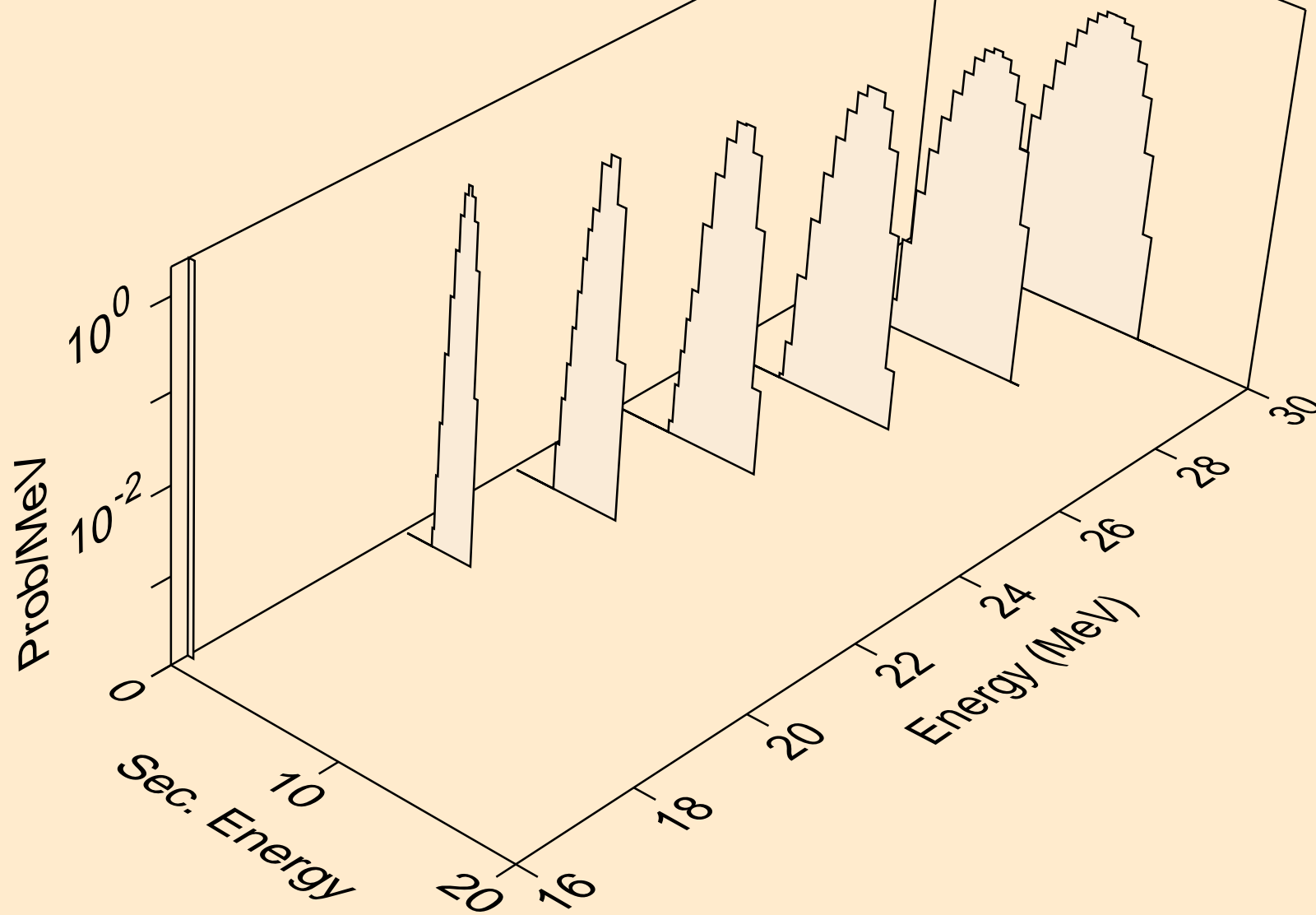

AC222 NEUTRON ACER TENDL-2023 LIBRARY; T=0.K
protons from (n,n2p)

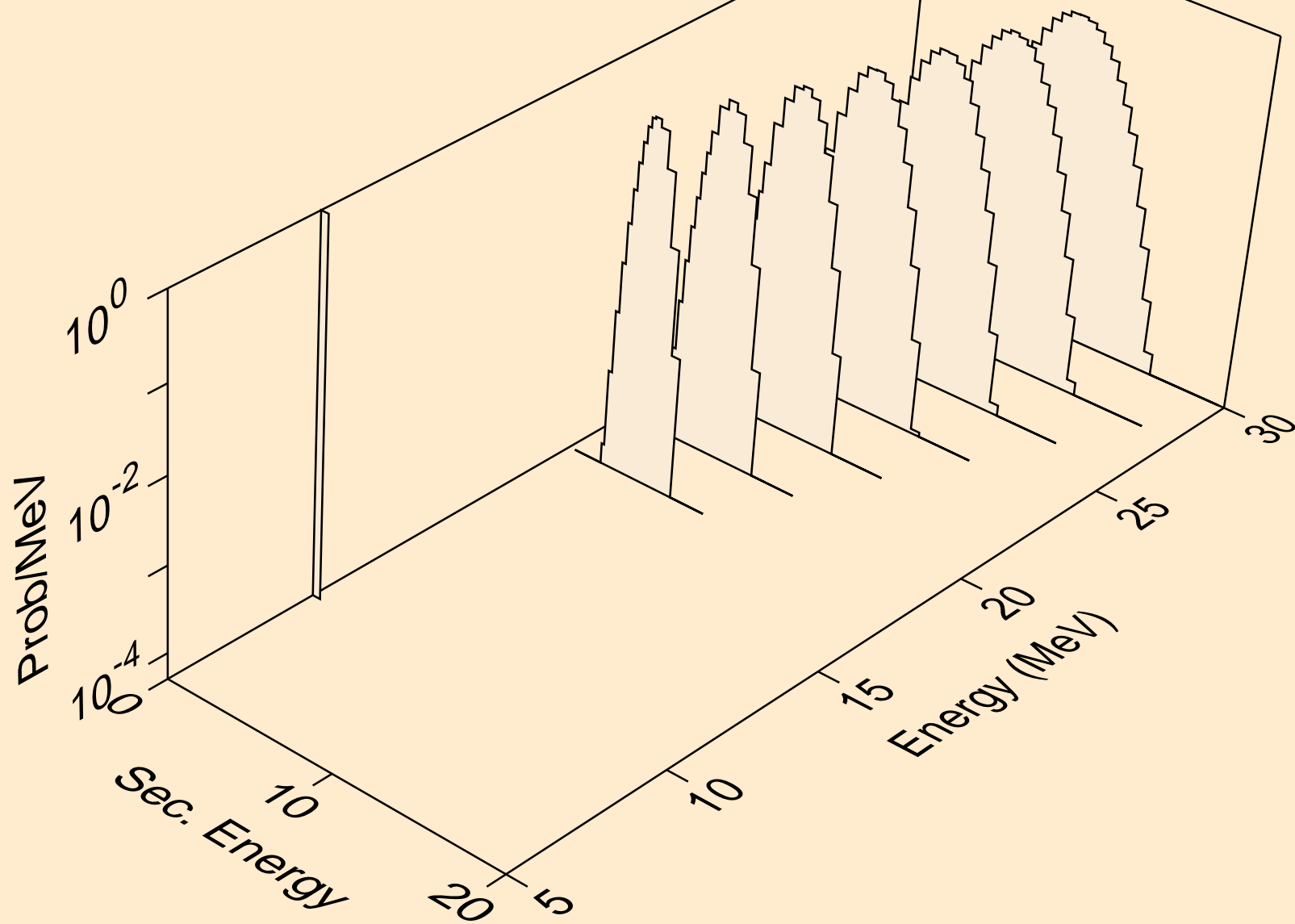

AC222 NEUTRON ACER TENDL-2023 LIBRARY; T=0.K
protons from (n,npa)

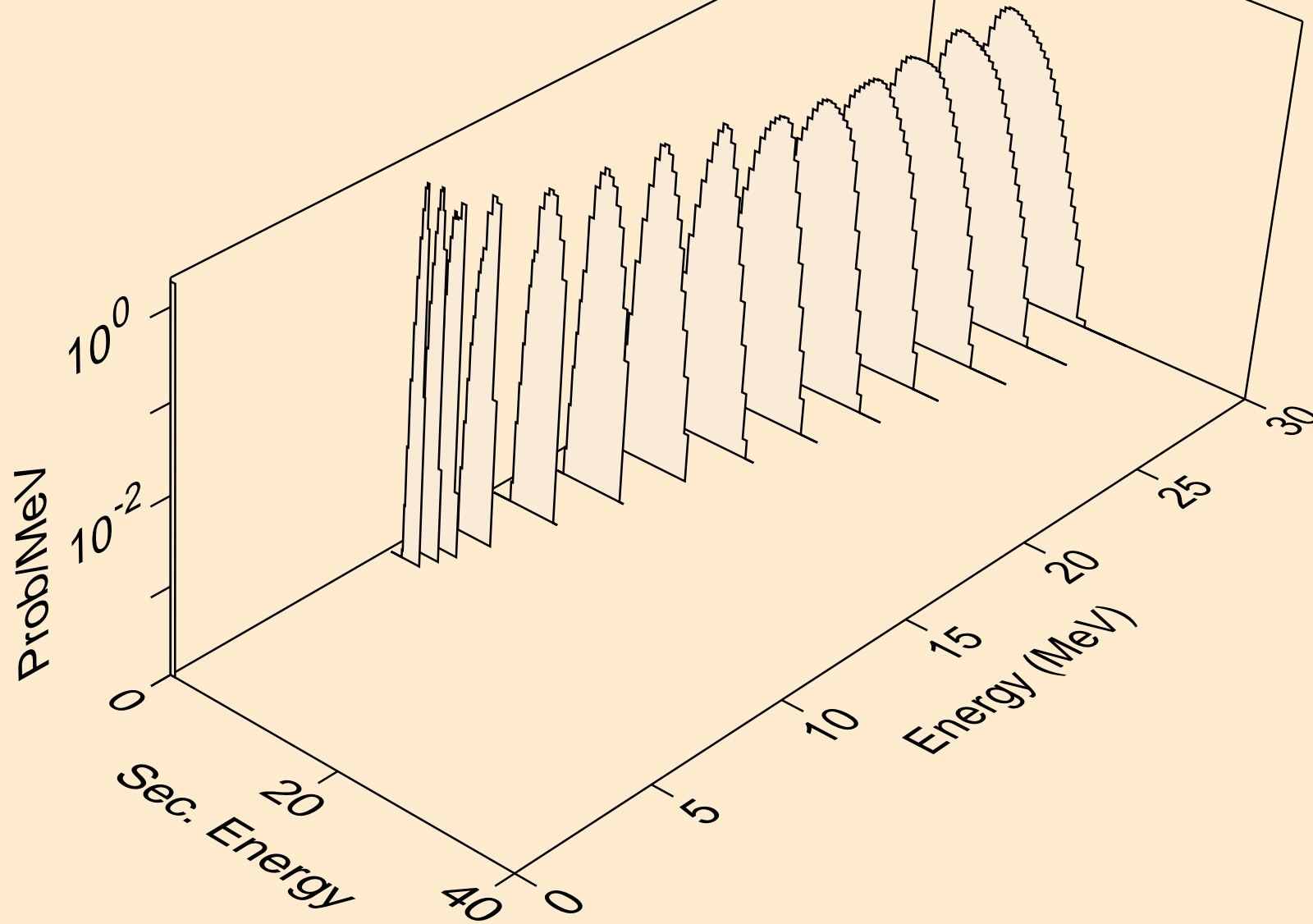

AC222 NEUTRON ACER TENDL-2023 LIBRARY; T=0.K
protons from (n,p)

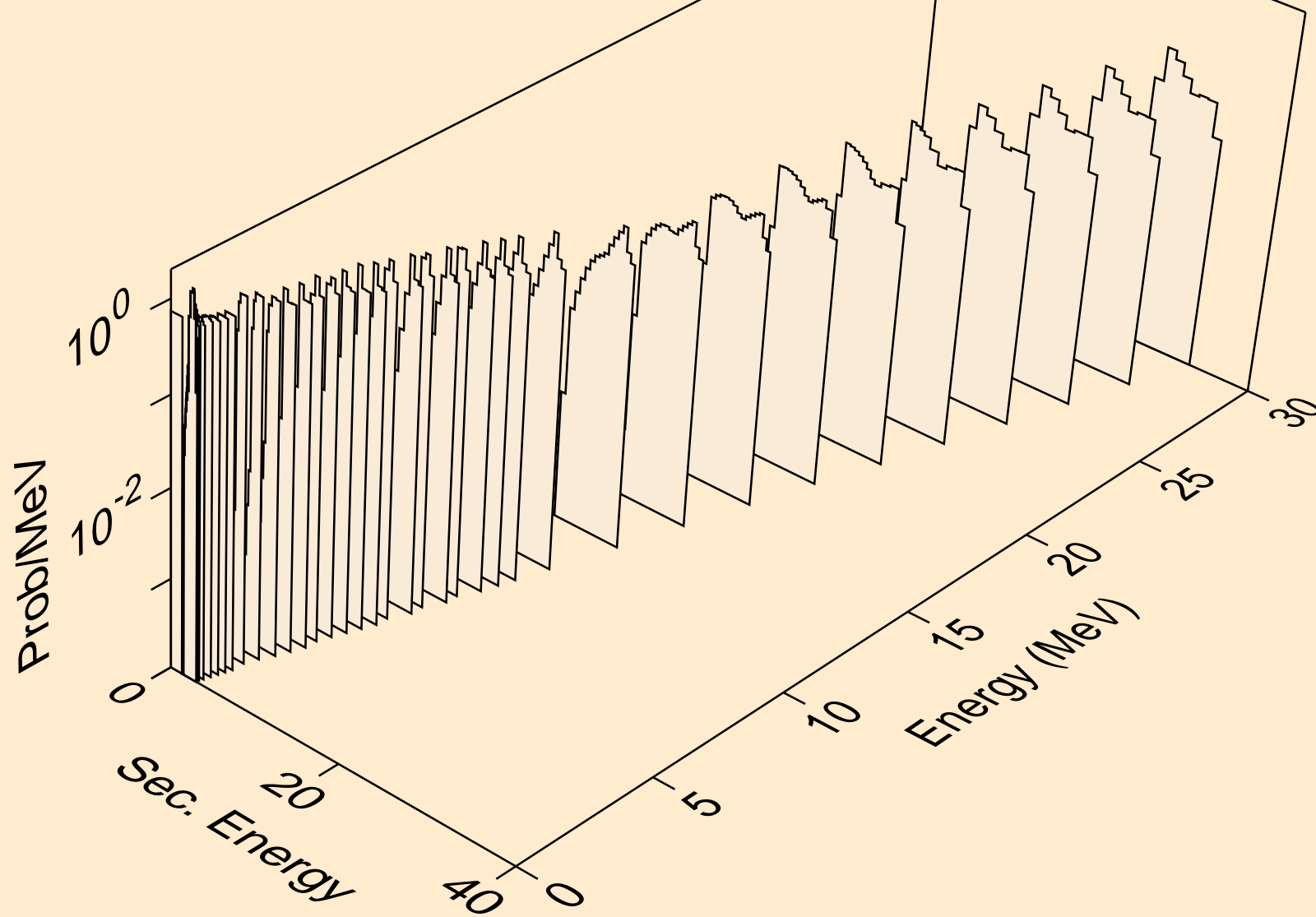

AC222 NEUTRON ACER TENDL-2023 LIBRARY; T=0.K
protons from (n,2p)

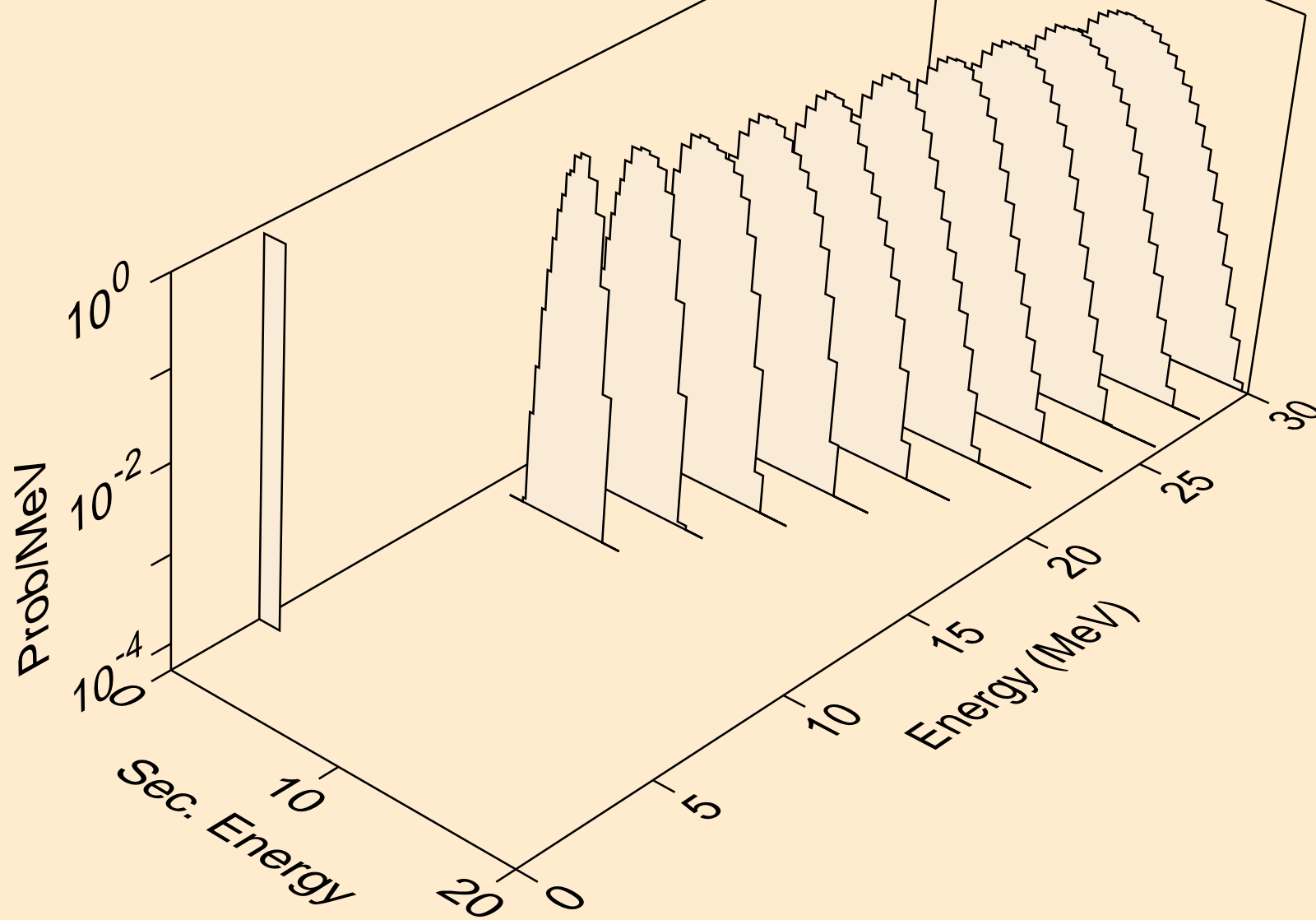

AC222 NEUTRON ACER TENDL-2023 LIBRARY; T=0.K
protons from (n,p)

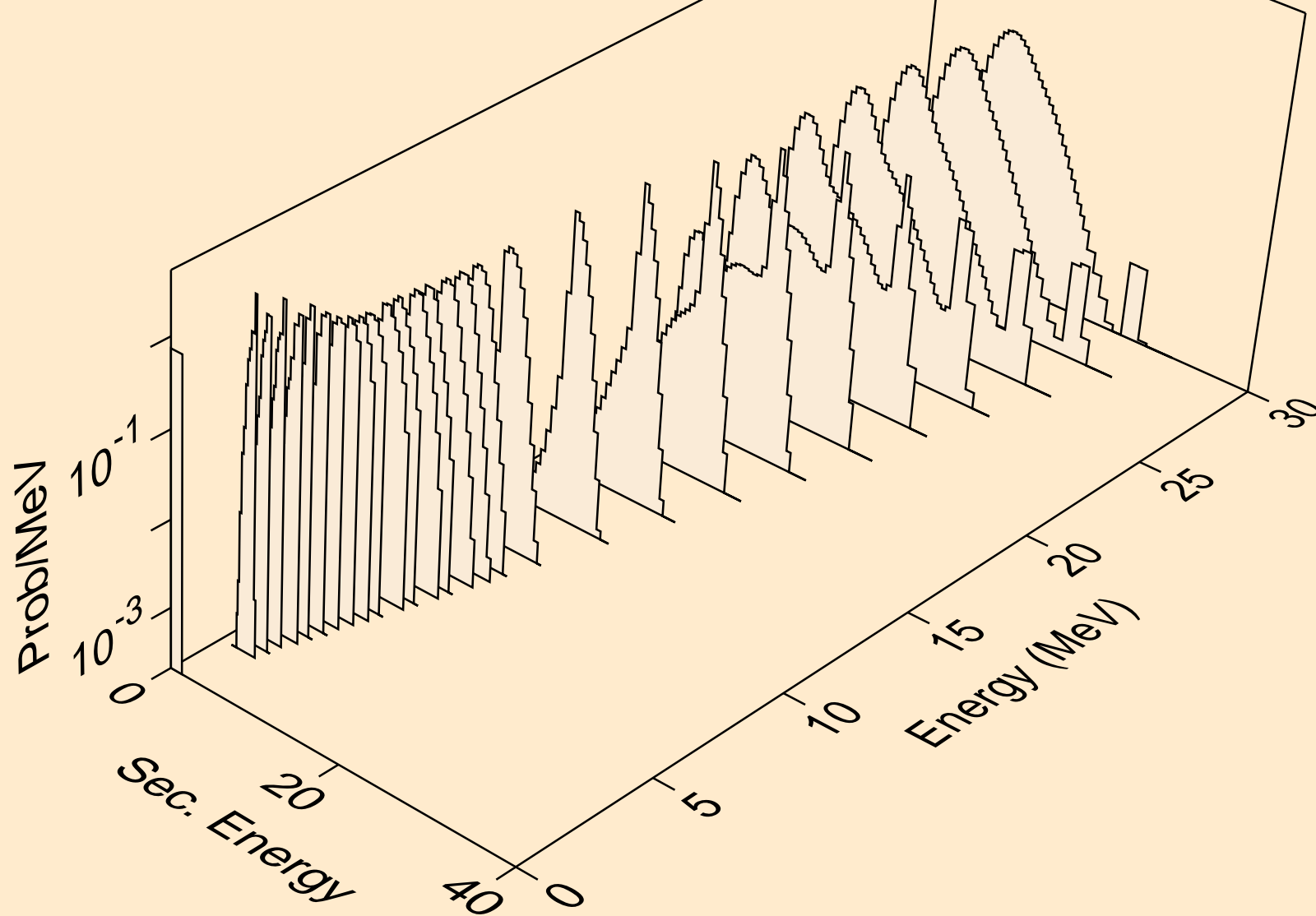

AC222 NEUTRON ACER TENDL-2023 LIBRARY; T=0.K
protons from (n,pd)

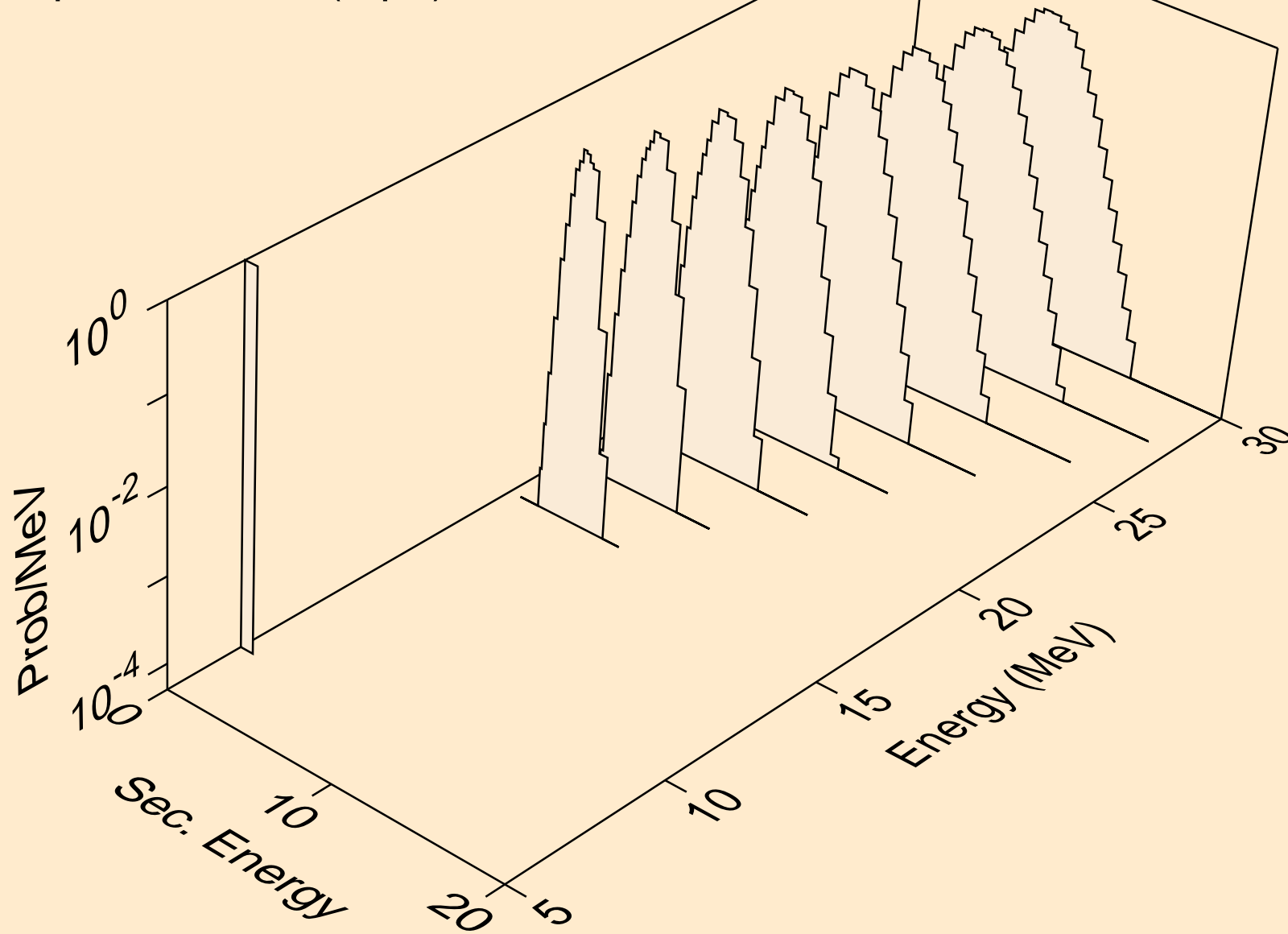

AC222 NEUTRON ACER TENDL-2023 LIBRARY; T=0.K
protons from (n,pt)

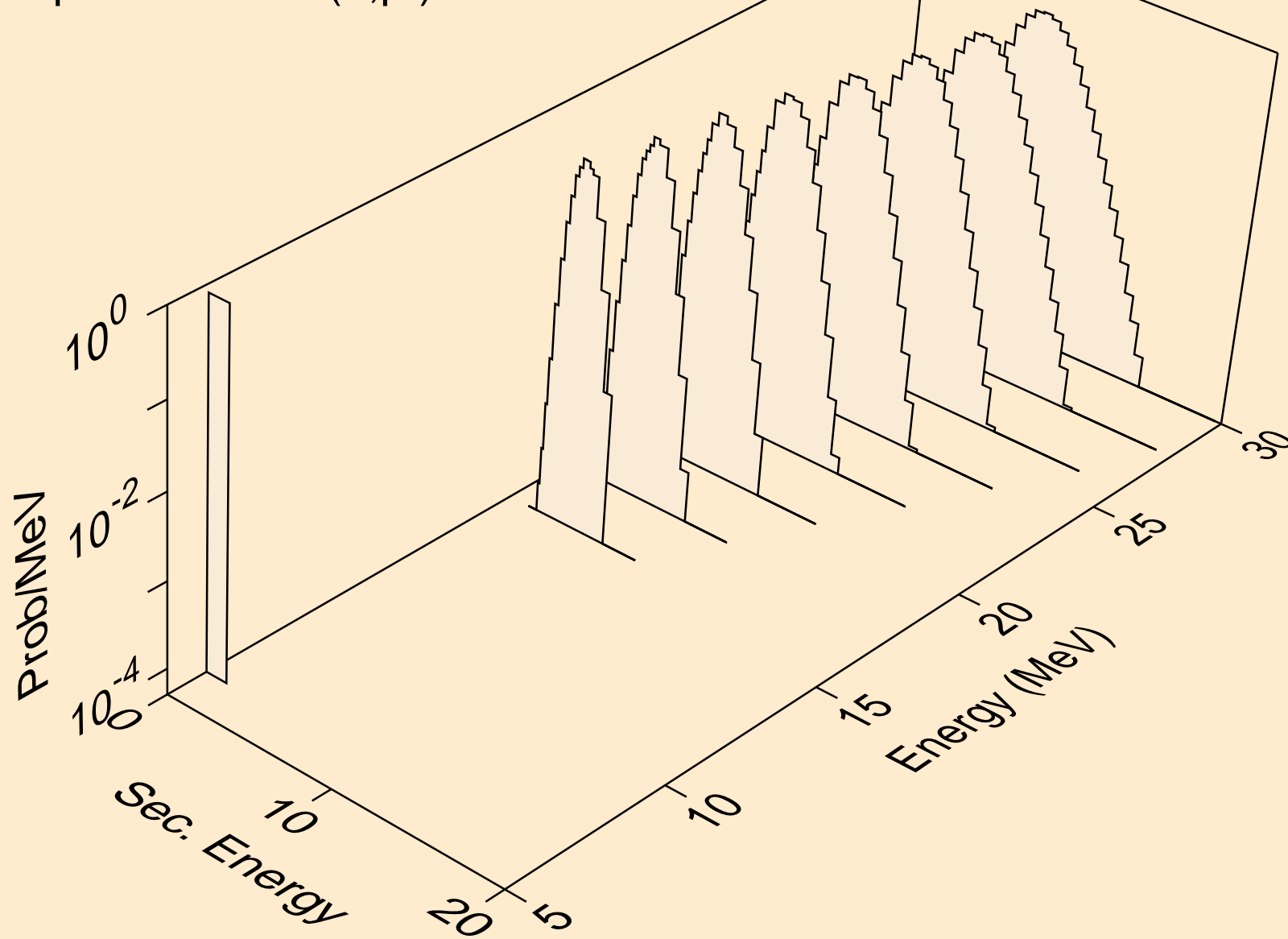

AC222 NEUTRON ACER TENDL-2023 LIBRARY; T=0.K
deuterons from (n,x)

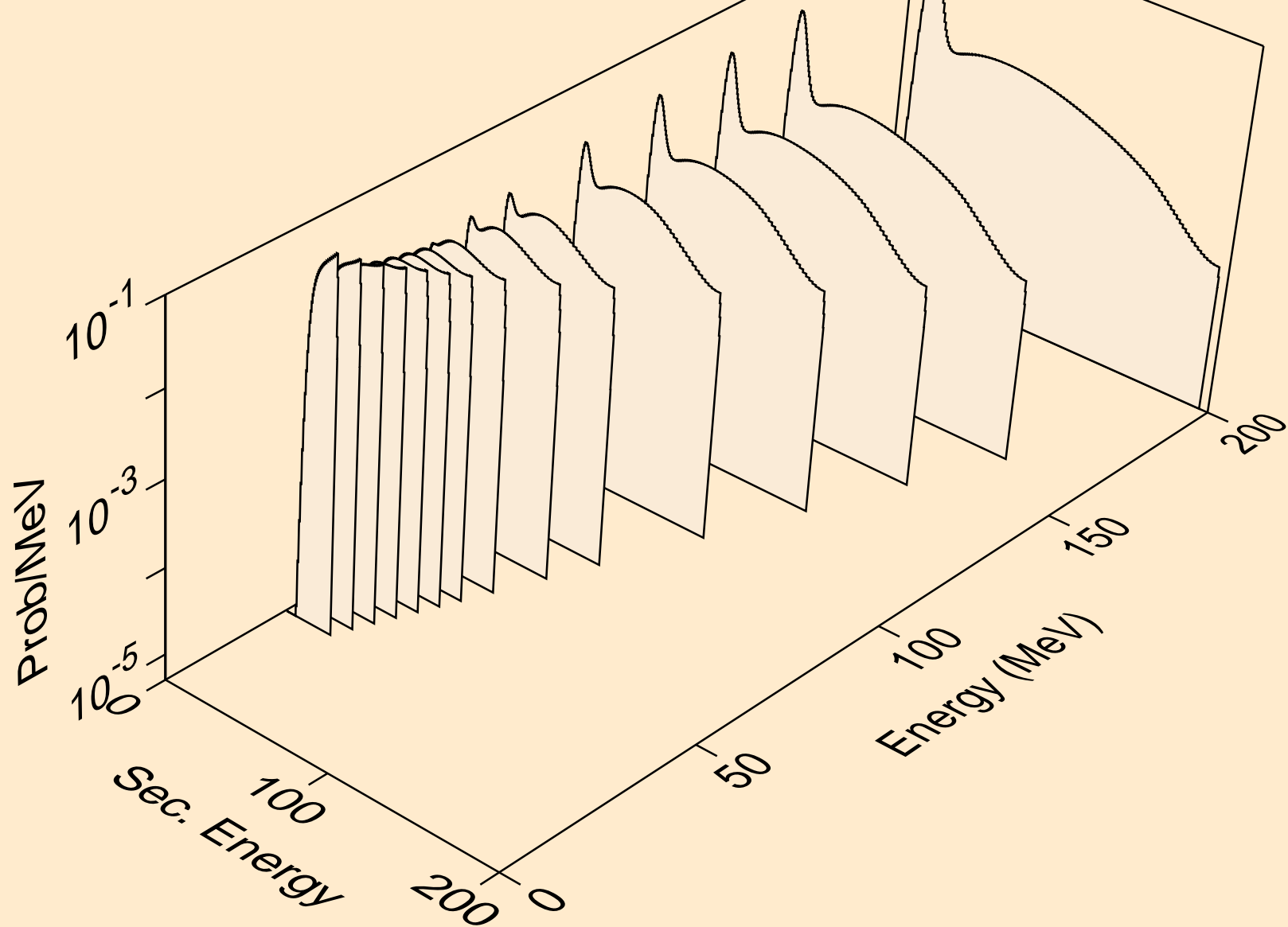

AC222 NEUTRON ACER TENDL-2023 LIBRARY; T=0.K
deuterons from (n,2nd)

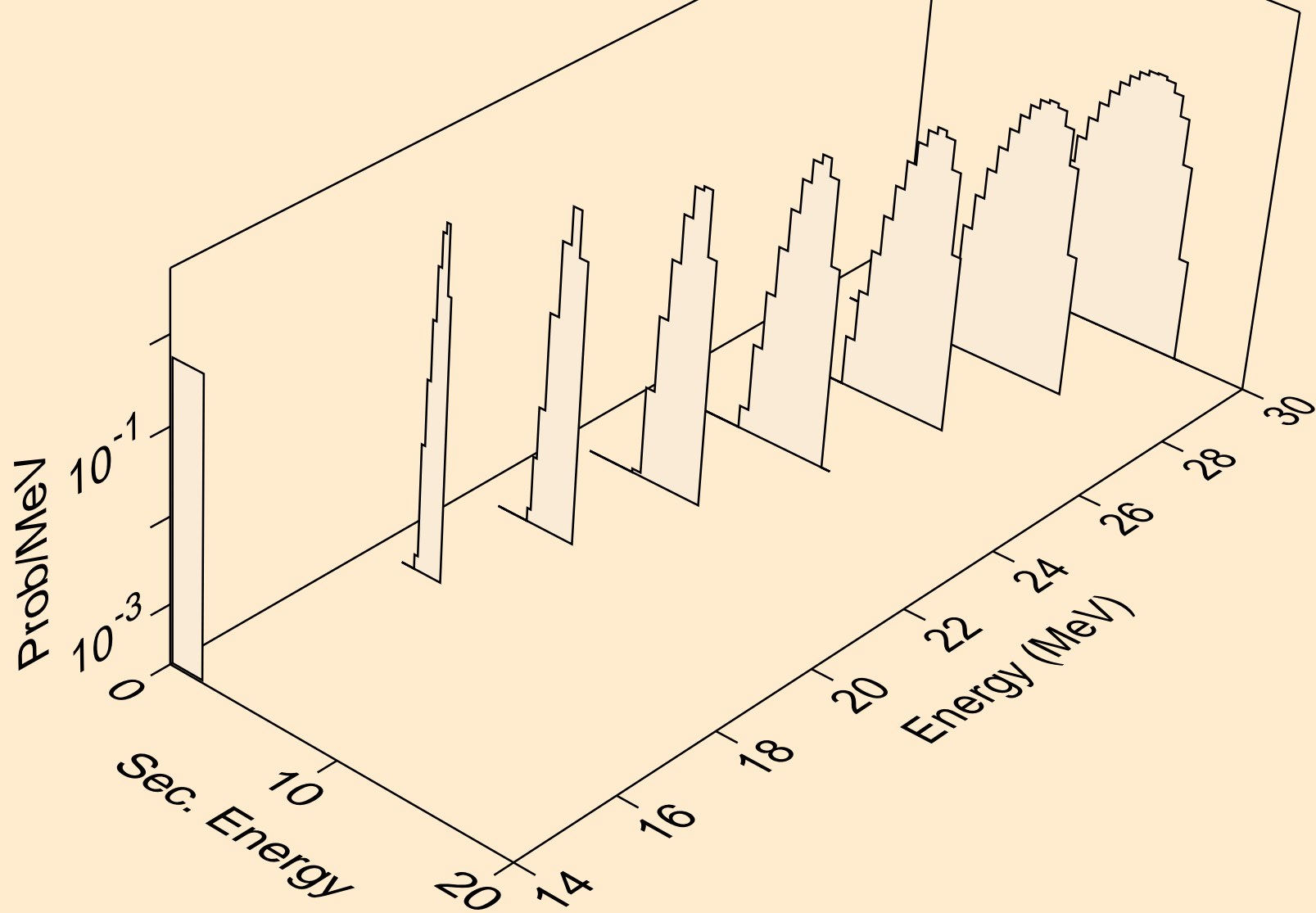

AC222 NEUTRON ACER TENDL-2023 LIBRARY; T=0.K
deuterons from (n,n*)d

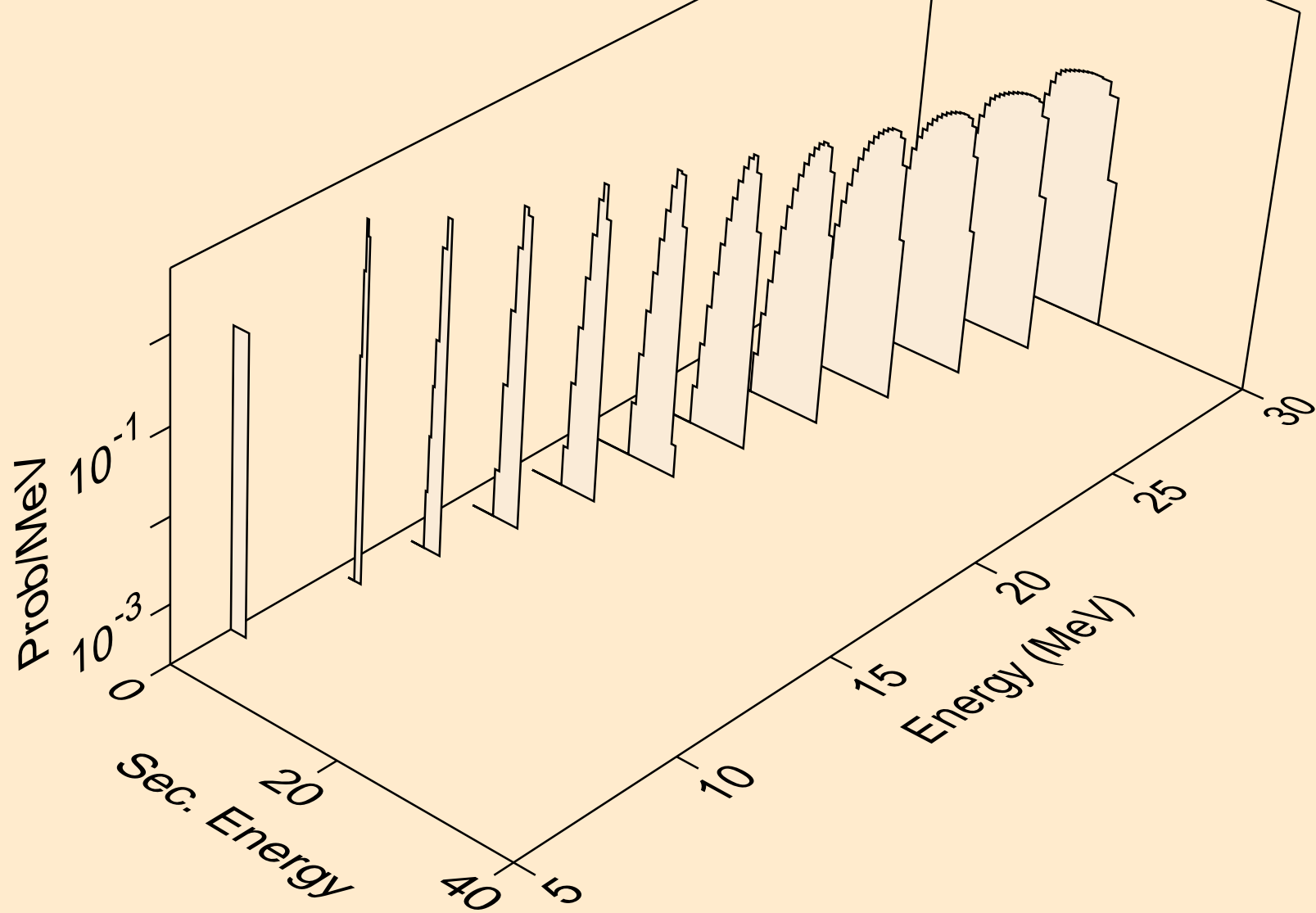

AC222 NEUTRON ACER TENDL-2023 LIBRARY; T=0.K
deuterons from (n,n*)d2a

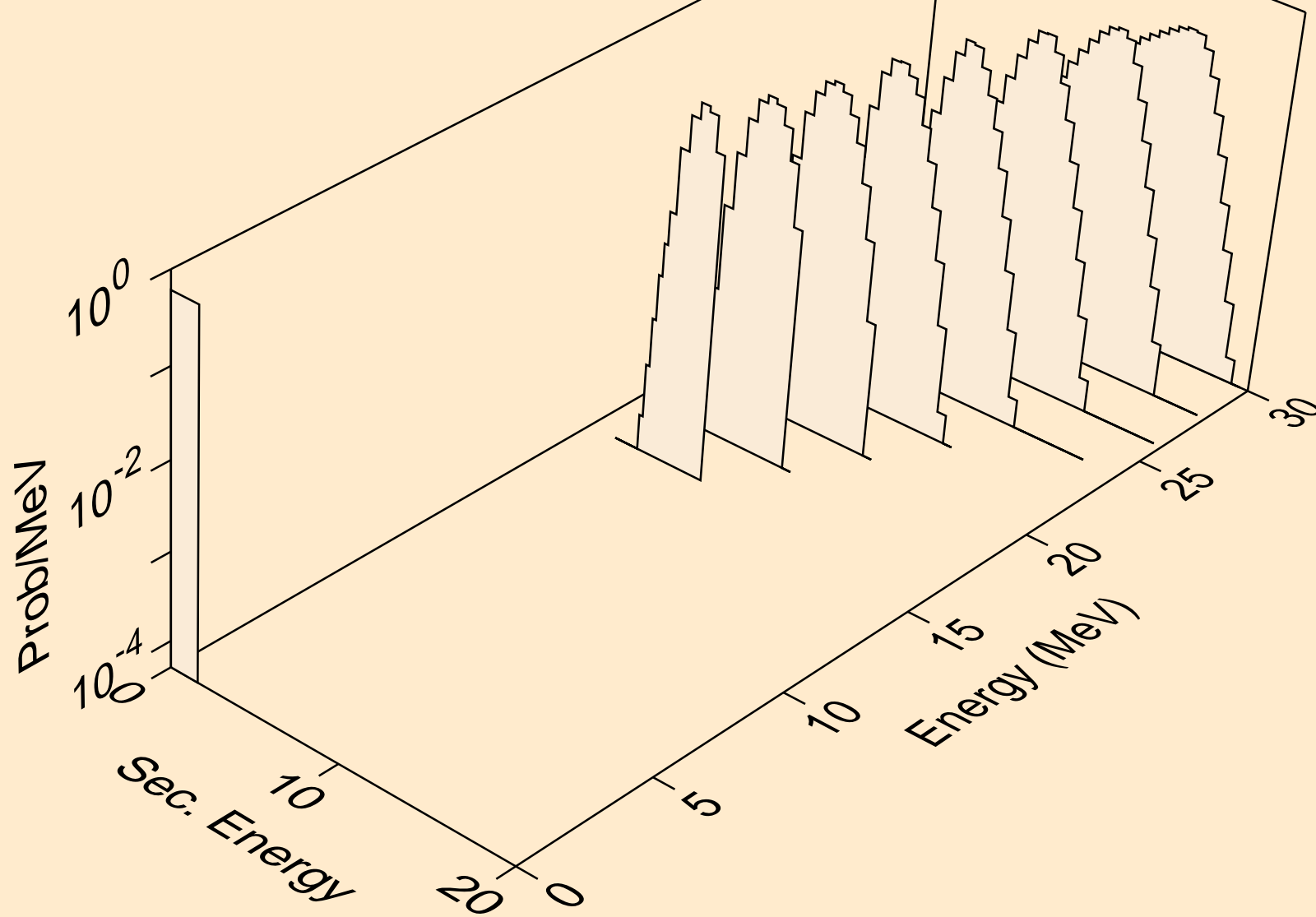

AC222 NEUTRON ACER TENDL-2023 LIBRARY; T=0.K
deuterons from (n,d)

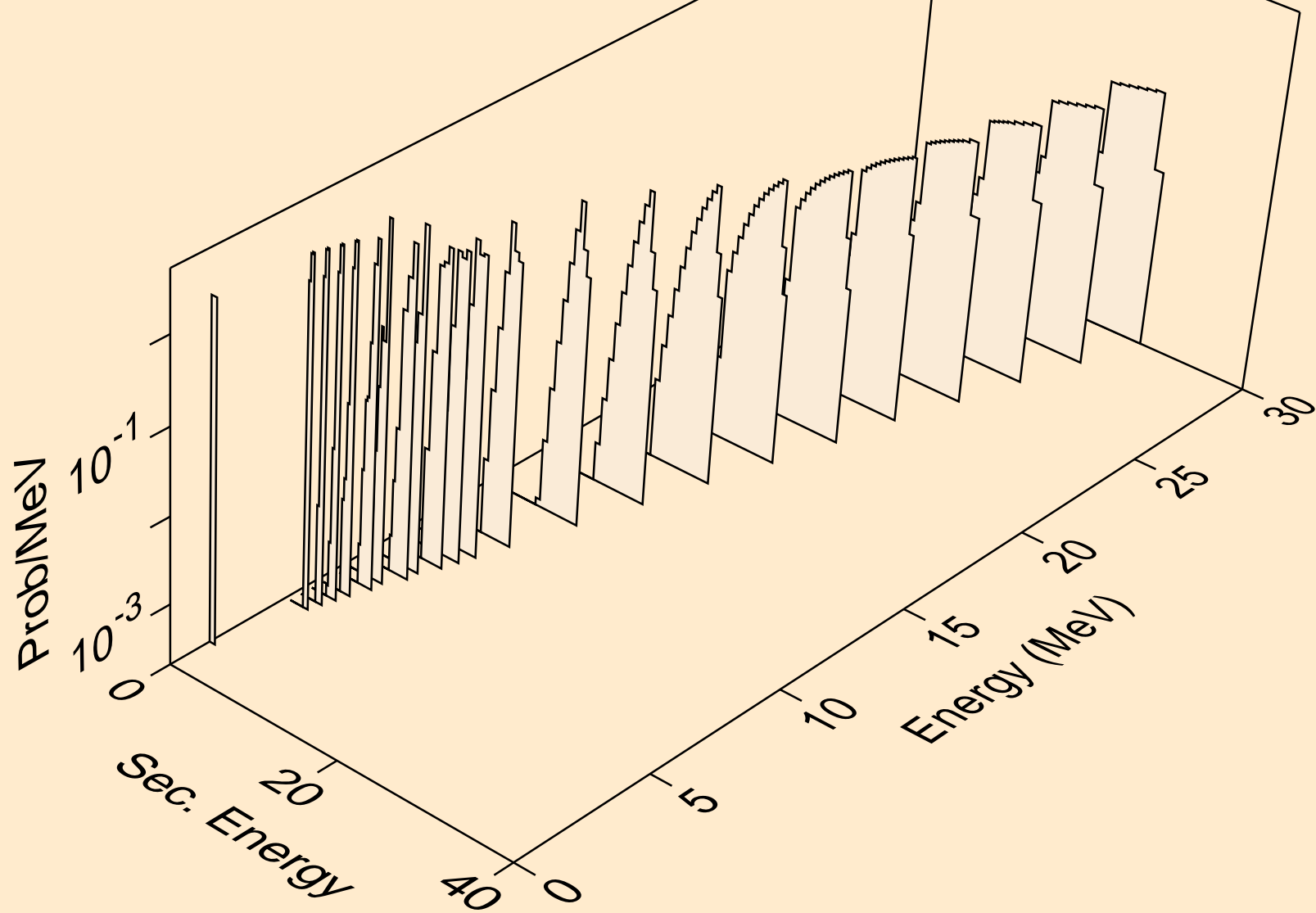

AC222 NEUTRON ACER TENDL-2023 LIBRARY; T=0.K
deuterons from (n,pd)

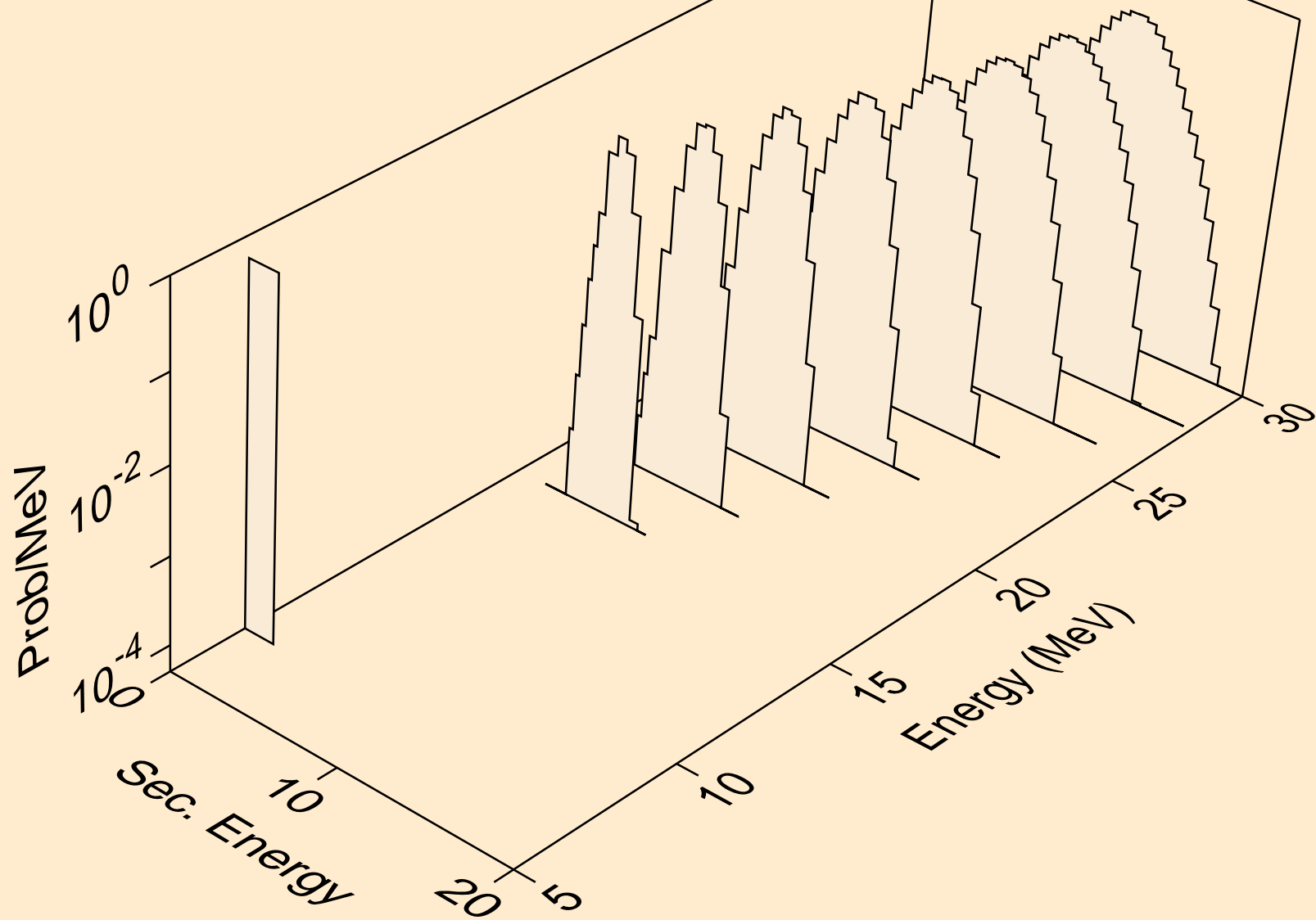

AC222 NEUTRON ACER TENDL-2023 LIBRARY; T=0.K
deuterons from (n,da)

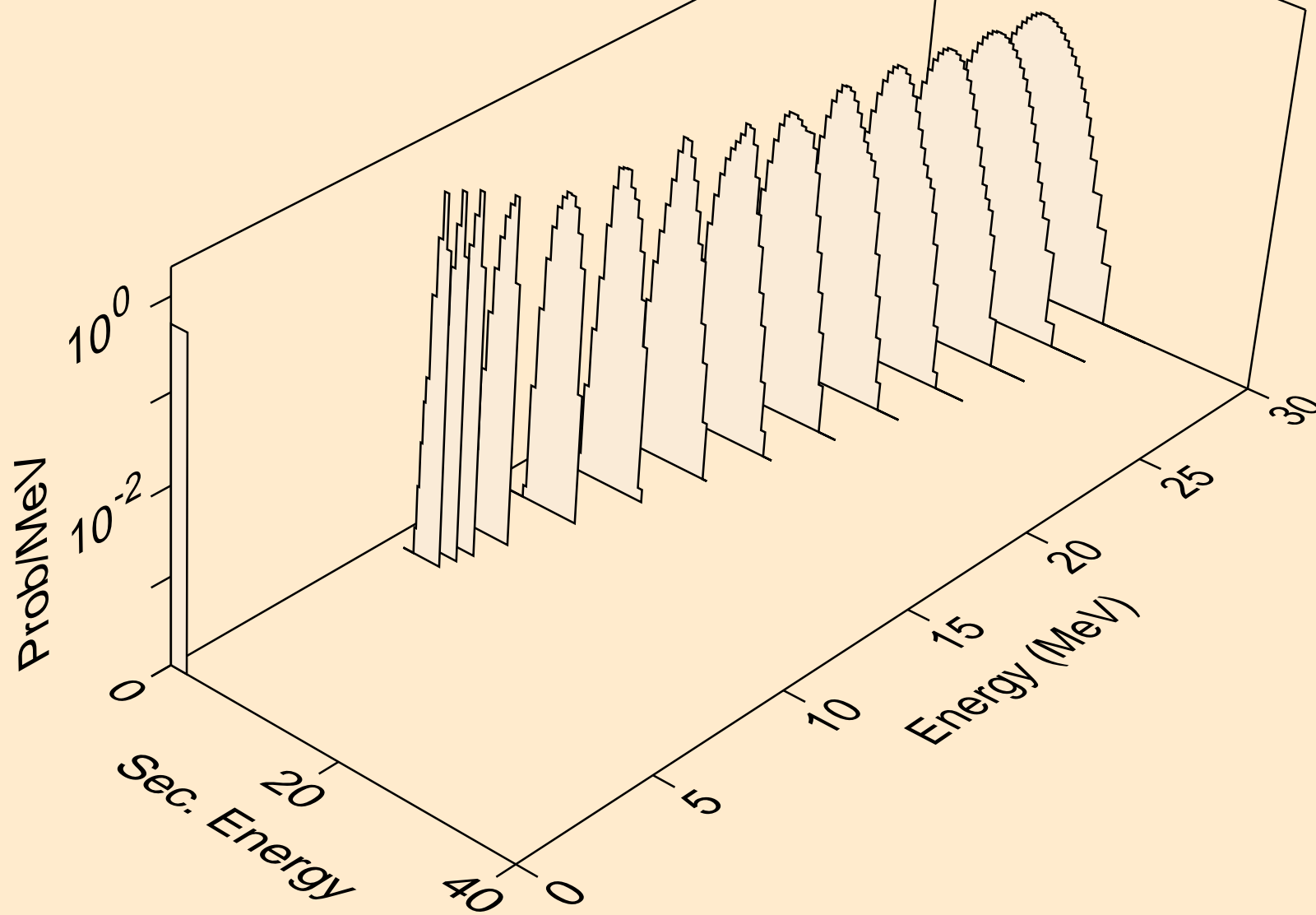

AC222 NEUTRON ACER TENDL-2023 LIBRARY; T=0.K
tritons from (n,x)

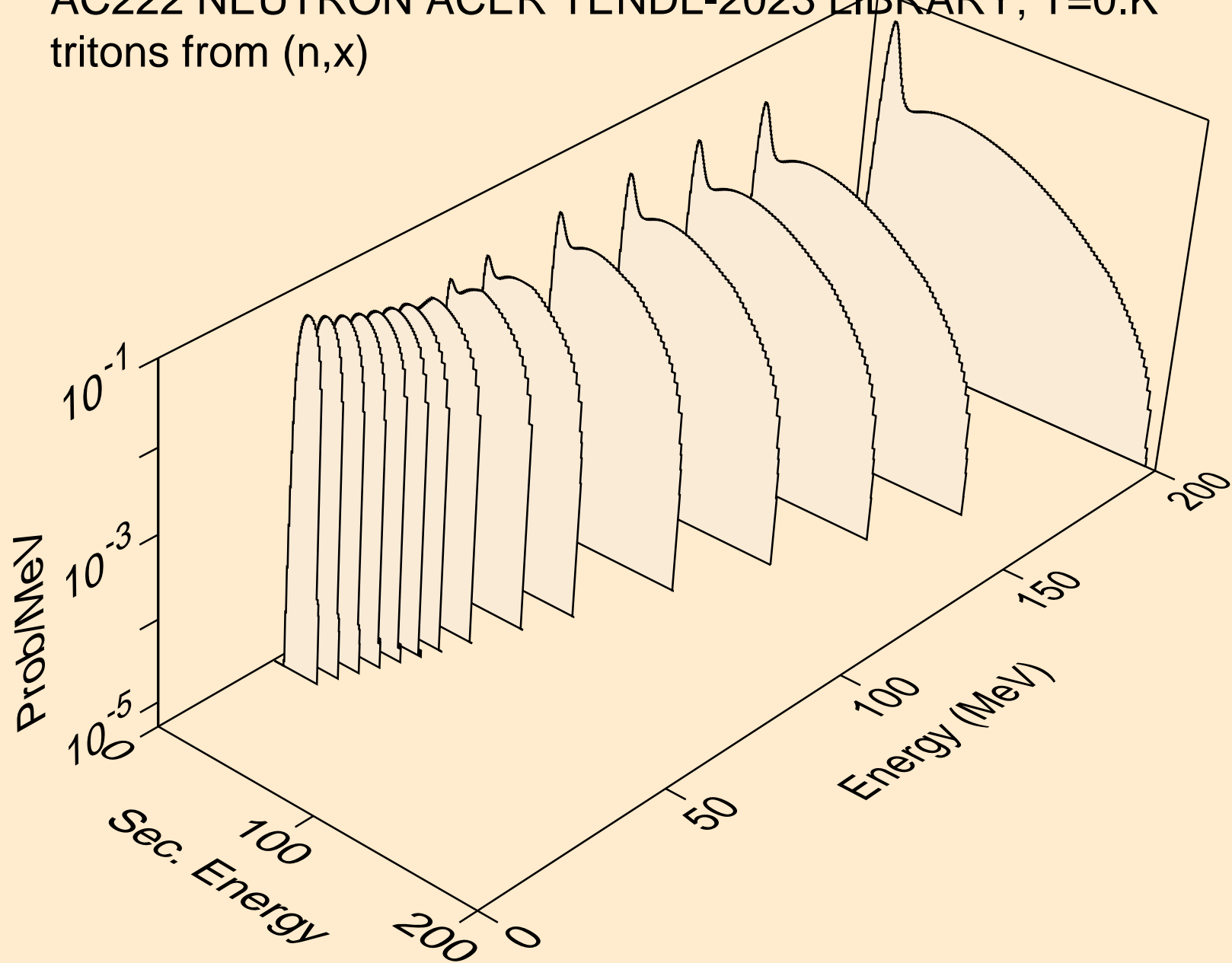

AC222 NEUTRON ACER TENDL-2023 LIBRARY; T=0.K
tritons from (n,n*)t

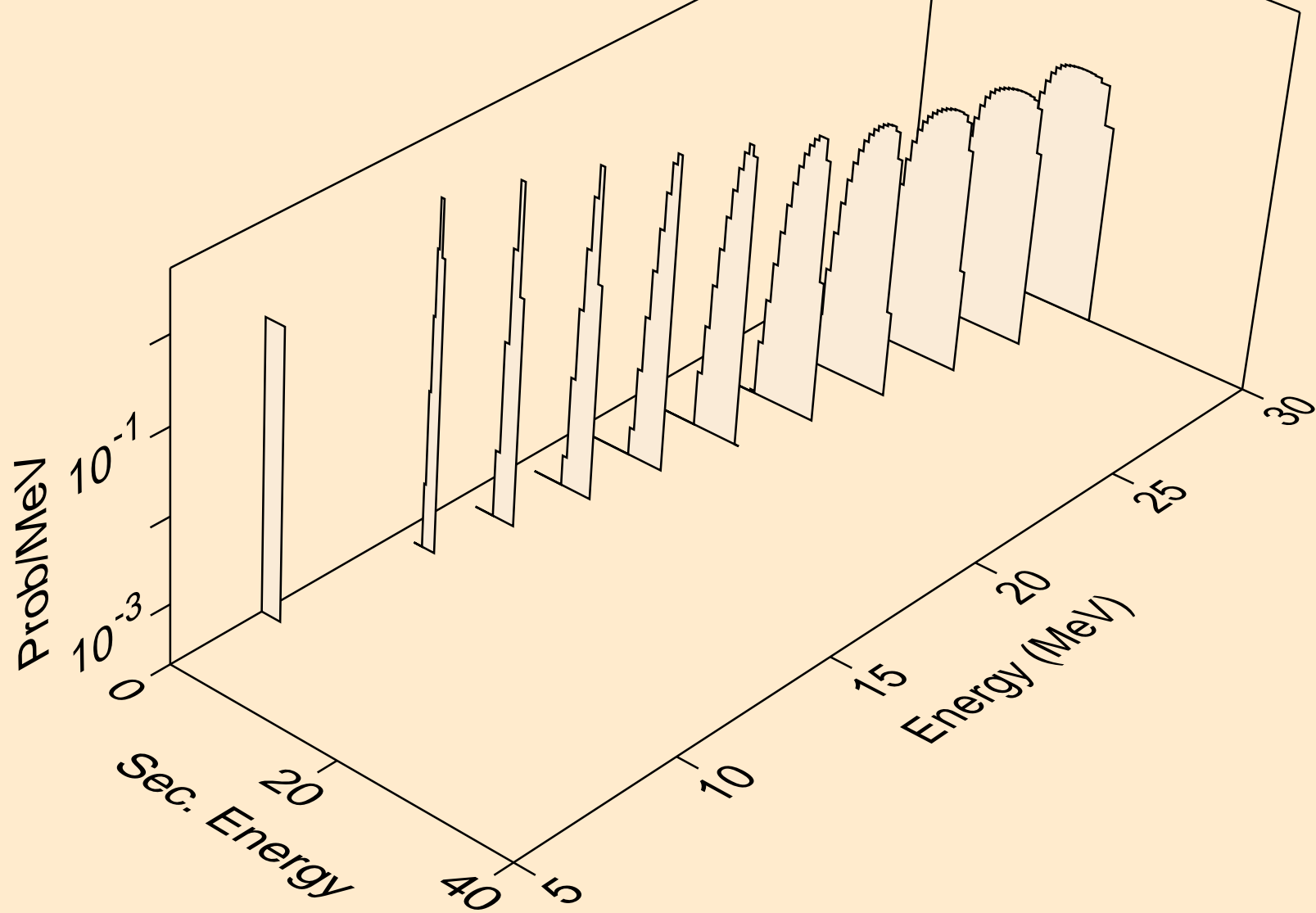

AC222 NEUTRON ACER TENDL-2023 LIBRARY; T=0.K
tritons from (n,n*)t2a

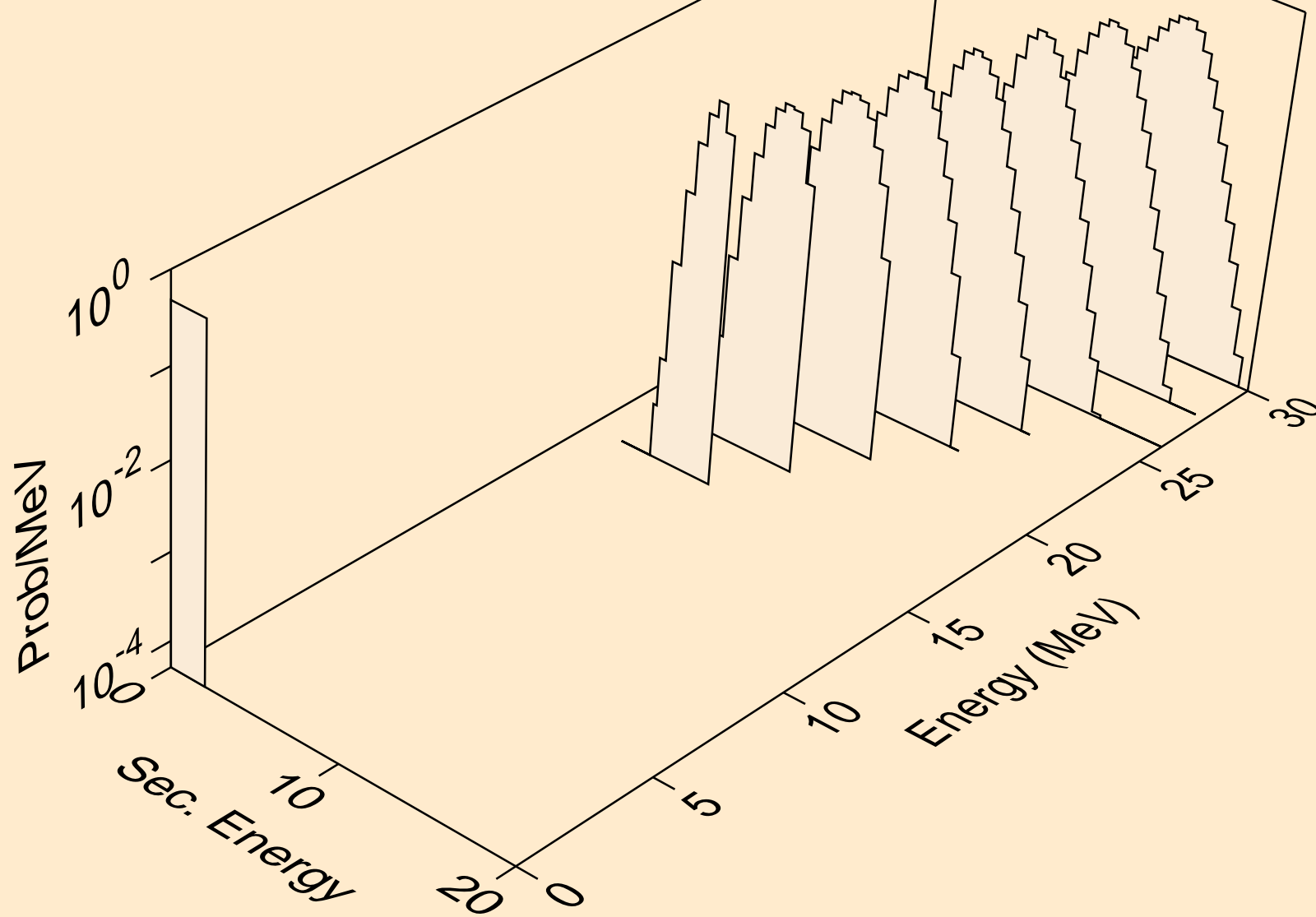

AC222 NEUTRON ACER TENDL-2023 LIBRARY; T=0.K
tritons from (n,t)

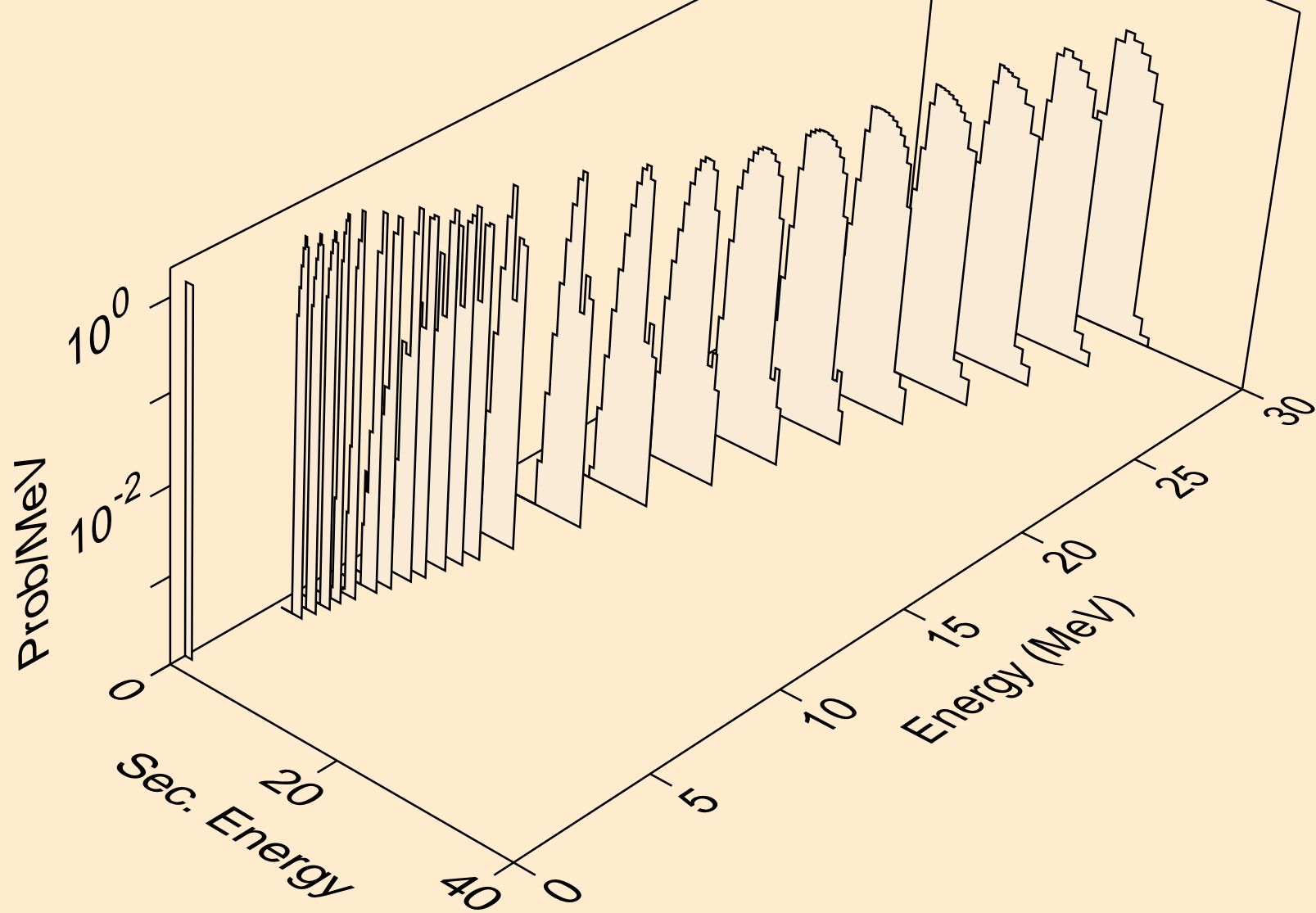

AC222 NEUTRON ACER TENDL-2023 LIBRARY; T=0.K
tritons from (n,t2a)

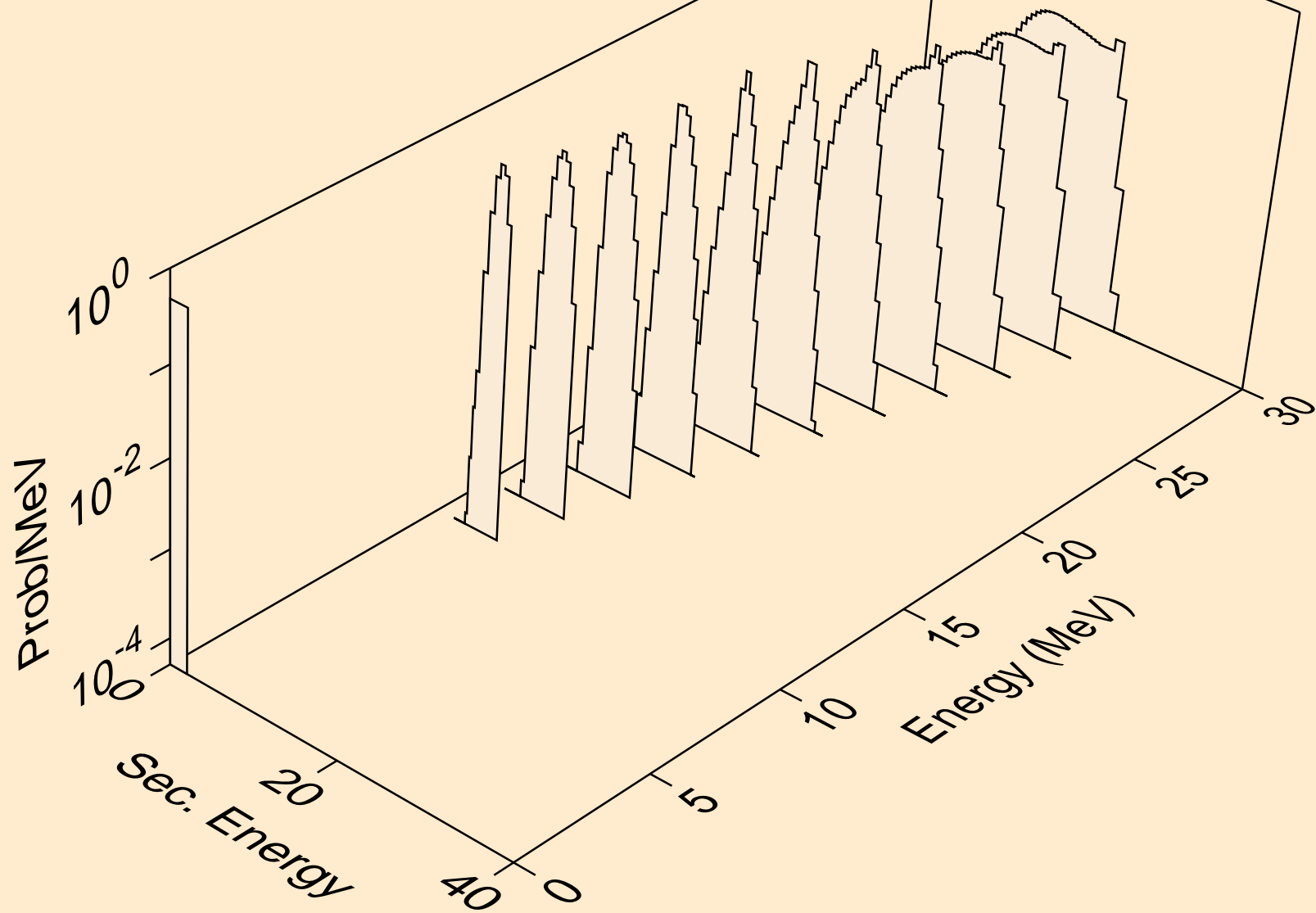

AC222 NEUTRON ACER TENDL-2023 LIBRARY; T=0.K
tritons from (n,pt)

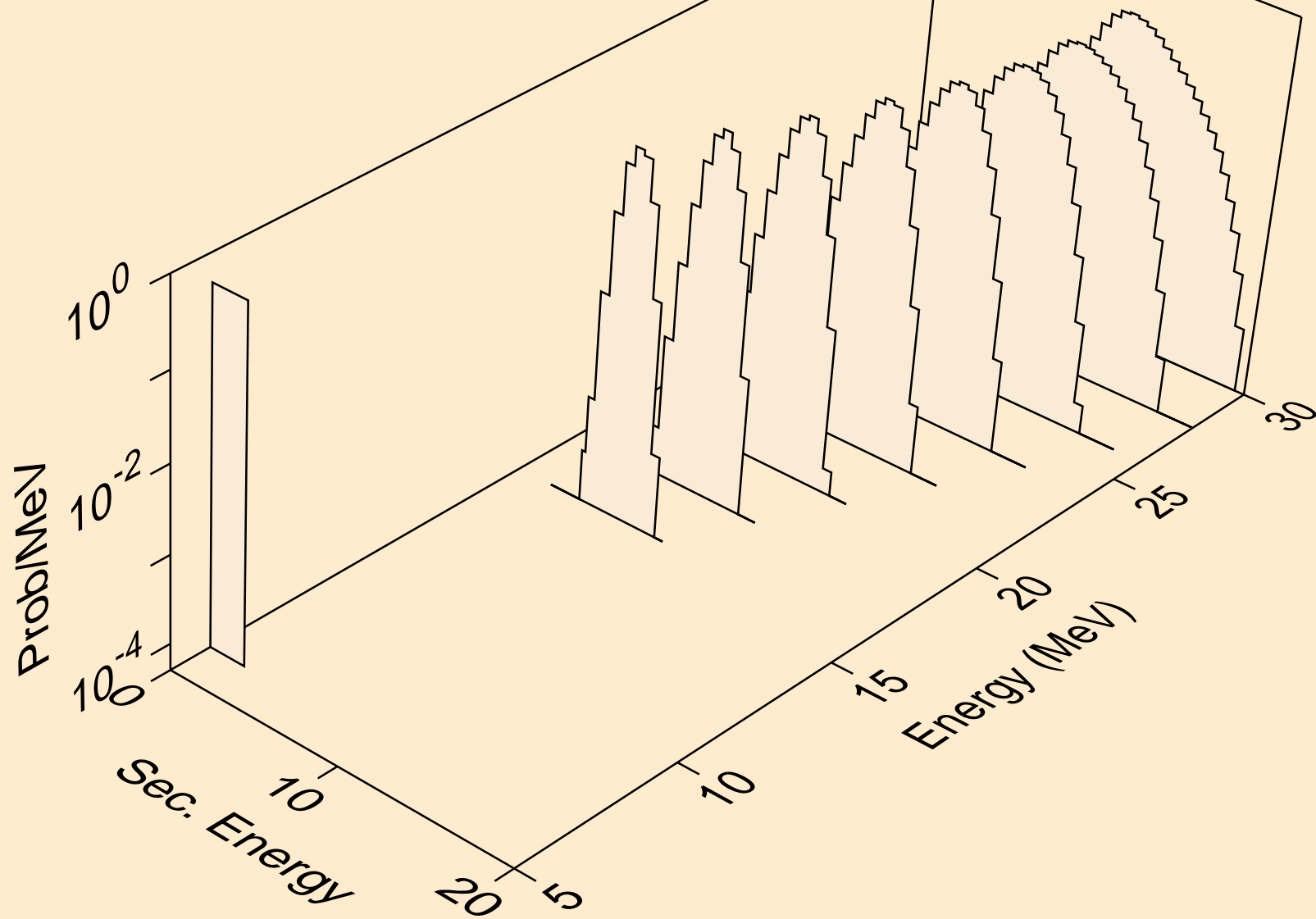

AC222 NEUTRON ACER TENDL-2023 LIBRARY; T=0.K
he3s from (n,x)

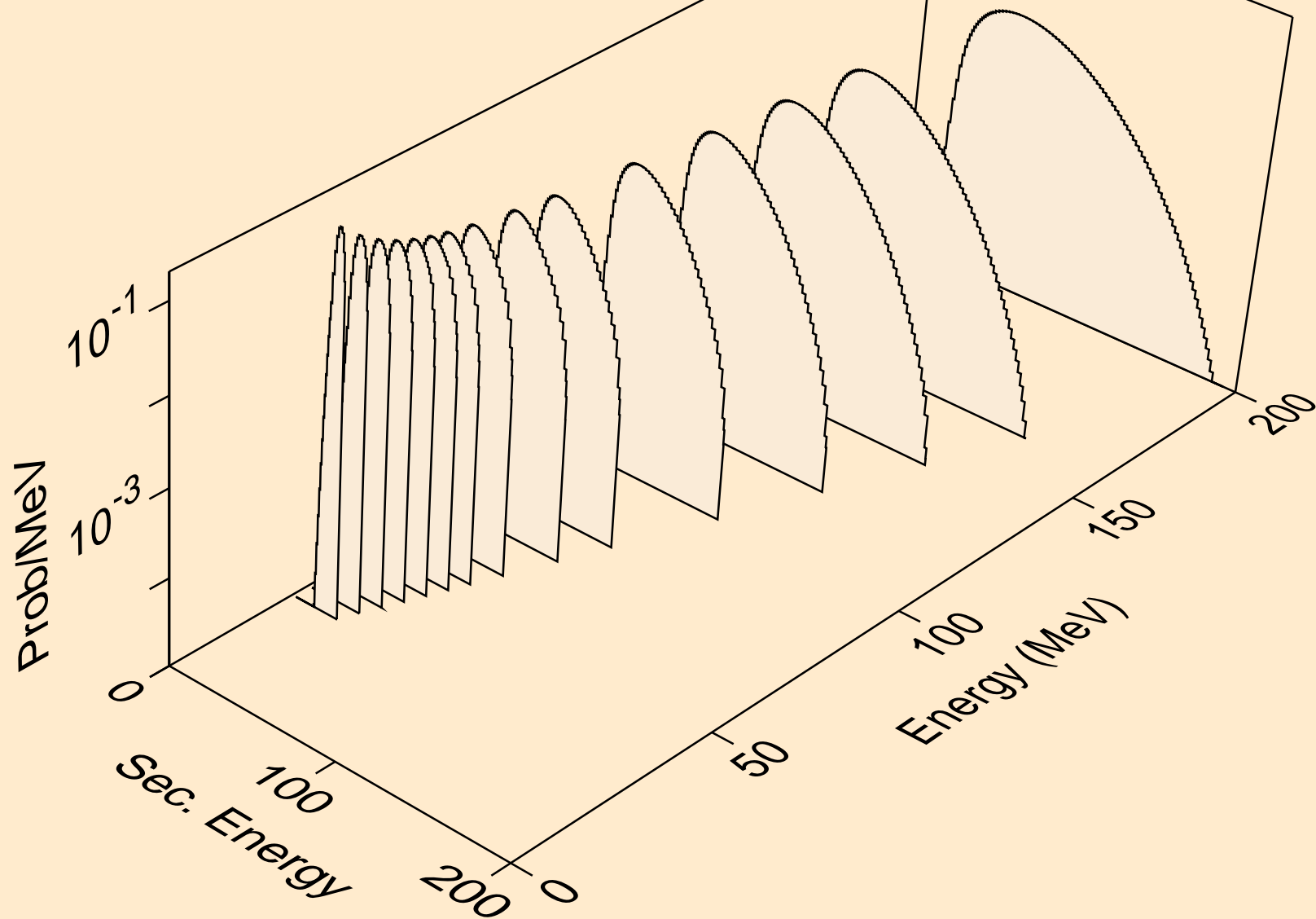

AC222 NEUTRON ACER TENDL-2023 LIBRARY; T=0.K
he3s from (n,n*)he3

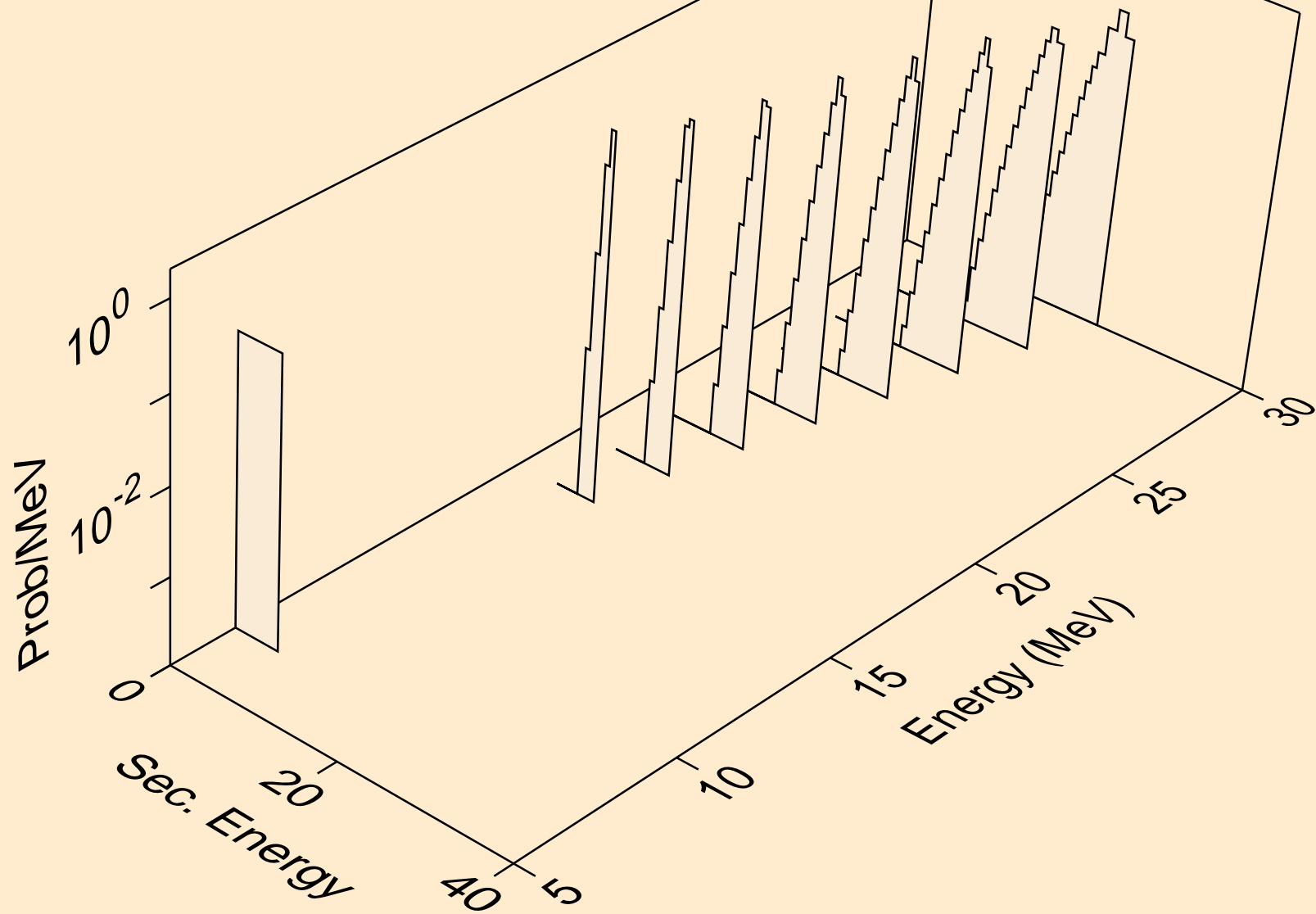

AC222 NEUTRON ACER TENDL-2023 LIBRARY; T=0.K
he3s from (n,he3)

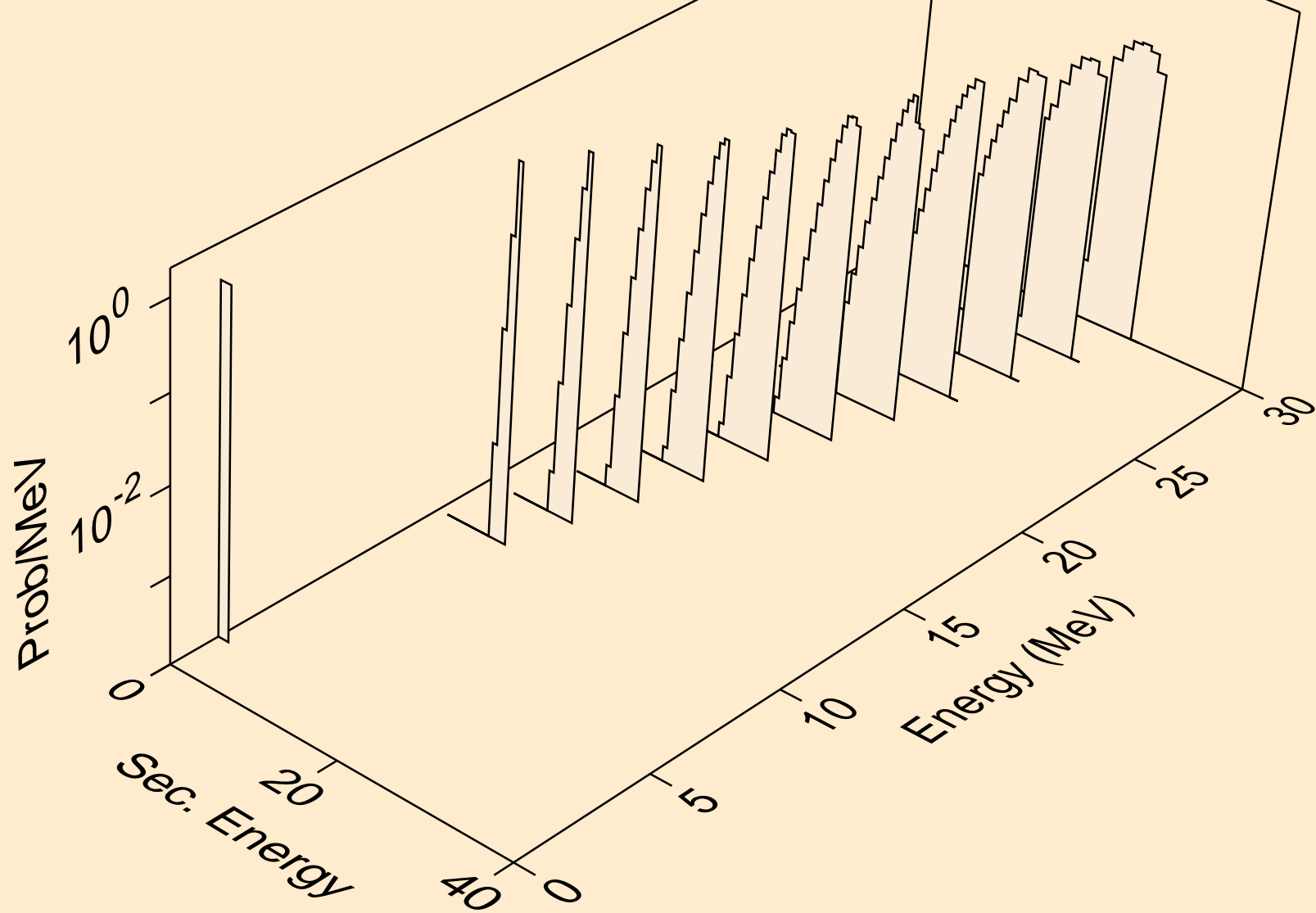

AC222 NEUTRON ACER TENDL-2023 LIBRARY; T=0.K
alphas from (n,x)

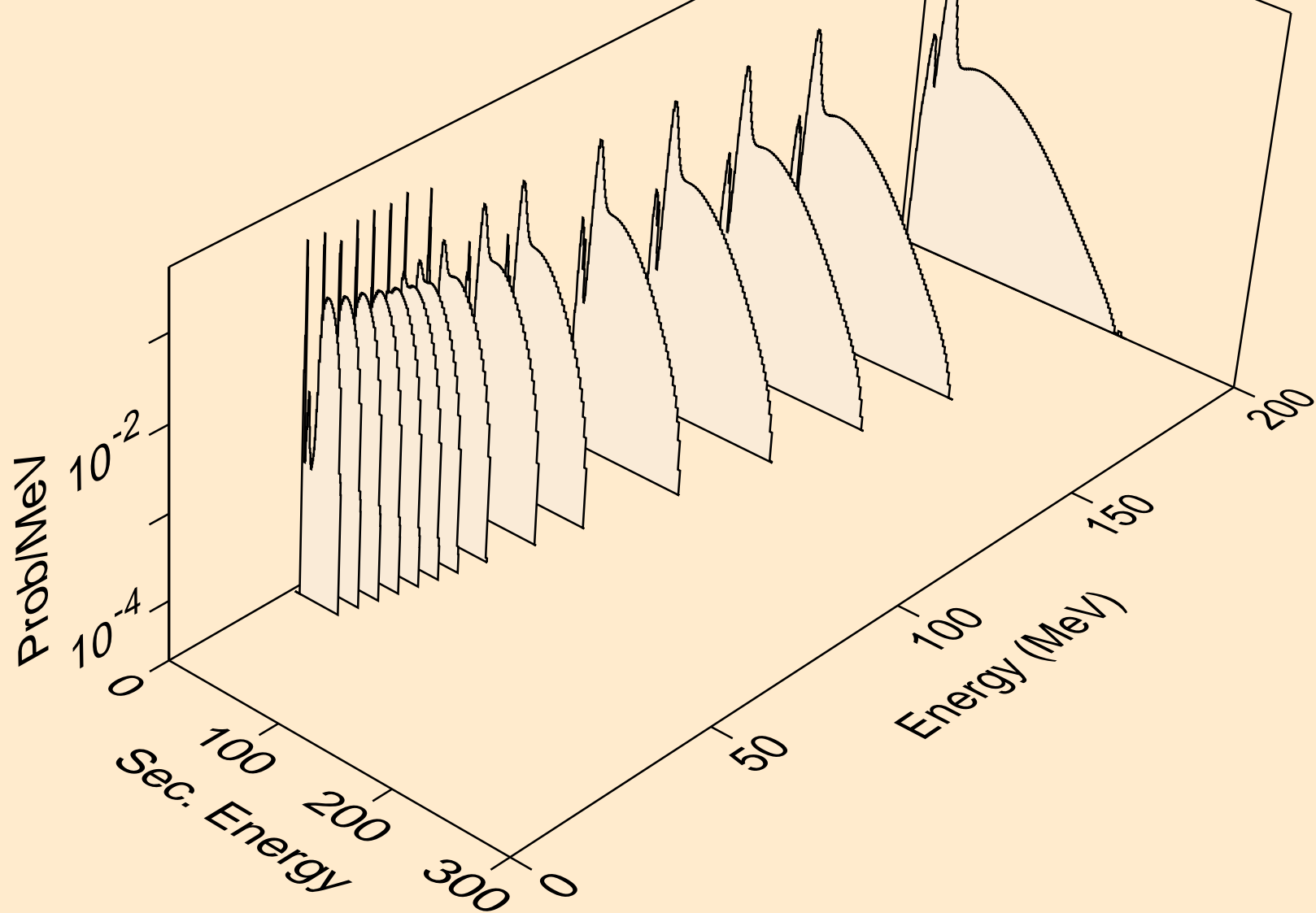

AC222 NEUTRON ACER TENDL-2023 LIBRARY; T=0.K
alphas from (n,n*)a

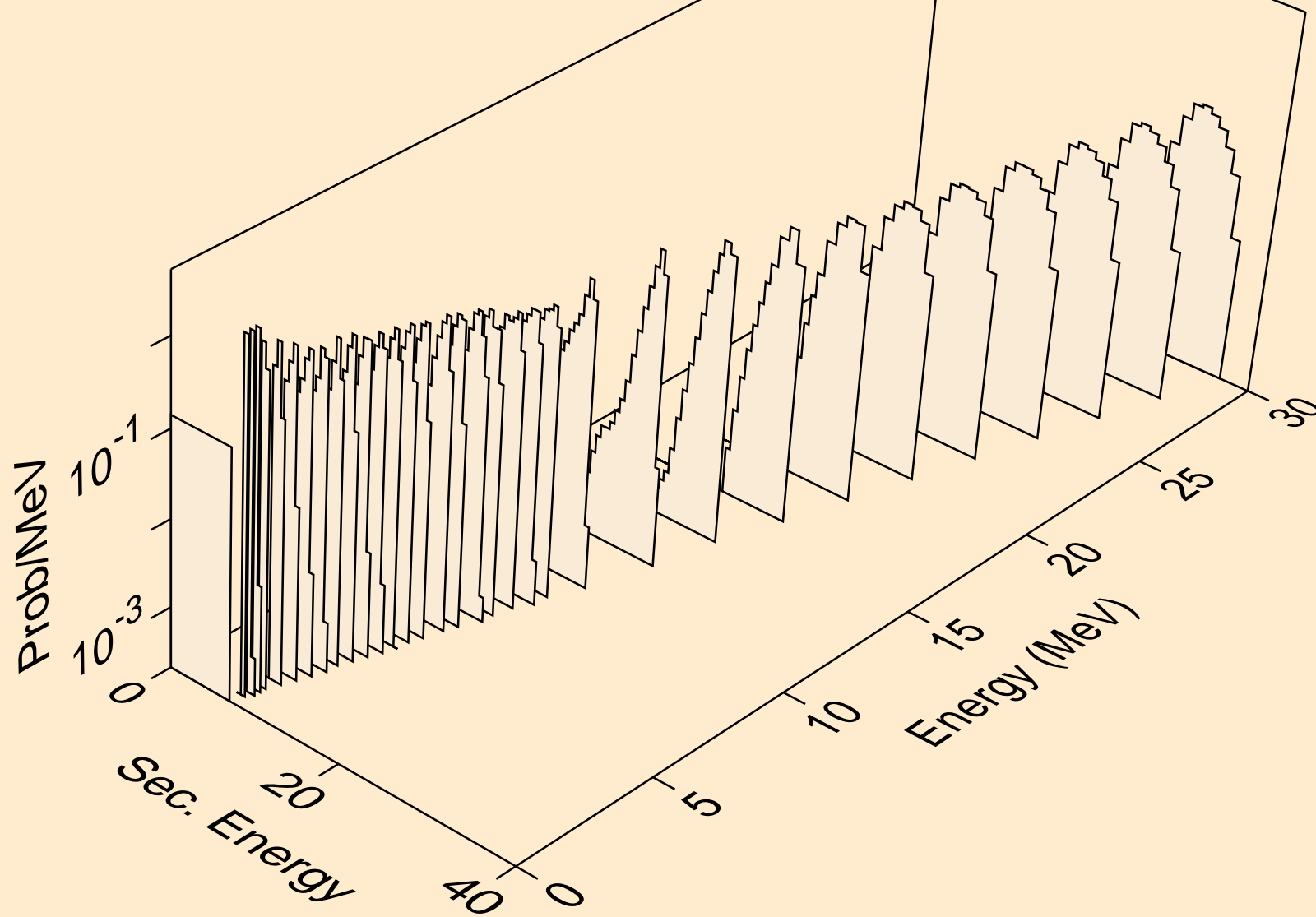

AC222 NEUTRON ACER TENDL-2023 LIBRARY; T=0.K
alphas from (n,n*)3a

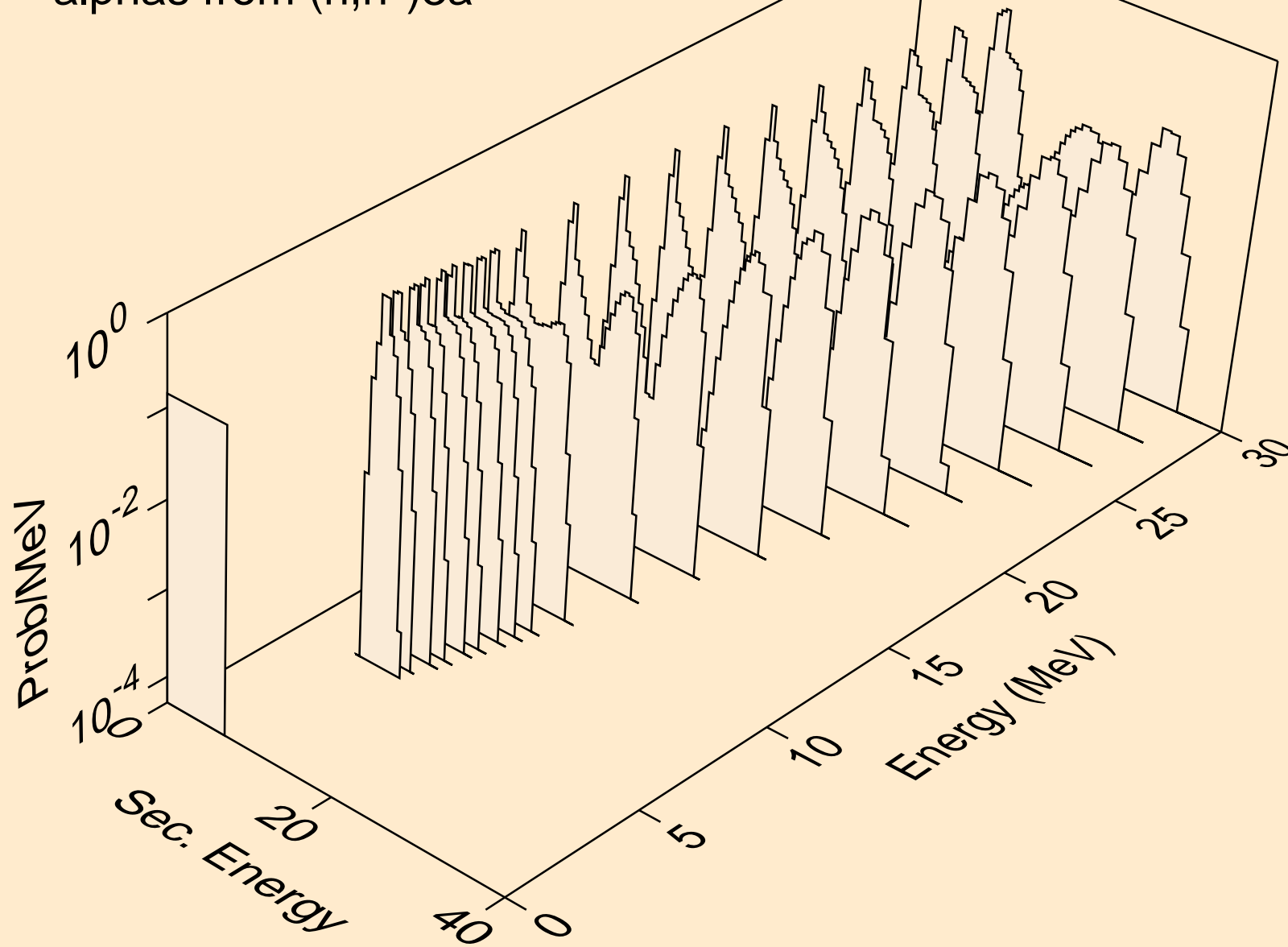

AC222 NEUTRON ACER TENDL-2023 LIBRARY; T=0.K
alphas from (n,2n)a

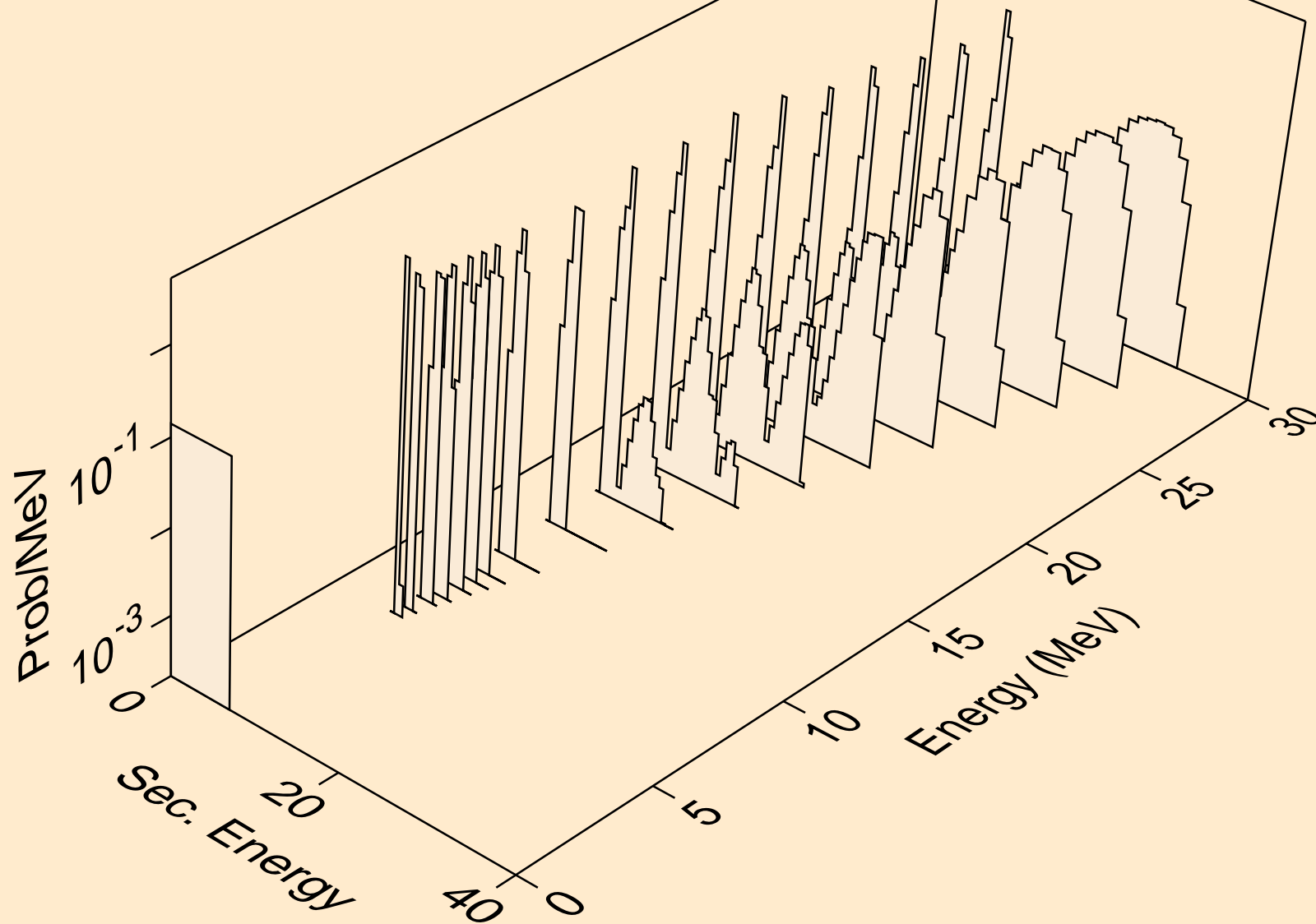

AC222 NEUTRON ACER TENDL-2023 LIBRARY; T=0.K
alphas from (n,3n)a

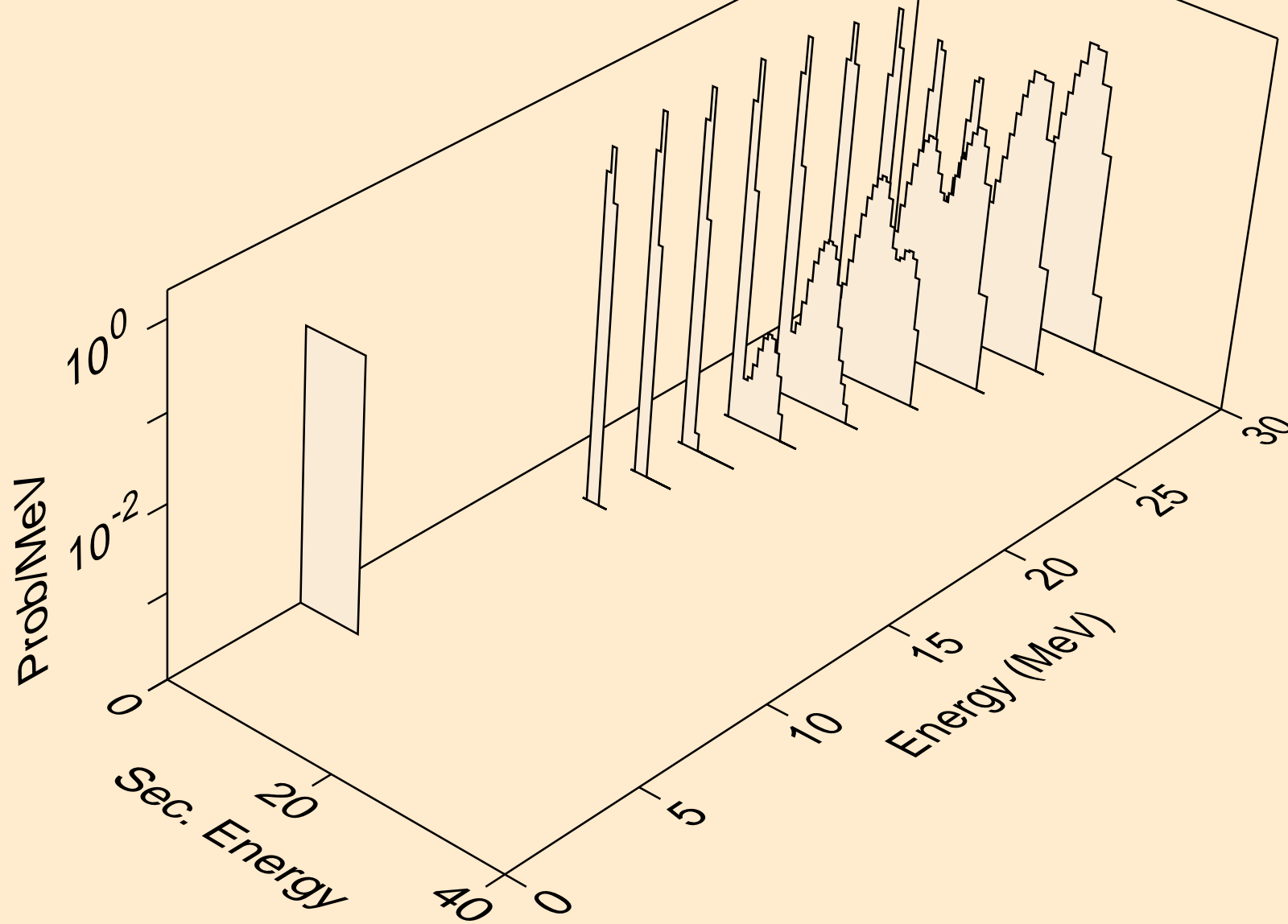

AC222 NEUTRON ACER TENDL-2023 LIBRARY; T=0.K
alphas from (n,n*)2a

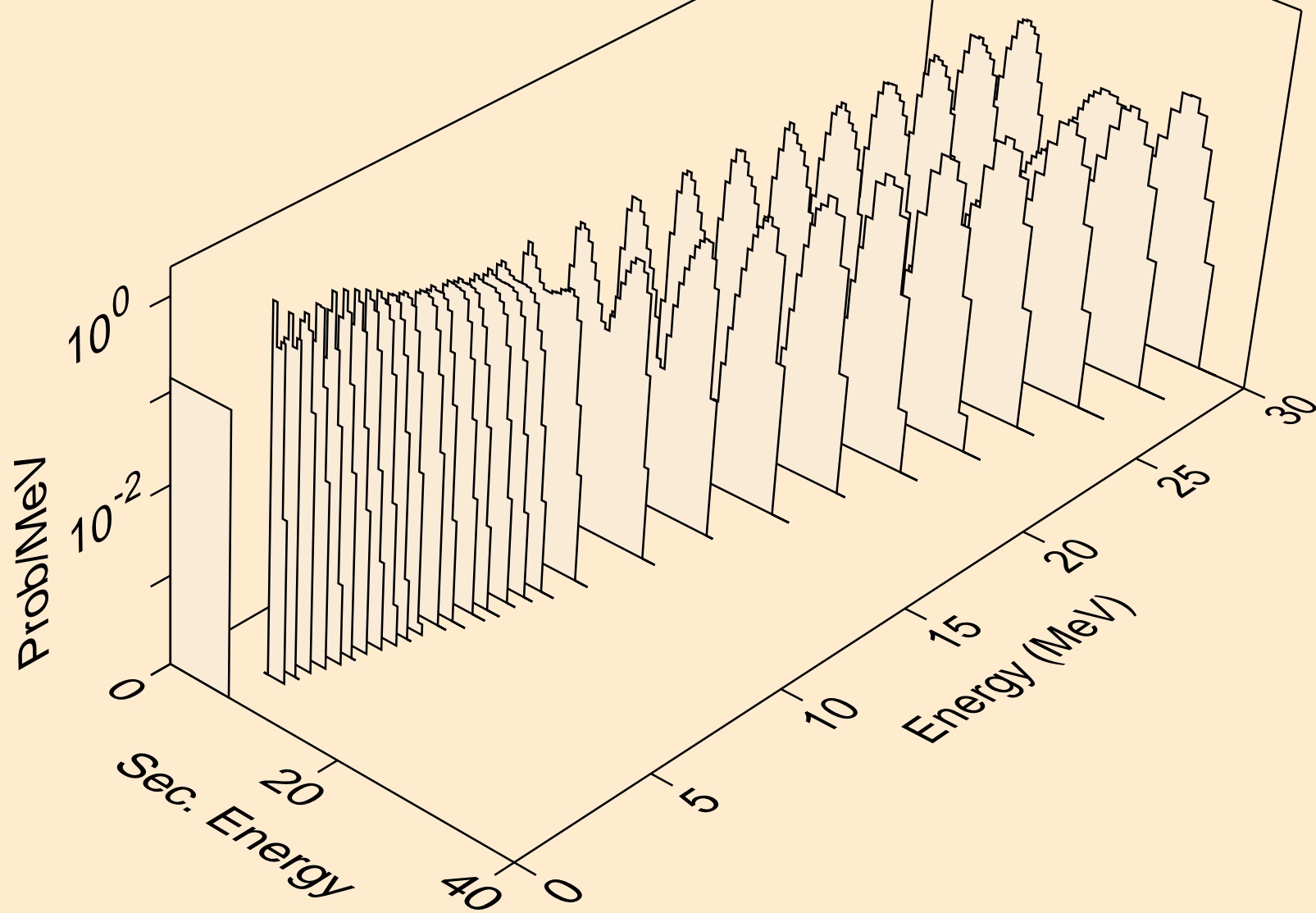

AC222 NEUTRON ACER TENDL-2023 LIBRARY; T=0.K
alphas from (n,2n)2a

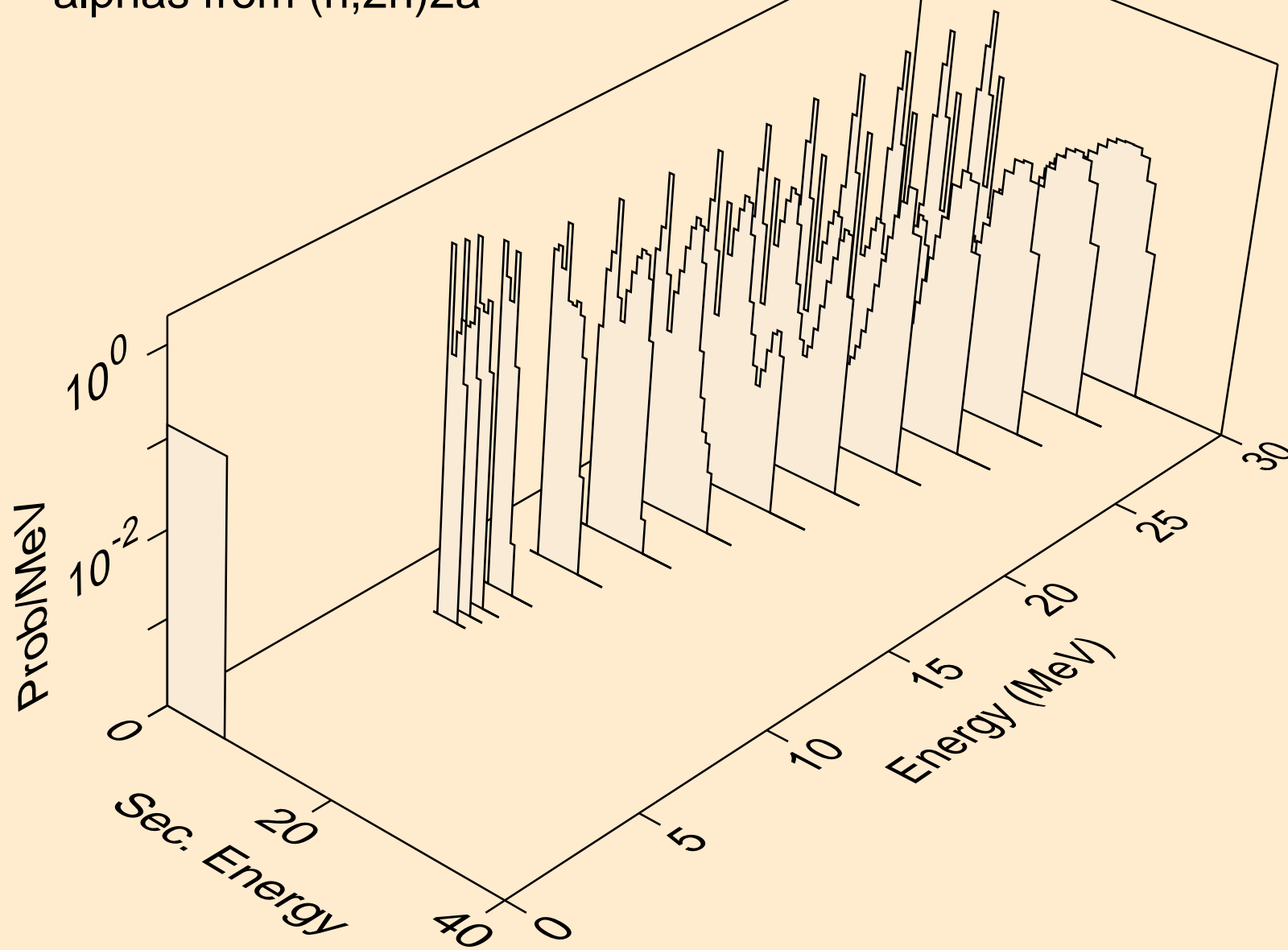

AC222 NEUTRON ACER TENDL-2023 LIBRARY; T=0.K
alphas from (n,n*)d2a

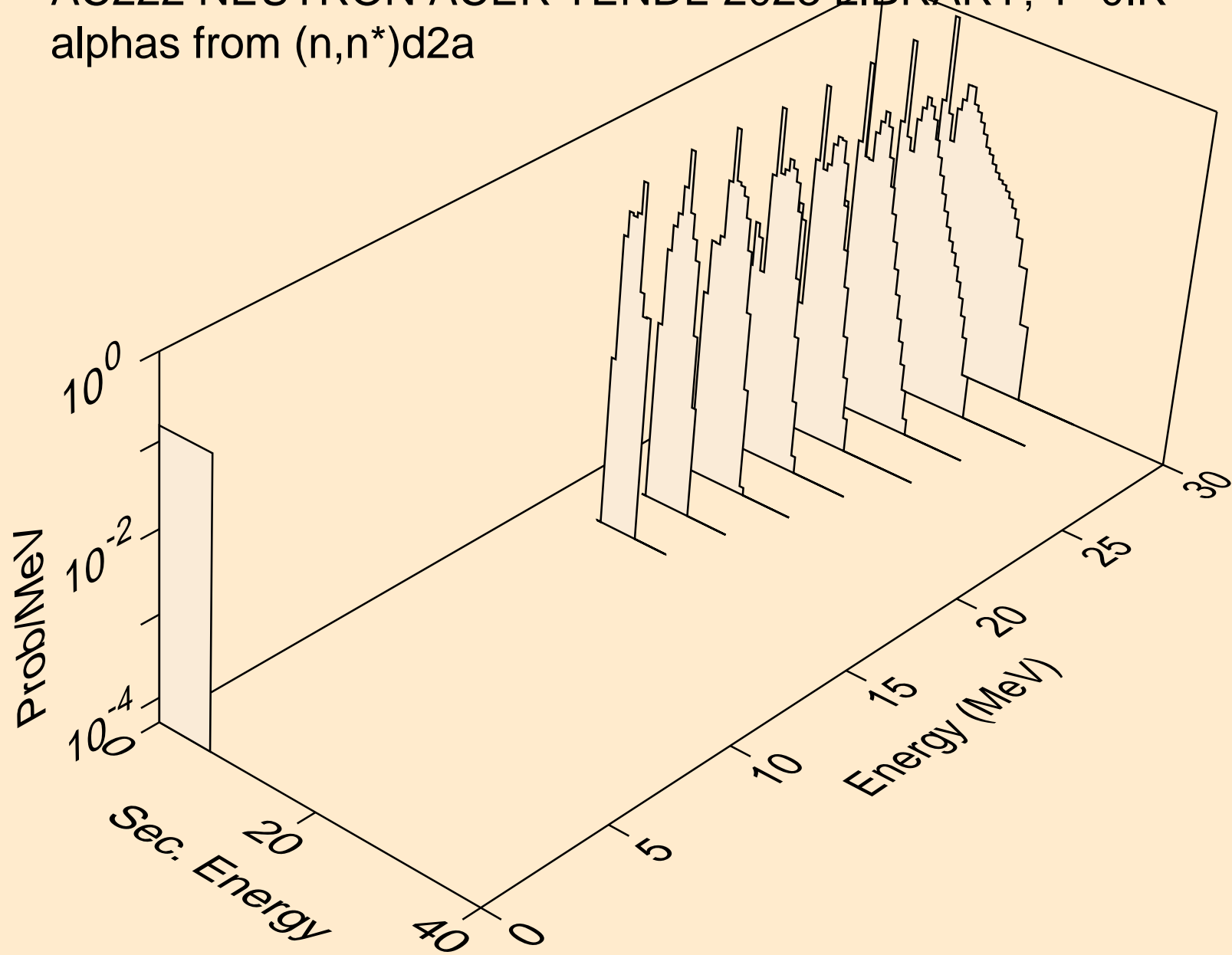

AC222 NEUTRON ACER TENDL-2023 LIBRARY; T=0.K
alphas from (n,n*)t2a

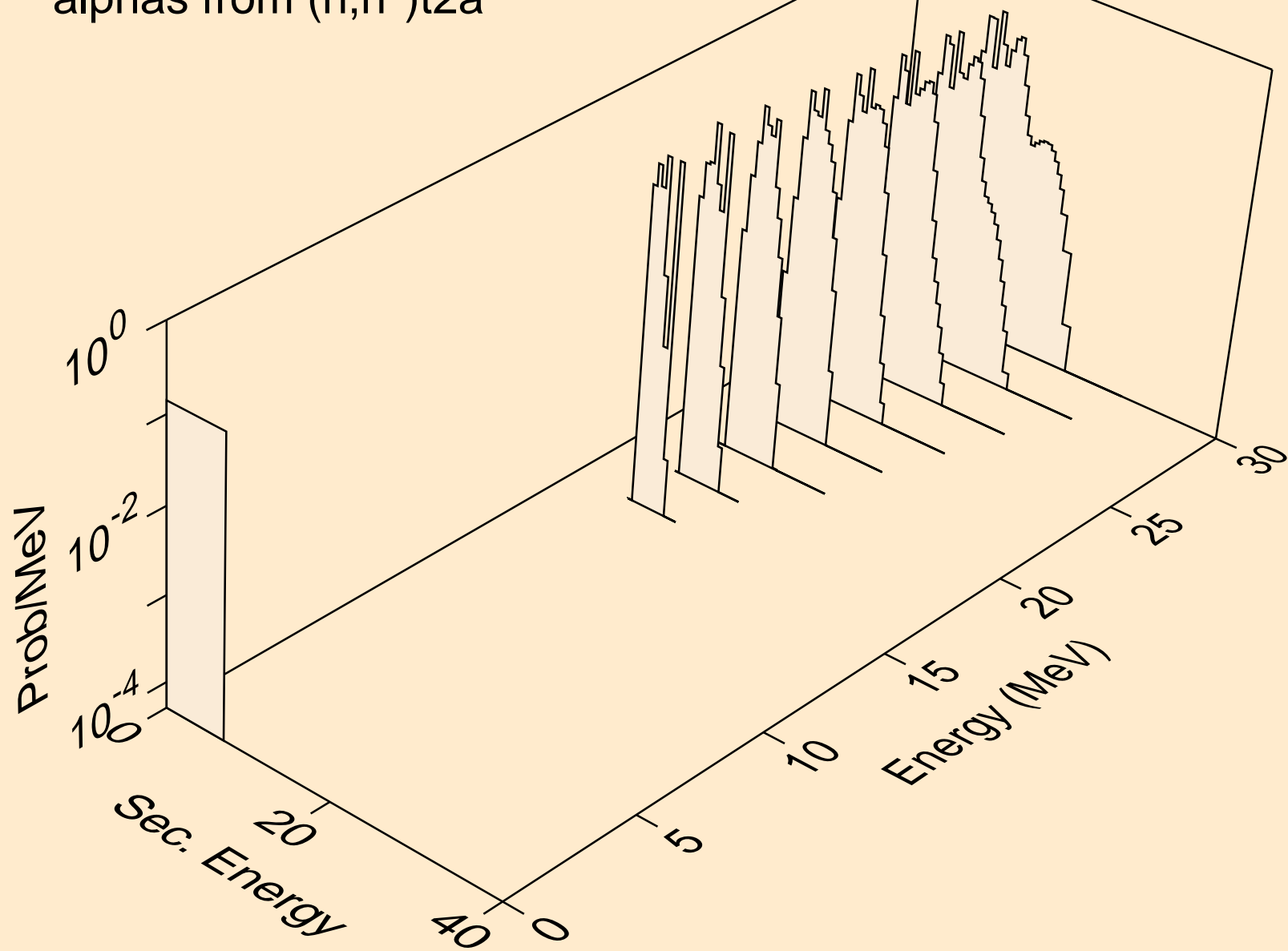

AC222 NEUTRON ACER TENDL-2023 LIBRARY; T=0.K
alphas from (n,npa)

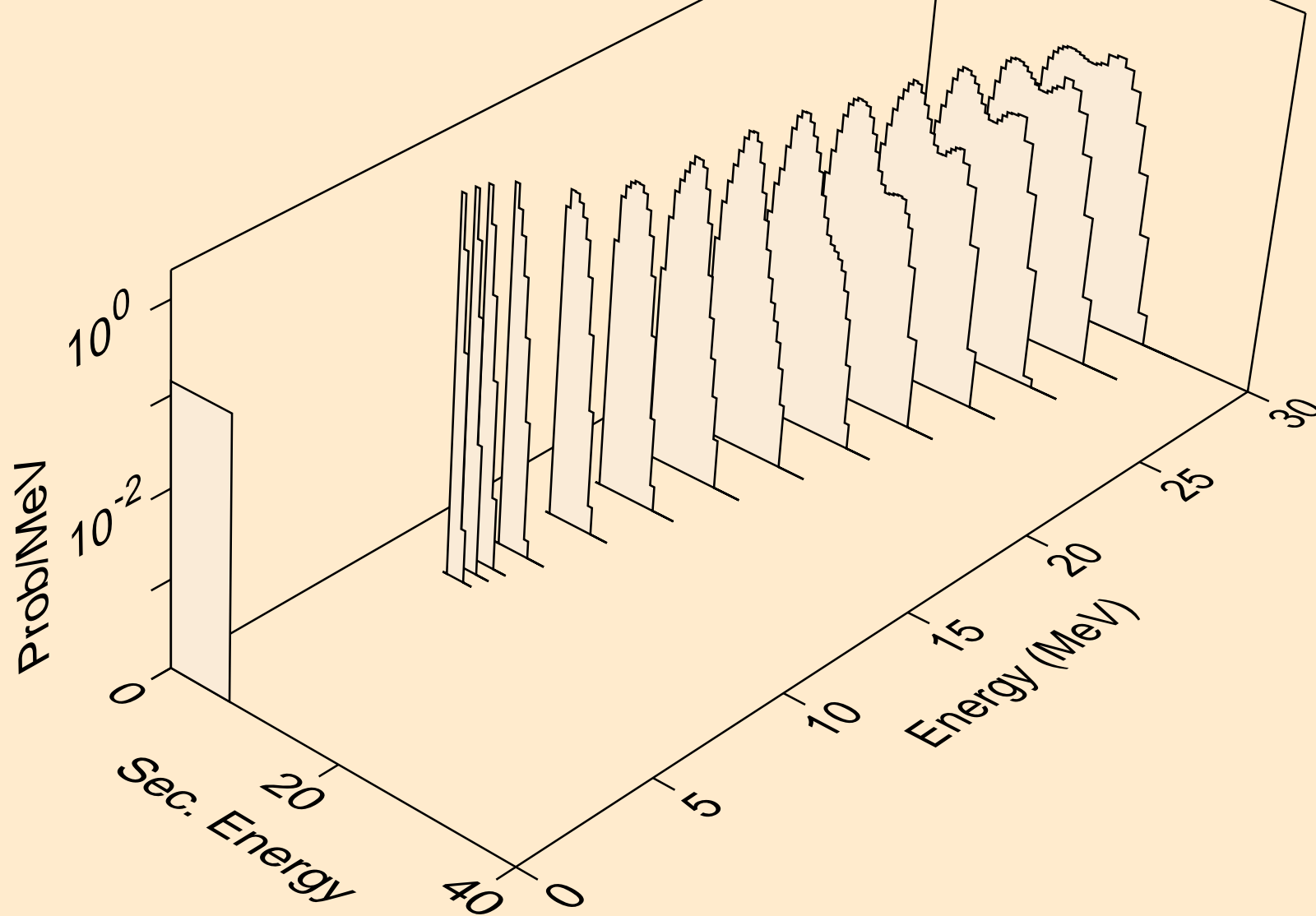

AC222 NEUTRON ACER TENDL-2023 LIBRARY; T=0.K
alphas from (n,a)

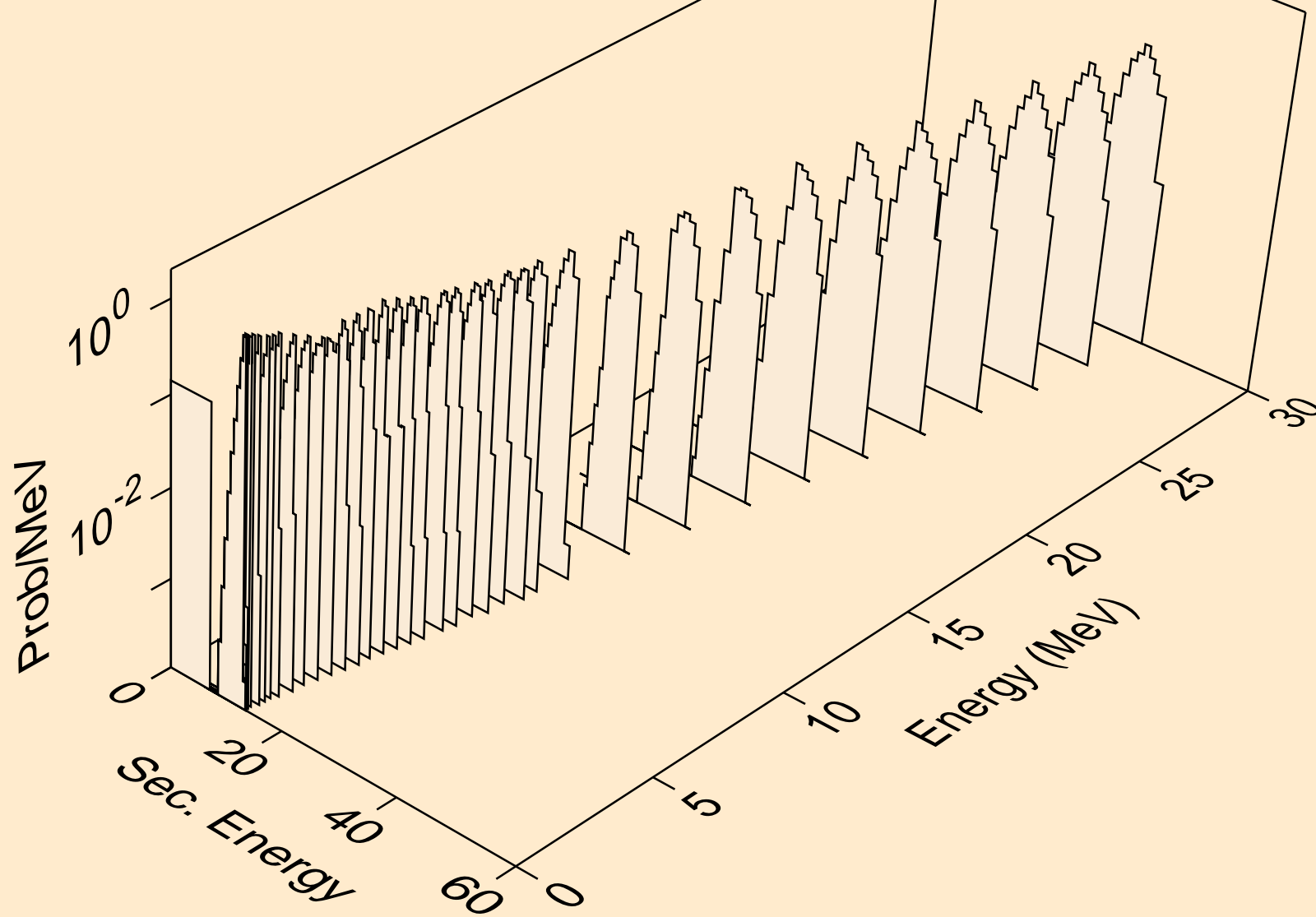

AC222 NEUTRON ACER TENDL-2023 LIBRARY; T=0.K
alphas from (n,2a)

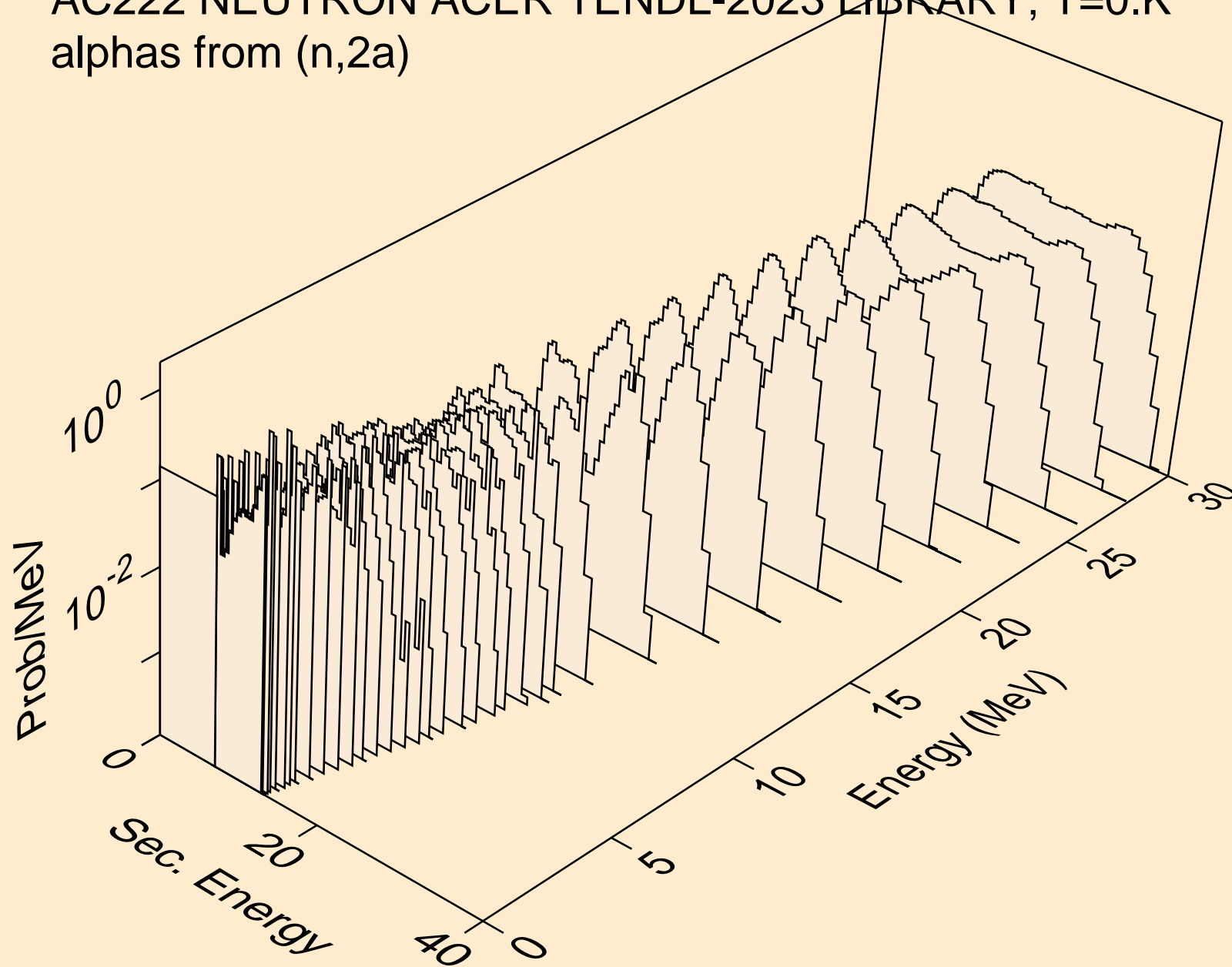

AC222 NEUTRON ACER TENDL-2023 LIBRARY; T=0.K
alphas from (n,3a)

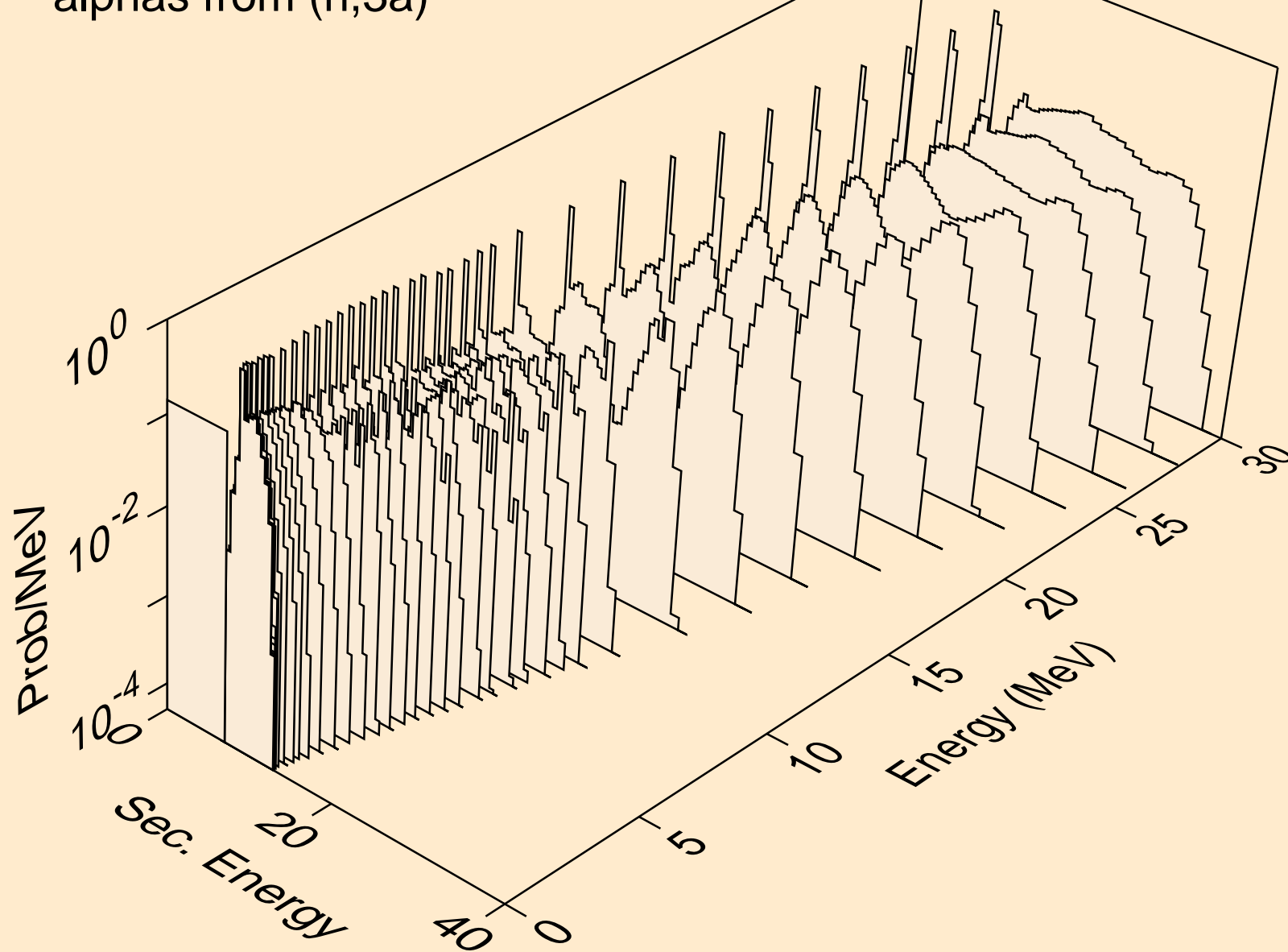

AC222 NEUTRON ACER TENDL-2023 LIBRARY; T=0.K
alphas from (n,pa)

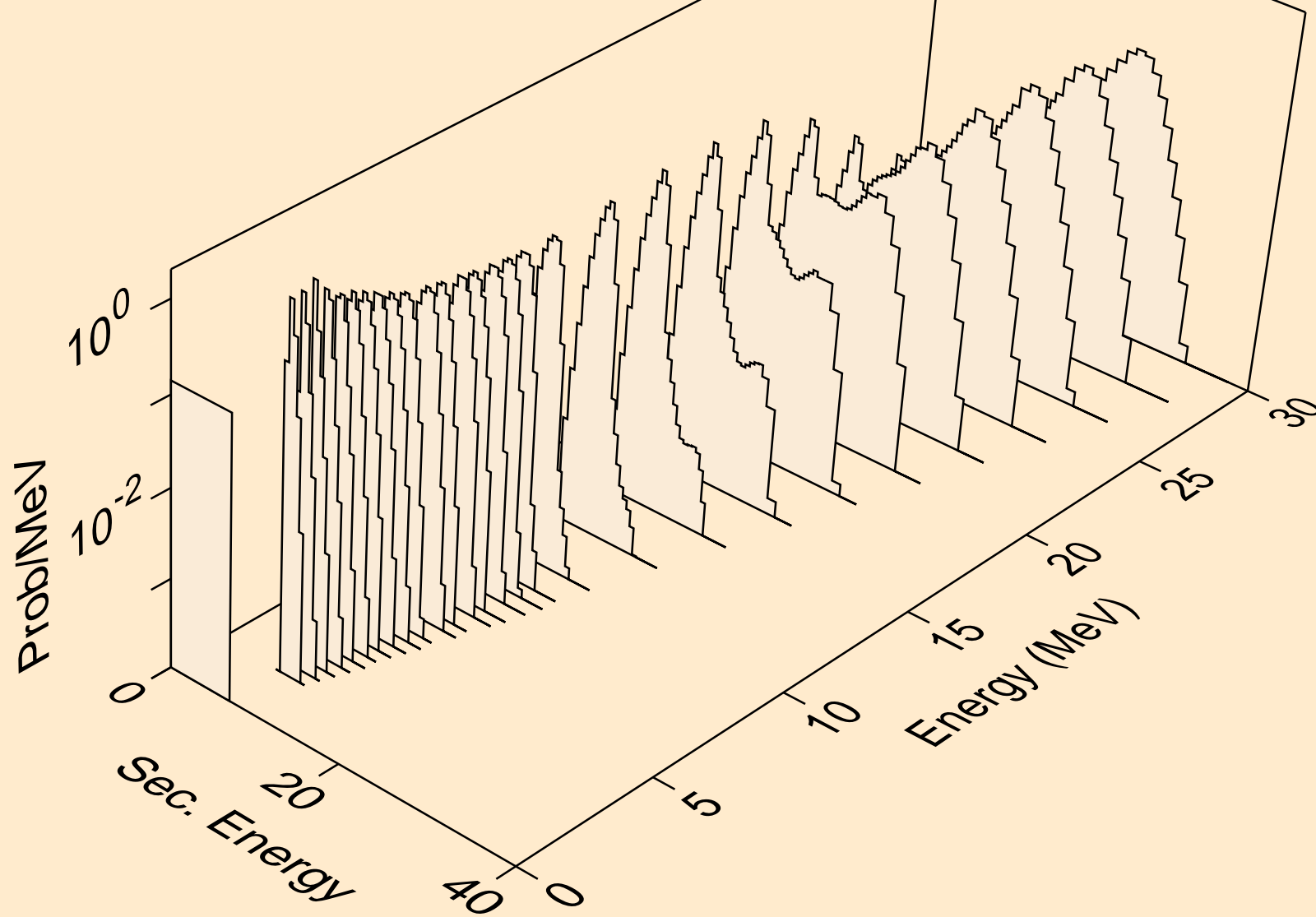

AC222 NEUTRON ACER TENDL-2023 LIBRARY; T=0.K
alphas from (n,t2a)

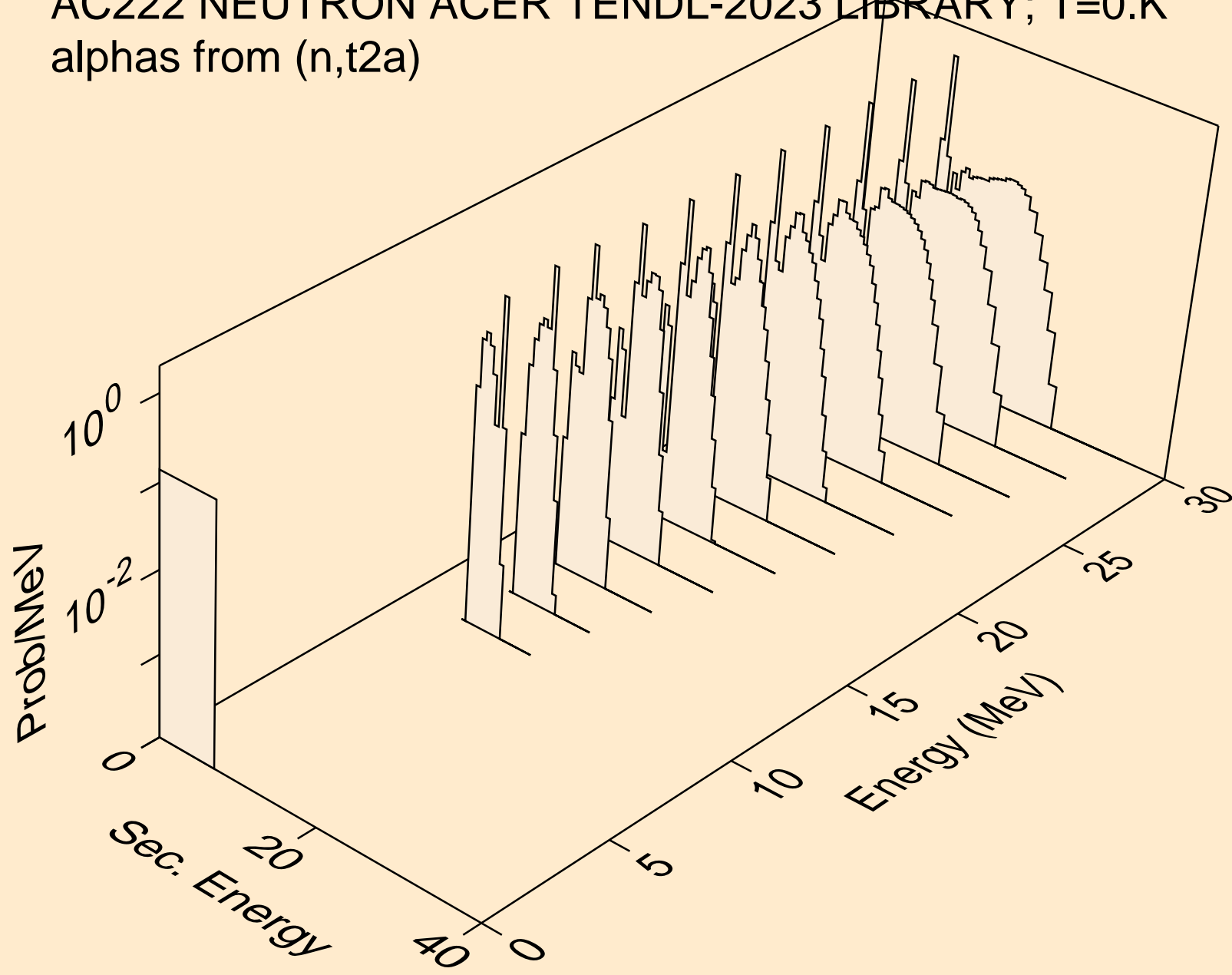

AC222 NEUTRON ACER TENDL-2023 LIBRARY; T=0.K
alphas from (n,da)

