

# AM248 NEUTRON ACER TENDL-2023 LIBRARY; T=0.K

## Principal cross sections

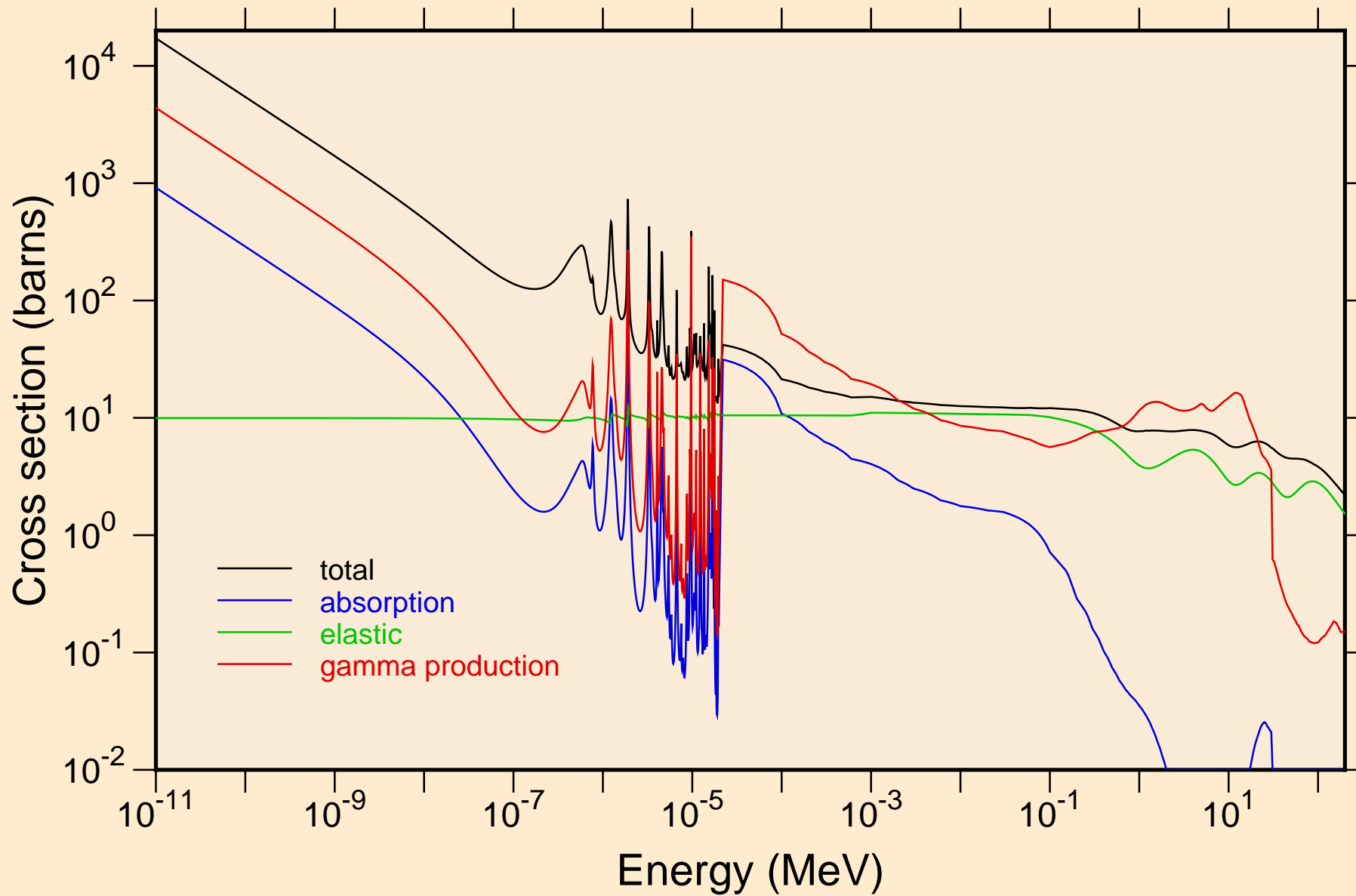

AM248 NEUTRON ACER TENDL-2023 LIBRARY; T=0.K  
resonance total cross section

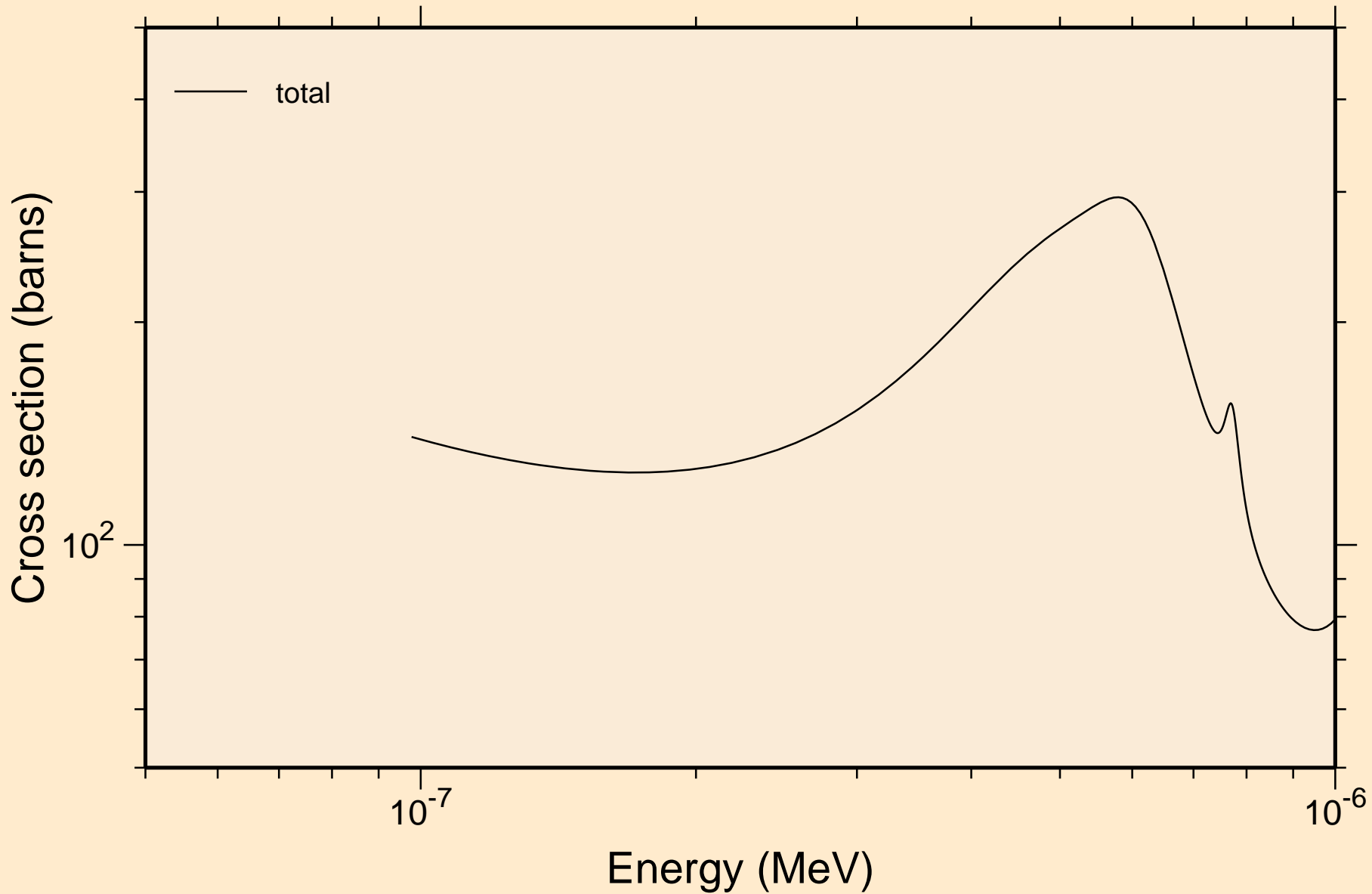

AM248 NEUTRON ACER TENDL-2023 LIBRARY; T=0.K  
resonance total cross section

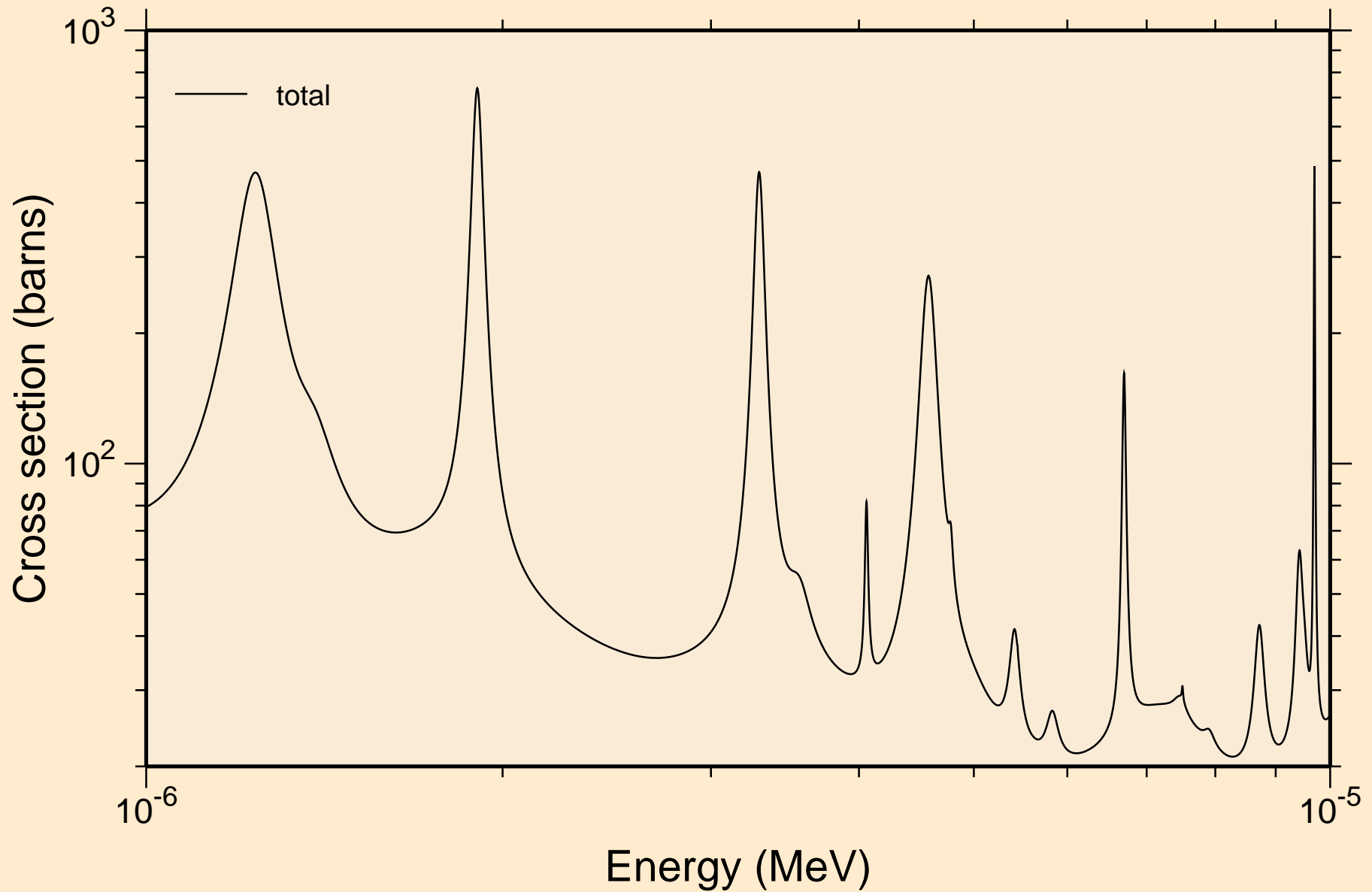

AM248 NEUTRON ACER TENDL-2023 LIBRARY; T=0.K  
resonance total cross section

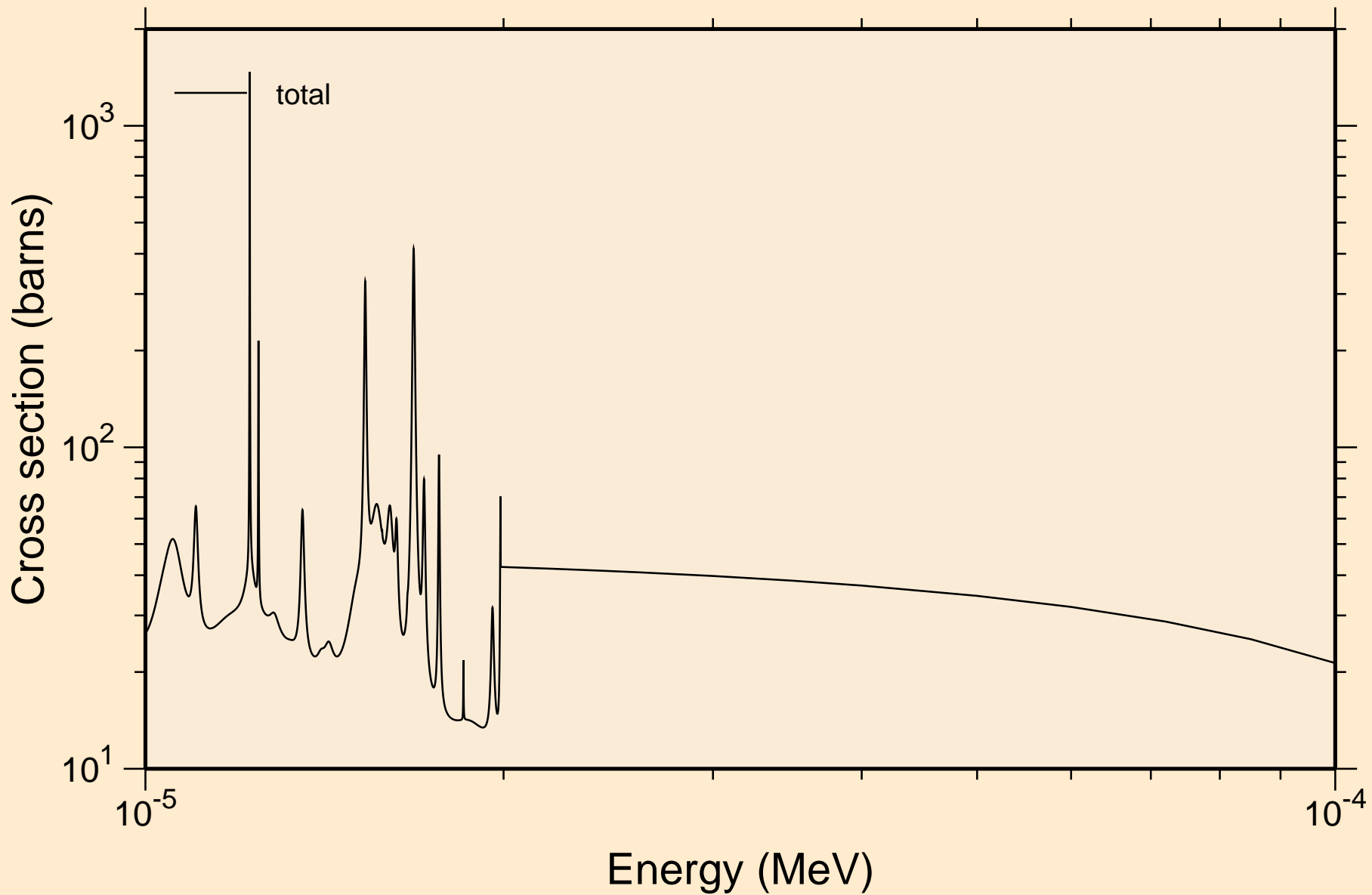

AM248 NEUTRON ACER TENDL-2023 LIBRARY; T=0.K  
resonance total cross section

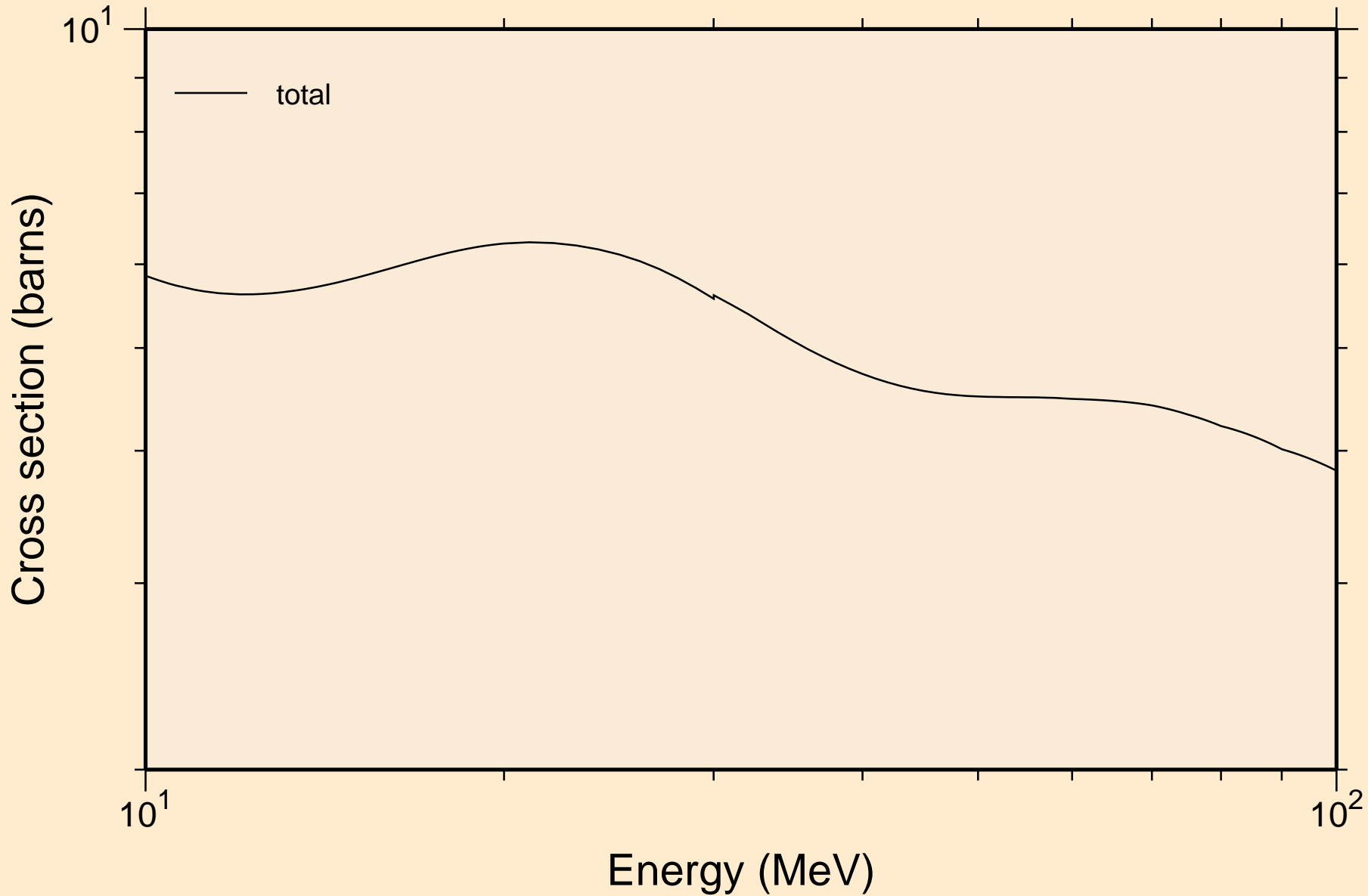

AM248 NEUTRON ACER TENDL-2023 LIBRARY; T=0.K  
resonance absorption cross sections

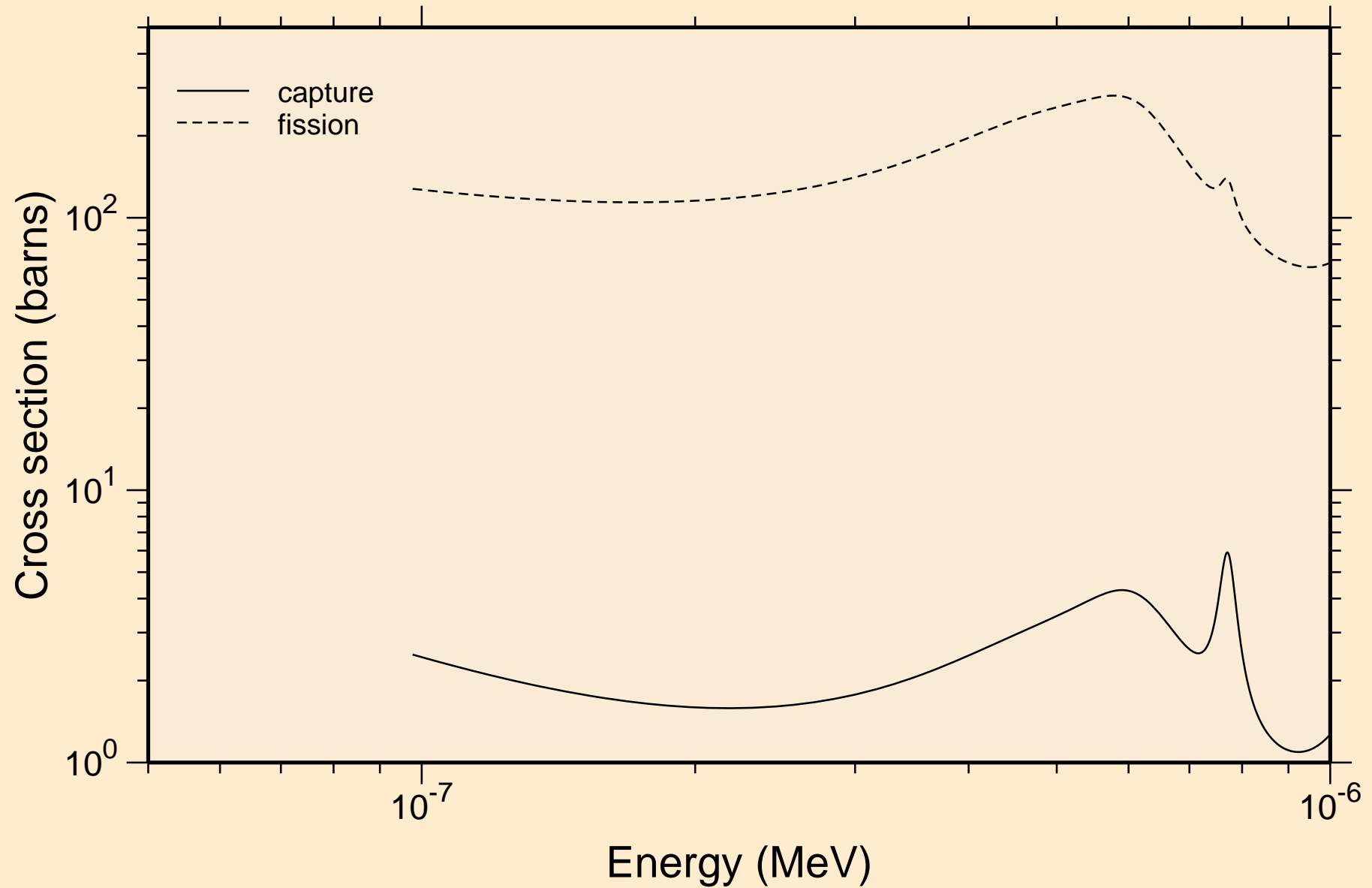

AM248 NEUTRON ACER TENDL-2023 LIBRARY; T=0.K  
resonance absorption cross sections

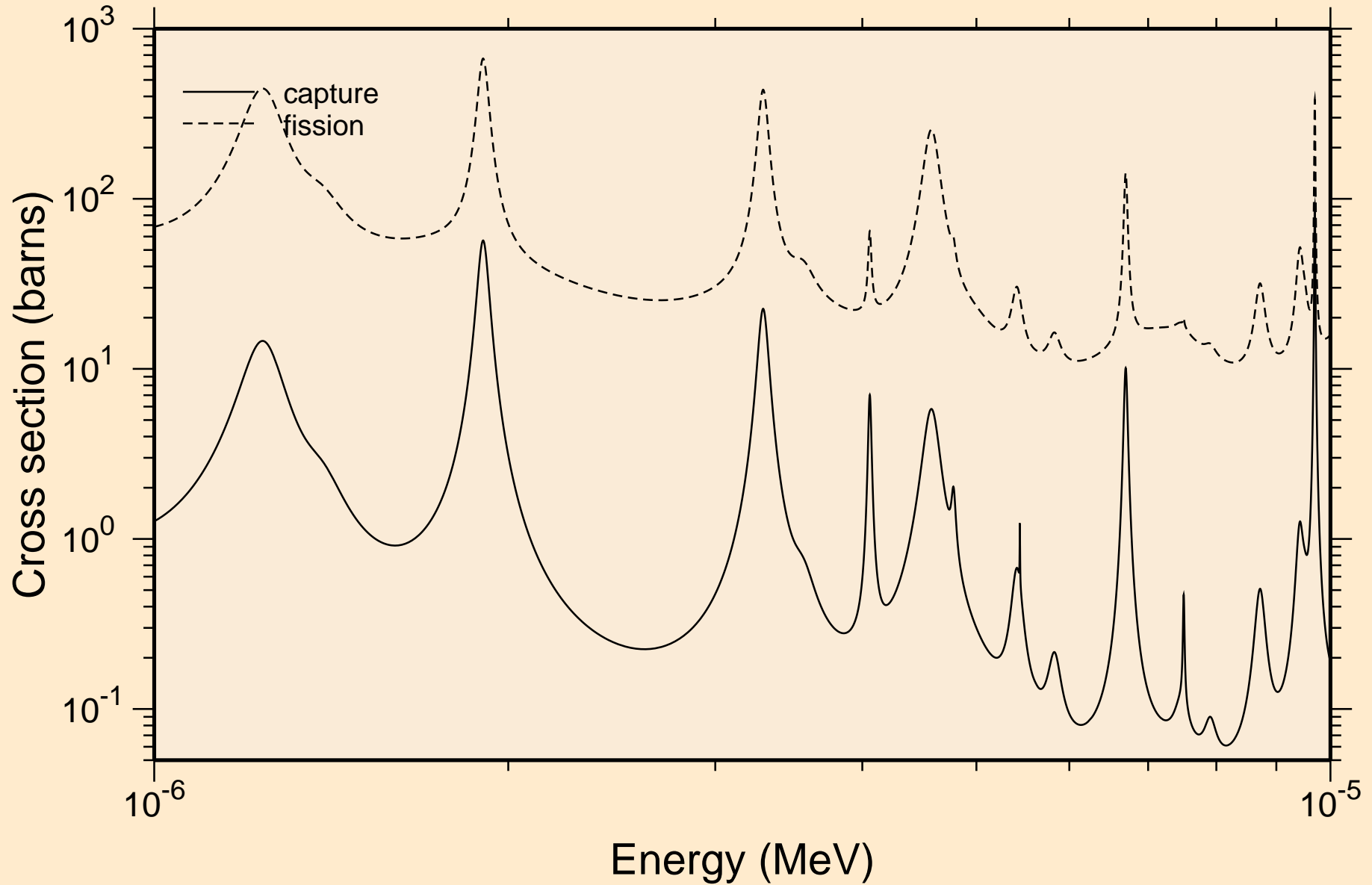

AM248 NEUTRON ACER TENDL-2023 LIBRARY; T=0.K  
resonance absorption cross sections

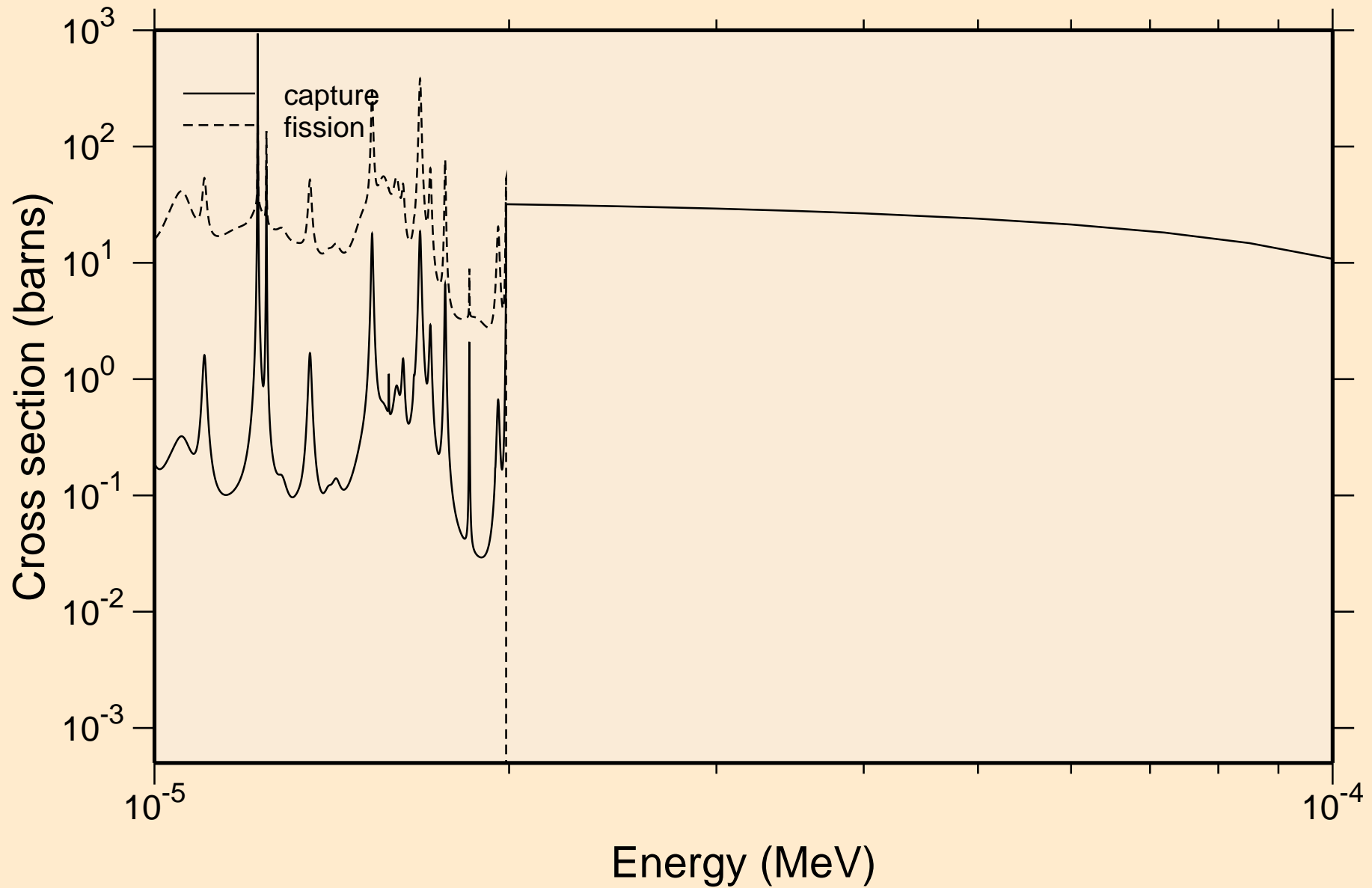



AM248 NEUTRON ACER TENDL-2023 LIBRARY; T=0.K  
resonance absorption cross sections

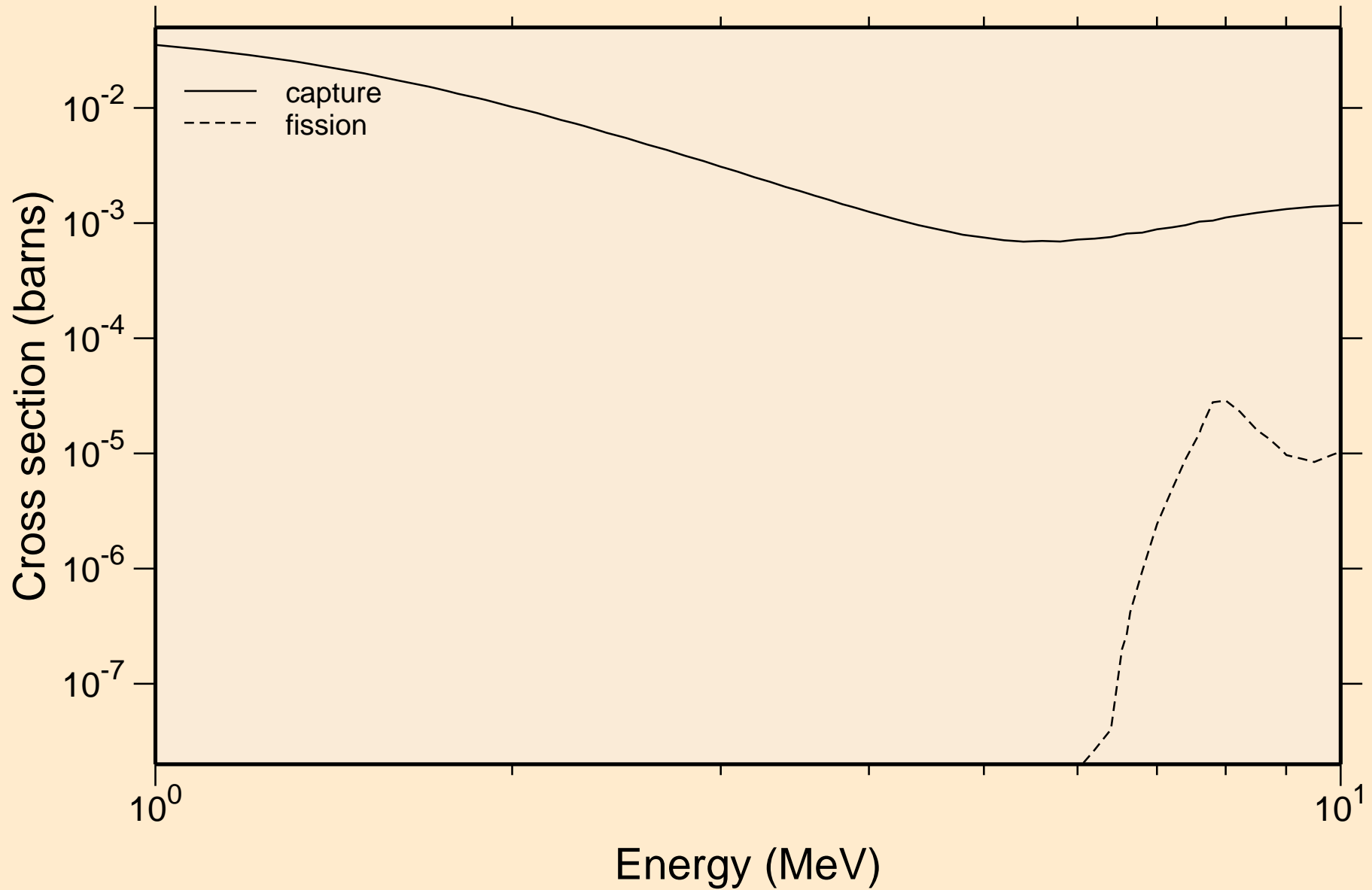

# AM248 NEUTRON ACER TENDL-2023 LIBRARY; T=0.K

## Heating

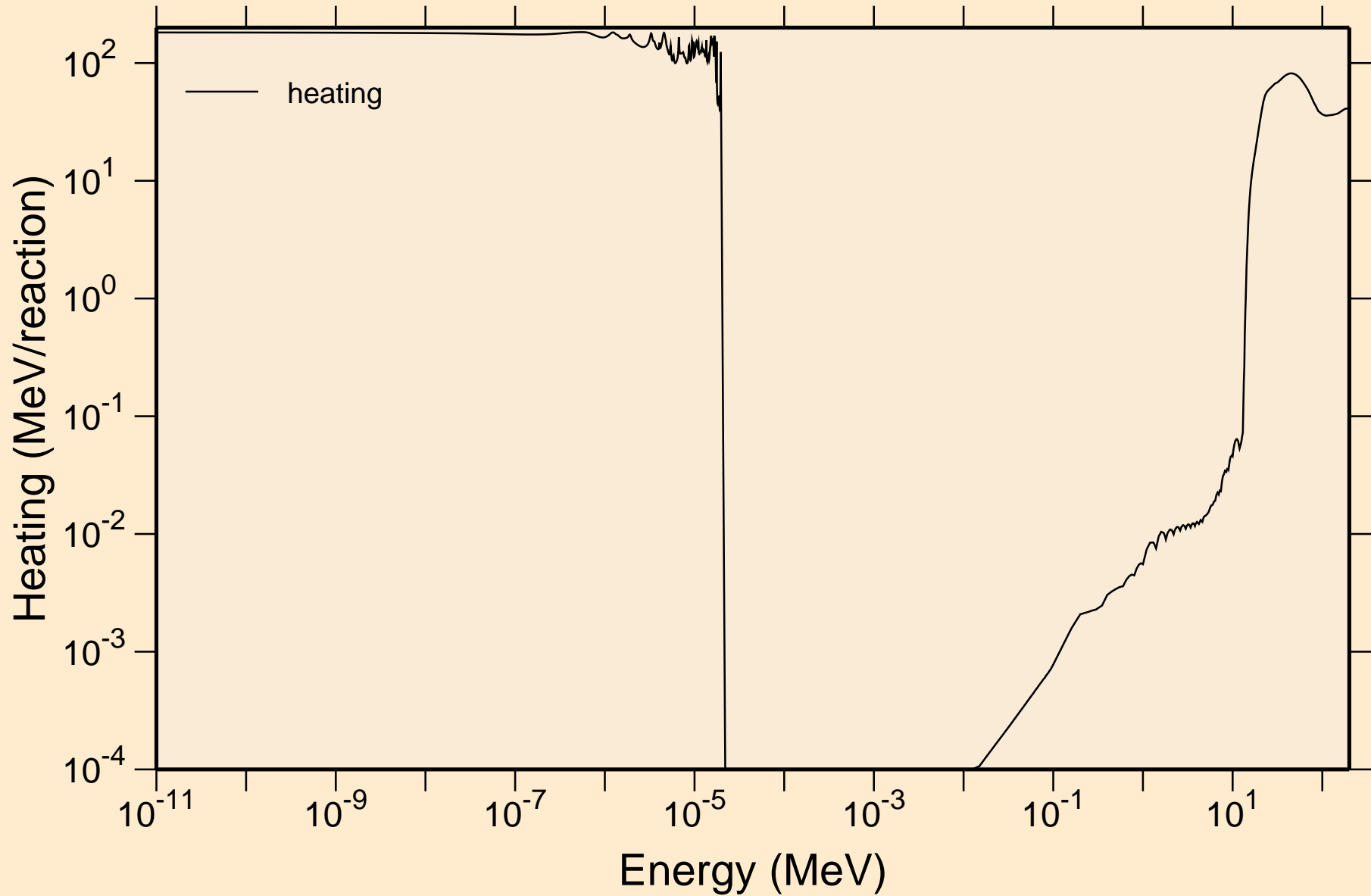

AM248 NEUTRON ACER TENDL-2023 LIBRARY; T=0.K  
Damage

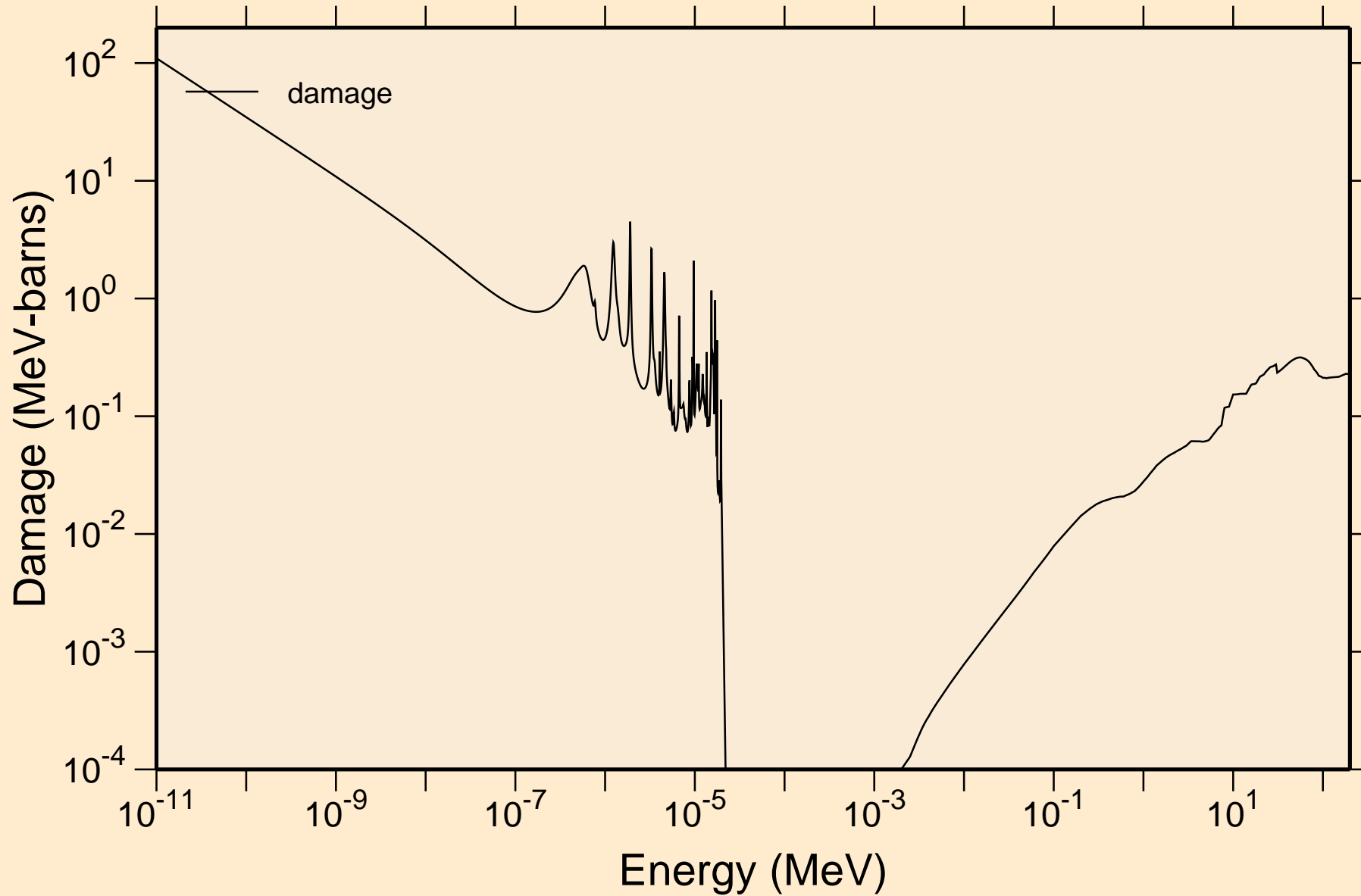

# AM248 NEUTRON ACER TENDL-2023 LIBRARY; T=0.K

## Non-threshold reactions

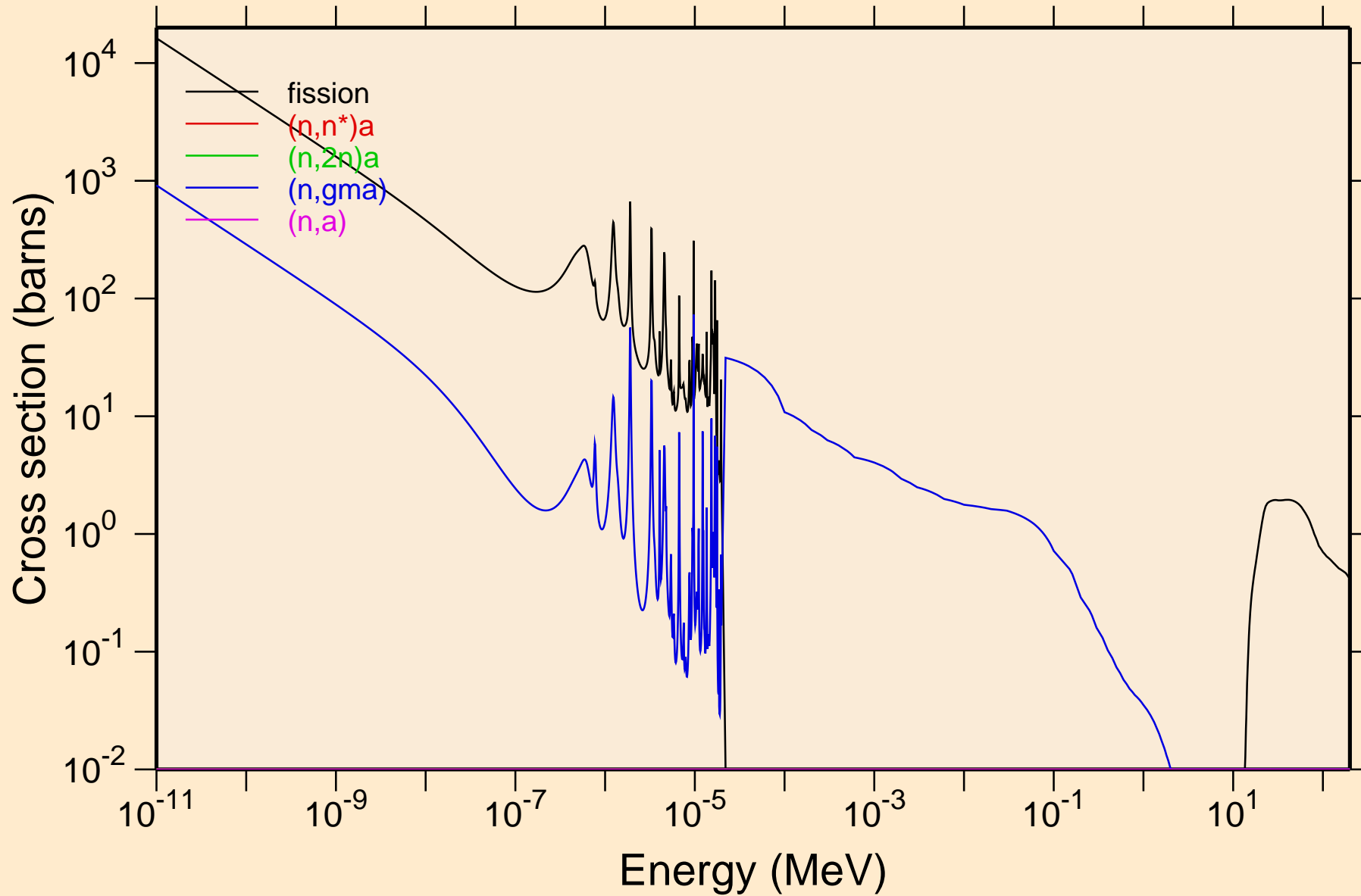

AM248 NEUTRON ACER TENDL-2023 LIBRARY; T=0.K  
Non-threshold reactions

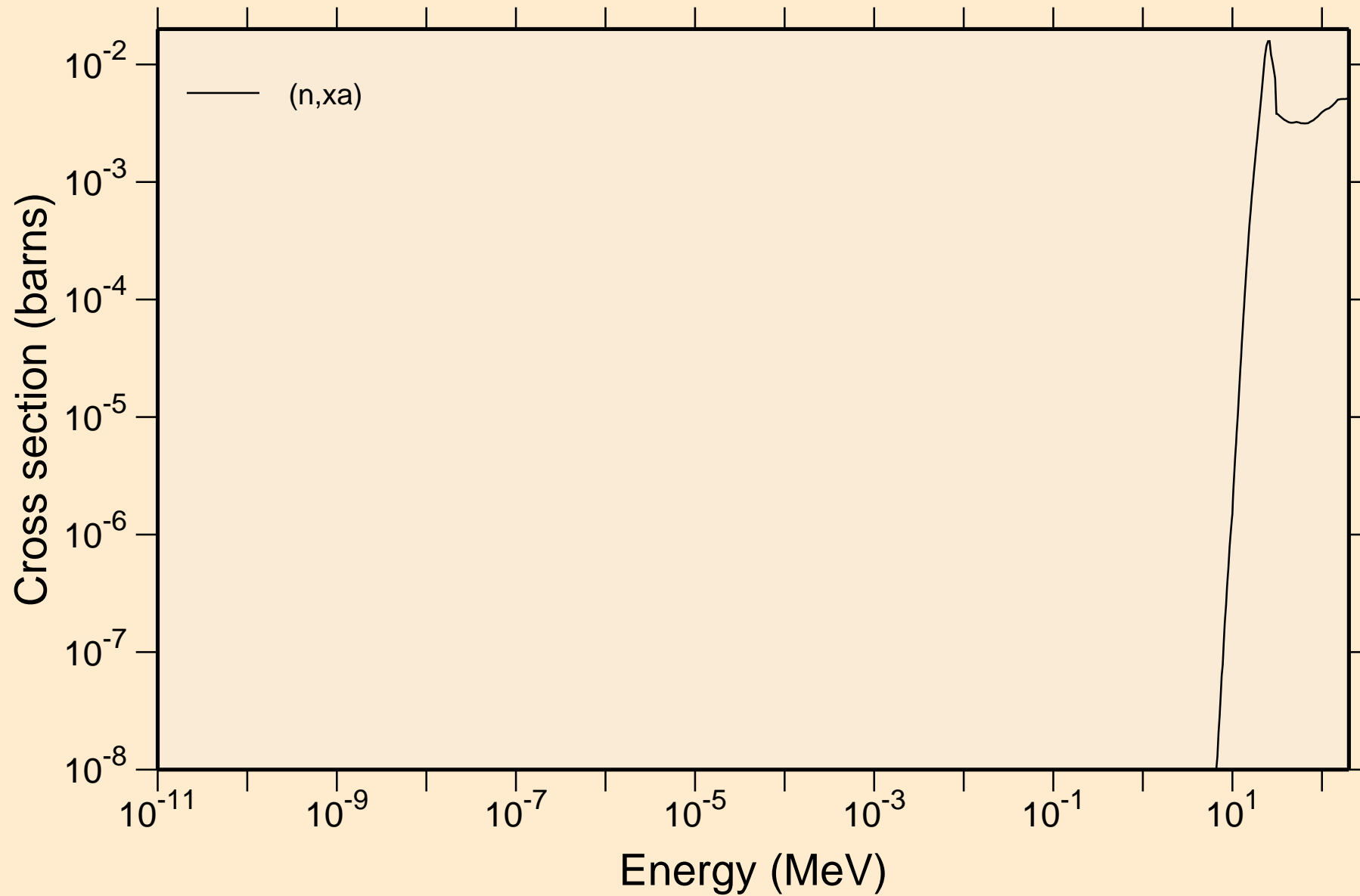

# AM248 NEUTRON ACER TENDL-2023 LIBRARY; T=0.K

## Principal cross sections

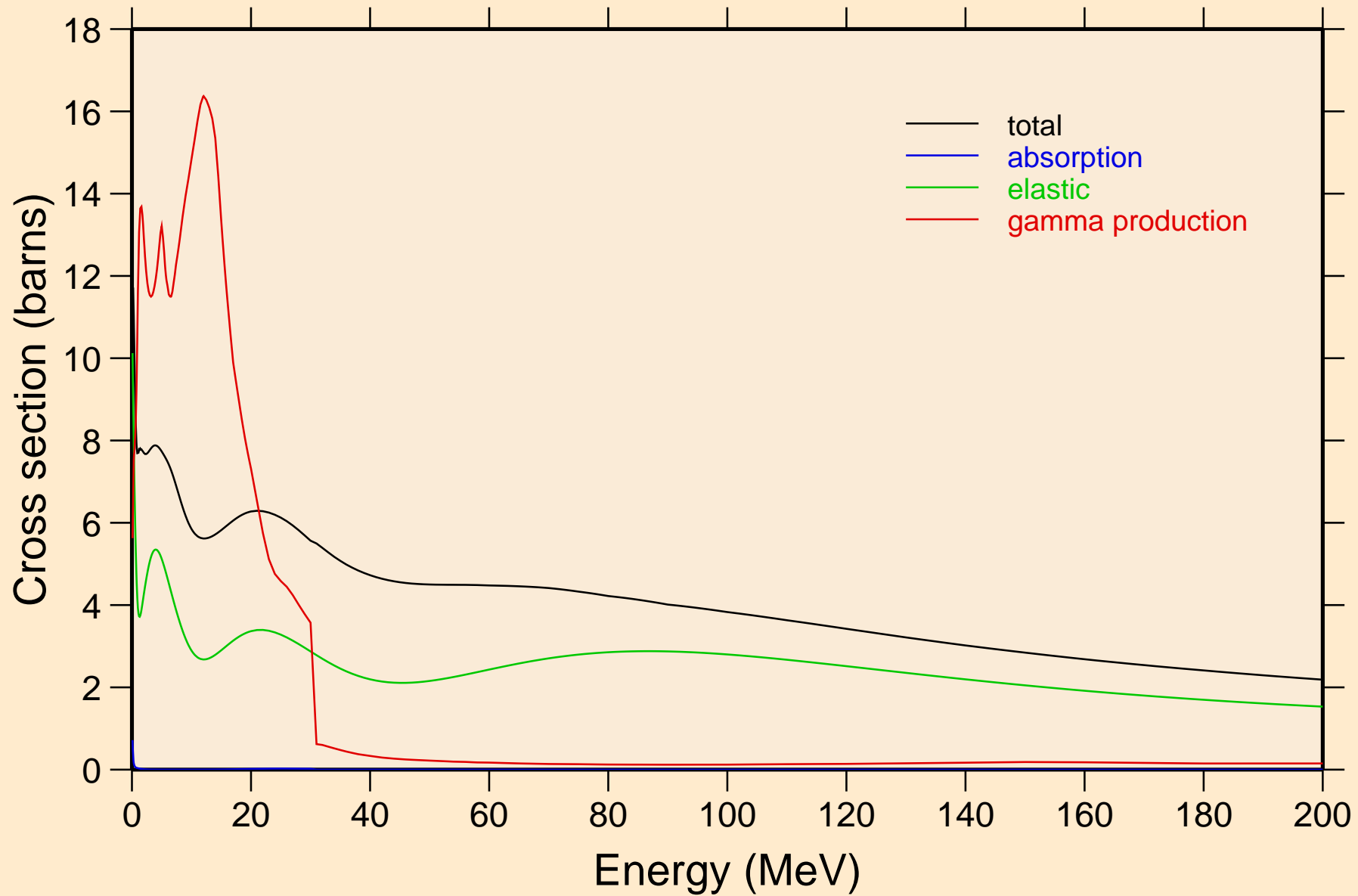

# AM248 NEUTRON ACER TENDL-2023 LIBRARY; T=0.K

## Heating

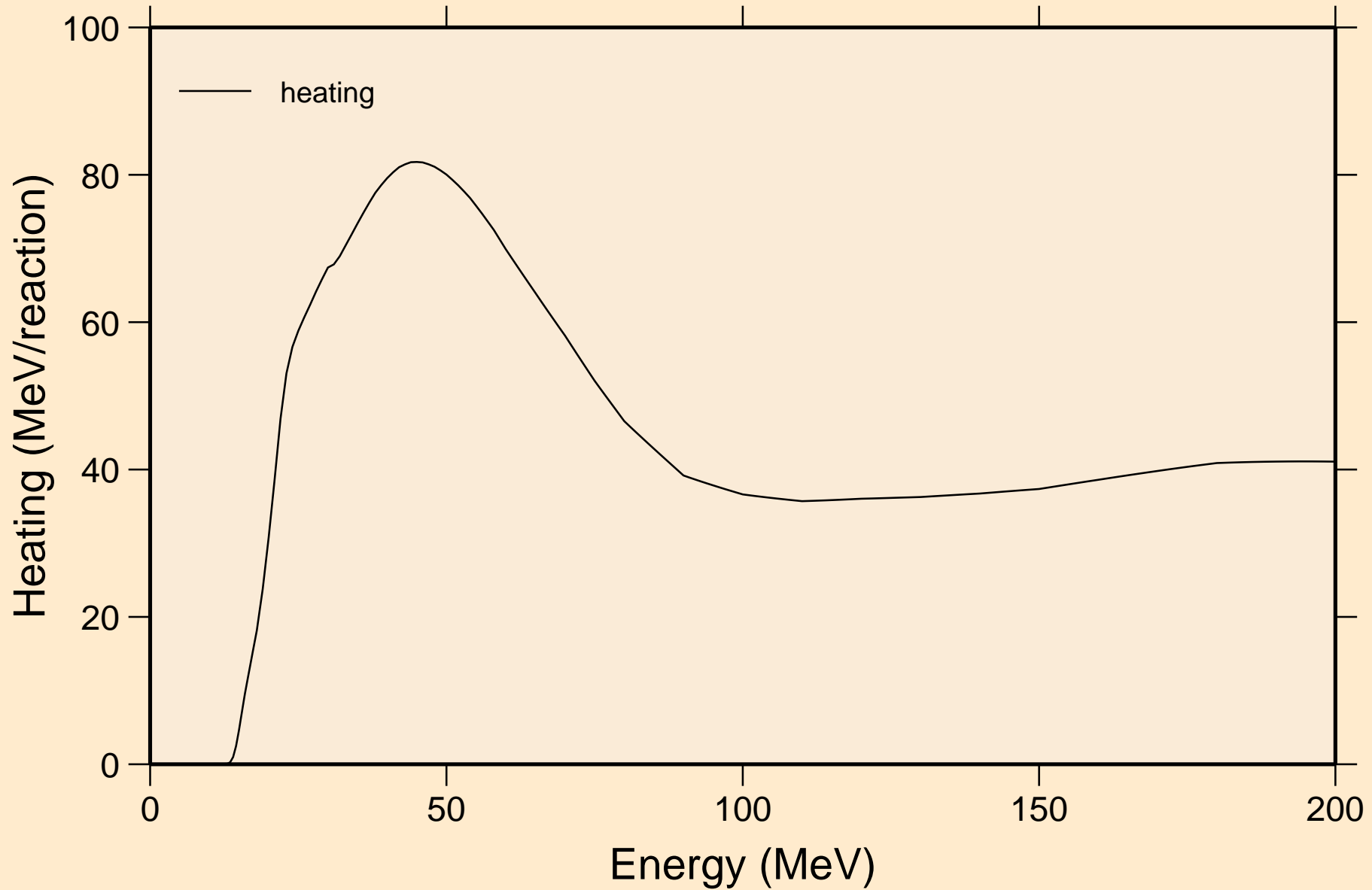

# AM248 NEUTRON ACER TENDL-2023 LIBRARY; T=0.K

## Damage

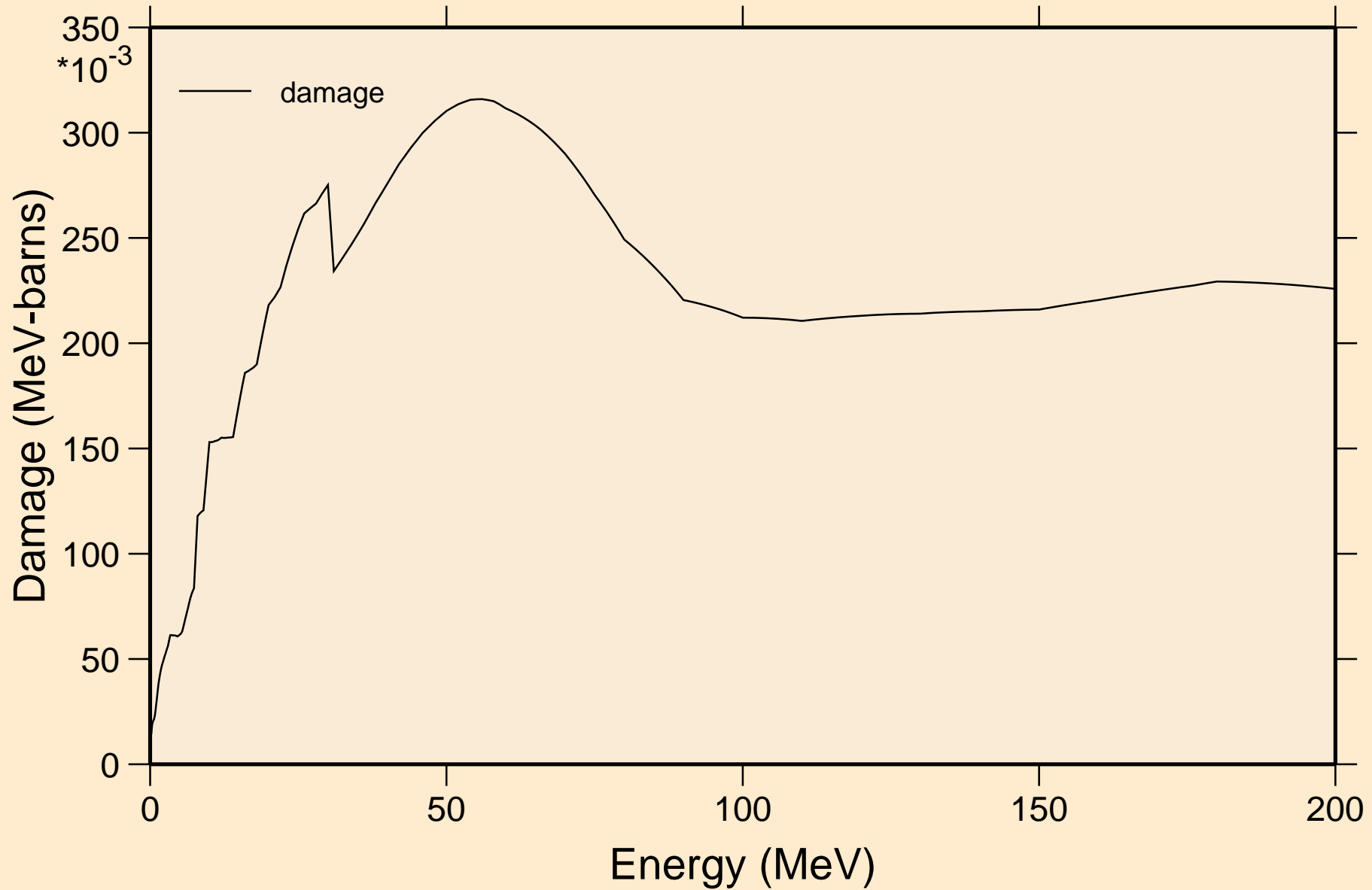



AM248 NEUTRON ACER TENDL-2023 LIBRARY; T=0.K  
Non-threshold reactions

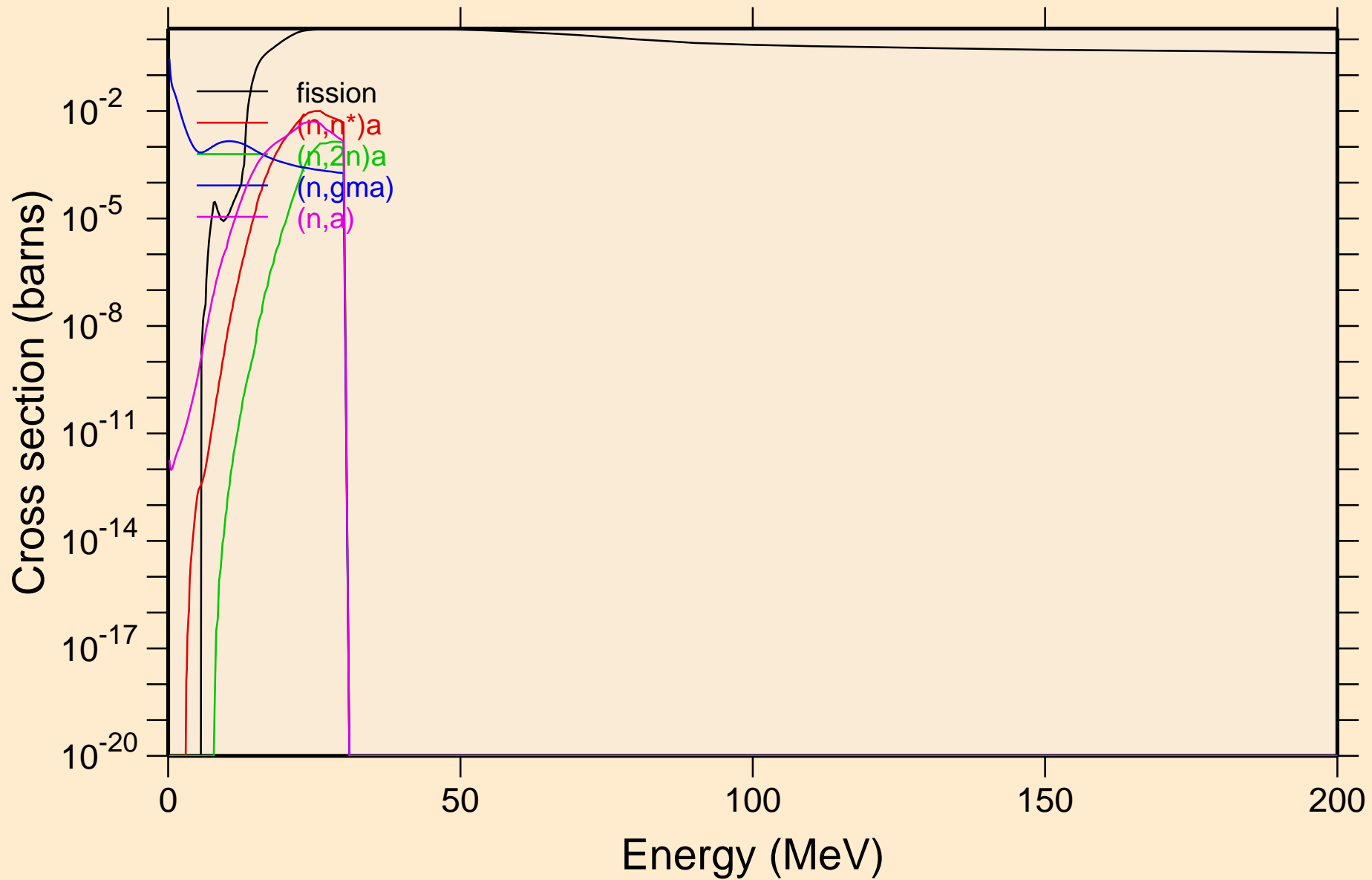

AM248 NEUTRON ACER TENDL-2023 LIBRARY; T=0.K  
Non-threshold reactions

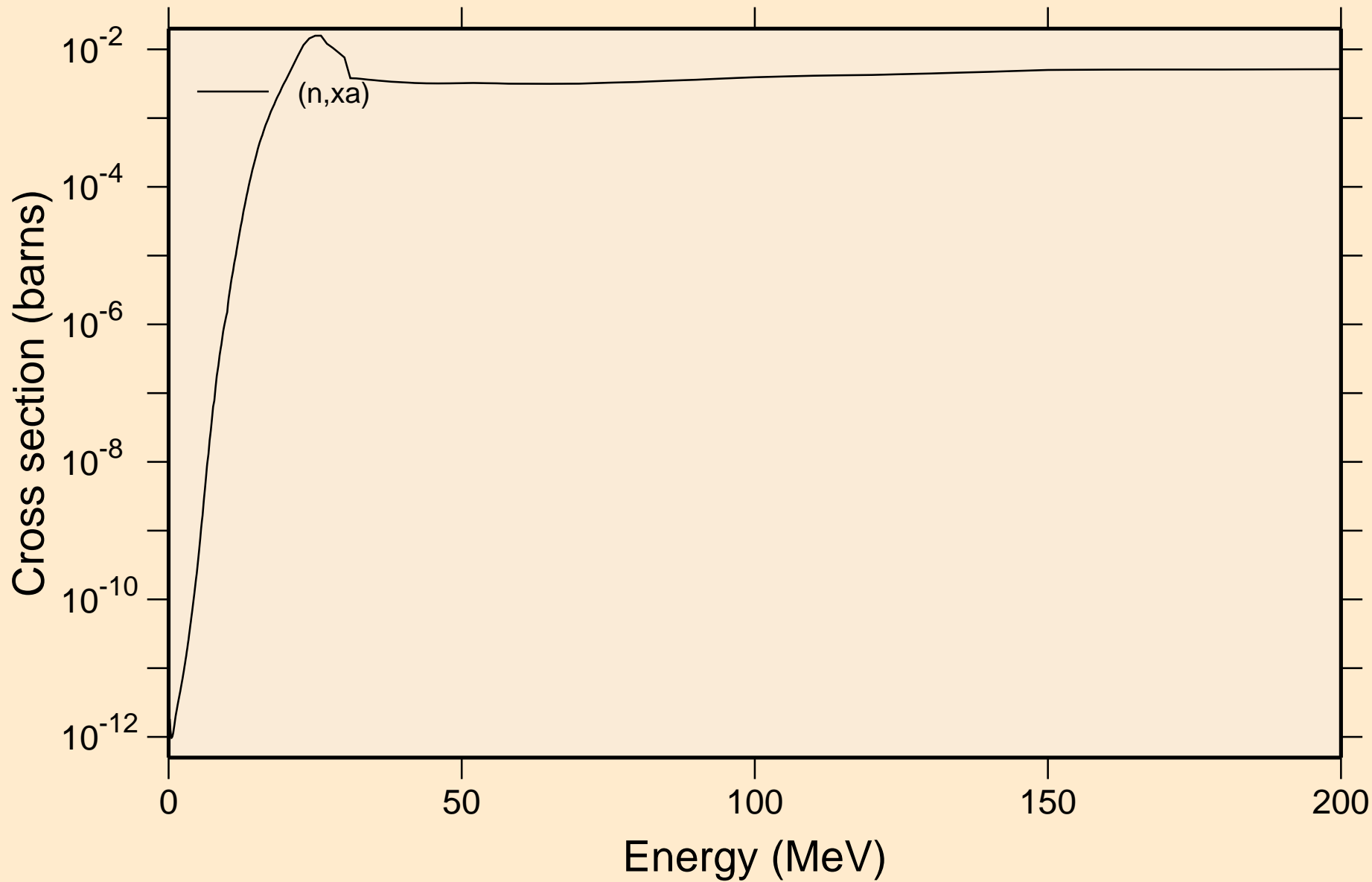

AM248 NEUTRON ACER TENDL-2023 LIBRARY; T=0.K  
Inelastic levels

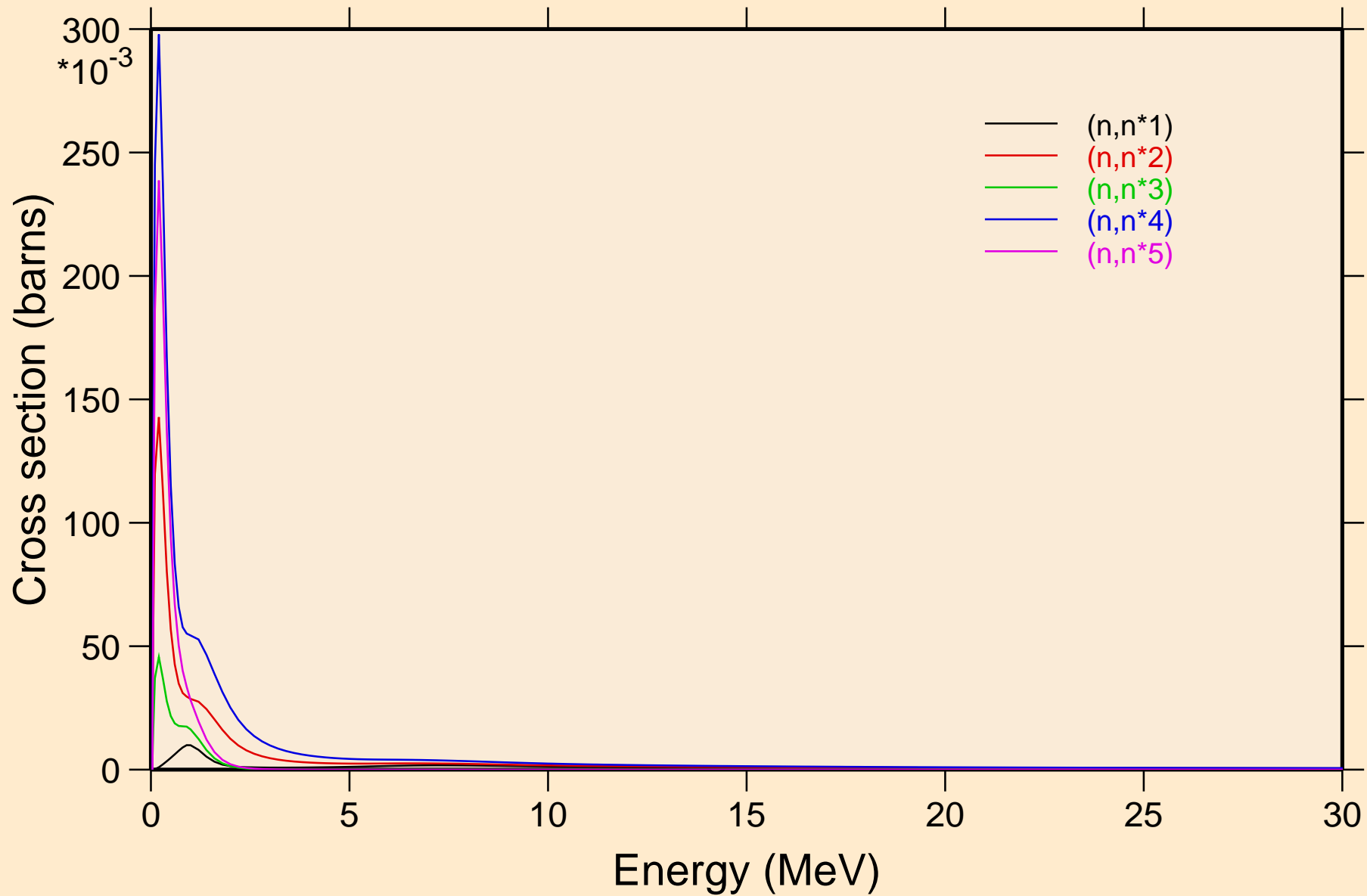

AM248 NEUTRON ACER TENDL-2023 LIBRARY; T=0.K  
Inelastic levels

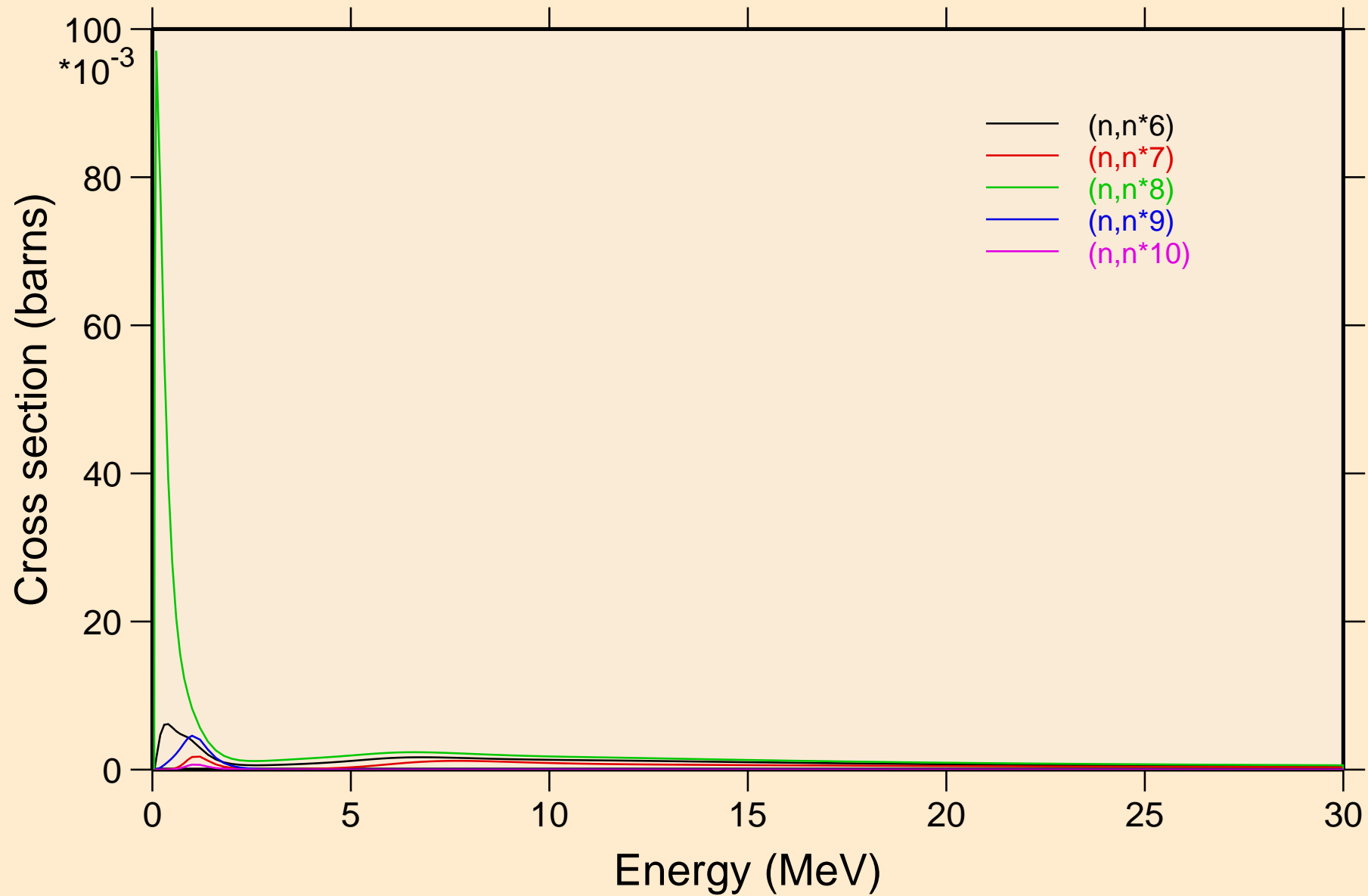

AM248 NEUTRON ACER TENDL-2023 LIBRARY; T=0.K  
Inelastic levels

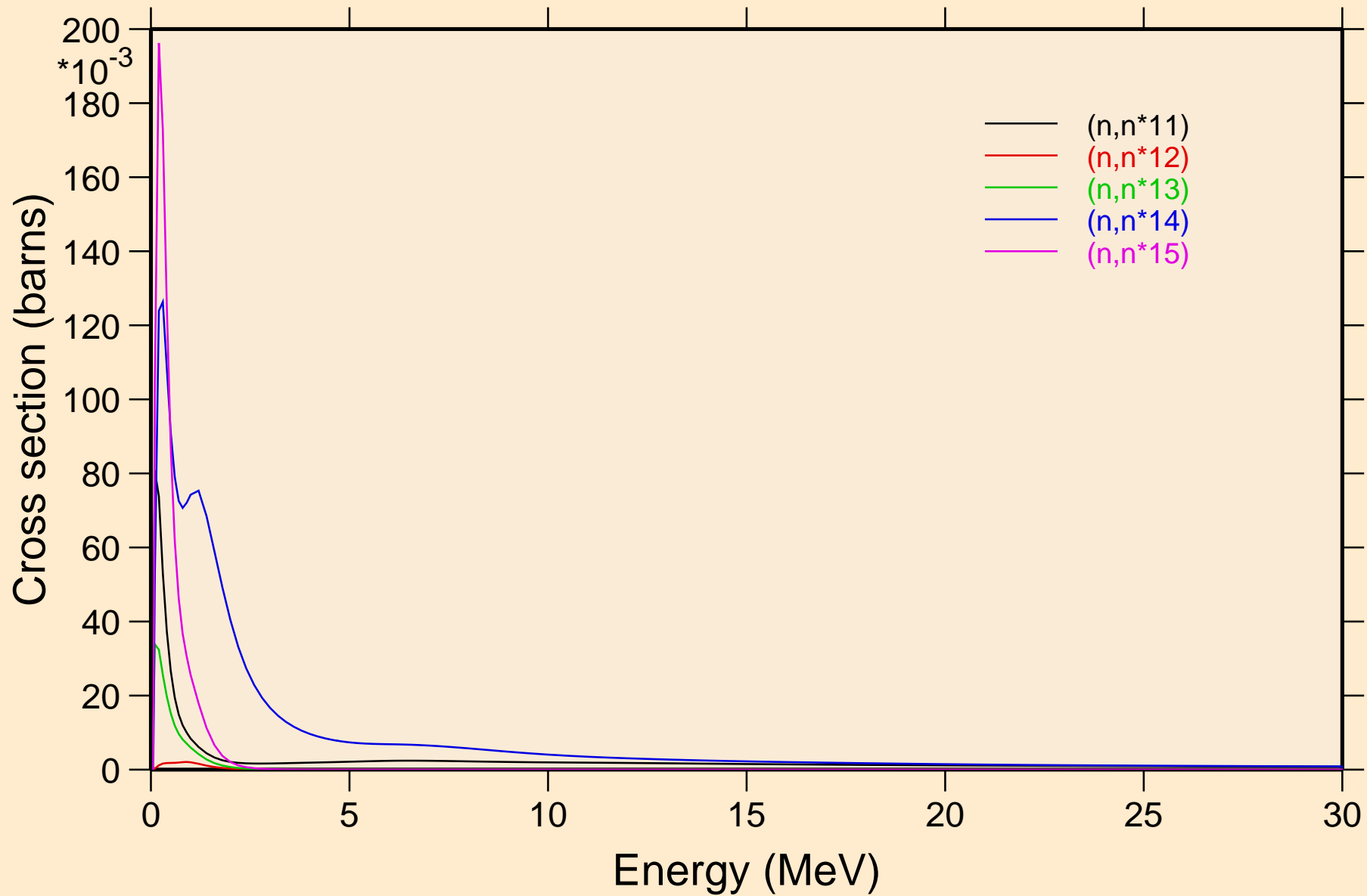

AM248 NEUTRON ACER TENDL-2023 LIBRARY; T=0.K  
Inelastic levels

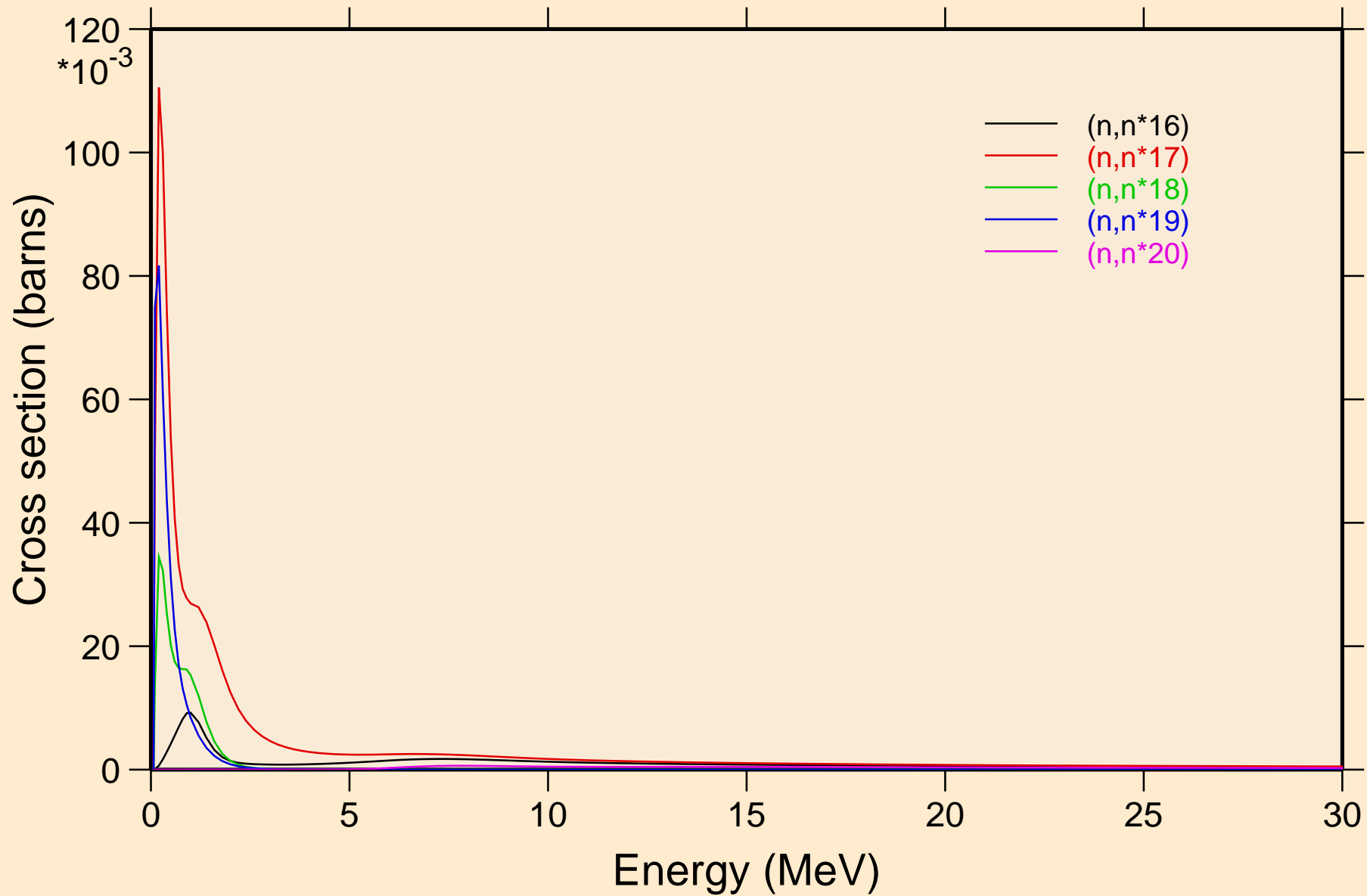

AM248 NEUTRON ACER TENDL-2023 LIBRARY; T=0.K  
Inelastic levels

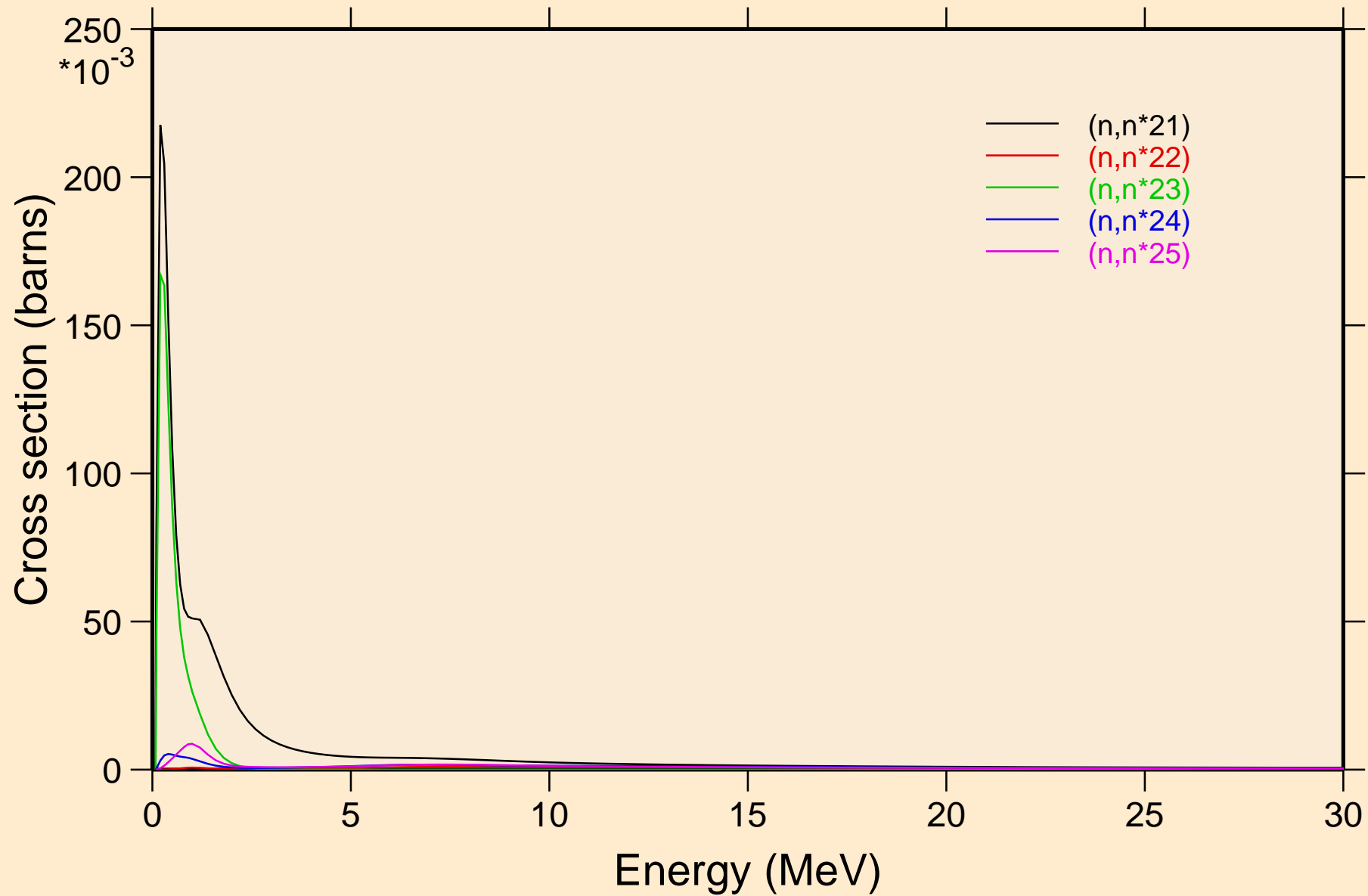

AM248 NEUTRON ACER TENDL-2023 LIBRARY; T=0.K  
Inelastic levels

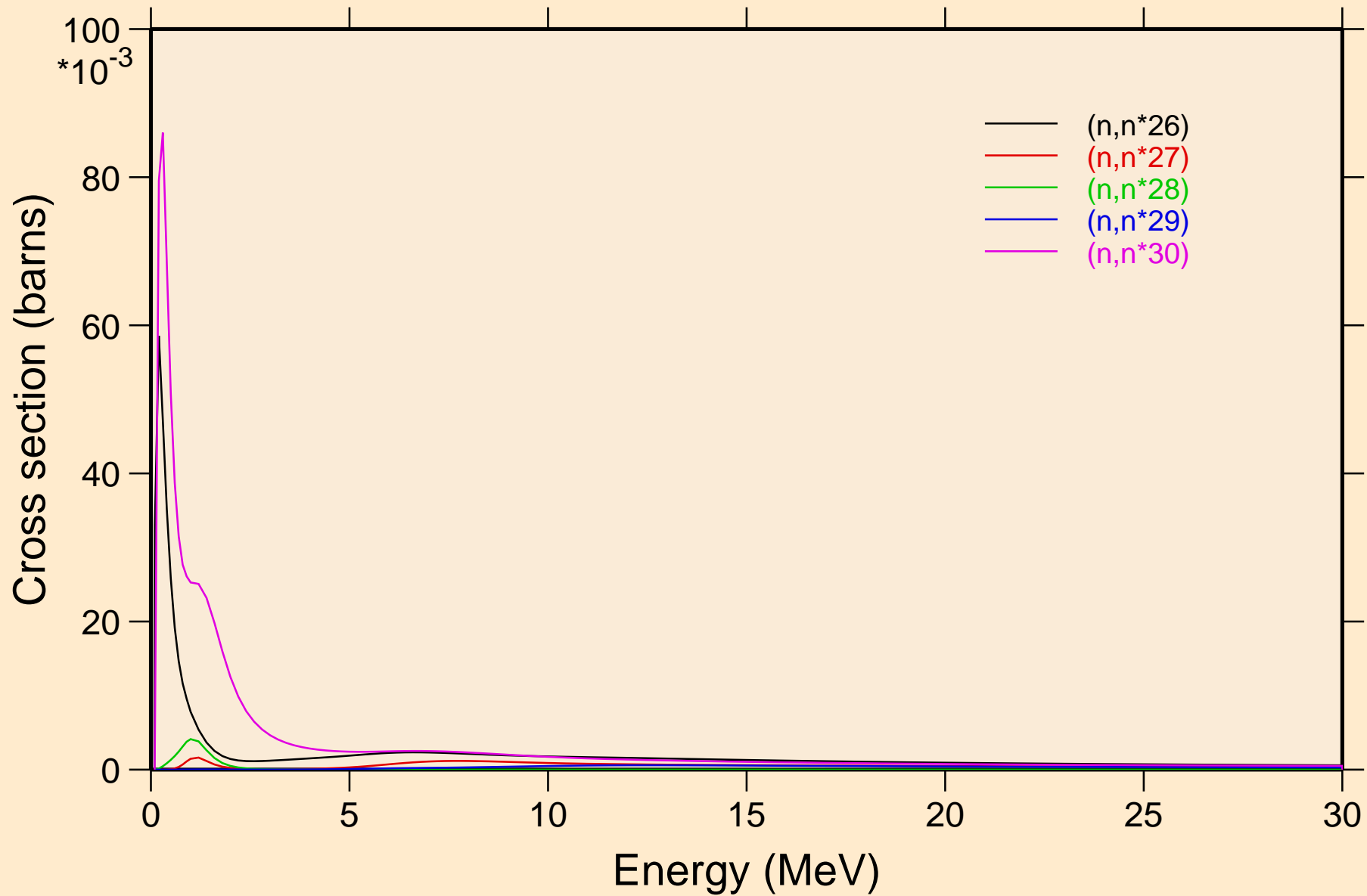



# AM248 NEUTRON ACER TENDL-2023 LIBRARY; T=0.K

## Threshold reactions

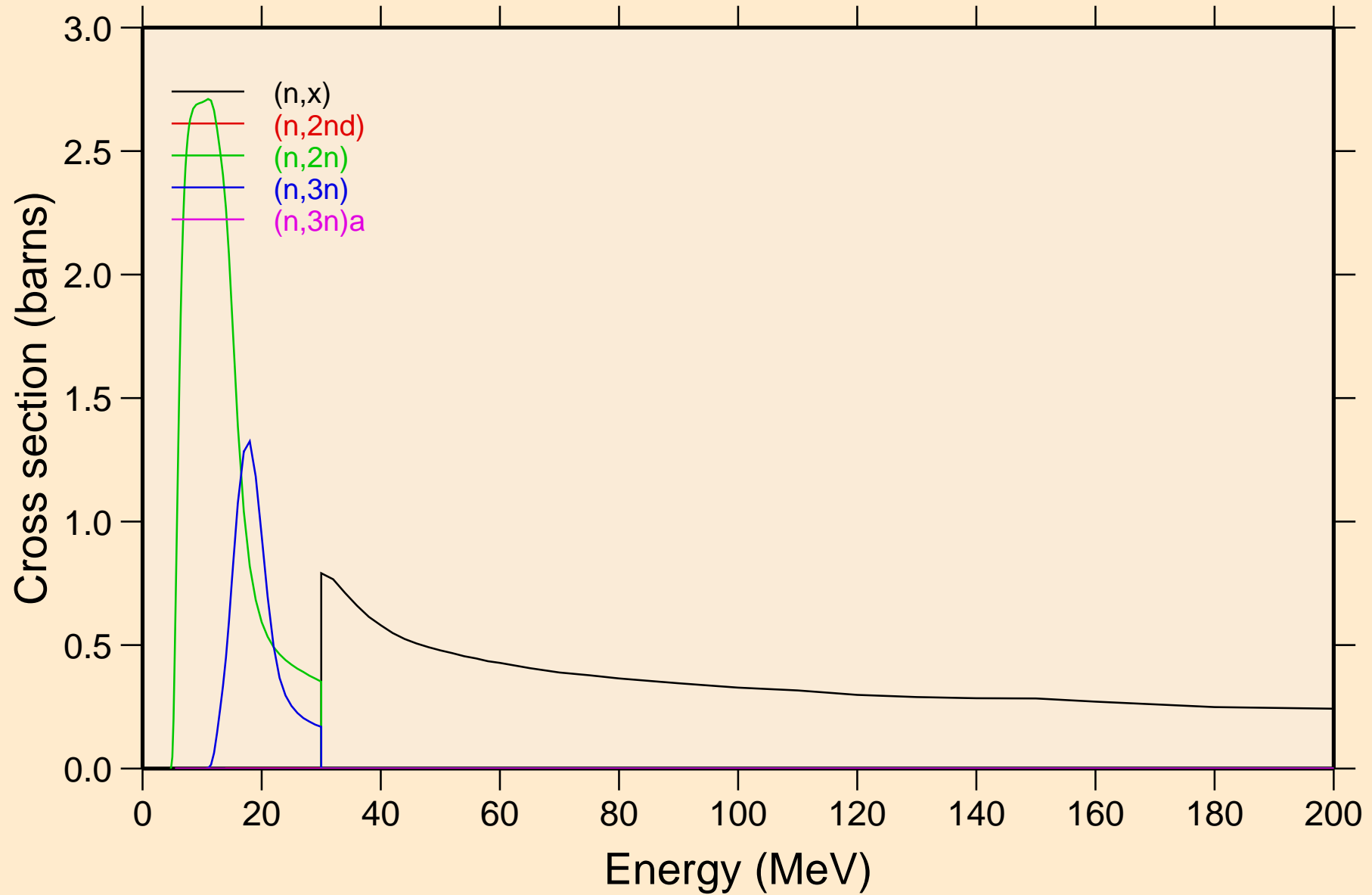

# AM248 NEUTRON ACER TENDL-2023 LIBRARY; T=0.K

## Threshold reactions

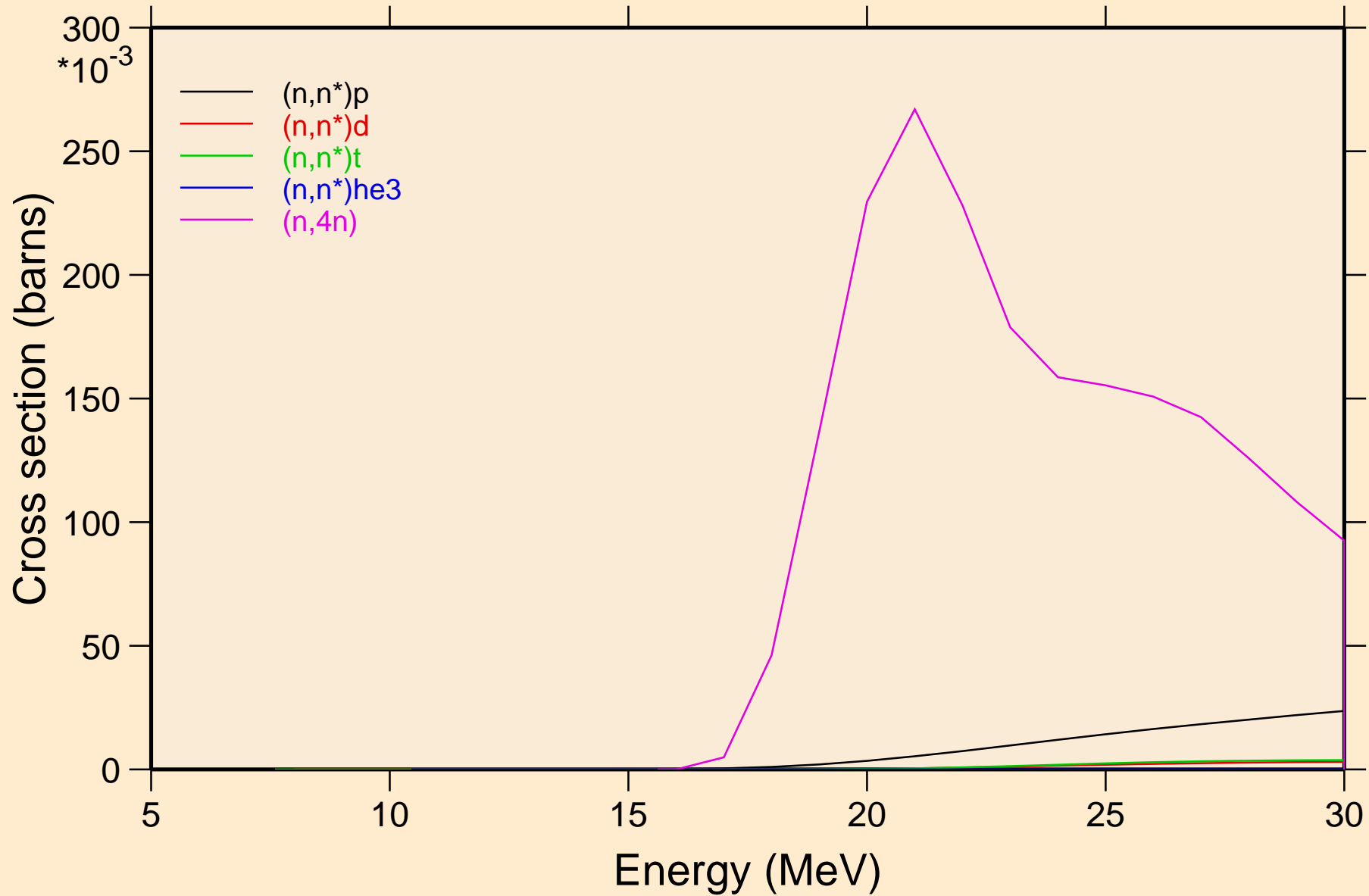

AM248 NEUTRON ACER TENDL-2023 LIBRARY; T=0.K  
Threshold reactions

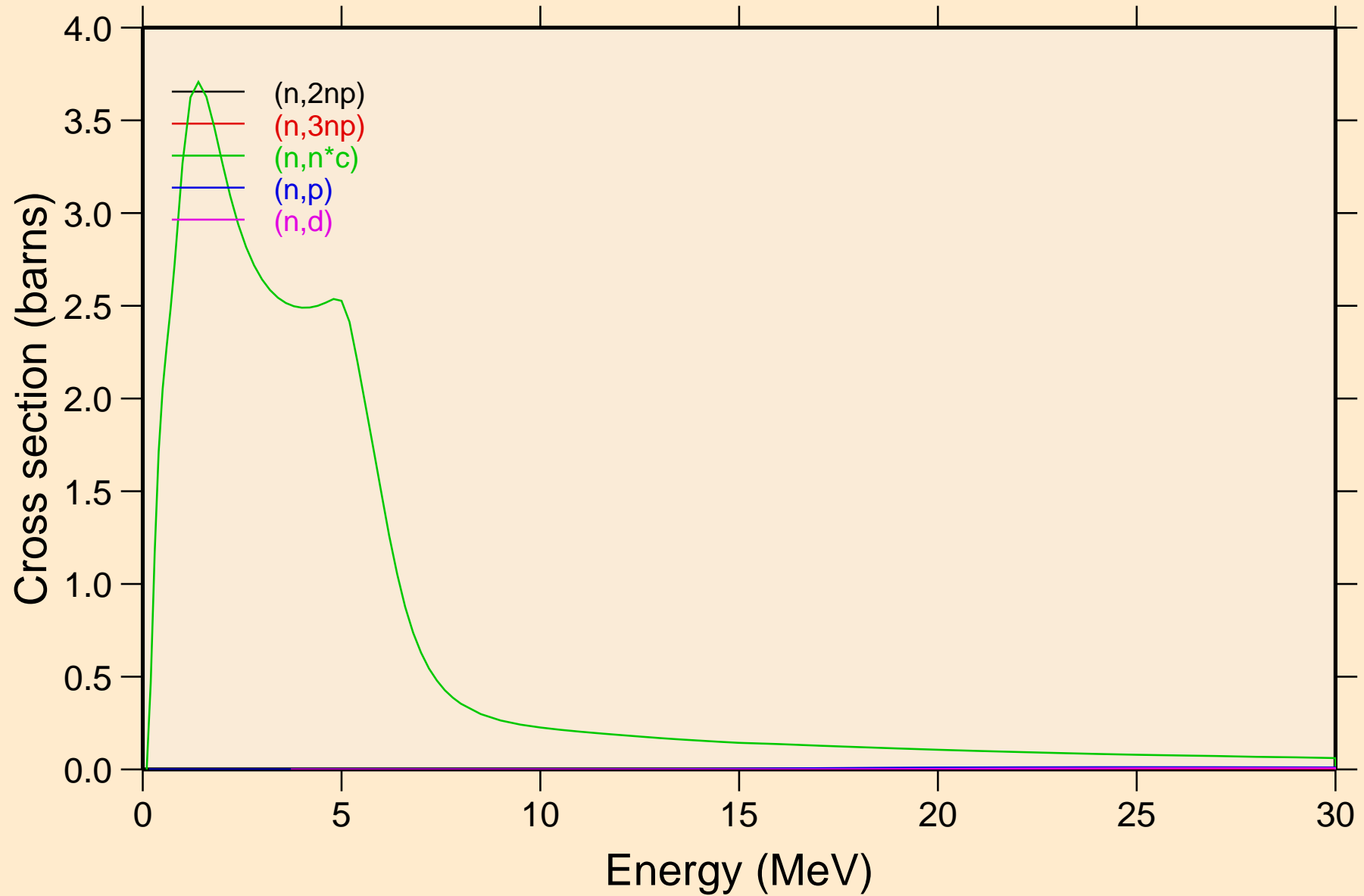

AM248 NEUTRON ACER TENDL-2023 LIBRARY; T=0.K  
Threshold reactions

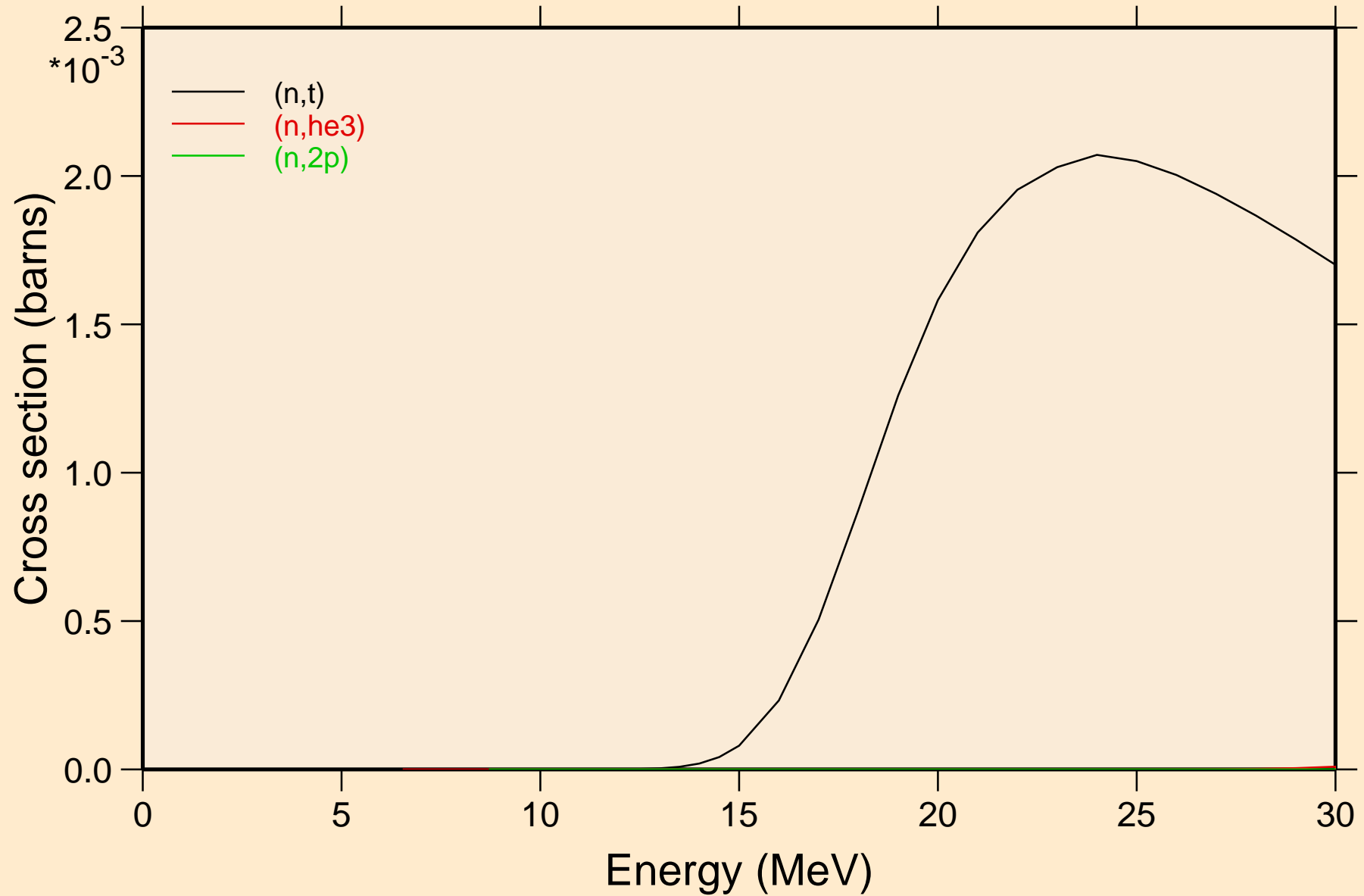

# AM248 NEUTRON ACER TENDL-2023 LIBRARY; T=0.K

## Threshold reactions

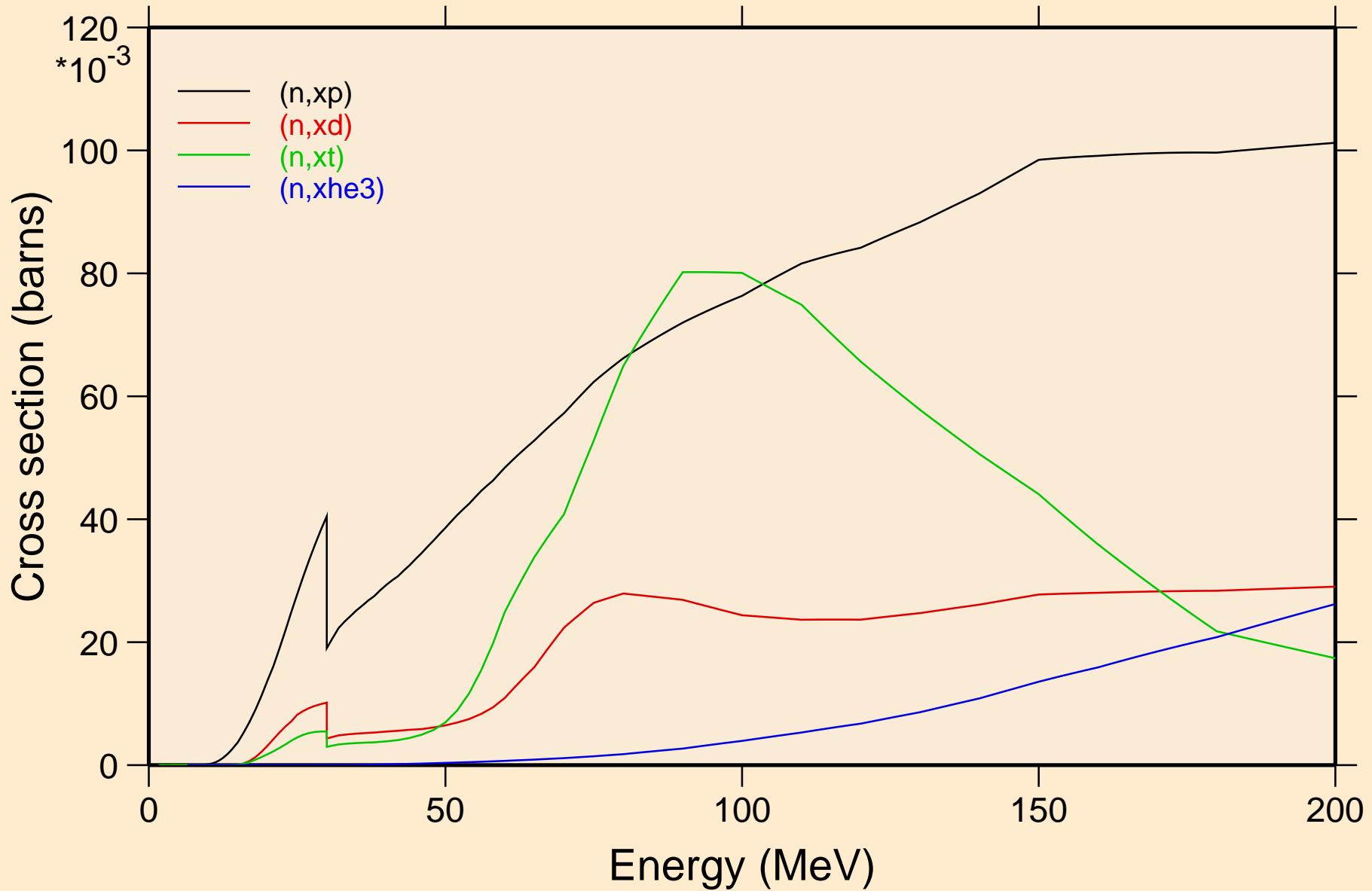

AM248 NEUTRON ACER TENDL-2023 LIBRARY; T=0.K  
angular distribution for elastic

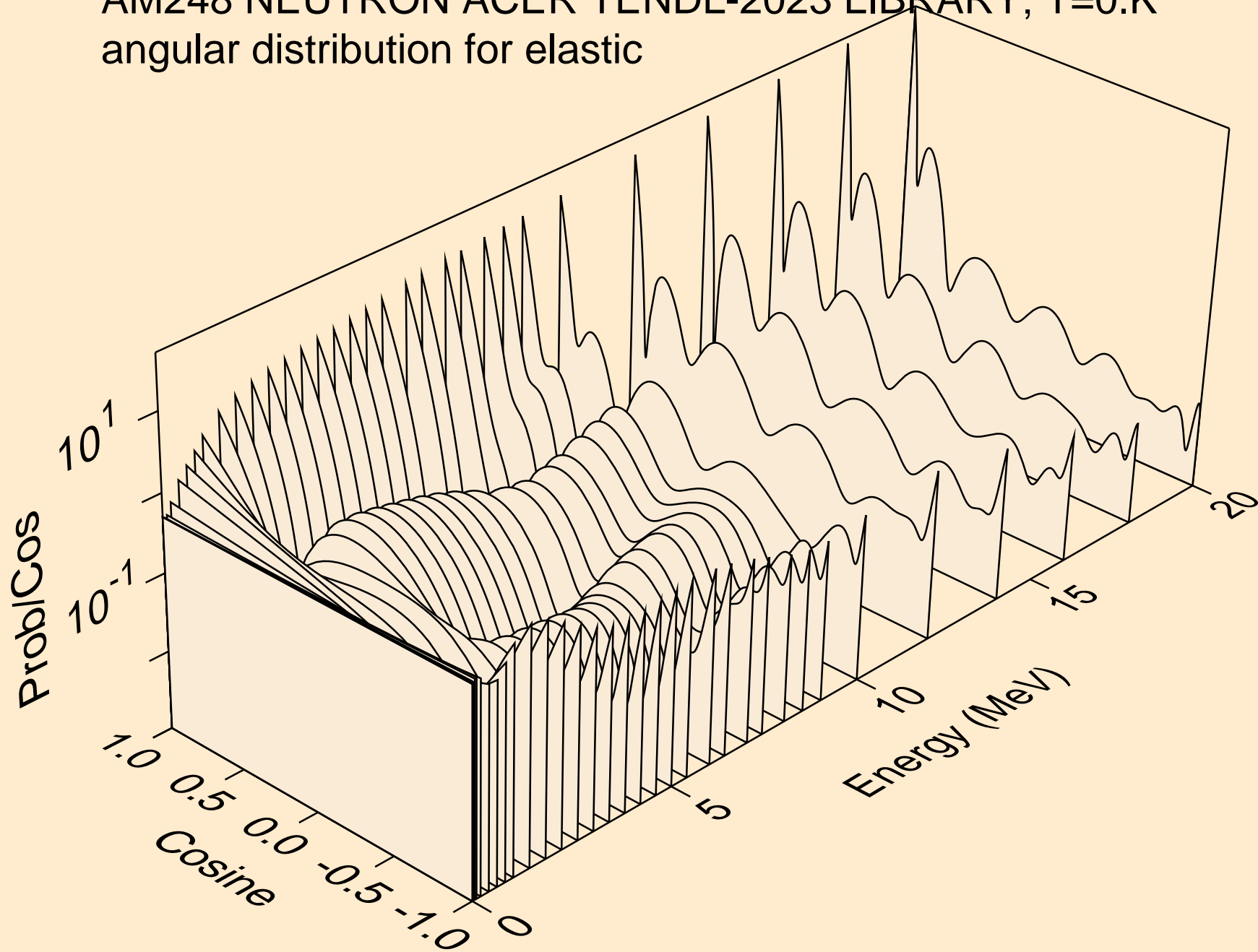

AM248 NEUTRON ACER TENDL-2023 LIBRARY; T=0.K  
angular distribution for elastic

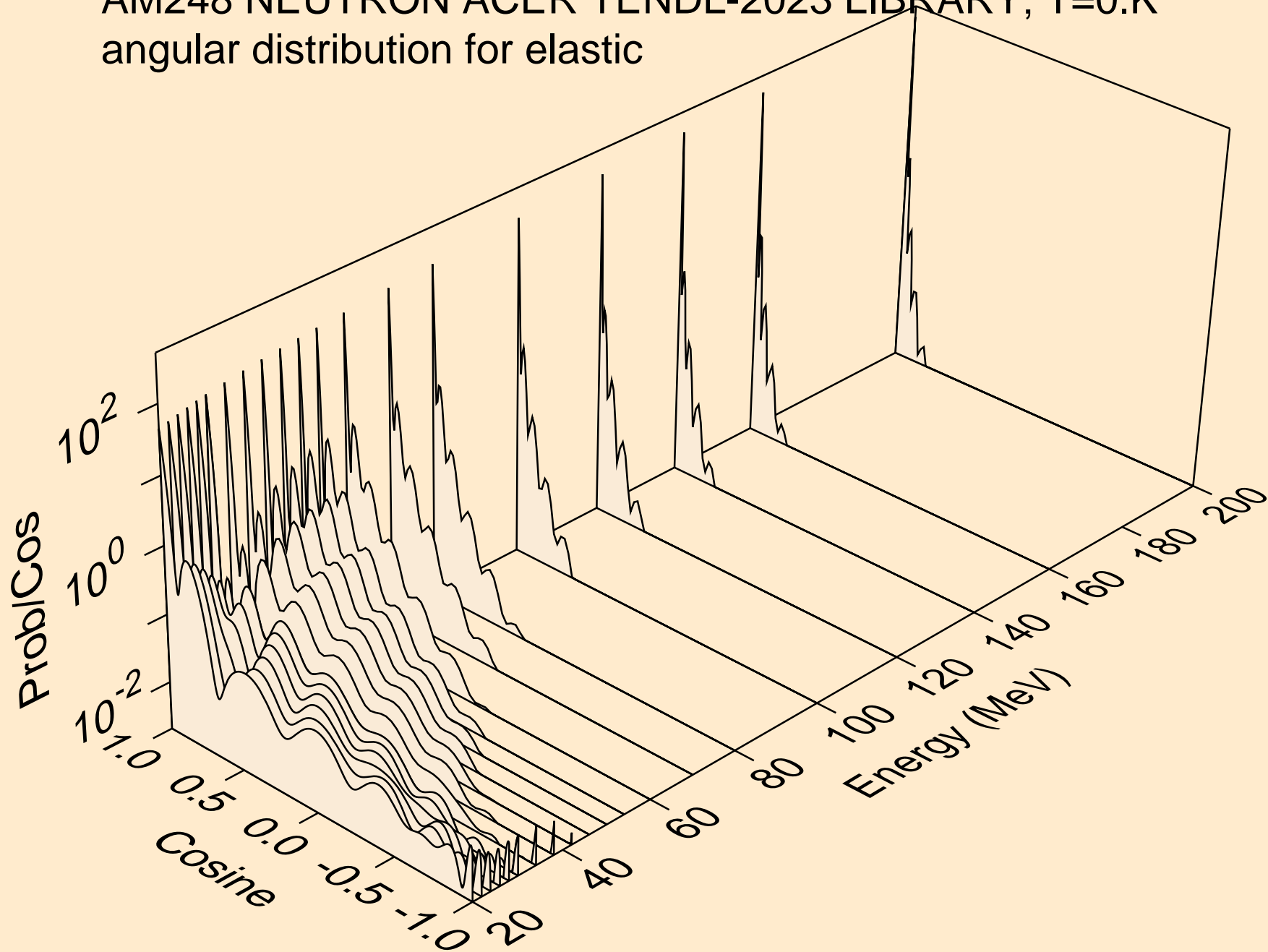

AM248 NEUTRON ACER TENDL-2023 LIBRARY; T=0.K  
angular distribution for (n,n\*1)

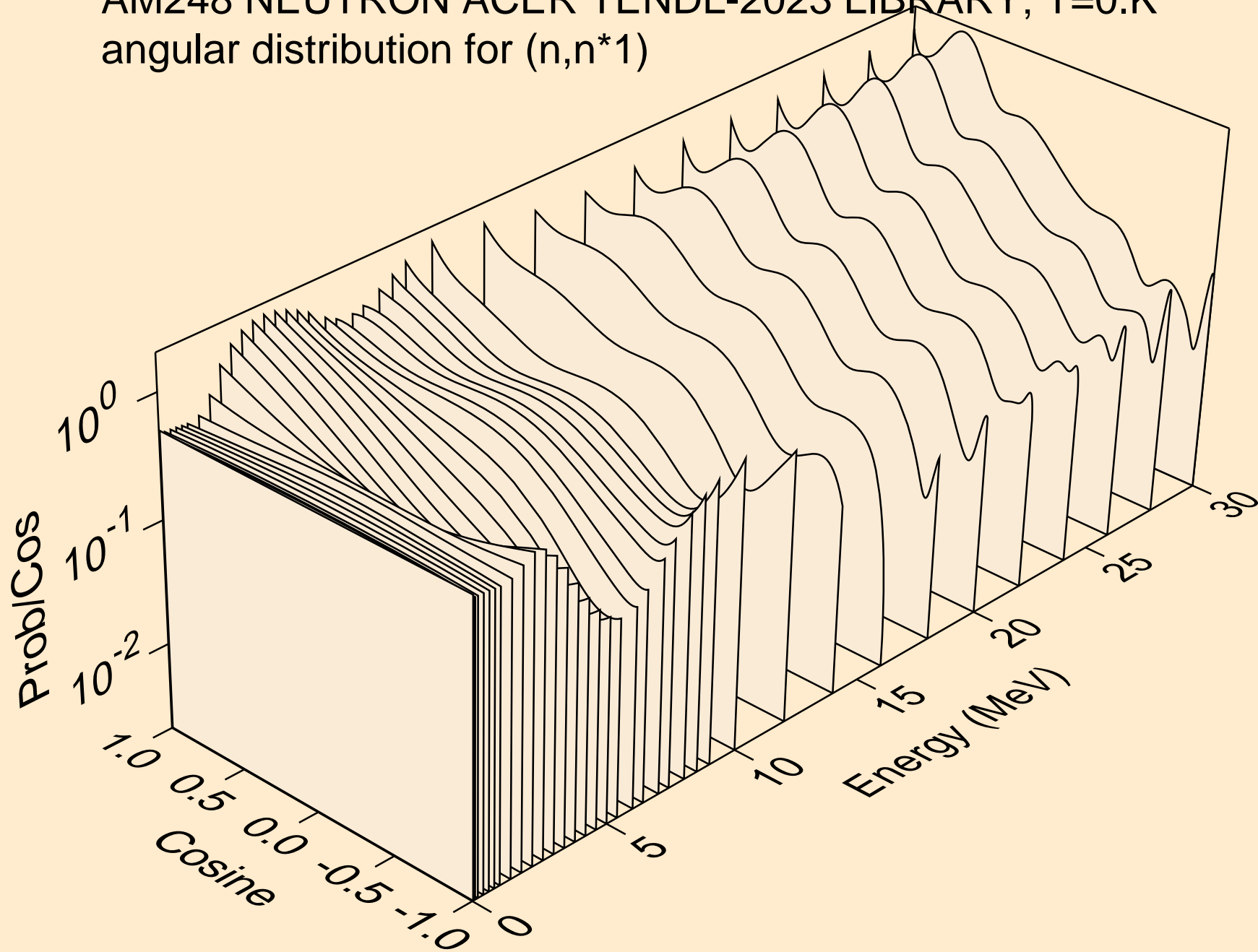



AM248 NEUTRON ACER TENDL-2023 LIBRARY; T=0.K  
angular distribution for (n,n\*2)

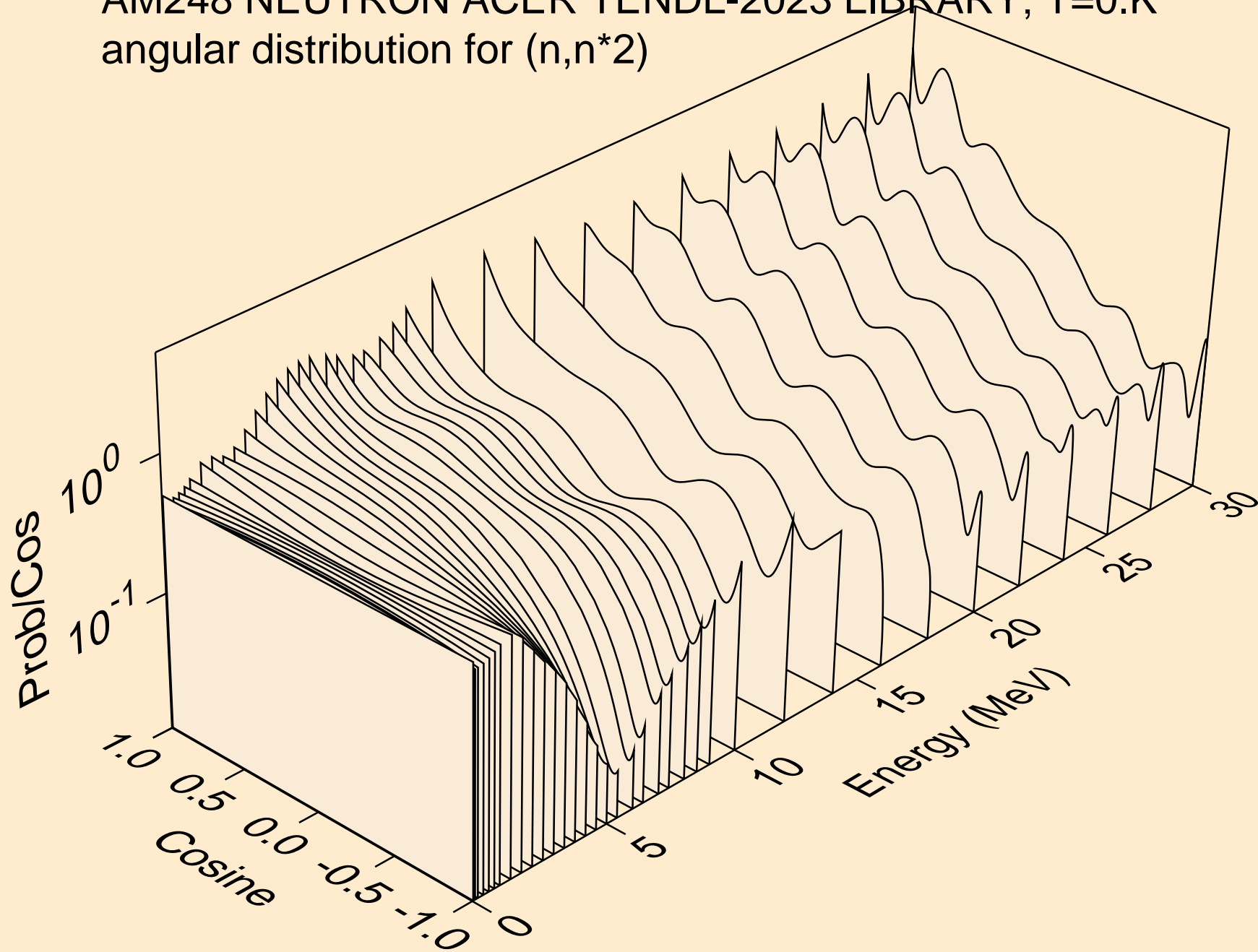

AM248 NEUTRON ACER TENDL-2023 LIBRARY; T=0.K  
angular distribution for (n,n\*3)

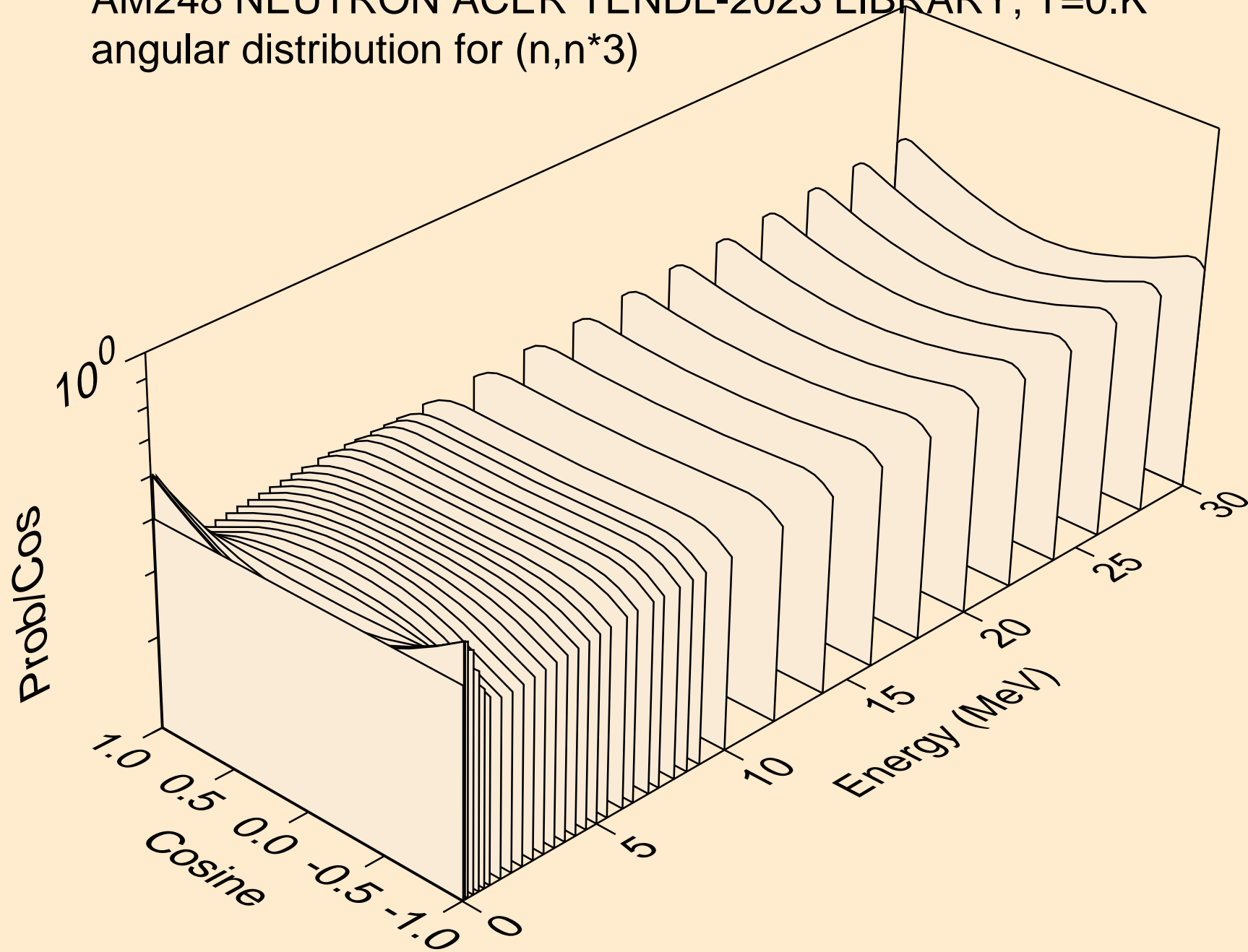

AM248 NEUTRON ACER TENDL-2023 LIBRARY; T=0.K  
angular distribution for (n,n\*4)

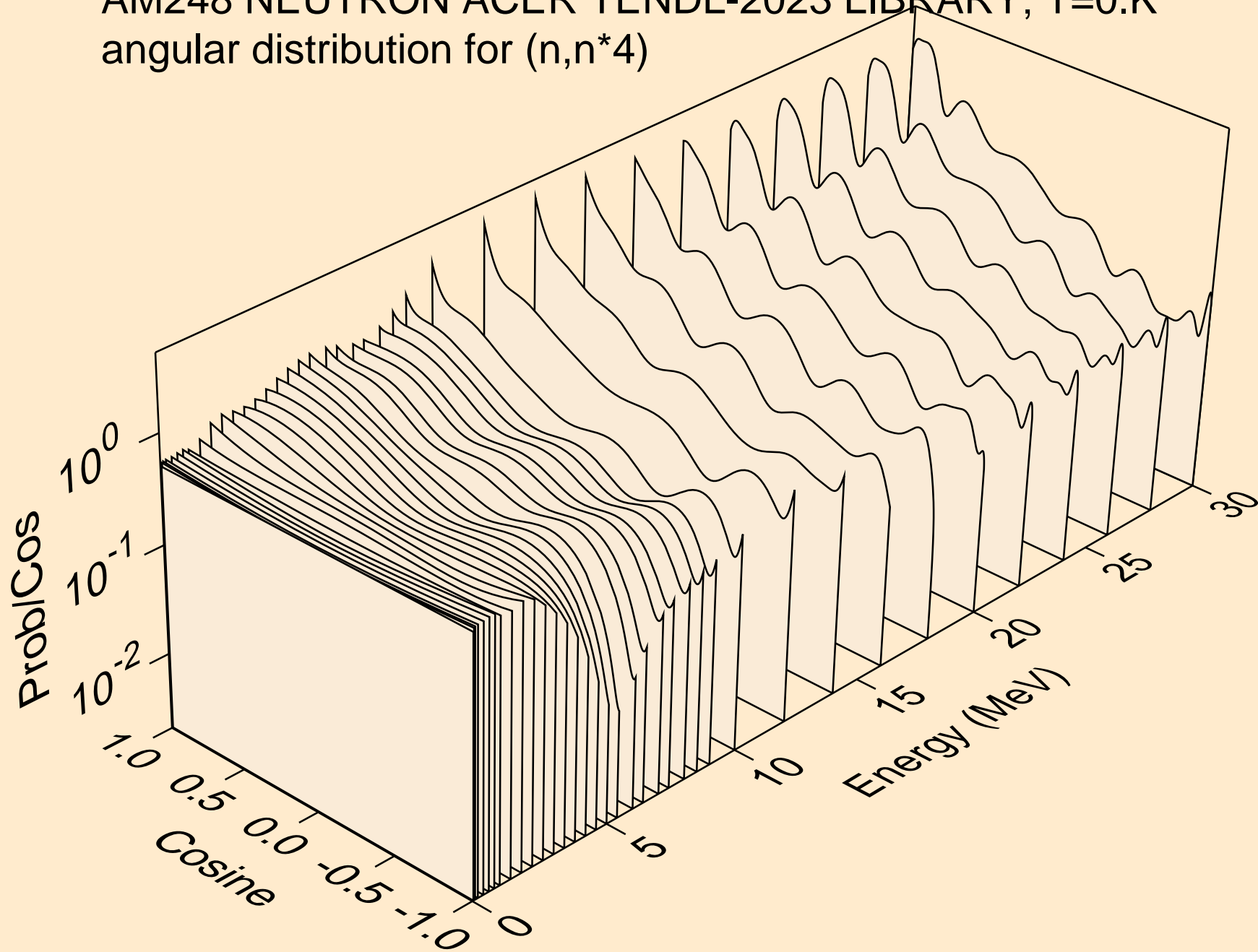

AM248 NEUTRON ACER TENDL-2023 LIBRARY; T=0.K  
angular distribution for (n,n\*5)

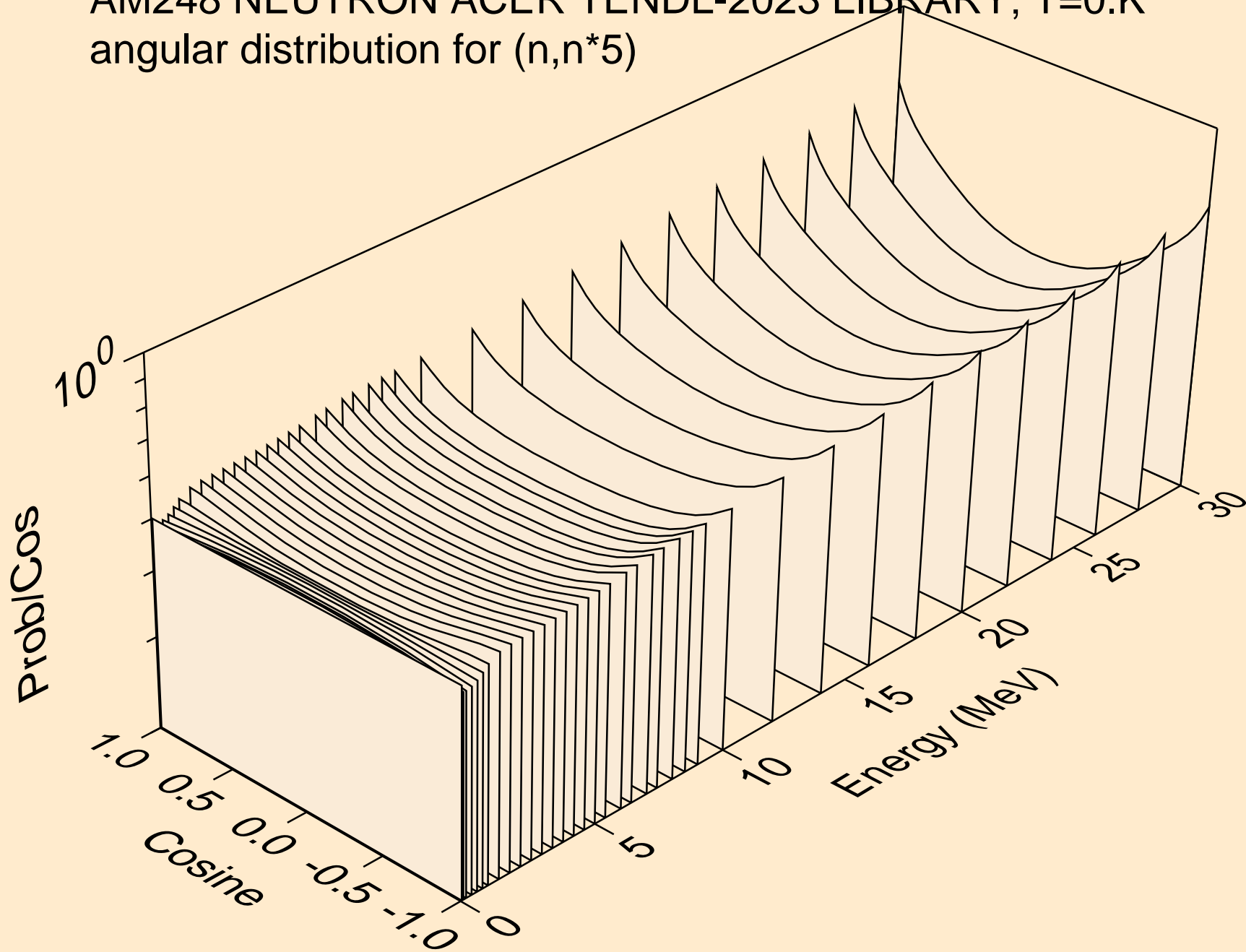

AM248 NEUTRON ACER TENDL-2023 LIBRARY; T=0.K  
angular distribution for (n,n\*6)

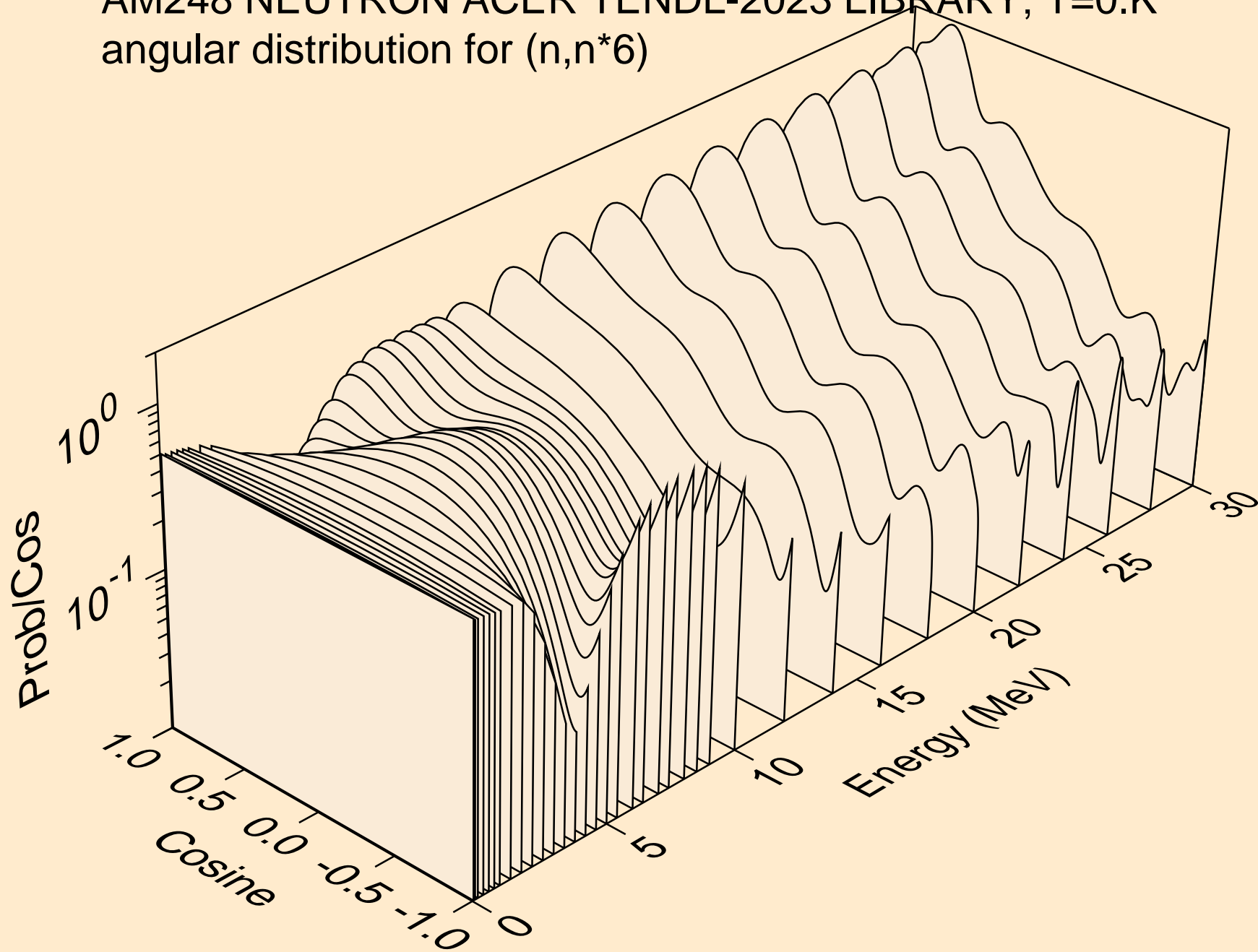

AM248 NEUTRON ACER TENDL-2023 LIBRARY; T=0.K  
angular distribution for (n,n\*7)

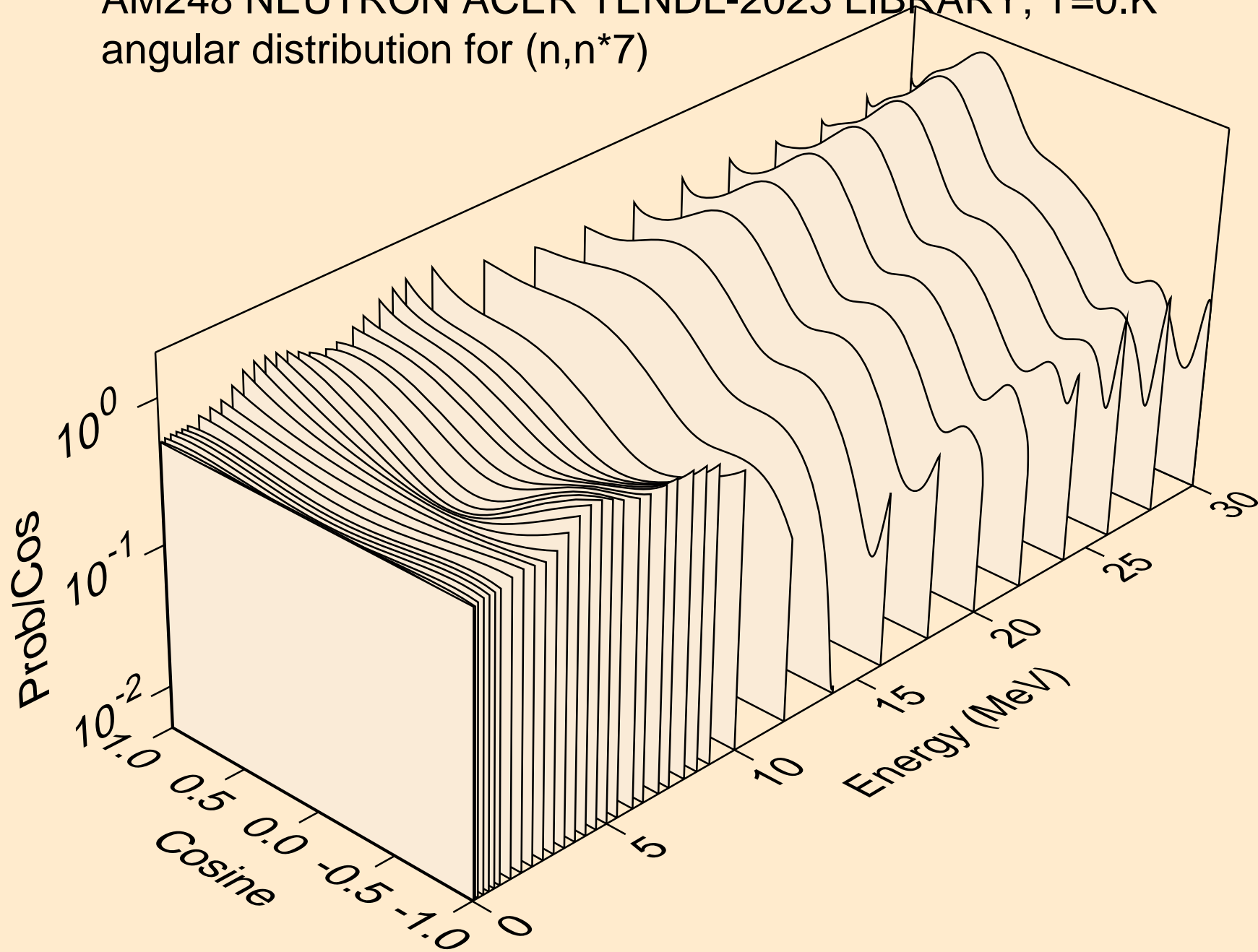

AM248 NEUTRON ACER TENDL-2023 LIBRARY; T=0.K  
angular distribution for (n,n\*8)

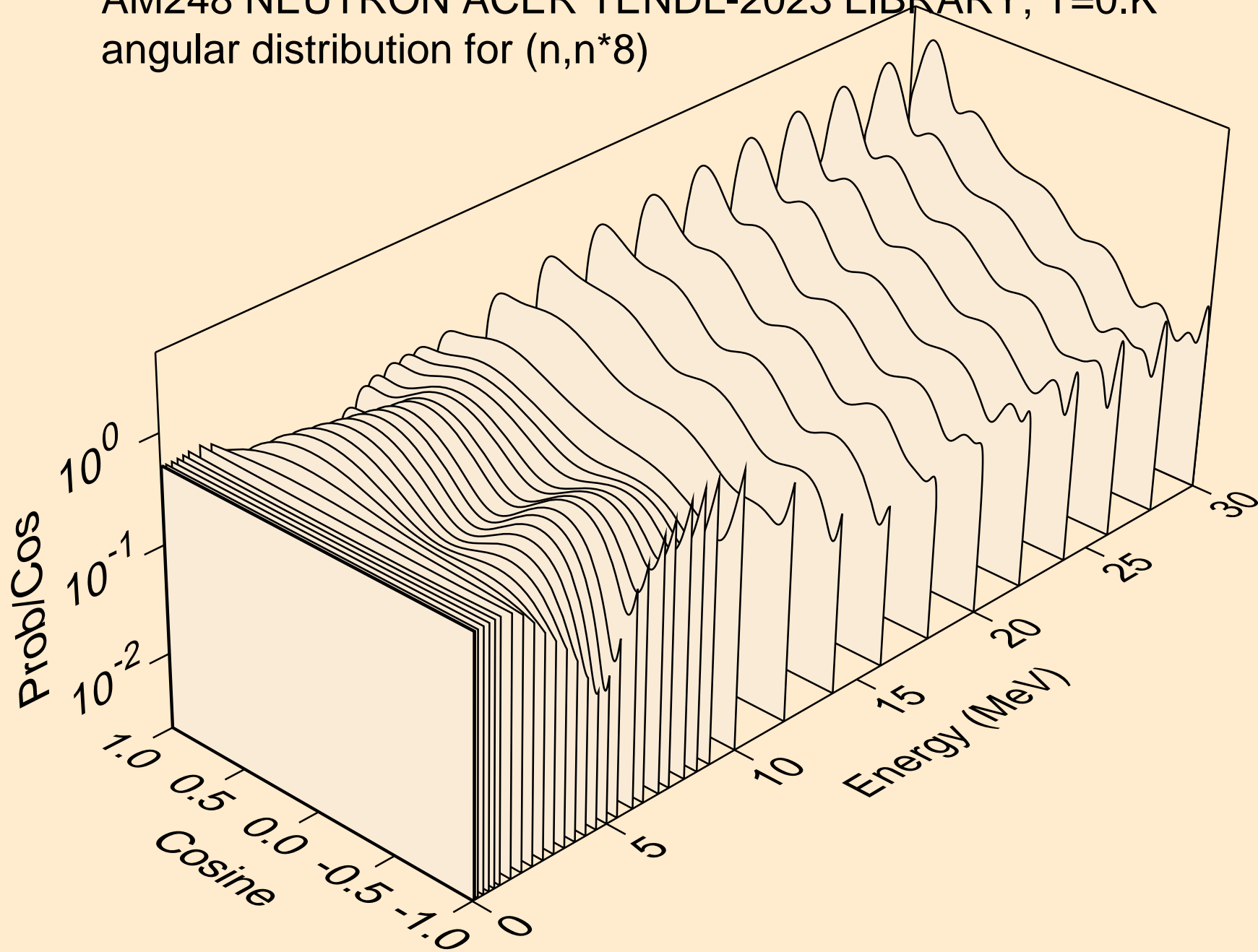

AM248 NEUTRON ACER TENDL-2023 LIBRARY; T=0.K  
angular distribution for (n,n\*9)

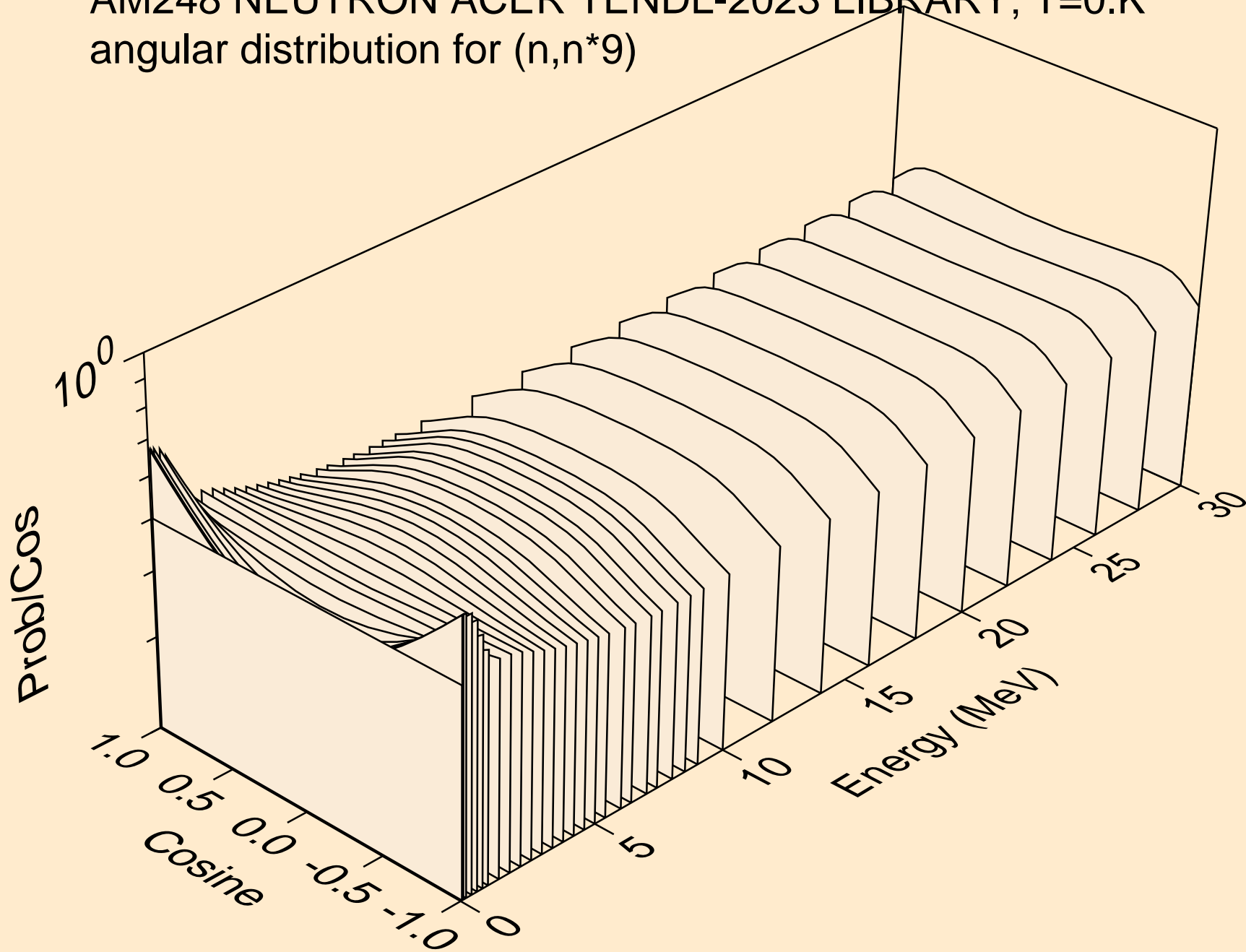



AM248 NEUTRON ACER TENDL-2023 LIBRARY; T=0.K  
angular distribution for (n,n\*10)

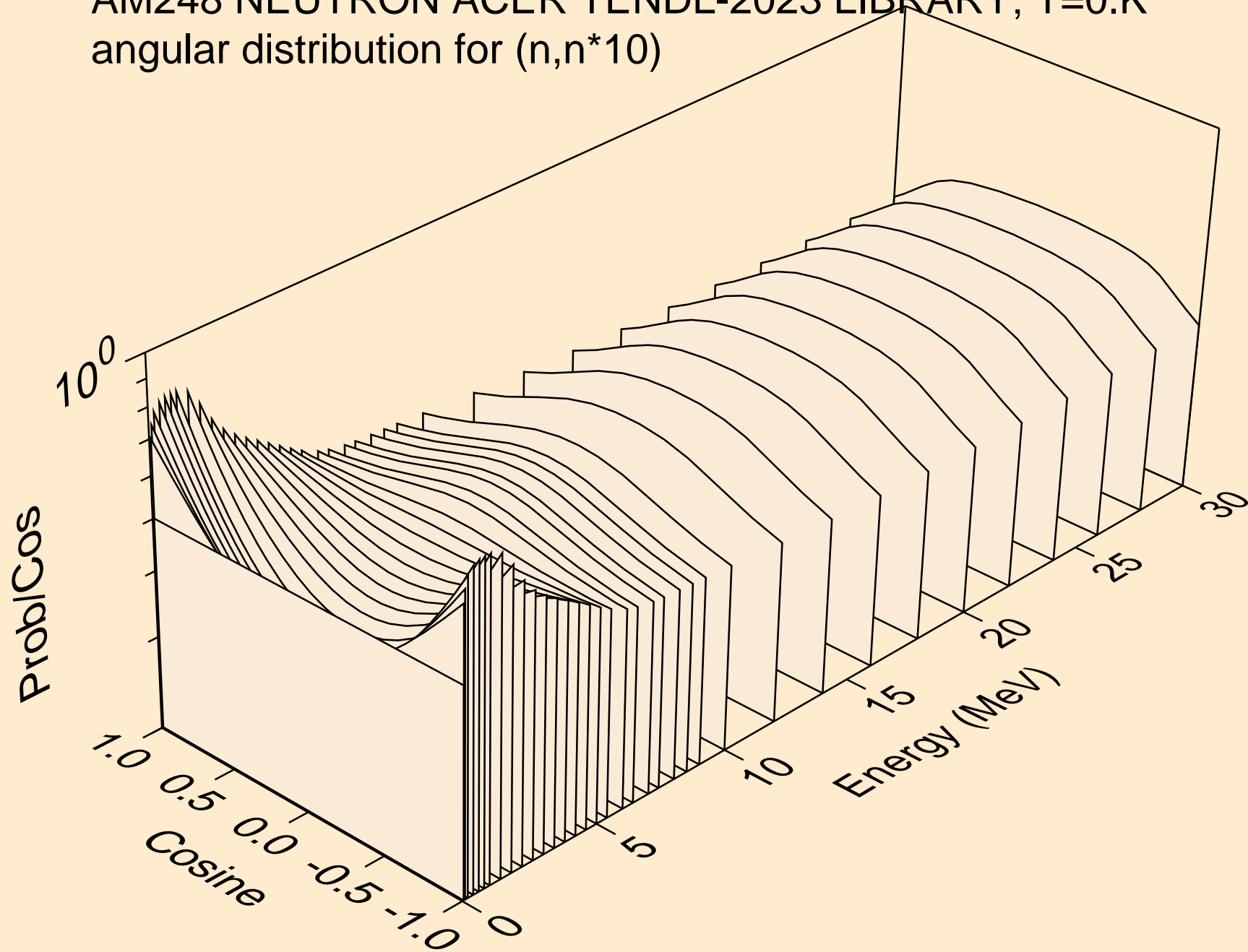

AM248 NEUTRON ACER TENDL-2023 LIBRARY; T=0.K  
angular distribution for (n,n\*11)

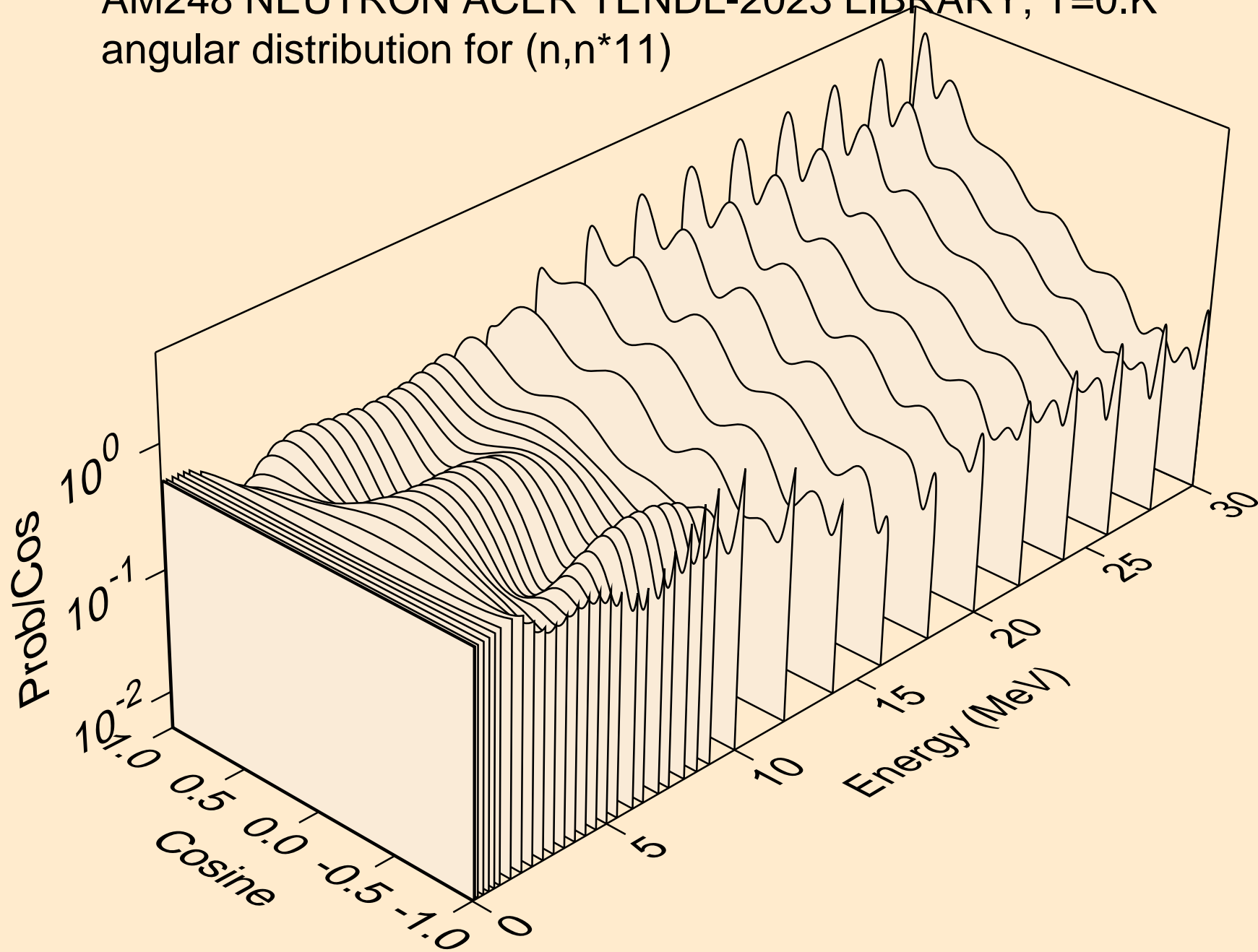

AM248 NEUTRON ACER TENDL-2023 LIBRARY; T=0.K  
angular distribution for (n,n\*12)

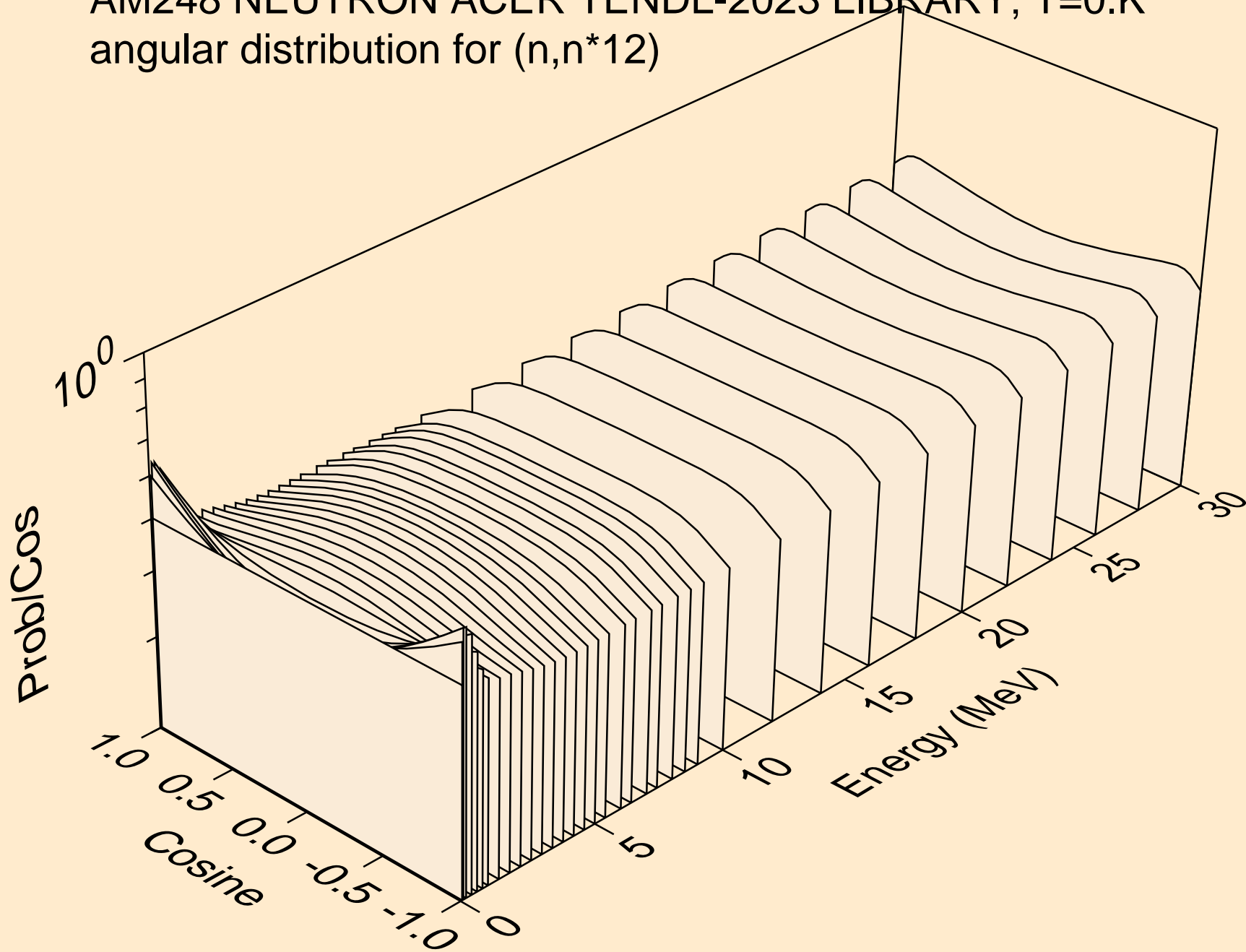

AM248 NEUTRON ACER TENDL-2023 LIBRARY; T=0.K  
angular distribution for (n,n\*13)

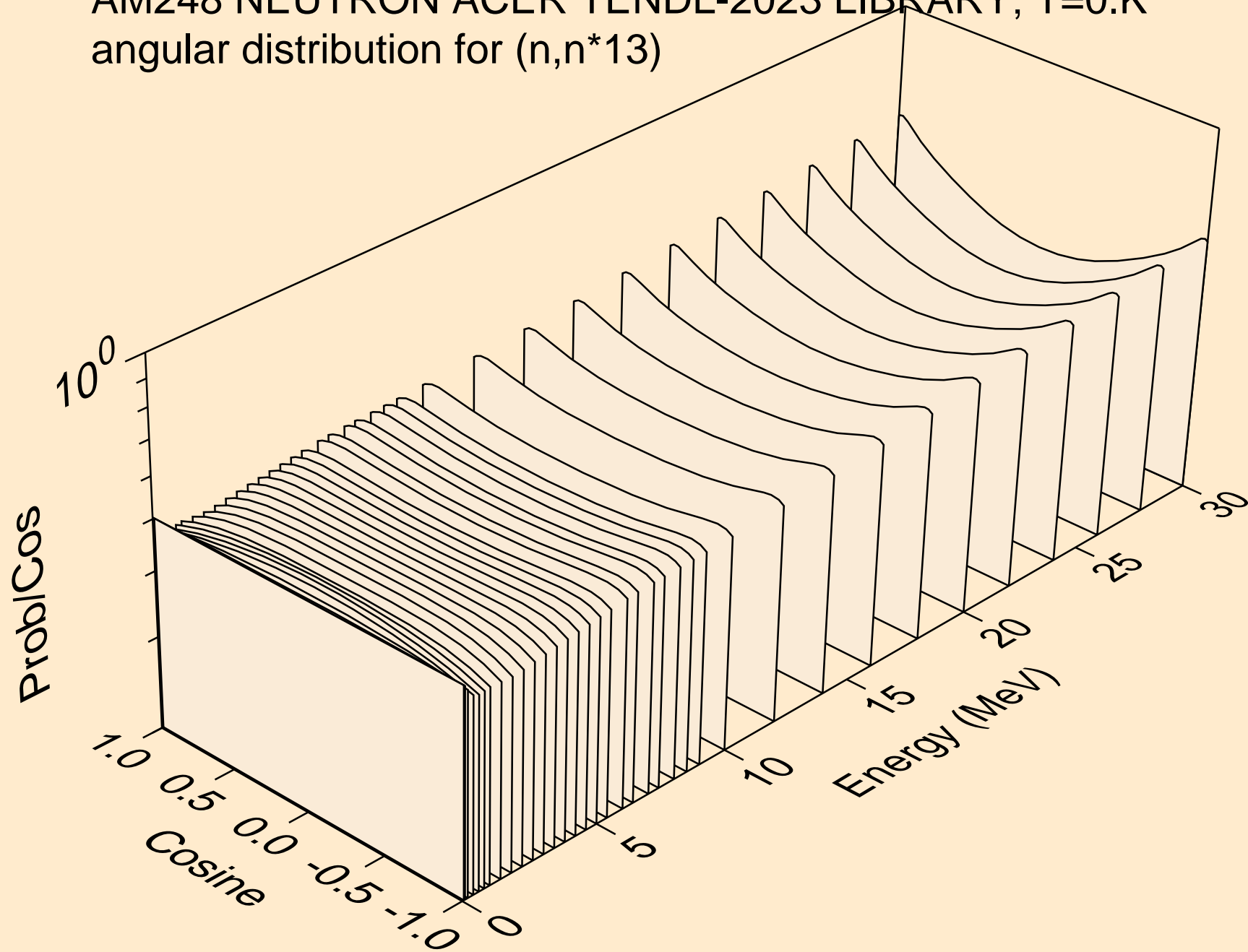

AM248 NEUTRON ACER TENDL-2023 LIBRARY; T=0.K  
angular distribution for (n,n\*14)

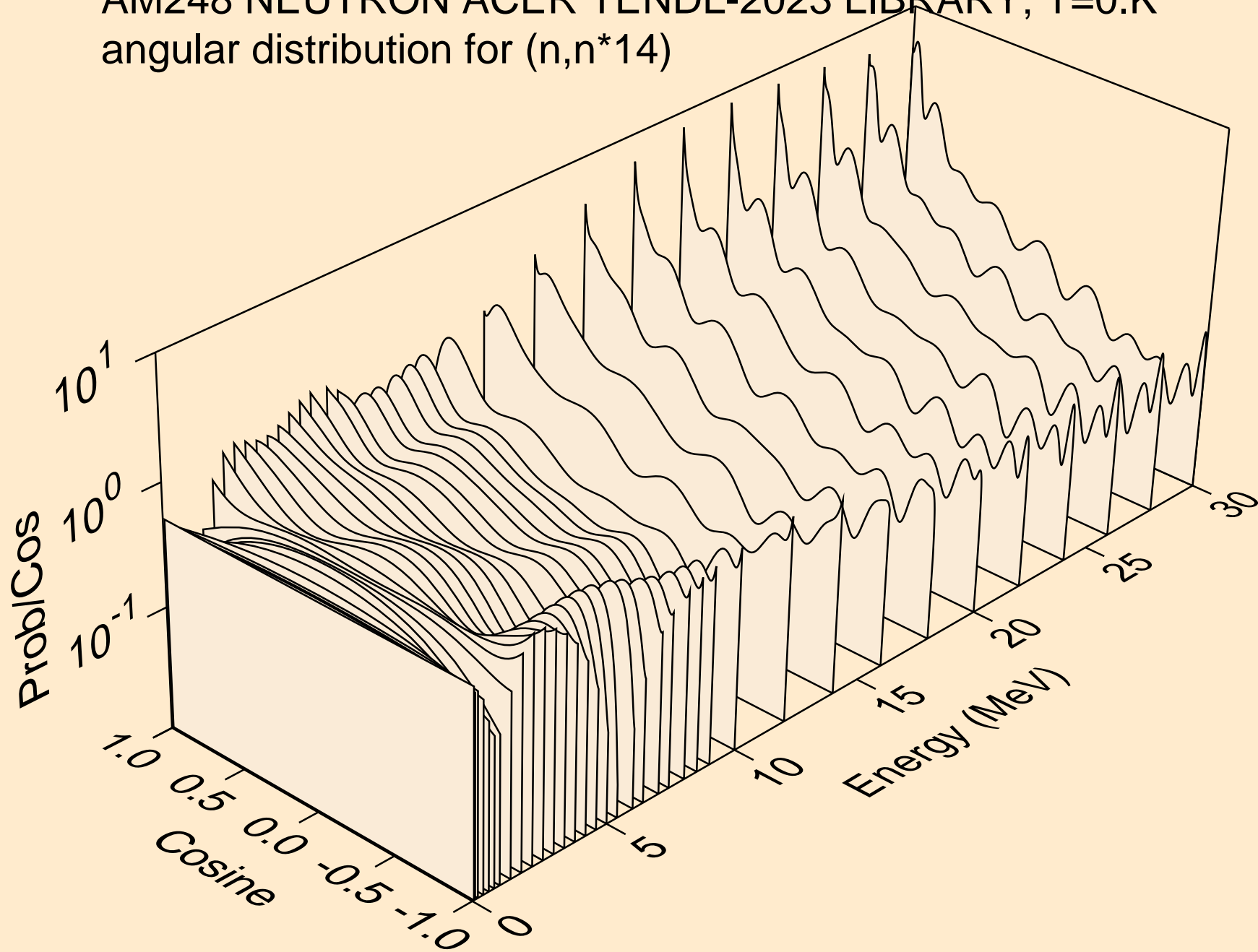

AM248 NEUTRON ACER TENDL-2023 LIBRARY; T=0.K  
angular distribution for (n,n\*15)

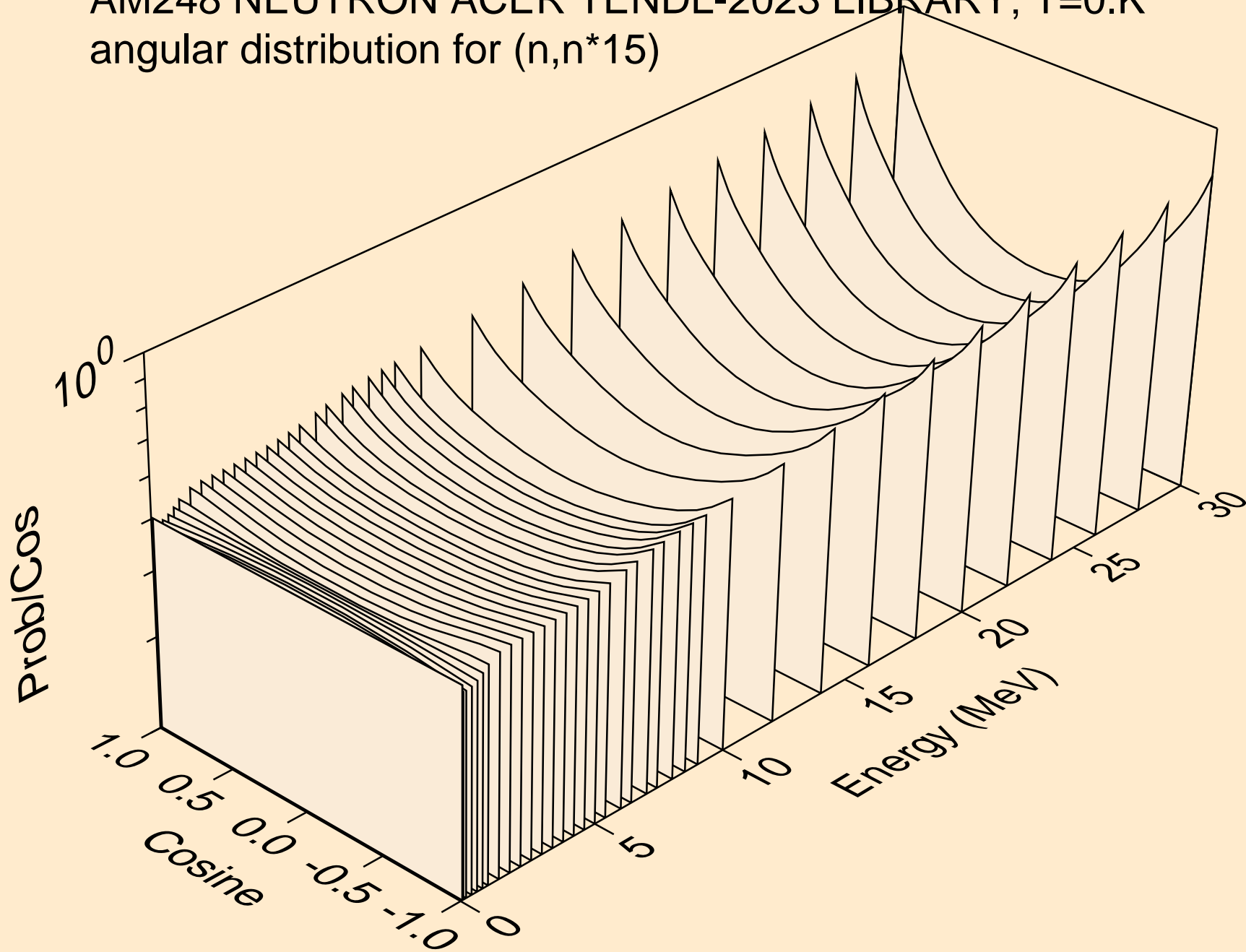

AM248 NEUTRON ACER TENDL-2023 LIBRARY; T=0.K  
angular distribution for (n,n\*16)

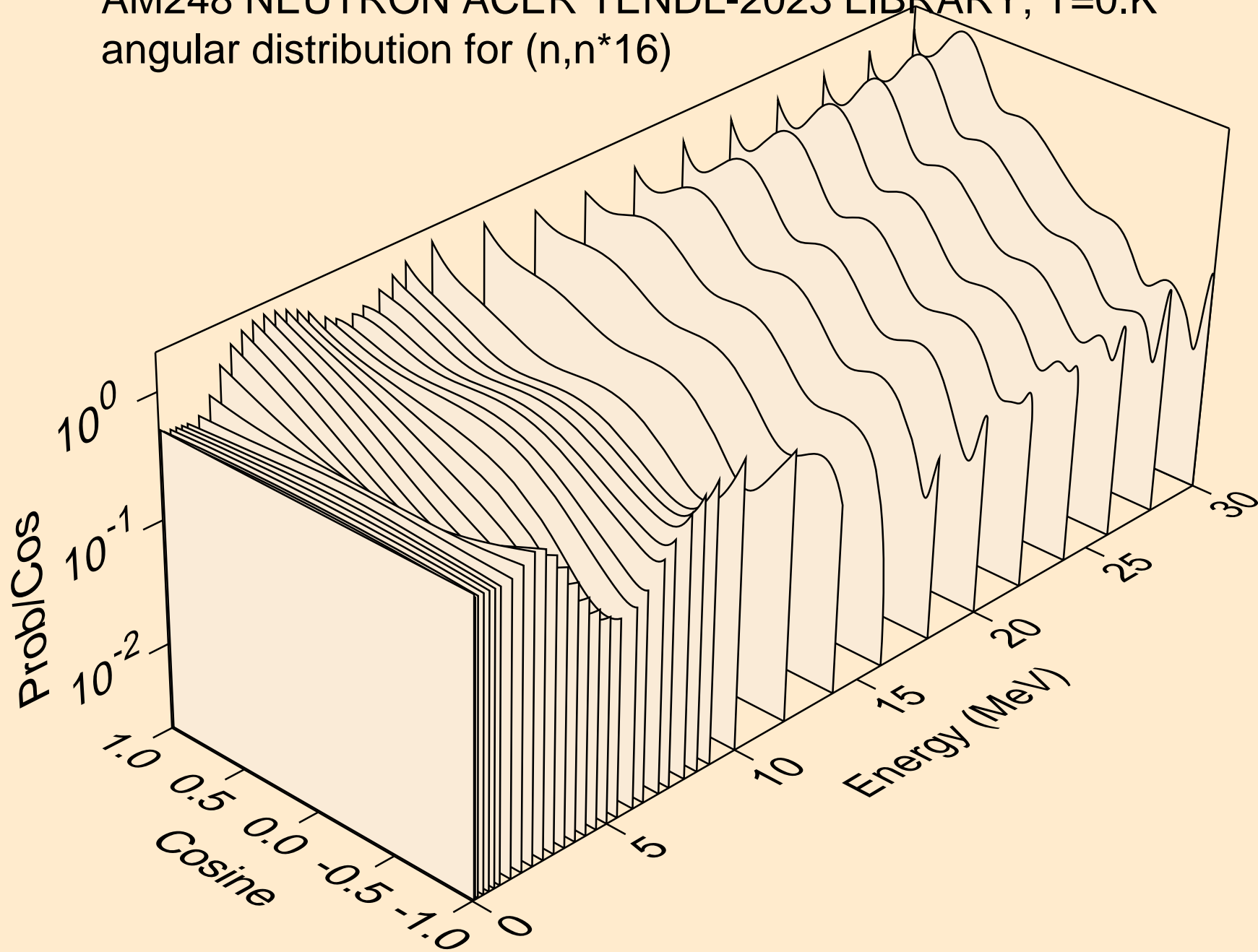

AM248 NEUTRON ACER TENDL-2023 LIBRARY; T=0.K  
angular distribution for (n,n\*17)

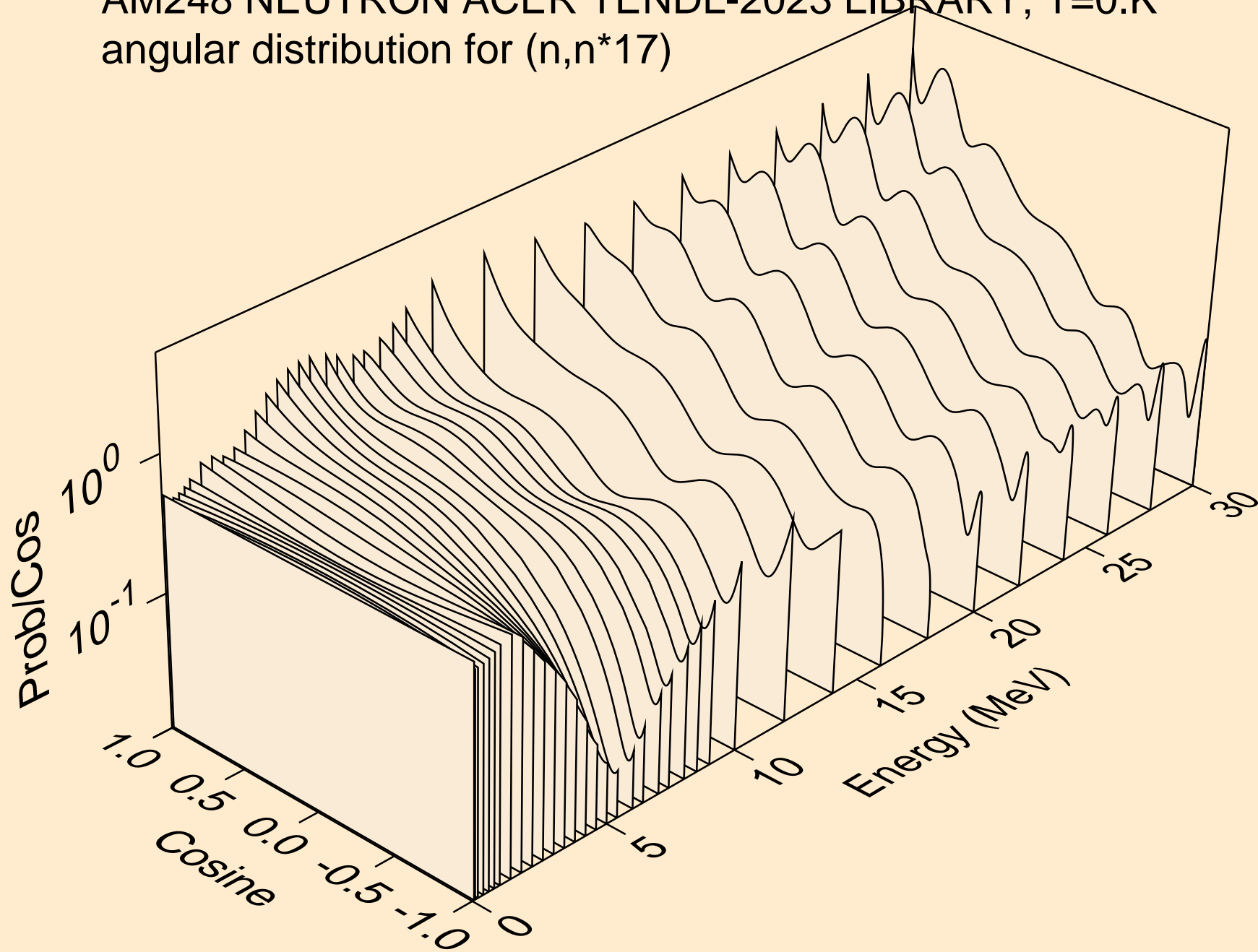



AM248 NEUTRON ACER TENDL-2023 LIBRARY; T=0.K  
angular distribution for (n,n\*18)

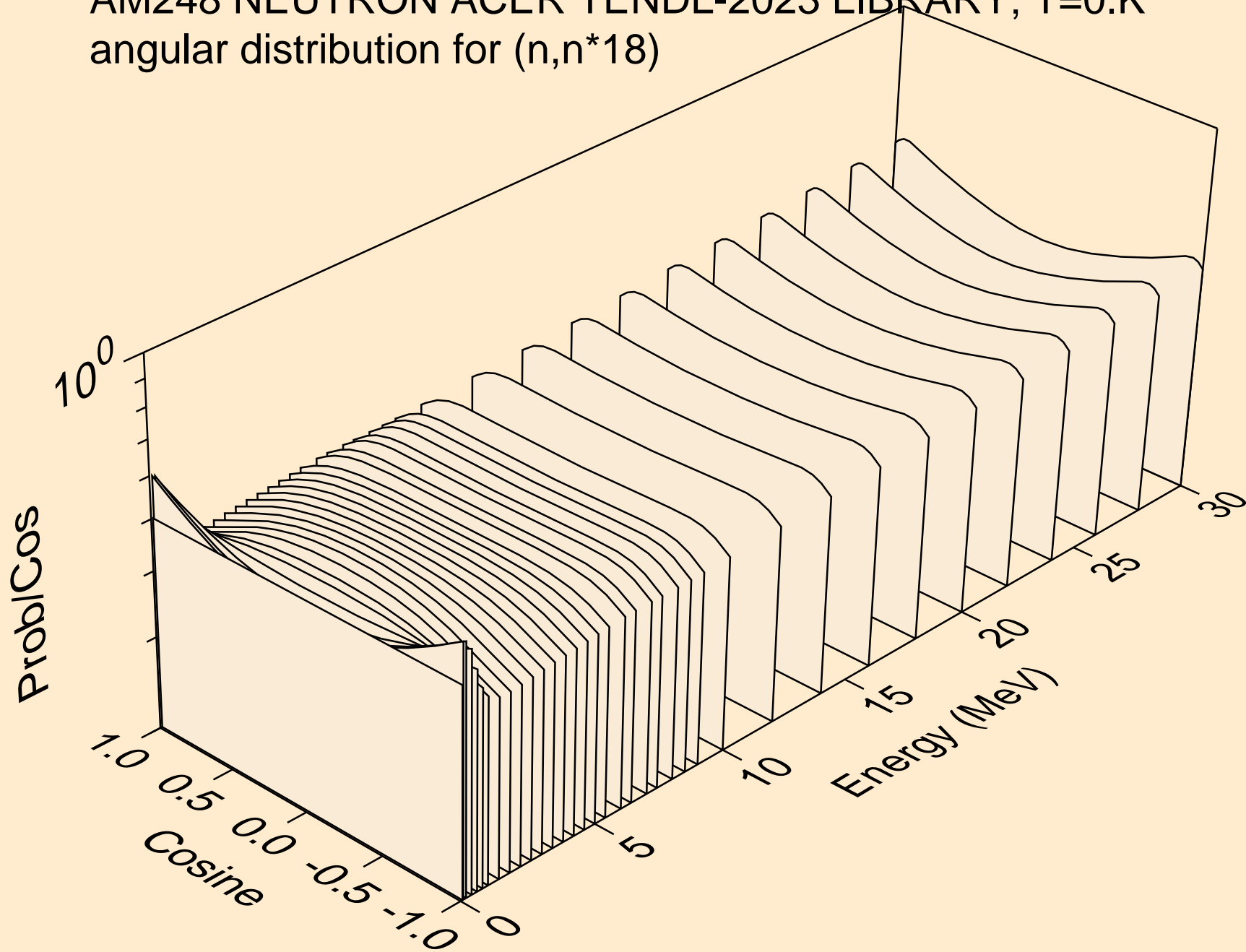

AM248 NEUTRON ACER TENDL-2023 LIBRARY; T=0.K  
angular distribution for (n,n\*19)

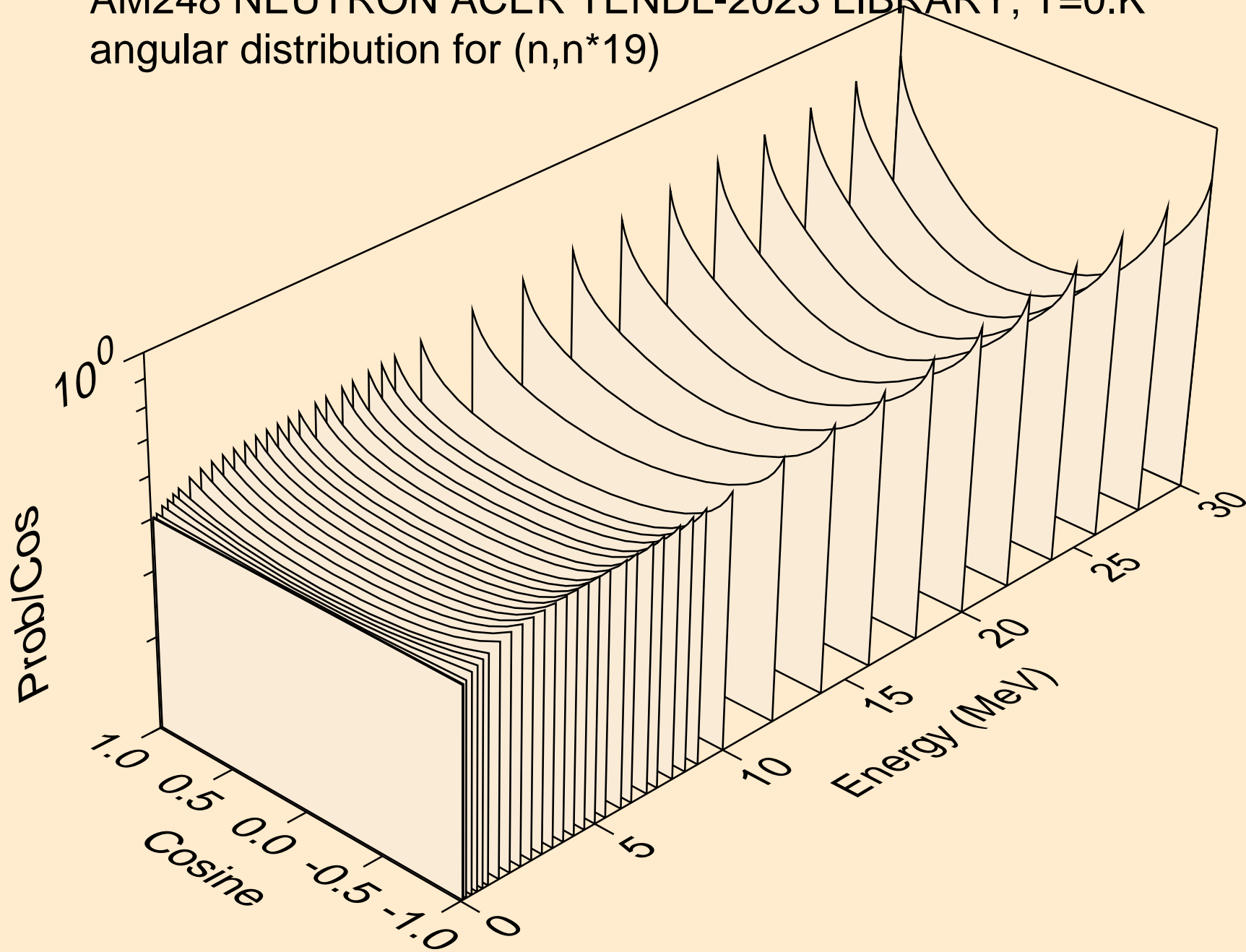

AM248 NEUTRON ACER TENDL-2023 LIBRARY; T=0.K  
angular distribution for (n,n\*20)

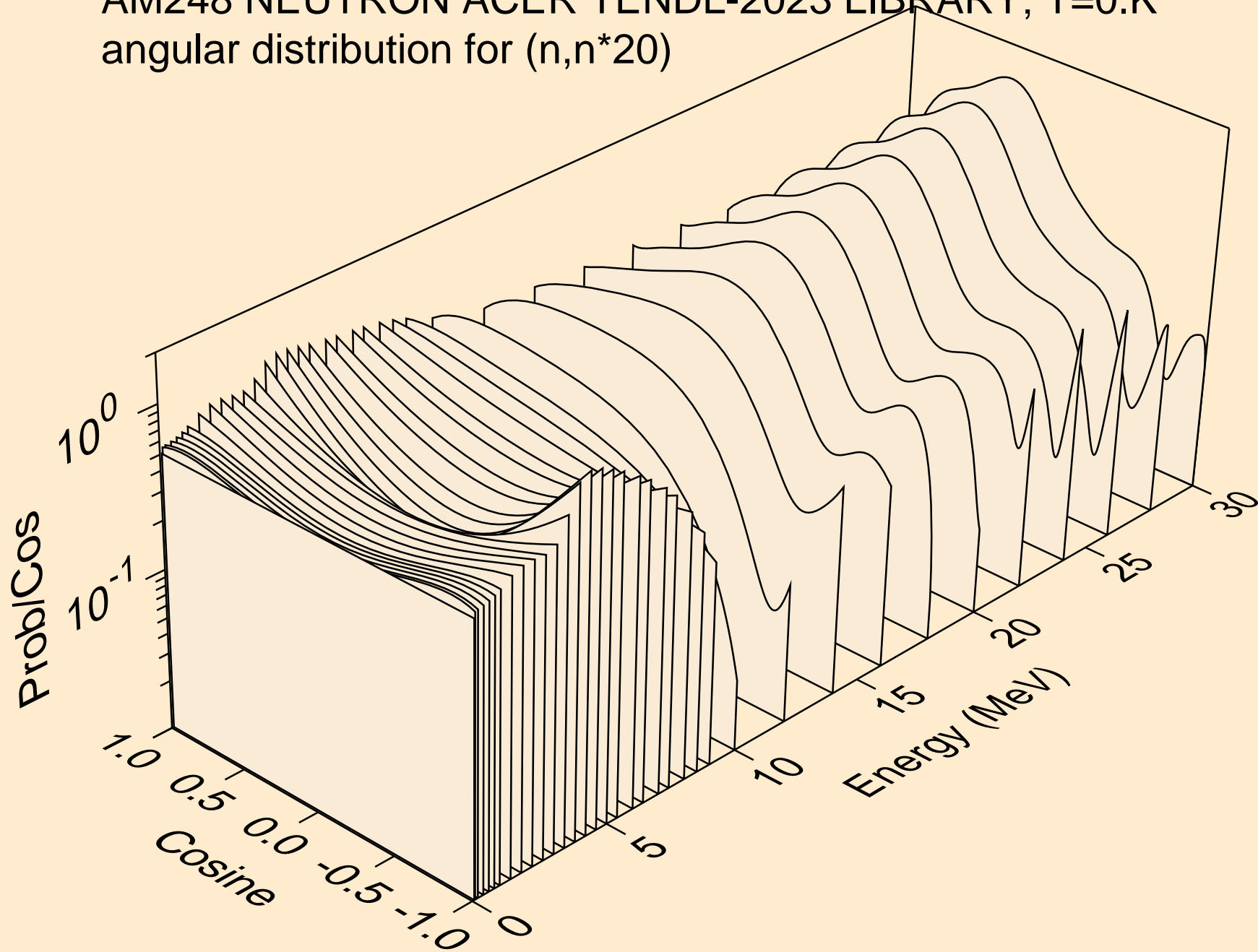

AM248 NEUTRON ACER TENDL-2023 LIBRARY; T=0.K  
angular distribution for (n,n\*21)

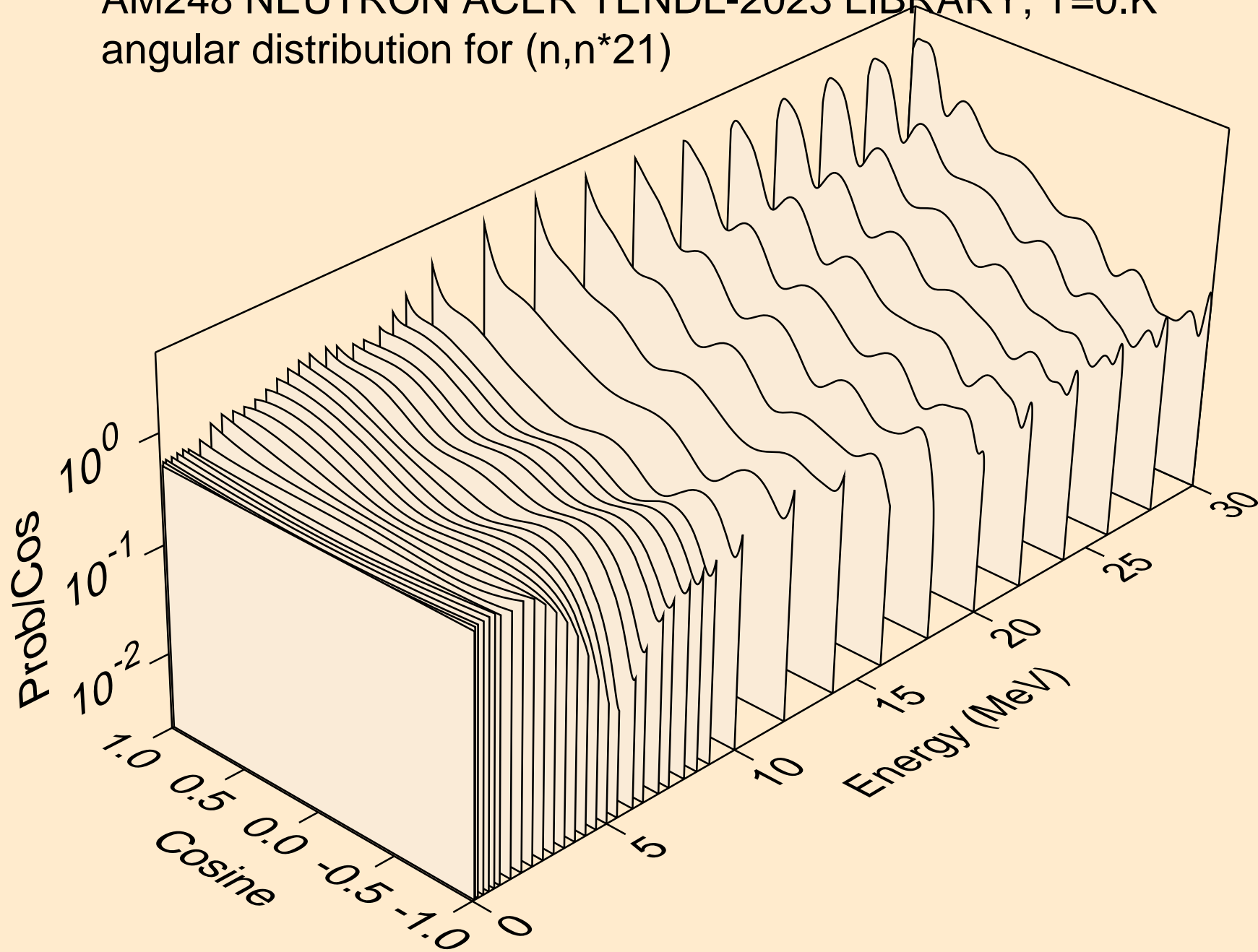

AM248 NEUTRON ACER TENDL-2023 LIBRARY; T=0.K  
angular distribution for (n,n\*22)

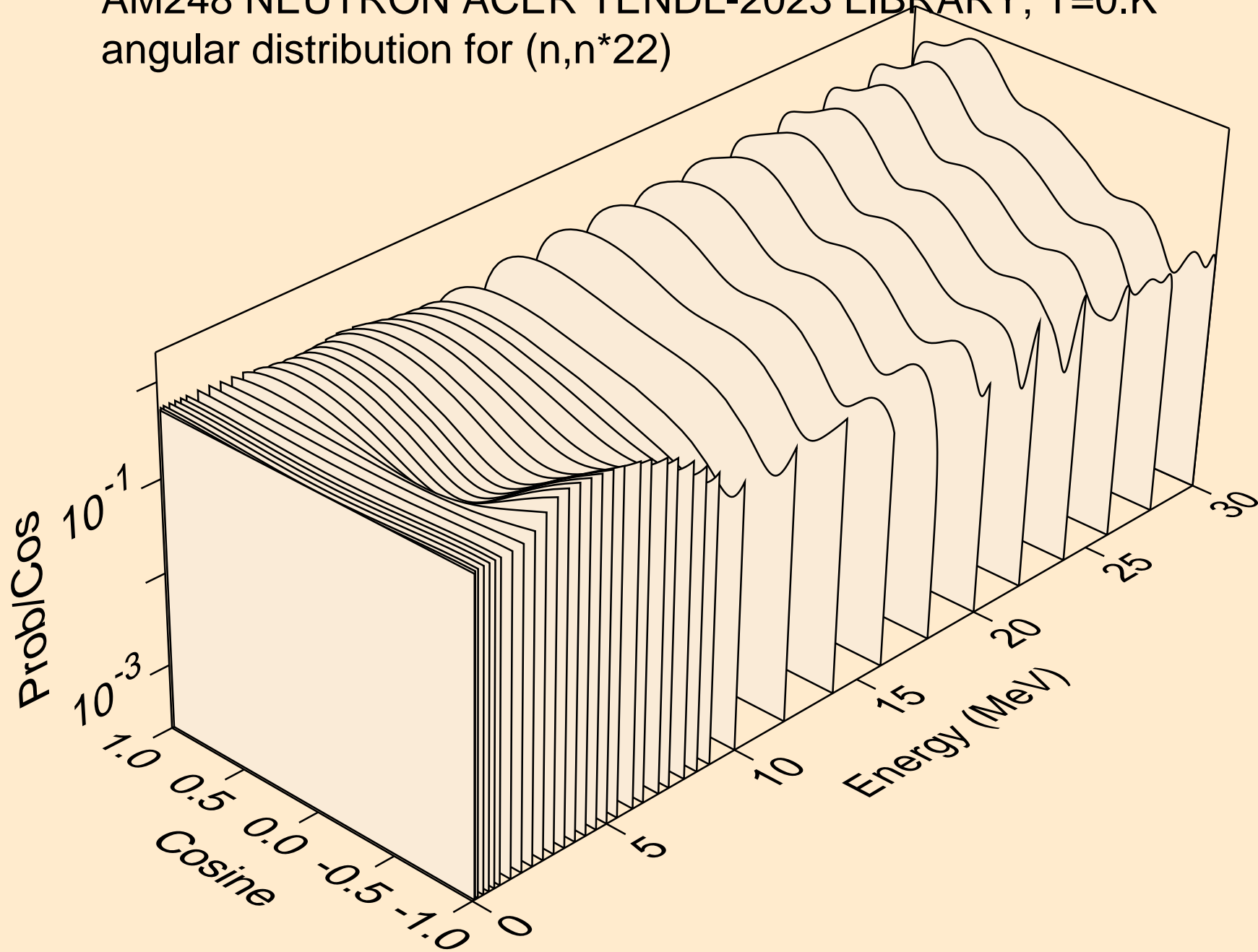

AM248 NEUTRON ACER TENDL-2023 LIBRARY; T=0.K  
angular distribution for (n,n\*23)

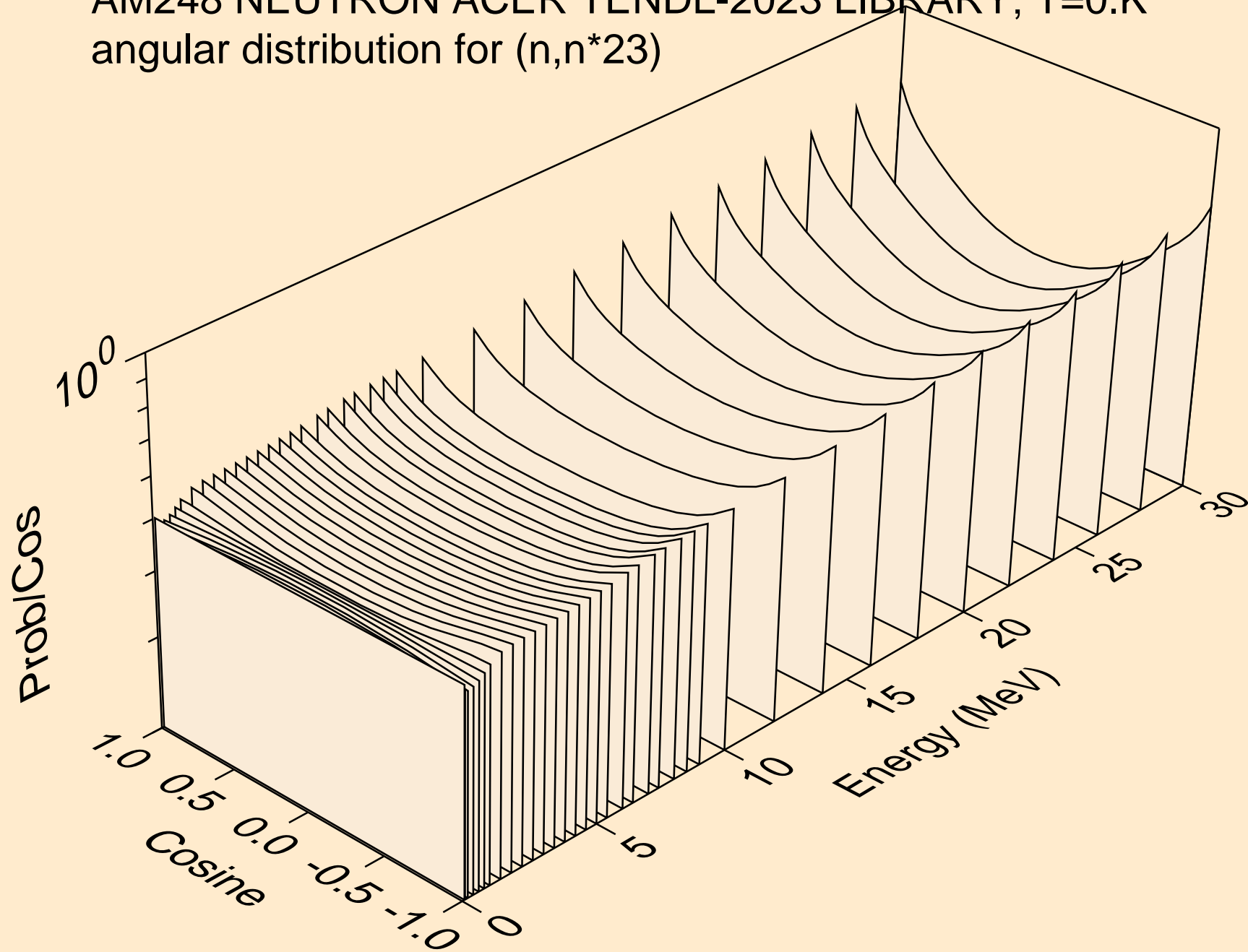

AM248 NEUTRON ACER TENDL-2023 LIBRARY; T=0.K  
angular distribution for (n,n\*24)

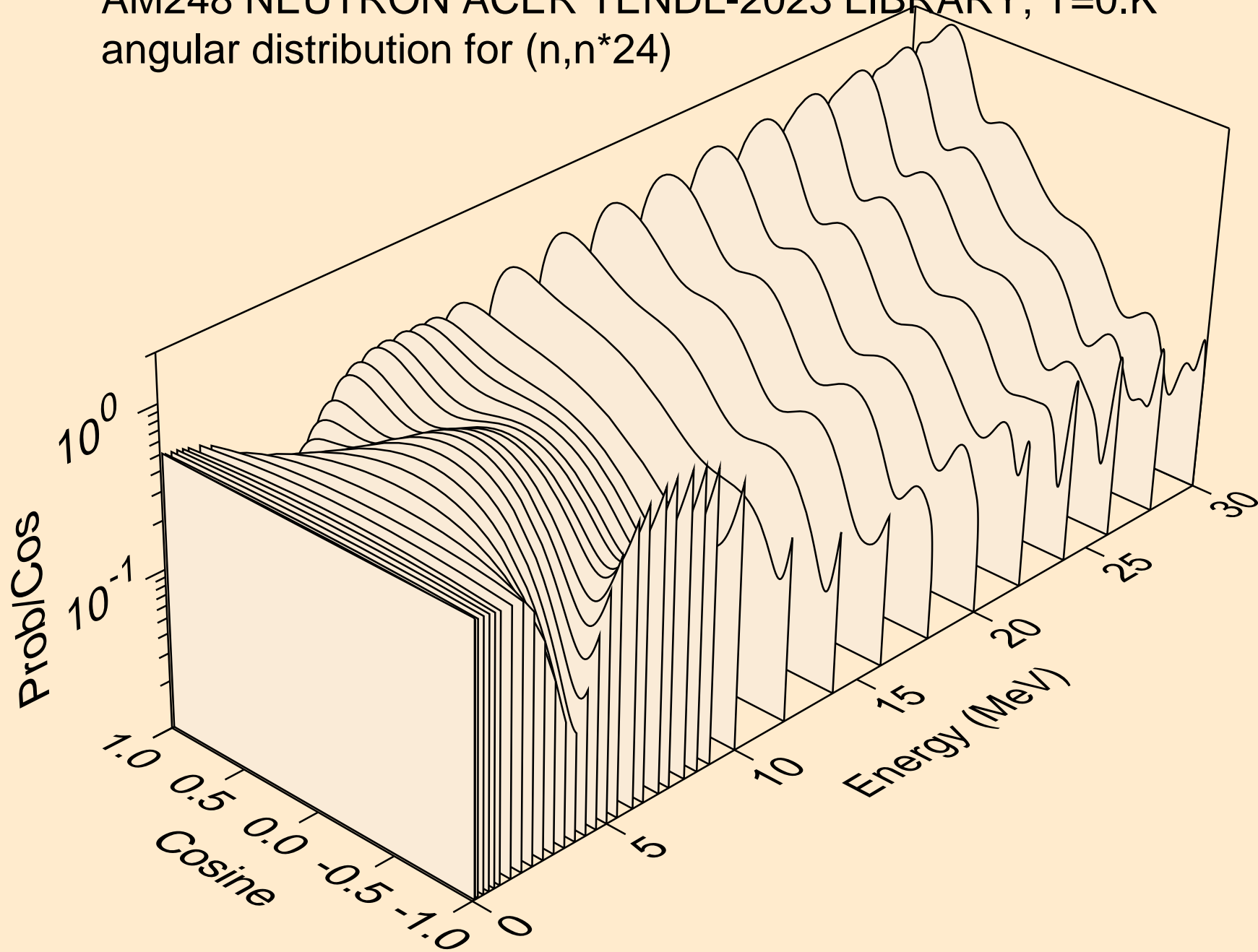

AM248 NEUTRON ACER TENDL-2023 LIBRARY; T=0.K  
angular distribution for (n,n\*25)

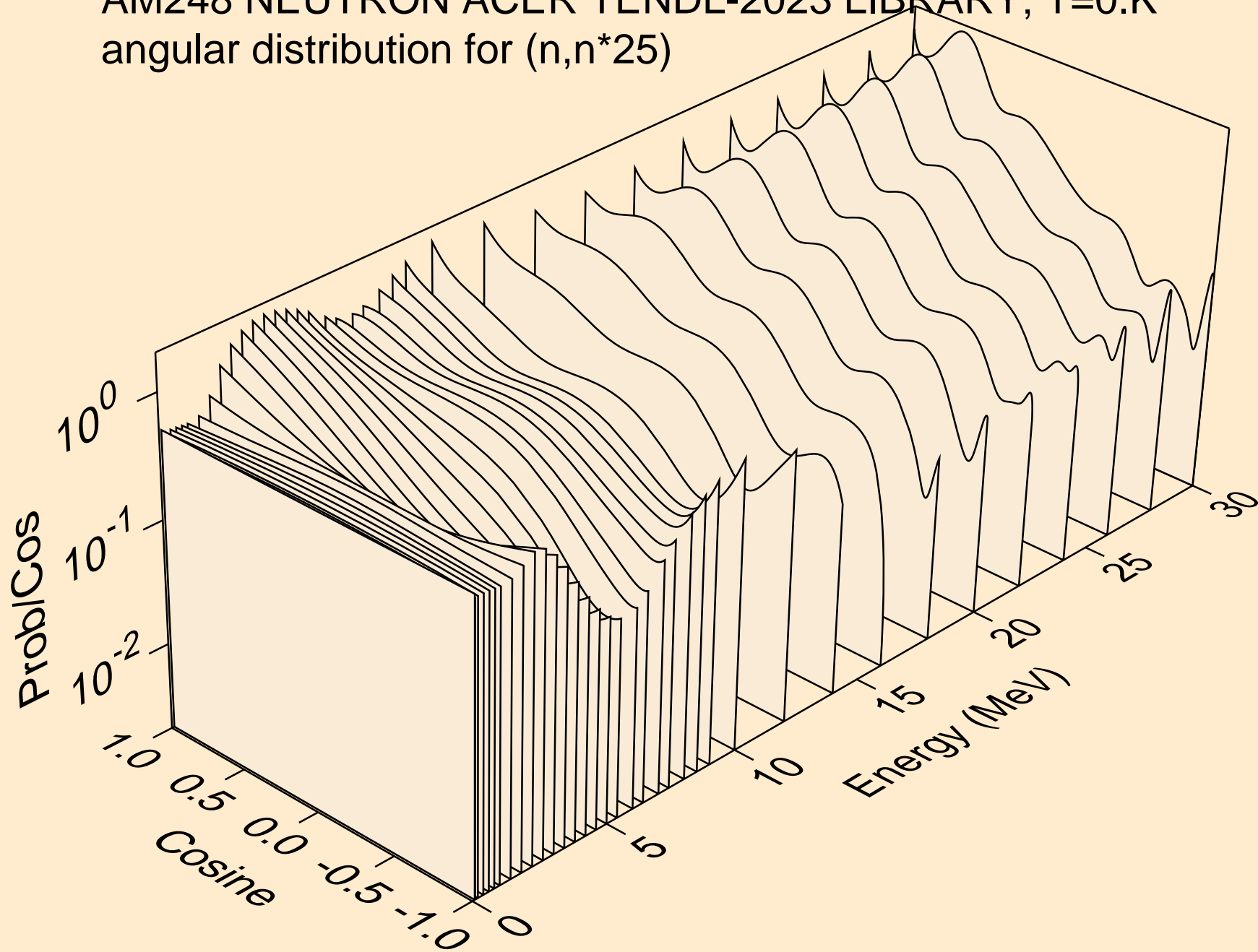



AM248 NEUTRON ACER TENDL-2023 LIBRARY; T=0.K  
angular distribution for (n,n\*26)

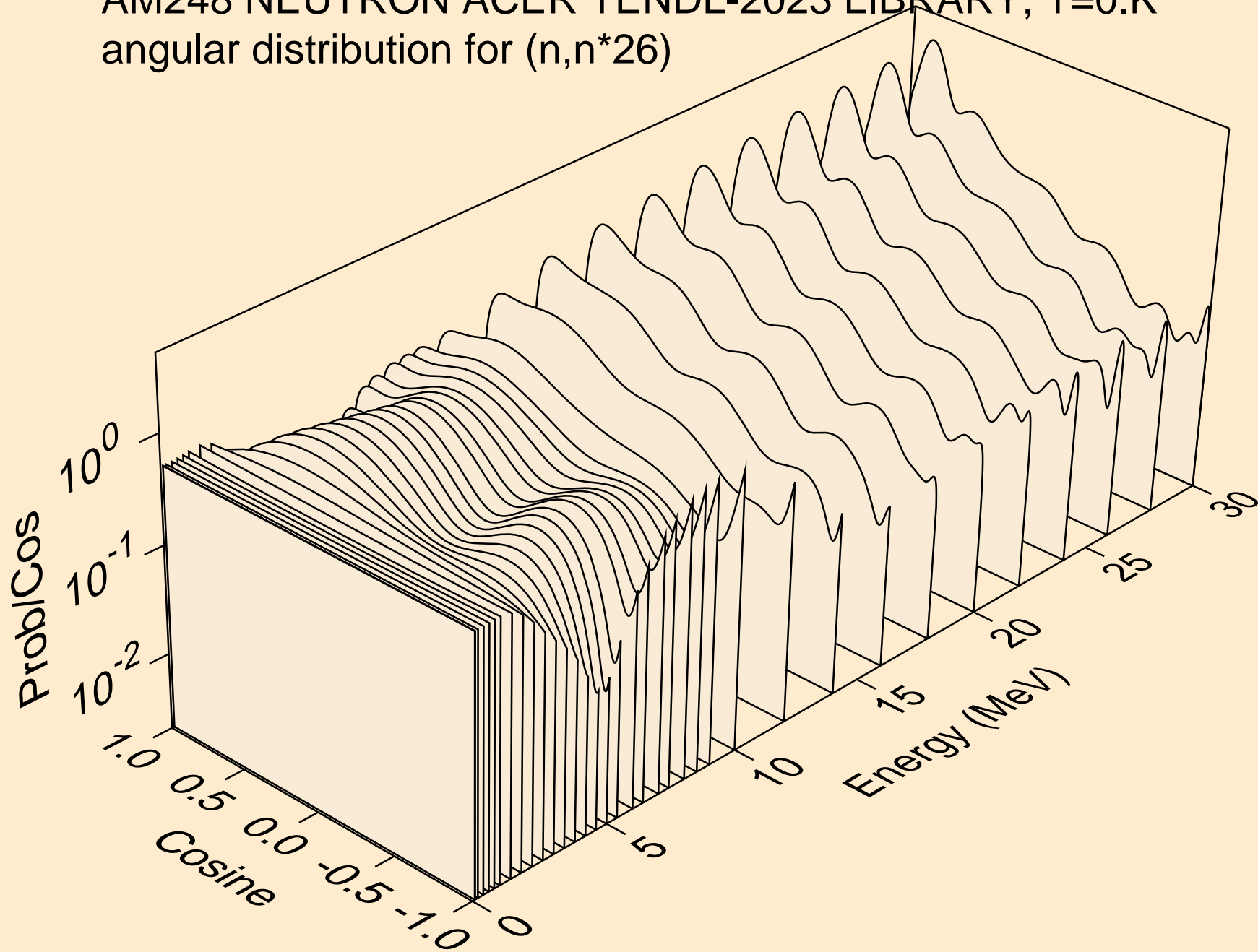

AM248 NEUTRON ACER TENDL-2023 LIBRARY; T=0.K  
angular distribution for (n,n\*27)

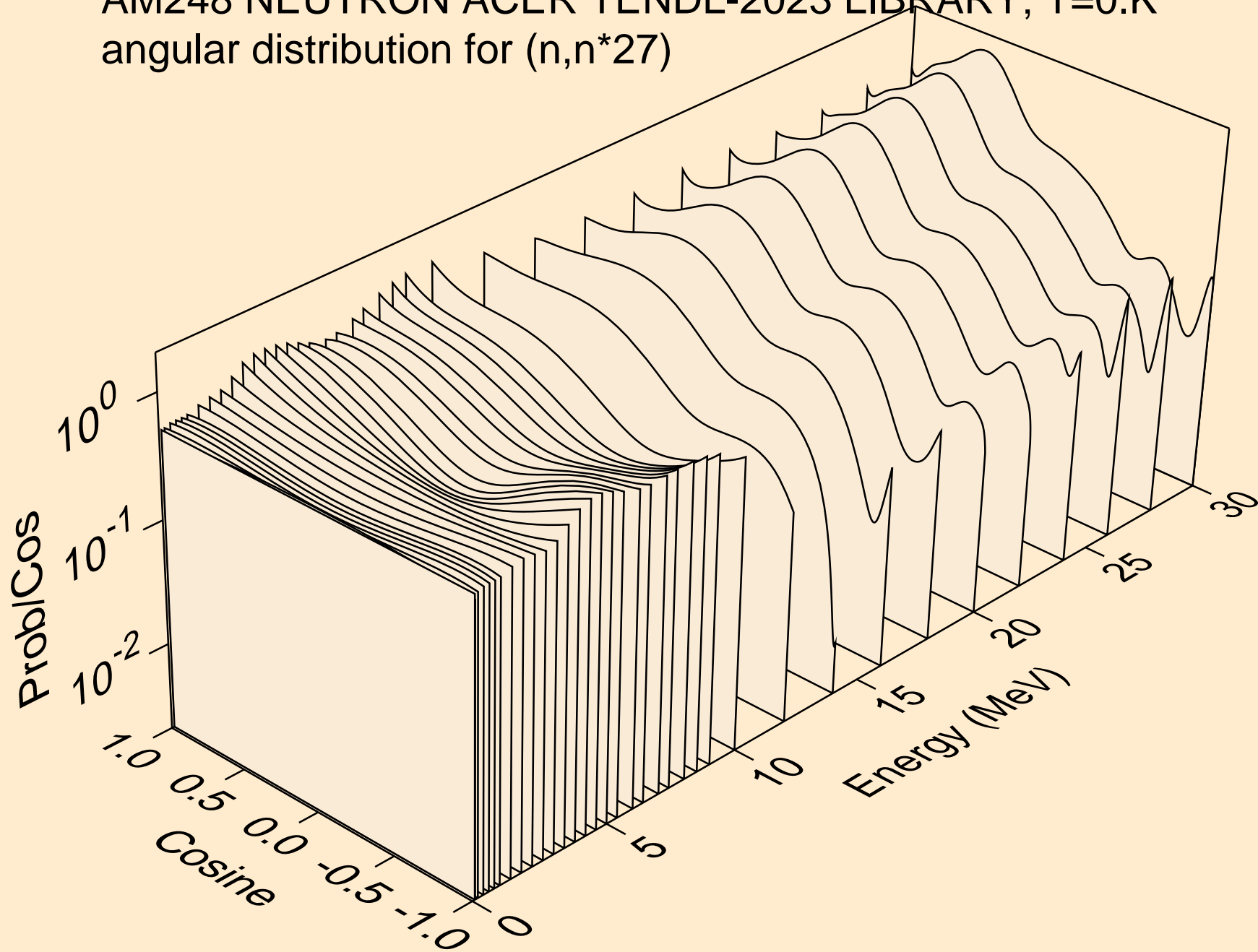

AM248 NEUTRON ACER TENDL-2023 LIBRARY; T=0.K  
angular distribution for (n,n\*28)

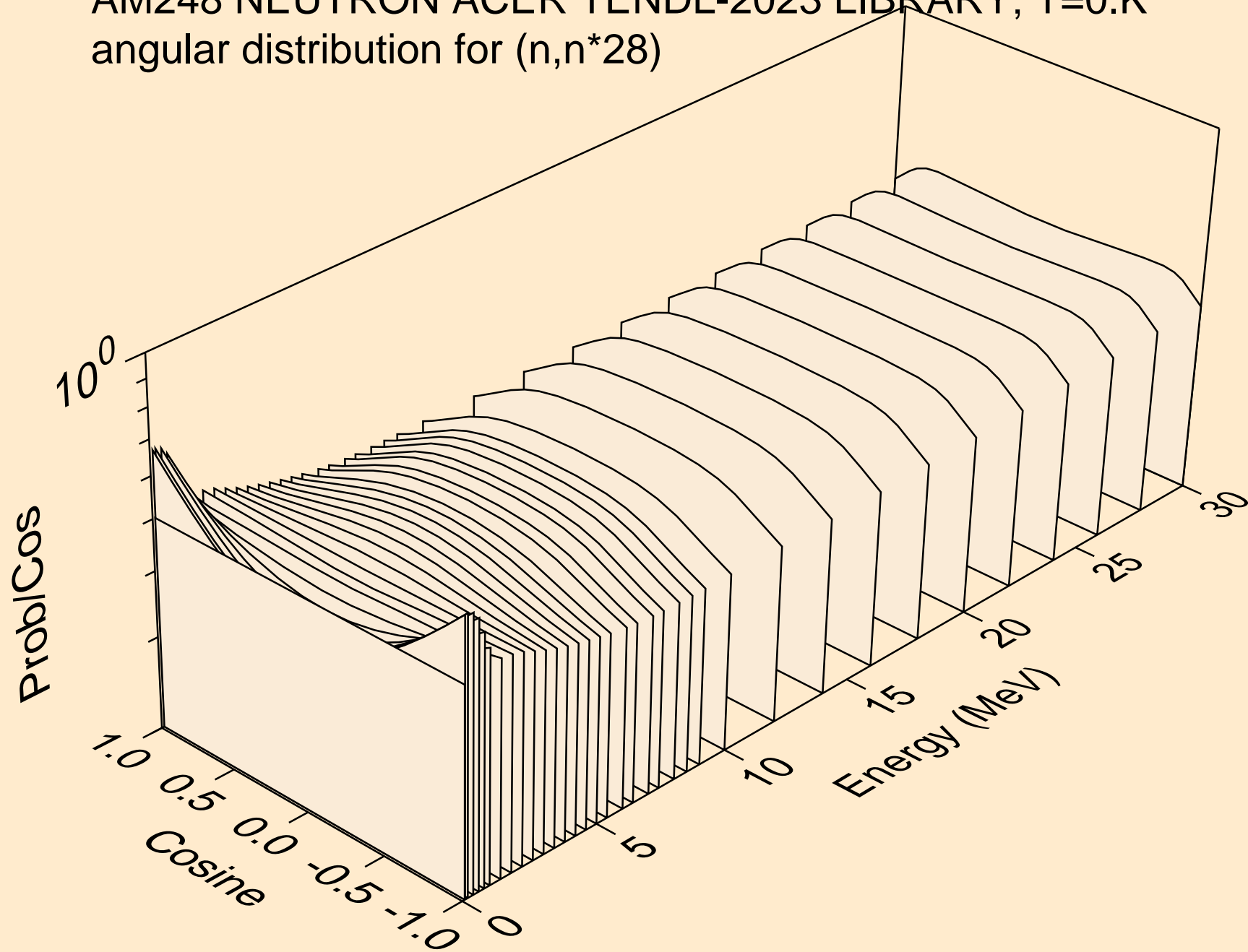

AM248 NEUTRON ACER TENDL-2023 LIBRARY; T=0.K  
angular distribution for (n,n\*29)

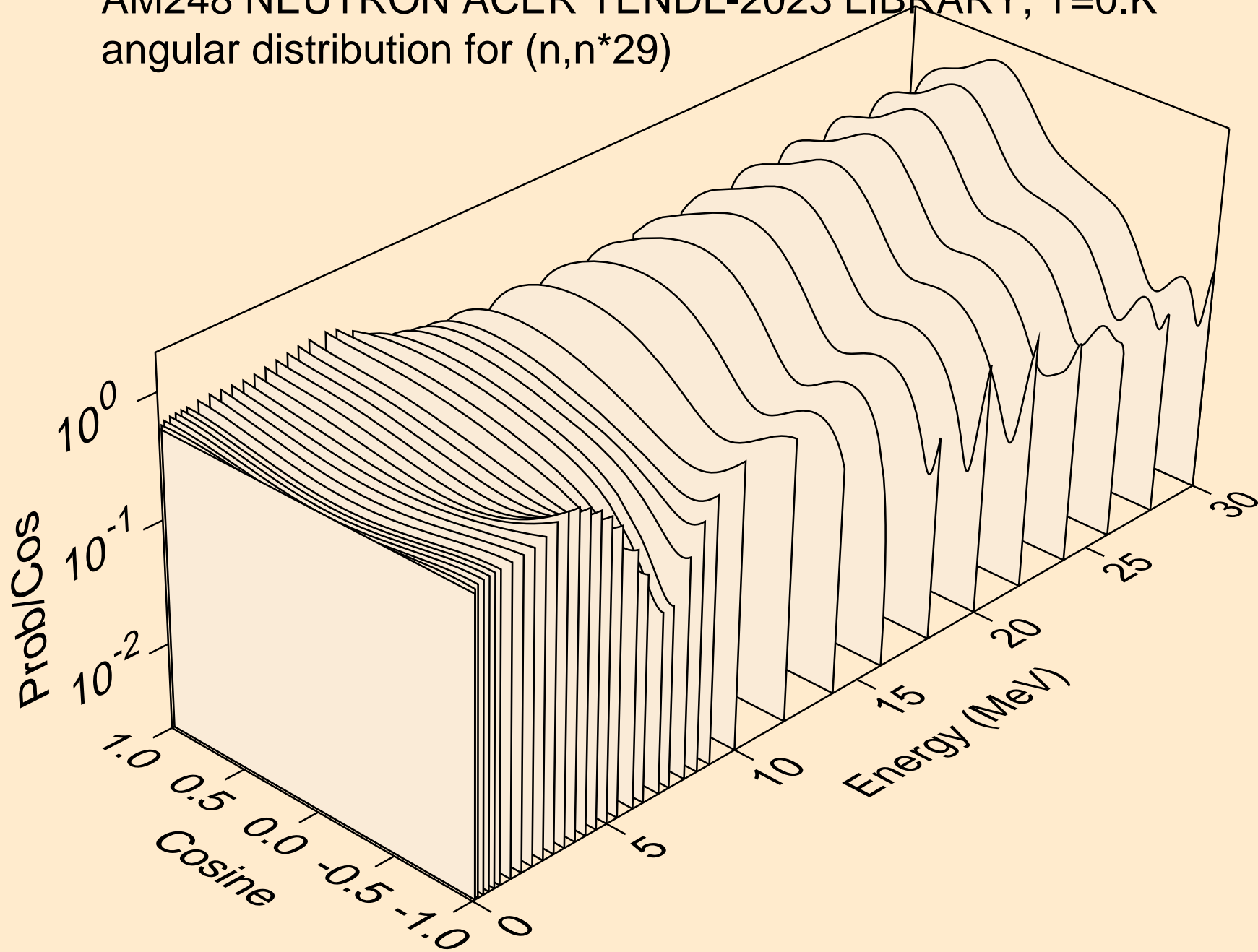

AM248 NEUTRON ACER TENDL-2023 LIBRARY; T=0.K  
angular distribution for (n,n\*30)

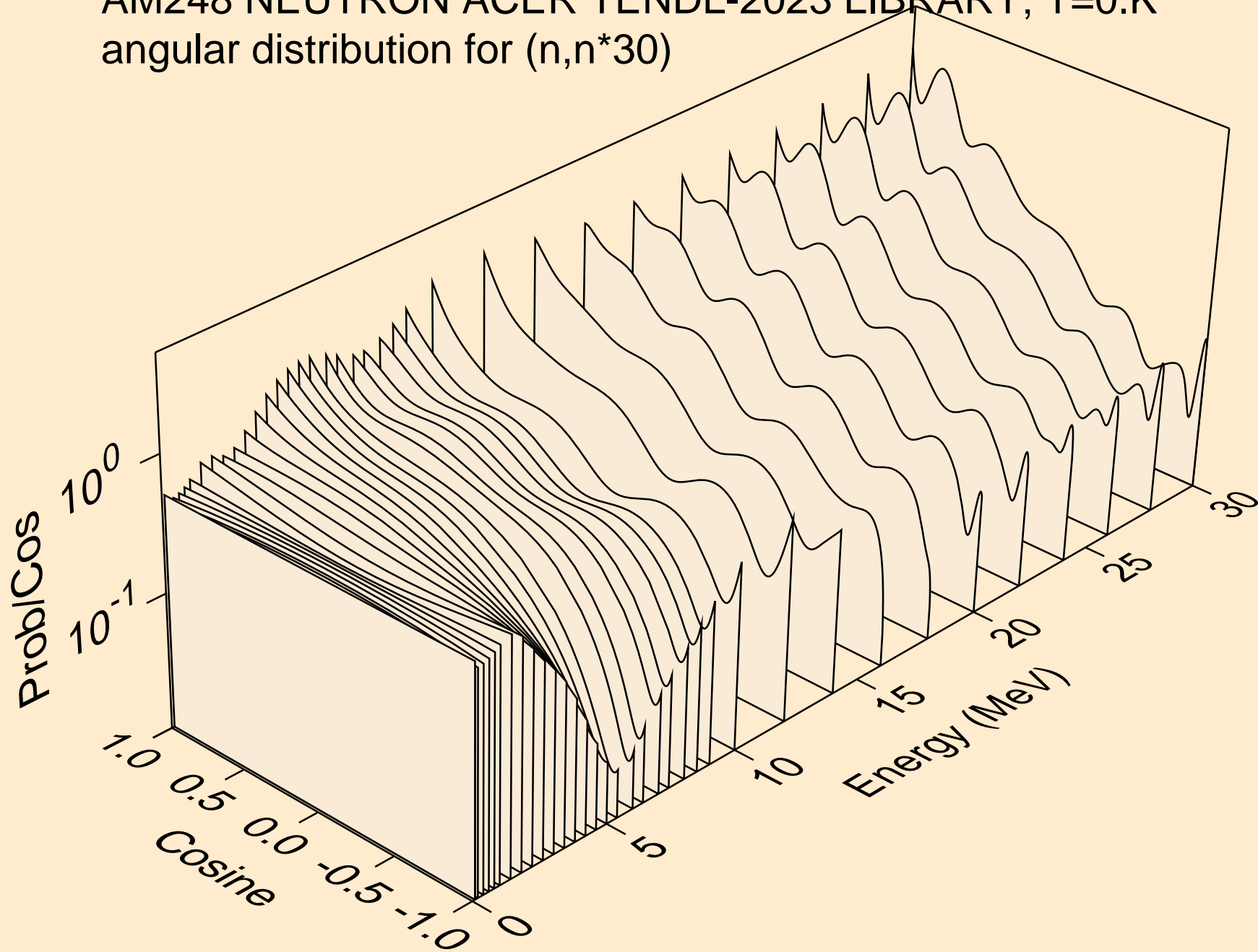

# AM248 NEUTRON ACER TENDL-2023 LIBRARY; T=0.K

## Total fission nubar

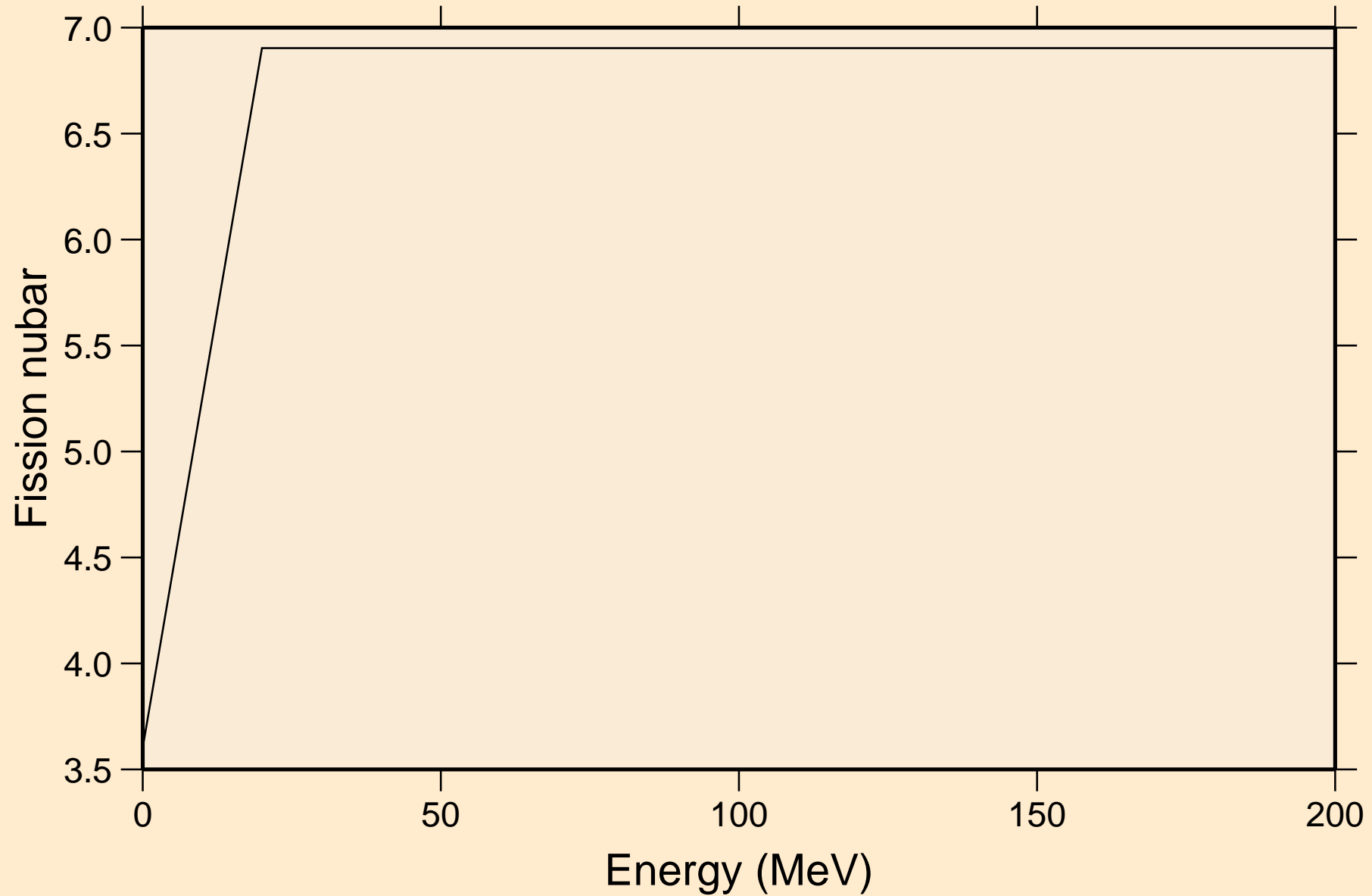

AM248 NEUTRON ACER TENDL-2023 LIBRARY; T=0.K  
Neutron emission for (n,x)

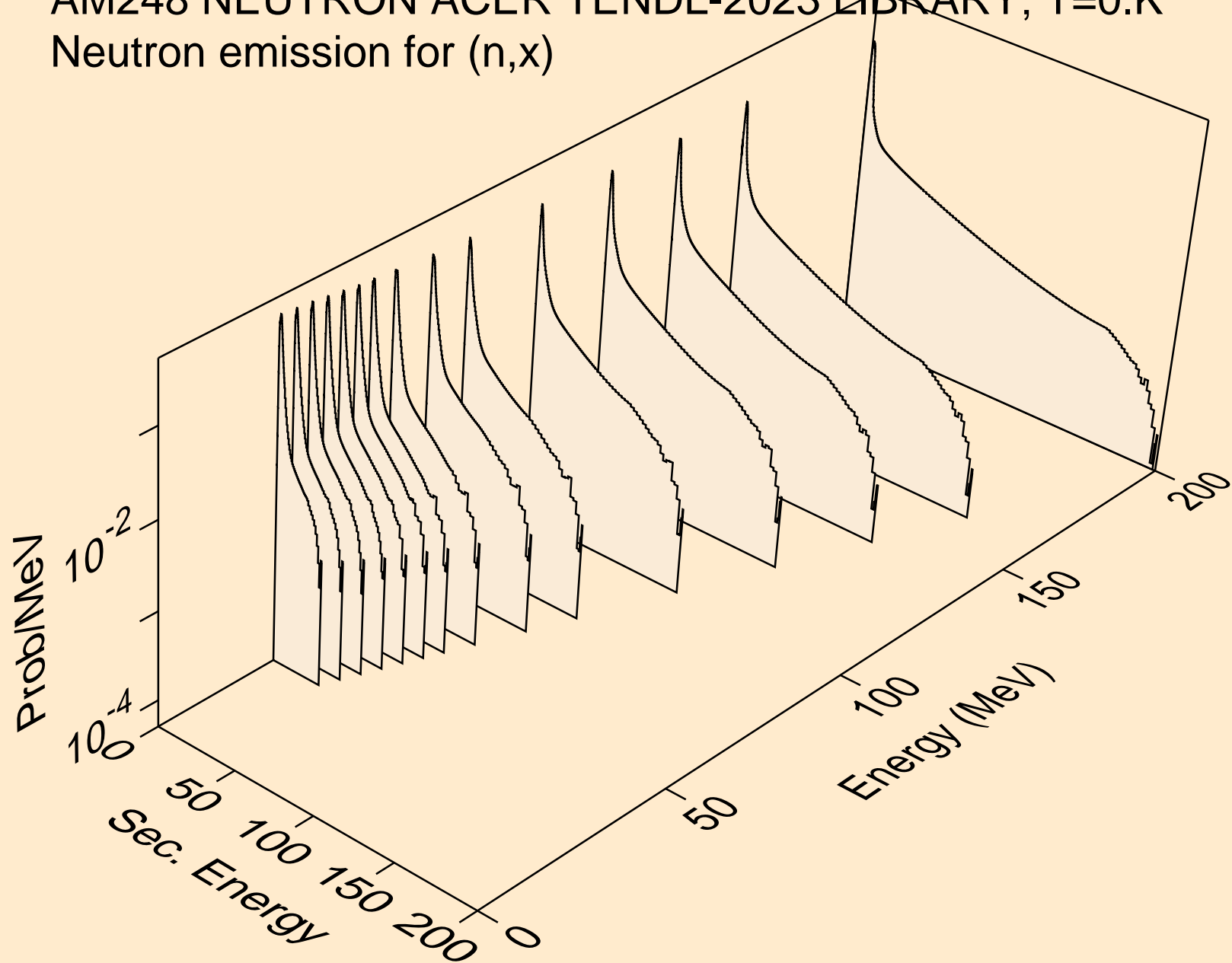

AM248 NEUTRON ACER TENDL-2023 LIBRARY; T=0.K  
Neutron emission for (n,2nd)

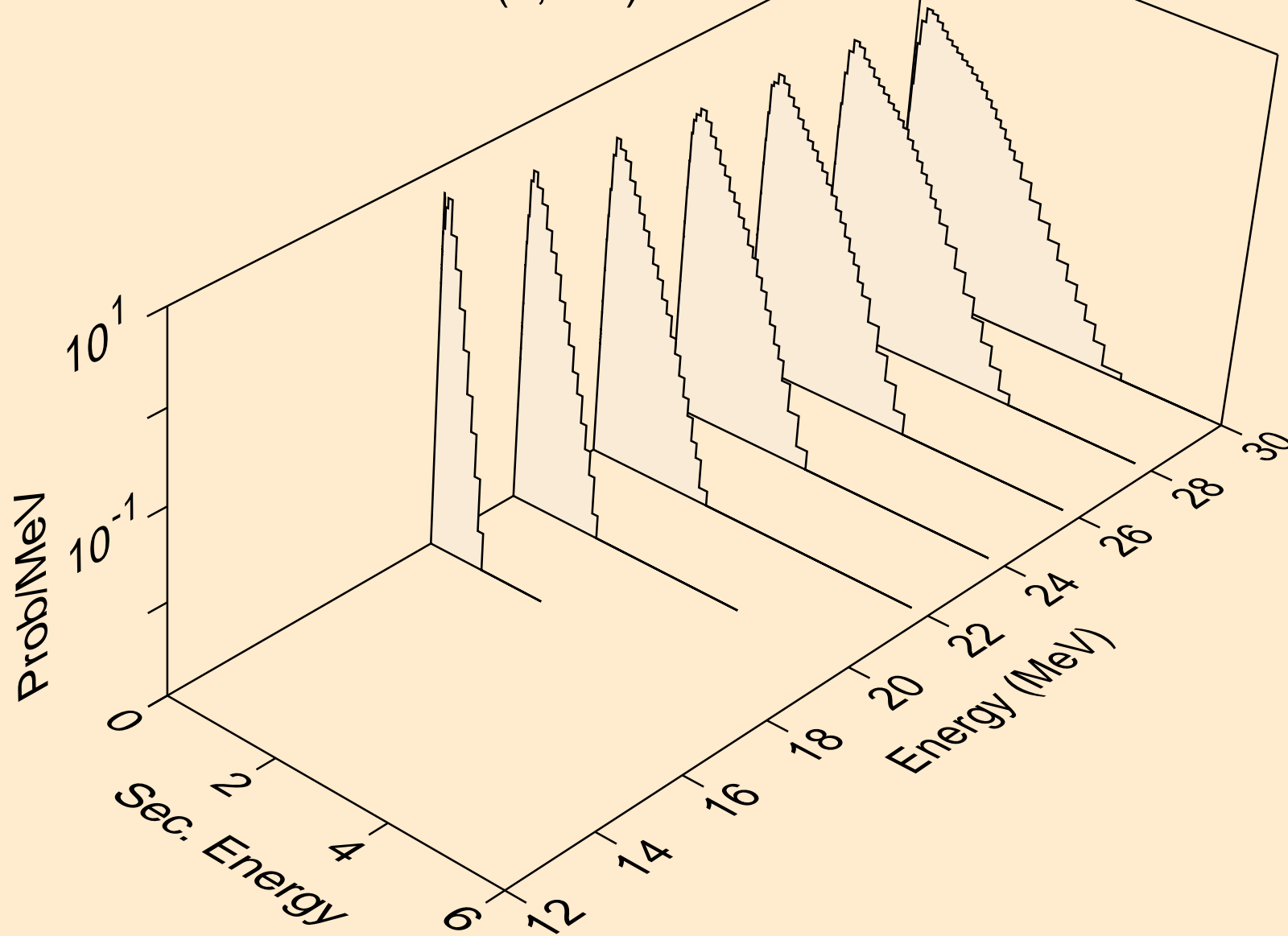



AM248 NEUTRON ACER TENDL-2023 LIBRARY; T=0.K  
Neutron emission for (n,2n)

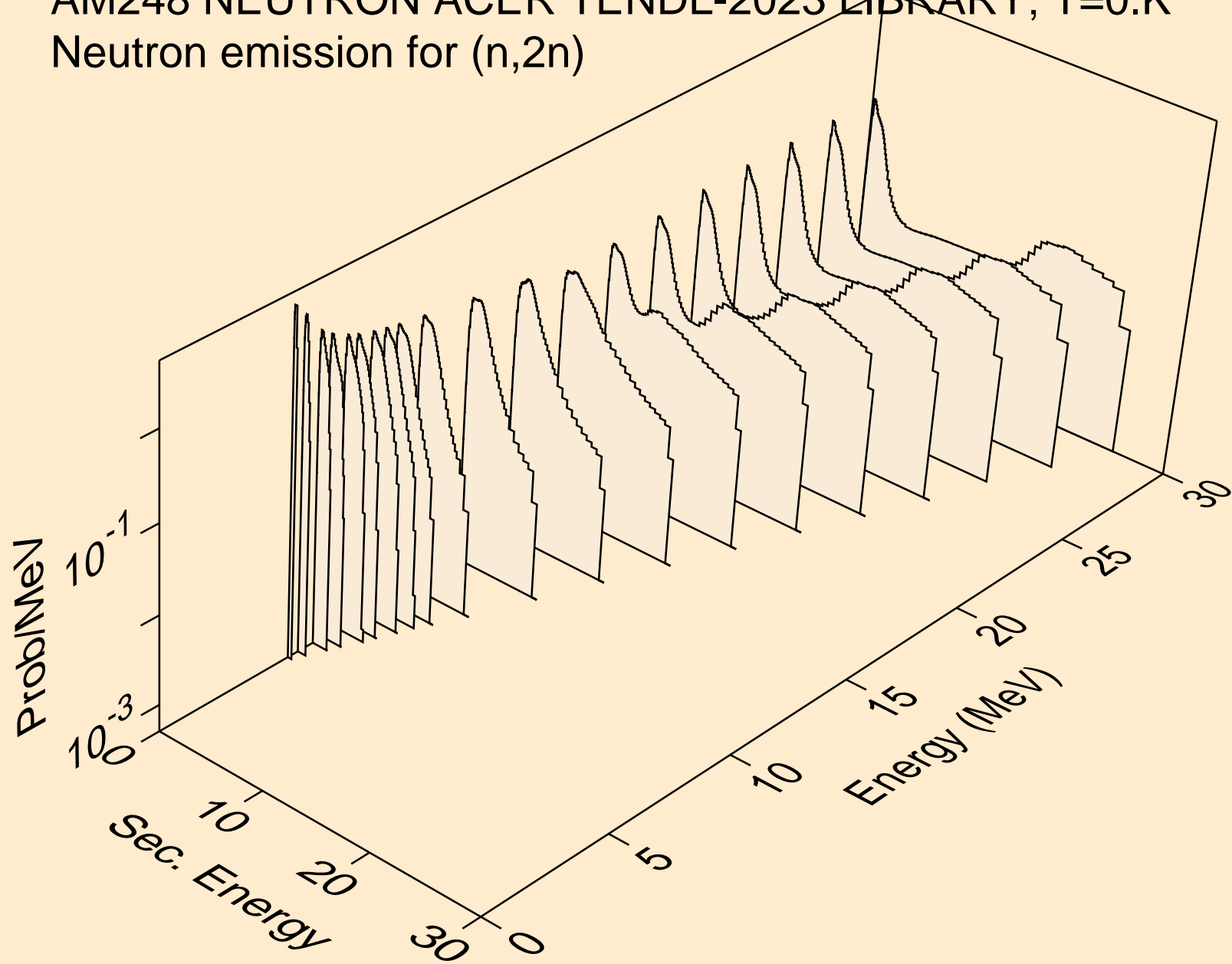

AM248 NEUTRON ACER TENDL-2023 LIBRARY; T=0.K  
Neutron emission for (n,3n)

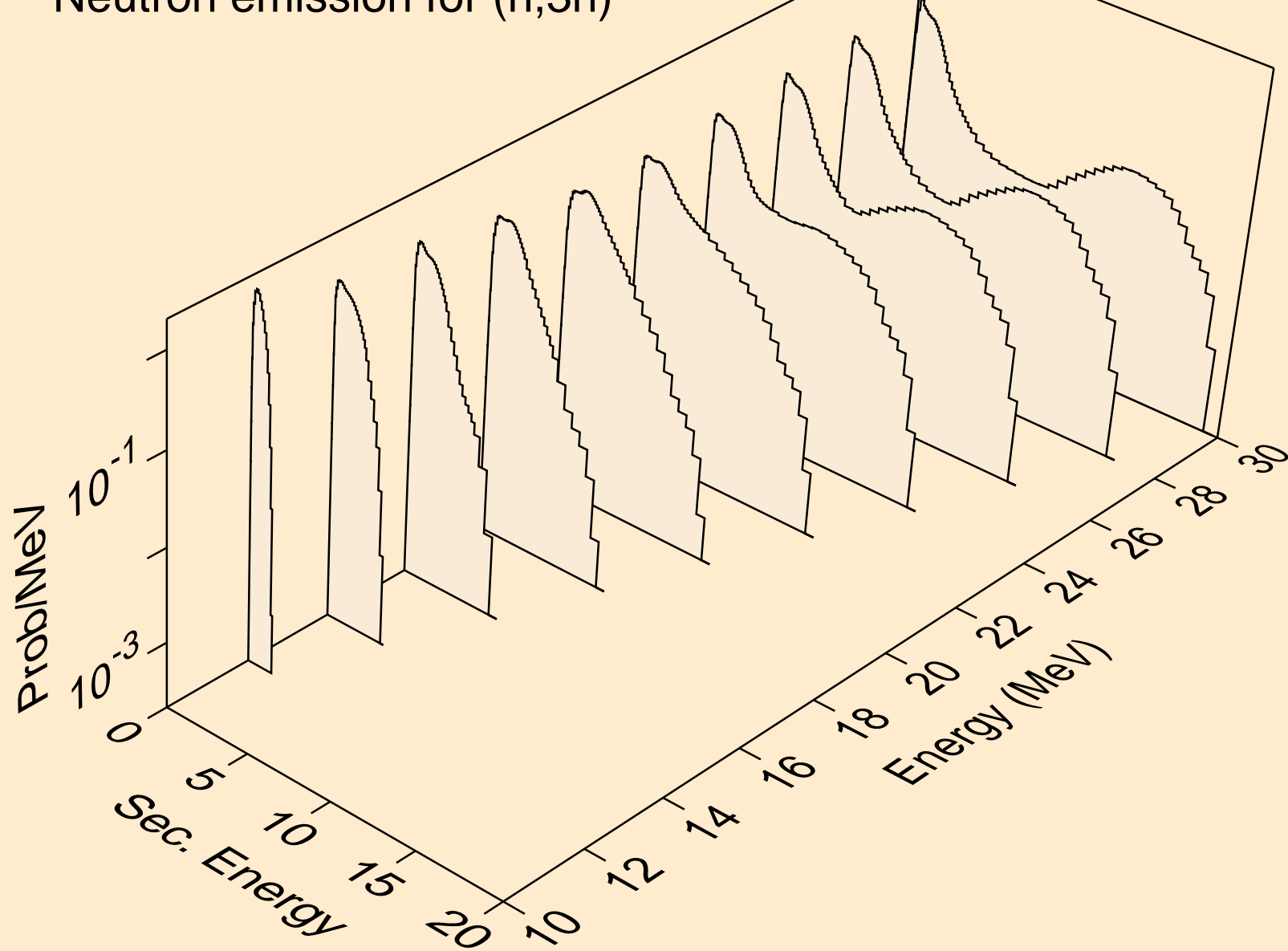

AM248 NEUTRON ACER TENDL-2023 LIBRARY; T=0.K  
Neutron emission for fission

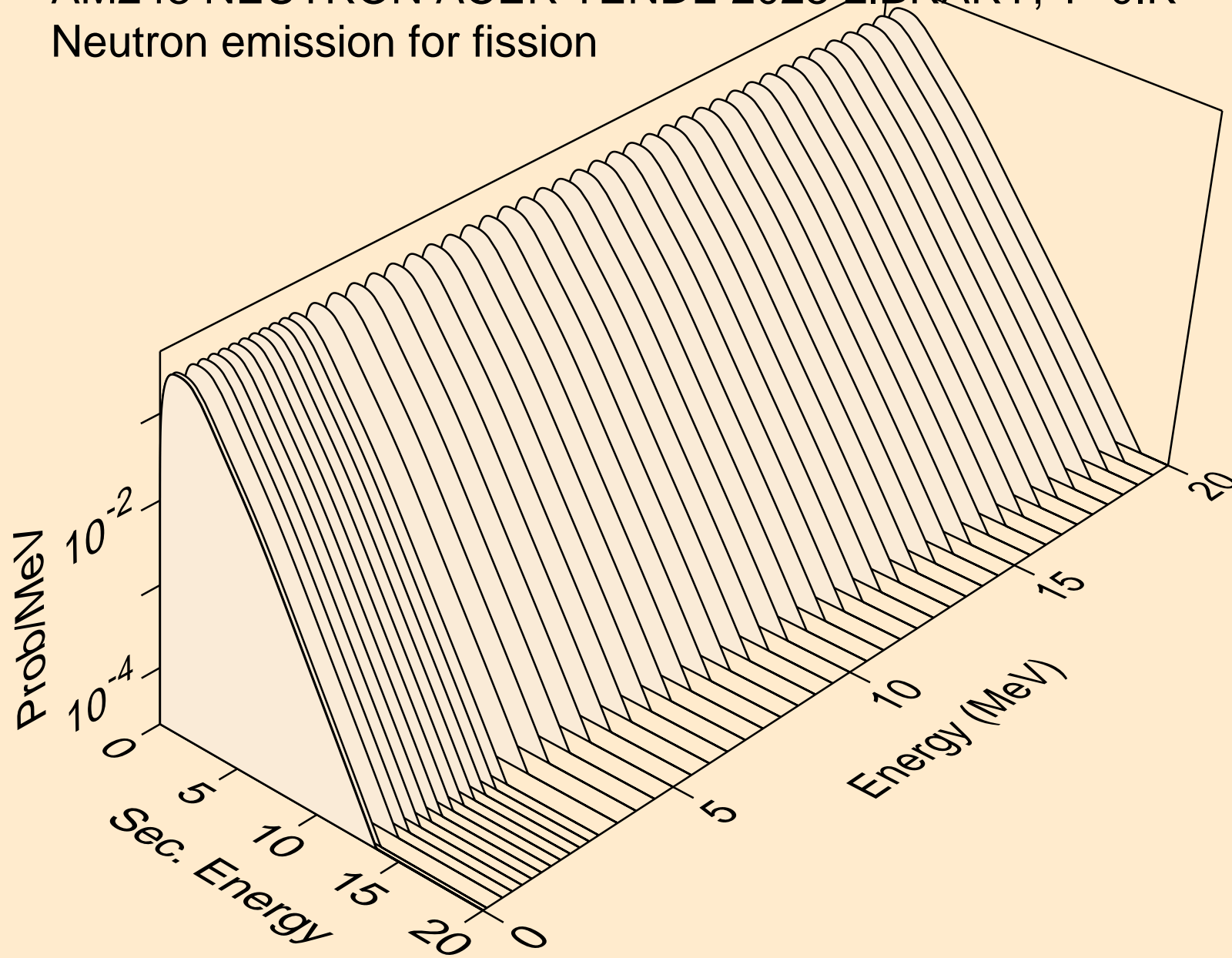

AM248 NEUTRON ACER TENDL-2023 LIBRARY; T=0.K  
Neutron emission for (n,n\*)a

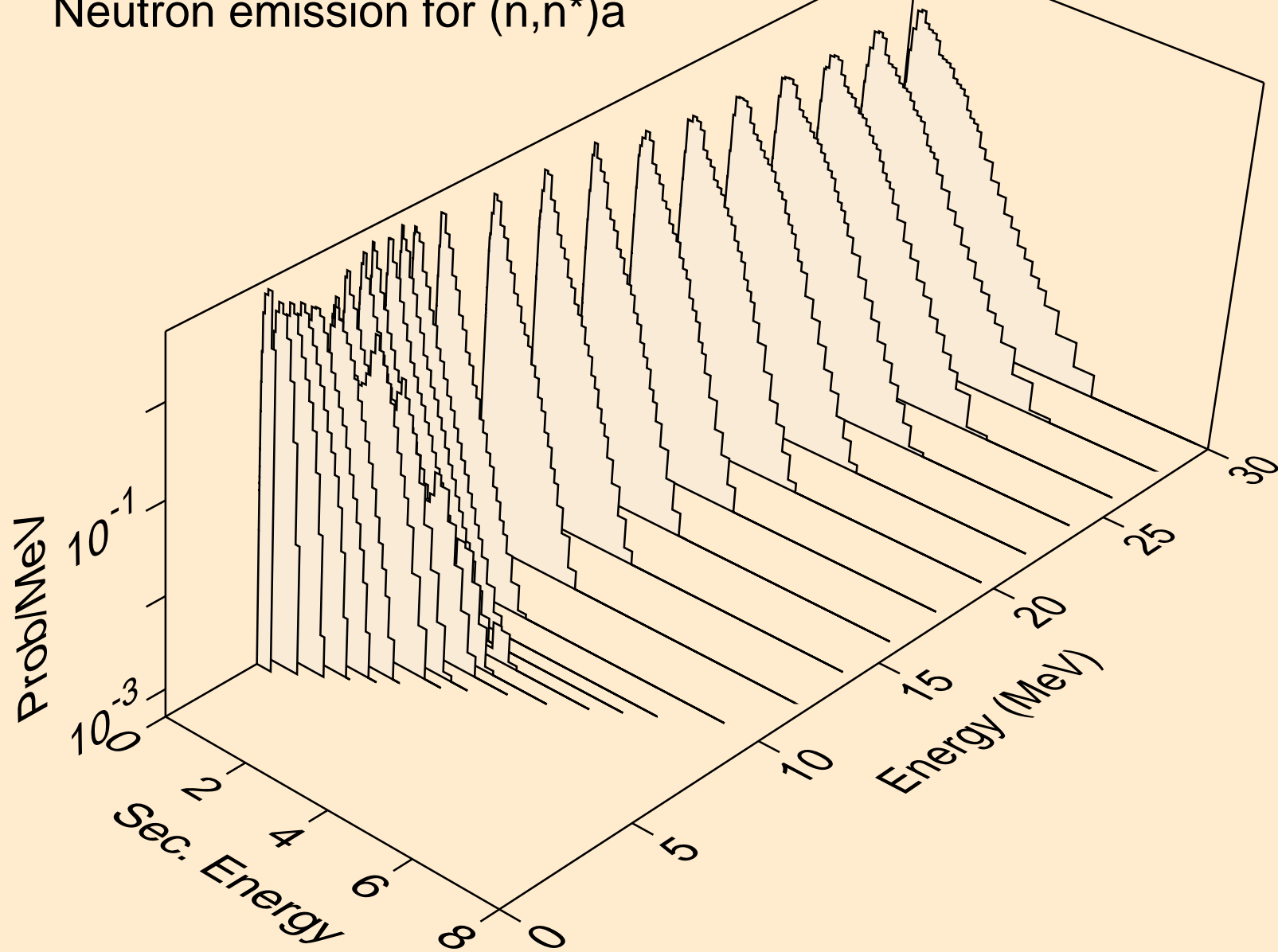

AM248 NEUTRON ACER TENDL-2023 LIBRARY; T=0.K  
Neutron emission for (n,2n)a

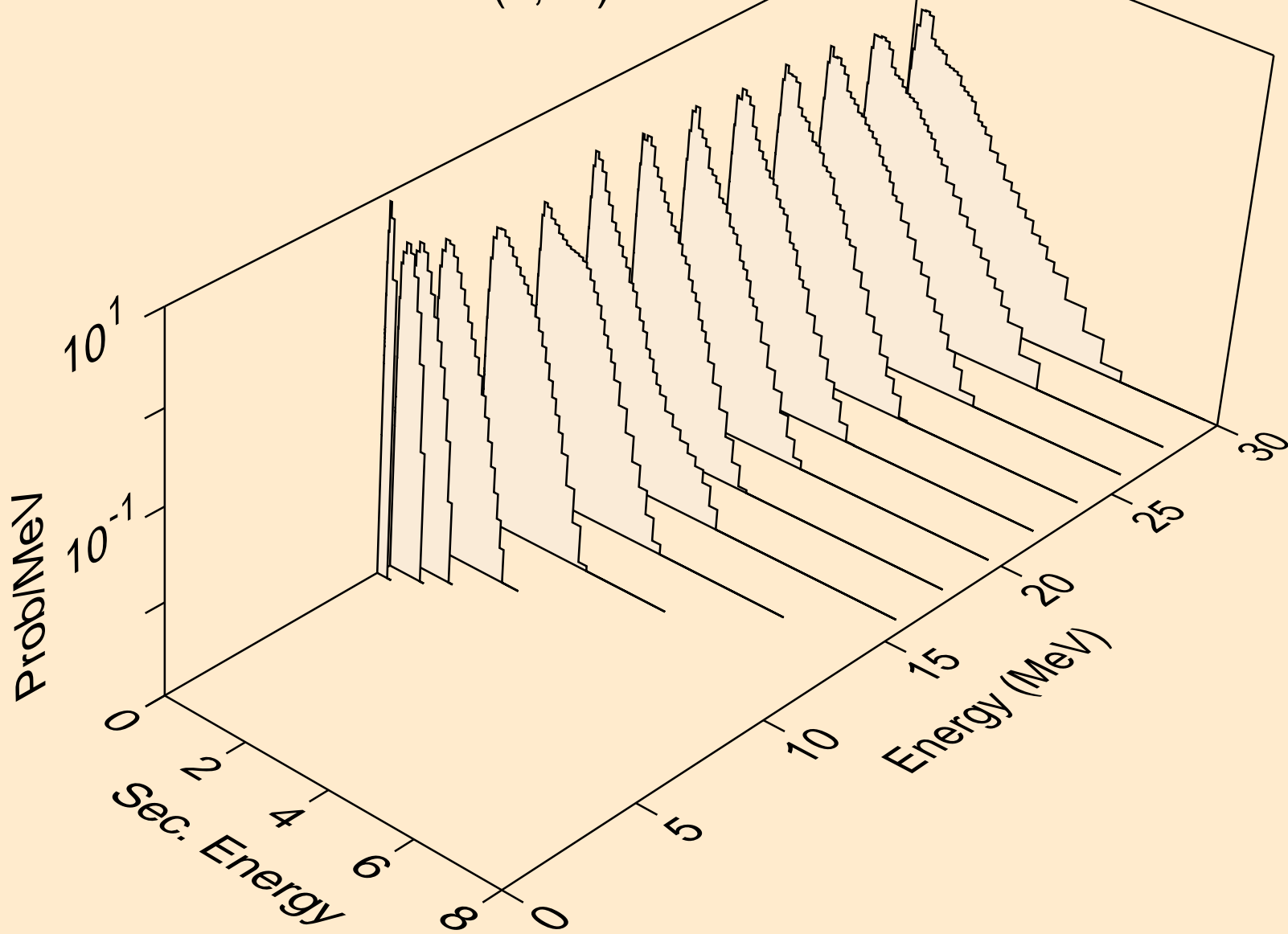

AM248 NEUTRON ACER TENDL-2023 LIBRARY; T=0.K  
Neutron emission for (n,3n)a

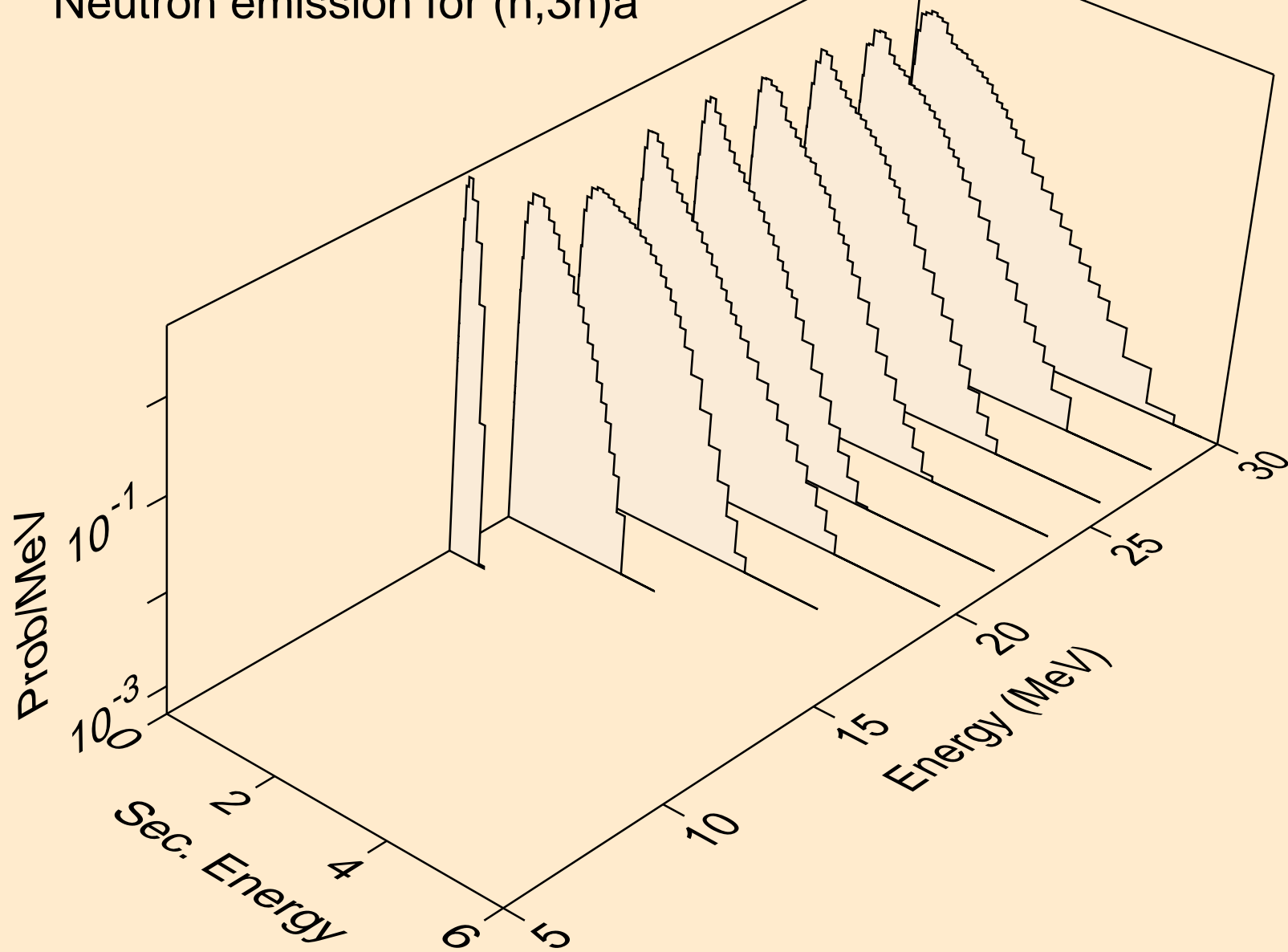

AM248 NEUTRON ACER TENDL-2023 LIBRARY; T=0.K  
Neutron emission for (n,n\*)p

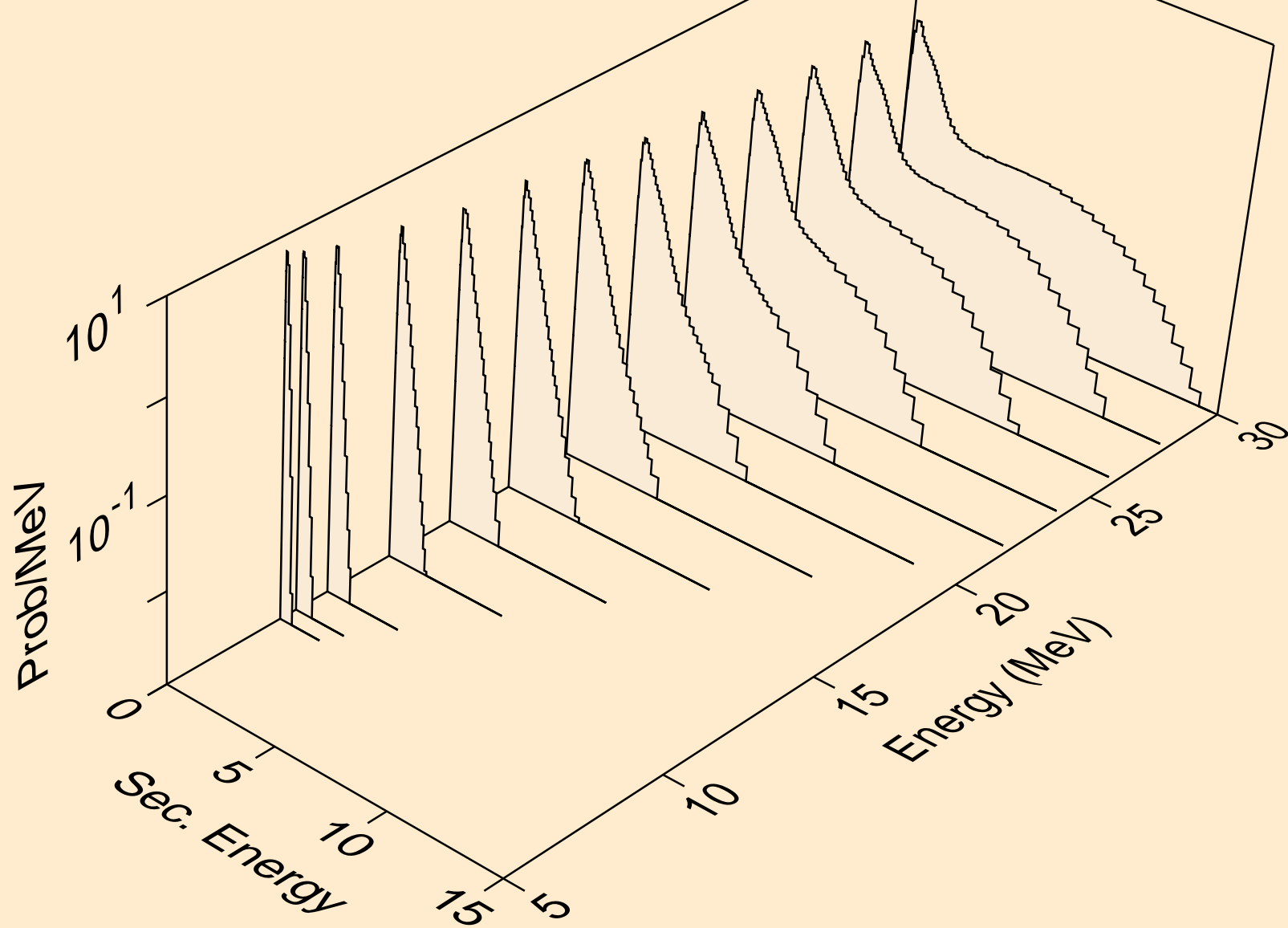

AM248 NEUTRON ACER TENDL-2023 LIBRARY; T=0.K  
Neutron emission for (n,n\*)d

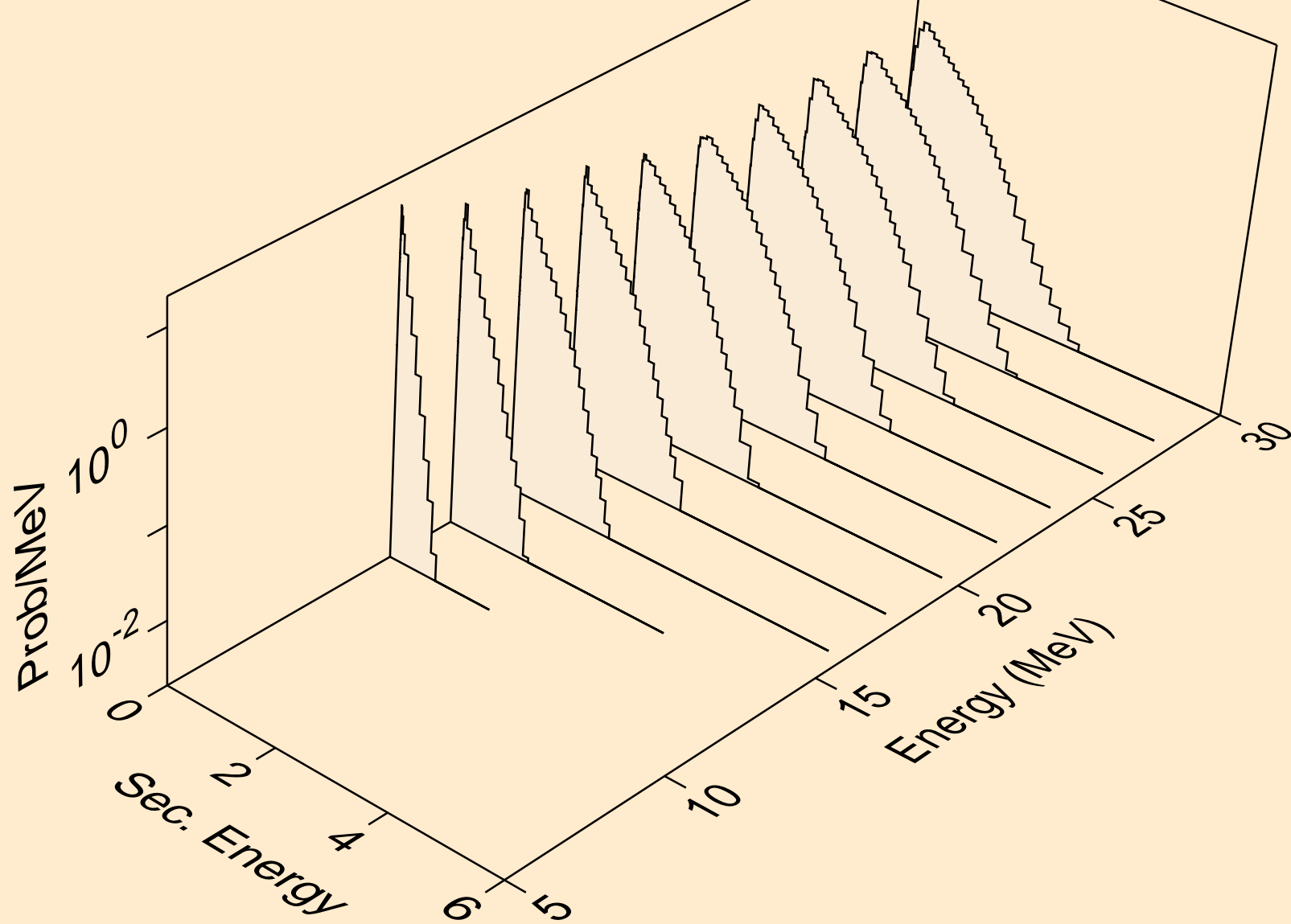



AM248 NEUTRON ACER TENDL-2023 LIBRARY; T=0.K  
Neutron emission for (n,n\*)t

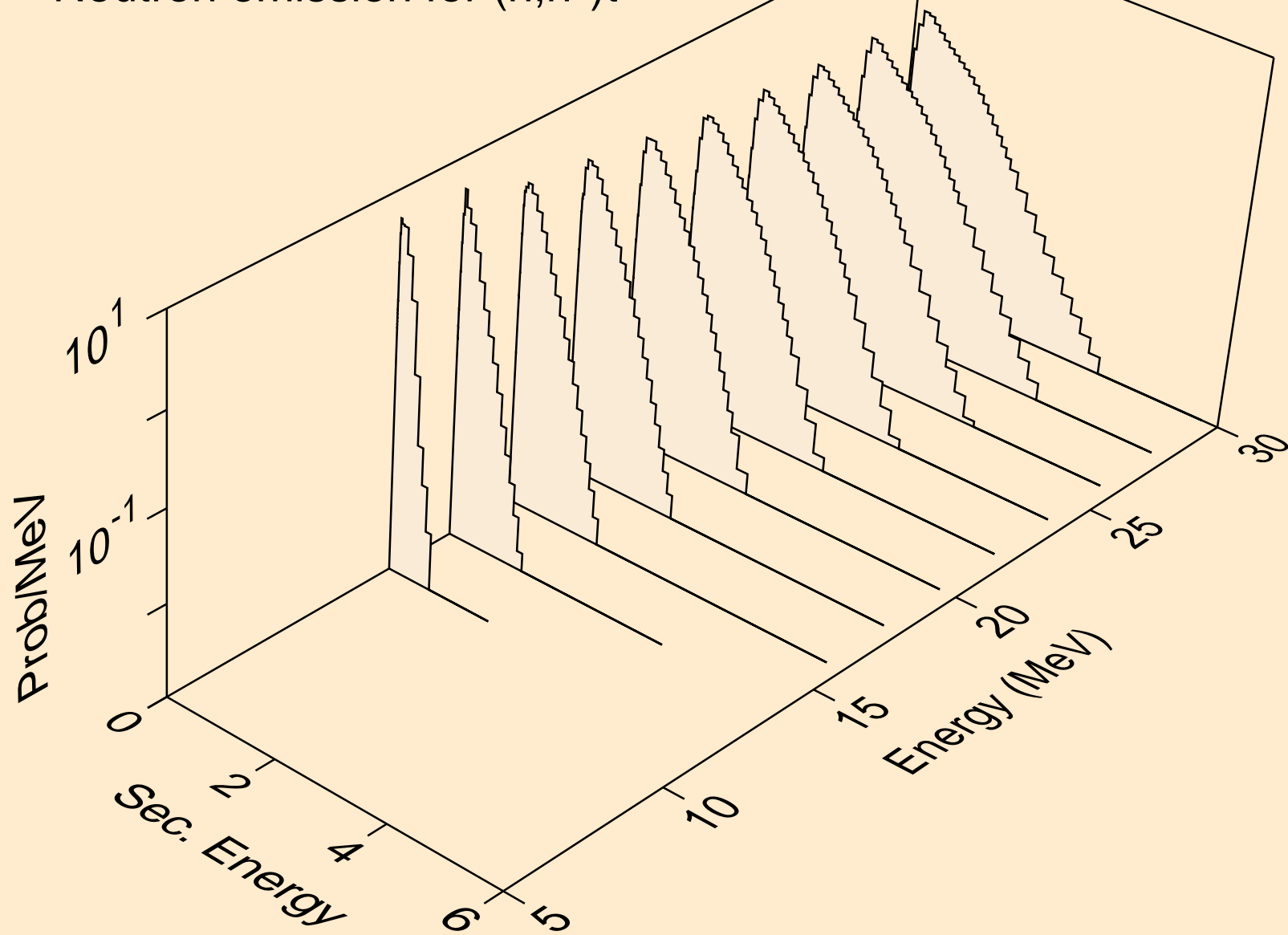

AM248 NEUTRON ACER TENDL-2023 LIBRARY; T=0.K  
Neutron emission for (n,n\*)he3

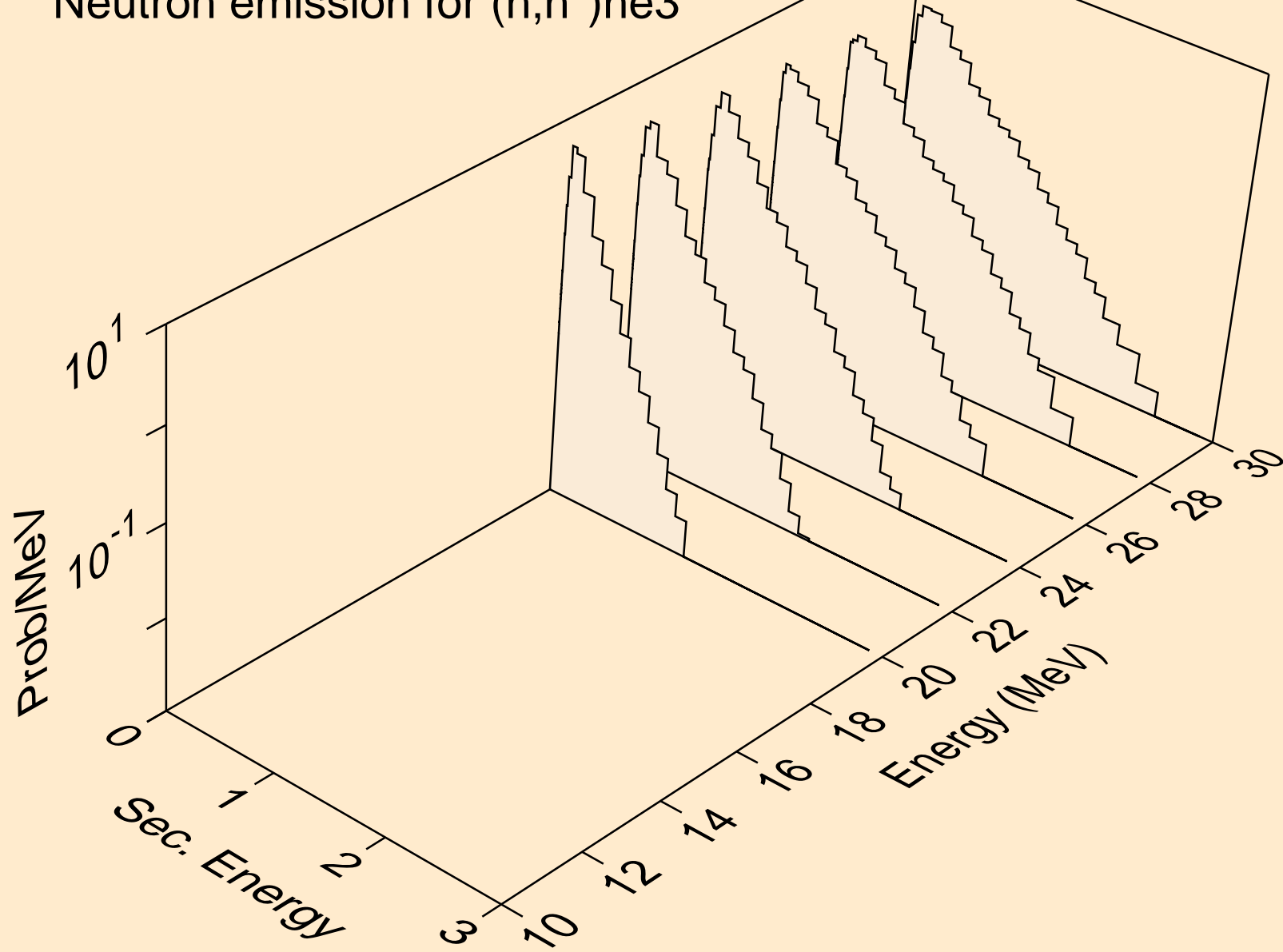

AM248 NEUTRON ACER TENDL-2023 LIBRARY; T=0.K  
Neutron emission for (n,4n)

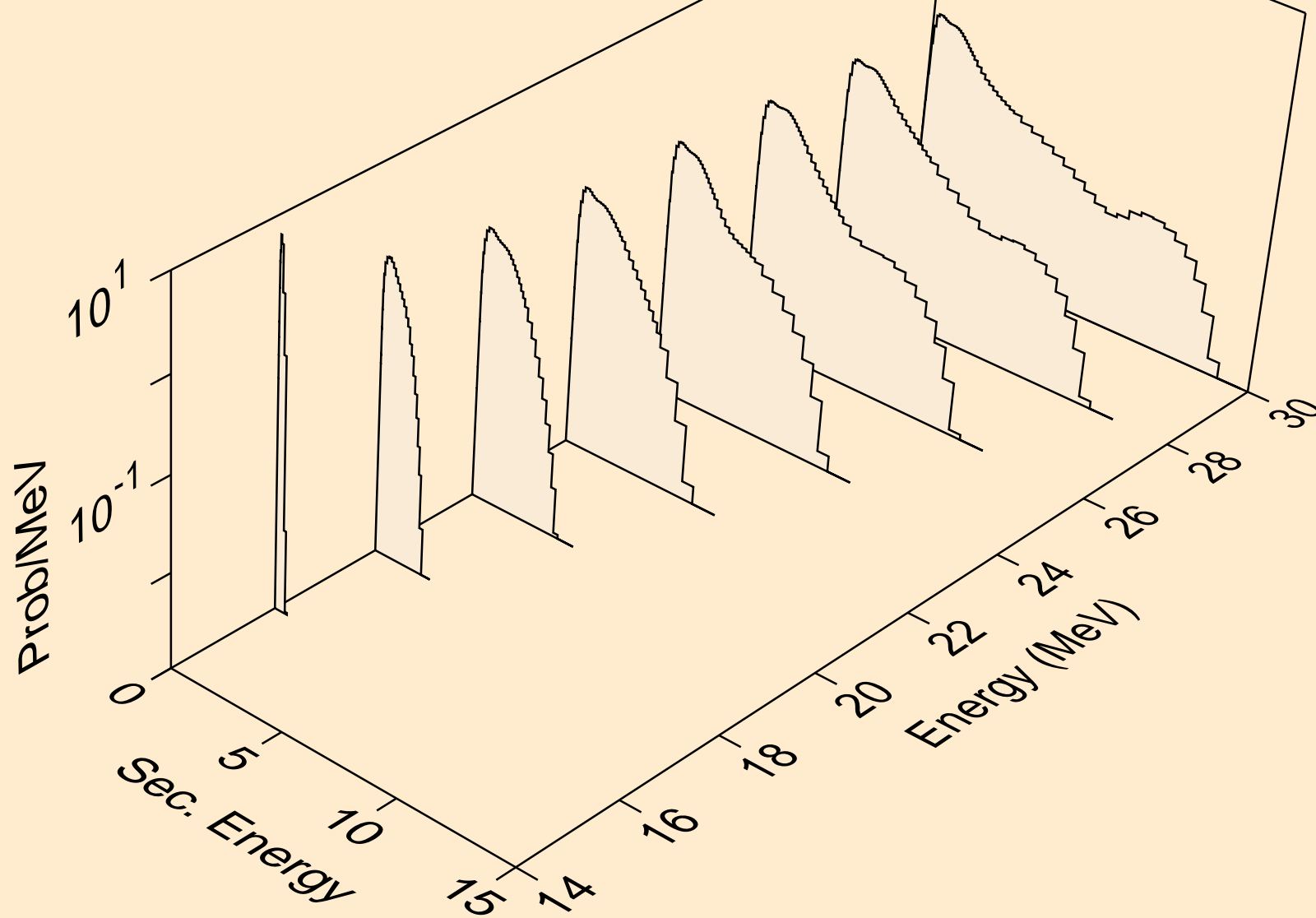

AM248 NEUTRON ACER TENDL-2023 LIBRARY; T=0.K  
Neutron emission for (n,2np)

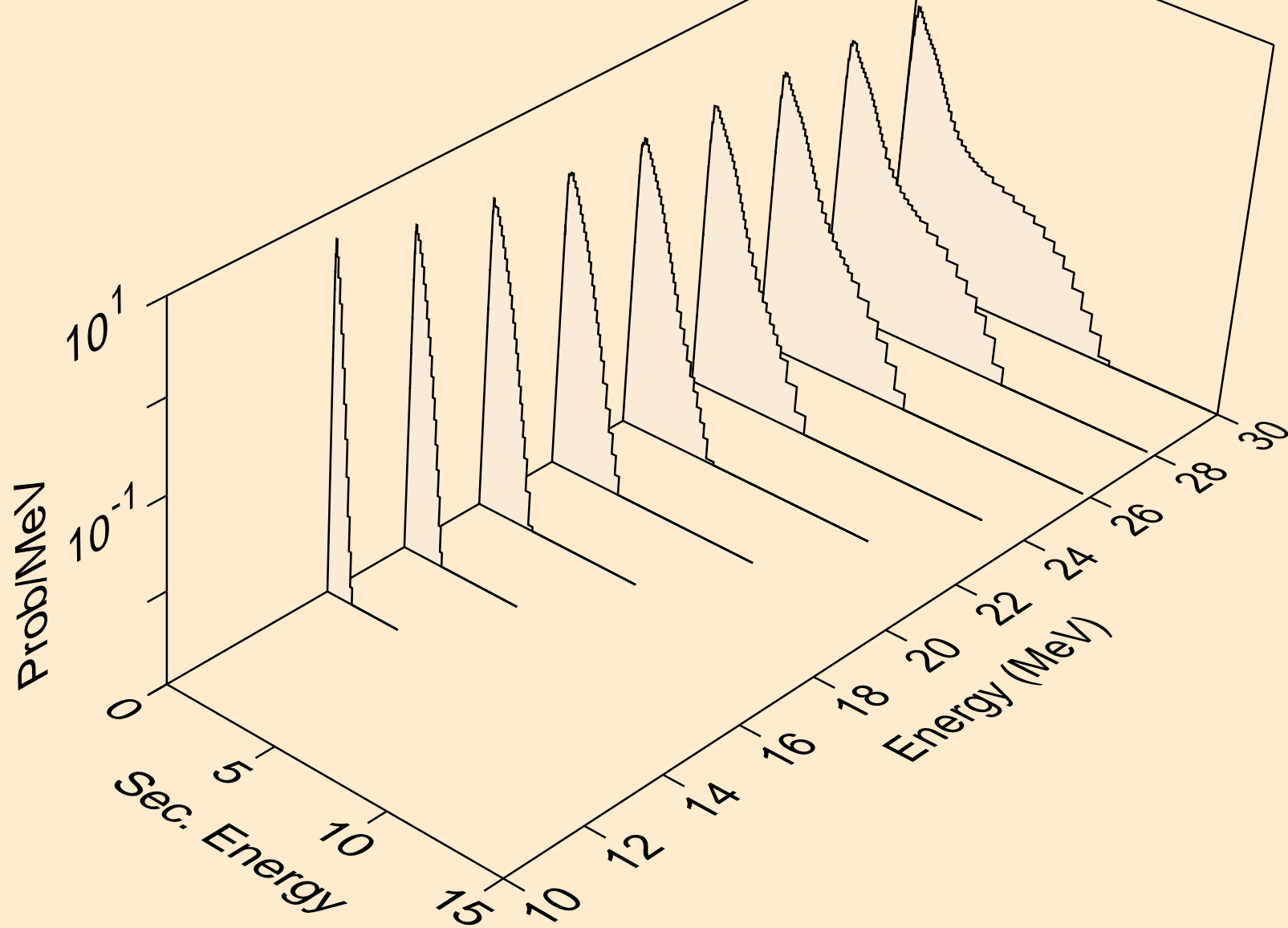

AM248 NEUTRON ACER TENDL-2023 LIBRARY; T=0.K  
Neutron emission for (n,3np)

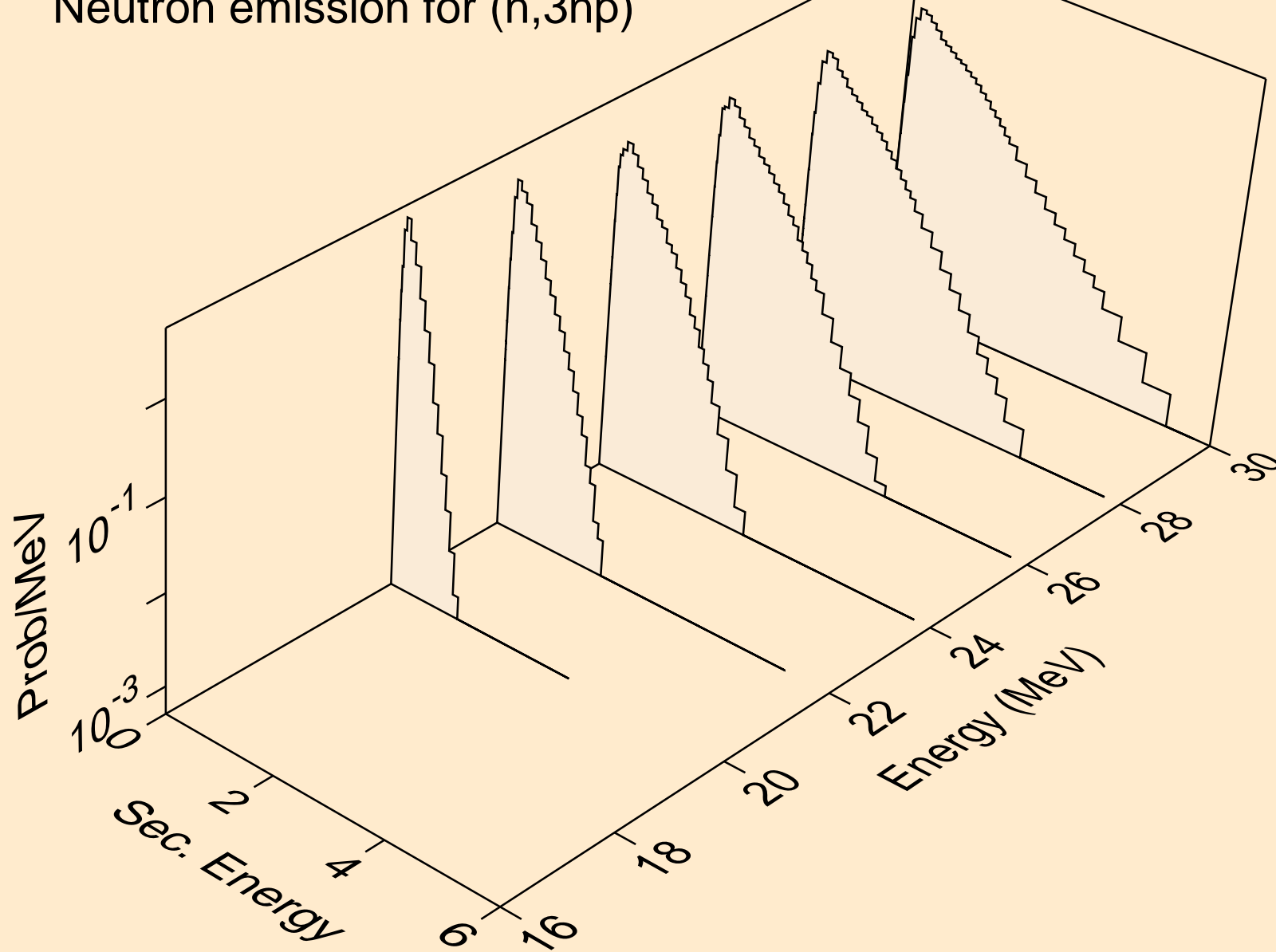

AM248 NEUTRON ACER TENDL-2023 LIBRARY; T=0.K  
Neutron emission for (n,n\*c)

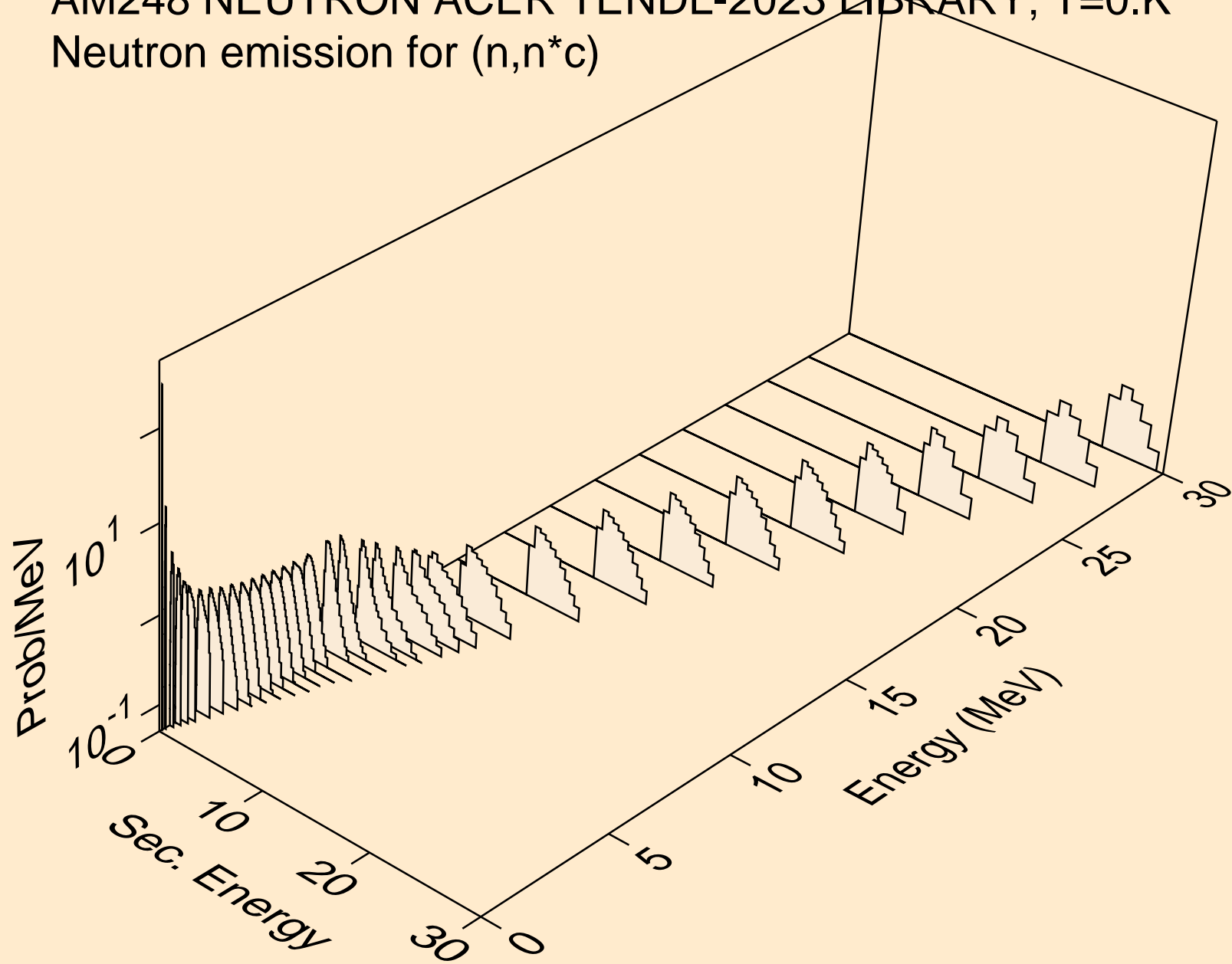

# AM248 NEUTRON ACER TENDL-2023 LIBRARY; T=0.K

## Delayed nubar

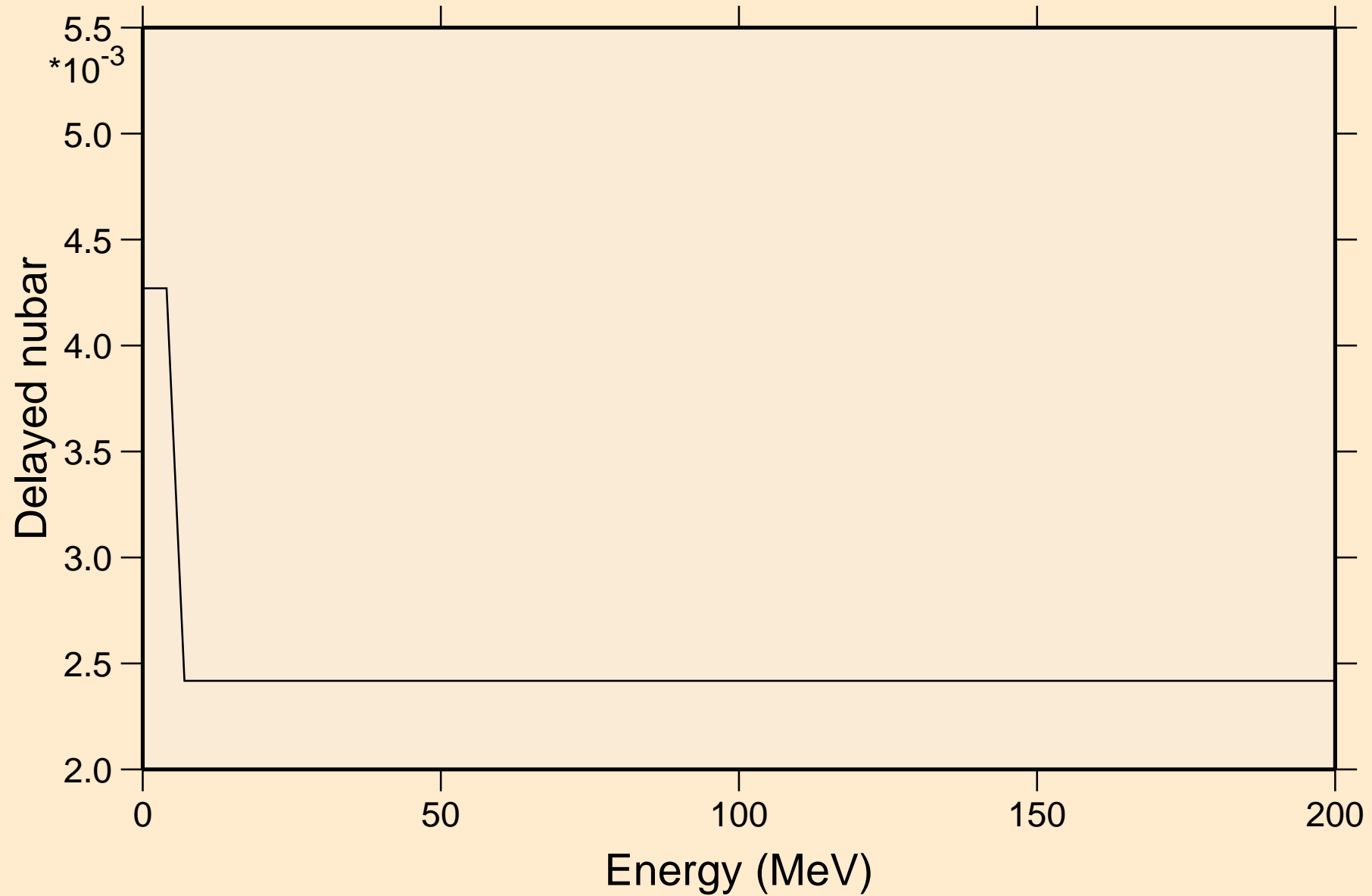

# AM248 NEUTRON ACER TENDL-2023 LIBRARY; T=0.K

## Delayed neutron spectra

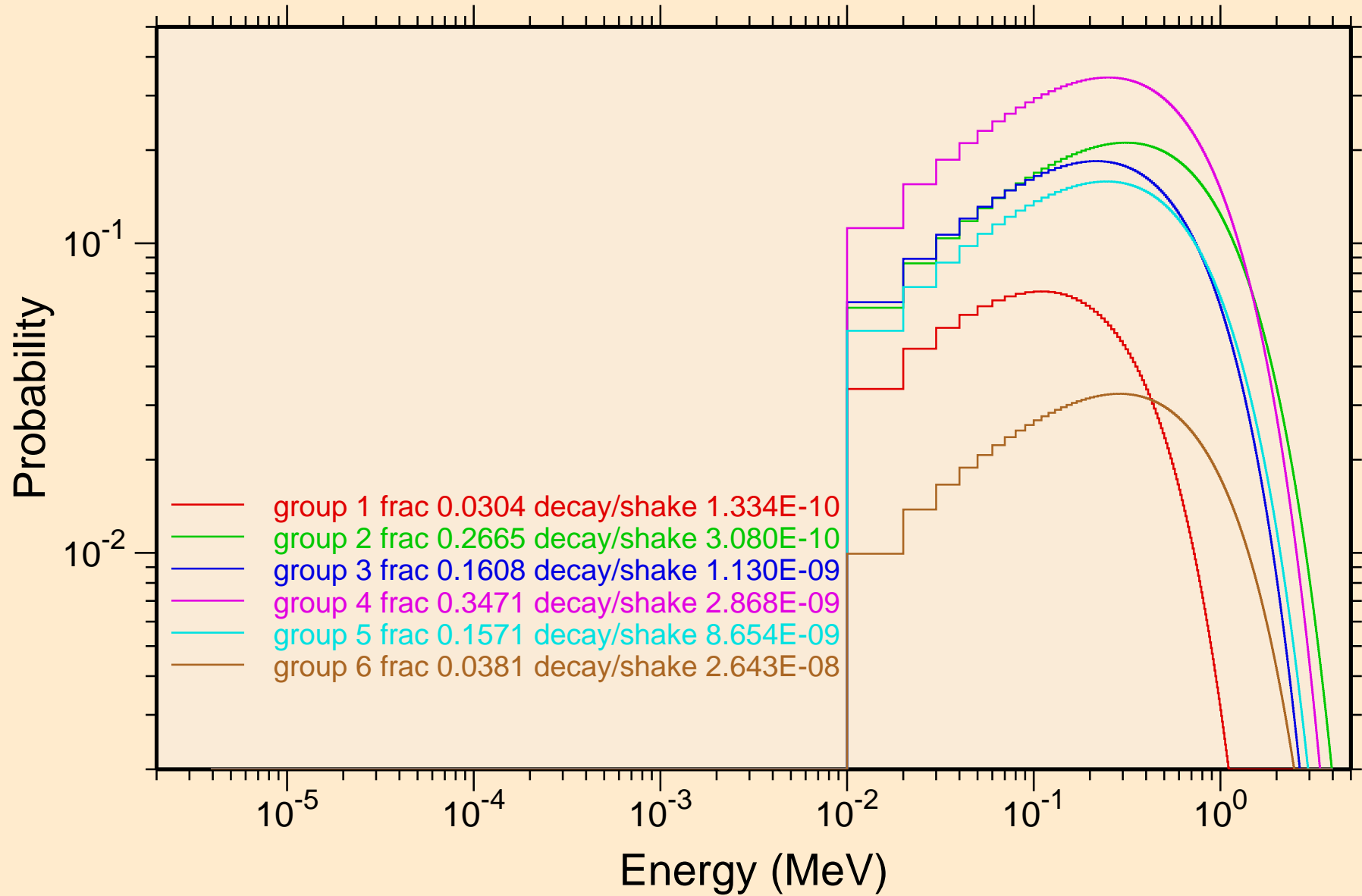



AM248 NEUTRON ACER TENDL-2023 LIBRARY; T=0.K  
Photon emission for (n,x)

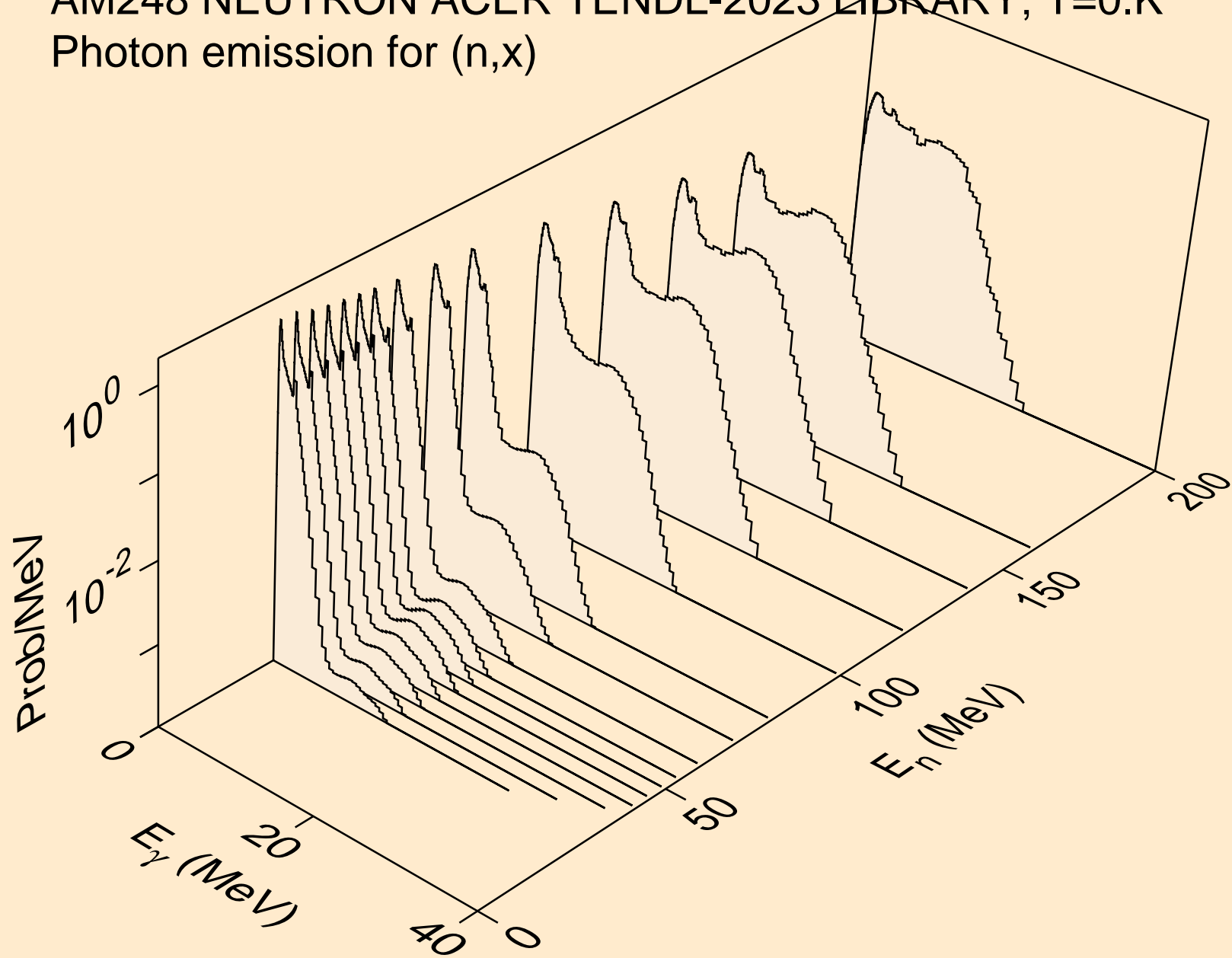

AM248 NEUTRON ACER TENDL-2023 LIBRARY; T=0.K  
Photon emission for (n,2nd)

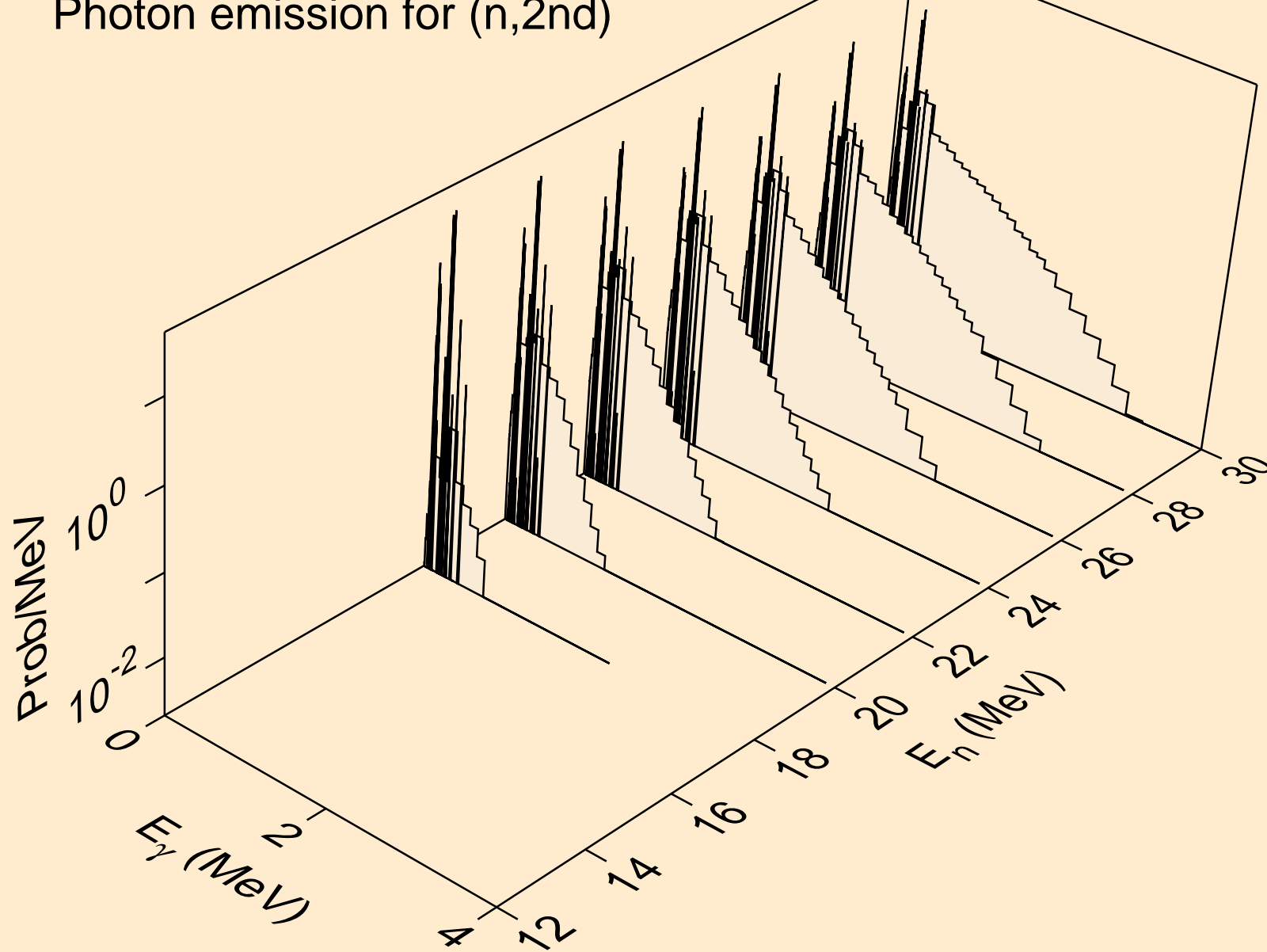

AM248 NEUTRON ACER TENDL-2023 LIBRARY; T=0.K  
Photon emission for (n,2n)

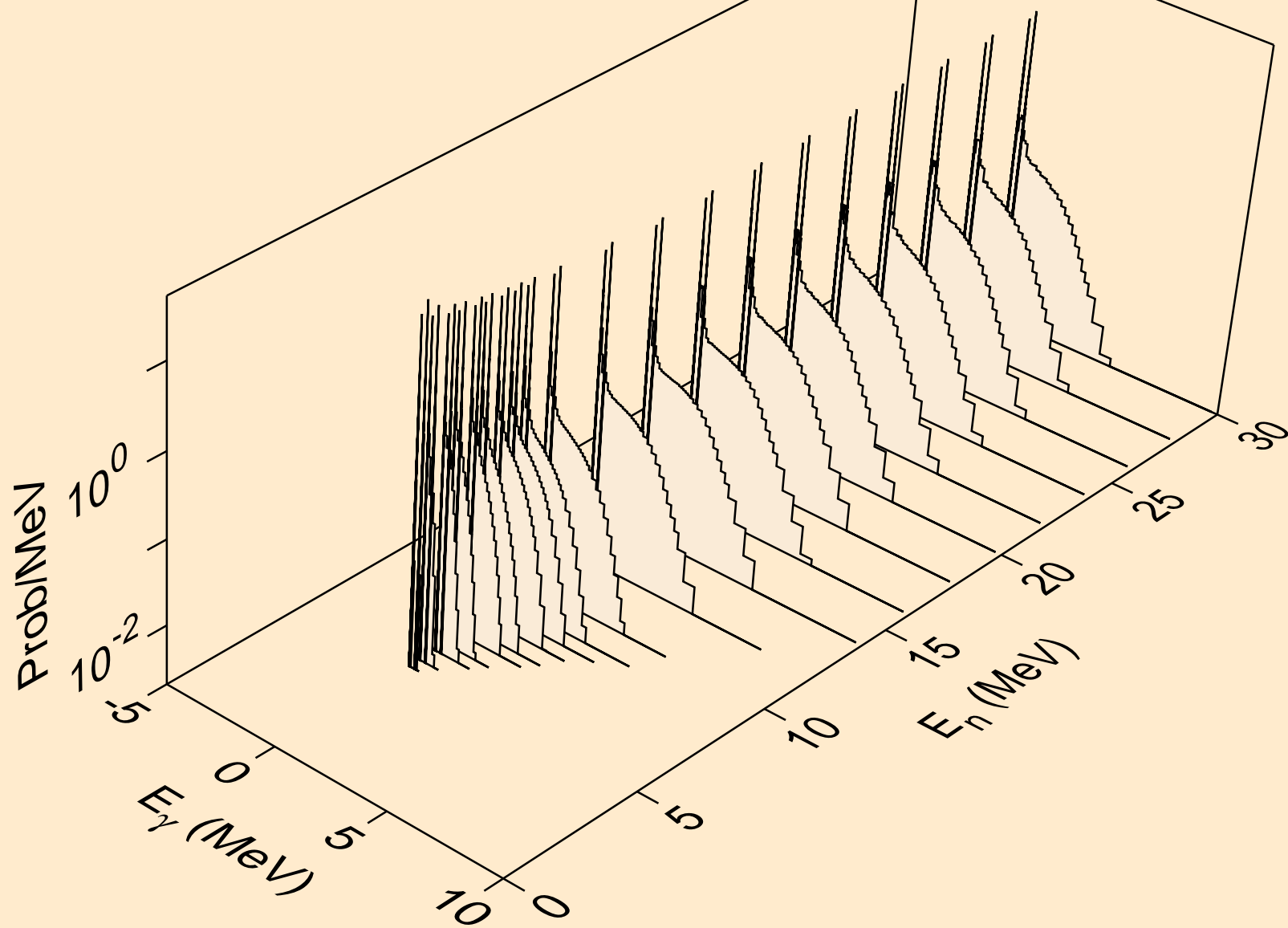

AM248 NEUTRON ACER TENDL-2023 LIBRARY; T=0.K  
Photon emission for (n,3n)

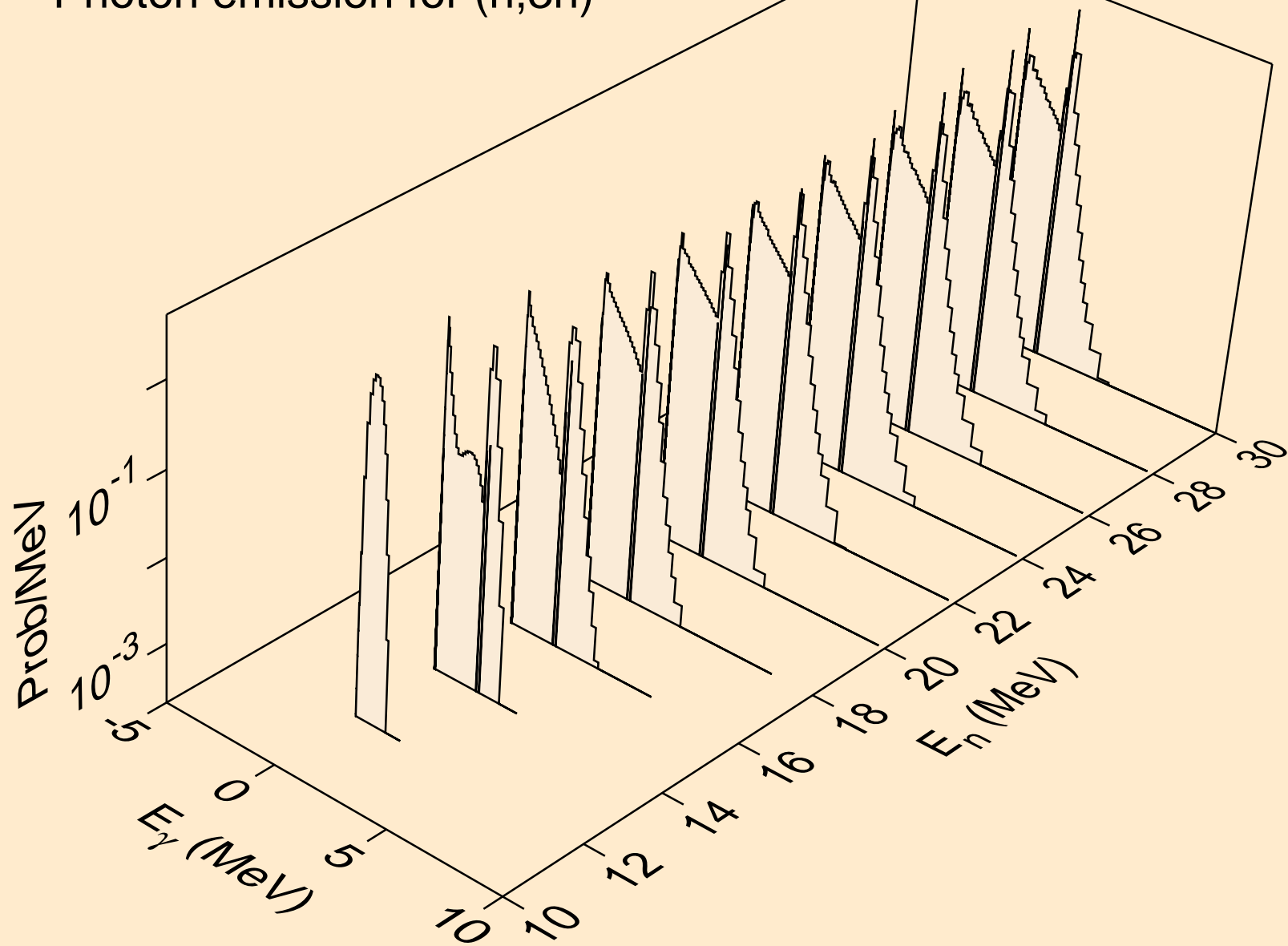

AM248 NEUTRON ACER TENDL-2023 LIBRARY; T=0.K  
Photon emission for (n,n\*)a

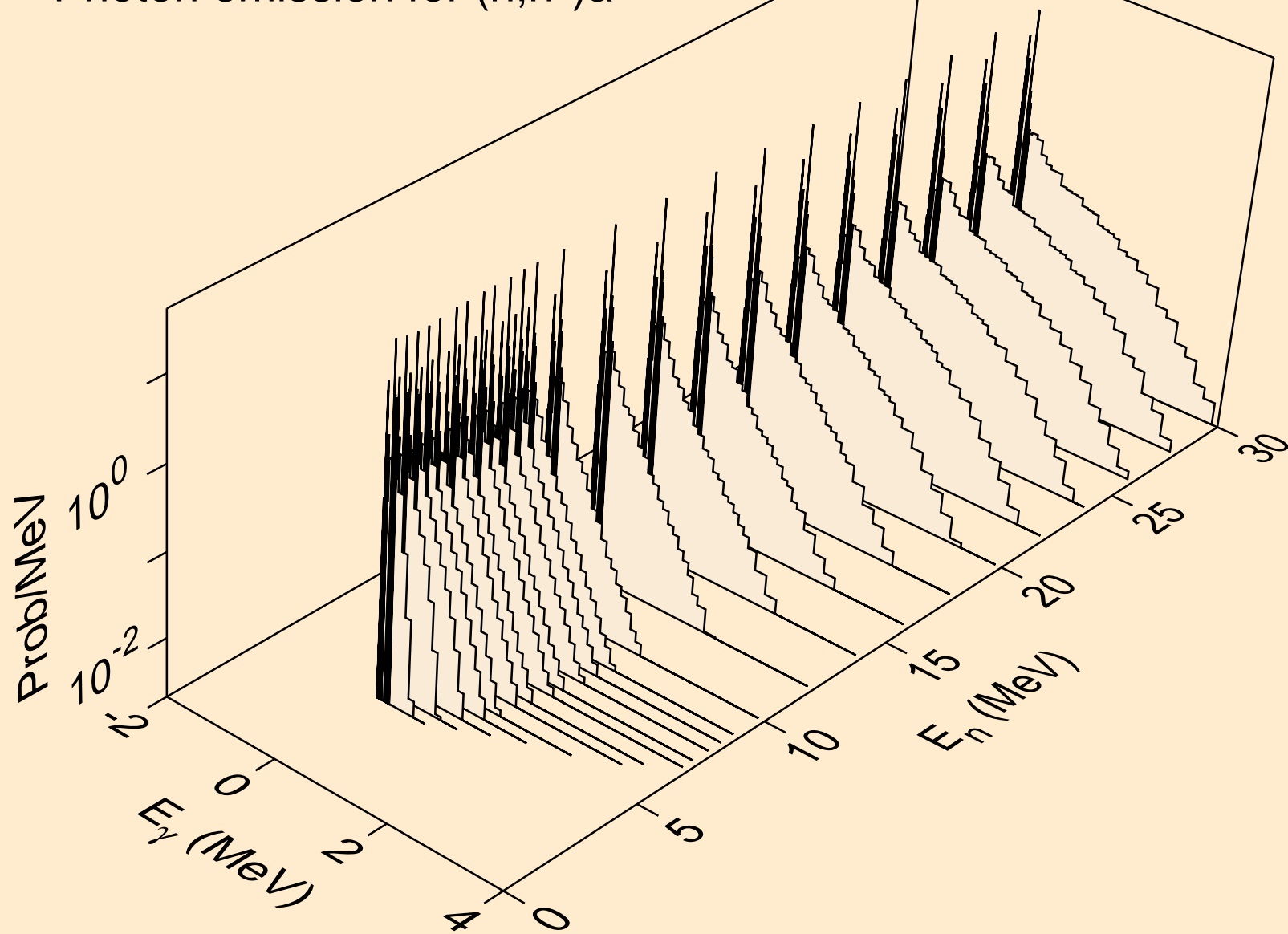

AM248 NEUTRON ACER TENDL-2023 LIBRARY; T=0.K  
Photon emission for (n,2n)a

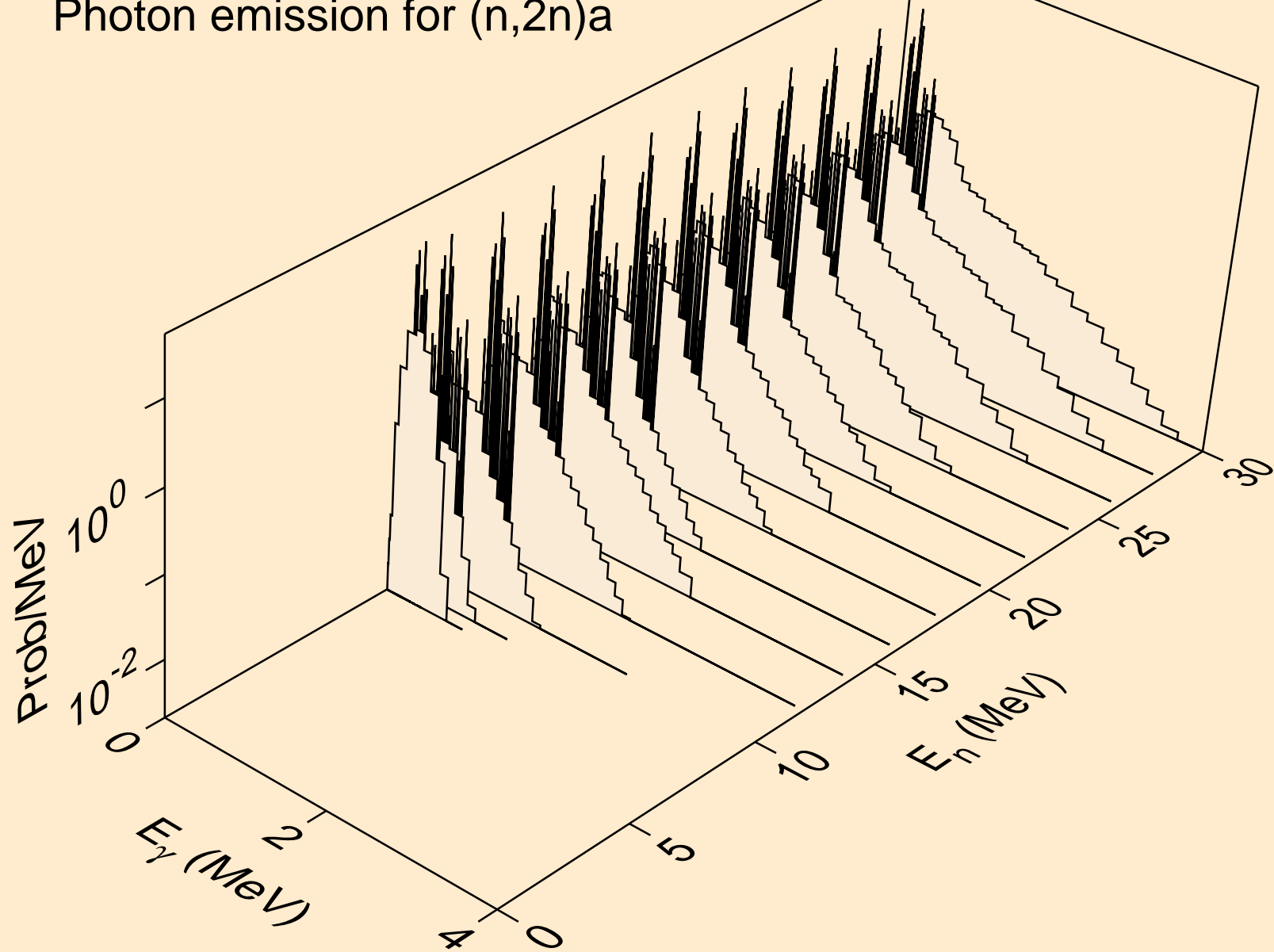

AM248 NEUTRON ACER TENDL-2023 LIBRARY; T=0.K  
Photon emission for (n,3n)a

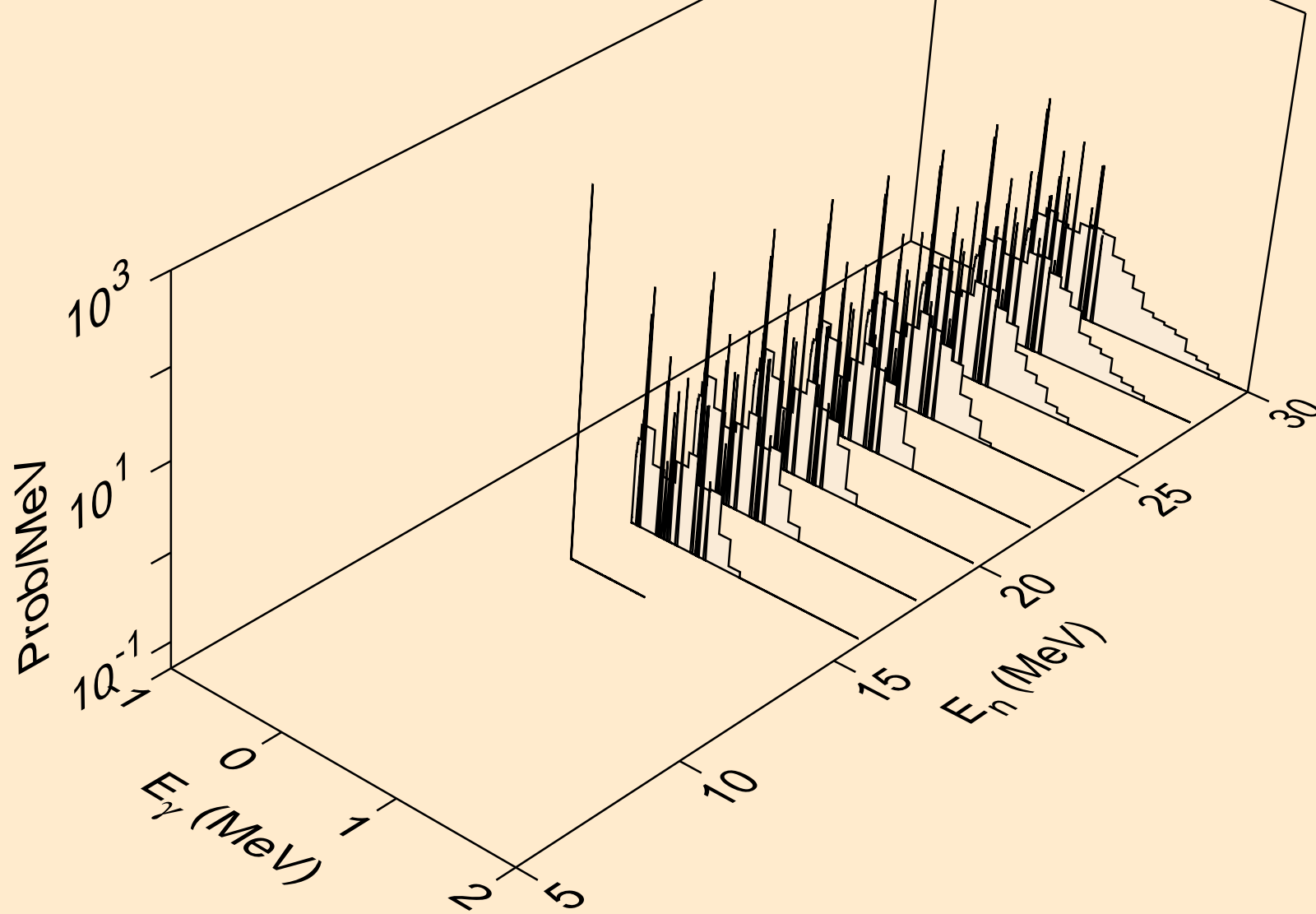

AM248 NEUTRON ACER TENDL-2023 LIBRARY; T=0.K  
Photon emission for (n,n\*)p

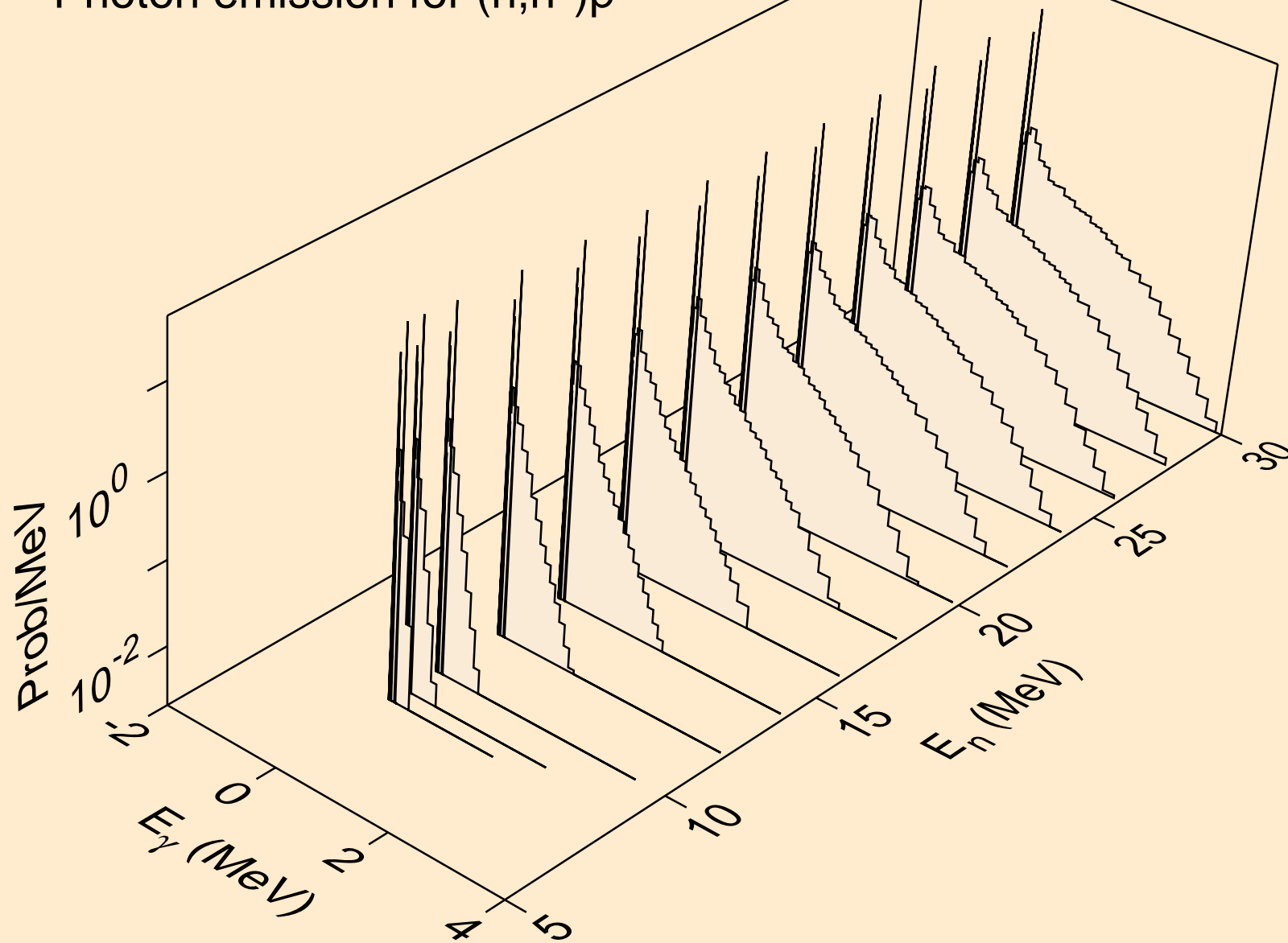



AM248 NEUTRON ACER TENDL-2023 LIBRARY; T=0.K  
Photon emission for (n,n\*)d

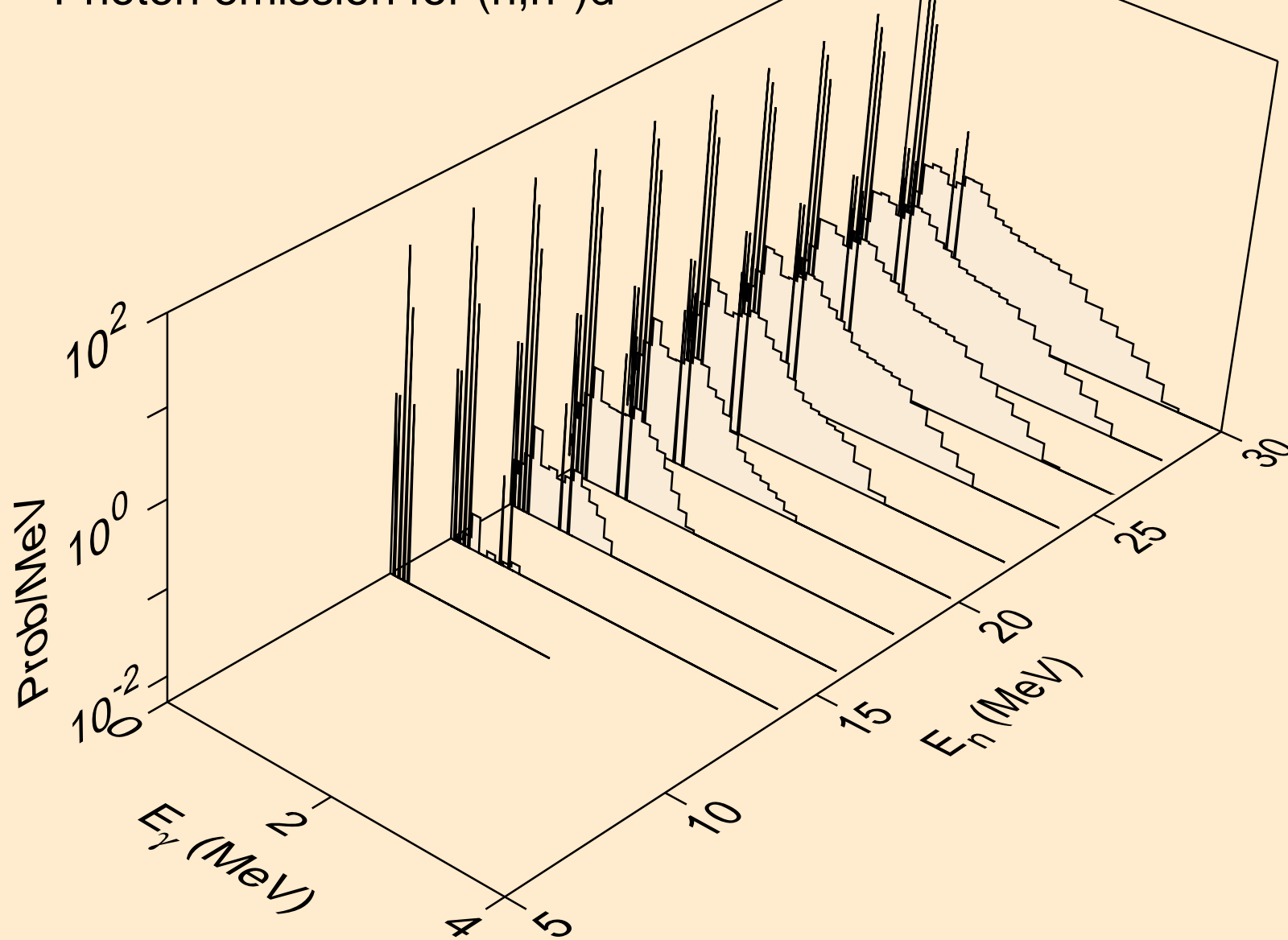

AM248 NEUTRON ACER TENDL-2023 LIBRARY; T=0.K  
Photon emission for (n,n\*)t

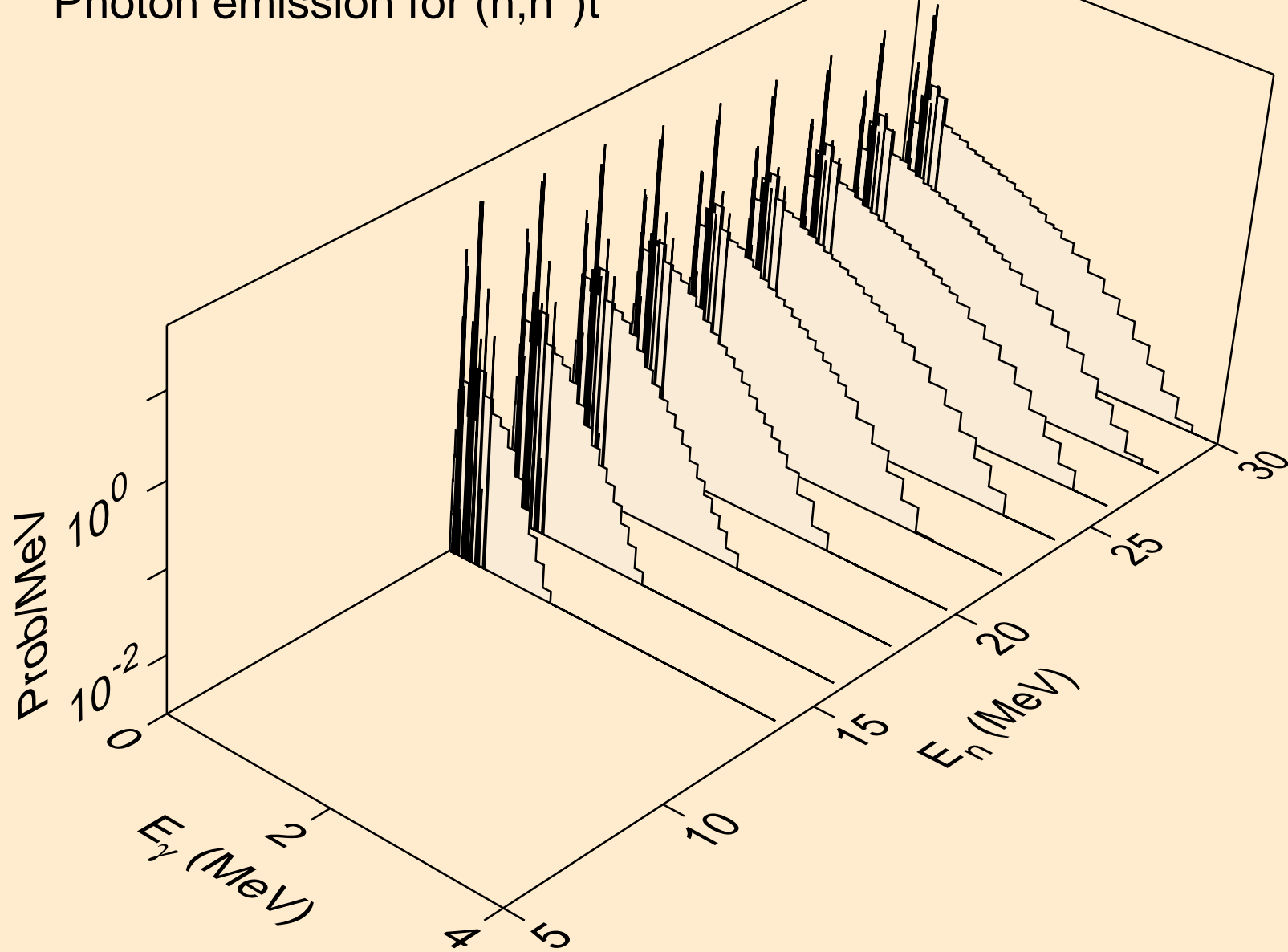

AM248 NEUTRON ACER TENDL-2023 LIBRARY; T=0.K  
Photon emission for (n,n\*)he3

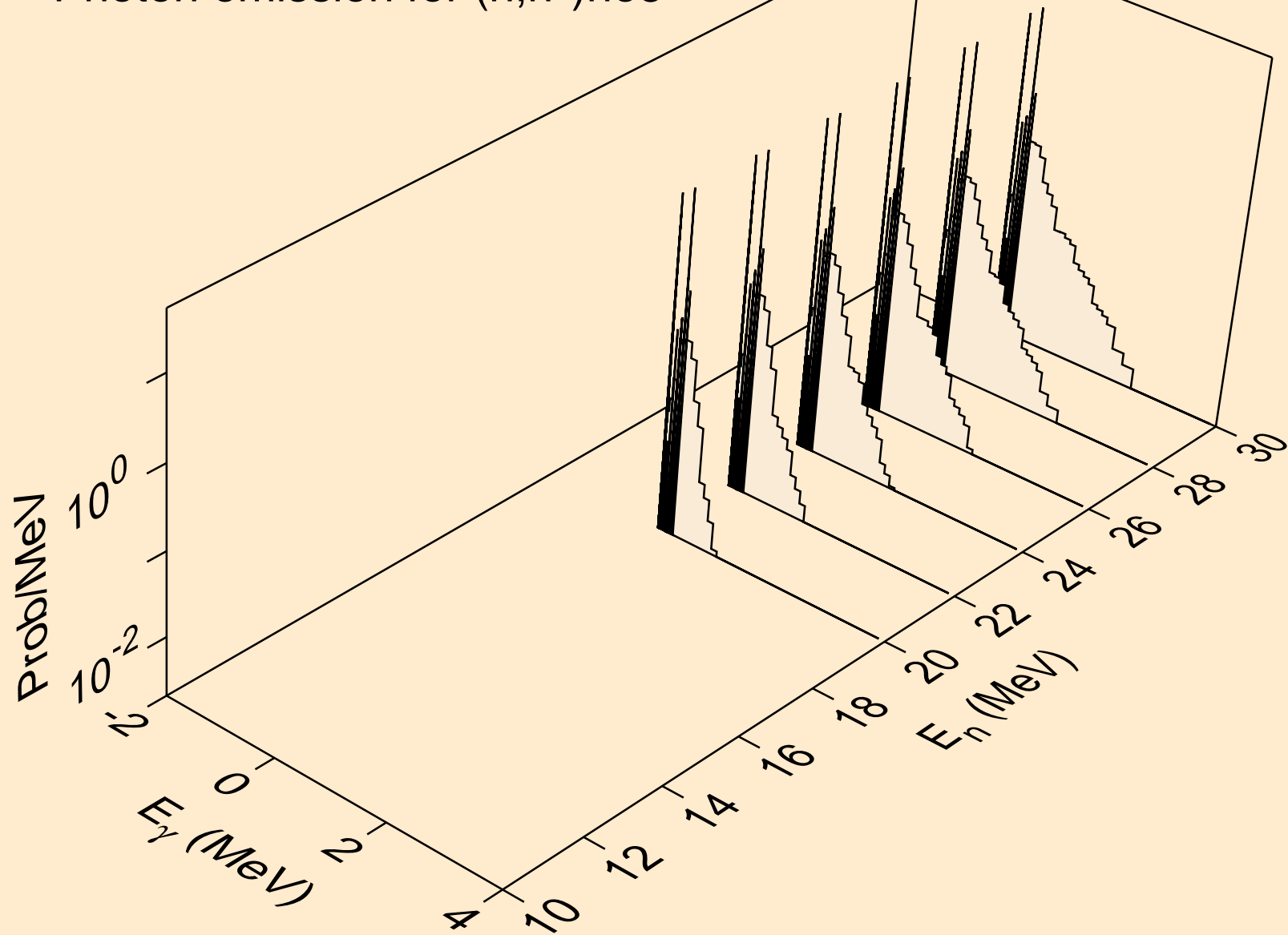

AM248 NEUTRON ACER TENDL-2023 LIBRARY; T=0.K  
Photon emission for (n,4n)

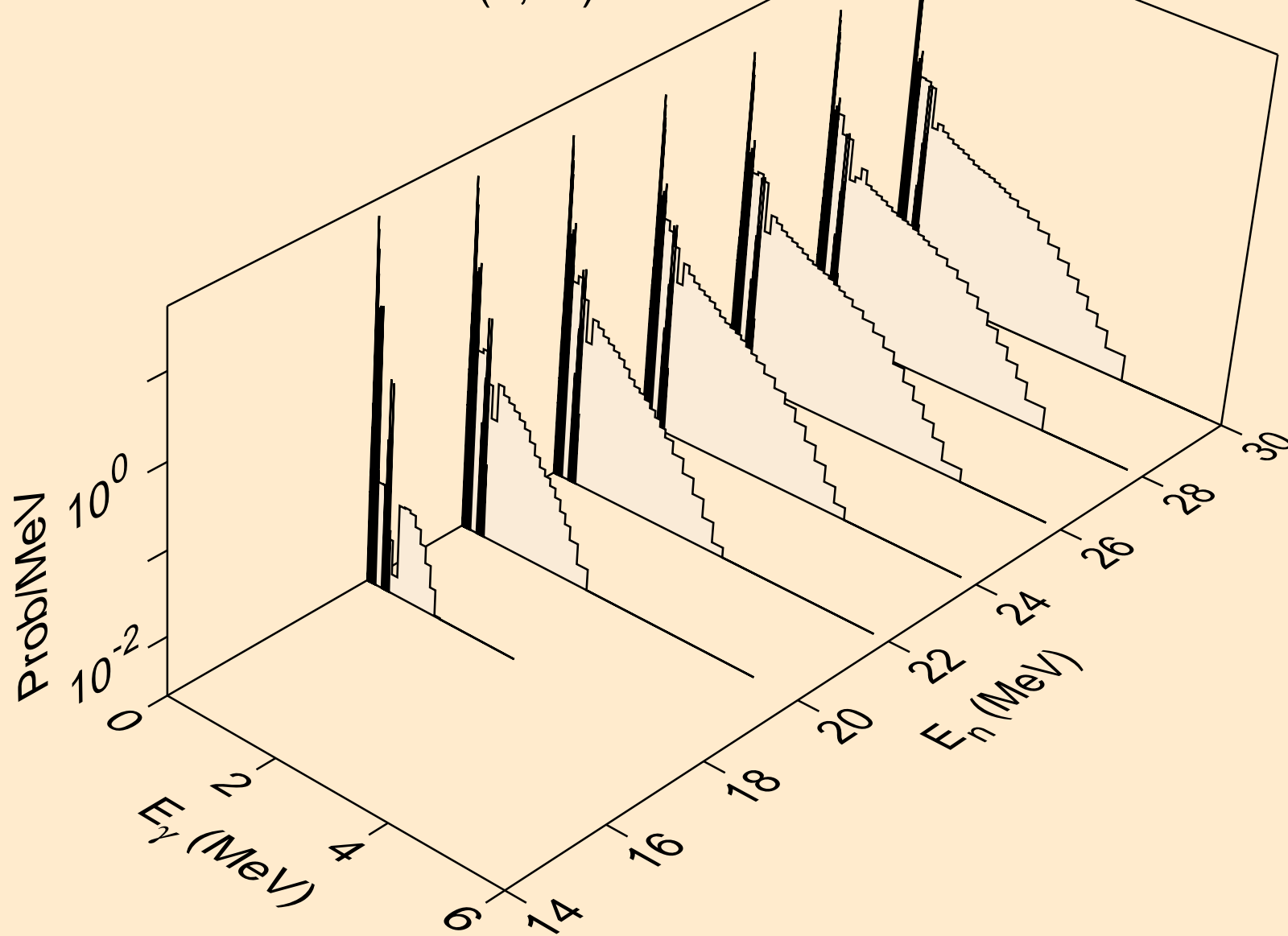

AM248 NEUTRON ACER TENDL-2023 LIBRARY; T=0.K  
Photon emission for (n,2np)

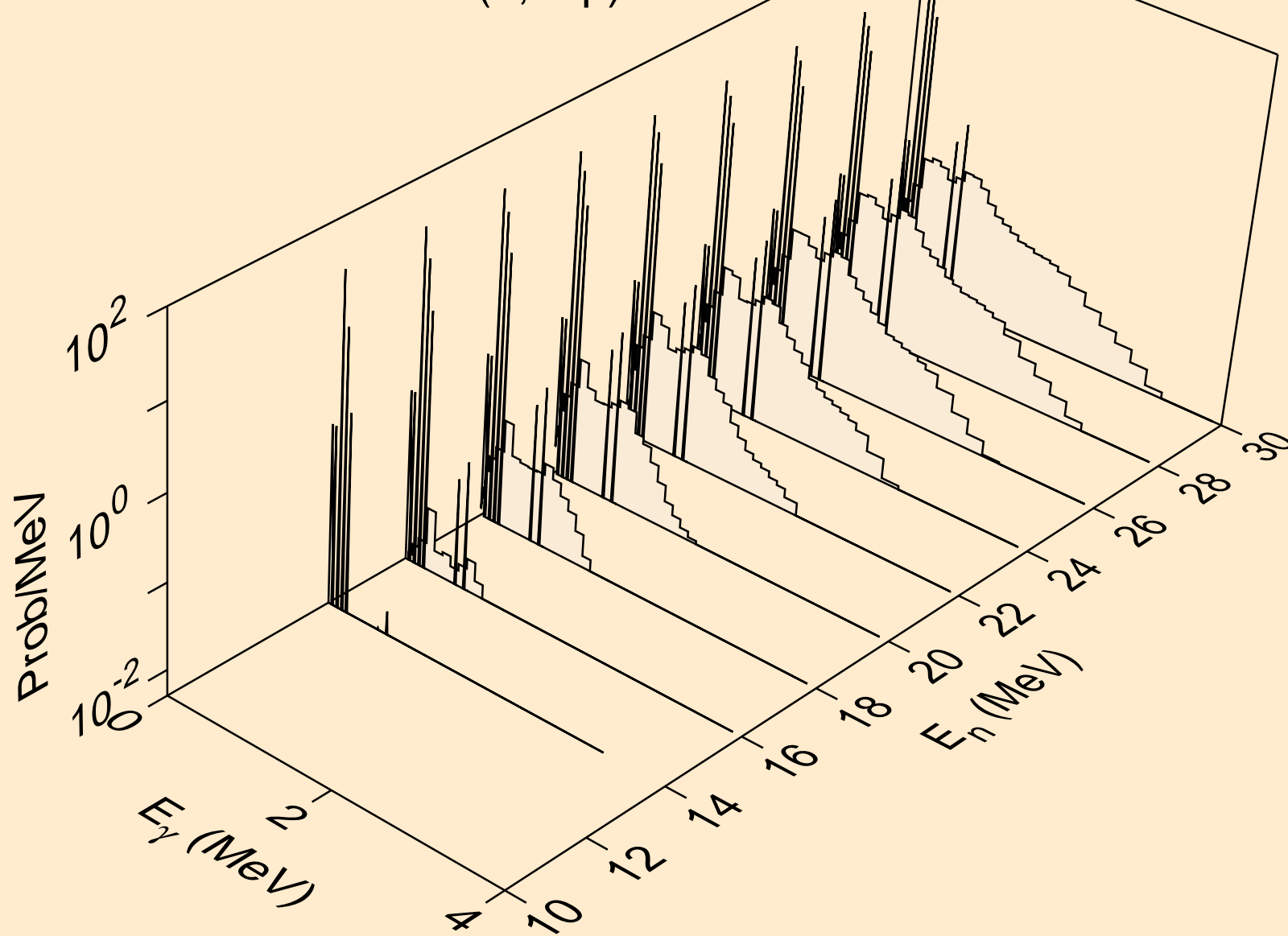

AM248 NEUTRON ACER TENDL-2023 LIBRARY; T=0.K  
Photon emission for (n,3np)

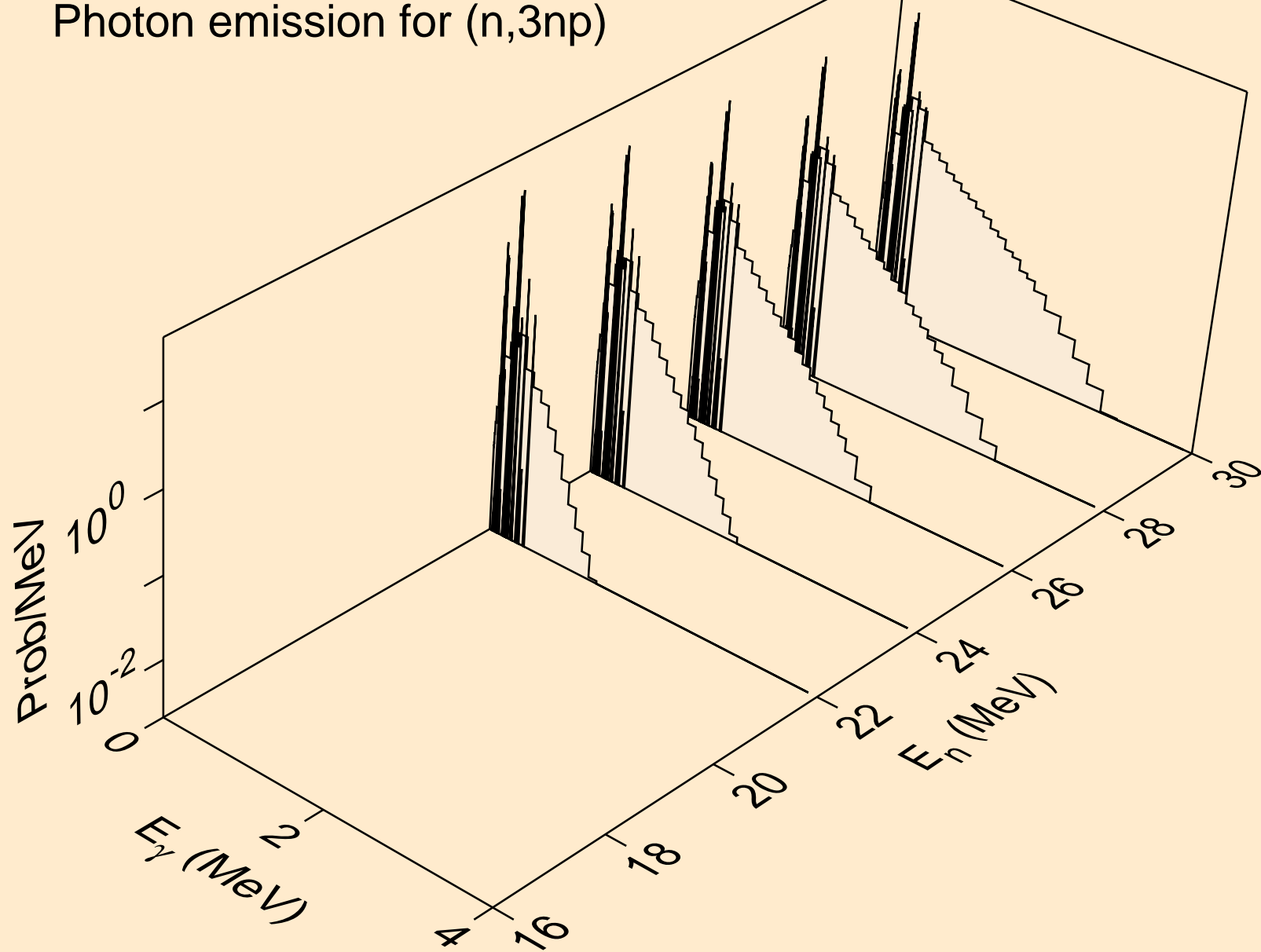

AM248 NEUTRON ACER TENDL-2023 LIBRARY; T=0.K  
Photon emission for (n,n\*c)

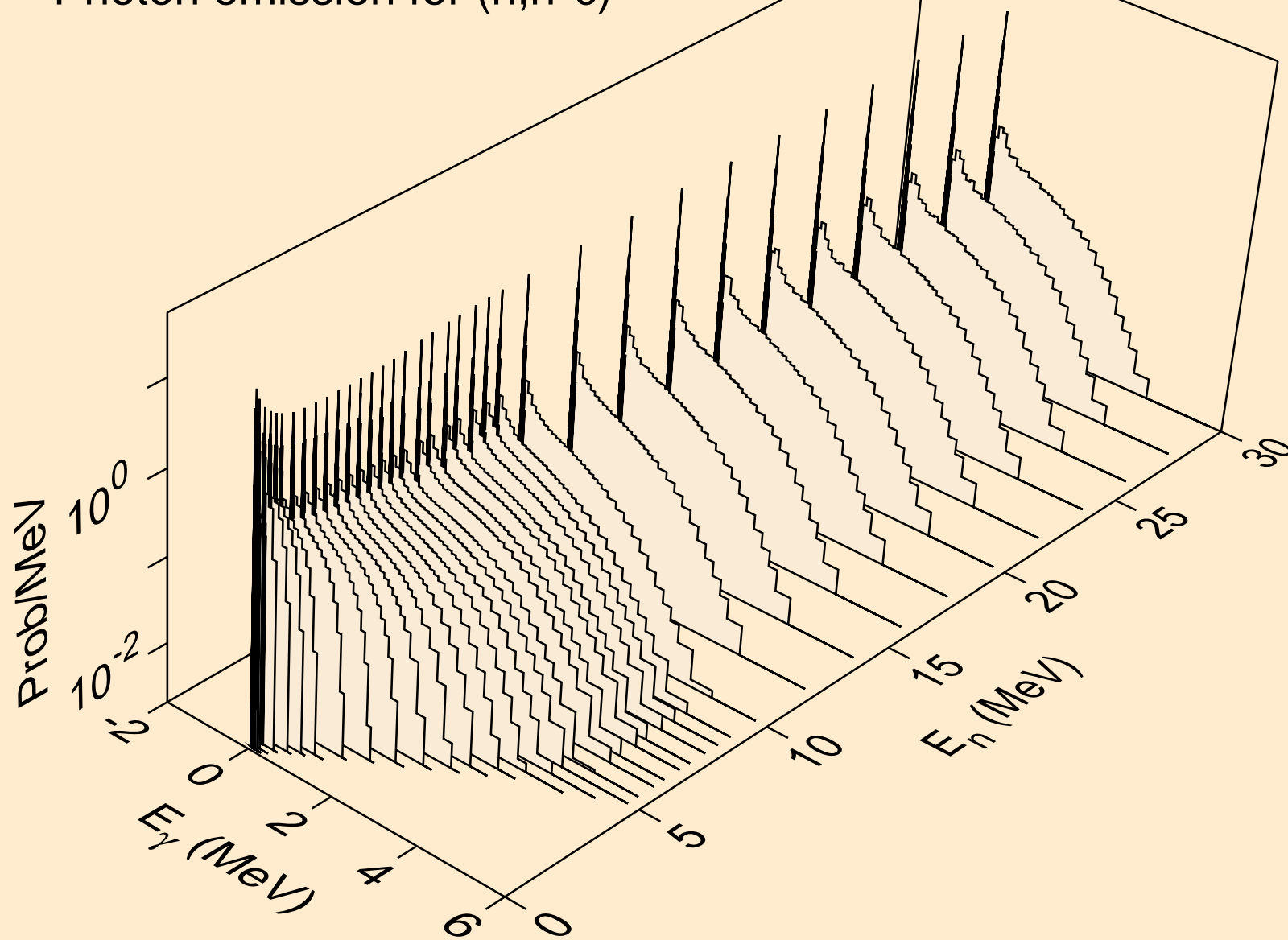

AM248 NEUTRON ACER TENDL-2023 LIBRARY; T=0.K  
Photon emission for (n,gma)

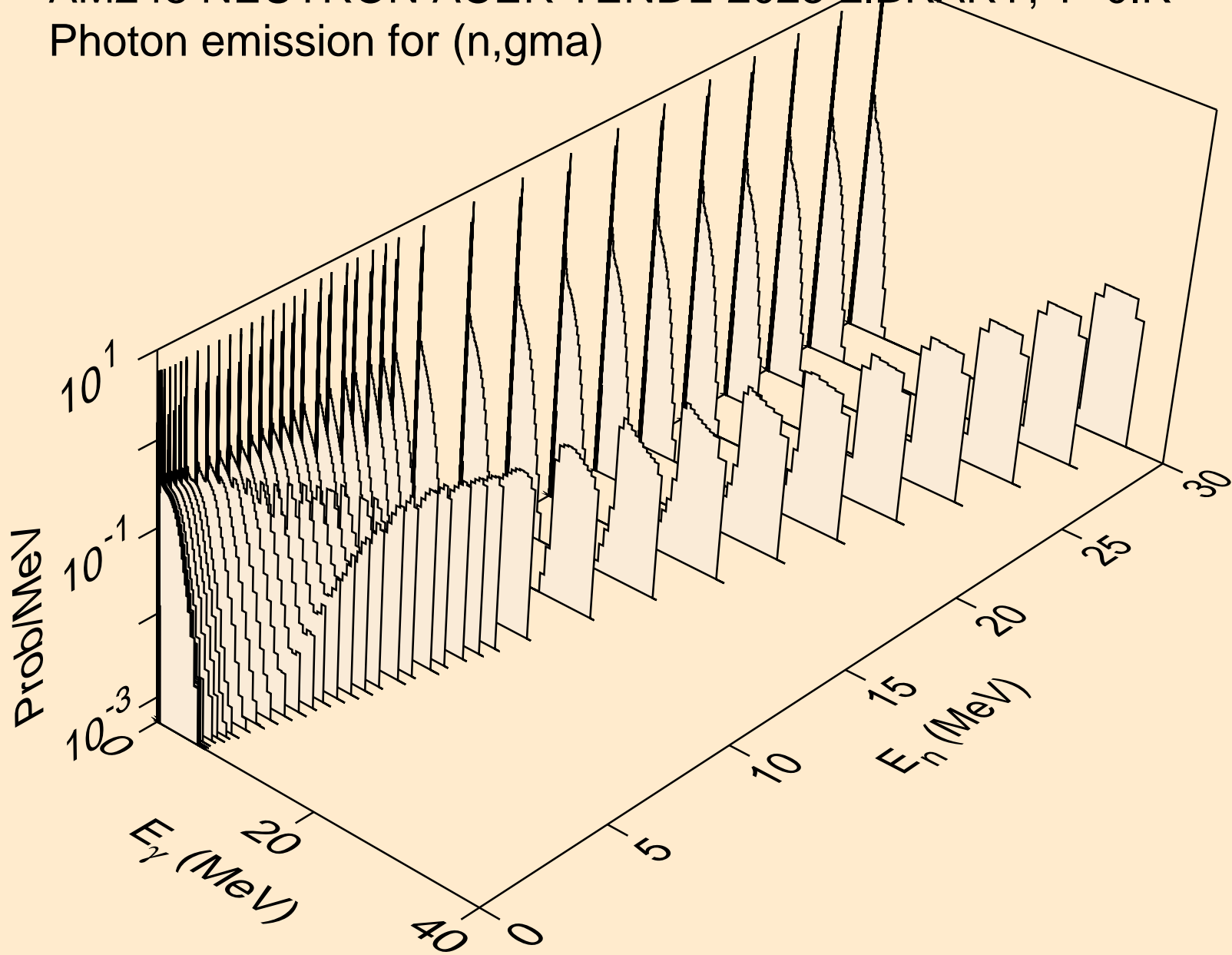



AM248 NEUTRON ACER TENDL-2023 LIBRARY; T=0.K  
Photon emission for (n,p)

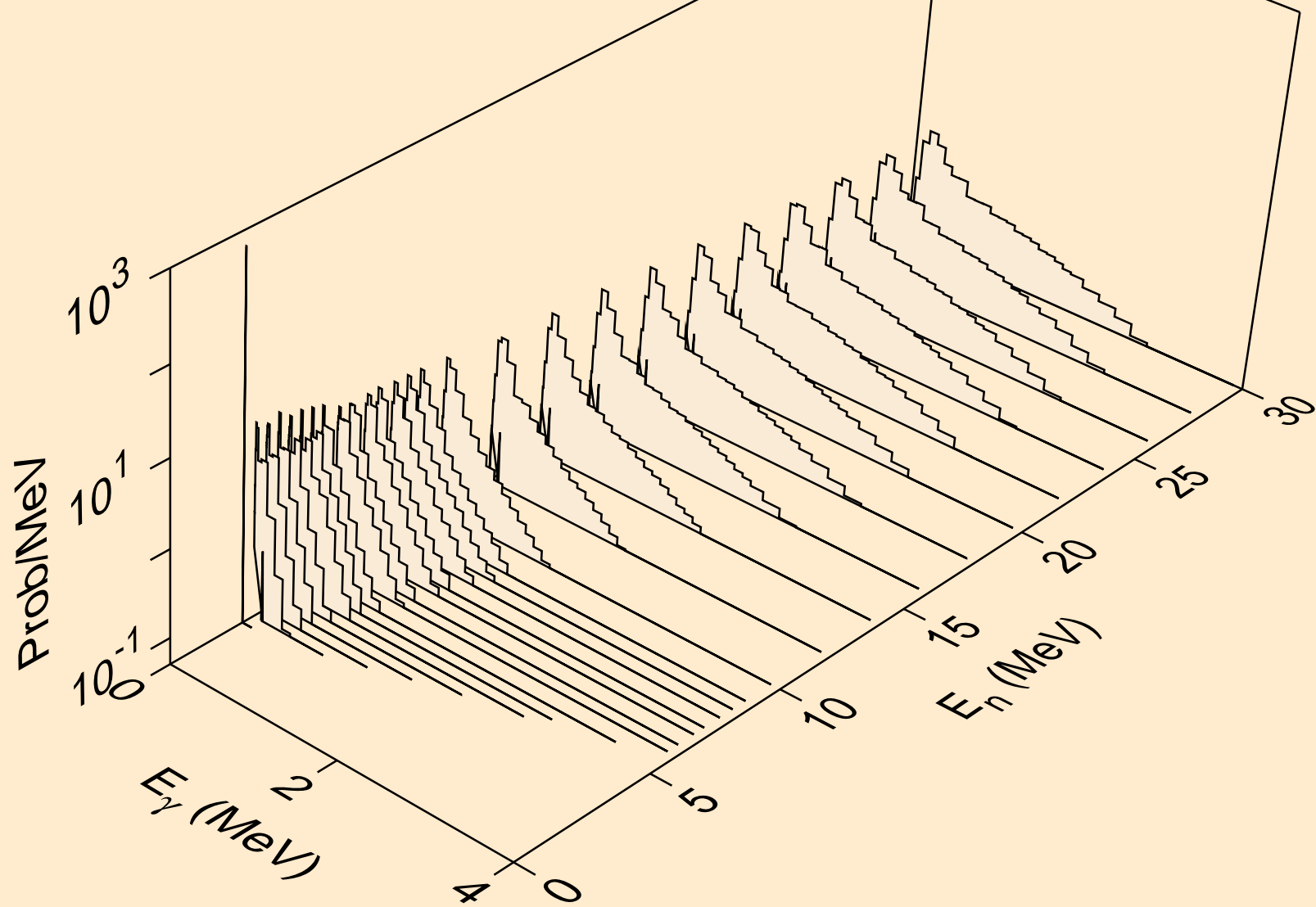

AM248 NEUTRON ACER TENDL-2023 LIBRARY; T=0.K  
Photon emission for (n,d)

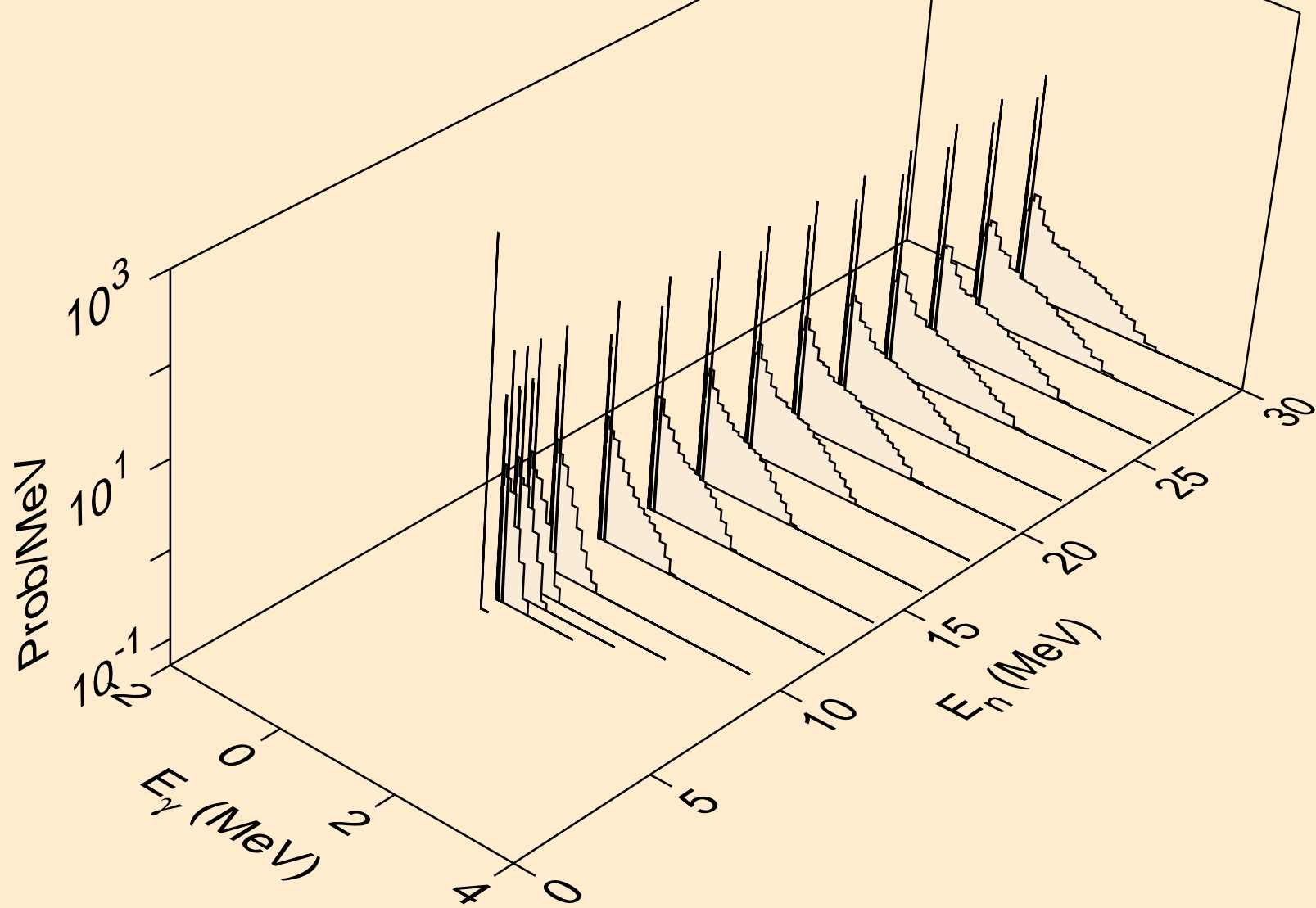

AM248 NEUTRON ACER TENDL-2023 LIBRARY; T=0.K  
Photon emission for (n,t)

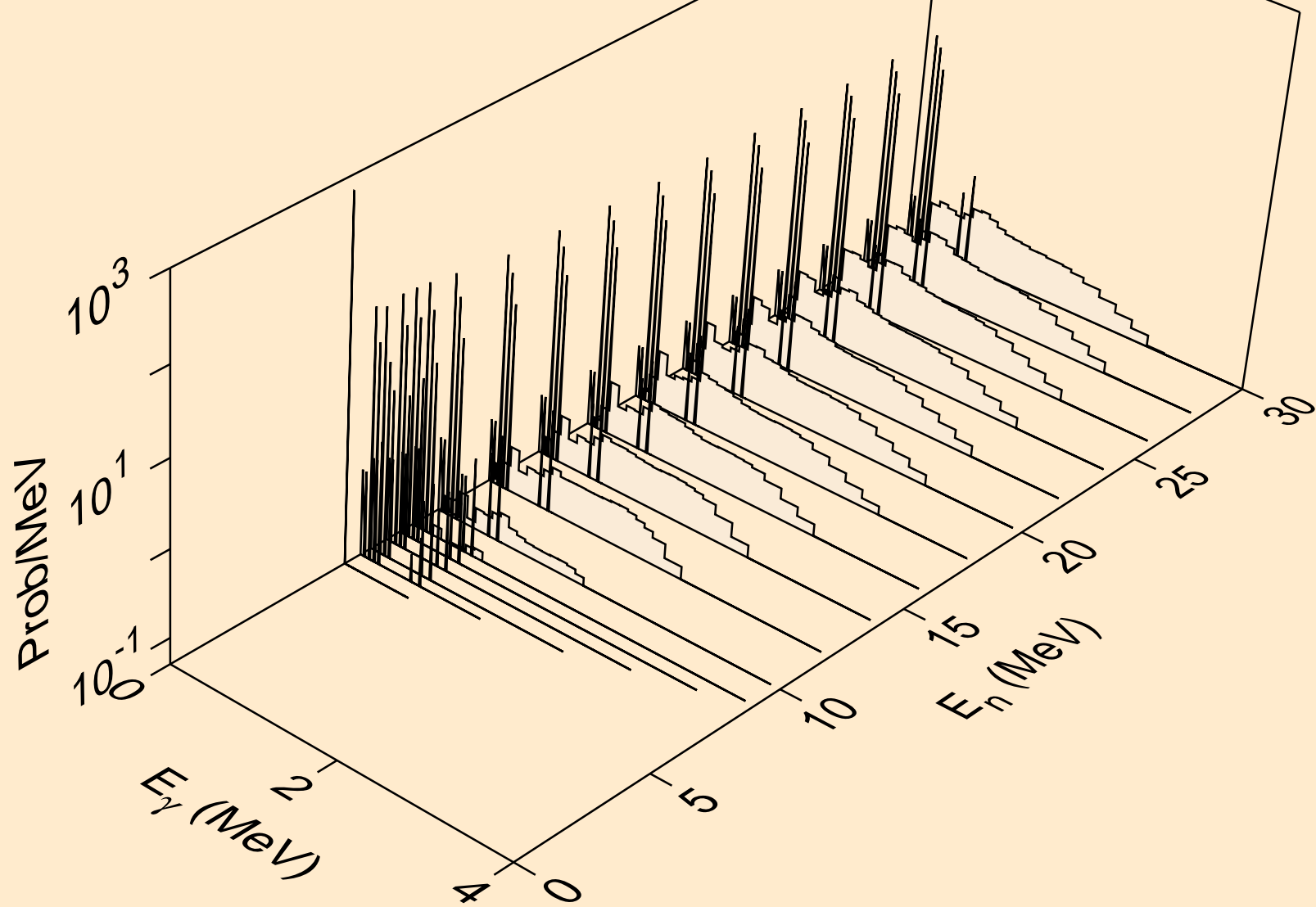

AM248 NEUTRON ACER TENDL-2023 LIBRARY; T=0.K  
Photon emission for (n,he3)

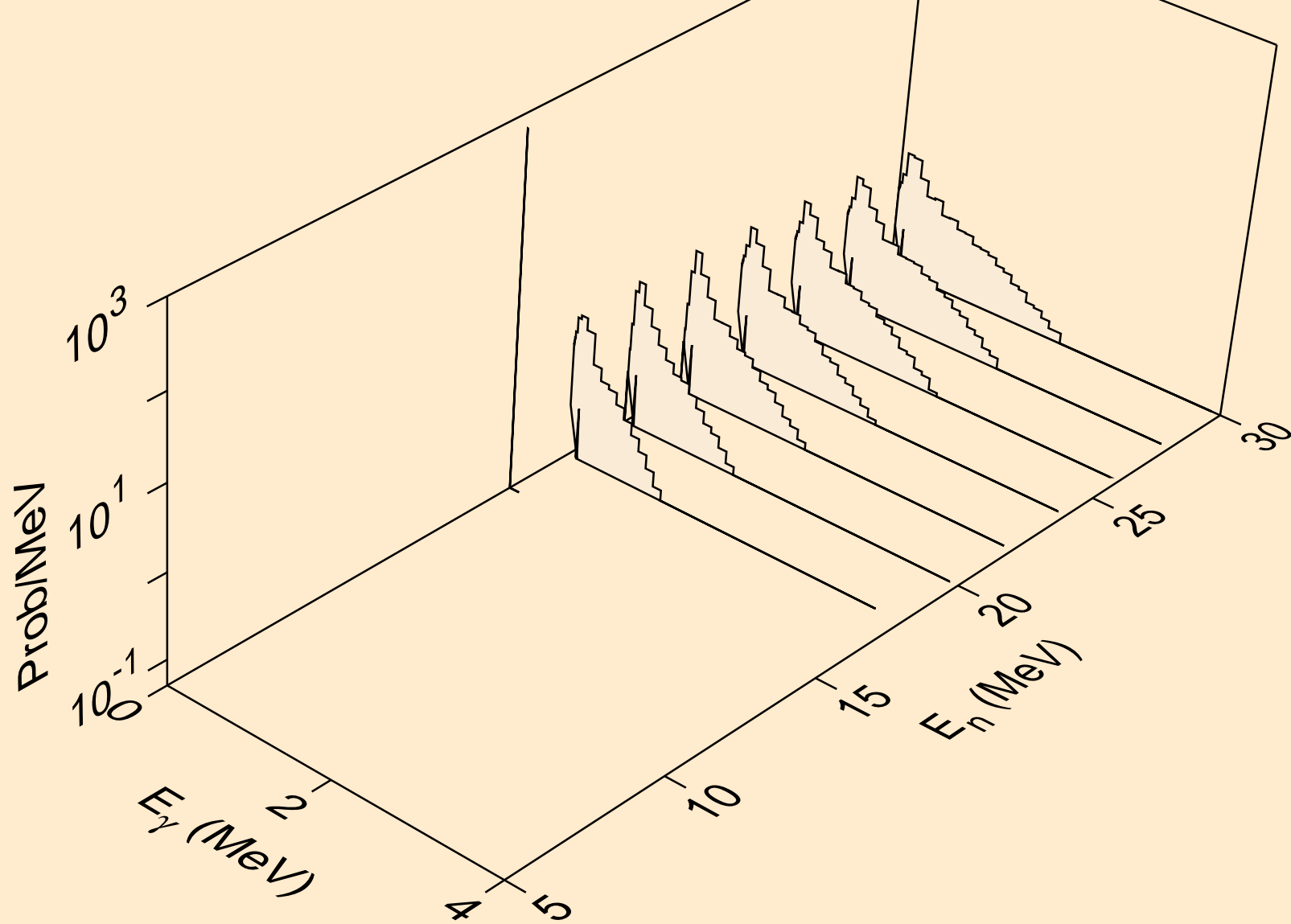

AM248 NEUTRON ACER TENDL-2023 LIBRARY; T=0.K  
Photon emission for (n,a)

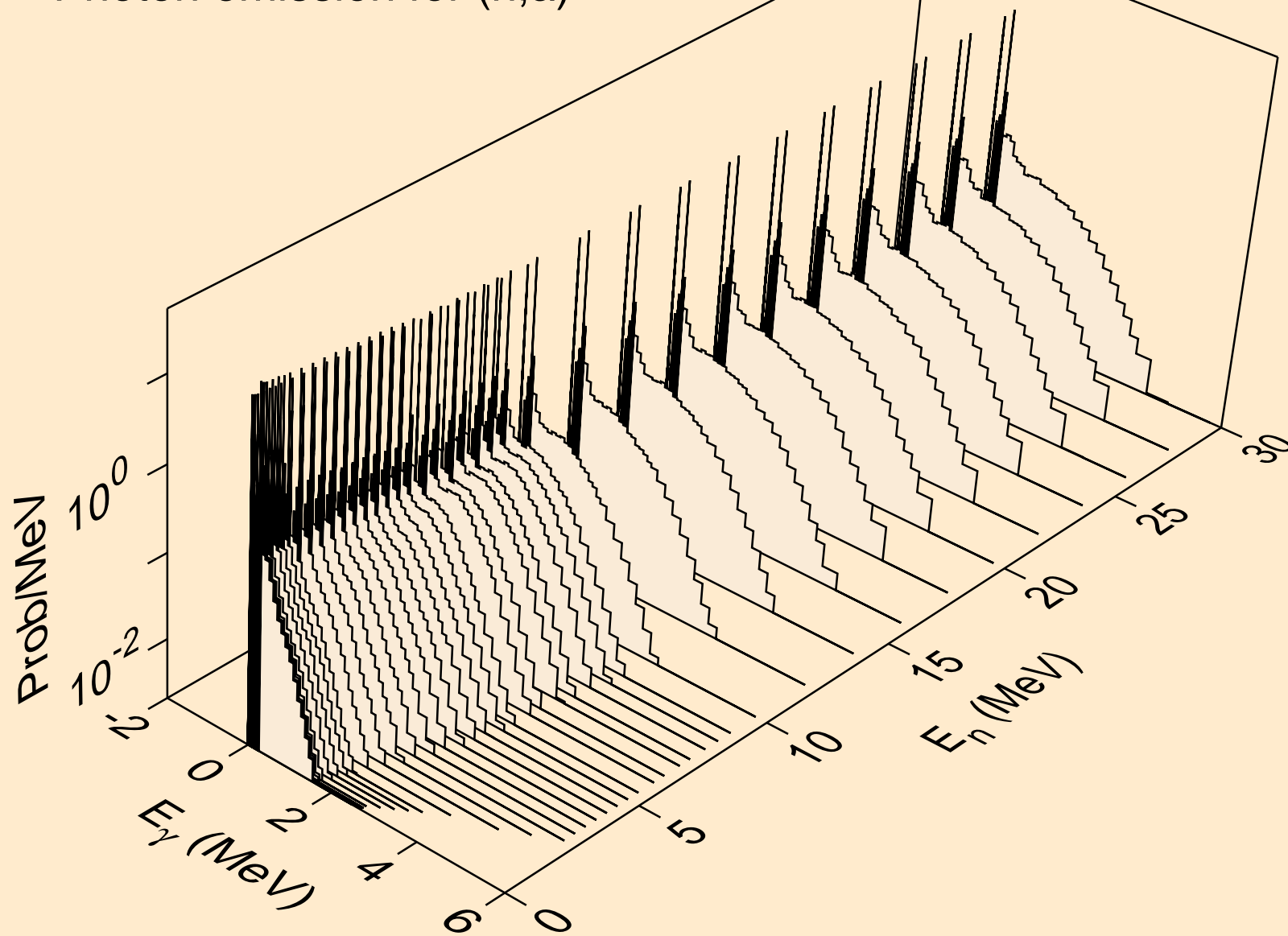

AM248 NEUTRON ACER TENDL-2023 LIBRARY; T=0.K  
Photon emission for (n,2p)

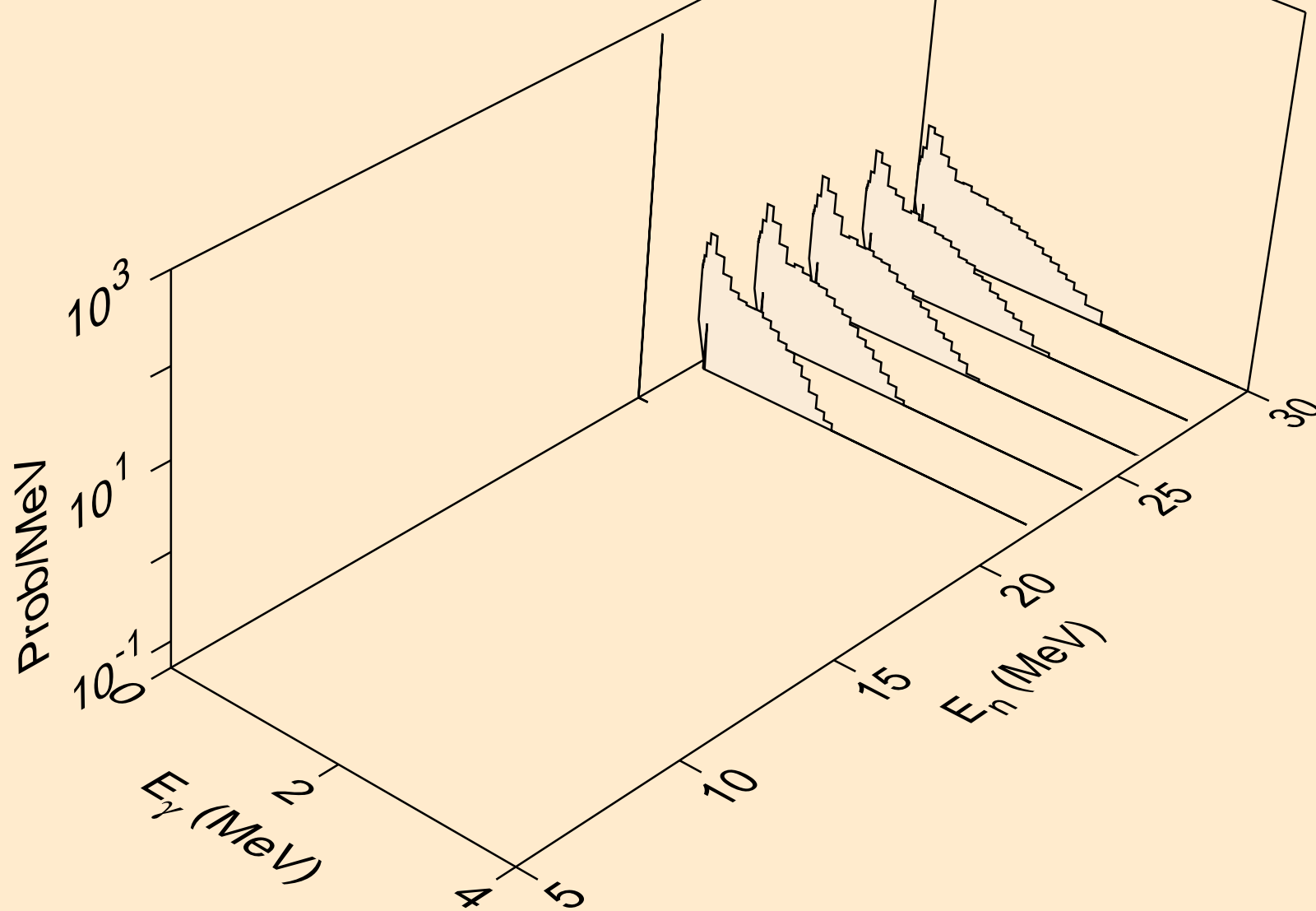

AM248 NEUTRON ACER TENDL-2023 LIBRARY; T=0.K  
thermal capture photon spectrum

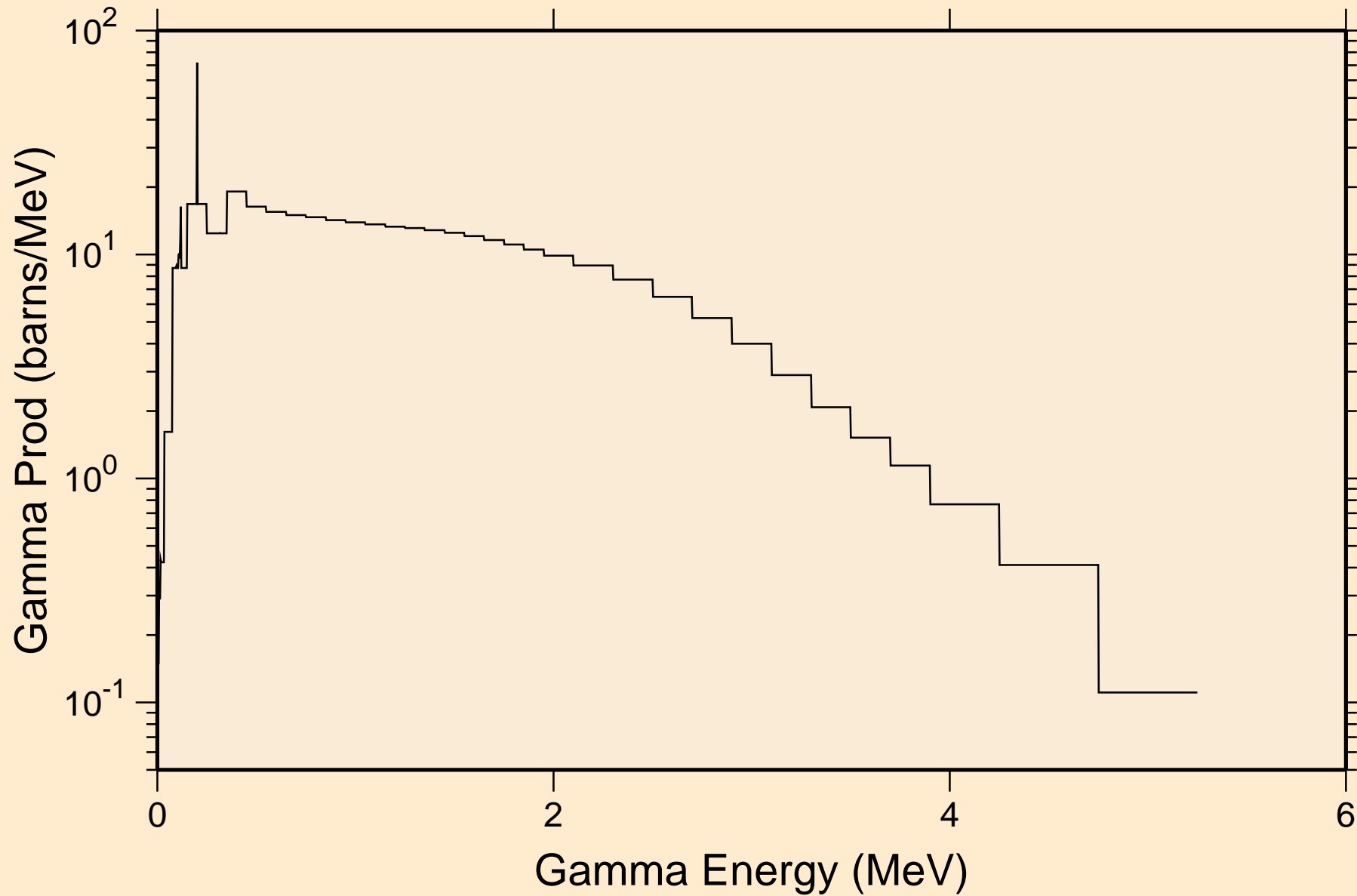

AM248 NEUTRON ACER TENDL-2023 LIBRARY; T=0.K  
14 MeV photon spectrum

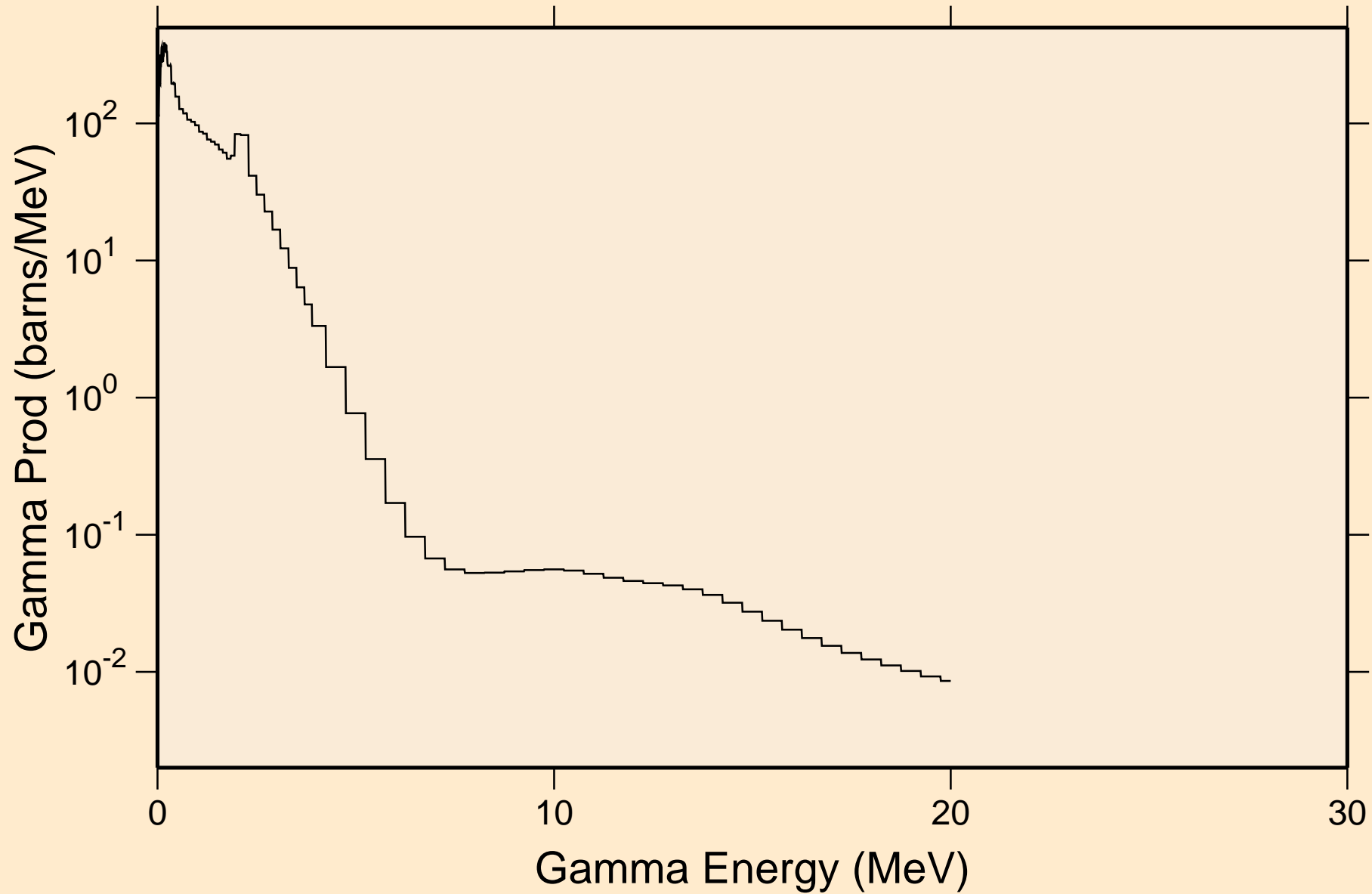



# AM248 NEUTRON ACER TENDL-2023 LIBRARY; T=0.K

## Particle heating contributions

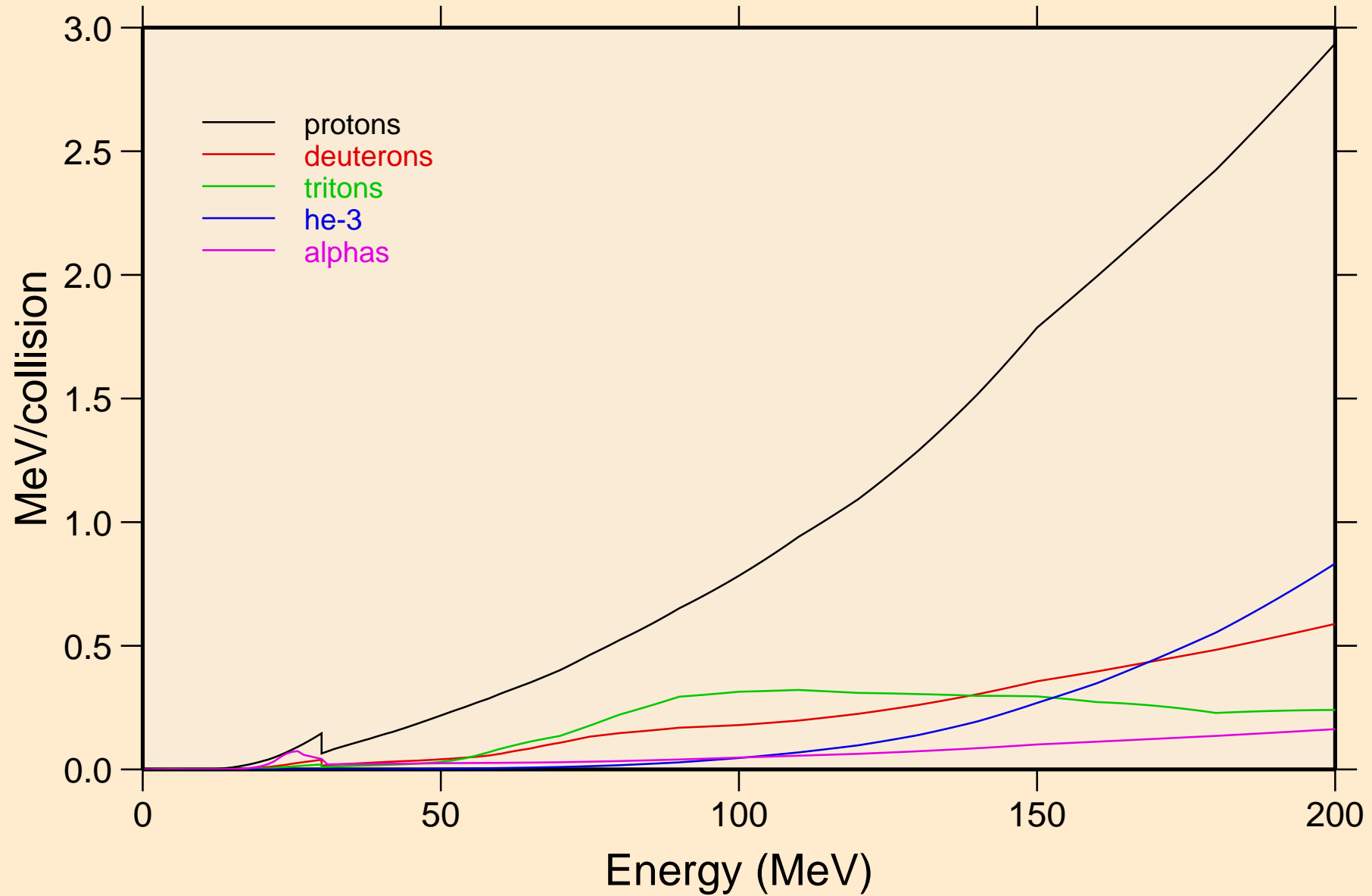

AM248 NEUTRON ACER TENDL-2023 LIBRARY; T=0.K  
Recoil Heating

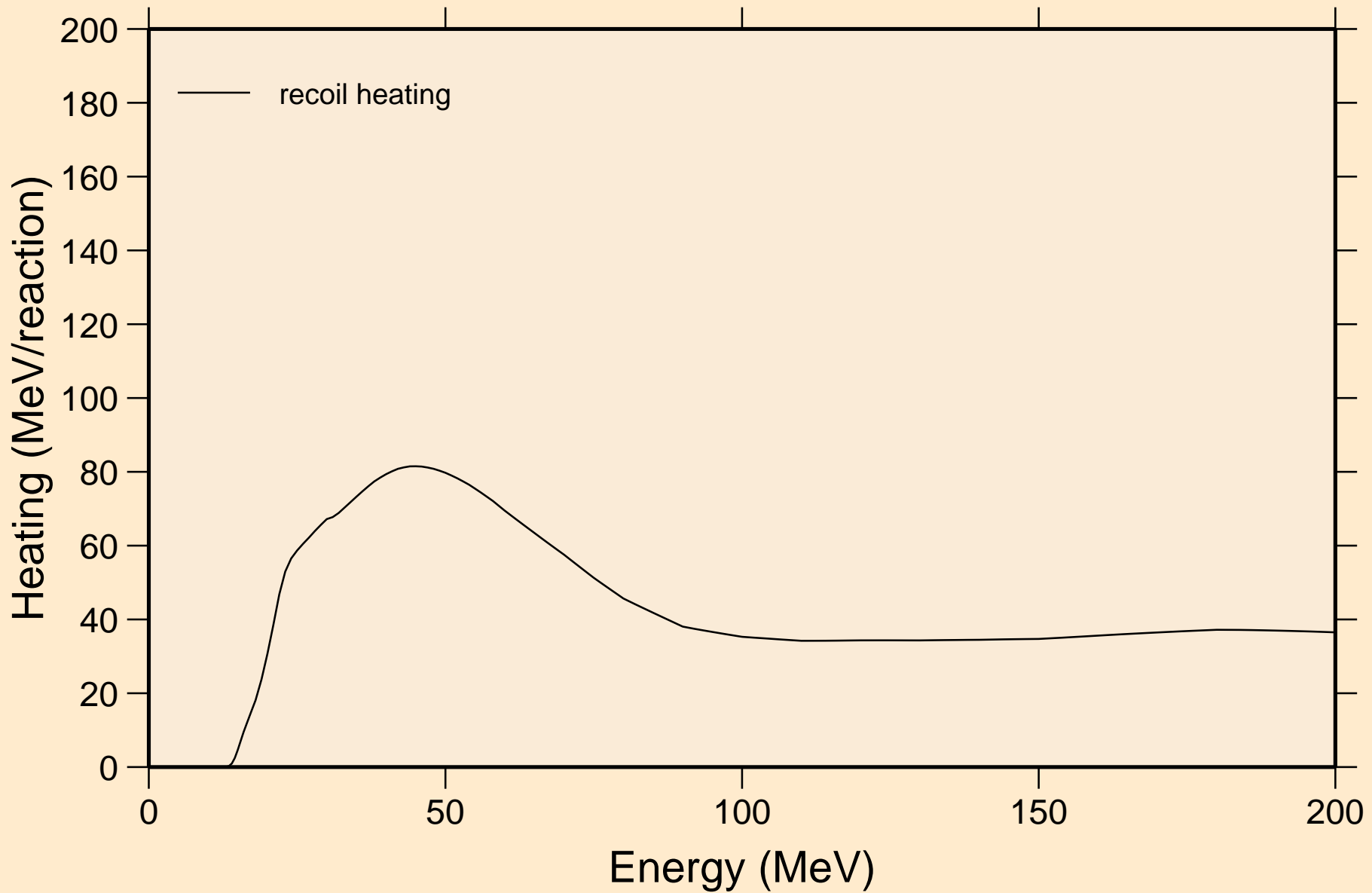

# AM248 NEUTRON ACER TENDL-2023 LIBRARY; T=0.K

## Particle production cross sections

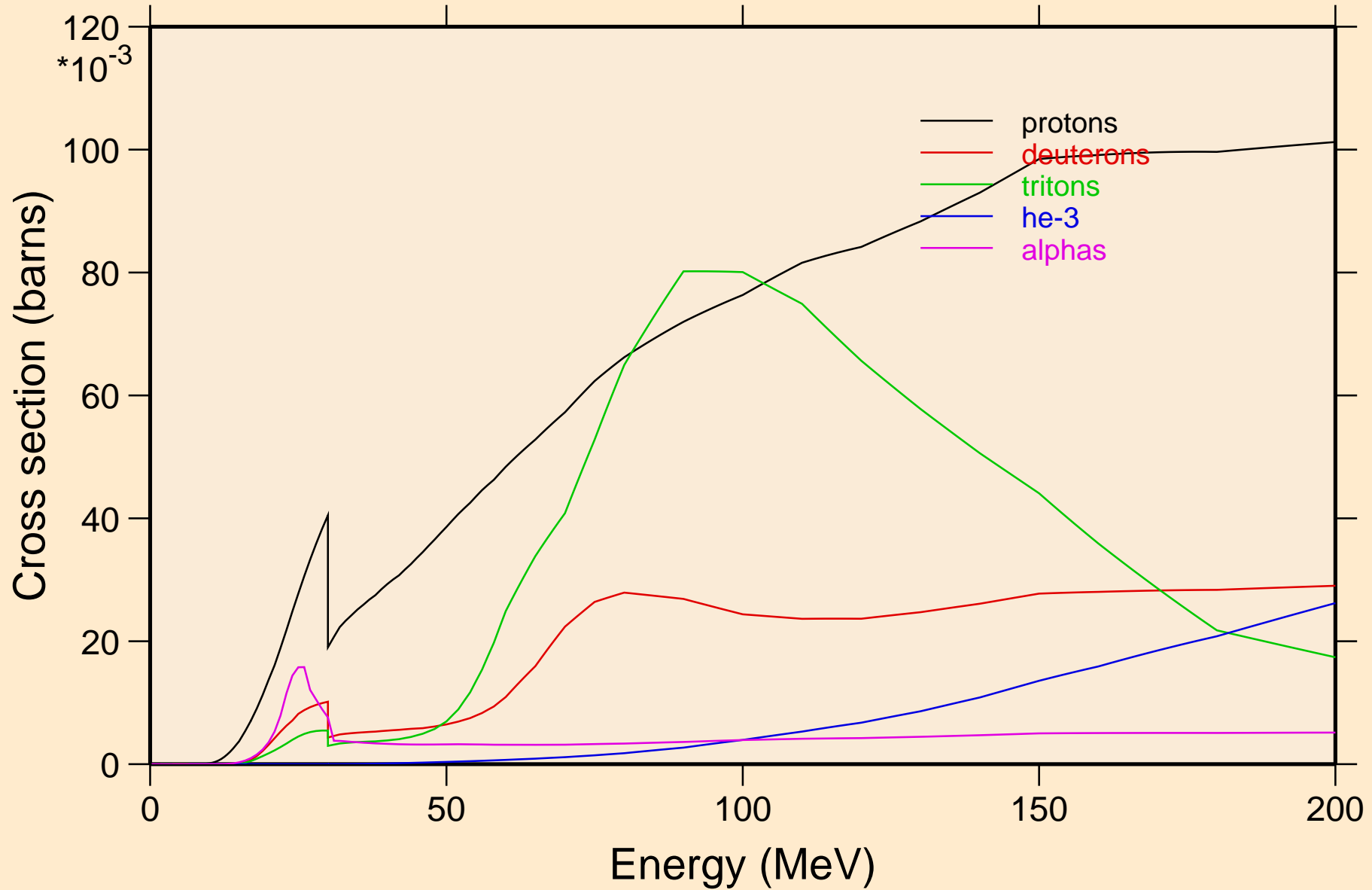

AM248 NEUTRON ACER TENDL-2023 LIBRARY; T=0.K  
protons from (n,x)

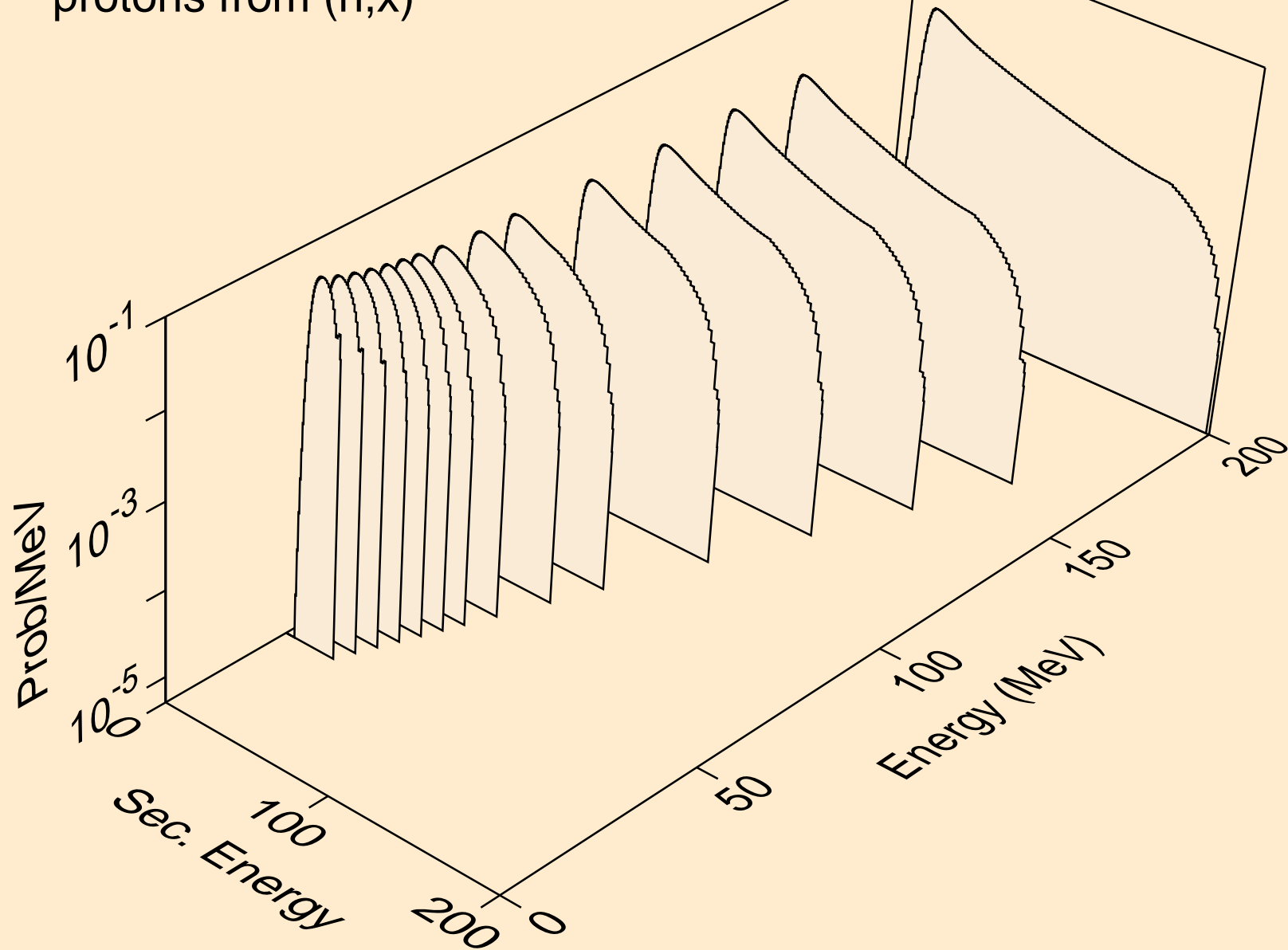

AM248 NEUTRON ACER TENDL-2023 LIBRARY; T=0.K  
protons from (n,n\*)p

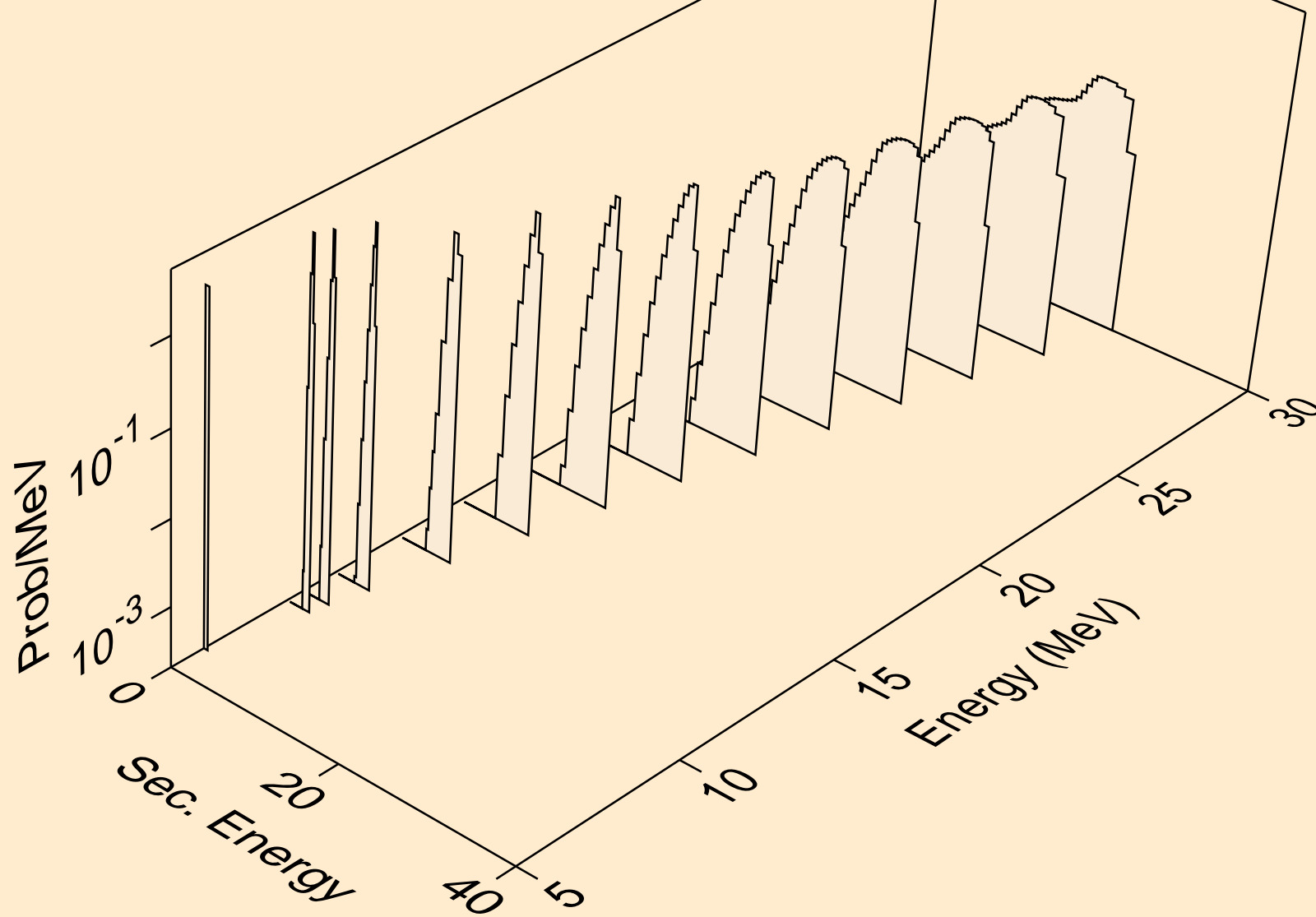

AM248 NEUTRON ACER TENDL-2023 LIBRARY; T=0.K  
protons from (n,2np)

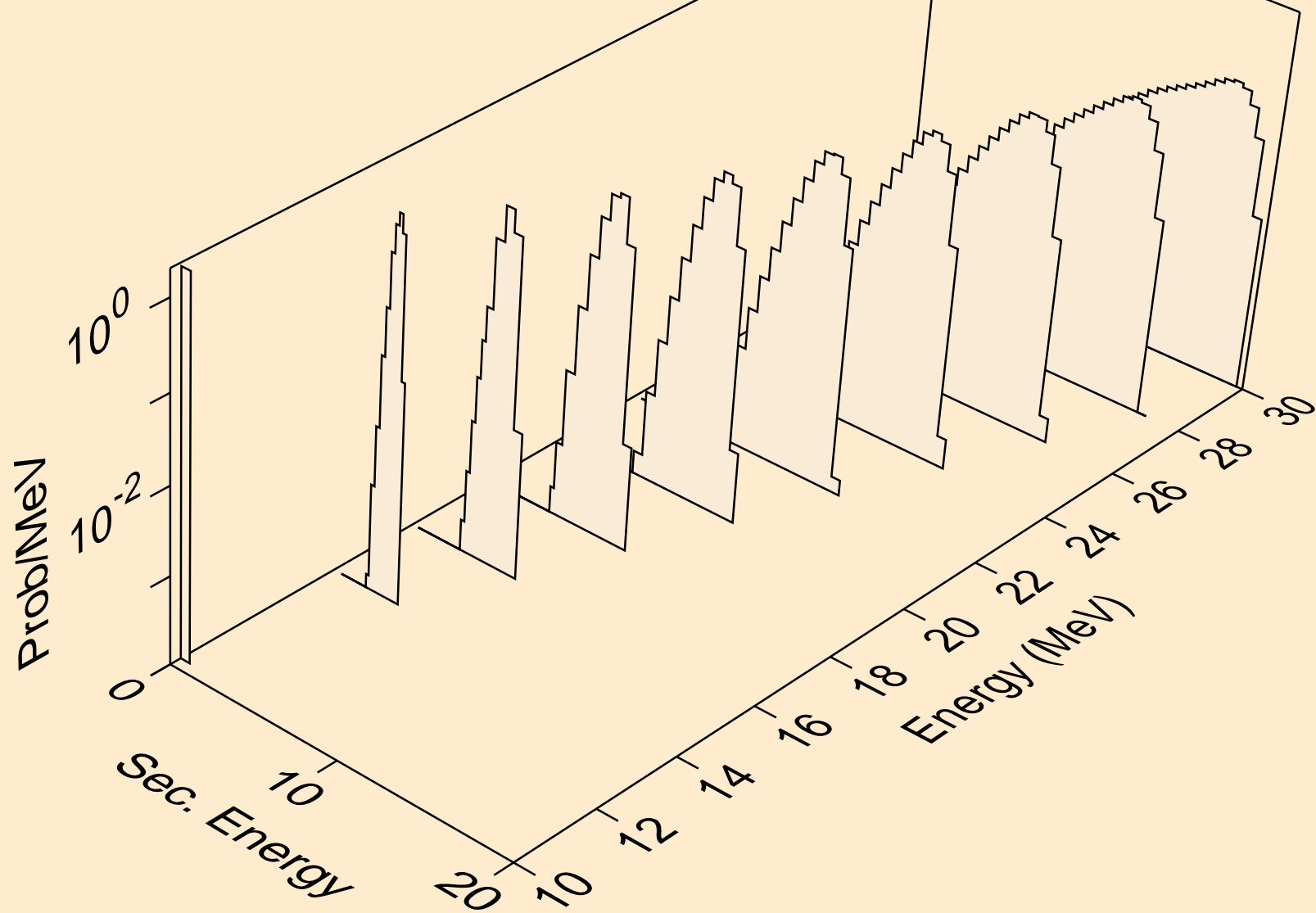

AM248 NEUTRON ACER TENDL-2023 LIBRARY; T=0.K  
protons from (n,3np)

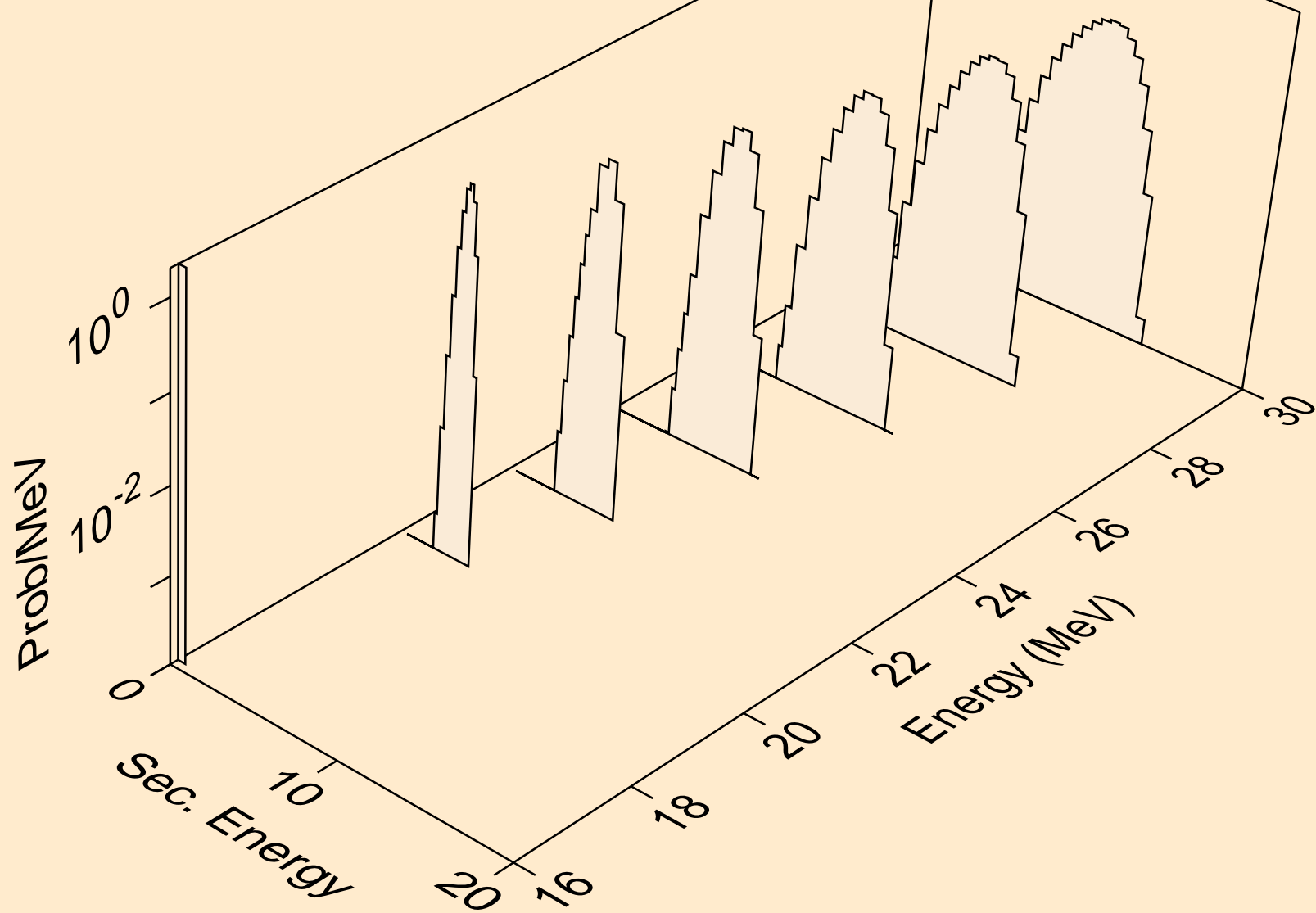

AM248 NEUTRON ACER TENDL-2023 LIBRARY; T=0.K  
protons from (n,p)

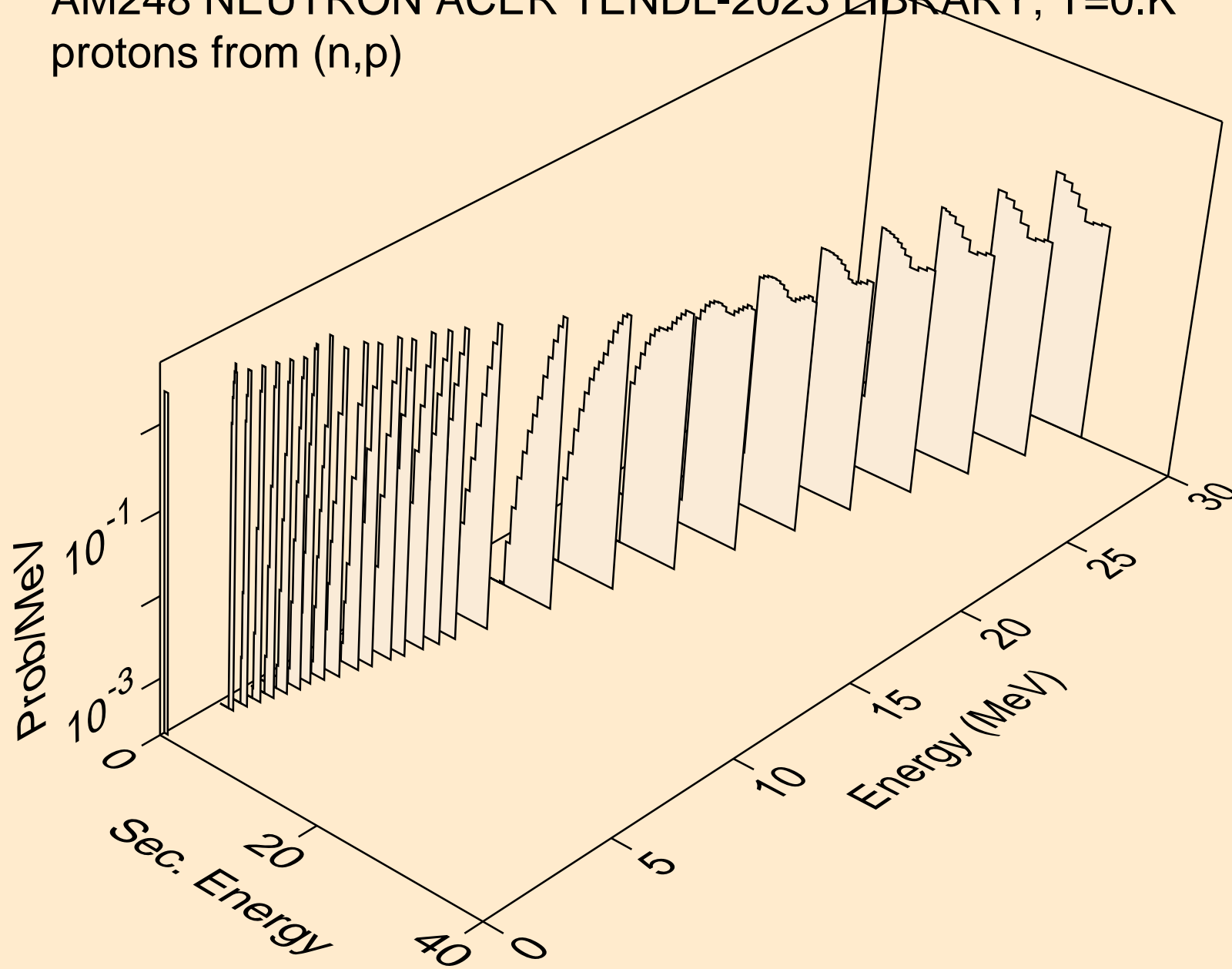



AM248 NEUTRON ACER TENDL-2023 LIBRARY; T=0.K  
protons from (n,2p)

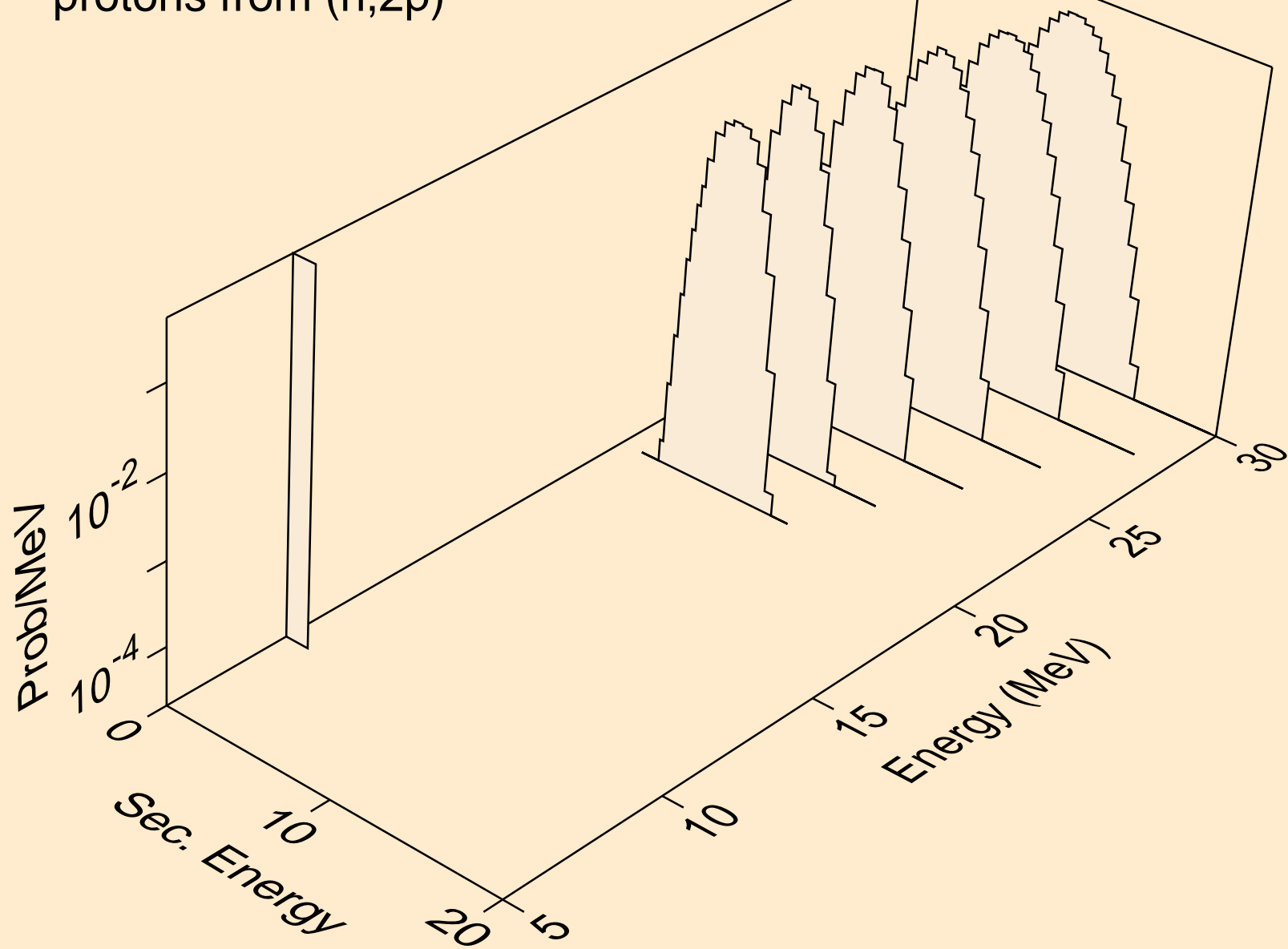

AM248 NEUTRON ACER TENDL-2023 LIBRARY; T=0.K  
deuterons from (n,x)

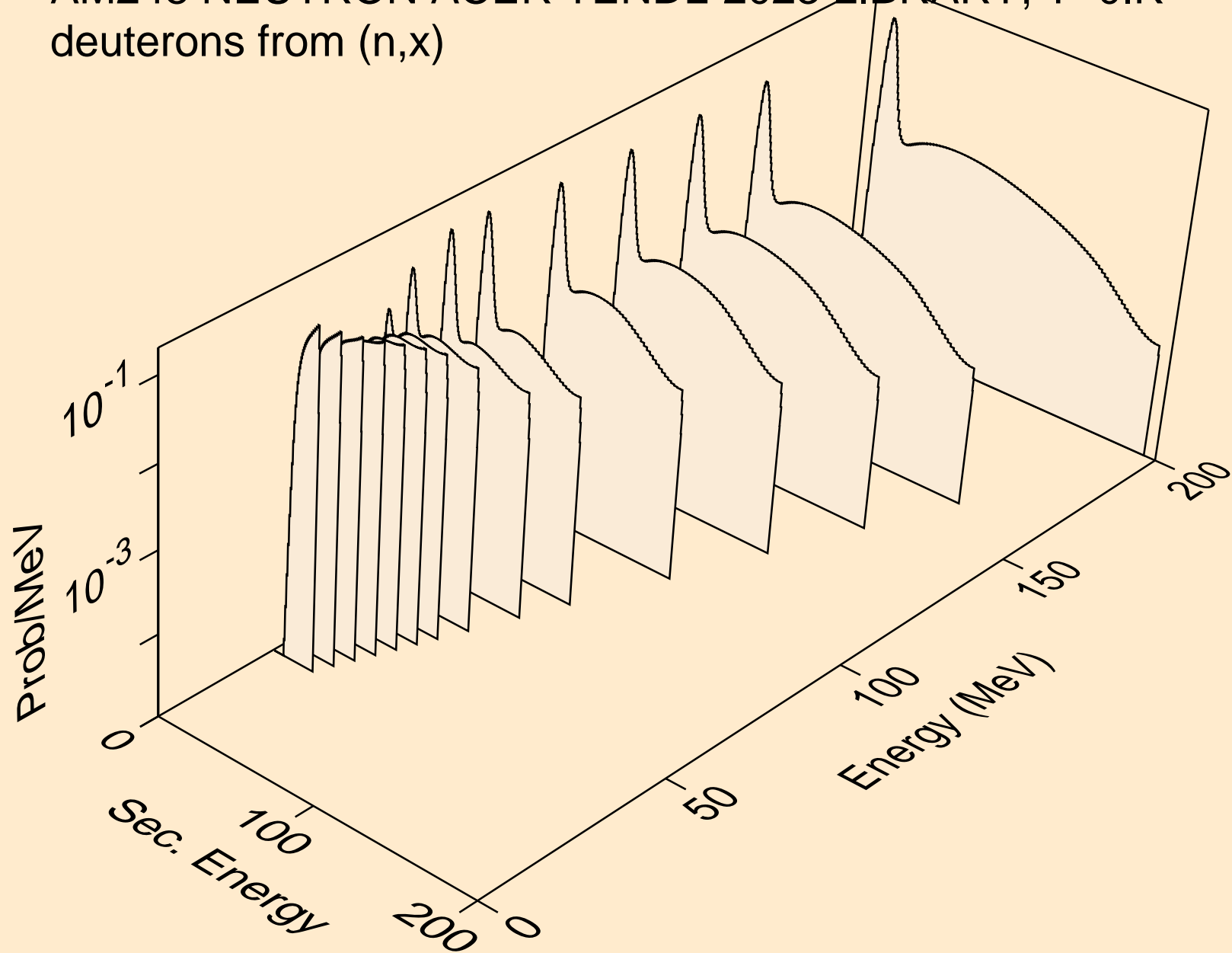

AM248 NEUTRON ACER TENDL-2023 LIBRARY; T=0.K  
deuterons from (n,2nd)

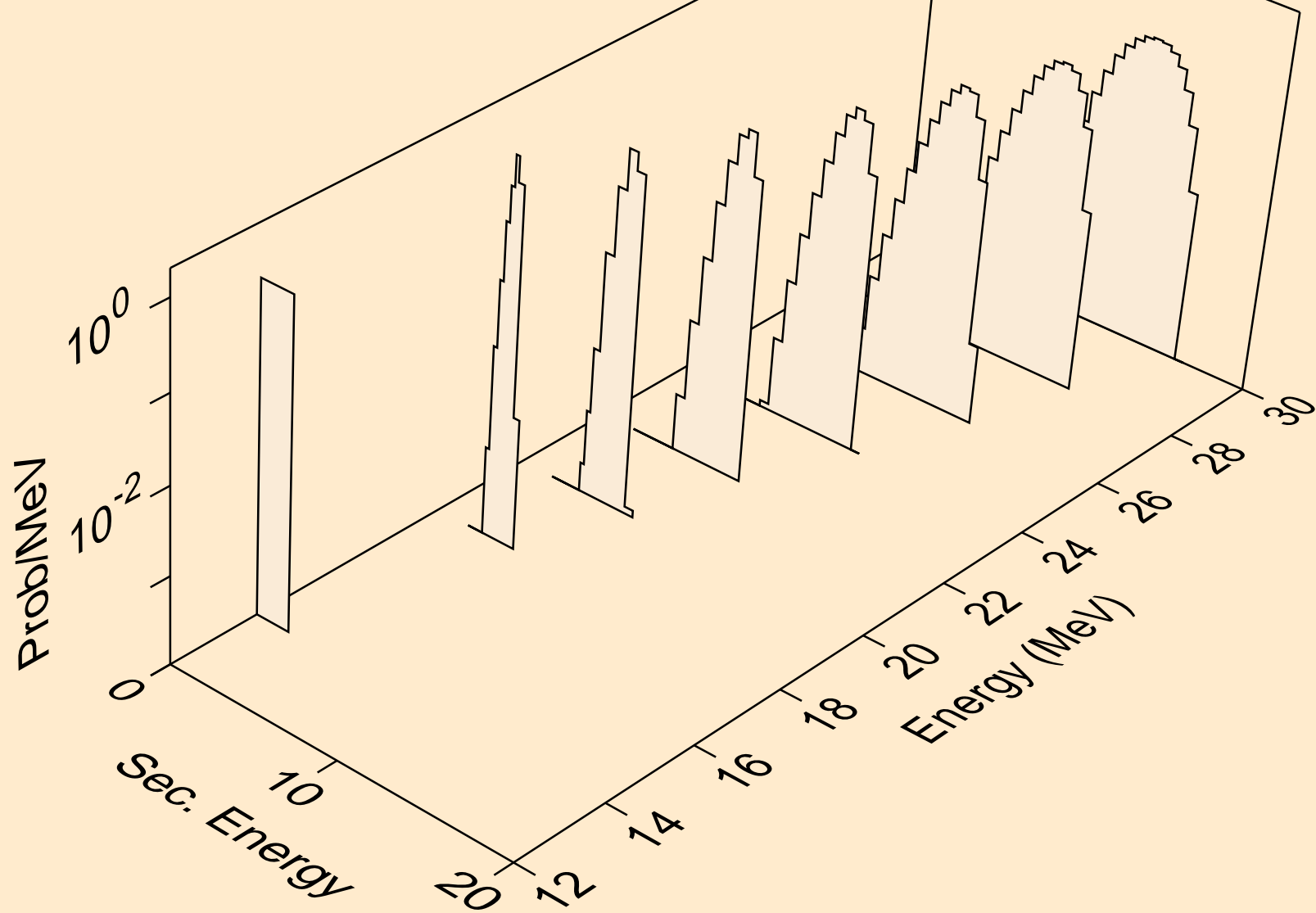

AM248 NEUTRON ACER TENDL-2023 LIBRARY; T=0.K  
deuterons from (n,n\*)d

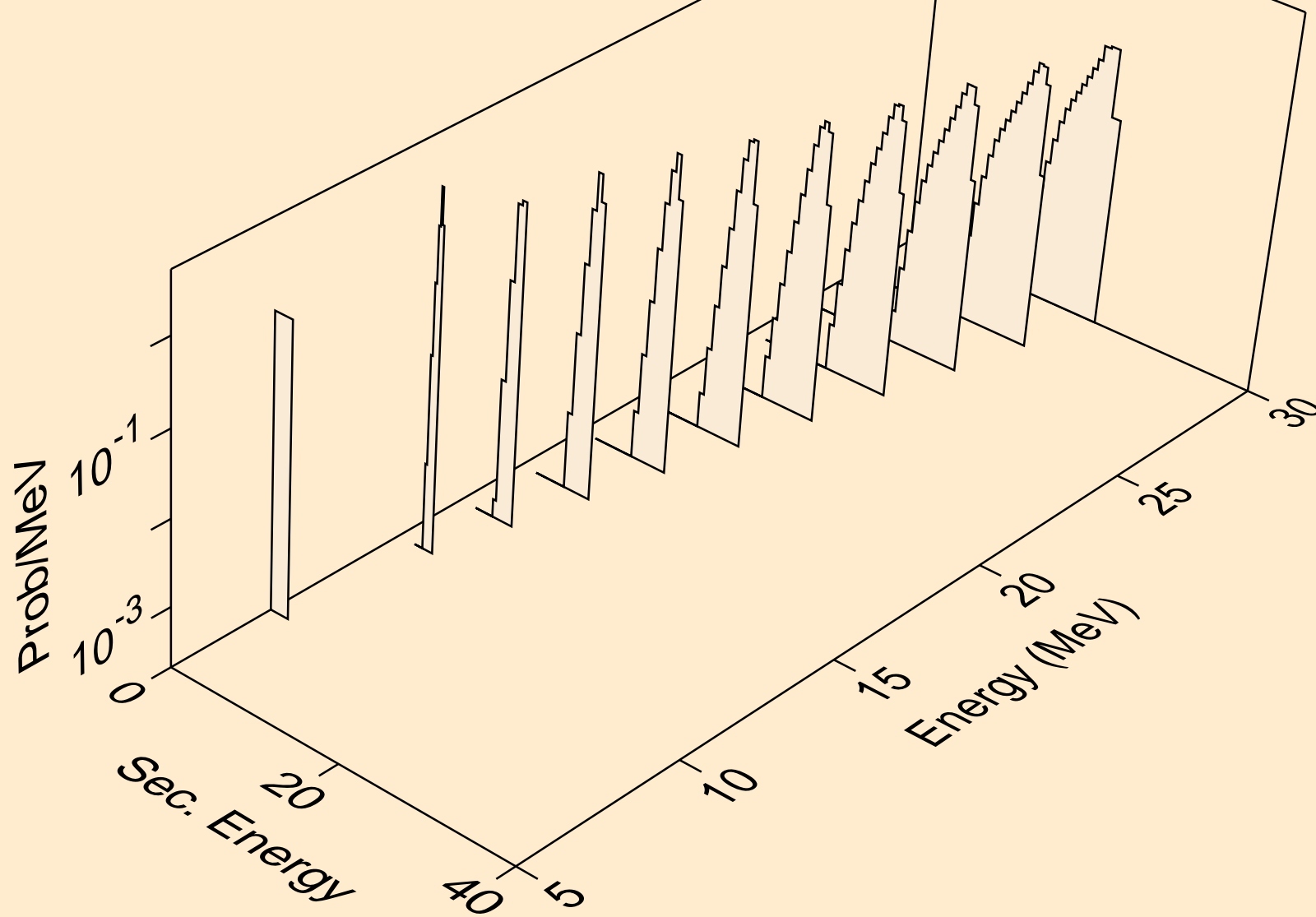

AM248 NEUTRON ACER TENDL-2023 LIBRARY; T=0.K  
deuterons from (n,d)

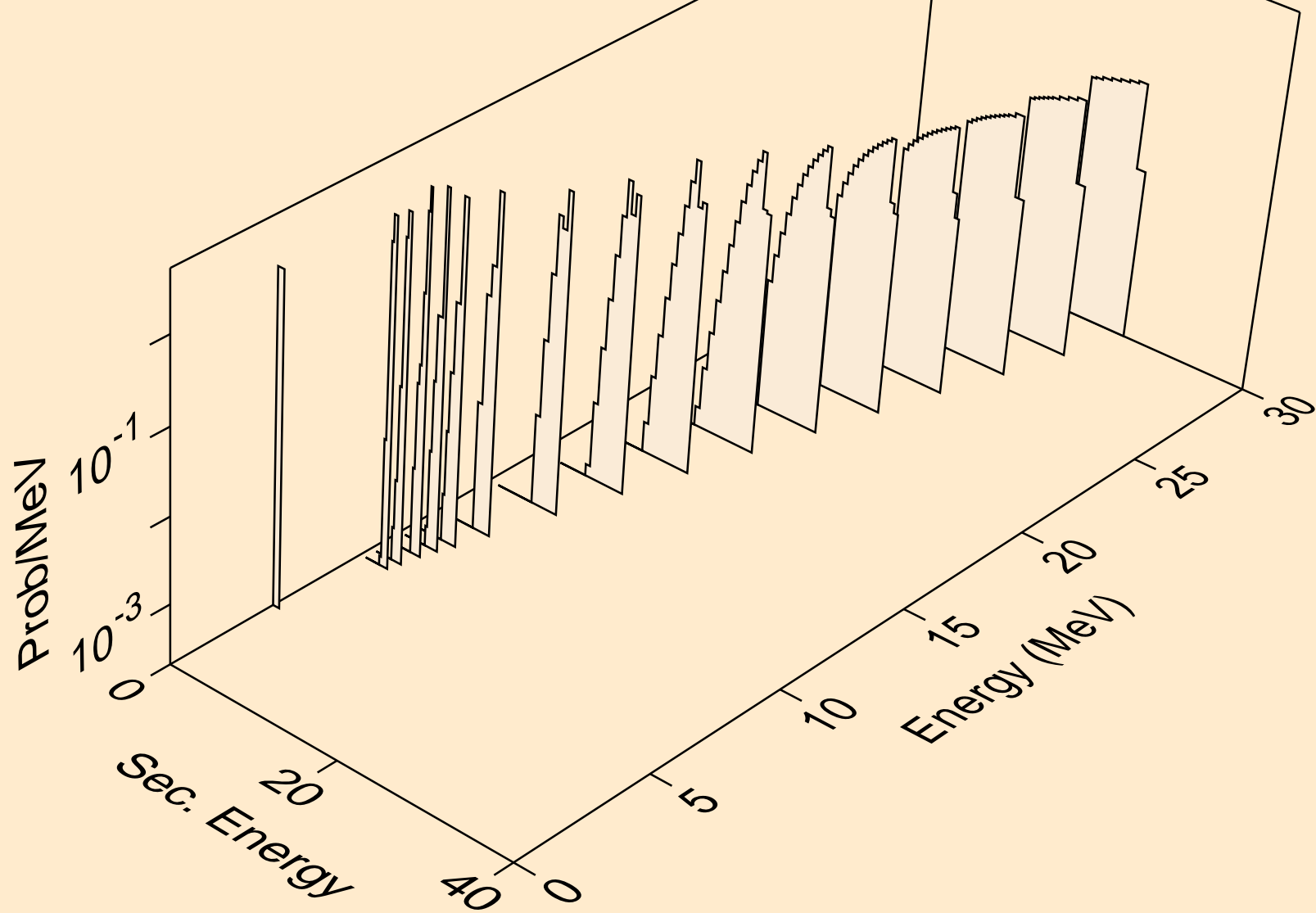

AM248 NEUTRON ACER TENDL-2023 LIBRARY; T=0.K  
tritons from (n,x)

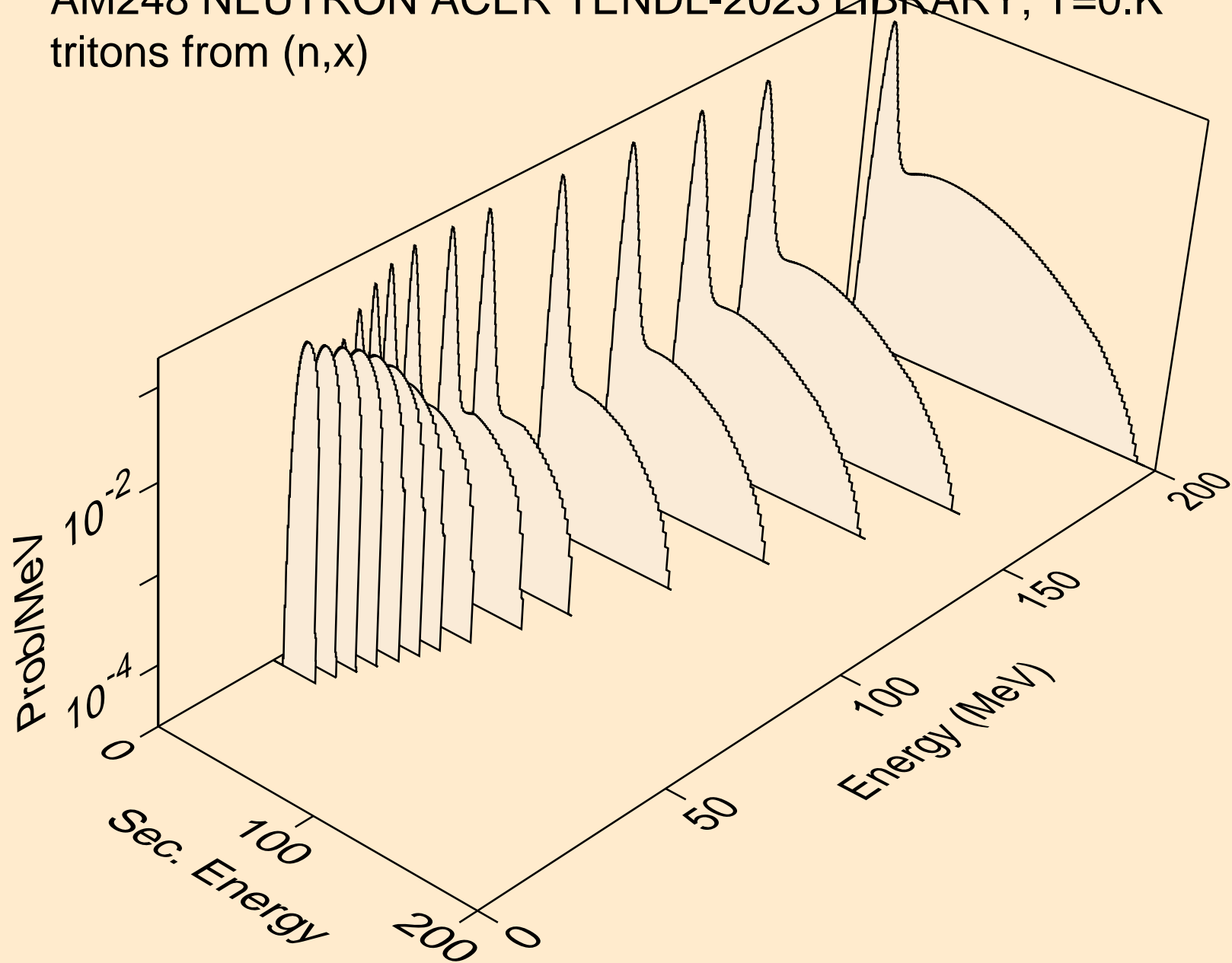

AM248 NEUTRON ACER TENDL-2023 LIBRARY; T=0.K  
tritons from (n,n\*)t

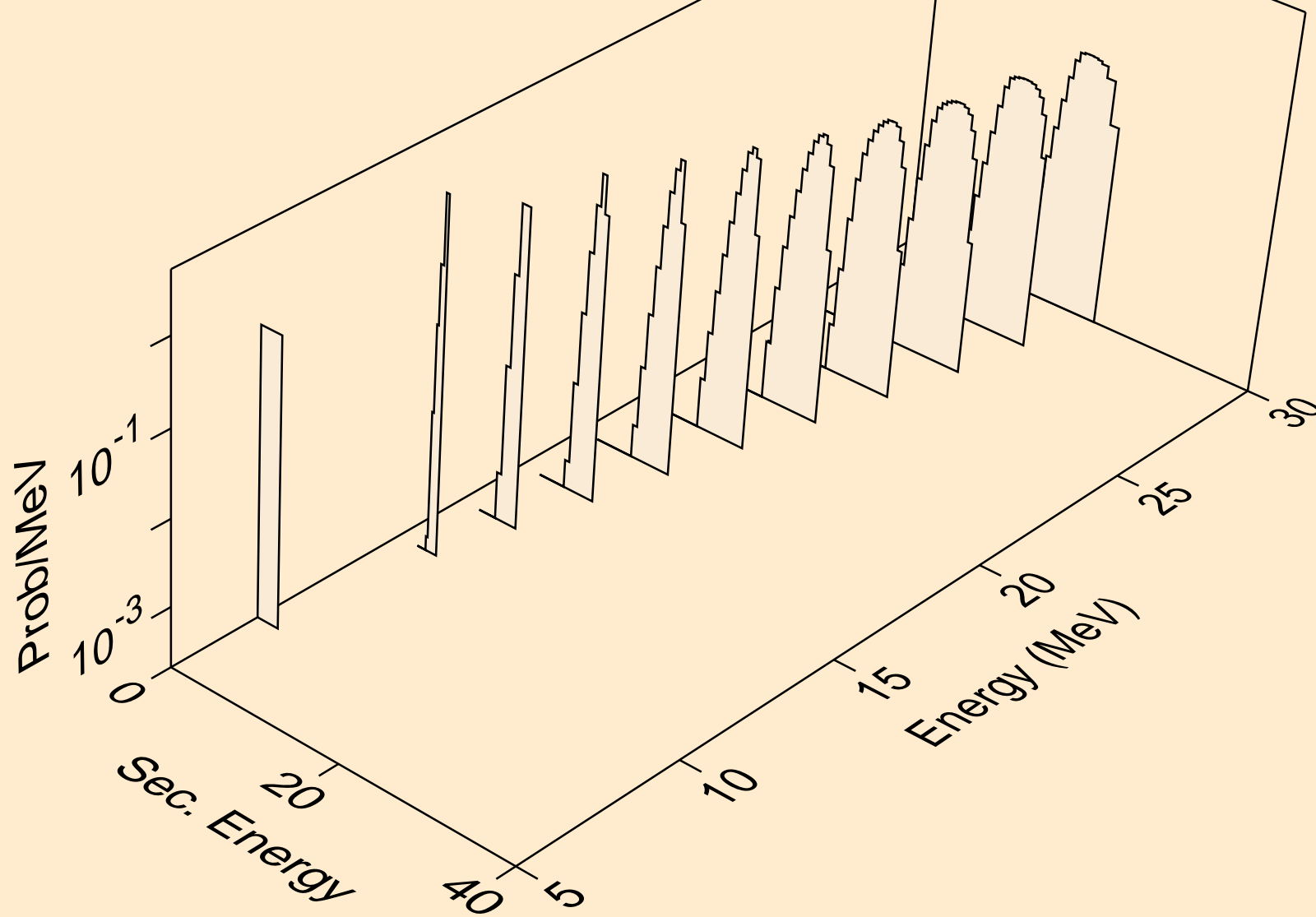

AM248 NEUTRON ACER TENDL-2023 LIBRARY; T=0.K  
tritons from (n,t)

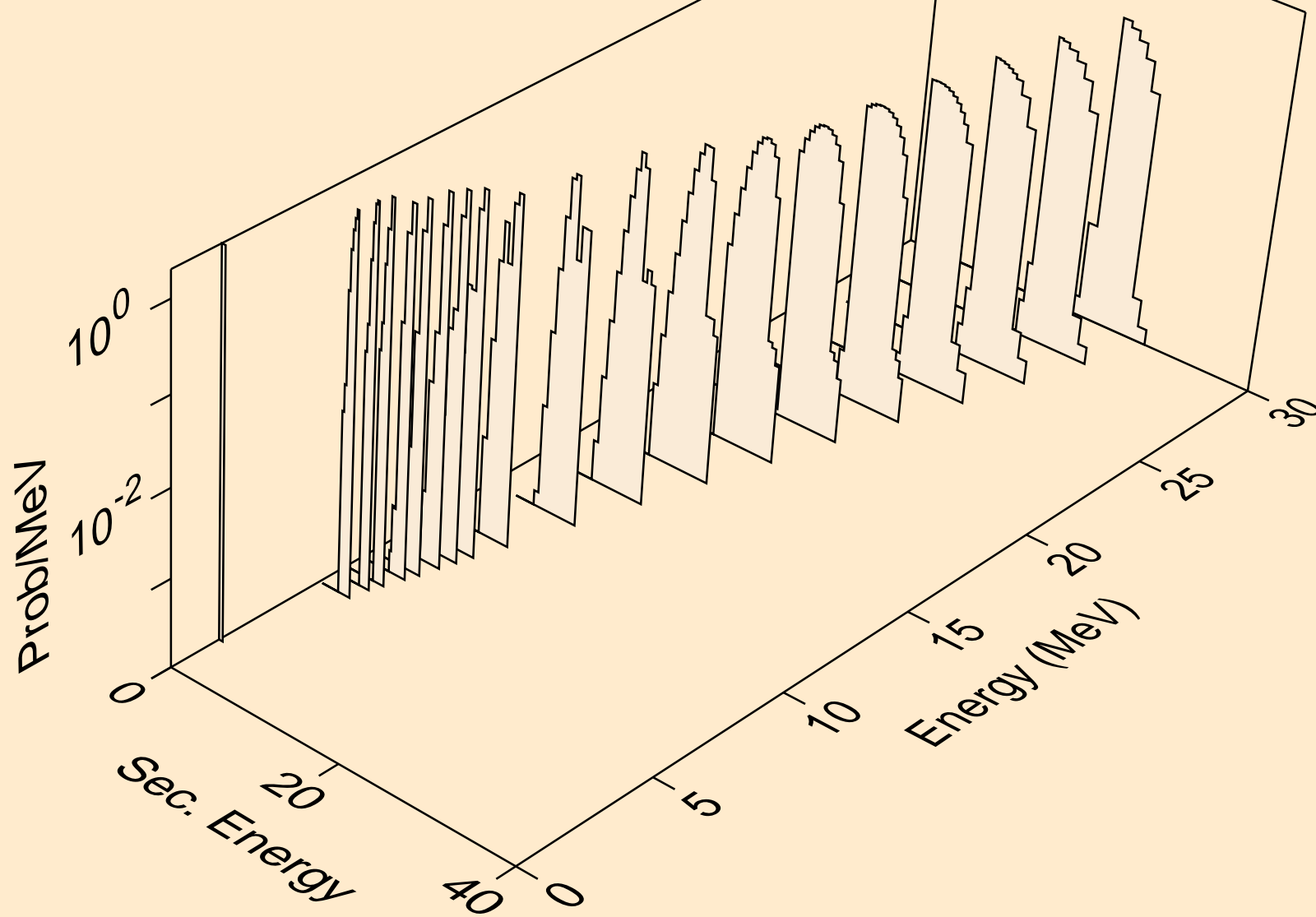



AM248 NEUTRON ACER TENDL-2023 LIBRARY; T=0.K  
he3s from (n,x)

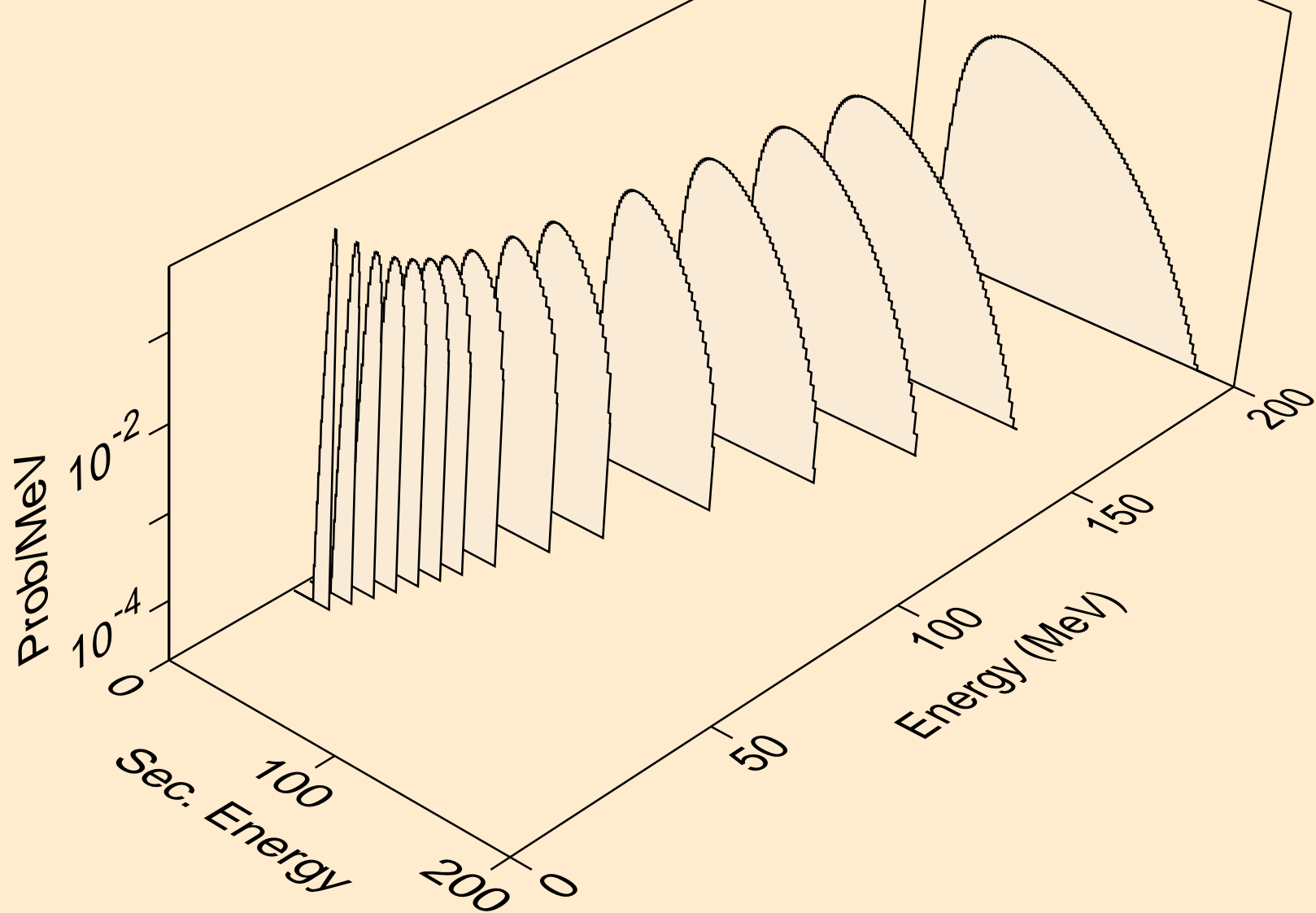

AM248 NEUTRON ACER TENDL-2023 LIBRARY; T=0.K  
he3s from (n,n\*)he3

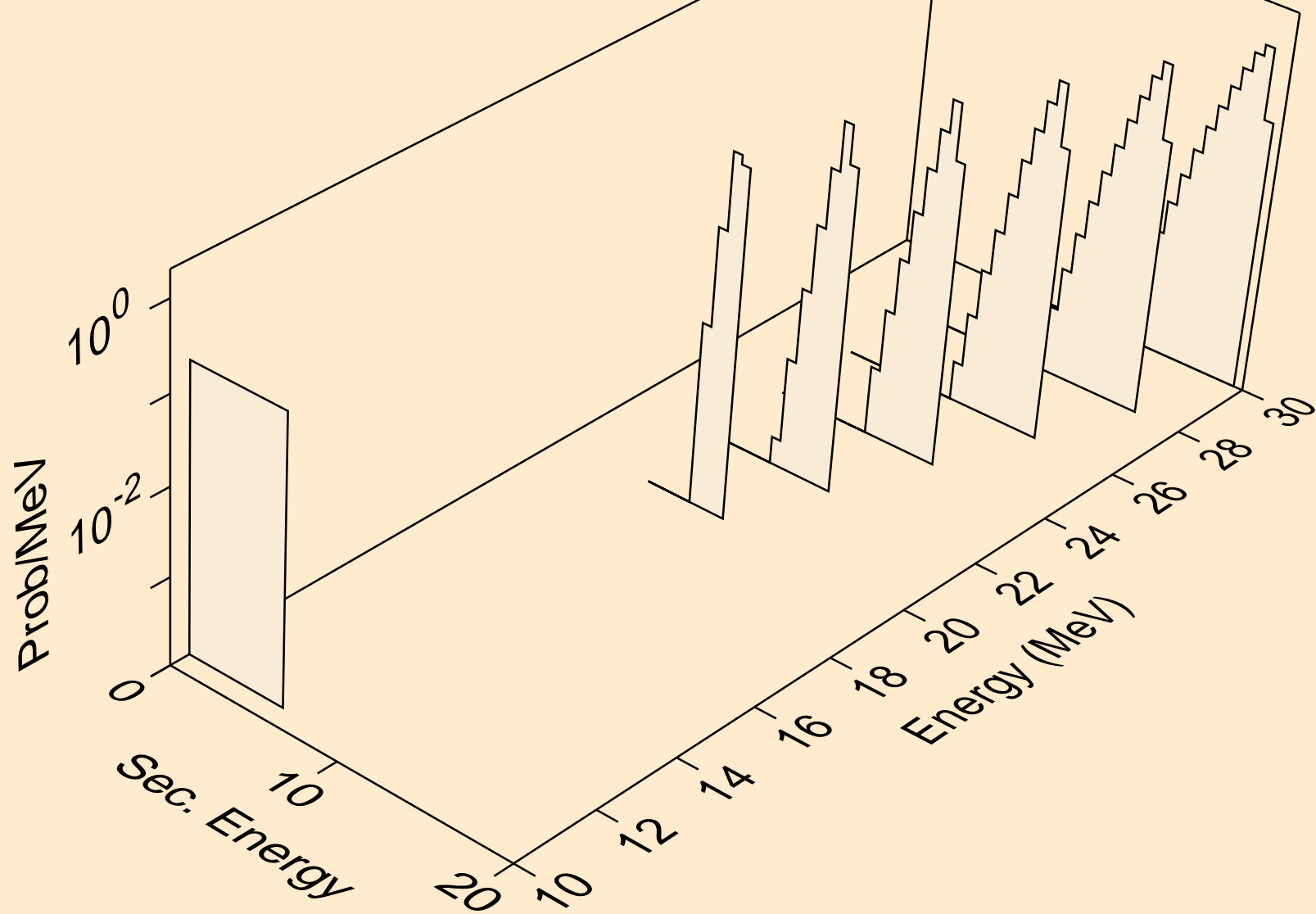

AM248 NEUTRON ACER TENDL-2023 LIBRARY; T=0.K  
he3s from (n,he3)

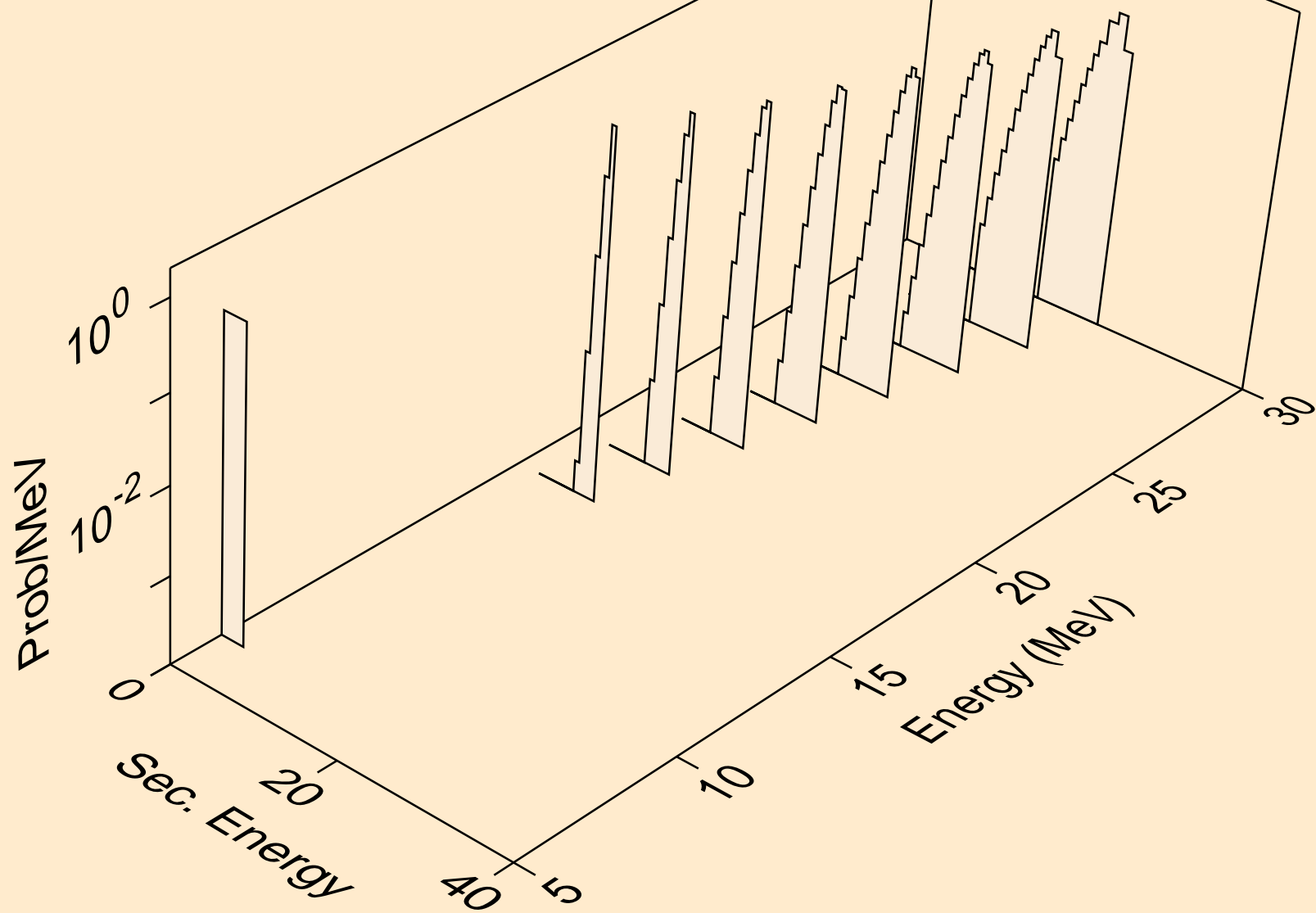

AM248 NEUTRON ACER TENDL-2023 LIBRARY; T=0.K  
alphas from (n,x)

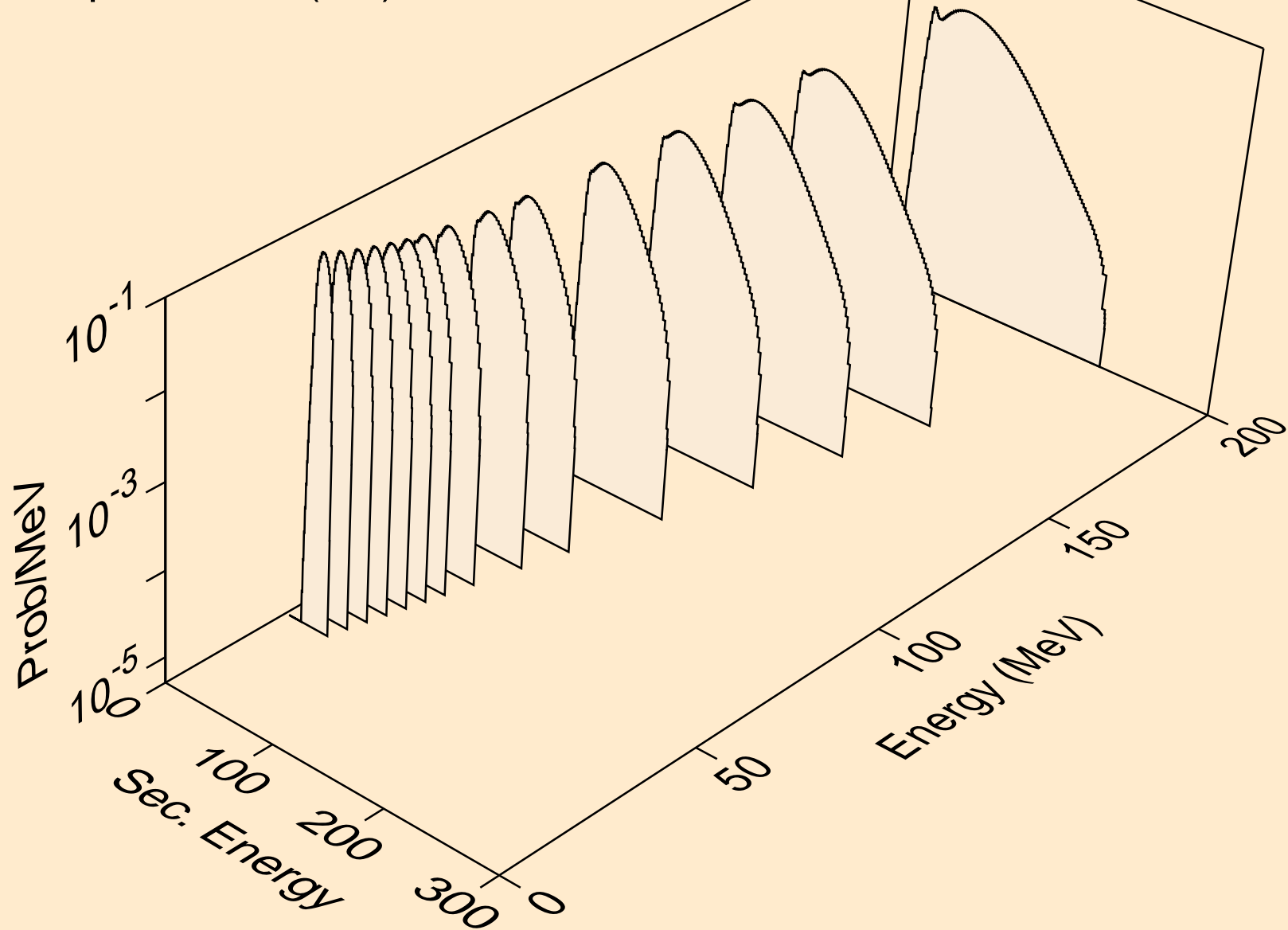

AM248 NEUTRON ACER TENDL-2023 LIBRARY; T=0.K  
alphas from (n,n\*)a

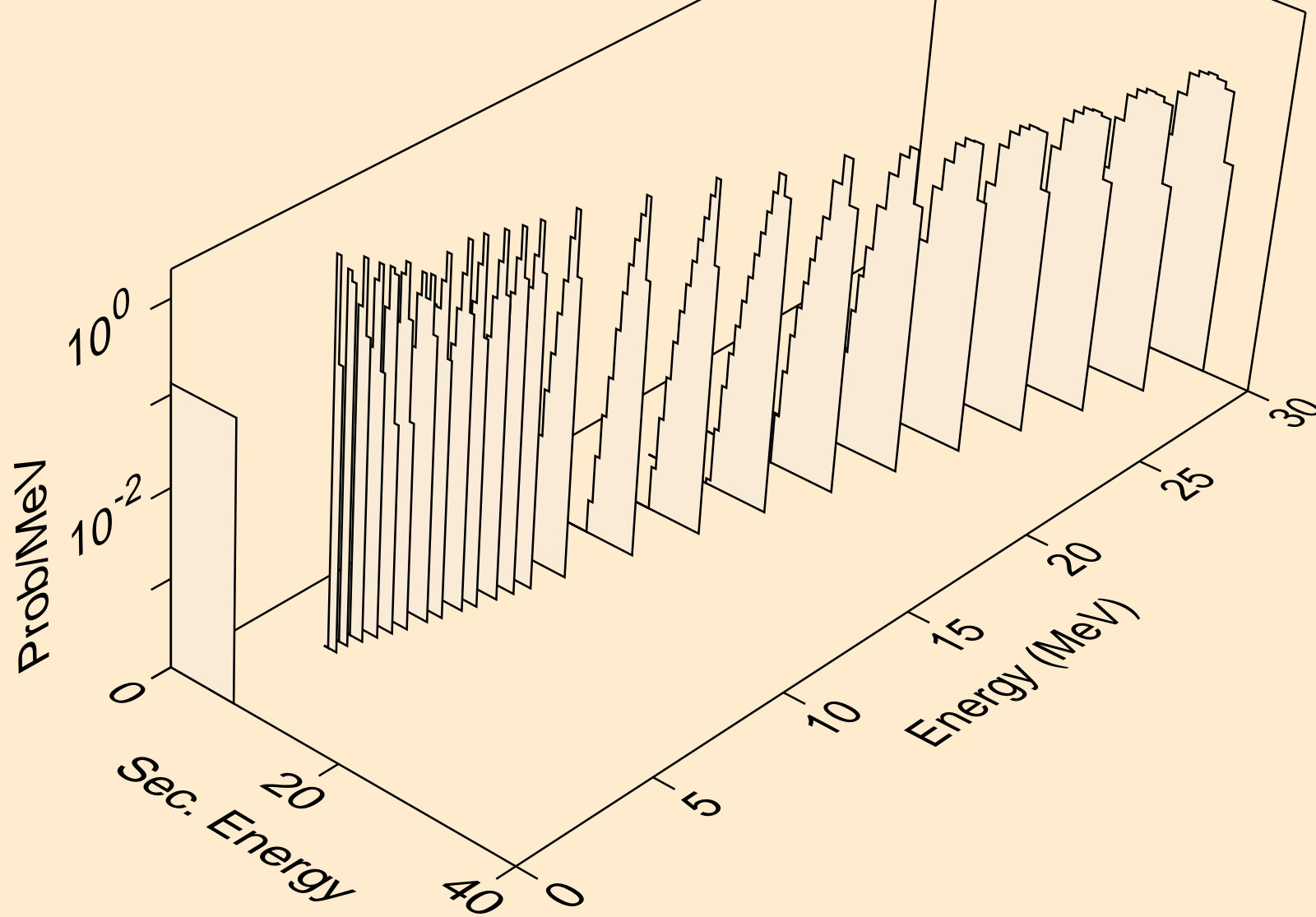

AM248 NEUTRON ACER TENDL-2023 LIBRARY; T=0.K  
alphas from (n,2n)a

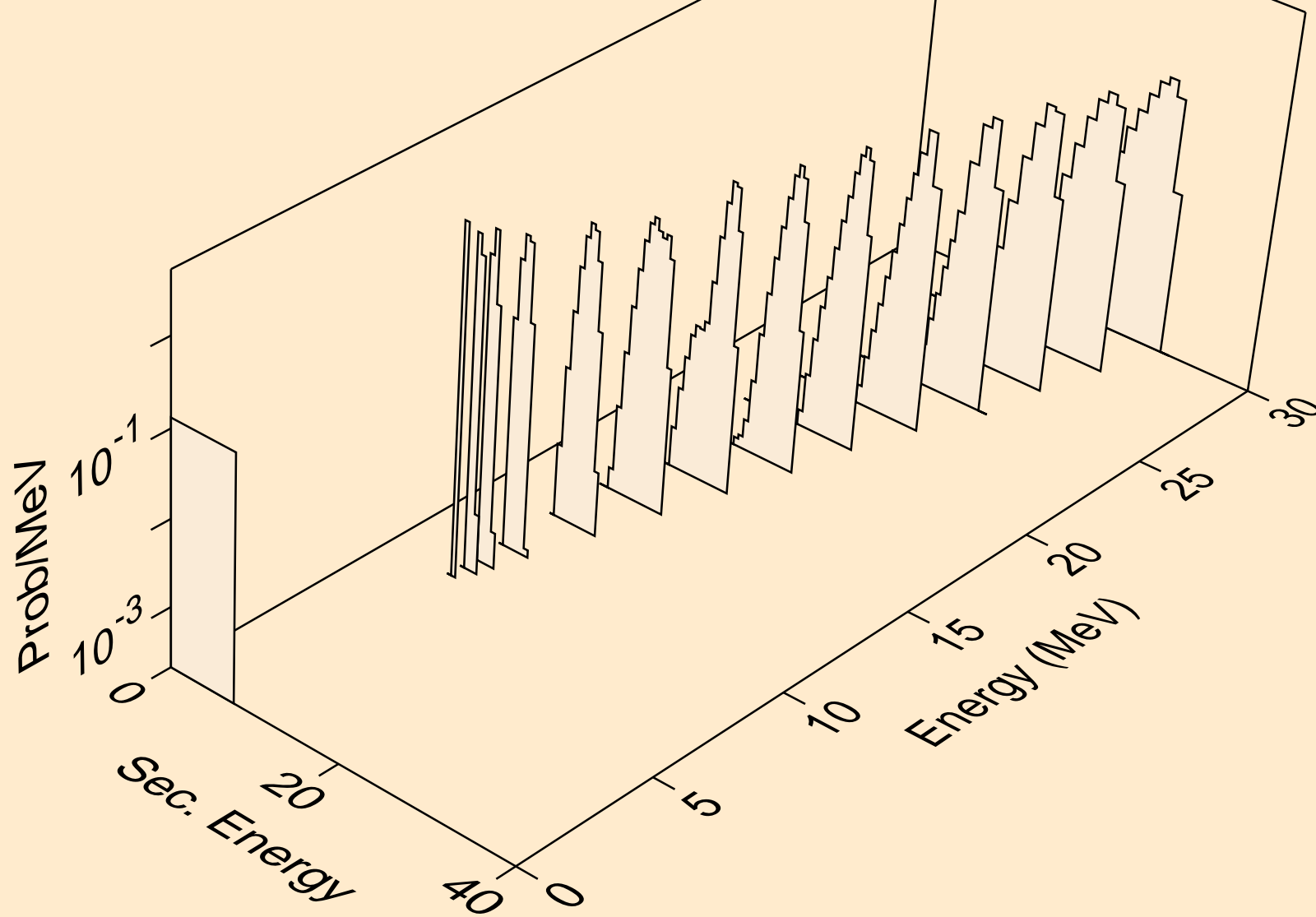

AM248 NEUTRON ACER TENDL-2023 LIBRARY; T=0.K  
alphas from (n,3n)a

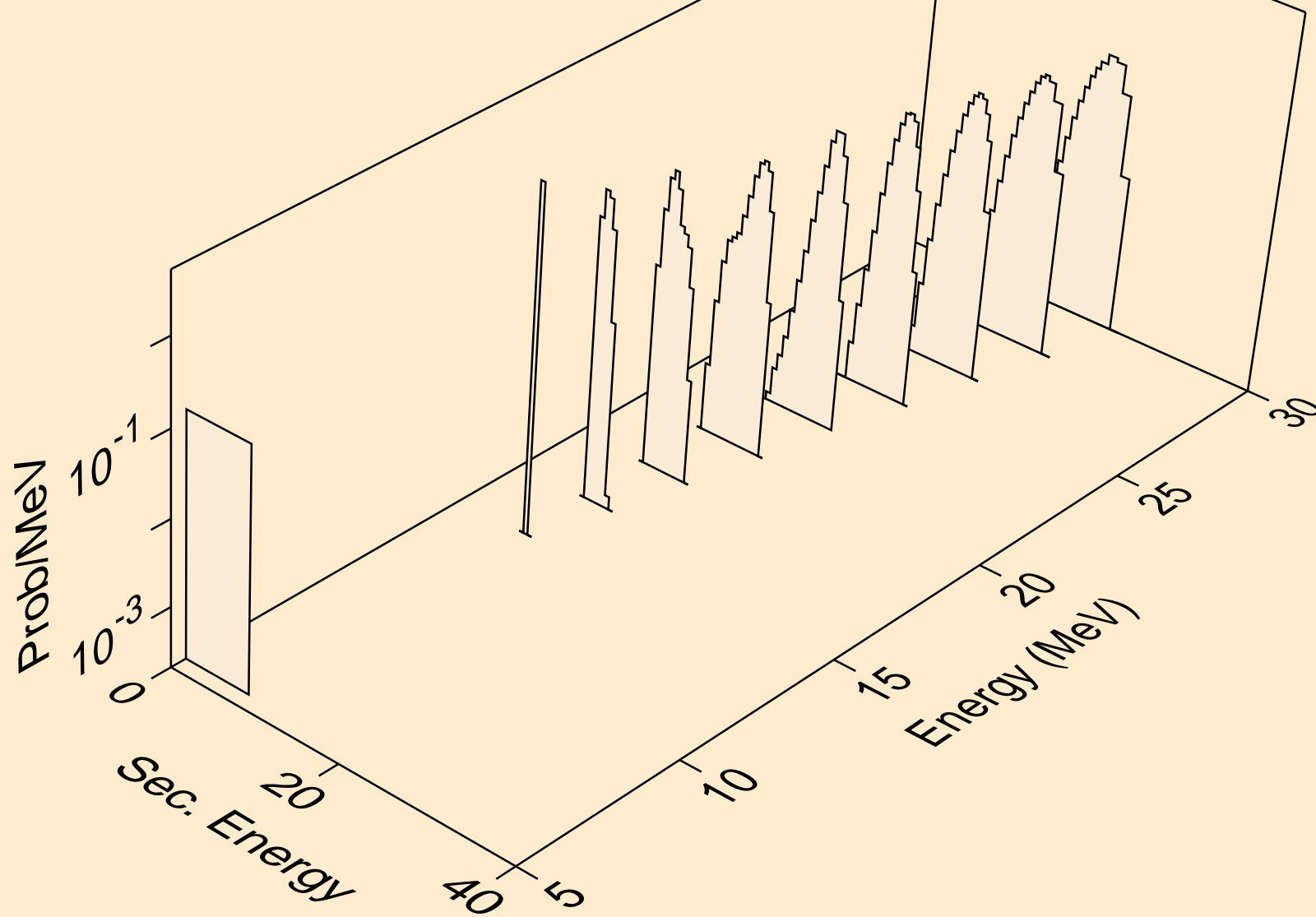

AM248 NEUTRON ACER TENDL-2023 LIBRARY; T=0.K  
alphas from (n,a)

