

# AT200M NEUTRON ACER TENDL-2023 LIBRARY; T=0.K

## Principal cross sections

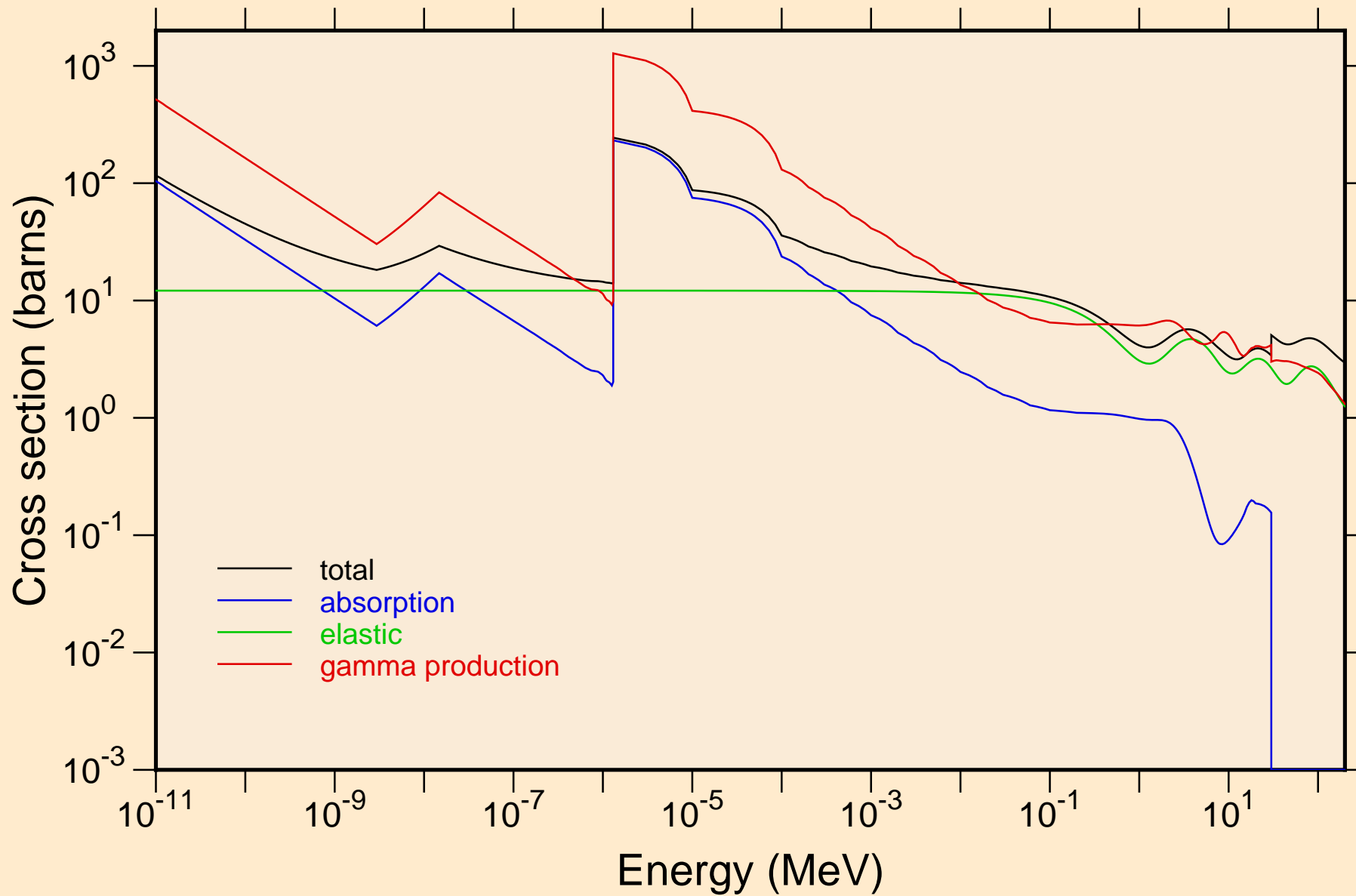

# AT200M NEUTRON ACER TENDL-2023 LIBRARY; T=0.K

## Heating

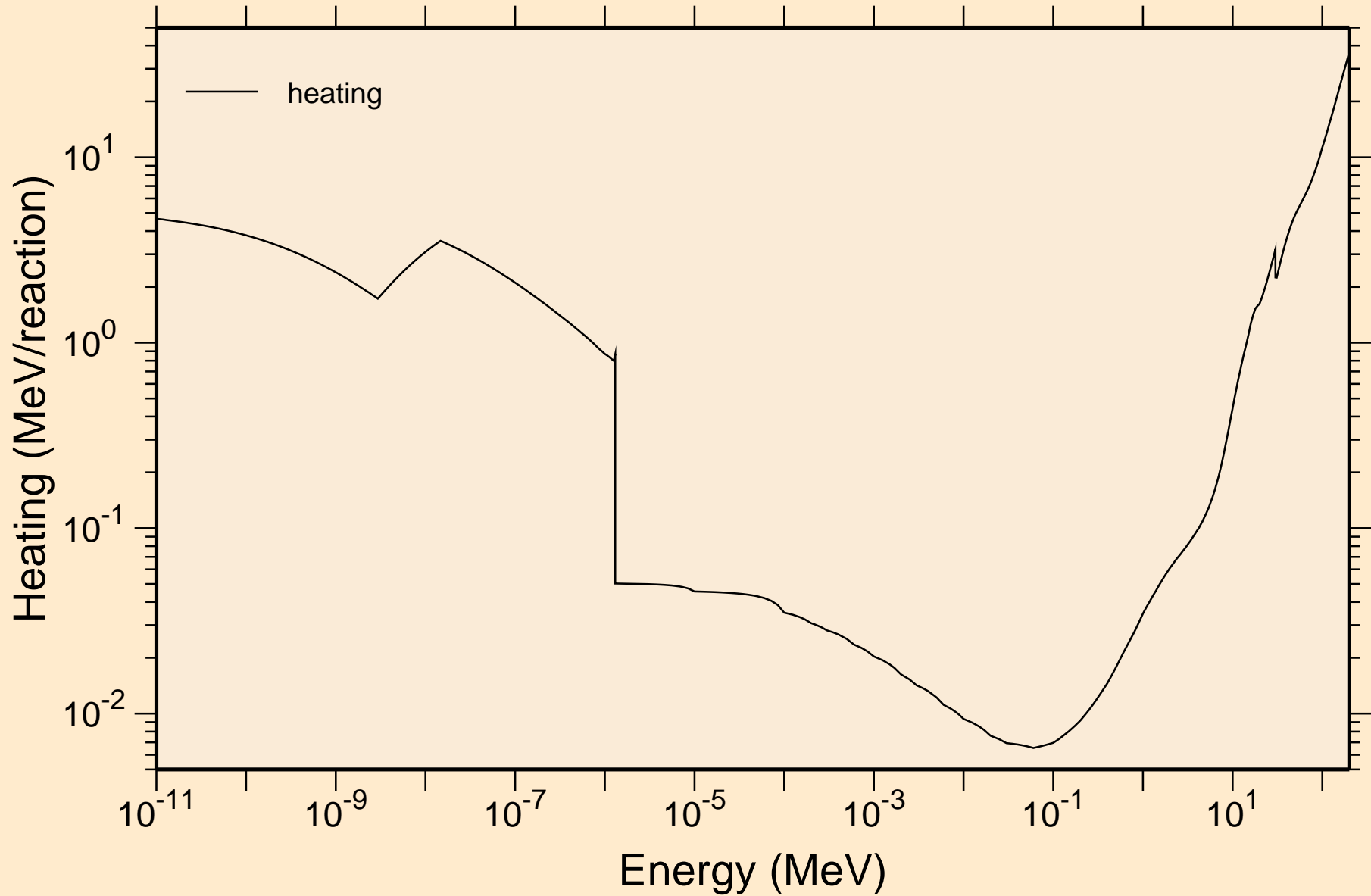

# AT200M NEUTRON ACER TENDL-2023 LIBRARY; T=0.K

## Damage

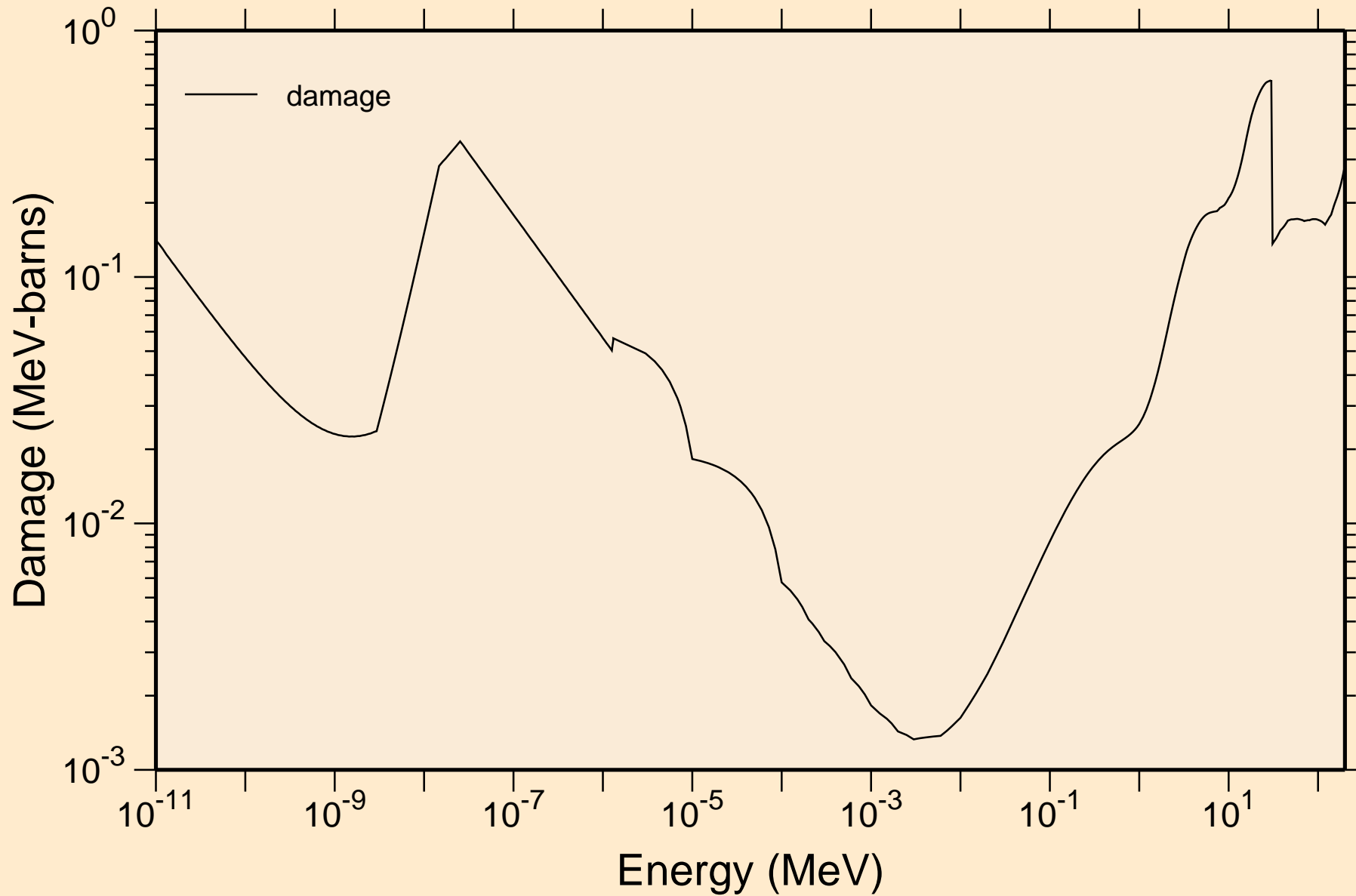

AT200M NEUTRON ACER TENDL-2023 LIBRARY; T=0.K  
Non-threshold reactions

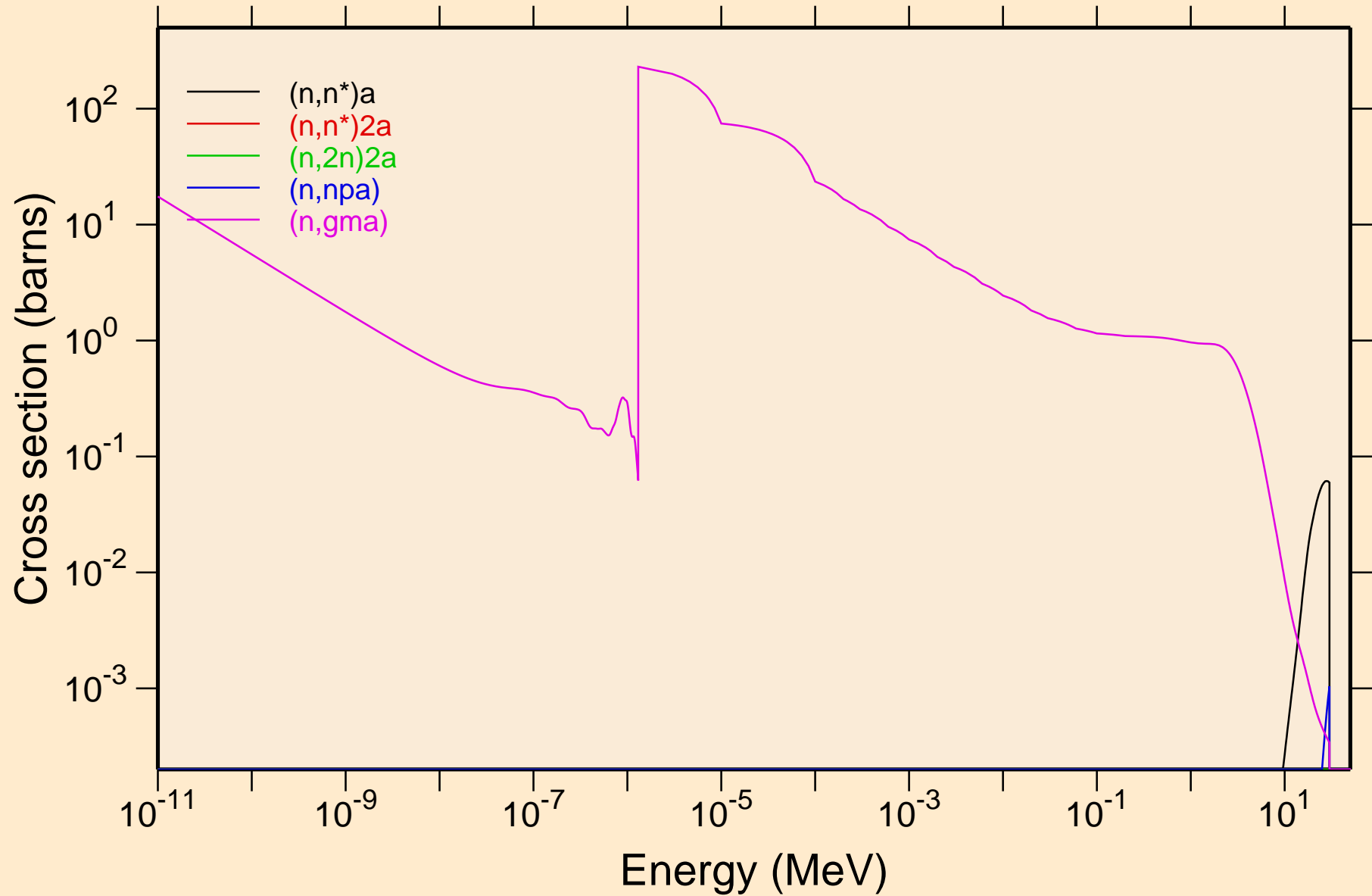

AT200M NEUTRON ACER TENDL-2023 LIBRARY; T=0.K  
Non-threshold reactions

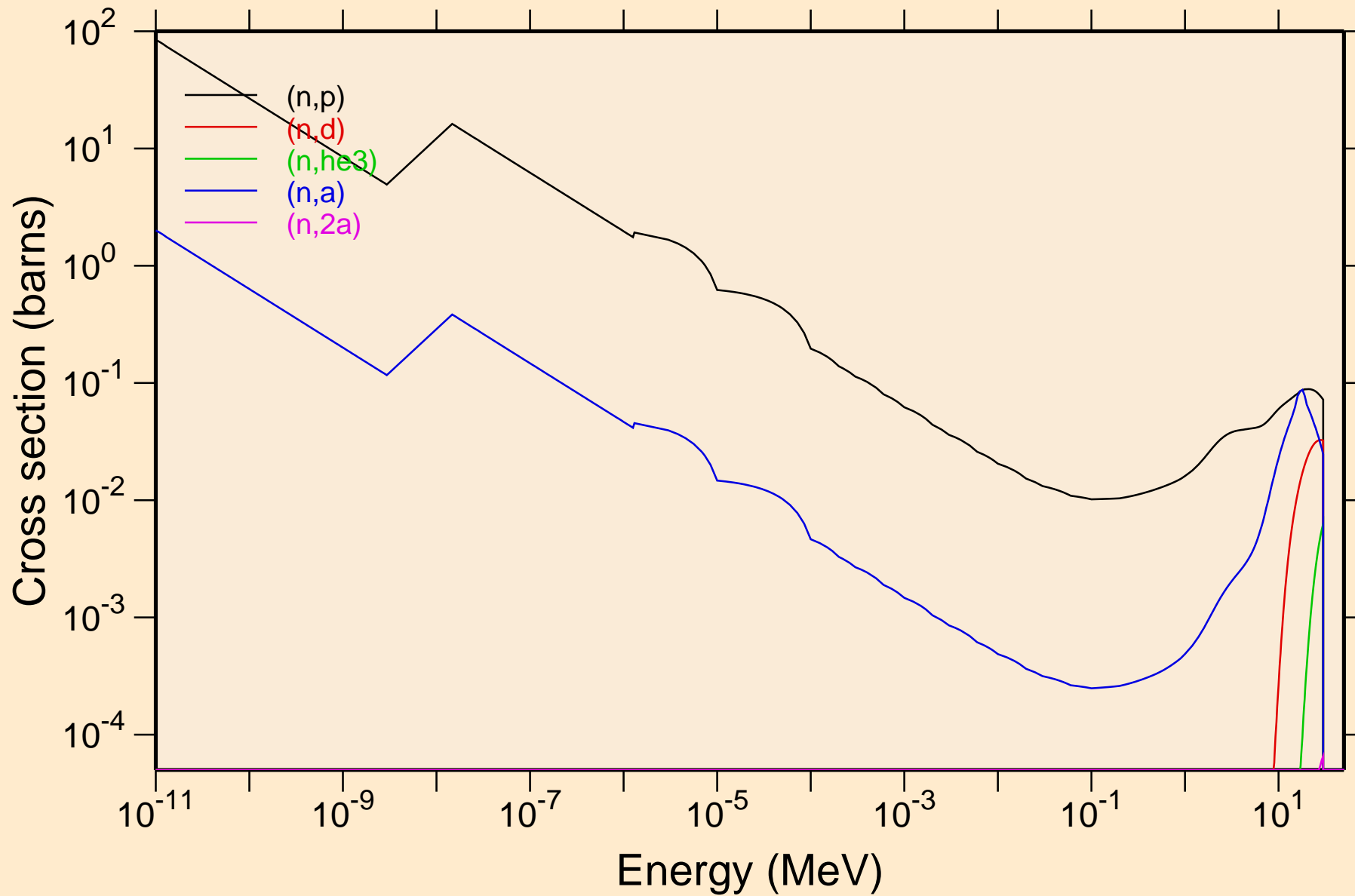

AT200M NEUTRON ACER TENDL-2023 LIBRARY; T=0.K  
Non-threshold reactions

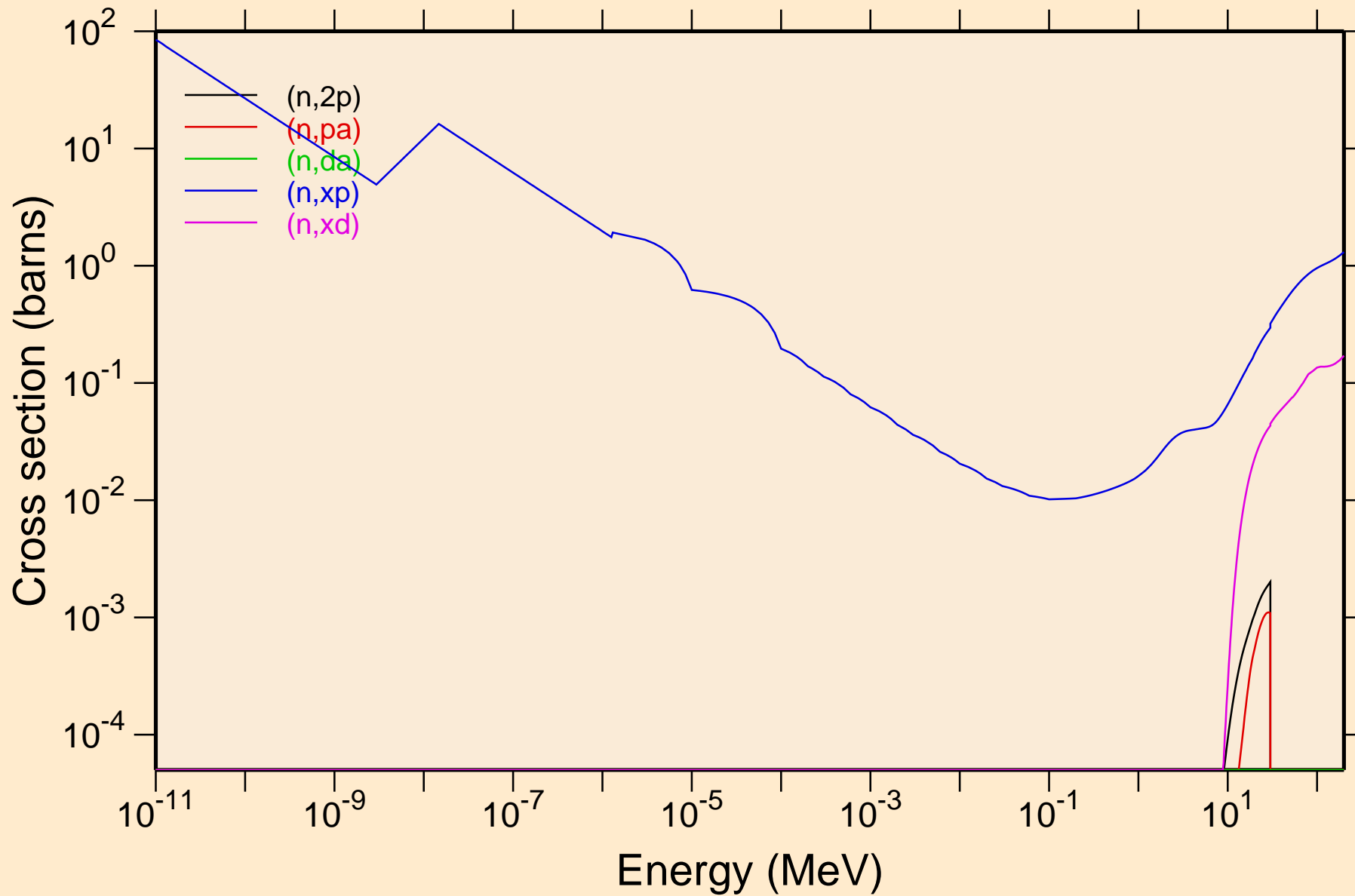

AT200M NEUTRON ACER TENDL-2023 LIBRARY; T=0.K  
Non-threshold reactions

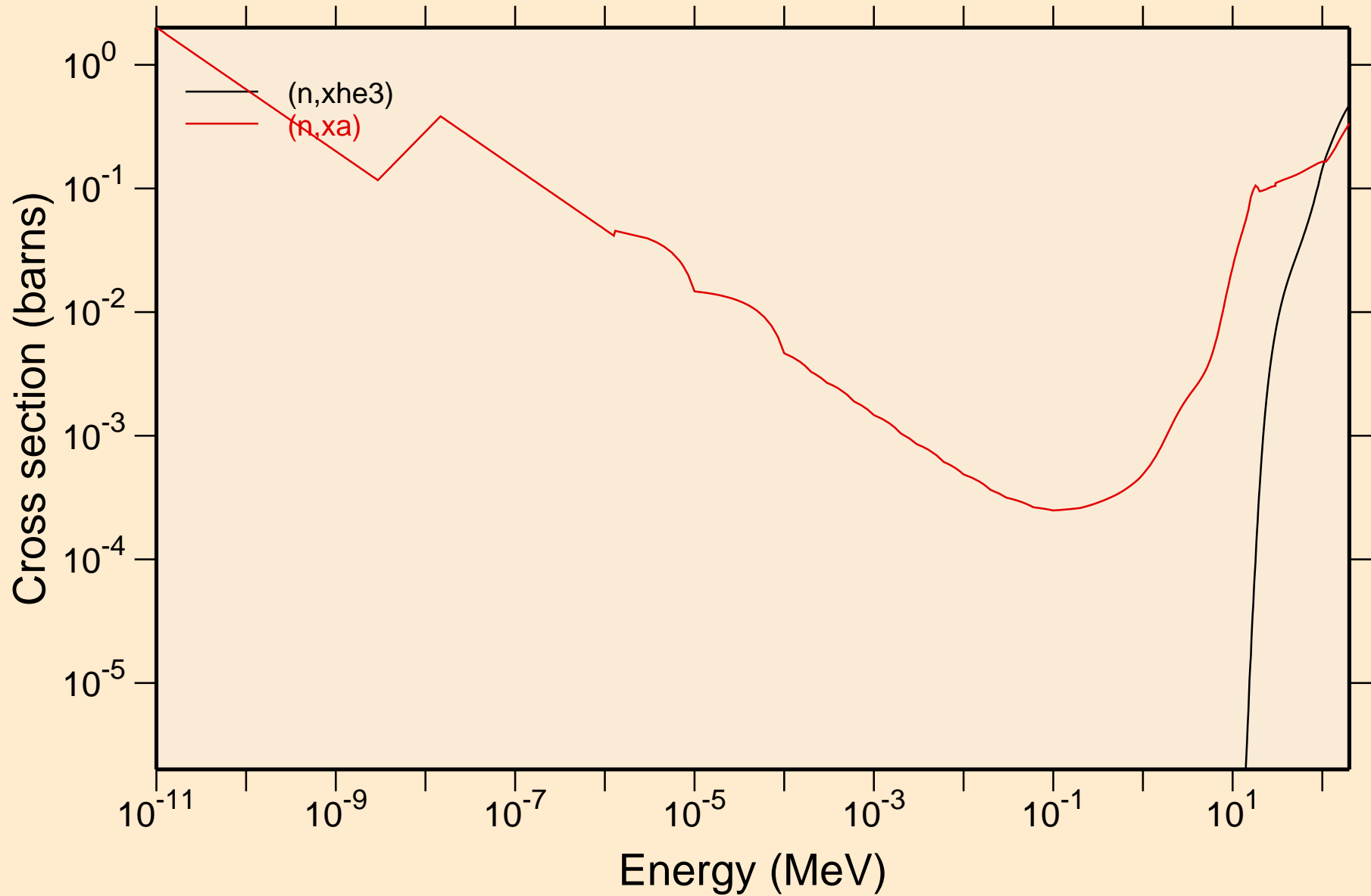

# AT200M NEUTRON ACER TENDL-2023 LIBRARY; T=0.K

## Principal cross sections

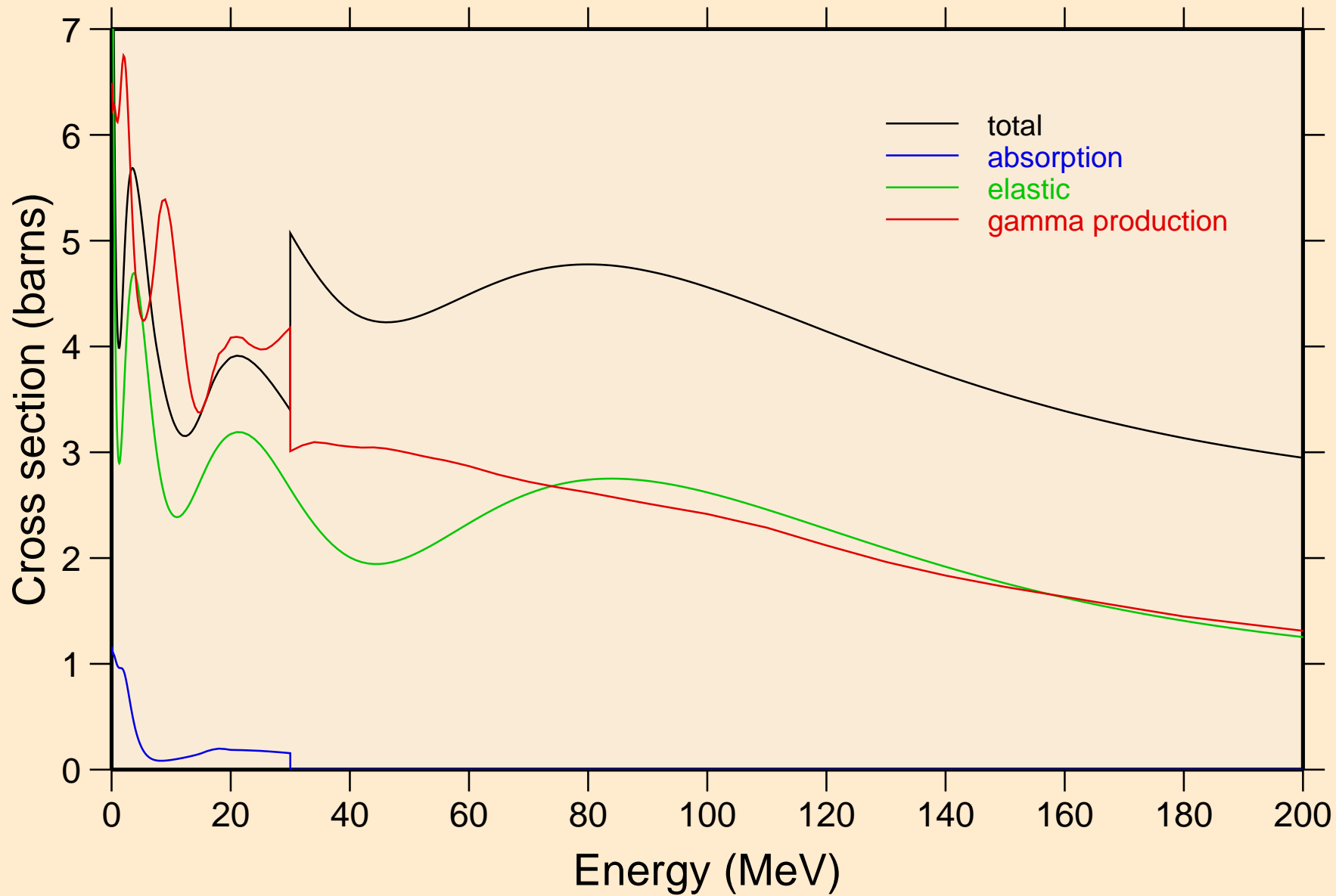



# AT200M NEUTRON ACER TENDL-2023 LIBRARY; T=0.K

## Heating

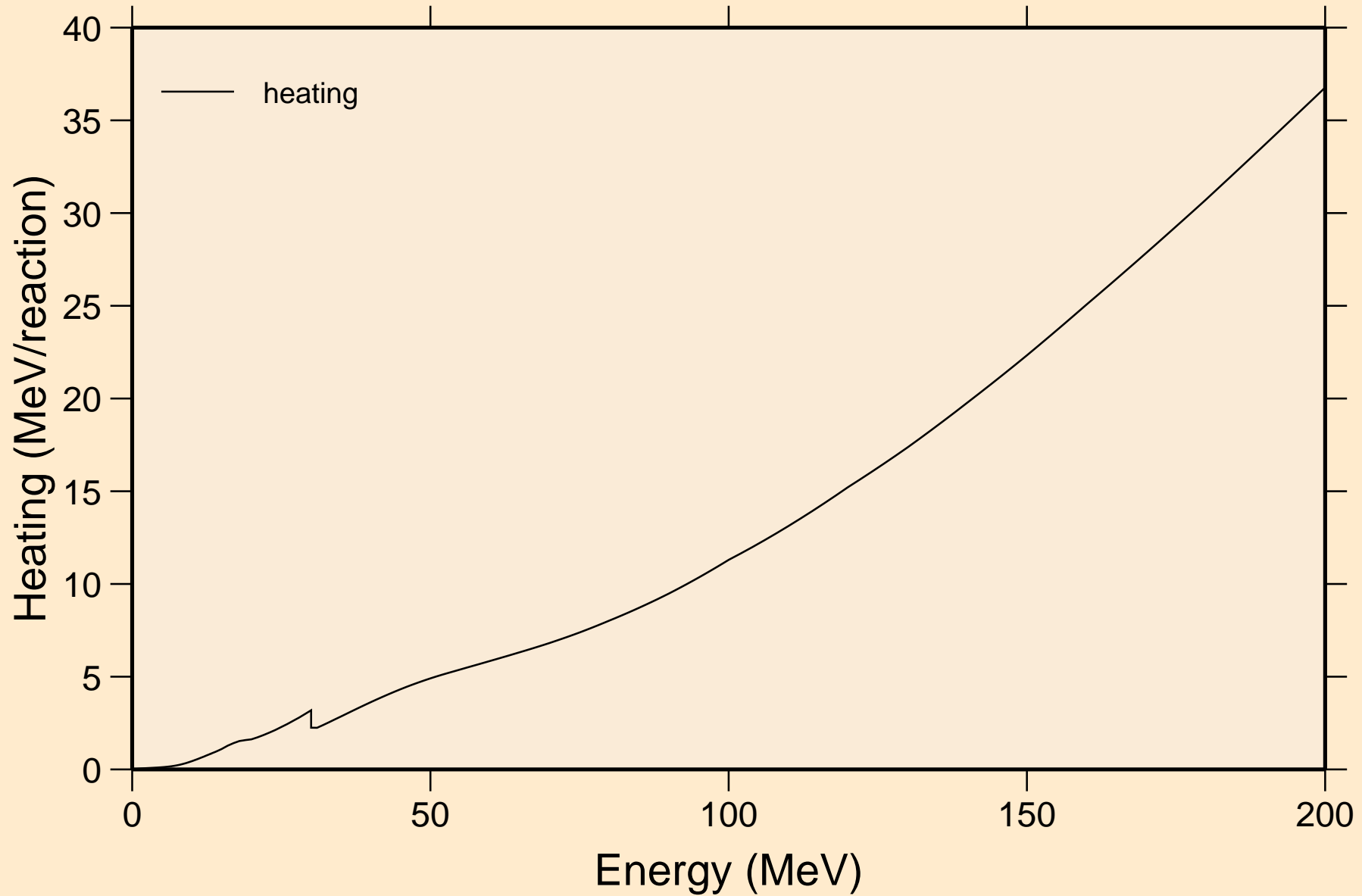

# AT200M NEUTRON ACER TENDL-2023 LIBRARY; T=0.K

## Damage

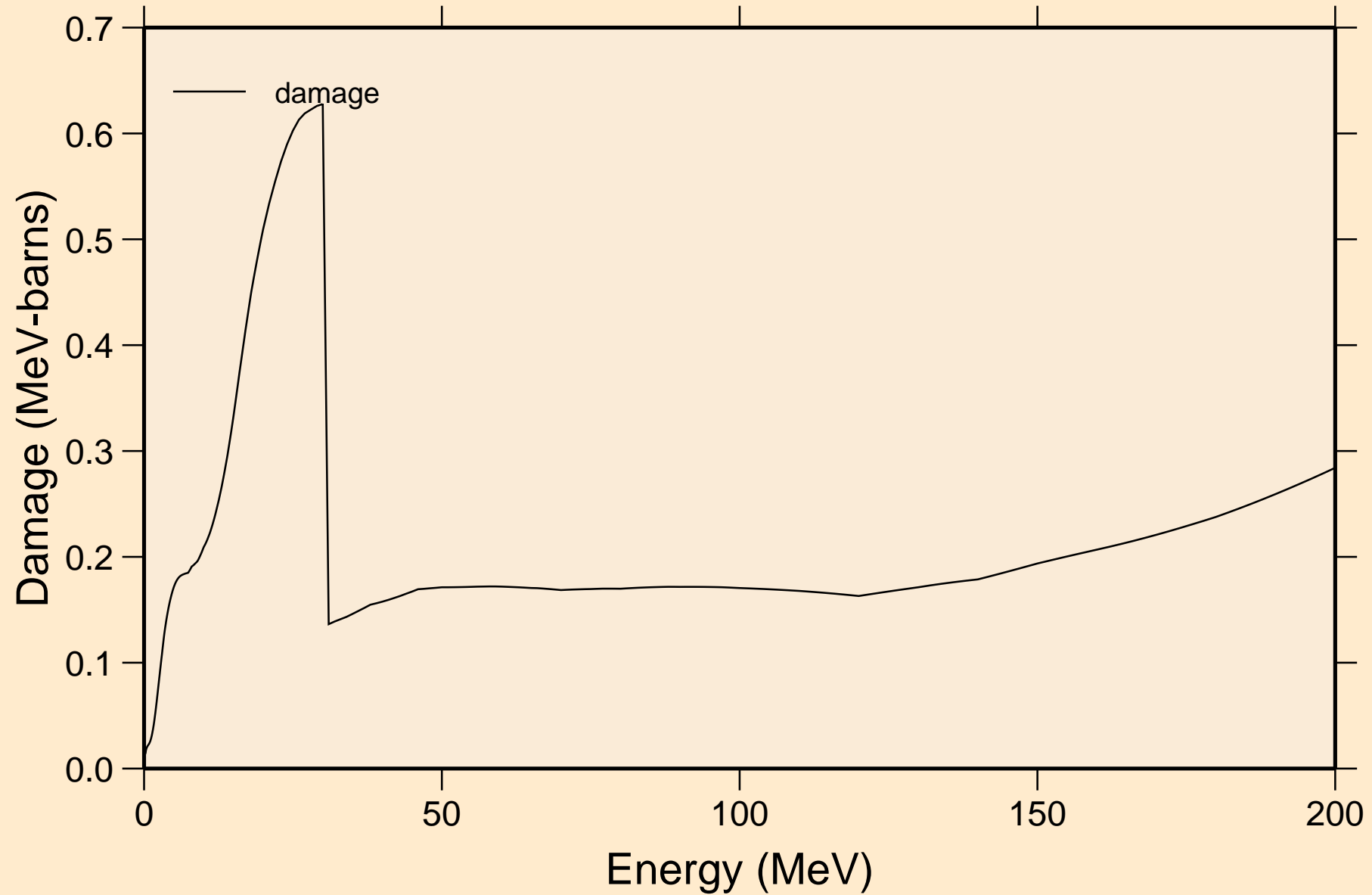

AT200M NEUTRON ACER TENDL-2023 LIBRARY; T=0.K  
Non-threshold reactions

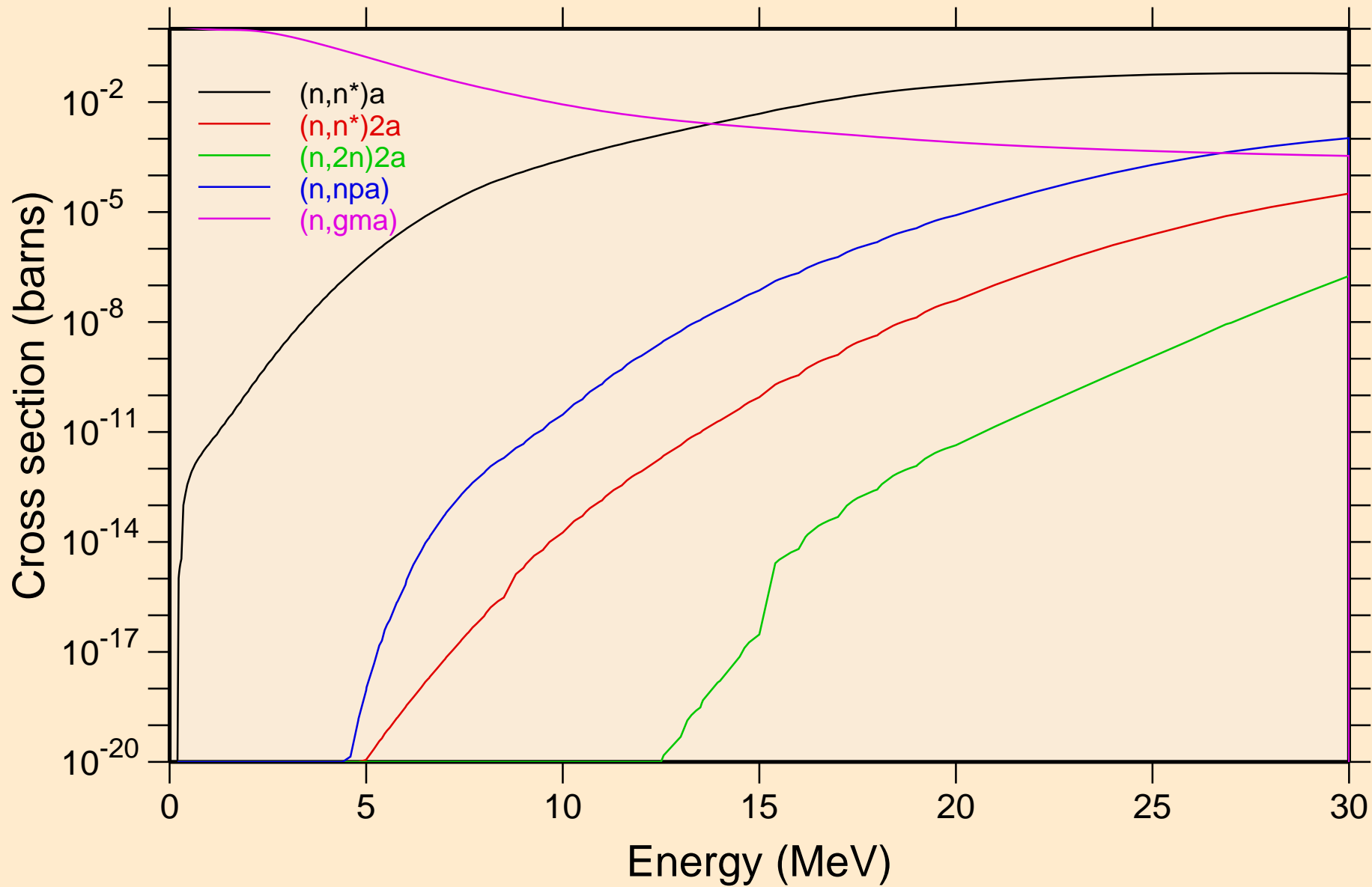

AT200M NEUTRON ACER TENDL-2023 LIBRARY; T=0.K  
Non-threshold reactions

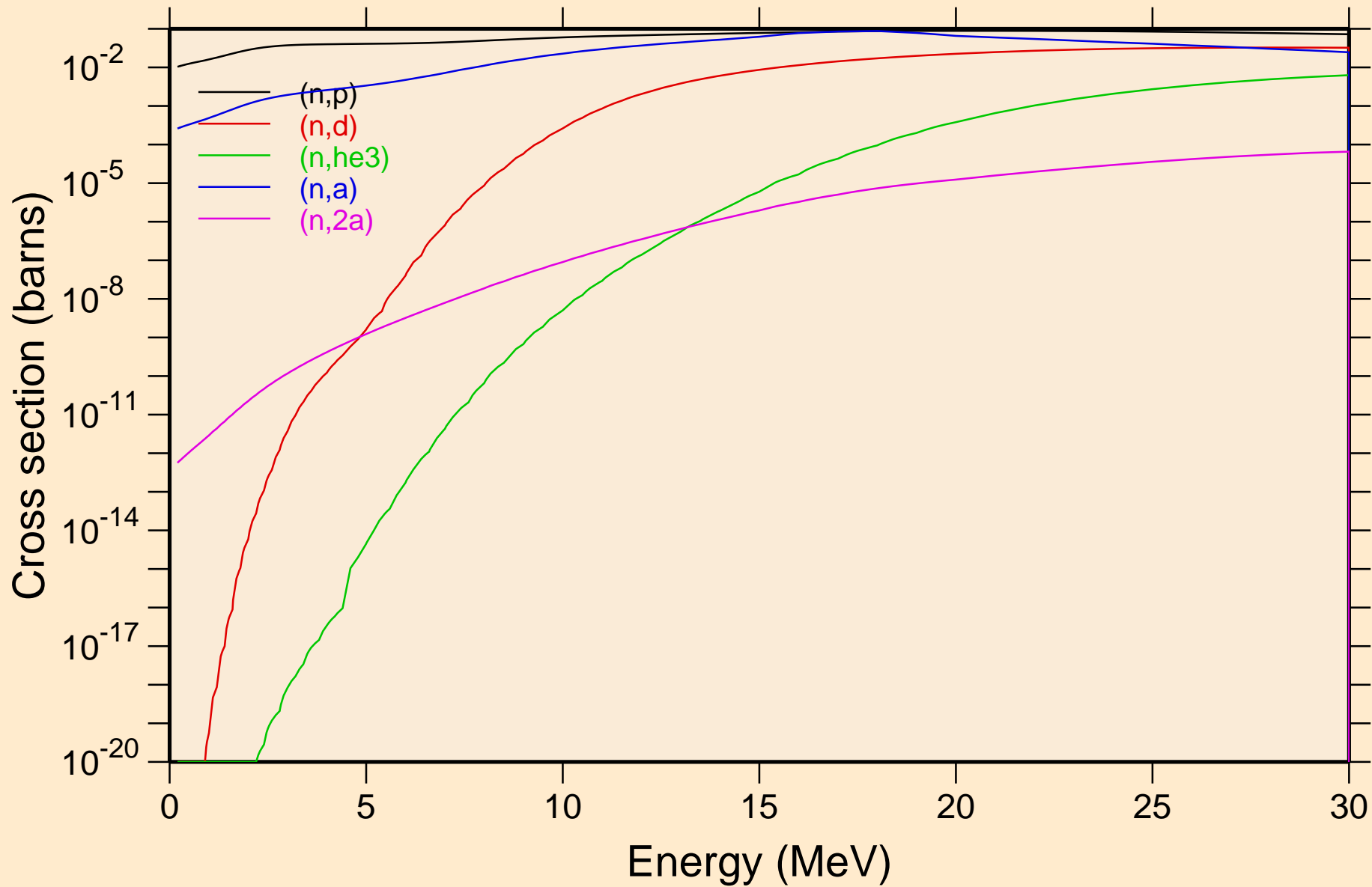

# AT200M NEUTRON ACER TENDL-2023 LIBRARY; T=0.K

## Non-threshold reactions

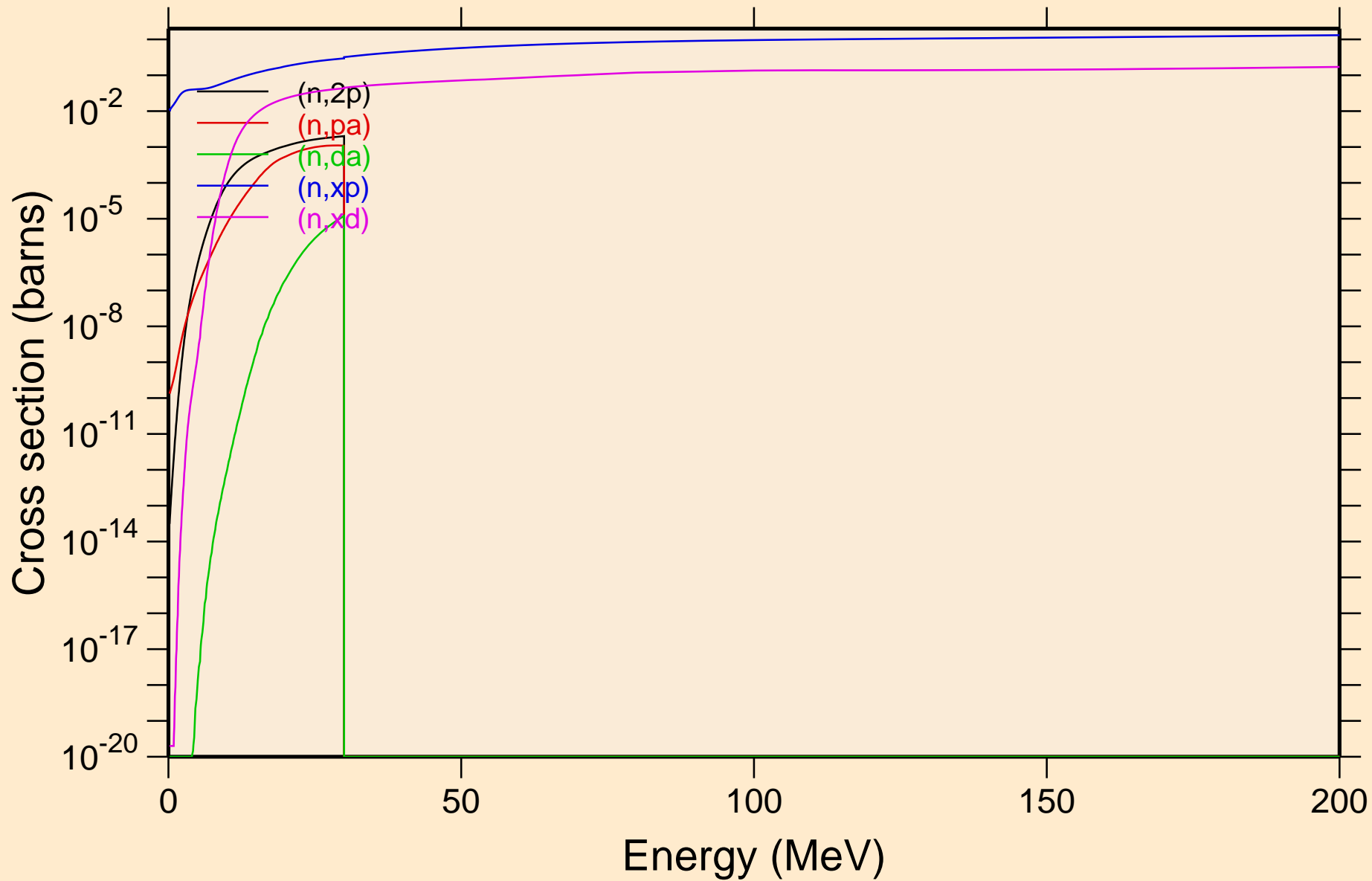

AT200M NEUTRON ACER TENDL-2023 LIBRARY; T=0.K  
Non-threshold reactions

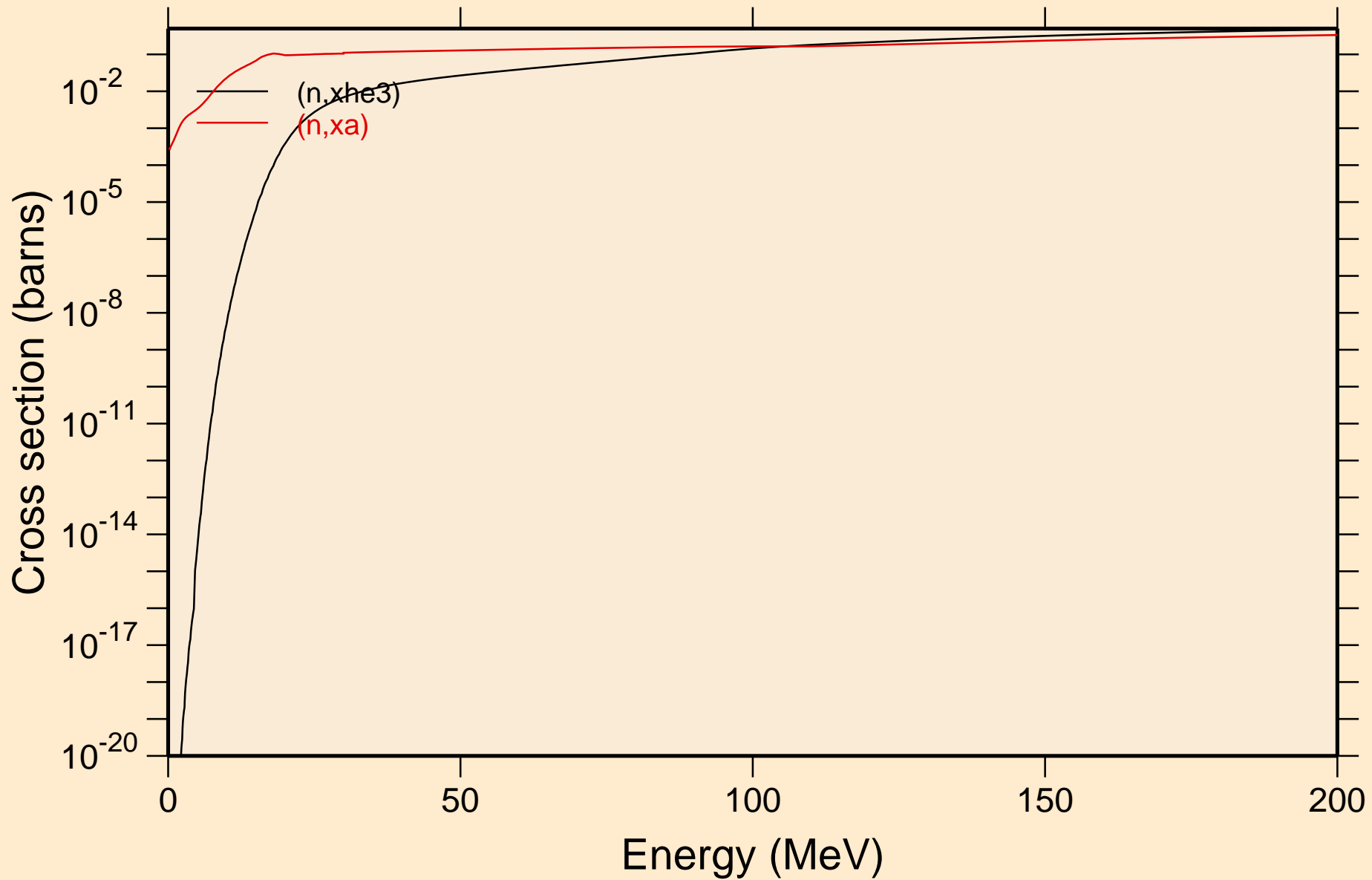

AT200M NEUTRON ACER TENDL-2023 LIBRARY; T=0.K  
Inelastic levels

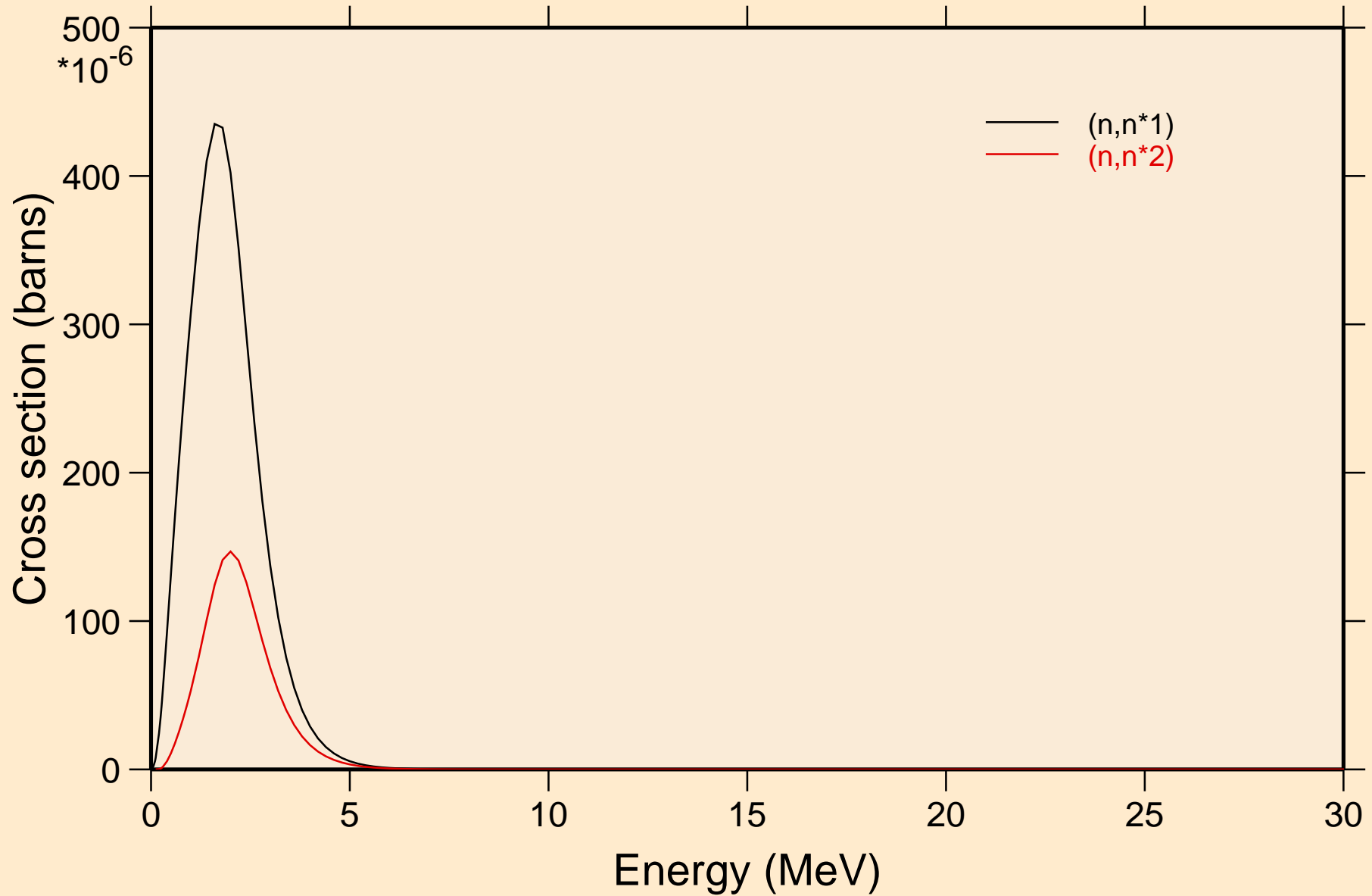

AT200M NEUTRON ACER TENDL-2023 LIBRARY; T=0.K  
Threshold reactions

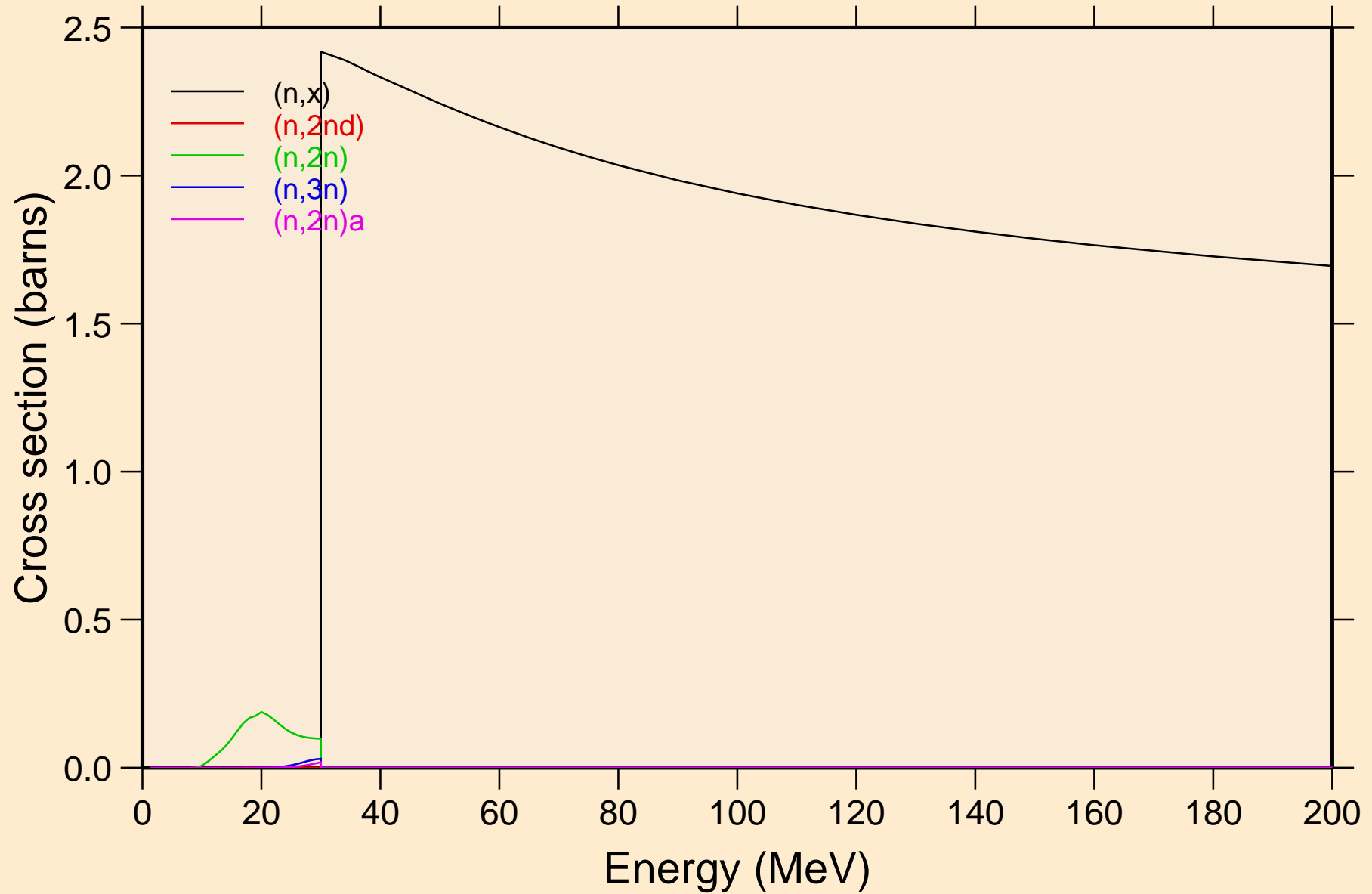



AT200M NEUTRON ACER TENDL-2023 LIBRARY; T=0.K  
Threshold reactions

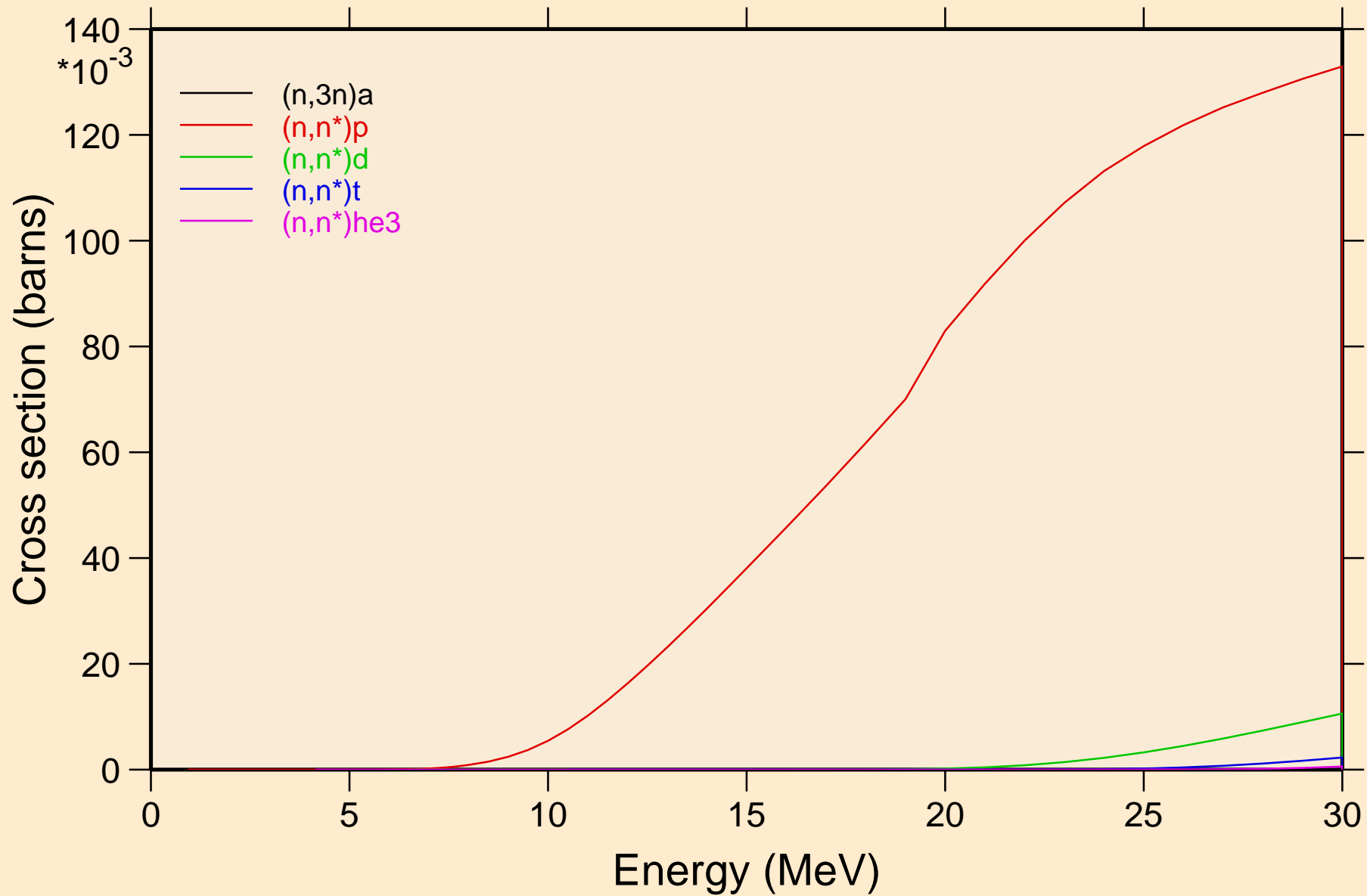

AT200M NEUTRON ACER TENDL-2023 LIBRARY; T=0.K  
Threshold reactions

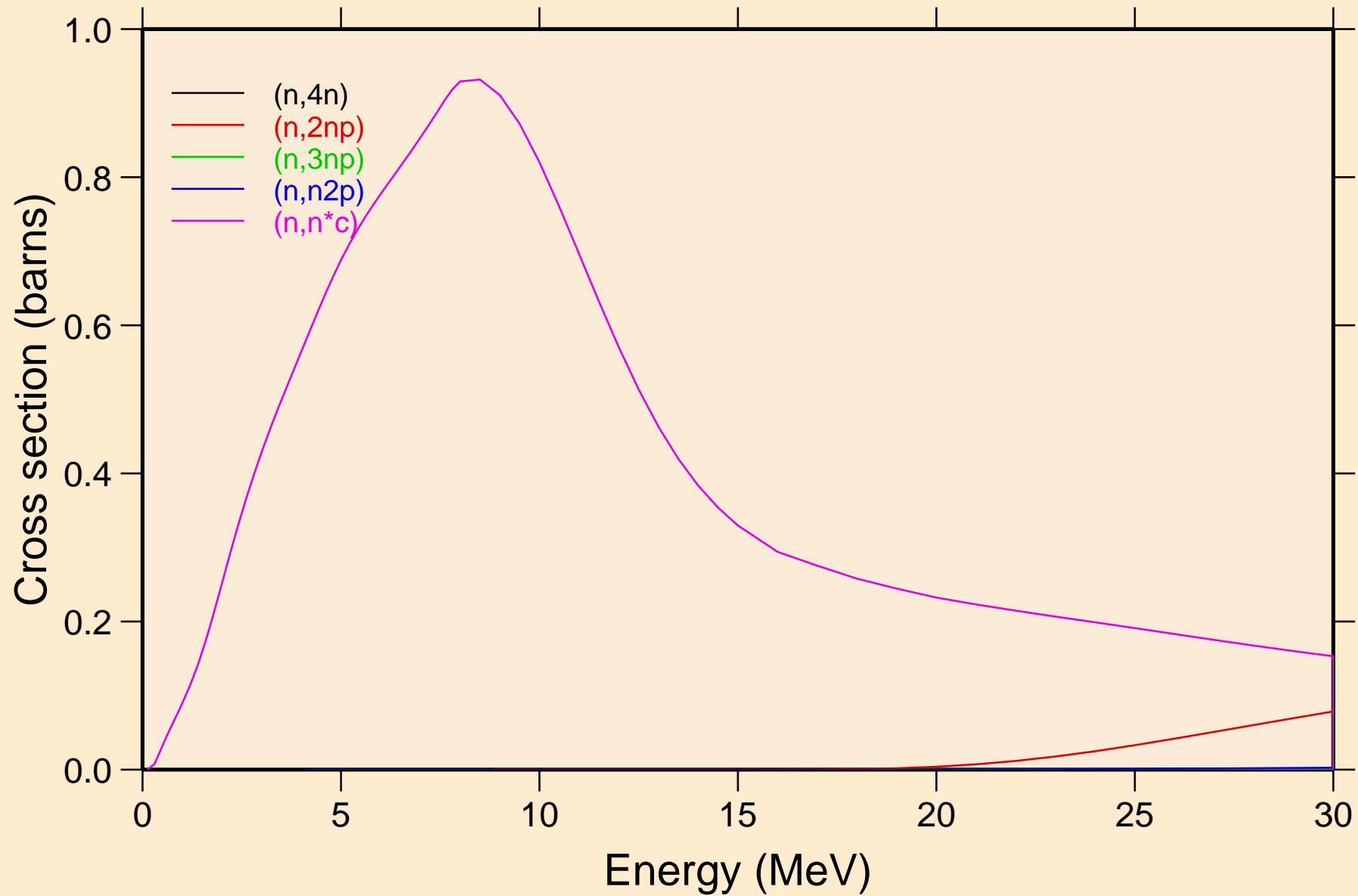

AT200M NEUTRON ACER TENDL-2023 LIBRARY; T=0.K  
Threshold reactions

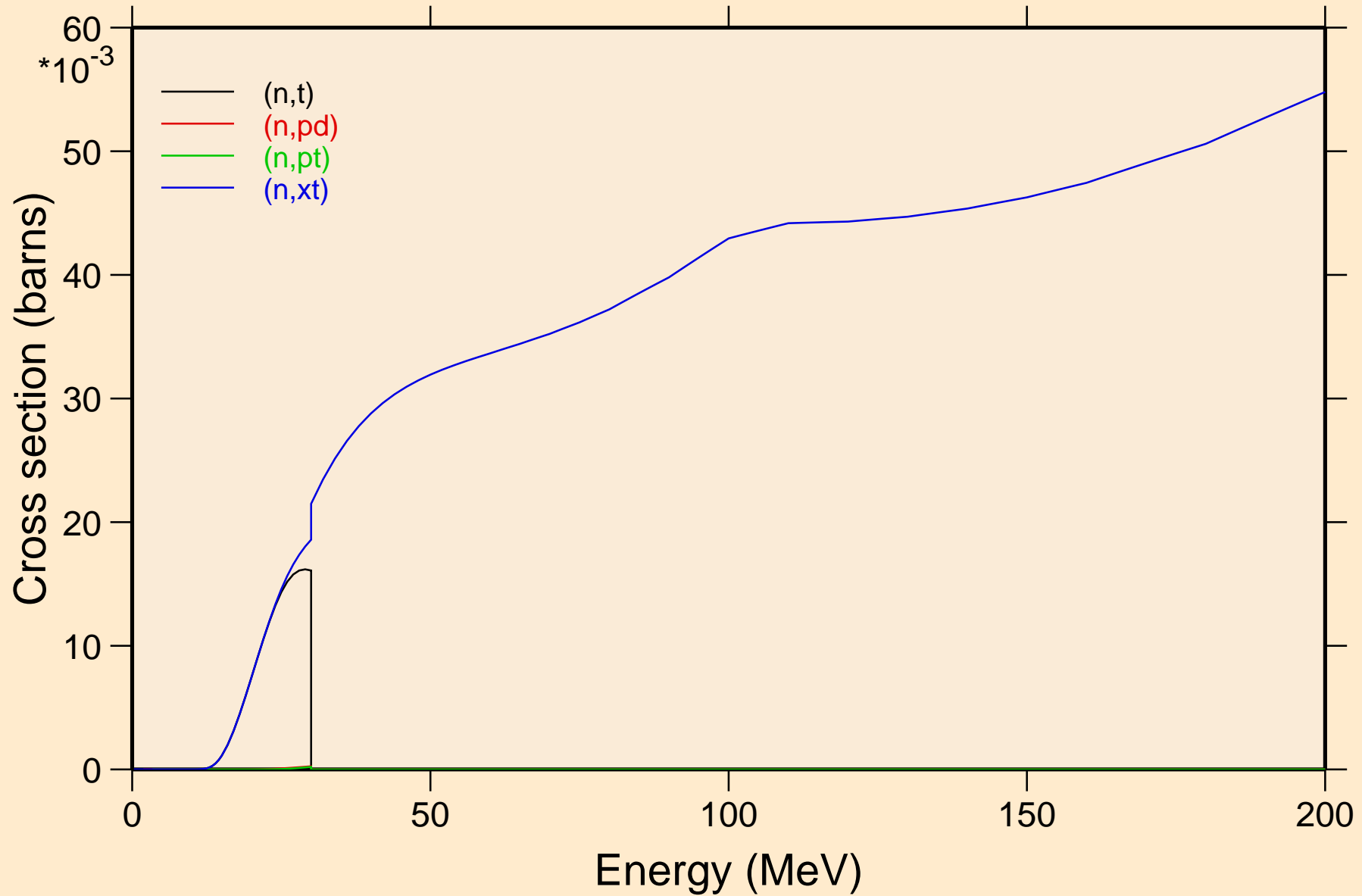

AT200M NEUTRON ACER TENDL-2023 LIBRARY; T=0.K  
angular distribution for elastic

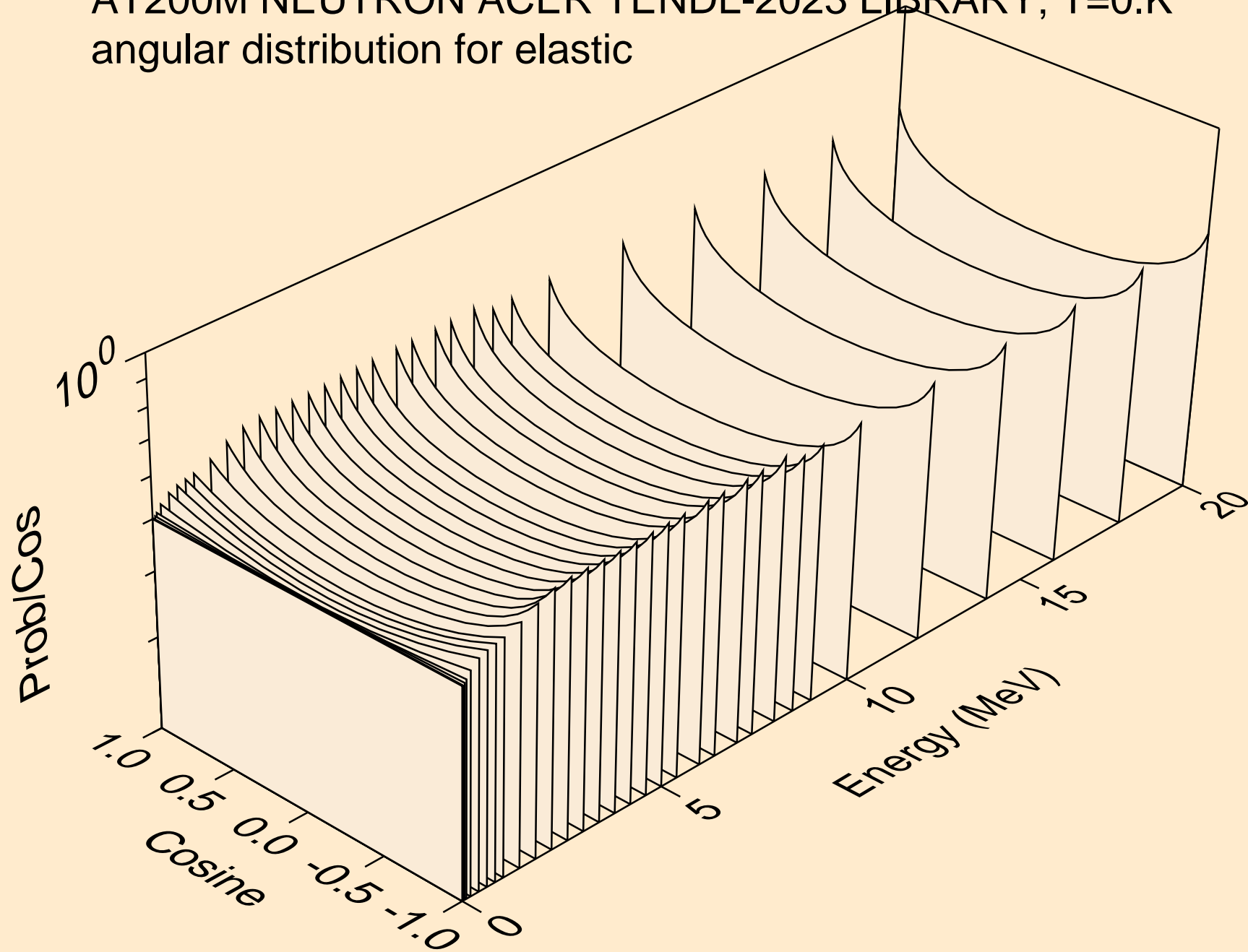

AT200M NEUTRON ACER TENDL-2023 LIBRARY; T=0.K  
angular distribution for elastic

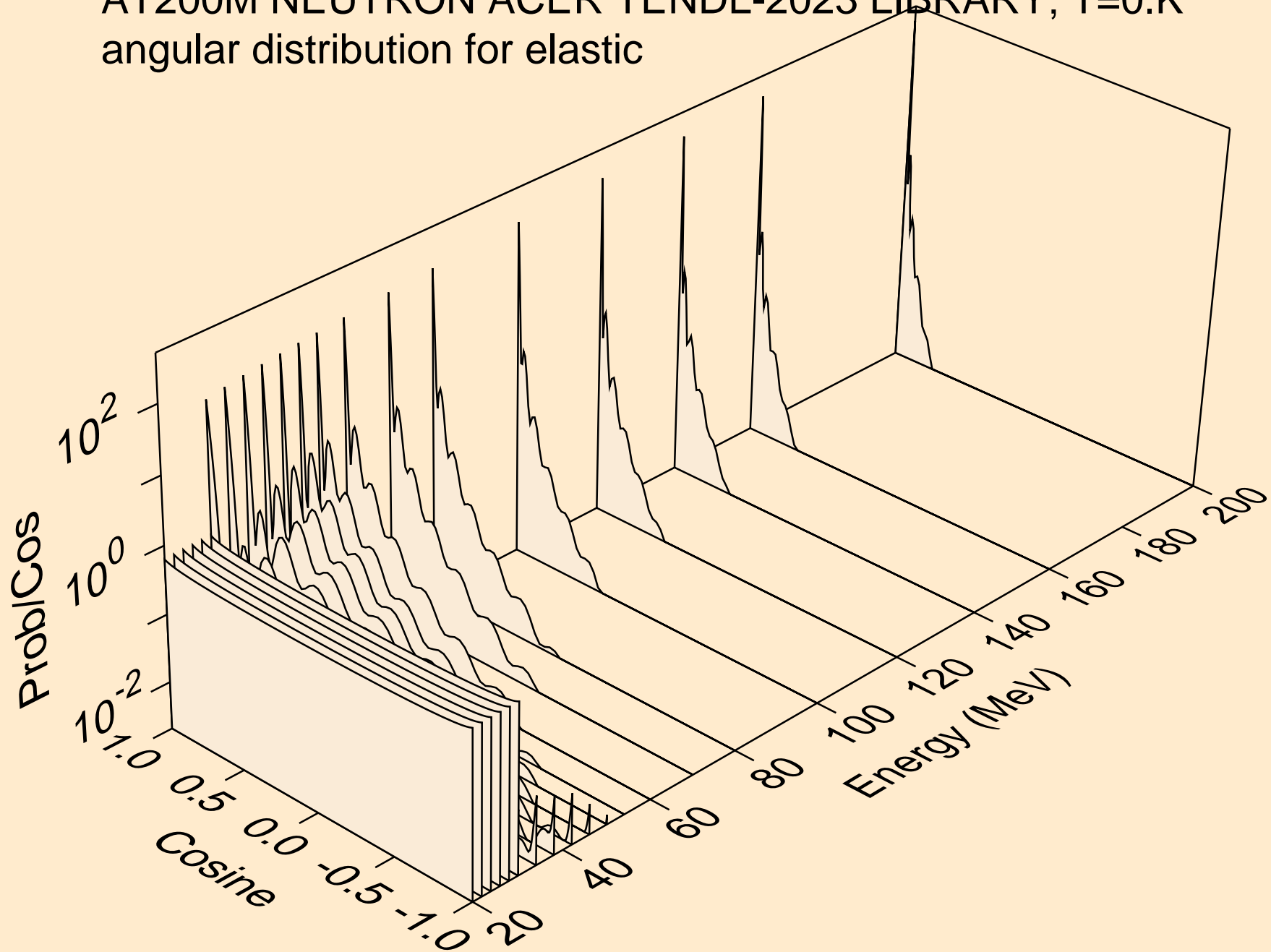

AT200M NEUTRON ACER TENDL-2023 LIBRARY; T=0.K  
angular distribution for (n,n\*1)

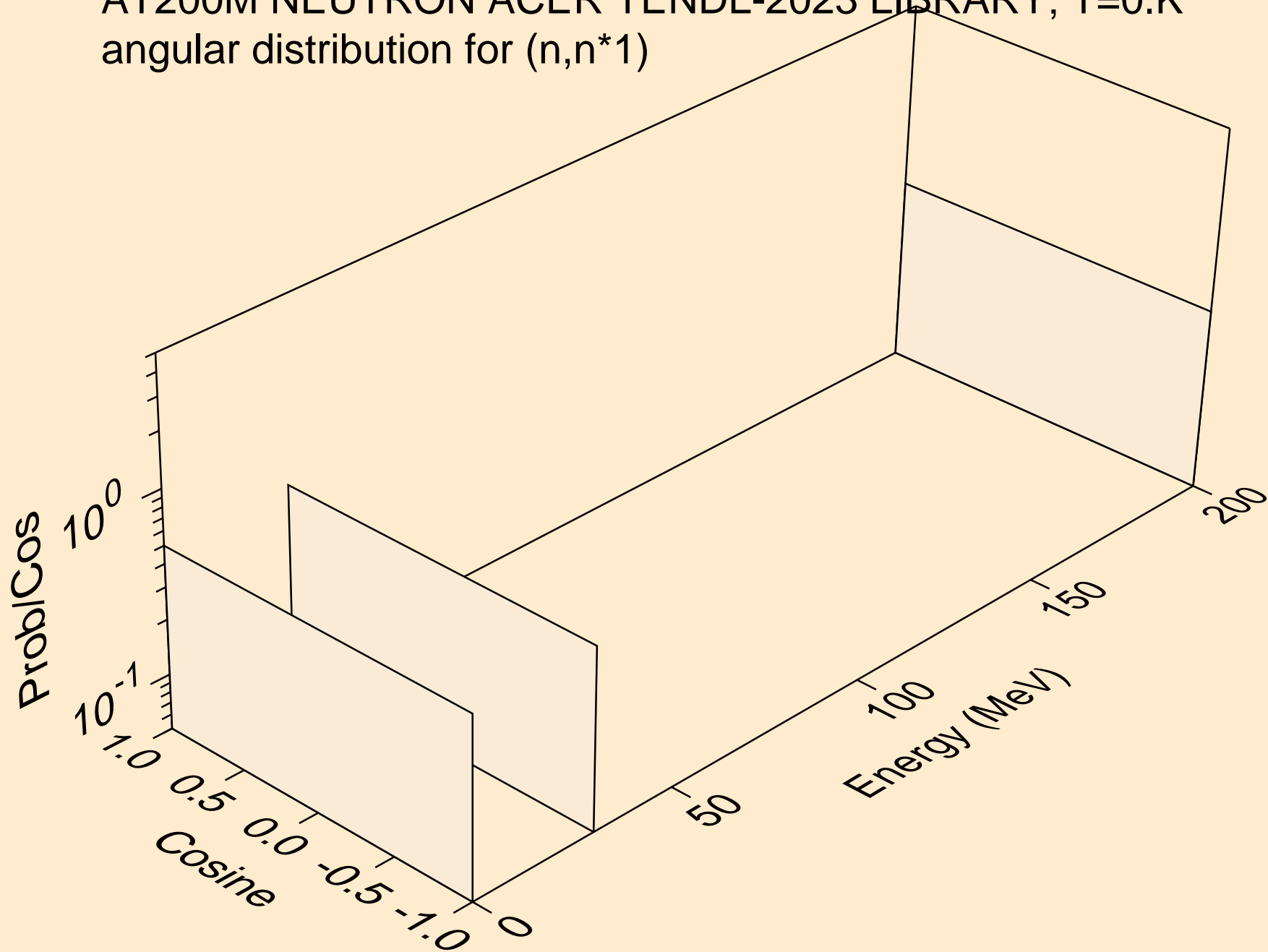

AT200M NEUTRON ACER TENDL-2023 LIBRARY; T=0.K  
angular distribution for (n,n\*2)

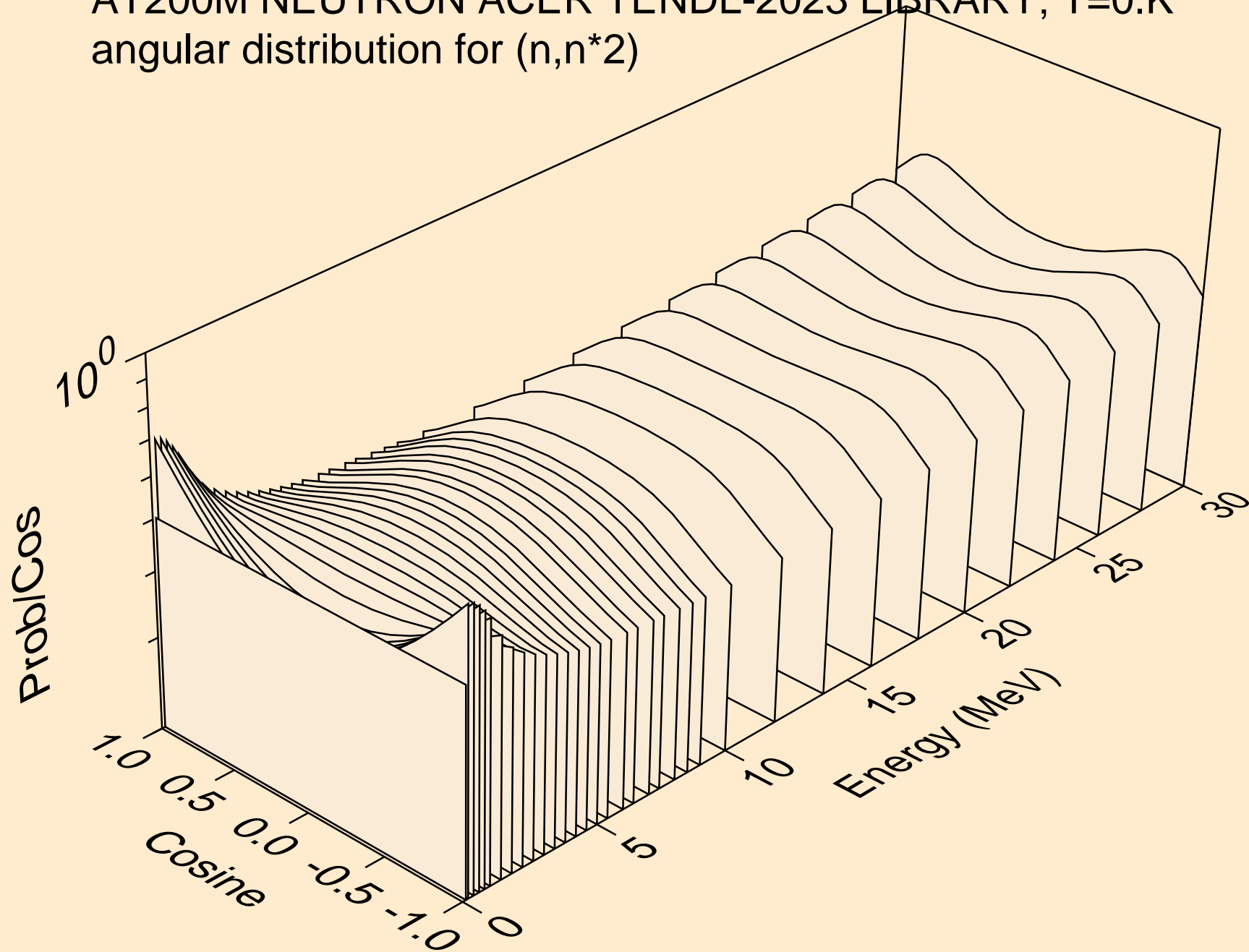

AT200M NEUTRON ACER TENDL-2023 LIBRARY; T=0.K  
Neutron emission for (n,x)

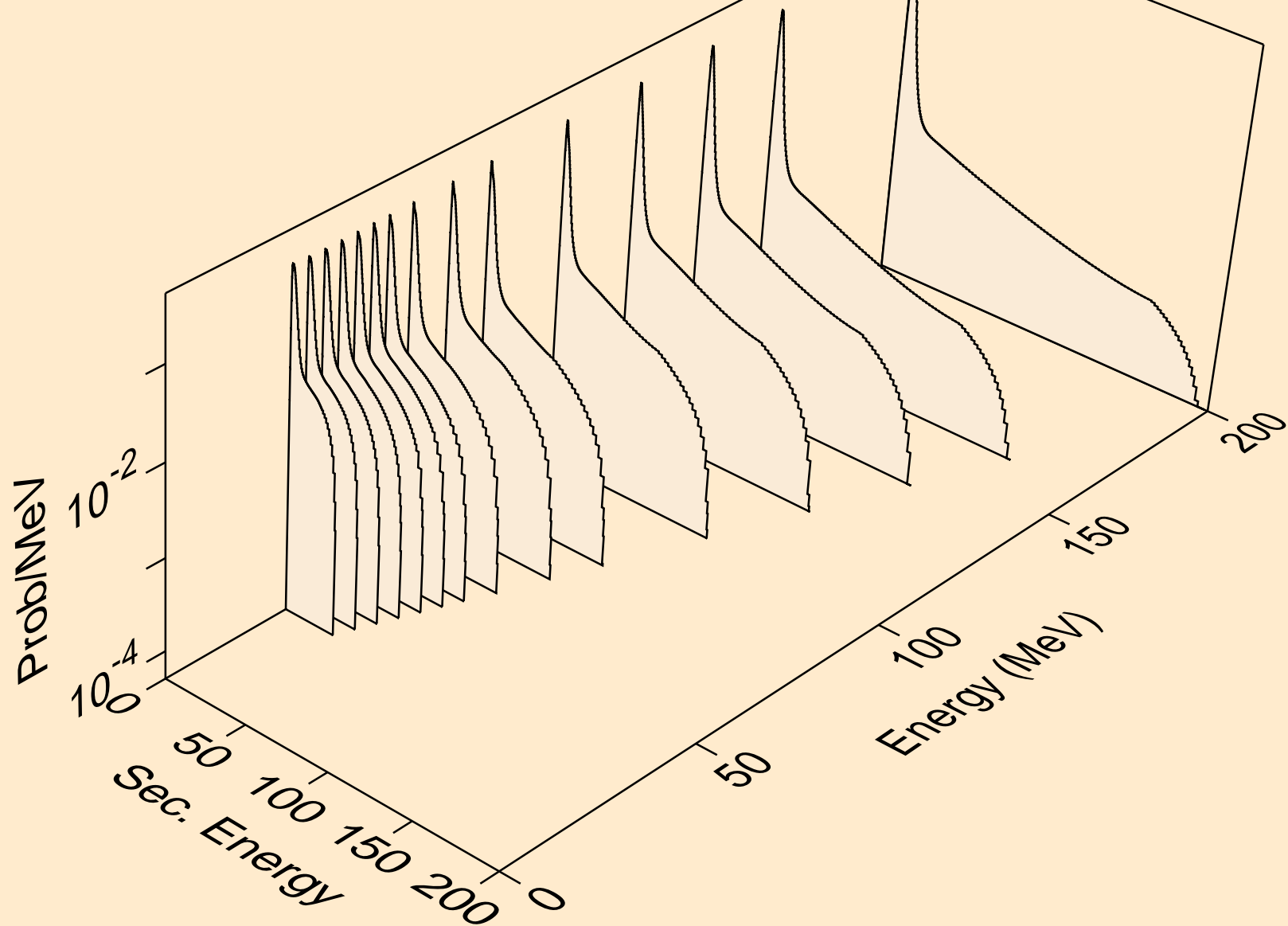



AT200M NEUTRON ACER TENDL-2023 LIBRARY; T=0.K  
Neutron emission for (n,2nd)

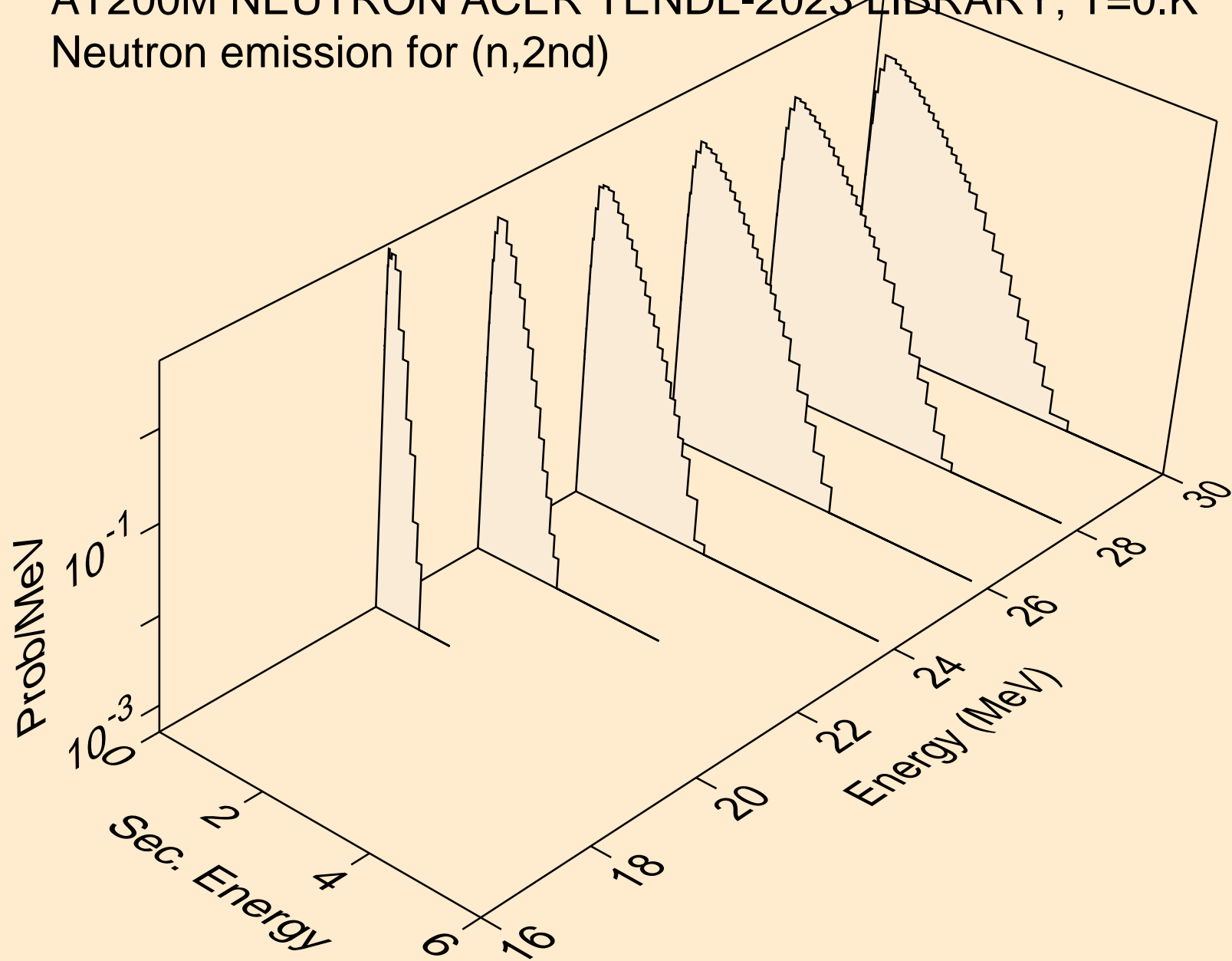

AT200M NEUTRON ACER TENDL-2023 LIBRARY; T=0.K  
Neutron emission for (n,2n)

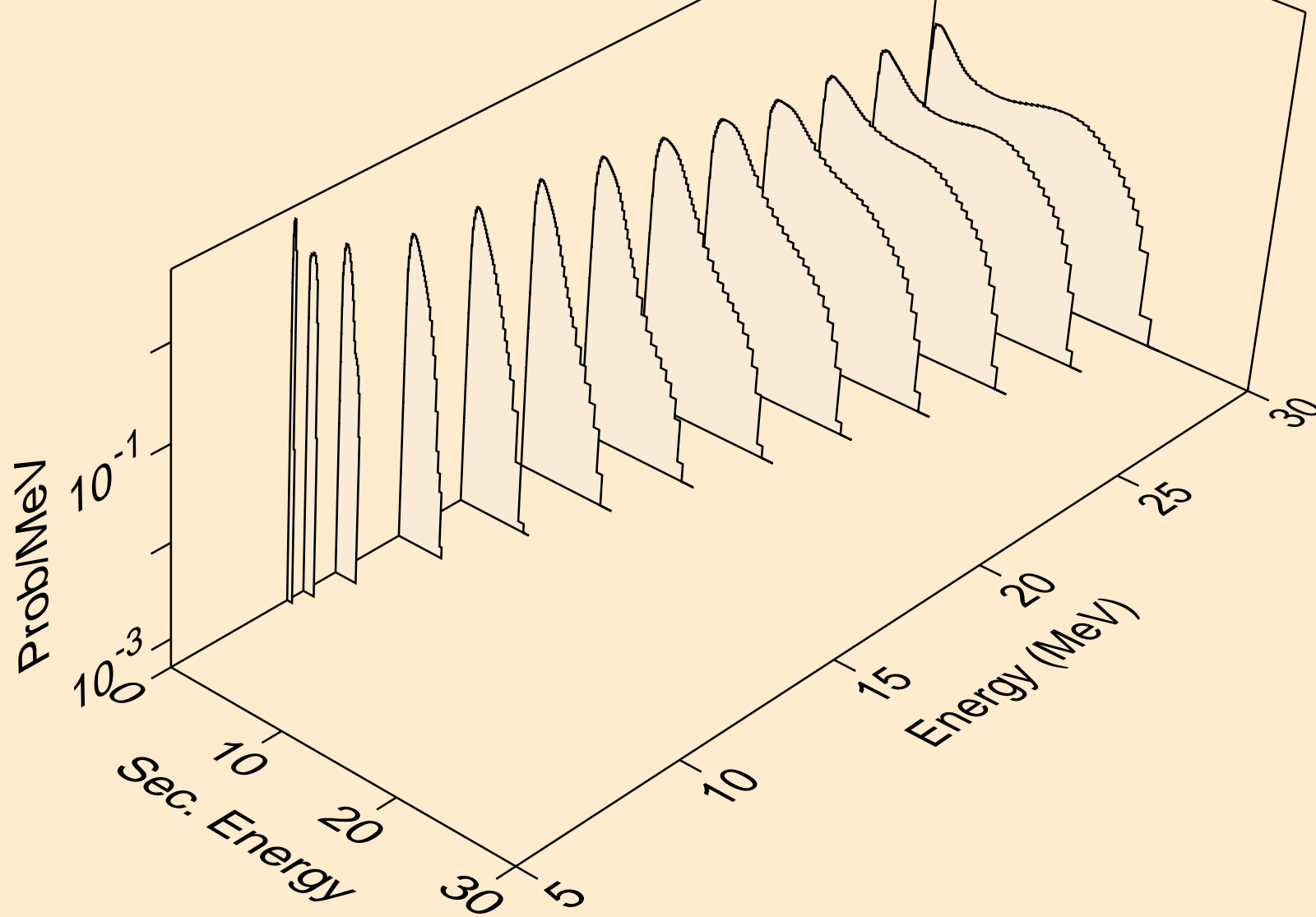

AT200M NEUTRON ACER TENDL-2023 LIBRARY; T=0.K  
Neutron emission for (n,3n)

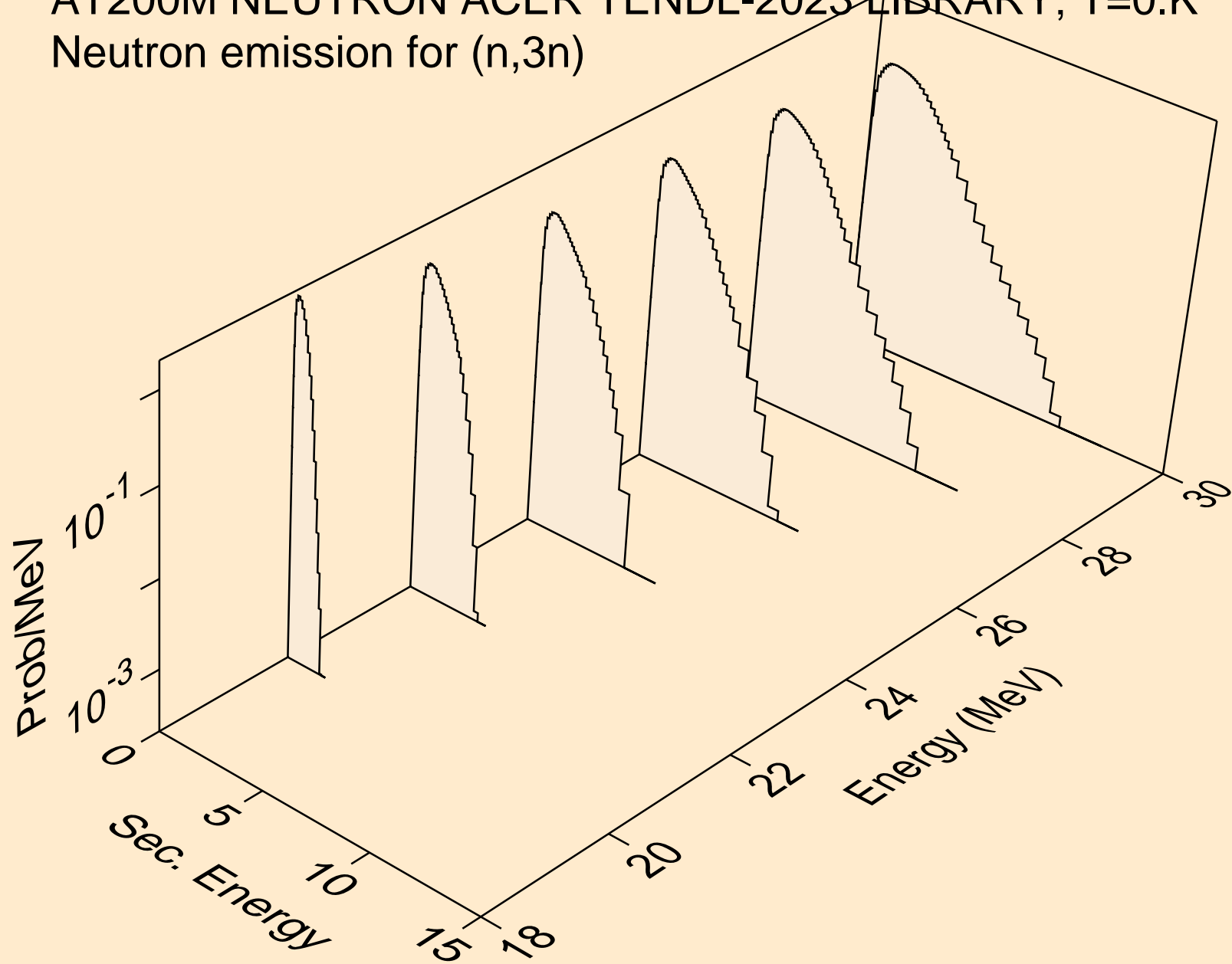

AT200M NEUTRON ACER TENDL-2023 LIBRARY; T=0.K  
Neutron emission for (n,n\*)a

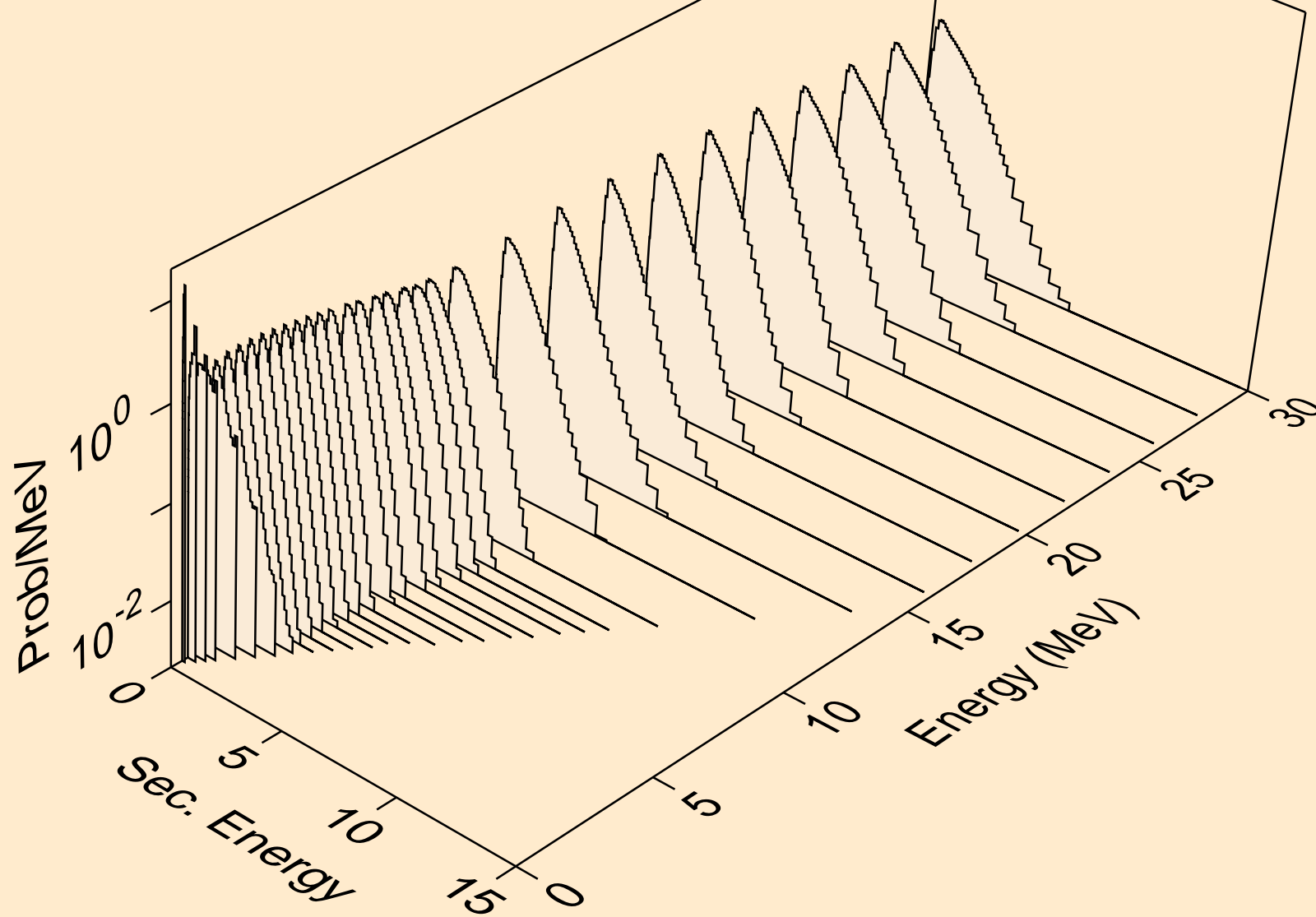

AT200M NEUTRON ACER TENDL-2023 LIBRARY; T=0.K  
Neutron emission for (n,2n)a

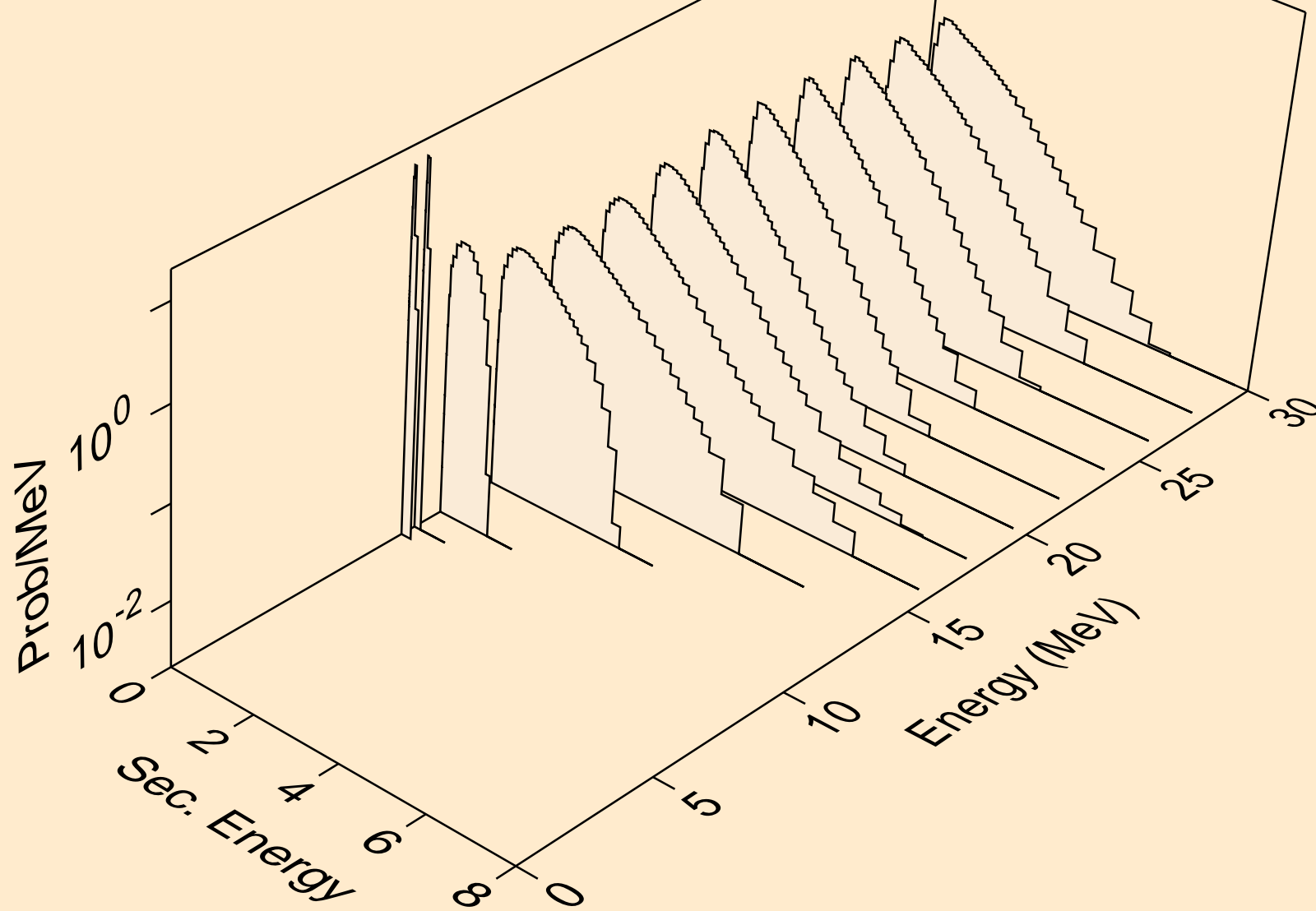

AT200M NEUTRON ACER TENDL-2023 LIBRARY; T=0.K  
Neutron emission for (n,3n)a

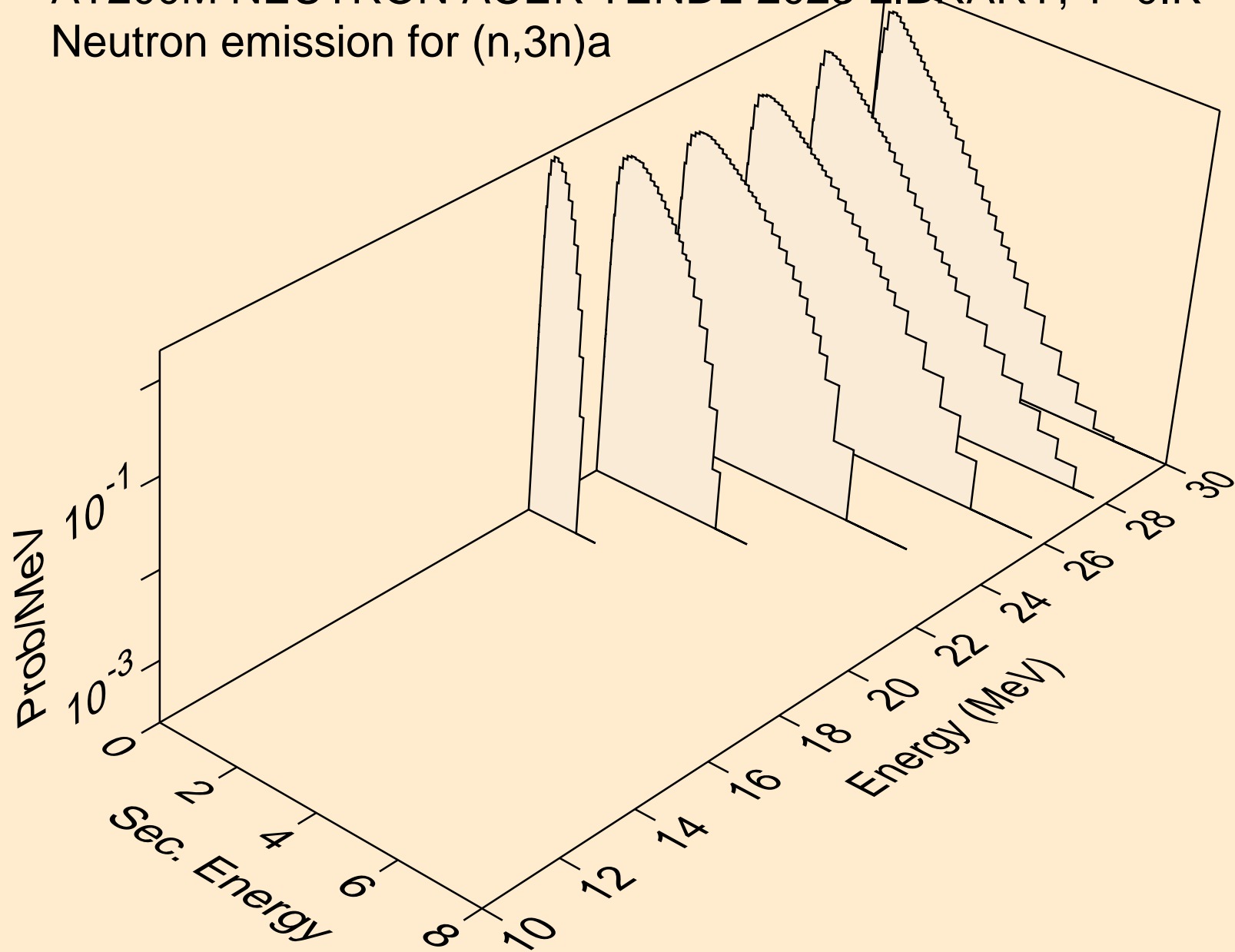

AT200M NEUTRON ACER TENDL-2023 LIBRARY; T=0.K  
Neutron emission for (n,n\*)p

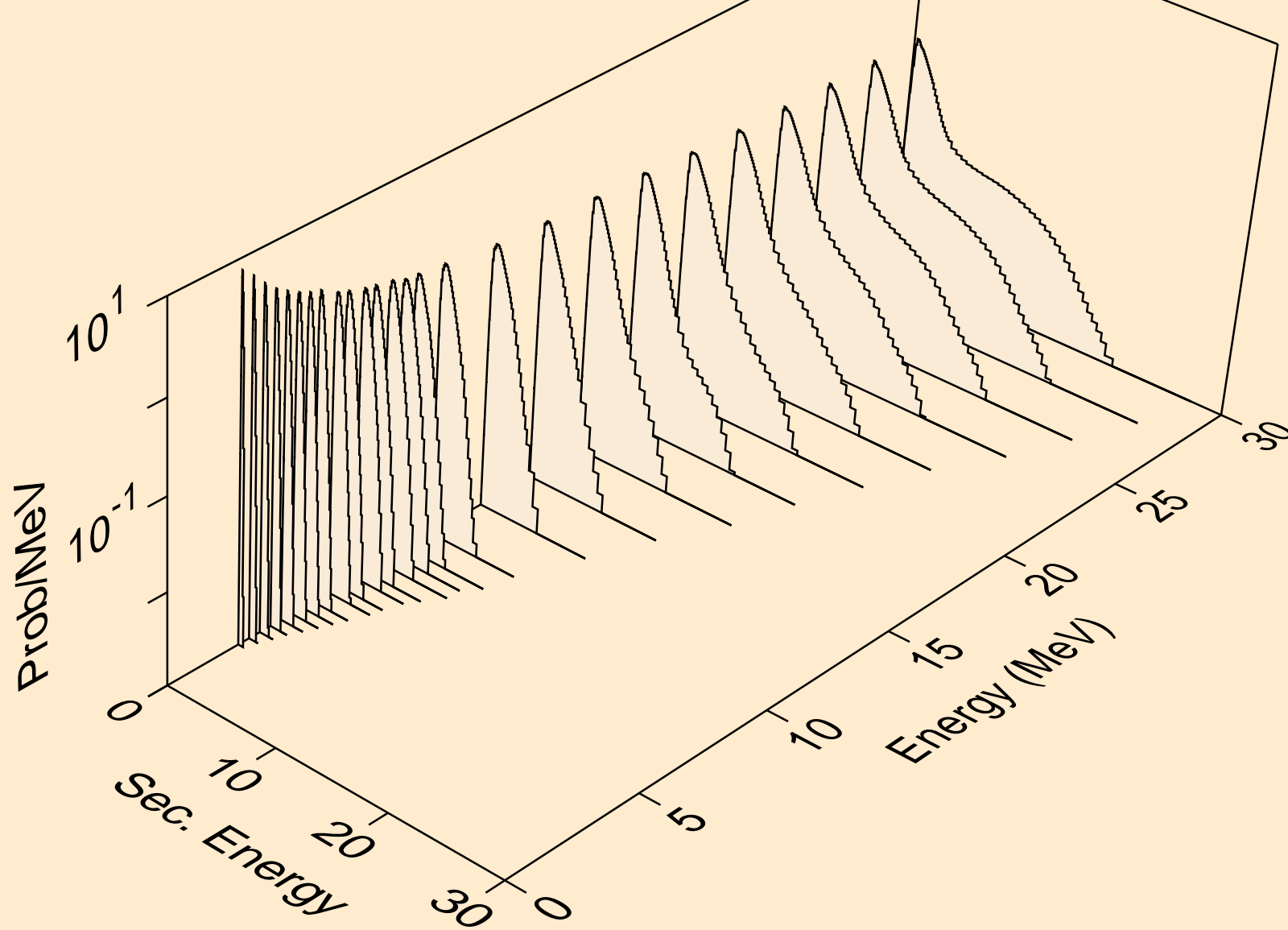

AT200M NEUTRON ACER TENDL-2023 LIBRARY; T=0.K  
Neutron emission for (n,n\*)2a

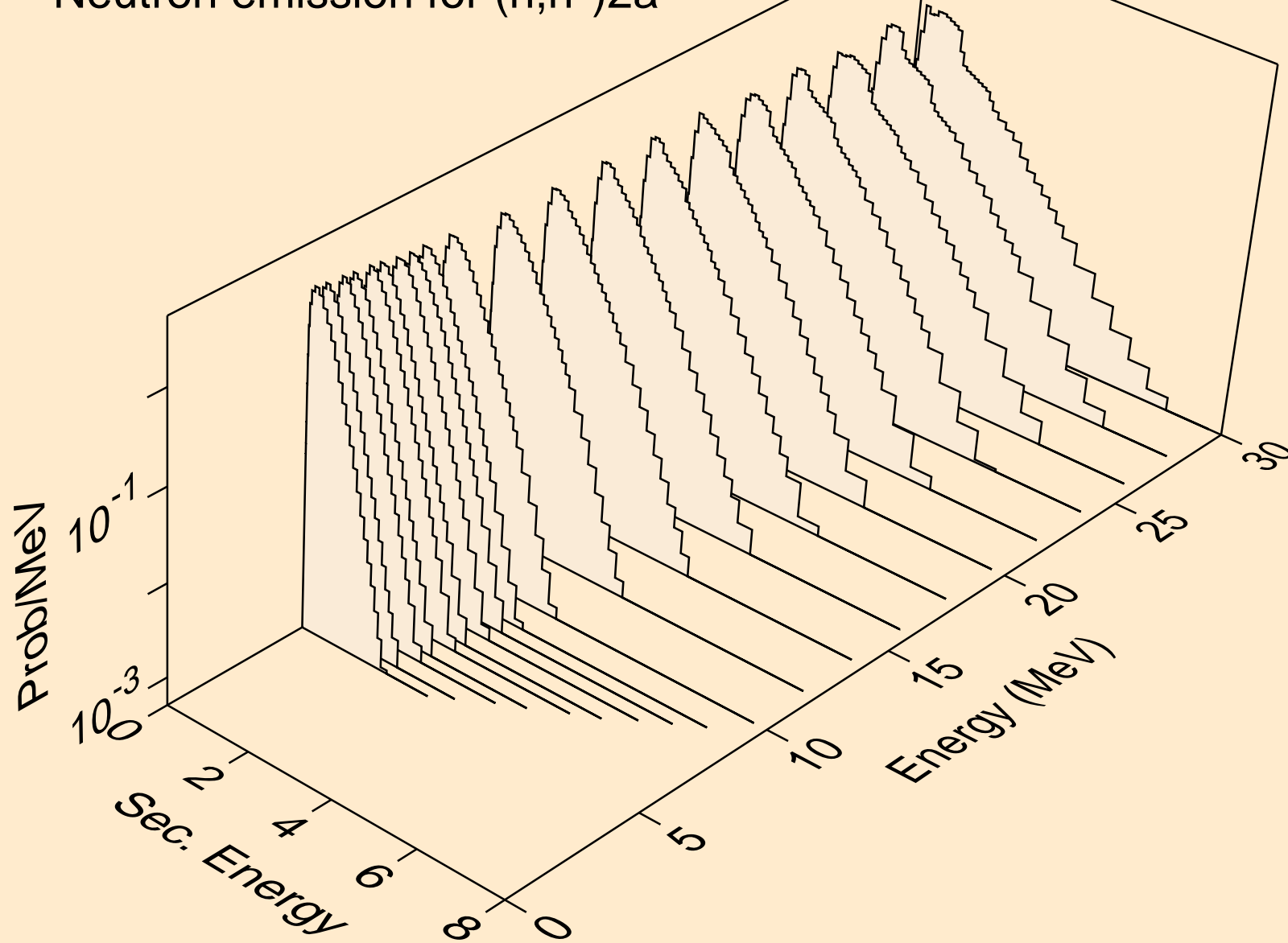



AT200M NEUTRON ACER TENDL-2023 LIBRARY; T=0.K  
Neutron emission for (n,2n)2a

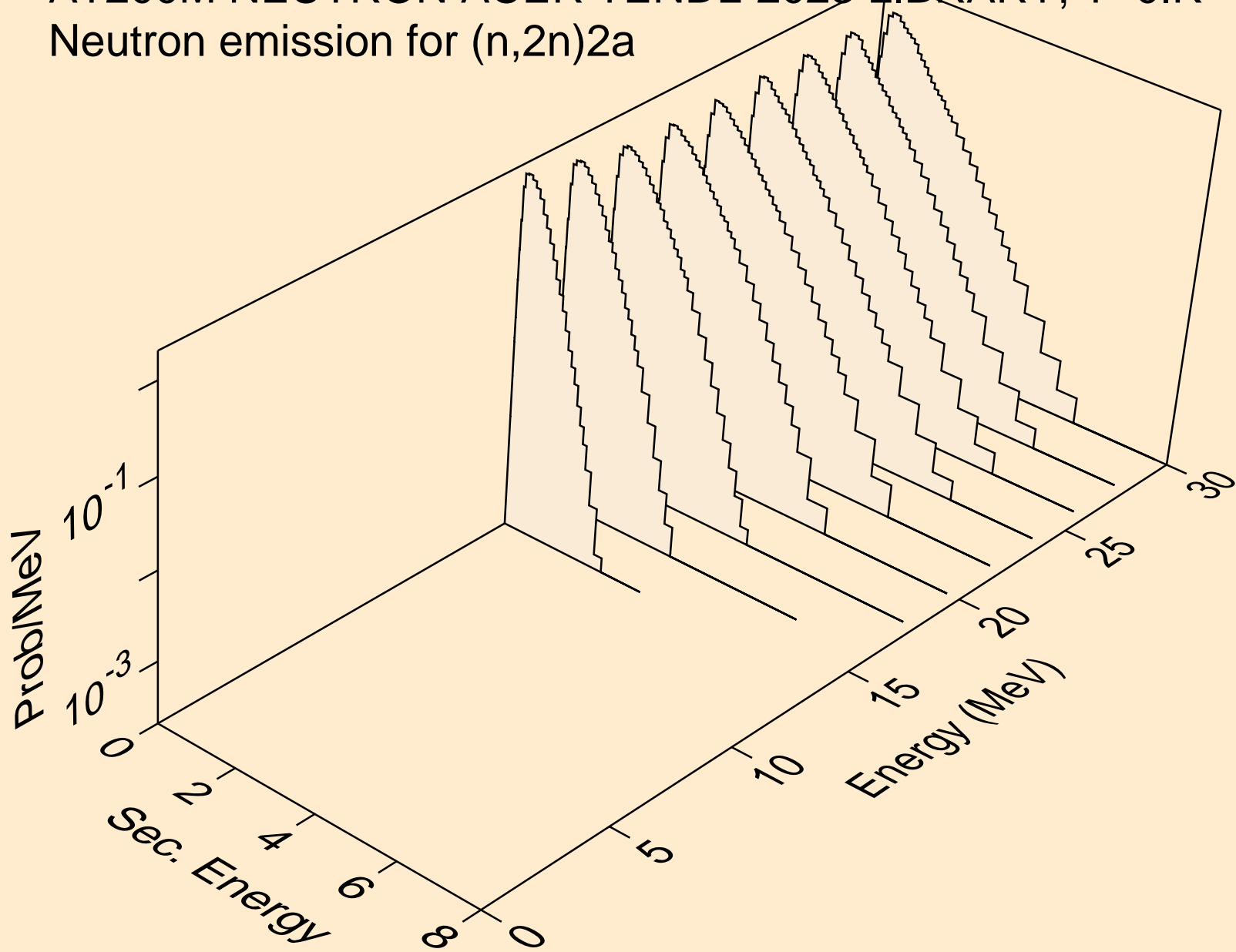

AT200M NEUTRON ACER TENDL-2023 LIBRARY; T=0.K  
Neutron emission for (n,n\*)d

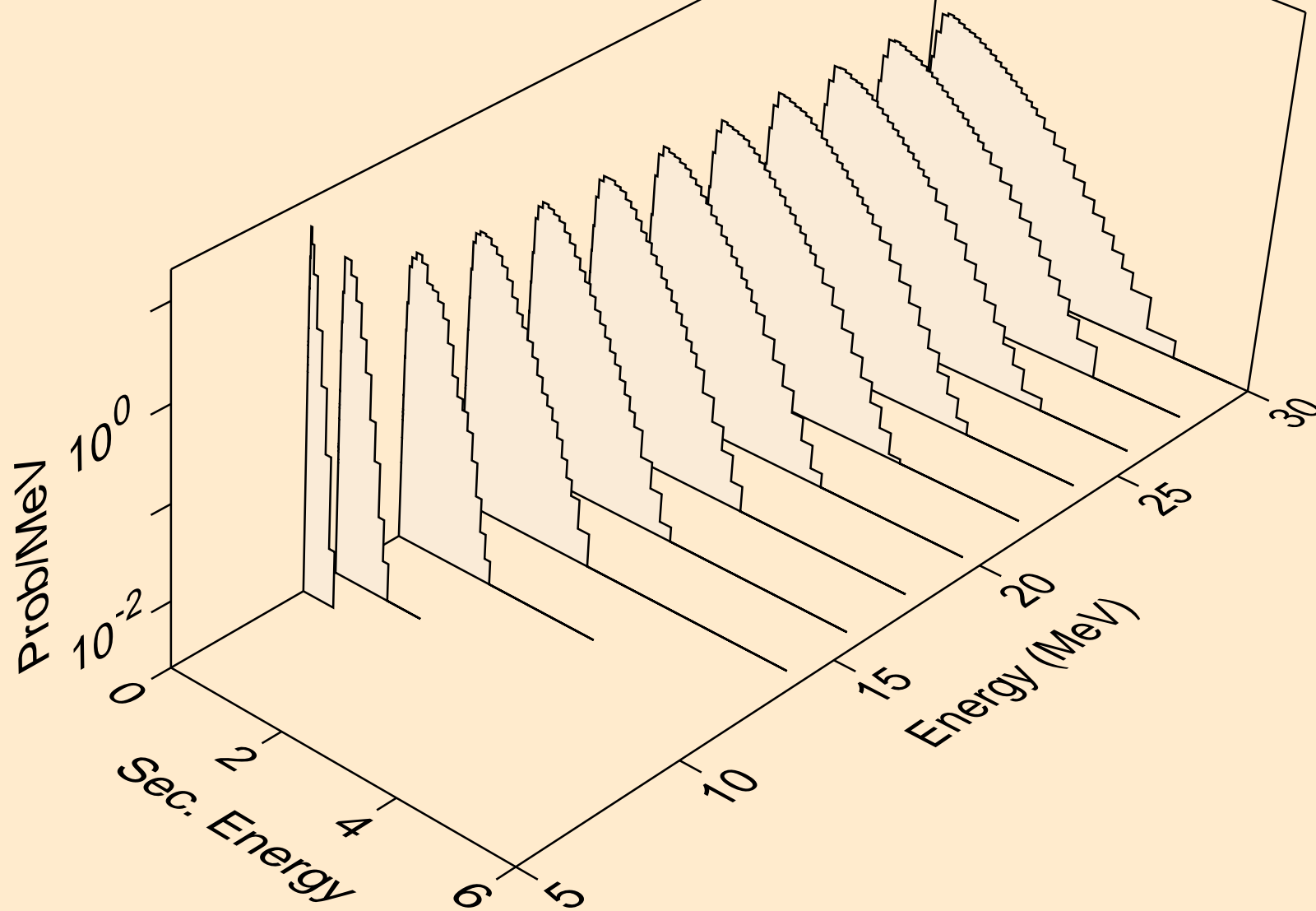

AT200M NEUTRON ACER TENDL-2023 LIBRARY; T=0.K  
Neutron emission for (n,n\*)t

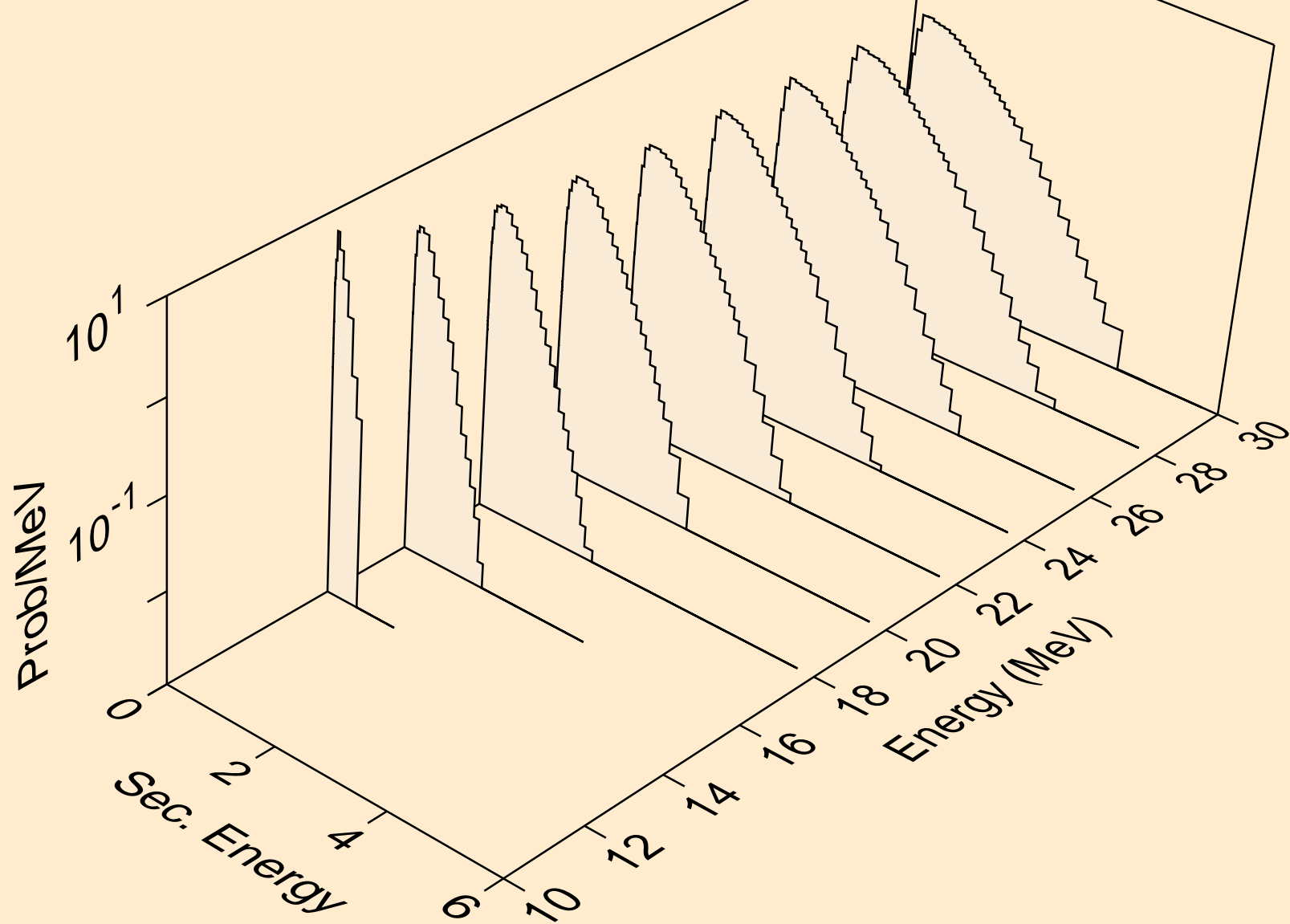

AT200M NEUTRON ACER TENDL-2023 LIBRARY; T=0.K  
Neutron emission for (n,n\*)he3

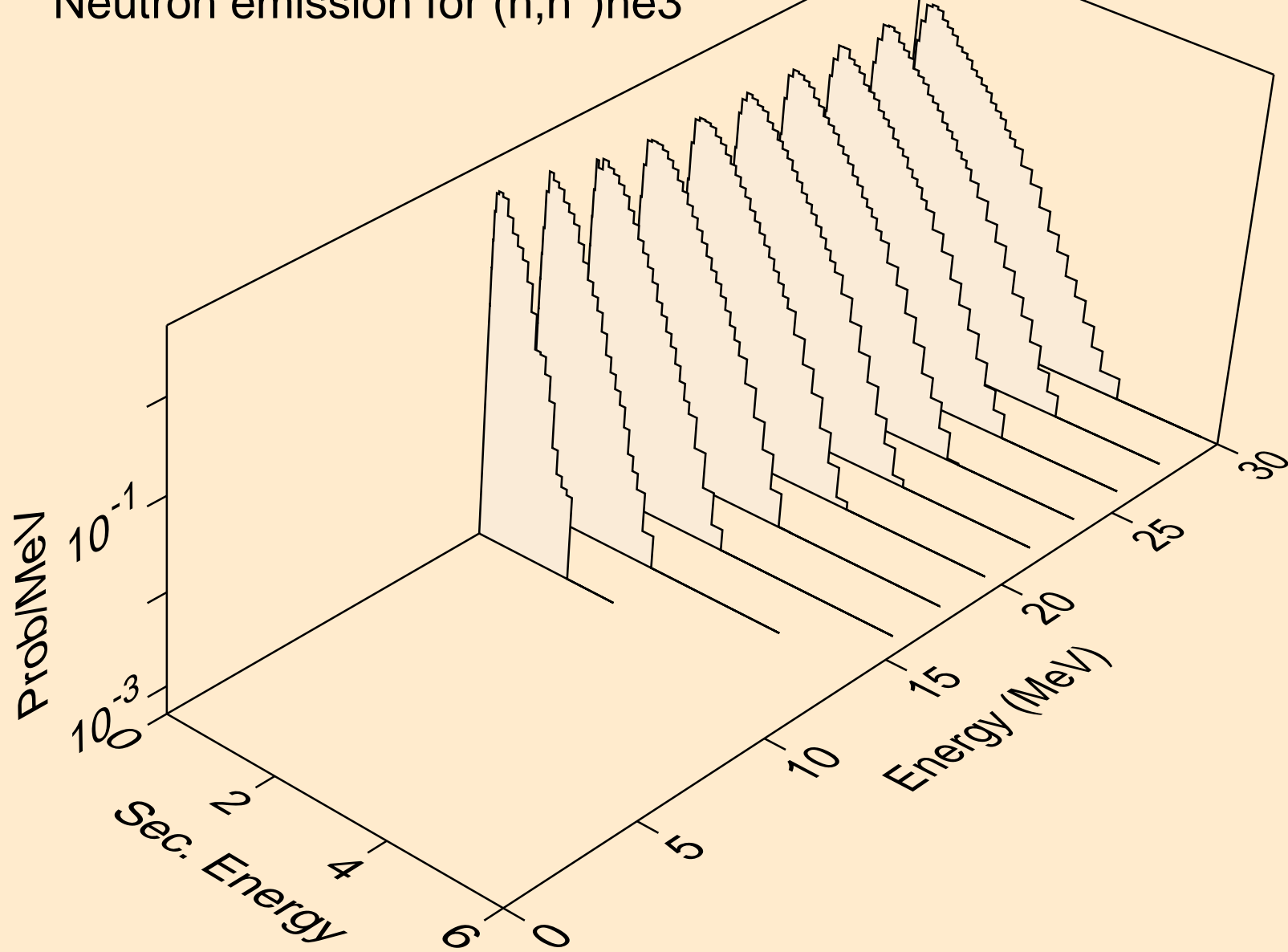

AT200M NEUTRON ACER TENDL-2023 LIBRARY; T=0.K  
Neutron emission for (n,4n)

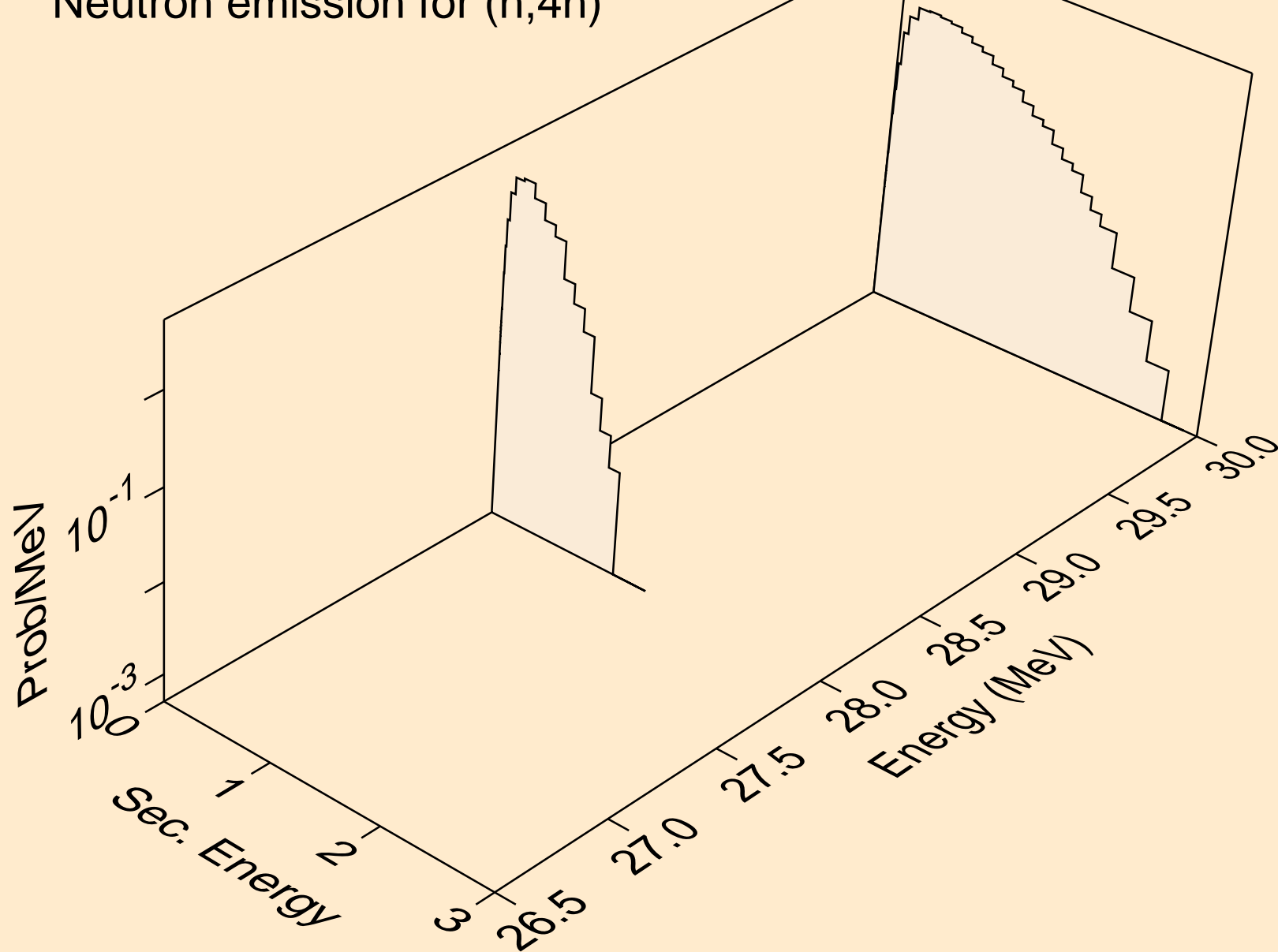

AT200M NEUTRON ACER TENDL-2023 LIBRARY; T=0.K  
Neutron emission for (n,2np)

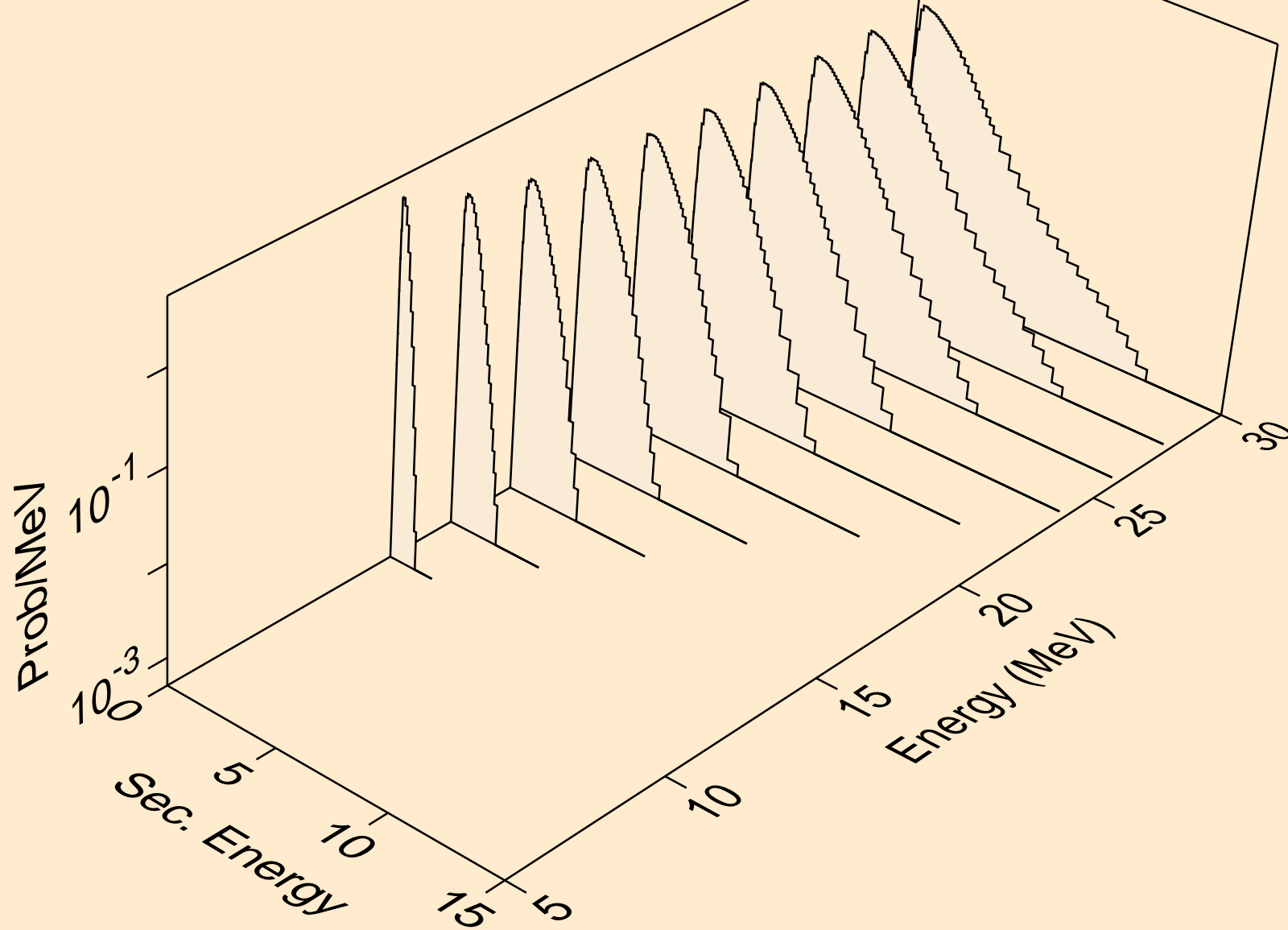

AT200M NEUTRON ACER TENDL-2023 LIBRARY; T=0.K  
Neutron emission for (n,3np)

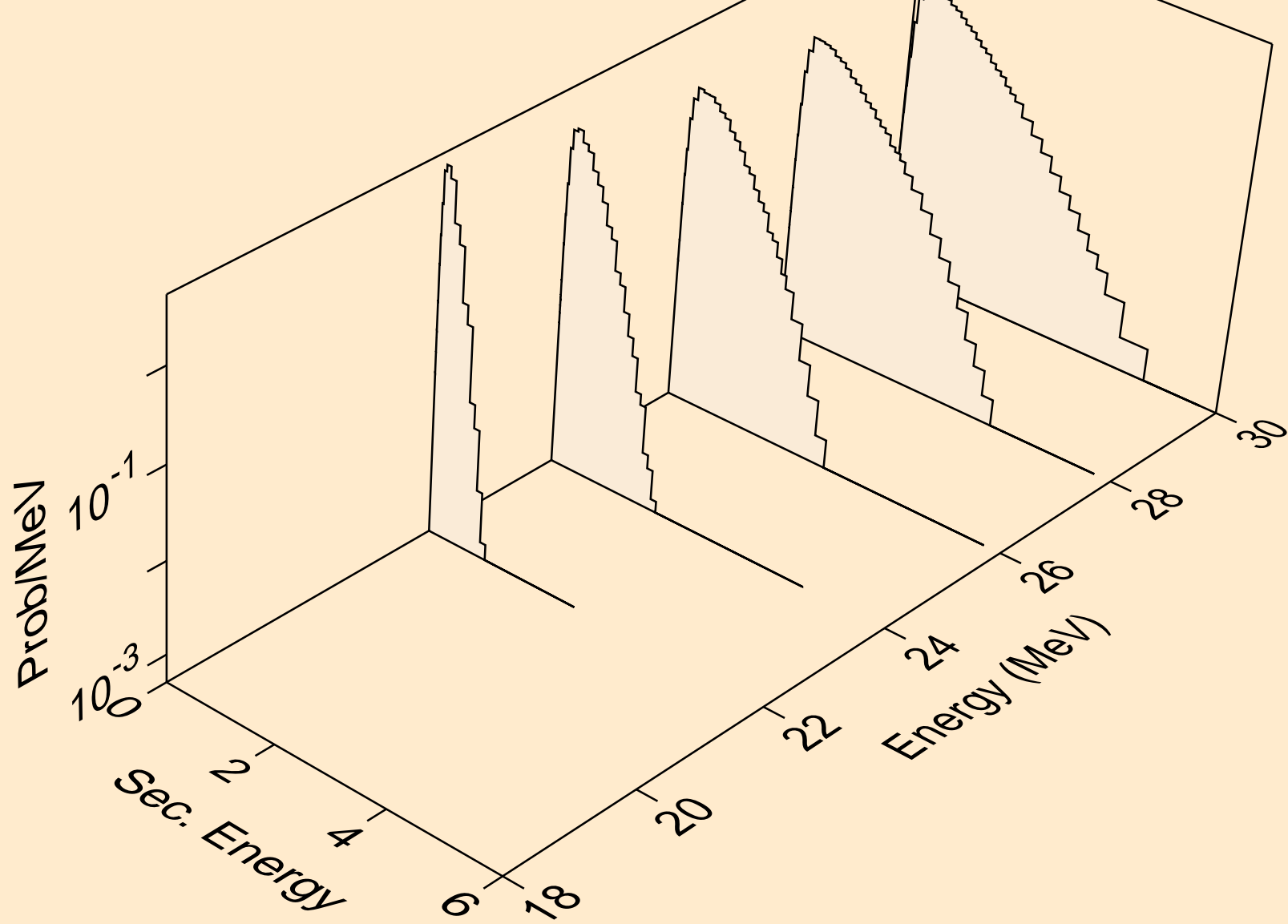

AT200M NEUTRON ACER TENDL-2023 LIBRARY; T=0.K  
Neutron emission for (n,n2p)

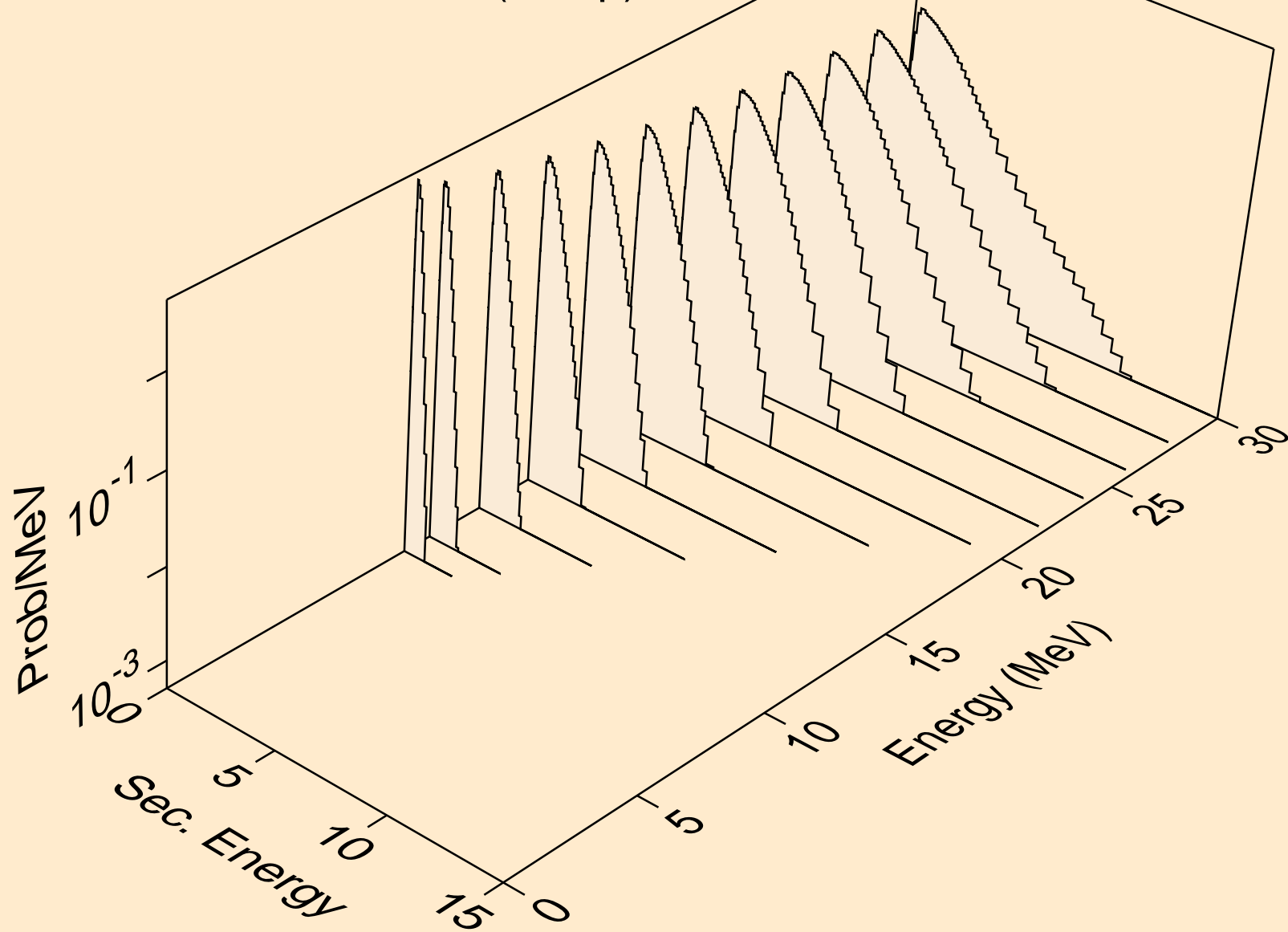



AT200M NEUTRON ACER TENDL-2023 LIBRARY; T=0.K  
Neutron emission for (n,npa)

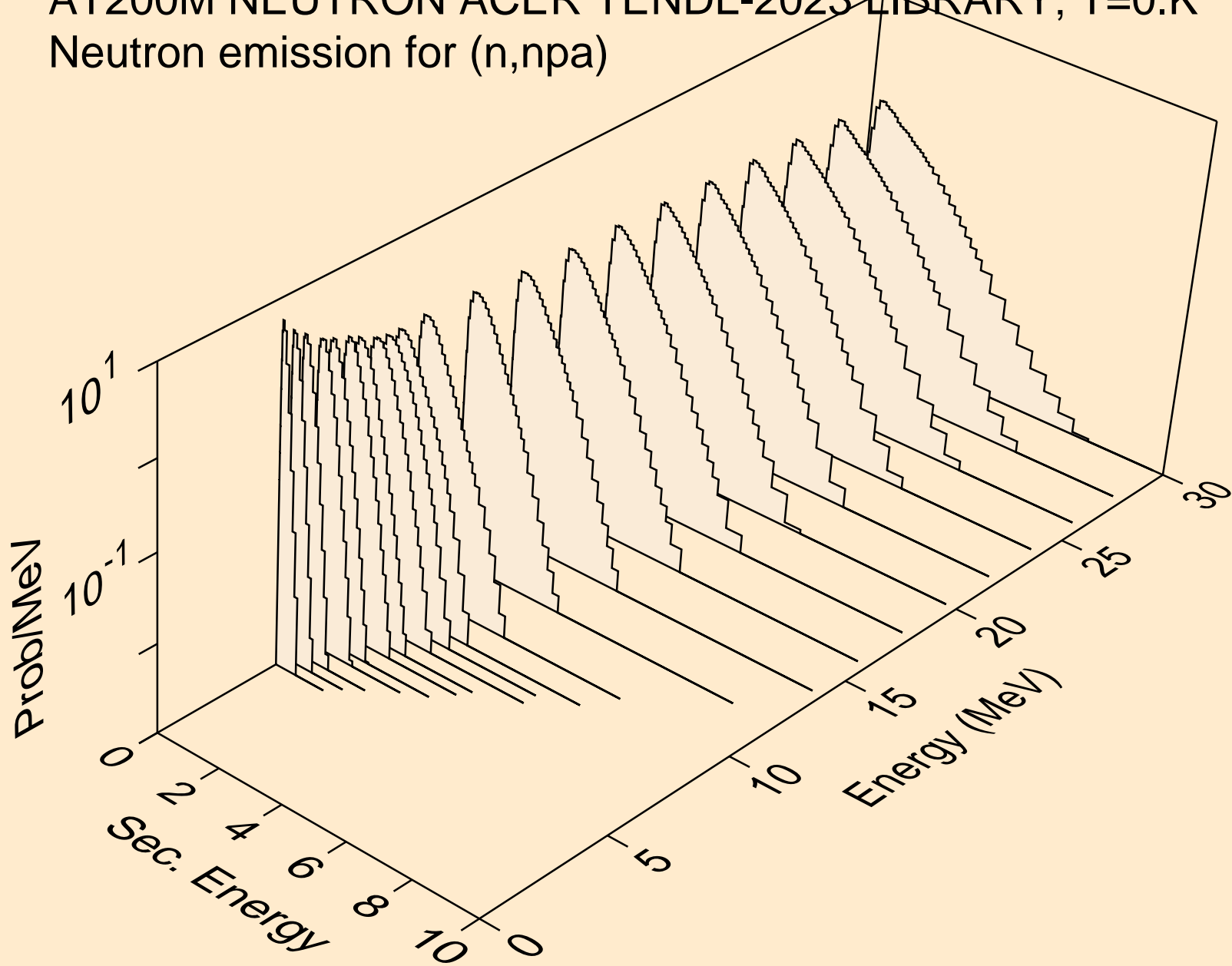

AT200M NEUTRON ACER TENDL-2023 LIBRARY; T=0.K  
Neutron emission for (n,n\*c)

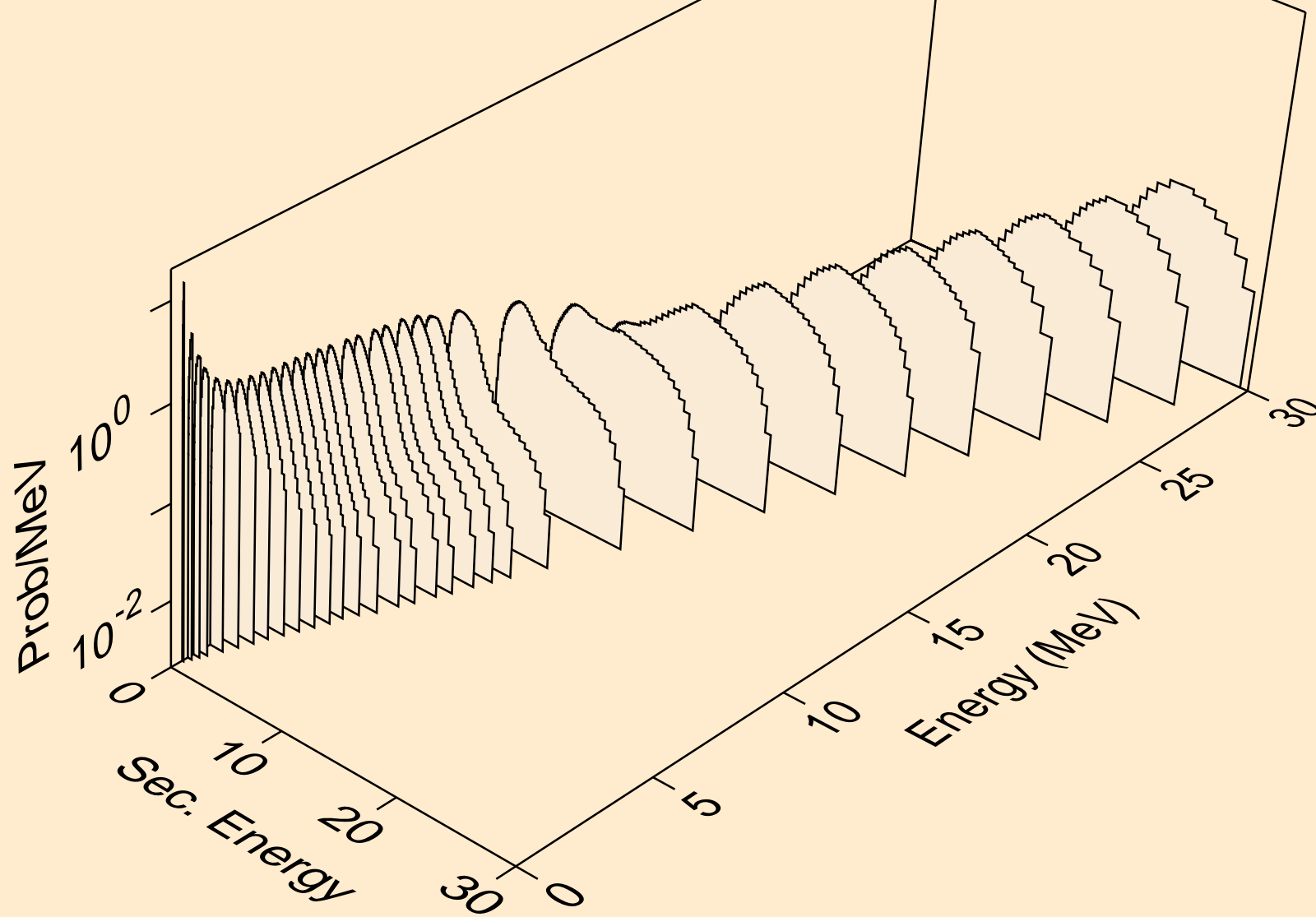

AT200M NEUTRON ACER TENDL-2023 LIBRARY; T=0.K  
Photon emission for (n,x)

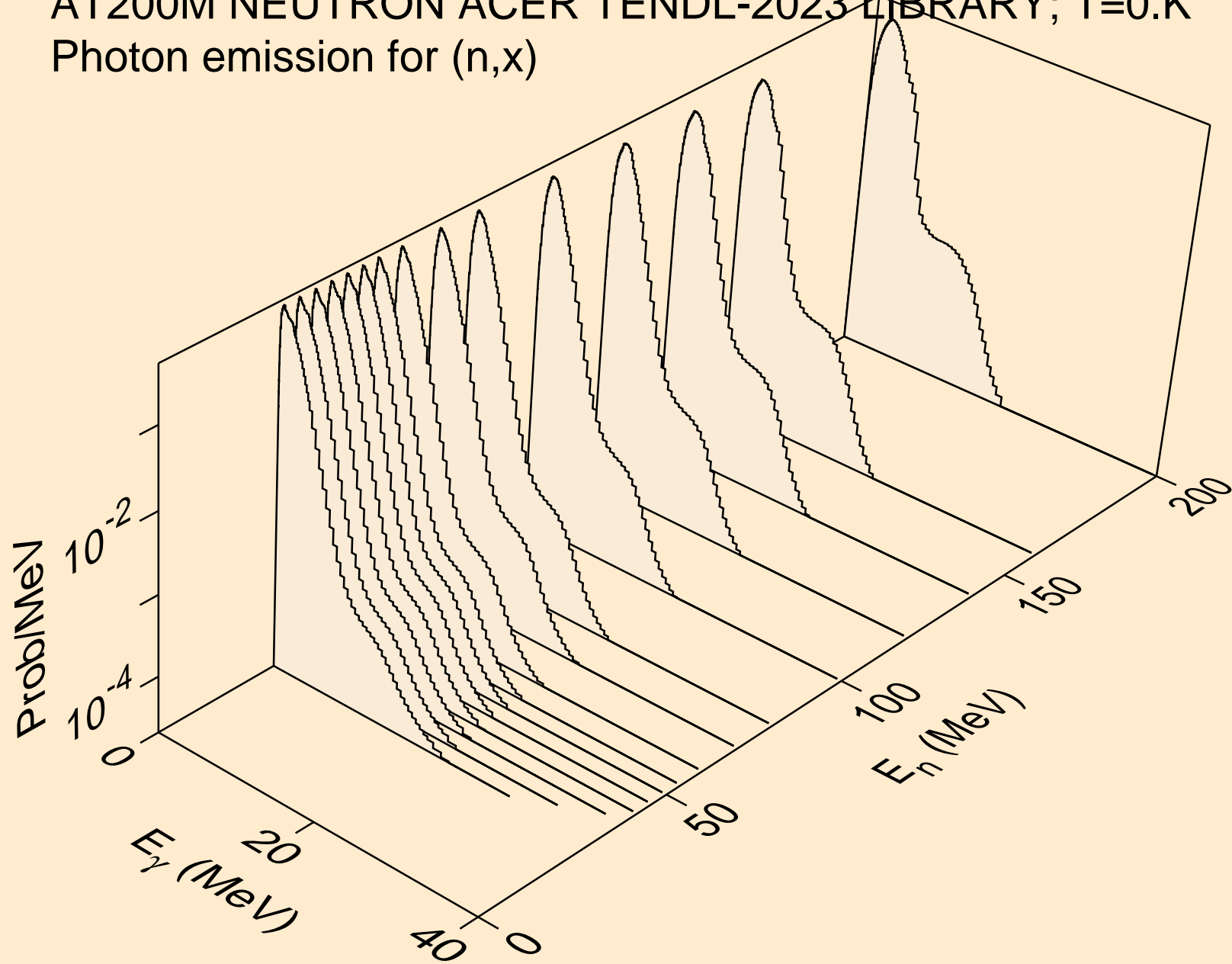

AT200M NEUTRON ACER TENDL-2023 LIBRARY; T=0.K  
Photon emission for (n,2nd)

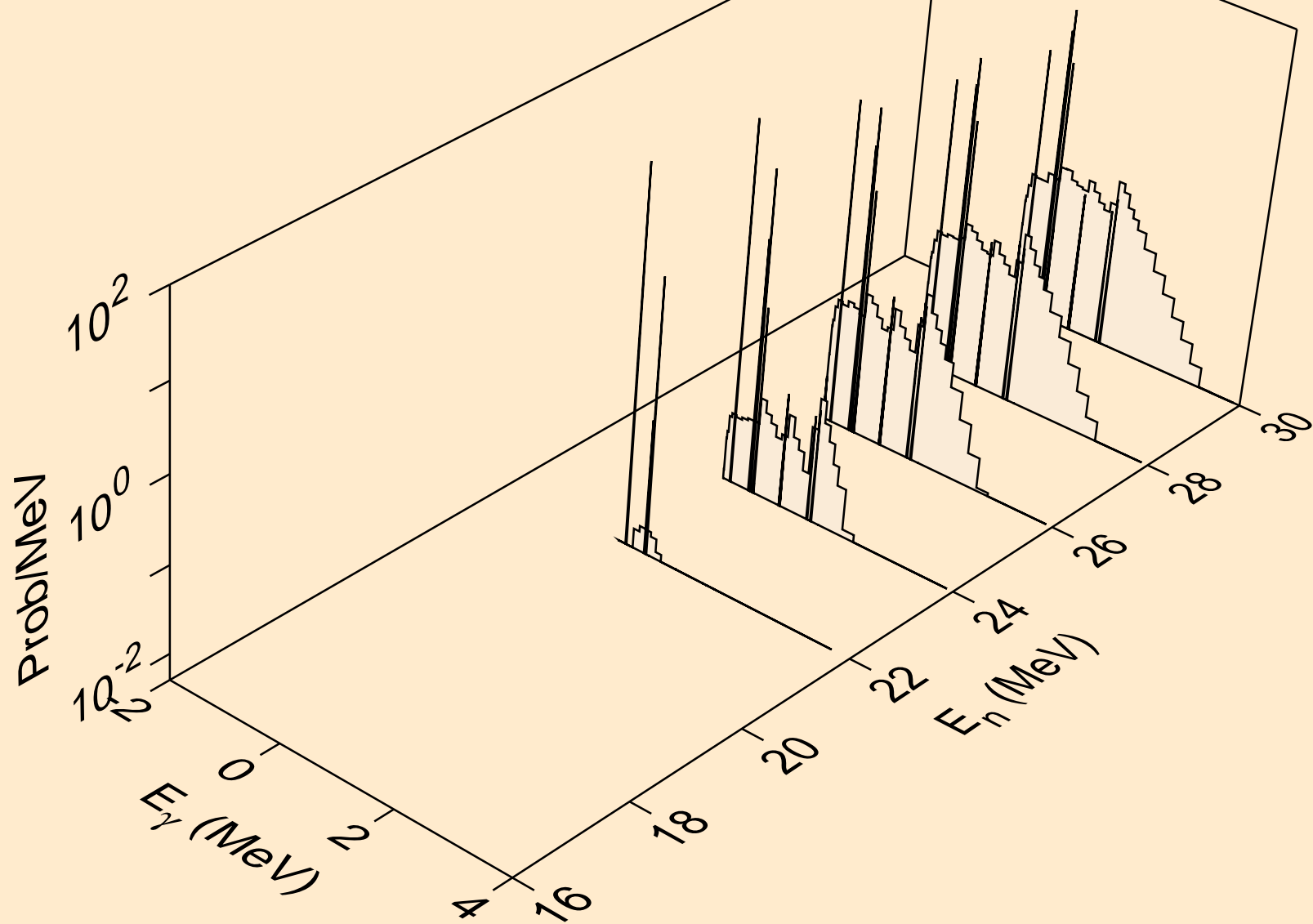

AT200M NEUTRON ACER TENDL-2023 LIBRARY; T=0.K  
Photon emission for (n,2n)

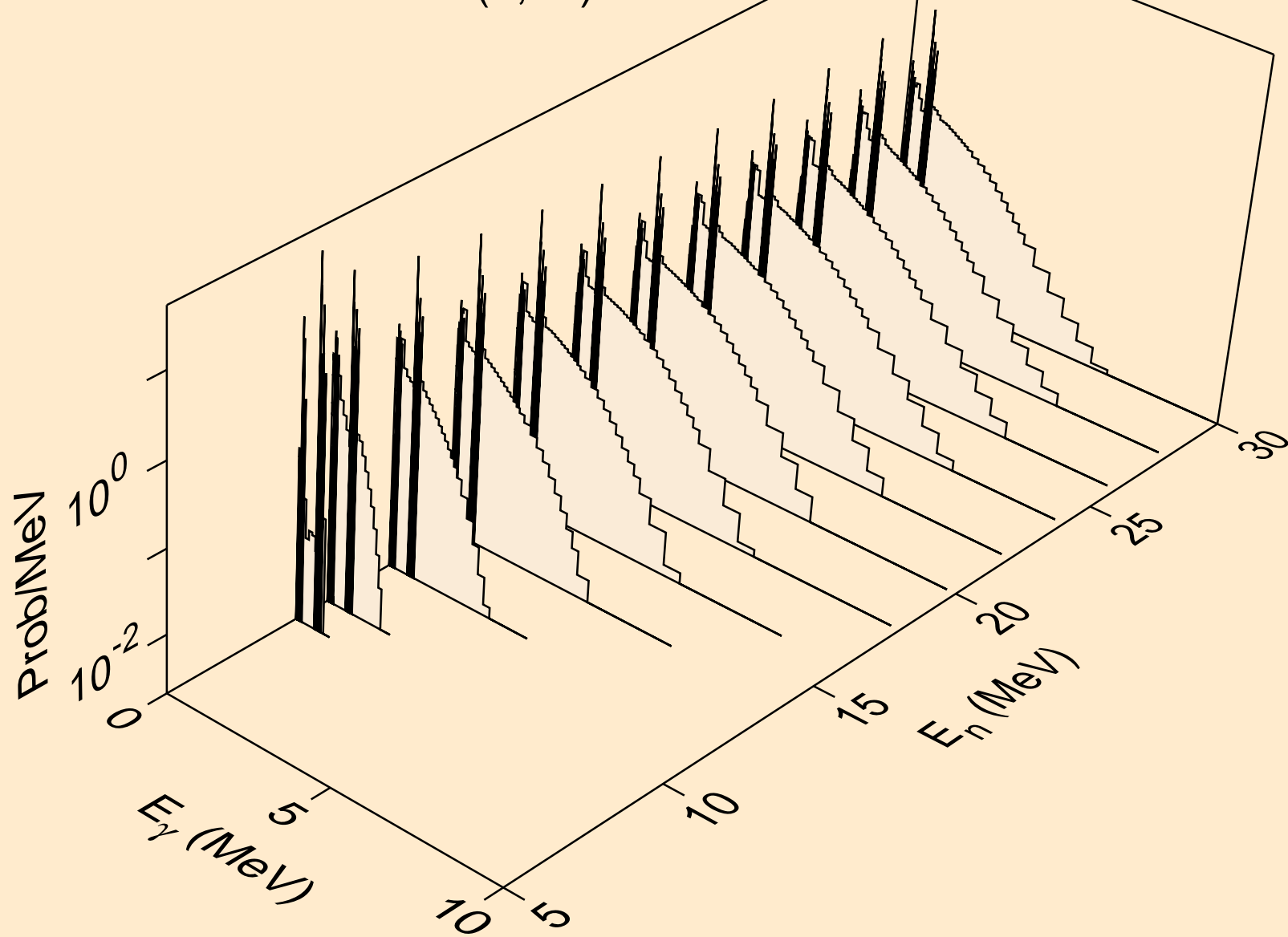

AT200M NEUTRON ACER TENDL-2023 LIBRARY; T=0.K  
Photon emission for (n,3n)

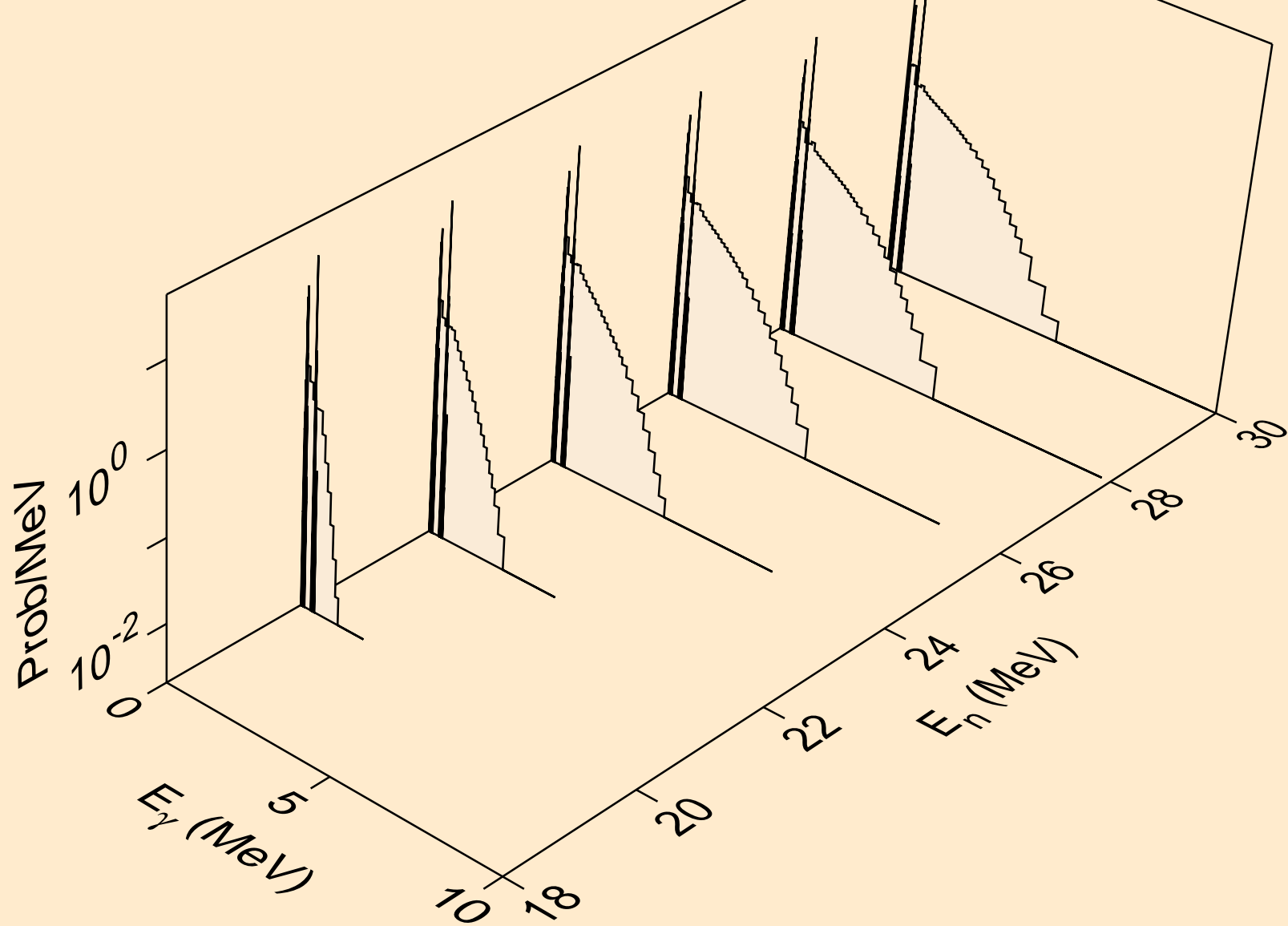

AT200M NEUTRON ACER TENDL-2023 LIBRARY; T=0.K  
Photon emission for (n,n\*)a

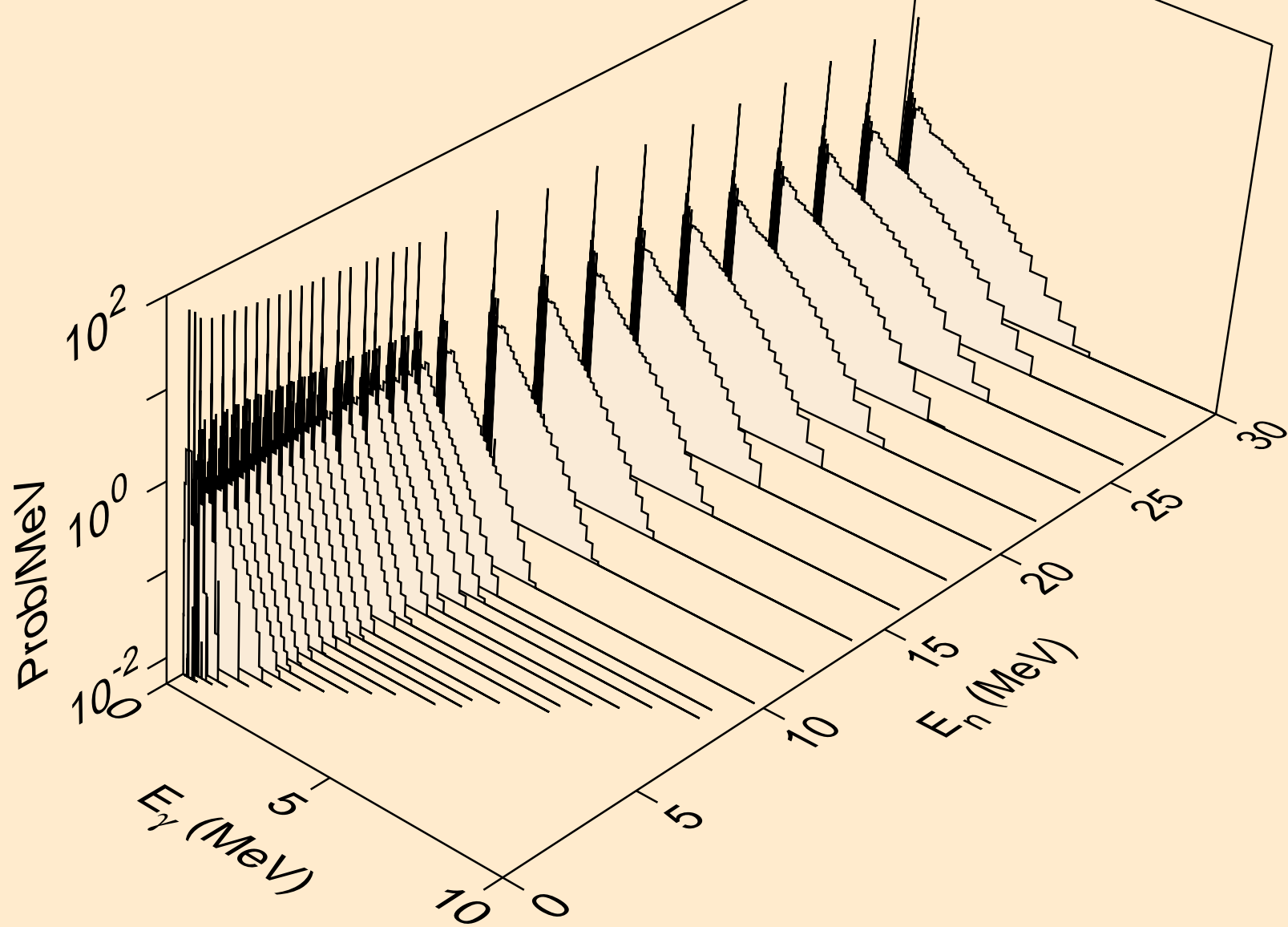

AT200M NEUTRON ACER TENDL-2023 LIBRARY; T=0.K  
Photon emission for (n,2n)a

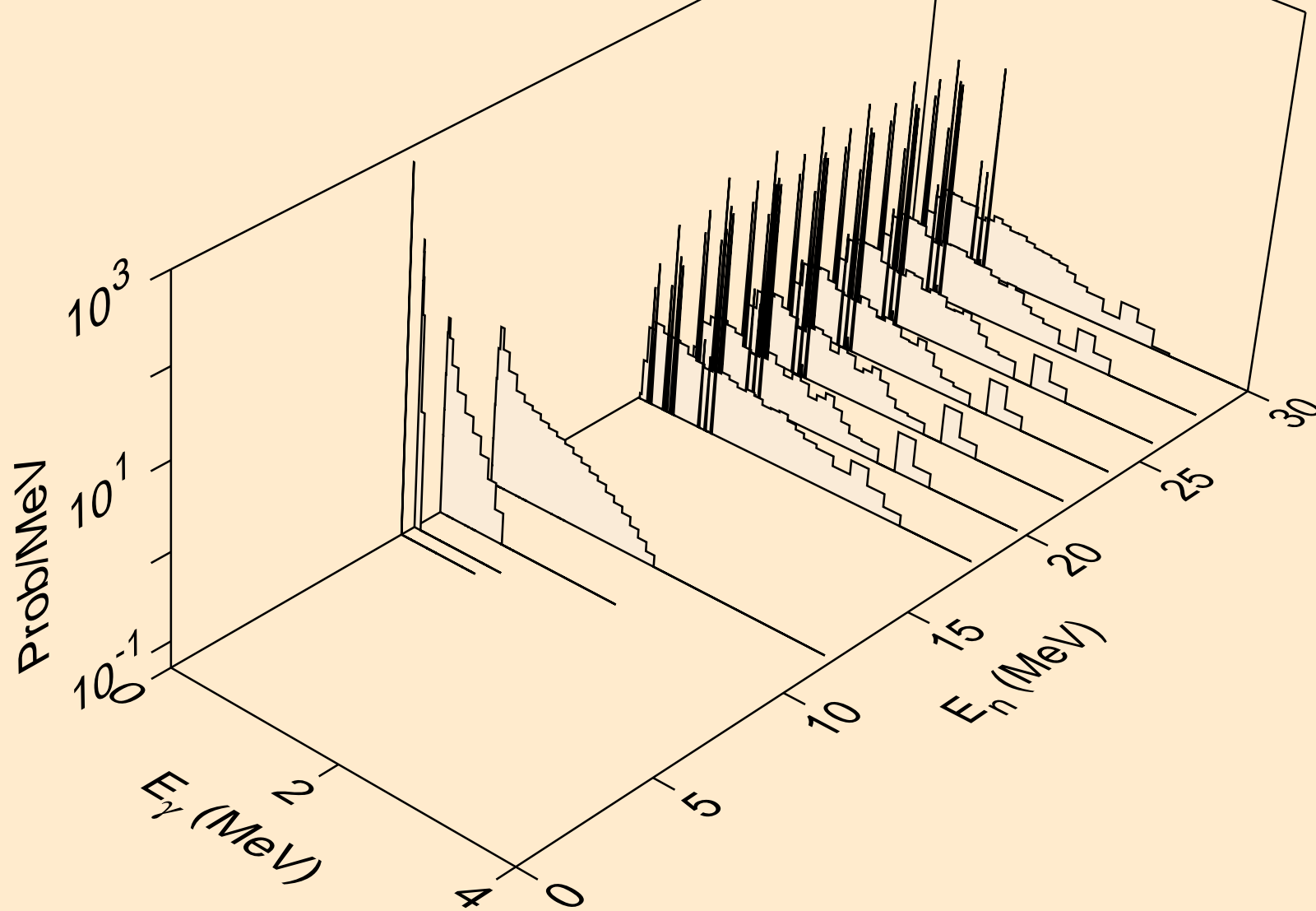



AT200M NEUTRON ACER TENDL-2023 LIBRARY; T=0.K  
Photon emission for (n,3n)a

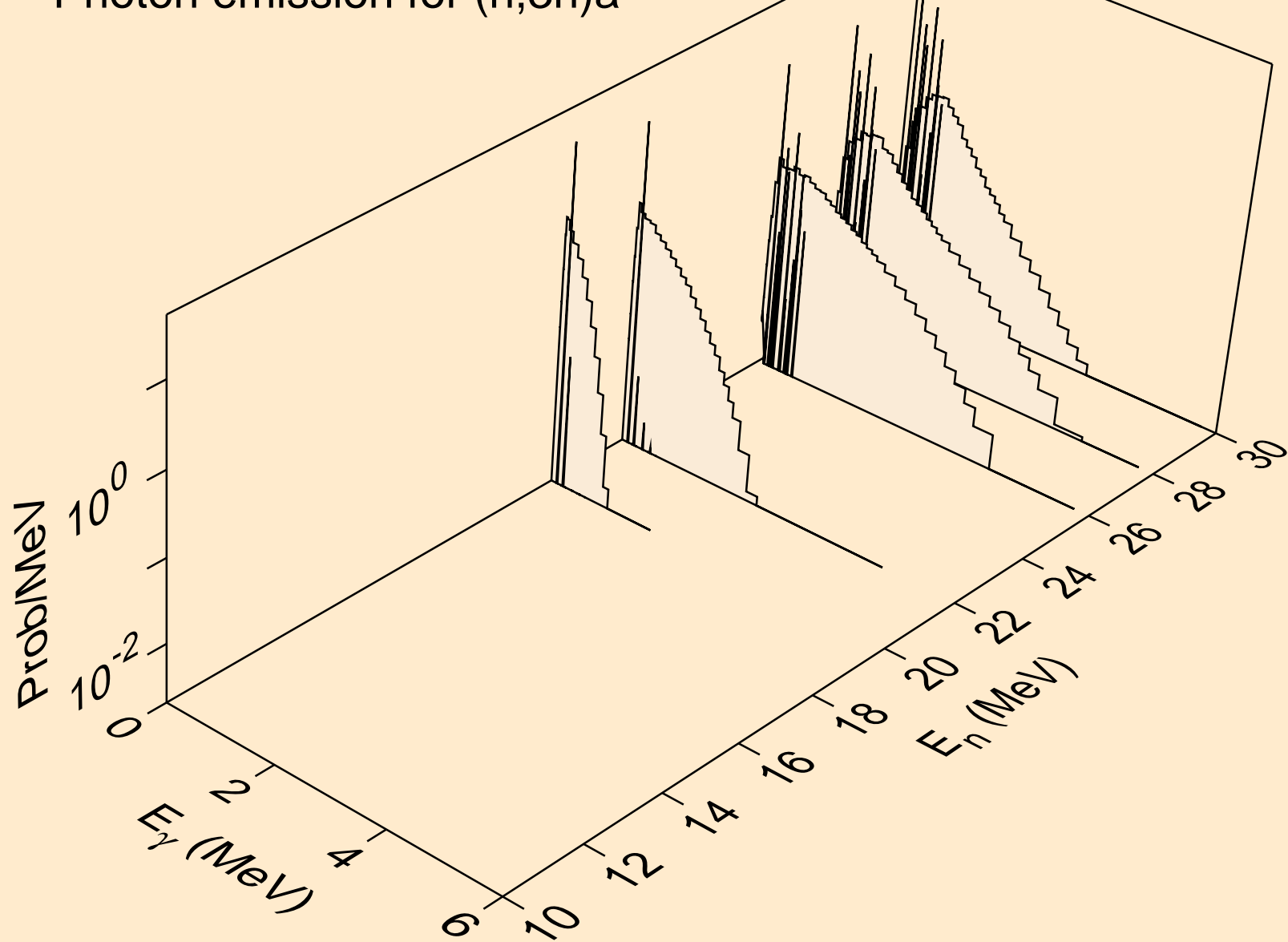

AT200M NEUTRON ACER TENDL-2023 LIBRARY; T=0.K  
Photon emission for (n,n\*)p

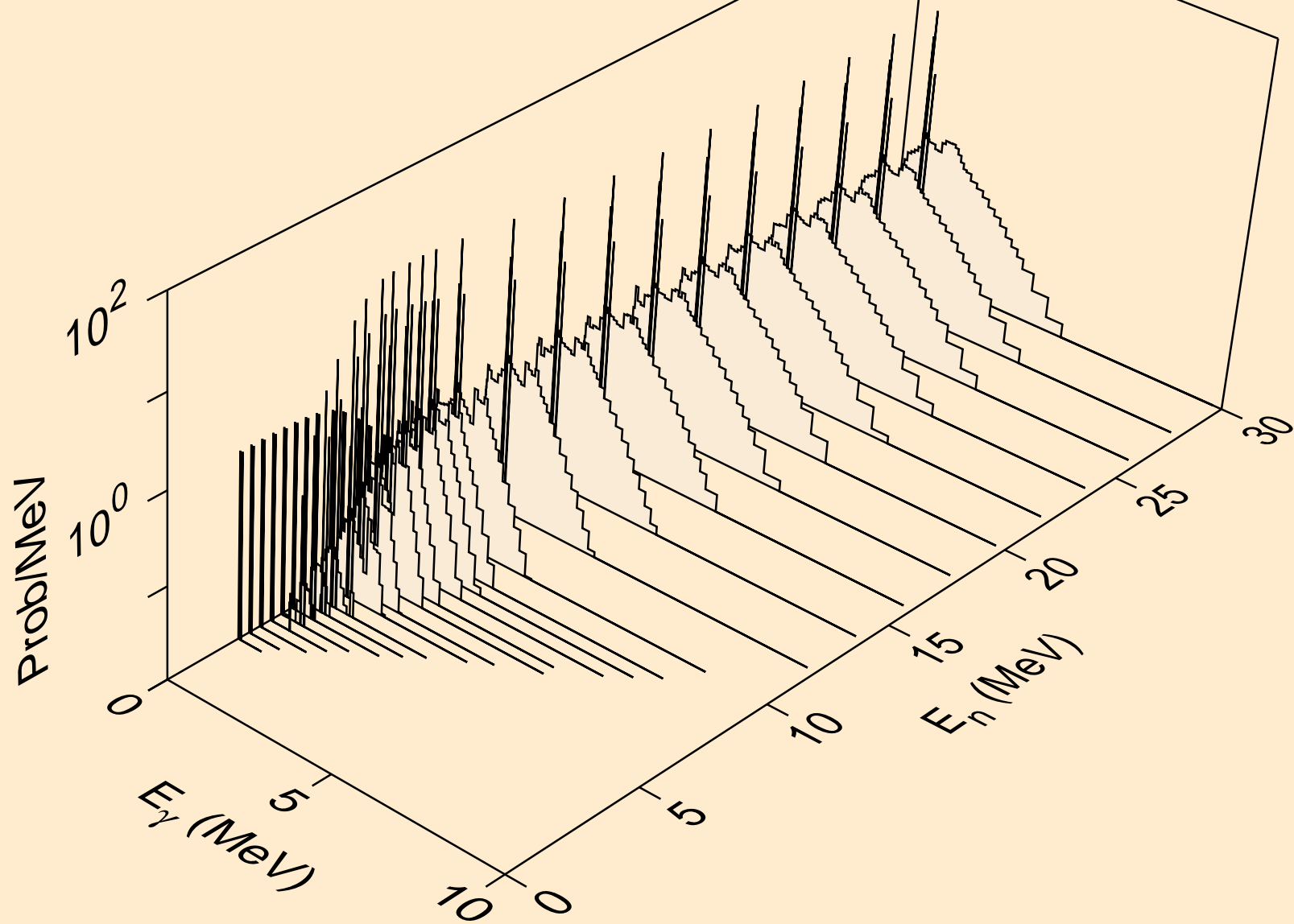

AT200M NEUTRON ACER TENDL-2023 LIBRARY; T=0.K  
Photon emission for (n,n\*)2a

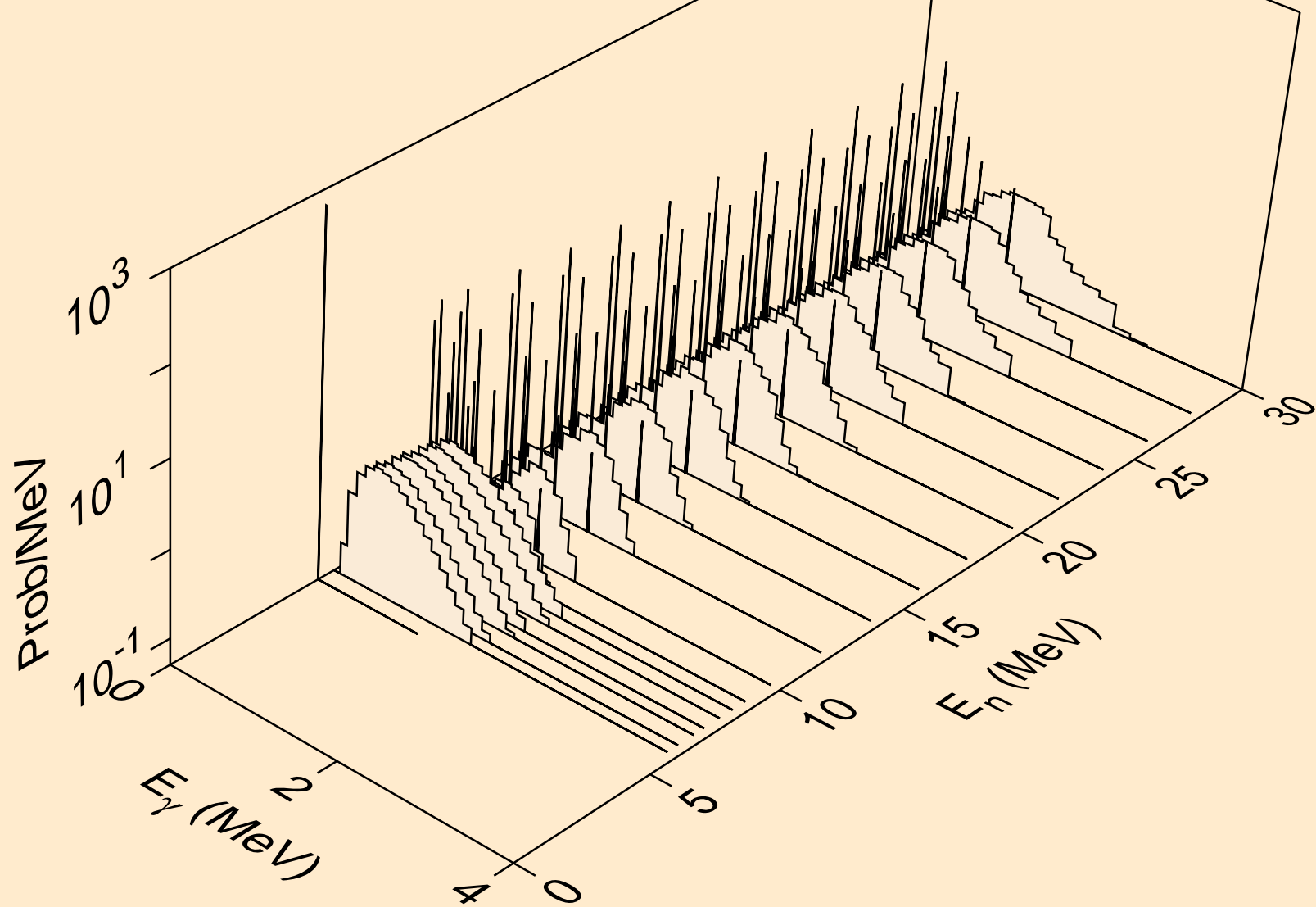

AT200M NEUTRON ACER TENDL-2023 LIBRARY; T=0.K  
Photon emission for (n,2n)2a

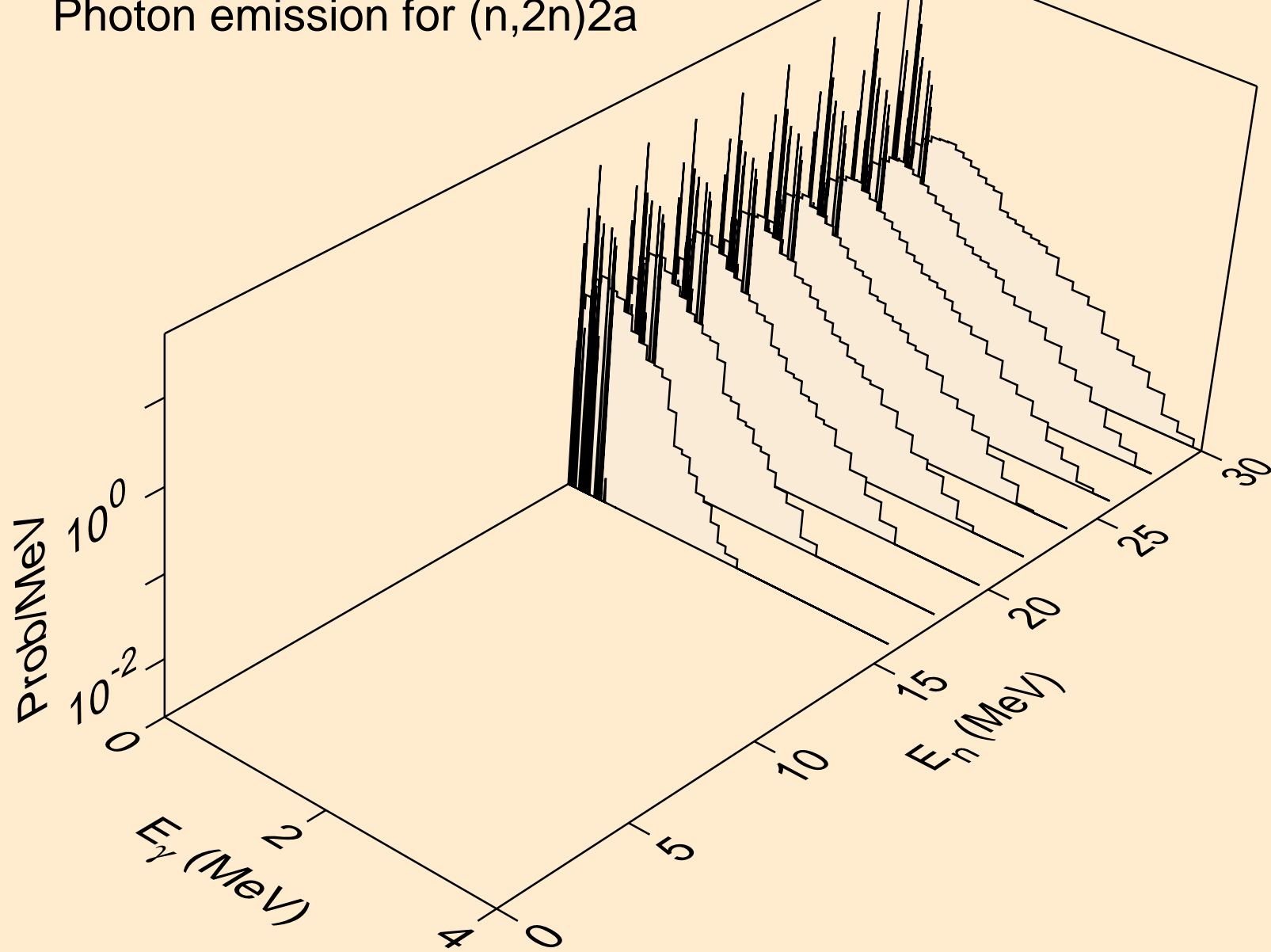

AT200M NEUTRON ACER TENDL-2023 LIBRARY; T=0.K  
Photon emission for (n,n\*)d

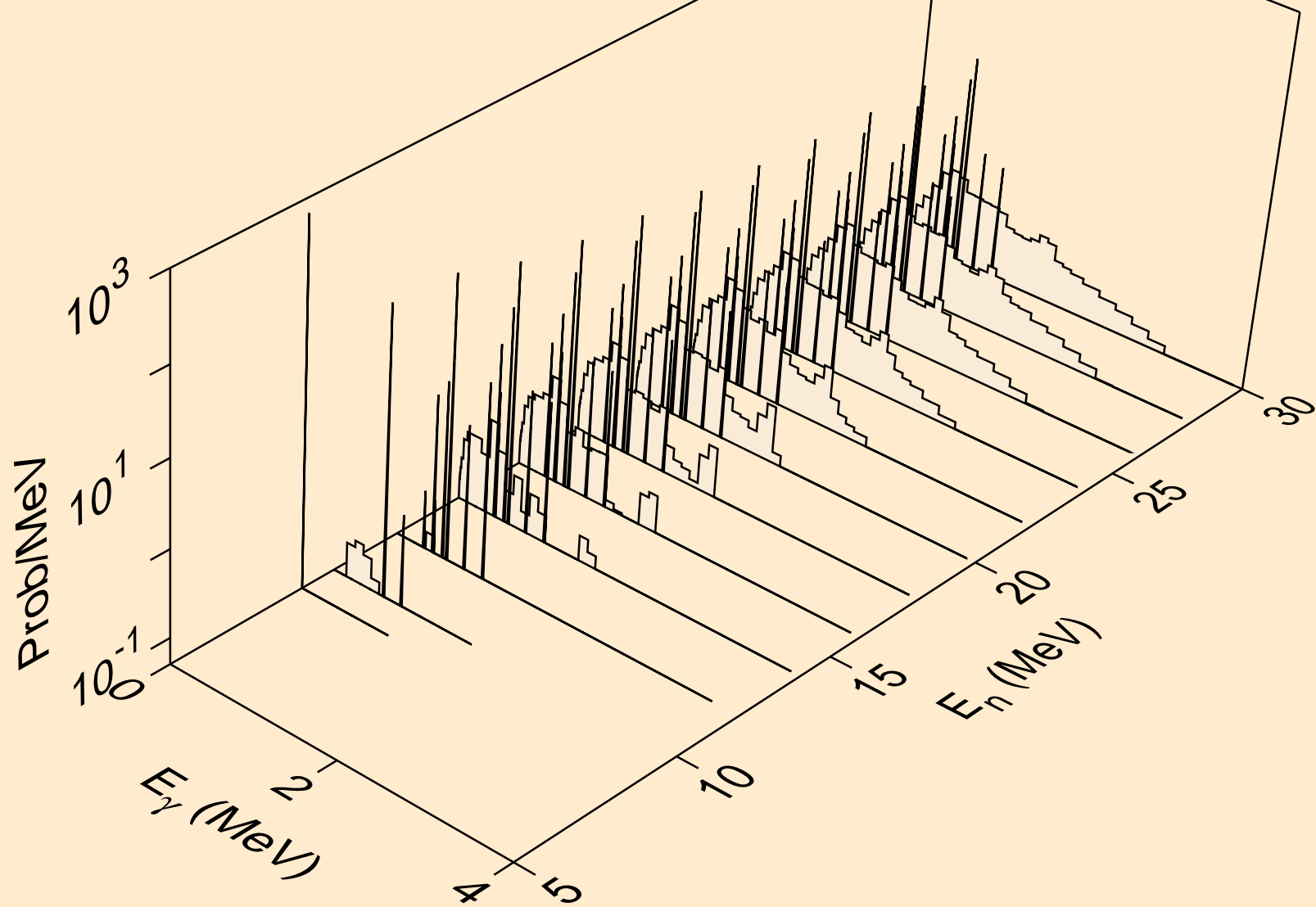

AT200M NEUTRON ACER TENDL-2023 LIBRARY; T=0.K  
Photon emission for (n,n\*)t

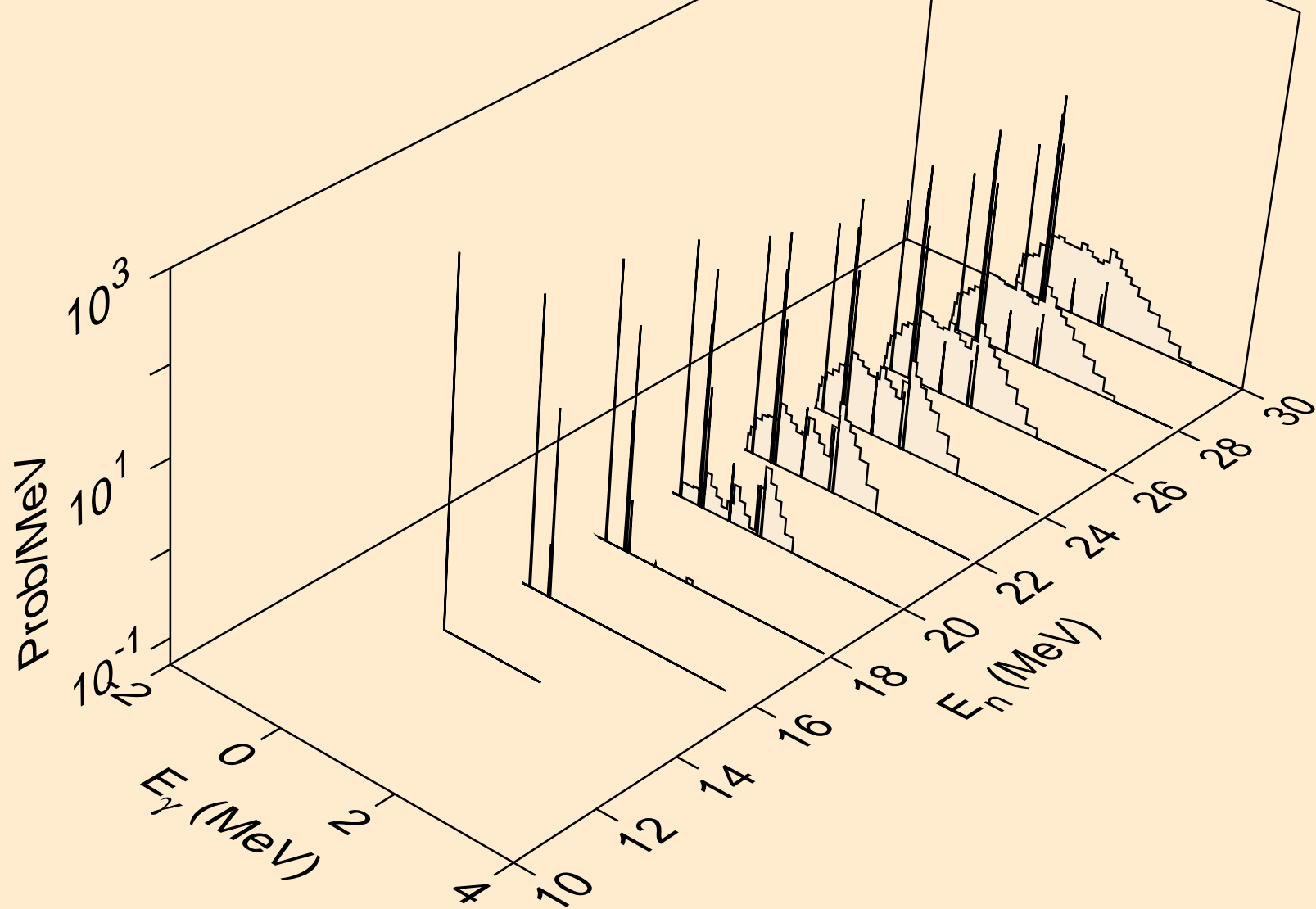

AT200M NEUTRON ACER TENDL-2023 LIBRARY; T=0.K  
Photon emission for (n,n\*)he3

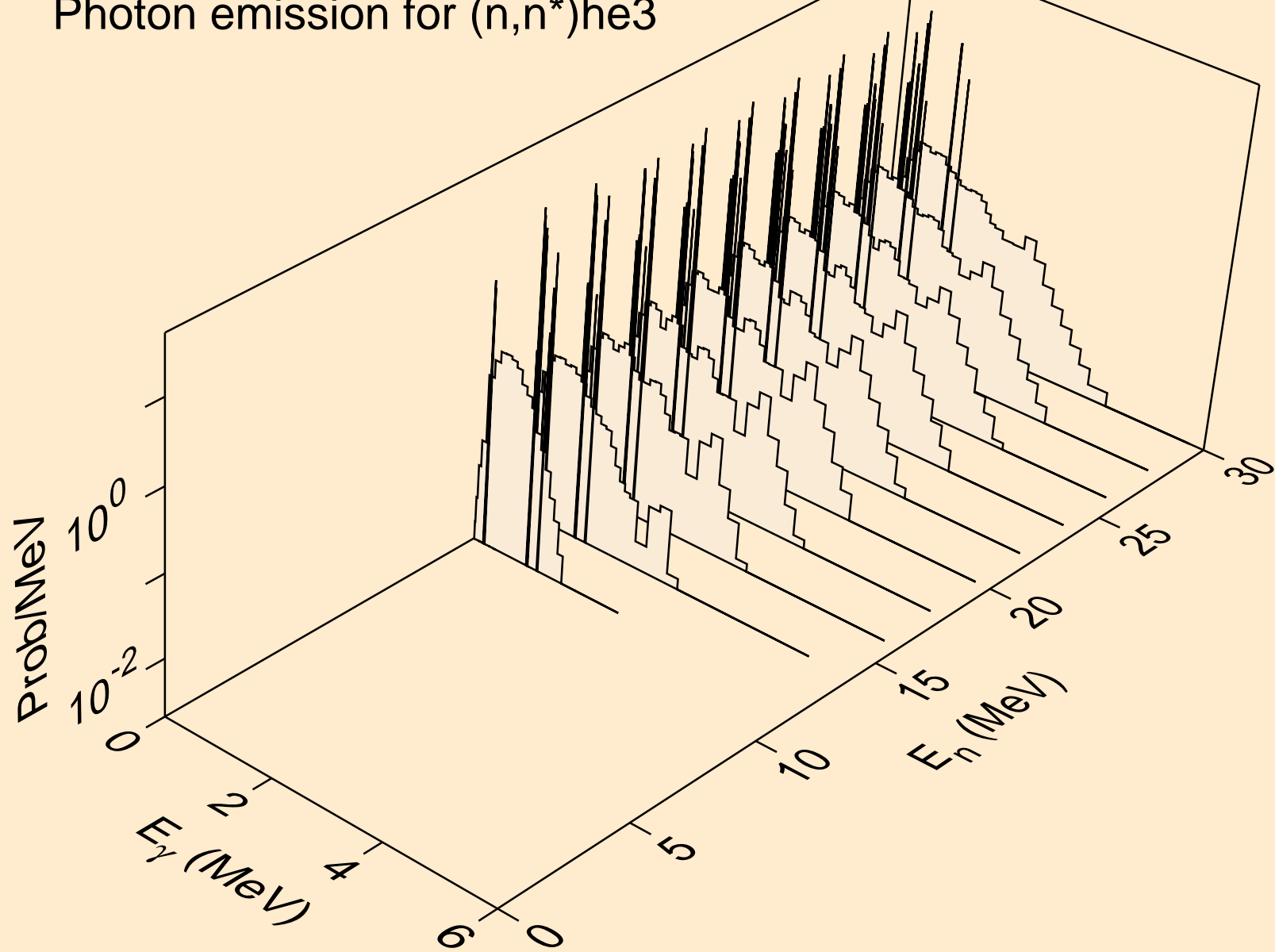

AT200M NEUTRON ACER TENDL-2023 LIBRARY; T=0.K  
Photon emission for (n,4n)

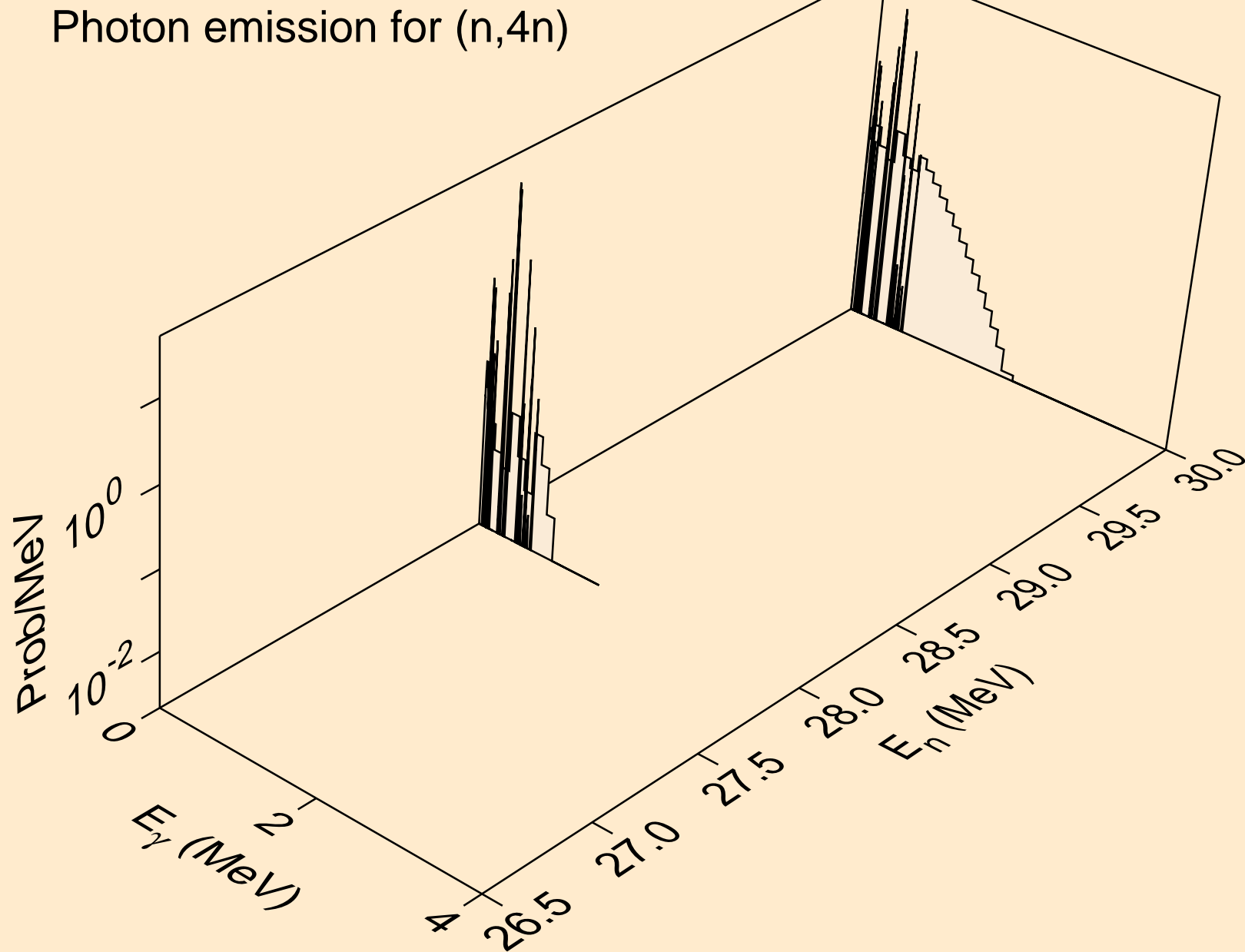



AT200M NEUTRON ACER TENDL-2023 LIBRARY; T=0.K  
Photon emission for (n,2np)

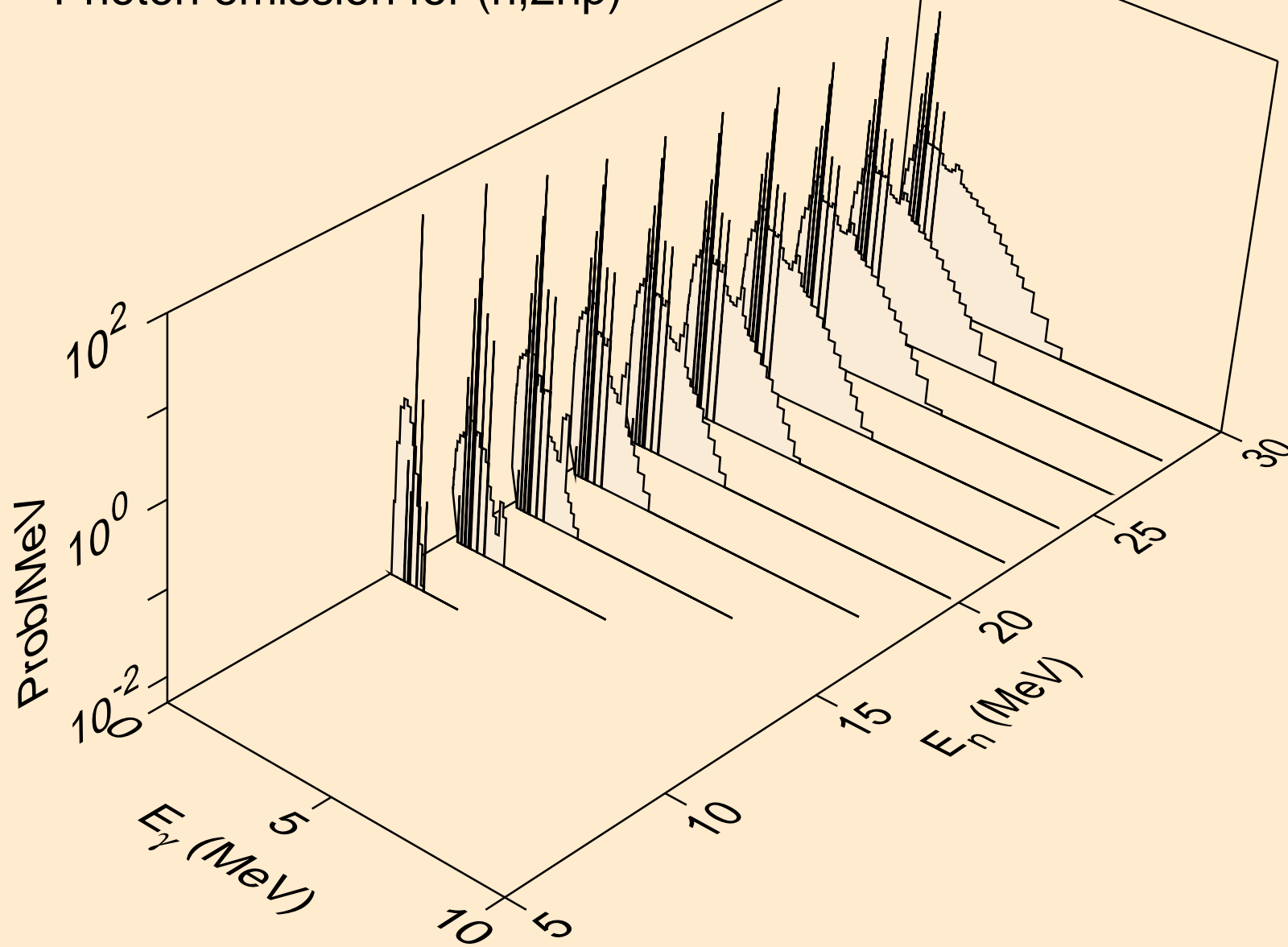

AT200M NEUTRON ACER TENDL-2023 LIBRARY; T=0.K  
Photon emission for (n,3np)

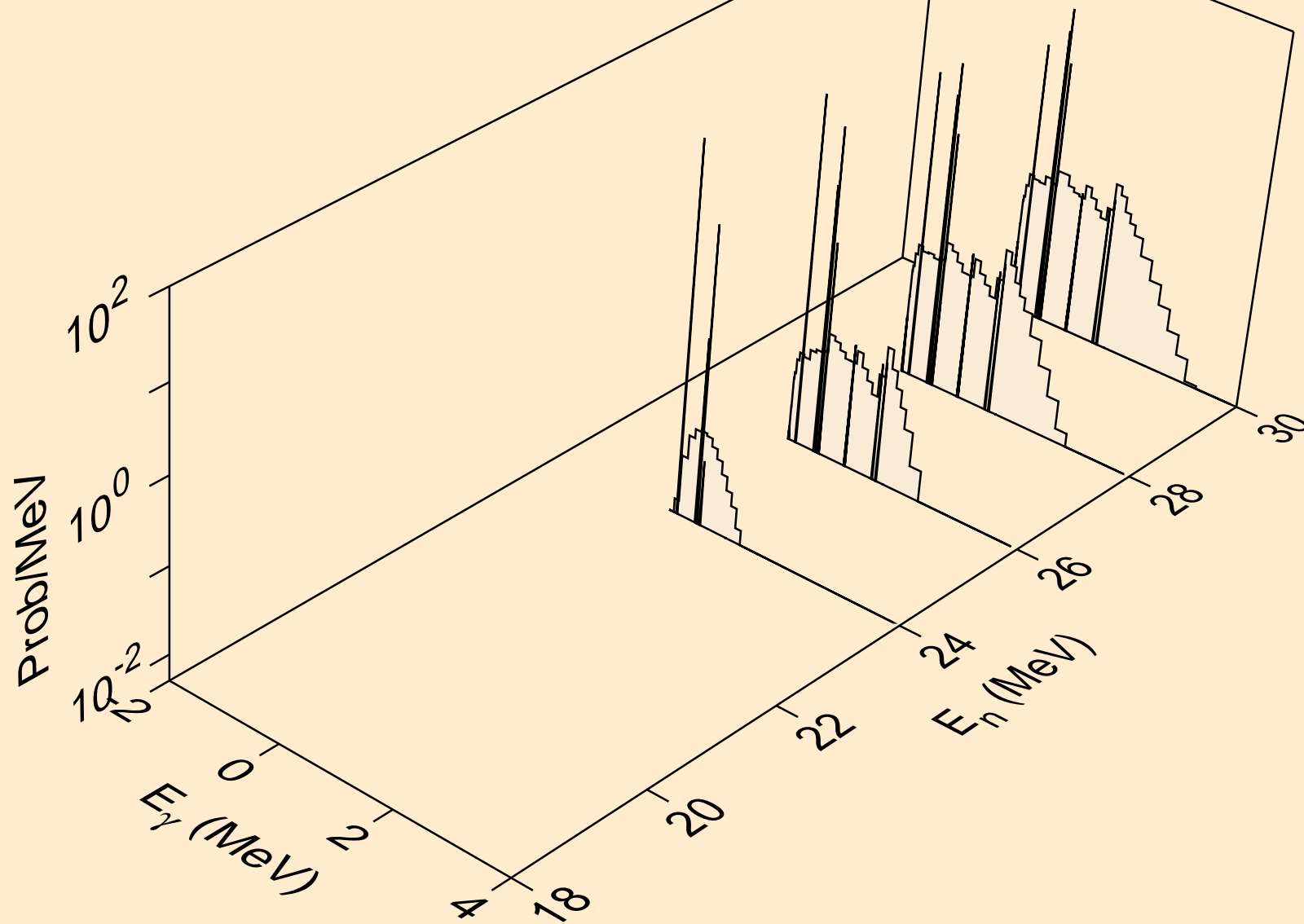

AT200M NEUTRON ACER TENDL-2023 LIBRARY; T=0.K  
Photon emission for (n,n2p)

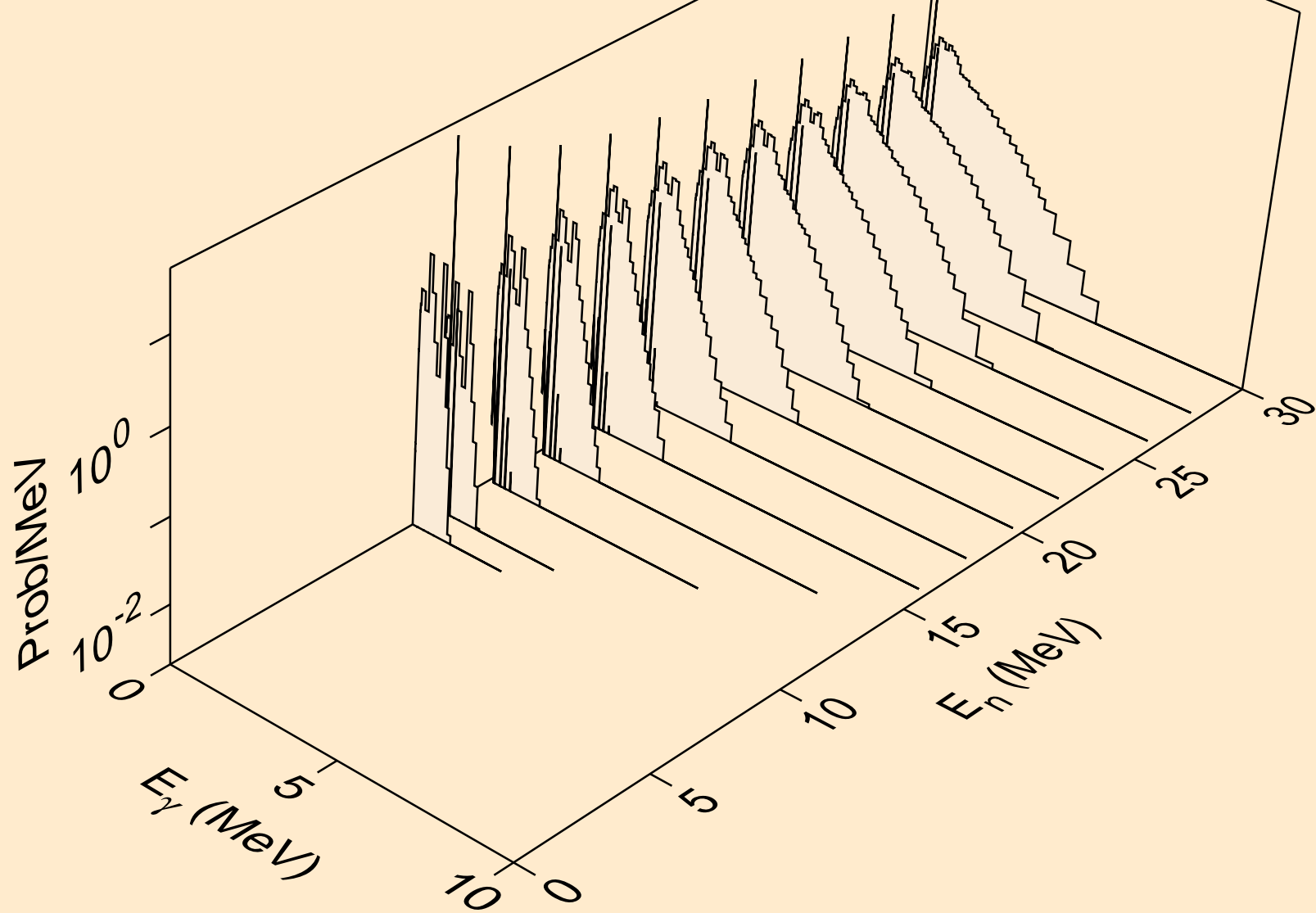

AT200M NEUTRON ACER TENDL-2023 LIBRARY; T=0.K  
Photon emission for (n,npa)

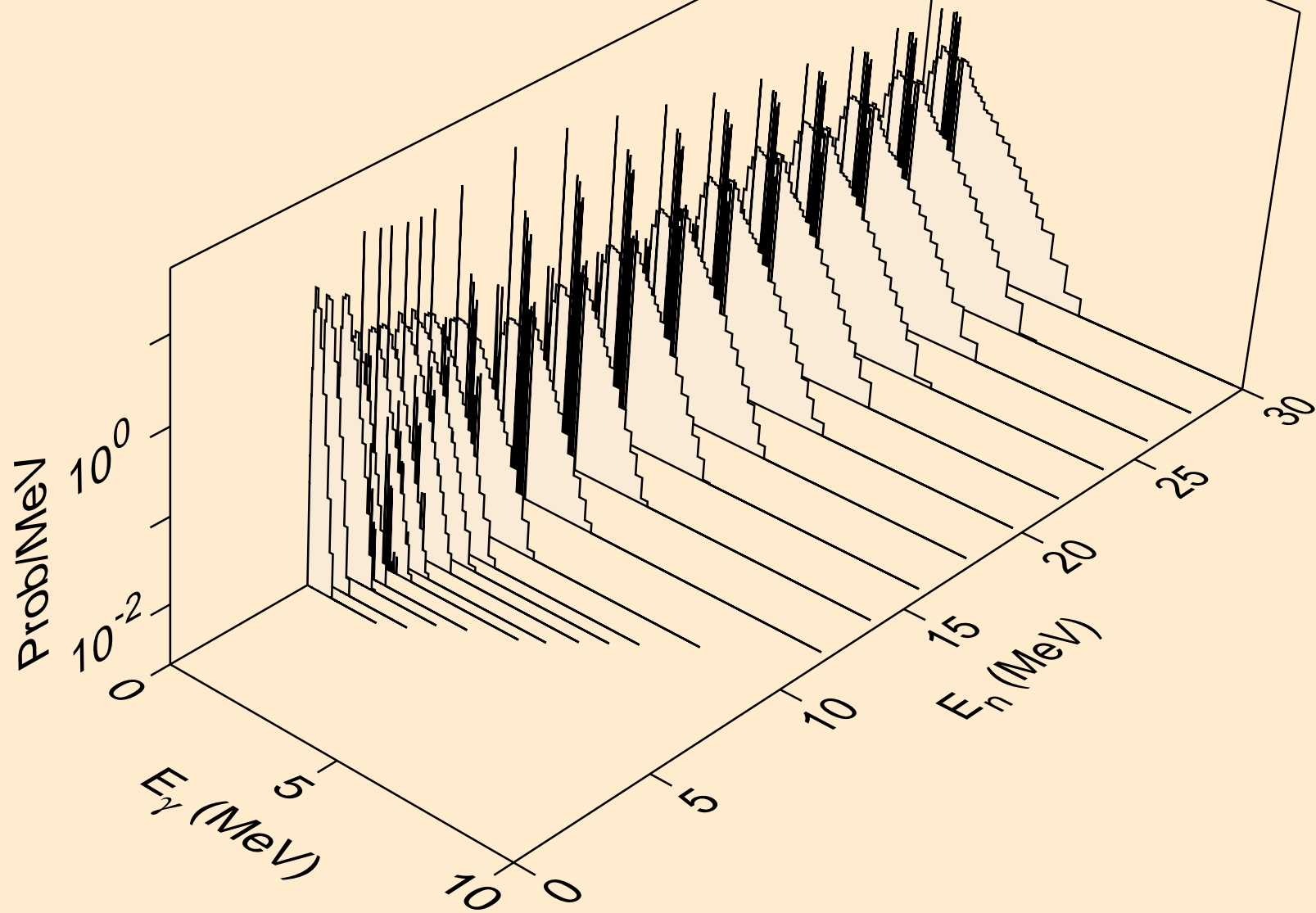

AT200M NEUTRON ACER TENDL-2023 LIBRARY; T=0.K  
Photon emission for (n,n\*2)

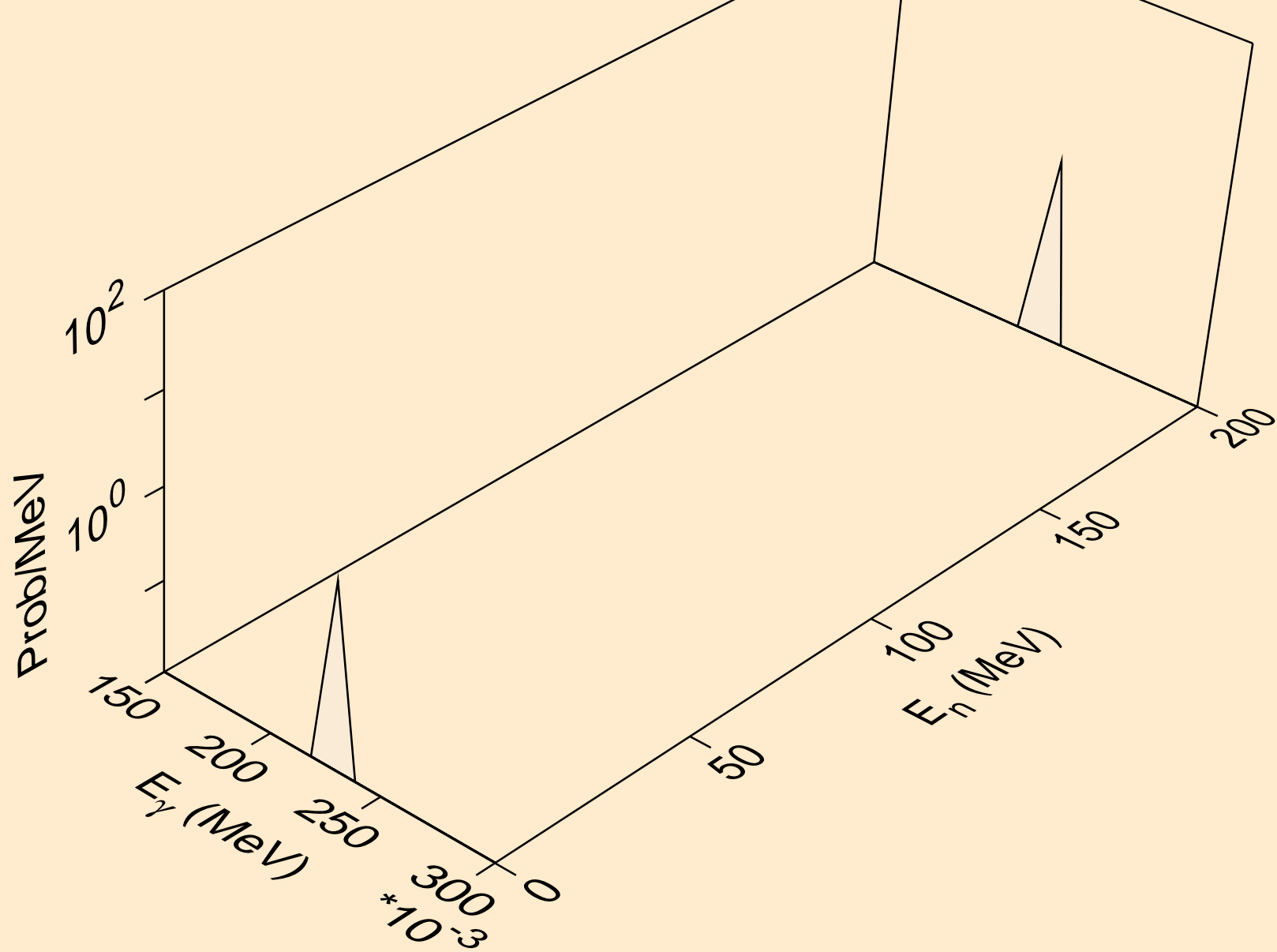

AT200M NEUTRON ACER TENDL-2023 LIBRARY; T=0.K  
Photon emission for (n,n\*c)

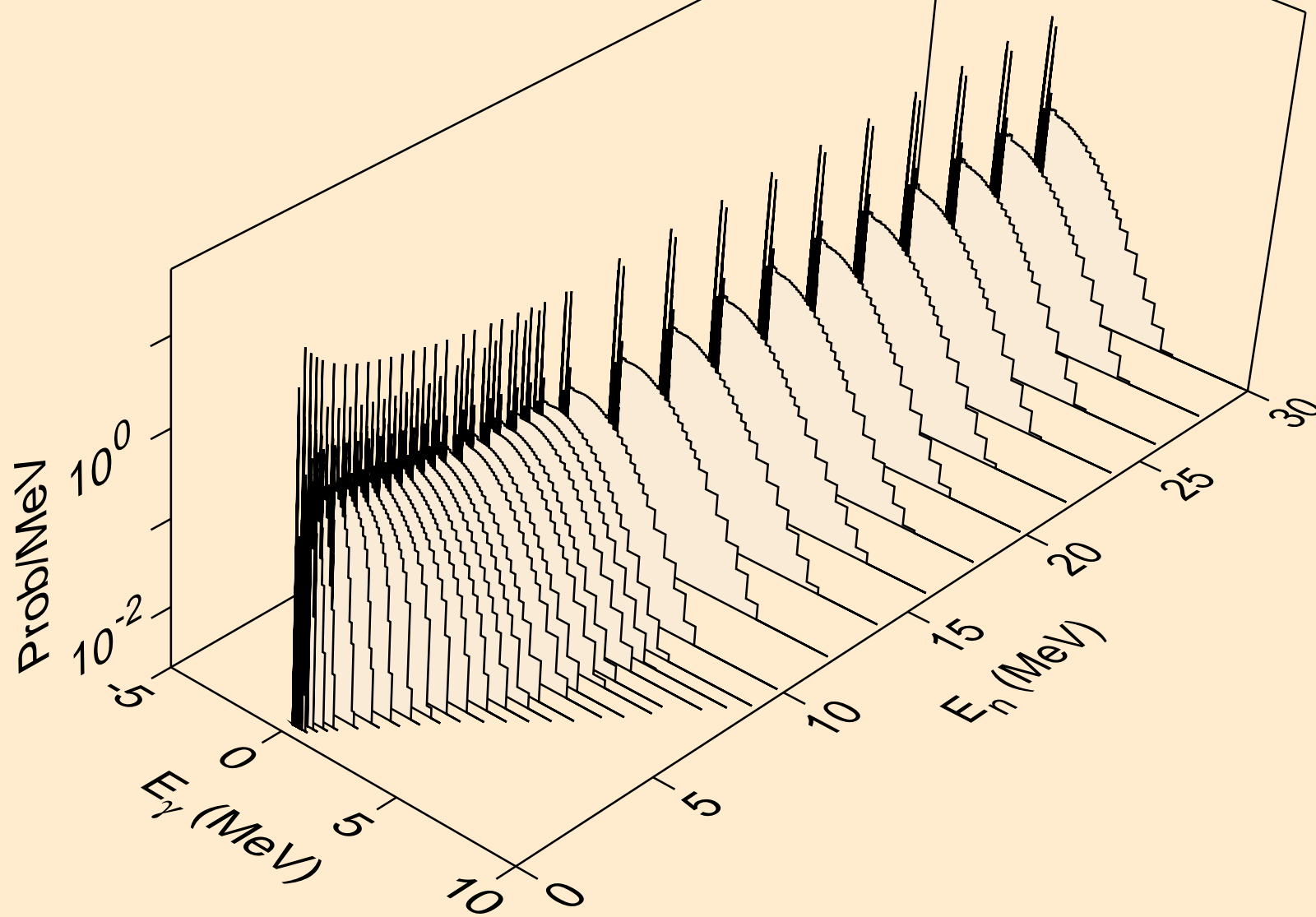

AT200M NEUTRON ACER TENDL-2023 LIBRARY; T=0.K  
Photon emission for (n,gma)

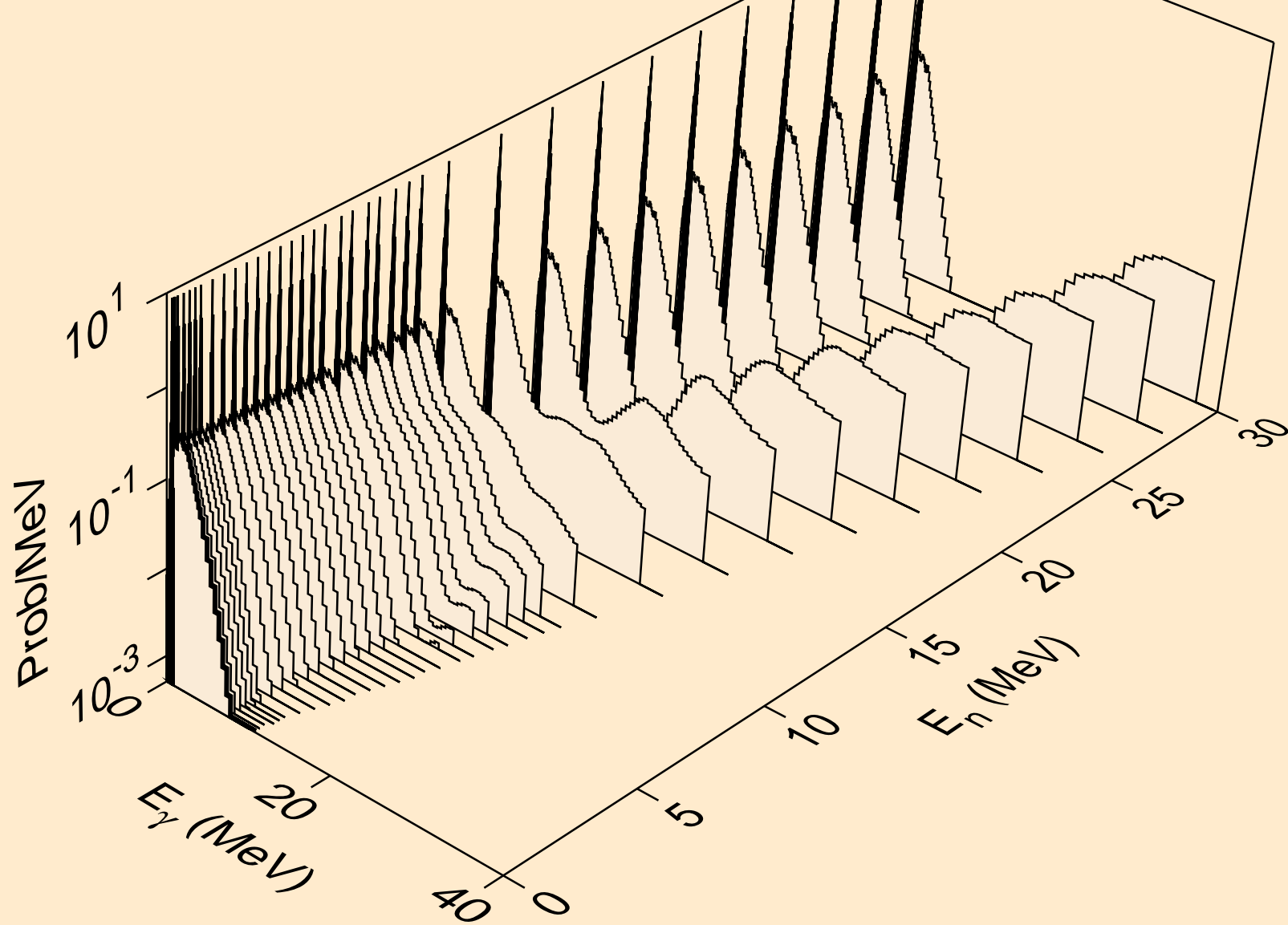

AT200M NEUTRON ACER TENDL-2023 LIBRARY; T=0.K  
Photon emission for (n,p)

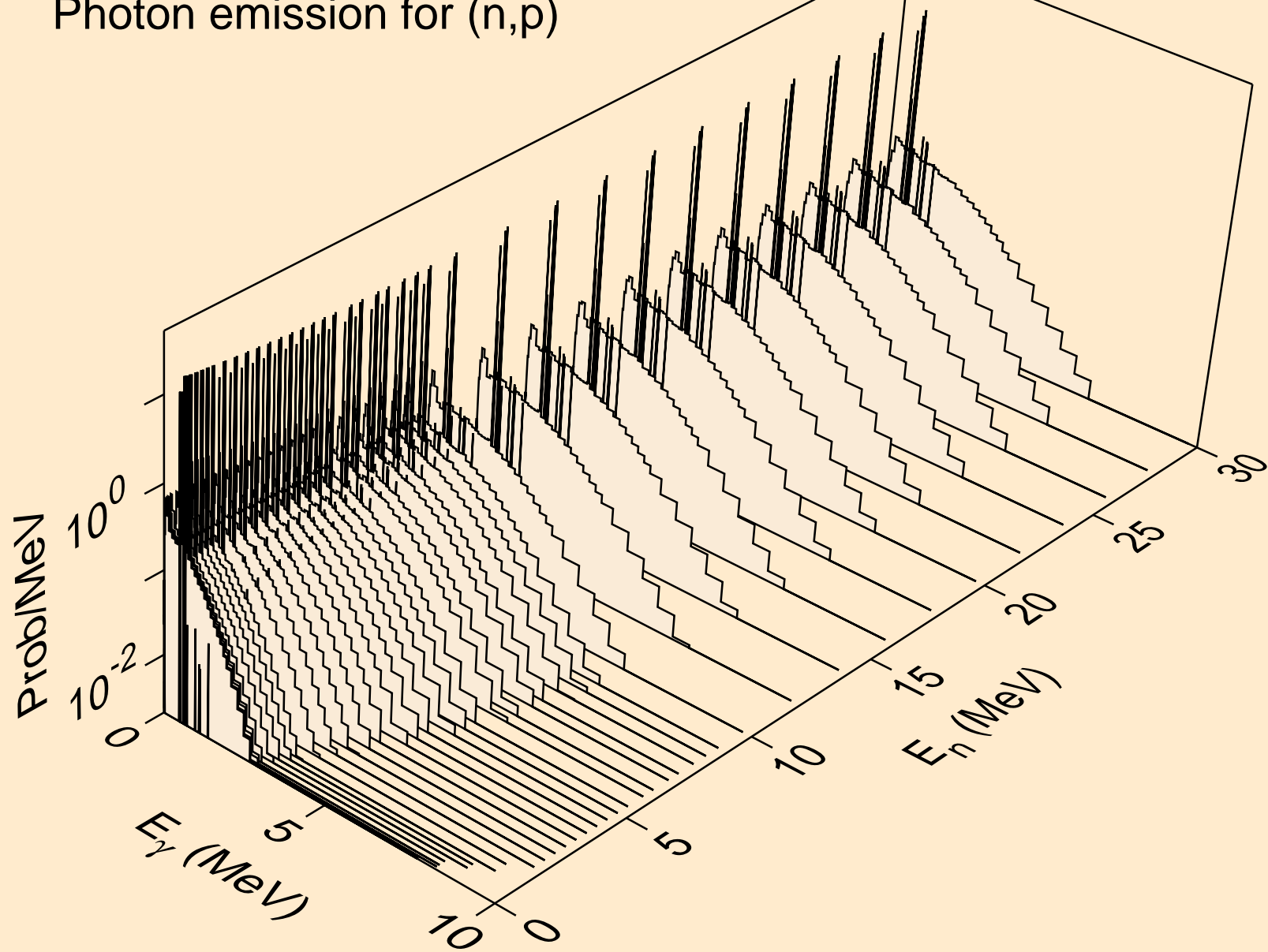



AT200M NEUTRON ACER TENDL-2023 LIBRARY; T=0.K  
Photon emission for (n,d)

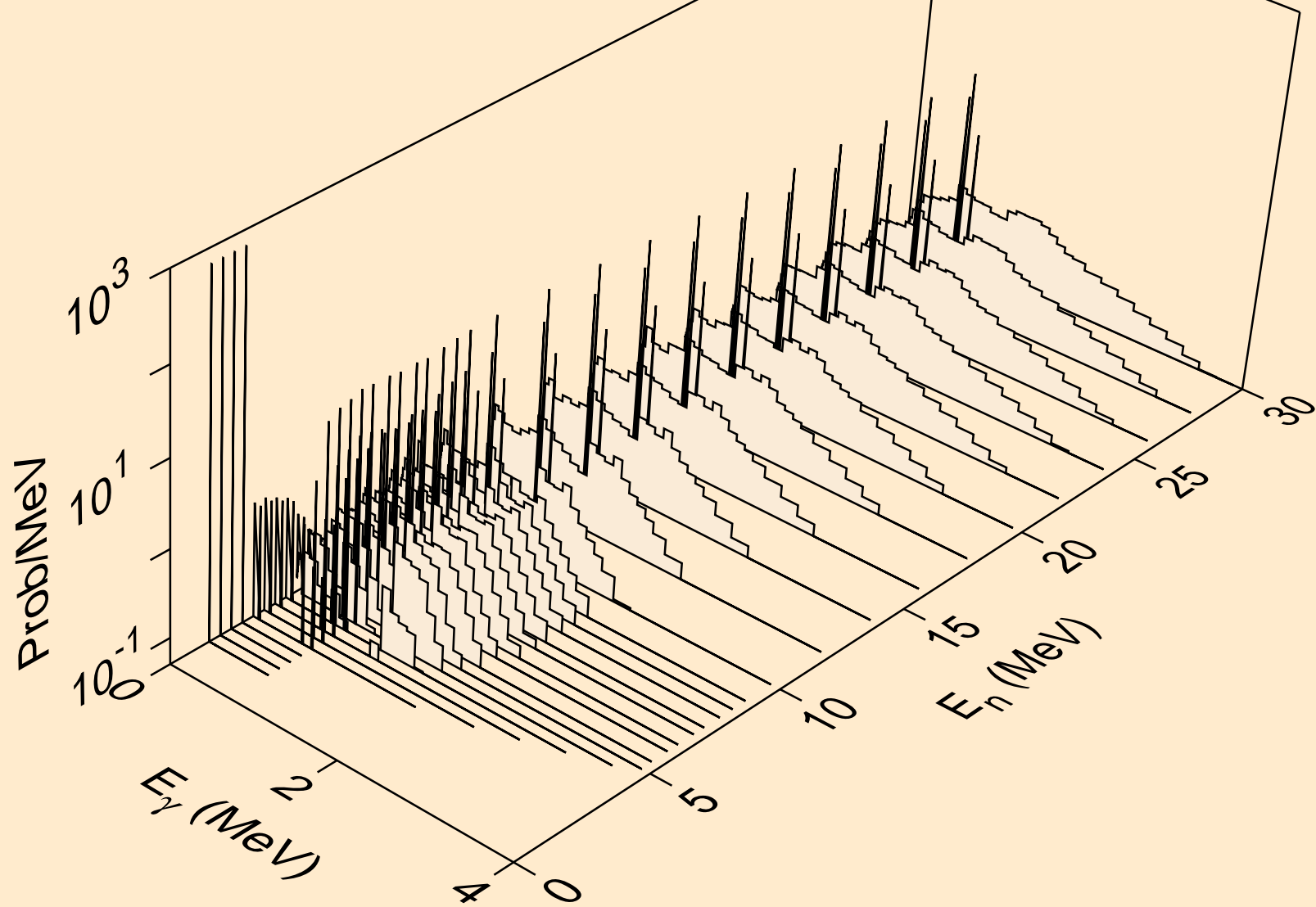

AT200M NEUTRON ACER TENDL-2023 LIBRARY; T=0.K  
Photon emission for (n,t)

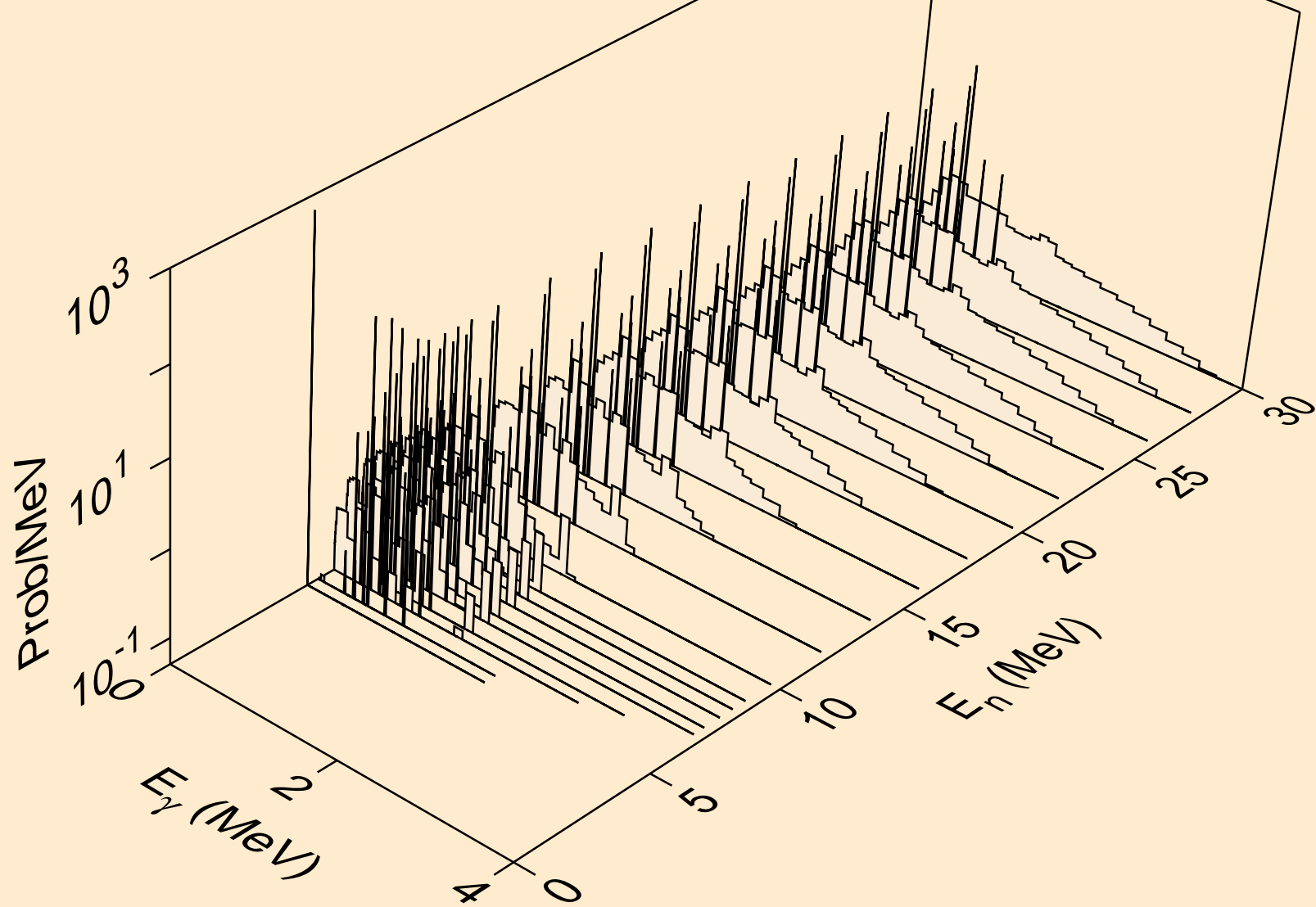

AT200M NEUTRON ACER TENDL-2023 LIBRARY; T=0.K  
Photon emission for (n,he3)

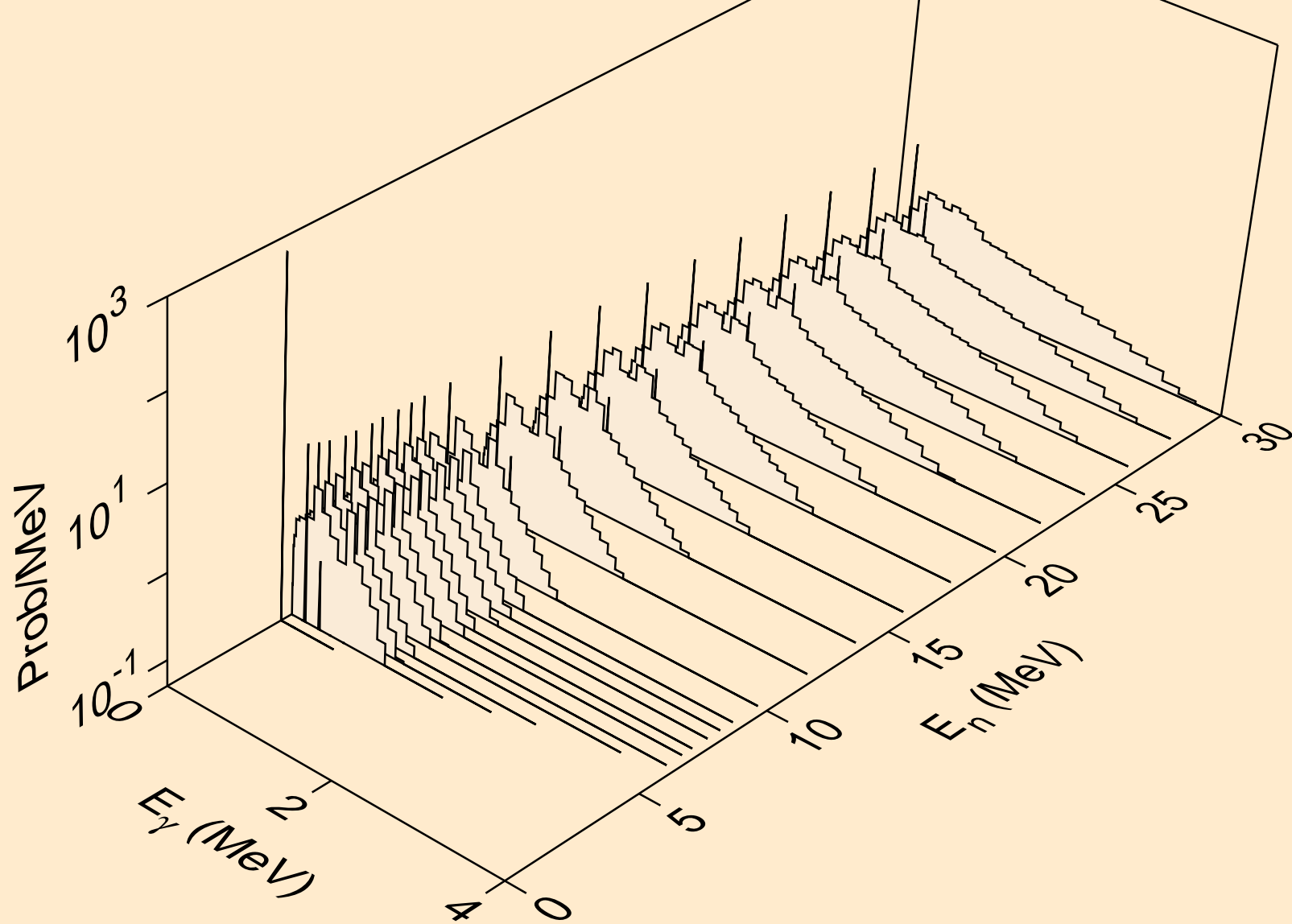

AT200M NEUTRON ACER TENDL-2023 LIBRARY; T=0.K  
Photon emission for (n,a)

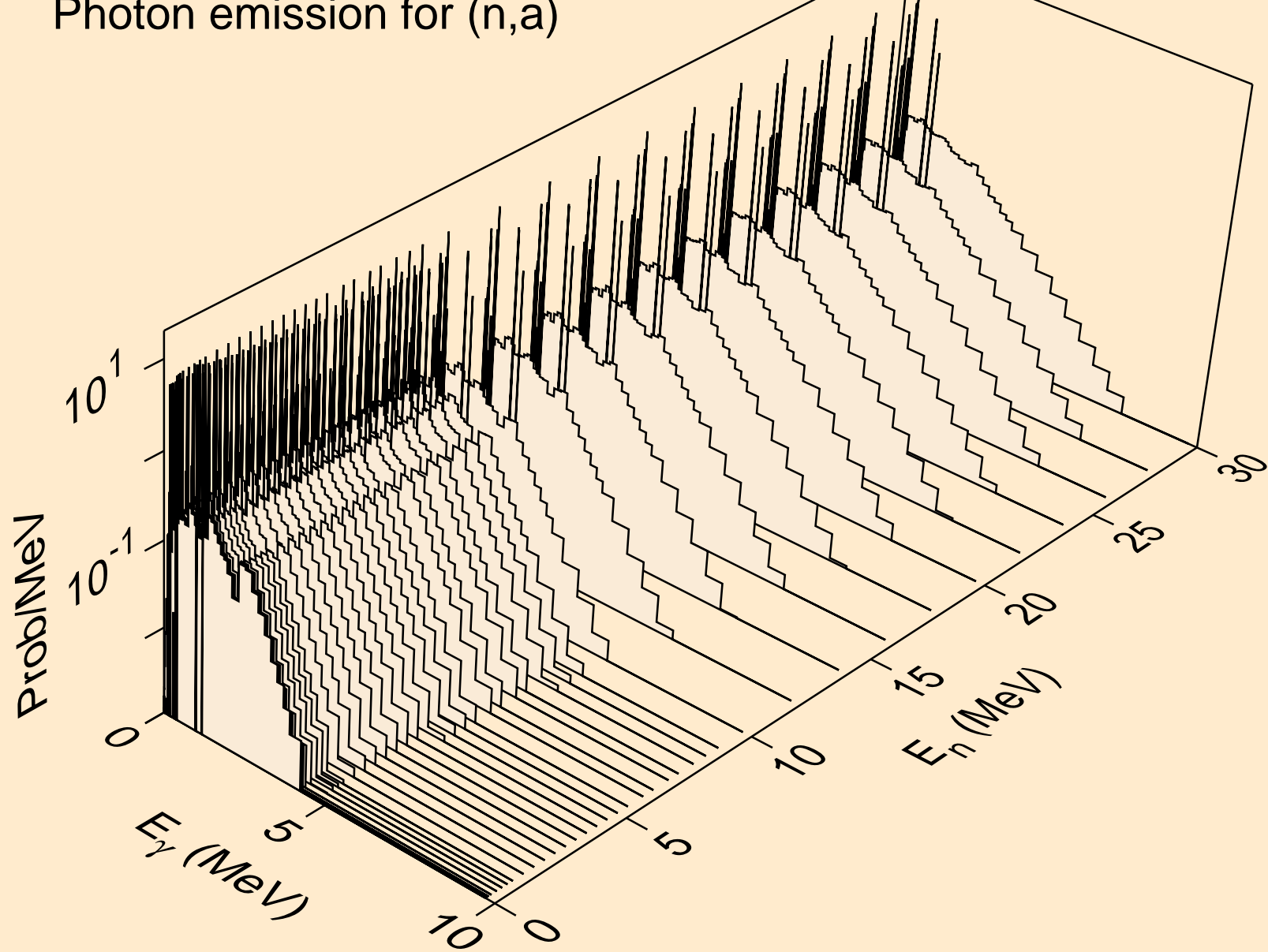

AT200M NEUTRON ACER TENDL-2023 LIBRARY; T=0.K  
Photon emission for (n,2a)

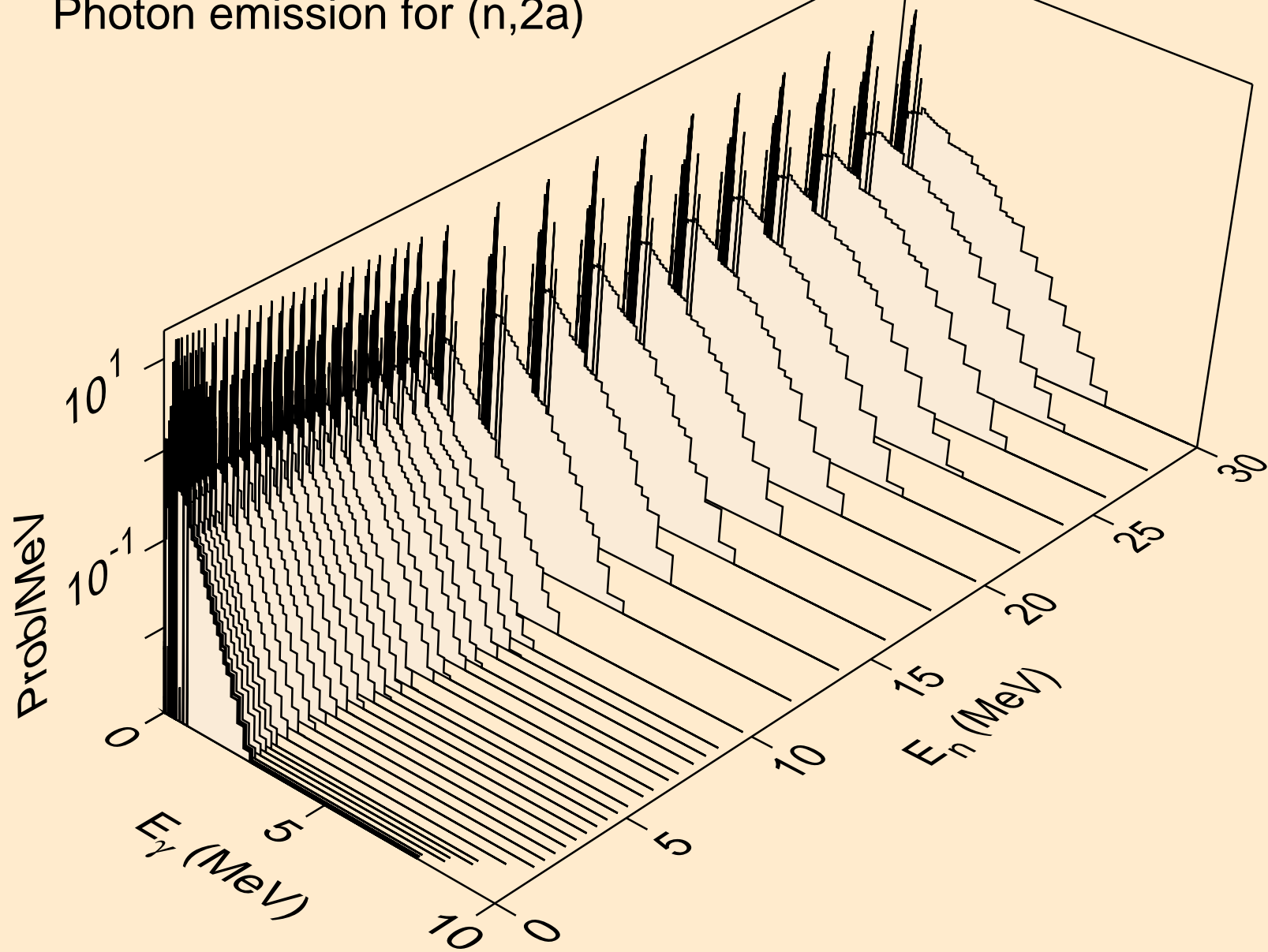

AT200M NEUTRON ACER TENDL-2023 LIBRARY; T=0.K  
Photon emission for (n,2p)

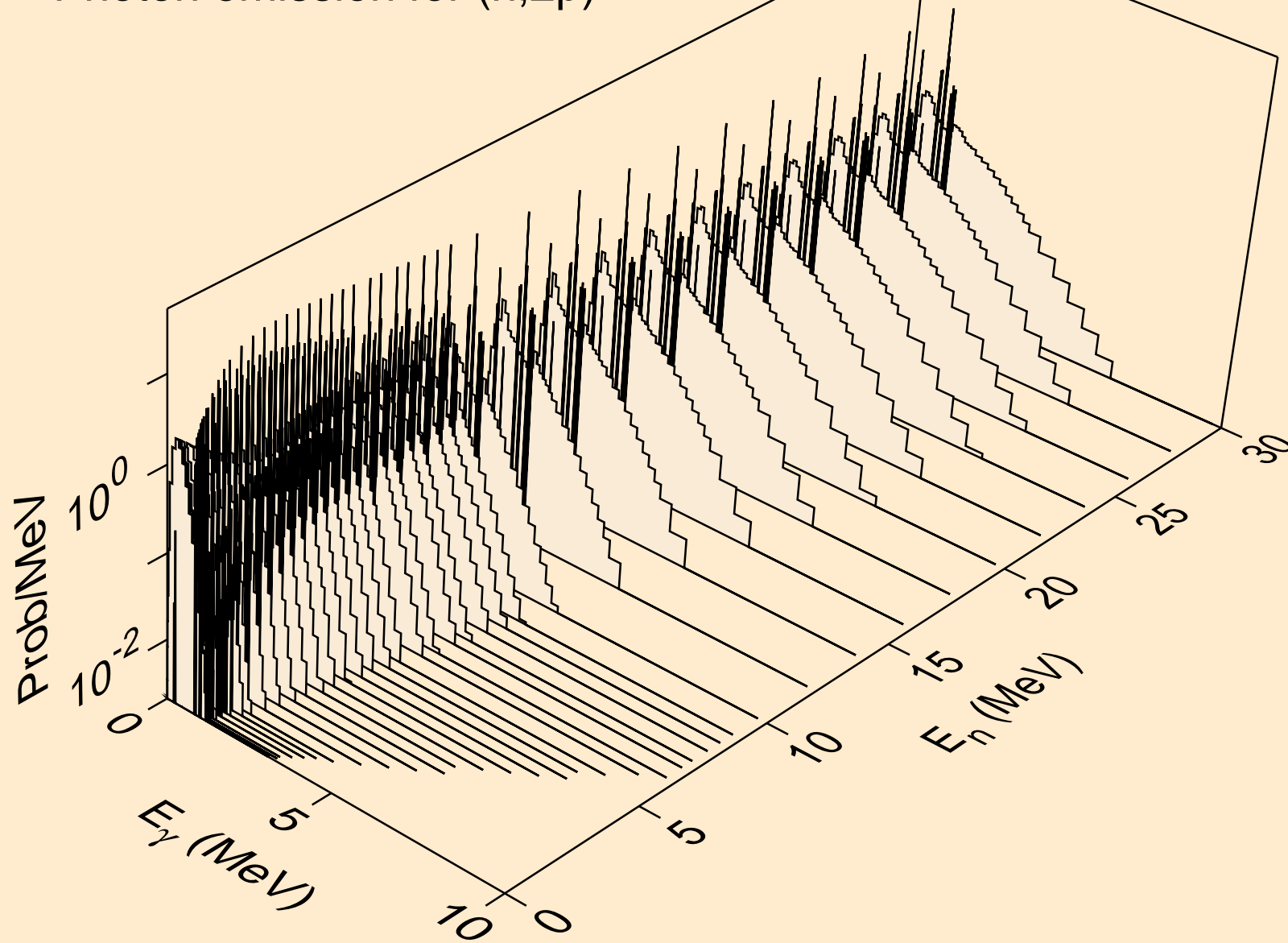

AT200M NEUTRON ACER TENDL-2023 LIBRARY; T=0.K  
Photon emission for (n,p)

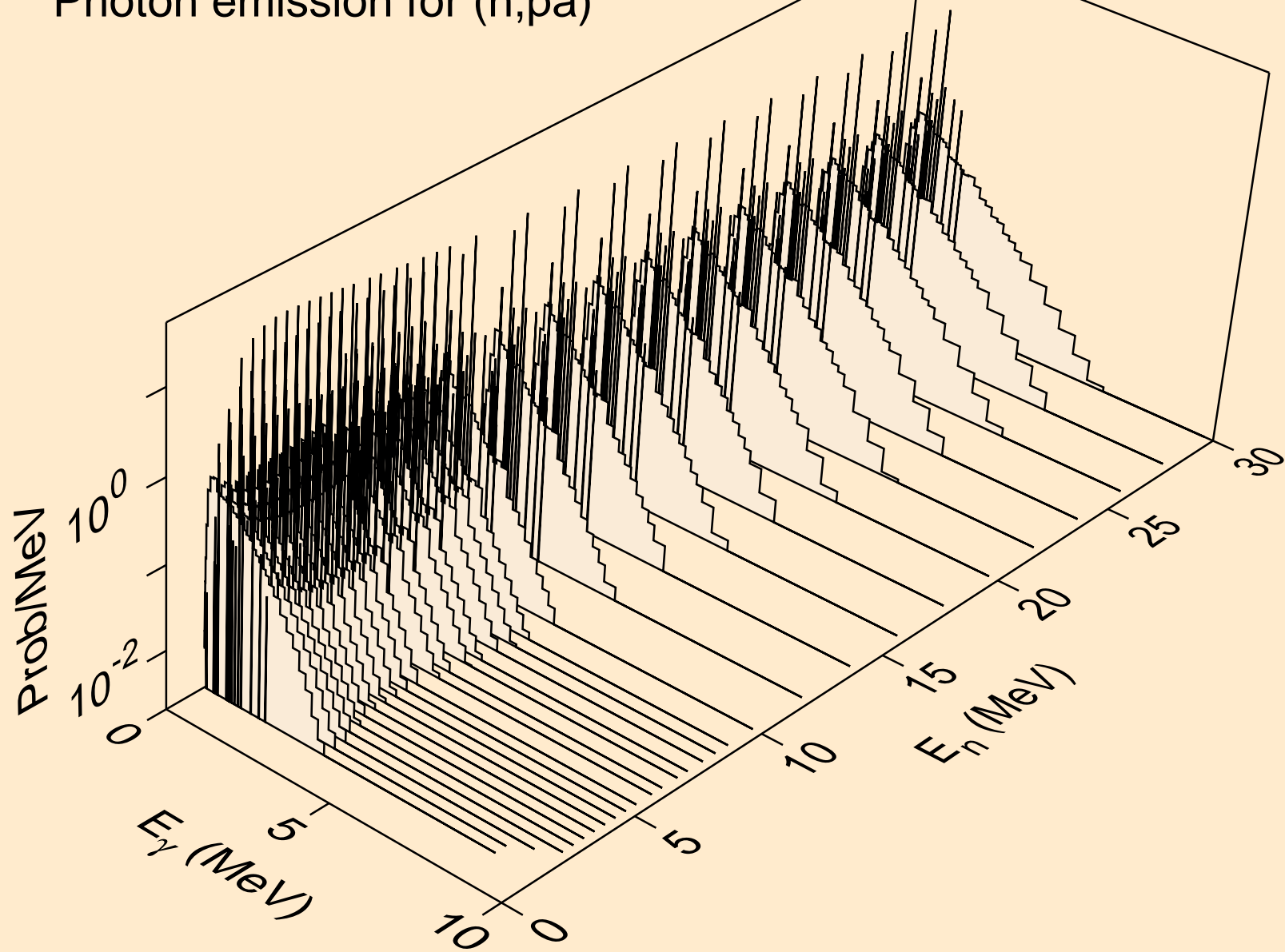

AT200M NEUTRON ACER TENDL-2023 LIBRARY; T=0.K  
Photon emission for (n,pd)

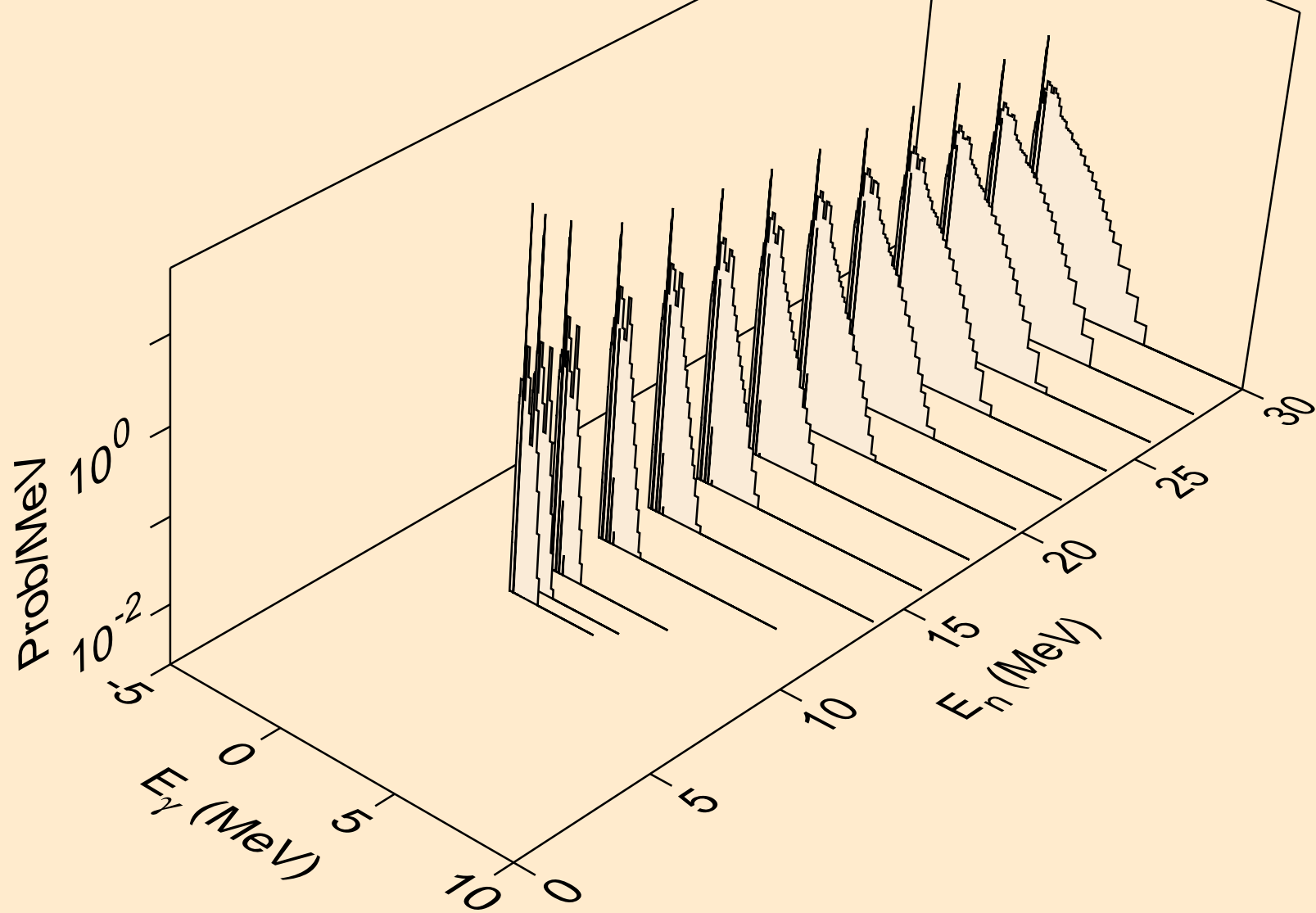



AT200M NEUTRON ACER TENDL-2023 LIBRARY; T=0.K  
Photon emission for (n,pt)

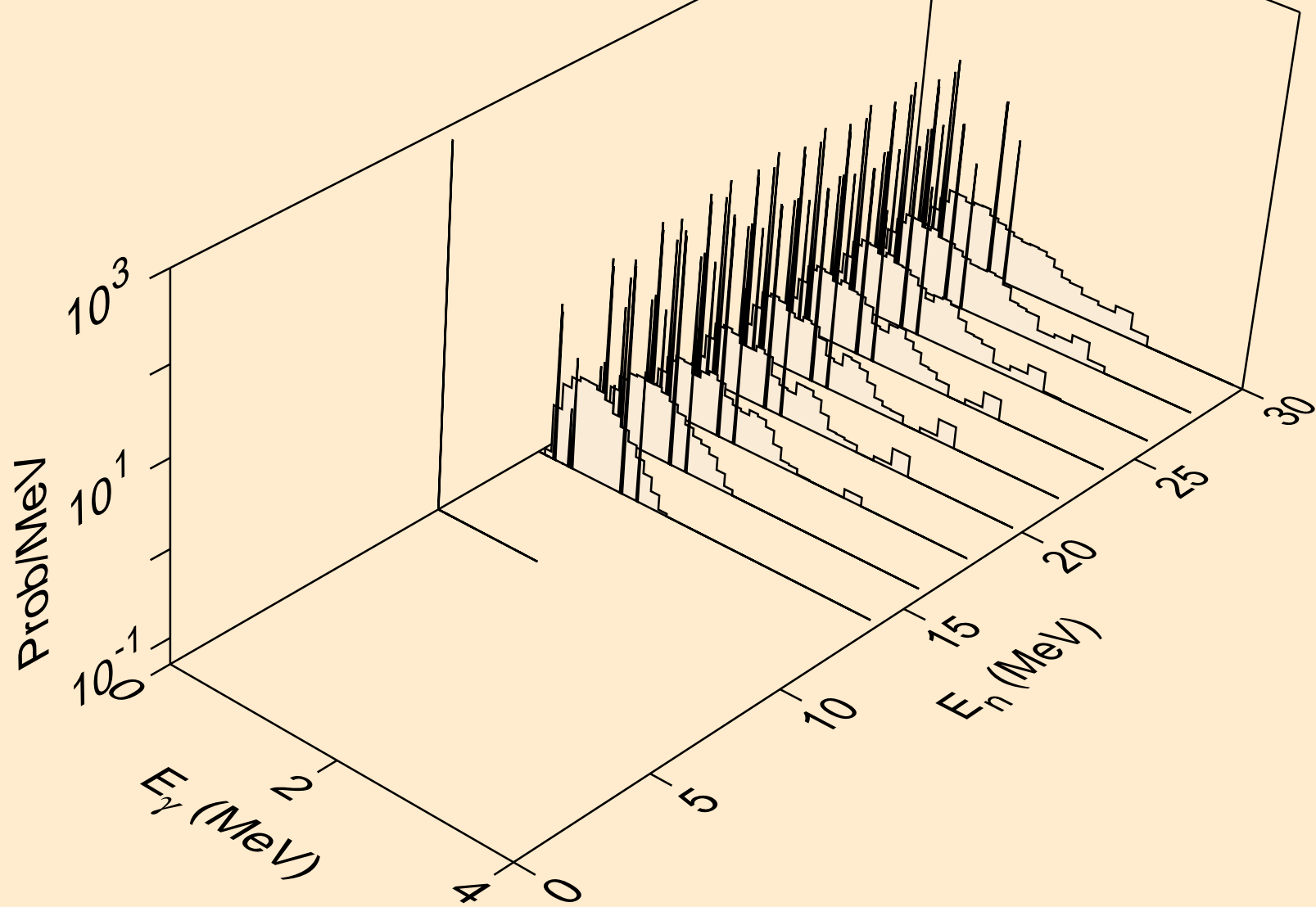

AT200M NEUTRON ACER TENDL-2023 LIBRARY; T=0.K  
Photon emission for (n,da)

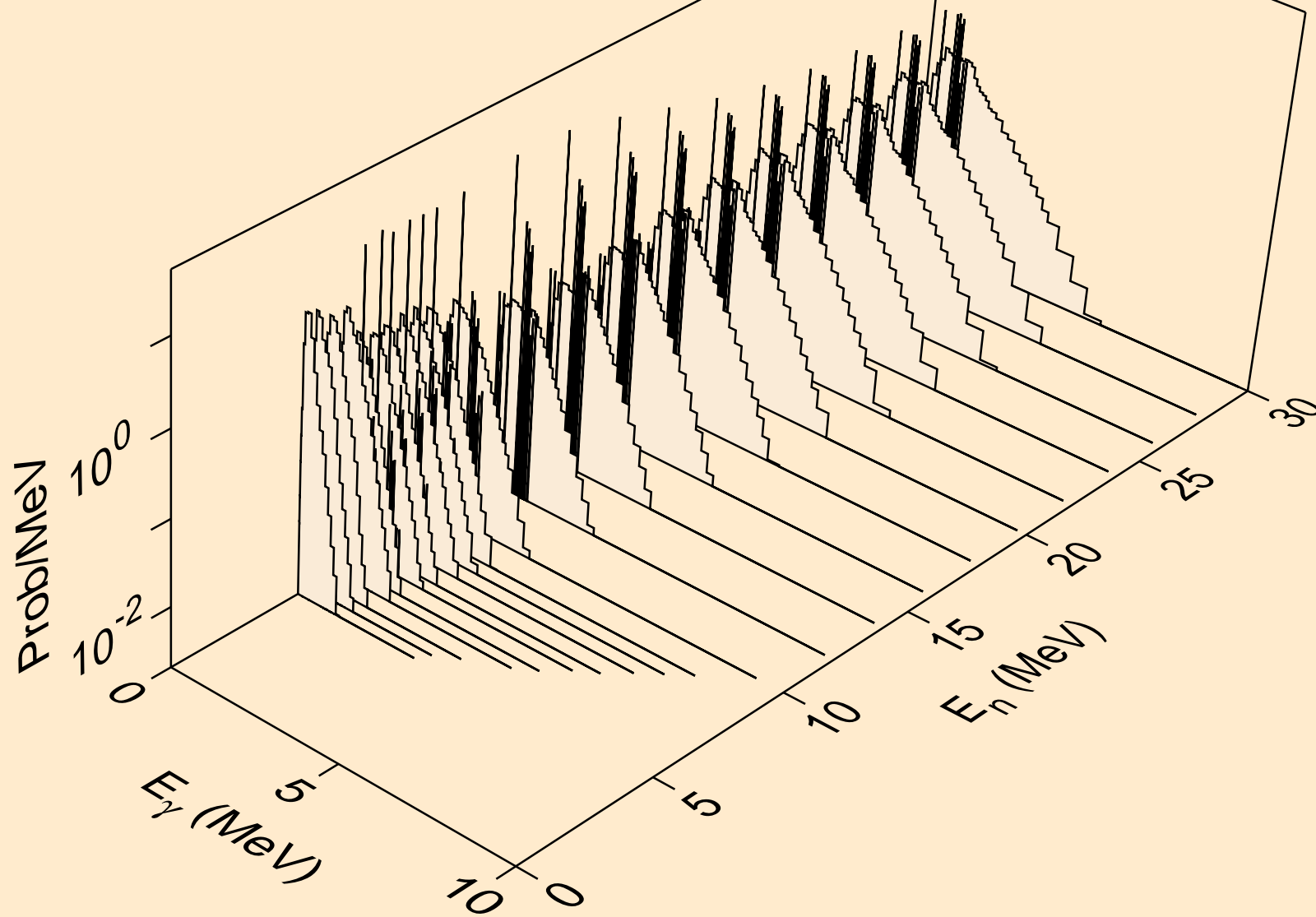

AT200M NEUTRON ACER TENDL-2023 LIBRARY; T=0.K  
thermal capture photon spectrum

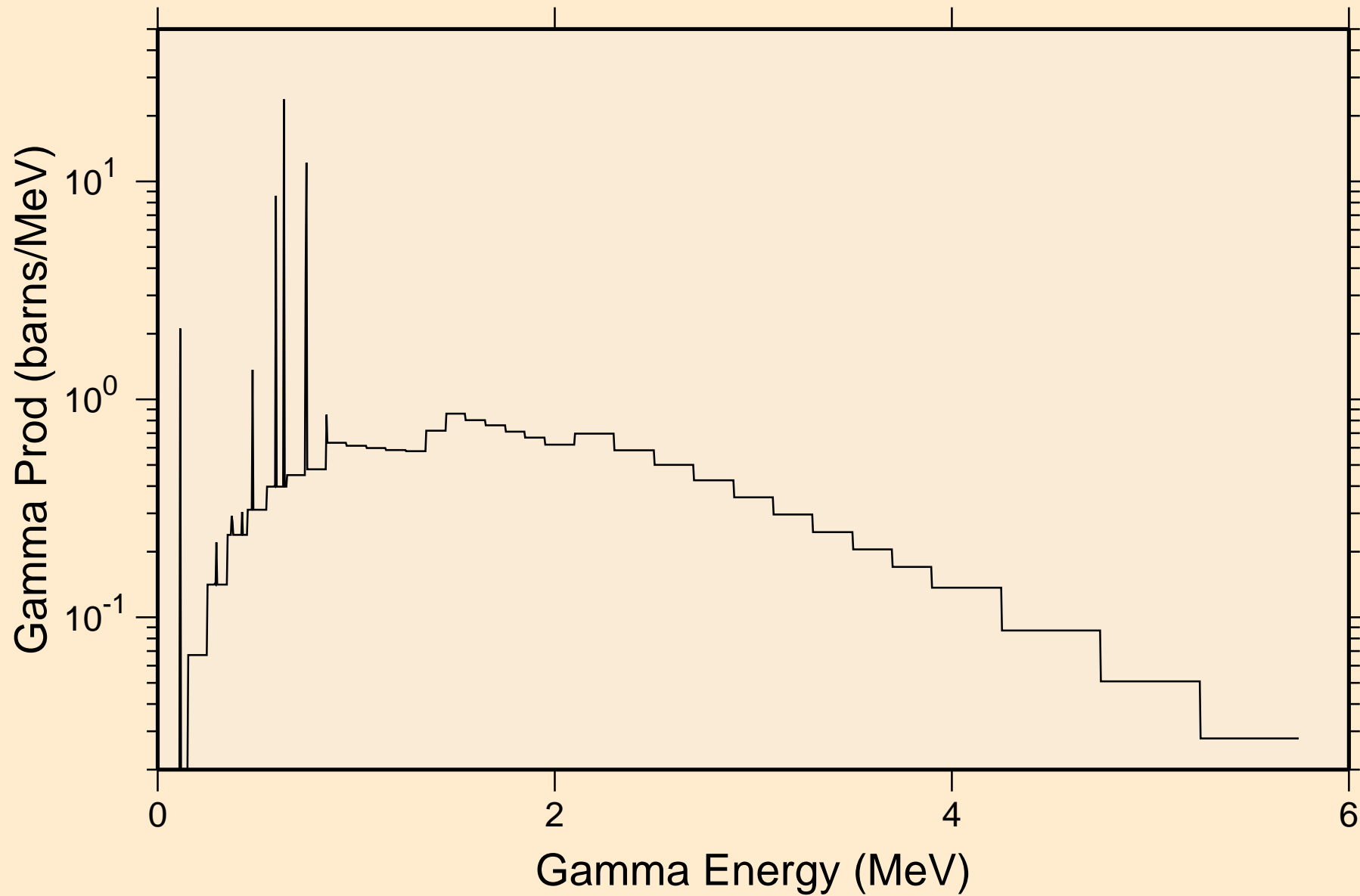

AT200M NEUTRON ACER TENDL-2023 LIBRARY; T=0.K  
14 MeV photon spectrum

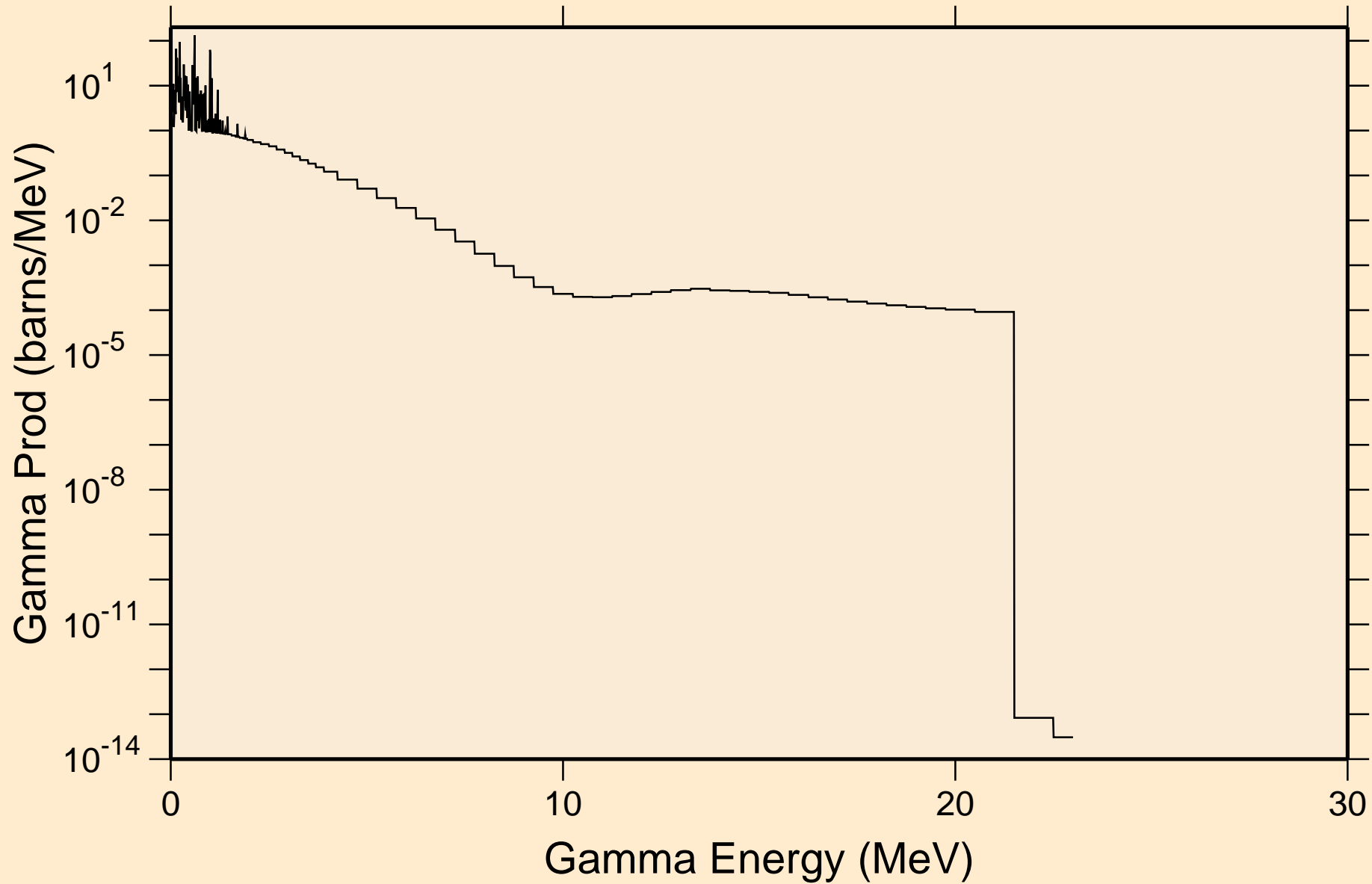

# AT200M NEUTRON ACER TENDL-2023 LIBRARY; T=0.K

## Particle heating contributions

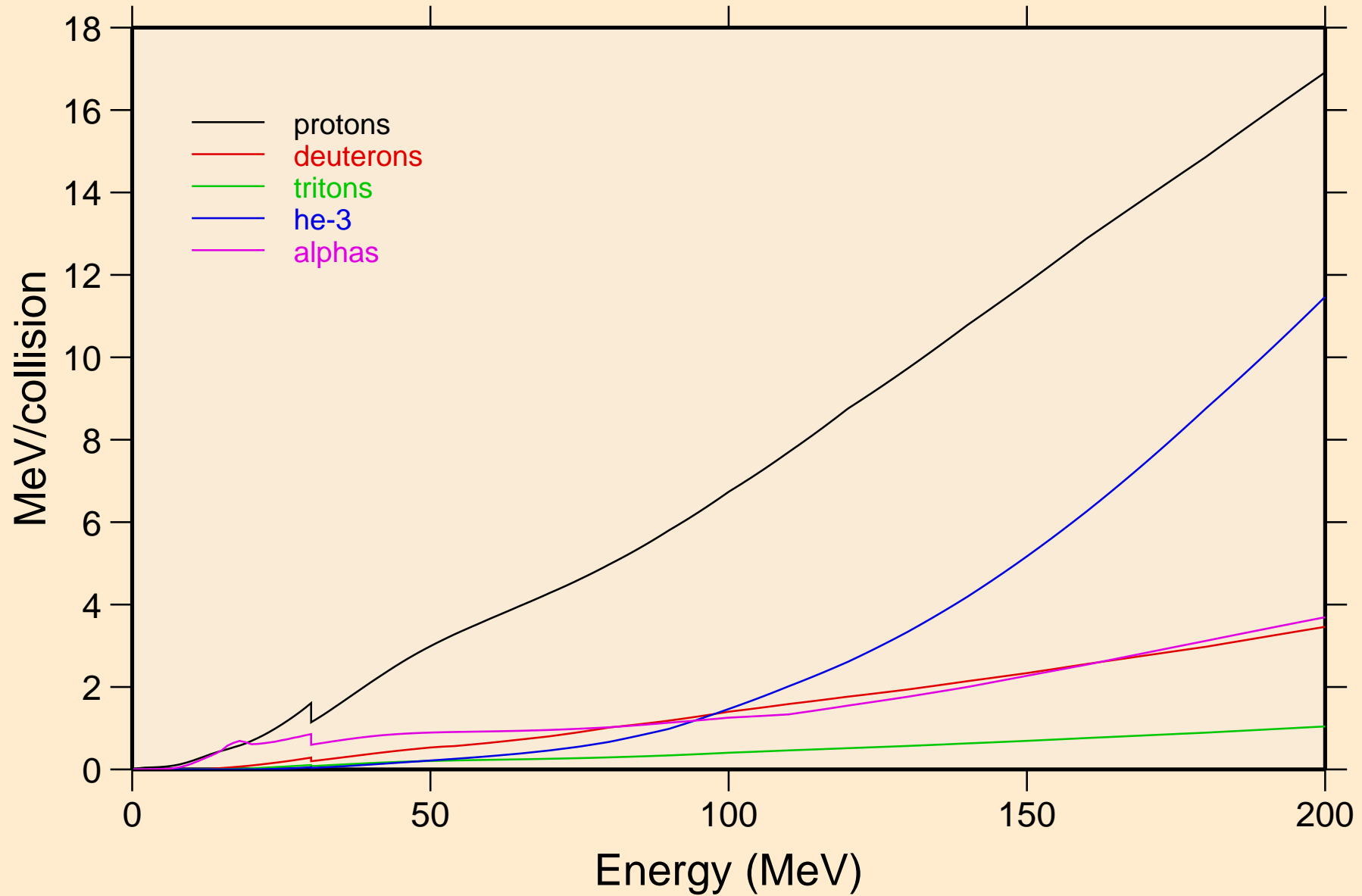

AT200M NEUTRON ACER TENDL-2023 LIBRARY; T=0.K  
Recoil Heating

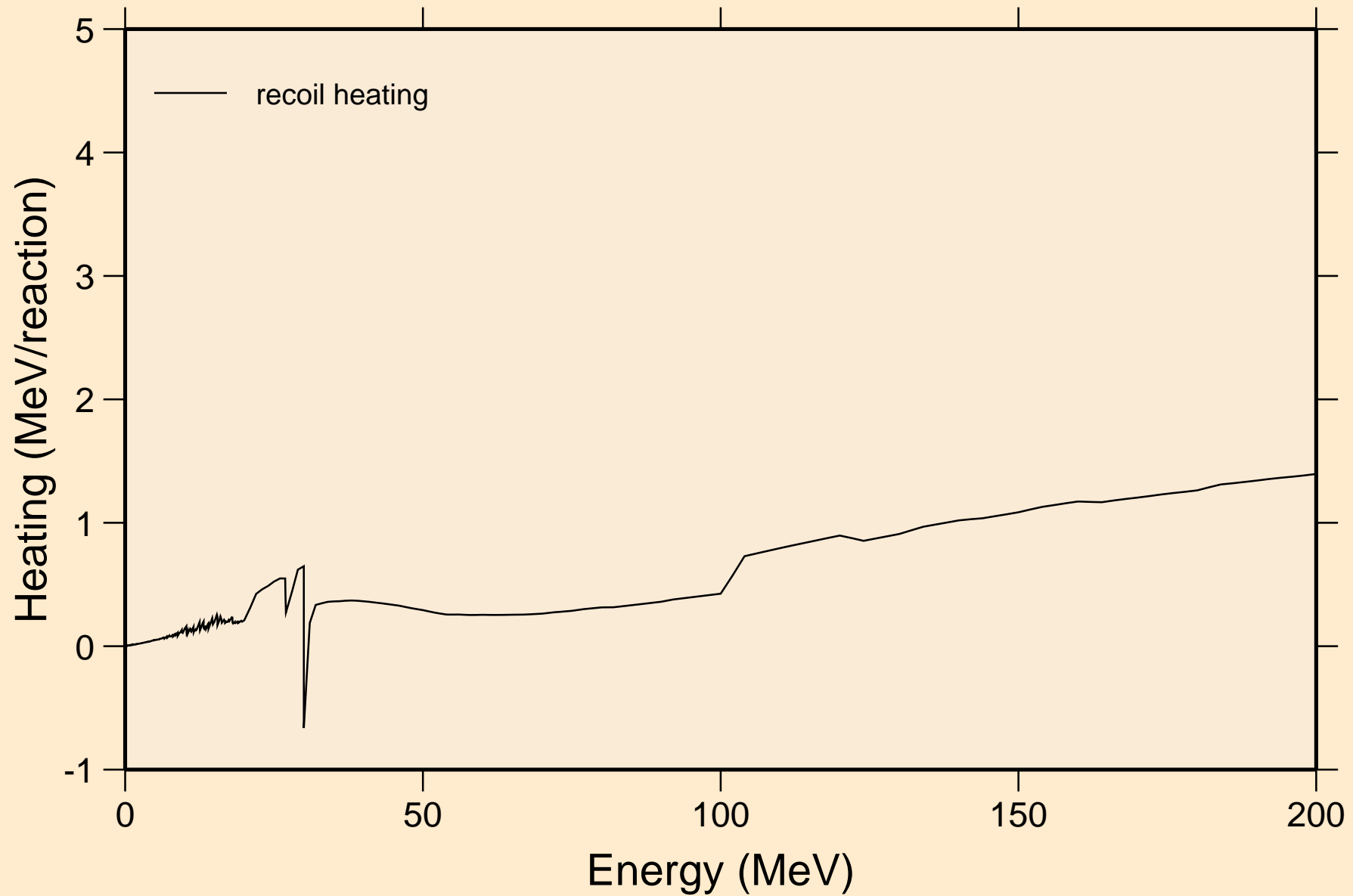

# AT200M NEUTRON ACER TENDL-2023 LIBRARY; T=0.K

## Particle production cross sections

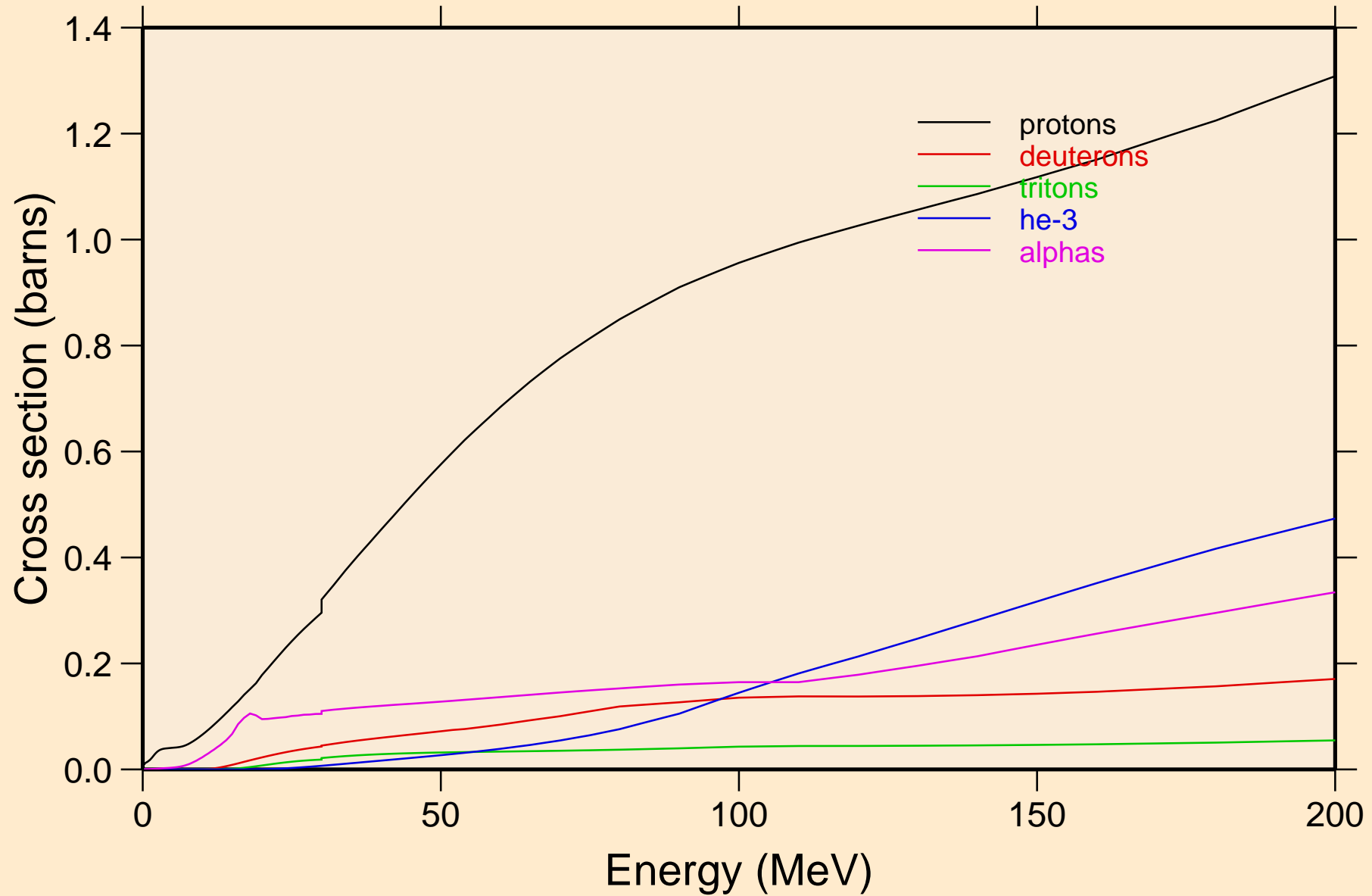

AT200M NEUTRON ACER TENDL-2023 LIBRARY; T=0.K  
protons from (n,x)

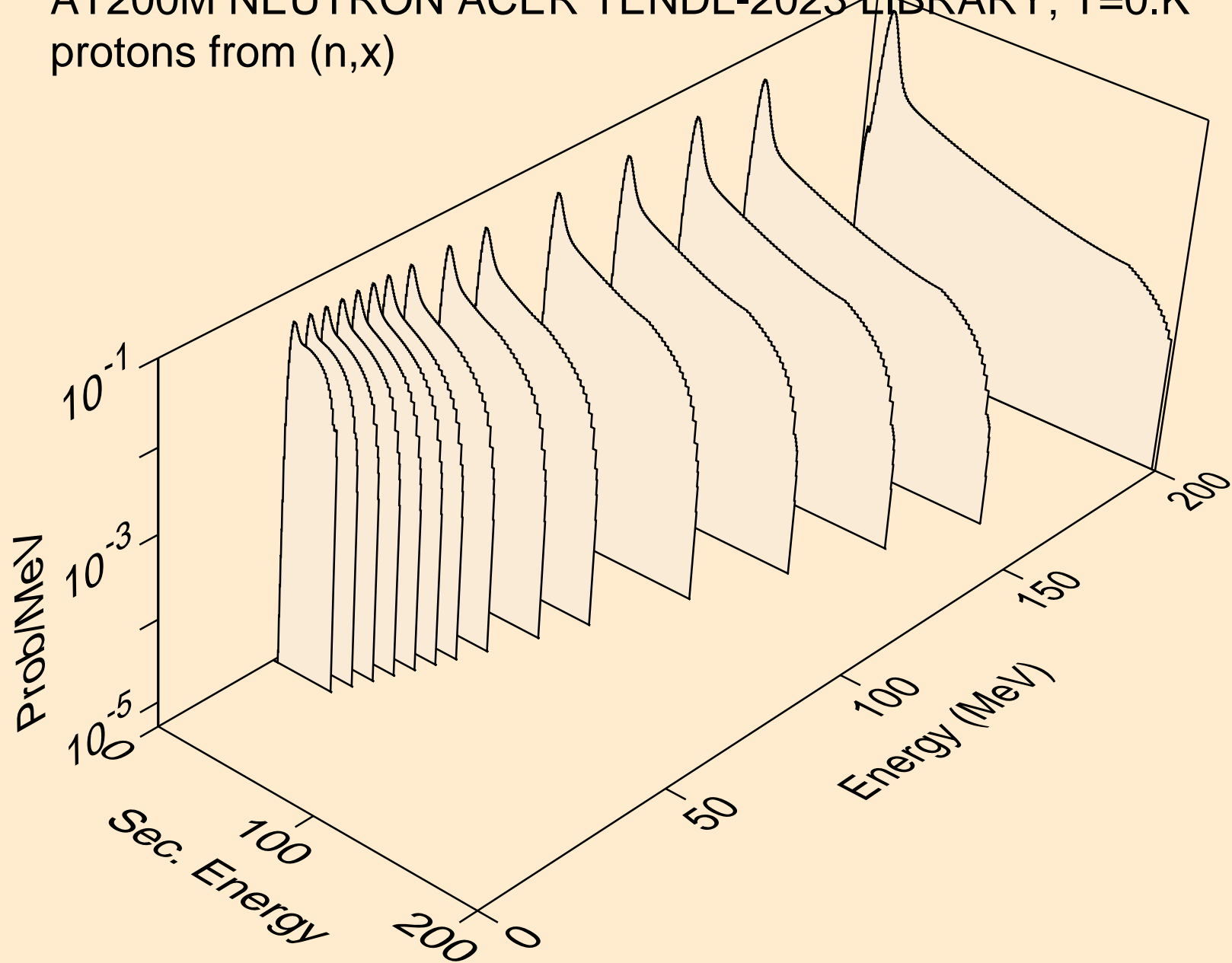



AT200M NEUTRON ACER TENDL-2023 LIBRARY; T=0.K  
protons from (n,n\*)p

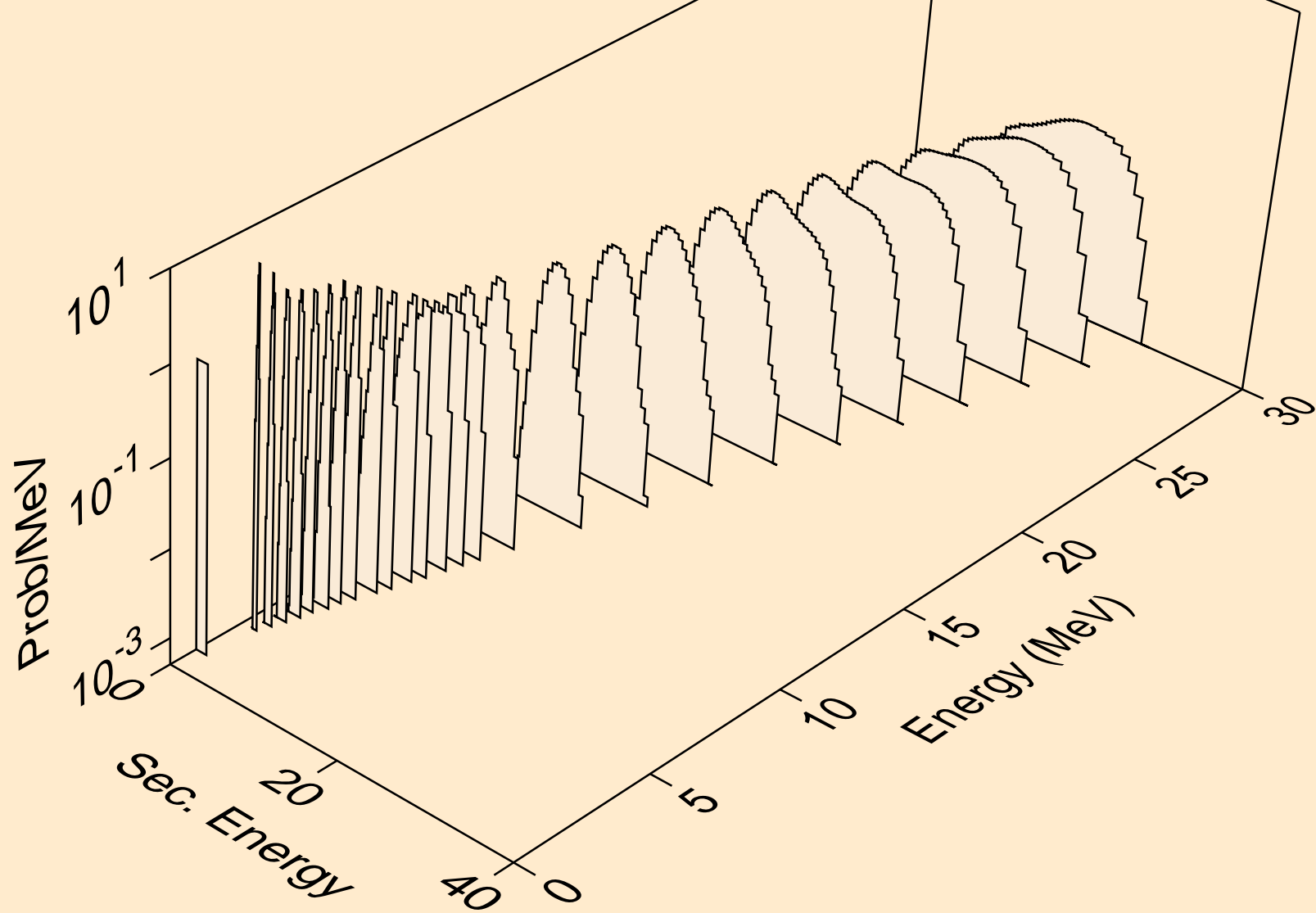

AT200M NEUTRON ACER TENDL-2023 LIBRARY; T=0.K  
protons from (n,2np)

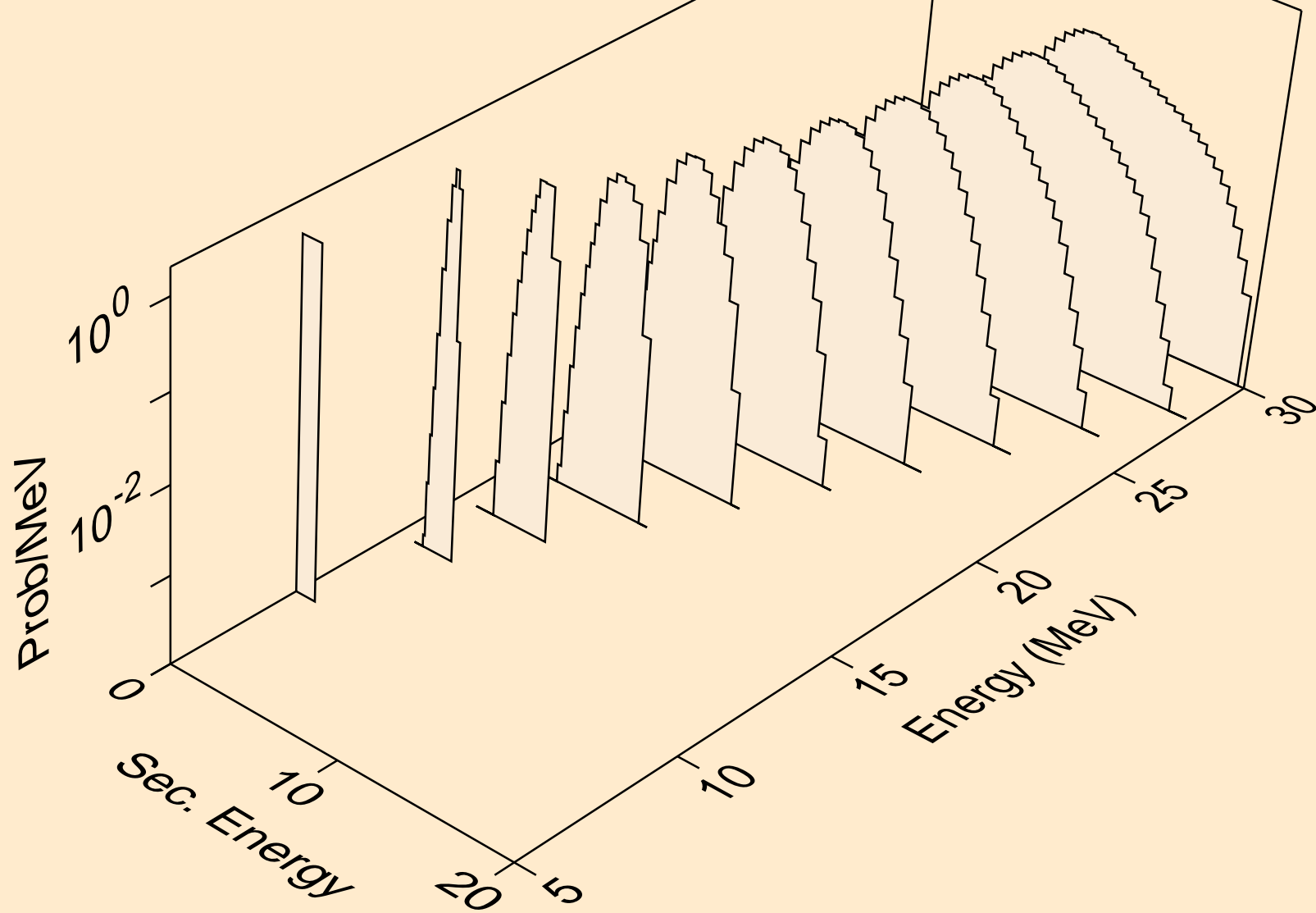

AT200M NEUTRON ACER TENDL-2023 LIBRARY; T=0.K  
protons from (n,3np)

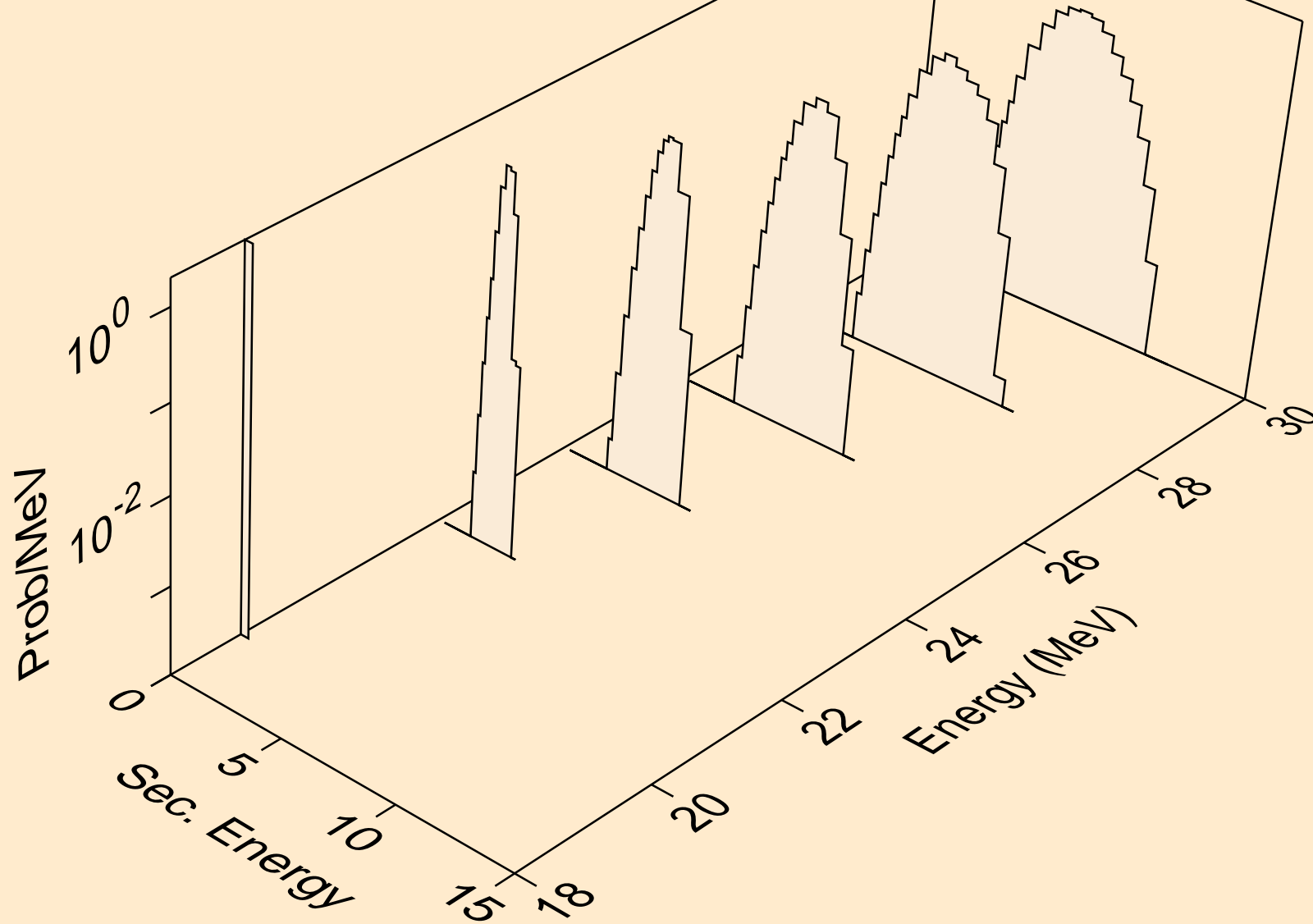

AT200M NEUTRON ACER TENDL-2023 LIBRARY; T=0.K  
protons from (n,n2p)

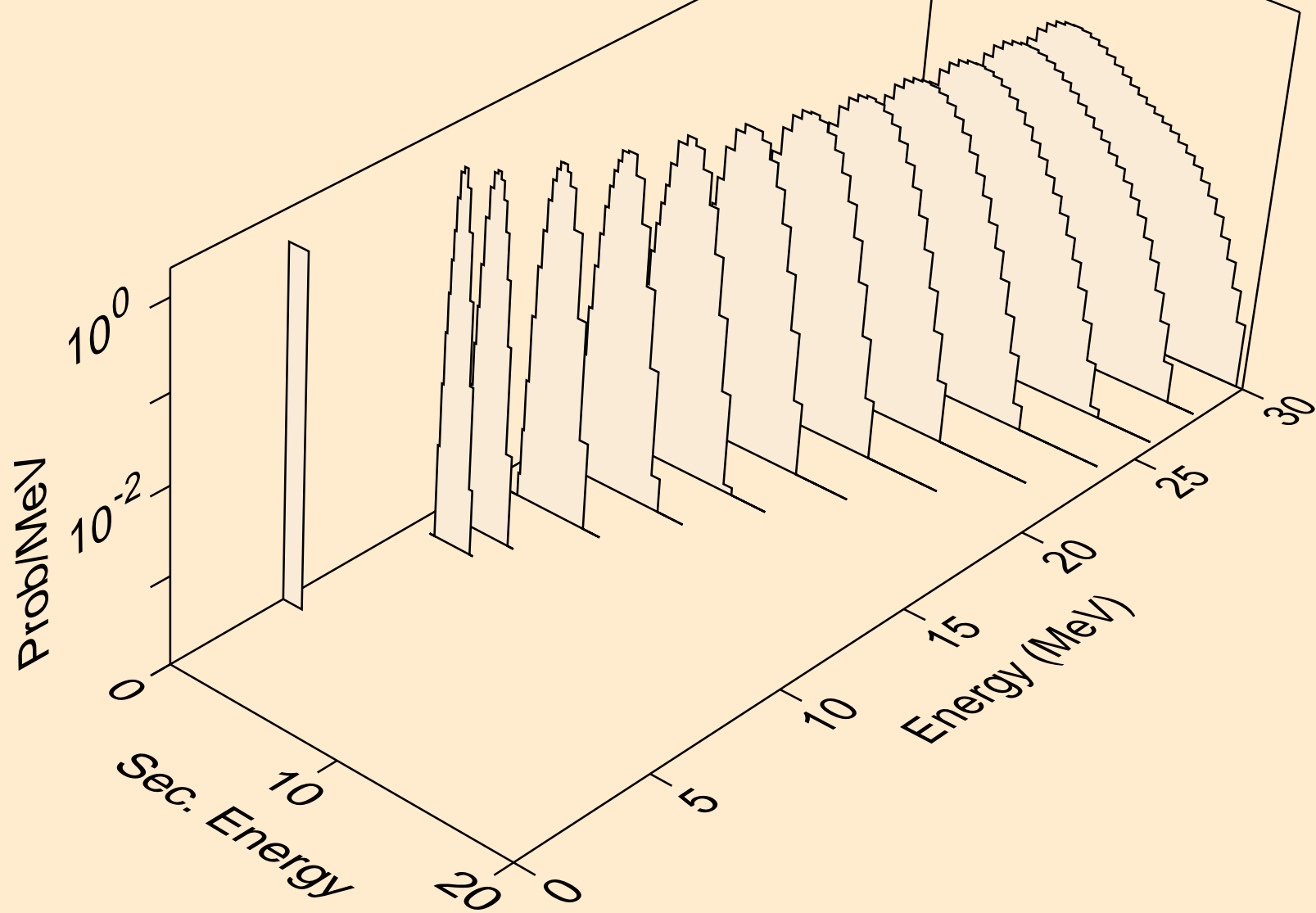

AT200M NEUTRON ACER TENDL-2023 LIBRARY; T=0.K  
protons from (n,npa)

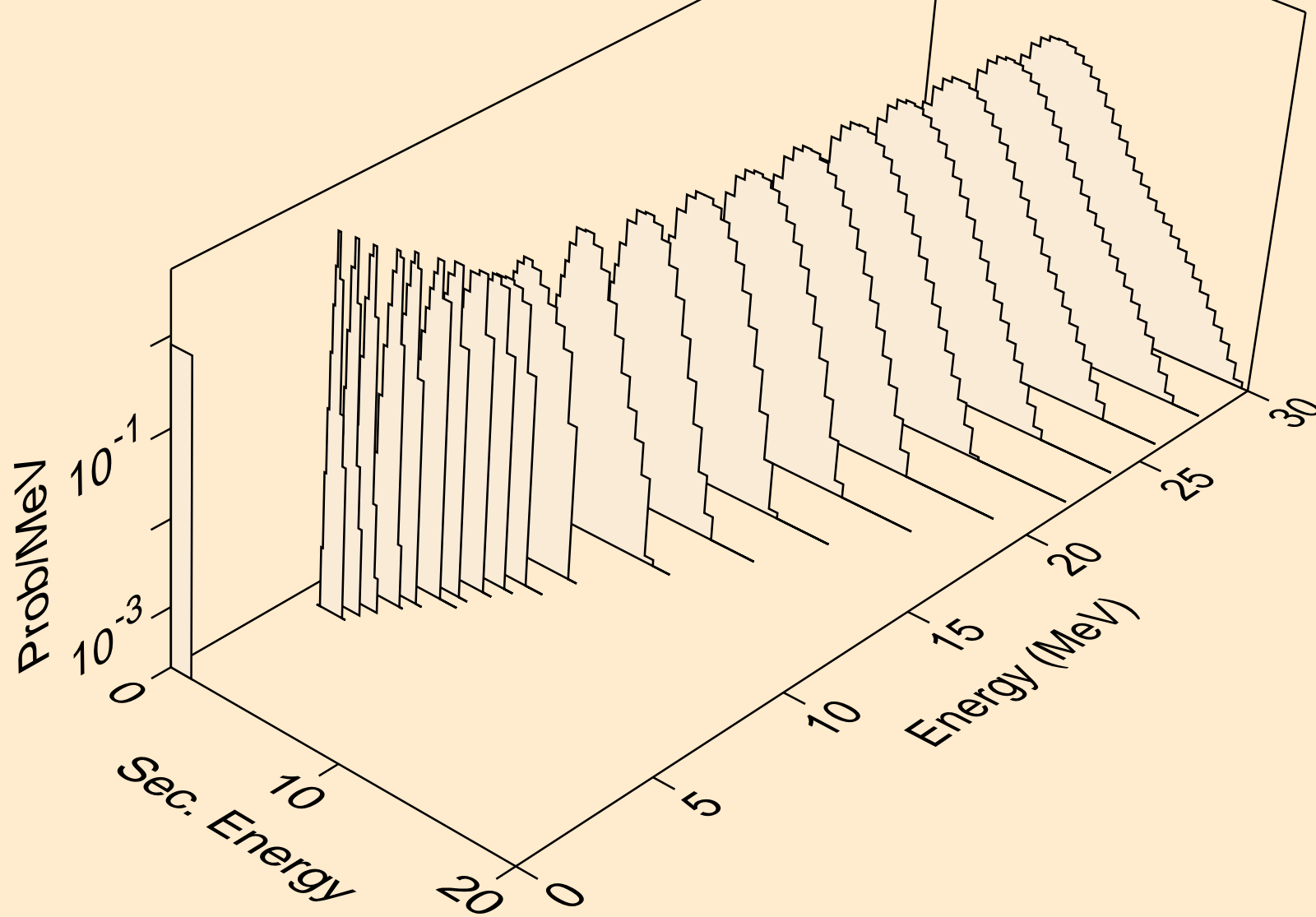

AT200M NEUTRON ACER TENDL-2023 LIBRARY; T=0.K  
protons from (n,p)

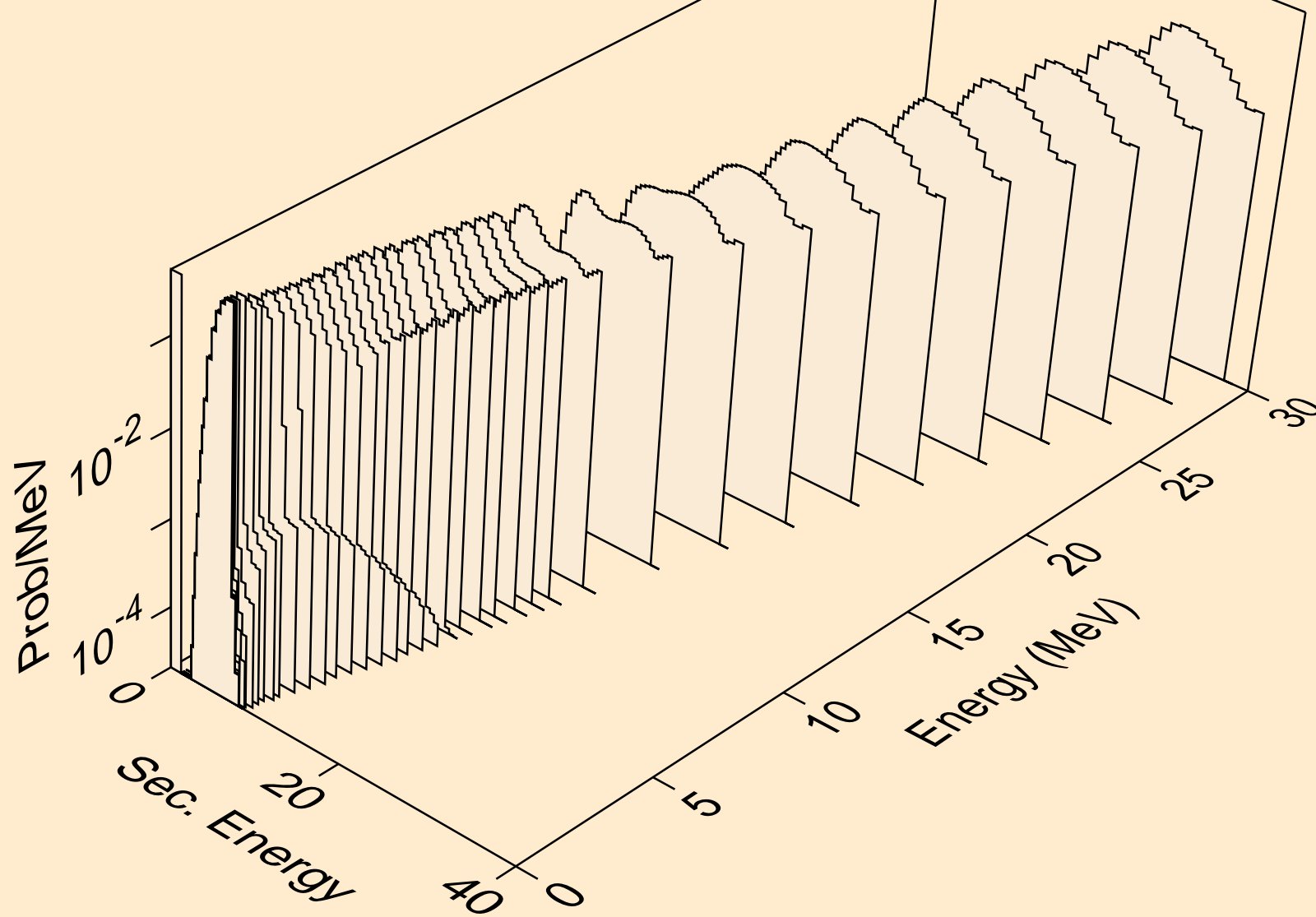

AT200M NEUTRON ACER TENDL-2023 LIBRARY; T=0.K  
protons from (n,2p)

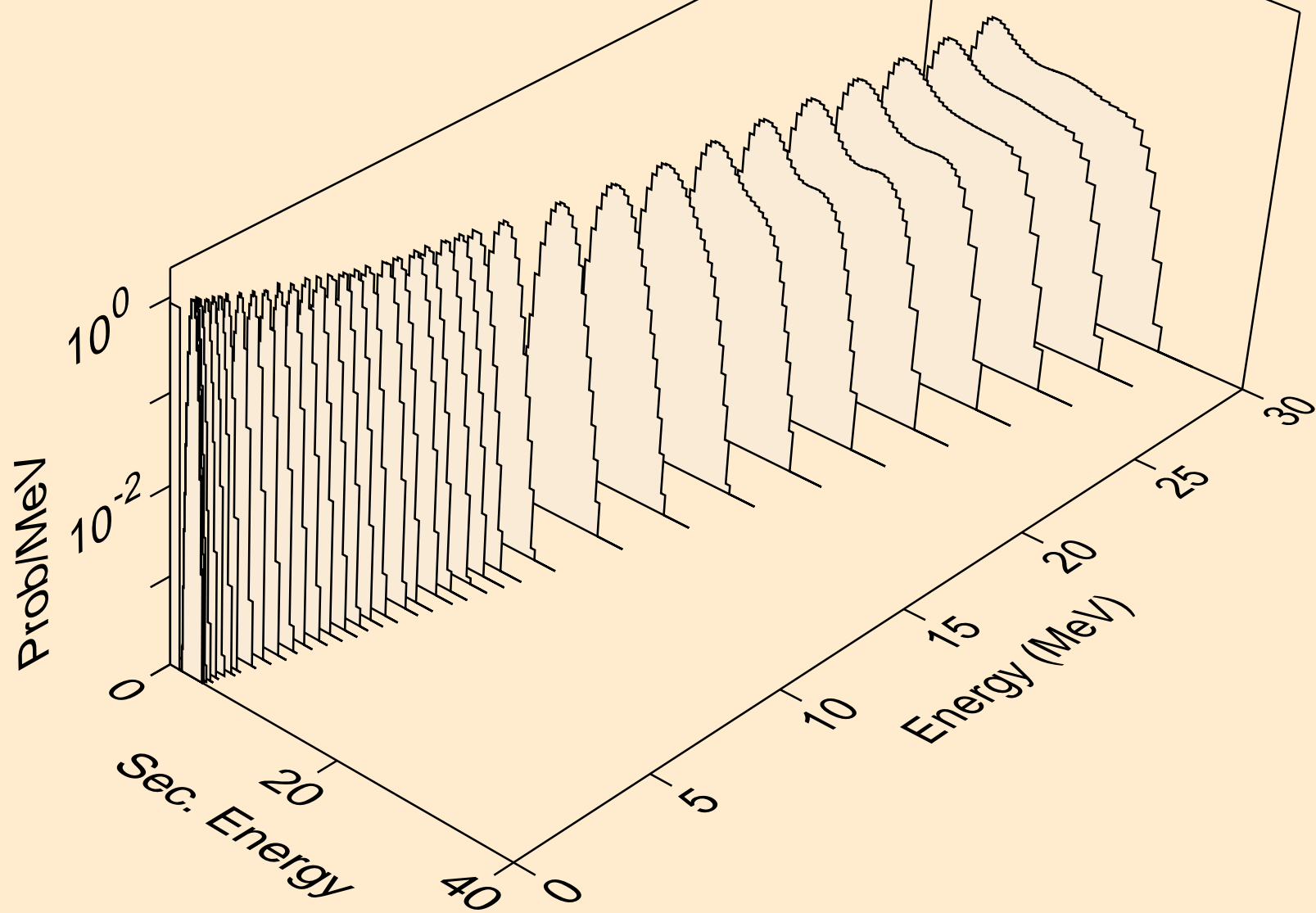

AT200M NEUTRON ACER TENDL-2023 LIBRARY; T=0.K  
protons from (n,p)

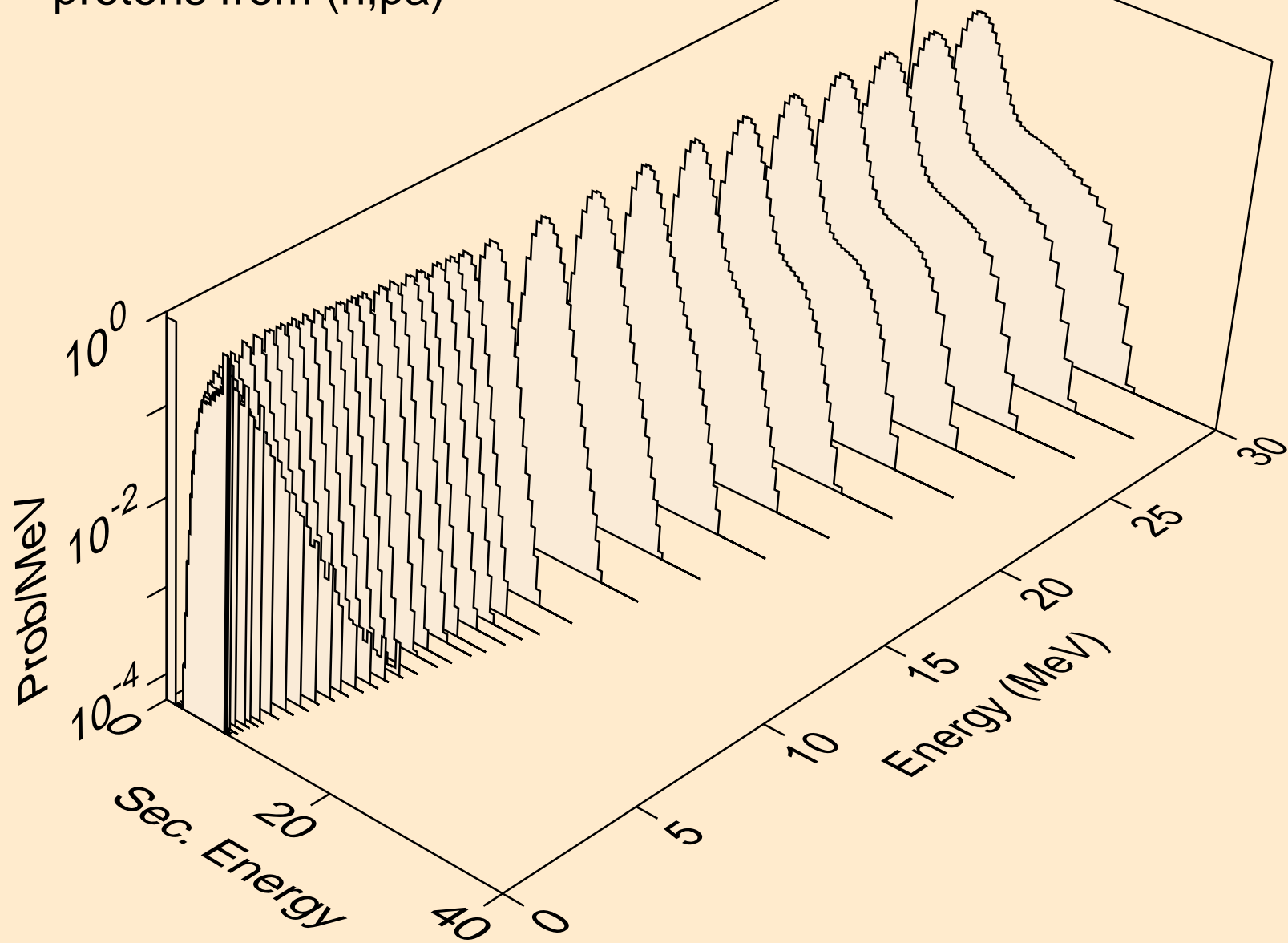



AT200M NEUTRON ACER TENDL-2023 LIBRARY; T=0.K  
protons from (n,pd)

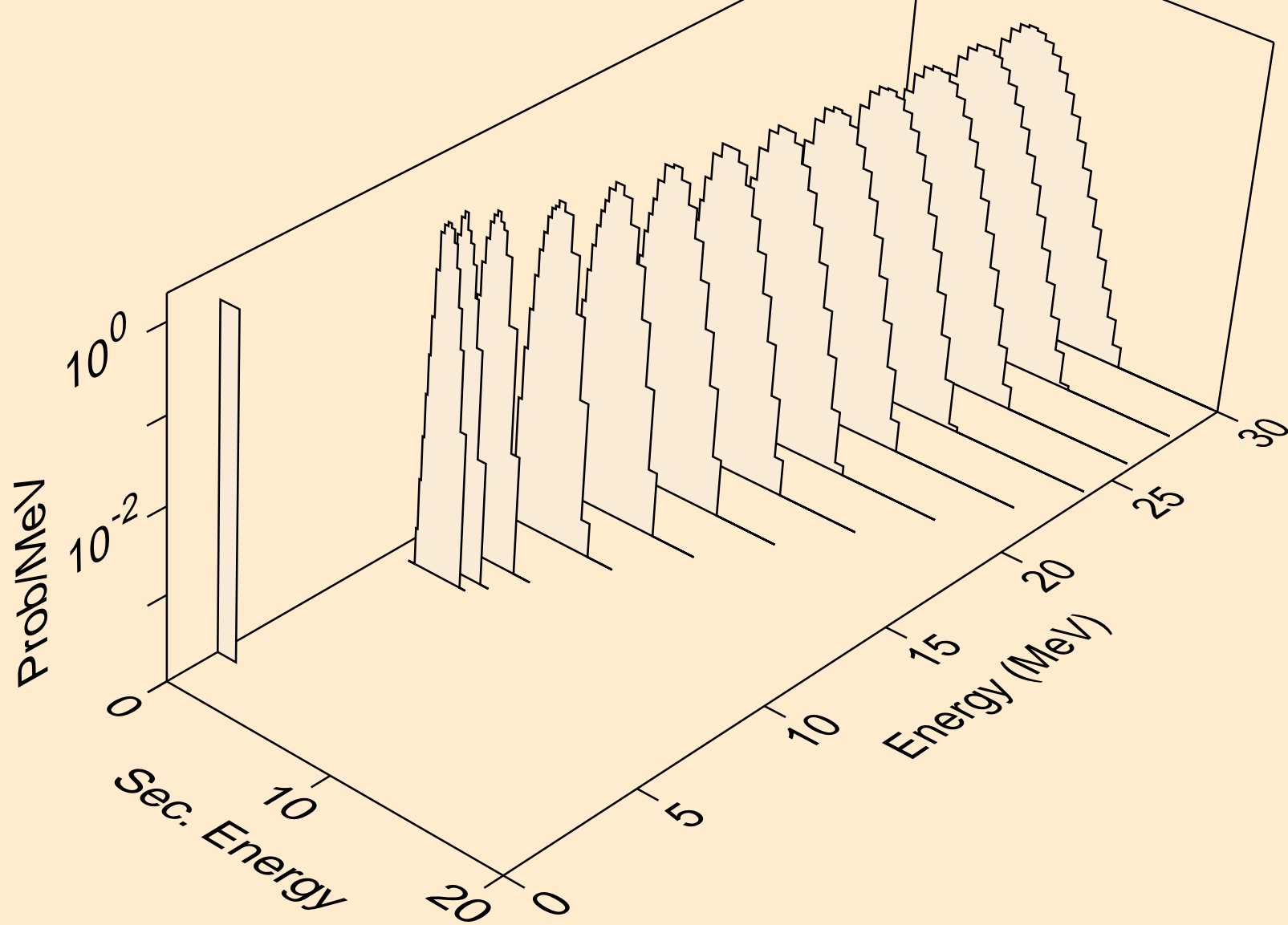

AT200M NEUTRON ACER TENDL-2023 LIBRARY; T=0.K  
protons from (n,pt)

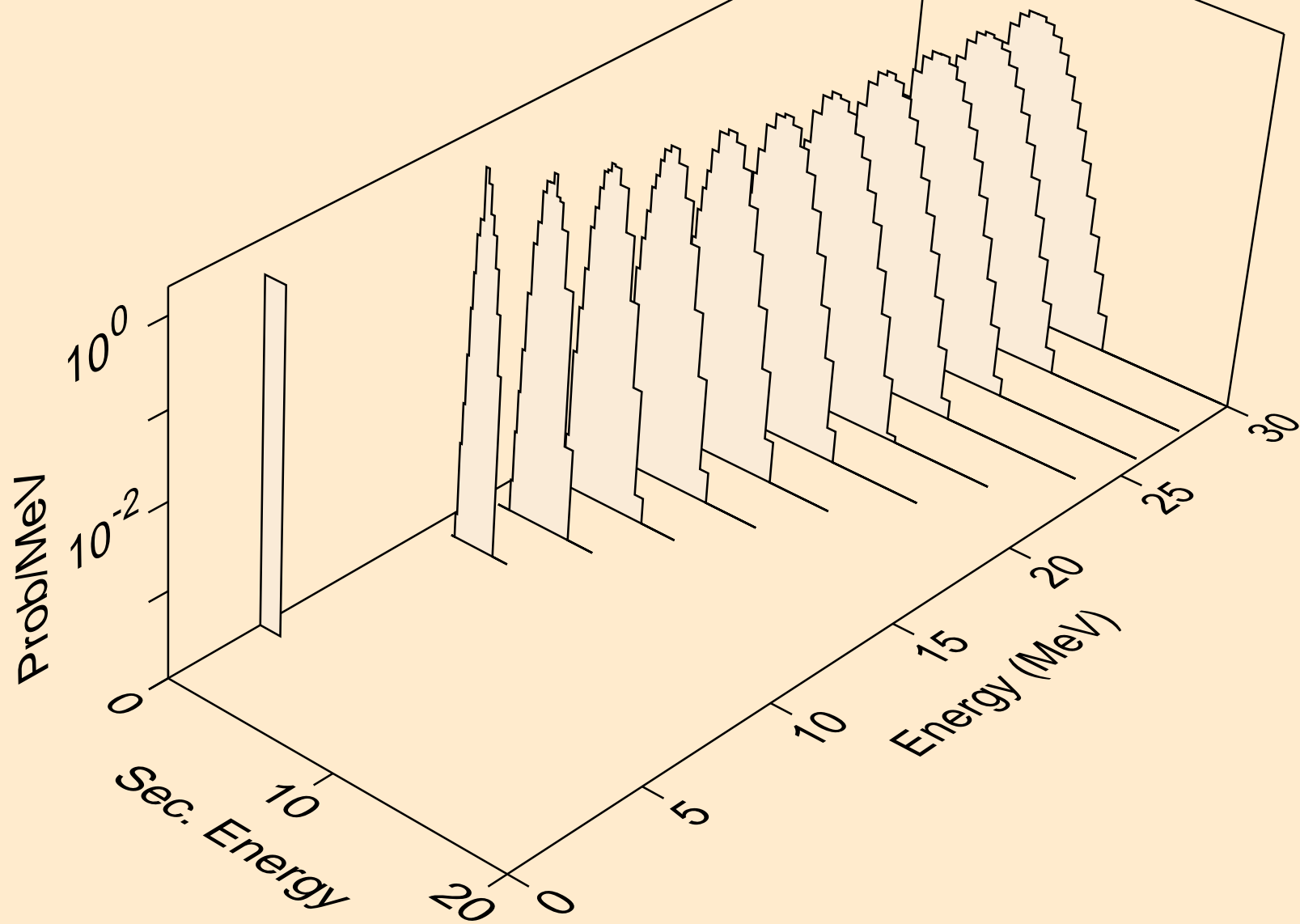

AT200M NEUTRON ACER TENDL-2023 LIBRARY; T=0.K  
deuterons from (n,x)

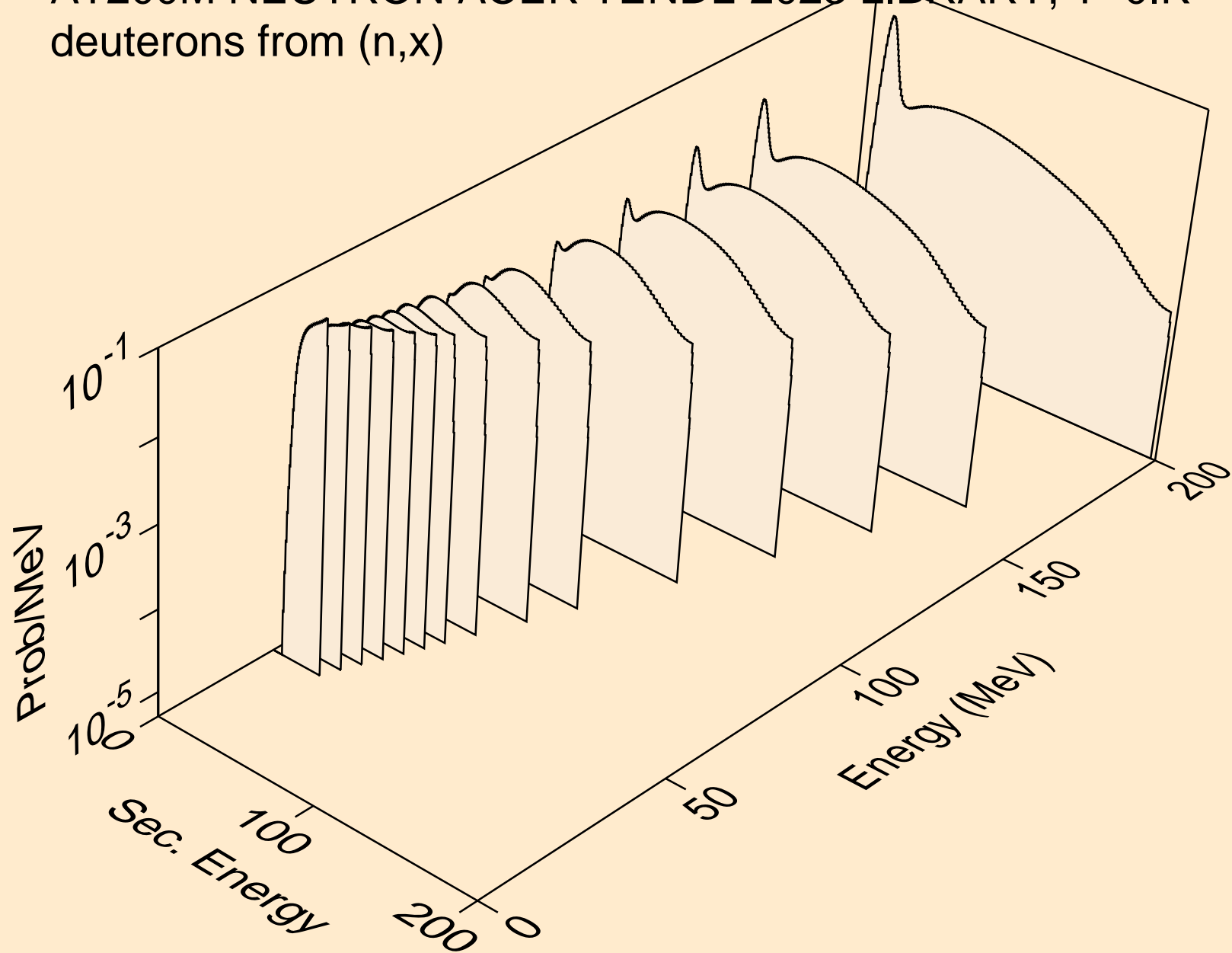

AT200M NEUTRON ACER TENDL-2023 LIBRARY; T=0.K  
deuterons from (n,2nd)

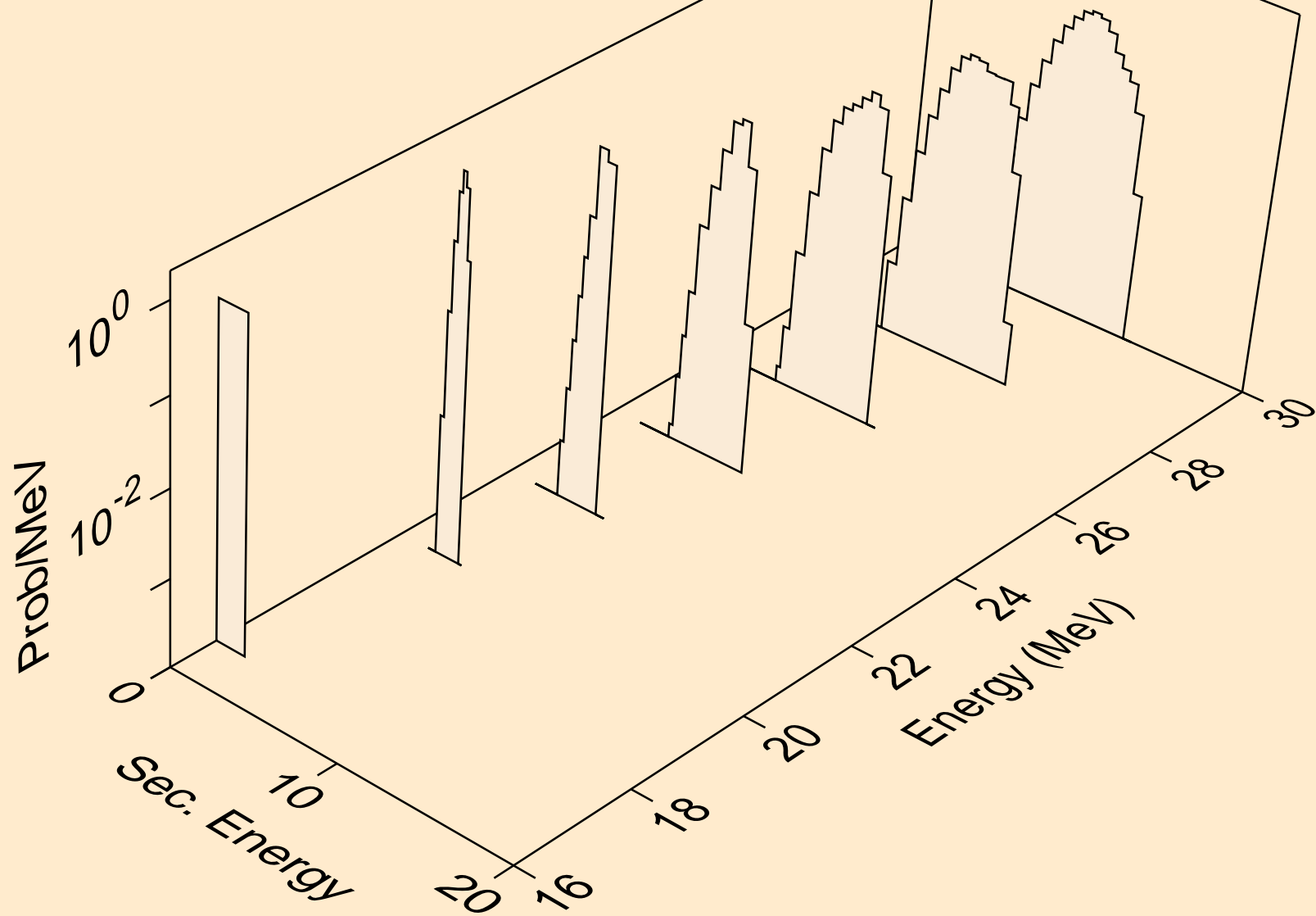

AT200M NEUTRON ACER TENDL-2023 LIBRARY; T=0.K  
deuterons from (n,n\*)d

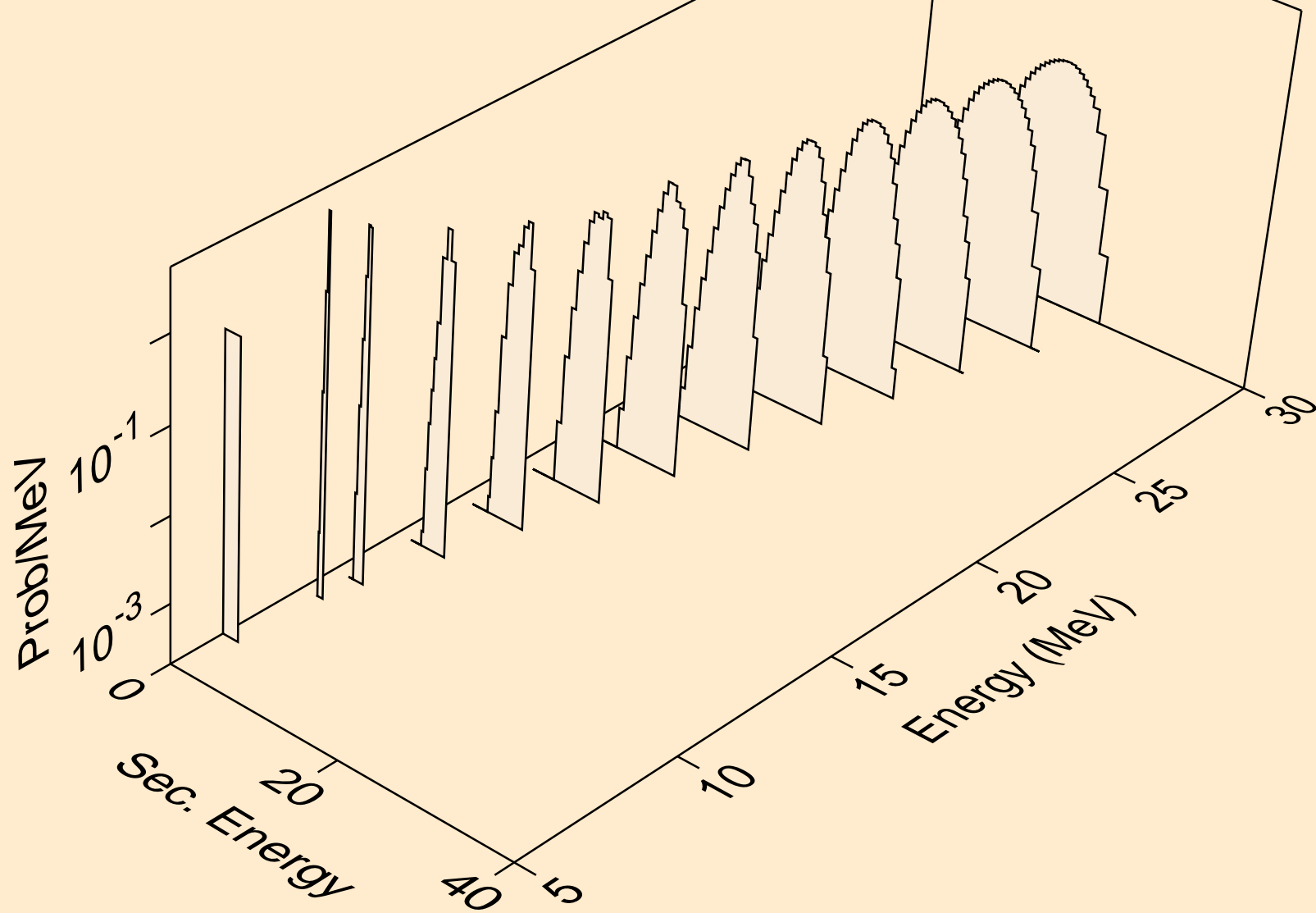

AT200M NEUTRON ACER TENDL-2023 LIBRARY; T=0.K  
deuterons from (n,d)

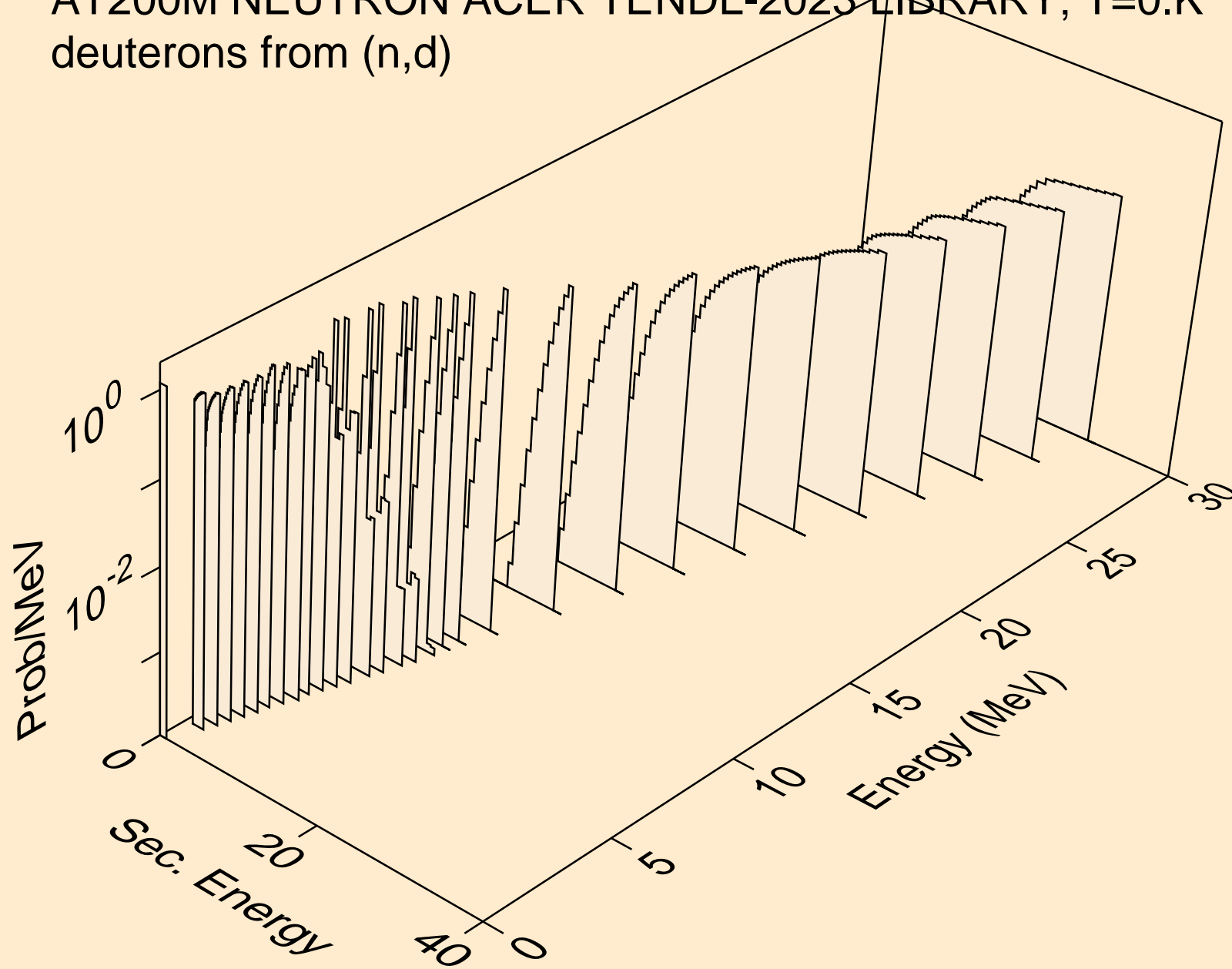

AT200M NEUTRON ACER TENDL-2023 LIBRARY; T=0.K  
deuterons from (n,pd)

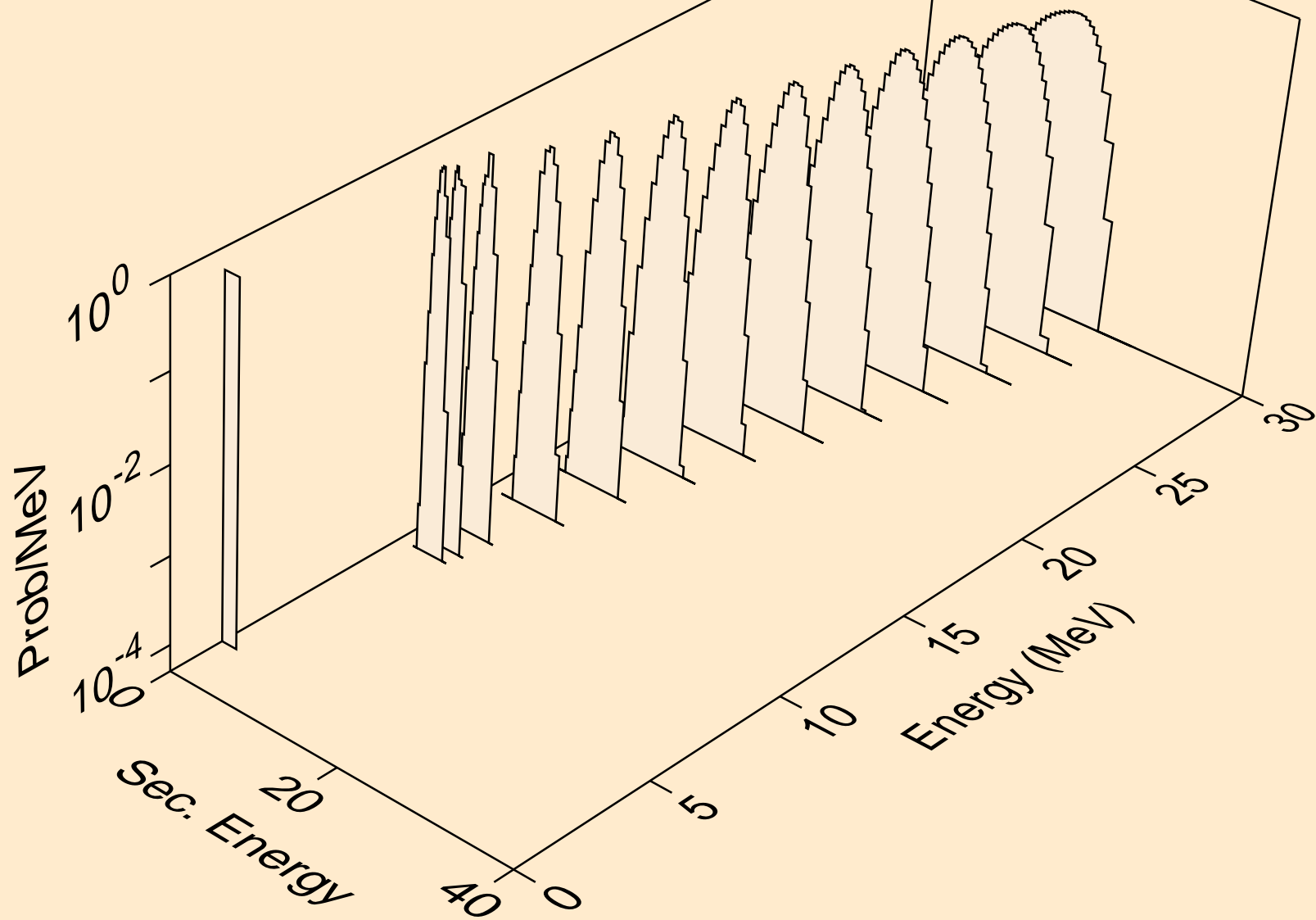

AT200M NEUTRON ACER TENDL-2023 LIBRARY; T=0.K  
deuterons from (n,da)

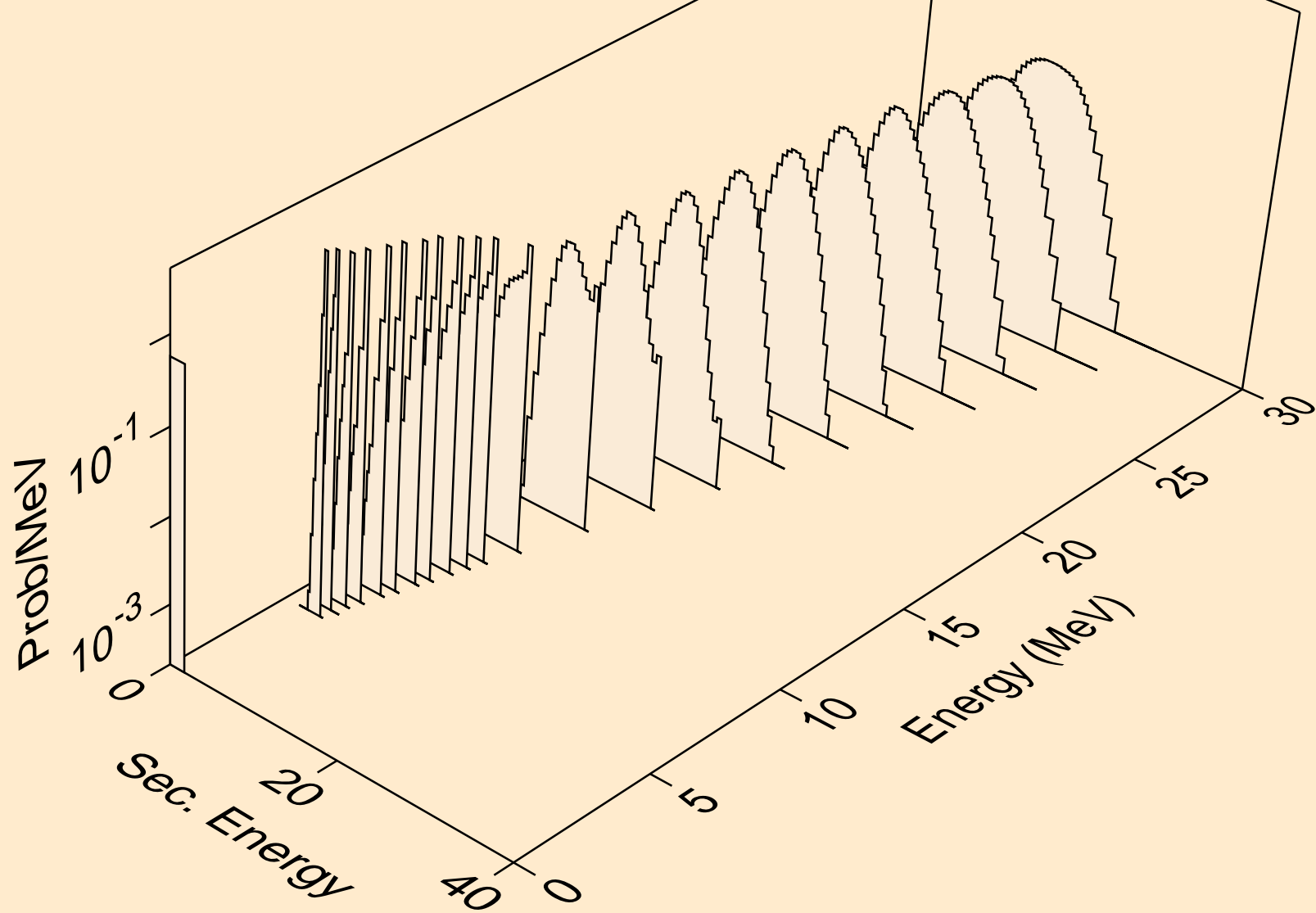



AT200M NEUTRON ACER TENDL-2023 LIBRARY; T=0.K  
tritons from (n,x)

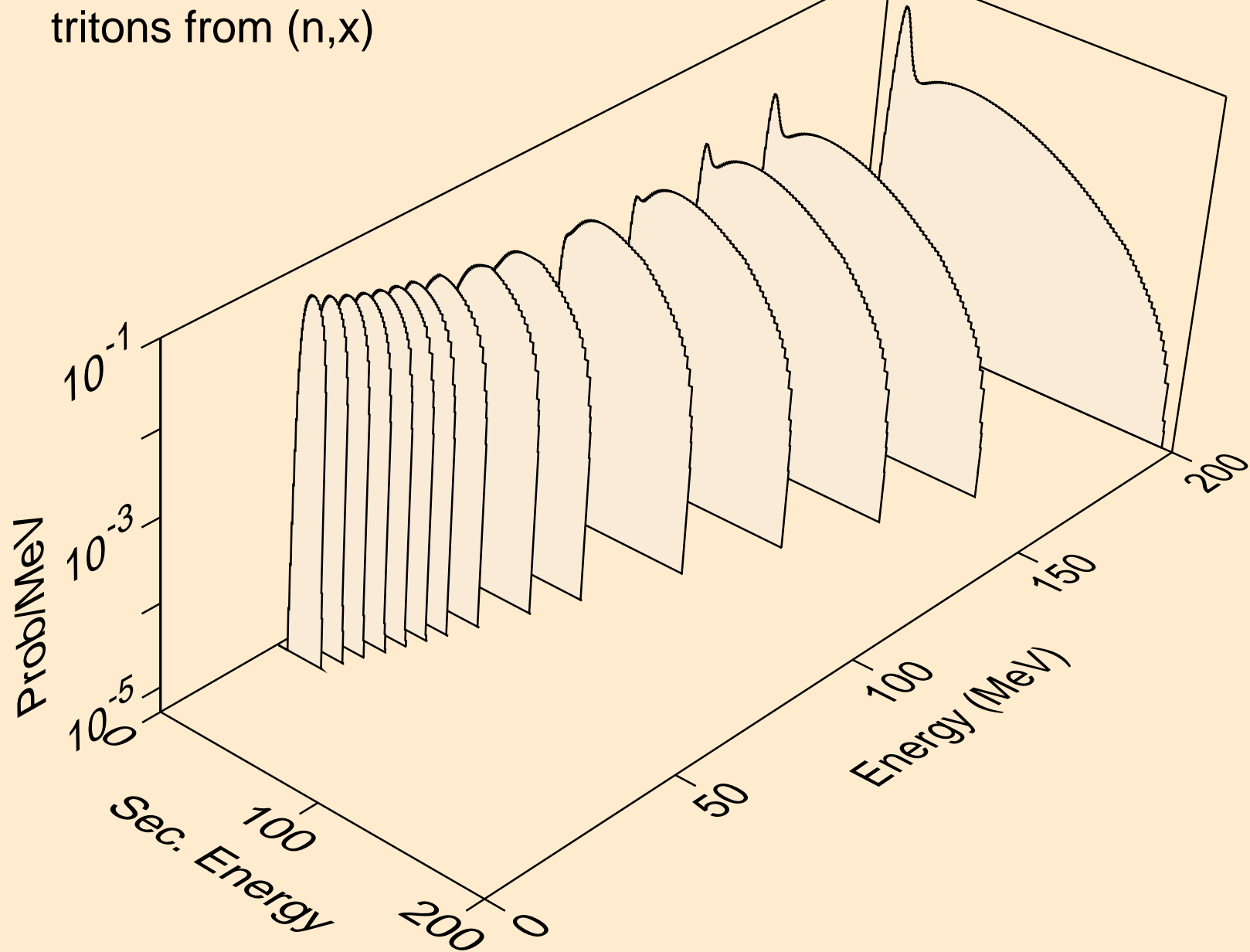

AT200M NEUTRON ACER TENDL-2023 LIBRARY; T=0.K  
tritons from (n,n\*)t

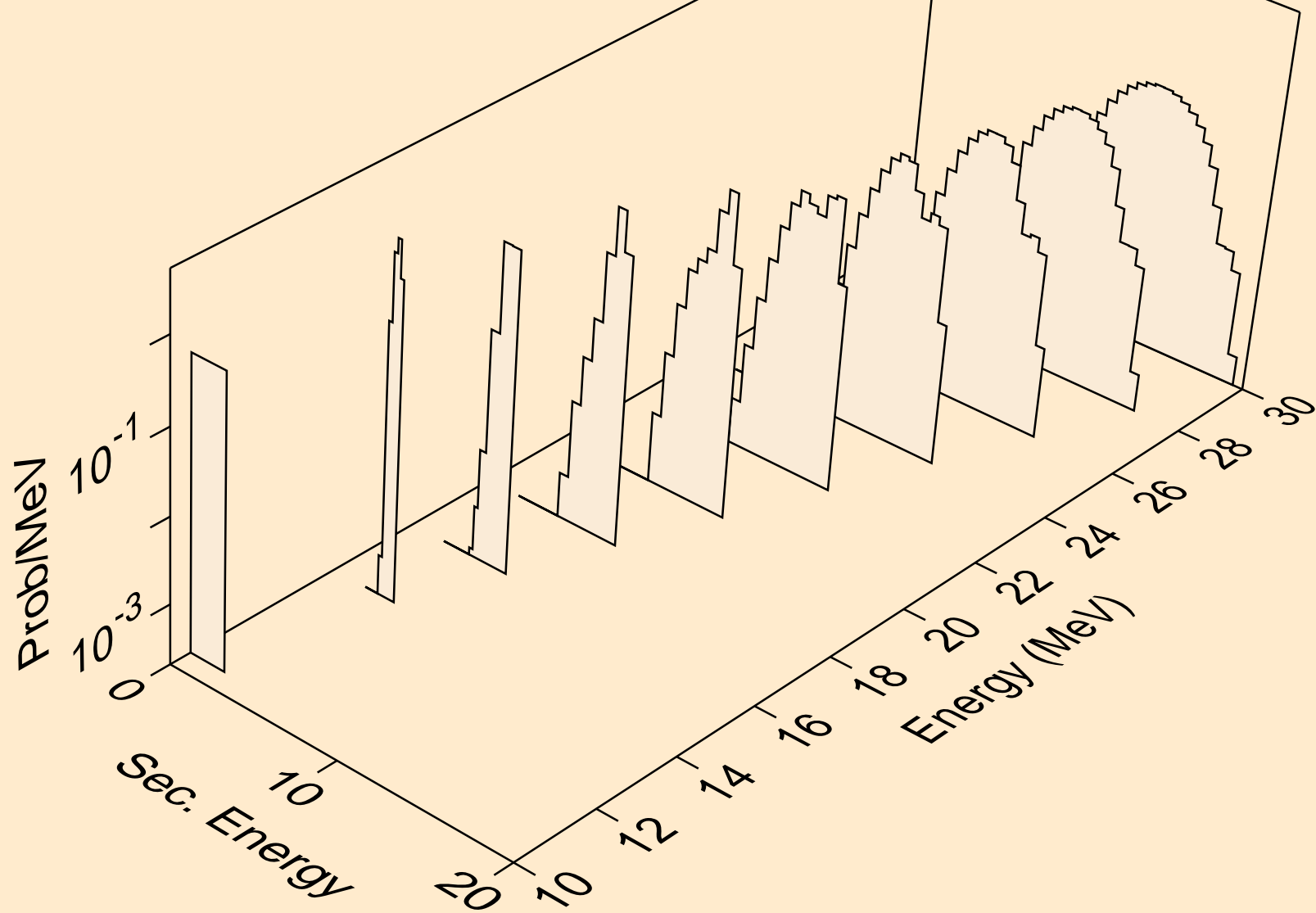

AT200M NEUTRON ACER TENDL-2023 LIBRARY; T=0.K  
tritons from (n,t)

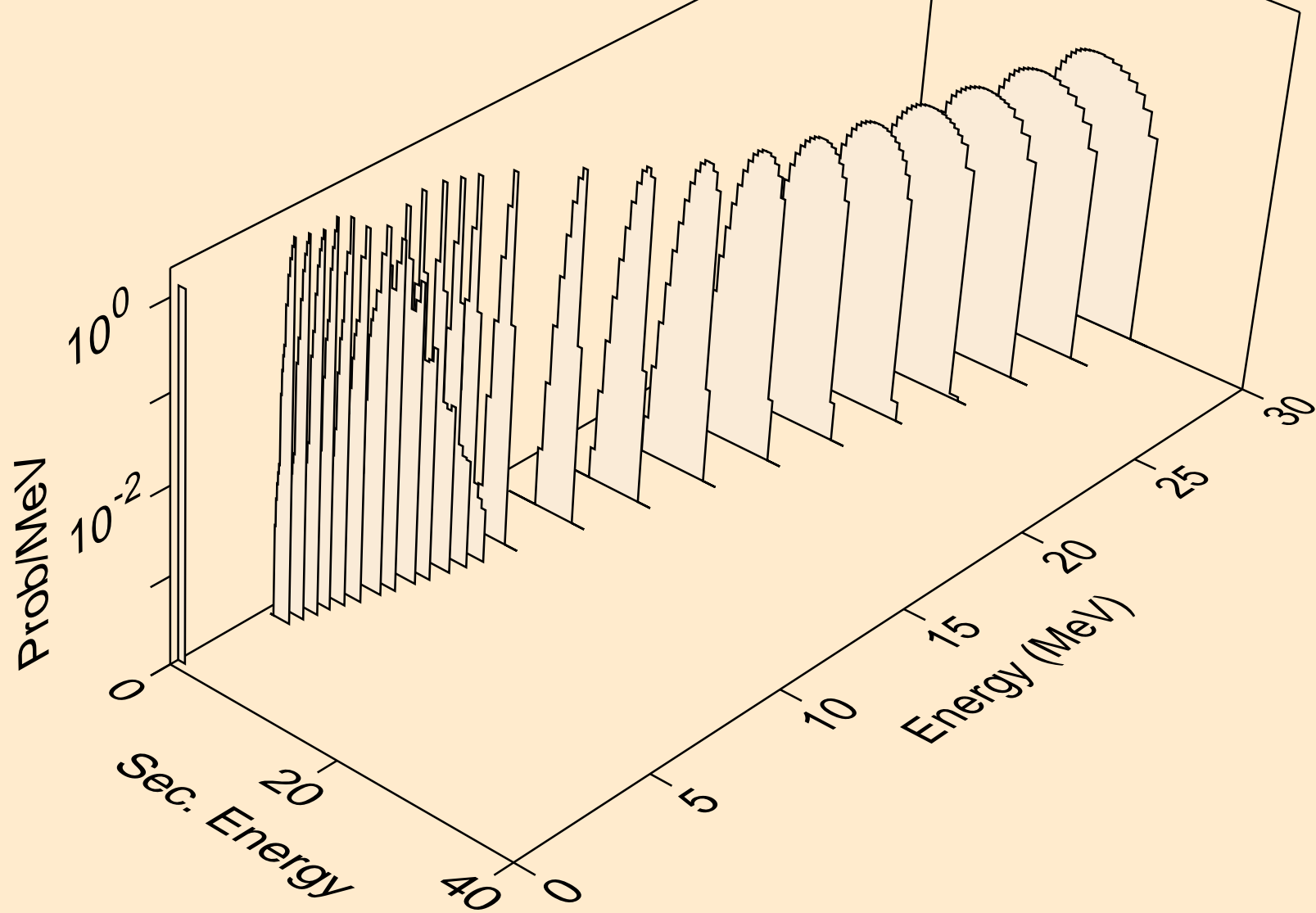

AT200M NEUTRON ACER TENDL-2023 LIBRARY; T=0.K  
tritons from (n,pt)

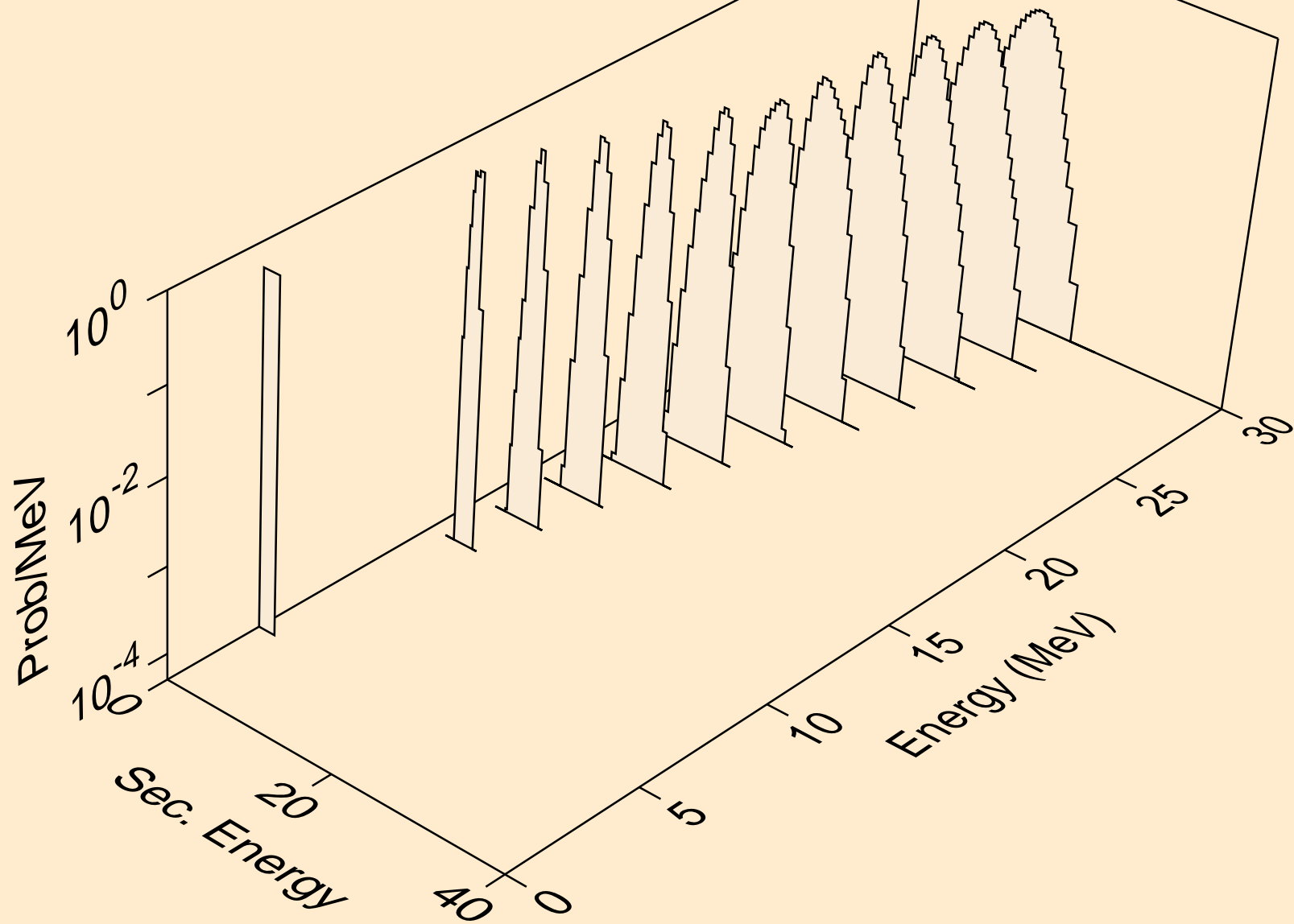

AT200M NEUTRON ACER TENDL-2023 LIBRARY; T=0.K  
he3s from (n,x)

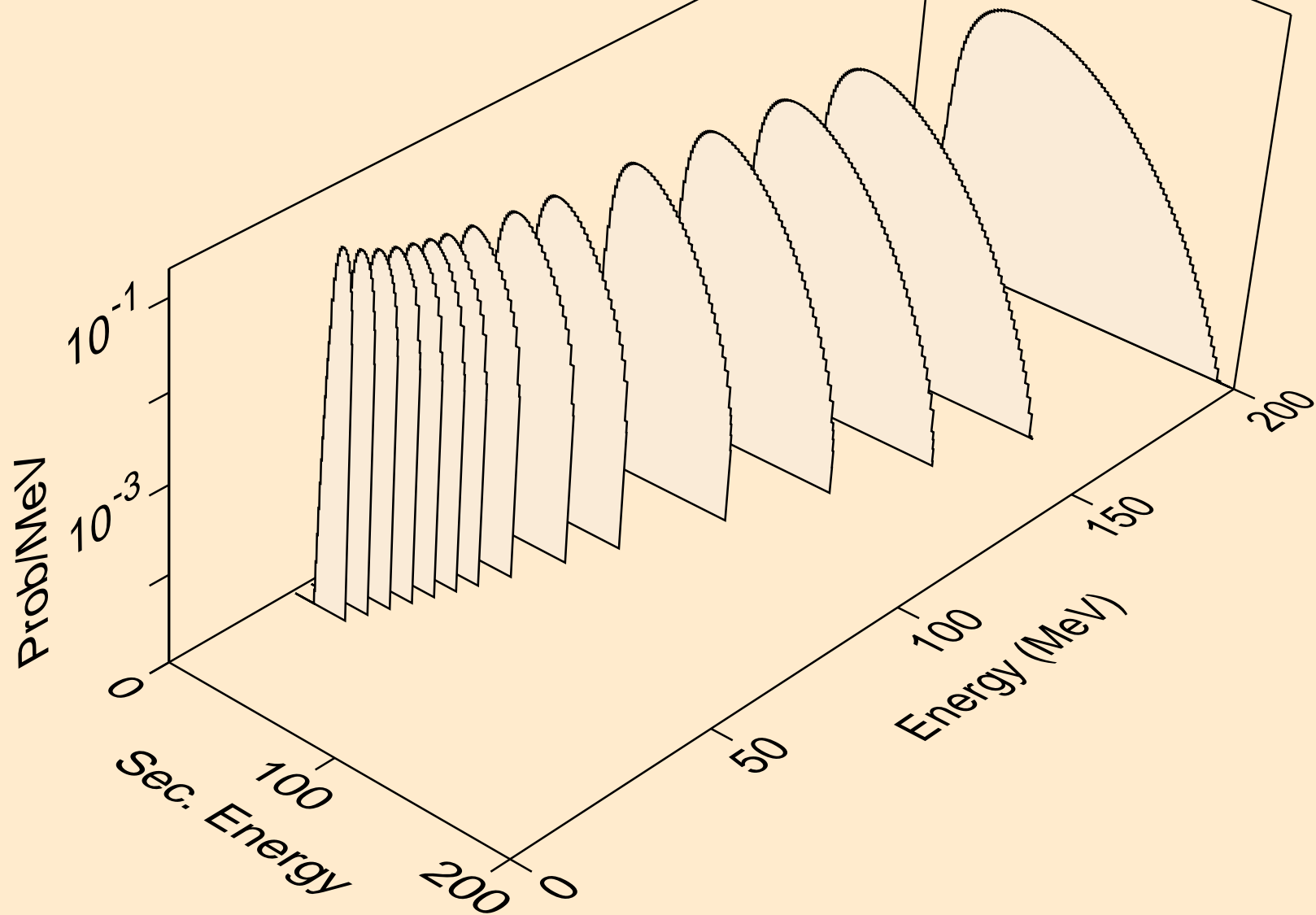

AT200M NEUTRON ACER TENDL-2023 LIBRARY; T=0.K  
he3s from (n,n\*)he3

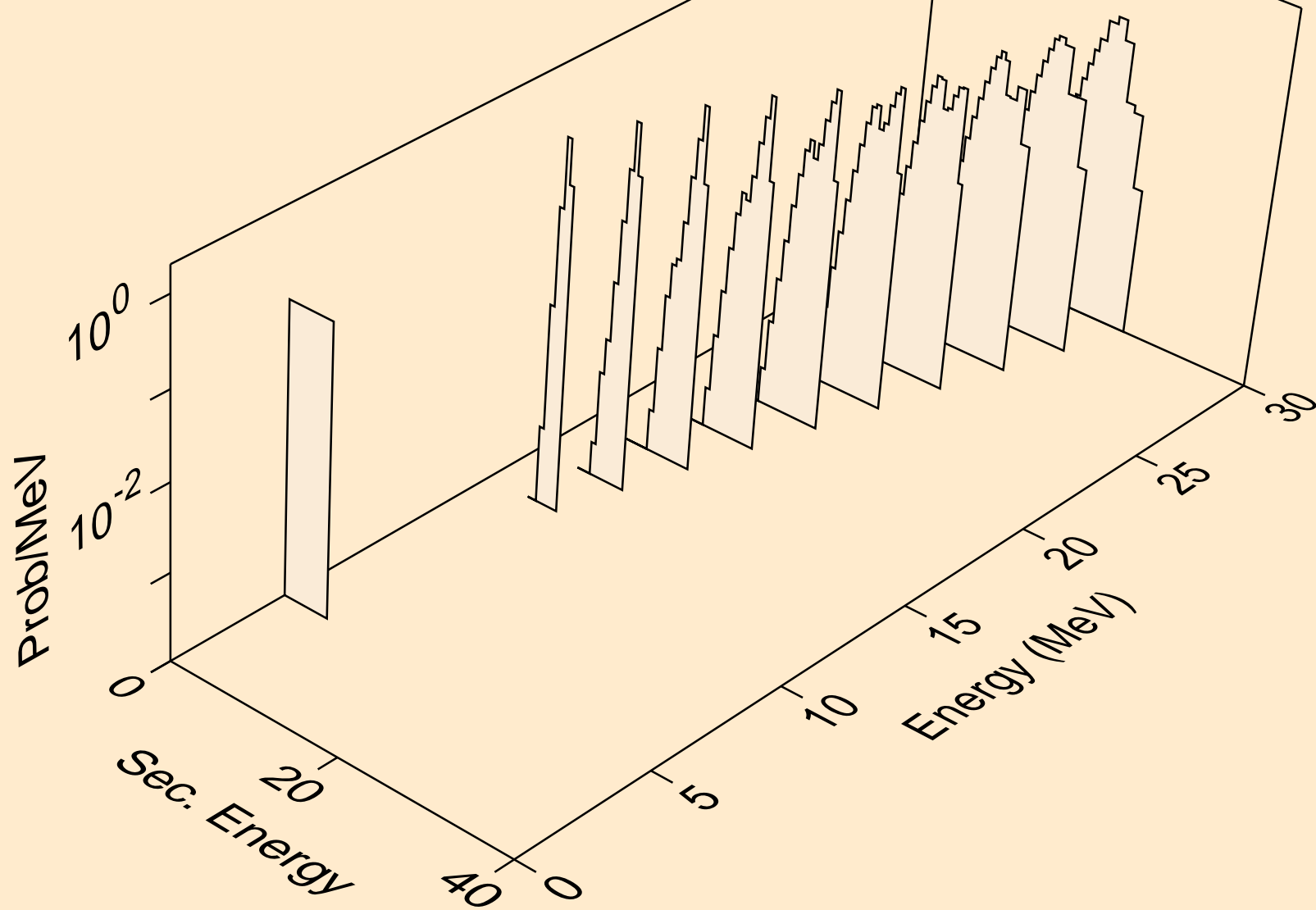

AT200M NEUTRON ACER TENDL-2023 LIBRARY; T=0.K  
he3s from (n,he3)

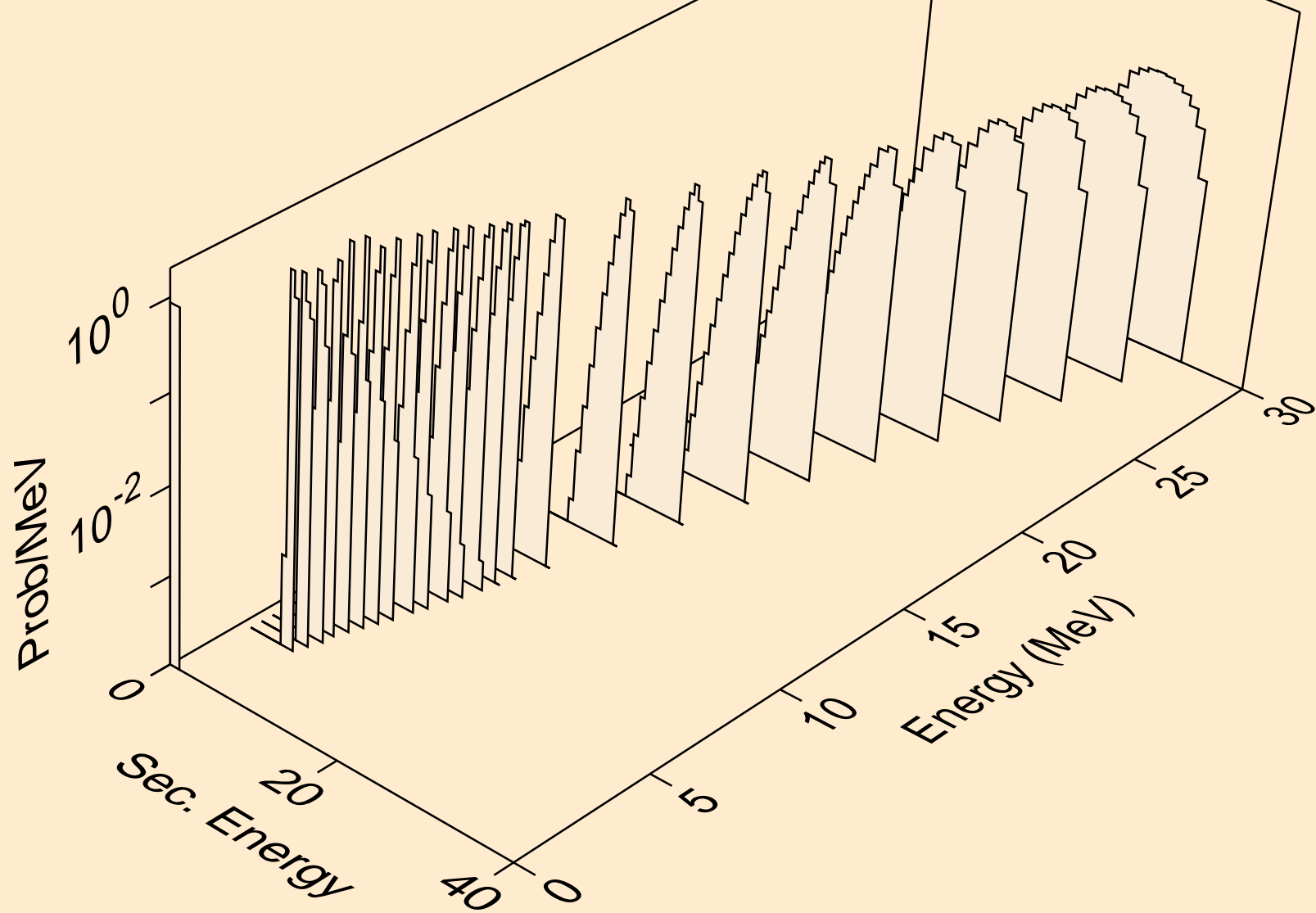

AT200M NEUTRON ACER TENDL-2023 LIBRARY; T=0.K  
alphas from (n,x)

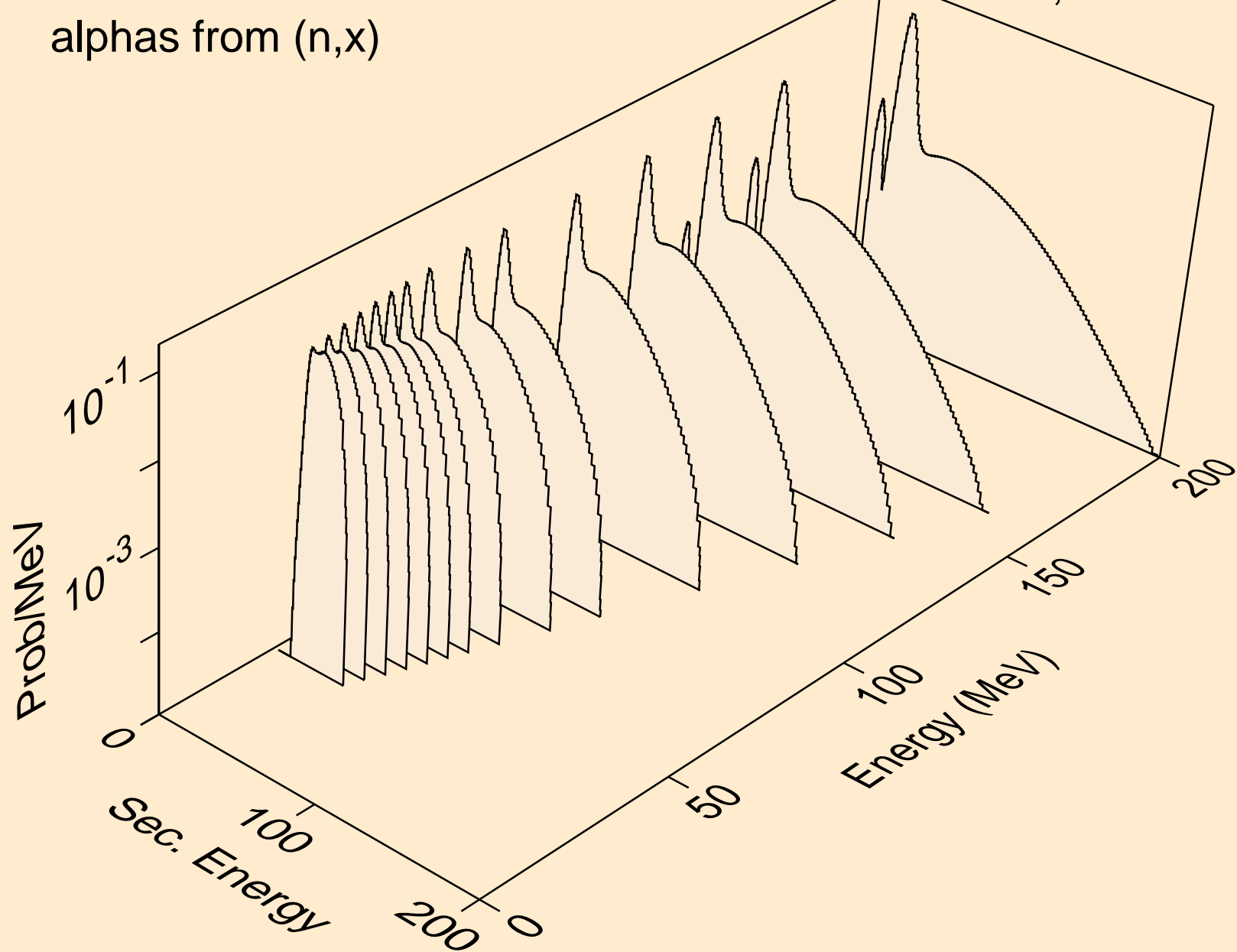



AT200M NEUTRON ACER TENDL-2023 LIBRARY; T=0.K  
alphas from (n,n\*)a

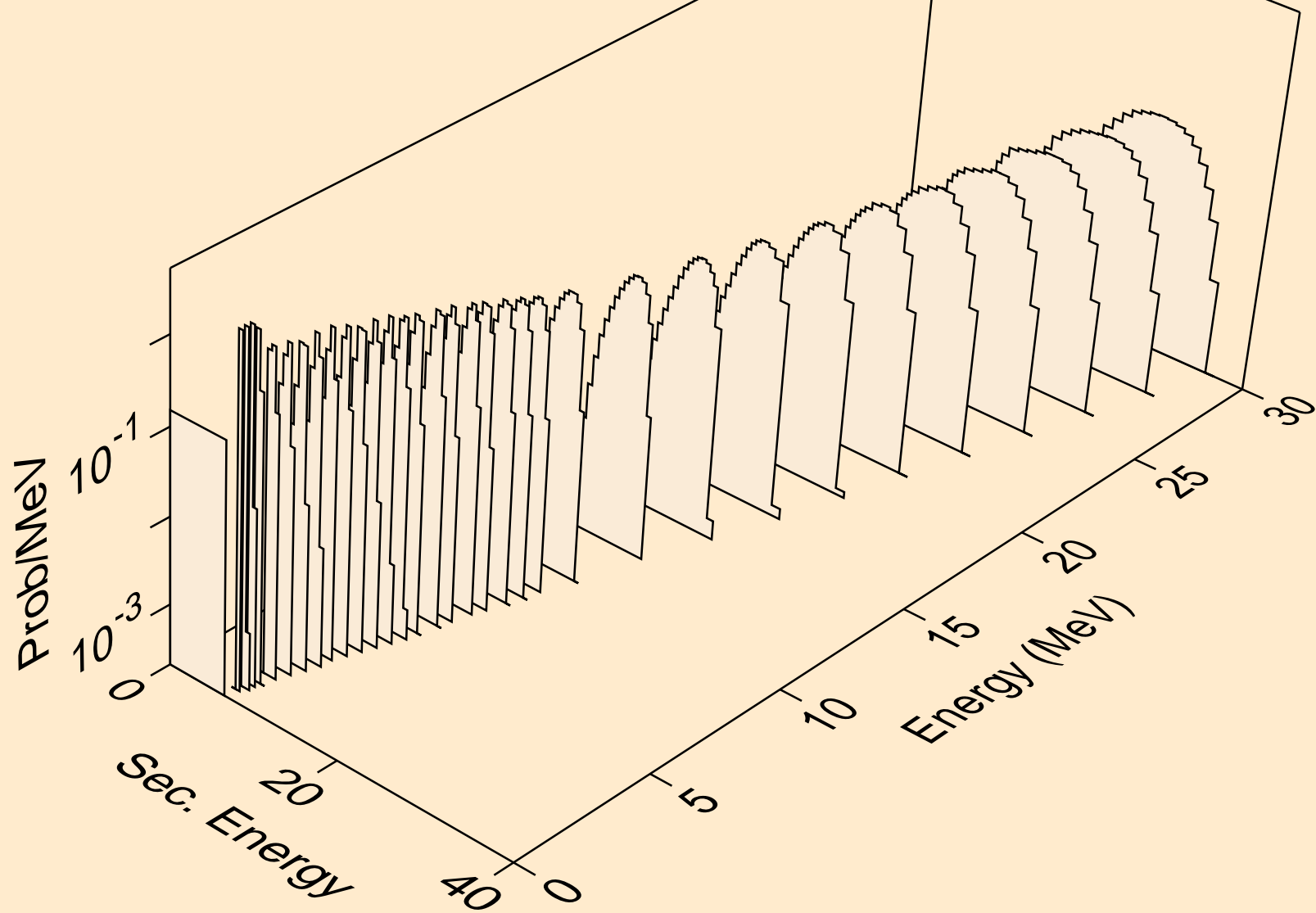

AT200M NEUTRON ACER TENDL-2023 LIBRARY; T=0.K  
alphas from (n,2n)a

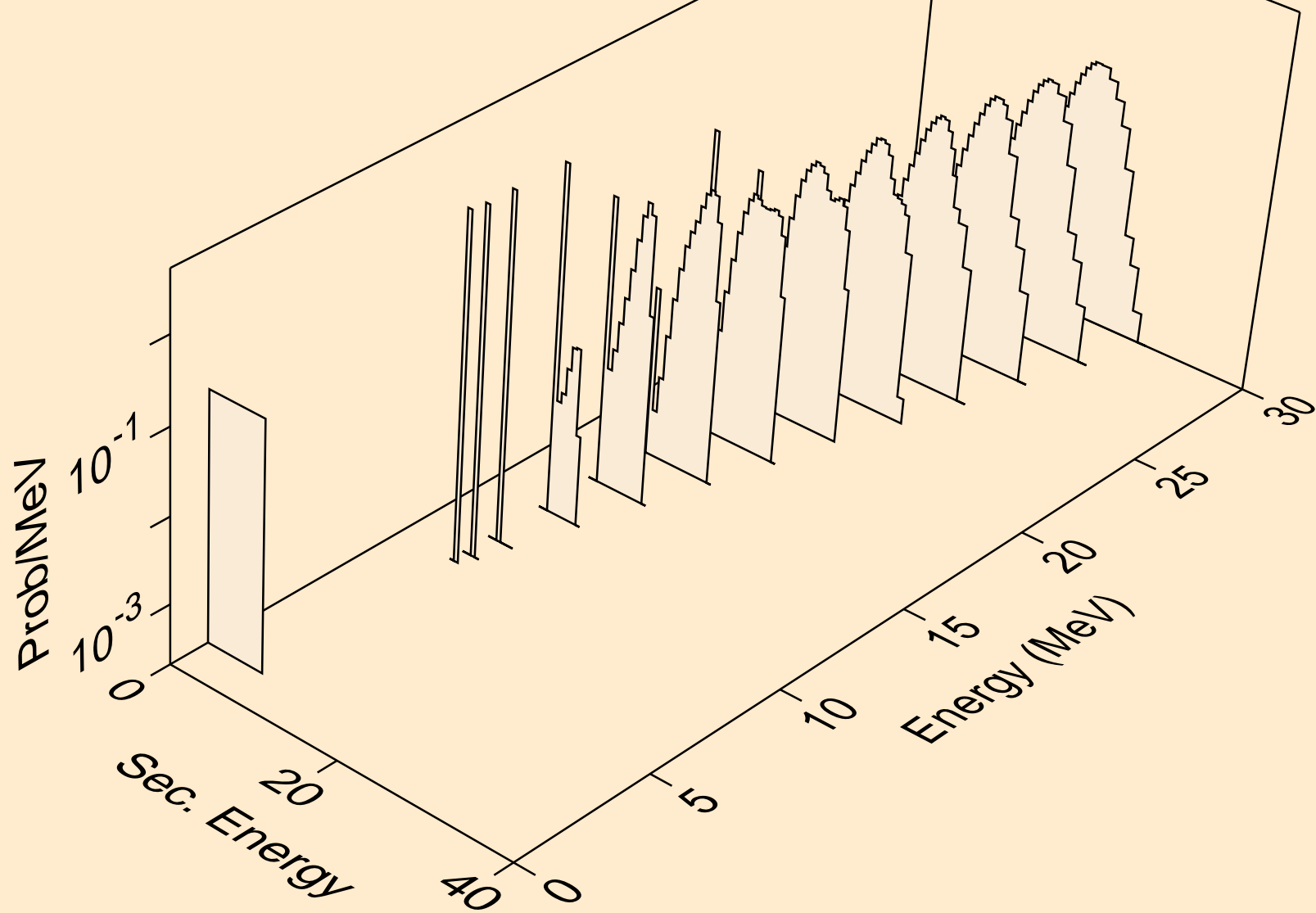

AT200M NEUTRON ACER TENDL-2023 LIBRARY; T=0.K  
alphas from (n,3n)a

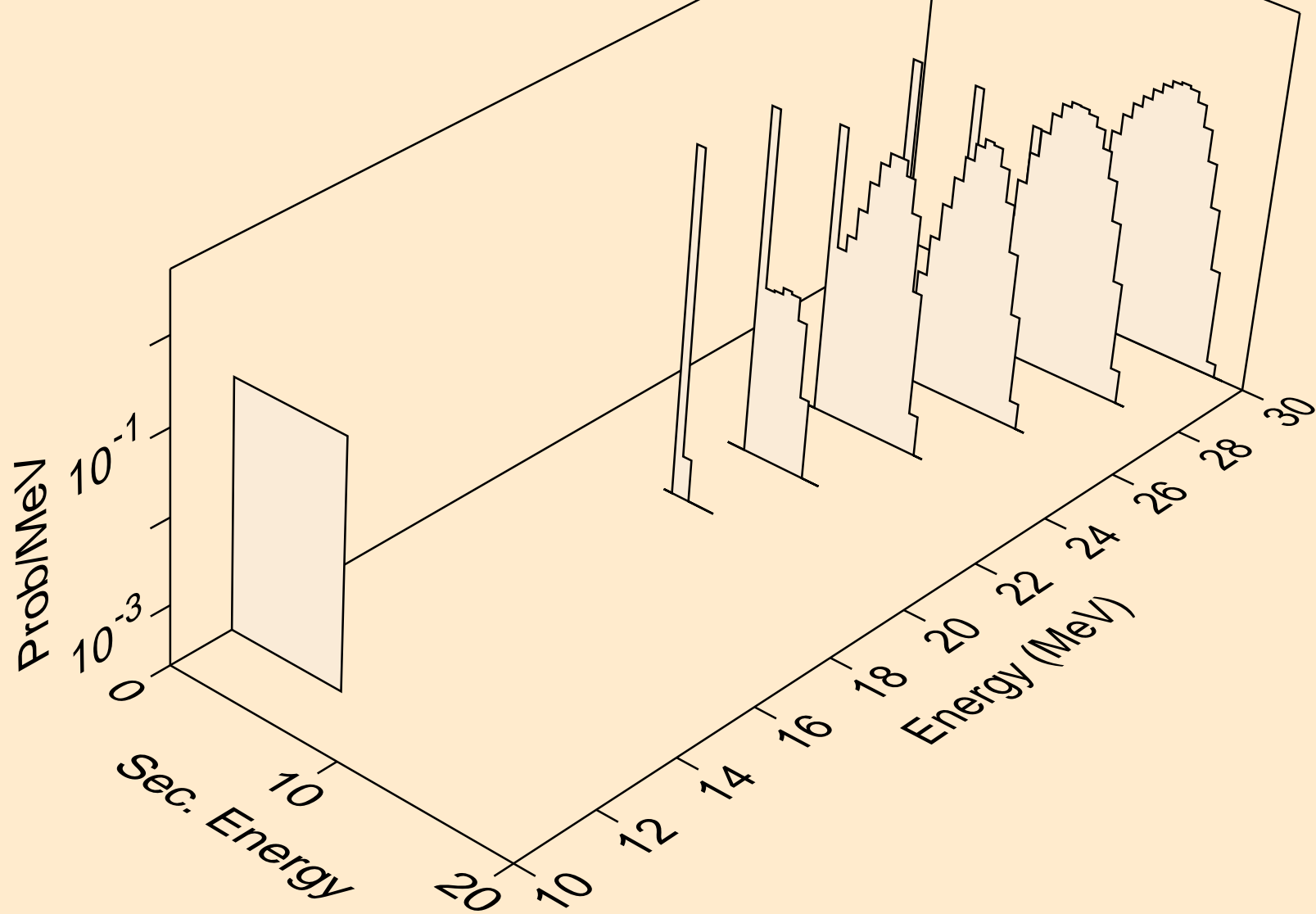

AT200M NEUTRON ACER TENDL-2023 LIBRARY; T=0.K  
alphas from (n,n\*)2a

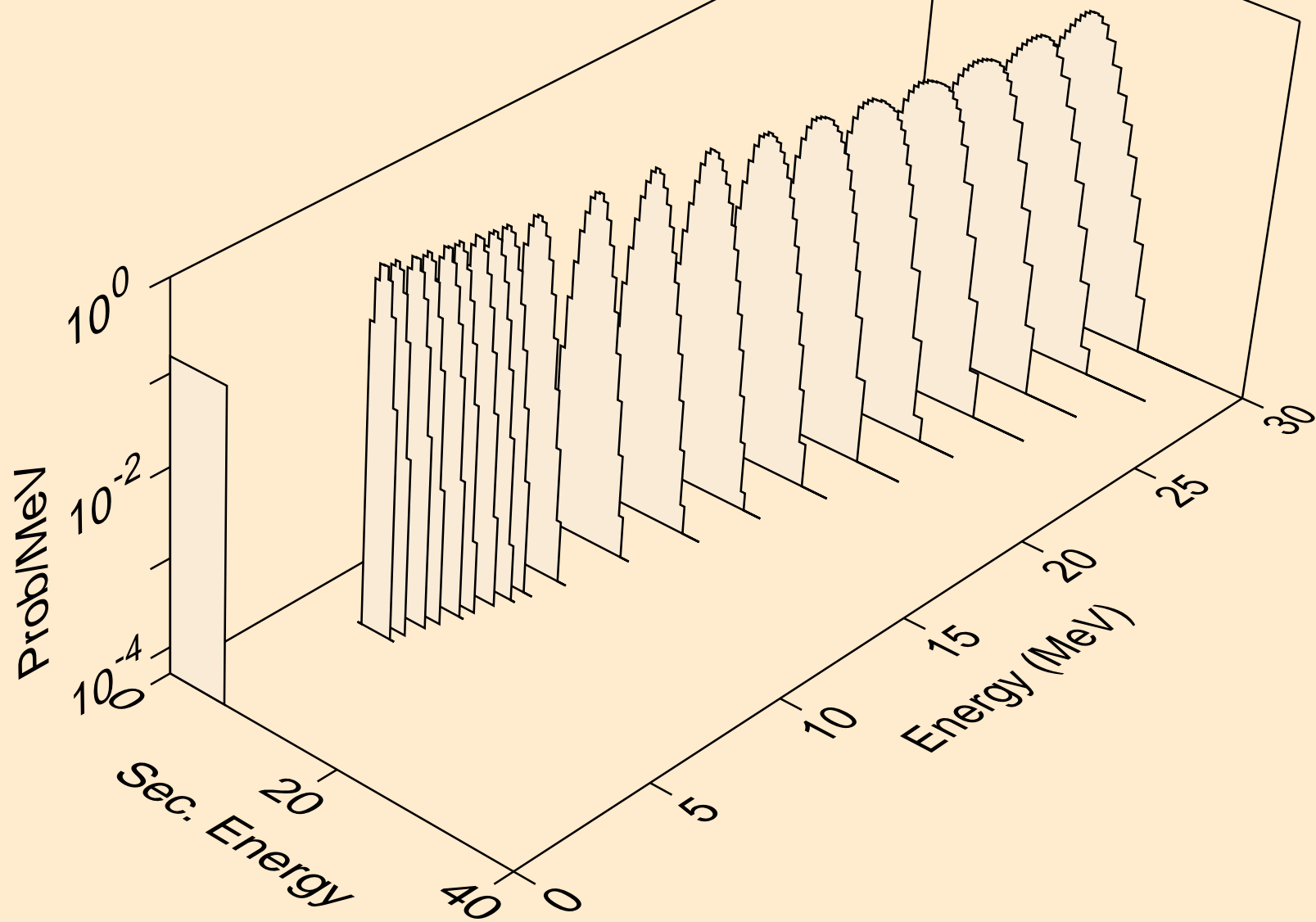

AT200M NEUTRON ACER TENDL-2023 LIBRARY; T=0.K  
alphas from (n,2n)2a

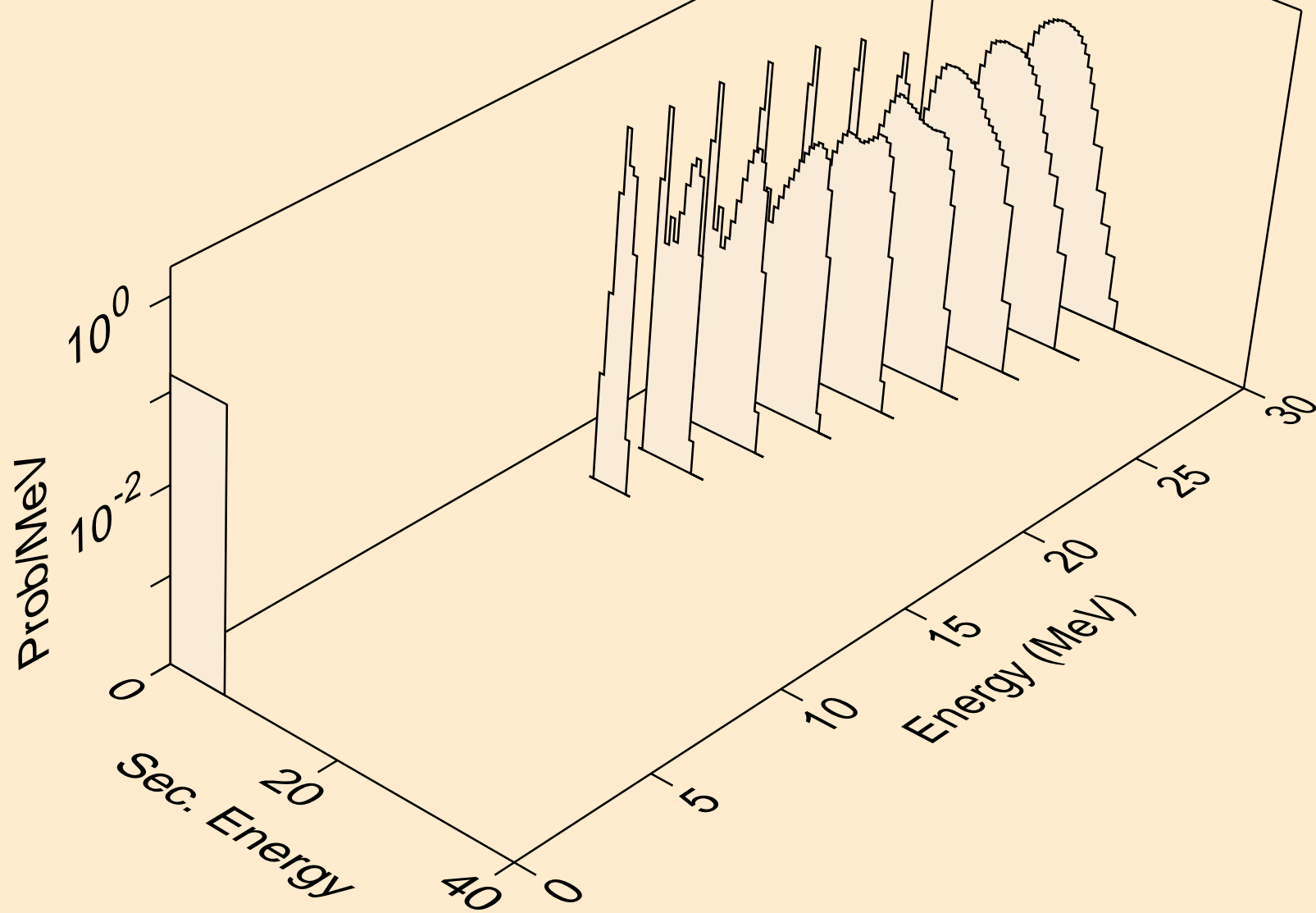

AT200M NEUTRON ACER TENDL-2023 LIBRARY; T=0.K  
alphas from (n,npa)

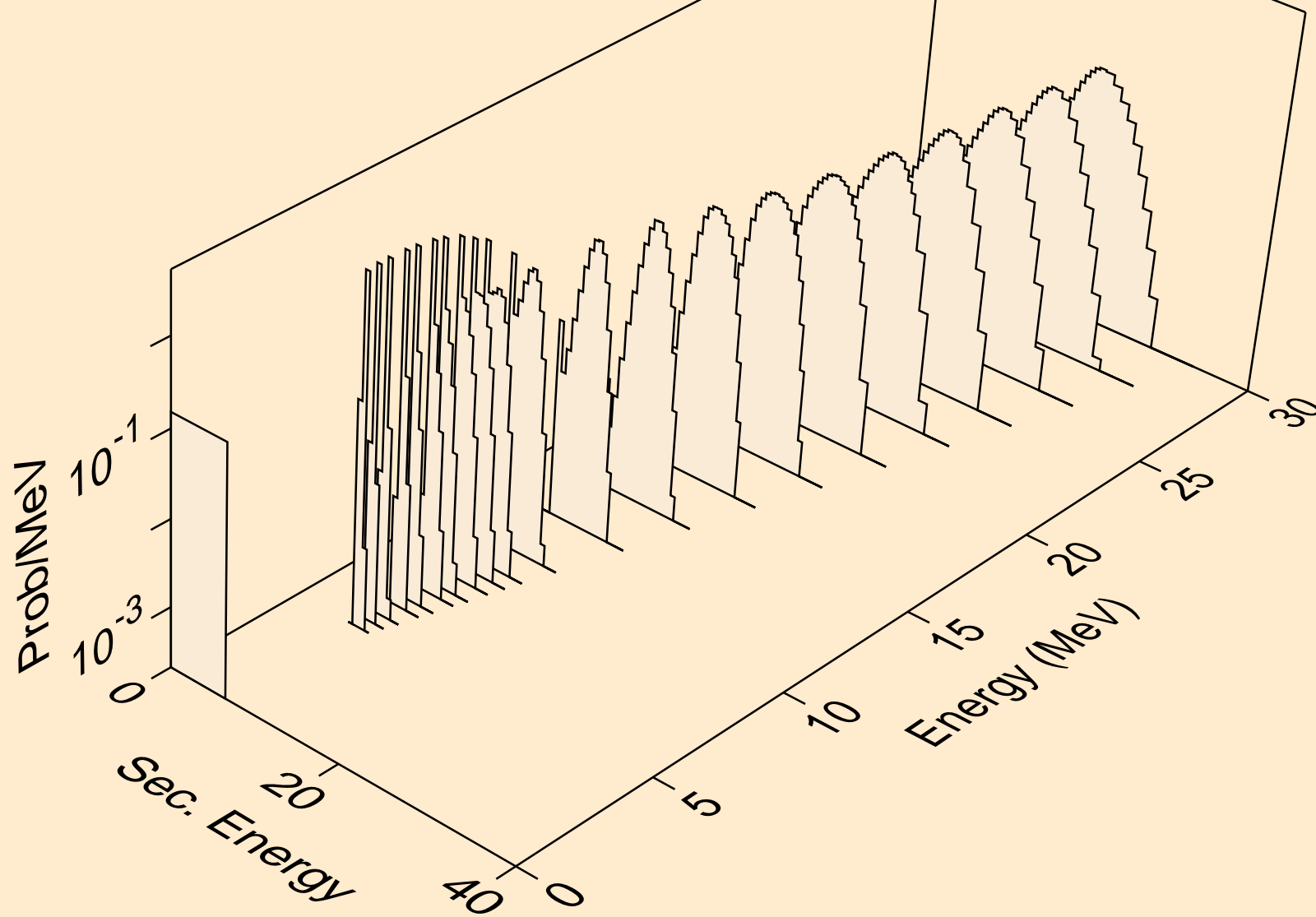

AT200M NEUTRON ACER TENDL-2023 LIBRARY; T=0.K  
alphas from (n,a)

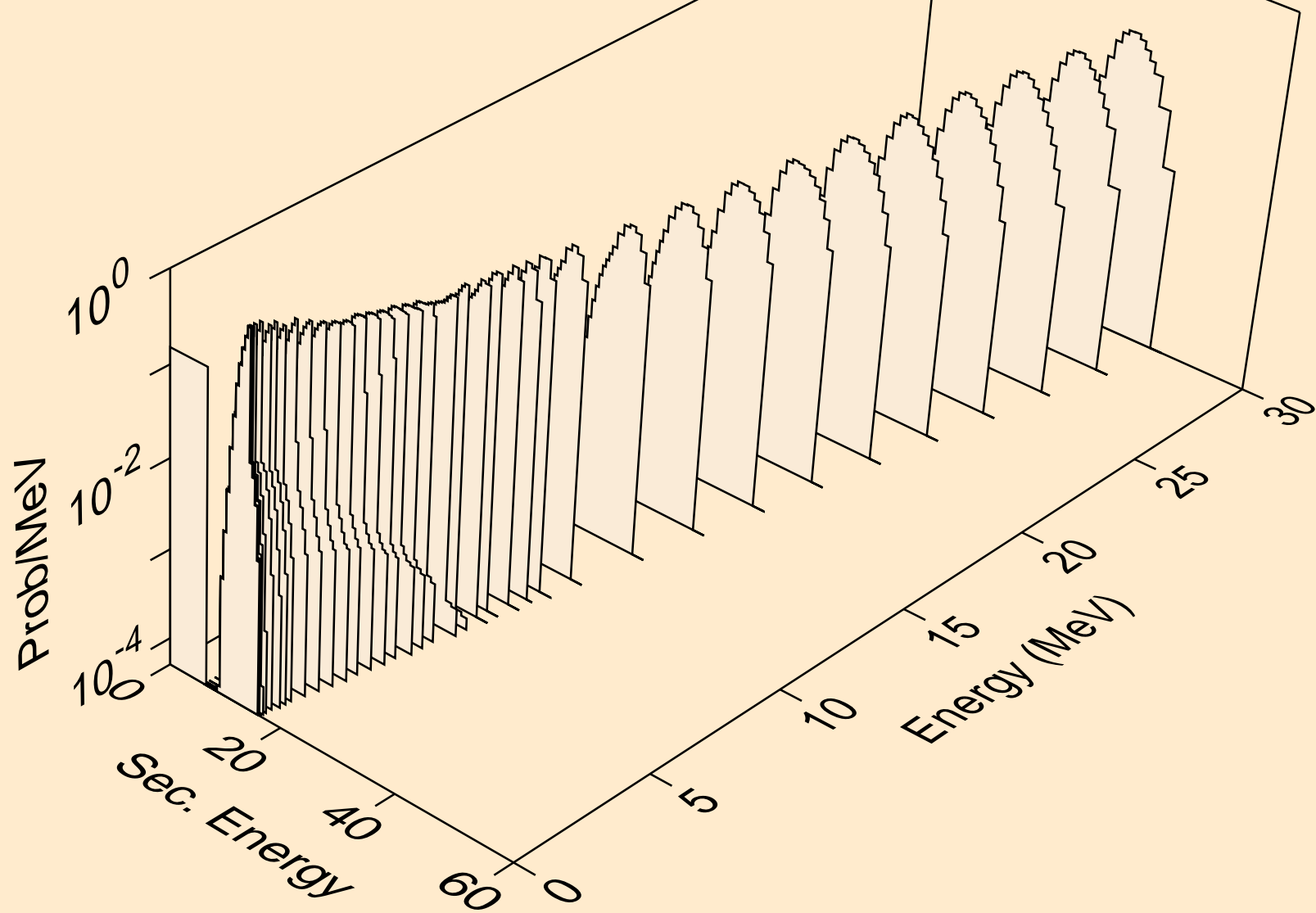

AT200M NEUTRON ACER TENDL-2023 LIBRARY; T=0.K  
alphas from (n,2a)

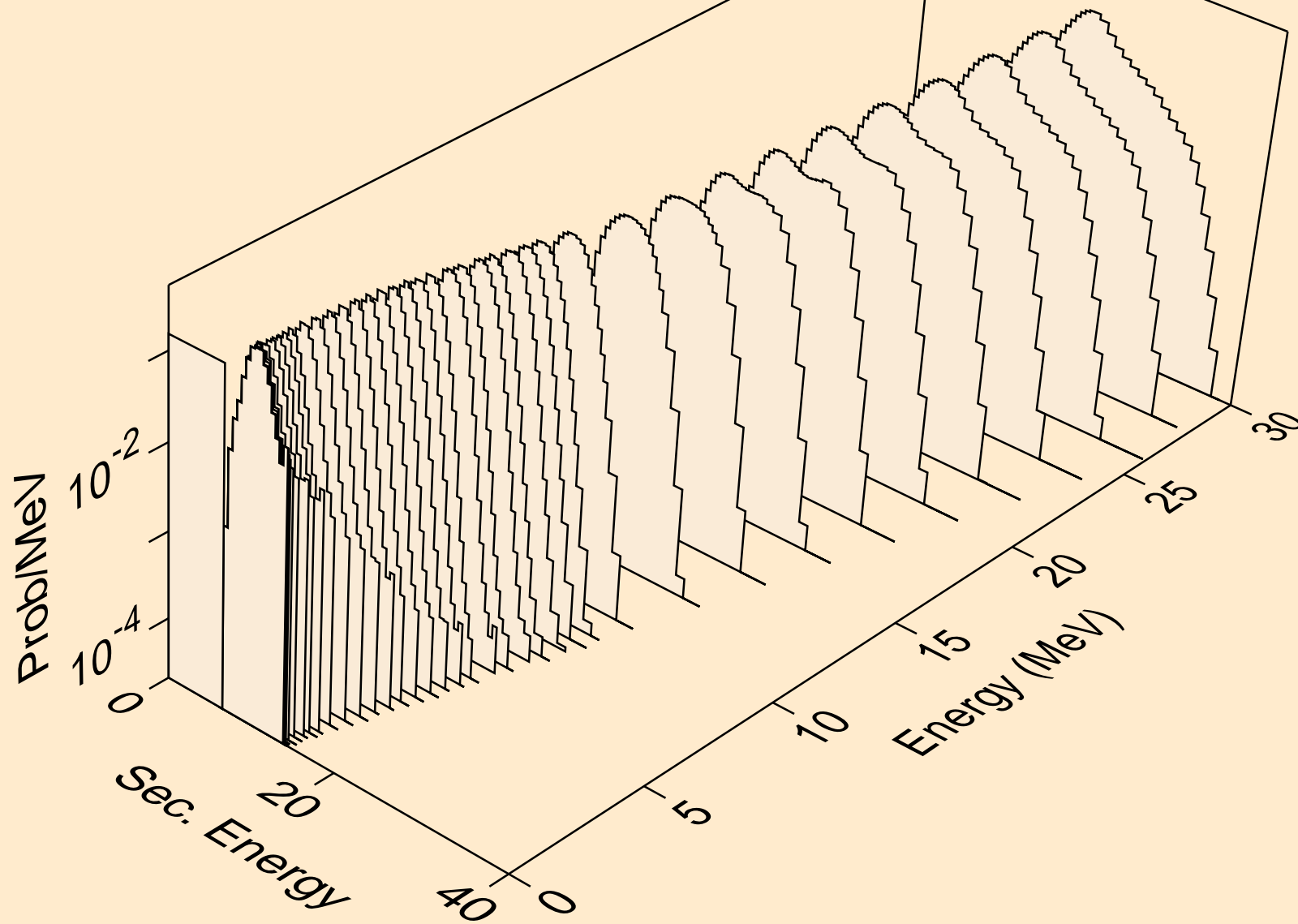



AT200M NEUTRON ACER TENDL-2023 LIBRARY; T=0.K  
alphas from (n,pa)

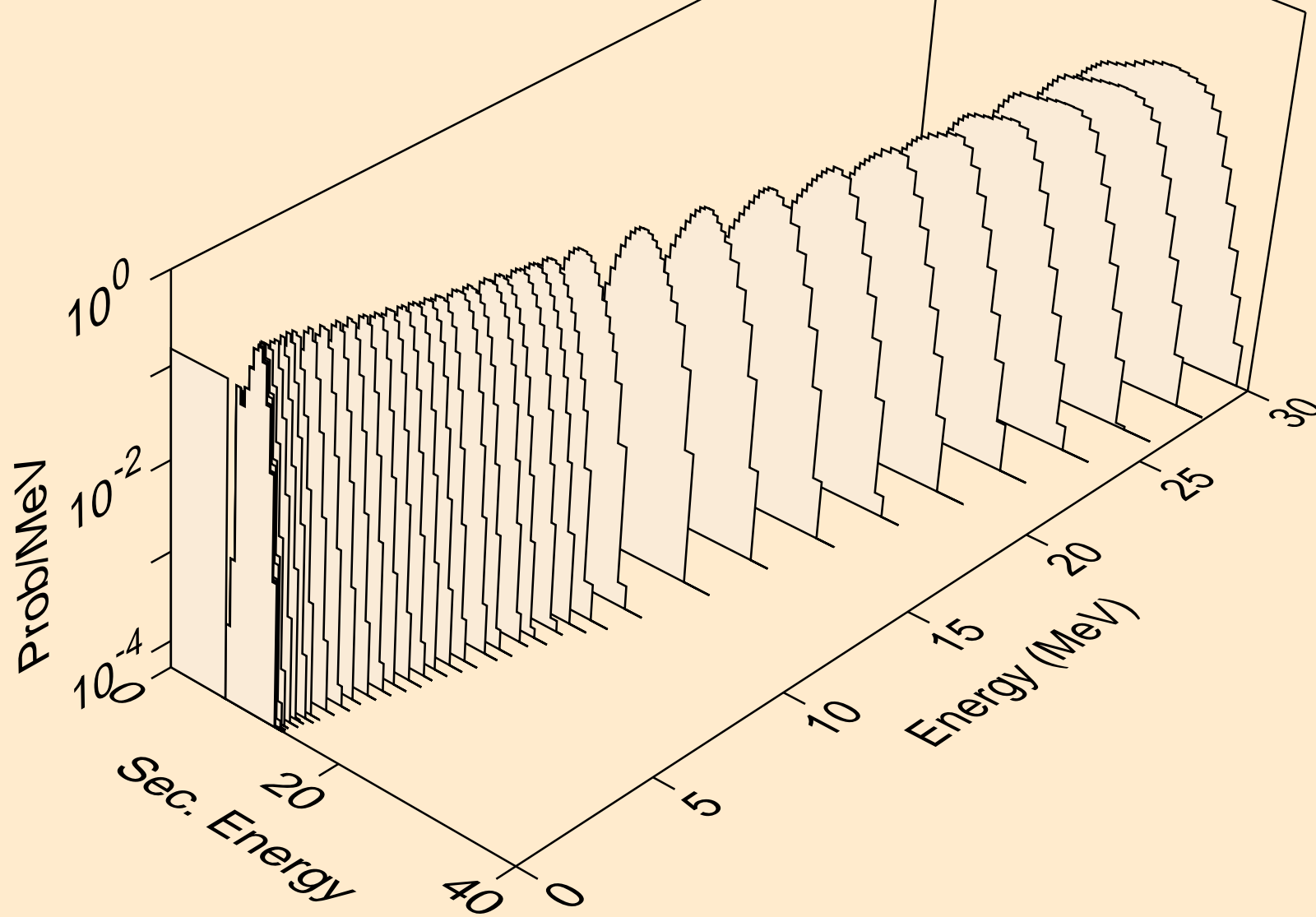

AT200M NEUTRON ACER TENDL-2023 LIBRARY; T=0.K  
alphas from (n,da)

