

# BH275 NEUTRON ACER TENDL-2023 LIBRARY; T=0.K

## Principal cross sections

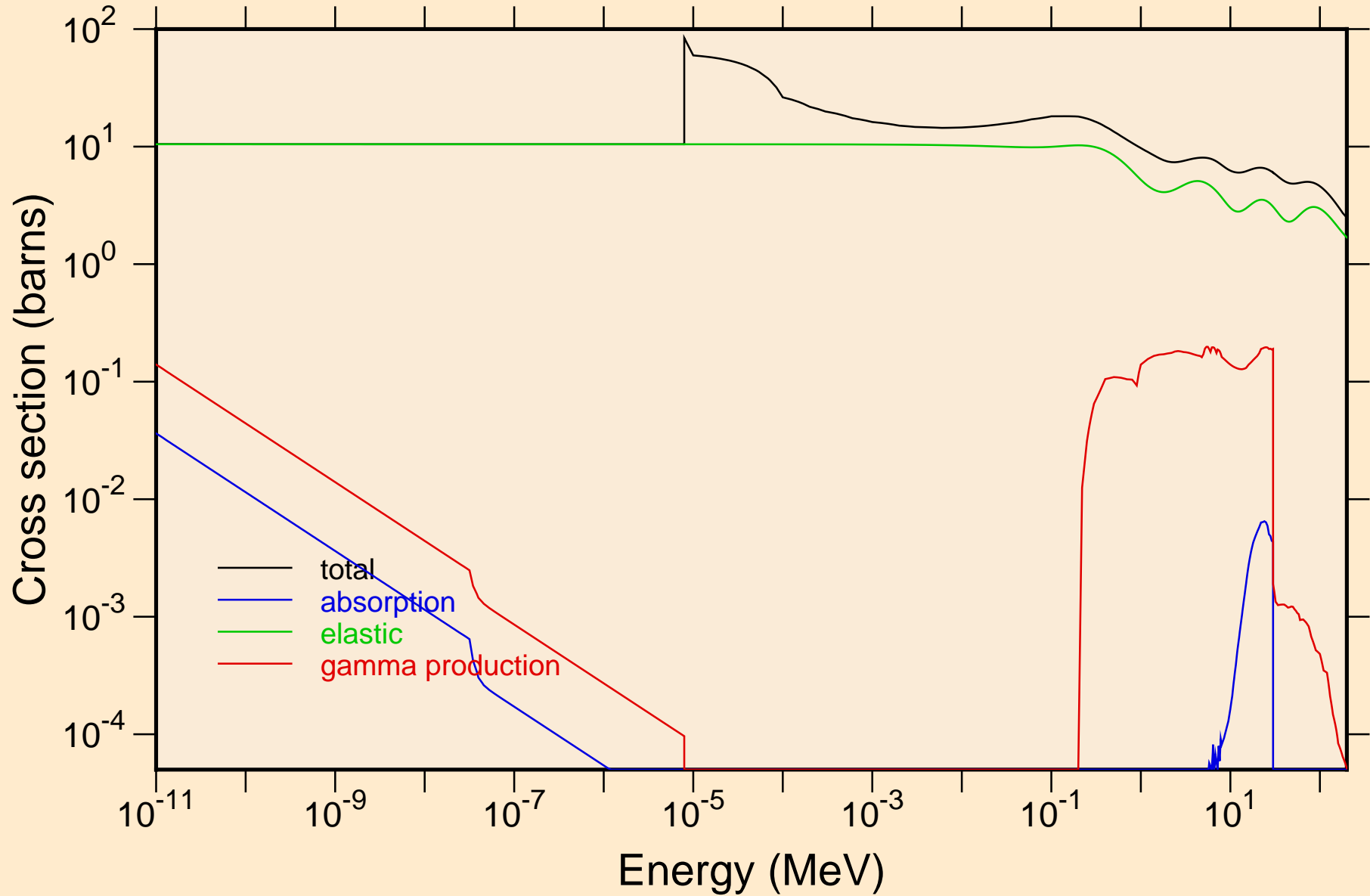

# BH275 NEUTRON ACER TENDL-2023 LIBRARY; T=0.K

## Heating

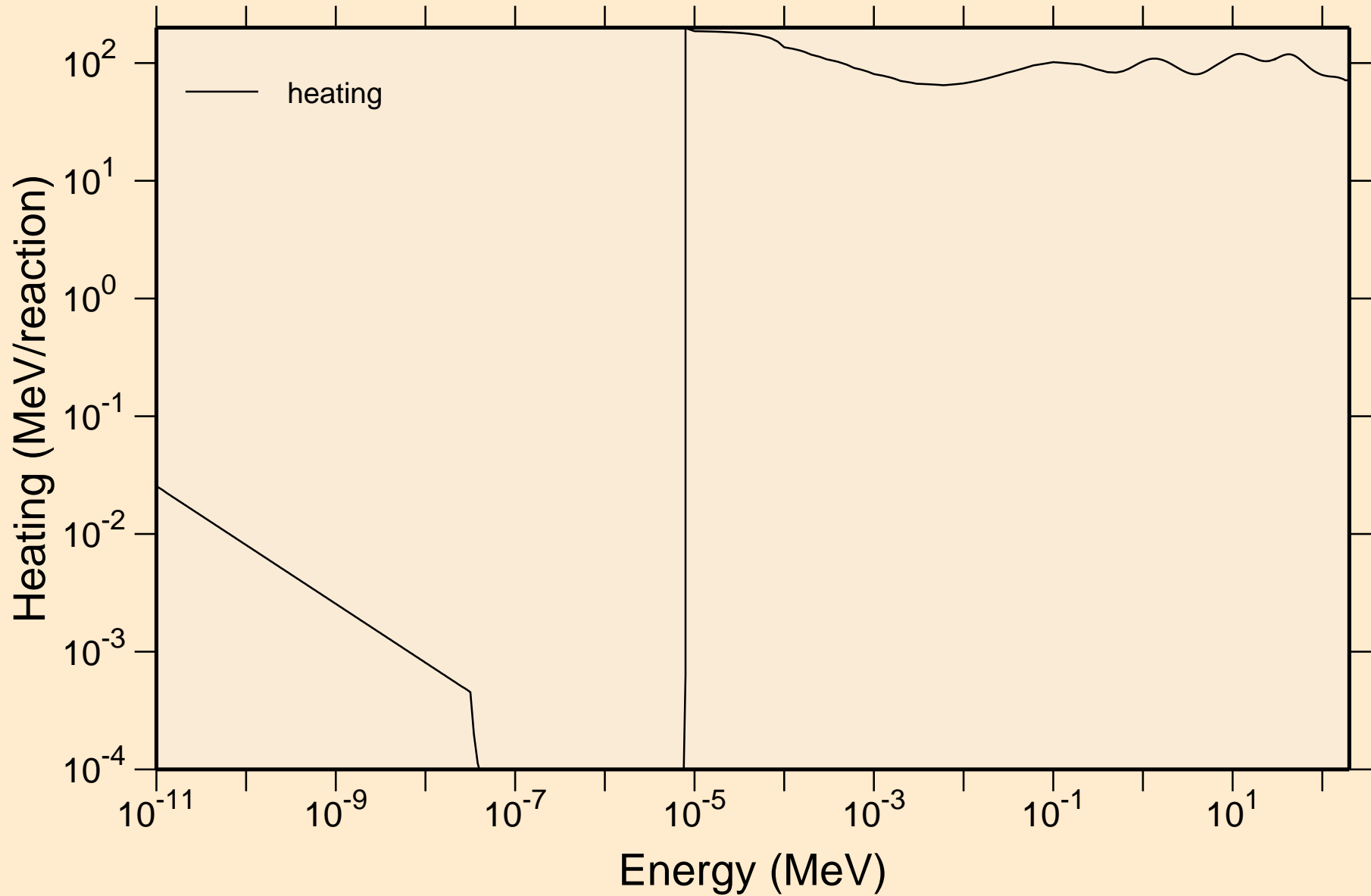

BH275 NEUTRON ACER TENDL-2023 LIBRARY; T=0.K  
Damage

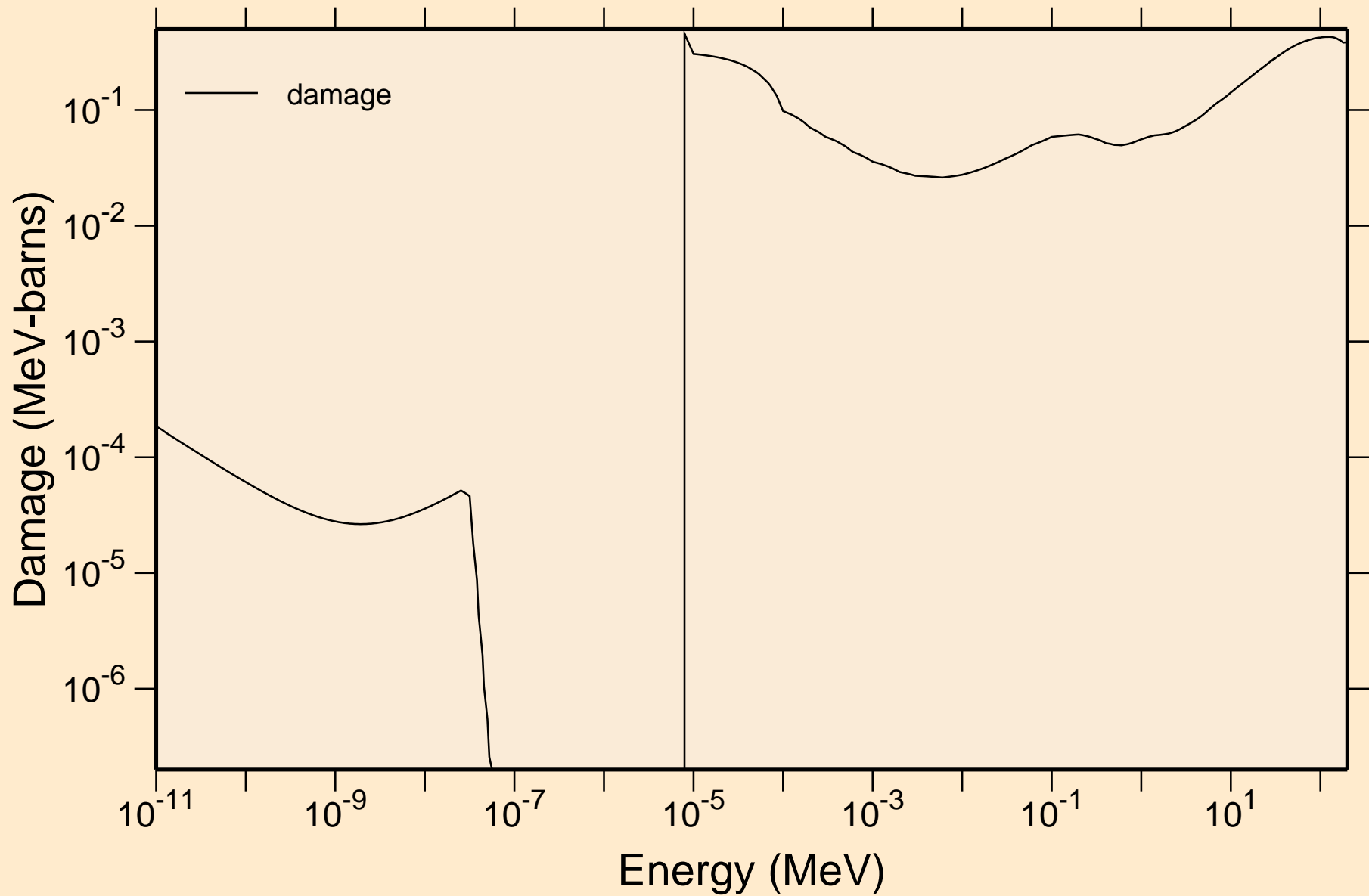

# BH275 NEUTRON ACER TENDL-2023 LIBRARY; T=0.K

## Non-threshold reactions

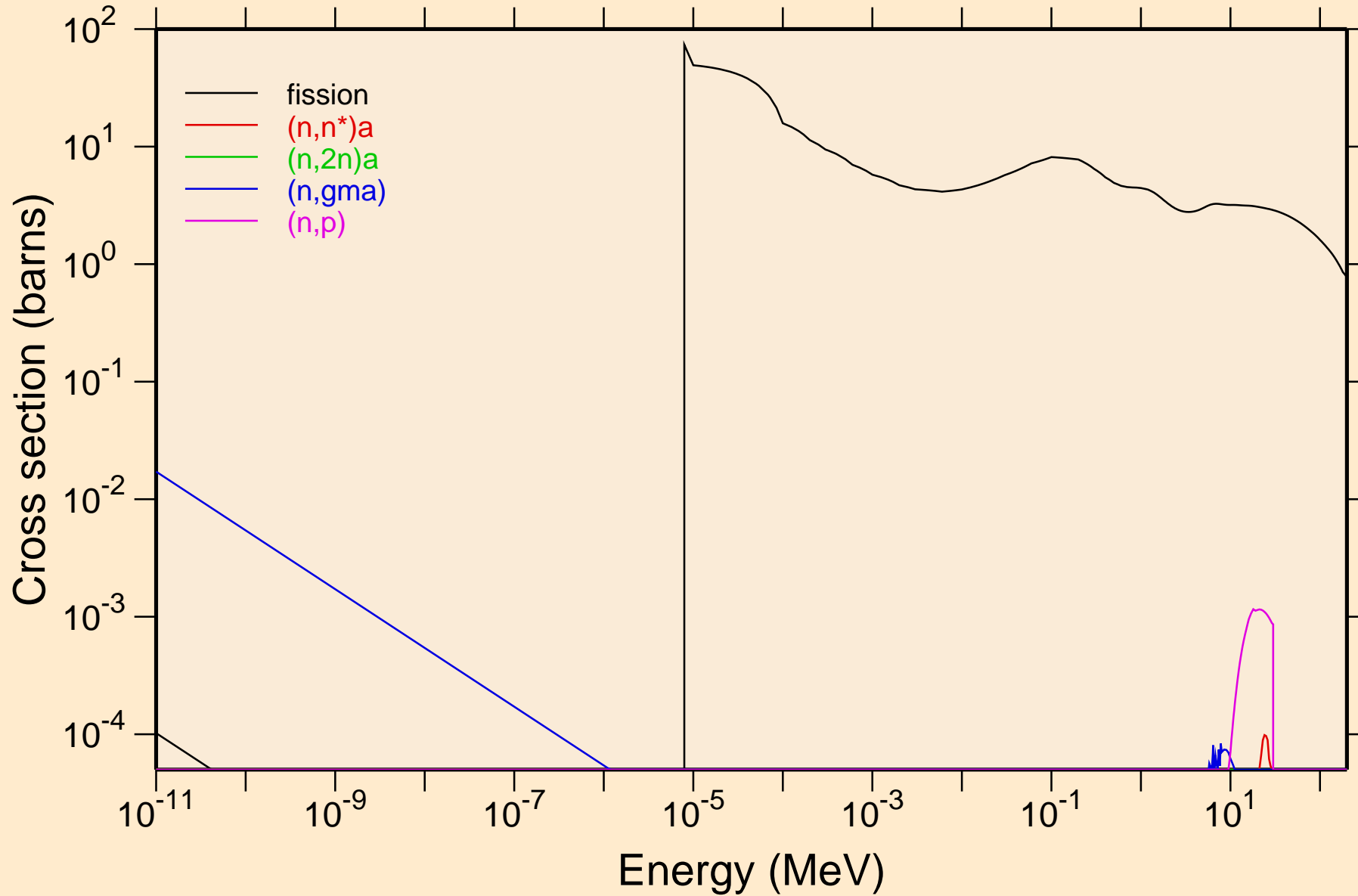

# BH275 NEUTRON ACER TENDL-2023 LIBRARY; T=0.K

## Non-threshold reactions

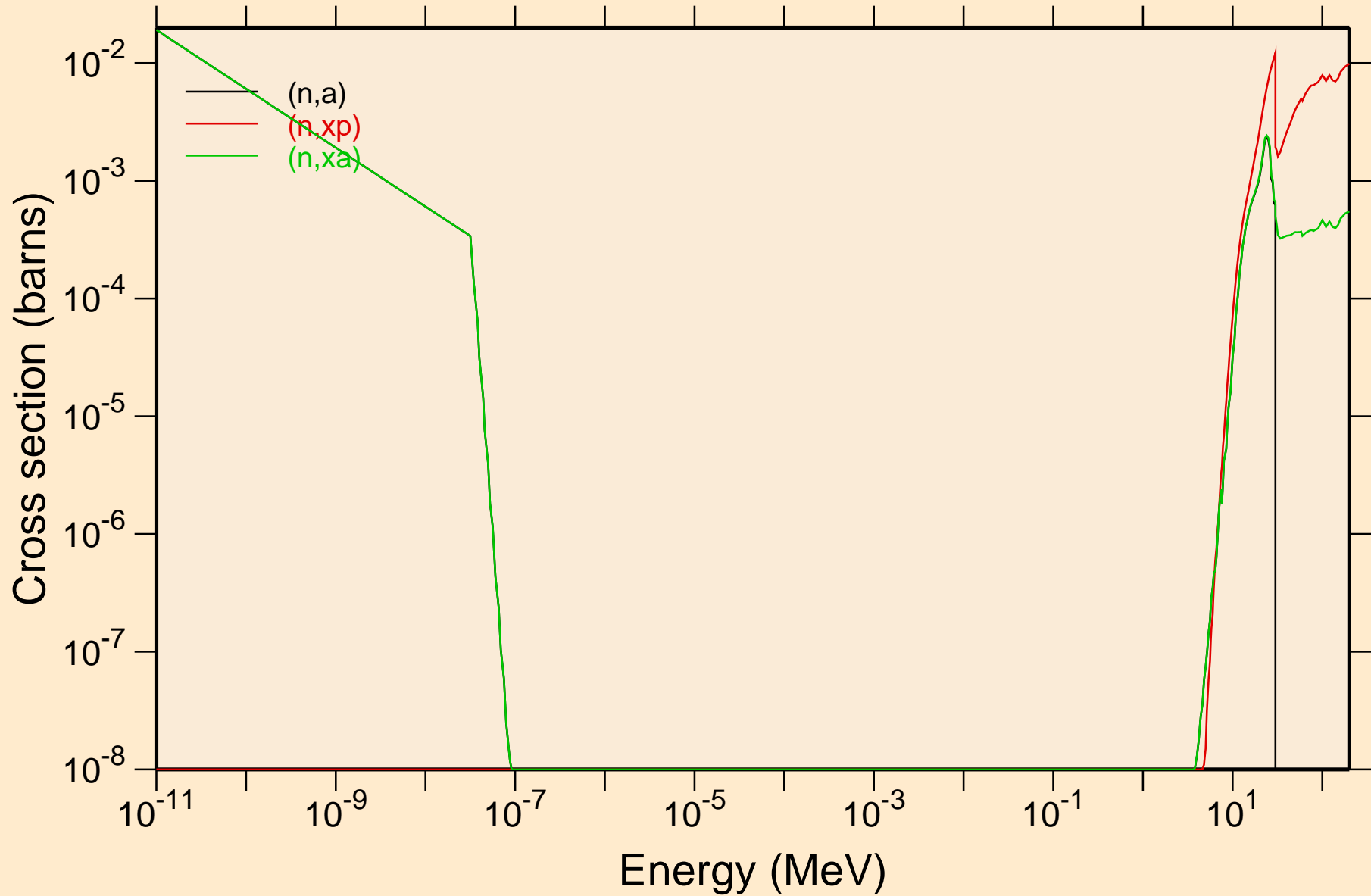

# BH275 NEUTRON ACER TENDL-2023 LIBRARY; T=0.K

## Principal cross sections

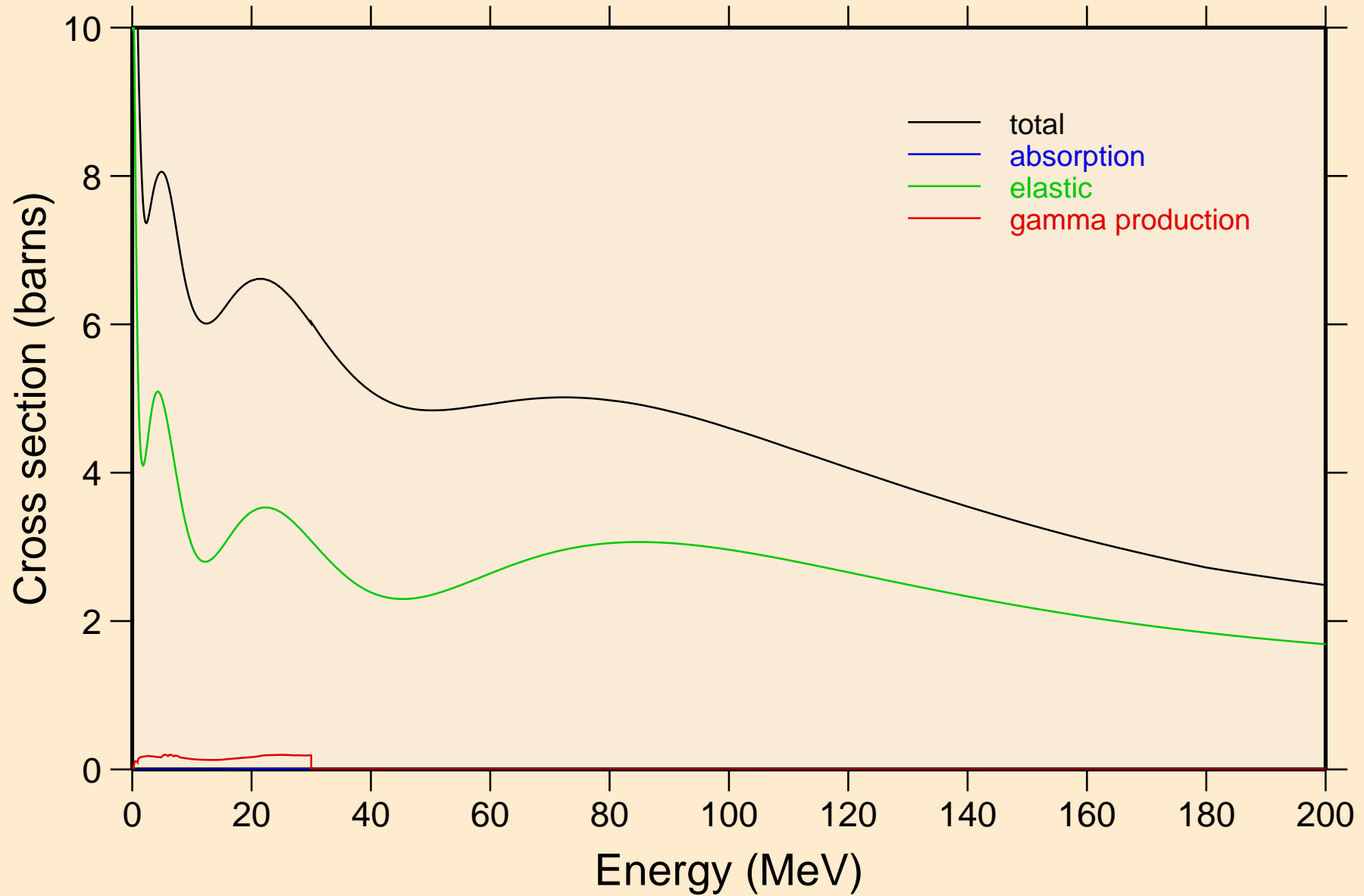

# BH275 NEUTRON ACER TENDL-2023 LIBRARY; T=0.K

## Heating

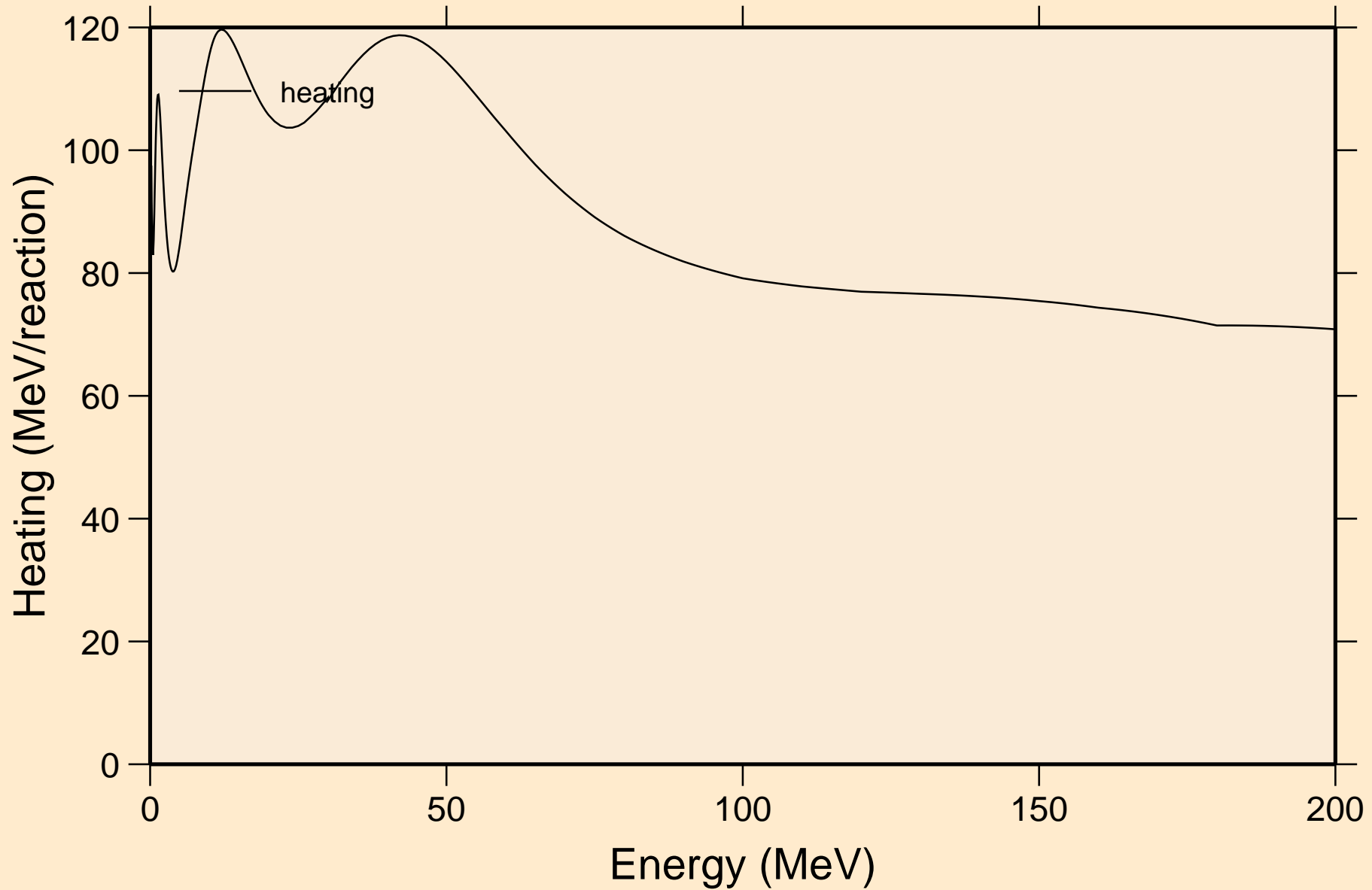

BH275 NEUTRON ACER TENDL-2023 LIBRARY; T=0.K  
Damage

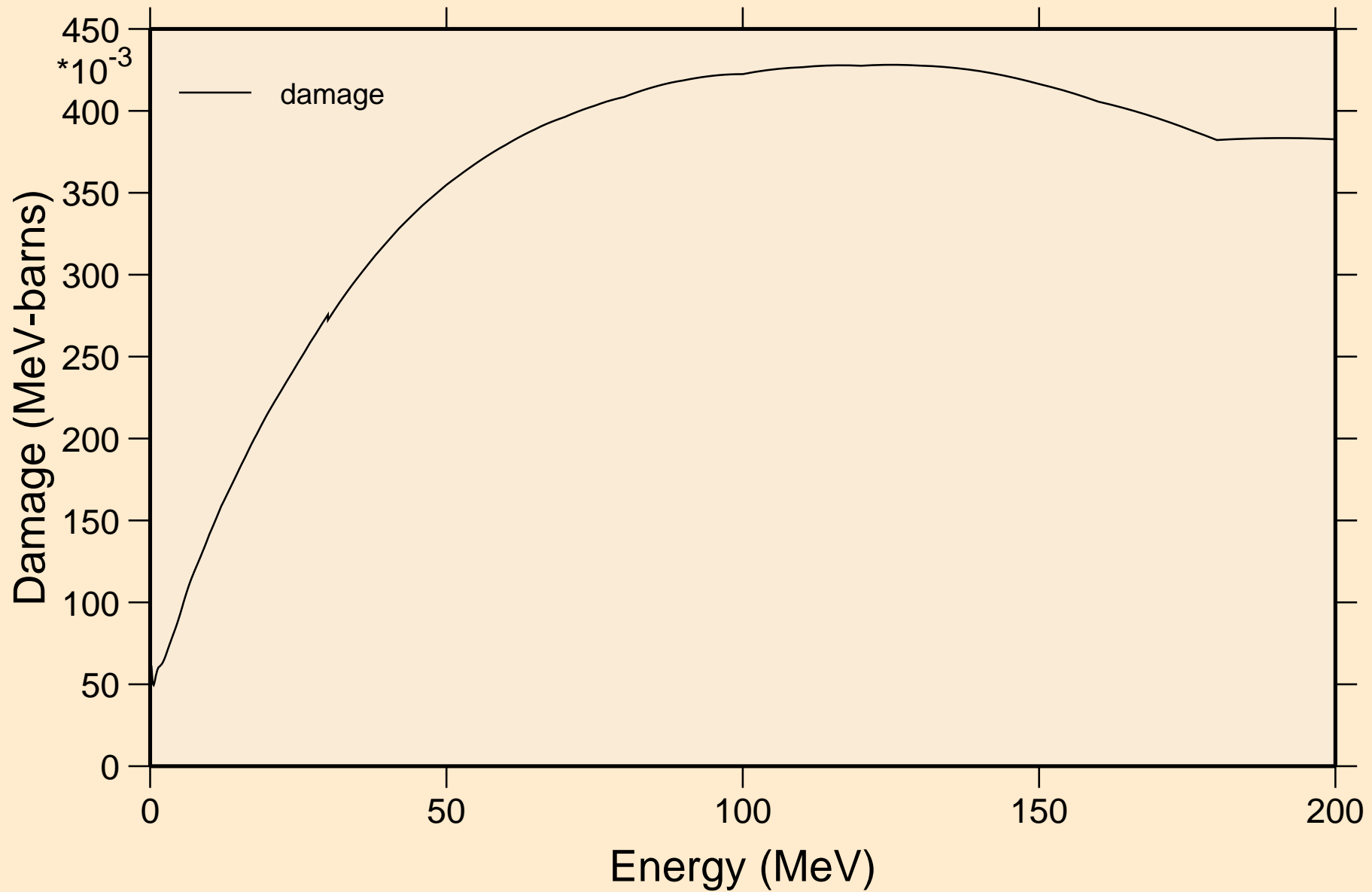



# BH275 NEUTRON ACER TENDL-2023 LIBRARY; T=0.K

## Non-threshold reactions

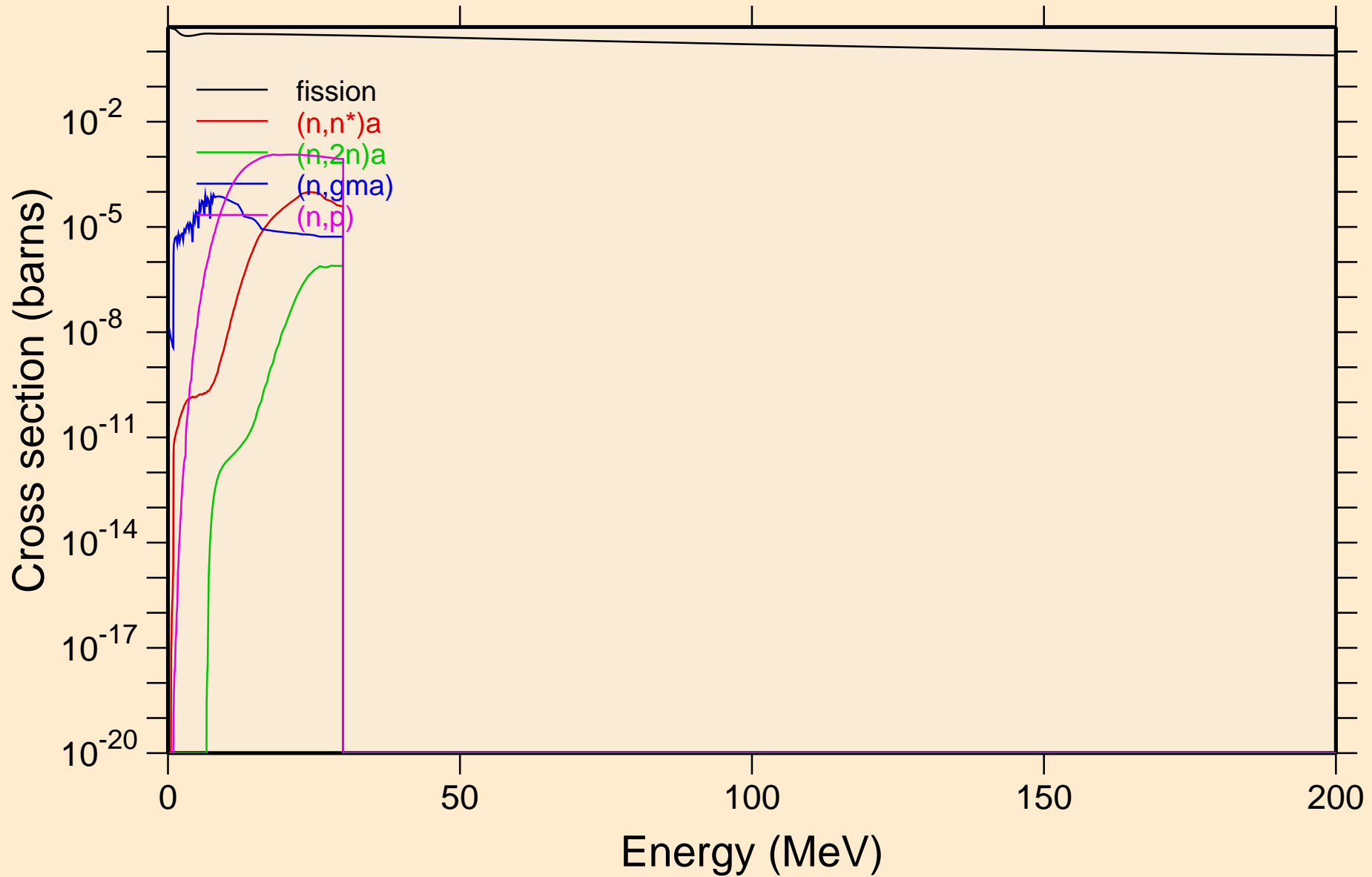

BH275 NEUTRON ACER TENDL-2023 LIBRARY; T=0.K  
Non-threshold reactions

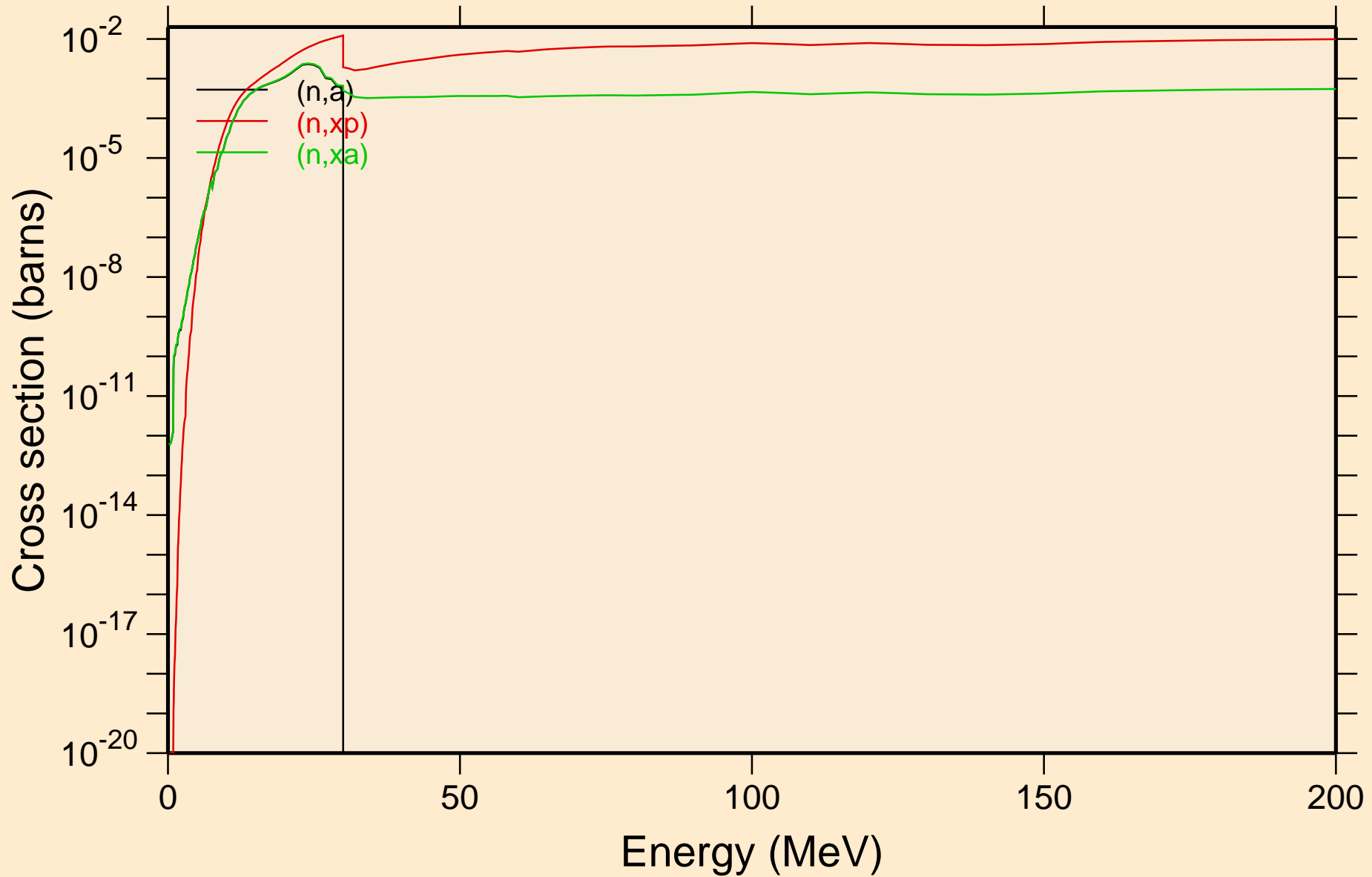

BH275 NEUTRON ACER TENDL-2023 LIBRARY; T=0.K  
Inelastic levels

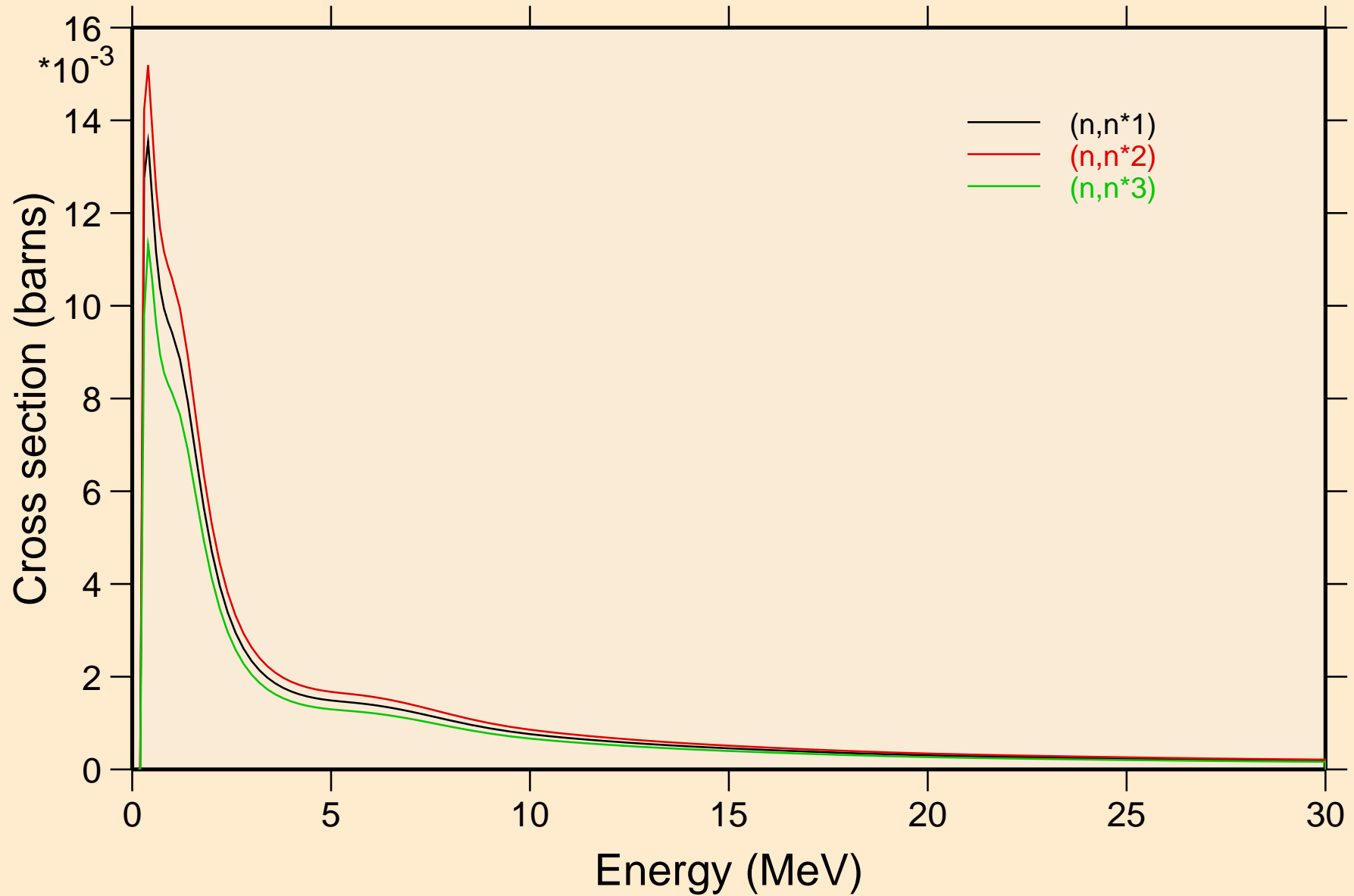

# BH275 NEUTRON ACER TENDL-2023 LIBRARY; T=0.K

## Threshold reactions

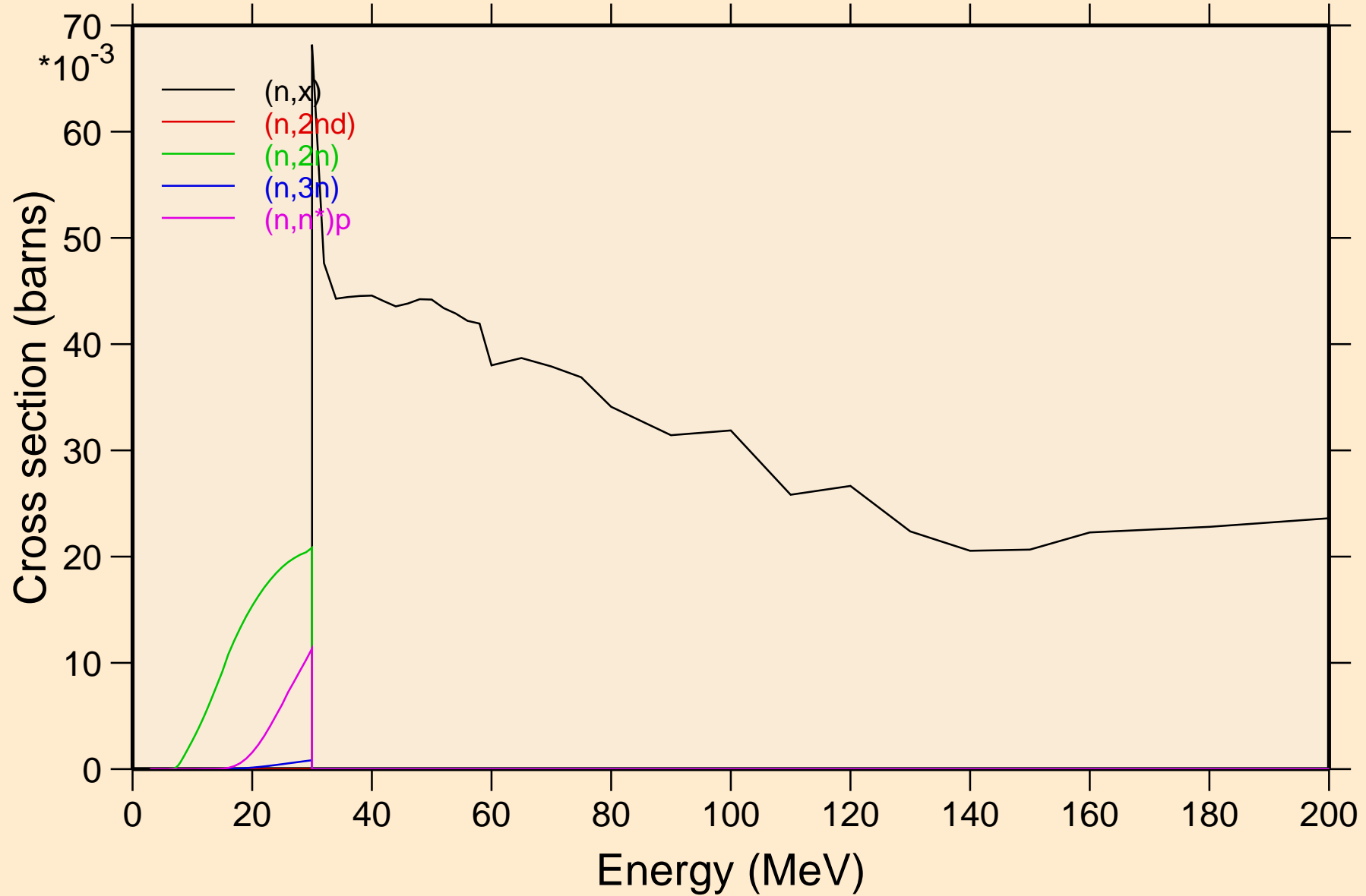

# BH275 NEUTRON ACER TENDL-2023 LIBRARY; T=0.K

## Threshold reactions

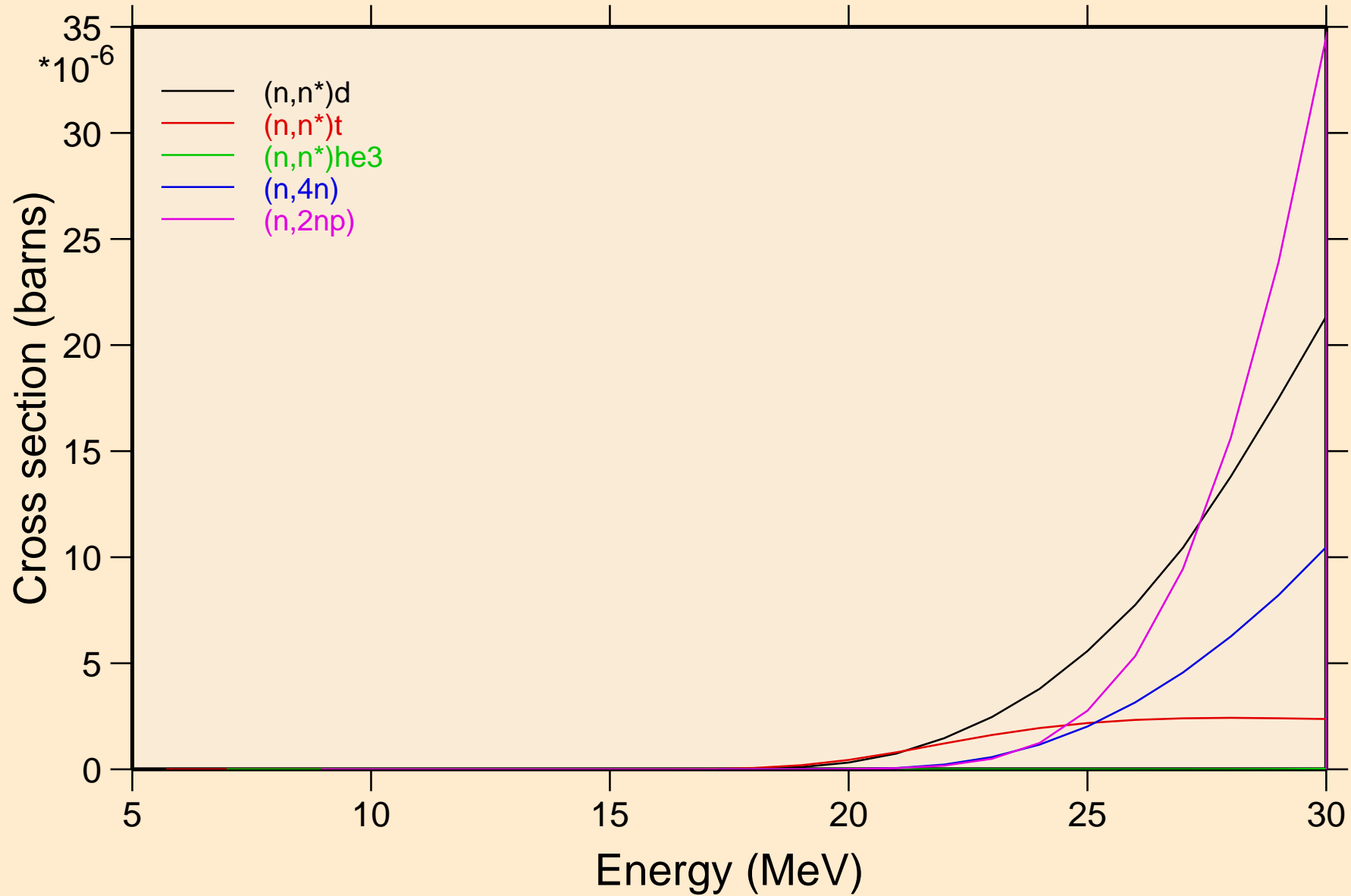

# BH275 NEUTRON ACER TENDL-2023 LIBRARY; T=0.K

## Threshold reactions

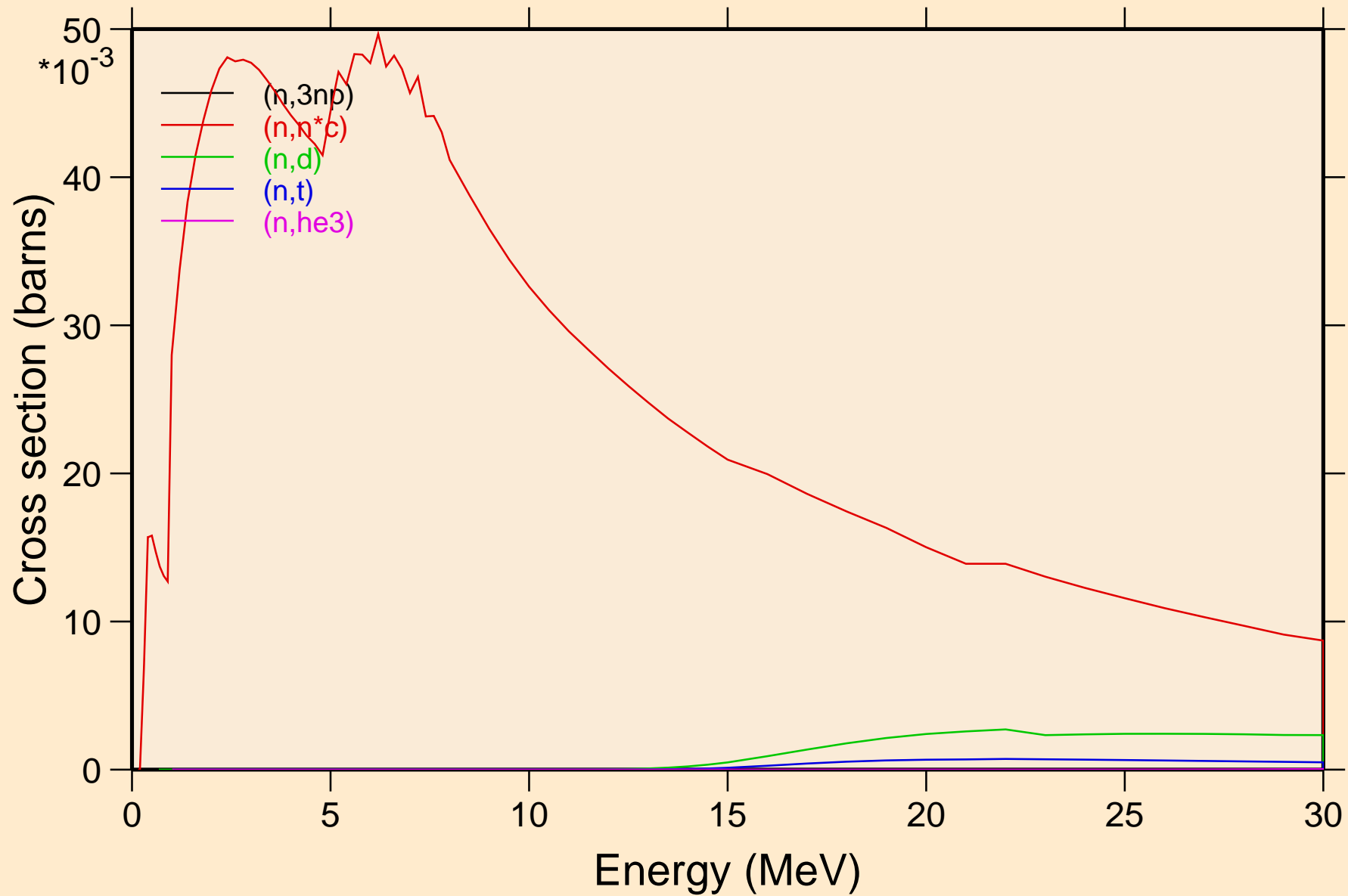

BH275 NEUTRON ACER TENDL-2023 LIBRARY; T=0.K  
Threshold reactions

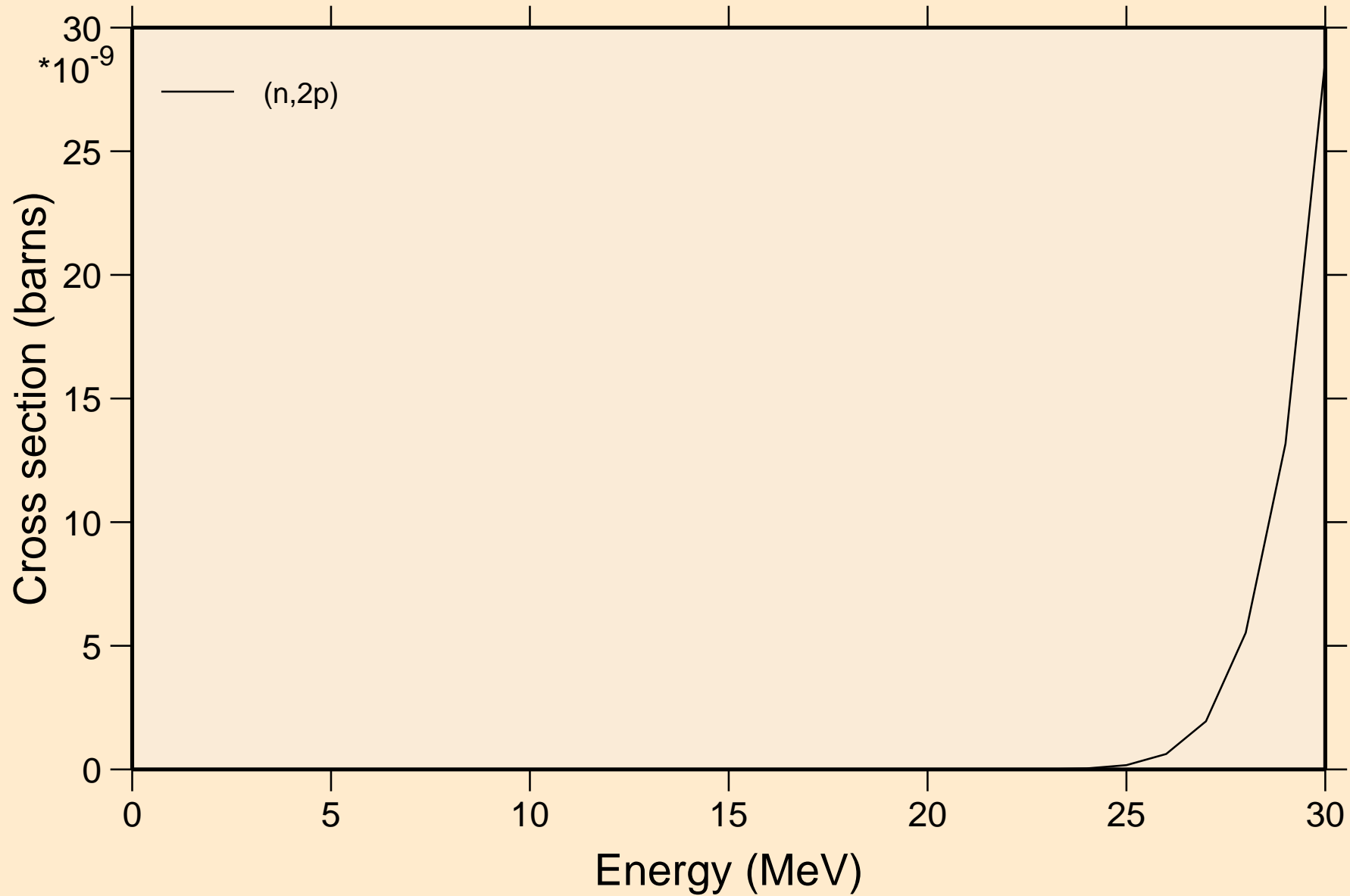

# BH275 NEUTRON ACER TENDL-2023 LIBRARY; T=0.K

## Threshold reactions

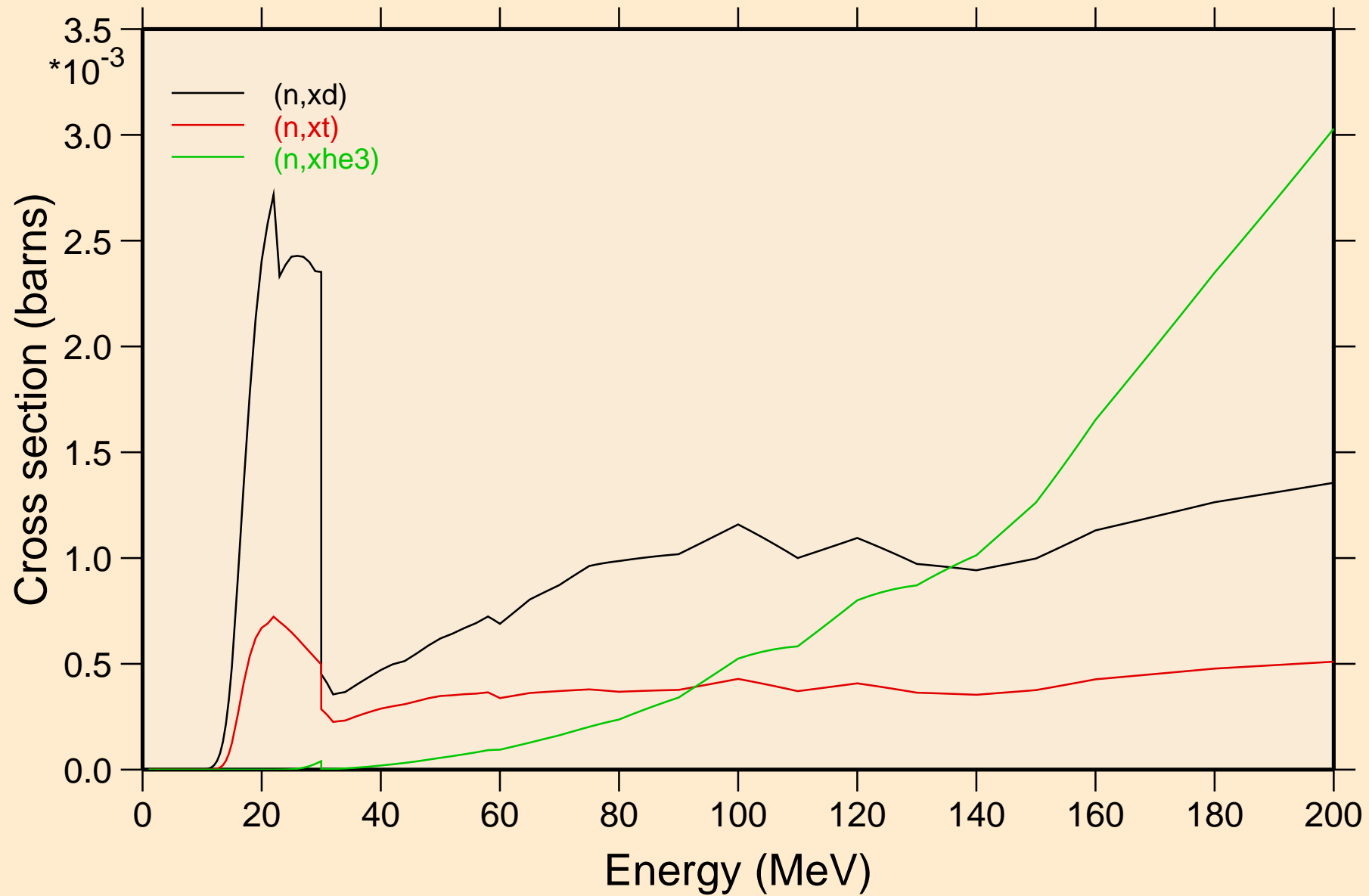



BH275 NEUTRON ACER TENDL-2023 LIBRARY; T=0.K  
angular distribution for elastic

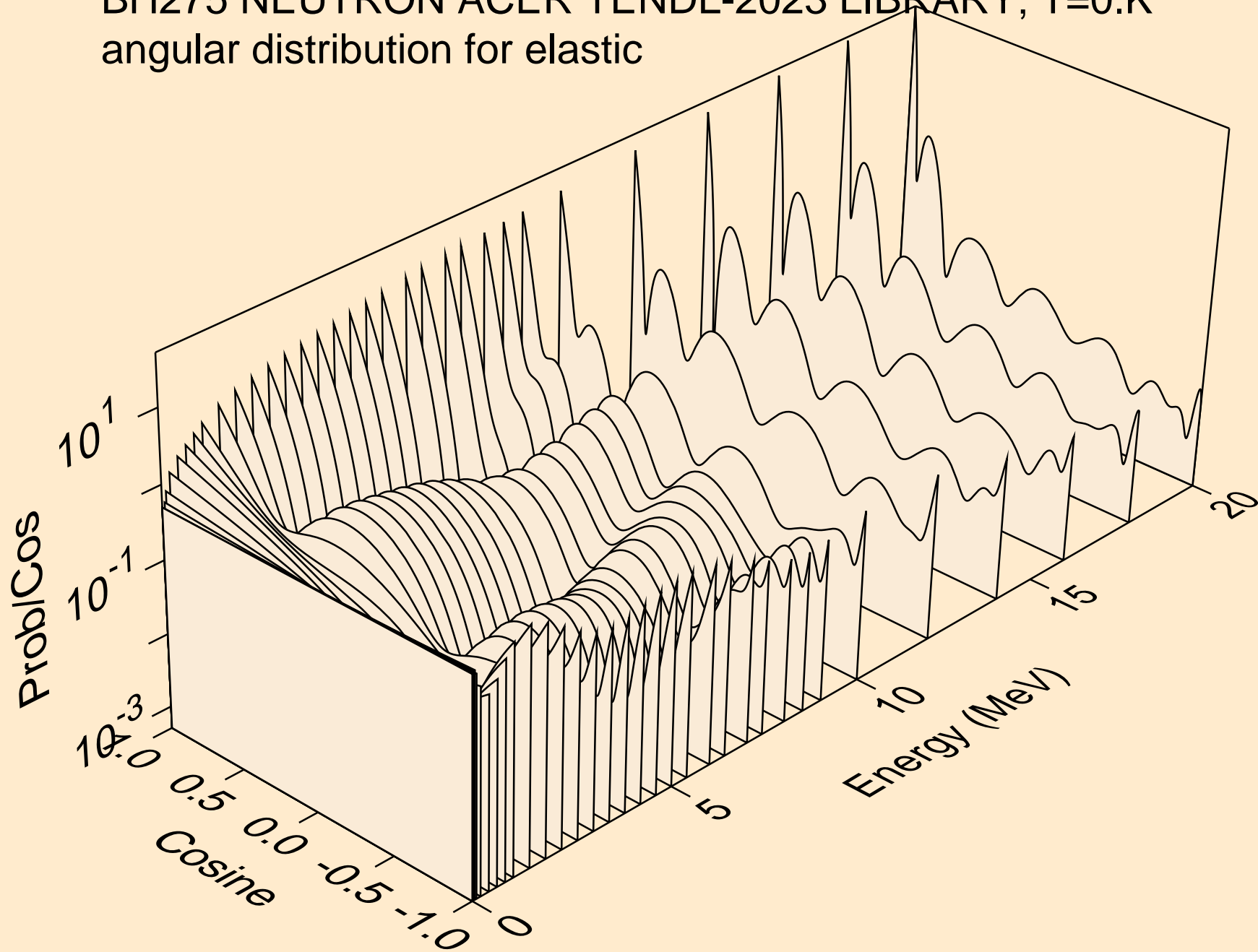

BH275 NEUTRON ACER TENDL-2023 LIBRARY; T=0.K  
angular distribution for elastic

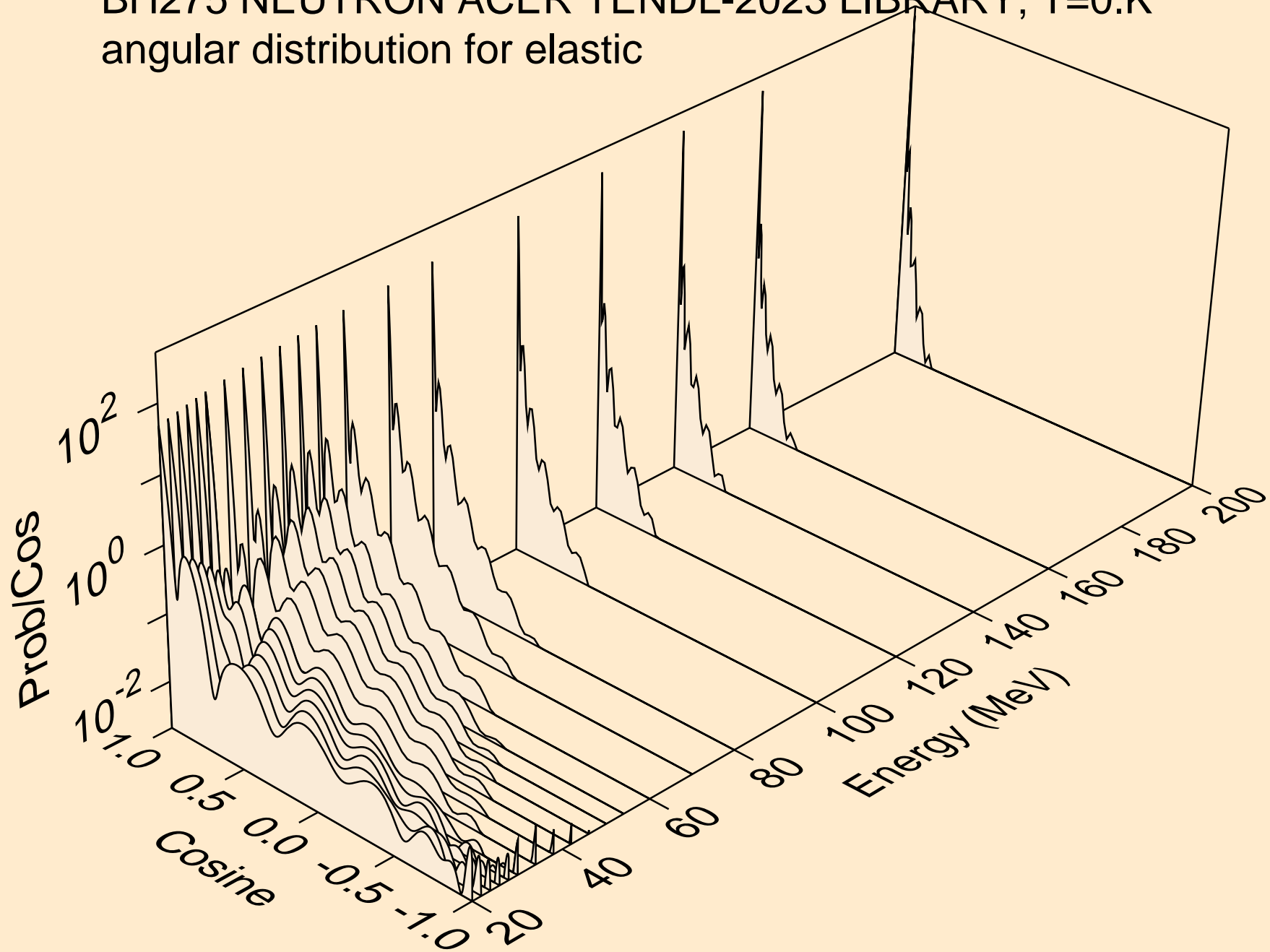

BH275 NEUTRON ACER TENDL-2023 LIBRARY; T=0.K  
angular distribution for (n,n\*1)

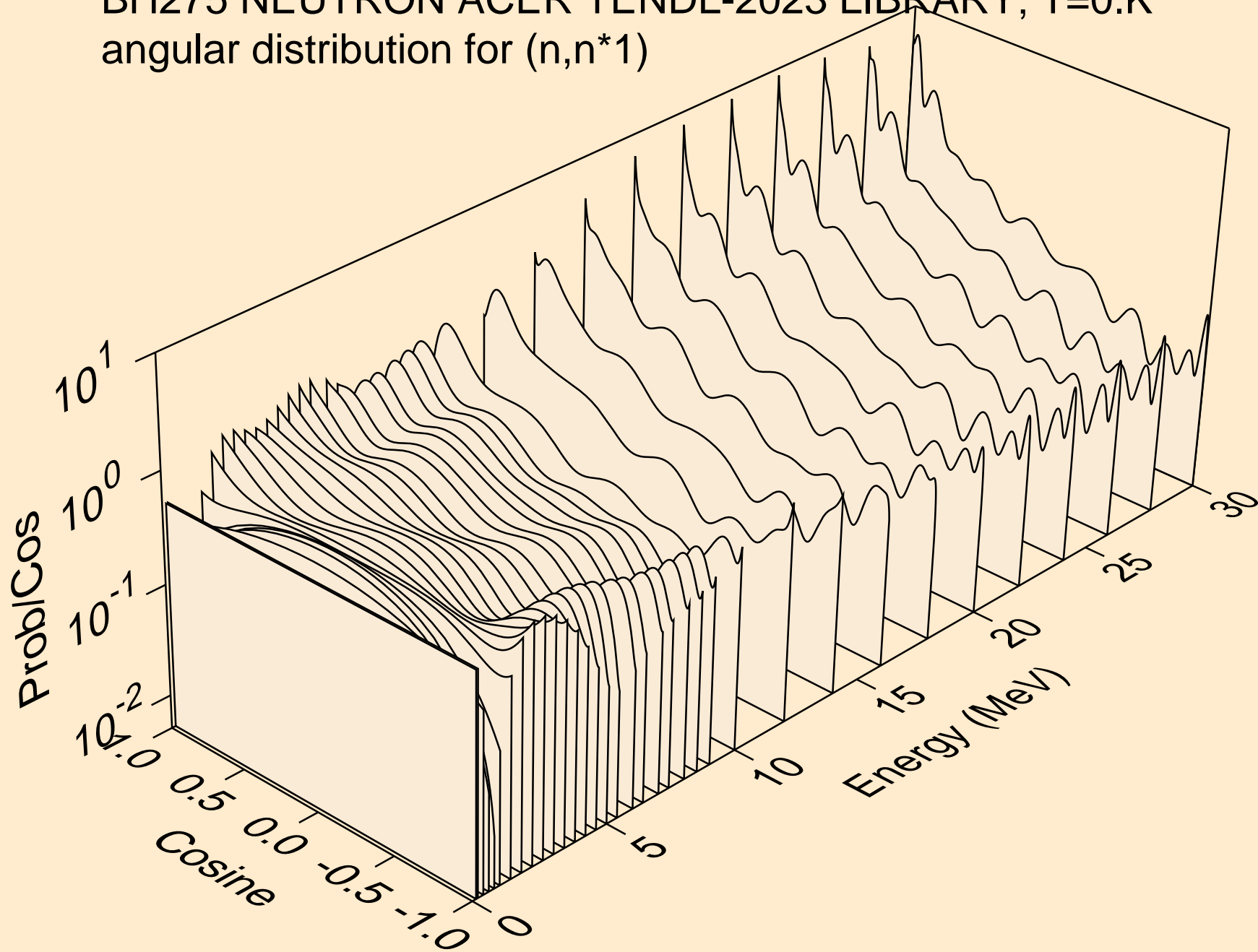

BH275 NEUTRON ACER TENDL-2023 LIBRARY; T=0.K  
angular distribution for (n,n\*2)

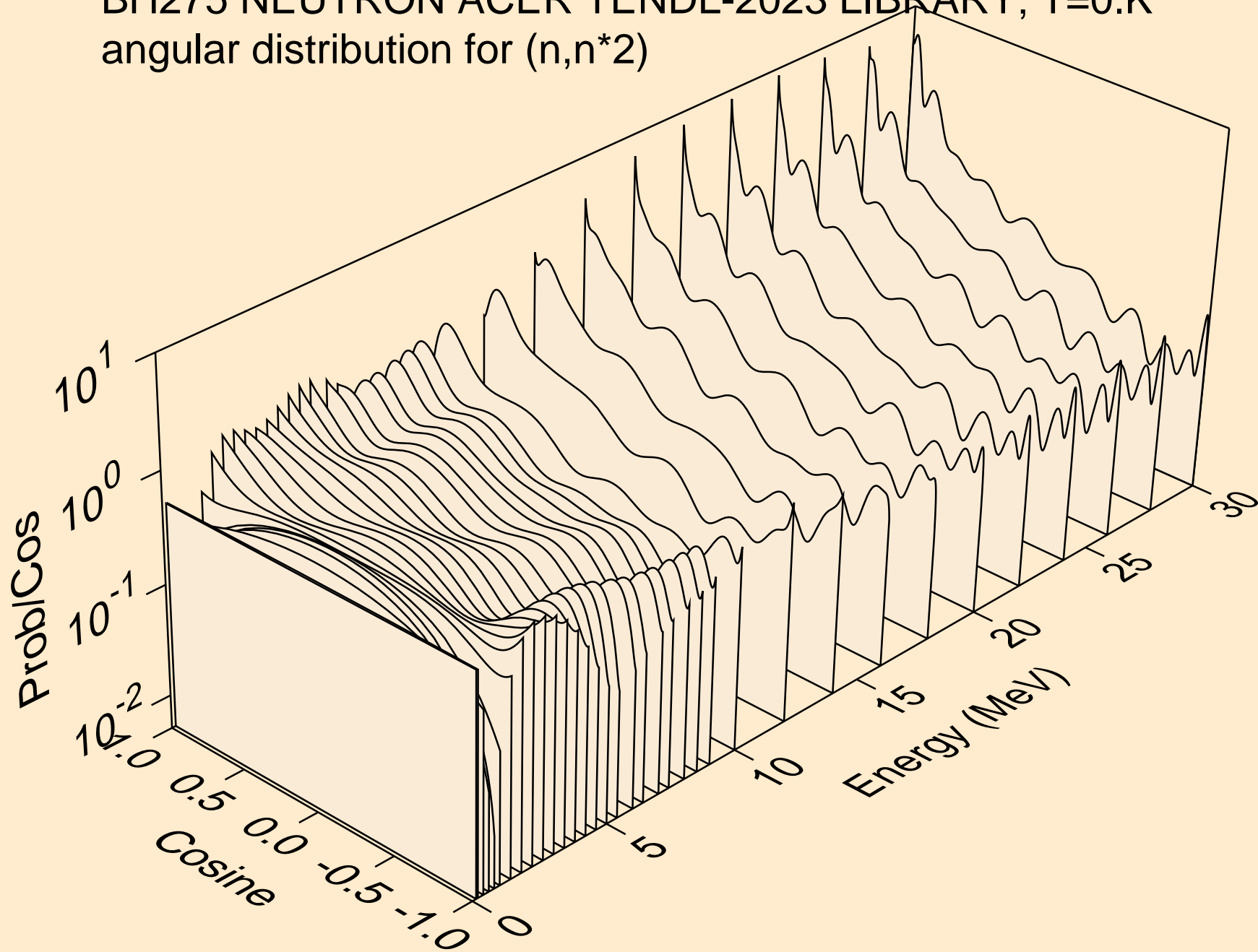

BH275 NEUTRON ACER TENDL-2023 LIBRARY; T=0.K  
angular distribution for (n,n\*3)

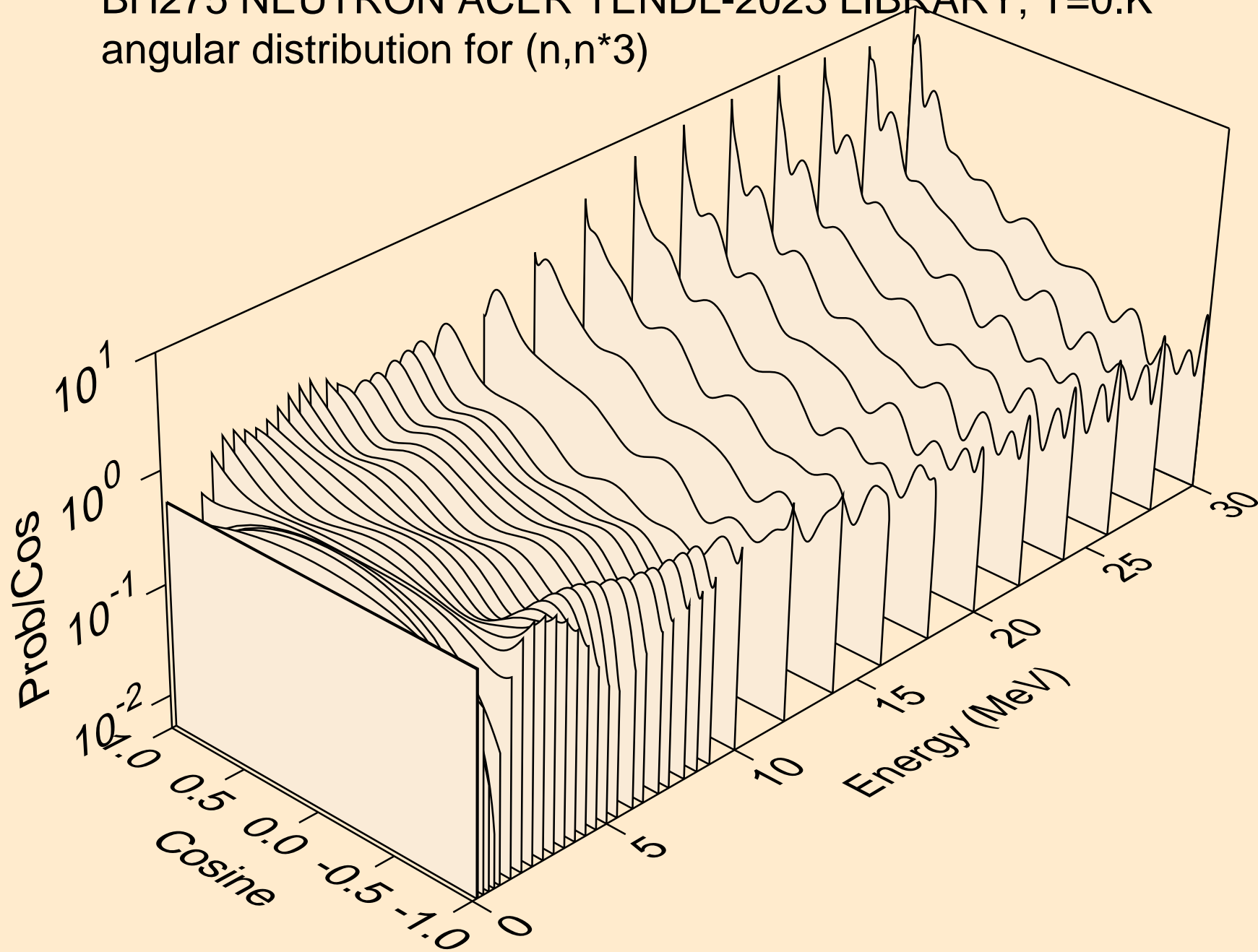

BH275 NEUTRON ACER TENDL-2023 LIBRARY; T=0.K

Total fission nubar

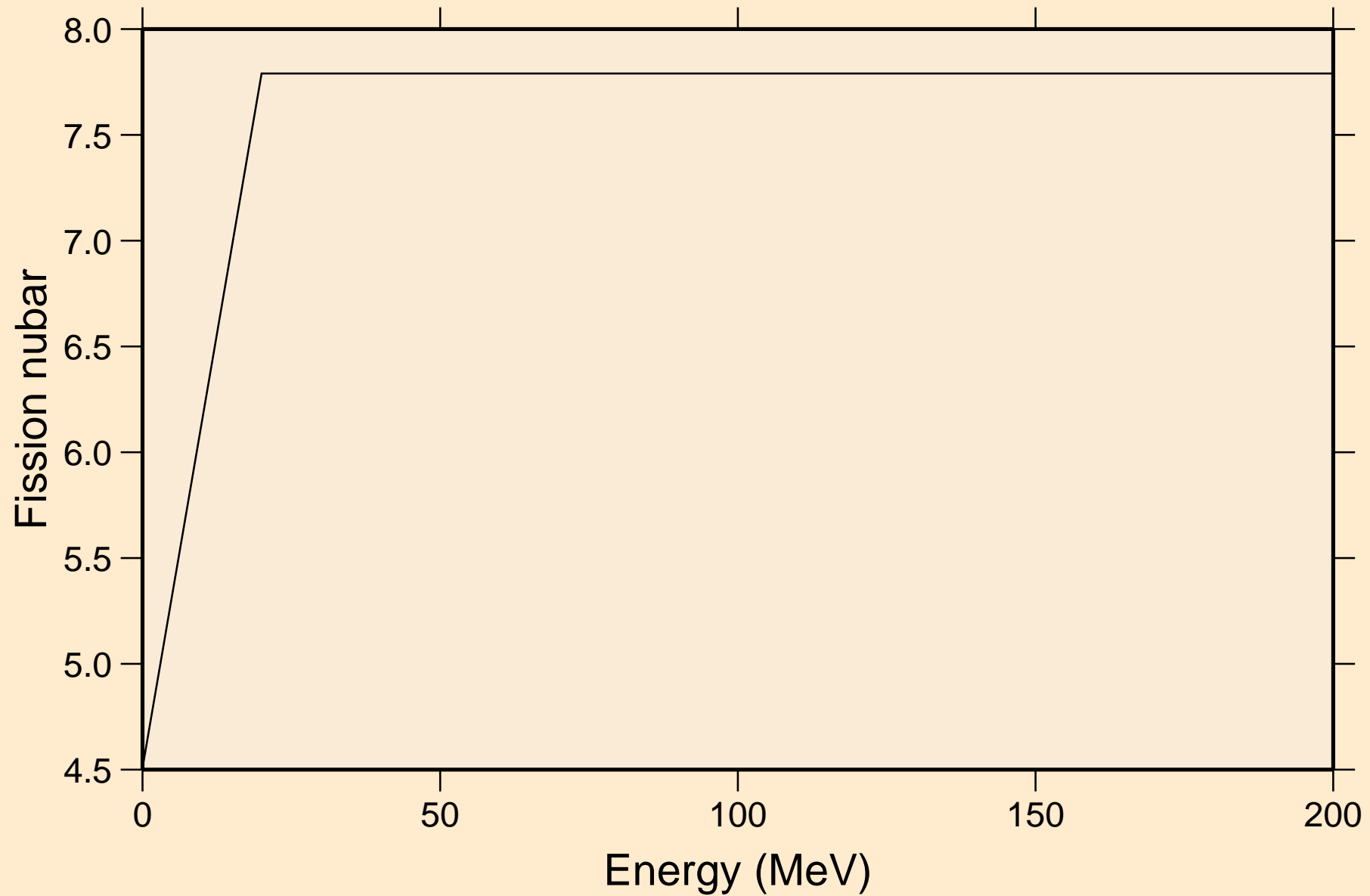

BH275 NEUTRON ACER TENDL-2023 LIBRARY; T=0.K  
Neutron emission for (n,x)

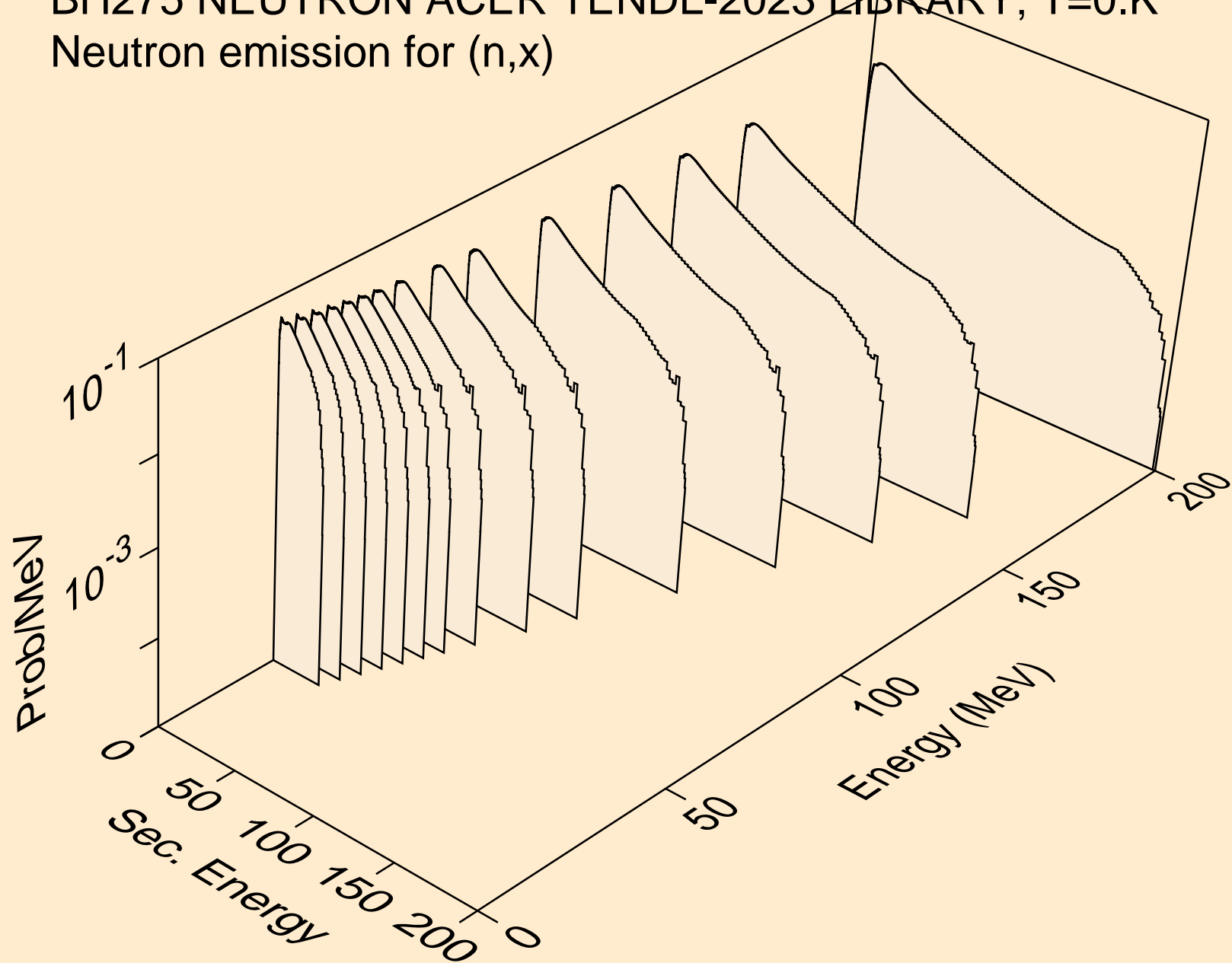

BH275 NEUTRON ACER TENDL-2023 LIBRARY; T=0.K  
Neutron emission for (n,2nd)

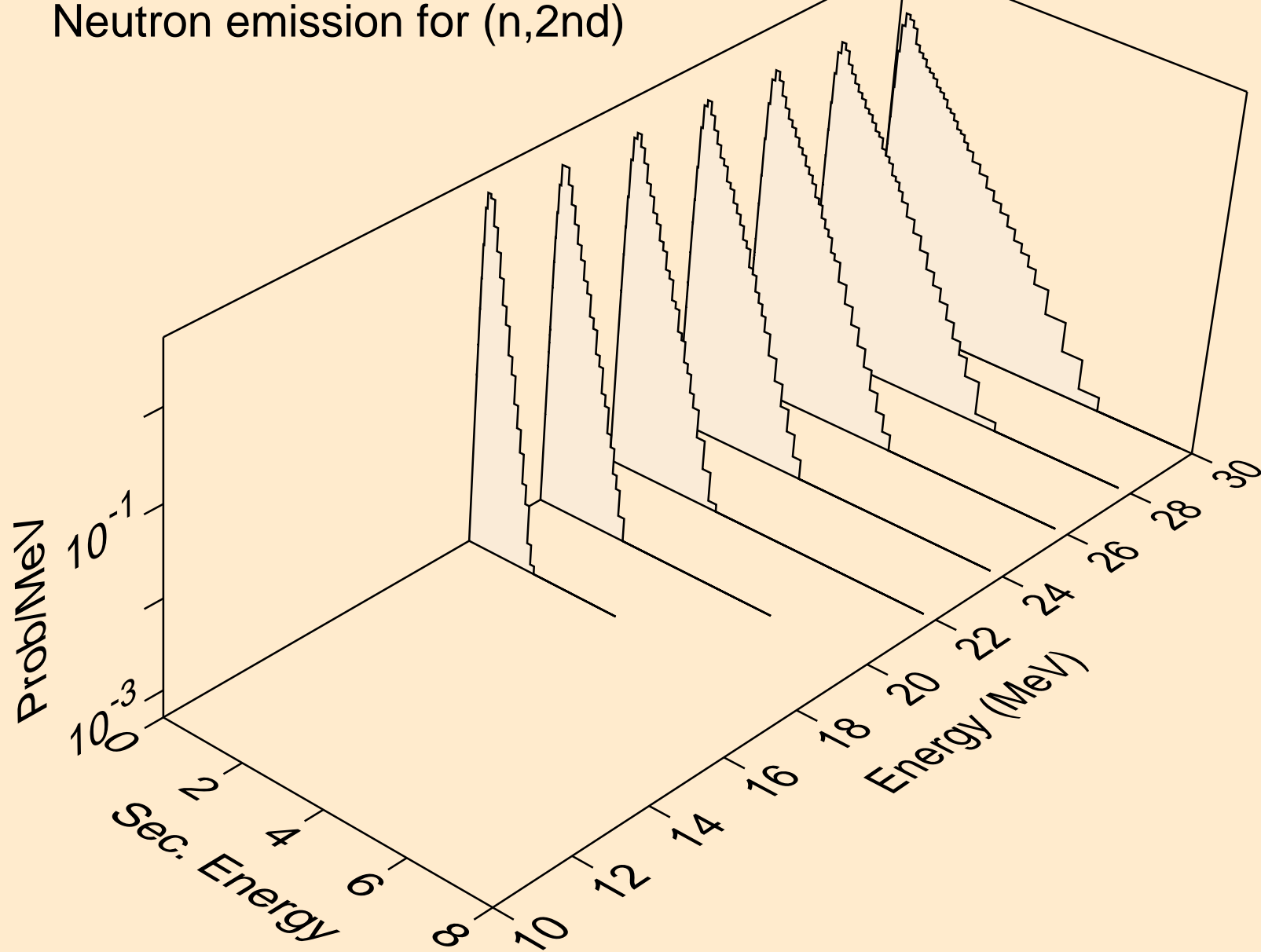



BH275 NEUTRON ACER TENDL-2023 LIBRARY; T=0.K  
Neutron emission for (n,2n)

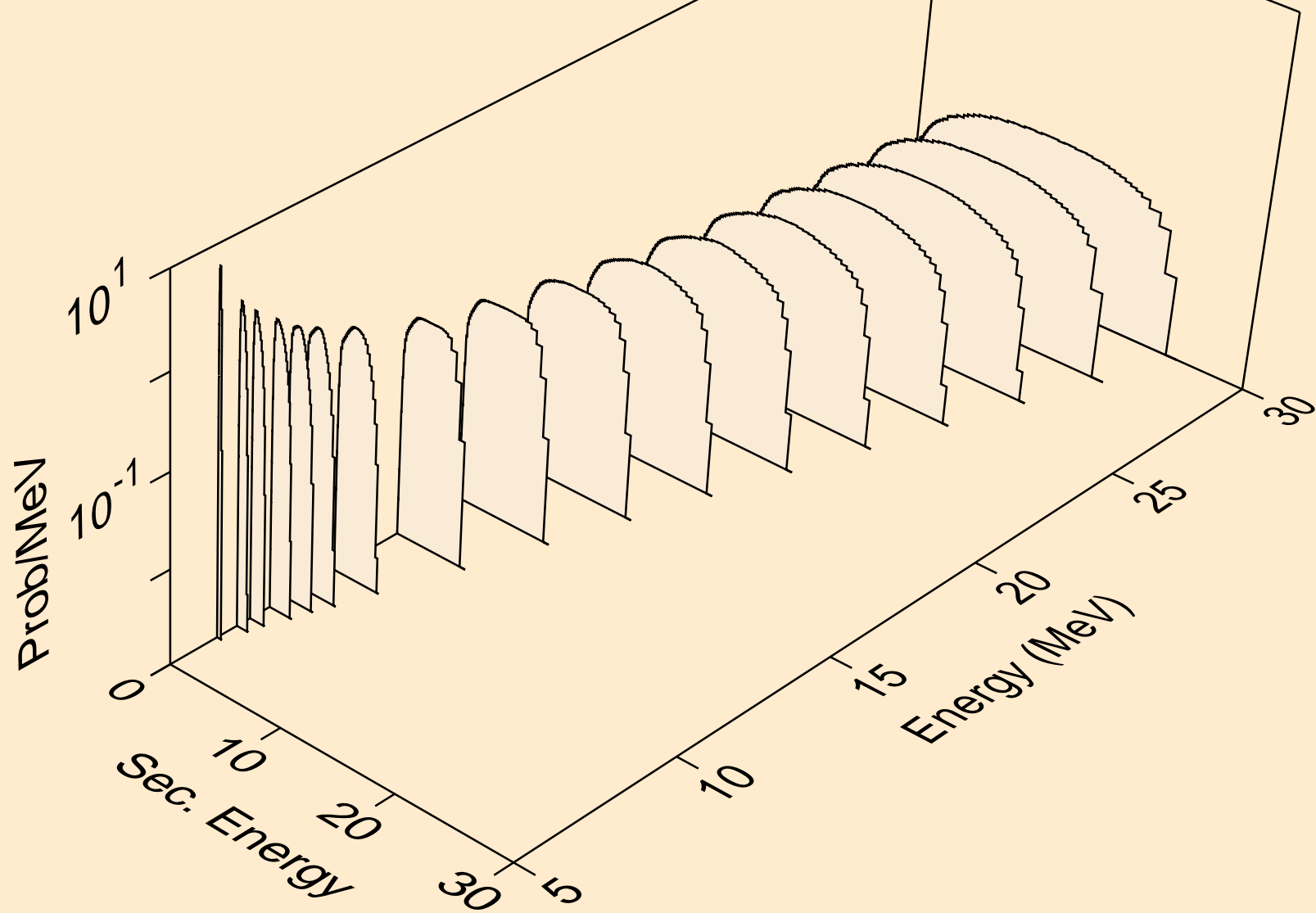

BH275 NEUTRON ACER TENDL-2023 LIBRARY; T=0.K  
Neutron emission for (n,3n)

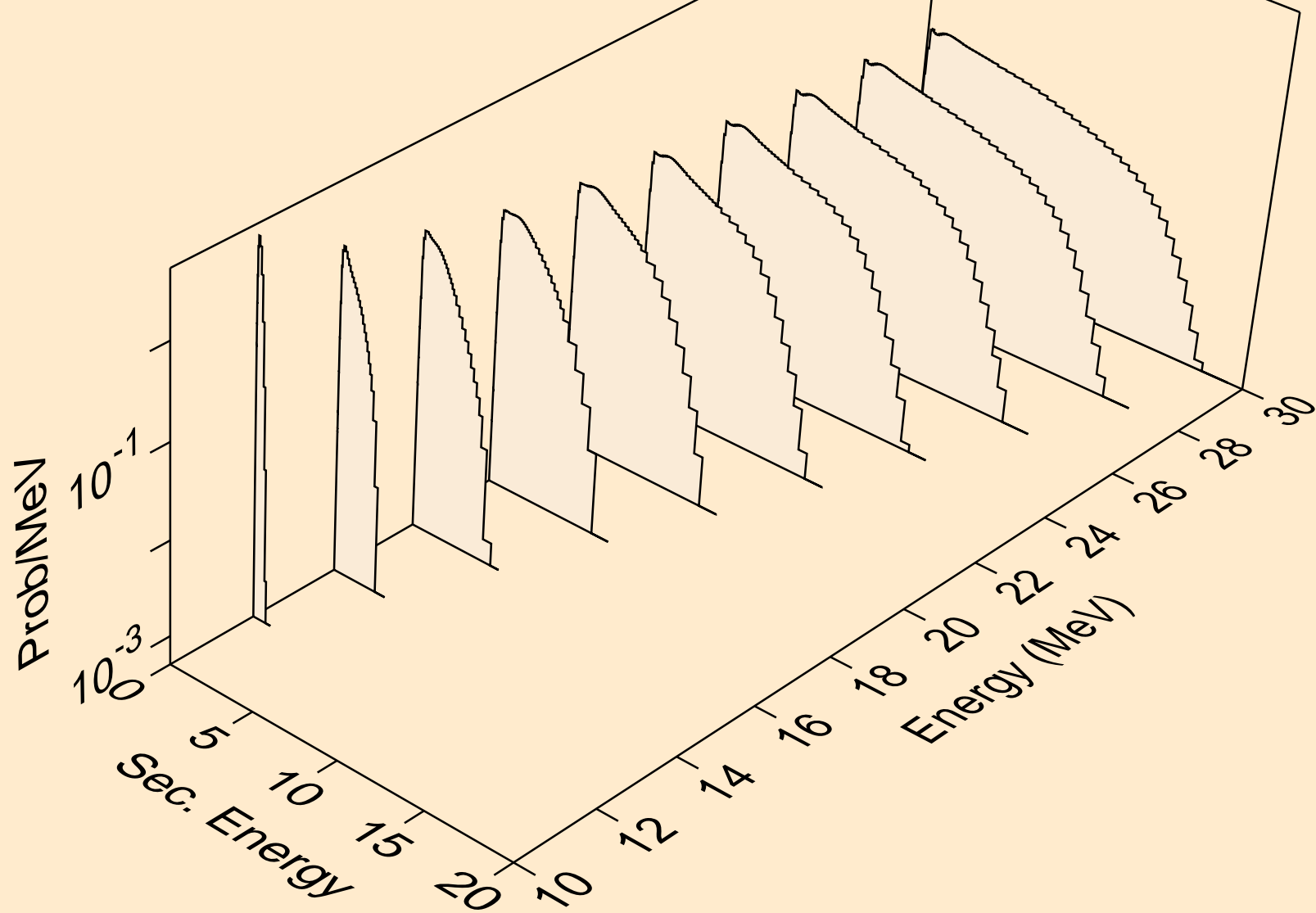

BH275 NEUTRON ACER TENDL-2023 LIBRARY; T=0.K  
Neutron emission for fission

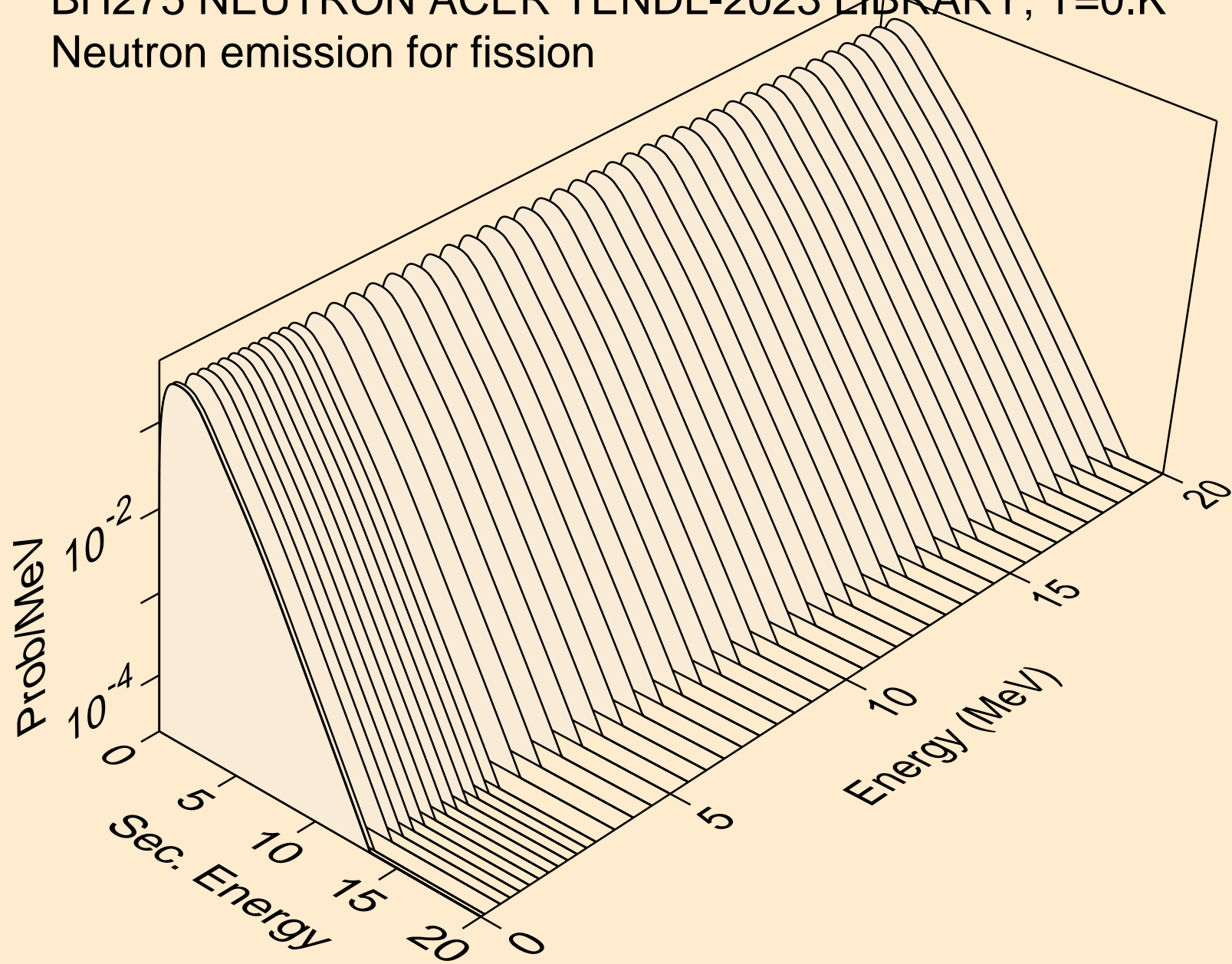

BH275 NEUTRON ACER TENDL-2023 LIBRARY; T=0.K  
Neutron emission for (n,n\*)a

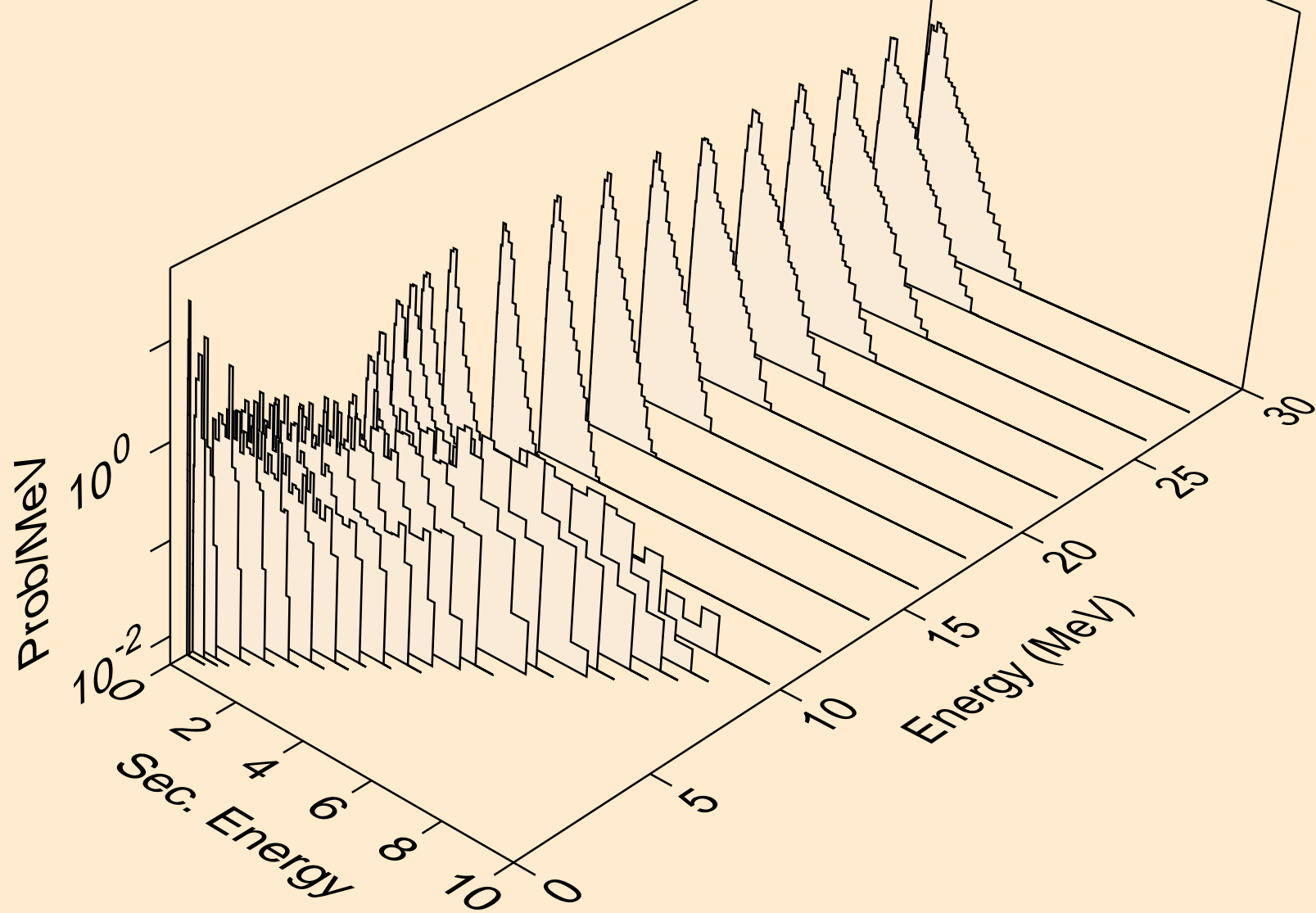

BH275 NEUTRON ACER TENDL-2023 LIBRARY; T=0.K  
Neutron emission for (n,2n)a

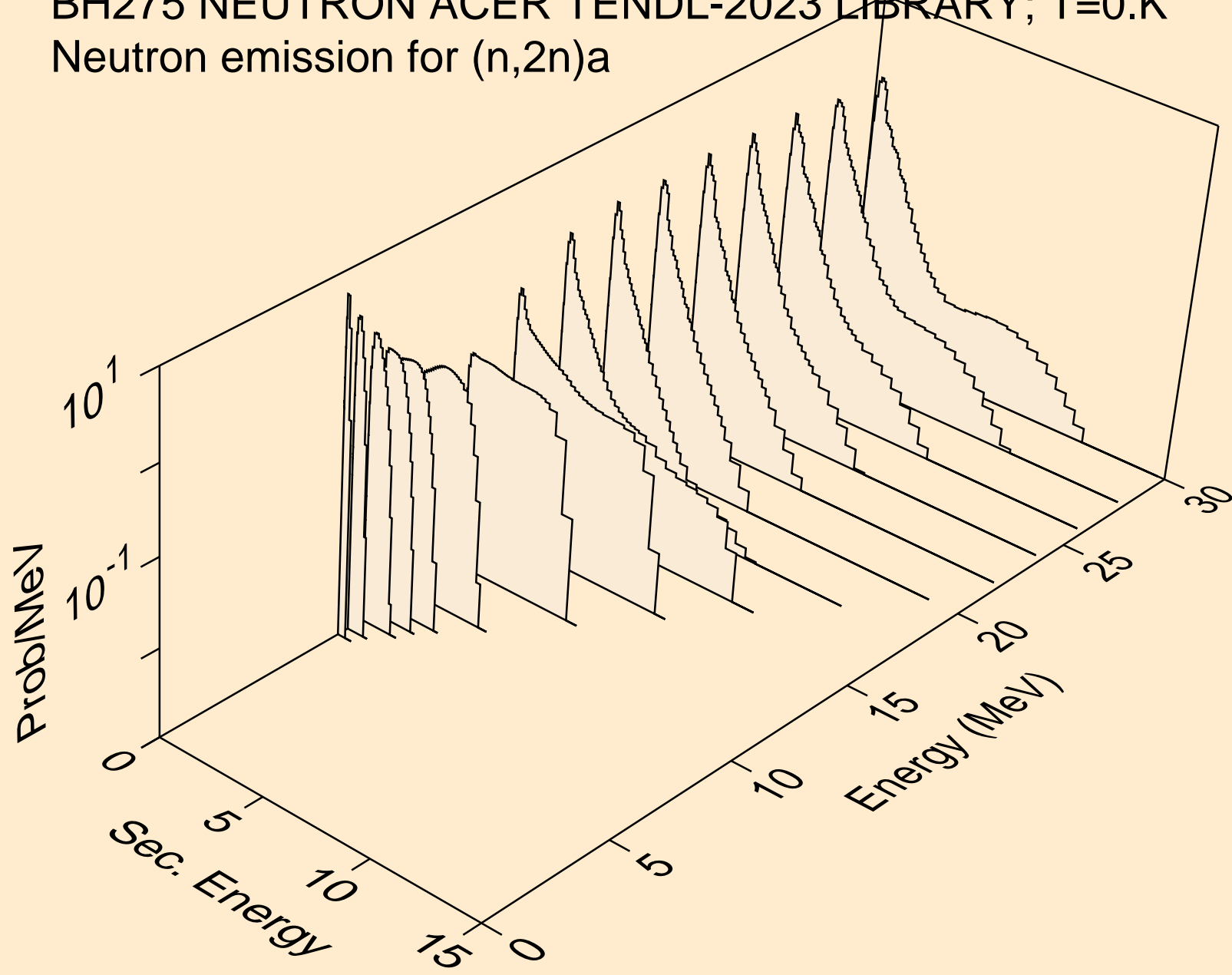

BH275 NEUTRON ACER TENDL-2023 LIBRARY; T=0.K  
Neutron emission for (n,n\*)p

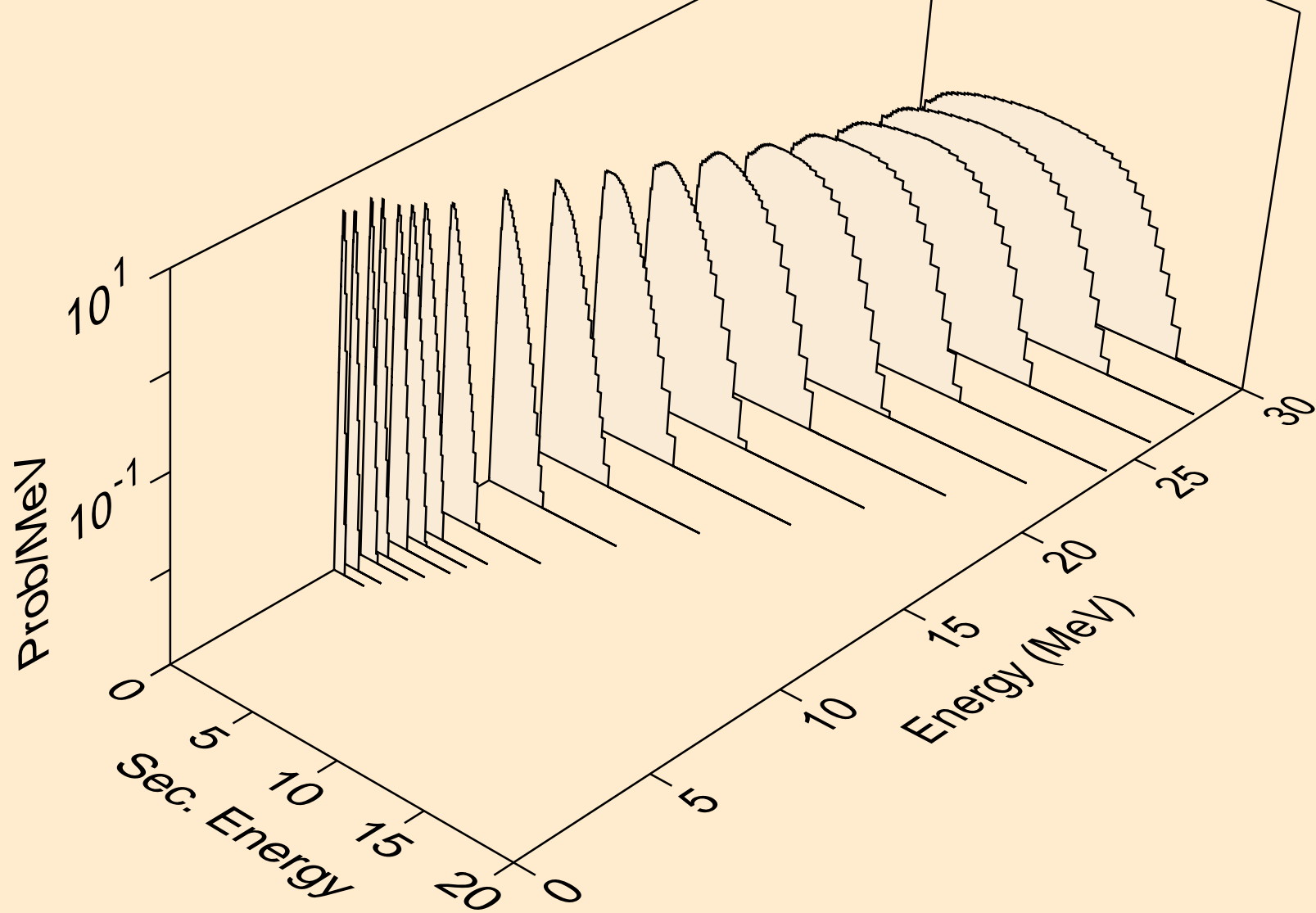

BH275 NEUTRON ACER TENDL-2023 LIBRARY; T=0.K  
Neutron emission for (n,n\*)d

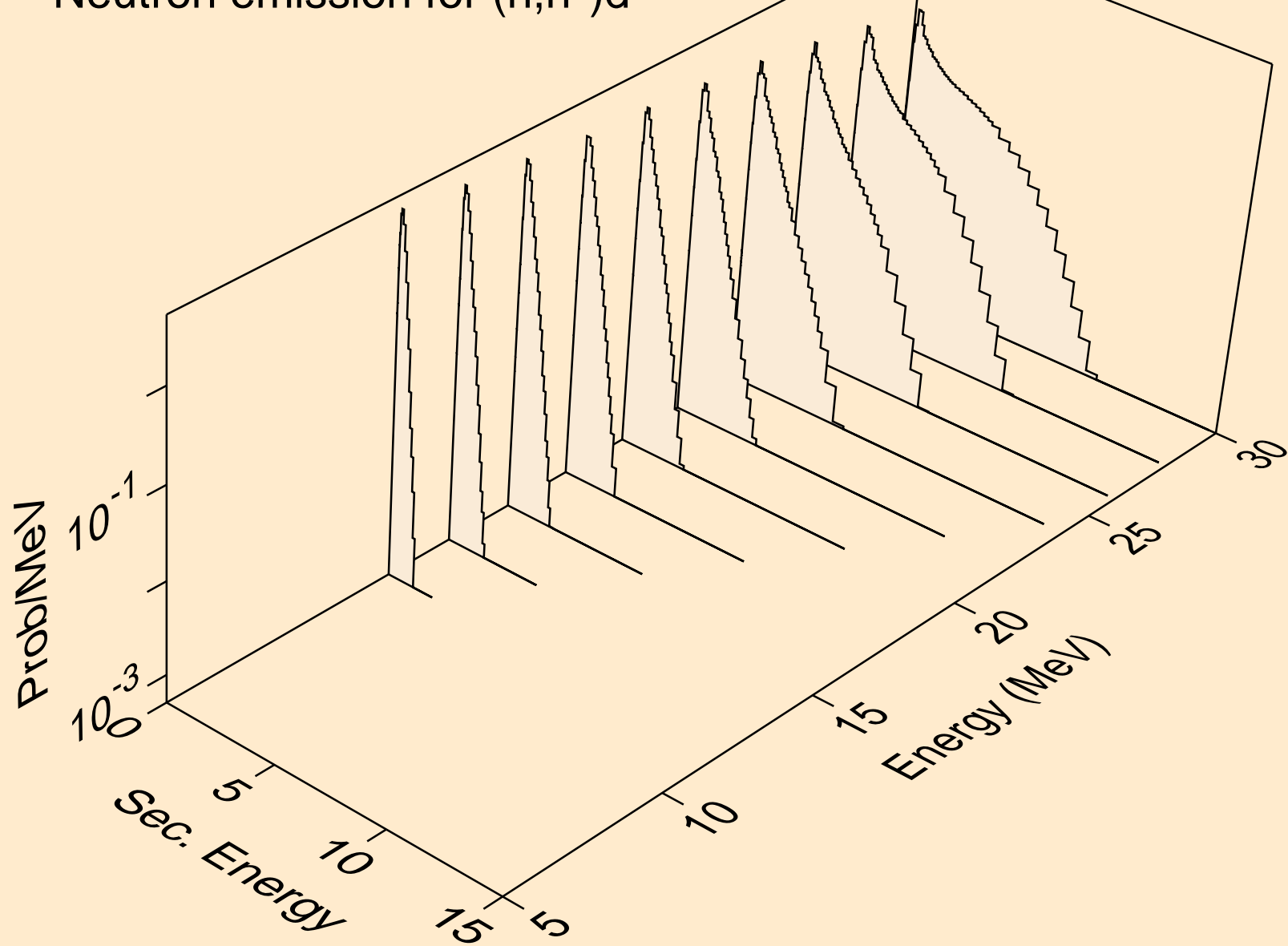

BH275 NEUTRON ACER TENDL-2023 LIBRARY; T=0.K  
Neutron emission for (n,n\*)t

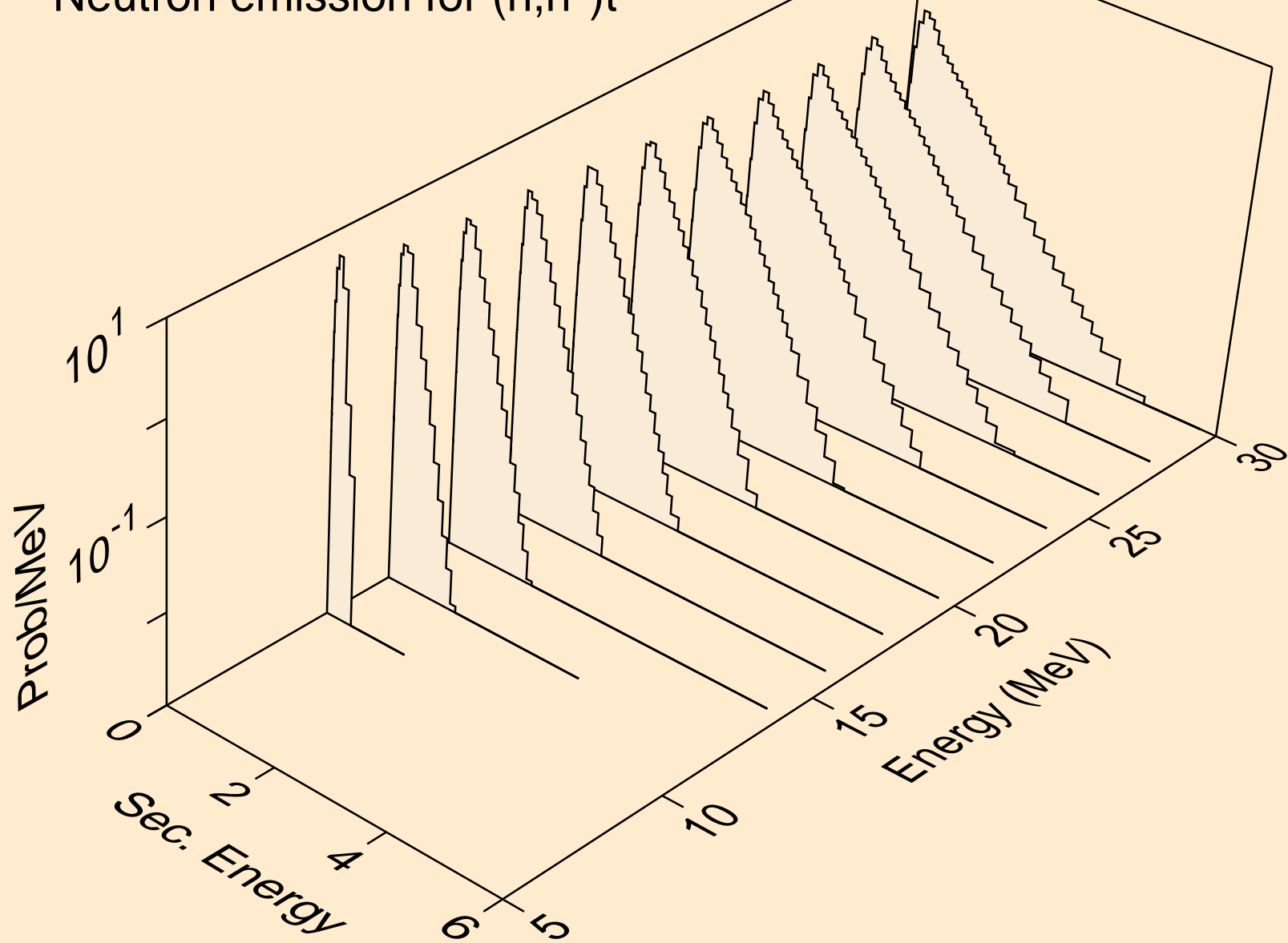



BH275 NEUTRON ACER TENDL-2023 LIBRARY; T=0.K  
Neutron emission for (n,n\*)he3

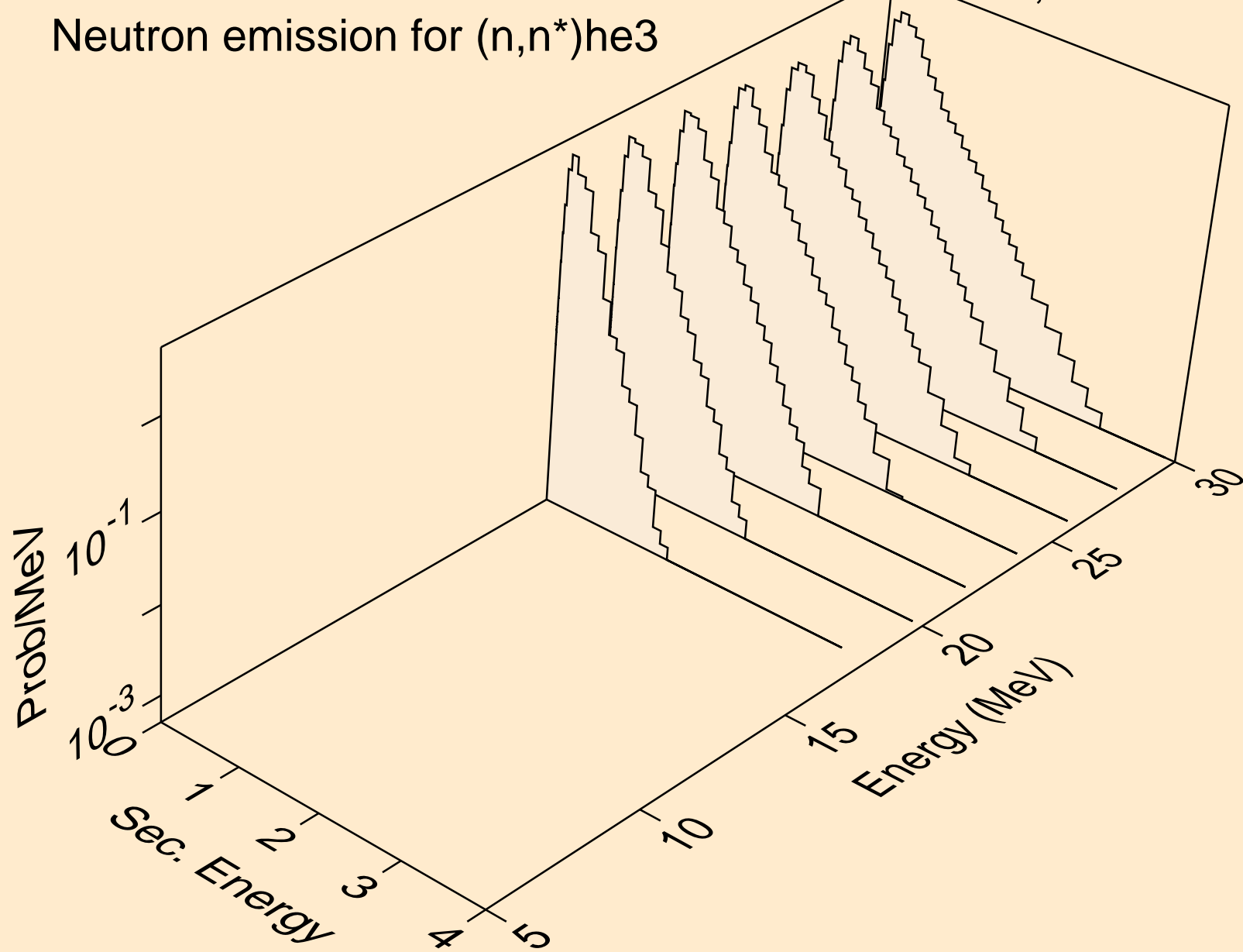

BH275 NEUTRON ACER TENDL-2023 LIBRARY; T=0.K  
Neutron emission for (n,4n)

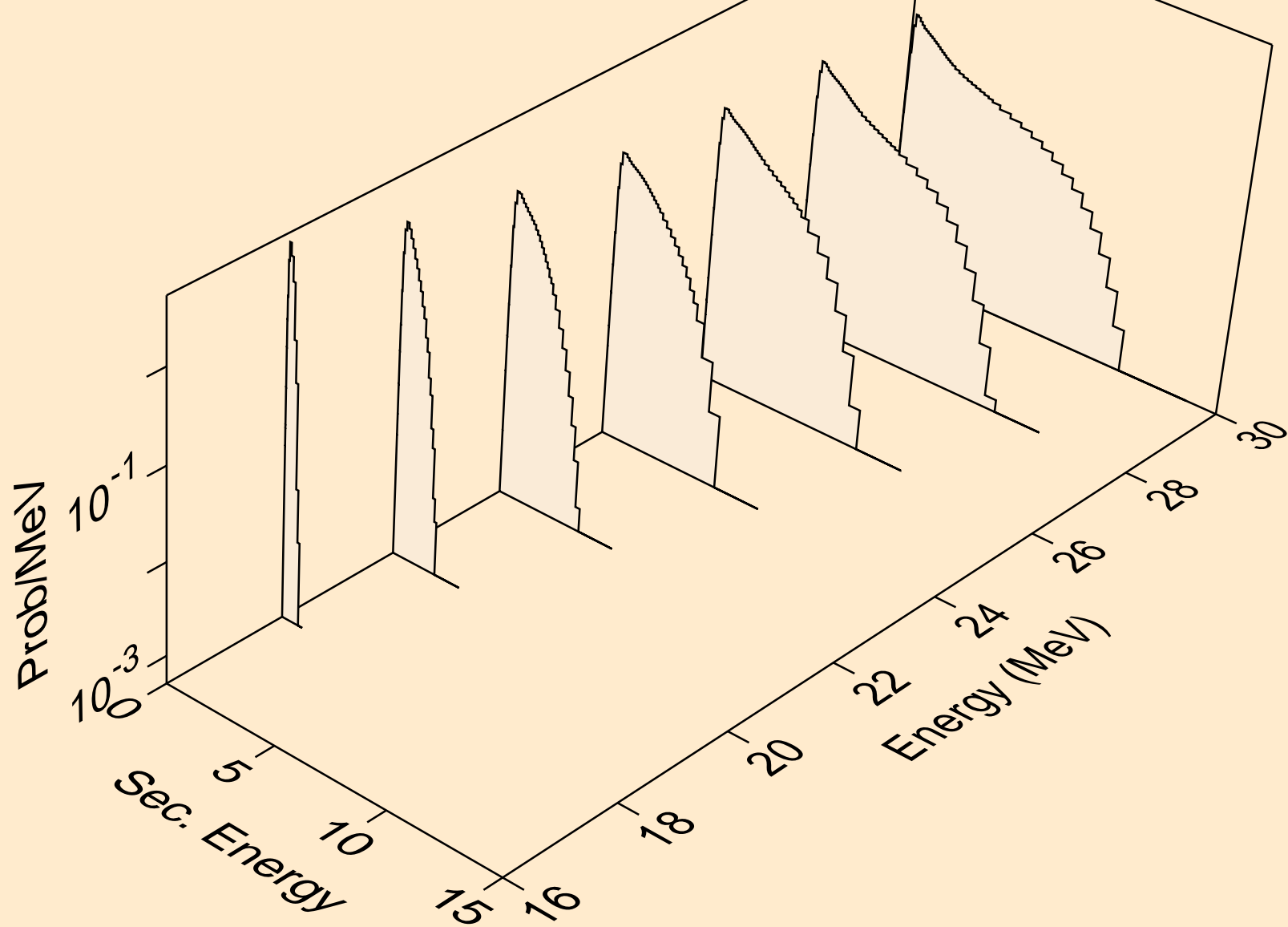

BH275 NEUTRON ACER TENDL-2023 LIBRARY; T=0.K  
Neutron emission for (n,2np)

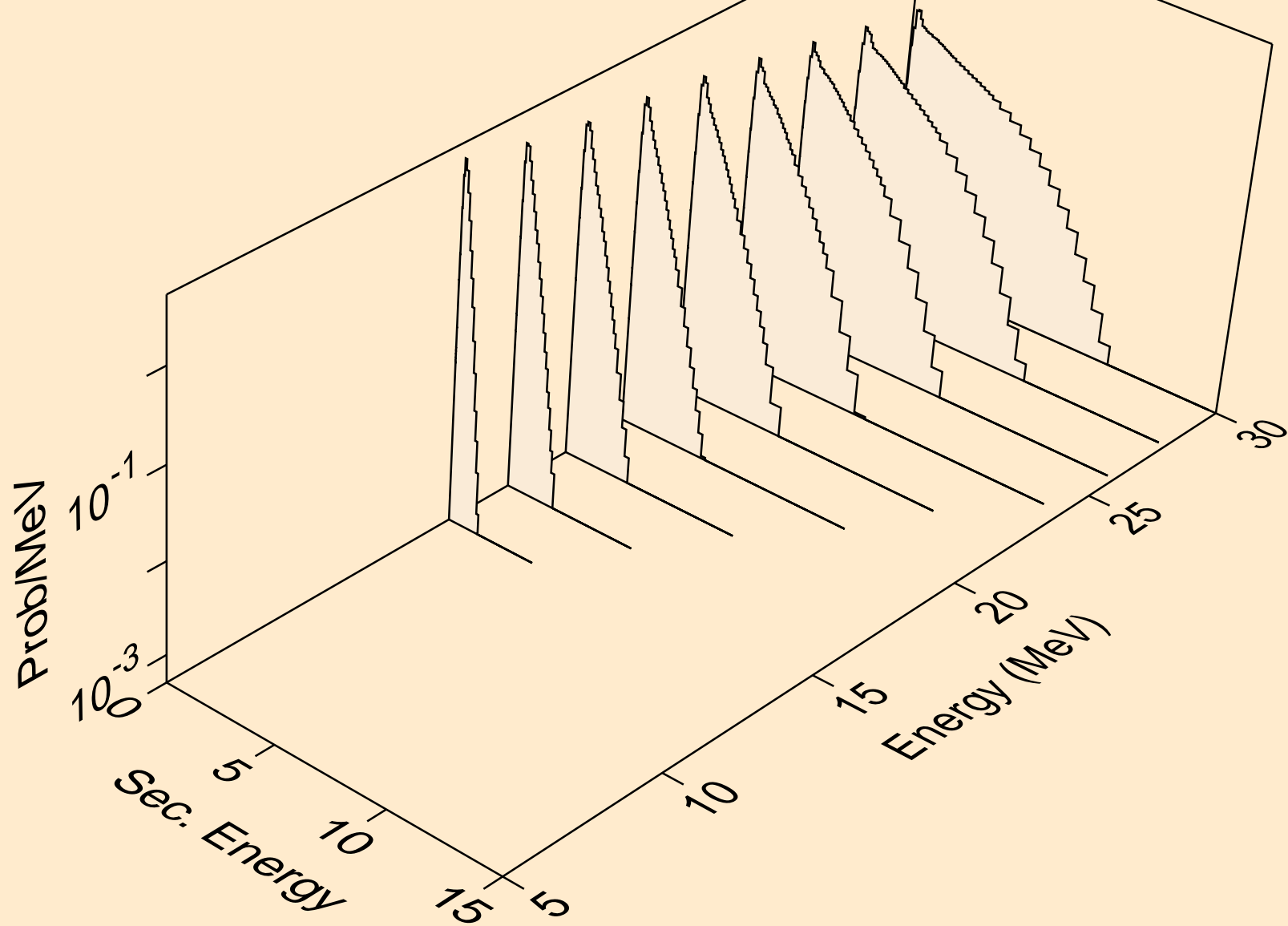

BH275 NEUTRON ACER TENDL-2023 LIBRARY; T=0.K  
Neutron emission for (n,3np)

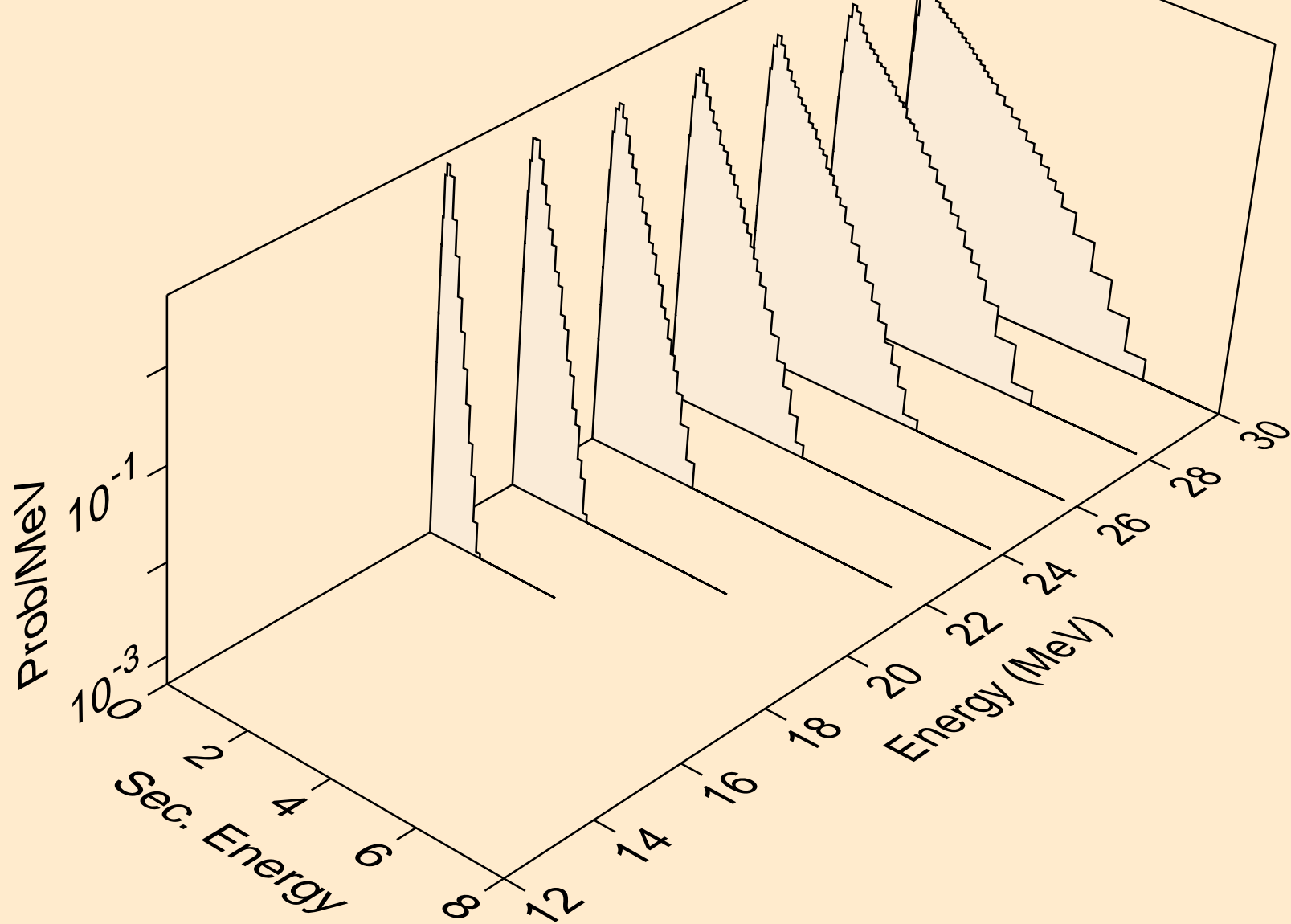

BH275 NEUTRON ACER TENDL-2023 LIBRARY; T=0.K  
Neutron emission for (n,n\*c)

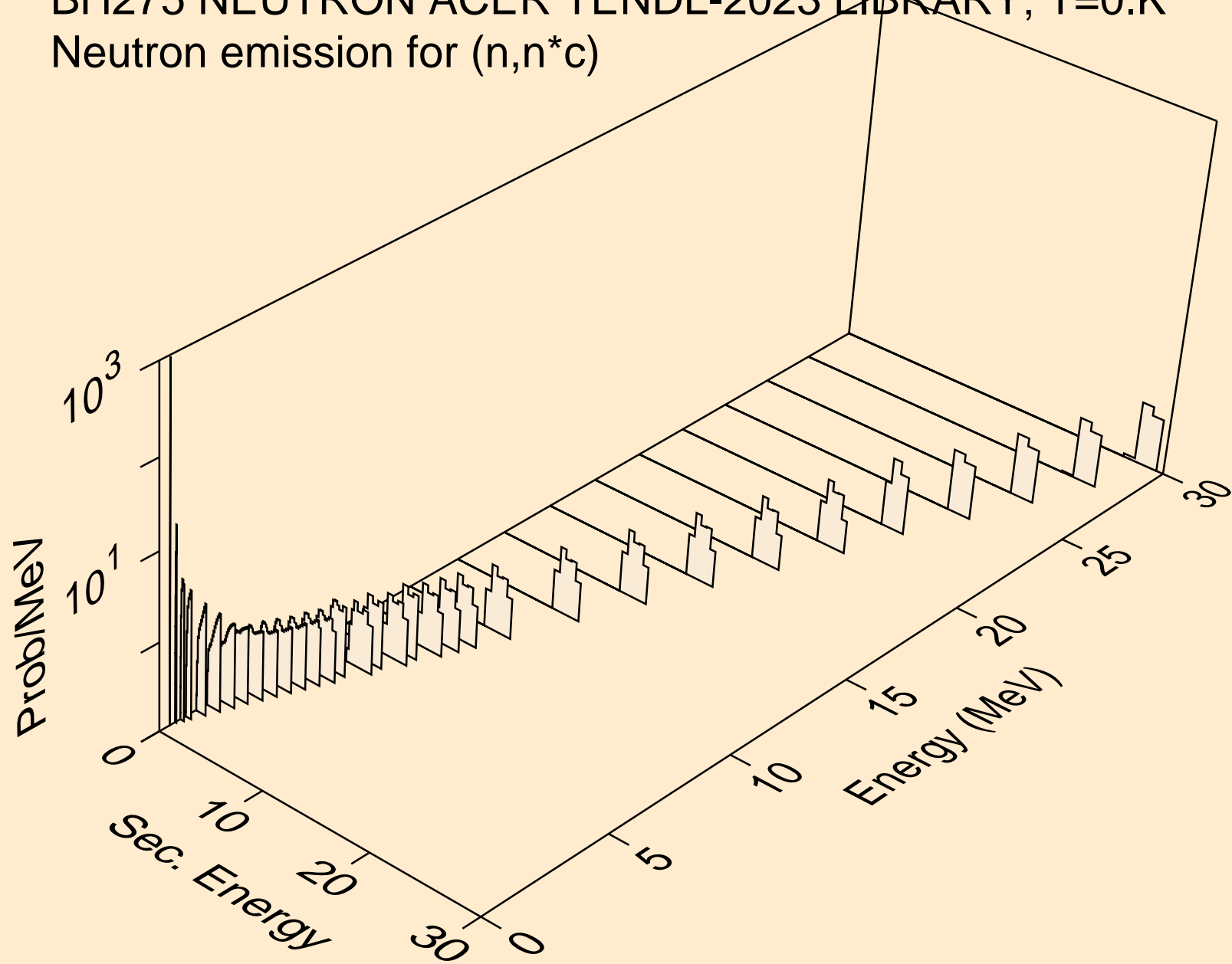

# BH275 NEUTRON ACER TENDL-2023 LIBRARY; T=0.K

## Delayed nubar

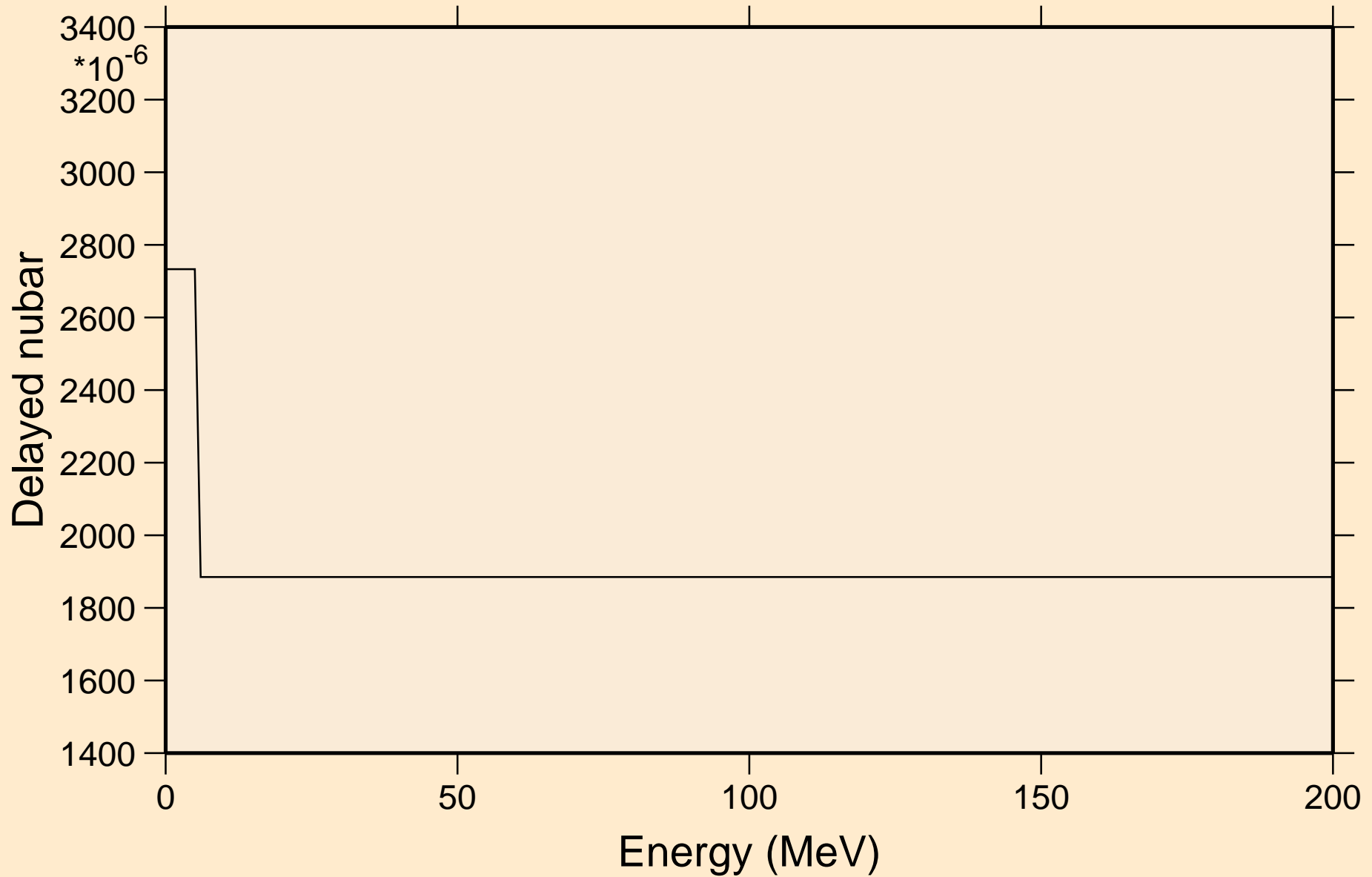

# BH275 NEUTRON ACER TENDL-2023 LIBRARY; T=0.K

## Delayed neutron spectra

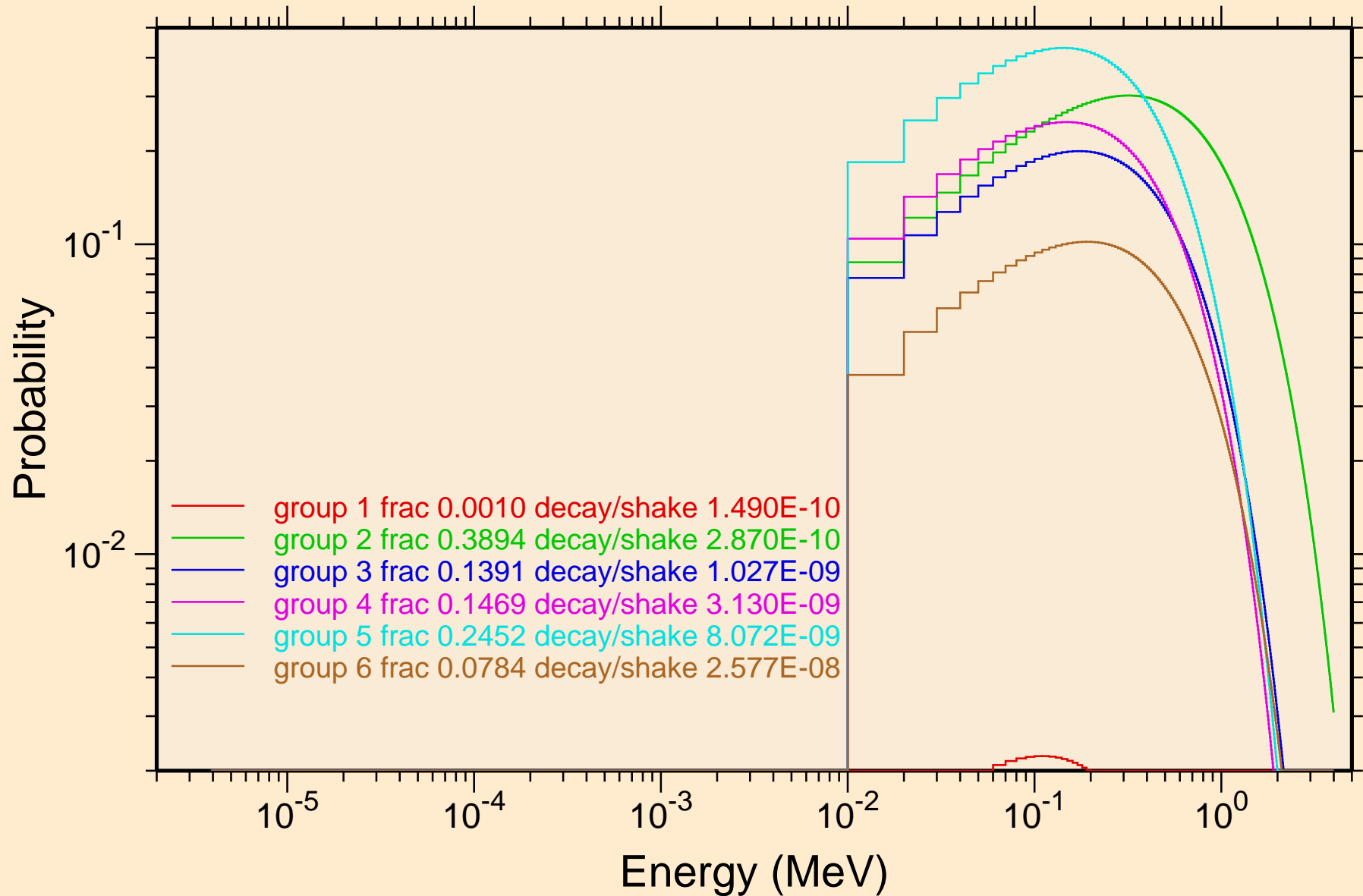

BH275 NEUTRON ACER TENDL-2023 LIBRARY; T=0.K  
Photon emission for (n,x)

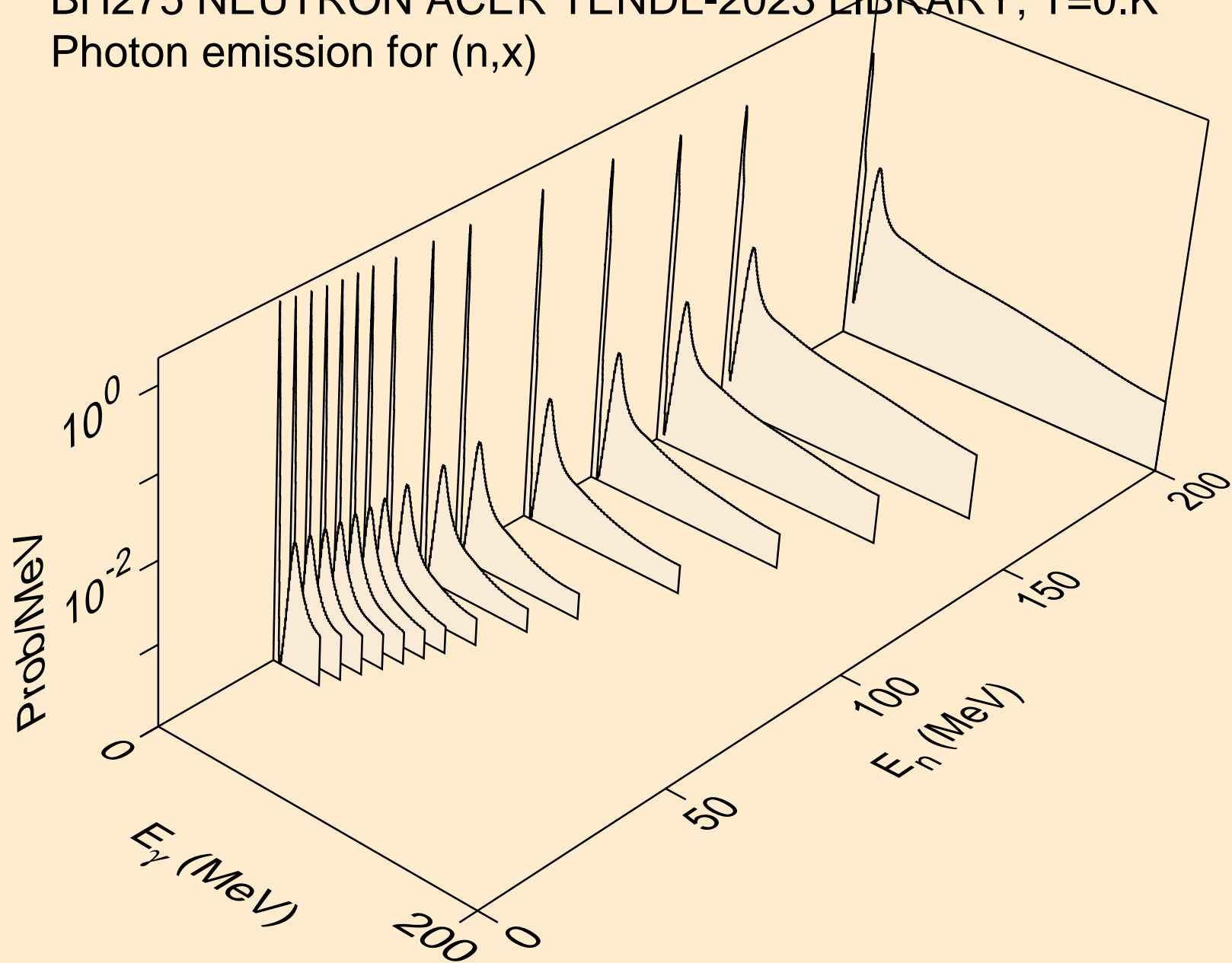



BH275 NEUTRON ACER TENDL-2023 LIBRARY; T=0.K  
Photon emission for (n,2nd)

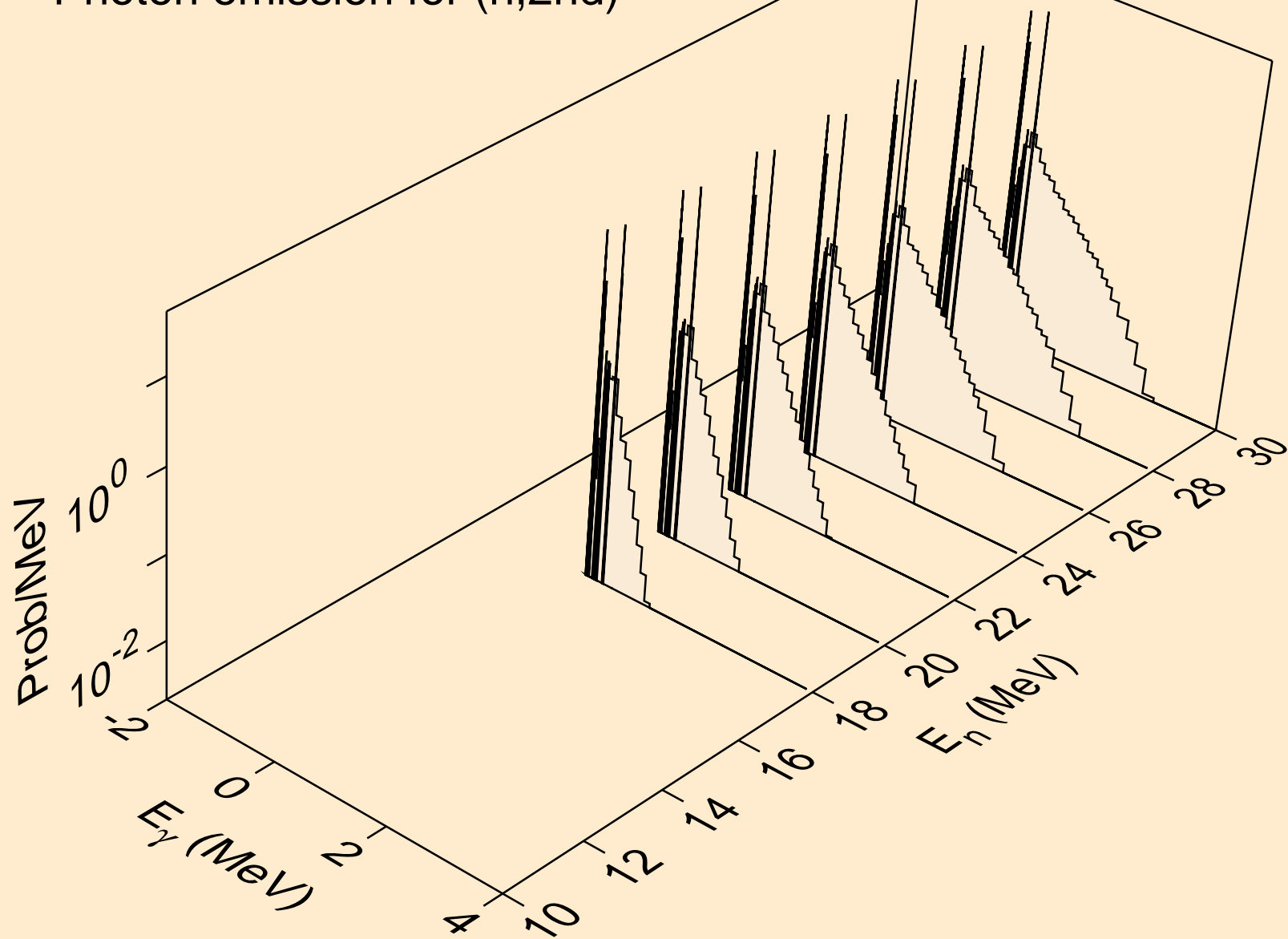

BH275 NEUTRON ACER TENDL-2023 LIBRARY; T=0.K  
Photon emission for (n,2n)

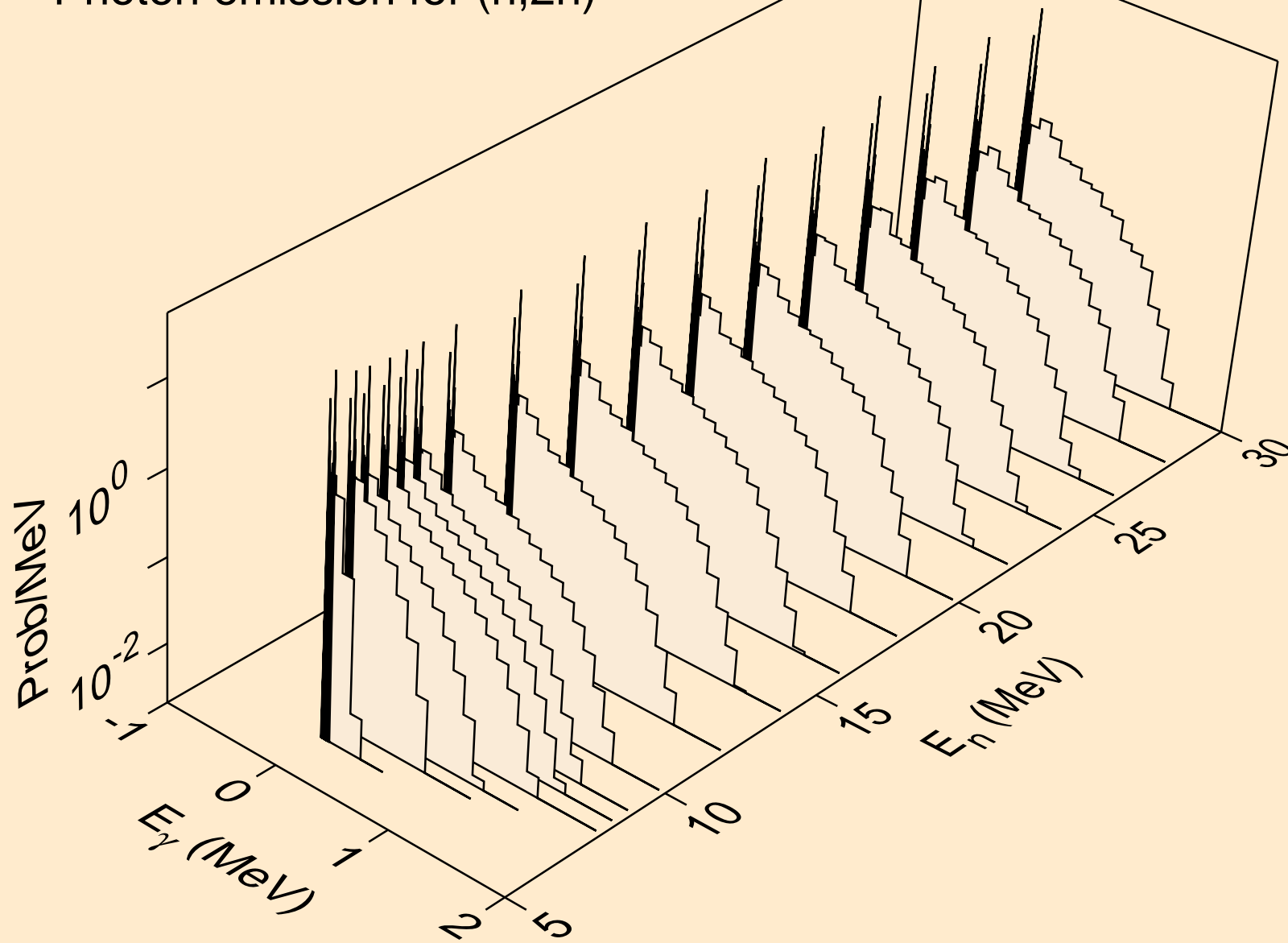

BH275 NEUTRON ACER TENDL-2023 LIBRARY; T=0.K  
Photon emission for (n,3n)

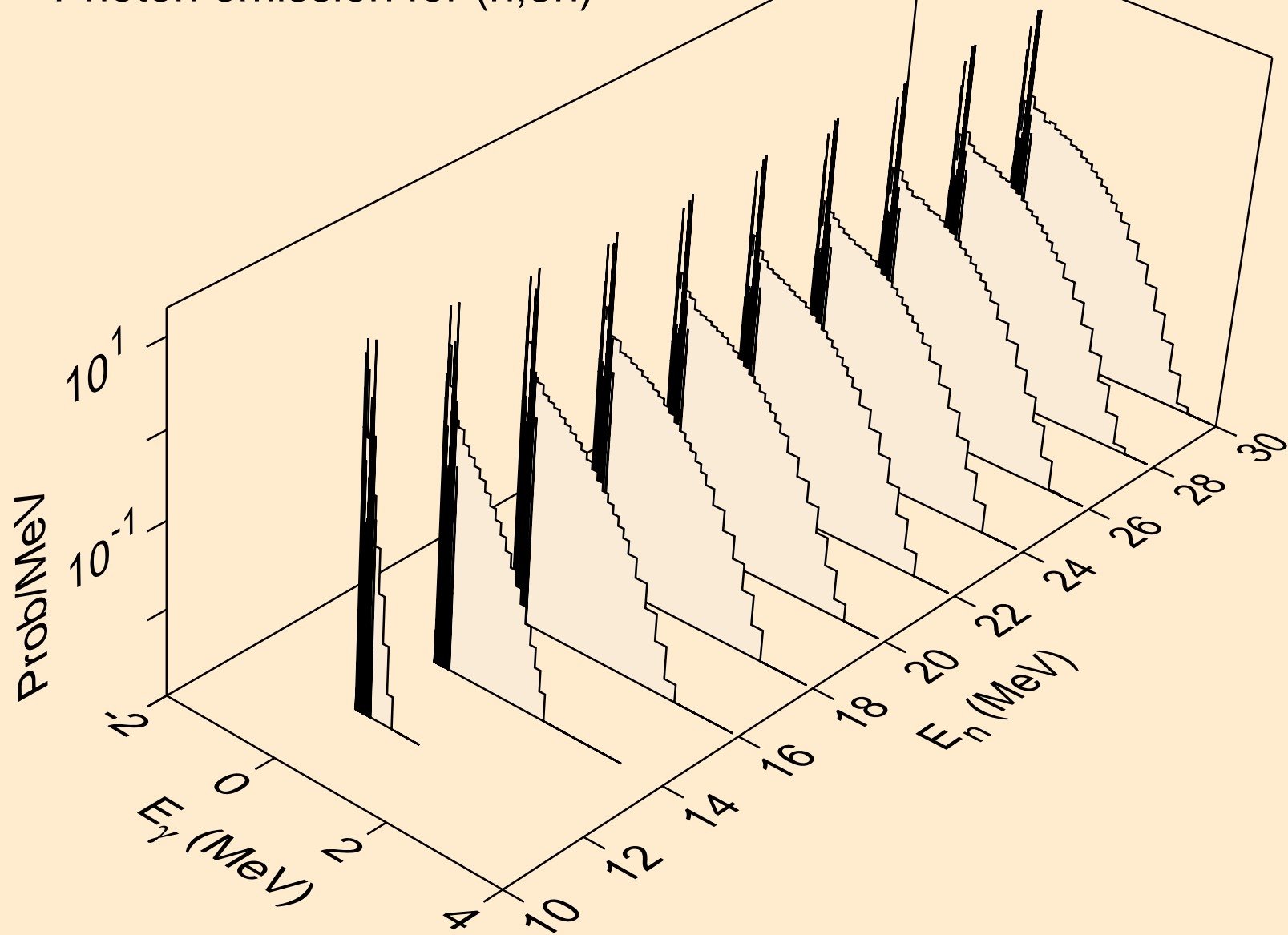

BH275 NEUTRON ACER TENDL-2023 LIBRARY; T=0.K  
Photon emission for (n,n\*)a

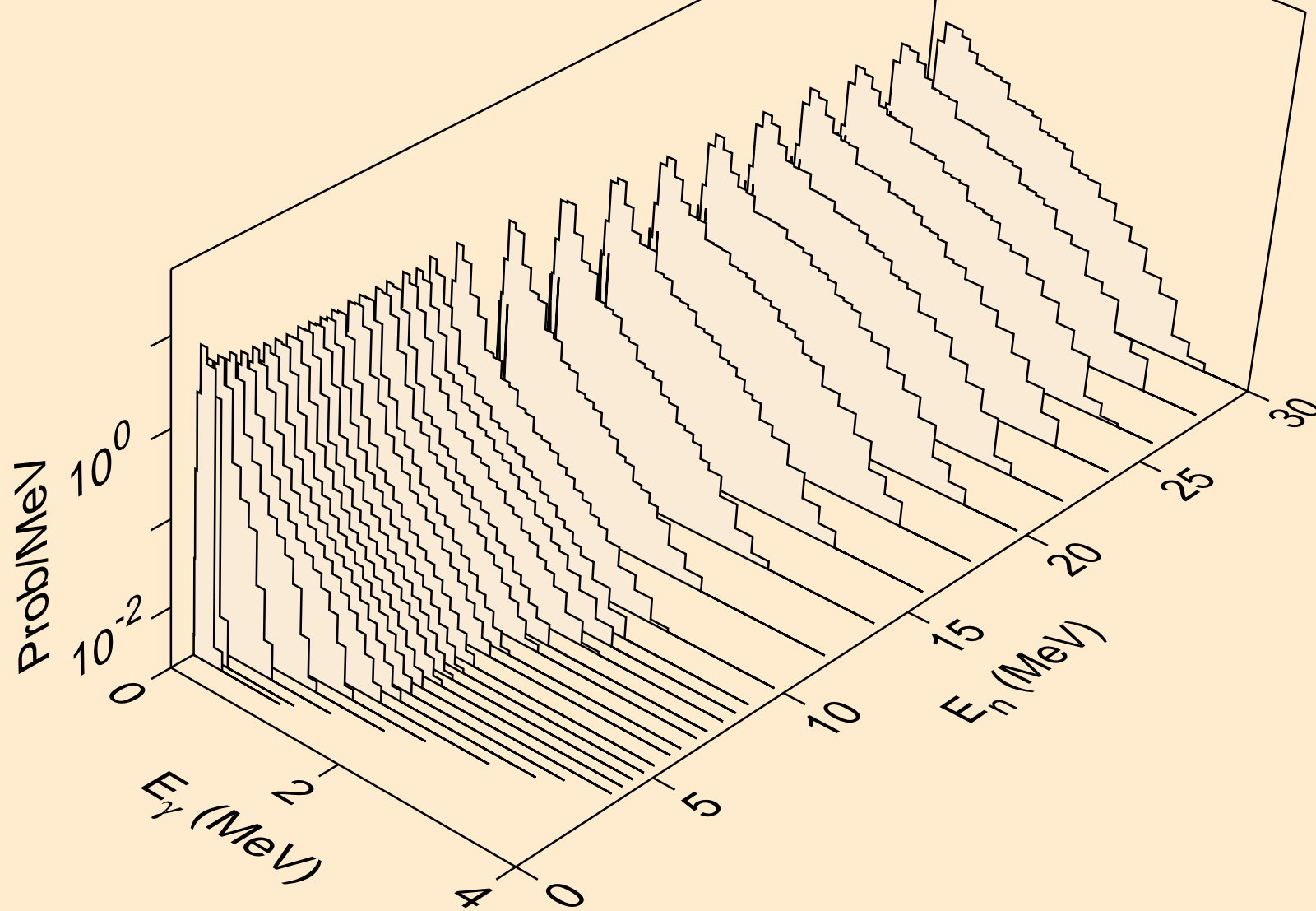

BH275 NEUTRON ACER TENDL-2023 LIBRARY; T=0.K  
Photon emission for (n,2n)a

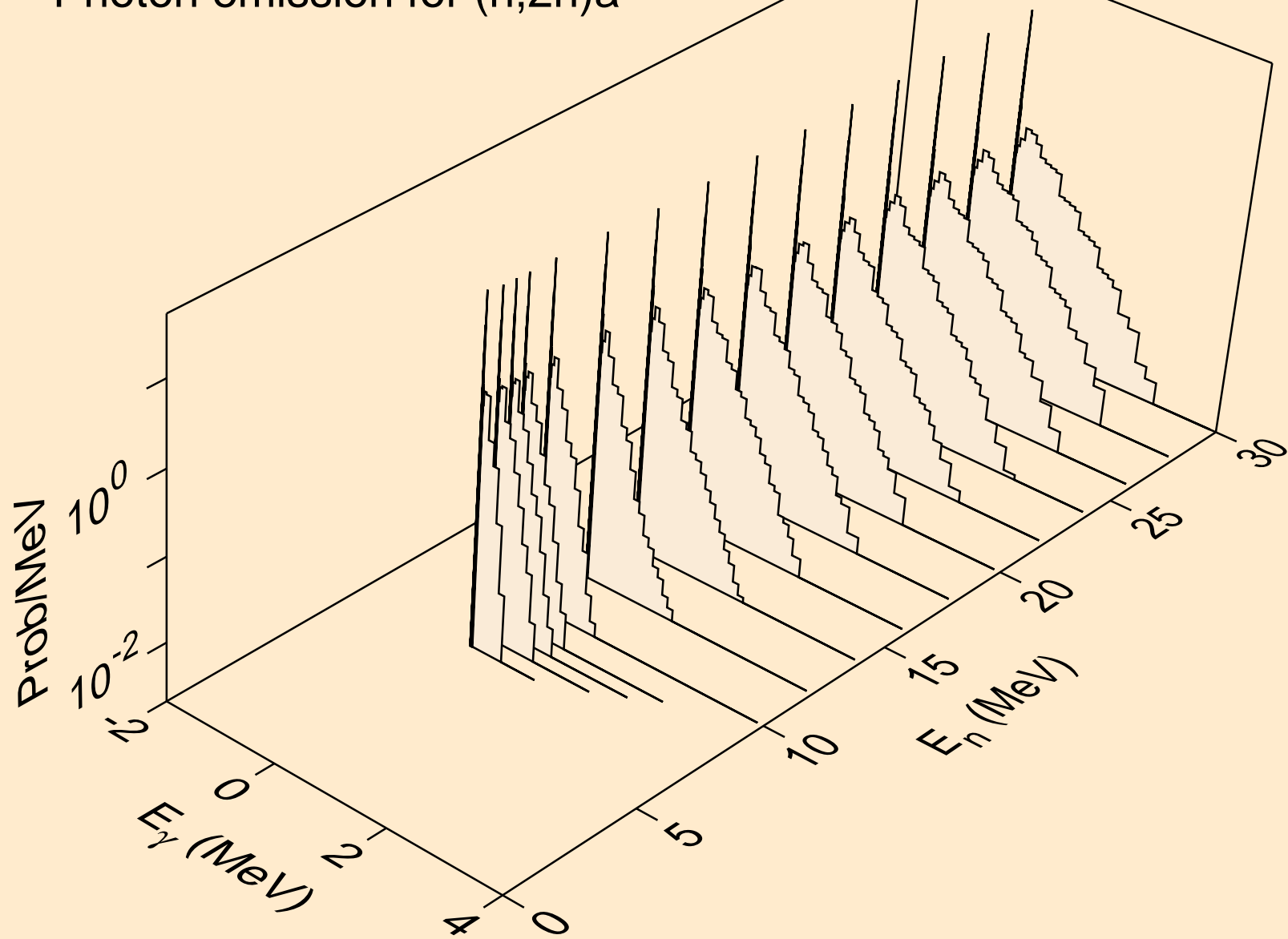

BH275 NEUTRON ACER TENDL-2023 LIBRARY; T=0.K  
Photon emission for (n,n\*)p

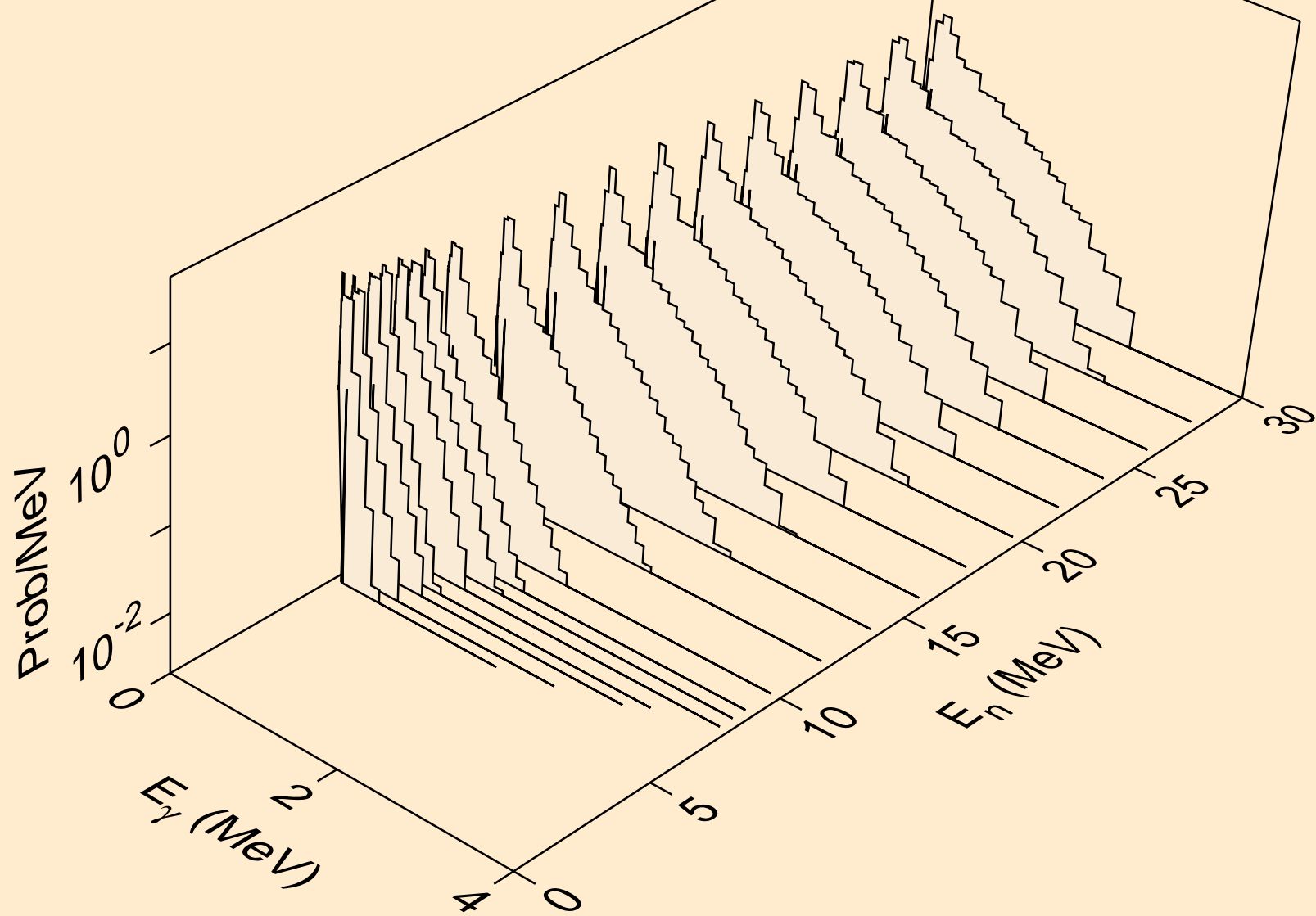

BH275 NEUTRON ACER TENDL-2023 LIBRARY; T=0.K  
Photon emission for (n,n\*)d

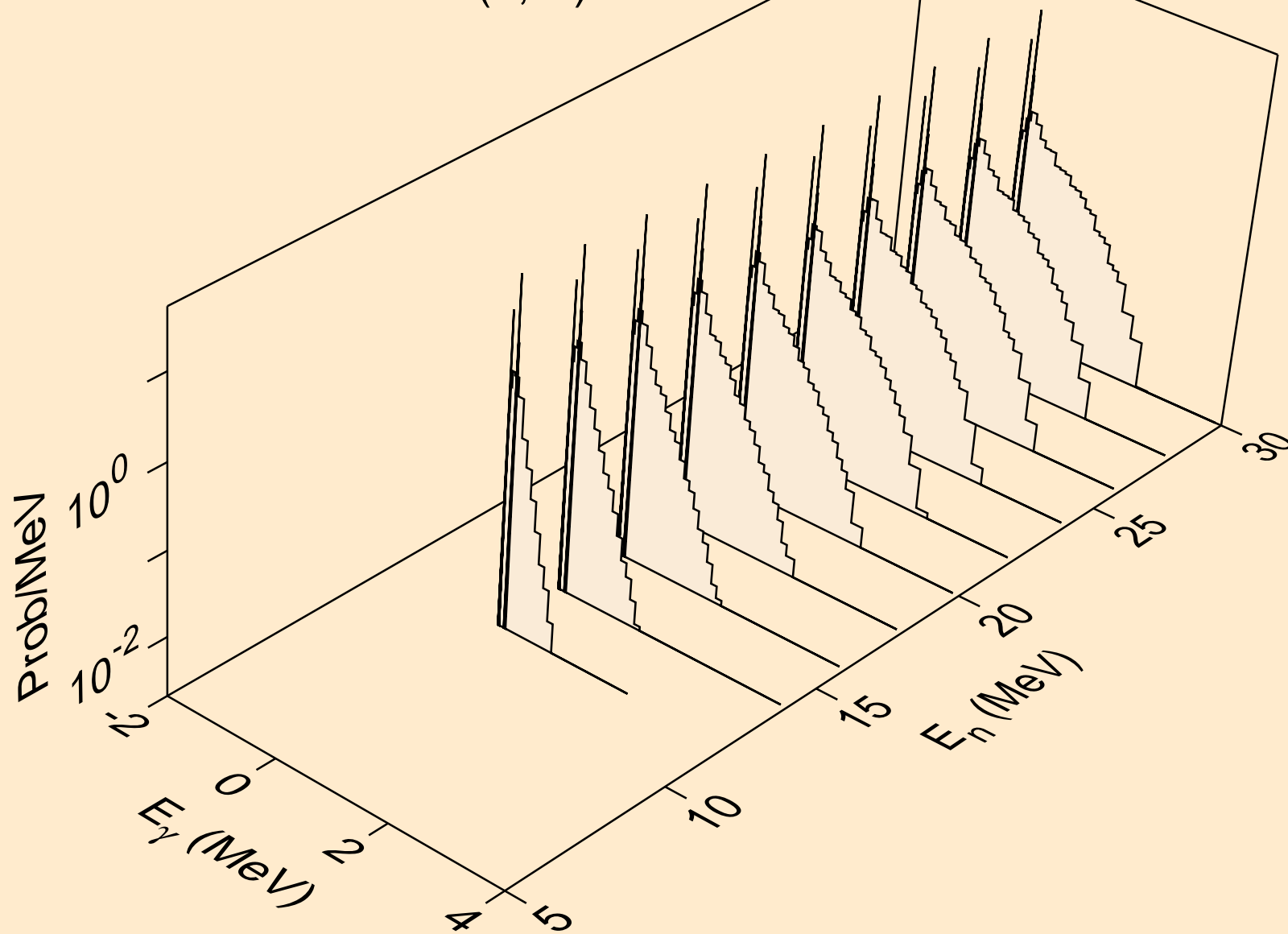

BH275 NEUTRON ACER TENDL-2023 LIBRARY; T=0.K  
Photon emission for (n,n\*)t

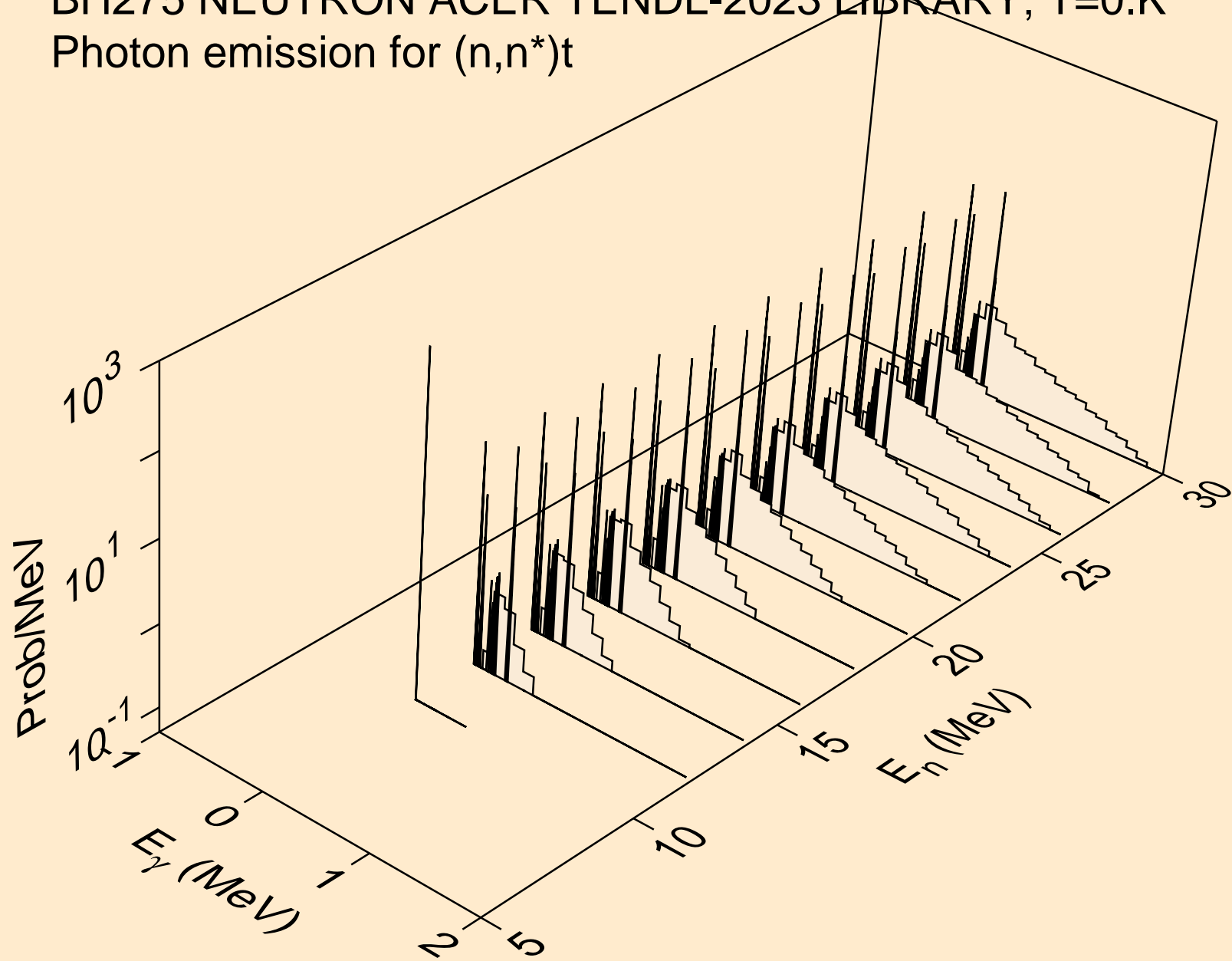



BH275 NEUTRON ACER TENDL-2023 LIBRARY; T=0.K  
Photon emission for (n,n\*)he3

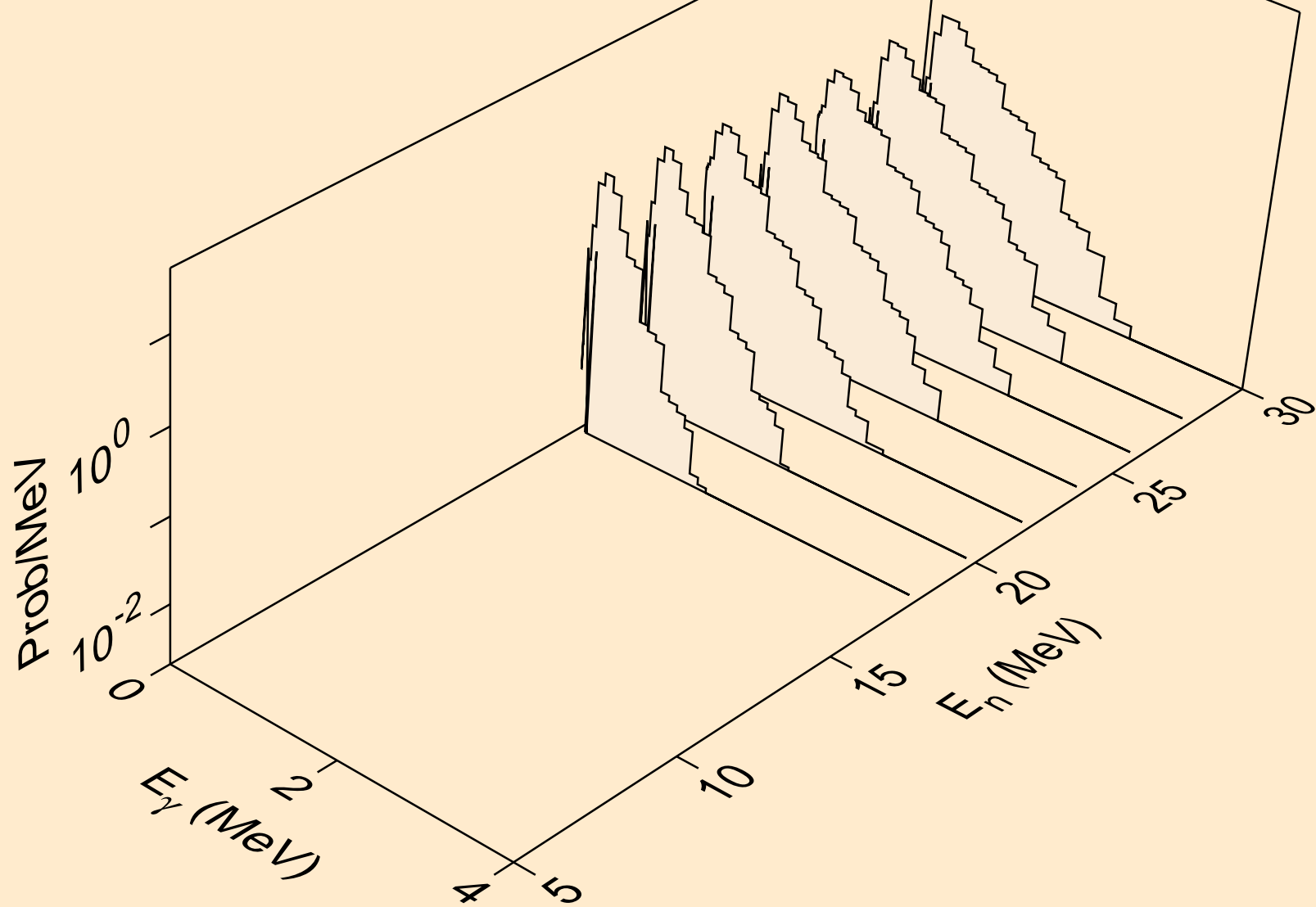

BH275 NEUTRON ACER TENDL-2023 LIBRARY; T=0.K  
Photon emission for (n,4n)

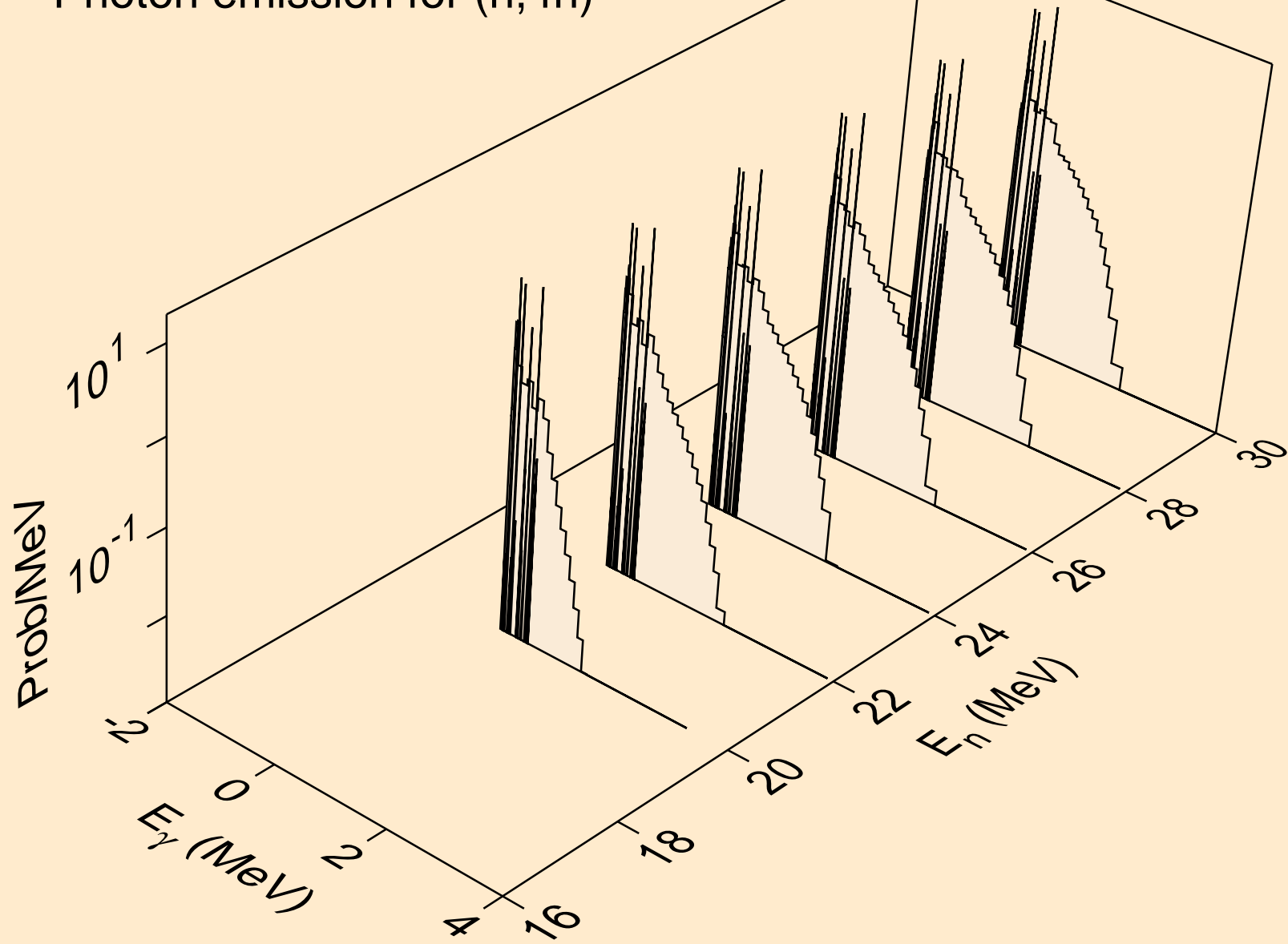

BH275 NEUTRON ACER TENDL-2023 LIBRARY; T=0.K  
Photon emission for (n,2np)

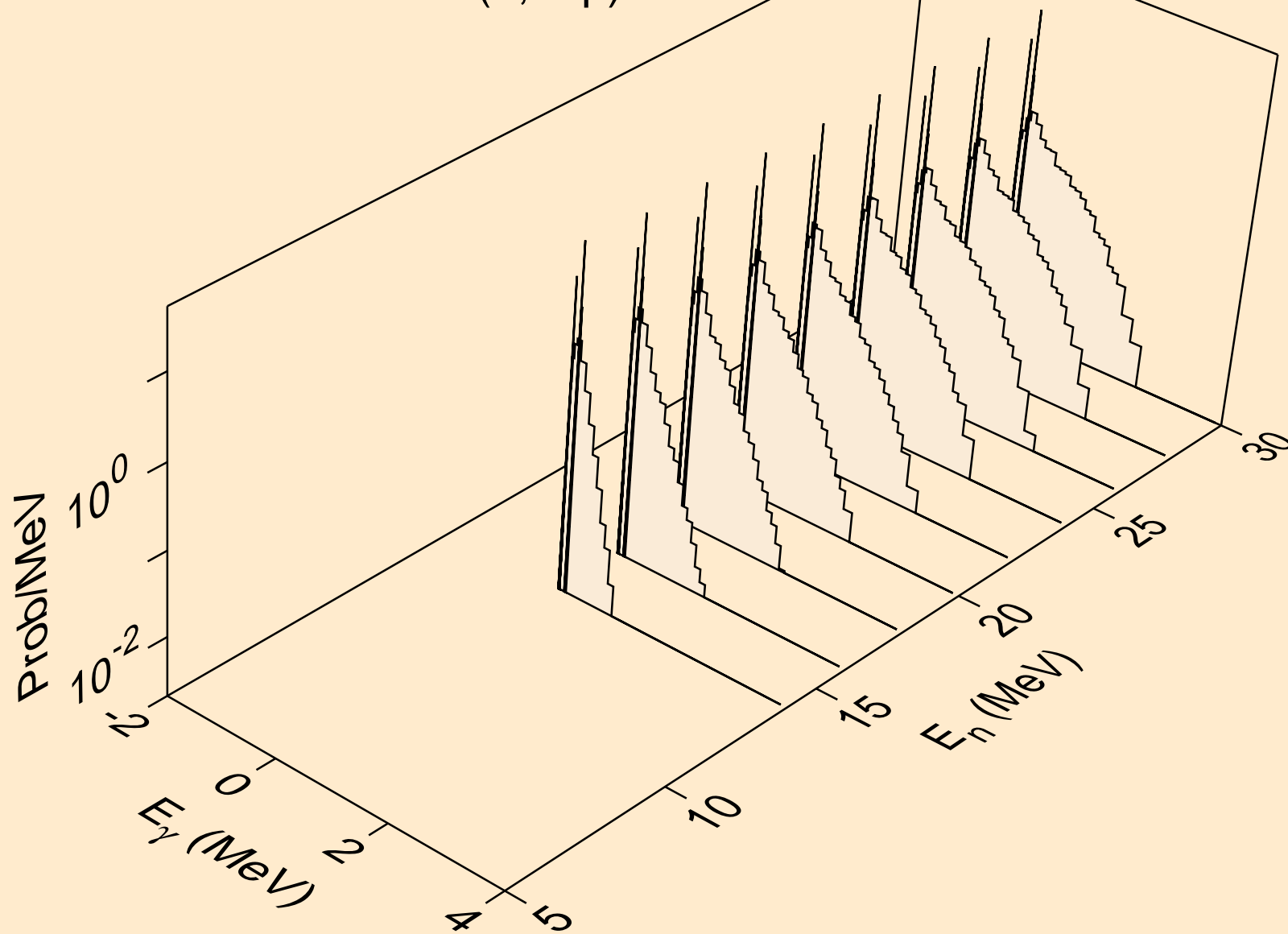

BH275 NEUTRON ACER TENDL-2023 LIBRARY; T=0.K  
Photon emission for (n,3np)

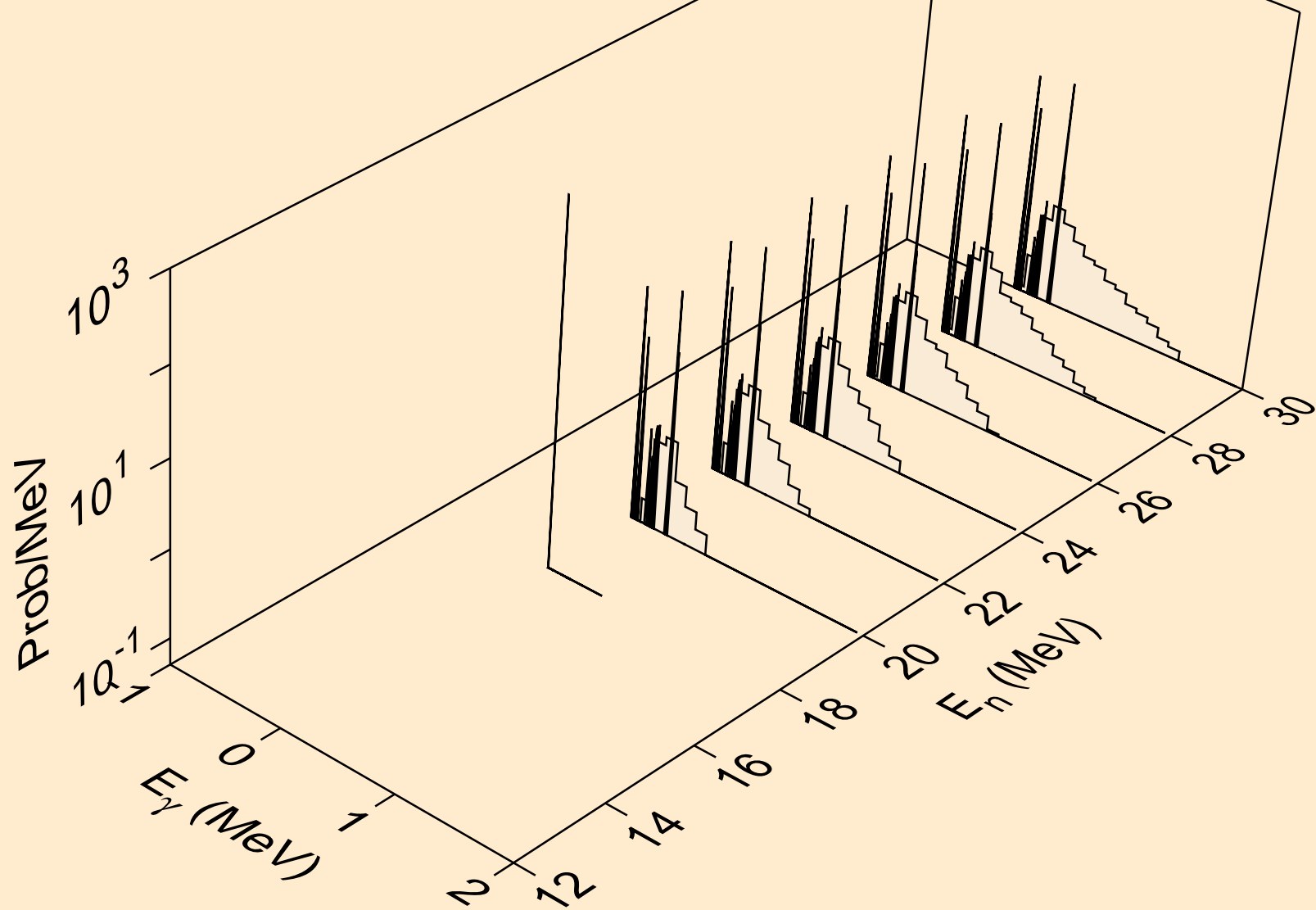

BH275 NEUTRON ACER TENDL-2023 LIBRARY; T=0.K  
Photon emission for (n,n\*c)

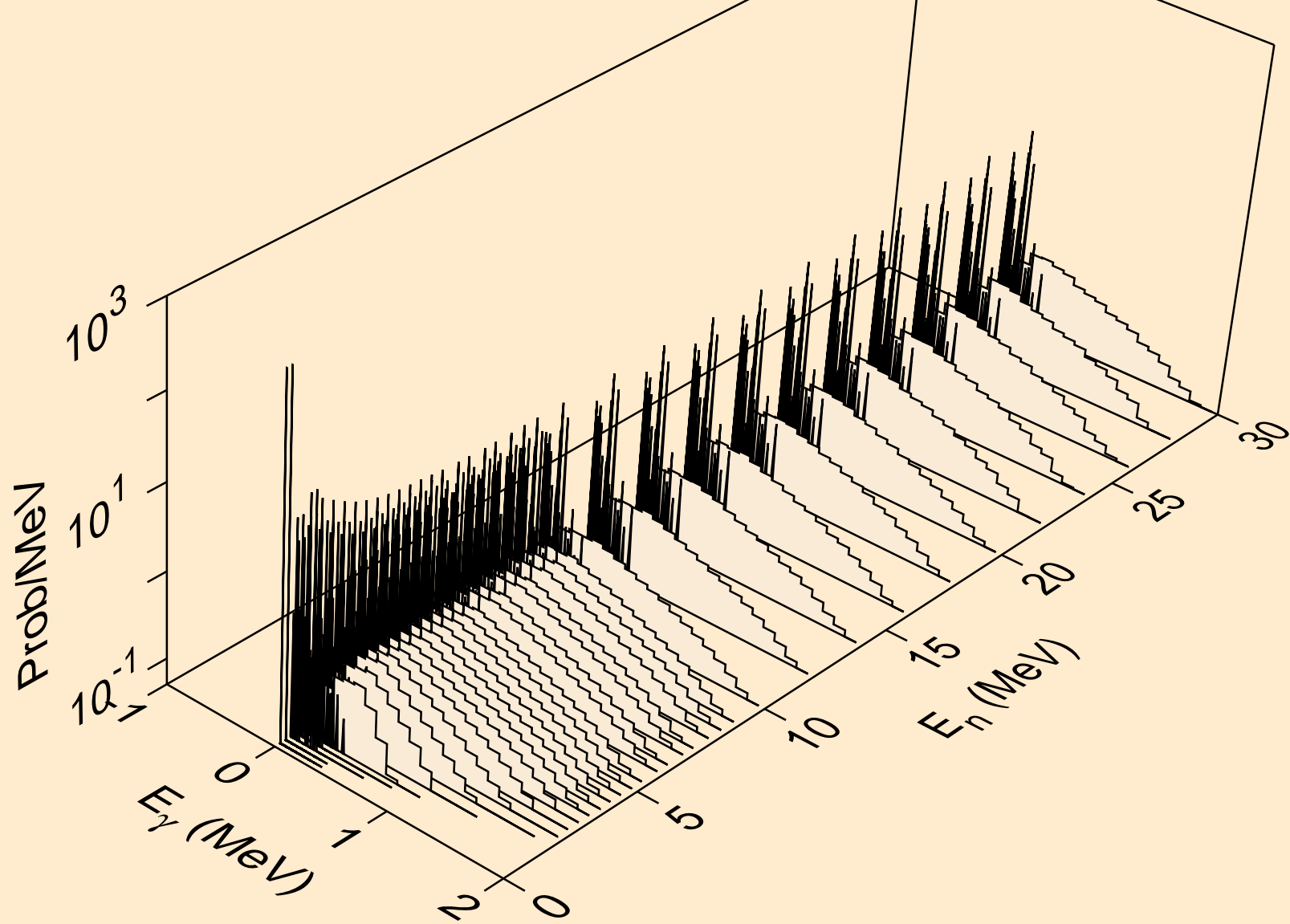

BH275 NEUTRON ACER TENDL-2023 LIBRARY; T=0.K  
Photon emission for (n,gma)

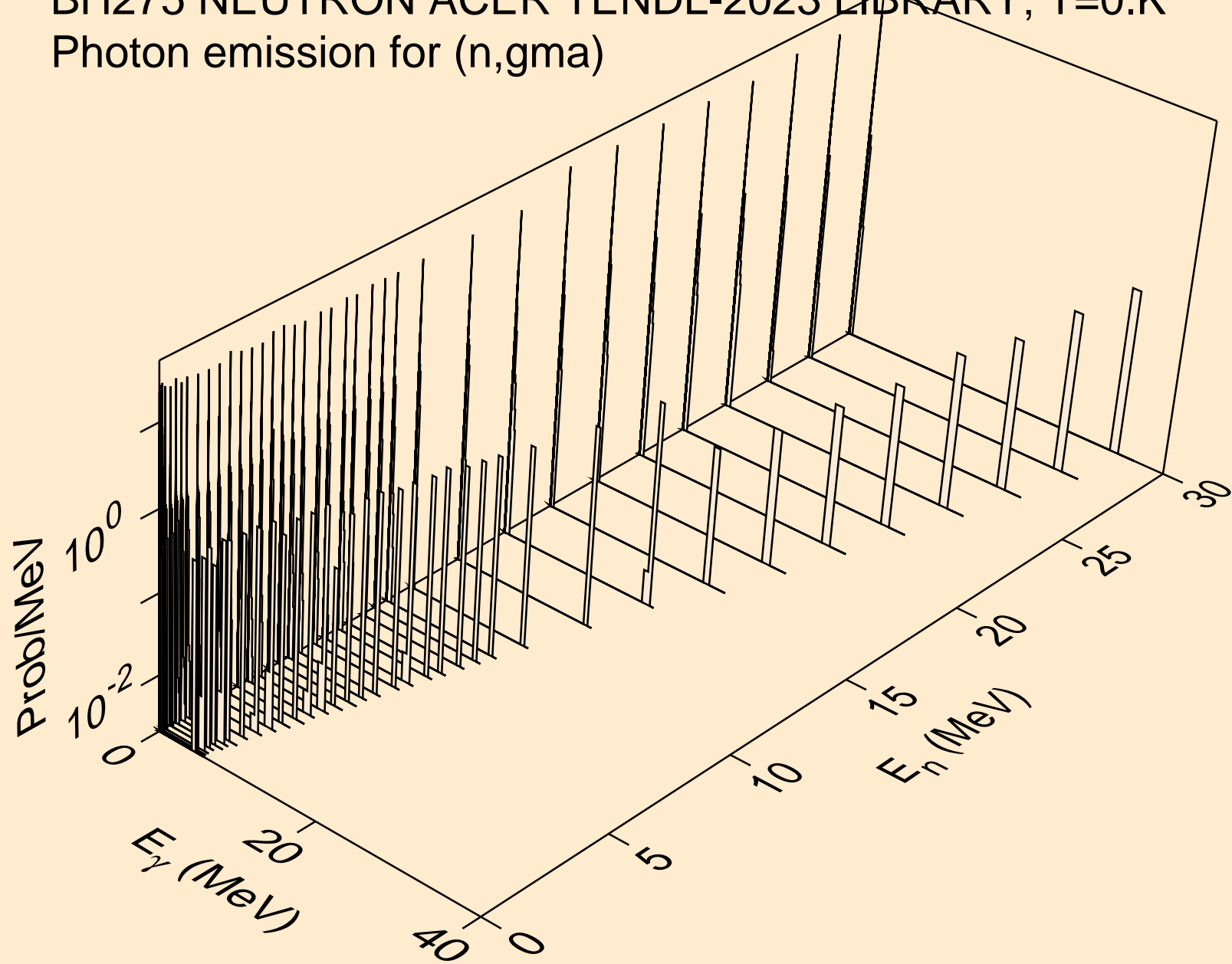

BH275 NEUTRON ACER TENDL-2023 LIBRARY; T=0.K  
Photon emission for (n,p)

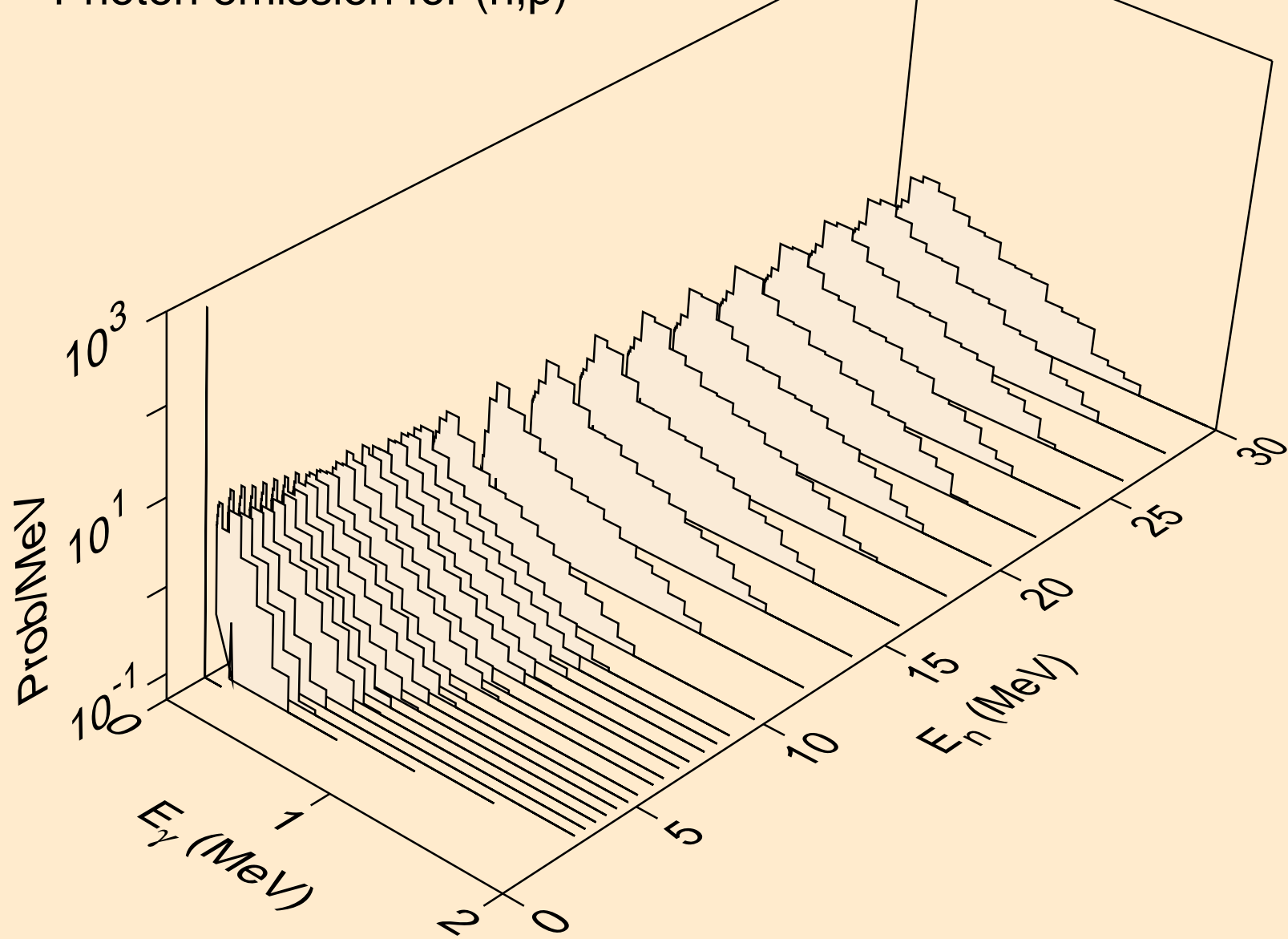

BH275 NEUTRON ACER TENDL-2023 LIBRARY; T=0.K  
Photon emission for (n,d)

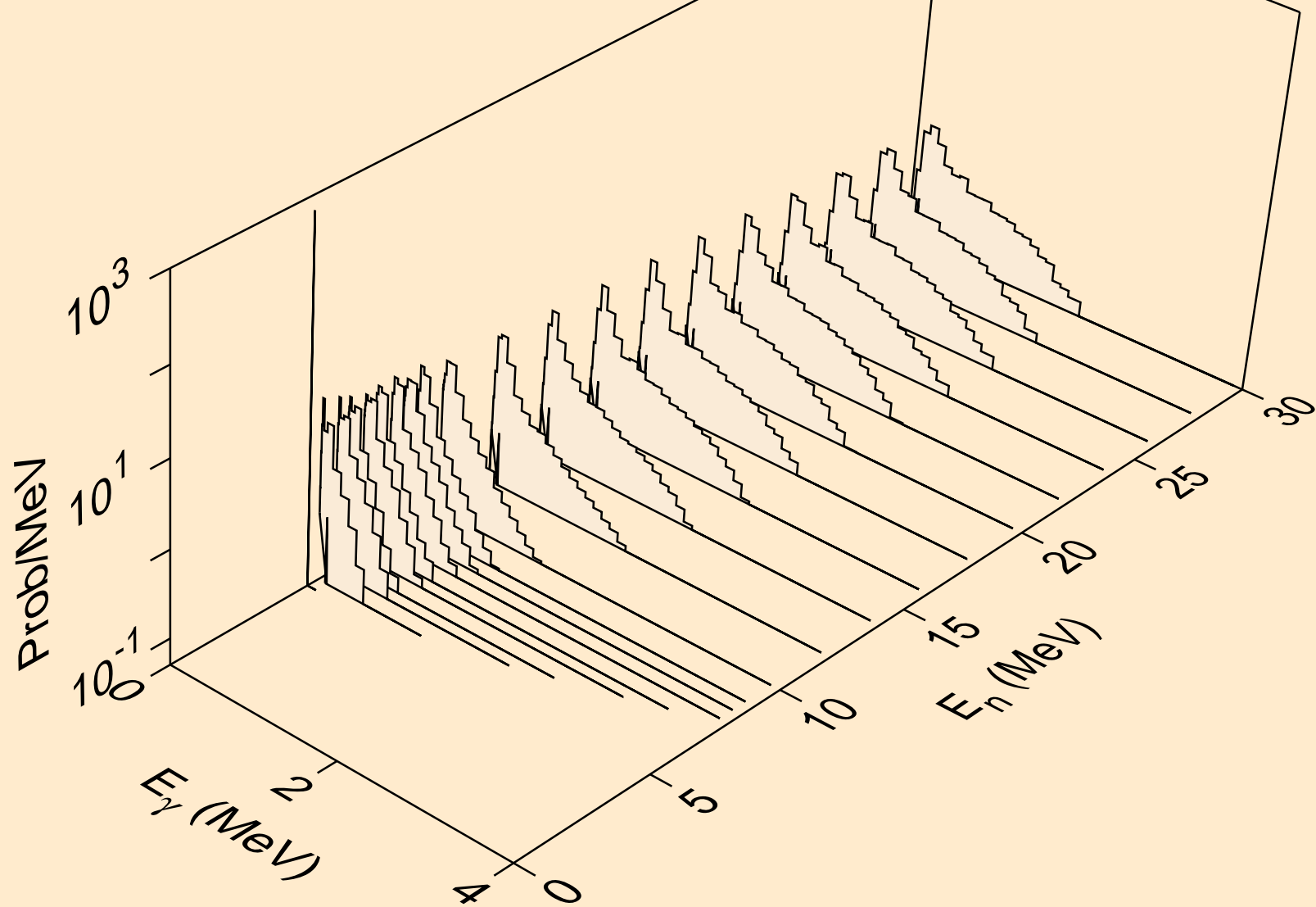



BH275 NEUTRON ACER TENDL-2023 LIBRARY; T=0.K  
Photon emission for (n,t)

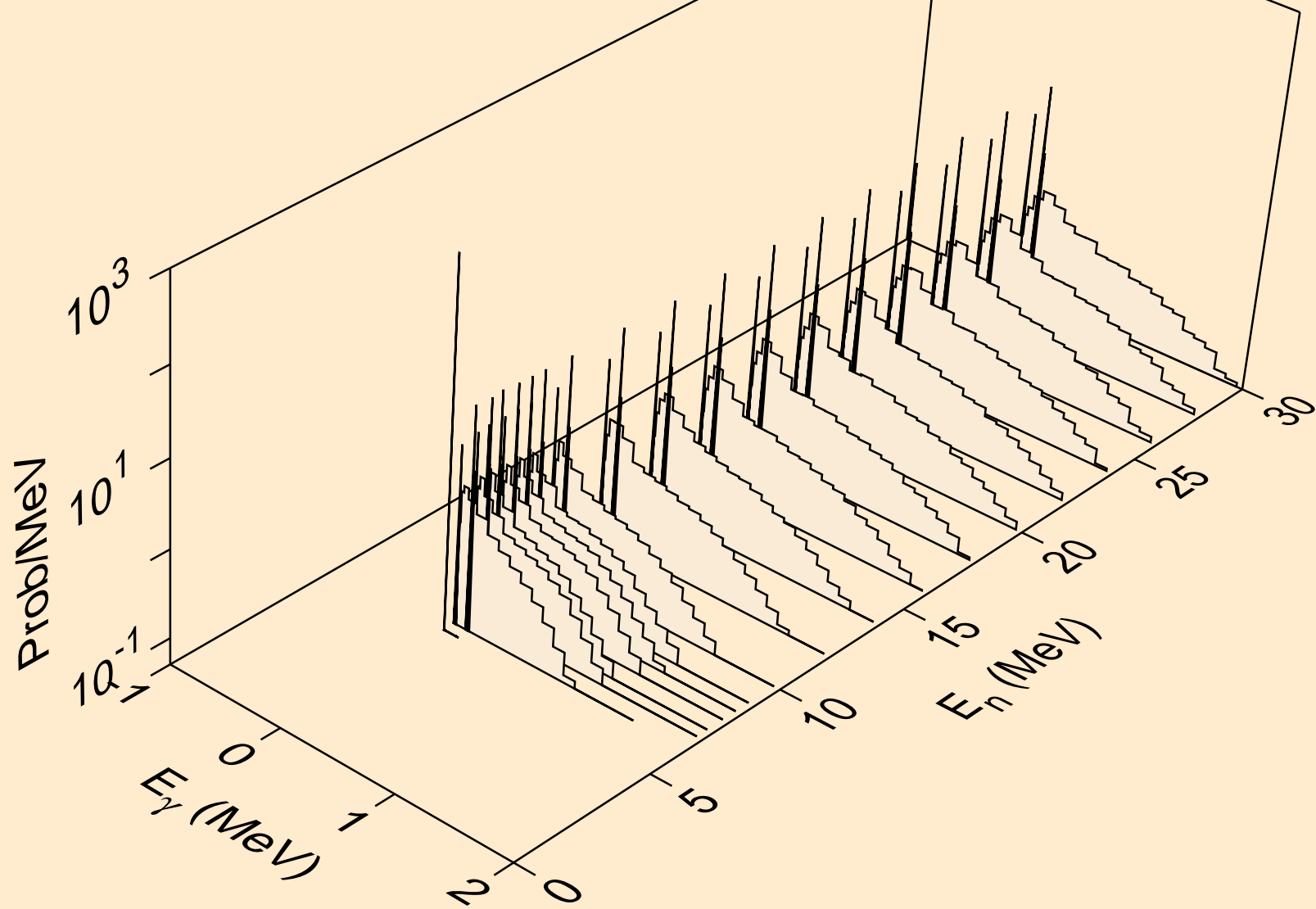

BH275 NEUTRON ACER TENDL-2023 LIBRARY; T=0.K  
Photon emission for (n,he3)

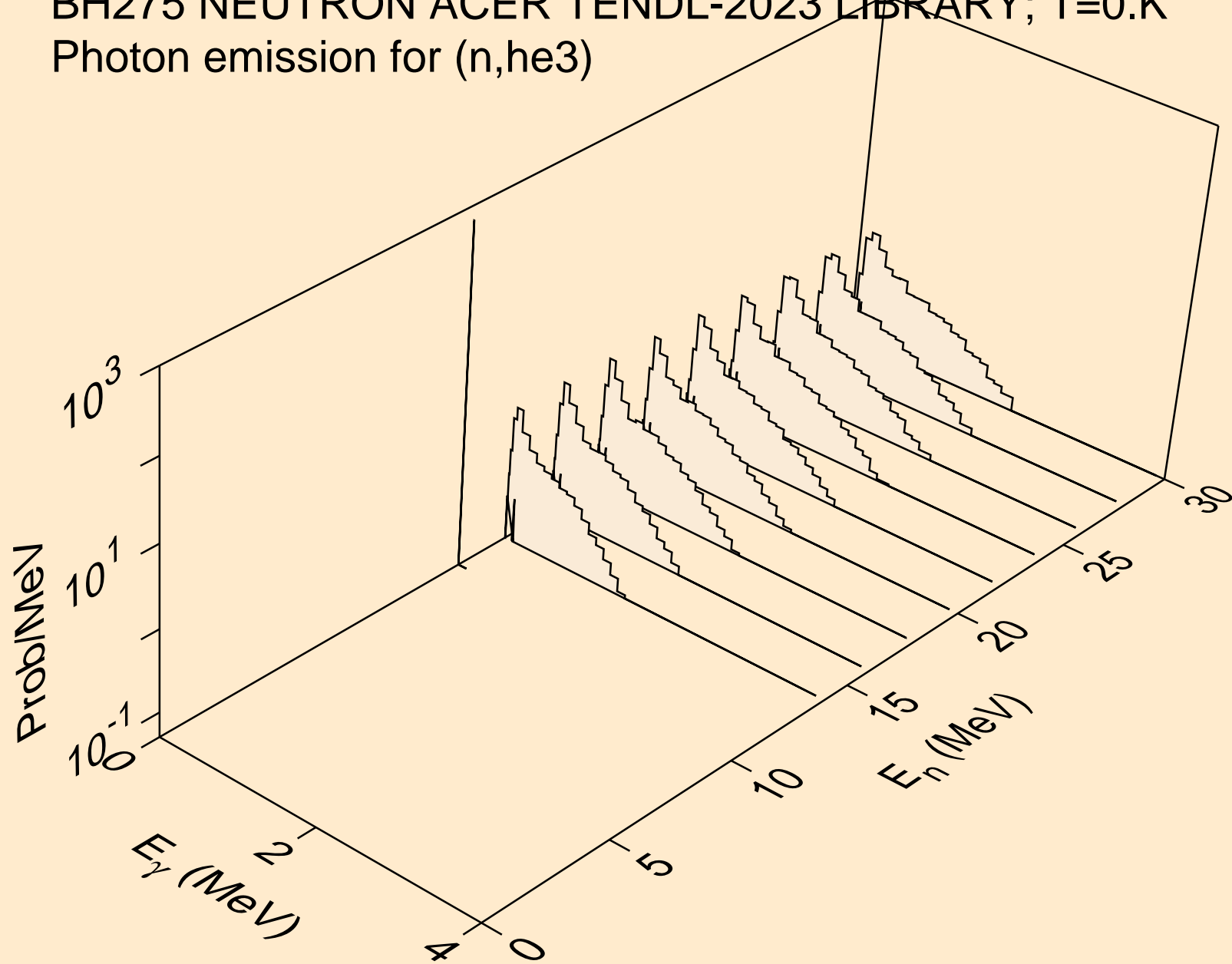

BH275 NEUTRON ACER TENDL-2023 LIBRARY; T=0.K  
Photon emission for (n,a)

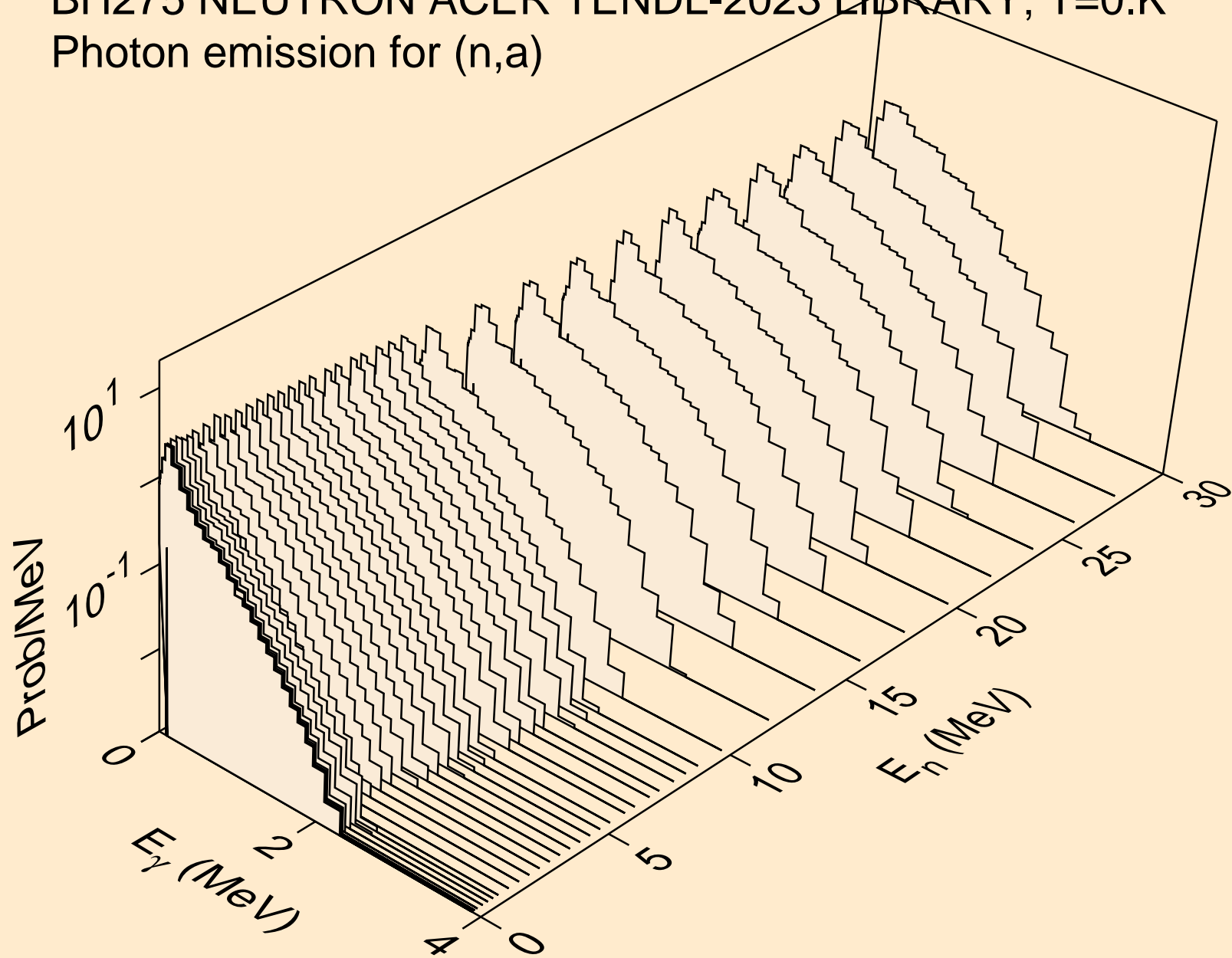

BH275 NEUTRON ACER TENDL-2023 LIBRARY; T=0.K  
Photon emission for (n,2p)

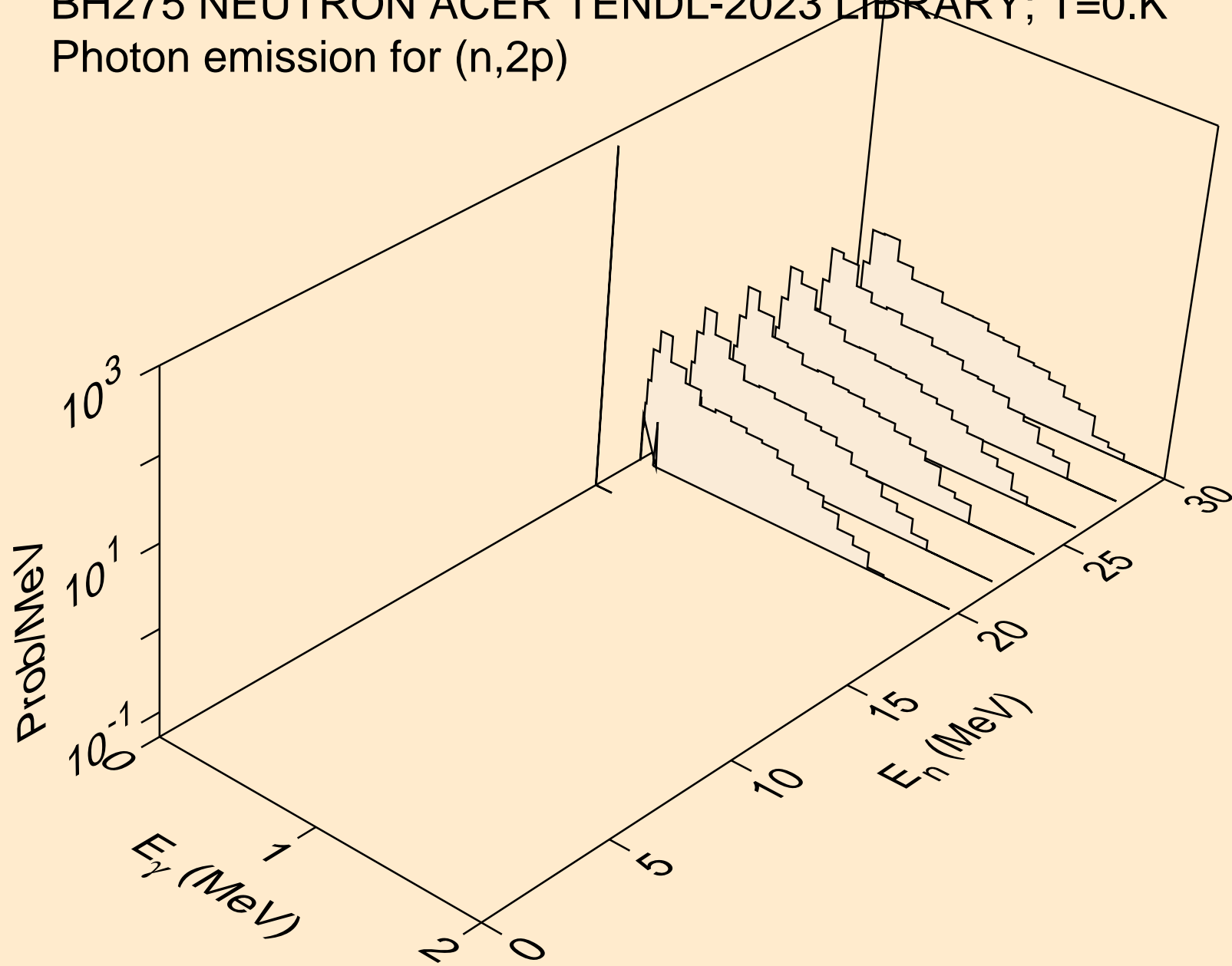

BH275 NEUTRON ACER TENDL-2023 LIBRARY; T=0.K  
thermal capture photon spectrum

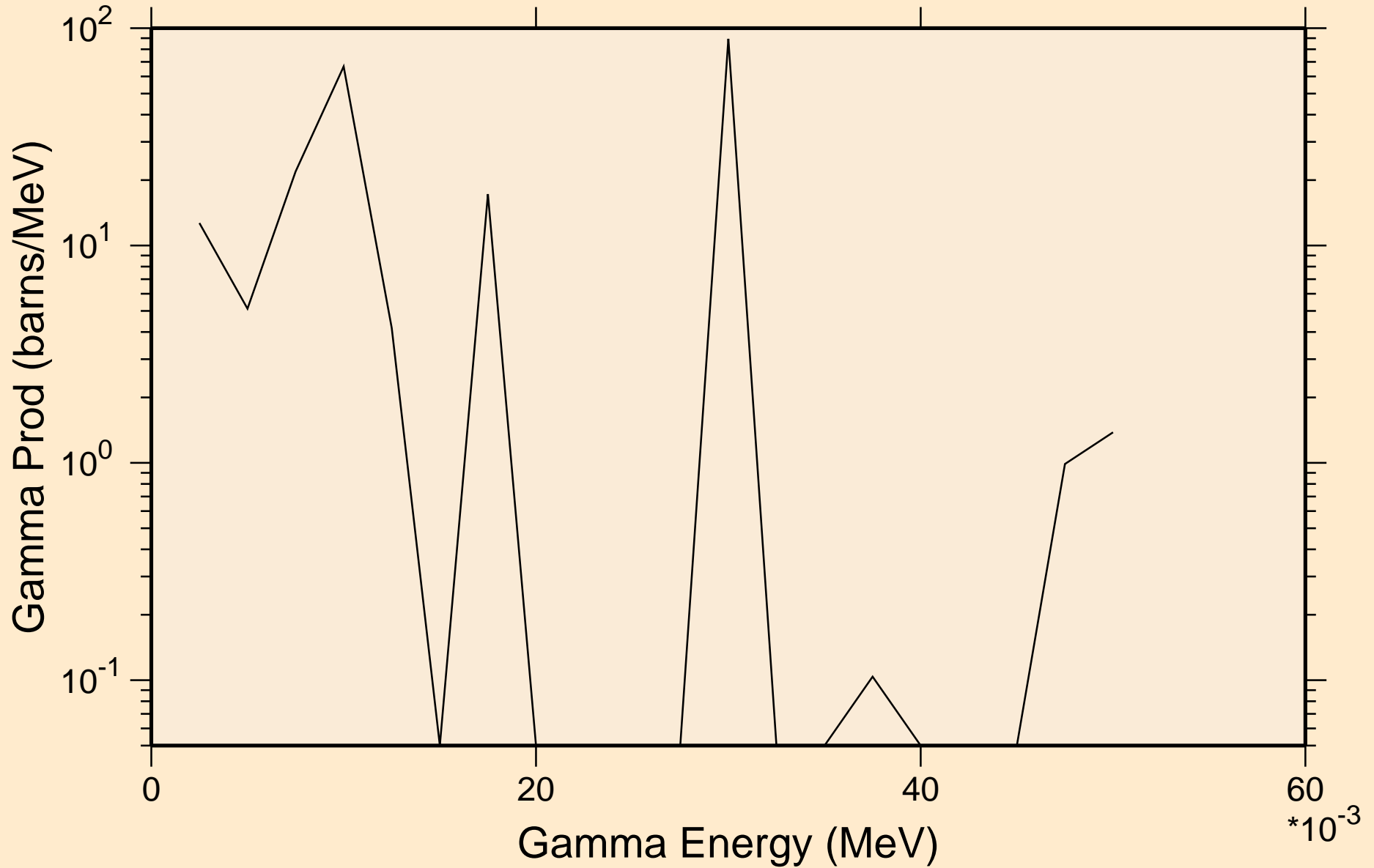

BH275 NEUTRON ACER TENDL-2023 LIBRARY; T=0.K  
14 MeV photon spectrum

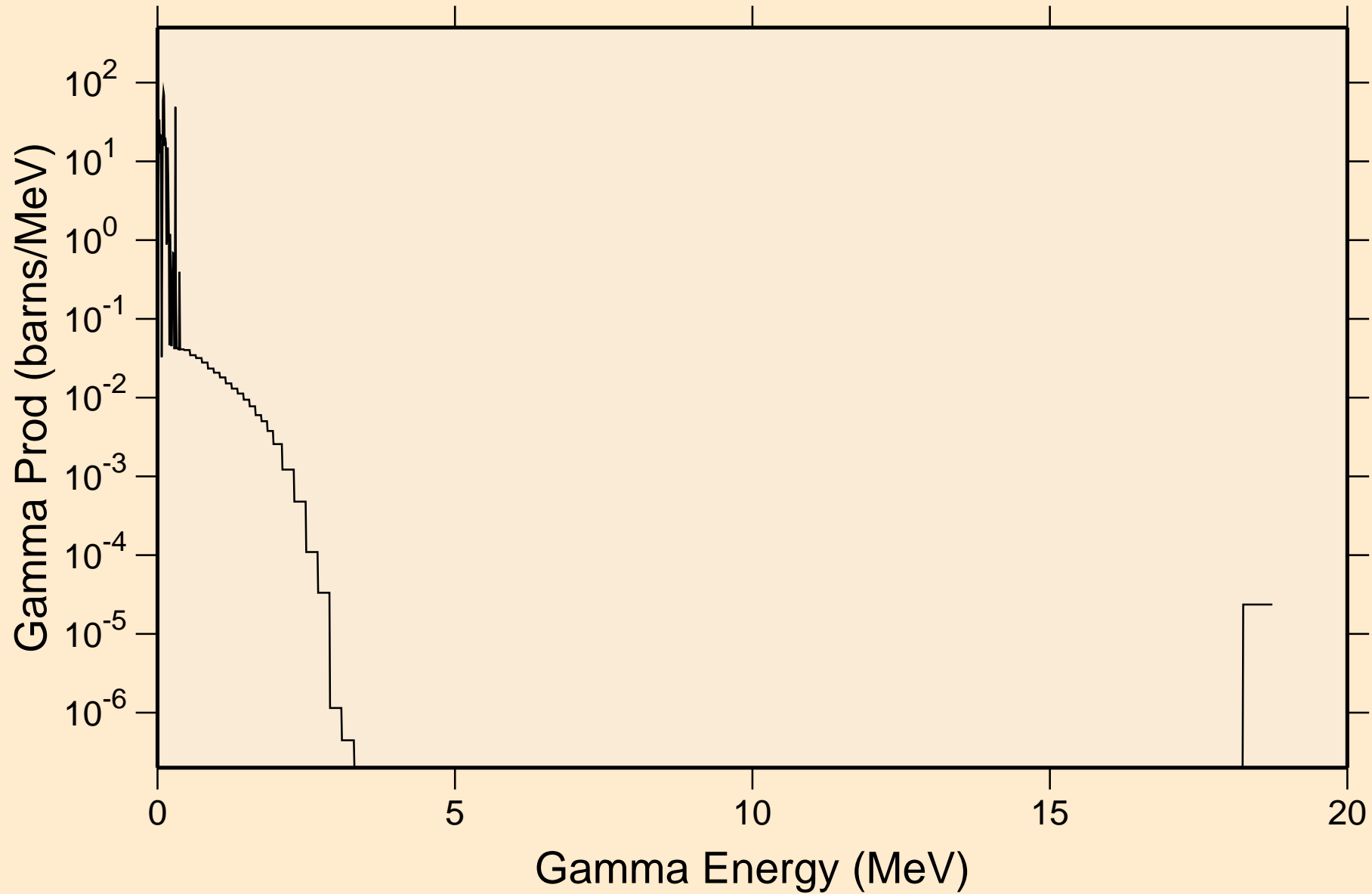

# BH275 NEUTRON ACER TENDL-2023 LIBRARY; T=0.K

## Particle heating contributions

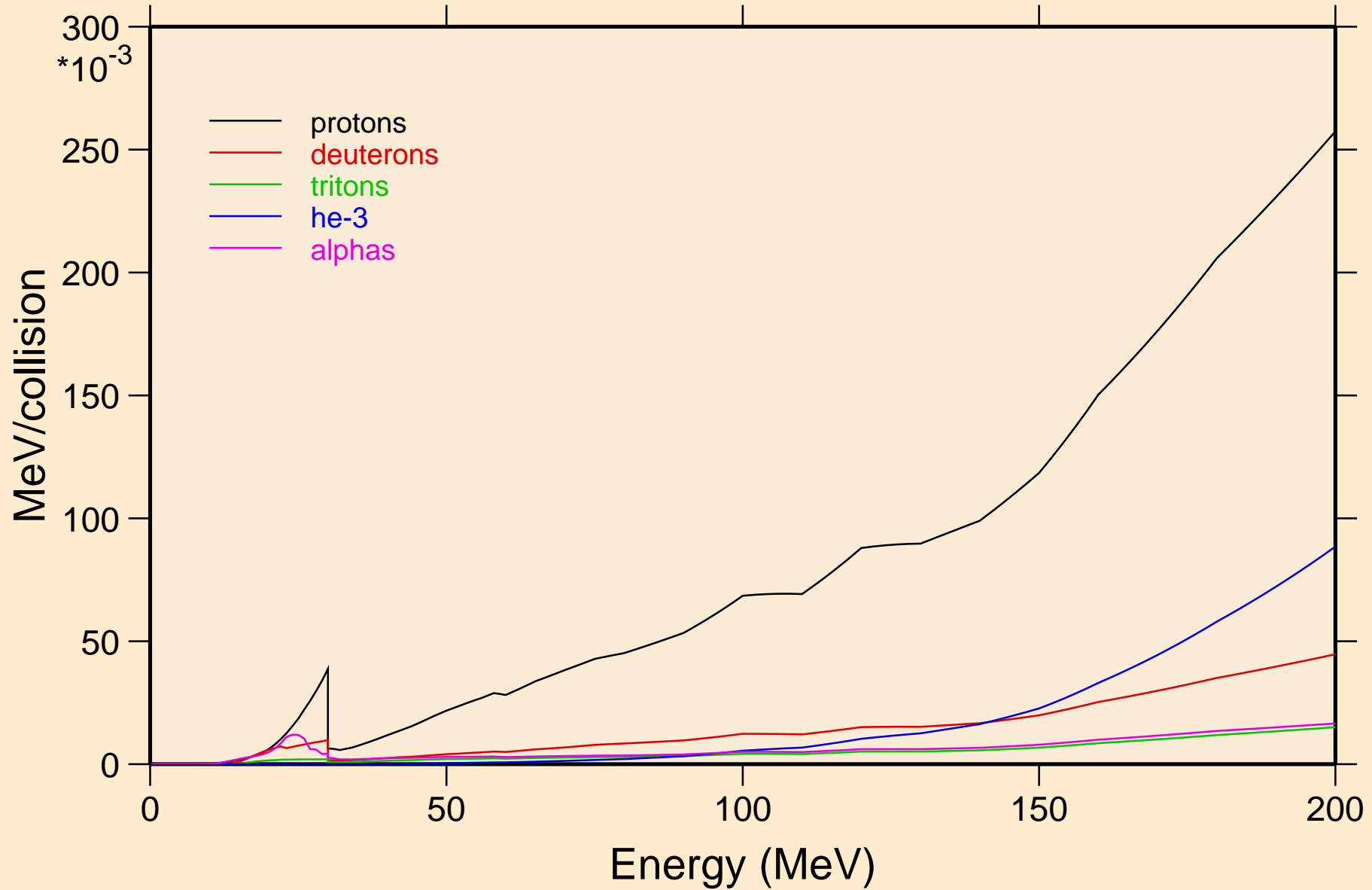

# BH275 NEUTRON ACER TENDL-2023 LIBRARY; T=0.K

## Recoil Heating

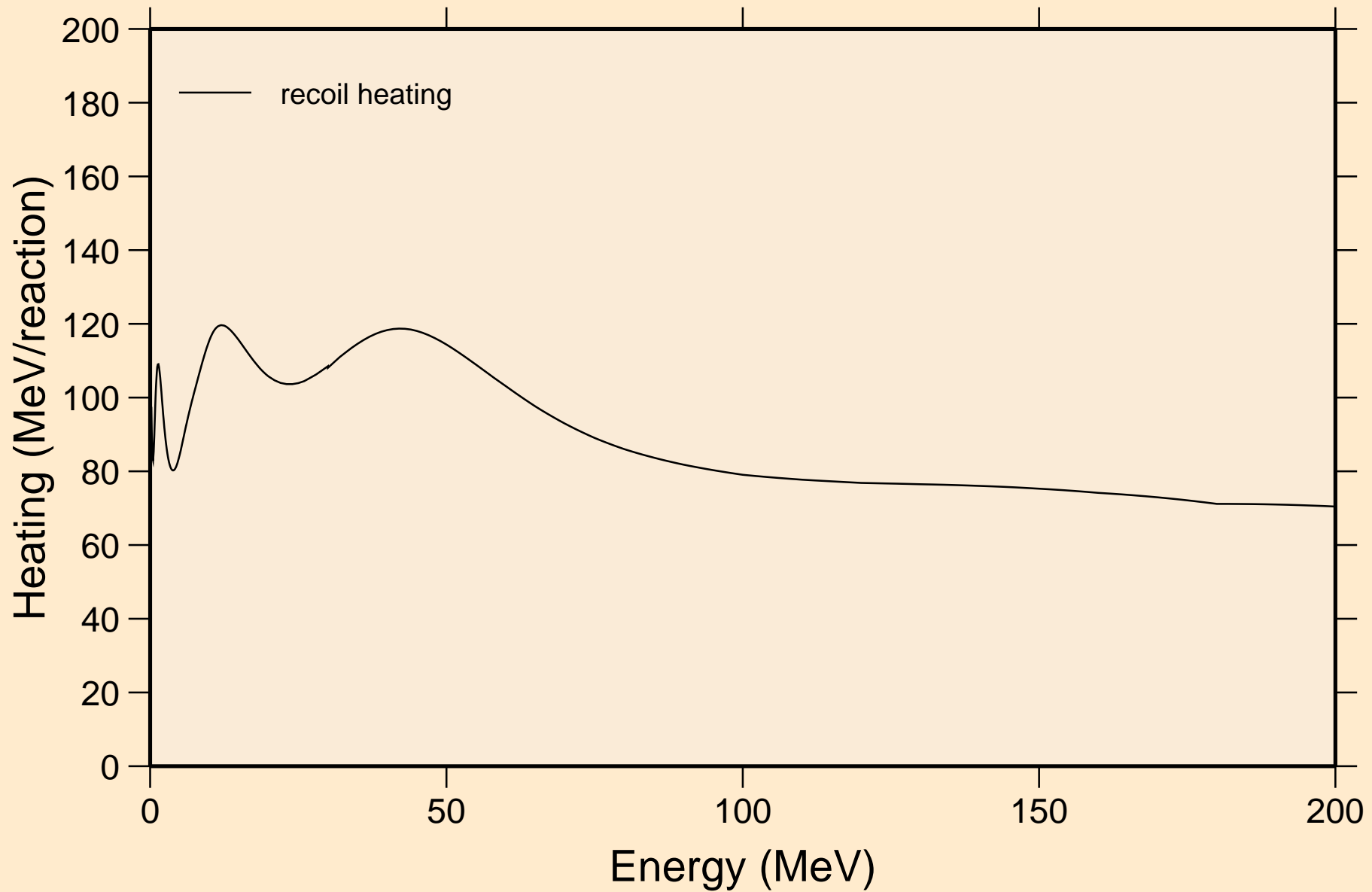



# BH275 NEUTRON ACER TENDL-2023 LIBRARY; T=0.K

## Particle production cross sections

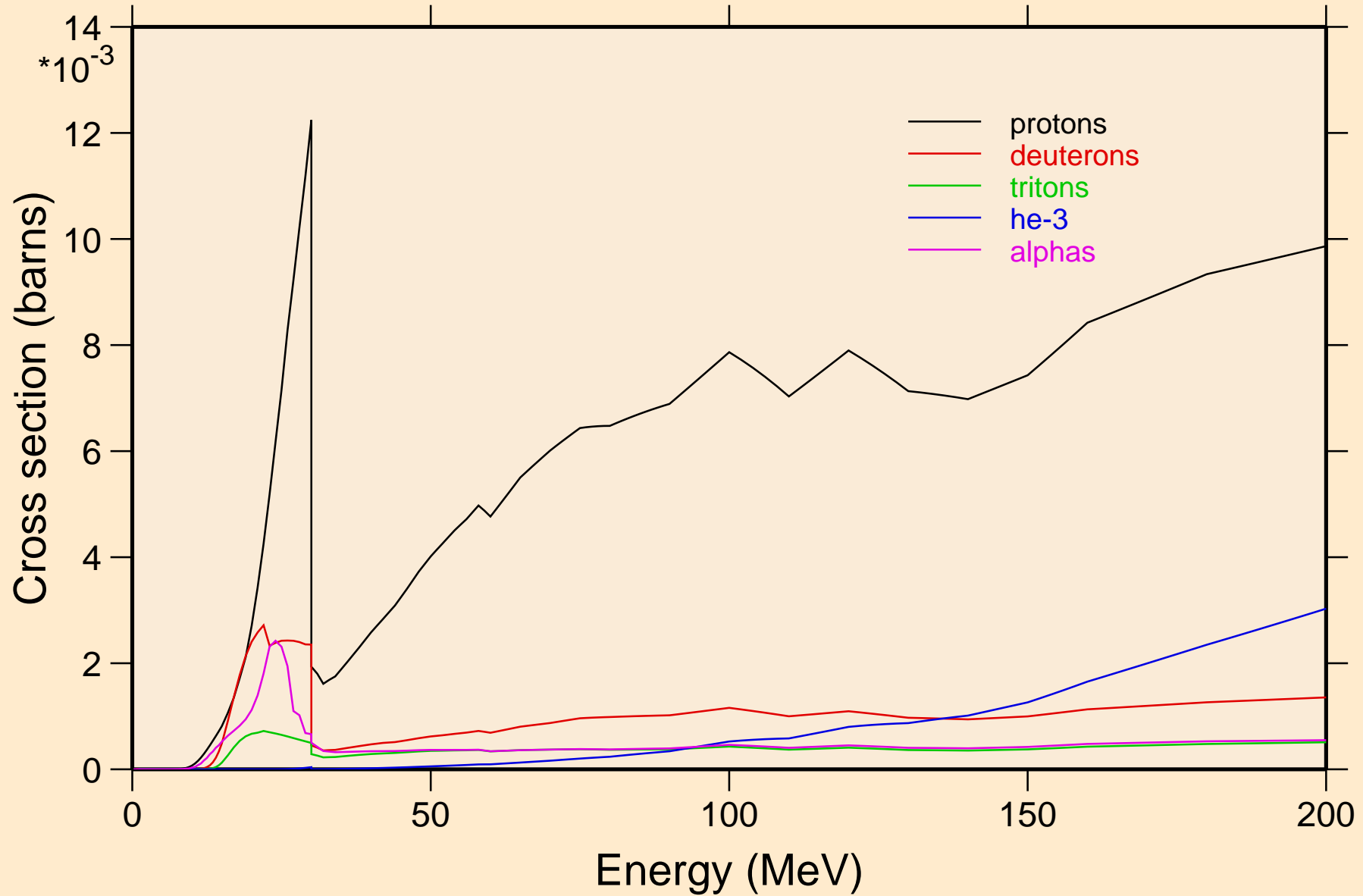

BH275 NEUTRON ACER TENDL-2023 LIBRARY; T=0.K  
protons from (n,x)

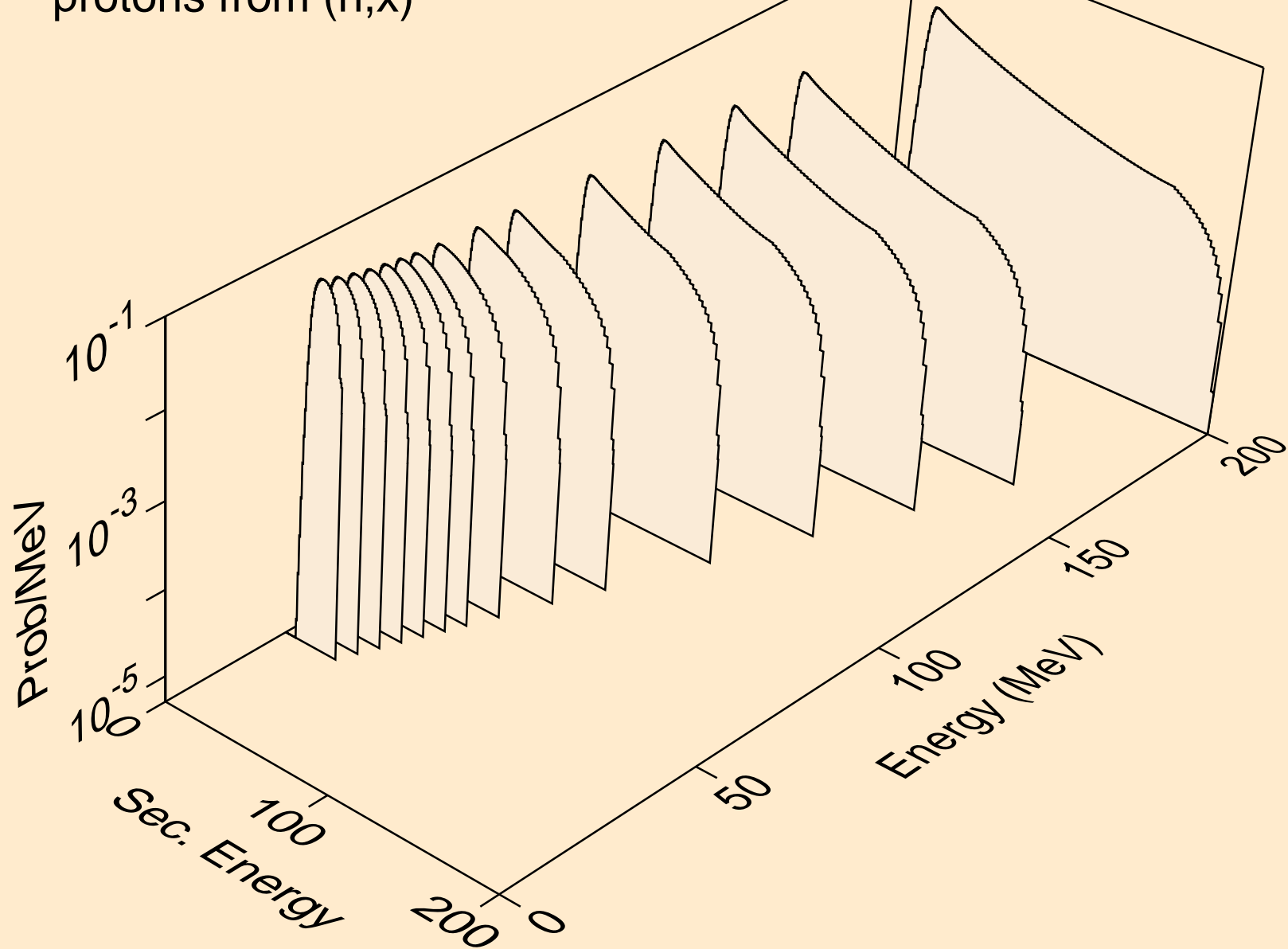

BH275 NEUTRON ACER TENDL-2023 LIBRARY; T=0.K  
protons from (n,n\*)p

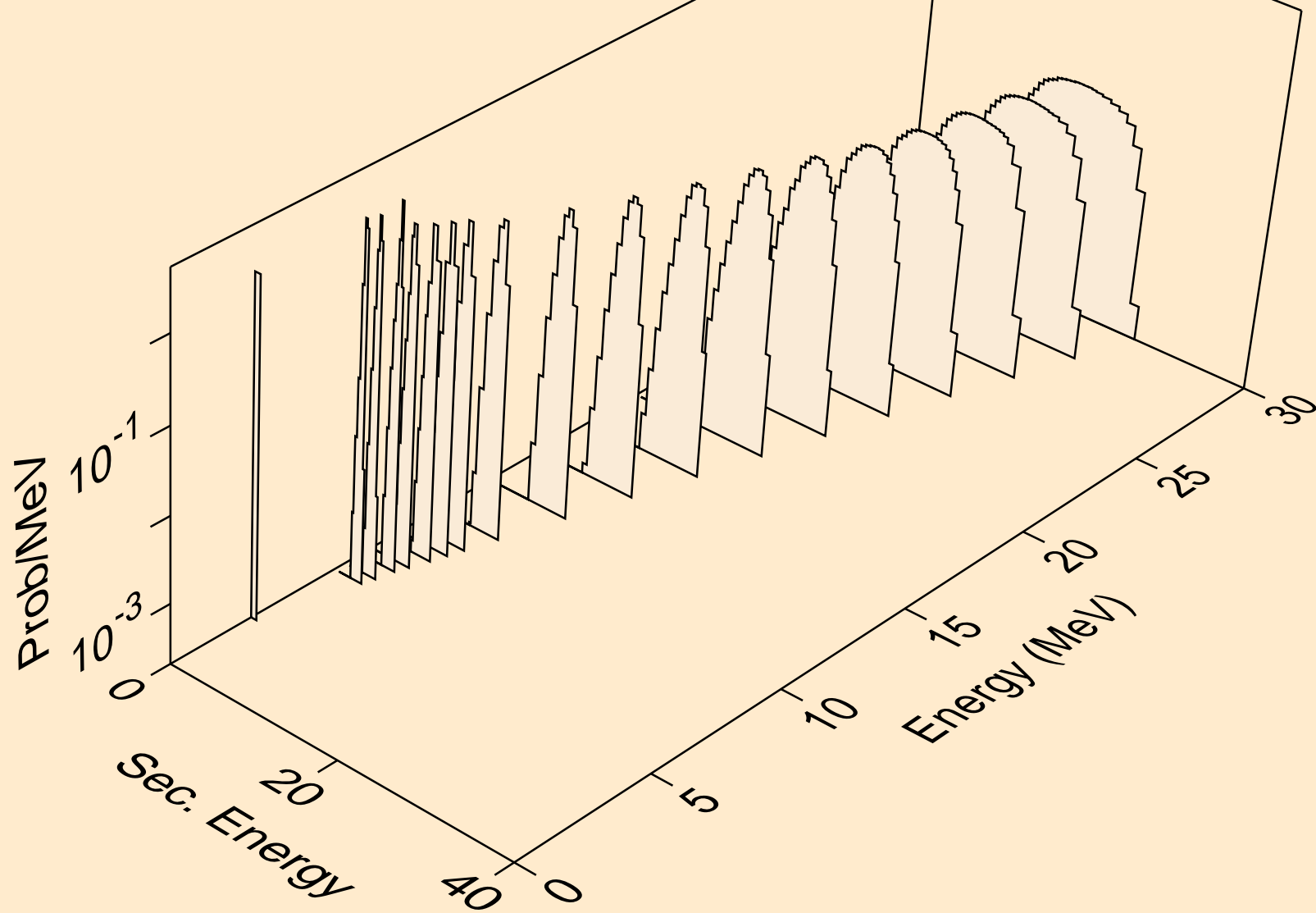

BH275 NEUTRON ACER TENDL-2023 LIBRARY; T=0.K  
protons from (n,2np)

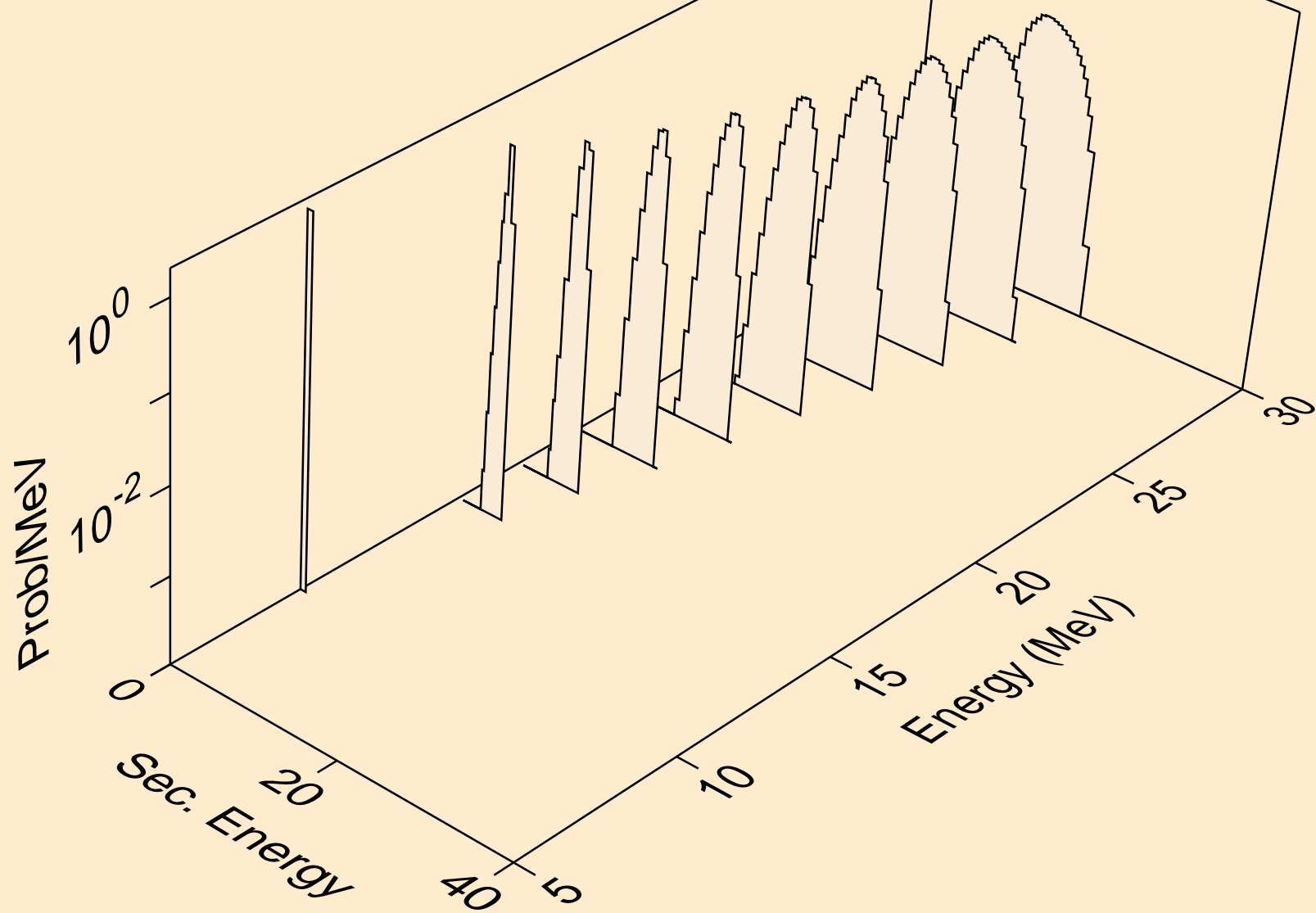

BH275 NEUTRON ACER TENDL-2023 LIBRARY; T=0.K  
protons from (n,3np)

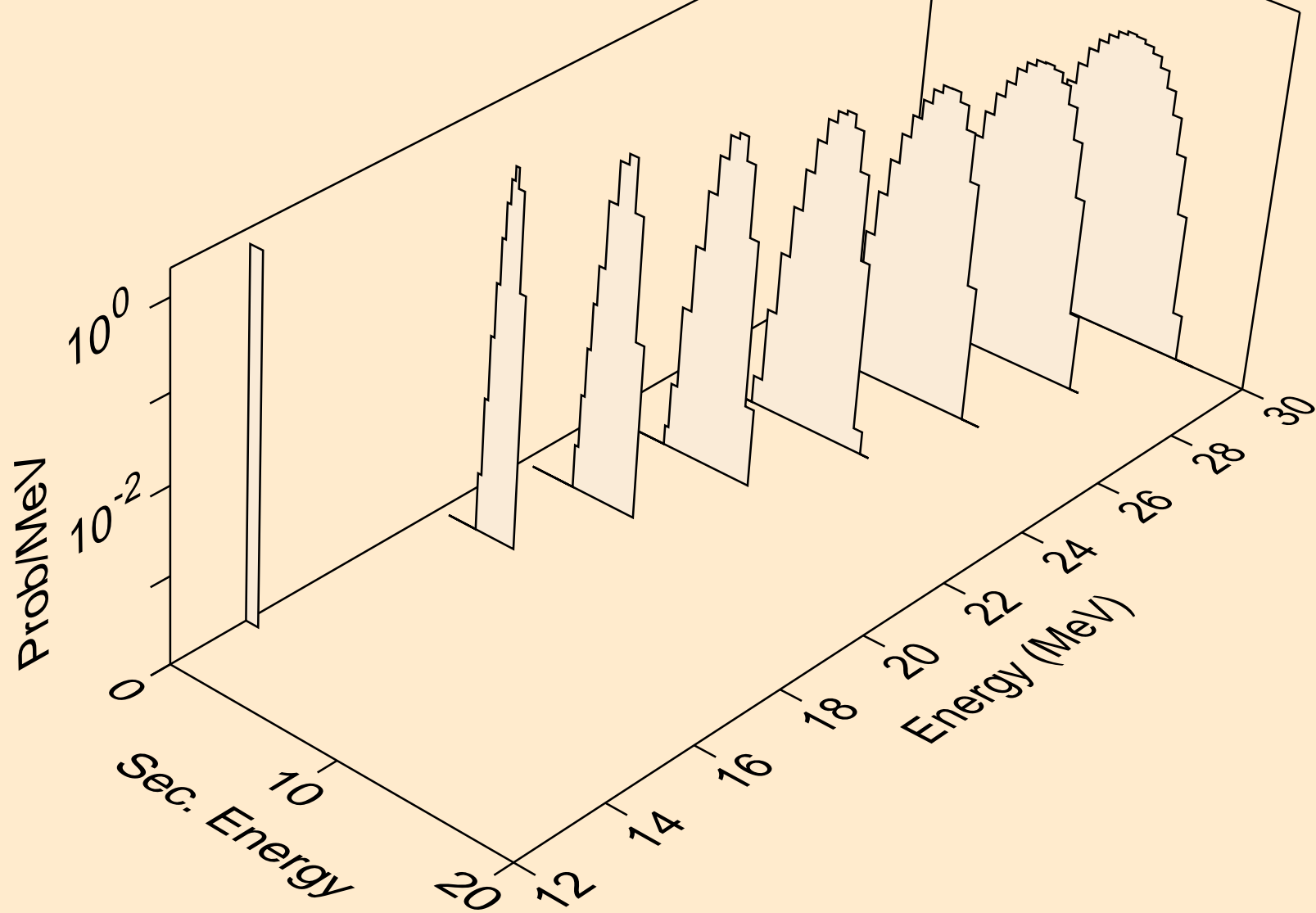

BH275 NEUTRON ACER TENDL-2023 LIBRARY; T=0.K  
protons from (n,p)

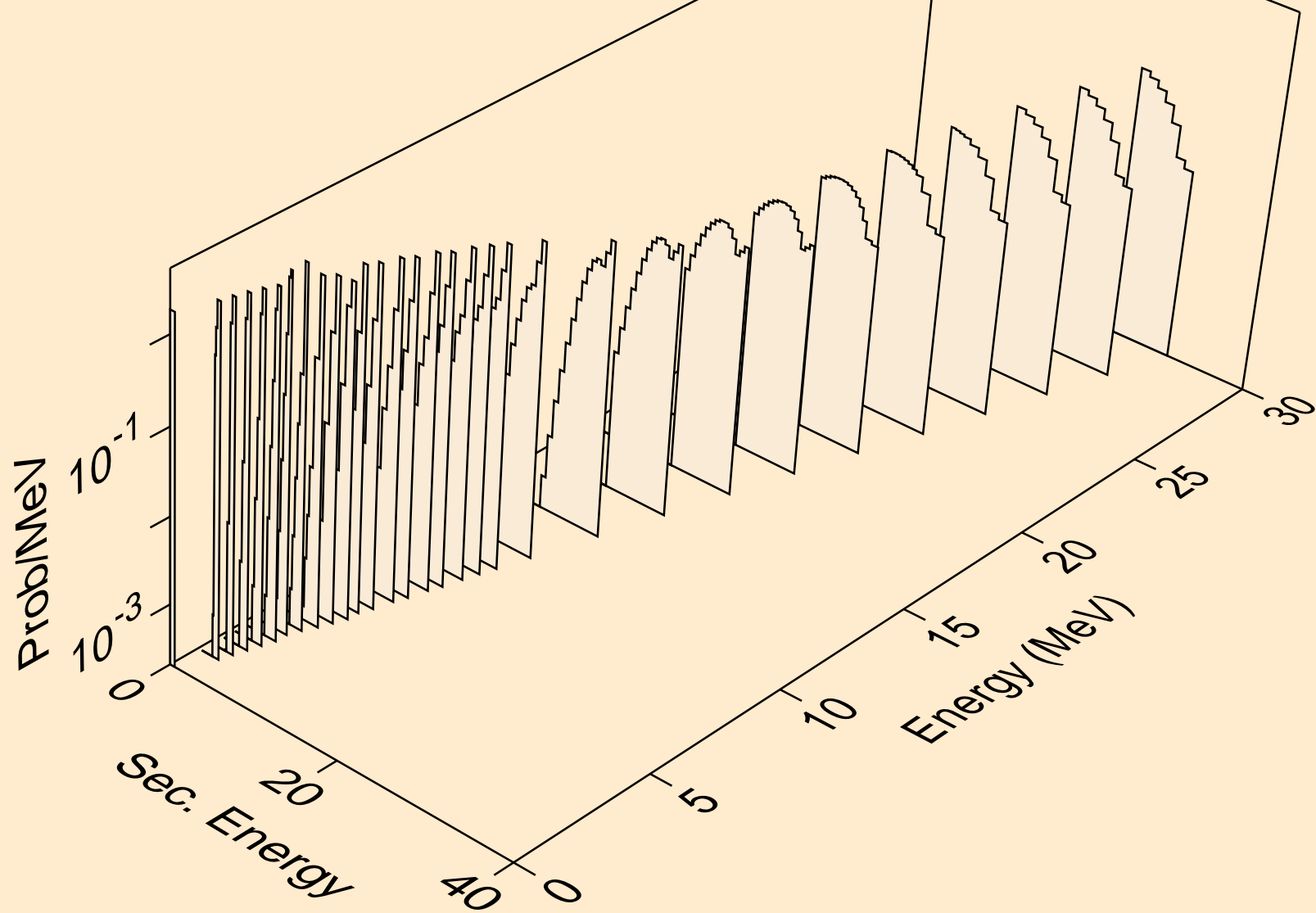

BH275 NEUTRON ACER TENDL-2023 LIBRARY; T=0.K  
protons from (n,2p)

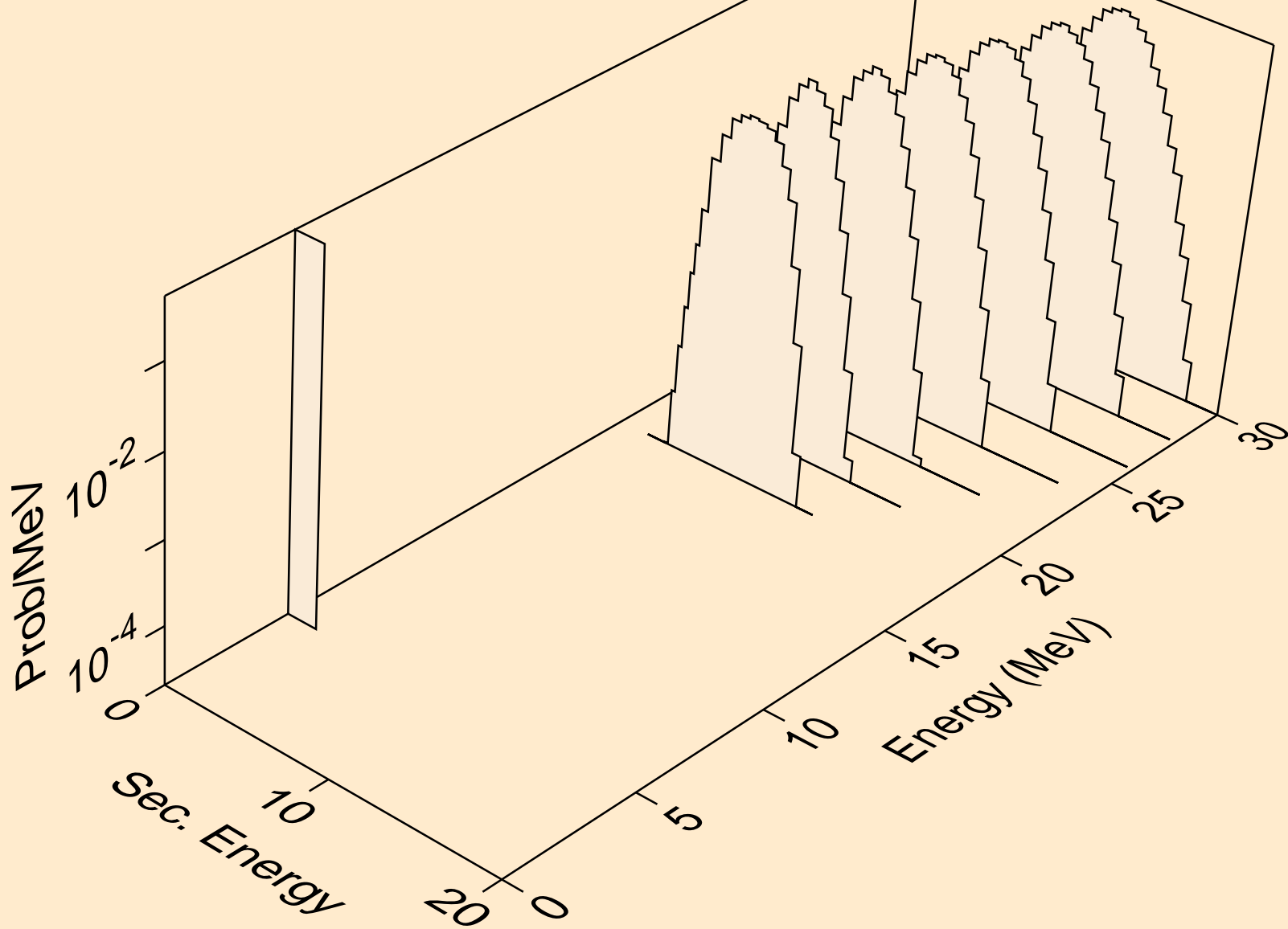

BH275 NEUTRON ACER TENDL-2023 LIBRARY; T=0.K  
deuterons from (n,x)

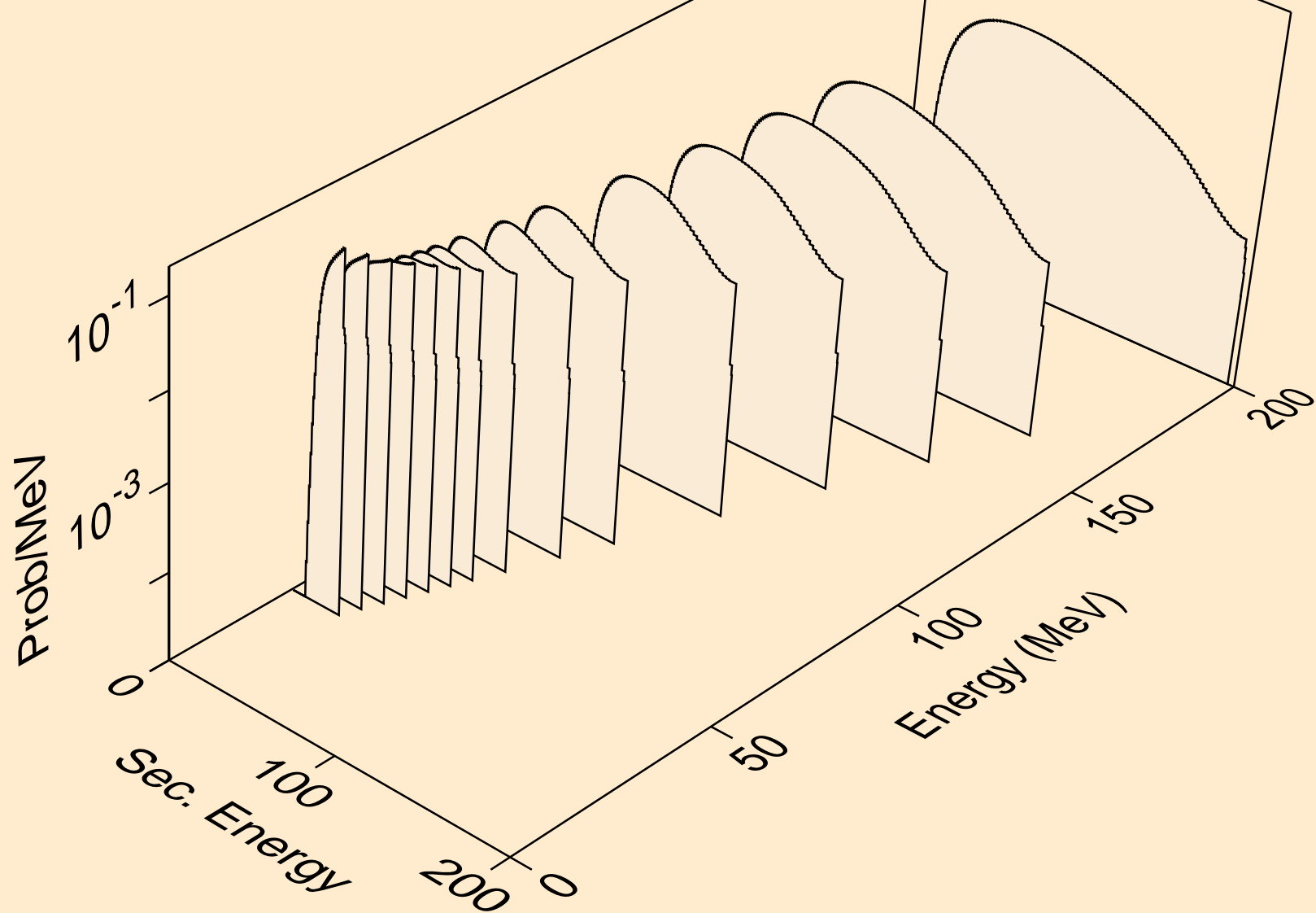



BH275 NEUTRON ACER TENDL-2023 LIBRARY; T=0.K  
deuterons from (n,2nd)

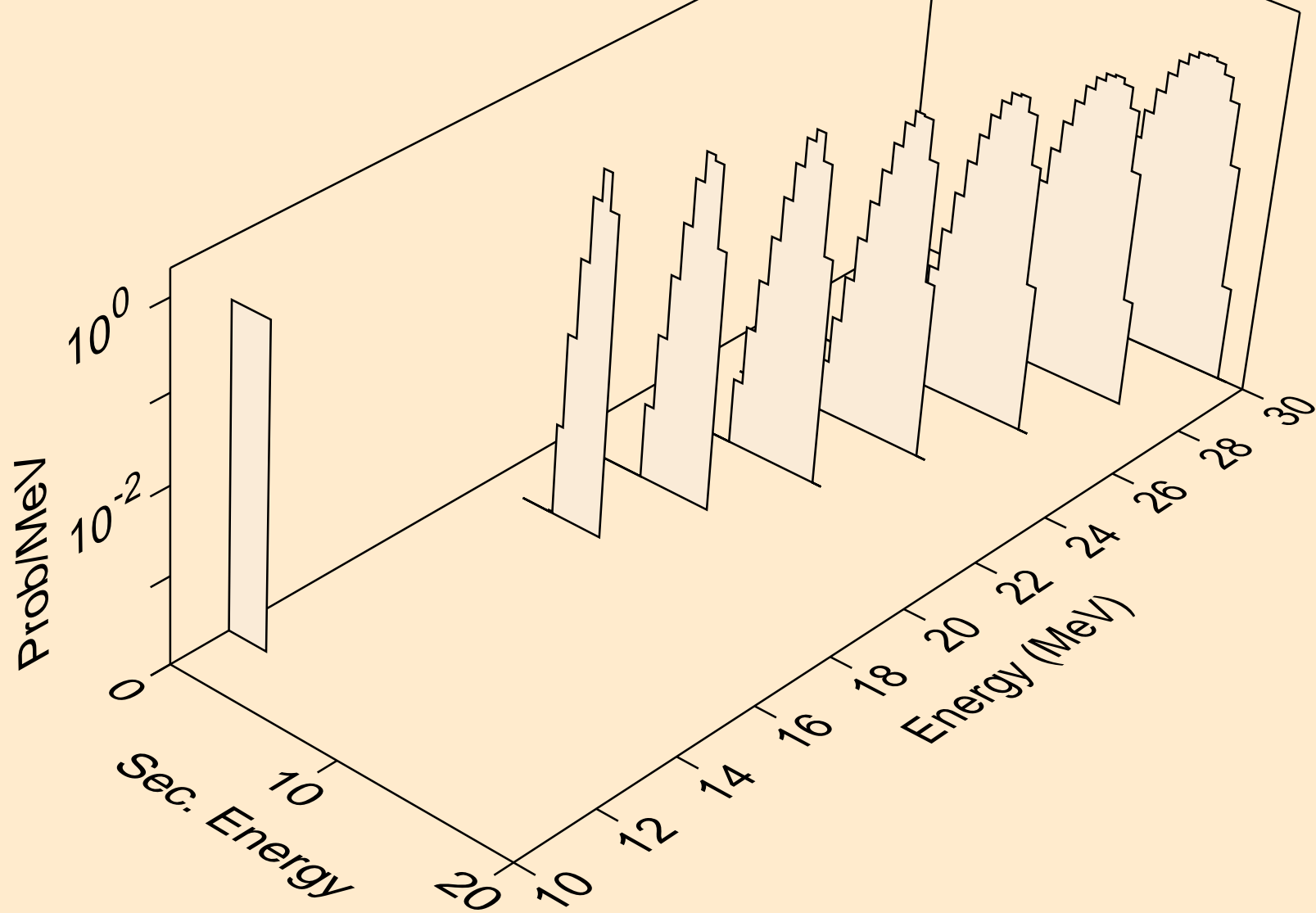

BH275 NEUTRON ACER TENDL-2023 LIBRARY; T=0.K  
deuterons from (n,n\*)d

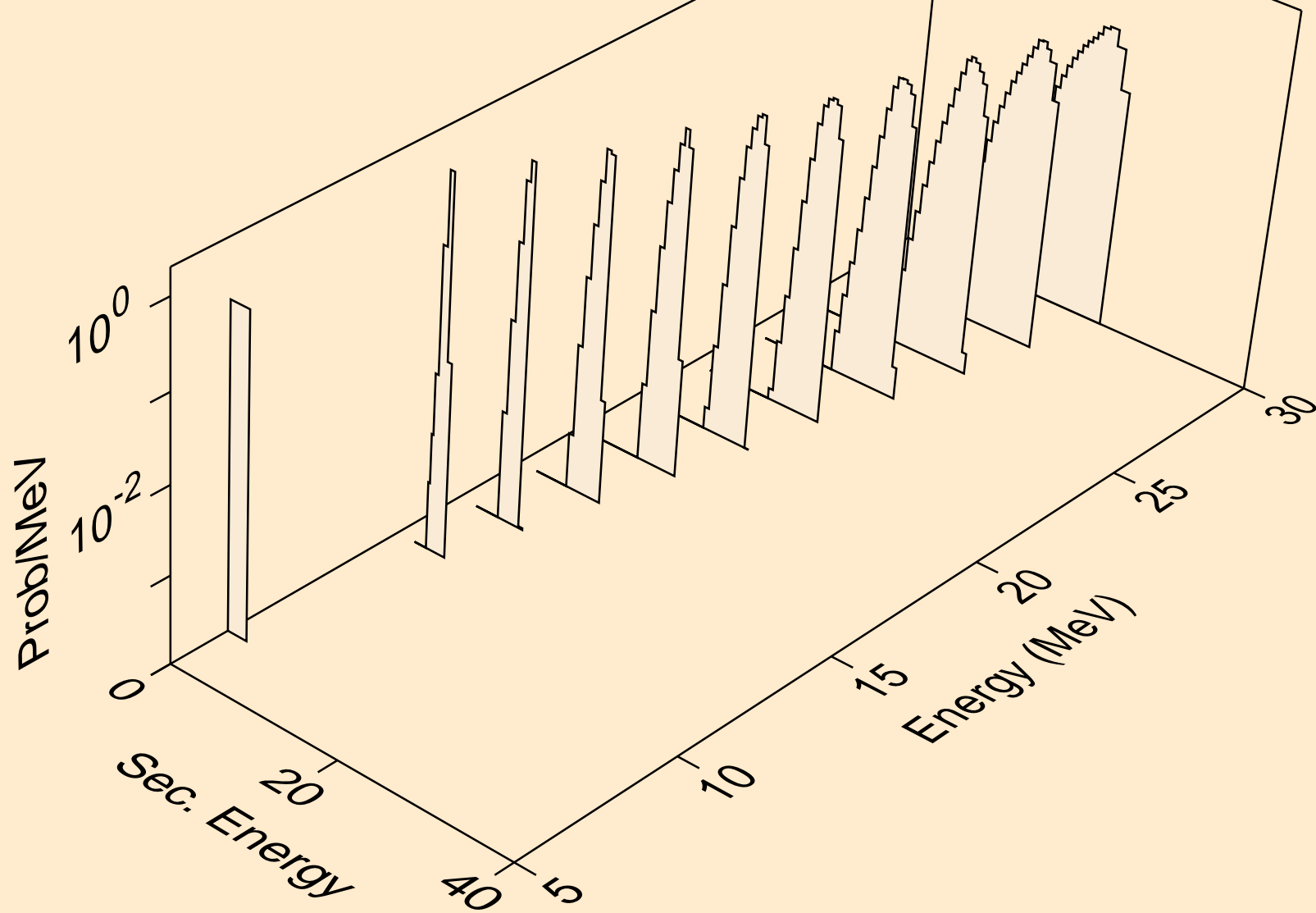

BH275 NEUTRON ACER TENDL-2023 LIBRARY; T=0.K  
deuterons from (n,d)

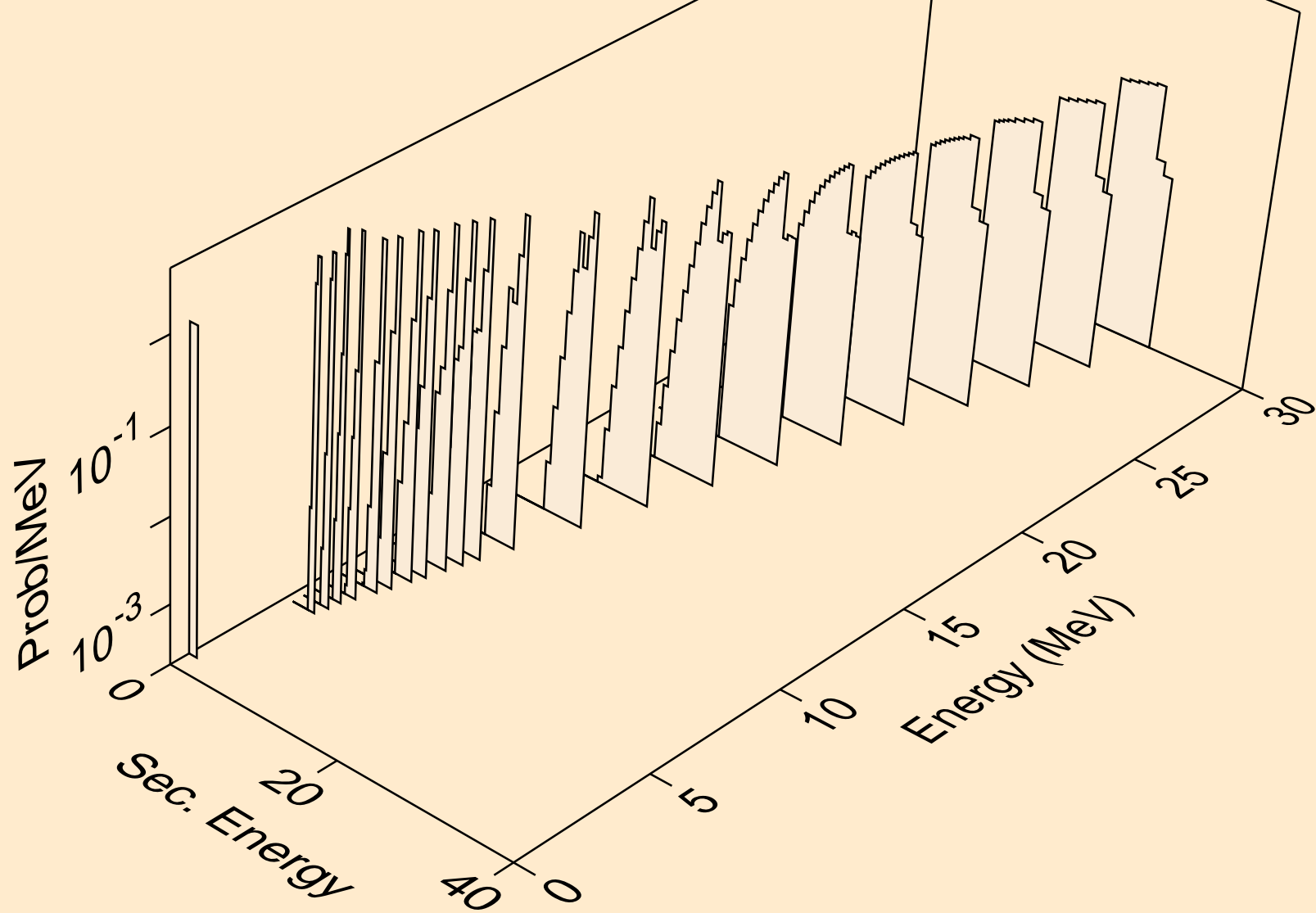

BH275 NEUTRON ACER TENDL-2023 LIBRARY; T=0.K  
tritons from (n,x)

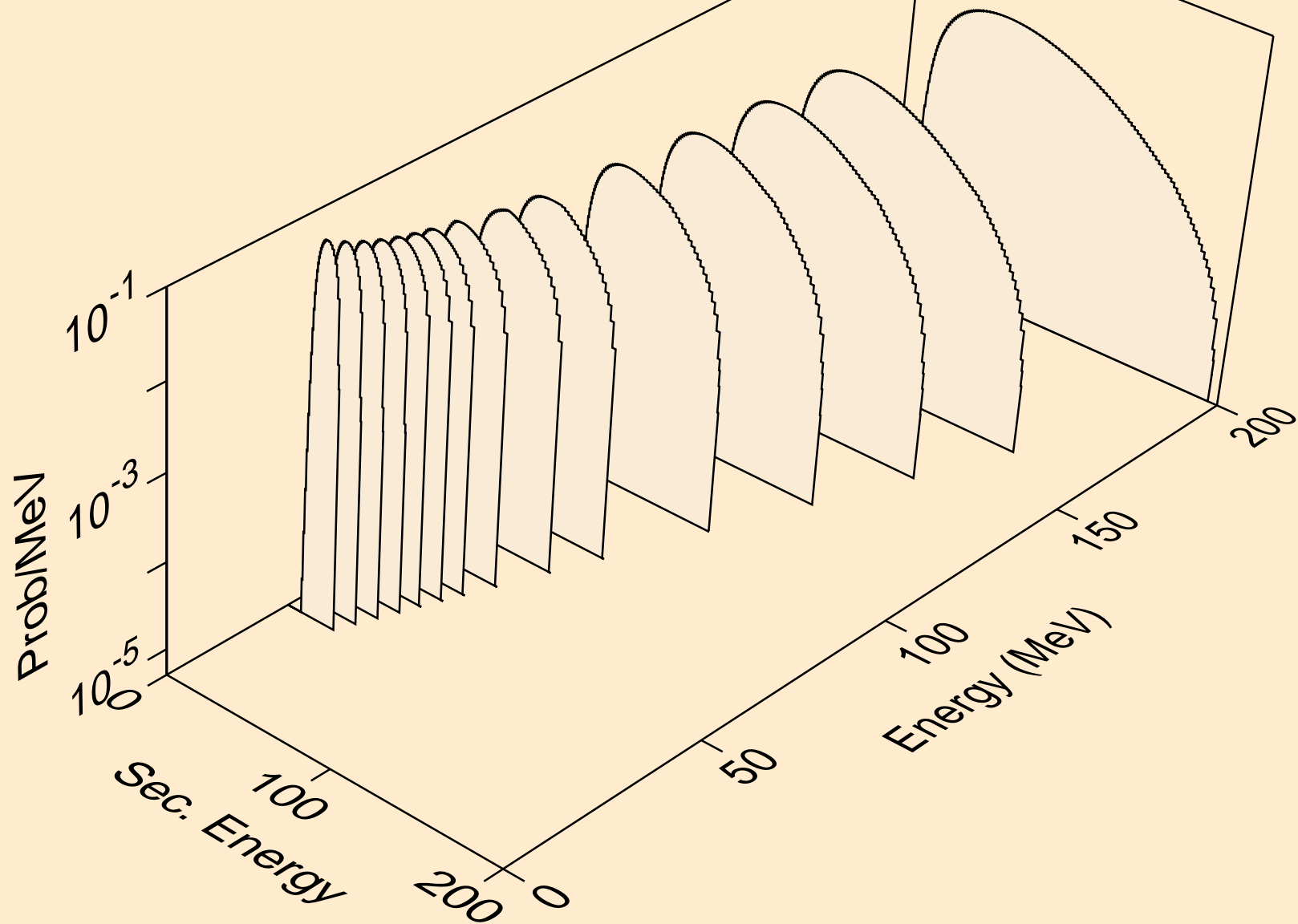

BH275 NEUTRON ACER TENDL-2023 LIBRARY; T=0.K  
tritons from (n,n\*)t

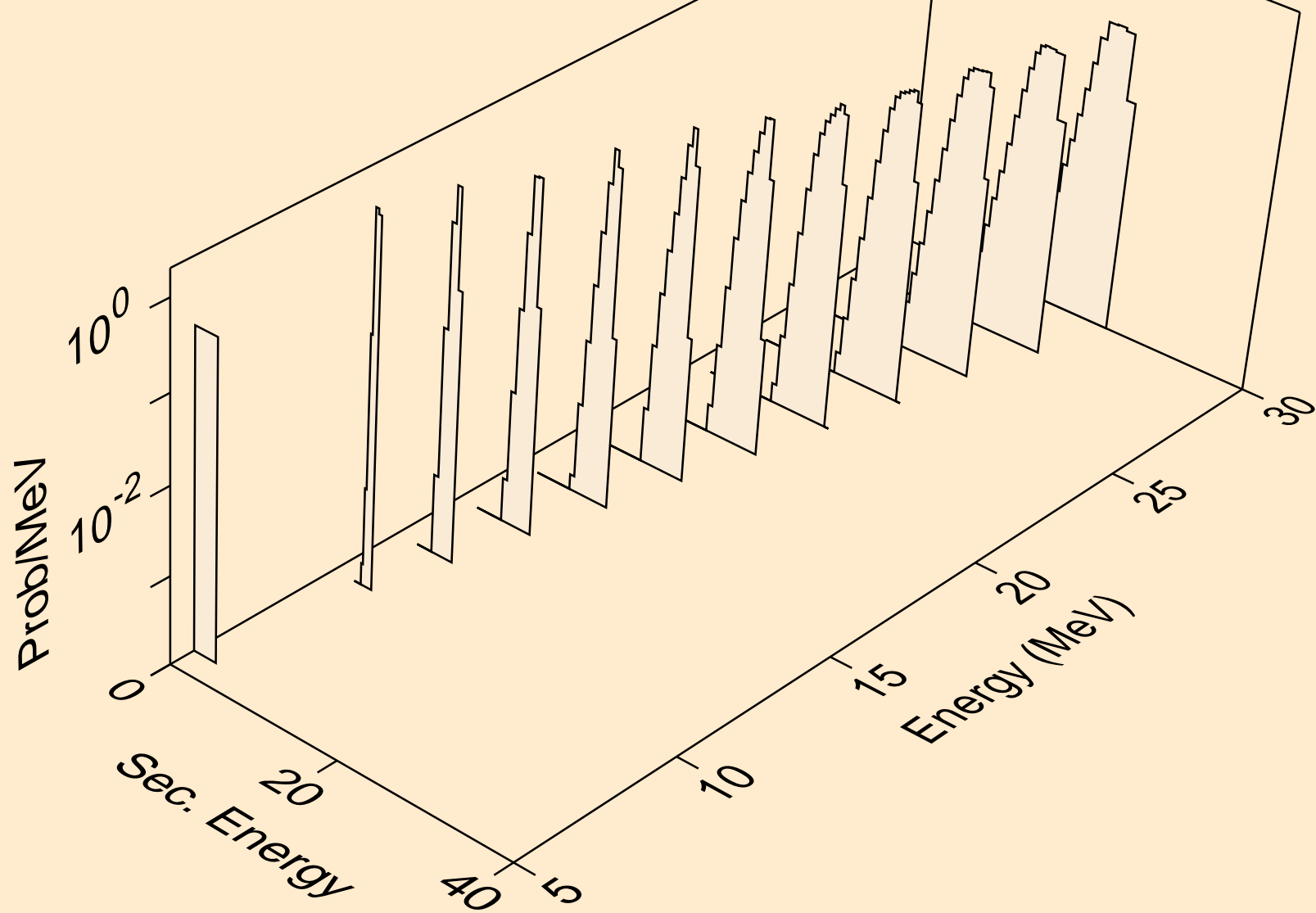

BH275 NEUTRON ACER TENDL-2023 LIBRARY; T=0.K  
tritons from (n,t)

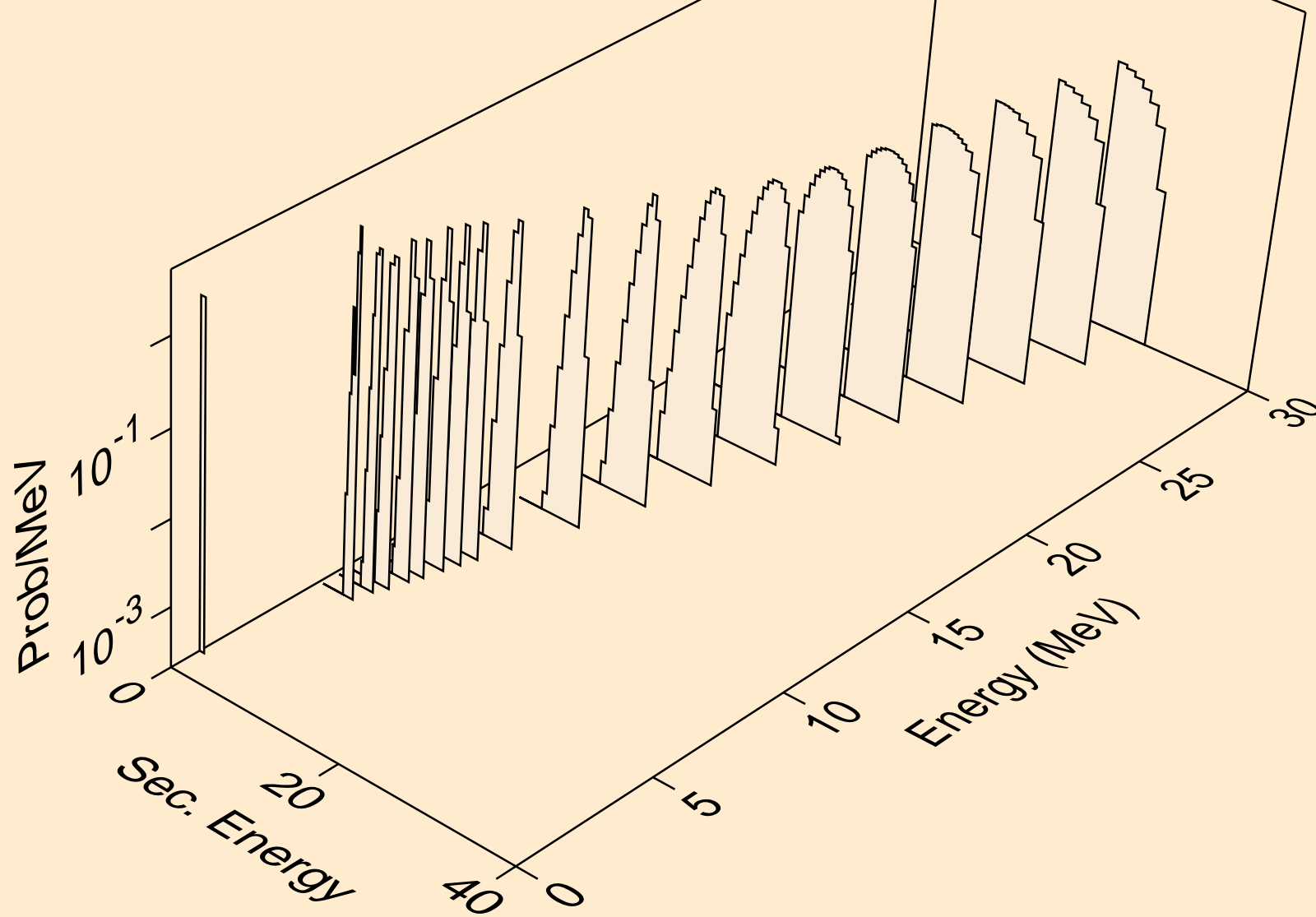

BH275 NEUTRON ACER TENDL-2023 LIBRARY; T=0.K  
he3s from (n,x)

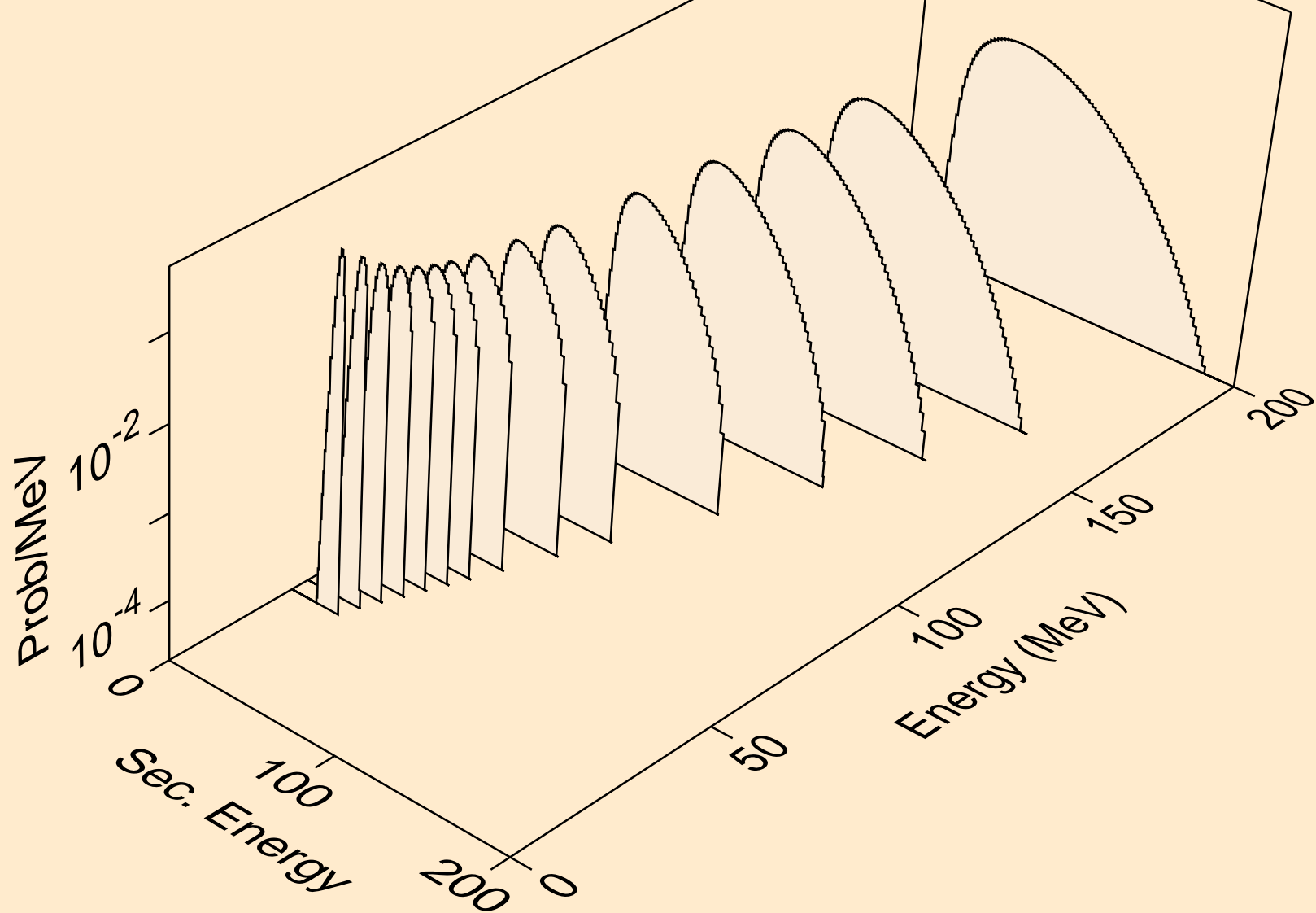

BH275 NEUTRON ACER TENDL-2023 LIBRARY; T=0.K  
he3s from (n,n\*)he3

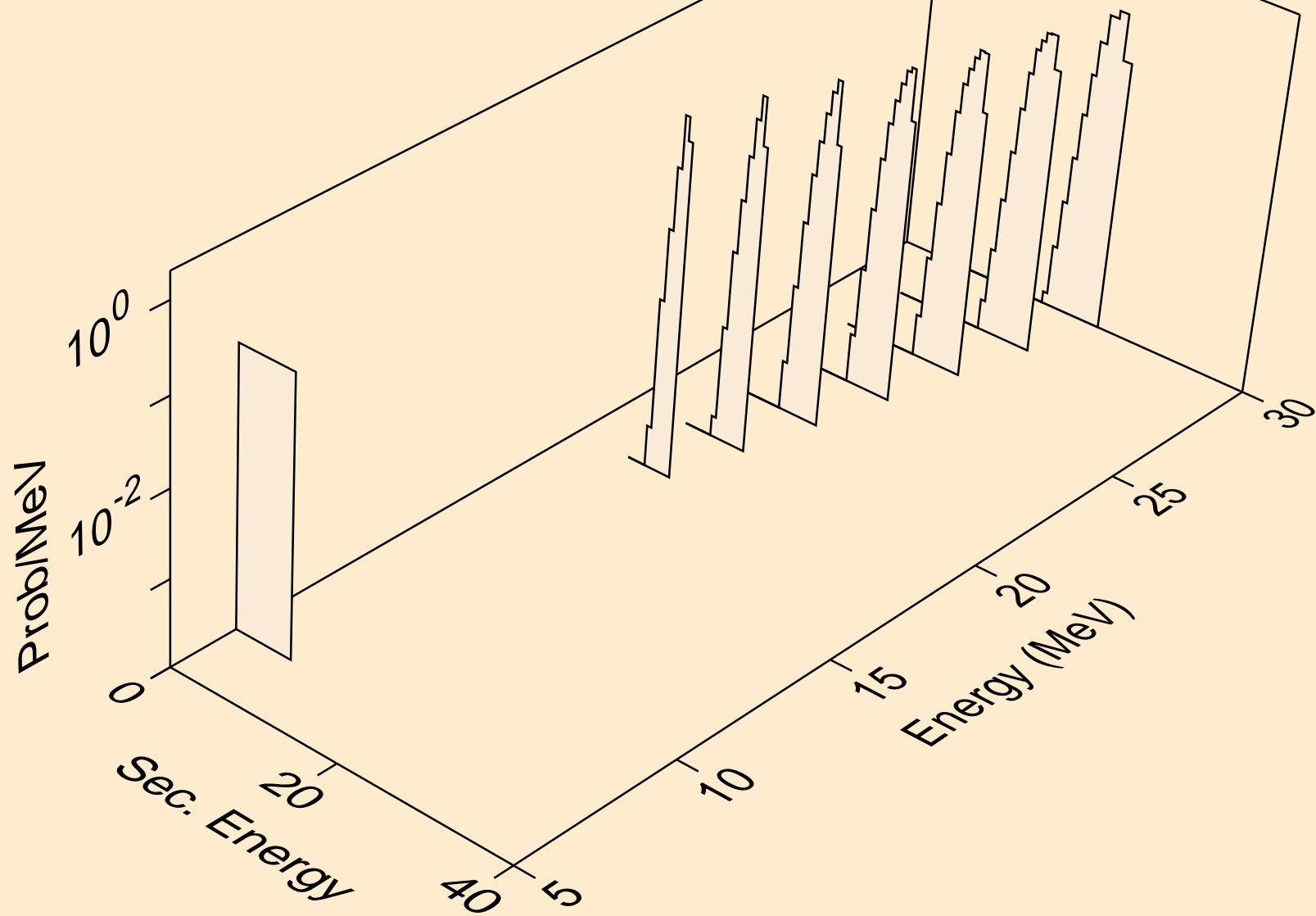



BH275 NEUTRON ACER TENDL-2023 LIBRARY; T=0.K  
he3s from (n,he3)

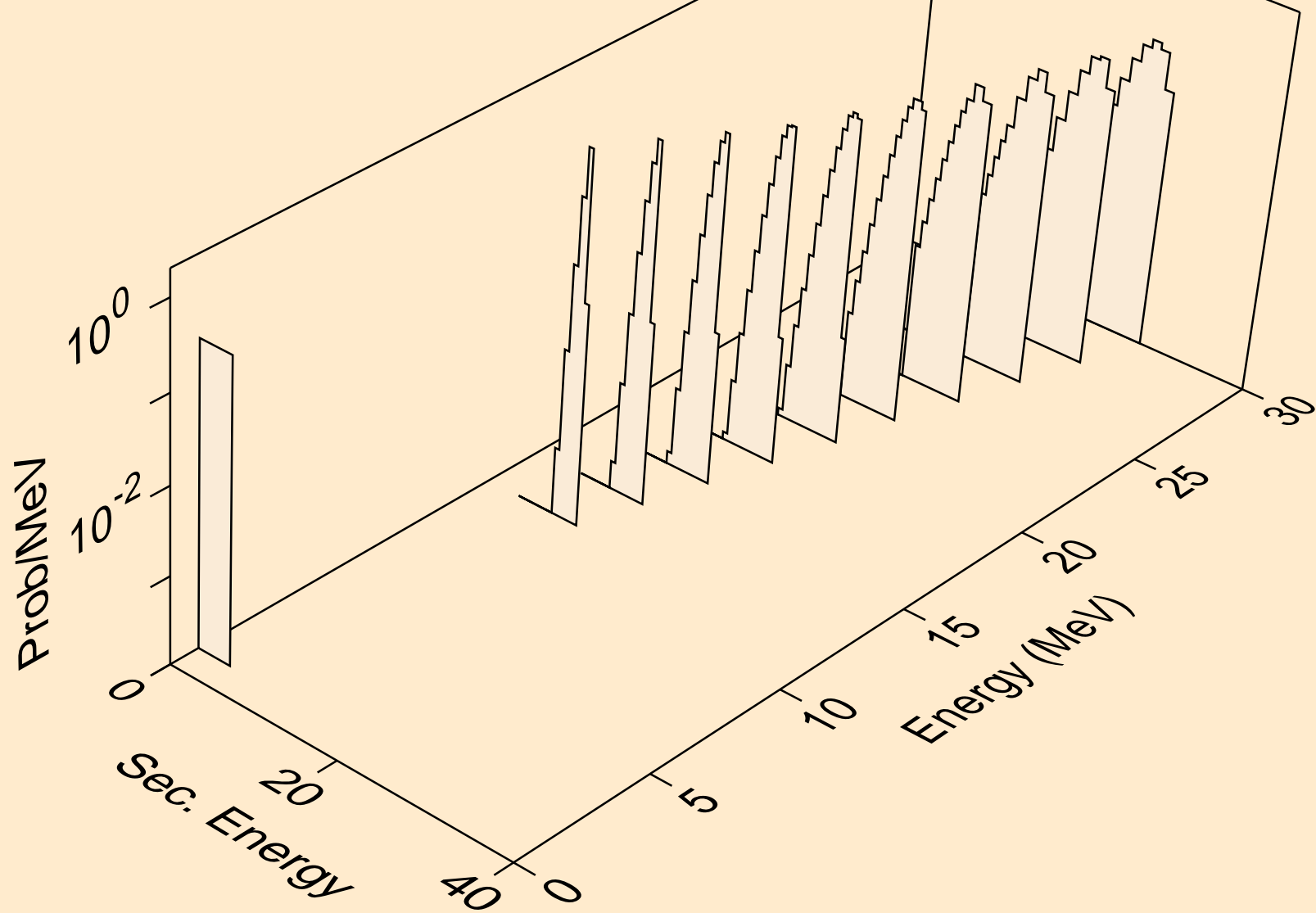

BH275 NEUTRON ACER TENDL-2023 LIBRARY; T=0.K  
alphas from (n,x)

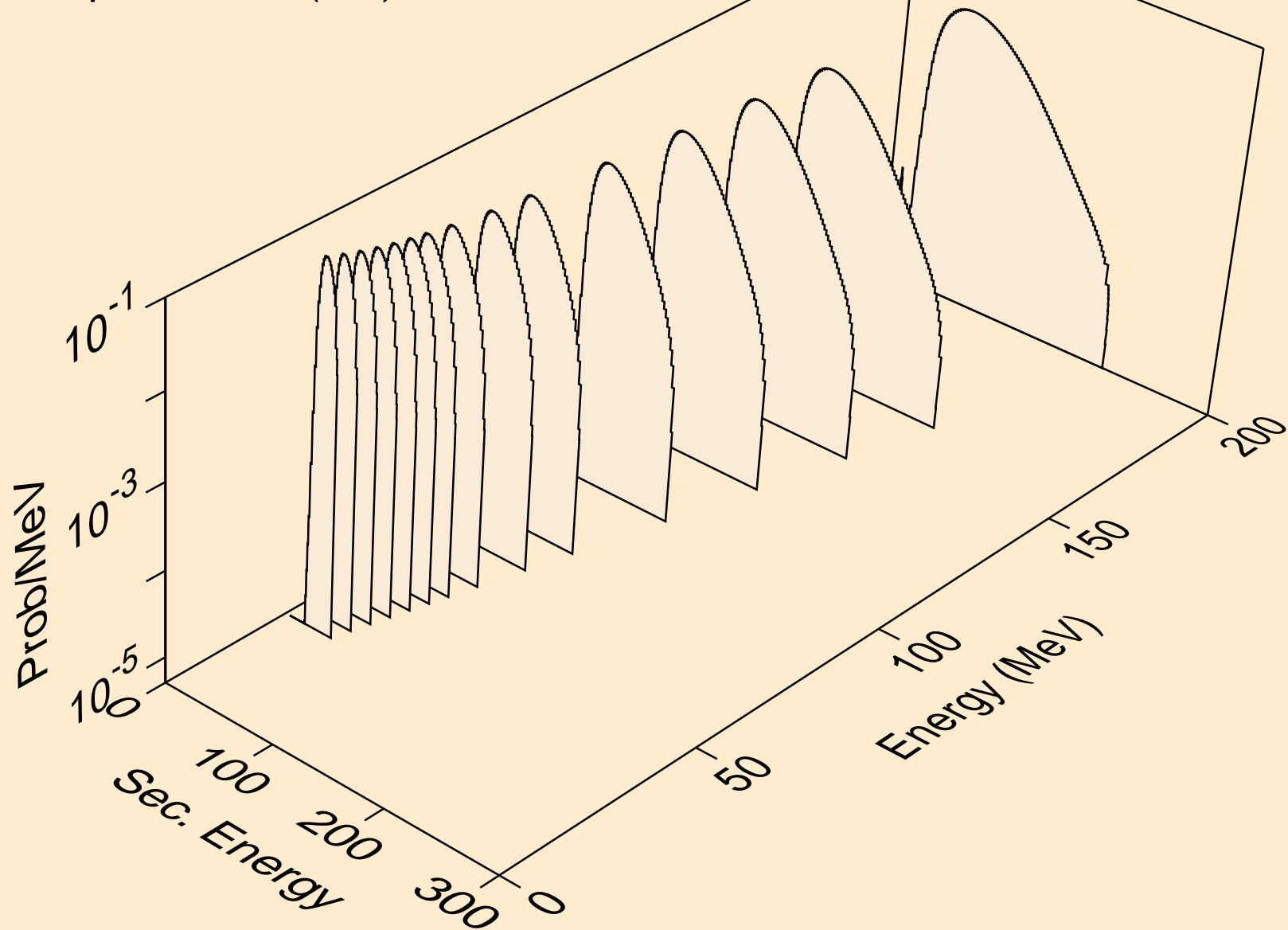

BH275 NEUTRON ACER TENDL-2023 LIBRARY; T=0.K  
alphas from (n,n\*)a

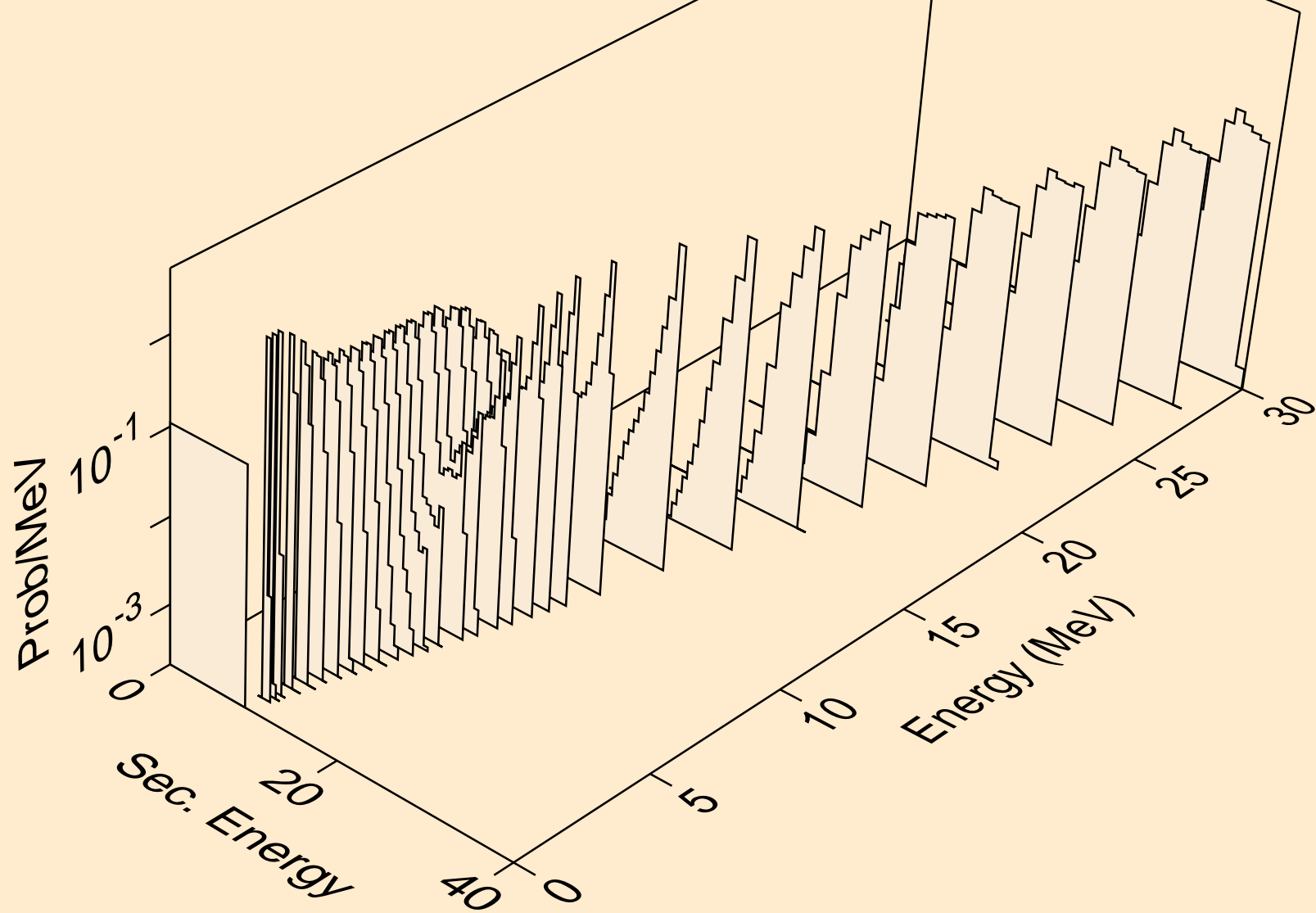

BH275 NEUTRON ACER TENDL-2023 LIBRARY; T=0.K  
alphas from (n,2n)a

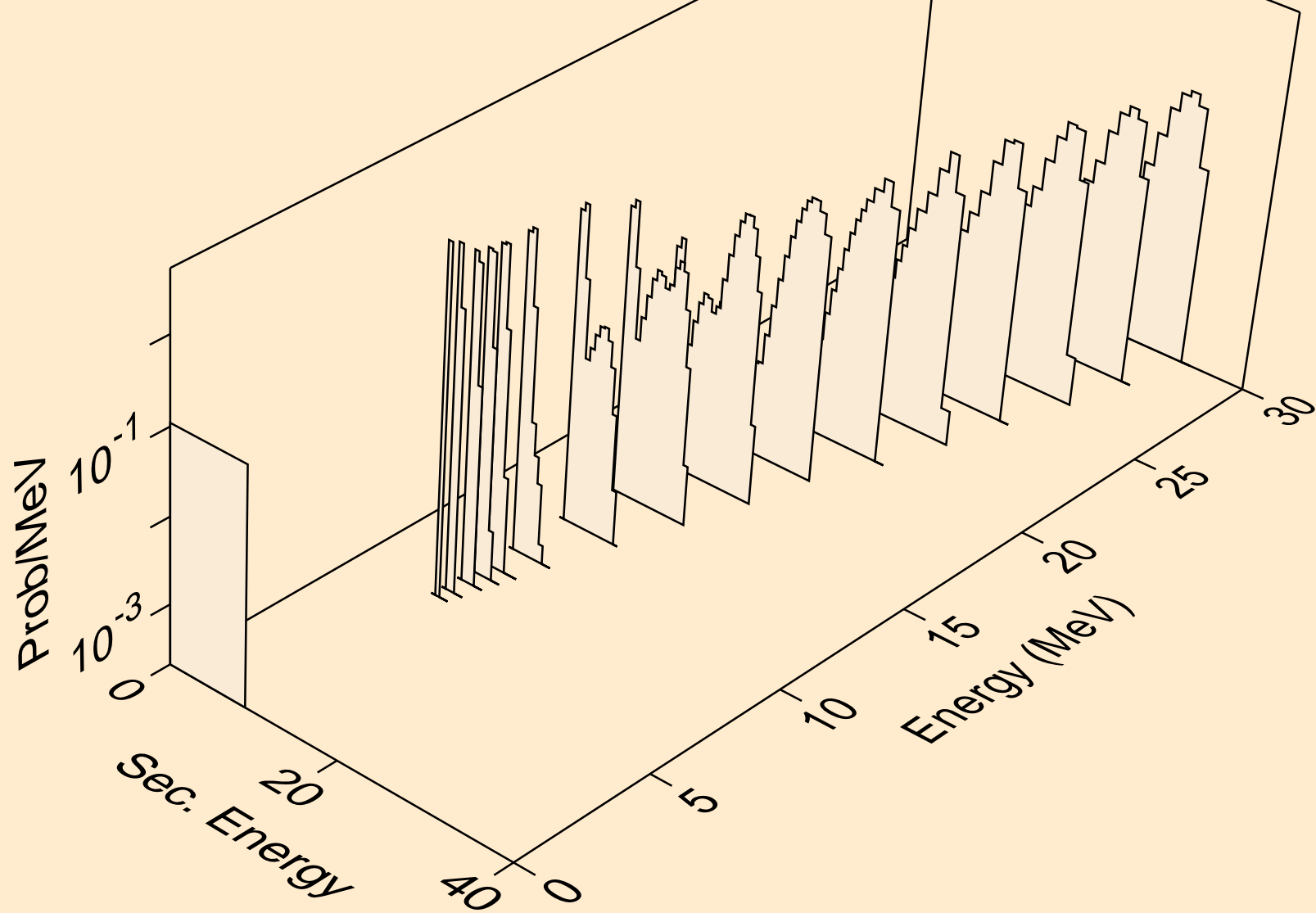

BH275 NEUTRON ACER TENDL-2023 LIBRARY; T=0.K  
alphas from (n,a)

