

BR070M NEUTRON ACER TENDL-2023 LIBRARY; T=0.K

Principal cross sections

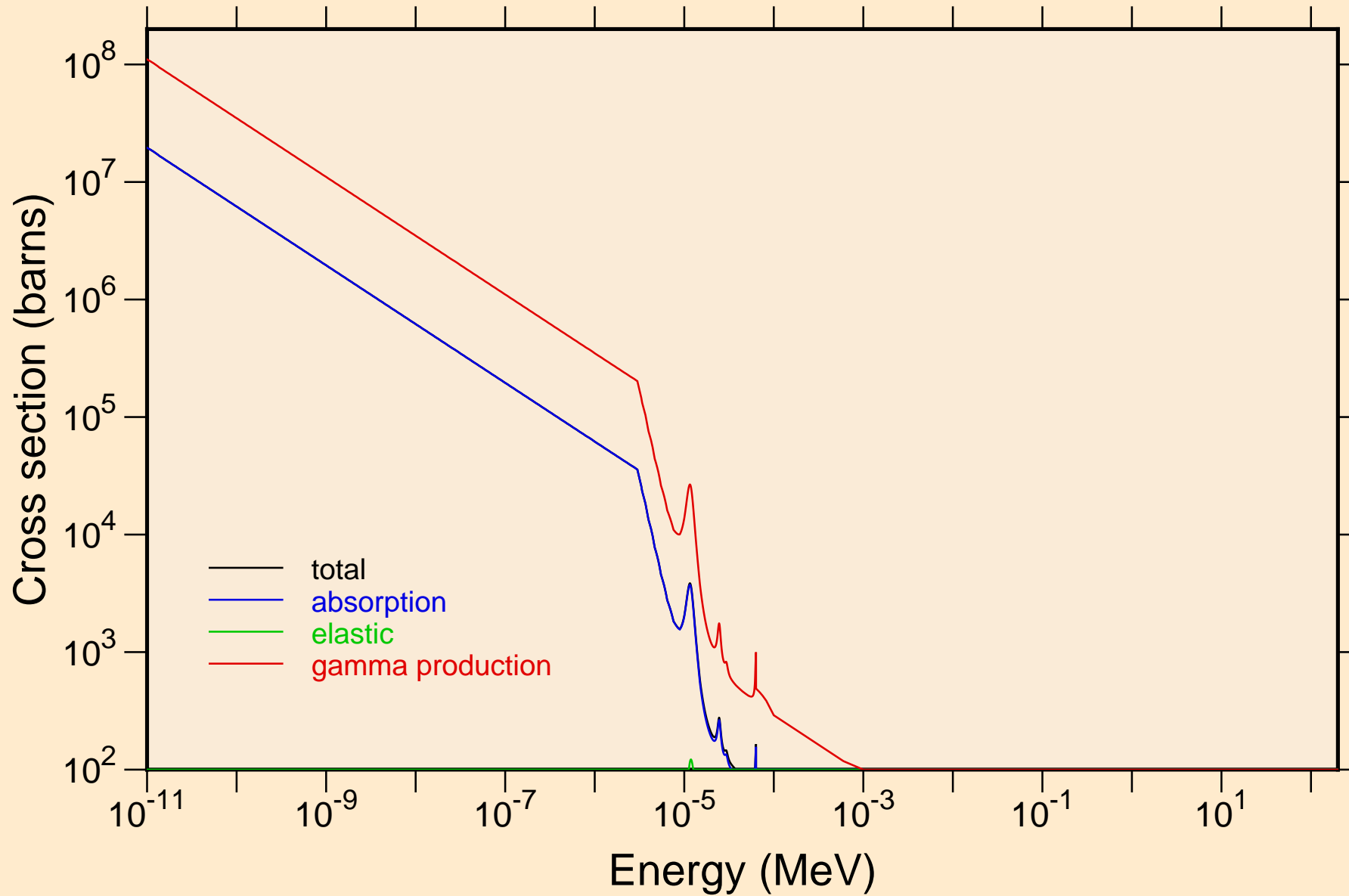

BR070M NEUTRON ACER TENDL-2023 LIBRARY; T=0.K

Heating

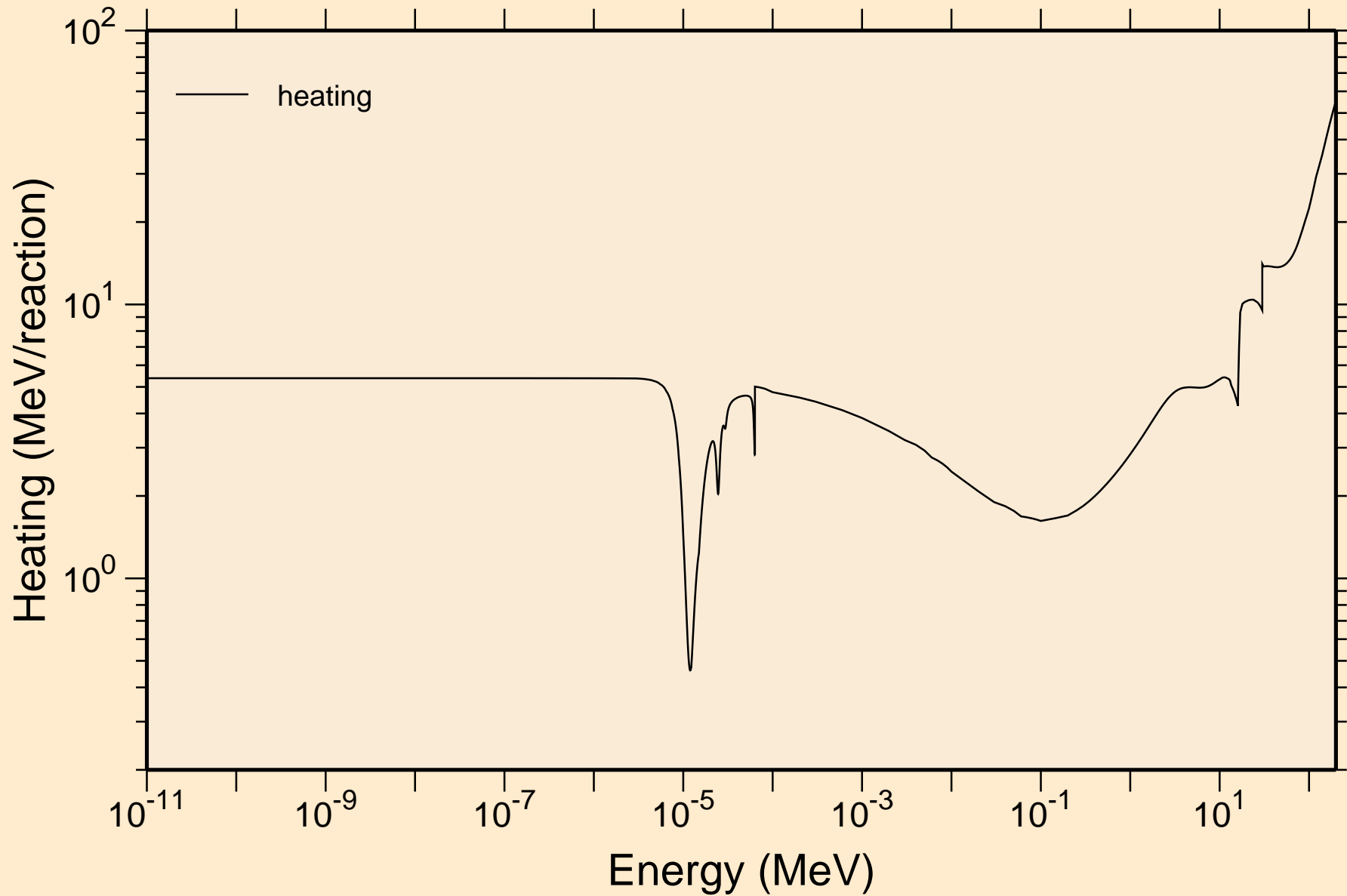

BR070M NEUTRON ACER TENDL-2023 LIBRARY; T=0.K
Damage

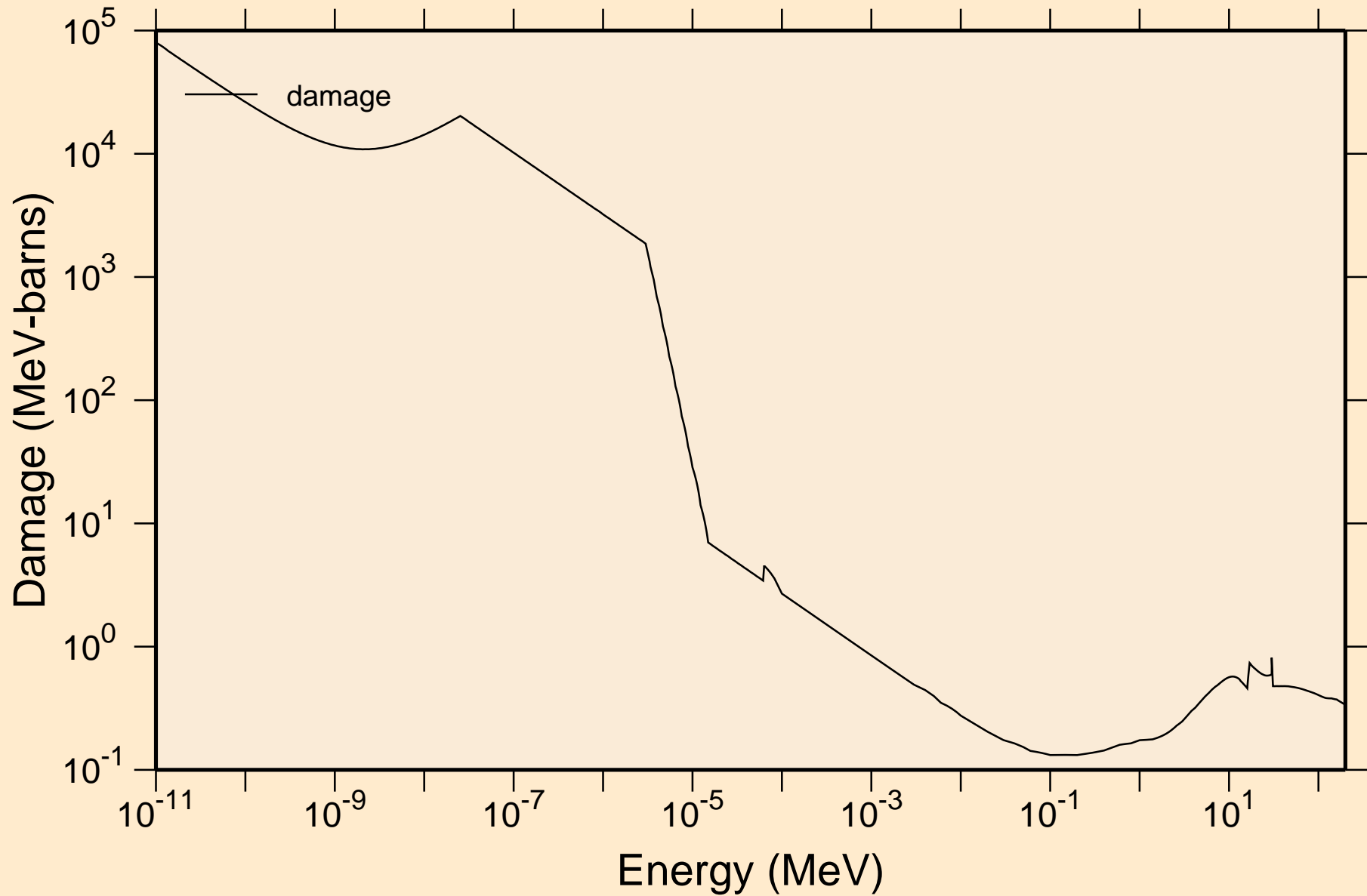

BR070M NEUTRON ACER TENDL-2023 LIBRARY; T=0.K
Non-threshold reactions

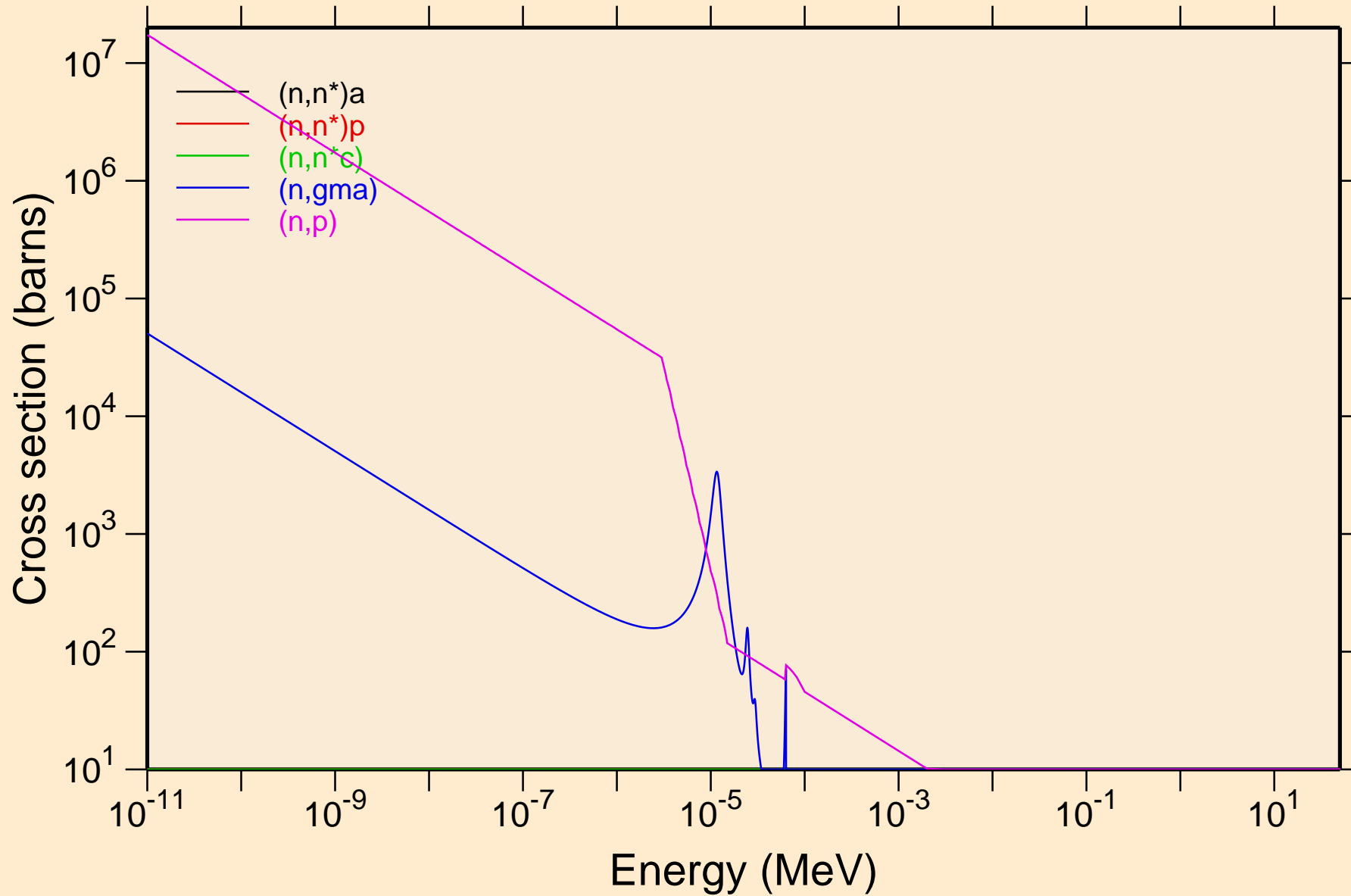

BR070M NEUTRON ACER TENDL-2023 LIBRARY; T=0.K
Non-threshold reactions

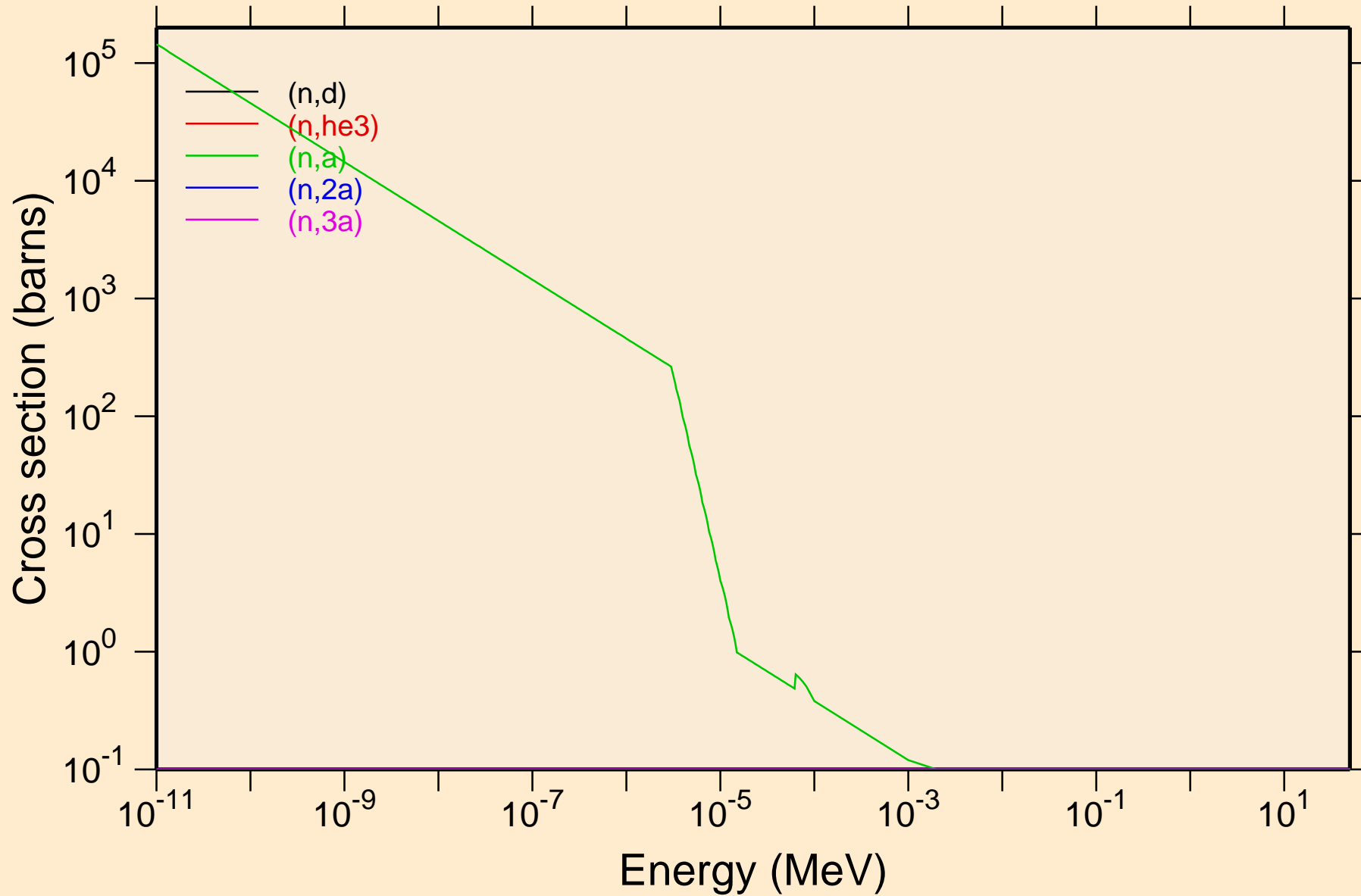

BR070M NEUTRON ACER TENDL-2023 LIBRARY; T=0.K
Non-threshold reactions

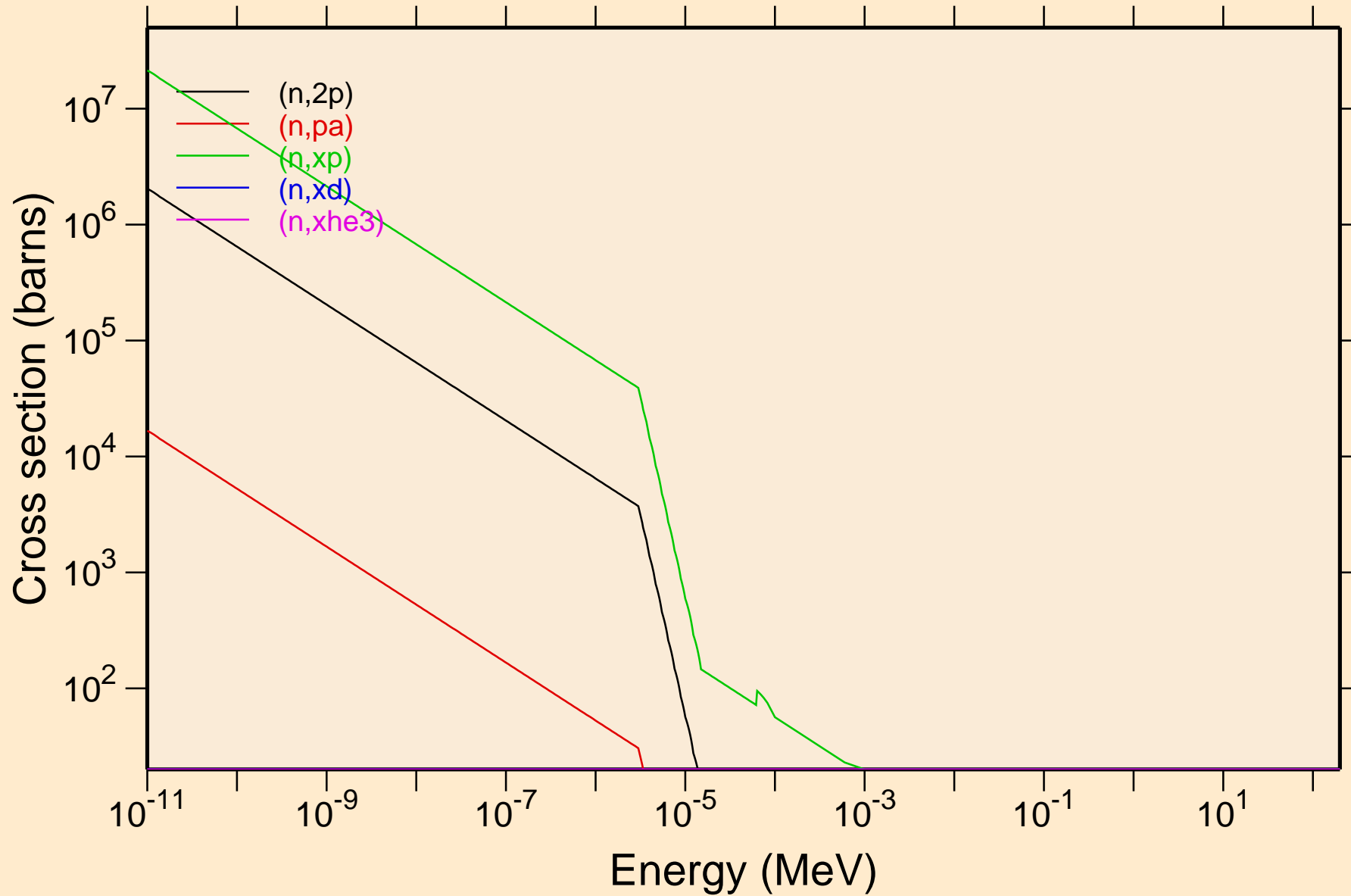

BR070M NEUTRON ACER TENDL-2023 LIBRARY; T=0.K
Non-threshold reactions

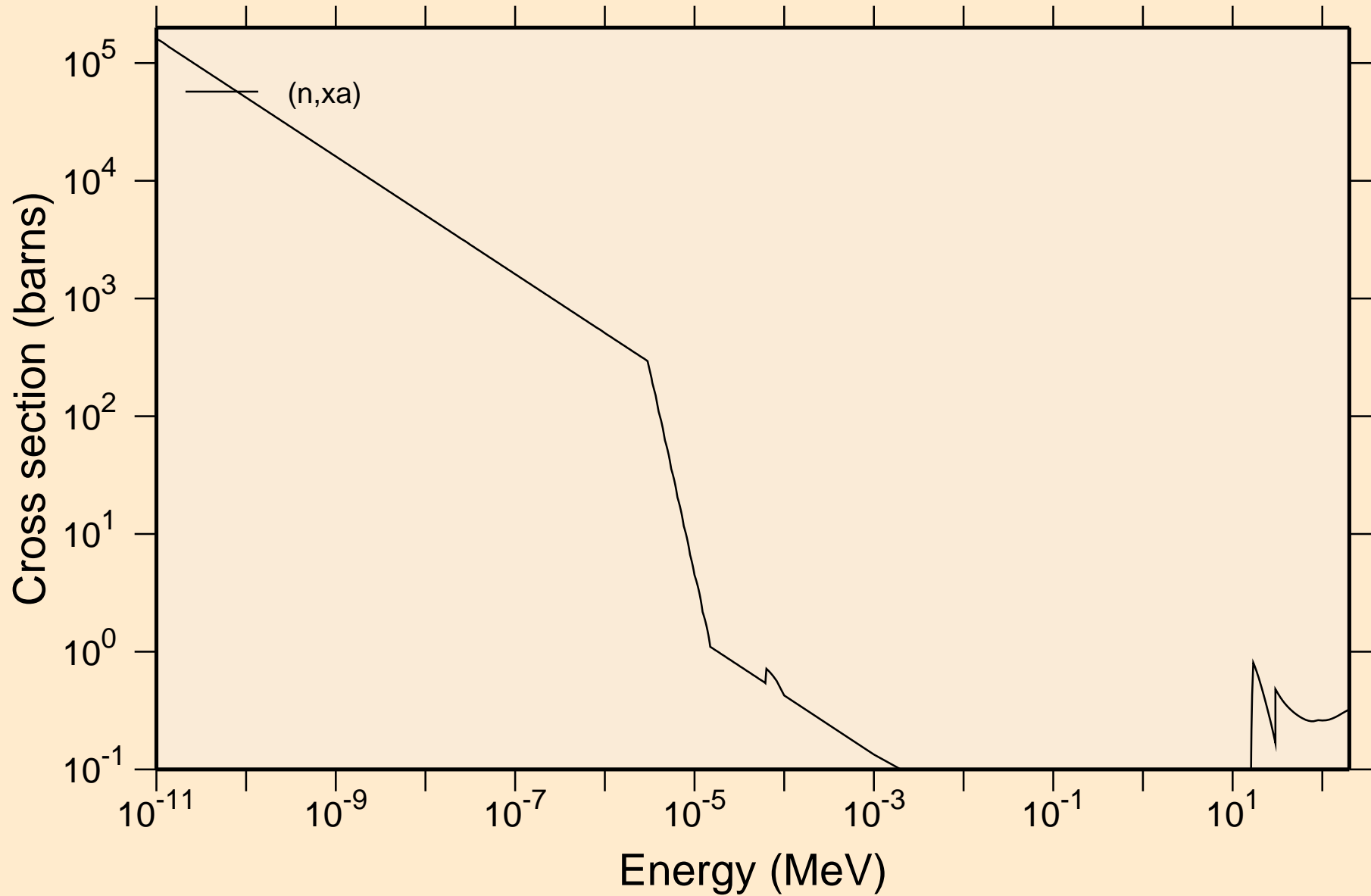

BR070M NEUTRON ACER TENDL-2023 LIBRARY; T=0.K

Principal cross sections

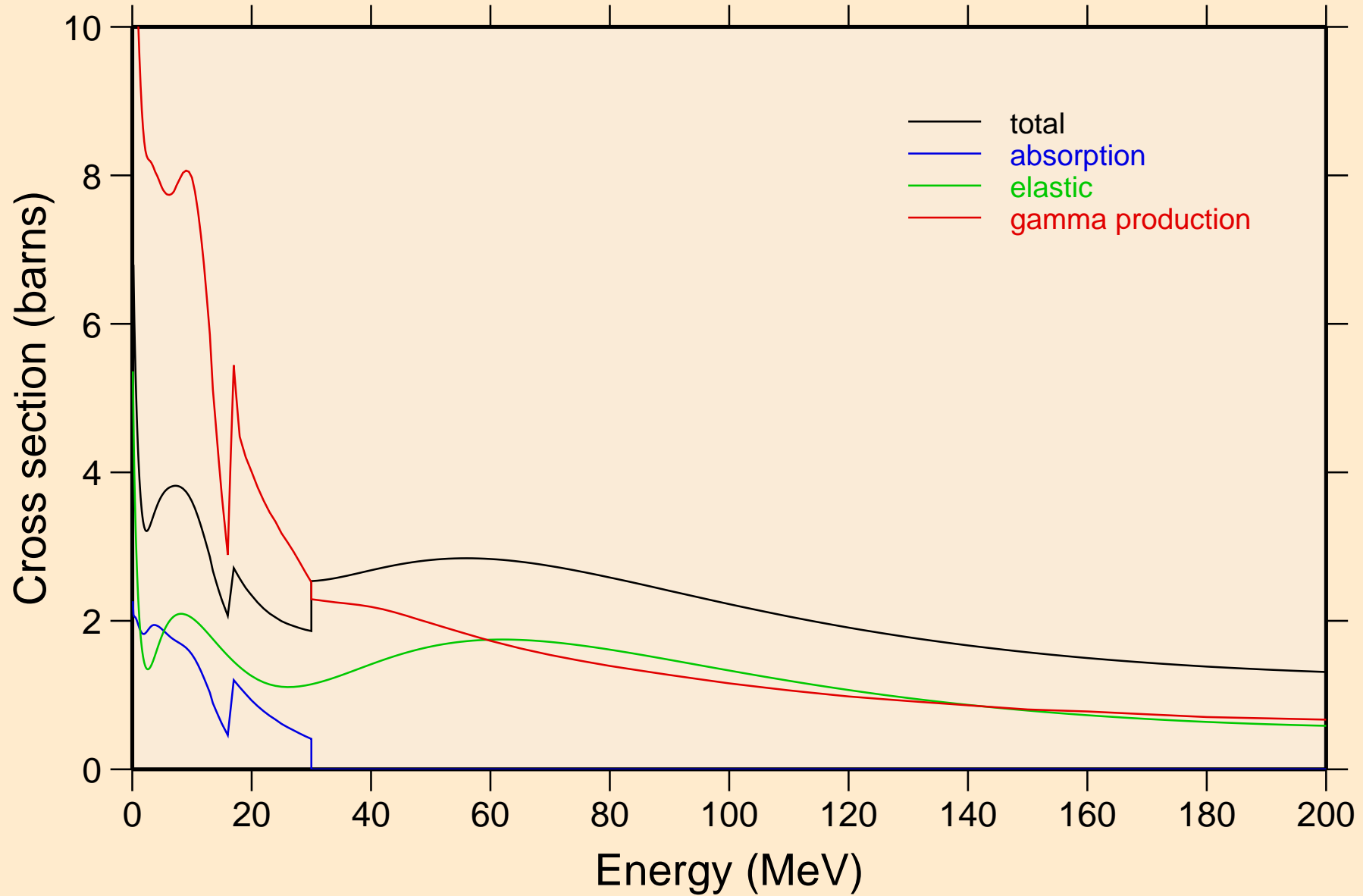

BR070M NEUTRON ACER TENDL-2023 LIBRARY; T=0.K

Heating

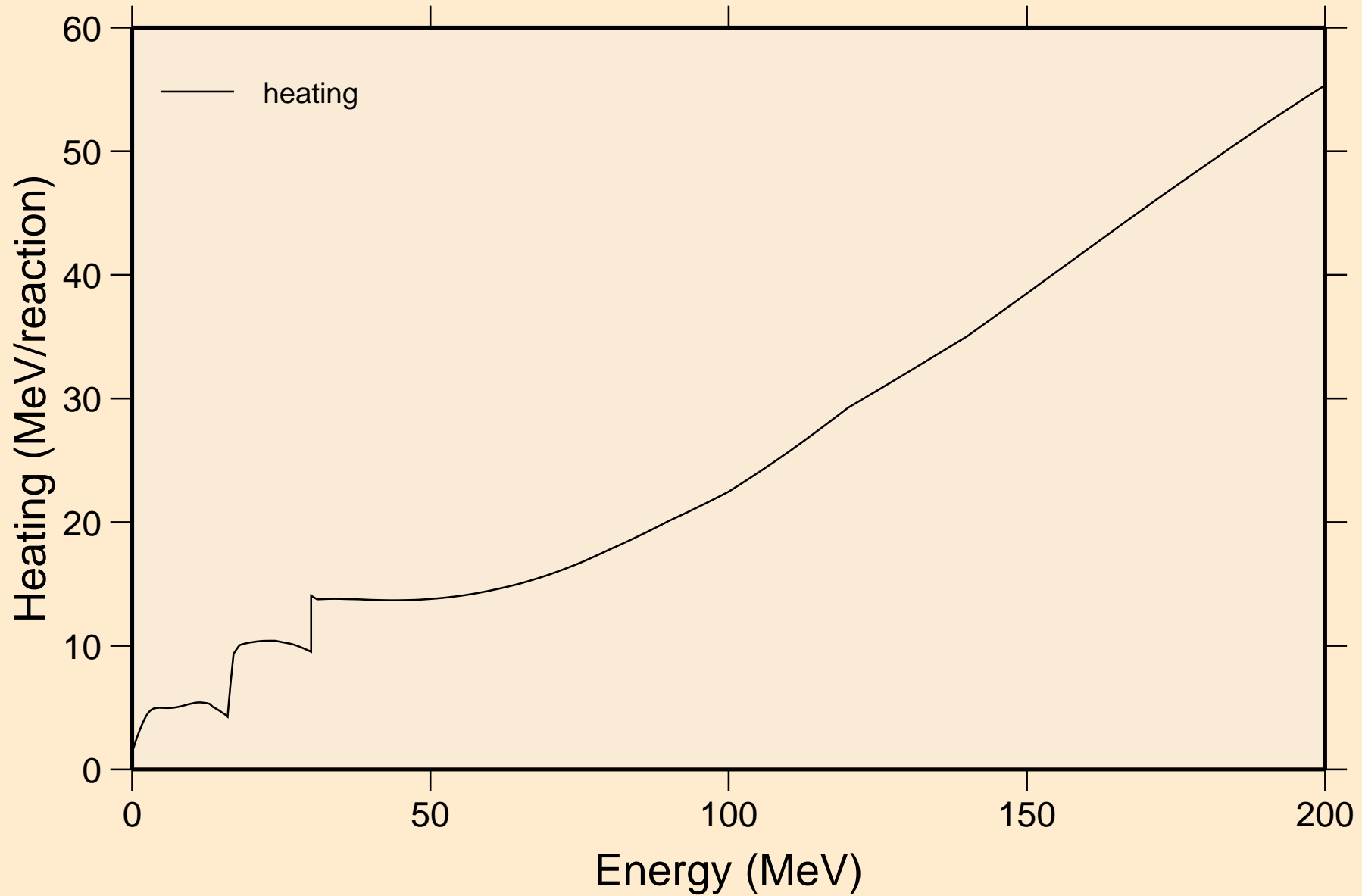

BR070M NEUTRON ACER TENDL-2023 LIBRARY; T=0.K
Damage

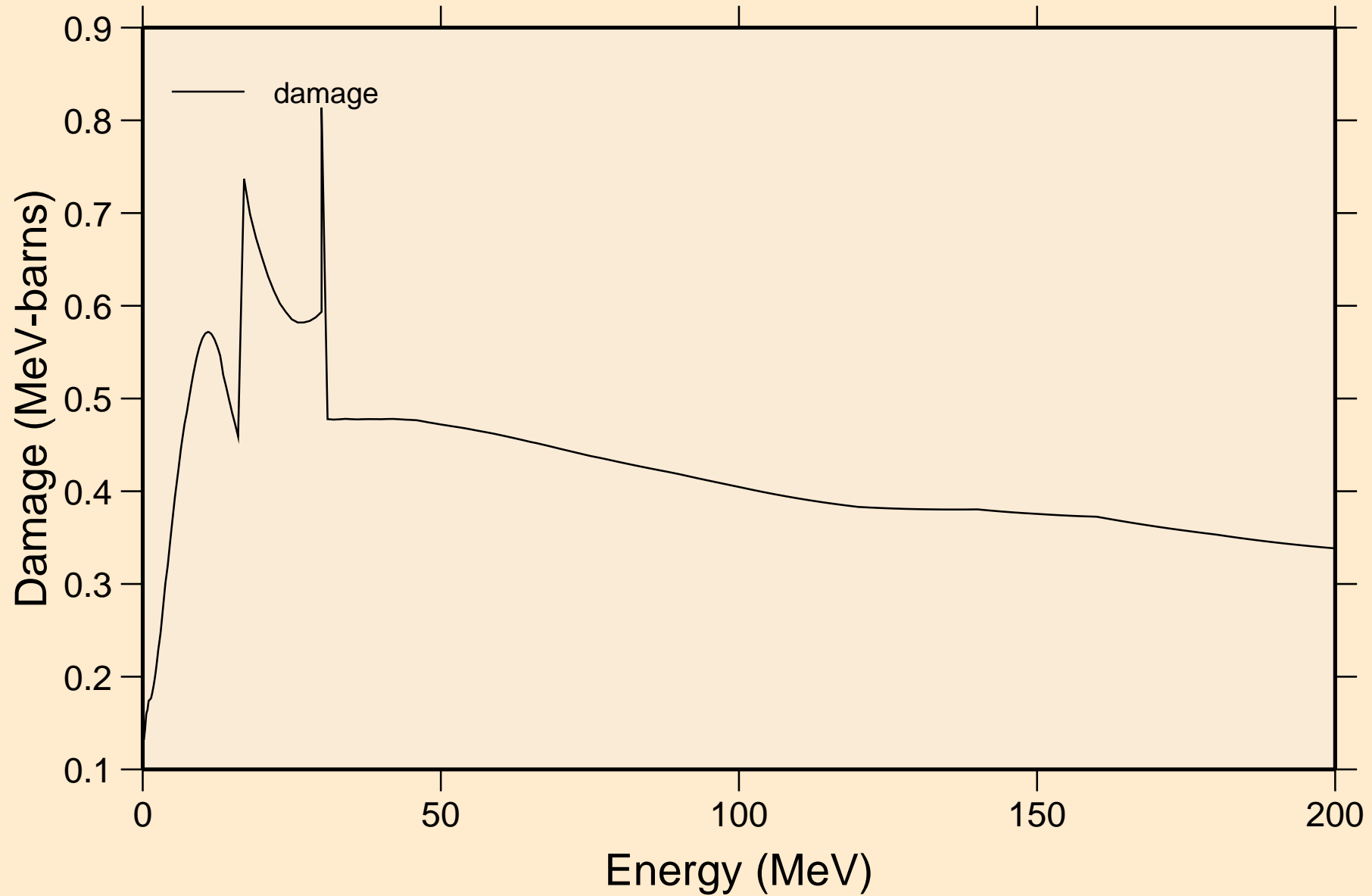

BR070M NEUTRON ACER TENDL-2023 LIBRARY; T=0.K

Non-threshold reactions

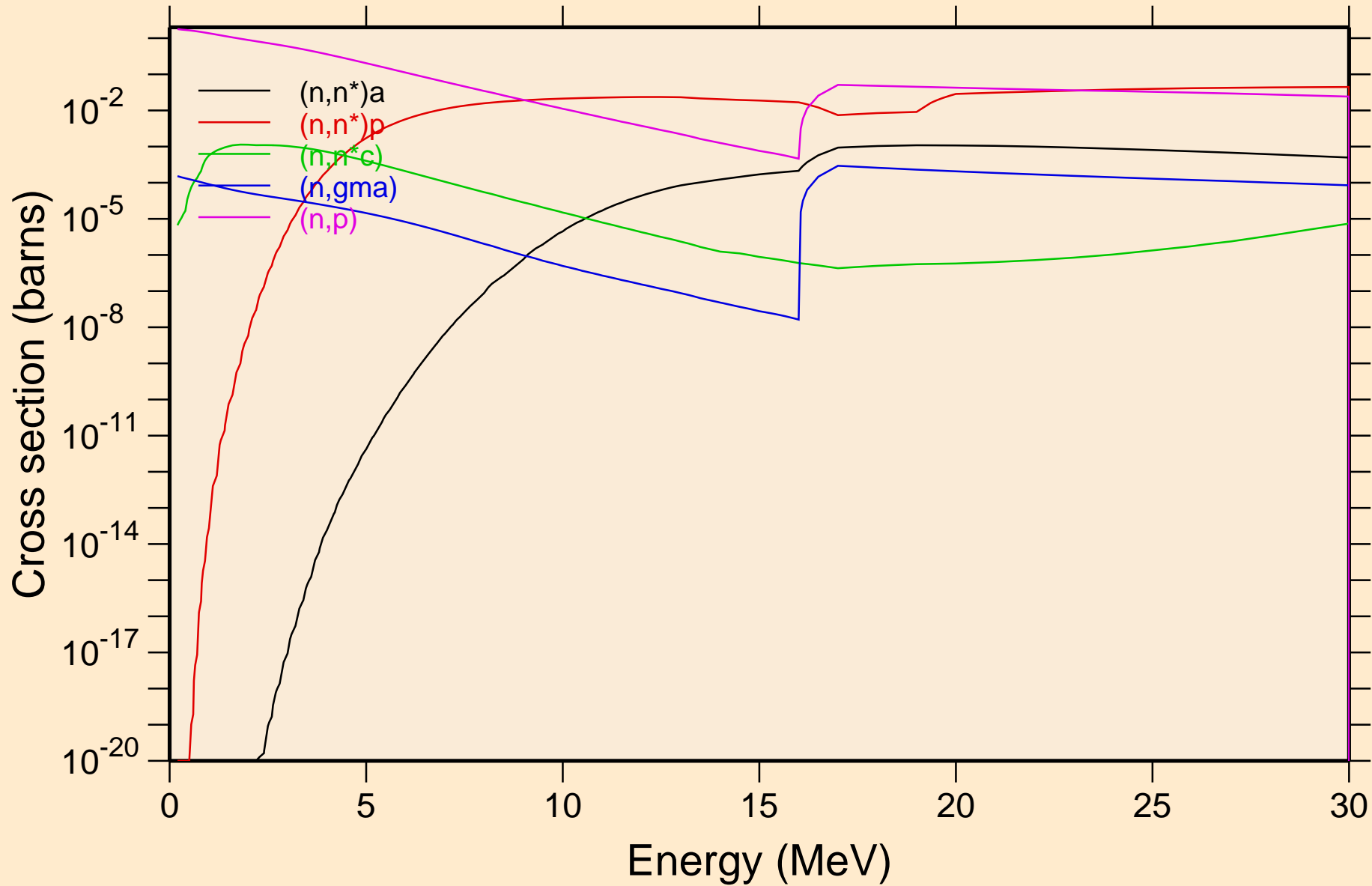

BR070M NEUTRON ACER TENDL-2023 LIBRARY; T=0.K
Non-threshold reactions

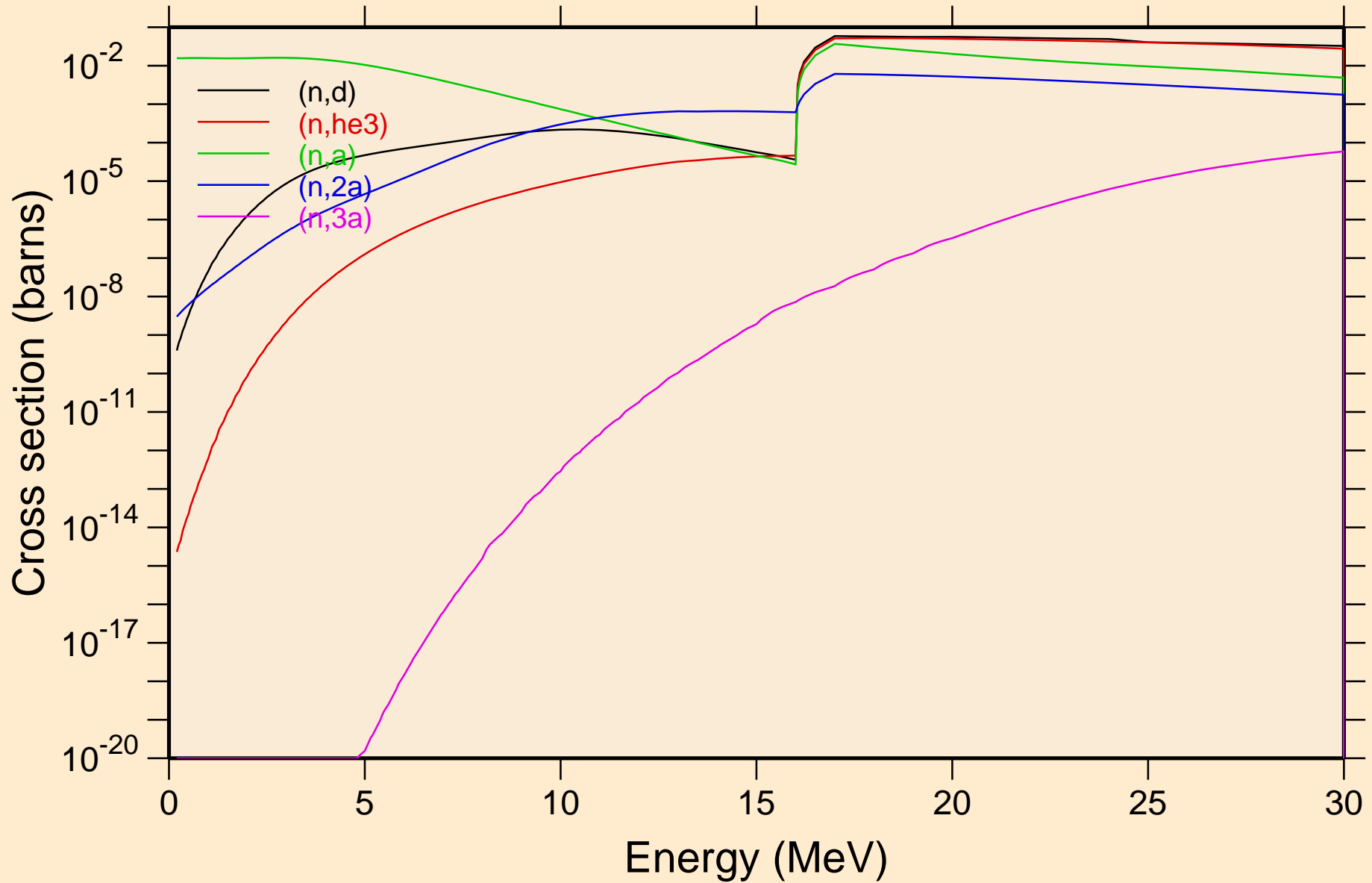

BR070M NEUTRON ACER TENDL-2023 LIBRARY; T=0.K
Non-threshold reactions

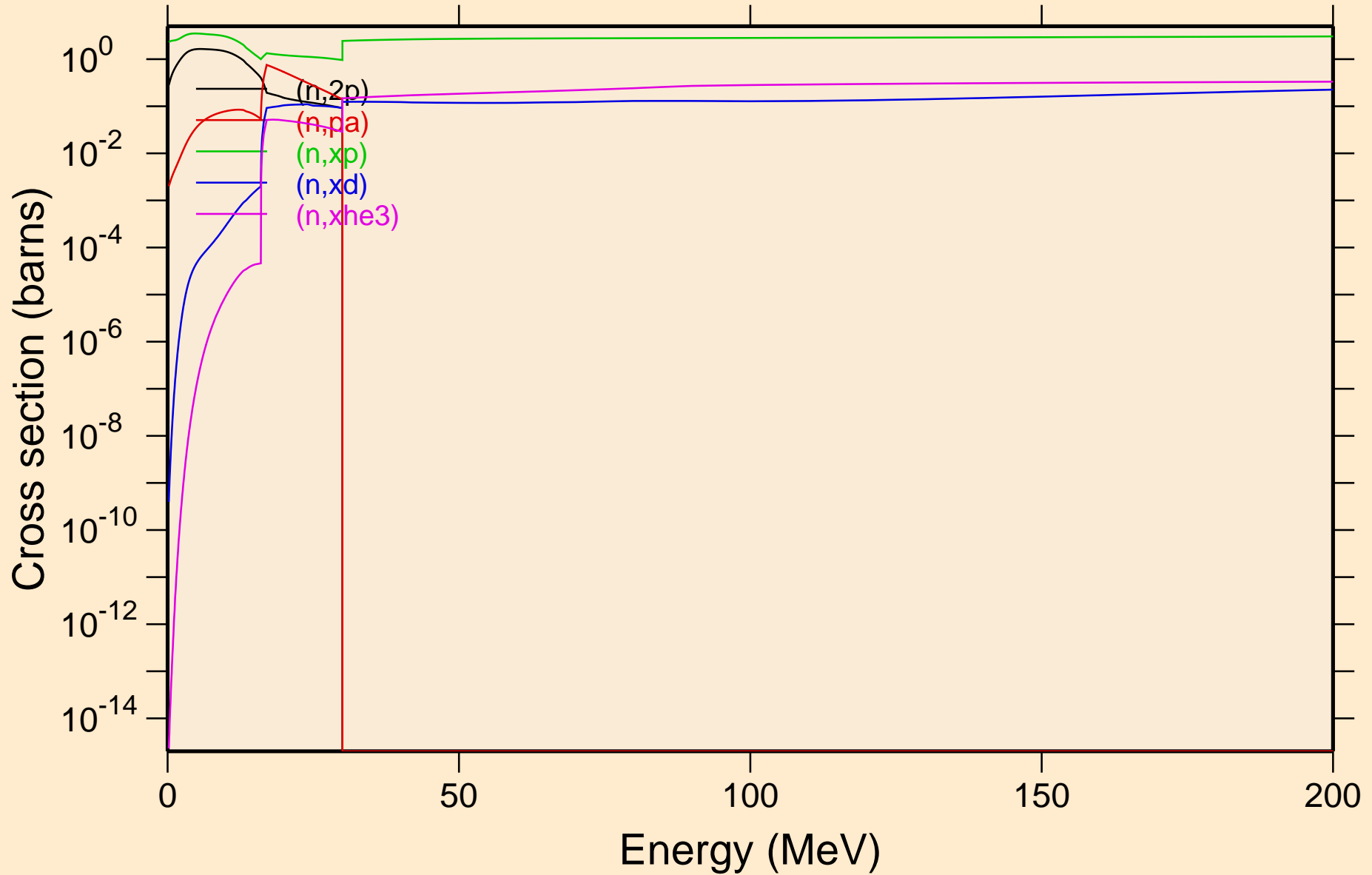

BR070M NEUTRON ACER TENDL-2023 LIBRARY; T=0.K
Non-threshold reactions

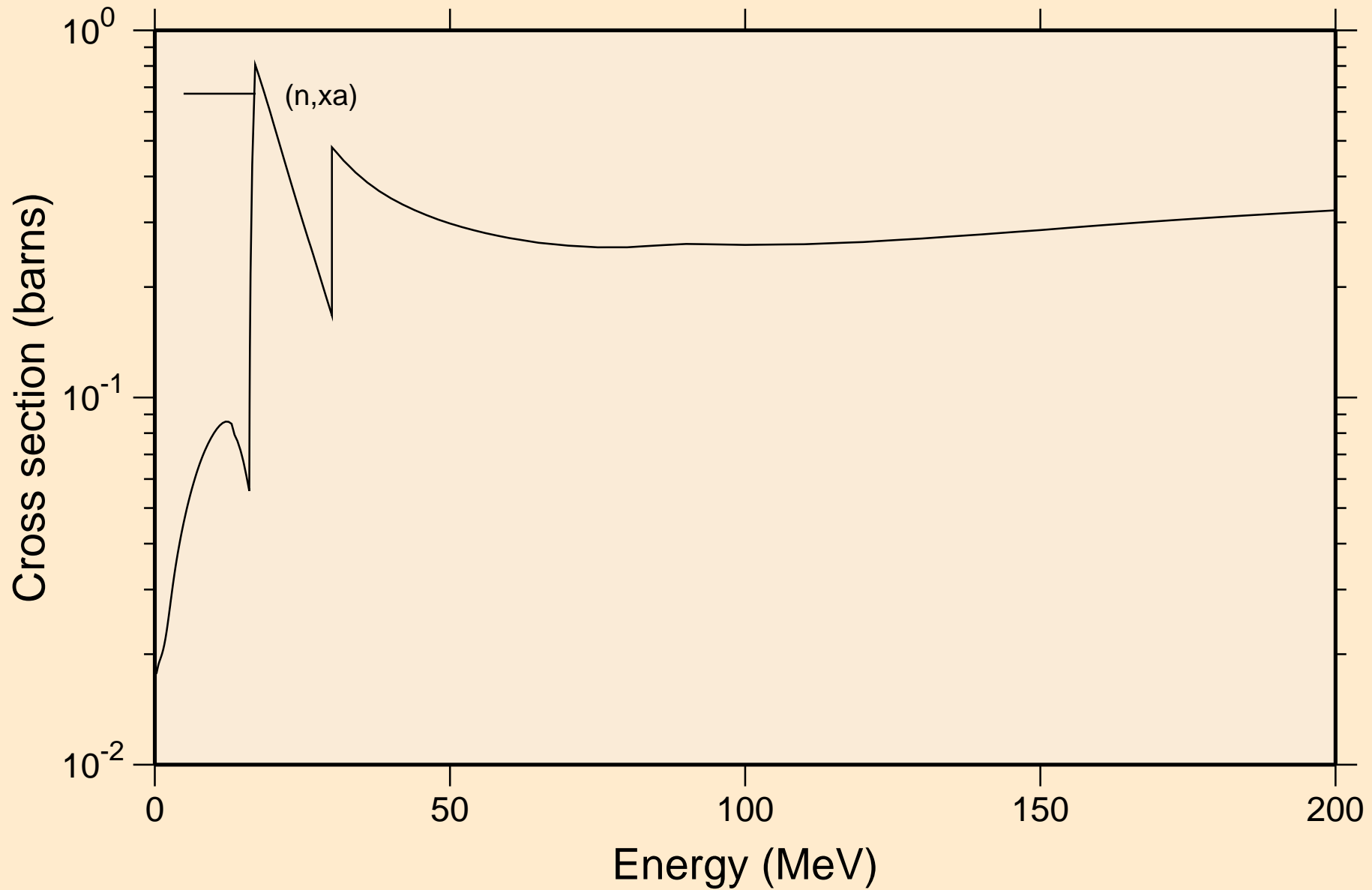

BR070M NEUTRON ACER TENDL-2023 LIBRARY; T=0.K
Inelastic levels

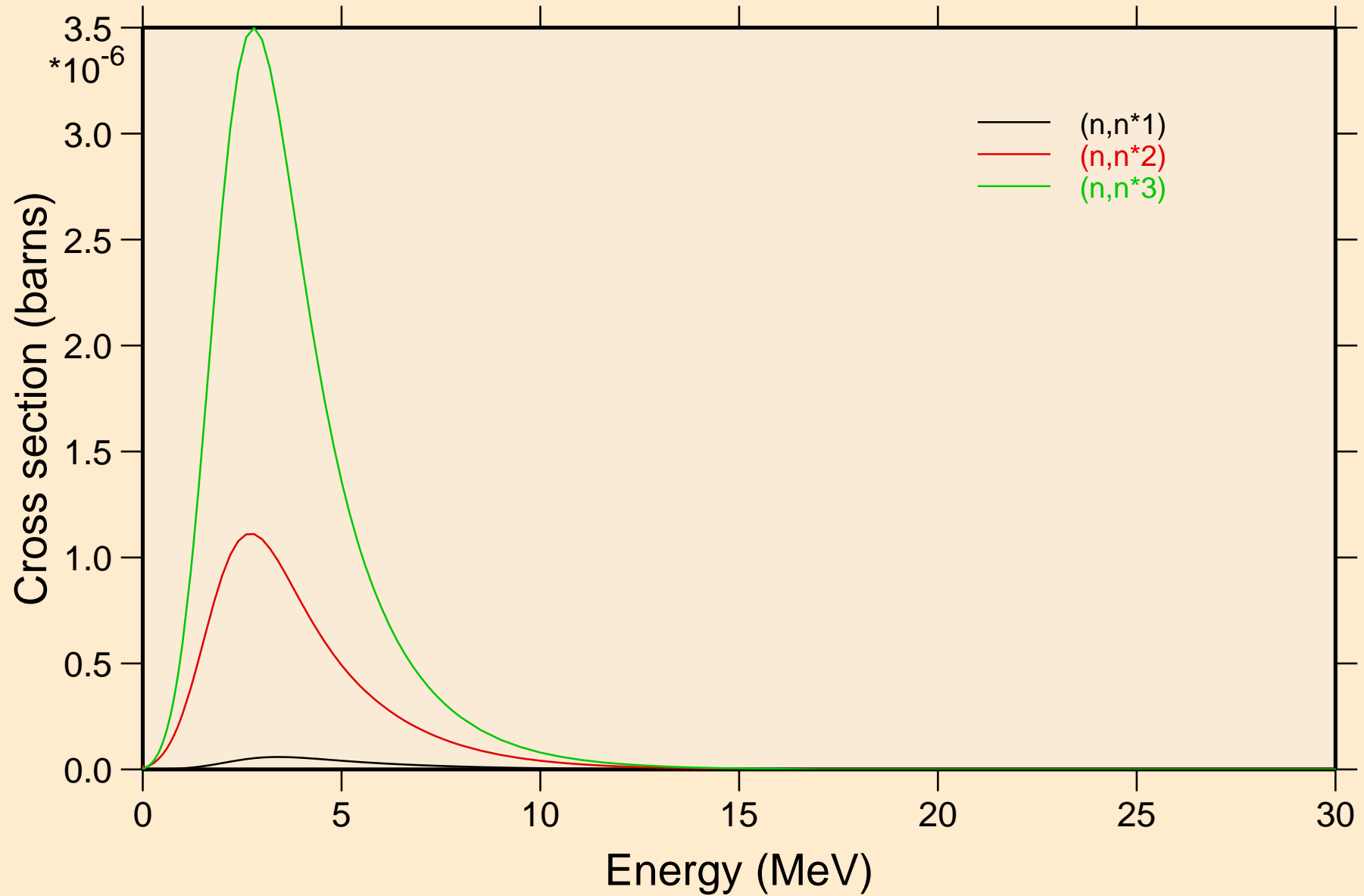

BR070M NEUTRON ACER TENDL-2023 LIBRARY; T=0.K
Threshold reactions

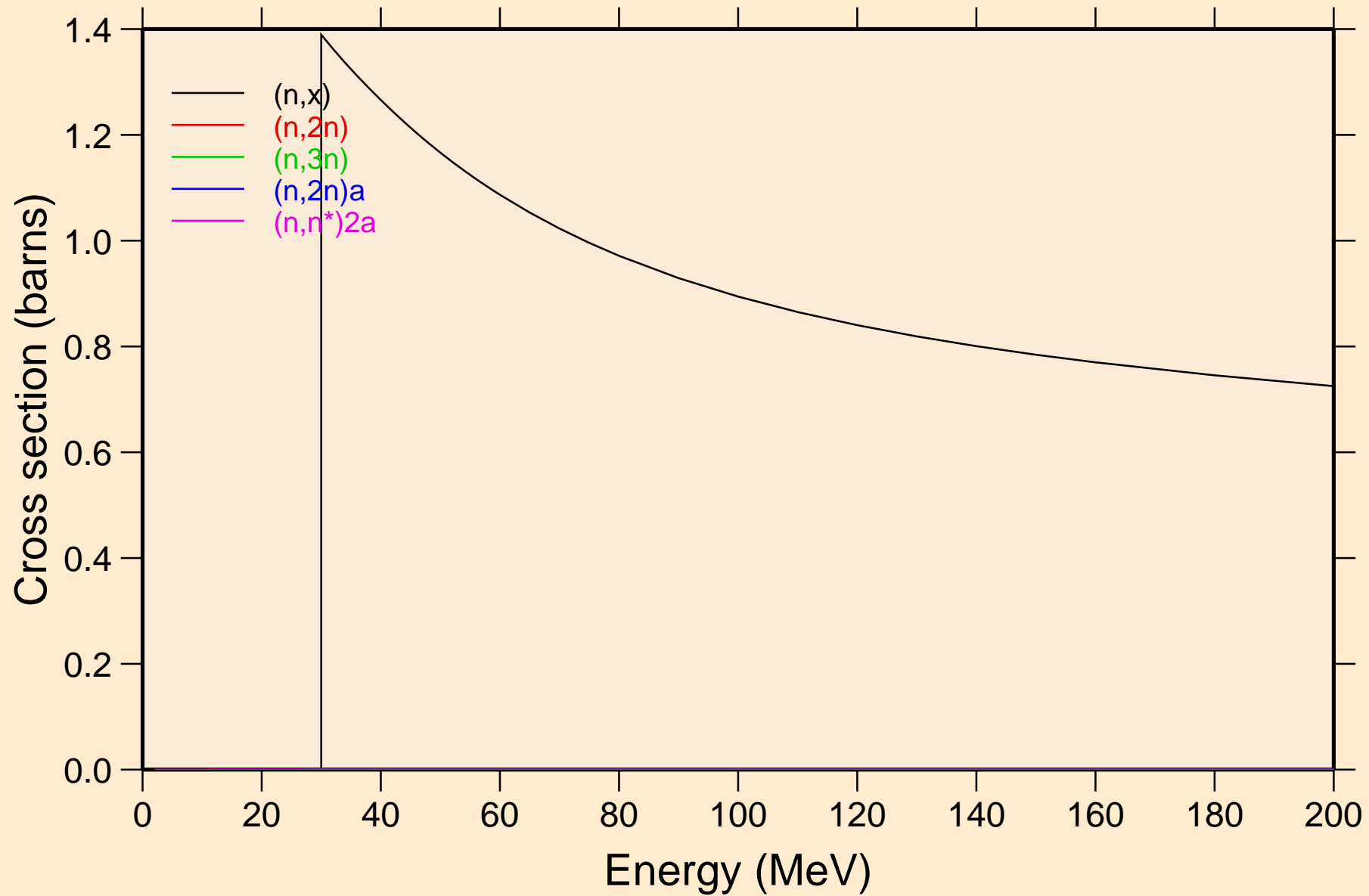

BR070M NEUTRON ACER TENDL-2023 LIBRARY; T=0.K
Threshold reactions

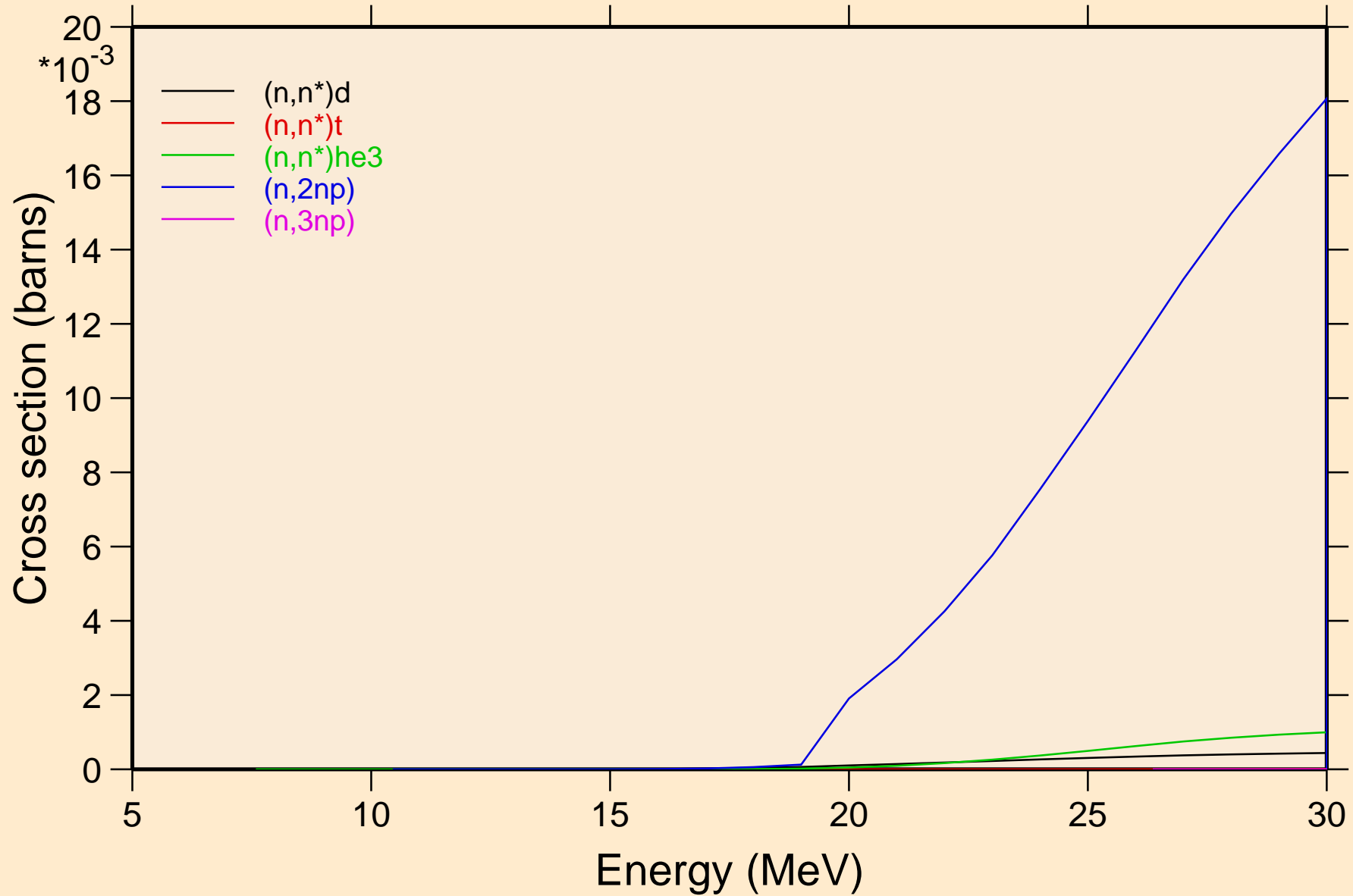

BR070M NEUTRON ACER TENDL-2023 LIBRARY; T=0.K

Threshold reactions

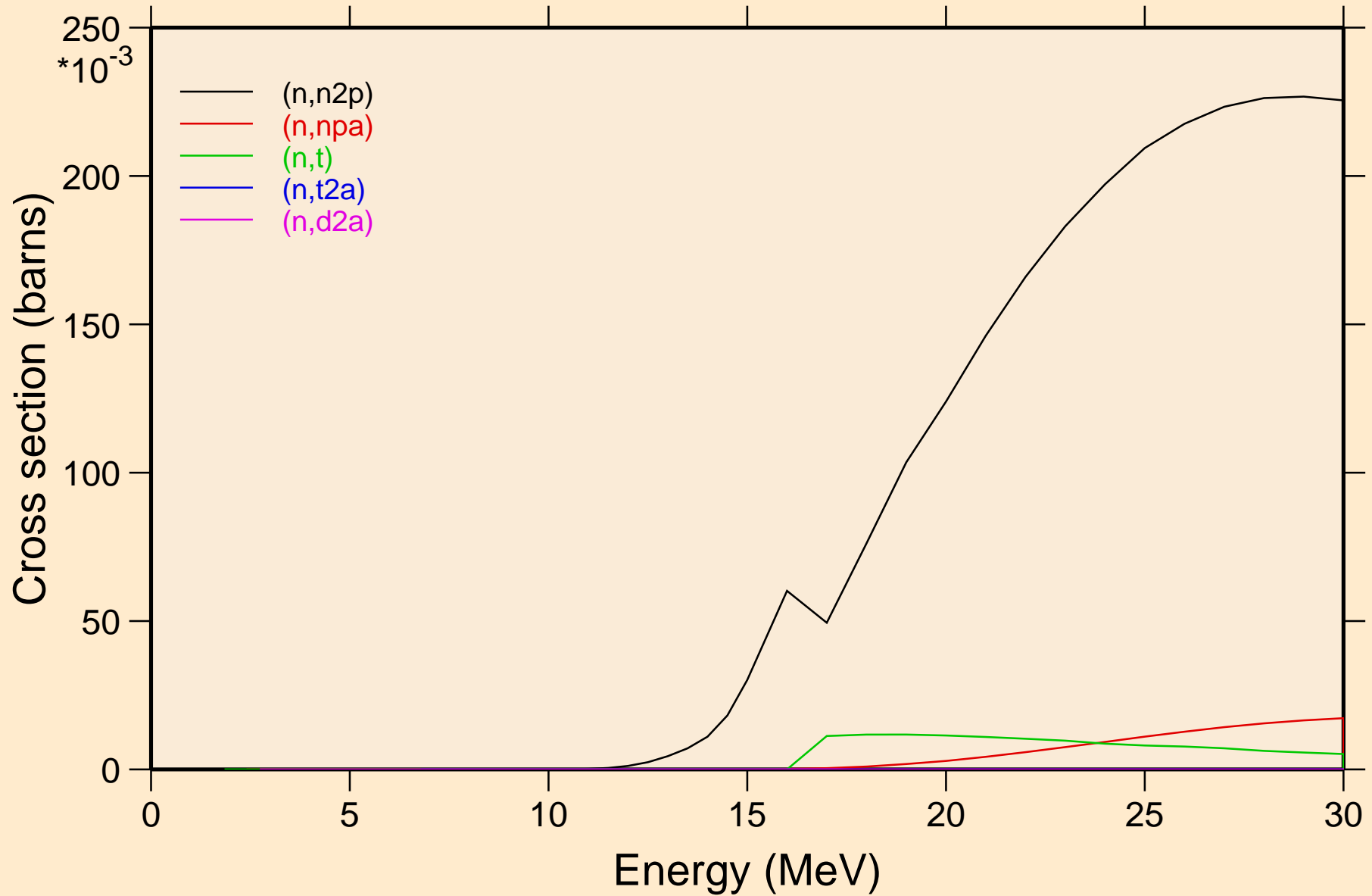

BR070M NEUTRON ACER TENDL-2023 LIBRARY; T=0.K
Threshold reactions

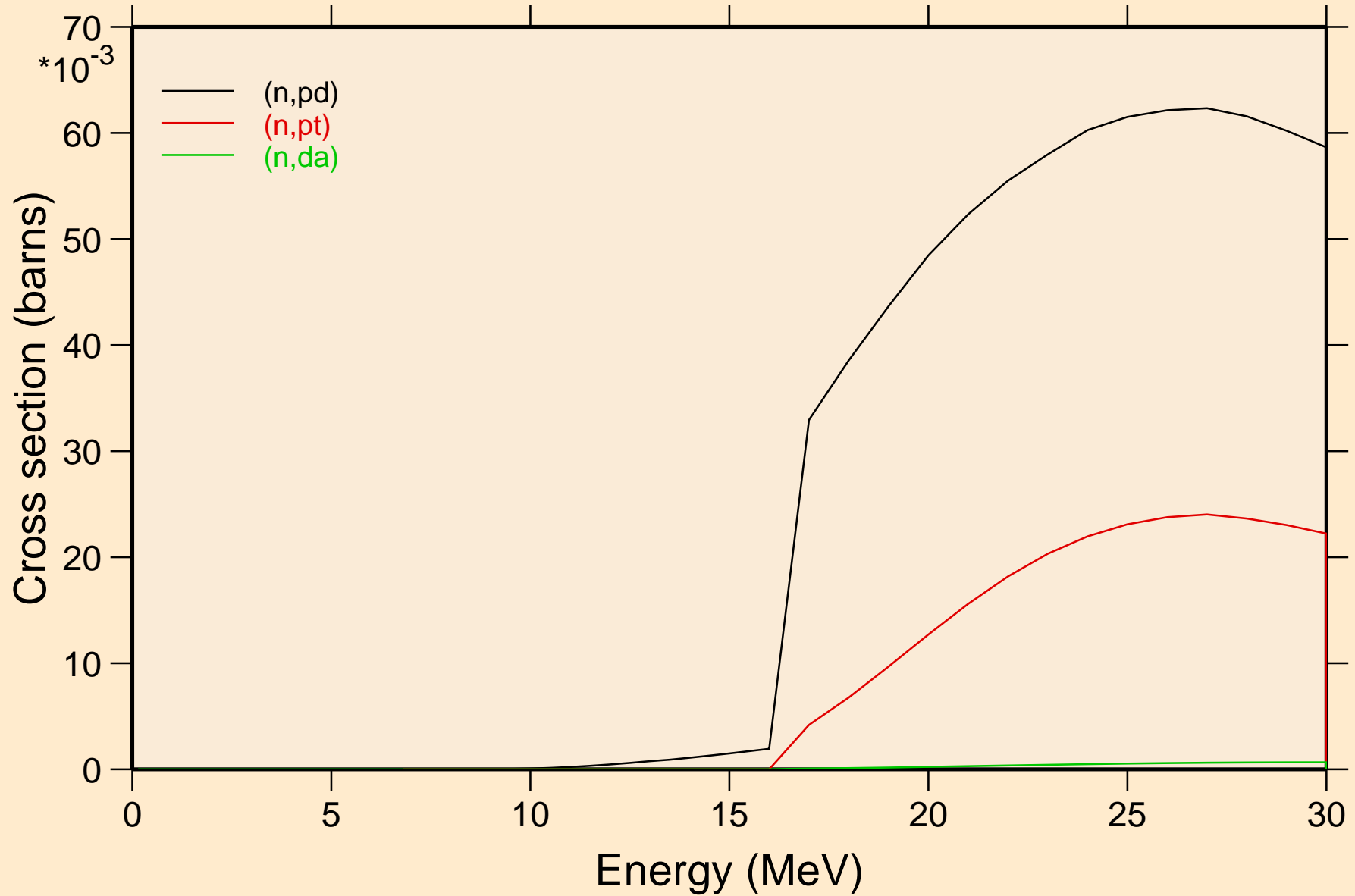

BR070M NEUTRON ACER TENDL-2023 LIBRARY; T=0.K
Threshold reactions

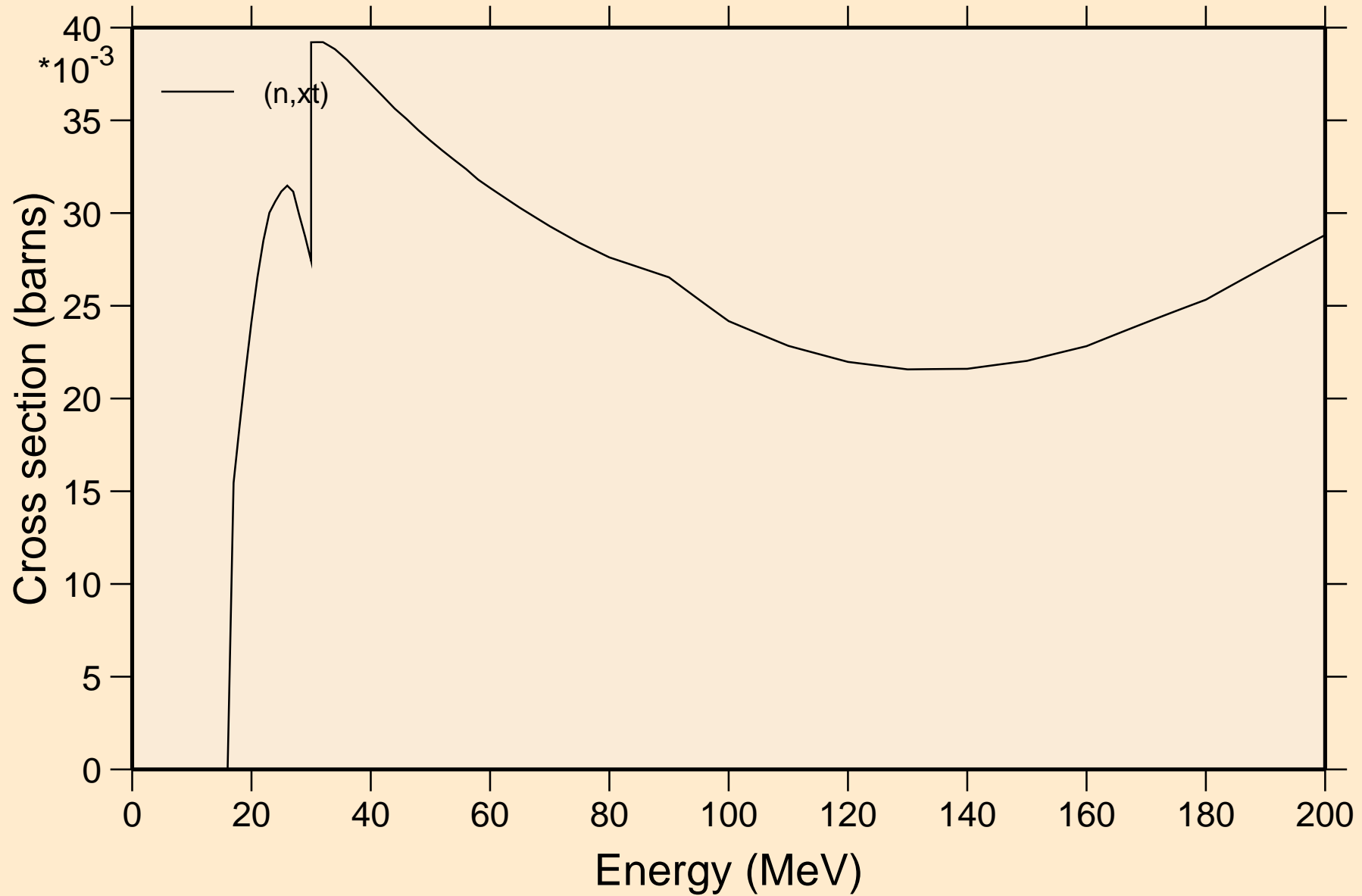

BR070M NEUTRON ACER TENDL-2023 LIBRARY; T=0.K
angular distribution for elastic

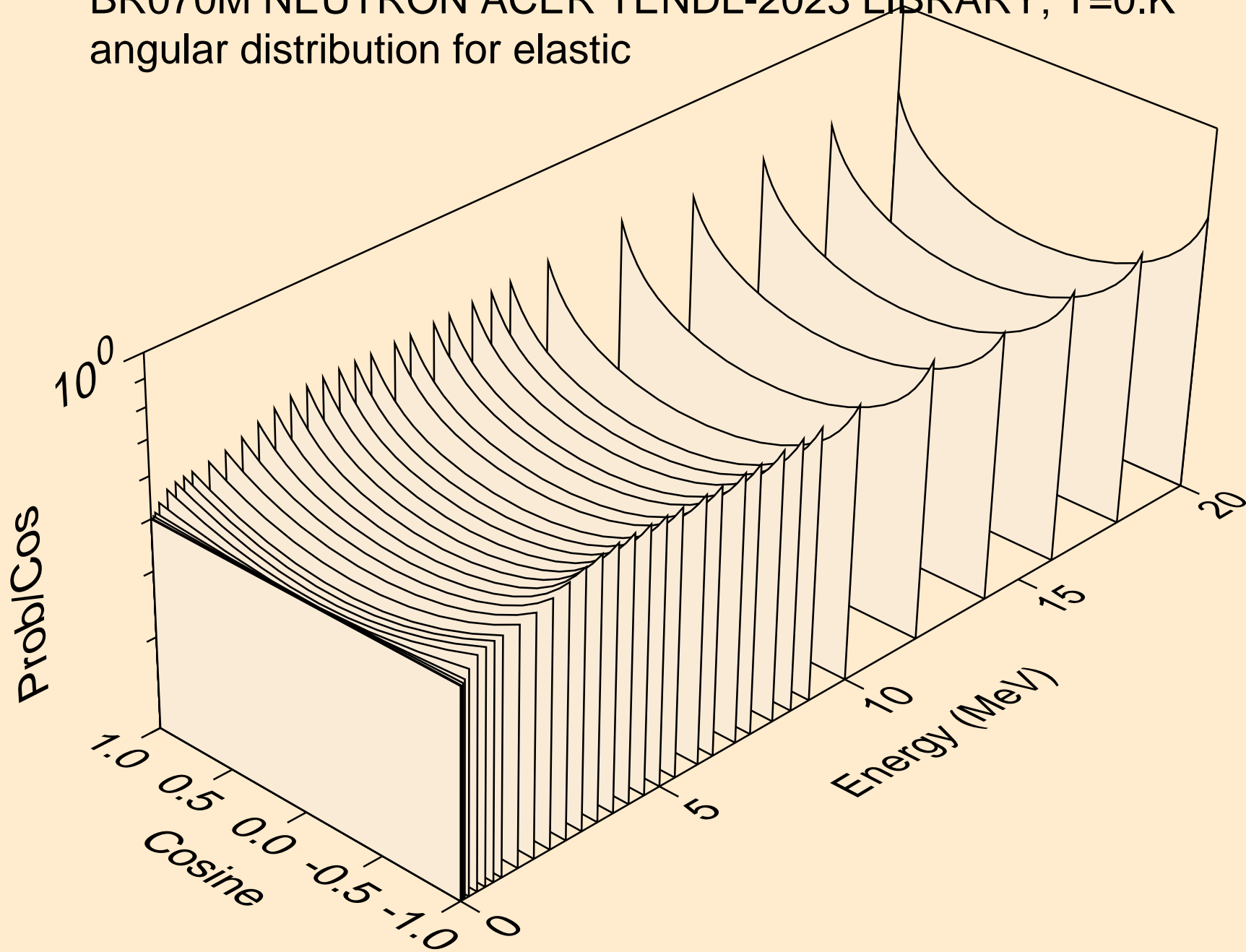

BR070M NEUTRON ACER TENDL-2023 LIBRARY; T=0.K
angular distribution for elastic

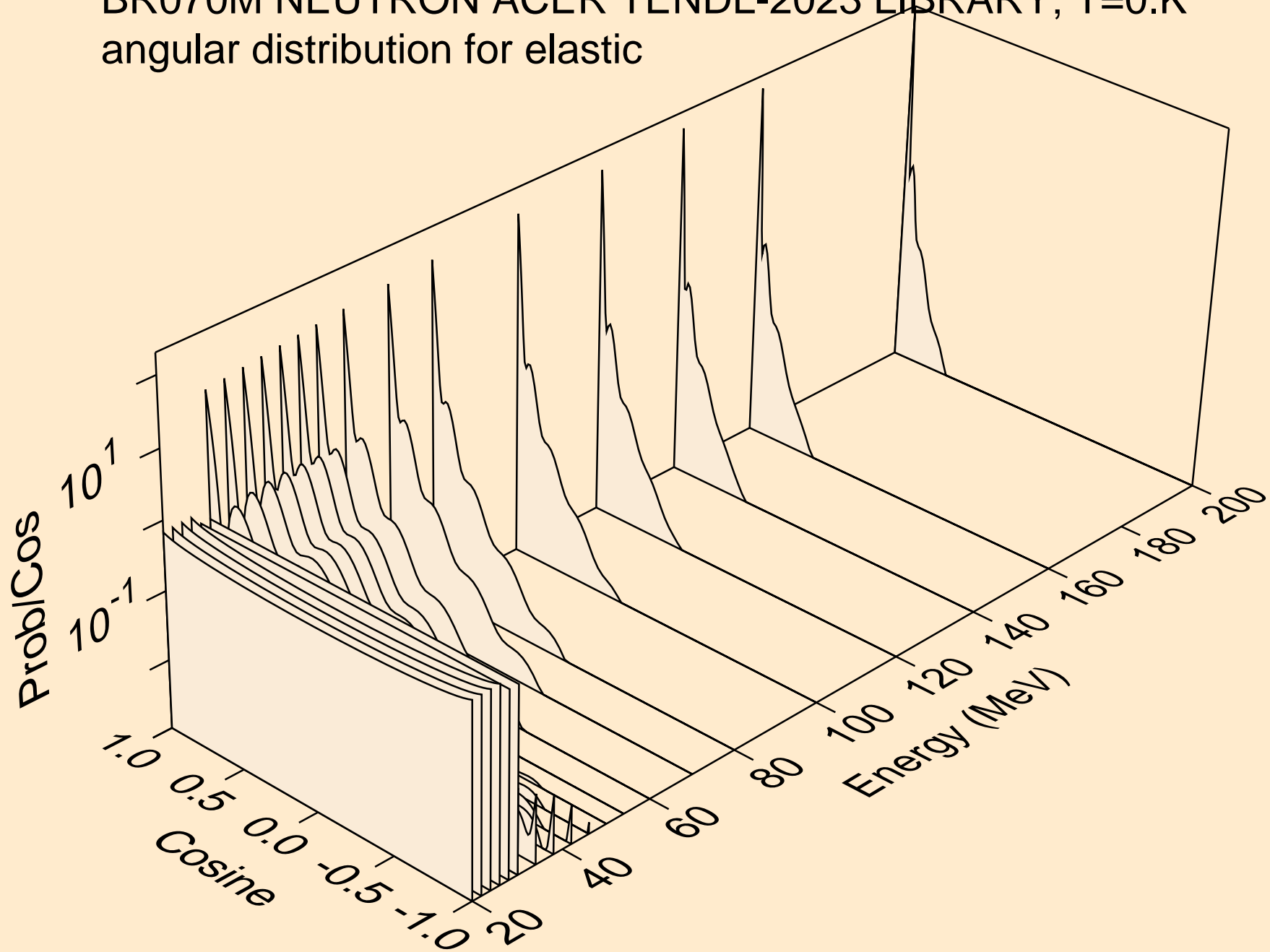

BR070M NEUTRON ACER TENDL-2023 LIBRARY; T=0.K
angular distribution for (n,n*1)

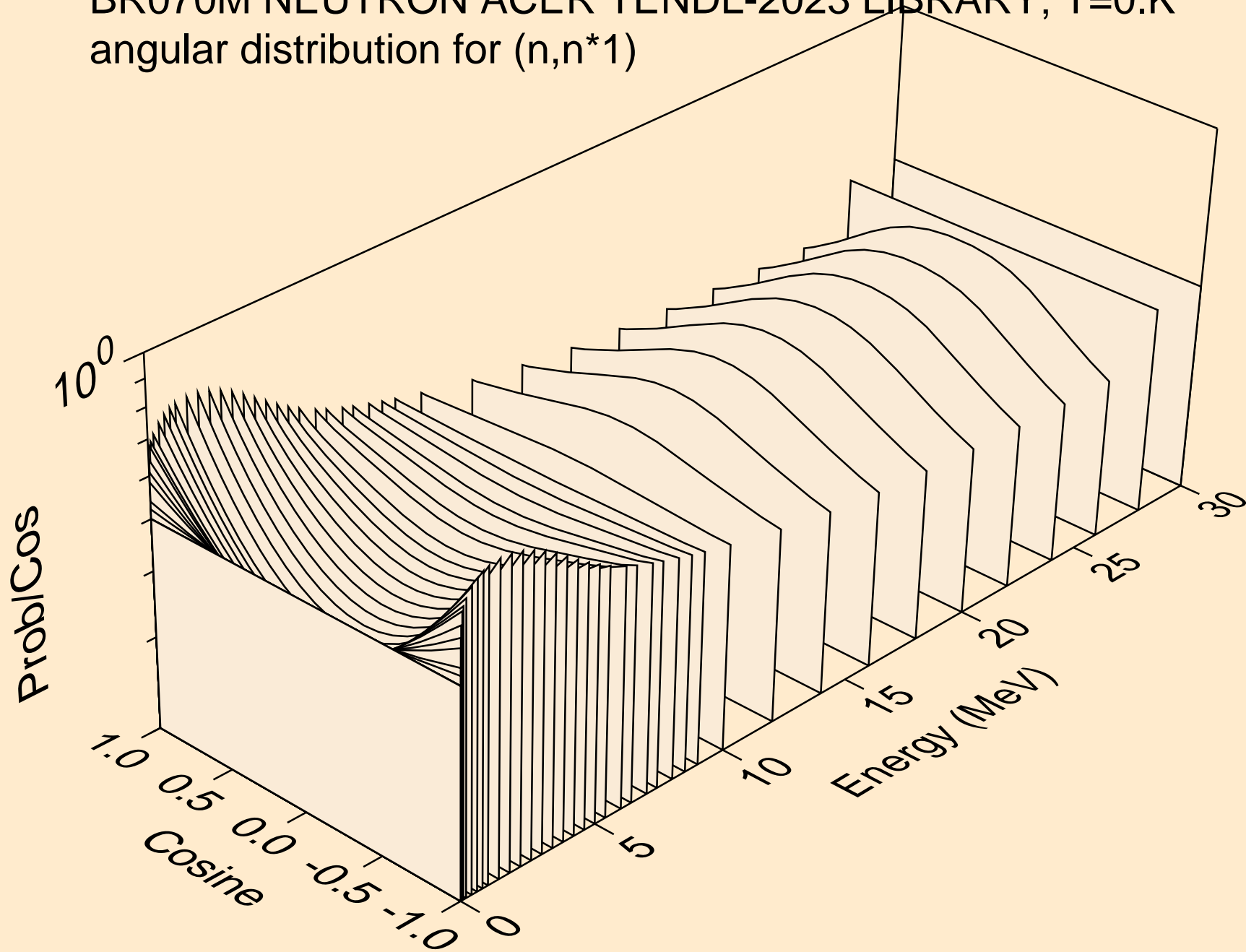

BR070M NEUTRON ACER TENDL-2023 LIBRARY; T=0.K
angular distribution for (n,n*2)

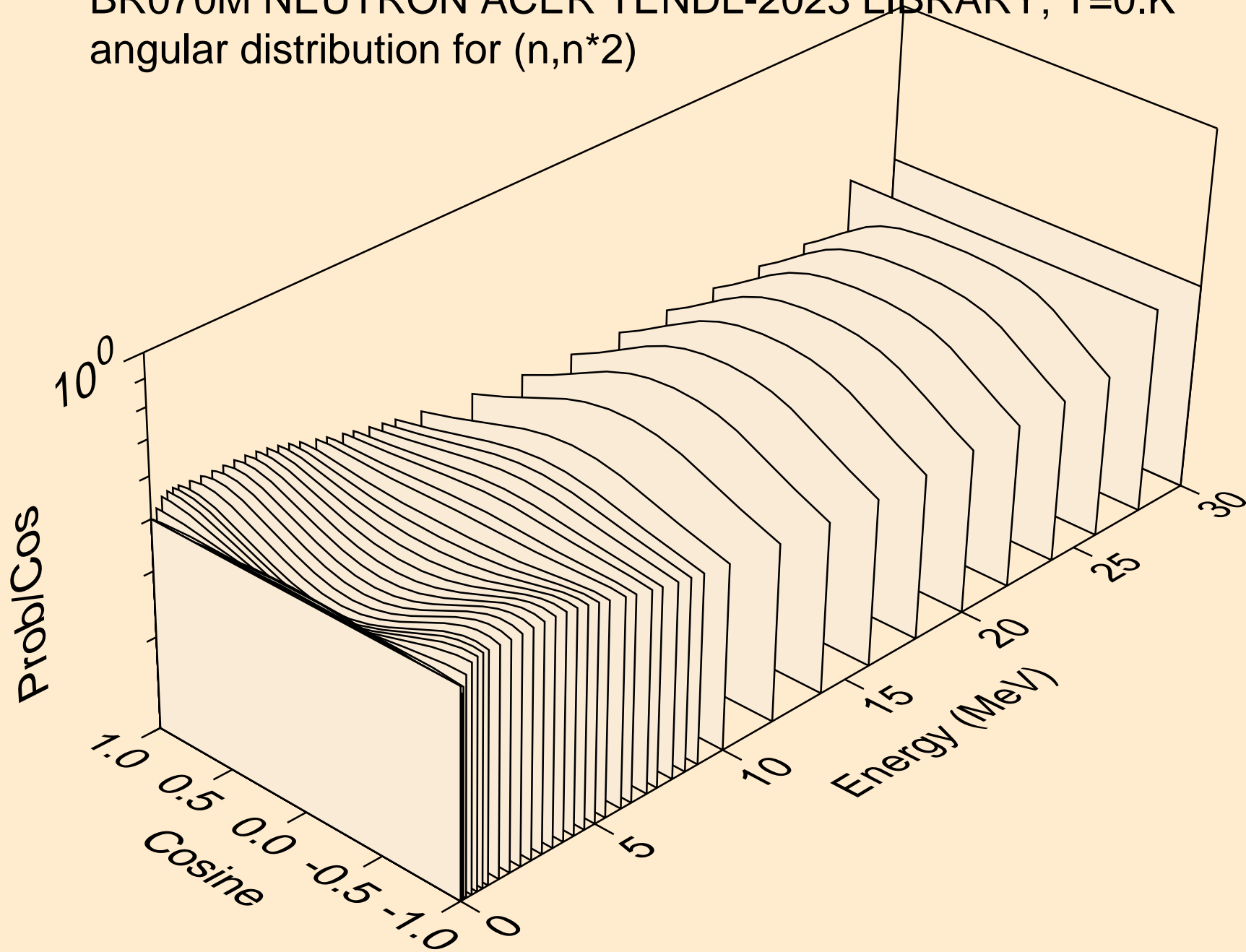

BR070M NEUTRON ACER TENDL-2023 LIBRARY; T=0.K
angular distribution for (n,n*3)

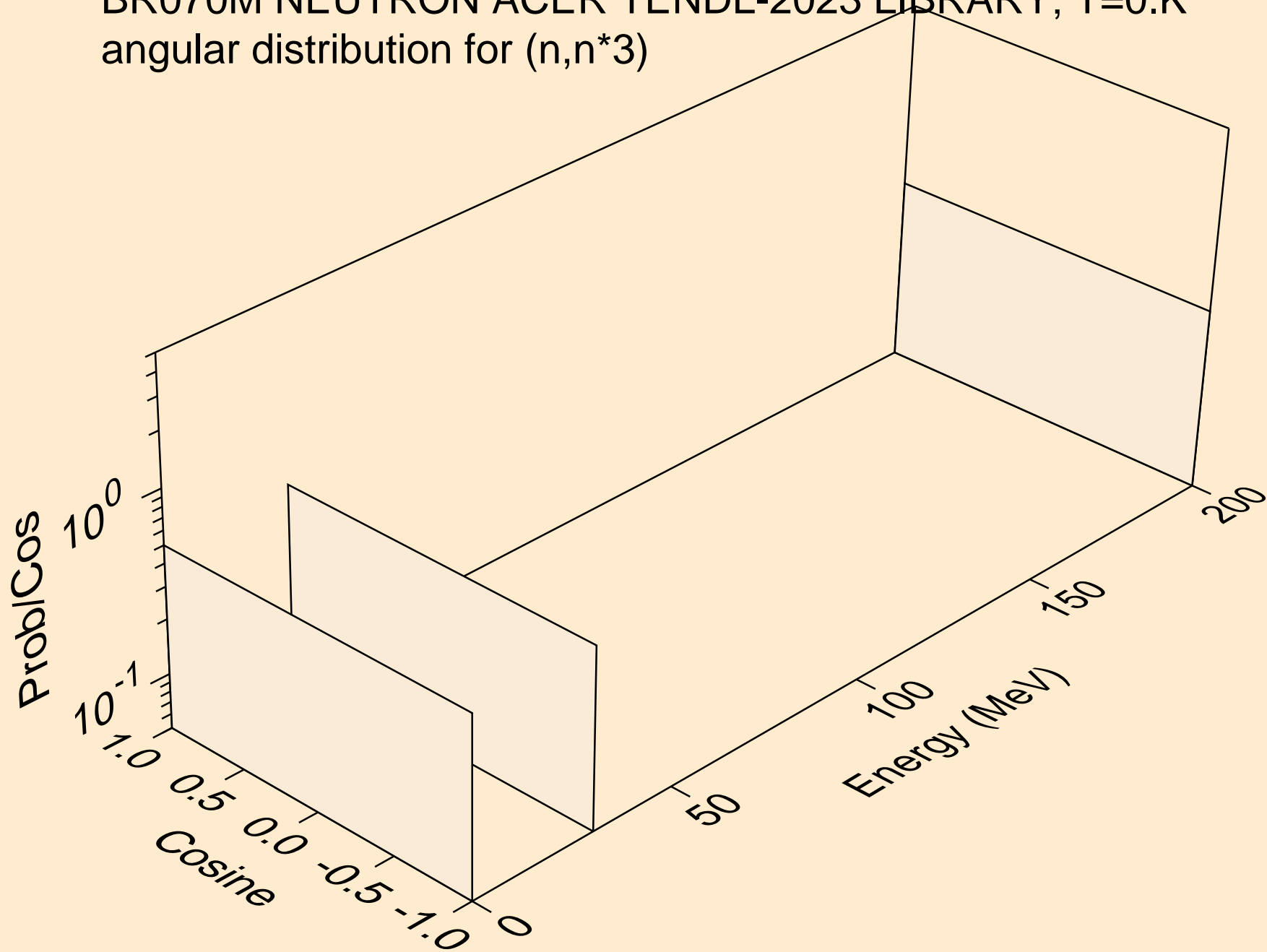

BR070M NEUTRON ACER TENDL-2023 LIBRARY; T=0.K
Neutron emission for (n,x)

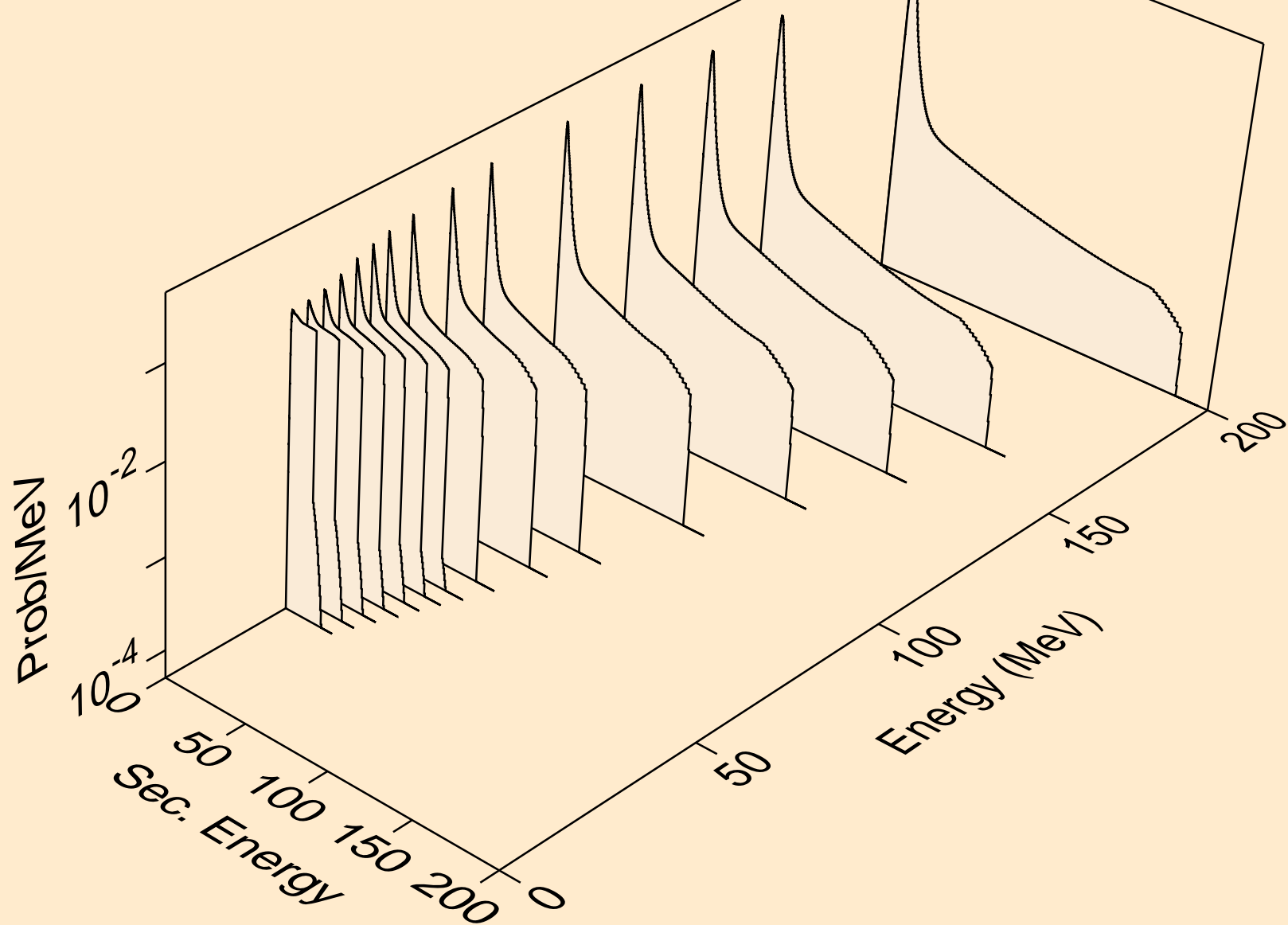

BR070M NEUTRON ACER TENDL-2023 LIBRARY; T=0.K
Neutron emission for (n,2n)

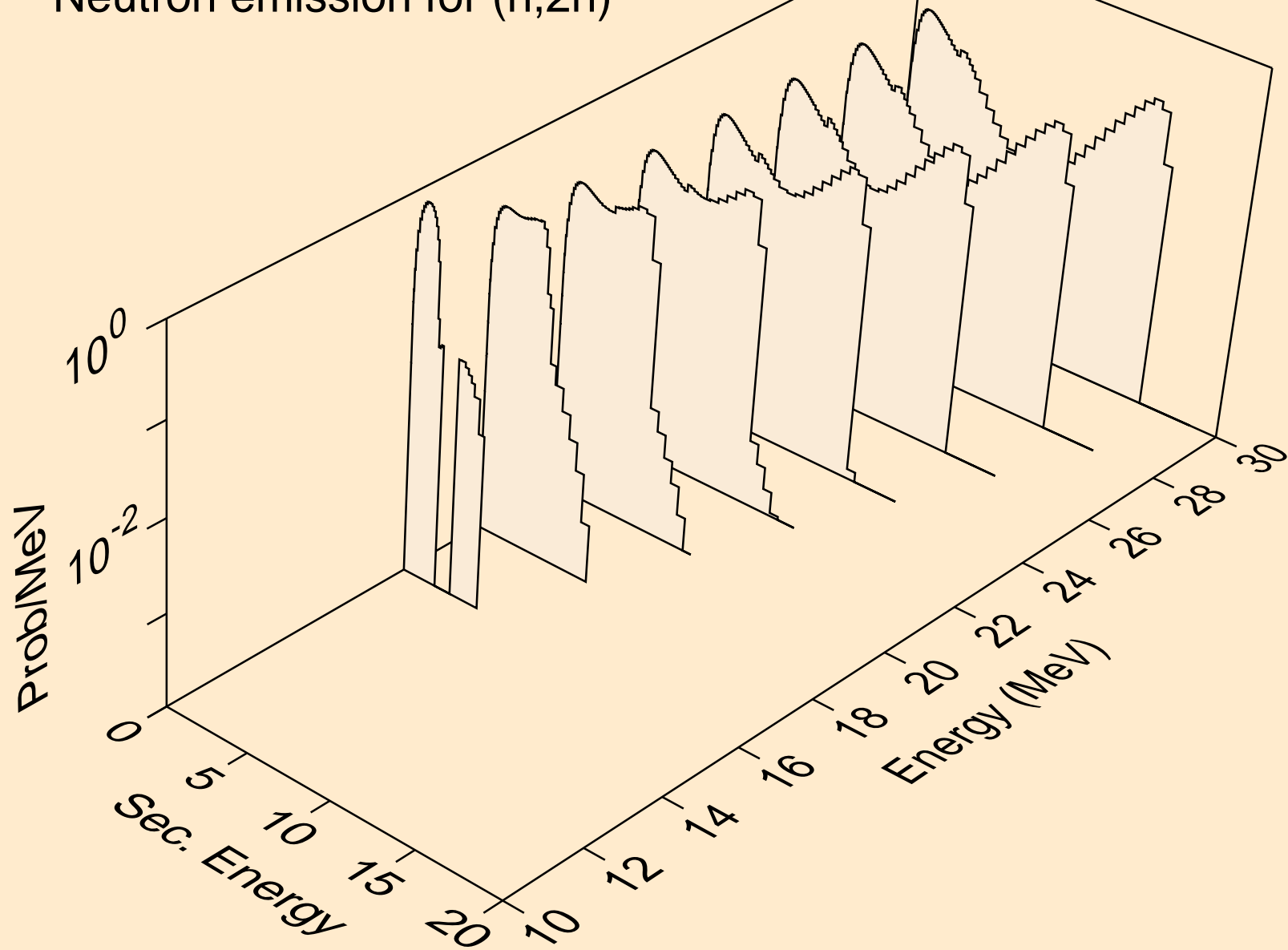

BR070M NEUTRON ACER TENDL-2023 LIBRARY; T=0.K
Neutron emission for (n,3n)

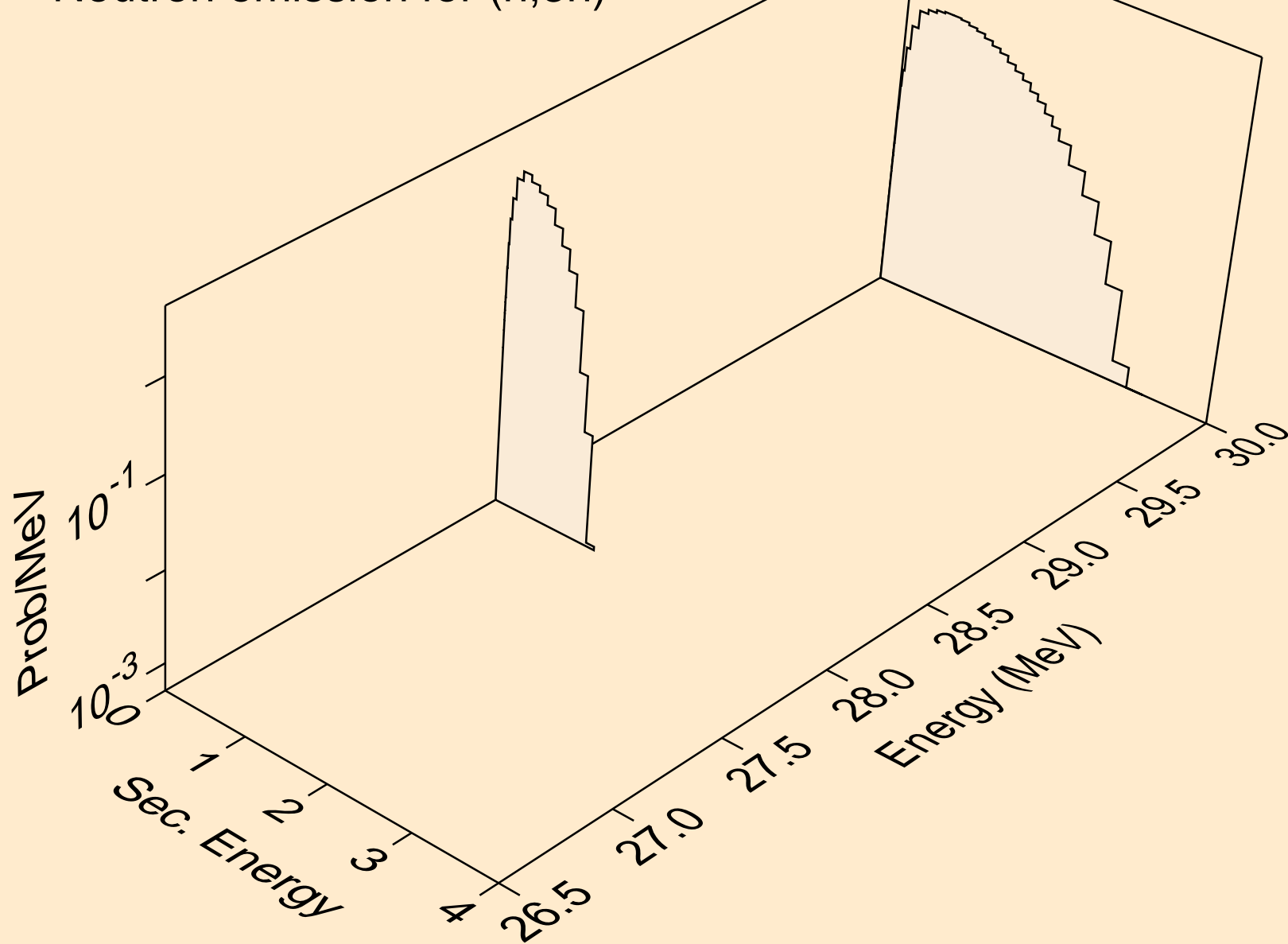

BR070M NEUTRON ACER TENDL-2023 LIBRARY; T=0.K
Neutron emission for (n,n*)a

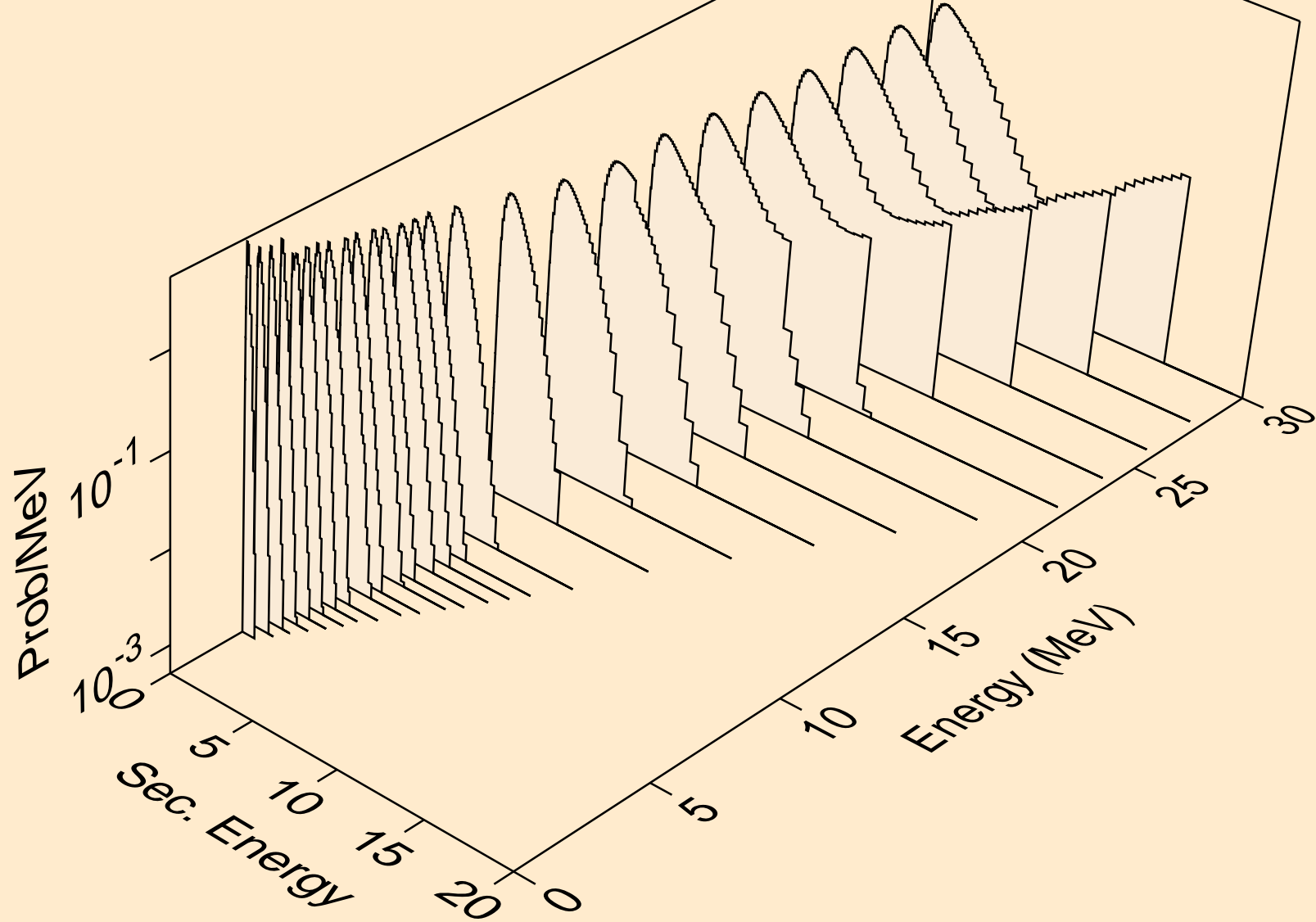

BR070M NEUTRON ACER TENDL-2023 LIBRARY; T=0.K
Neutron emission for (n,2n)a

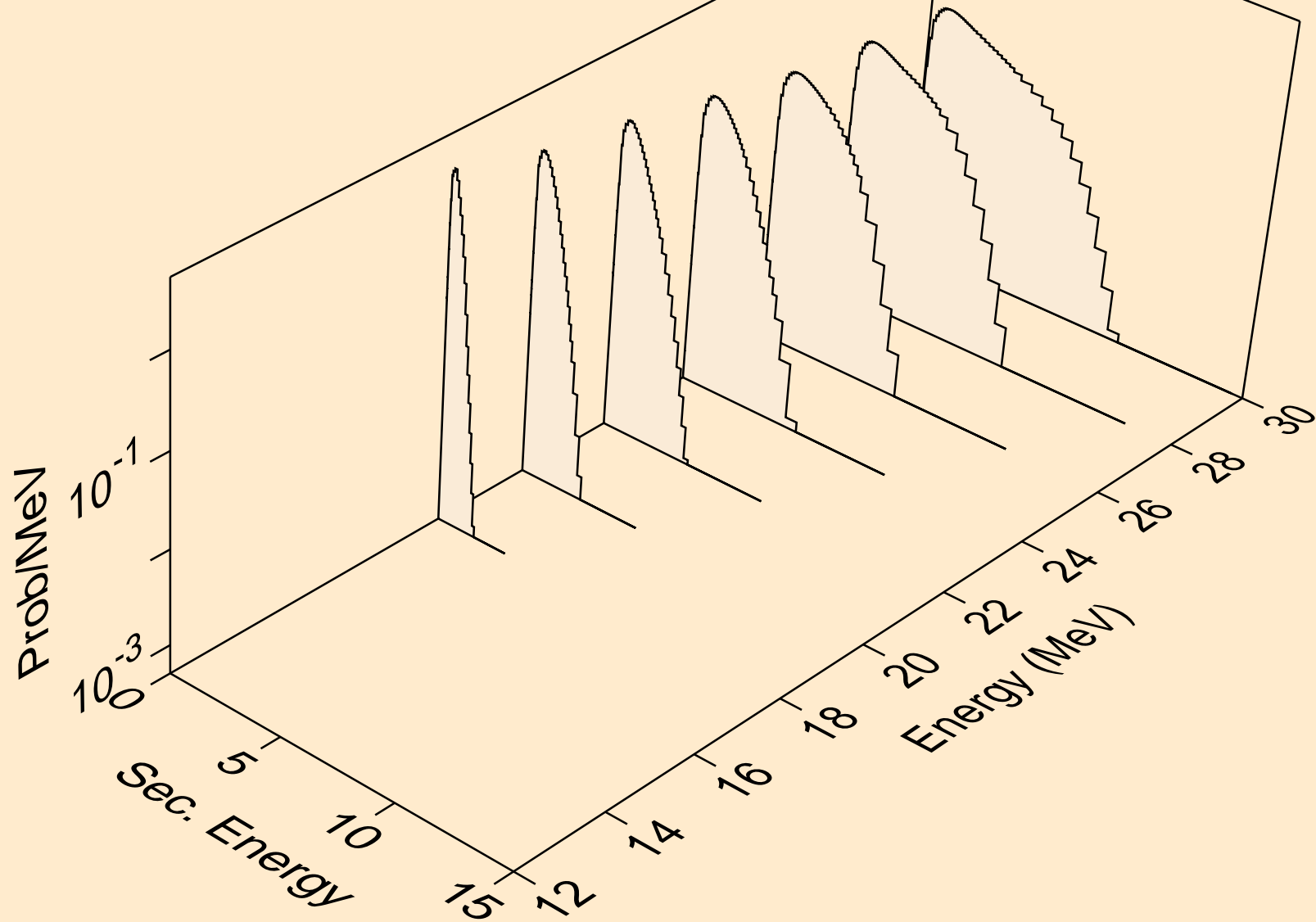

BR070M NEUTRON ACER TENDL-2023 LIBRARY; T=0.K
Neutron emission for (n,n*)p

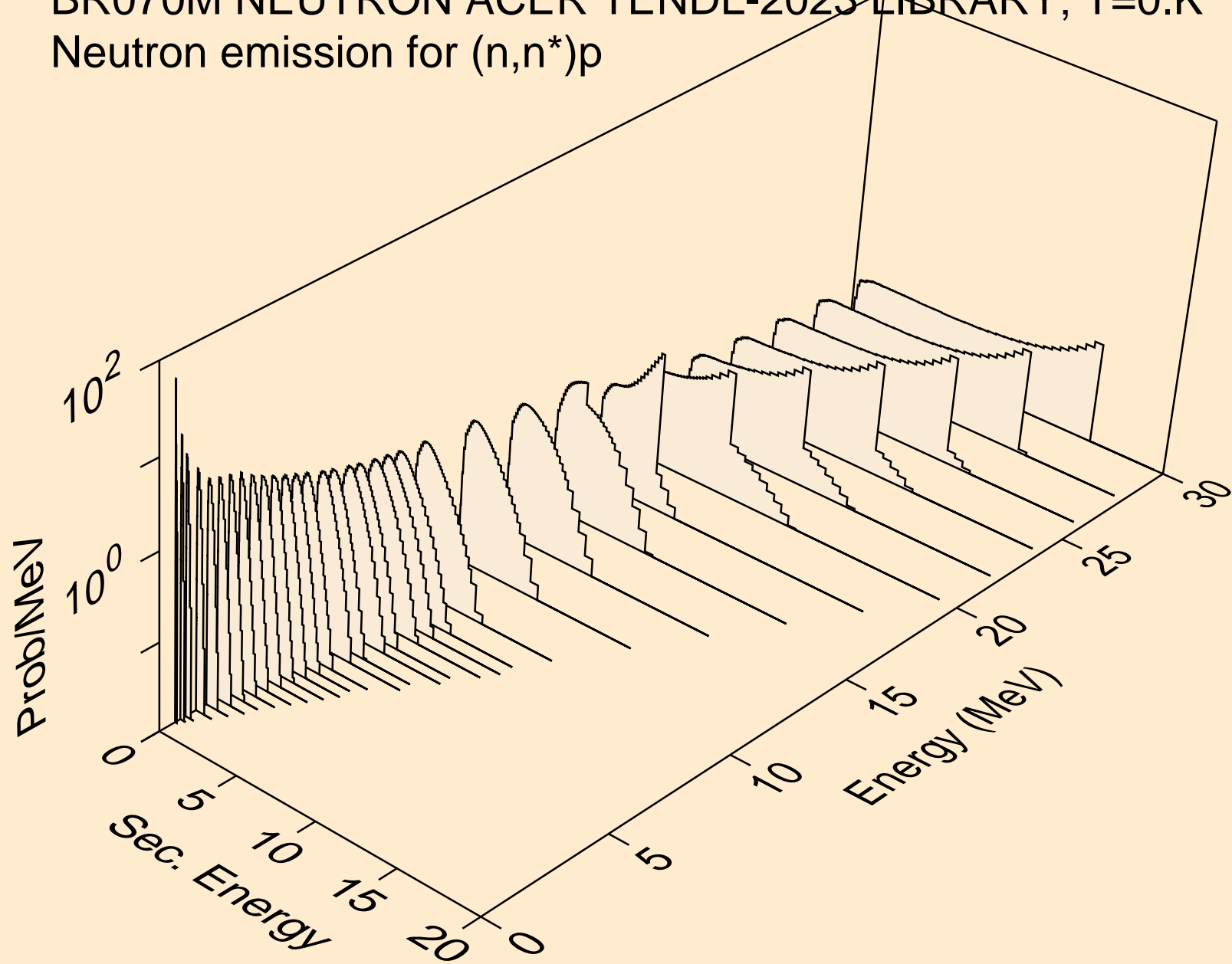

BR070M NEUTRON ACER TENDL-2023 LIBRARY; T=0.K
Neutron emission for (n,n*)2a

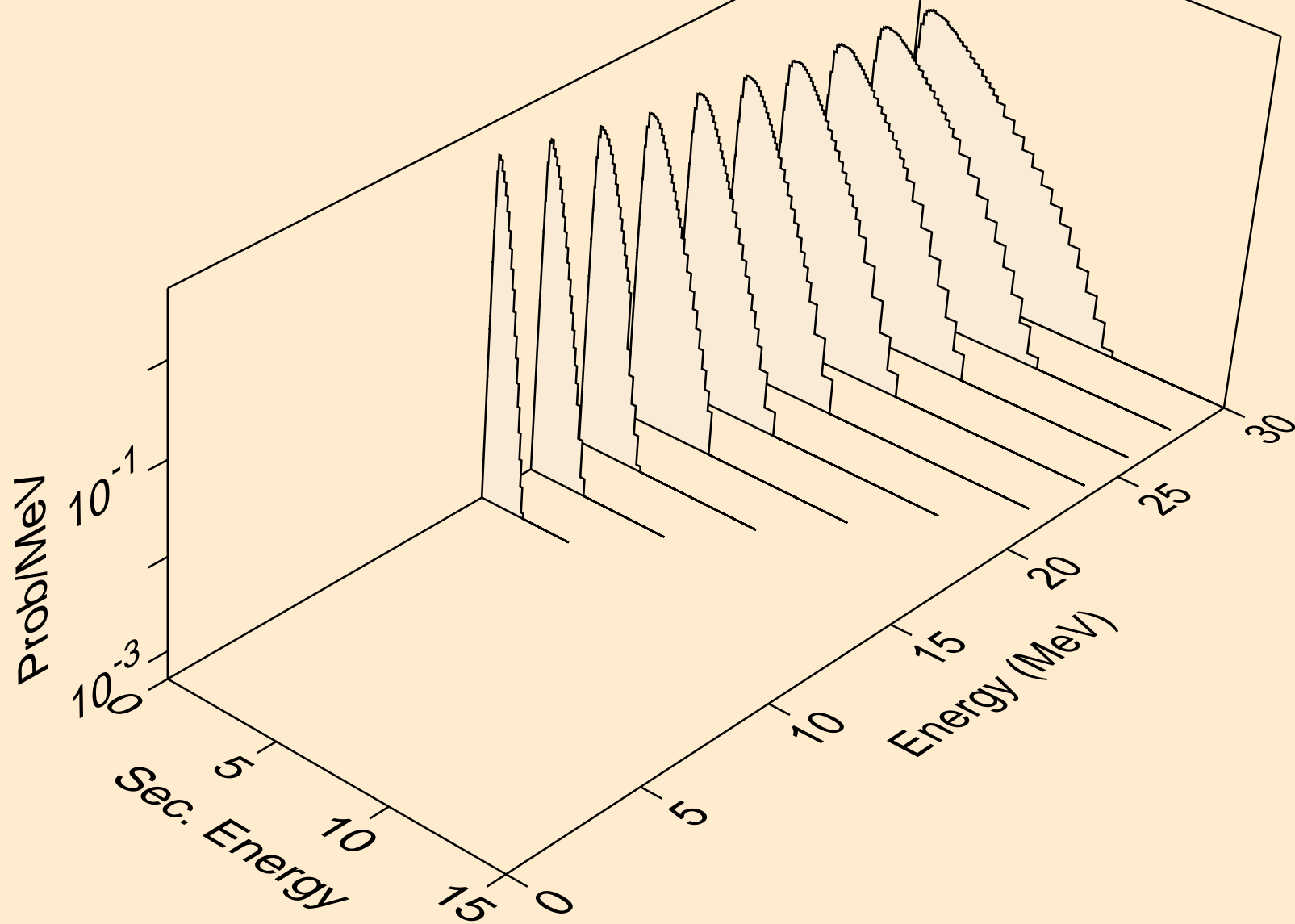

BR070M NEUTRON ACER TENDL-2023 LIBRARY; T=0.K
Neutron emission for (n,n*)d

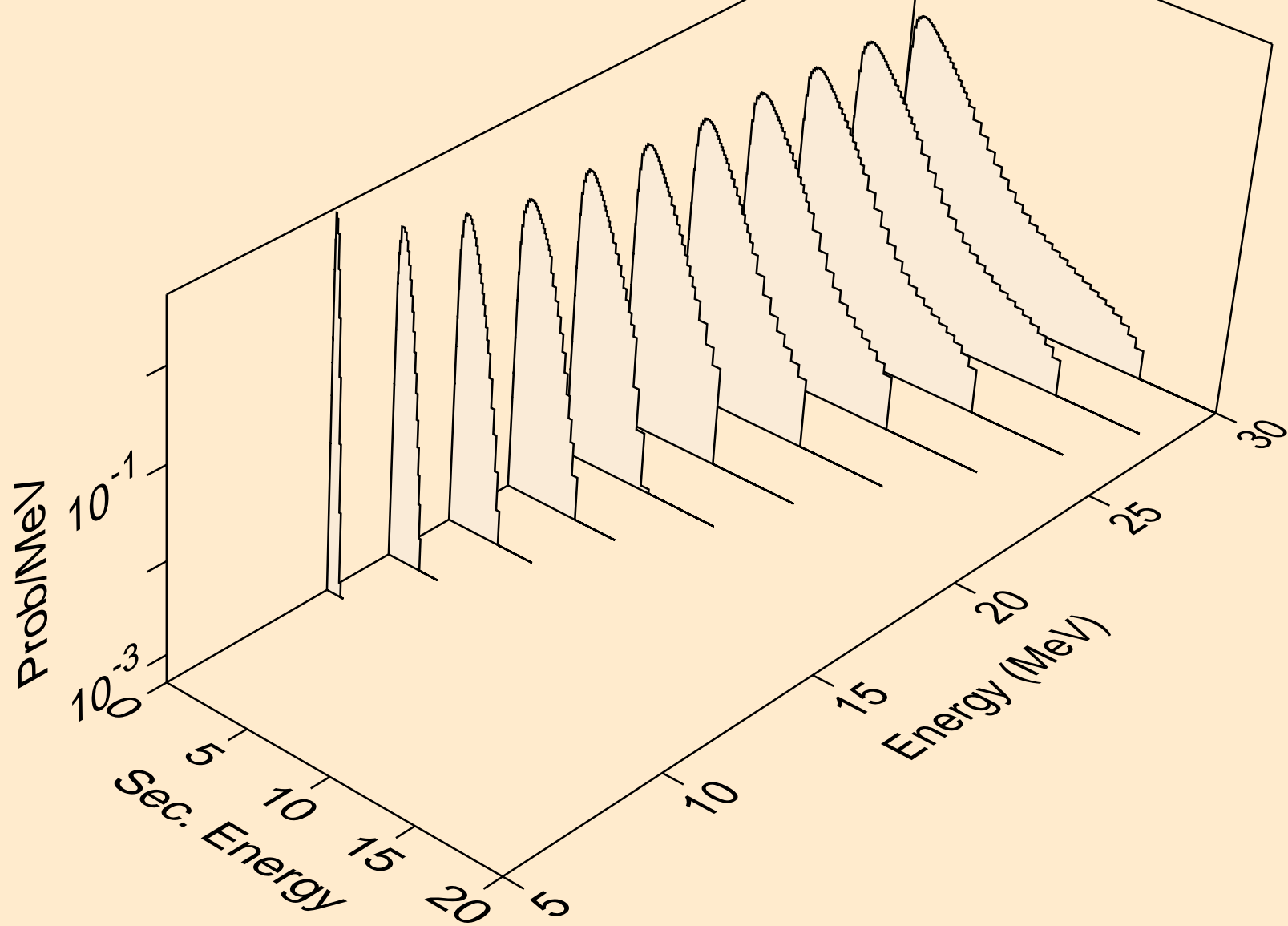

BR070M NEUTRON ACER TENDL-2023 LIBRARY; T=0.K
Neutron emission for (n,n*)t

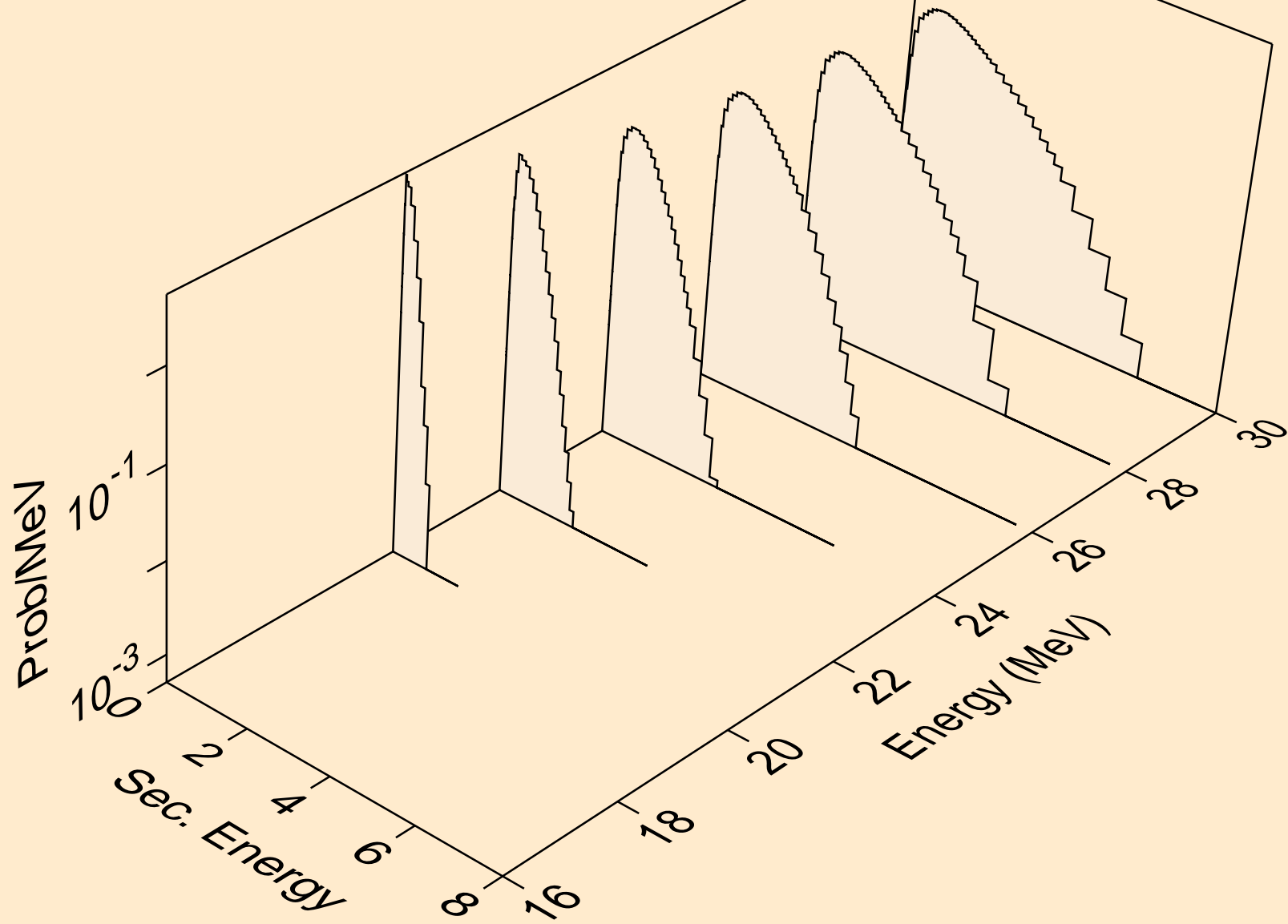

BR070M NEUTRON ACER TENDL-2023 LIBRARY; T=0.K
Neutron emission for (n,n*)he3

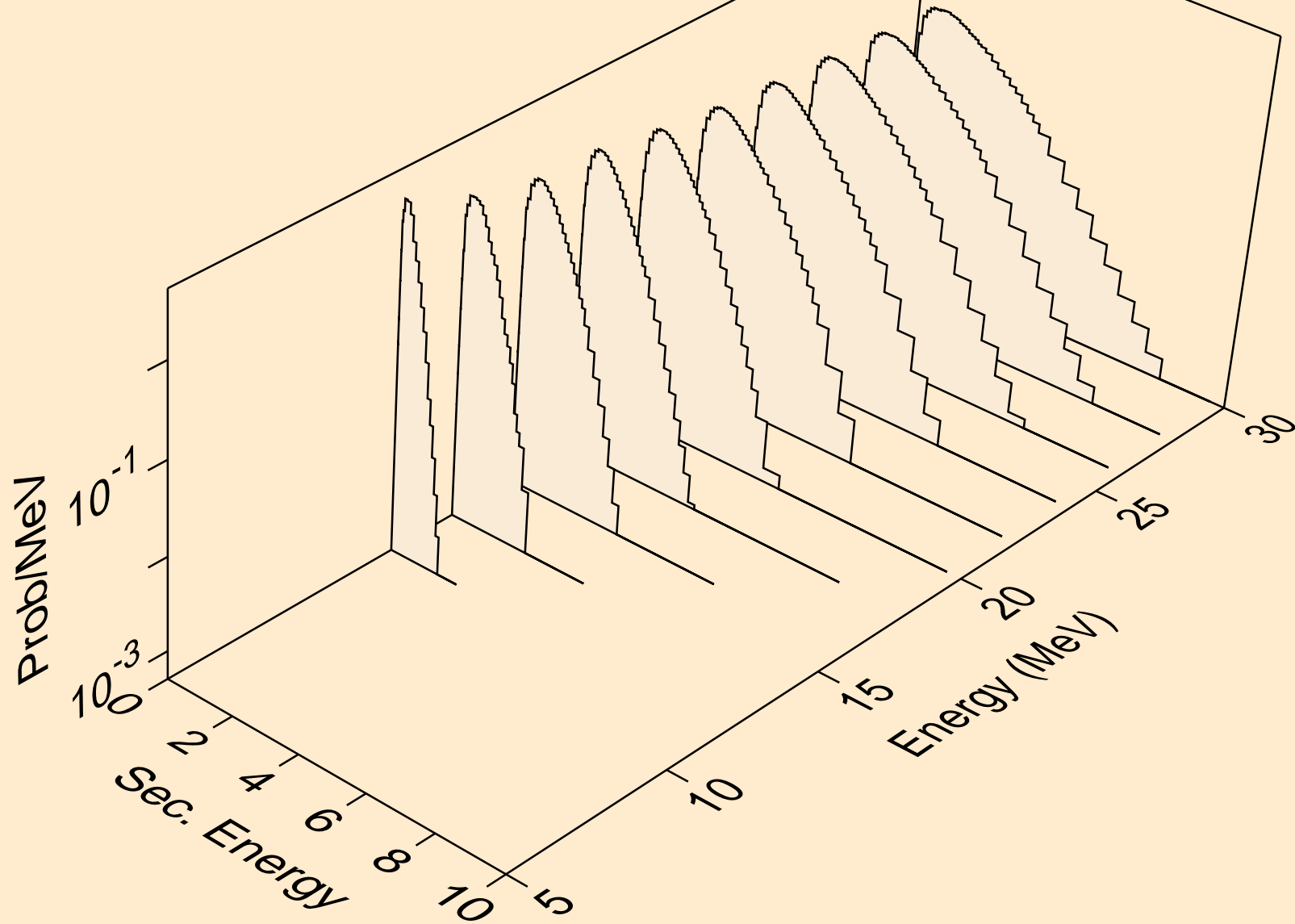

BR070M NEUTRON ACER TENDL-2023 LIBRARY; T=0.K
Neutron emission for (n,2np)

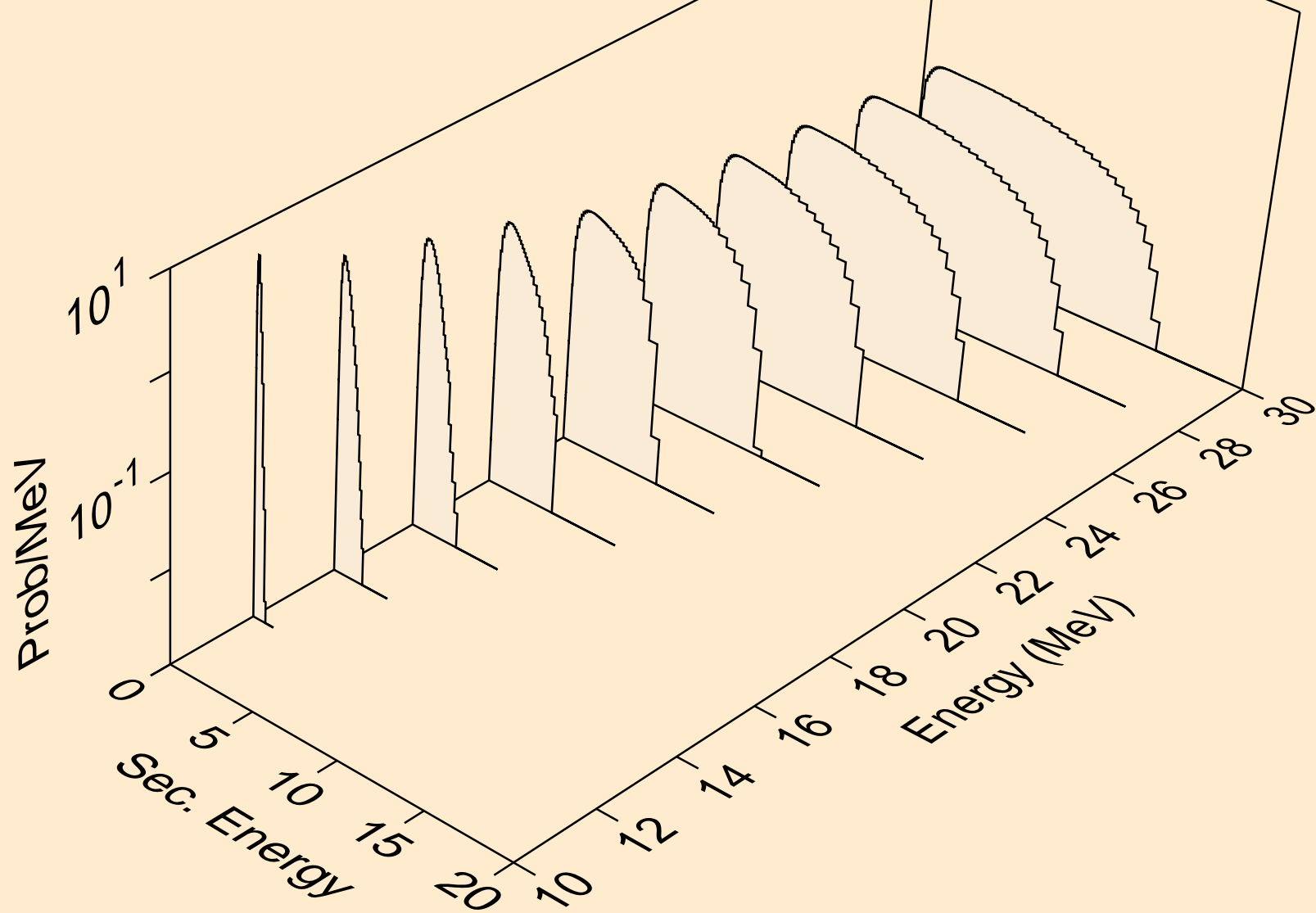

BR070M NEUTRON ACER TENDL-2023 LIBRARY; T=0.K
Neutron emission for (n,3np)

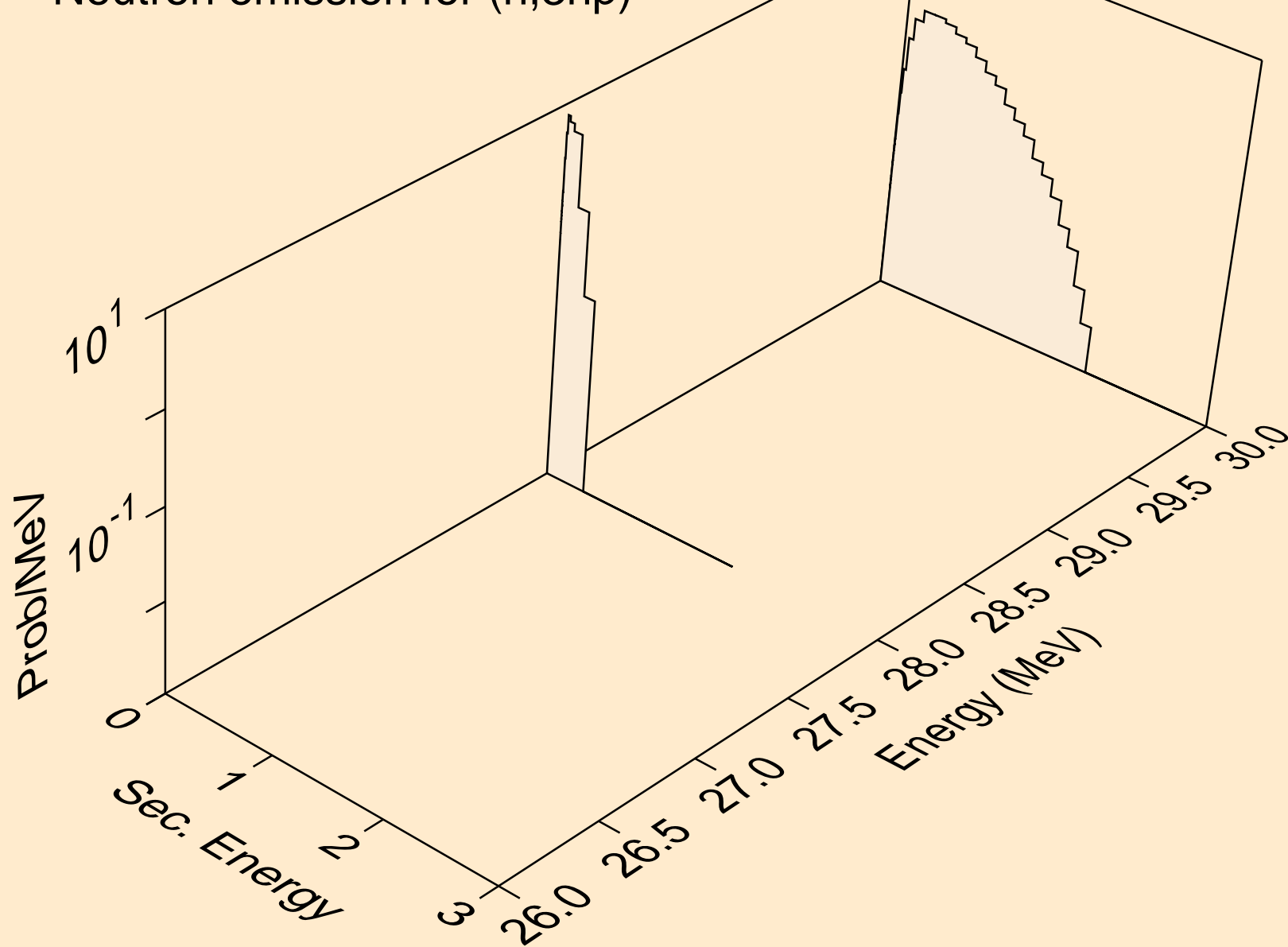

BR070M NEUTRON ACER TENDL-2023 LIBRARY; T=0.K
Neutron emission for (n,n2p)

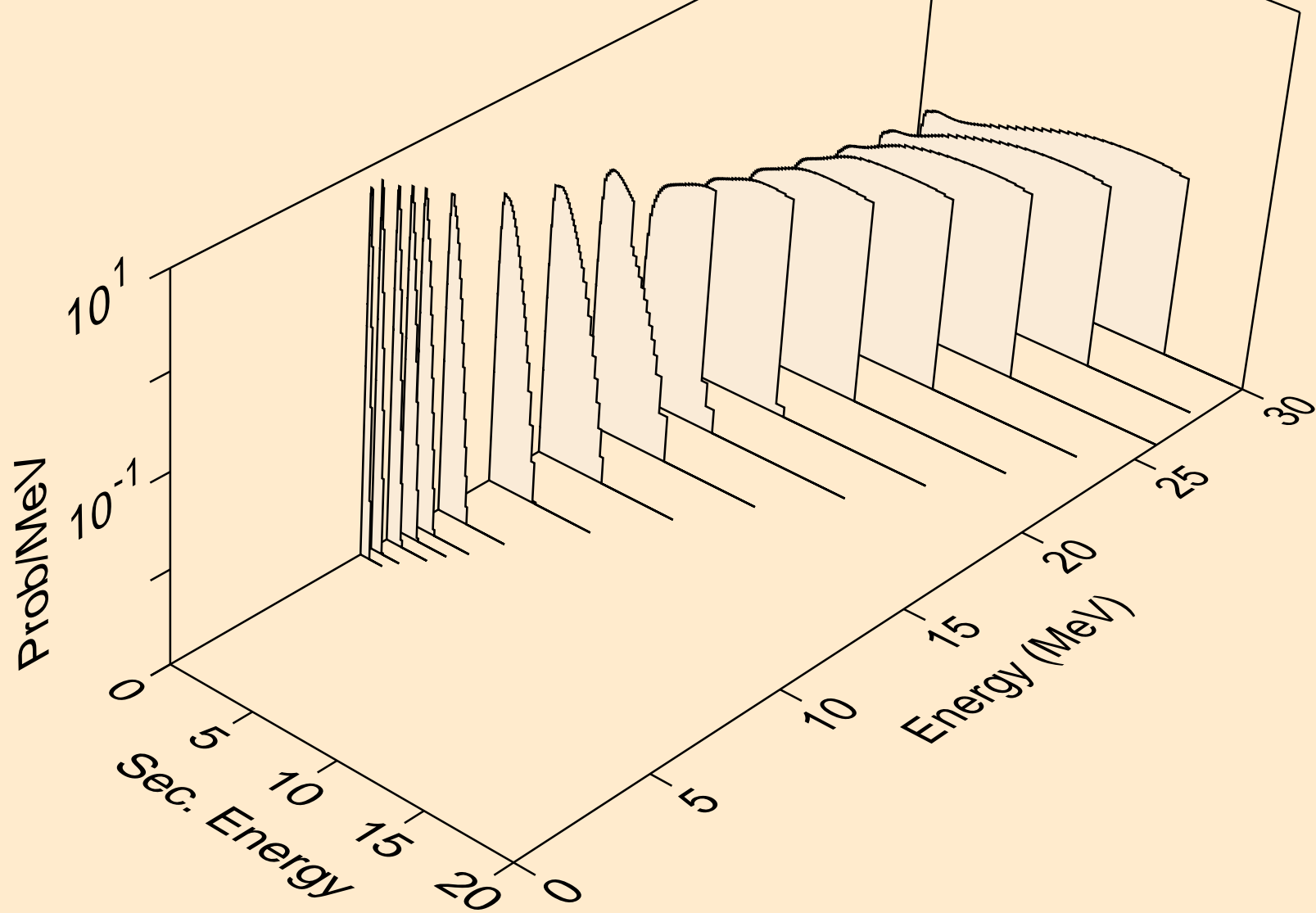

BR070M NEUTRON ACER TENDL-2023 LIBRARY; T=0.K
Neutron emission for (n,npa)

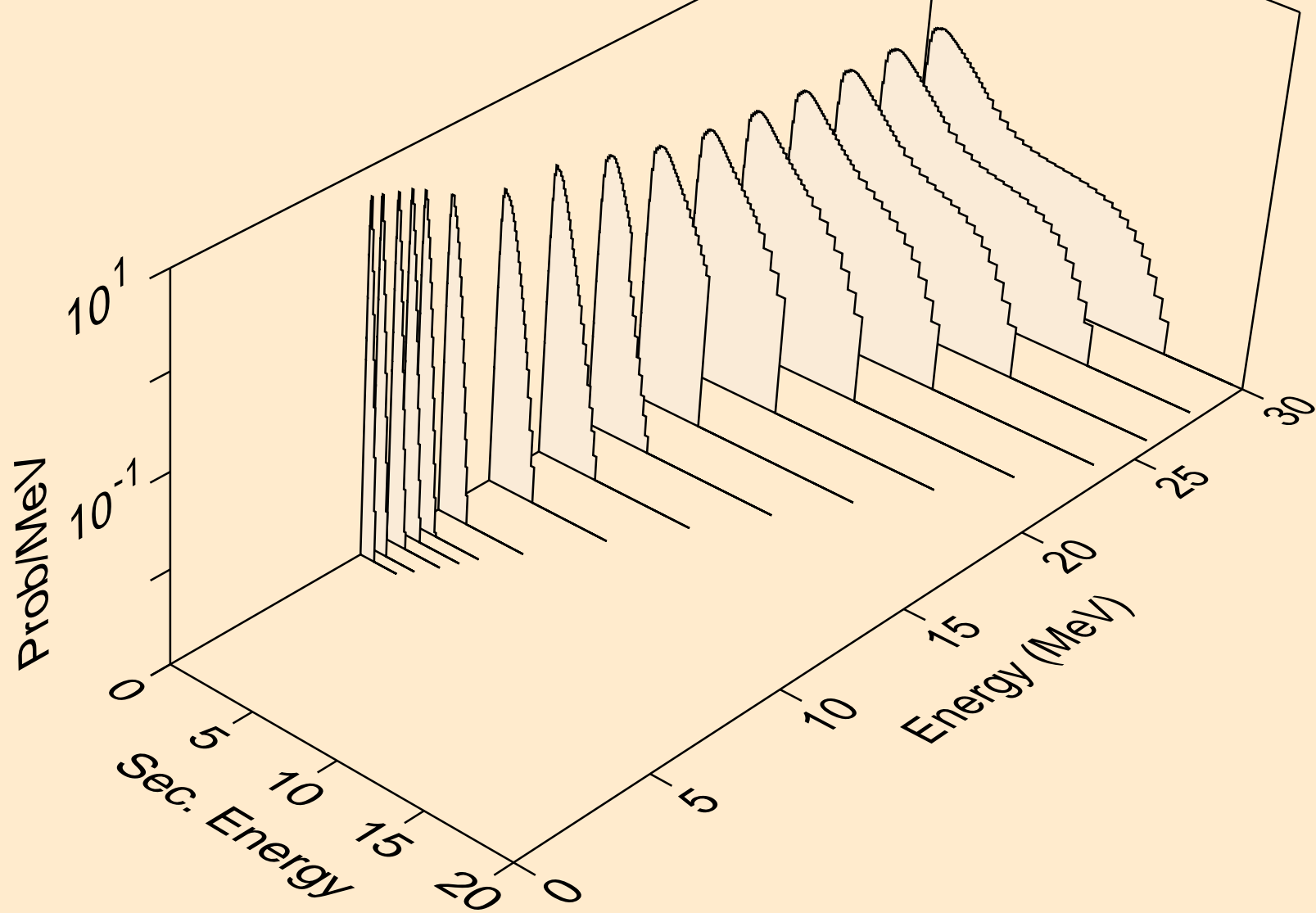

BR070M NEUTRON ACER TENDL-2023 LIBRARY; T=0.K
Neutron emission for (n,n*c)

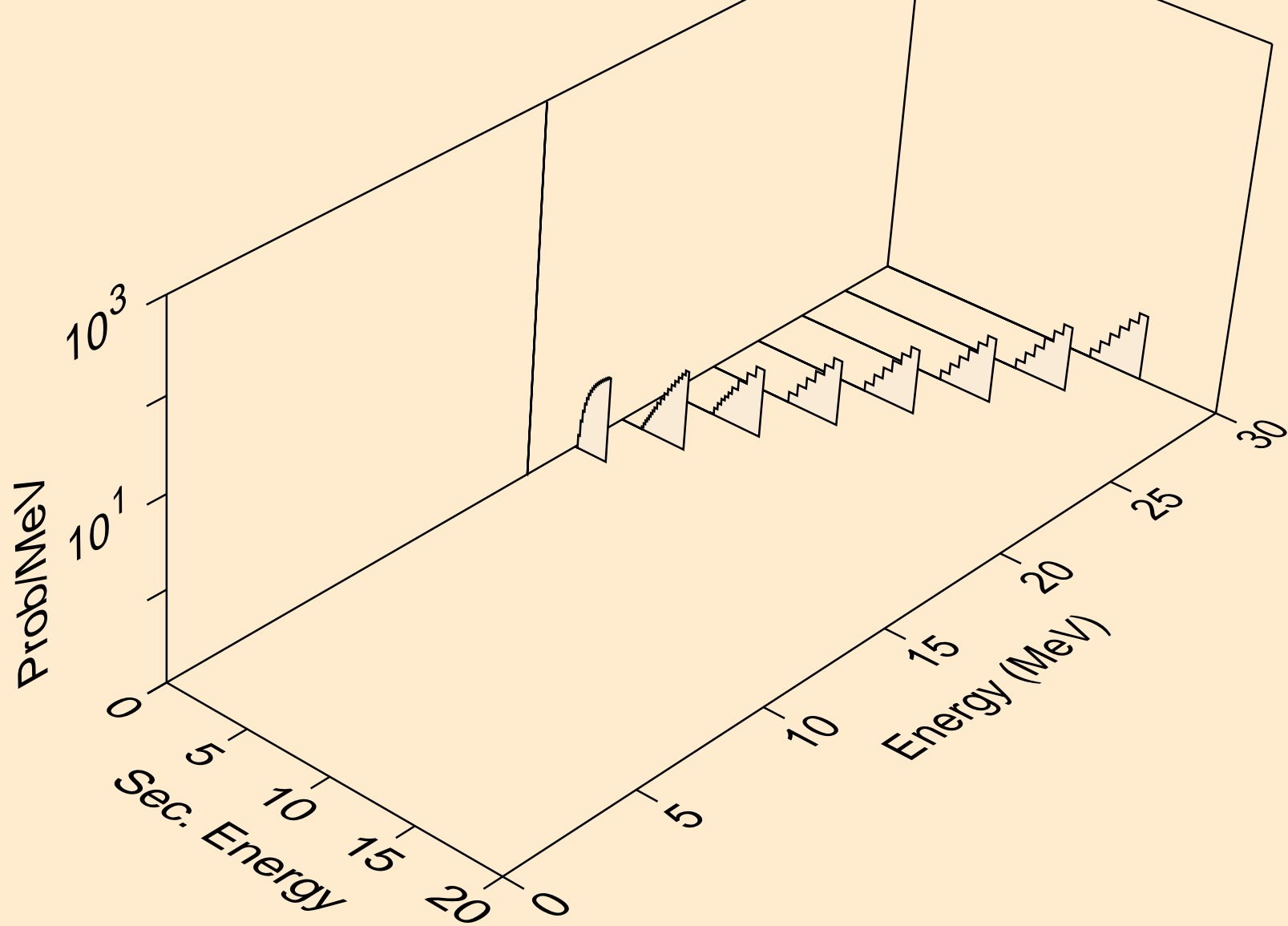

BR070M NEUTRON ACER TENDL-2023 LIBRARY; T=0.K
Photon emission for (n,x)

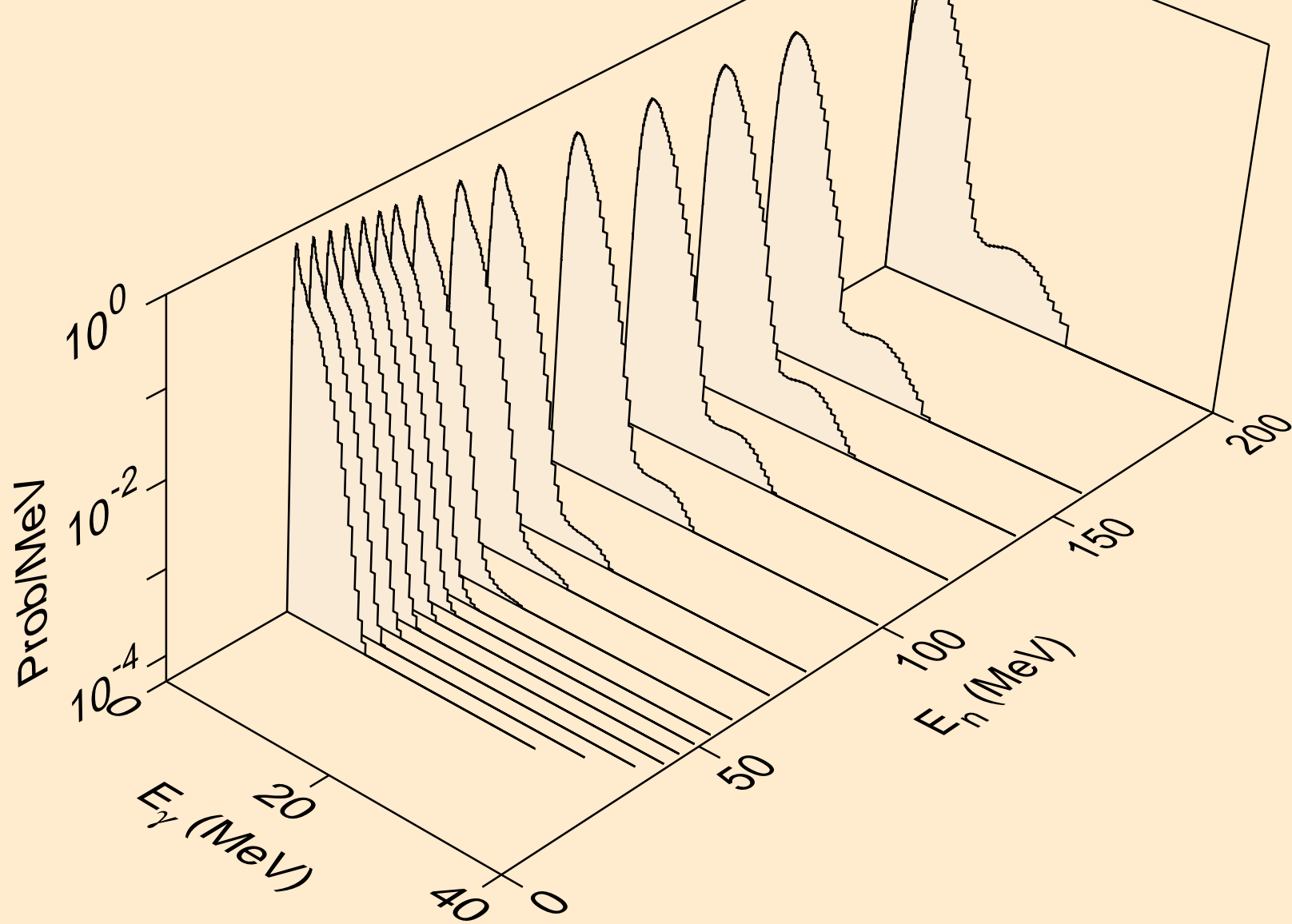

BR070M NEUTRON ACER TENDL-2023 LIBRARY; T=0.K
Photon emission for (n,2n)

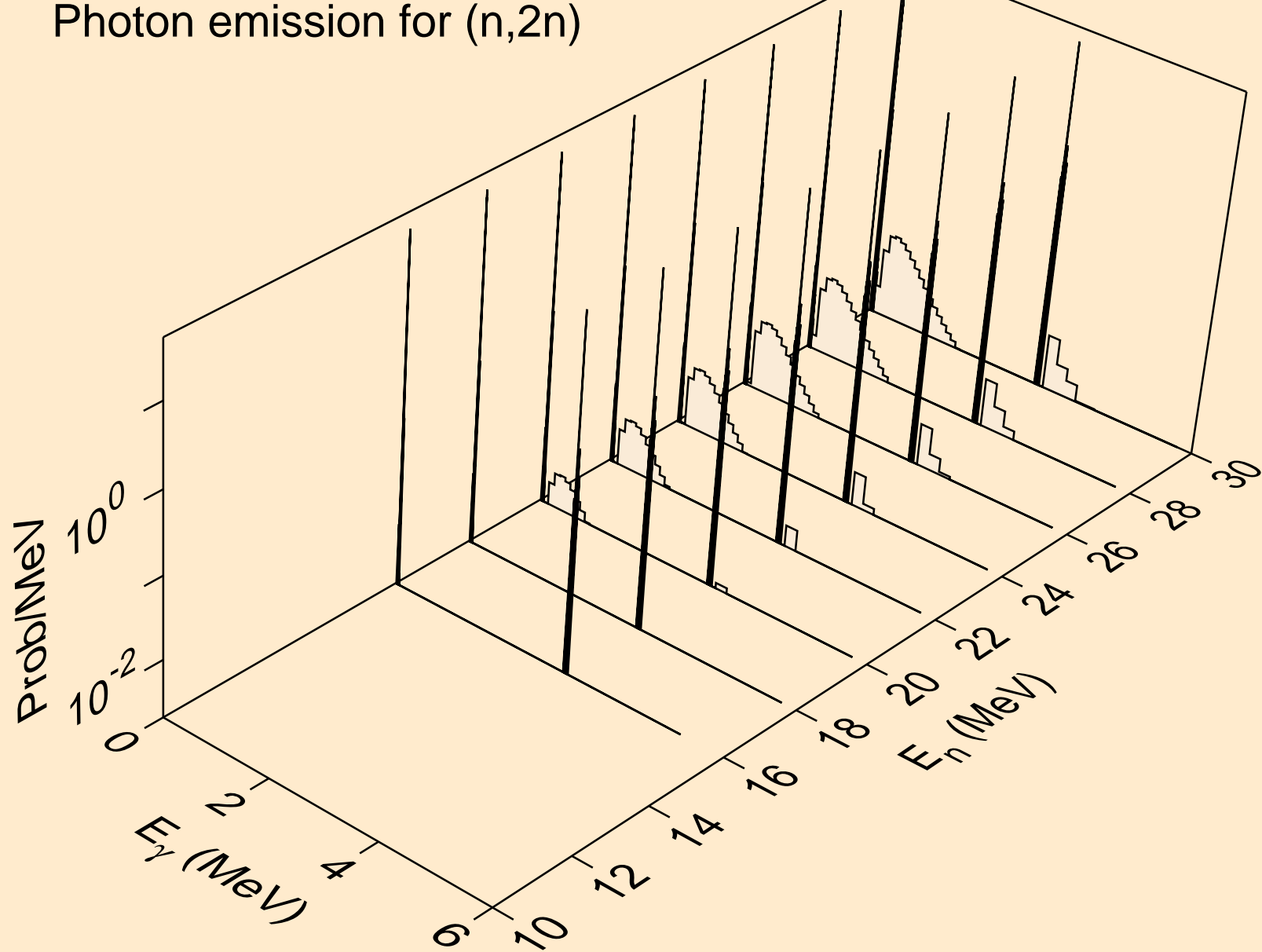

BR070M NEUTRON ACER TENDL-2023 LIBRARY; T=0.K
Photon emission for (n,3n)

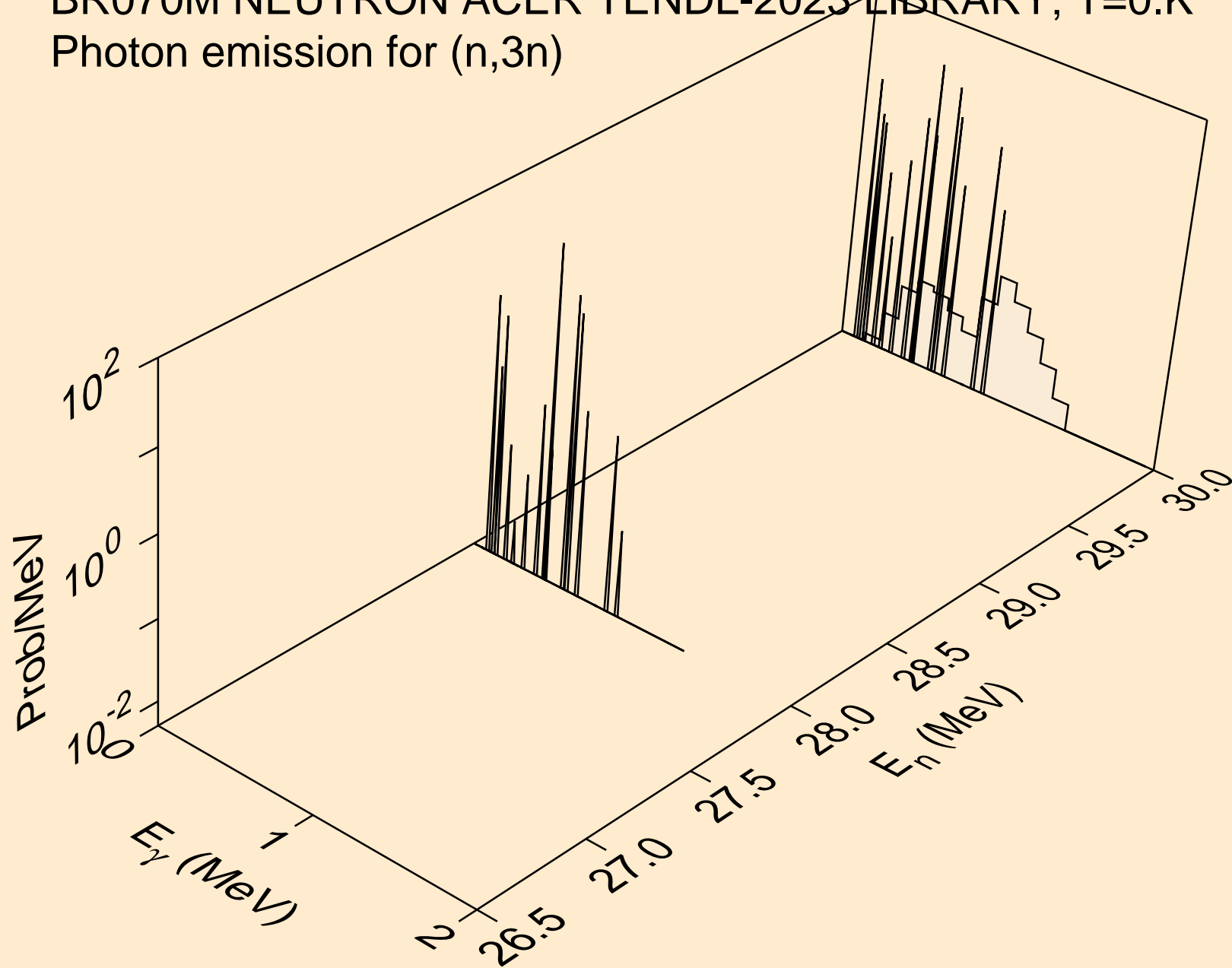

BR070M NEUTRON ACER TENDL-2023 LIBRARY; T=0.K
Photon emission for (n,n*)a

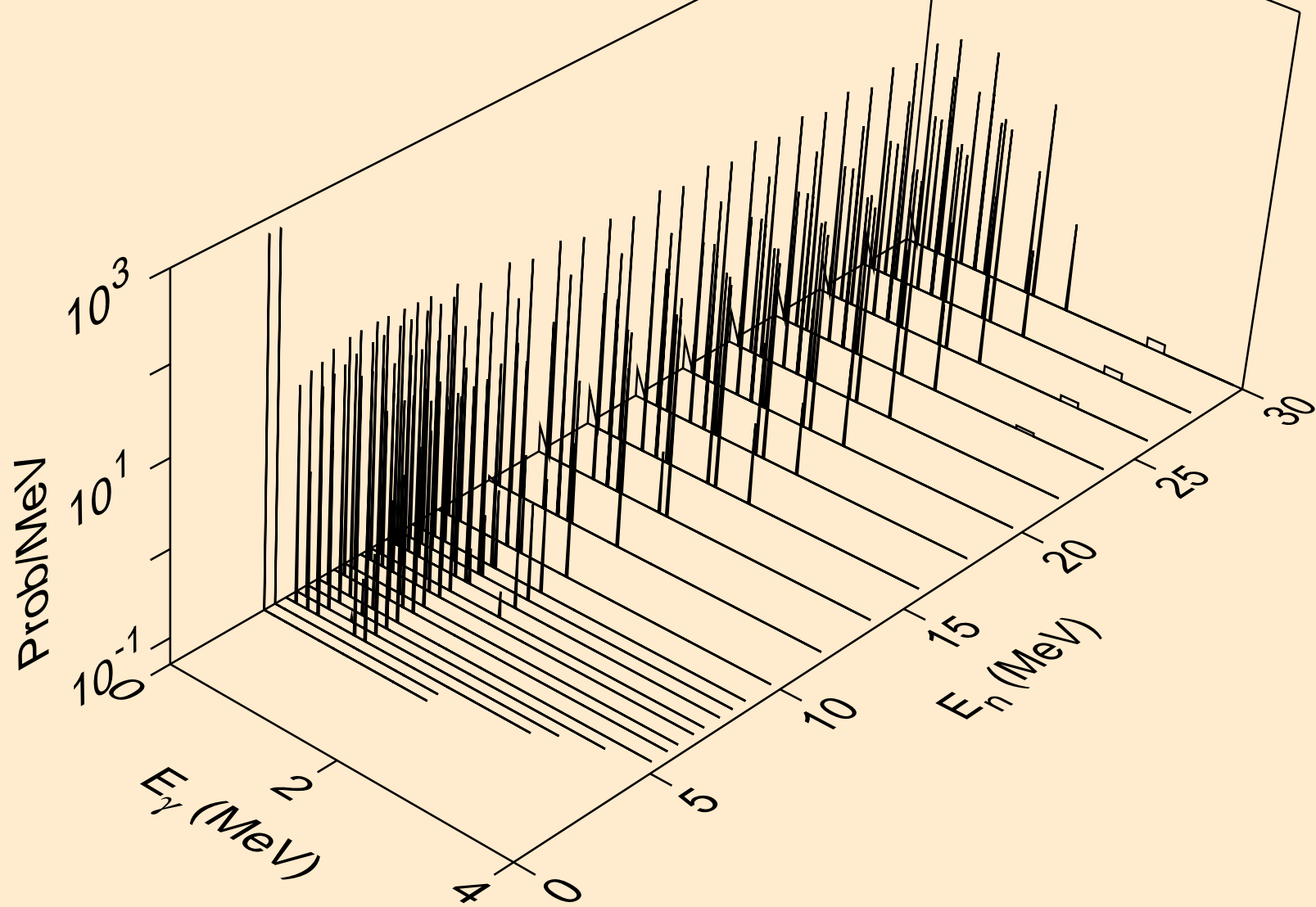

BR070M NEUTRON ACER TENDL-2023 LIBRARY; T=0.K
Photon emission for (n,2n)a

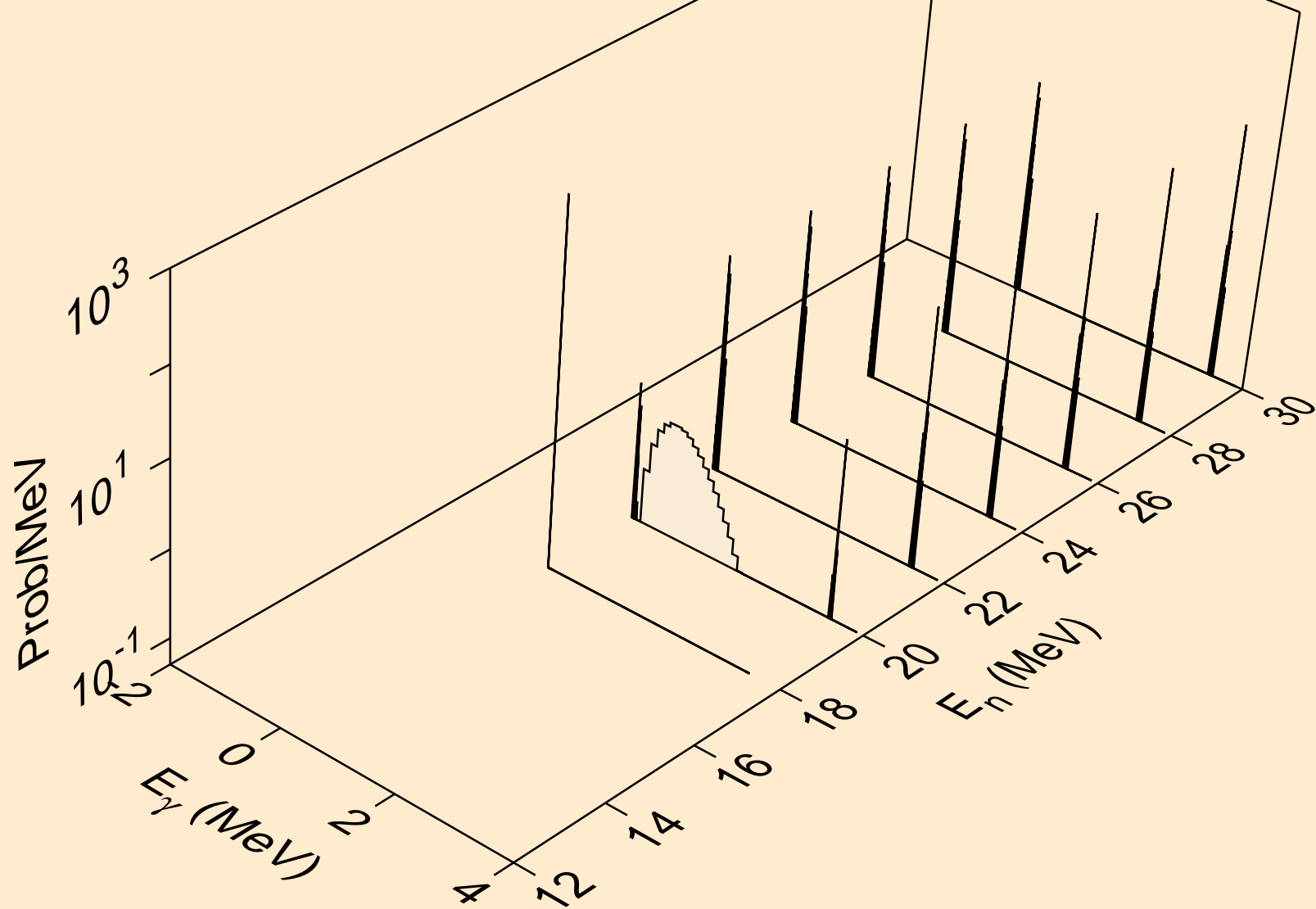

BR070M NEUTRON ACER TENDL-2023 LIBRARY; T=0.K
Photon emission for (n,n*)p

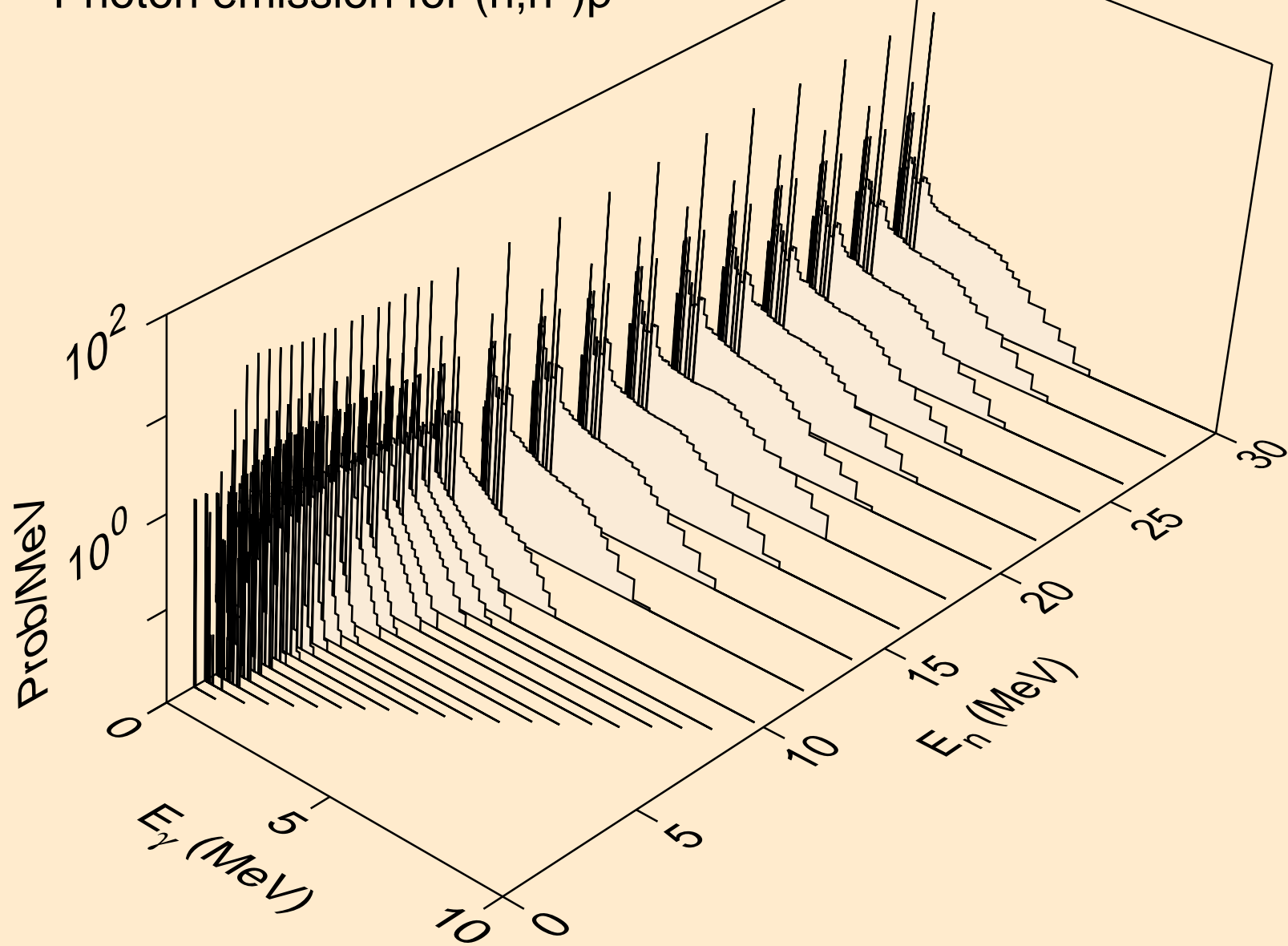

BR070M NEUTRON ACER TENDL-2023 LIBRARY; T=0.K
Photon emission for (n,n*)2a

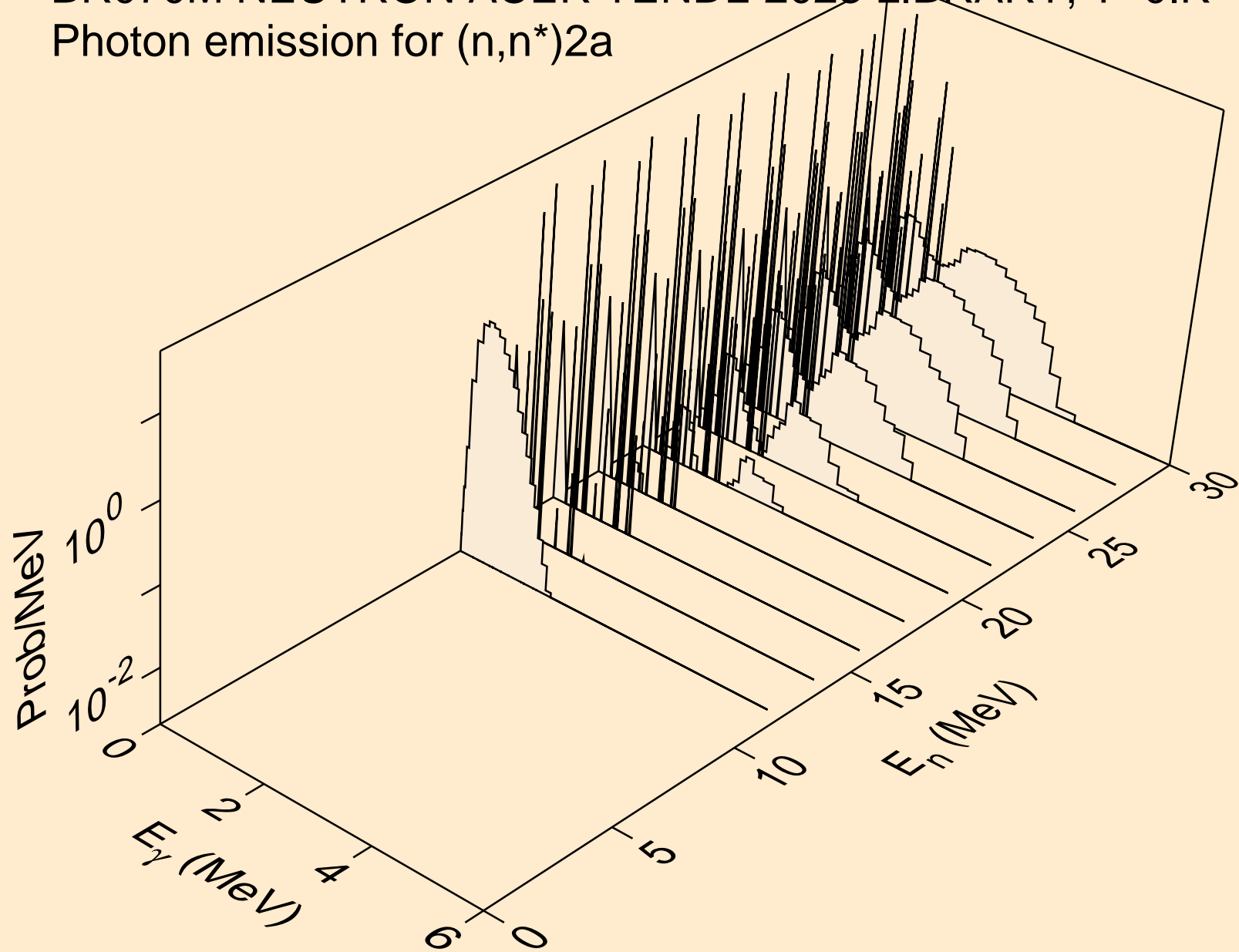

BR070M NEUTRON ACER TENDL-2023 LIBRARY; T=0.K
Photon emission for (n,n*)d

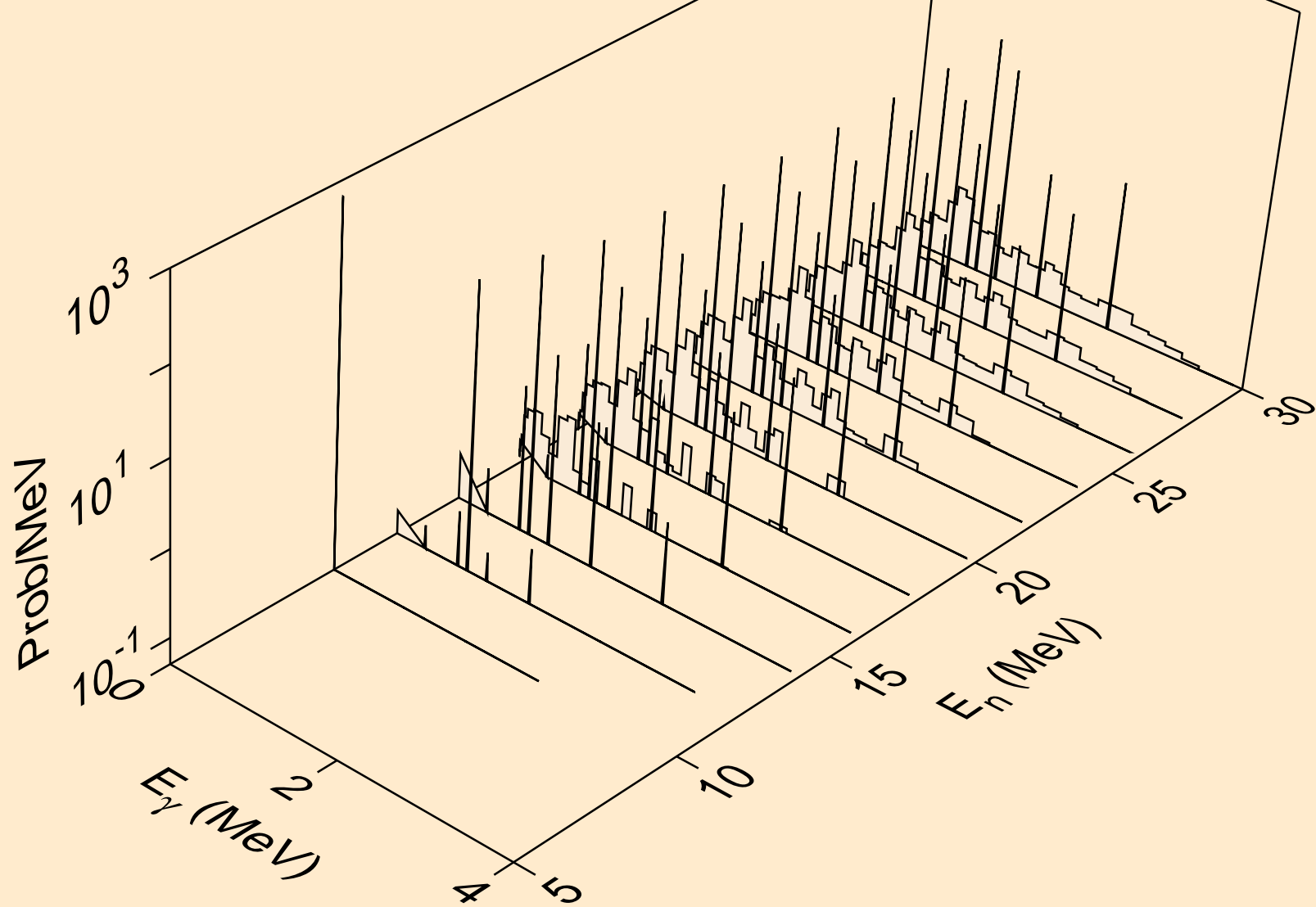

BR070M NEUTRON ACER TENDL-2023 LIBRARY; T=0.K
Photon emission for (n,n*)t

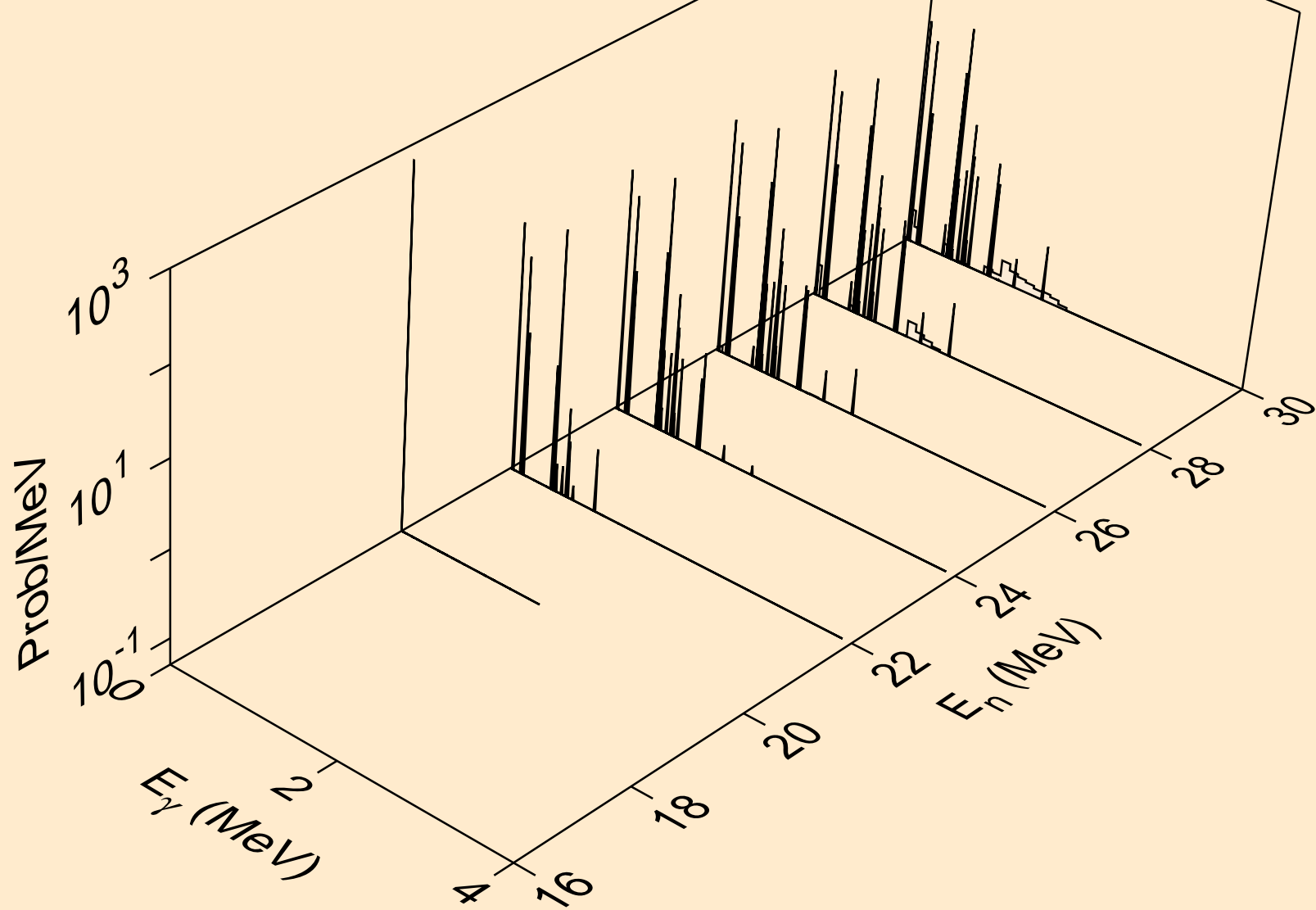

BR070M NEUTRON ACER TENDL-2023 LIBRARY; T=0.K
Photon emission for (n,n*)he3

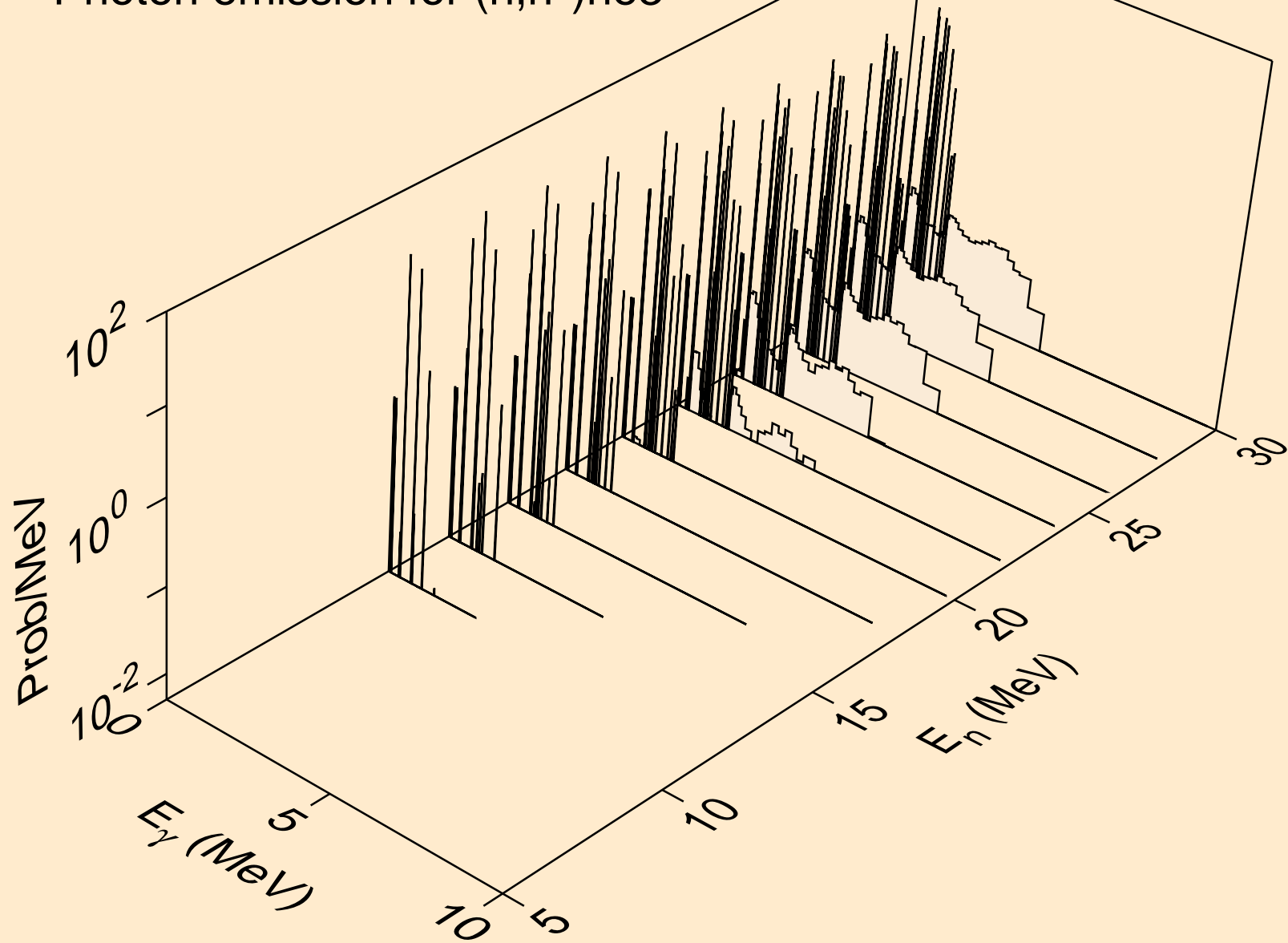

BR070M NEUTRON ACER TENDL-2023 LIBRARY; T=0.K
Photon emission for (n,2np)

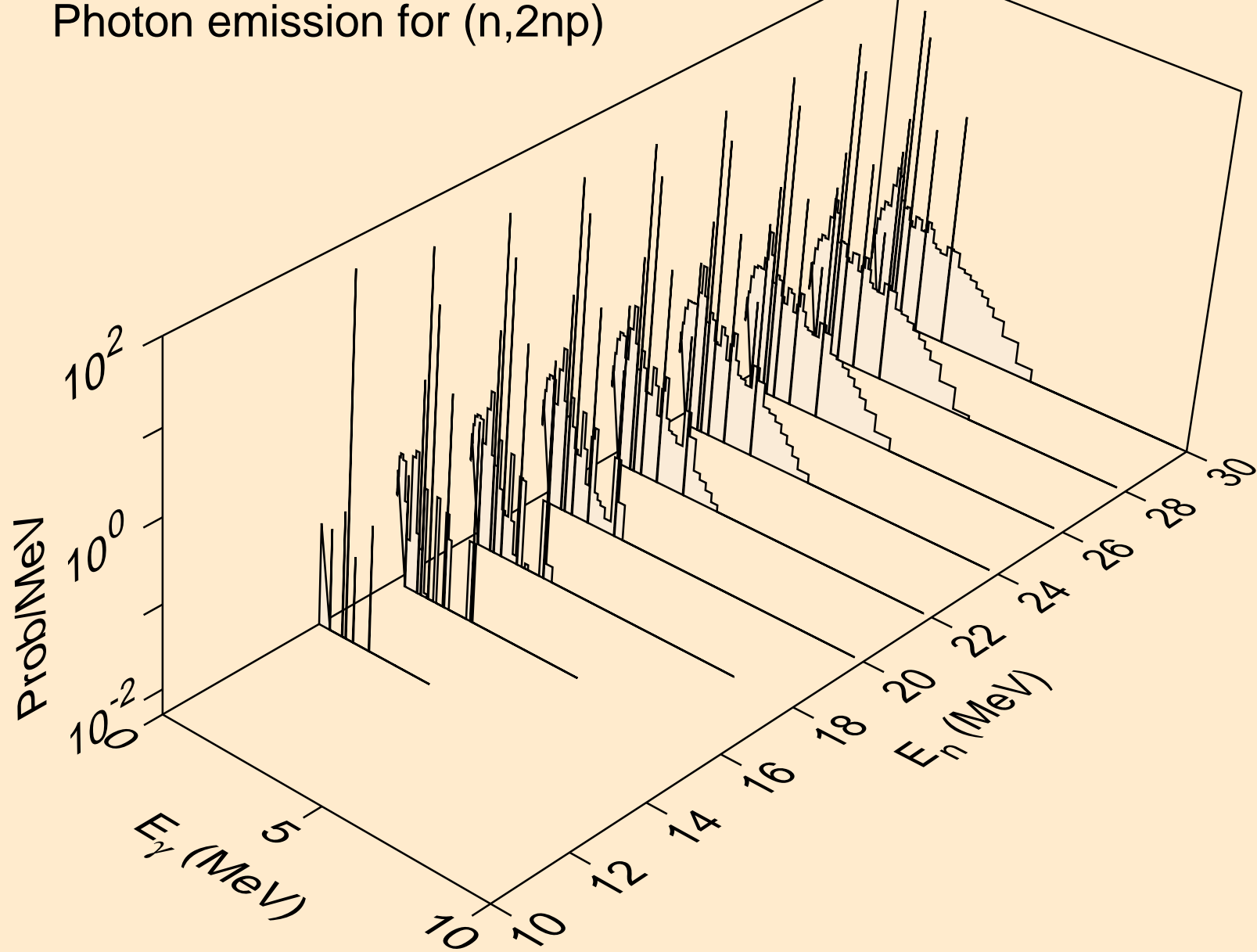

BR070M NEUTRON ACER TENDL-2023 LIBRARY; T=0.K
Photon emission for (n,3np)

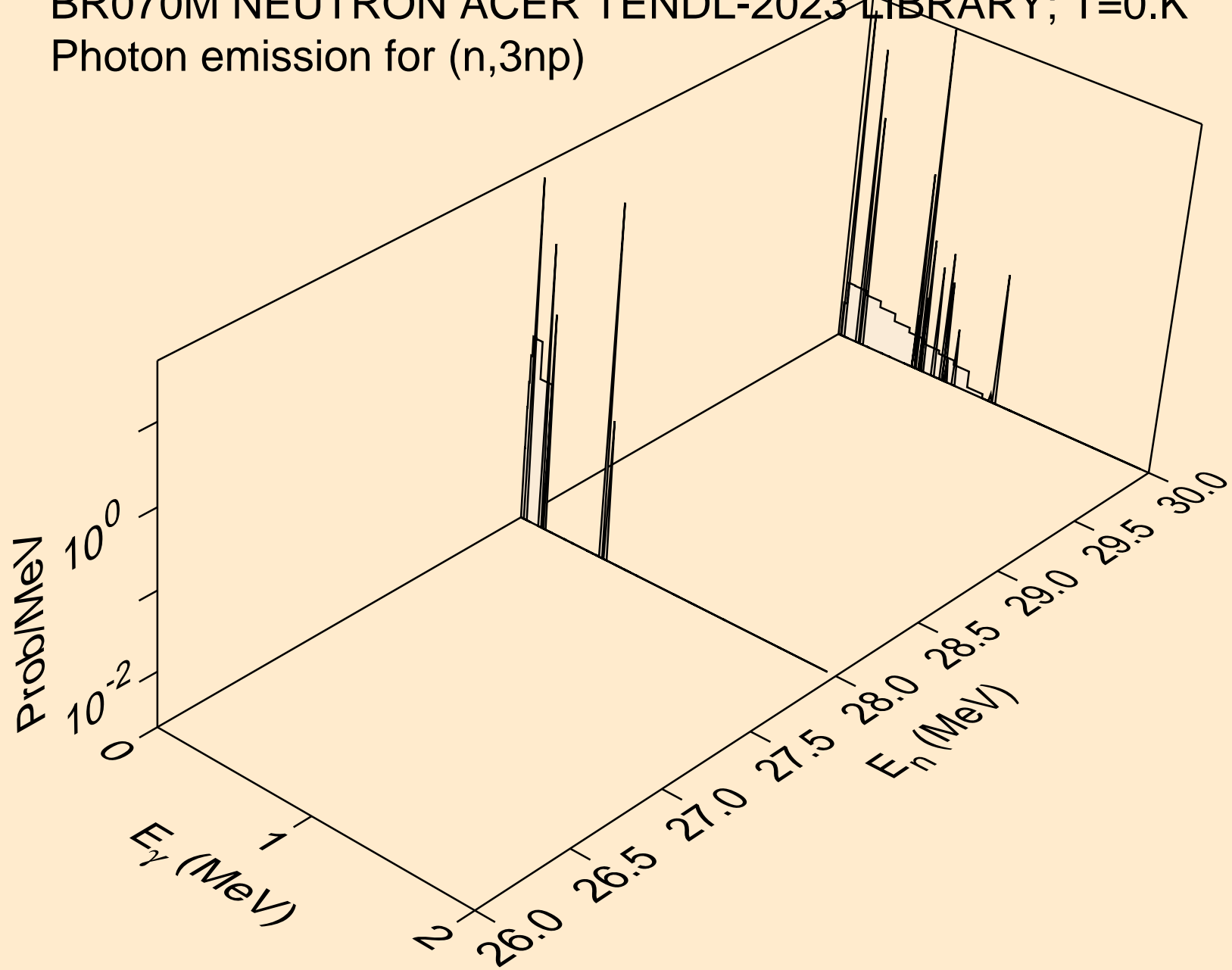

BR070M NEUTRON ACER TENDL-2023 LIBRARY; T=0.K
Photon emission for (n,n2p)

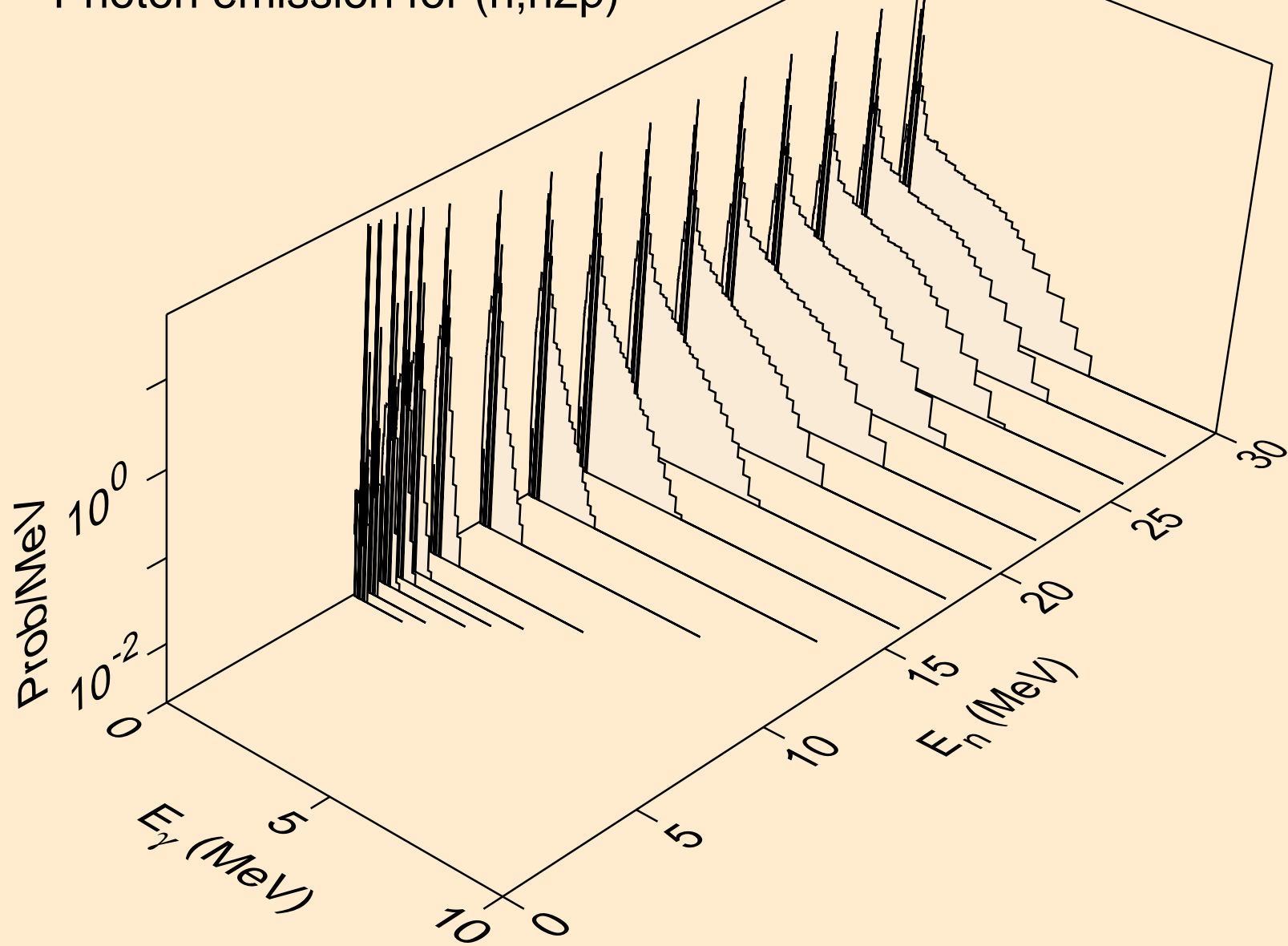

BR070M NEUTRON ACER TENDL-2023 LIBRARY; T=0.K
Photon emission for (n,npa)

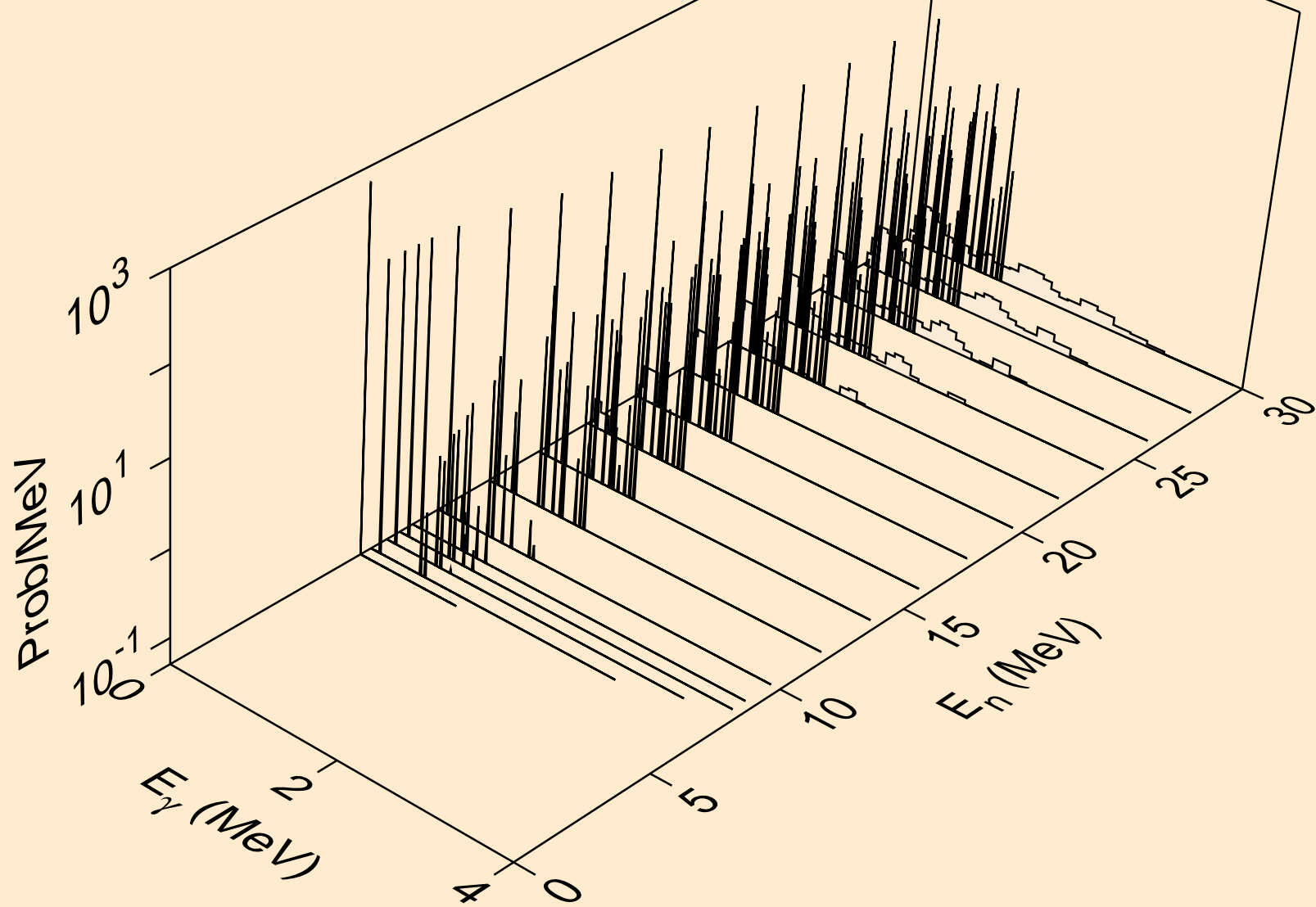

BR070M NEUTRON ACER TENDL-2023 LIBRARY; T=0.K
Photon emission for (n,n*1)

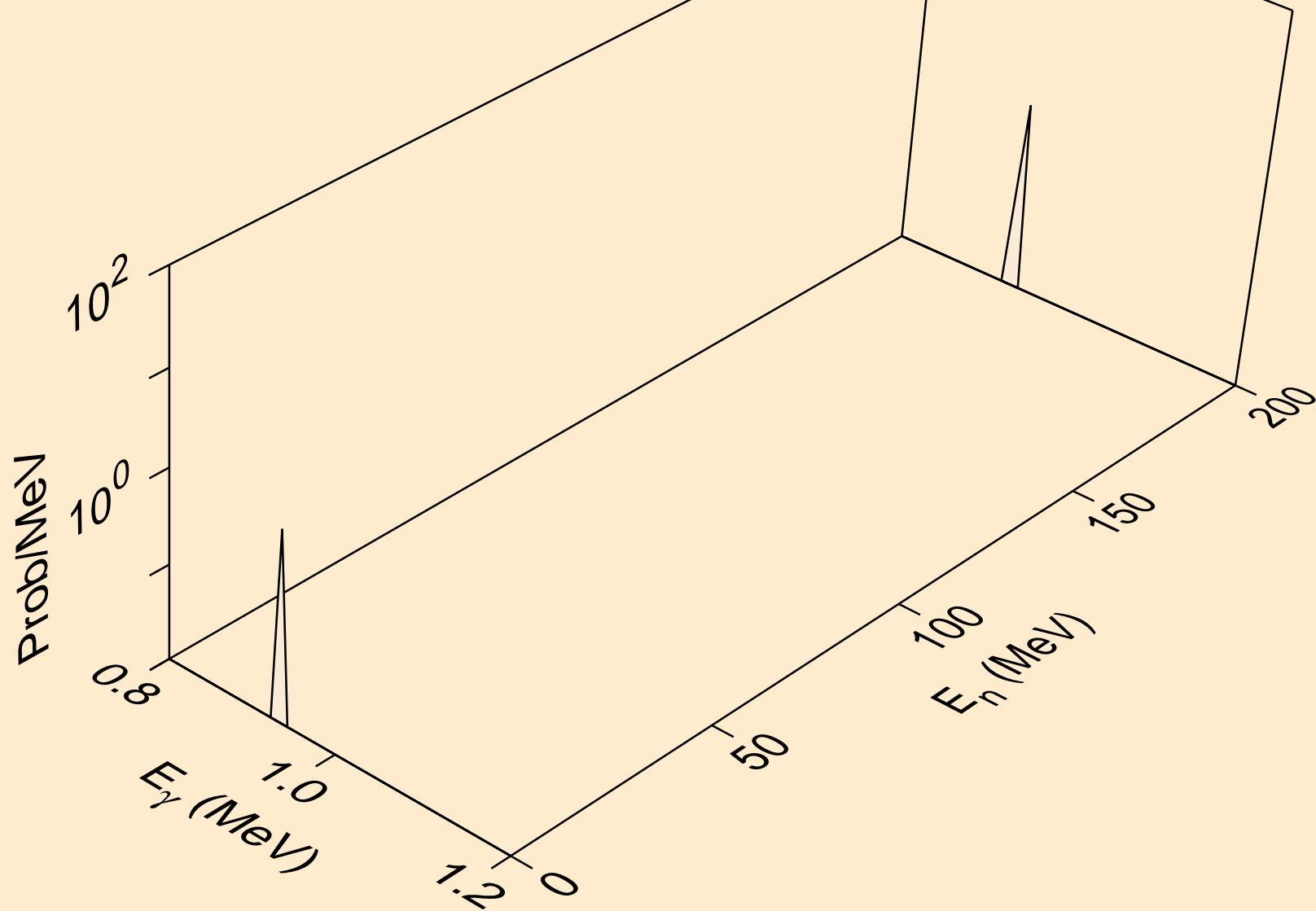

BR070M NEUTRON ACER TENDL-2023 LIBRARY; T=0.K
Photon emission for (n,n*2)

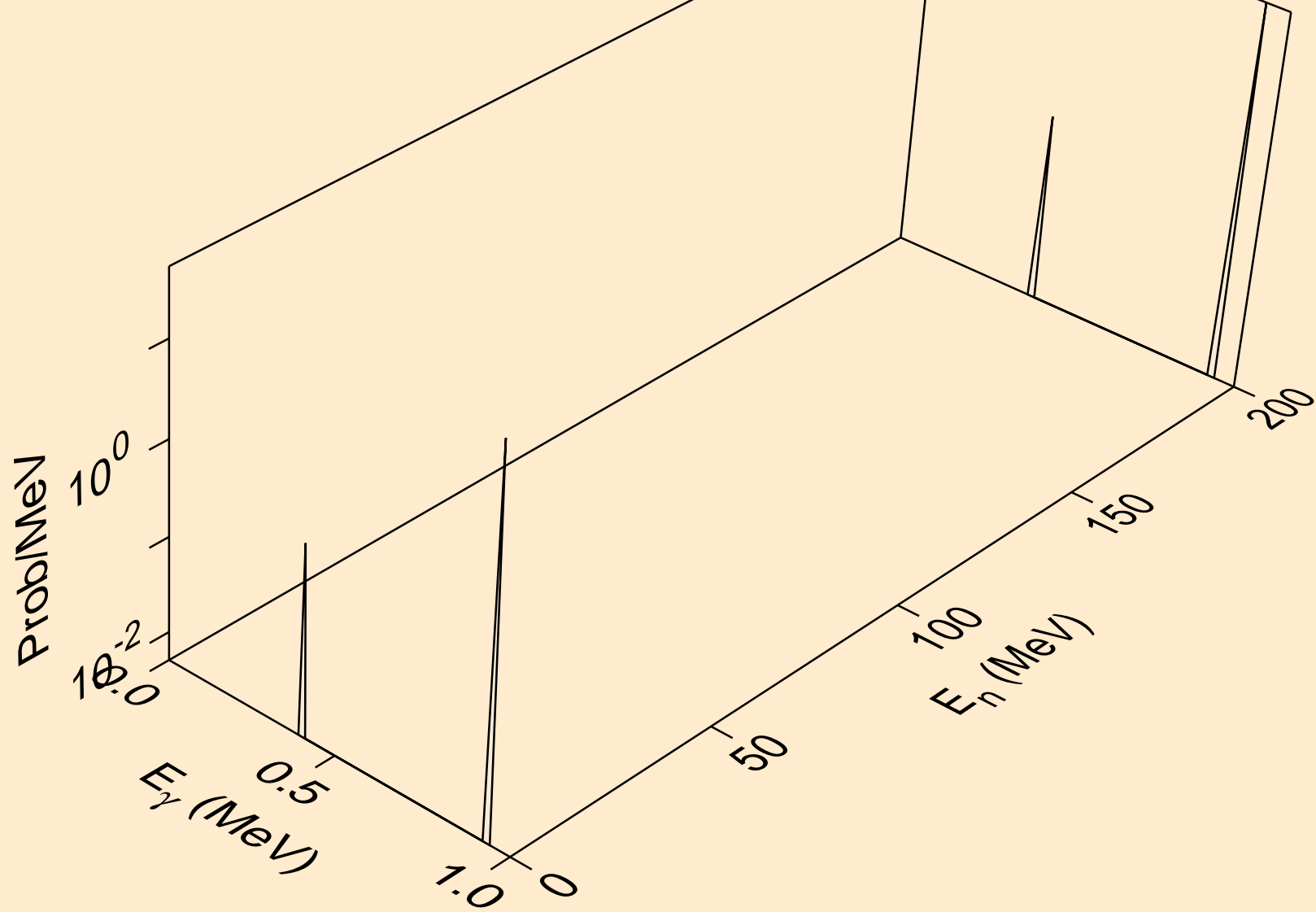

BR070M NEUTRON ACER TENDL-2023 LIBRARY; T=0.K
Photon emission for (n,n*3)

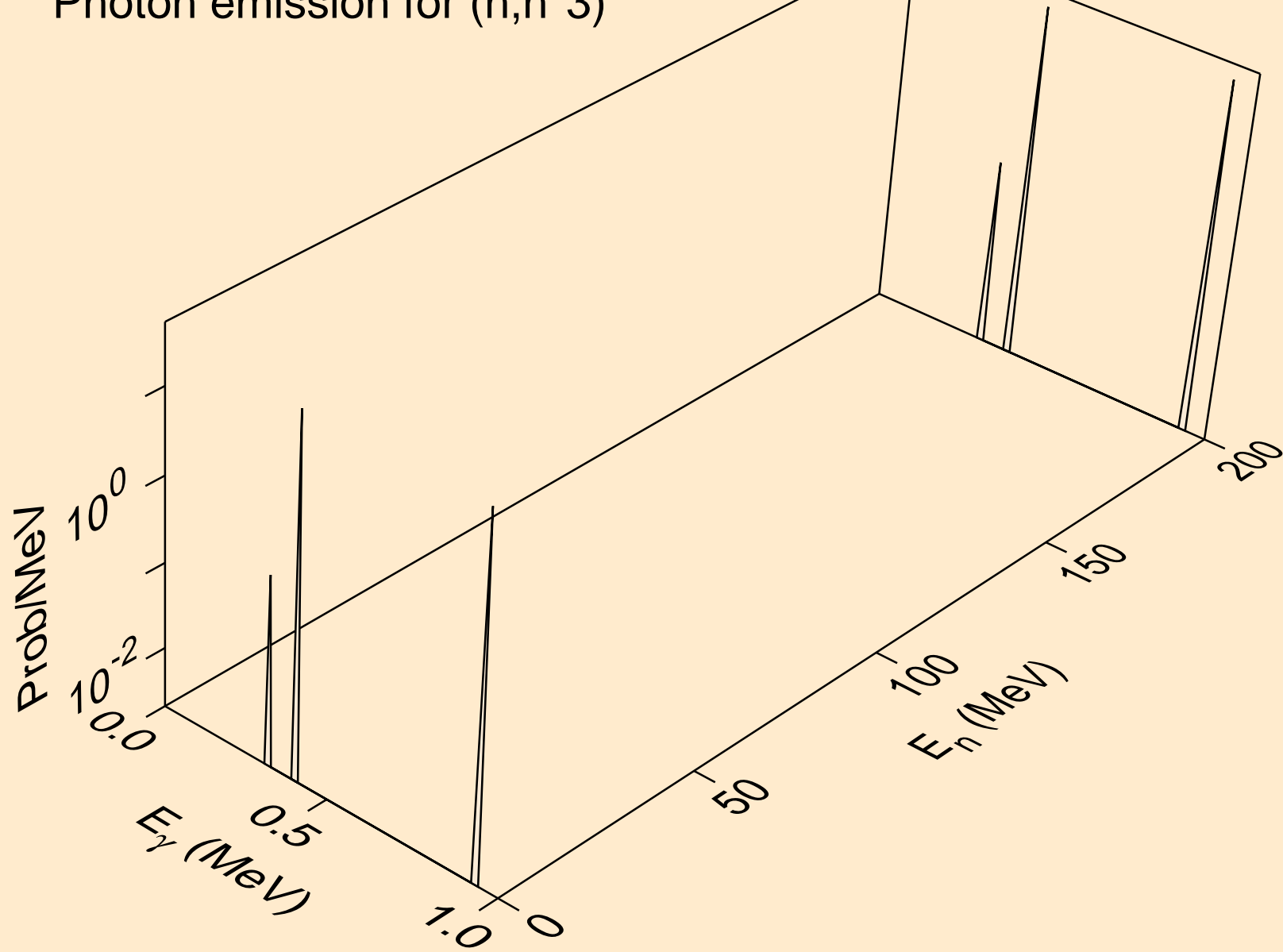

BR070M NEUTRON ACER TENDL-2023 LIBRARY; T=0.K
Photon emission for (n,n*c)

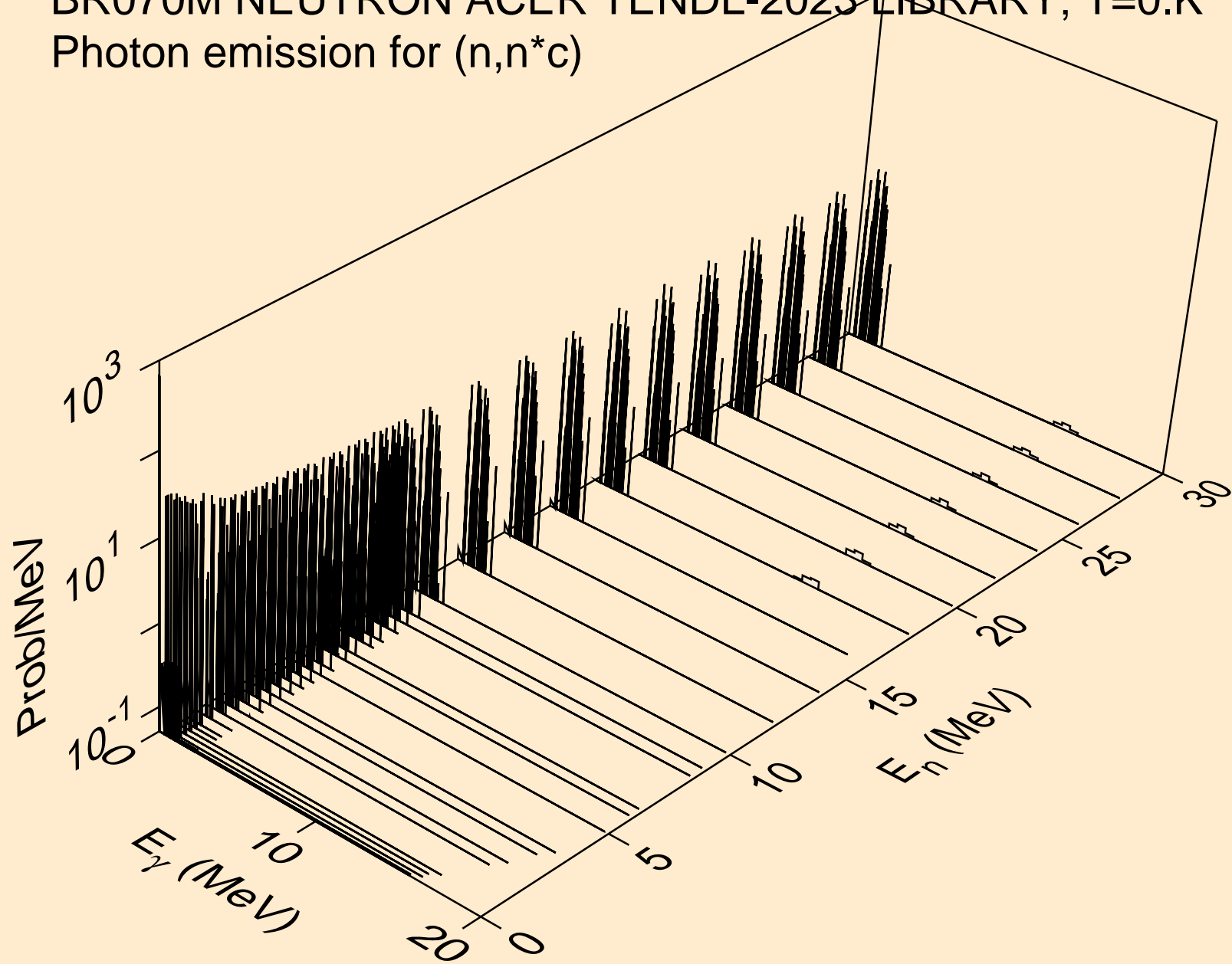

BR070M NEUTRON ACER TENDL-2023 LIBRARY; T=0.K
Photon emission for (n,gma)

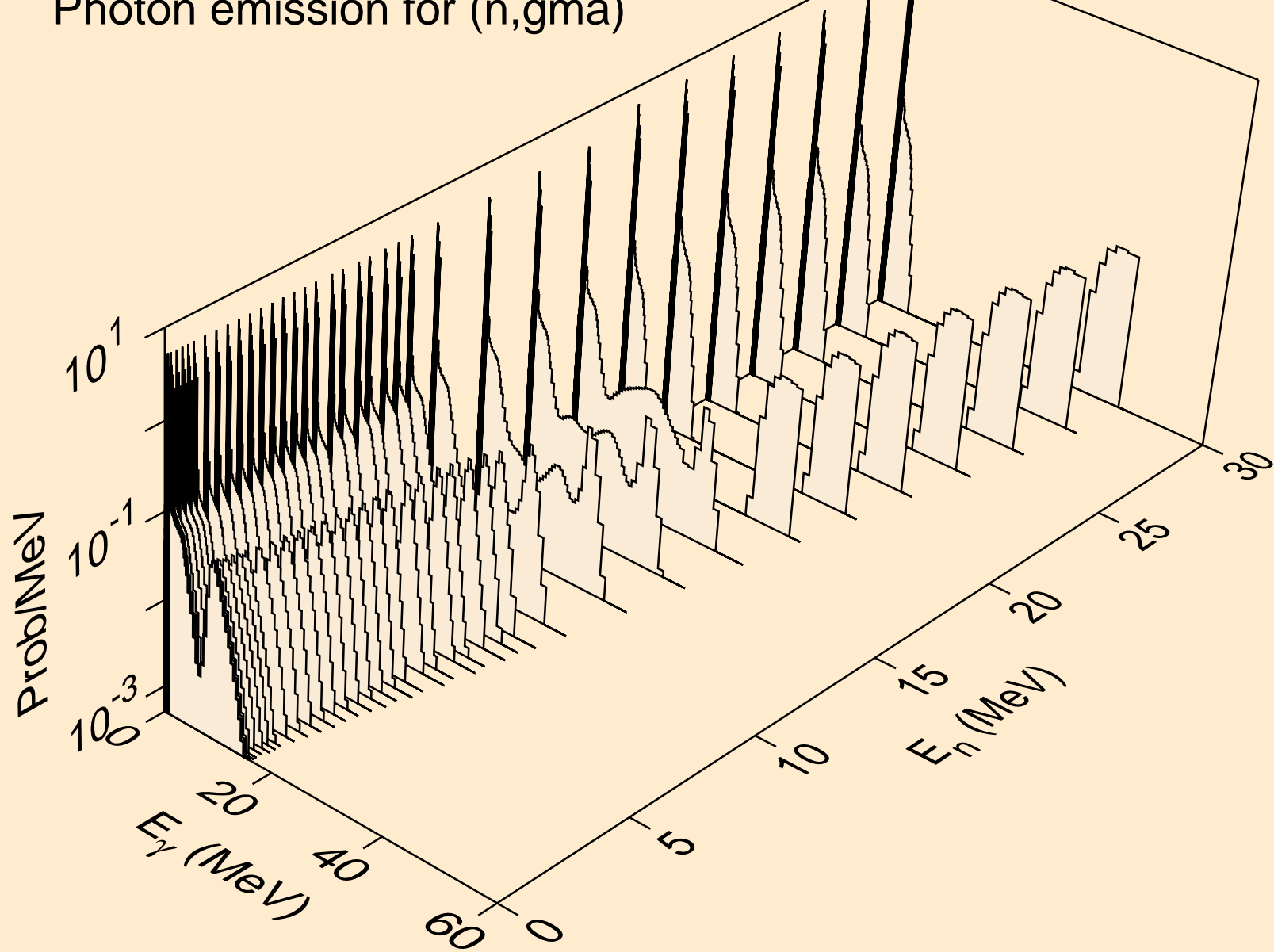

BR070M NEUTRON ACER TENDL-2023 LIBRARY; T=0.K
Photon emission for (n,p)

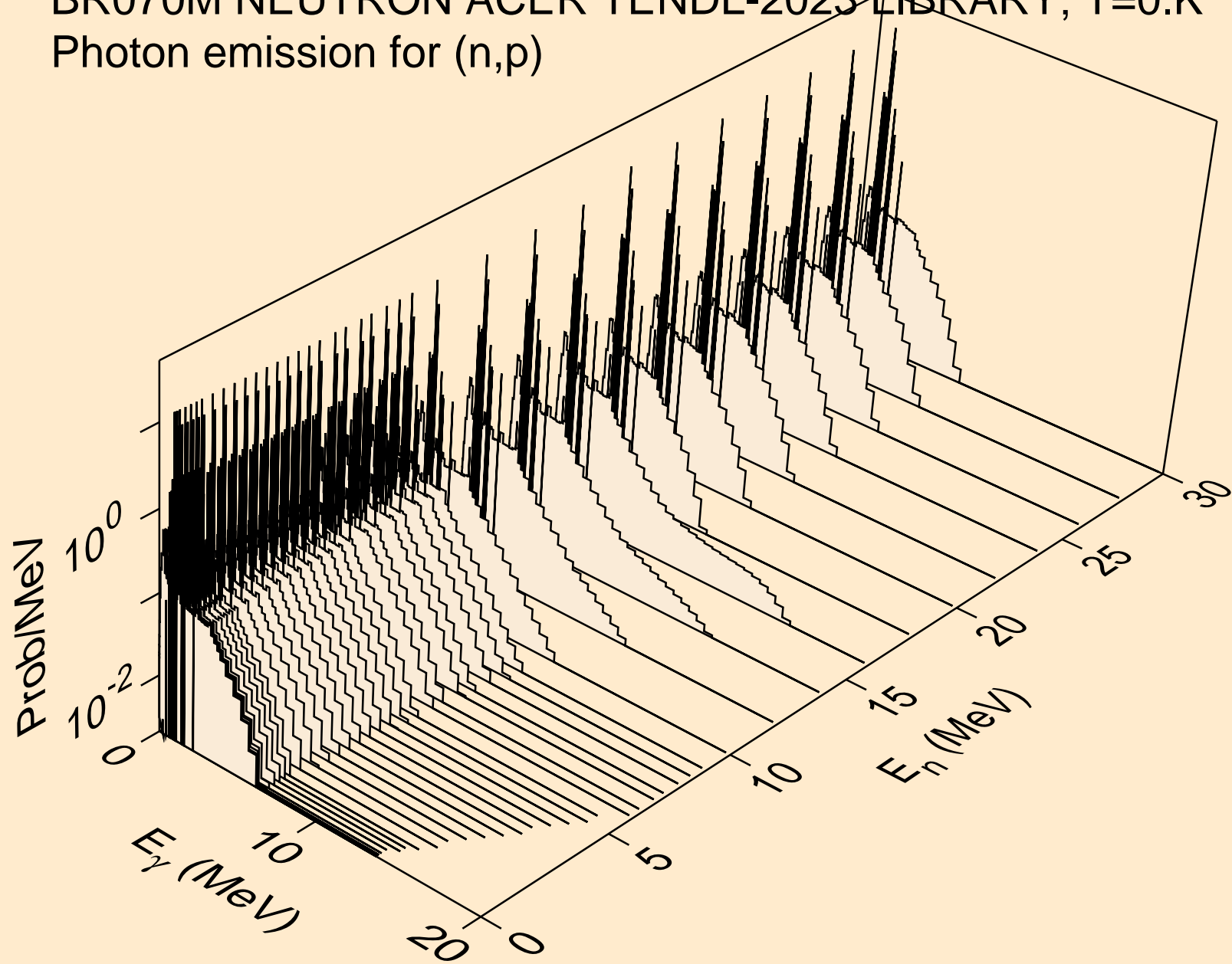

BR070M NEUTRON ACER TENDL-2023 LIBRARY; T=0.K
Photon emission for (n,d)

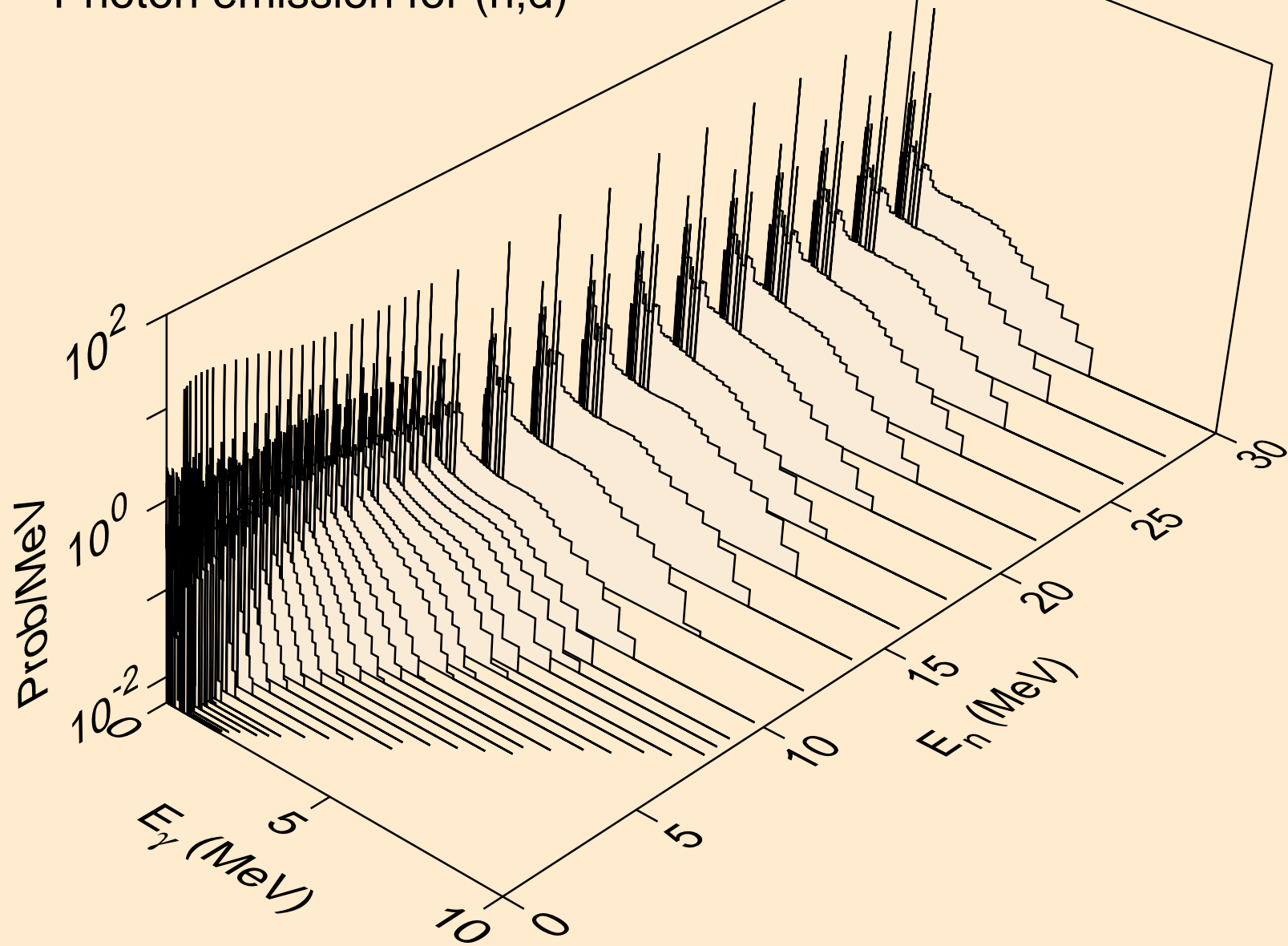

BR070M NEUTRON ACER TENDL-2023 LIBRARY; T=0.K
Photon emission for (n,t)

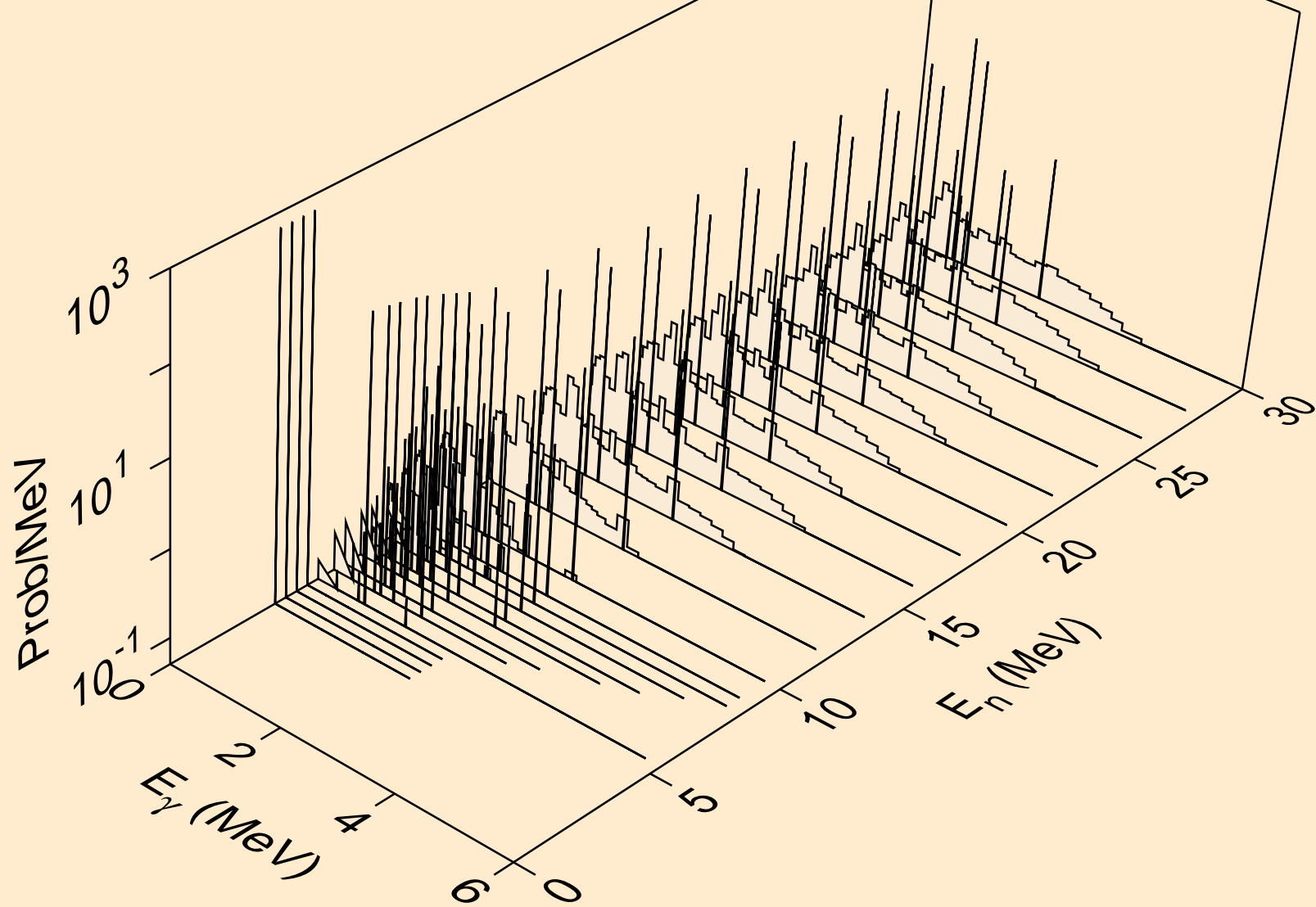

BR070M NEUTRON ACER TENDL-2023 LIBRARY; T=0.K
Photon emission for (n,he3)

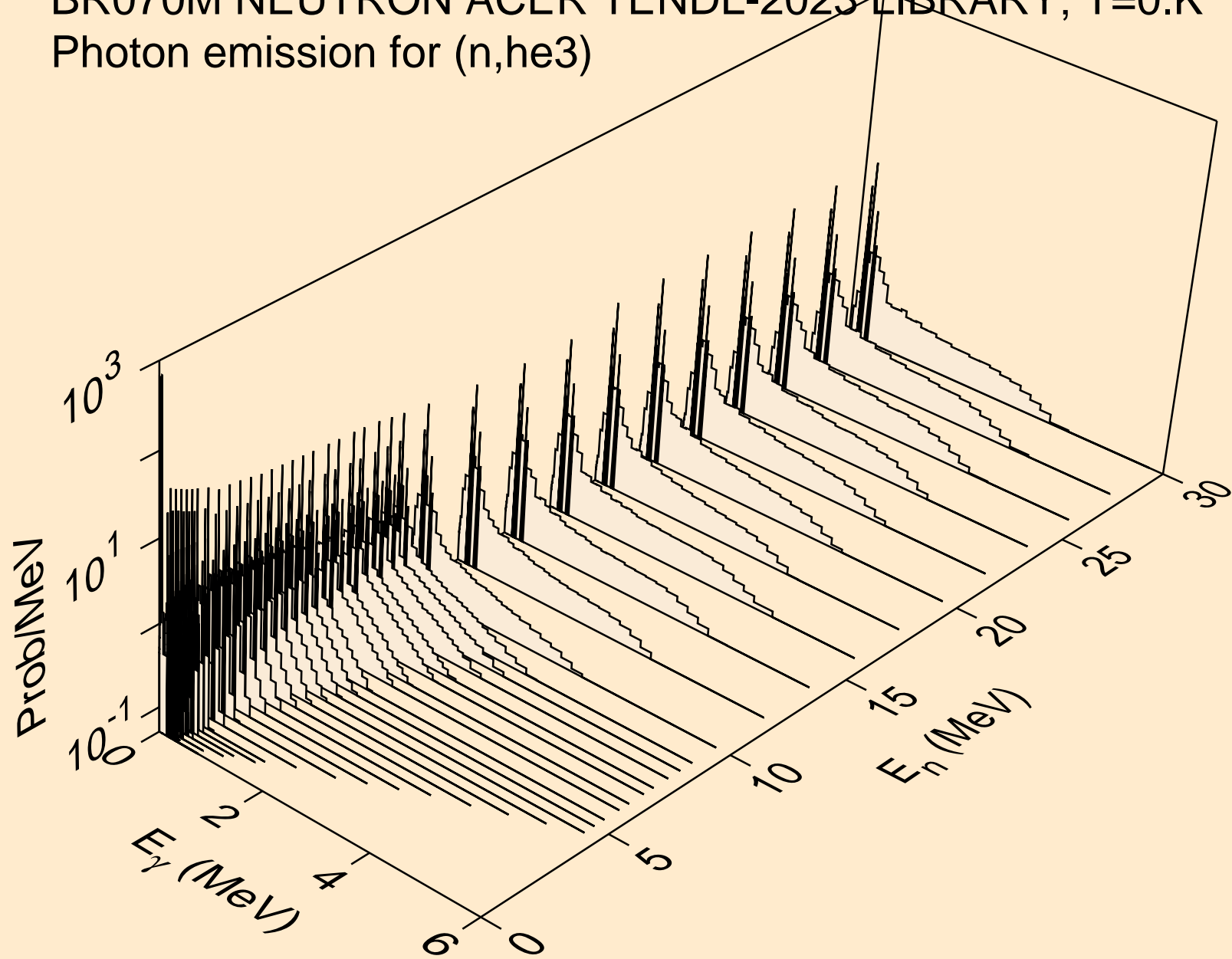

BR070M NEUTRON ACER TENDL-2023 LIBRARY; T=0.K
Photon emission for (n,a)

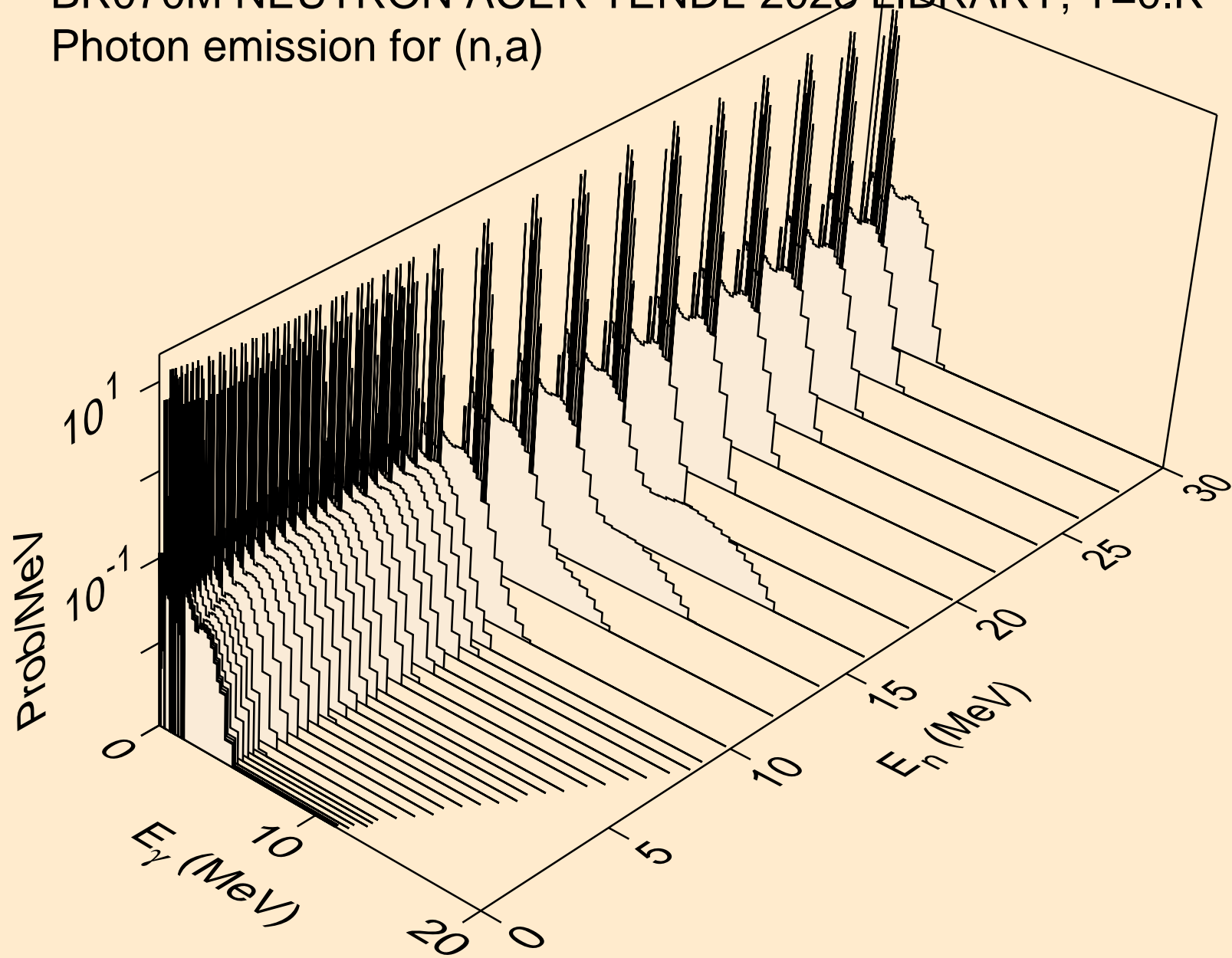

BR070M NEUTRON ACER TENDL-2023 LIBRARY; T=0.K
Photon emission for (n,2a)

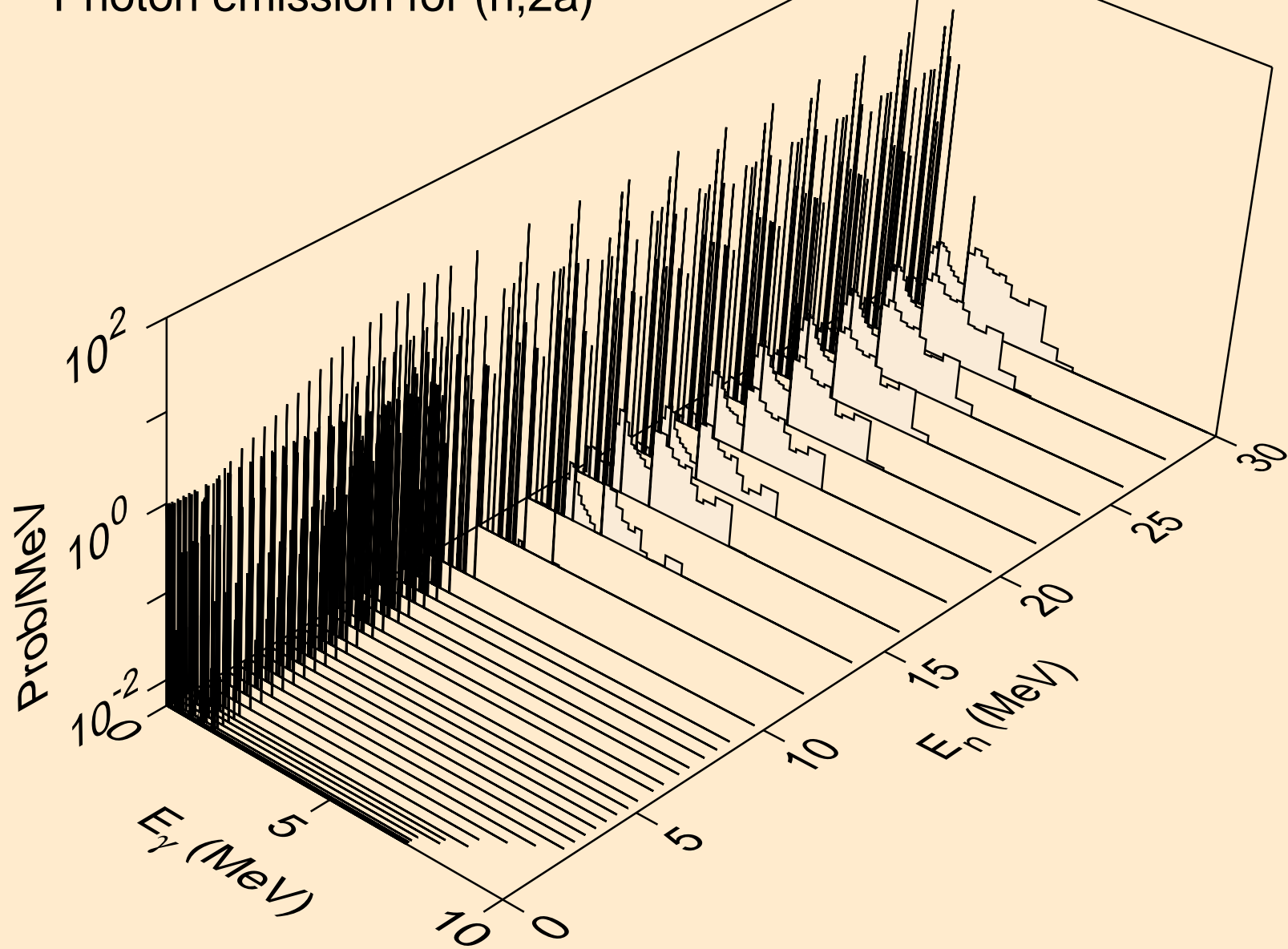

BR070M NEUTRON ACER TENDL-2023 LIBRARY; T=0.K
Photon emission for (n,3a)

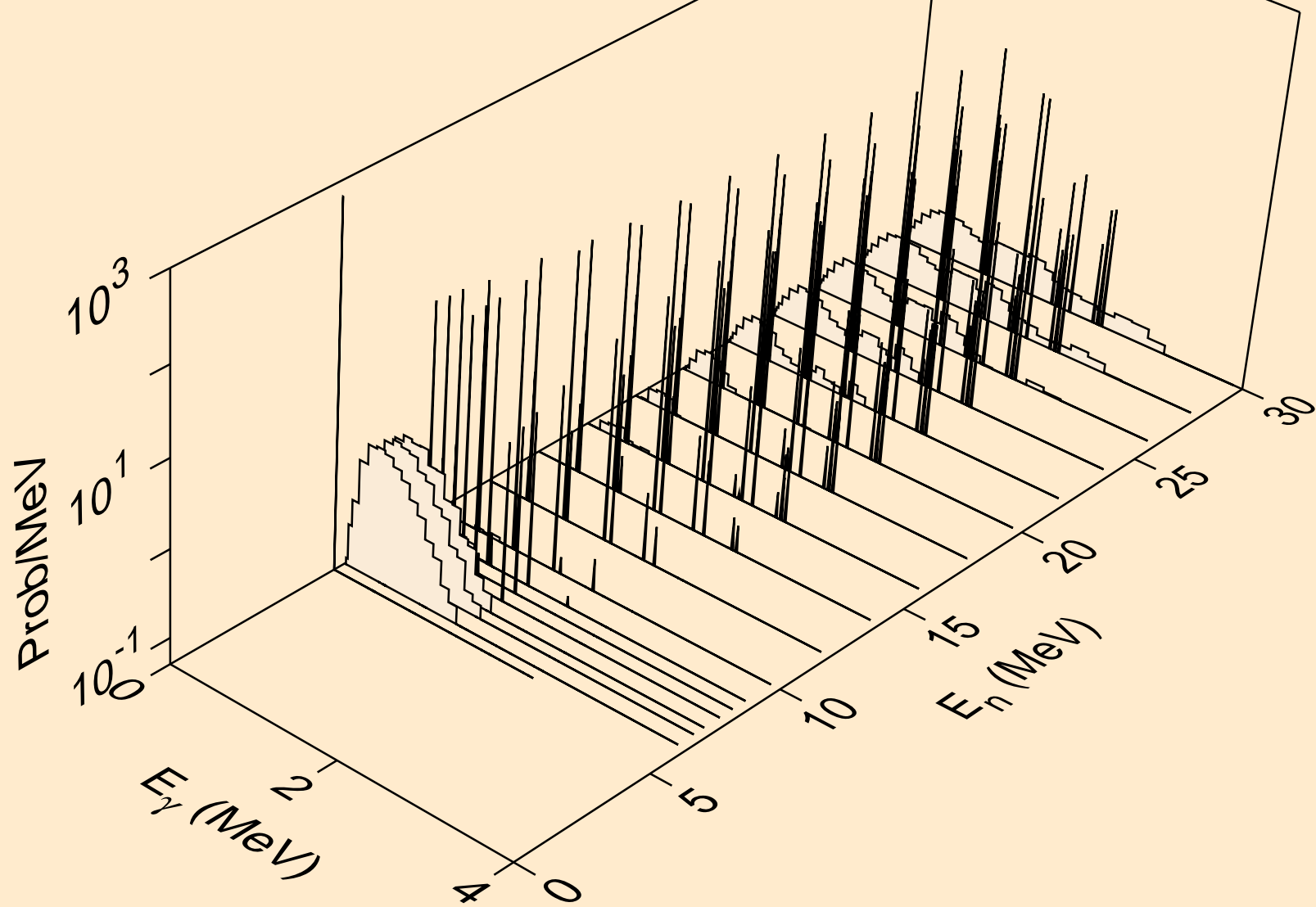

BR070M NEUTRON ACER TENDL-2023 LIBRARY; T=0.K
Photon emission for (n,2p)

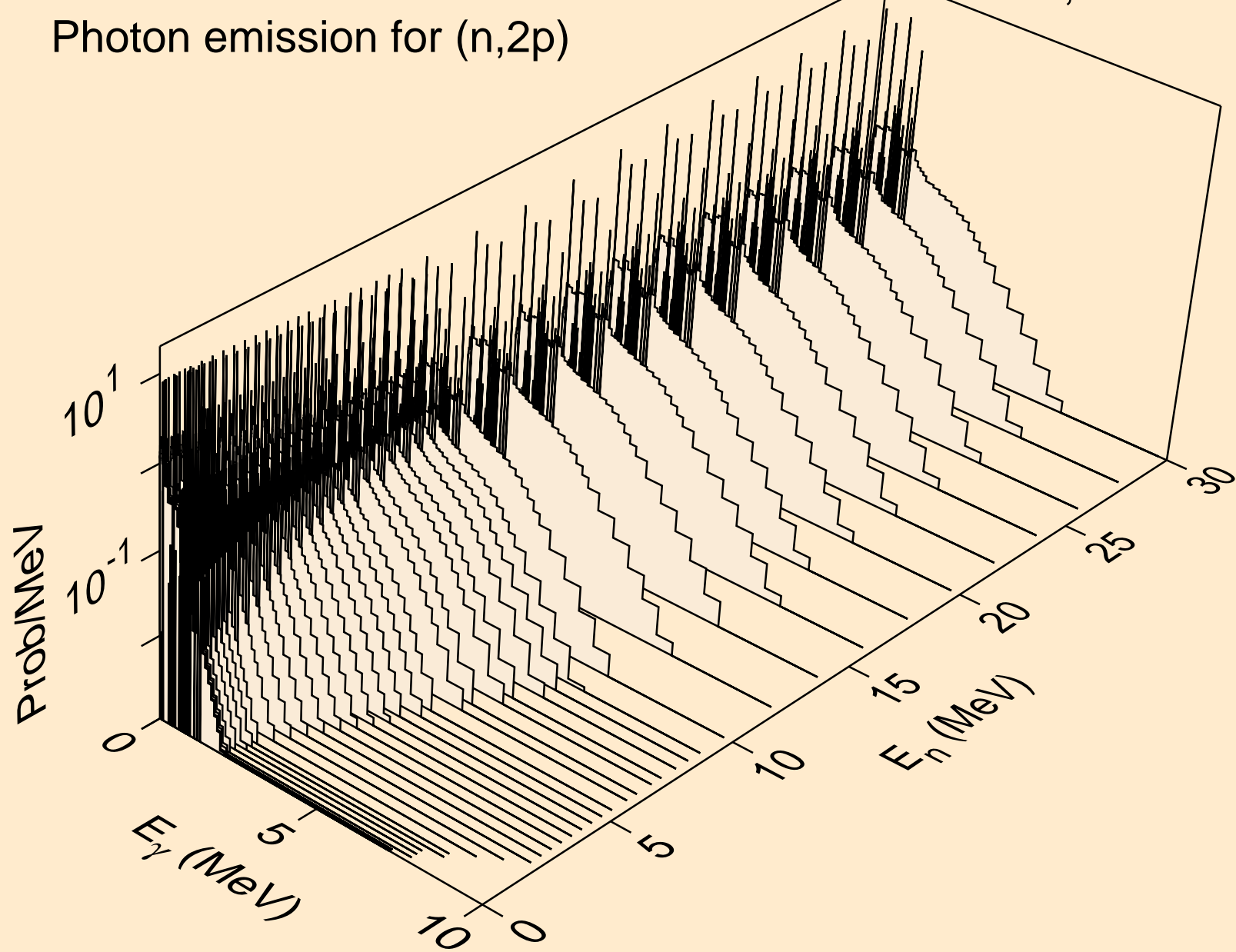

BR070M NEUTRON ACER TENDL-2023 LIBRARY; T=0.K
Photon emission for (n,p α)

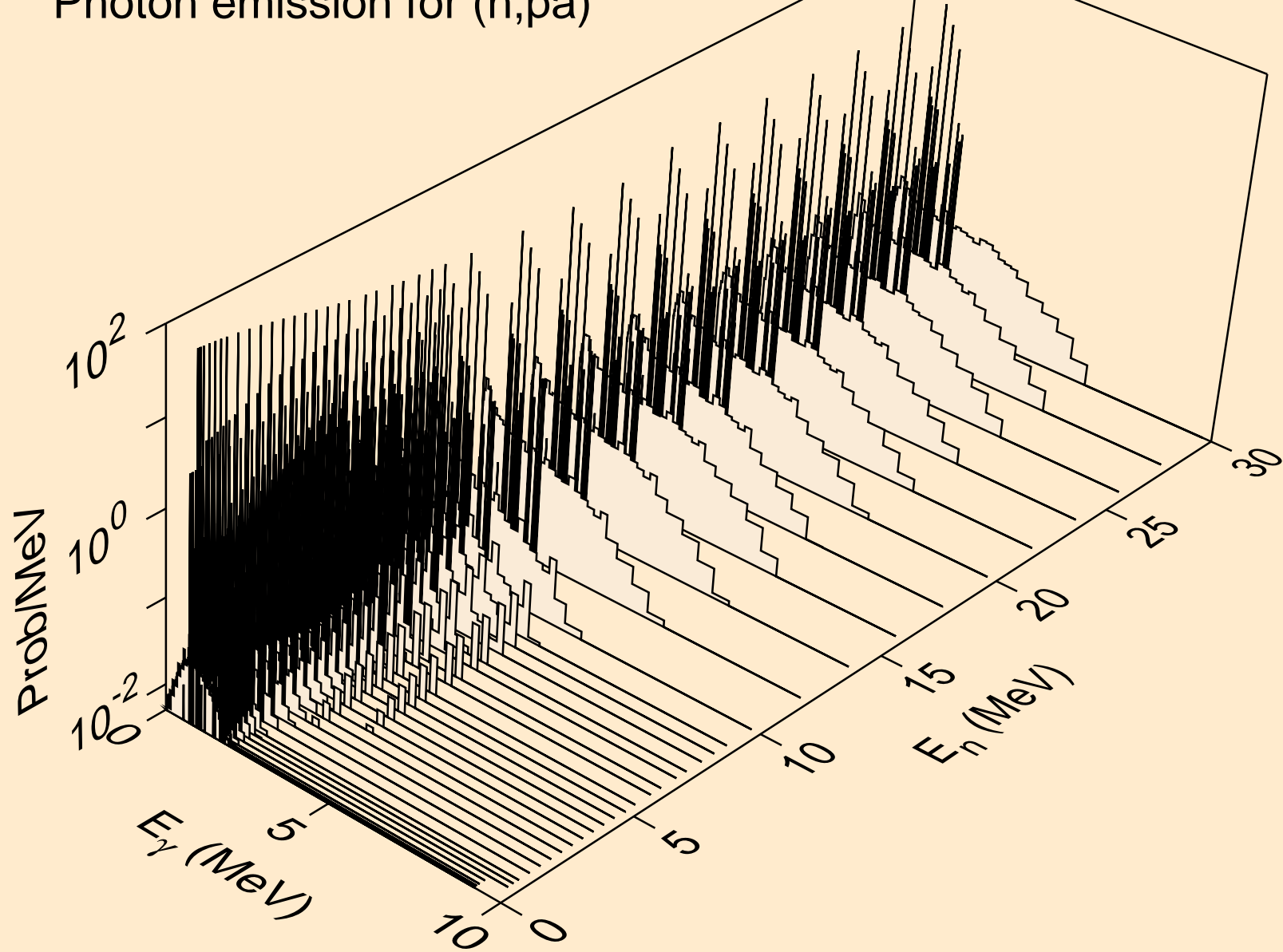

BR070M NEUTRON ACER TENDL-2023 LIBRARY; T=0.K
Photon emission for (n,t2a)

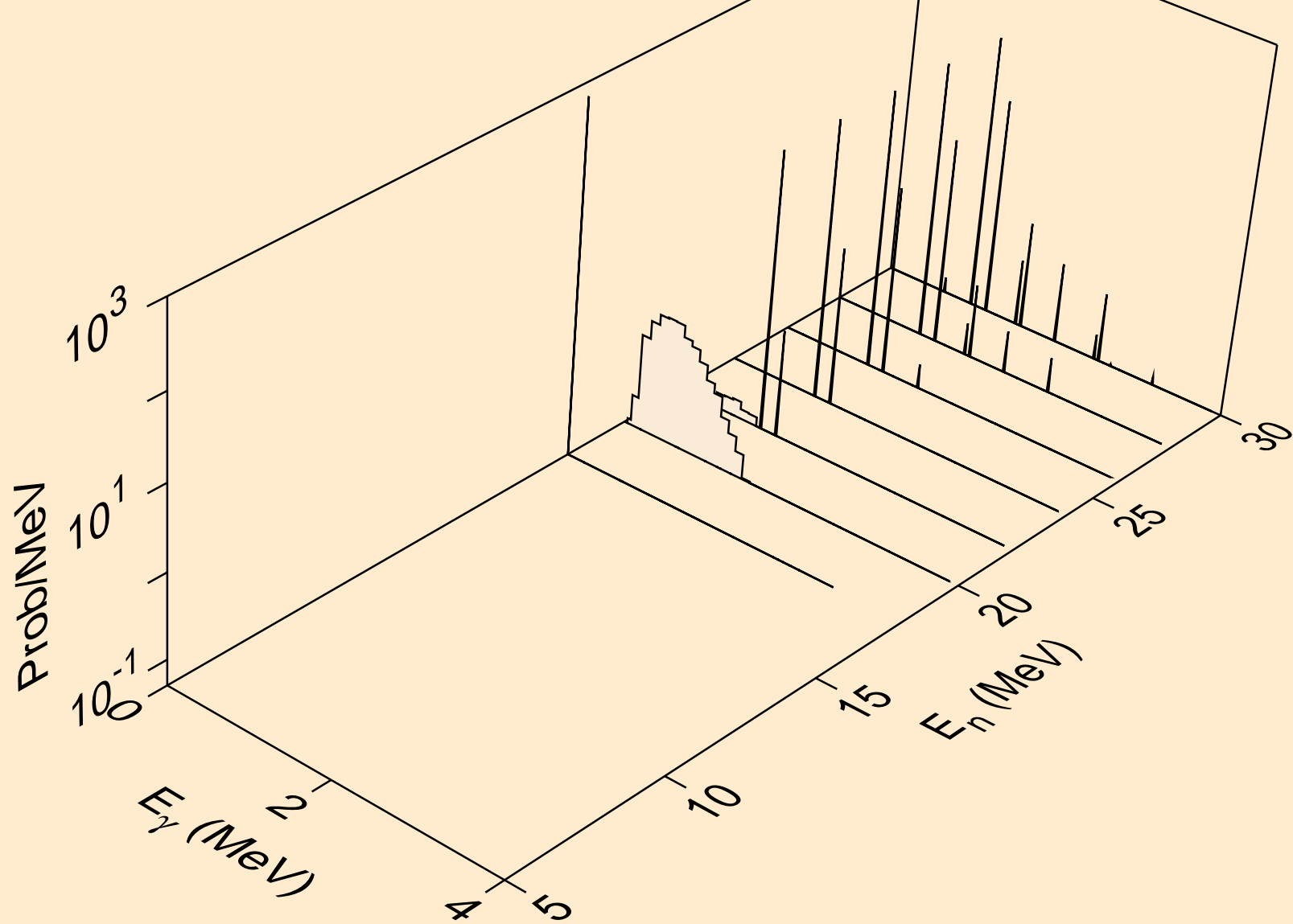

BR070M NEUTRON ACER TENDL-2023 LIBRARY; T=0.K
Photon emission for (n,d2a)

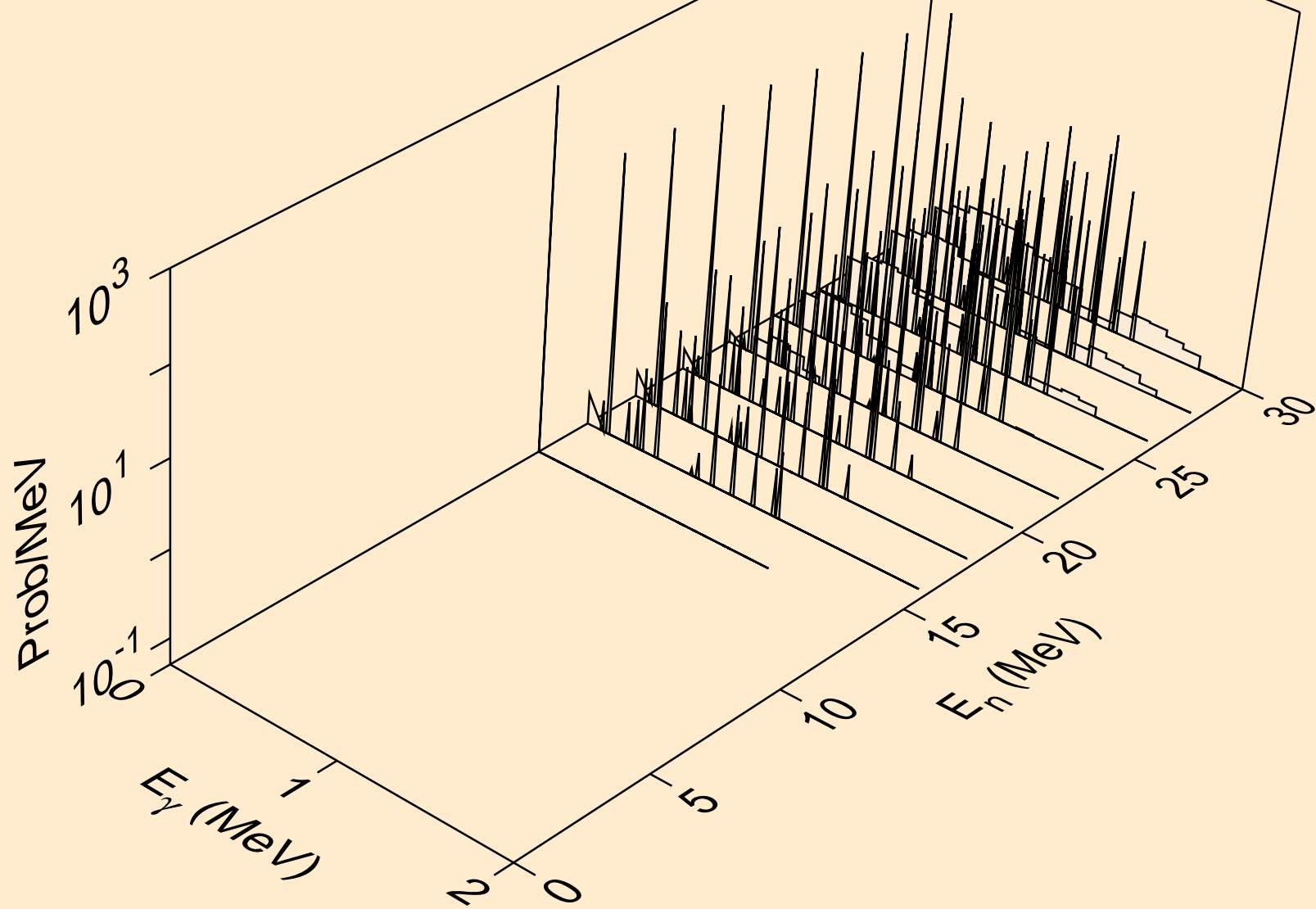

BR070M NEUTRON ACER TENDL-2023 LIBRARY; T=0.K
Photon emission for (n,pd)

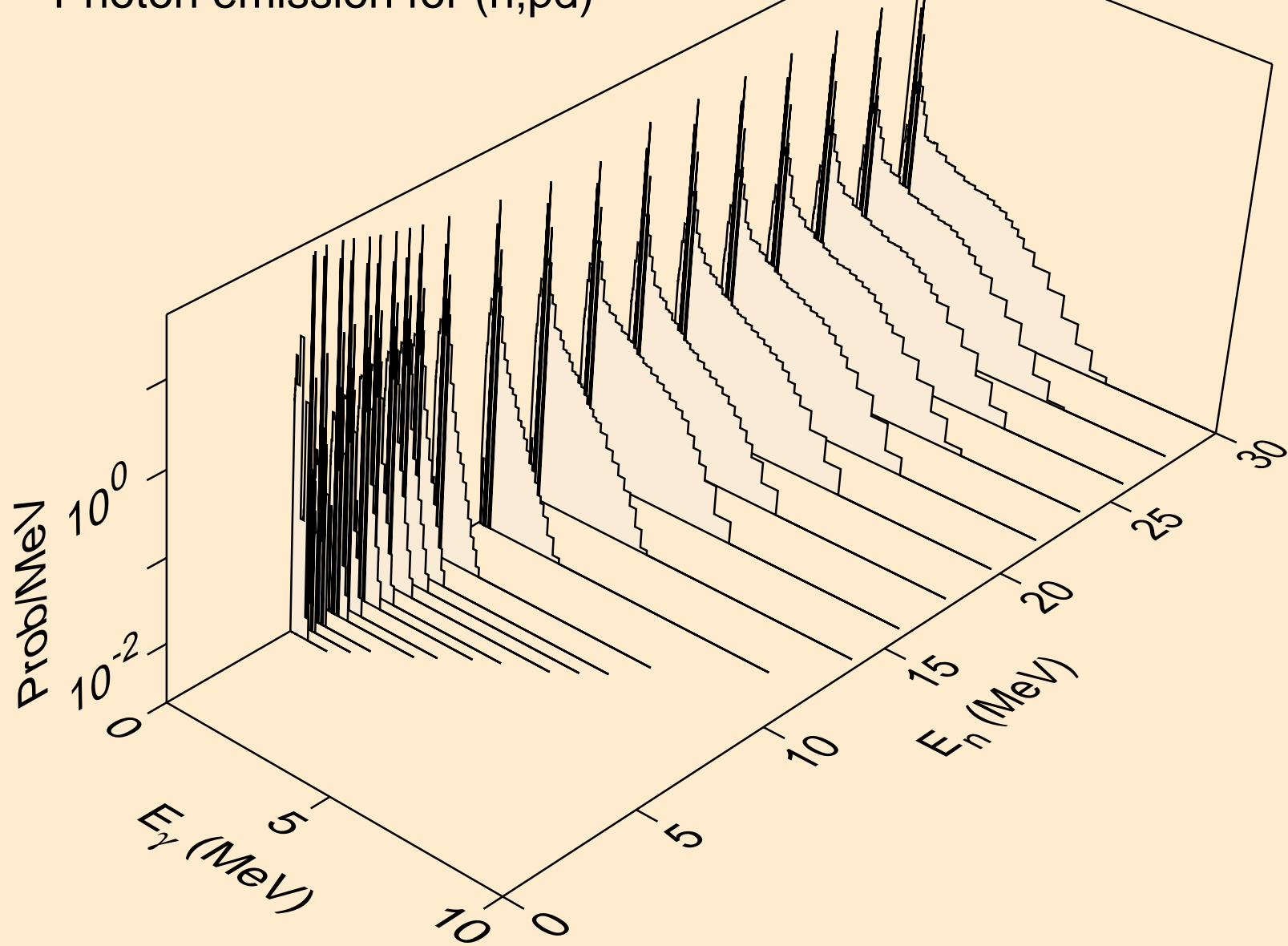

BR070M NEUTRON ACER TENDL-2023 LIBRARY; T=0.K
Photon emission for (n,pt)

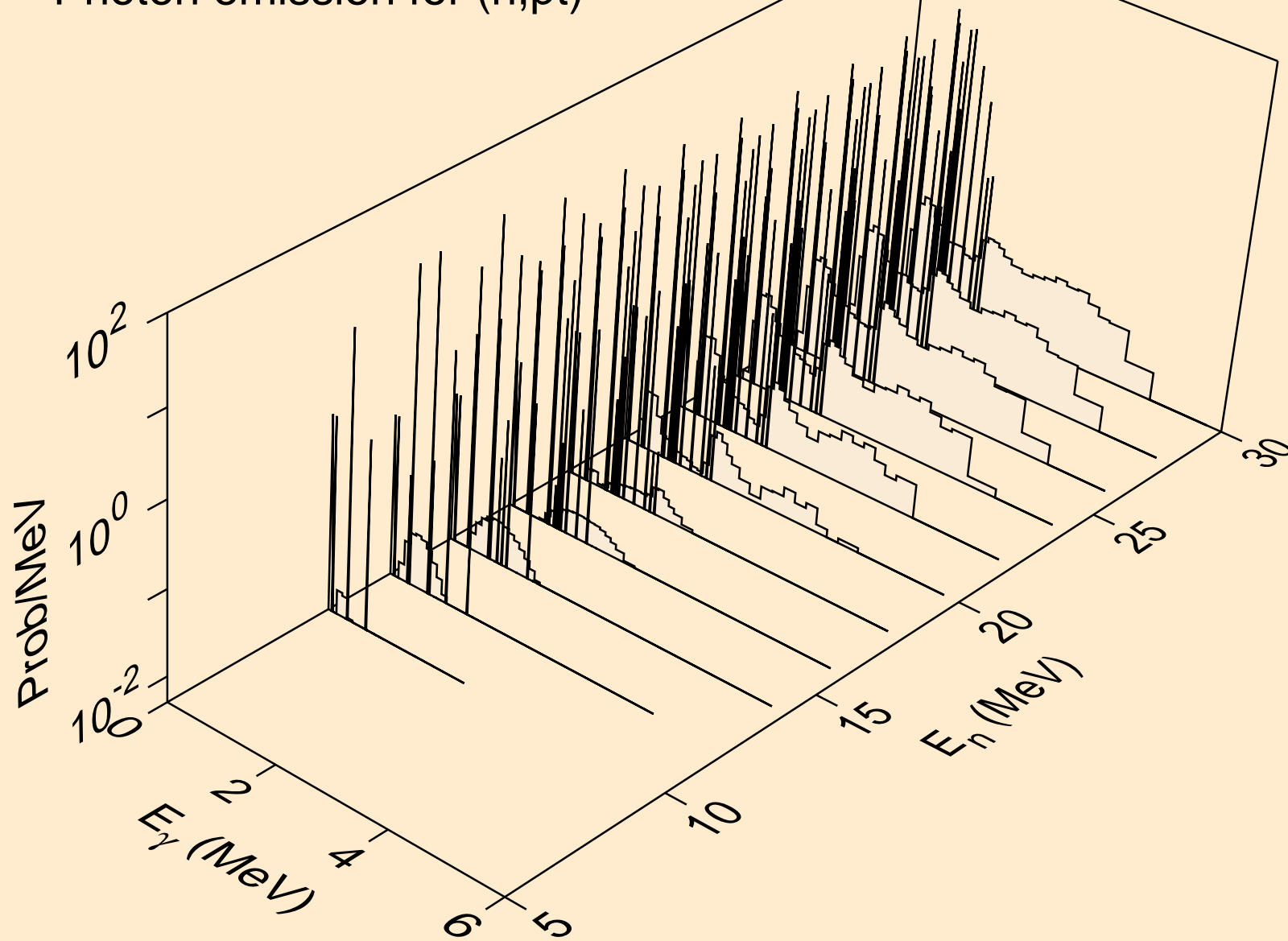

BR070M NEUTRON ACER TENDL-2023 LIBRARY; T=0.K
Photon emission for (n,da)

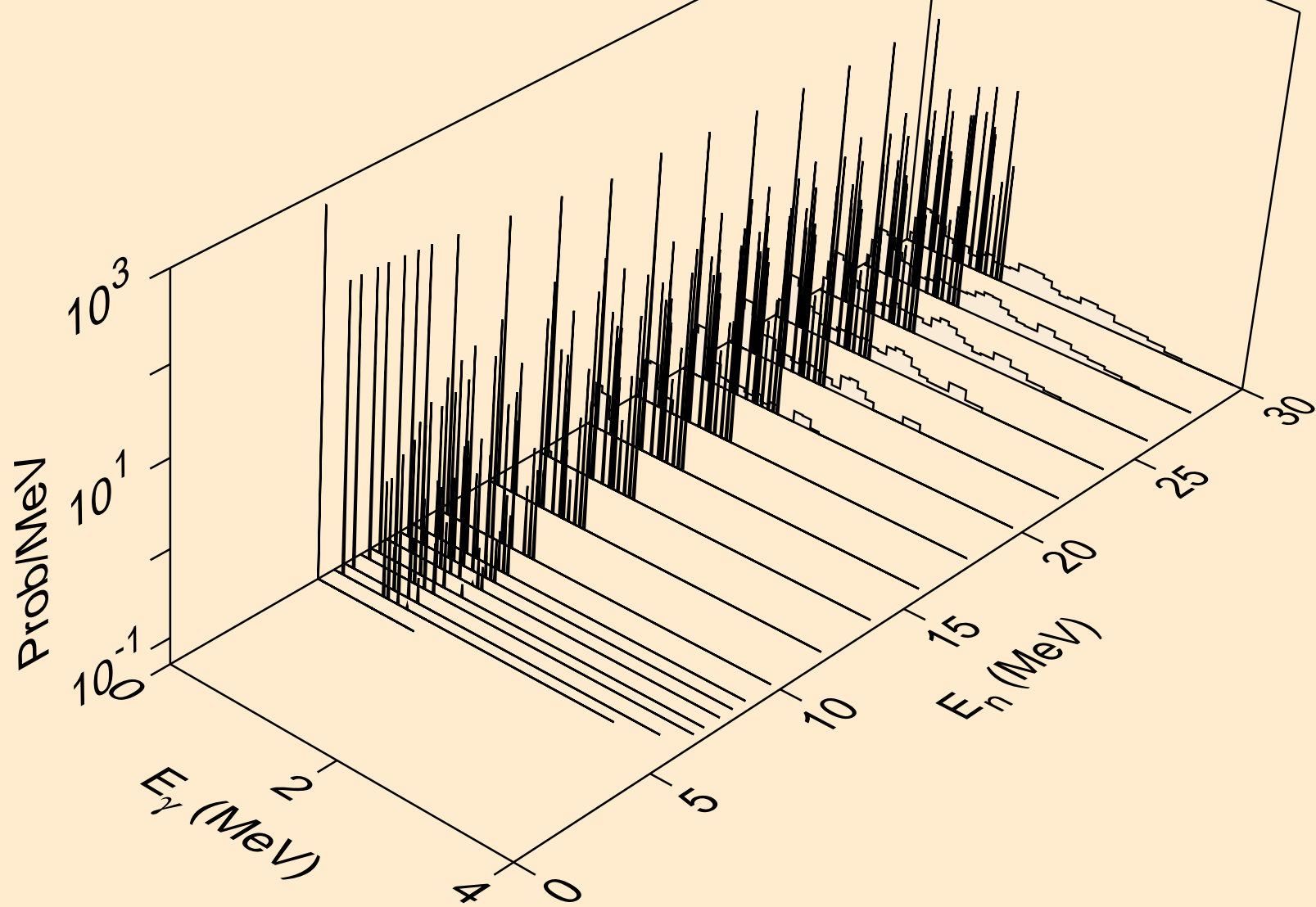

BR070M NEUTRON ACER TENDL-2023 LIBRARY; T=0.K
thermal capture photon spectrum

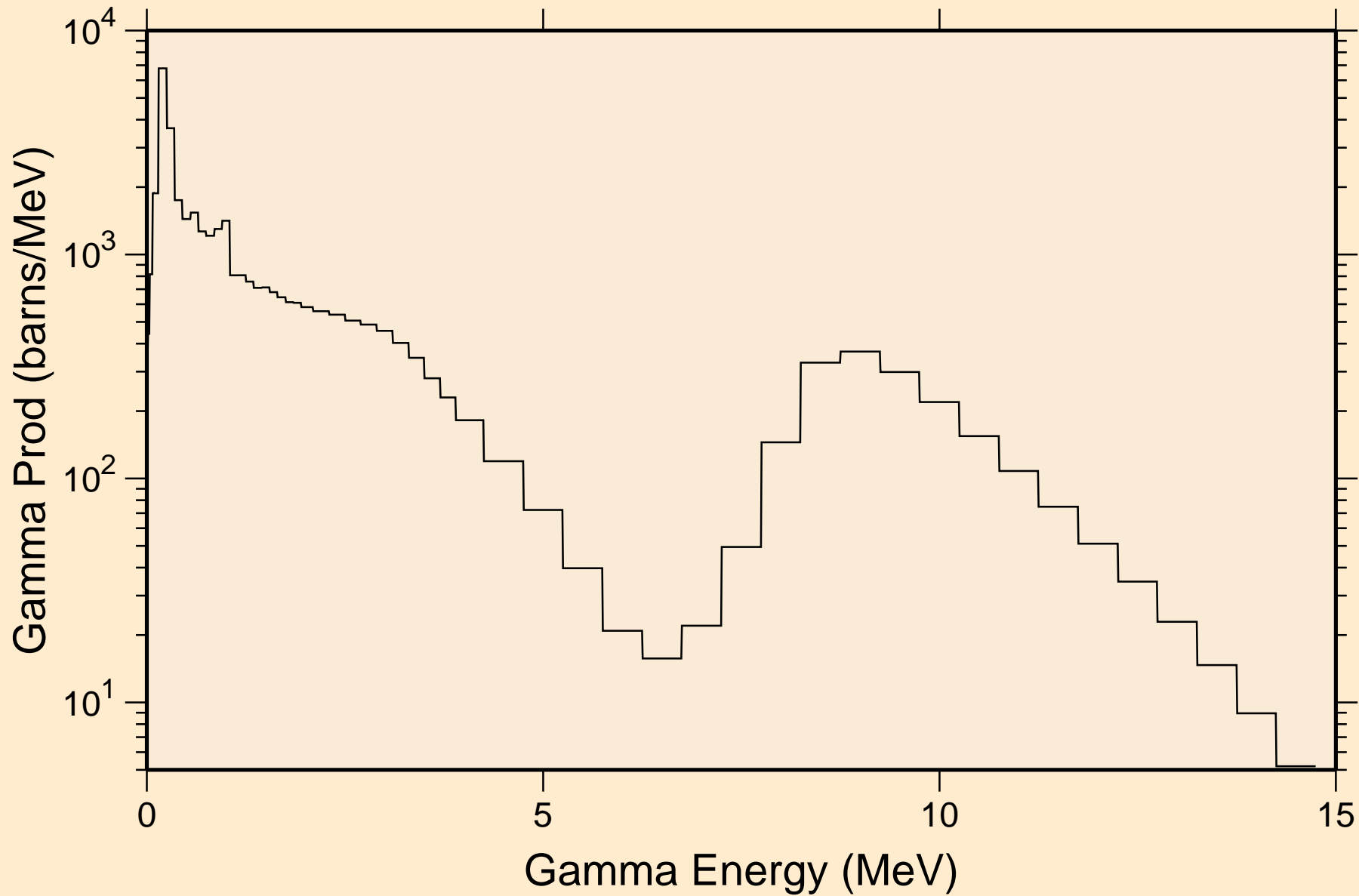

BR070M NEUTRON ACER TENDL-2023 LIBRARY; T=0.K
14 MeV photon spectrum

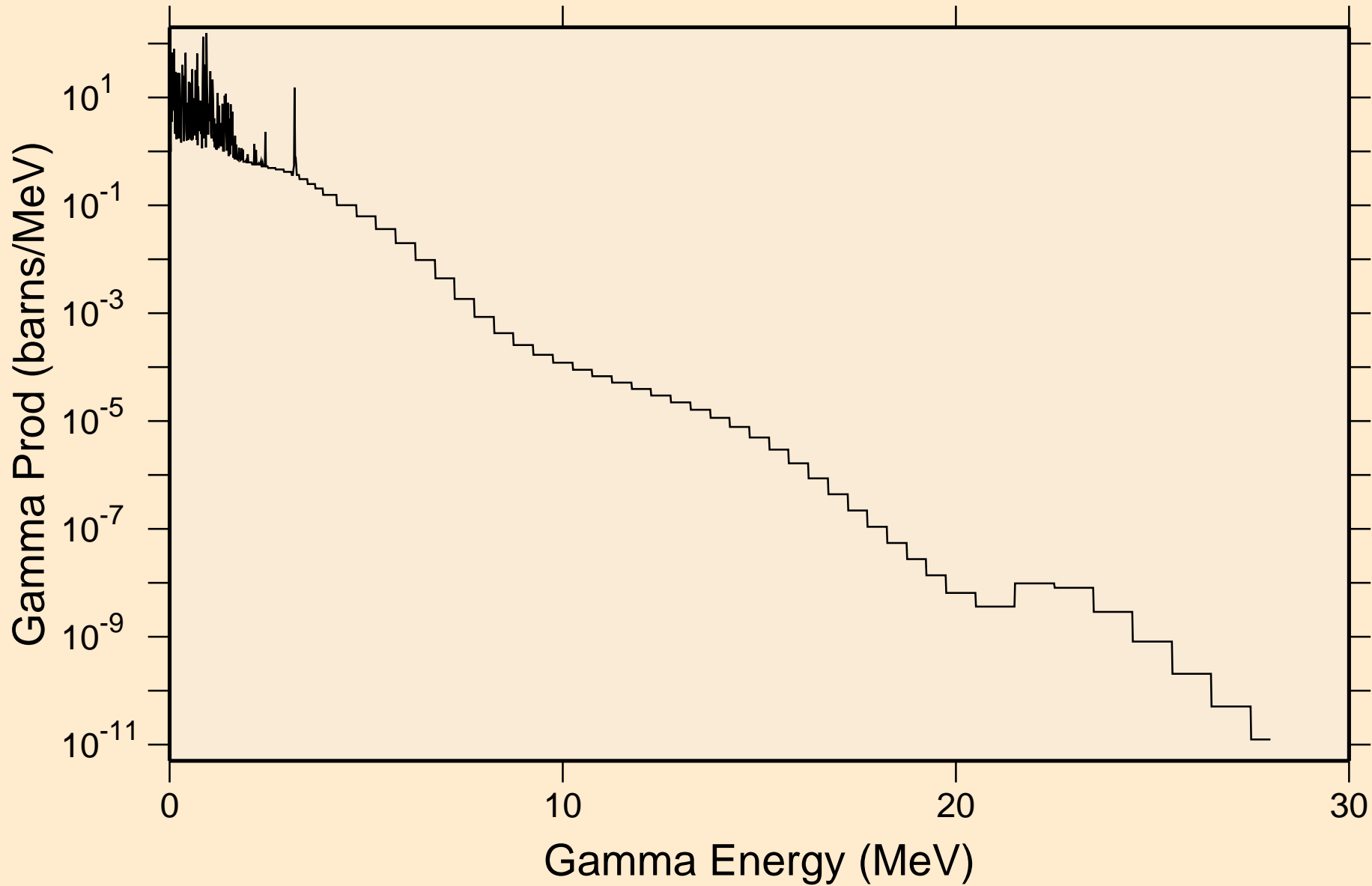

BR070M NEUTRON ACER TENDL-2023 LIBRARY; T=0.K

Particle heating contributions

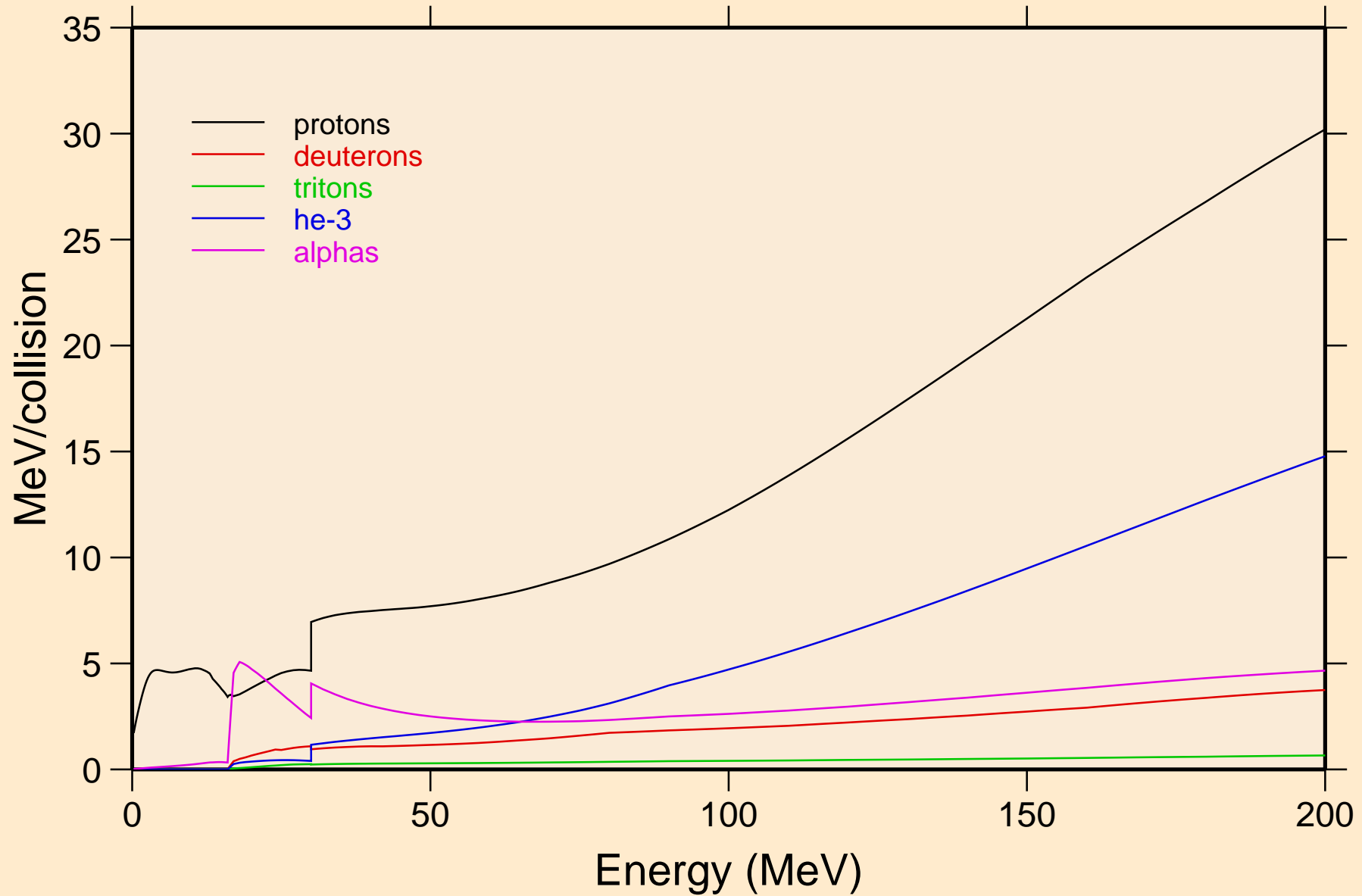

BR070M NEUTRON ACER TENDL-2023 LIBRARY; T=0.K
Recoil Heating

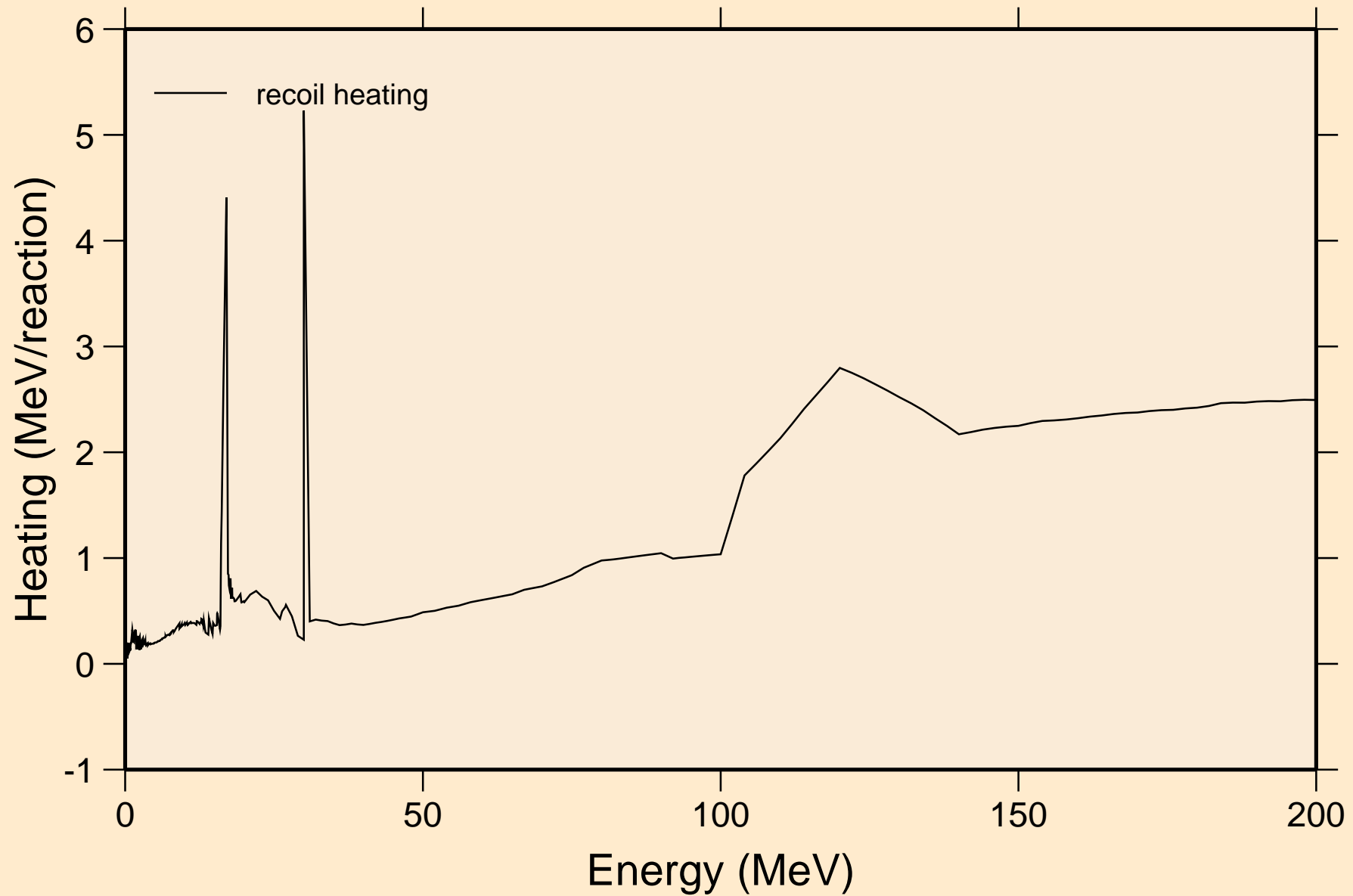

BR070M NEUTRON ACER TENDL-2023 LIBRARY; T=0.K
Particle production cross sections

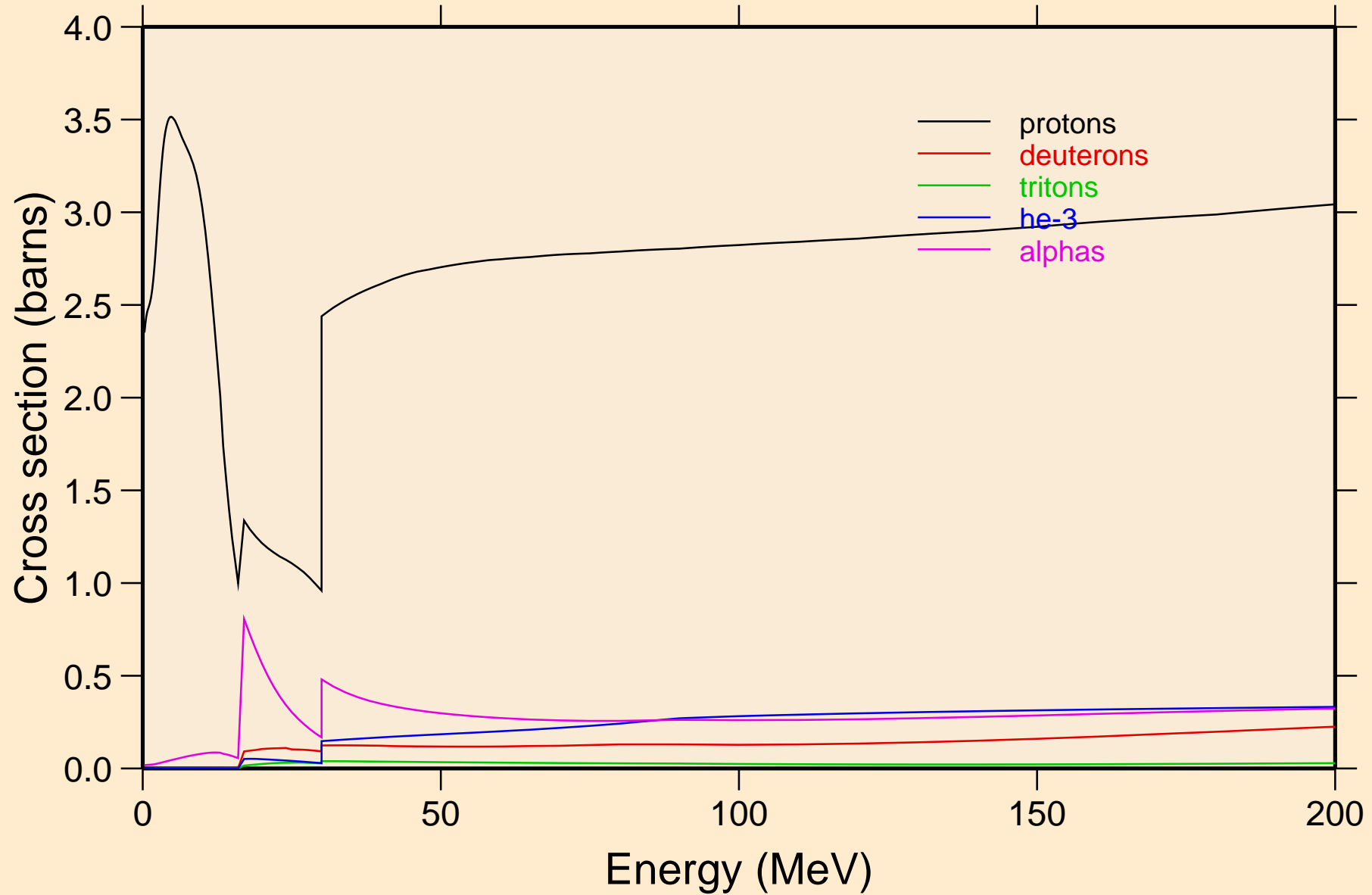

BR070M NEUTRON ACER TENDL-2023 LIBRARY; T=0.K
protons from (n,x)

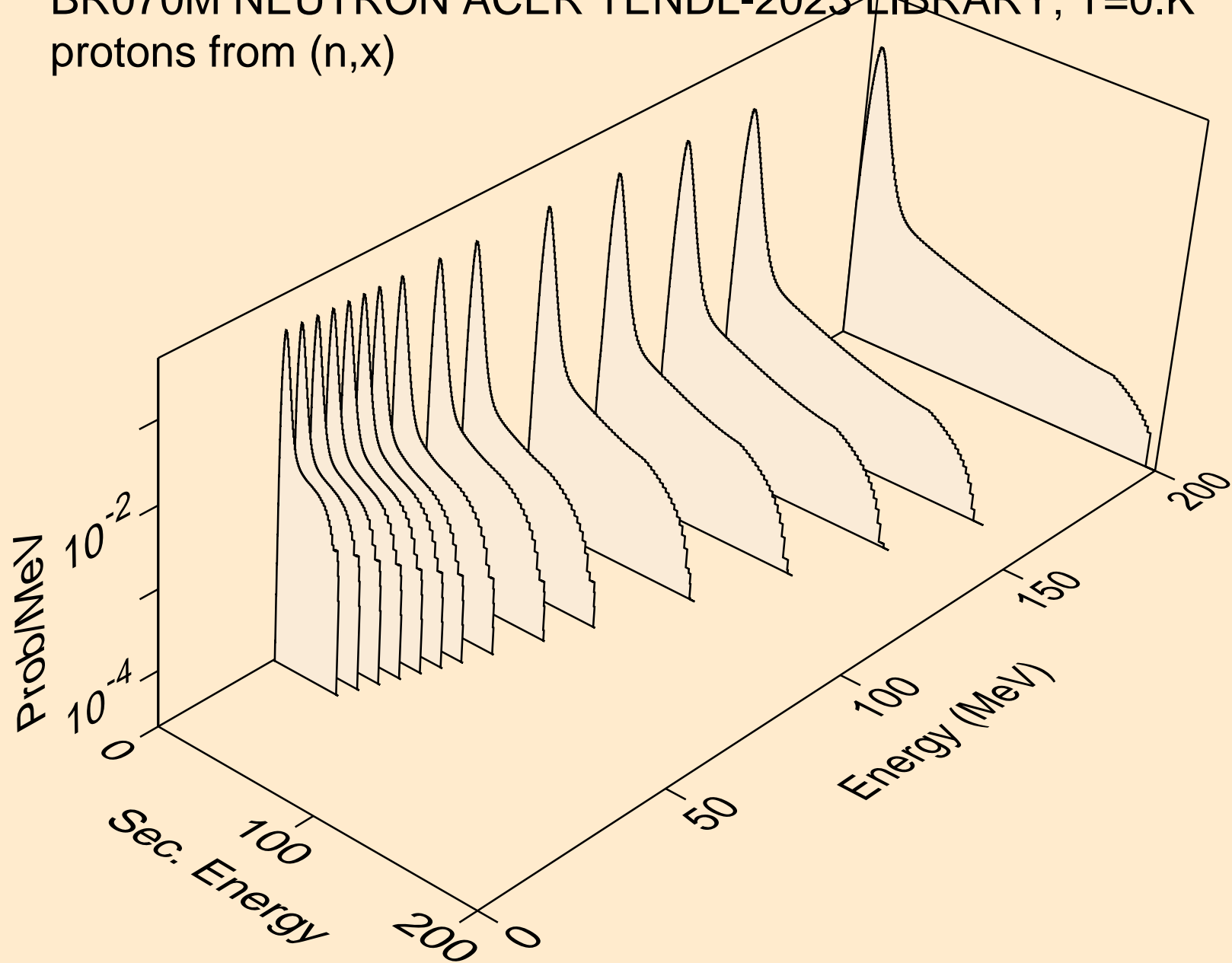

BR070M NEUTRON ACER TENDL-2023 LIBRARY; T=0.K
protons from (n,n*)p

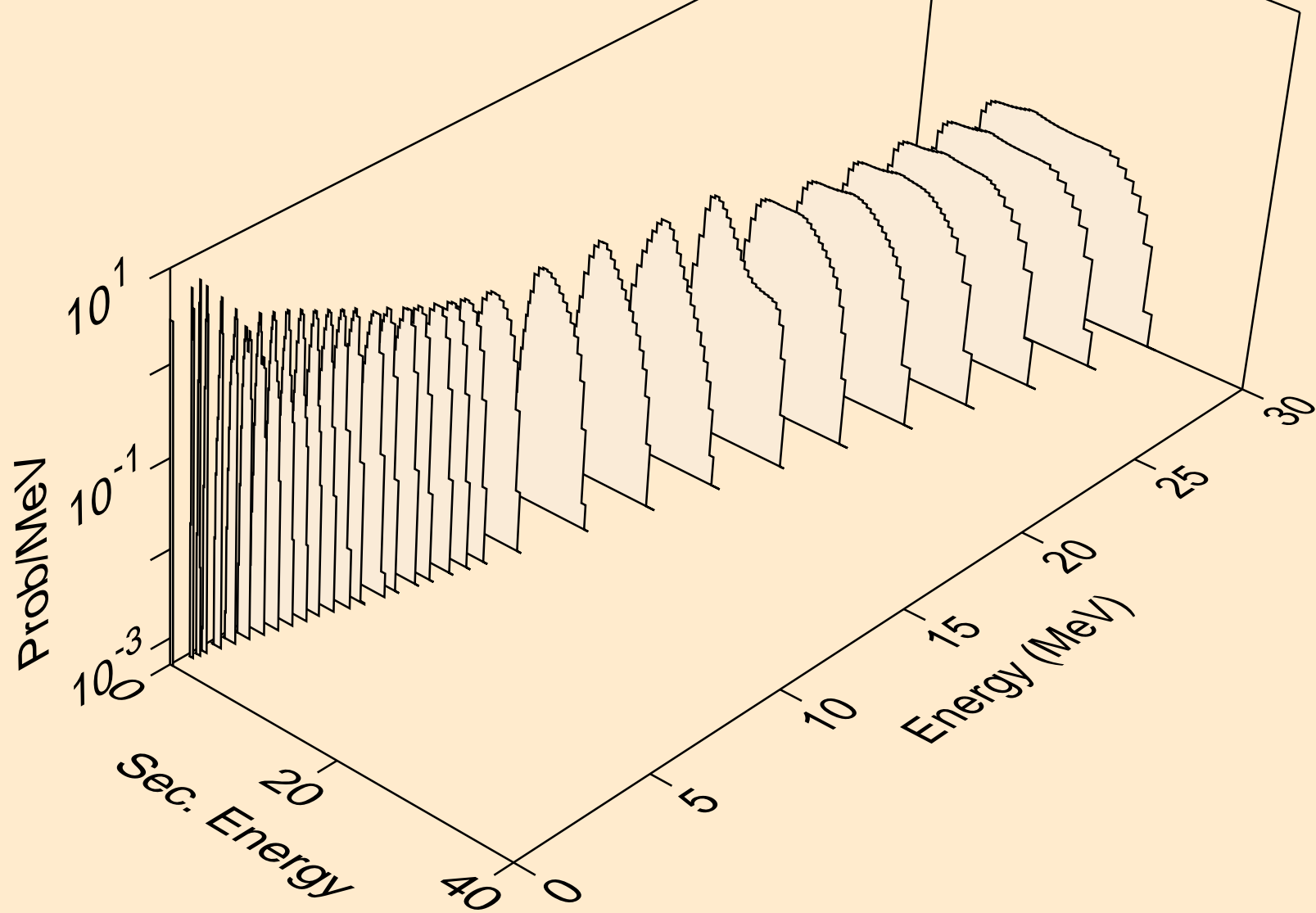

BR070M NEUTRON ACER TENDL-2023 LIBRARY; T=0.K
protons from (n,2np)

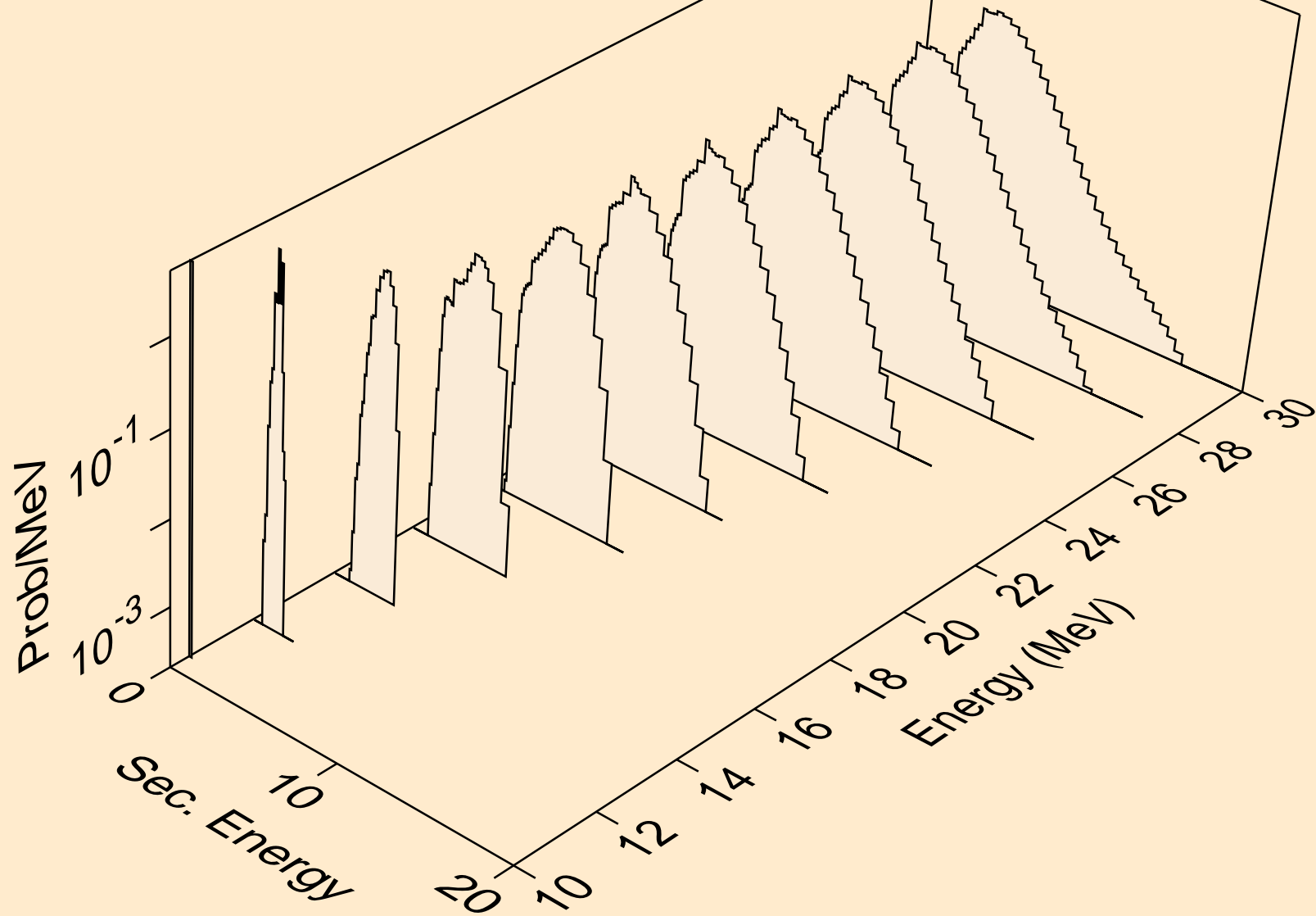

BR070M NEUTRON ACER TENDL-2023 LIBRARY; T=0.K
protons from (n,3np)

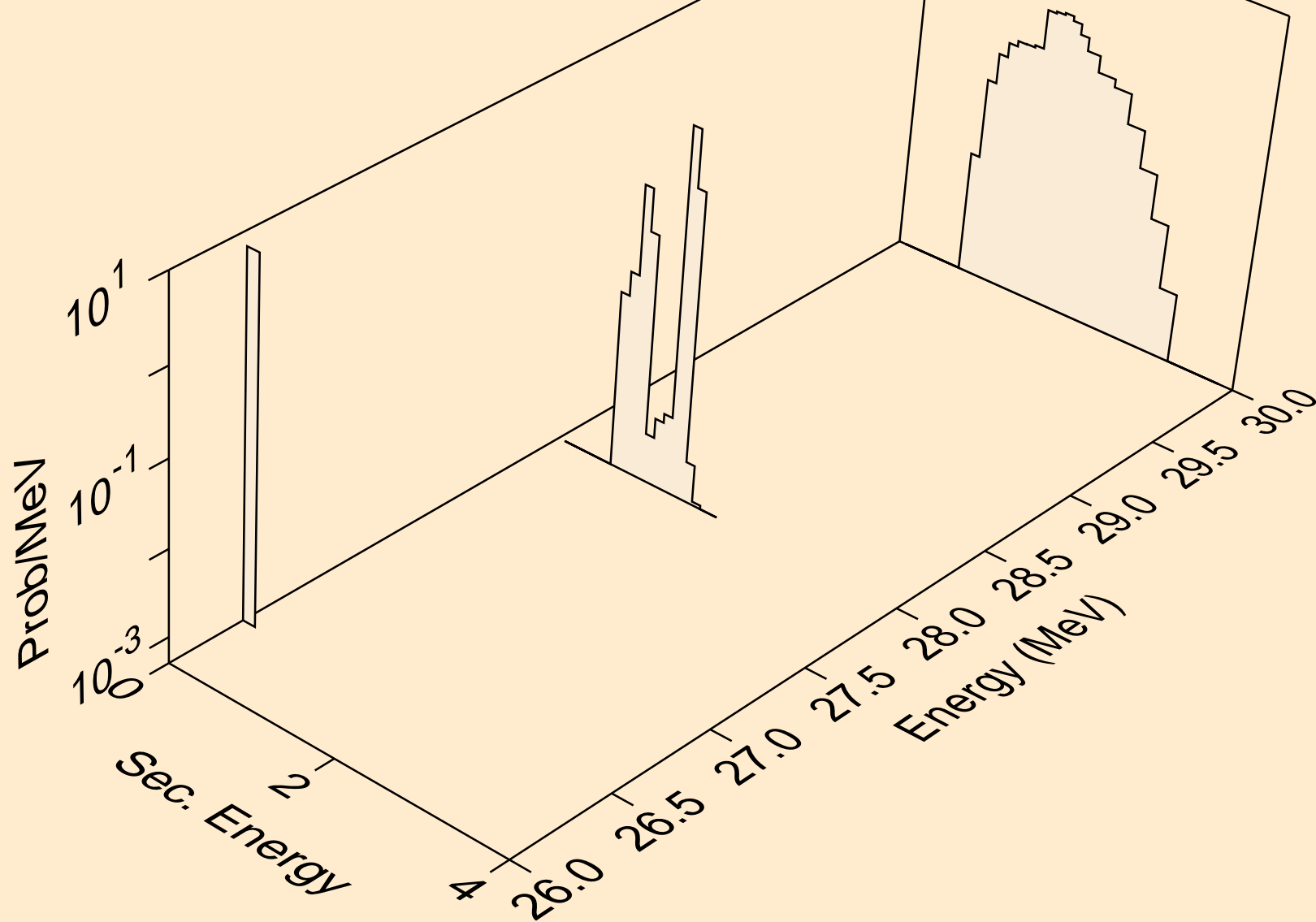

BR070M NEUTRON ACER TENDL-2023 LIBRARY; T=0.K
protons from (n,n2p)

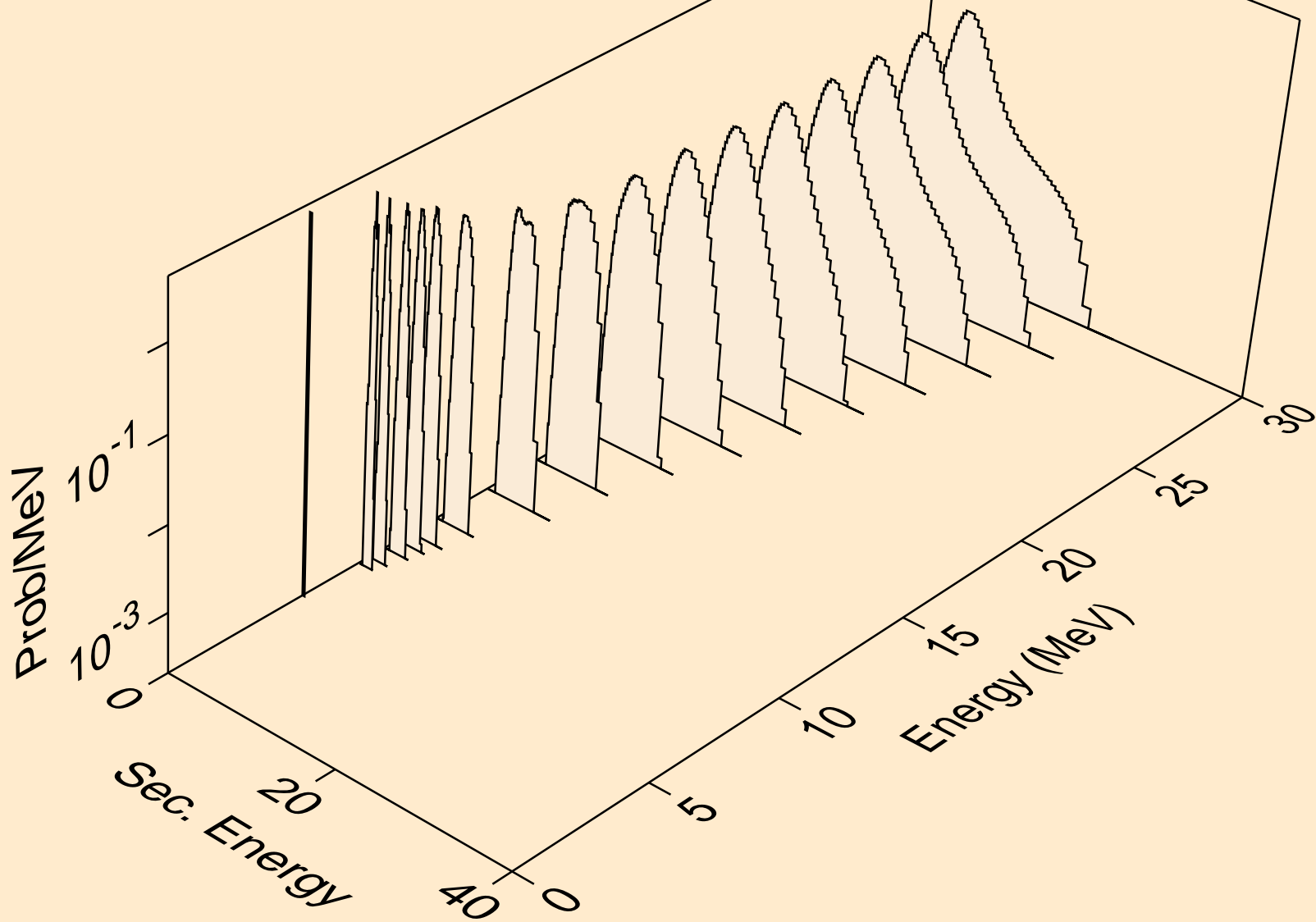

BR070M NEUTRON ACER TENDL-2023 LIBRARY; T=0.K
protons from (n,npa)

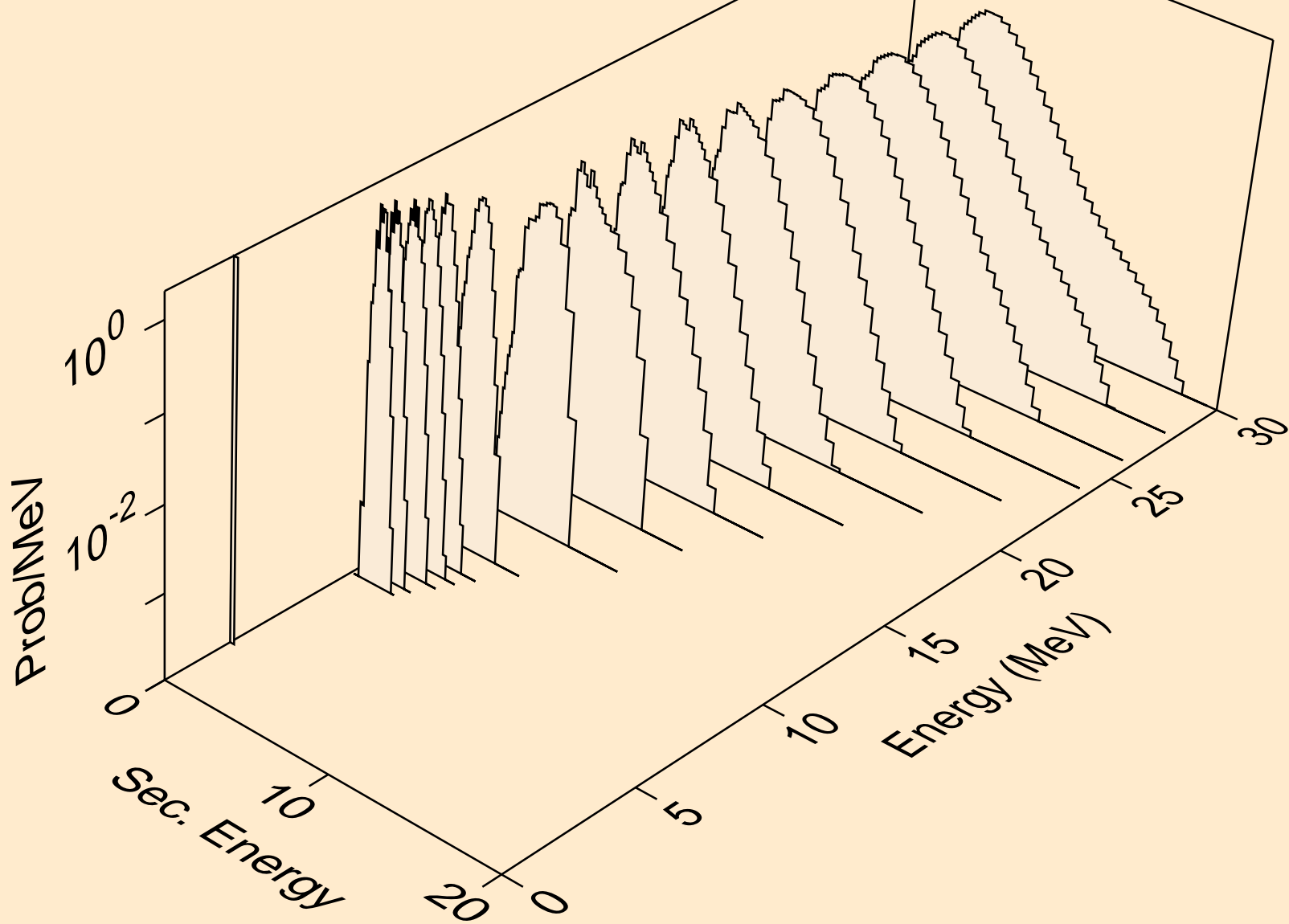

BR070M NEUTRON ACER TENDL-2023 LIBRARY; T=0.K
protons from (n,p)

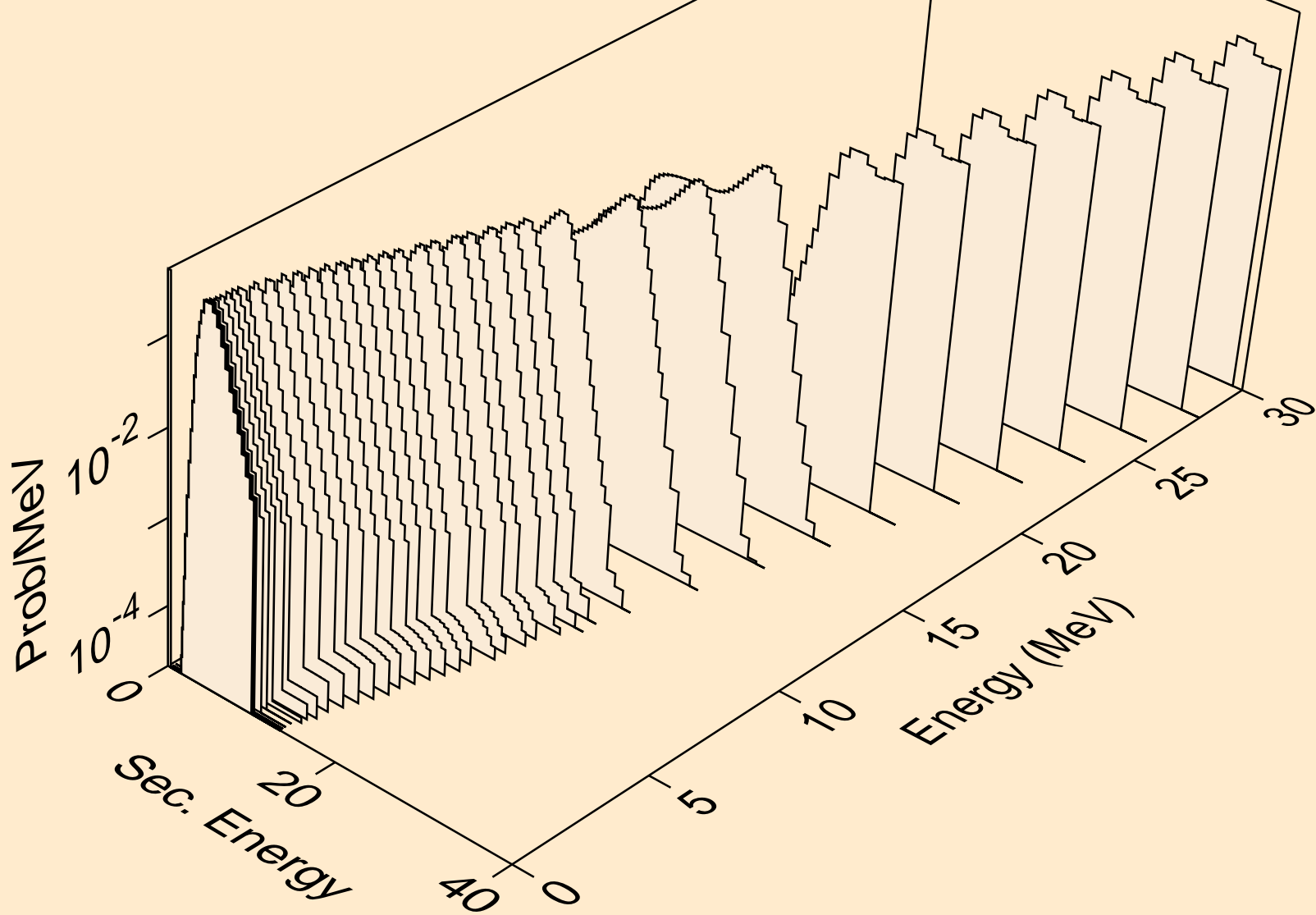

BR070M NEUTRON ACER TENDL-2023 LIBRARY; T=0.K
protons from (n,2p)

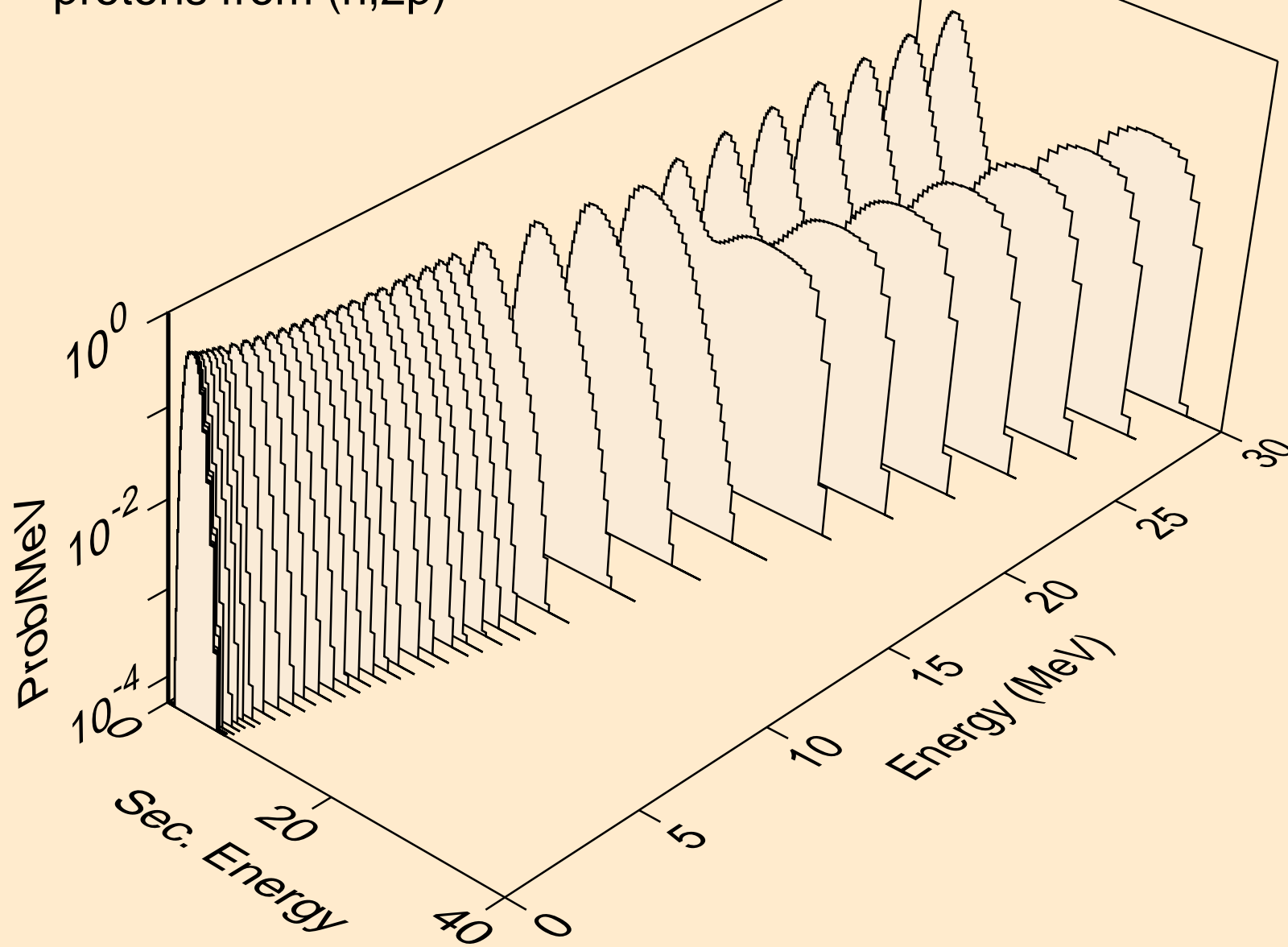

BR070M NEUTRON ACER TENDL-2023 LIBRARY; T=0.K
protons from (n,p)

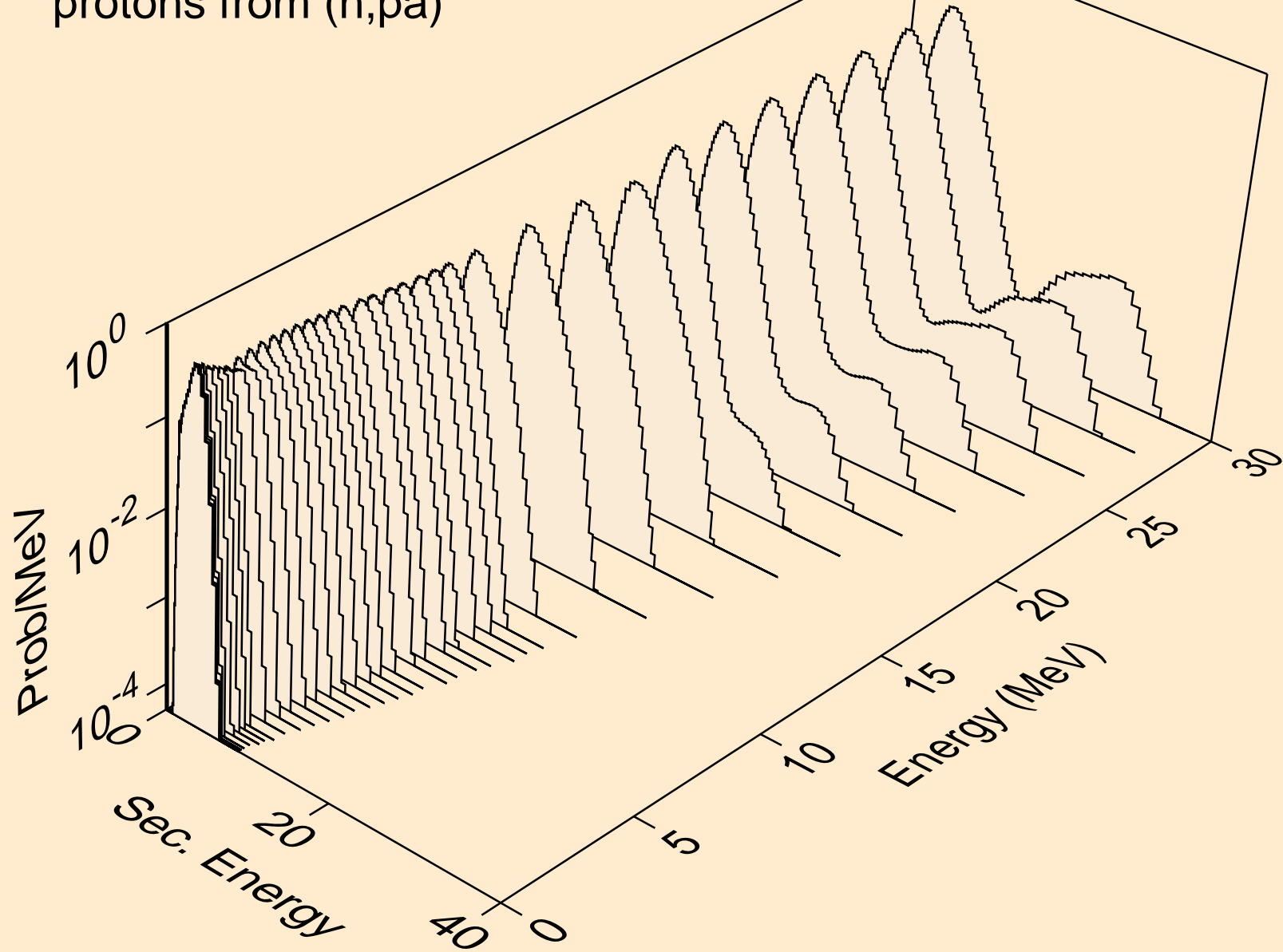

BR070M NEUTRON ACER TENDL-2023 LIBRARY; T=0.K
protons from (n,pd)

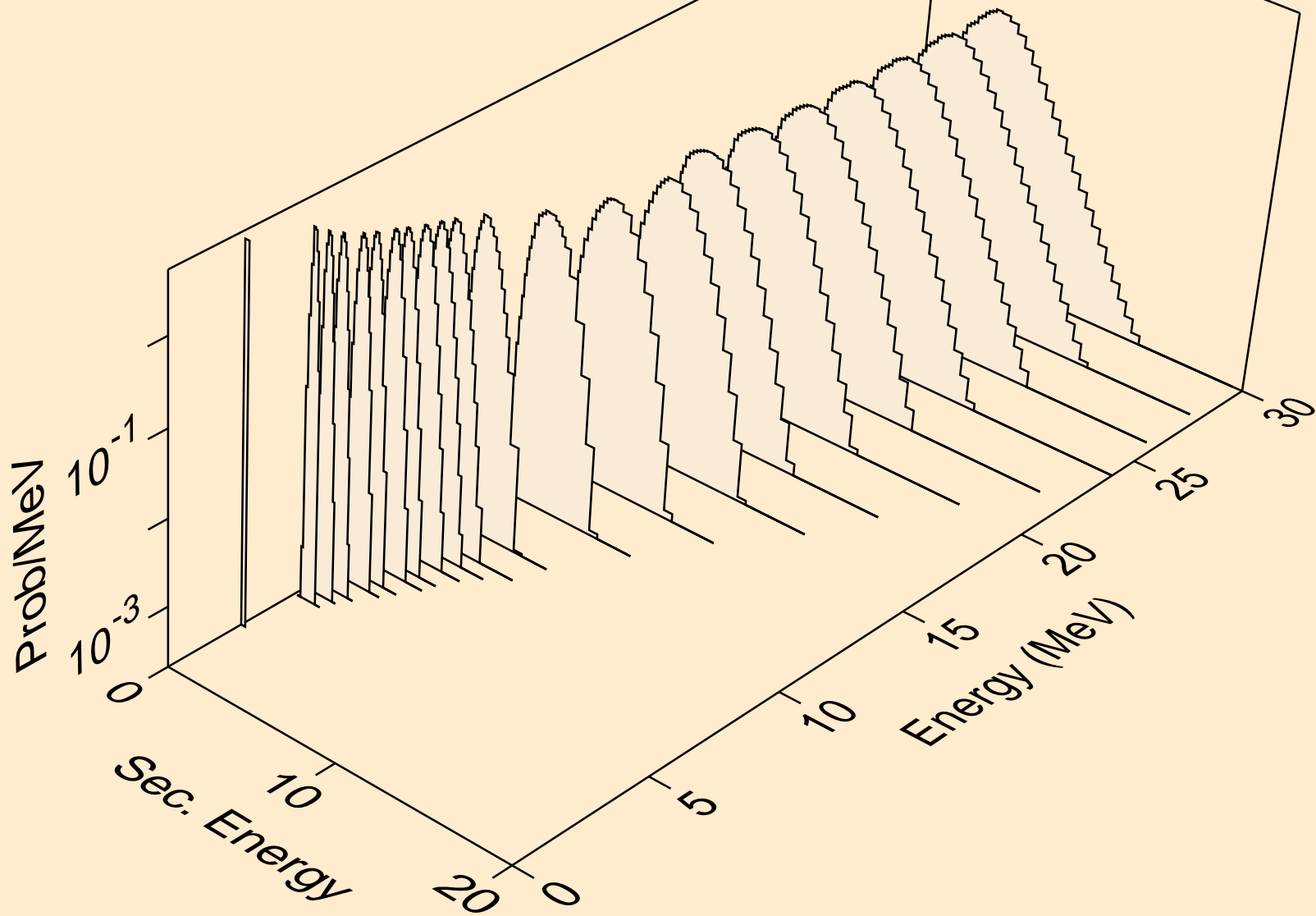

BR070M NEUTRON ACER TENDL-2023 LIBRARY; T=0.K
protons from (n,pt)

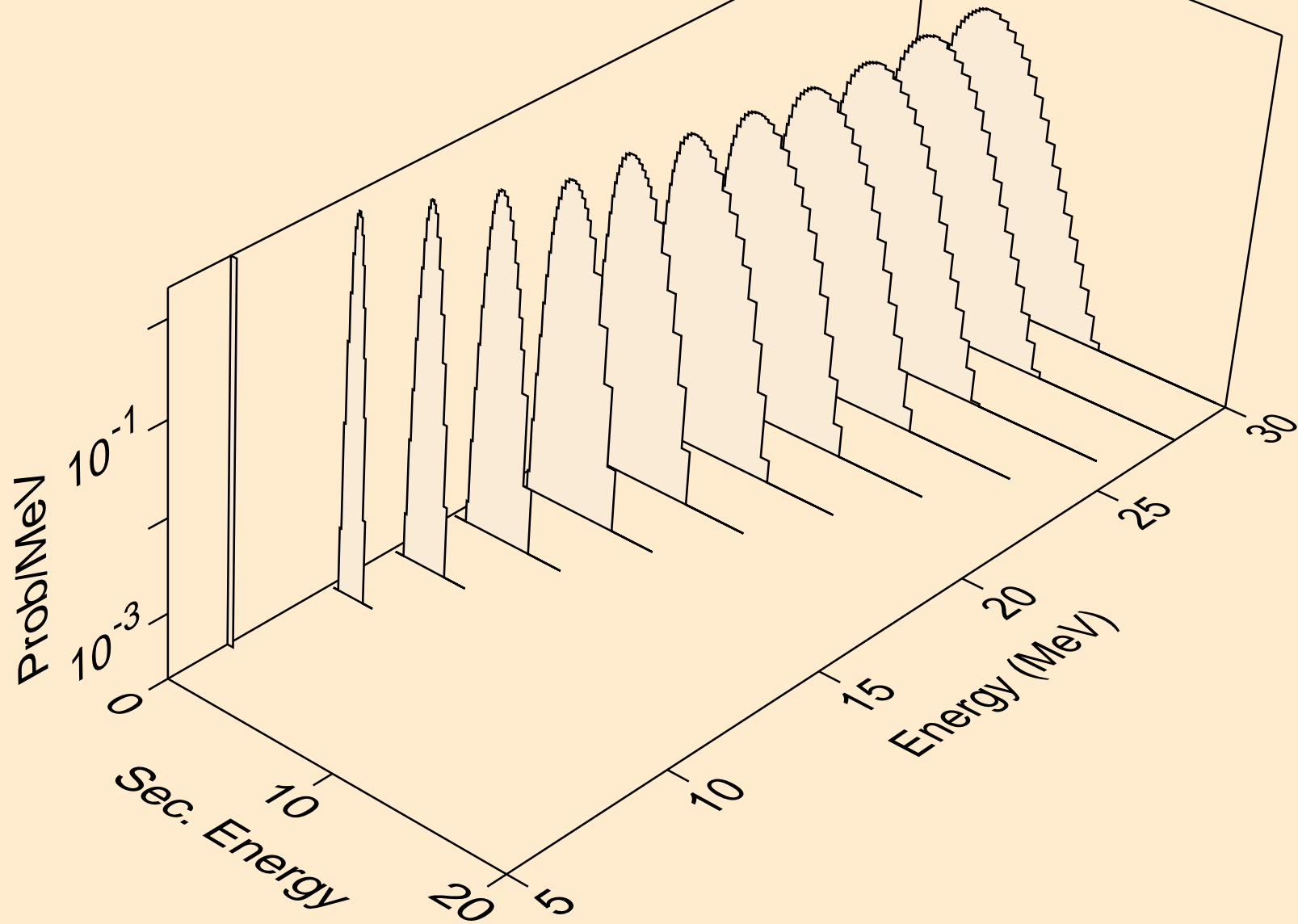

BR070M NEUTRON ACER TENDL-2023 LIBRARY; T=0.K
deuterons from (n,x)

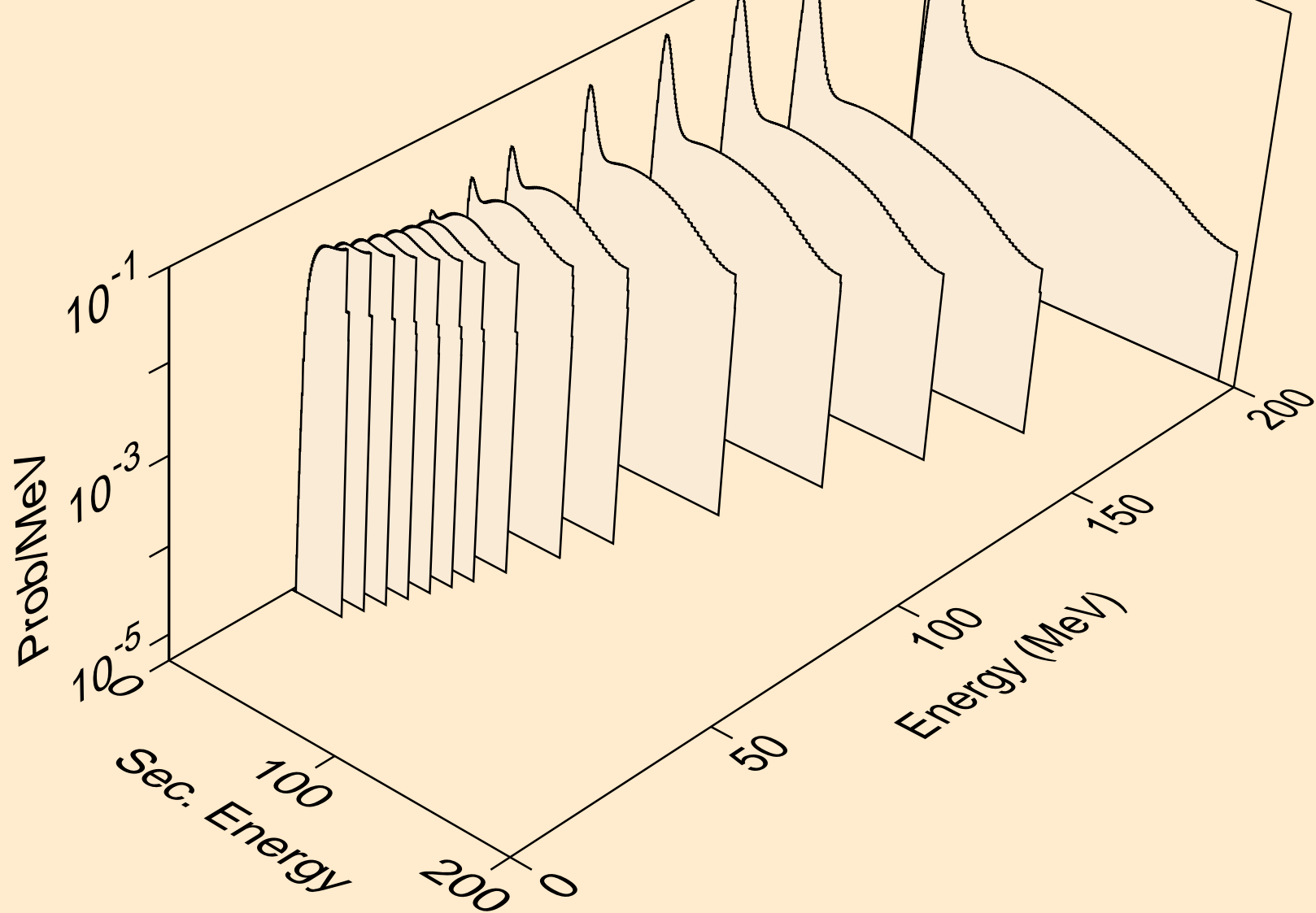

BR070M NEUTRON ACER TENDL-2023 LIBRARY; T=0.K
deuterons from (n,n*)d

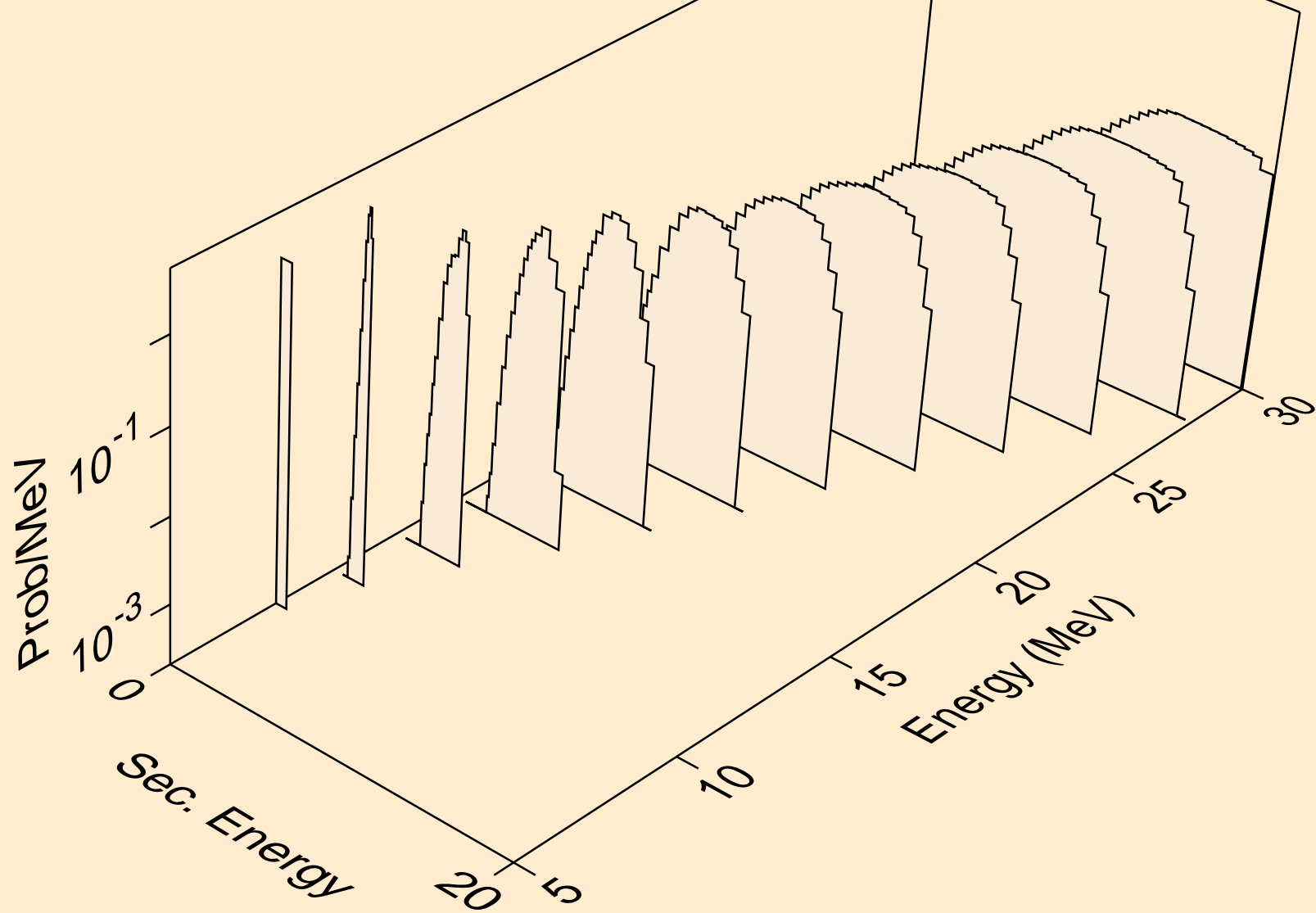

BR070M NEUTRON ACER TENDL-2023 LIBRARY; T=0.K
deuterons from (n,d)

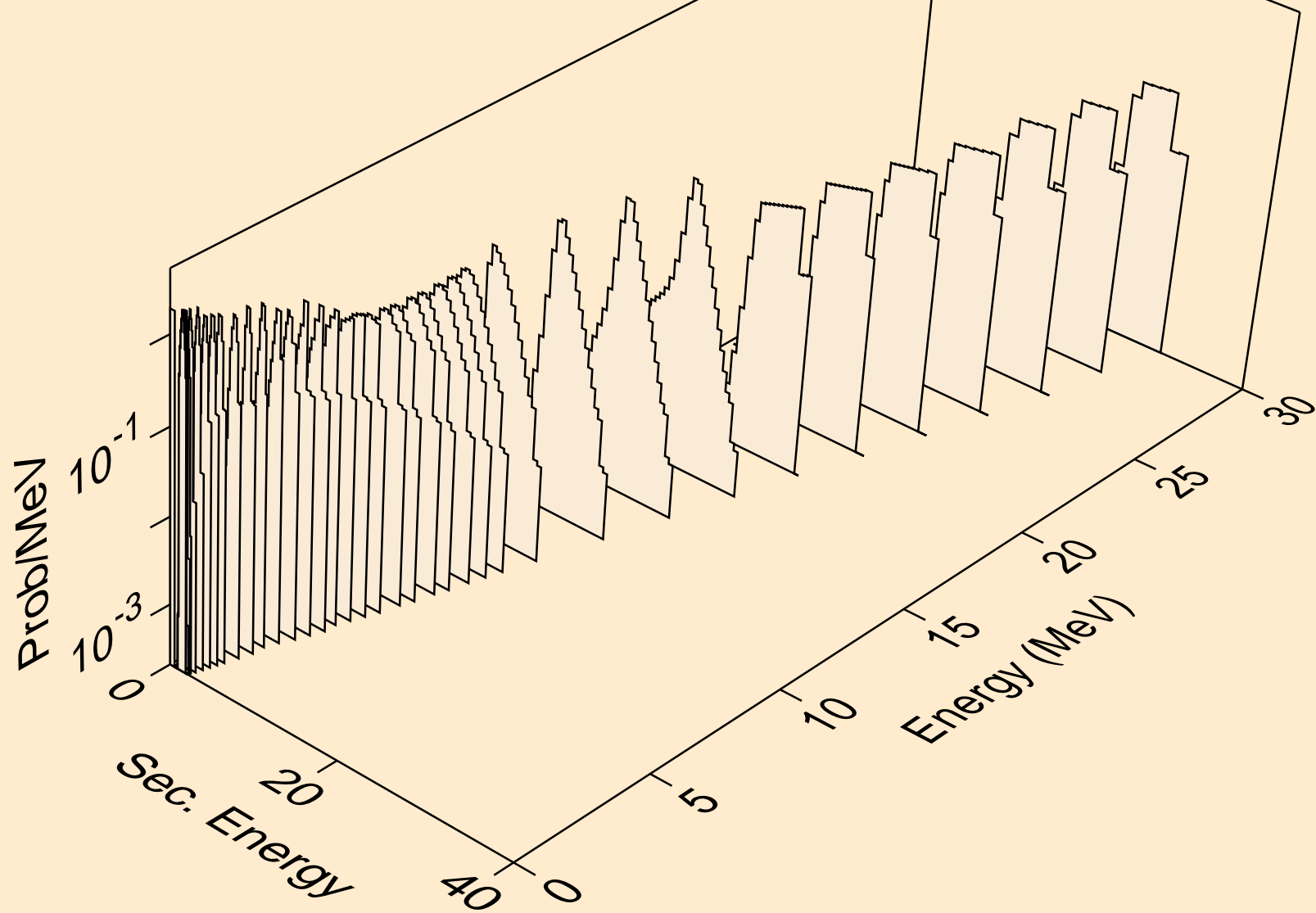

BR070M NEUTRON ACER TENDL-2023 LIBRARY; T=0.K
deuterons from (n,d2a)

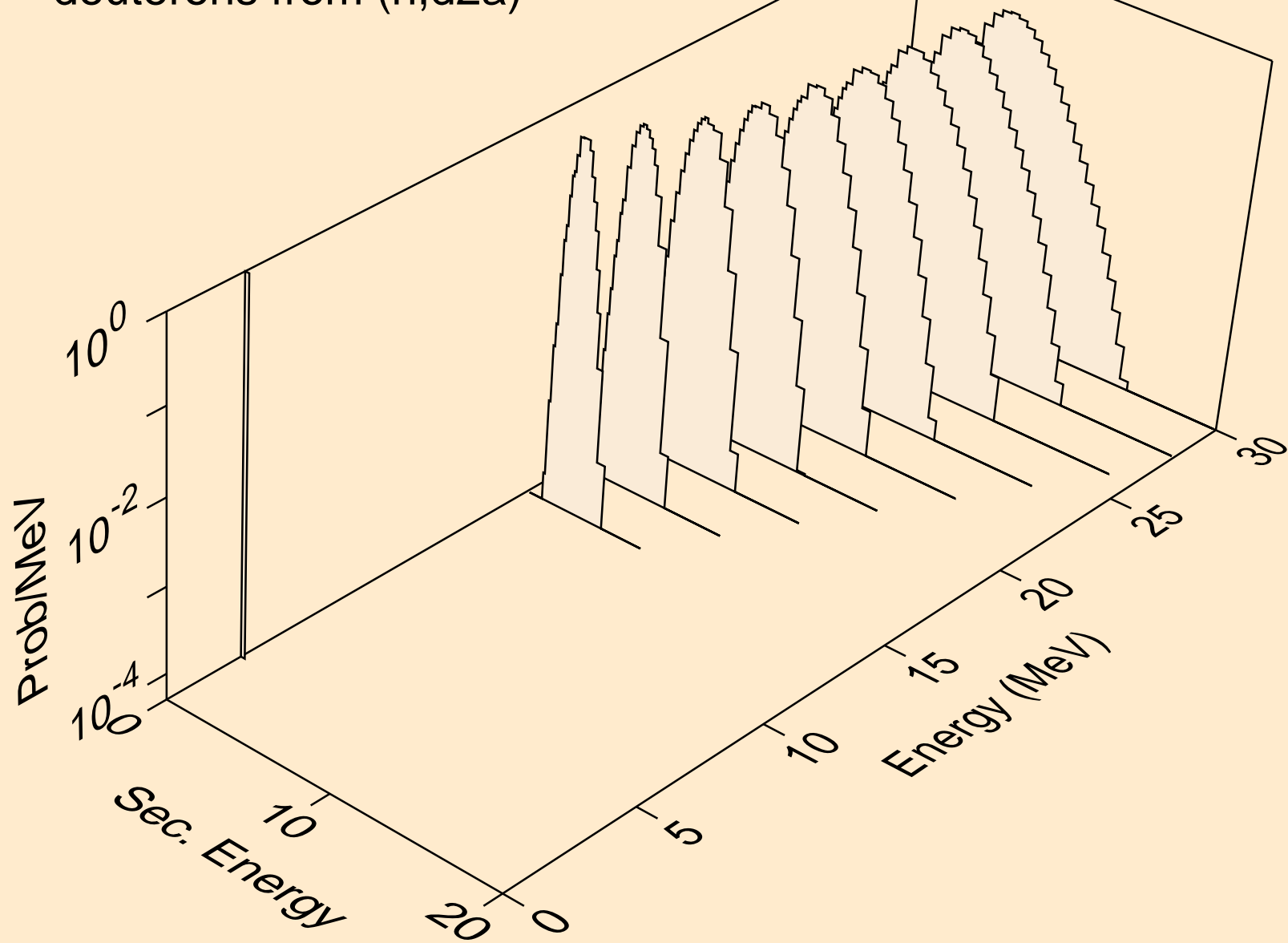

BR070M NEUTRON ACER TENDL-2023 LIBRARY; T=0.K
deuterons from (n,pd)

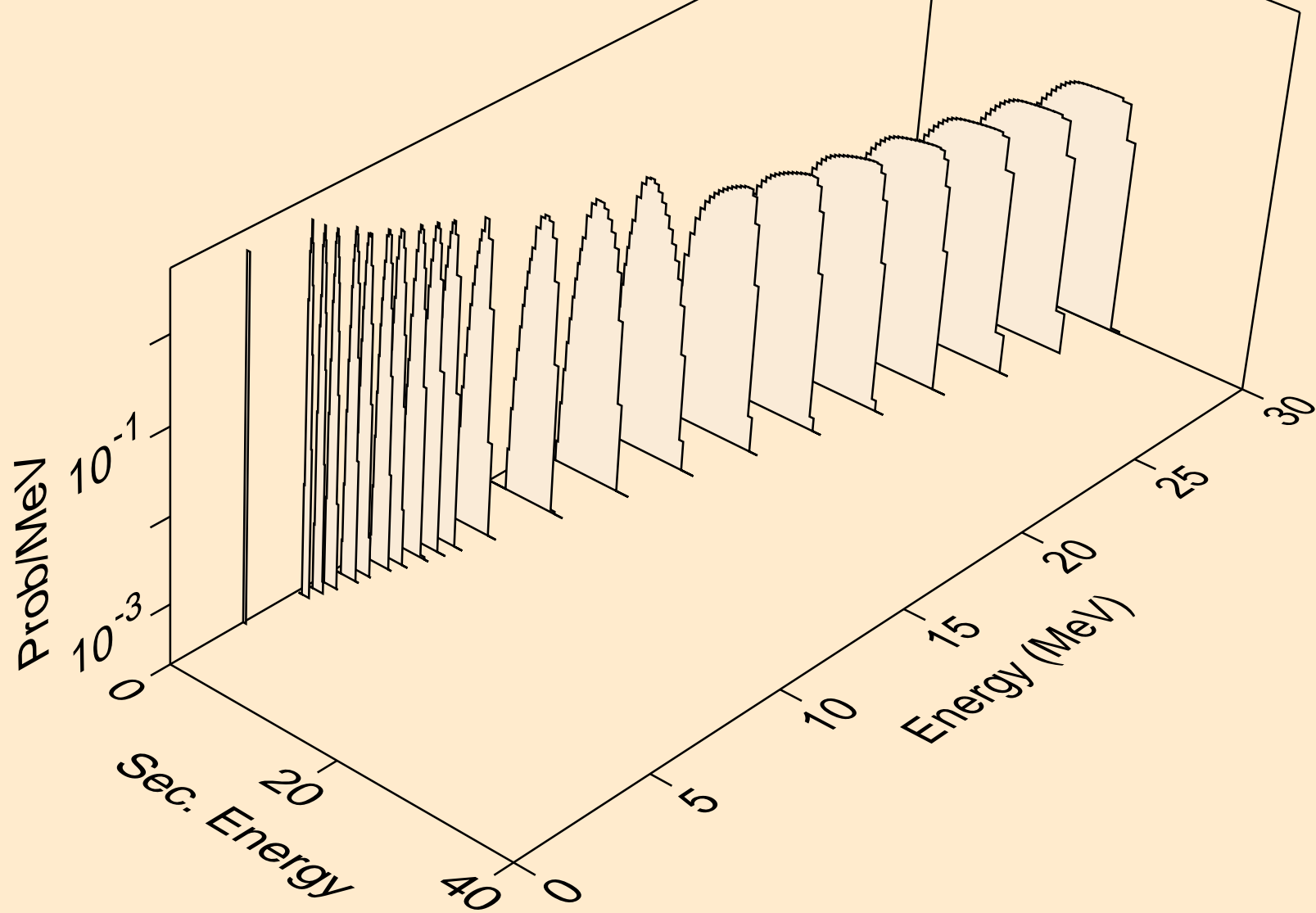

BR070M NEUTRON ACER TENDL-2023 LIBRARY; T=0.K
deuterons from (n,da)

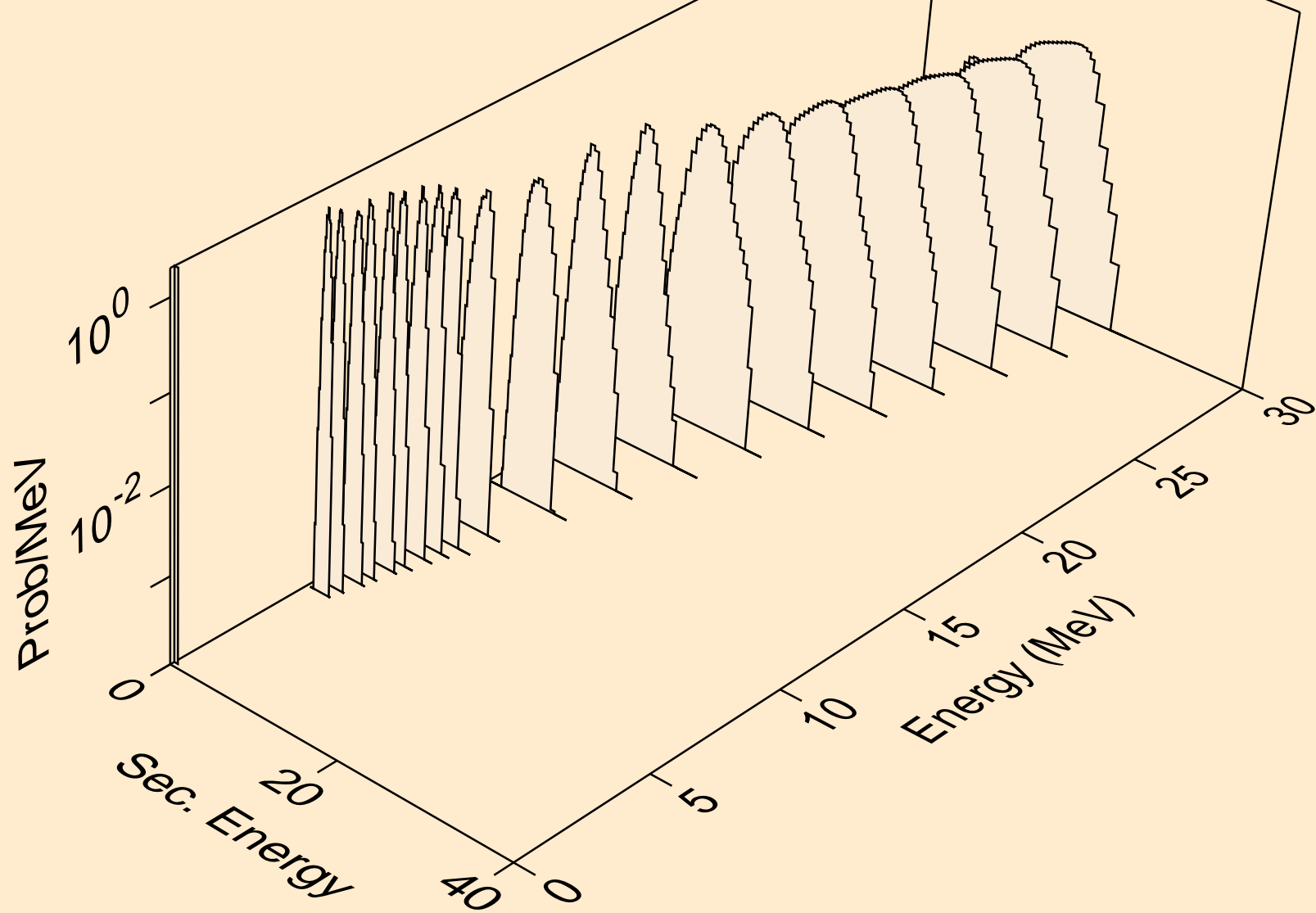

BR070M NEUTRON ACER TENDL-2023 LIBRARY; T=0.K
tritons from (n,x)

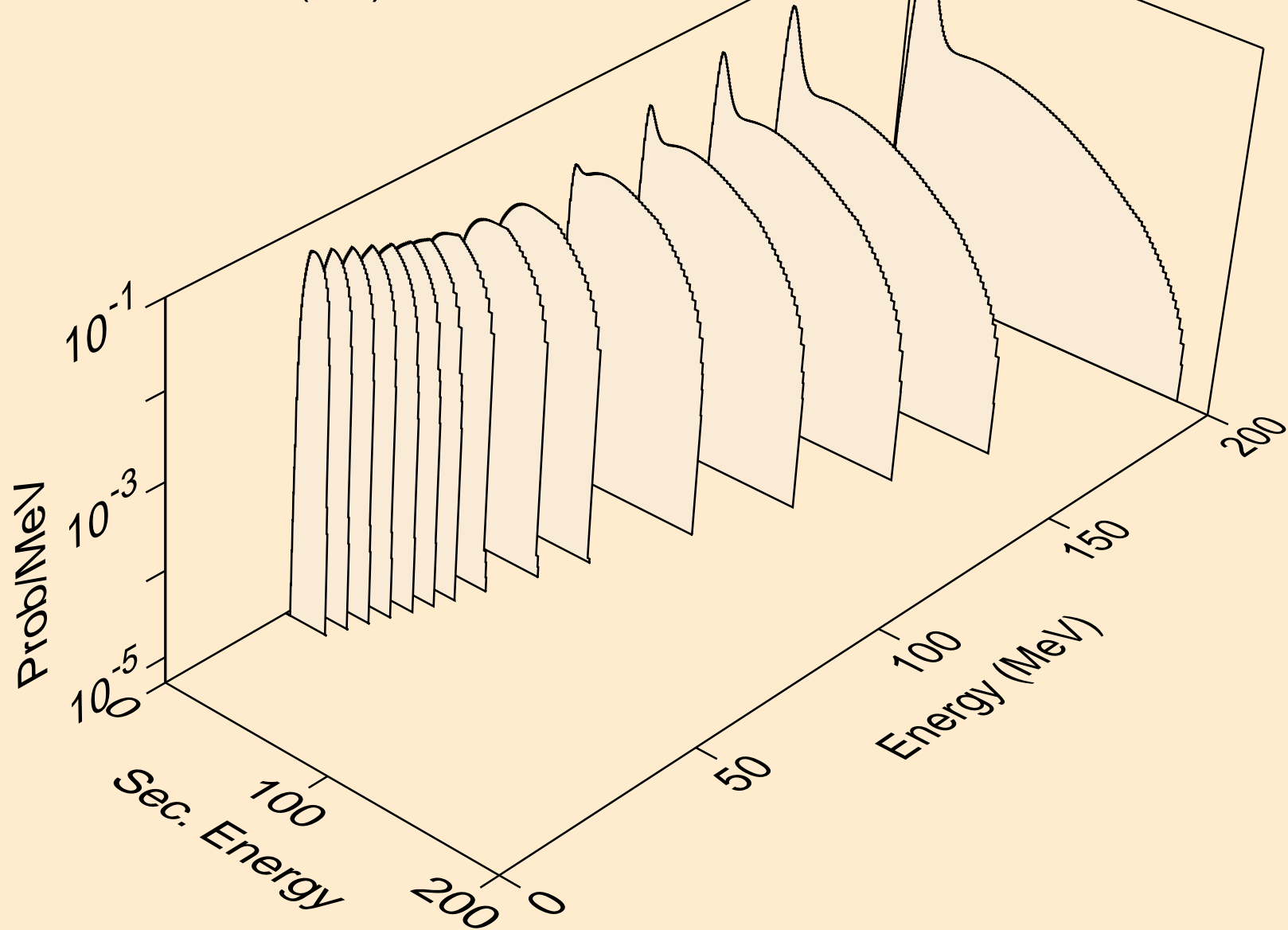

BR070M NEUTRON ACER TENDL-2023 LIBRARY; T=0.K
tritons from (n,n*)t

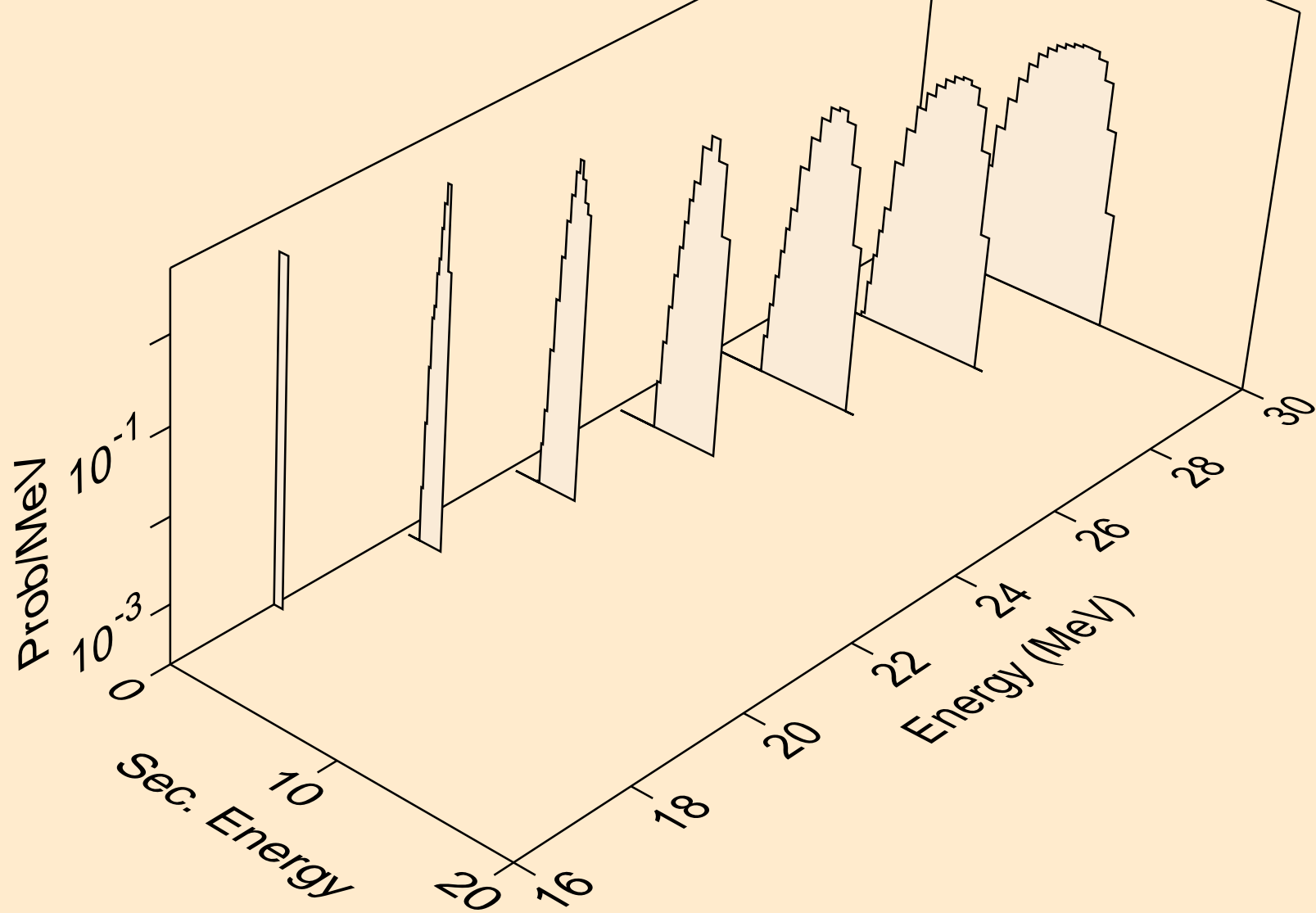

BR070M NEUTRON ACER TENDL-2023 LIBRARY; T=0.K
tritons from (n,t)

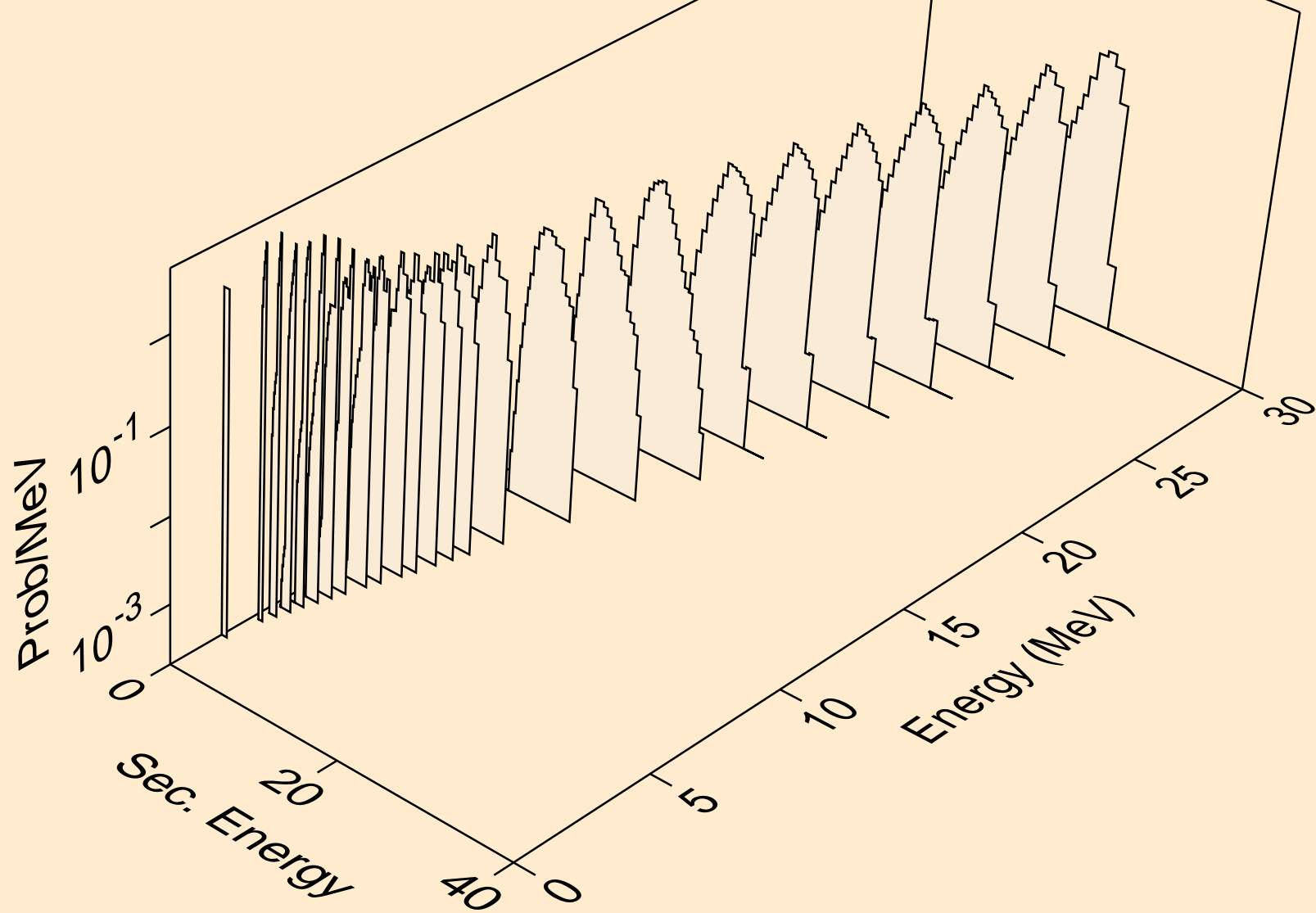

BR070M NEUTRON ACER TENDL-2023 LIBRARY; T=0.K
tritons from (n,t2a)

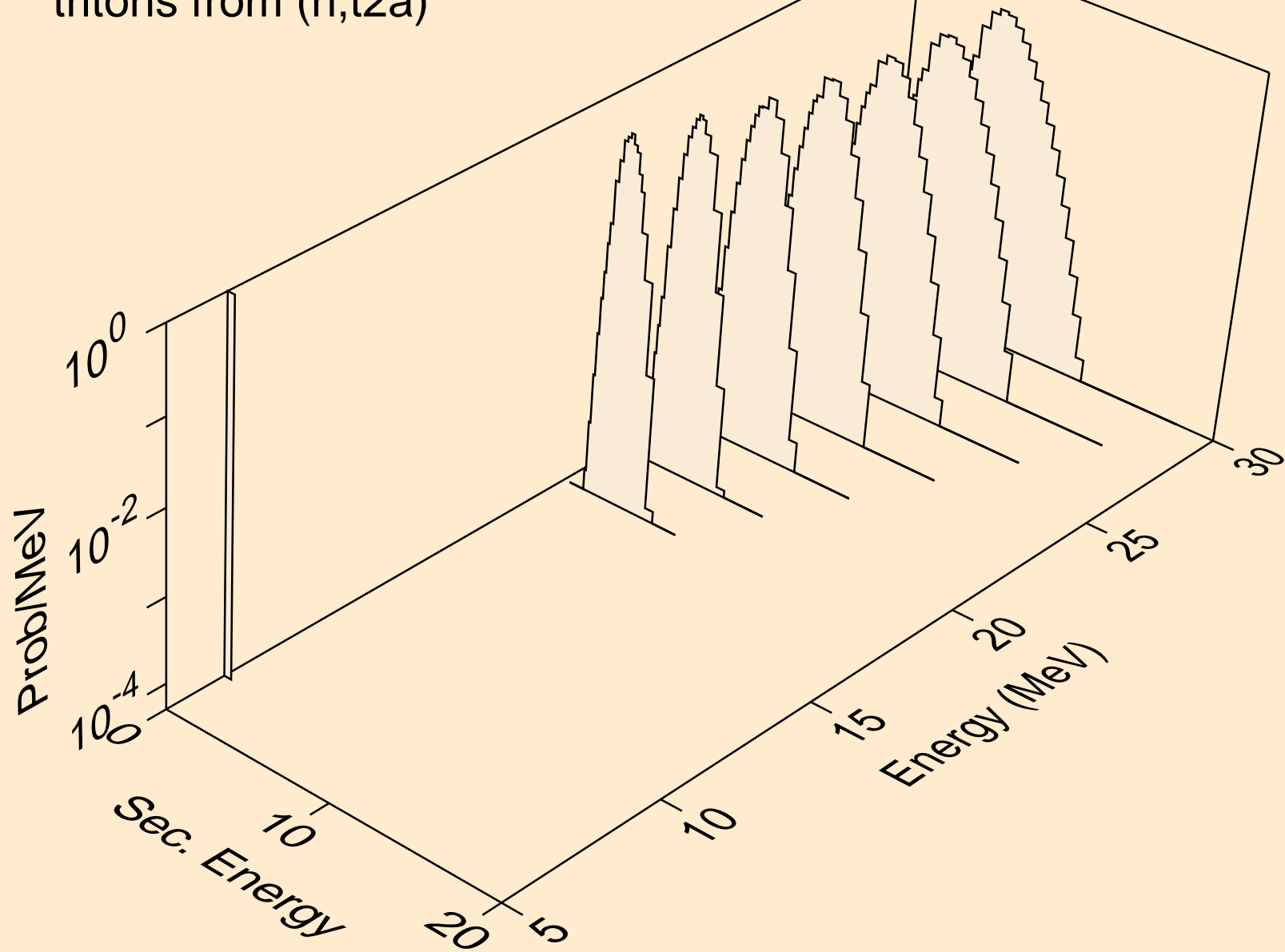

BR070M NEUTRON ACER TENDL-2023 LIBRARY; T=0.K
tritons from (n,pt)

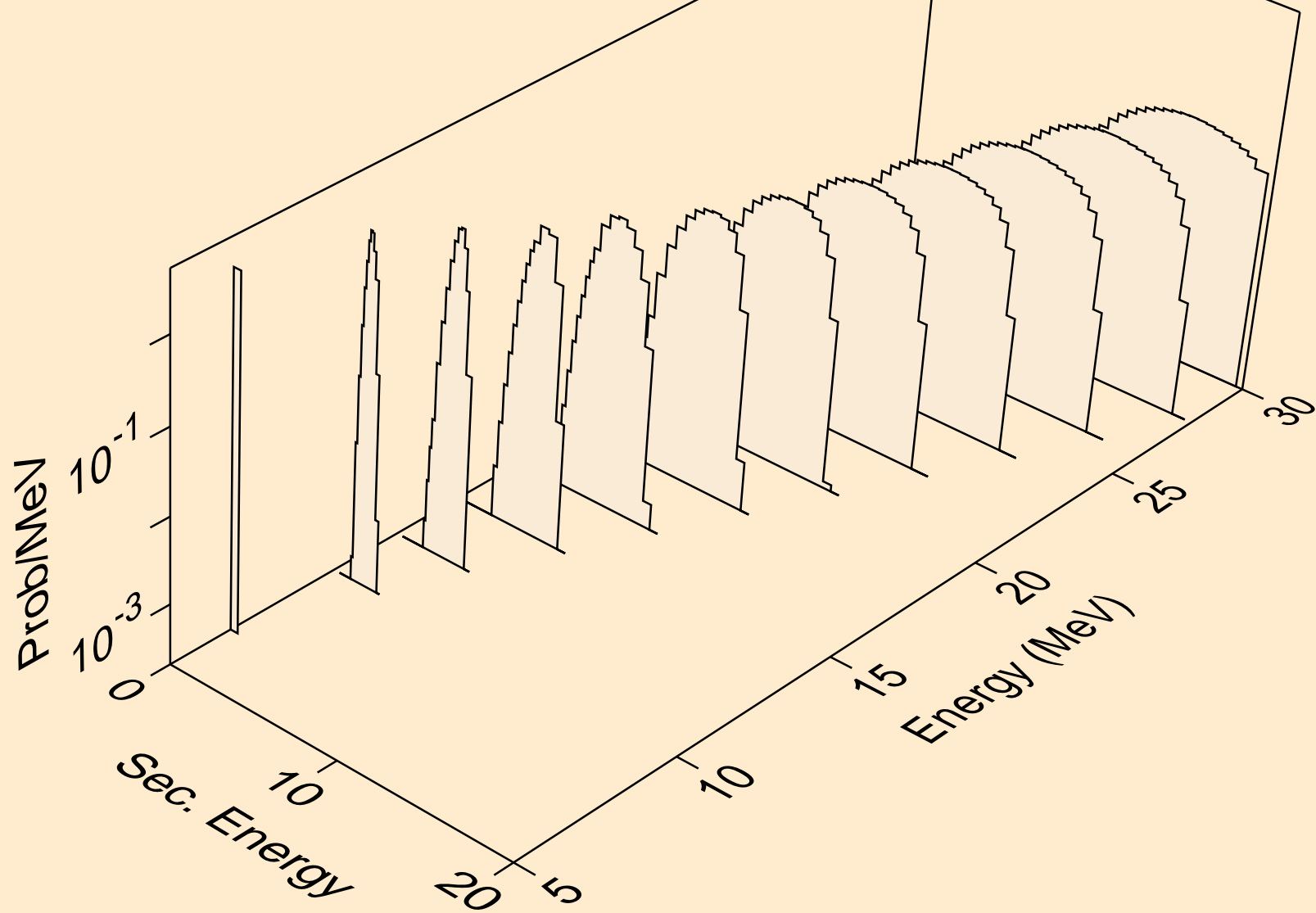

BR070M NEUTRON ACER TENDL-2023 LIBRARY; T=0.K
he3s from (n,x)

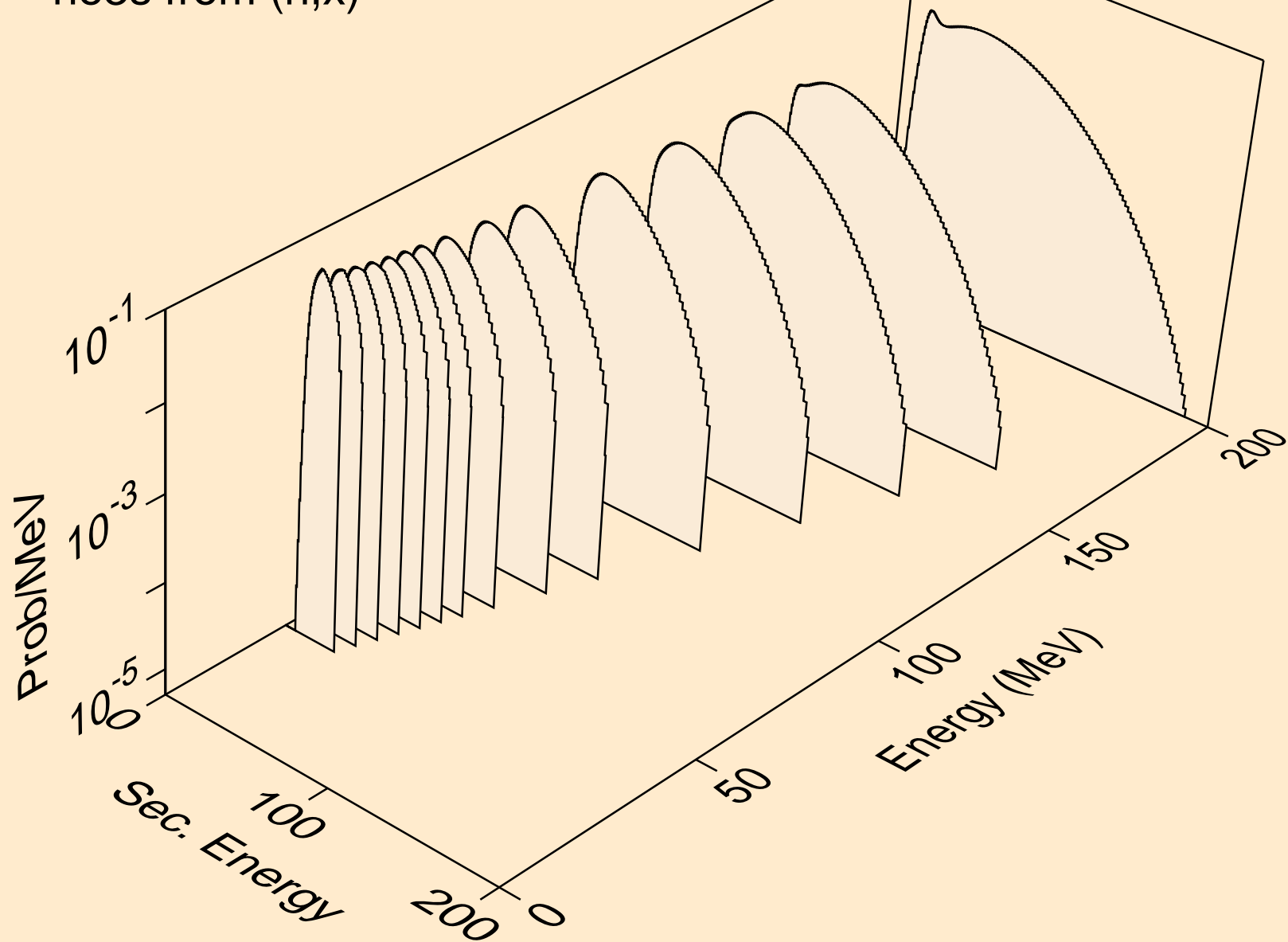

BR070M NEUTRON ACER TENDL-2023 LIBRARY; T=0.K
he3s from (n,n*)he3

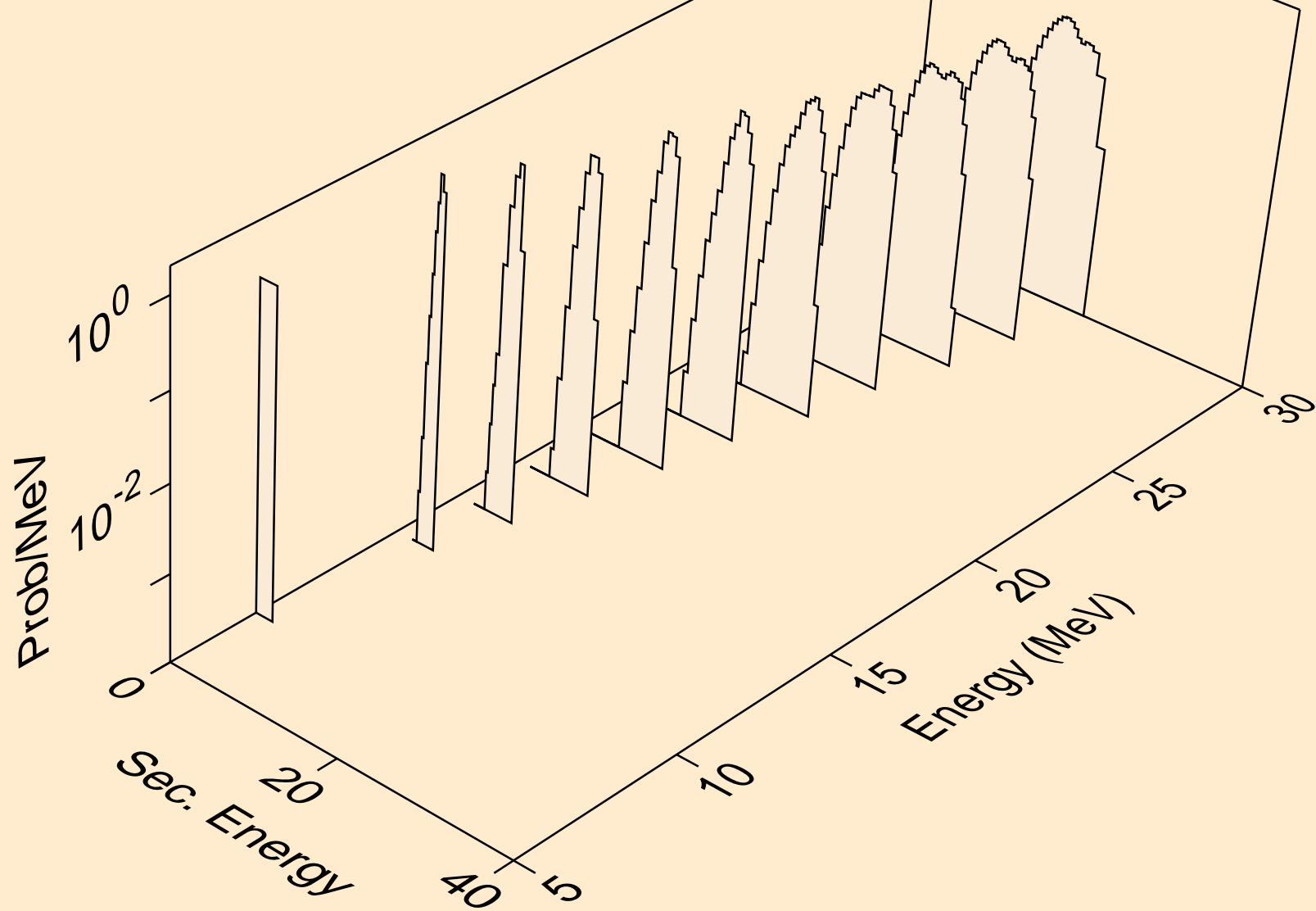

BR070M NEUTRON ACER TENDL-2023 LIBRARY; T=0.K
he3s from (n,he3)

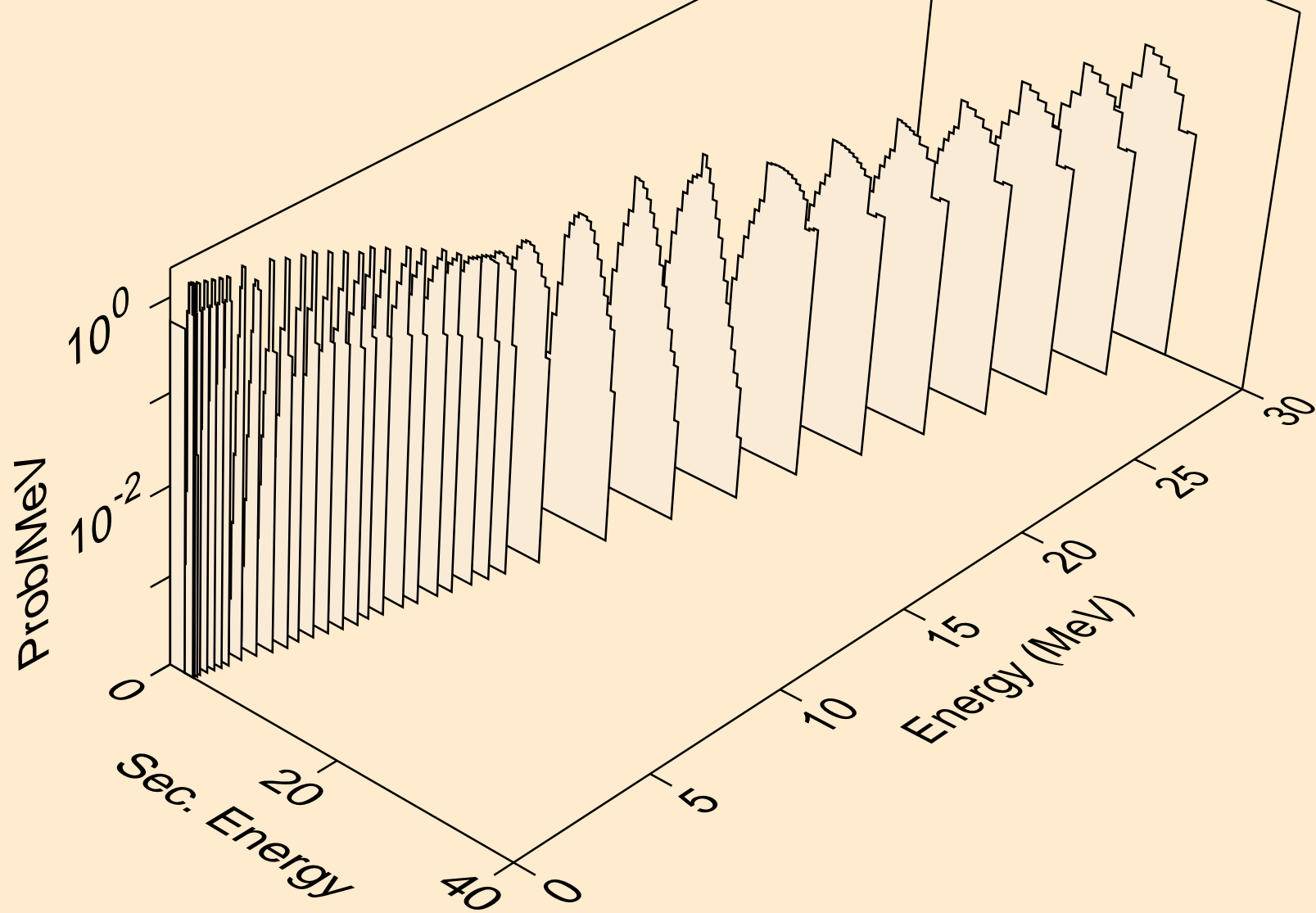

BR070M NEUTRON ACER TENDL-2023 LIBRARY; T=0.K
alphas from (n,x)

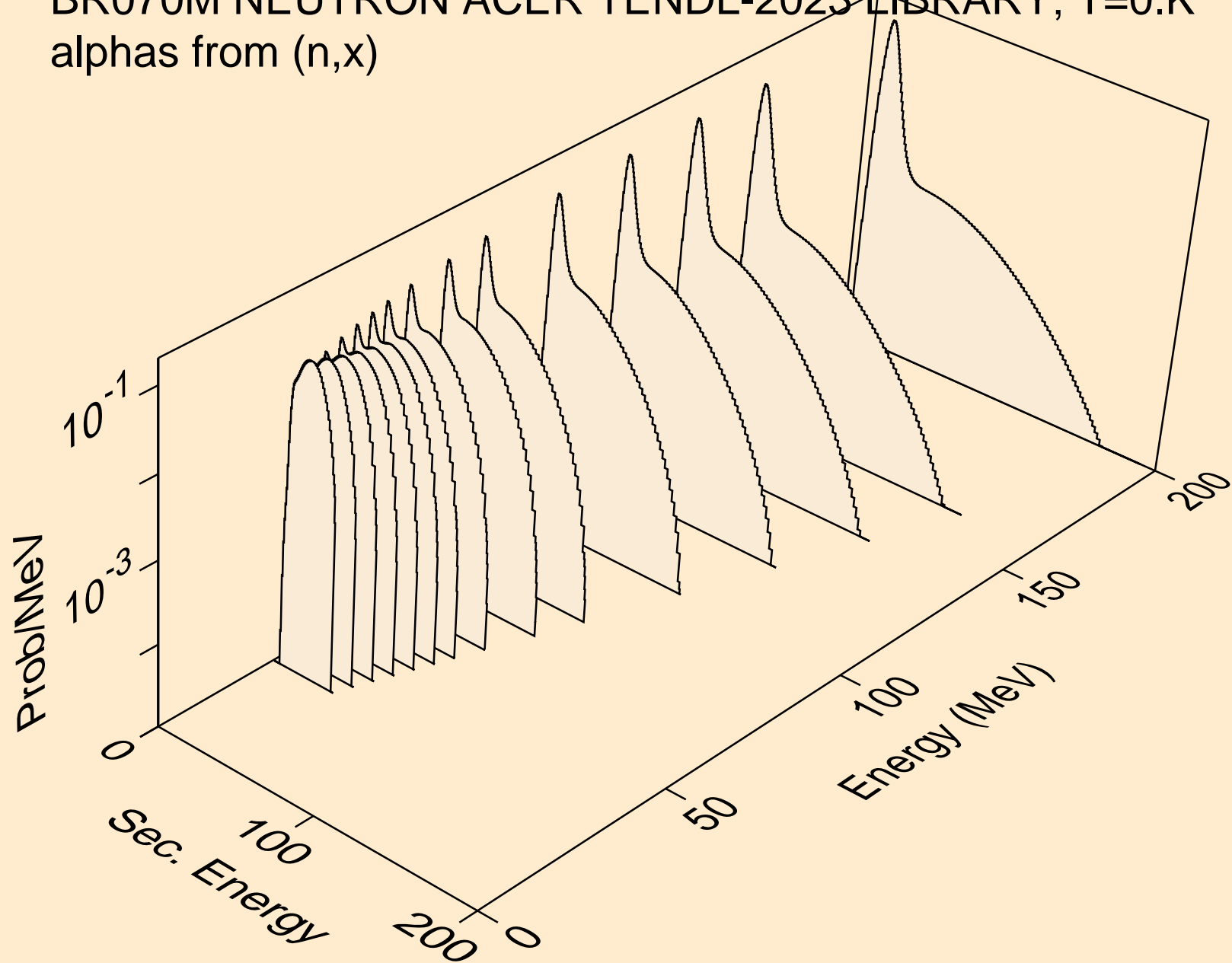

BR070M NEUTRON ACER TENDL-2023 LIBRARY; T=0.K
alphas from (n,n*)a

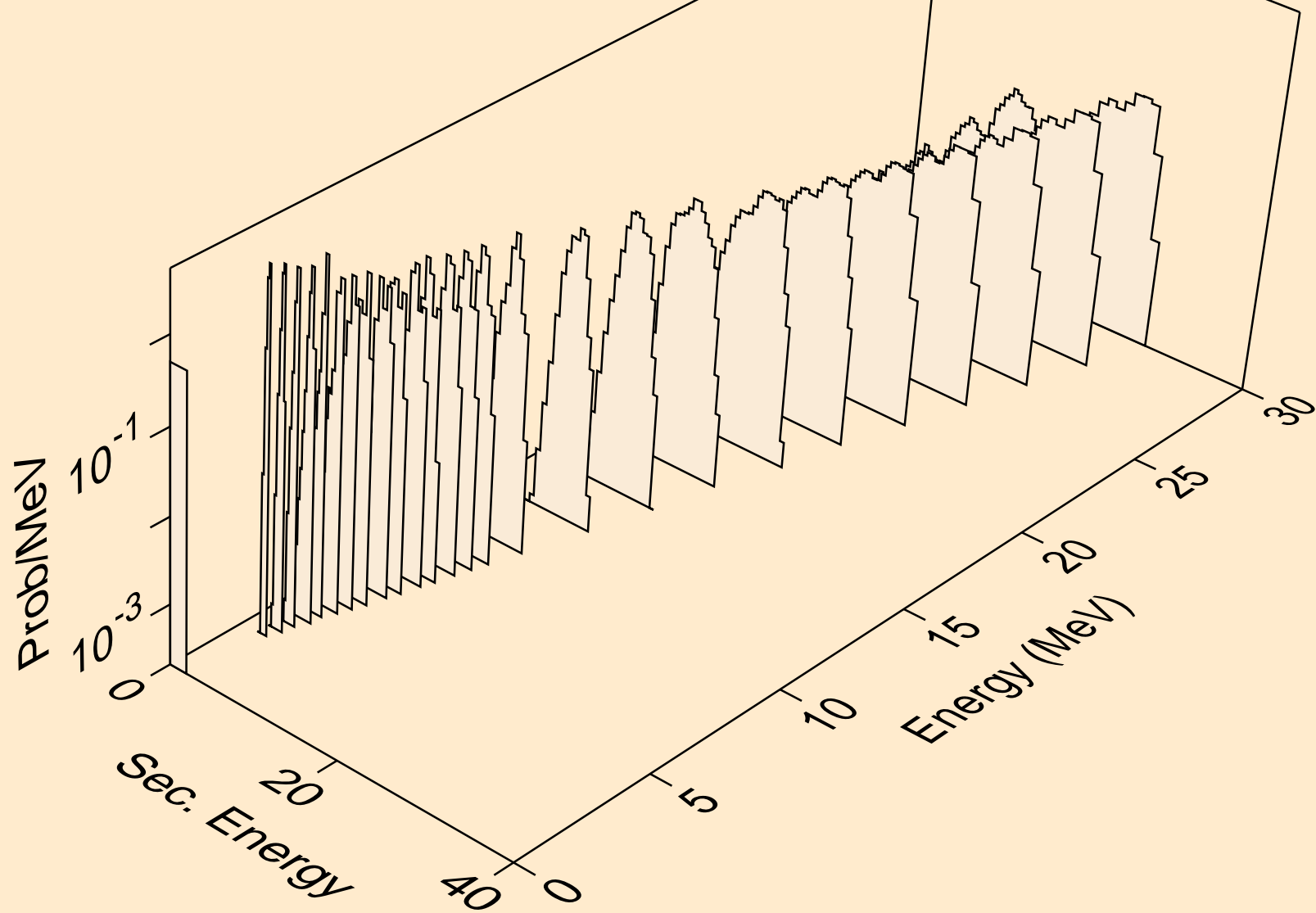

BR070M NEUTRON ACER TENDL-2023 LIBRARY; T=0.K
alphas from (n,2n)a

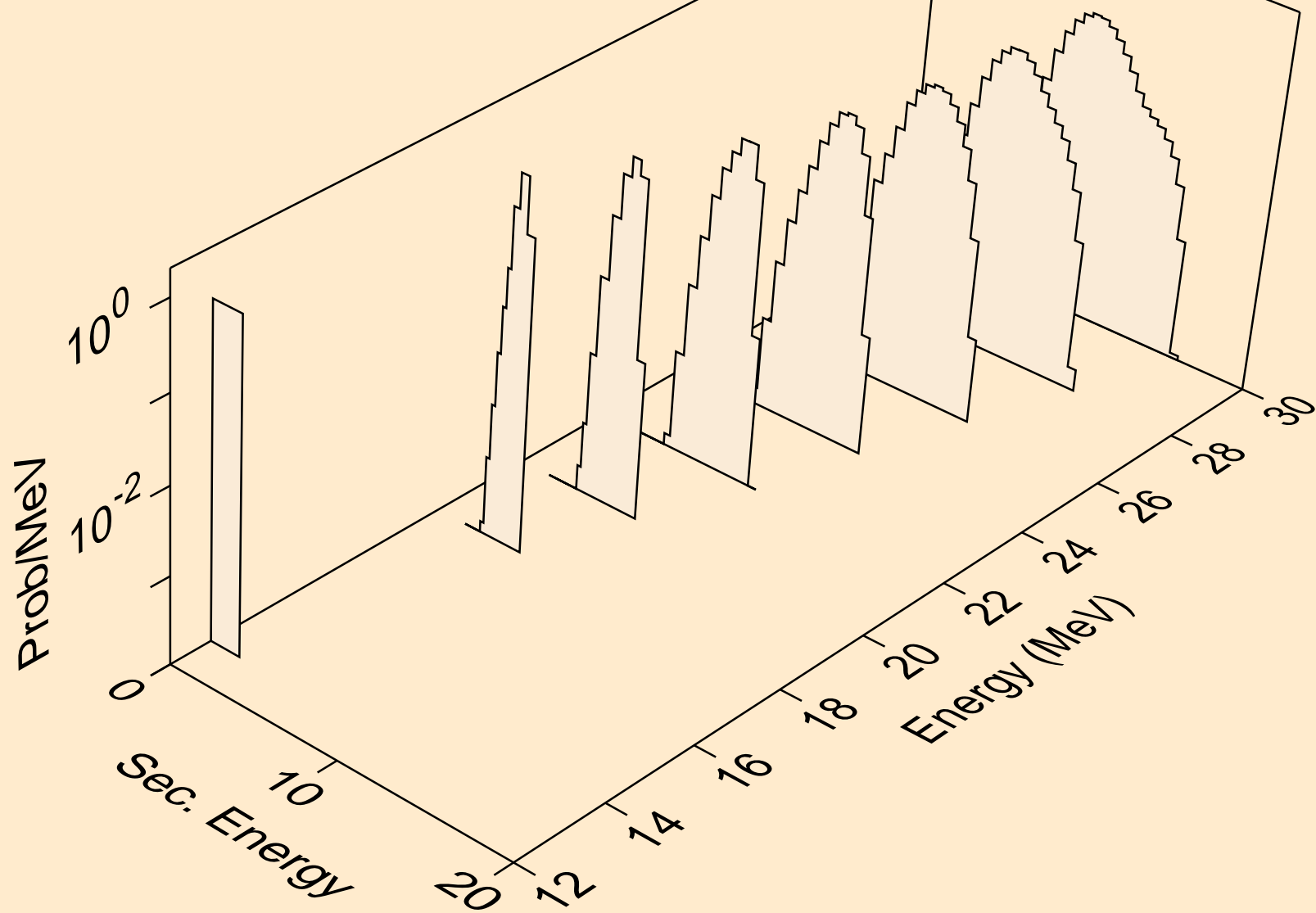

BR070M NEUTRON ACER TENDL-2023 LIBRARY; T=0.K
alphas from (n,n*)2a

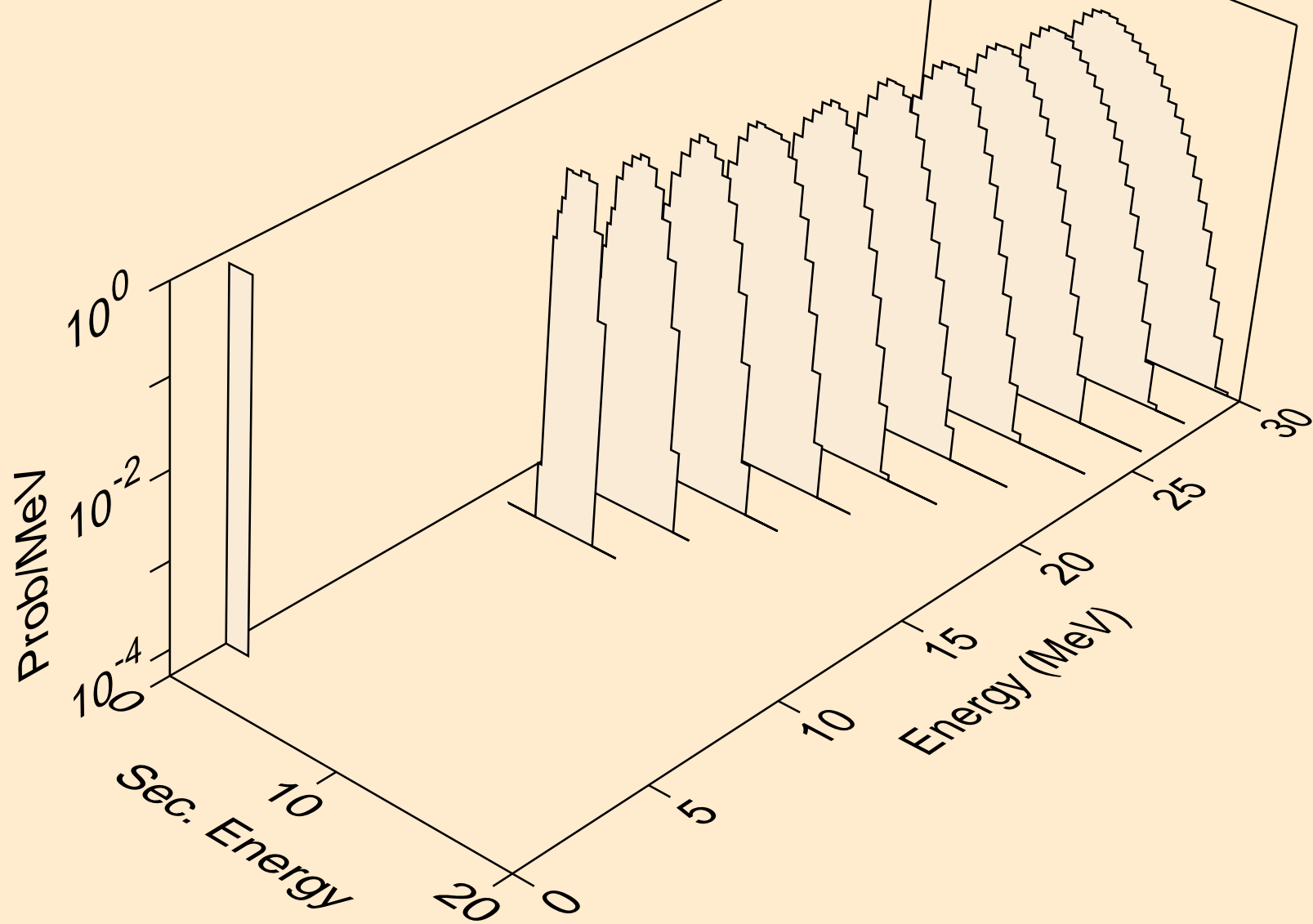

BR070M NEUTRON ACER TENDL-2023 LIBRARY; T=0.K
alphas from (n,npa)

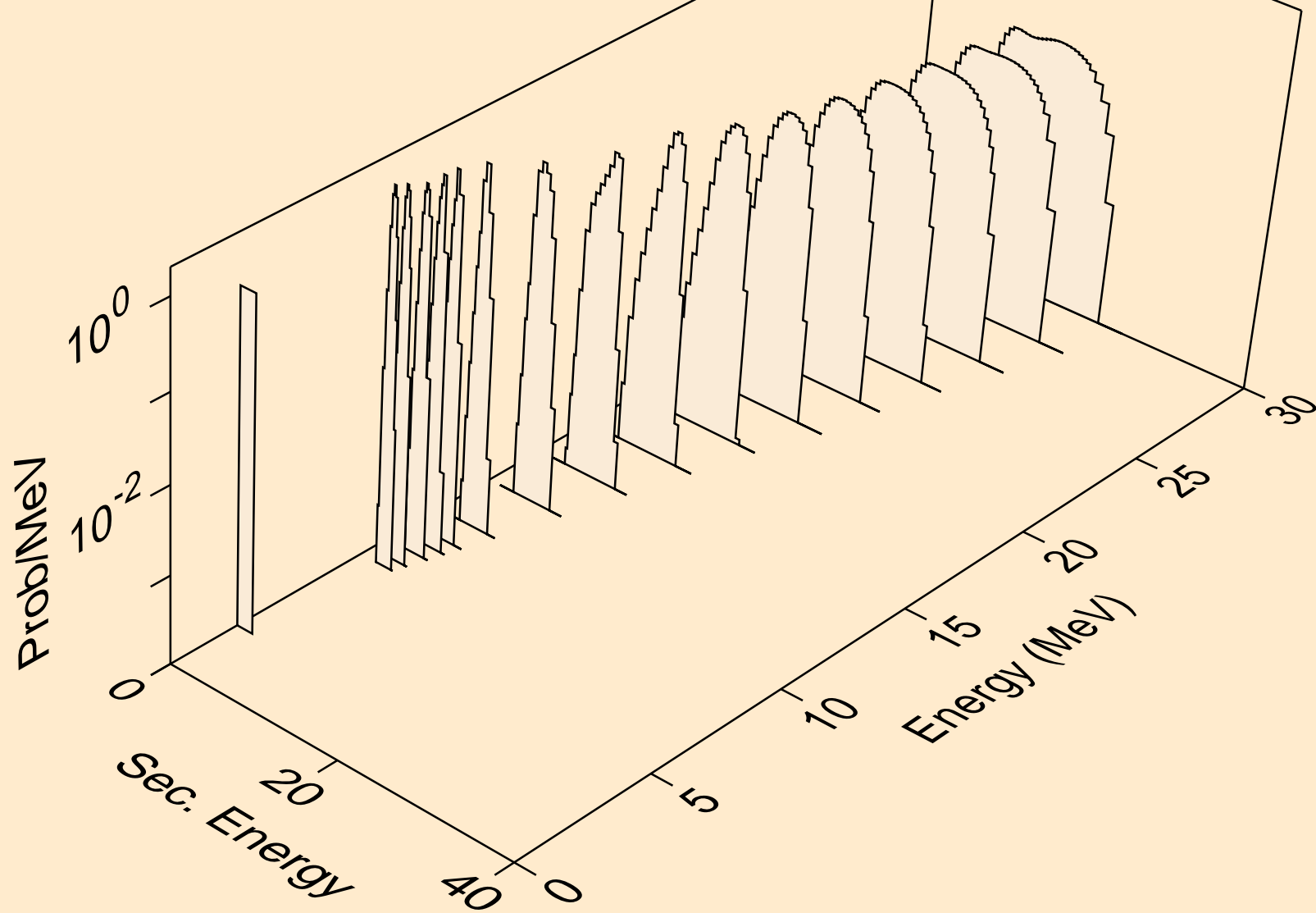

BR070M NEUTRON ACER TENDL-2023 LIBRARY; T=0.K
alphas from (n,a)

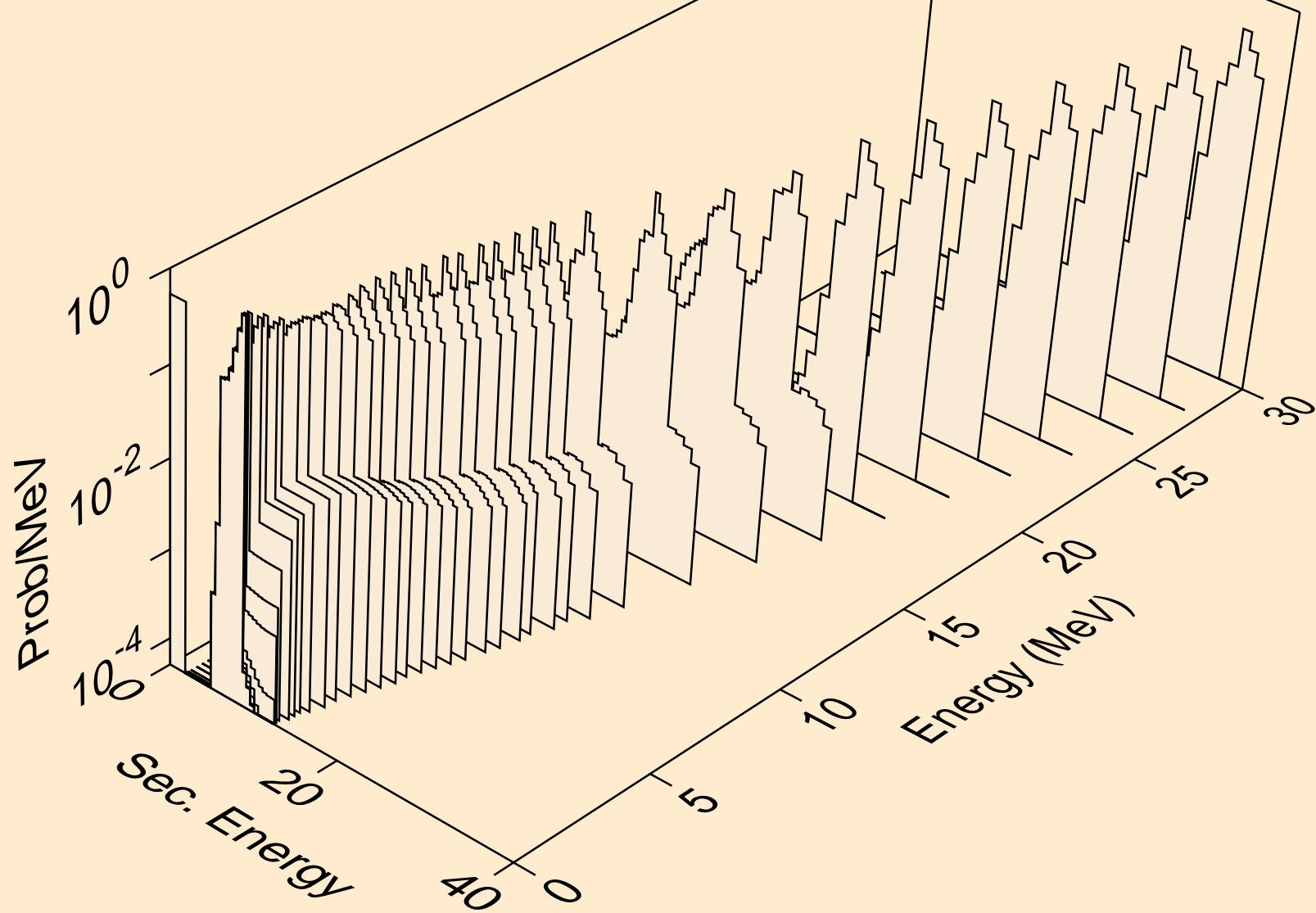

BR070M NEUTRON ACER TENDL-2023 LIBRARY; T=0.K
alphas from (n,2a)

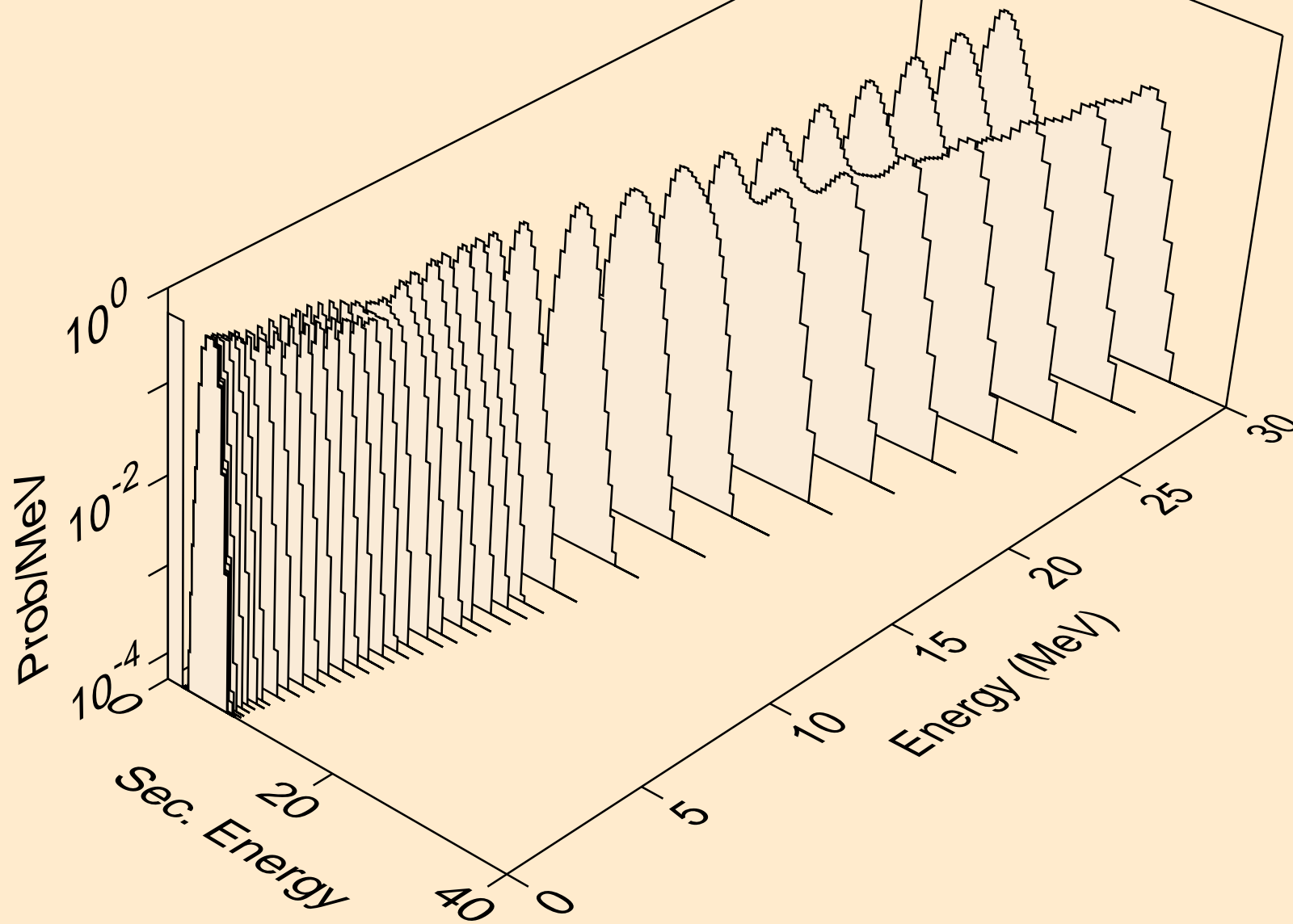

BR070M NEUTRON ACER TENDL-2023 LIBRARY; T=0.K
alphas from (n,3a)

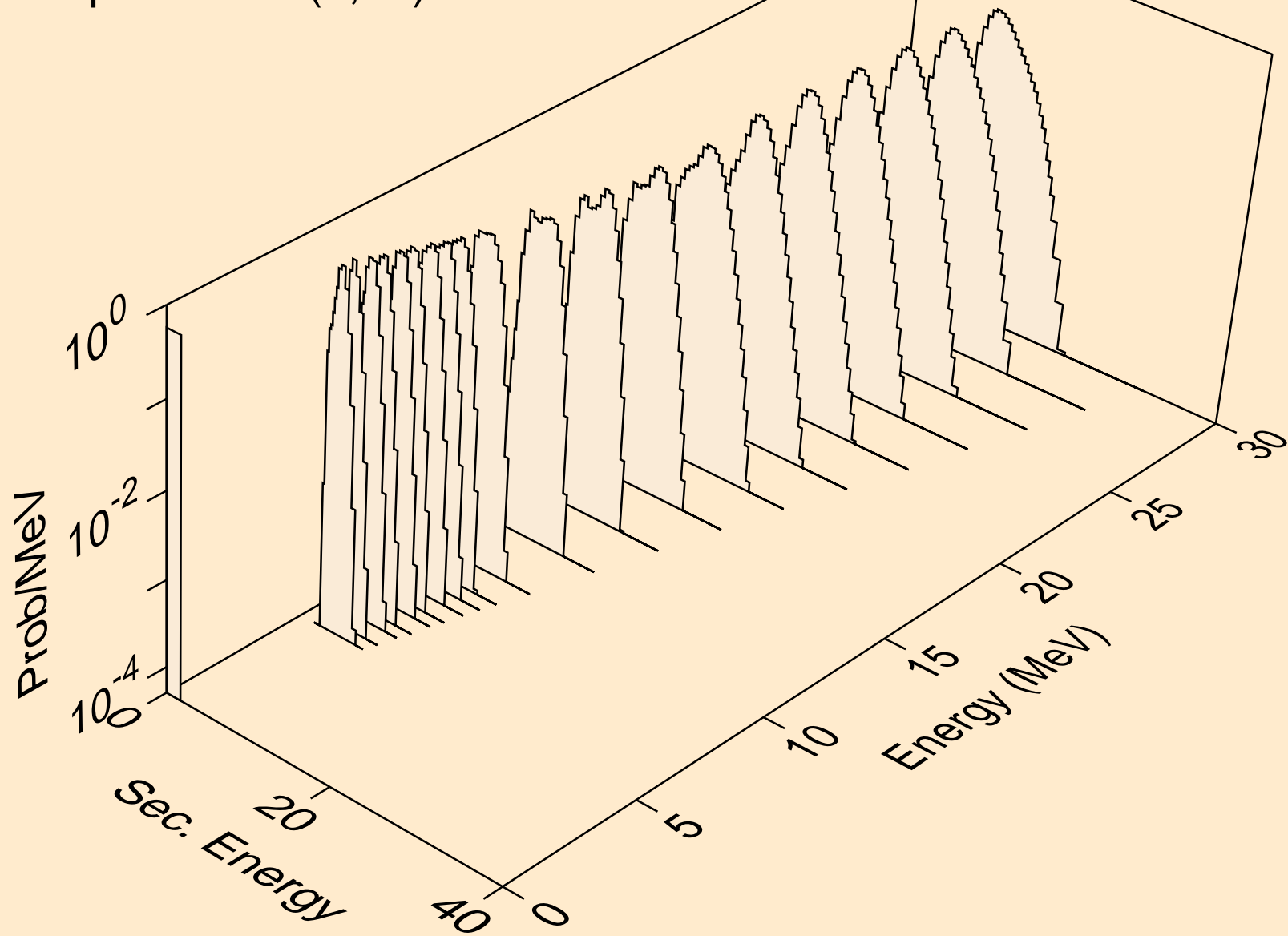

BR070M NEUTRON ACER TENDL-2023 LIBRARY; T=0.K
alphas from (n,pa)

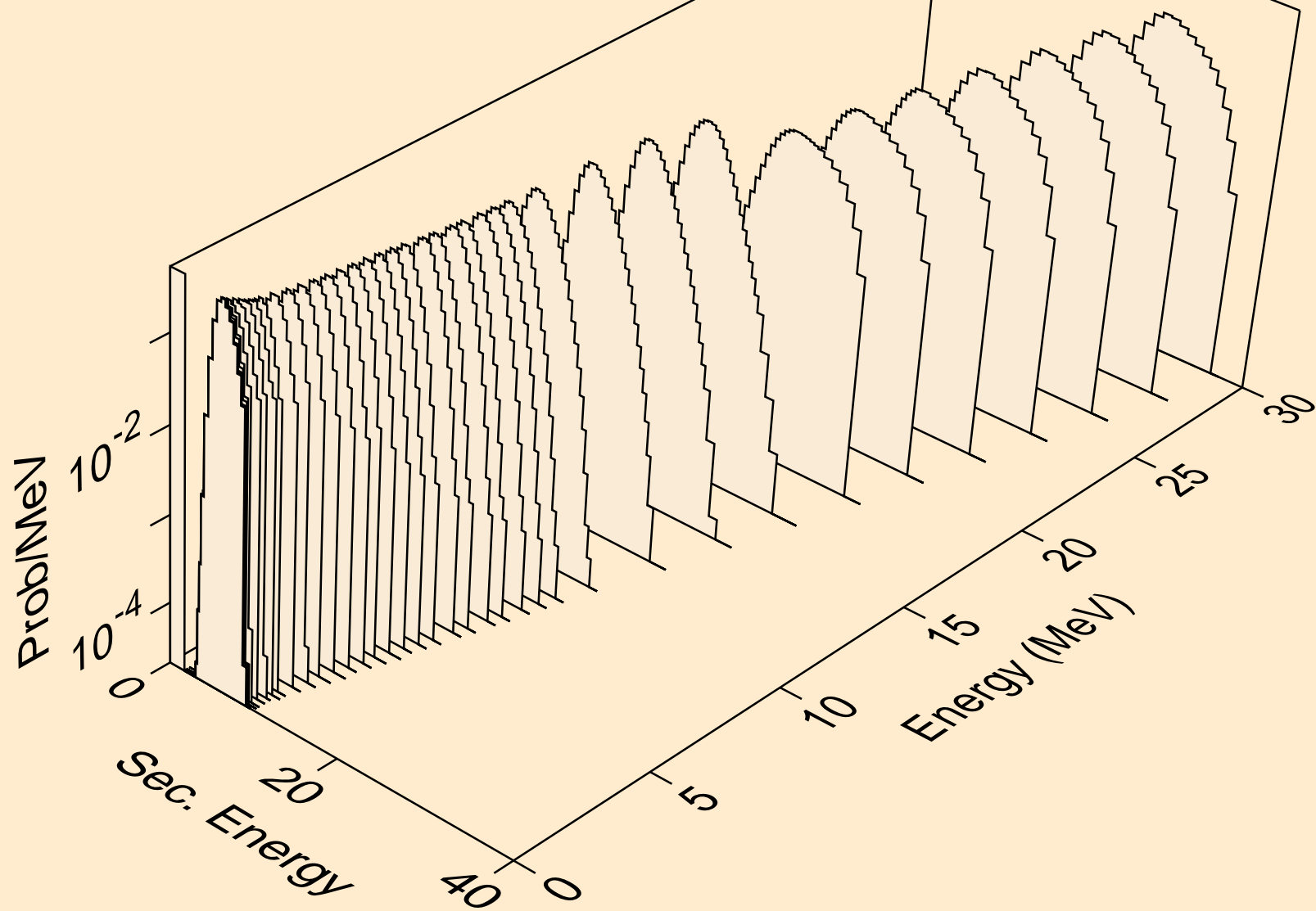

BR070M NEUTRON ACER TENDL-2023 LIBRARY; T=0.K
alphas from (n,t2a)

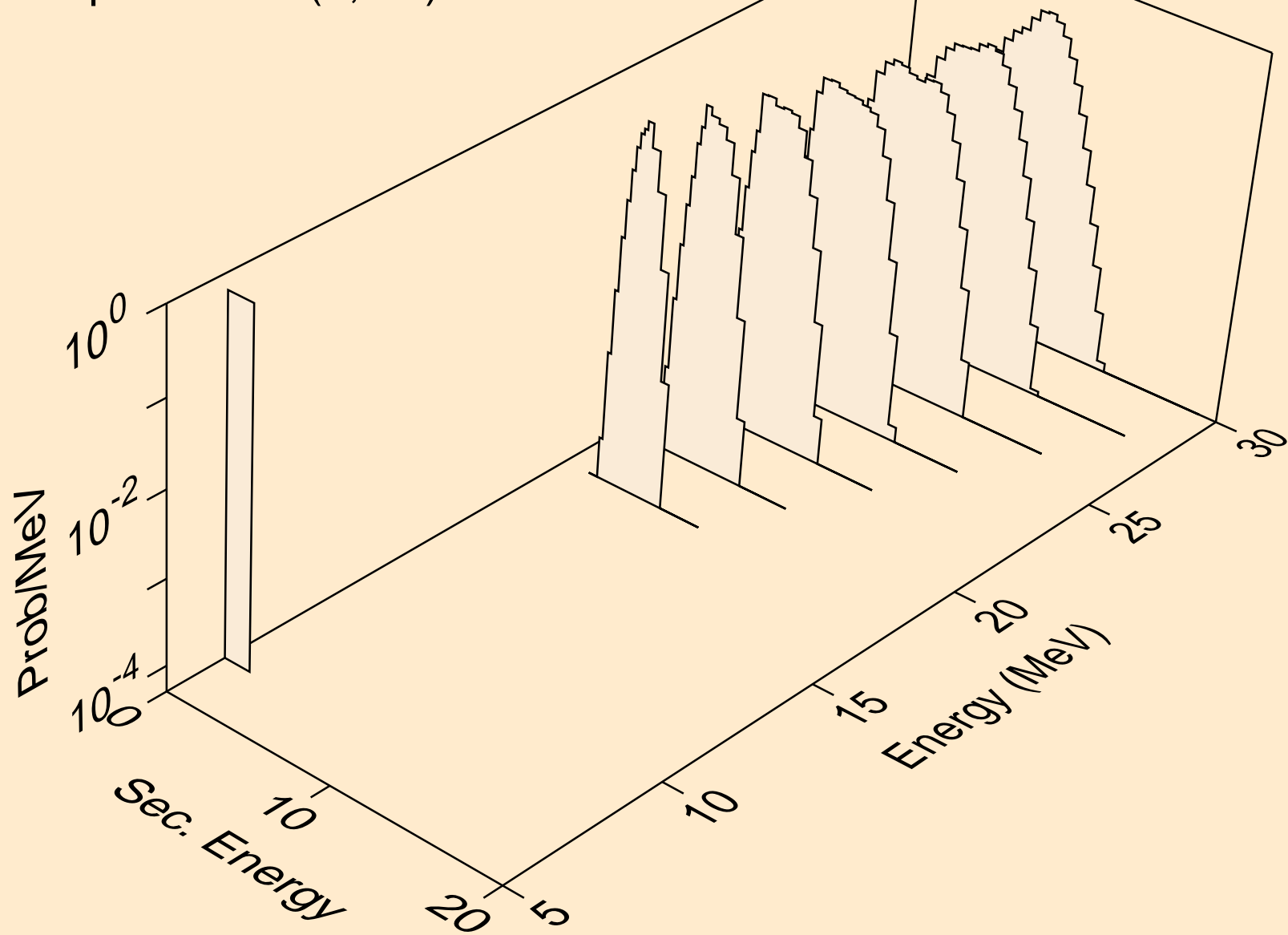

BR070M NEUTRON ACER TENDL-2023 LIBRARY; T=0.K
alphas from (n,d2a)

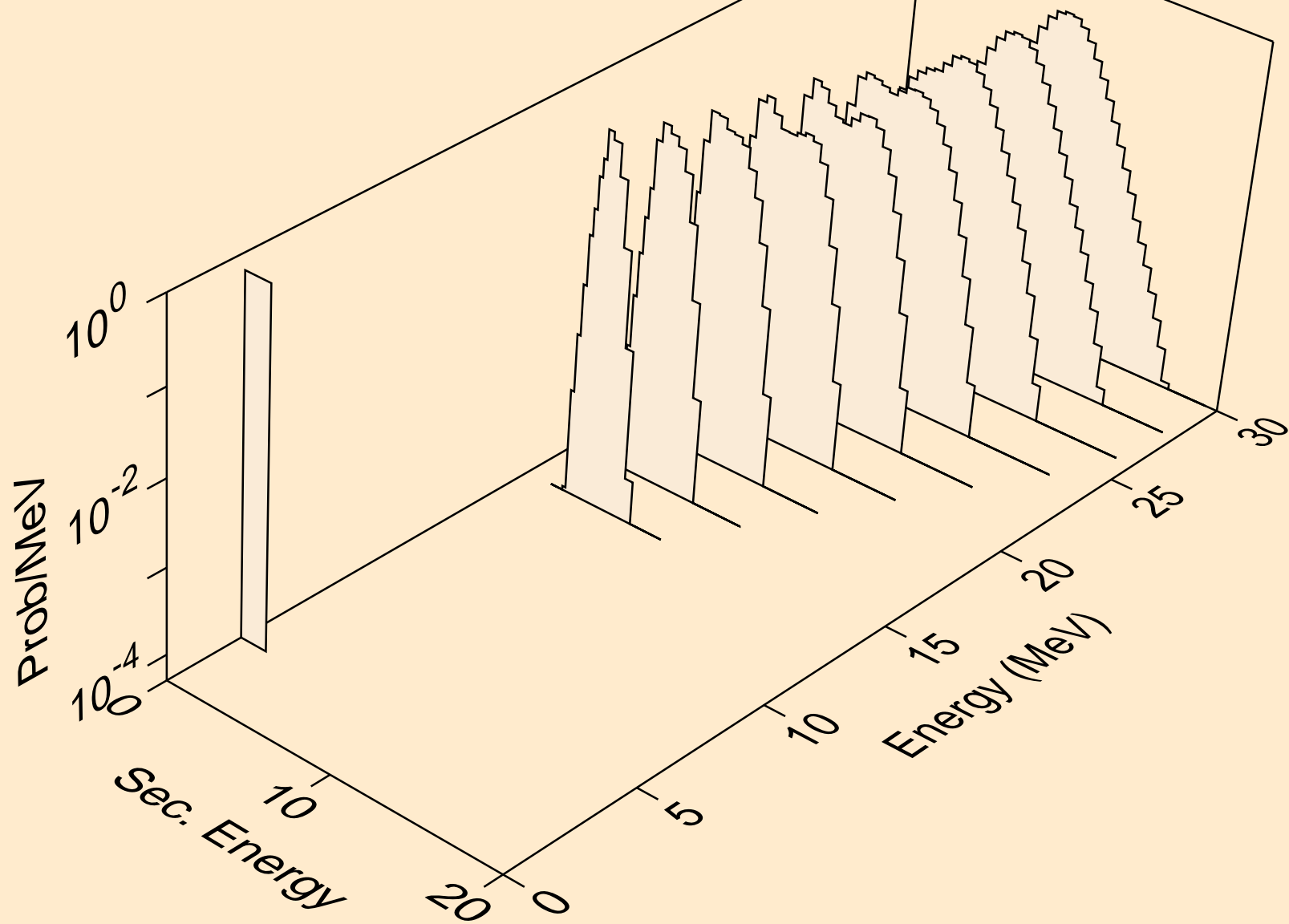

BR070M NEUTRON ACER TENDL-2023 LIBRARY; T=0.K
alphas from (n,da)

