

# C014 NEUTRON ACER TENDL-2023 LIBRARY; T=0.K

## Principal cross sections

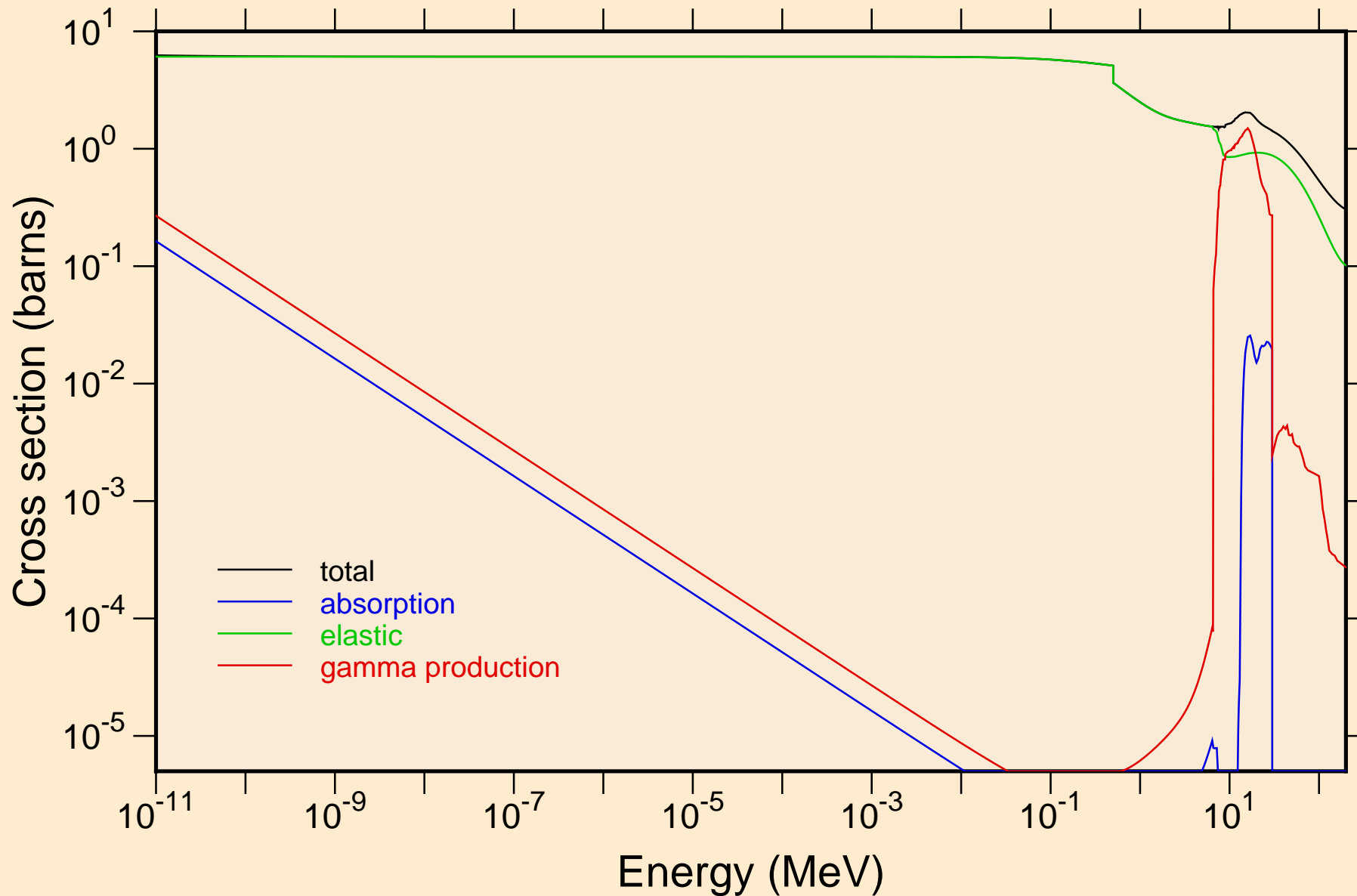

# C014 NEUTRON ACER TENDL-2023 LIBRARY; T=0.K

## Heating

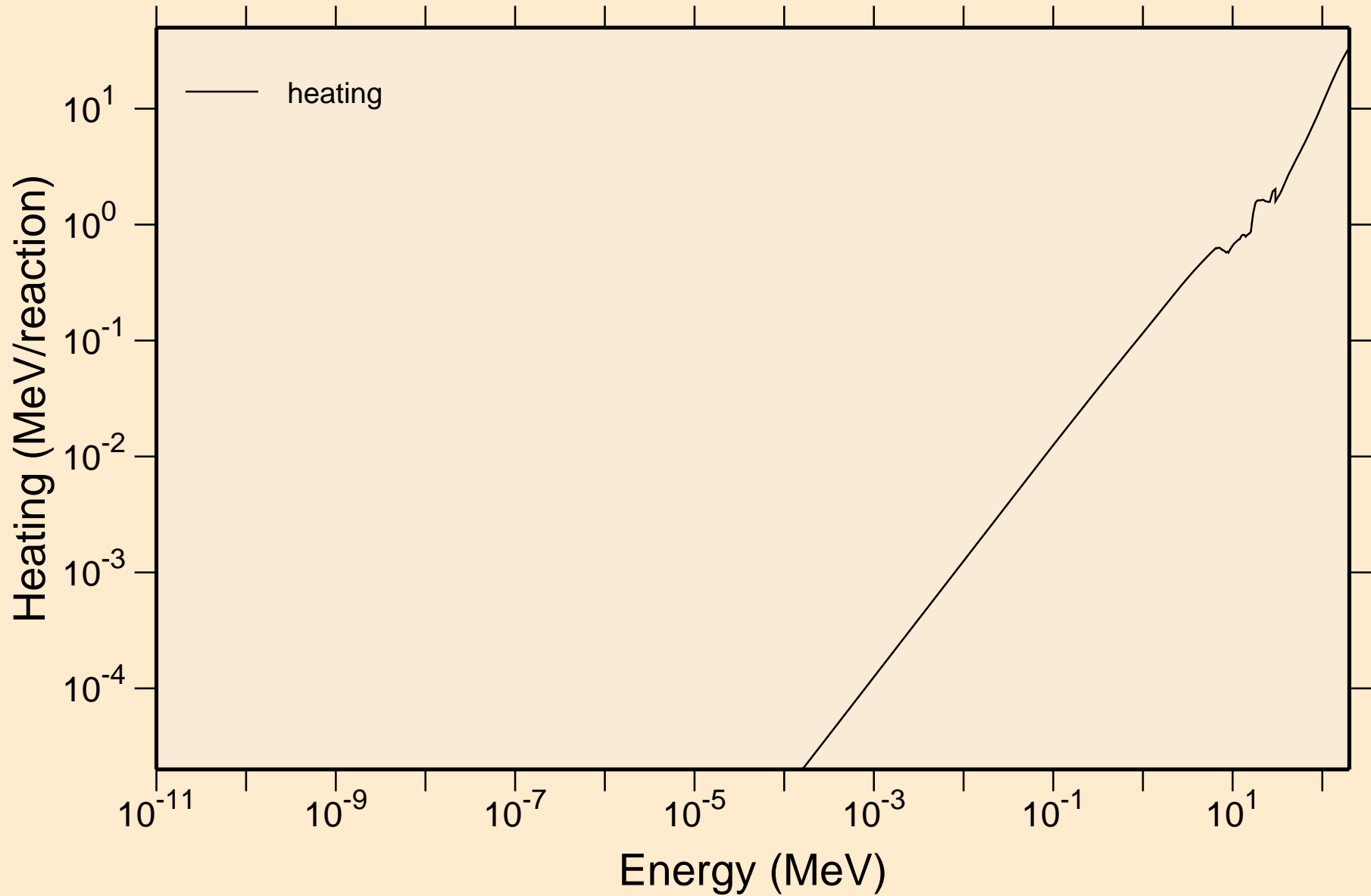

# C014 NEUTRON ACER TENDL-2023 LIBRARY; T=0.K

## Damage

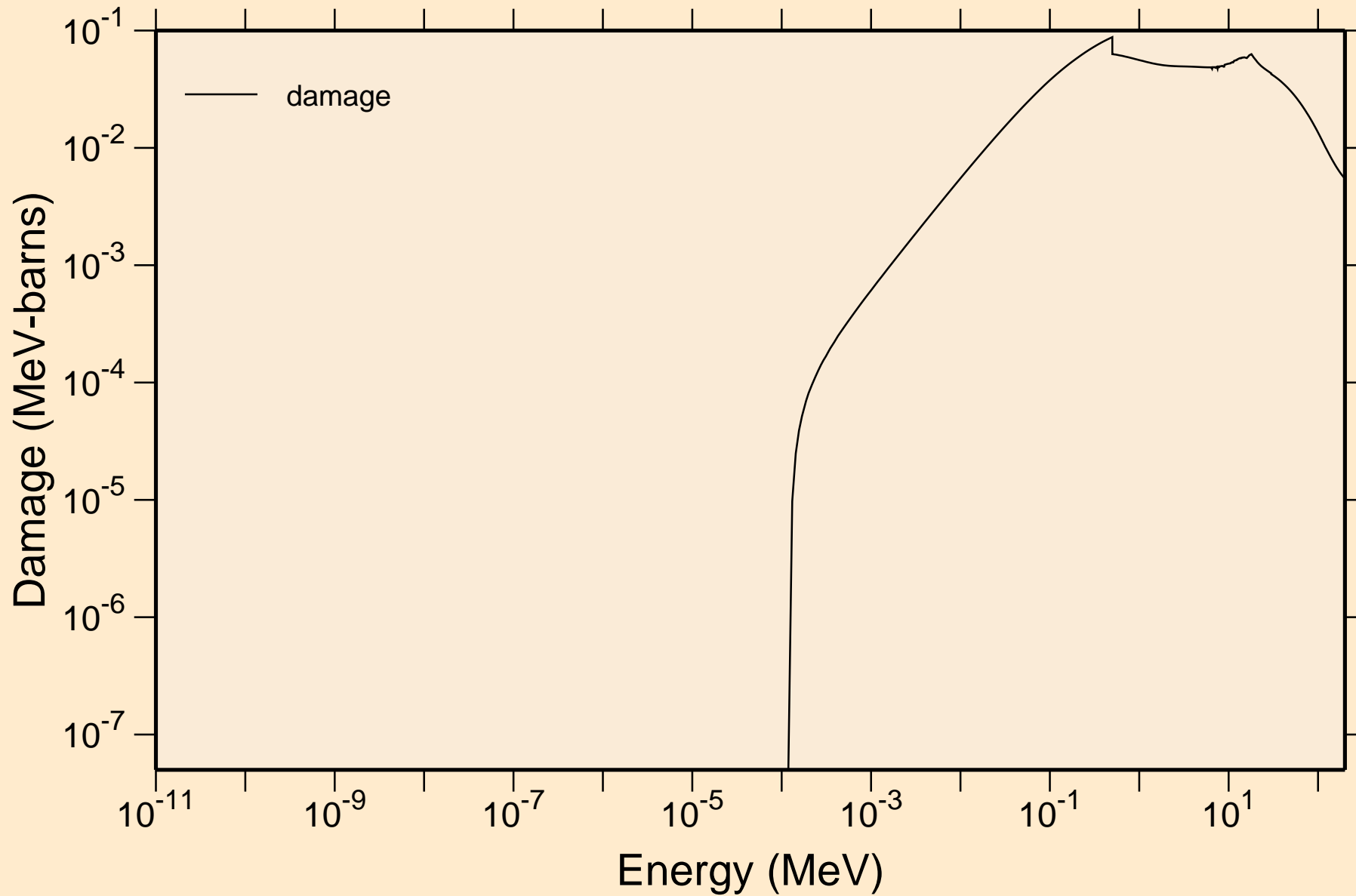

C014 NEUTRON ACER TENDL-2023 LIBRARY; T=0.K  
Non-threshold reactions

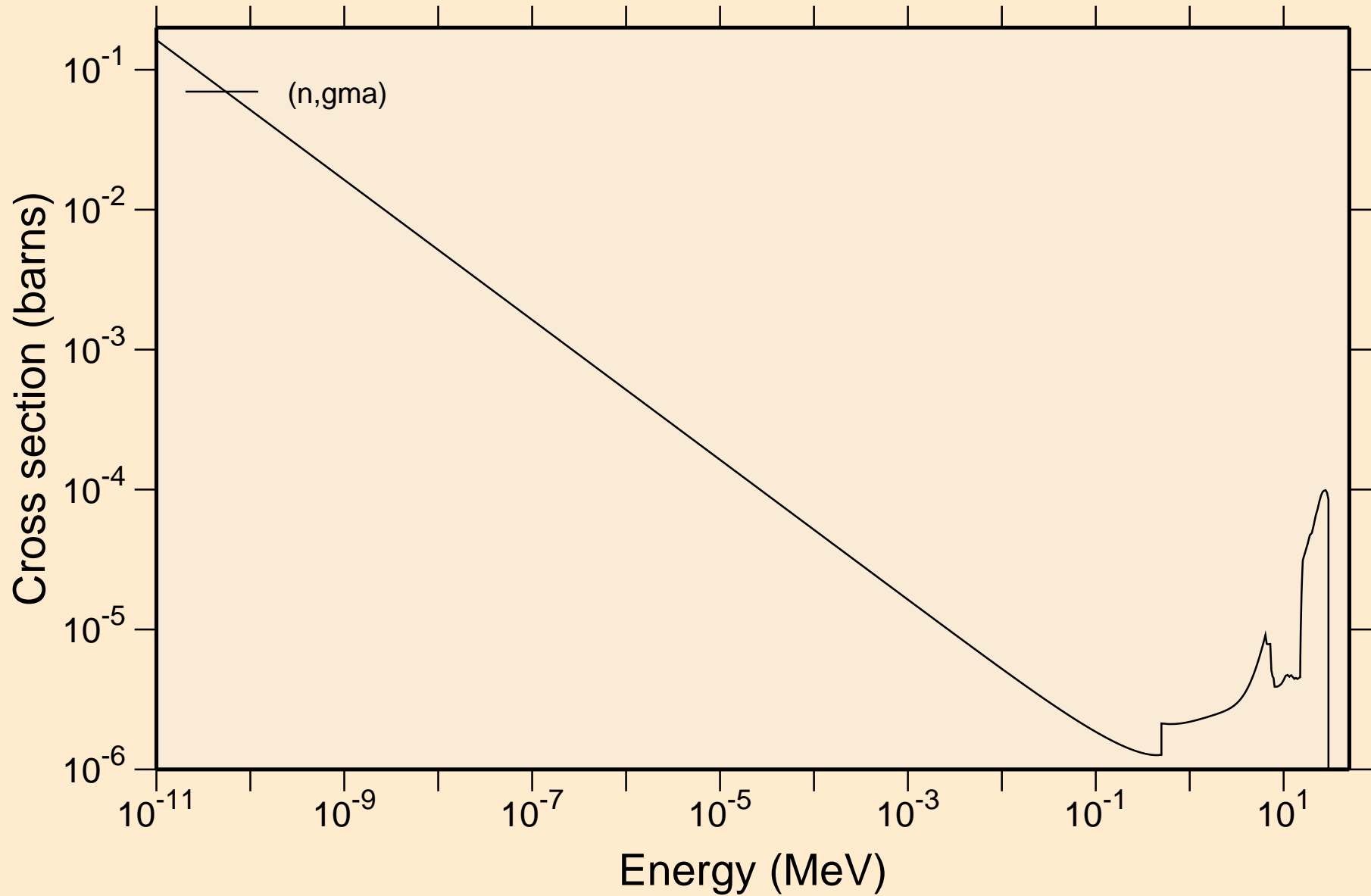

# C014 NEUTRON ACER TENDL-2023 LIBRARY; T=0.K

## Principal cross sections

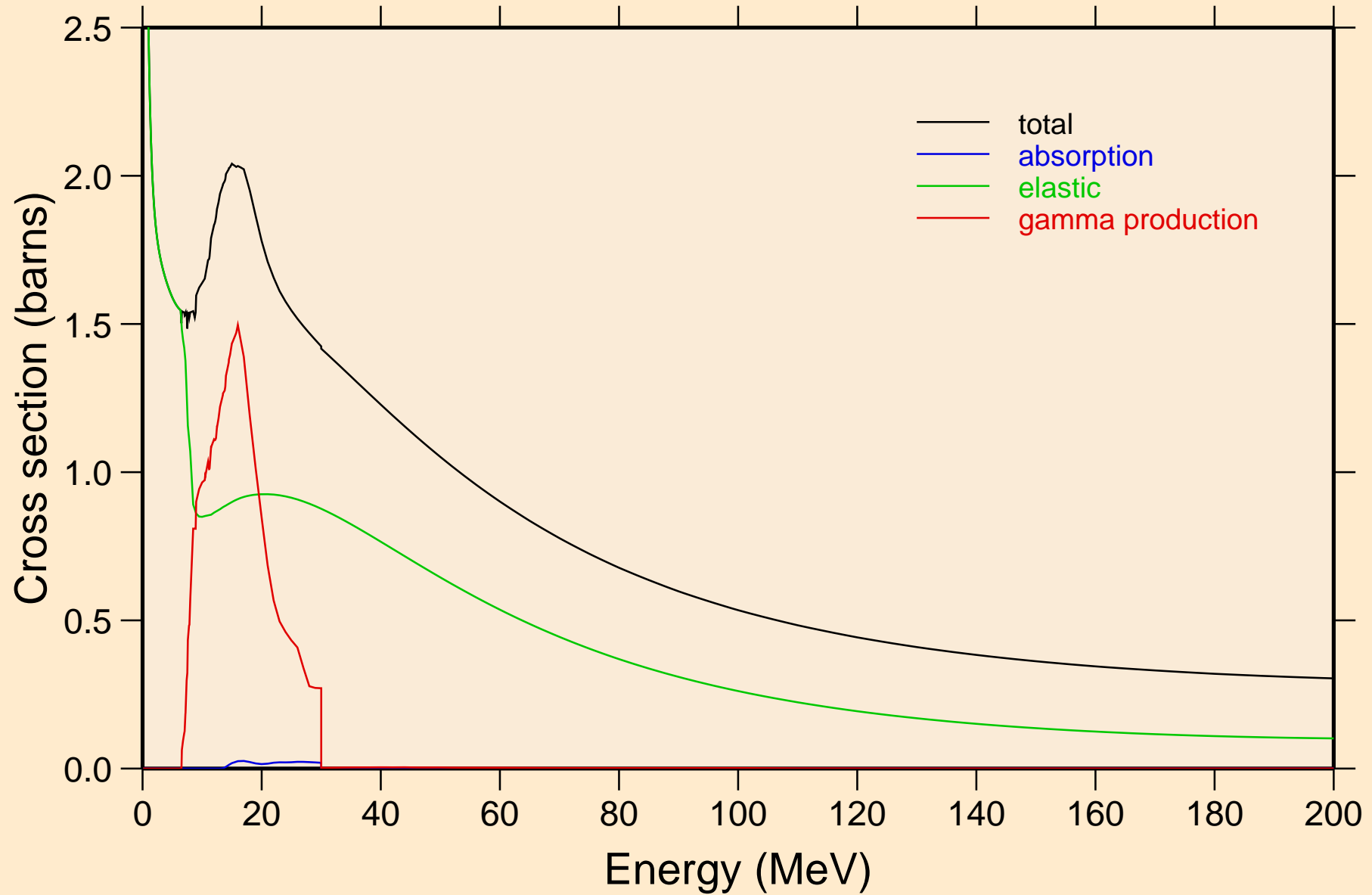

# C014 NEUTRON ACER TENDL-2023 LIBRARY; T=0.K

## Heating

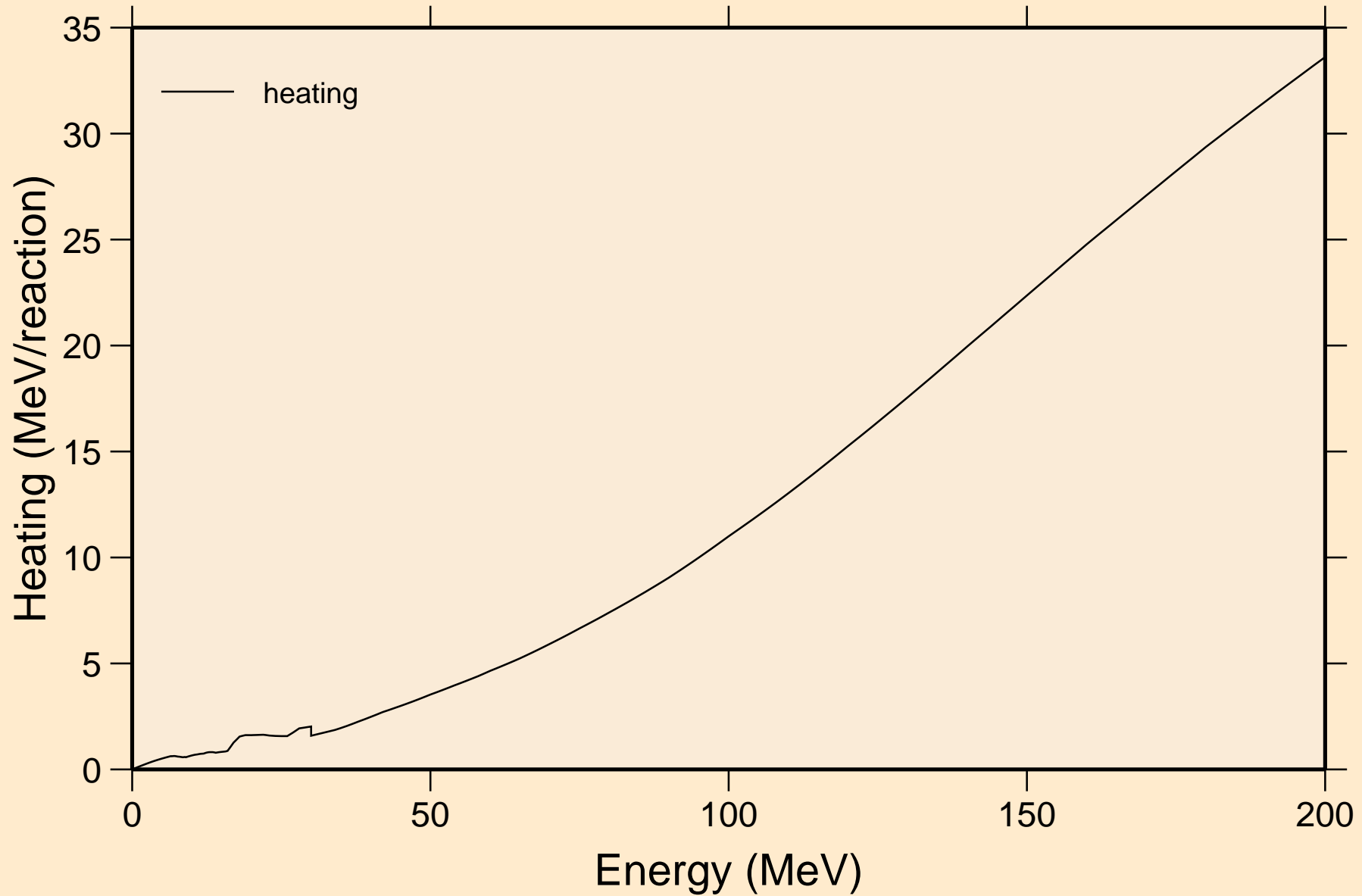

# C014 NEUTRON ACER TENDL-2023 LIBRARY; T=0.K

## Damage

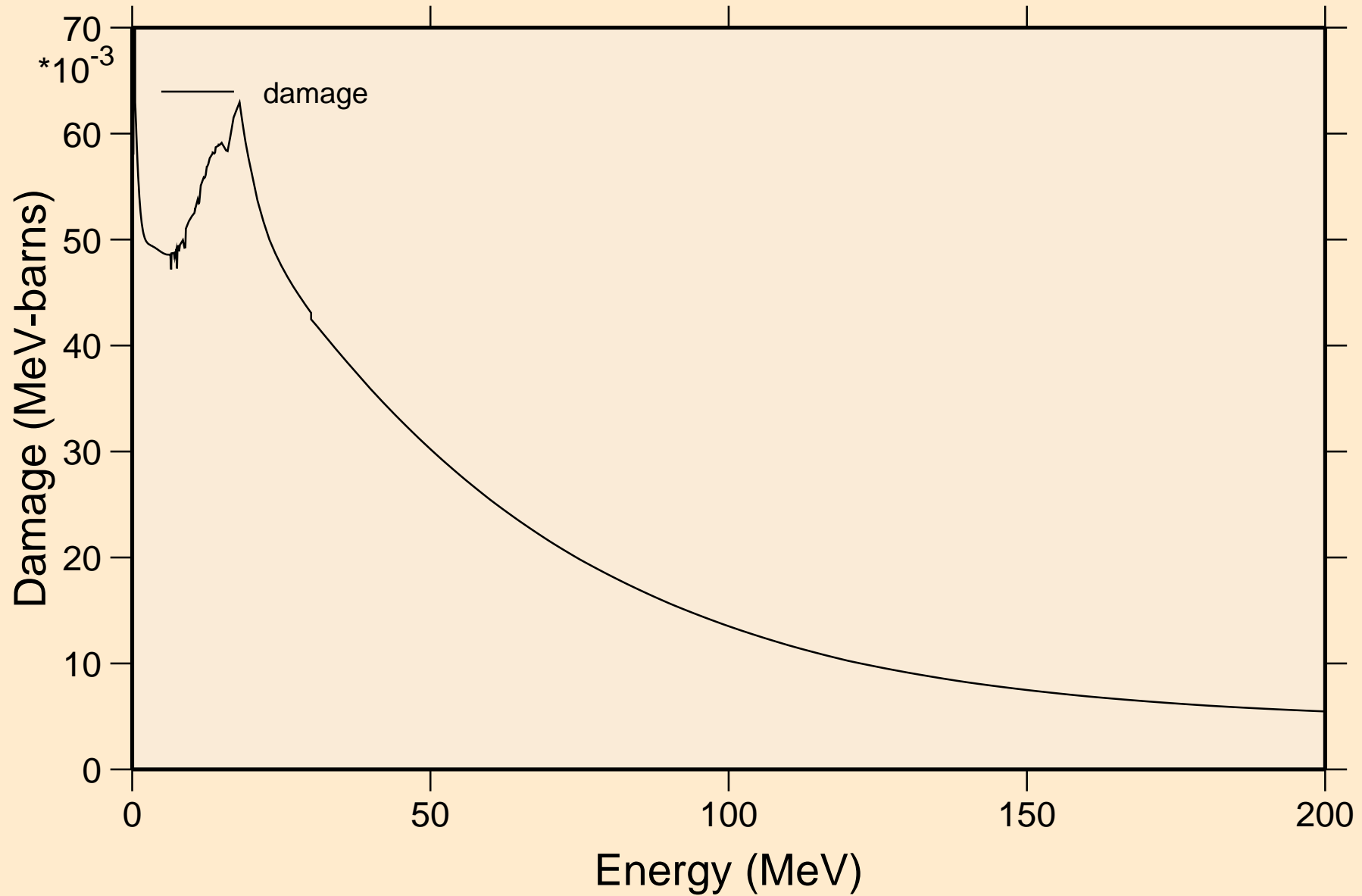

C014 NEUTRON ACER TENDL-2023 LIBRARY; T=0.K  
Non-threshold reactions

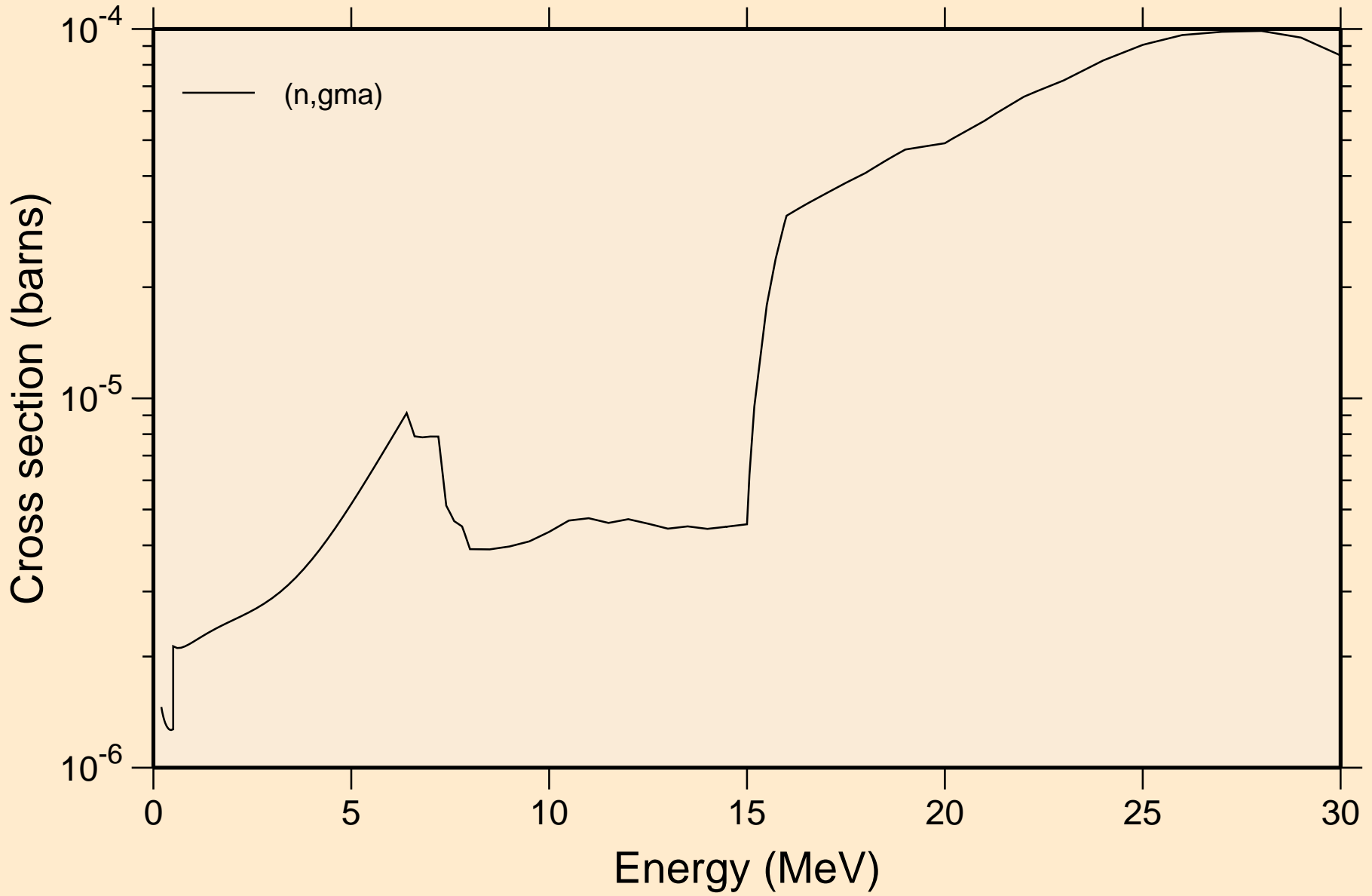



C014 NEUTRON ACER TENDL-2023 LIBRARY; T=0.K  
Inelastic levels

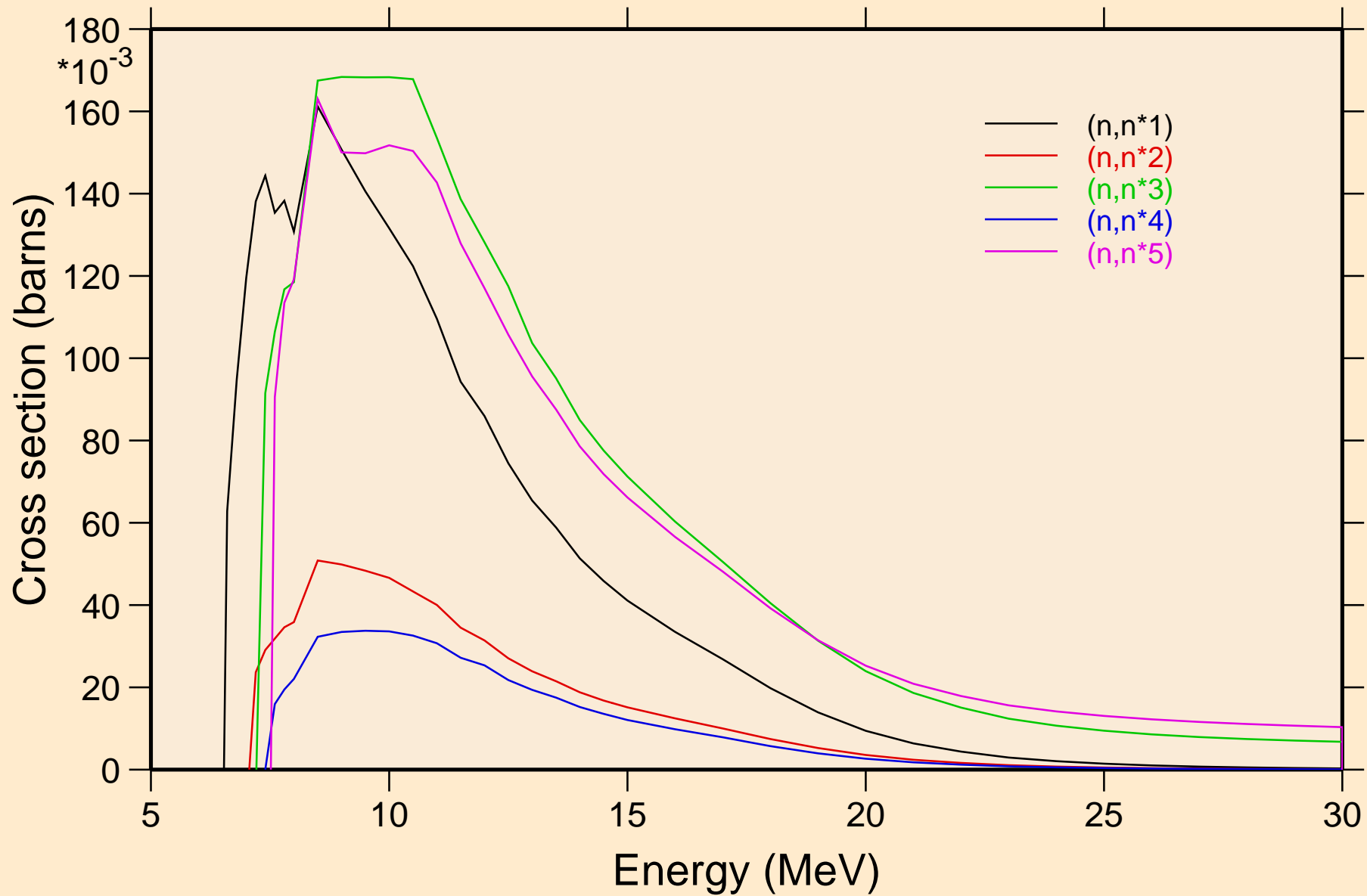

# C014 NEUTRON ACER TENDL-2023 LIBRARY; T=0.K

## Inelastic levels

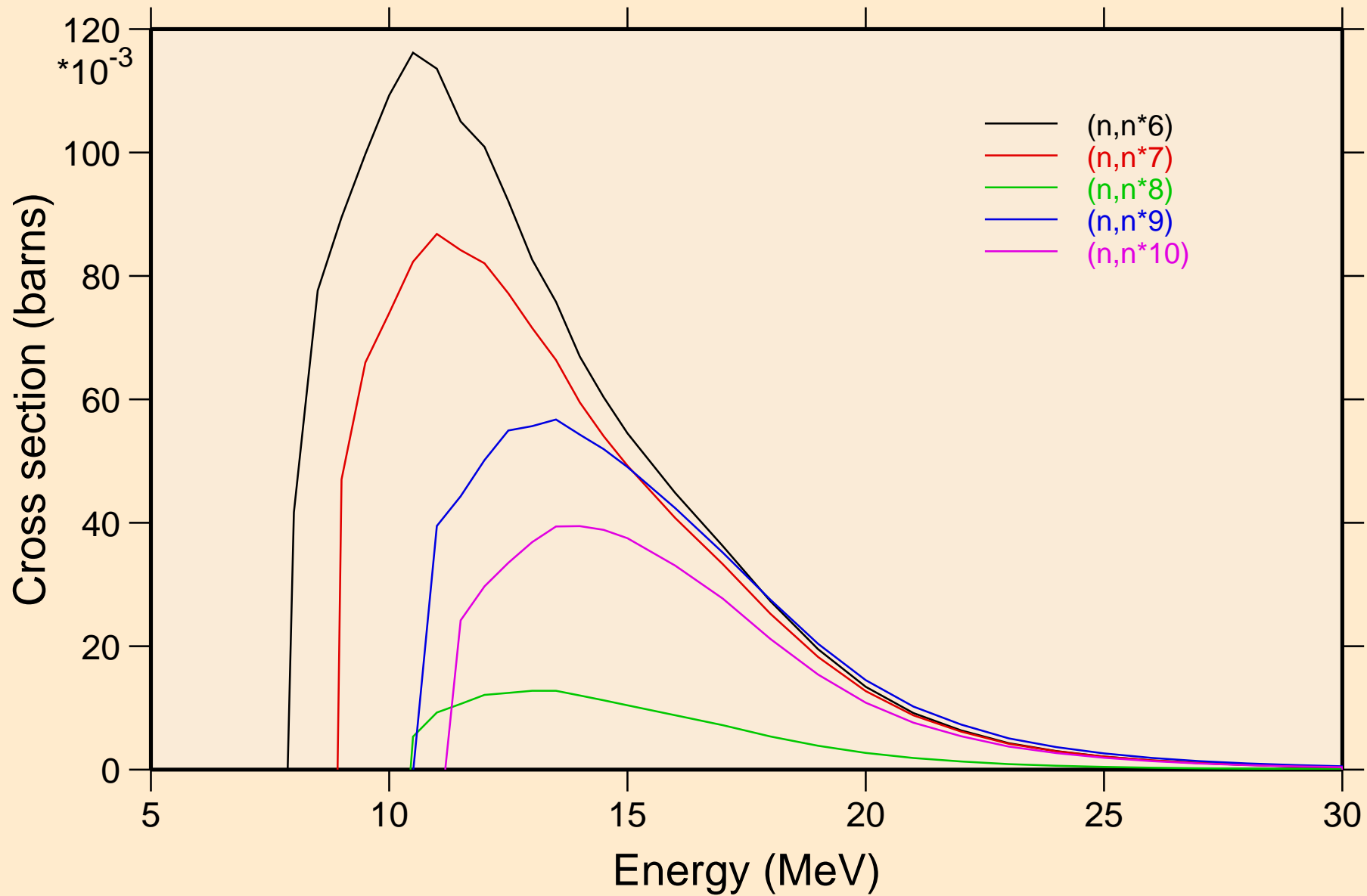

C014 NEUTRON ACER TENDL-2023 LIBRARY; T=0.K  
Inelastic levels

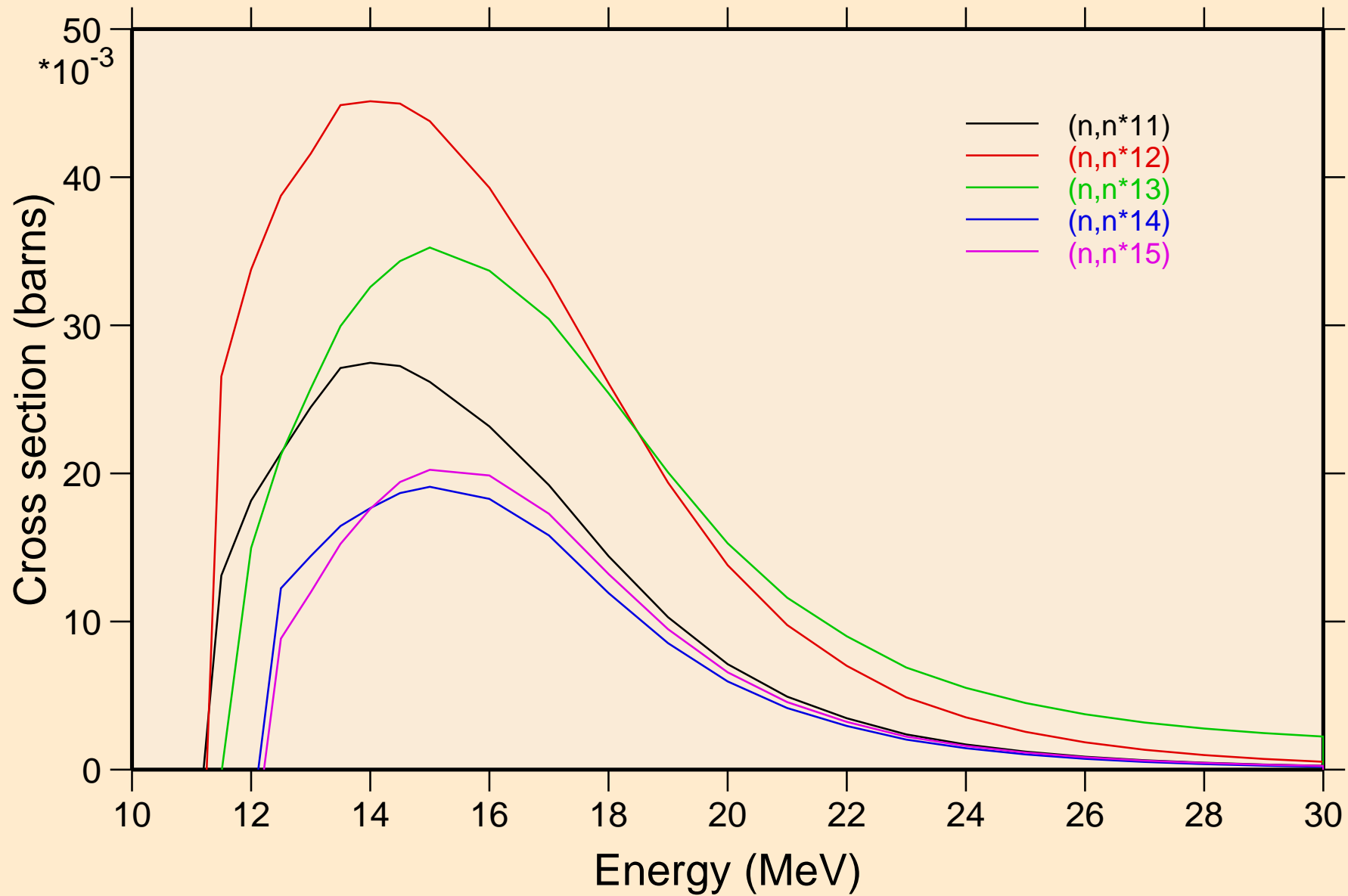

C014 NEUTRON ACER TENDL-2023 LIBRARY; T=0.K  
Inelastic levels

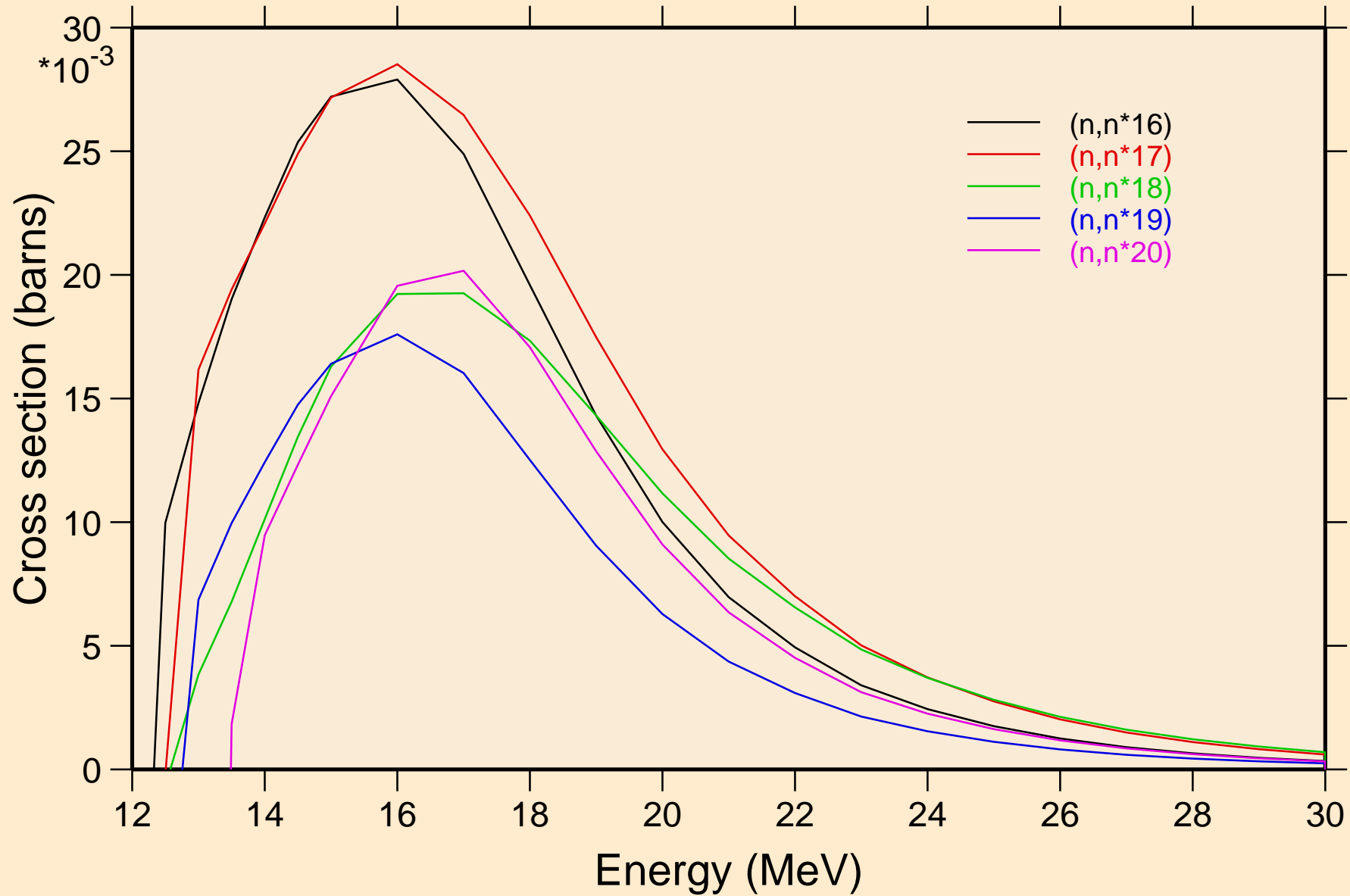

C014 NEUTRON ACER TENDL-2023 LIBRARY; T=0.K  
Inelastic levels

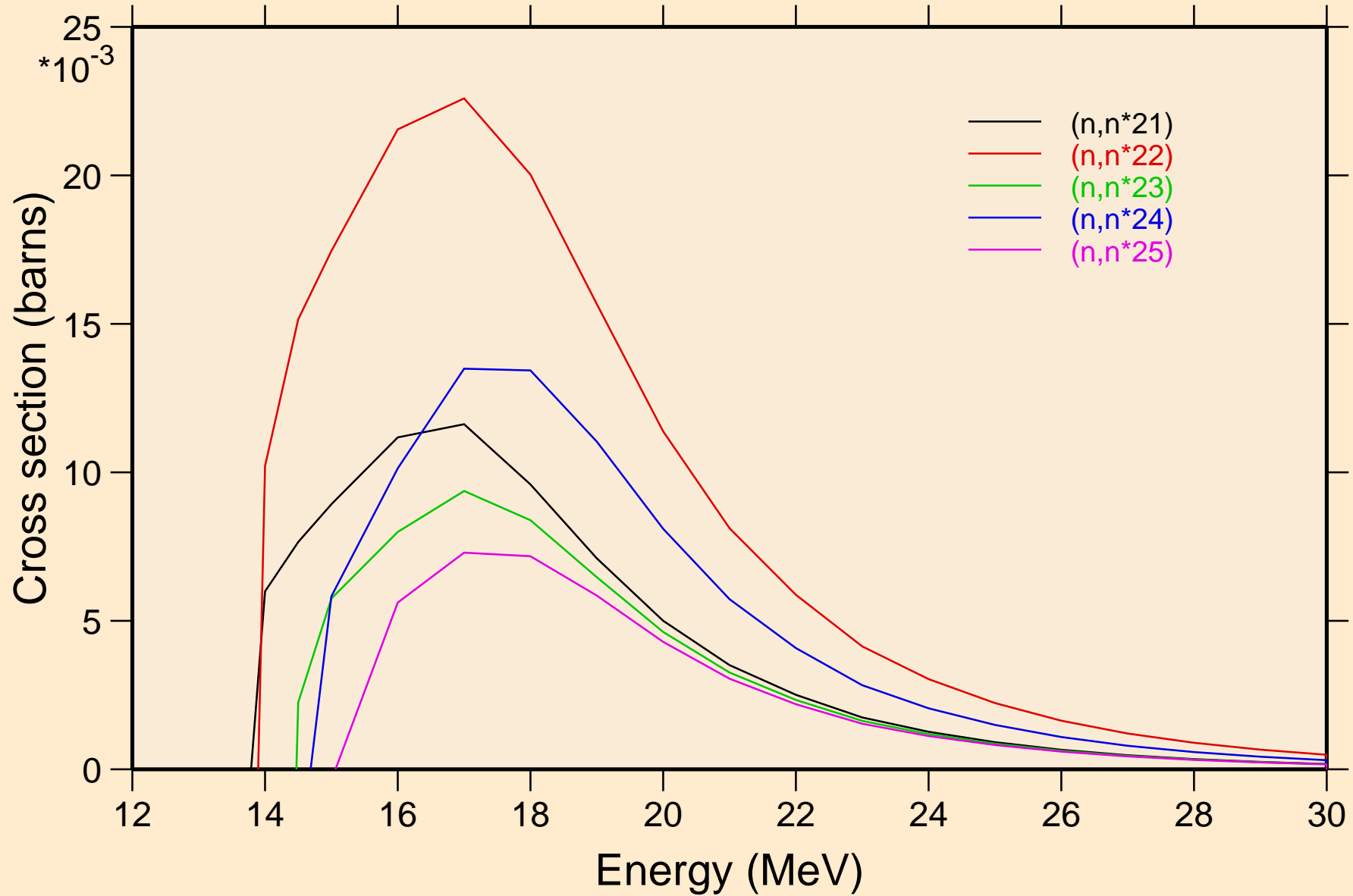

C014 NEUTRON ACER TENDL-2023 LIBRARY; T=0.K  
Inelastic levels

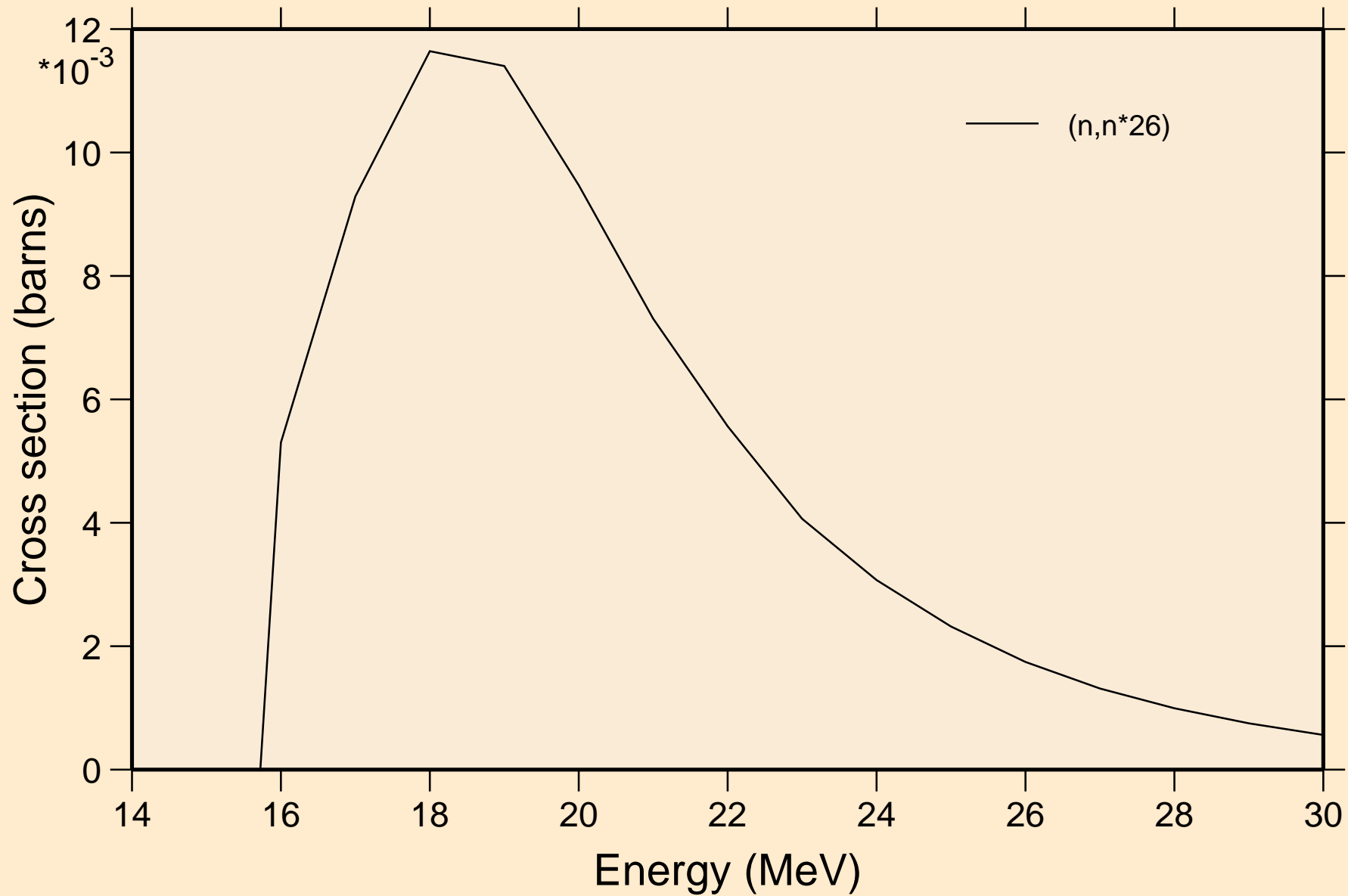

C014 NEUTRON ACER TENDL-2023 LIBRARY; T=0.K  
Threshold reactions

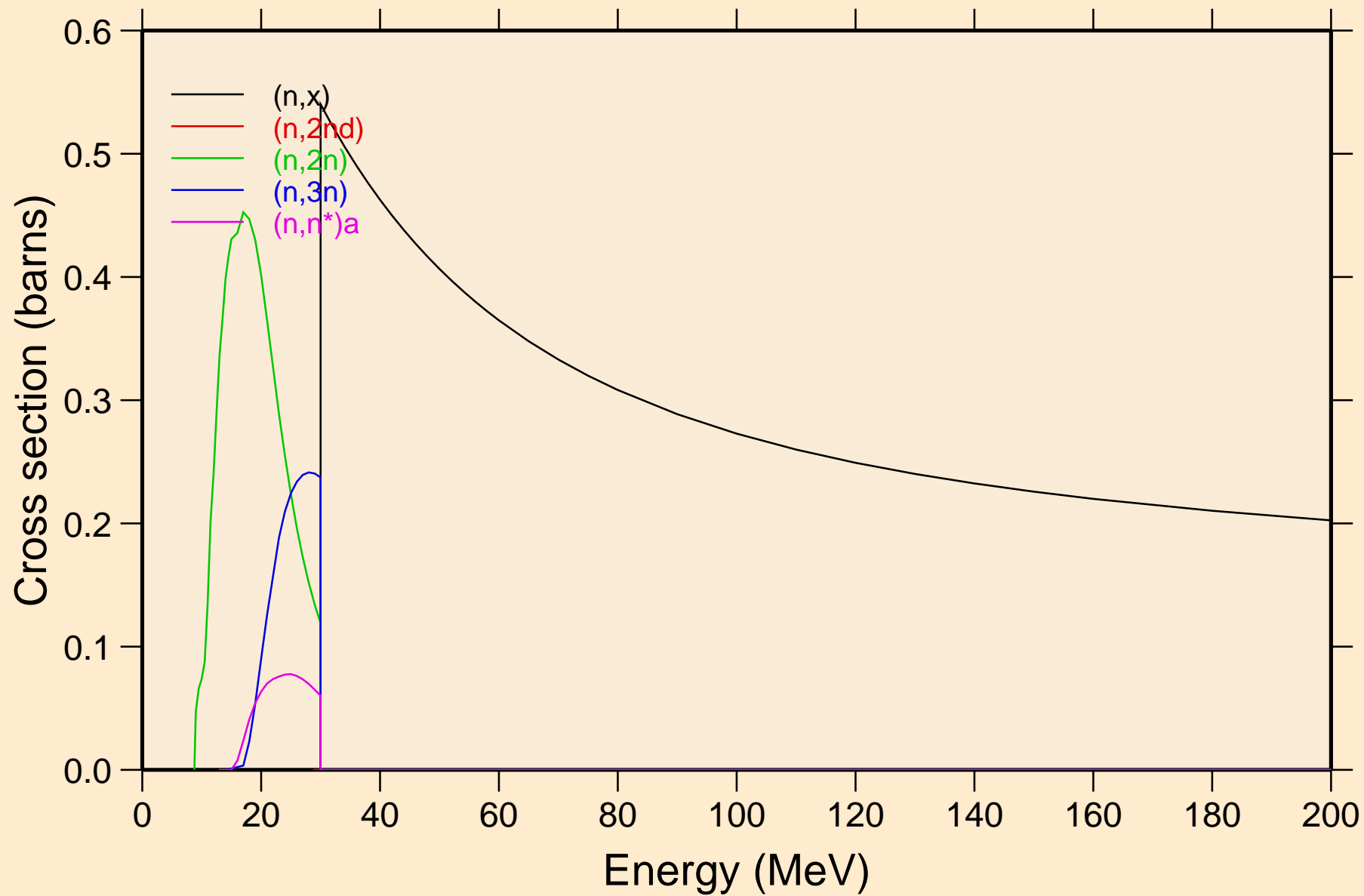

# C014 NEUTRON ACER TENDL-2023 LIBRARY; T=0.K

## Threshold reactions

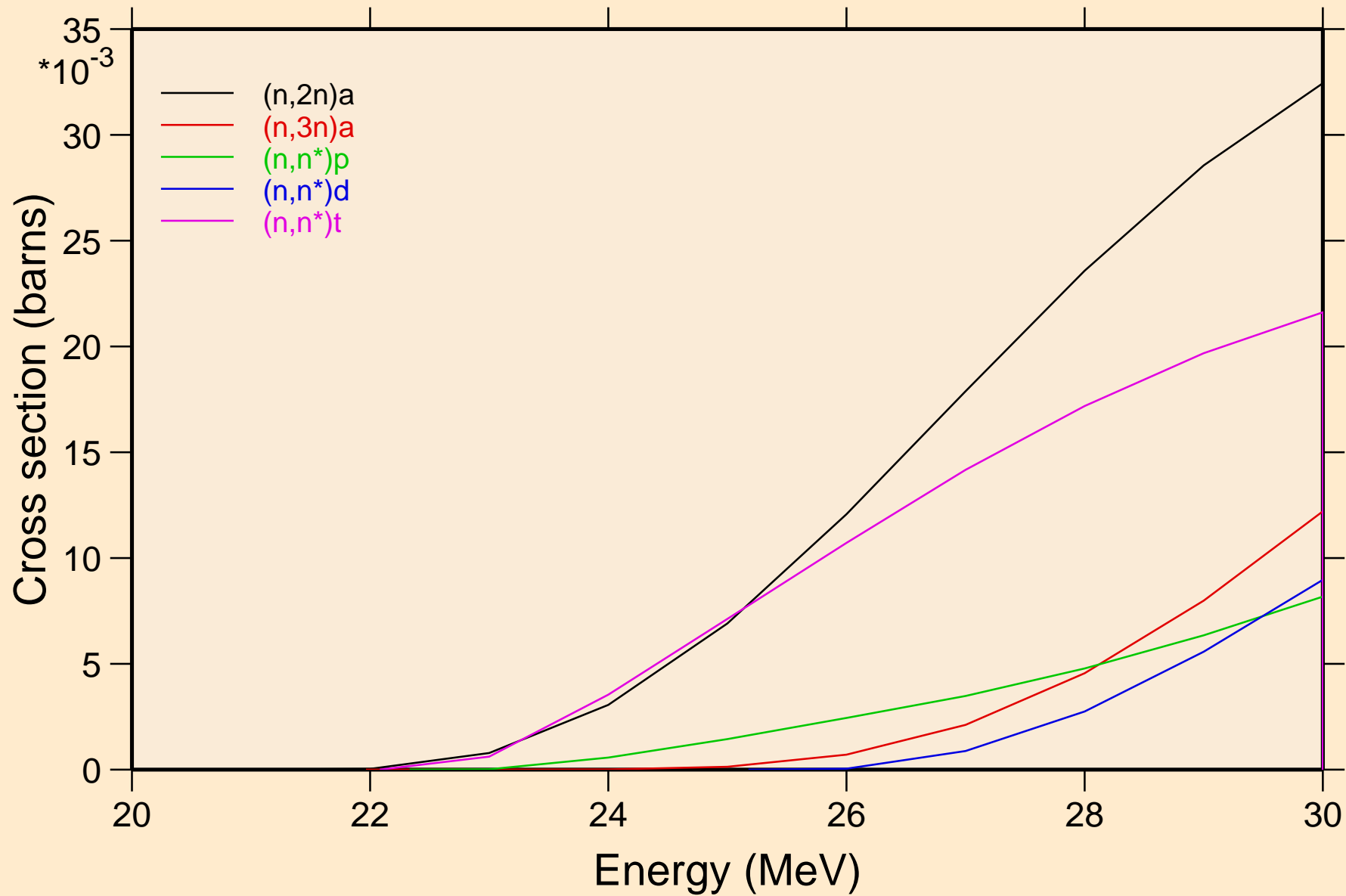



# C014 NEUTRON ACER TENDL-2023 LIBRARY; T=0.K

## Threshold reactions

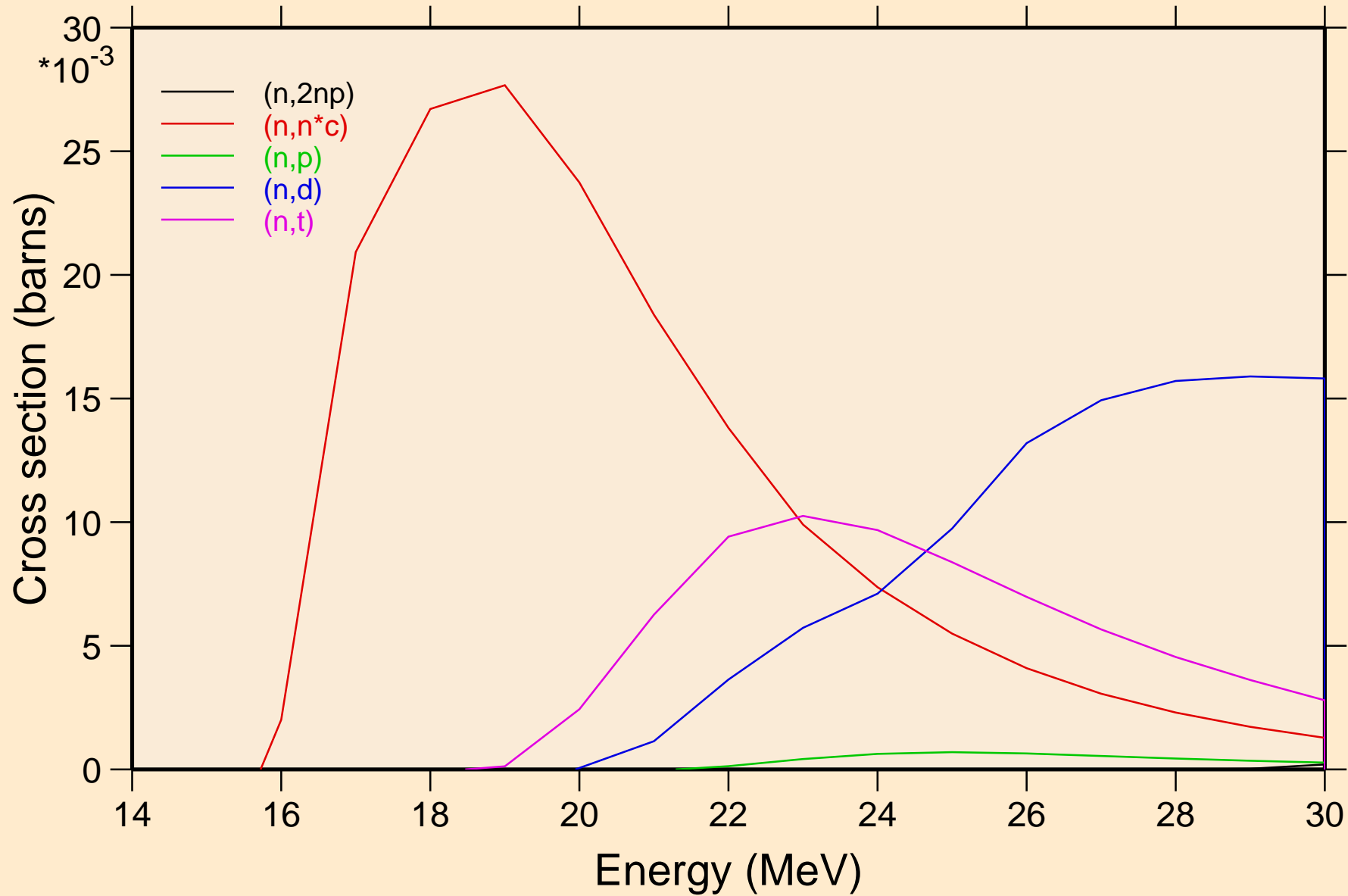

C014 NEUTRON ACER TENDL-2023 LIBRARY; T=0.K  
Threshold reactions

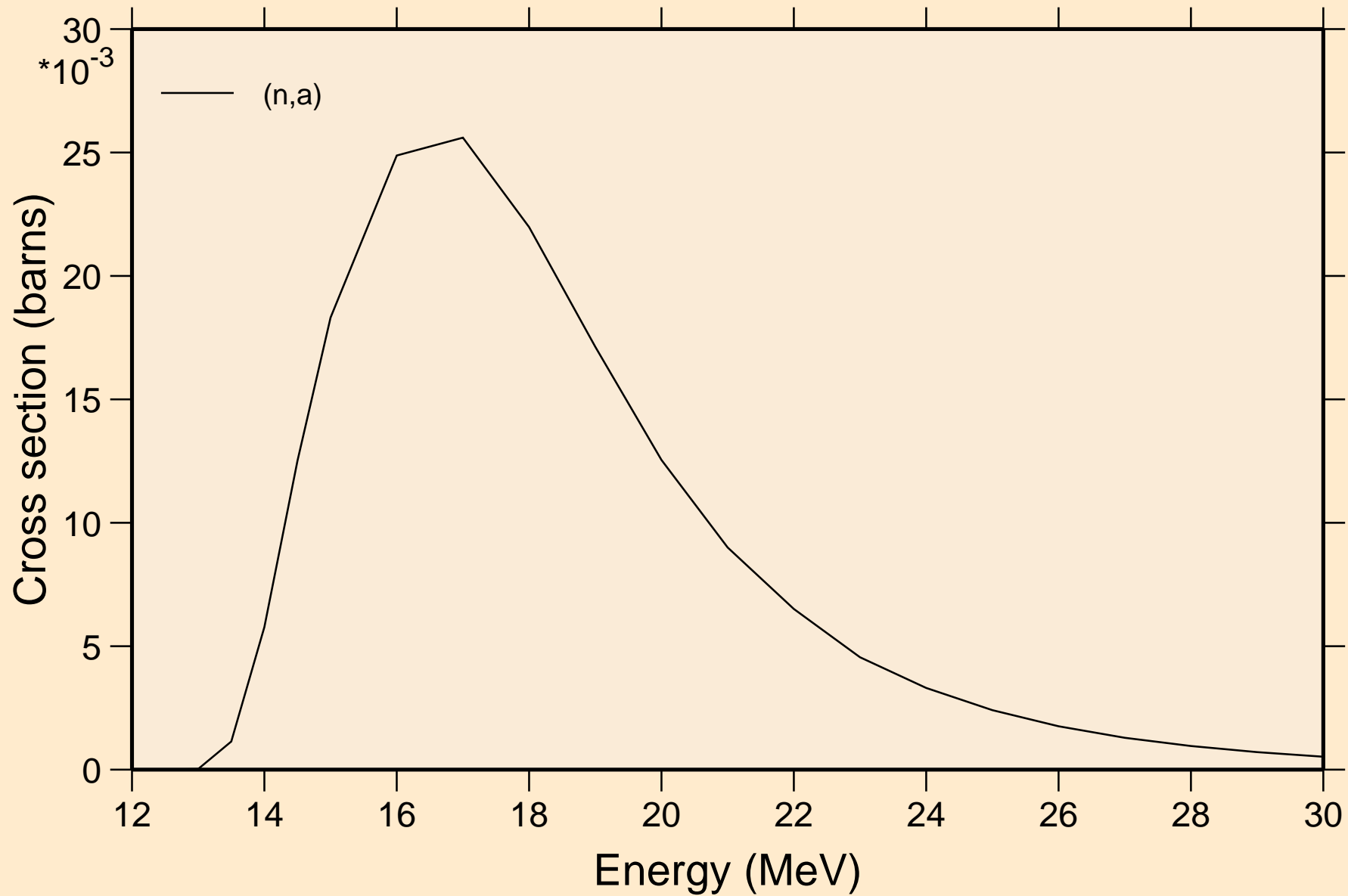

# C014 NEUTRON ACER TENDL-2023 LIBRARY; T=0.K

## Threshold reactions

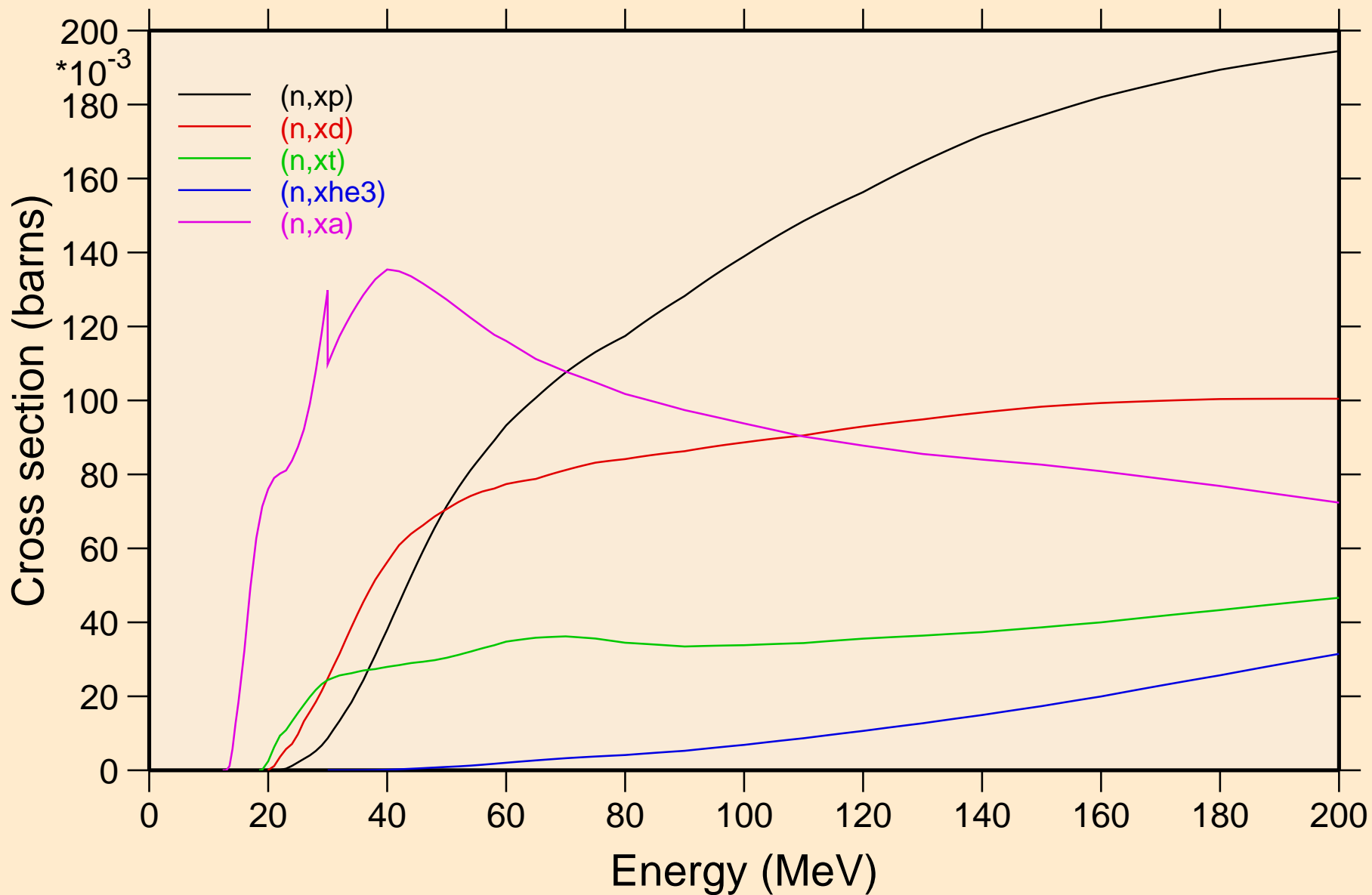

C014 NEUTRON ACER TENDL-2023 LIBRARY; T=0.K  
angular distribution for elastic

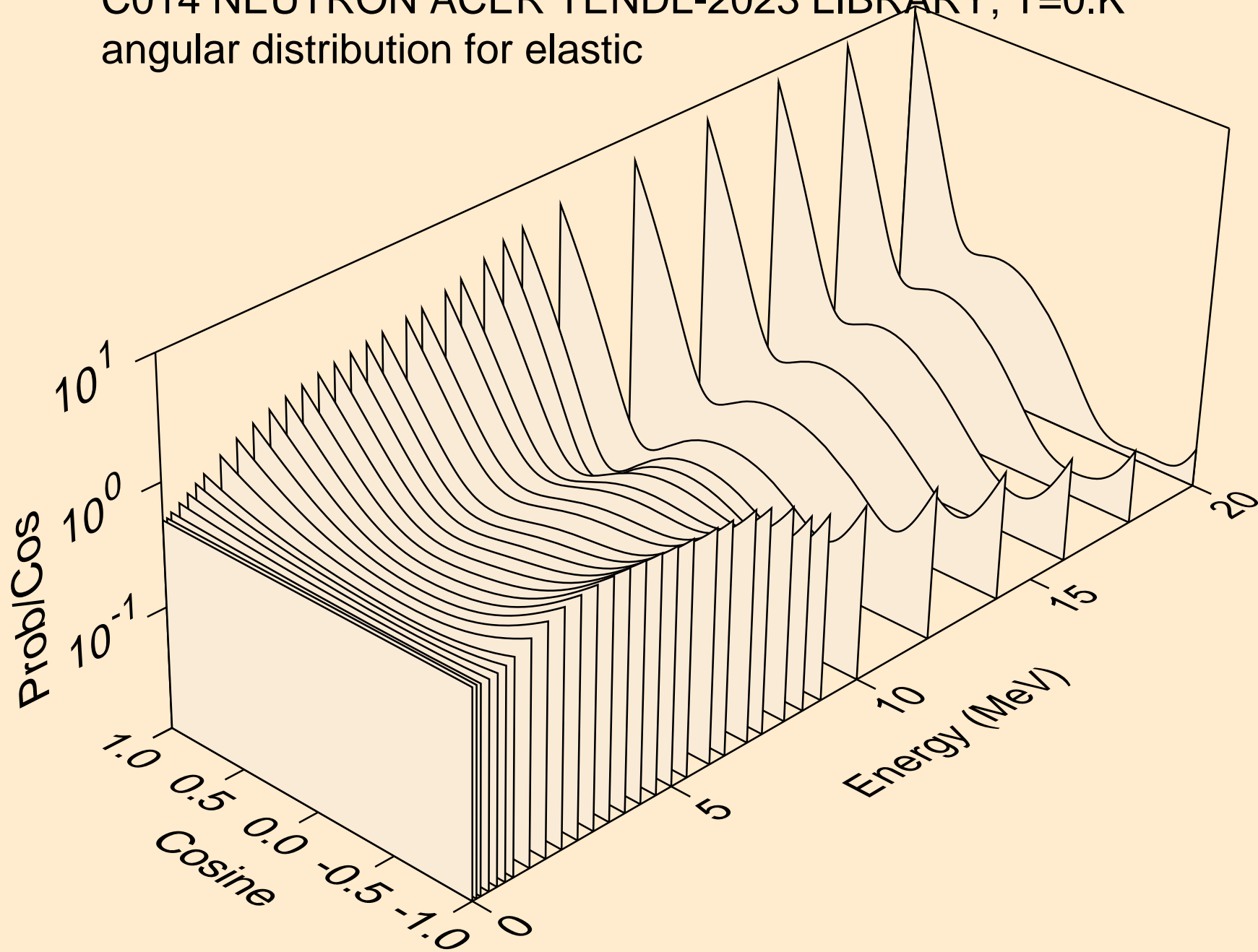

C014 NEUTRON ACER TENDL-2023 LIBRARY; T=0.K  
angular distribution for elastic

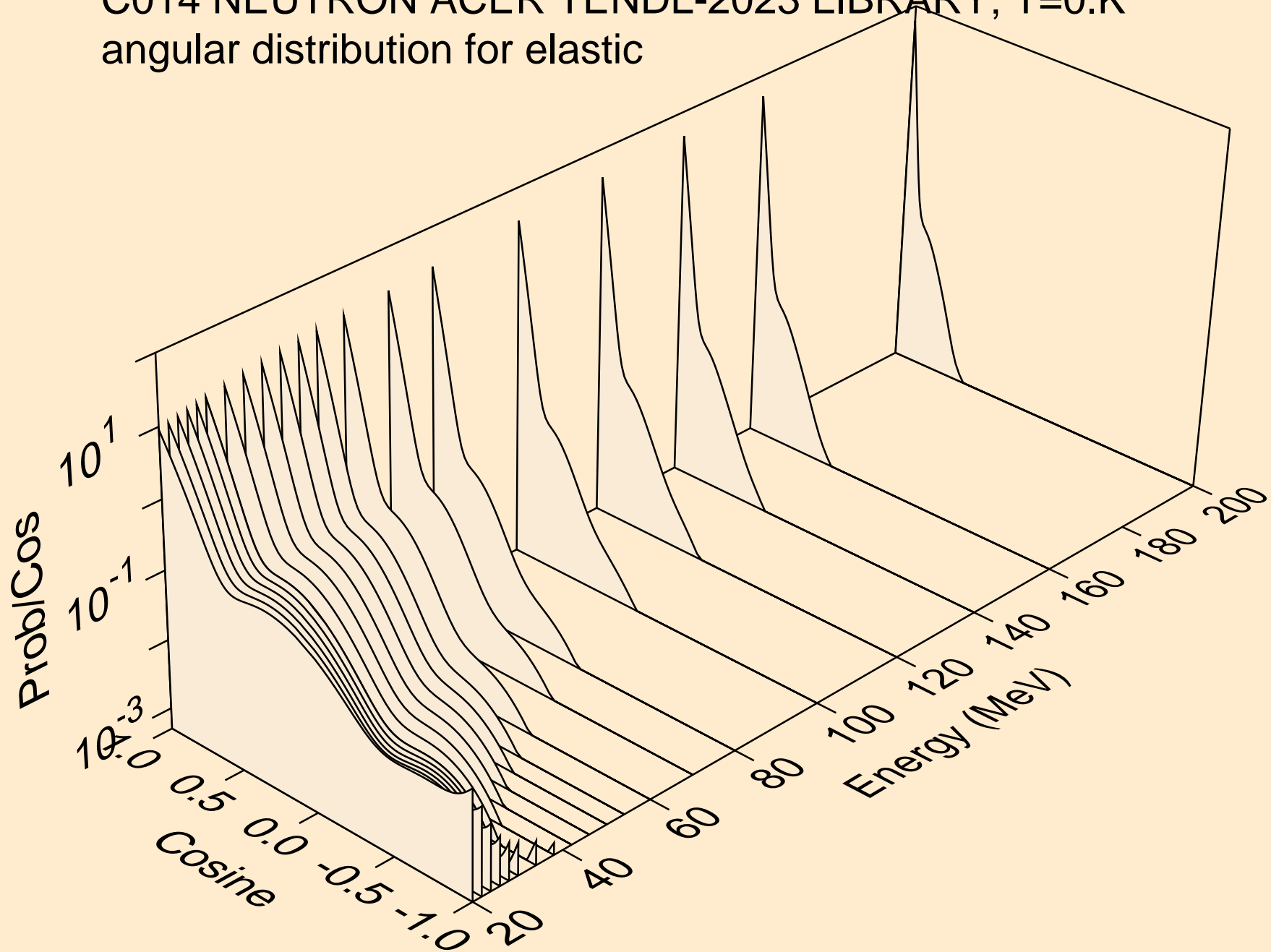

C014 NEUTRON ACER TENDL-2023 LIBRARY; T=0.K  
angular distribution for (n,n\*1)

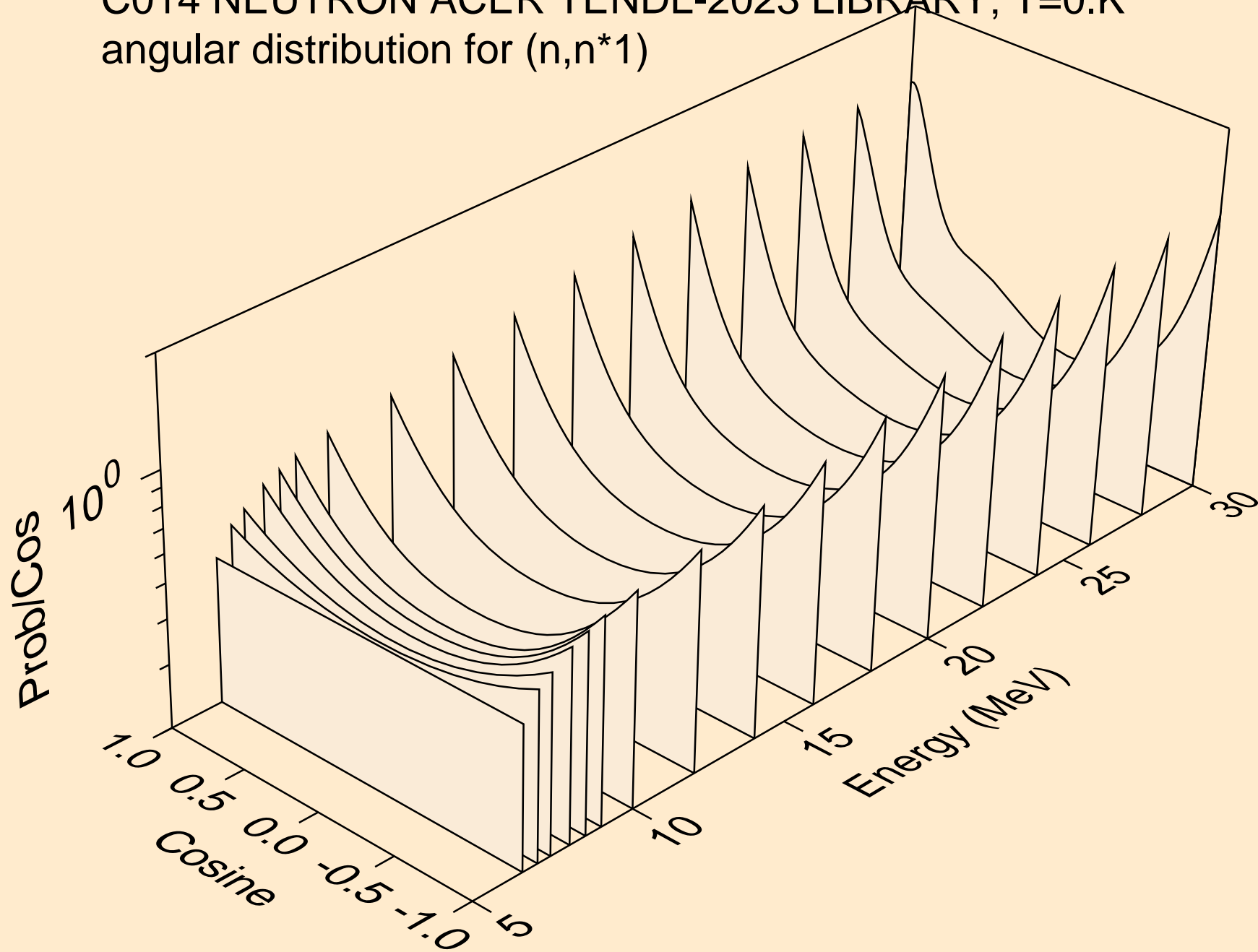

C014 NEUTRON ACER TENDL-2023 LIBRARY; T=0.K  
angular distribution for (n,n\*2)

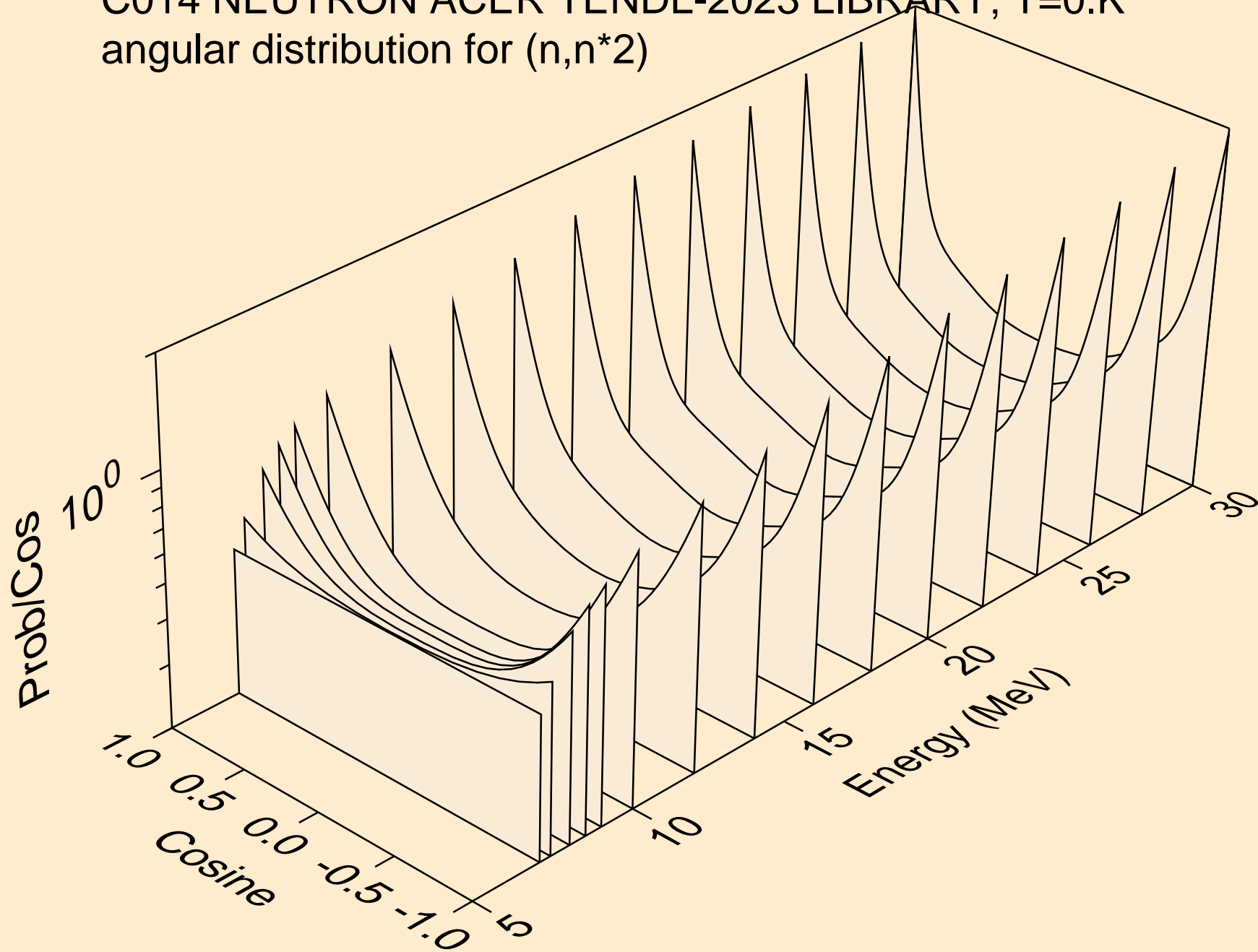

C014 NEUTRON ACER TENDL-2023 LIBRARY; T=0.K  
angular distribution for (n,n\*3)

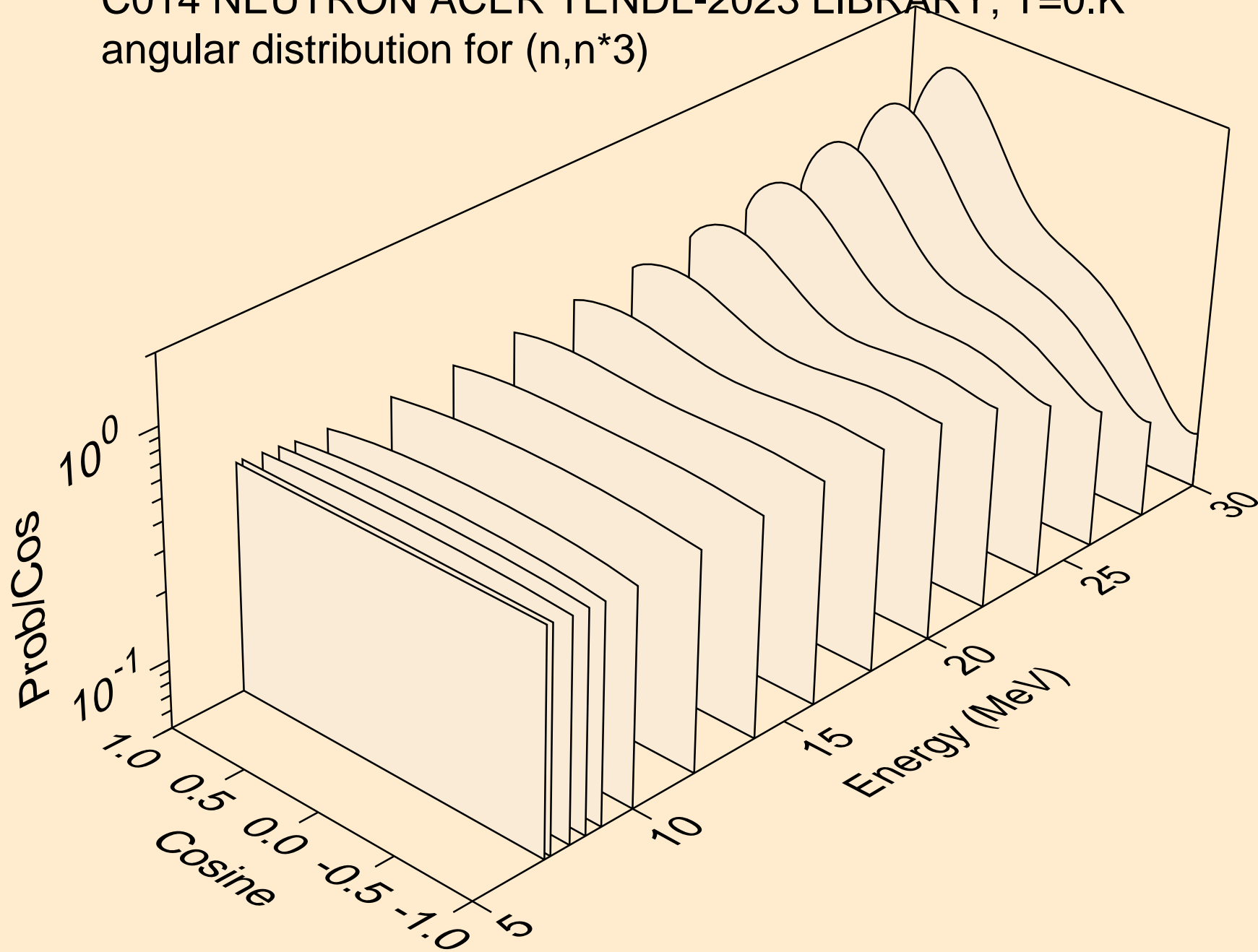



C014 NEUTRON ACER TENDL-2023 LIBRARY; T=0.K  
angular distribution for (n,n\*4)

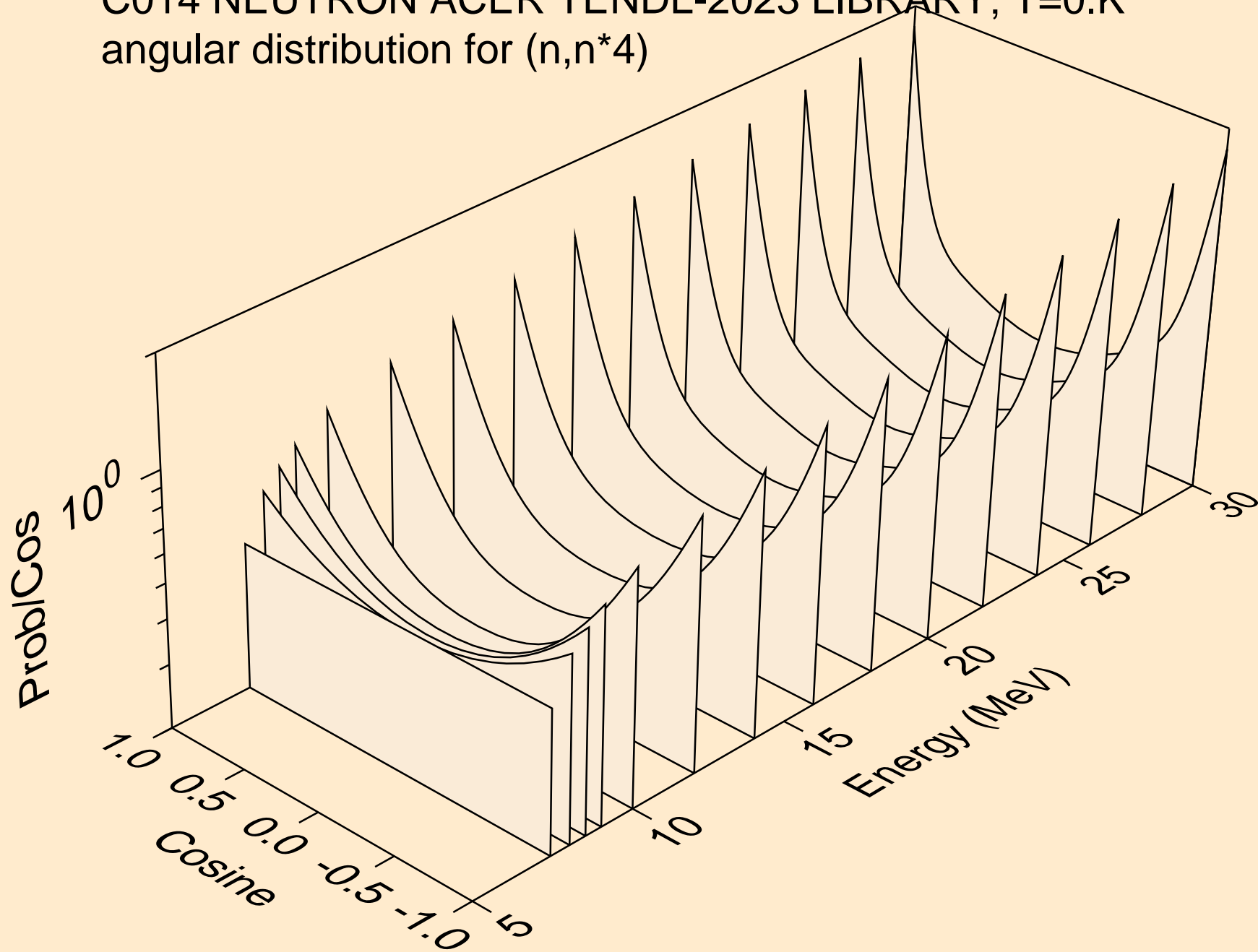

C014 NEUTRON ACER TENDL-2023 LIBRARY; T=0.K  
angular distribution for (n,n\*5)

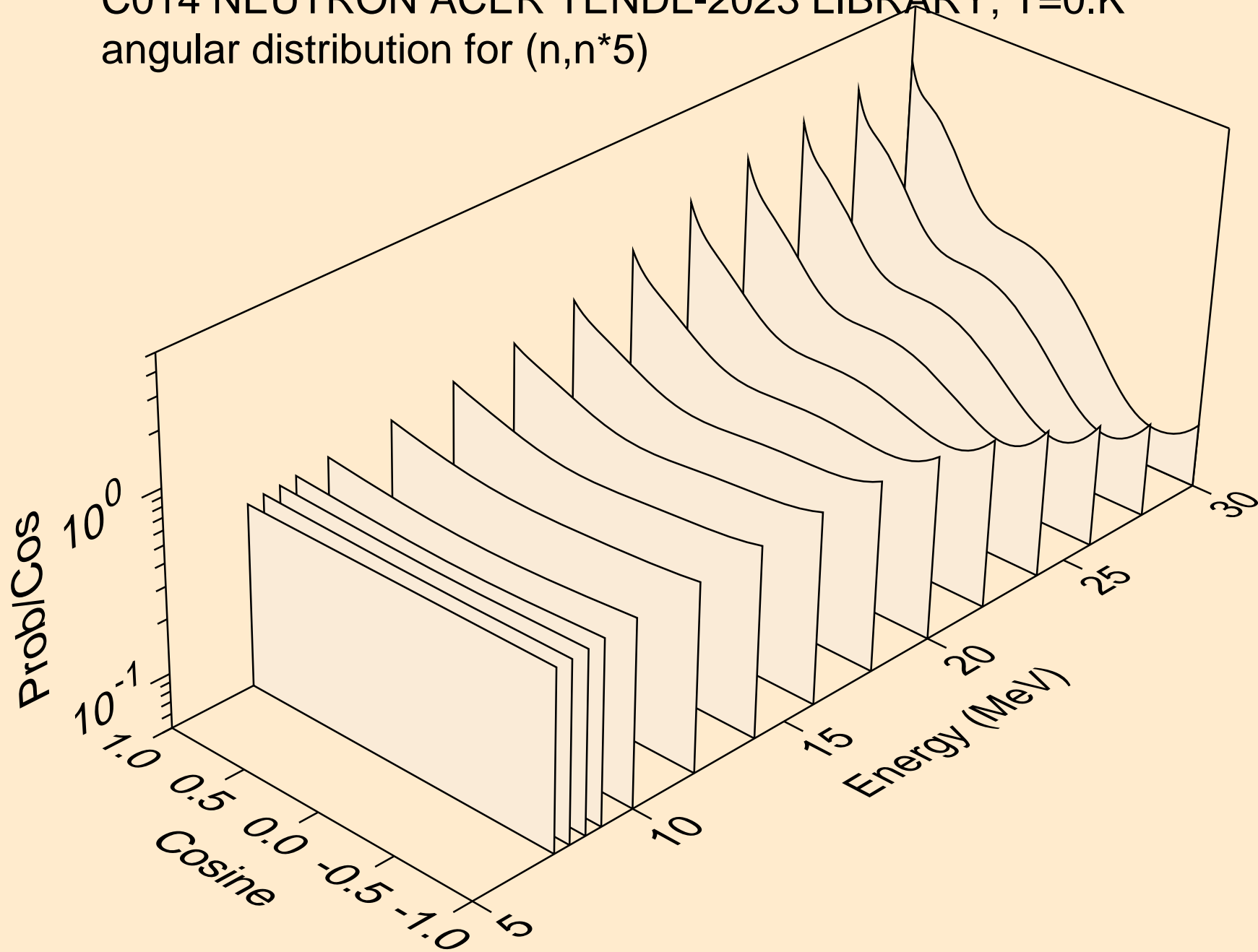

C014 NEUTRON ACER TENDL-2023 LIBRARY; T=0.K  
angular distribution for (n,n\*6)

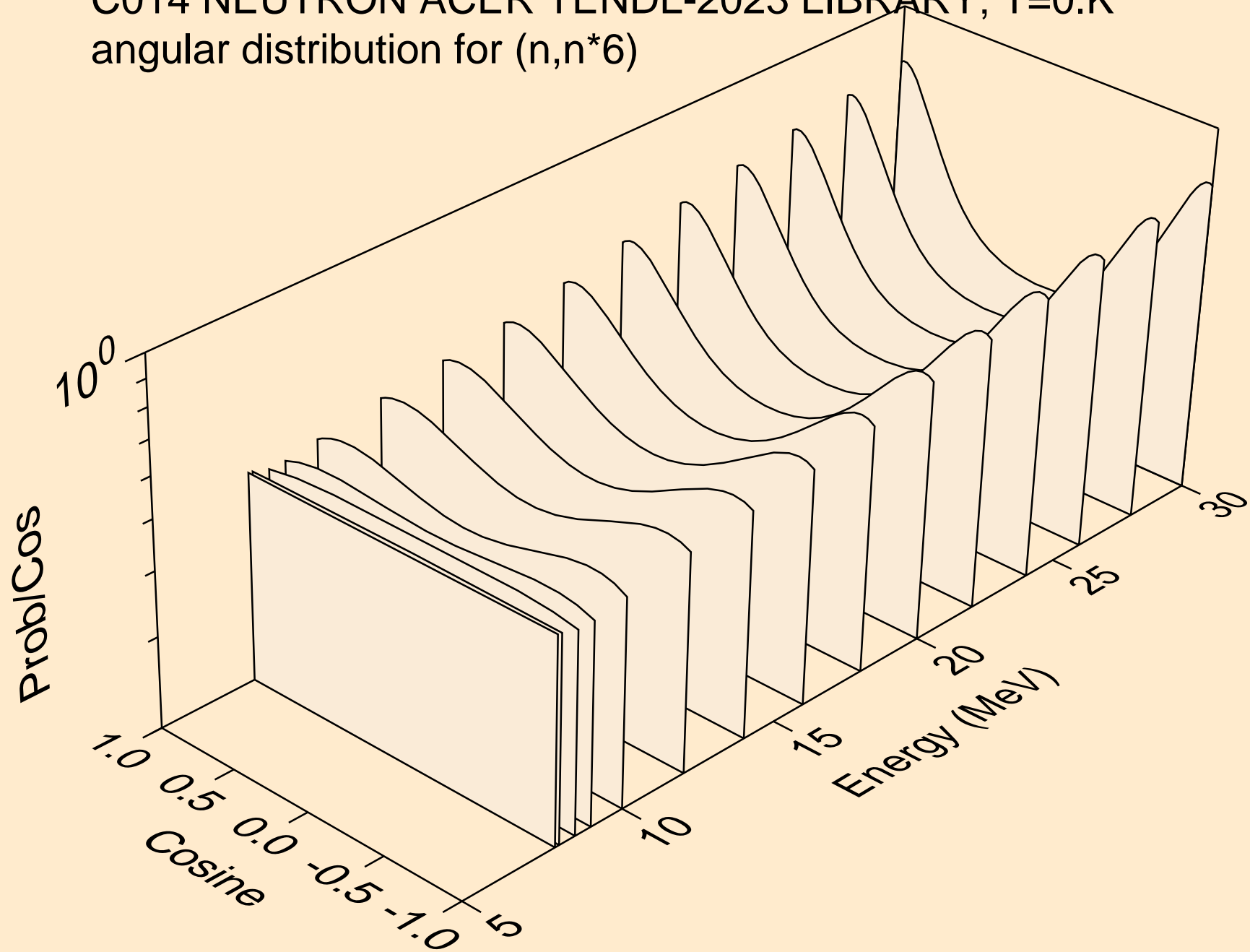

C014 NEUTRON ACER TENDL-2023 LIBRARY; T=0.K  
angular distribution for (n,n\*7)

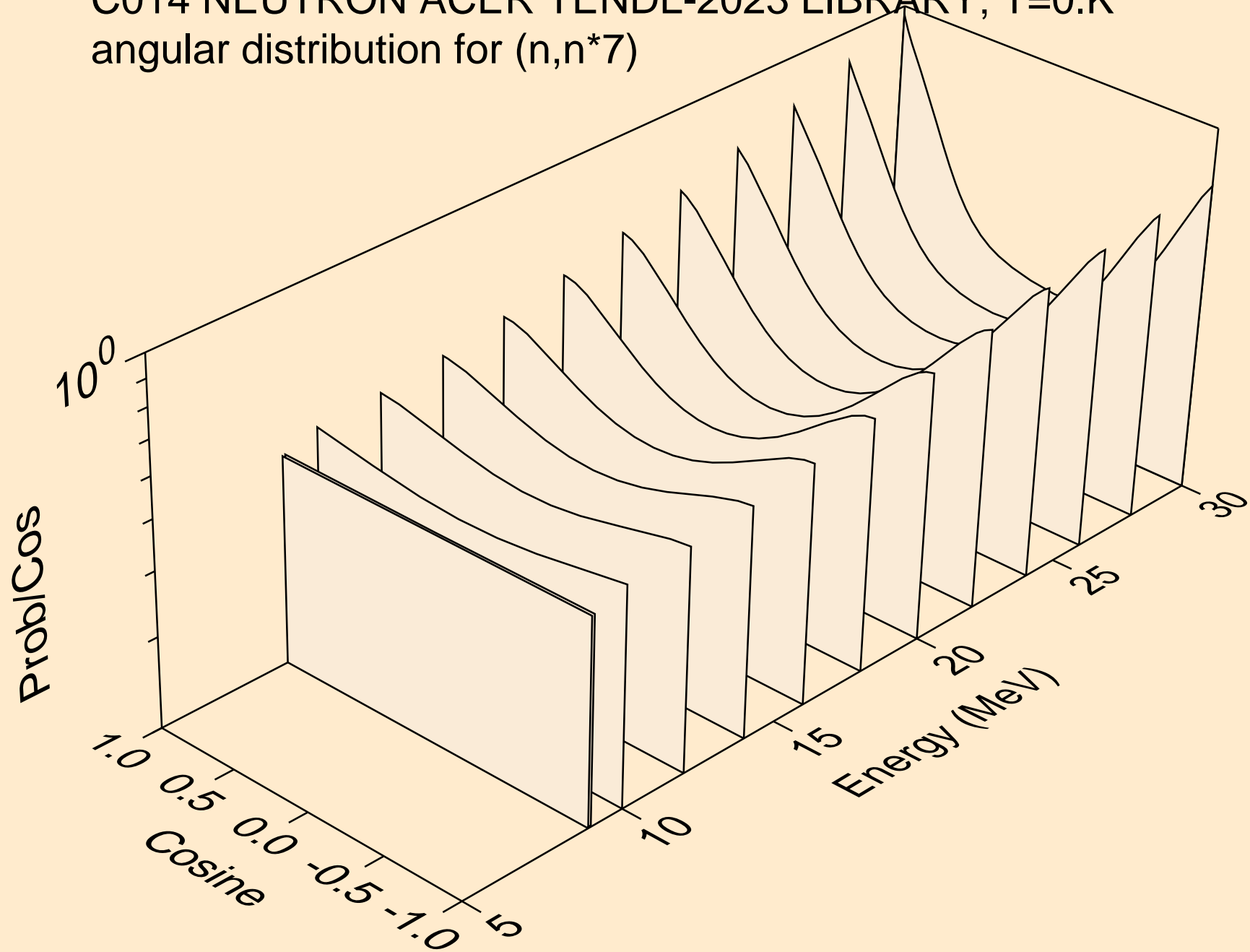

C014 NEUTRON ACER TENDL-2023 LIBRARY; T=0.K  
angular distribution for (n,n\*8)

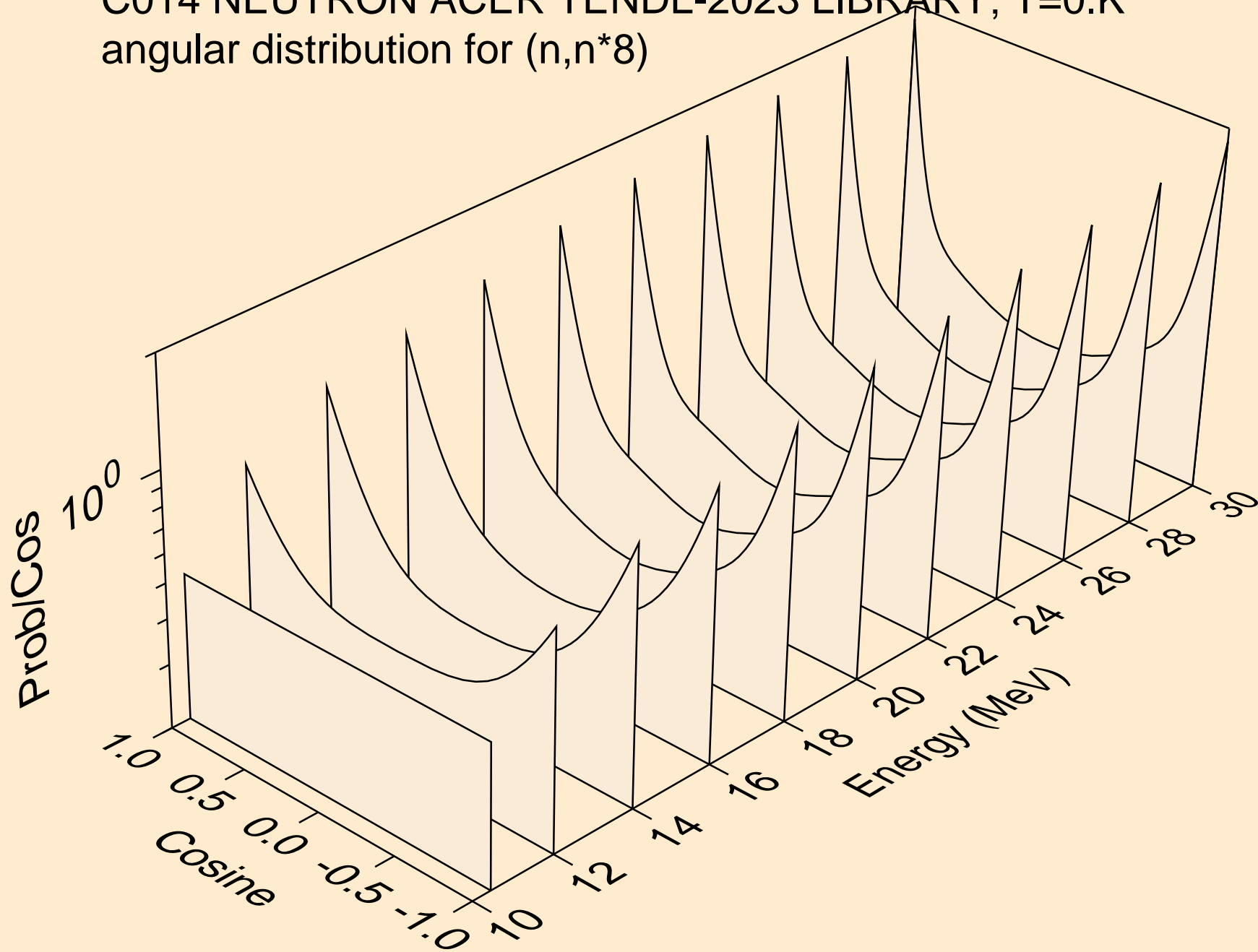

C014 NEUTRON ACER TENDL-2023 LIBRARY; T=0.K  
angular distribution for (n,n\*9)

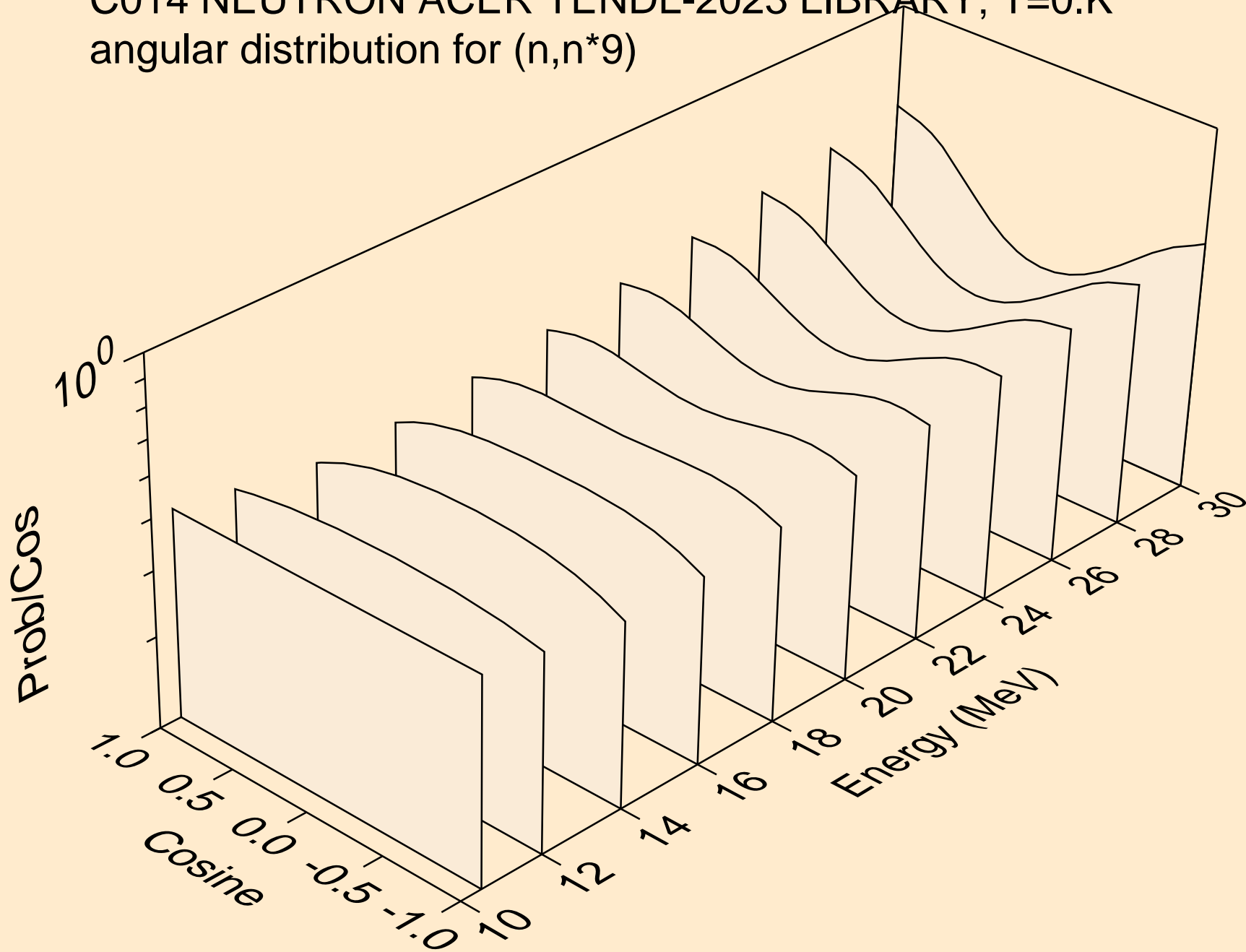

C014 NEUTRON ACER TENDL-2023 LIBRARY; T=0.K  
angular distribution for (n,n\*10)

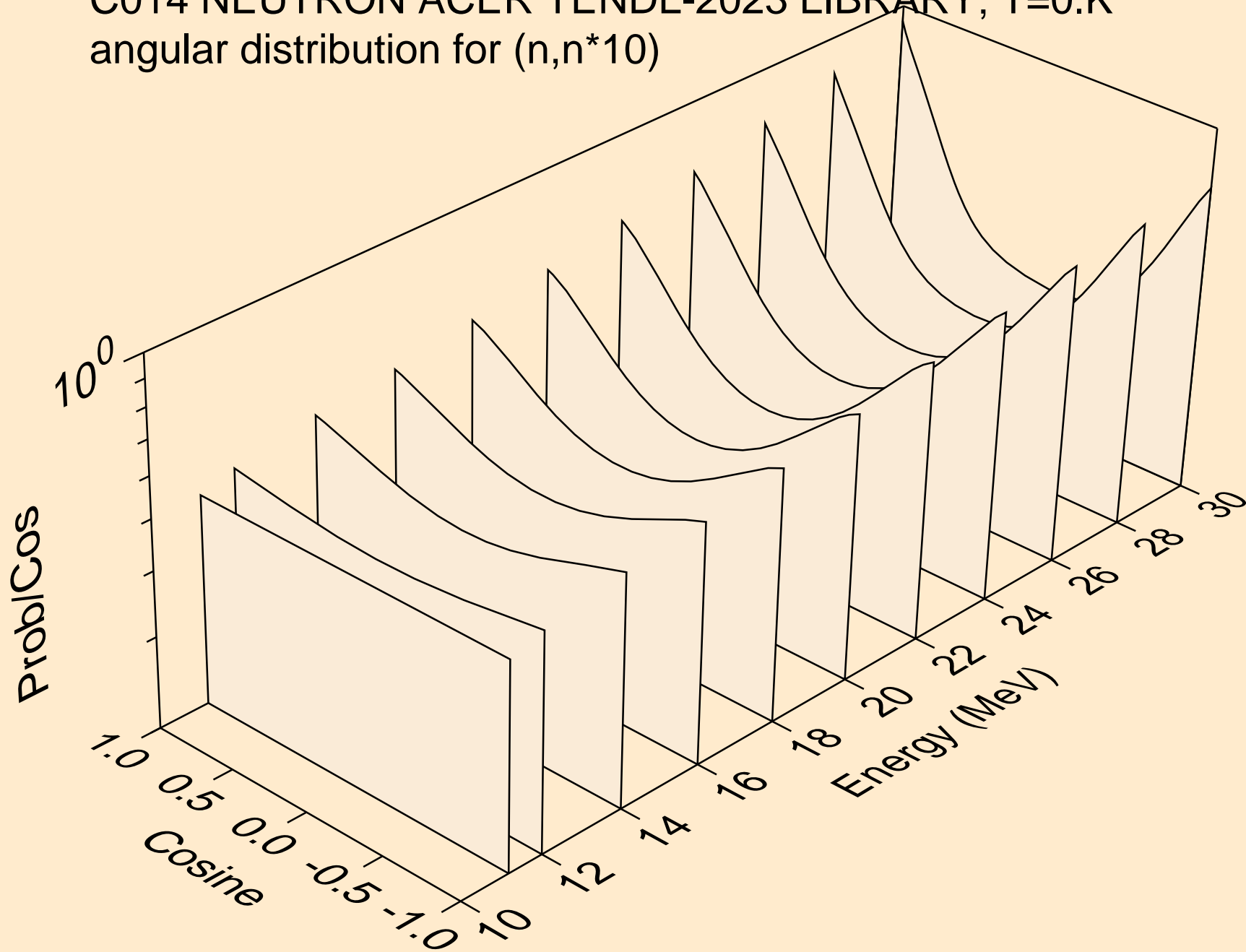

C014 NEUTRON ACER TENDL-2023 LIBRARY; T=0.K  
angular distribution for (n,n\*11)

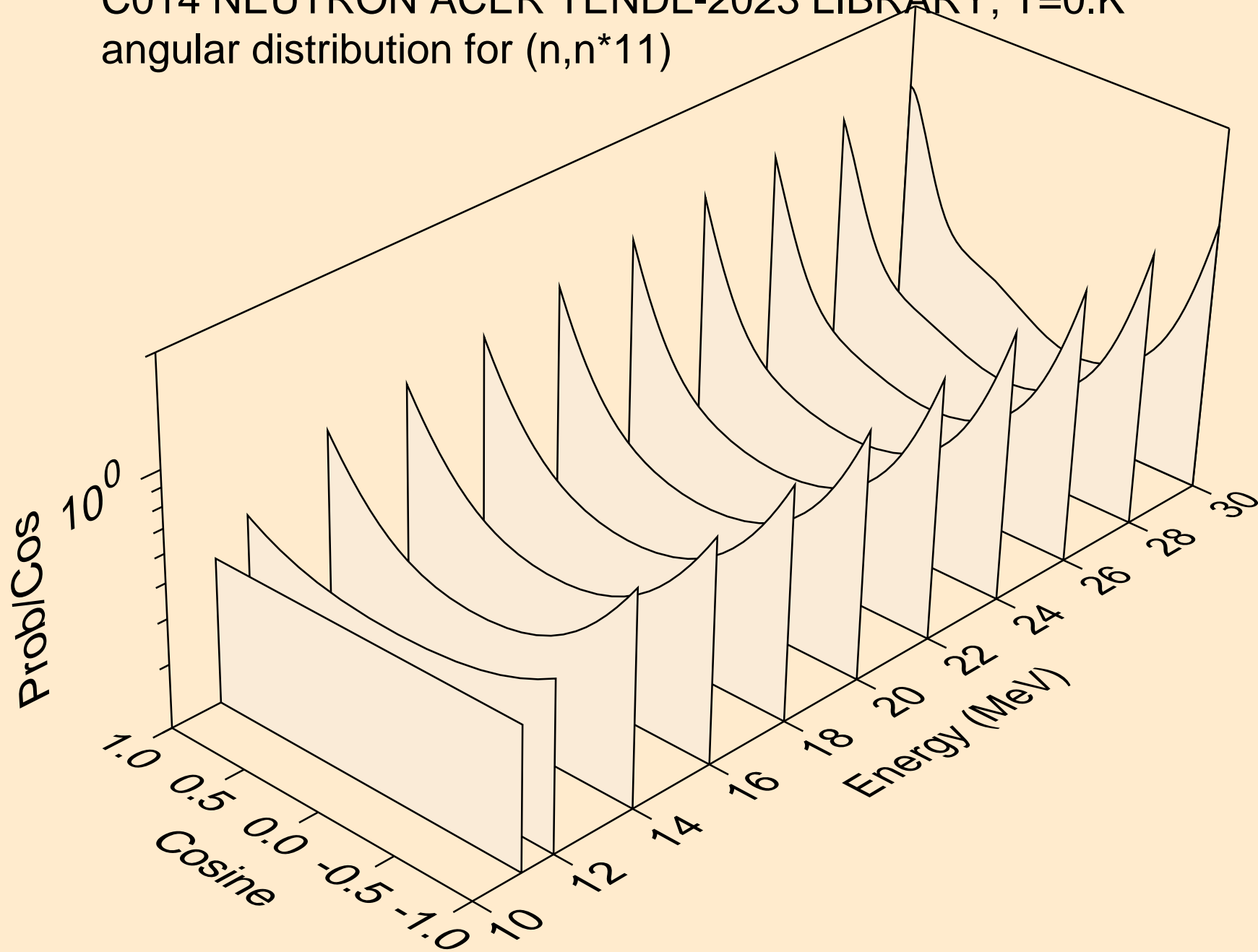



C014 NEUTRON ACER TENDL-2023 LIBRARY; T=0.K  
angular distribution for (n,n\*12)

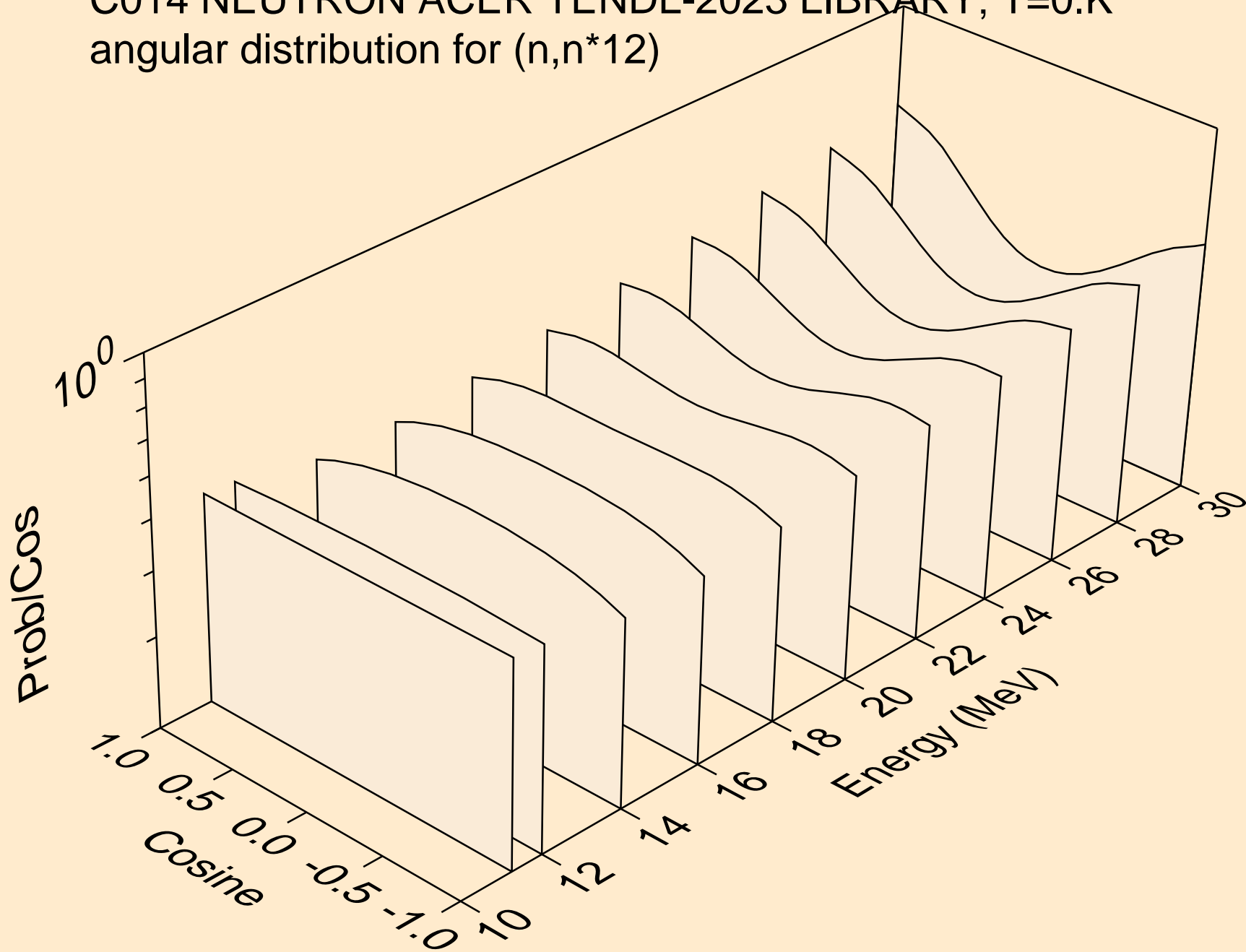

C014 NEUTRON ACER TENDL-2023 LIBRARY; T=0.K  
angular distribution for (n,n\*13)

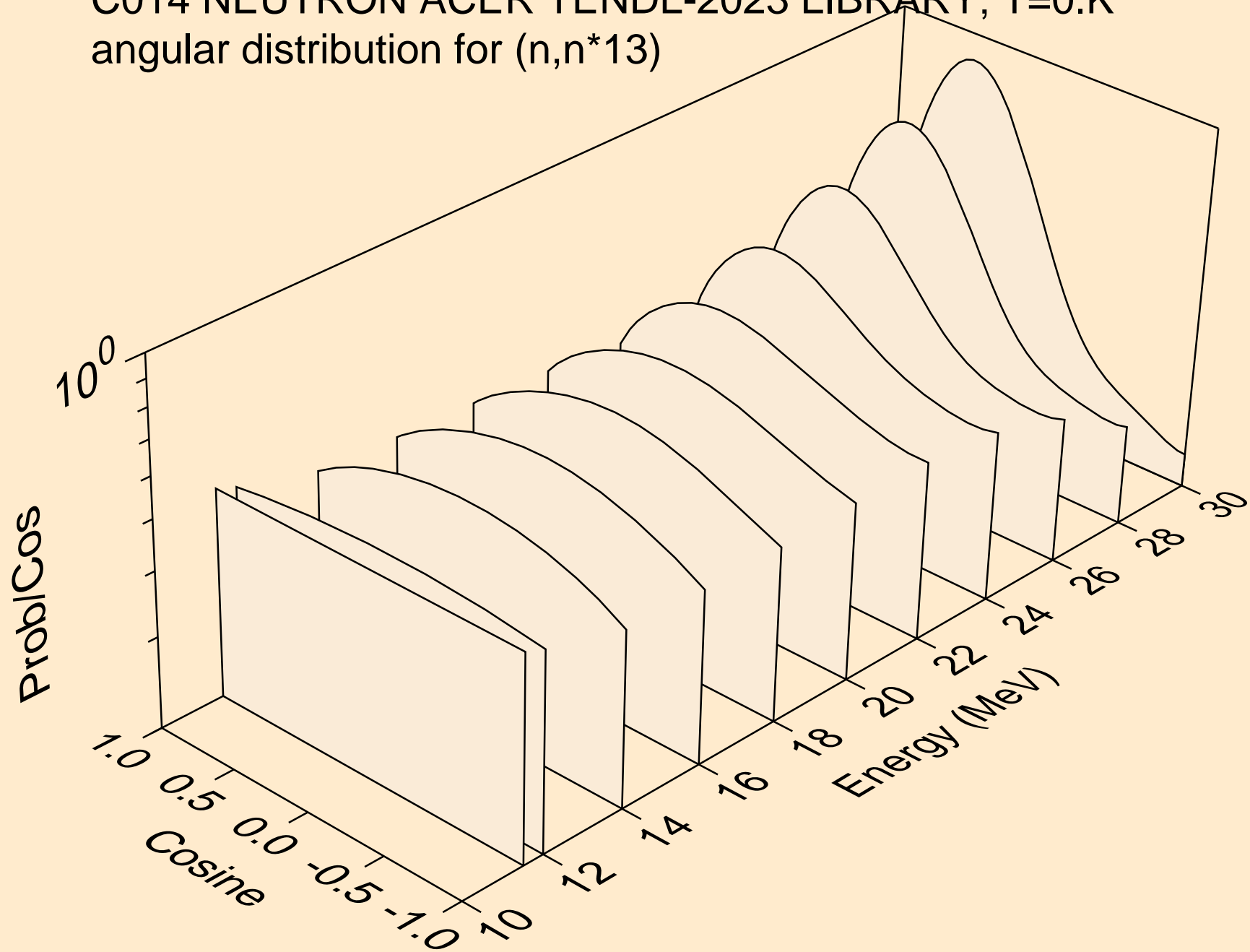

C014 NEUTRON ACER TENDL-2023 LIBRARY; T=0.K  
angular distribution for (n,n\*14)

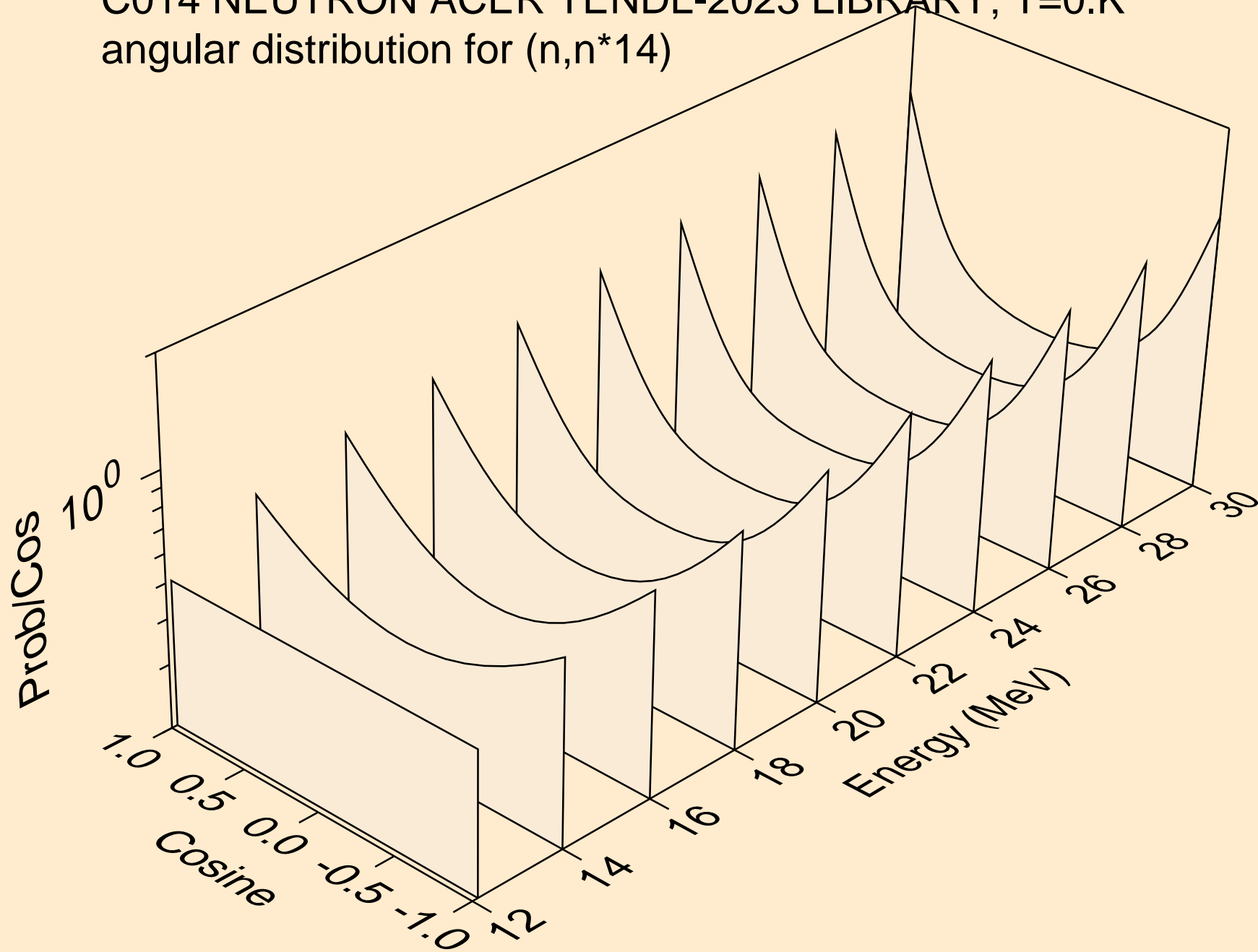

C014 NEUTRON ACER TENDL-2023 LIBRARY; T=0.K  
angular distribution for (n,n\*15)

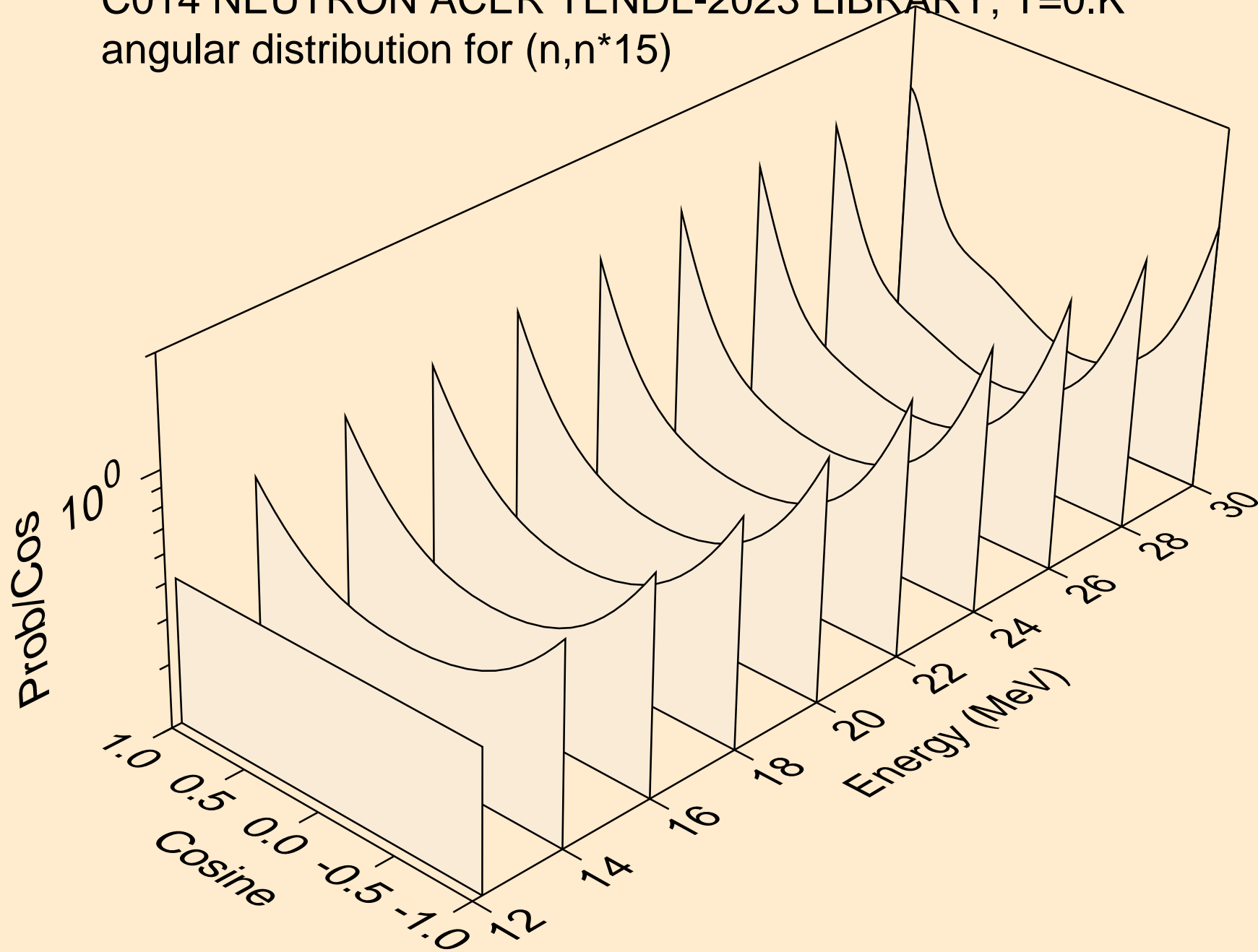

C014 NEUTRON ACER TENDL-2023 LIBRARY; T=0.K  
angular distribution for (n,n\*16)

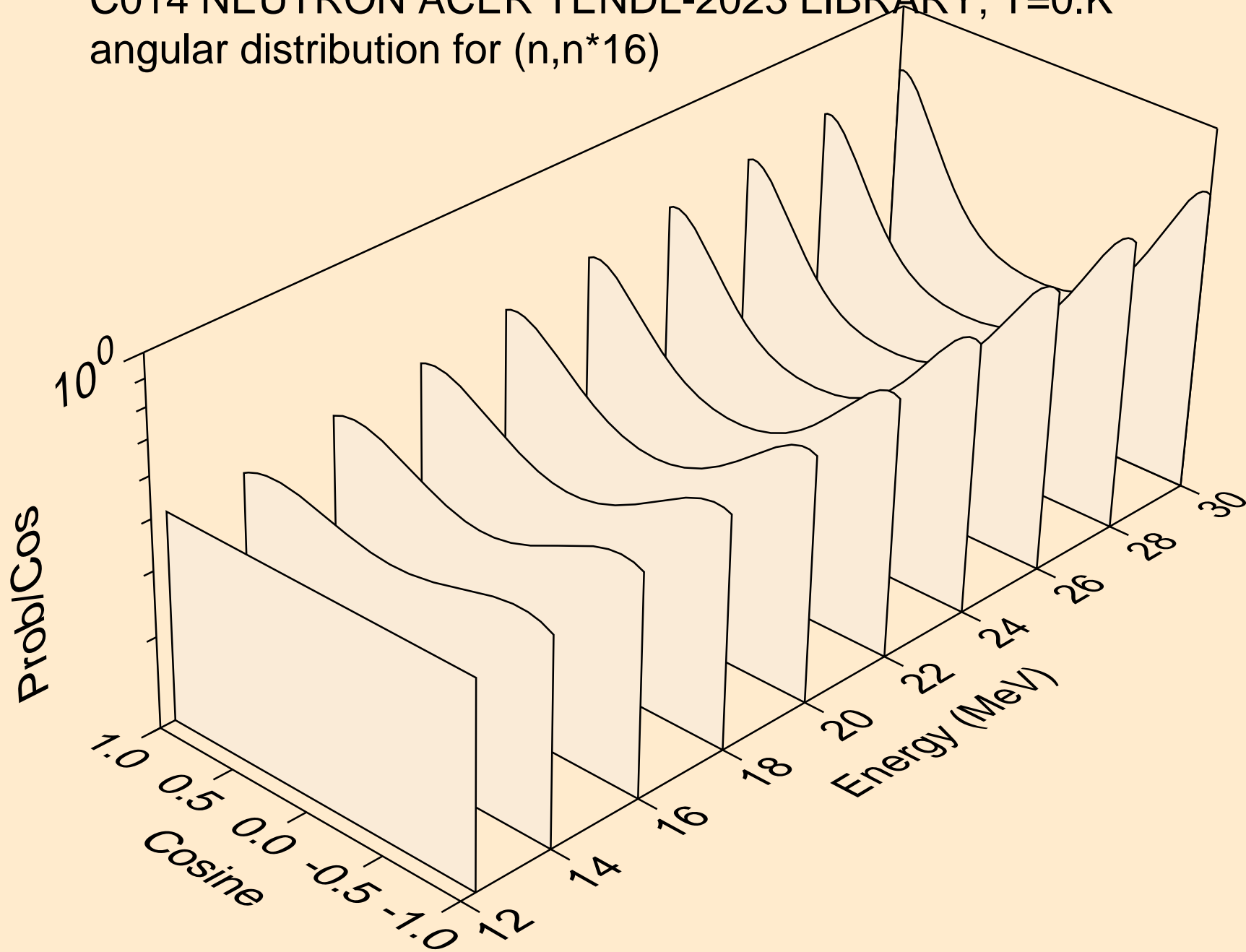

C014 NEUTRON ACER TENDL-2023 LIBRARY; T=0.K  
angular distribution for (n,n\*17)

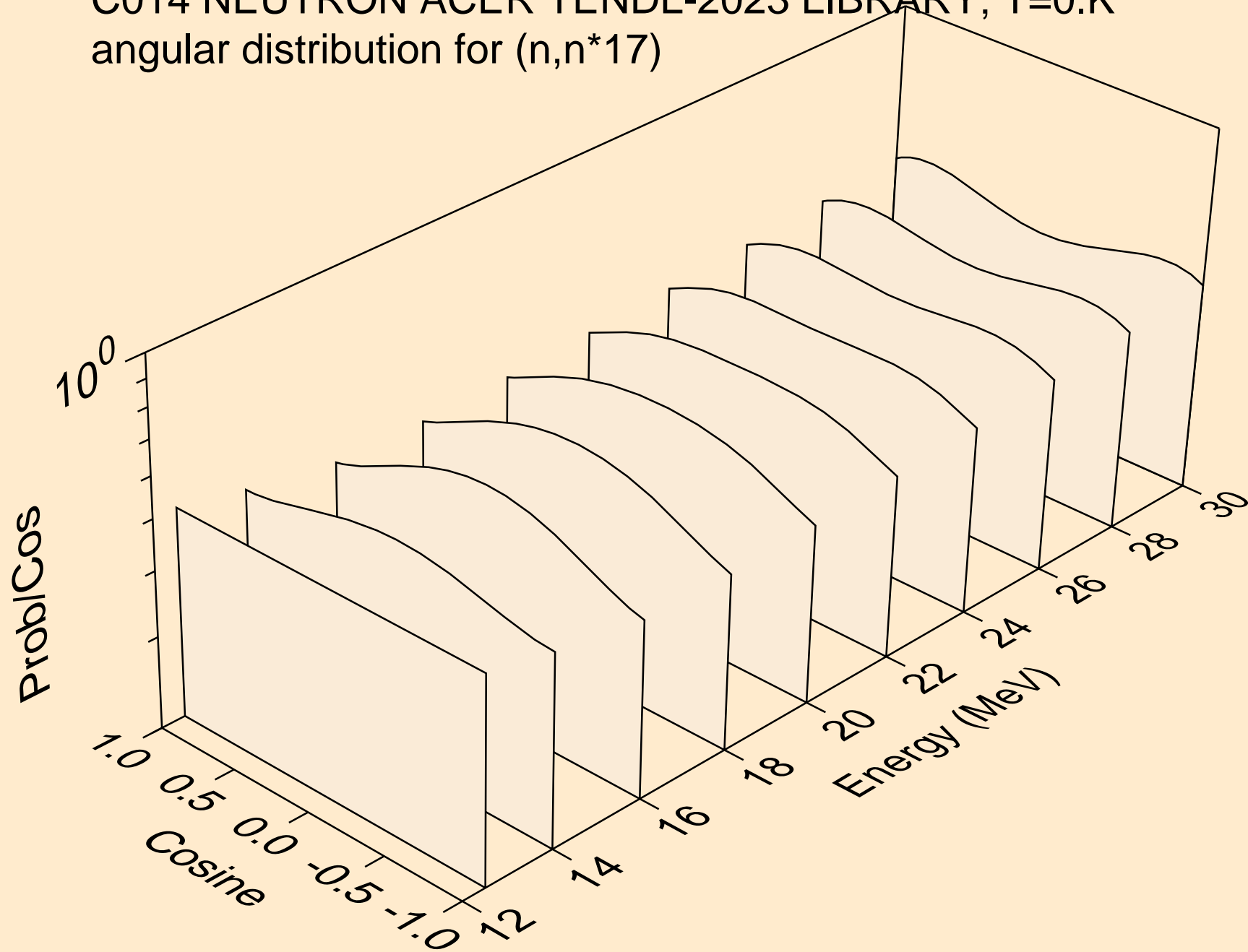

C014 NEUTRON ACER TENDL-2023 LIBRARY; T=0.K  
angular distribution for (n,n\*18)

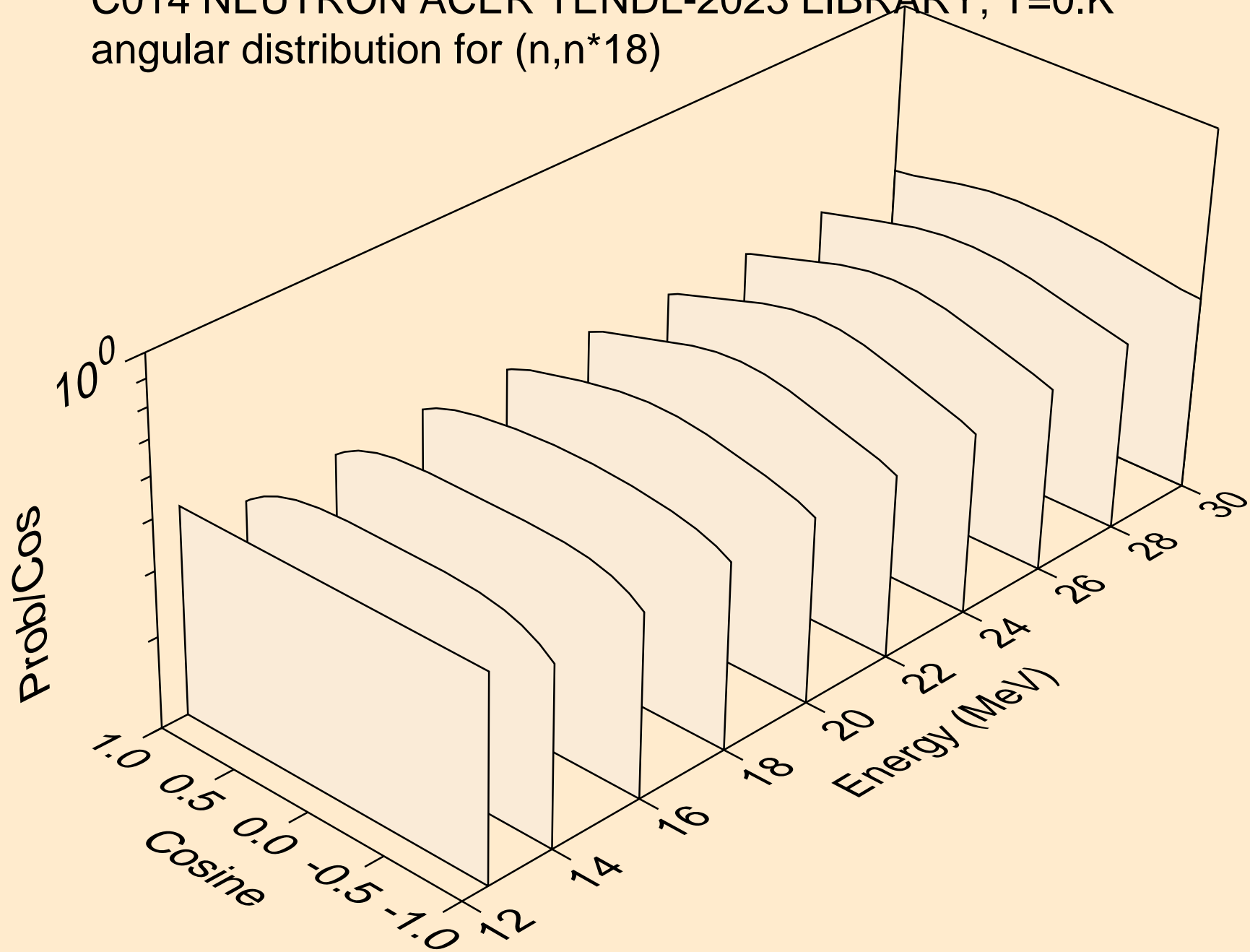

C014 NEUTRON ACER TENDL-2023 LIBRARY; T=0.K  
angular distribution for (n,n\*19)

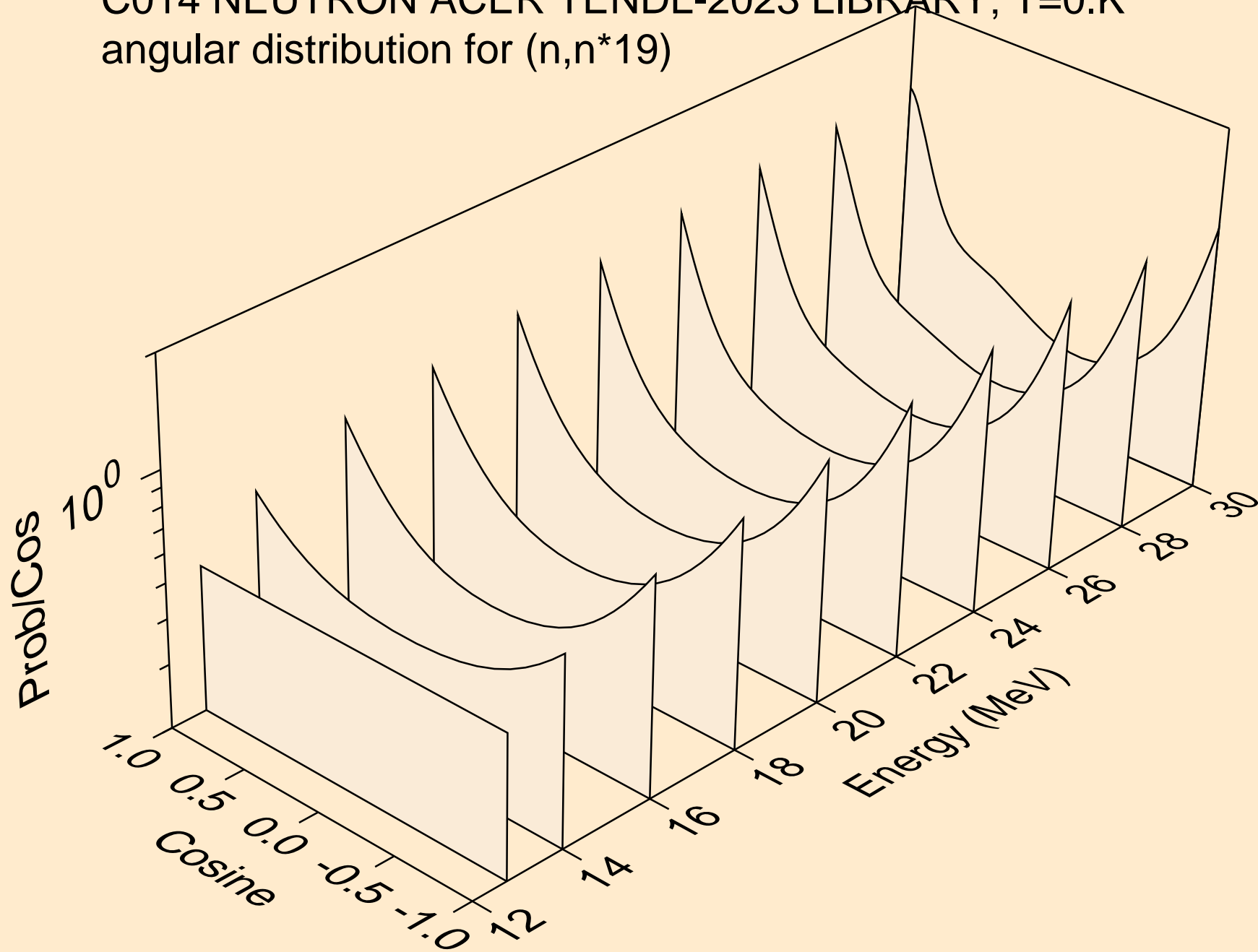



C014 NEUTRON ACER TENDL-2023 LIBRARY; T=0.K  
angular distribution for (n,n\*20)

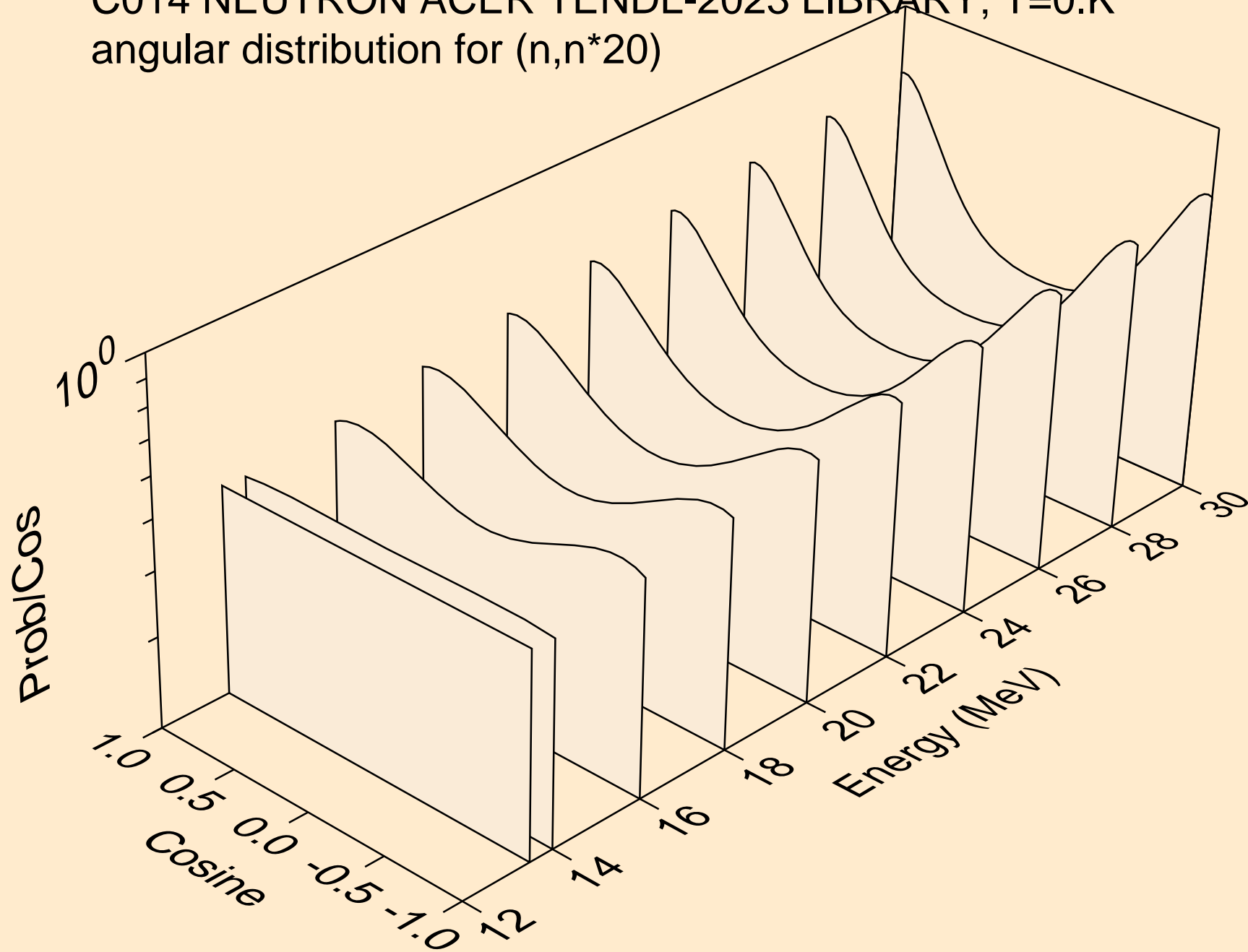

C014 NEUTRON ACER TENDL-2023 LIBRARY; T=0.K  
angular distribution for (n,n\*21)

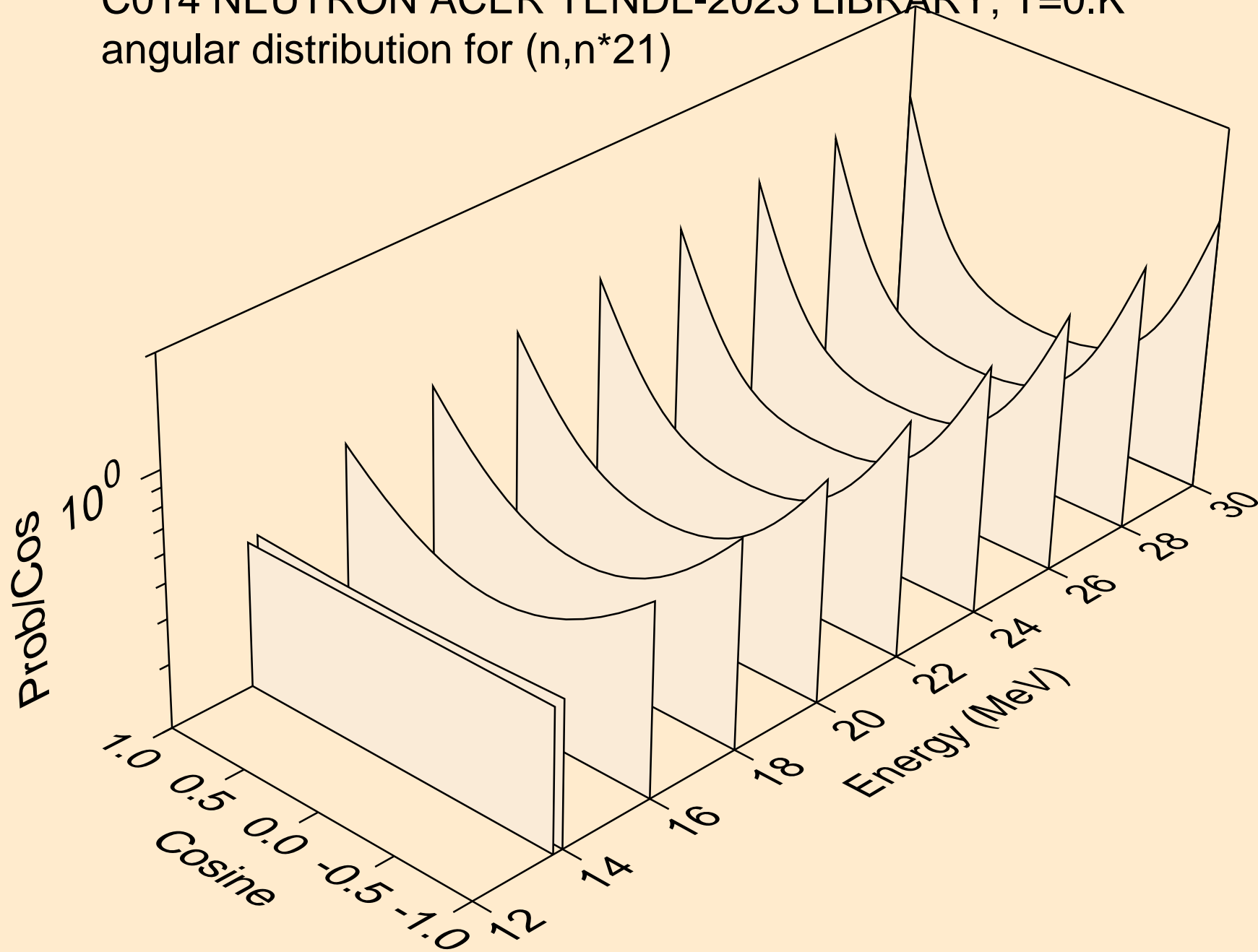

C014 NEUTRON ACER TENDL-2023 LIBRARY; T=0.K  
angular distribution for (n,n\*22)

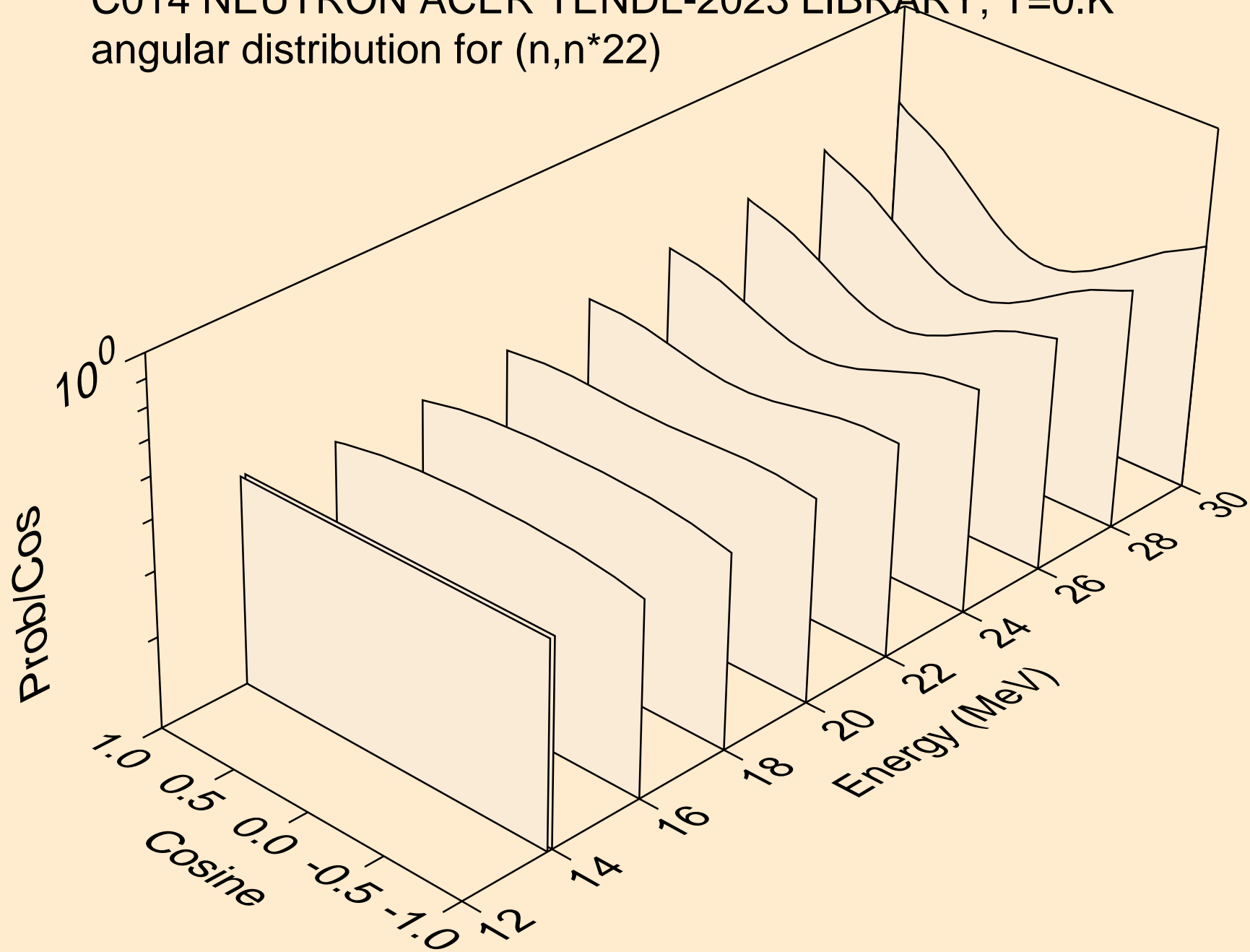

C014 NEUTRON ACER TENDL-2023 LIBRARY; T=0.K  
angular distribution for (n,n\*23)

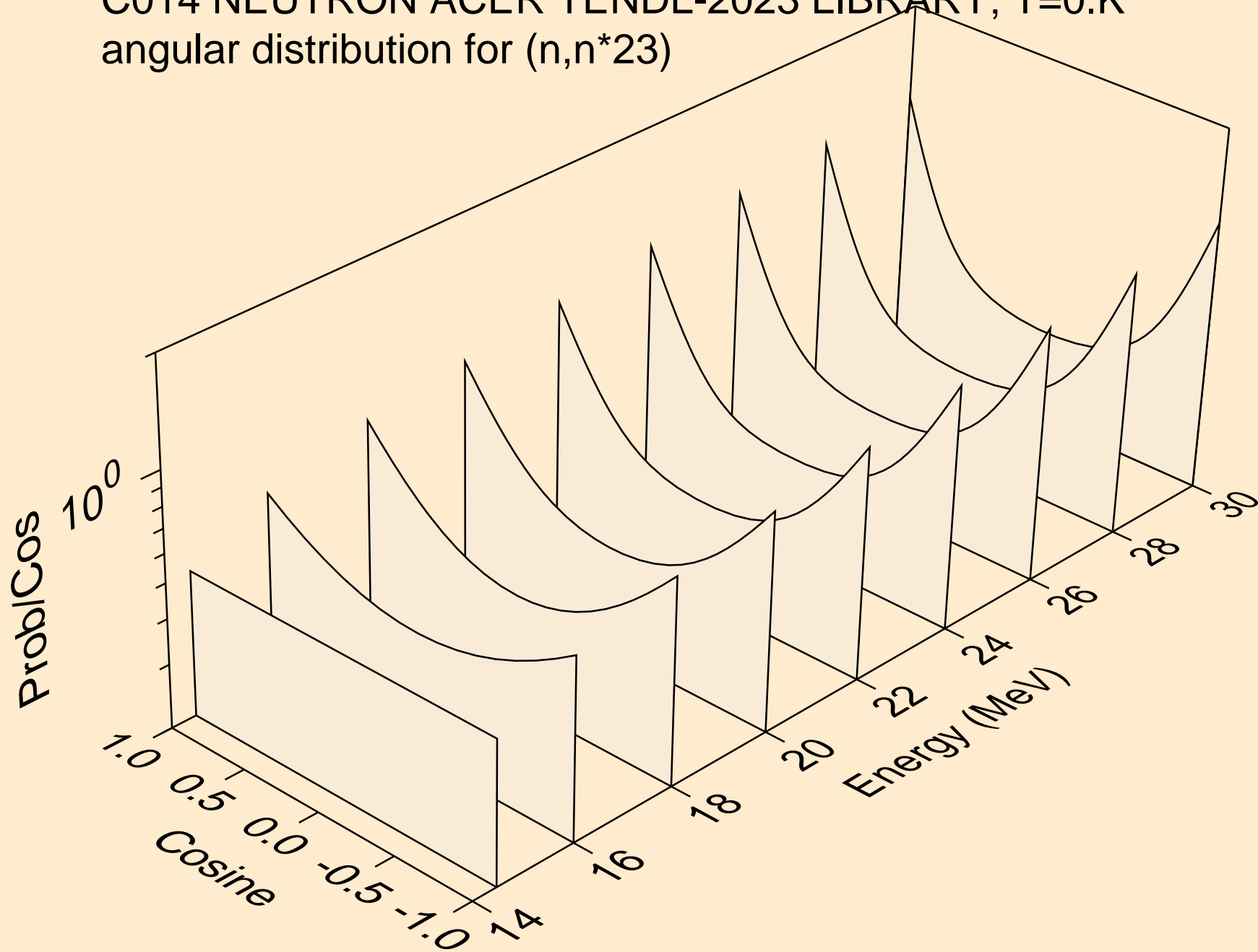

C014 NEUTRON ACER TENDL-2023 LIBRARY; T=0.K  
angular distribution for (n,n\*24)

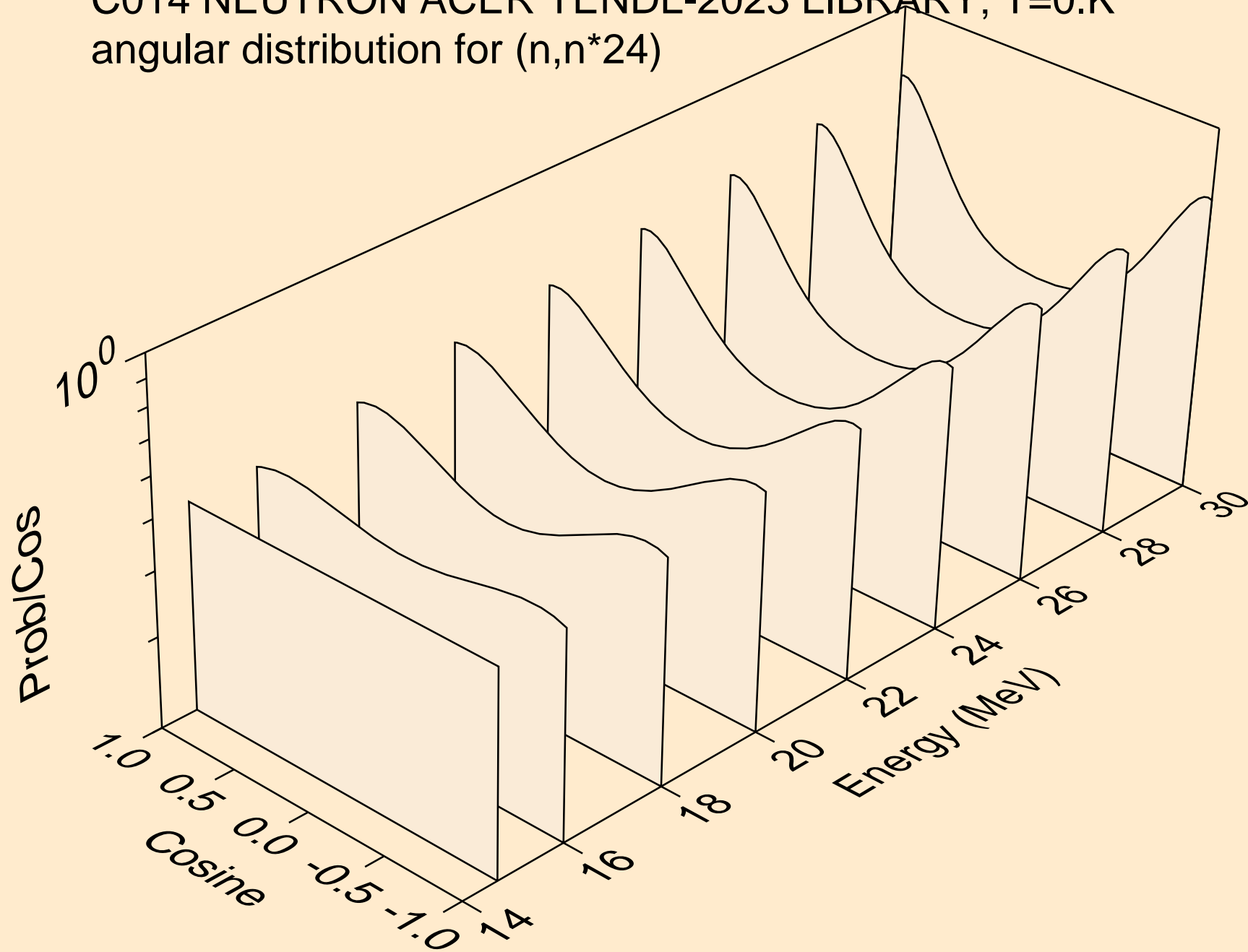

C014 NEUTRON ACER TENDL-2023 LIBRARY; T=0.K  
angular distribution for (n,n\*25)

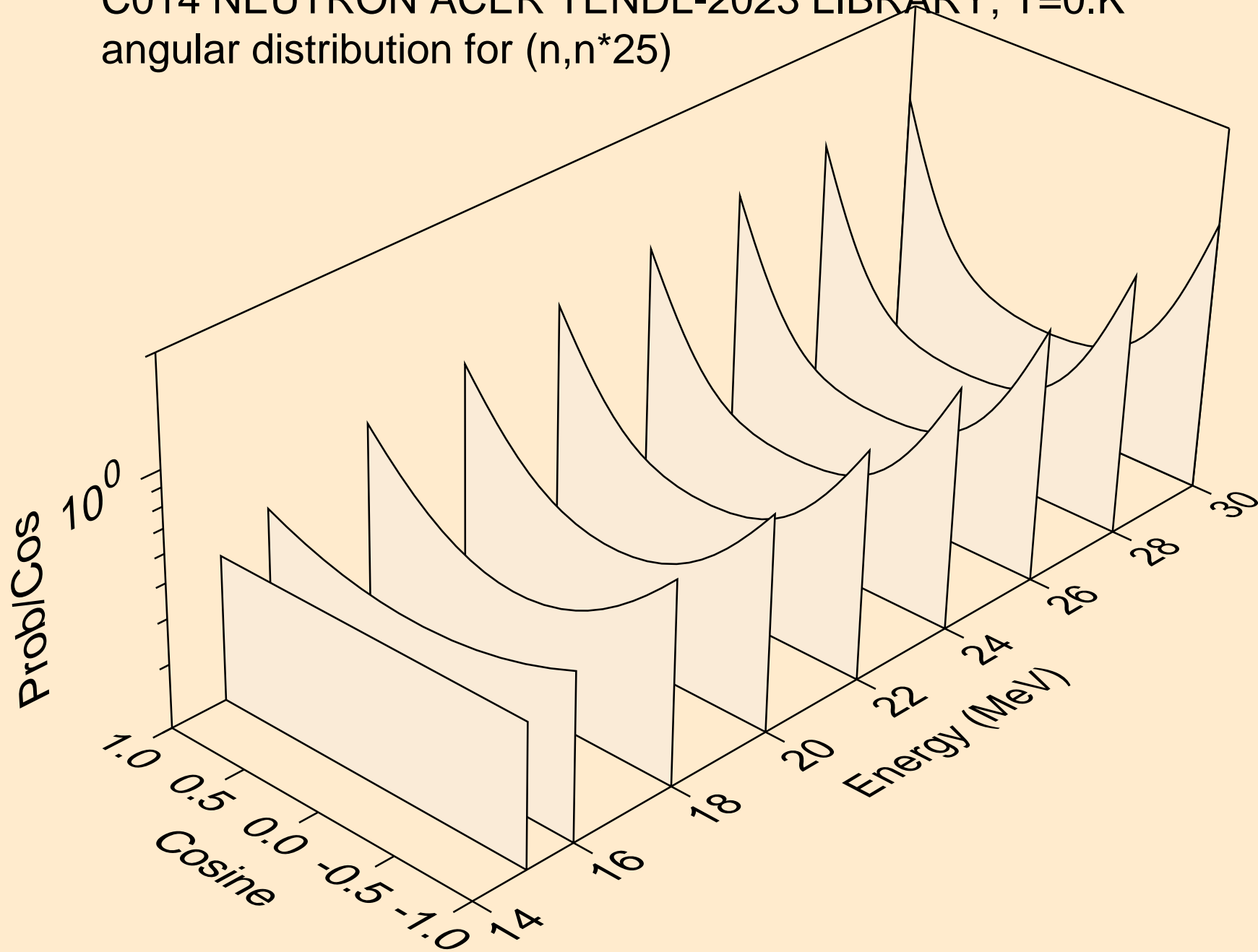

C014 NEUTRON ACER TENDL-2023 LIBRARY; T=0.K  
angular distribution for (n,n\*26)

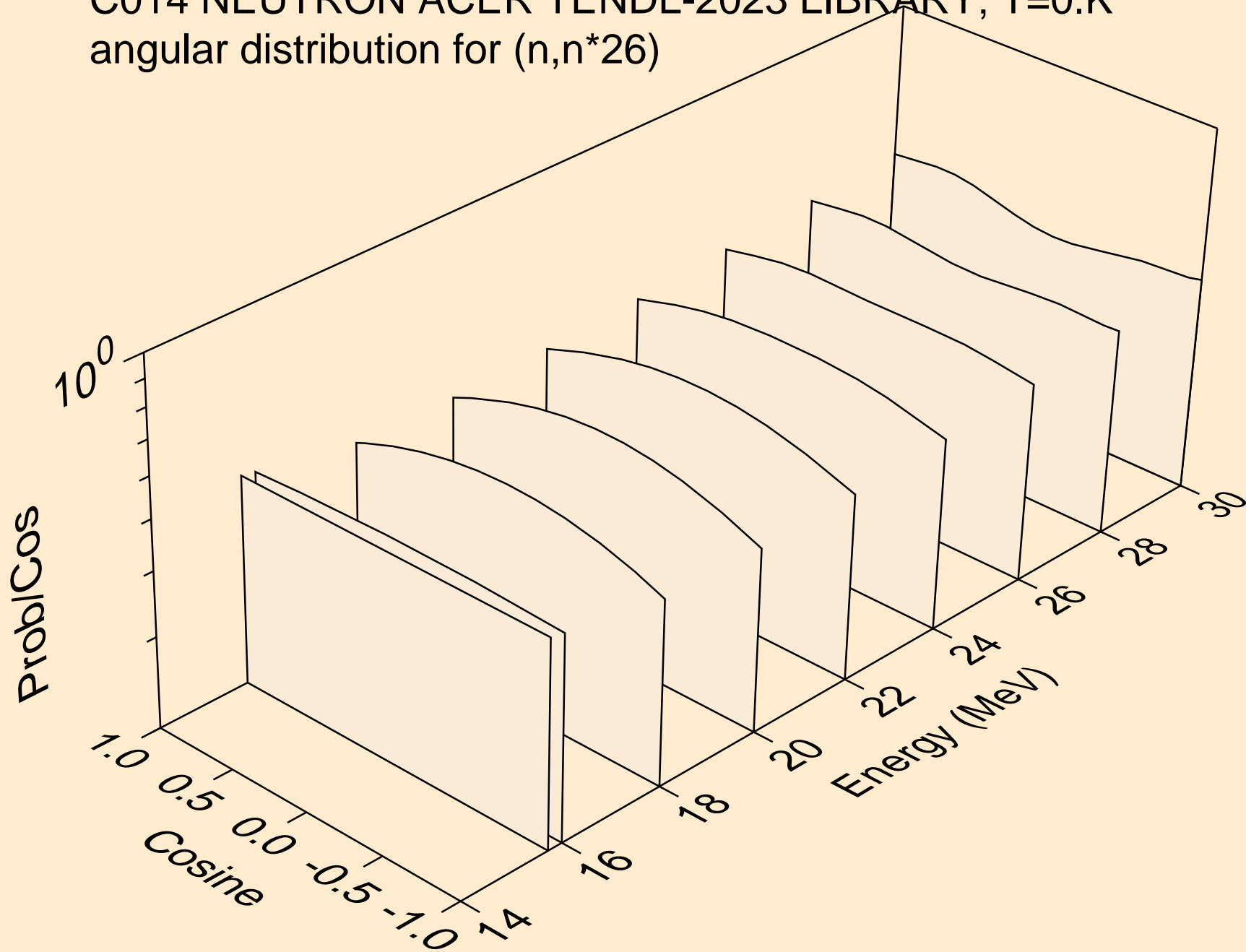

C014 NEUTRON ACER TENDL-2023 LIBRARY; T=0.K  
Neutron emission for (n,x)

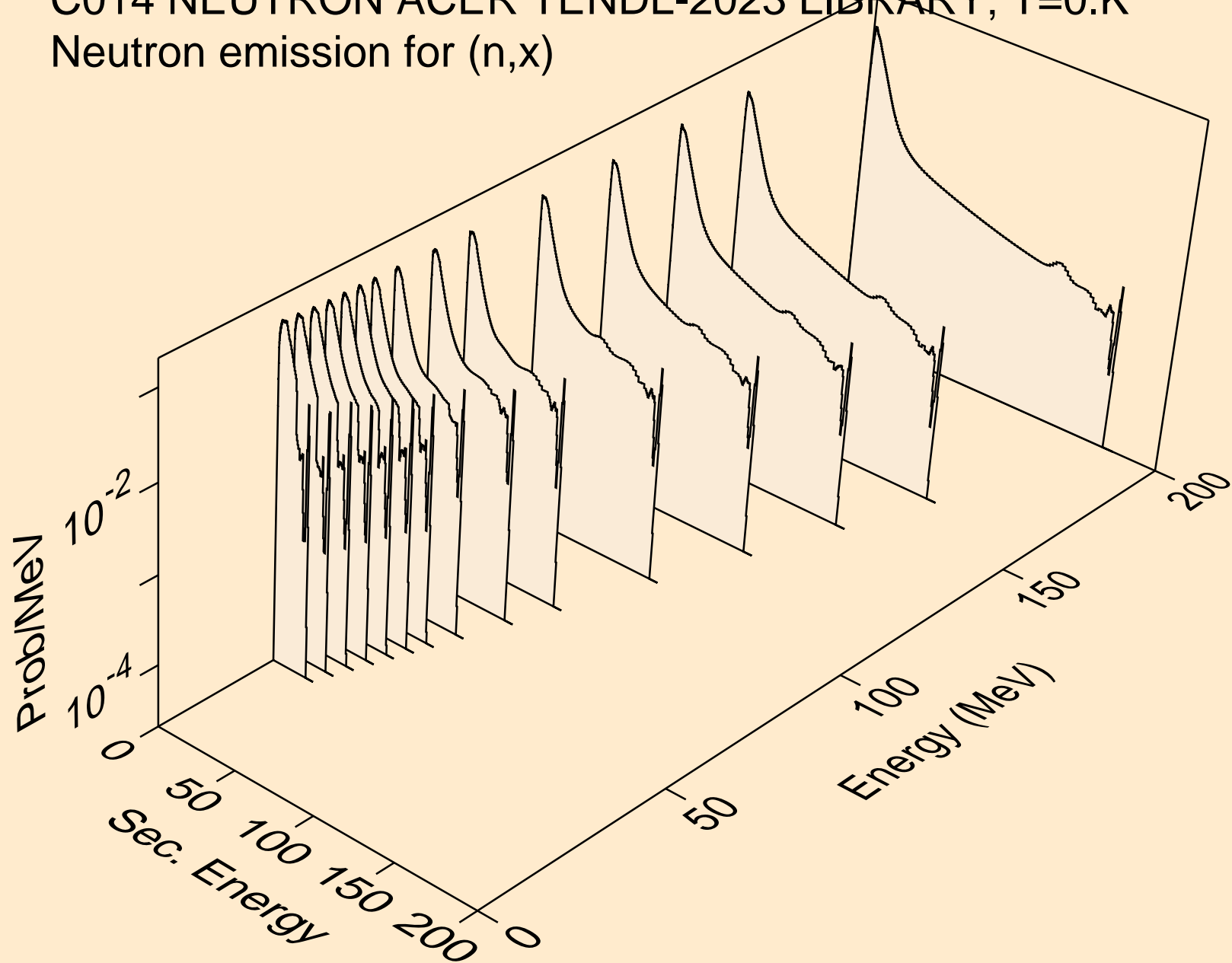



C014 NEUTRON ACER TENDL-2023 LIBRARY; T=0.K  
Neutron emission for (n,2nd)

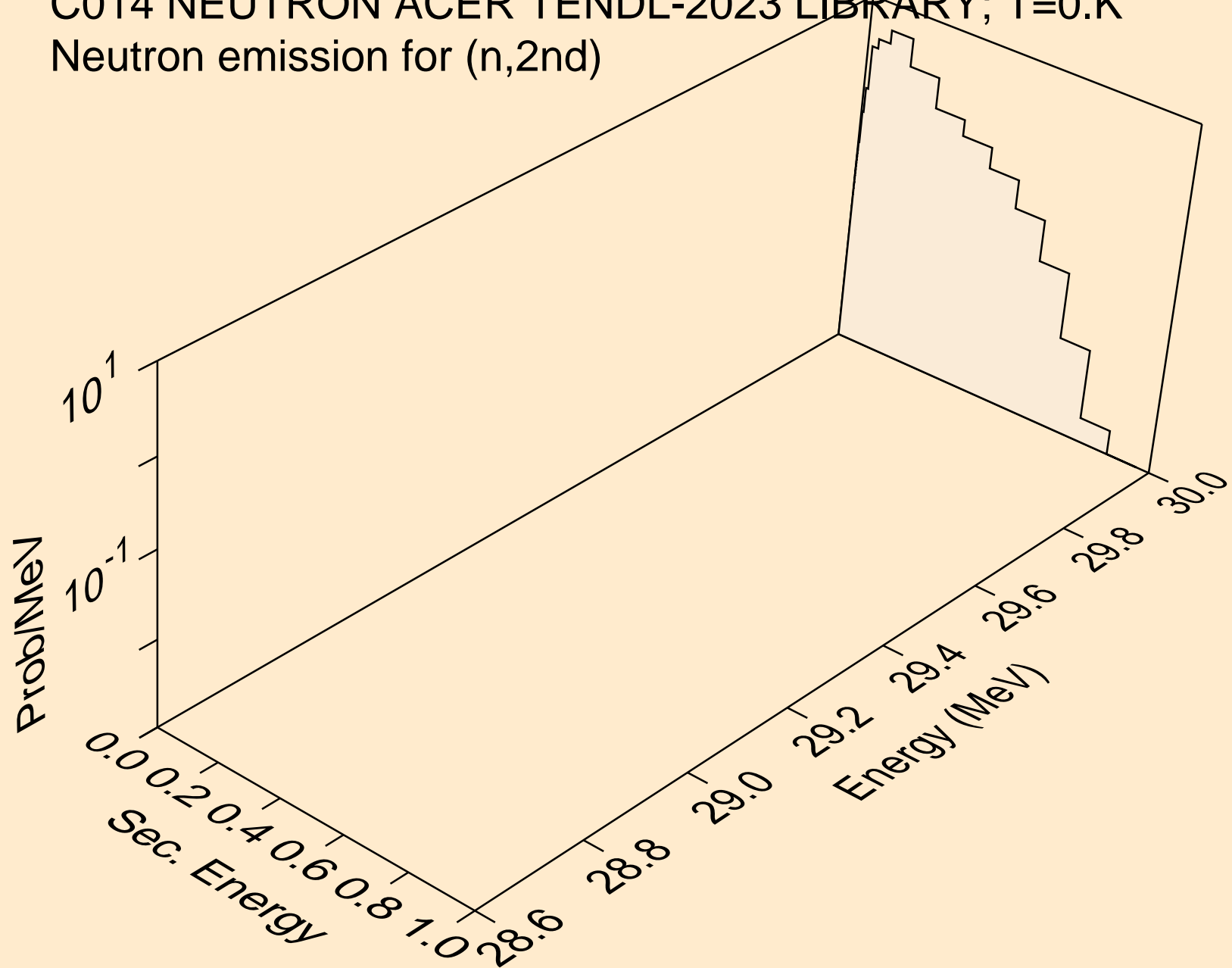

C014 NEUTRON ACER TENDL-2023 LIBRARY; T=0.K  
Neutron emission for (n,2n)

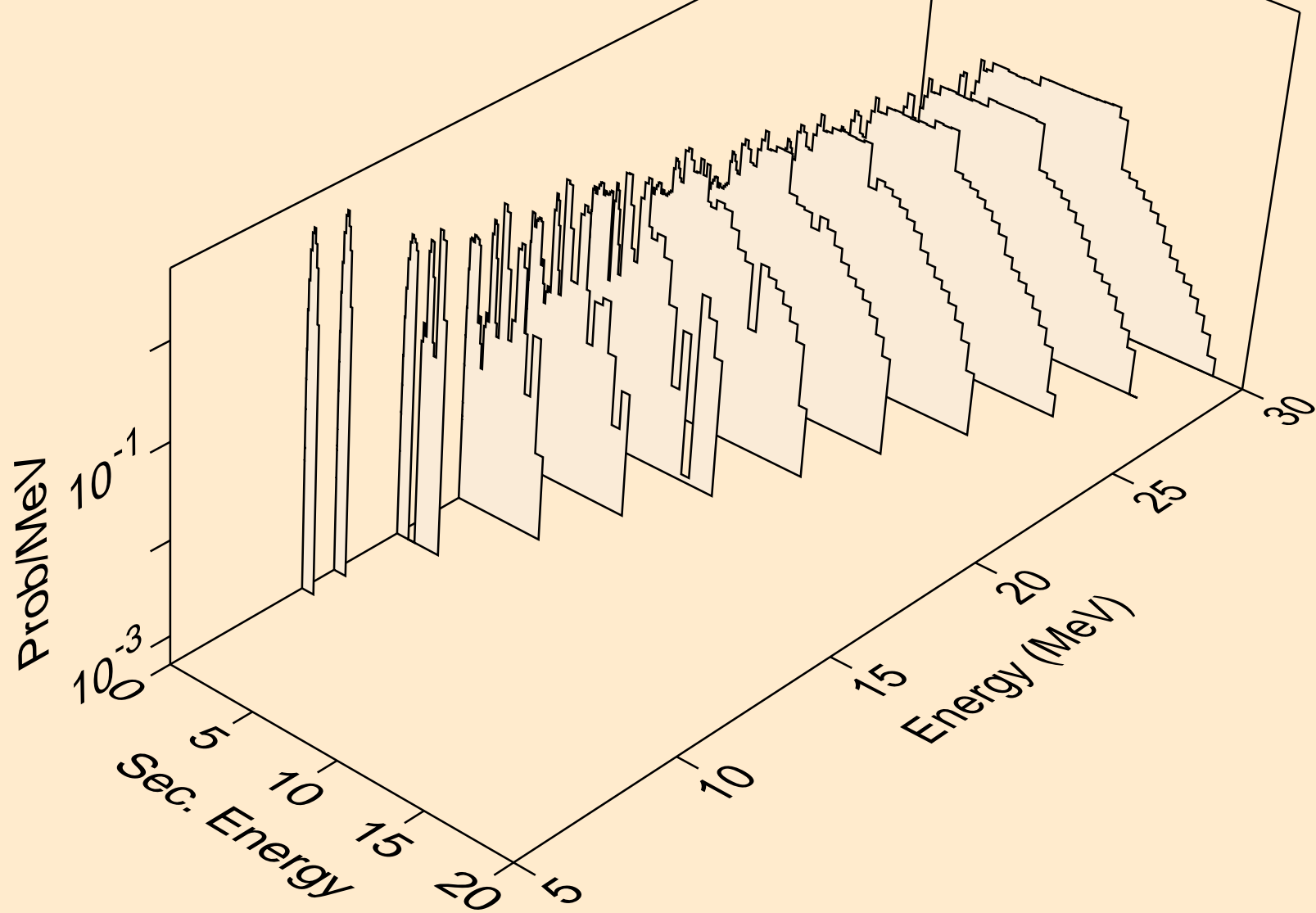

C014 NEUTRON ACER TENDL-2023 LIBRARY; T=0.K  
Neutron emission for (n,3n)

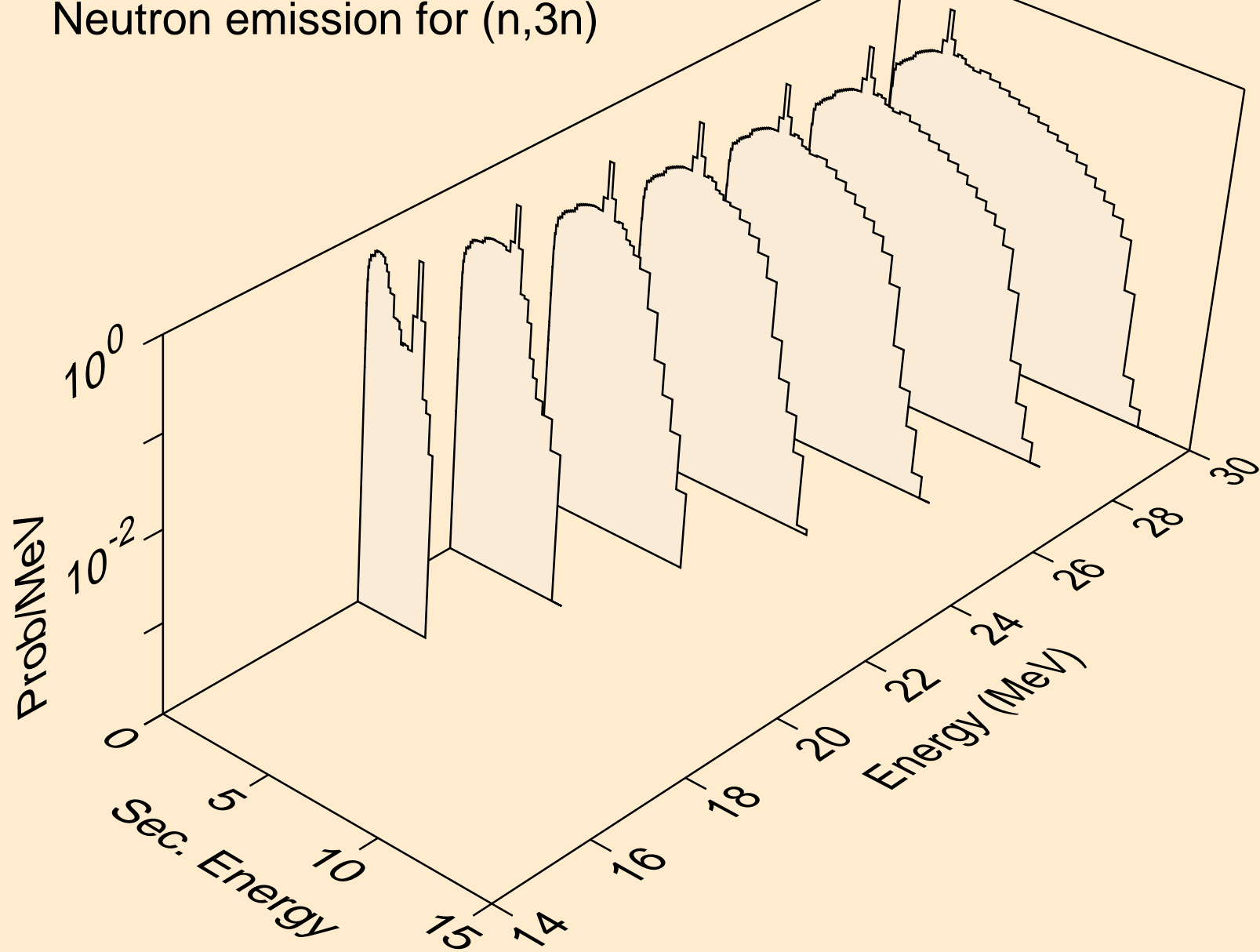

C014 NEUTRON ACER TENDL-2023 LIBRARY; T=0.K  
Neutron emission for (n,n\*)a

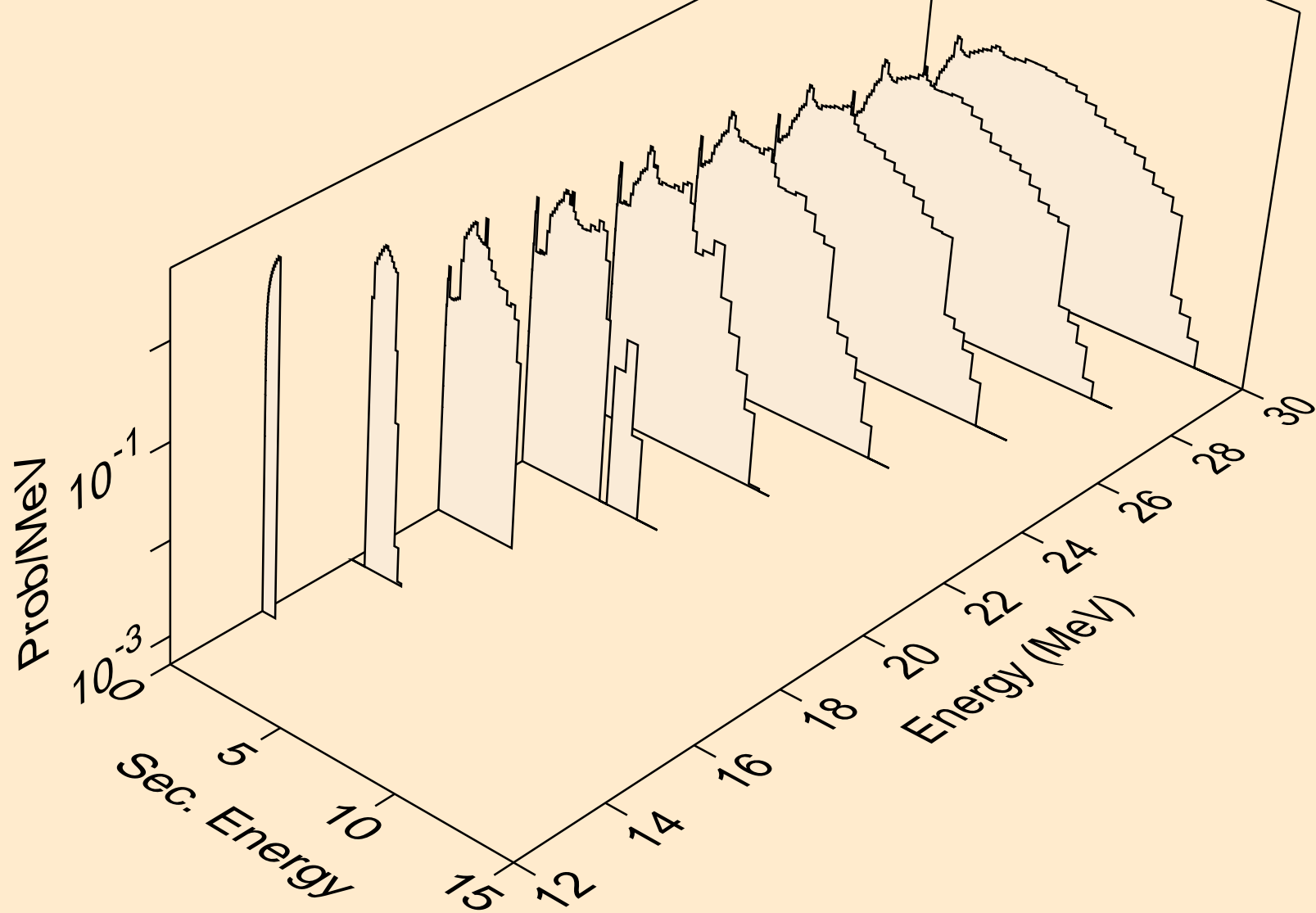

C014 NEUTRON ACER TENDL-2023 LIBRARY; T=0.K  
Neutron emission for (n,2n)a

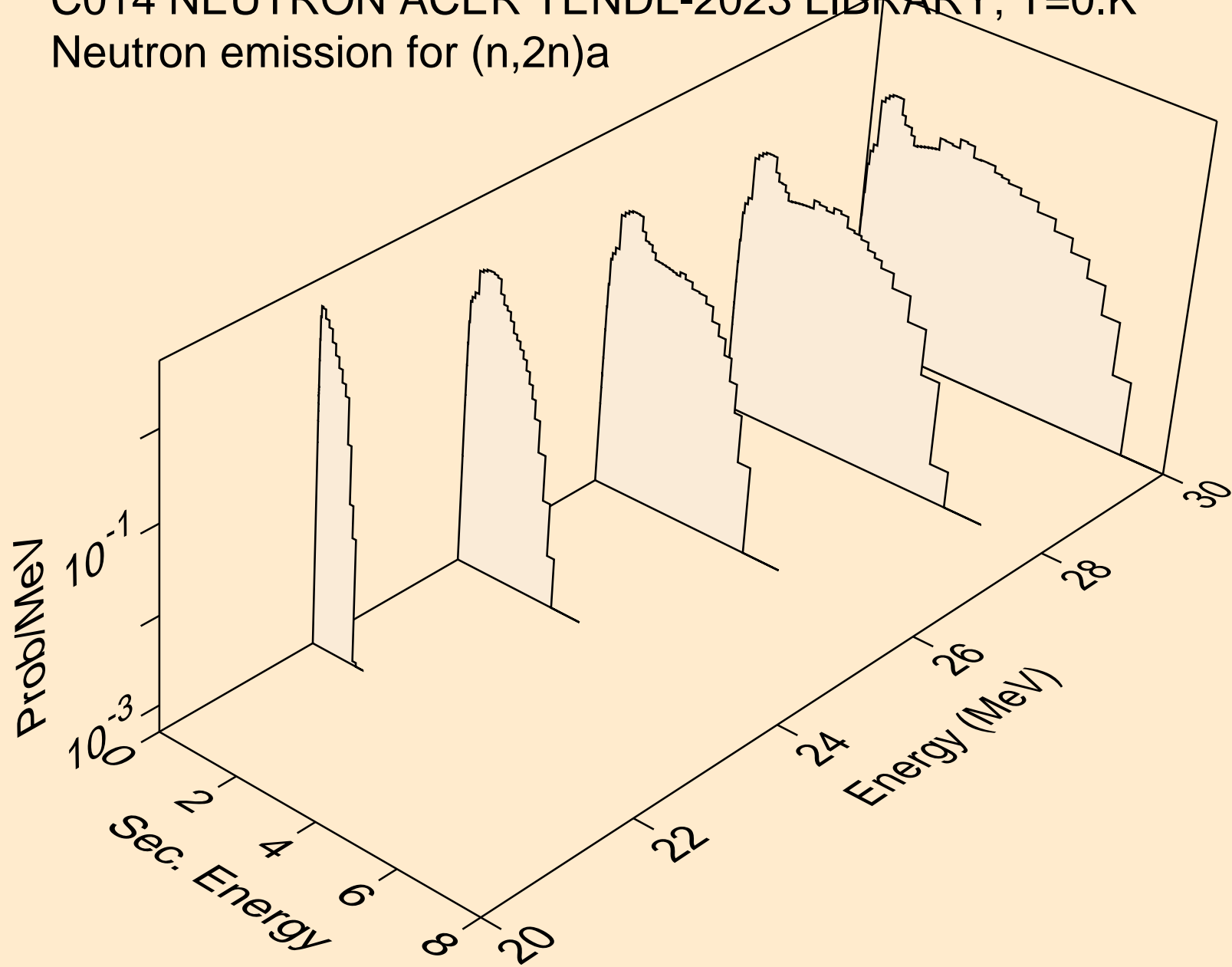

C014 NEUTRON ACER TENDL-2023 LIBRARY; T=0.K  
Neutron emission for (n,3n)a

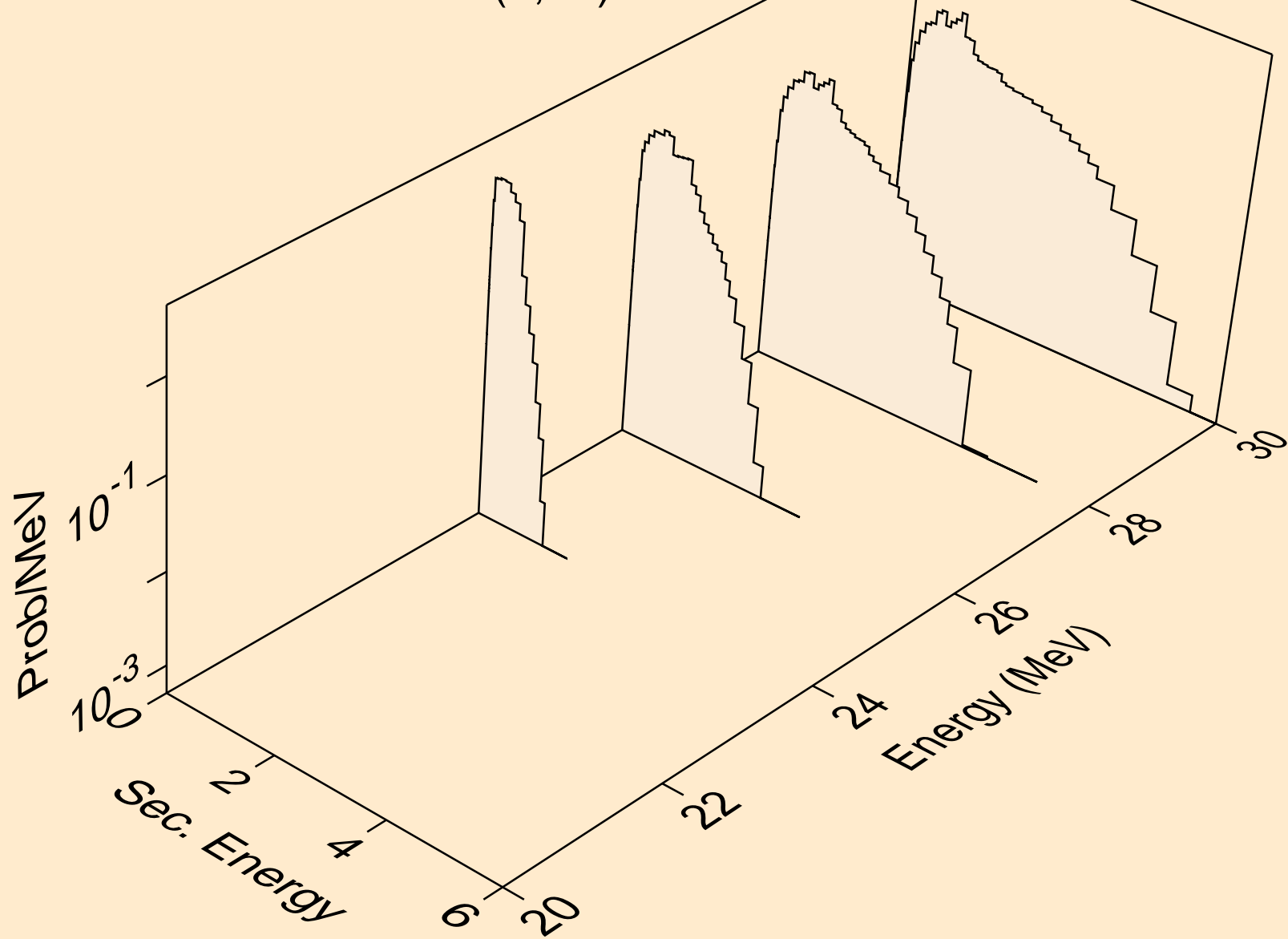

C014 NEUTRON ACER TENDL-2023 LIBRARY; T=0.K  
Neutron emission for (n,n\*)p

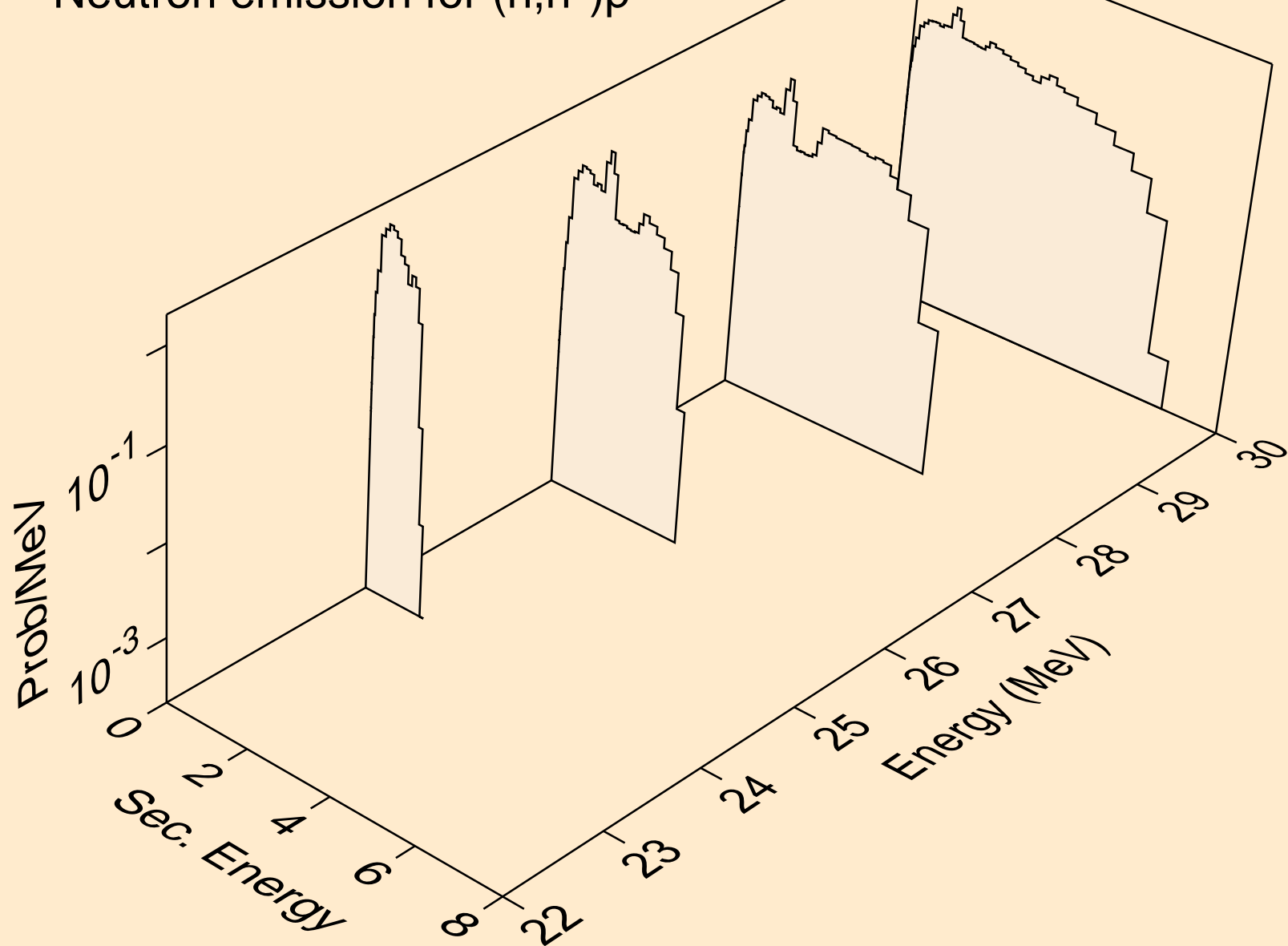

C014 NEUTRON ACER TENDL-2023 LIBRARY; T=0.K  
Neutron emission for (n,n\*)d

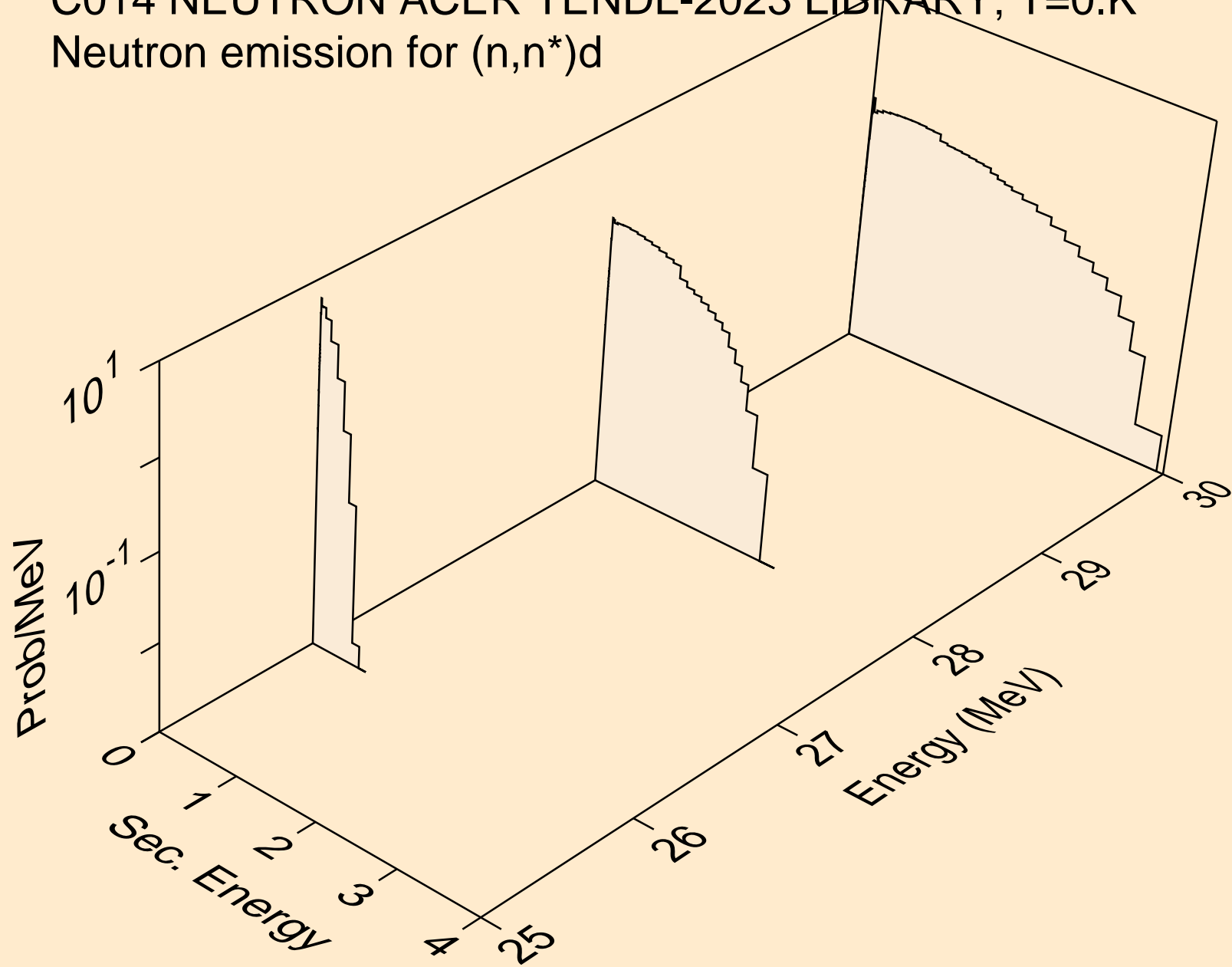



C014 NEUTRON ACER TENDL-2023 LIBRARY; T=0.K  
Neutron emission for (n,n\*)t

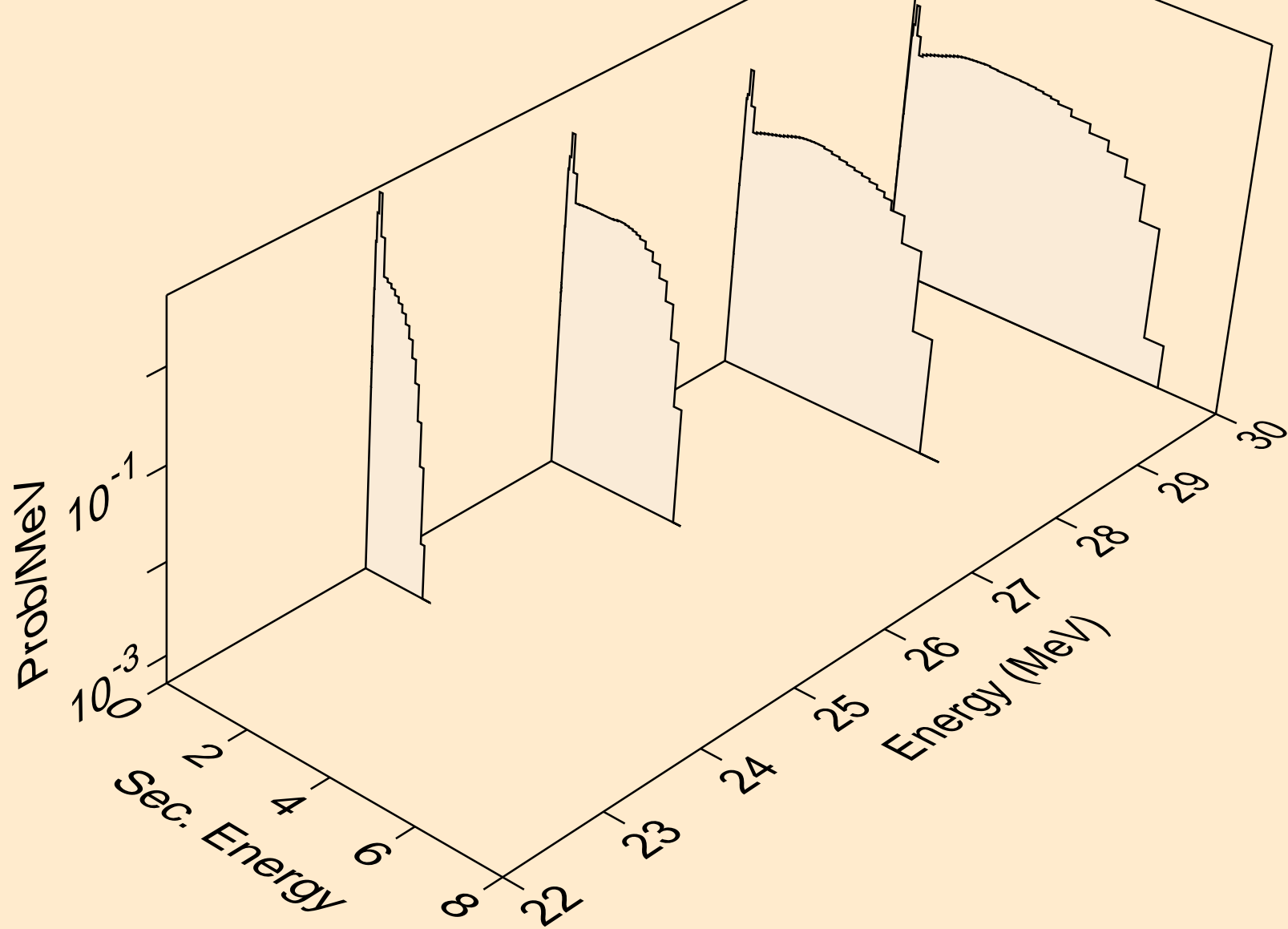

C014 NEUTRON ACER TENDL-2023 LIBRARY; T=0.K  
Neutron emission for (n,2np)

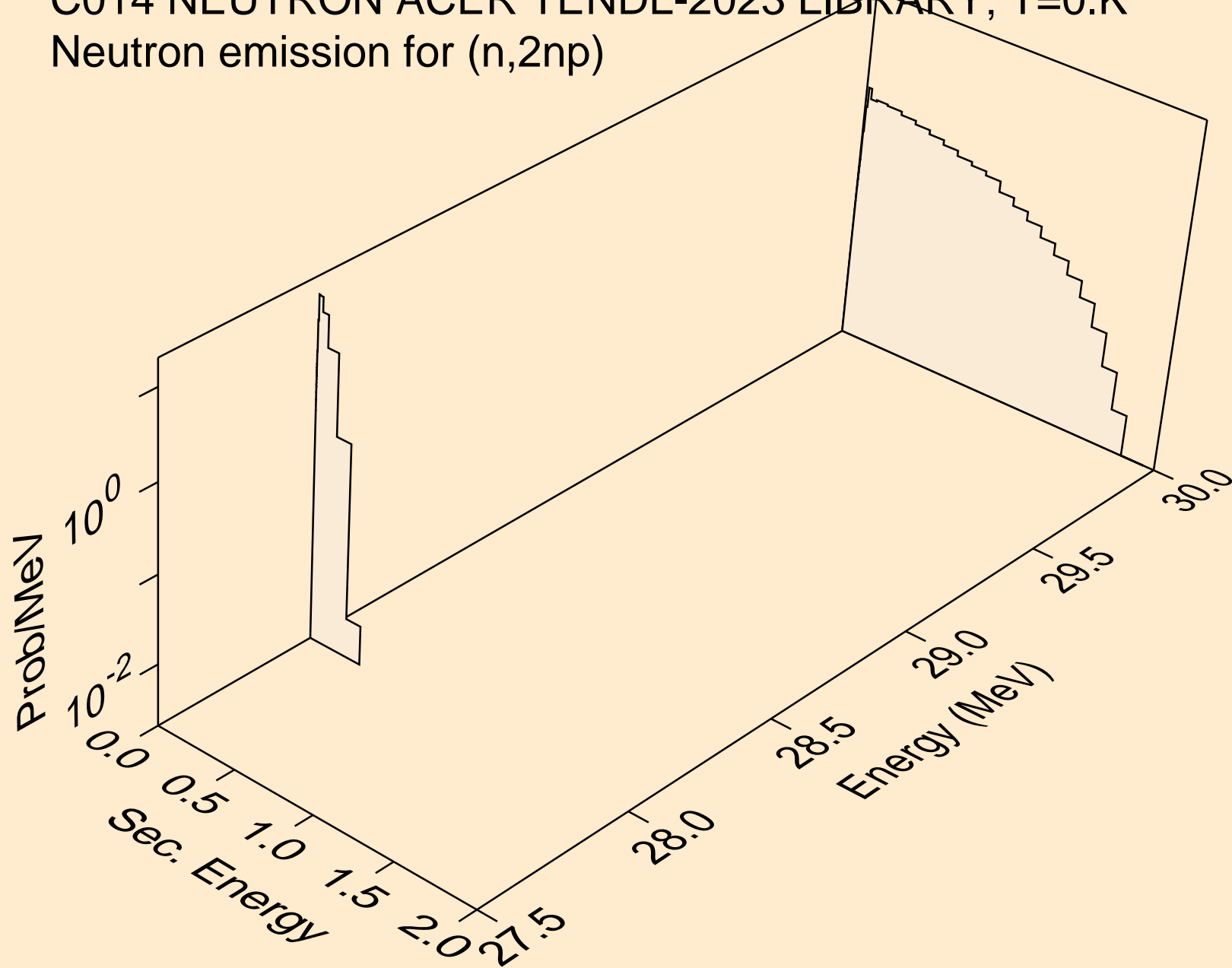

C014 NEUTRON ACER TENDL-2023 LIBRARY; T=0.K  
Photon emission for (n,x)

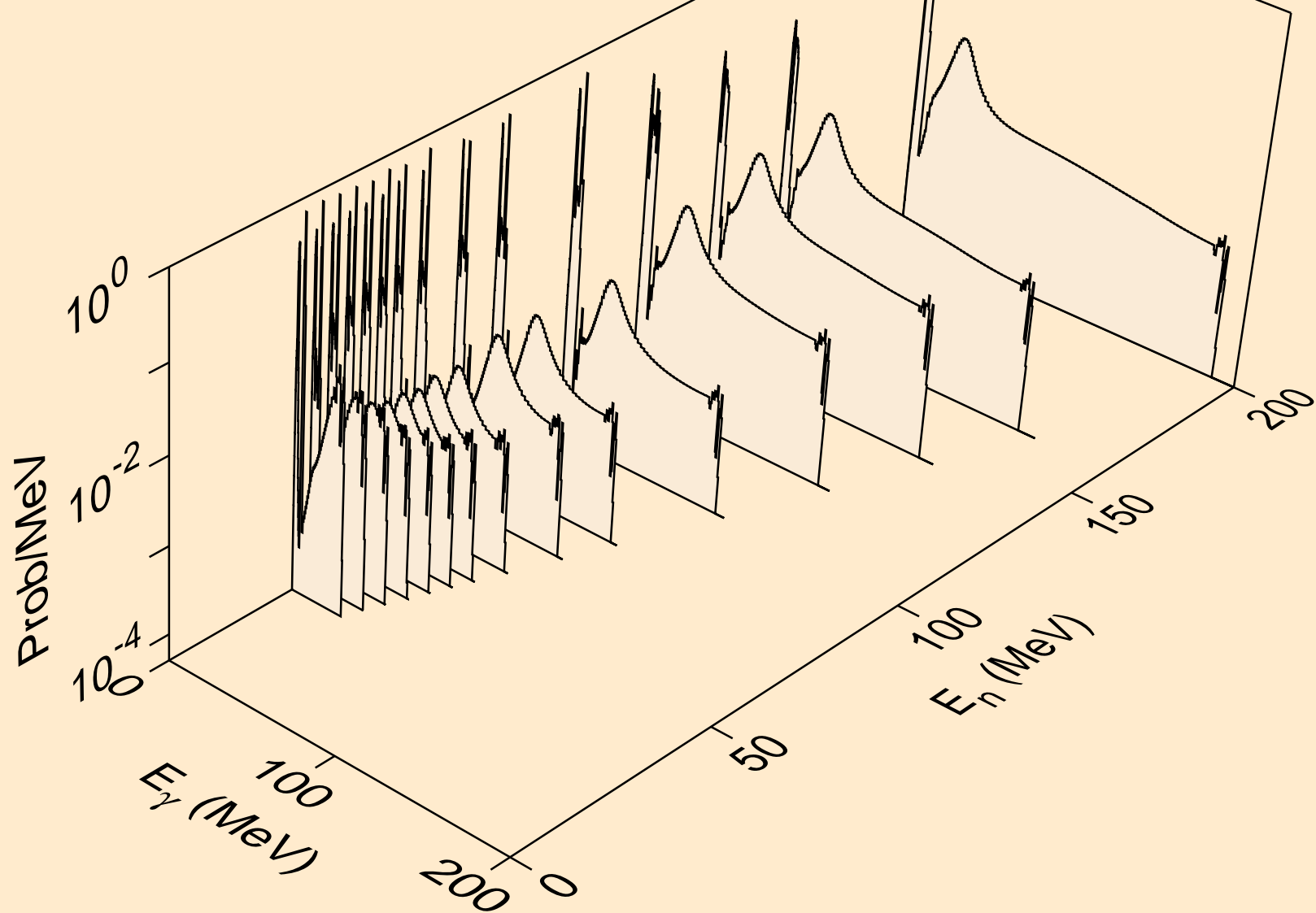

C014 NEUTRON ACER TENDL-2023 LIBRARY; T=0.K  
Photon emission for (n,2nd)

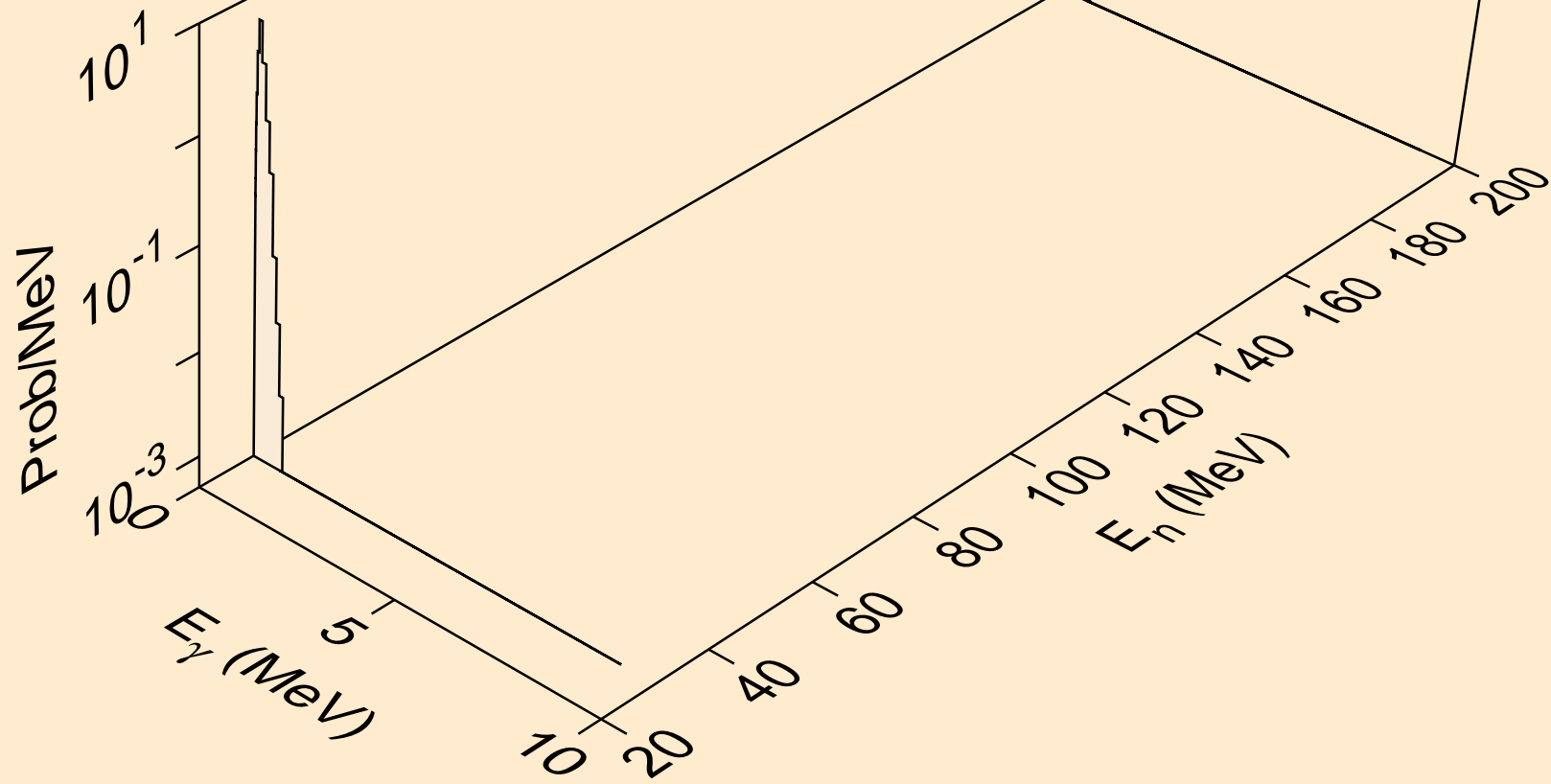

C014 NEUTRON ACER TENDL-2023 LIBRARY; T=0.K  
Photon emission for (n,2n)

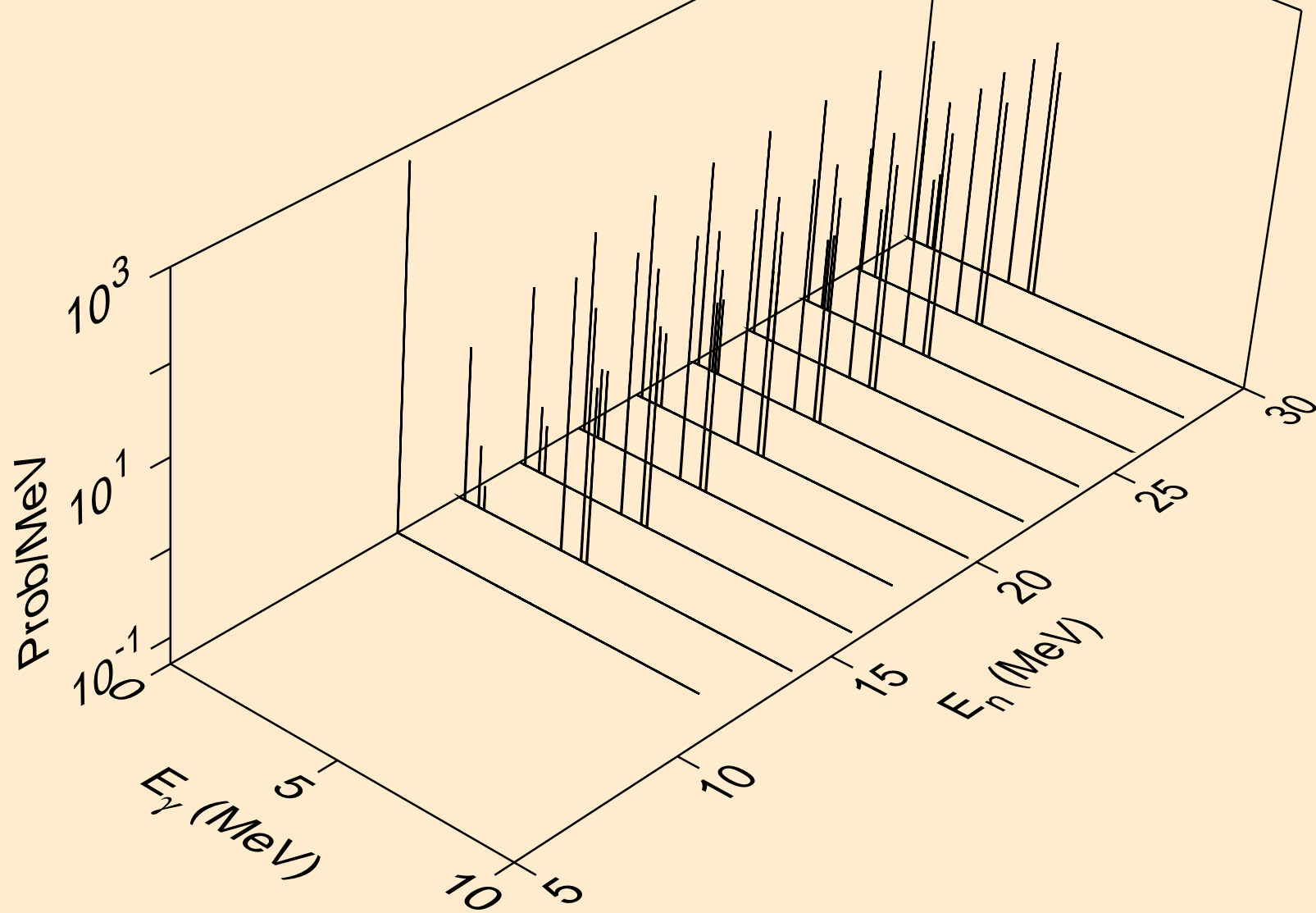

C014 NEUTRON ACER TENDL-2023 LIBRARY; T=0.K  
Photon emission for (n,3n)

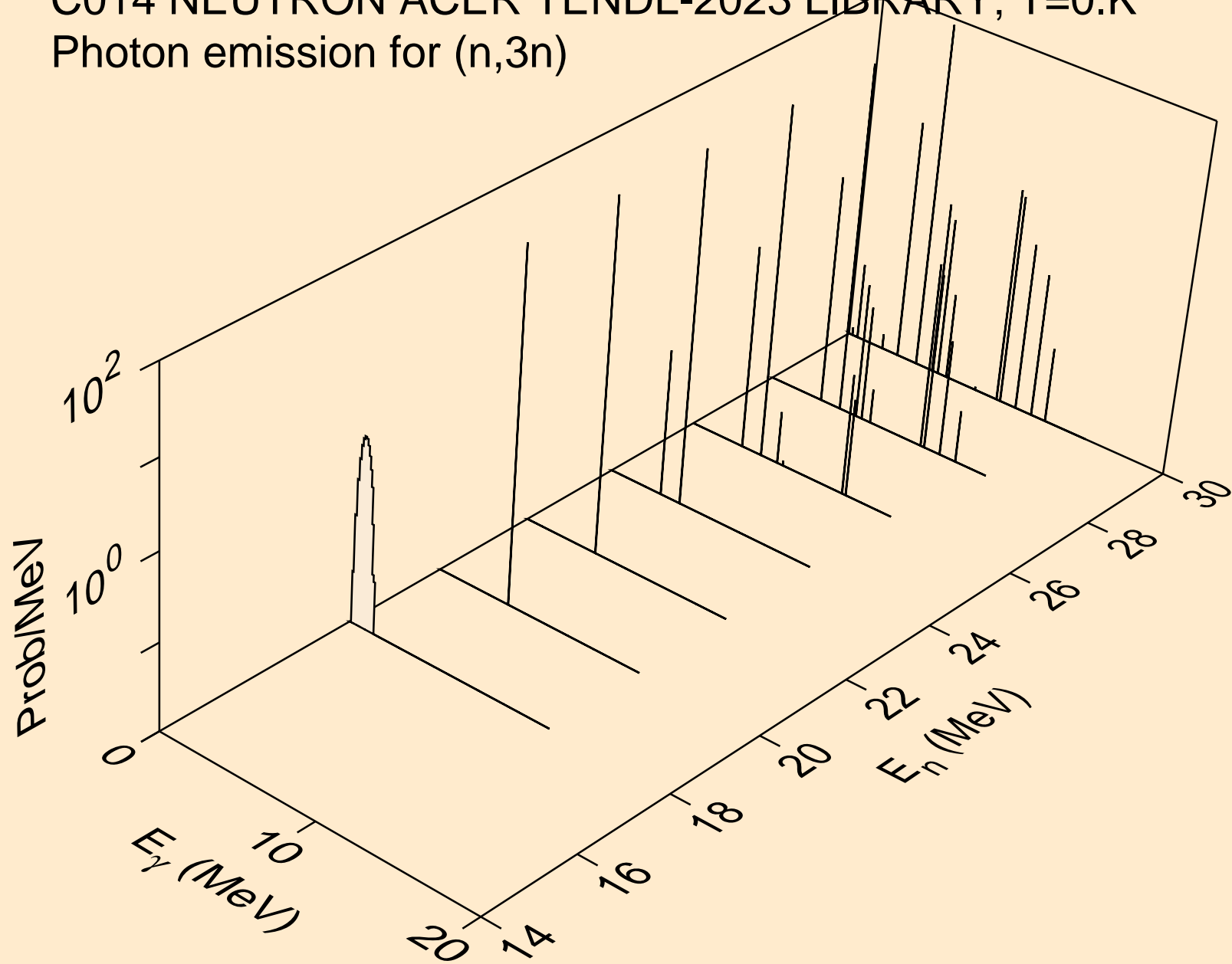

C014 NEUTRON ACER TENDL-2023 LIBRARY; T=0.K  
Photon emission for (n,n\*)a

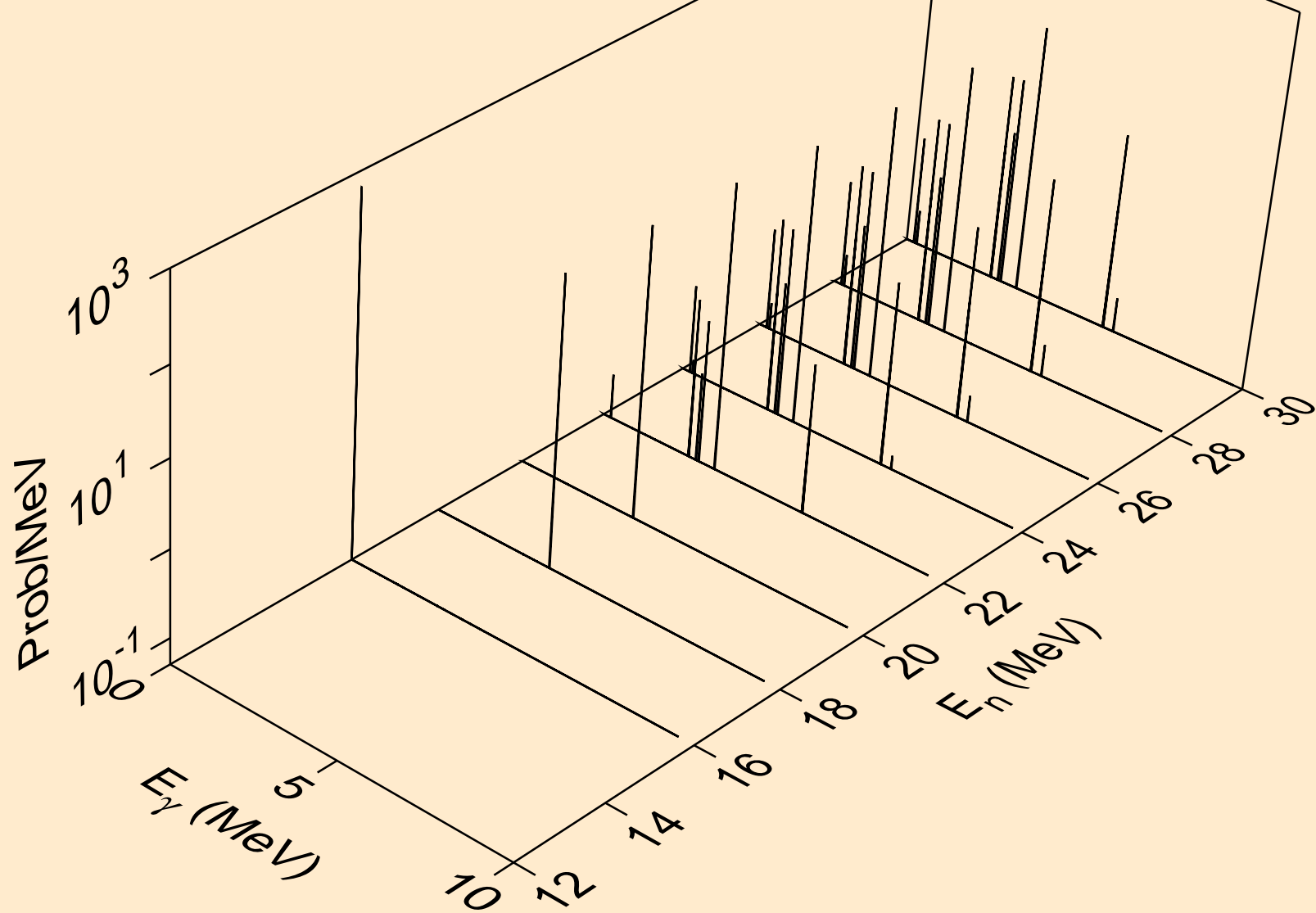

C014 NEUTRON ACER TENDL-2023 LIBRARY; T=0.K  
Photon emission for (n,2n)a

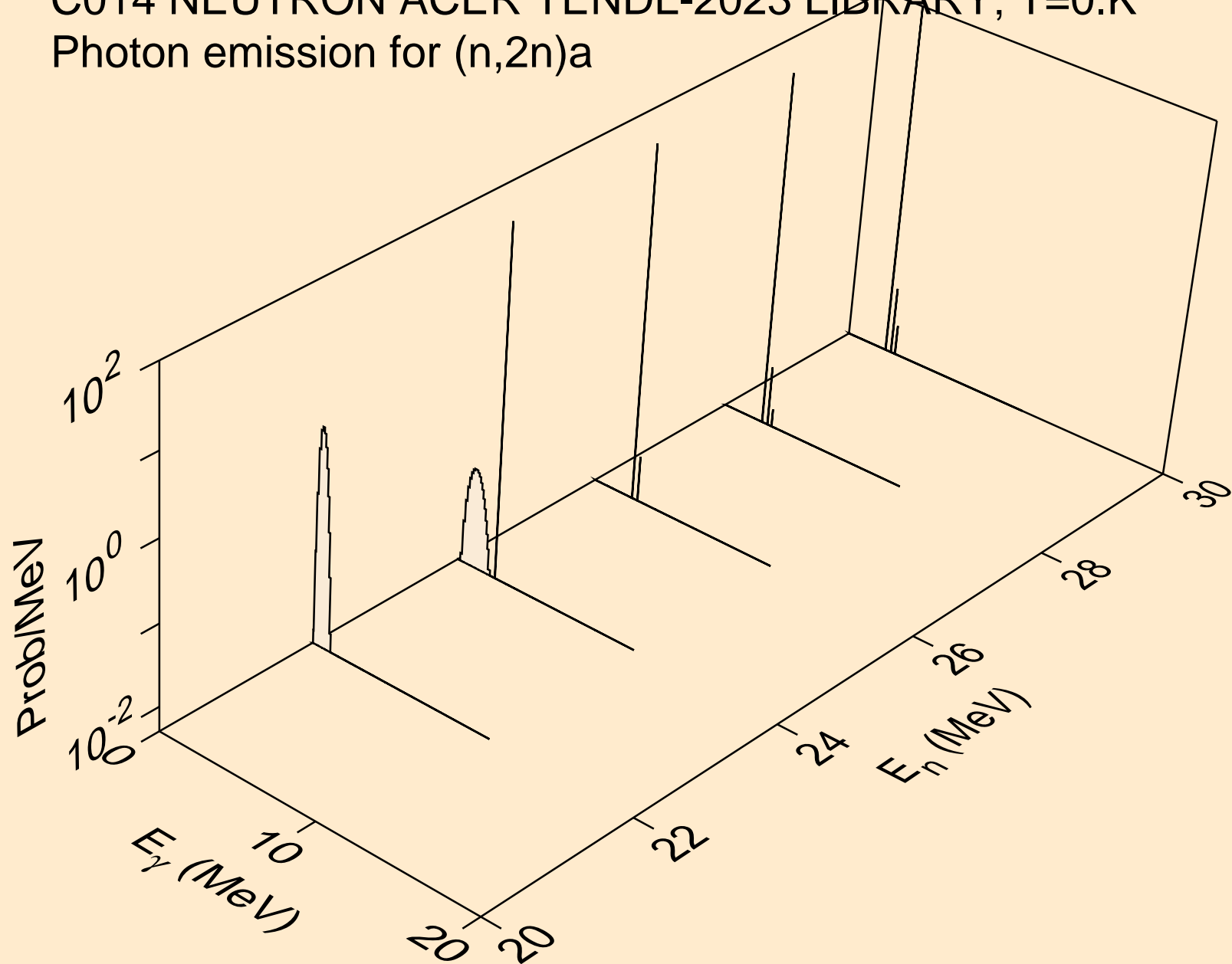



C014 NEUTRON ACER TENDL-2023 LIBRARY; T=0.K  
Photon emission for (n,3n)a

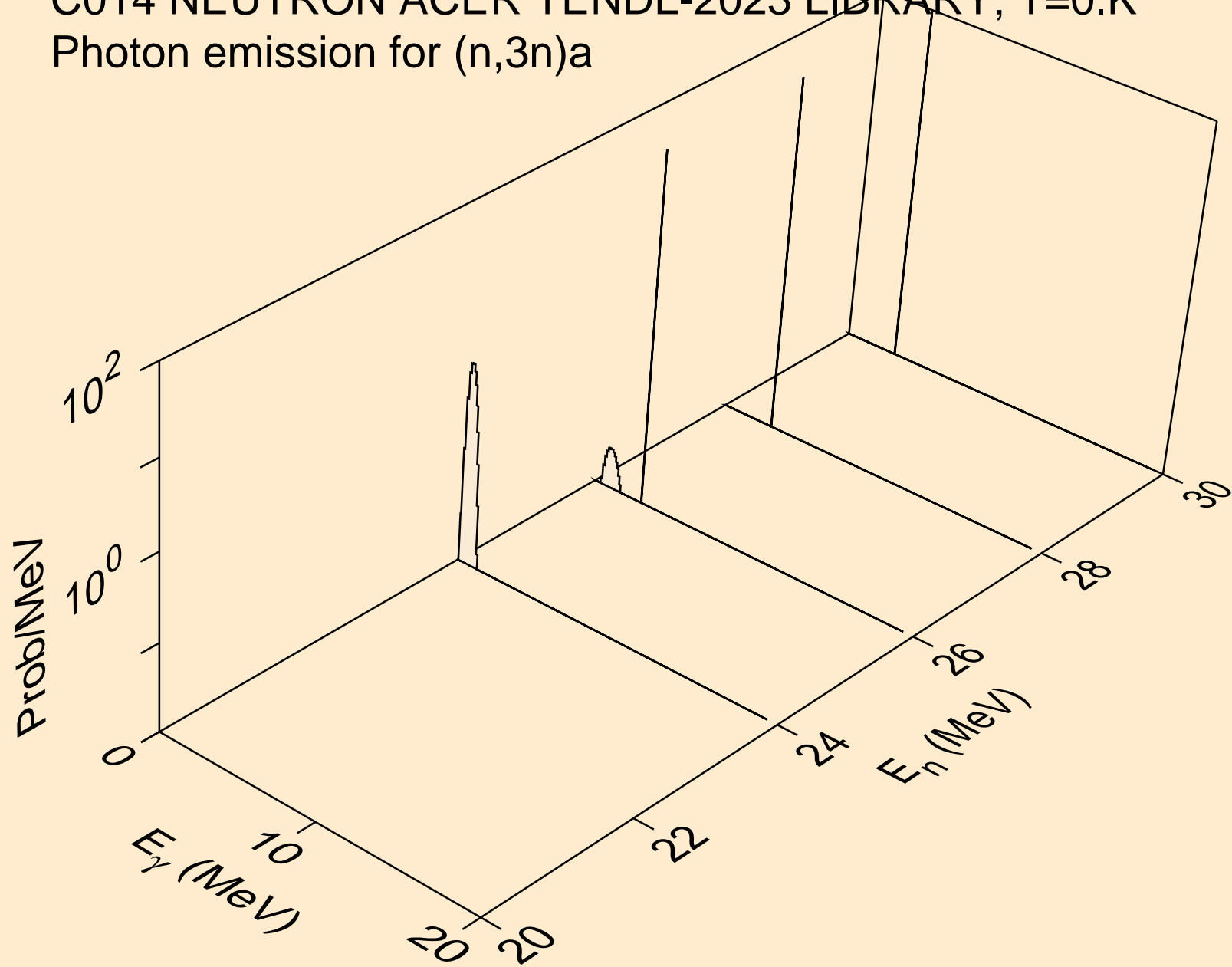

C014 NEUTRON ACER TENDL-2023 LIBRARY; T=0.K  
Photon emission for (n,n\*)p

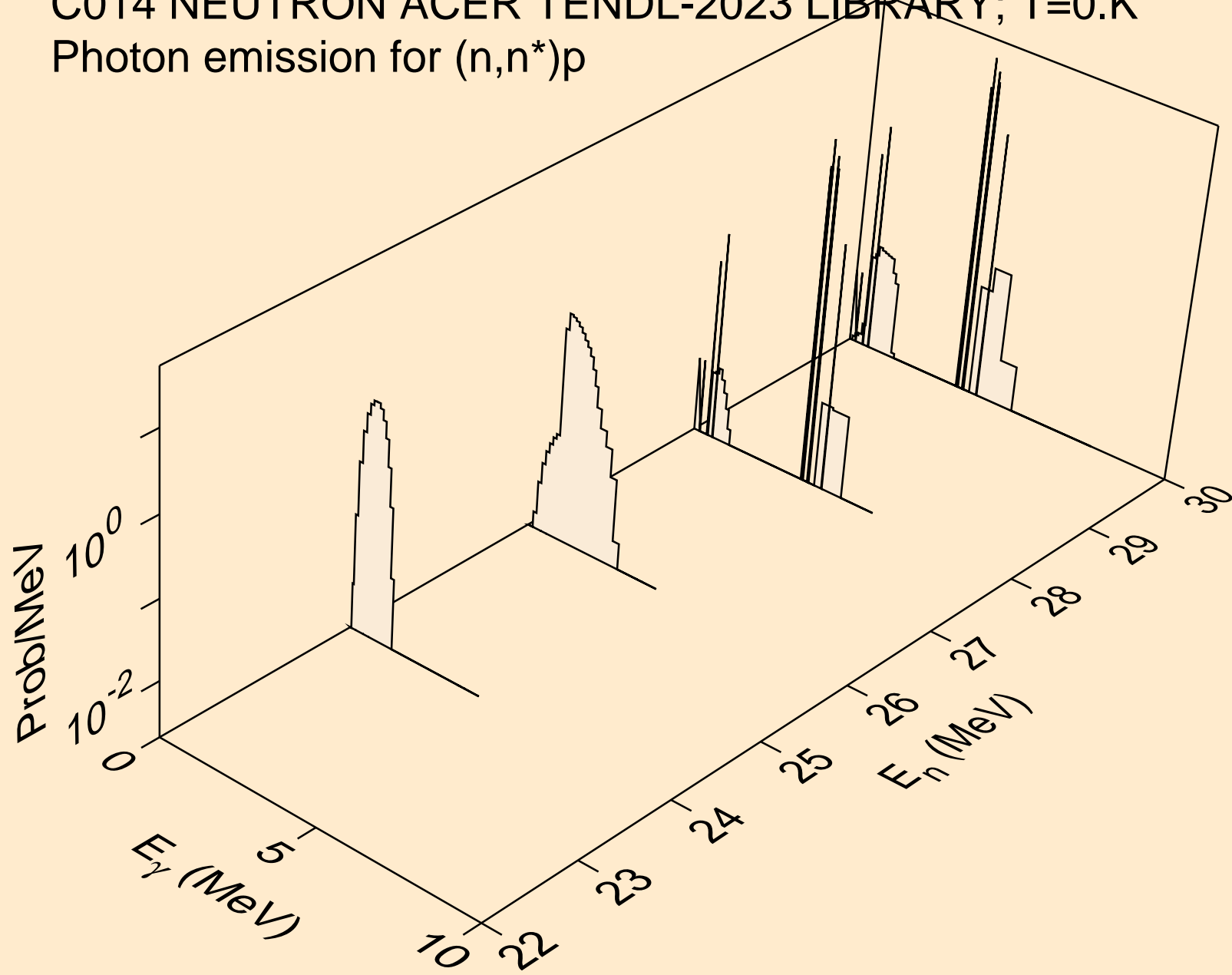

C014 NEUTRON ACER TENDL-2023 LIBRARY; T=0.K  
Photon emission for (n,n\*)d

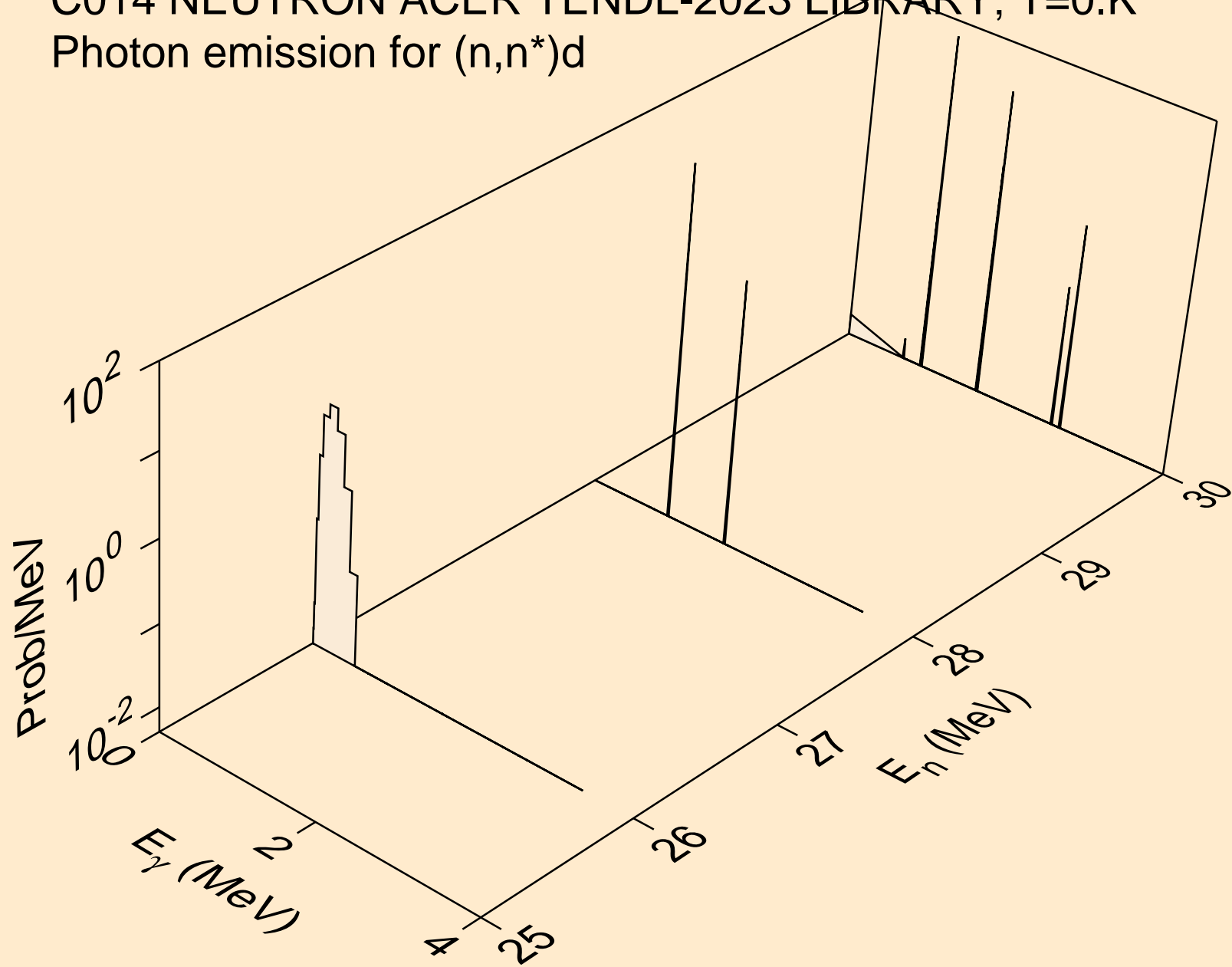

C014 NEUTRON ACER TENDL-2023 LIBRARY; T=0.K  
Photon emission for (n,n\*)t

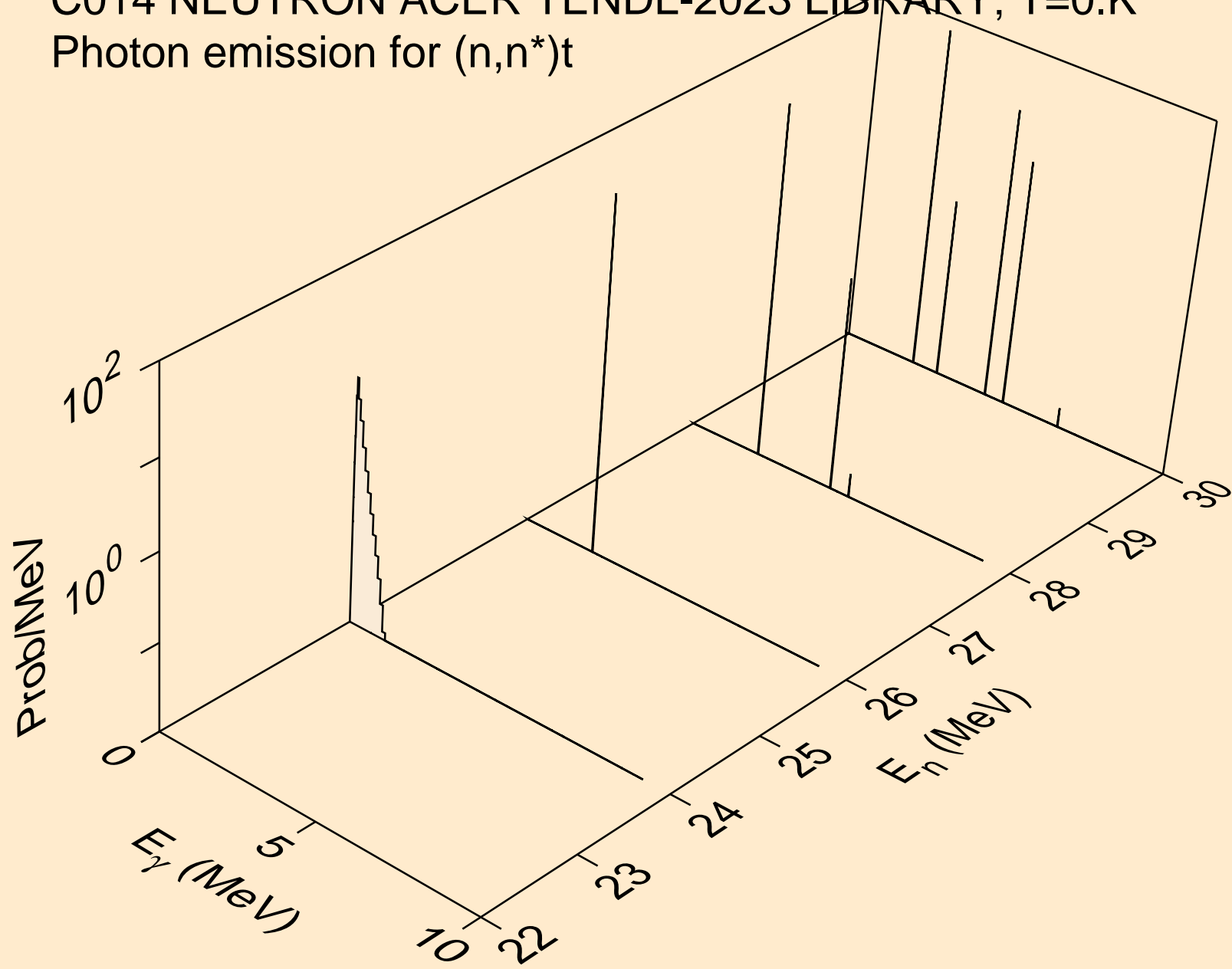

C014 NEUTRON ACER TENDL-2023 LIBRARY; T=0.K  
Photon emission for (n,2np)

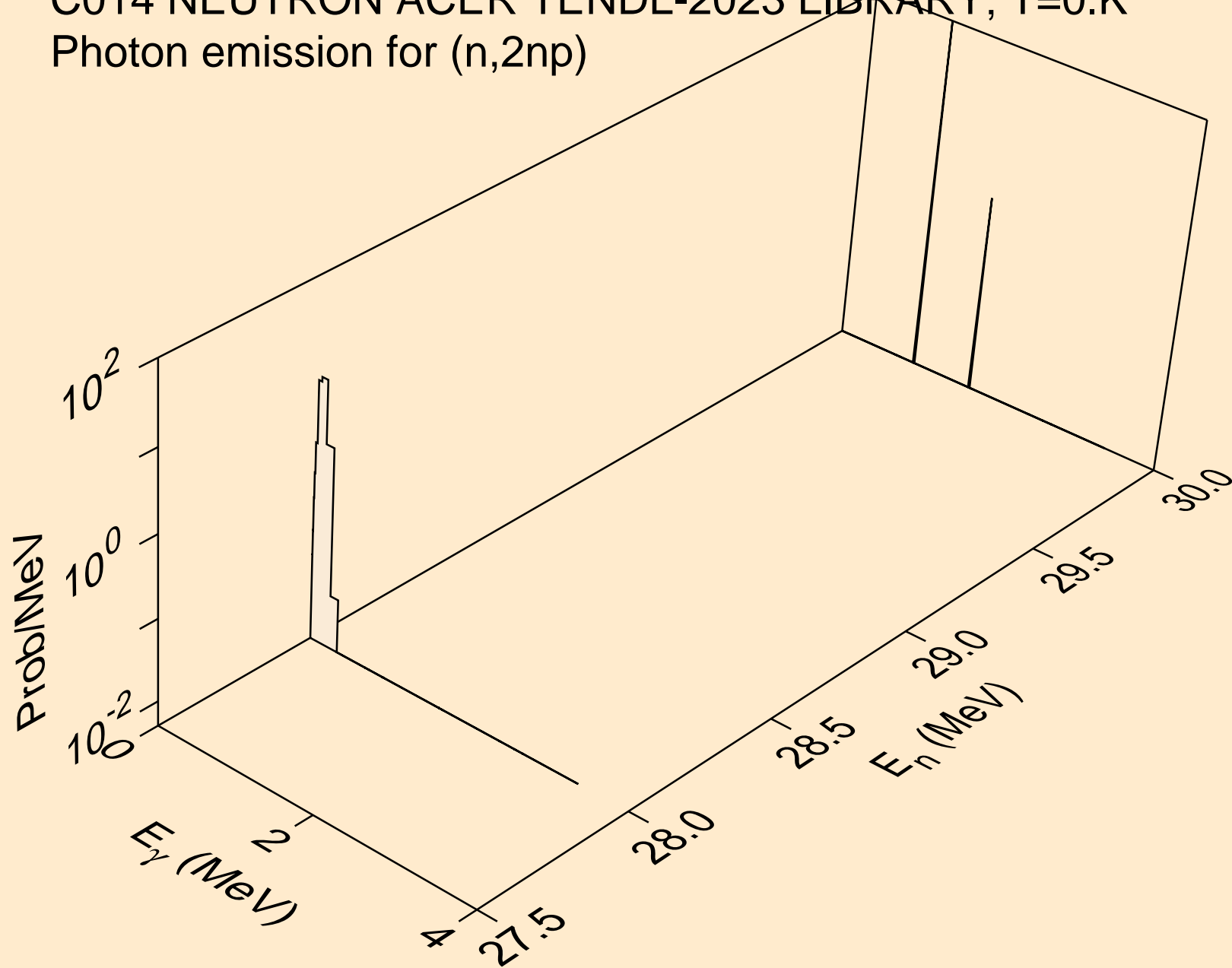

C014 NEUTRON ACER TENDL-2023 LIBRARY; T=0.K  
Photon emission for (n,n\*c)

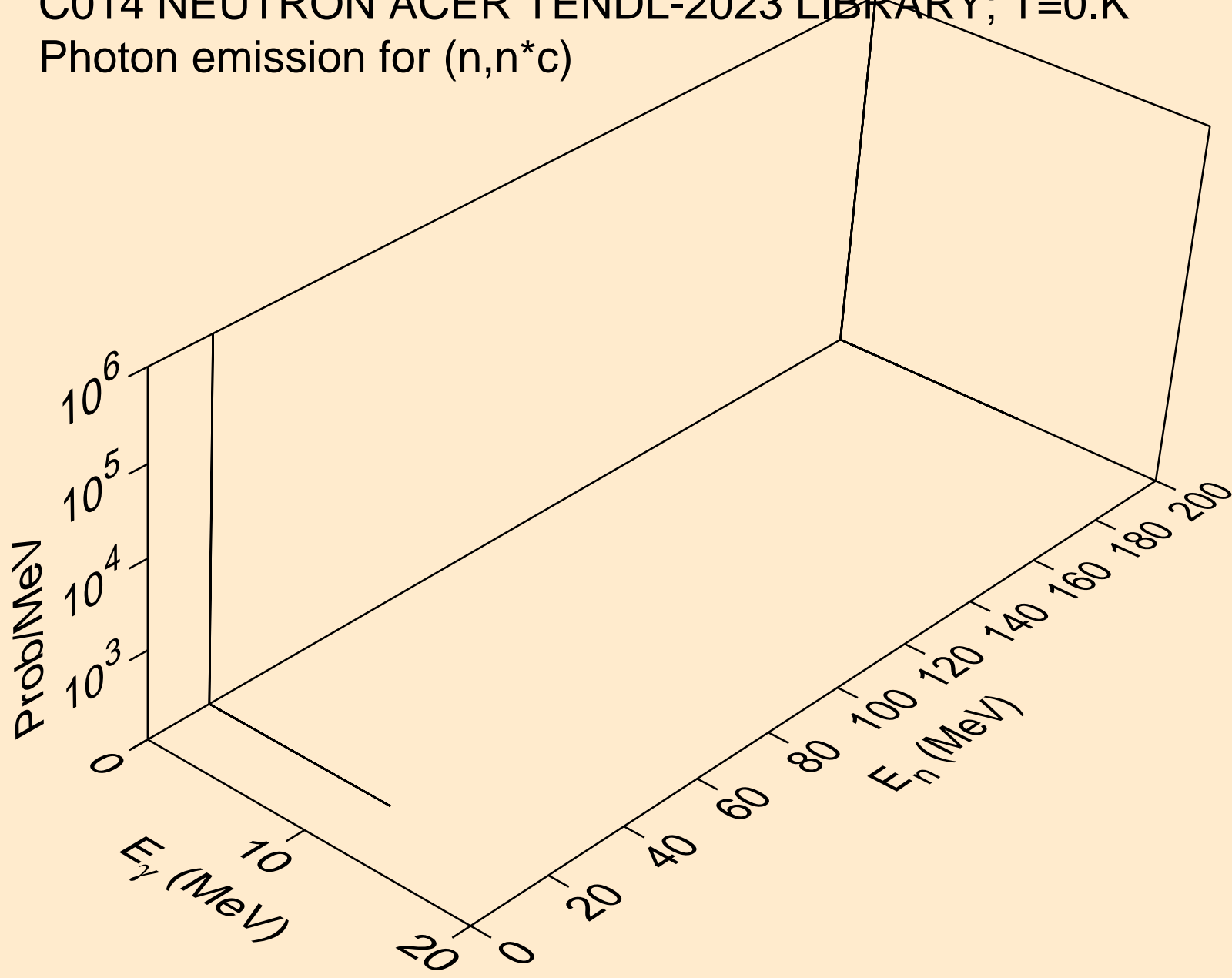

C014 NEUTRON ACER TENDL-2023 LIBRARY; T=0.K  
Photon emission for (n,gma)

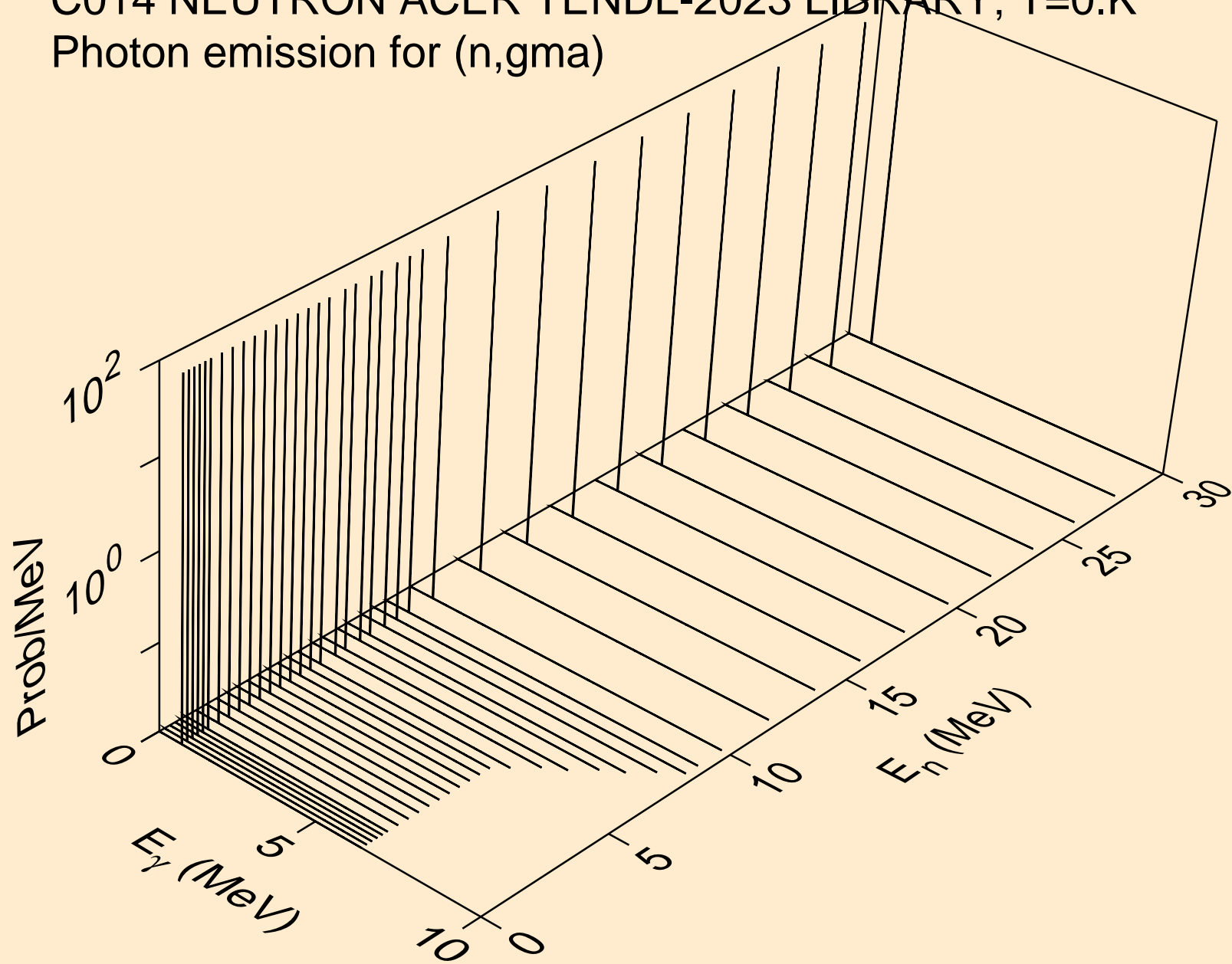

C014 NEUTRON ACER TENDL-2023 LIBRARY; T=0.K  
Photon emission for (n,p)

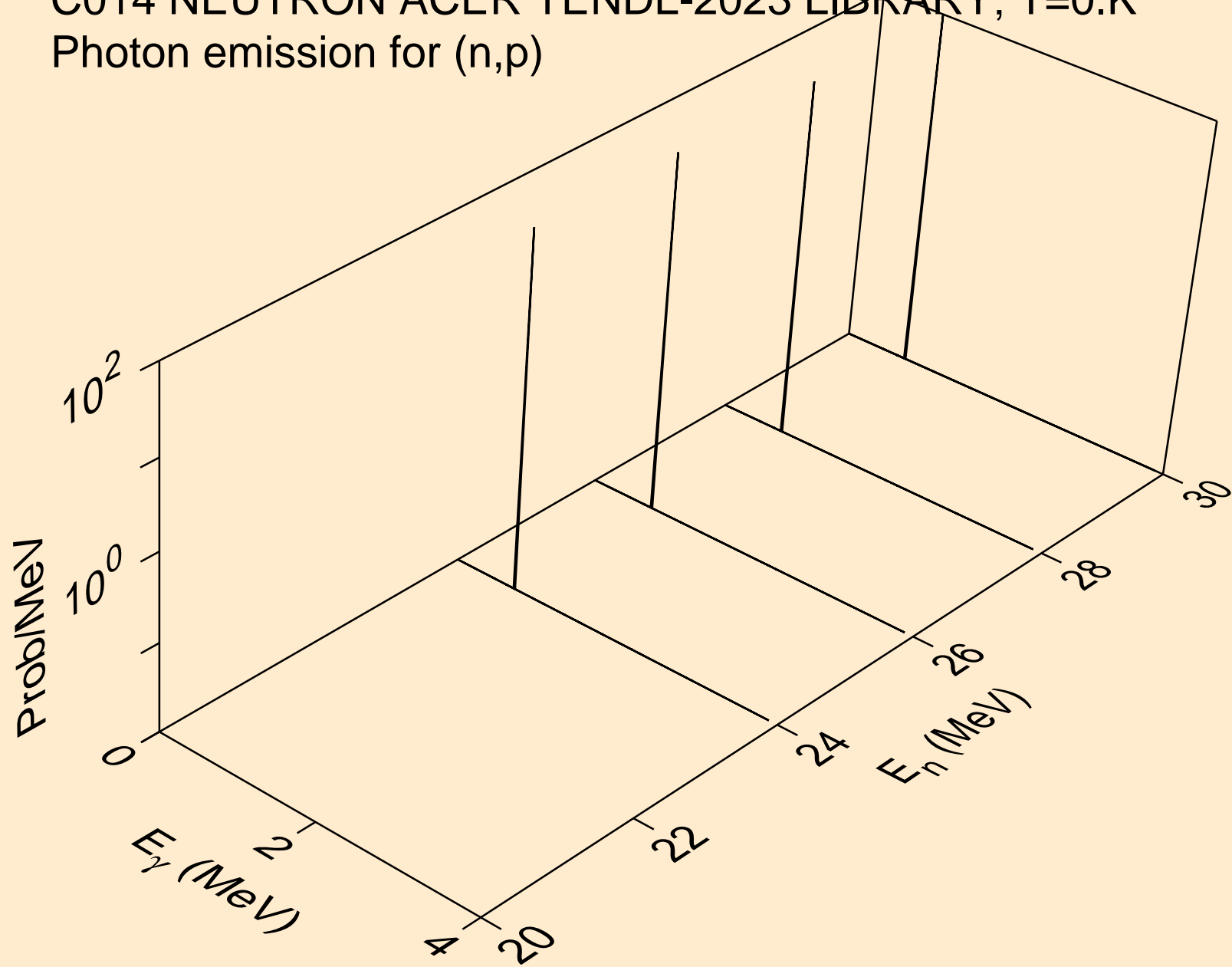



C014 NEUTRON ACER TENDL-2023 LIBRARY; T=0.K  
Photon emission for (n,d)

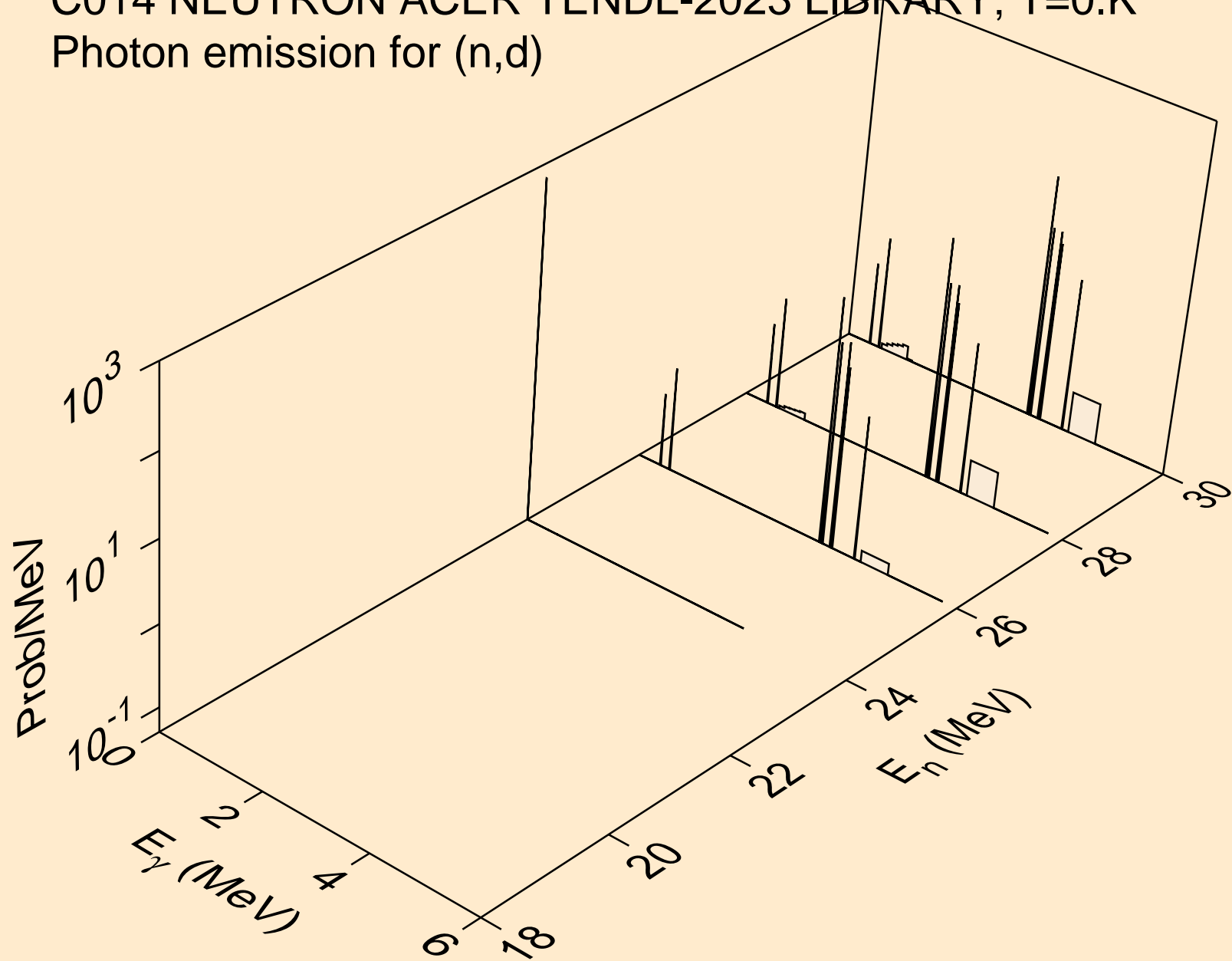

C014 NEUTRON ACER TENDL-2023 LIBRARY; T=0.K  
Photon emission for (n,t)

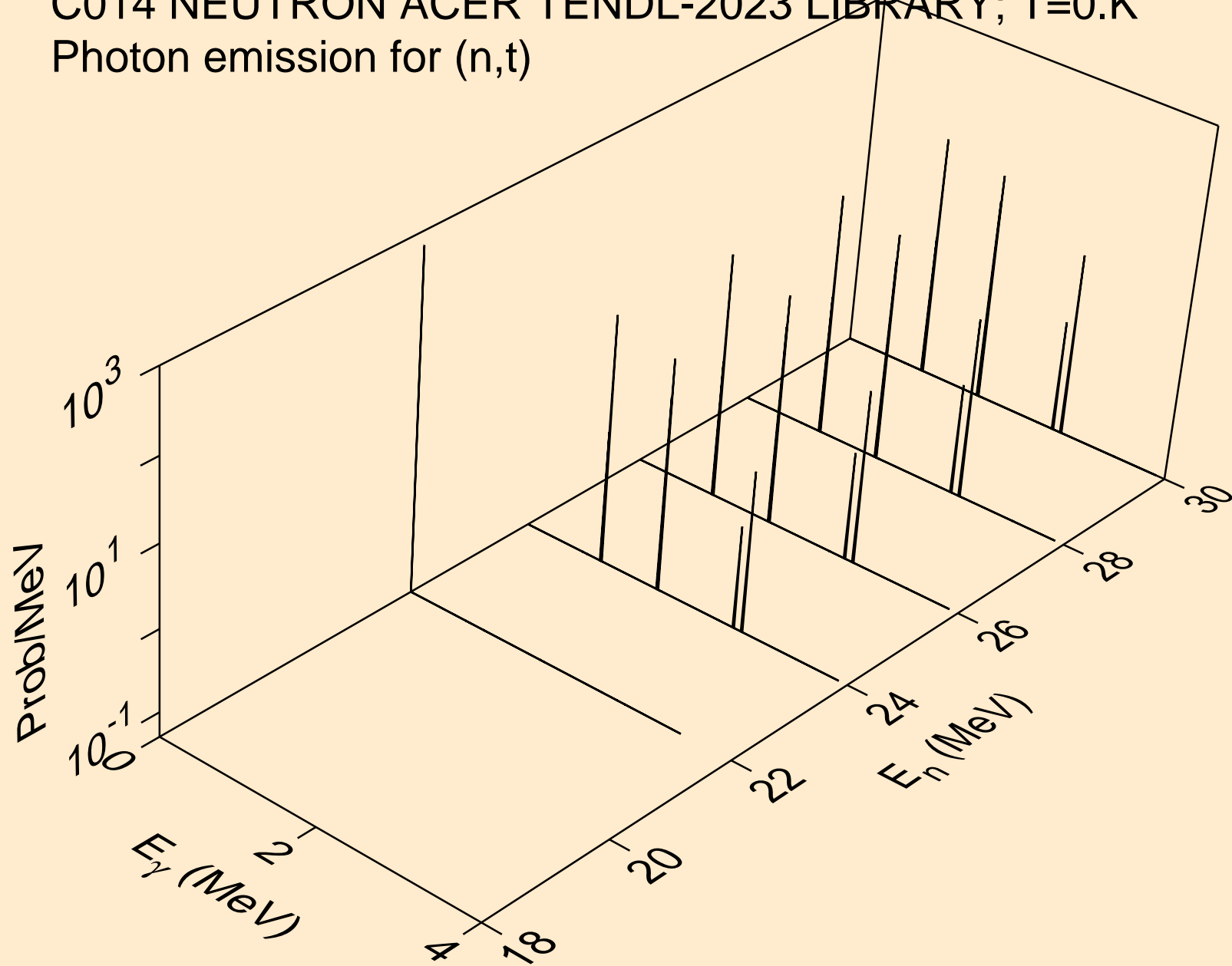

C014 NEUTRON ACER TENDL-2023 LIBRARY; T=0.K  
Photon emission for (n,a)

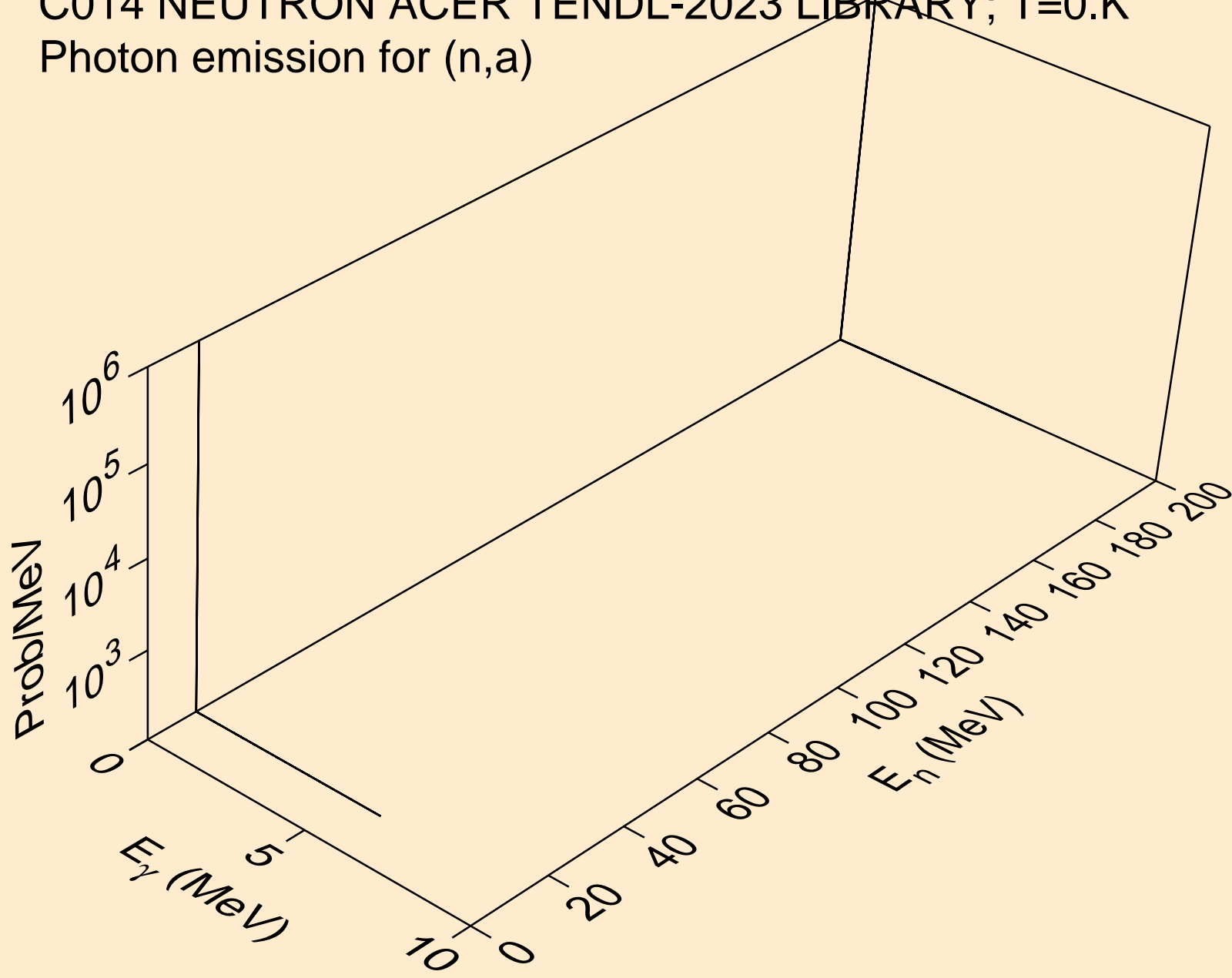

C014 NEUTRON ACER TENDL-2023 LIBRARY; T=0.K  
thermal capture photon spectrum

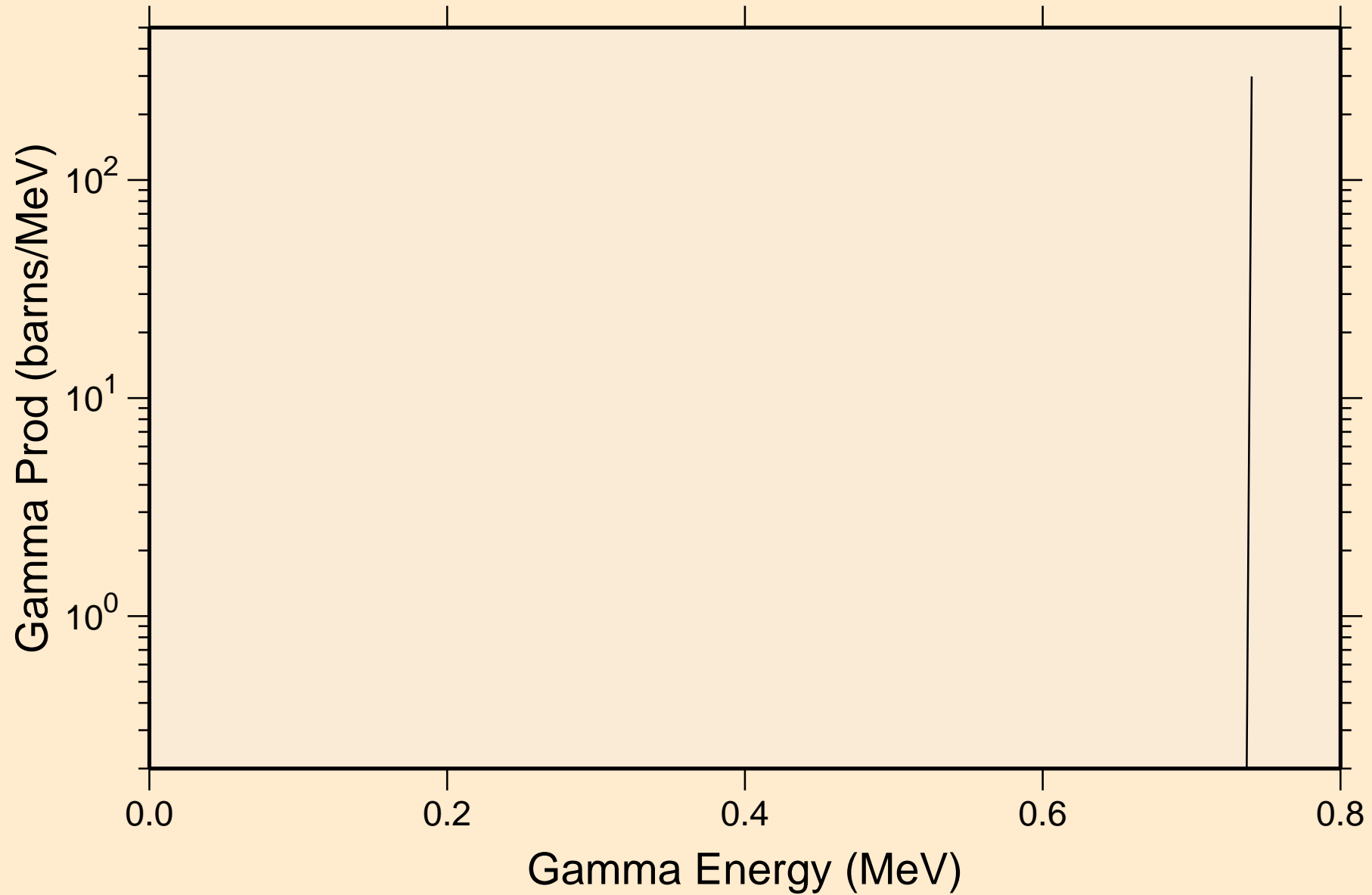

C014 NEUTRON ACER TENDL-2023 LIBRARY; T=0.K  
14 MeV photon spectrum

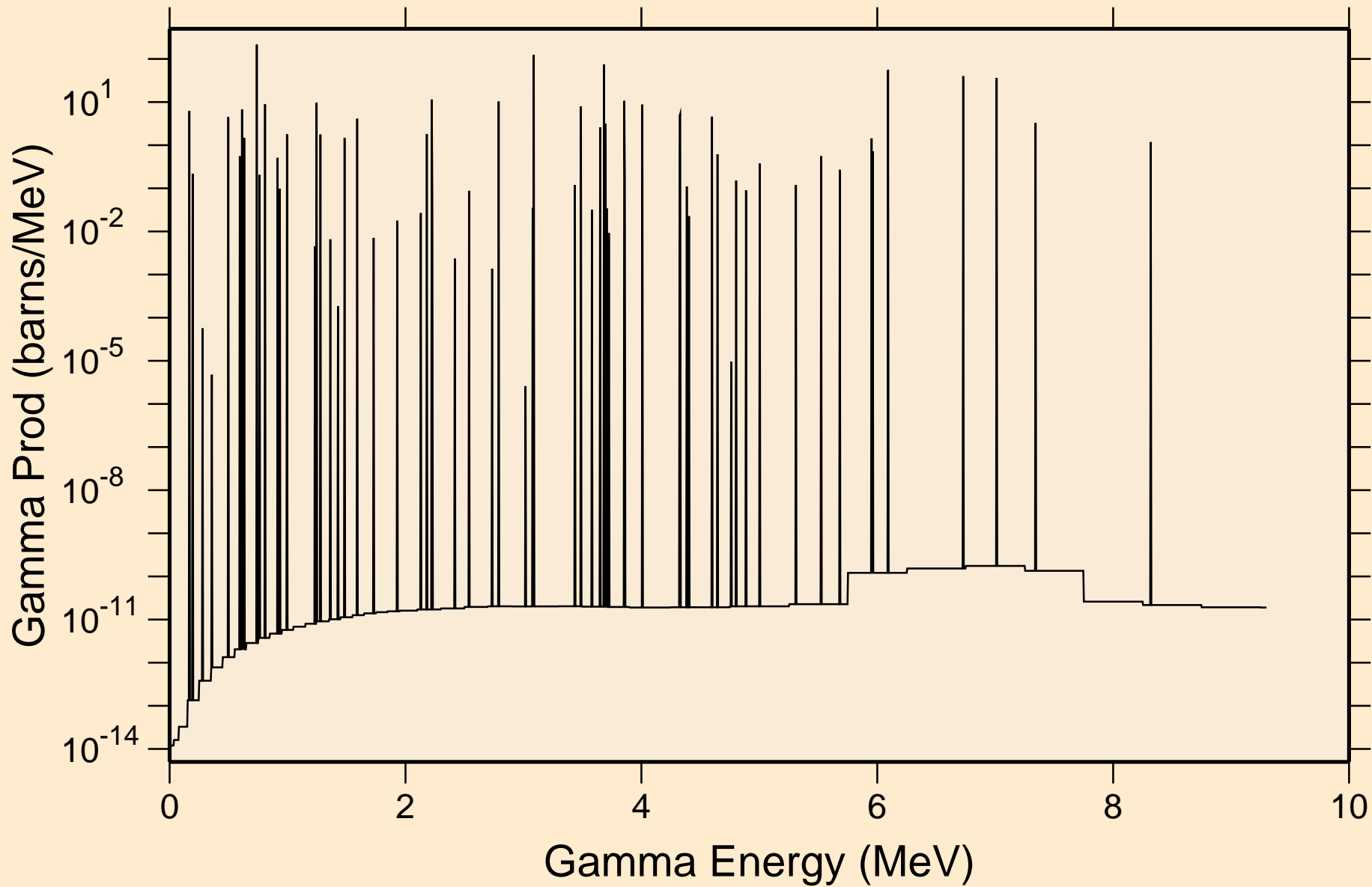

C014 NEUTRON ACER TENDL-2023 LIBRARY; T=0.K  
Particle heating contributions

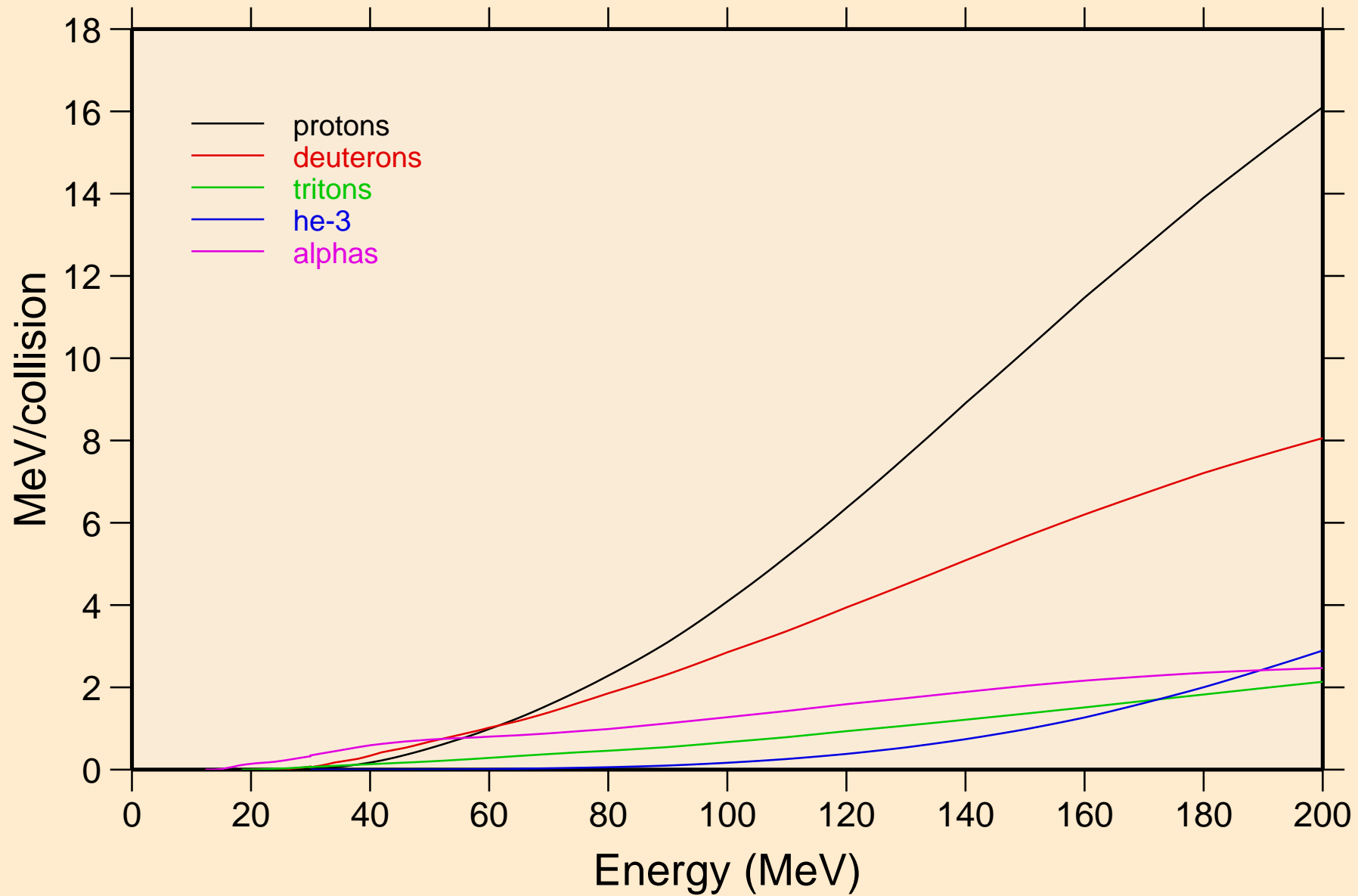

C014 NEUTRON ACER TENDL-2023 LIBRARY; T=0.K  
Recoil Heating

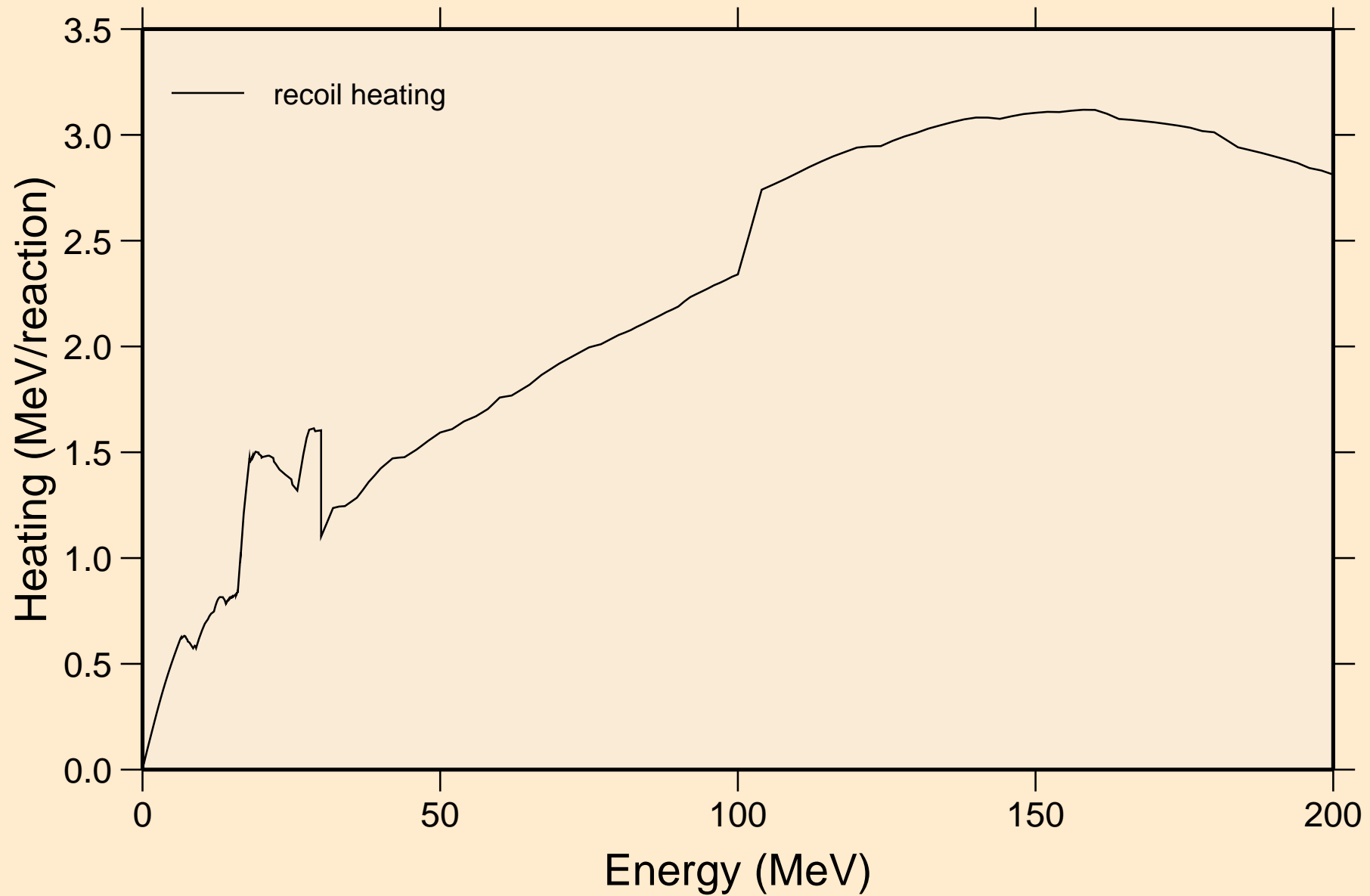

# C014 NEUTRON ACER TENDL-2023 LIBRARY; T=0.K

## Particle production cross sections

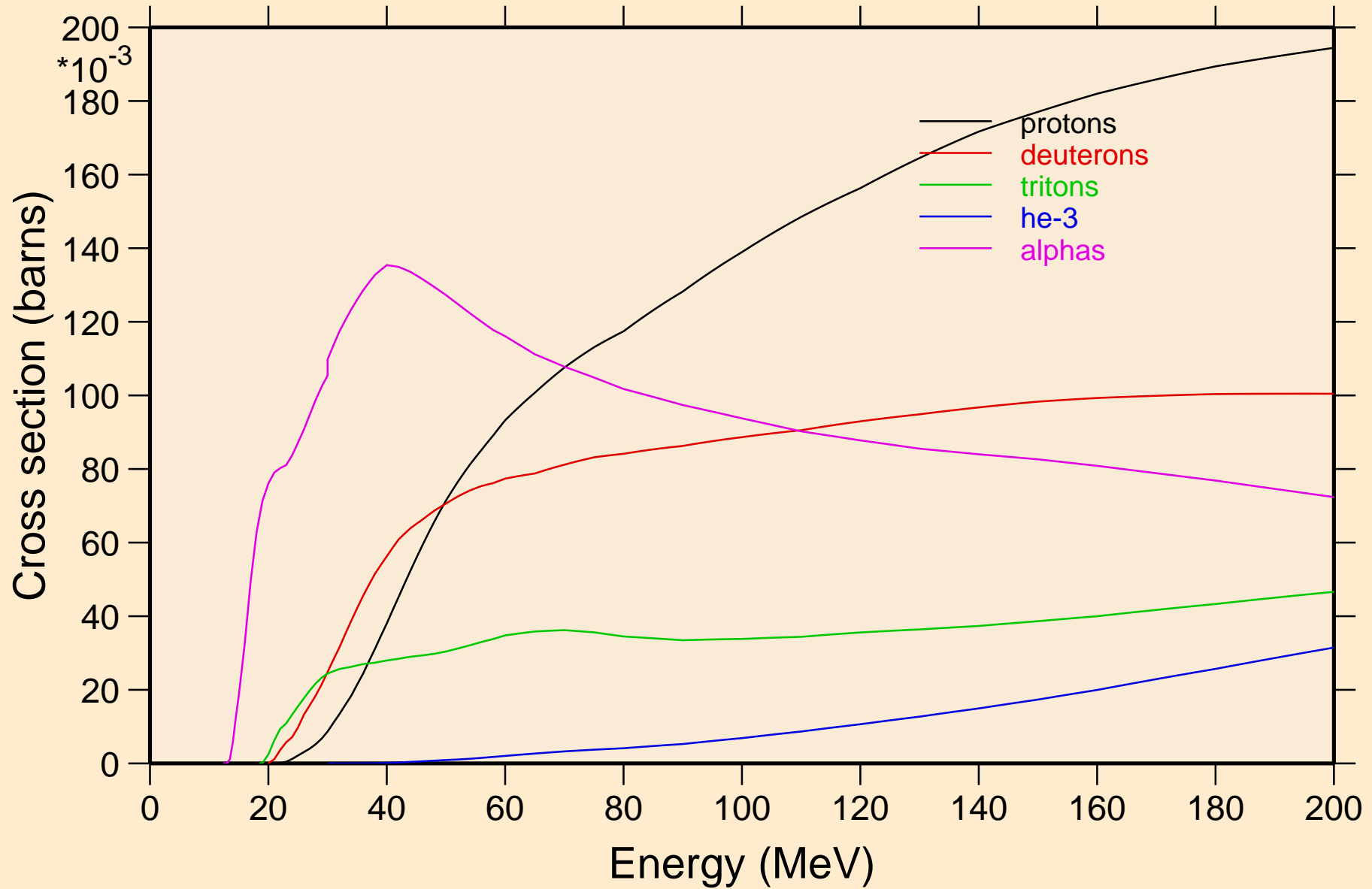



C014 NEUTRON ACER TENDL-2023 LIBRARY; T=0.K  
protons from (n,x)

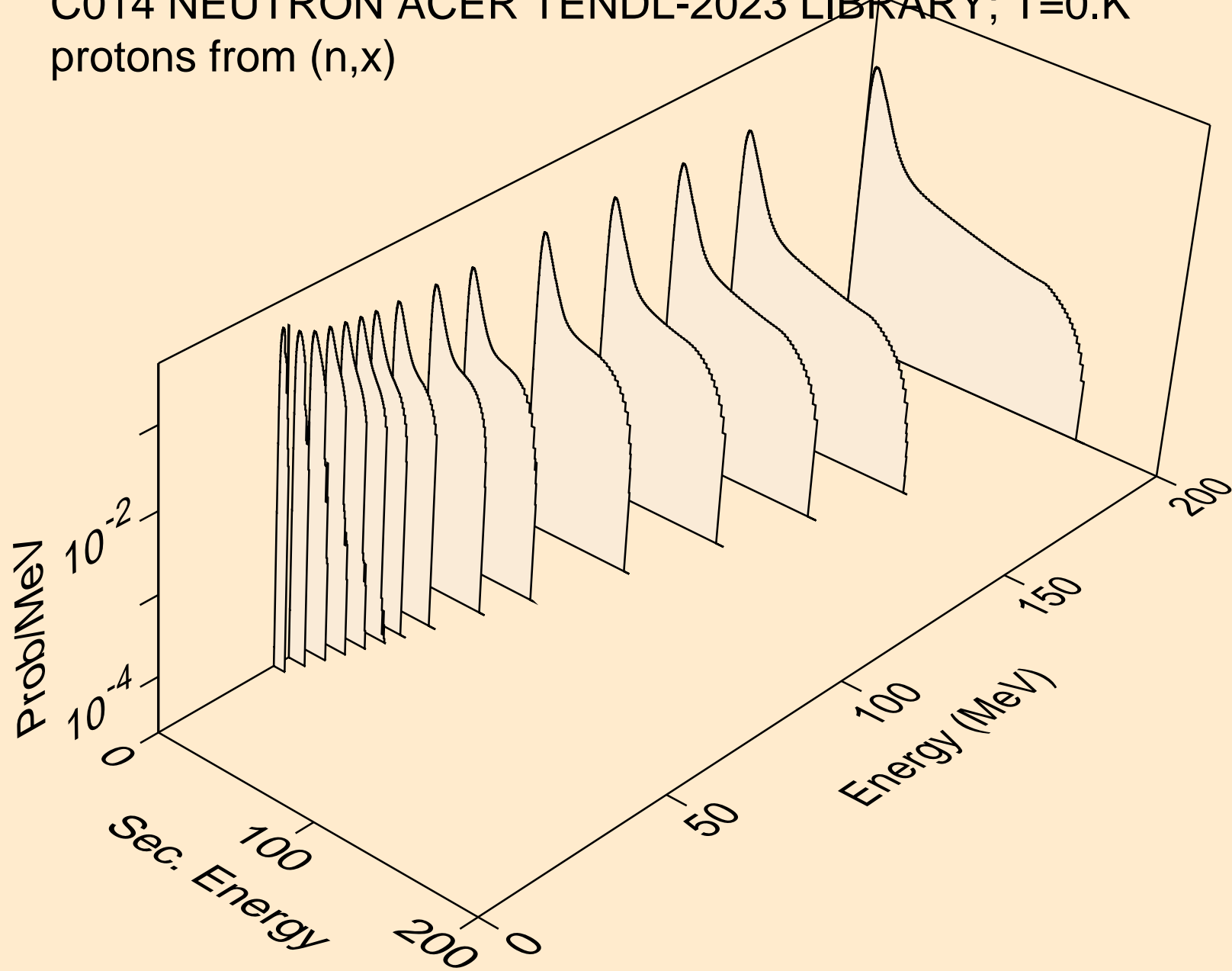

C014 NEUTRON ACER TENDL-2023 LIBRARY; T=0.K  
protons from (n,n\*)p

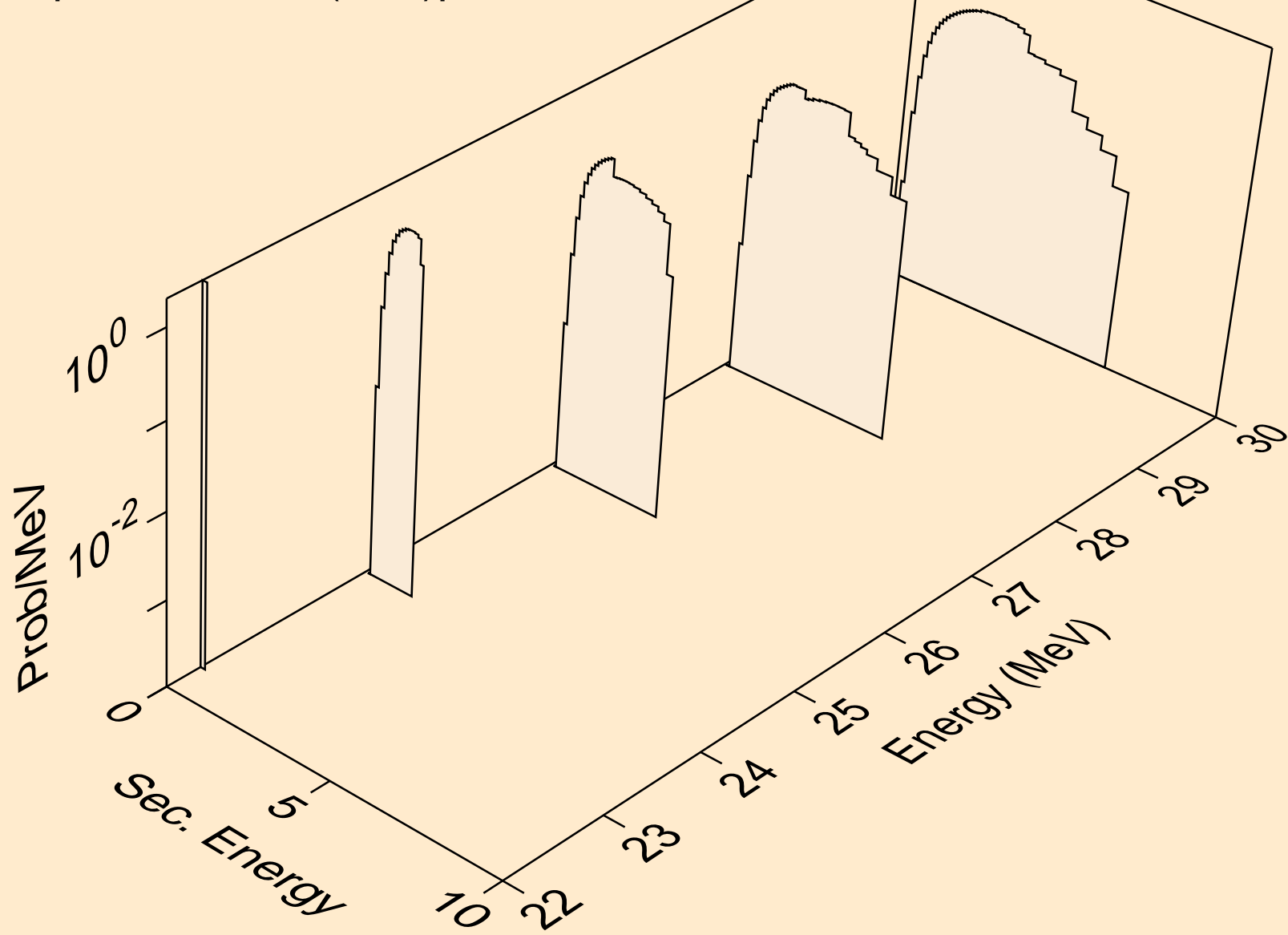

C014 NEUTRON ACER TENDL-2023 LIBRARY; T=0.K  
protons from (n,2np)

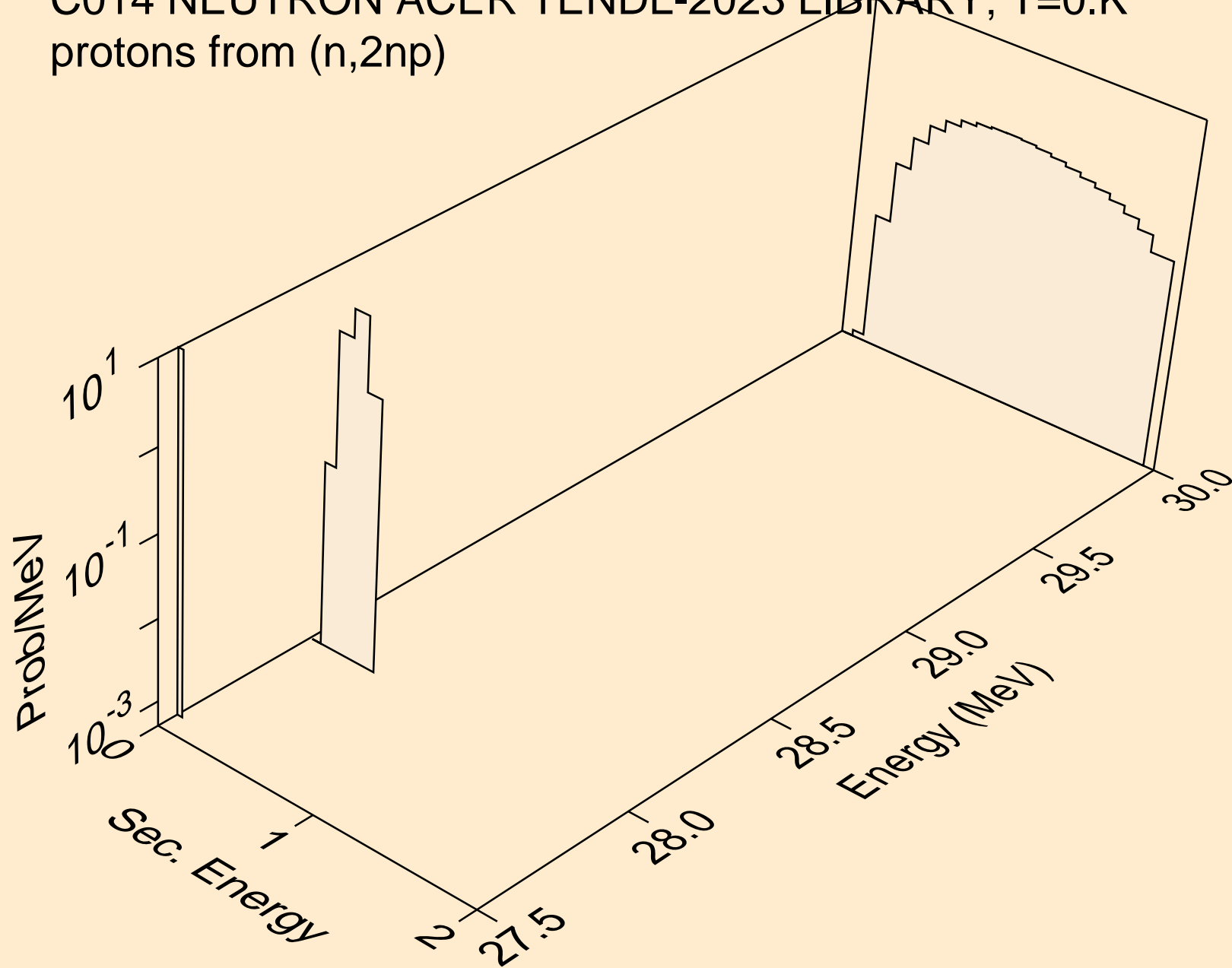

C014 NEUTRON ACER TENDL-2023 LIBRARY; T=0.K  
protons from (n,p)

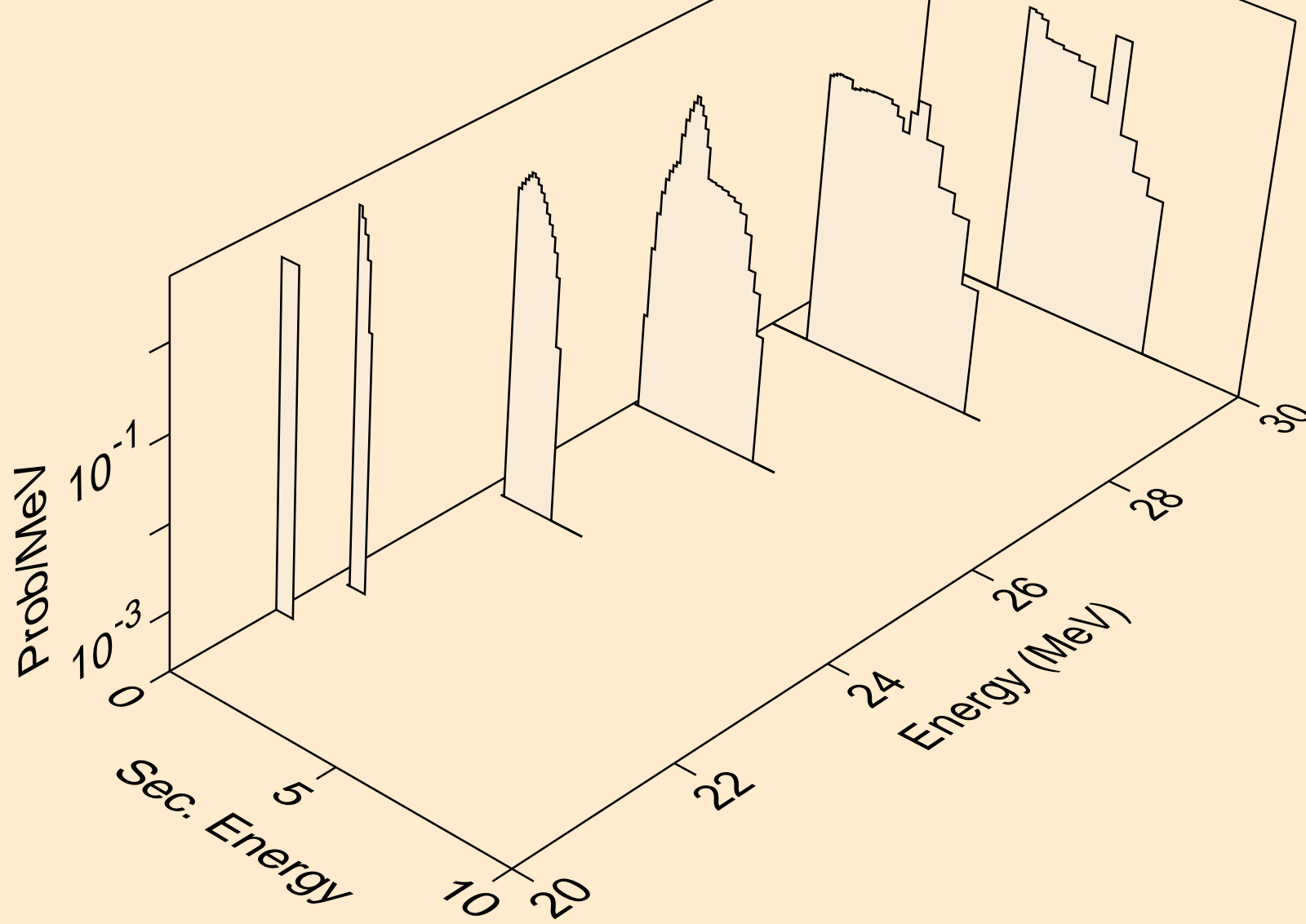

C014 NEUTRON ACER TENDL-2023 LIBRARY; T=0.K  
deuterons from (n,x)

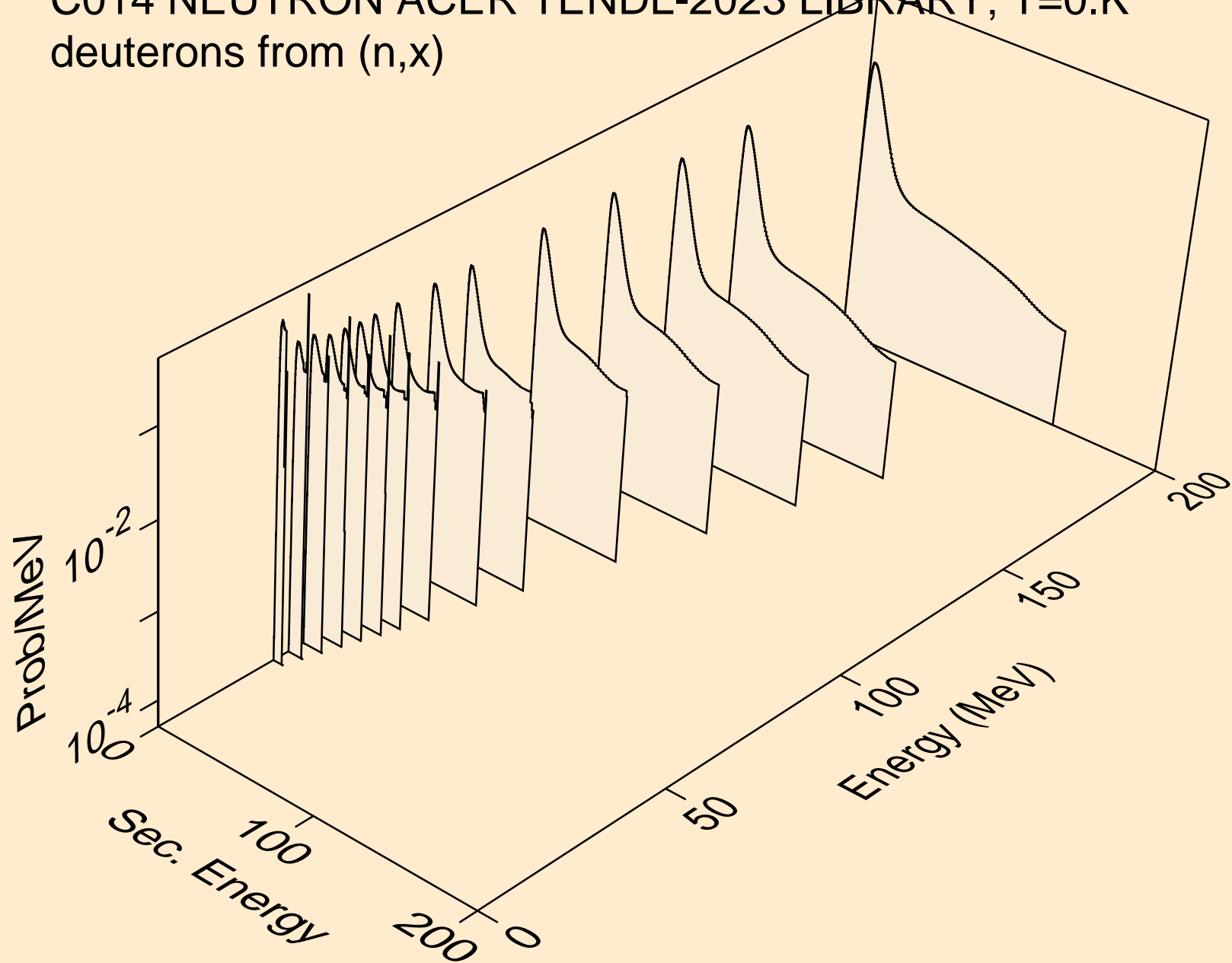

C014 NEUTRON ACER TENDL-2023 LIBRARY; T=0.K  
deuterons from (n,2nd)

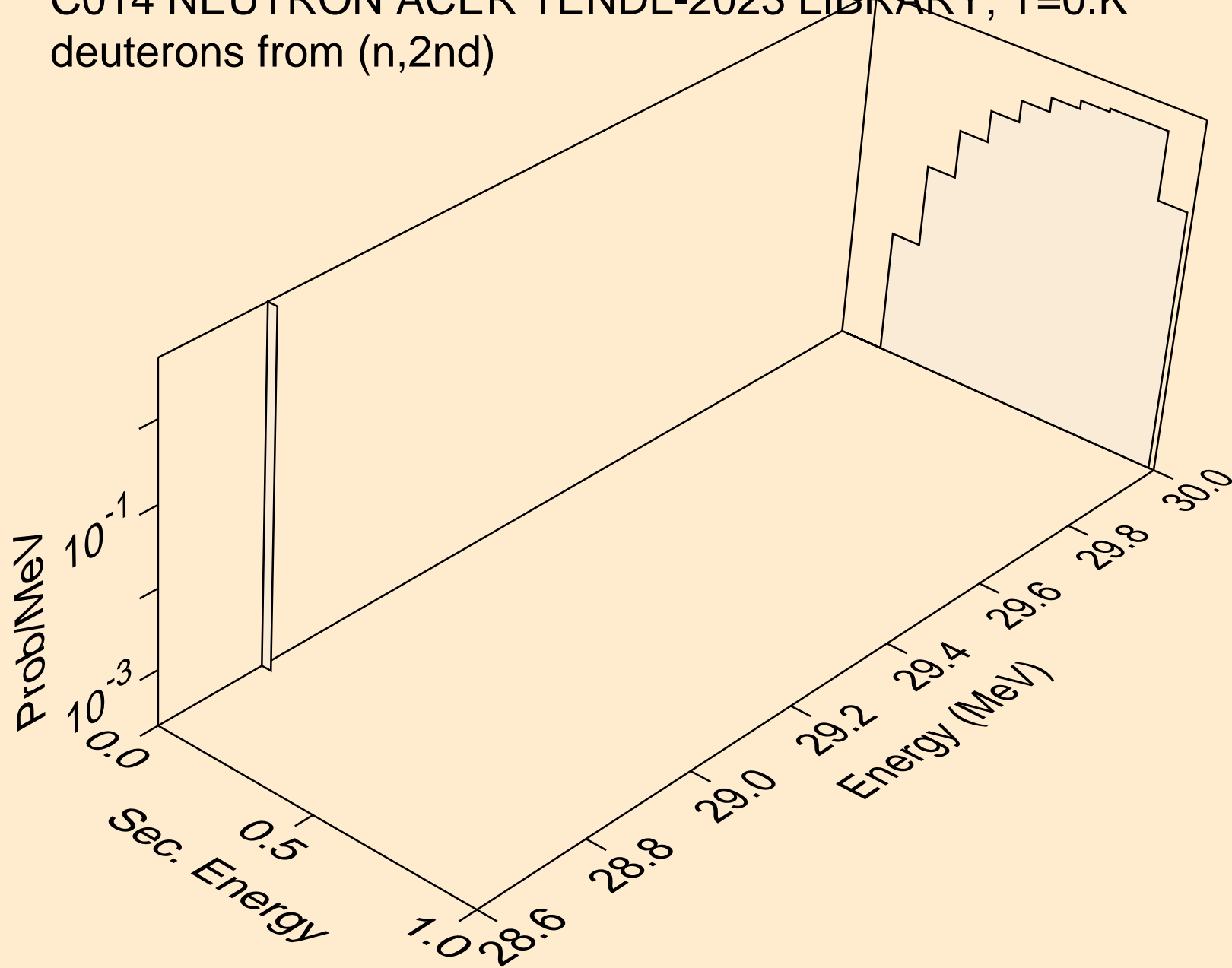

C014 NEUTRON ACER TENDL-2023 LIBRARY; T=0.K  
deuterons from (n,n\*)d

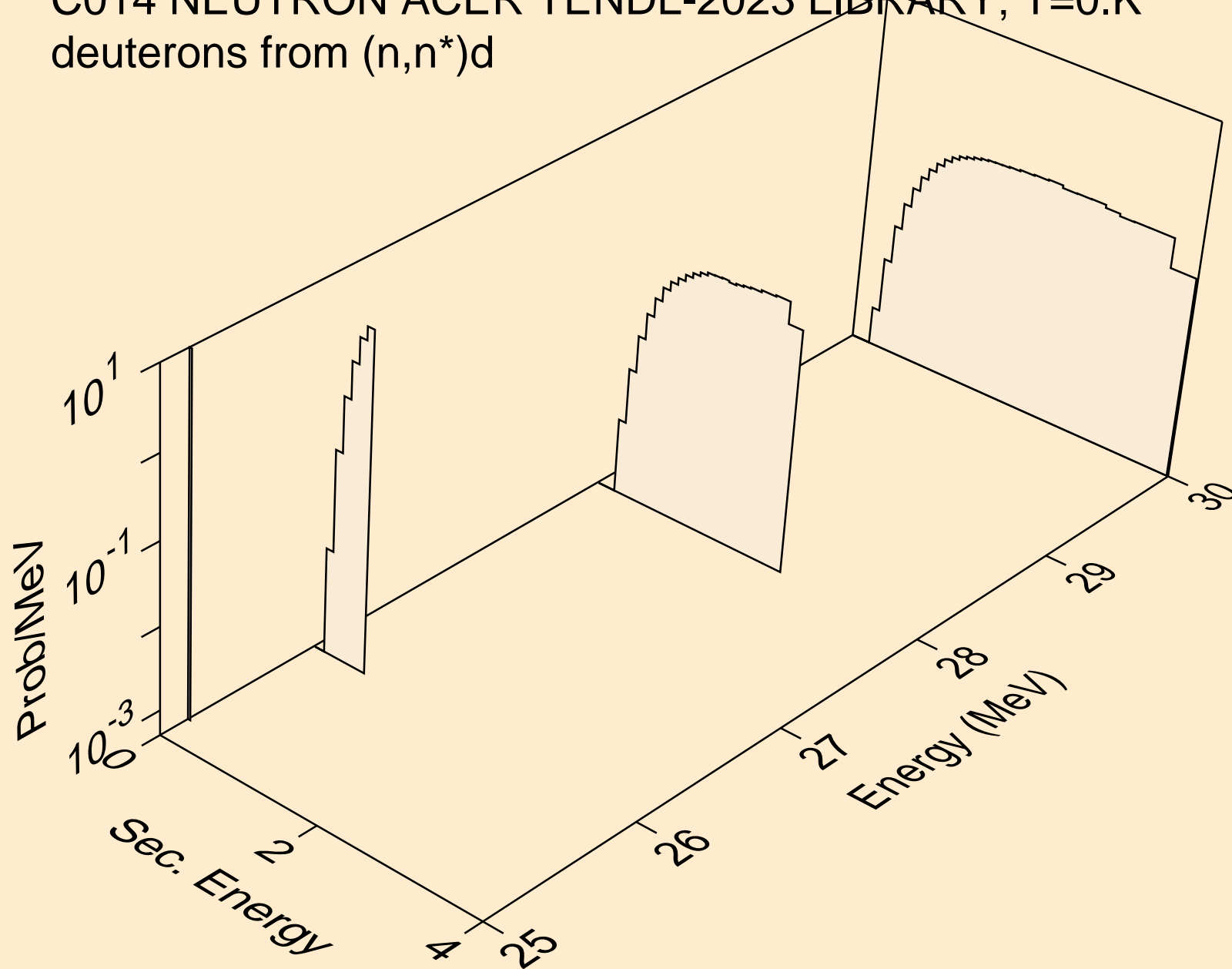

C014 NEUTRON ACER TENDL-2023 LIBRARY; T=0.K  
deuterons from (n,d)

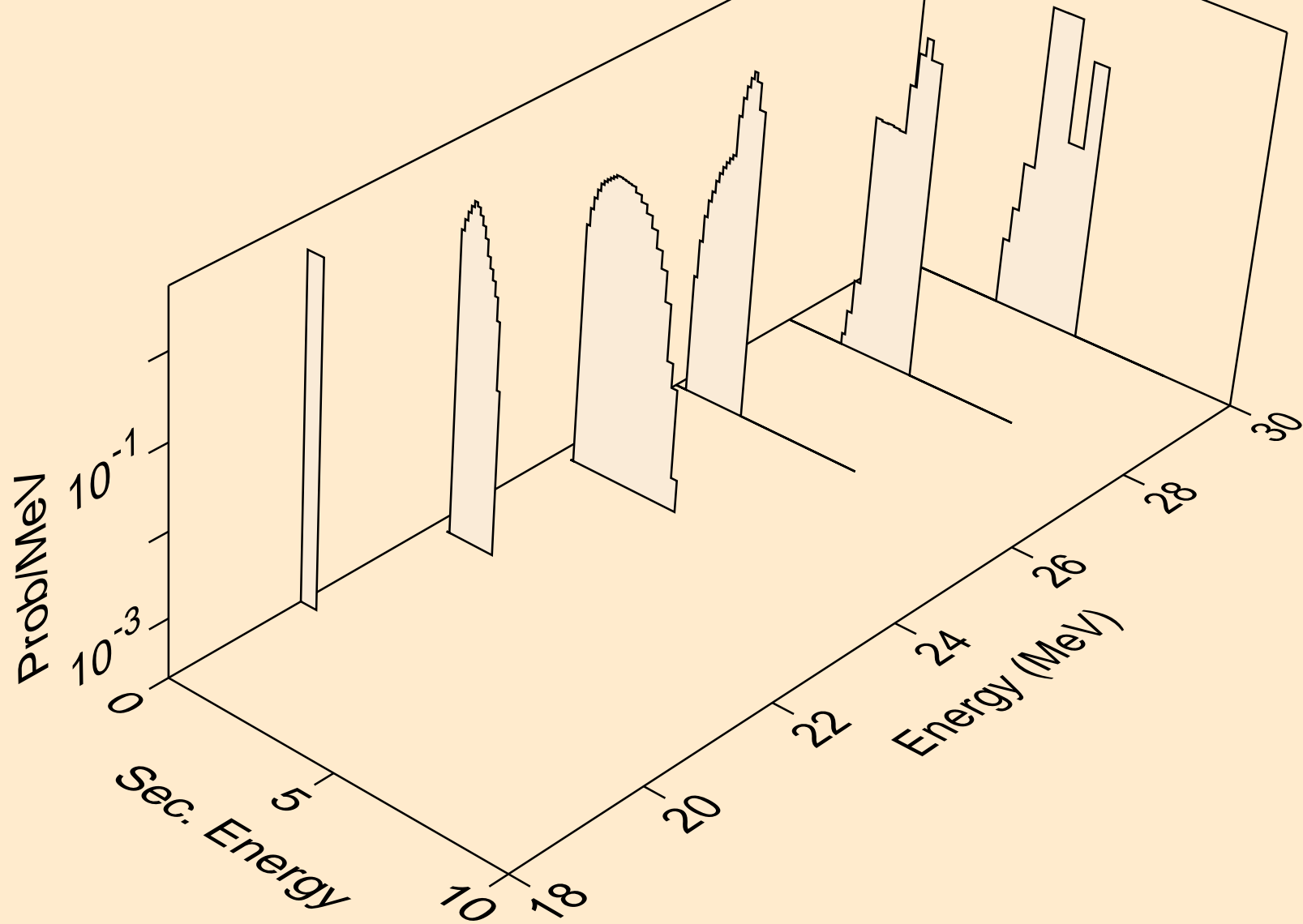



C014 NEUTRON ACER TENDL-2023 LIBRARY; T=0.K  
tritons from (n,x)

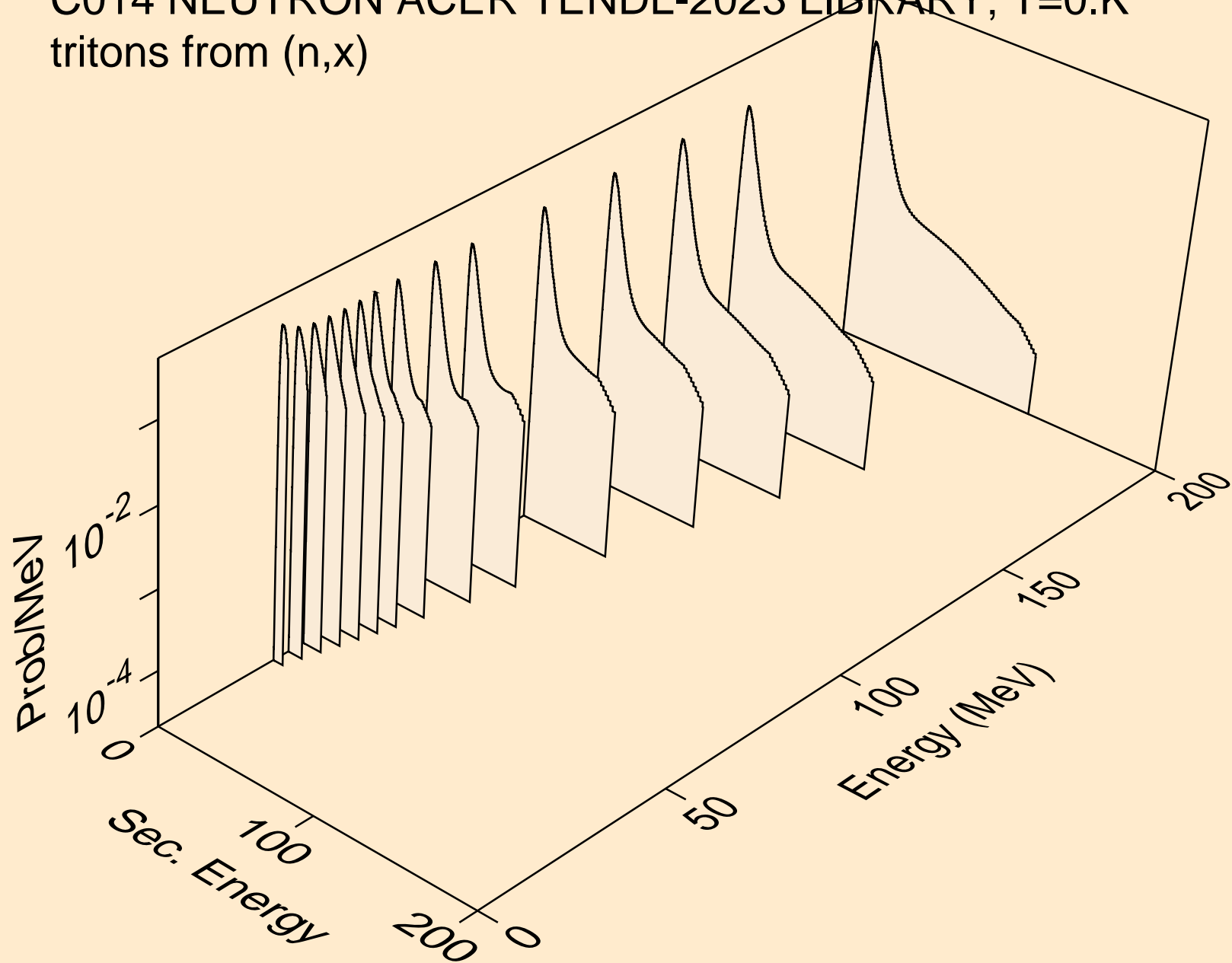

C014 NEUTRON ACER TENDL-2023 LIBRARY; T=0.K  
tritons from (n,n\*)t

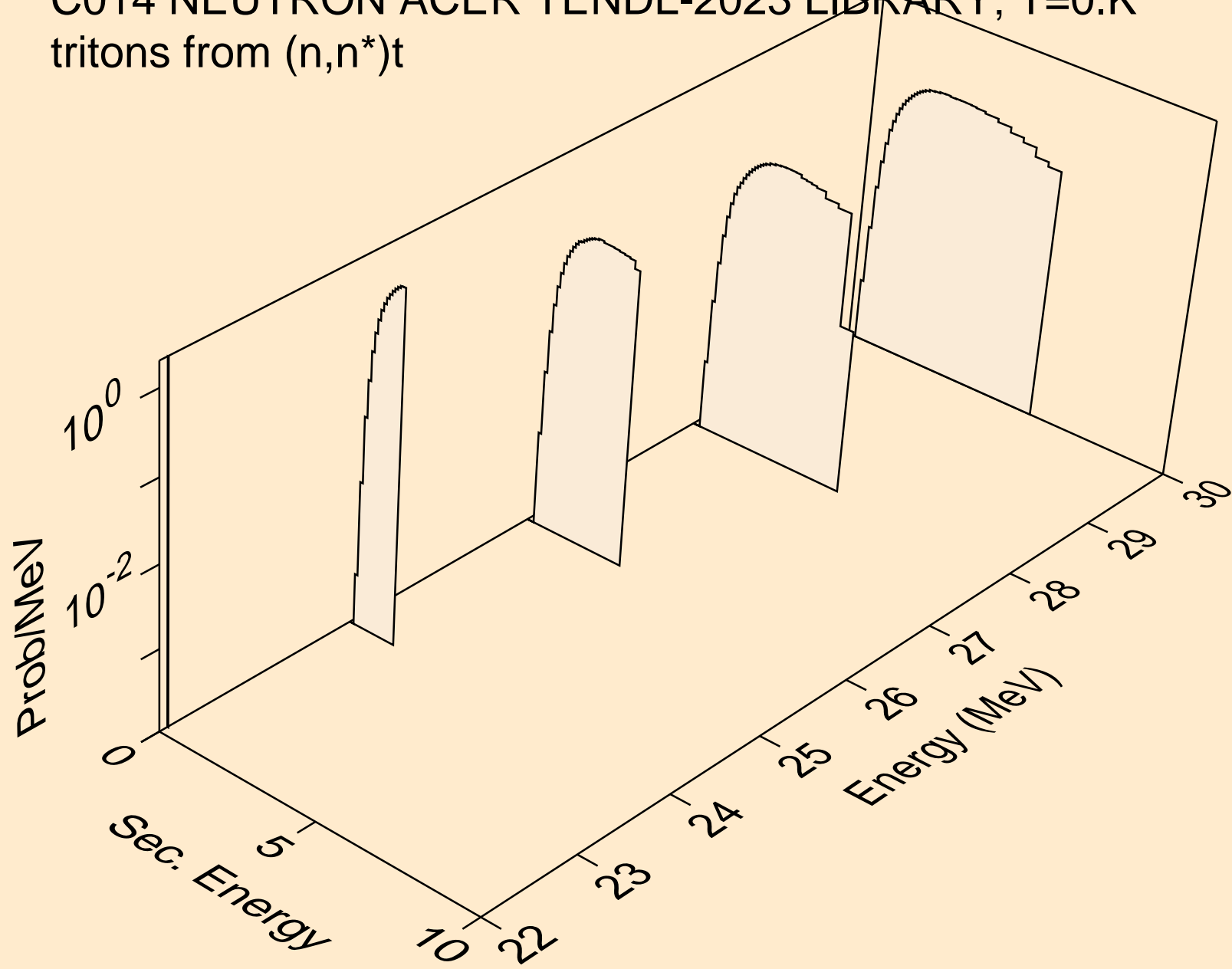

C014 NEUTRON ACER TENDL-2023 LIBRARY; T=0.K  
tritons from (n,t)

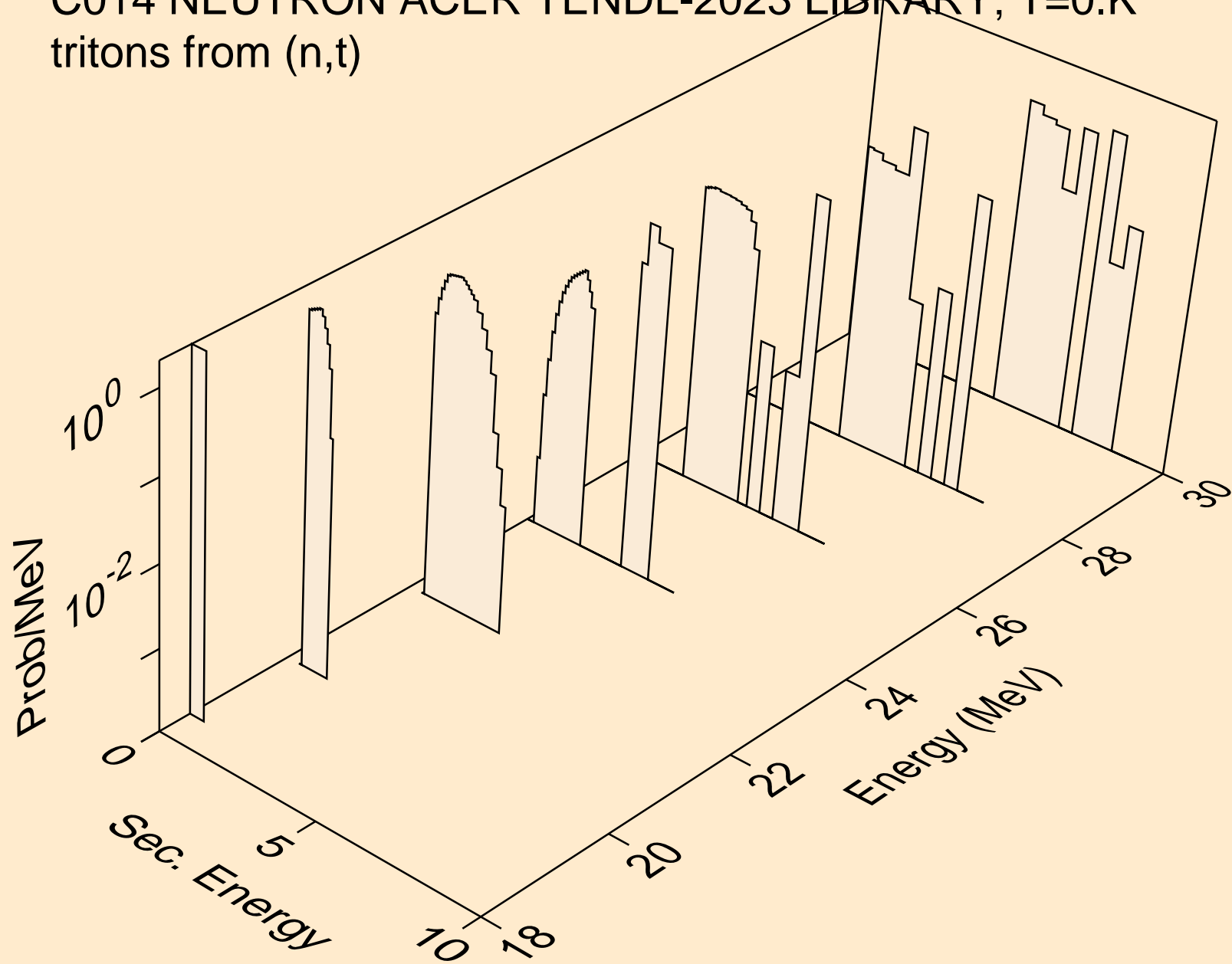

C014 NEUTRON ACER TENDL-2023 LIBRARY; T=0.K  
he3s from (n,x)

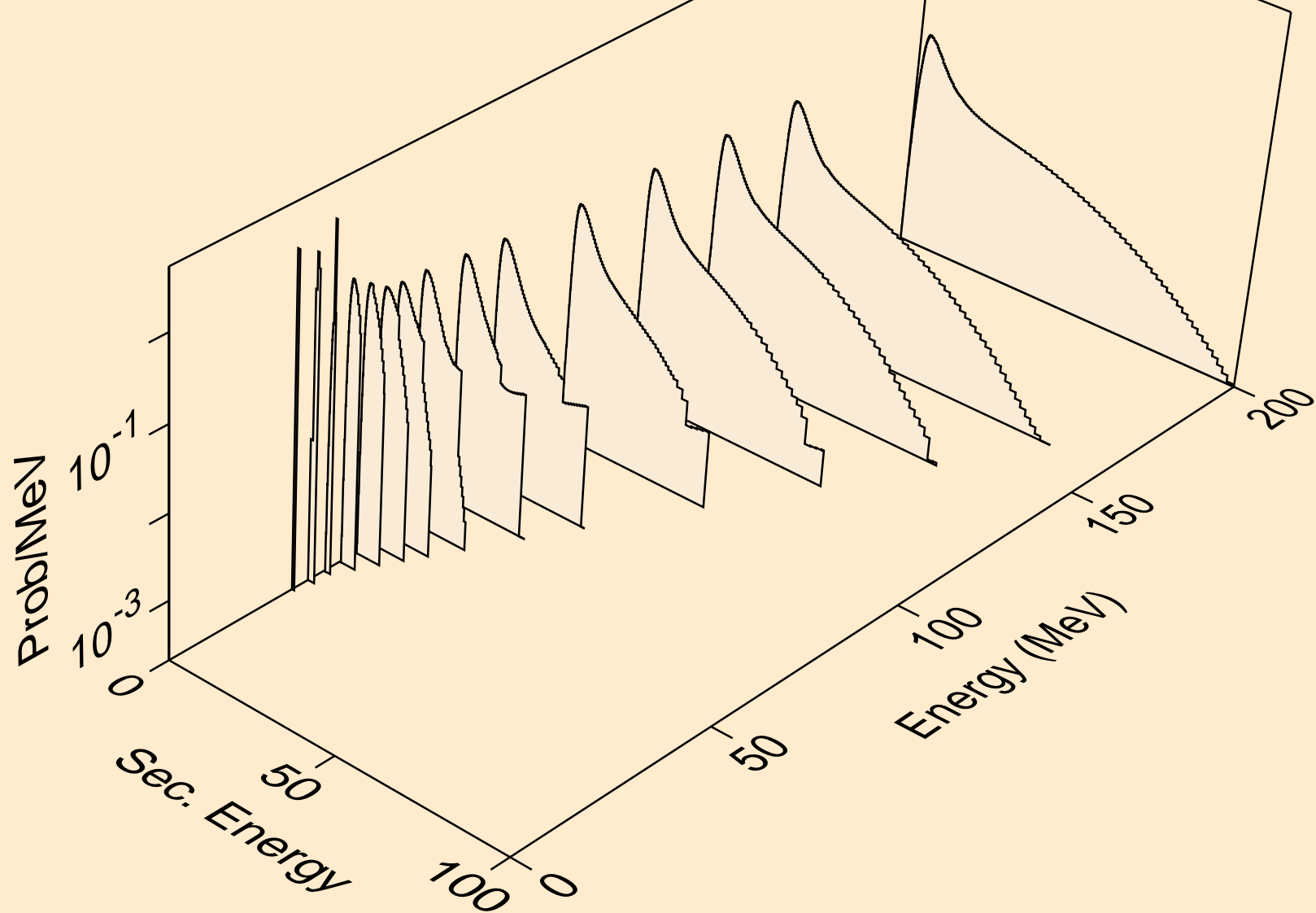

C014 NEUTRON ACER TENDL-2023 LIBRARY; T=0.K  
alphas from (n,x)

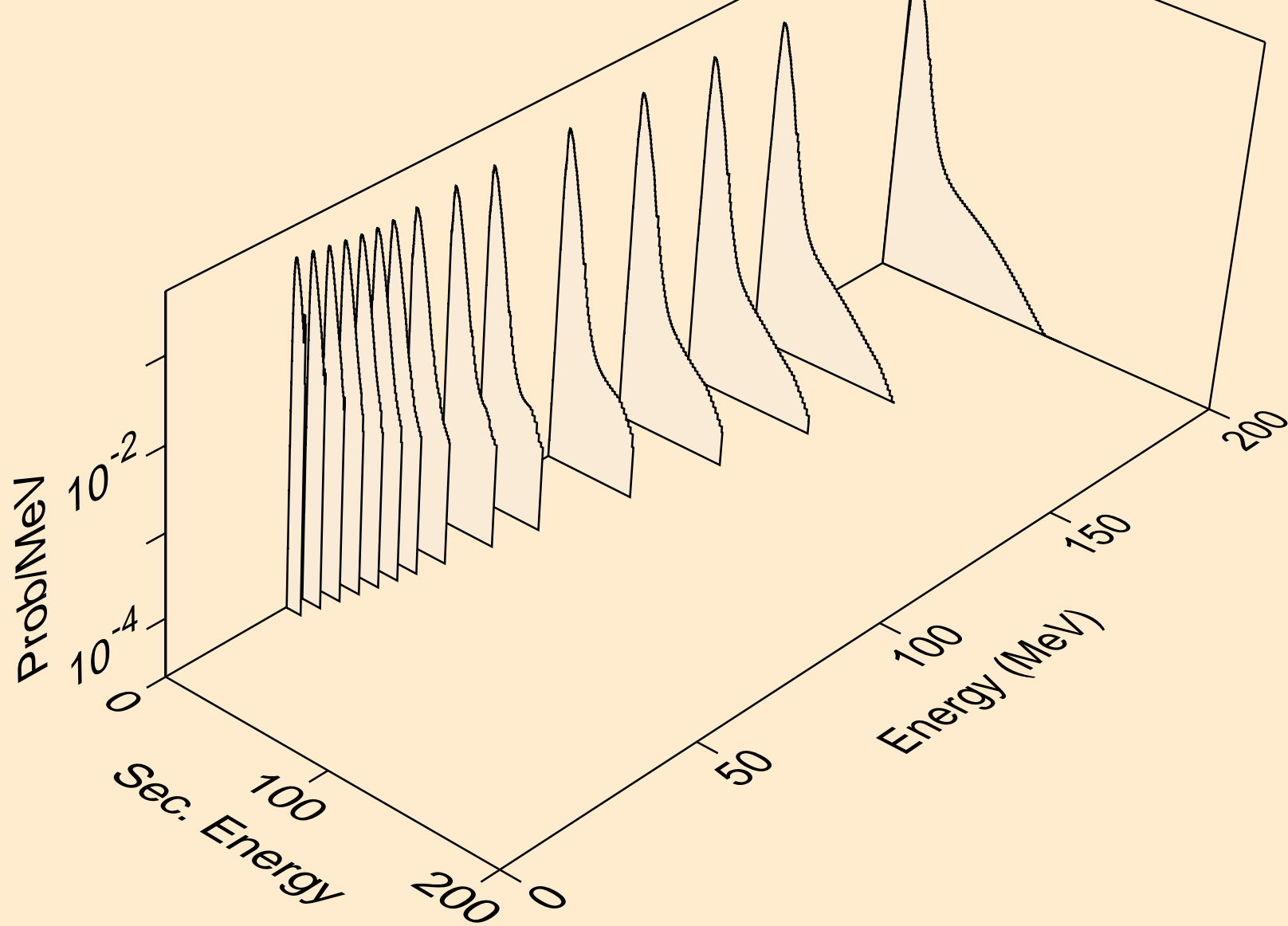

C014 NEUTRON ACER TENDL-2023 LIBRARY; T=0.K  
alphas from (n,n\*)a

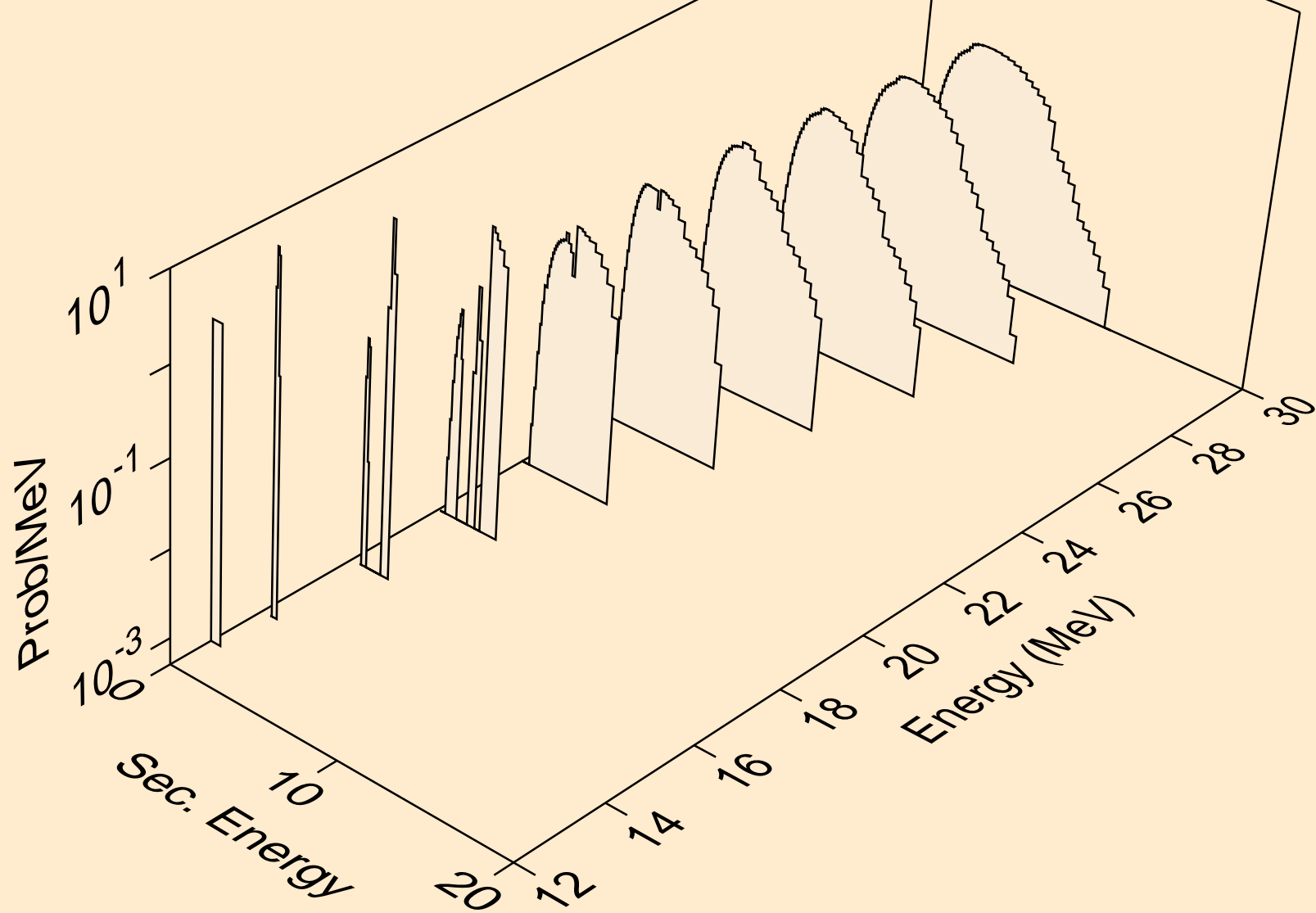

C014 NEUTRON ACER TENDL-2023 LIBRARY; T=0.K  
alphas from (n,2n)a

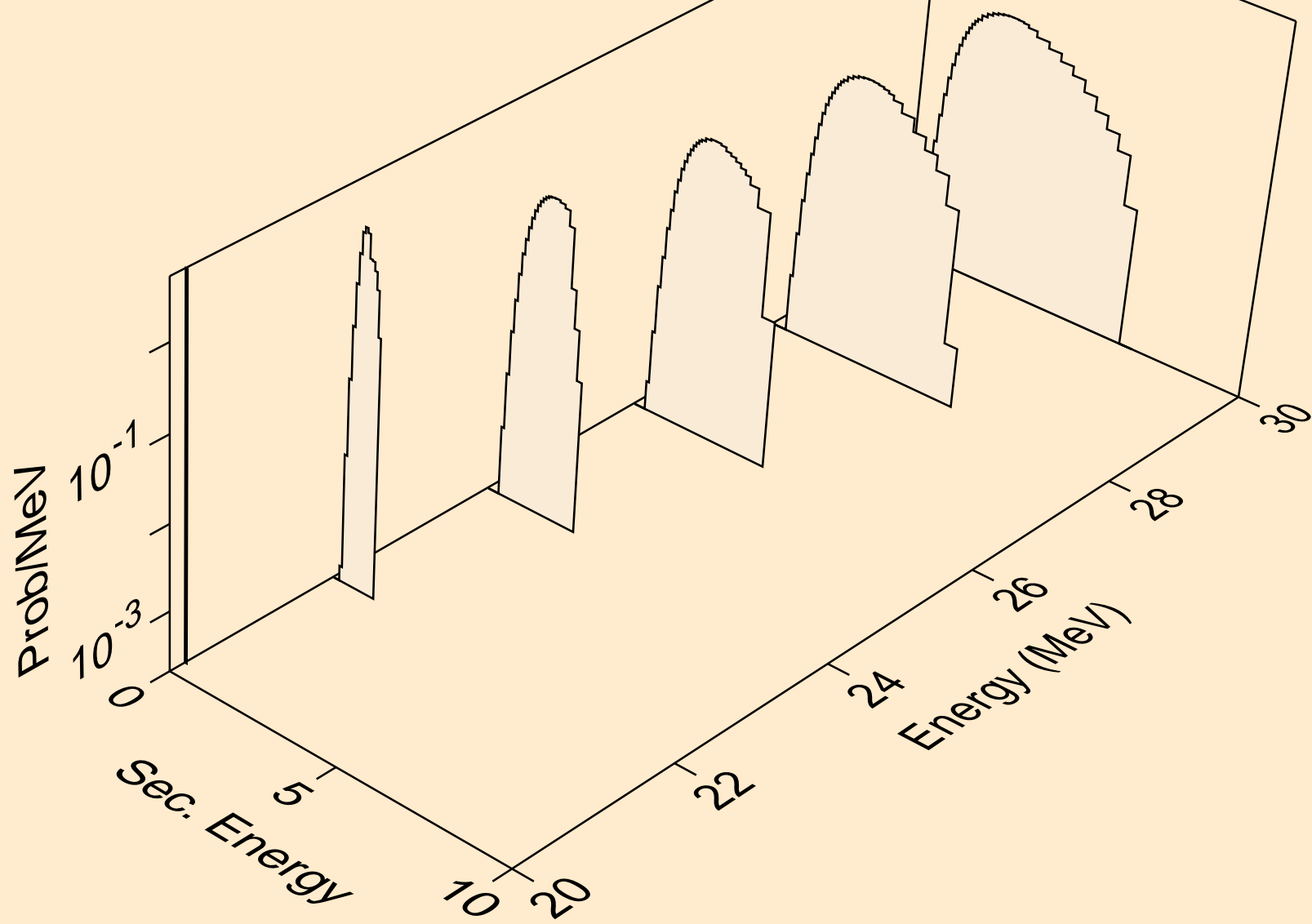

C014 NEUTRON ACER TENDL-2023 LIBRARY; T=0.K  
alphas from (n,3n)a

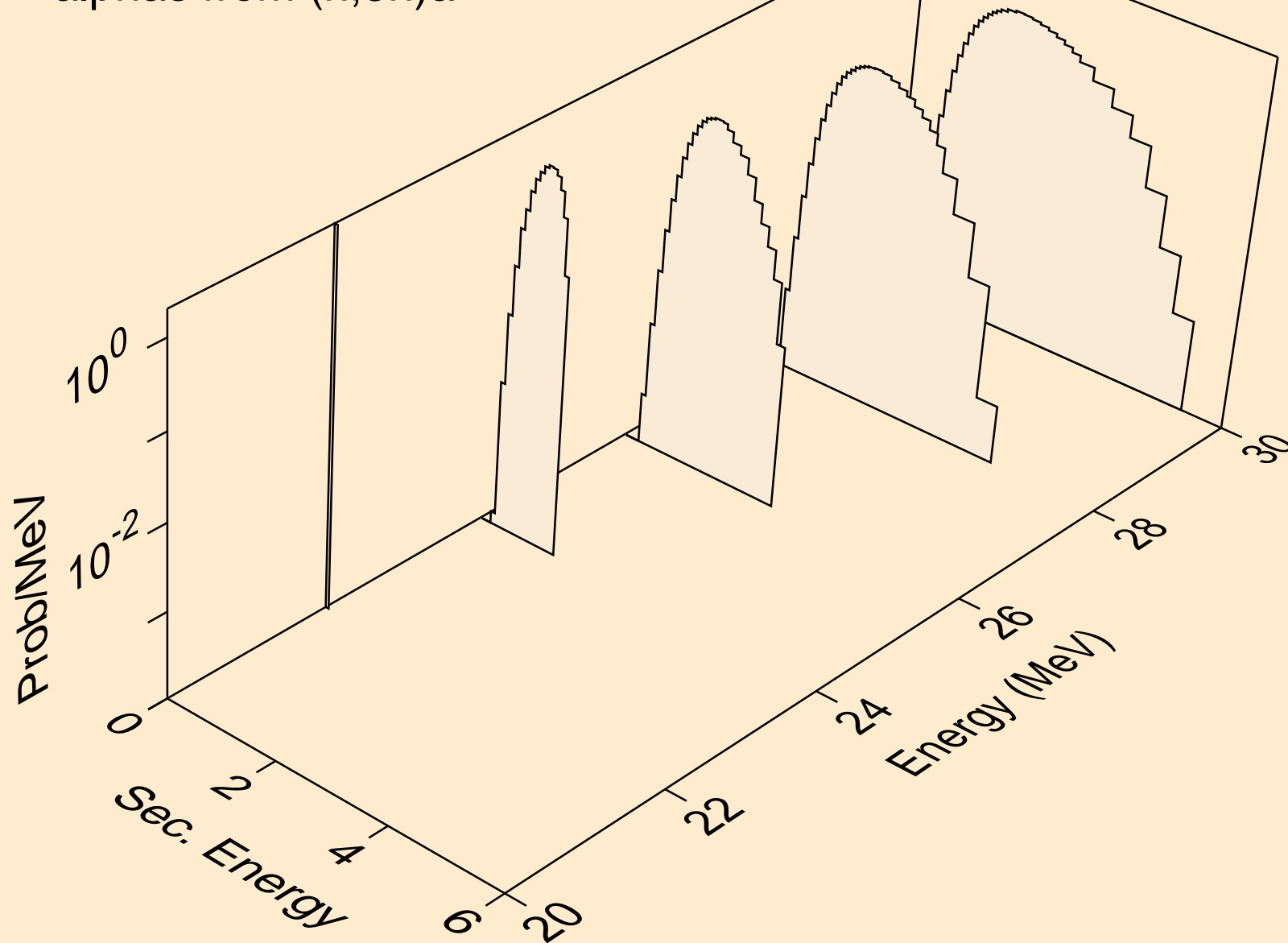



C014 NEUTRON ACER TENDL-2023 LIBRARY; T=0.K  
alphas from (n,a)

