

# CU059 NEUTRON ACER TENDL-2023 LIBRARY; T=0.K

## Principal cross sections

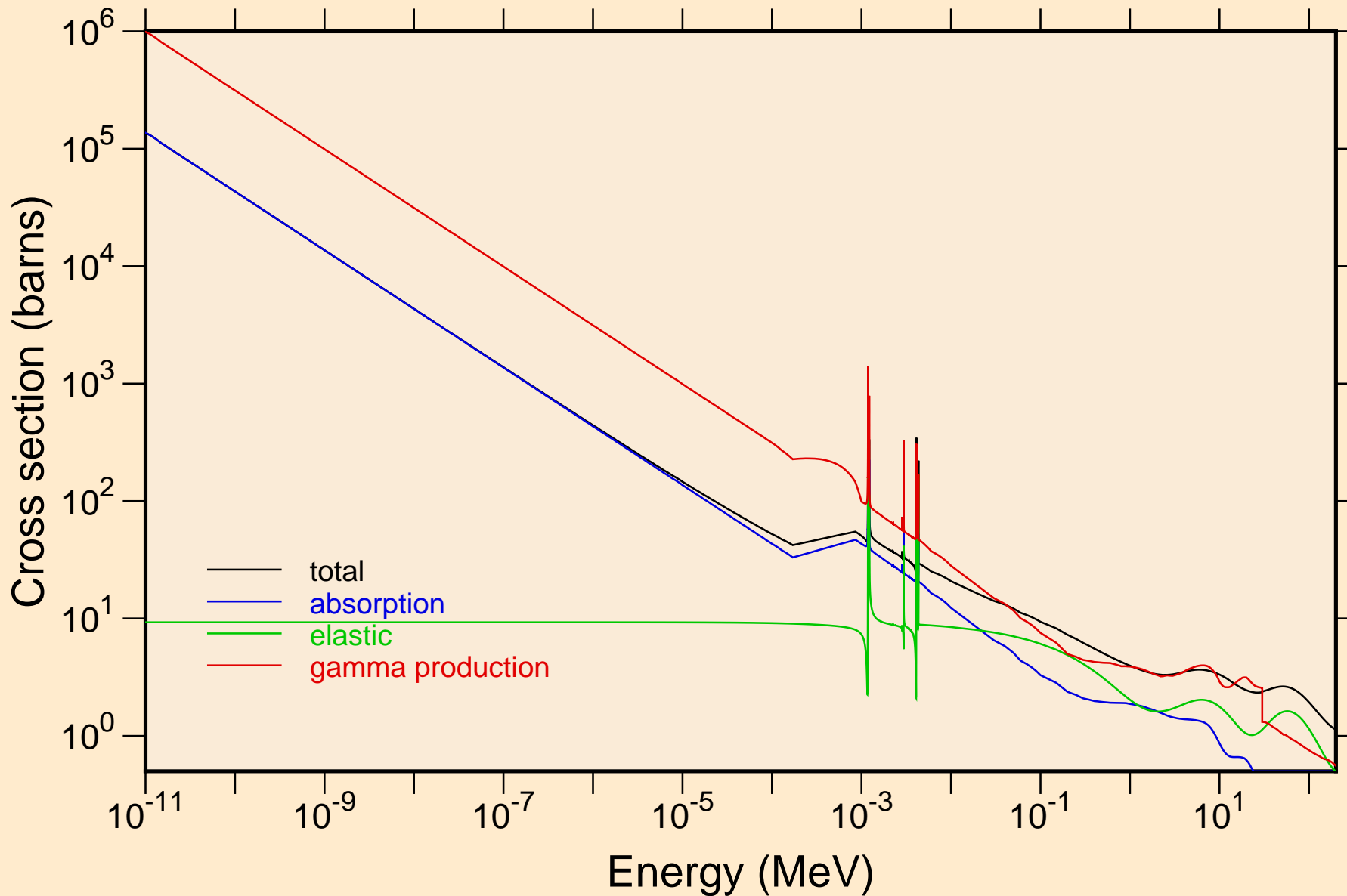

CU059 NEUTRON ACER TENDL-2023 LIBRARY; T=0.K  
resonance total cross section

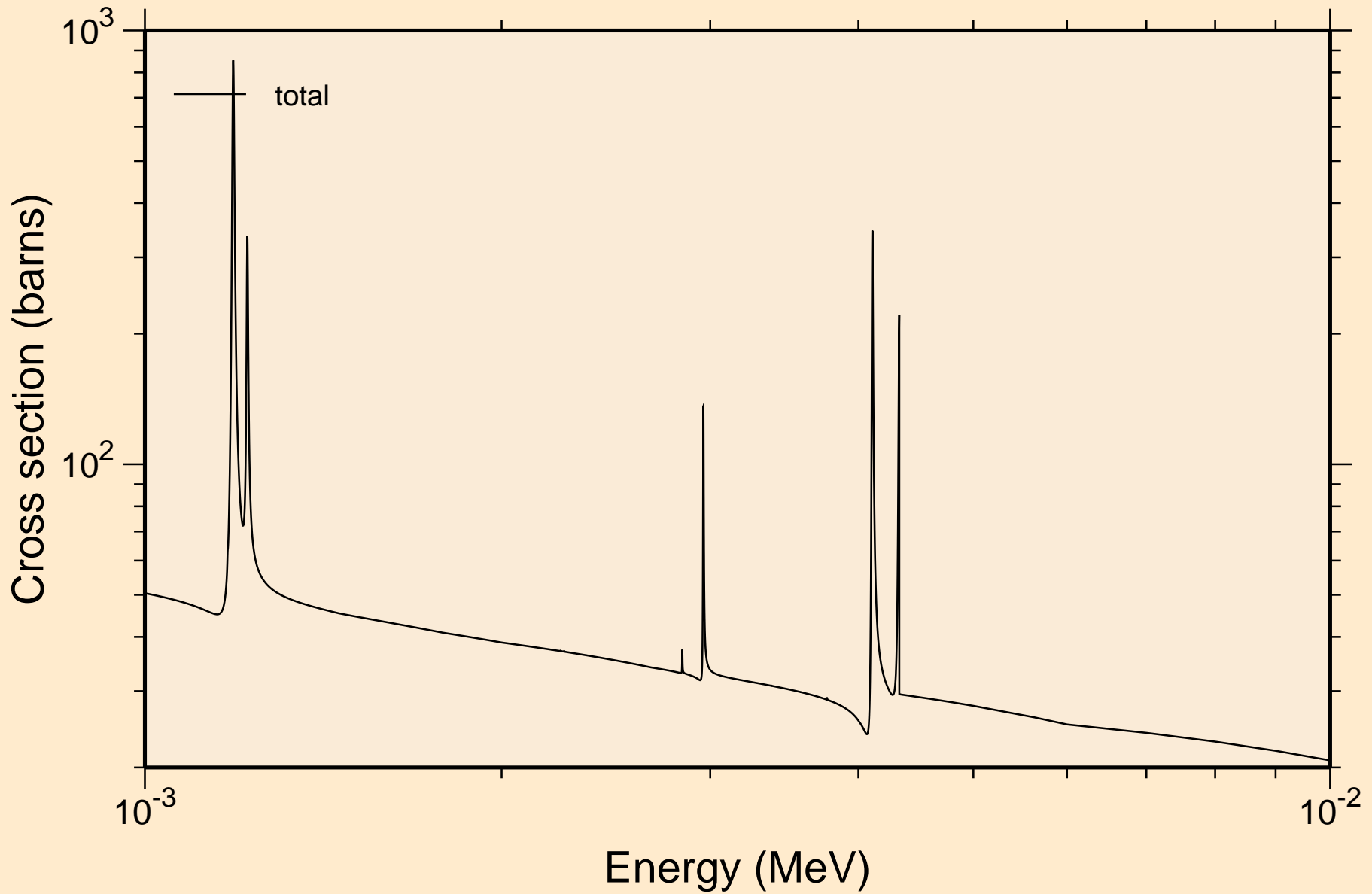

CU059 NEUTRON ACER TENDL-2023 LIBRARY; T=0.K  
resonance total cross section

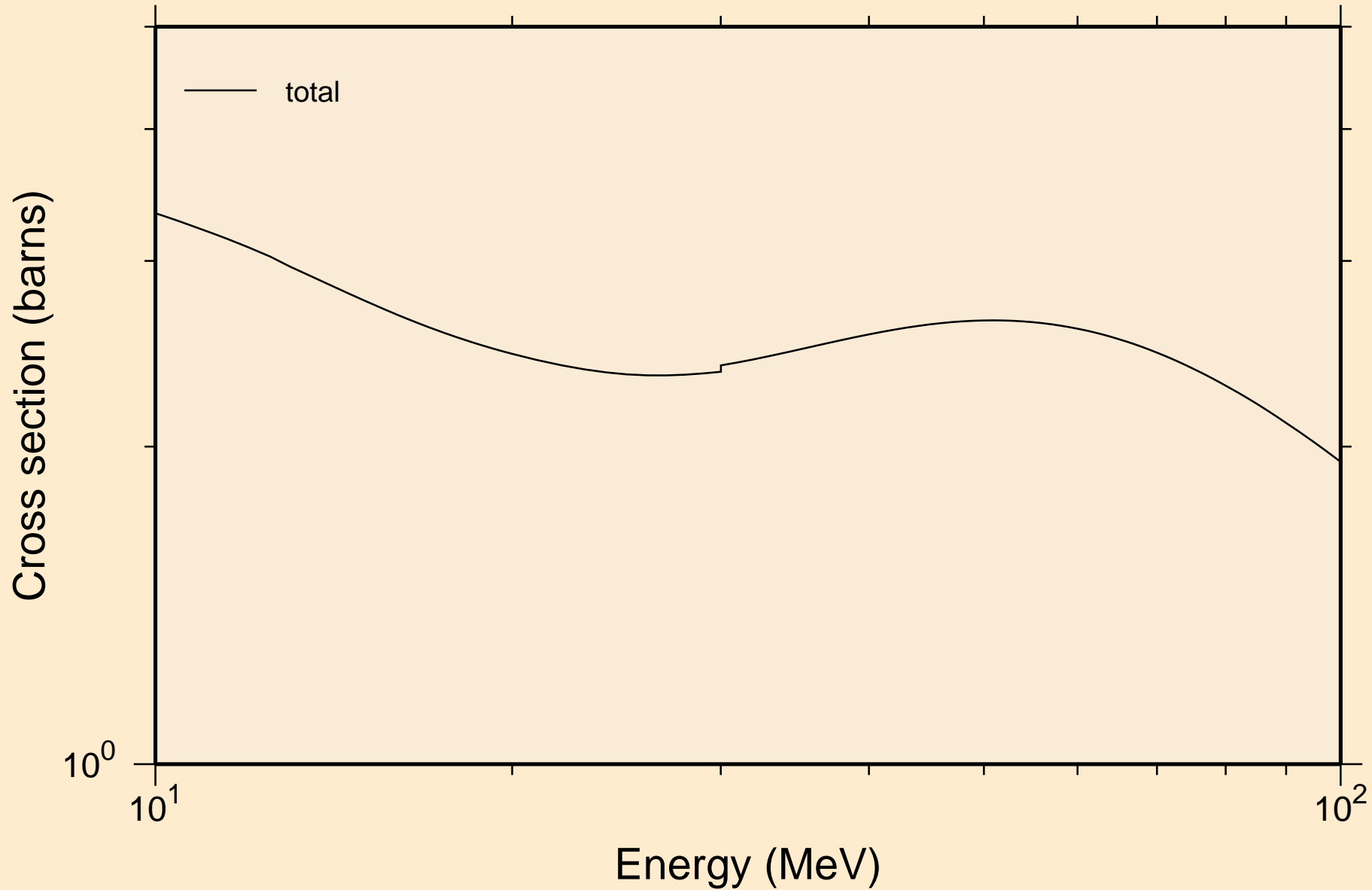

CU059 NEUTRON ACER TENDL-2023 LIBRARY; T=0.K  
resonance absorption cross sections

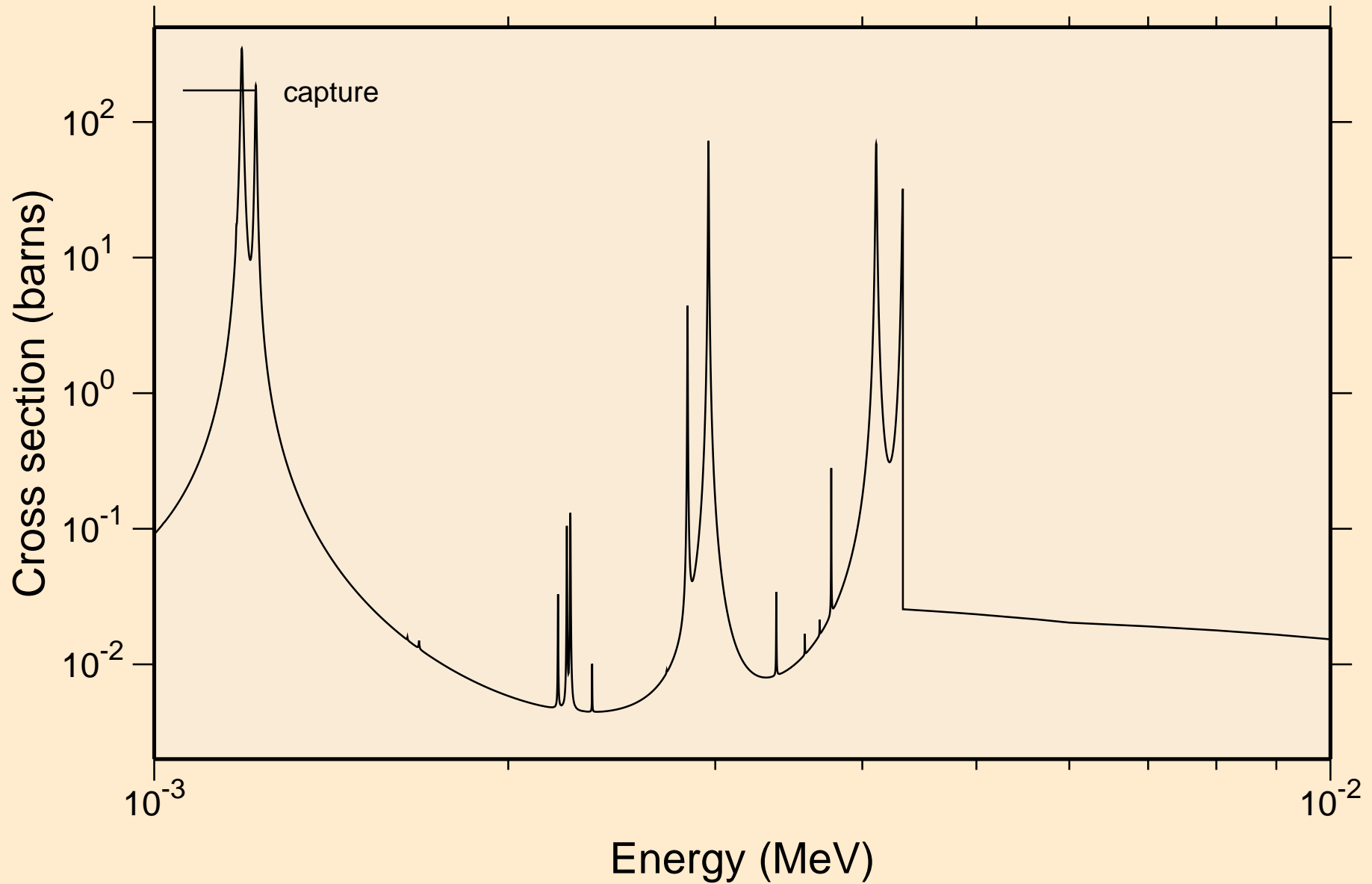

CU059 NEUTRON ACER TENDL-2023 LIBRARY; T=0.K  
resonance absorption cross sections

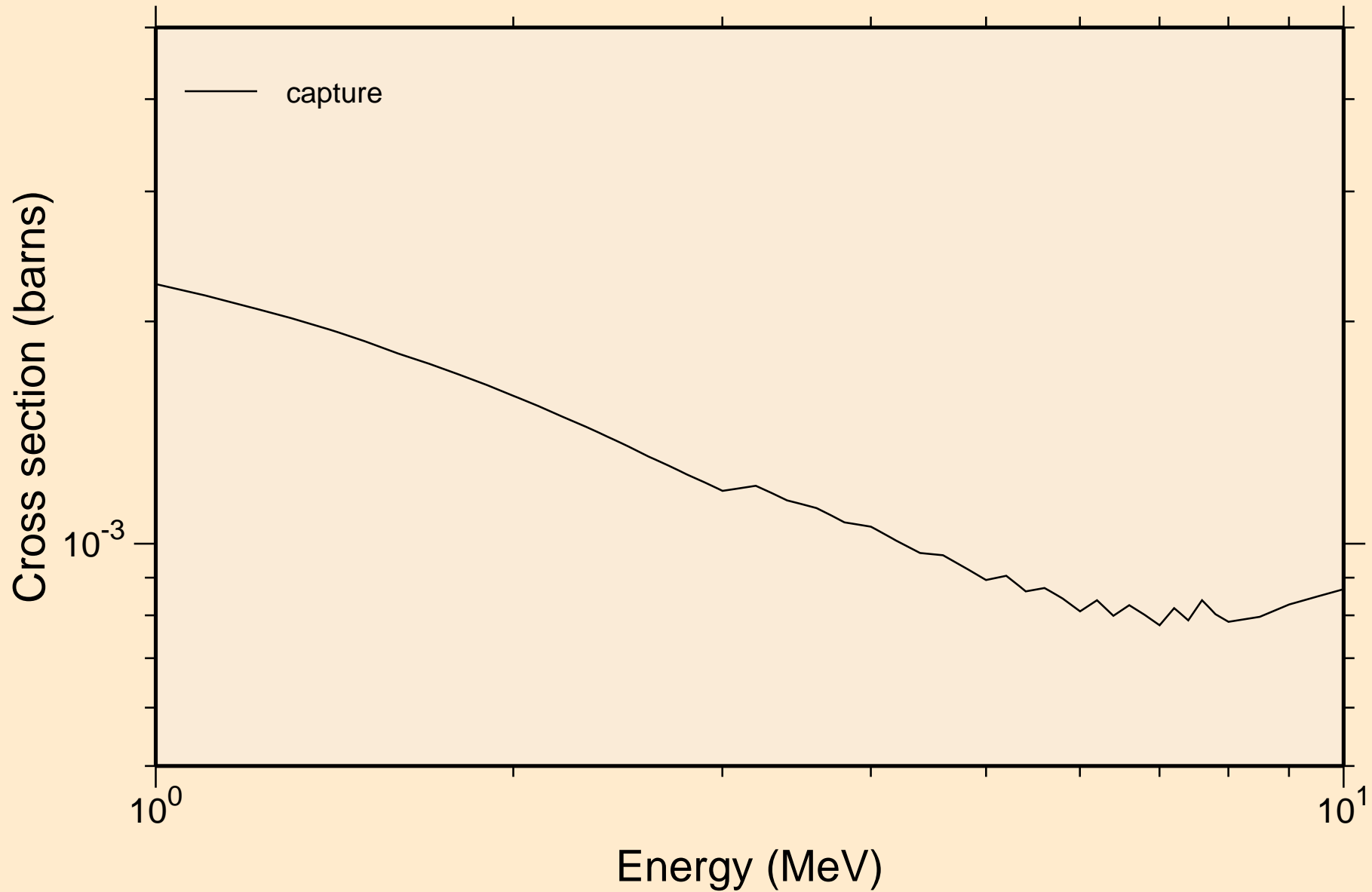

CU059 NEUTRON ACER TENDL-2023 LIBRARY; T=0.K  
Heating

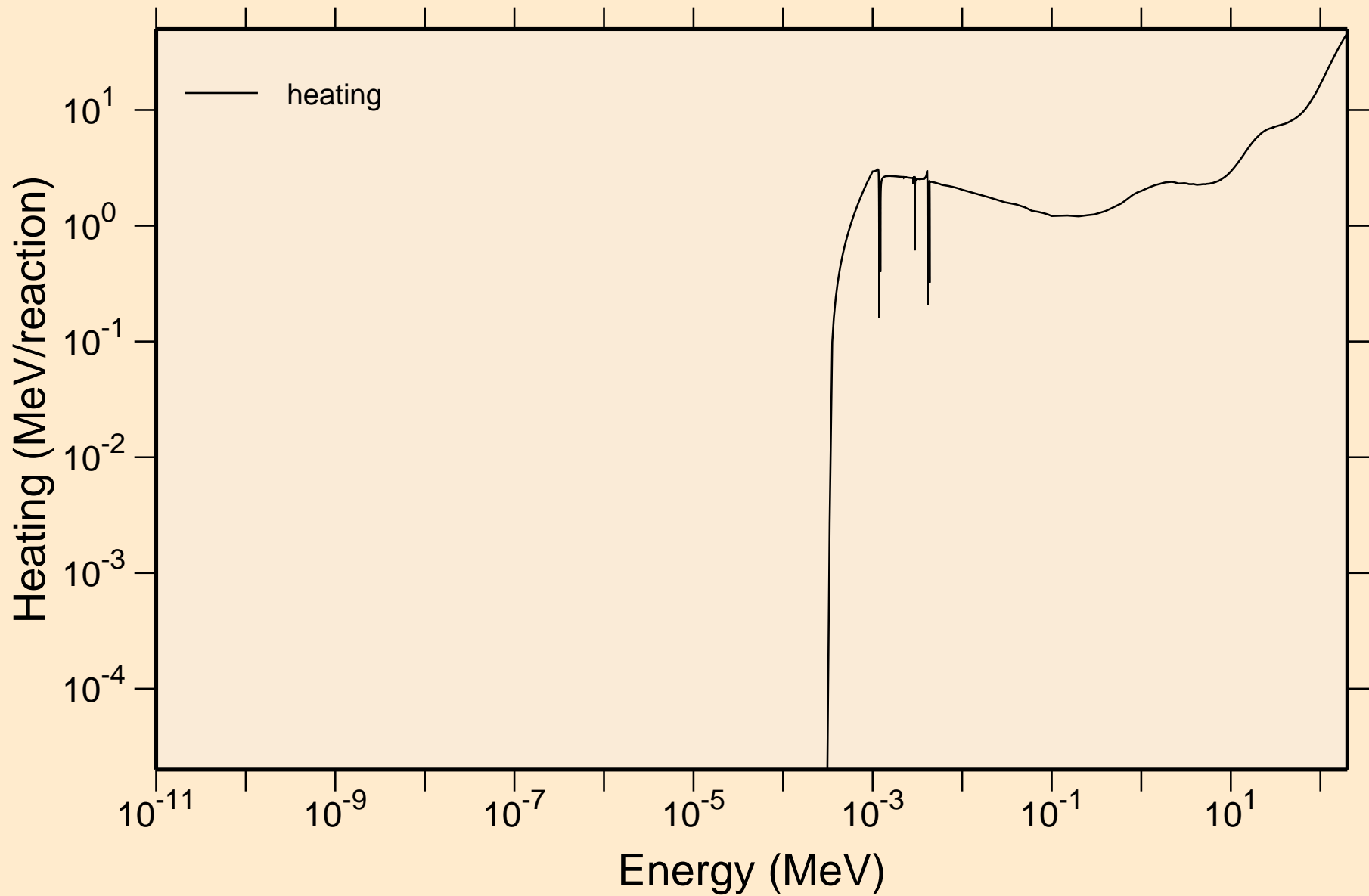

CU059 NEUTRON ACER TENDL-2023 LIBRARY; T=0.K  
Damage

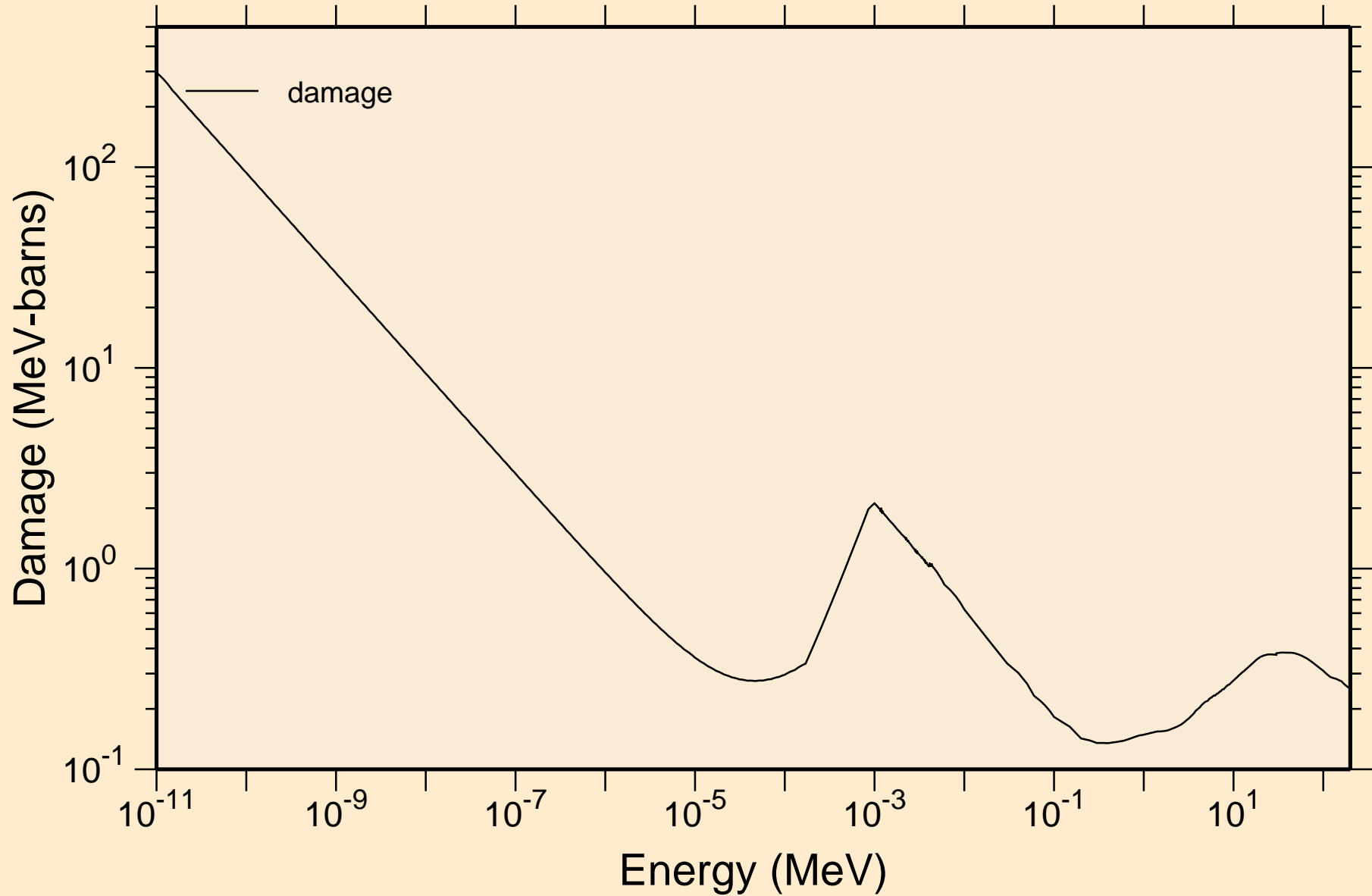

# CU059 NEUTRON ACER TENDL-2023 LIBRARY; T=0.K

## Non-threshold reactions

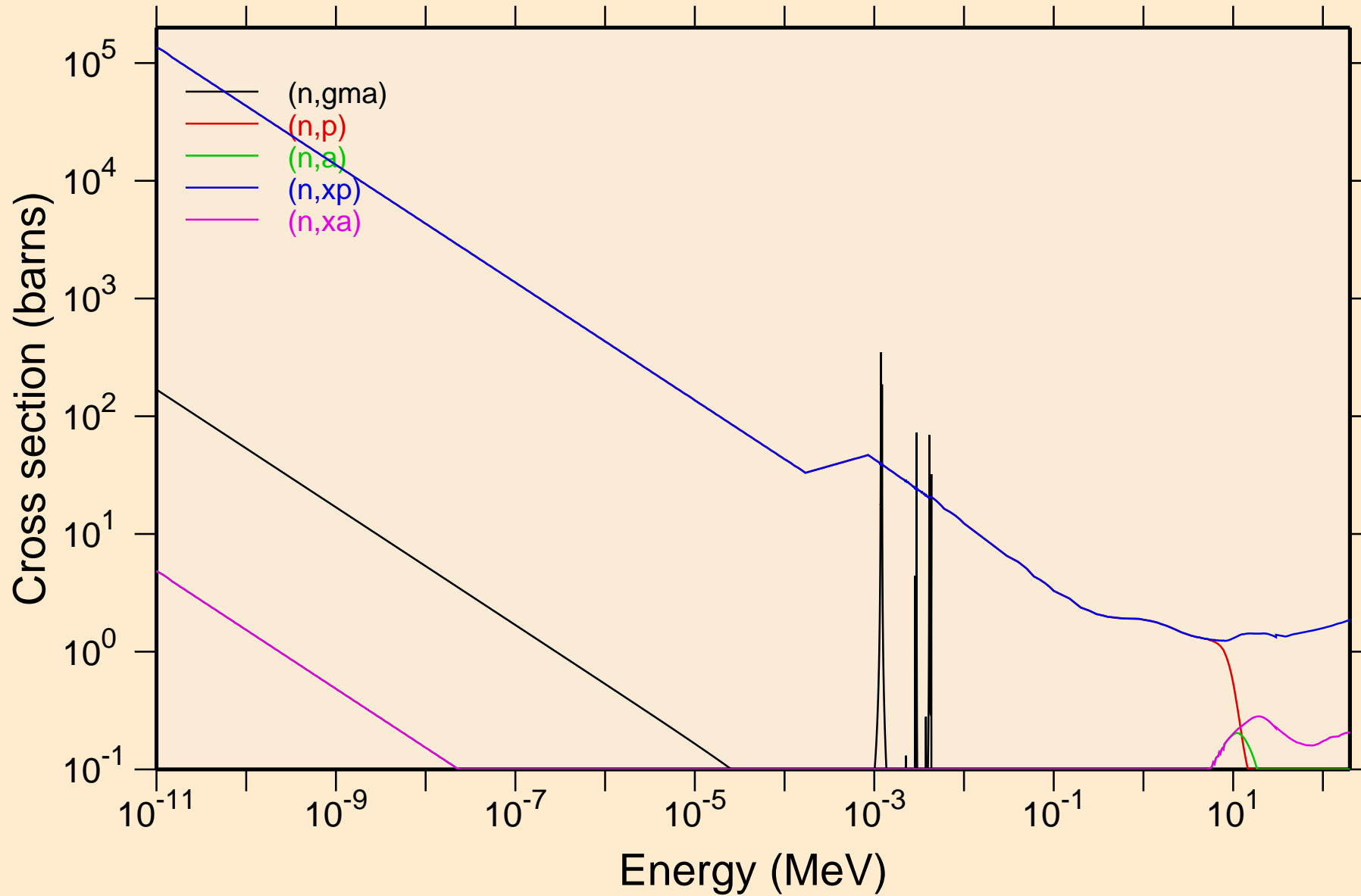



# CU059 NEUTRON ACER TENDL-2023 LIBRARY; T=0.K

## Principal cross sections

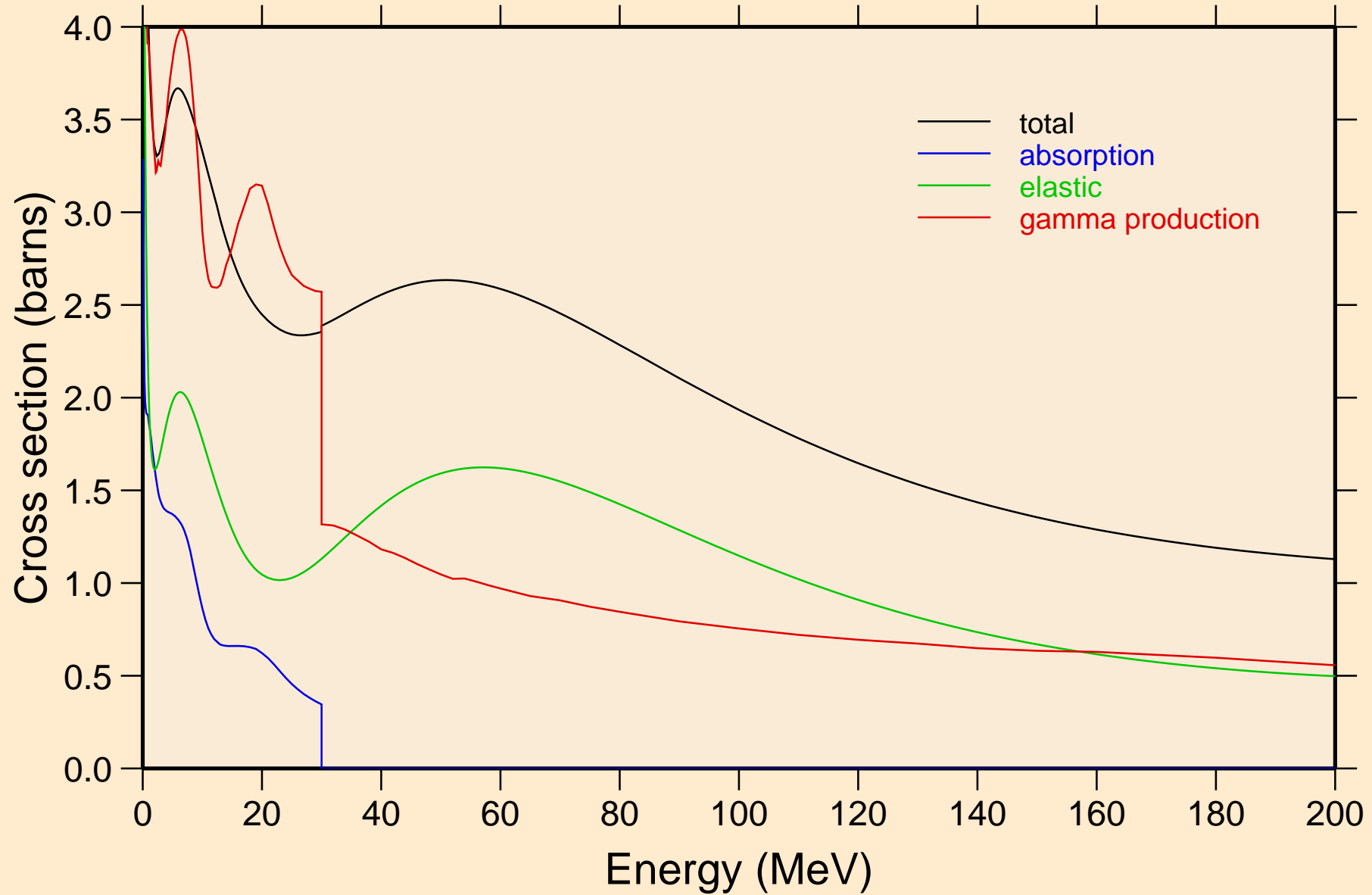

# CU059 NEUTRON ACER TENDL-2023 LIBRARY; T=0.K

## Heating

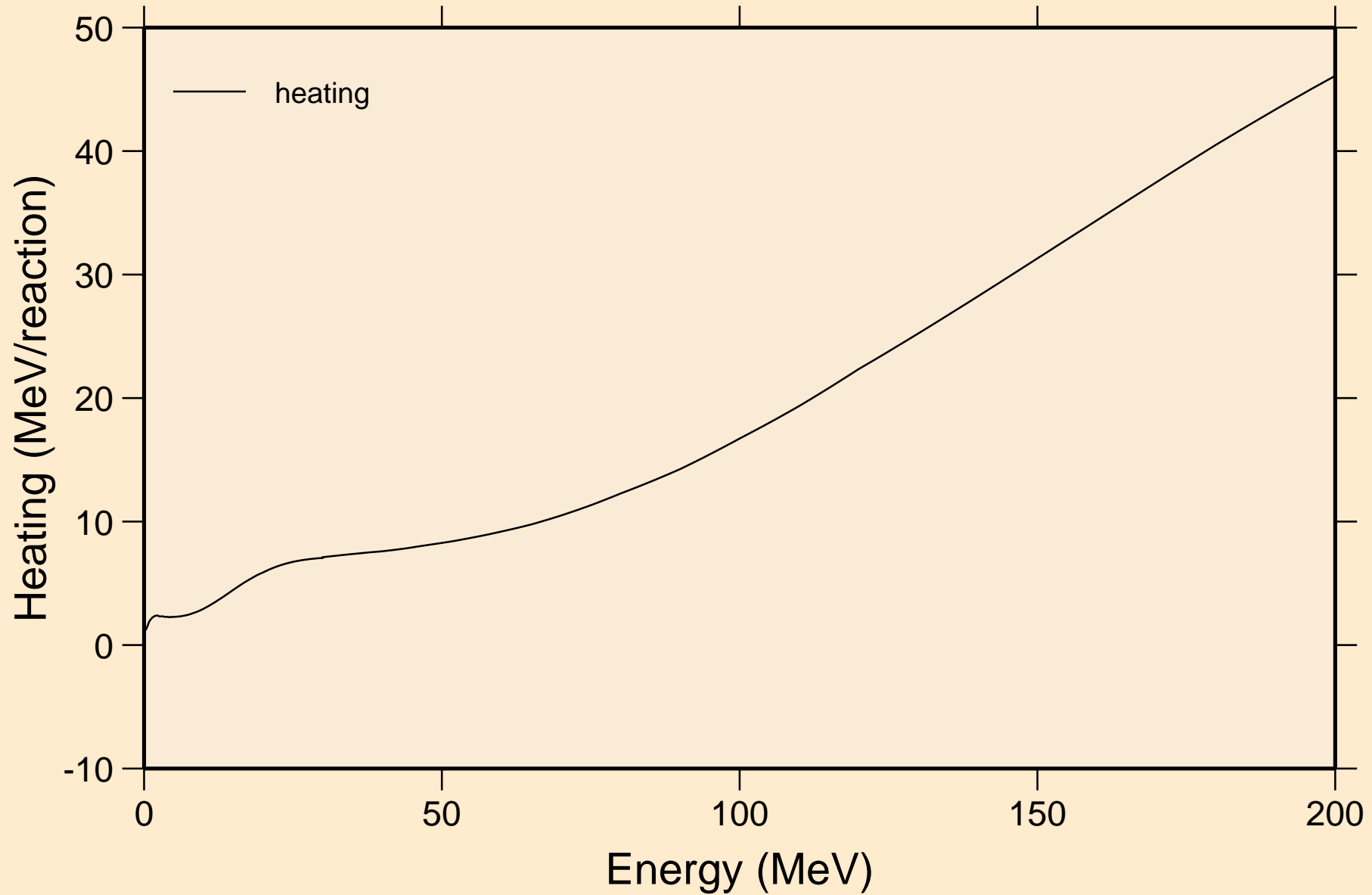

CU059 NEUTRON ACER TENDL-2023 LIBRARY; T=0.K  
Damage

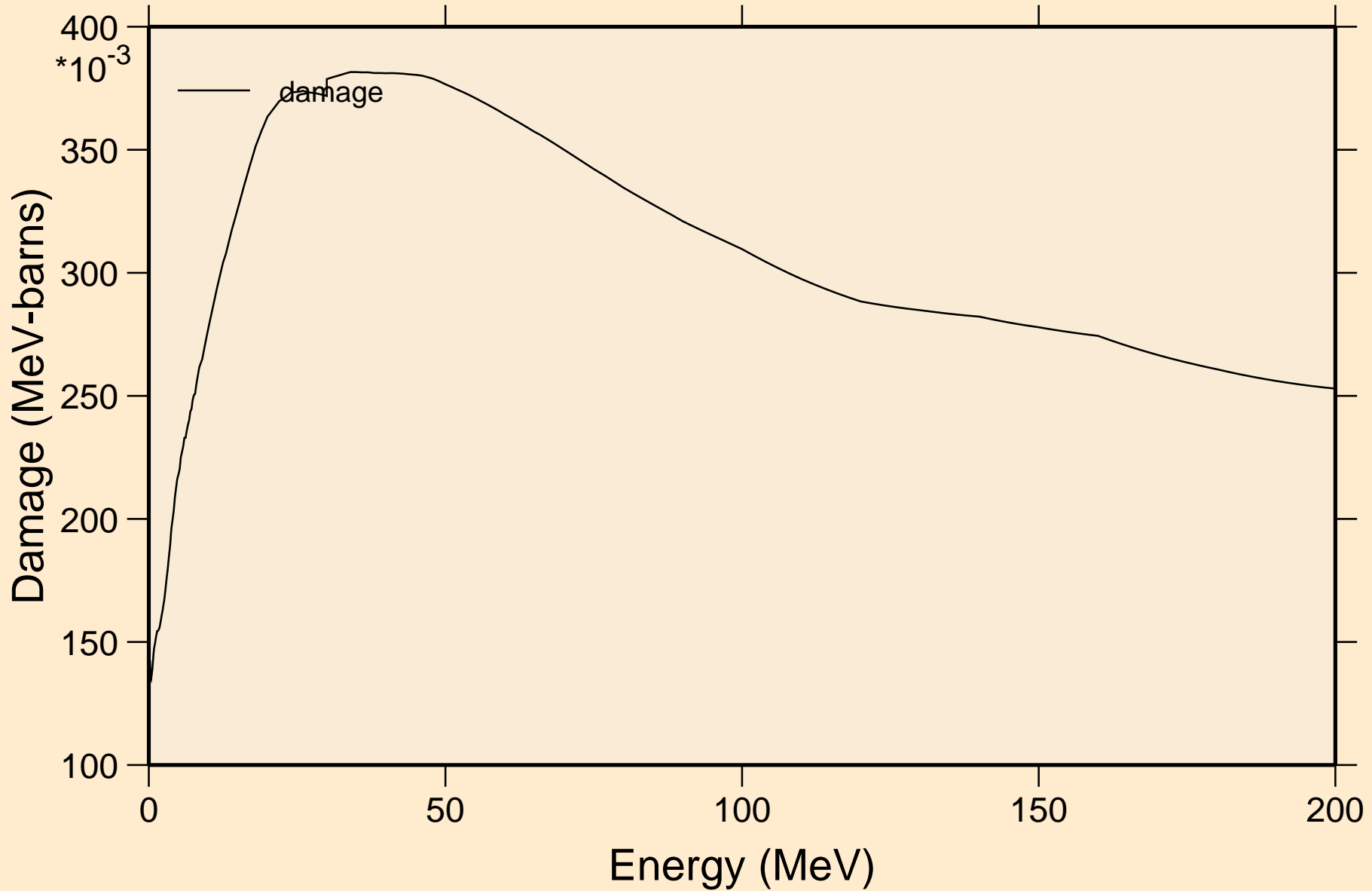

CU059 NEUTRON ACER TENDL-2023 LIBRARY; T=0.K  
Non-threshold reactions

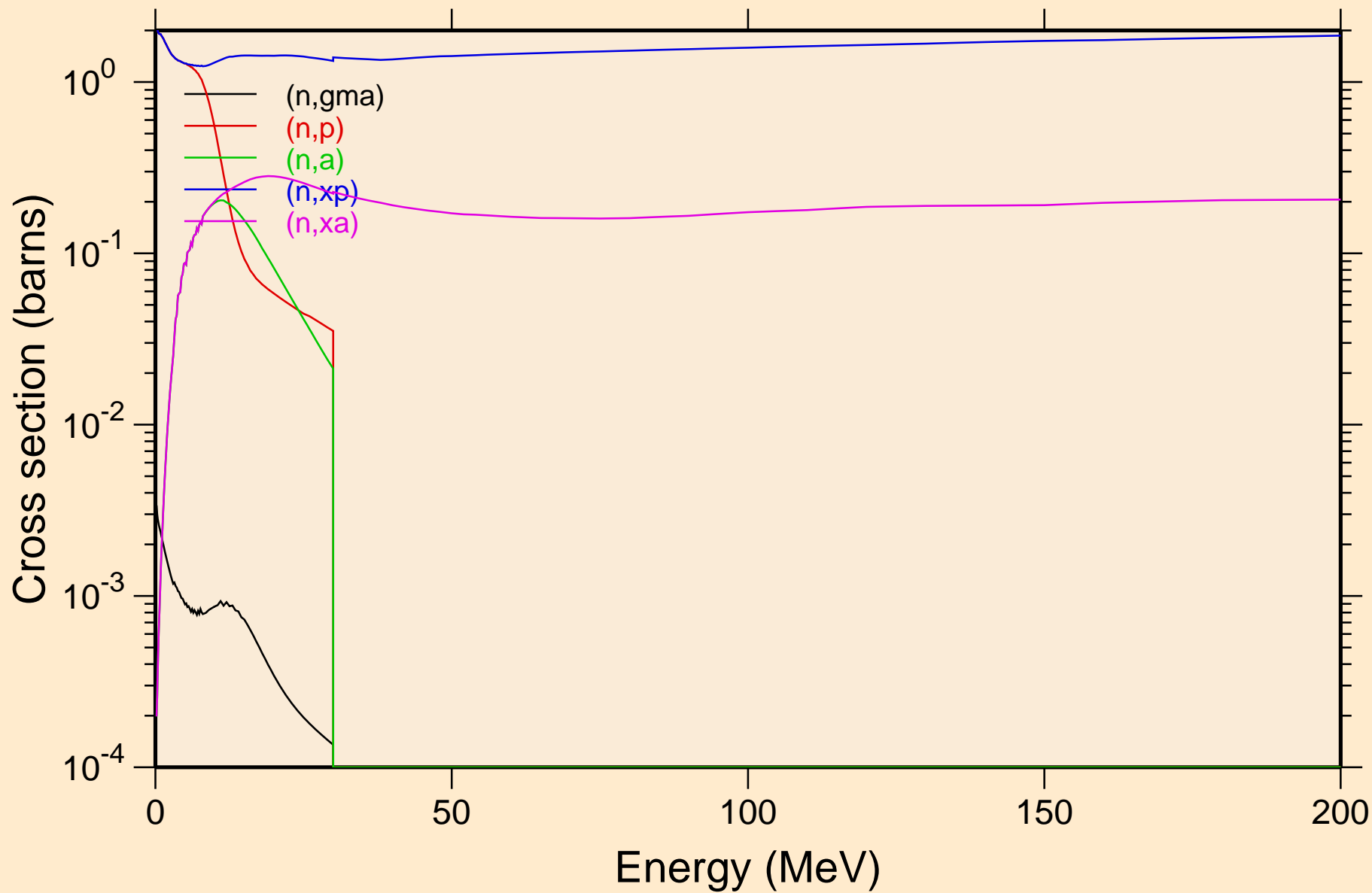

CU059 NEUTRON ACER TENDL-2023 LIBRARY; T=0.K  
Inelastic levels

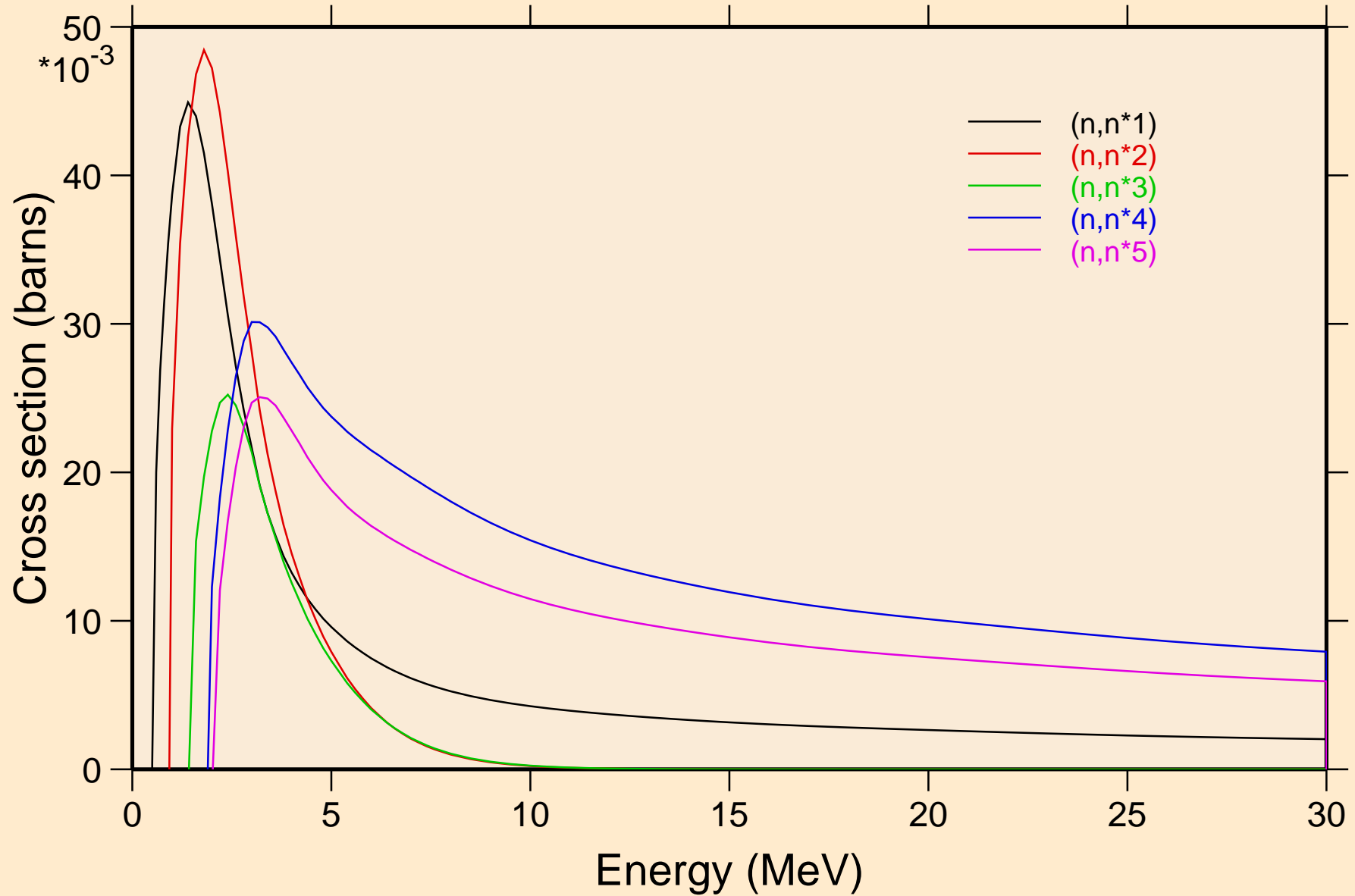

CU059 NEUTRON ACER TENDL-2023 LIBRARY; T=0.K  
Inelastic levels

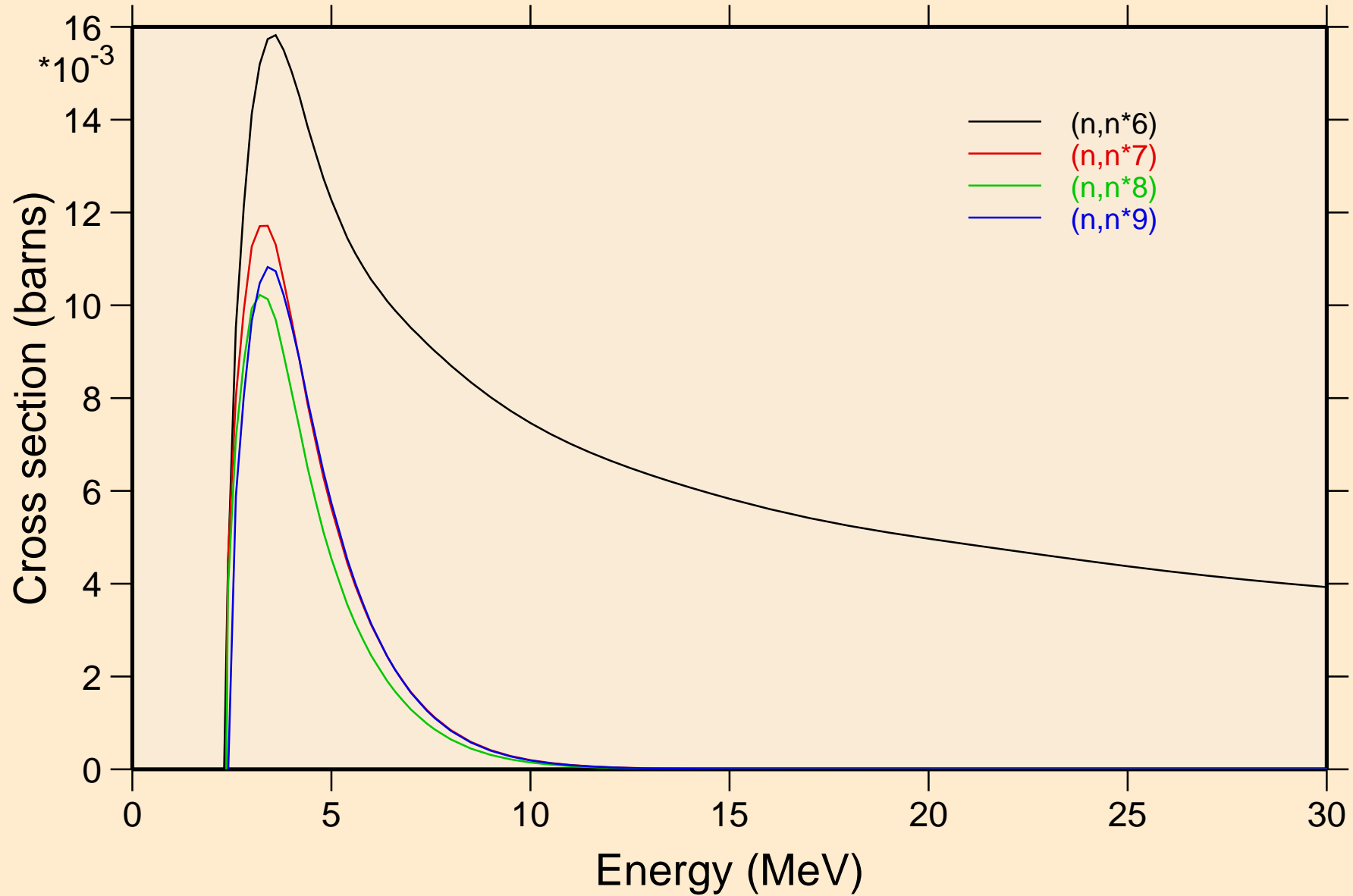

CU059 NEUTRON ACER TENDL-2023 LIBRARY; T=0.K  
Threshold reactions

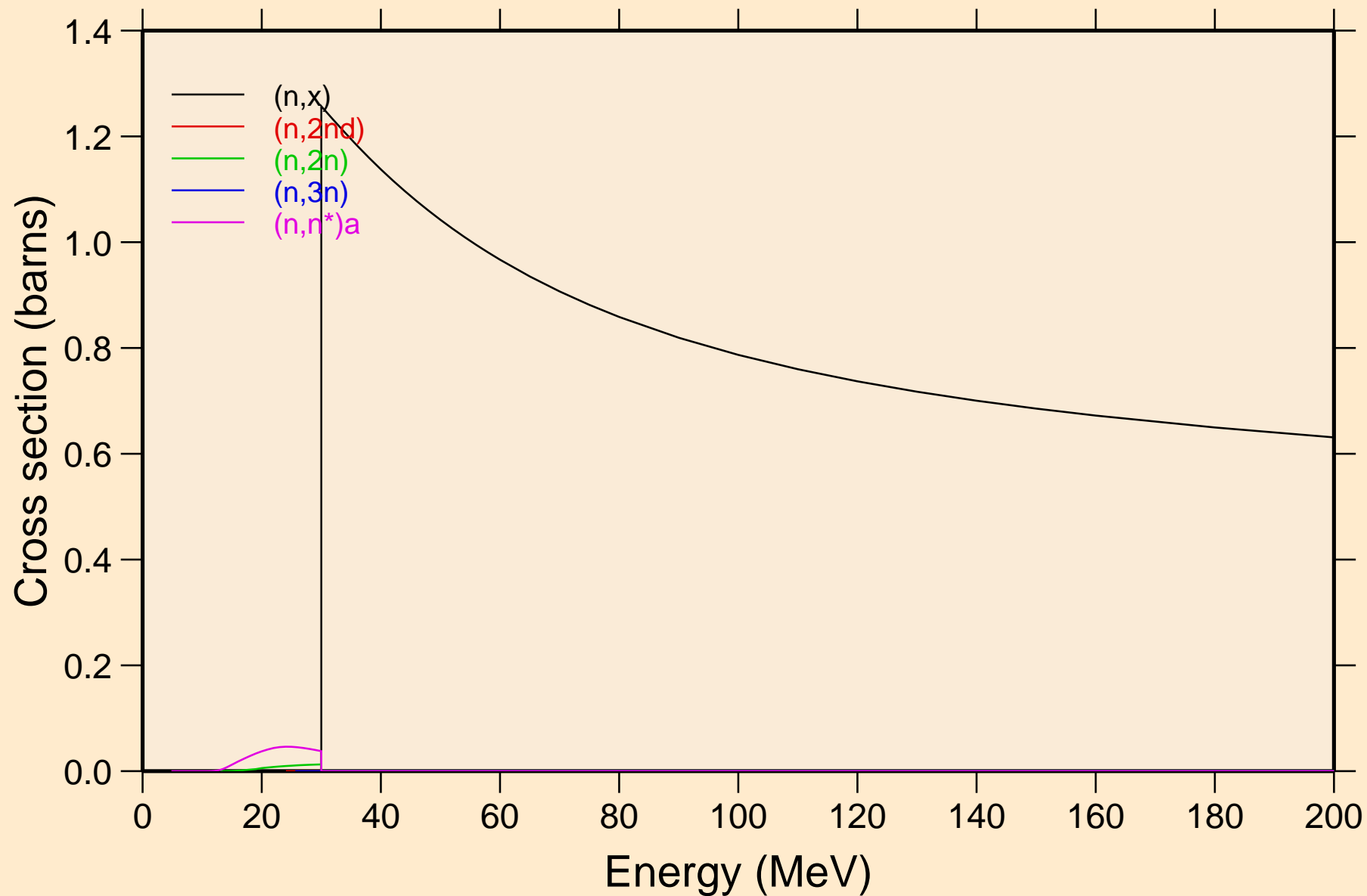

CU059 NEUTRON ACER TENDL-2023 LIBRARY; T=0.K  
Threshold reactions

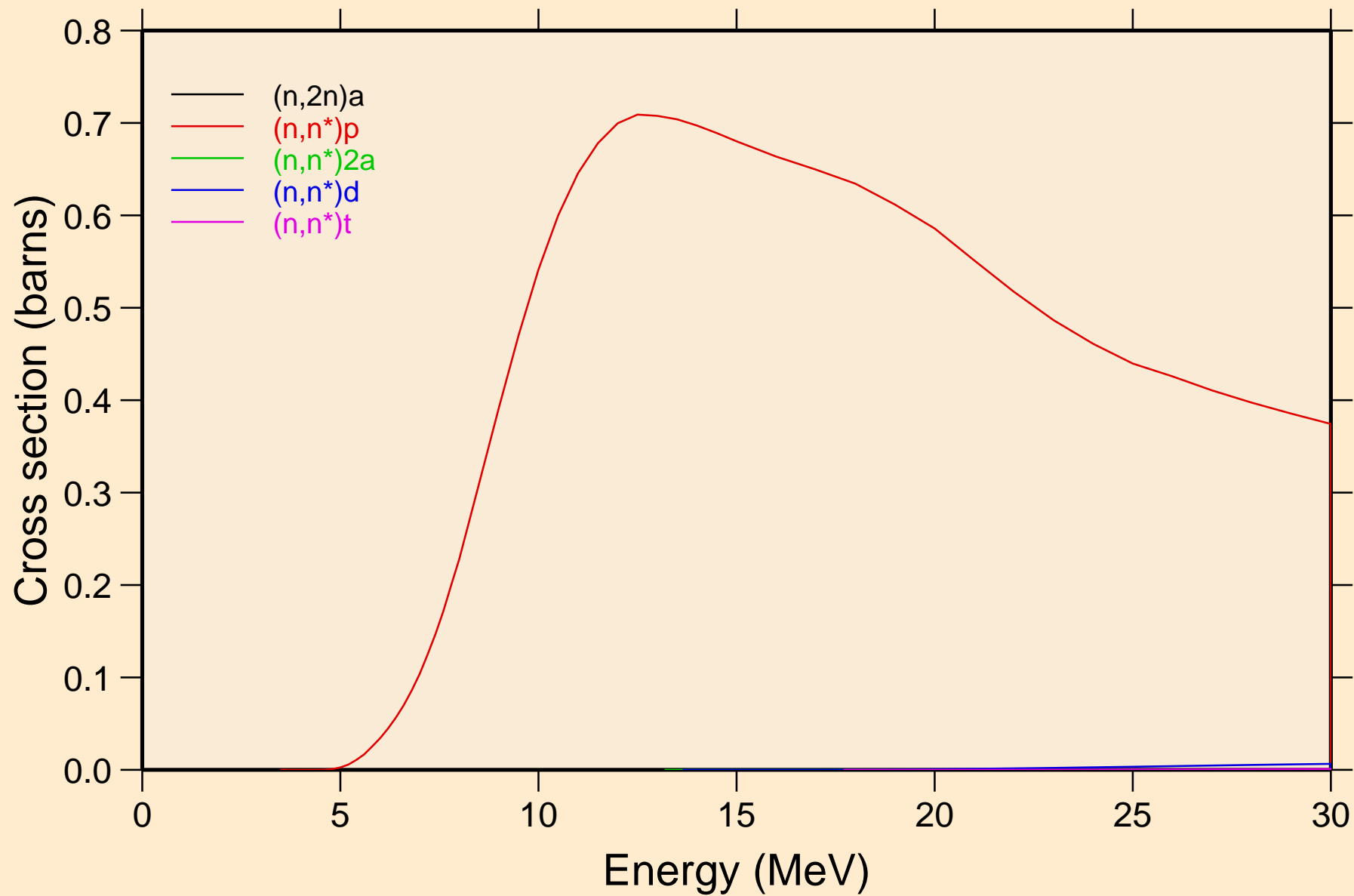



# CU059 NEUTRON ACER TENDL-2023 LIBRARY; T=0.K

## Threshold reactions

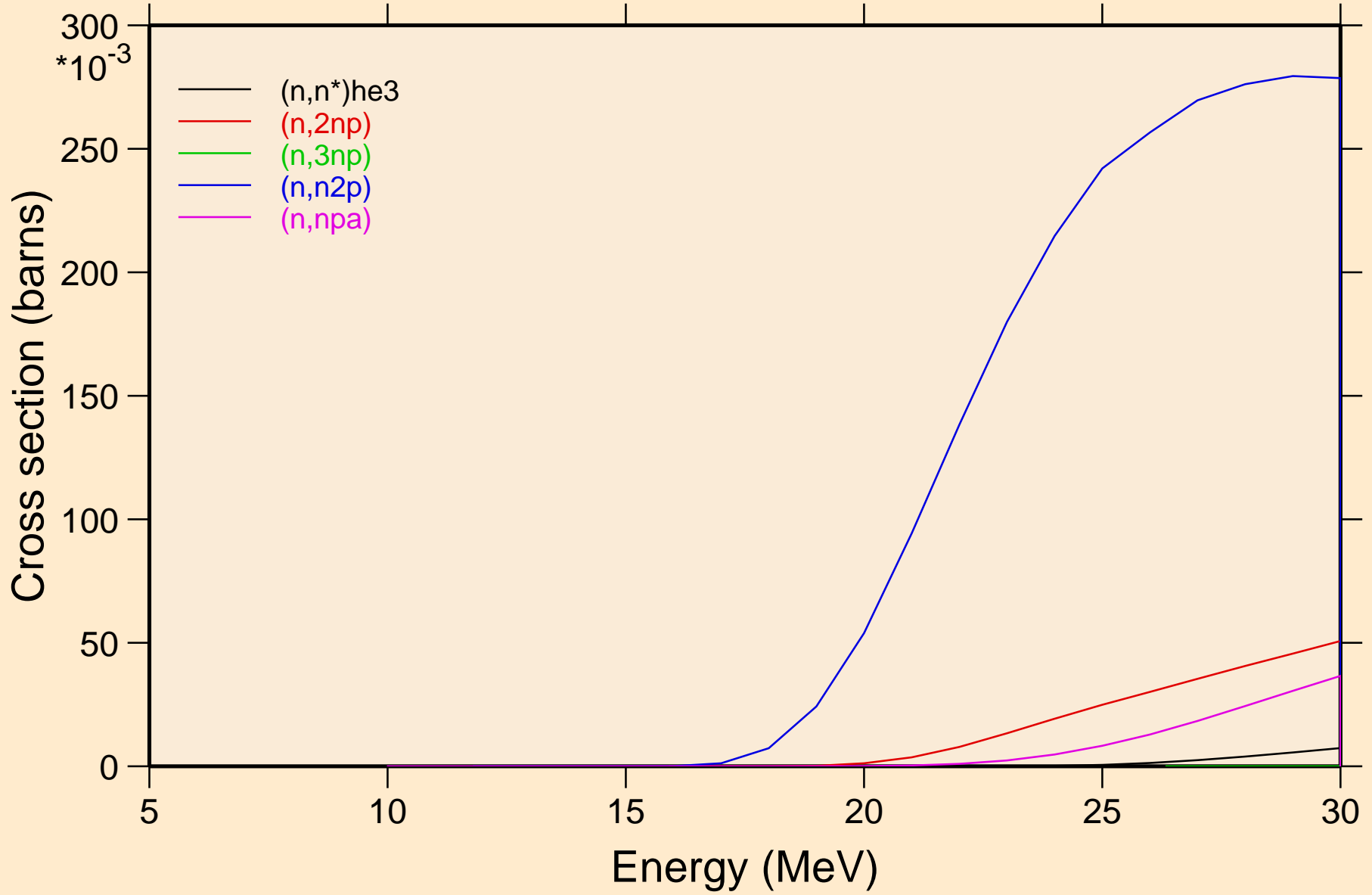

# CU059 NEUTRON ACER TENDL-2023 LIBRARY; T=0.K

## Threshold reactions

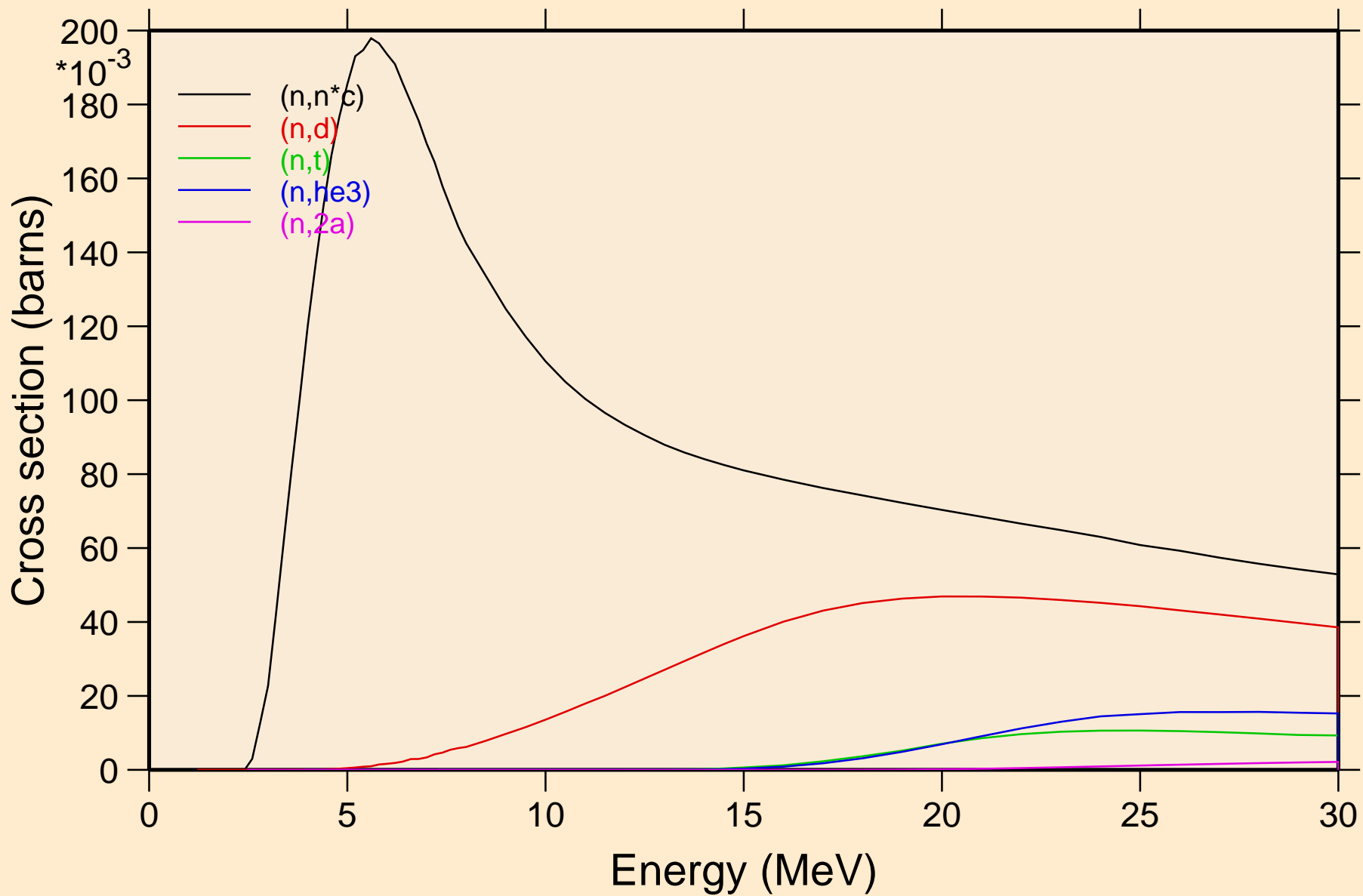

# CU059 NEUTRON ACER TENDL-2023 LIBRARY; T=0.K

## Threshold reactions

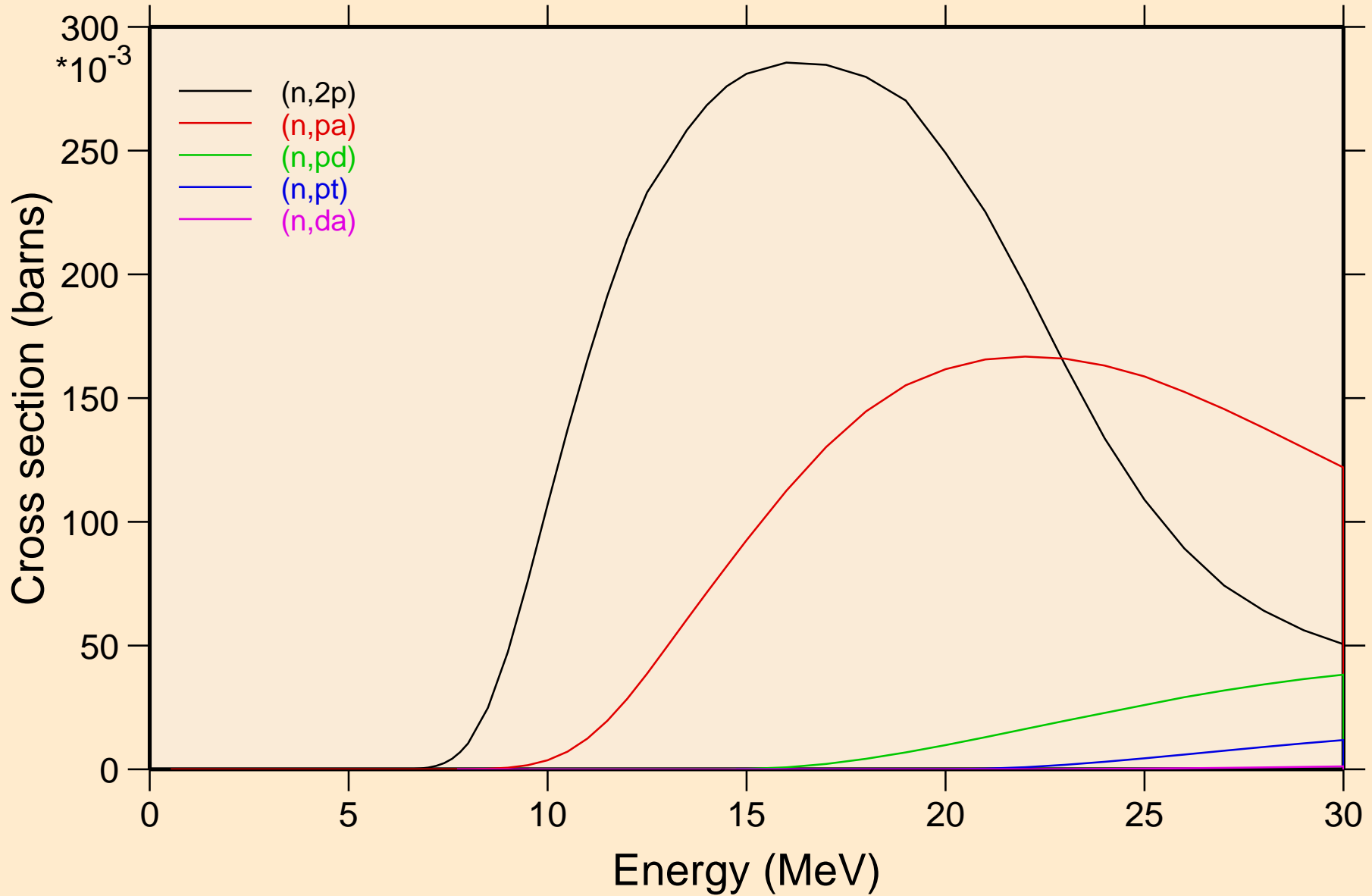

# CU059 NEUTRON ACER TENDL-2023 LIBRARY; T=0.K

## Threshold reactions

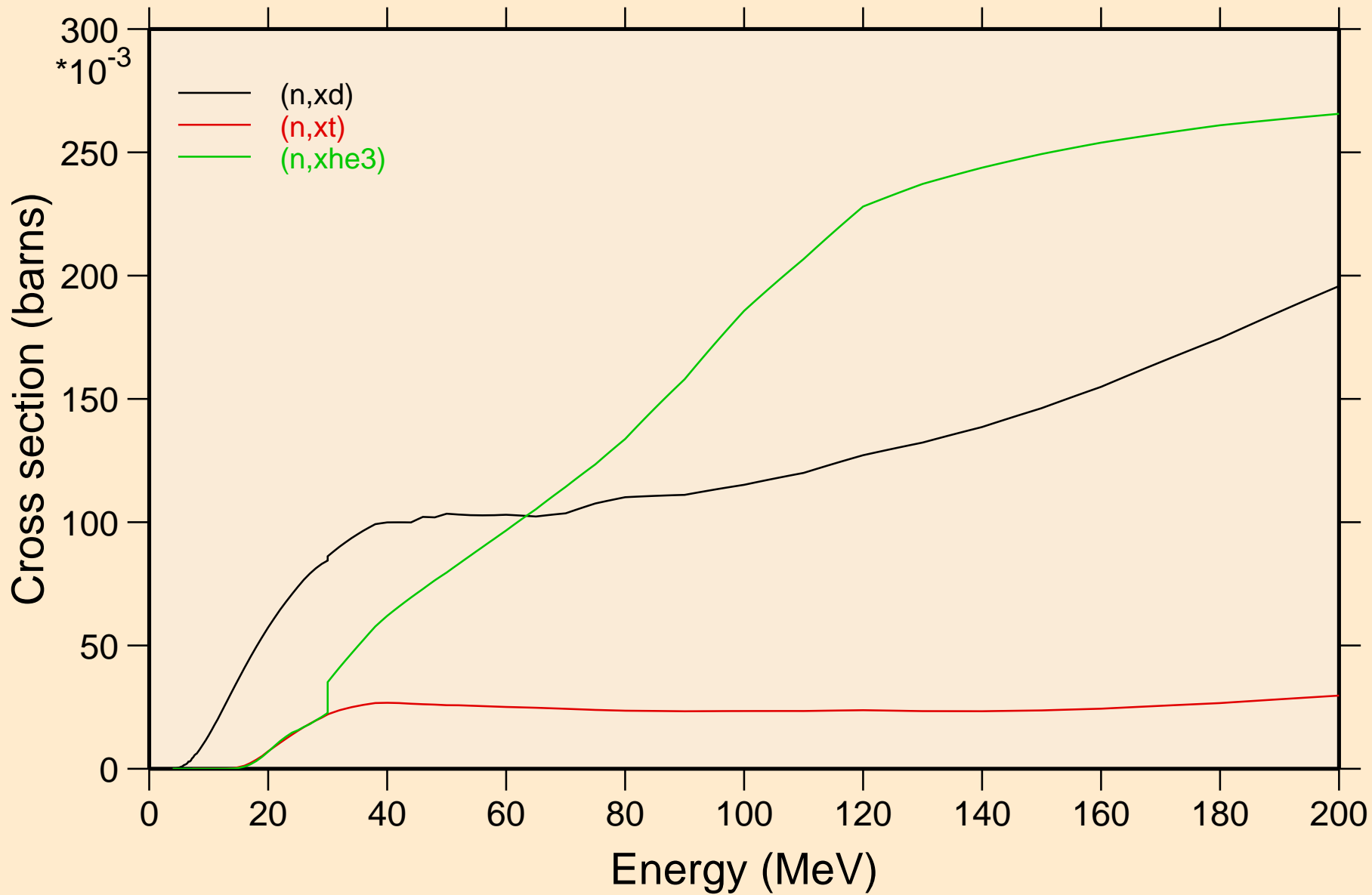

CU059 NEUTRON ACER TENDL-2023 LIBRARY; T=0.K  
angular distribution for elastic

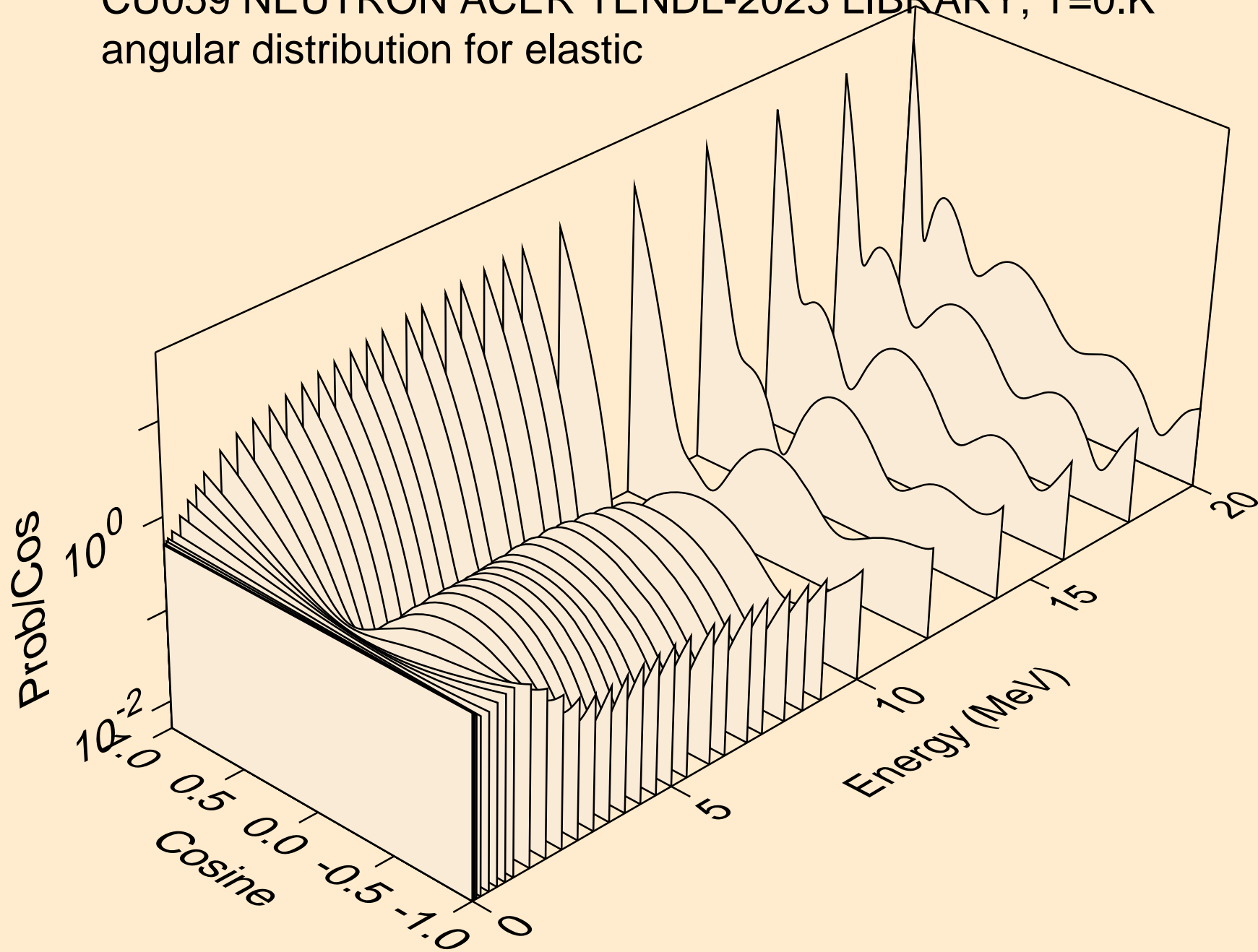

CU059 NEUTRON ACER TENDL-2023 LIBRARY; T=0.K  
angular distribution for elastic

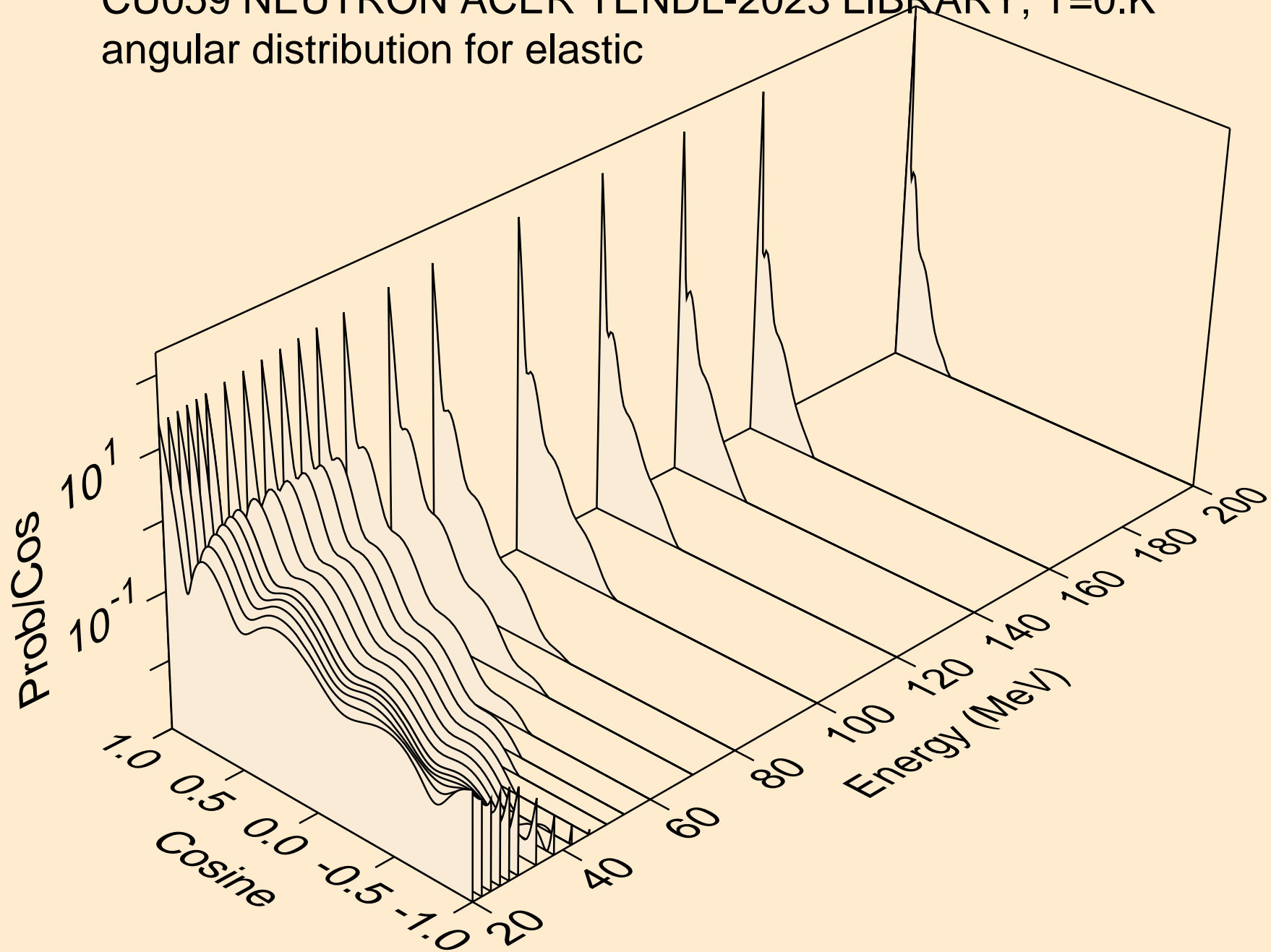

CU059 NEUTRON ACER TENDL-2023 LIBRARY; T=0.K  
angular distribution for (n,n\*1)

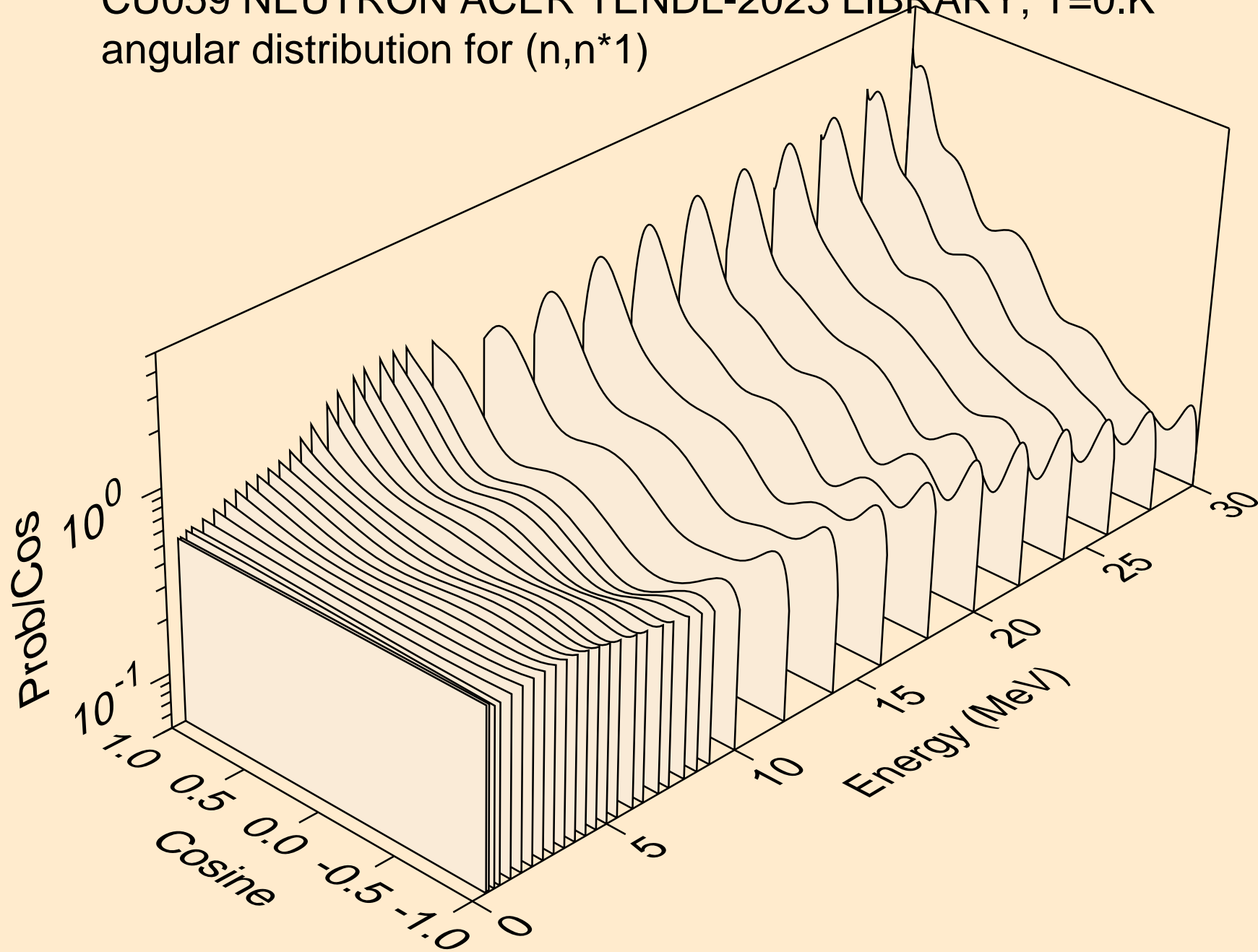

CU059 NEUTRON ACER TENDL-2023 LIBRARY; T=0.K  
angular distribution for (n,n\*2)

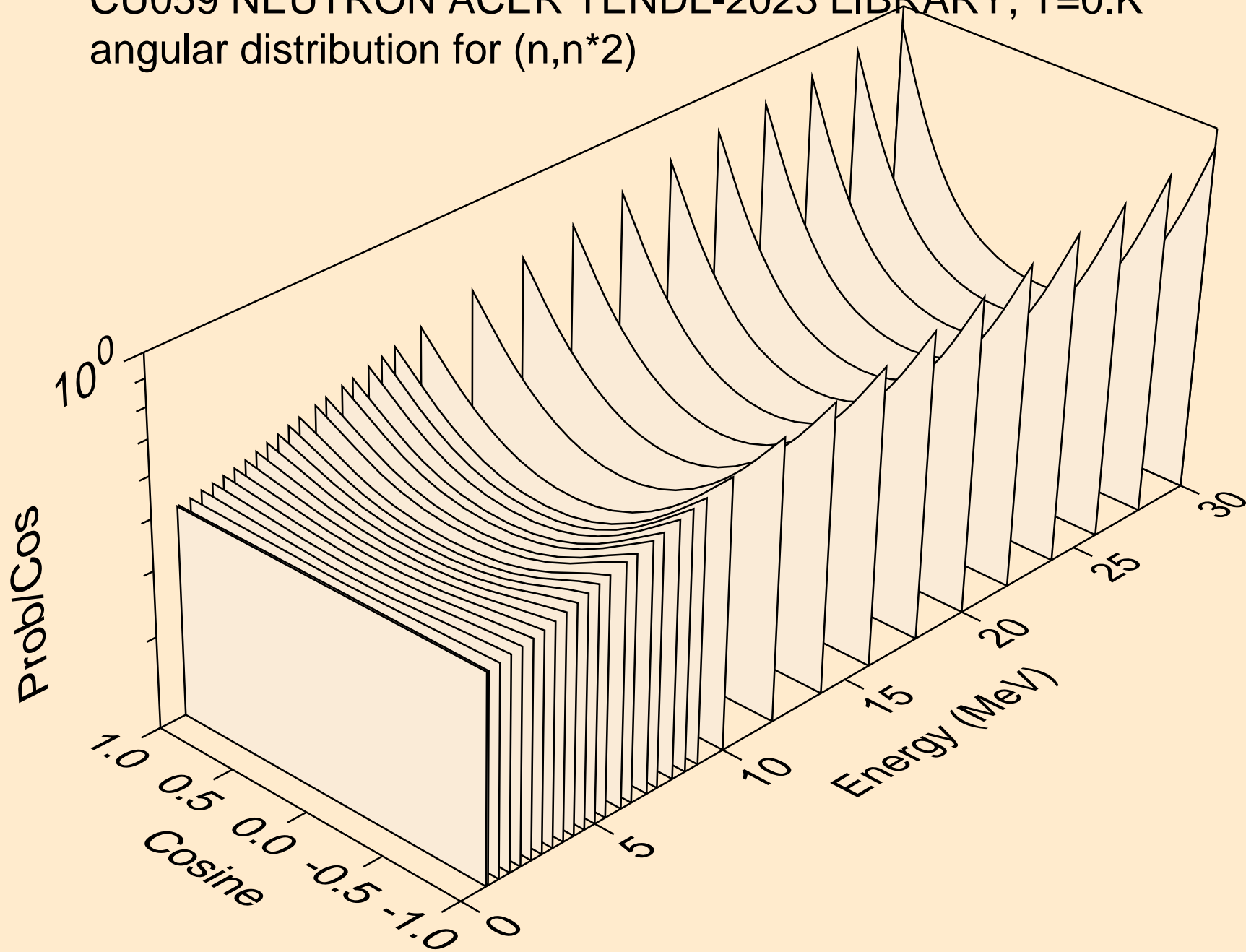



CU059 NEUTRON ACER TENDL-2023 LIBRARY; T=0.K  
angular distribution for (n,n\*3)

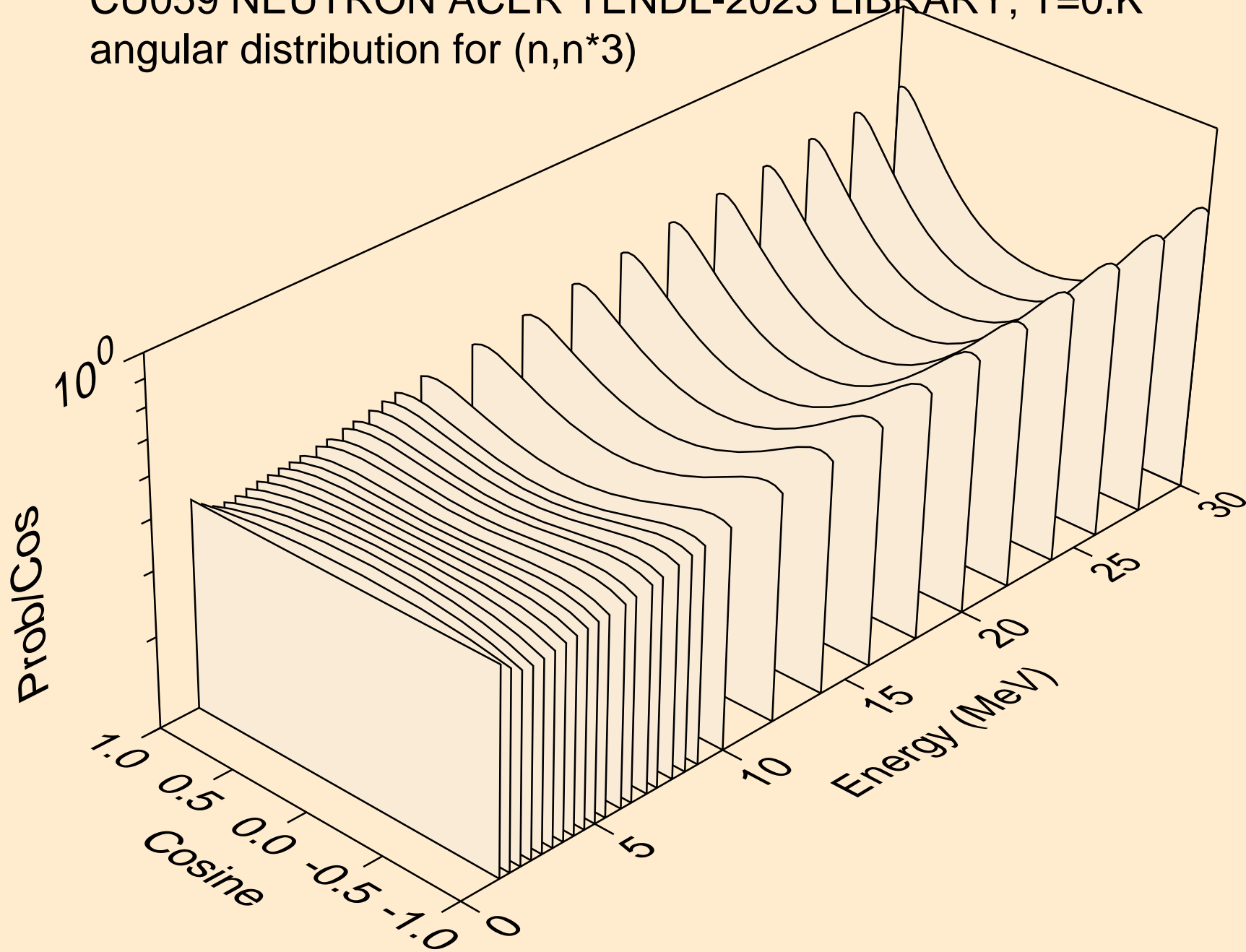

CU059 NEUTRON ACER TENDL-2023 LIBRARY; T=0.K  
angular distribution for (n,n\*4)

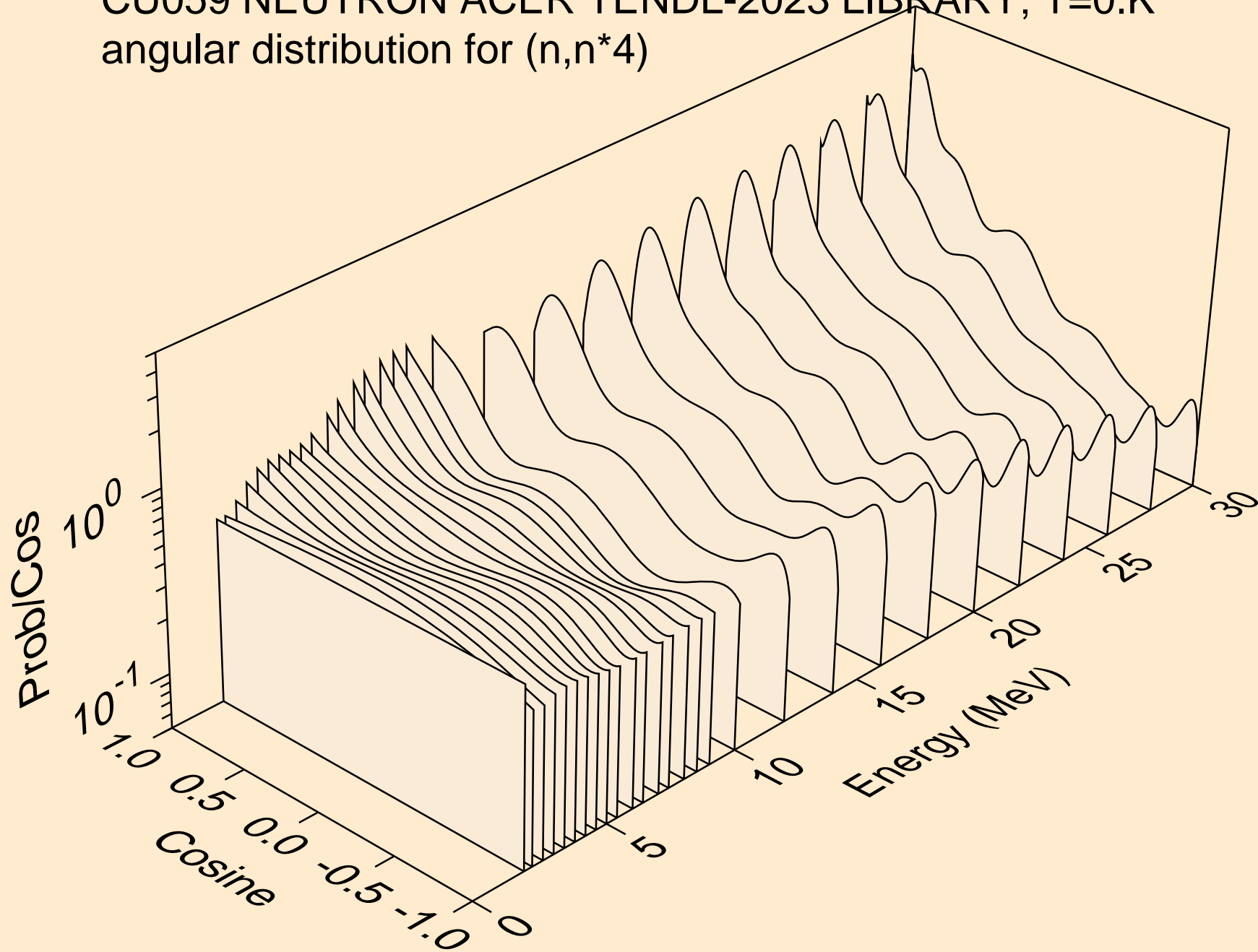

CU059 NEUTRON ACER TENDL-2023 LIBRARY; T=0.K  
angular distribution for (n,n\*5)

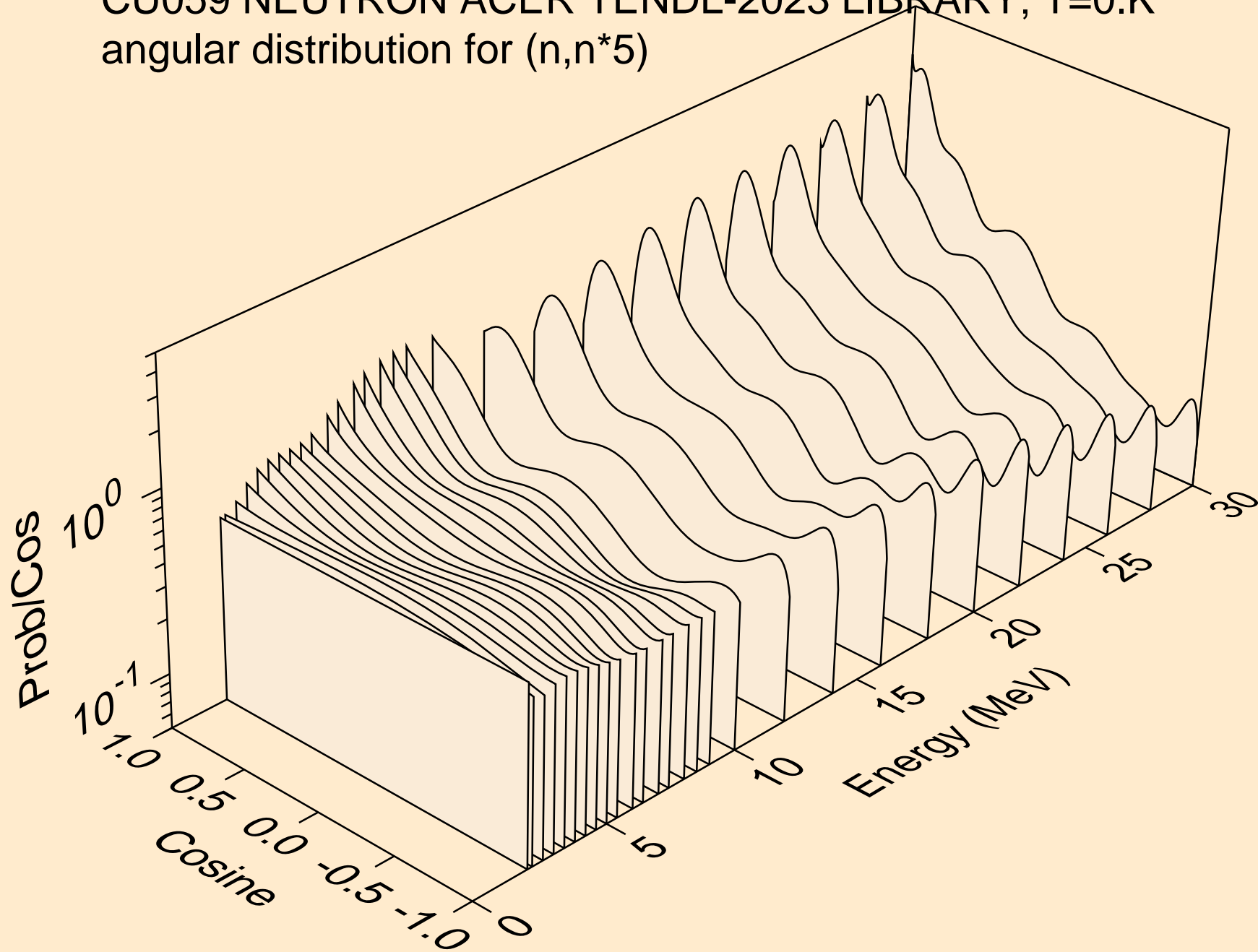

CU059 NEUTRON ACER TENDL-2023 LIBRARY; T=0.K  
angular distribution for (n,n\*6)

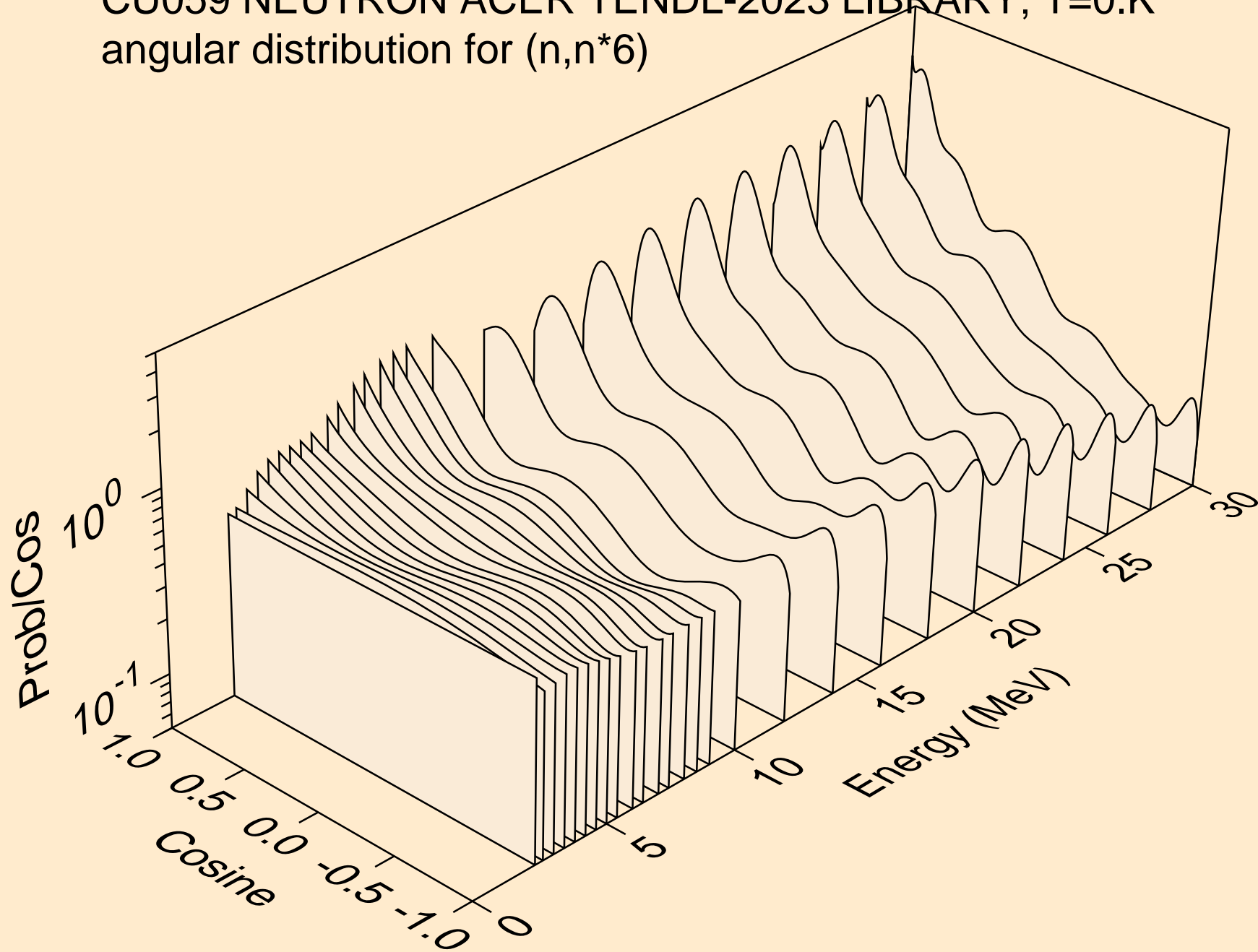

CU059 NEUTRON ACER TENDL-2023 LIBRARY; T=0.K  
angular distribution for (n,n\*7)

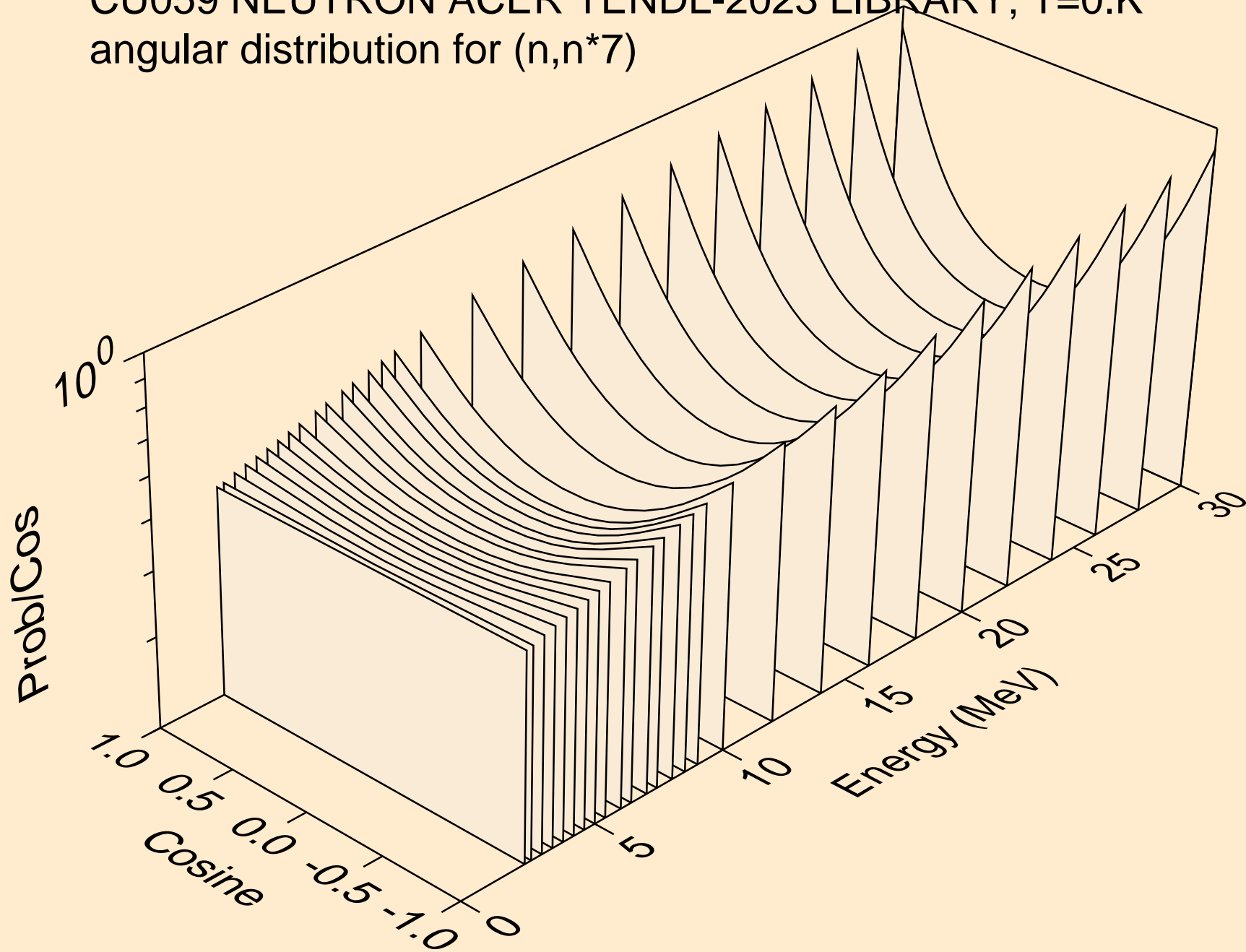

CU059 NEUTRON ACER TENDL-2023 LIBRARY; T=0.K  
angular distribution for (n,n\*8)

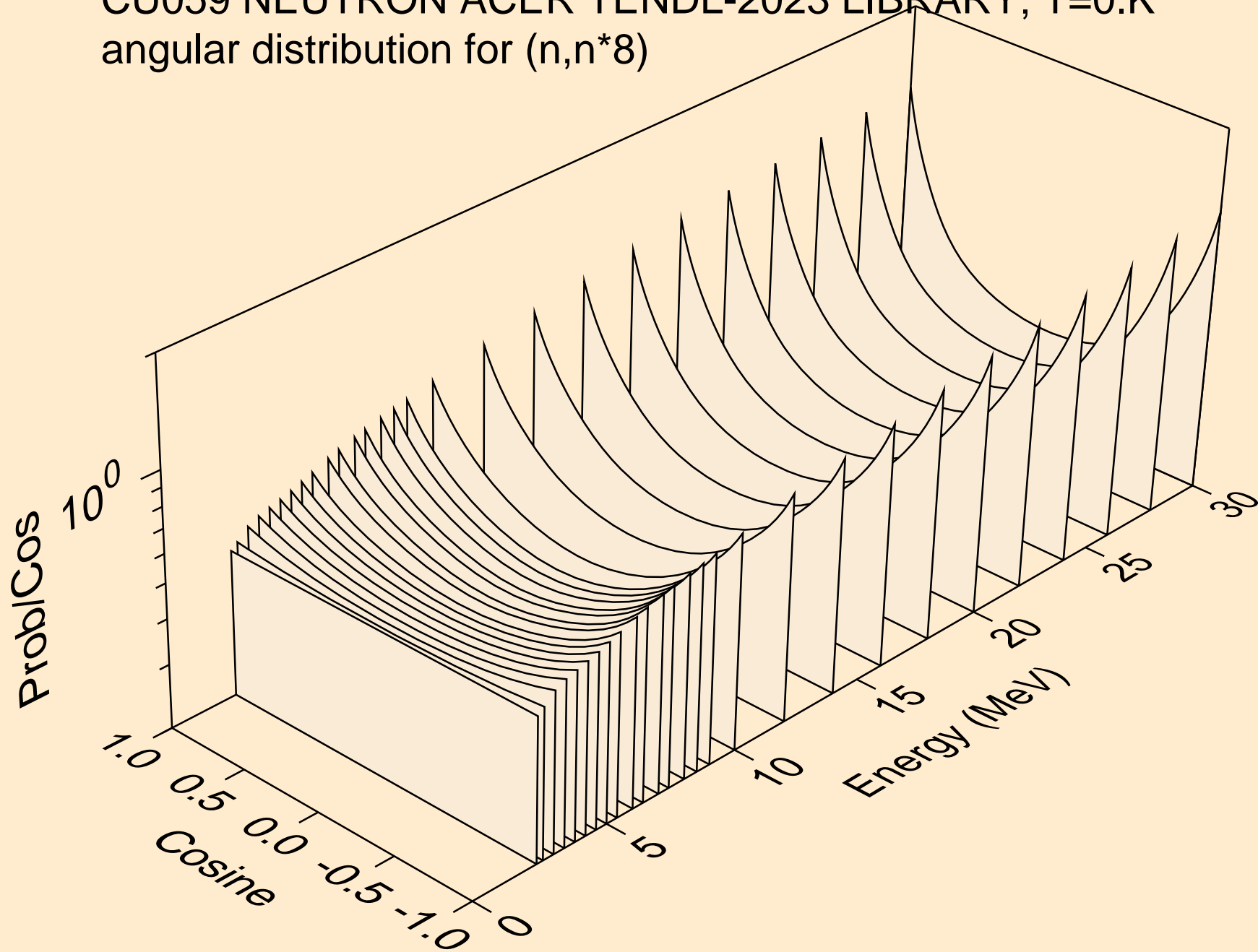

CU059 NEUTRON ACER TENDL-2023 LIBRARY; T=0.K  
angular distribution for (n,n\*9)

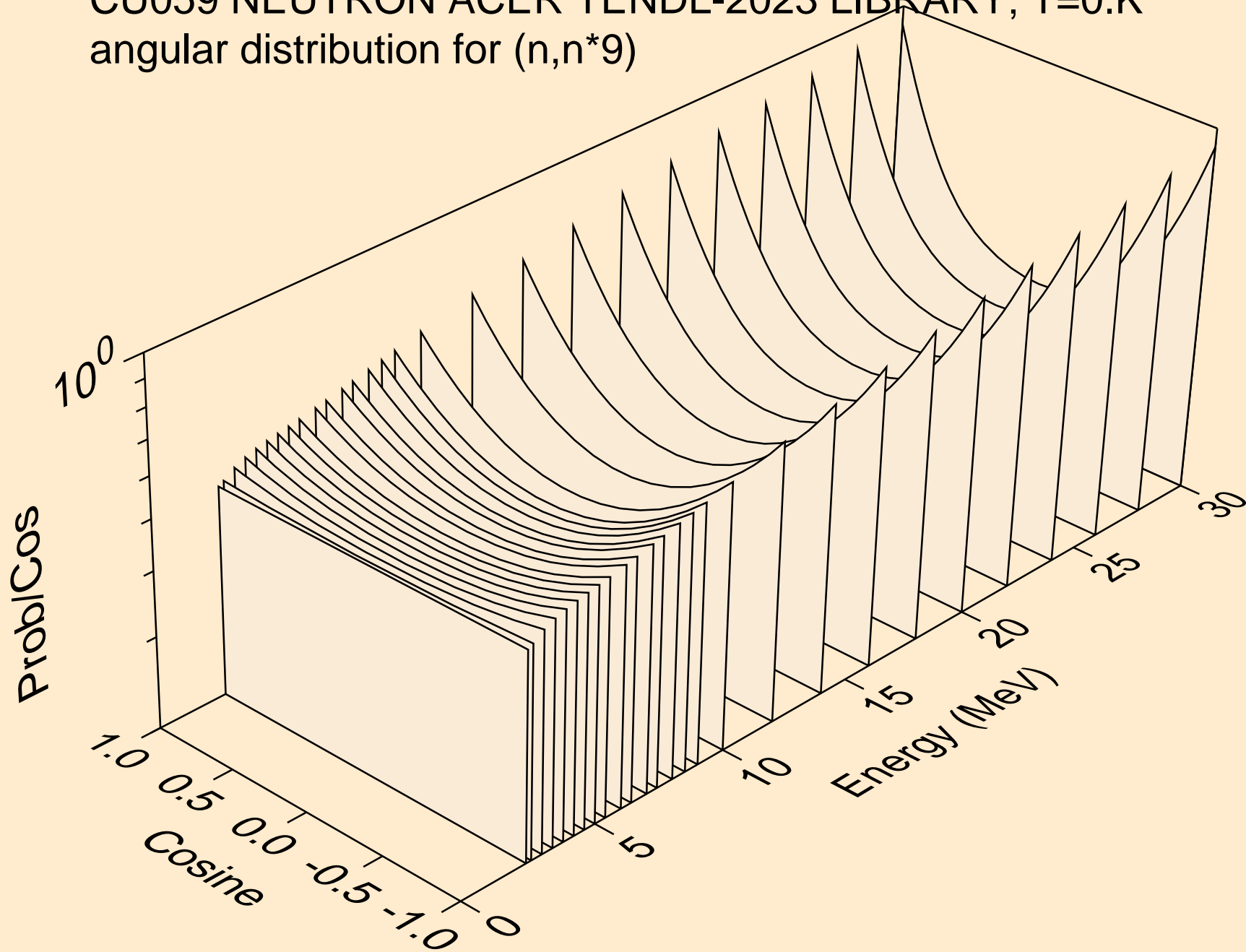

CU059 NEUTRON ACER TENDL-2023 LIBRARY; T=0.K  
Neutron emission for (n,x)

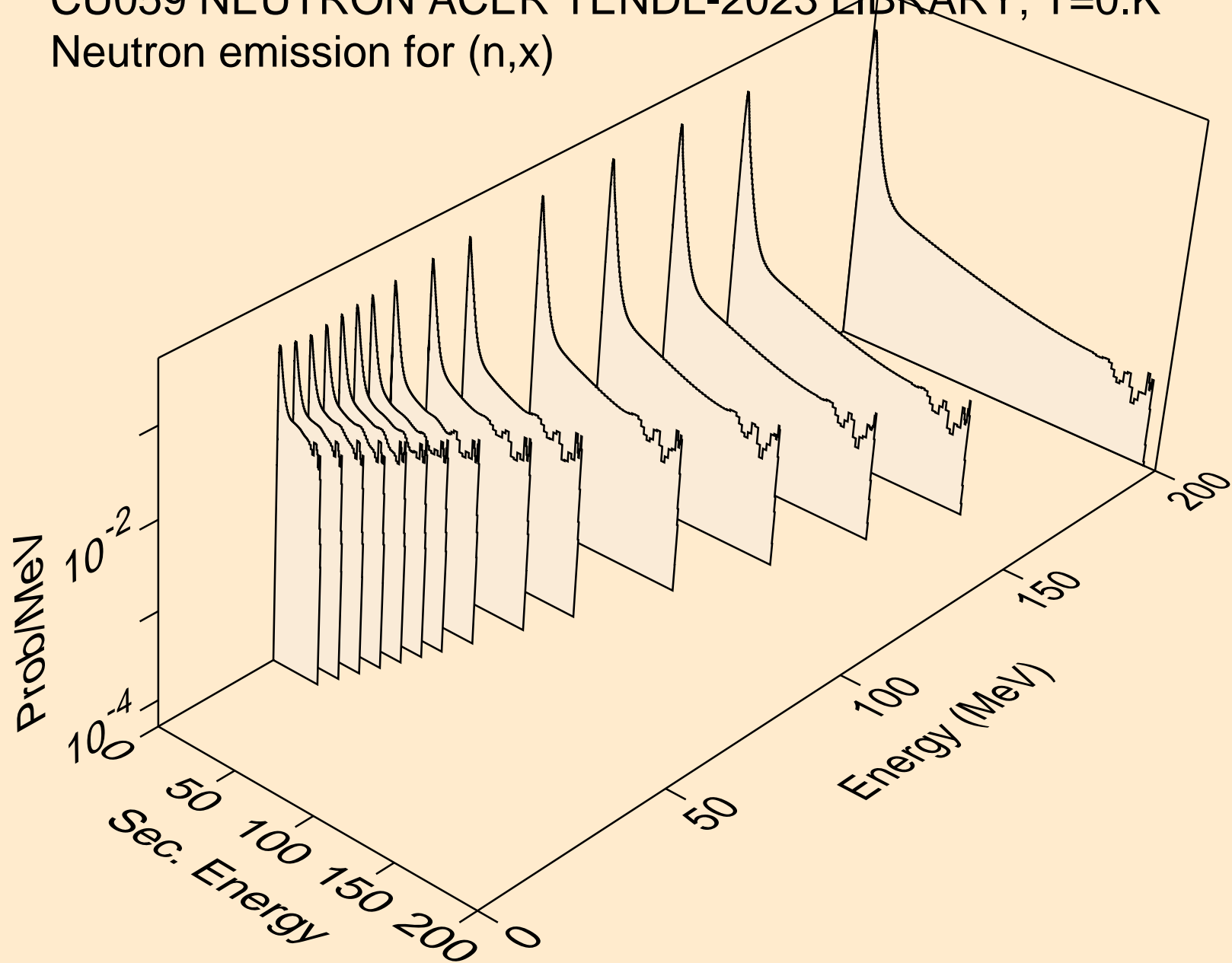



CU059 NEUTRON ACER TENDL-2023 LIBRARY; T=0.K  
Neutron emission for (n,2nd)

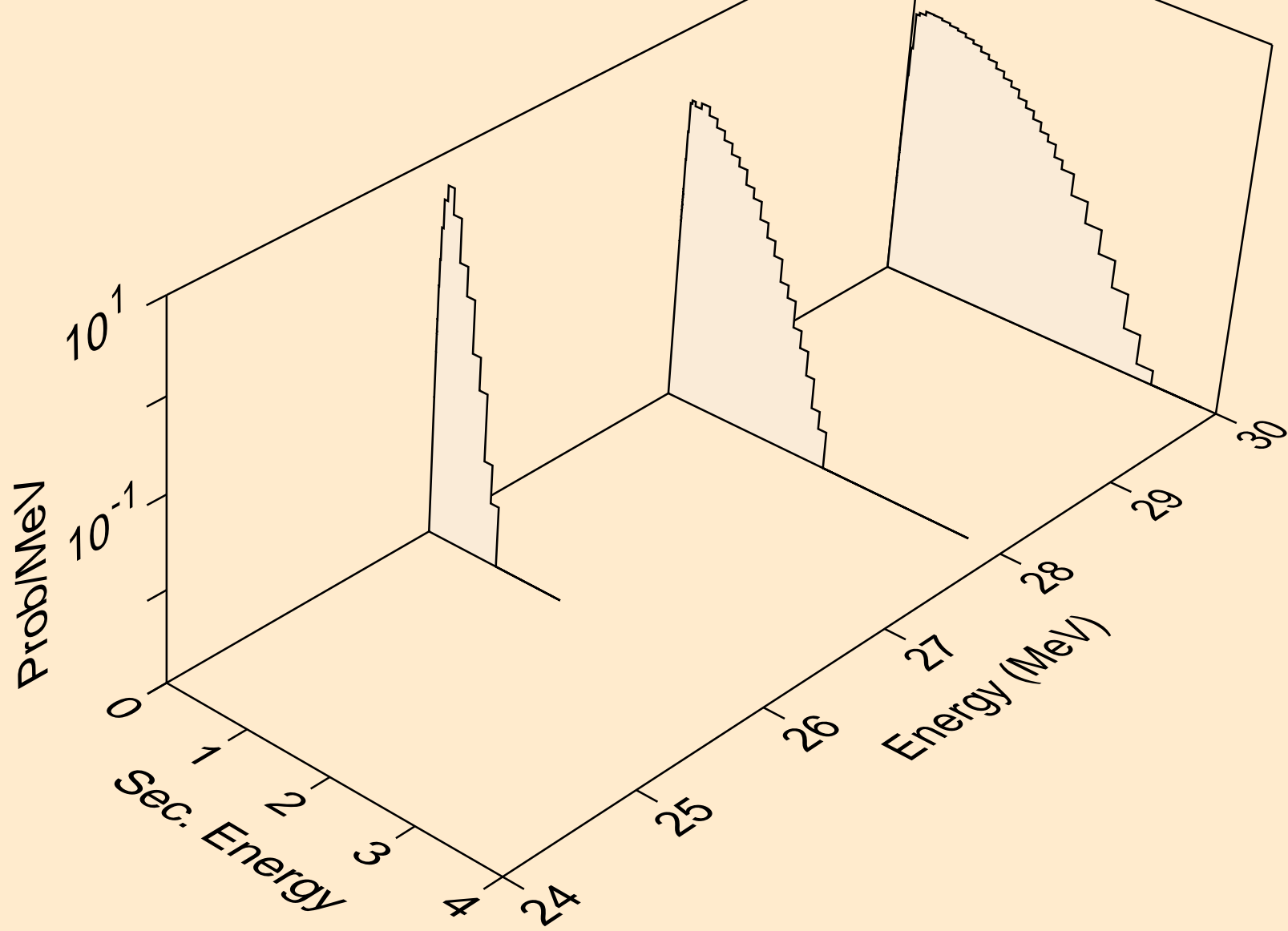

CU059 NEUTRON ACER TENDL-2023 LIBRARY; T=0.K  
Neutron emission for (n,2n)

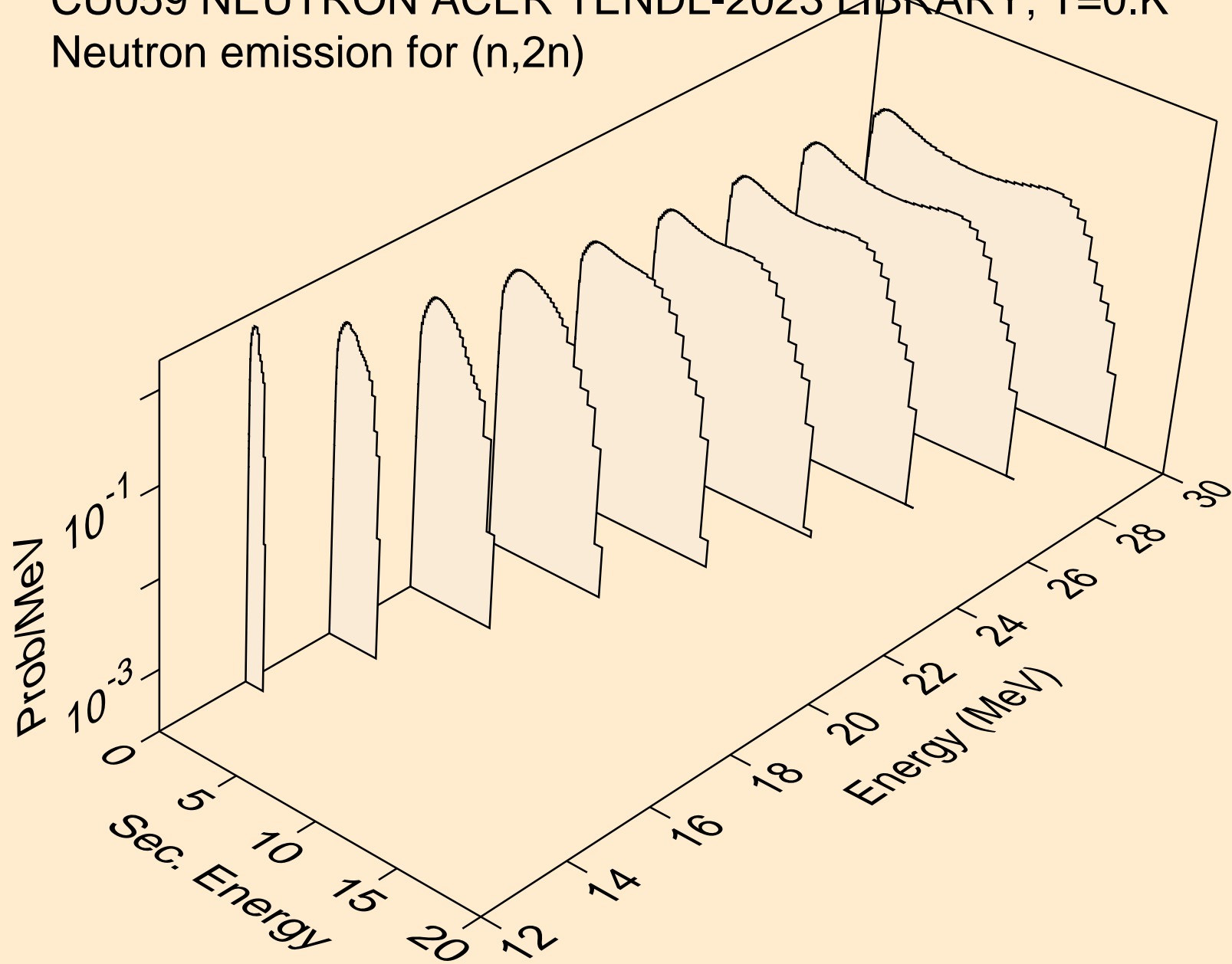

CU059 NEUTRON ACER TENDL-2023 LIBRARY; T=0.K  
Neutron emission for (n,3n)

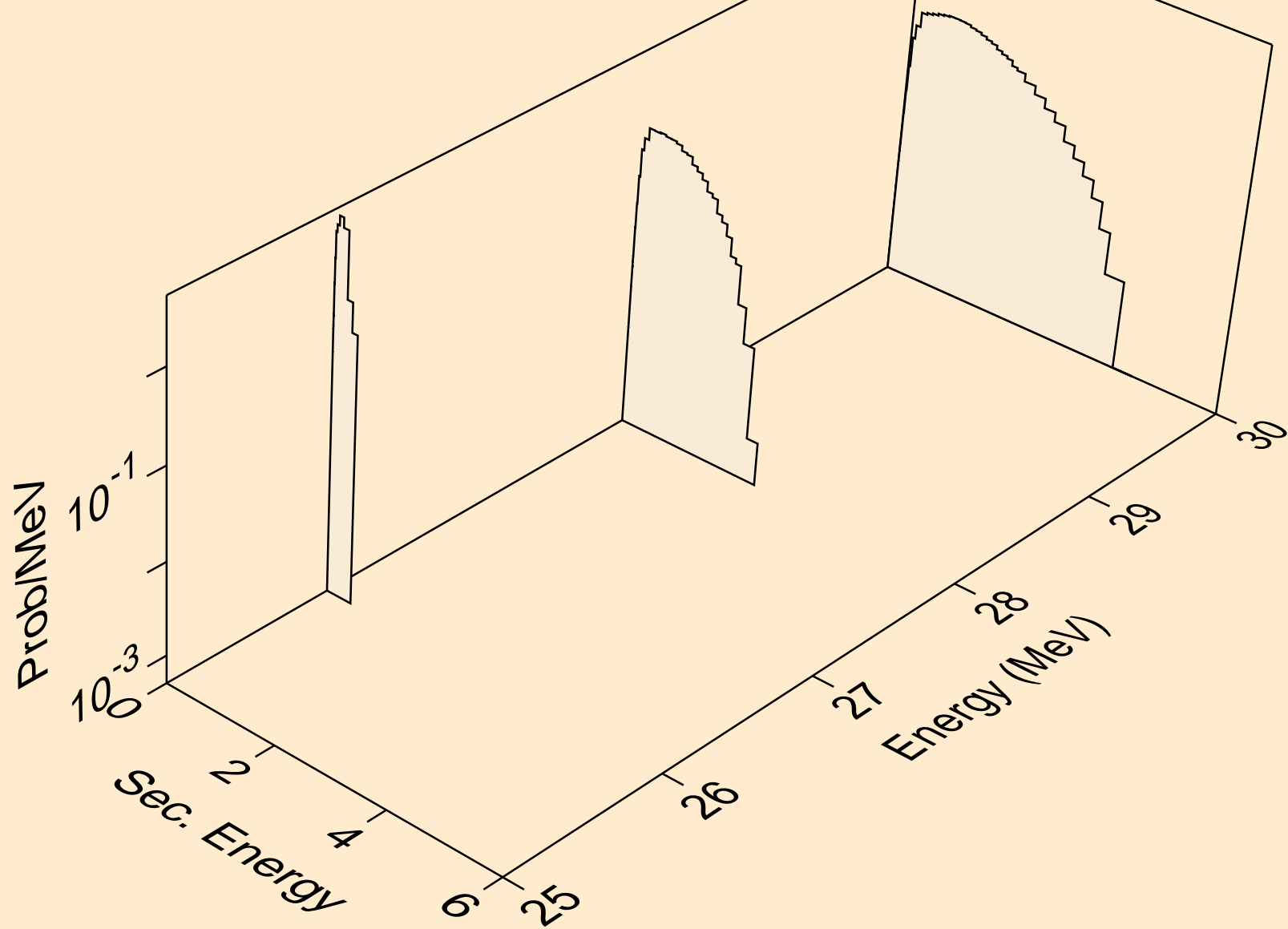

CU059 NEUTRON ACER TENDL-2023 LIBRARY; T=0.K  
Neutron emission for (n,n\*)a

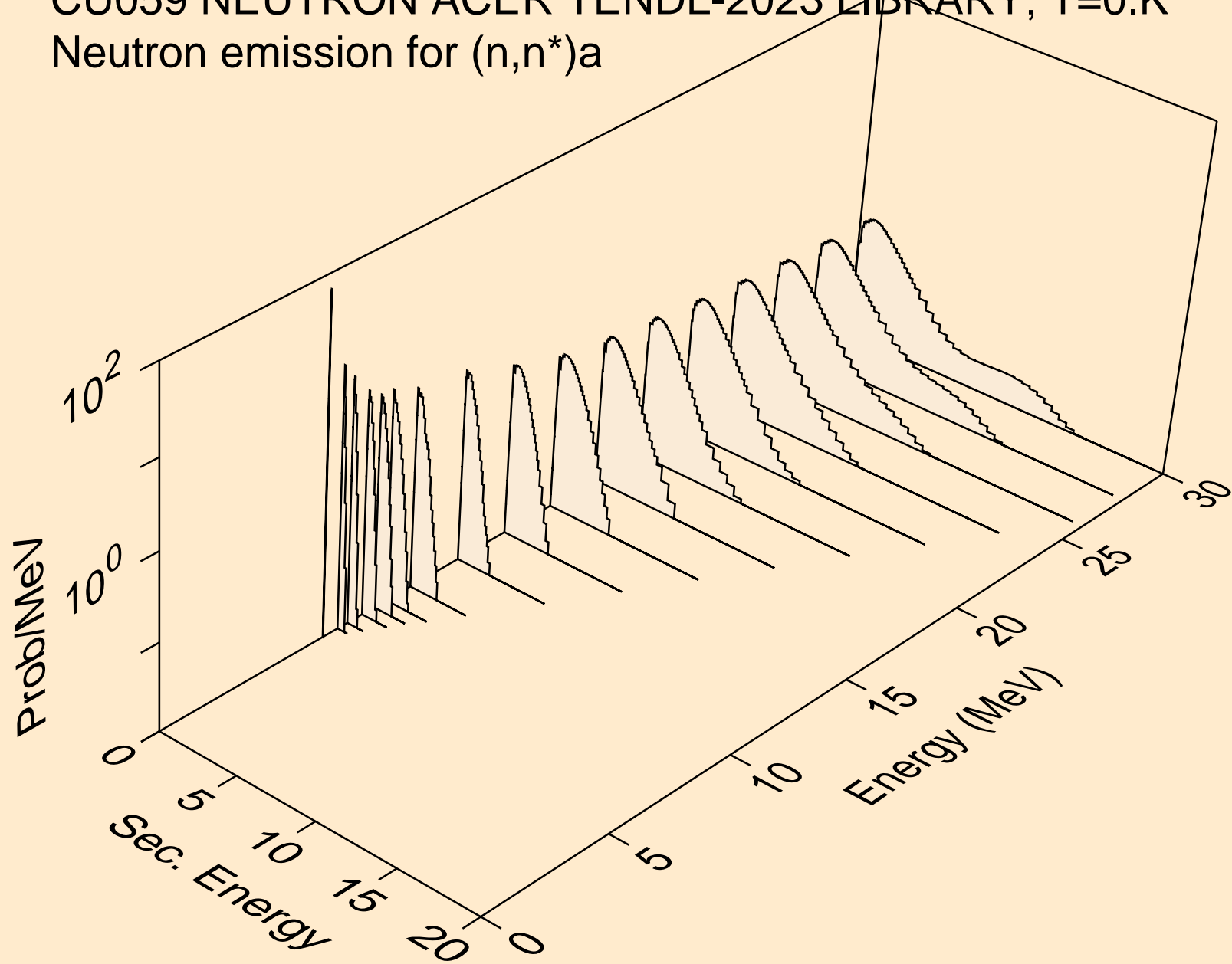

CU059 NEUTRON ACER TENDL-2023 LIBRARY; T=0.K  
Neutron emission for (n,2n)a

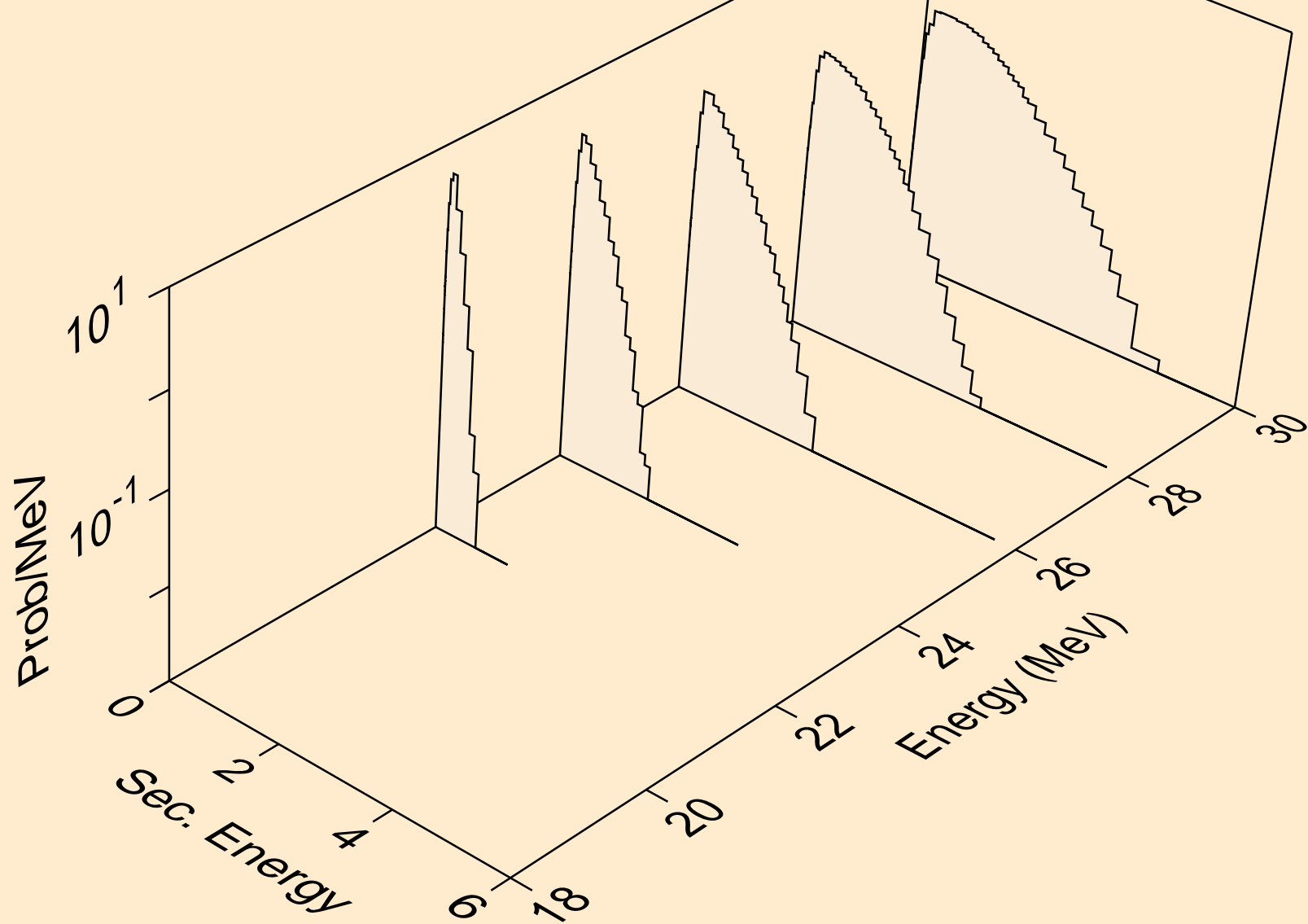

CU059 NEUTRON ACER TENDL-2023 LIBRARY; T=0.K  
Neutron emission for (n,n\*)p

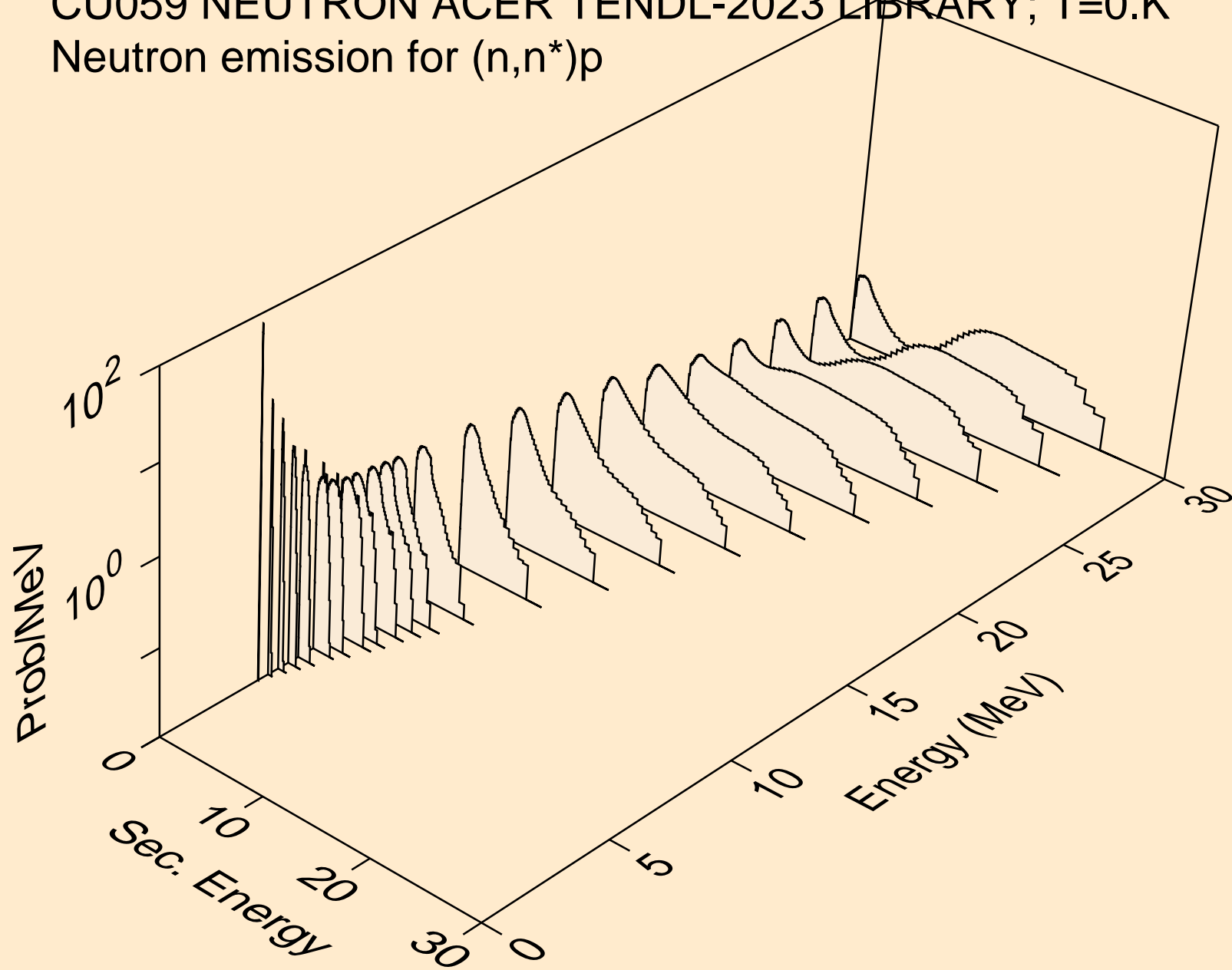

CU059 NEUTRON ACER TENDL-2023 LIBRARY; T=0.K  
Neutron emission for (n,n\*)2a

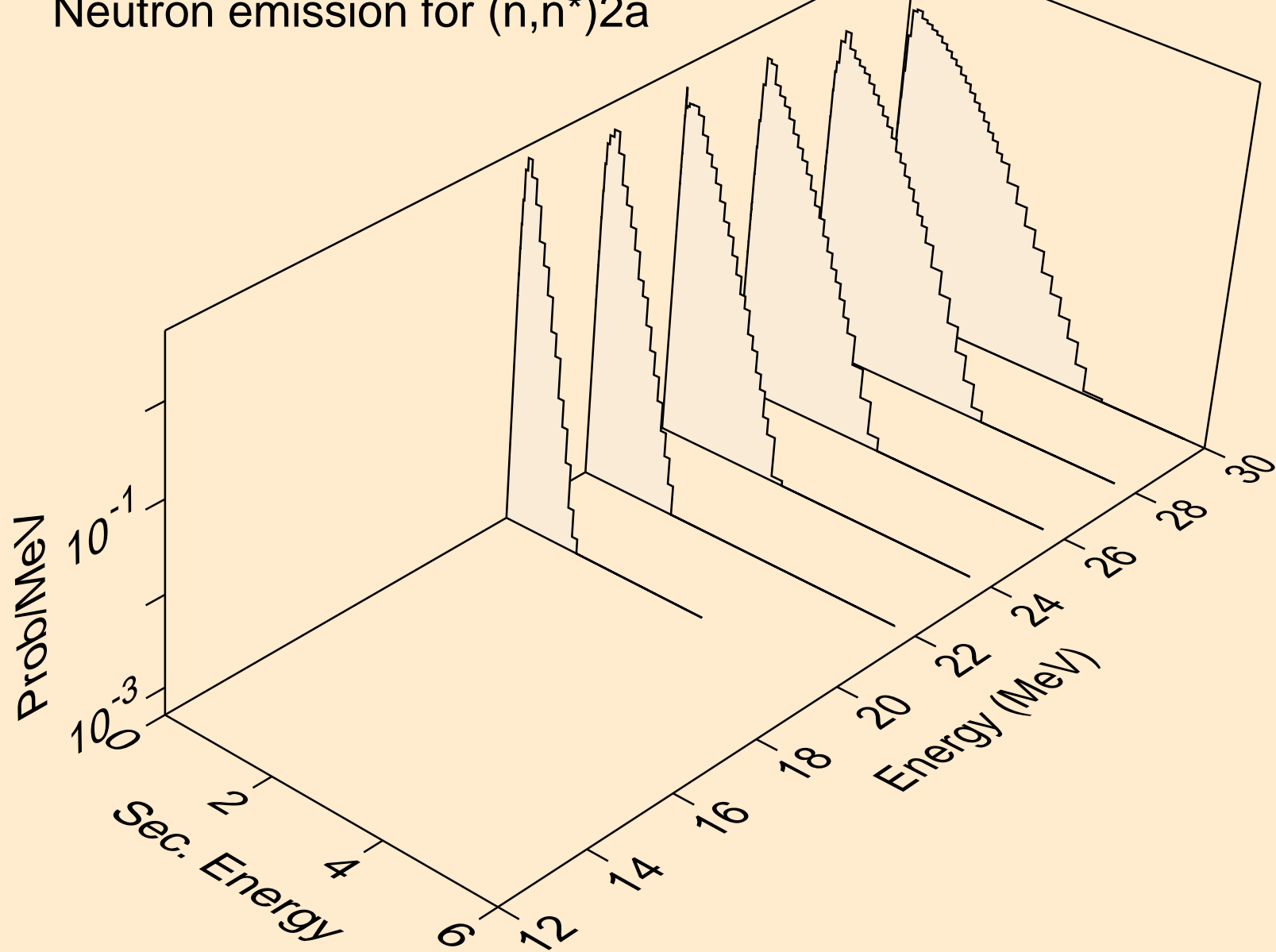

CU059 NEUTRON ACER TENDL-2023 LIBRARY; T=0.K  
Neutron emission for (n,n\*)d

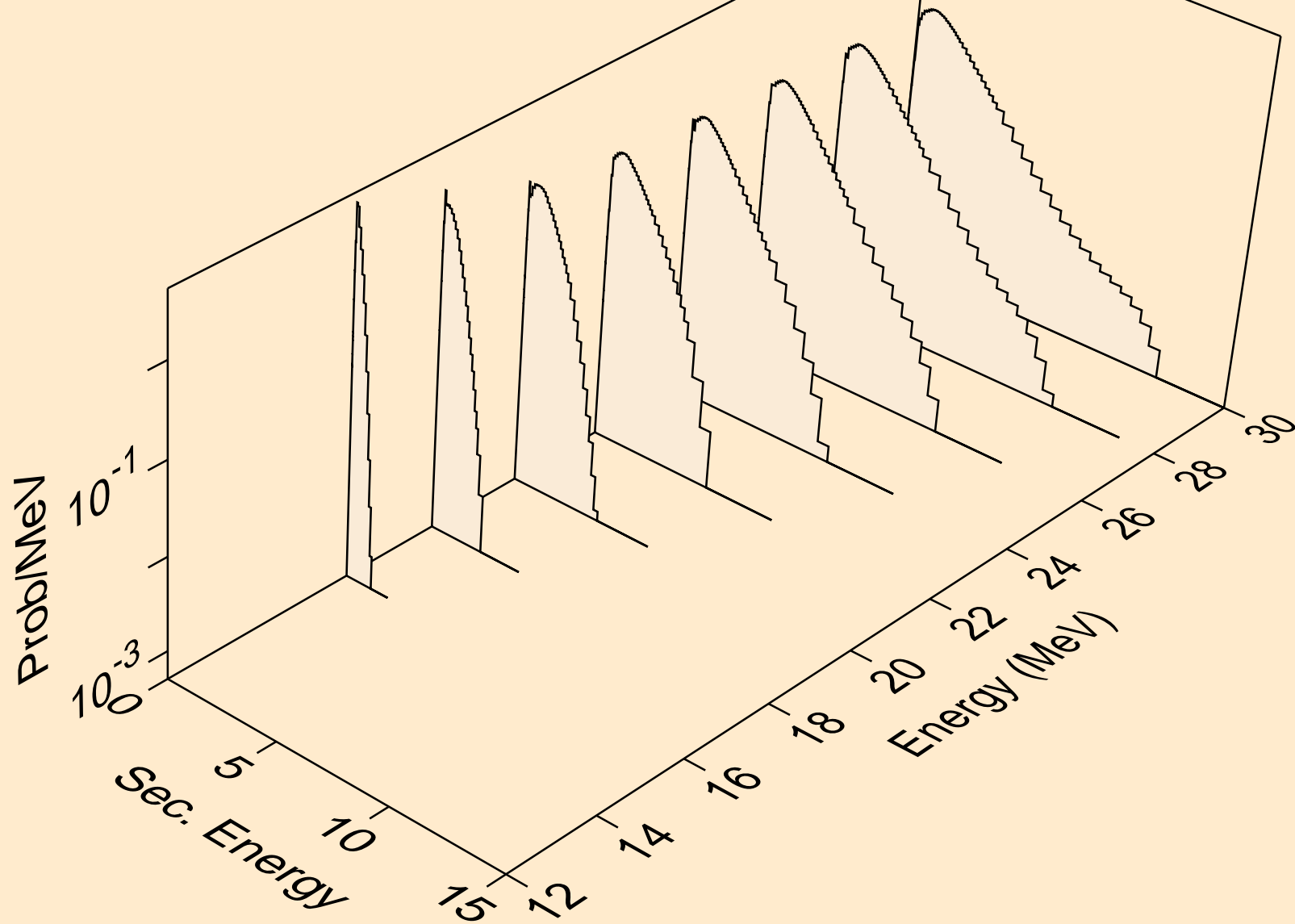



CU059 NEUTRON ACER TENDL-2023 LIBRARY; T=0.K  
Neutron emission for (n,n\*)t

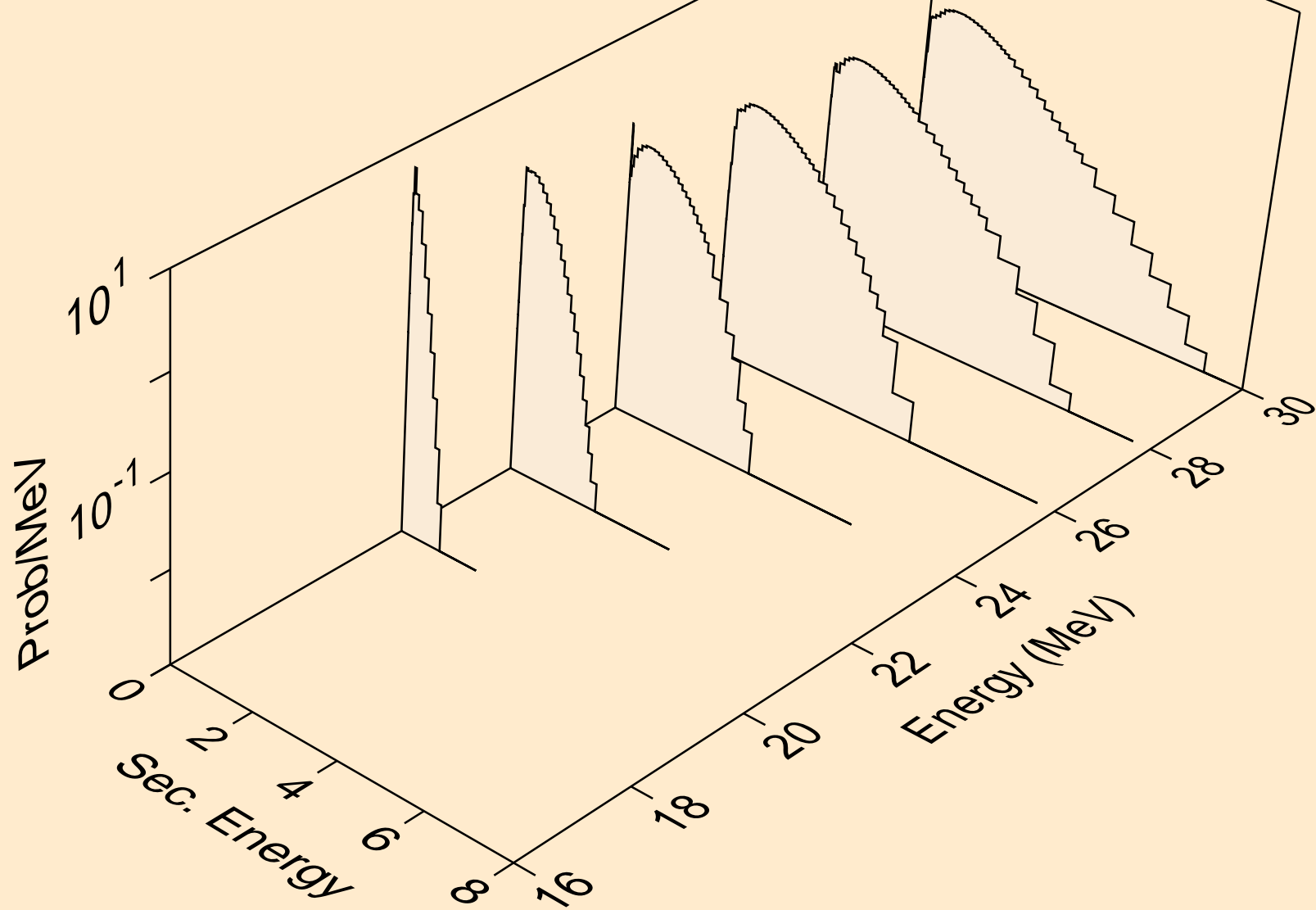

CU059 NEUTRON ACER TENDL-2023 LIBRARY; T=0.K  
Neutron emission for (n,n\*)he3

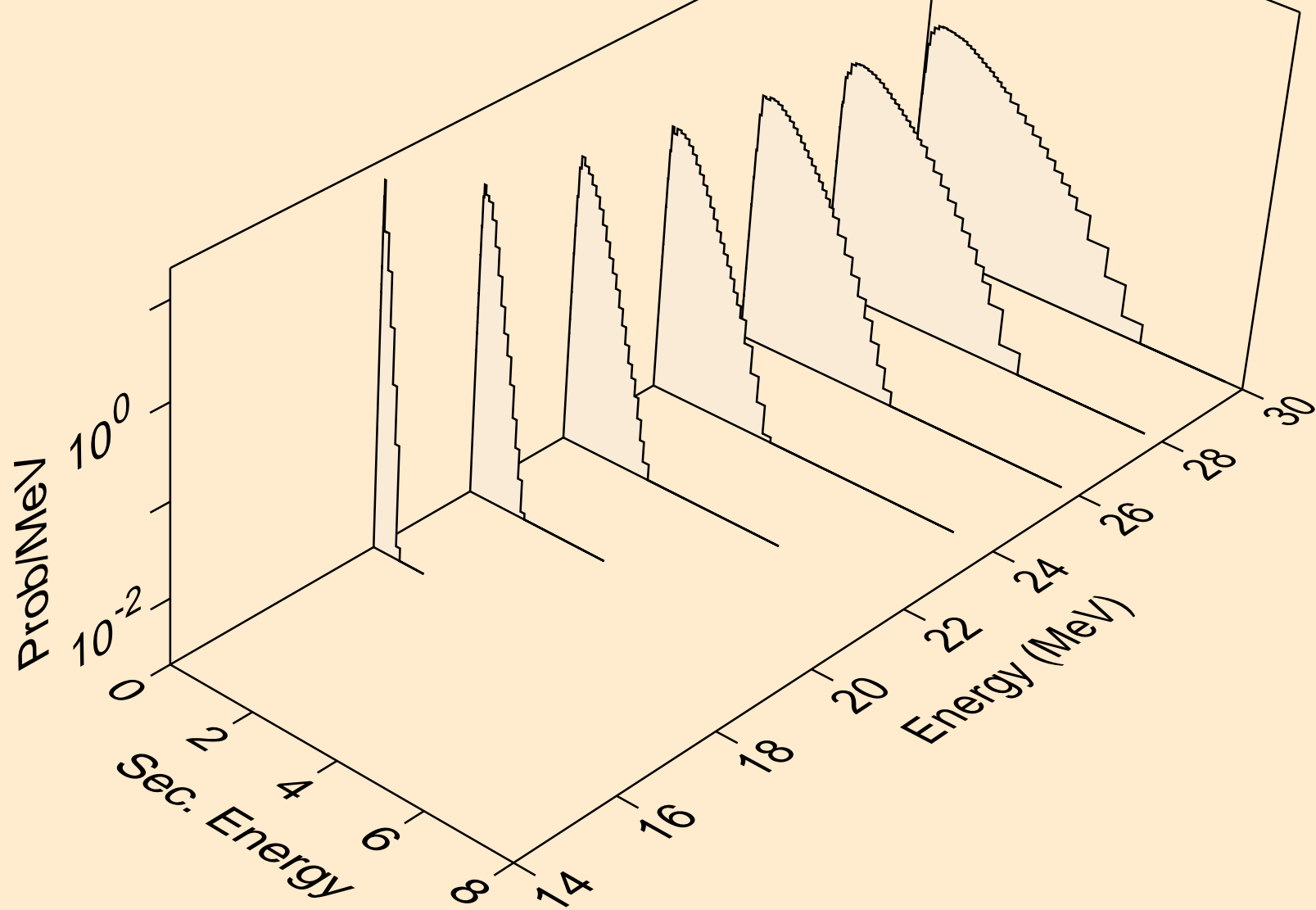

CU059 NEUTRON ACER TENDL-2023 LIBRARY; T=0.K  
Neutron emission for (n,2np)

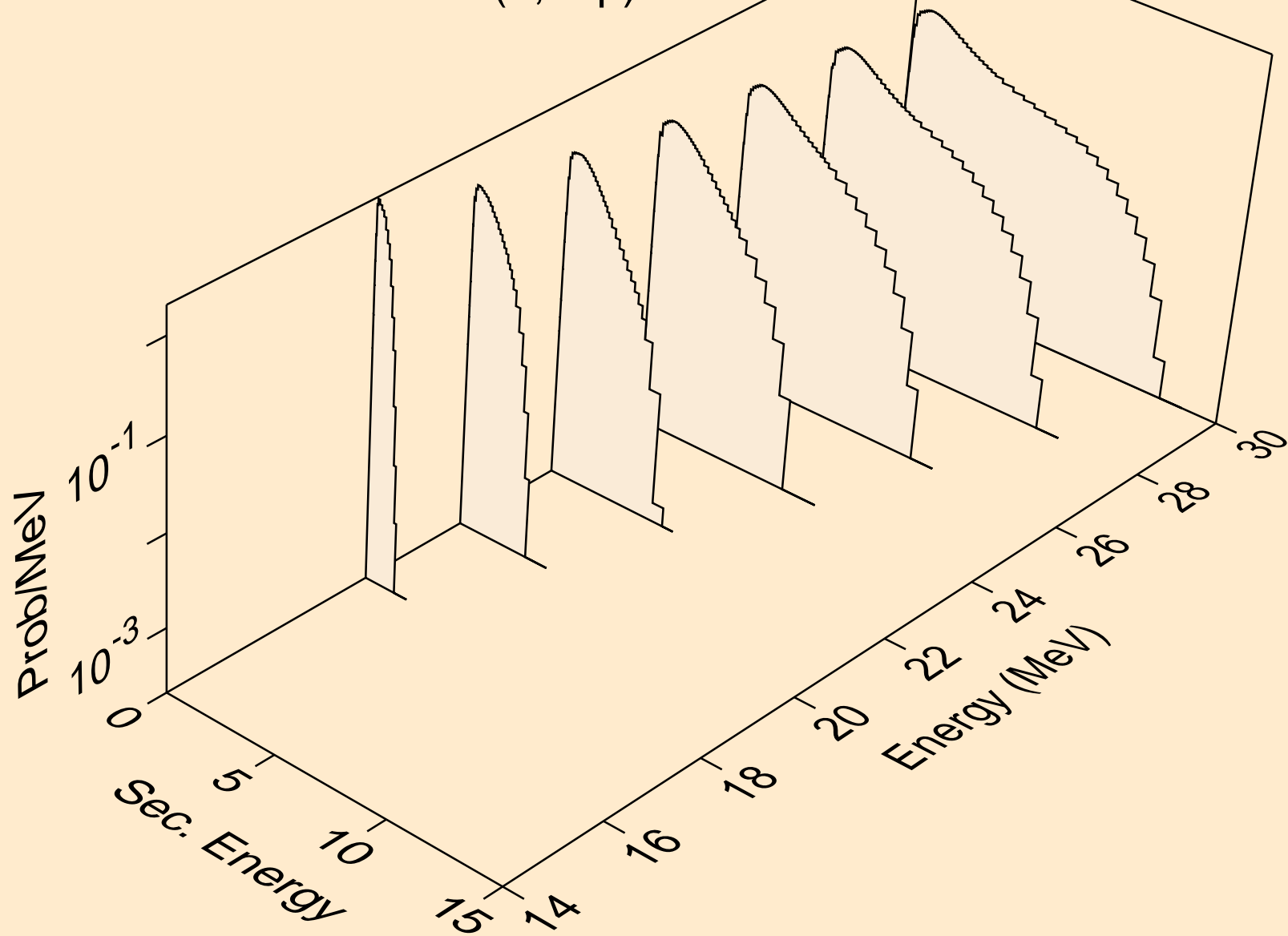

CU059 NEUTRON ACER TENDL-2023 LIBRARY; T=0.K  
Neutron emission for (n,3np)

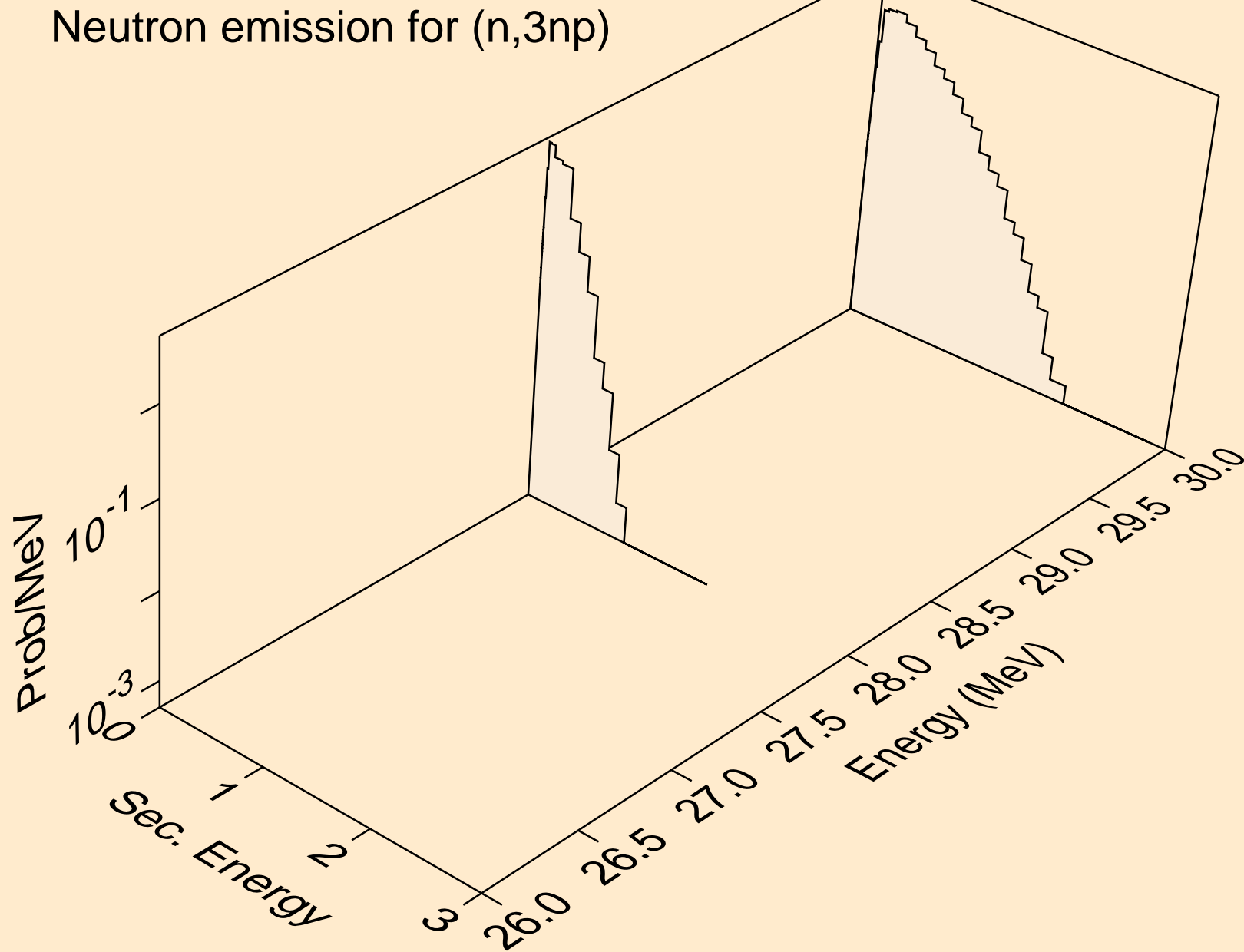

CU059 NEUTRON ACER TENDL-2023 LIBRARY; T=0.K  
Neutron emission for (n,n2p)

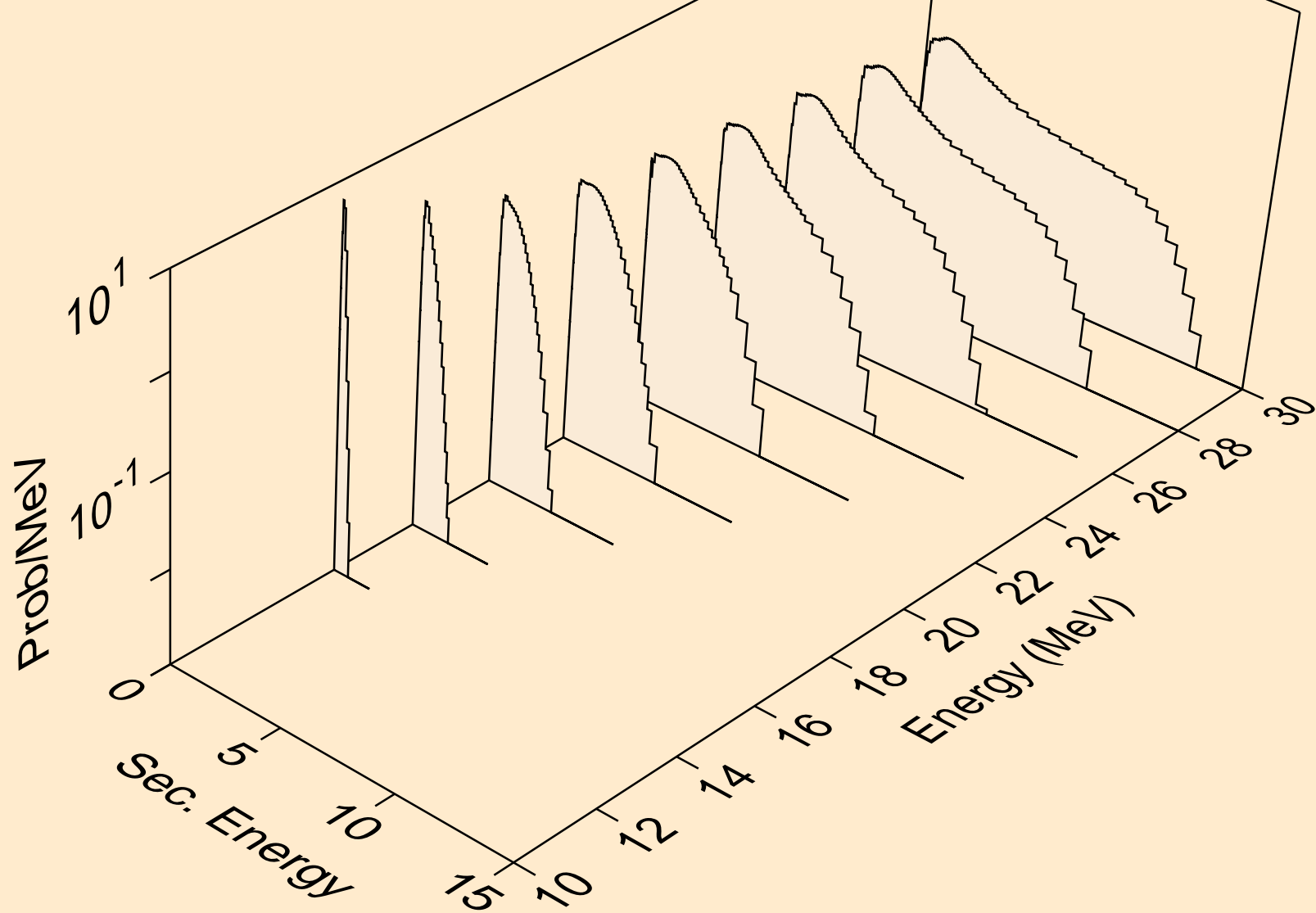

CU059 NEUTRON ACER TENDL-2023 LIBRARY; T=0.K  
Neutron emission for (n,npa)

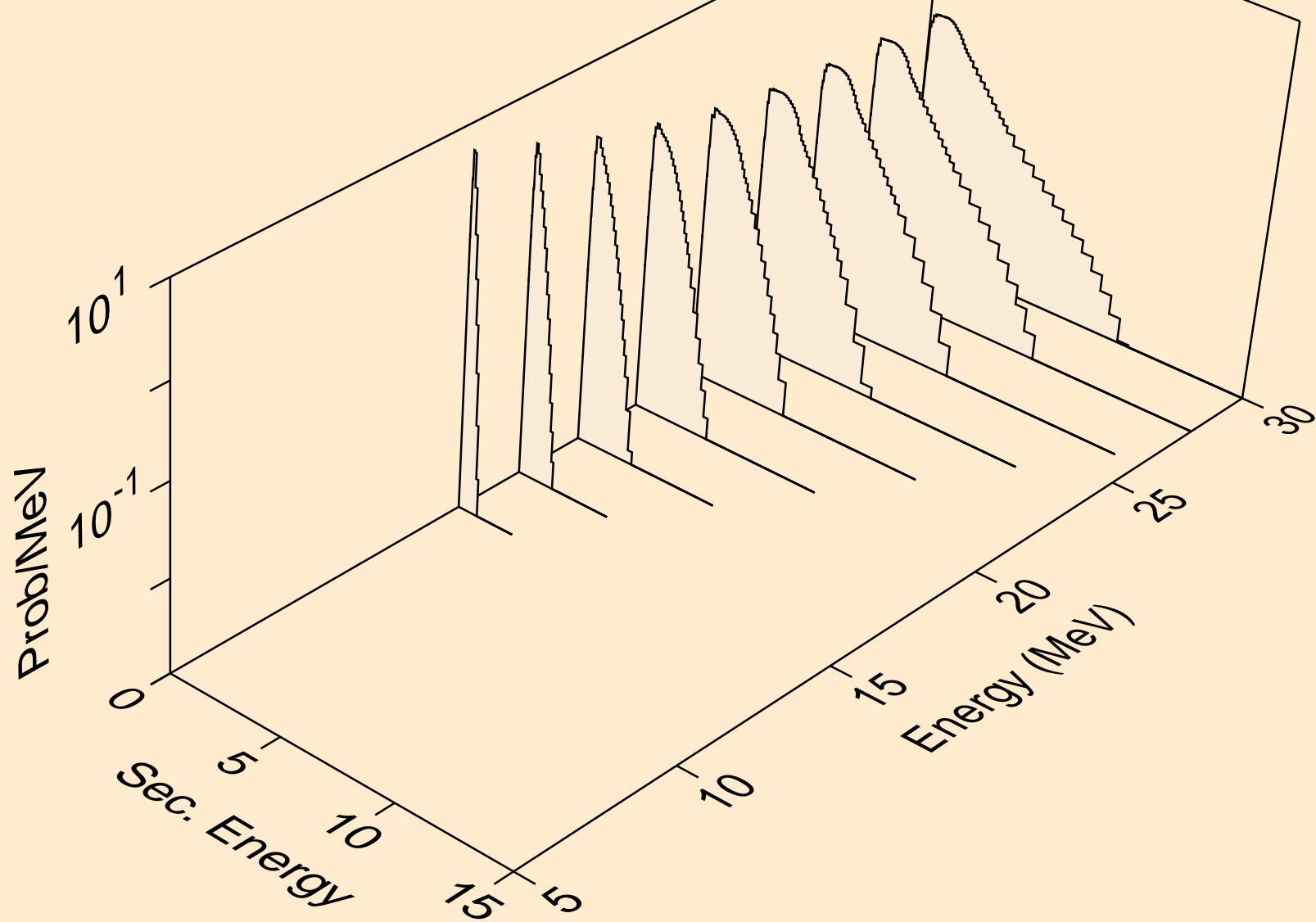

CU059 NEUTRON ACER TENDL-2023 LIBRARY; T=0.K  
Neutron emission for (n,n\*c)

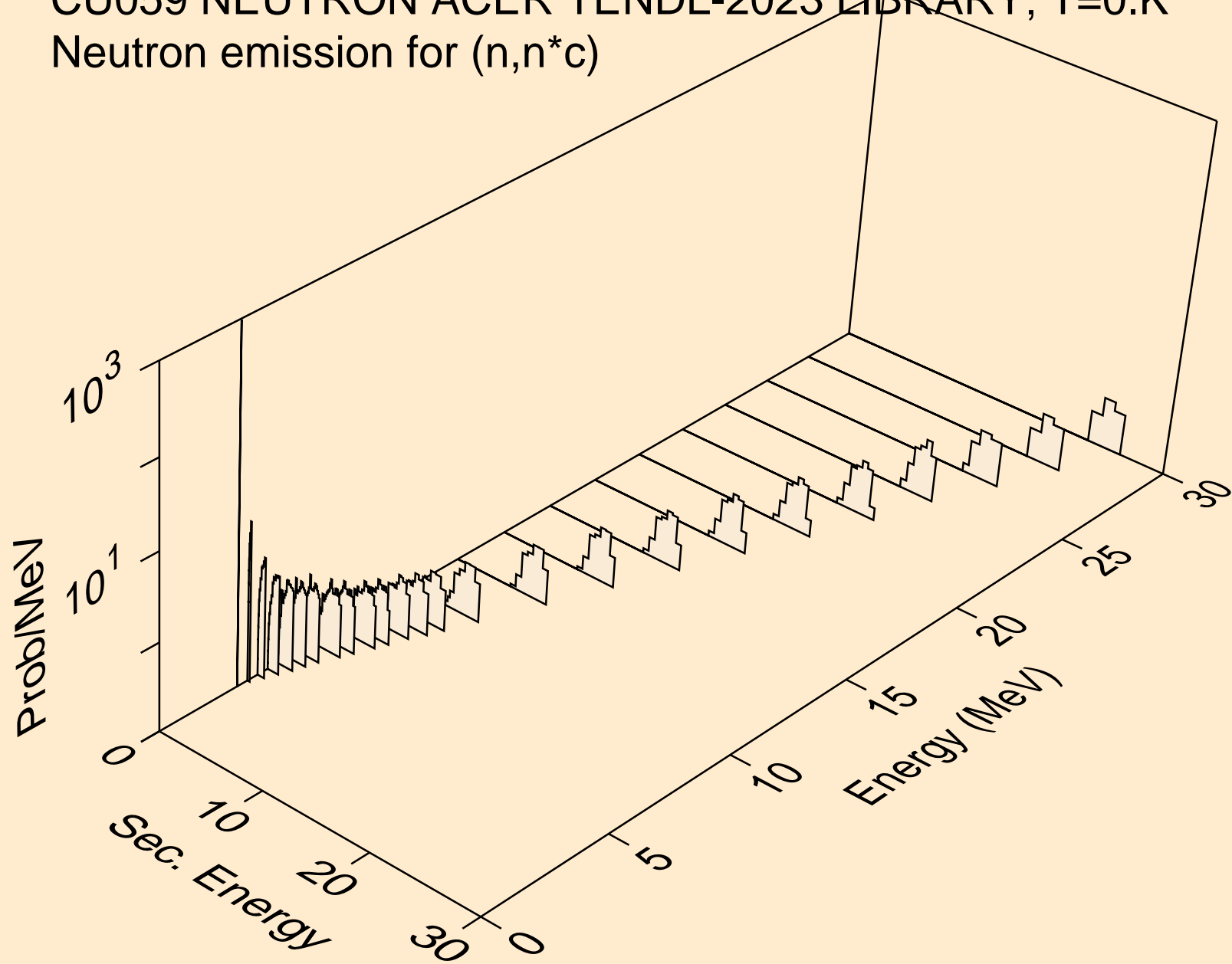

CU059 NEUTRON ACER TENDL-2023 LIBRARY; T=0.K  
Photon emission for (n,x)

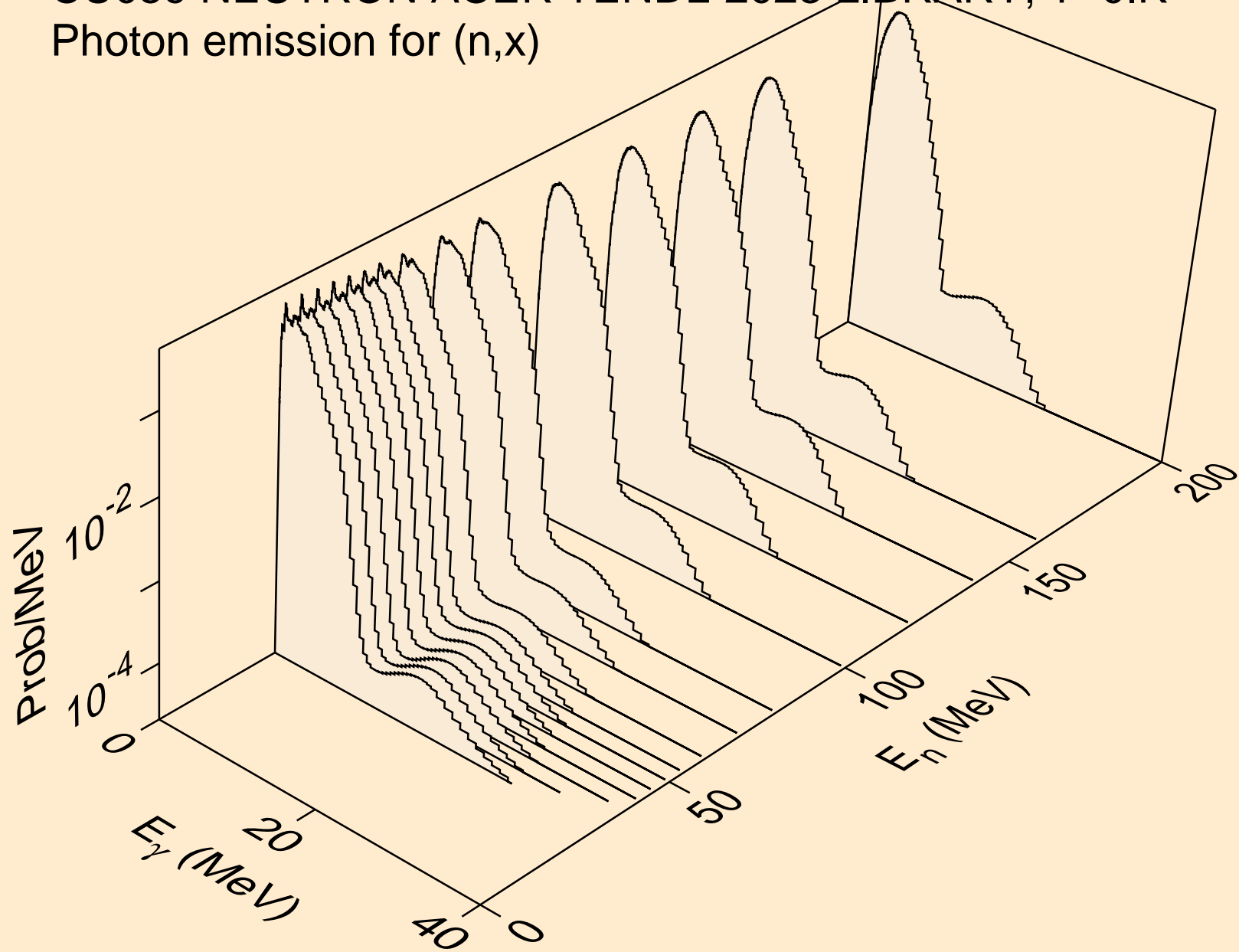



CU059 NEUTRON ACER TENDL-2023 LIBRARY; T=0.K  
Photon emission for (n,2nd)

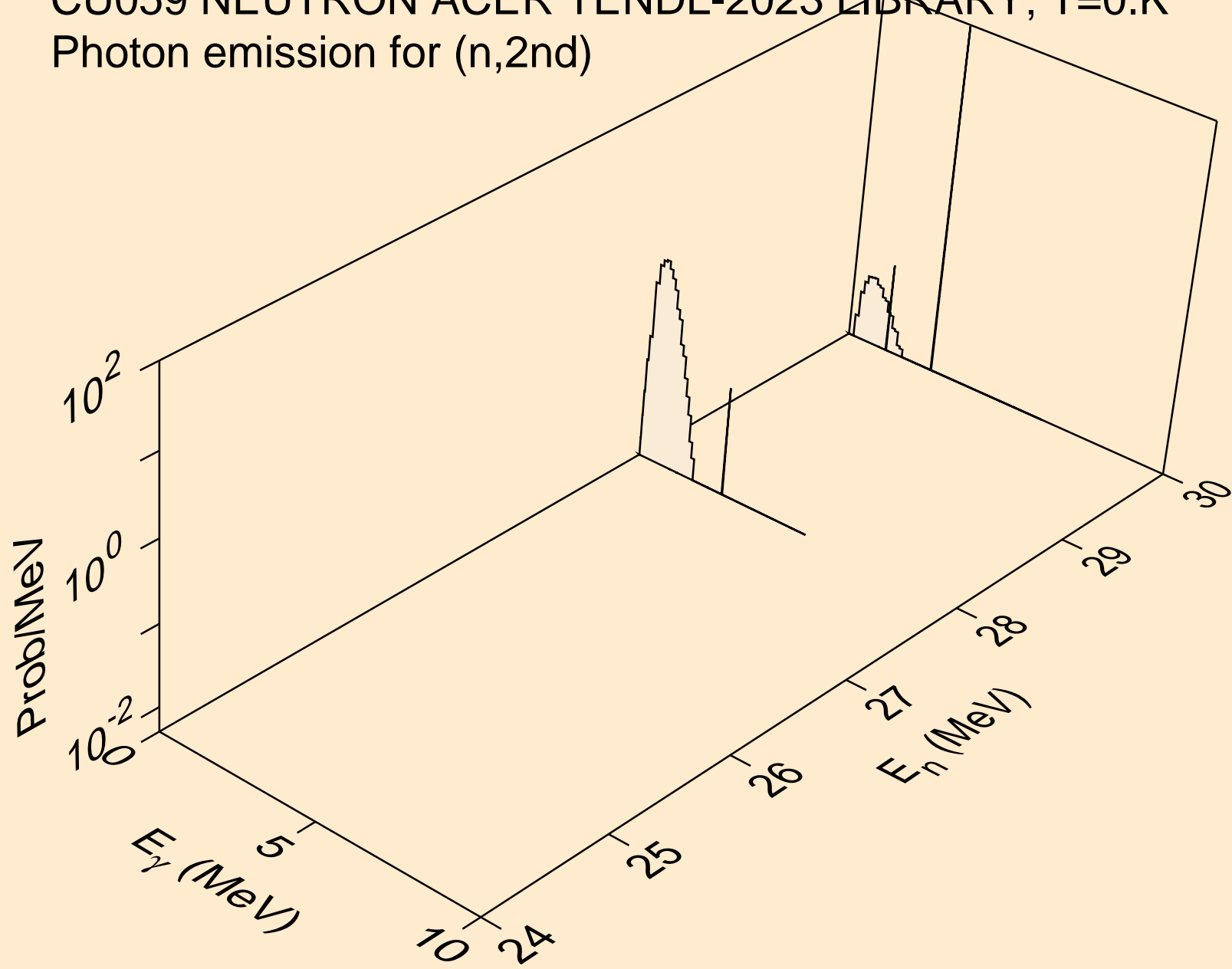

CU059 NEUTRON ACER TENDL-2023 LIBRARY; T=0.K  
Photon emission for (n,2n)

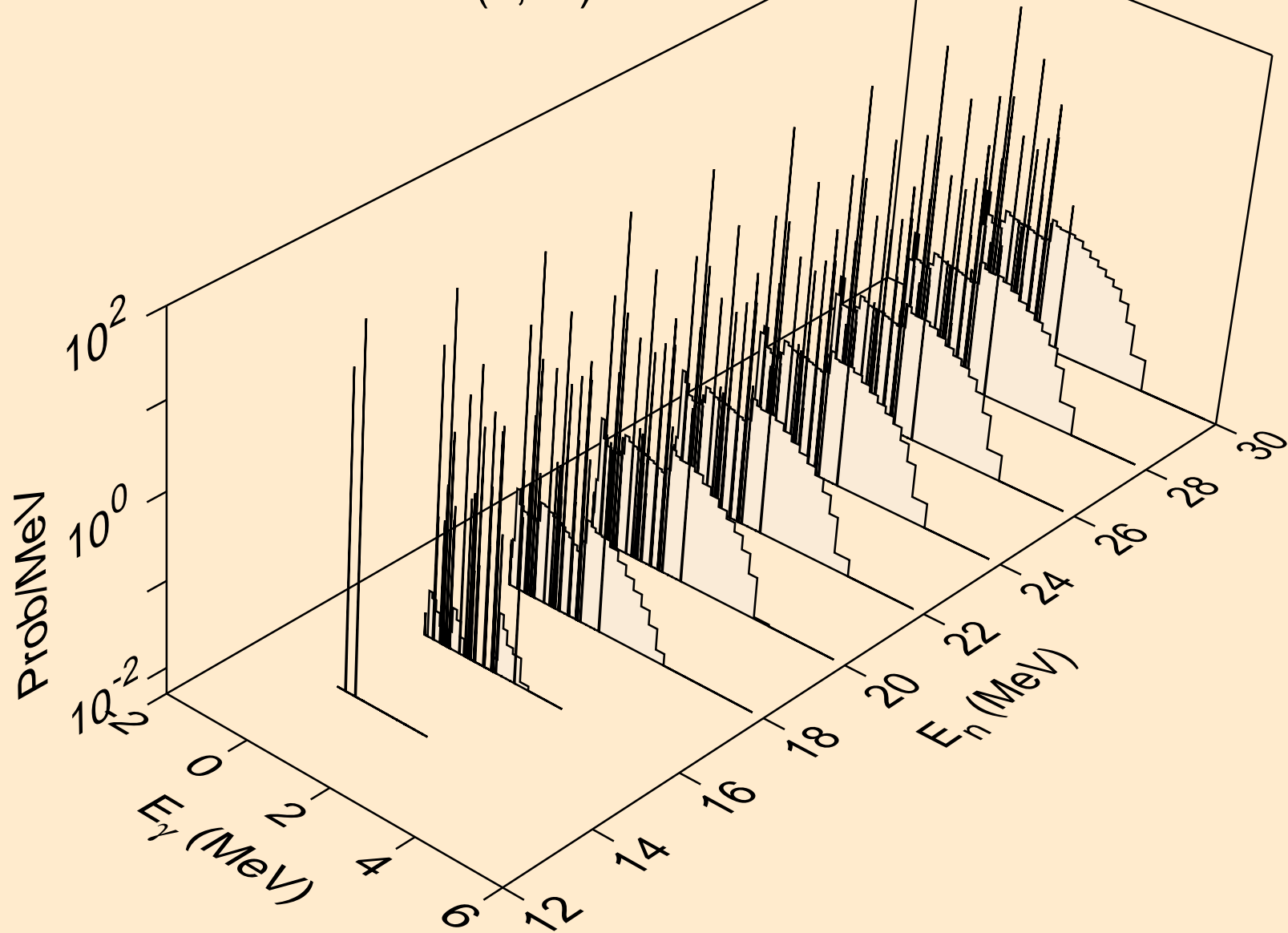

CU059 NEUTRON ACER TENDL-2023 LIBRARY; T=0.K  
Photon emission for (n,3n)

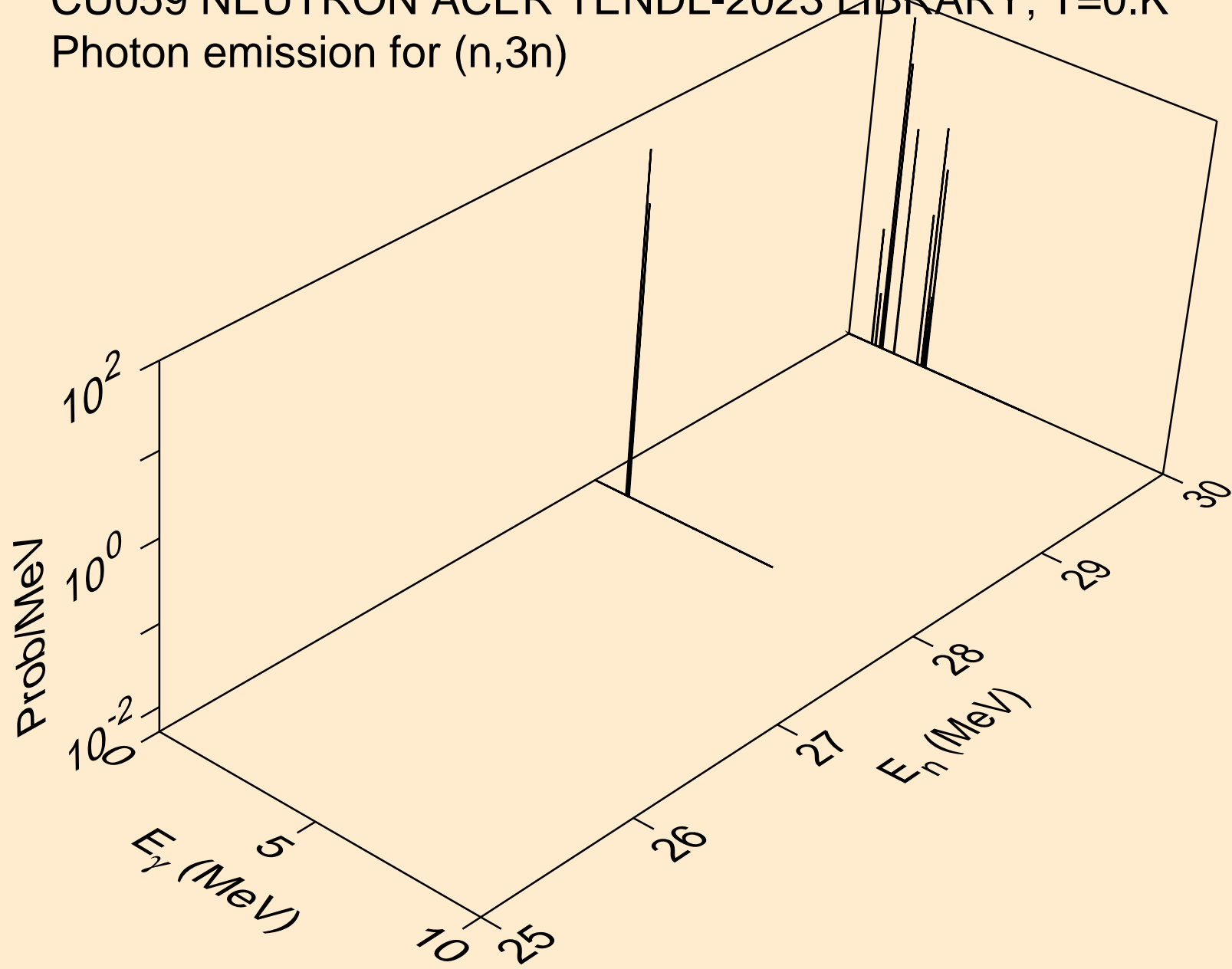

CU059 NEUTRON ACER TENDL-2023 LIBRARY; T=0.K  
Photon emission for (n,n\*)a

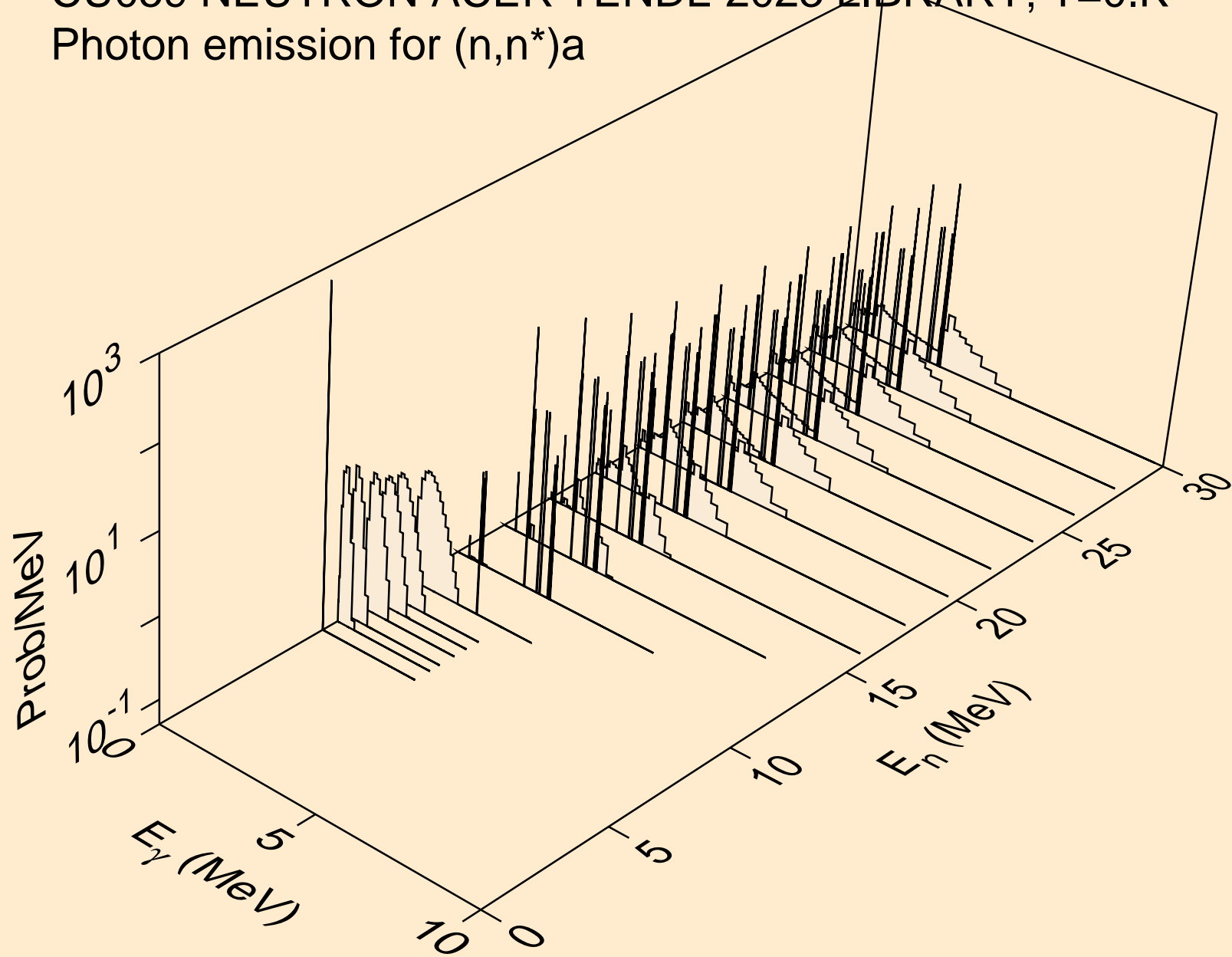

CU059 NEUTRON ACER TENDL-2023 LIBRARY; T=0.K  
Photon emission for (n,2n)a

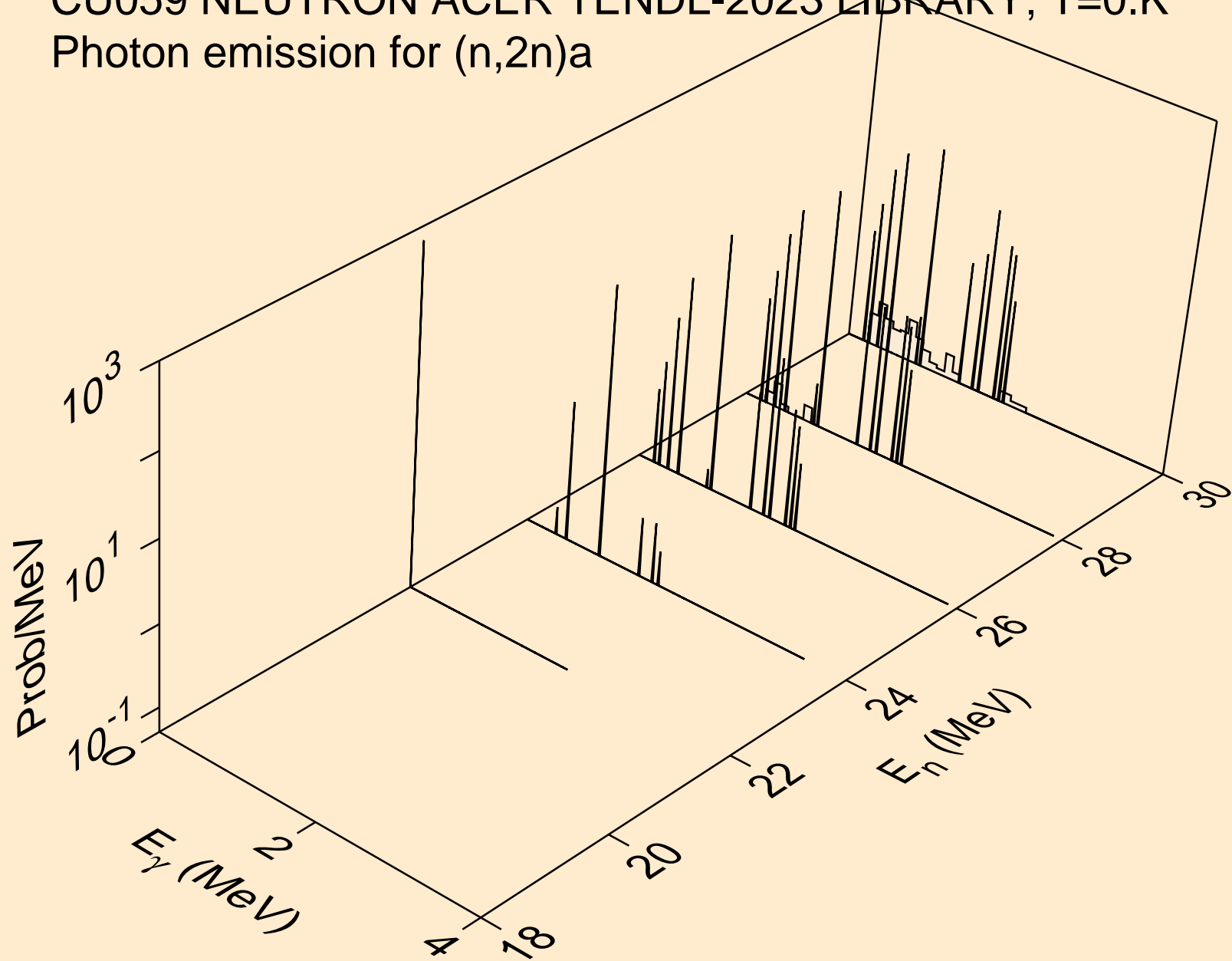

CU059 NEUTRON ACER TENDL-2023 LIBRARY; T=0.K  
Photon emission for (n,n\*)p

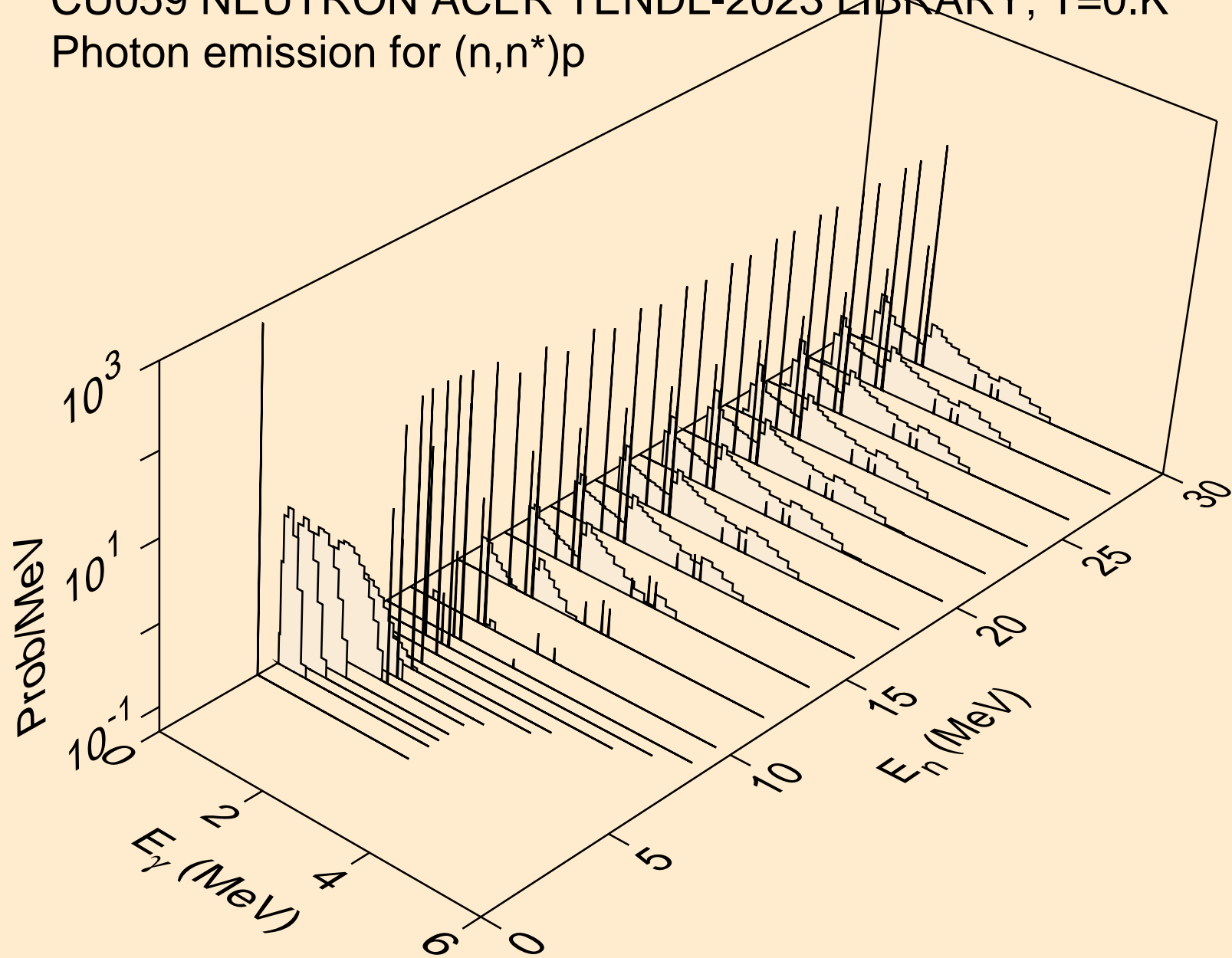

CU059 NEUTRON ACER TENDL-2023 LIBRARY; T=0.K  
Photon emission for (n,n\*)2a

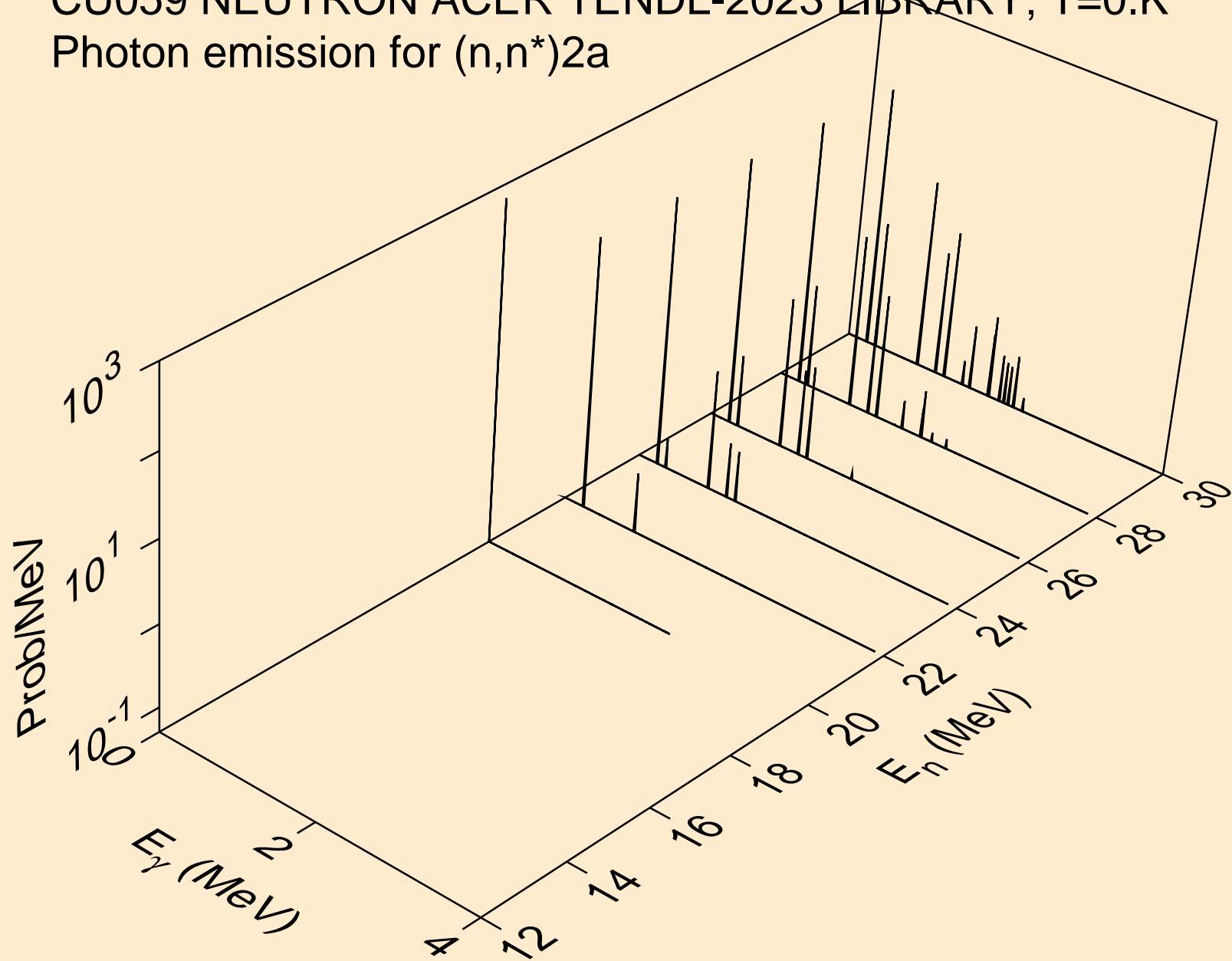

CU059 NEUTRON ACER TENDL-2023 LIBRARY; T=0.K  
Photon emission for (n,n\*)d

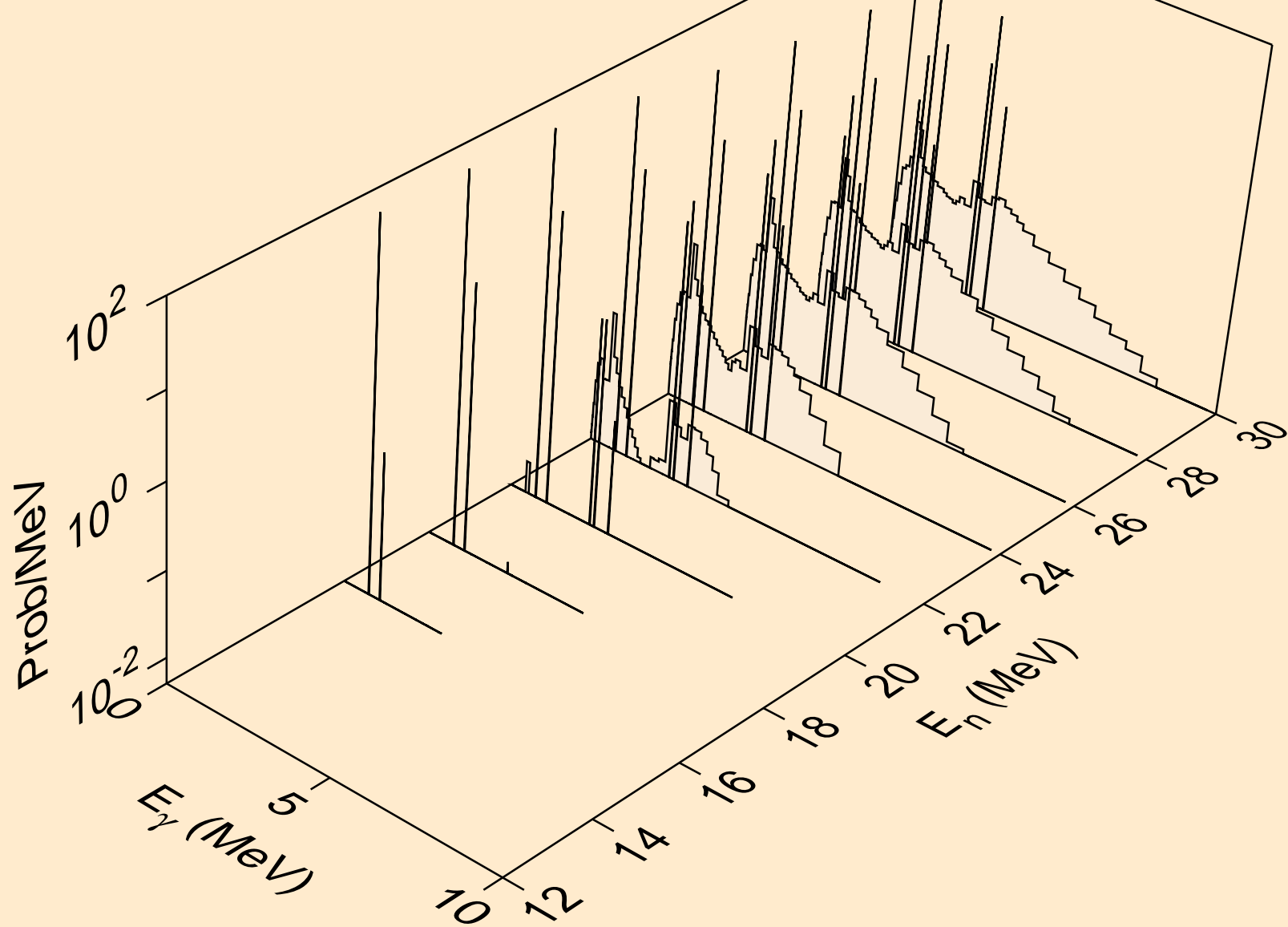



CU059 NEUTRON ACER TENDL-2023 LIBRARY; T=0.K  
Photon emission for (n,n\*)t

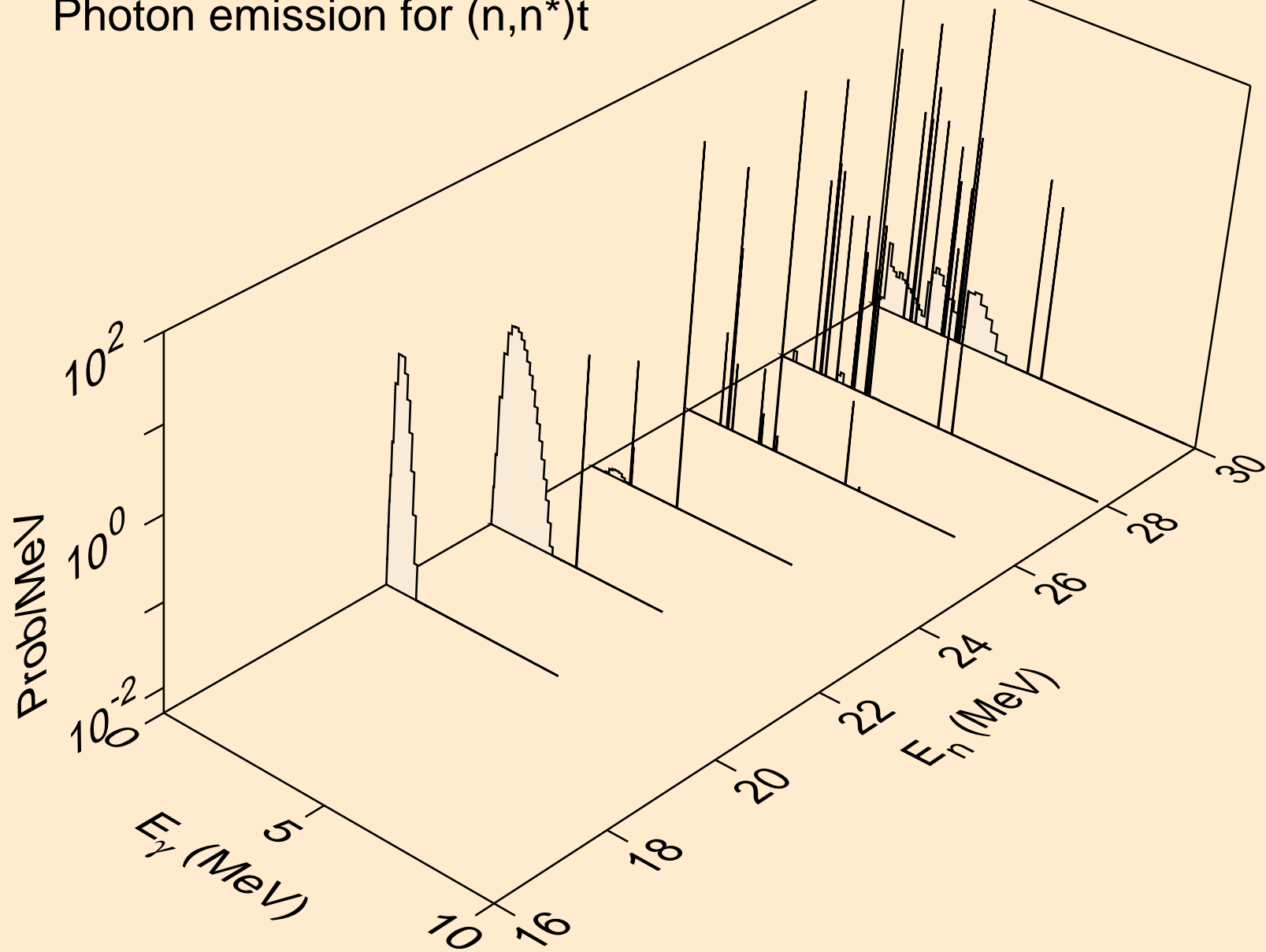

CU059 NEUTRON ACER TENDL-2023 LIBRARY; T=0.K  
Photon emission for (n,n\*)he3

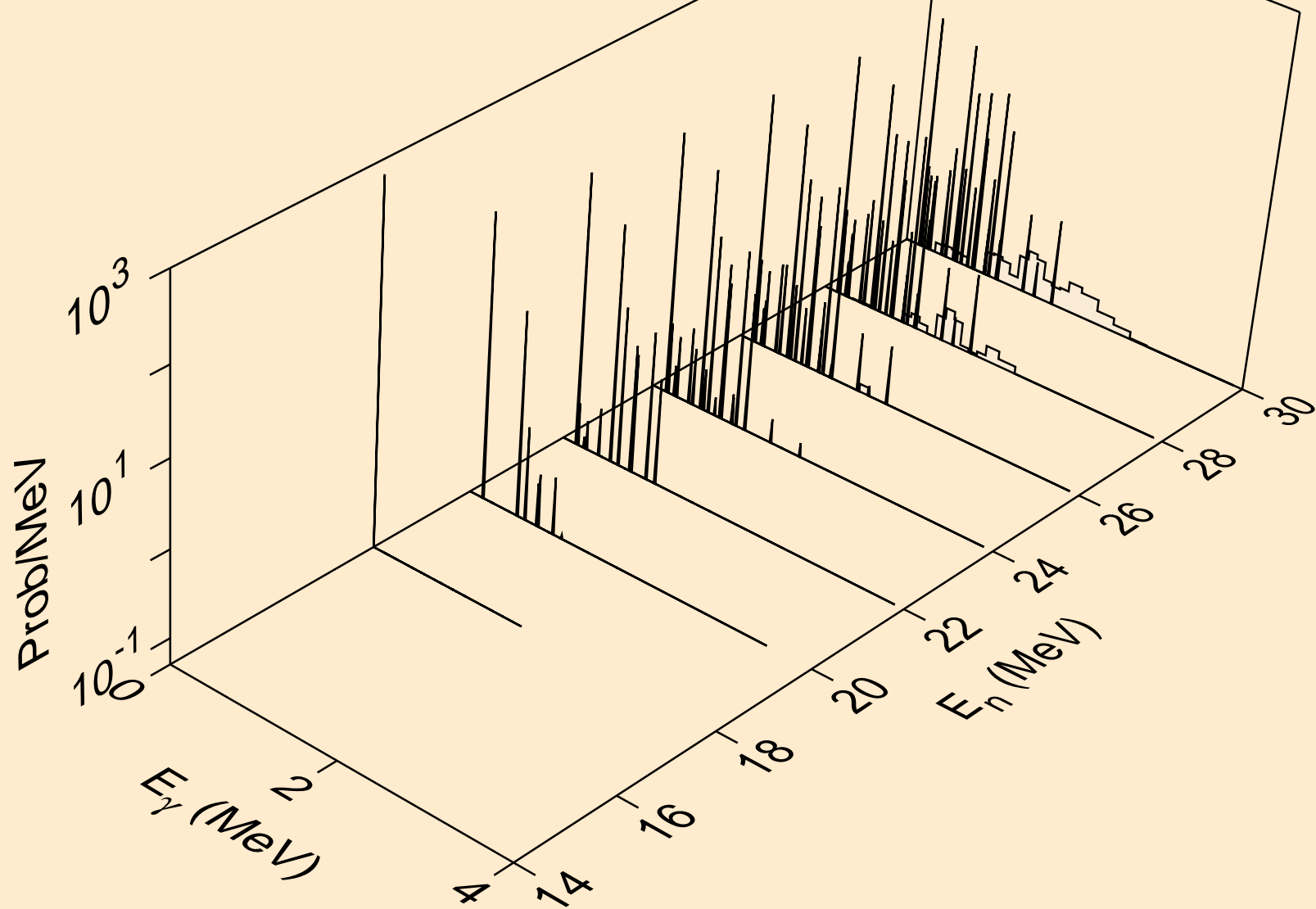

CU059 NEUTRON ACER TENDL-2023 LIBRARY; T=0.K  
Photon emission for (n,2np)

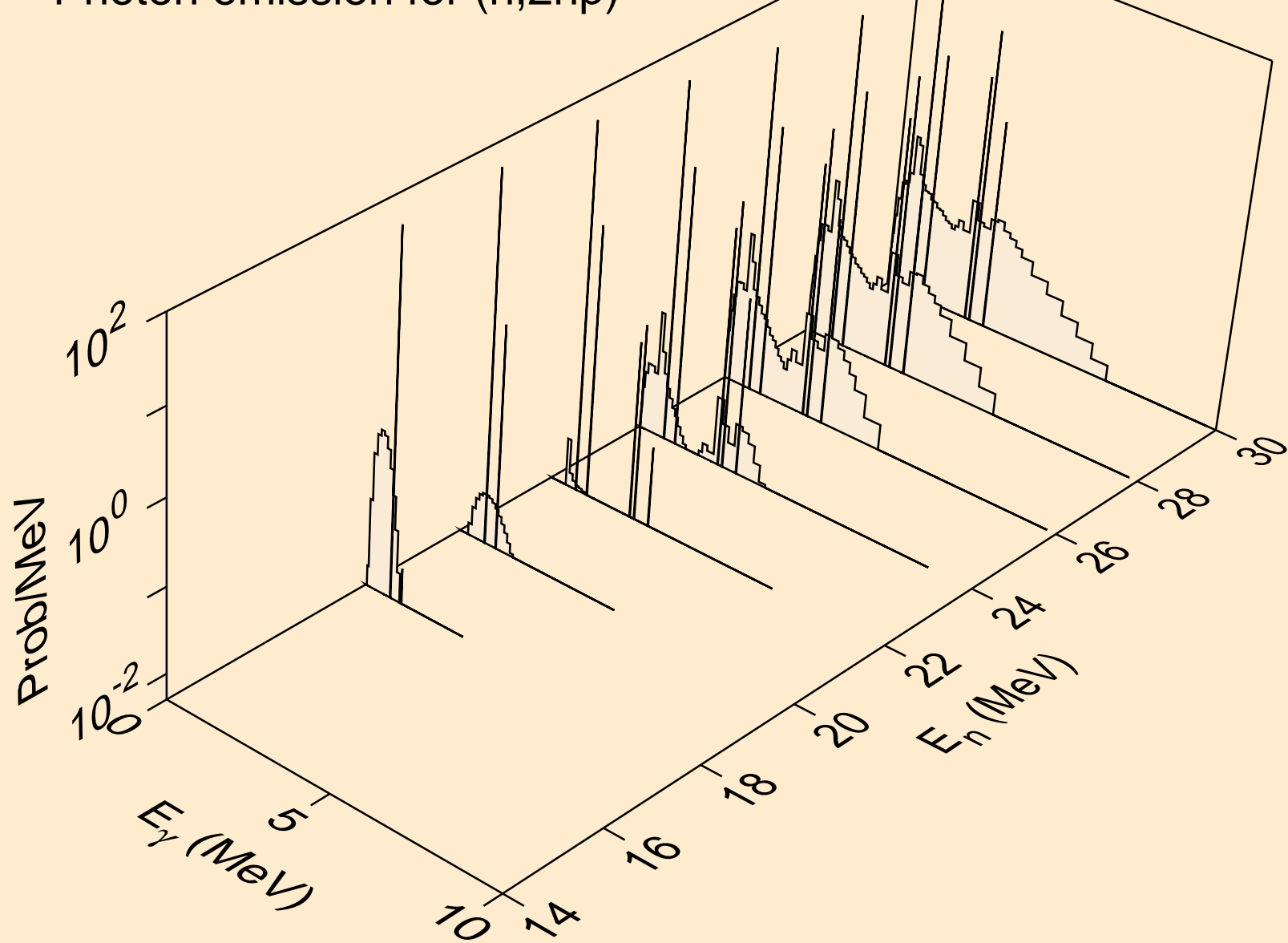

CU059 NEUTRON ACER TENDL-2023 LIBRARY; T=0.K  
Photon emission for (n,3np)

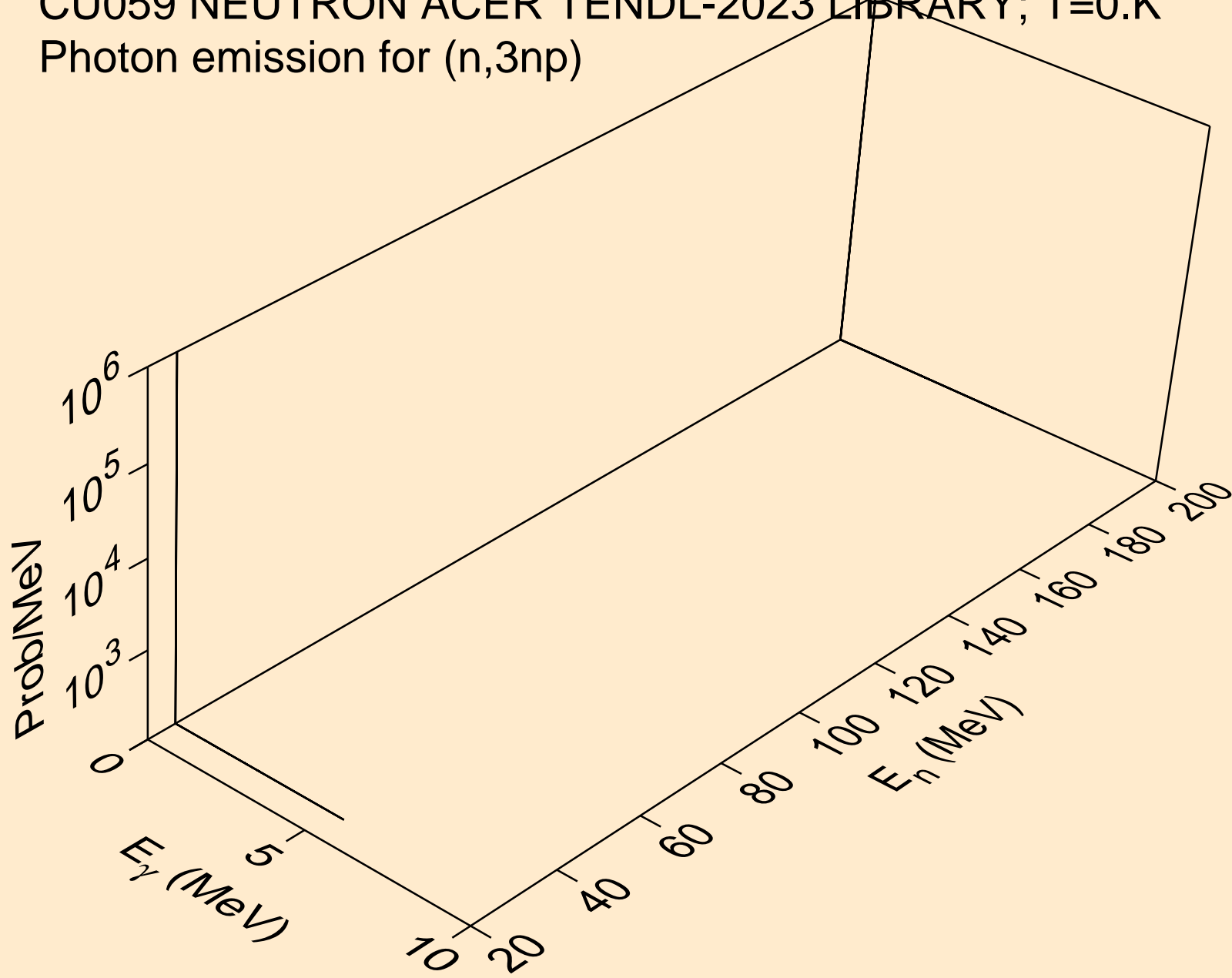

CU059 NEUTRON ACER TENDL-2023 LIBRARY; T=0.K  
Photon emission for (n,n2p)

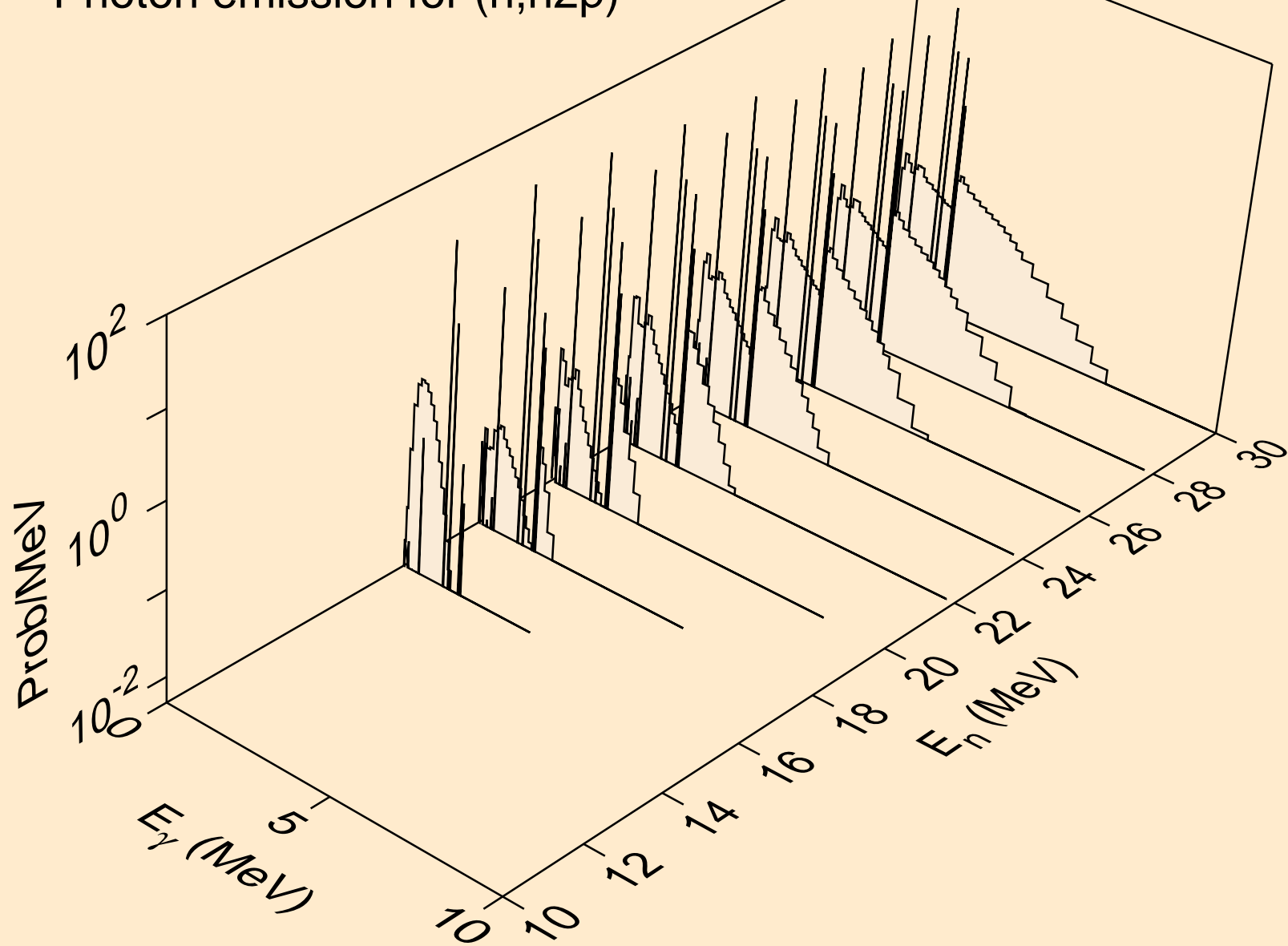

CU059 NEUTRON ACER TENDL-2023 LIBRARY; T=0.K  
Photon emission for (n,npa)

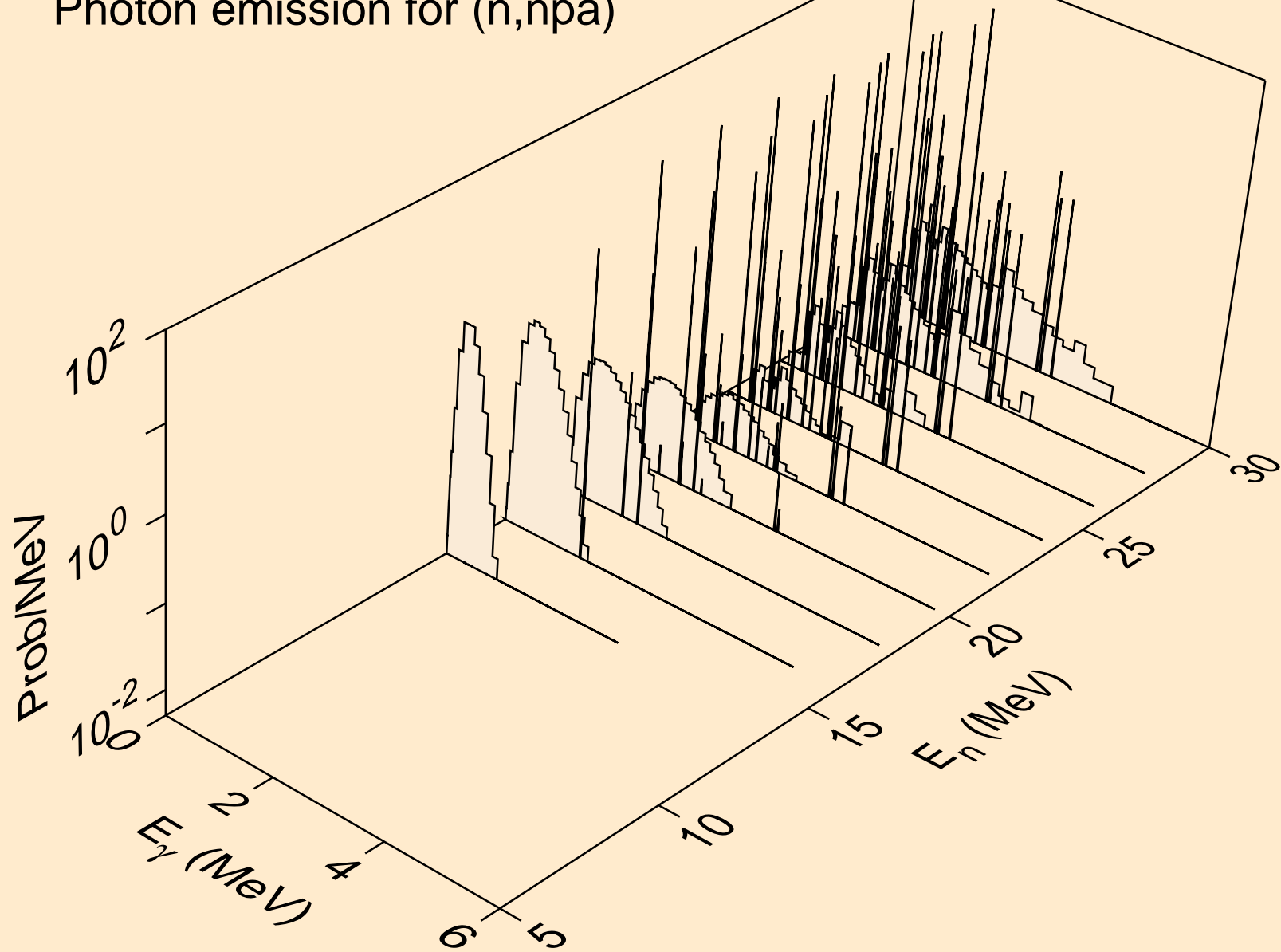

CU059 NEUTRON ACER TENDL-2023 LIBRARY; T=0.K  
Photon emission for (n,n\*c)

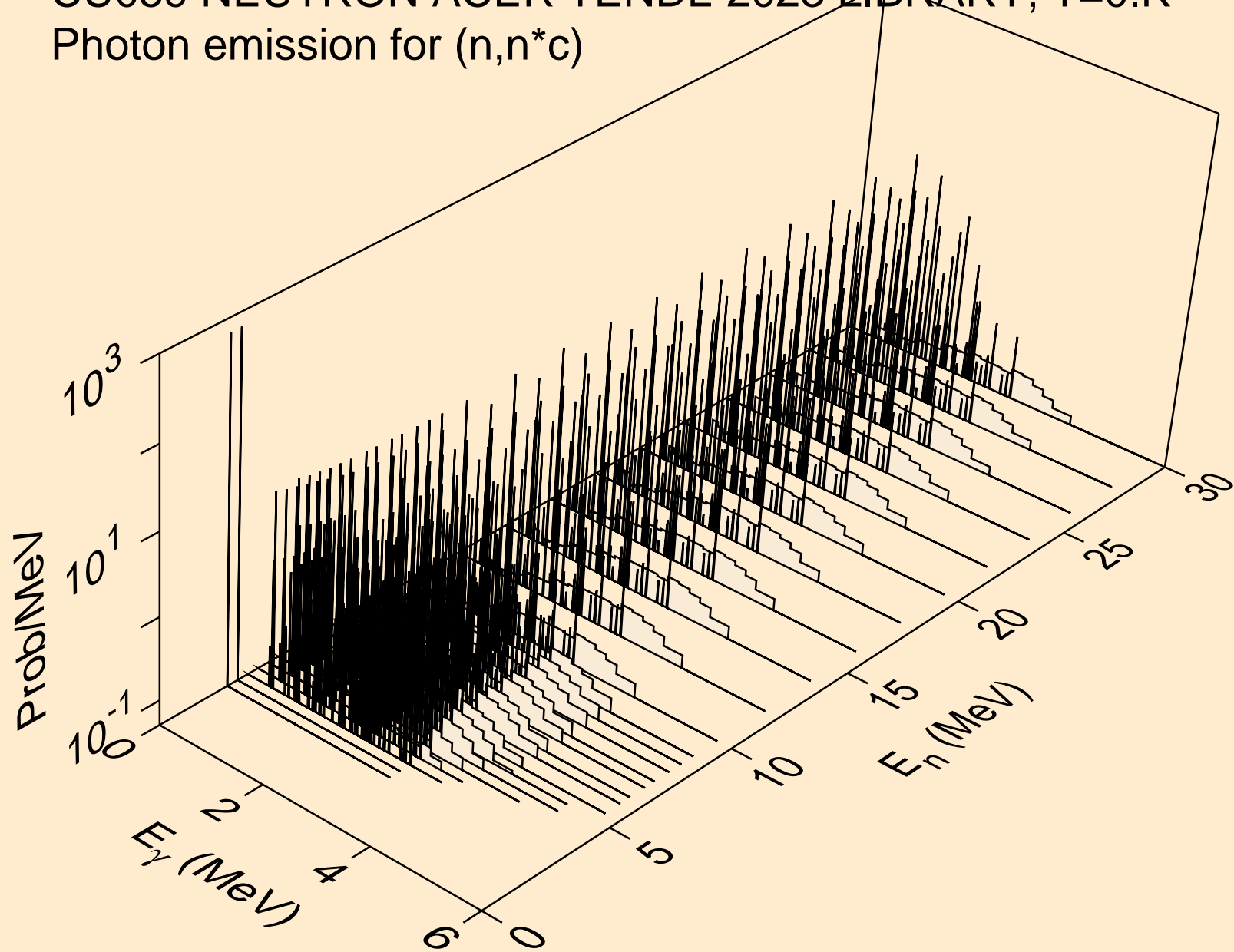

CU059 NEUTRON ACER TENDL-2023 LIBRARY; T=0.K  
Photon emission for (n,gma)

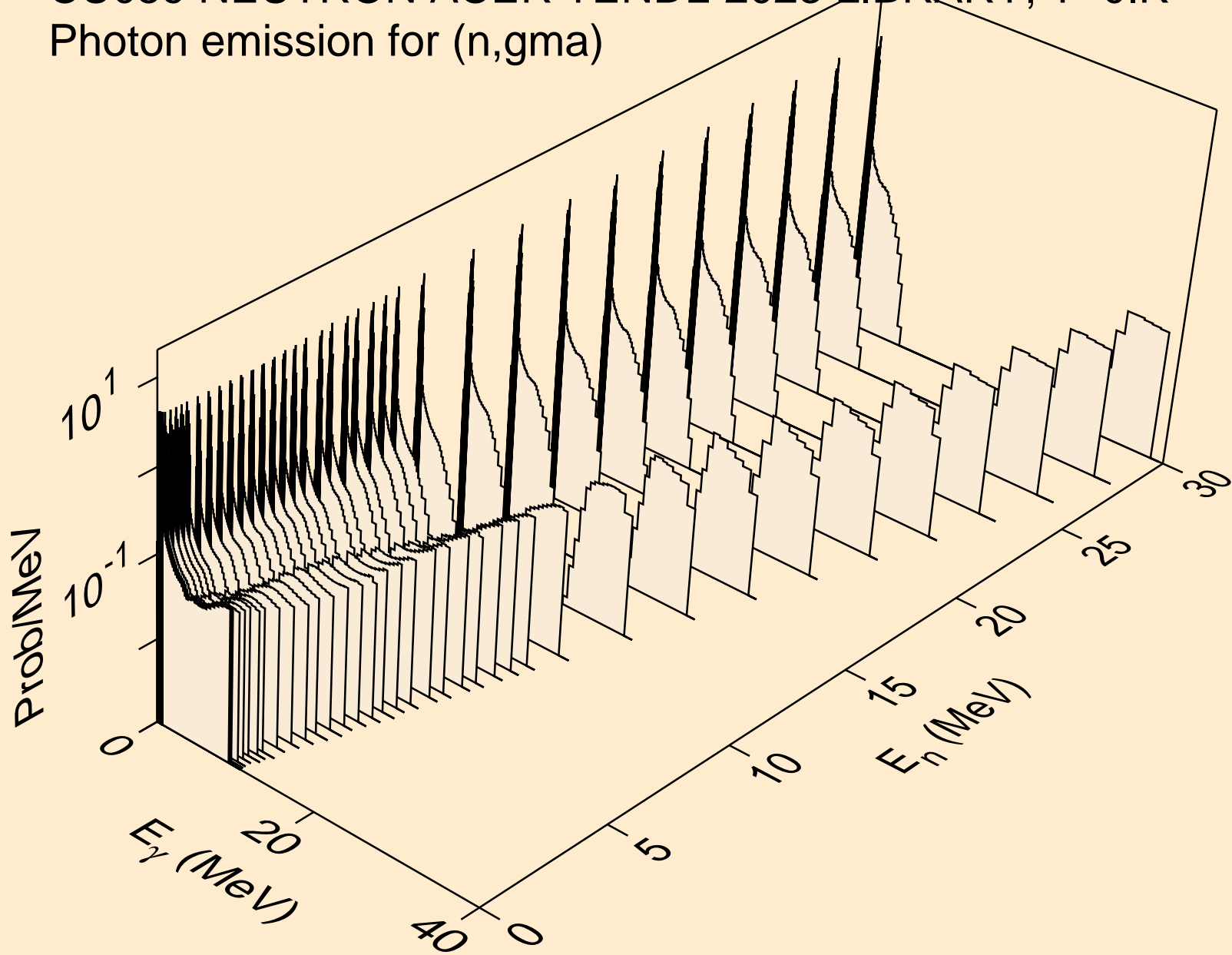



CU059 NEUTRON ACER TENDL-2023 LIBRARY; T=0.K  
Photon emission for (n,p)

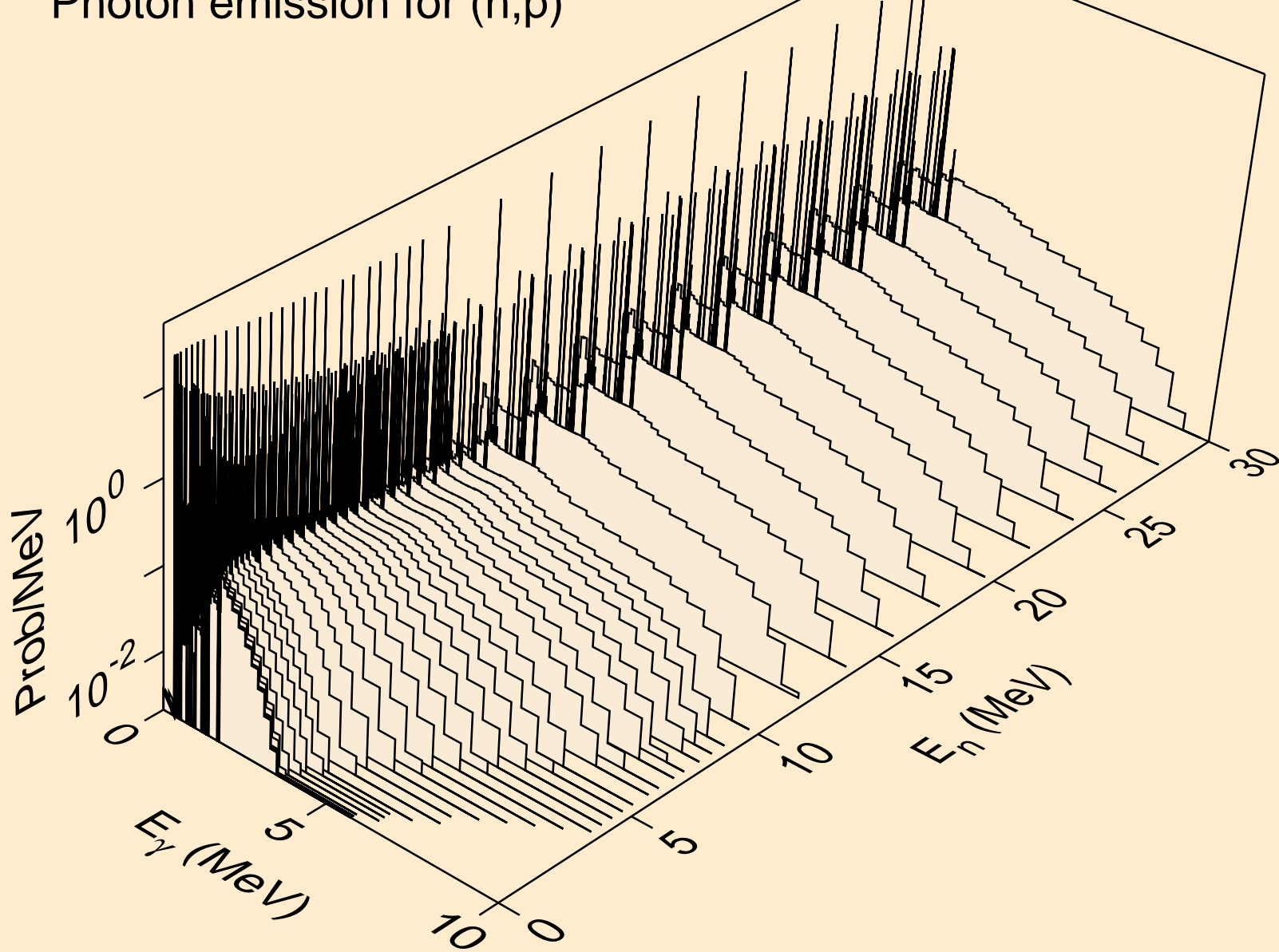

CU059 NEUTRON ACER TENDL-2023 LIBRARY; T=0.K  
Photon emission for (n,d)

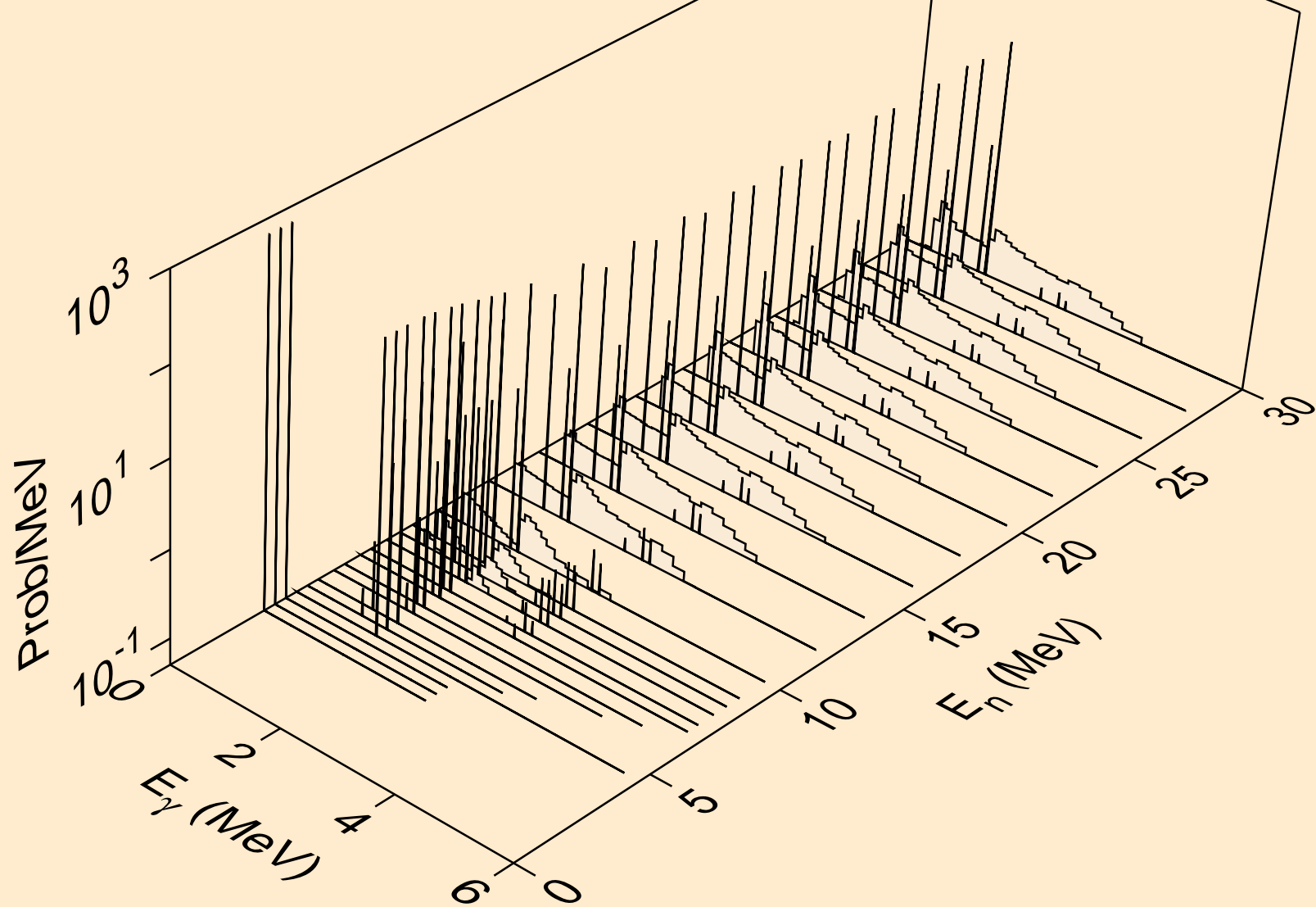

CU059 NEUTRON ACER TENDL-2023 LIBRARY; T=0.K  
Photon emission for (n,t)

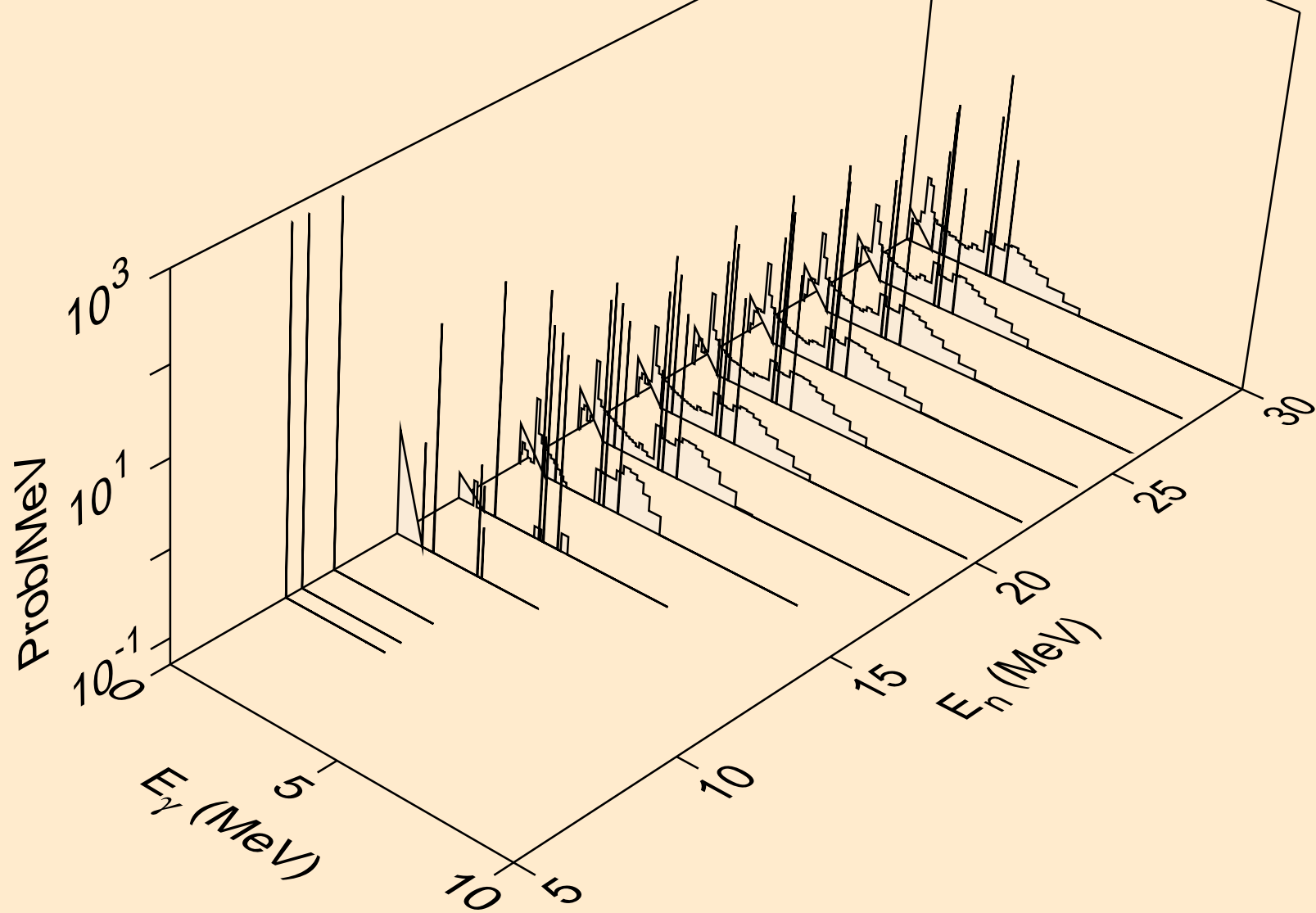

CU059 NEUTRON ACER TENDL-2023 LIBRARY; T=0.K  
Photon emission for (n,he3)

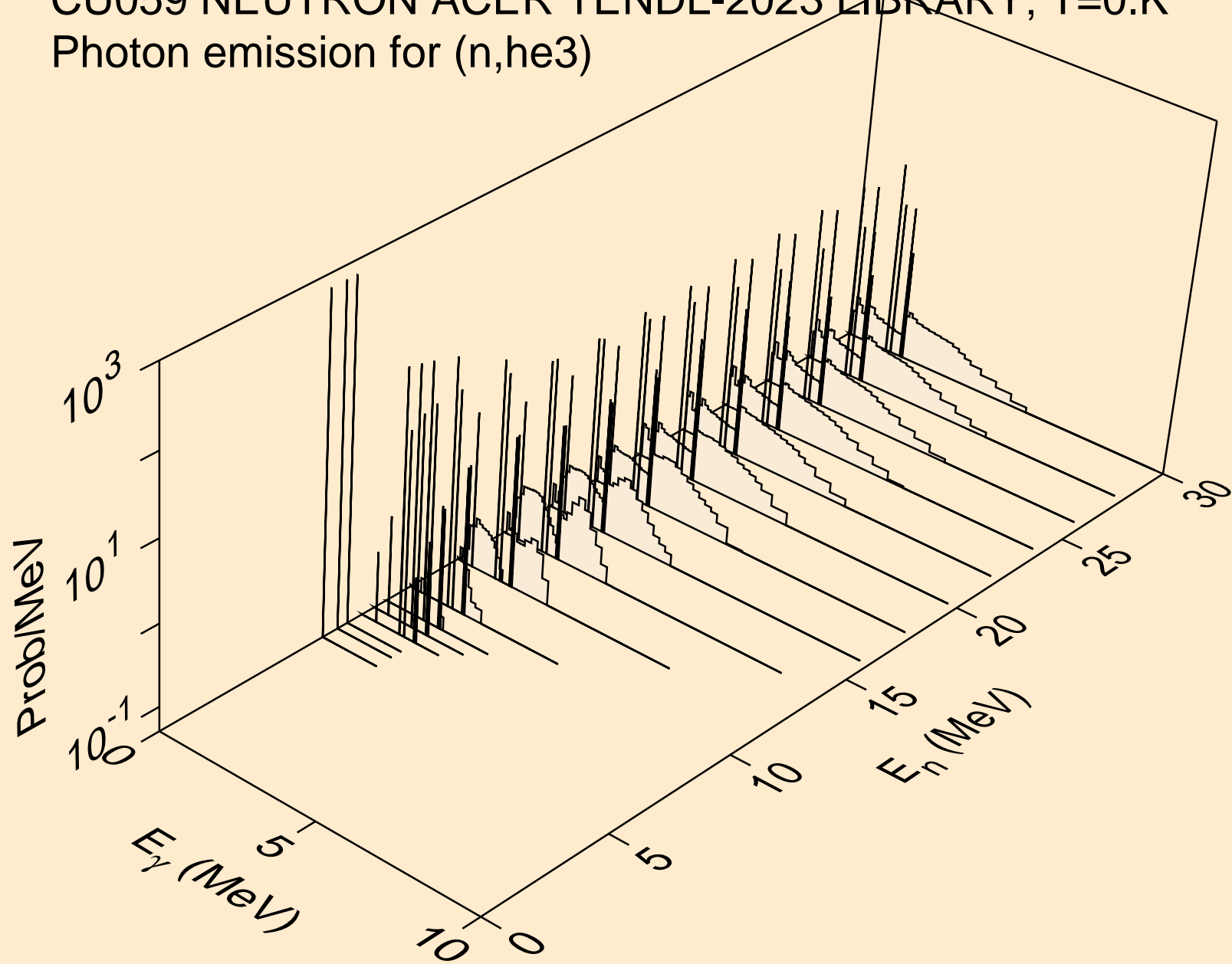

CU059 NEUTRON ACER TENDL-2023 LIBRARY; T=0.K  
Photon emission for (n,a)

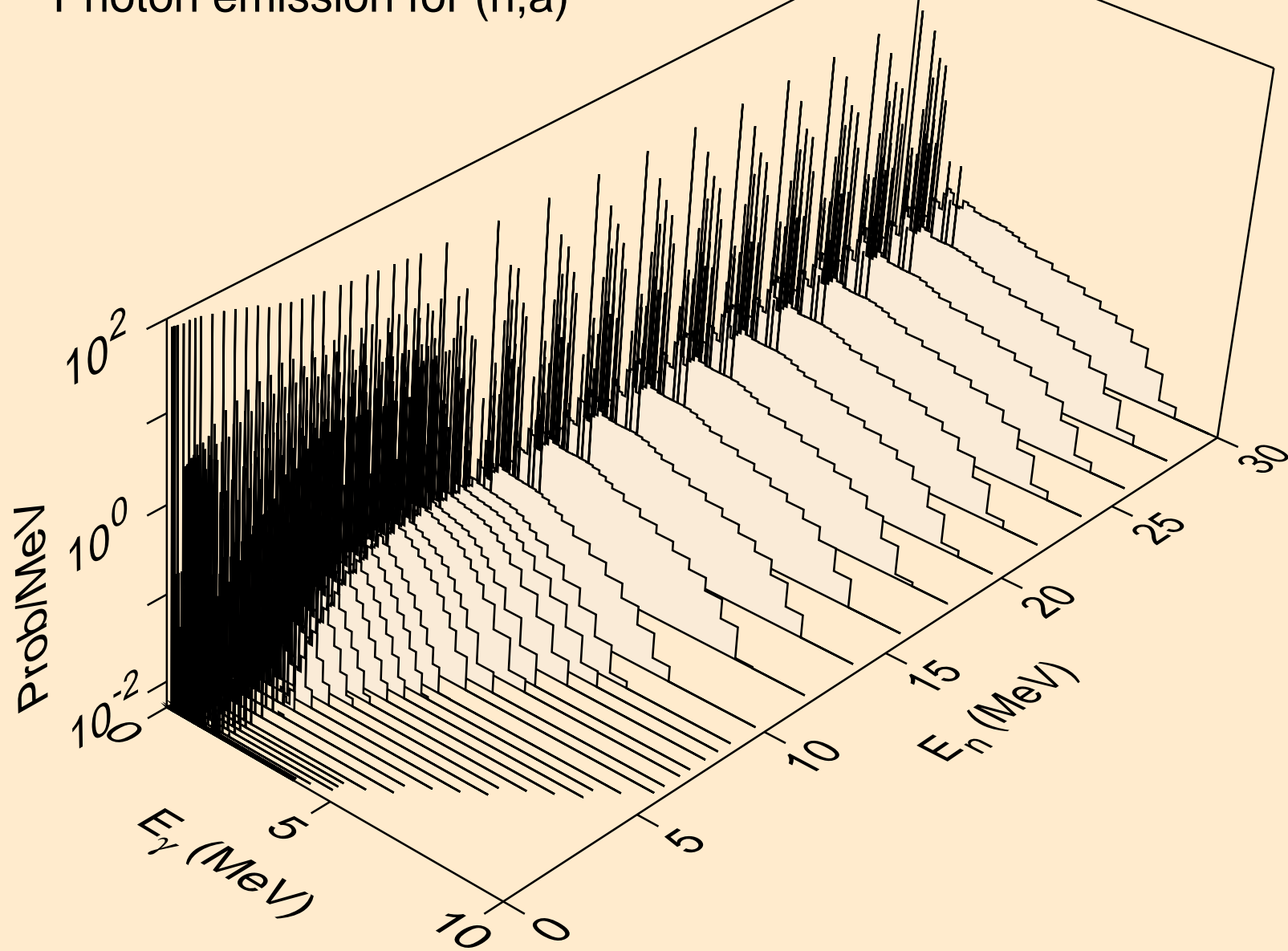

CU059 NEUTRON ACER TENDL-2023 LIBRARY; T=0.K  
Photon emission for (n,2a)

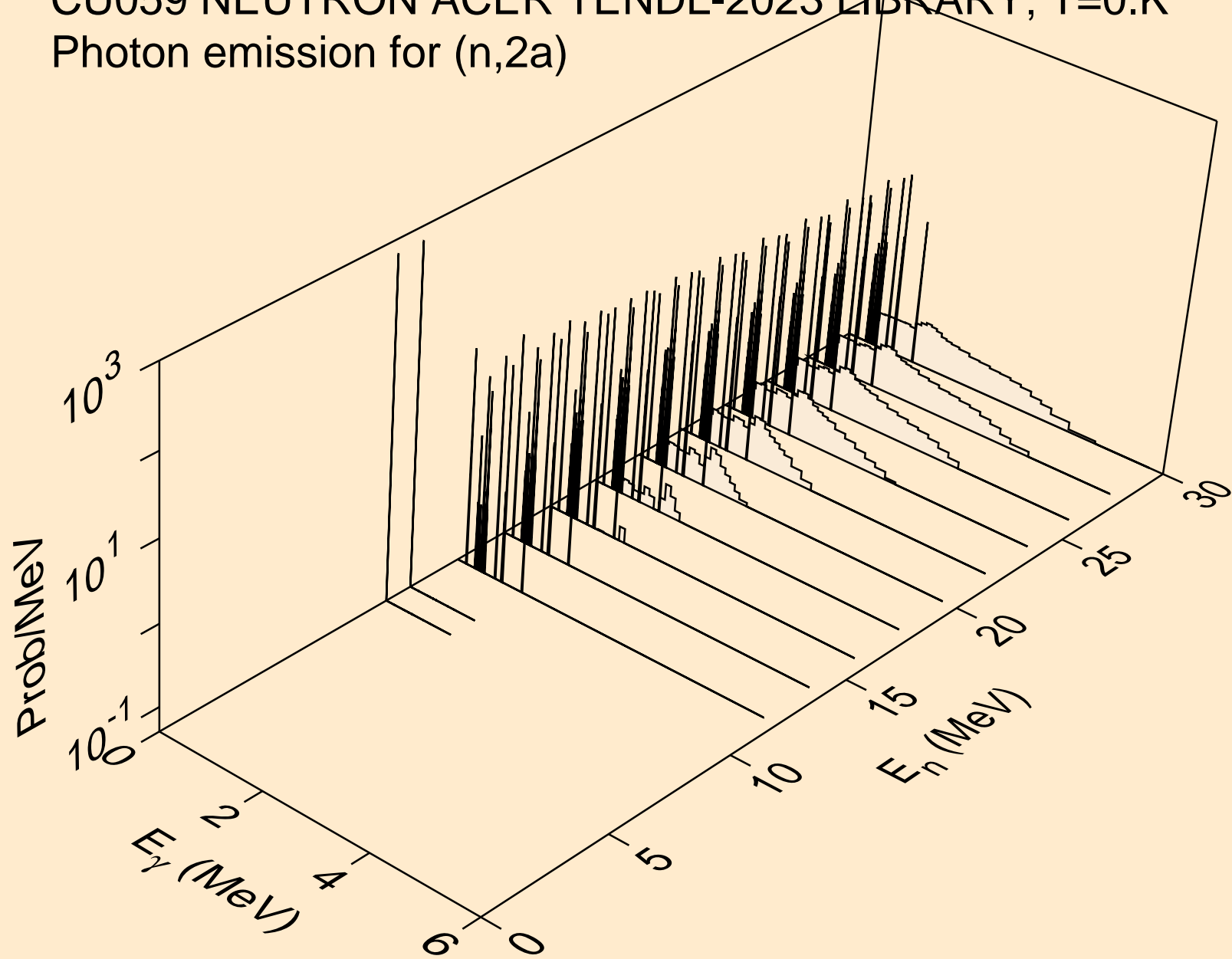

CU059 NEUTRON ACER TENDL-2023 LIBRARY; T=0.K  
Photon emission for (n,2p)

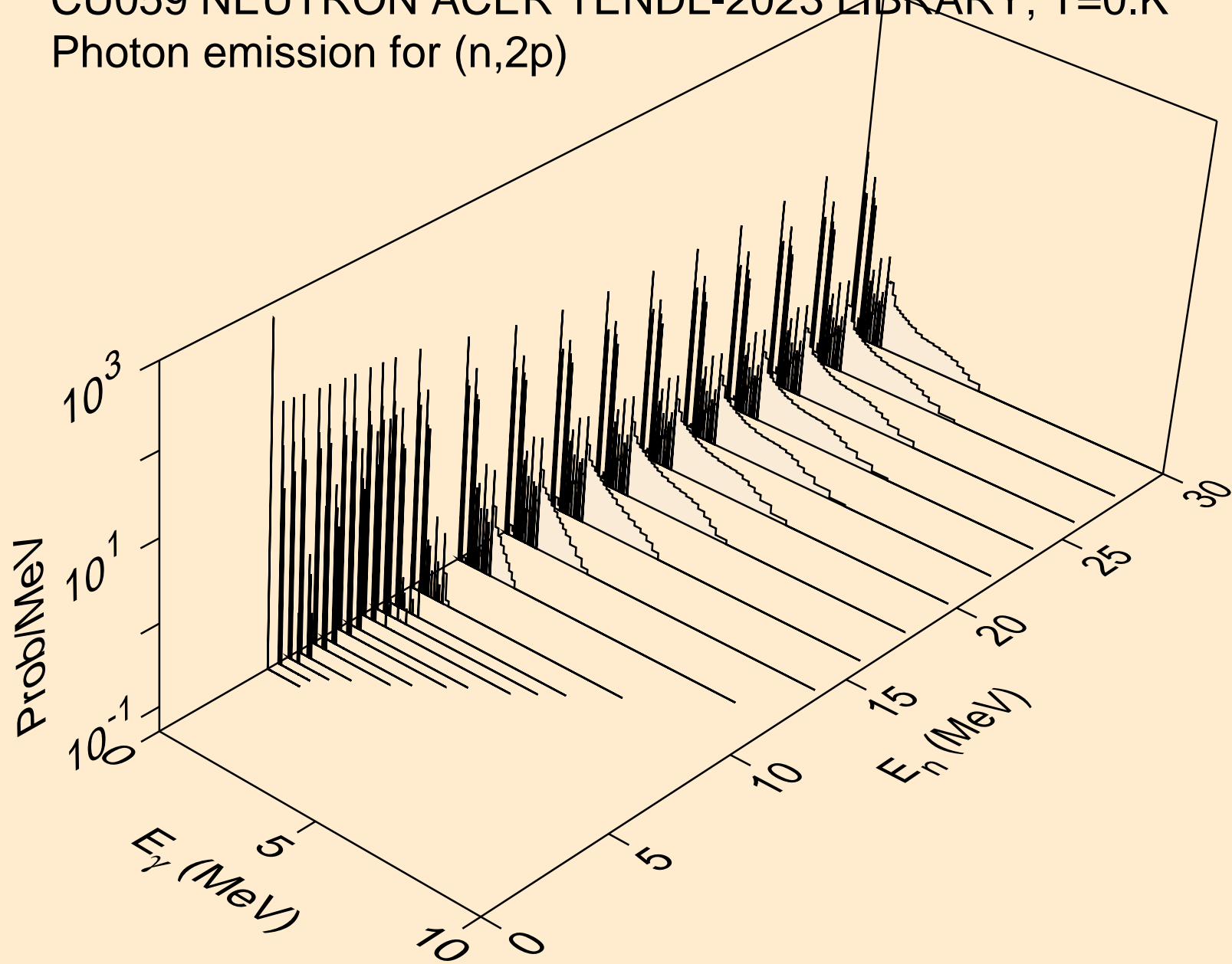

CU059 NEUTRON ACER TENDL-2023 LIBRARY; T=0.K  
Photon emission for (n,p $\alpha$ )

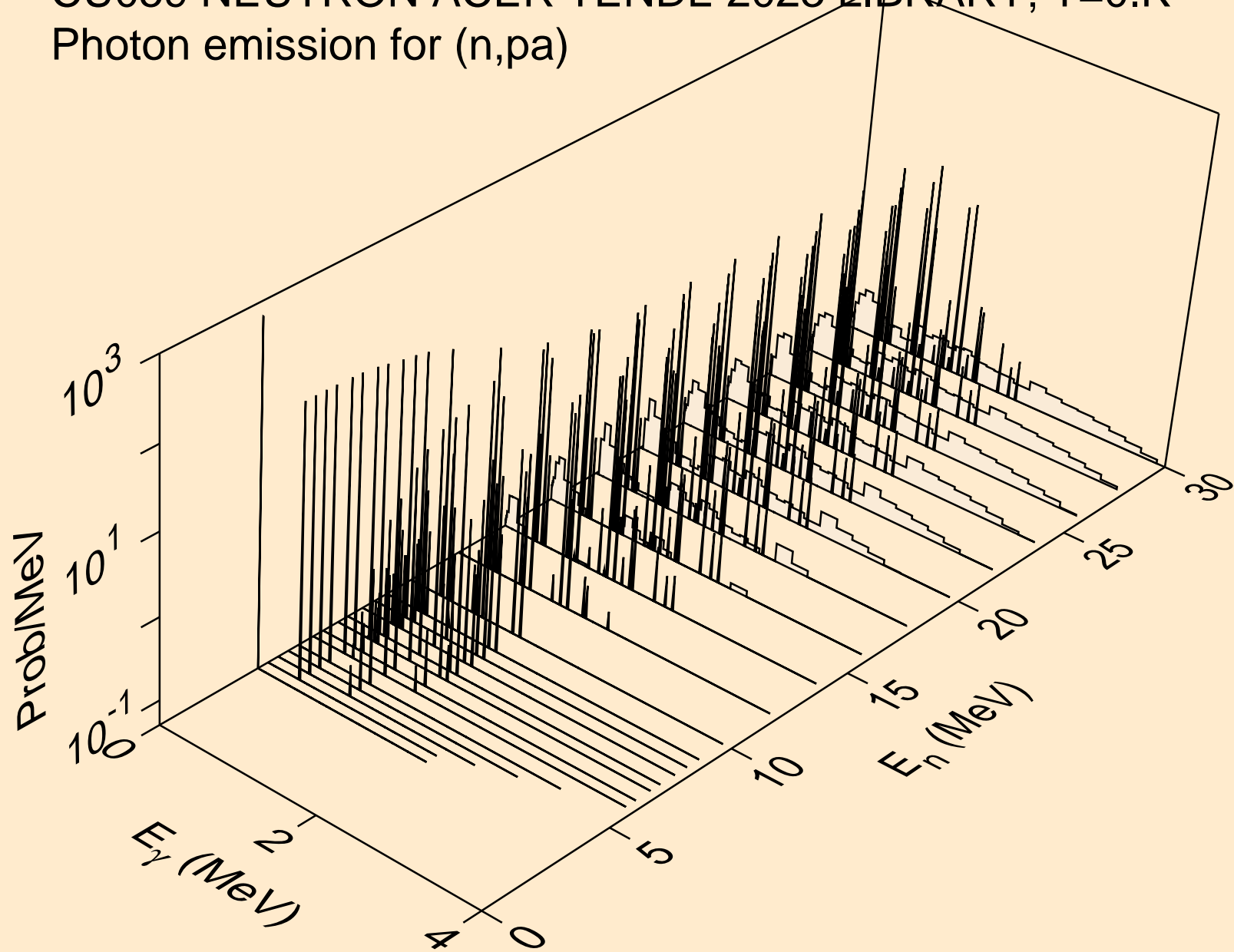



CU059 NEUTRON ACER TENDL-2023 LIBRARY; T=0.K  
Photon emission for (n,pd)

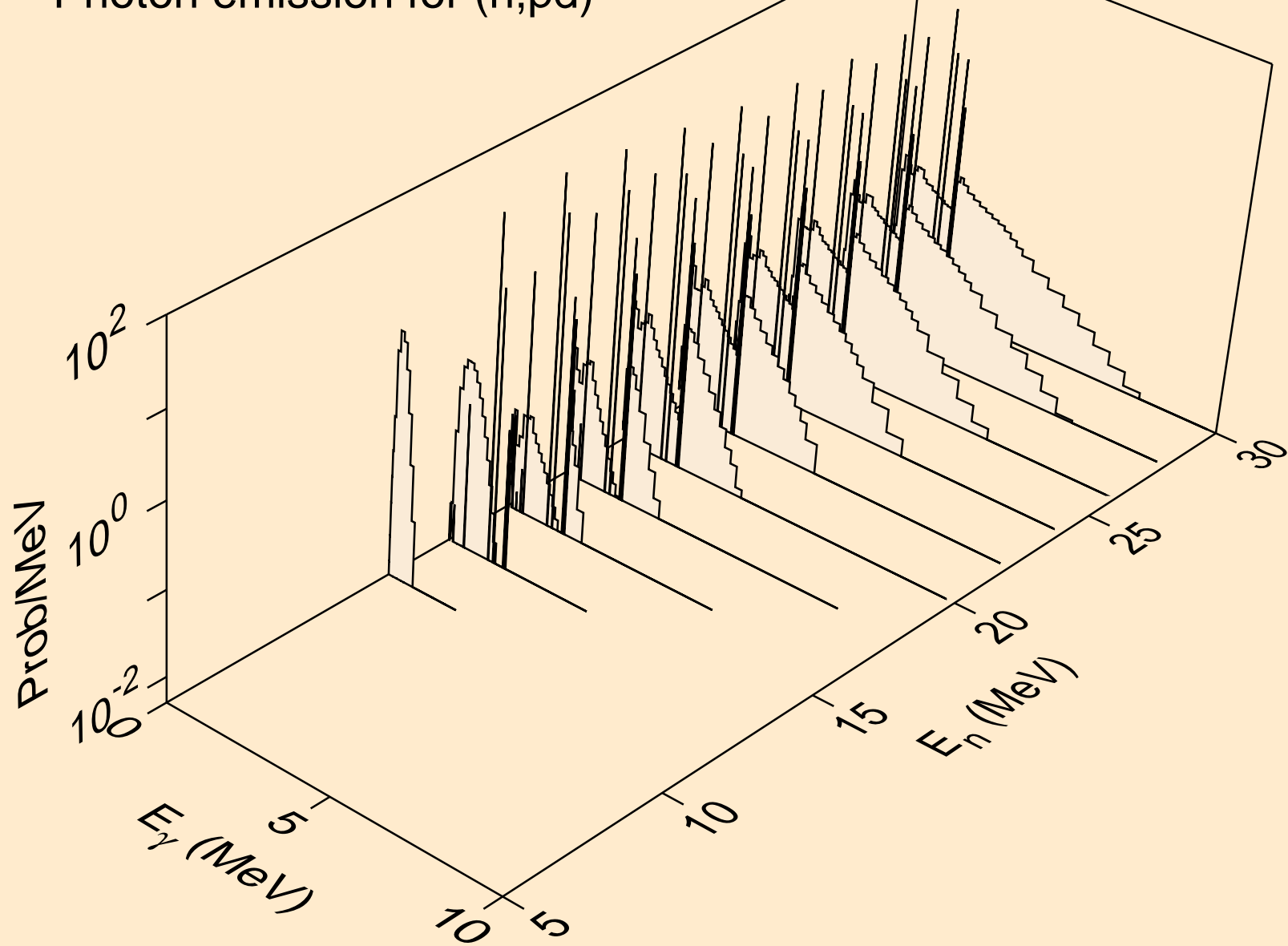

CU059 NEUTRON ACER TENDL-2023 LIBRARY; T=0.K  
Photon emission for (n,pt)

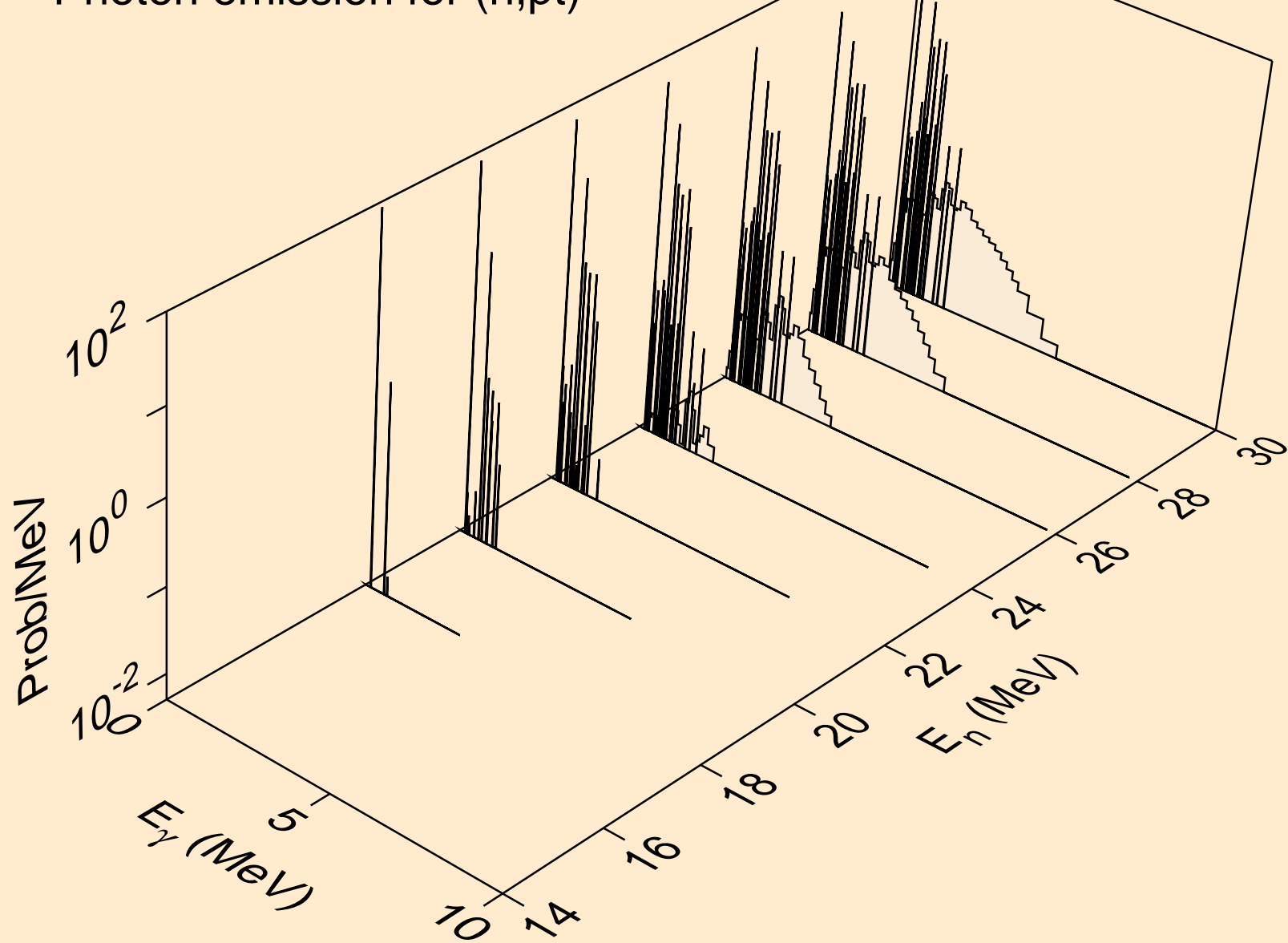

CU059 NEUTRON ACER TENDL-2023 LIBRARY; T=0.K  
Photon emission for (n,da)

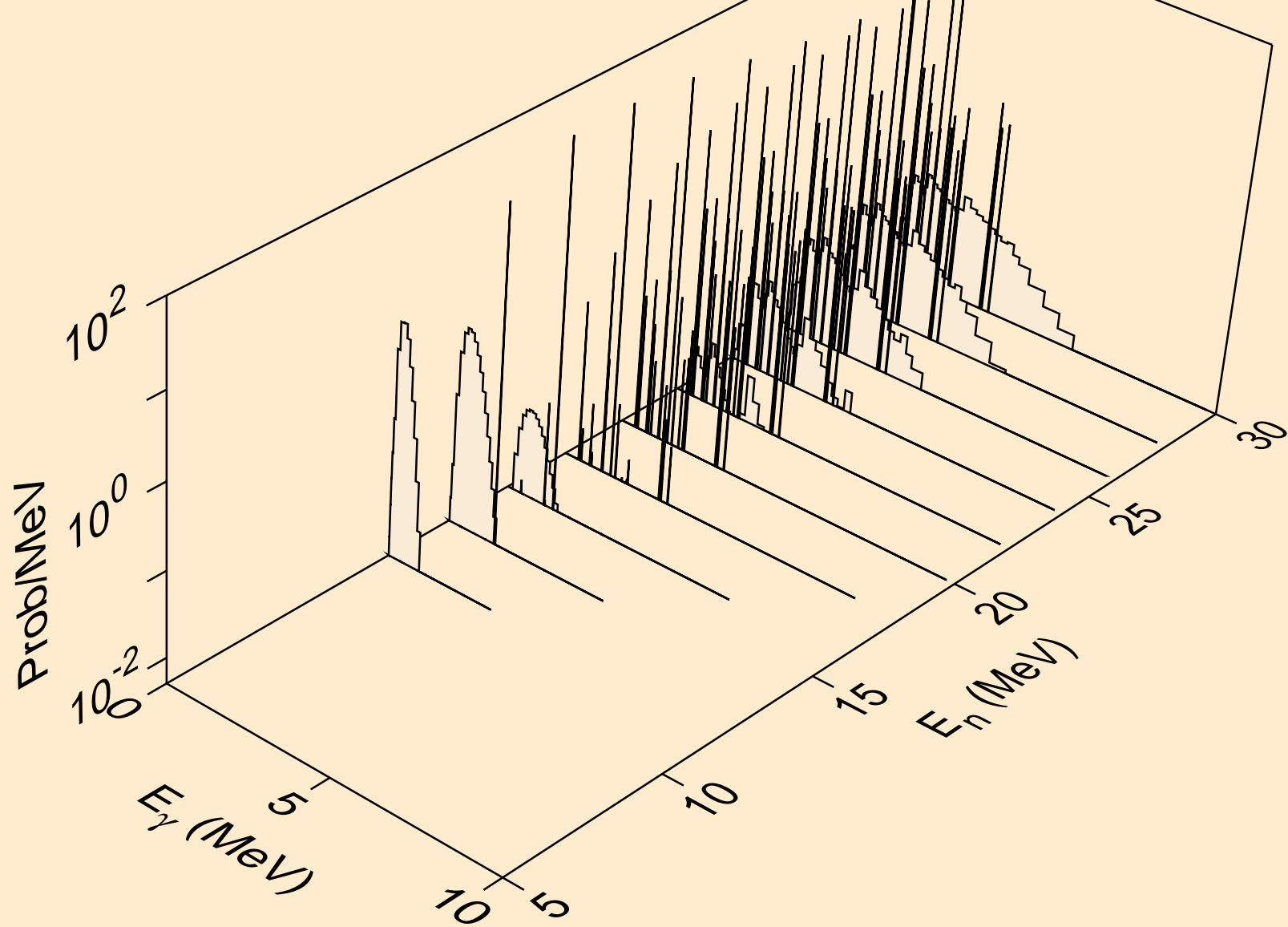

CU059 NEUTRON ACER TENDL-2023 LIBRARY; T=0.K  
thermal capture photon spectrum

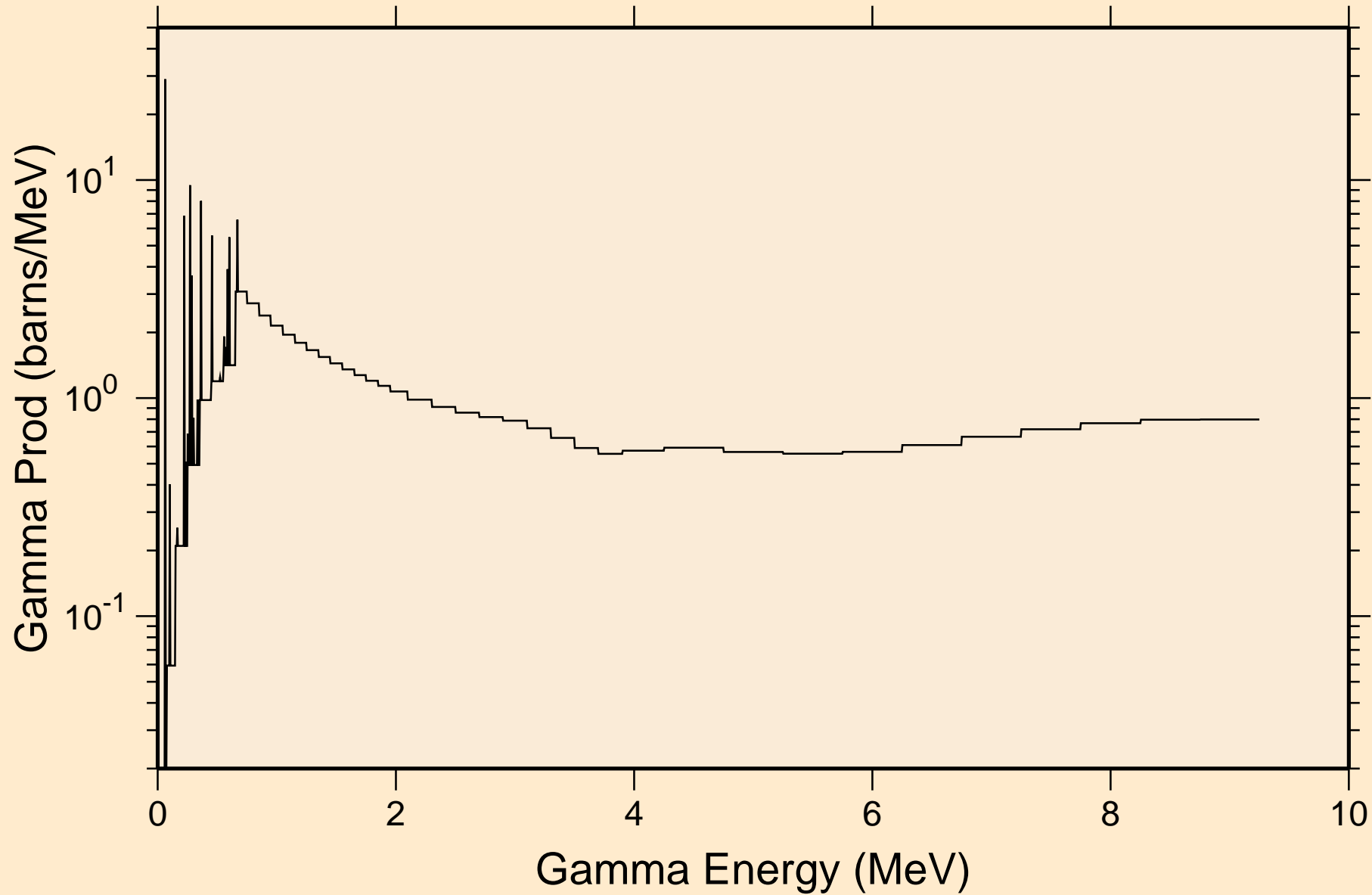

CU059 NEUTRON ACER TENDL-2023 LIBRARY; T=0.K  
14 MeV photon spectrum

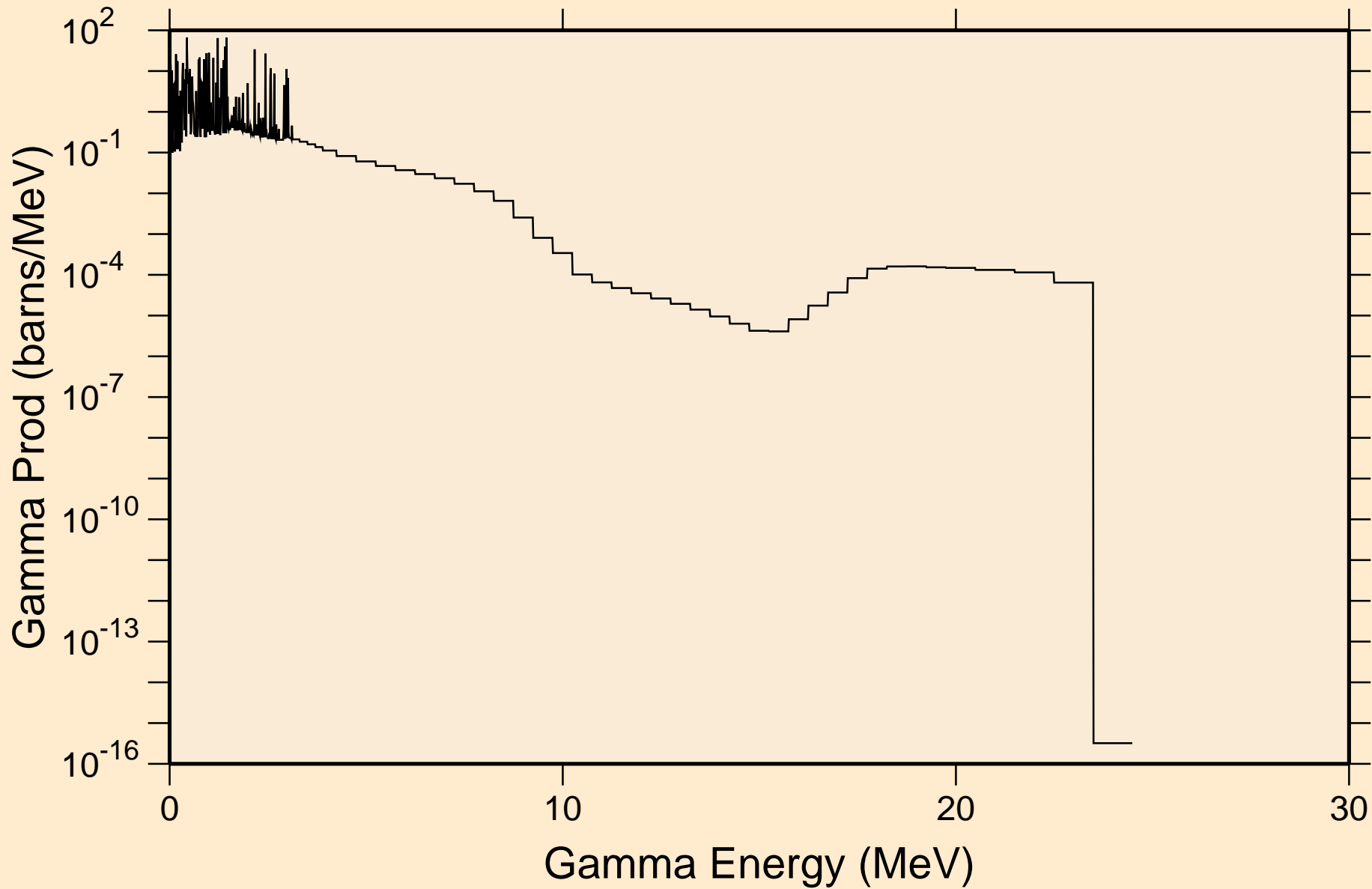

# CU059 NEUTRON ACER TENDL-2023 LIBRARY; T=0.K

## Particle heating contributions

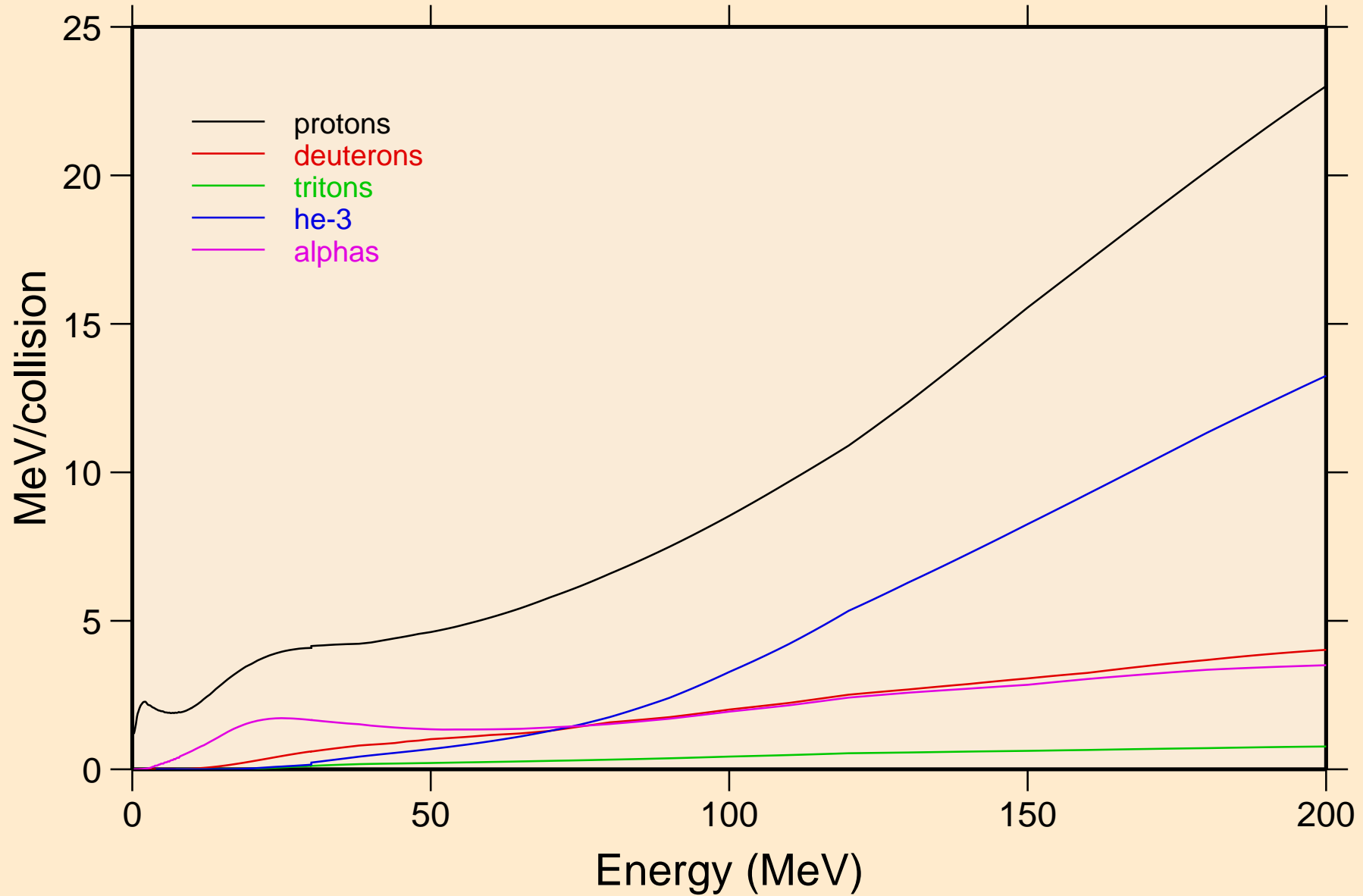

CU059 NEUTRON ACER TENDL-2023 LIBRARY; T=0.K  
Recoil Heating

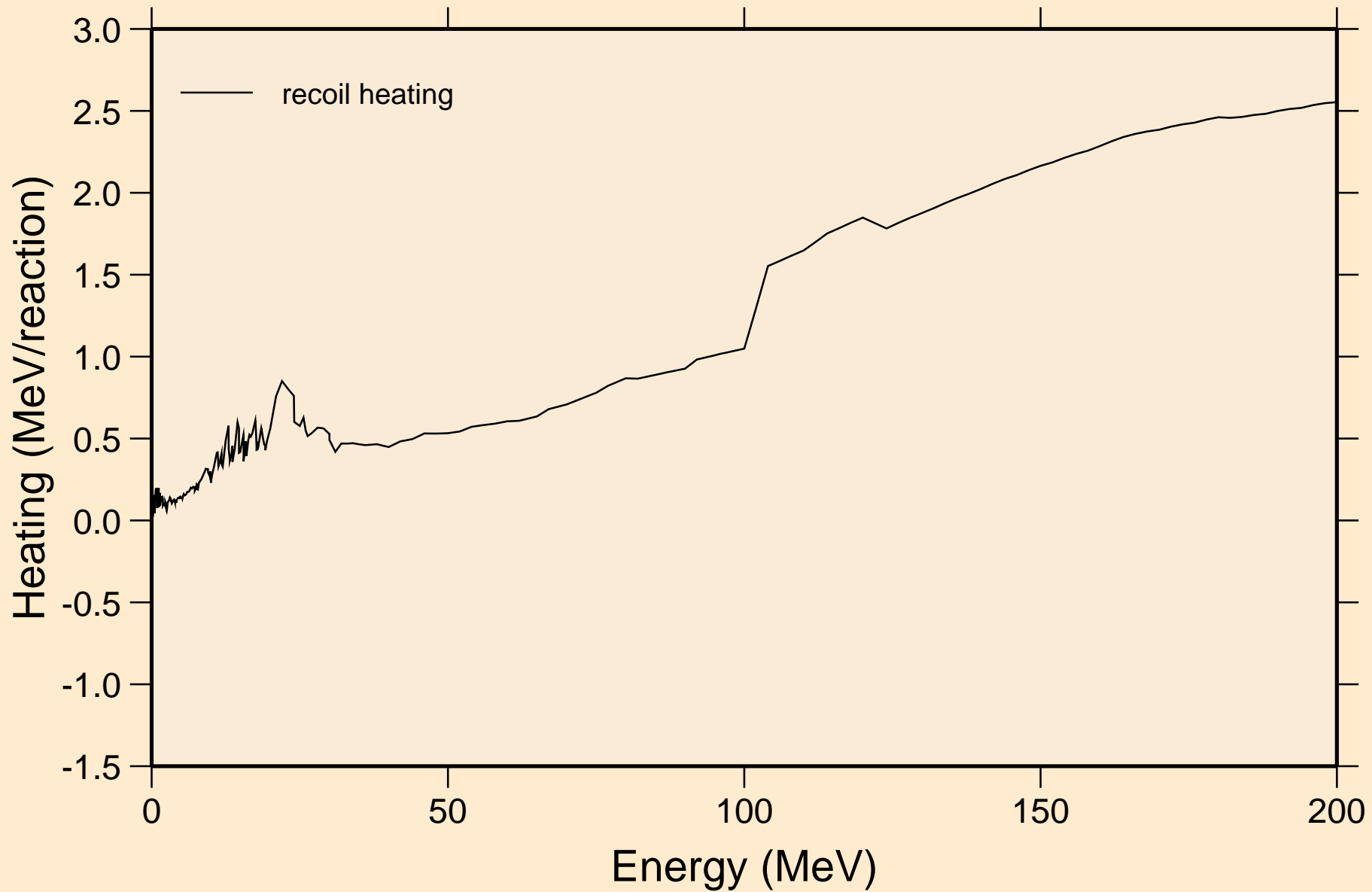

# CU059 NEUTRON ACER TENDL-2023 LIBRARY; T=0.K

## Particle production cross sections

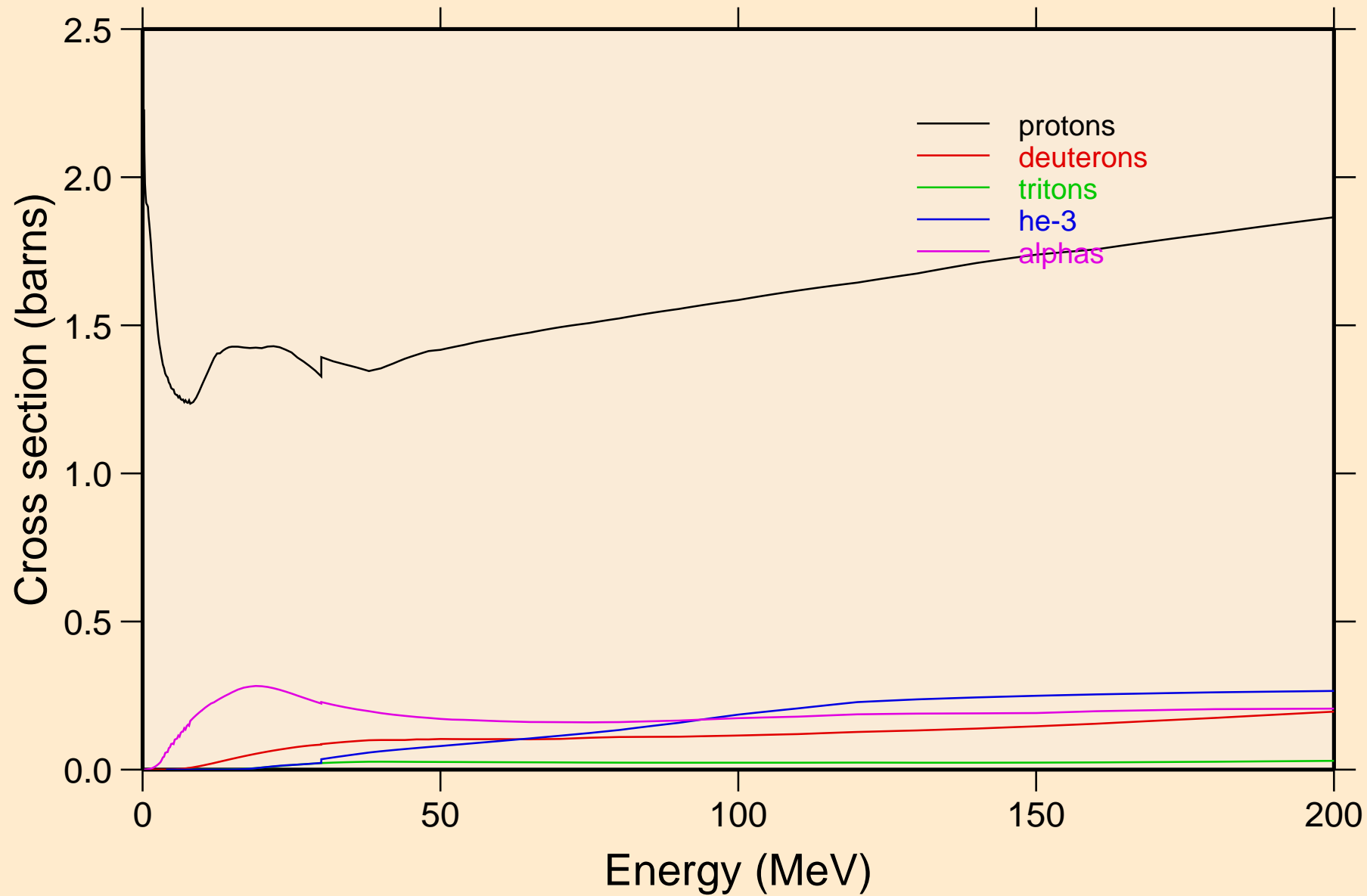



CU059 NEUTRON ACER TENDL-2023 LIBRARY; T=0.K  
protons from (n,x)

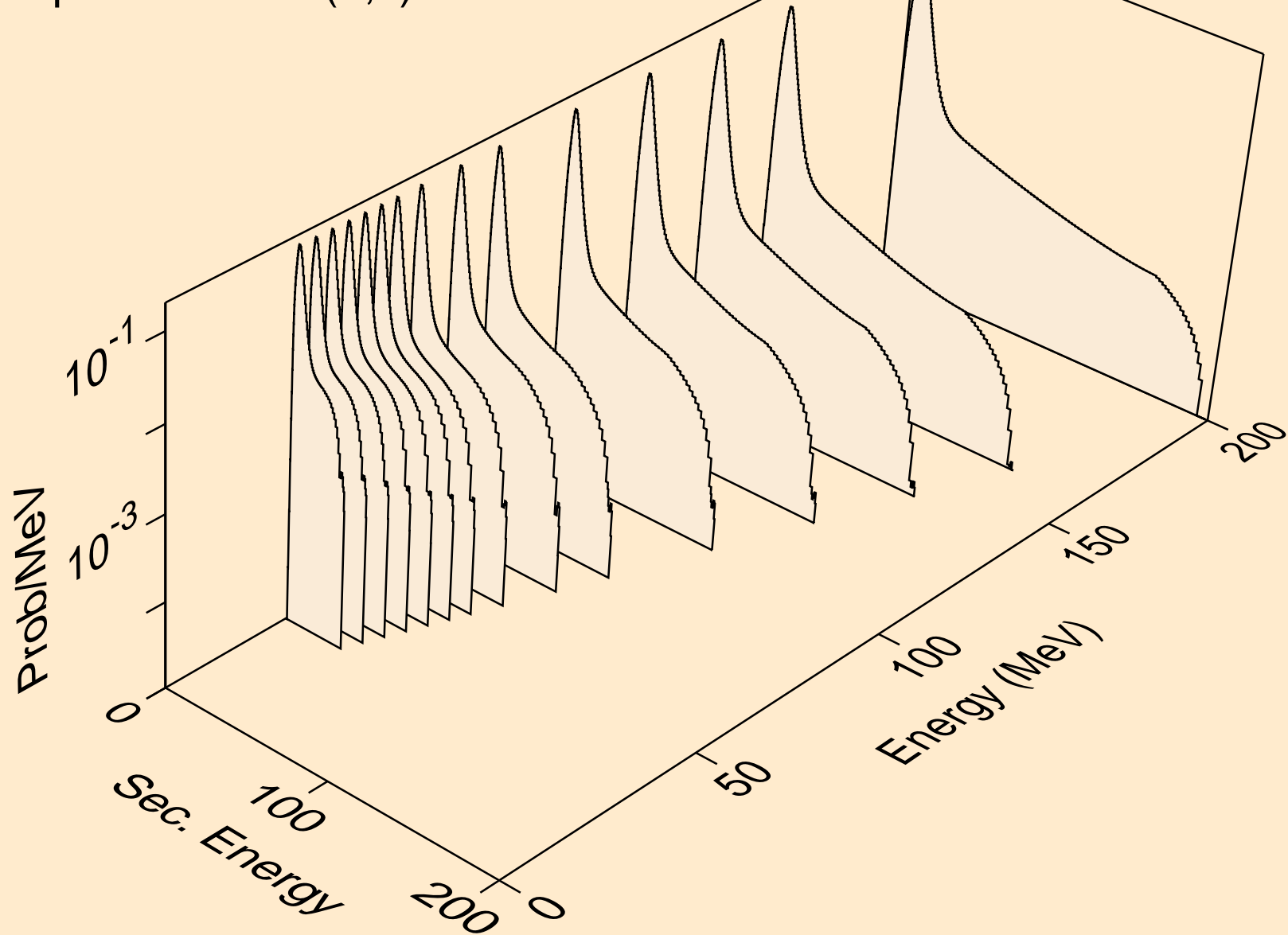

CU059 NEUTRON ACER TENDL-2023 LIBRARY; T=0.K  
protons from (n,n\*)p

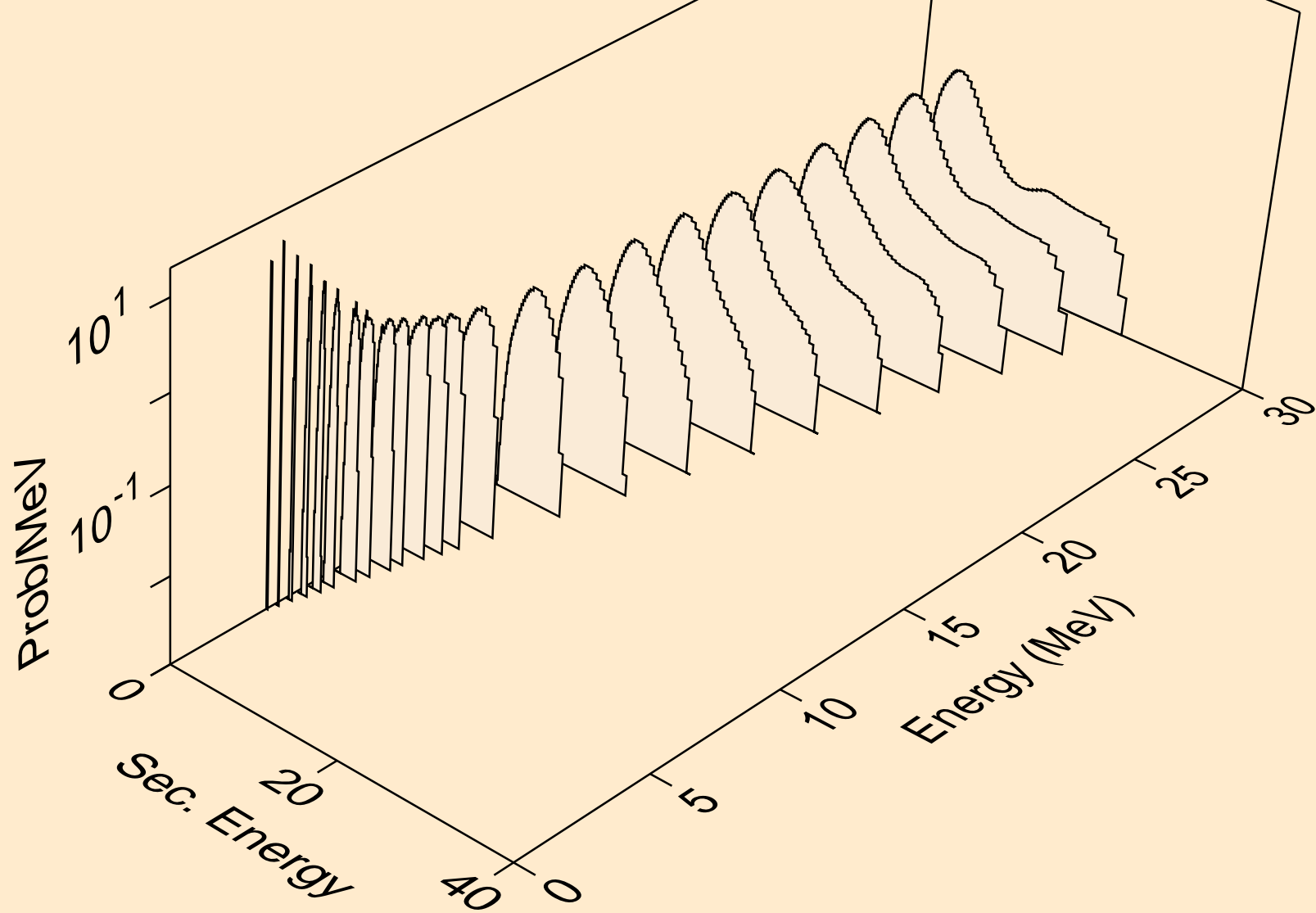

CU059 NEUTRON ACER TENDL-2023 LIBRARY; T=0.K  
protons from (n,2np)

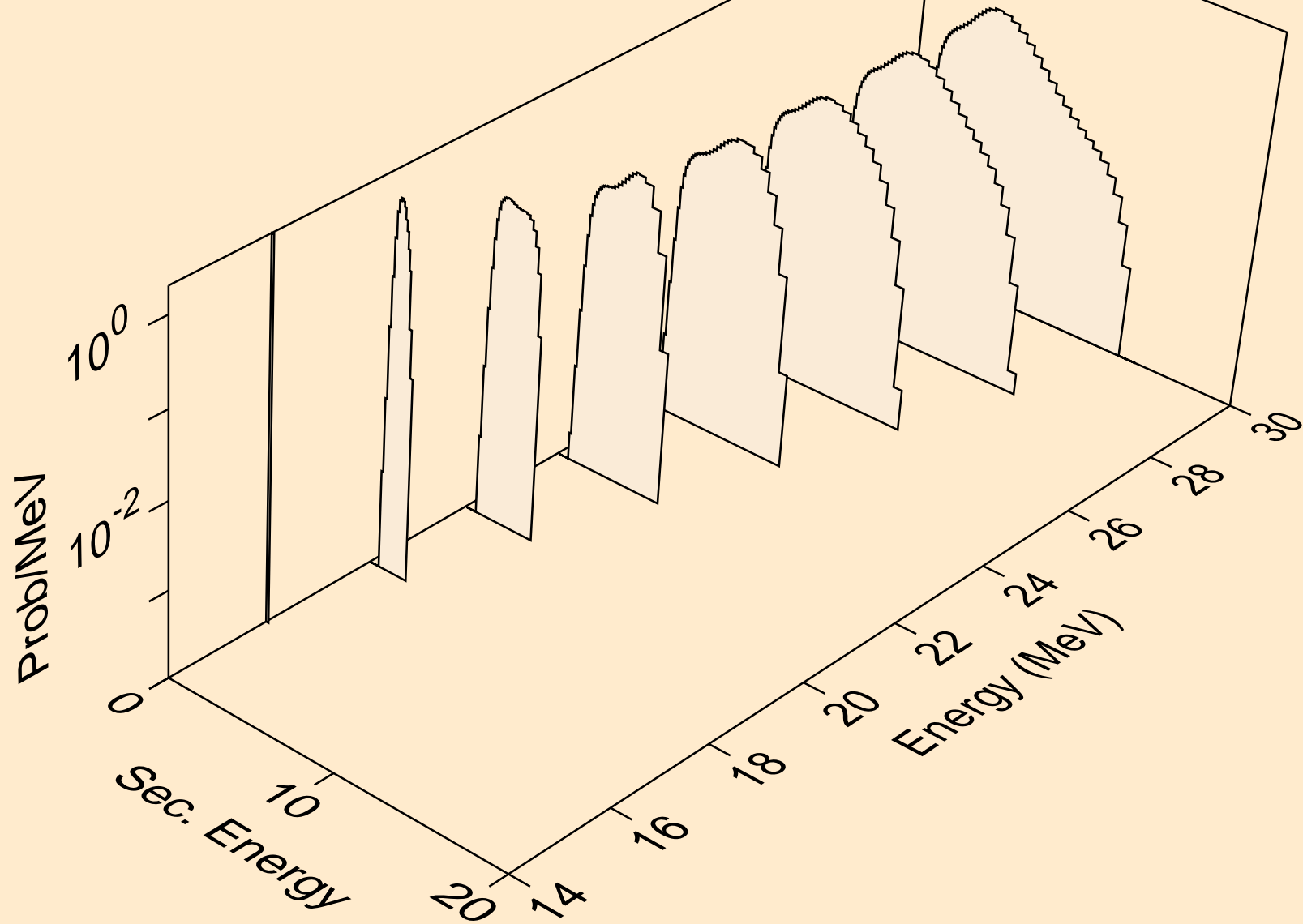

CU059 NEUTRON ACER TENDL-2023 LIBRARY; T=0.K  
protons from (n,3np)

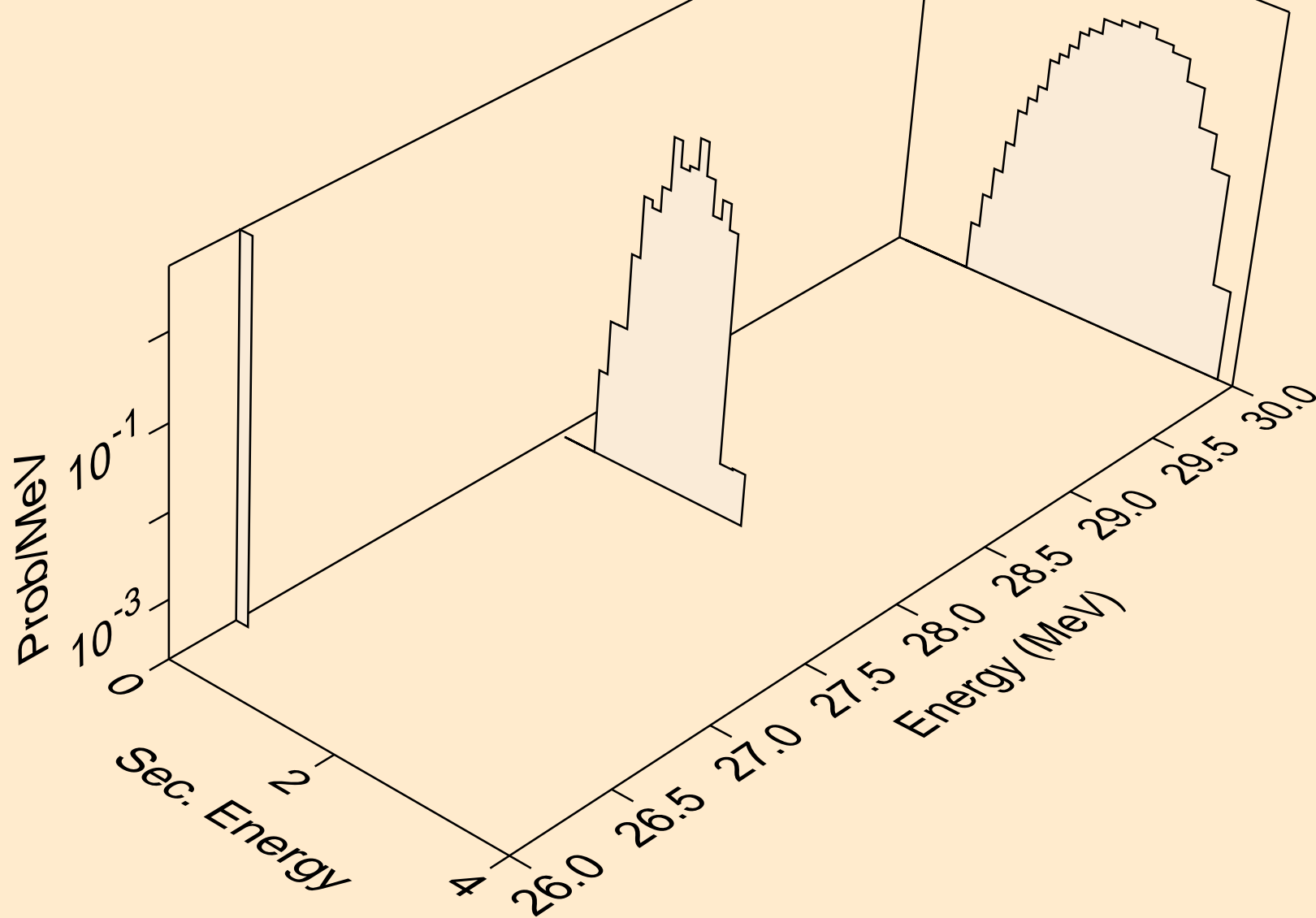

CU059 NEUTRON ACER TENDL-2023 LIBRARY; T=0.K  
protons from (n,n2p)

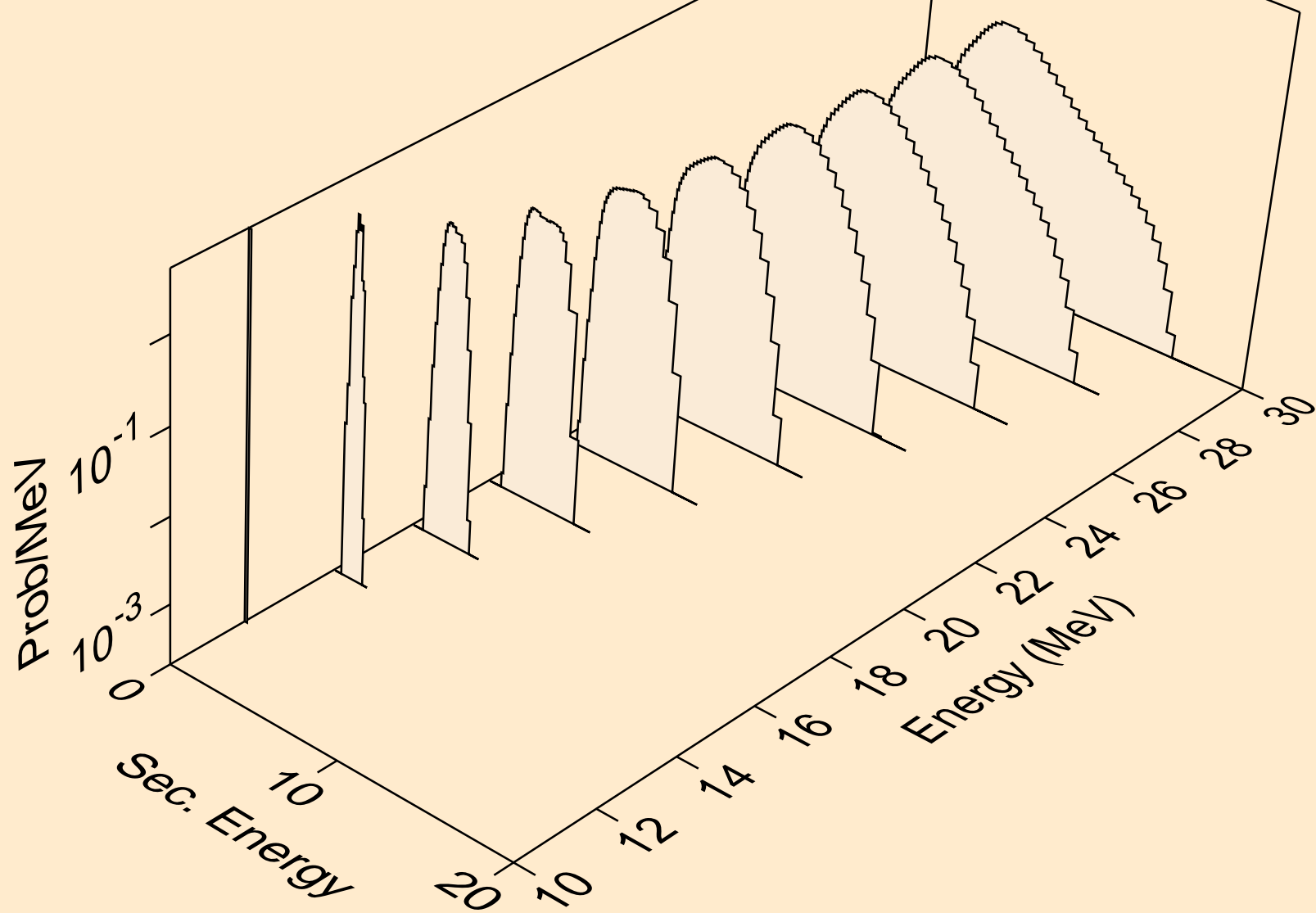

CU059 NEUTRON ACER TENDL-2023 LIBRARY; T=0.K  
protons from (n,npa)

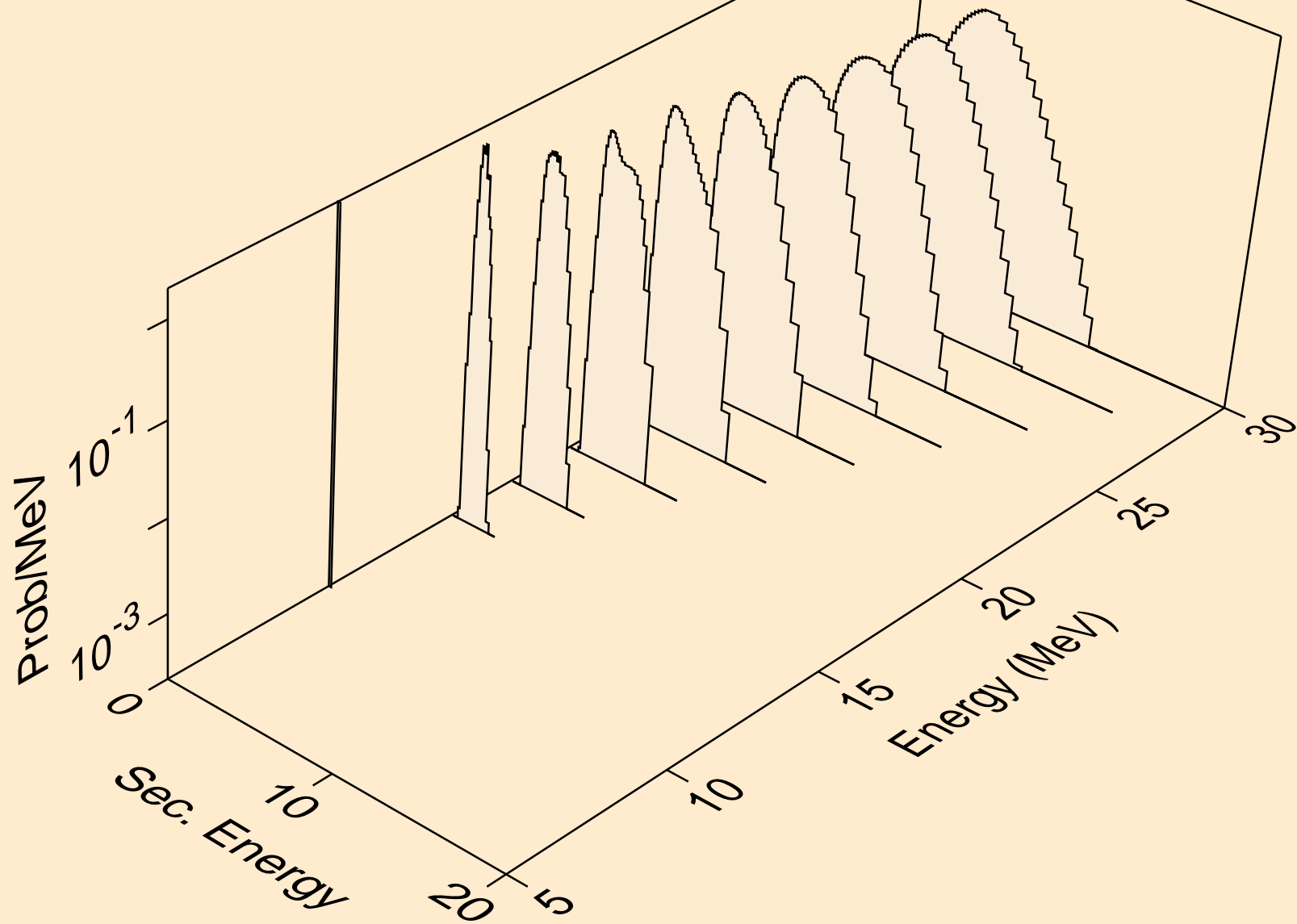

CU059 NEUTRON ACER TENDL-2023 LIBRARY; T=0.K  
protons from (n,p)

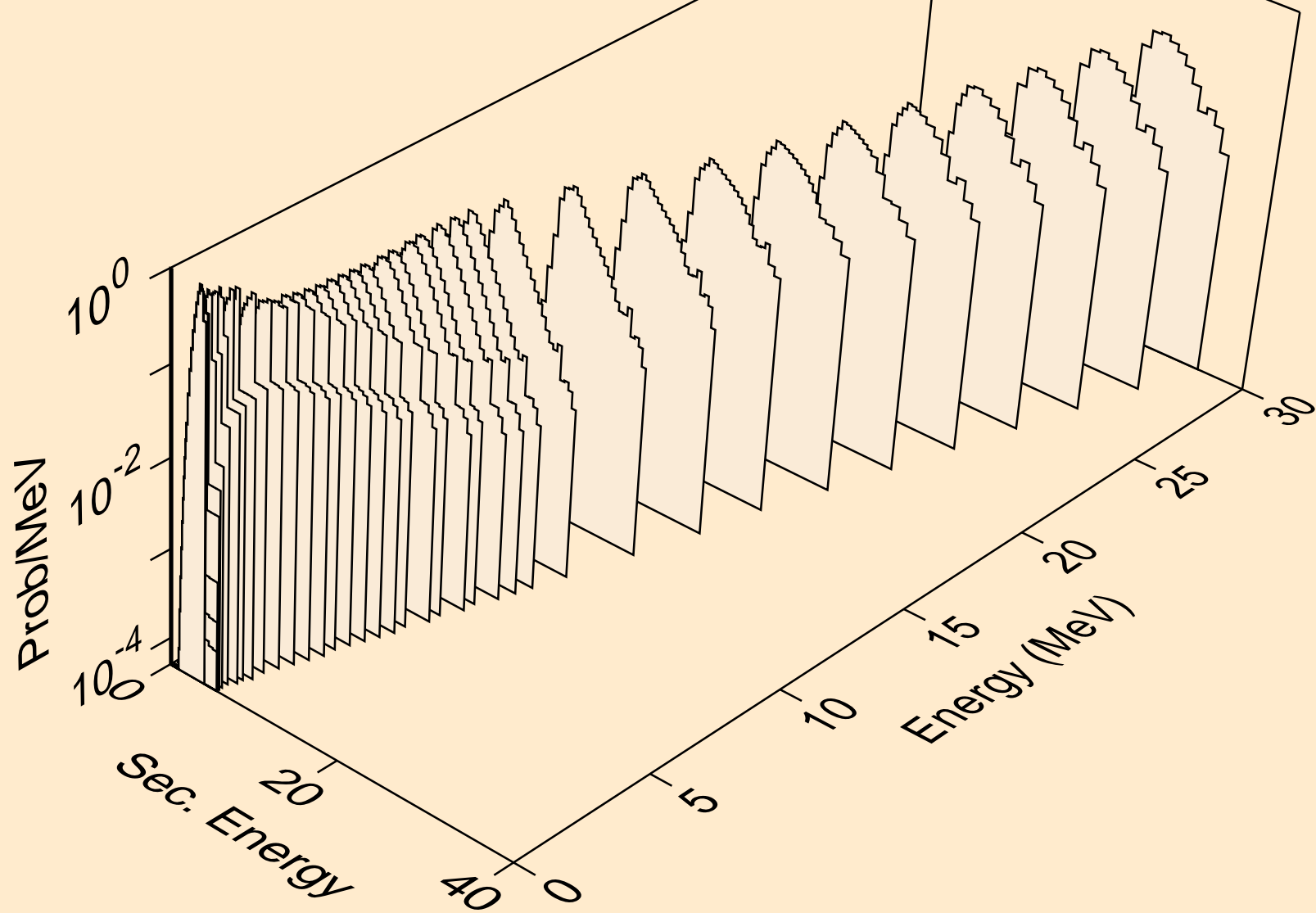

CU059 NEUTRON ACER TENDL-2023 LIBRARY; T=0.K  
protons from (n,2p)

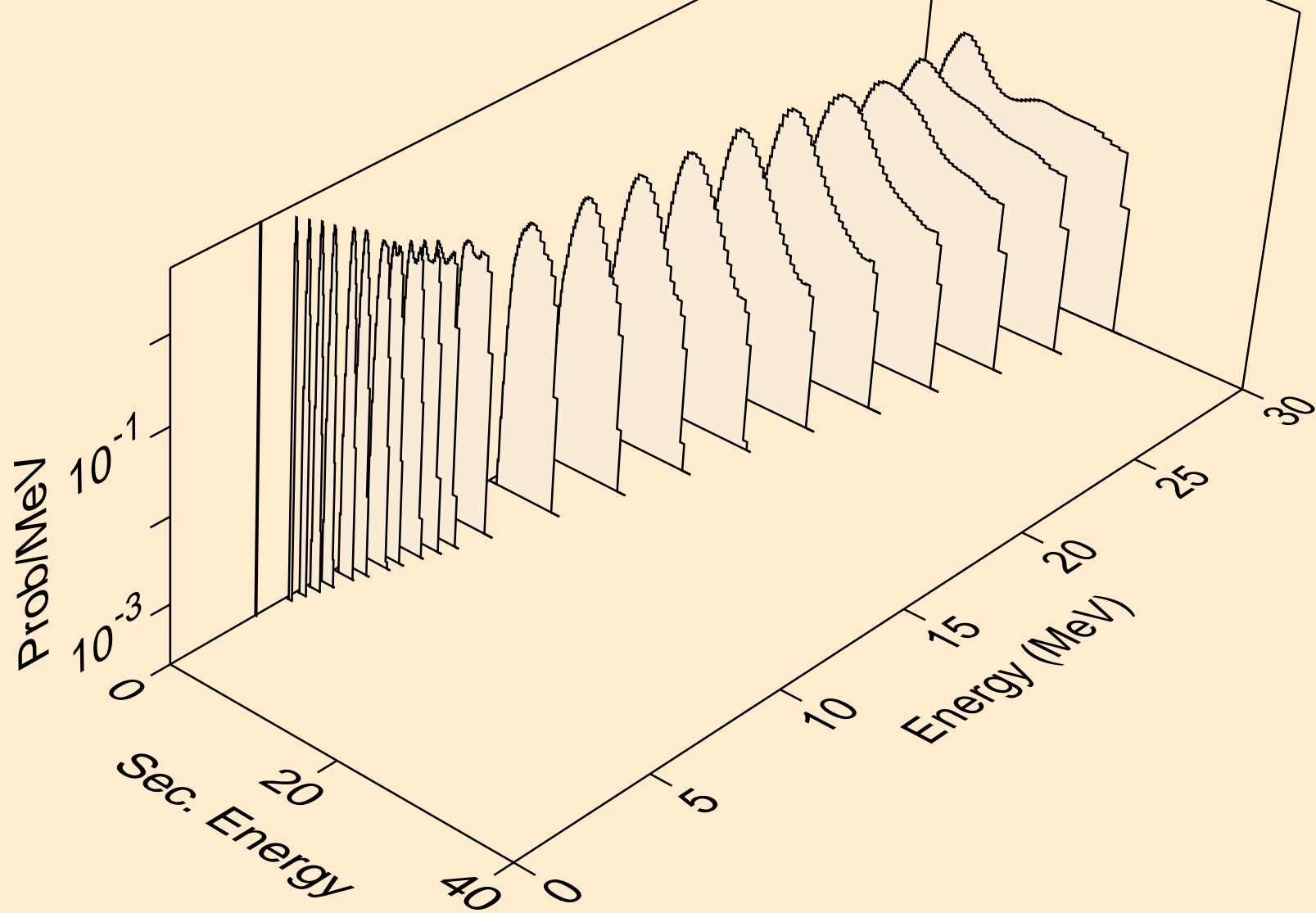



CU059 NEUTRON ACER TENDL-2023 LIBRARY; T=0.K  
protons from (n,p)

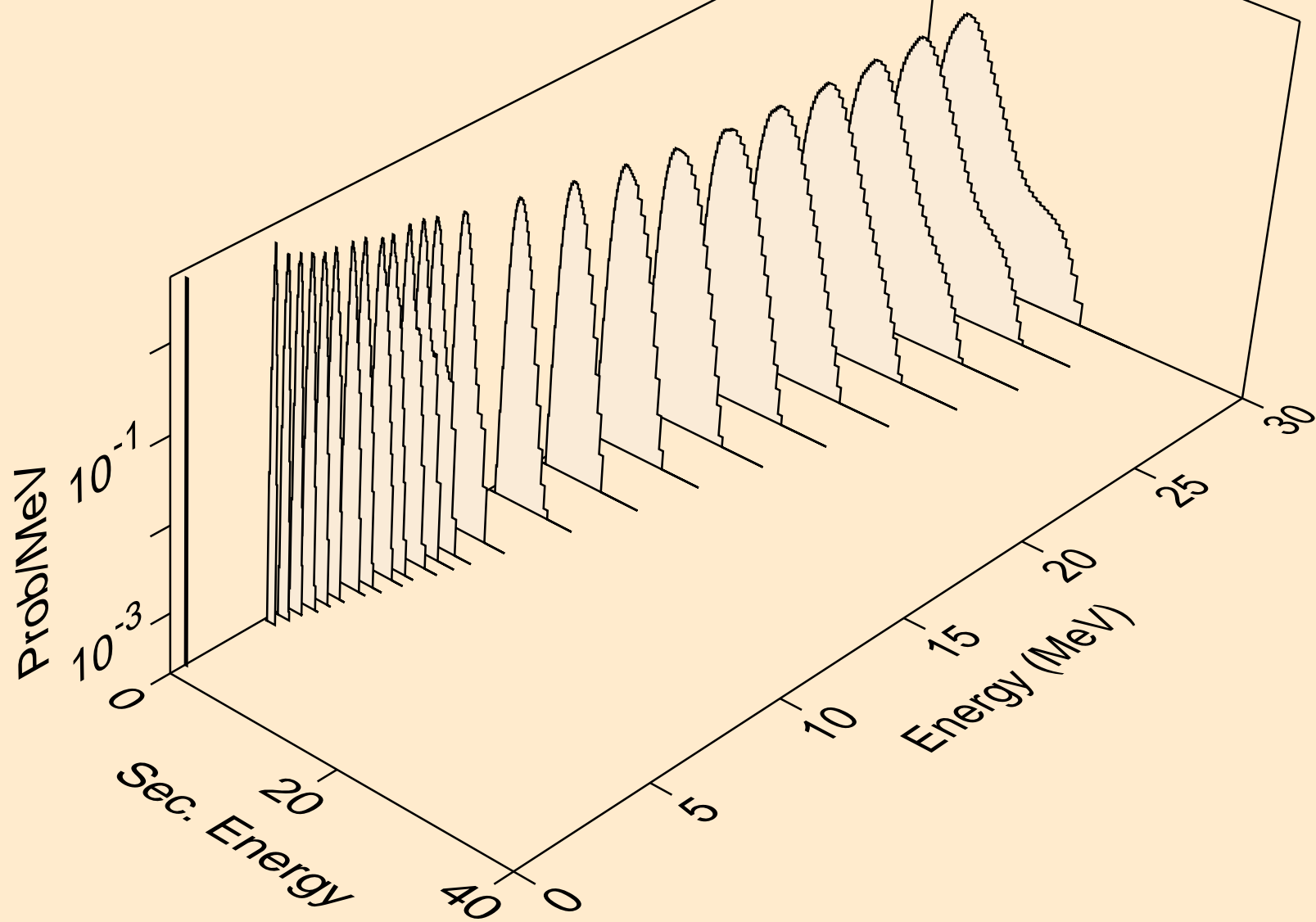

CU059 NEUTRON ACER TENDL-2023 LIBRARY; T=0.K  
protons from (n,pd)

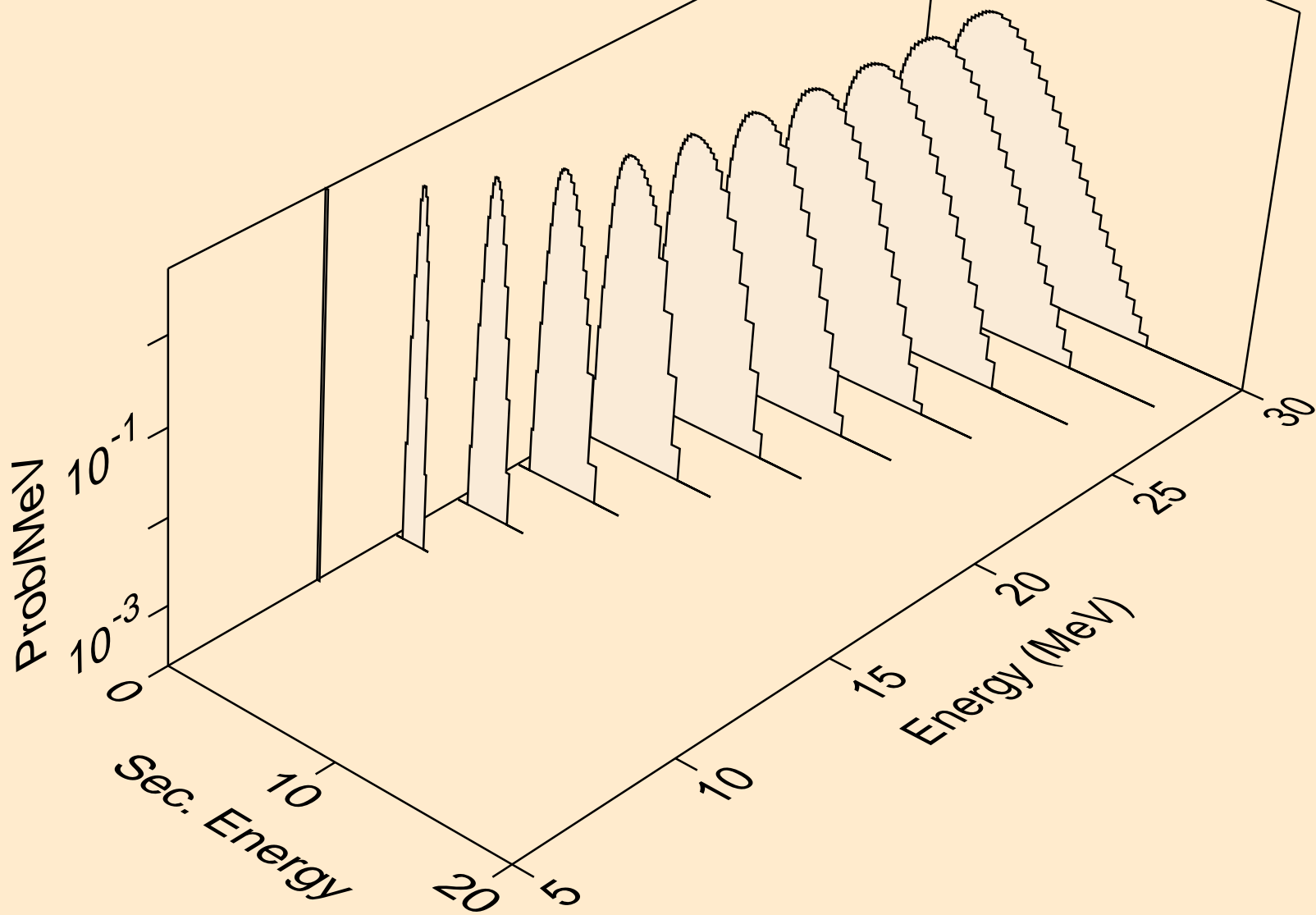

CU059 NEUTRON ACER TENDL-2023 LIBRARY; T=0.K  
protons from (n,pt)

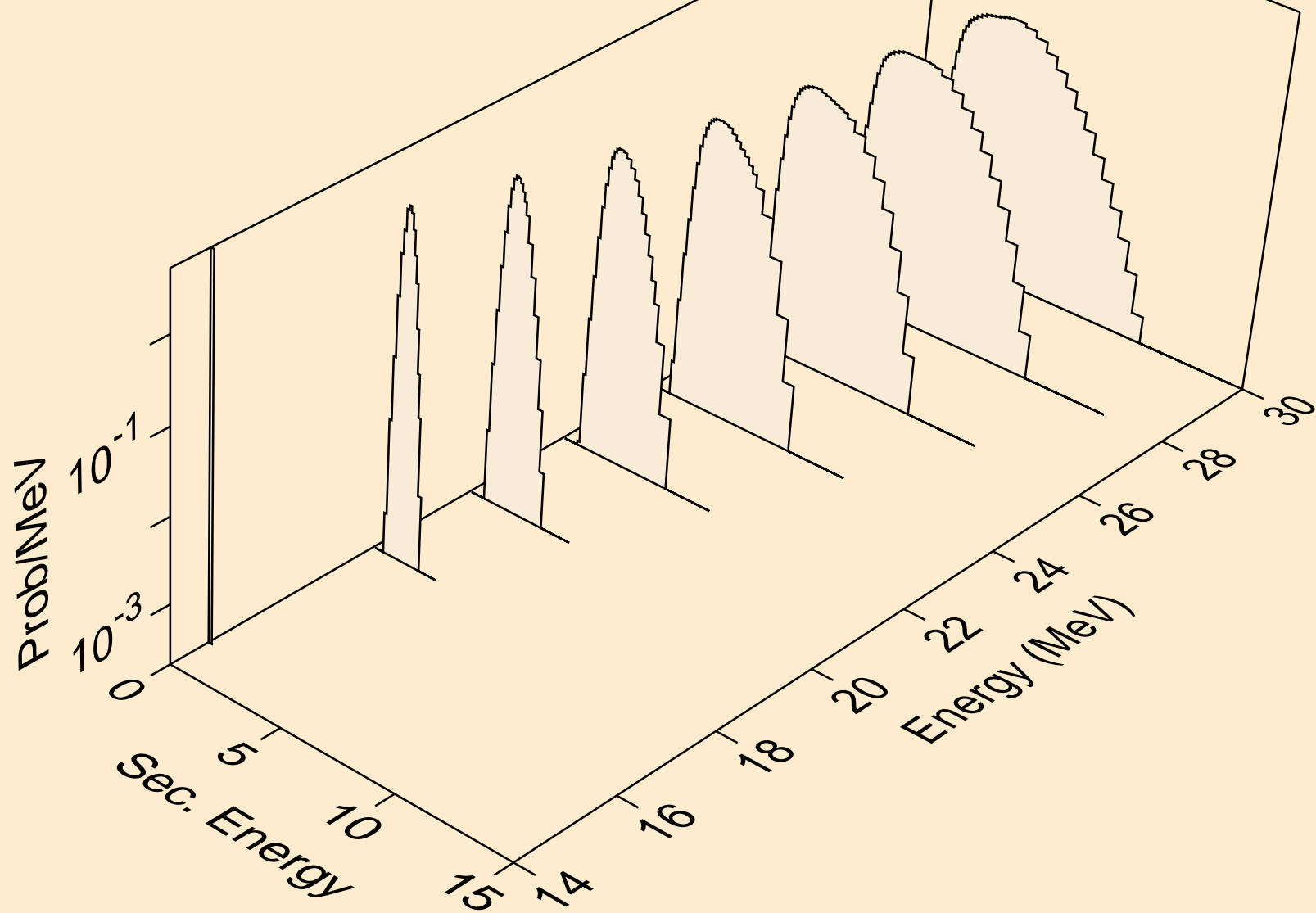

CU059 NEUTRON ACER TENDL-2023 LIBRARY; T=0.K  
deuterons from (n,x)

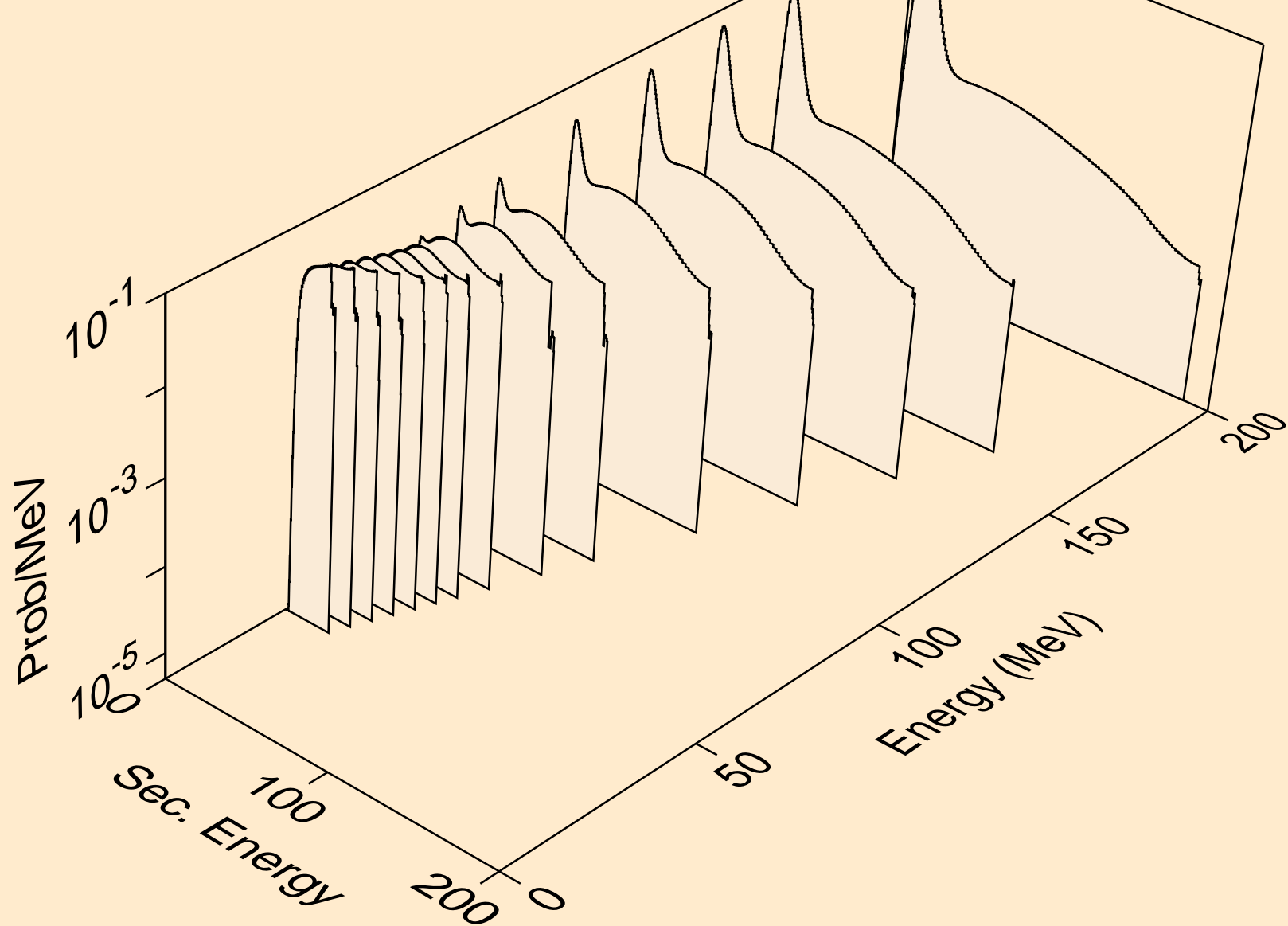

CU059 NEUTRON ACER TENDL-2023 LIBRARY; T=0.K  
deuterons from (n,2nd)

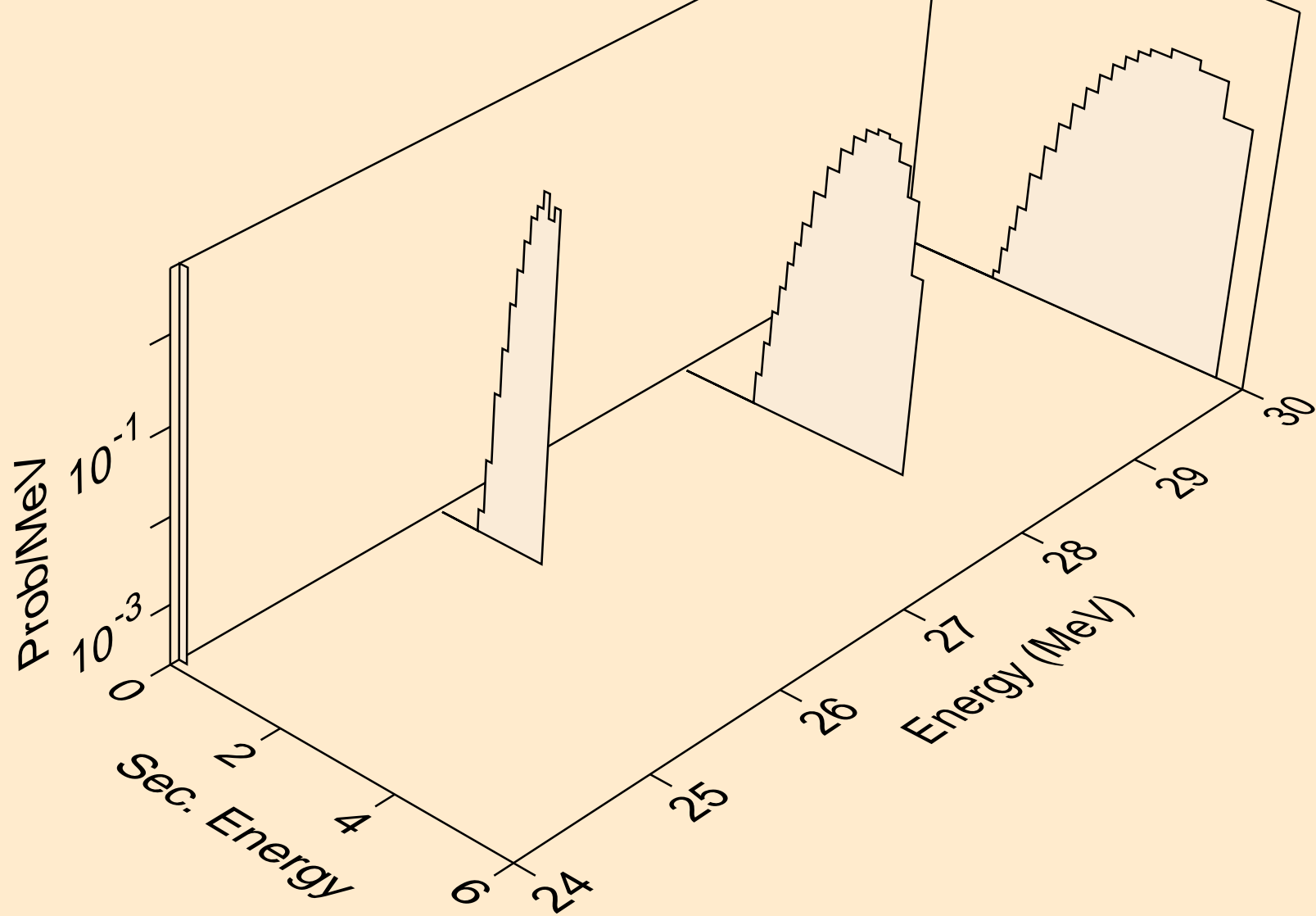

CU059 NEUTRON ACER TENDL-2023 LIBRARY; T=0.K  
deuterons from (n,n\*)d

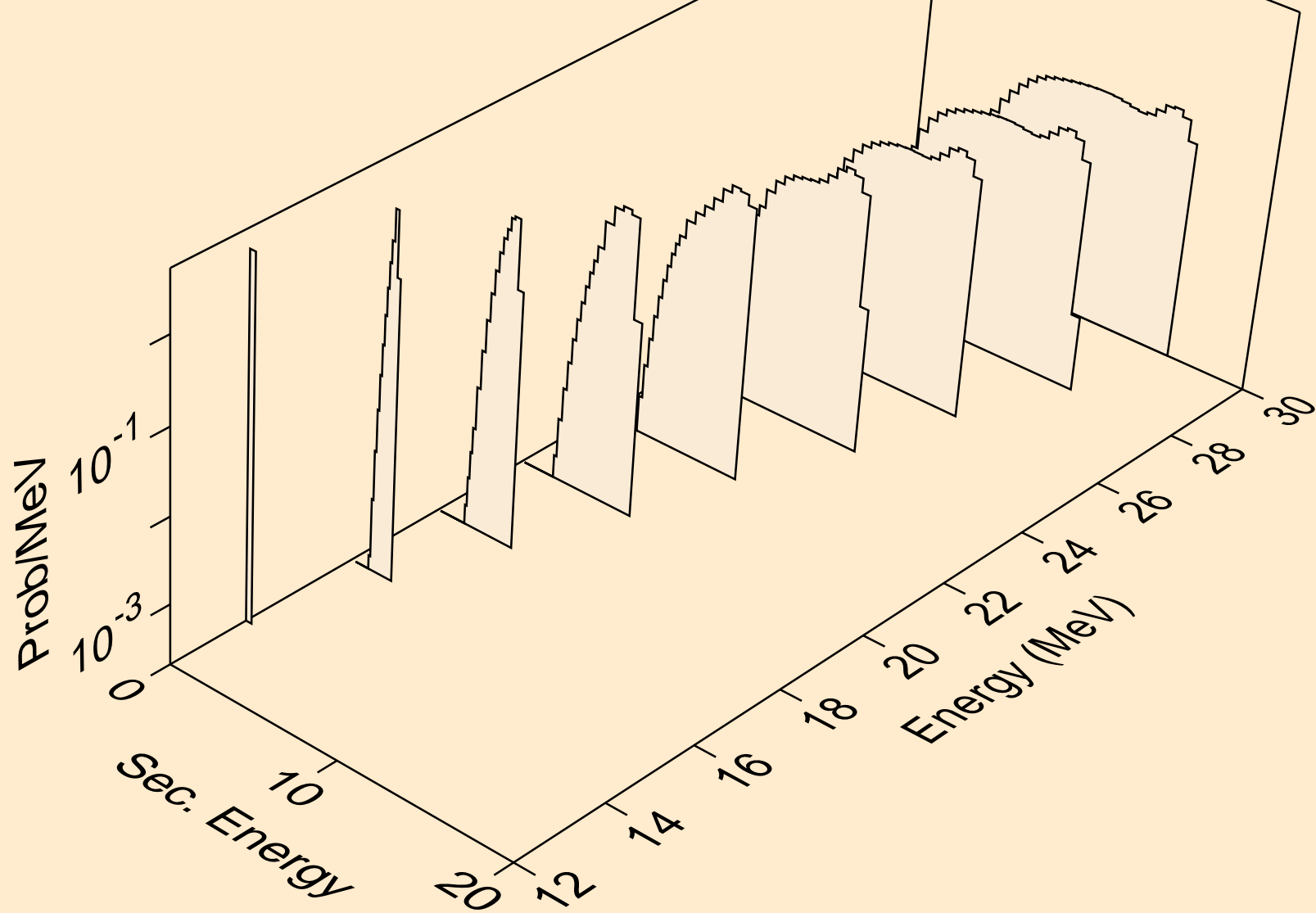

CU059 NEUTRON ACER TENDL-2023 LIBRARY; T=0.K  
deuterons from (n,d)

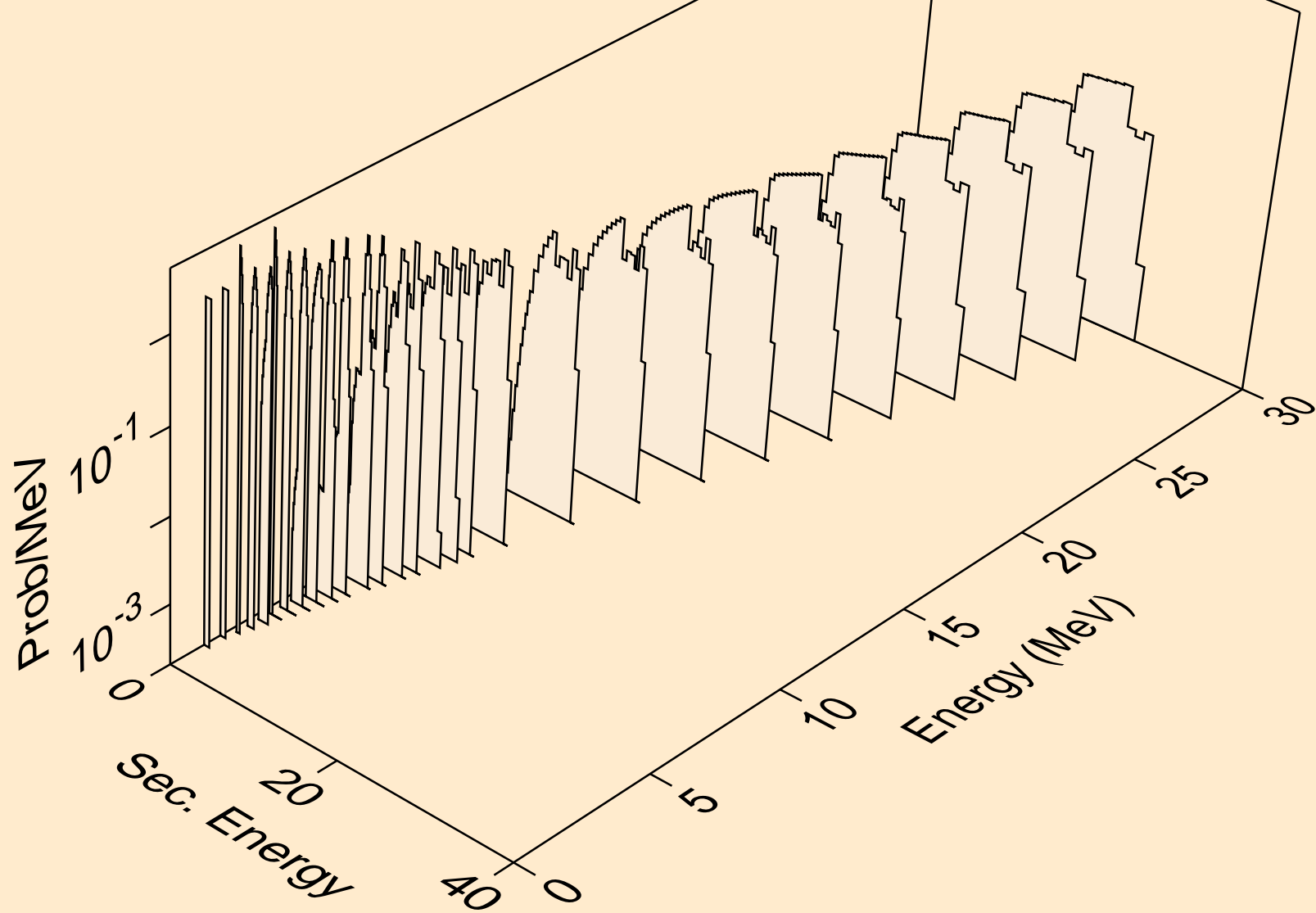

CU059 NEUTRON ACER TENDL-2023 LIBRARY; T=0.K  
deuterons from (n,pd)

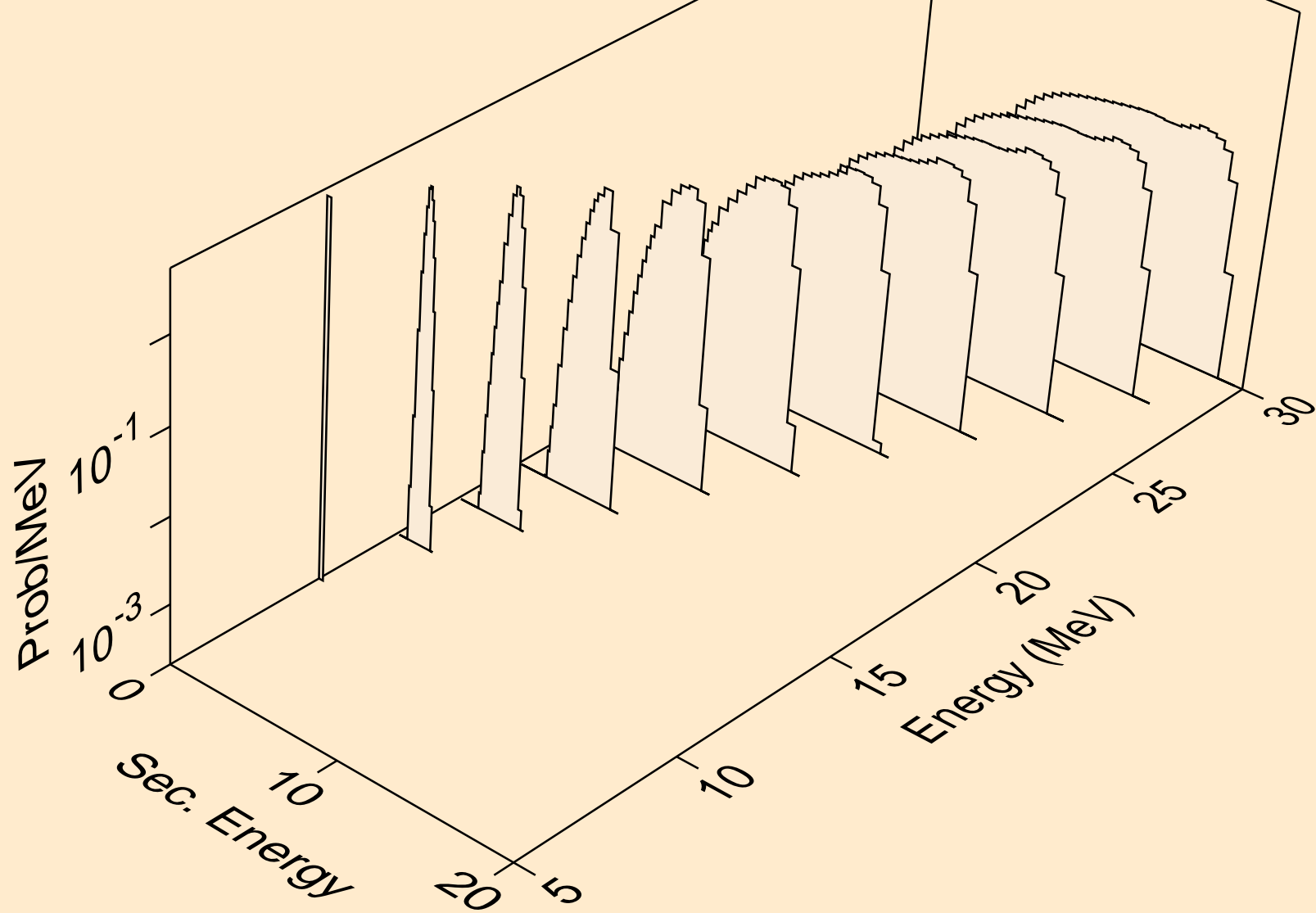



CU059 NEUTRON ACER TENDL-2023 LIBRARY; T=0.K  
deuterons from (n,da)

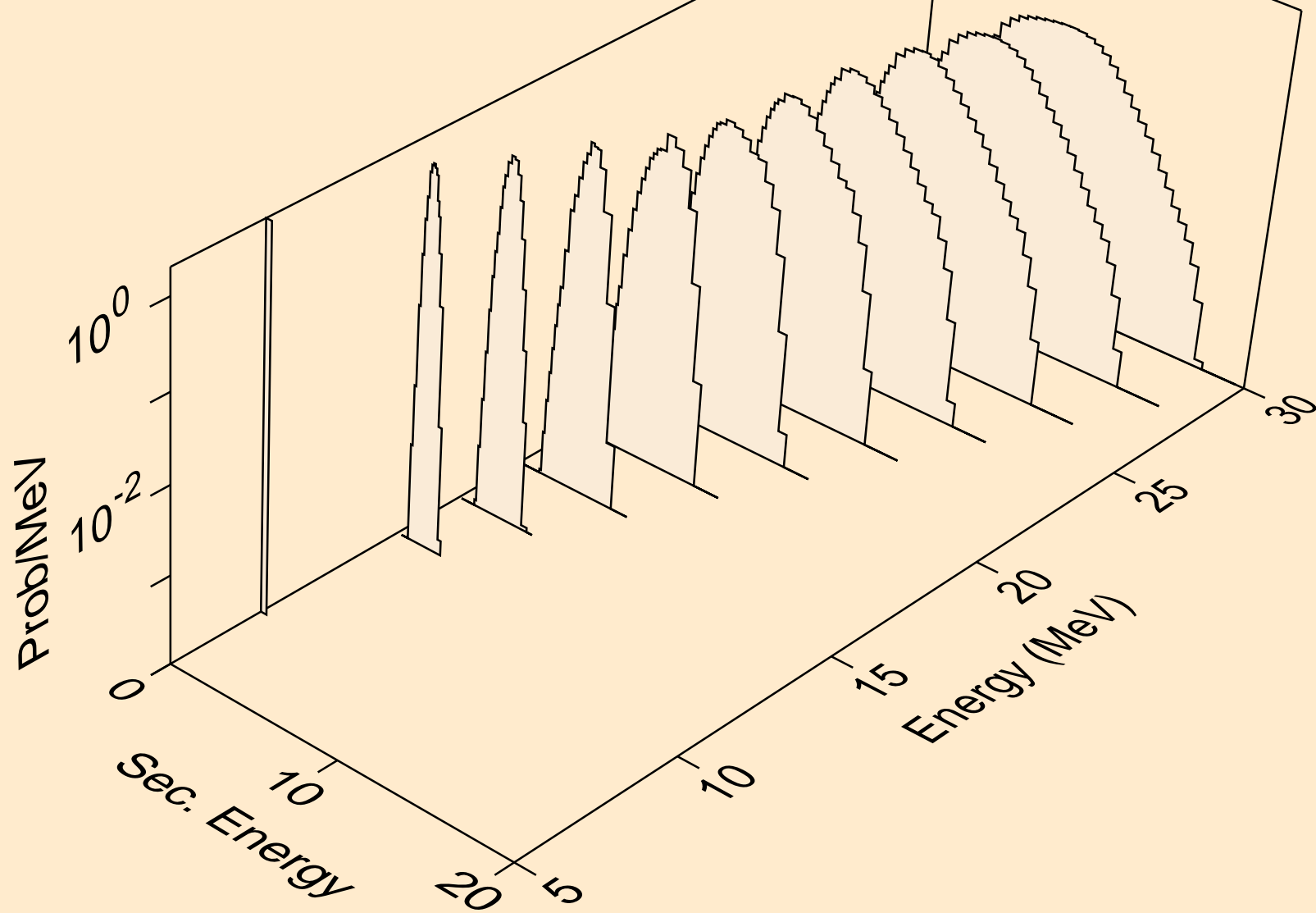

CU059 NEUTRON ACER TENDL-2023 LIBRARY; T=0.K  
tritons from (n,x)

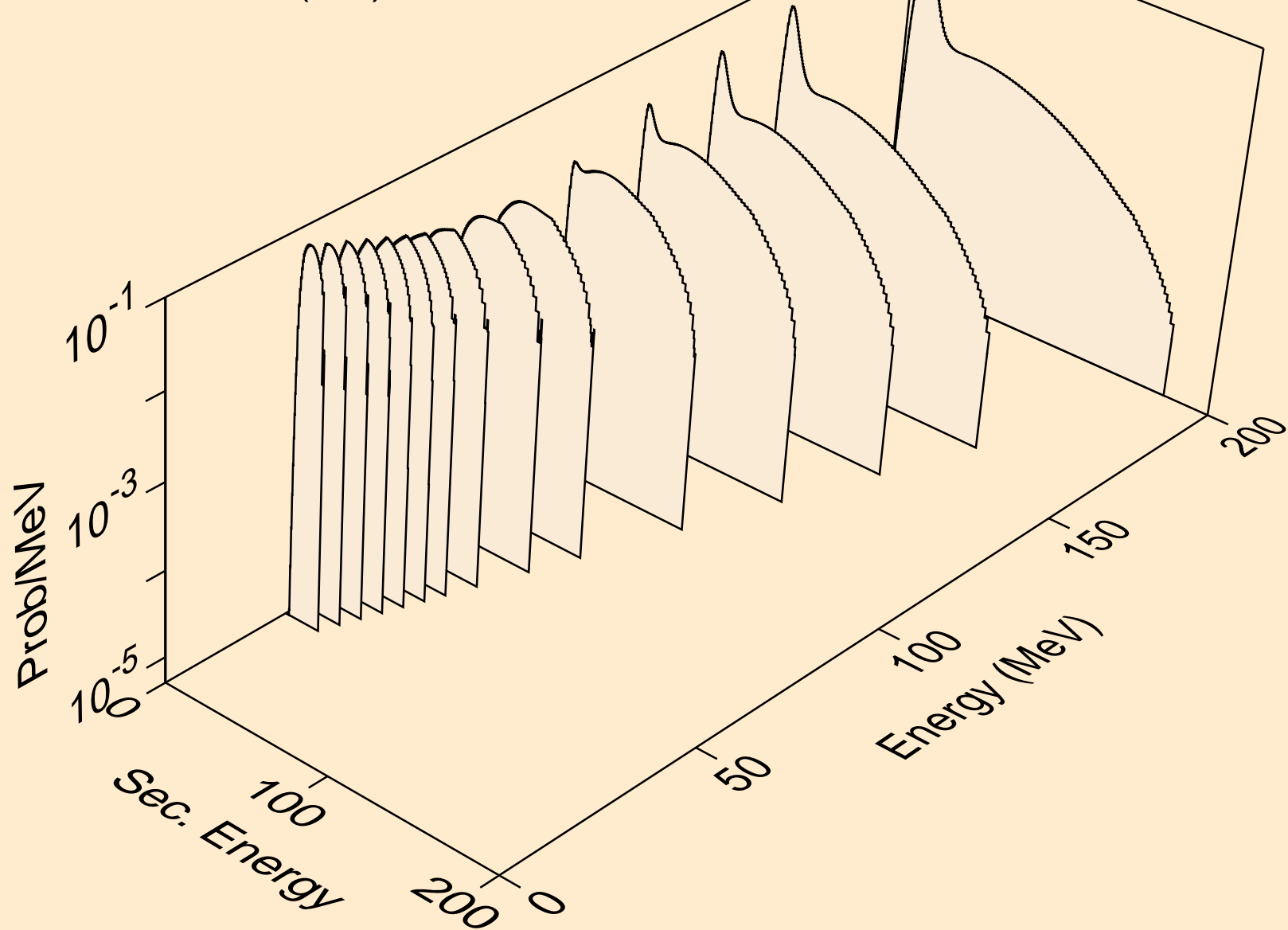

CU059 NEUTRON ACER TENDL-2023 LIBRARY; T=0.K  
tritons from (n,n\*)t

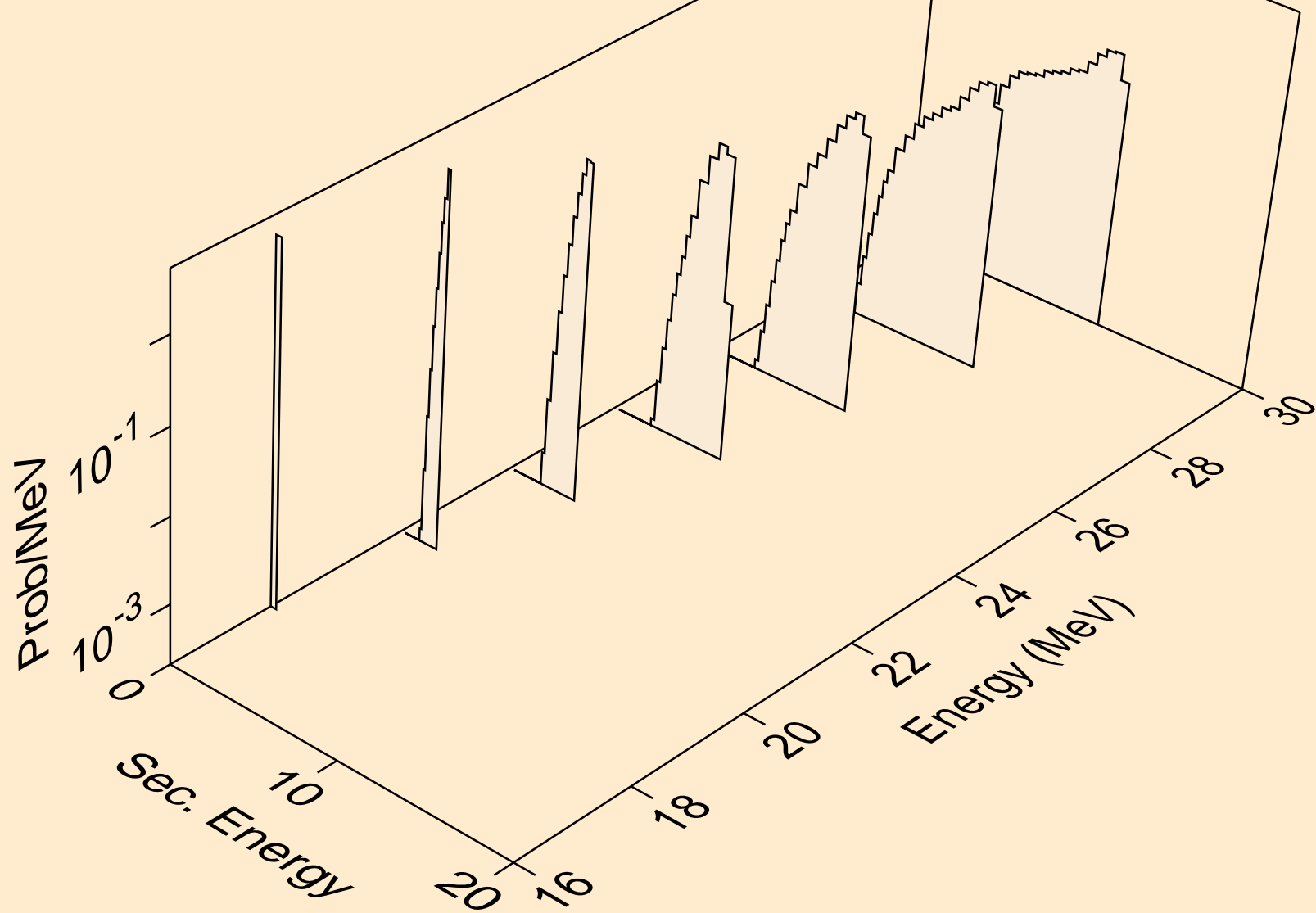

CU059 NEUTRON ACER TENDL-2023 LIBRARY; T=0.K  
tritons from (n,t)

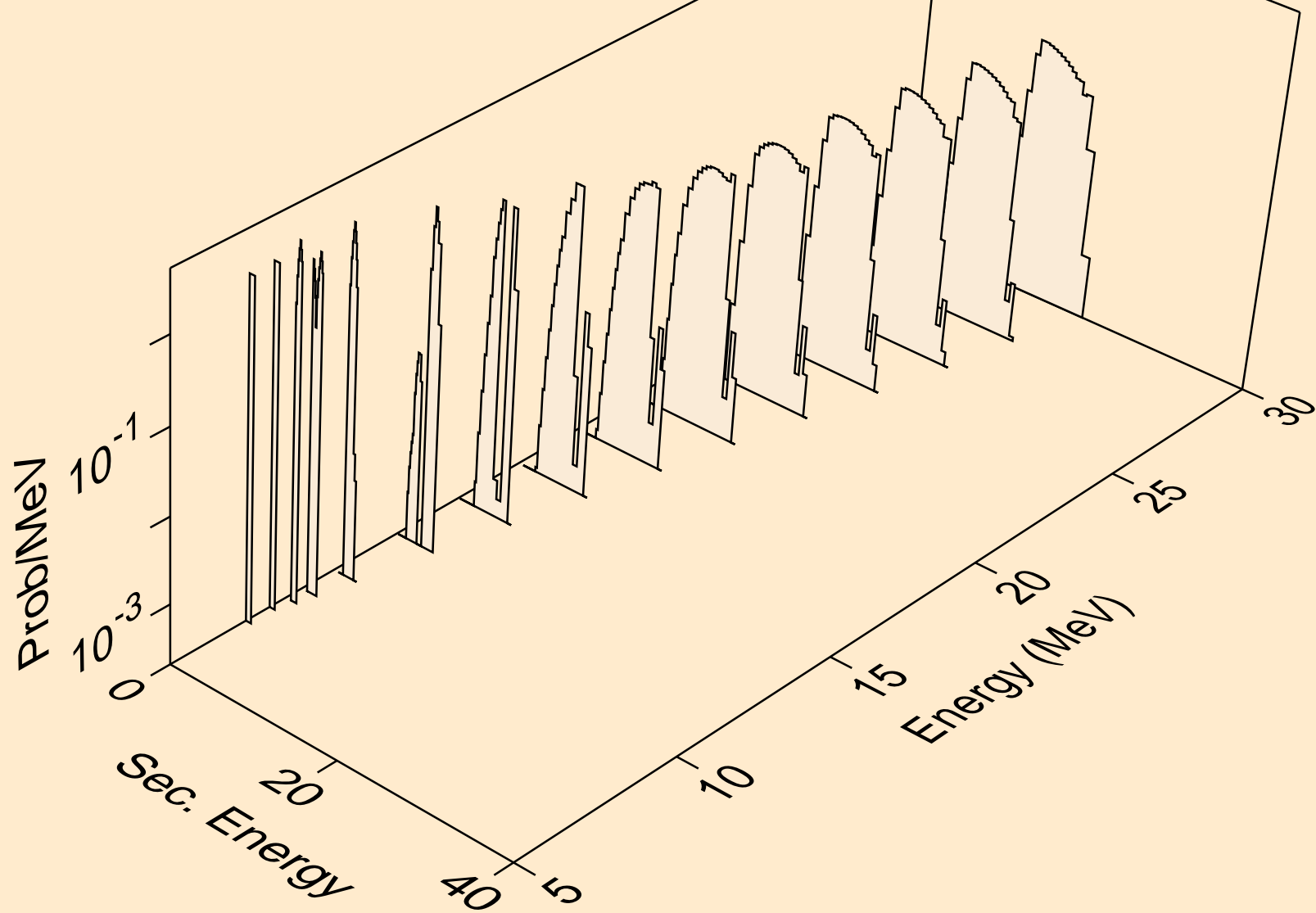

CU059 NEUTRON ACER TENDL-2023 LIBRARY; T=0.K  
tritons from (n,pt)

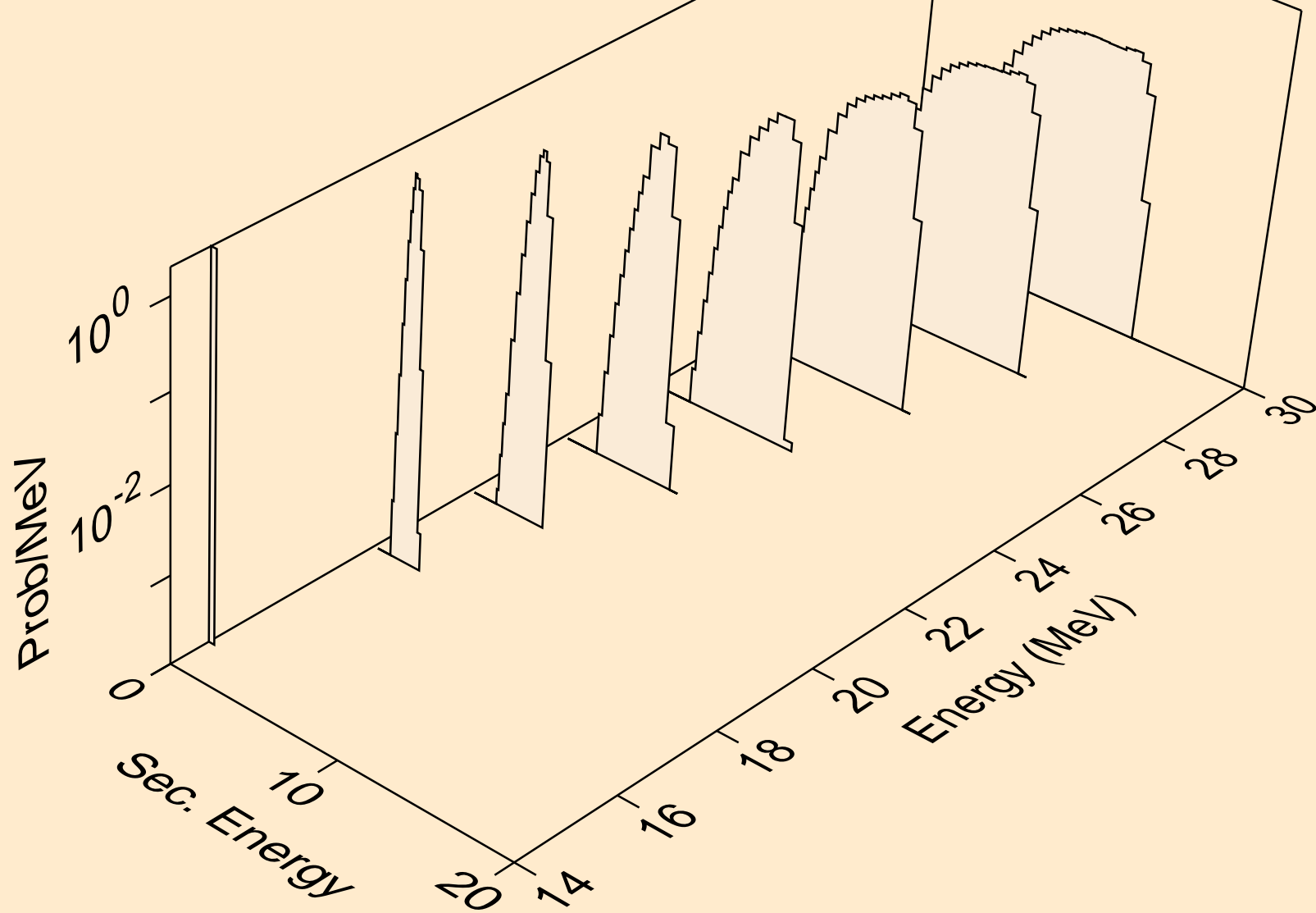

CU059 NEUTRON ACER TENDL-2023 LIBRARY; T=0.K  
he3s from (n,x)

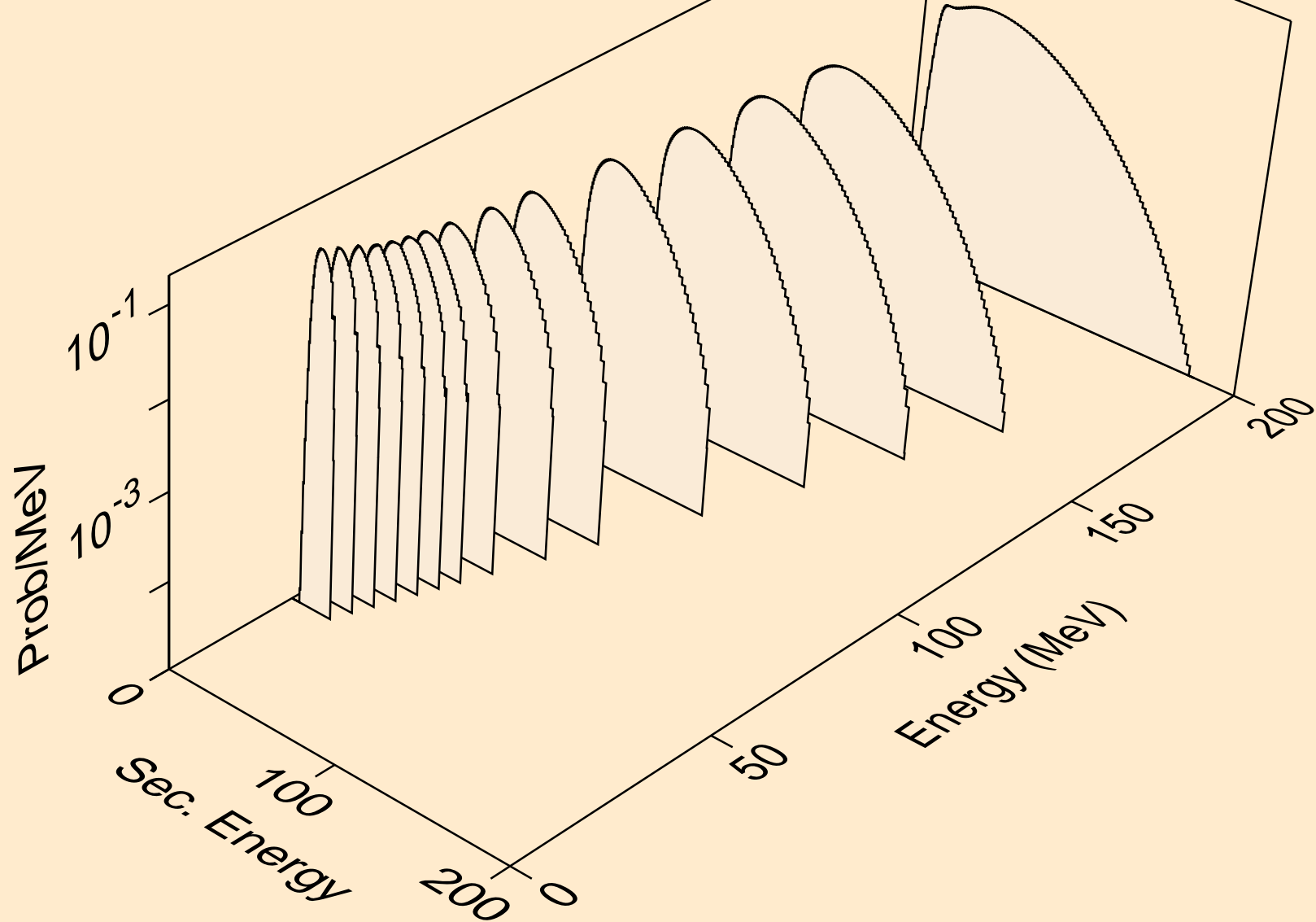

CU059 NEUTRON ACER TENDL-2023 LIBRARY; T=0.K  
he3s from (n,n\*)he3

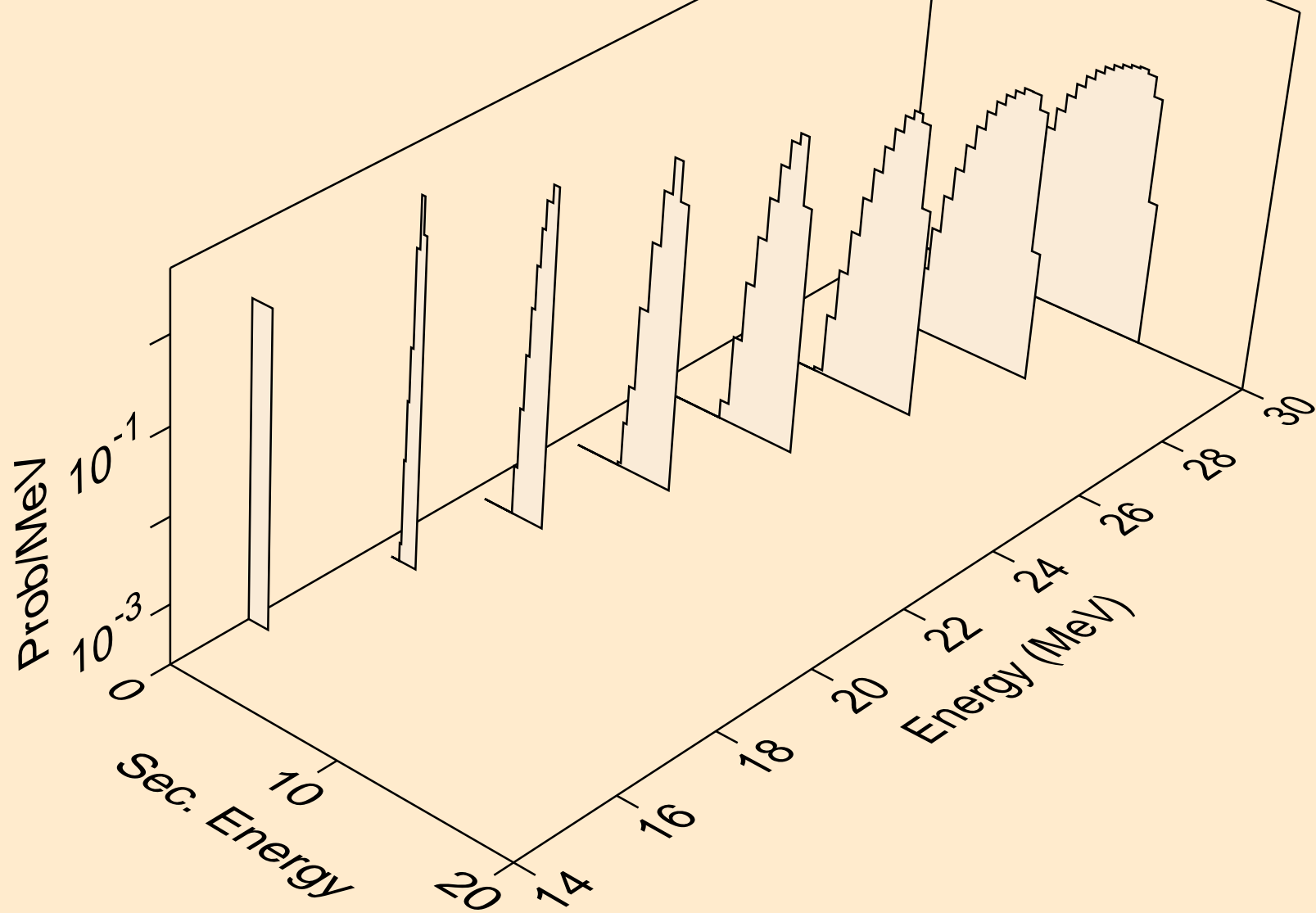

CU059 NEUTRON ACER TENDL-2023 LIBRARY; T=0.K  
he3s from (n,he3)

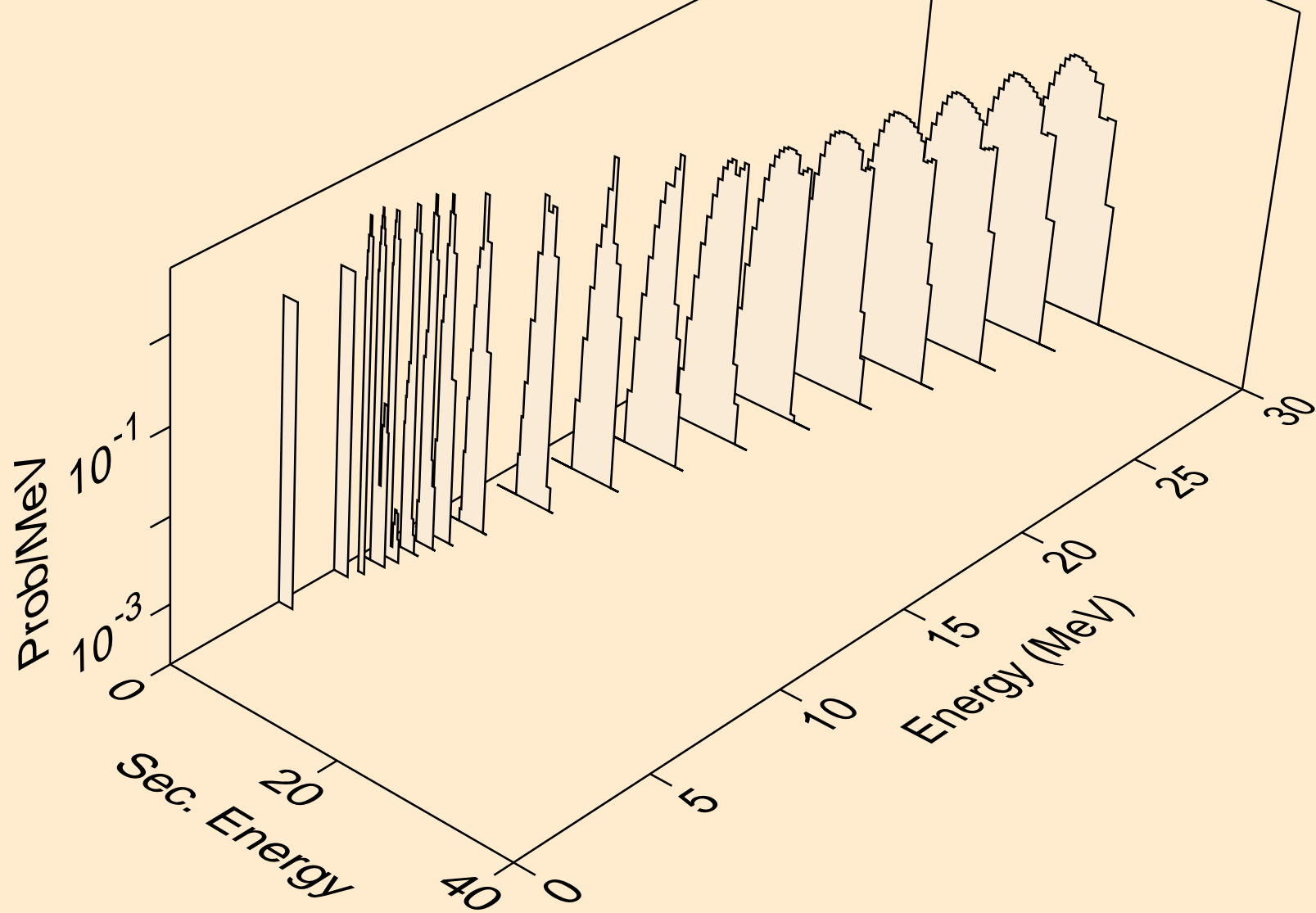



CU059 NEUTRON ACER TENDL-2023 LIBRARY; T=0.K  
alphas from (n,x)

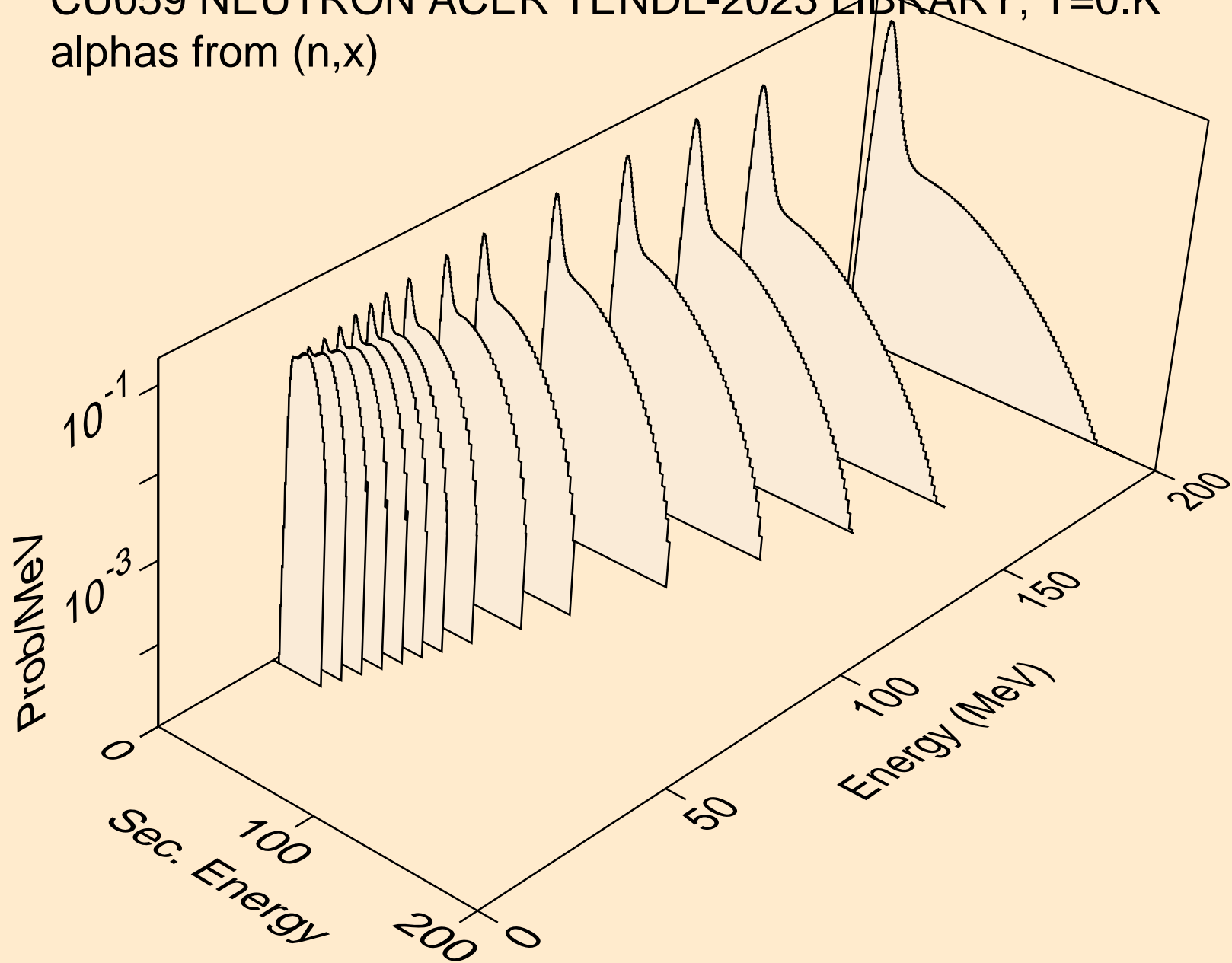

CU059 NEUTRON ACER TENDL-2023 LIBRARY; T=0.K  
alphas from (n,n\*)a

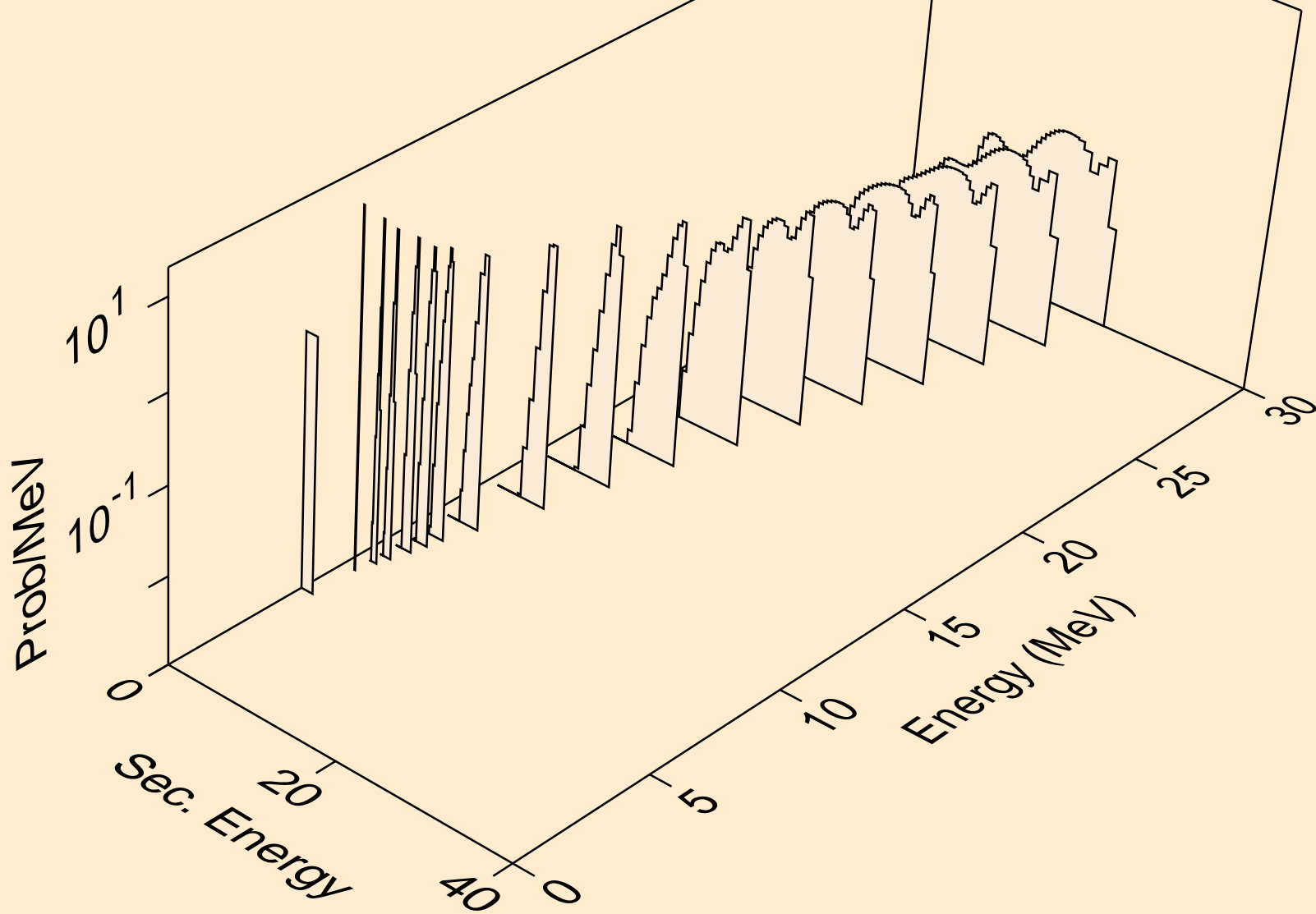

CU059 NEUTRON ACER TENDL-2023 LIBRARY; T=0.K  
alphas from (n,2n)a

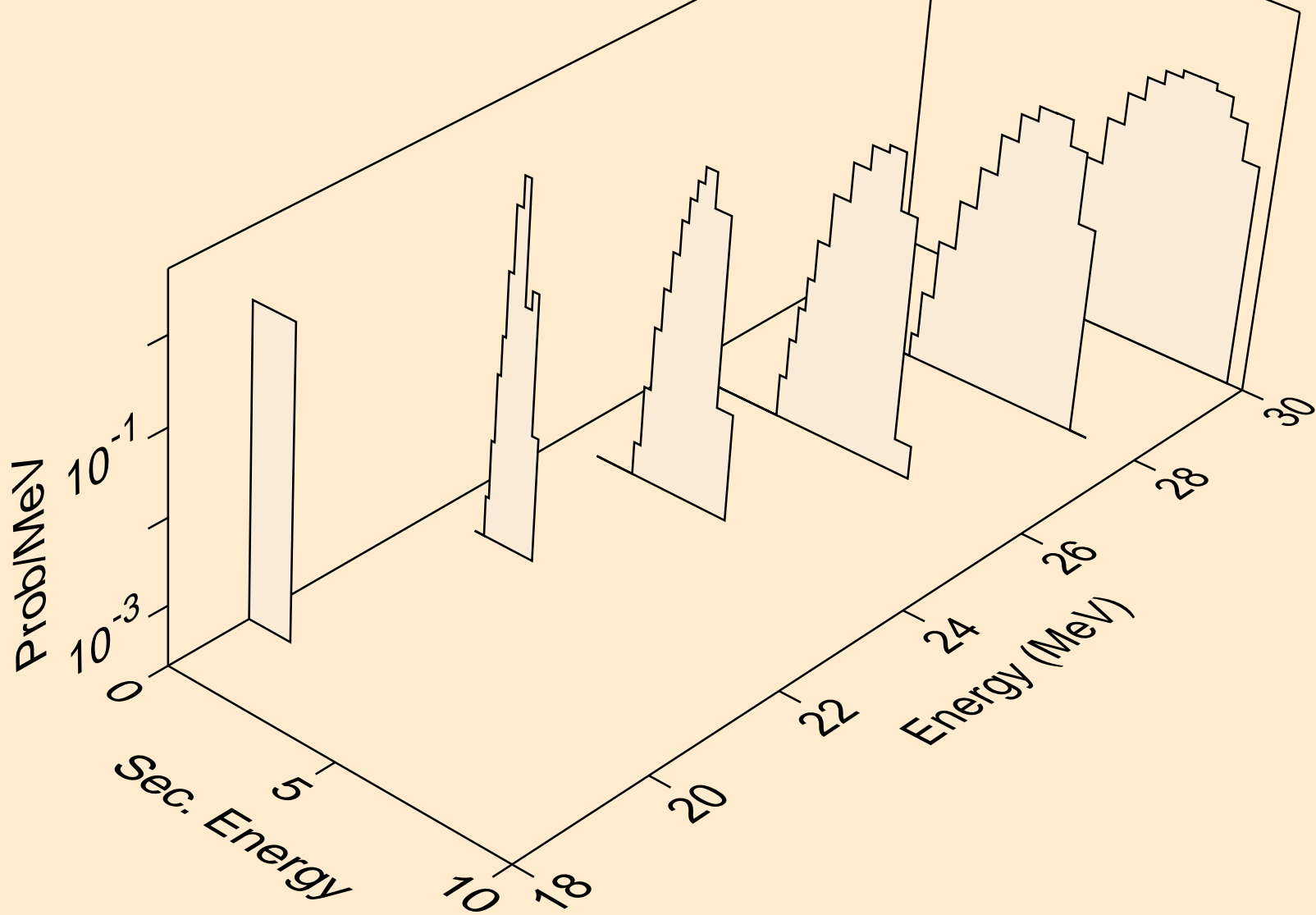

CU059 NEUTRON ACER TENDL-2023 LIBRARY; T=0.K  
alphas from (n,n\*)2a

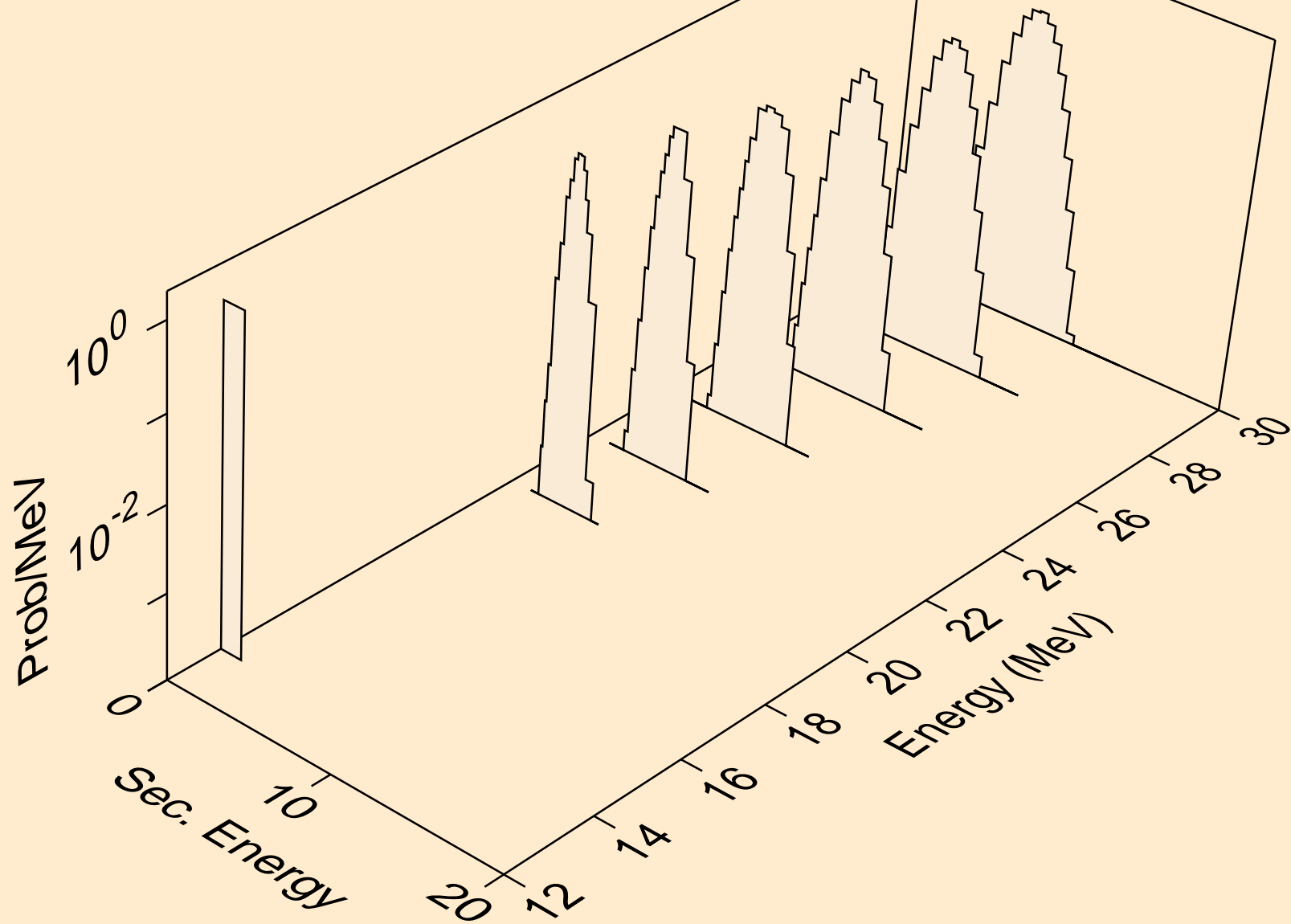

CU059 NEUTRON ACER TENDL-2023 LIBRARY; T=0.K  
alphas from (n,npa)

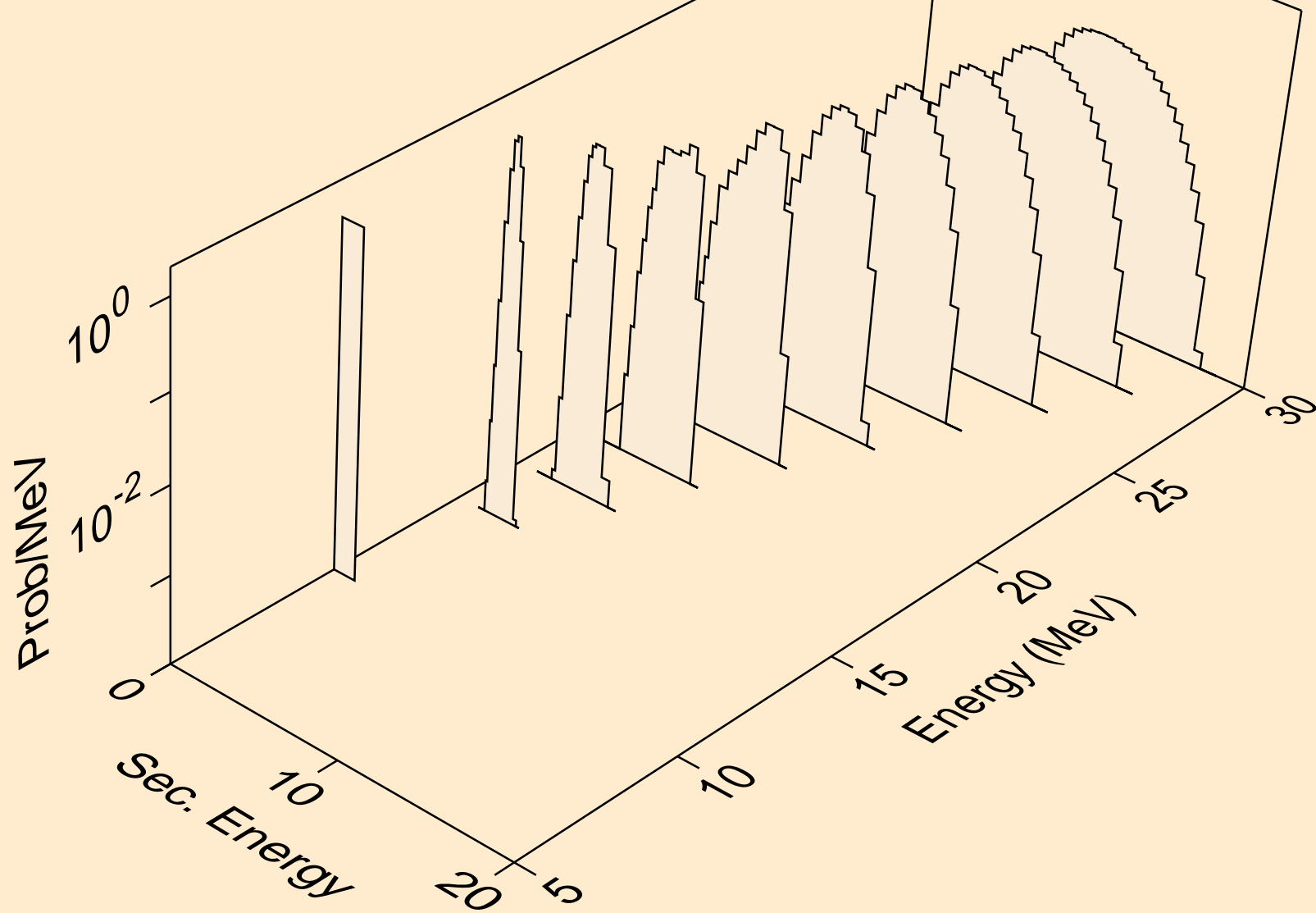

CU059 NEUTRON ACER TENDL-2023 LIBRARY; T=0.K  
alphas from (n,a)

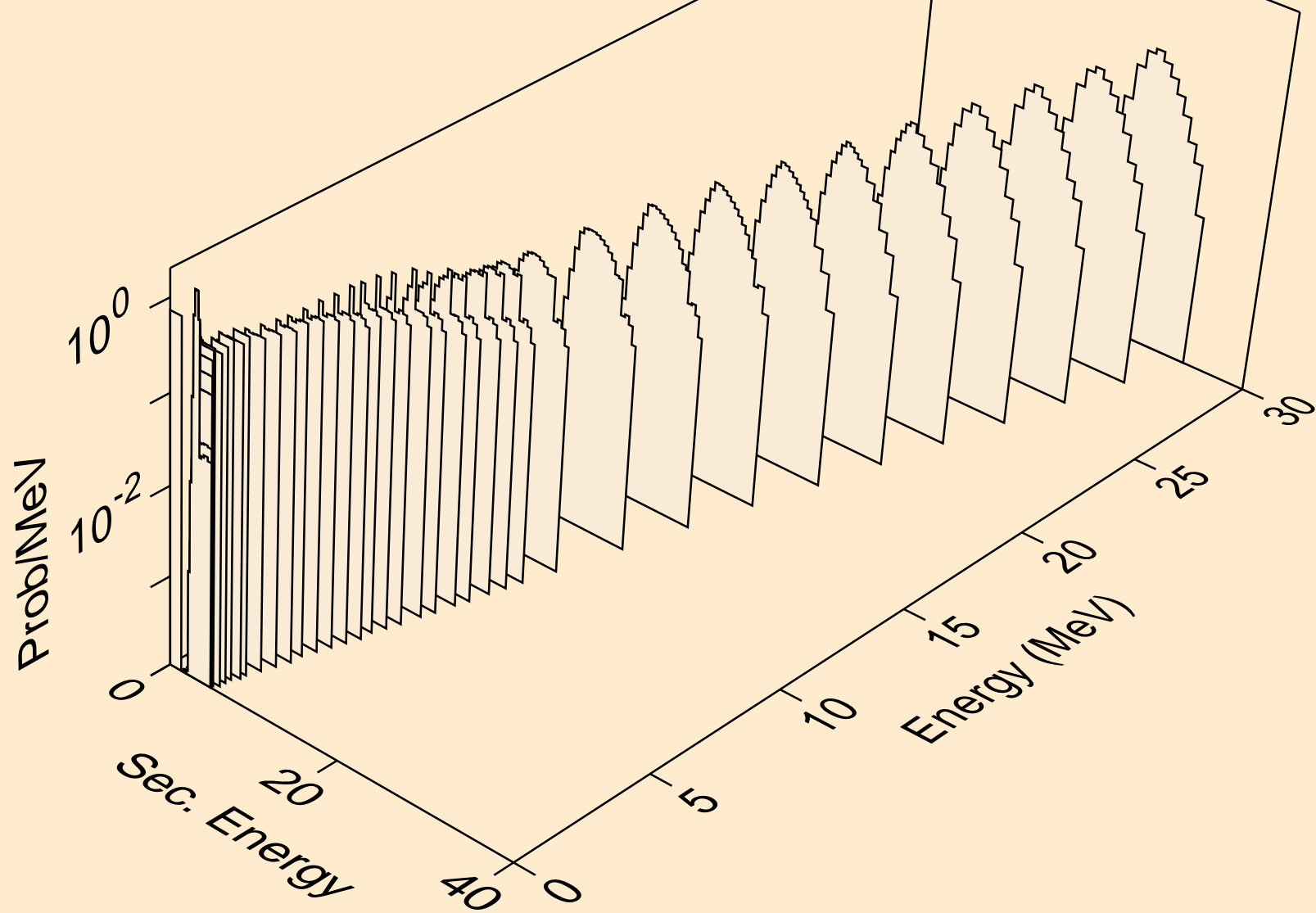

CU059 NEUTRON ACER TENDL-2023 LIBRARY; T=0.K  
alphas from (n,2a)

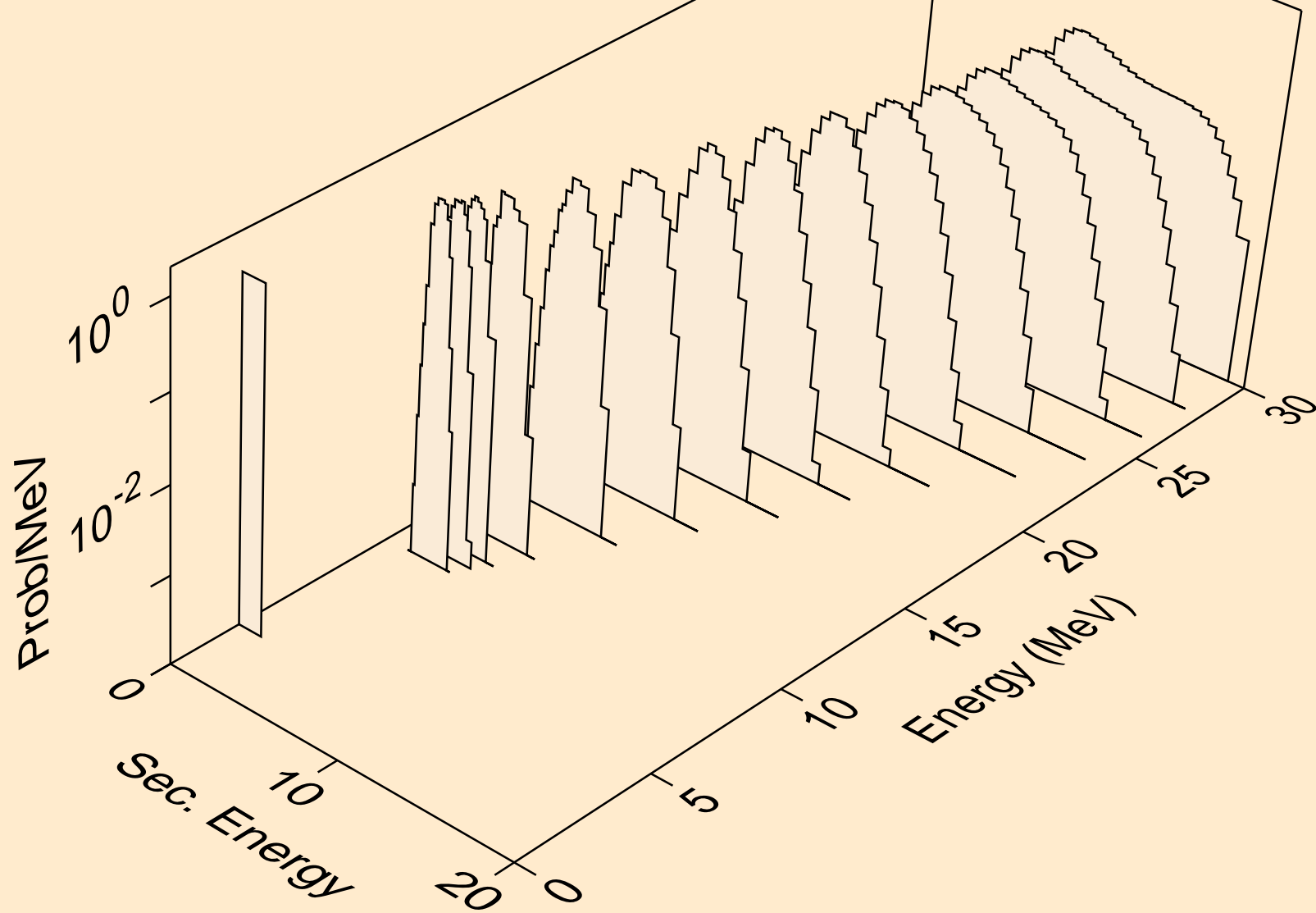

CU059 NEUTRON ACER TENDL-2023 LIBRARY; T=0.K  
alphas from (n,pa)

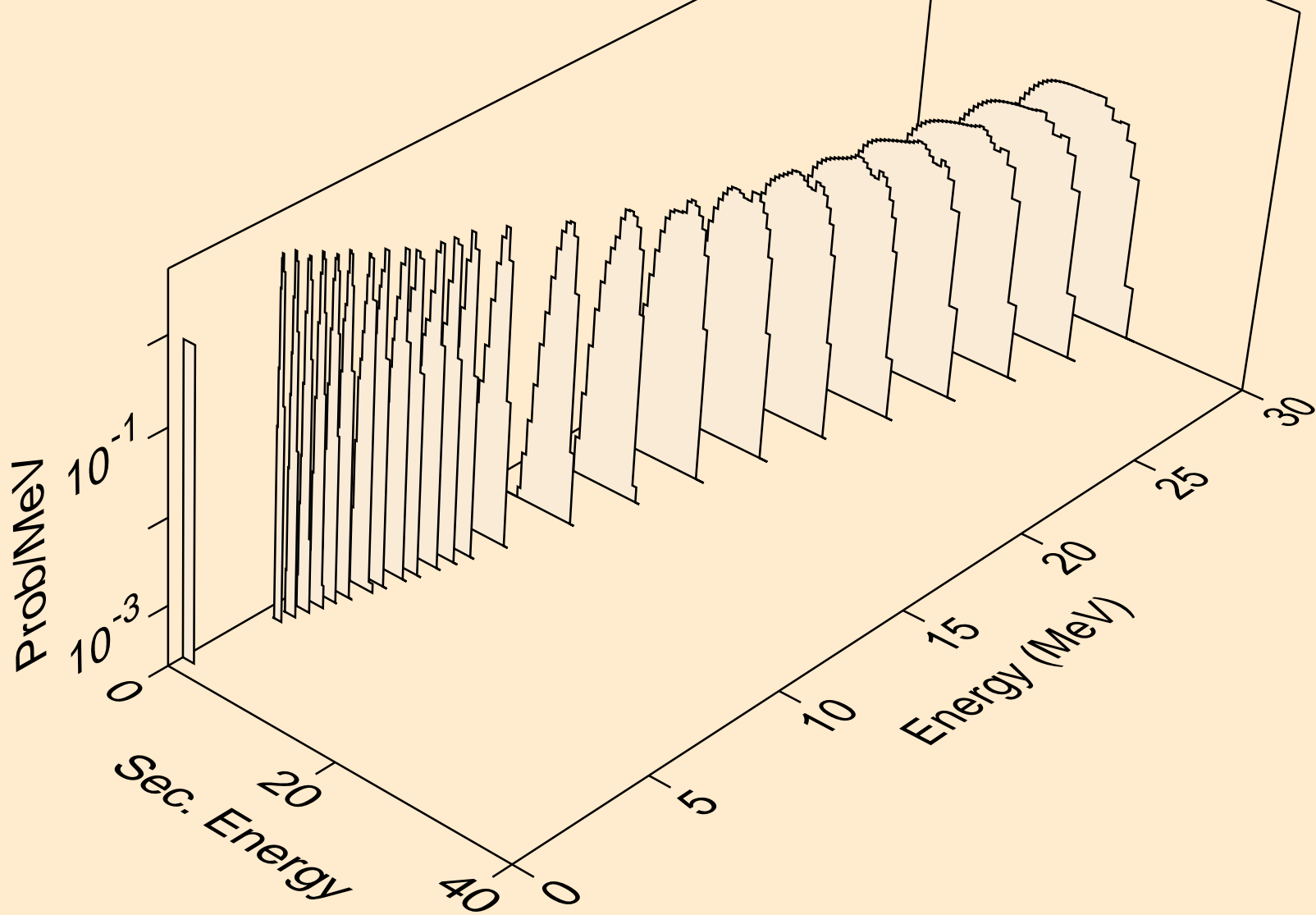



CU059 NEUTRON ACER TENDL-2023 LIBRARY; T=0.K  
alphas from (n,da)

