

# CU066 NEUTRON ACER TENDL-2023 LIBRARY; T=0.K

## Principal cross sections

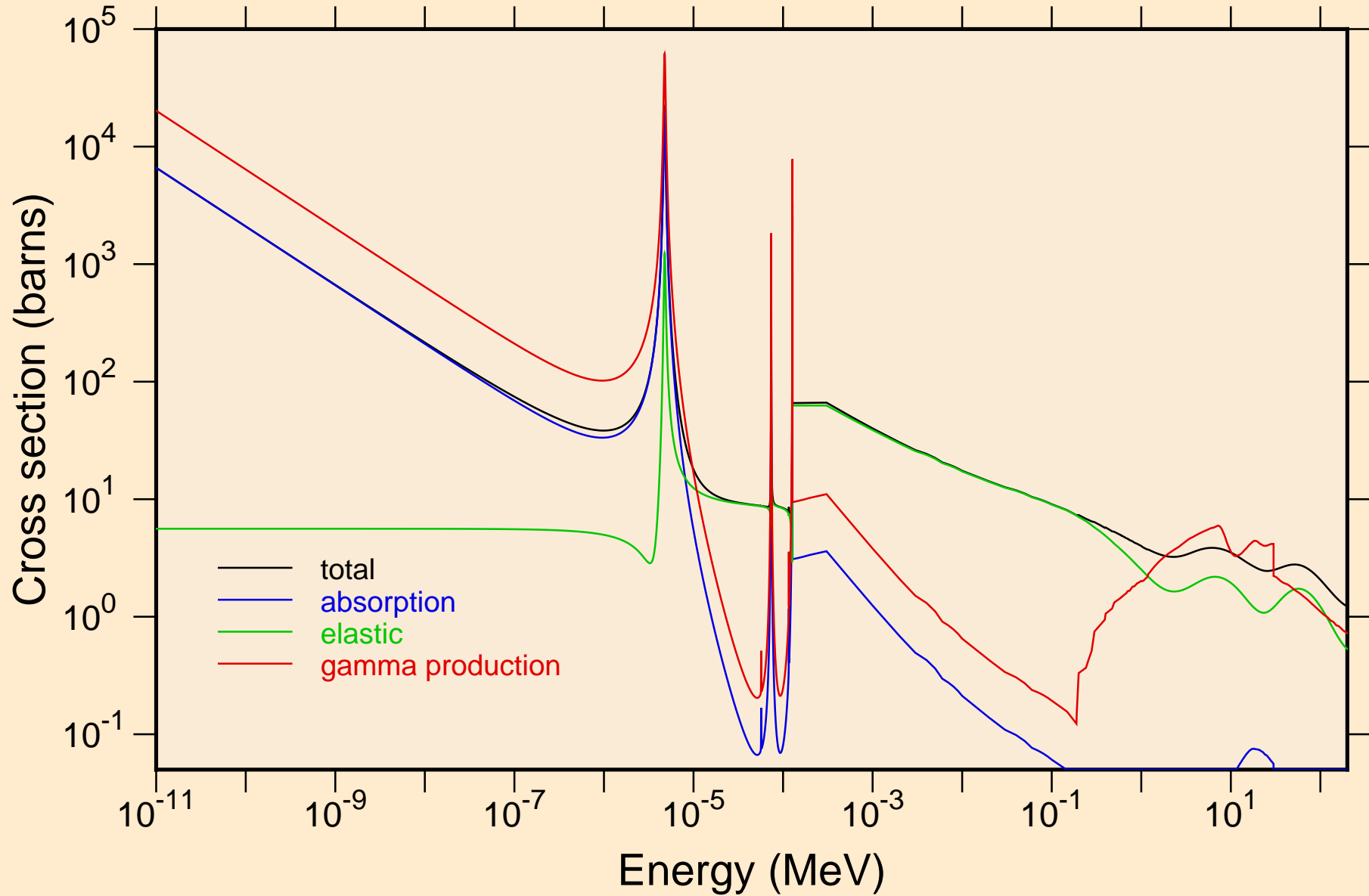

CU066 NEUTRON ACER TENDL-2023 LIBRARY; T=0.K  
resonance total cross section

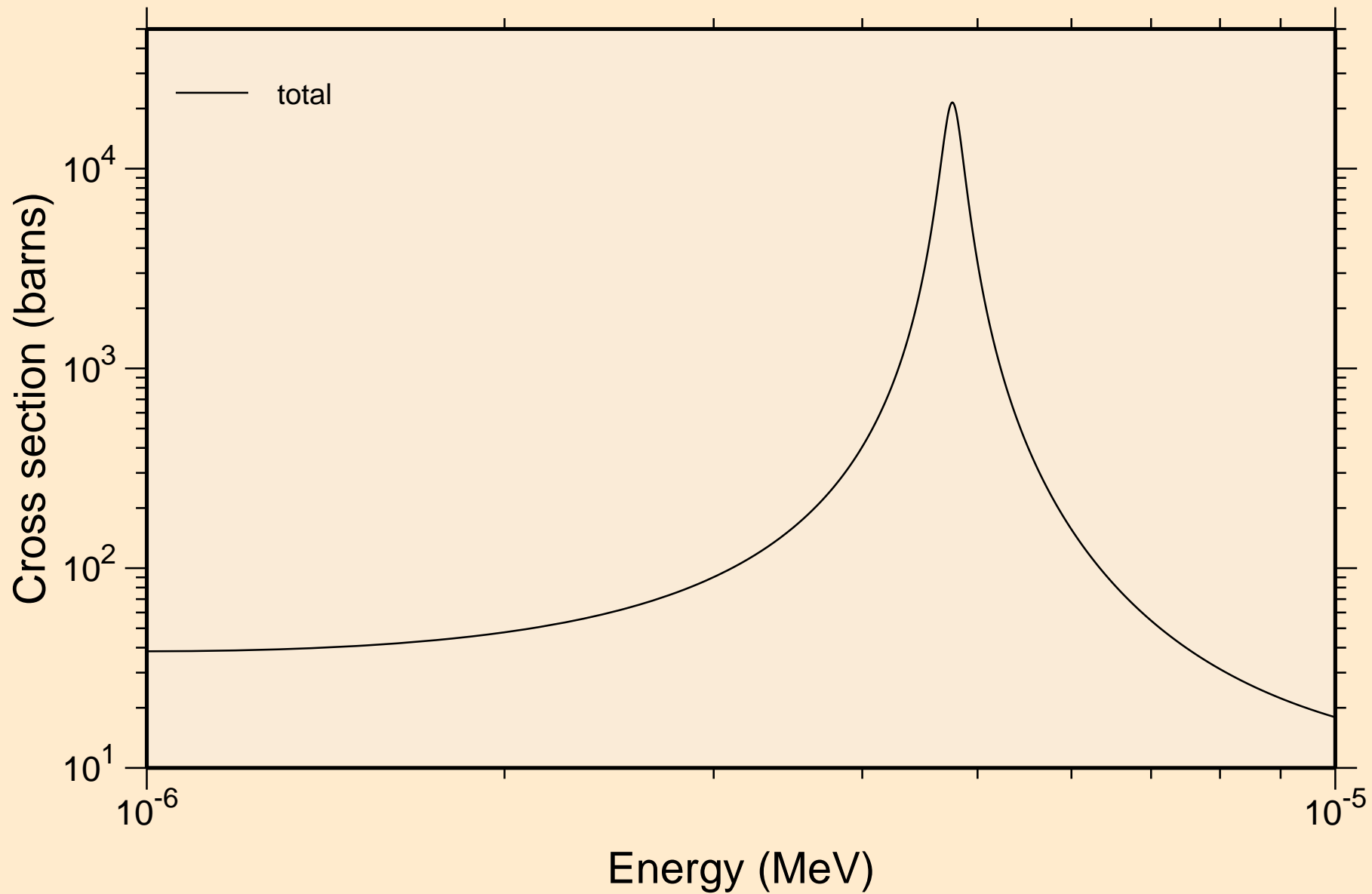

CU066 NEUTRON ACER TENDL-2023 LIBRARY; T=0.K  
resonance total cross section

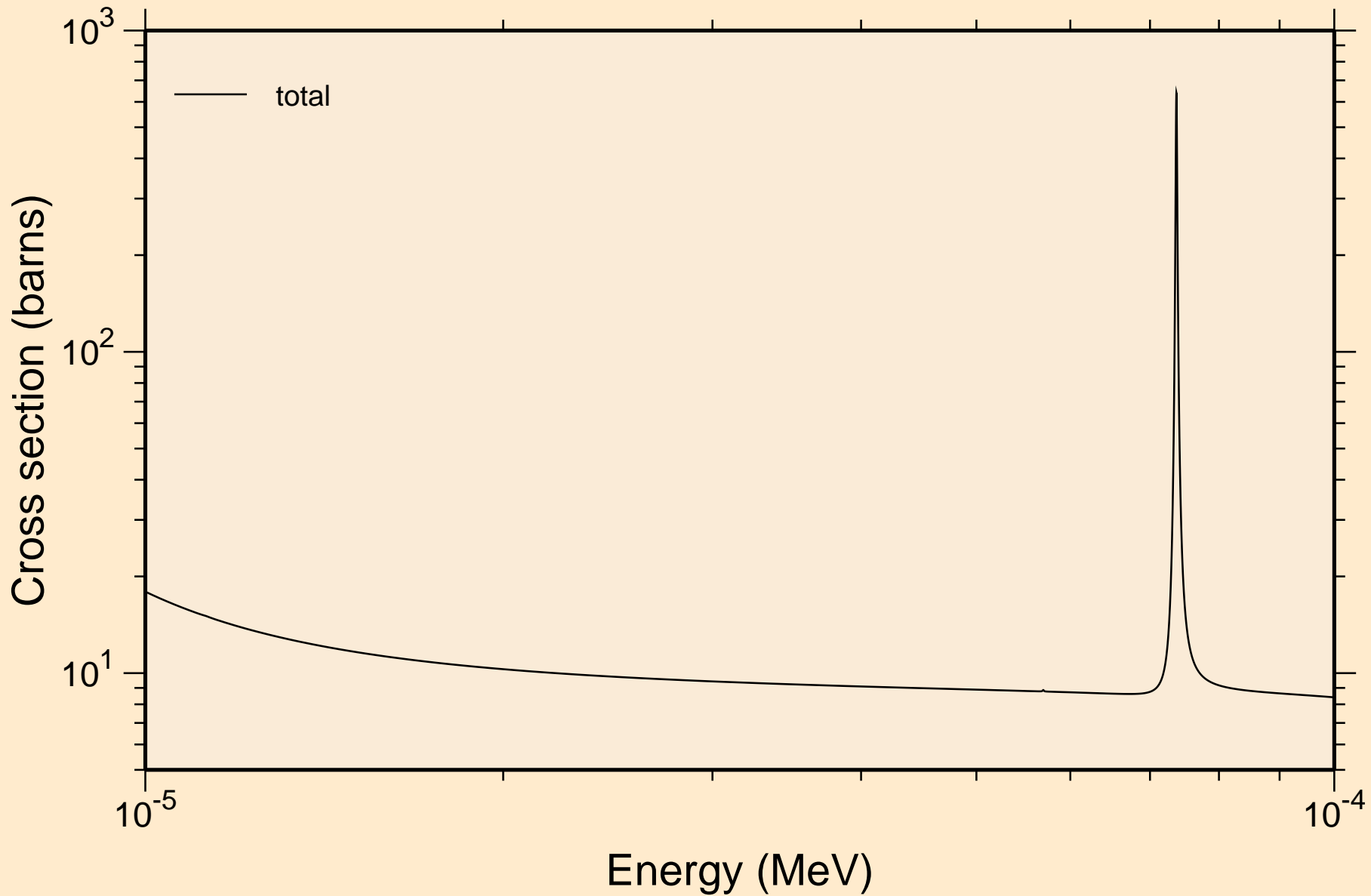

CU066 NEUTRON ACER TENDL-2023 LIBRARY; T=0.K  
resonance total cross section

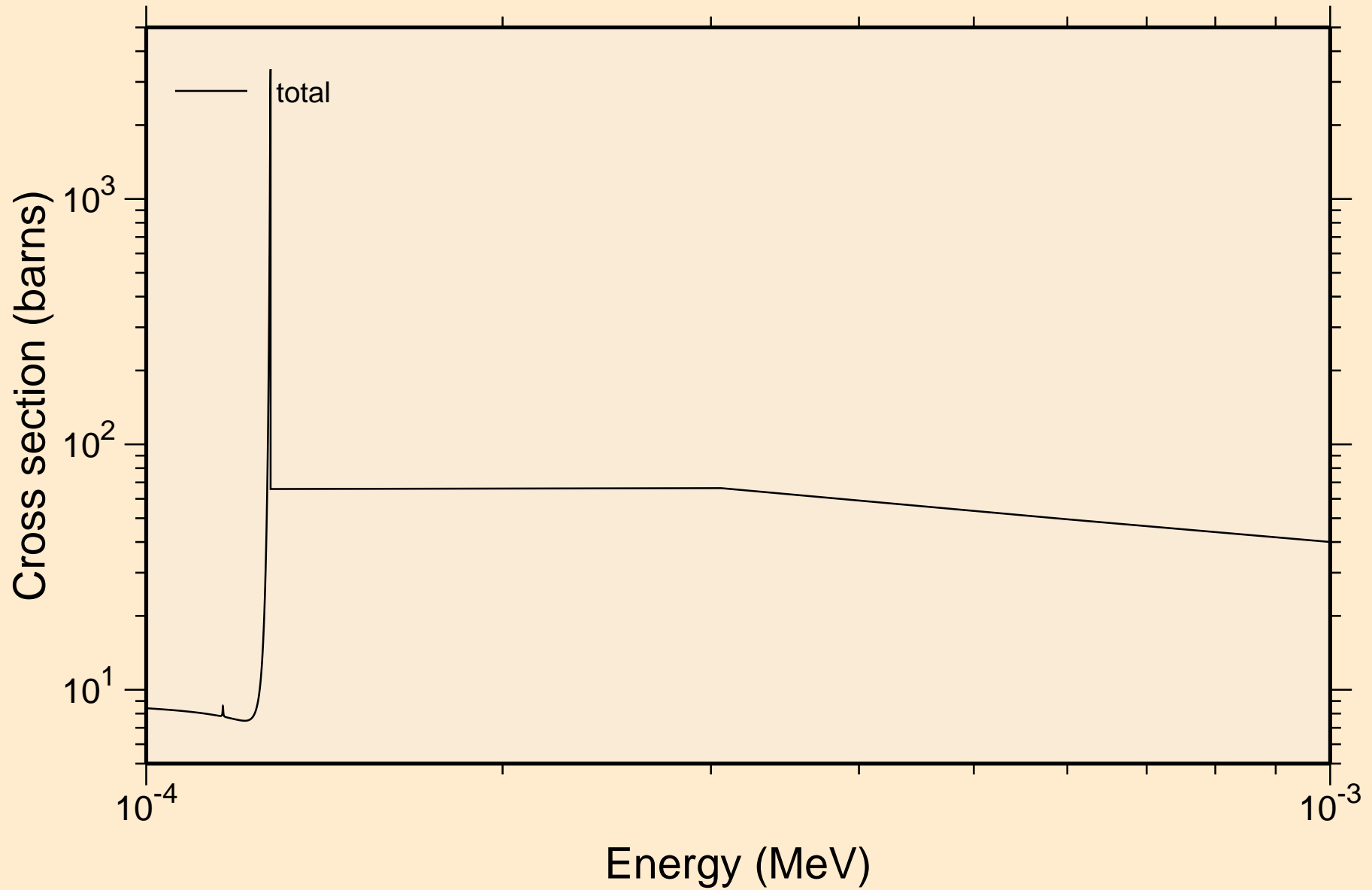

CU066 NEUTRON ACER TENDL-2023 LIBRARY; T=0.K  
resonance total cross section

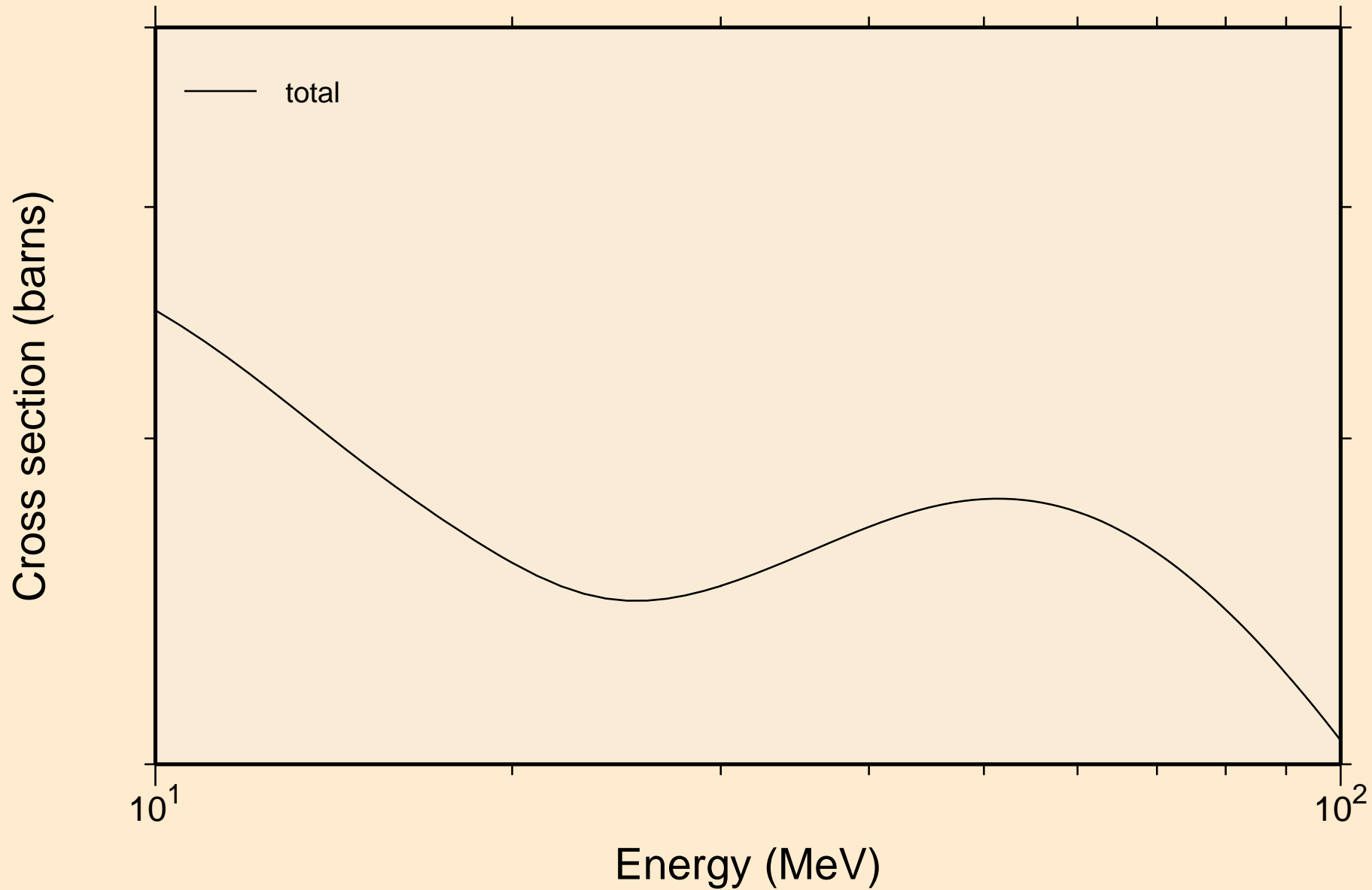

CU066 NEUTRON ACER TENDL-2023 LIBRARY; T=0.K  
resonance absorption cross sections

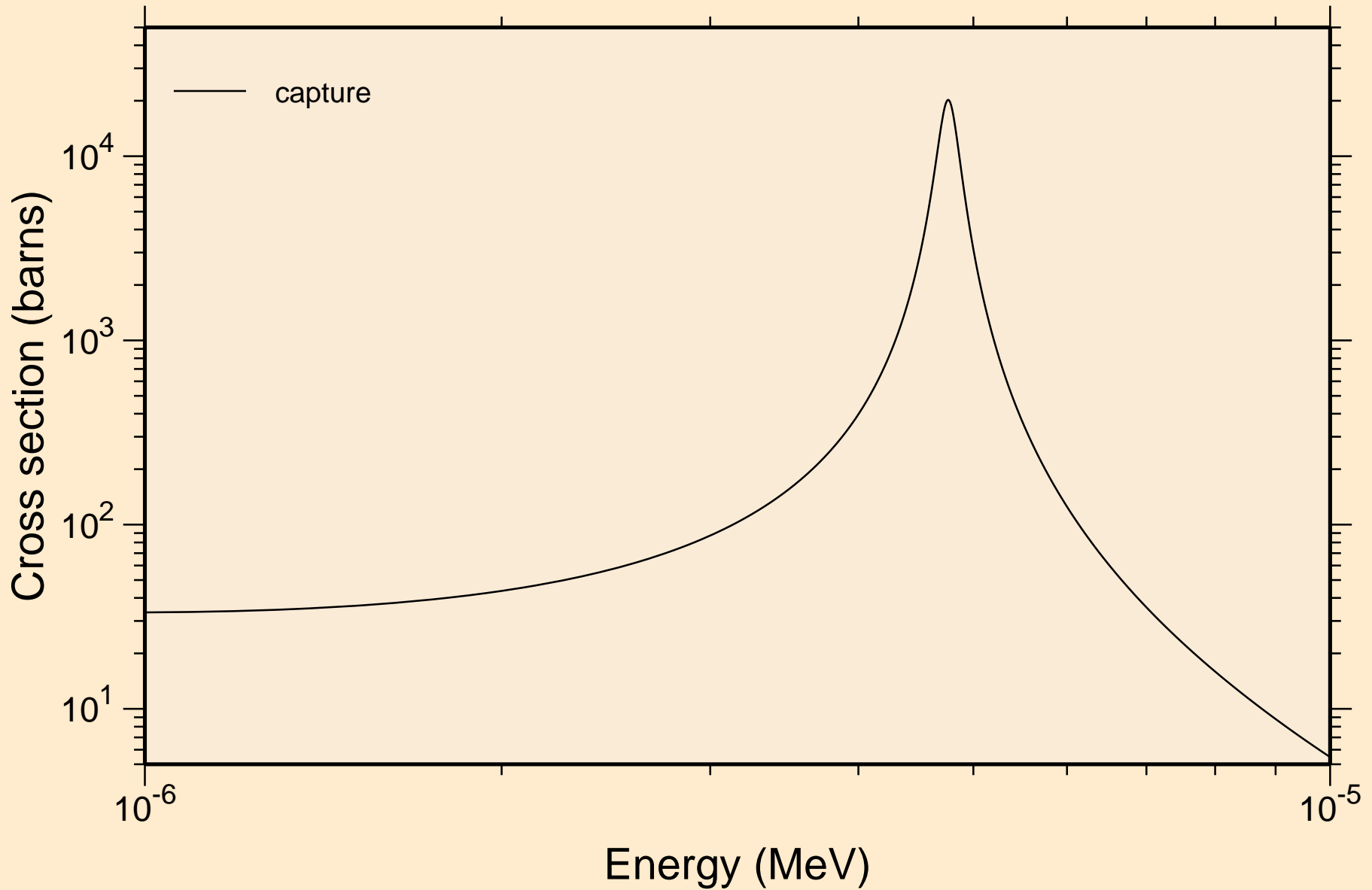

CU066 NEUTRON ACER TENDL-2023 LIBRARY; T=0.K  
resonance absorption cross sections

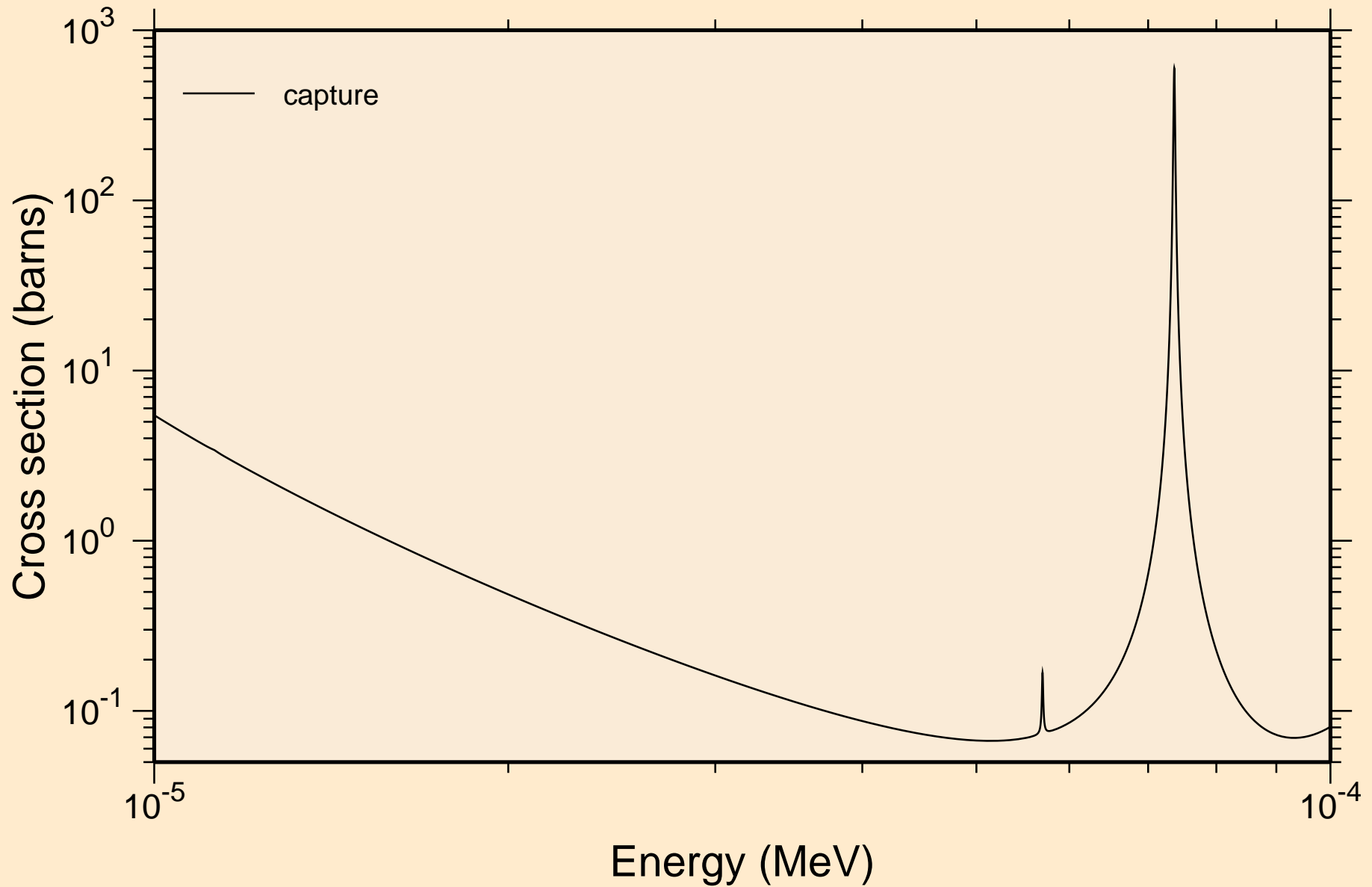

CU066 NEUTRON ACER TENDL-2023 LIBRARY; T=0.K  
resonance absorption cross sections

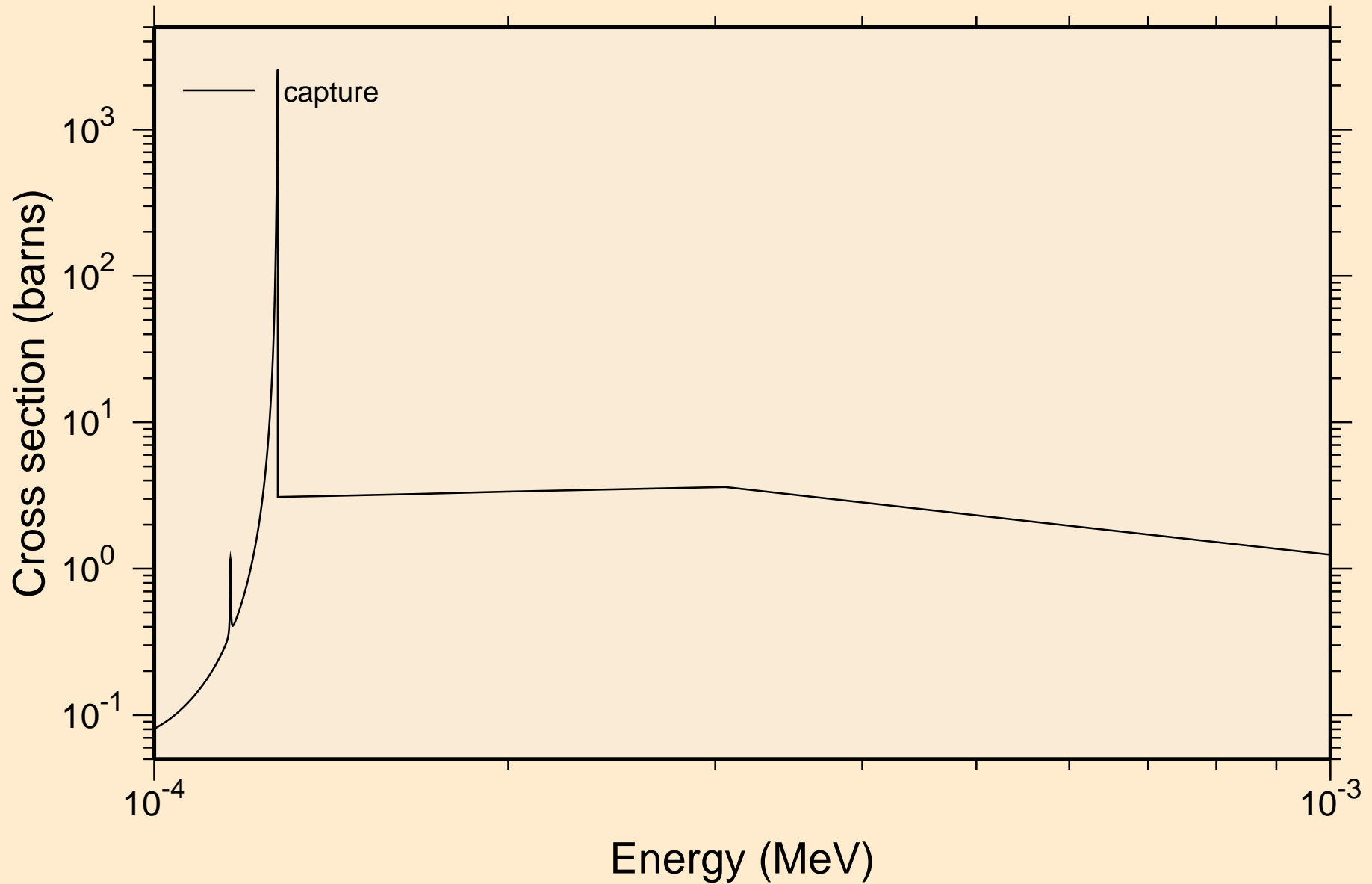



CU066 NEUTRON ACER TENDL-2023 LIBRARY; T=0.K  
resonance absorption cross sections

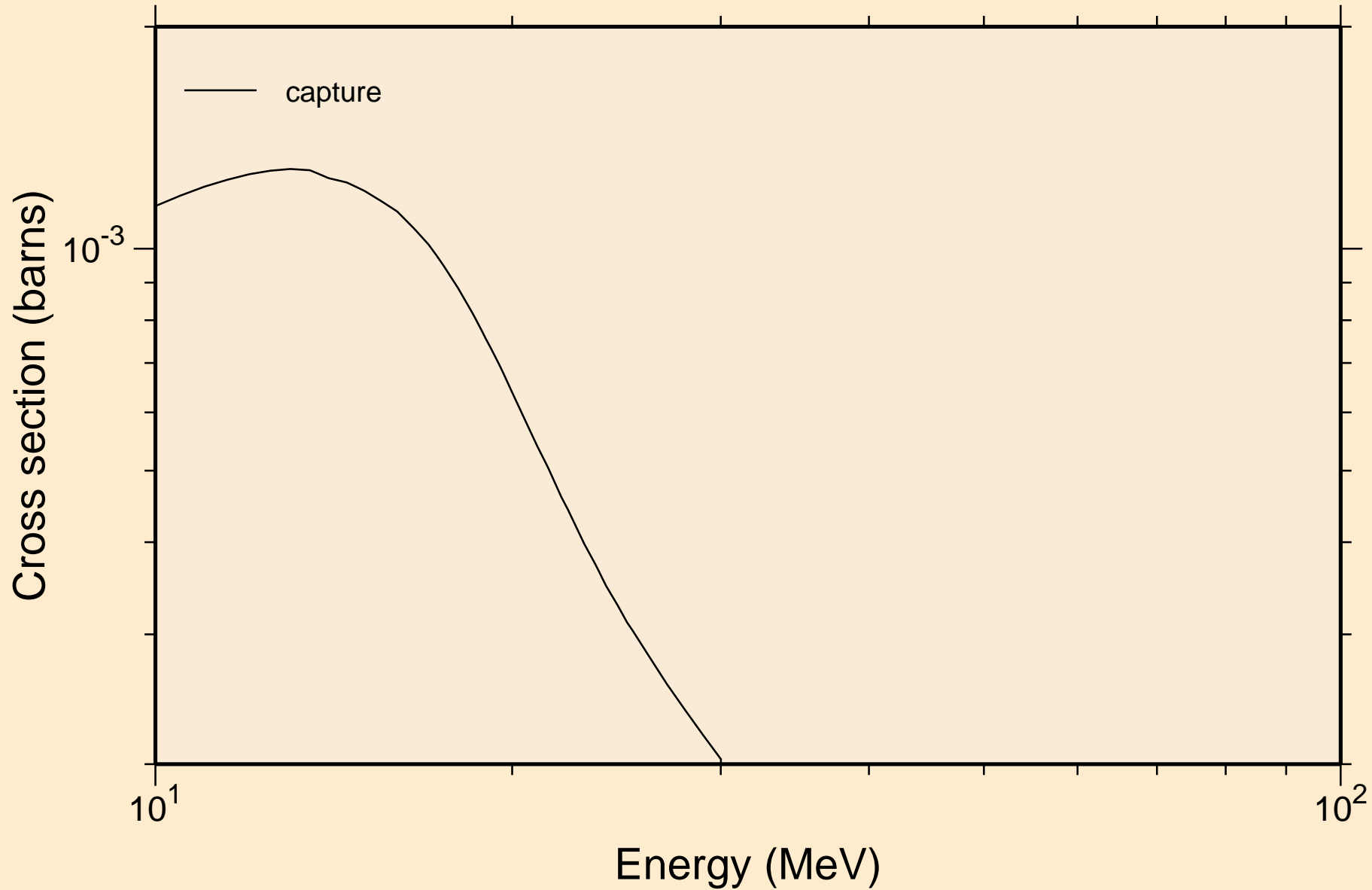

CU066 NEUTRON ACER TENDL-2023 LIBRARY; T=0.K  
Heating

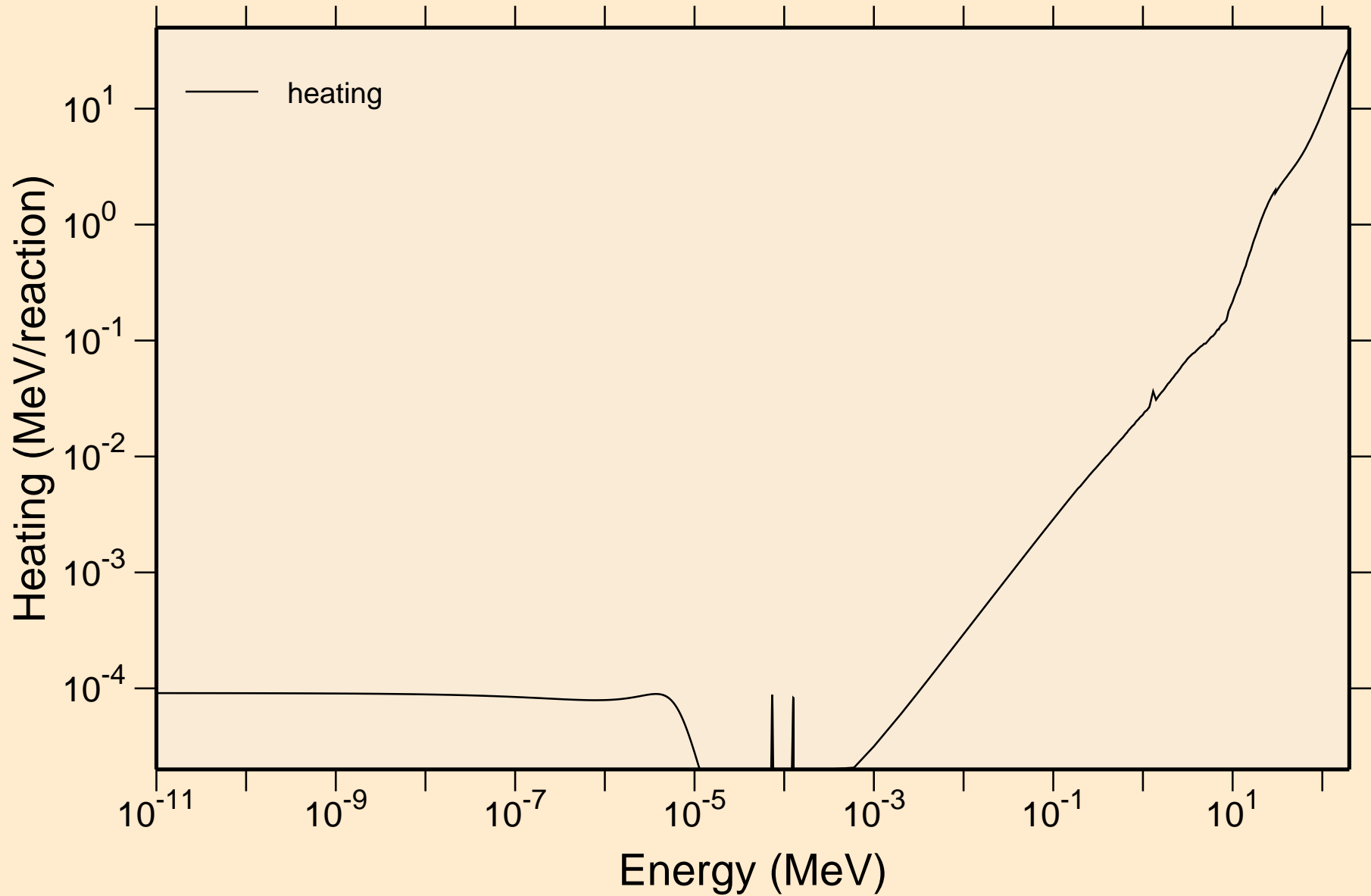

CU066 NEUTRON ACER TENDL-2023 LIBRARY; T=0.K  
Damage

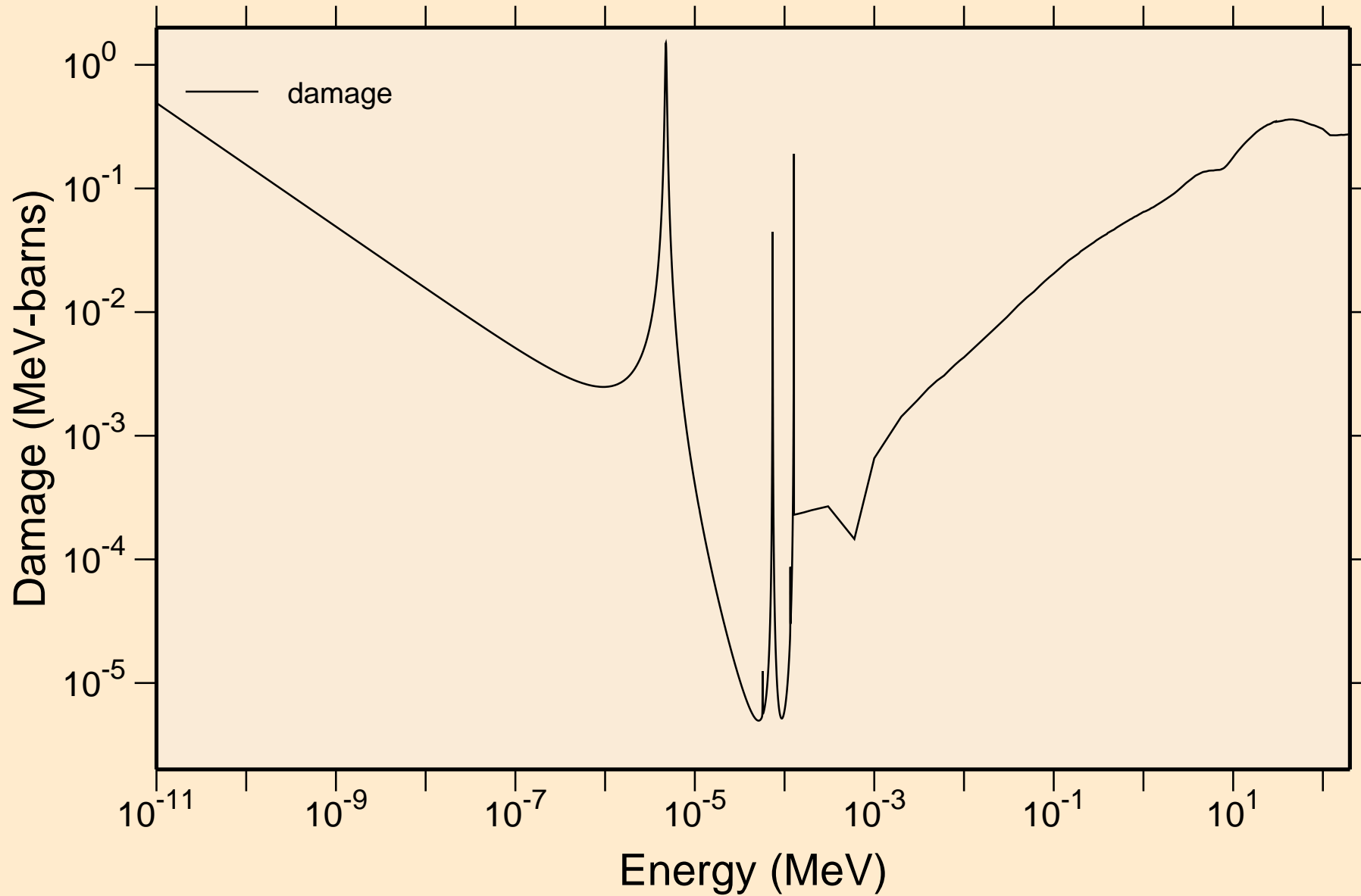

CU066 NEUTRON ACER TENDL-2023 LIBRARY; T=0.K  
Non-threshold reactions

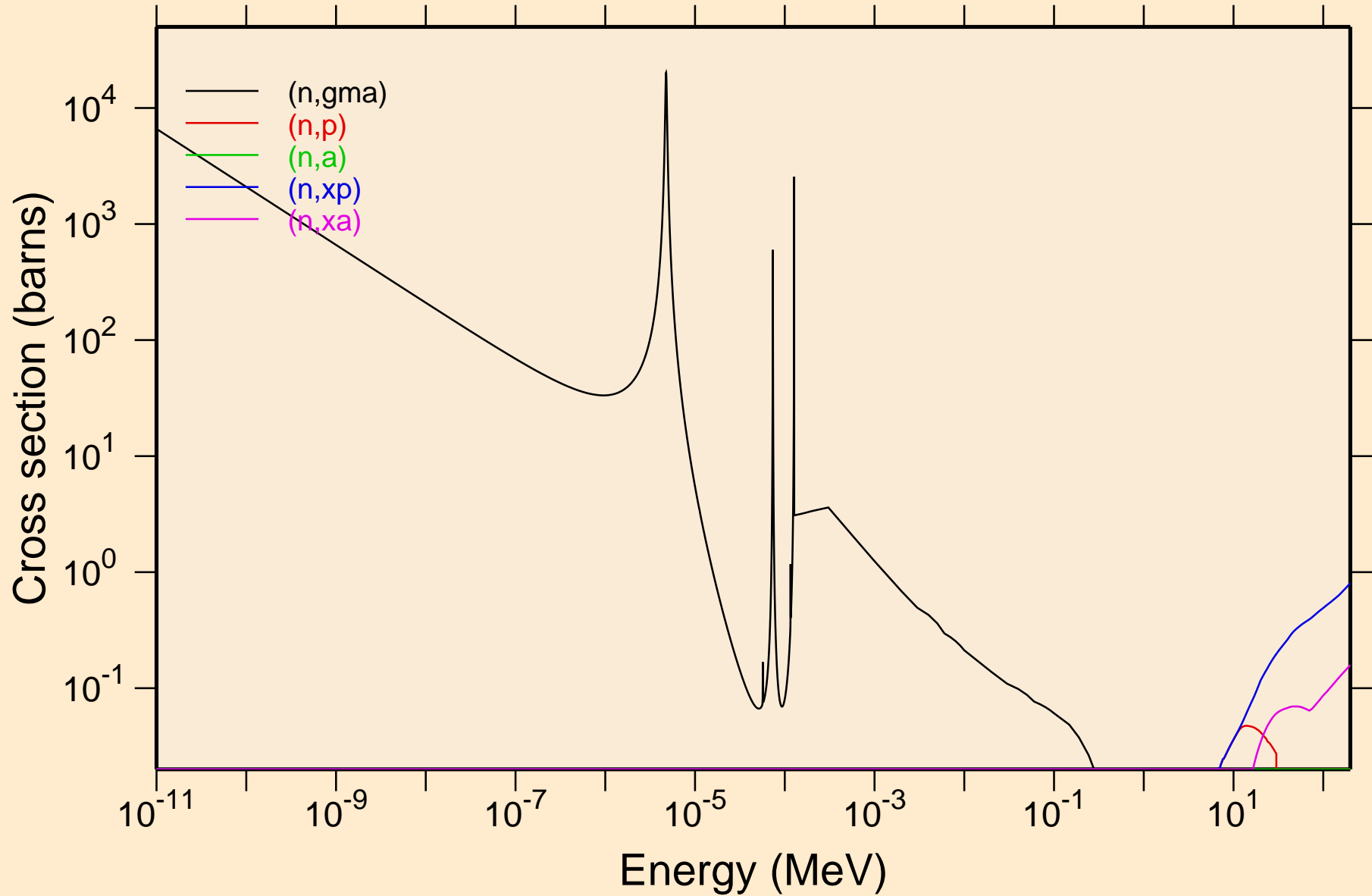

# CU066 NEUTRON ACER TENDL-2023 LIBRARY; T=0.K

## Principal cross sections

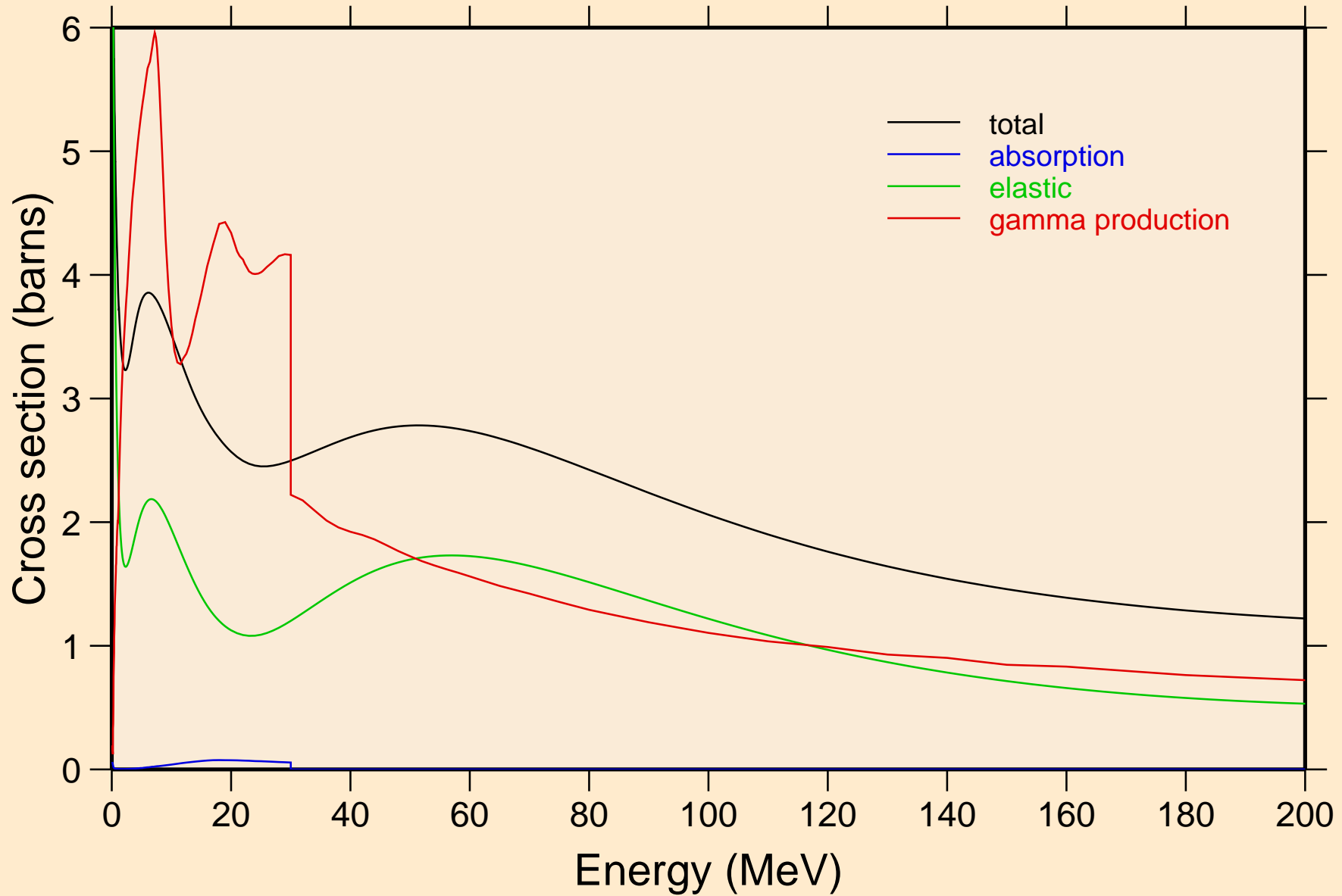

# CU066 NEUTRON ACER TENDL-2023 LIBRARY; T=0.K

## Heating

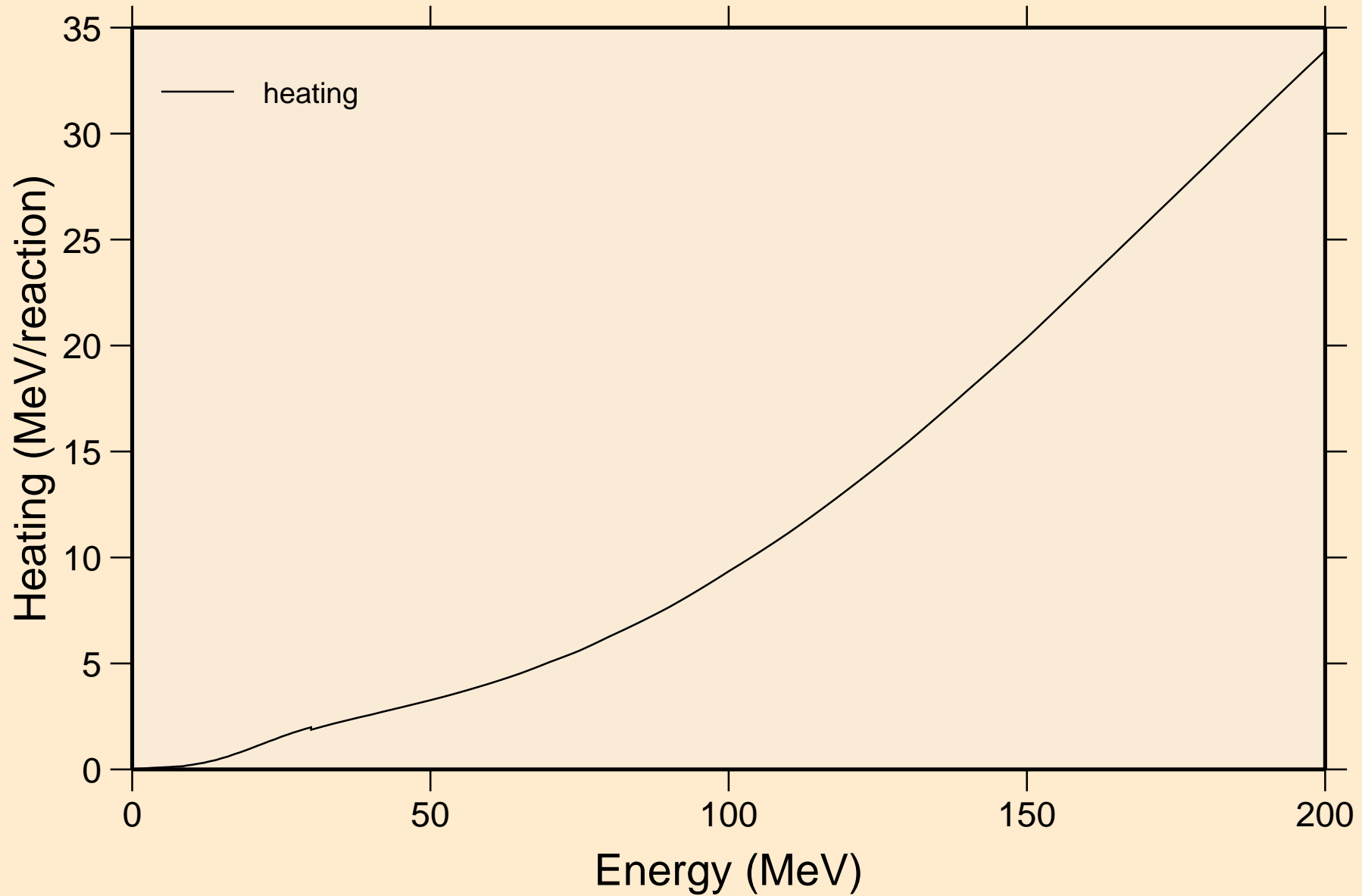

# CU066 NEUTRON ACER TENDL-2023 LIBRARY; T=0.K

## Damage

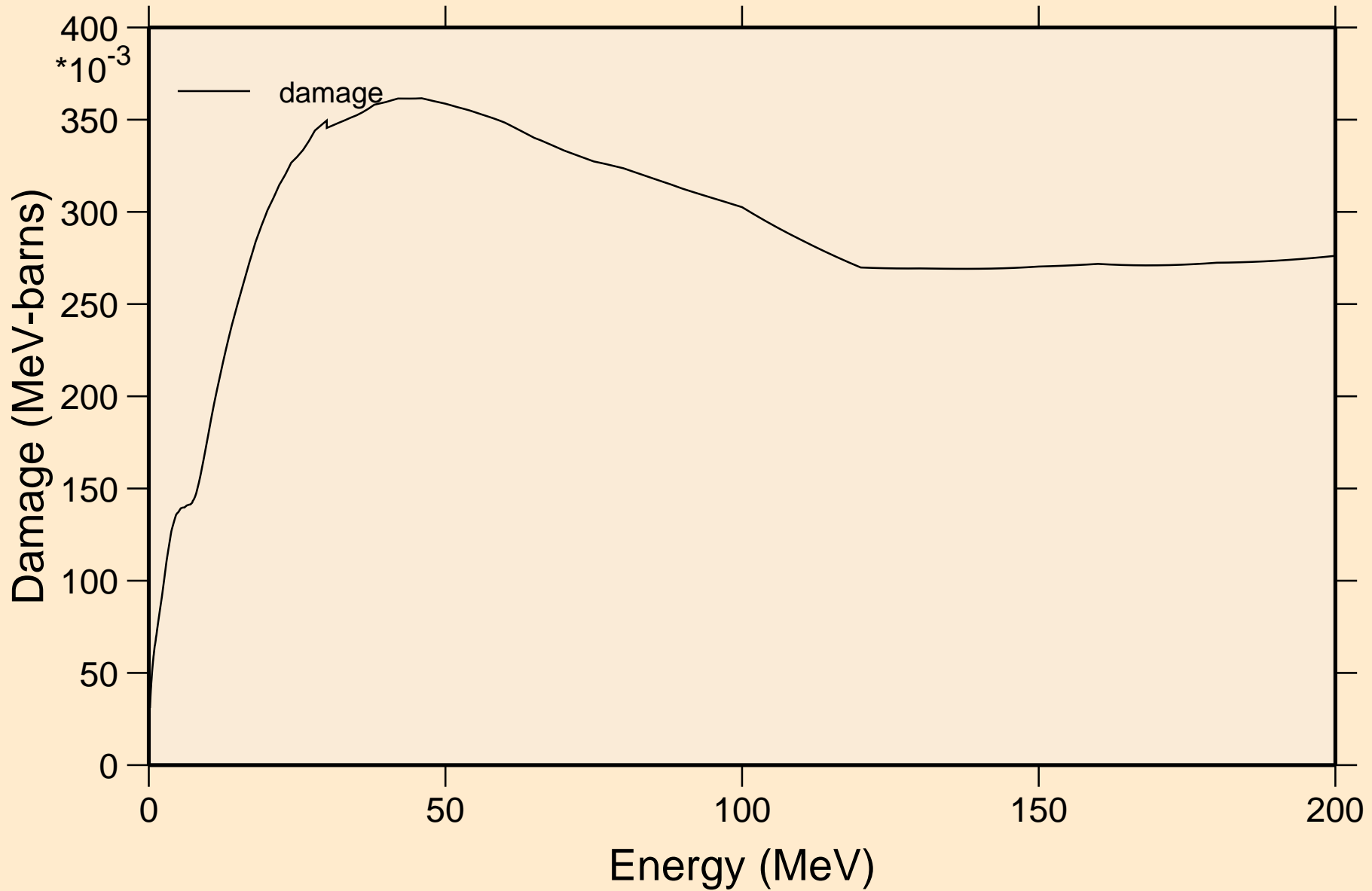

# CU066 NEUTRON ACER TENDL-2023 LIBRARY; T=0.K

## Non-threshold reactions

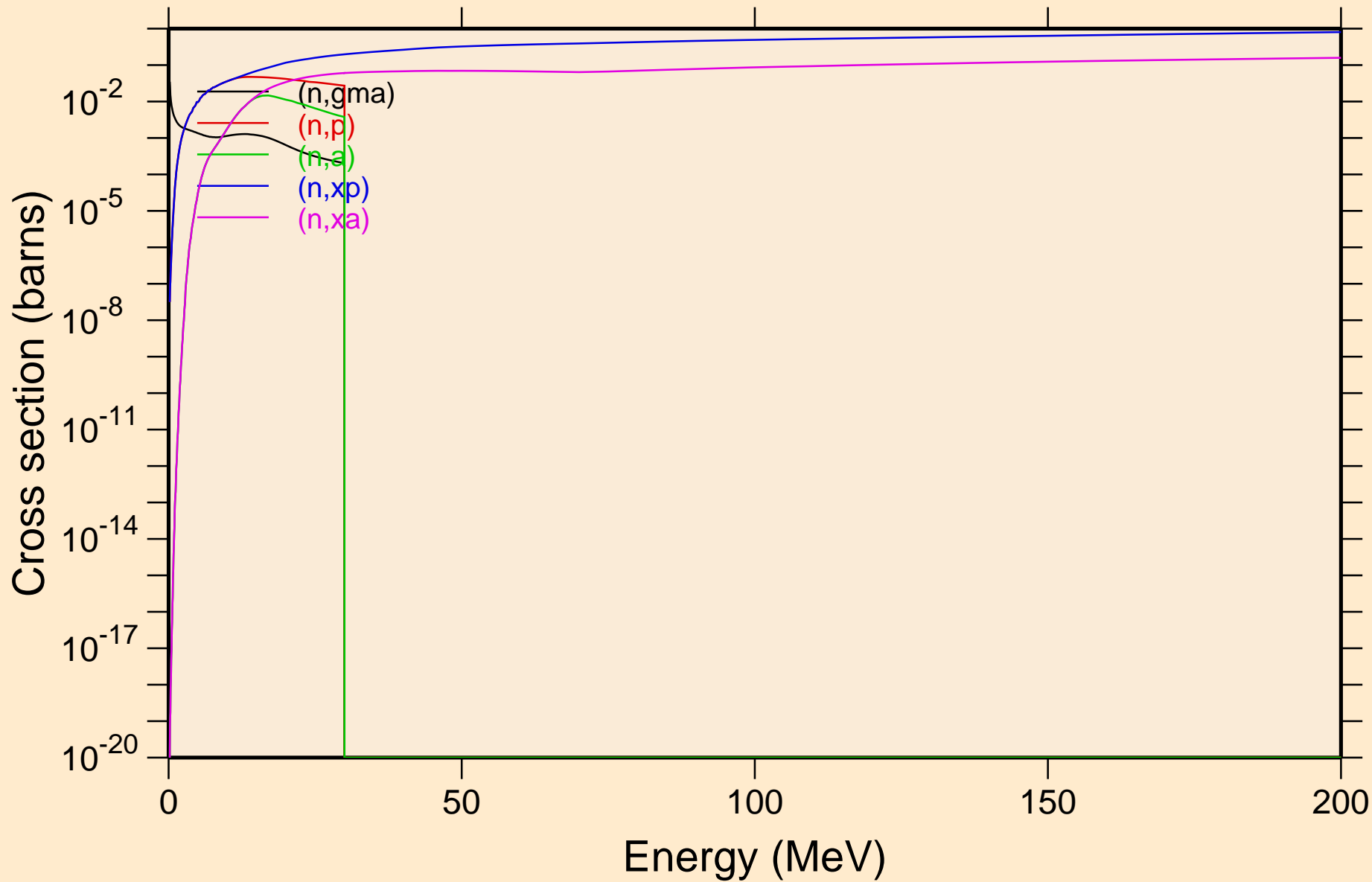



CU066 NEUTRON ACER TENDL-2023 LIBRARY; T=0.K  
Inelastic levels

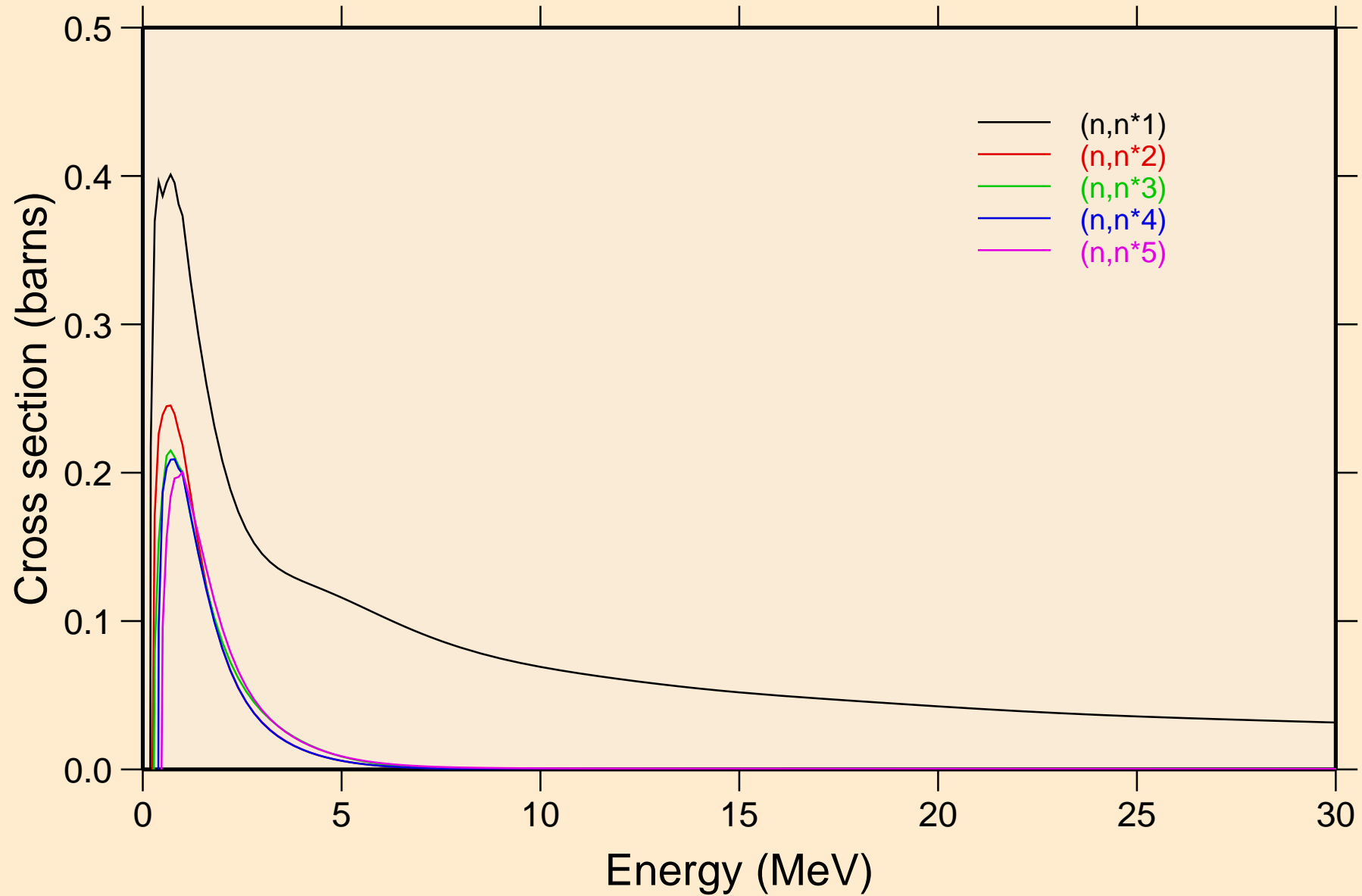

CU066 NEUTRON ACER TENDL-2023 LIBRARY; T=0.K  
Inelastic levels

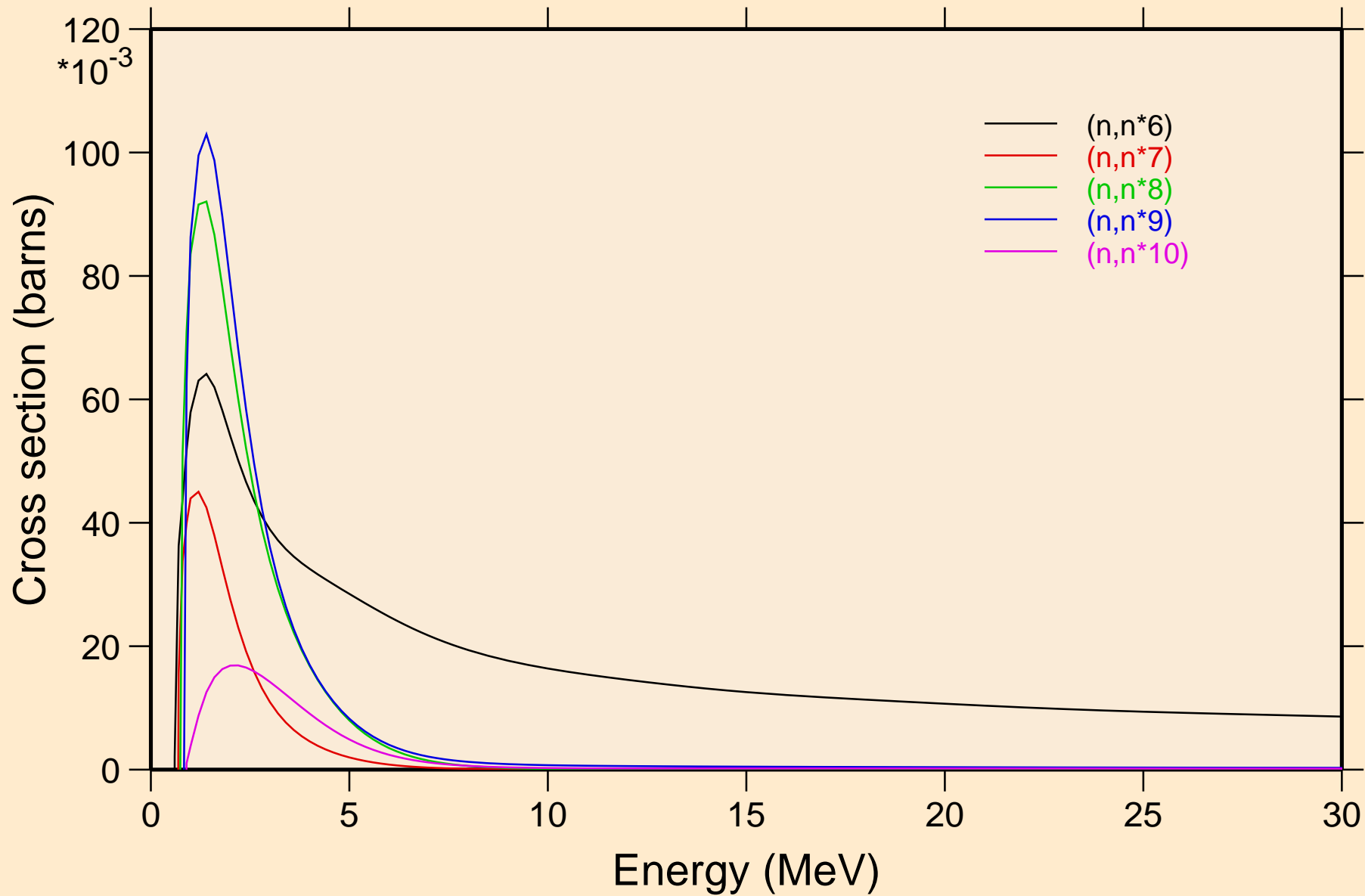

CU066 NEUTRON ACER TENDL-2023 LIBRARY; T=0.K  
Inelastic levels

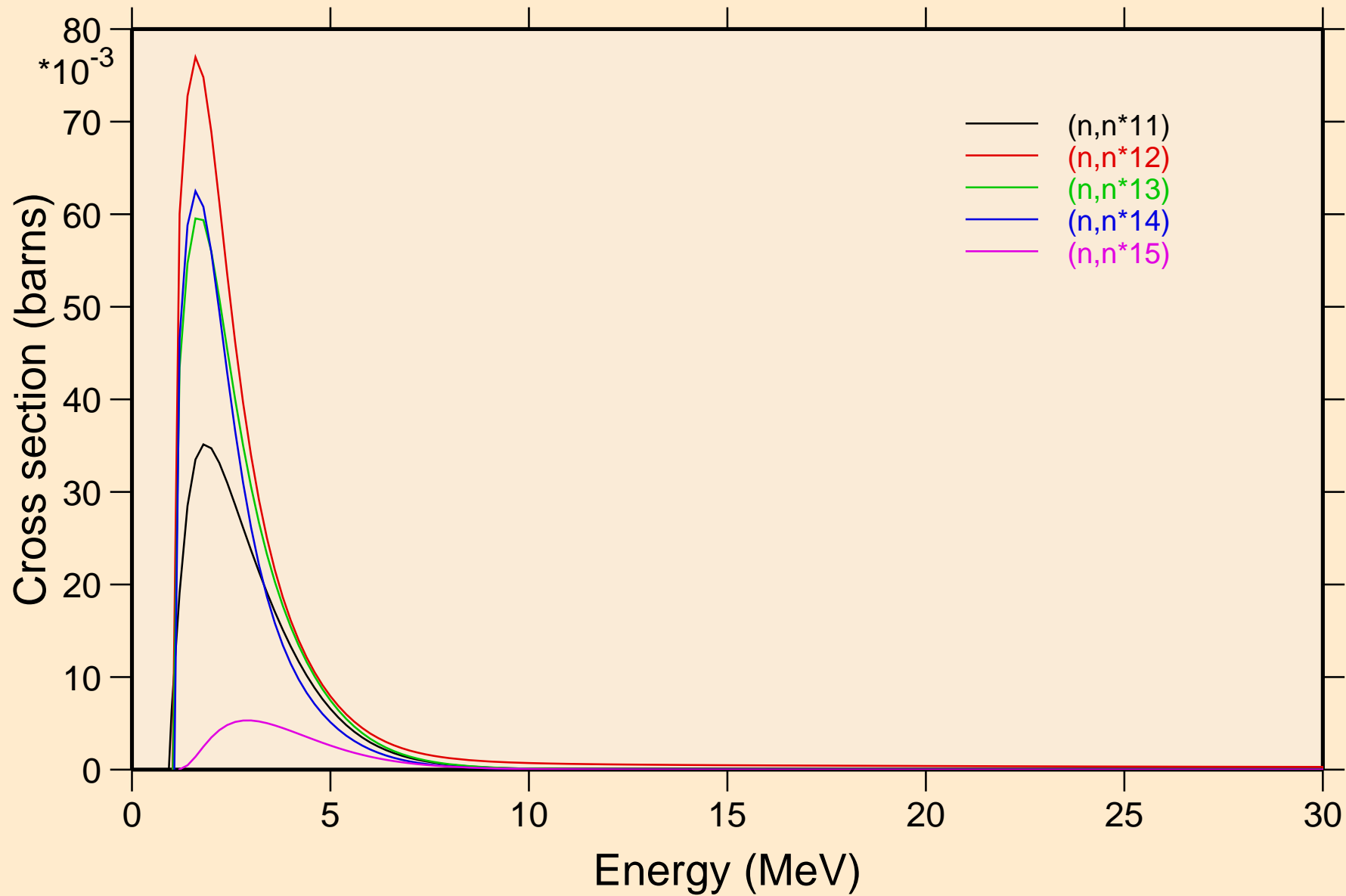

CU066 NEUTRON ACER TENDL-2023 LIBRARY; T=0.K  
Inelastic levels

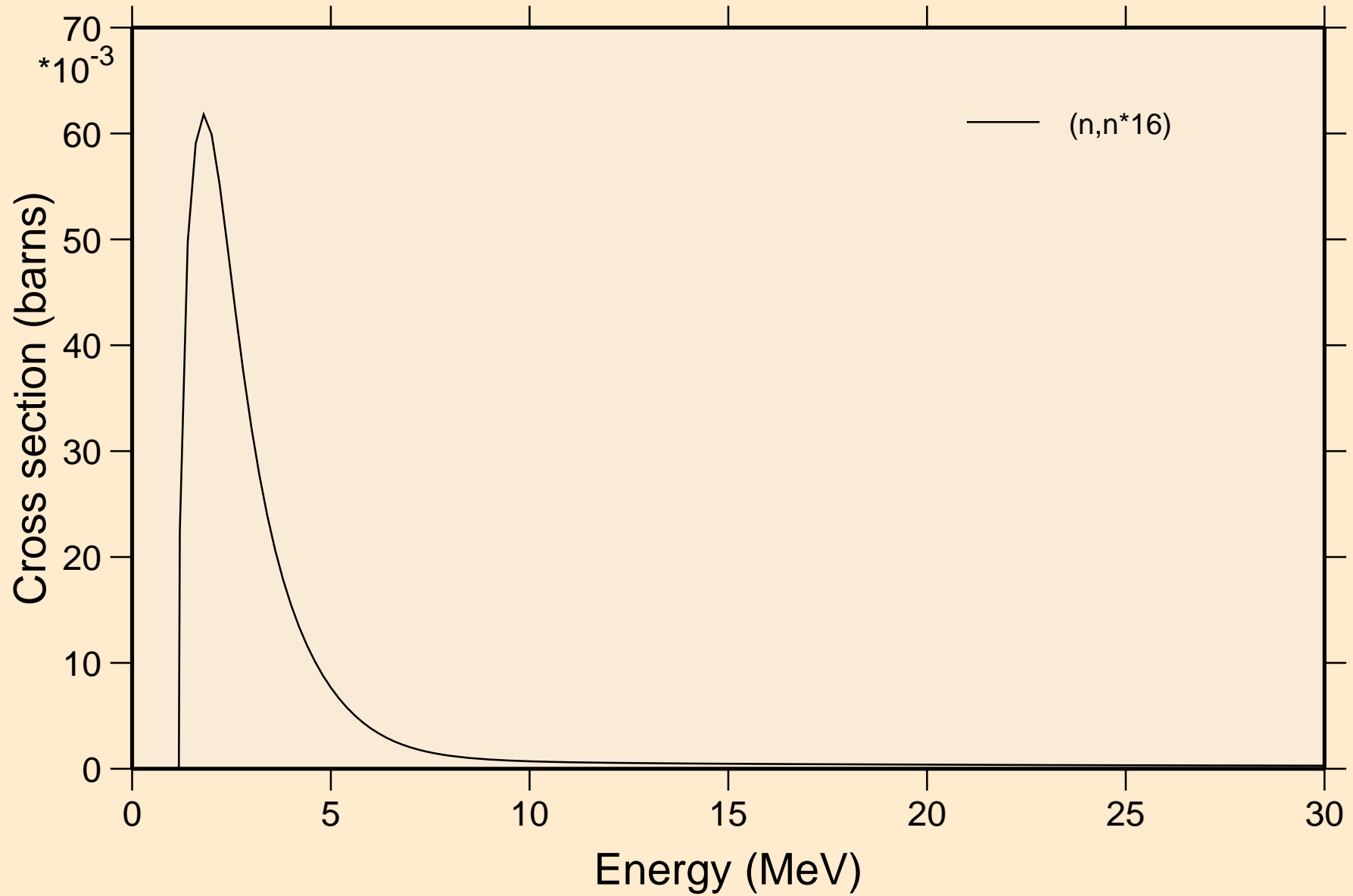

CU066 NEUTRON ACER TENDL-2023 LIBRARY; T=0.K  
Threshold reactions

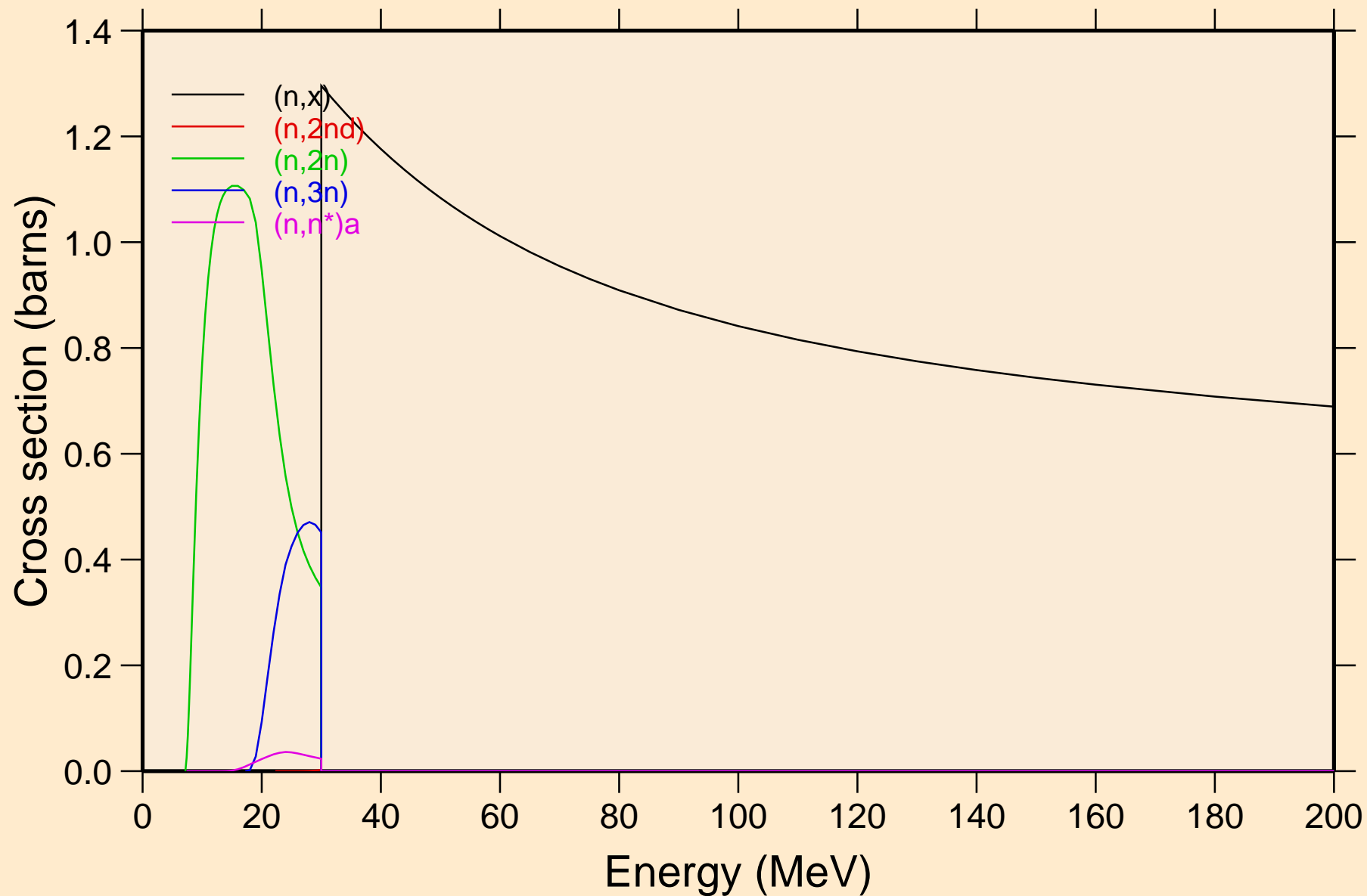

# CU066 NEUTRON ACER TENDL-2023 LIBRARY; T=0.K

## Threshold reactions

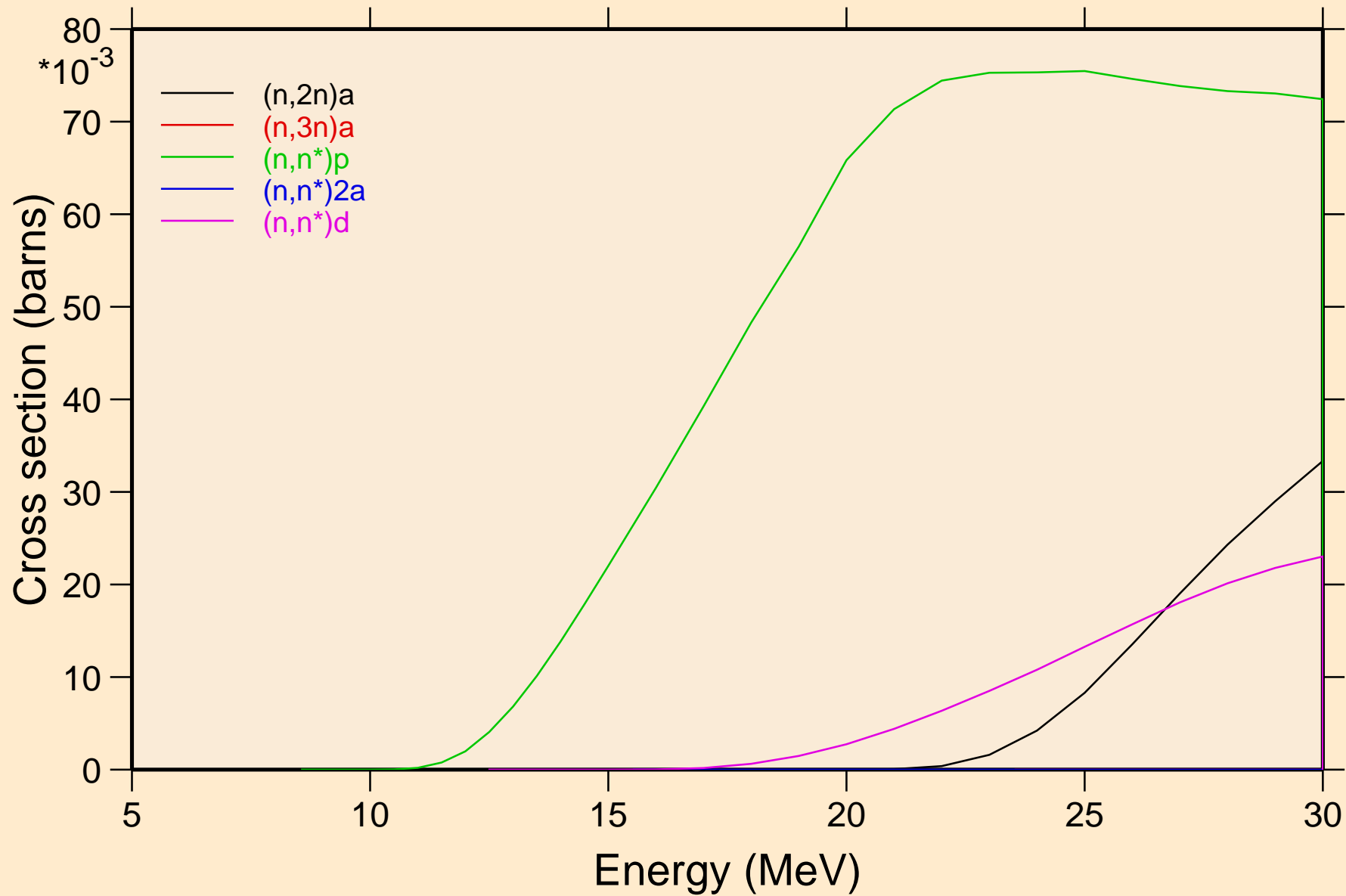

# CU066 NEUTRON ACER TENDL-2023 LIBRARY; T=0.K

## Threshold reactions

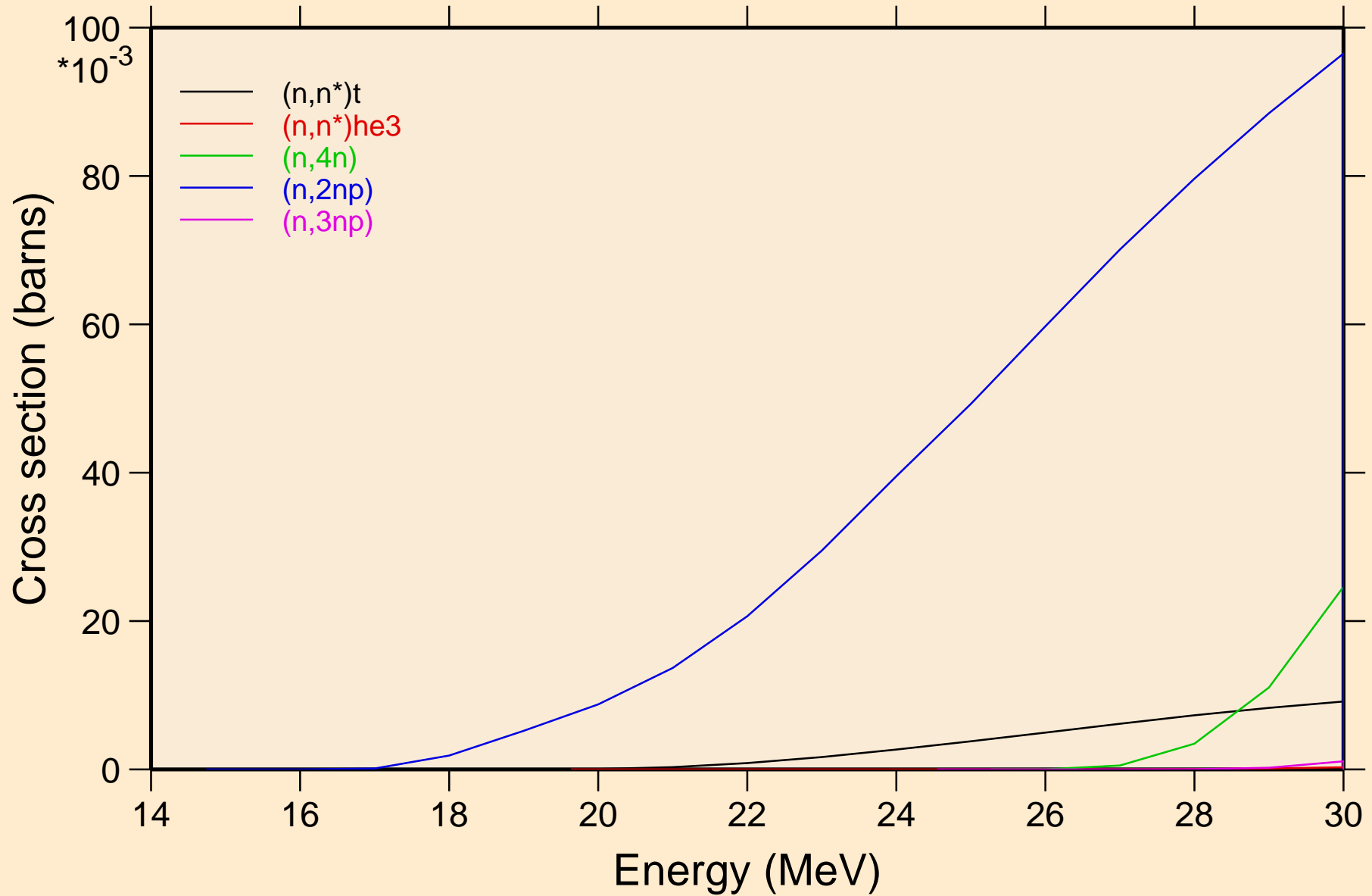

# CU066 NEUTRON ACER TENDL-2023 LIBRARY; T=0.K

## Threshold reactions

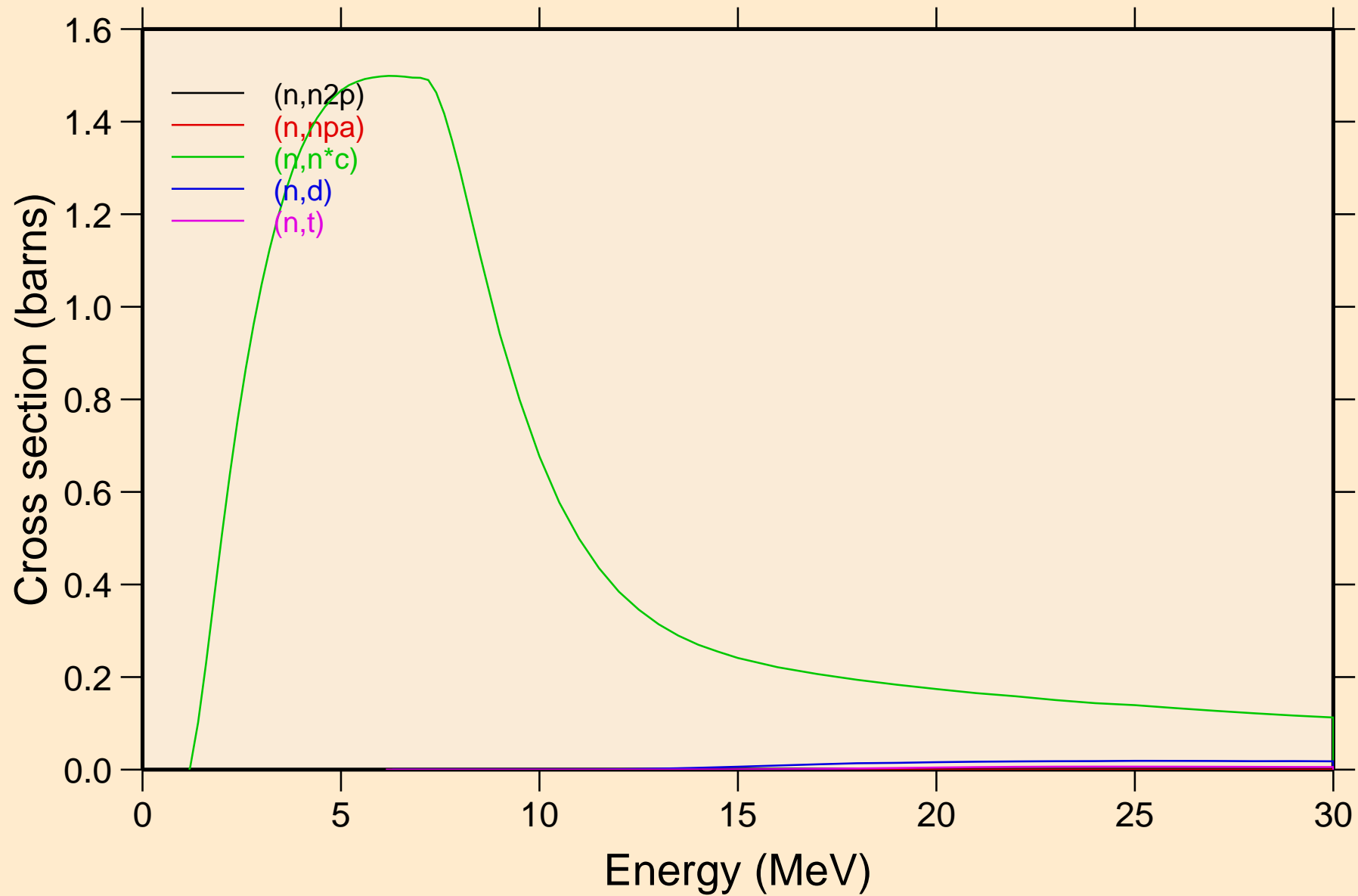



# CU066 NEUTRON ACER TENDL-2023 LIBRARY; T=0.K

## Threshold reactions

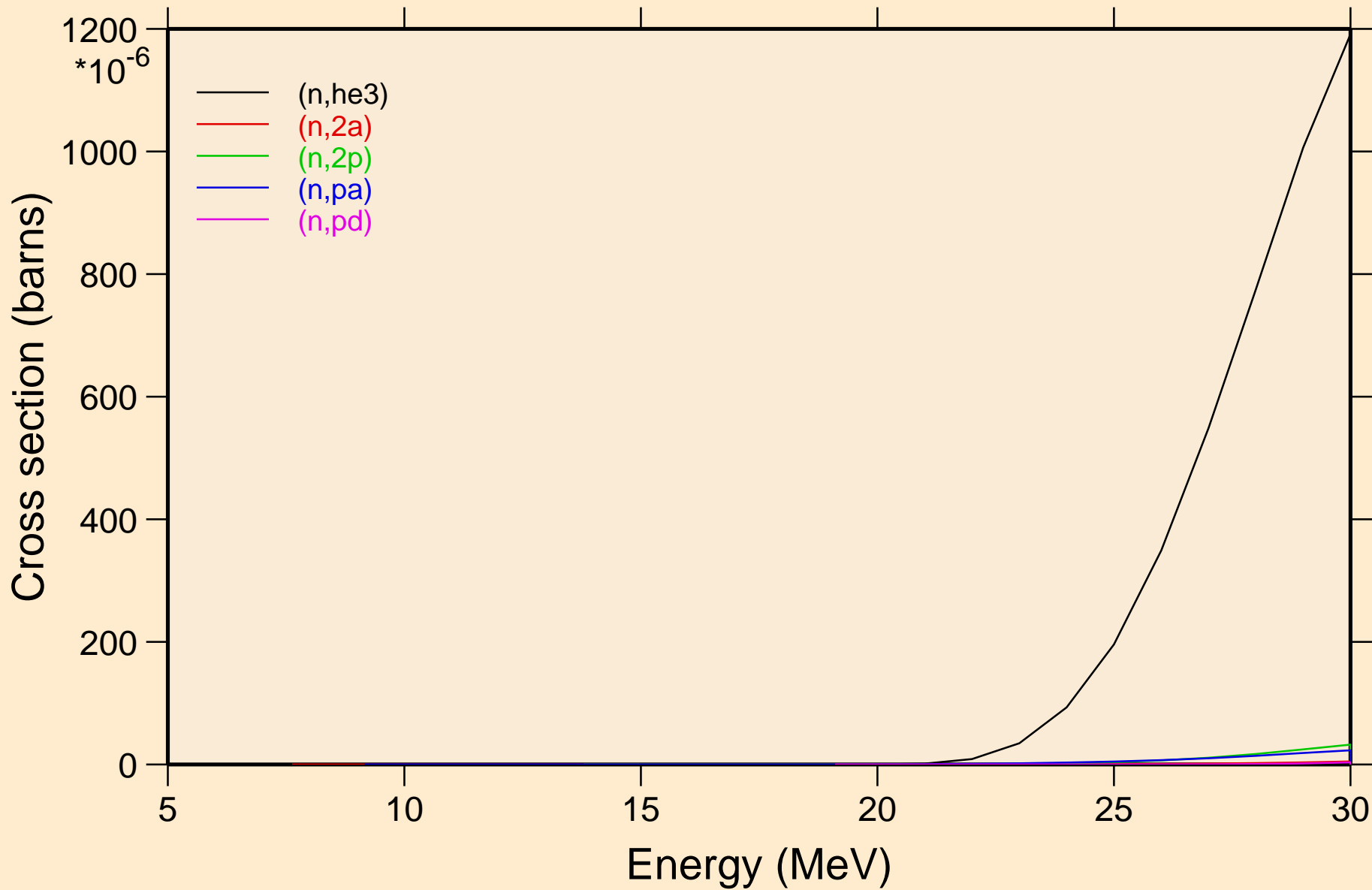

CU066 NEUTRON ACER TENDL-2023 LIBRARY; T=0.K  
Threshold reactions

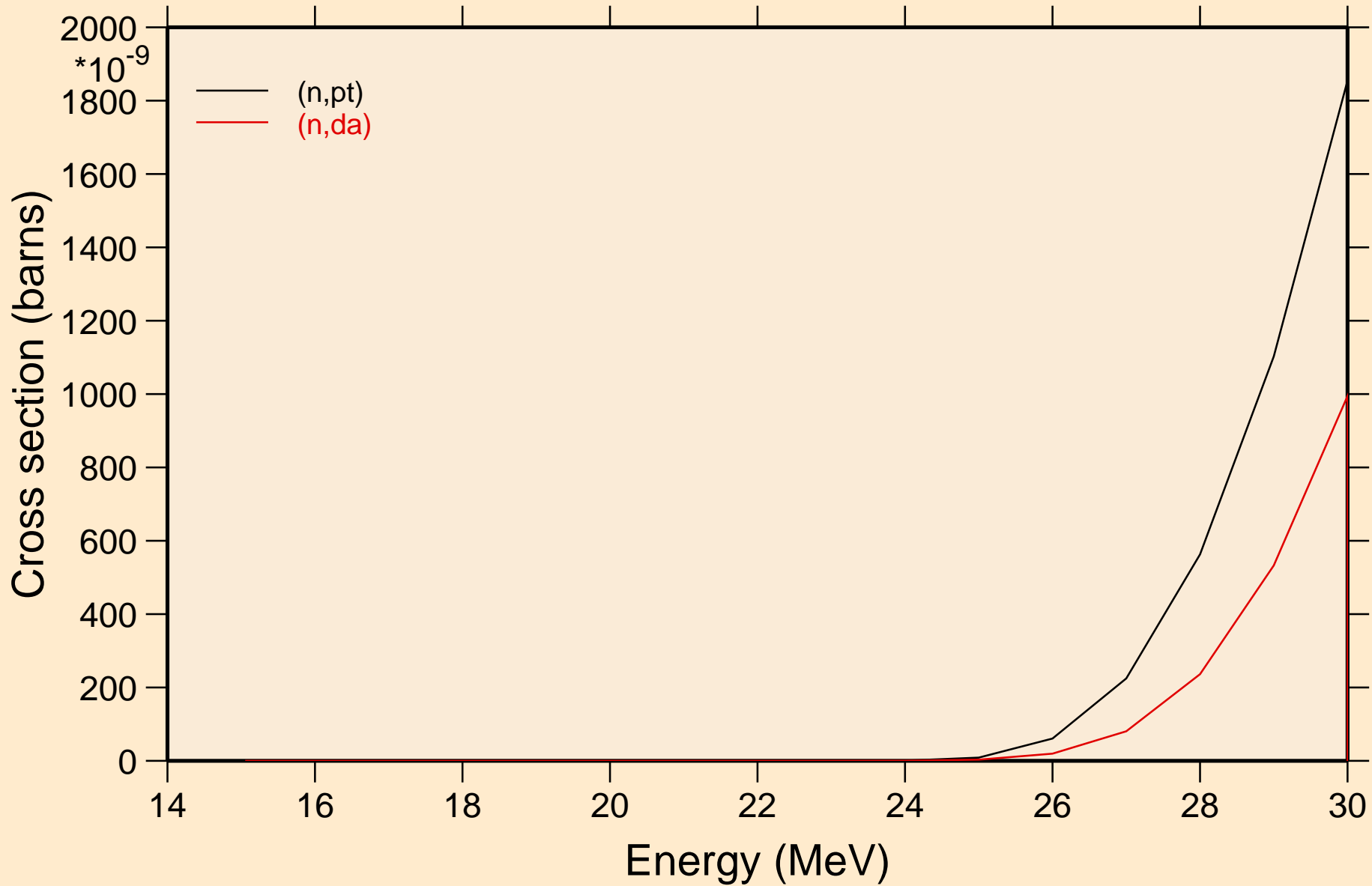

# CU066 NEUTRON ACER TENDL-2023 LIBRARY; T=0.K

## Threshold reactions

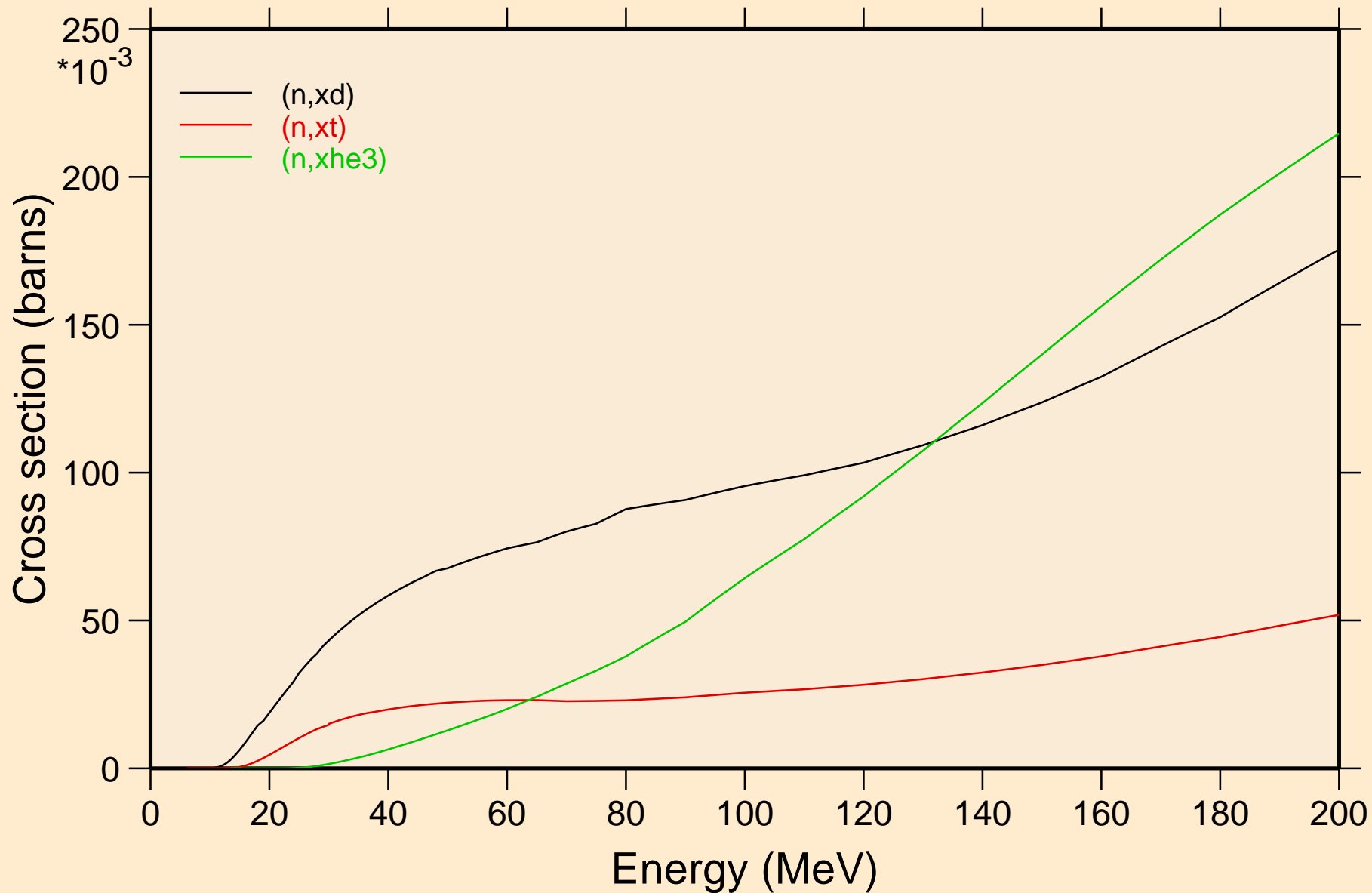

CU066 NEUTRON ACER TENDL-2023 LIBRARY; T=0.K  
angular distribution for elastic

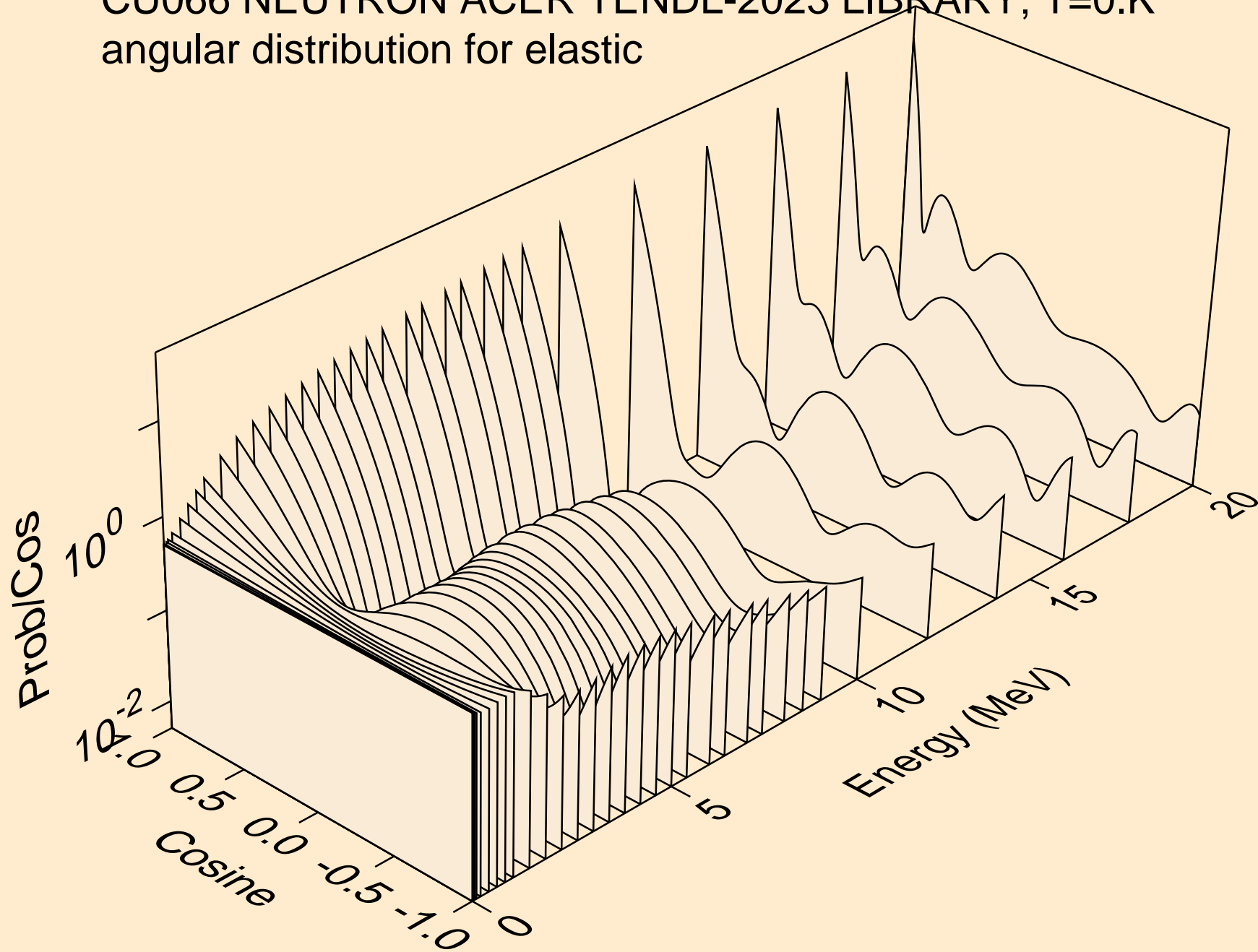

CU066 NEUTRON ACER TENDL-2023 LIBRARY; T=0.K  
angular distribution for elastic

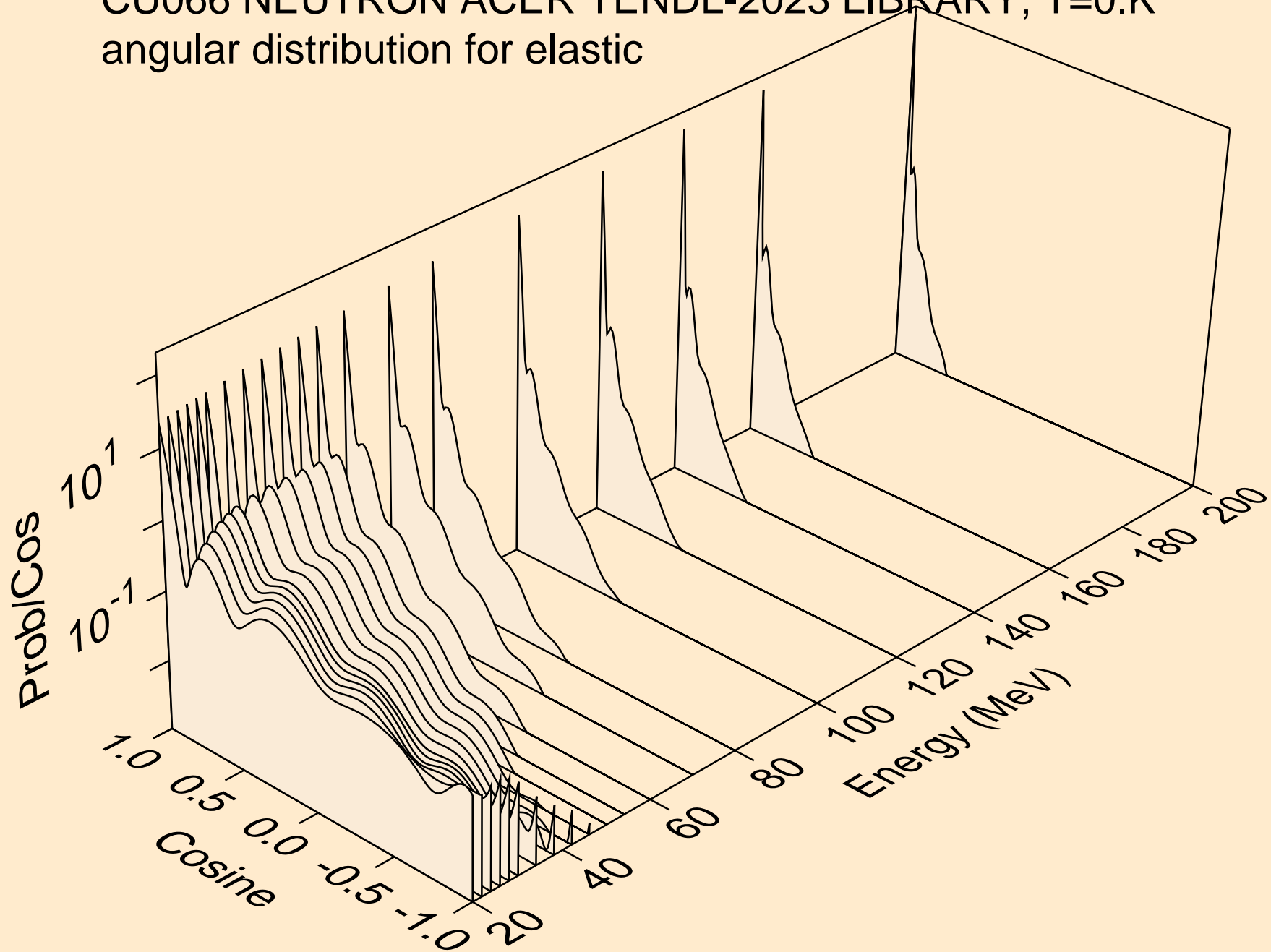

CU066 NEUTRON ACER TENDL-2023 LIBRARY; T=0.K  
angular distribution for (n,n\*1)

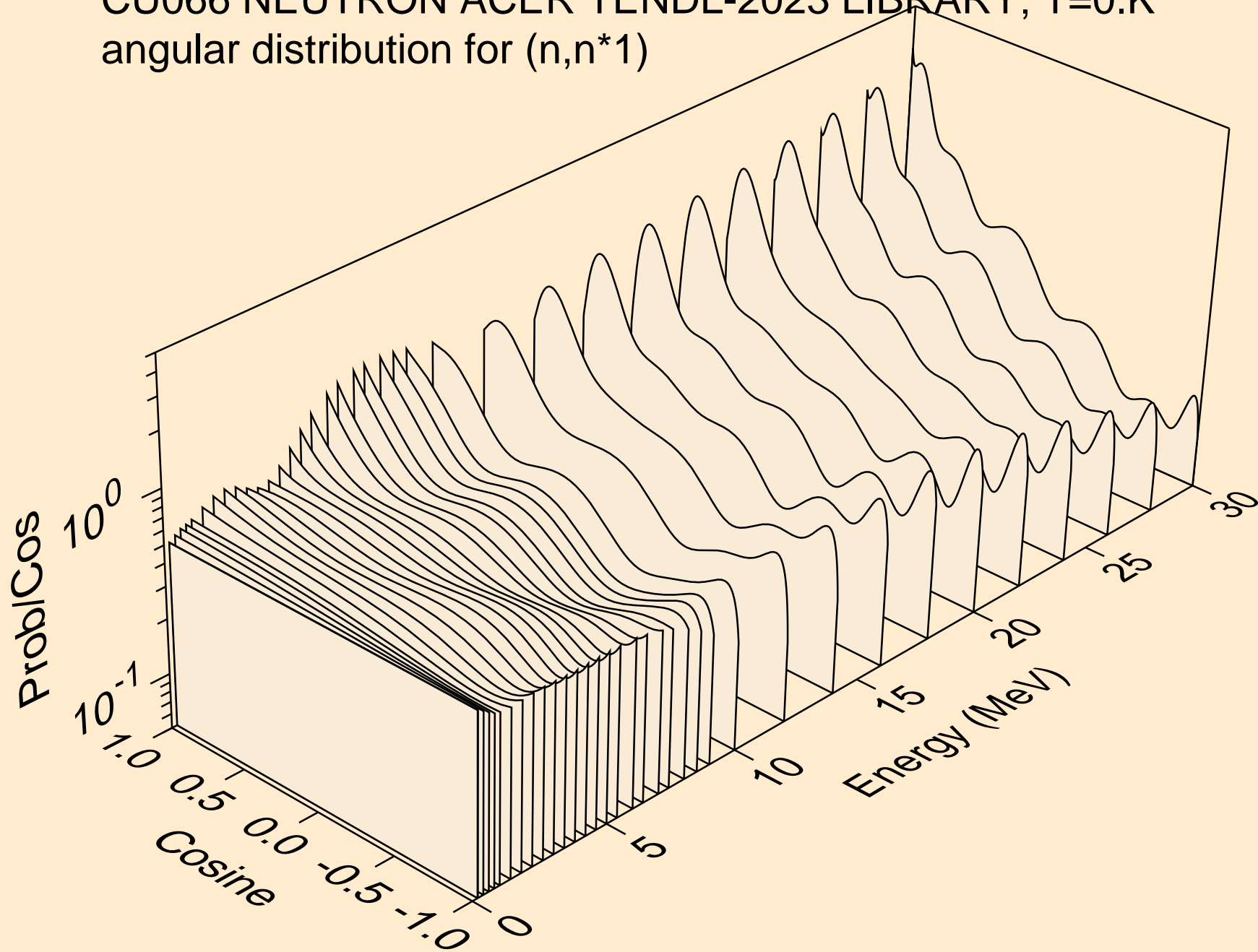

CU066 NEUTRON ACER TENDL-2023 LIBRARY; T=0.K  
angular distribution for (n,n\*2)

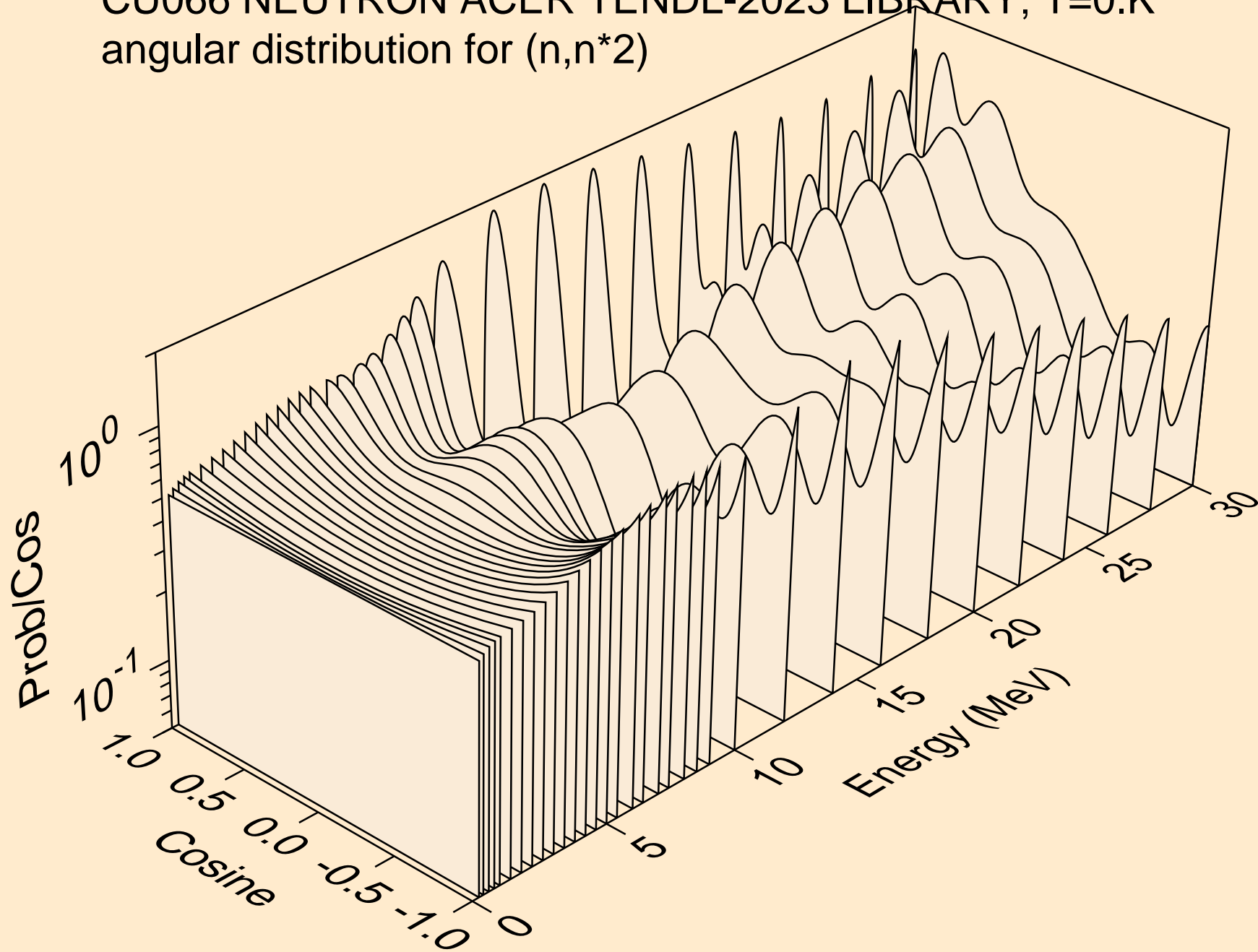

CU066 NEUTRON ACER TENDL-2023 LIBRARY; T=0.K  
angular distribution for (n,n\*3)

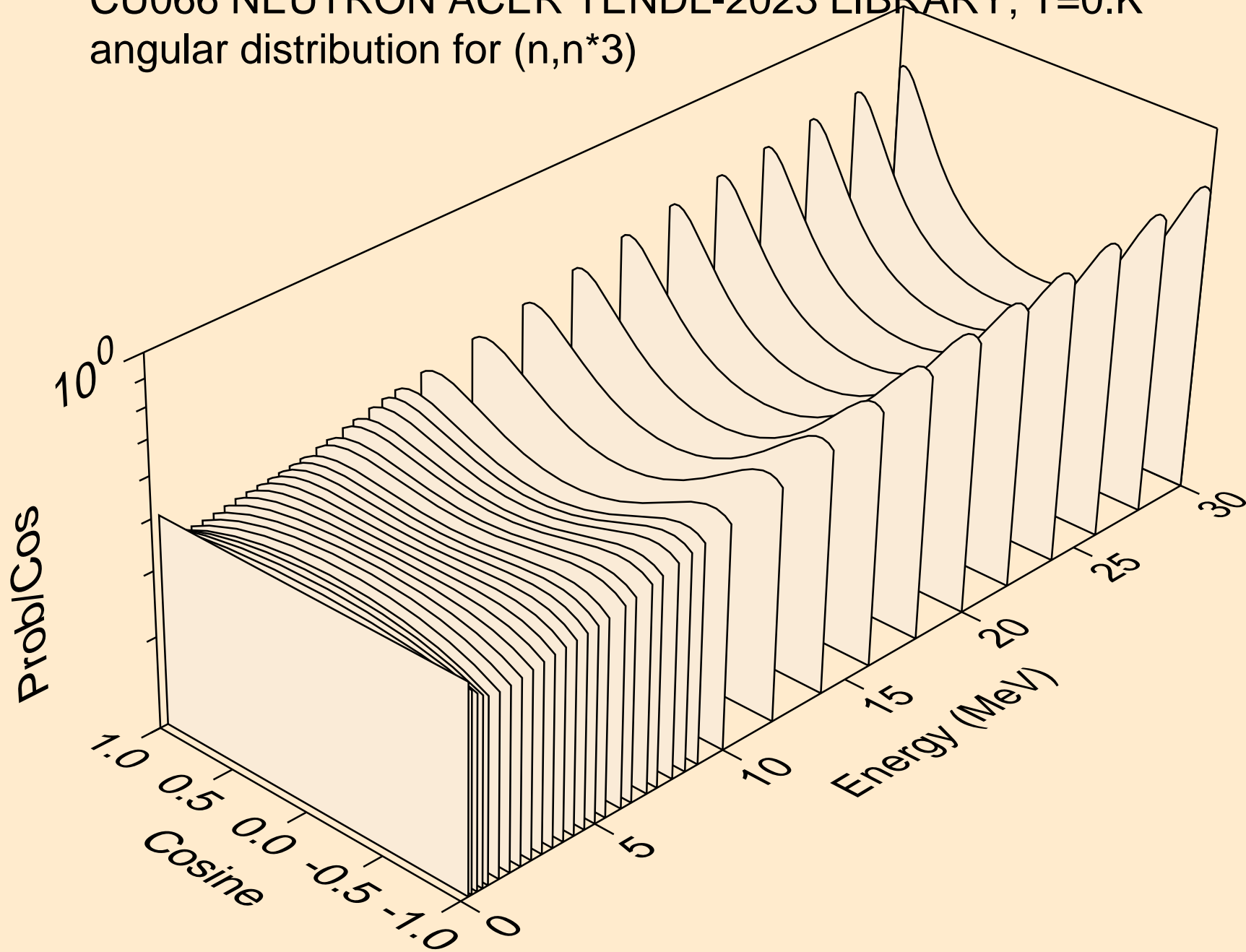



CU066 NEUTRON ACER TENDL-2023 LIBRARY; T=0.K  
angular distribution for (n,n\*4)

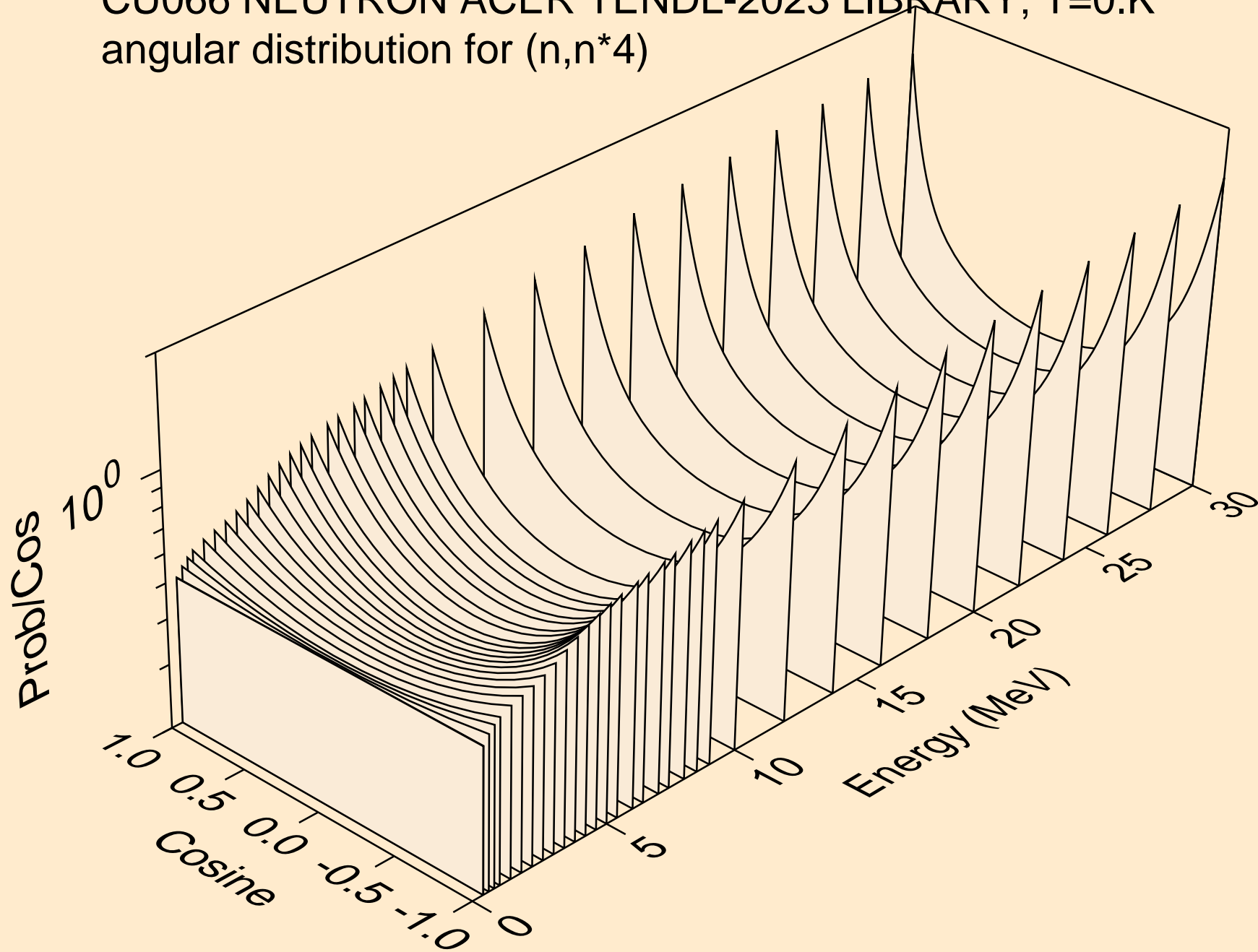

CU066 NEUTRON ACER TENDL-2023 LIBRARY; T=0.K  
angular distribution for (n,n\*5)

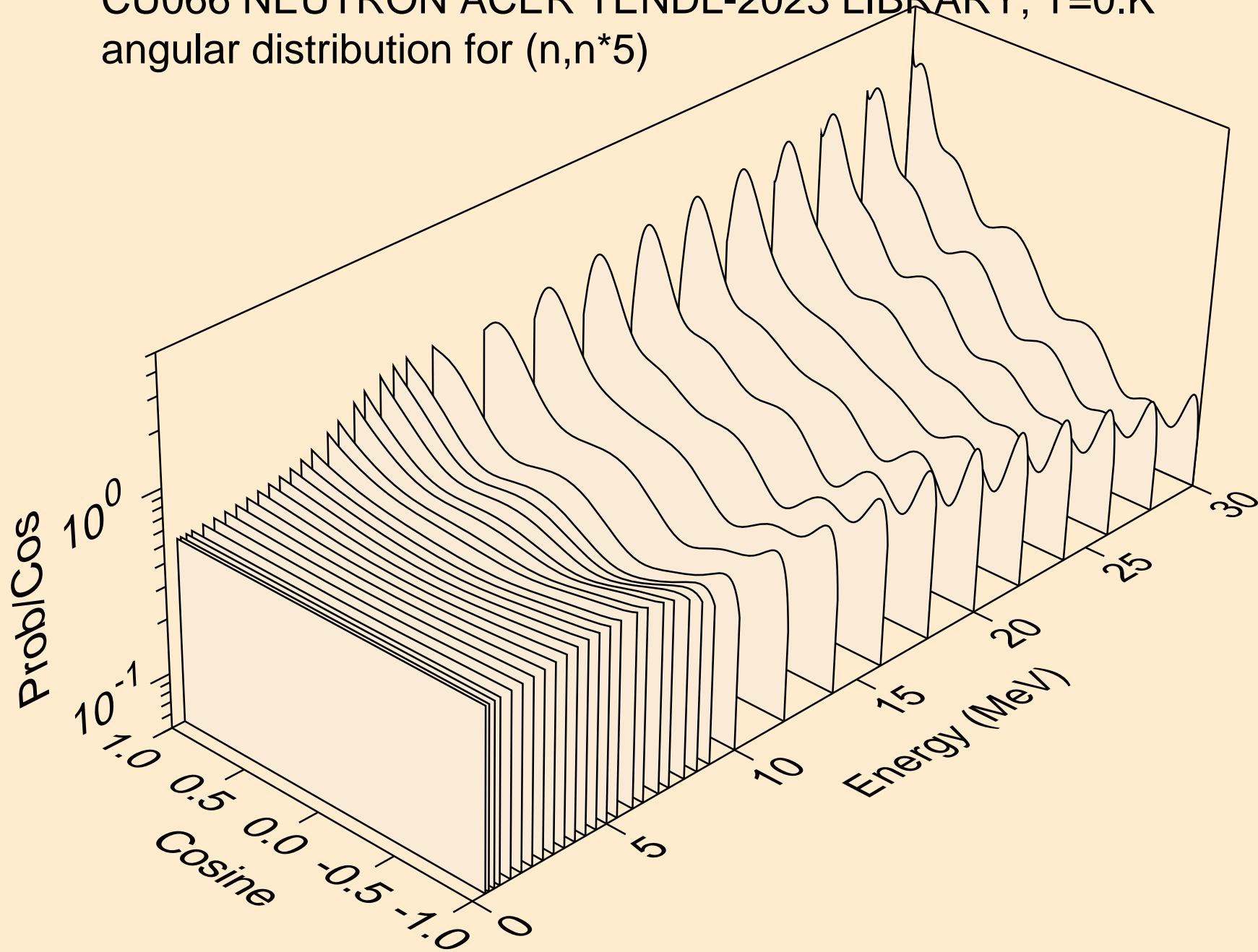

CU066 NEUTRON ACER TENDL-2023 LIBRARY; T=0.K  
angular distribution for (n,n\*6)

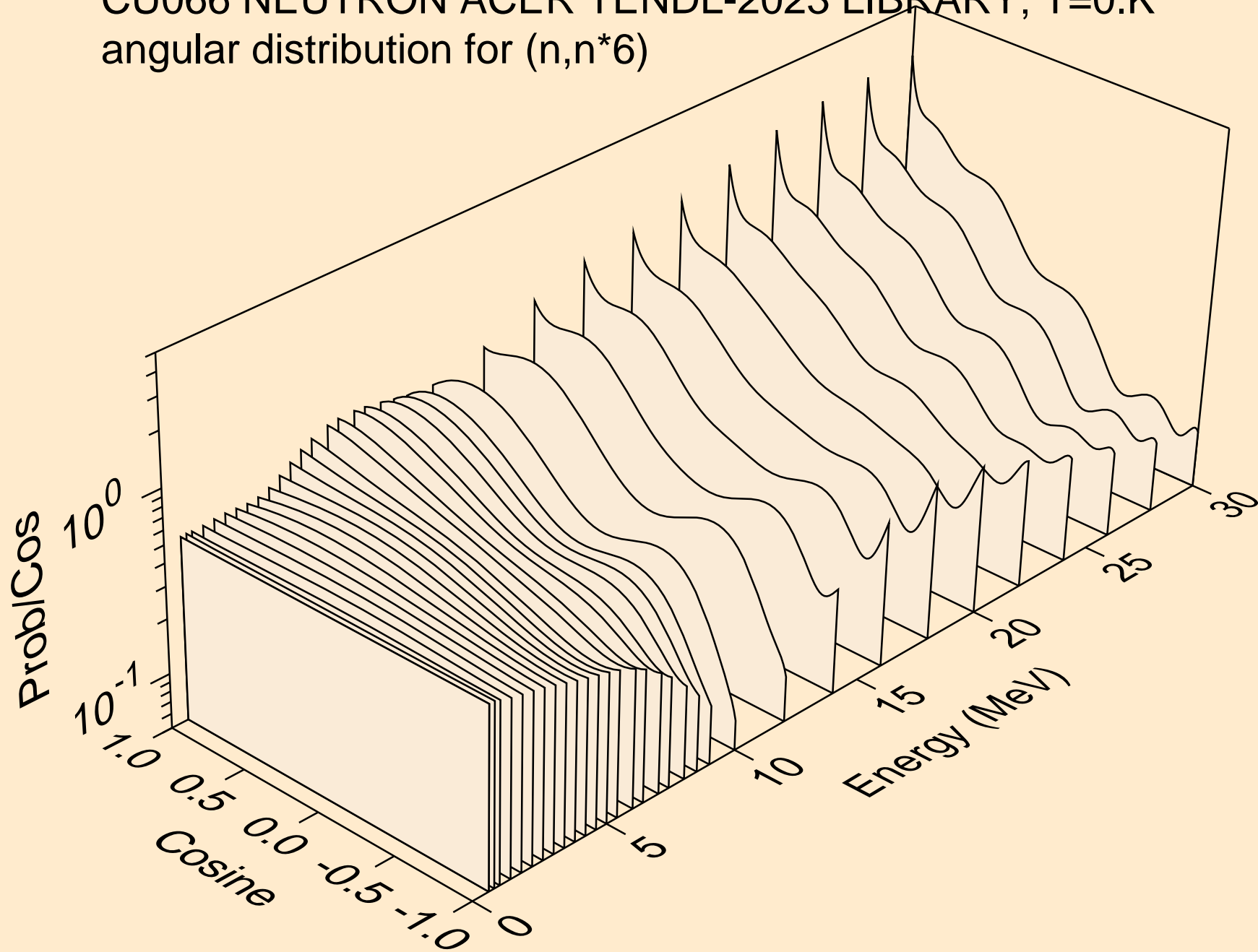

CU066 NEUTRON ACER TENDL-2023 LIBRARY; T=0.K  
angular distribution for (n,n\*7)

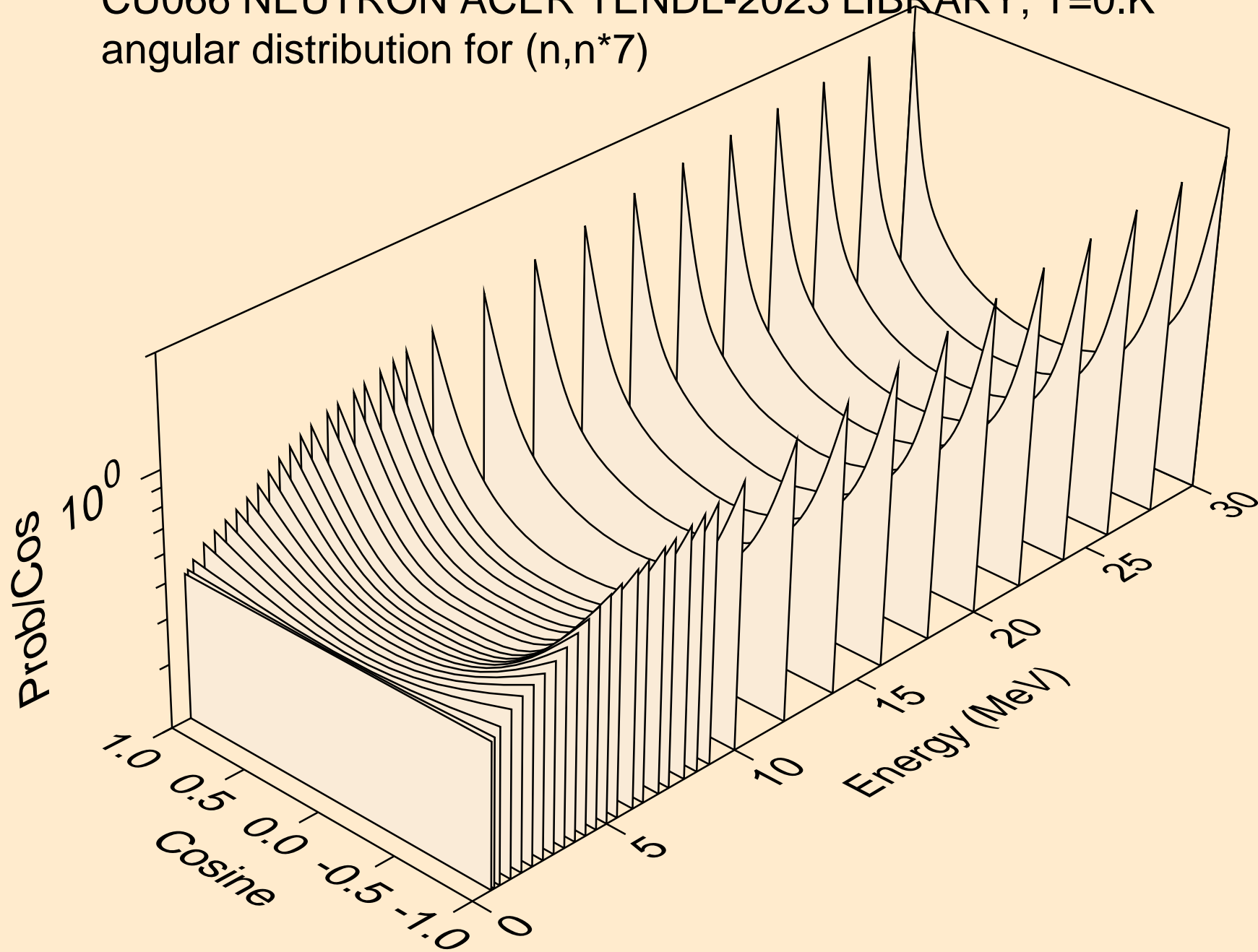

CU066 NEUTRON ACER TENDL-2023 LIBRARY; T=0.K  
angular distribution for (n,n\*8)

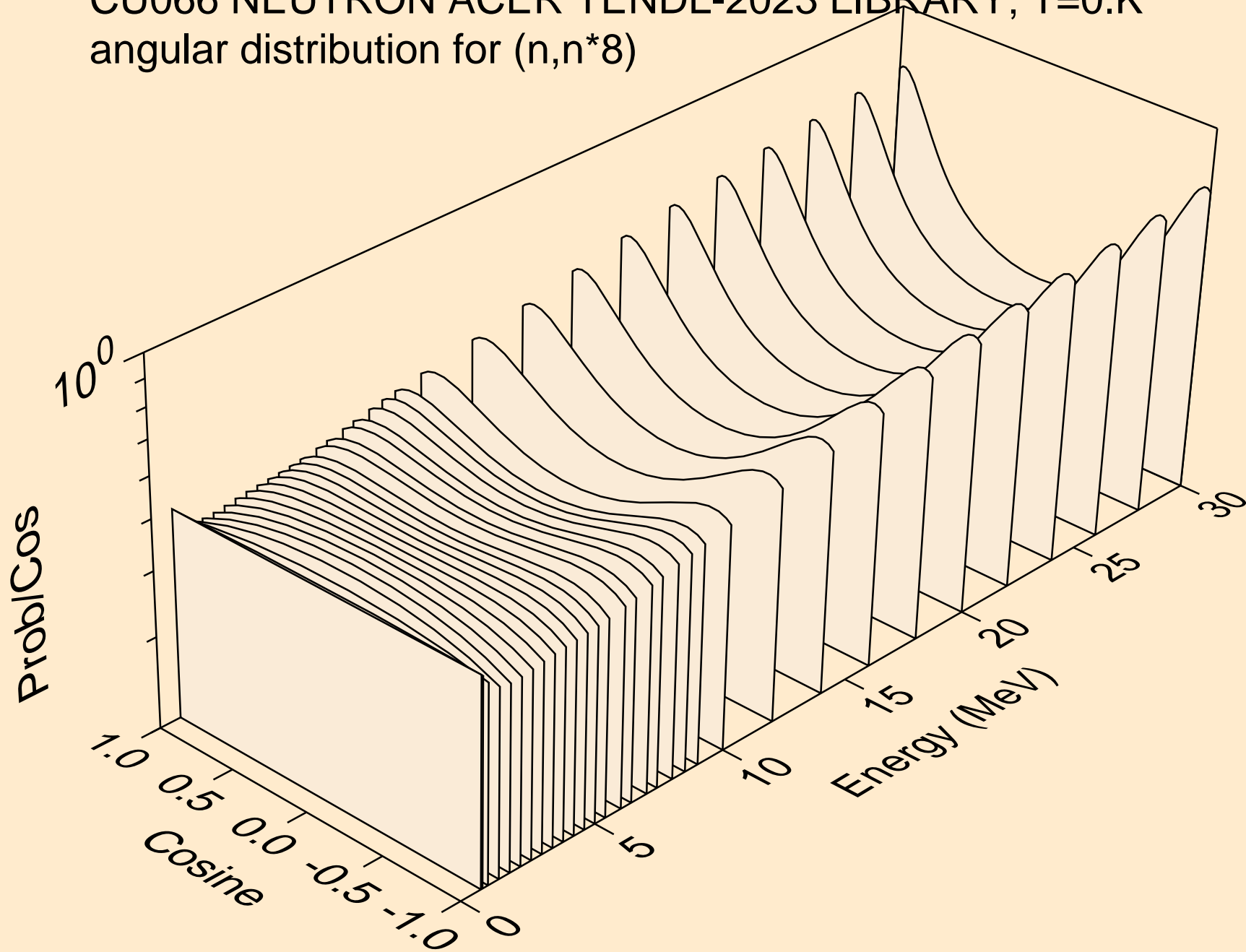

CU066 NEUTRON ACER TENDL-2023 LIBRARY; T=0.K  
angular distribution for (n,n\*9)

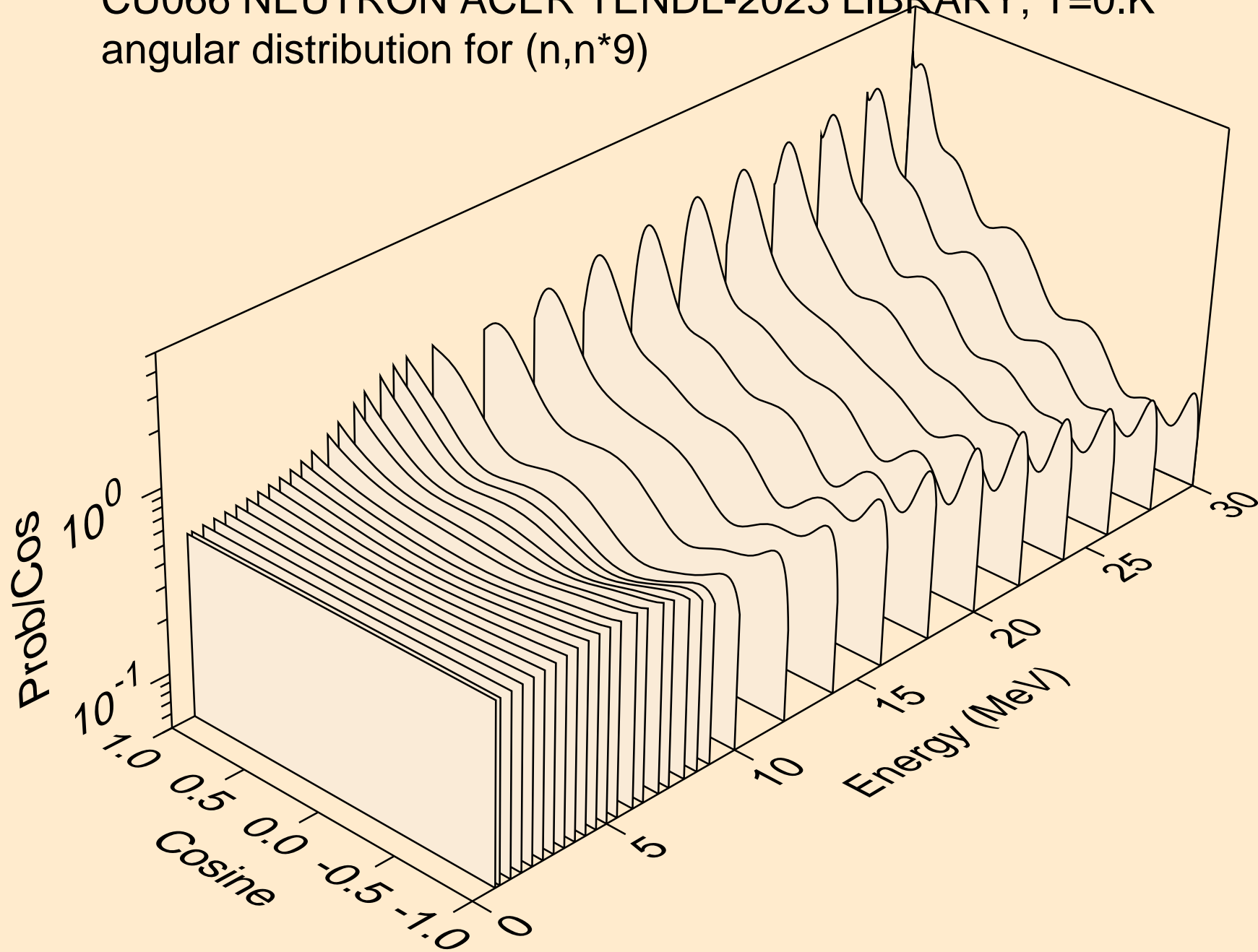

CU066 NEUTRON ACER TENDL-2023 LIBRARY; T=0.K  
angular distribution for (n,n\*10)

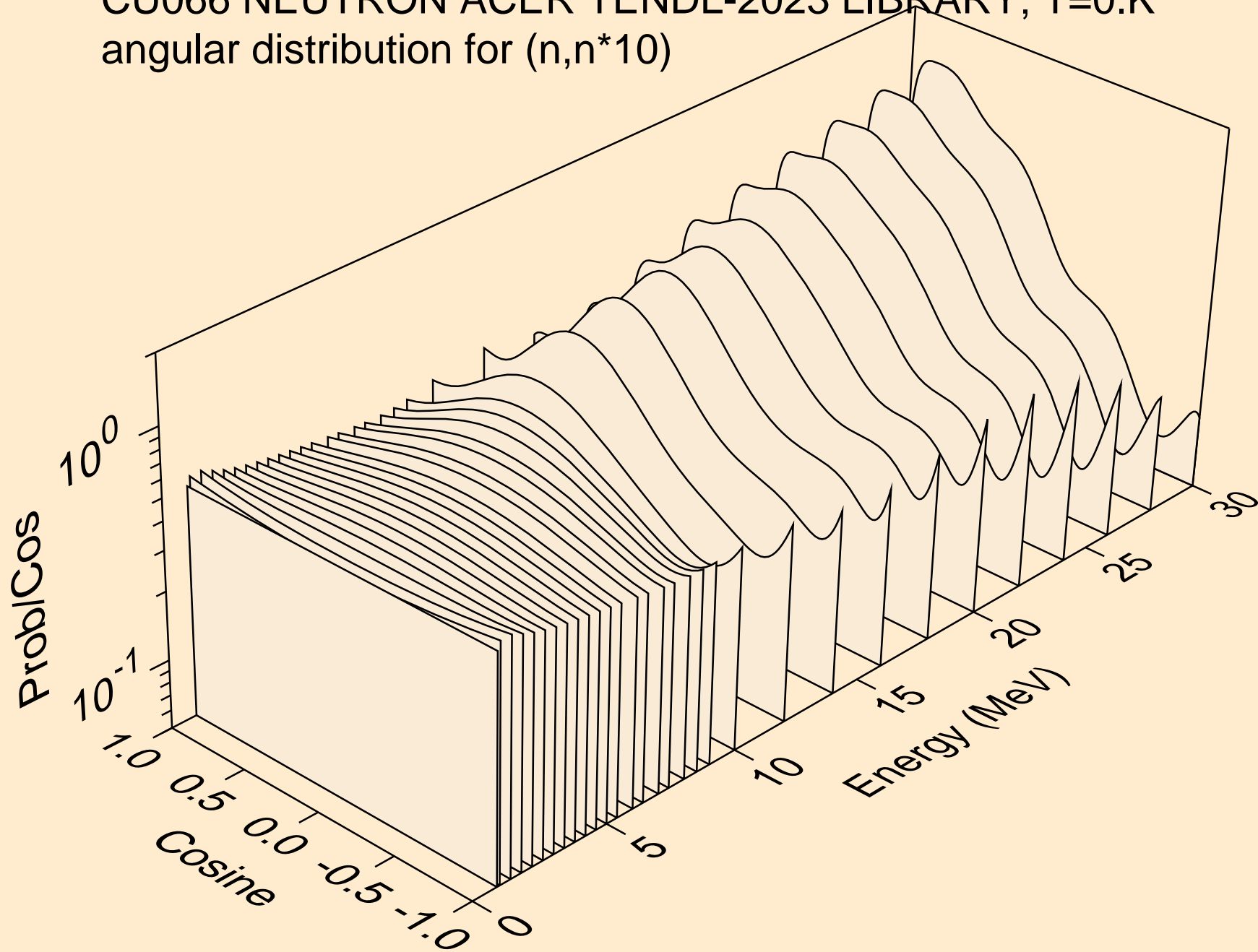

CU066 NEUTRON ACER TENDL-2023 LIBRARY; T=0.K  
angular distribution for (n,n\*11)

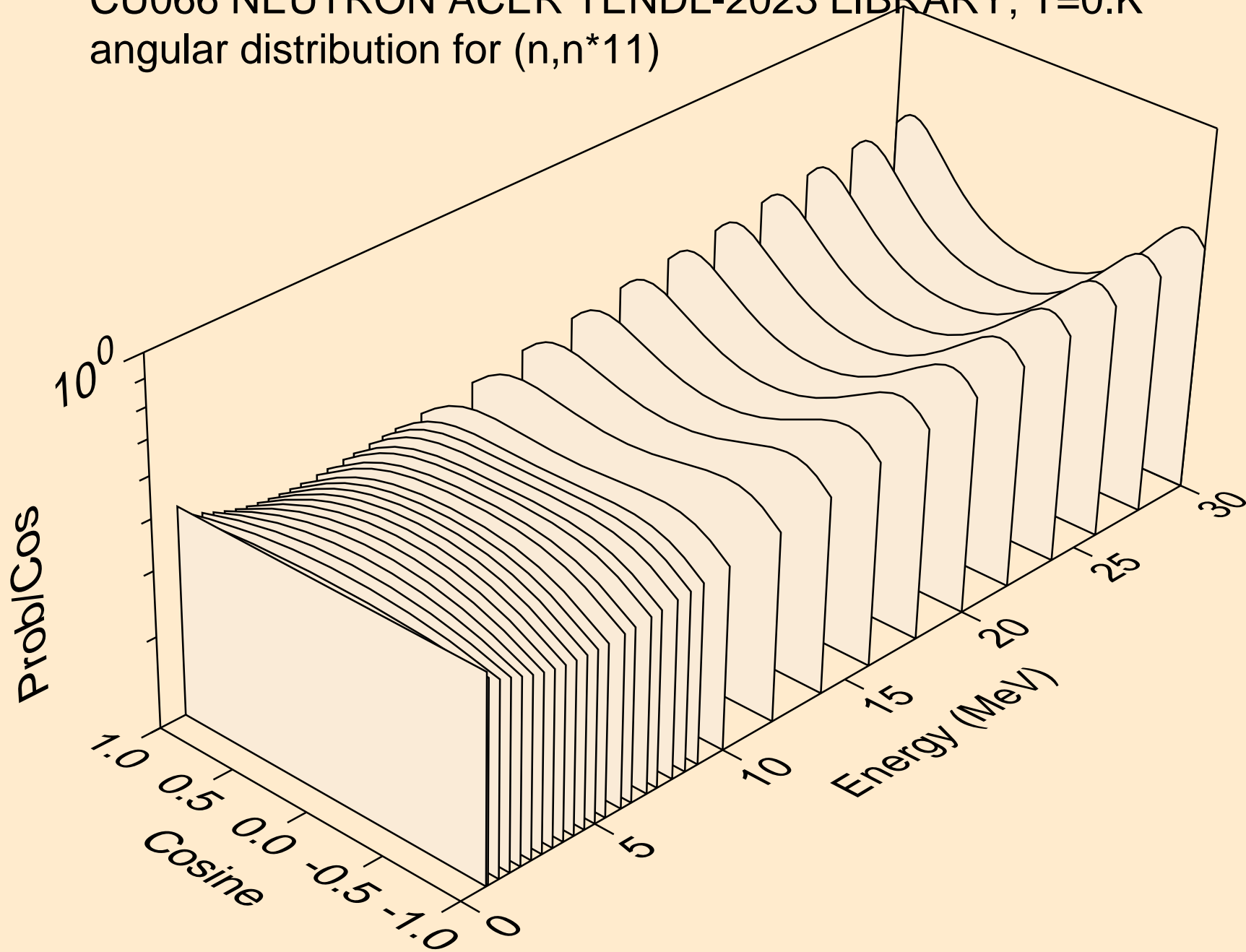



CU066 NEUTRON ACER TENDL-2023 LIBRARY; T=0.K  
angular distribution for (n,n\*12)

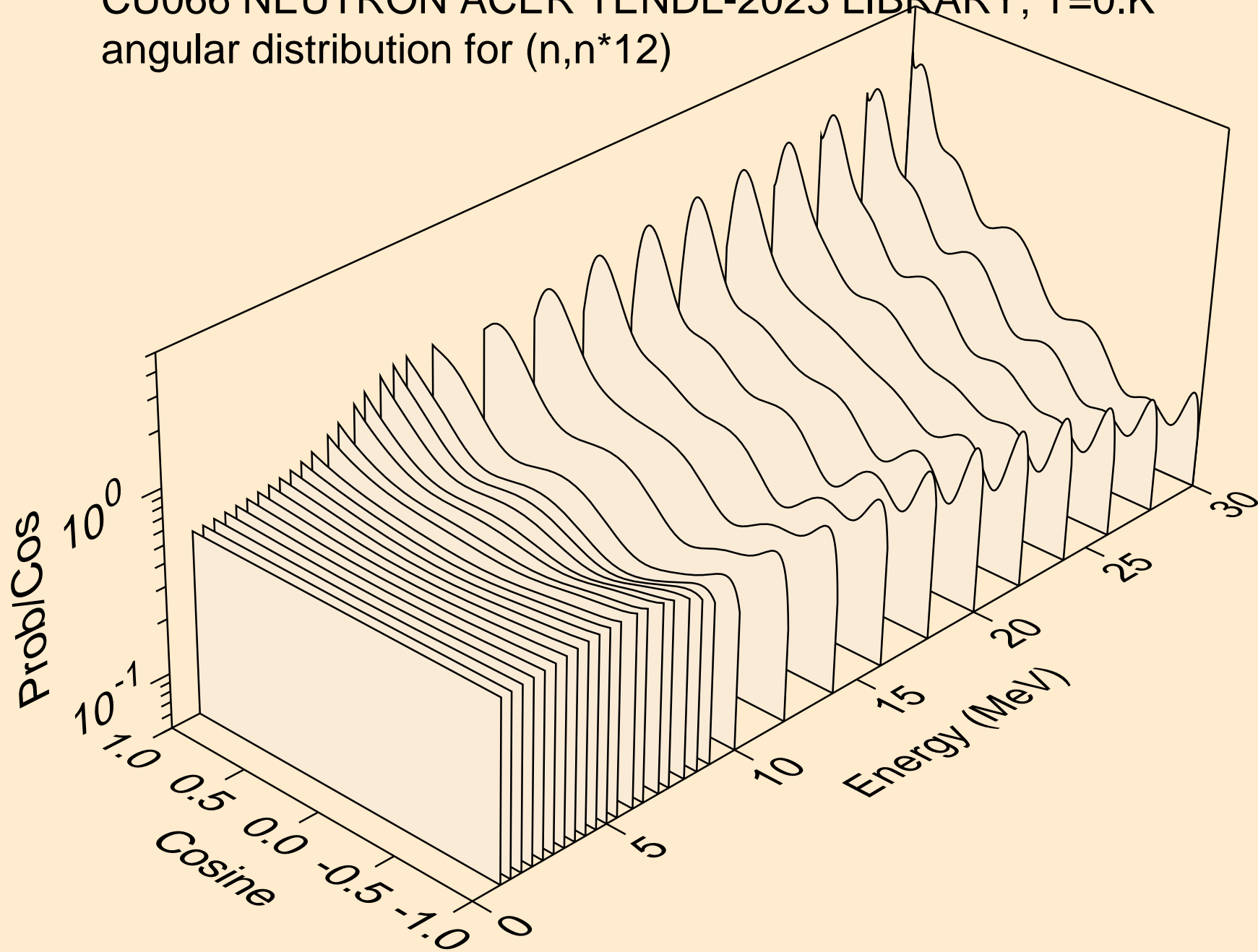

CU066 NEUTRON ACER TENDL-2023 LIBRARY; T=0.K  
angular distribution for (n,n\*13)

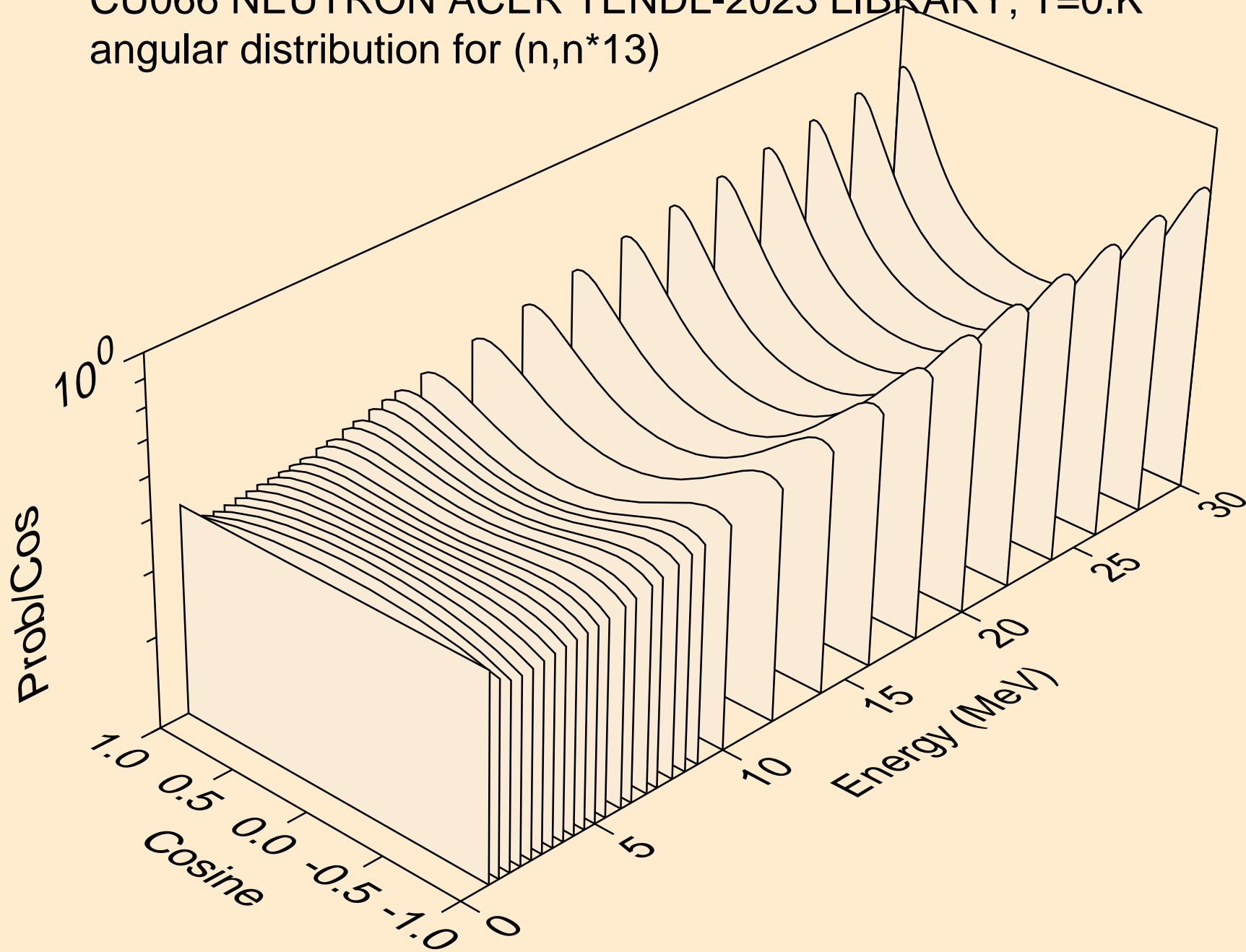

CU066 NEUTRON ACER TENDL-2023 LIBRARY; T=0.K  
angular distribution for (n,n\*14)

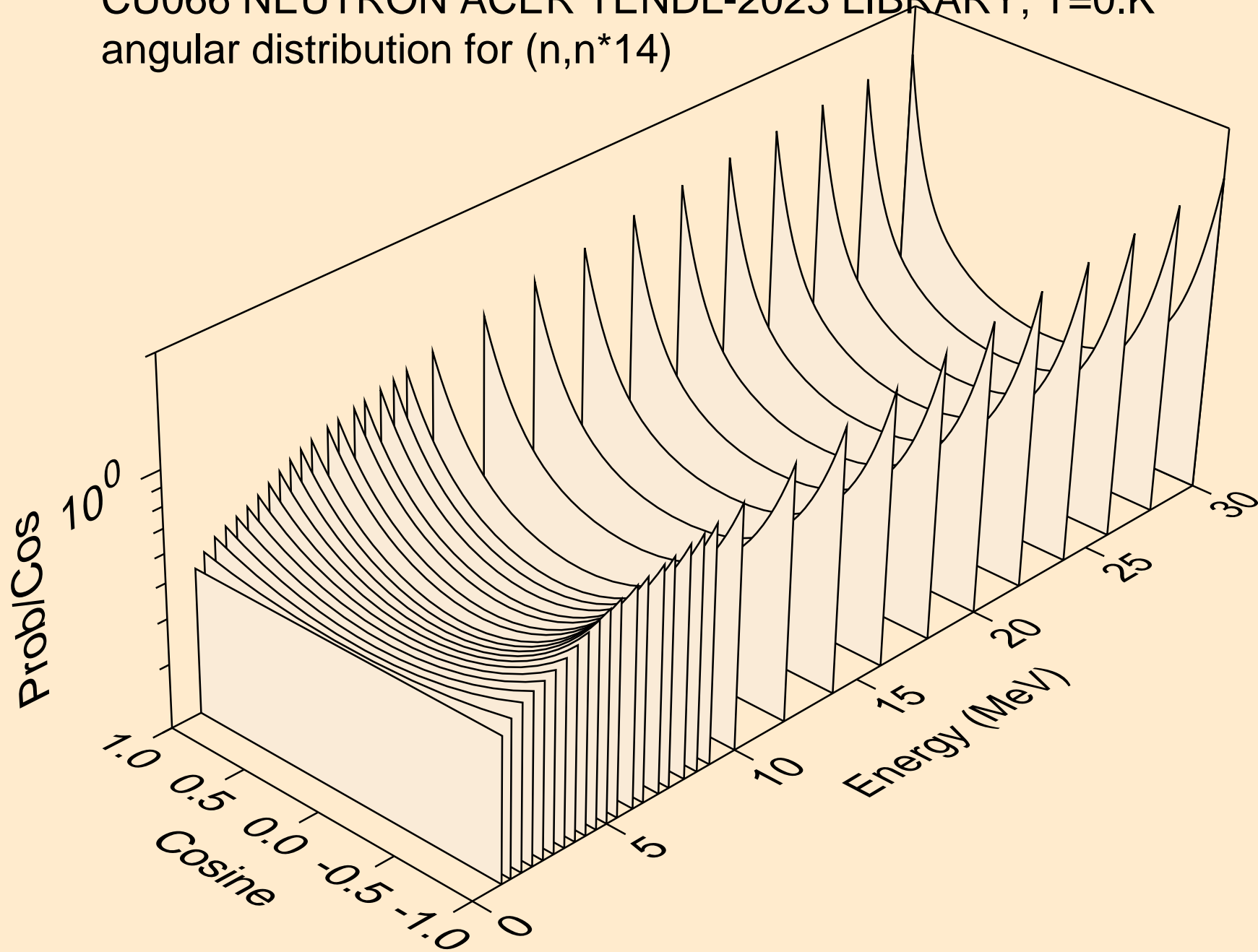

CU066 NEUTRON ACER TENDL-2023 LIBRARY; T=0.K  
angular distribution for (n,n\*15)

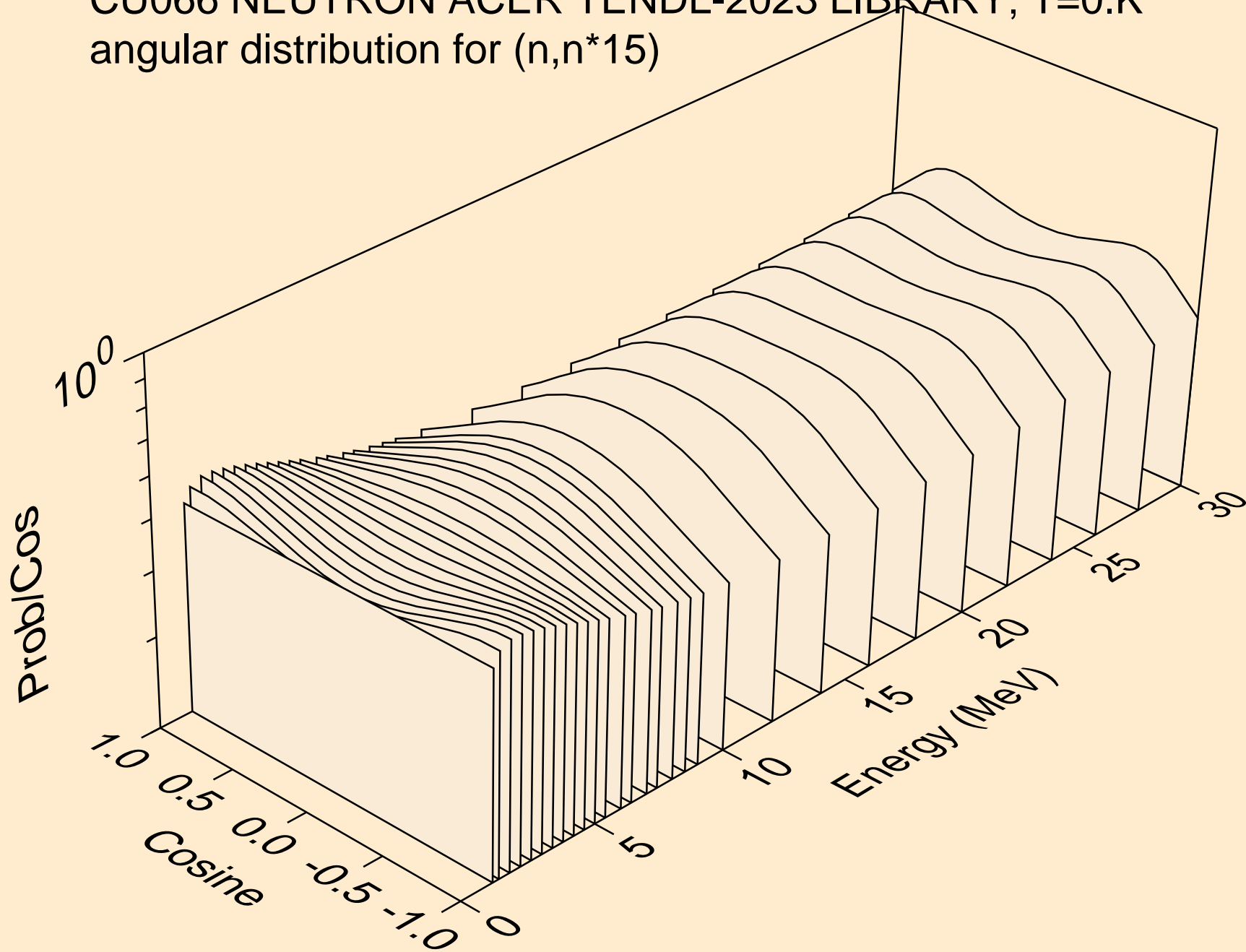

CU066 NEUTRON ACER TENDL-2023 LIBRARY; T=0.K  
angular distribution for (n,n\*16)

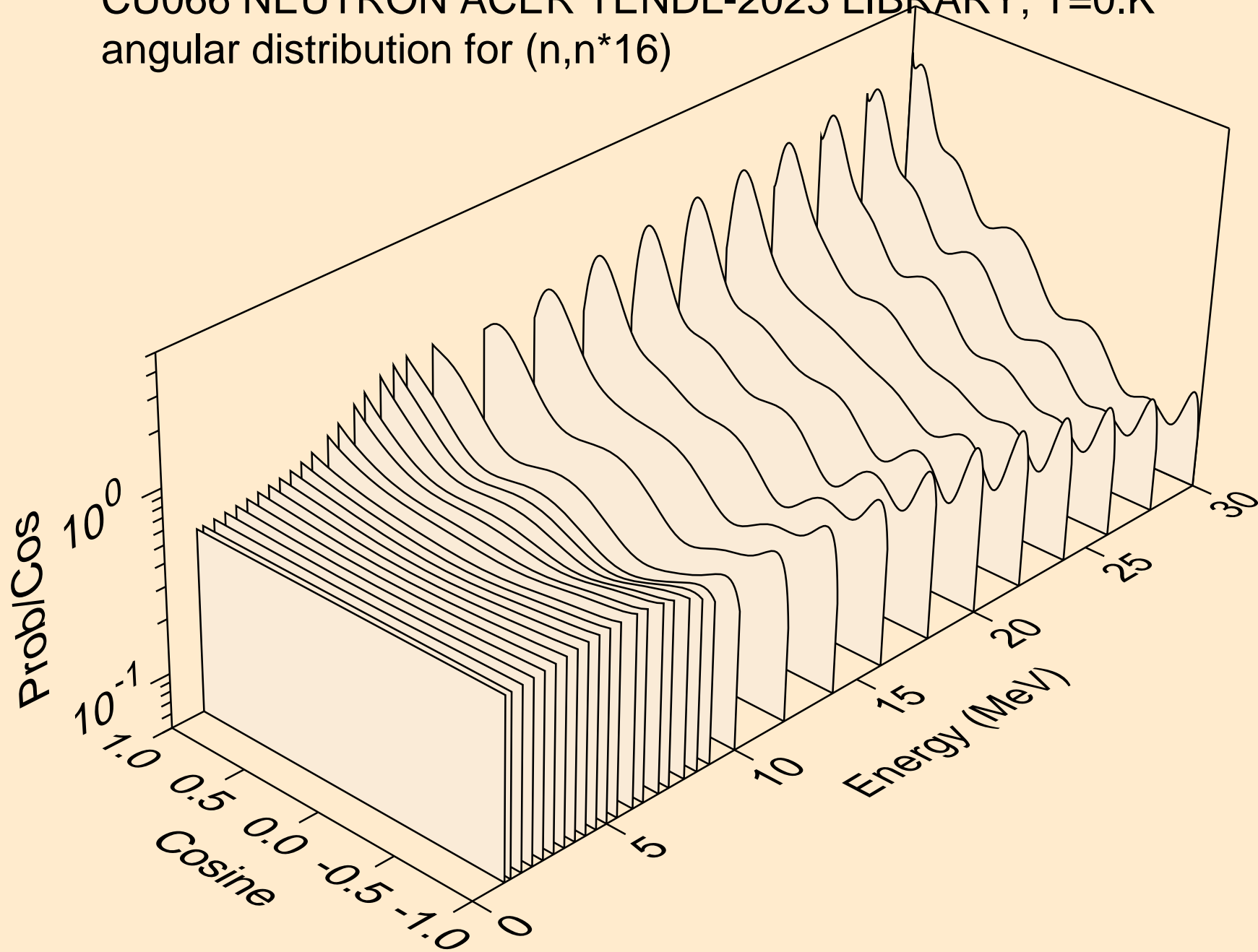

CU066 NEUTRON ACER TENDL-2023 LIBRARY; T=0.K  
Neutron emission for (n,x)

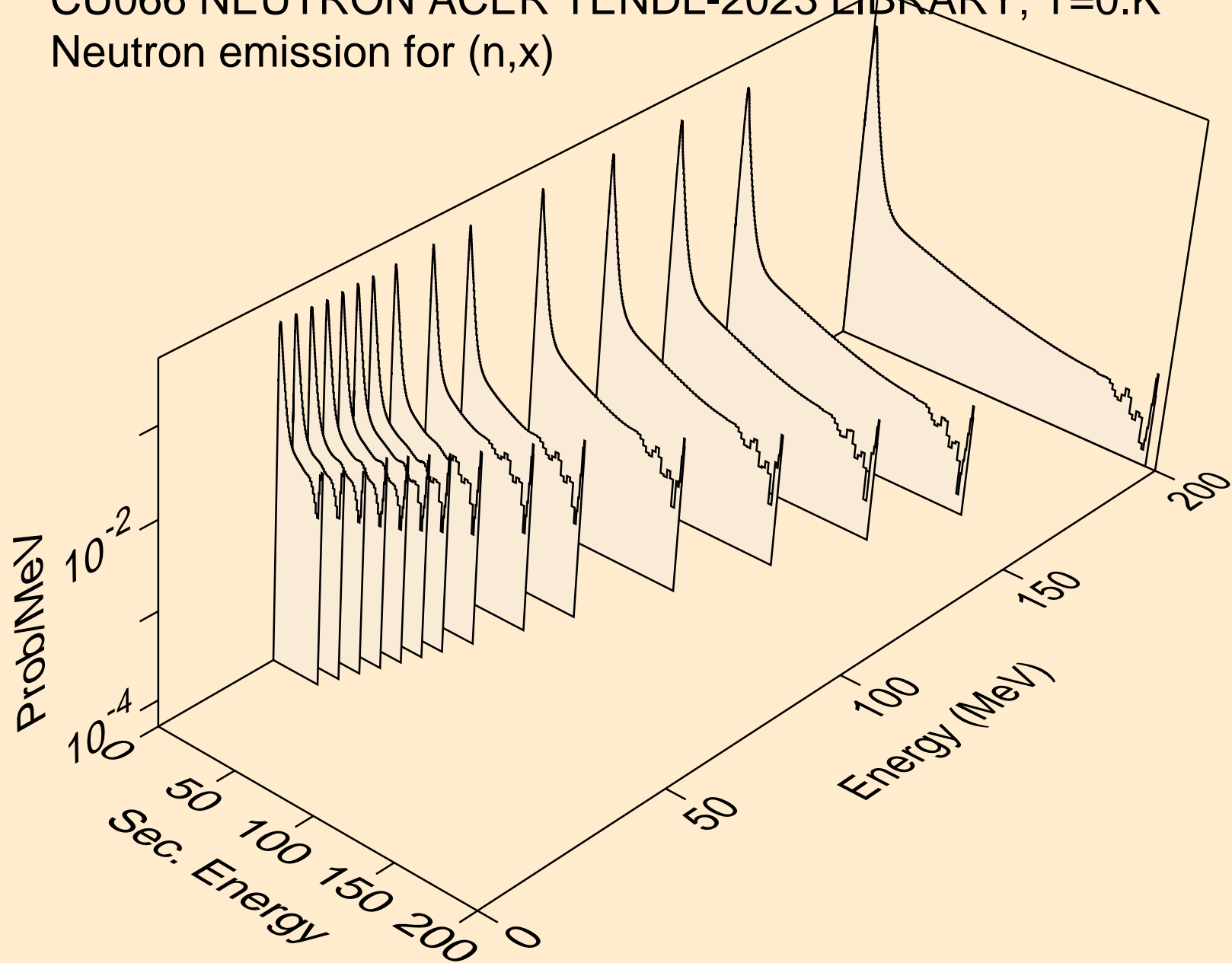

CU066 NEUTRON ACER TENDL-2023 LIBRARY; T=0.K  
Neutron emission for (n,2nd)

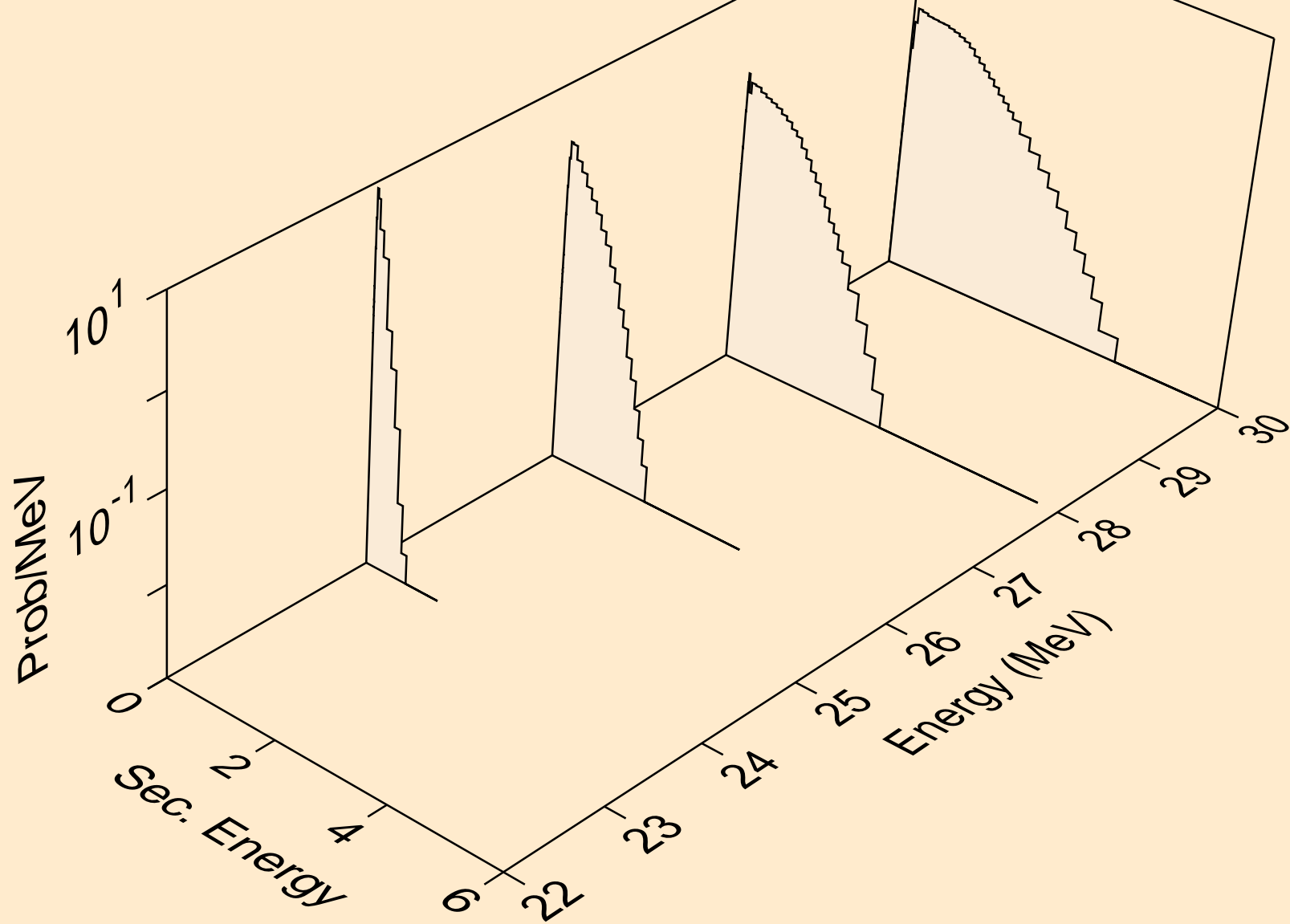

CU066 NEUTRON ACER TENDL-2023 LIBRARY; T=0.K  
Neutron emission for (n,2n)

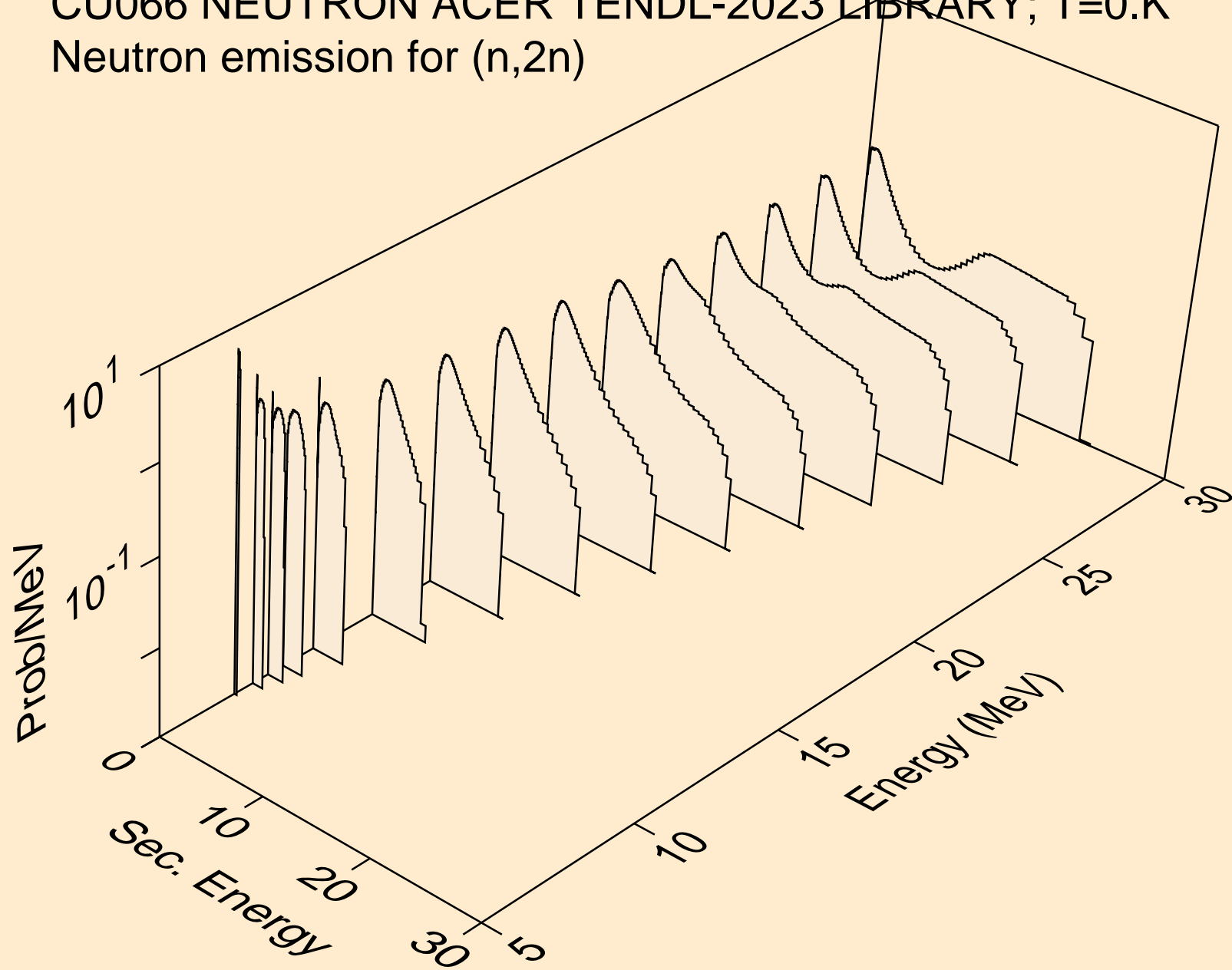



CU066 NEUTRON ACER TENDL-2023 LIBRARY; T=0.K  
Neutron emission for (n,3n)

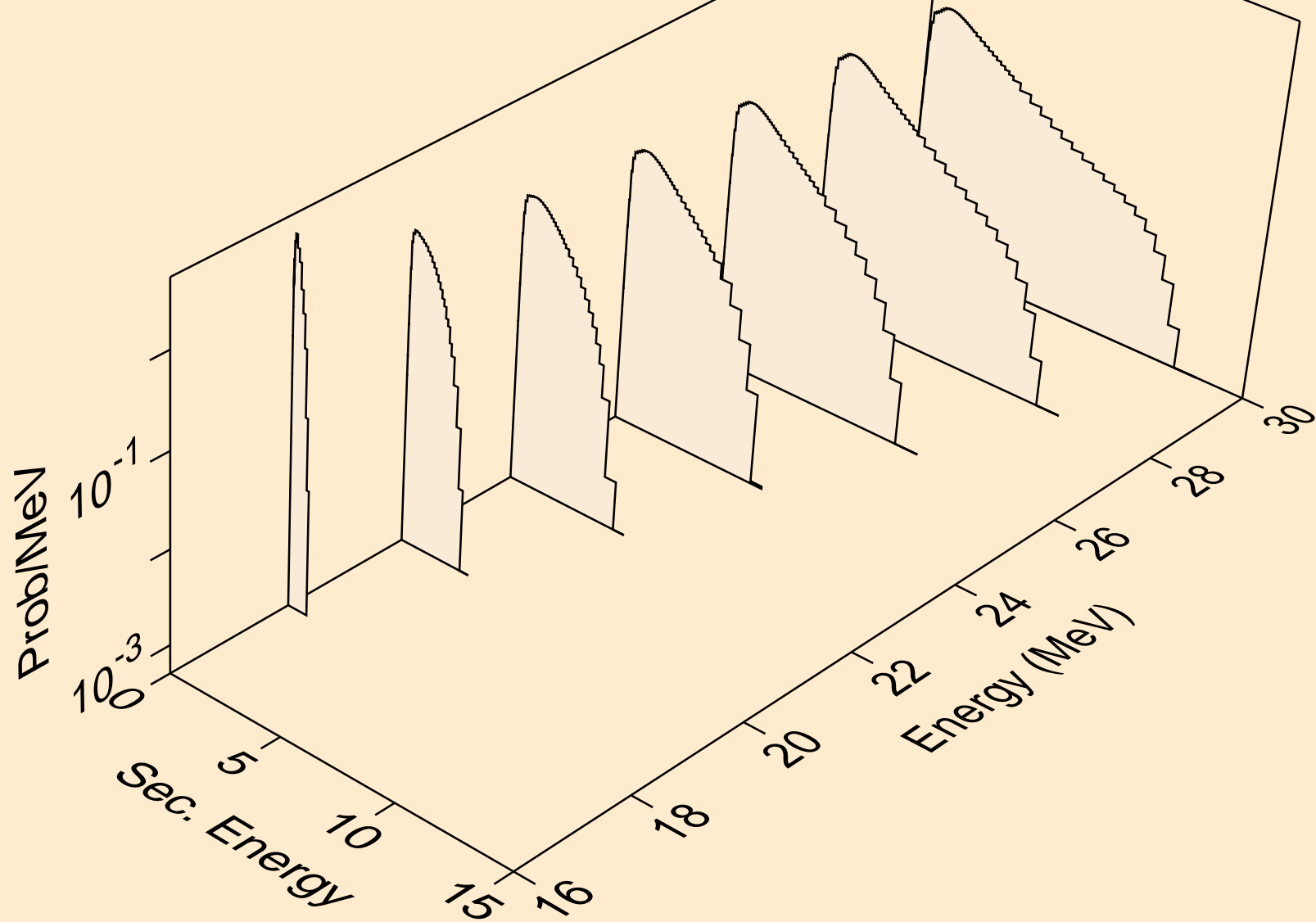

CU066 NEUTRON ACER TENDL-2023 LIBRARY; T=0.K  
Neutron emission for (n,n\*)a

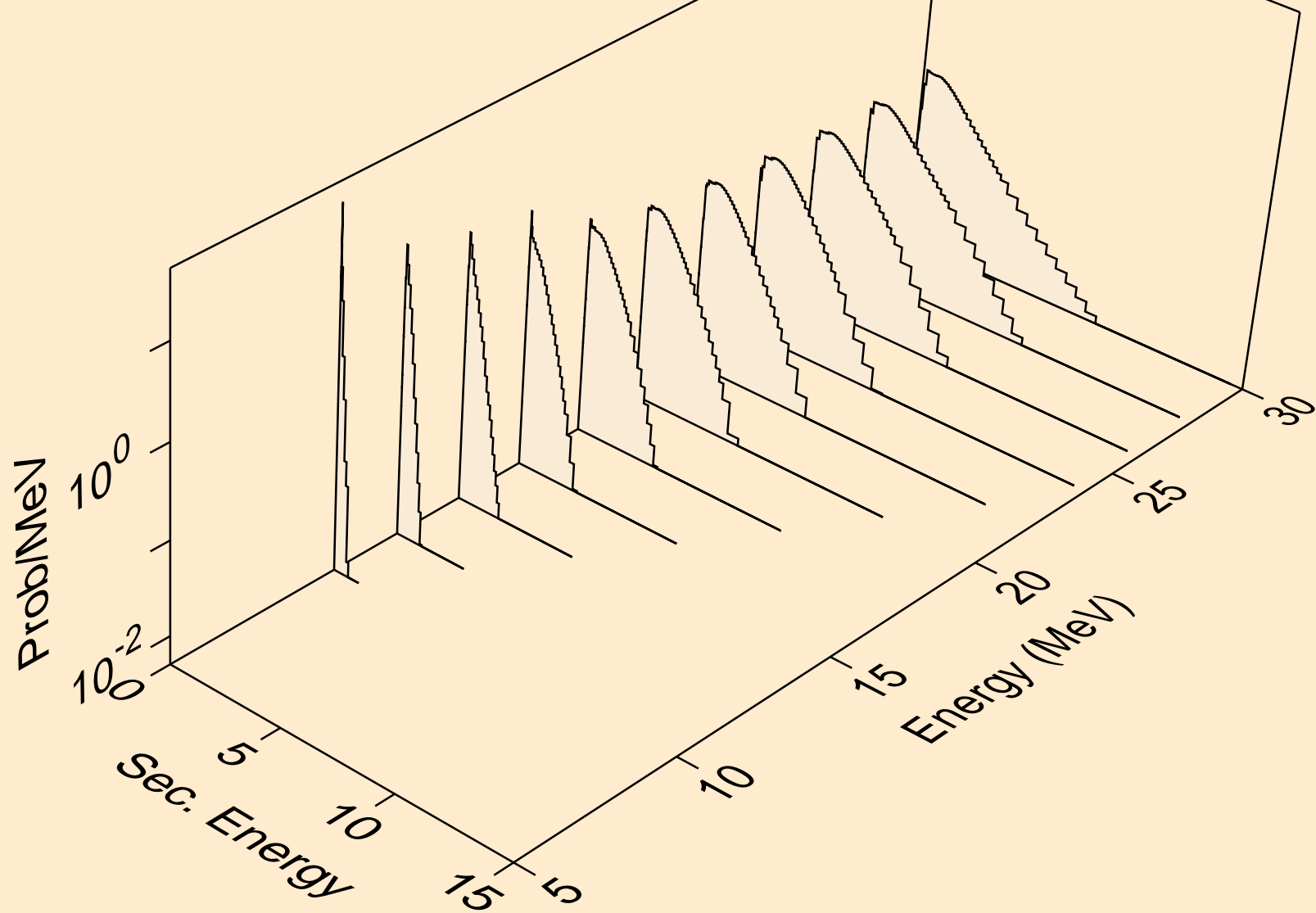

CU066 NEUTRON ACER TENDL-2023 LIBRARY; T=0.K  
Neutron emission for (n,2n)a

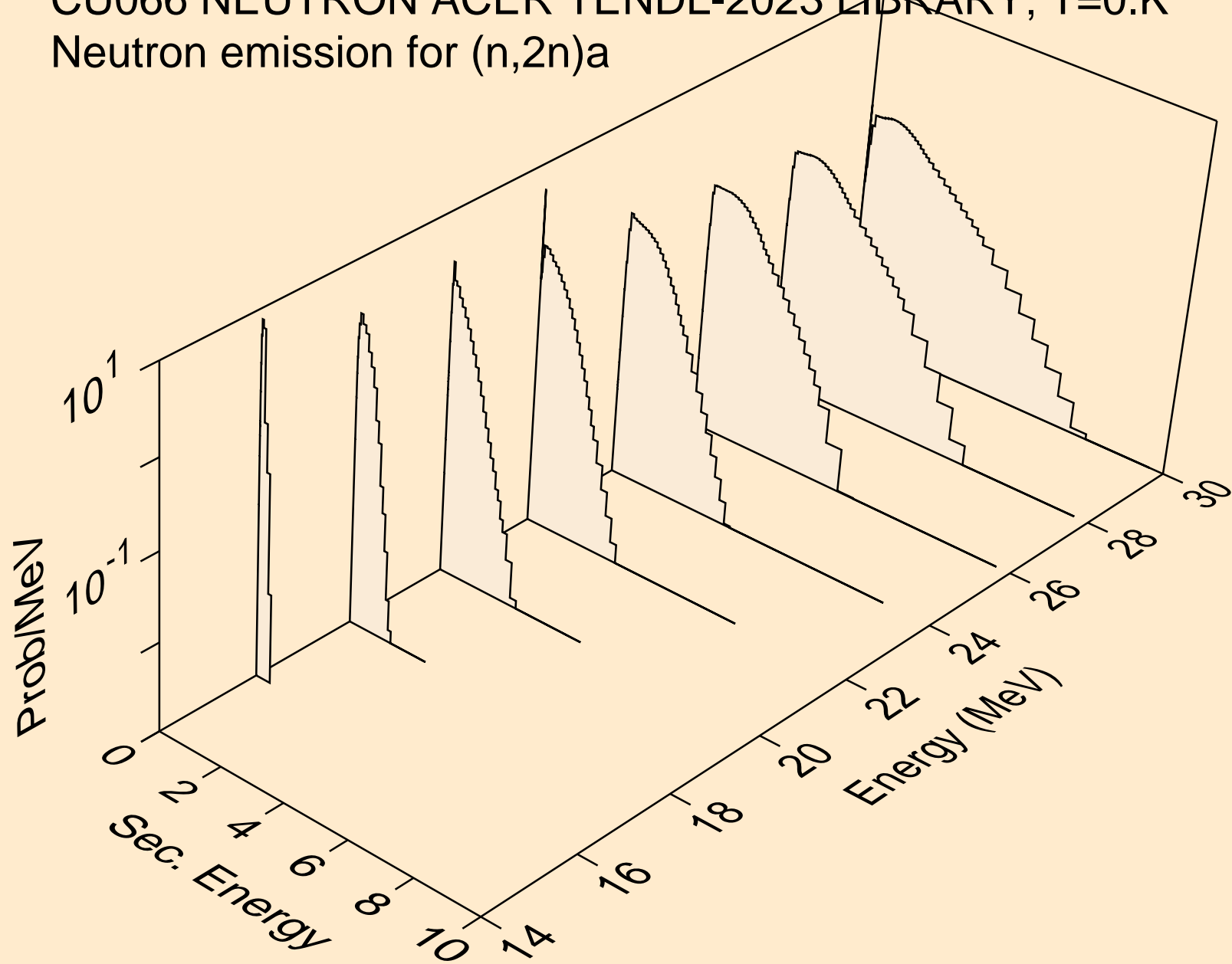

CU066 NEUTRON ACER TENDL-2023 LIBRARY; T=0.K  
Neutron emission for (n,3n)a

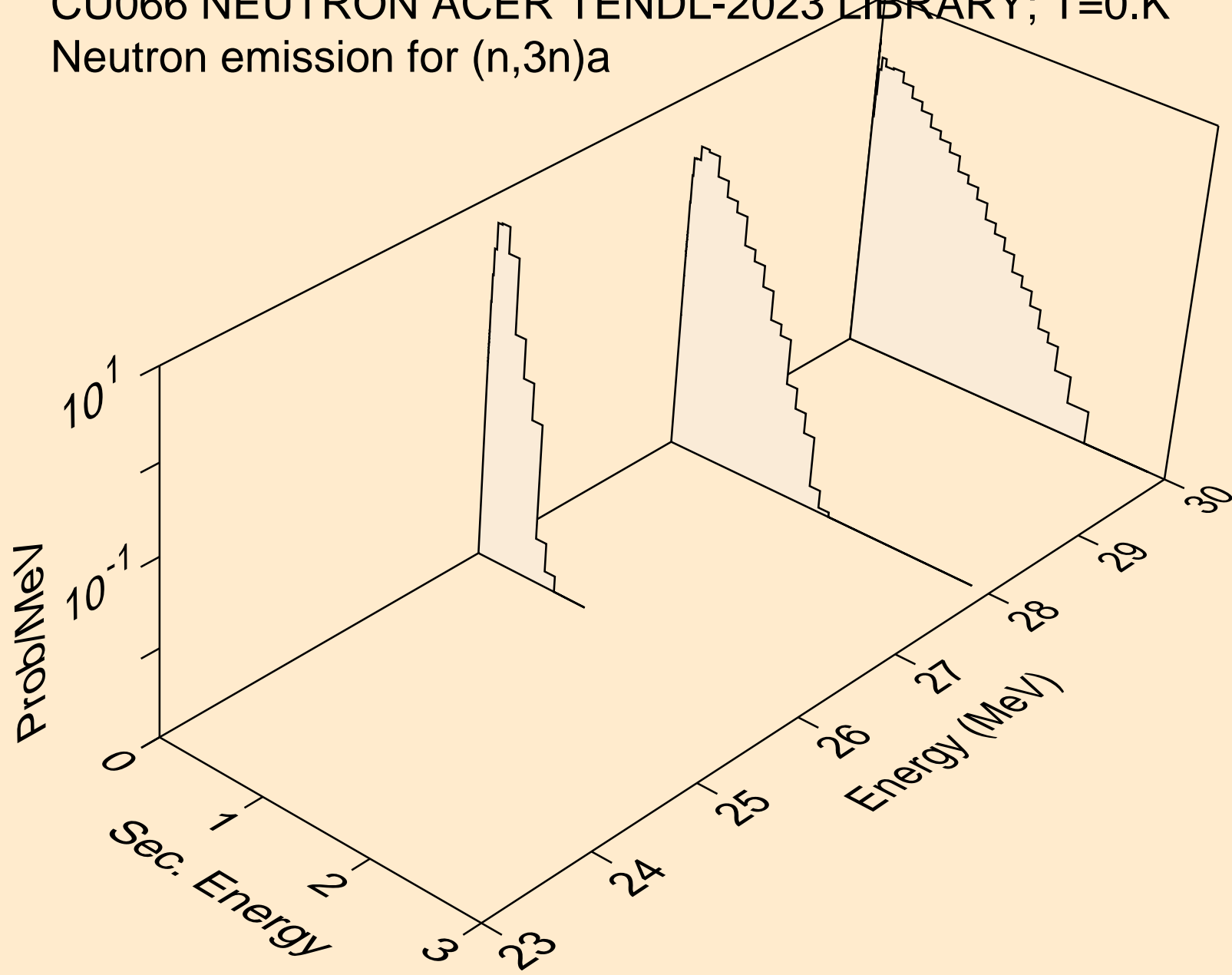

CU066 NEUTRON ACER TENDL-2023 LIBRARY; T=0.K  
Neutron emission for (n,n\*)p

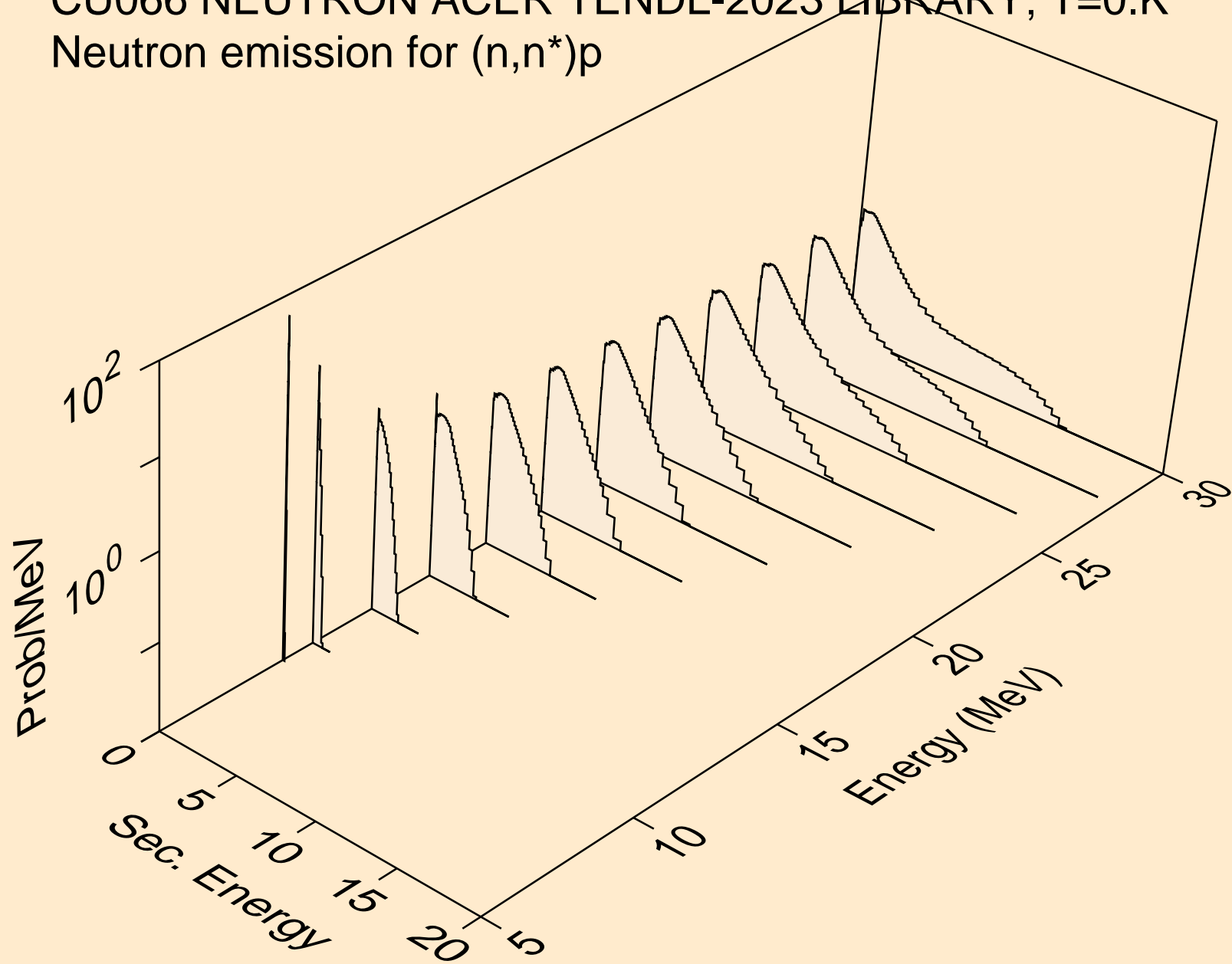

CU066 NEUTRON ACER TENDL-2023 LIBRARY; T=0.K  
Neutron emission for (n,n\*)2a

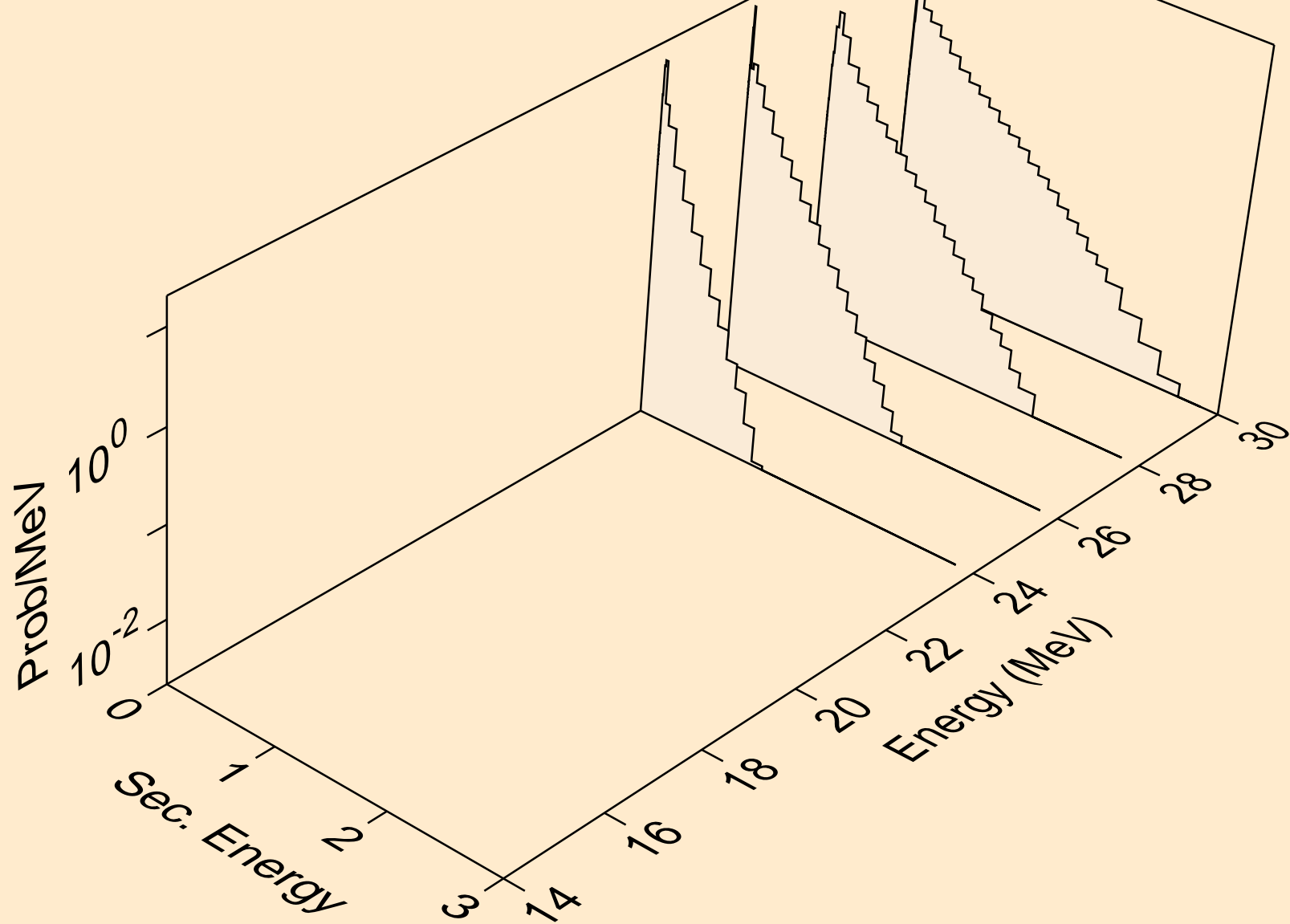

CU066 NEUTRON ACER TENDL-2023 LIBRARY; T=0.K  
Neutron emission for (n,n\*)d

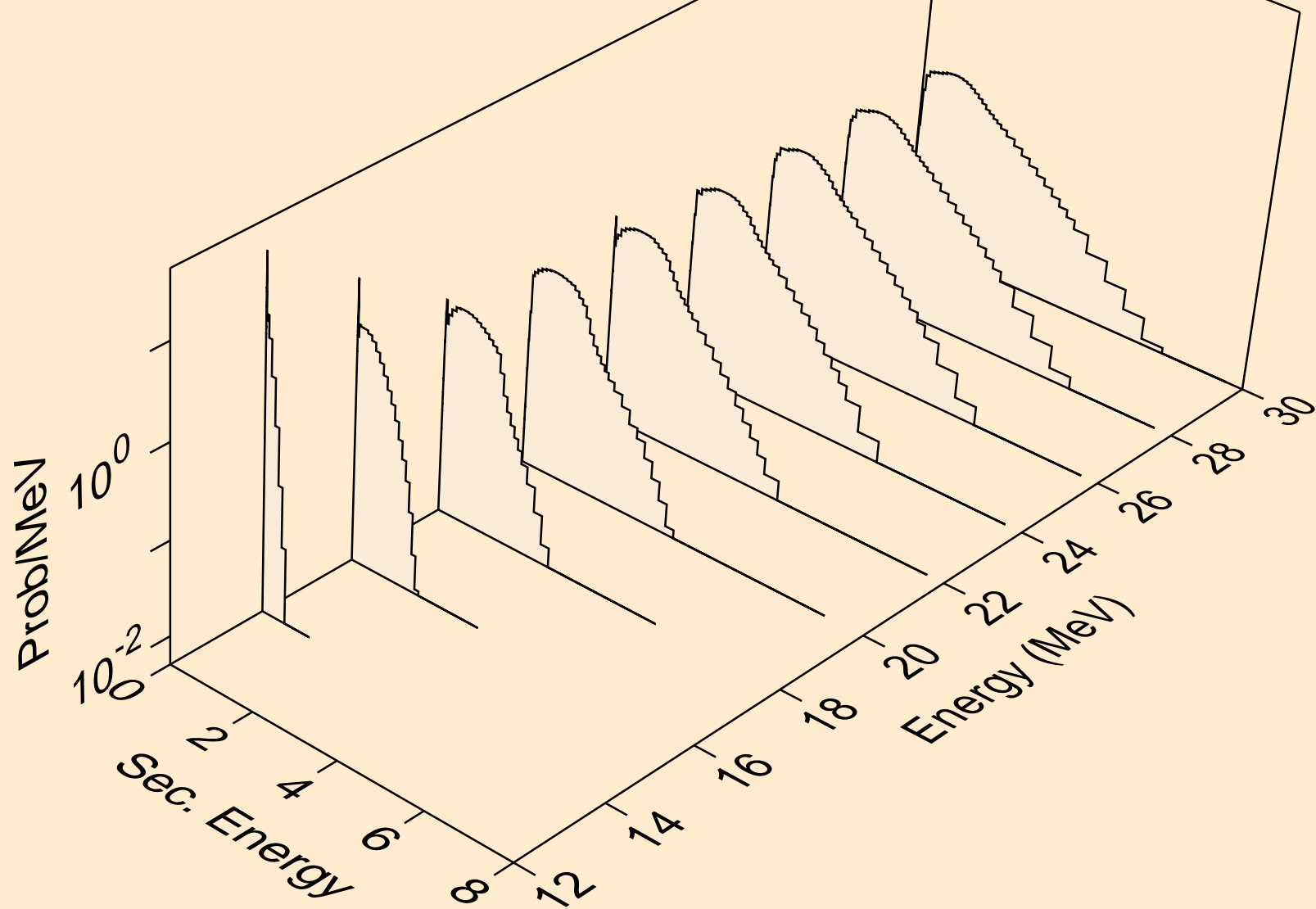

CU066 NEUTRON ACER TENDL-2023 LIBRARY; T=0.K  
Neutron emission for (n,n\*)t

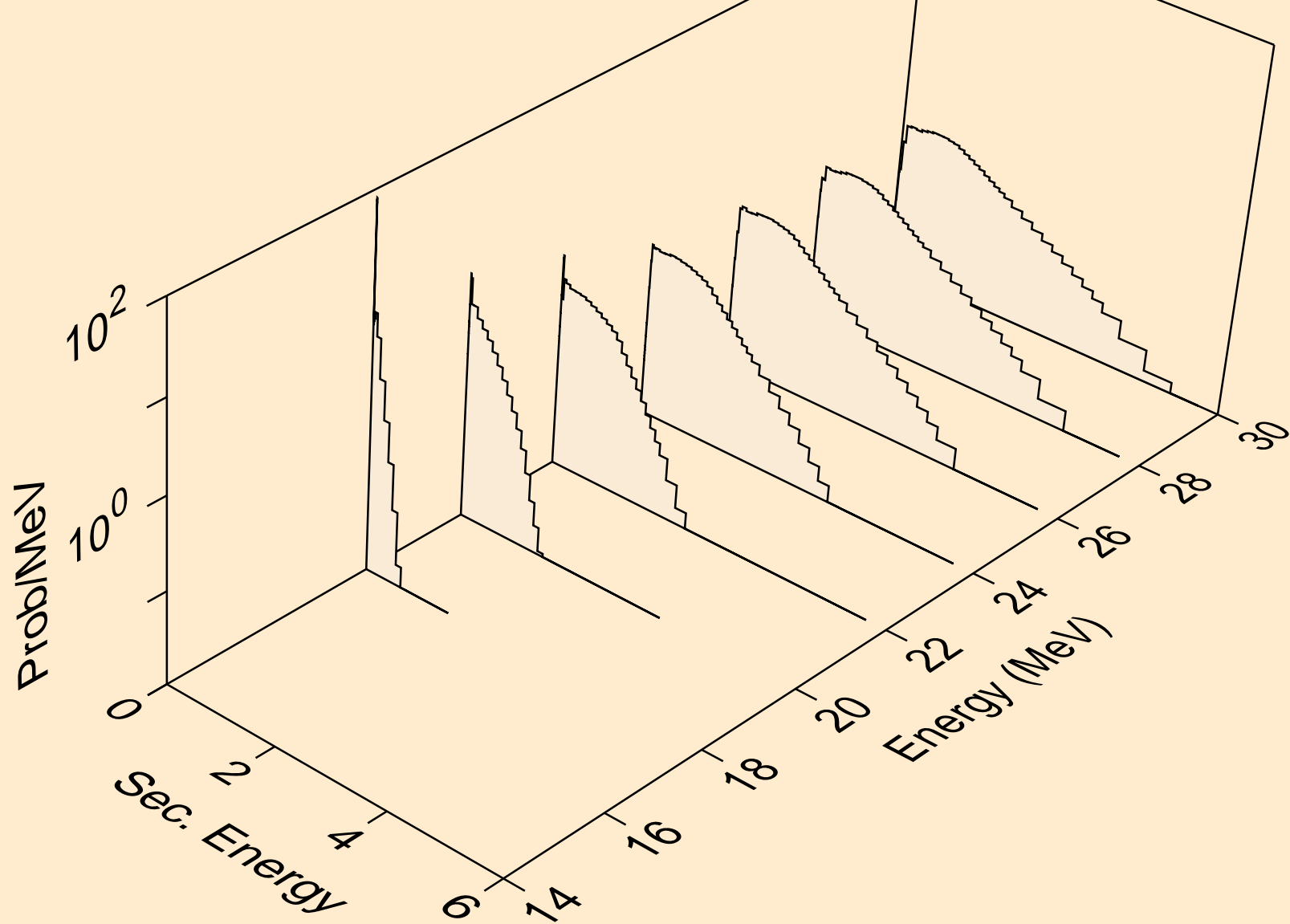



CU066 NEUTRON ACER TENDL-2023 LIBRARY; T=0.K  
Neutron emission for (n,n\*)he3

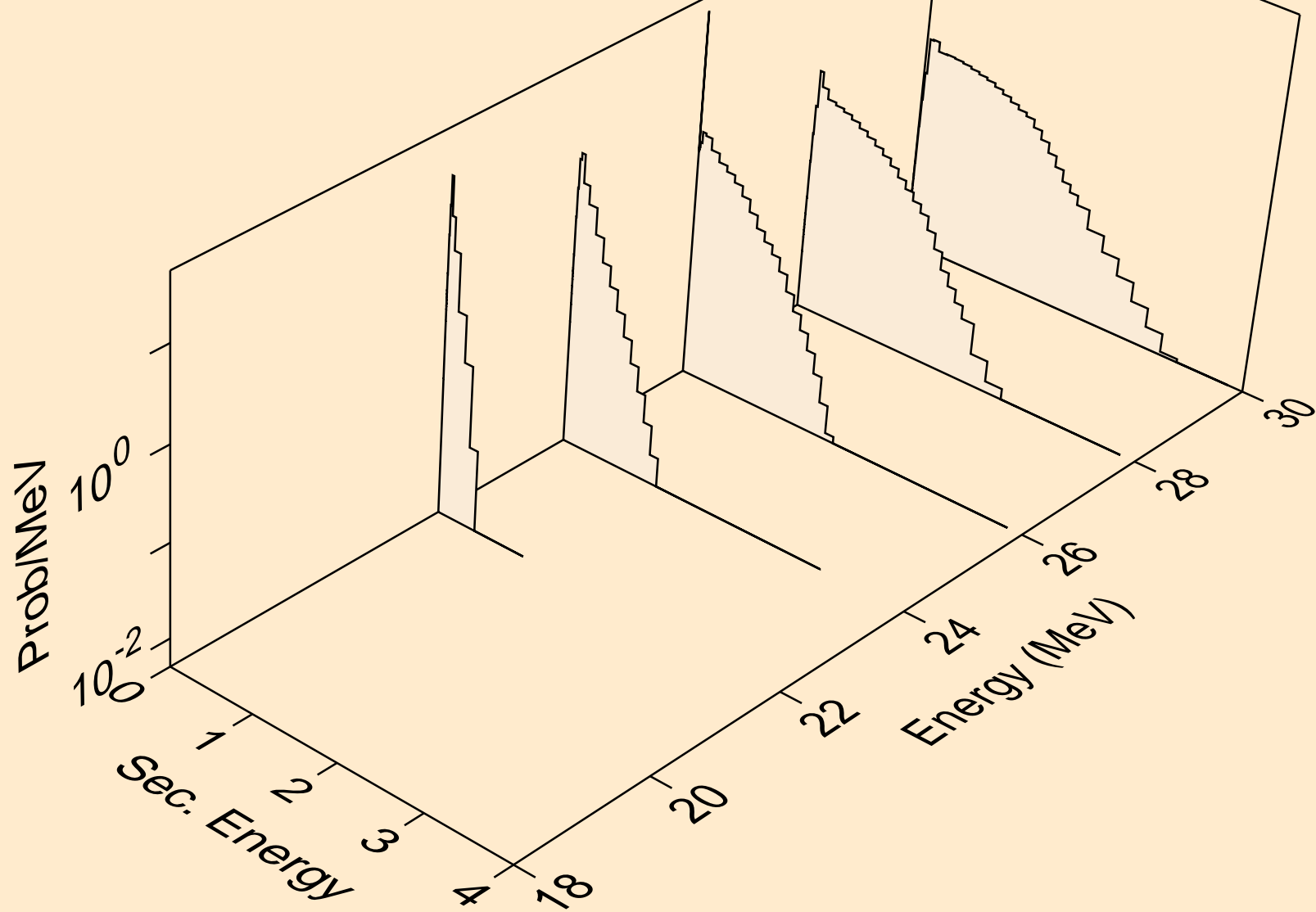

CU066 NEUTRON ACER TENDL-2023 LIBRARY; T=0.K  
Neutron emission for (n,4n)

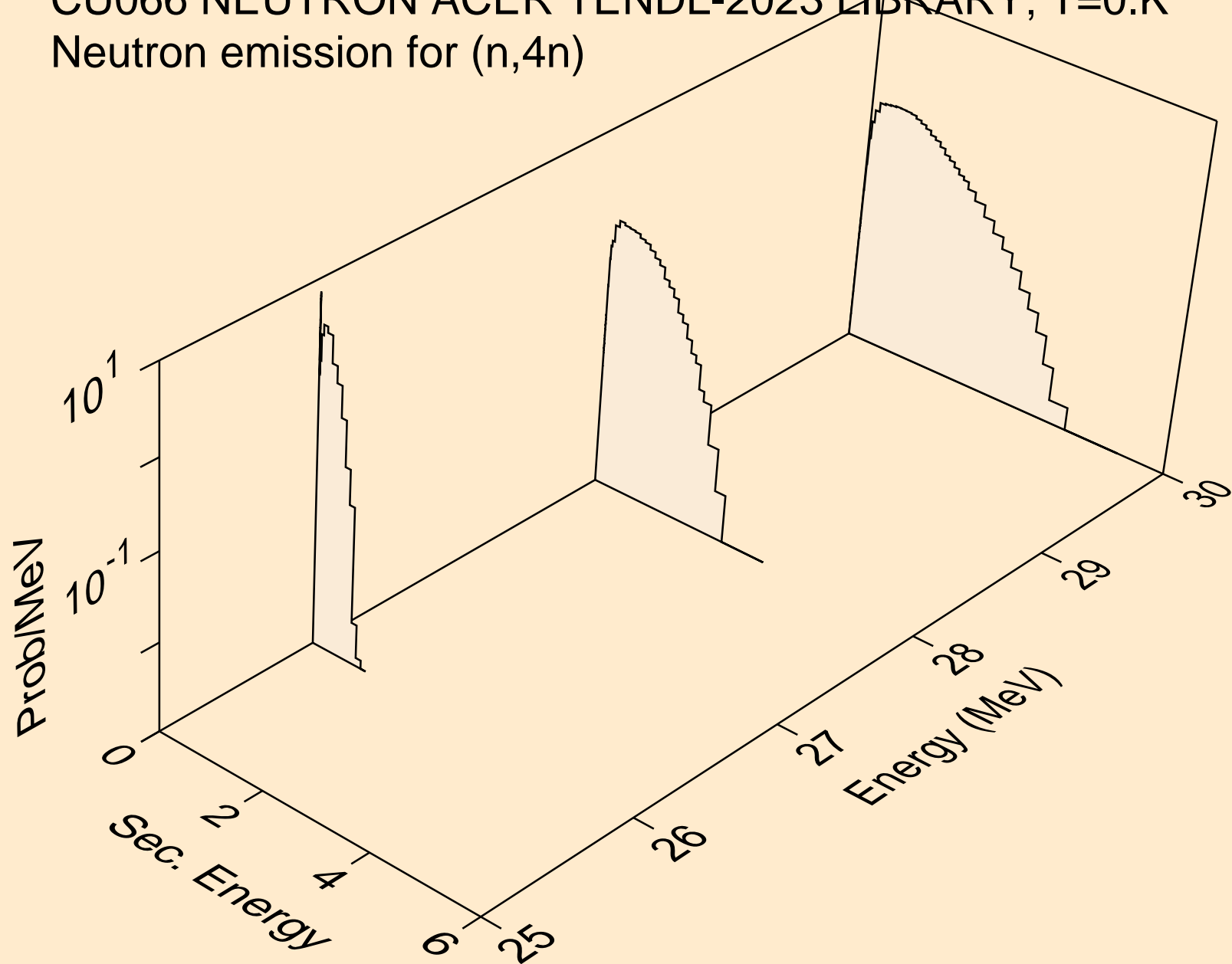

CU066 NEUTRON ACER TENDL-2023 LIBRARY; T=0.K  
Neutron emission for (n,2np)

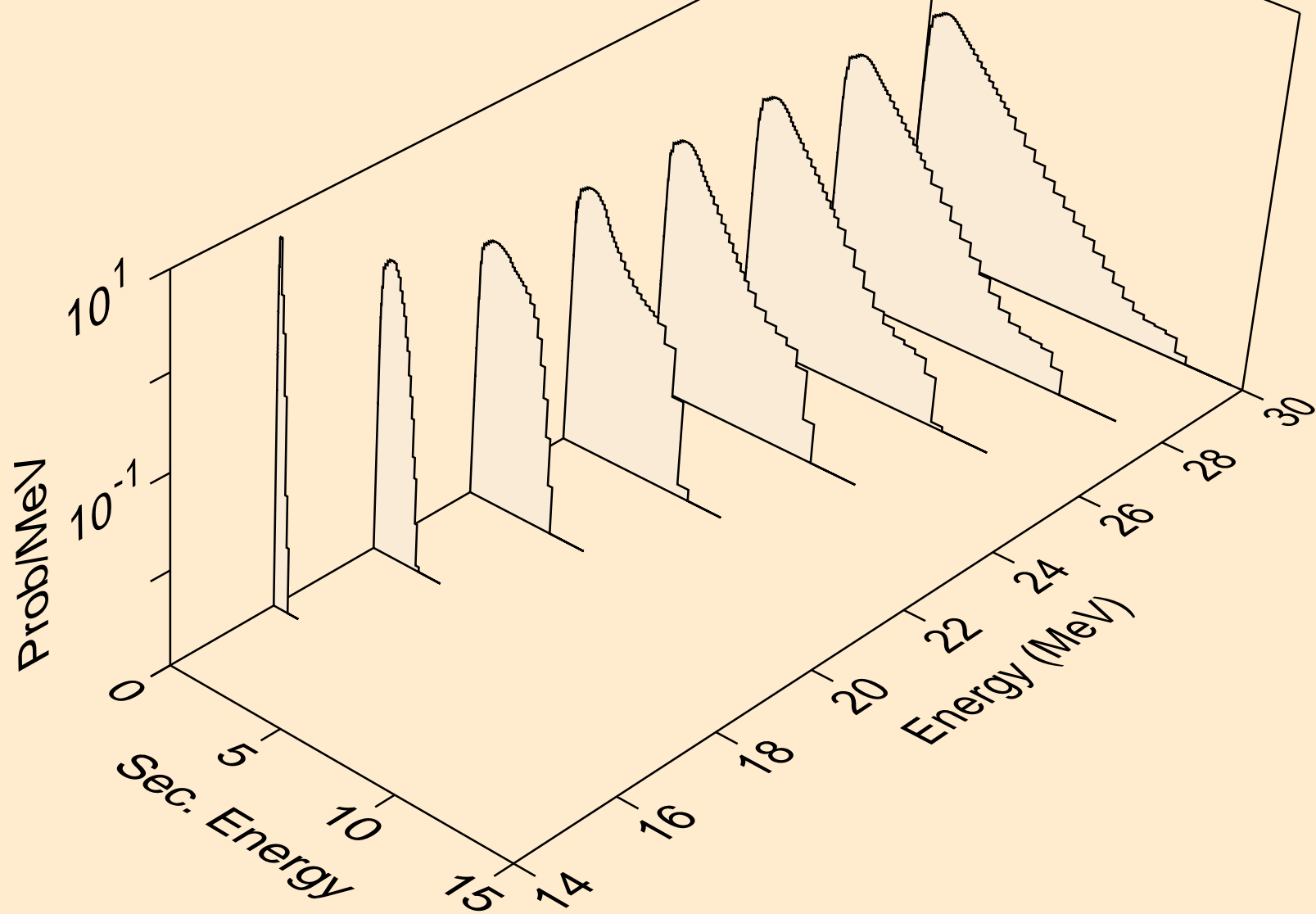

CU066 NEUTRON ACER TENDL-2023 LIBRARY; T=0.K  
Neutron emission for (n,3np)

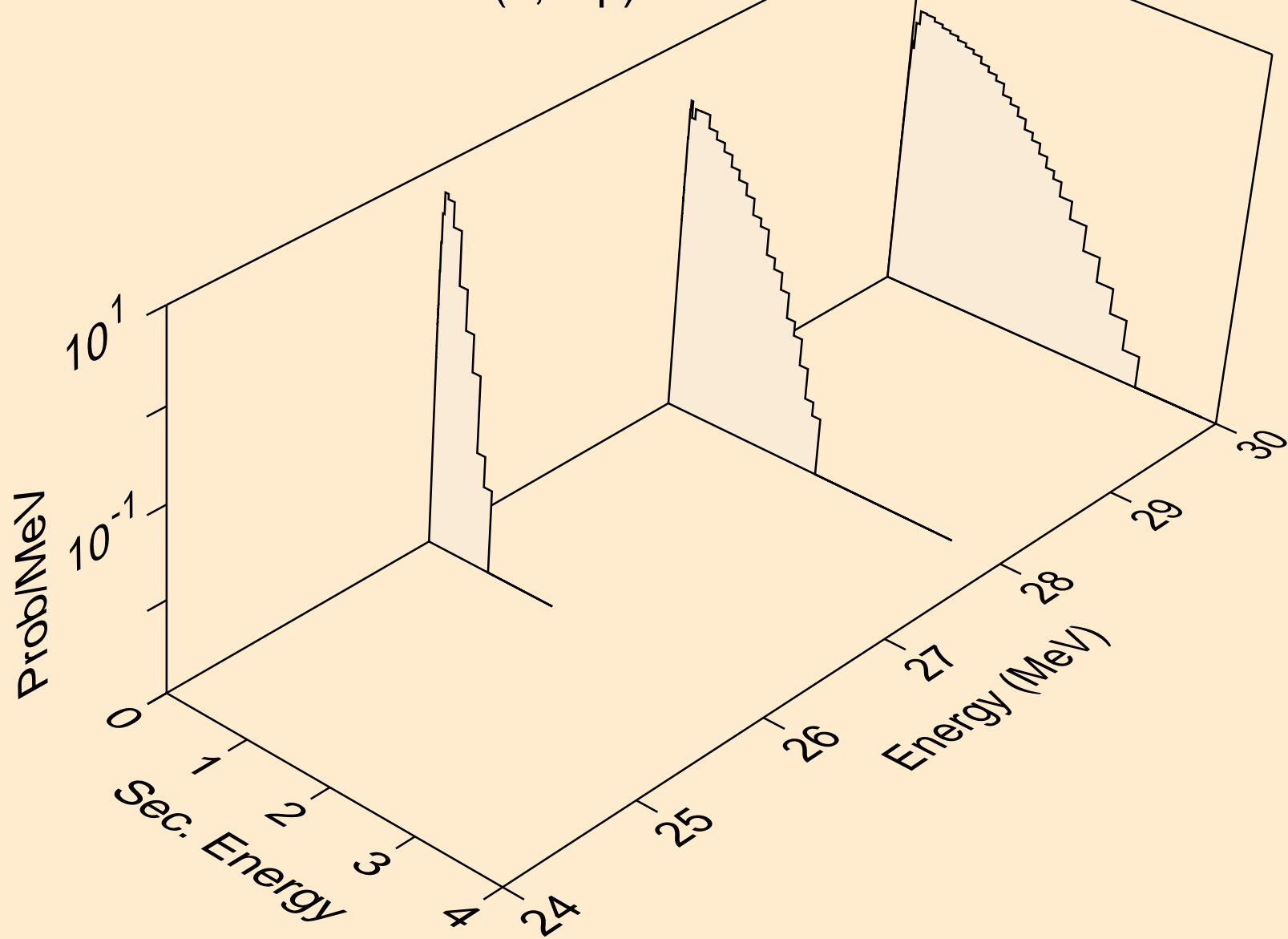

CU066 NEUTRON ACER TENDL-2023 LIBRARY; T=0.K  
Neutron emission for (n,n2p)

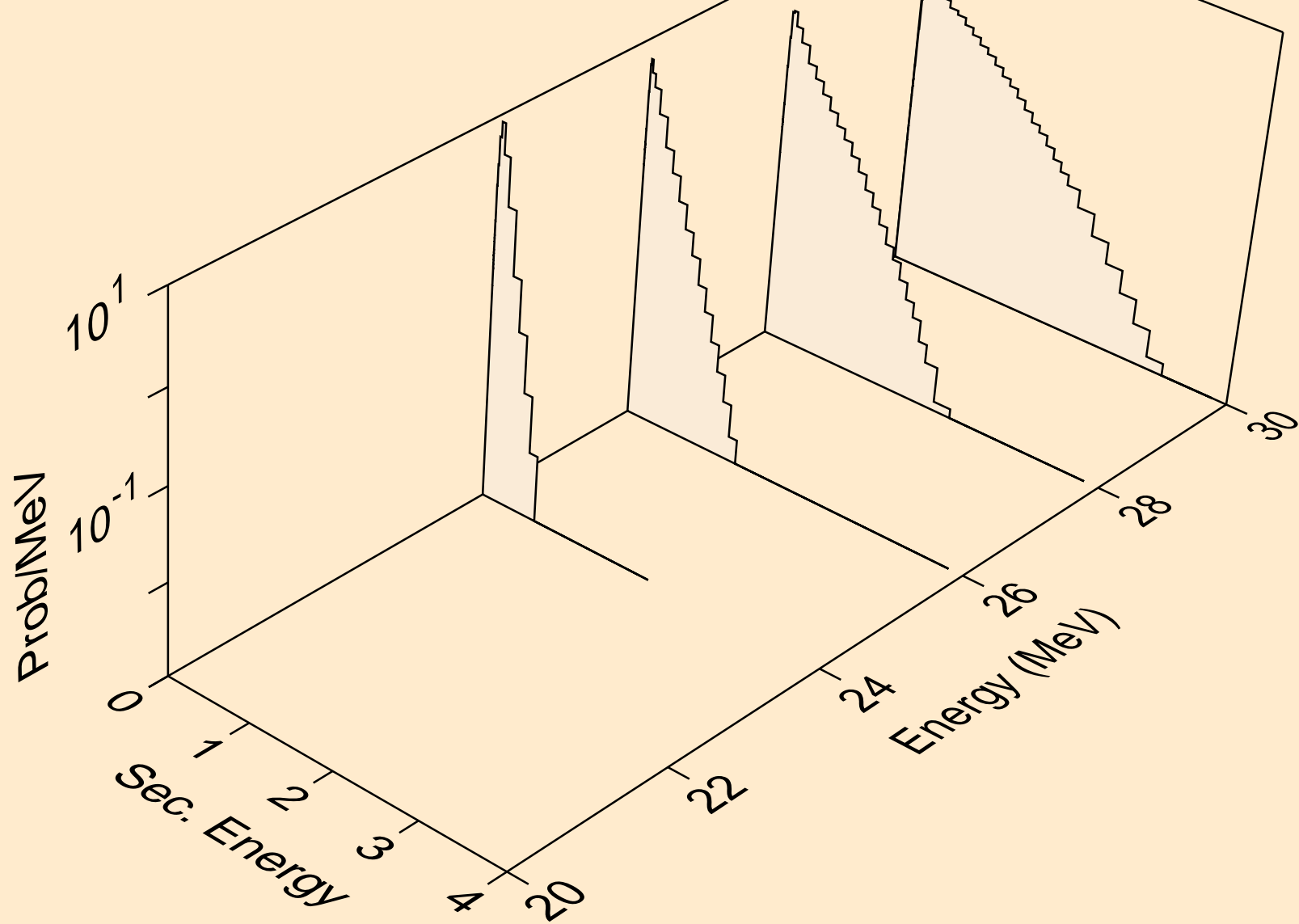

CU066 NEUTRON ACER TENDL-2023 LIBRARY; T=0.K  
Neutron emission for (n,npa)

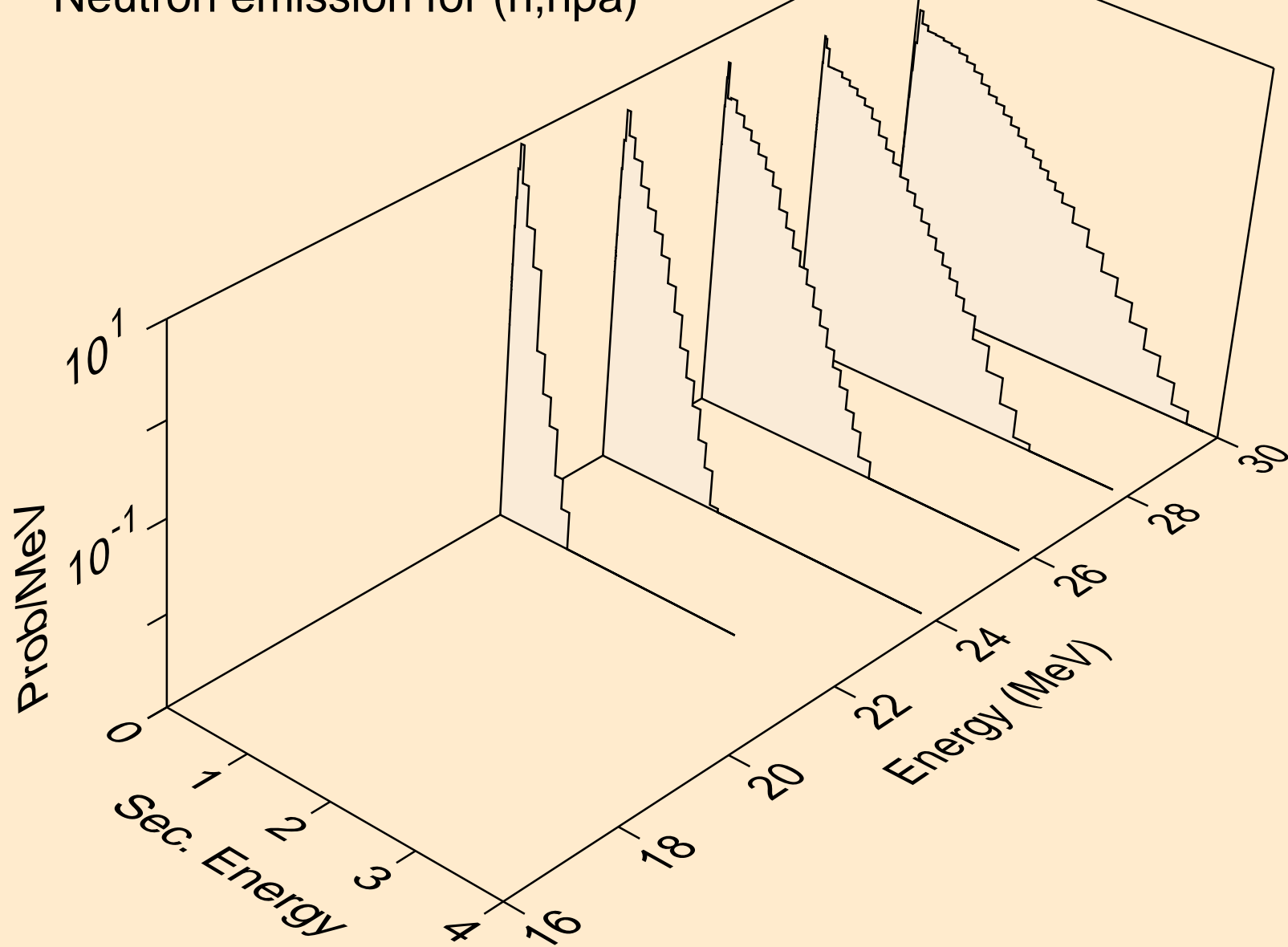

CU066 NEUTRON ACER TENDL-2023 LIBRARY; T=0.K  
Neutron emission for (n,n\*c)

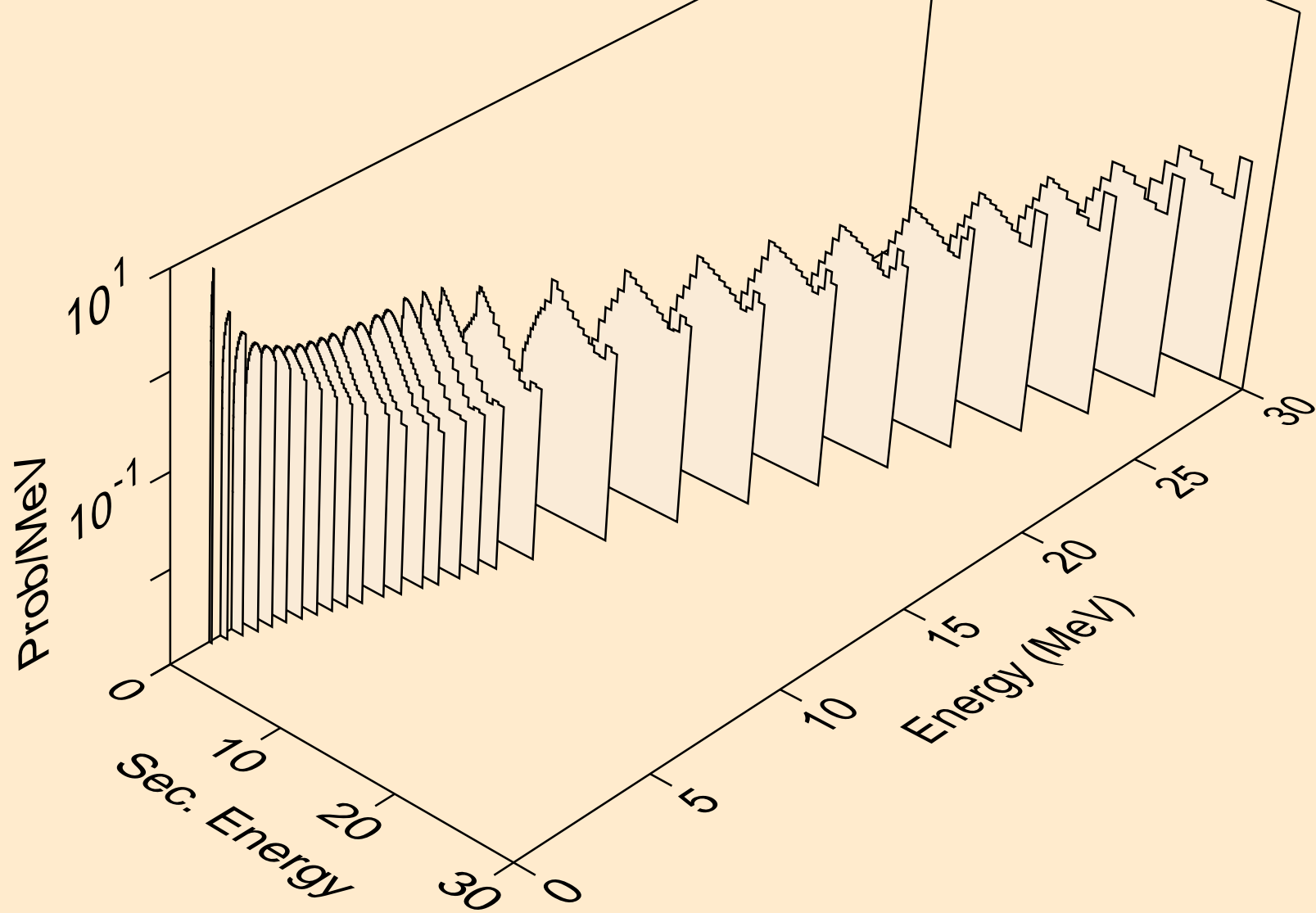

CU066 NEUTRON ACER TENDL-2023 LIBRARY; T=0.K  
Photon emission for (n,x)

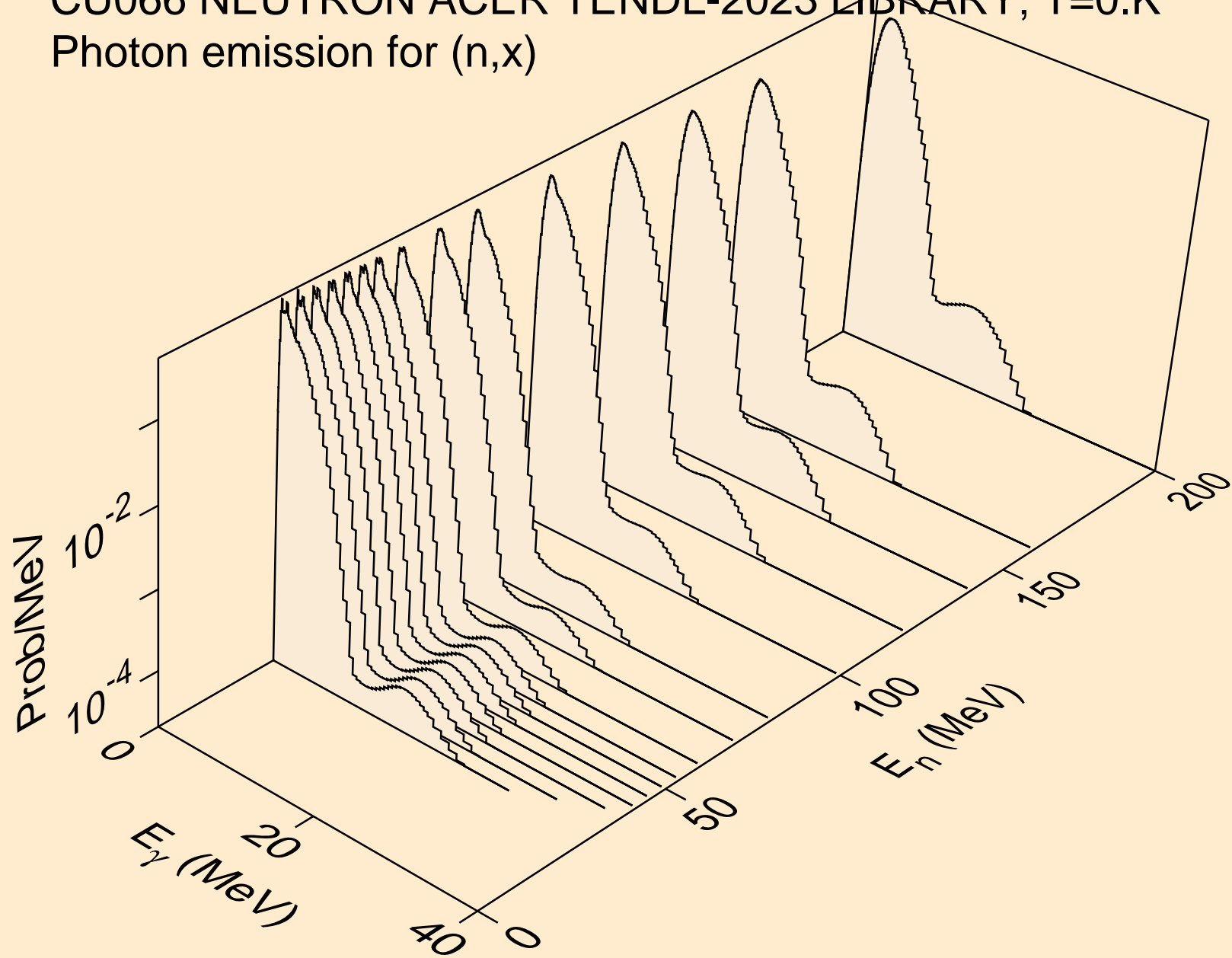



CU066 NEUTRON ACER TENDL-2023 LIBRARY; T=0.K  
Photon emission for (n,2nd)

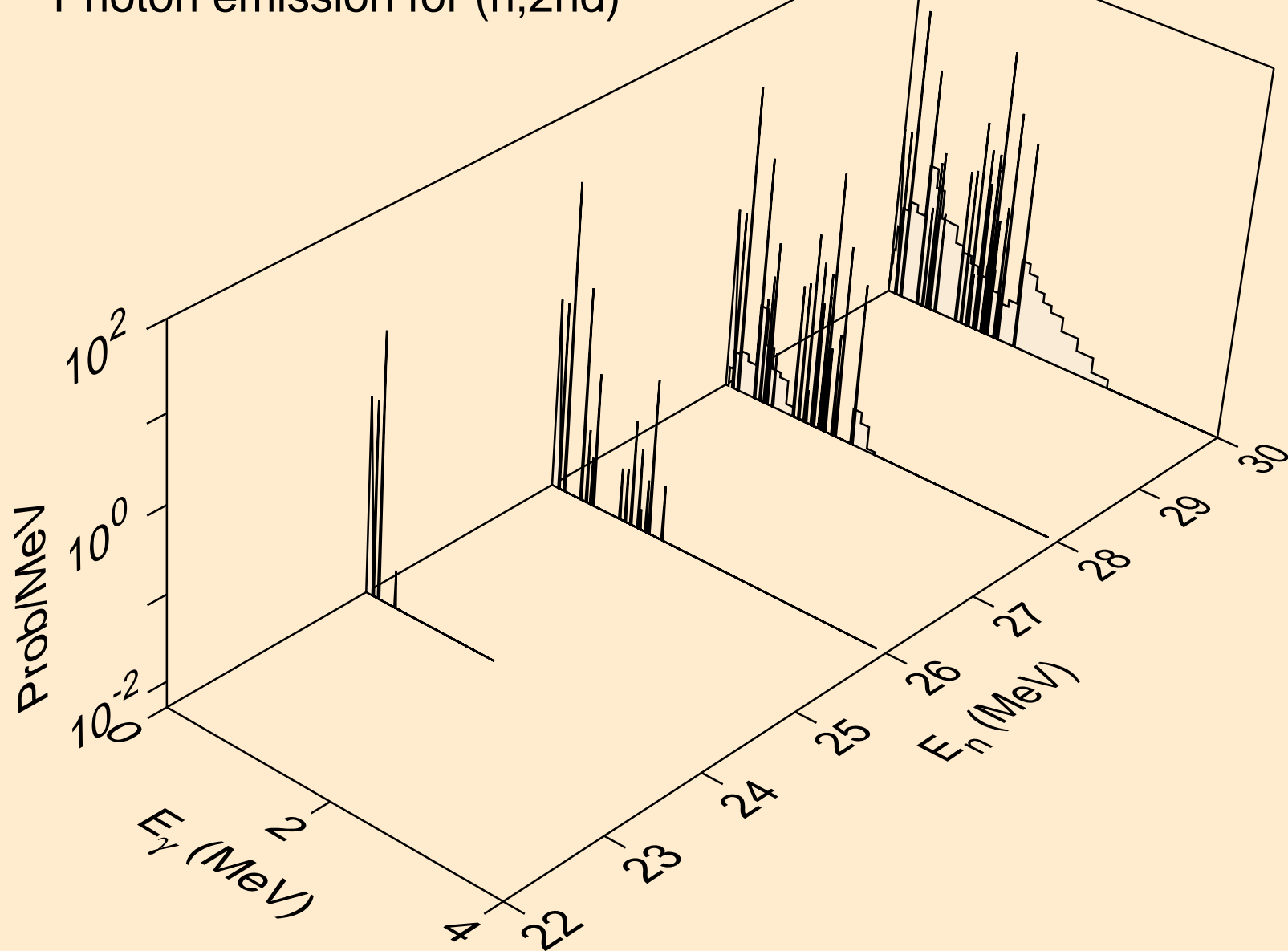

CU066 NEUTRON ACER TENDL-2023 LIBRARY; T=0.K  
Photon emission for (n,2n)

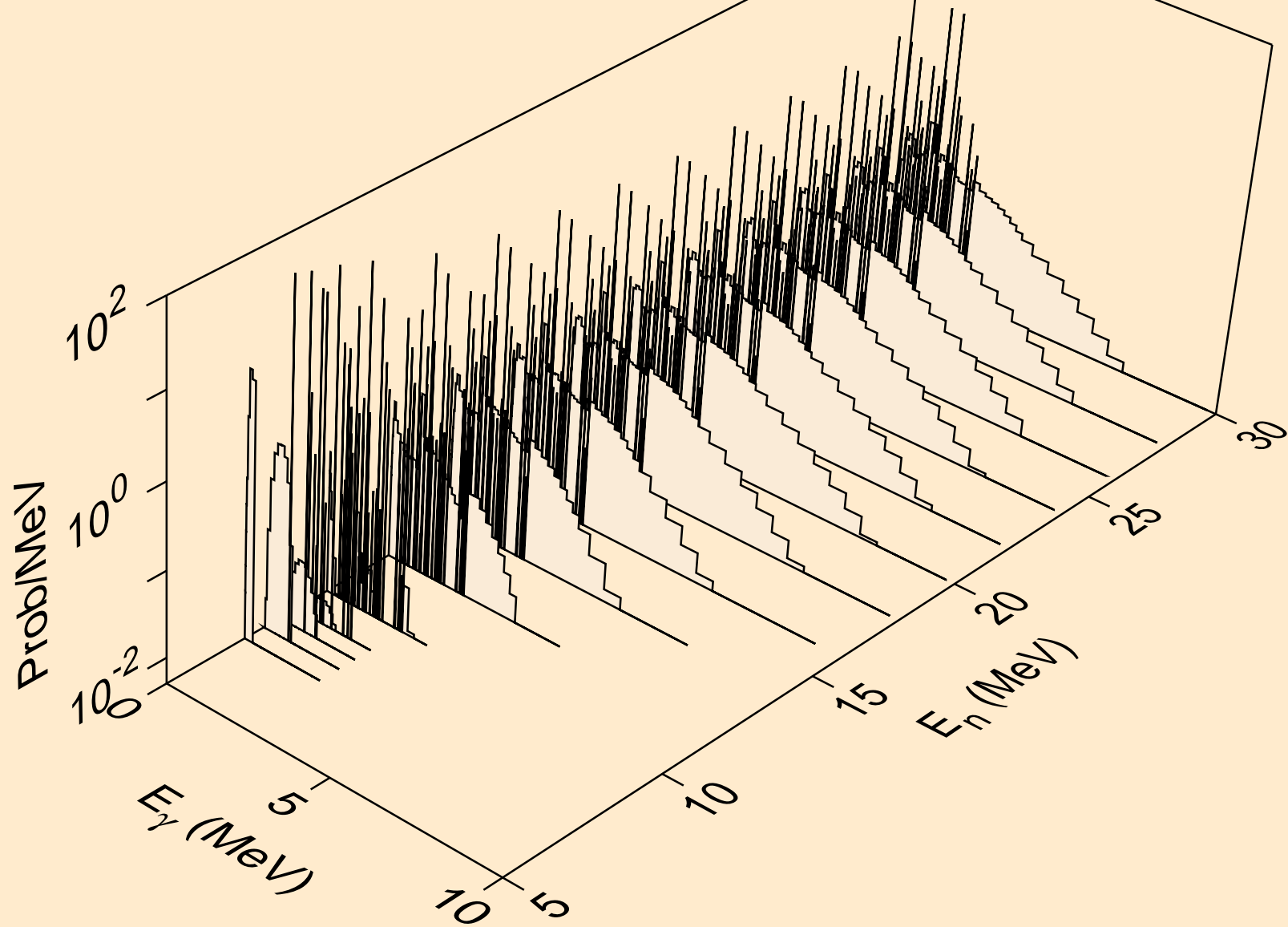

CU066 NEUTRON ACER TENDL-2023 LIBRARY; T=0.K  
Photon emission for (n,3n)

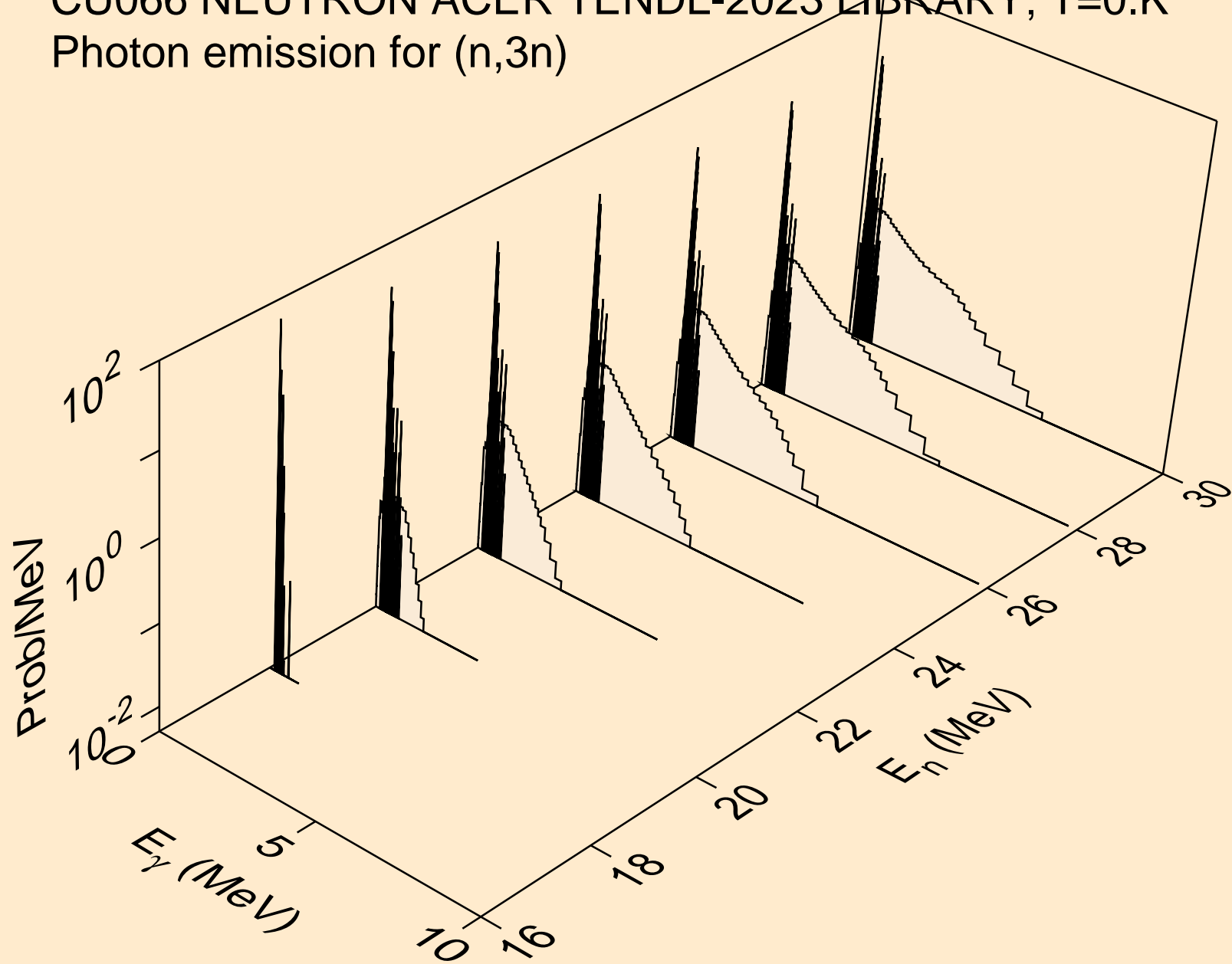

CU066 NEUTRON ACER TENDL-2023 LIBRARY; T=0.K  
Photon emission for (n,n\*)a

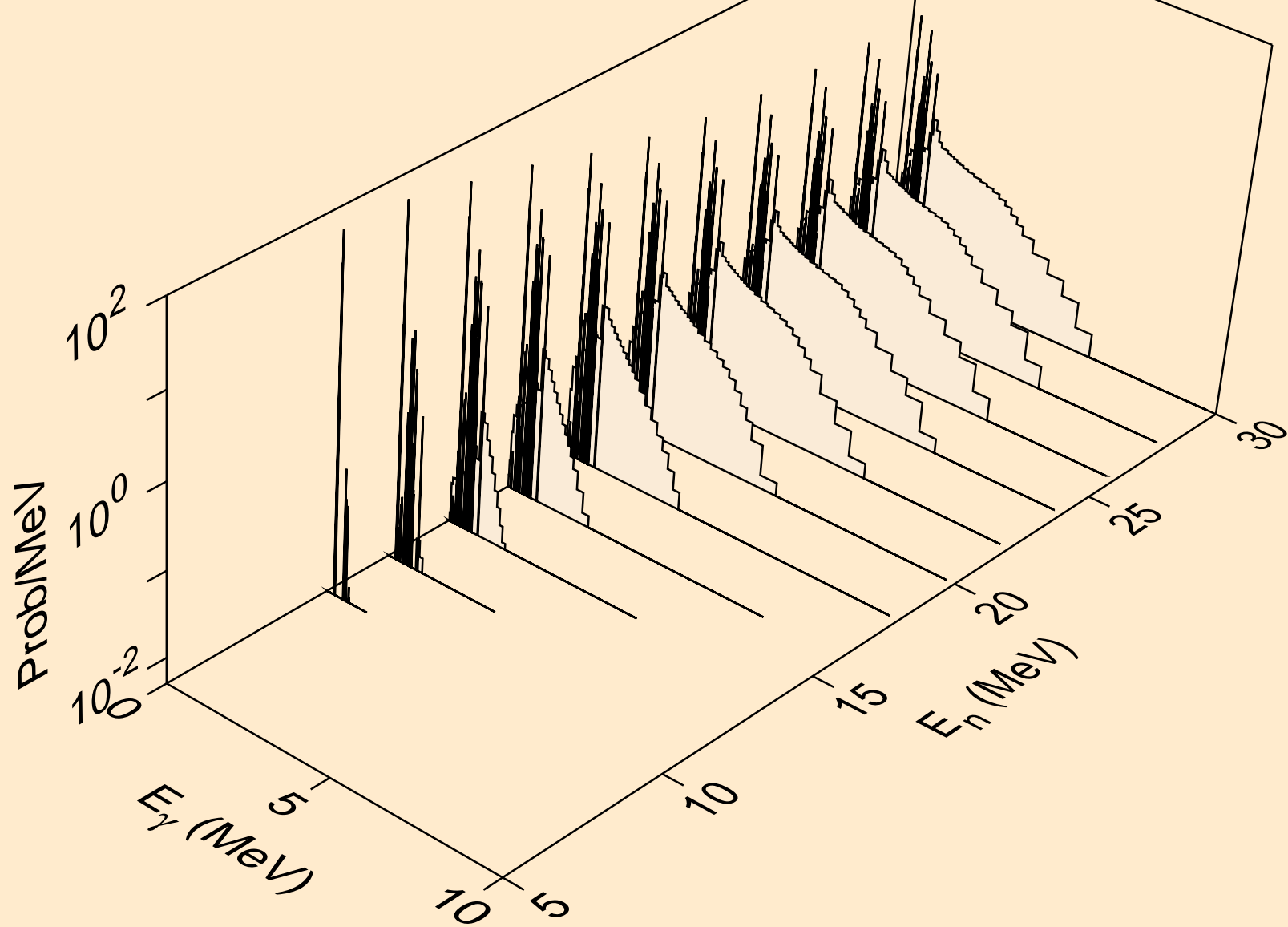

CU066 NEUTRON ACER TENDL-2023 LIBRARY; T=0.K  
Photon emission for (n,2n)a

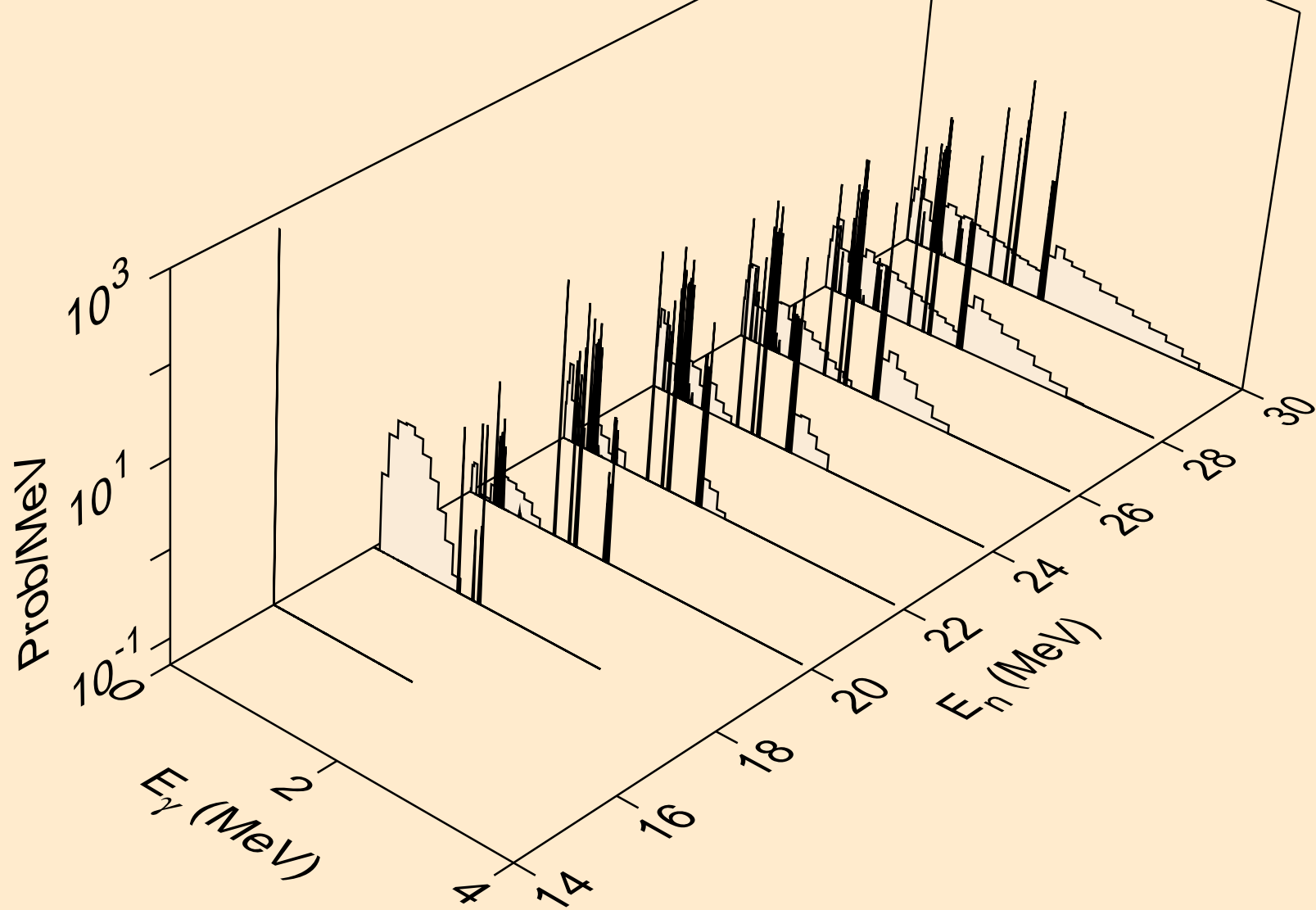

CU066 NEUTRON ACER TENDL-2023 LIBRARY; T=0.K  
Photon emission for (n,3n)a

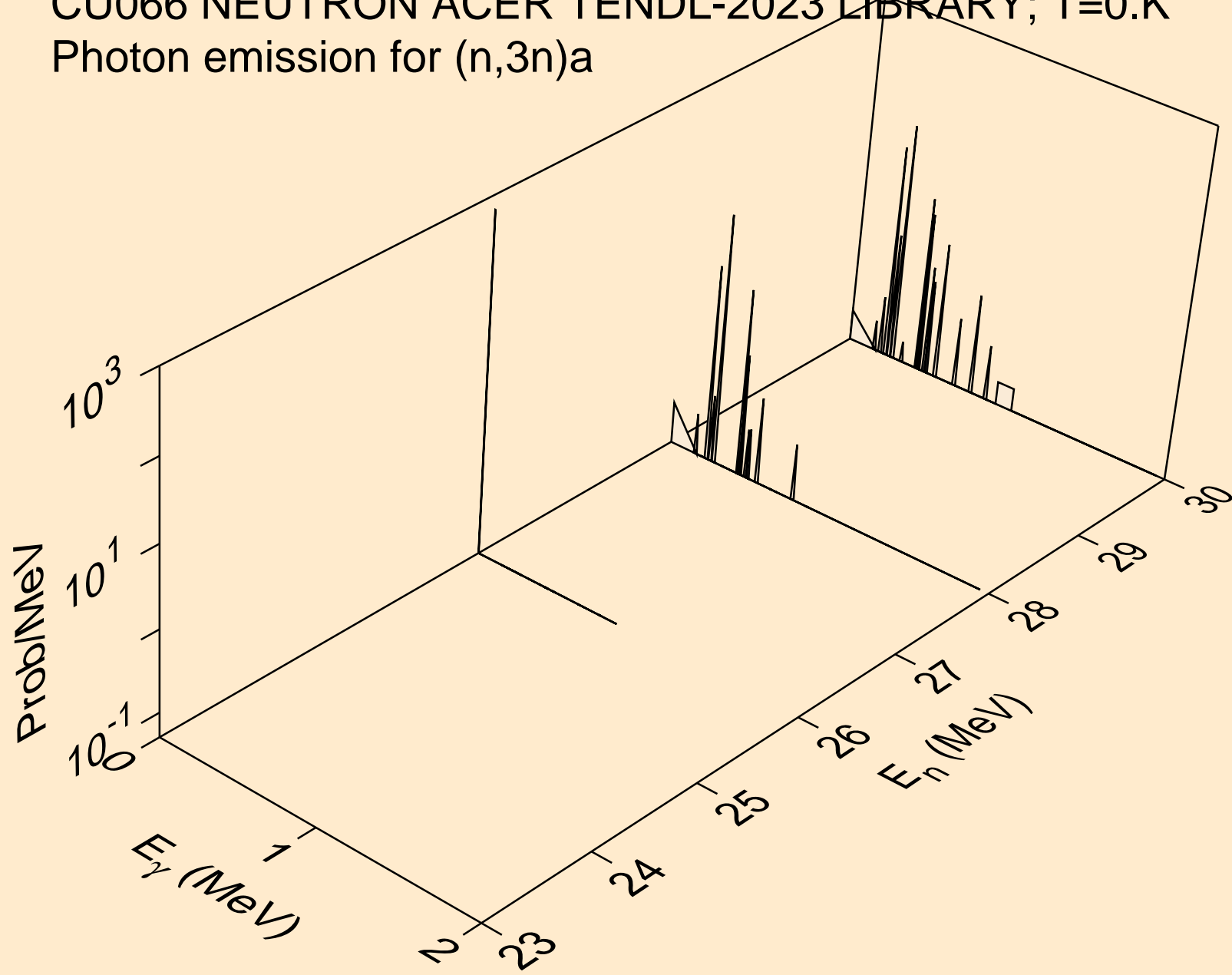

CU066 NEUTRON ACER TENDL-2023 LIBRARY; T=0.K  
Photon emission for (n,n\*)p

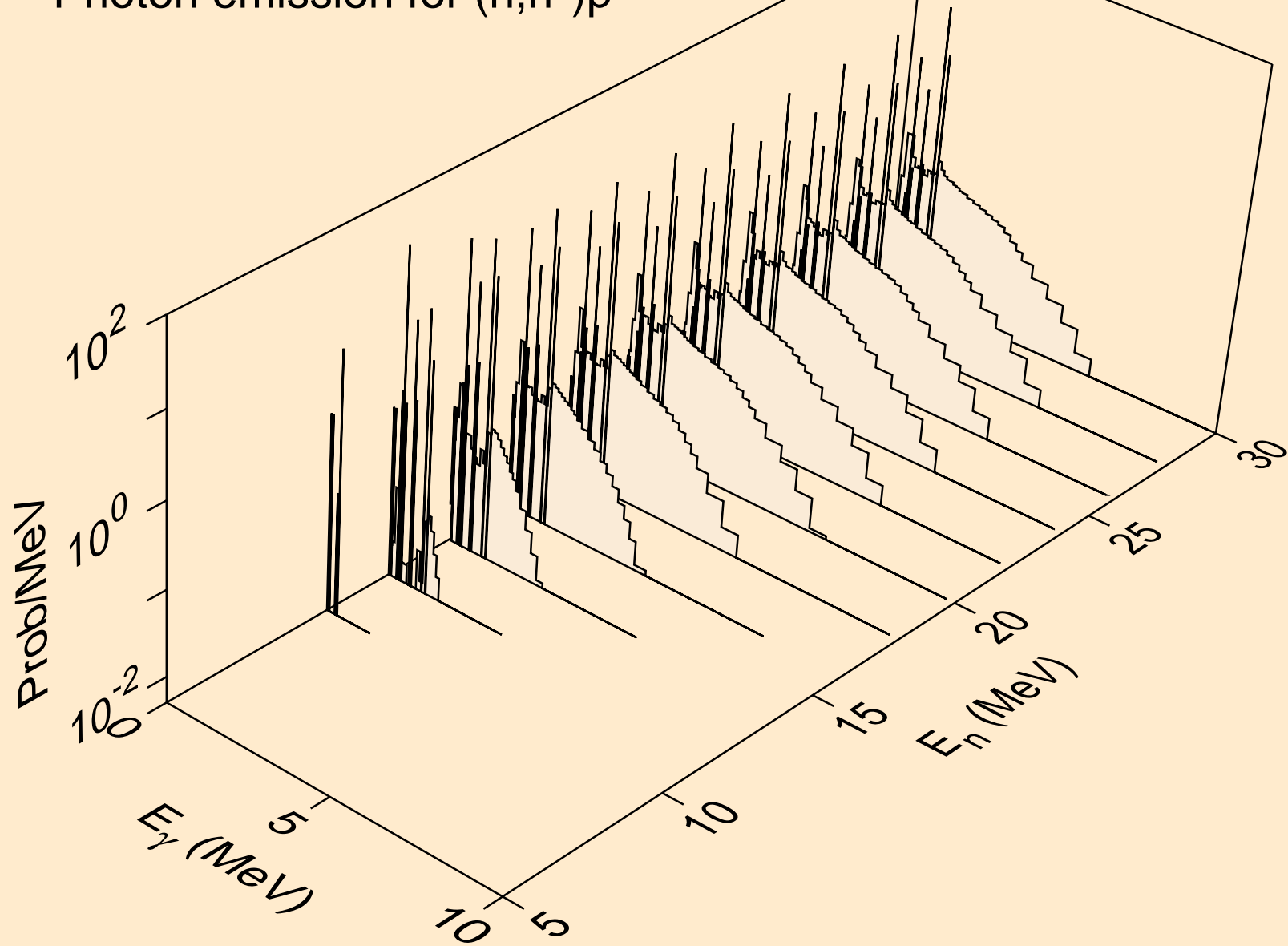

CU066 NEUTRON ACER TENDL-2023 LIBRARY; T=0.K  
Photon emission for (n,n\*)2a

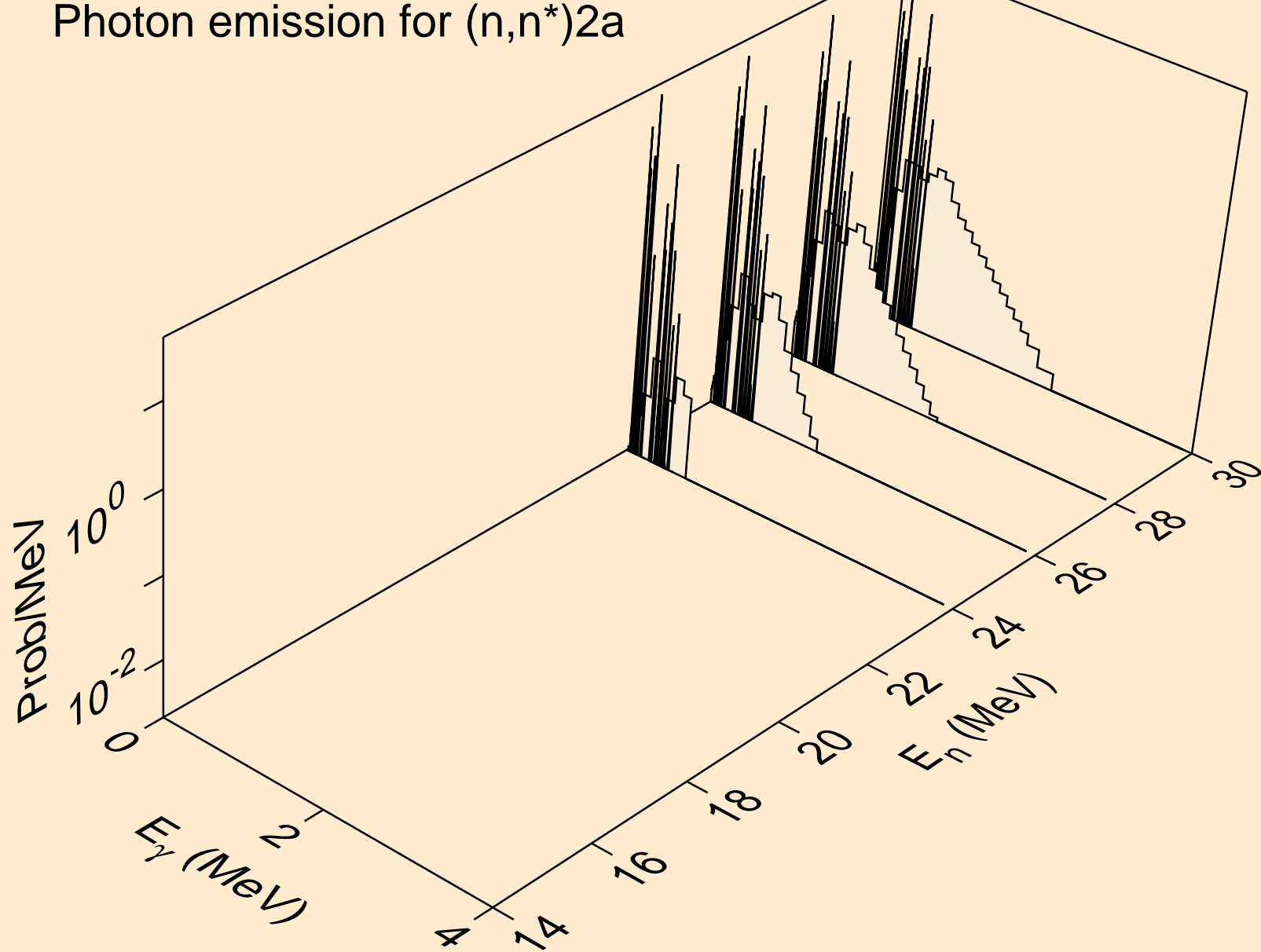



CU066 NEUTRON ACER TENDL-2023 LIBRARY; T=0.K  
Photon emission for (n,n\*)d

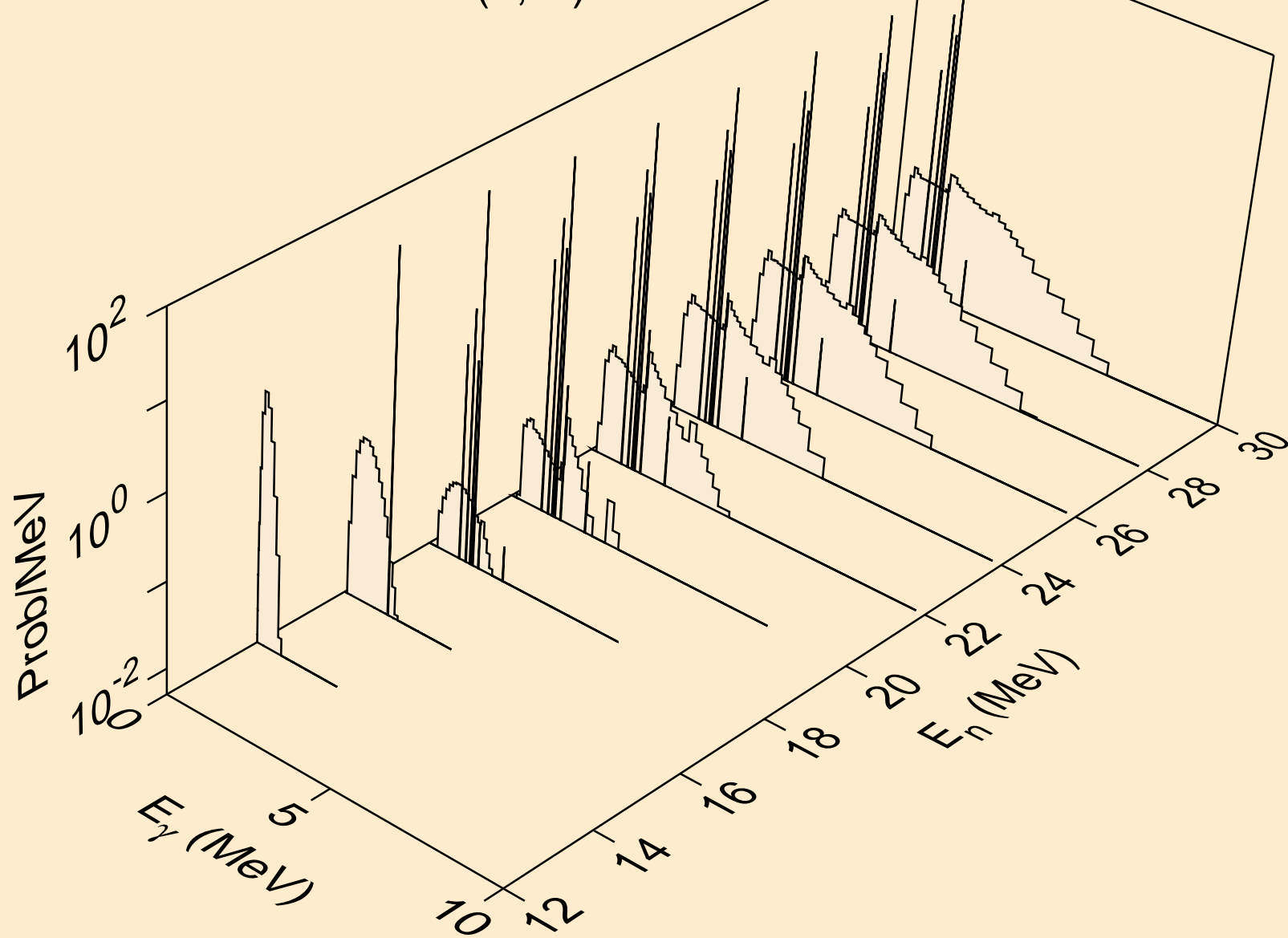

CU066 NEUTRON ACER TENDL-2023 LIBRARY; T=0.K  
Photon emission for (n,n\*)t

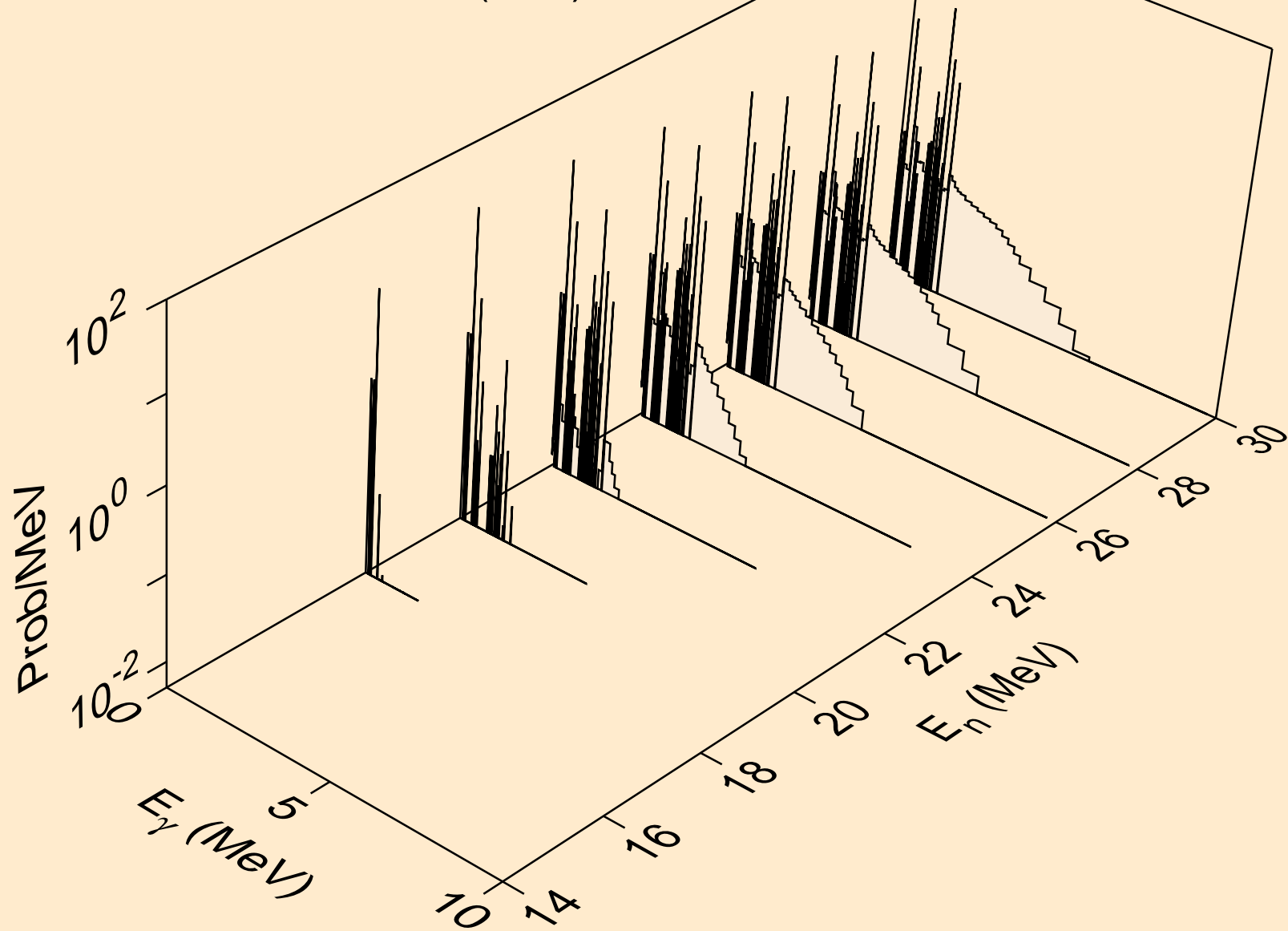

CU066 NEUTRON ACER TENDL-2023 LIBRARY; T=0.K  
Photon emission for (n,n\*)he3

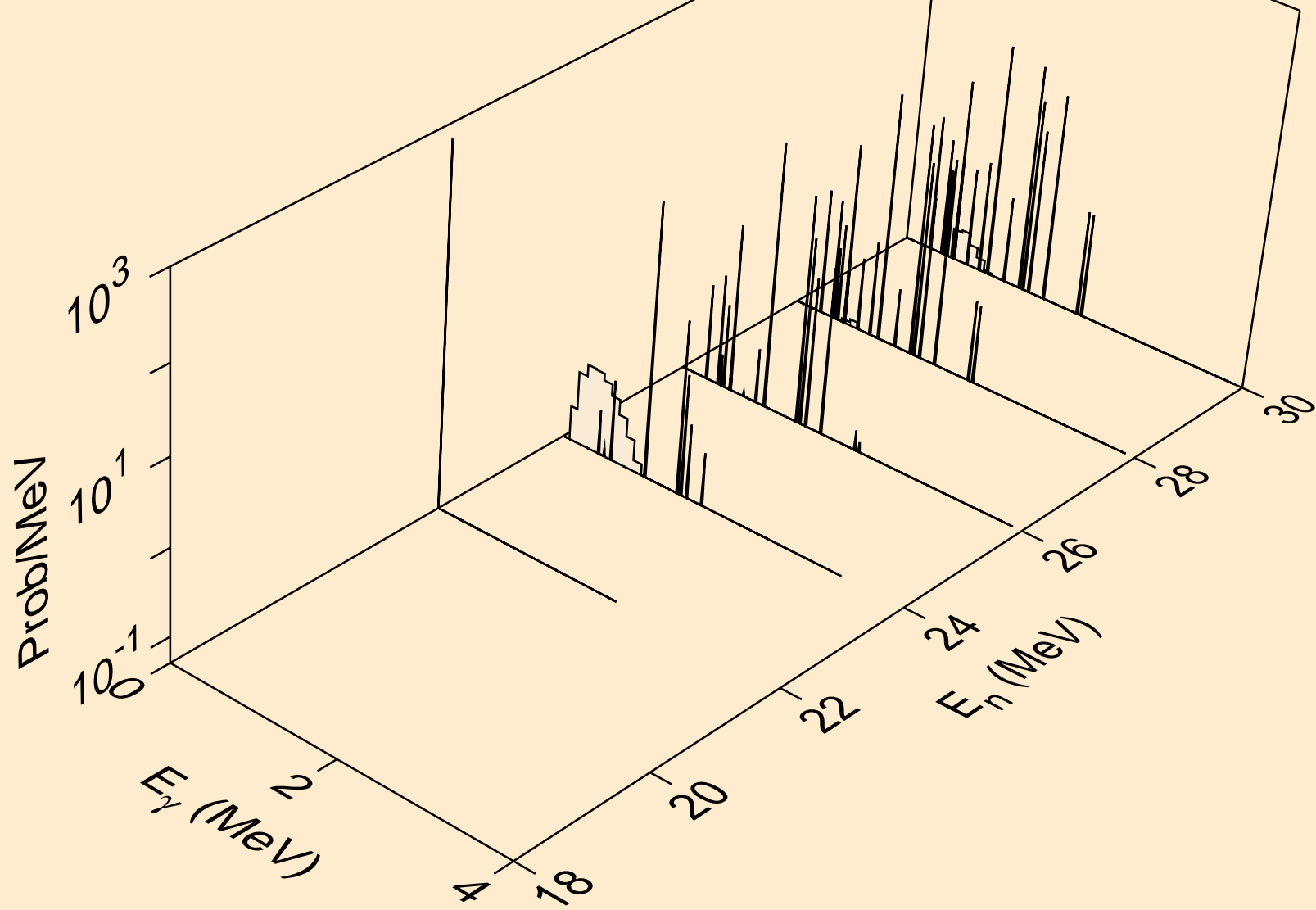

CU066 NEUTRON ACER TENDL-2023 LIBRARY; T=0.K  
Photon emission for (n,4n)

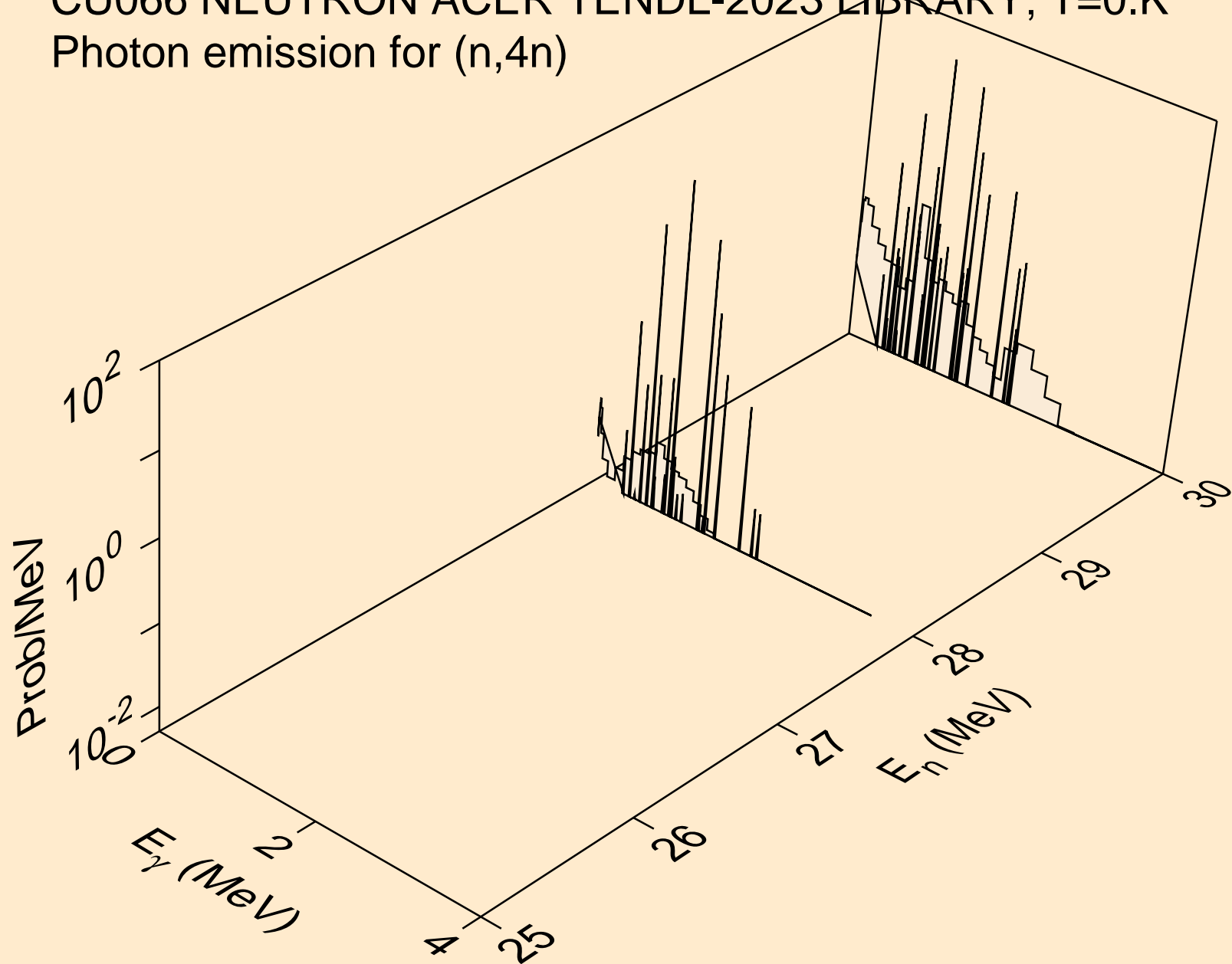

CU066 NEUTRON ACER TENDL-2023 LIBRARY; T=0.K  
Photon emission for (n,2np)

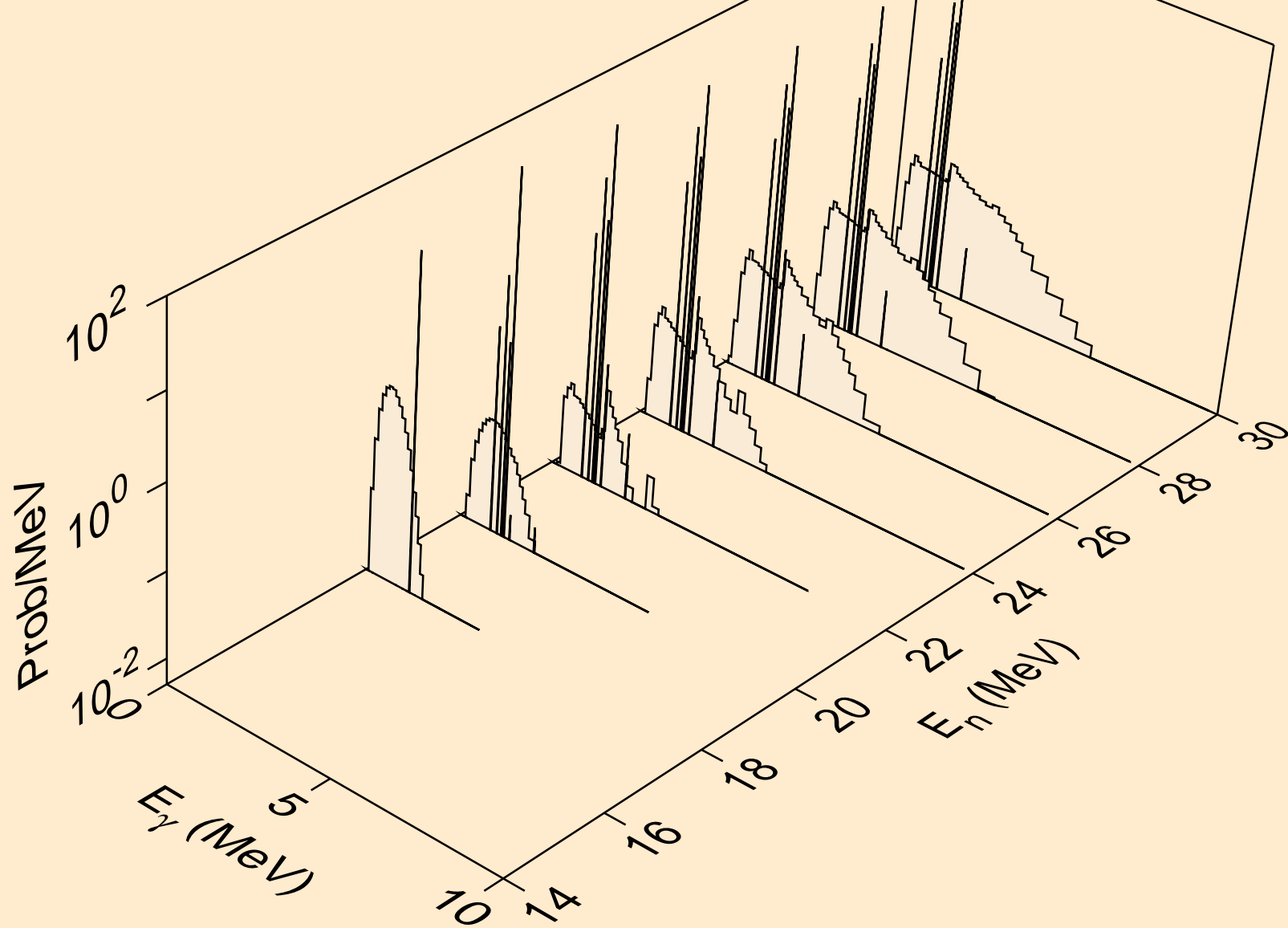

CU066 NEUTRON ACER TENDL-2023 LIBRARY; T=0.K  
Photon emission for (n,3np)

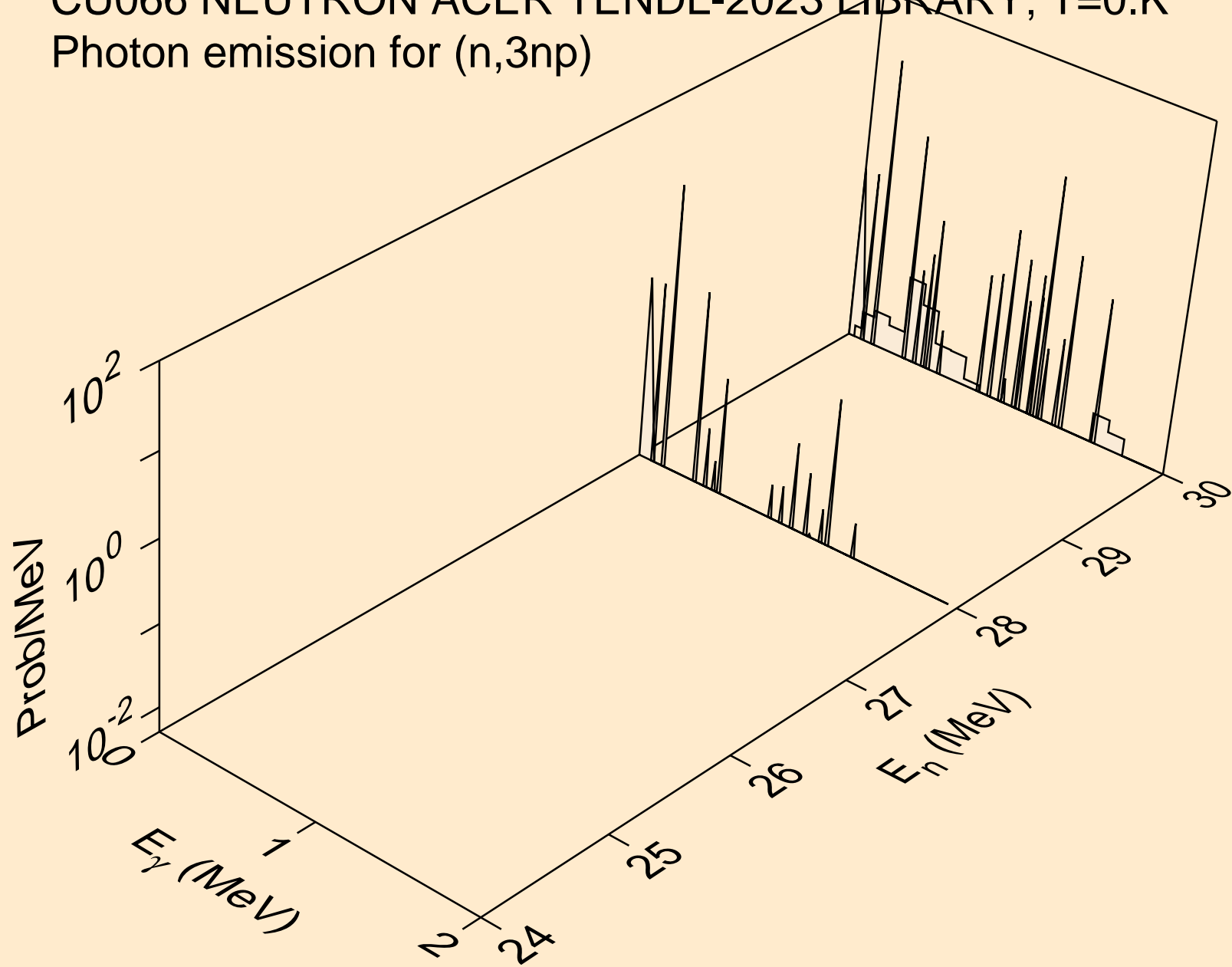

CU066 NEUTRON ACER TENDL-2023 LIBRARY; T=0.K  
Photon emission for (n,n2p)

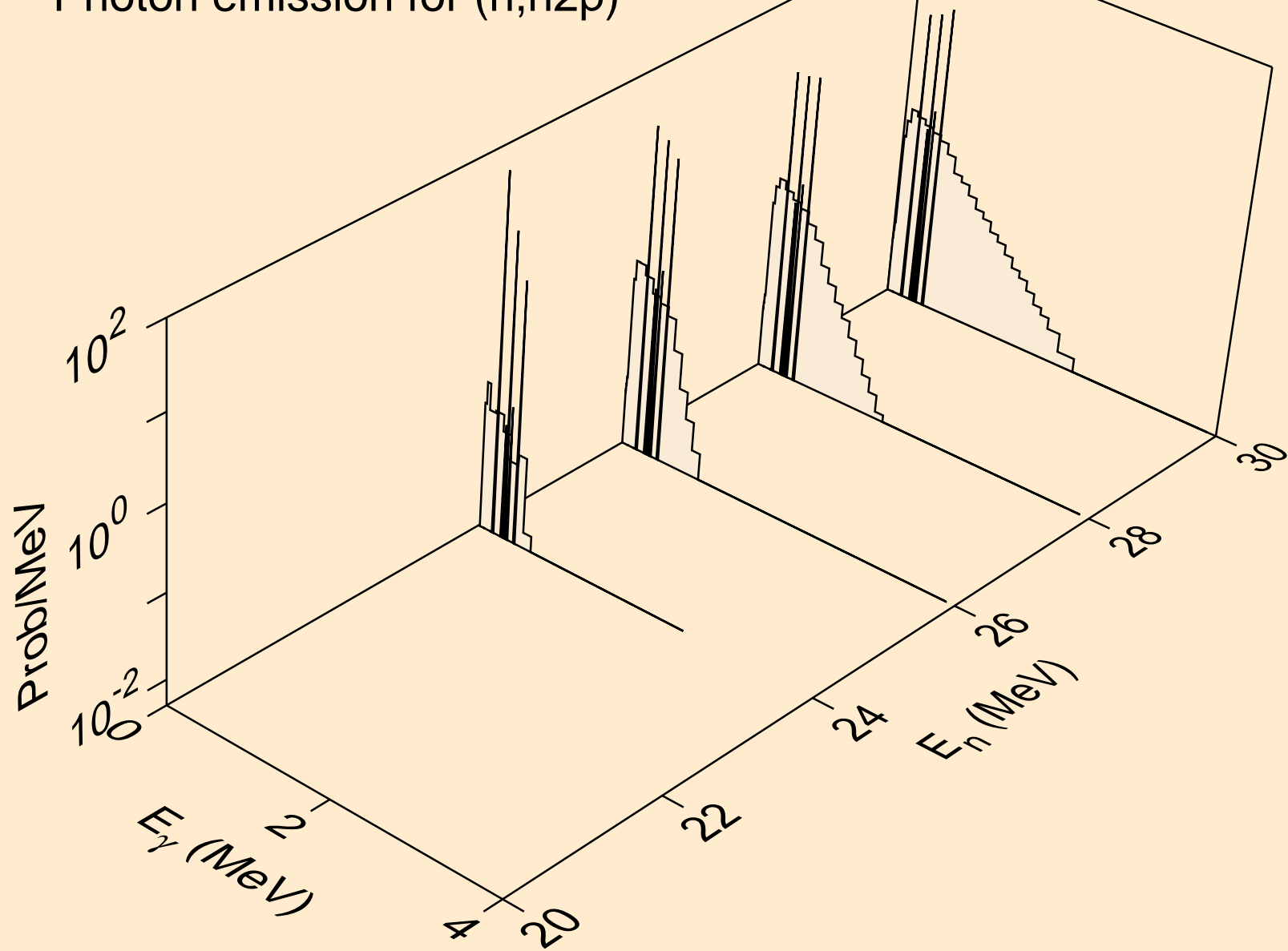

CU066 NEUTRON ACER TENDL-2023 LIBRARY; T=0.K  
Photon emission for (n,npa)

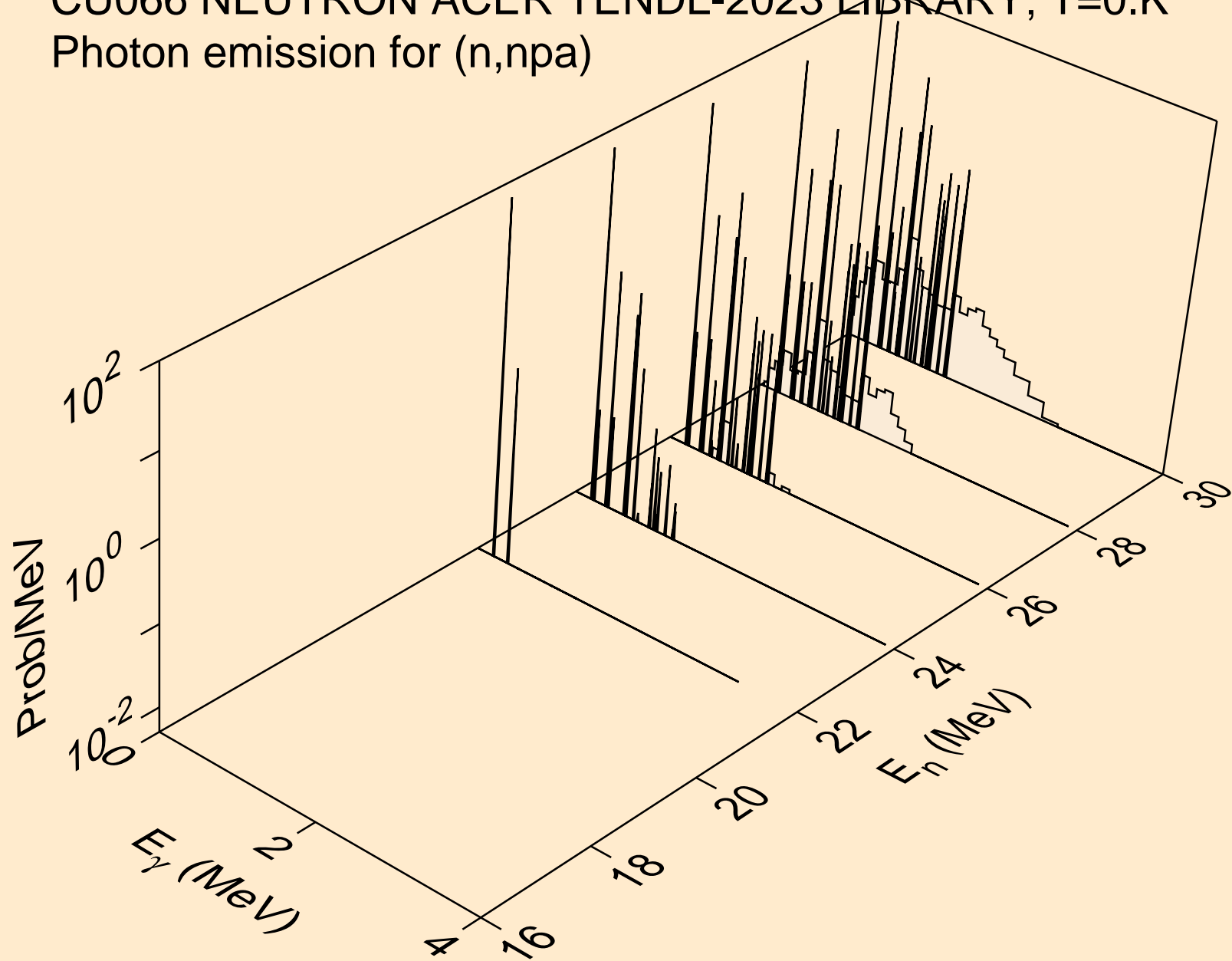



CU066 NEUTRON ACER TENDL-2023 LIBRARY; T=0.K  
Photon emission for (n,n\*c)

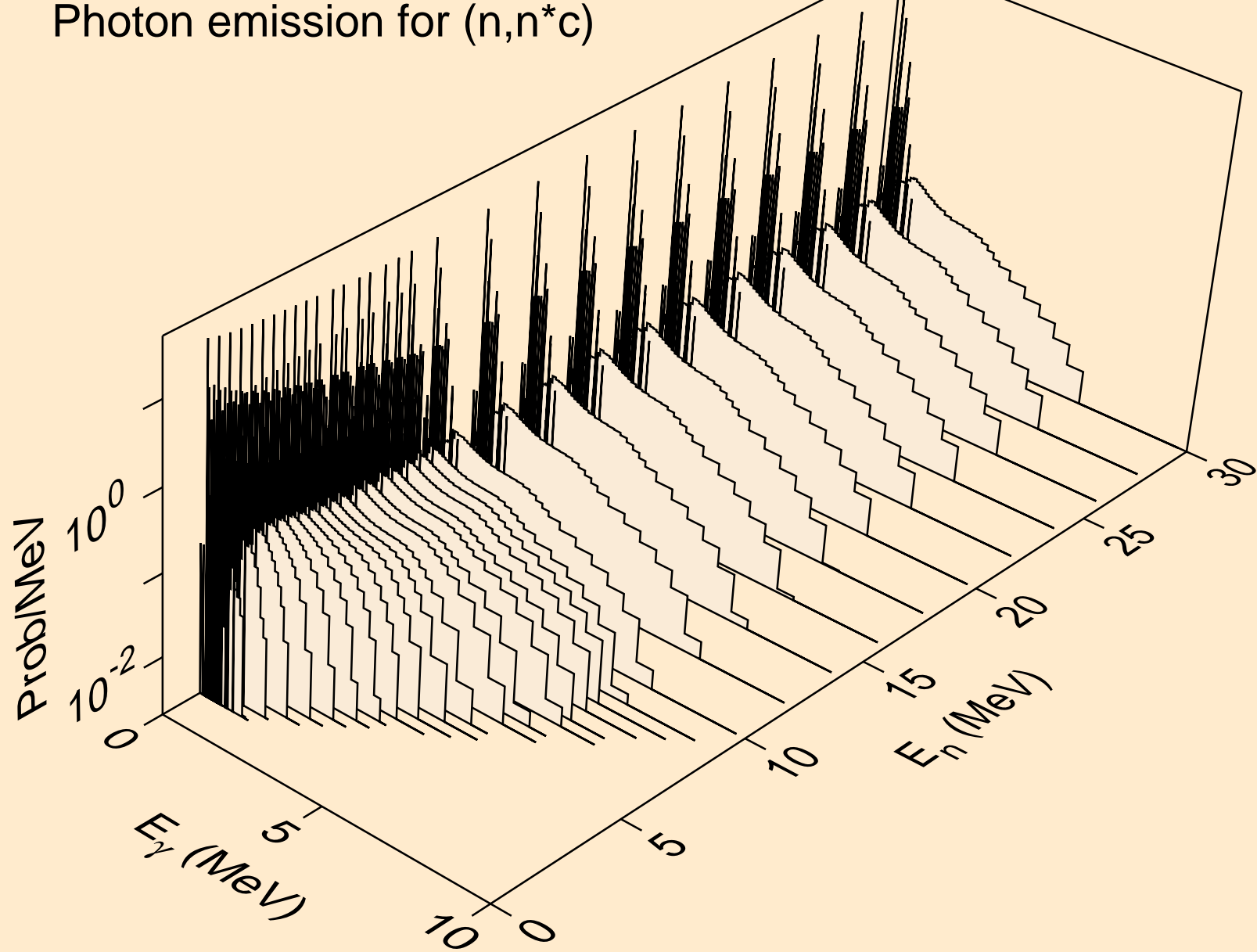

CU066 NEUTRON ACER TENDL-2023 LIBRARY; T=0.K  
Photon emission for (n,gma)

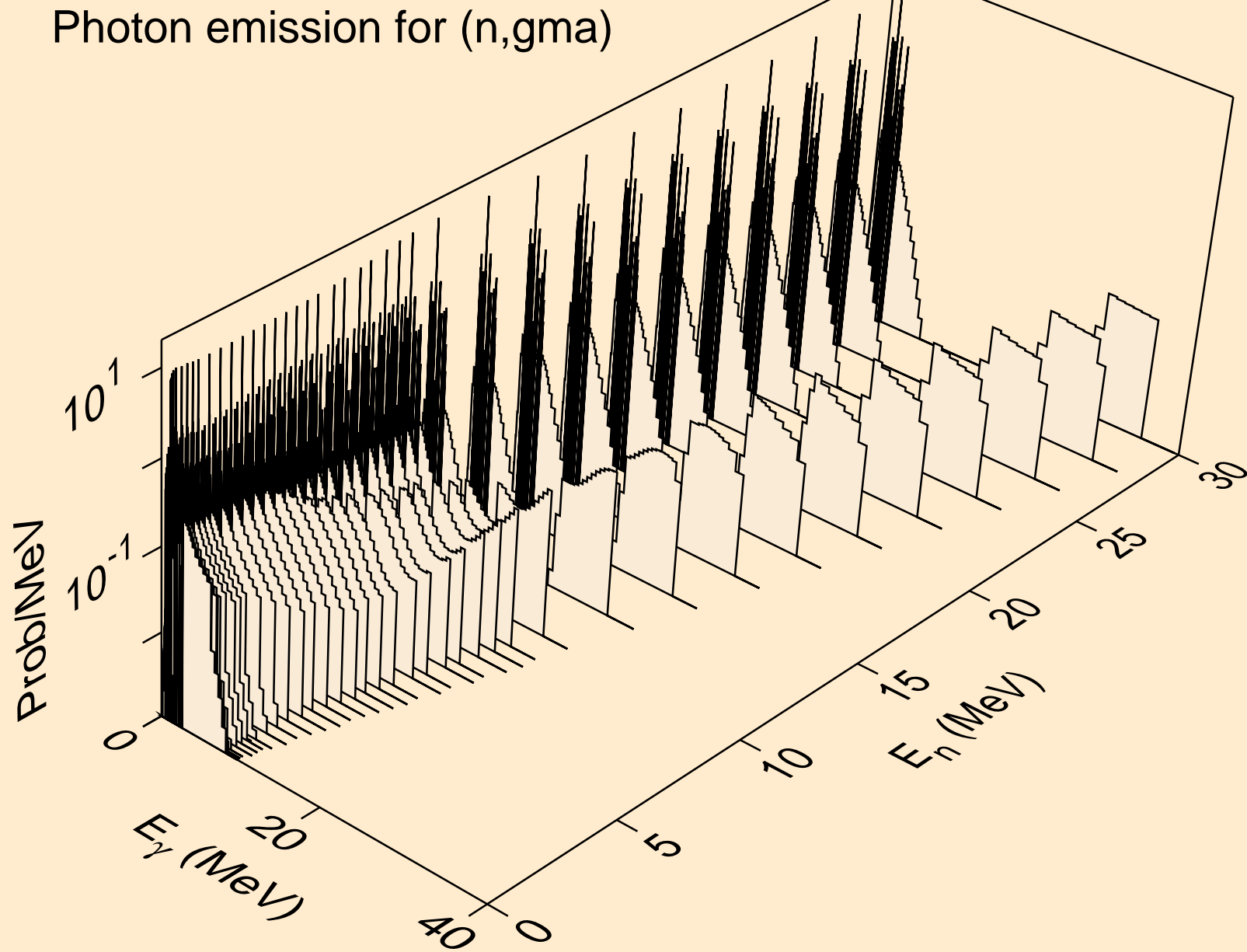

CU066 NEUTRON ACER TENDL-2023 LIBRARY; T=0.K  
Photon emission for (n,p)

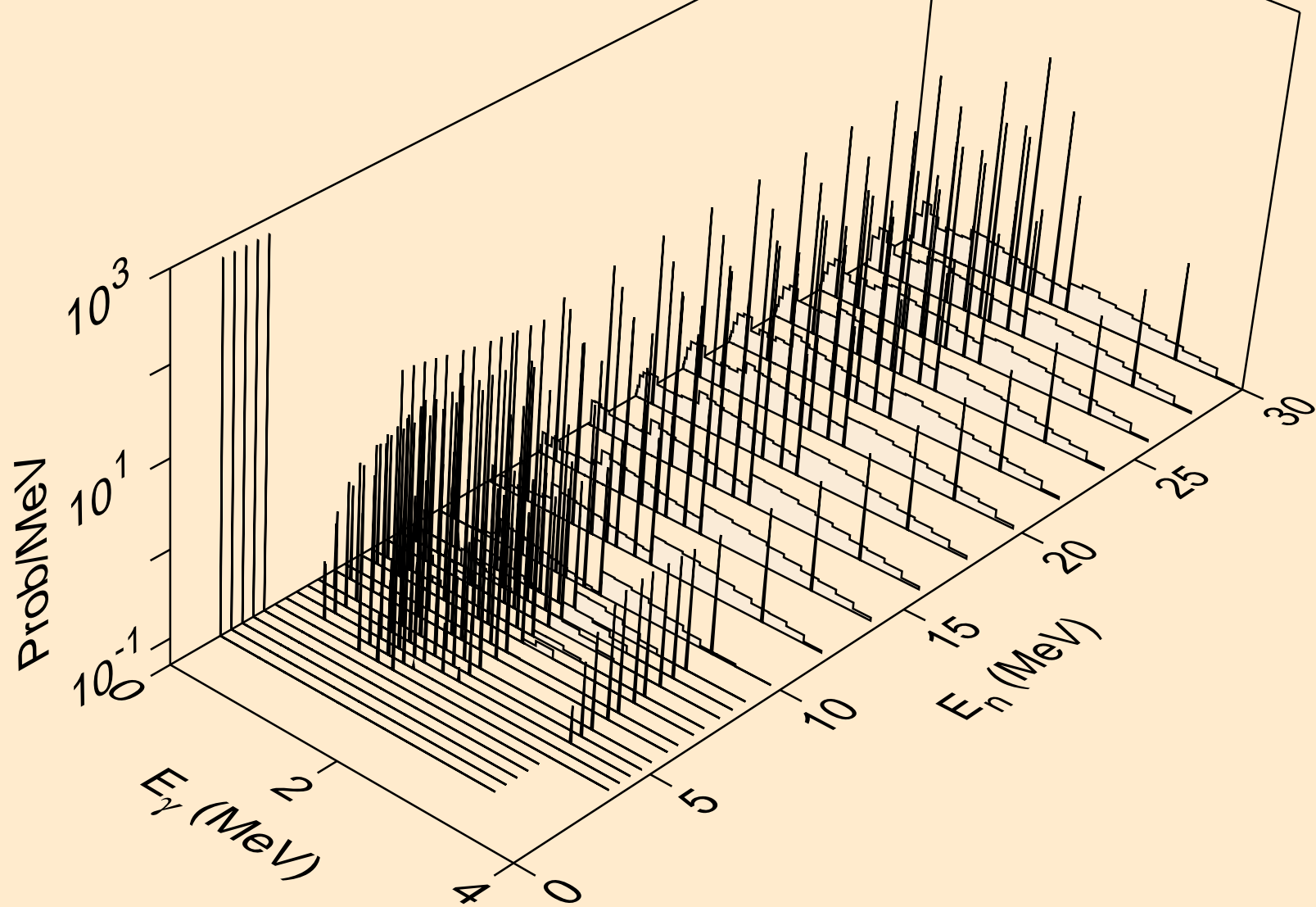

CU066 NEUTRON ACER TENDL-2023 LIBRARY; T=0.K  
Photon emission for (n,d)

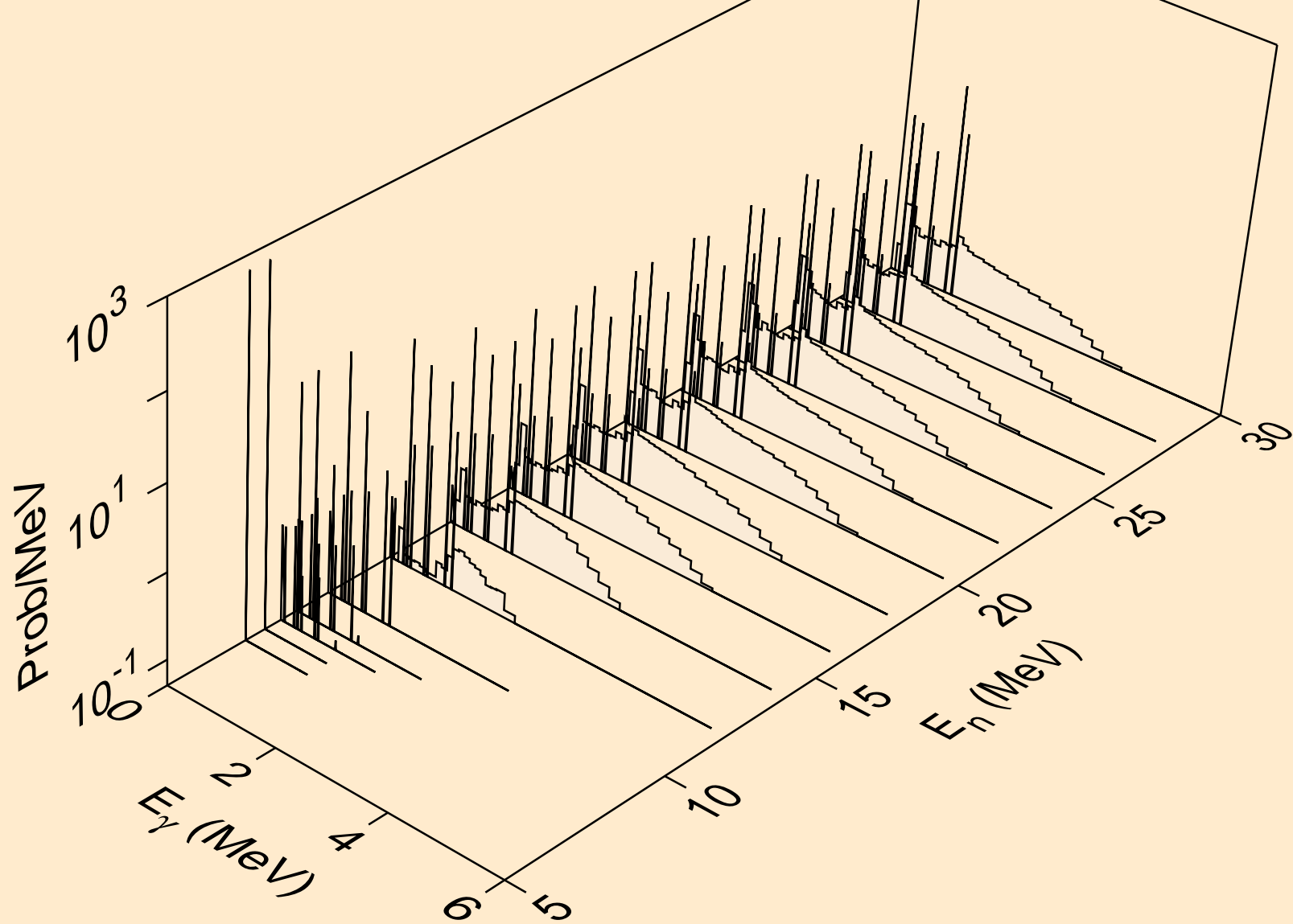

CU066 NEUTRON ACER TENDL-2023 LIBRARY; T=0.K  
Photon emission for (n,t)

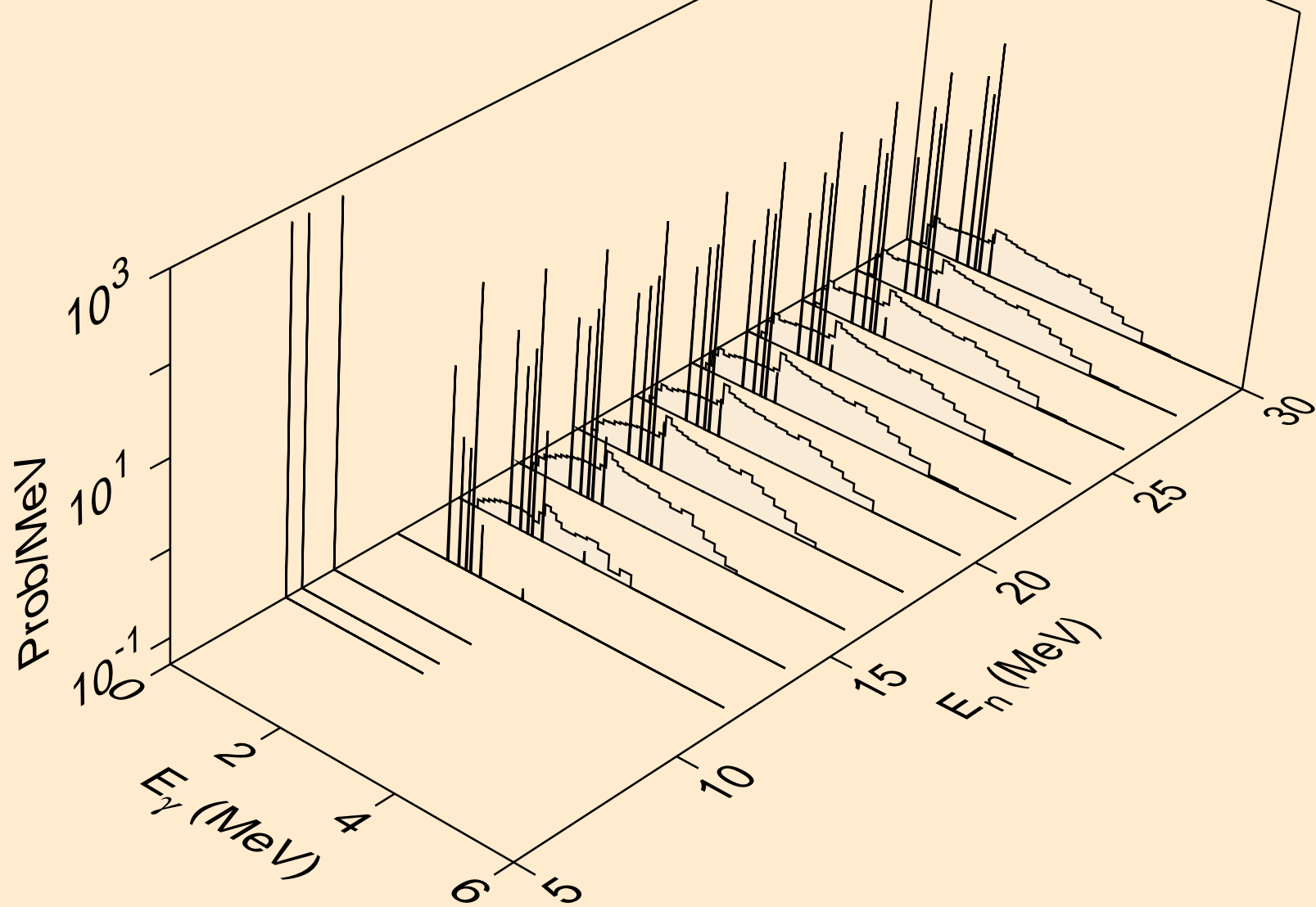

CU066 NEUTRON ACER TENDL-2023 LIBRARY; T=0.K  
Photon emission for (n,he3)

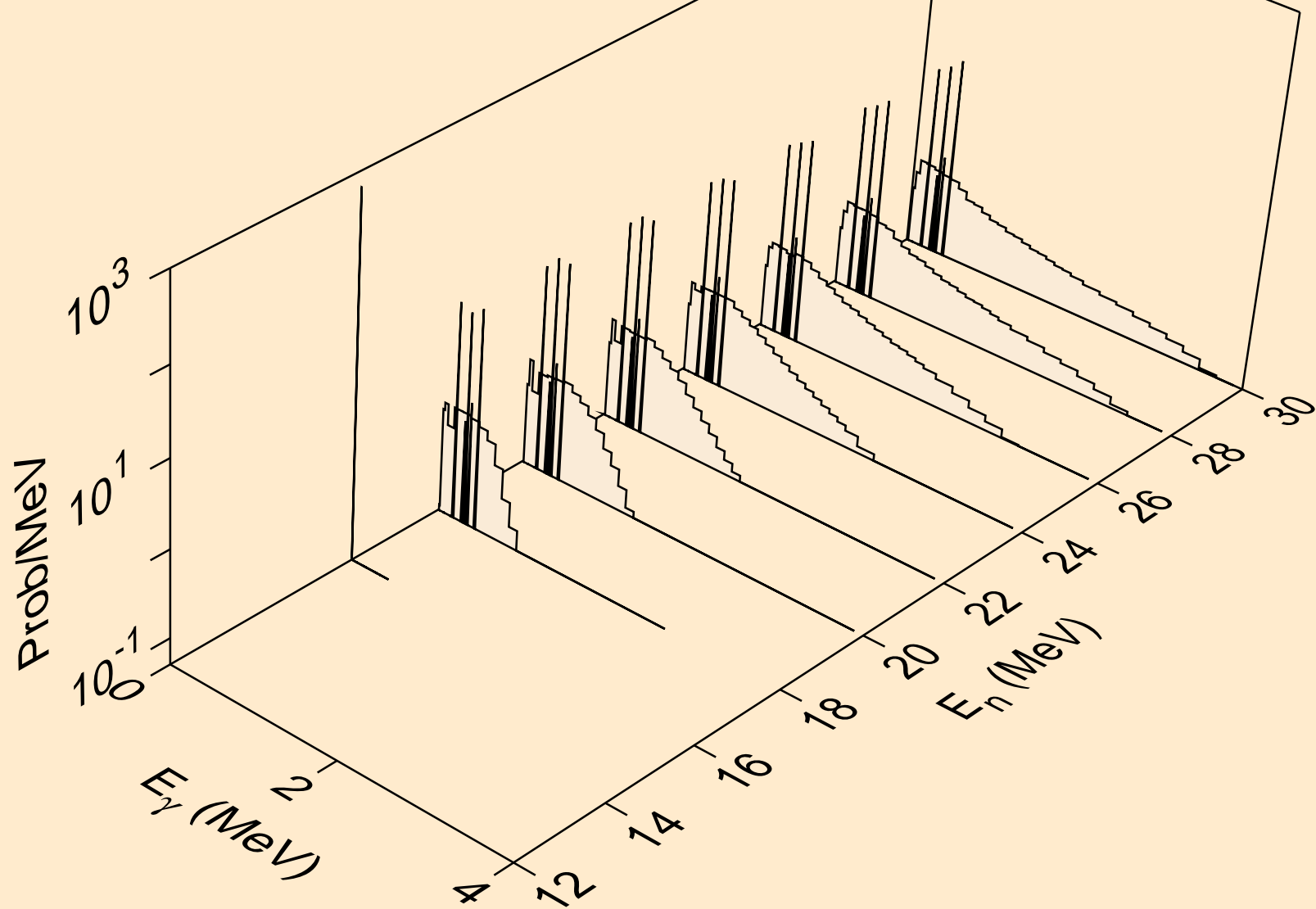

CU066 NEUTRON ACER TENDL-2023 LIBRARY; T=0.K  
Photon emission for (n,a)

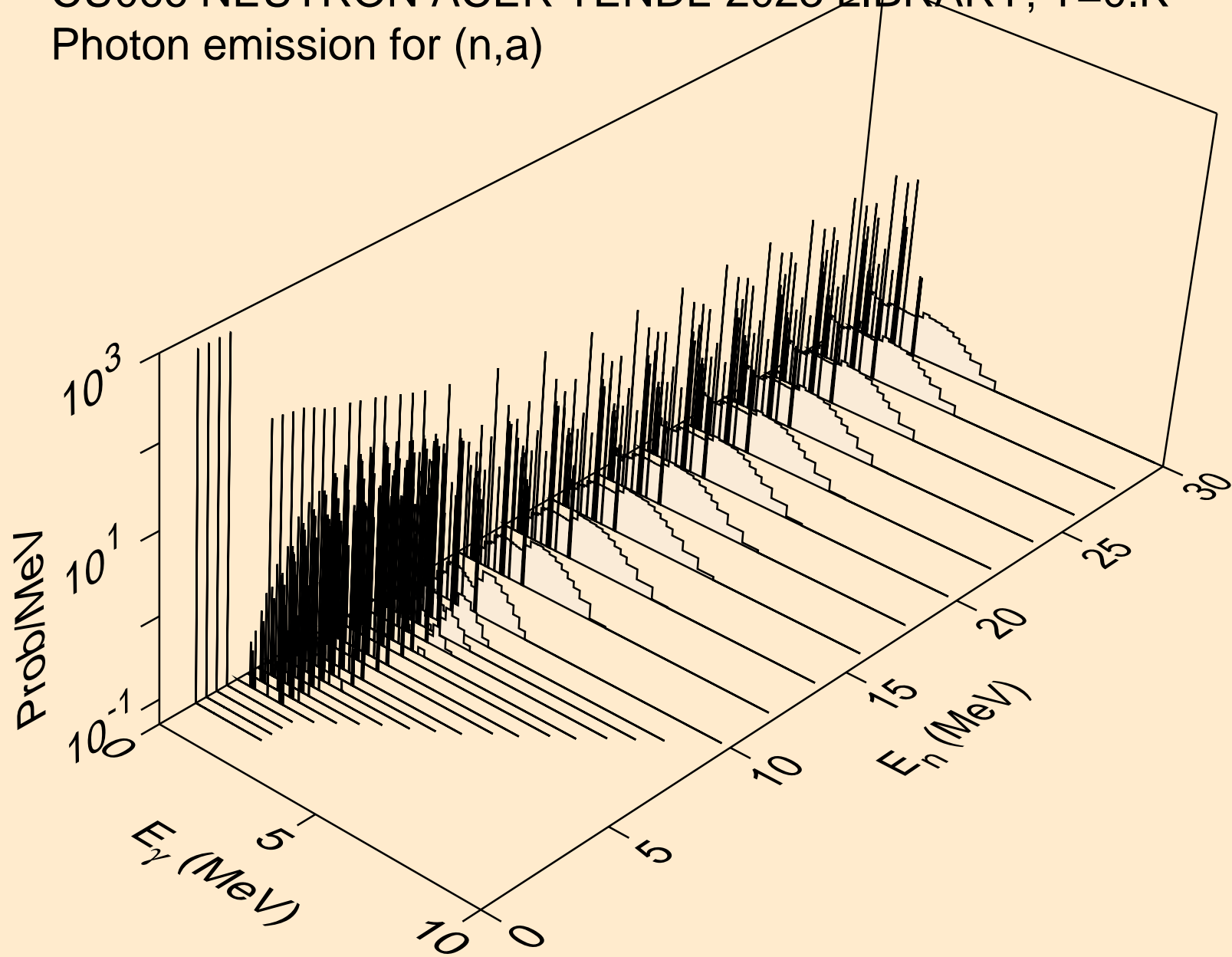

CU066 NEUTRON ACER TENDL-2023 LIBRARY; T=0.K  
Photon emission for (n,2a)

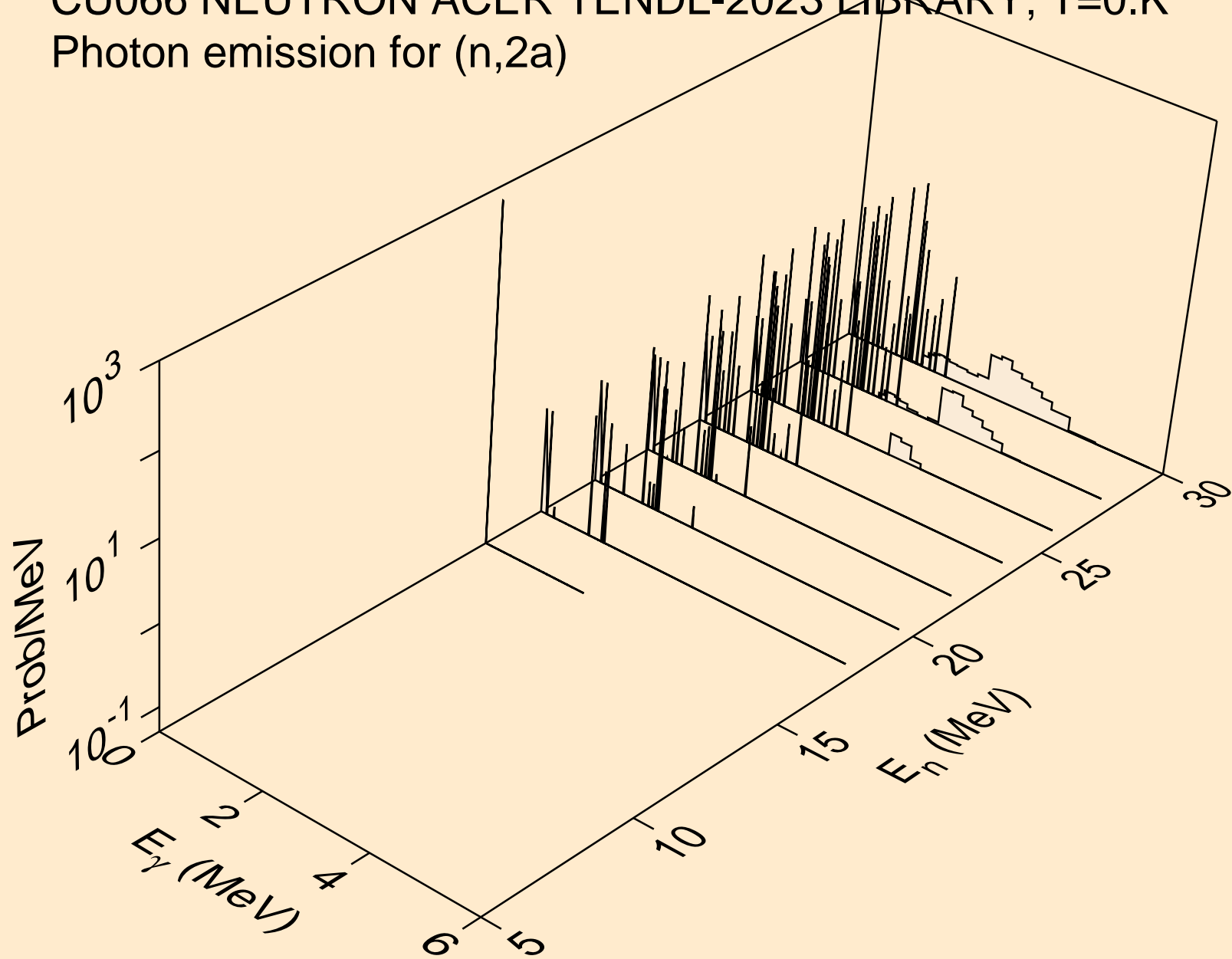



CU066 NEUTRON ACER TENDL-2023 LIBRARY; T=0.K  
Photon emission for (n,2p)

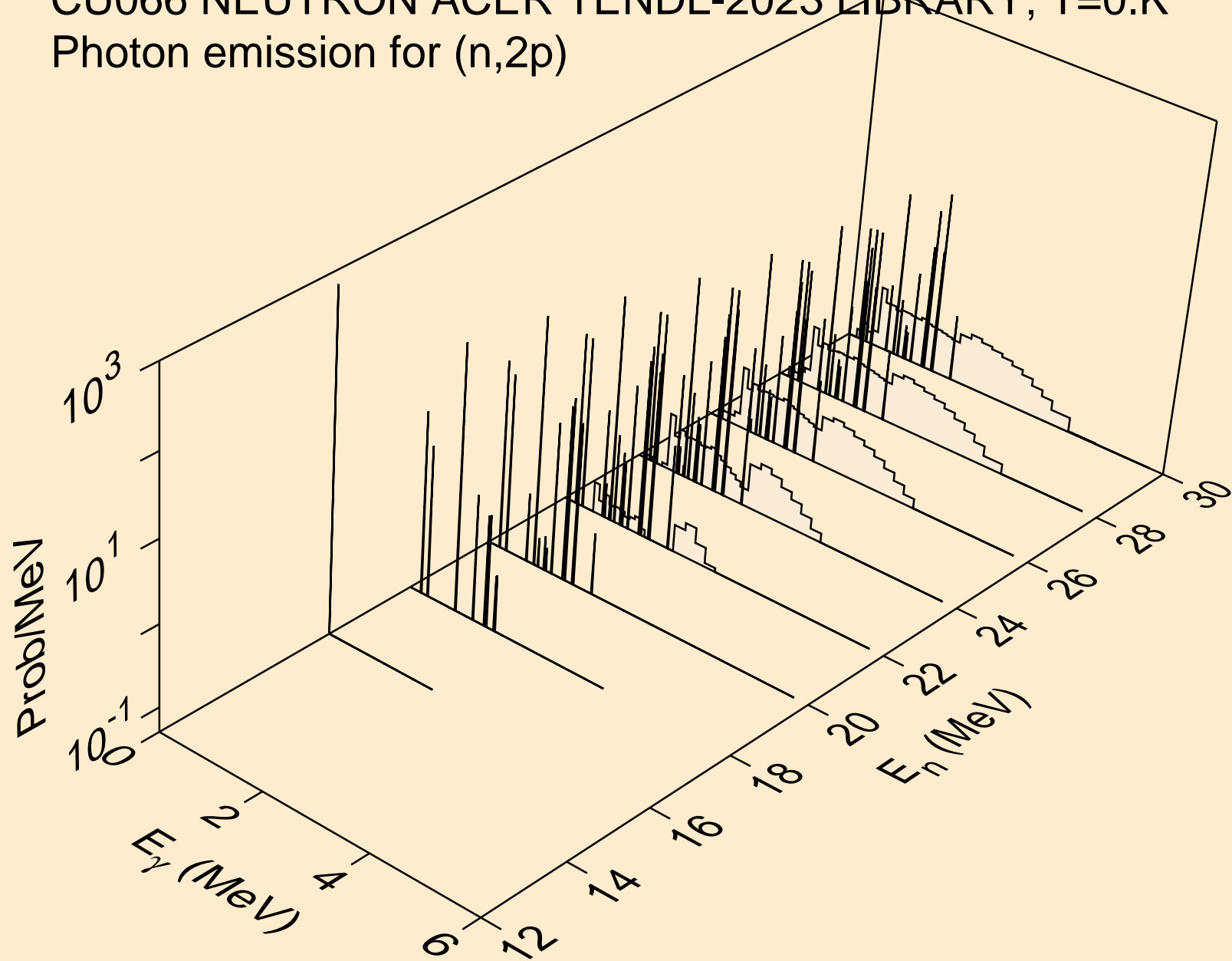

CU066 NEUTRON ACER TENDL-2023 LIBRARY; T=0.K  
Photon emission for (n,p)

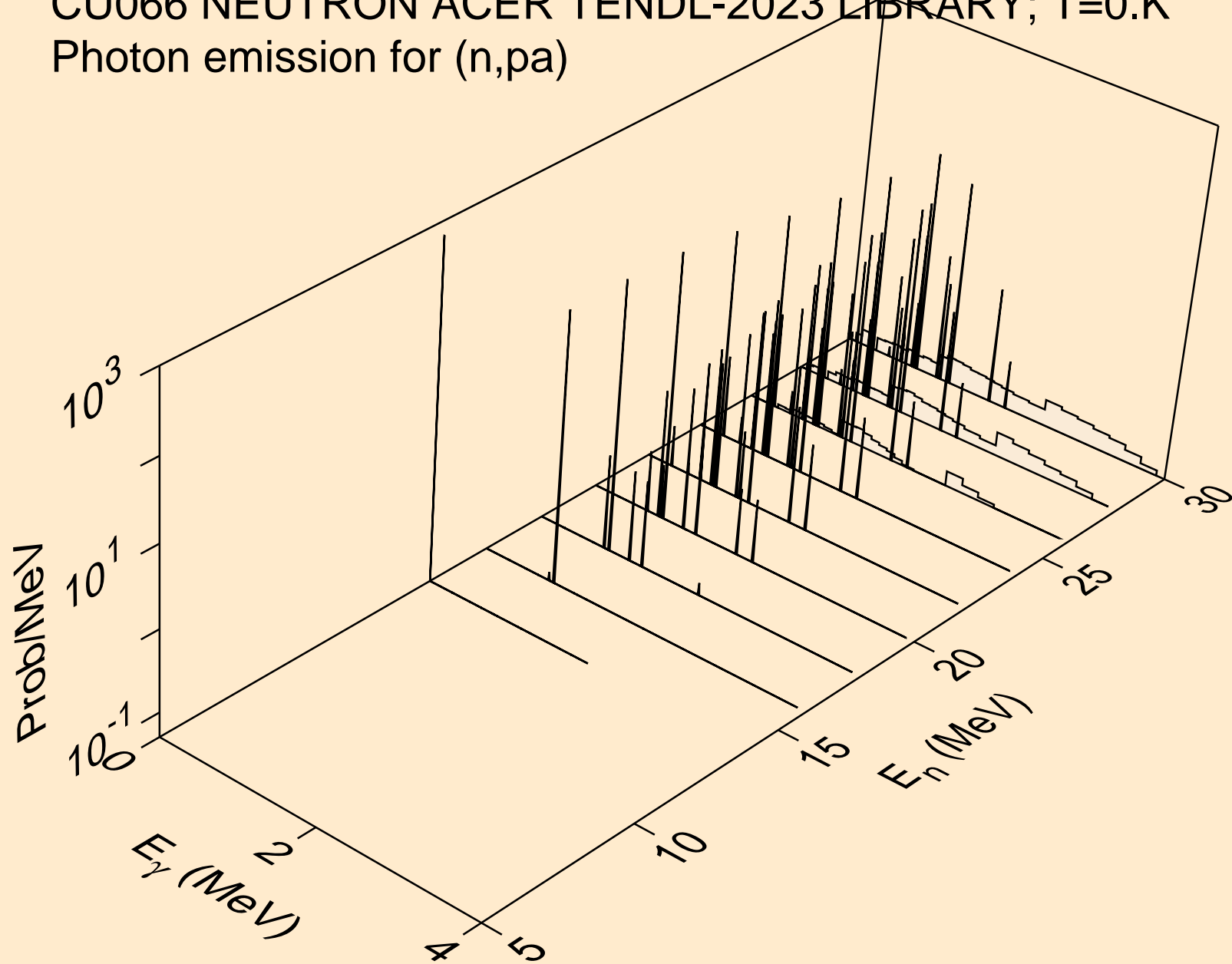

CU066 NEUTRON ACER TENDL-2023 LIBRARY; T=0.K  
Photon emission for (n,pd)

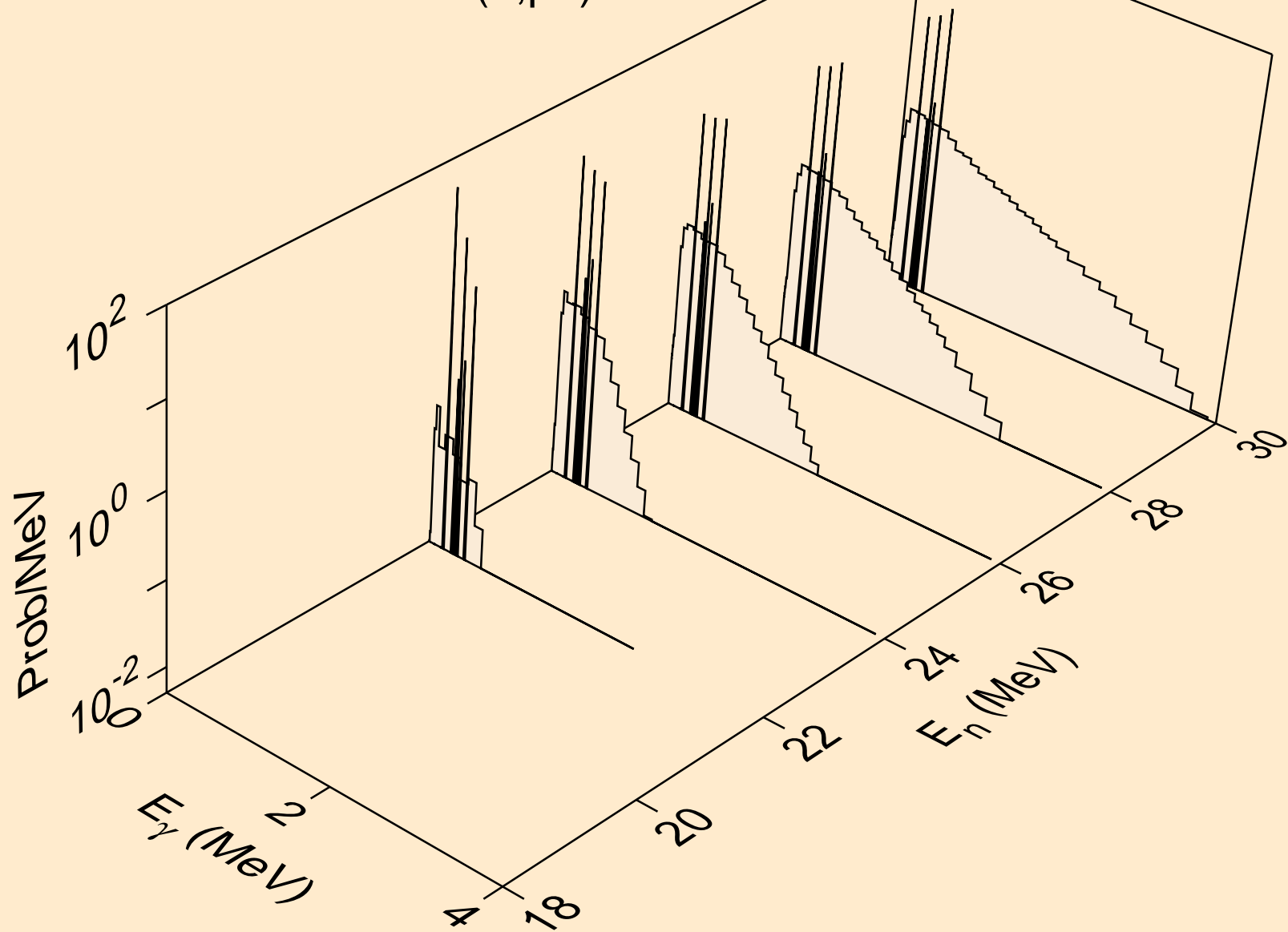

CU066 NEUTRON ACER TENDL-2023 LIBRARY; T=0.K  
Photon emission for (n,pt)

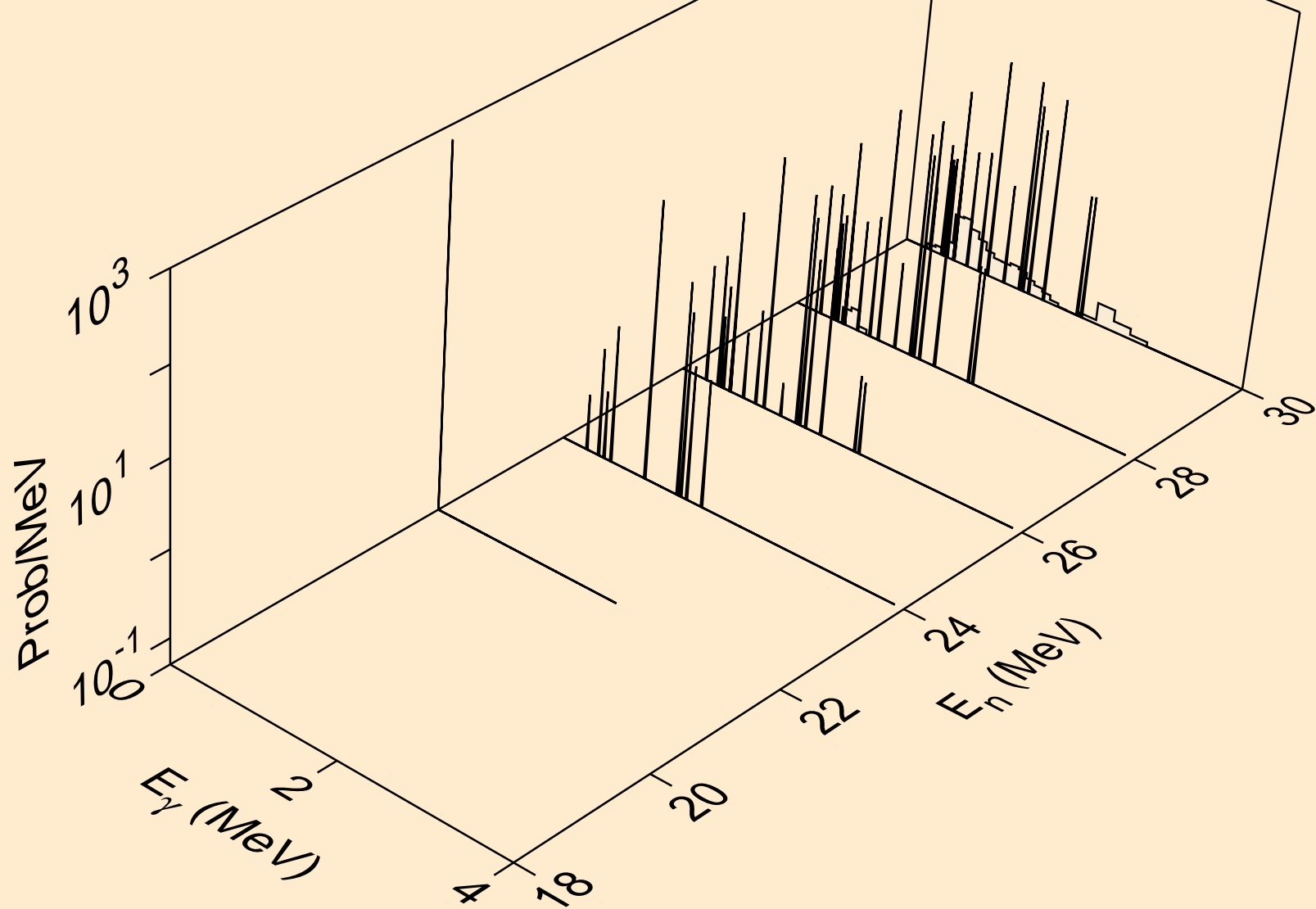

CU066 NEUTRON ACER TENDL-2023 LIBRARY; T=0.K  
Photon emission for (n,da)

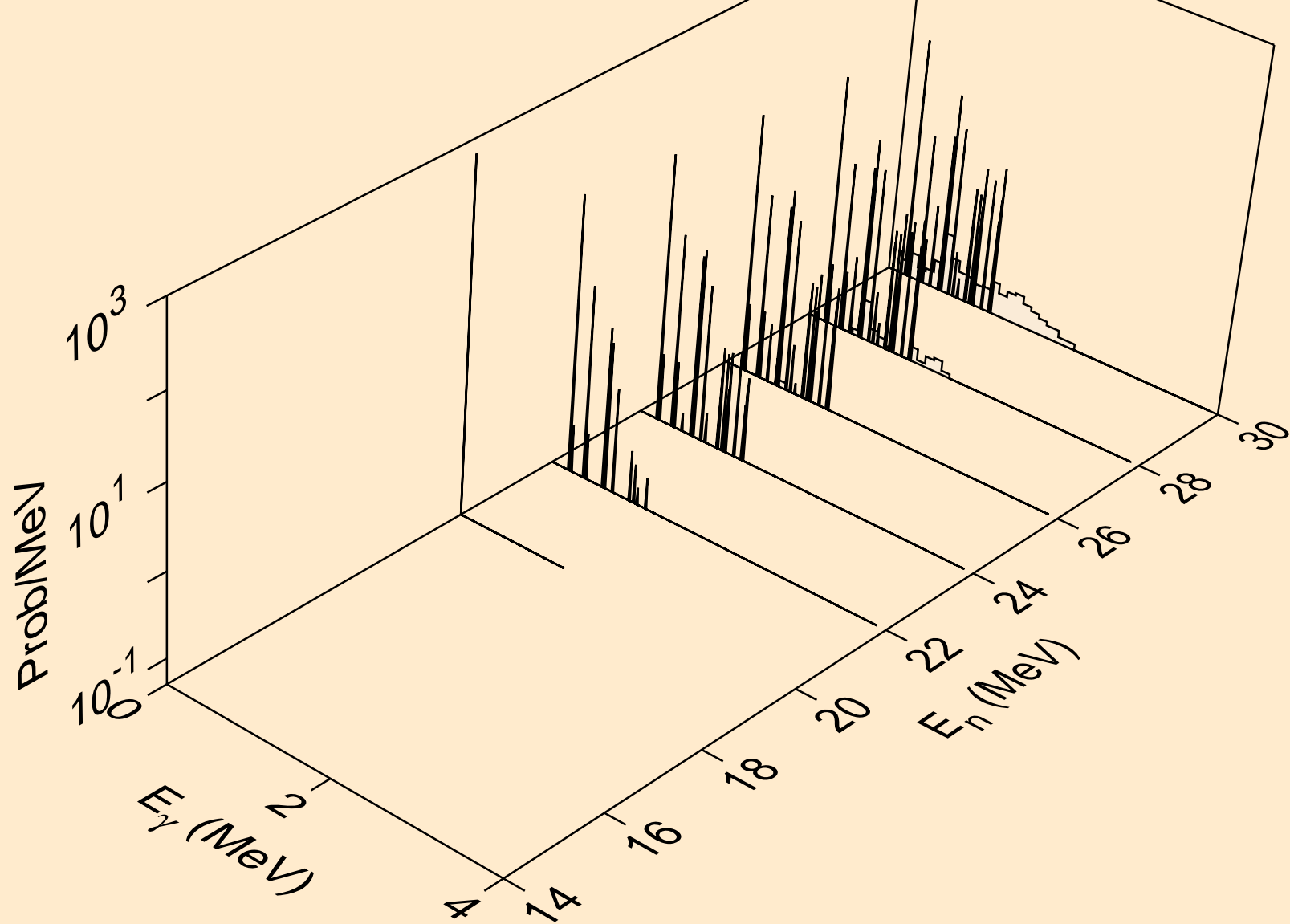

CU066 NEUTRON ACER TENDL-2023 LIBRARY; T=0.K  
thermal capture photon spectrum

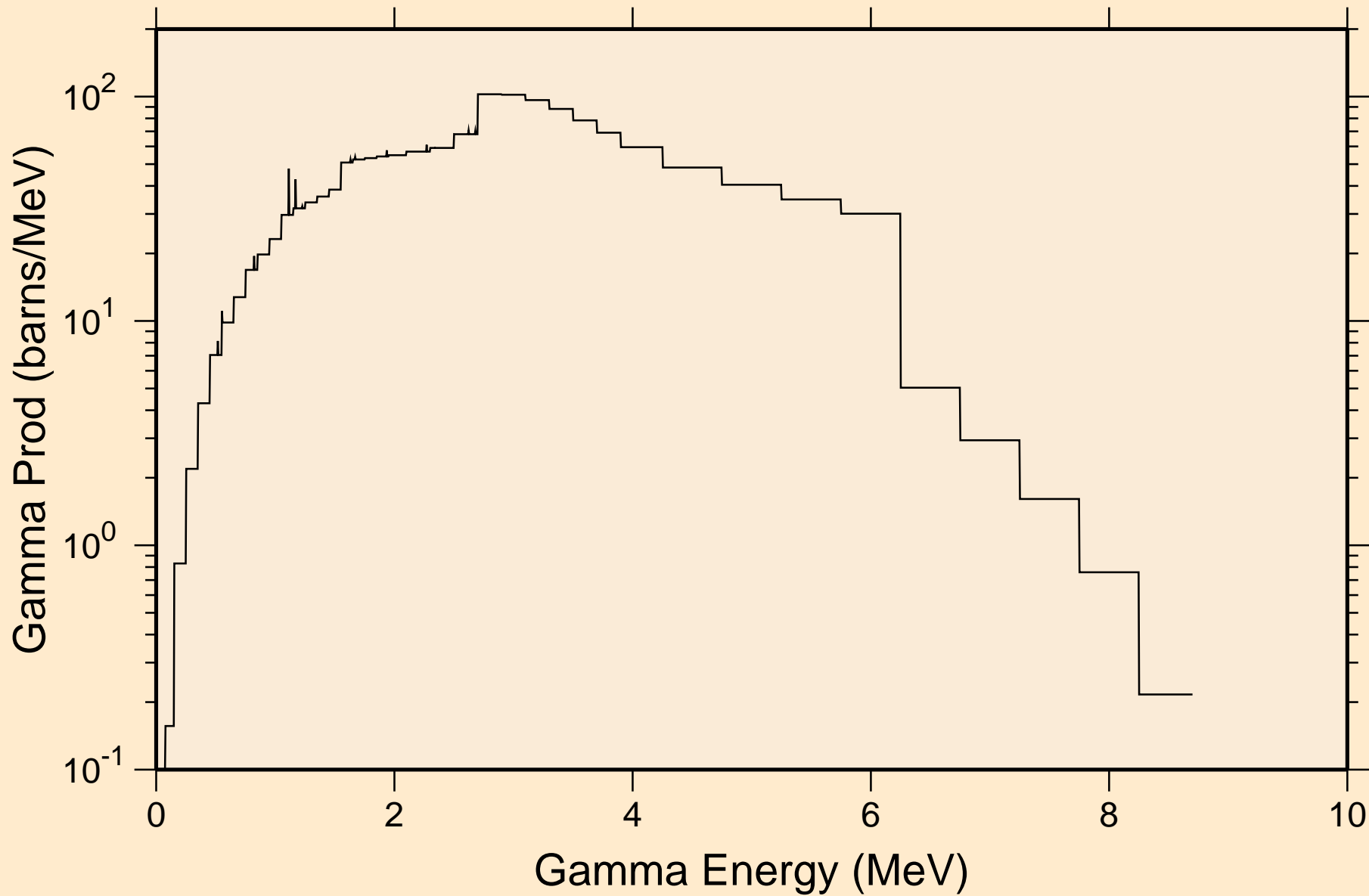

CU066 NEUTRON ACER TENDL-2023 LIBRARY; T=0.K  
14 MeV photon spectrum

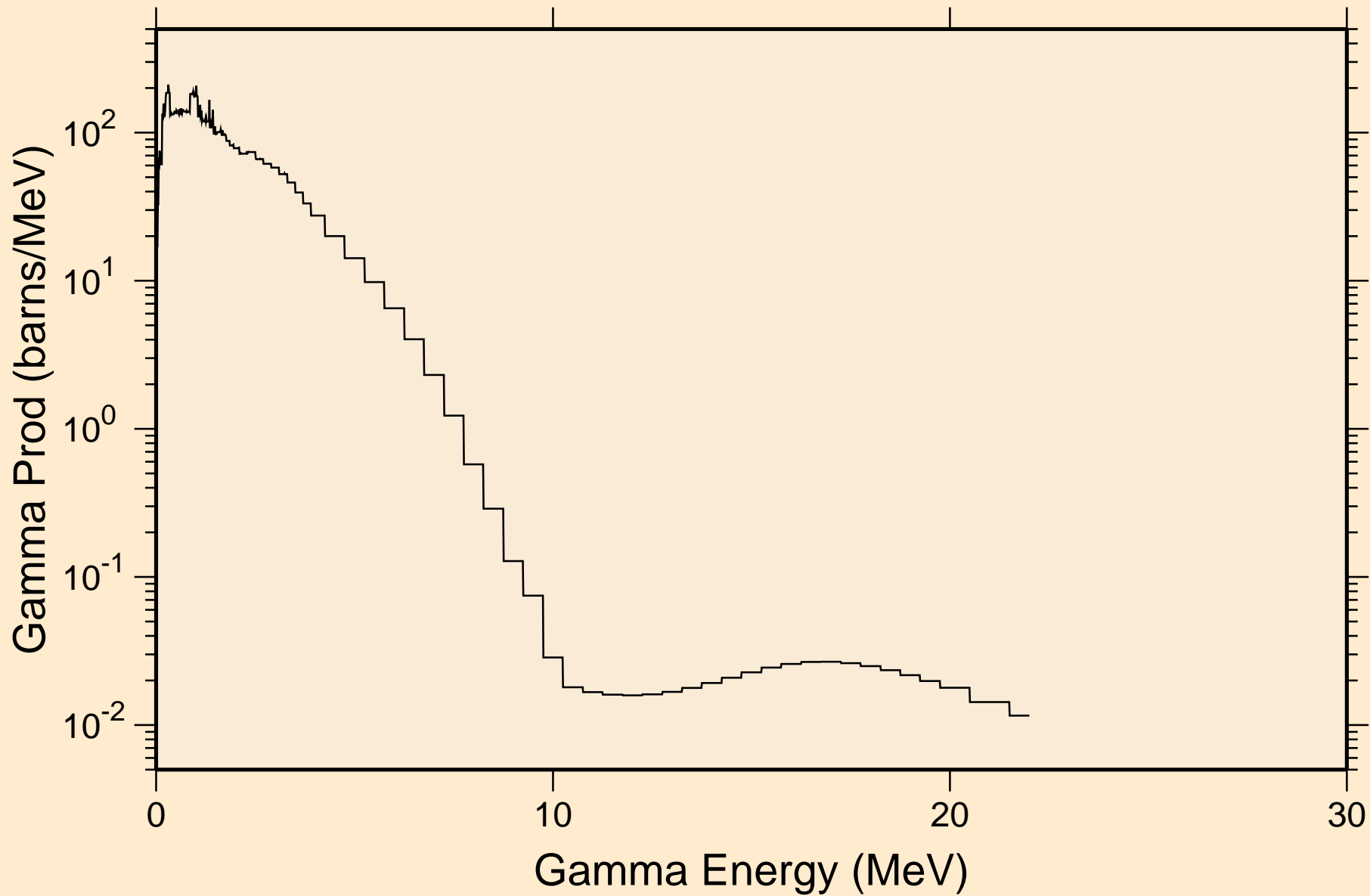

# CU066 NEUTRON ACER TENDL-2023 LIBRARY; T=0.K

## Particle heating contributions

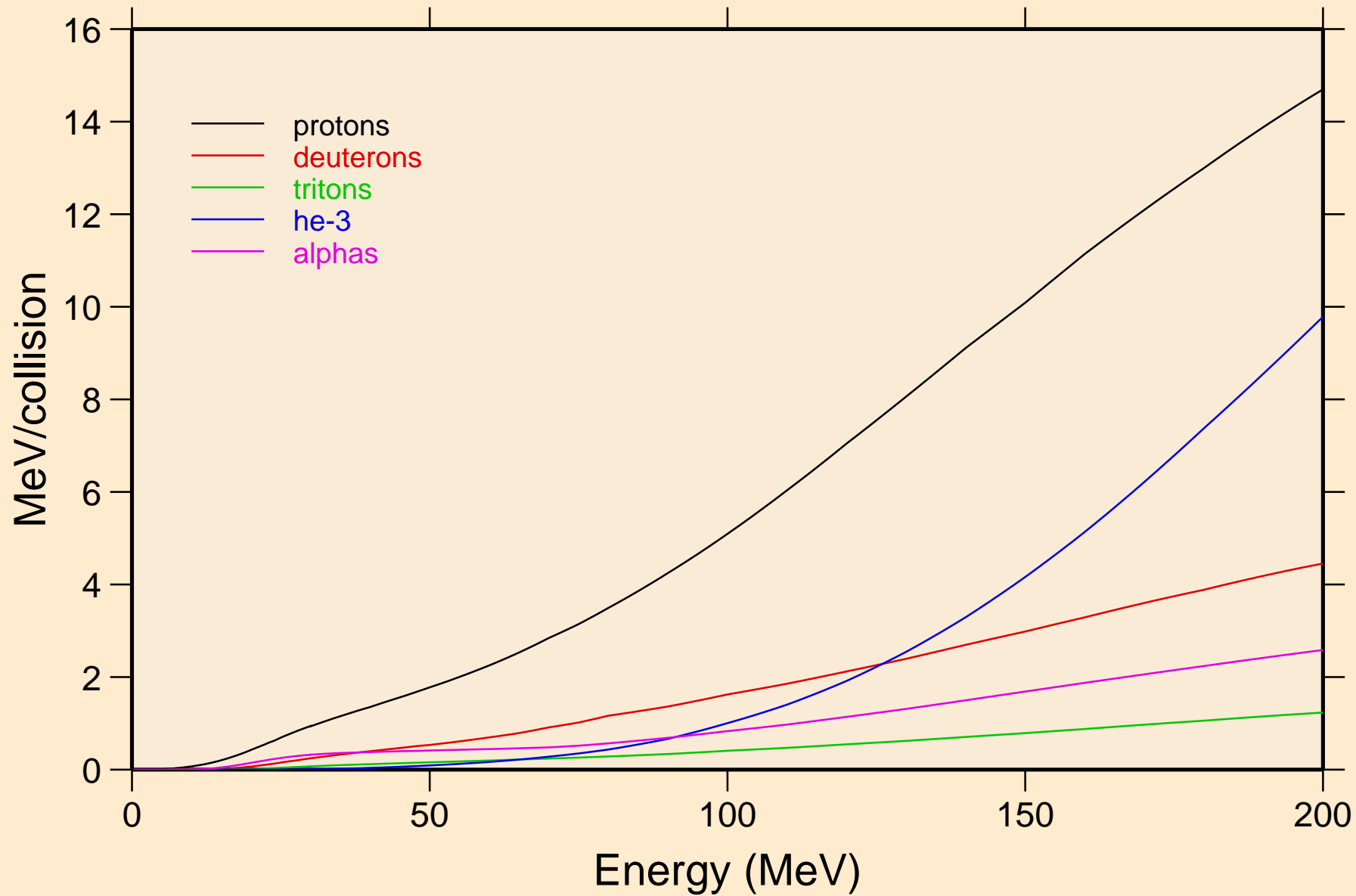



CU066 NEUTRON ACER TENDL-2023 LIBRARY; T=0.K  
Recoil Heating

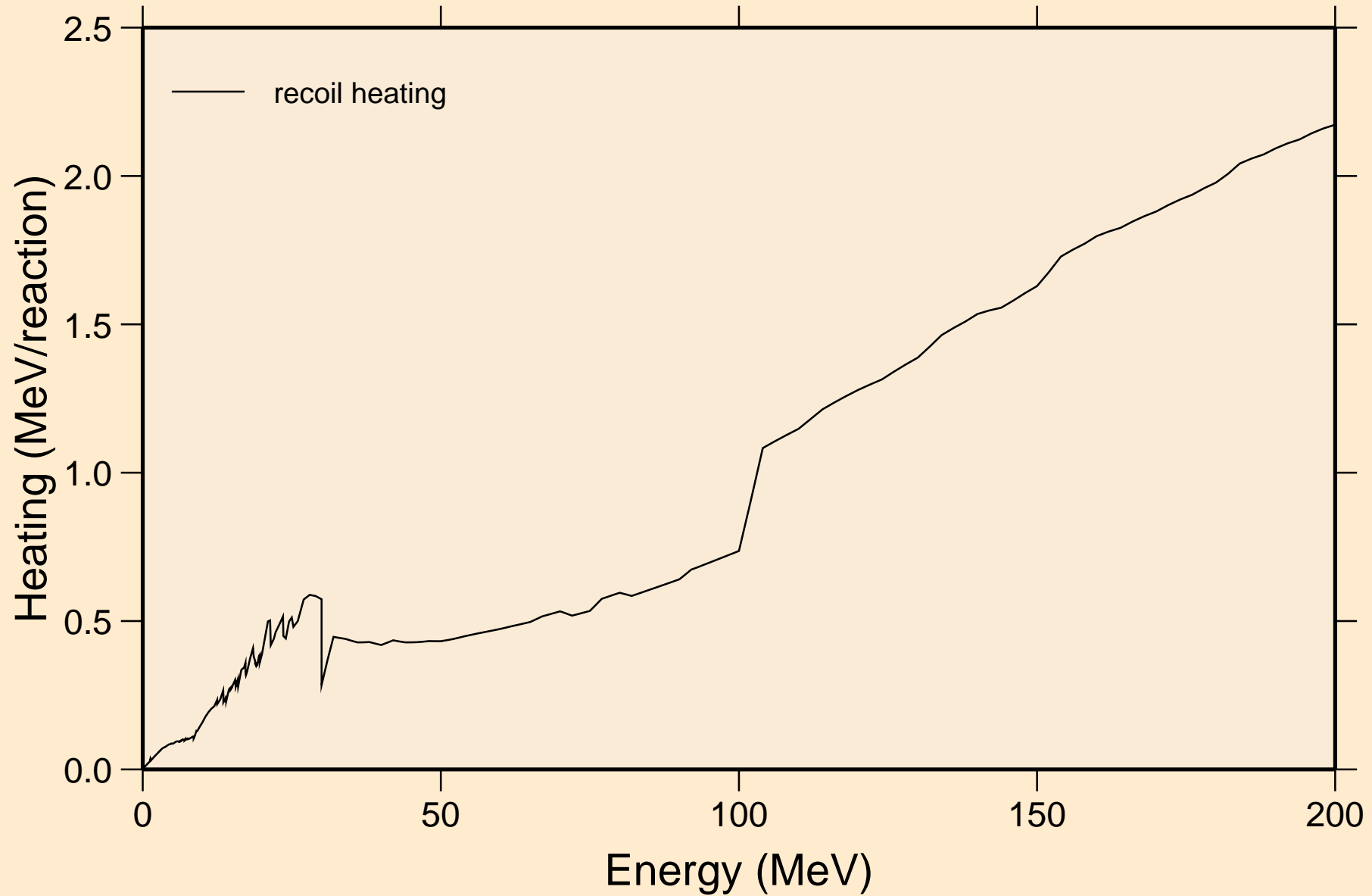

CU066 NEUTRON ACER TENDL-2023 LIBRARY; T=0.K  
Particle production cross sections

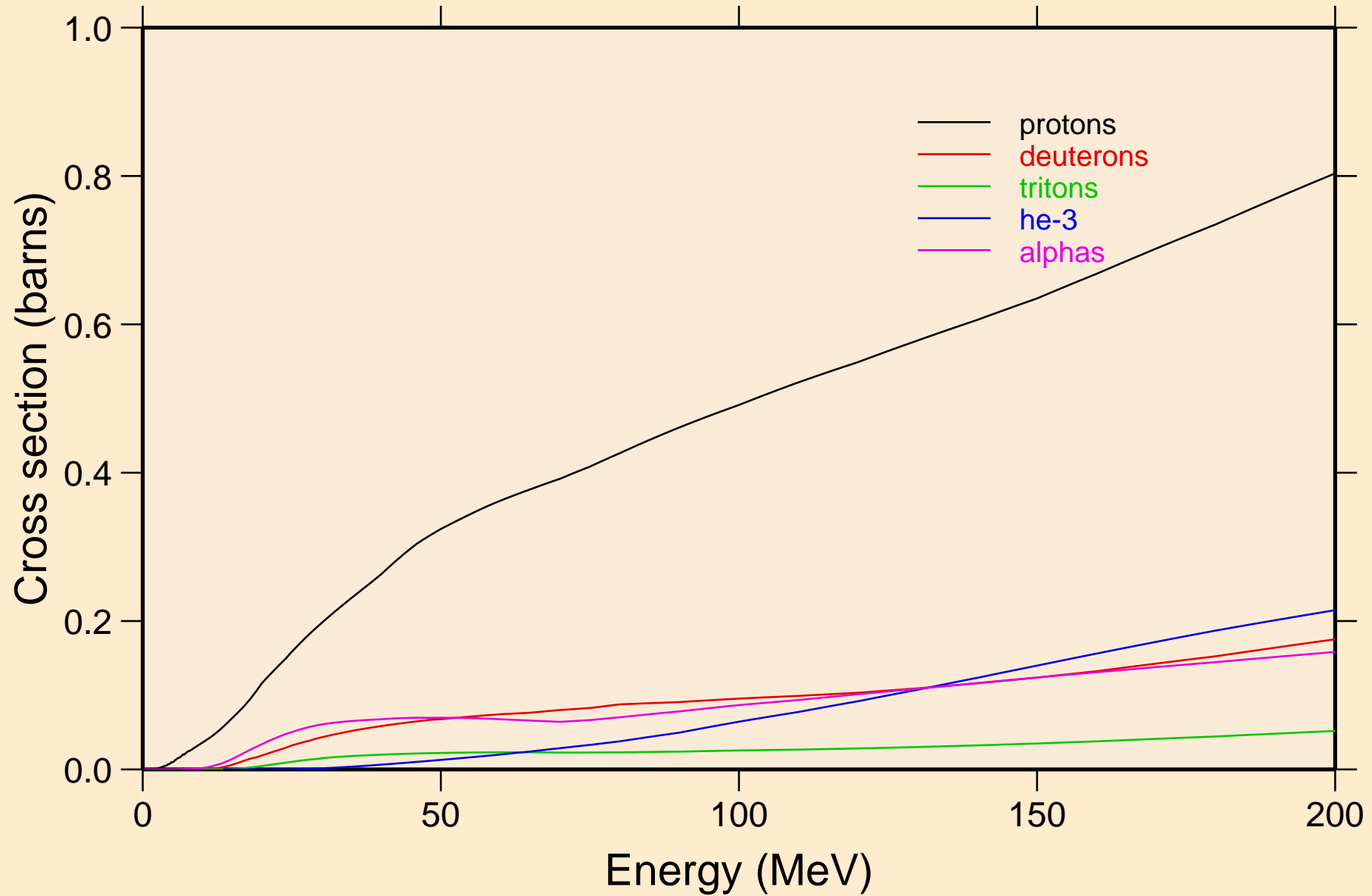

CU066 NEUTRON ACER TENDL-2023 LIBRARY; T=0.K  
protons from (n,x)

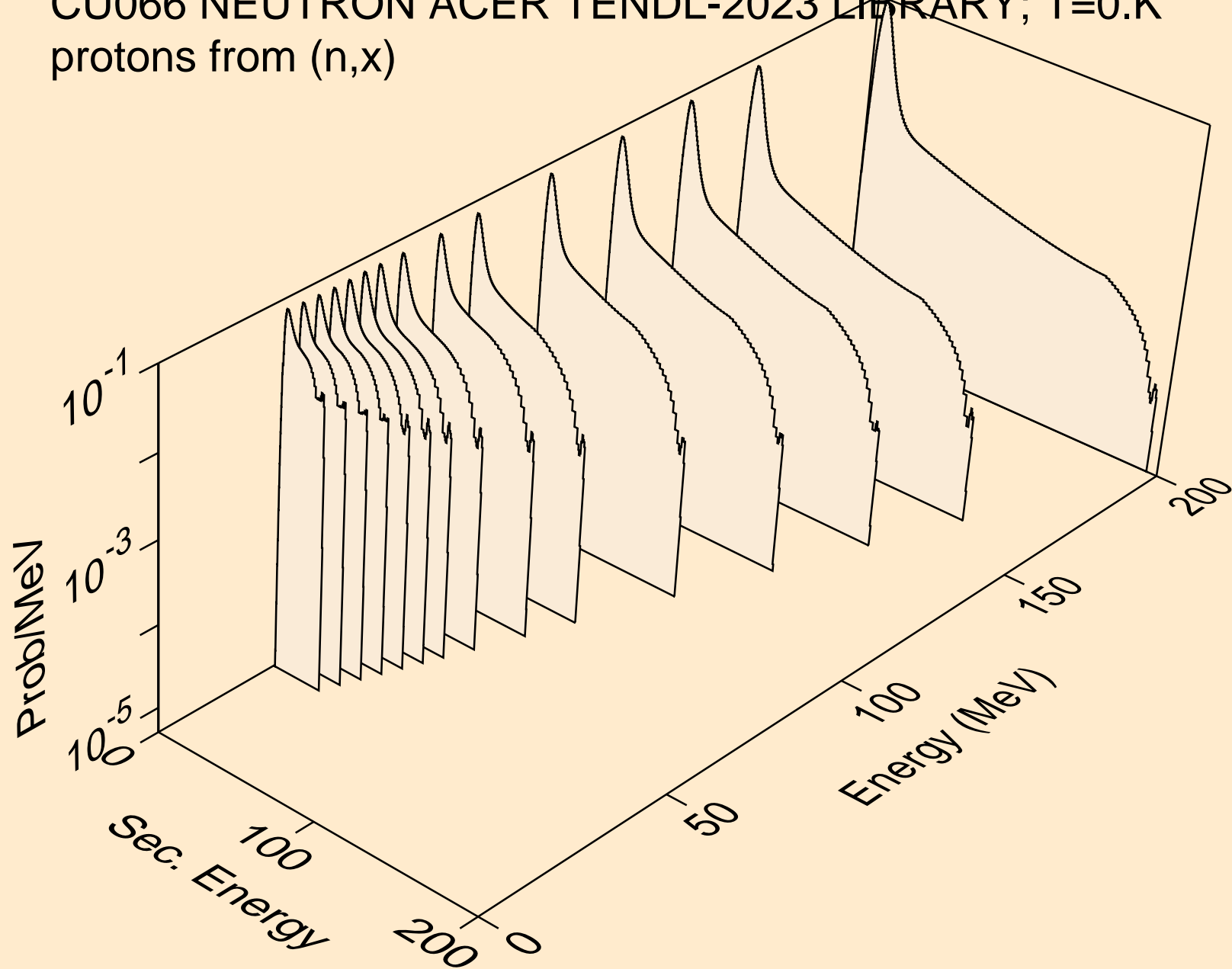

CU066 NEUTRON ACER TENDL-2023 LIBRARY; T=0.K  
protons from (n,n\*)p

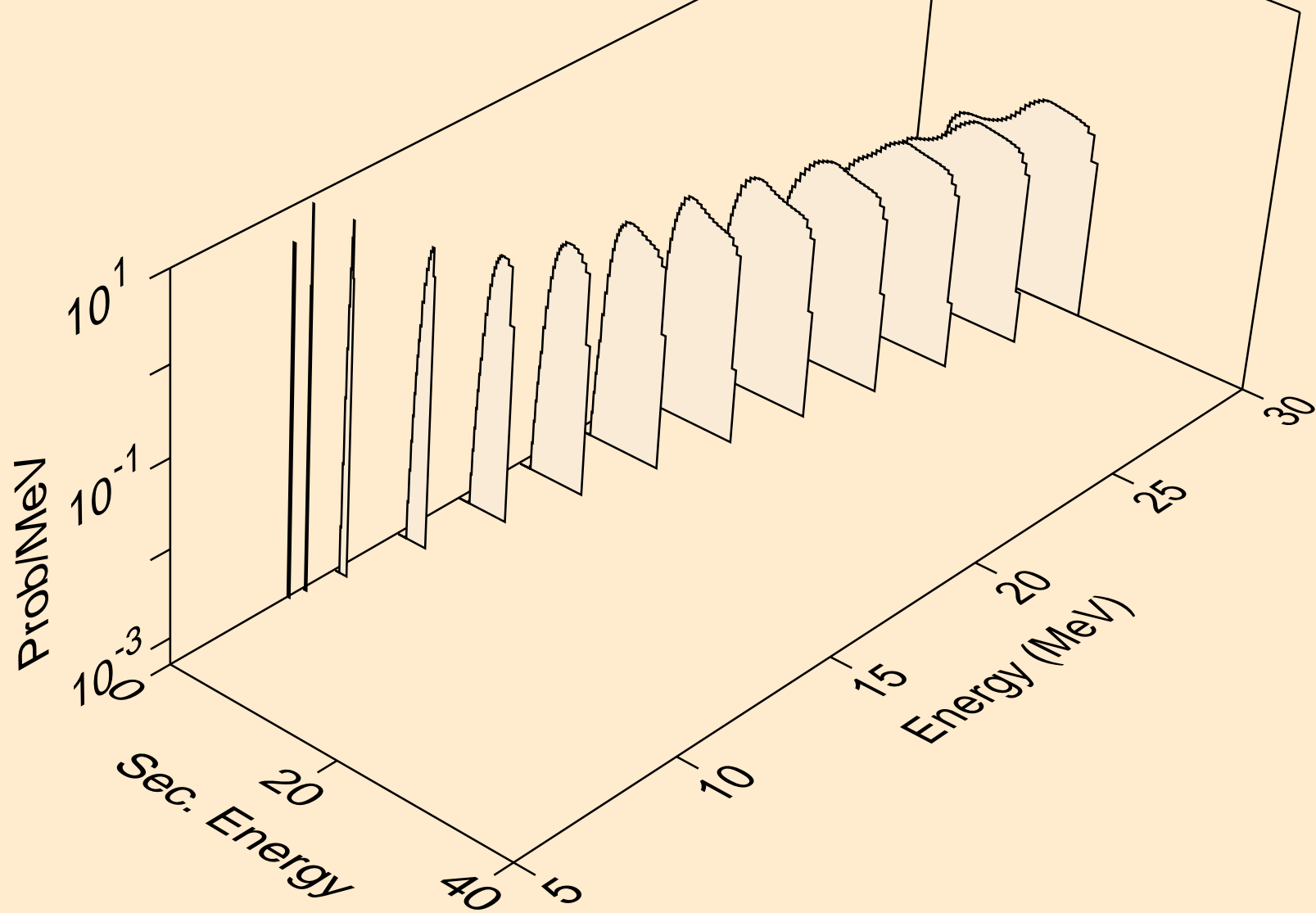

CU066 NEUTRON ACER TENDL-2023 LIBRARY; T=0.K  
protons from (n,2np)

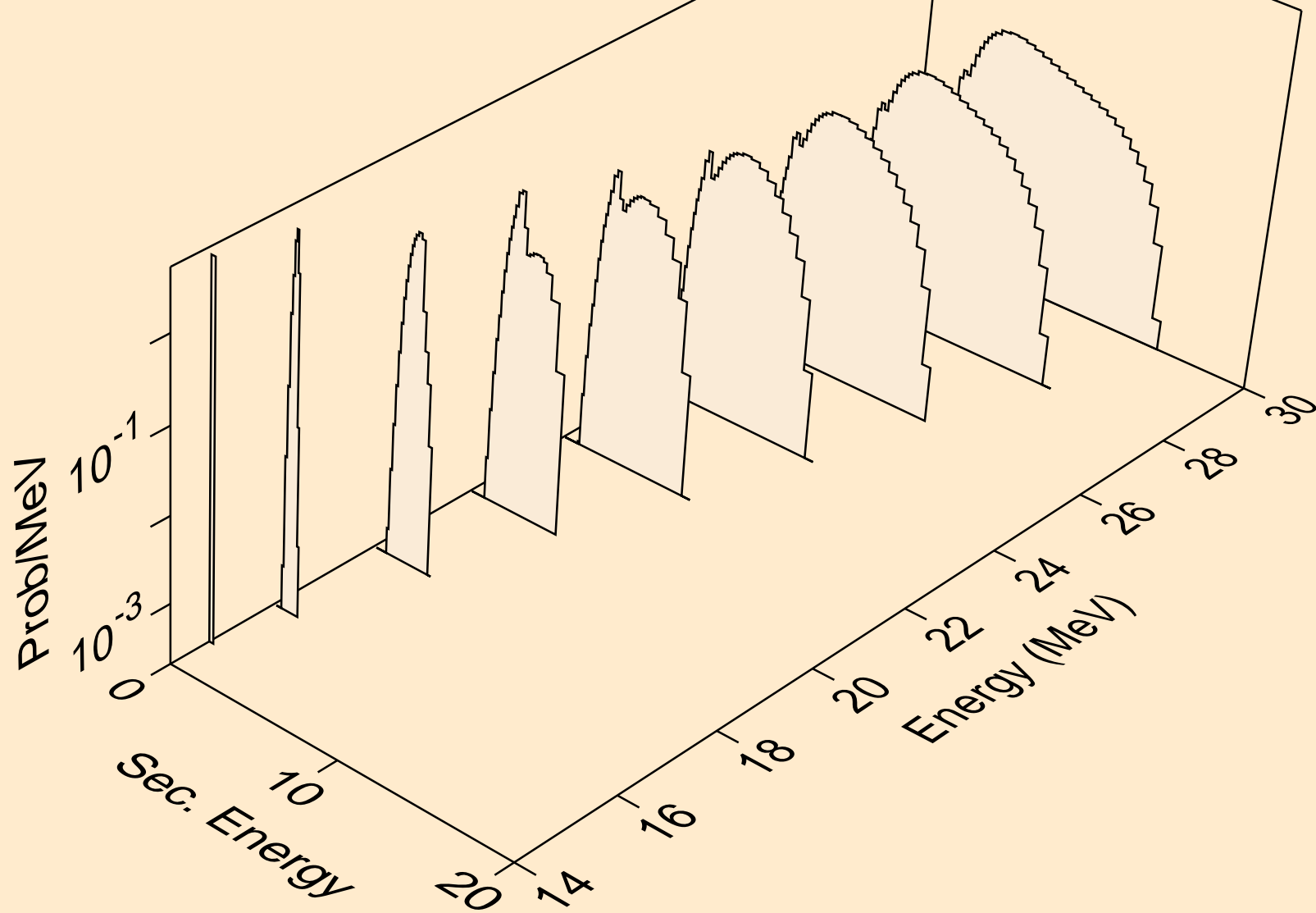

CU066 NEUTRON ACER TENDL-2023 LIBRARY; T=0.K  
protons from (n,3np)

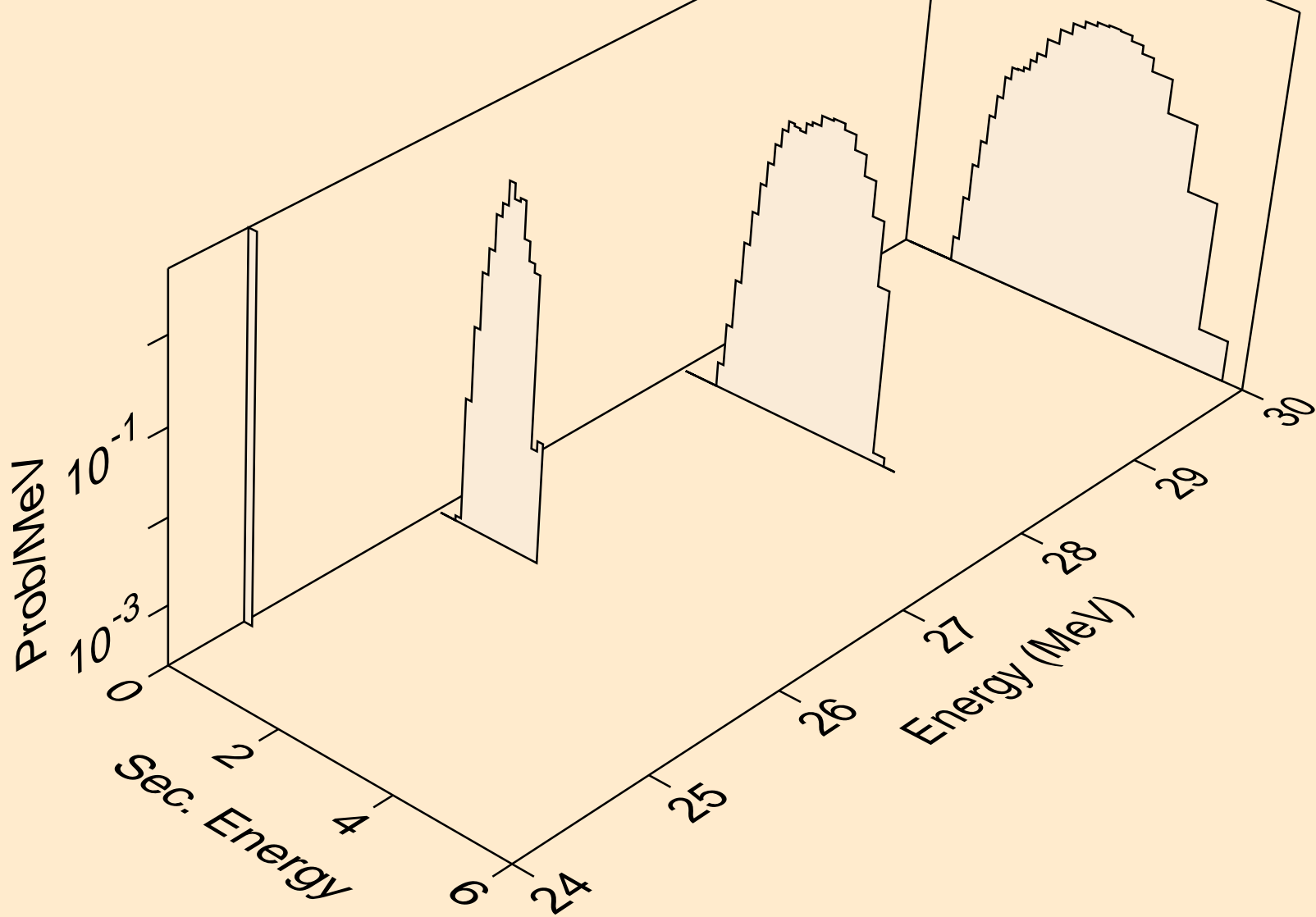

CU066 NEUTRON ACER TENDL-2023 LIBRARY; T=0.K  
protons from (n,n2p)

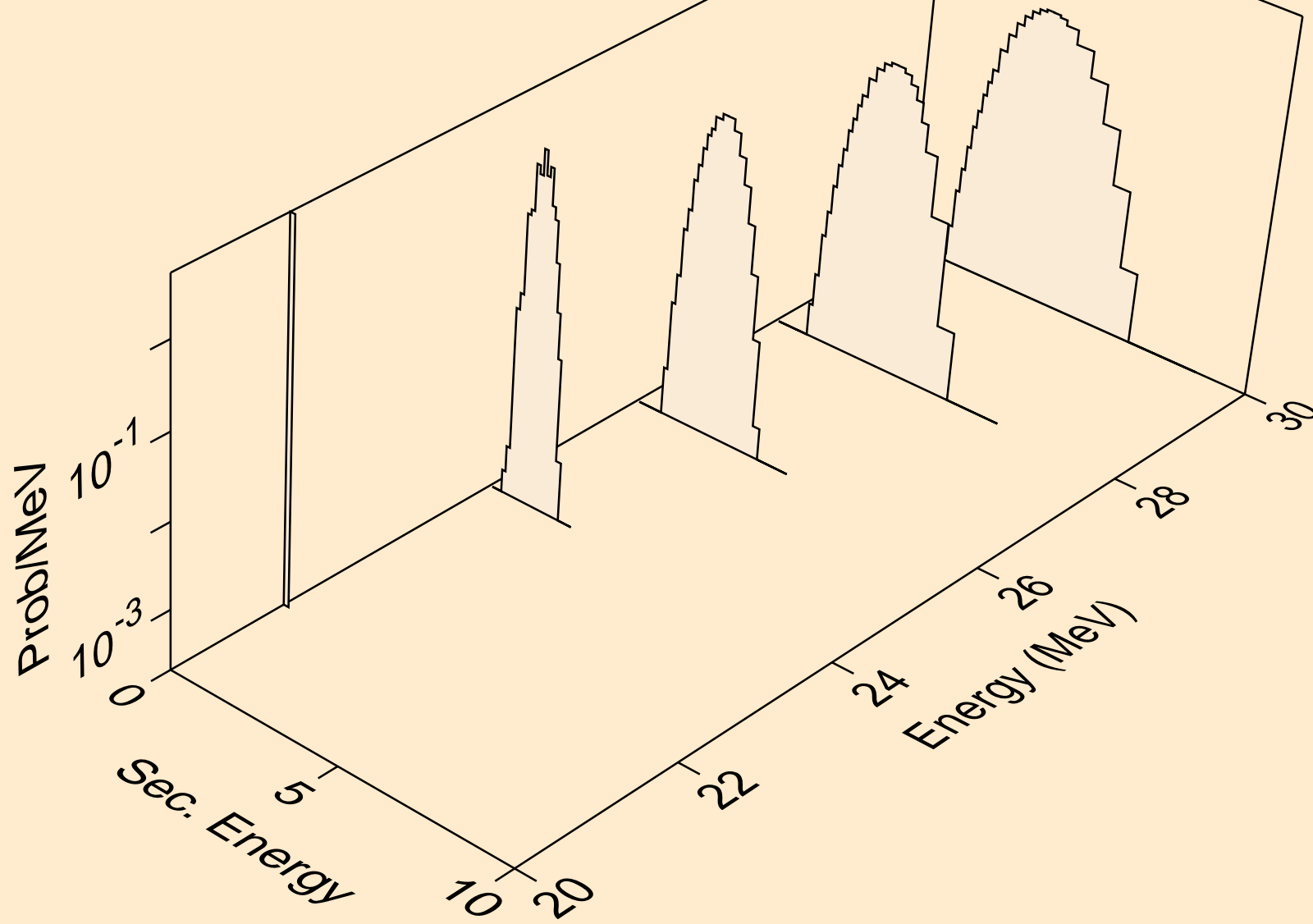

CU066 NEUTRON ACER TENDL-2023 LIBRARY; T=0.K  
protons from (n,npa)

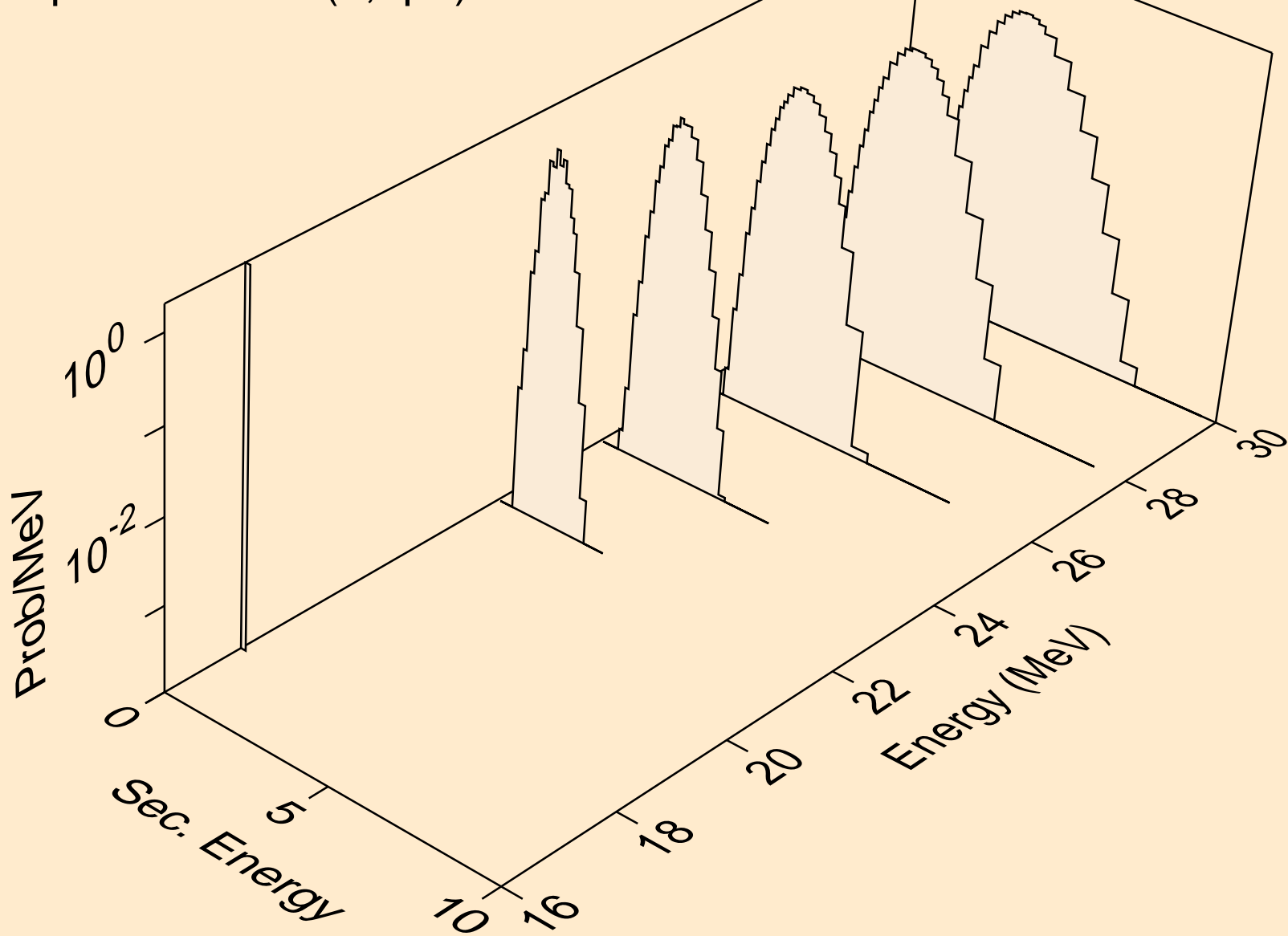



CU066 NEUTRON ACER TENDL-2023 LIBRARY; T=0.K  
protons from (n,p)

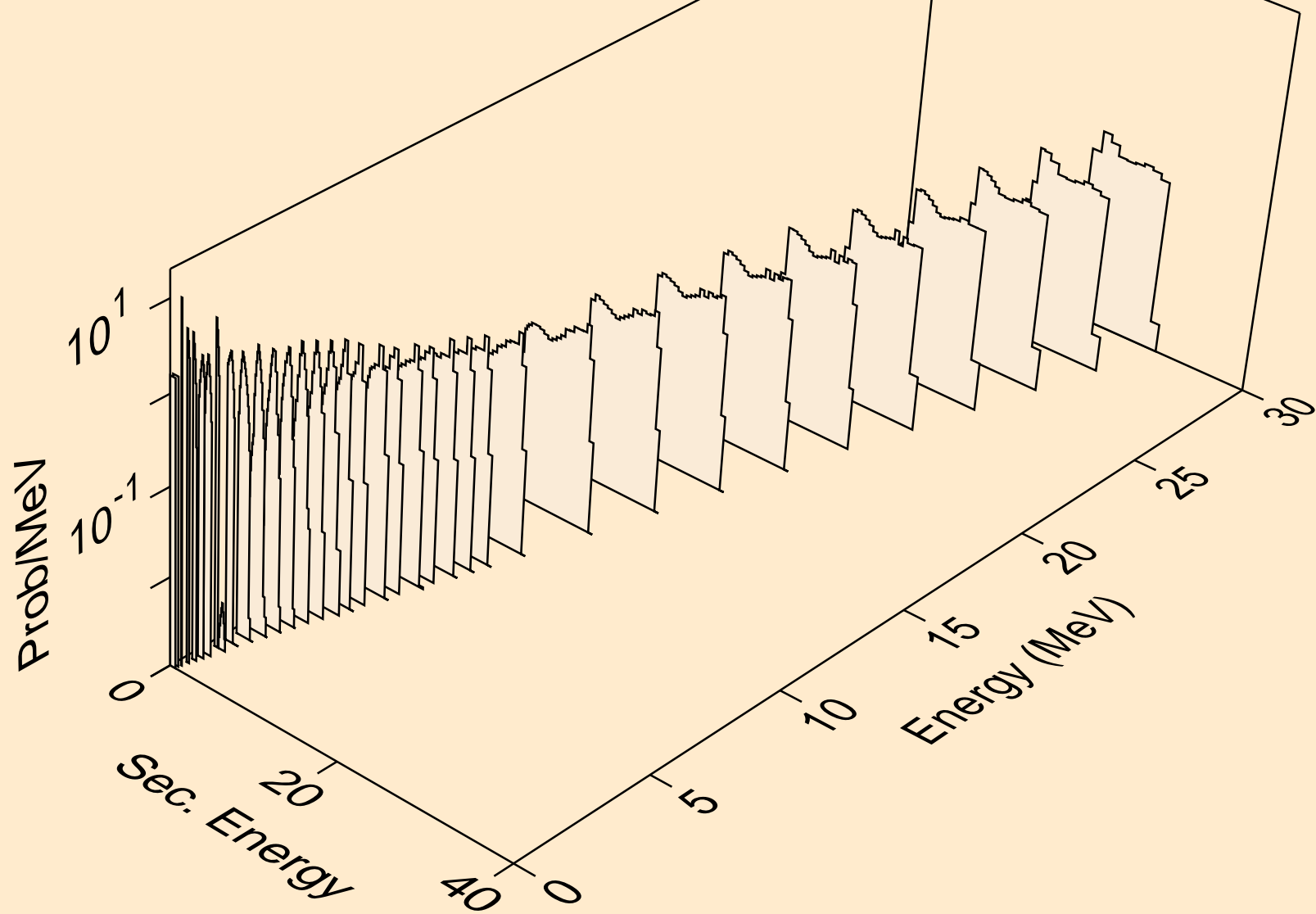

CU066 NEUTRON ACER TENDL-2023 LIBRARY; T=0.K  
protons from (n,2p)

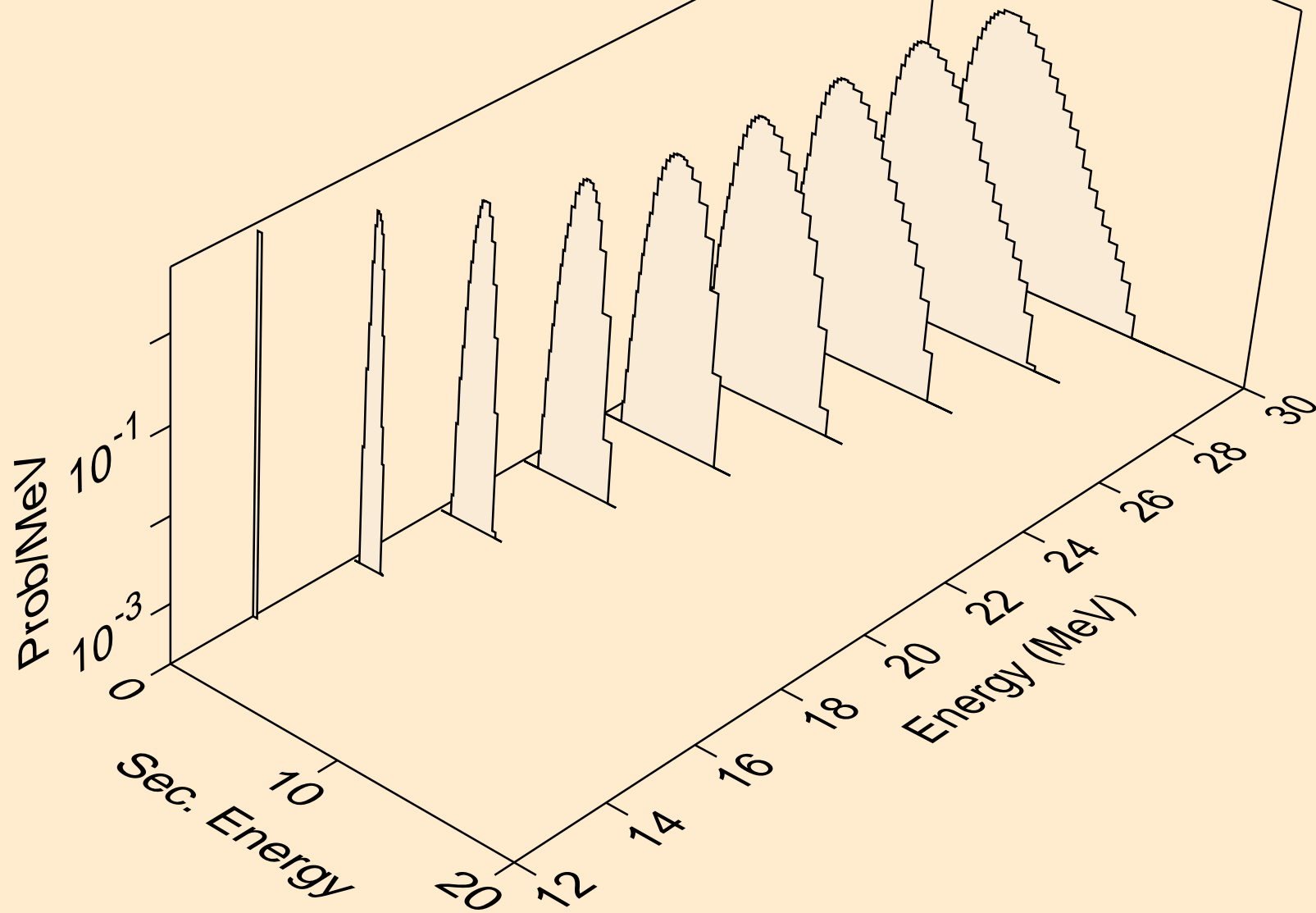

CU066 NEUTRON ACER TENDL-2023 LIBRARY; T=0.K  
protons from (n,p)

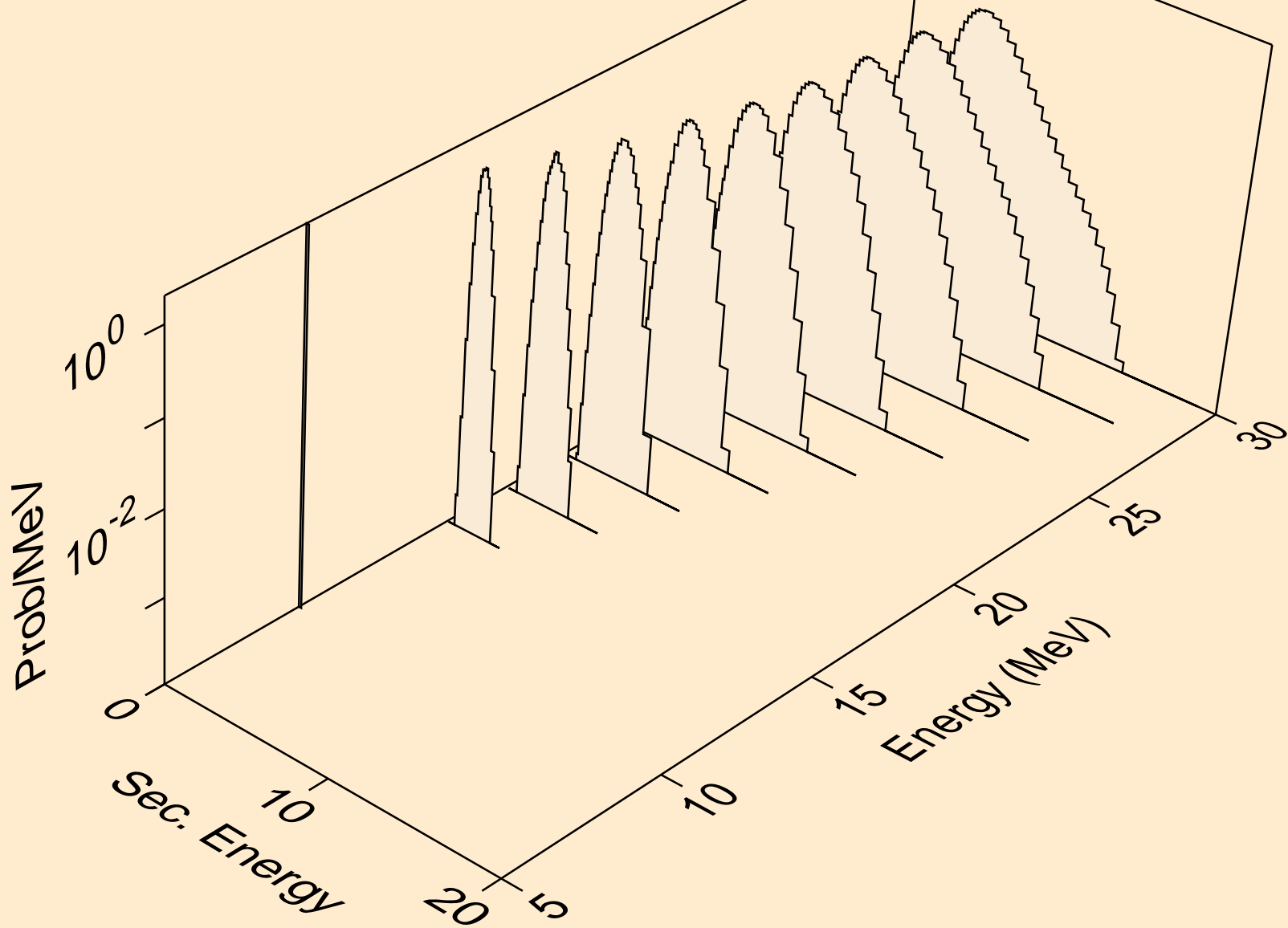

CU066 NEUTRON ACER TENDL-2023 LIBRARY; T=0.K  
protons from (n,pd)

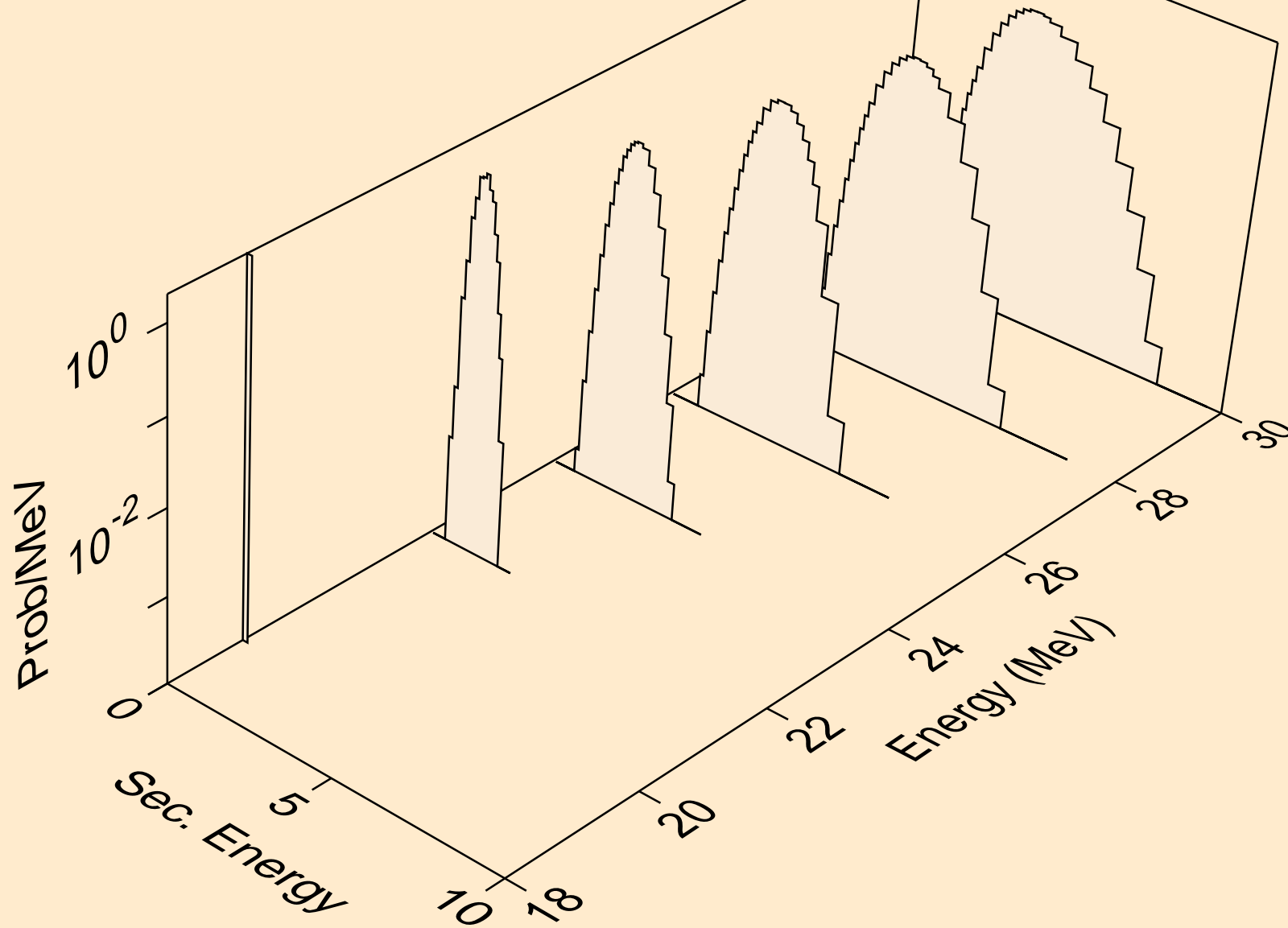

CU066 NEUTRON ACER TENDL-2023 LIBRARY; T=0.K  
protons from (n,pt)

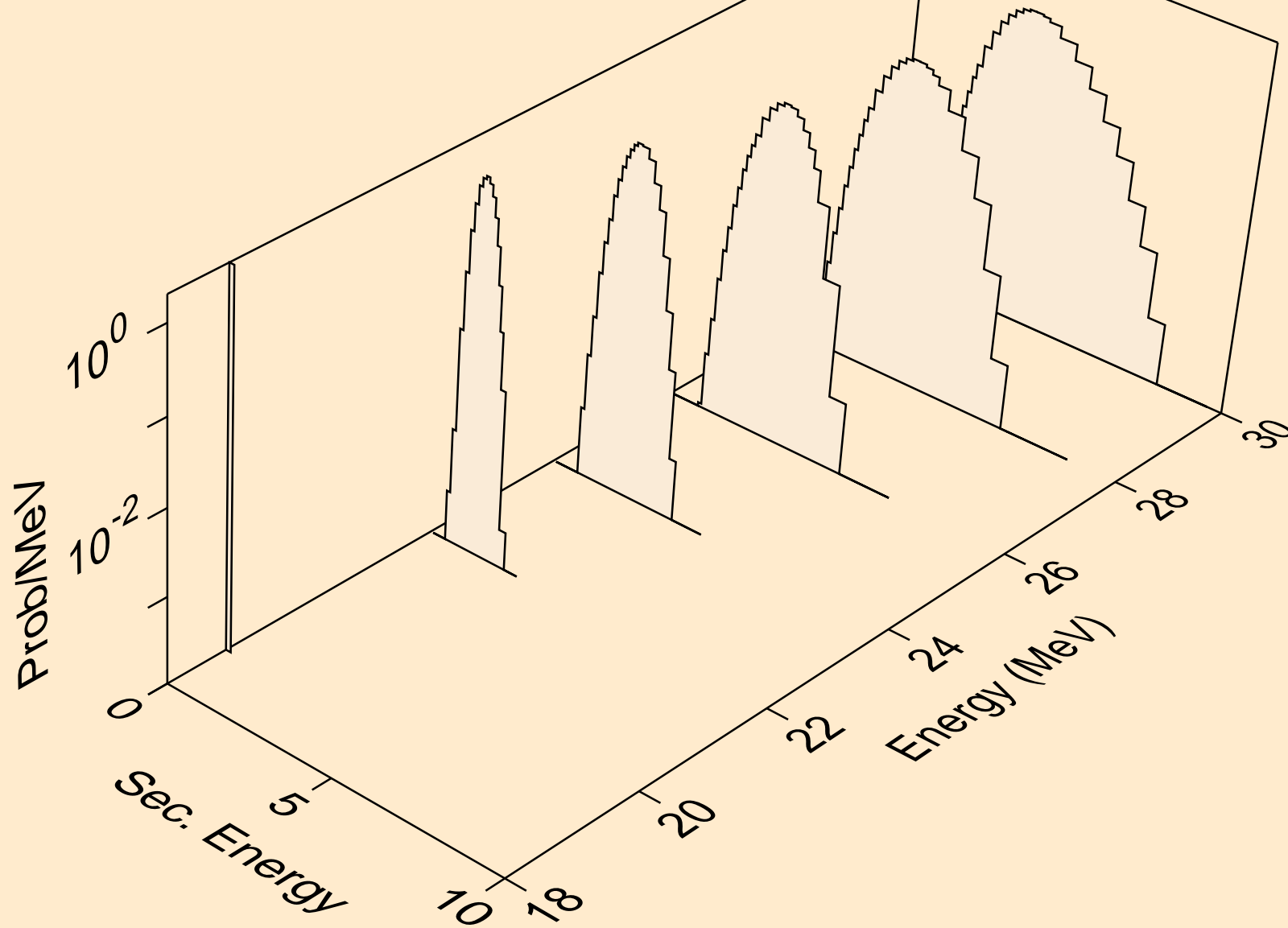

CU066 NEUTRON ACER TENDL-2023 LIBRARY; T=0.K  
deuterons from (n,x)

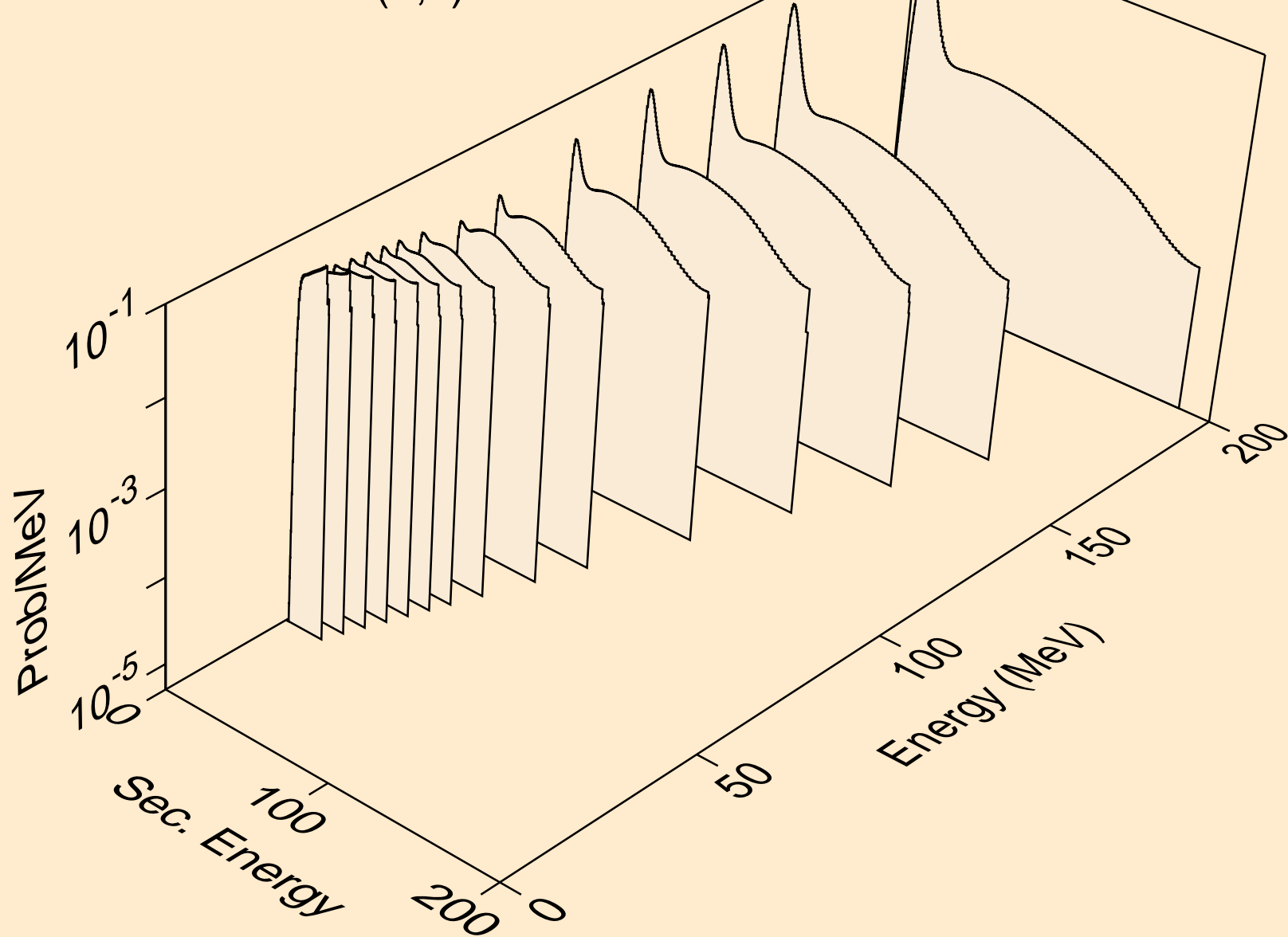

CU066 NEUTRON ACER TENDL-2023 LIBRARY; T=0.K  
deuterons from (n,2nd)

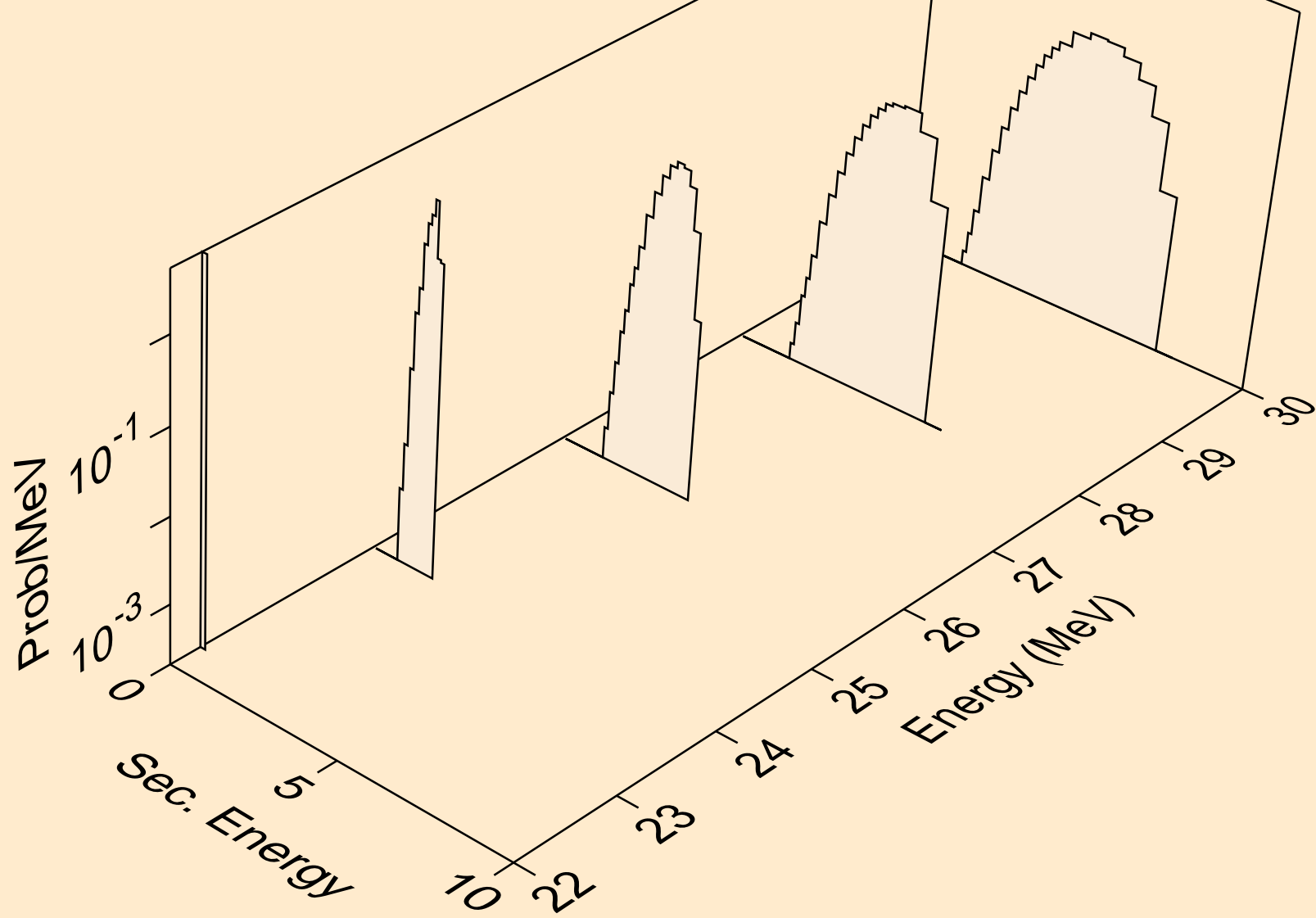

CU066 NEUTRON ACER TENDL-2023 LIBRARY; T=0.K  
deuterons from (n,n\*)d

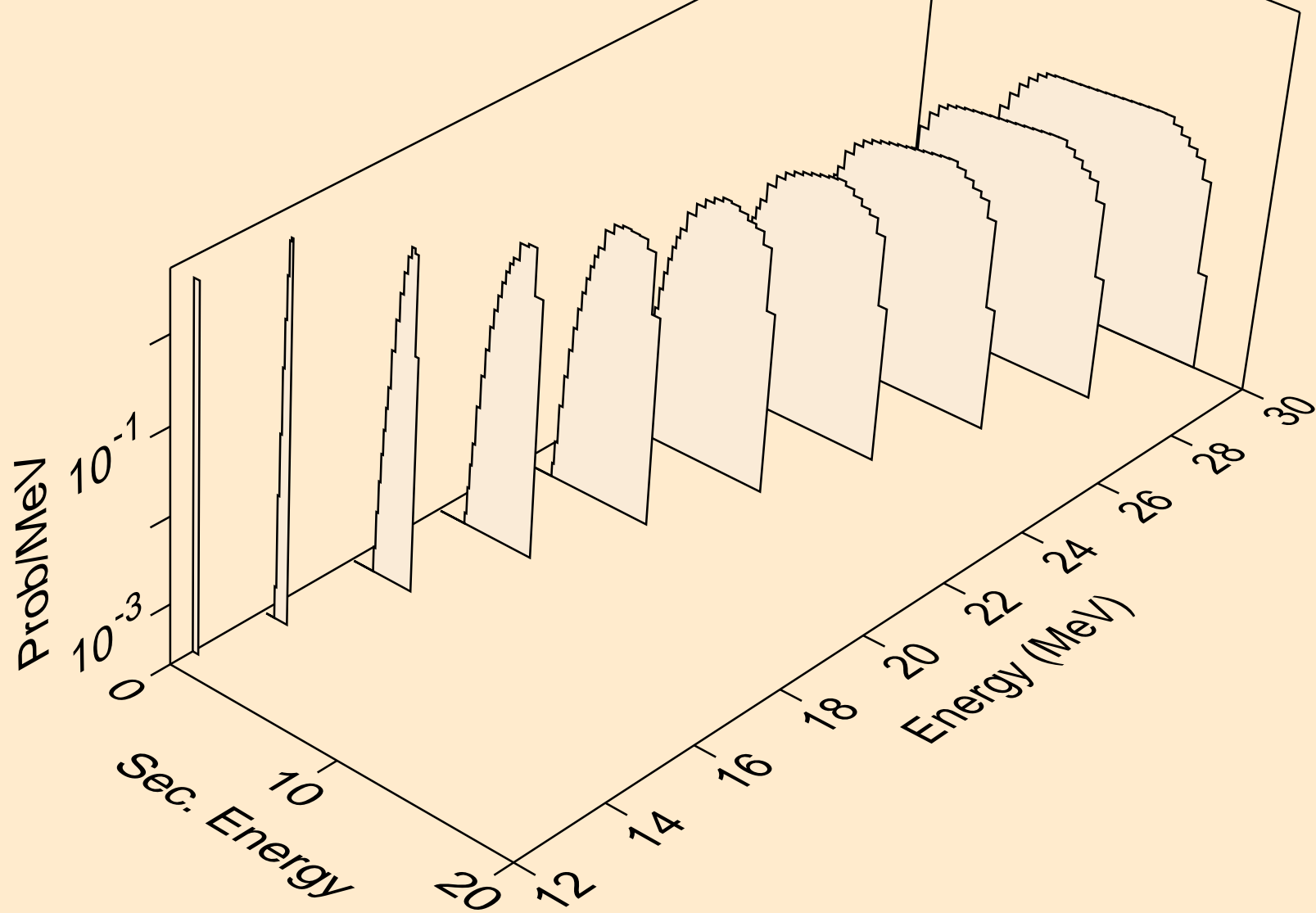



CU066 NEUTRON ACER TENDL-2023 LIBRARY; T=0.K  
deuterons from (n,d)

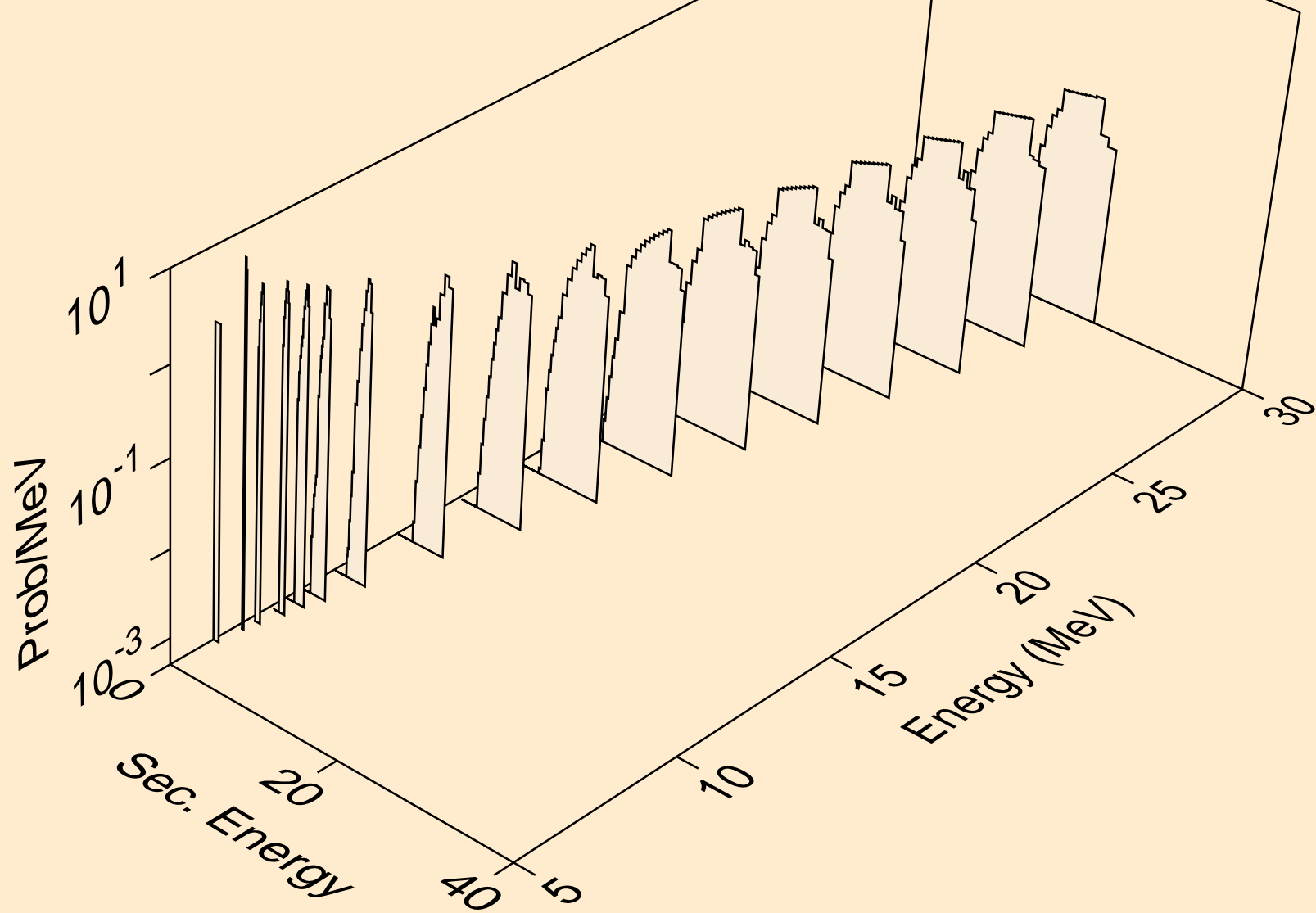

CU066 NEUTRON ACER TENDL-2023 LIBRARY; T=0.K  
deuterons from (n,pd)

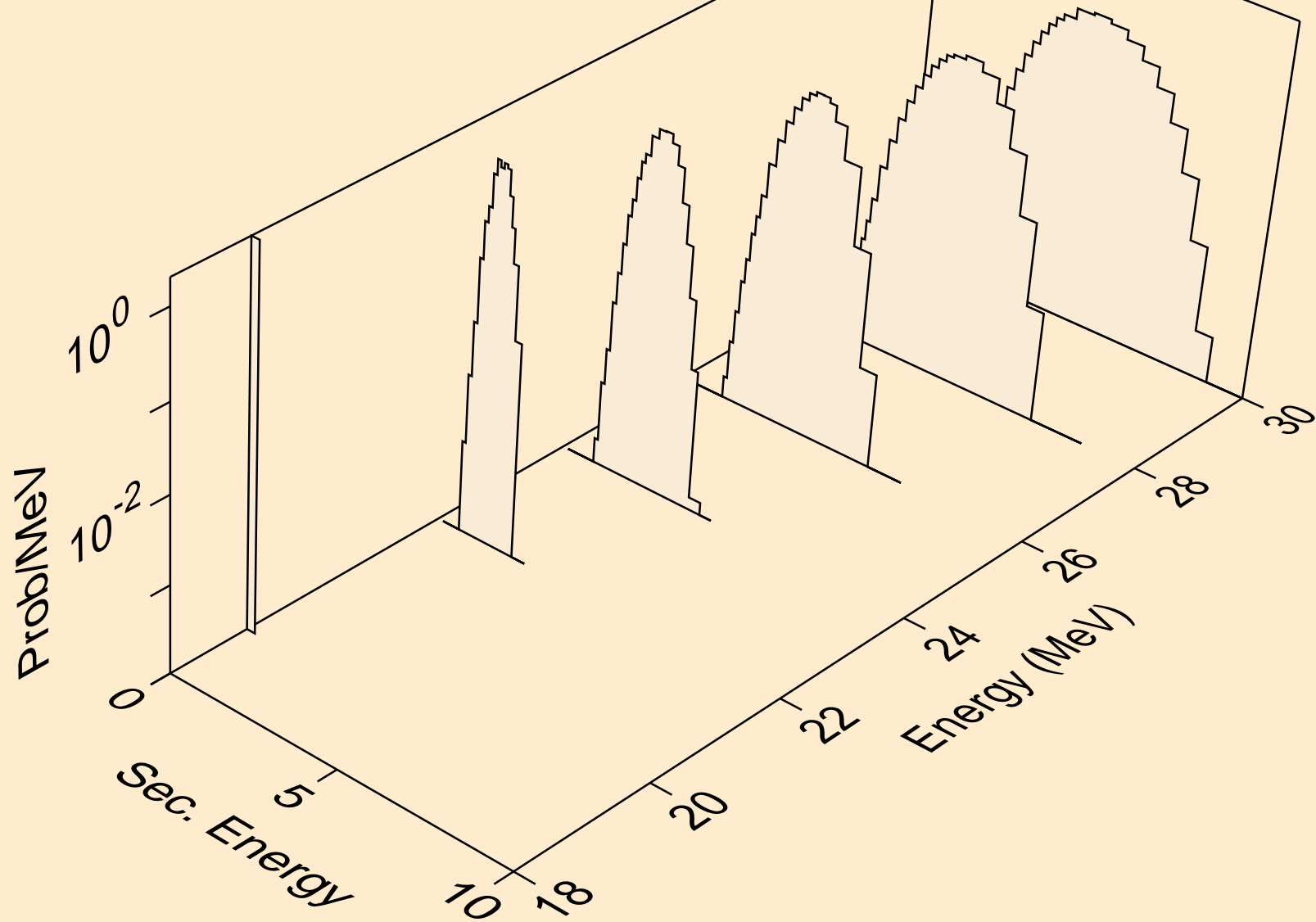

CU066 NEUTRON ACER TENDL-2023 LIBRARY; T=0.K  
deuterons from (n,da)

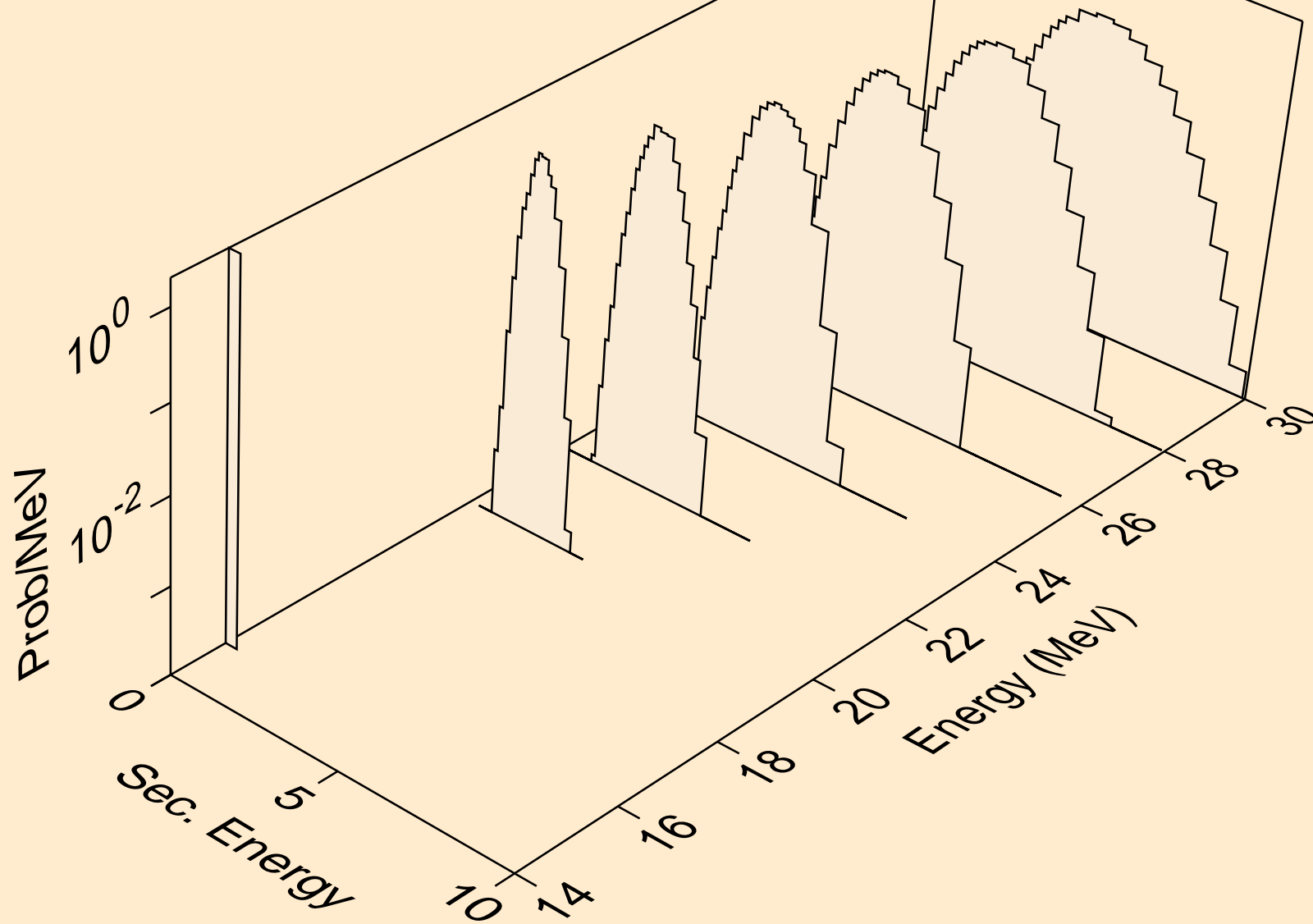

CU066 NEUTRON ACER TENDL-2023 LIBRARY; T=0.K  
tritons from (n,x)

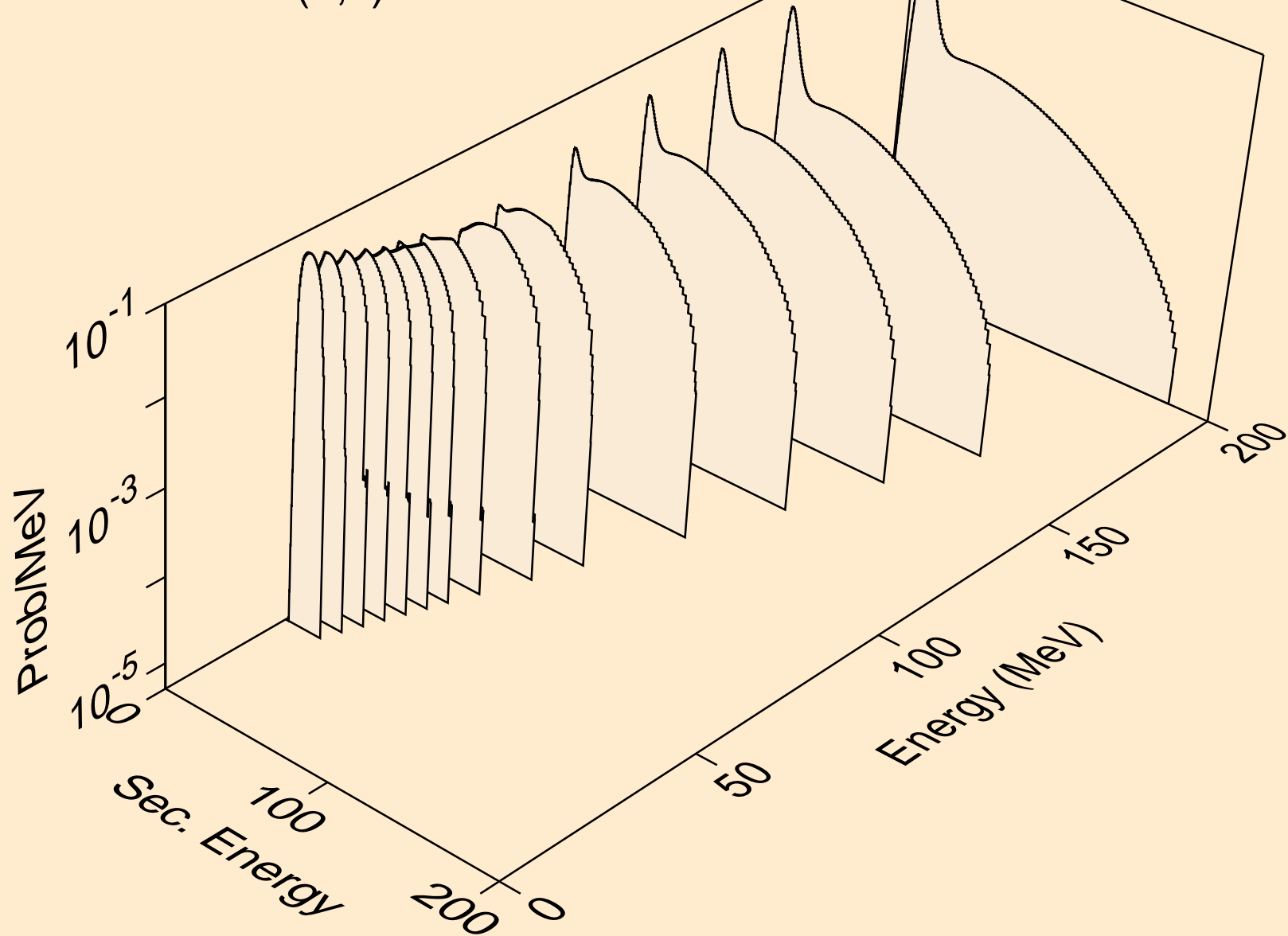

CU066 NEUTRON ACER TENDL-2023 LIBRARY; T=0.K  
tritons from (n,n\*)t

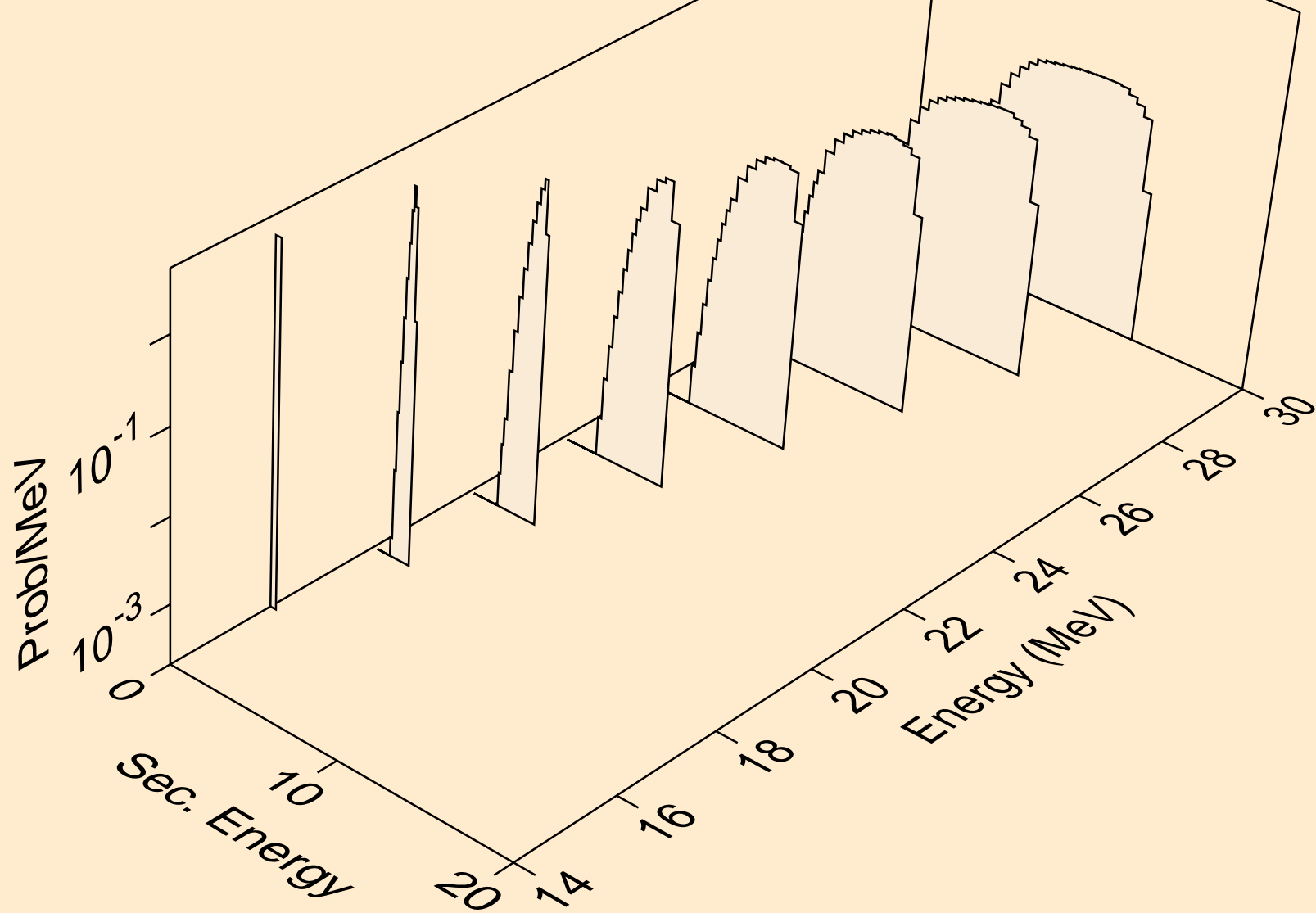

CU066 NEUTRON ACER TENDL-2023 LIBRARY; T=0.K  
tritons from (n,t)

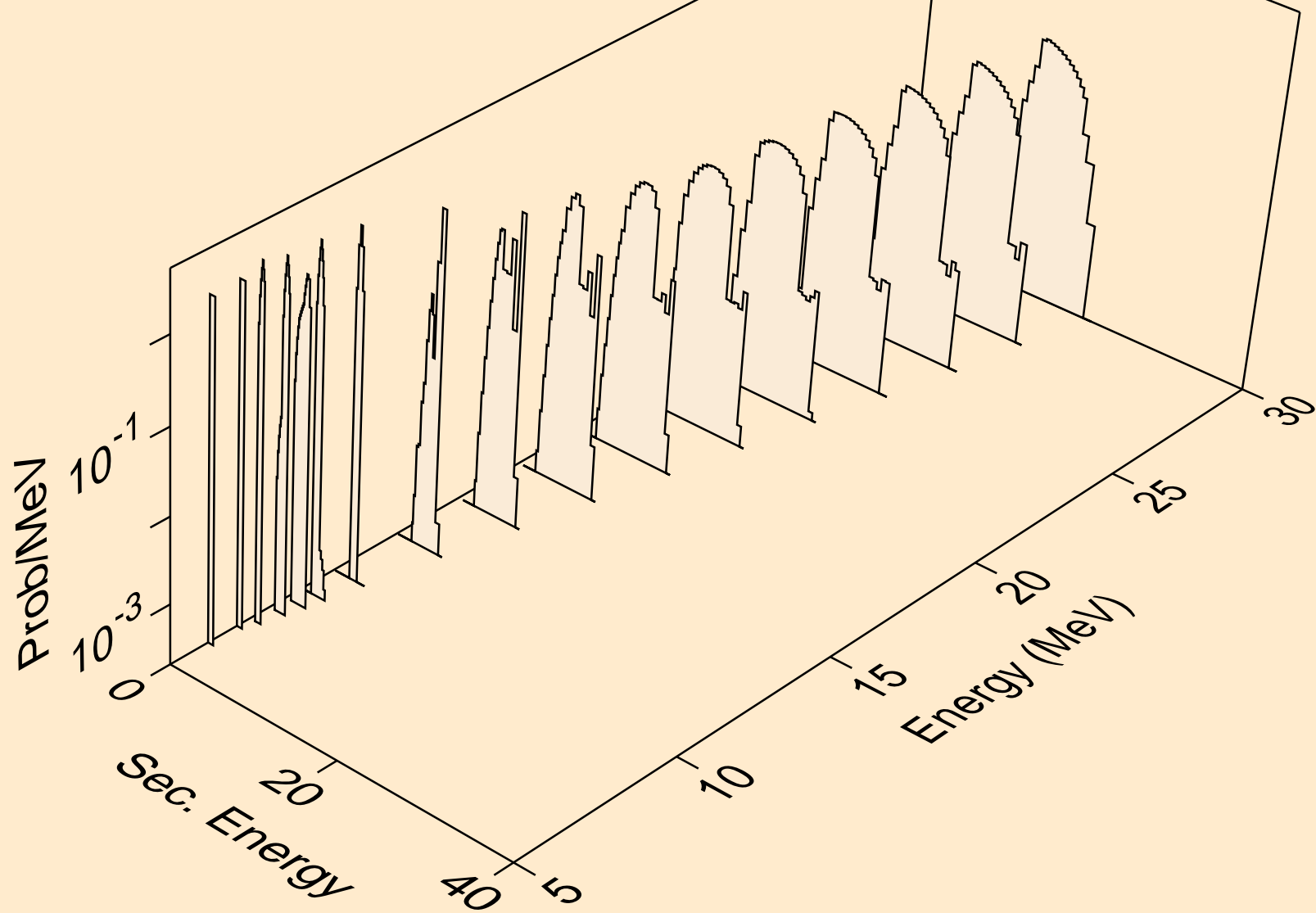

CU066 NEUTRON ACER TENDL-2023 LIBRARY; T=0.K  
tritons from (n,pt)

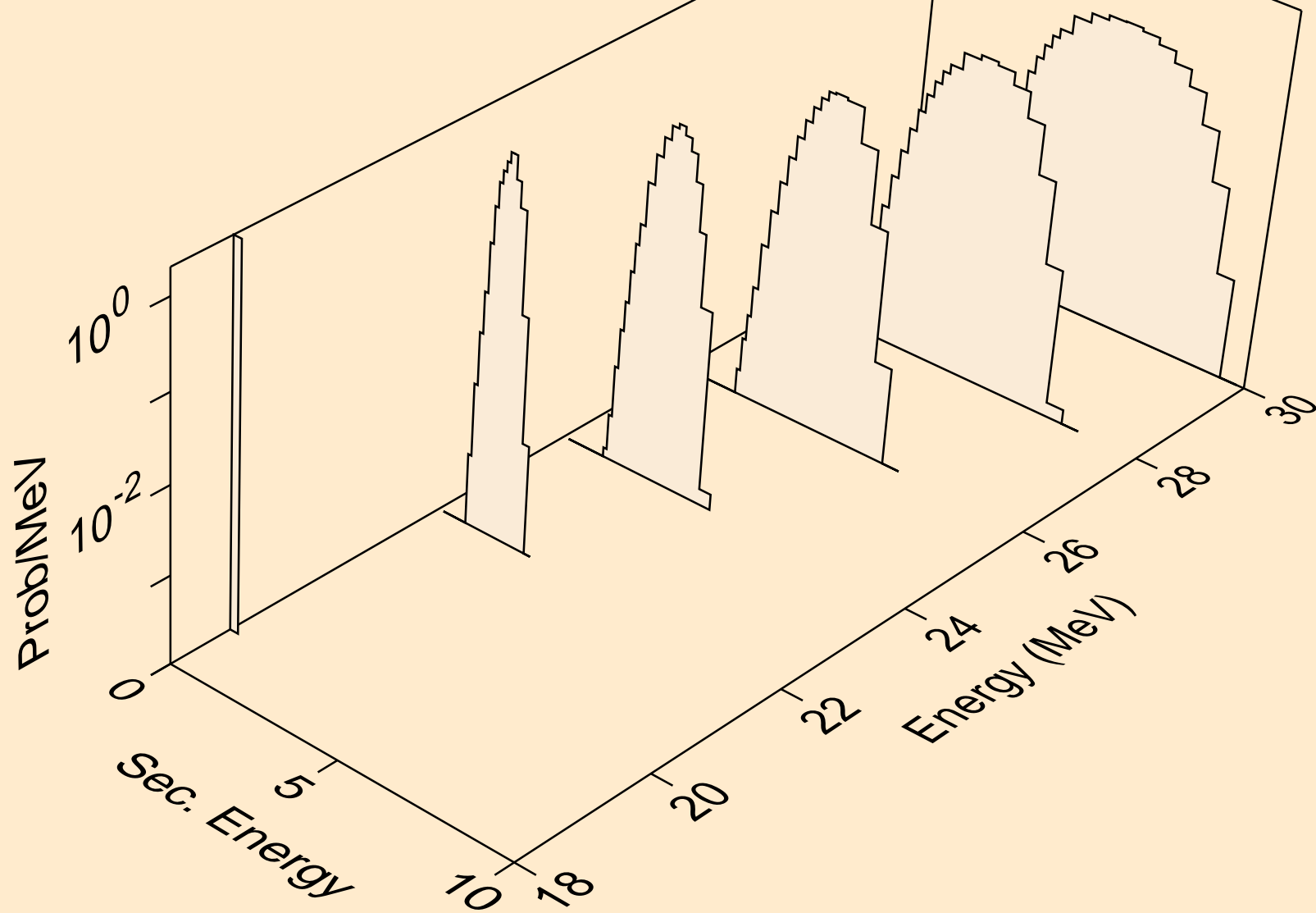

CU066 NEUTRON ACER TENDL-2023 LIBRARY; T=0.K  
he3s from (n,x)

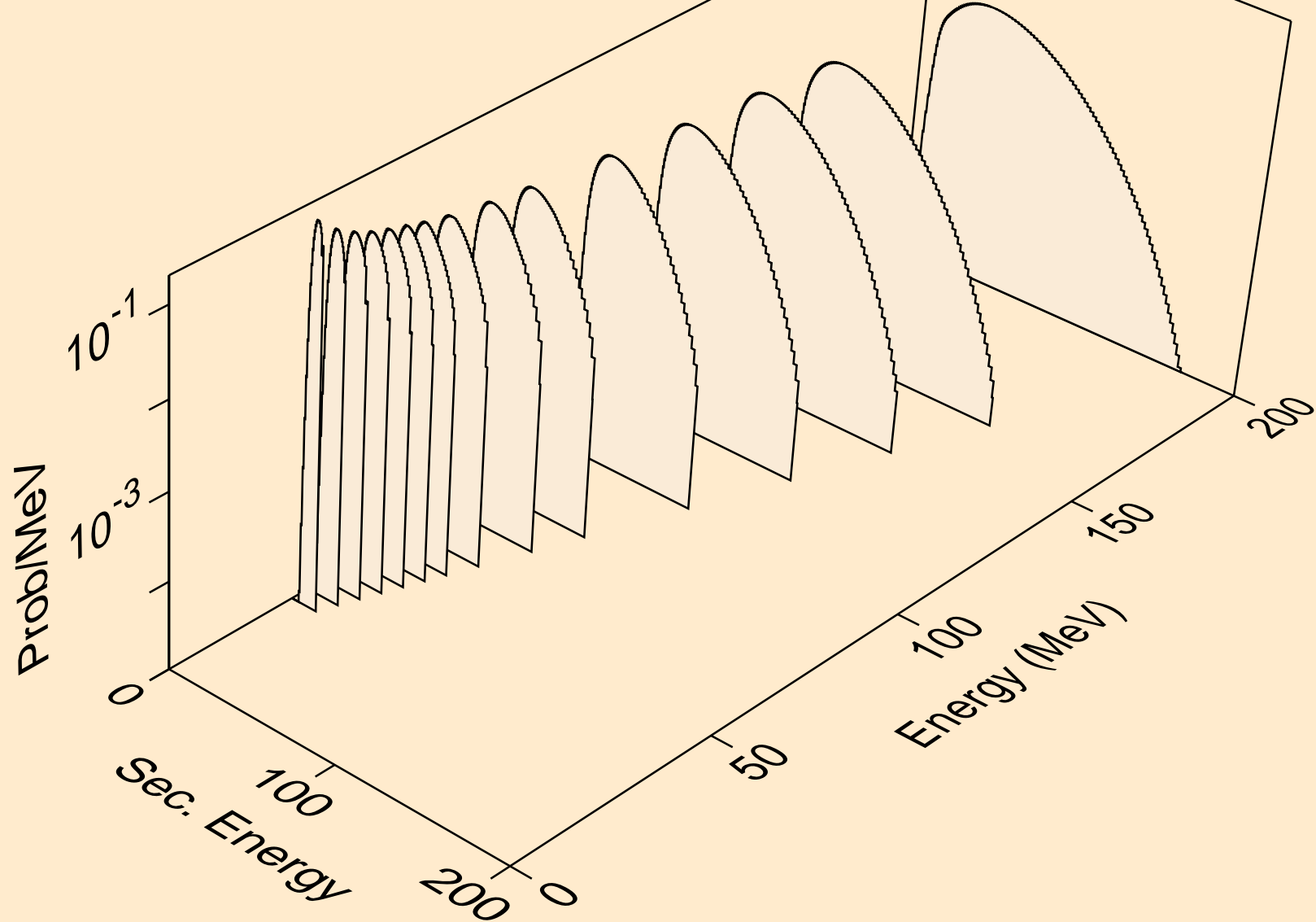



CU066 NEUTRON ACER TENDL-2023 LIBRARY; T=0.K  
he3s from (n,n\*)he3

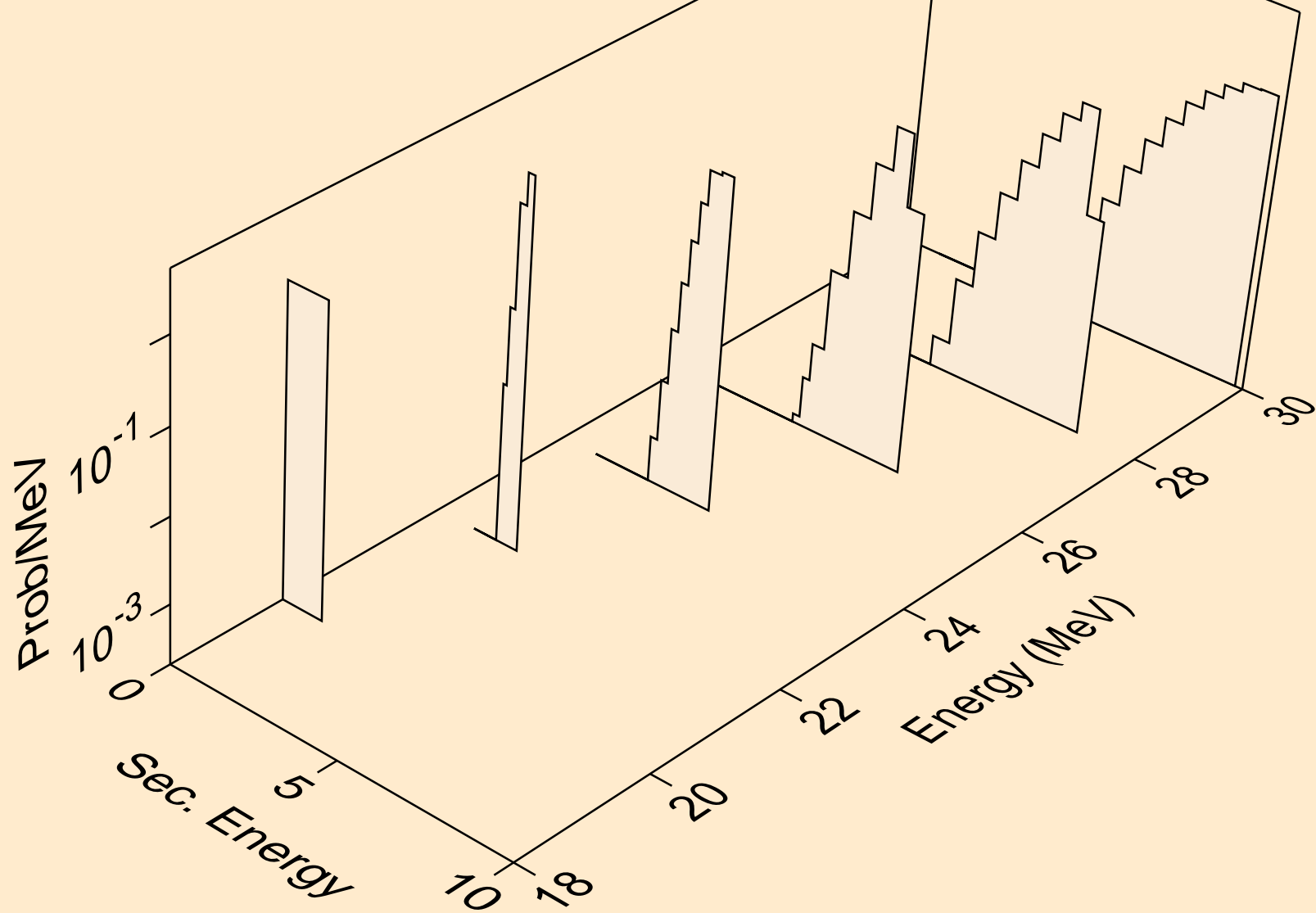

CU066 NEUTRON ACER TENDL-2023 LIBRARY; T=0.K  
he3s from (n,he3)

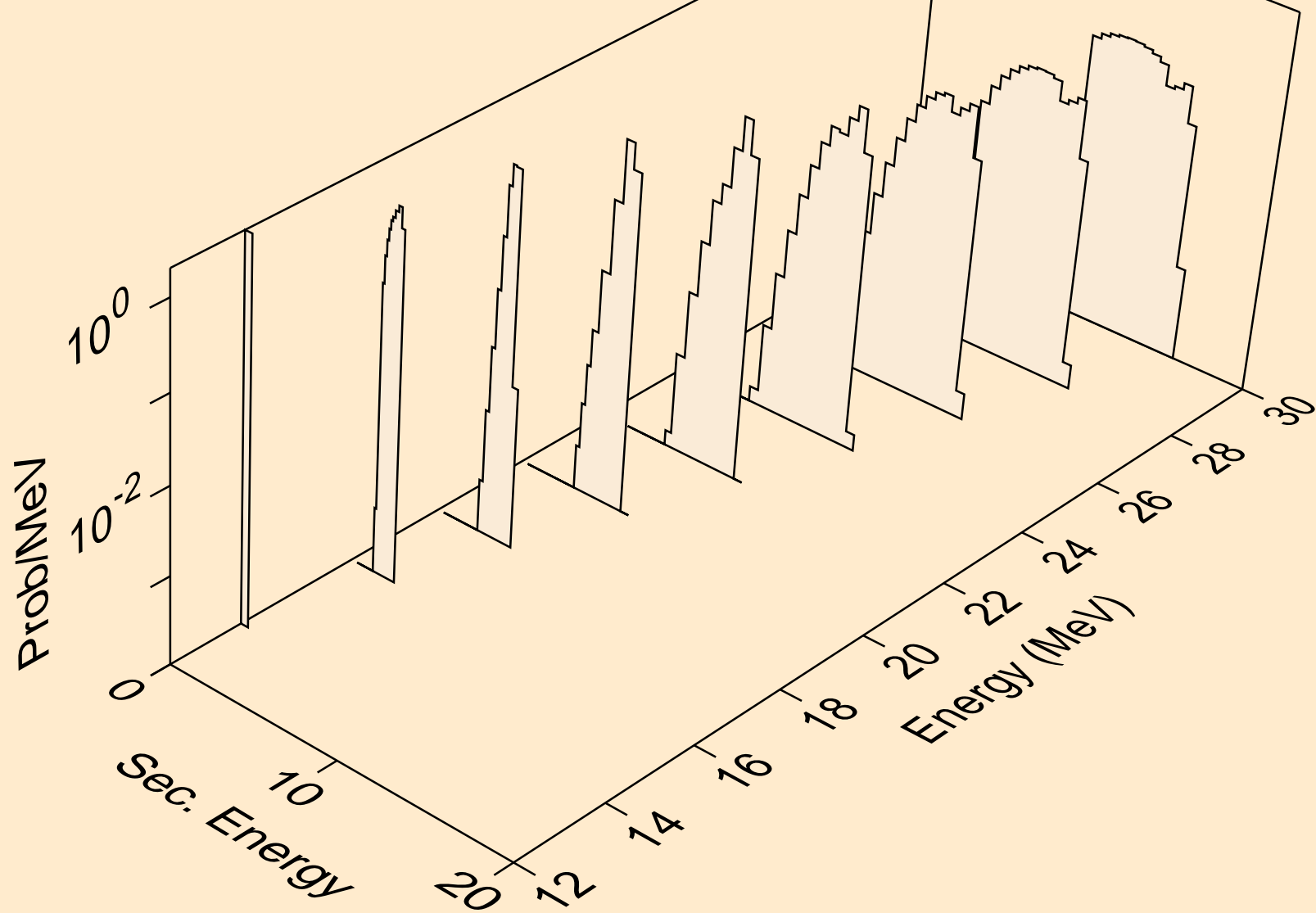

CU066 NEUTRON ACER TENDL-2023 LIBRARY; T=0.K  
alphas from (n,x)

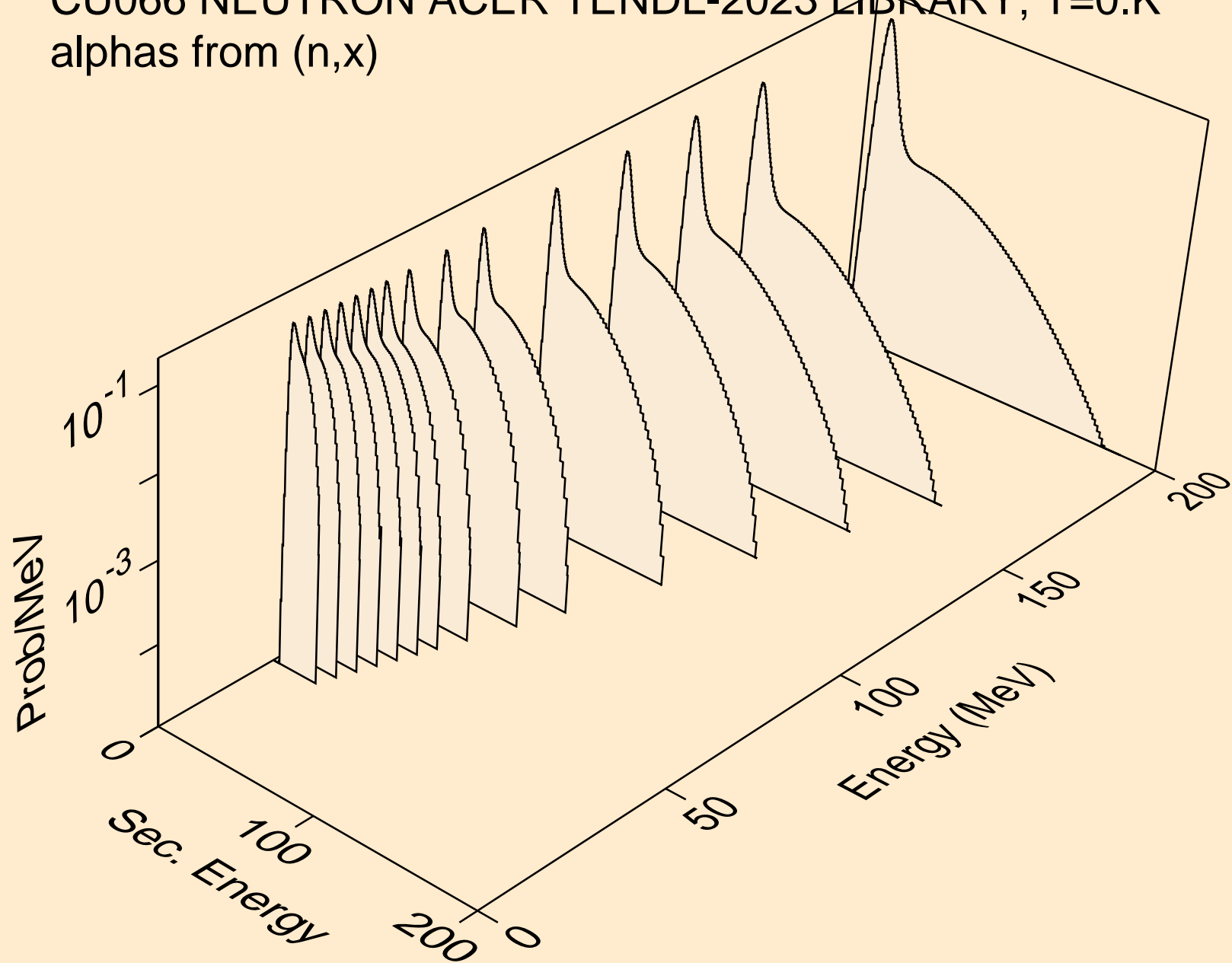

CU066 NEUTRON ACER TENDL-2023 LIBRARY; T=0.K  
alphas from (n,n\*)a

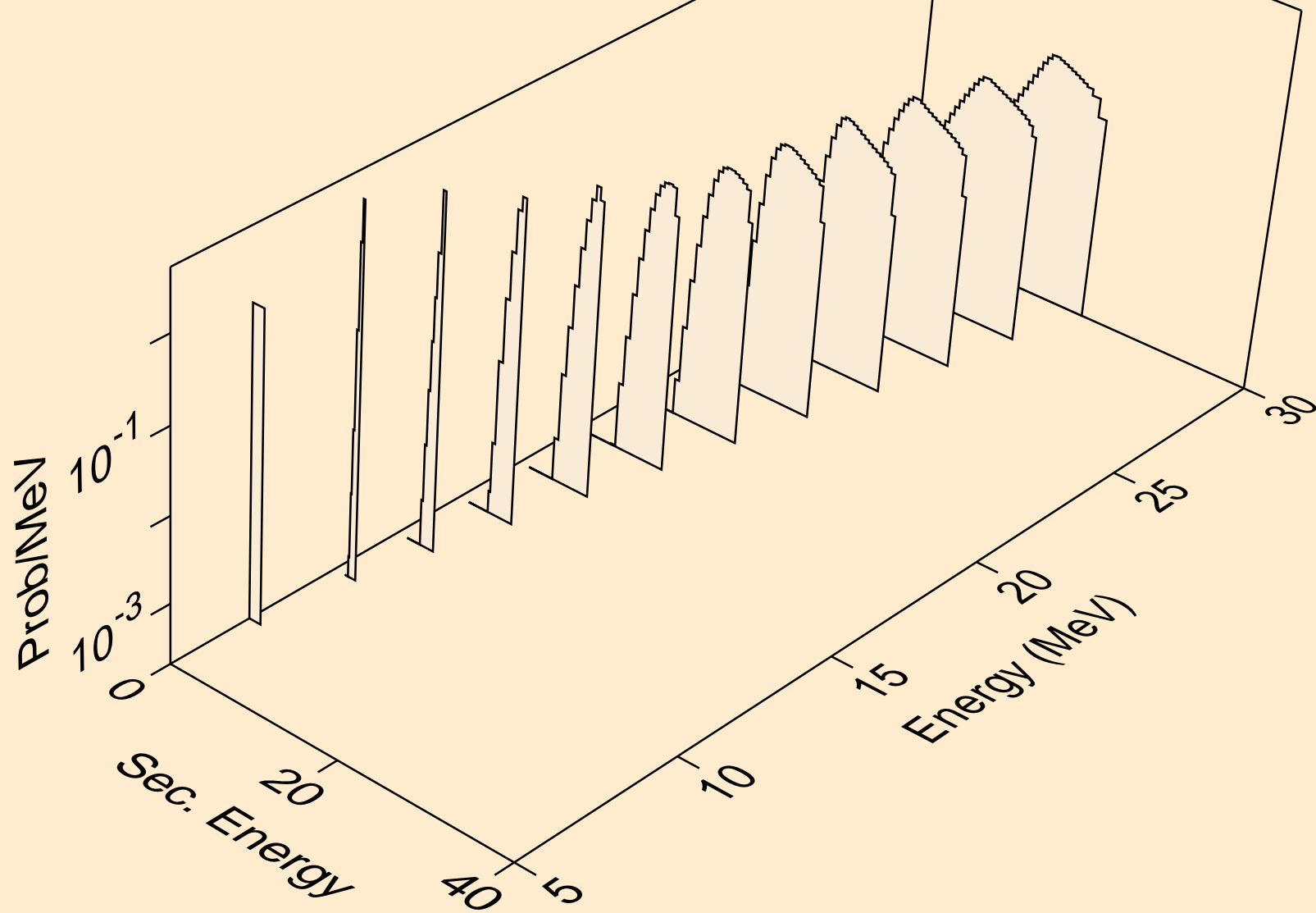

CU066 NEUTRON ACER TENDL-2023 LIBRARY; T=0.K  
alphas from (n,2n)a

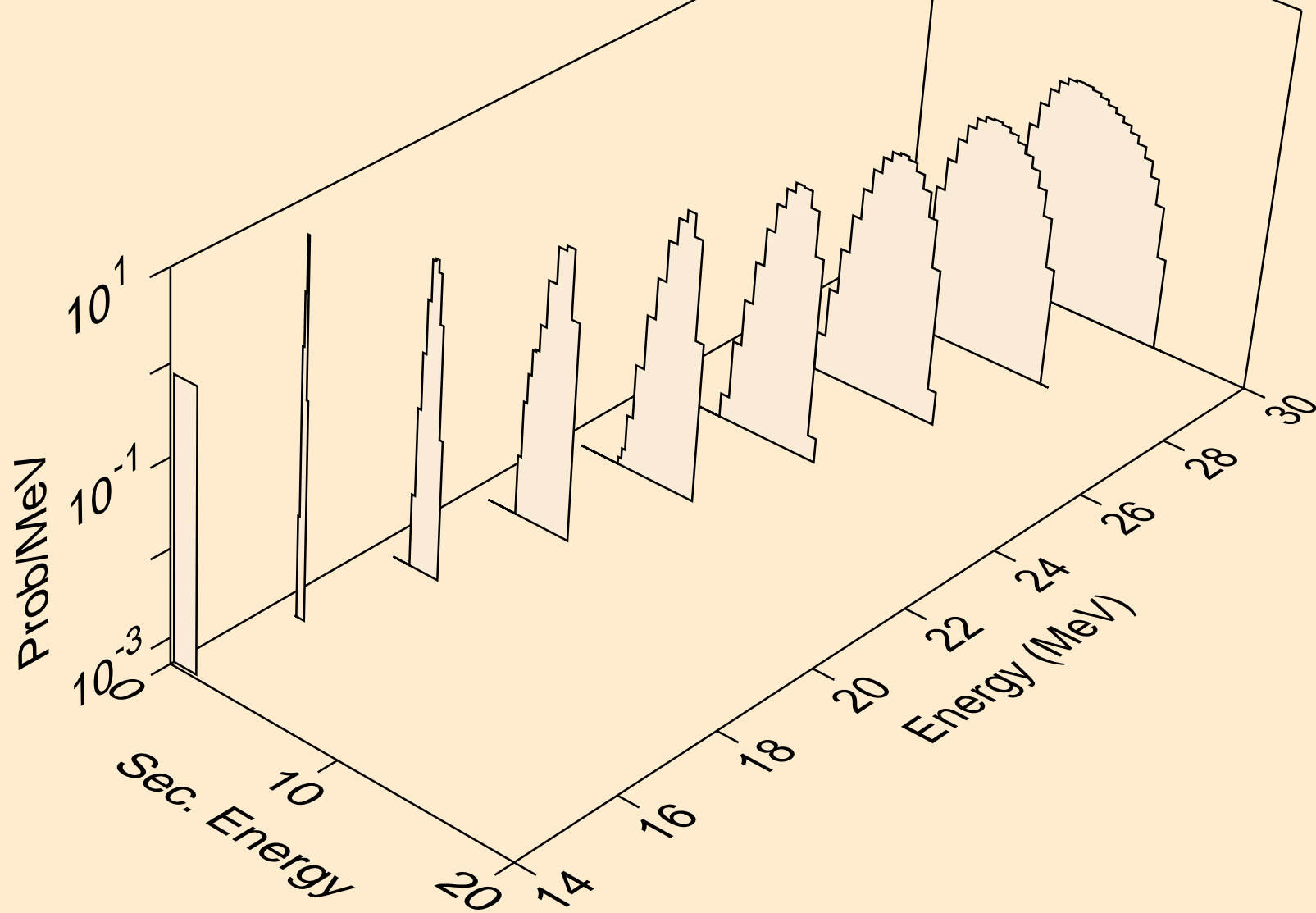

CU066 NEUTRON ACER TENDL-2023 LIBRARY; T=0.K  
alphas from (n,3n)a

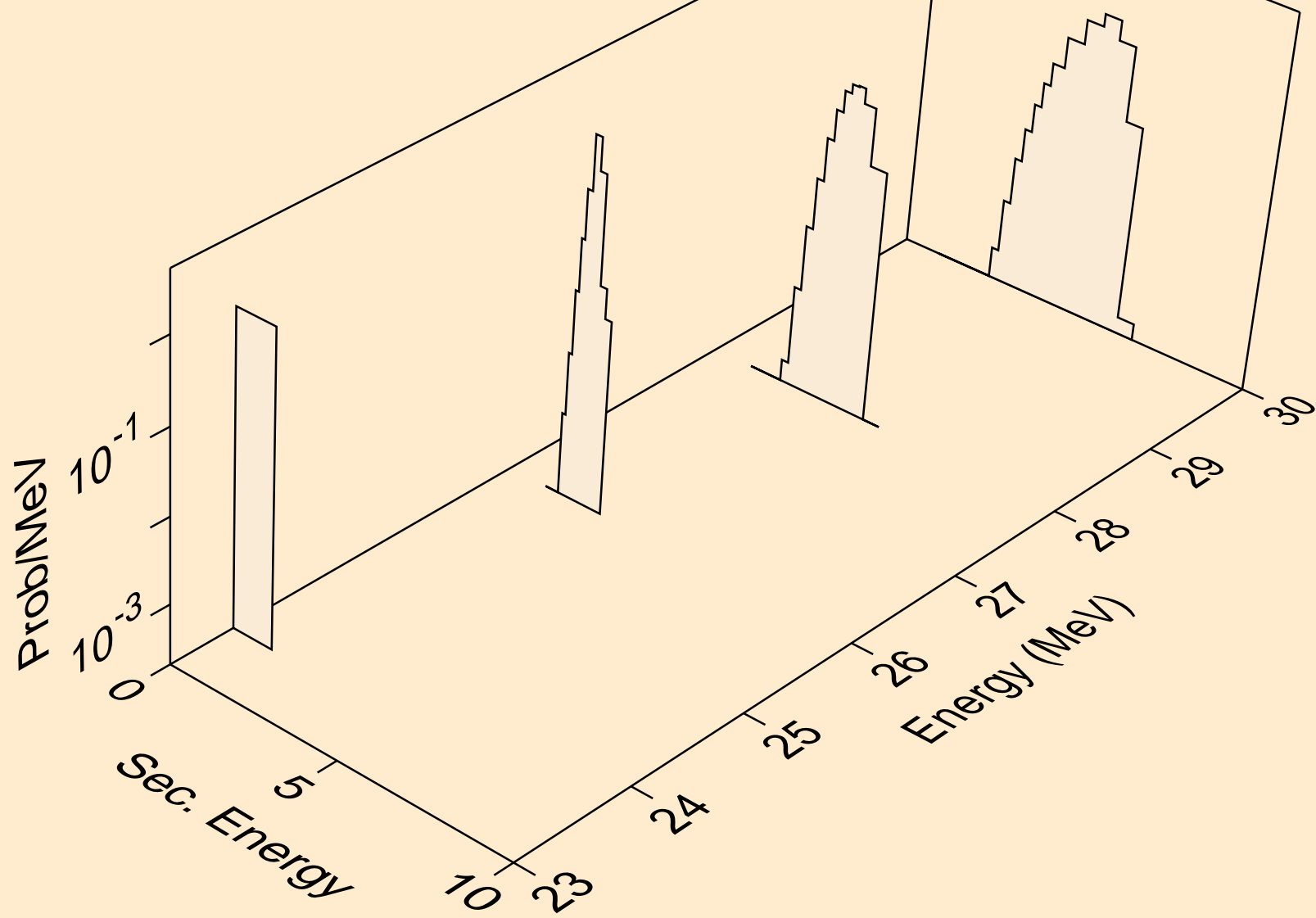

CU066 NEUTRON ACER TENDL-2023 LIBRARY; T=0.K  
alphas from (n,n\*)2a

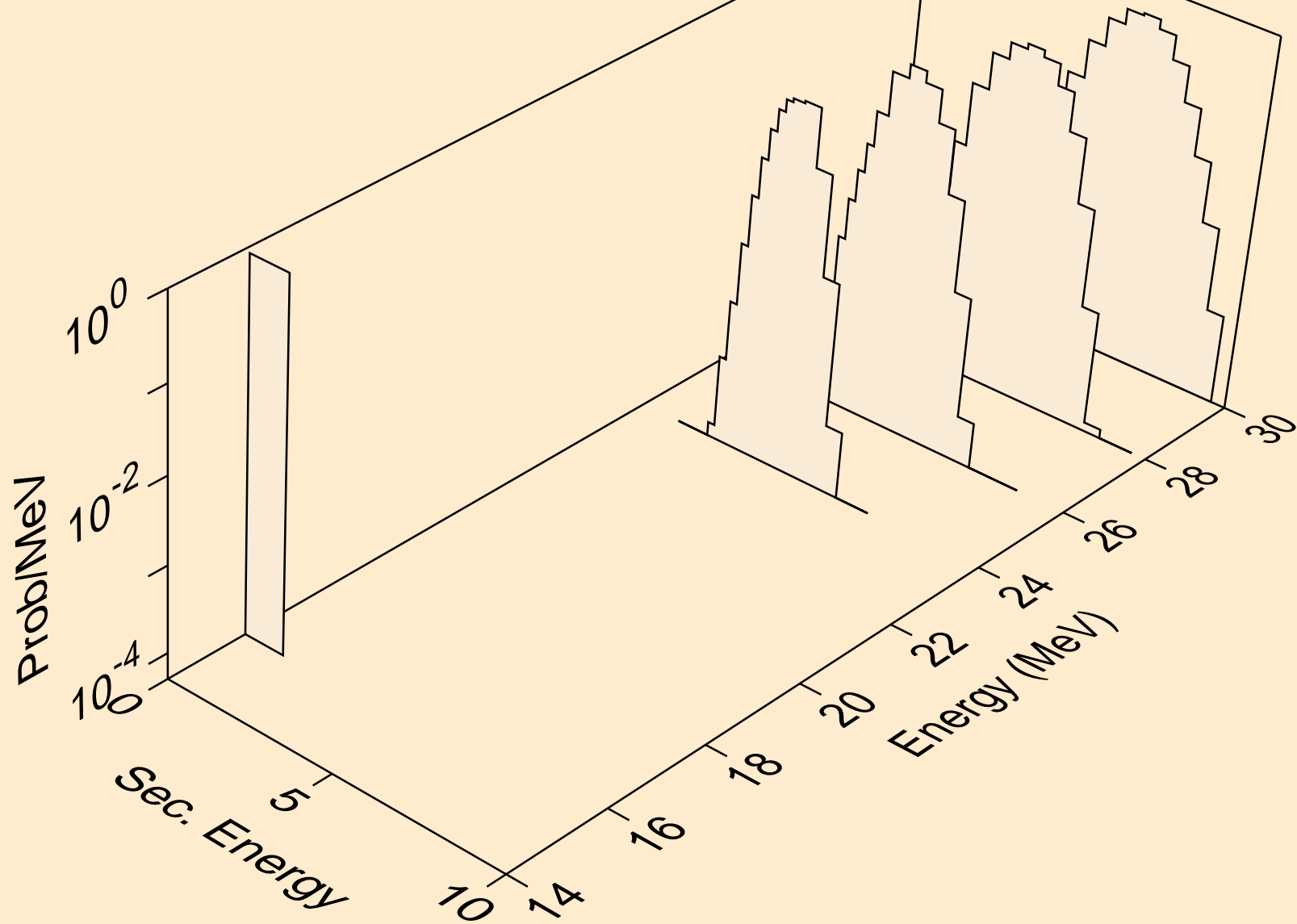

CU066 NEUTRON ACER TENDL-2023 LIBRARY; T=0.K  
alphas from (n,npa)

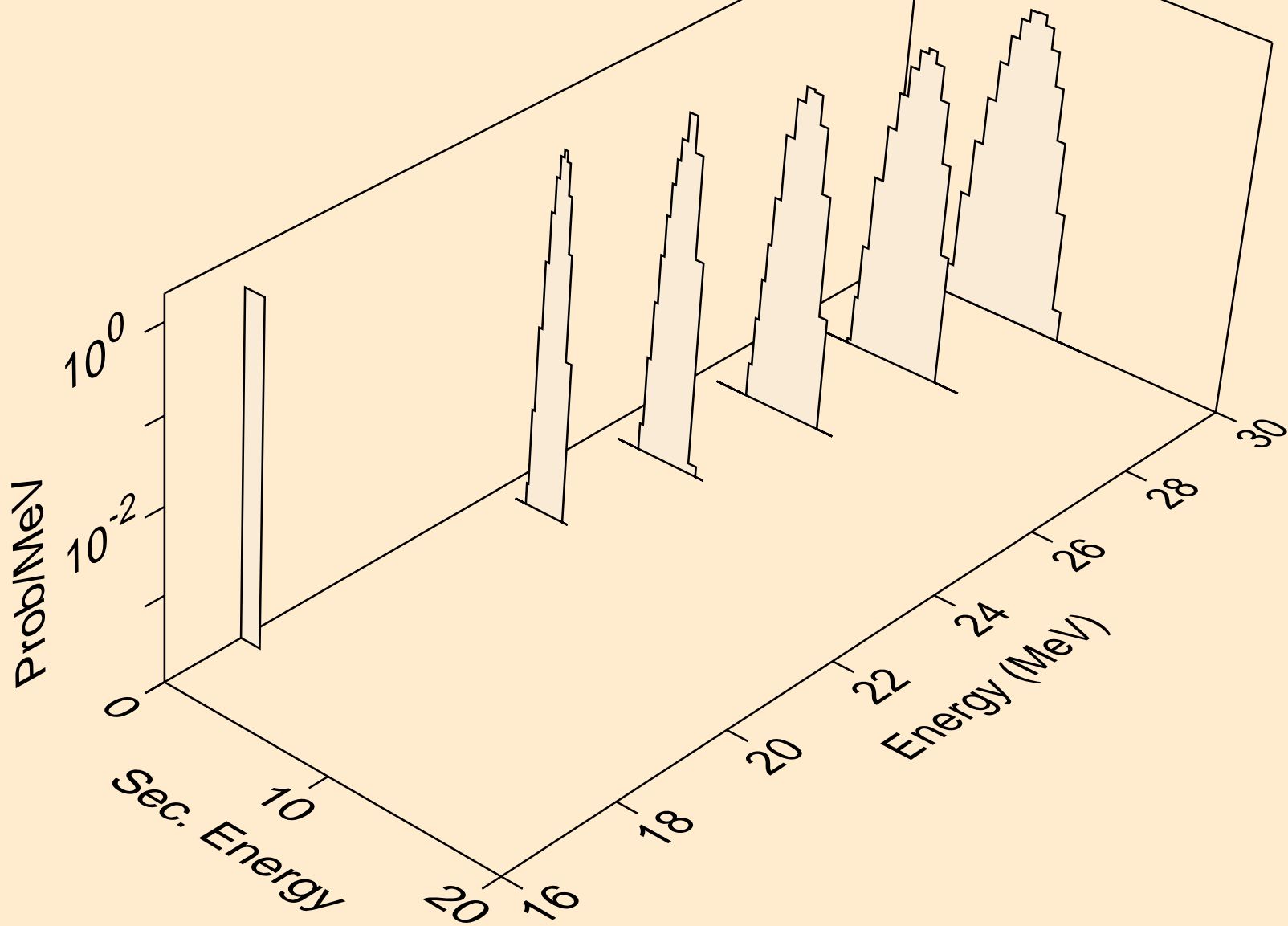



CU066 NEUTRON ACER TENDL-2023 LIBRARY; T=0.K  
alphas from (n,a)

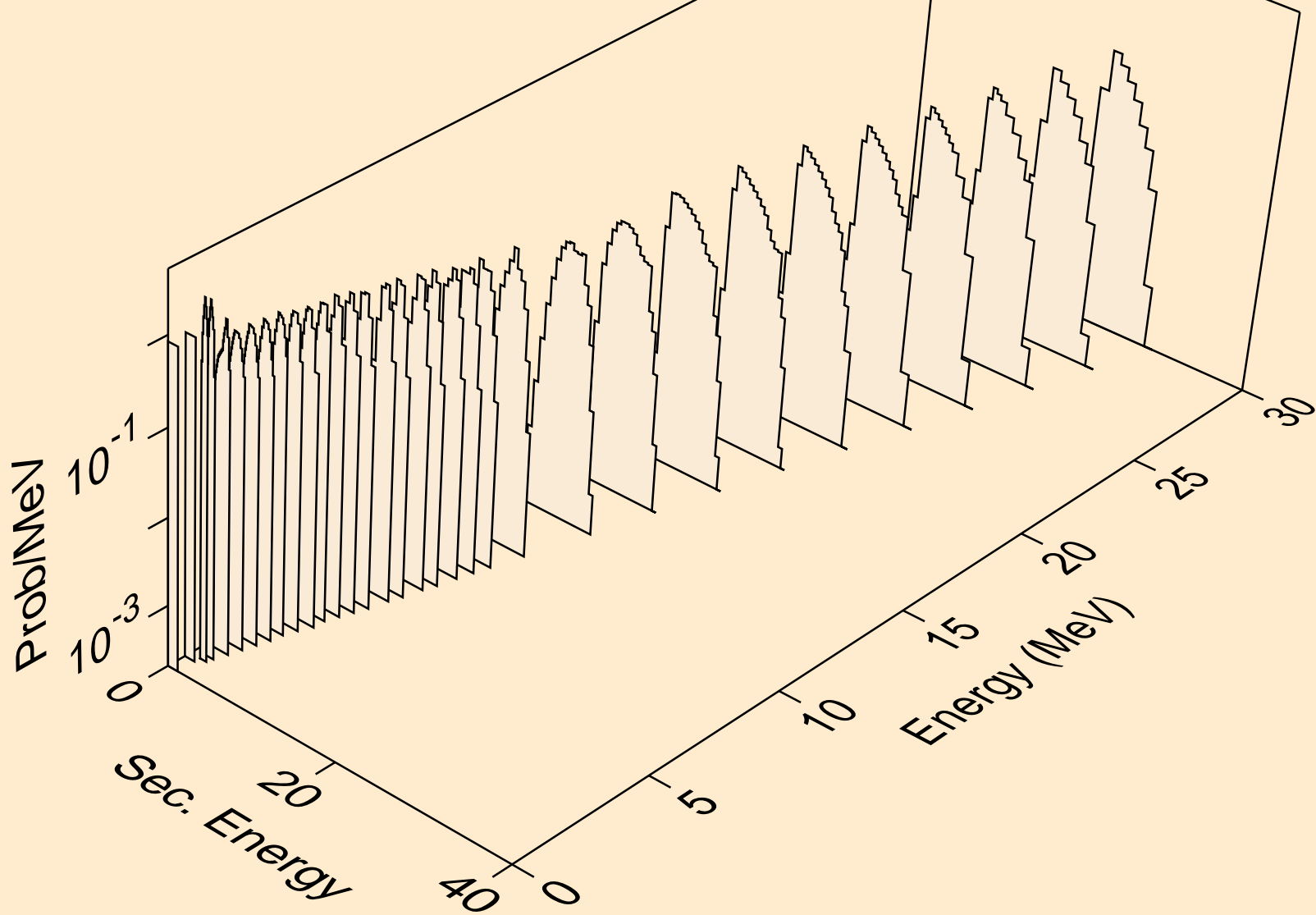

CU066 NEUTRON ACER TENDL-2023 LIBRARY; T=0.K  
alphas from (n,2a)

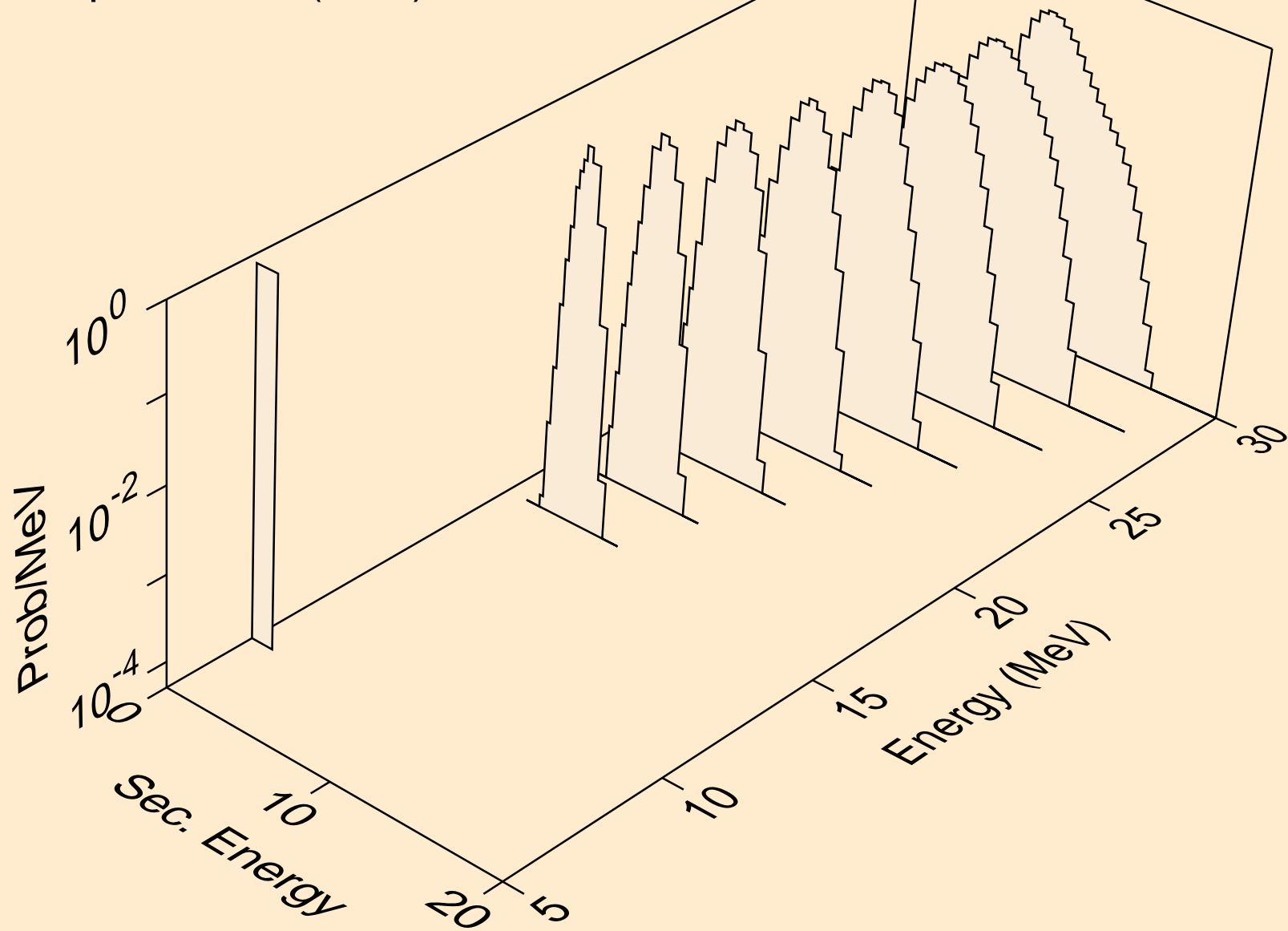

CU066 NEUTRON ACER TENDL-2023 LIBRARY; T=0.K  
alphas from (n,pa)

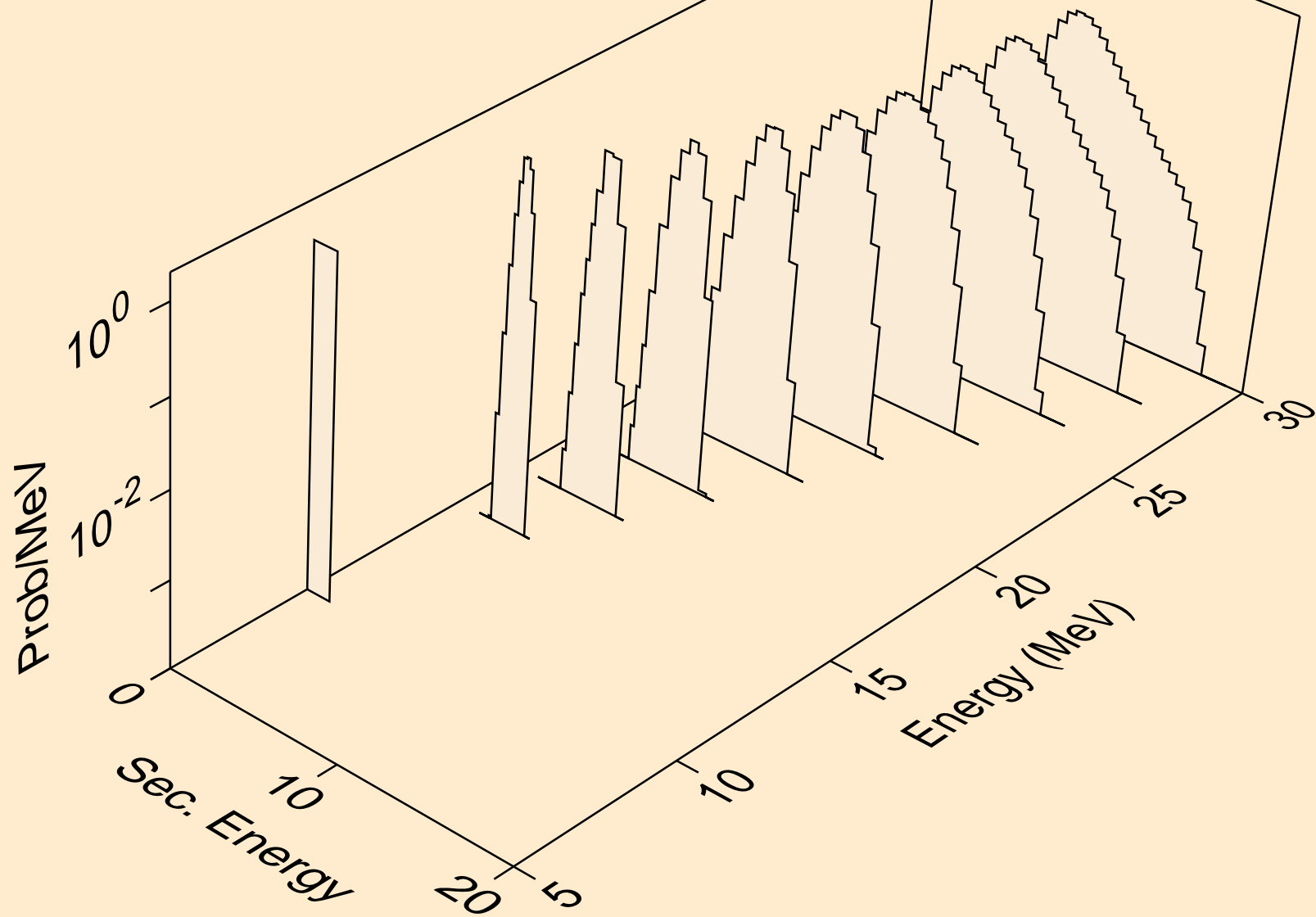

CU066 NEUTRON ACER TENDL-2023 LIBRARY; T=0.K  
alphas from (n,da)

