

# CU070 NEUTRON ACER TENDL-2023 LIBRARY; T=0.K

## Principal cross sections

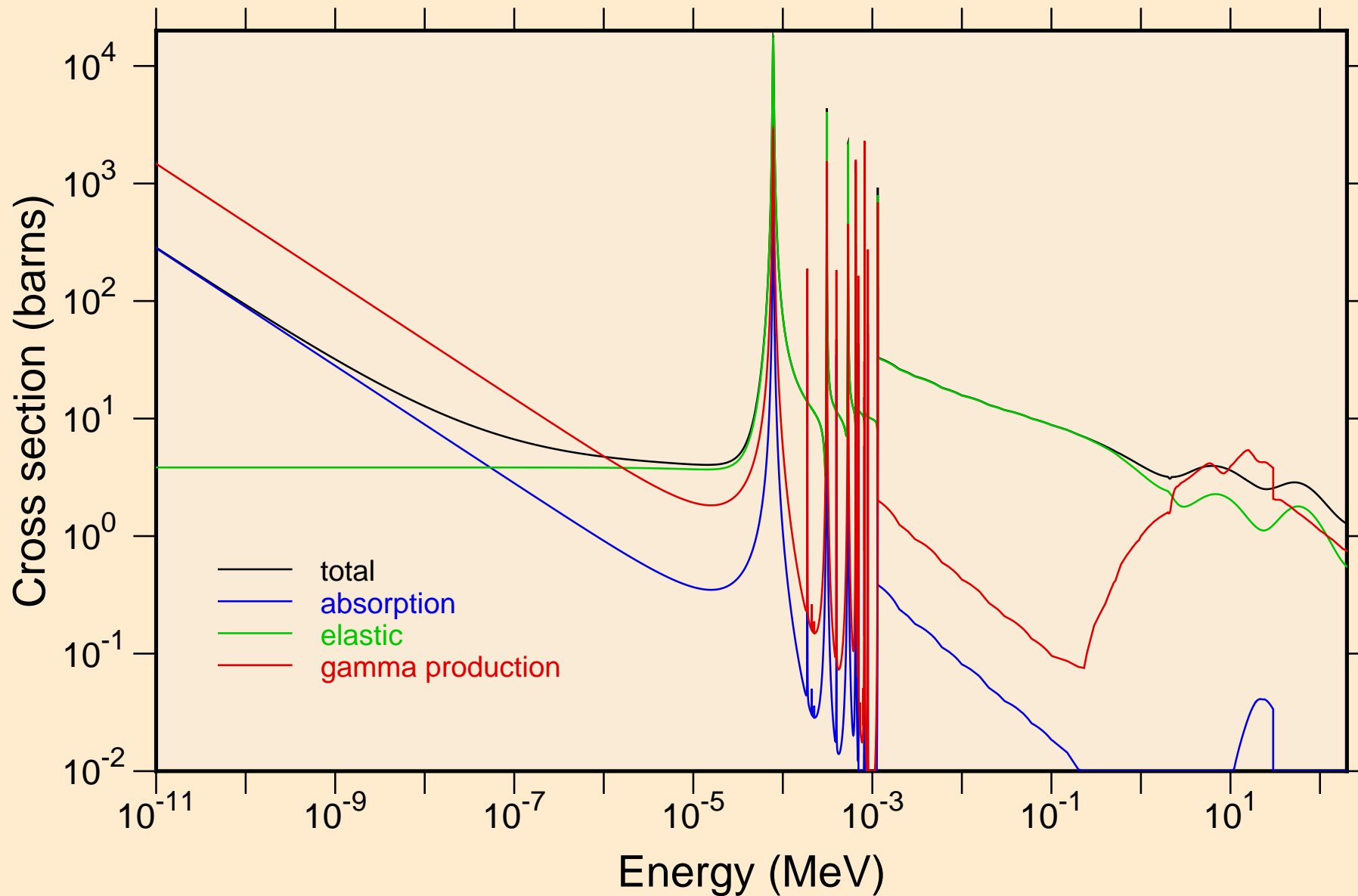

CU070 NEUTRON ACER TENDL-2023 LIBRARY; T=0.K  
resonance total cross section

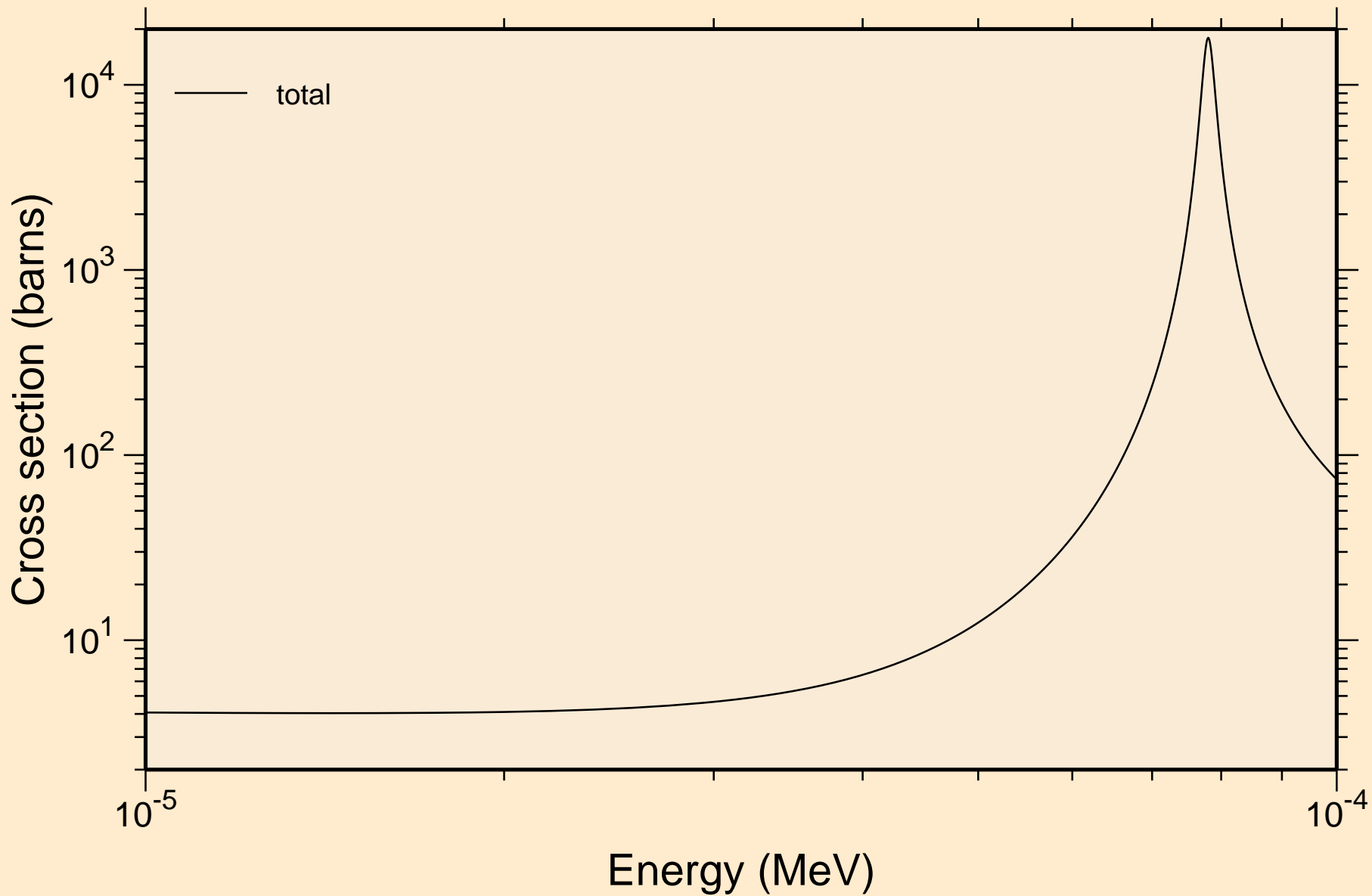

CU070 NEUTRON ACER TENDL-2023 LIBRARY; T=0.K  
resonance total cross section

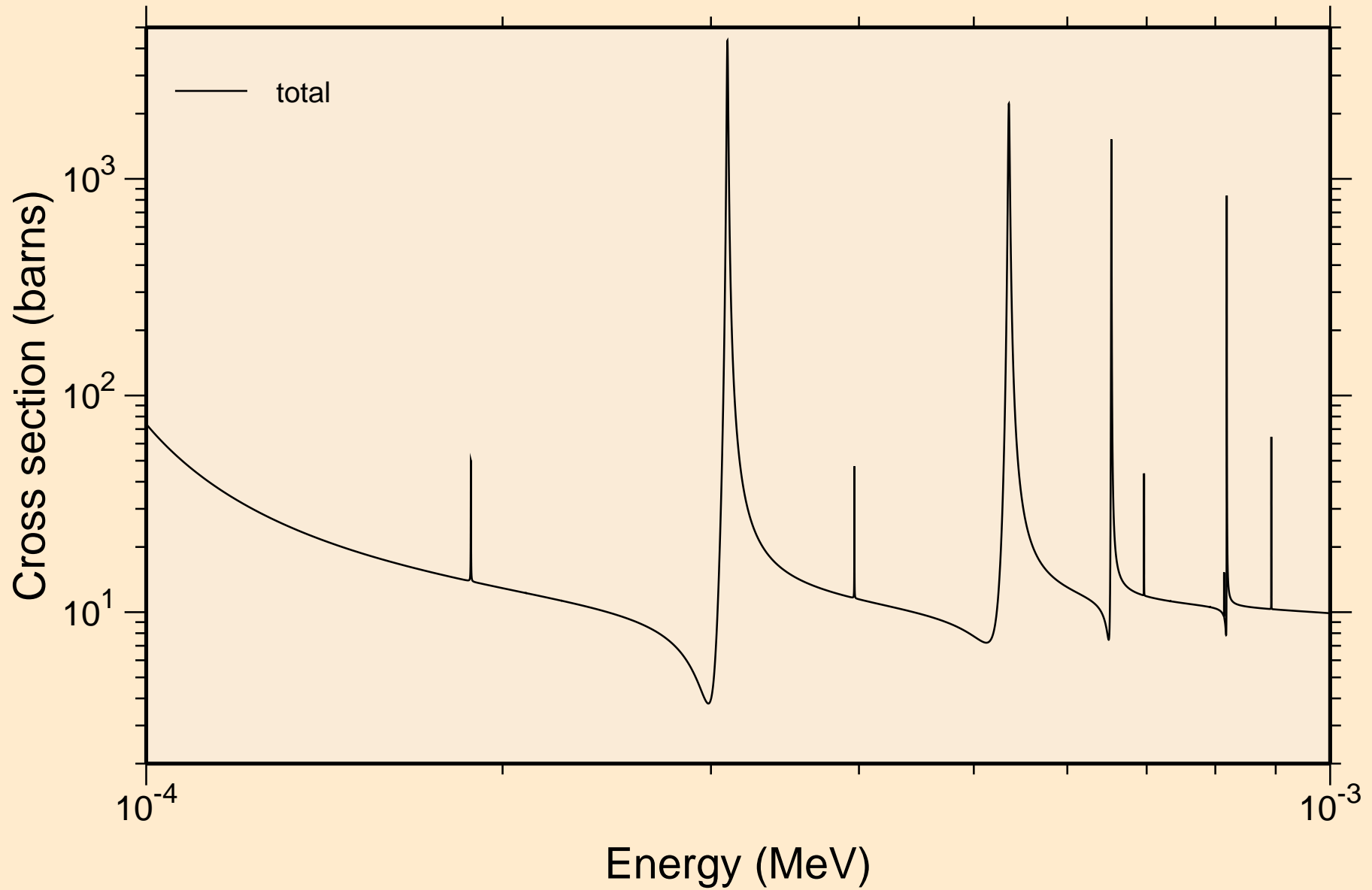

CU070 NEUTRON ACER TENDL-2023 LIBRARY; T=0.K  
resonance total cross section

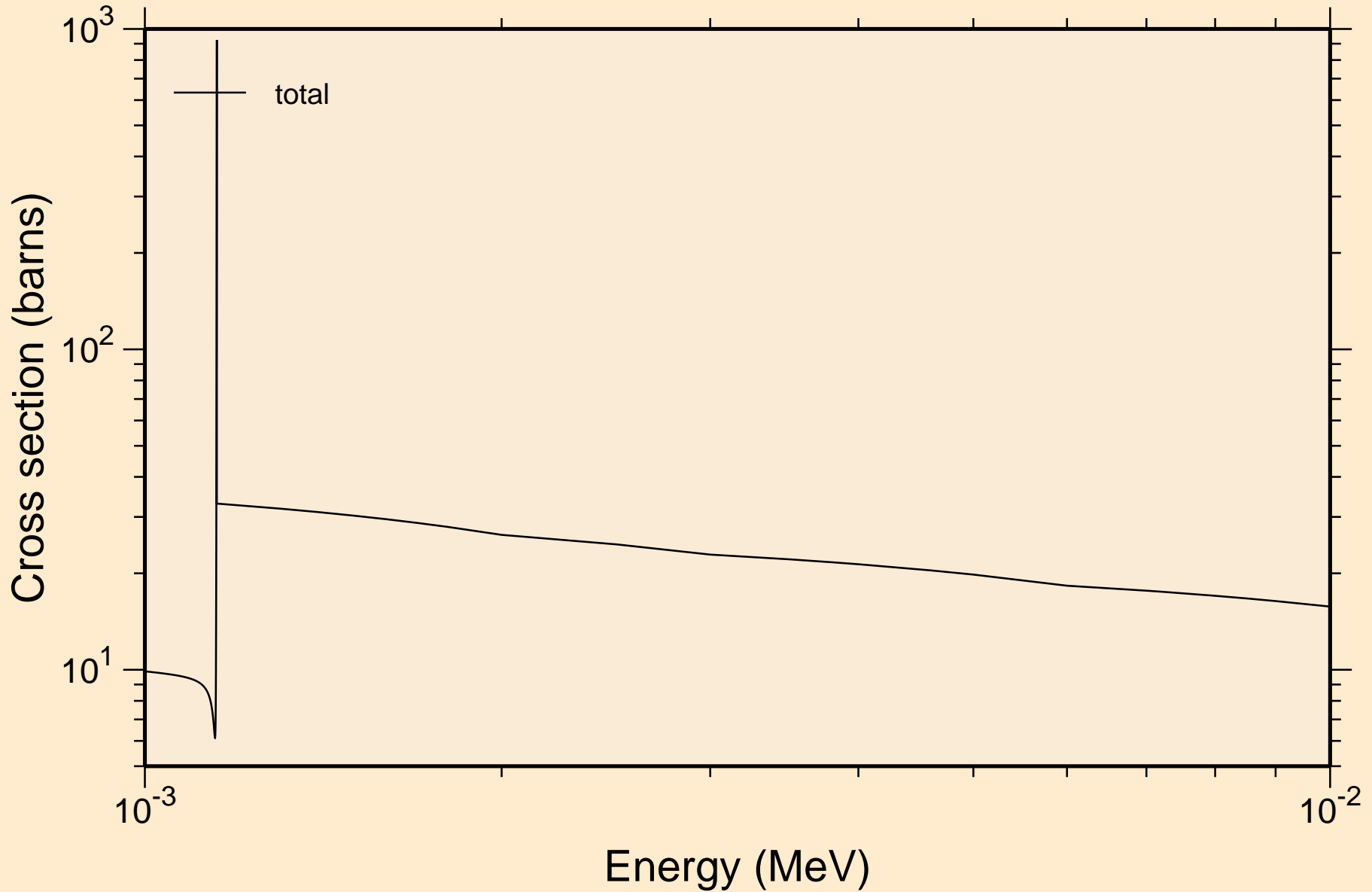

CU070 NEUTRON ACER TENDL-2023 LIBRARY; T=0.K  
resonance total cross section

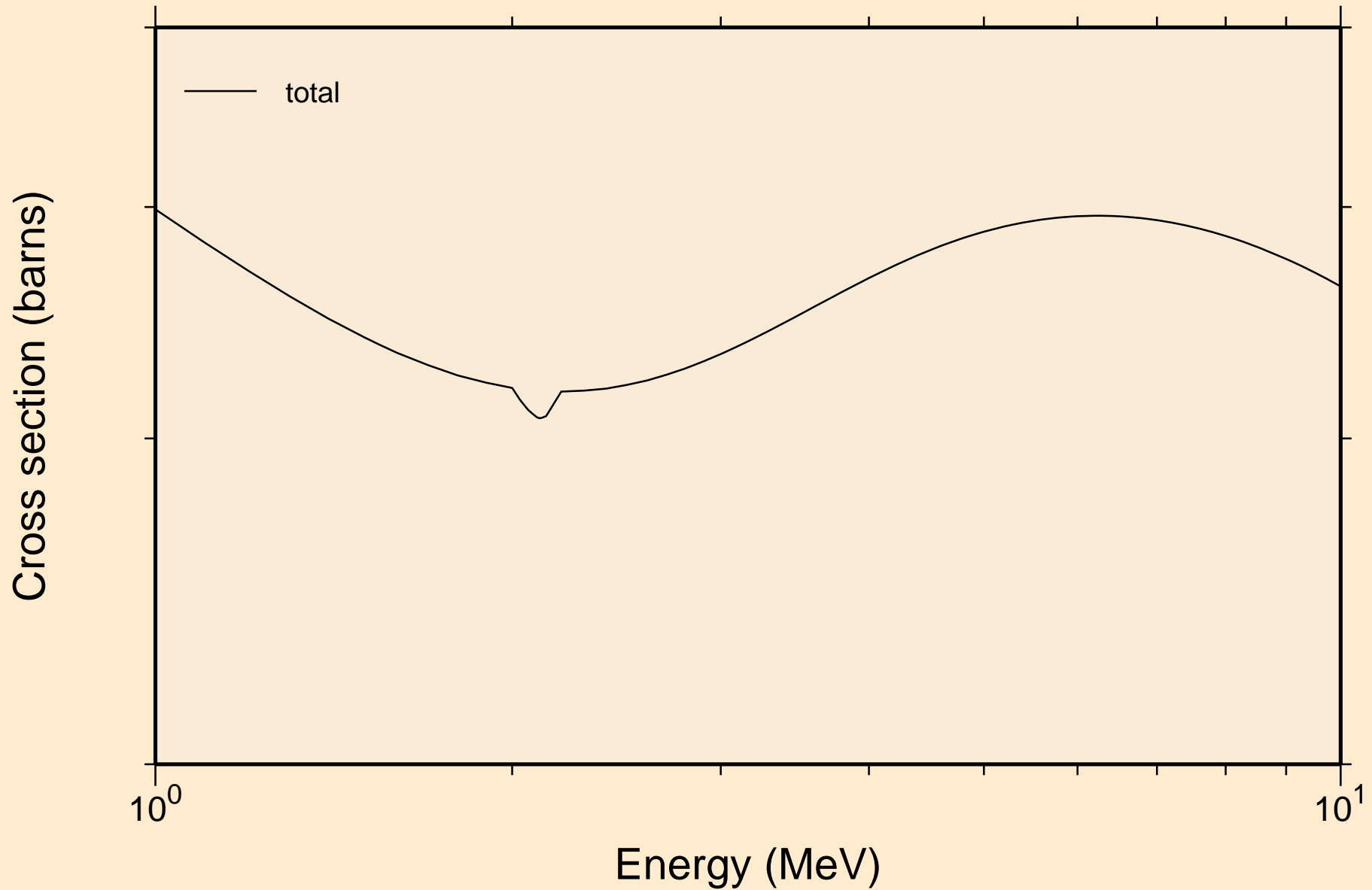

CU070 NEUTRON ACER TENDL-2023 LIBRARY; T=0.K  
resonance absorption cross sections

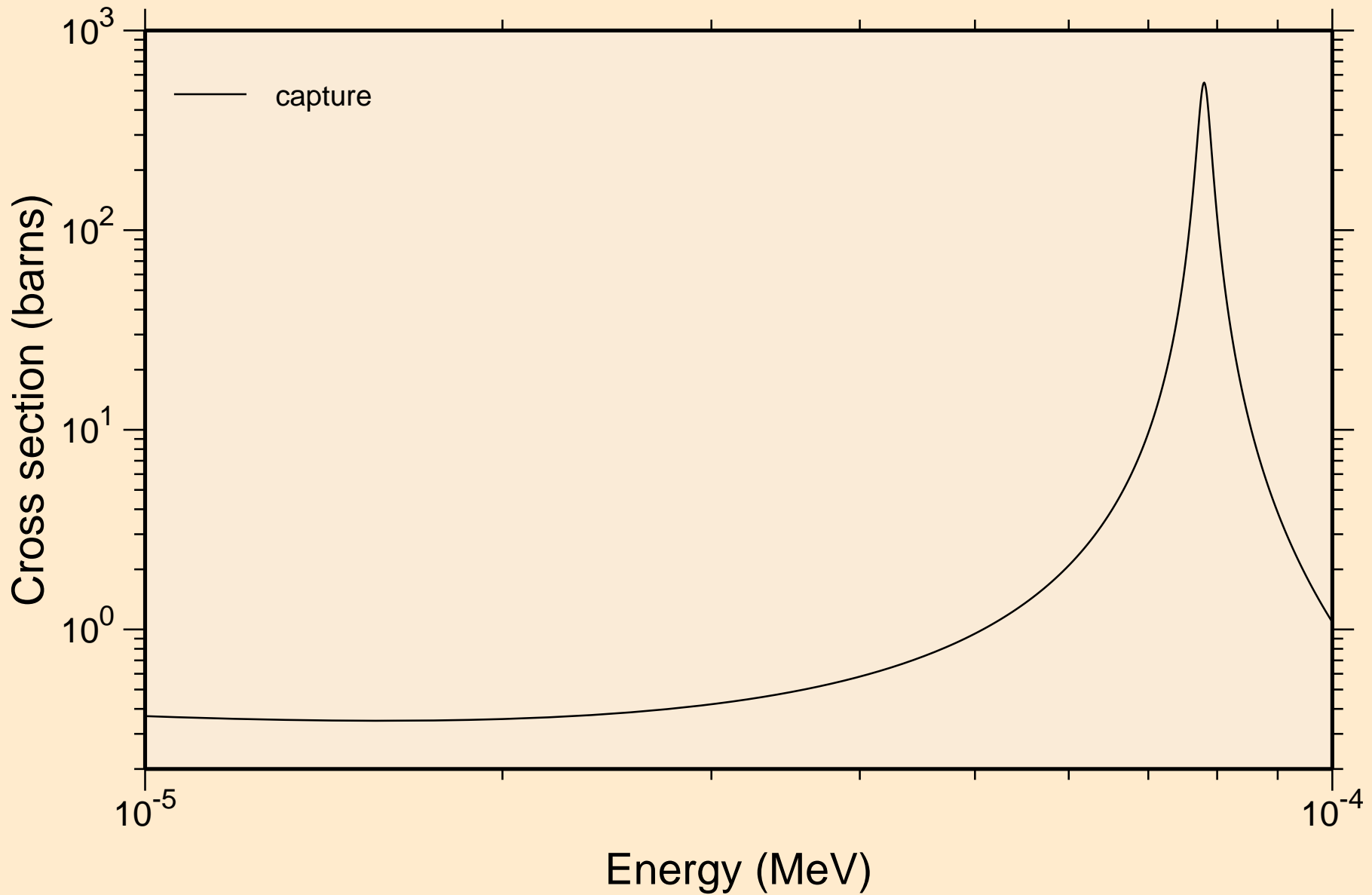

CU070 NEUTRON ACER TENDL-2023 LIBRARY; T=0.K  
resonance absorption cross sections

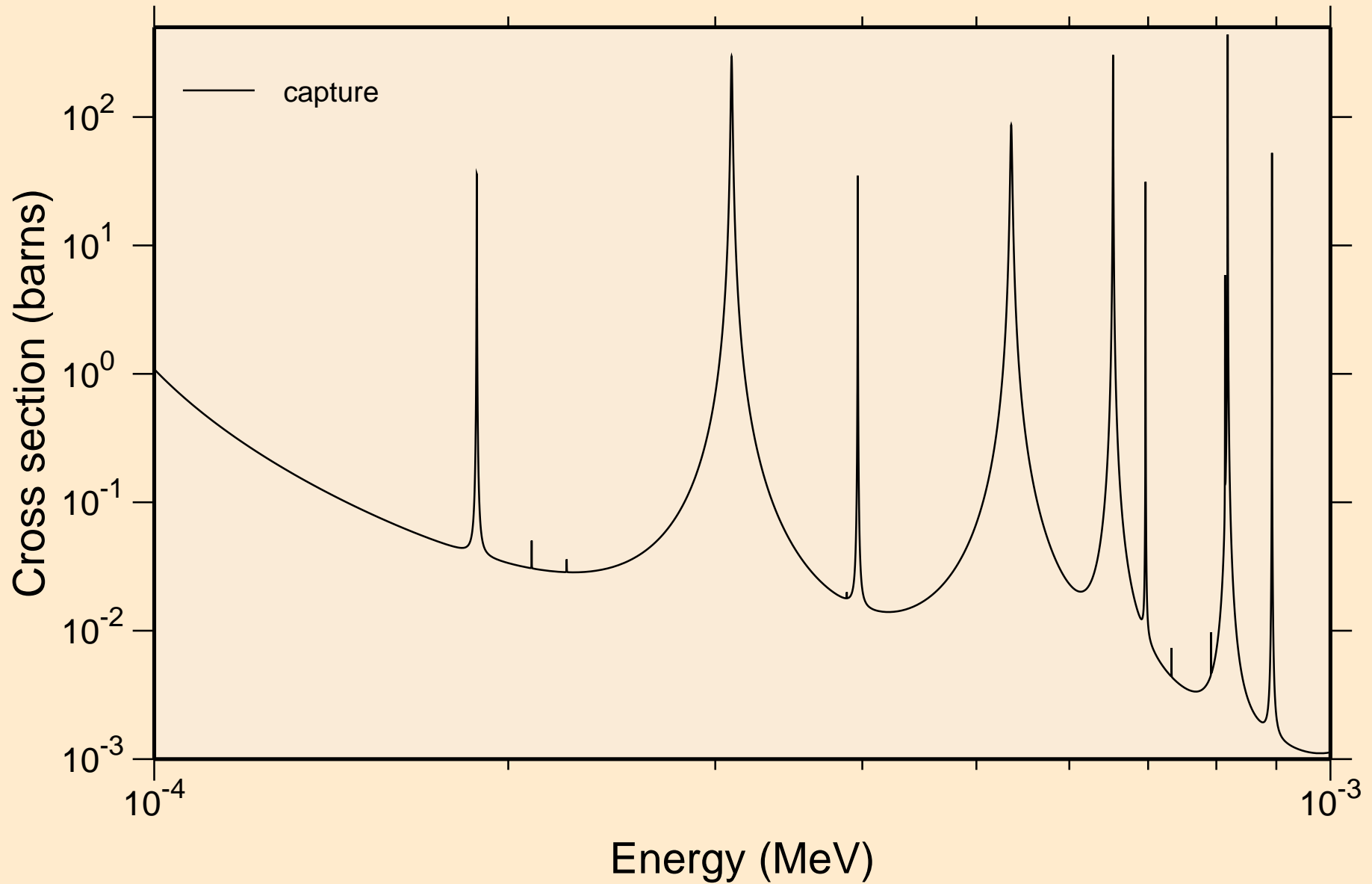

CU070 NEUTRON ACER TENDL-2023 LIBRARY; T=0.K  
resonance absorption cross sections

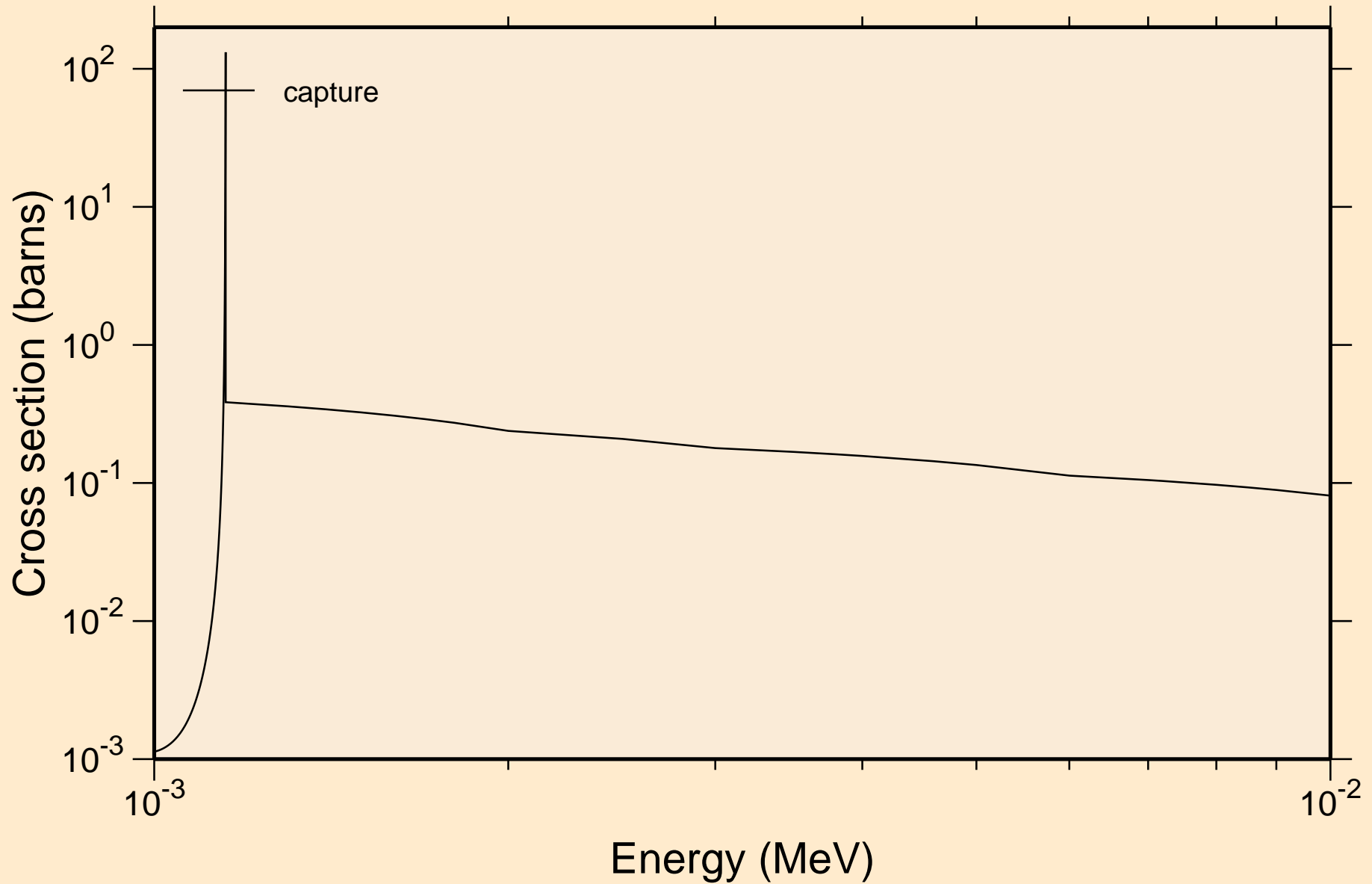



CU070 NEUTRON ACER TENDL-2023 LIBRARY; T=0.K  
resonance absorption cross sections

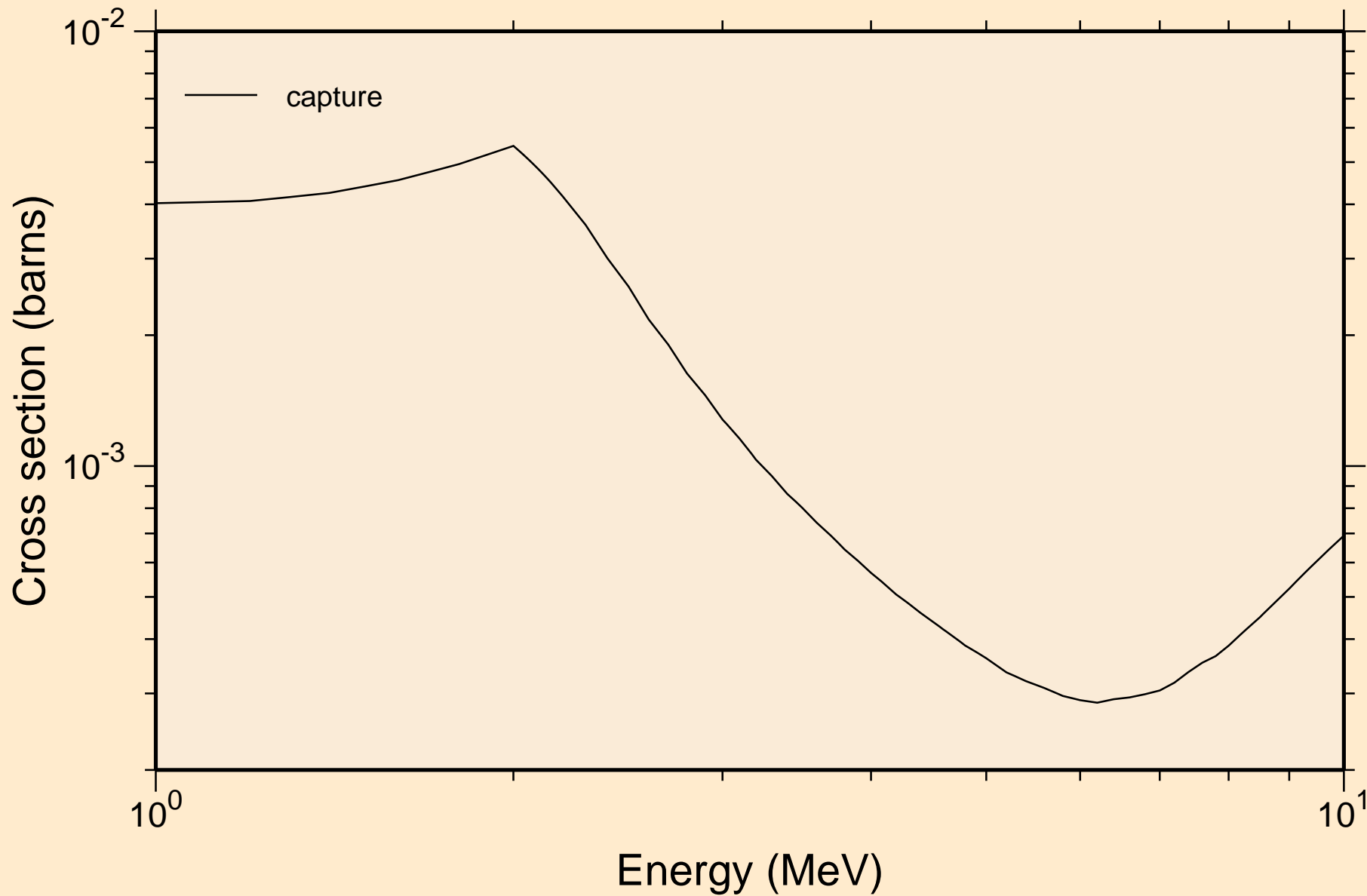

CU070 NEUTRON ACER TENDL-2023 LIBRARY; T=0.K  
Heating

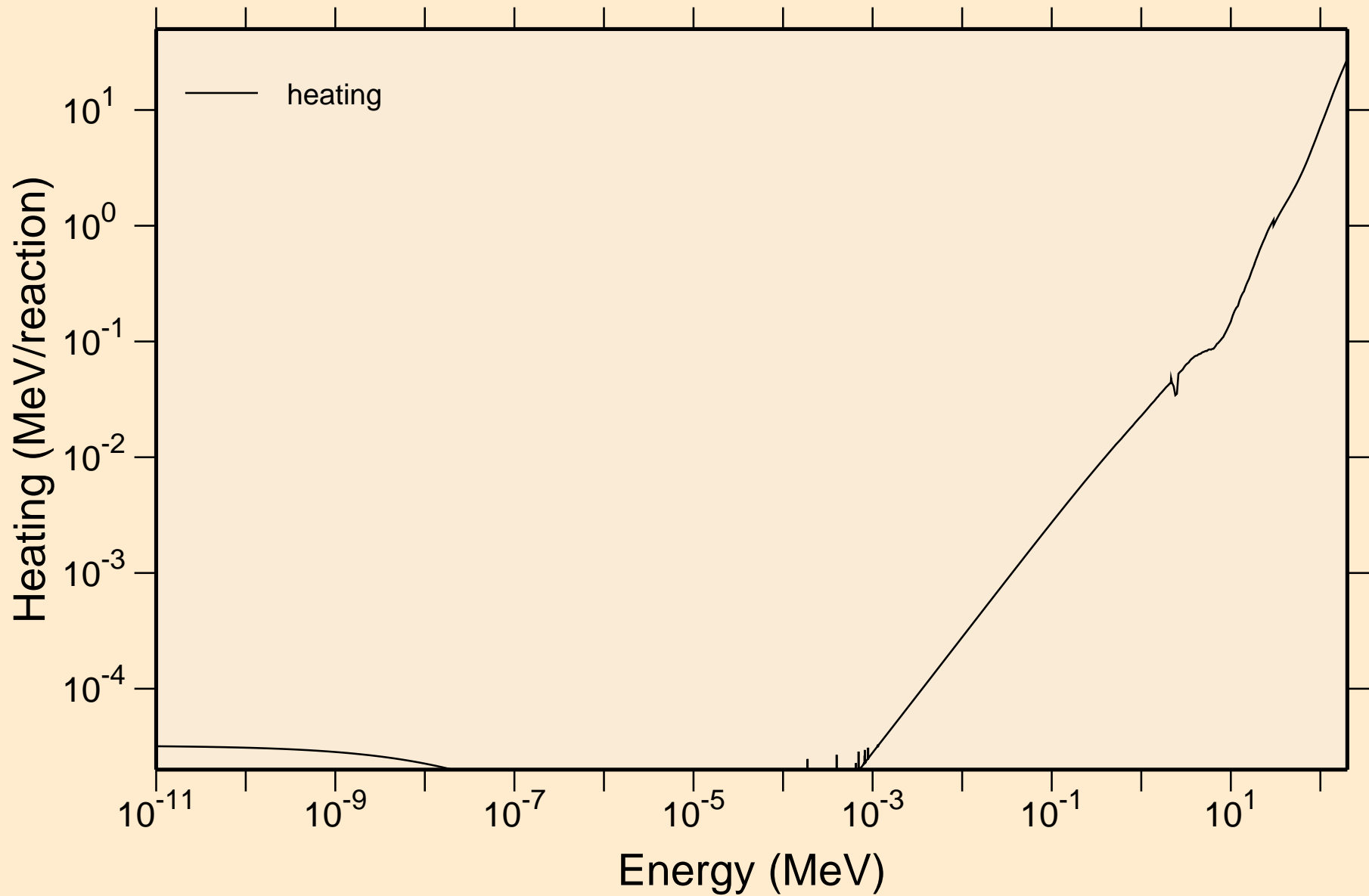

CU070 NEUTRON ACER TENDL-2023 LIBRARY; T=0.K  
Damage

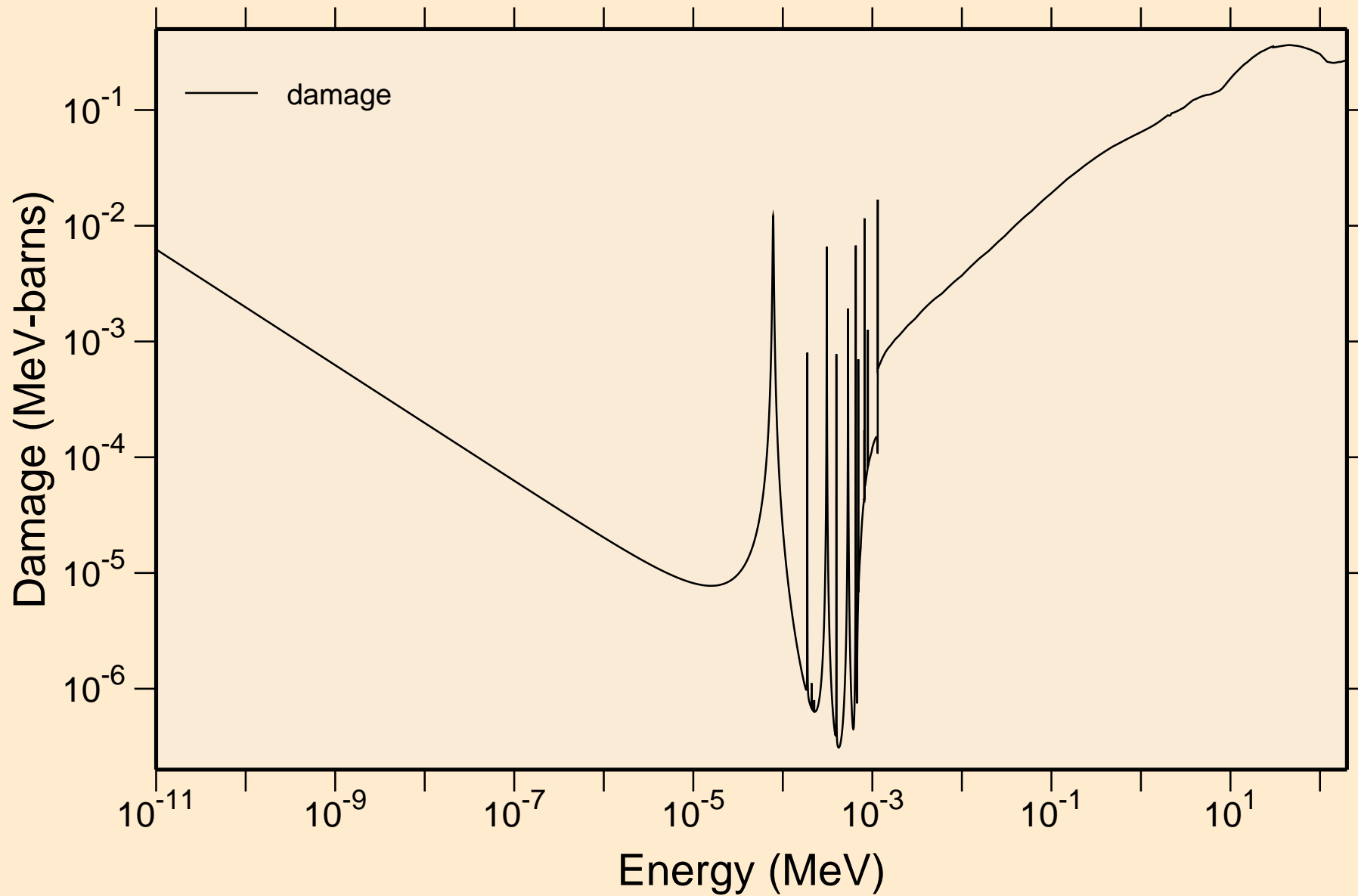

CU070 NEUTRON ACER TENDL-2023 LIBRARY; T=0.K  
Non-threshold reactions

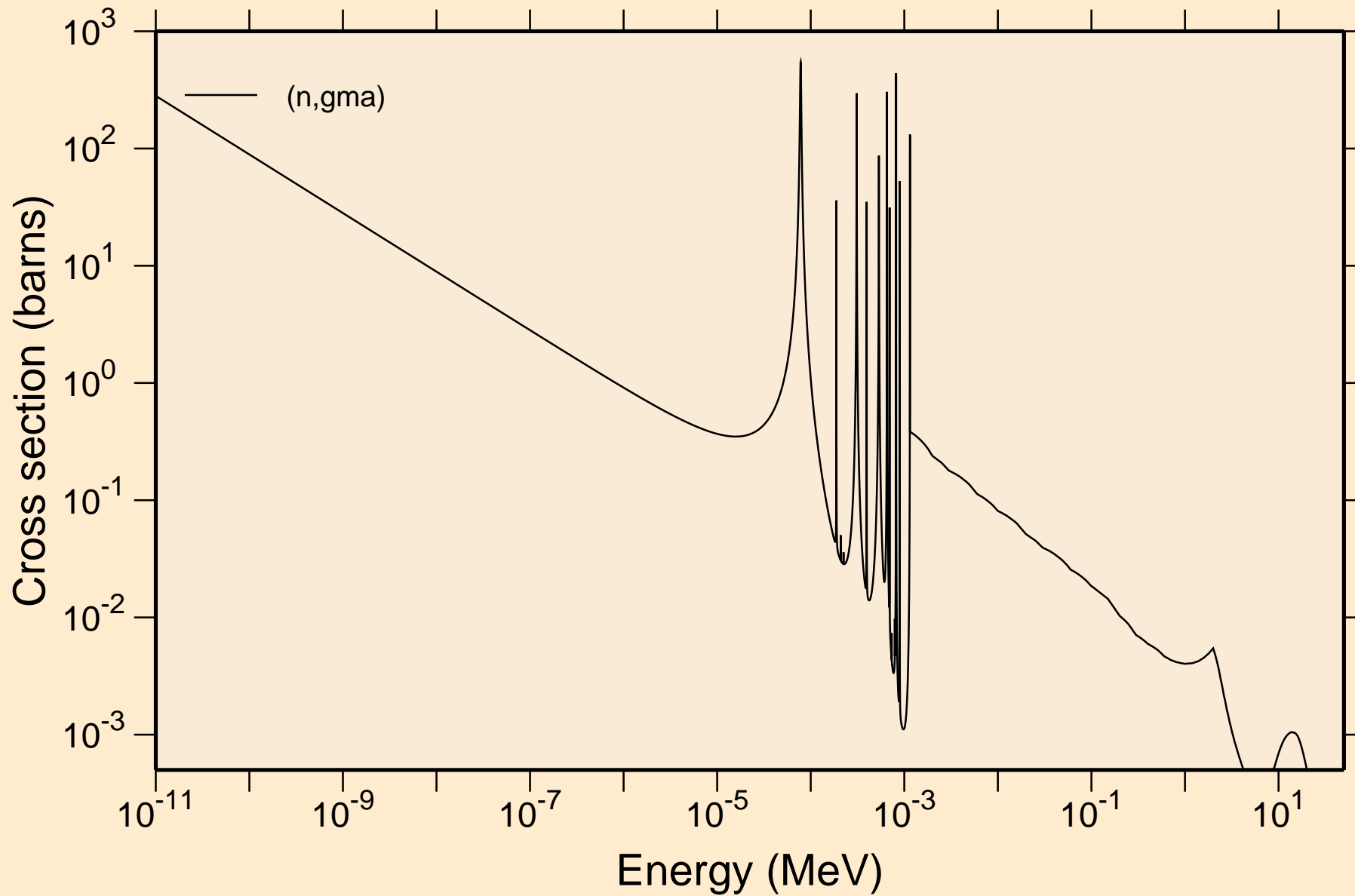

# CU070 NEUTRON ACER TENDL-2023 LIBRARY; T=0.K

## Principal cross sections

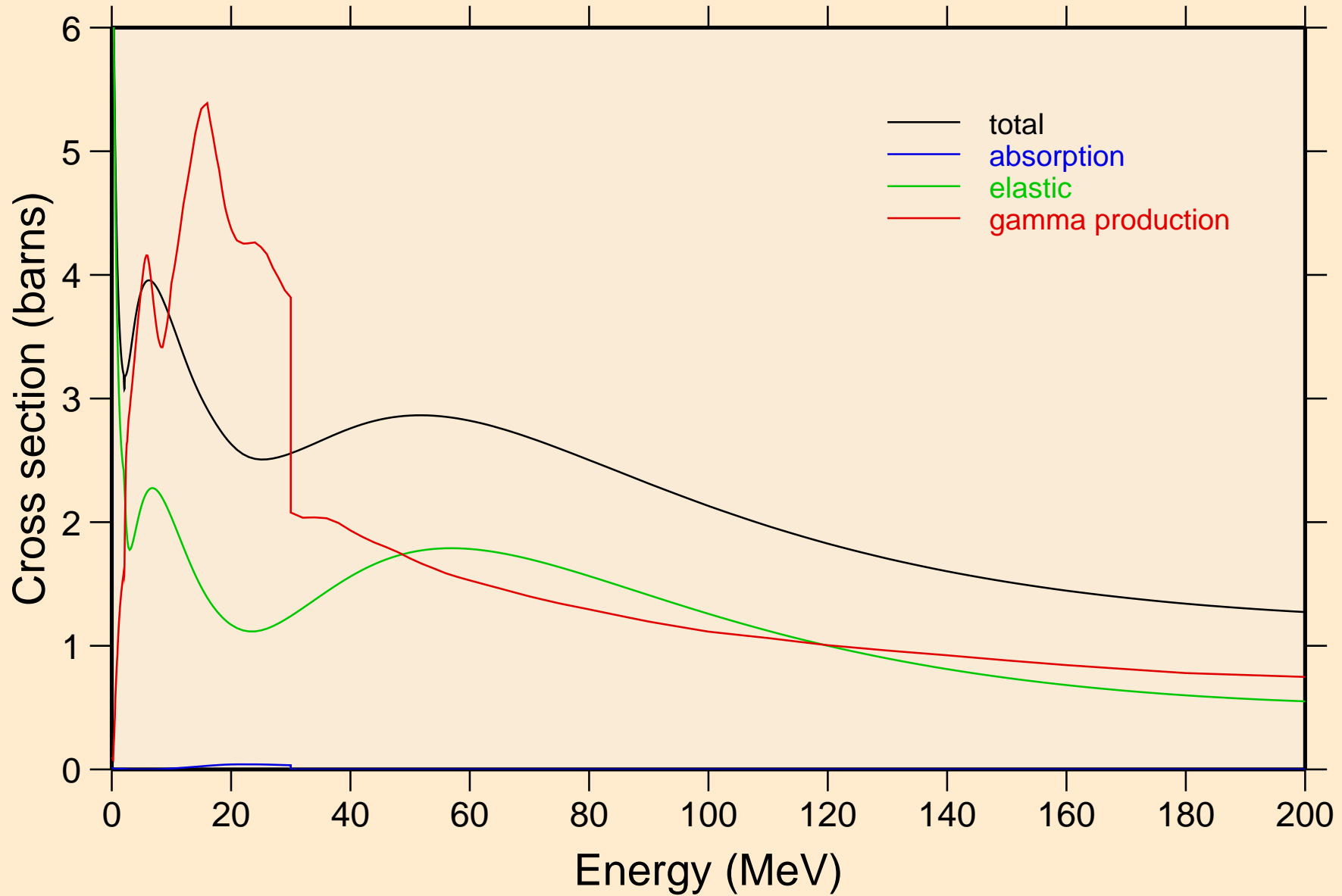

# CU070 NEUTRON ACER TENDL-2023 LIBRARY; T=0.K

## Heating

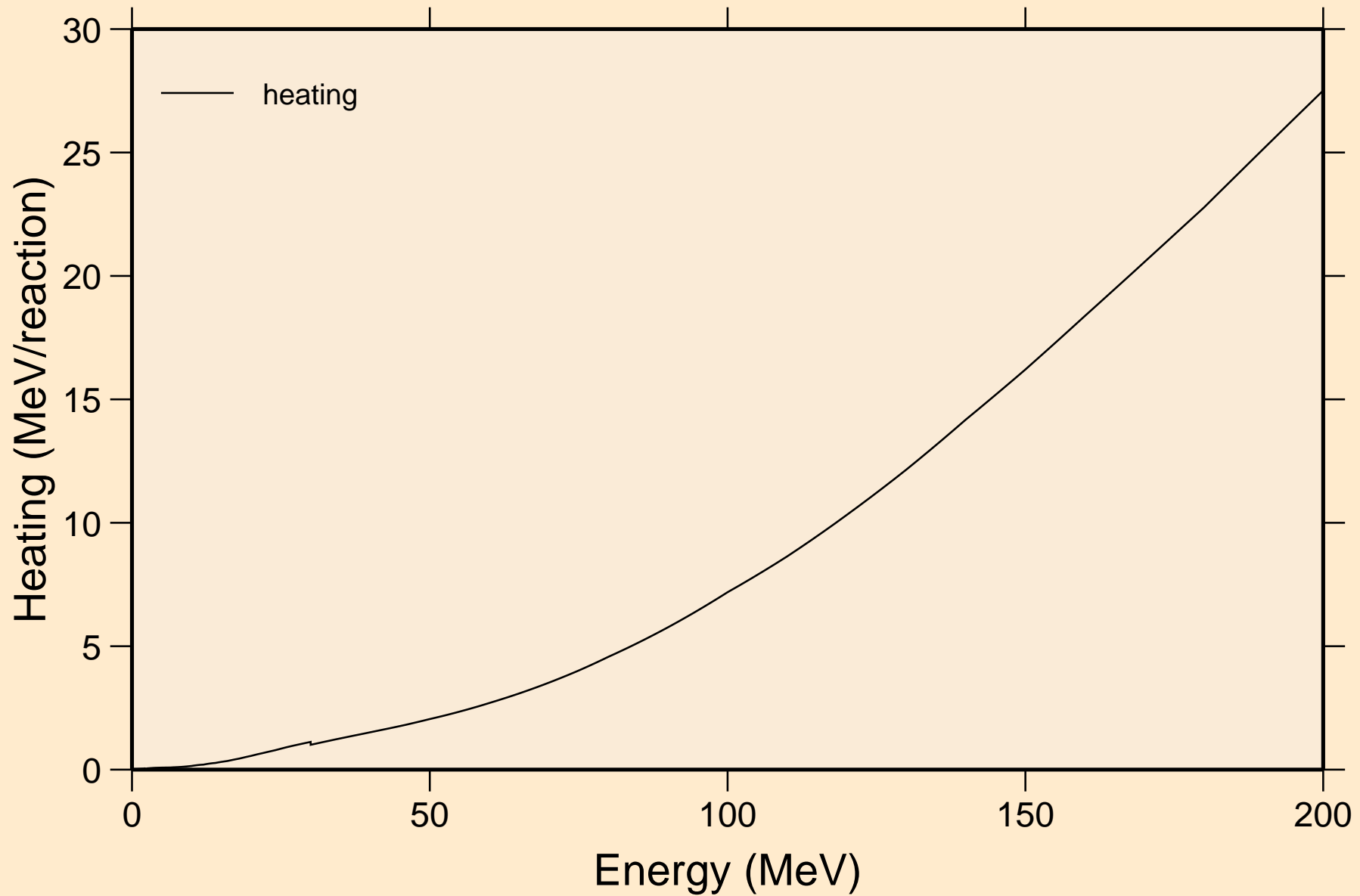

CU070 NEUTRON ACER TENDL-2023 LIBRARY; T=0.K  
Damage

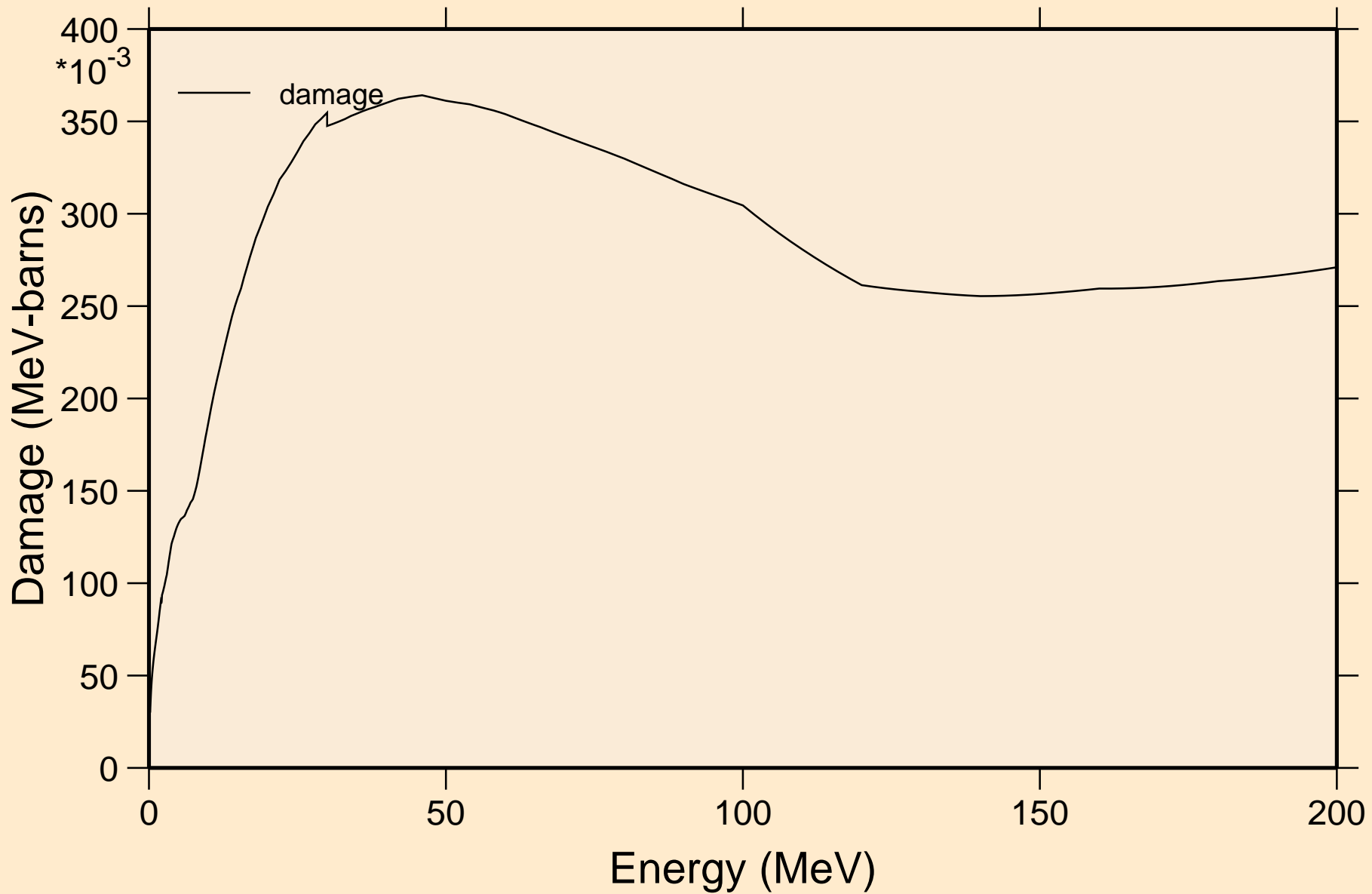

CU070 NEUTRON ACER TENDL-2023 LIBRARY; T=0.K  
Non-threshold reactions

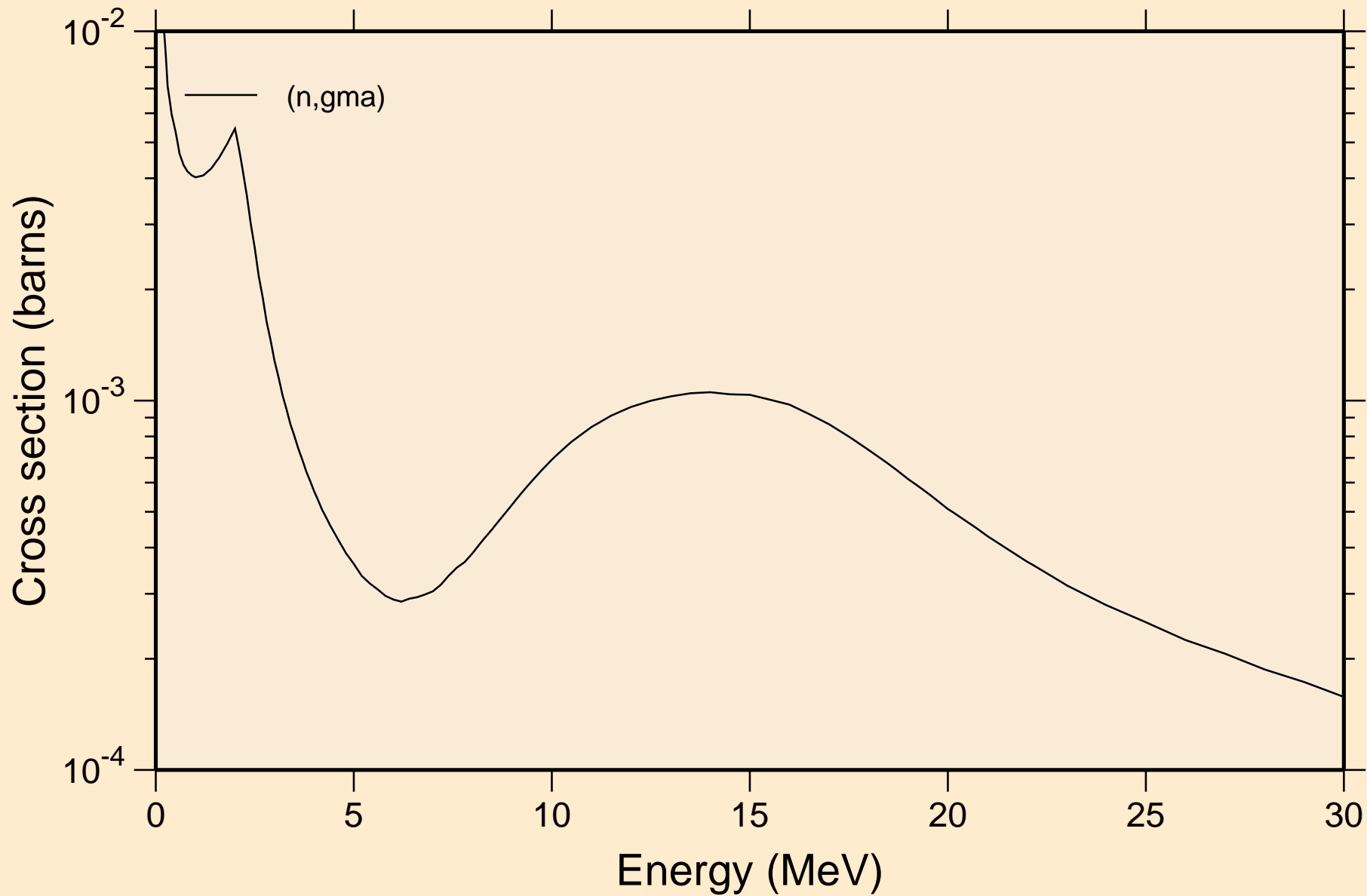



CU070 NEUTRON ACER TENDL-2023 LIBRARY; T=0.K  
Inelastic levels

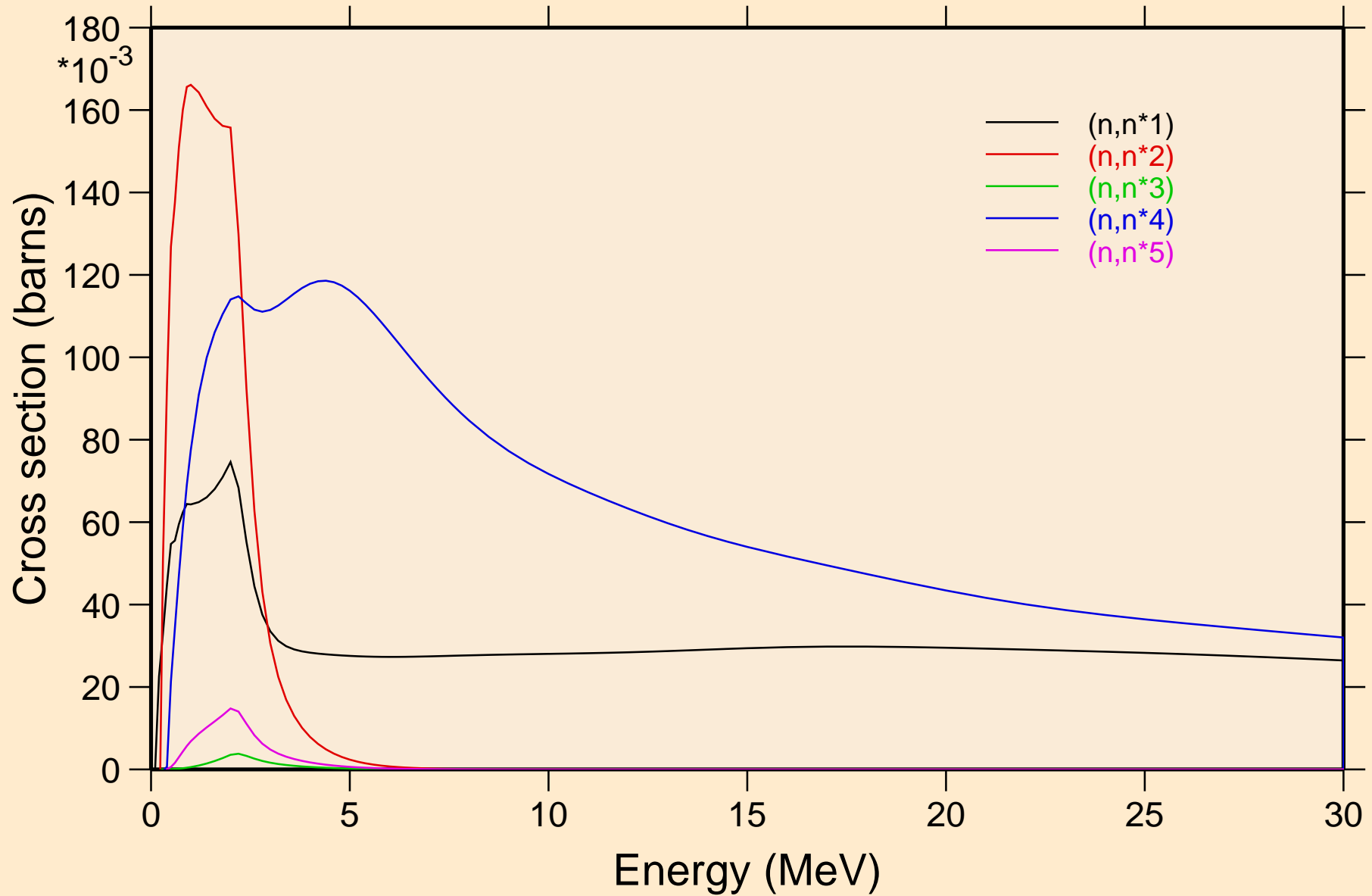

CU070 NEUTRON ACER TENDL-2023 LIBRARY; T=0.K  
Inelastic levels

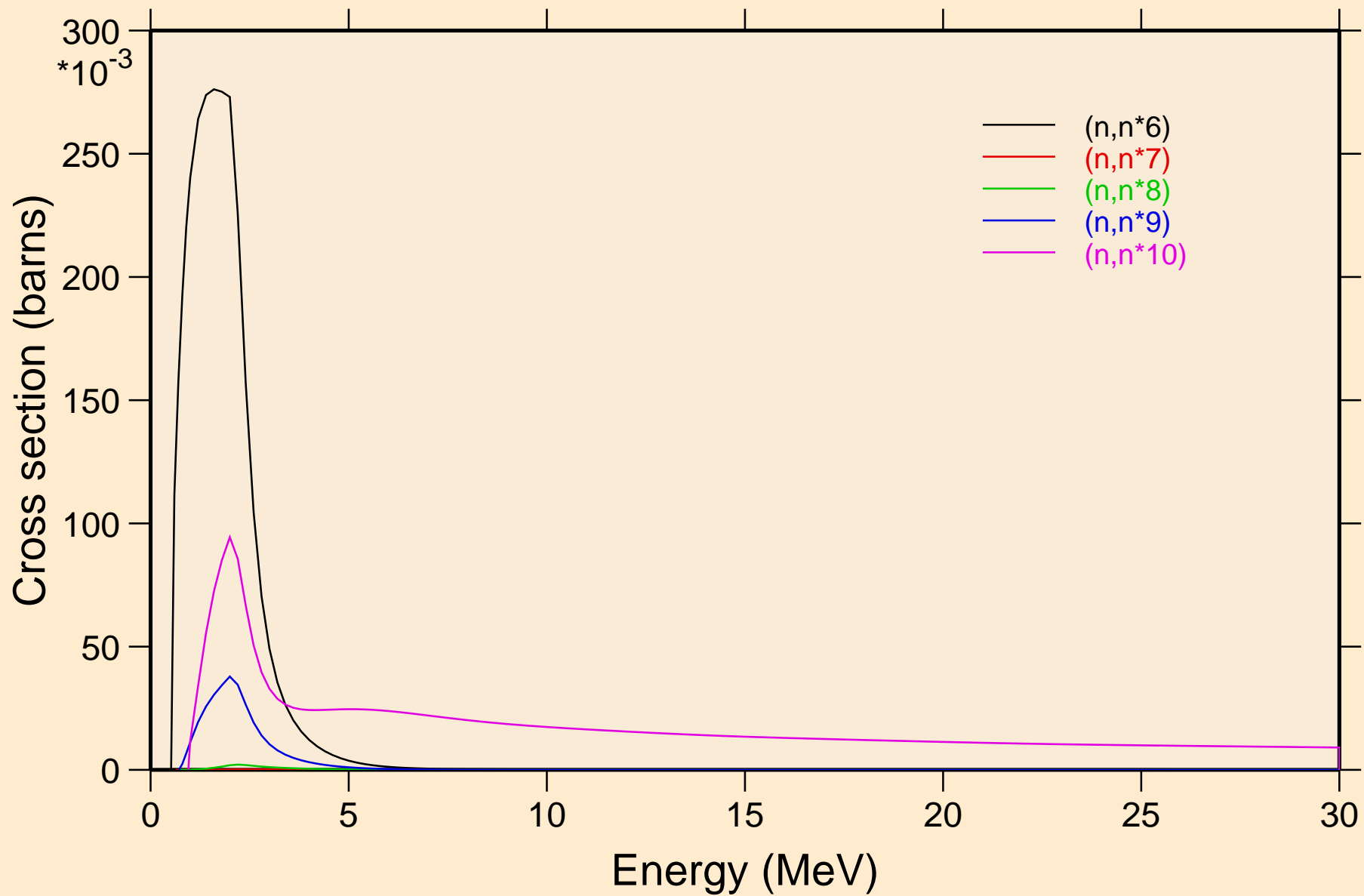

CU070 NEUTRON ACER TENDL-2023 LIBRARY; T=0.K  
Inelastic levels

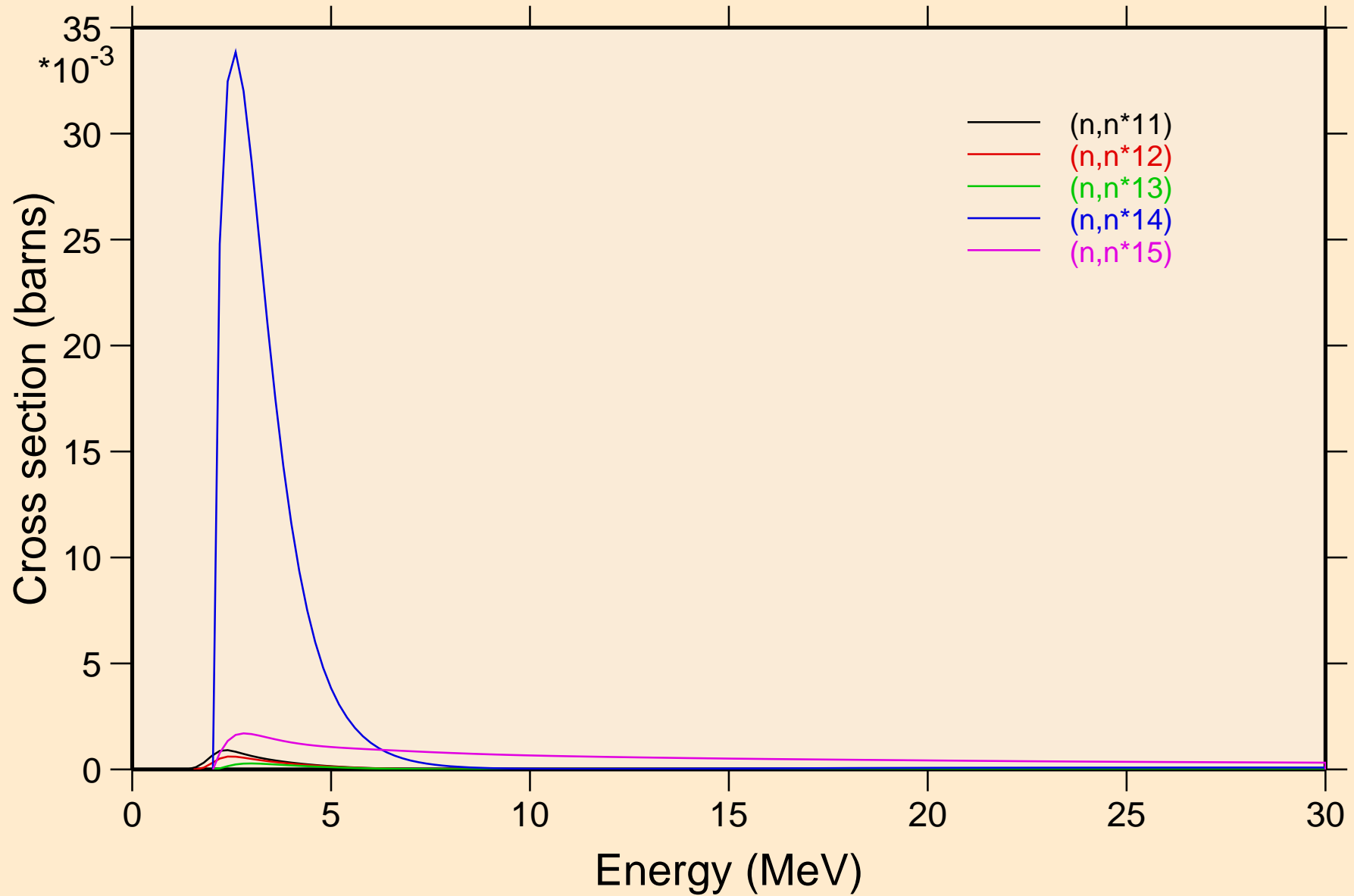

CU070 NEUTRON ACER TENDL-2023 LIBRARY; T=0.K  
Inelastic levels

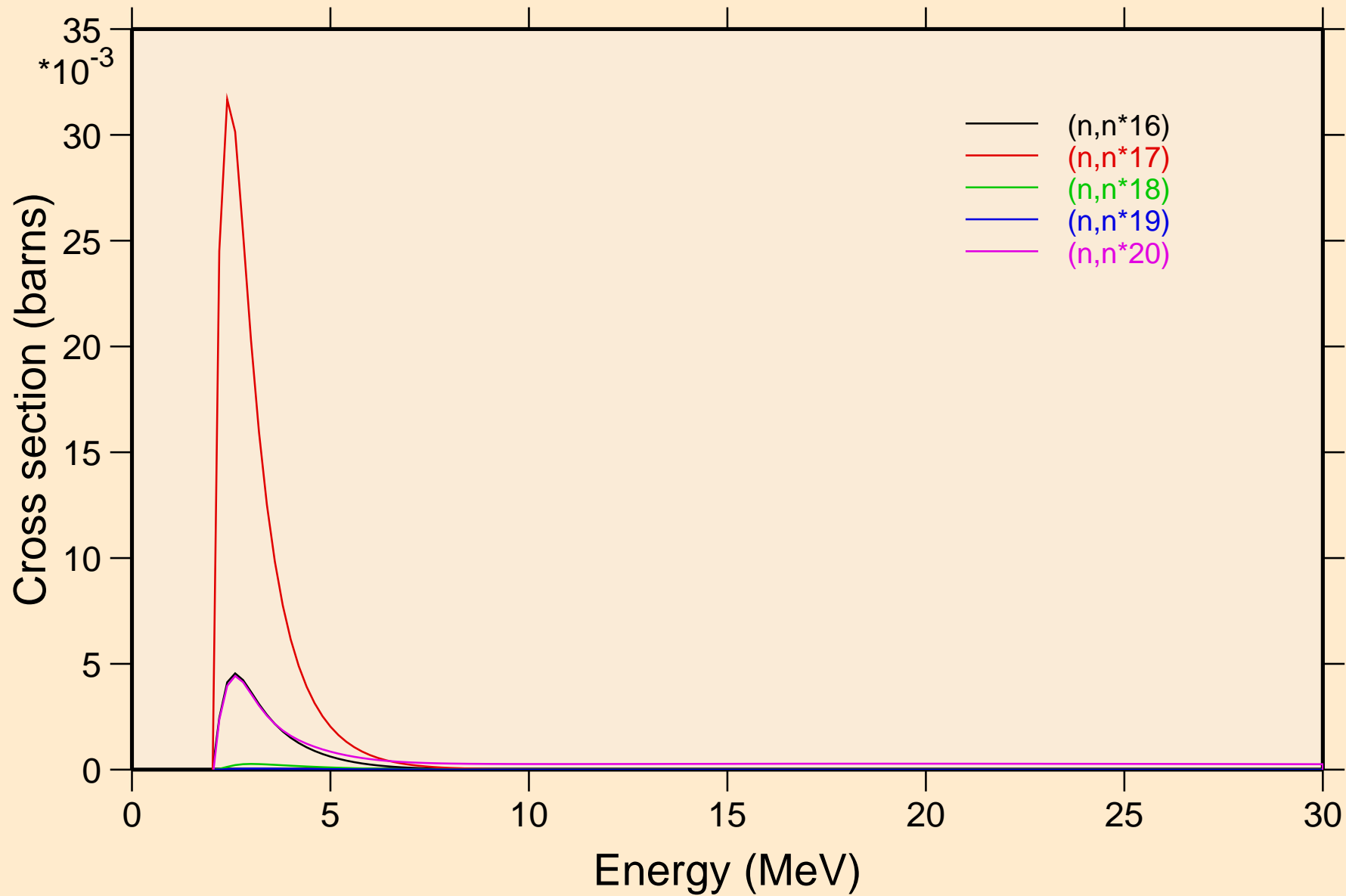

CU070 NEUTRON ACER TENDL-2023 LIBRARY; T=0.K  
Inelastic levels

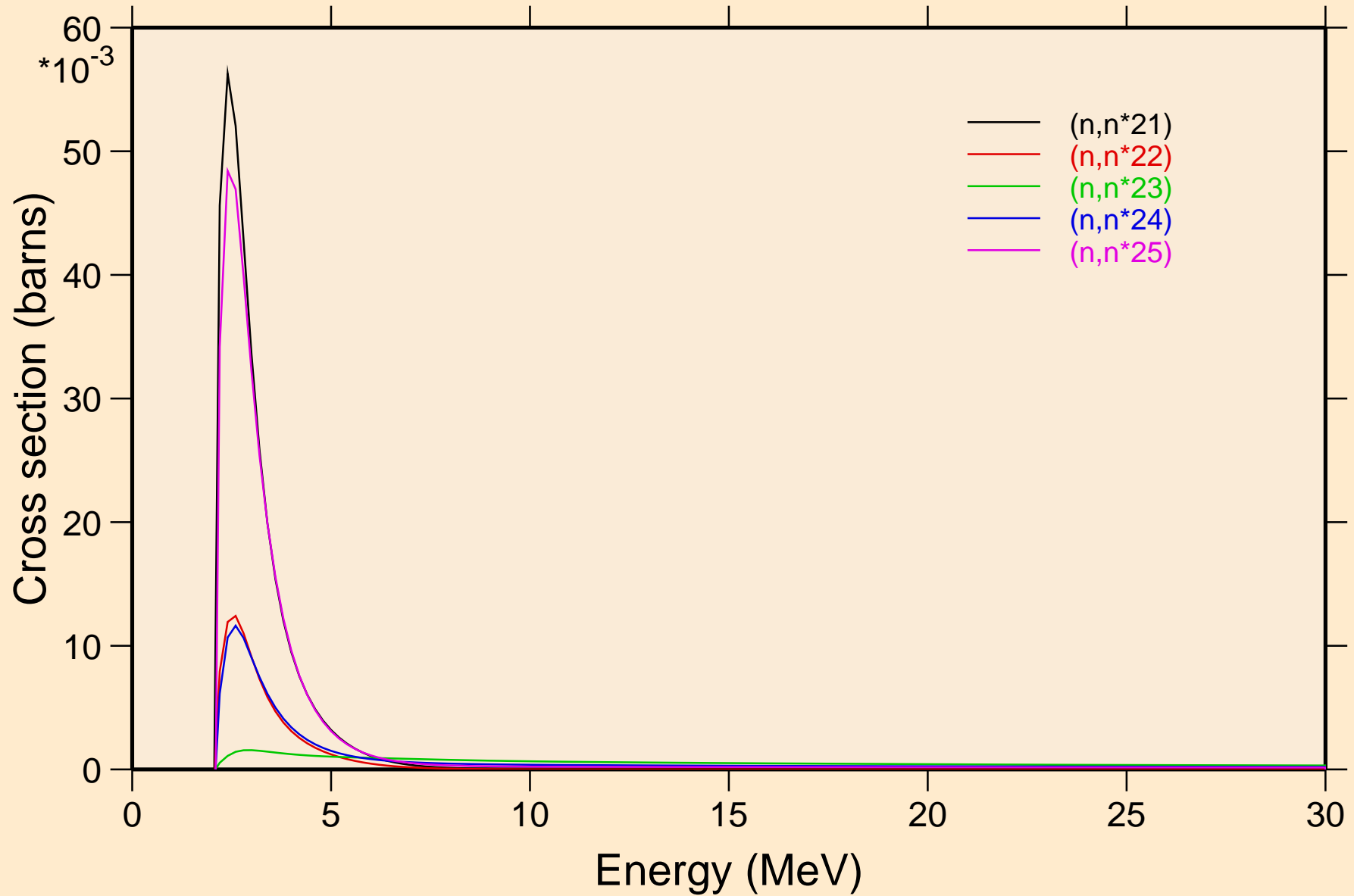

CU070 NEUTRON ACER TENDL-2023 LIBRARY; T=0.K  
Inelastic levels

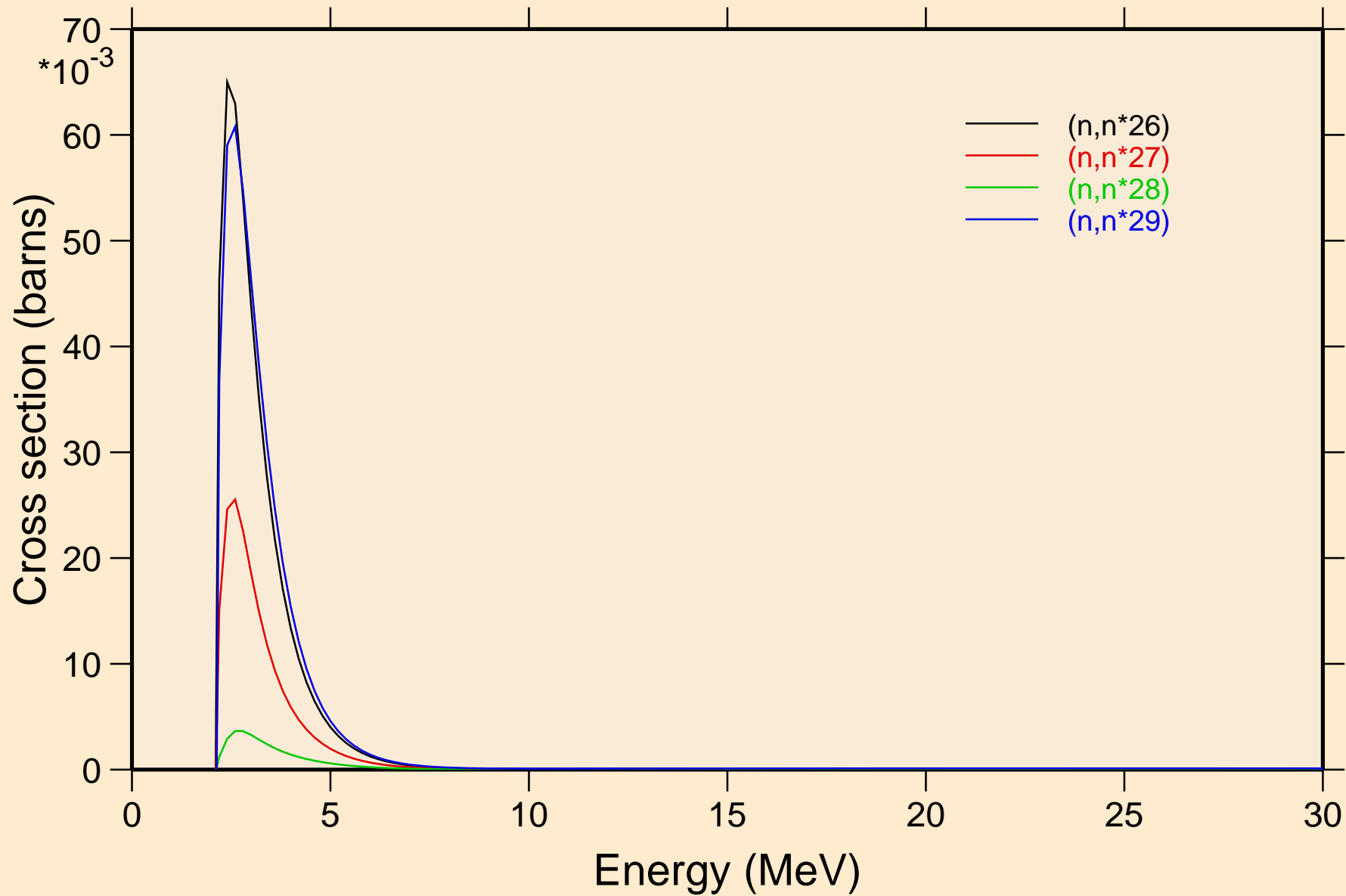

# CU070 NEUTRON ACER TENDL-2023 LIBRARY; T=0.K

## Threshold reactions

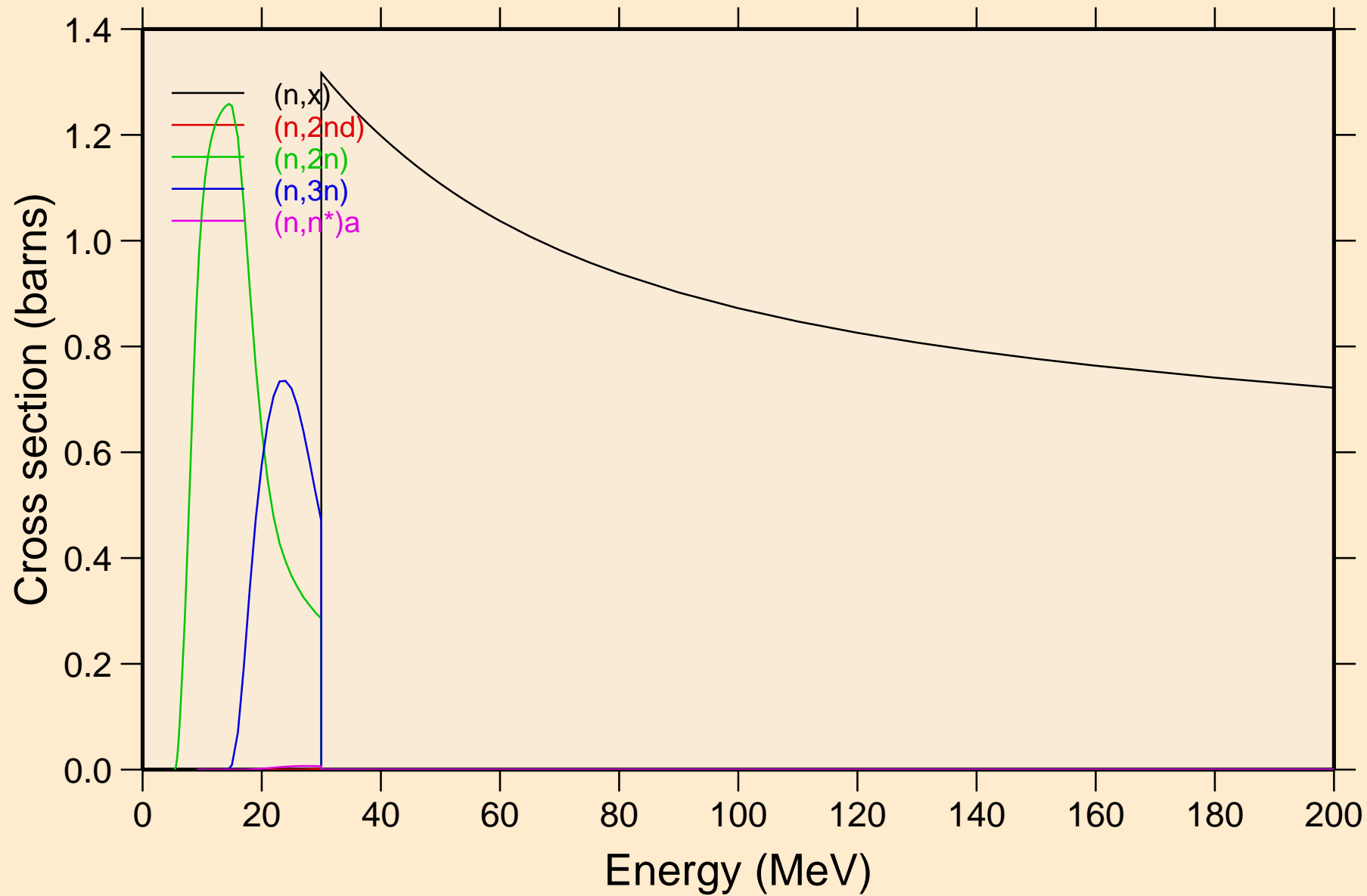

# CU070 NEUTRON ACER TENDL-2023 LIBRARY; T=0.K

## Threshold reactions

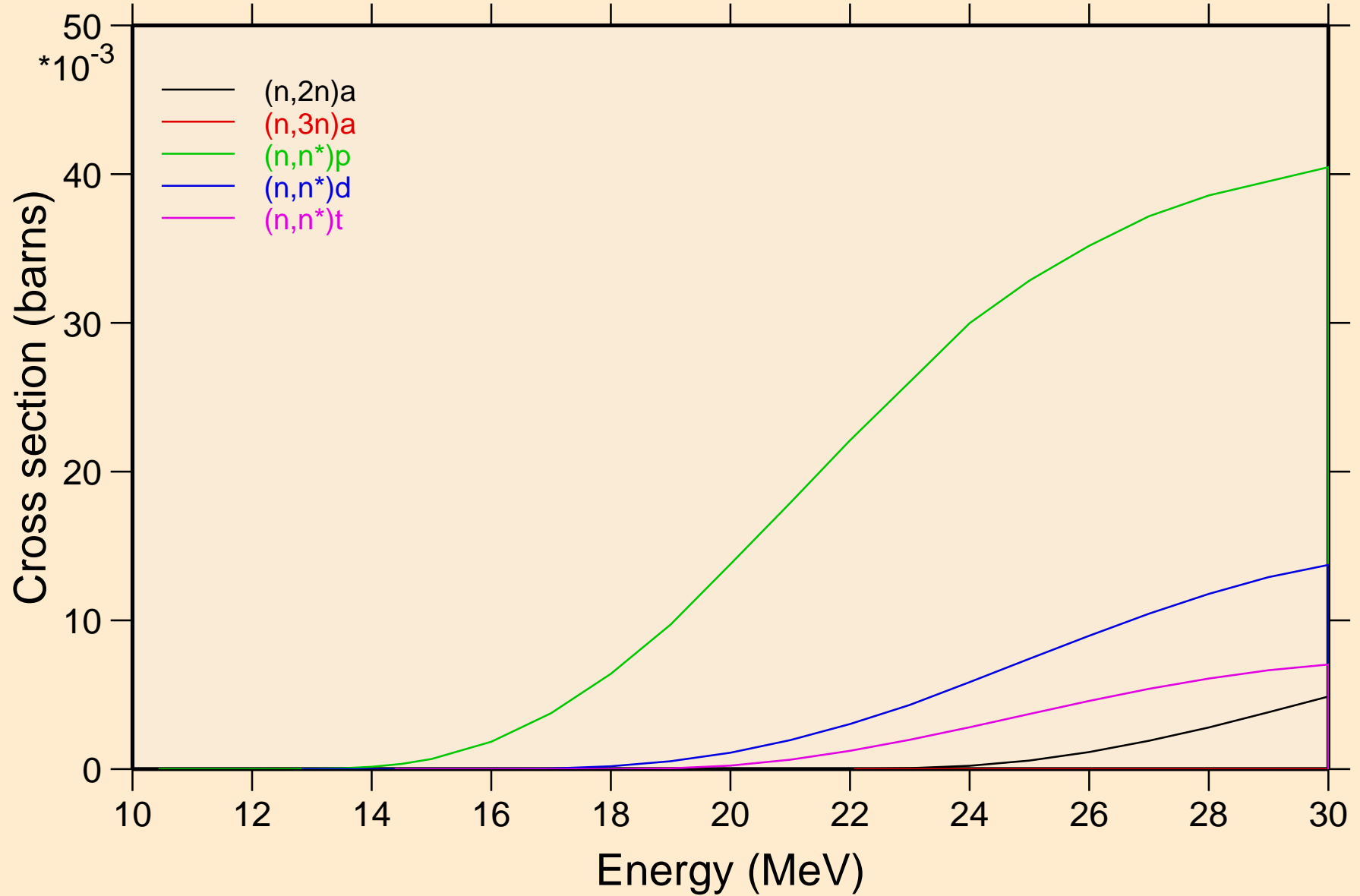



CU070 NEUTRON ACER TENDL-2023 LIBRARY; T=0.K  
Threshold reactions

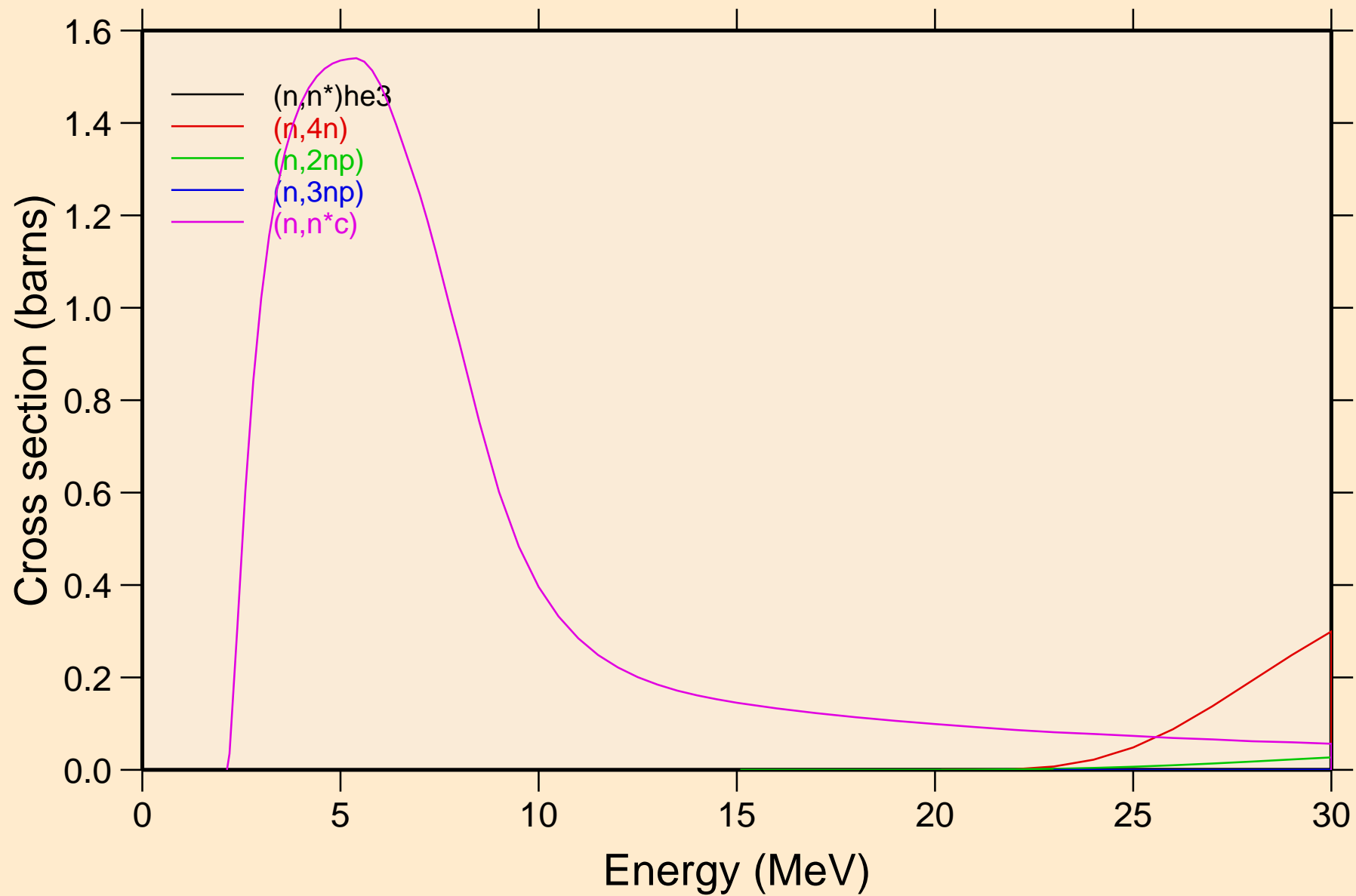

# CU070 NEUTRON ACER TENDL-2023 LIBRARY; T=0.K

## Threshold reactions

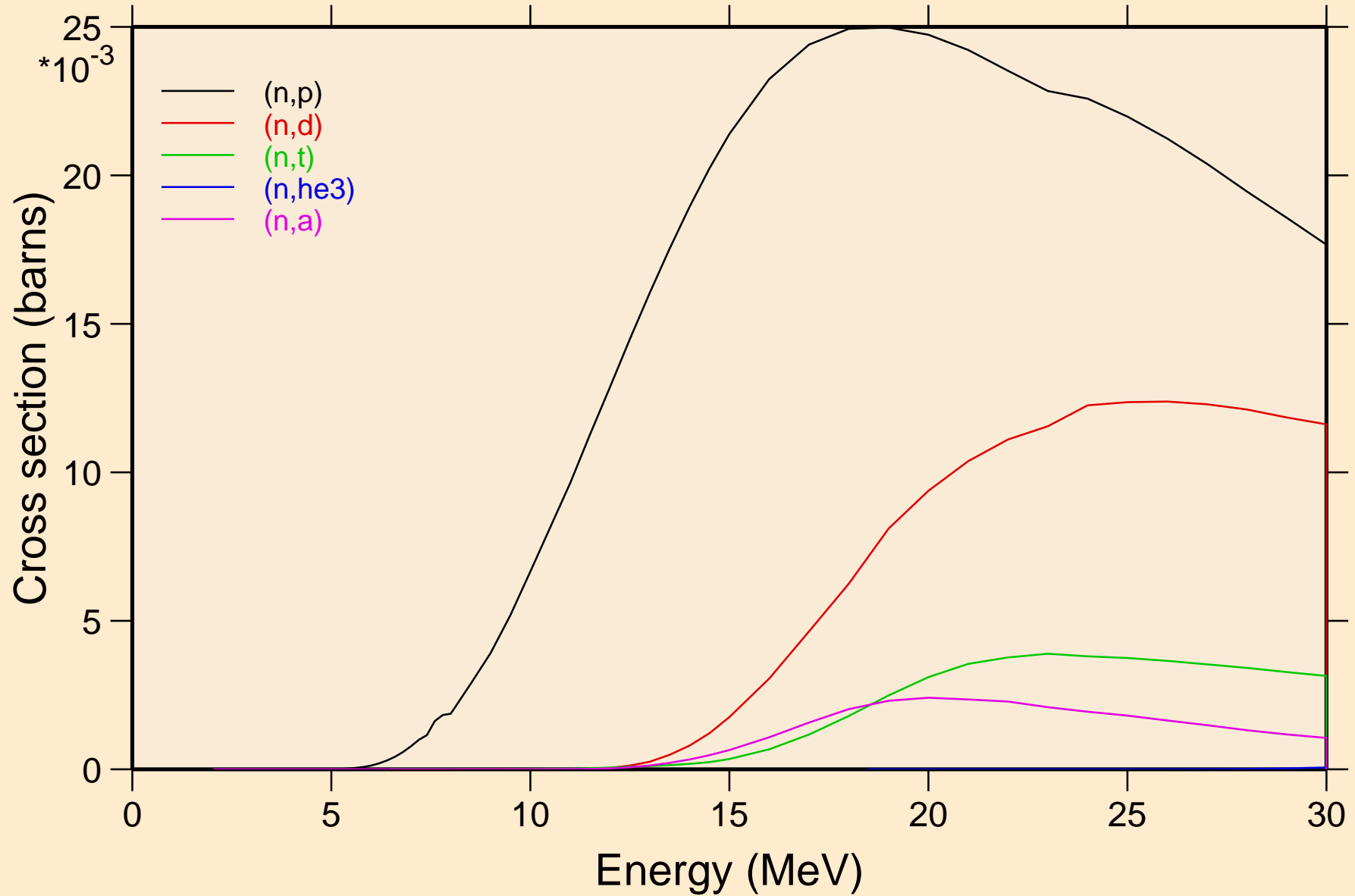

CU070 NEUTRON ACER TENDL-2023 LIBRARY; T=0.K  
Threshold reactions

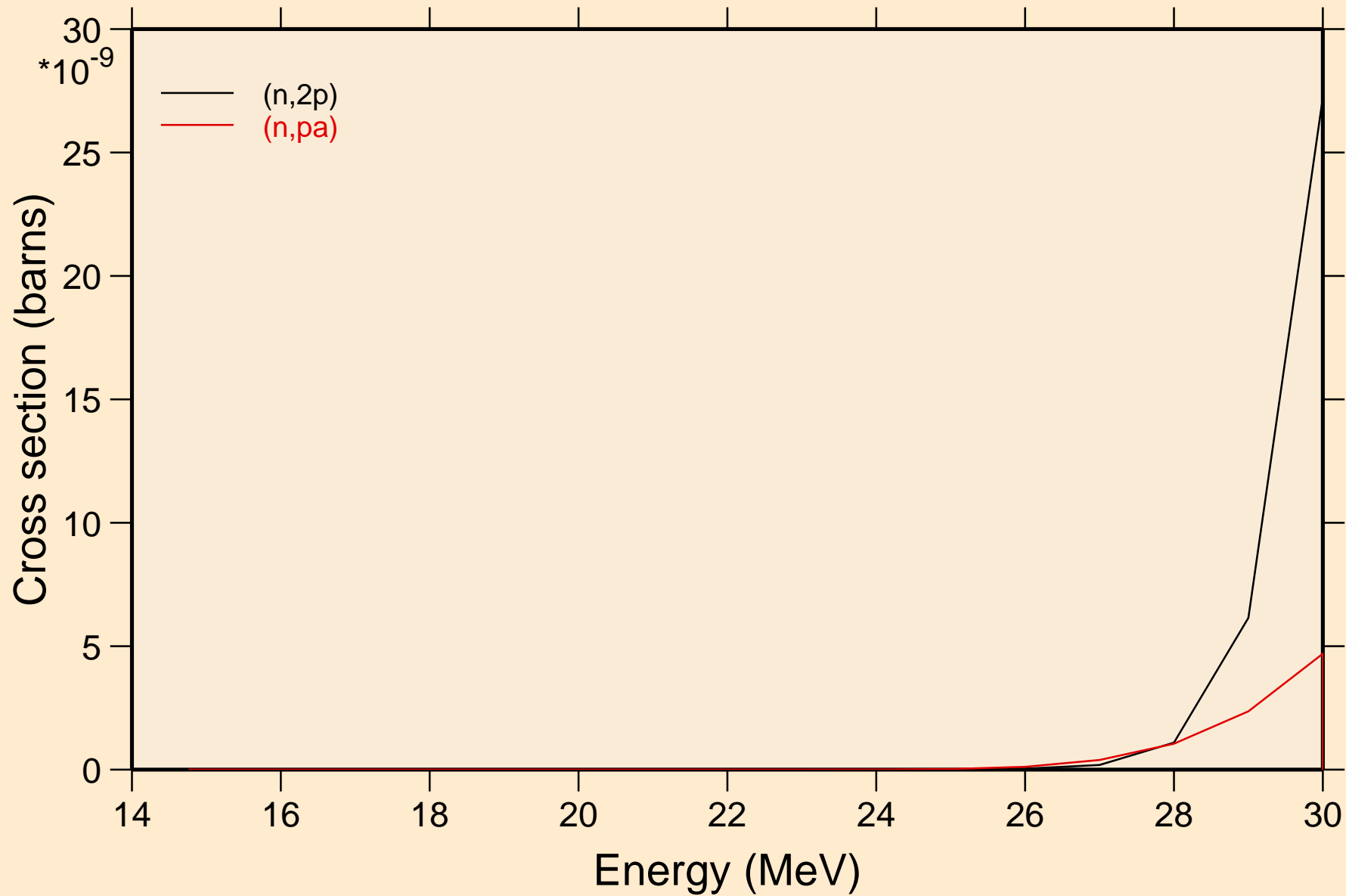

# CU070 NEUTRON ACER TENDL-2023 LIBRARY; T=0.K

## Threshold reactions

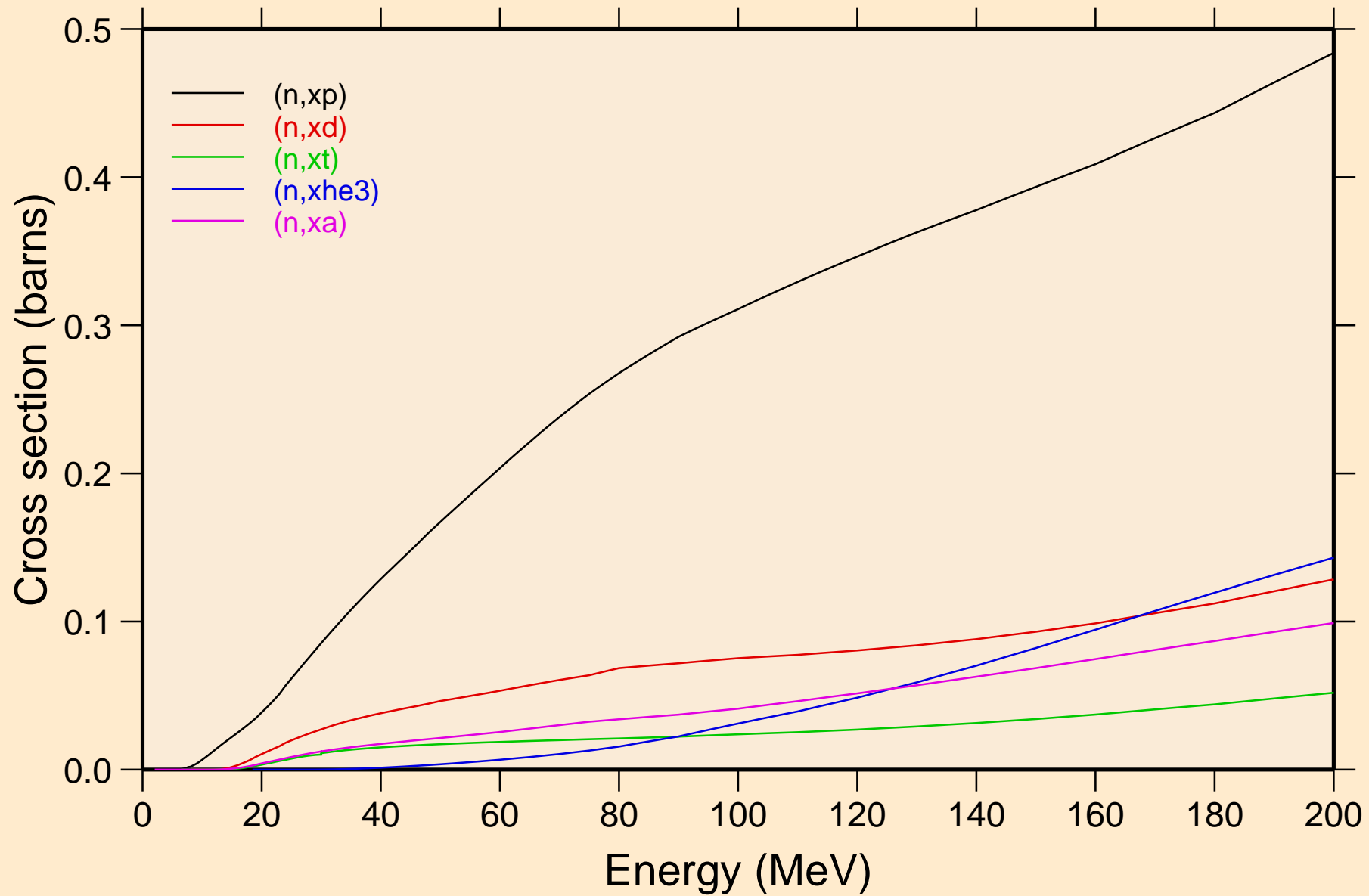

CU070 NEUTRON ACER TENDL-2023 LIBRARY; T=0.K  
angular distribution for elastic

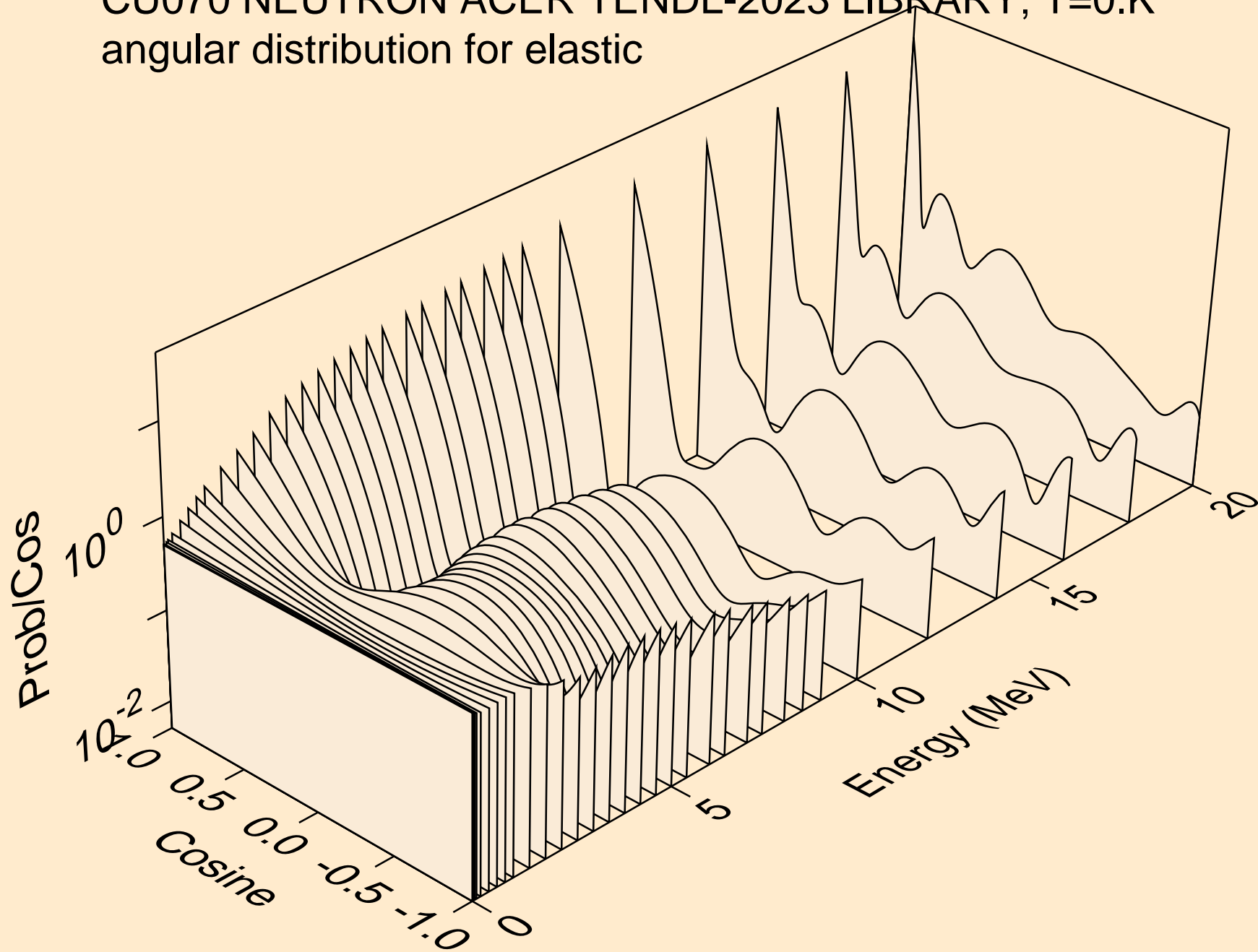

CU070 NEUTRON ACER TENDL-2023 LIBRARY; T=0.K  
angular distribution for elastic

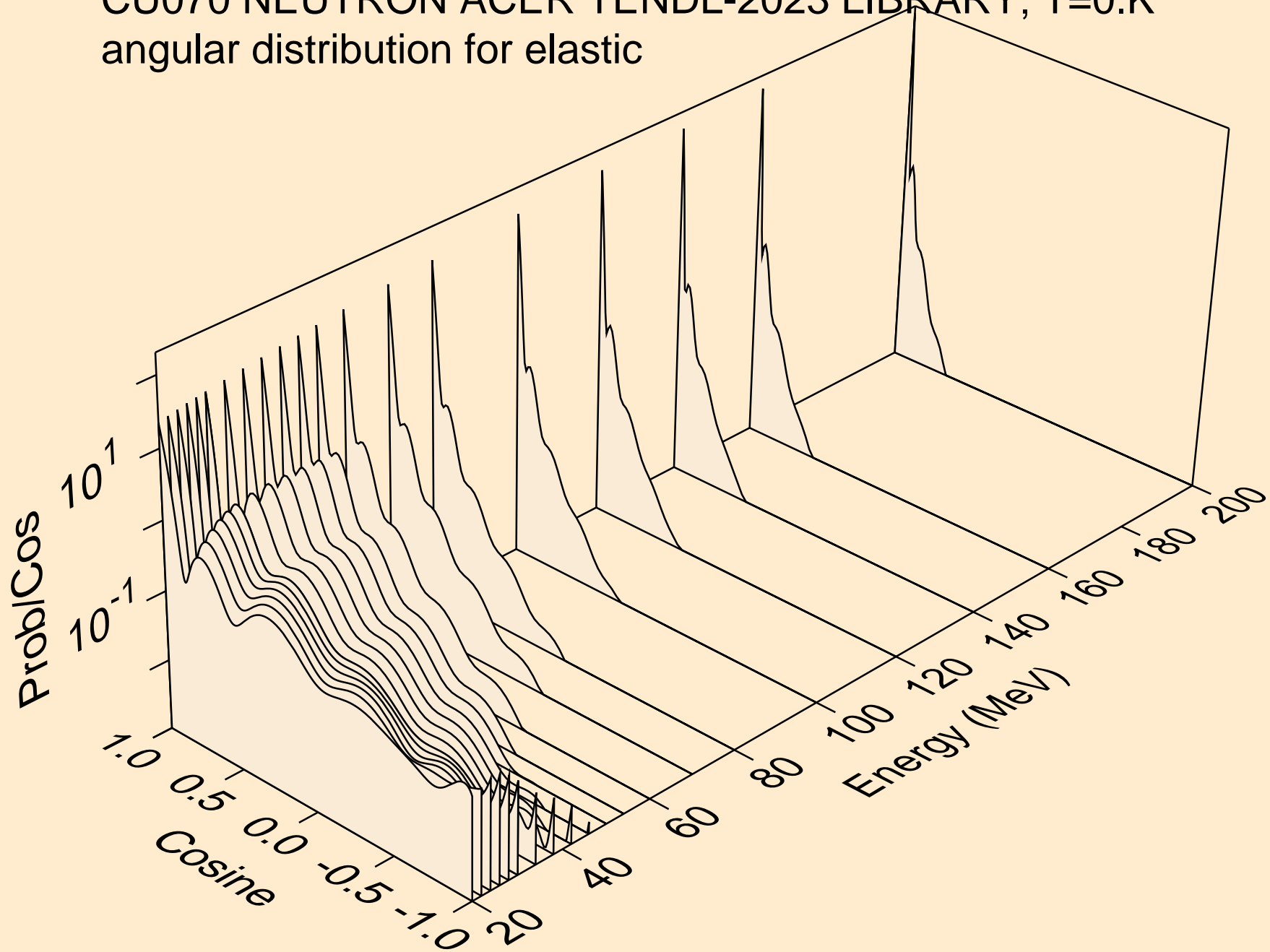

CU070 NEUTRON ACER TENDL-2023 LIBRARY; T=0.K  
angular distribution for (n,n\*1)

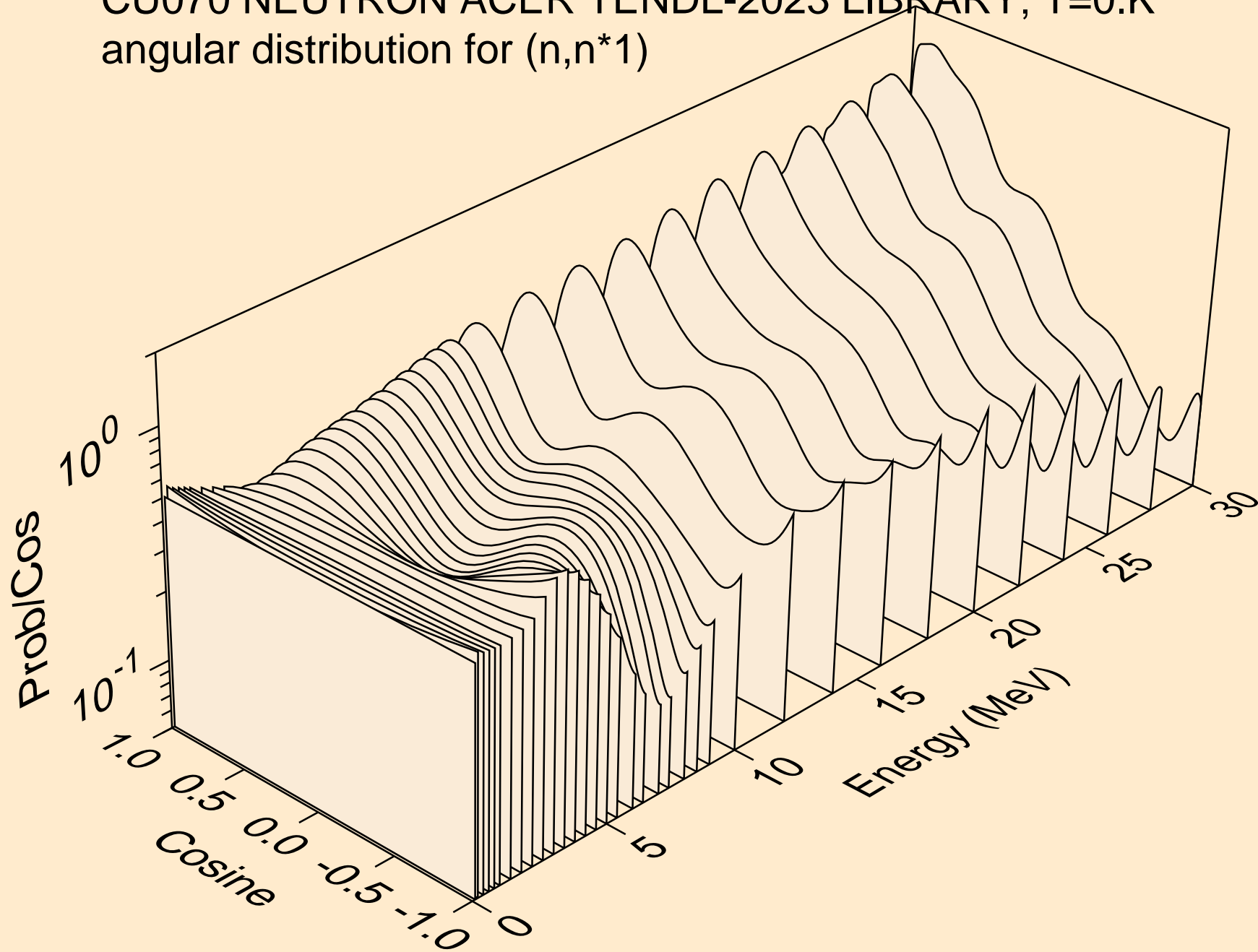

CU070 NEUTRON ACER TENDL-2023 LIBRARY; T=0.K  
angular distribution for (n,n\*2)

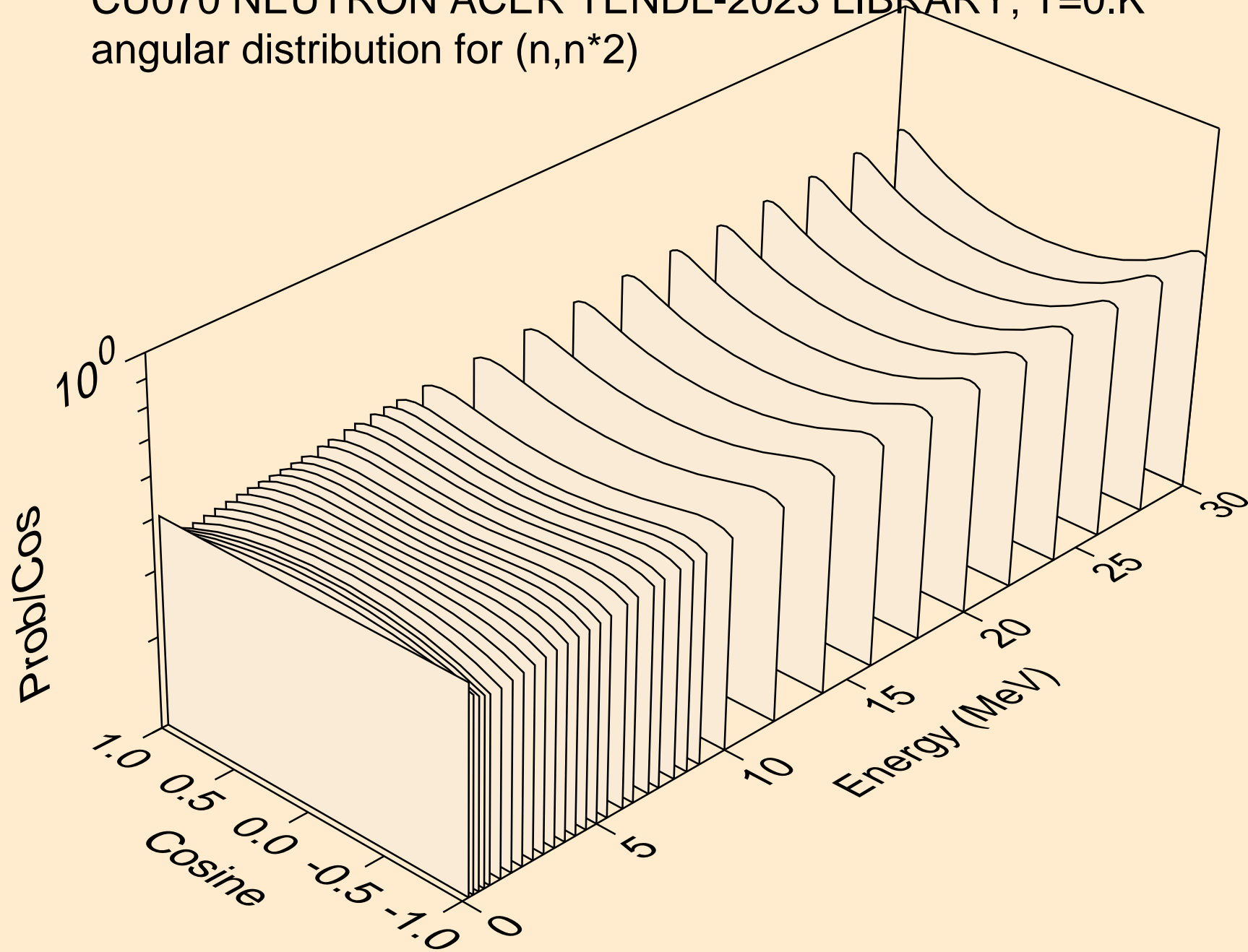



CU070 NEUTRON ACER TENDL-2023 LIBRARY; T=0.K  
angular distribution for (n,n\*3)

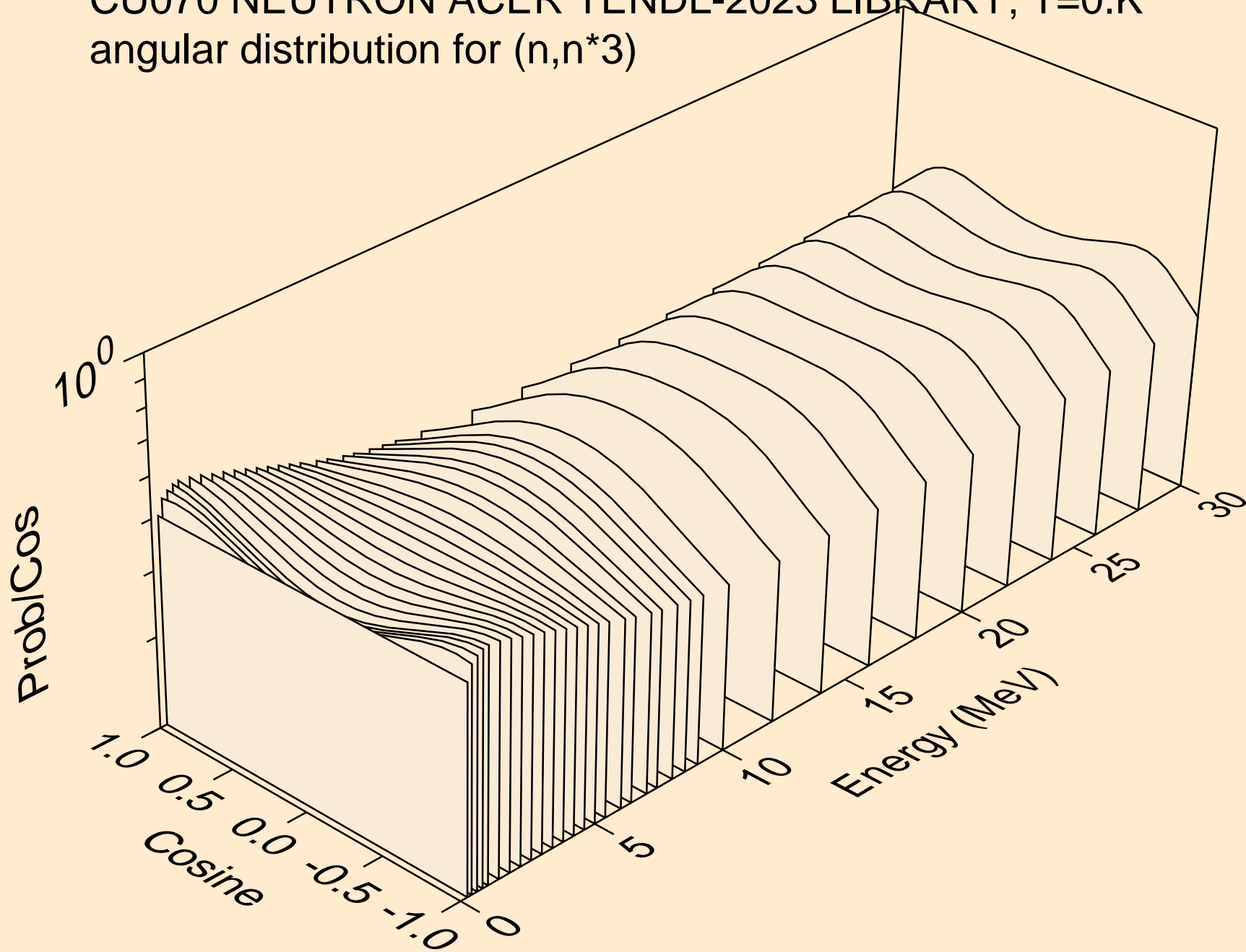

CU070 NEUTRON ACER TENDL-2023 LIBRARY; T=0.K  
angular distribution for (n,n\*4)

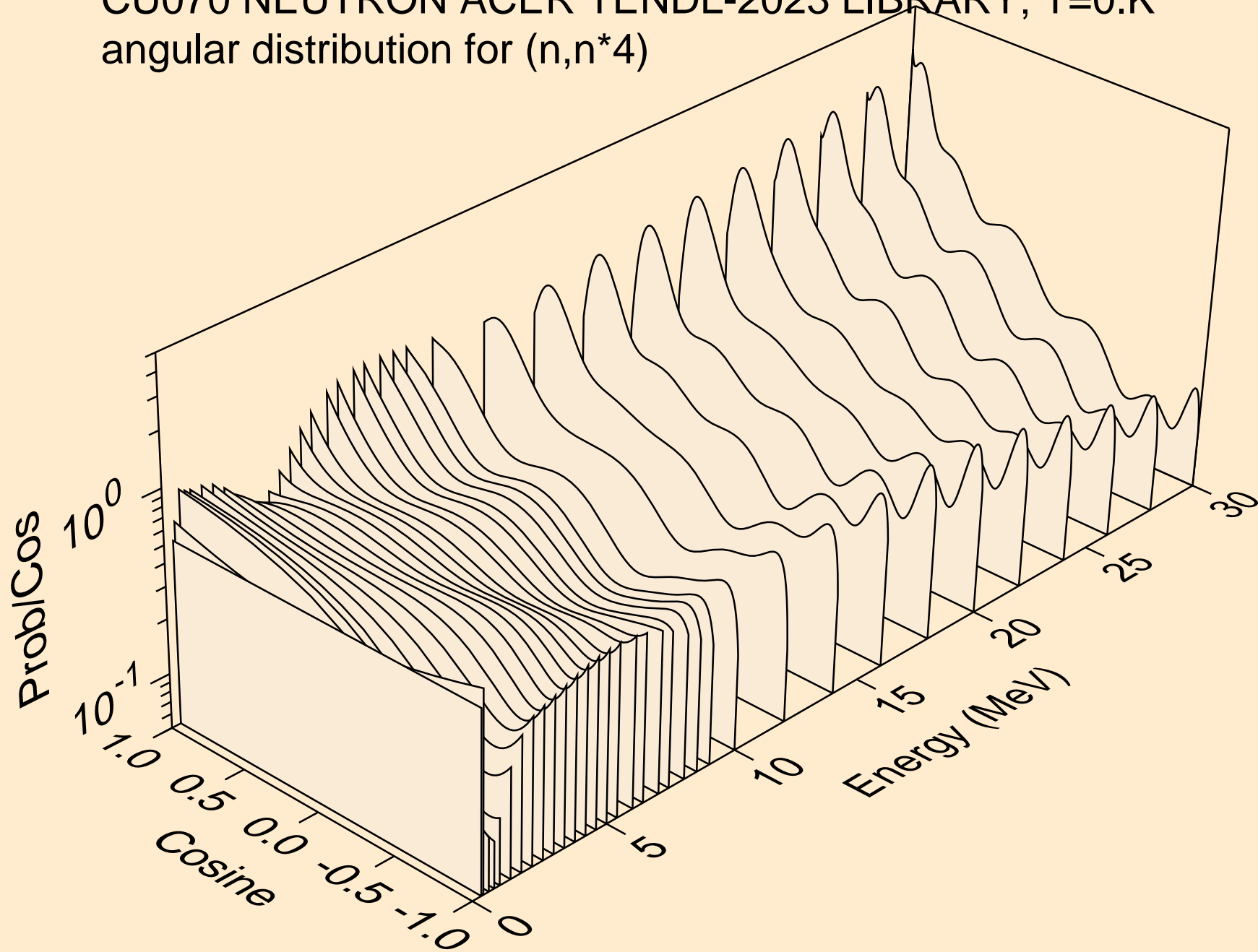

CU070 NEUTRON ACER TENDL-2023 LIBRARY; T=0.K  
angular distribution for (n,n\*5)

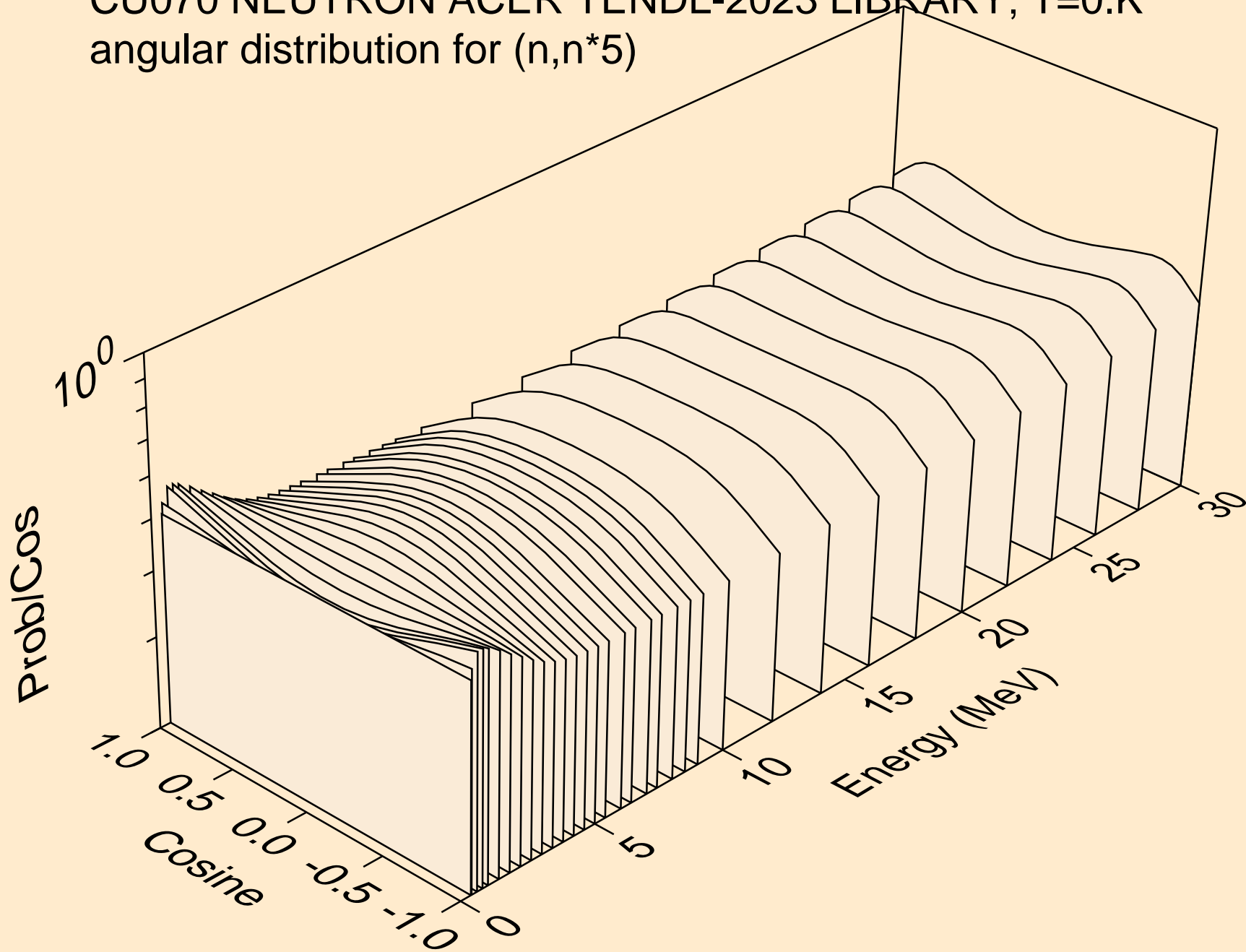

CU070 NEUTRON ACER TENDL-2023 LIBRARY; T=0.K  
angular distribution for (n,n\*6)

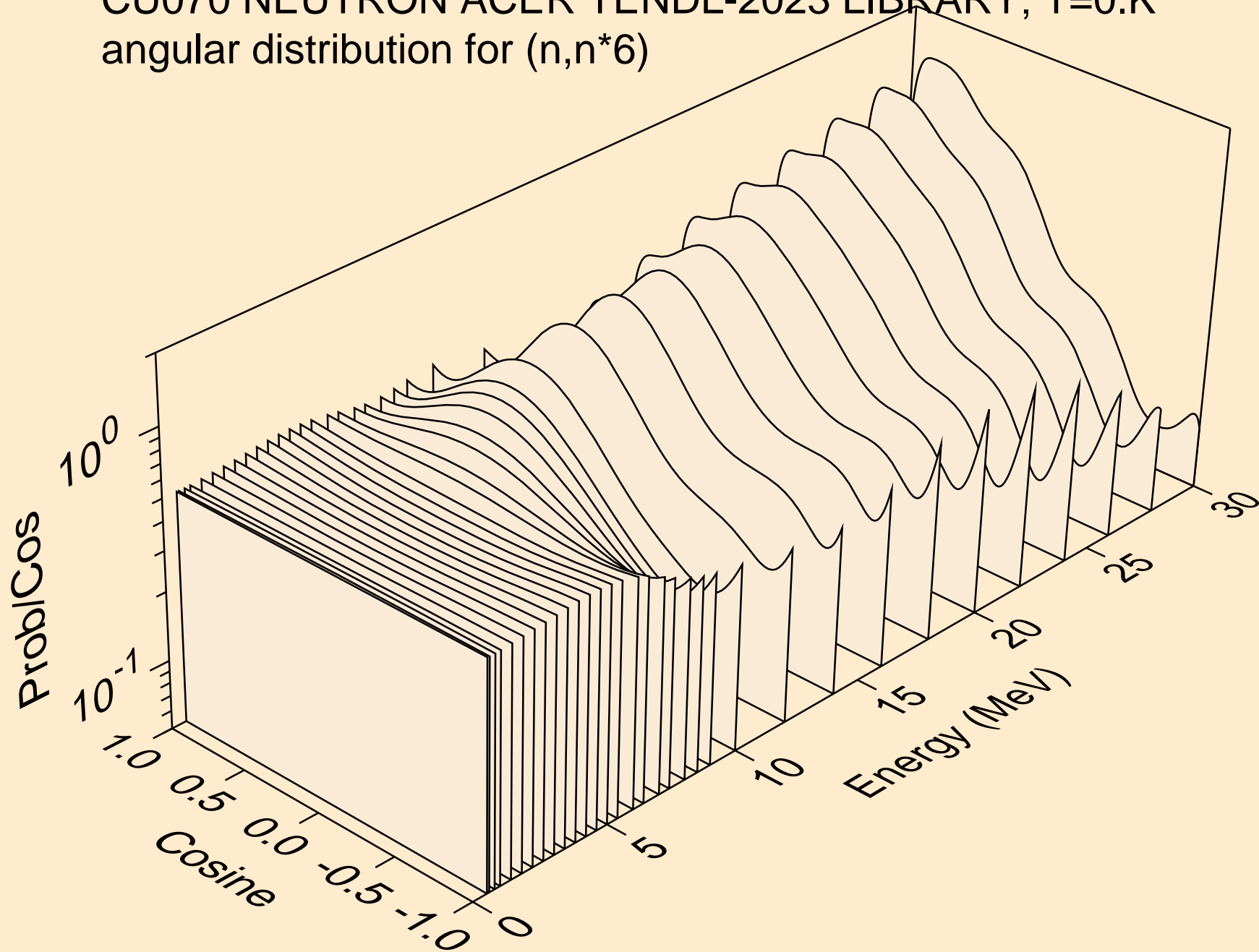

CU070 NEUTRON ACER TENDL-2023 LIBRARY; T=0.K  
angular distribution for (n,n\*7)

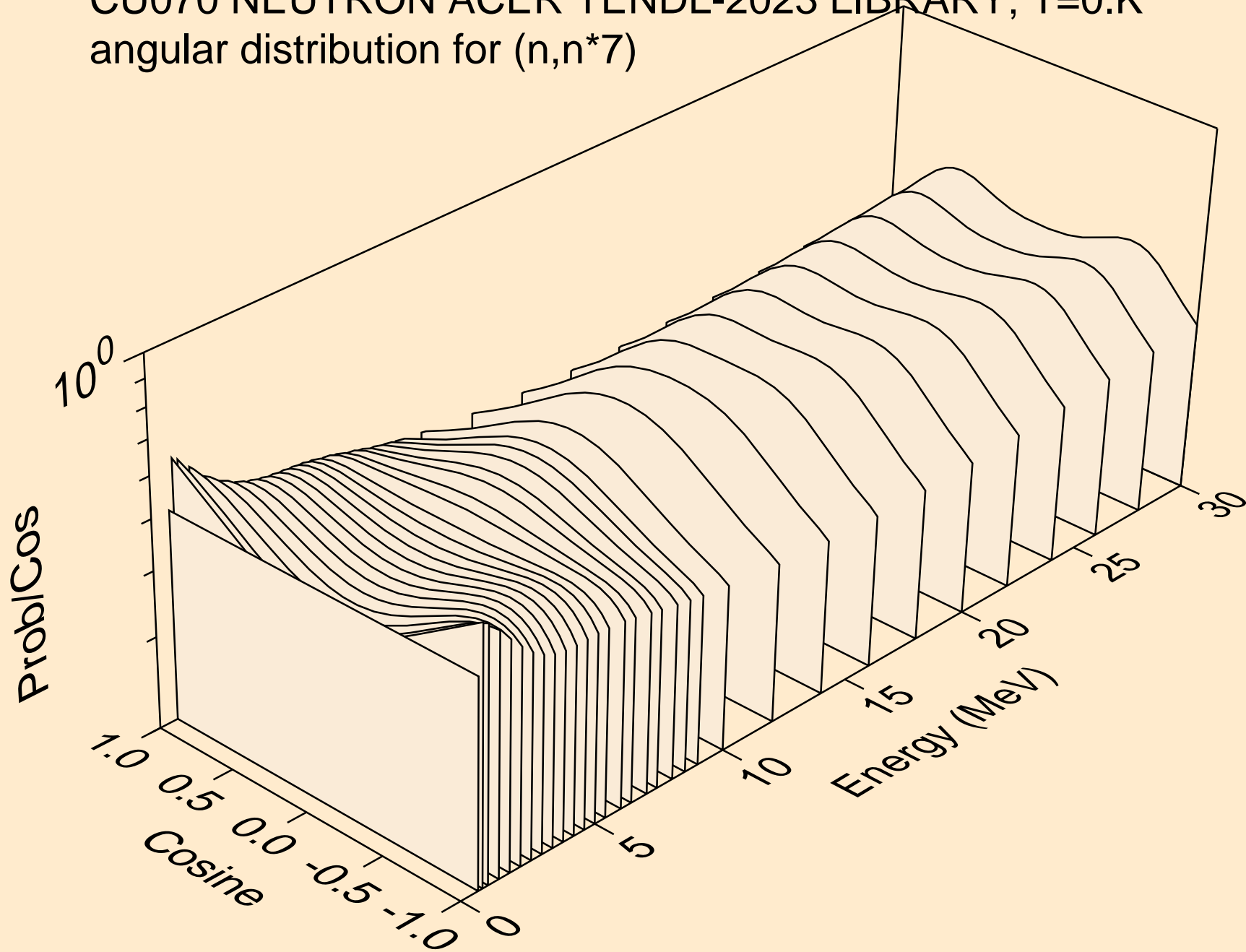

CU070 NEUTRON ACER TENDL-2023 LIBRARY; T=0.K  
angular distribution for (n,n\*8)

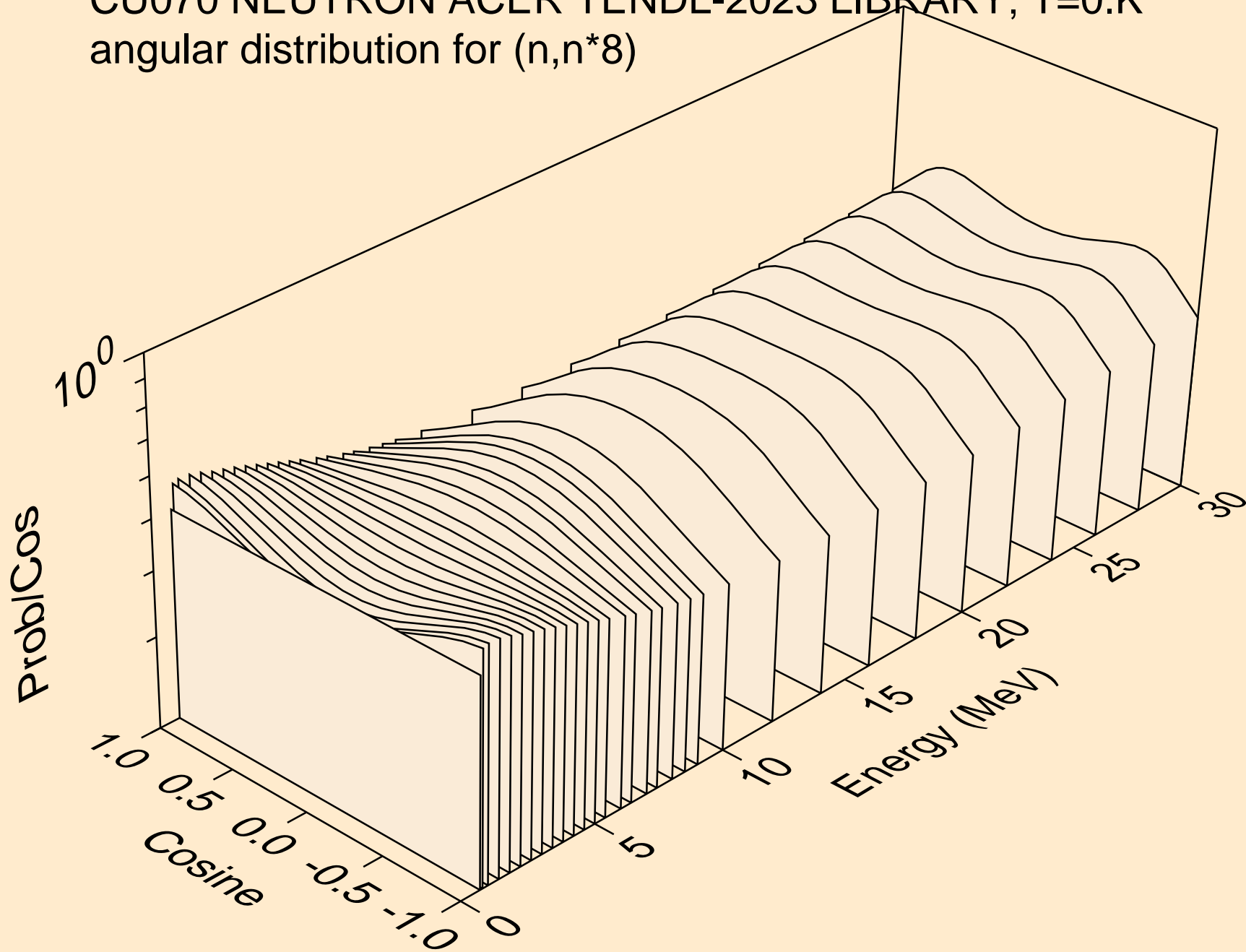

CU070 NEUTRON ACER TENDL-2023 LIBRARY; T=0.K  
angular distribution for (n,n\*9)

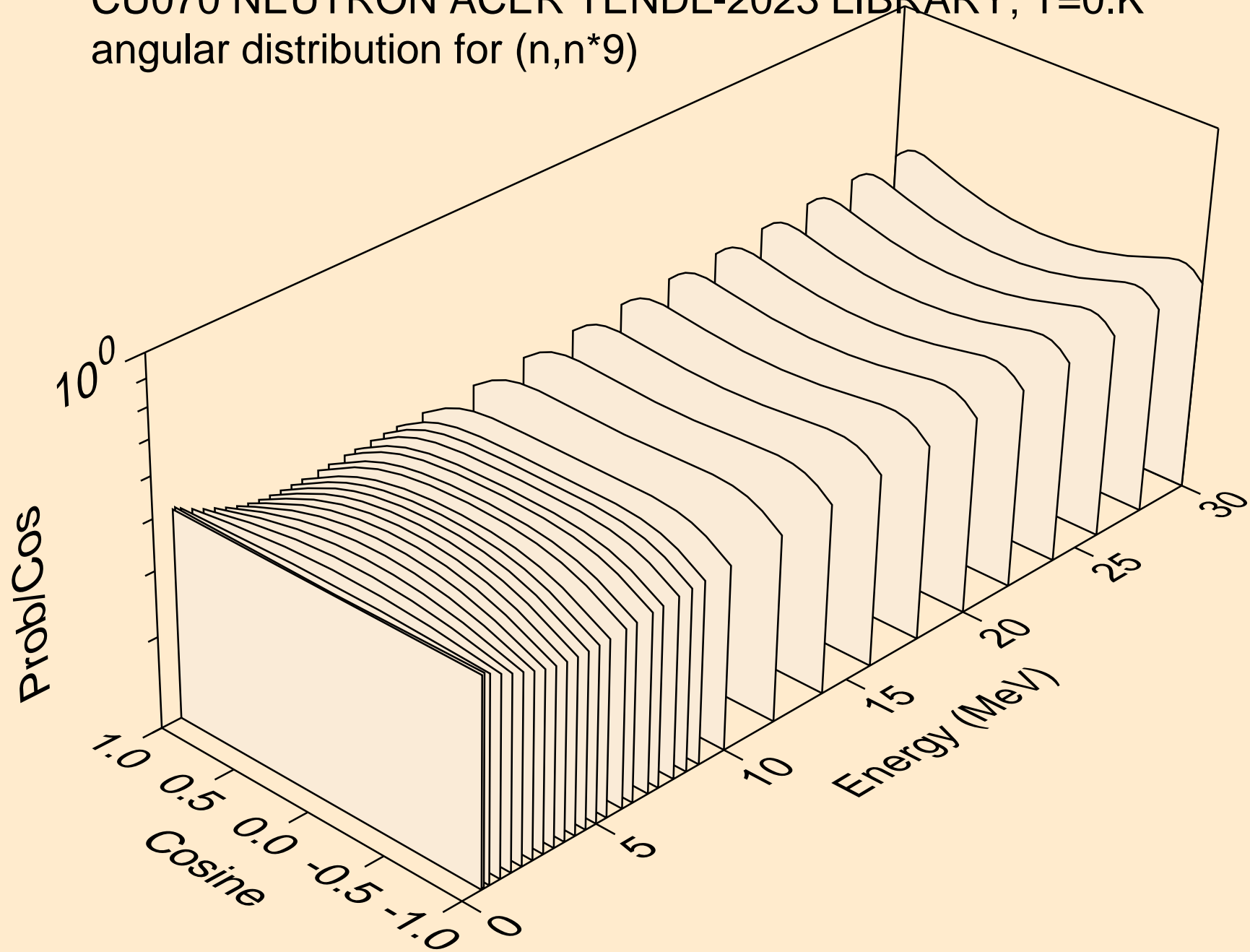

CU070 NEUTRON ACER TENDL-2023 LIBRARY; T=0.K  
angular distribution for (n,n\*10)

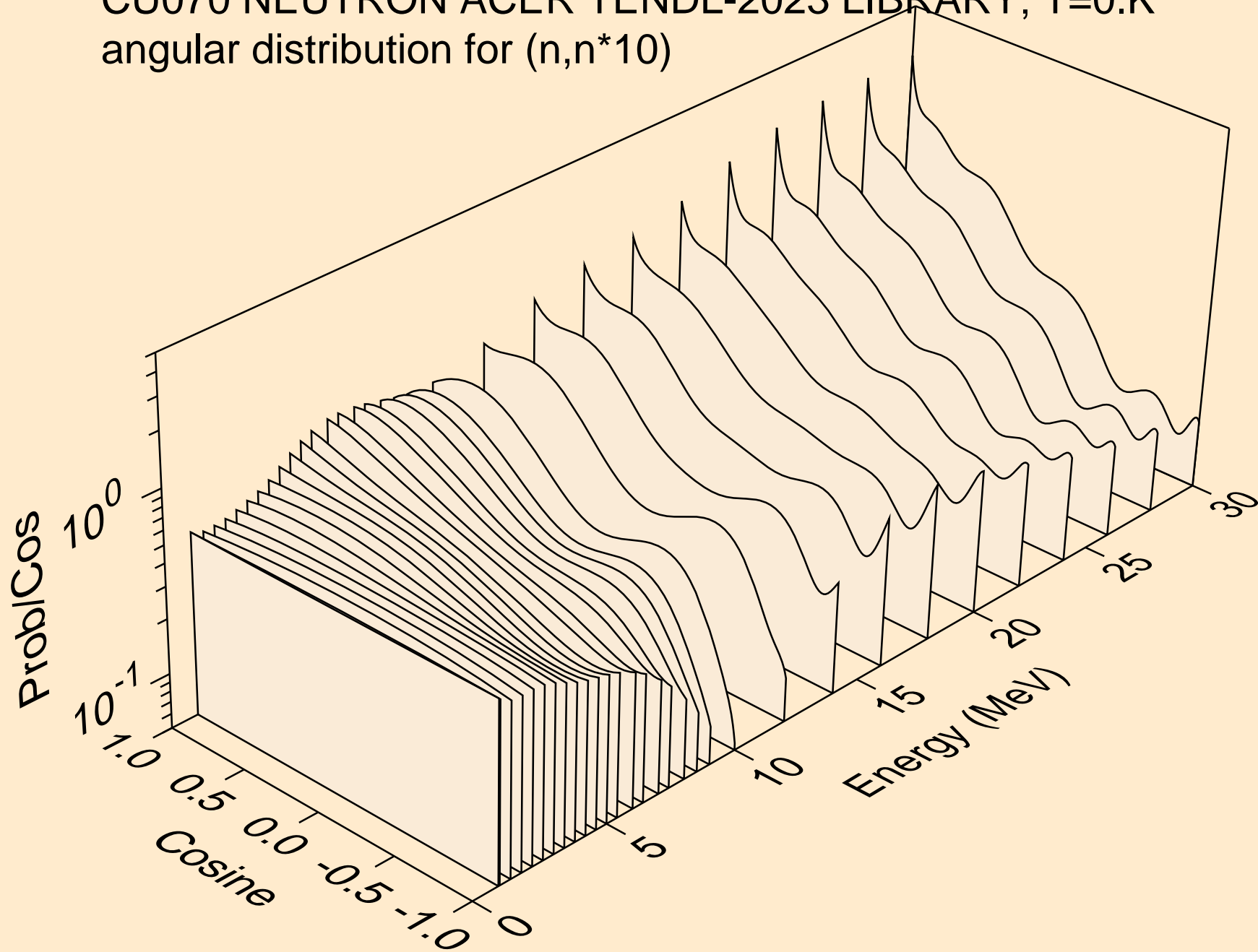



CU070 NEUTRON ACER TENDL-2023 LIBRARY; T=0.K  
angular distribution for (n,n\*11)

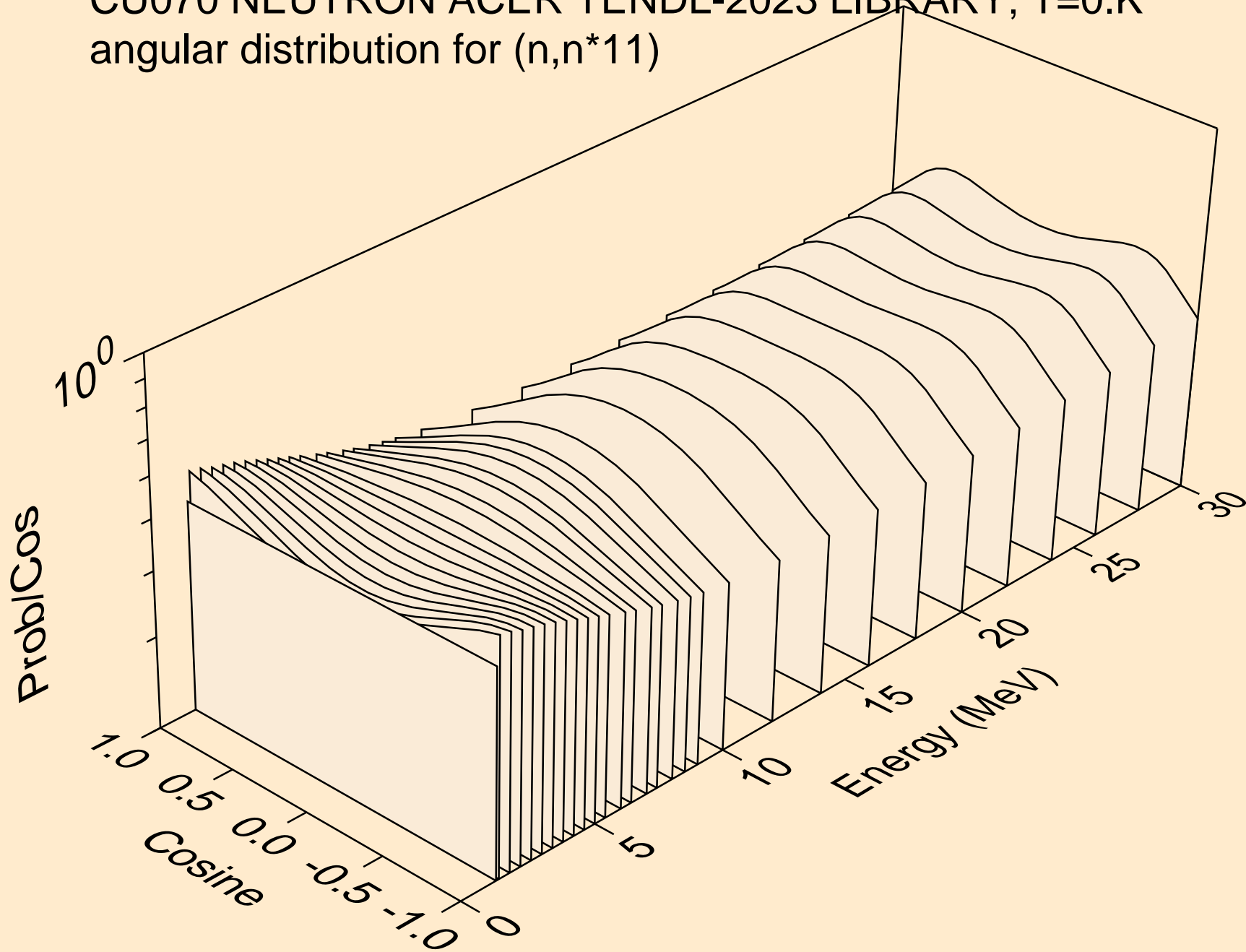

CU070 NEUTRON ACER TENDL-2023 LIBRARY; T=0.K  
angular distribution for (n,n\*12)

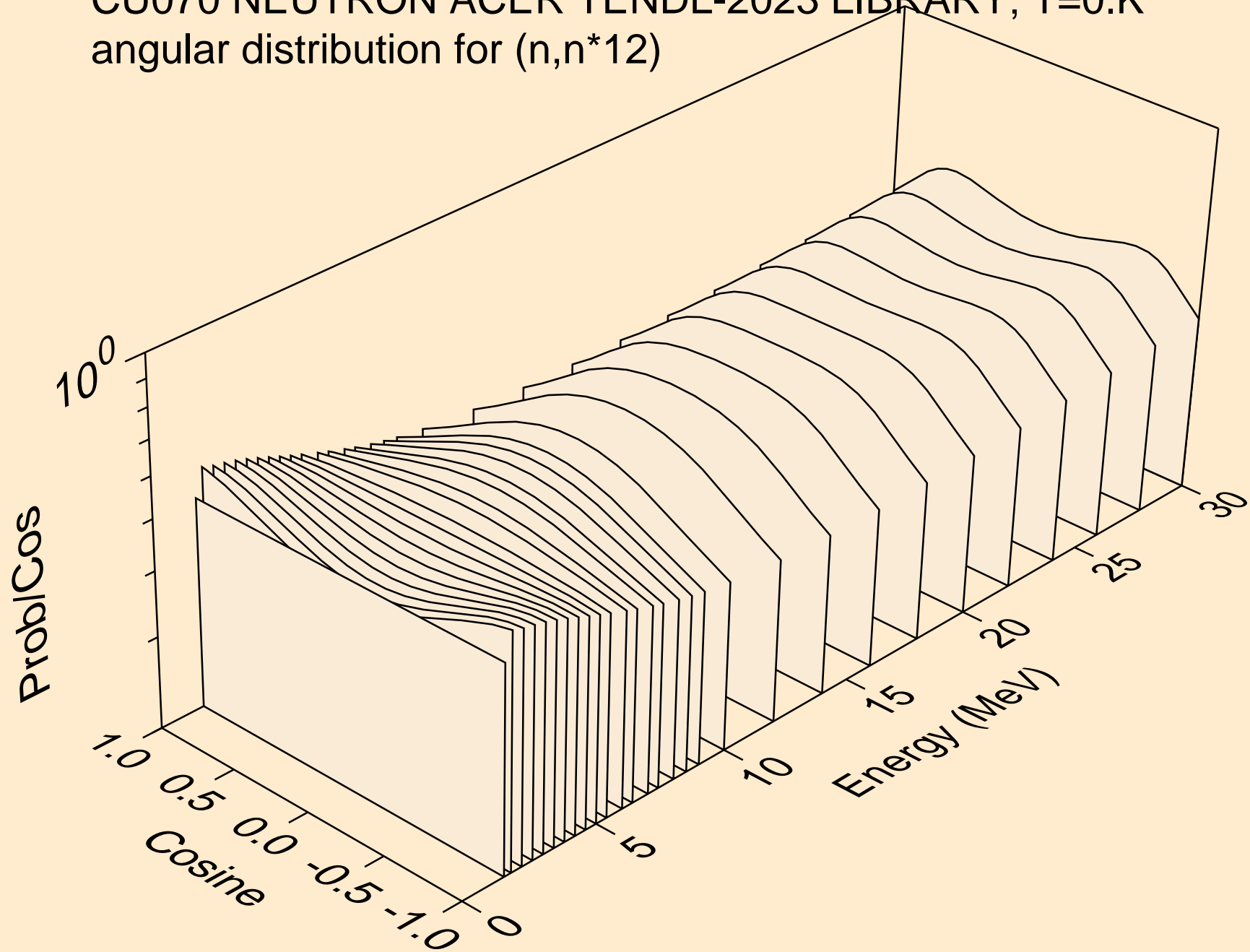

CU070 NEUTRON ACER TENDL-2023 LIBRARY; T=0.K  
angular distribution for (n,n\*13)

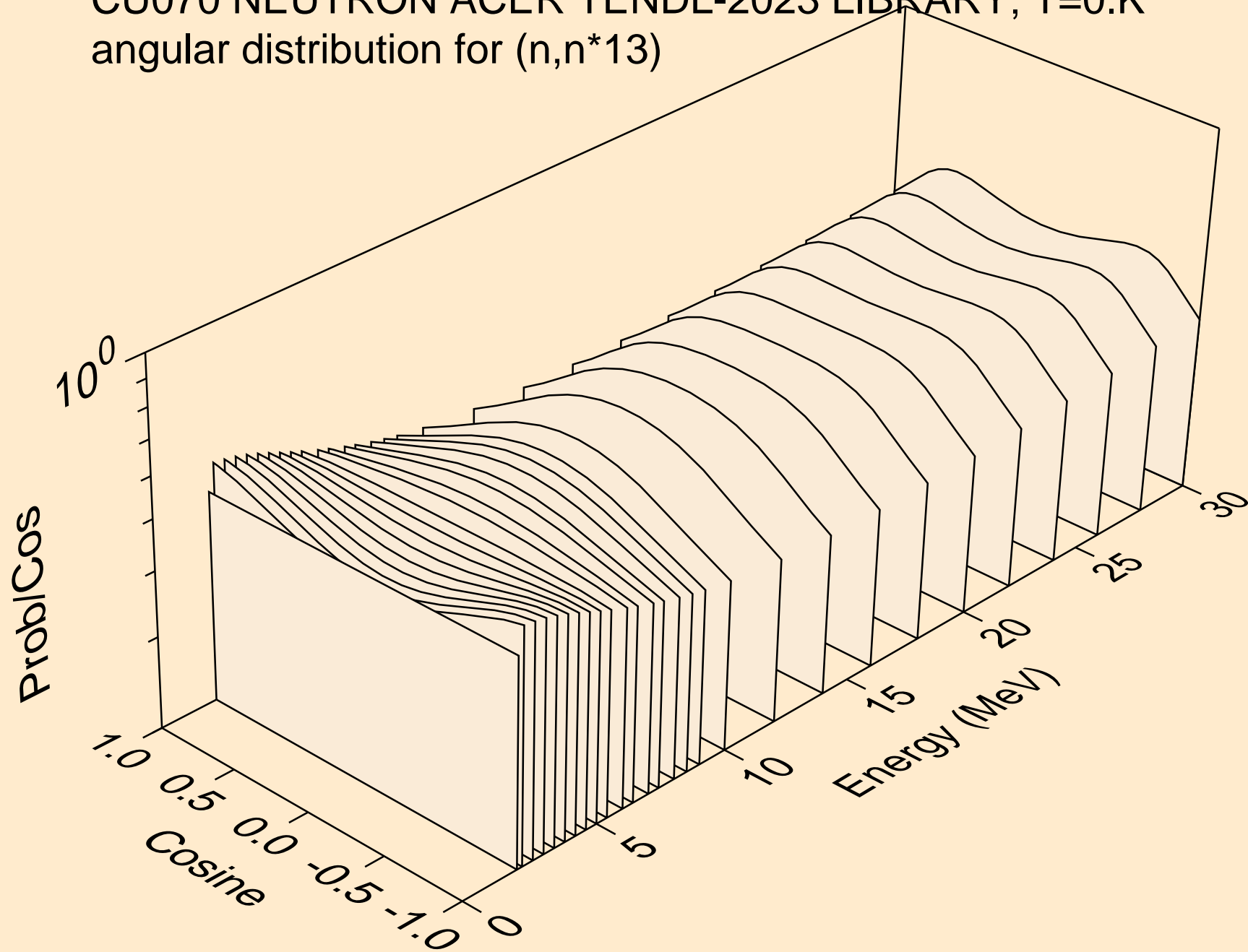

CU070 NEUTRON ACER TENDL-2023 LIBRARY; T=0.K  
angular distribution for (n,n\*14)

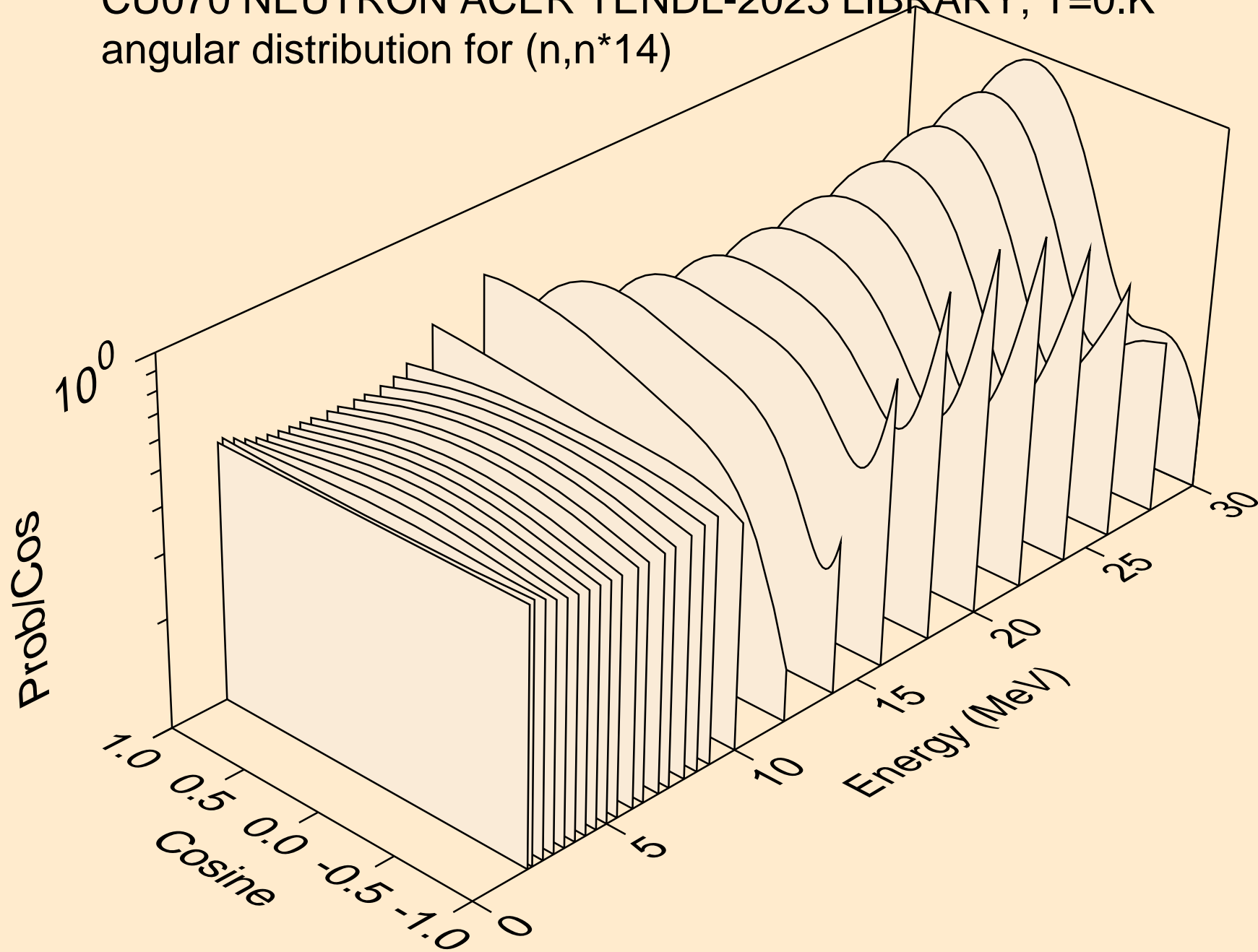

CU070 NEUTRON ACER TENDL-2023 LIBRARY; T=0.K  
angular distribution for (n,n\*15)

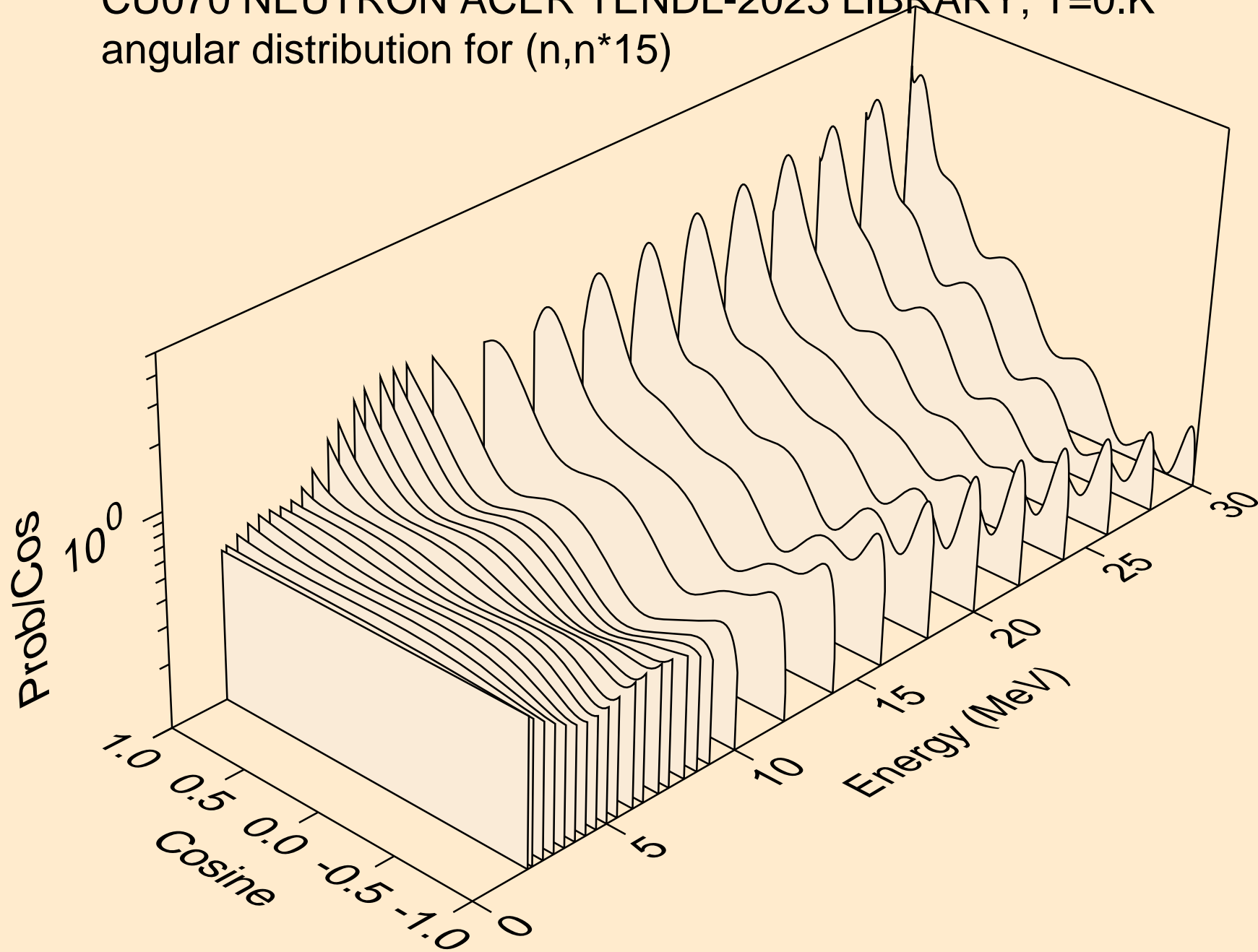

CU070 NEUTRON ACER TENDL-2023 LIBRARY; T=0.K  
angular distribution for (n,n\*16)

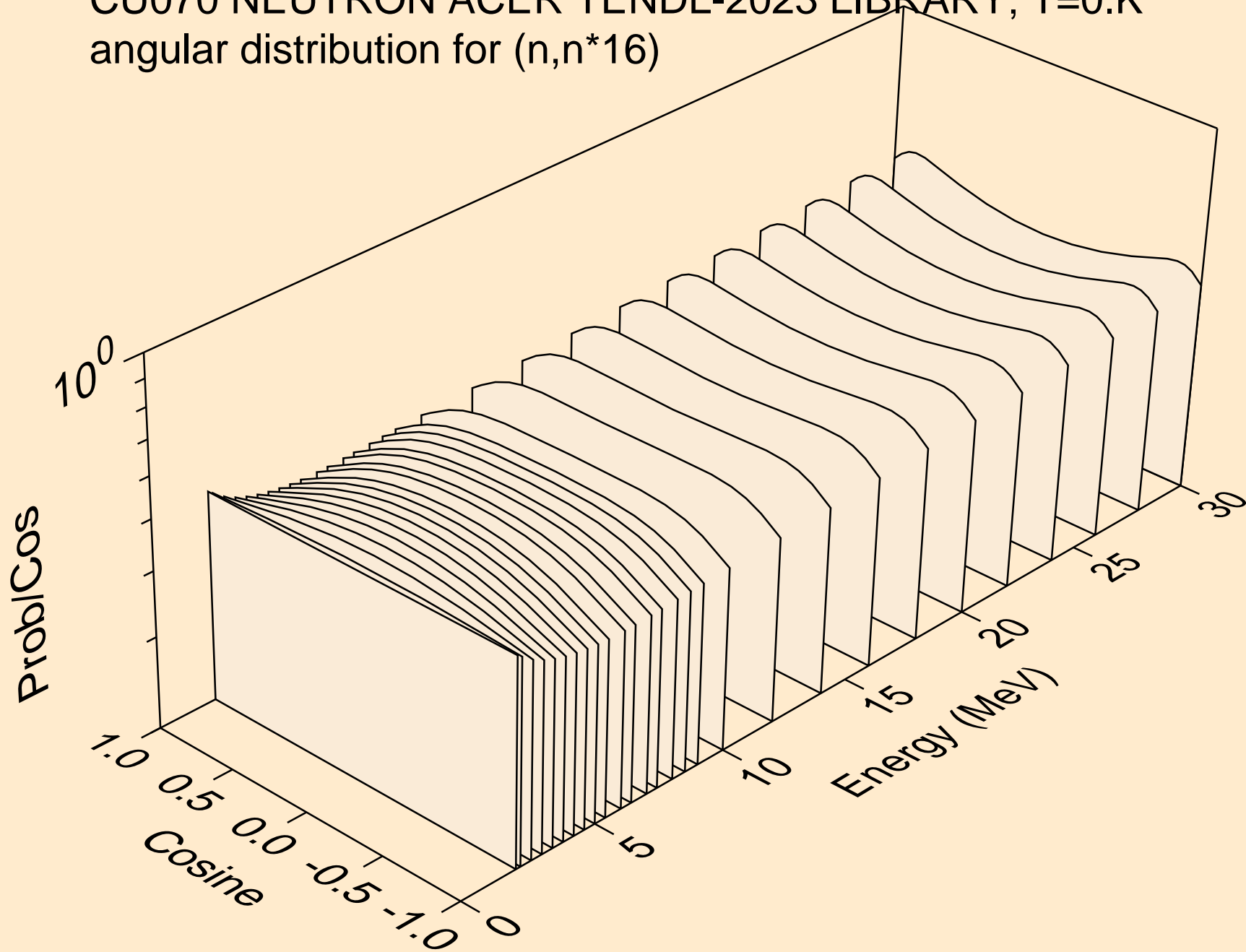

CU070 NEUTRON ACER TENDL-2023 LIBRARY; T=0.K  
angular distribution for (n,n\*17)

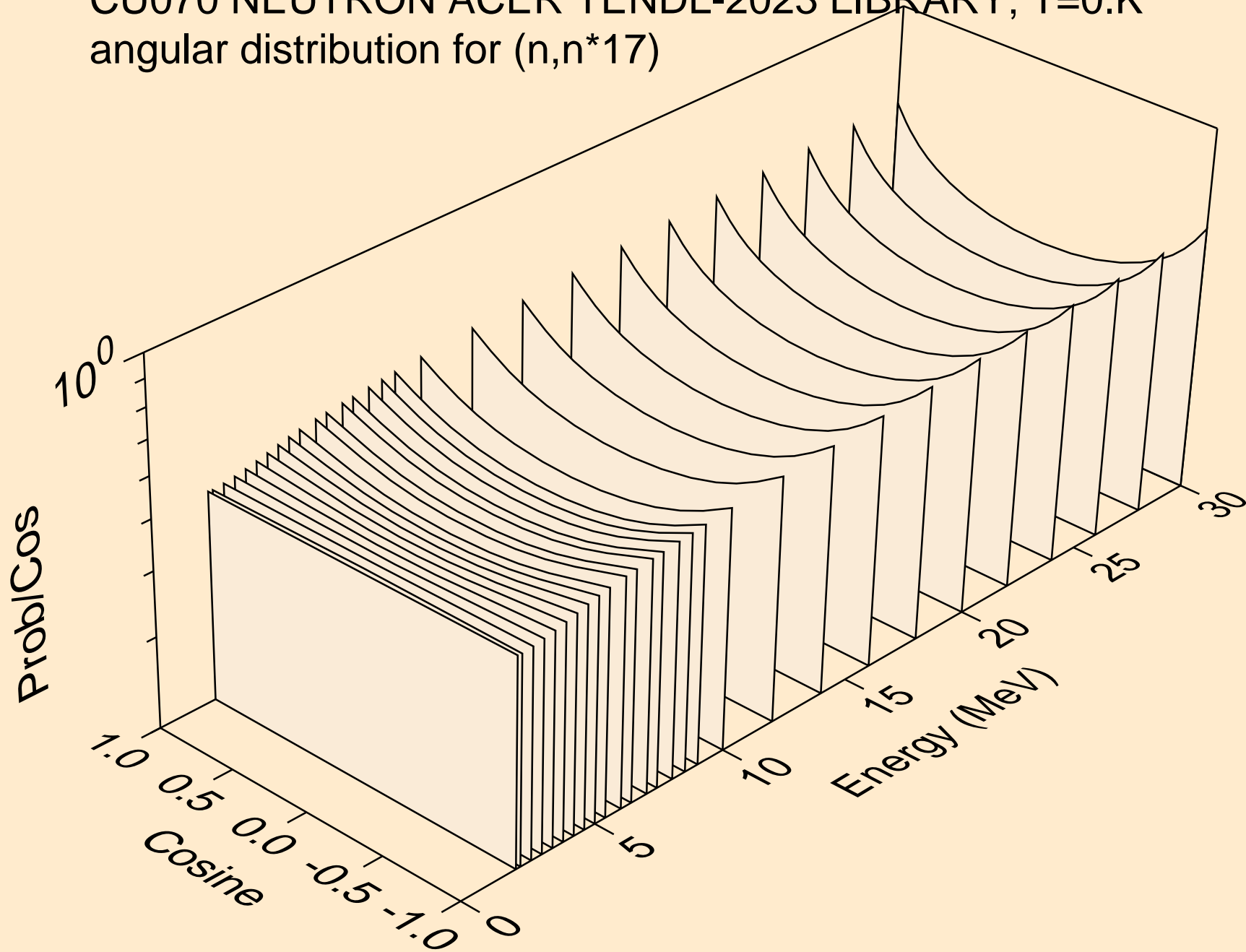

CU070 NEUTRON ACER TENDL-2023 LIBRARY; T=0.K  
angular distribution for (n,n\*18)

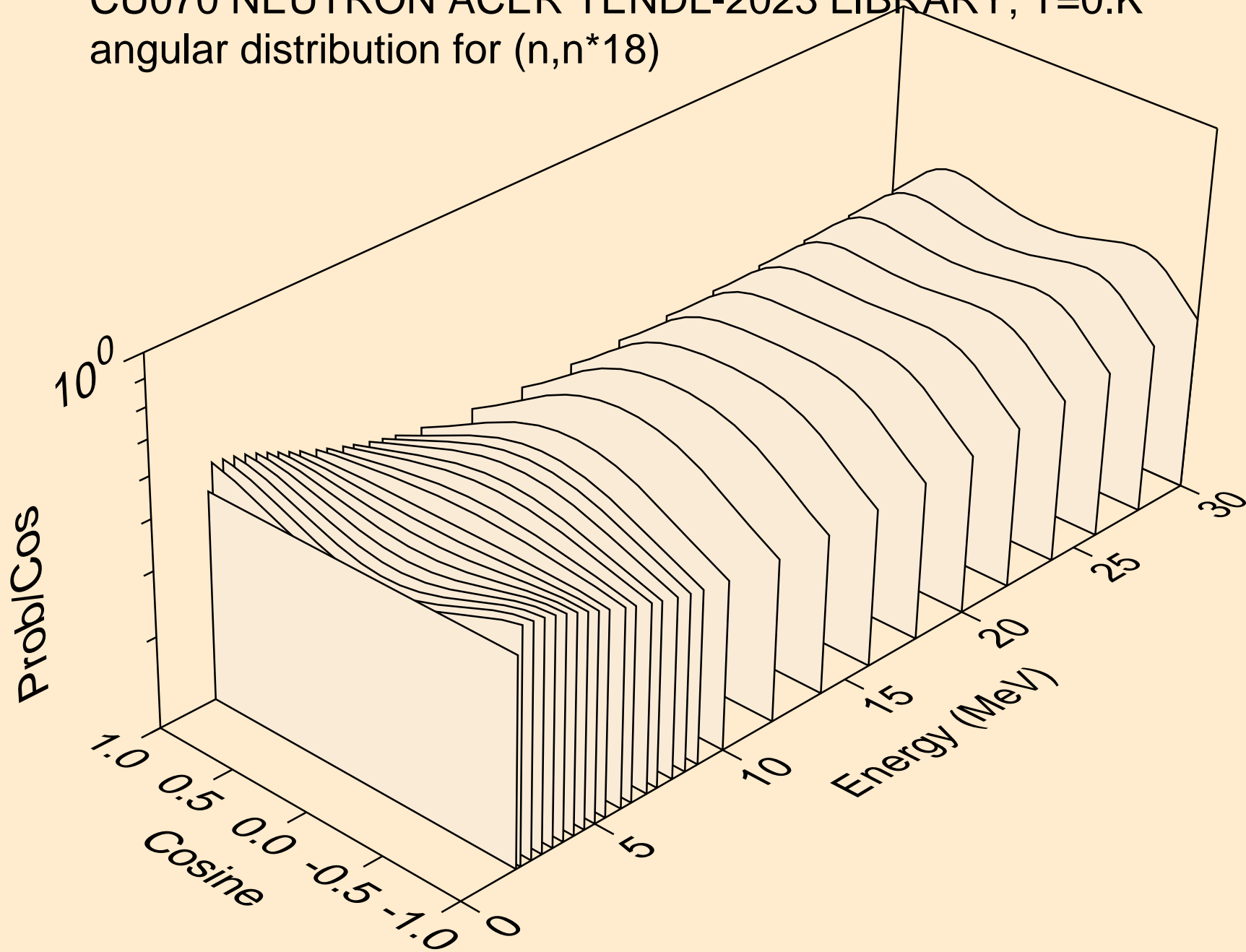



CU070 NEUTRON ACER TENDL-2023 LIBRARY; T=0.K  
angular distribution for (n,n\*19)

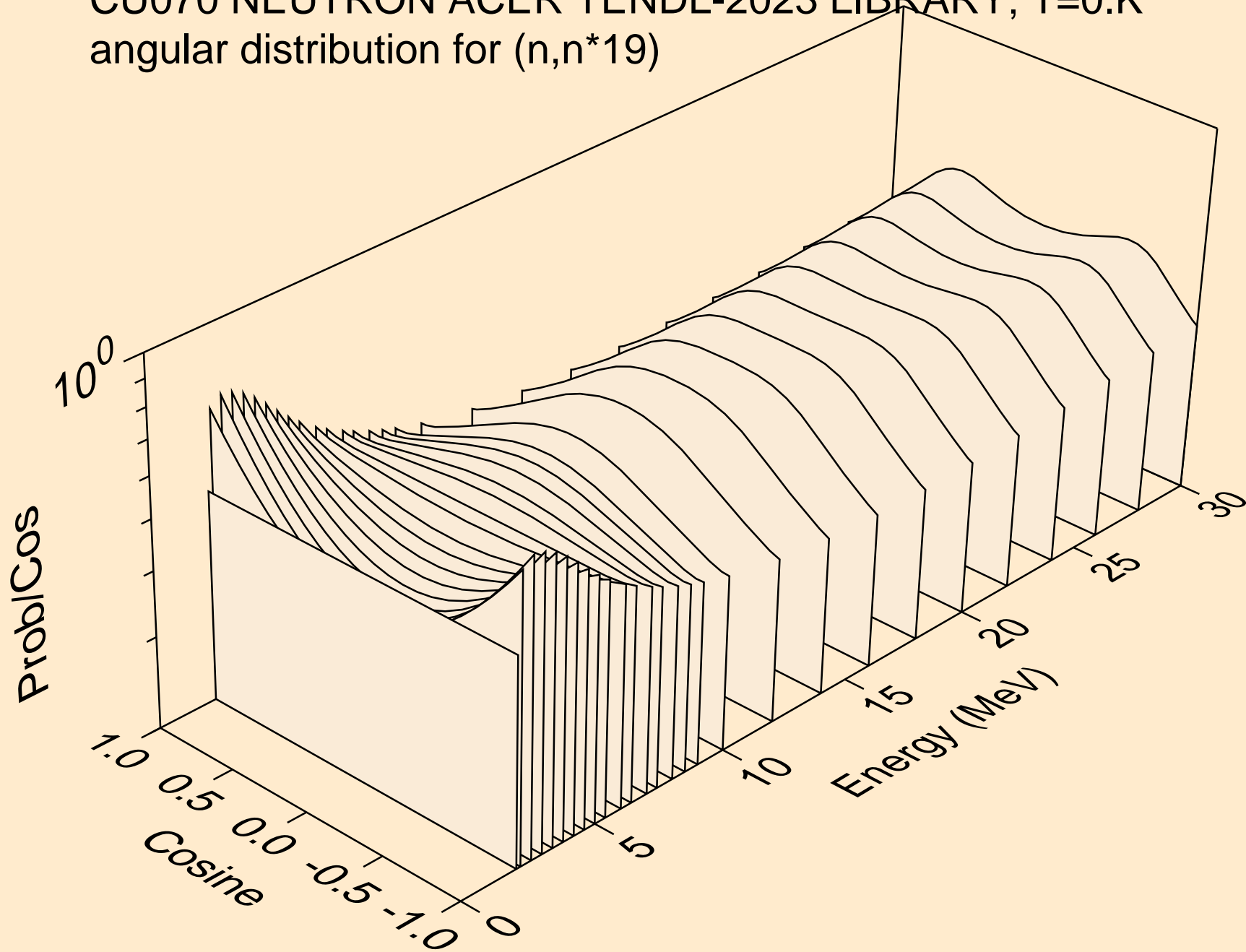

CU070 NEUTRON ACER TENDL-2023 LIBRARY; T=0.K  
angular distribution for (n,n\*20)

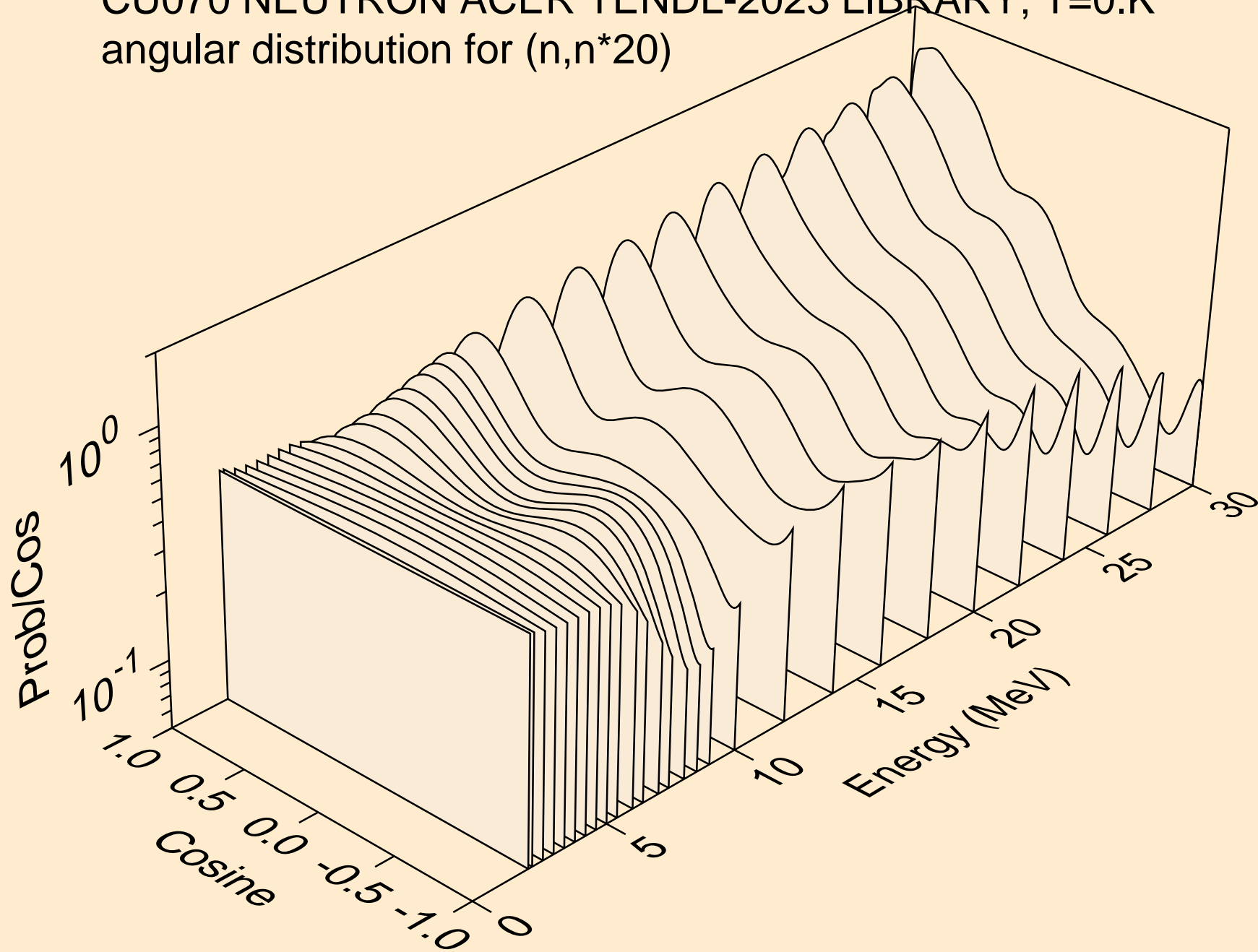

CU070 NEUTRON ACER TENDL-2023 LIBRARY; T=0.K  
angular distribution for (n,n\*21)

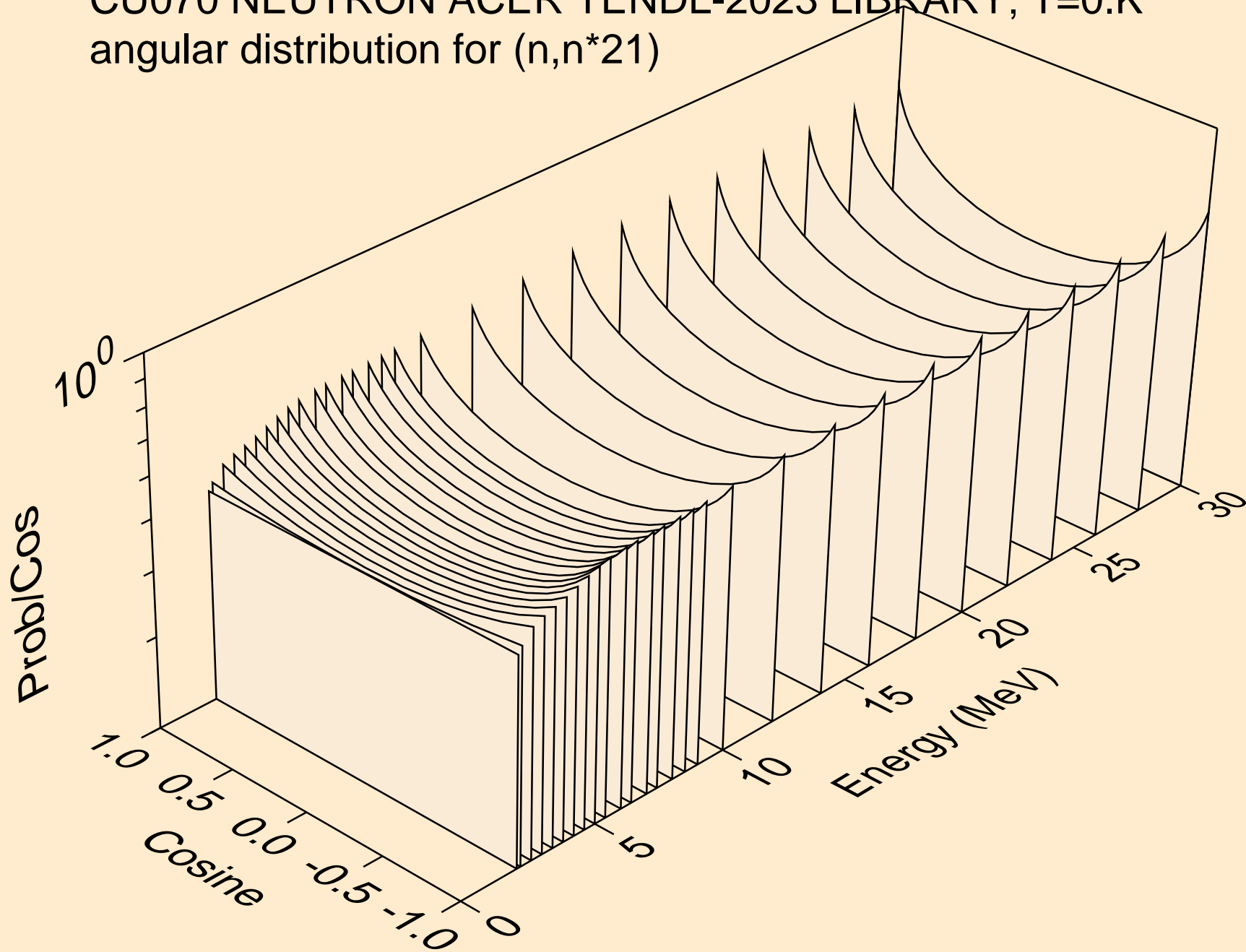

CU070 NEUTRON ACER TENDL-2023 LIBRARY; T=0.K  
angular distribution for (n,n\*22)

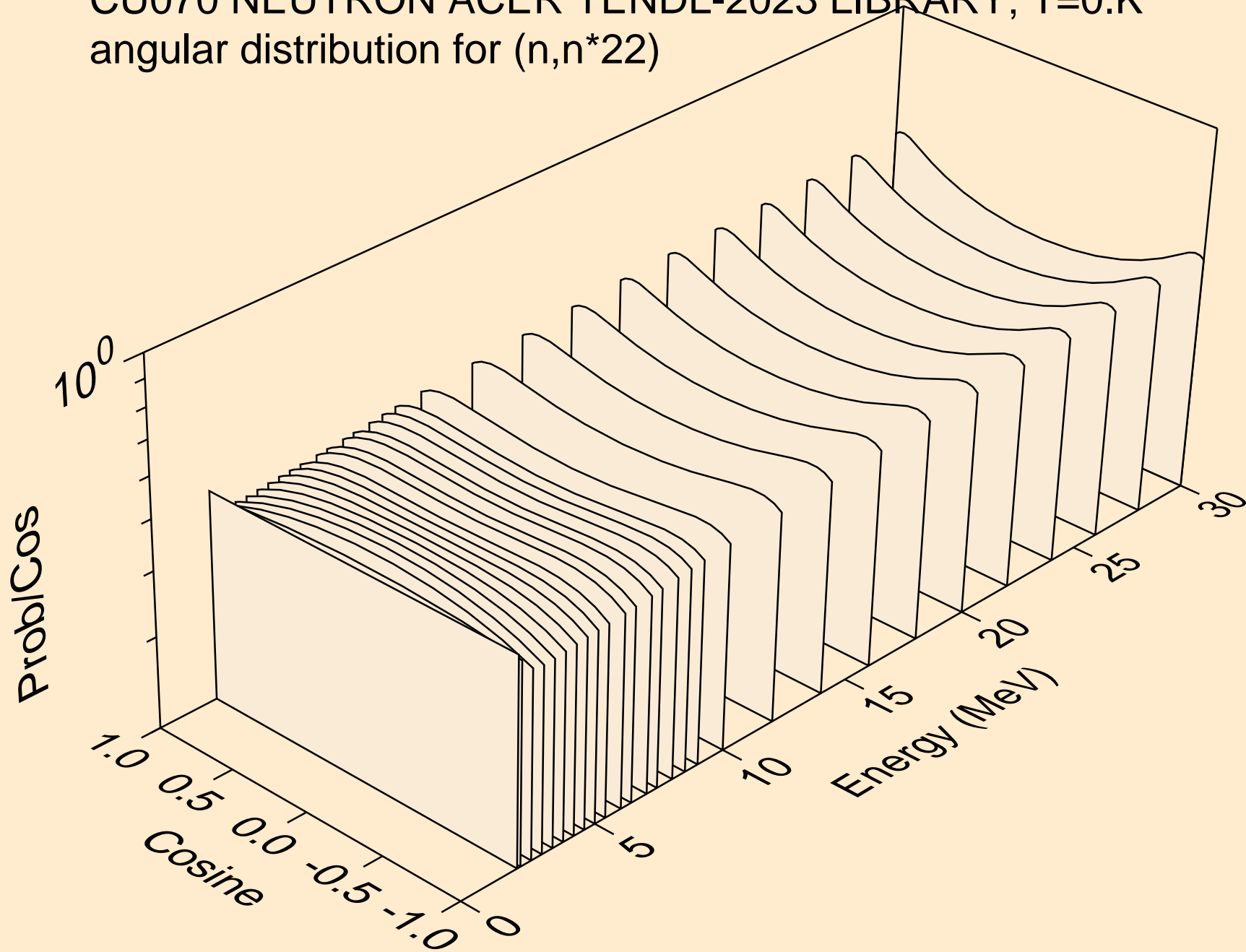

CU070 NEUTRON ACER TENDL-2023 LIBRARY; T=0.K  
angular distribution for (n,n\*23)

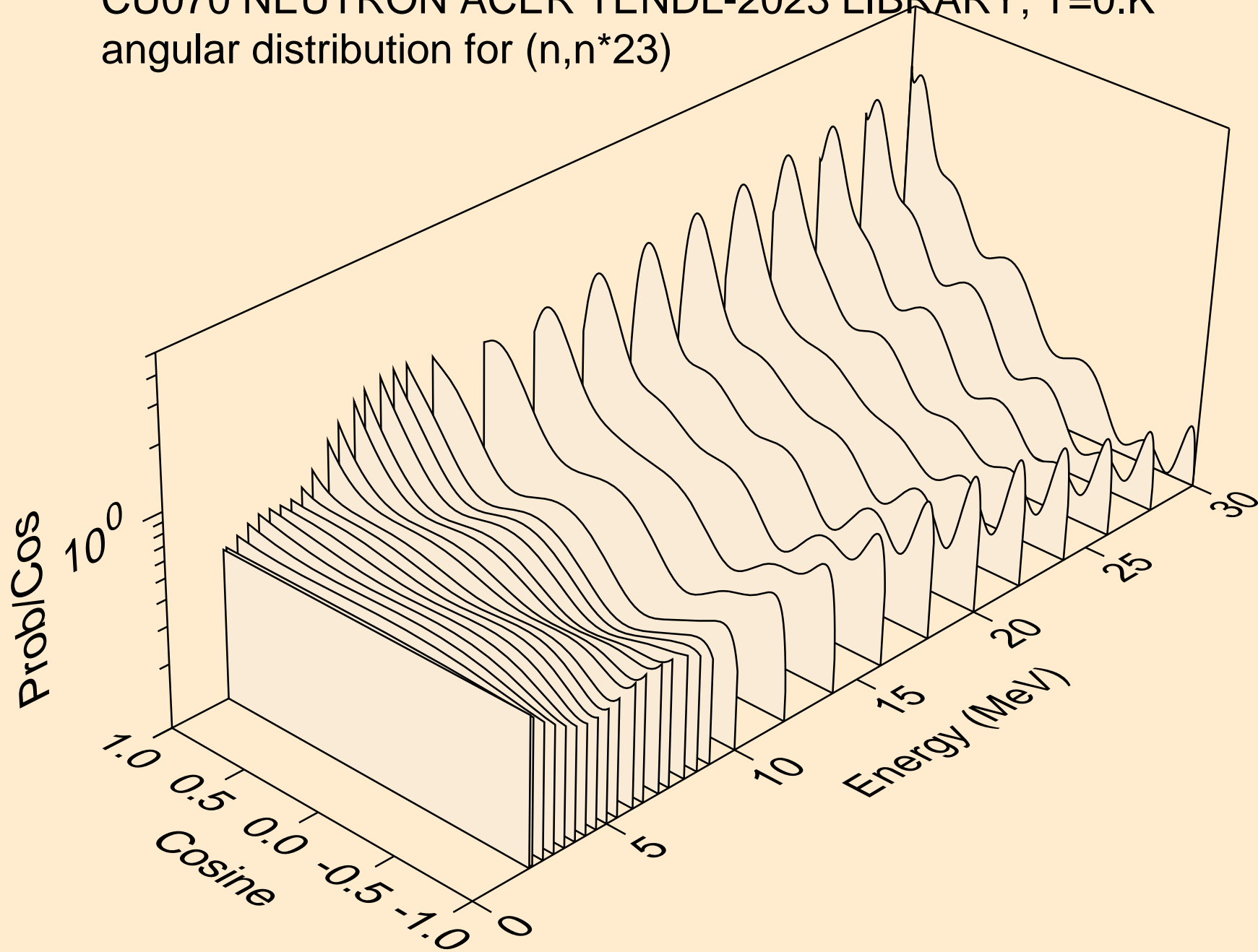

CU070 NEUTRON ACER TENDL-2023 LIBRARY; T=0.K  
angular distribution for (n,n\*24)

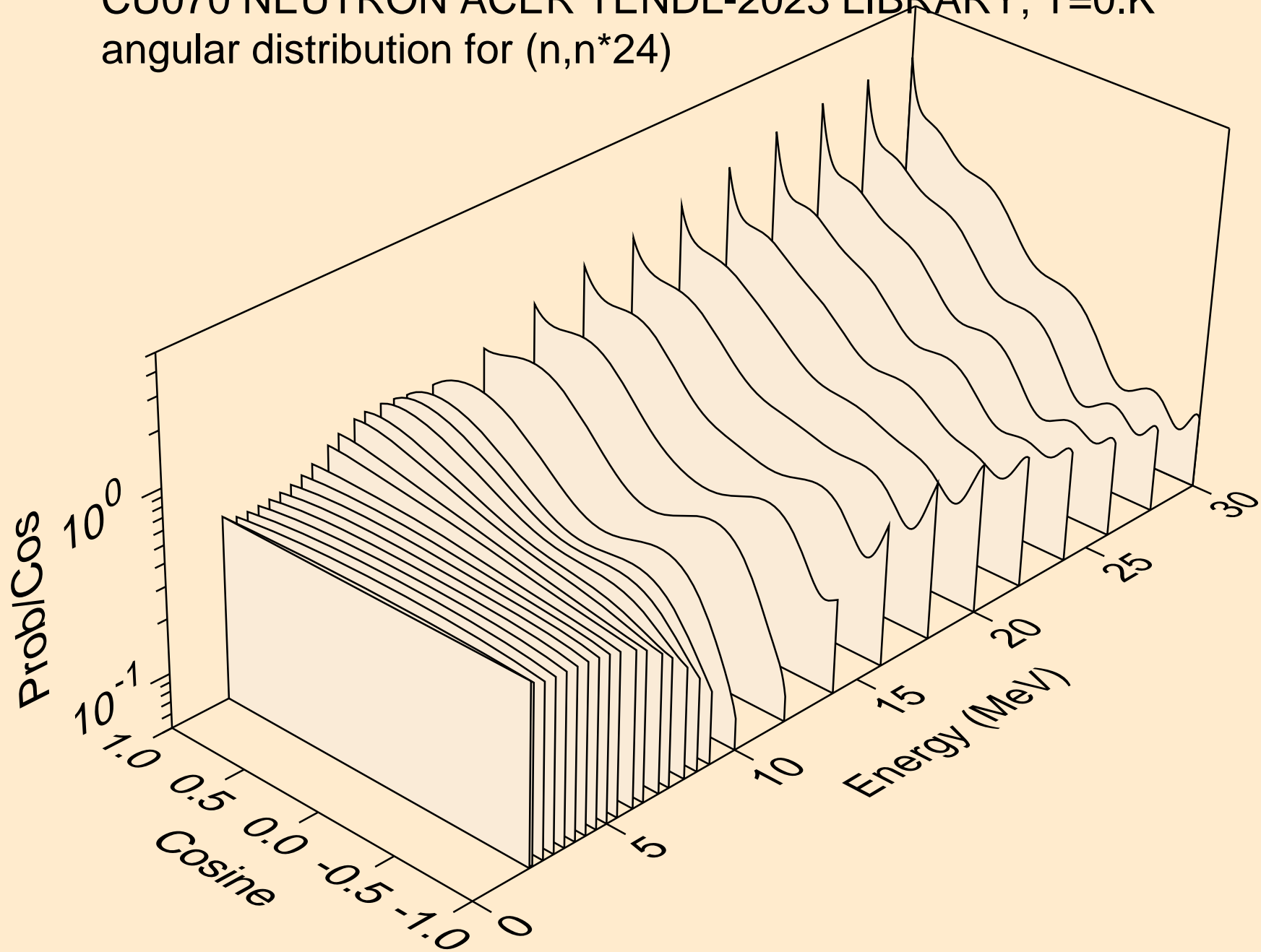

CU070 NEUTRON ACER TENDL-2023 LIBRARY; T=0.K  
angular distribution for (n,n\*25)

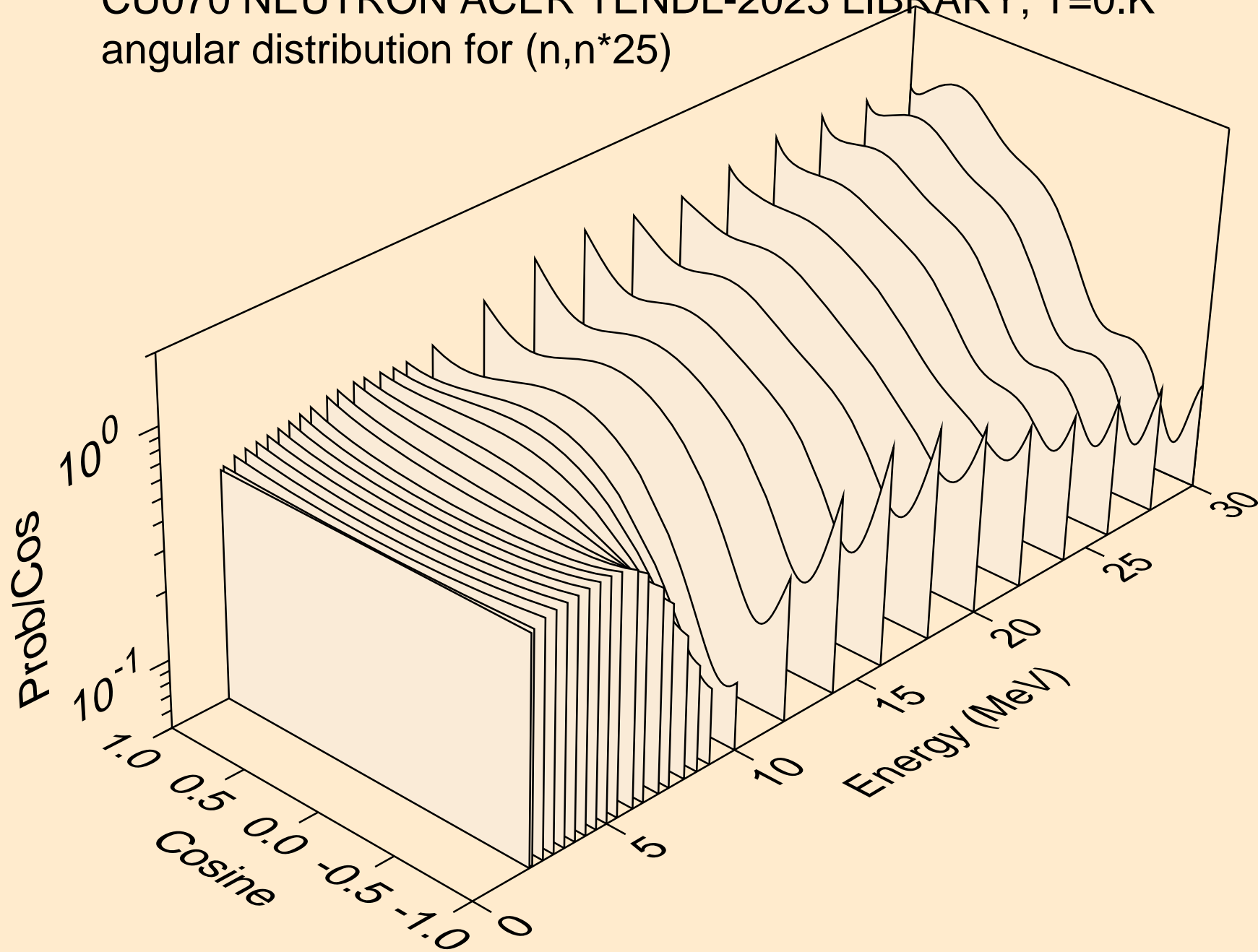

CU070 NEUTRON ACER TENDL-2023 LIBRARY; T=0.K  
angular distribution for (n,n\*26)

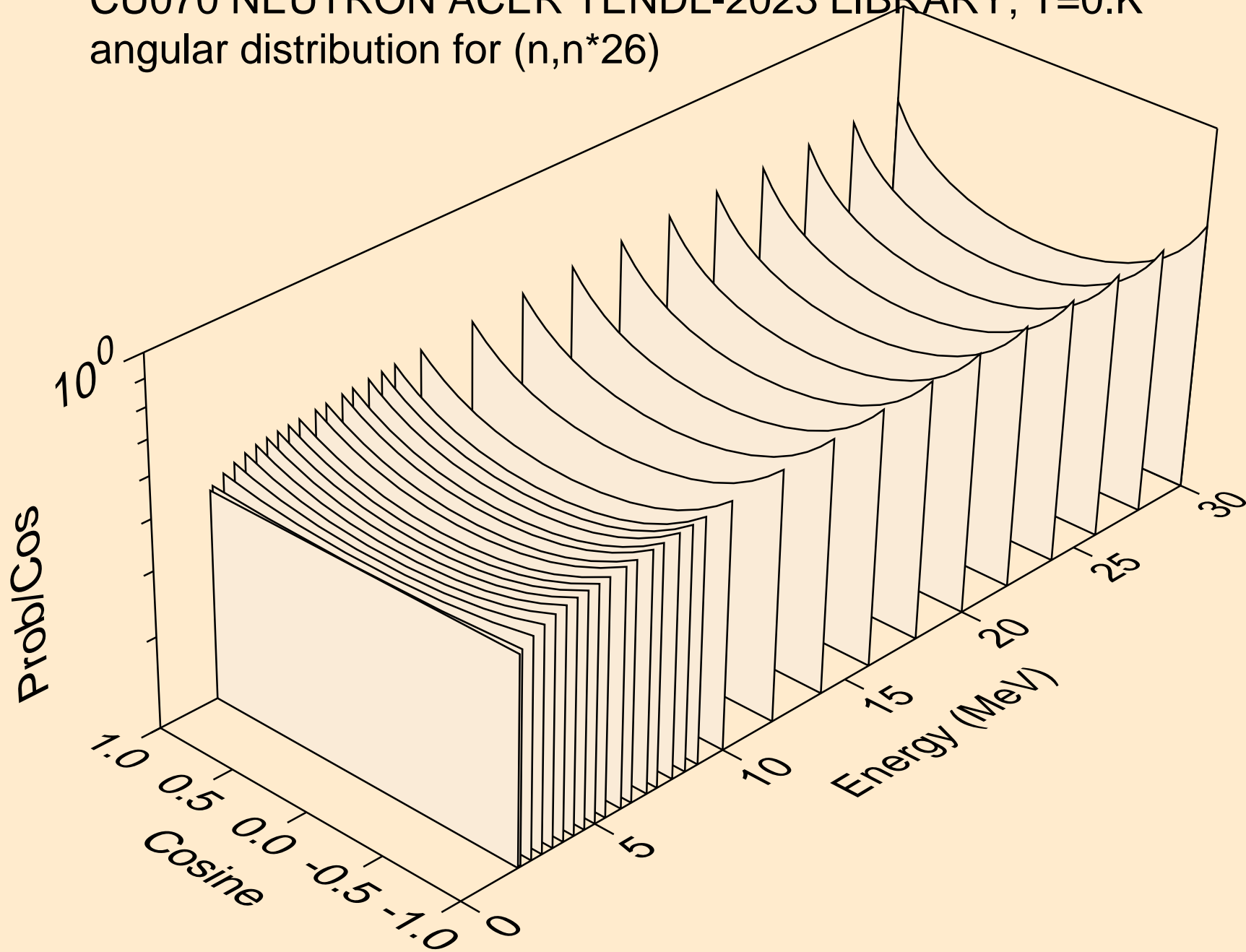



CU070 NEUTRON ACER TENDL-2023 LIBRARY; T=0.K  
angular distribution for (n,n\*27)

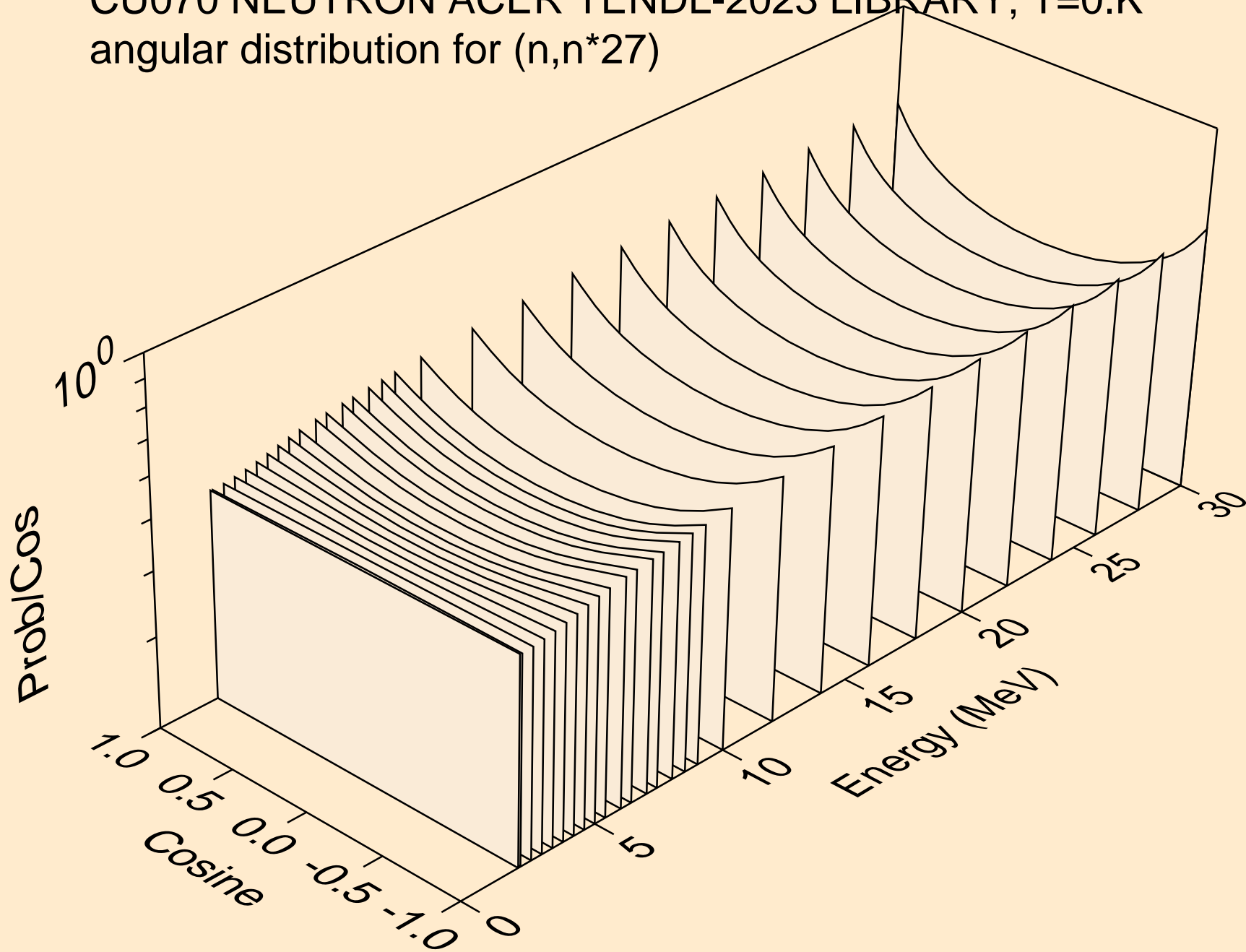

CU070 NEUTRON ACER TENDL-2023 LIBRARY; T=0.K  
angular distribution for (n,n\*28)

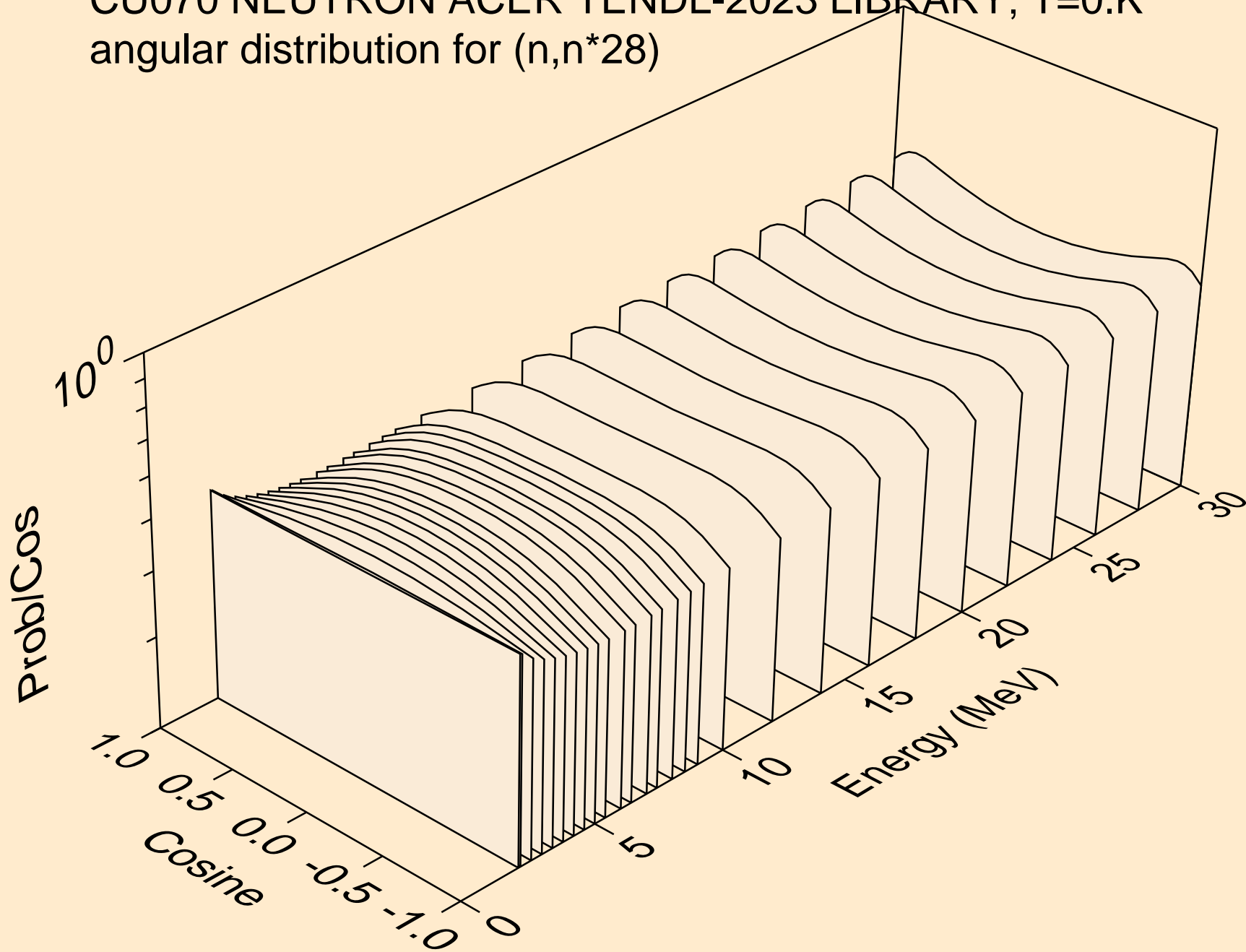

CU070 NEUTRON ACER TENDL-2023 LIBRARY; T=0.K  
angular distribution for (n,n\*29)

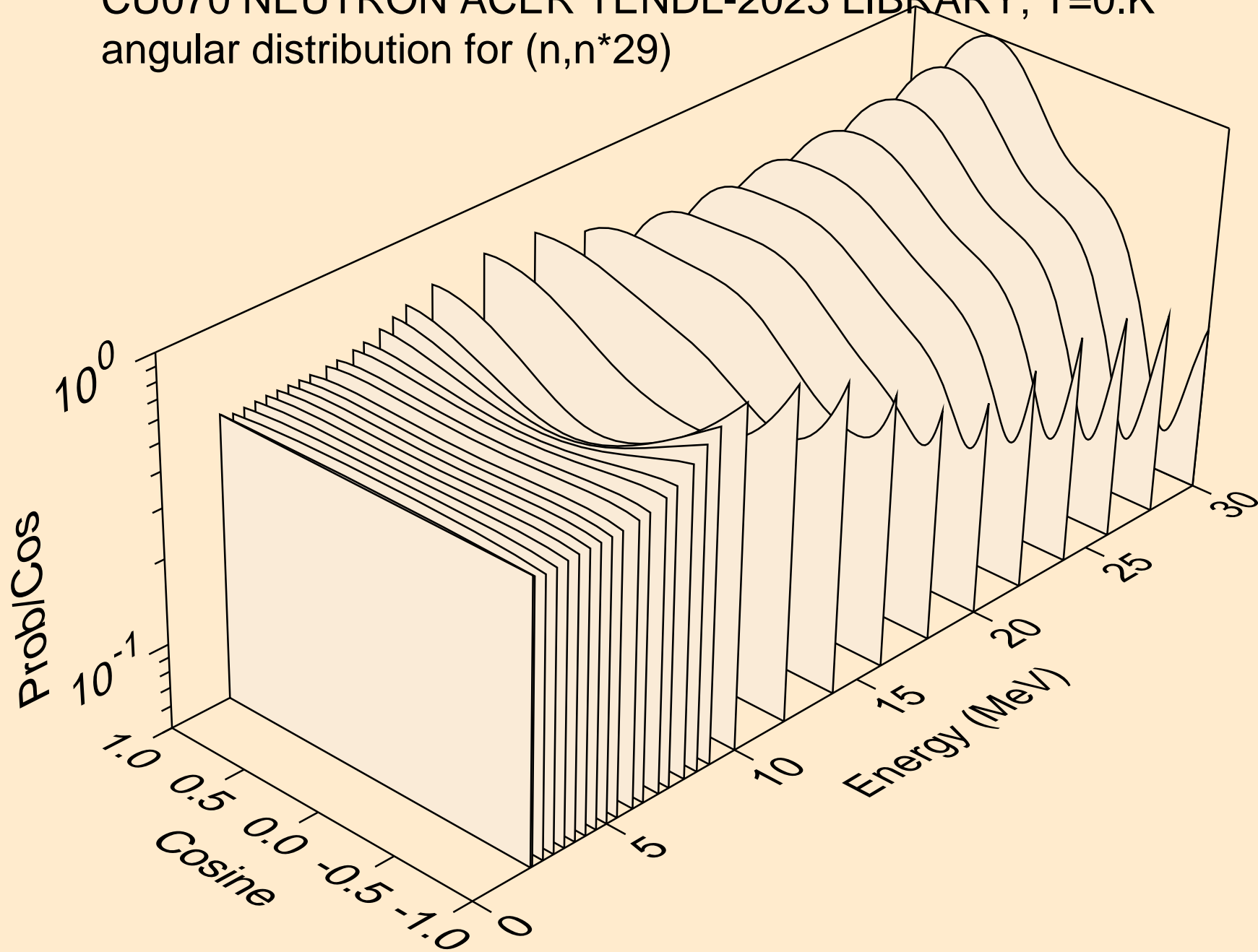

CU070 NEUTRON ACER TENDL-2023 LIBRARY; T=0.K  
Neutron emission for (n,x)

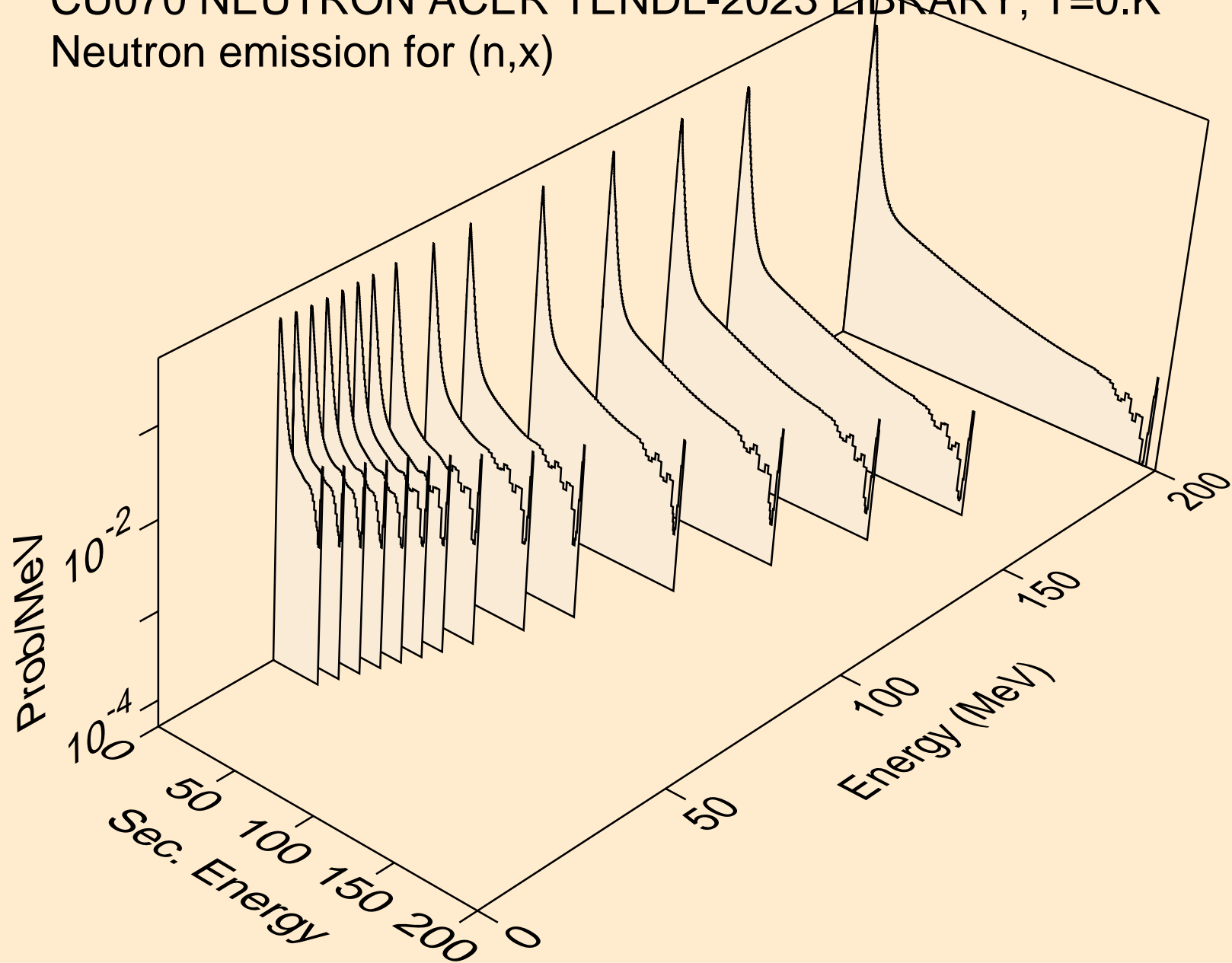

CU070 NEUTRON ACER TENDL-2023 LIBRARY; T=0.K  
Neutron emission for (n,2nd)

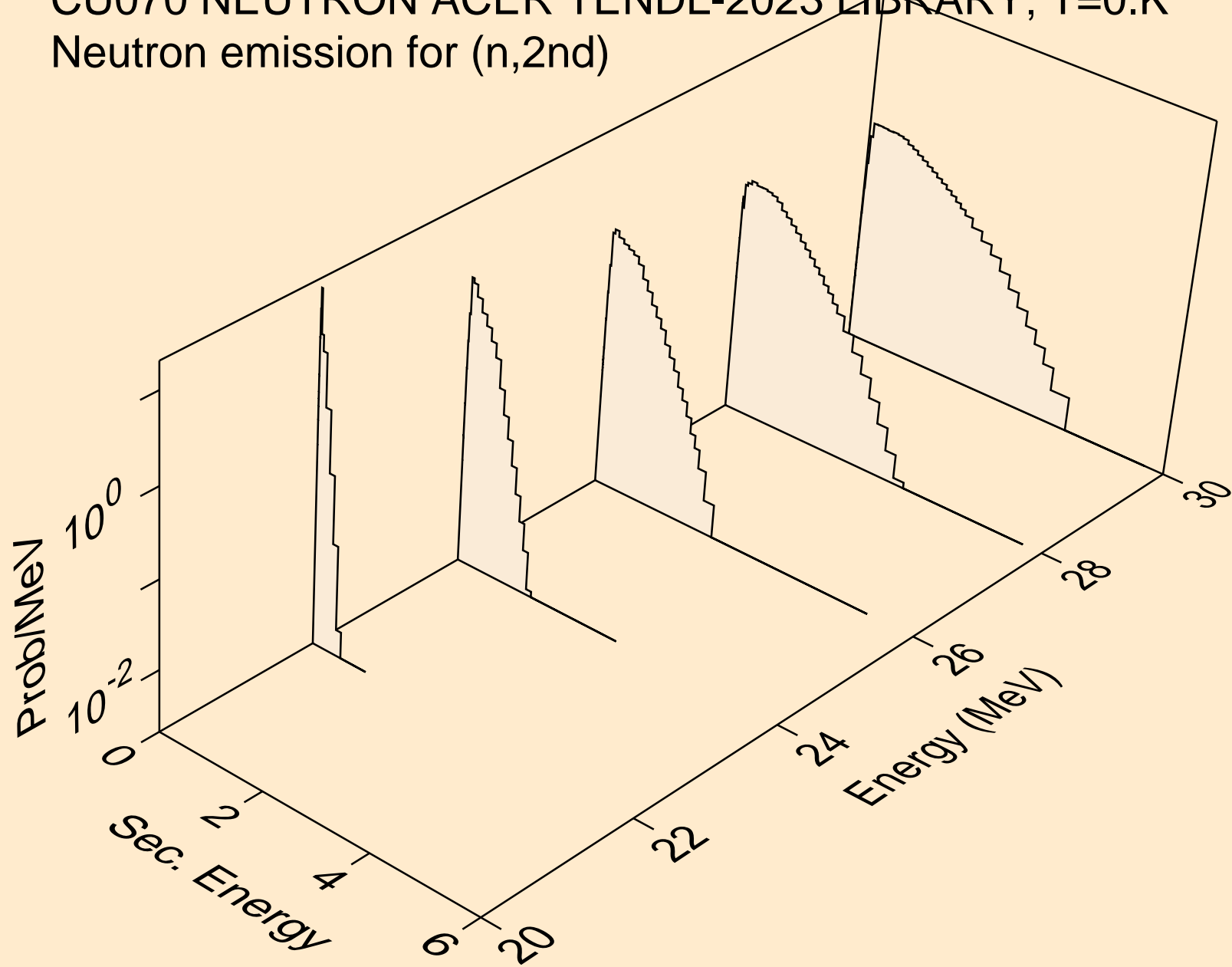

CU070 NEUTRON ACER TENDL-2023 LIBRARY; T=0.K  
Neutron emission for (n,2n)

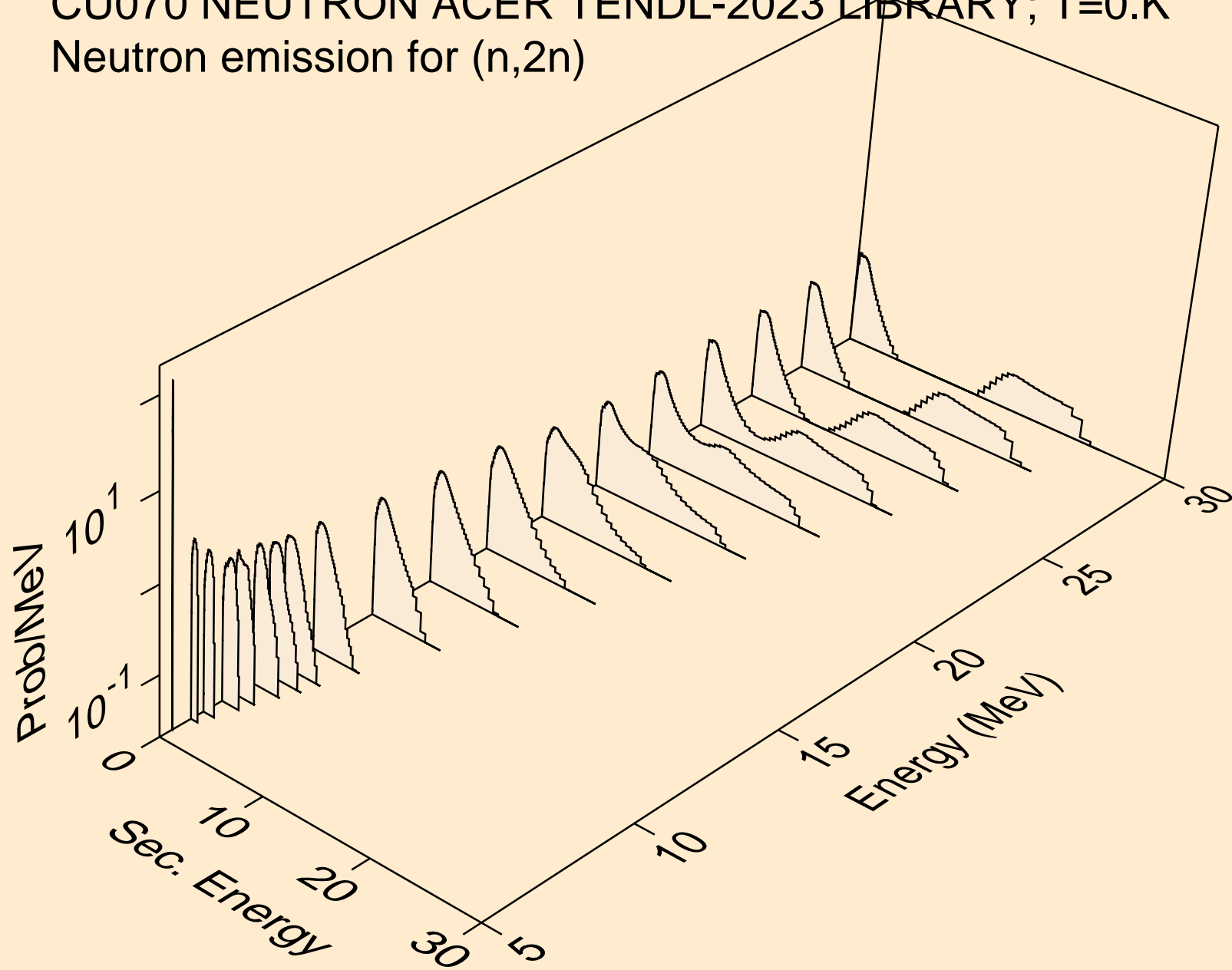

CU070 NEUTRON ACER TENDL-2023 LIBRARY; T=0.K  
Neutron emission for (n,3n)

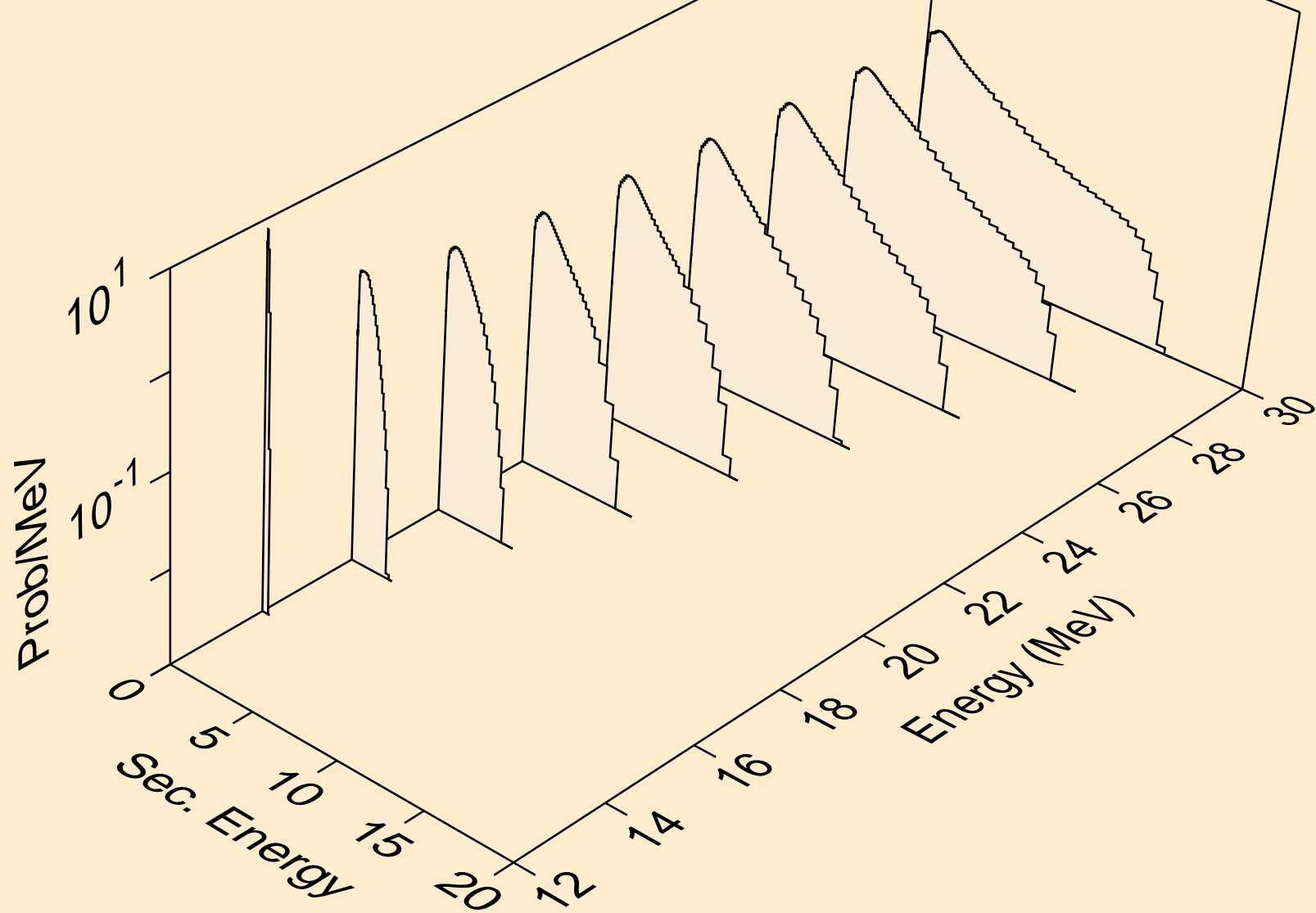

CU070 NEUTRON ACER TENDL-2023 LIBRARY; T=0.K  
Neutron emission for (n,n\*)a

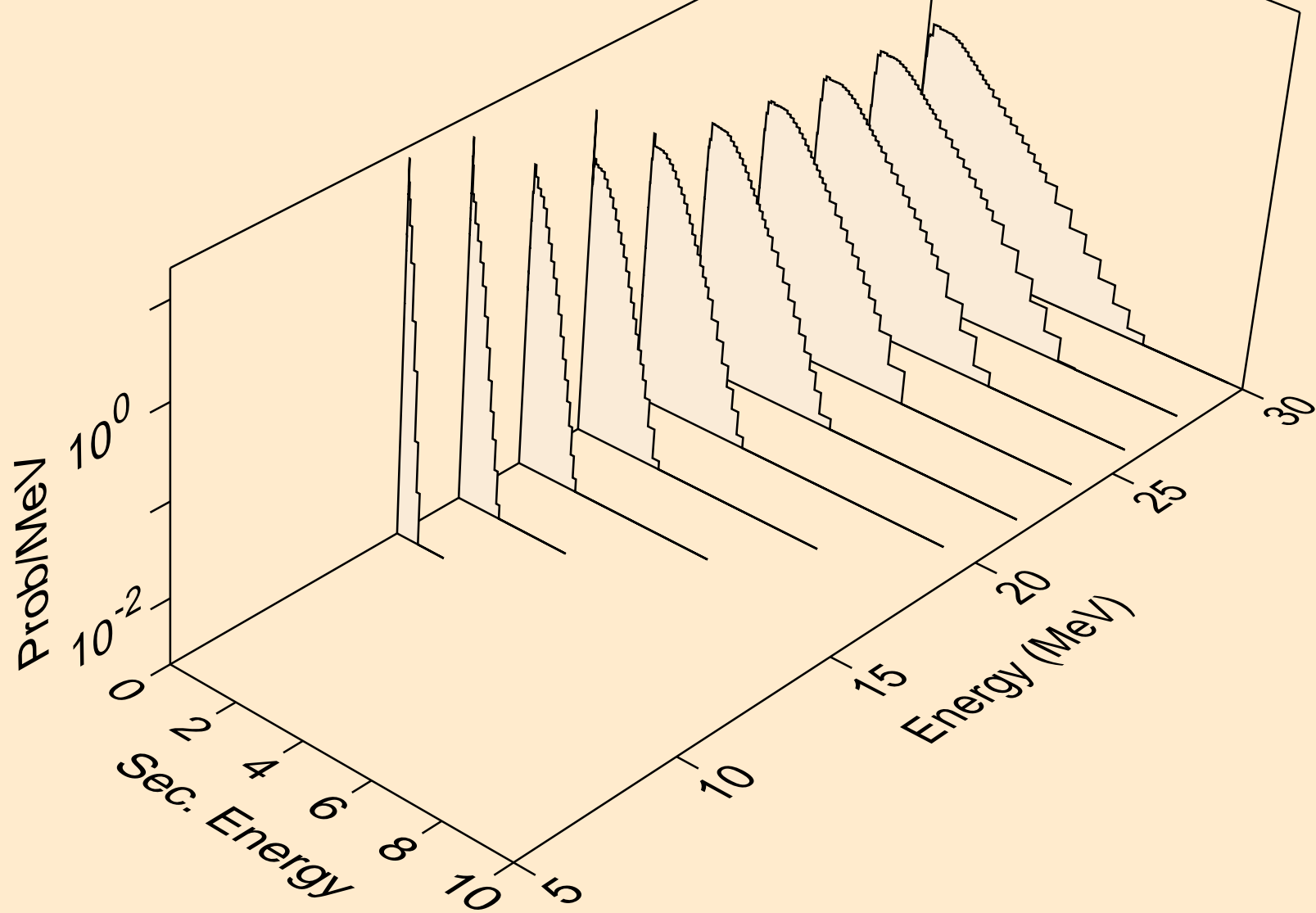



CU070 NEUTRON ACER TENDL-2023 LIBRARY; T=0.K  
Neutron emission for (n,2n)a

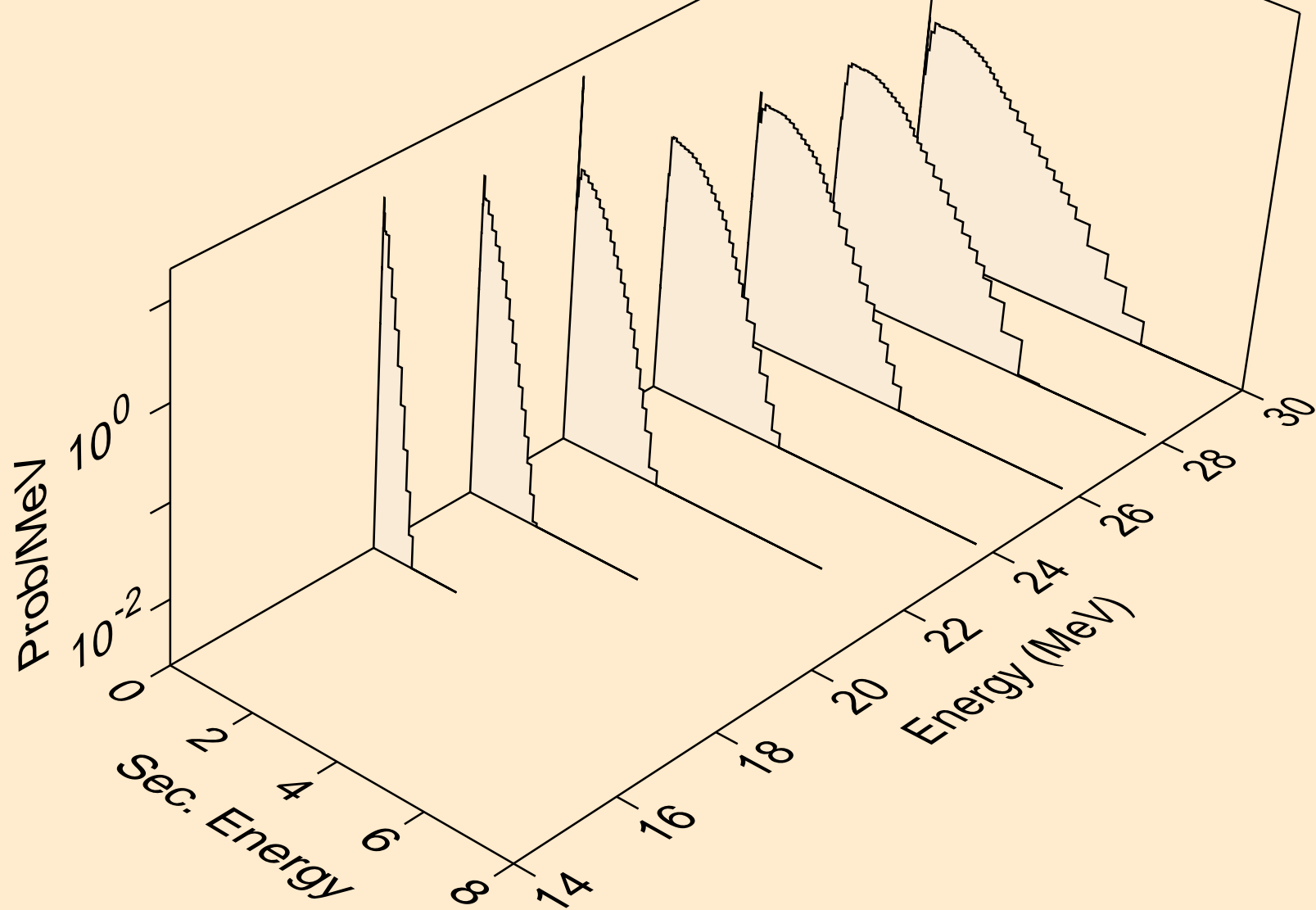

CU070 NEUTRON ACER TENDL-2023 LIBRARY; T=0.K  
Neutron emission for (n,3n)a

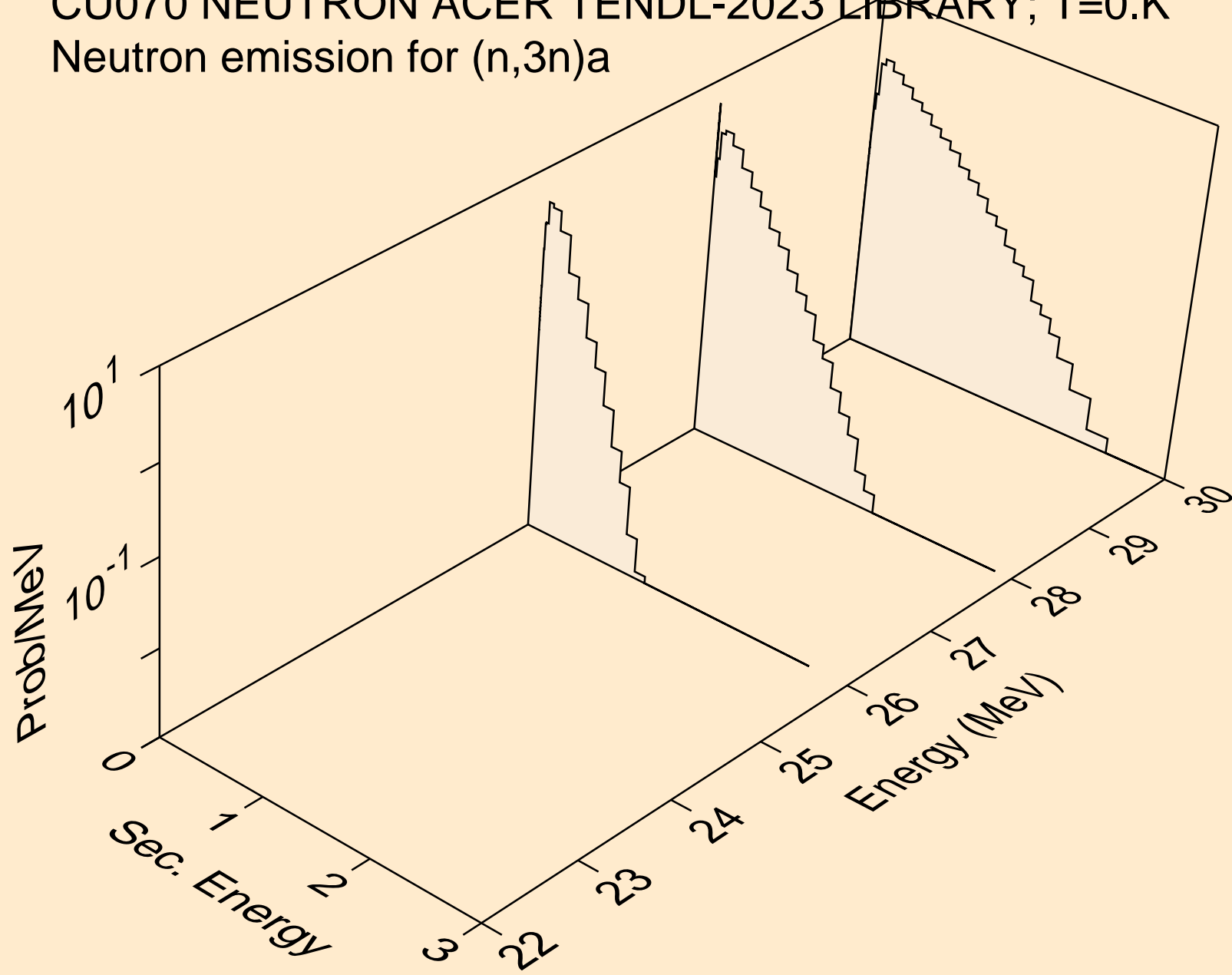

CU070 NEUTRON ACER TENDL-2023 LIBRARY; T=0.K  
Neutron emission for (n,n\*)p

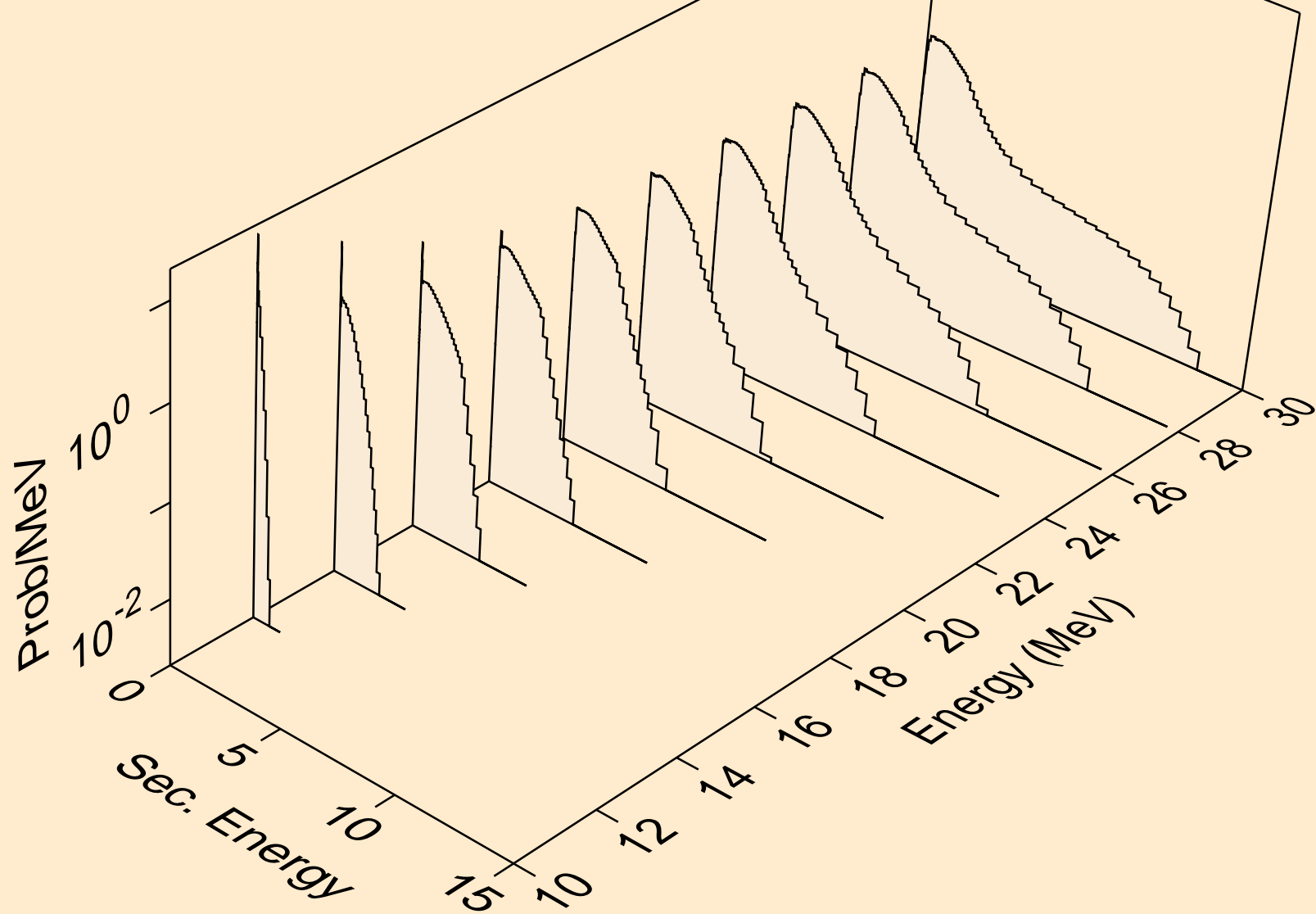

CU070 NEUTRON ACER TENDL-2023 LIBRARY; T=0.K  
Neutron emission for (n,n\*)d

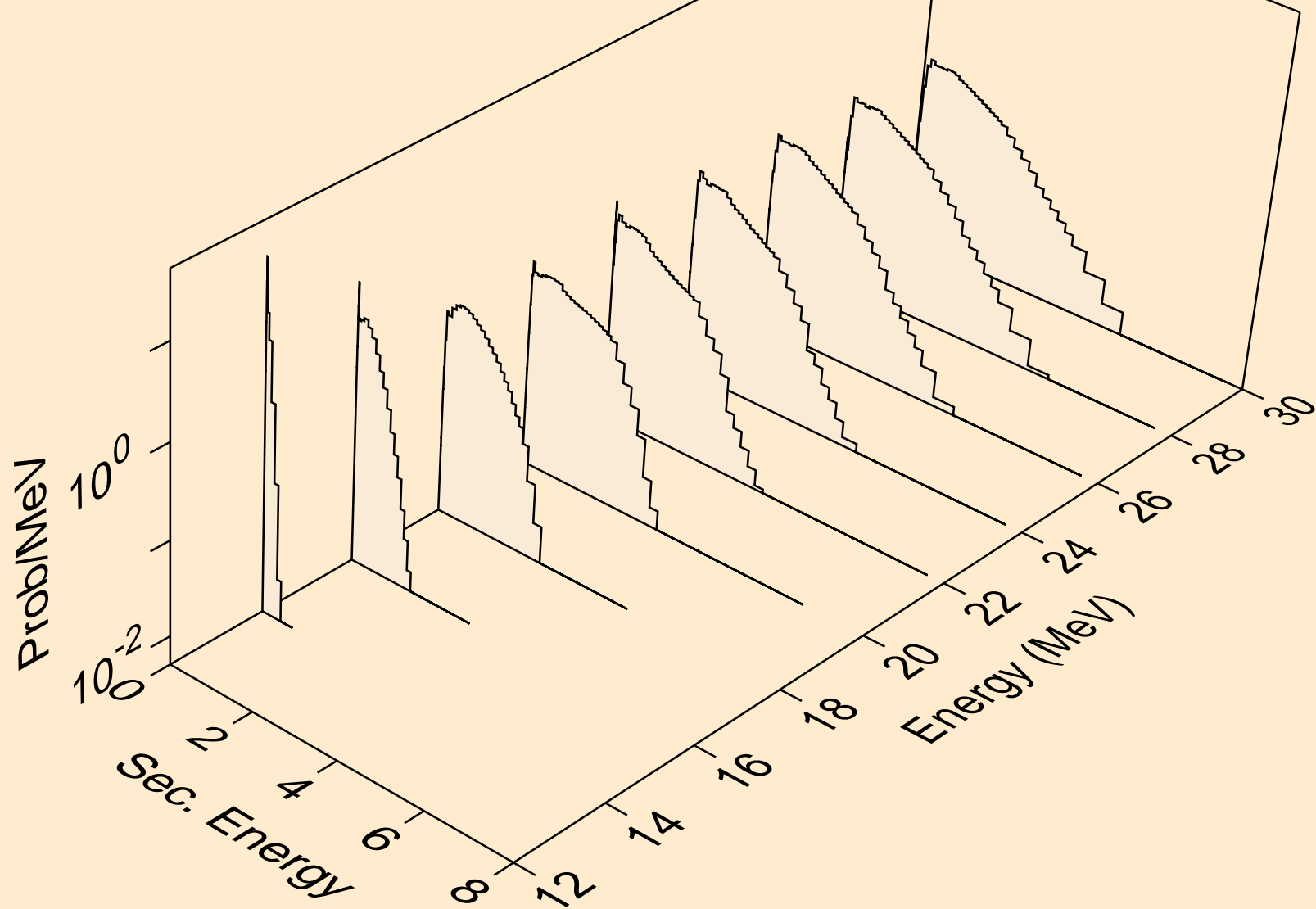

CU070 NEUTRON ACER TENDL-2023 LIBRARY; T=0.K  
Neutron emission for (n,n\*)t

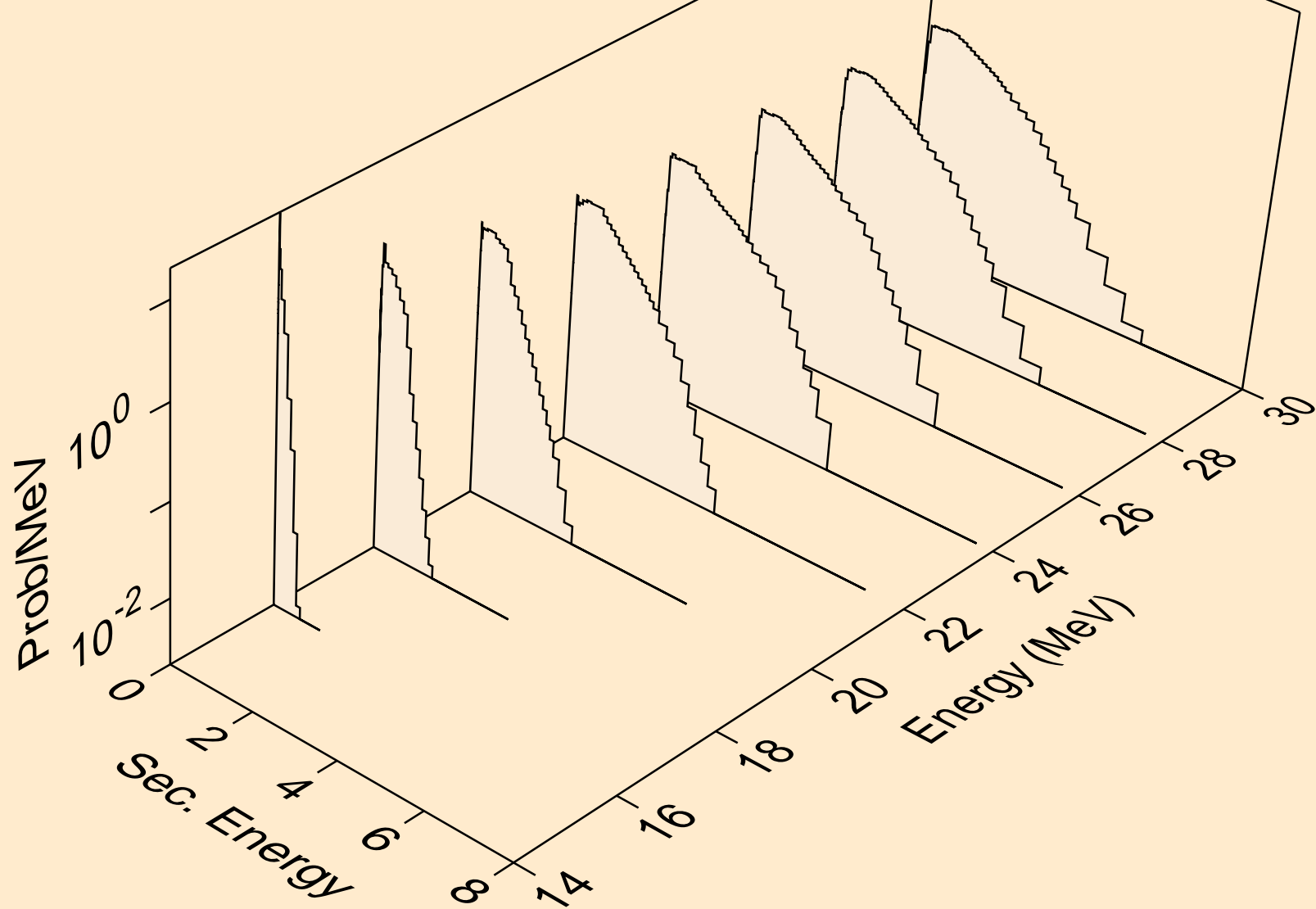

CU070 NEUTRON ACER TENDL-2023 LIBRARY; T=0.K  
Neutron emission for (n,n\*)he3

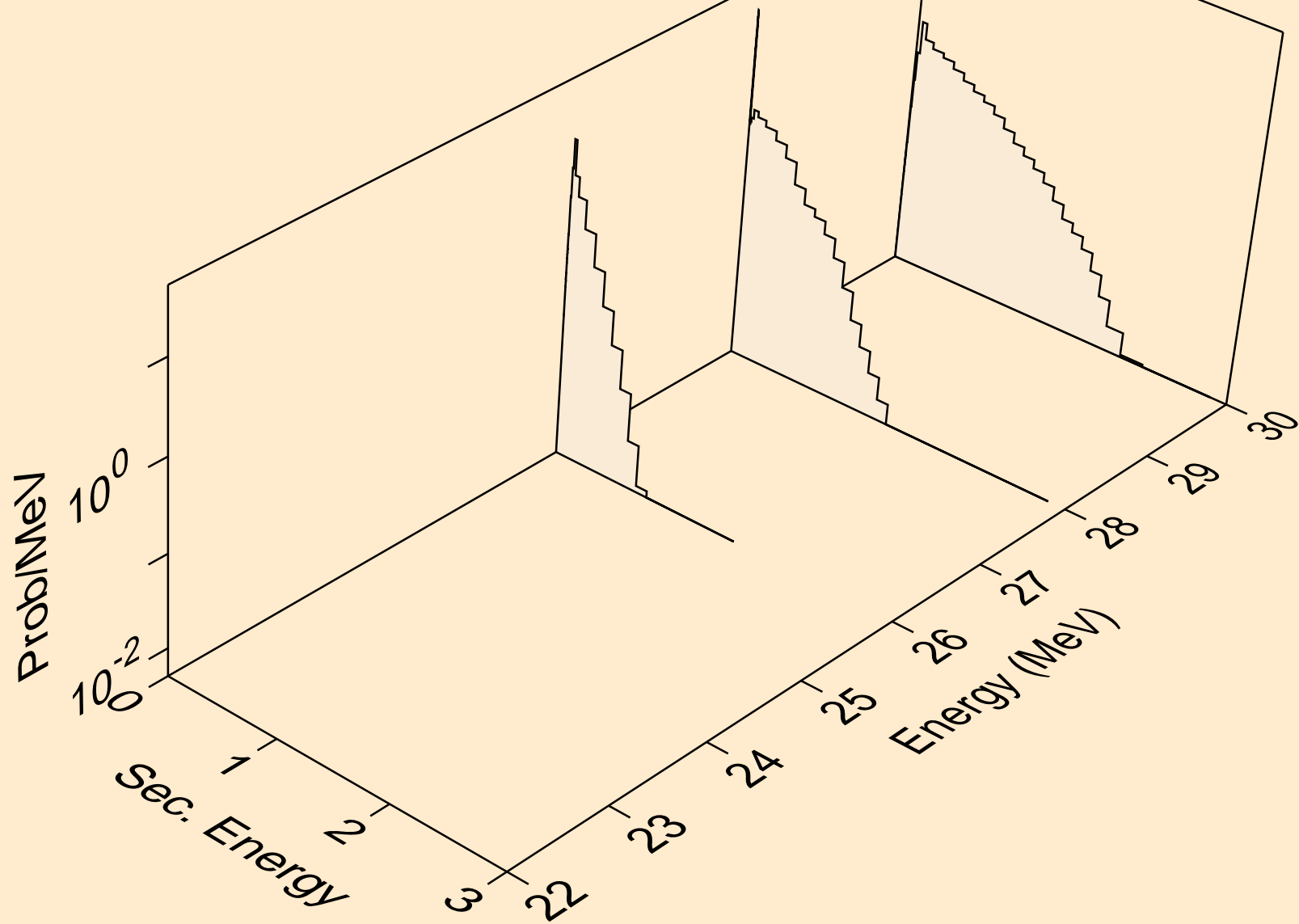

CU070 NEUTRON ACER TENDL-2023 LIBRARY; T=0.K  
Neutron emission for (n,4n)

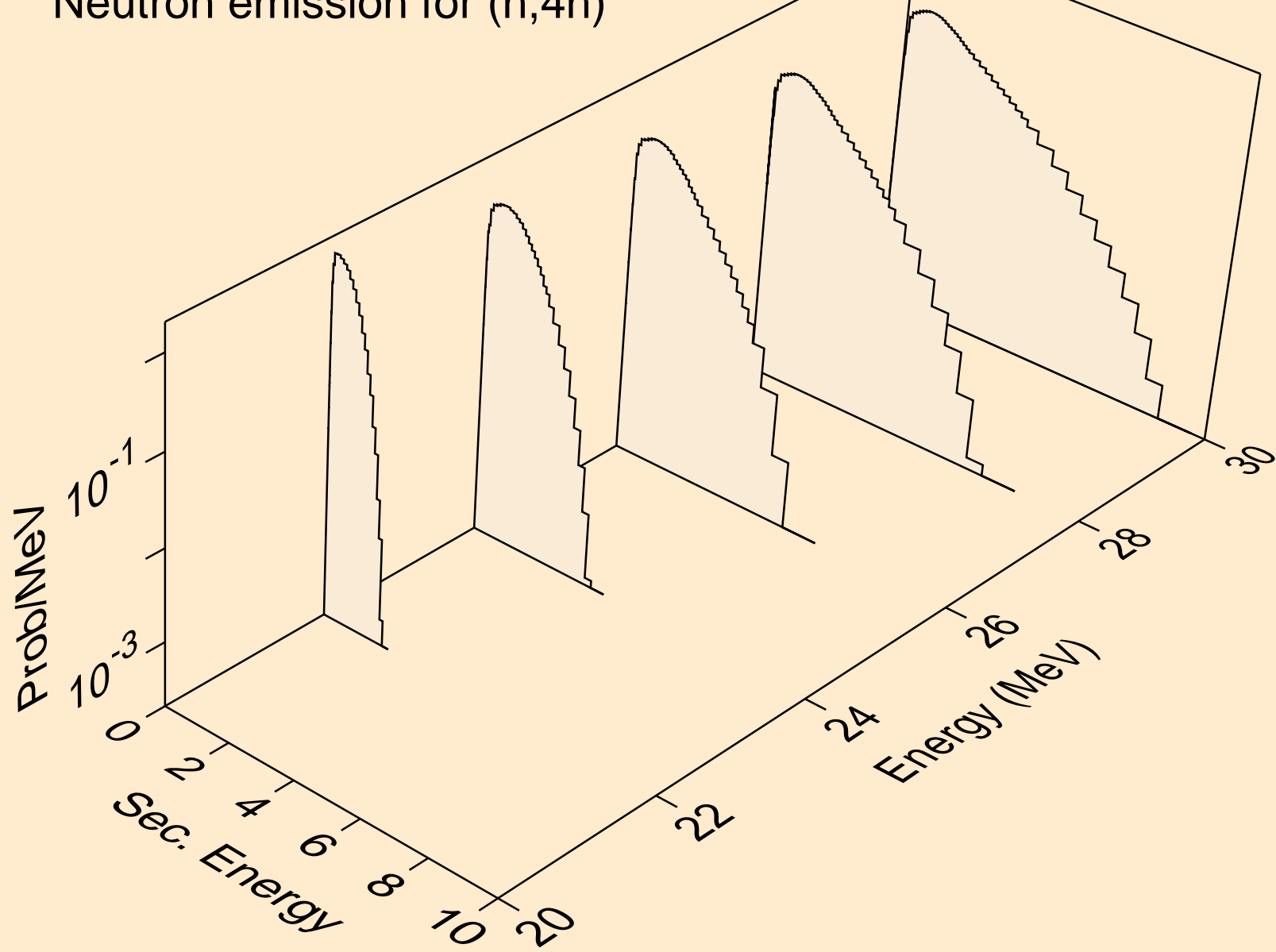

CU070 NEUTRON ACER TENDL-2023 LIBRARY; T=0.K  
Neutron emission for (n,2np)

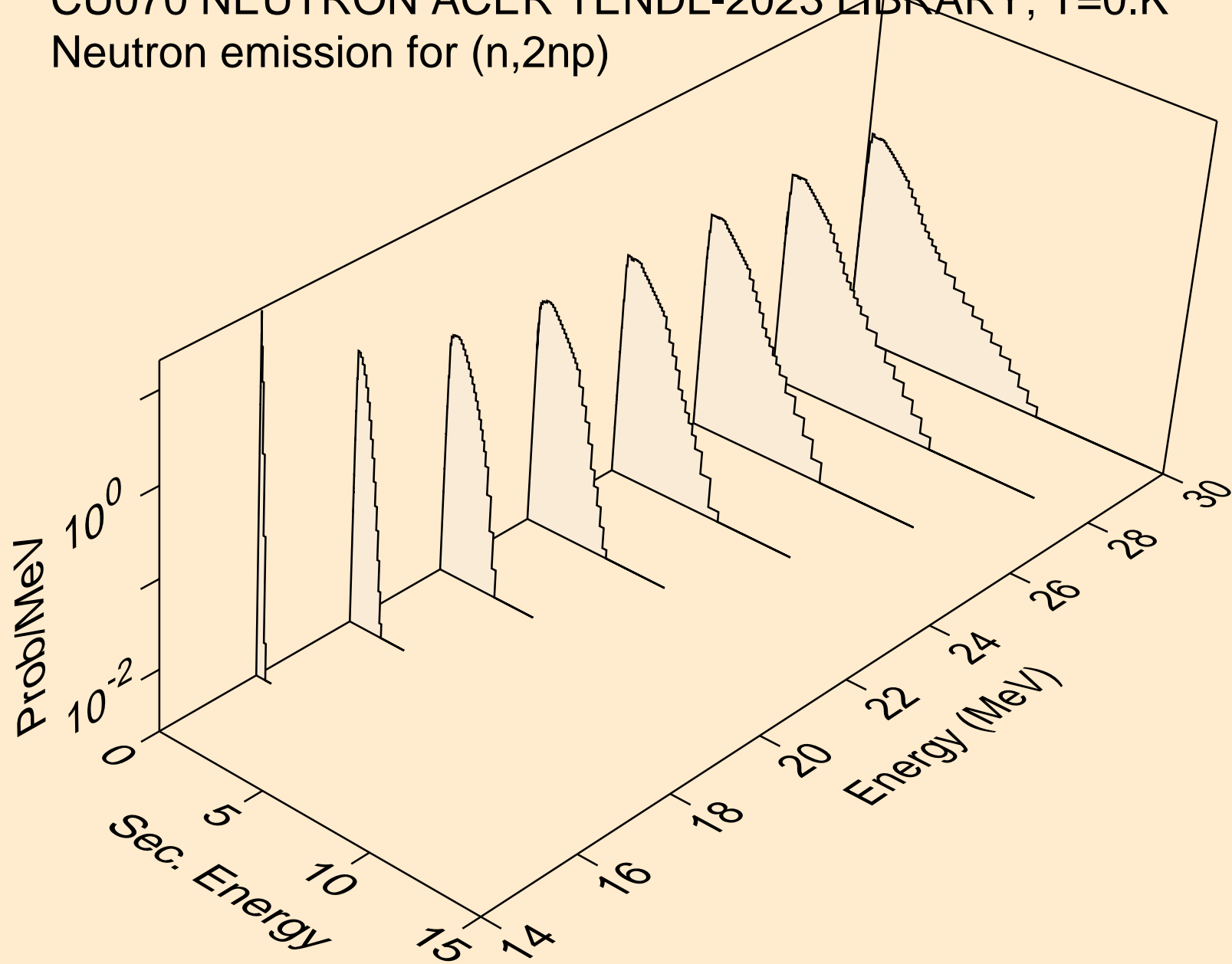



CU070 NEUTRON ACER TENDL-2023 LIBRARY; T=0.K  
Neutron emission for (n,3np)

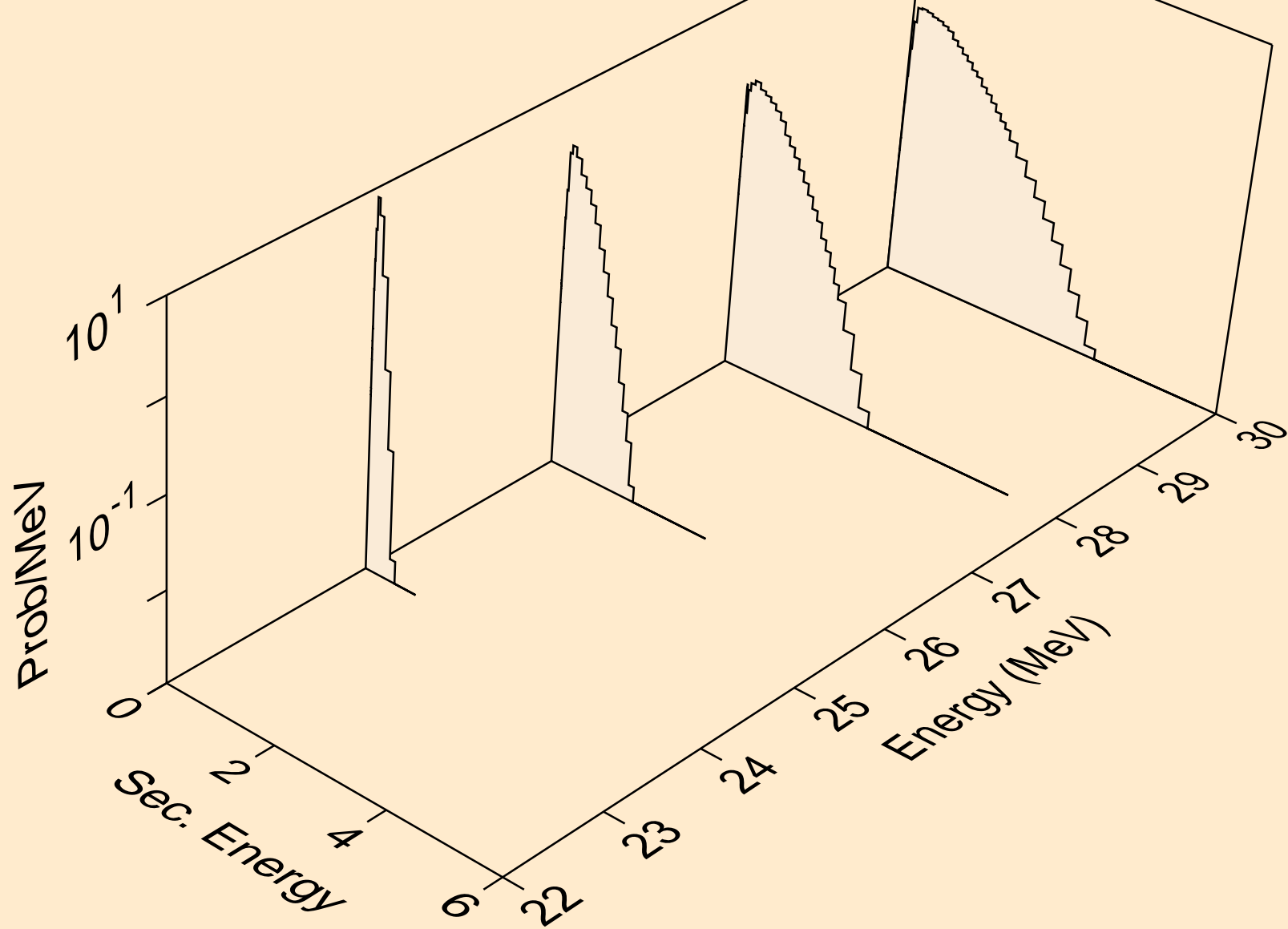

CU070 NEUTRON ACER TENDL-2023 LIBRARY; T=0.K  
Neutron emission for (n,n\*c)

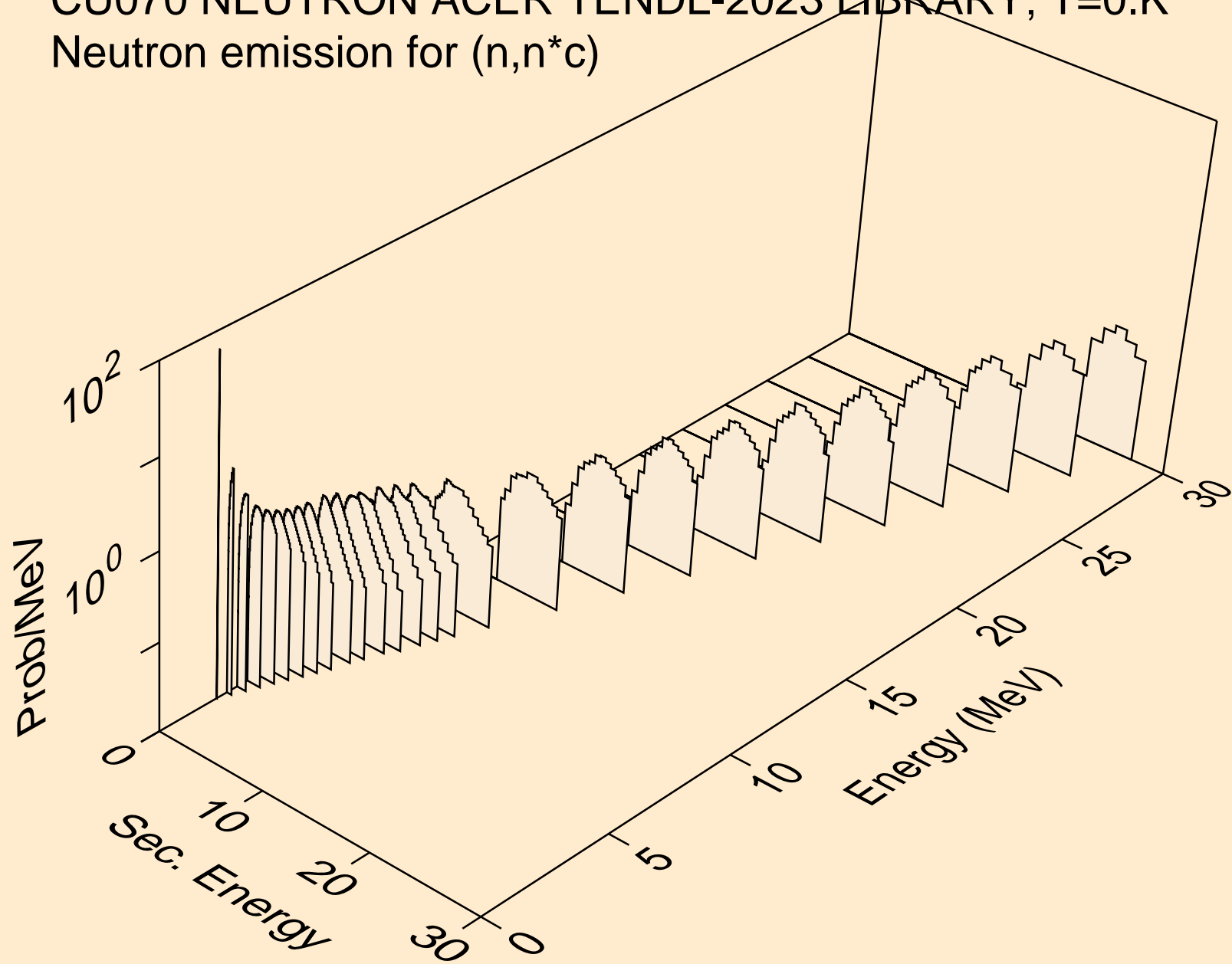

CU070 NEUTRON ACER TENDL-2023 LIBRARY; T=0.K  
Photon emission for (n,x)

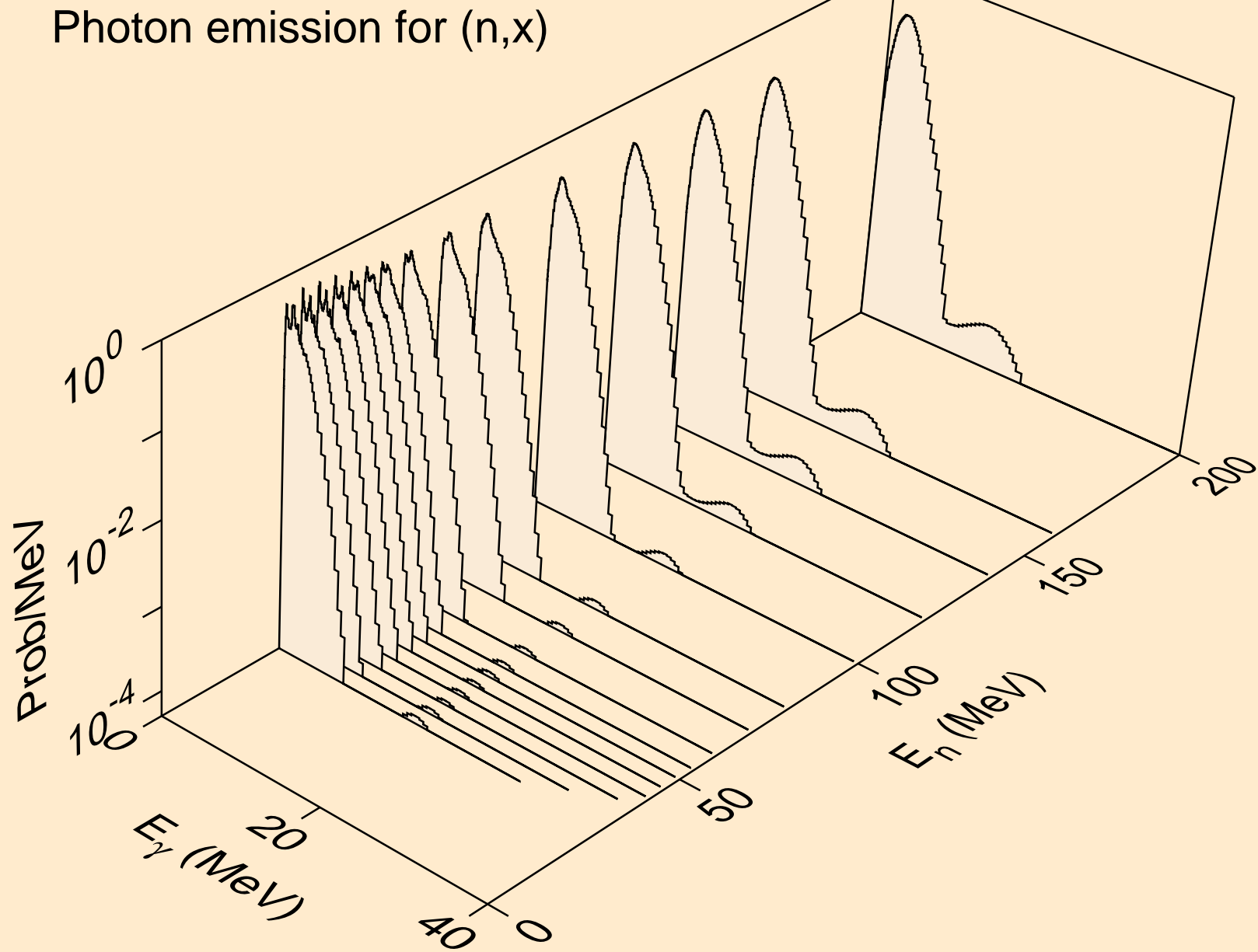

CU070 NEUTRON ACER TENDL-2023 LIBRARY; T=0.K  
Photon emission for (n,2nd)

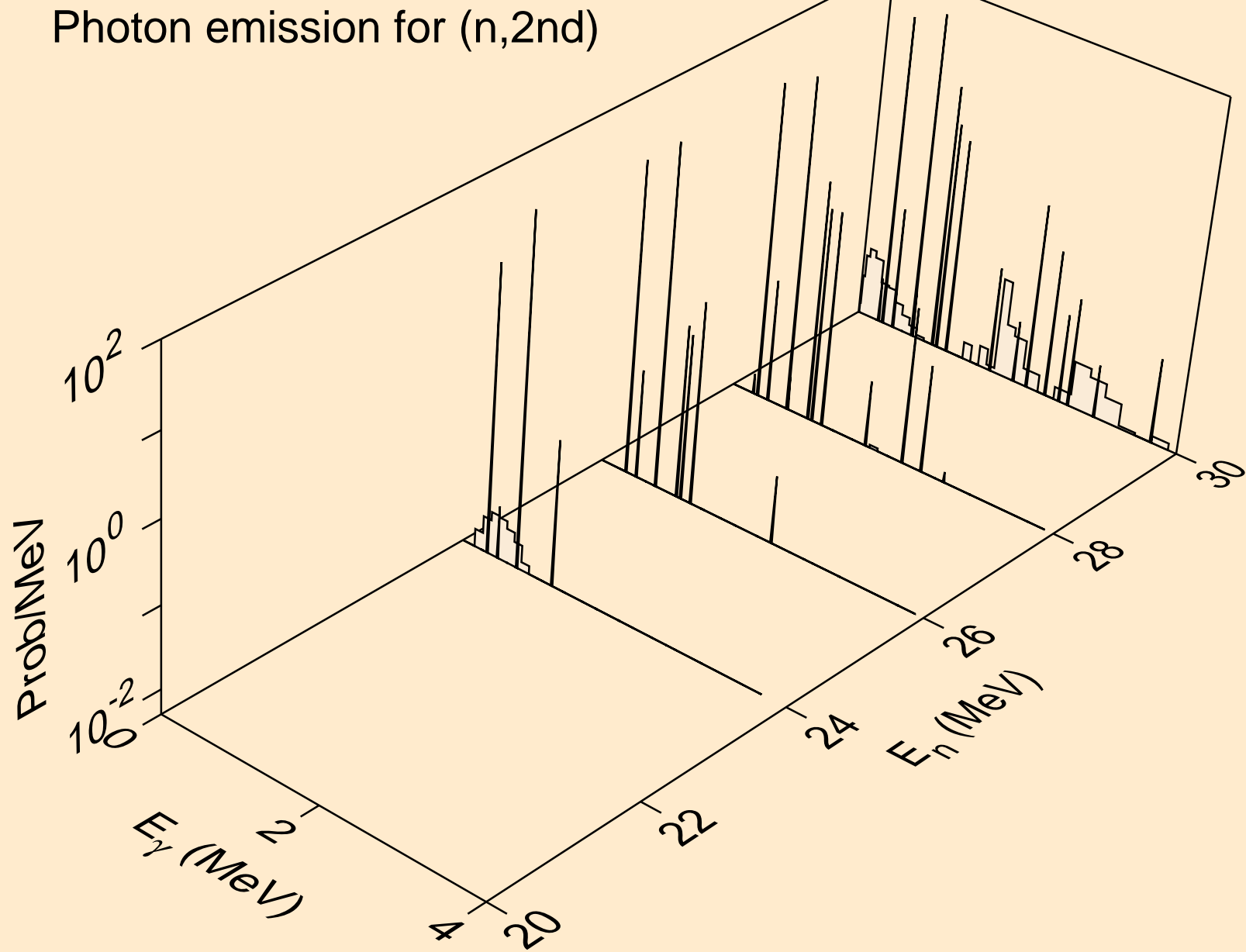

CU070 NEUTRON ACER TENDL-2023 LIBRARY; T=0.K  
Photon emission for (n,2n)

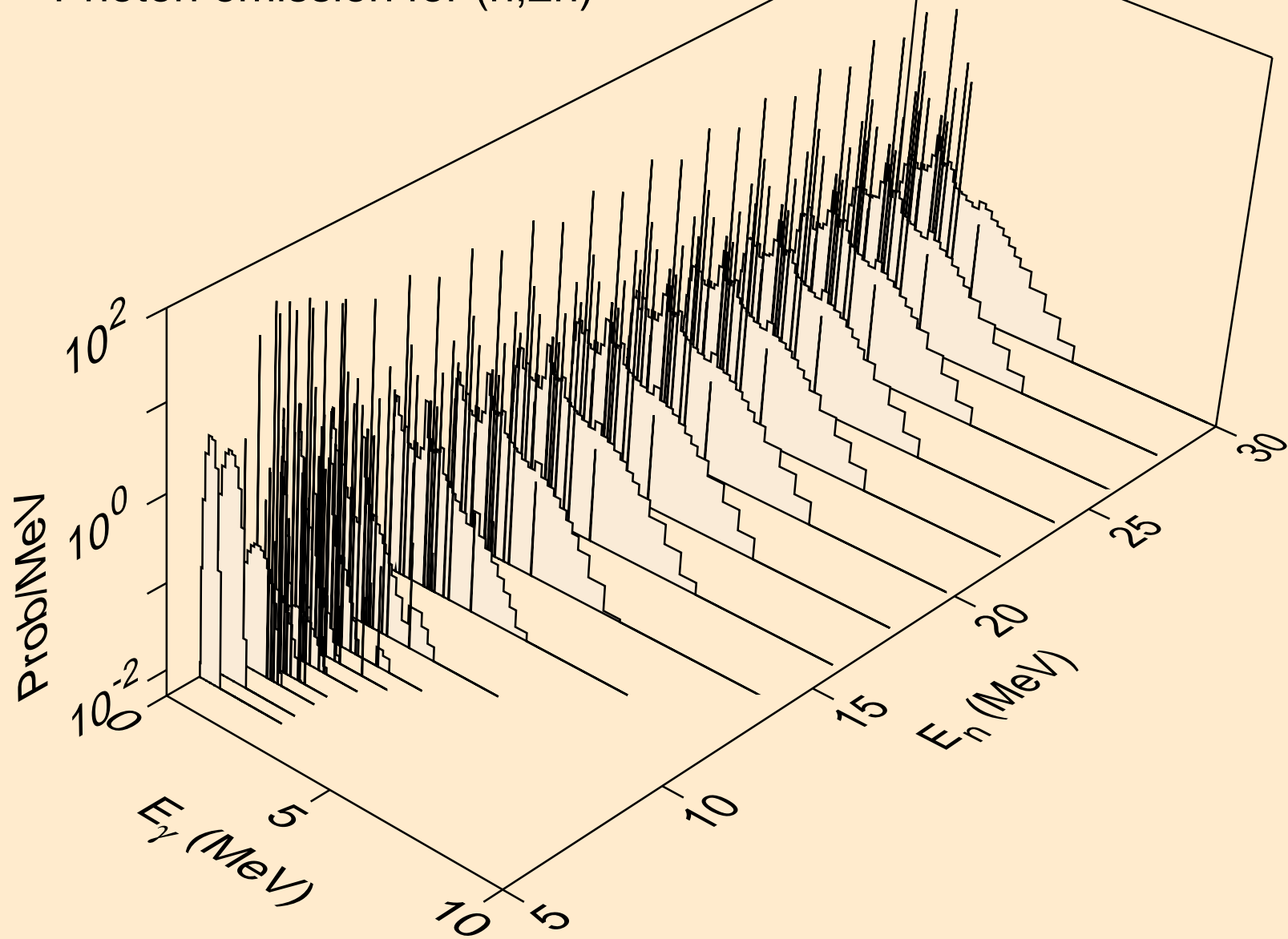

CU070 NEUTRON ACER TENDL-2023 LIBRARY; T=0.K  
Photon emission for (n,3n)

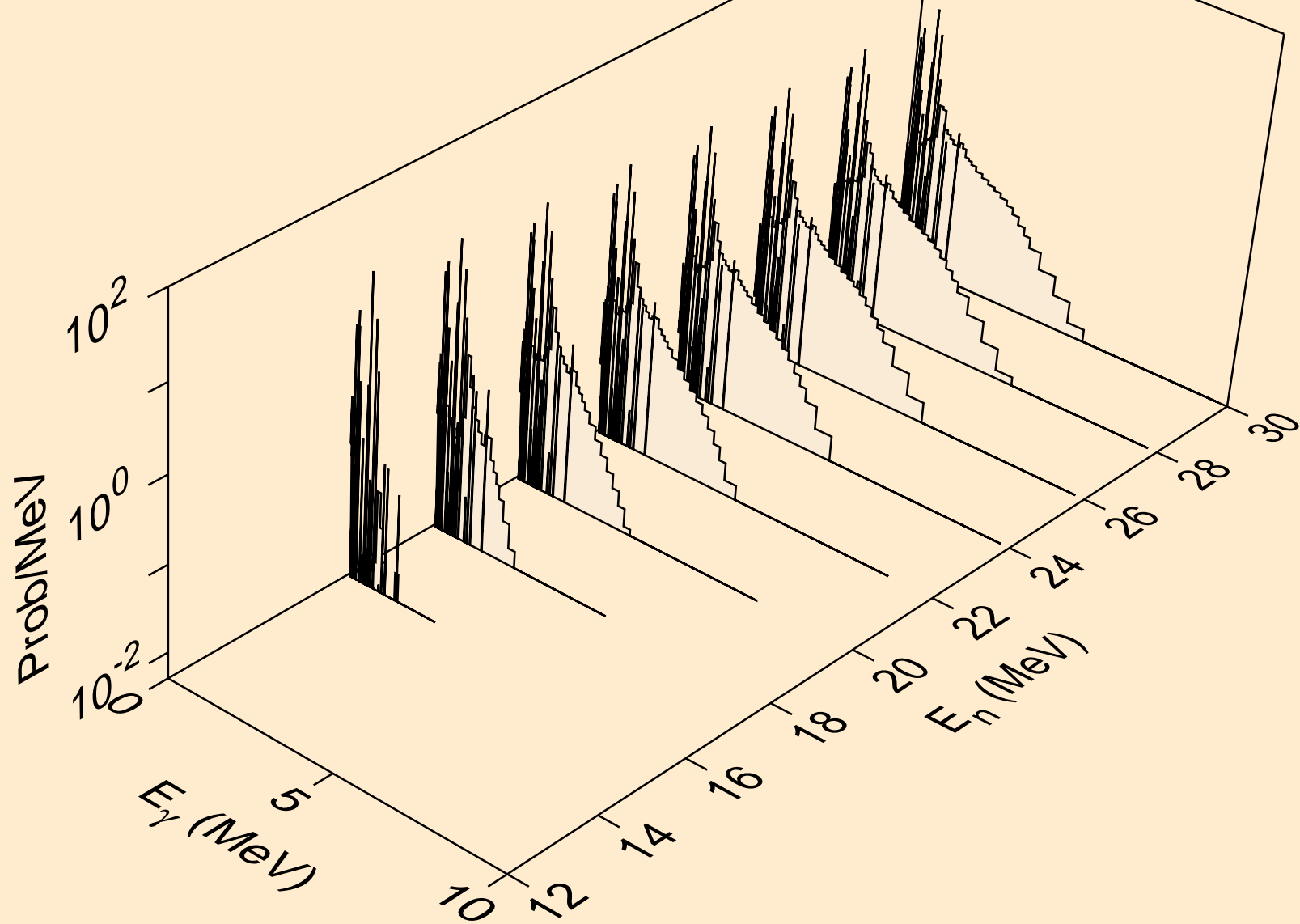

CU070 NEUTRON ACER TENDL-2023 LIBRARY; T=0.K  
Photon emission for (n,n\*)a

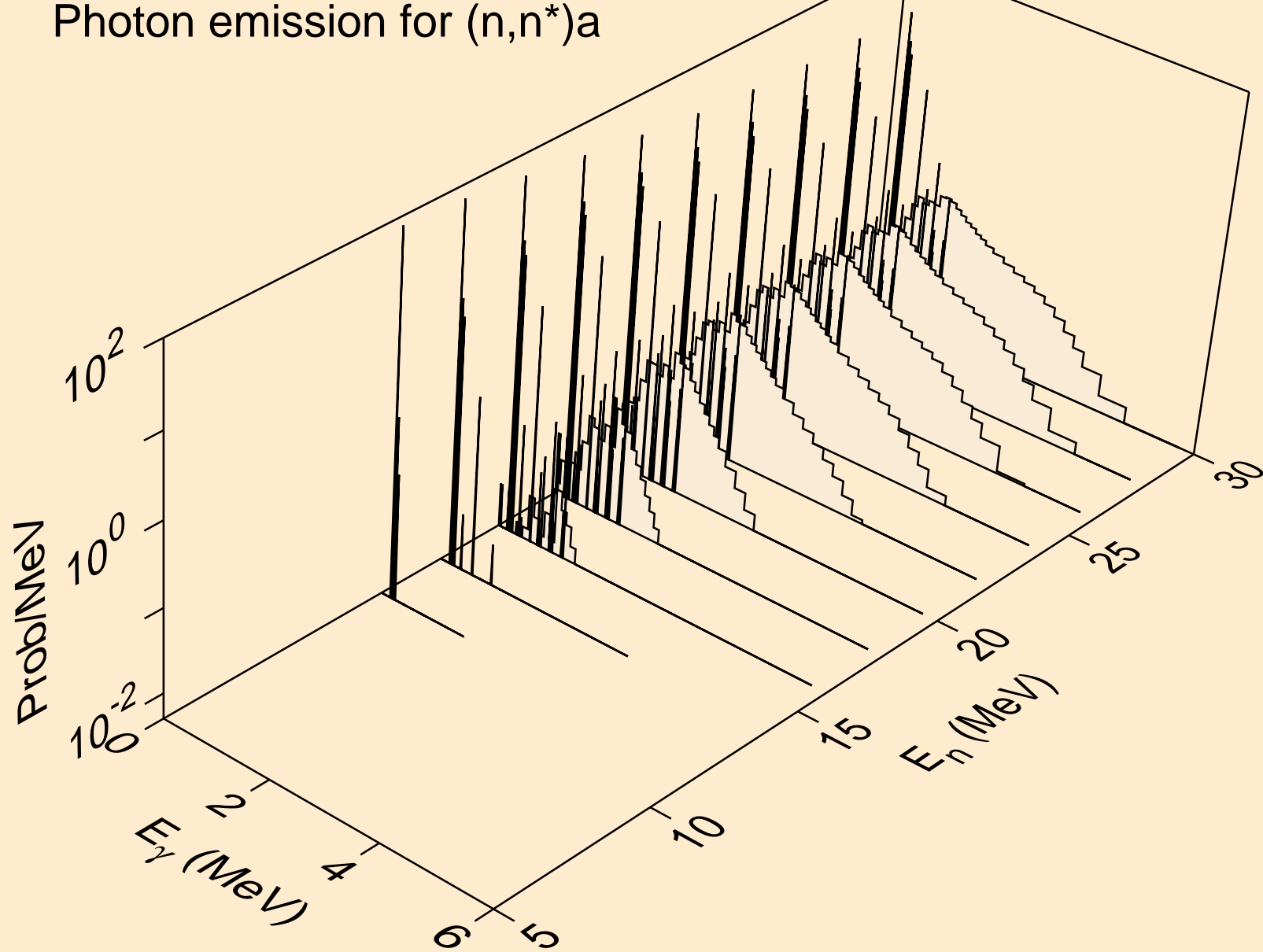

CU070 NEUTRON ACER TENDL-2023 LIBRARY; T=0.K  
Photon emission for (n,2n)a

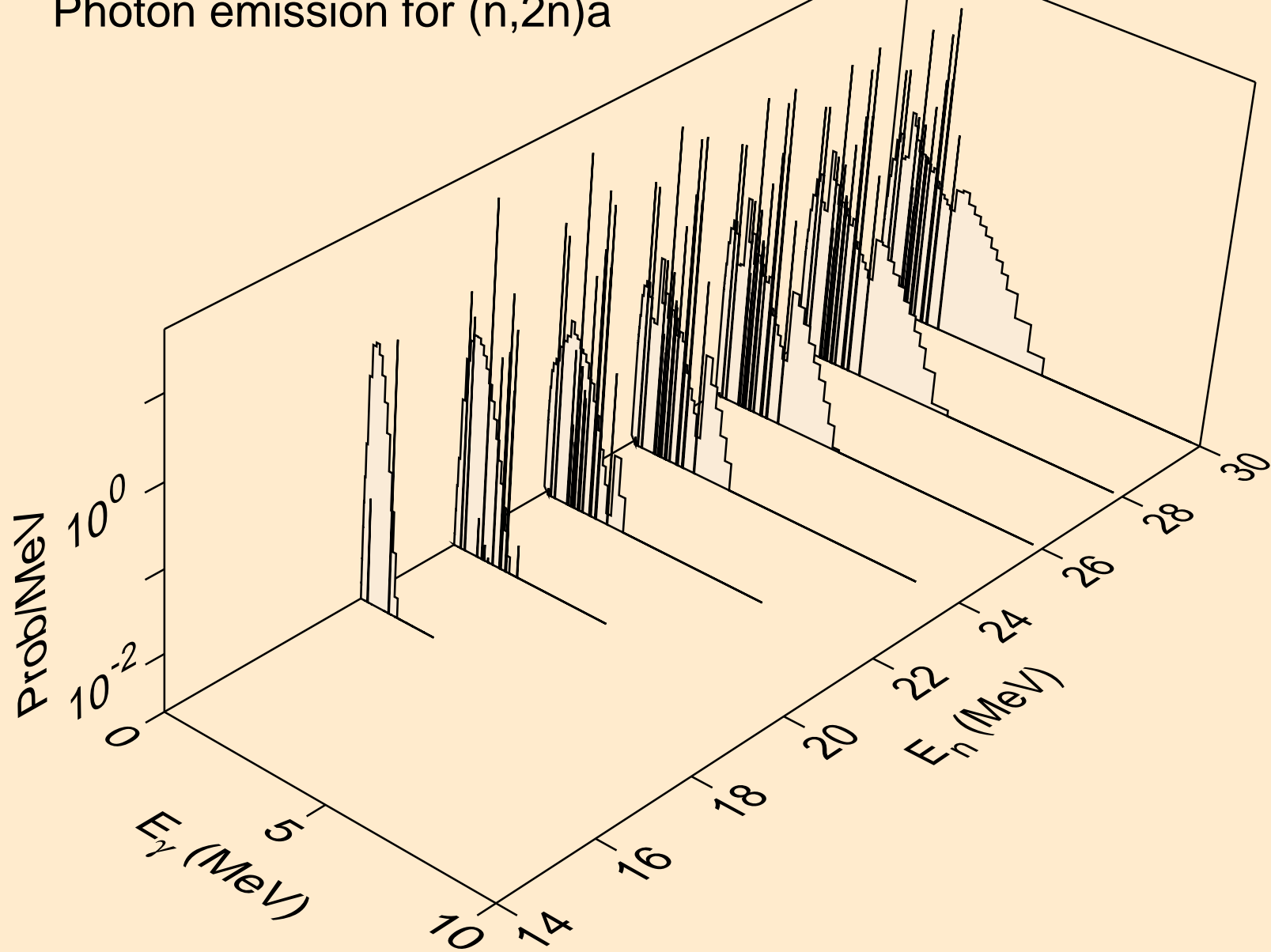



CU070 NEUTRON ACER TENDL-2023 LIBRARY; T=0.K  
Photon emission for (n,3n)a

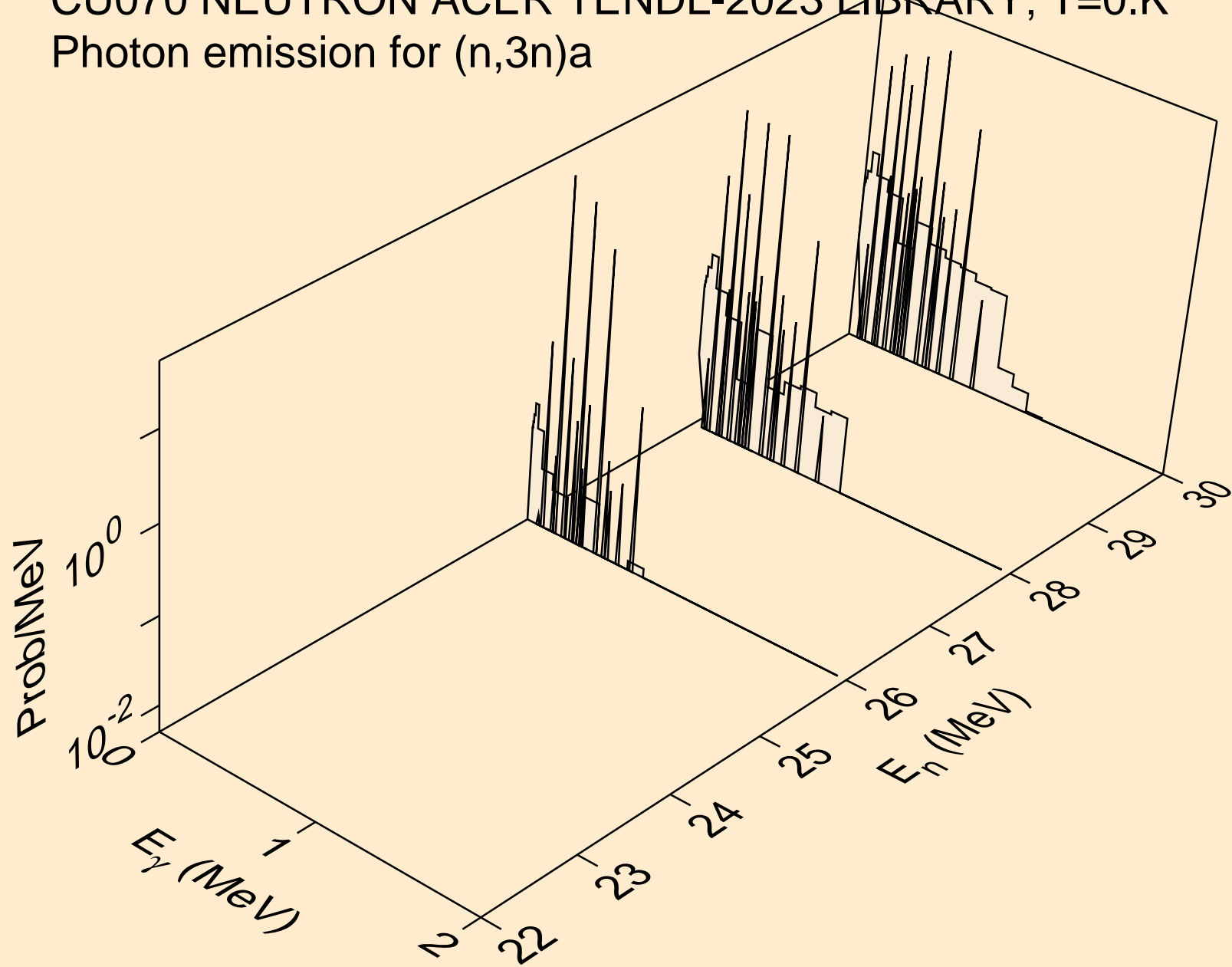

CU070 NEUTRON ACER TENDL-2023 LIBRARY; T=0.K  
Photon emission for (n,n\*)p

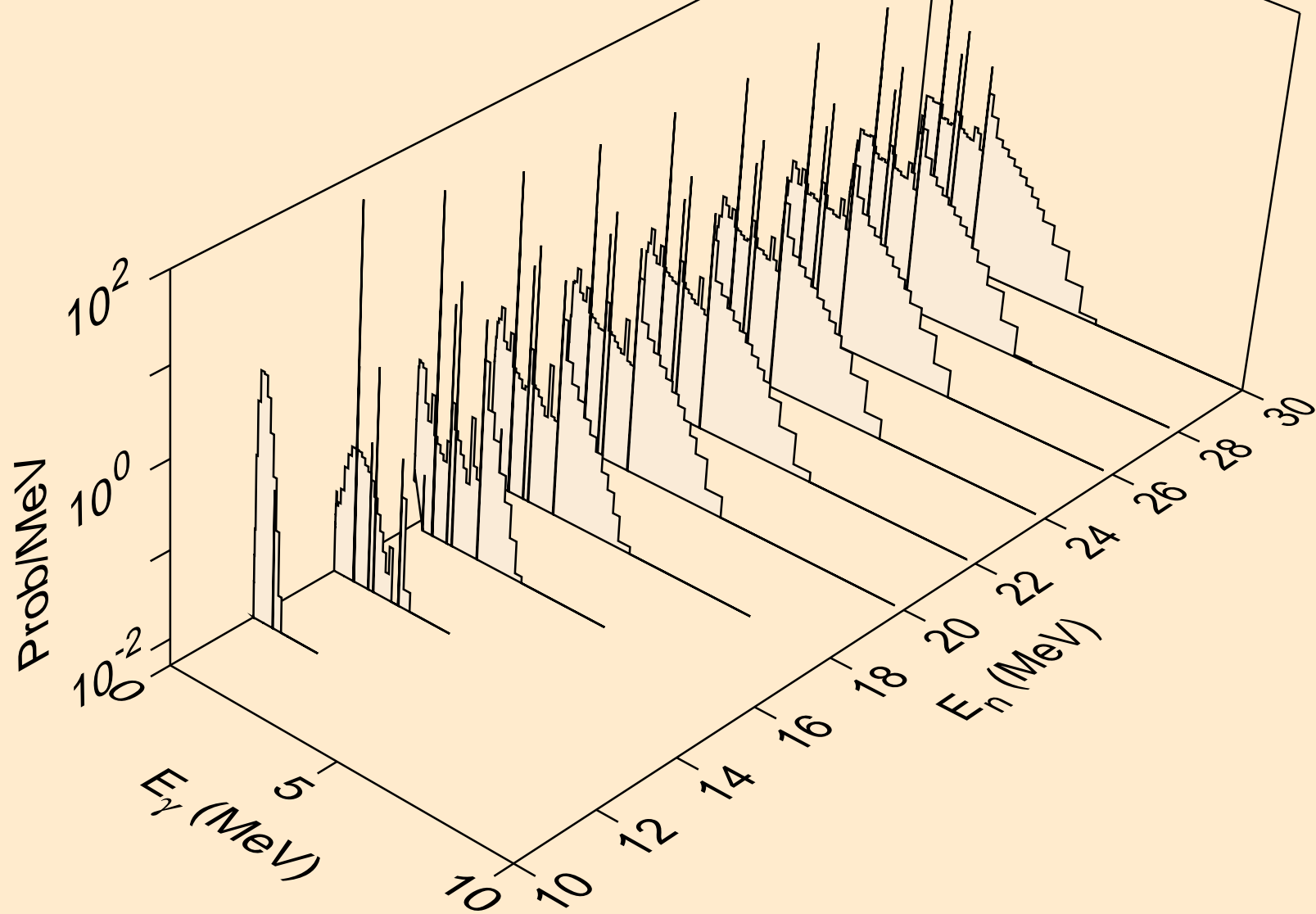

CU070 NEUTRON ACER TENDL-2023 LIBRARY; T=0.K  
Photon emission for (n,n\*)d

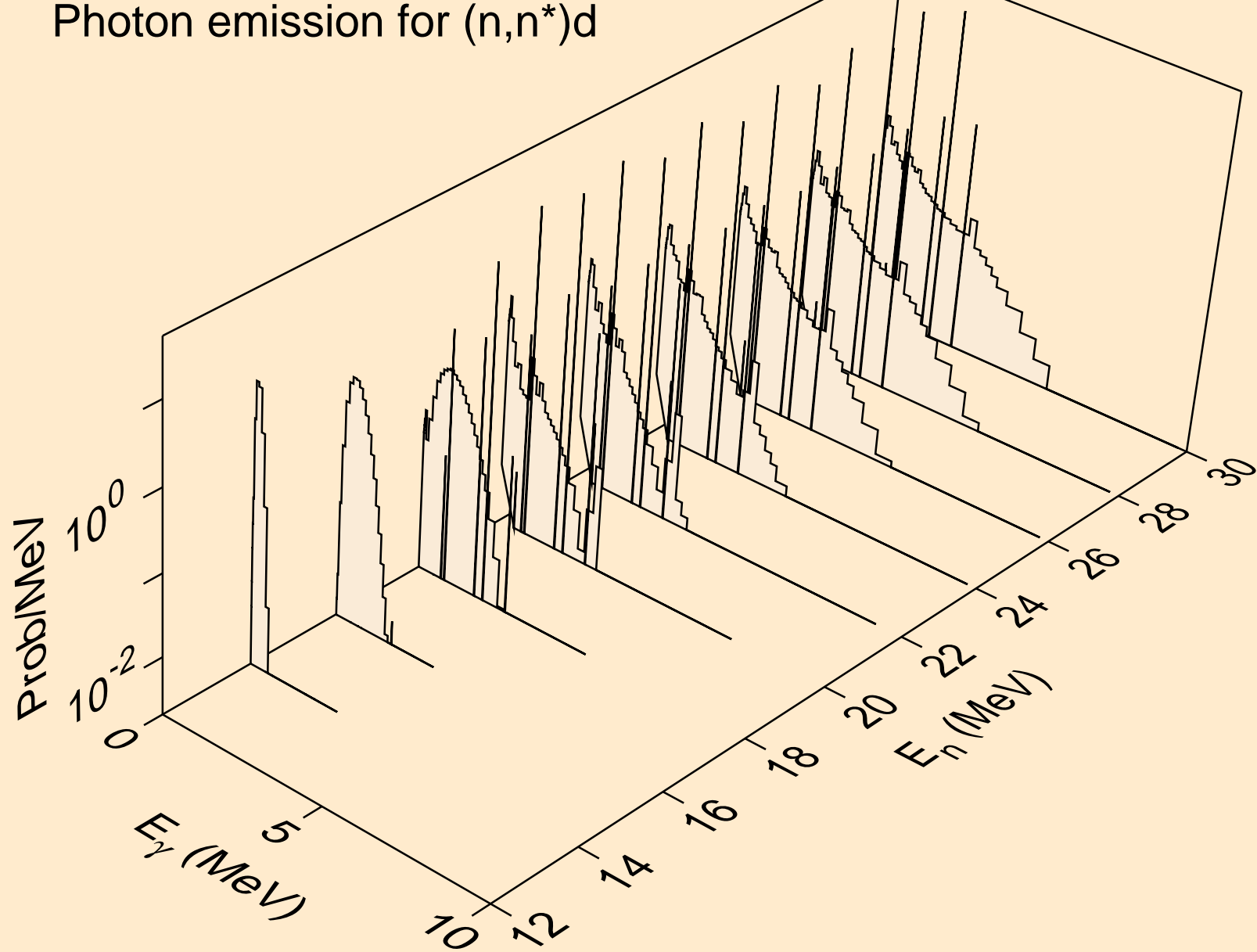

CU070 NEUTRON ACER TENDL-2023 LIBRARY; T=0.K  
Photon emission for (n,n\*)t

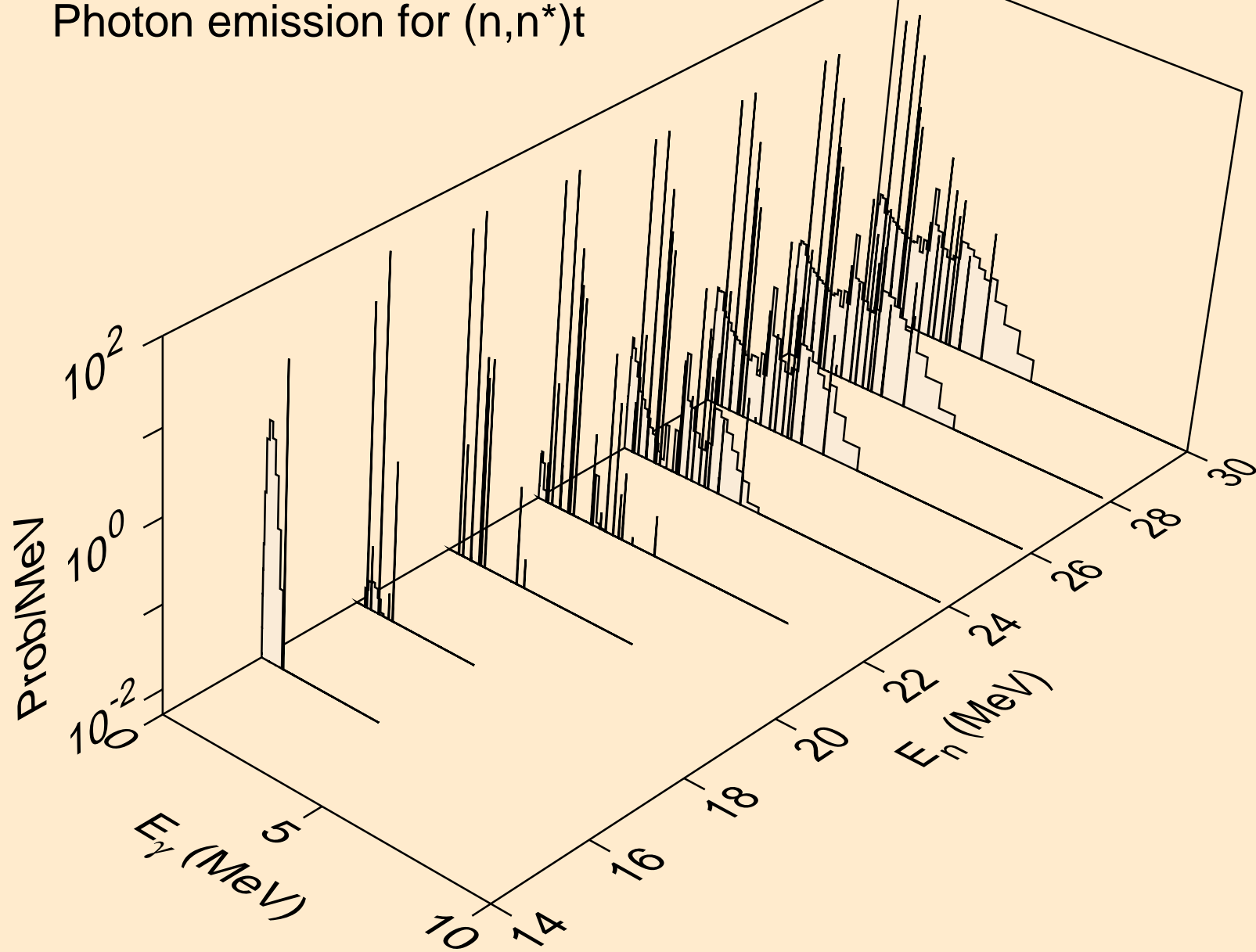

CU070 NEUTRON ACER TENDL-2023 LIBRARY; T=0.K  
Photon emission for (n,n\*)he3

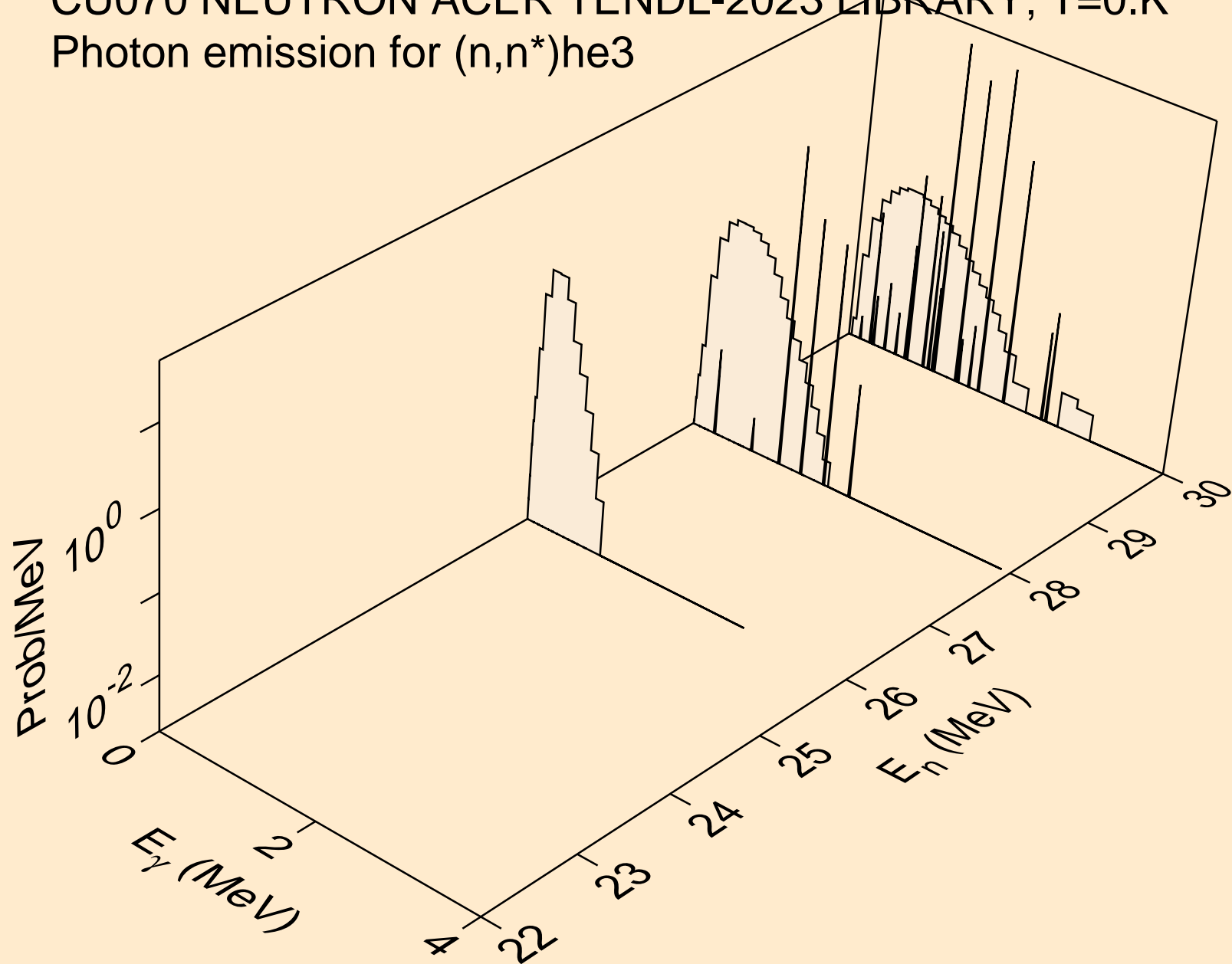

CU070 NEUTRON ACER TENDL-2023 LIBRARY; T=0.K  
Photon emission for (n,4n)

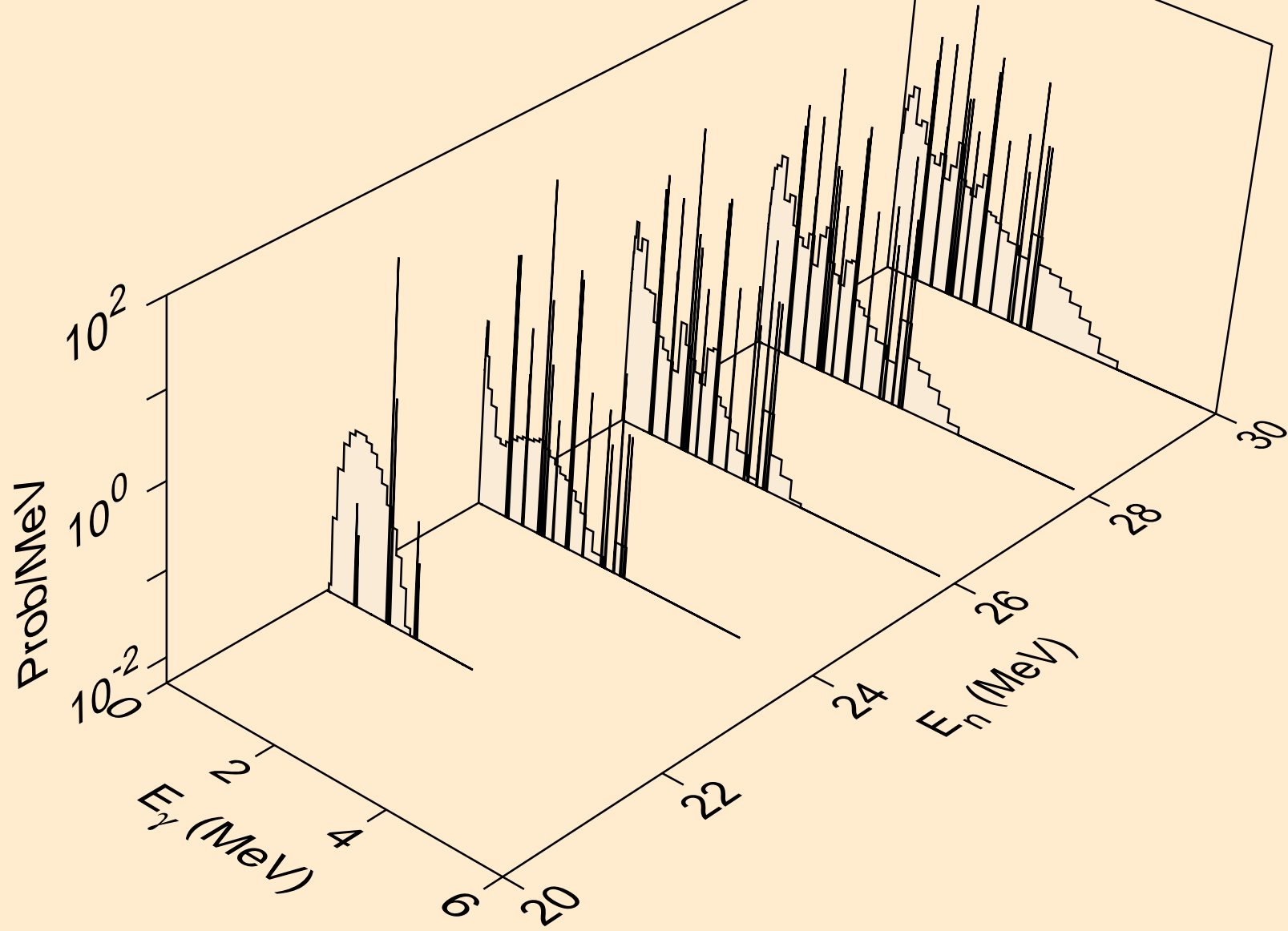

CU070 NEUTRON ACER TENDL-2023 LIBRARY; T=0.K  
Photon emission for (n,2np)

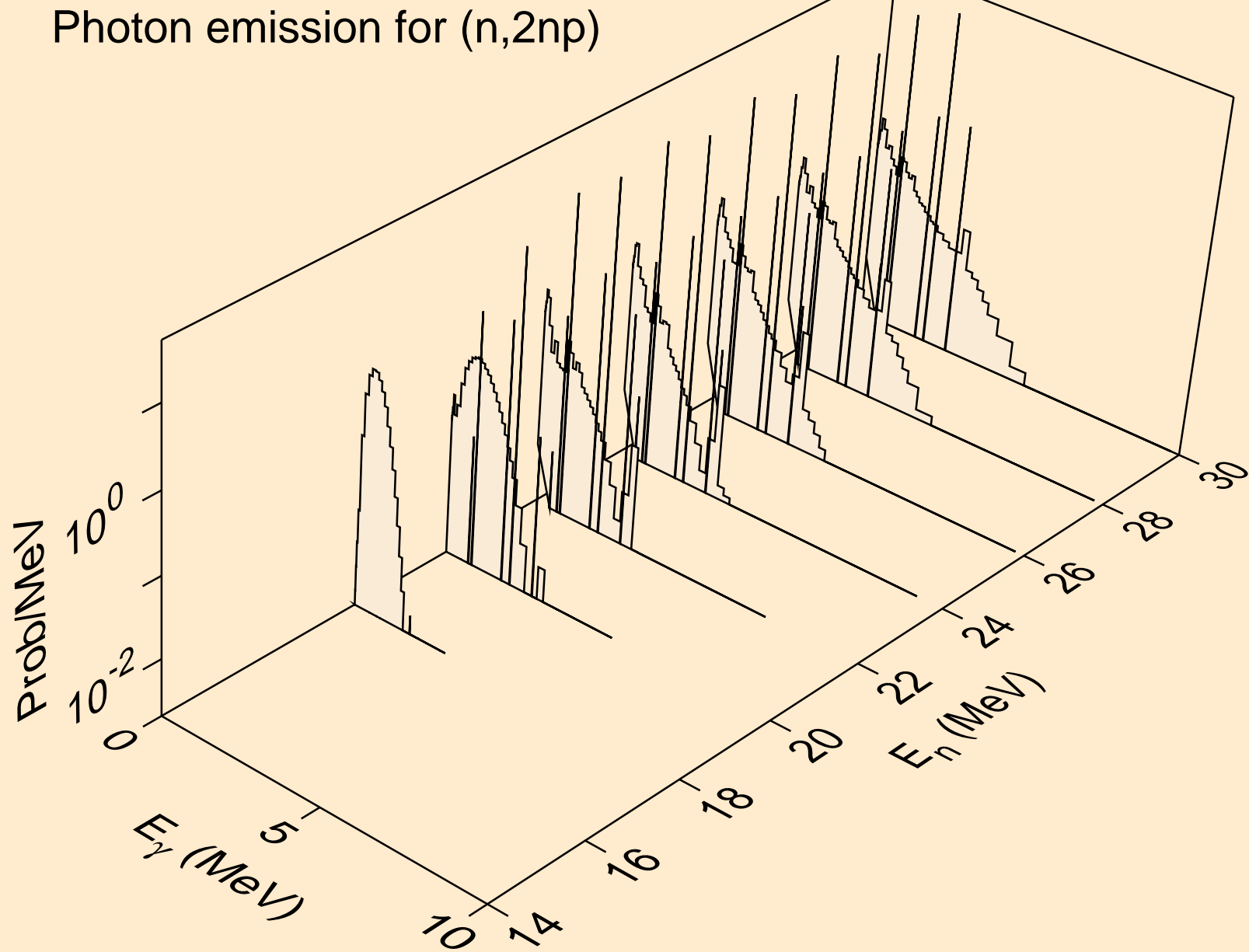

CU070 NEUTRON ACER TENDL-2023 LIBRARY; T=0.K  
Photon emission for (n,3np)

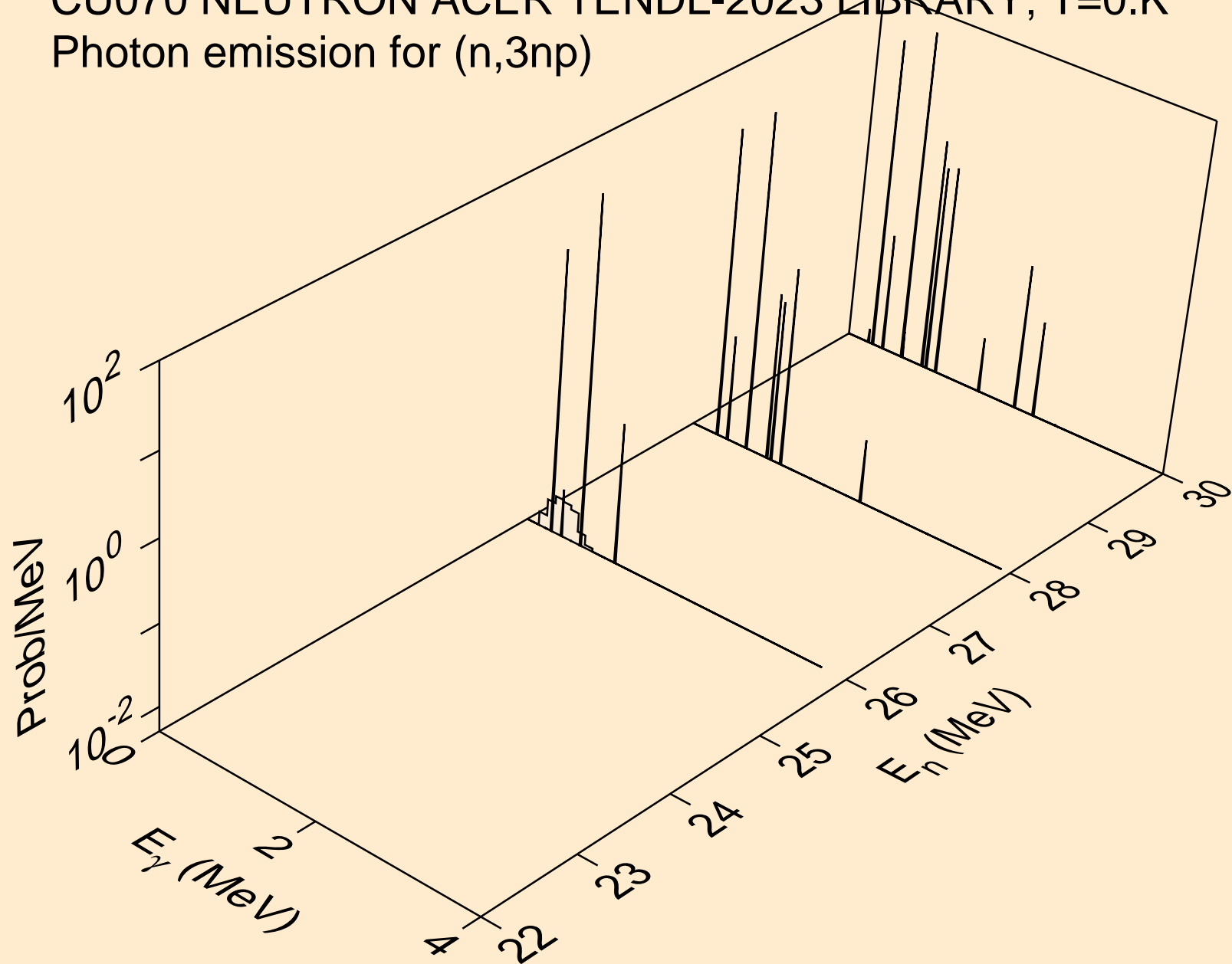



CU070 NEUTRON ACER TENDL-2023 LIBRARY; T=0.K  
Photon emission for (n,n\*c)

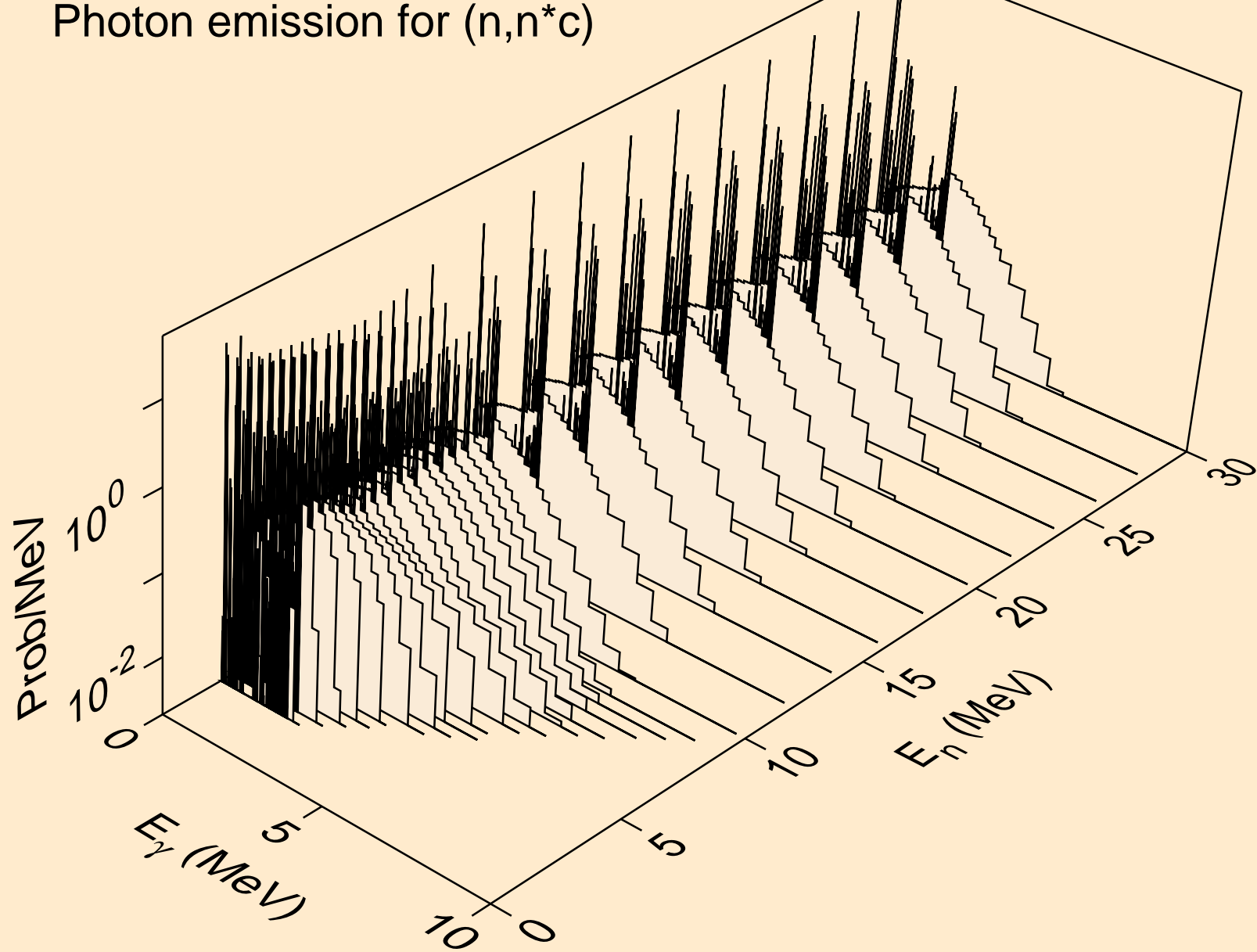

CU070 NEUTRON ACER TENDL-2023 LIBRARY; T=0.K  
Photon emission for (n,gma)

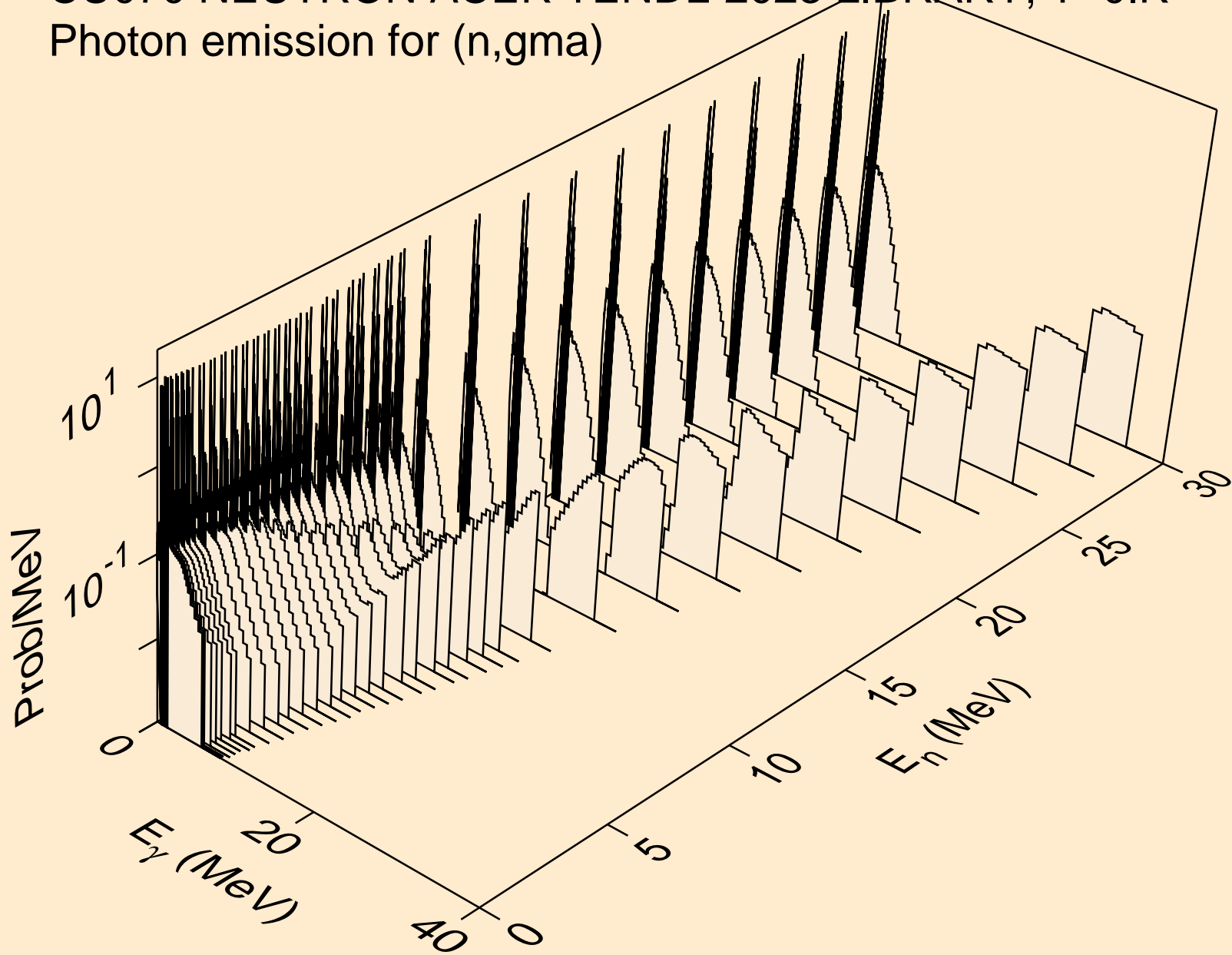

CU070 NEUTRON ACER TENDL-2023 LIBRARY; T=0.K  
Photon emission for (n,p)

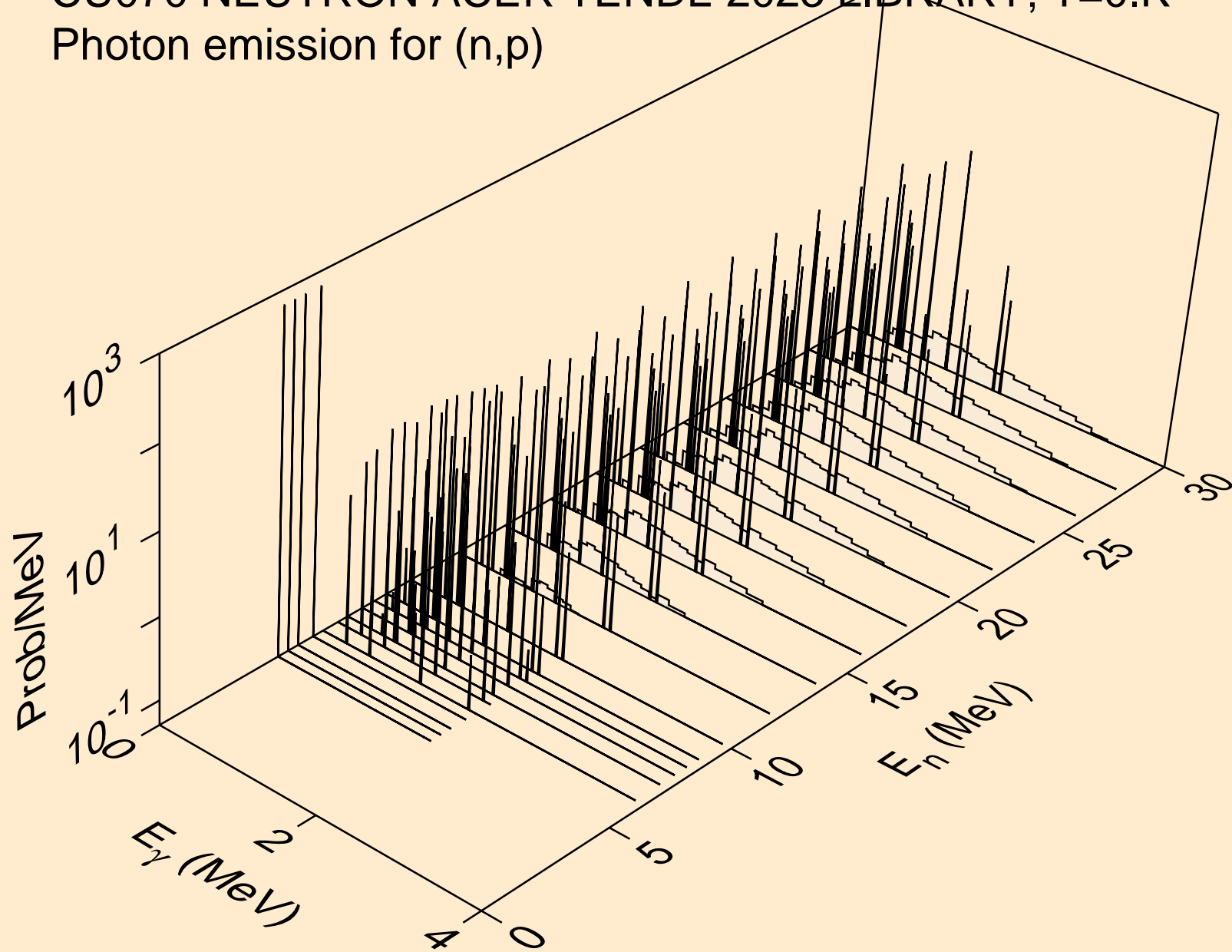

CU070 NEUTRON ACER TENDL-2023 LIBRARY; T=0.K  
Photon emission for (n,d)

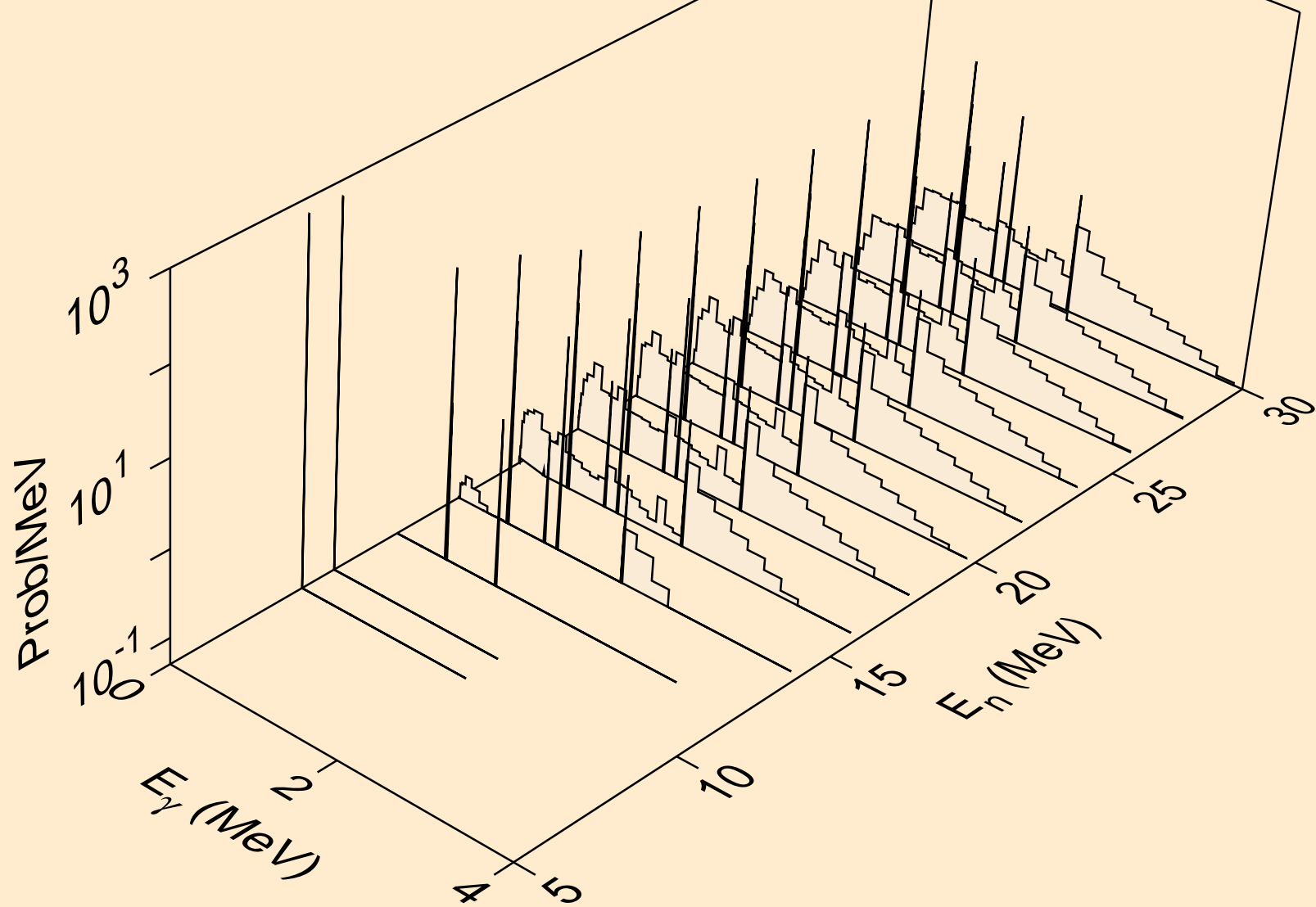

CU070 NEUTRON ACER TENDL-2023 LIBRARY; T=0.K  
Photon emission for (n,t)

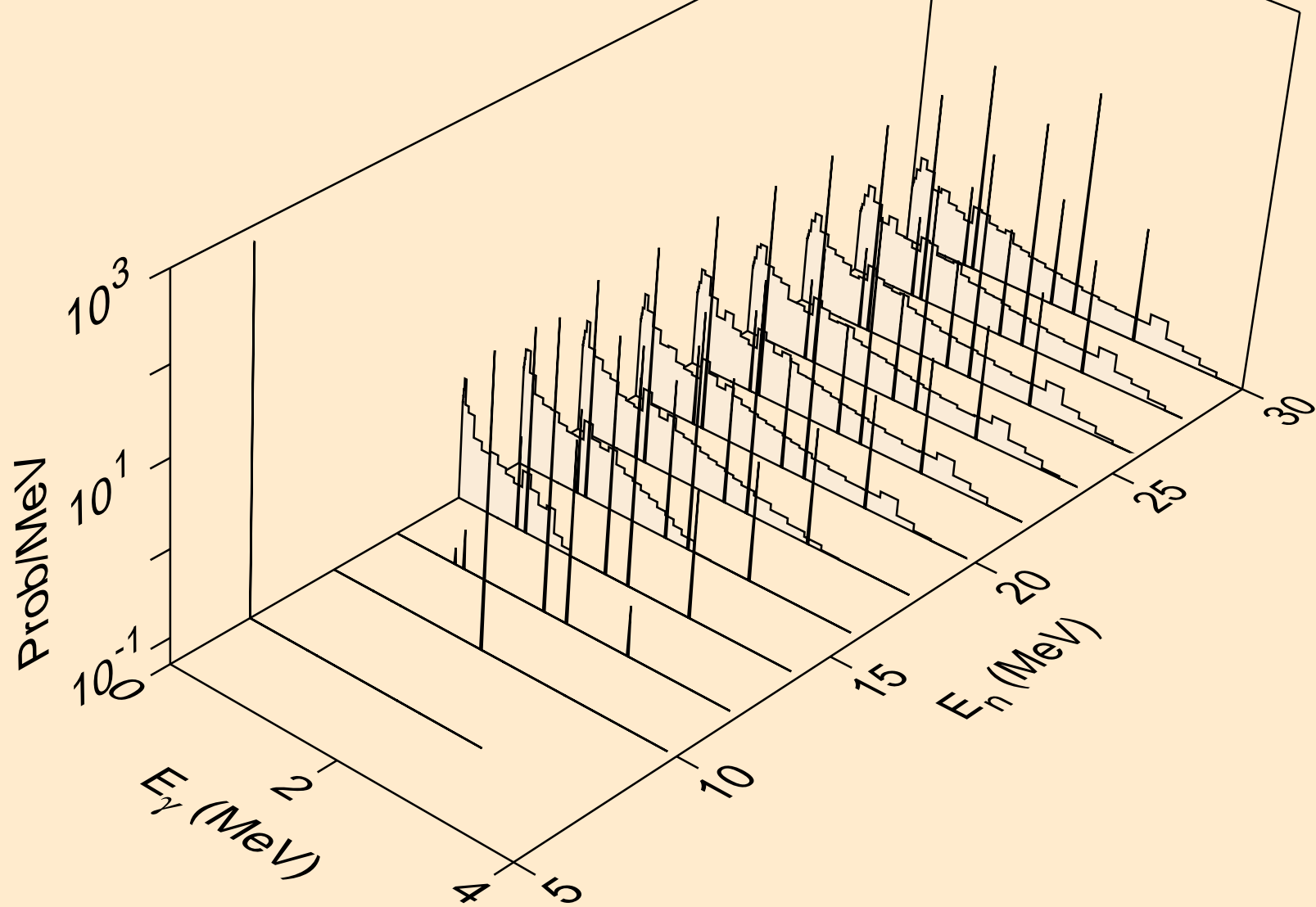

CU070 NEUTRON ACER TENDL-2023 LIBRARY; T=0.K  
Photon emission for (n,he3)

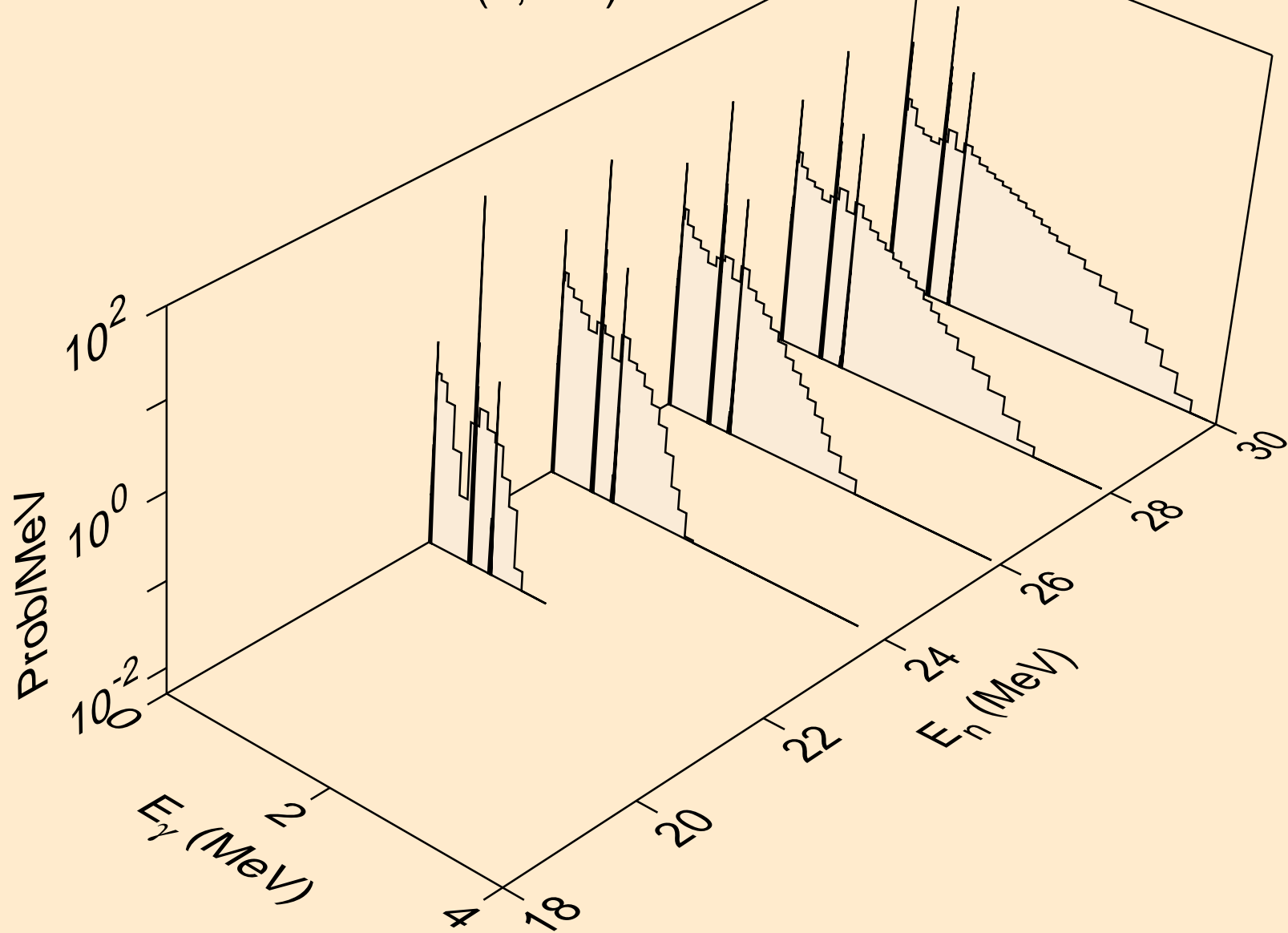

CU070 NEUTRON ACER TENDL-2023 LIBRARY; T=0.K  
Photon emission for (n,a)

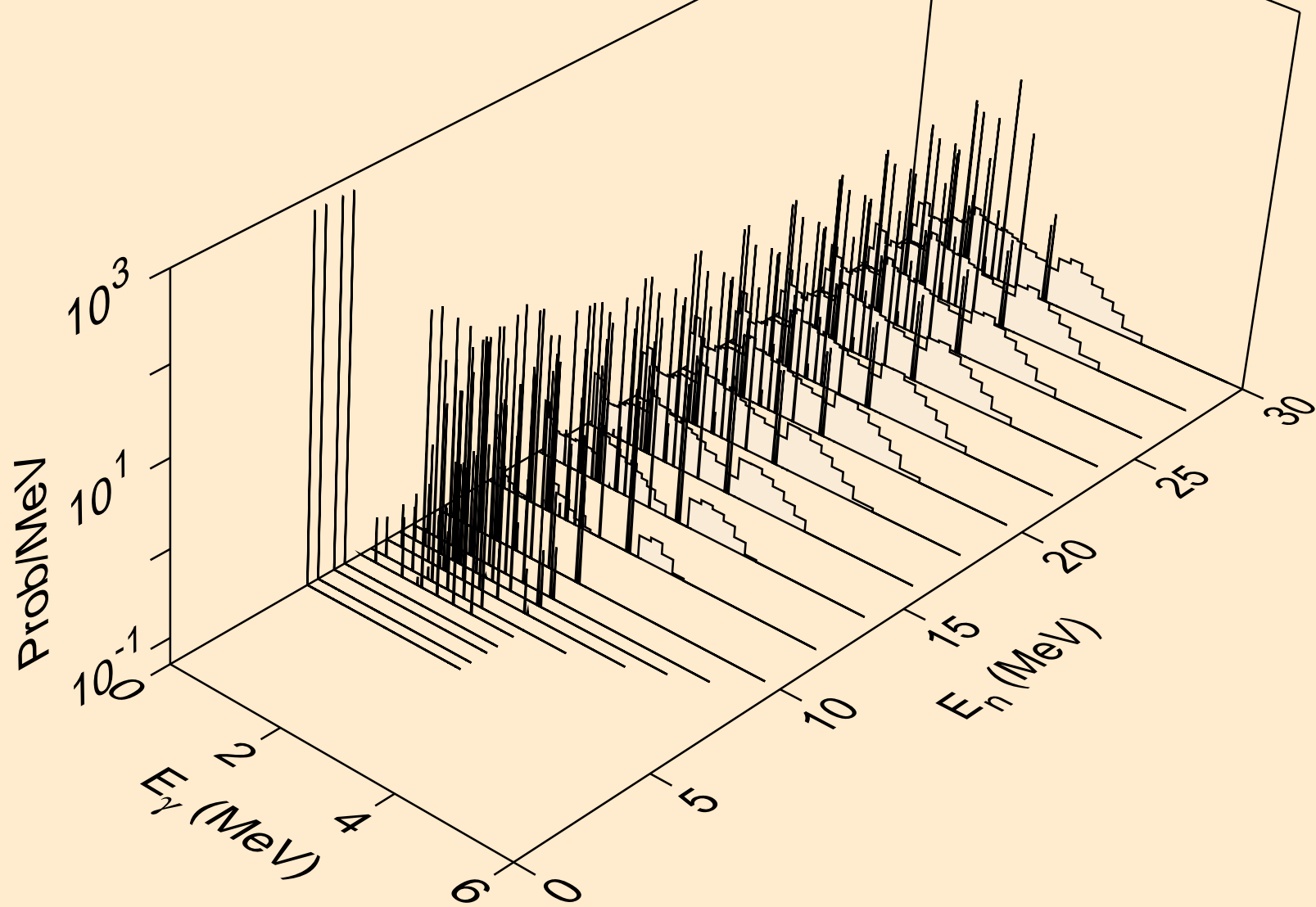

CU070 NEUTRON ACER TENDL-2023 LIBRARY; T=0.K  
Photon emission for (n,2p)

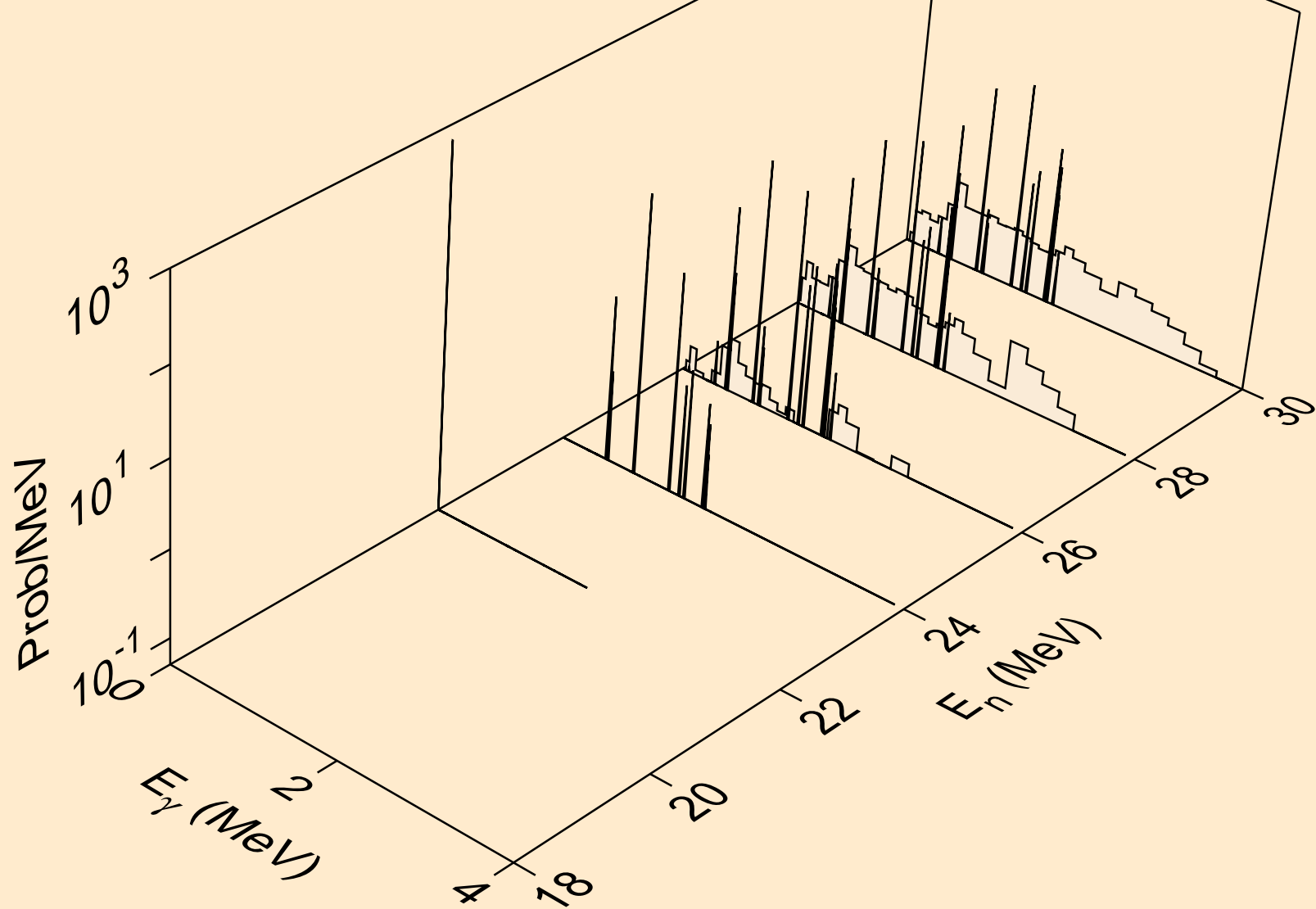



CU070 NEUTRON ACER TENDL-2023 LIBRARY; T=0.K  
Photon emission for (n,p)

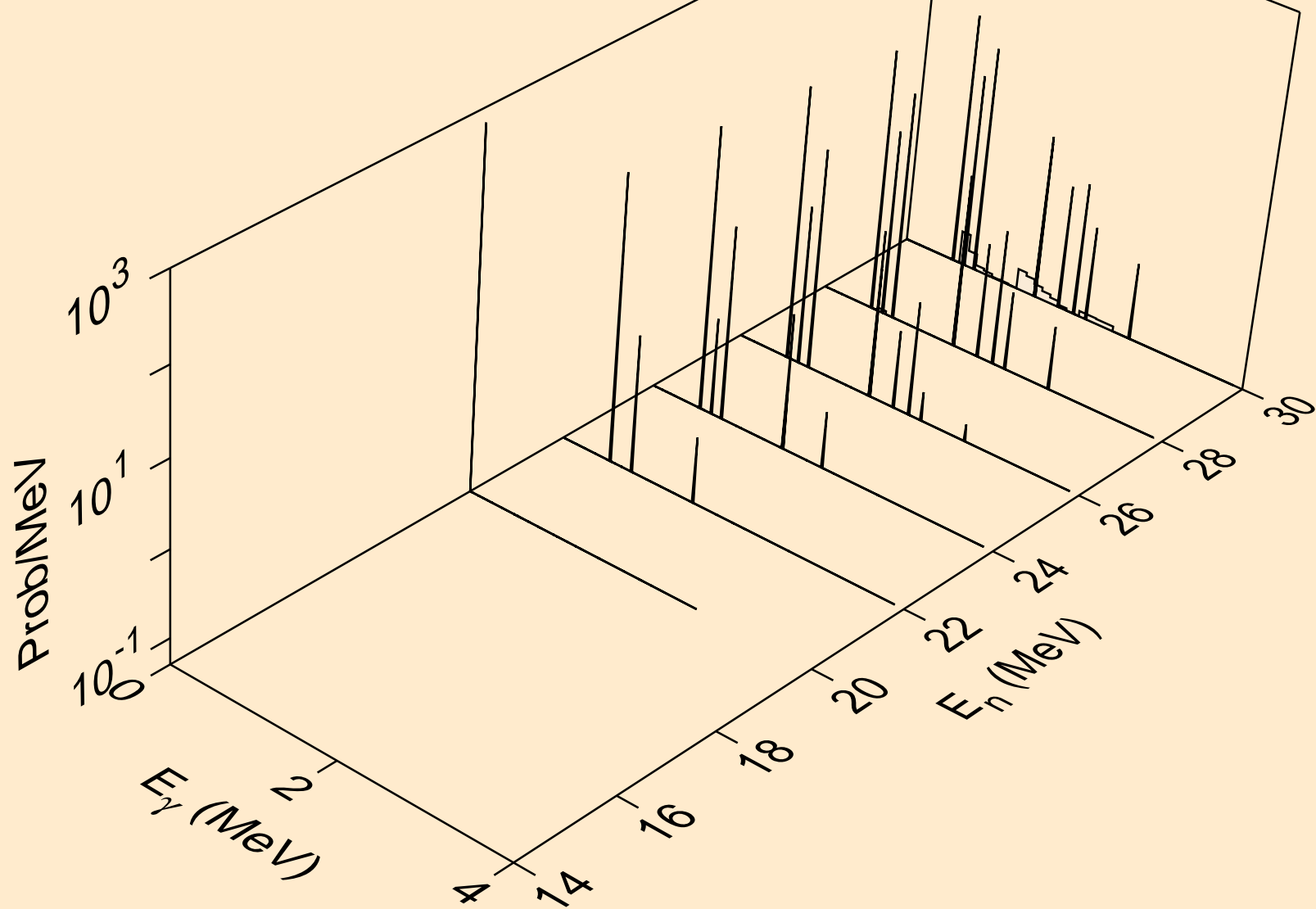

CU070 NEUTRON ACER TENDL-2023 LIBRARY; T=0.K  
thermal capture photon spectrum

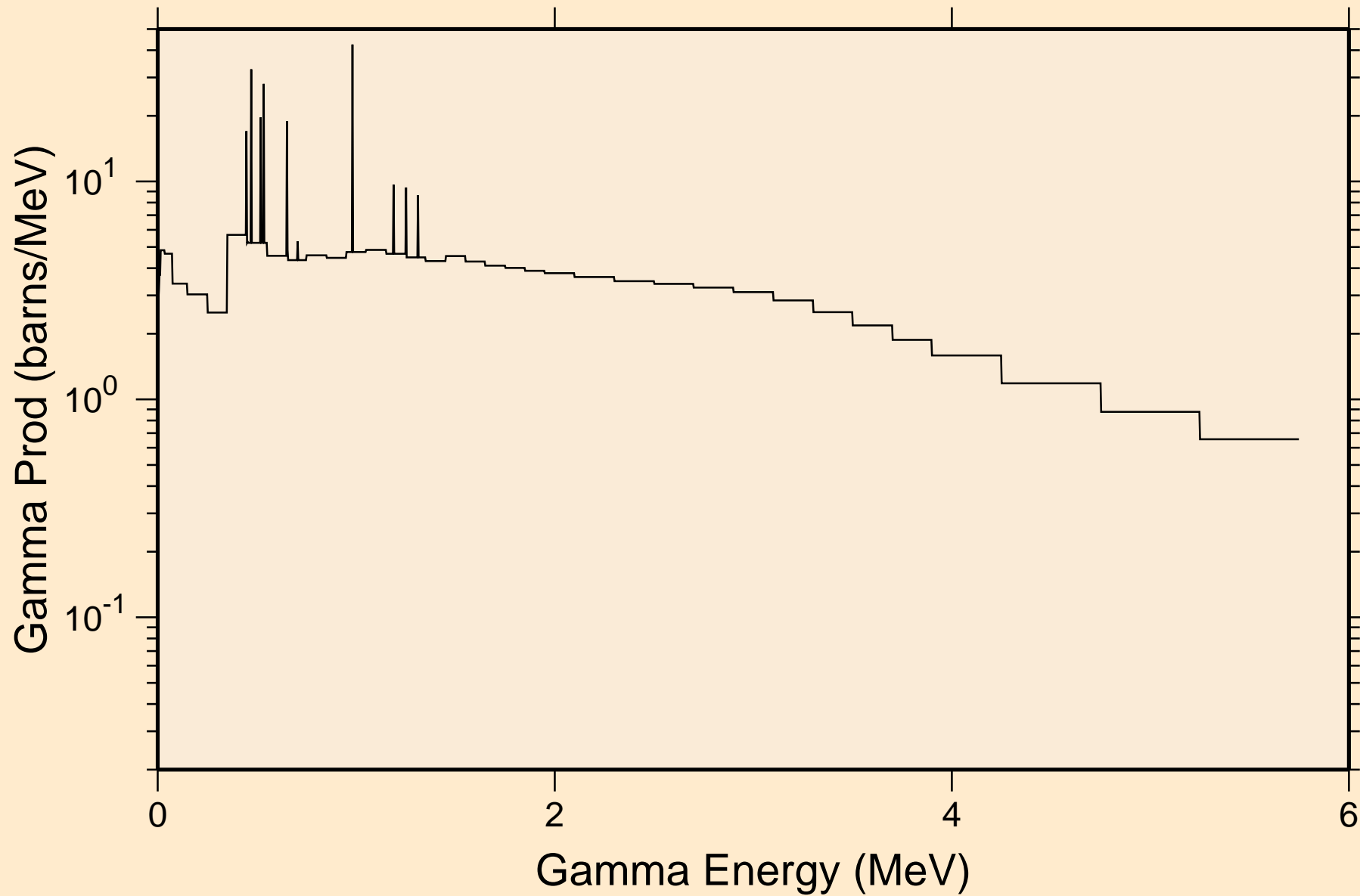

CU070 NEUTRON ACER TENDL-2023 LIBRARY; T=0.K  
14 MeV photon spectrum

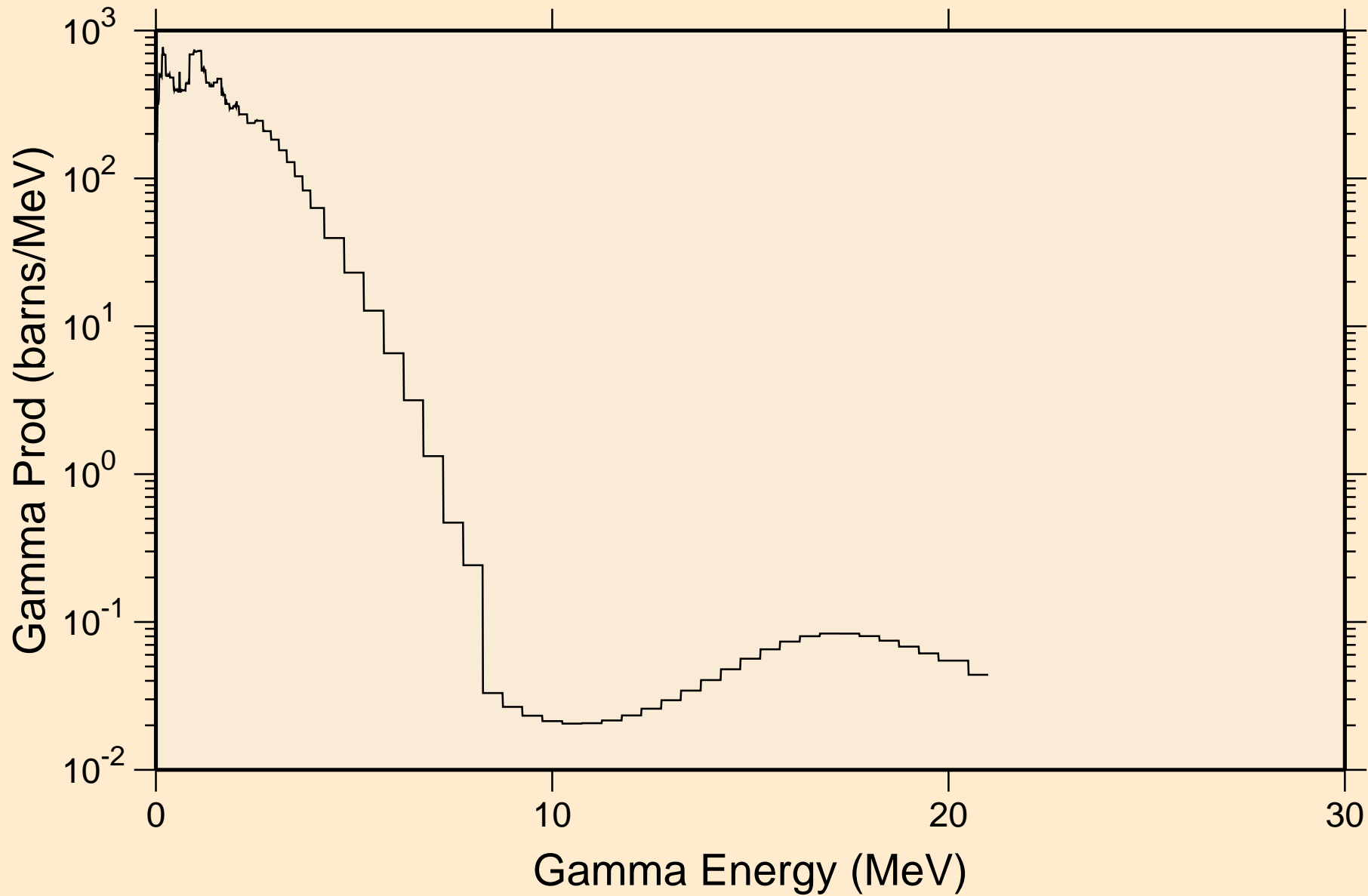

# CU070 NEUTRON ACER TENDL-2023 LIBRARY; T=0.K

## Particle heating contributions

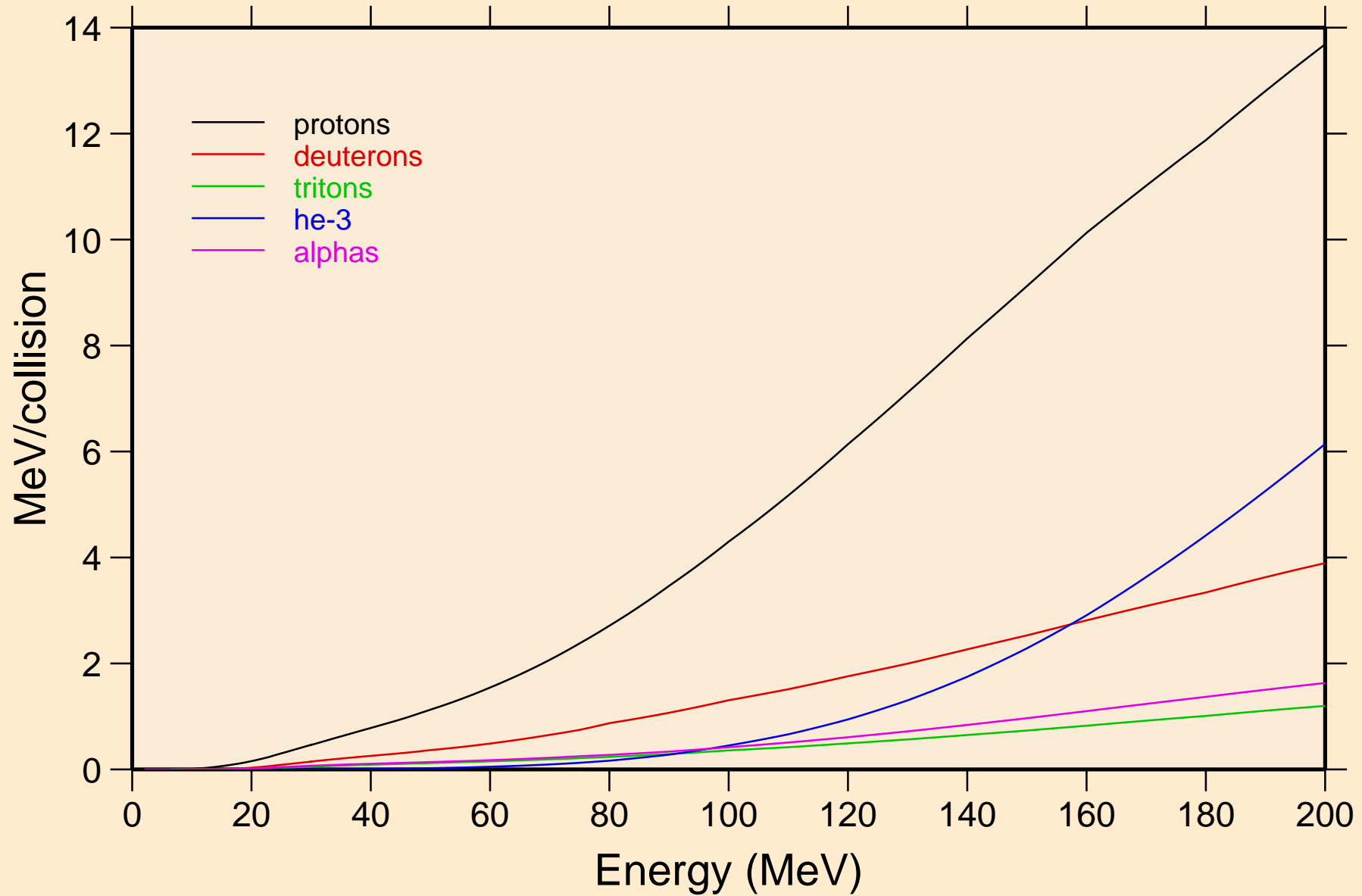

CU070 NEUTRON ACER TENDL-2023 LIBRARY; T=0.K  
Recoil Heating

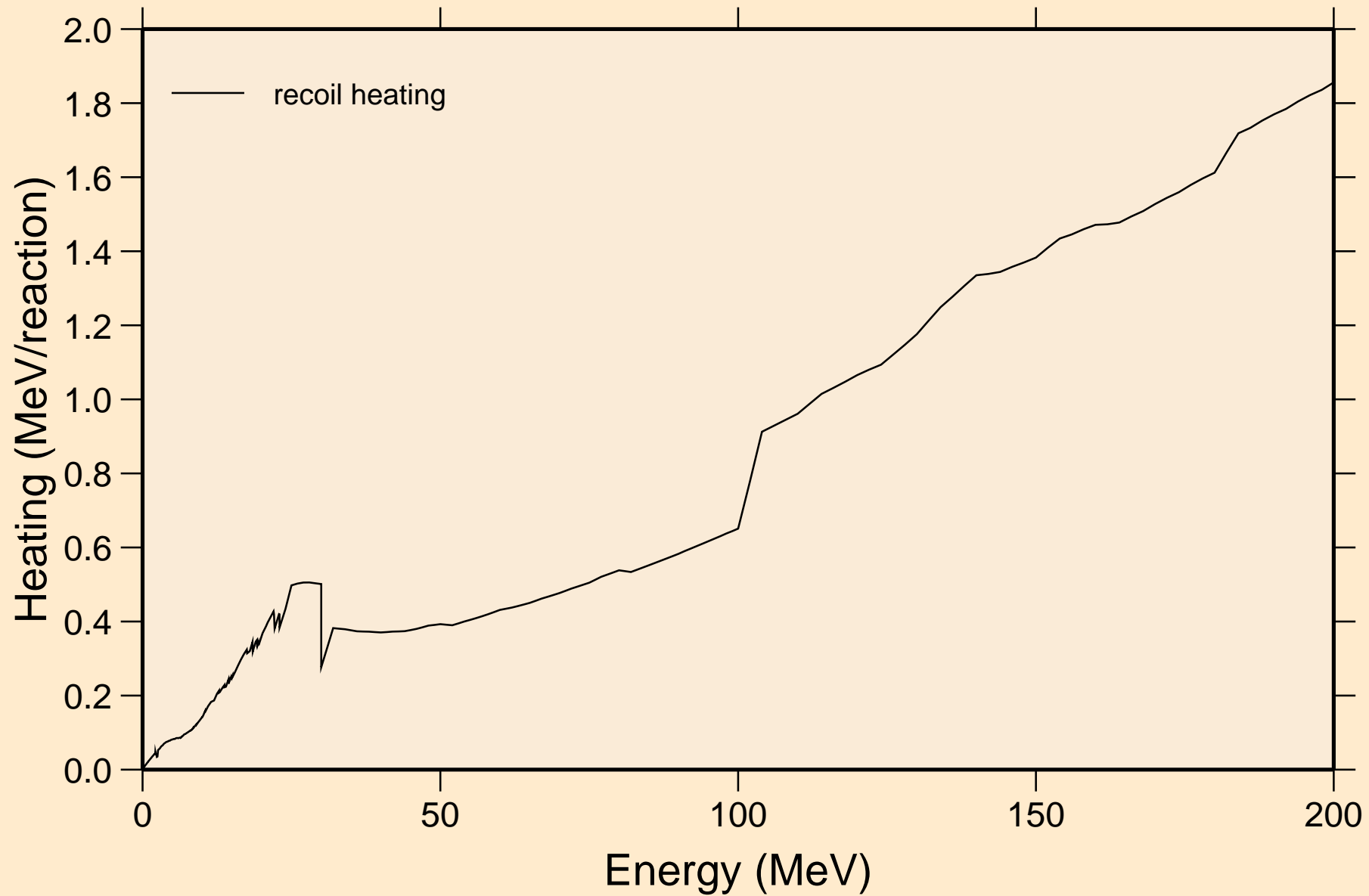

CU070 NEUTRON ACER TENDL-2023 LIBRARY; T=0.K  
Particle production cross sections

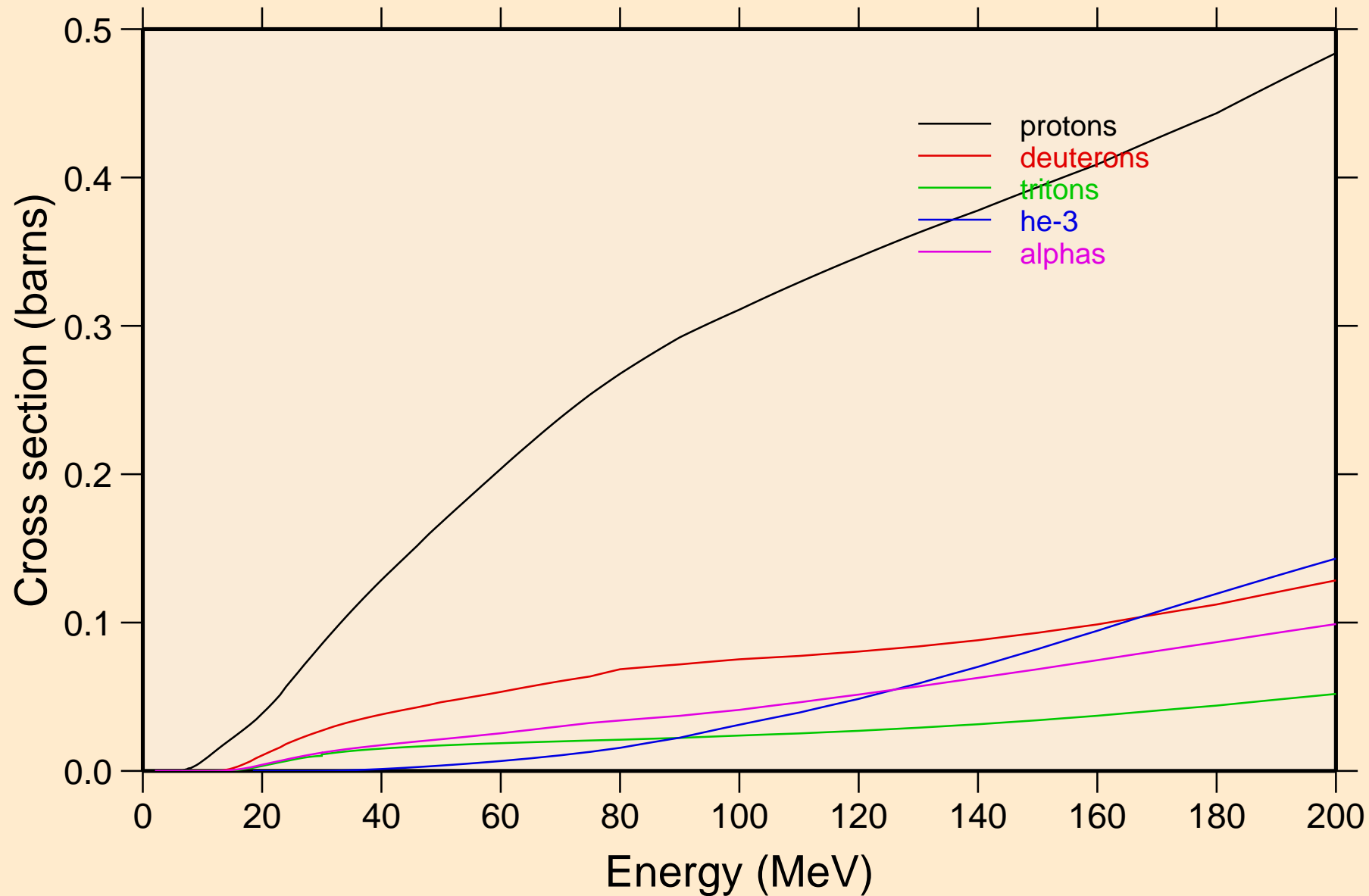

CU070 NEUTRON ACER TENDL-2023 LIBRARY; T=0.K  
protons from (n,x)

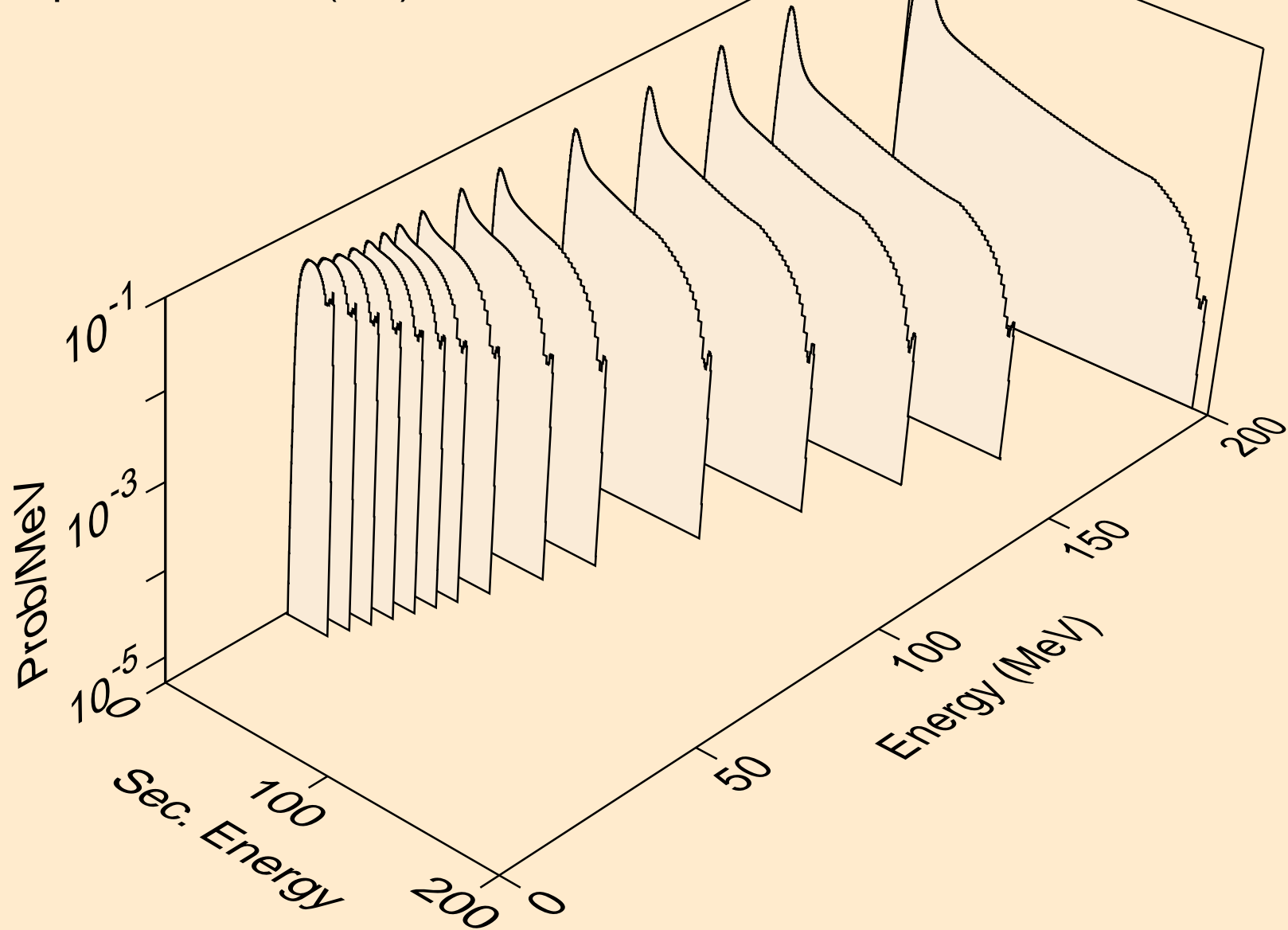

CU070 NEUTRON ACER TENDL-2023 LIBRARY; T=0.K  
protons from (n,n\*)p

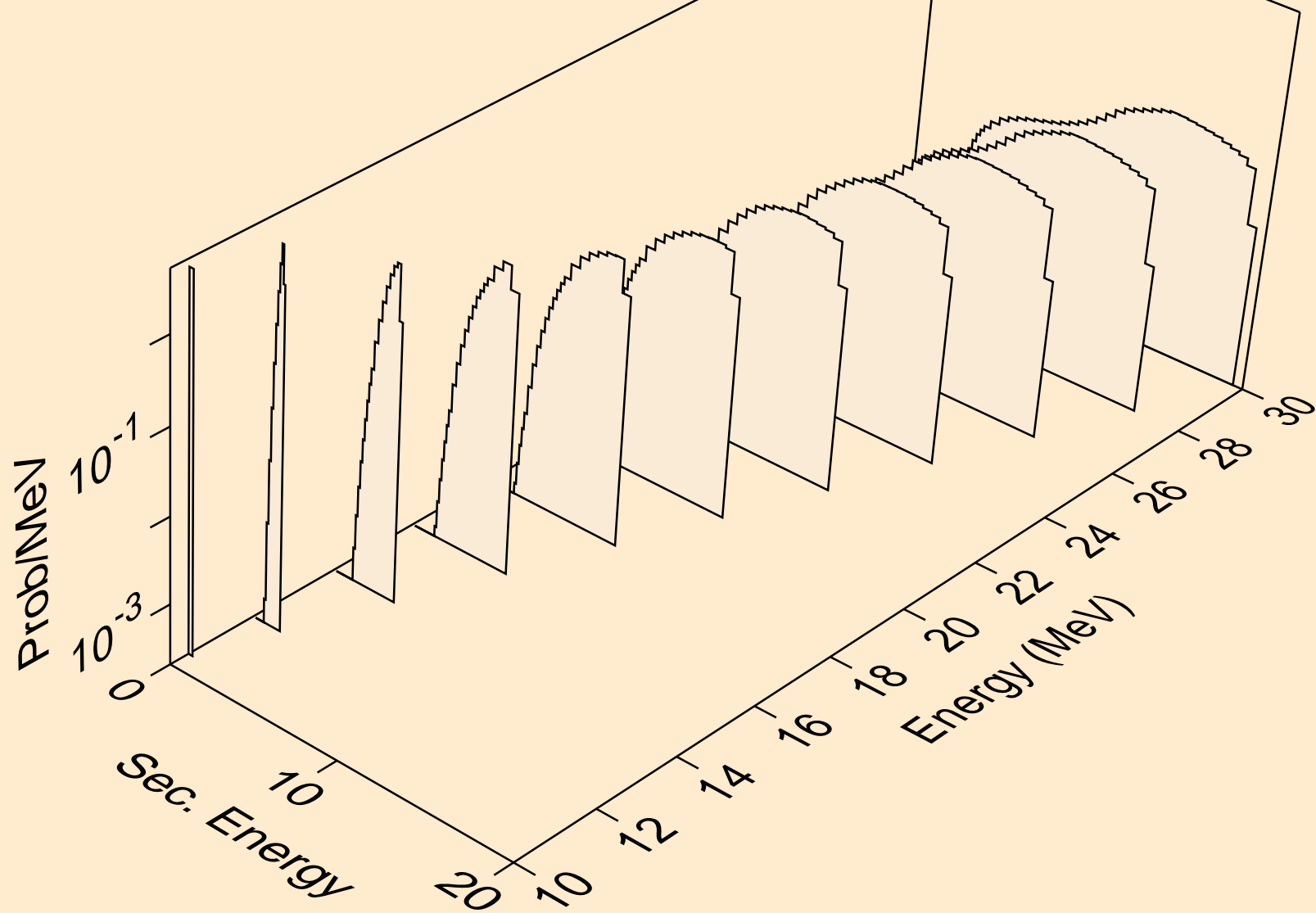



CU070 NEUTRON ACER TENDL-2023 LIBRARY; T=0.K  
protons from (n,2np)

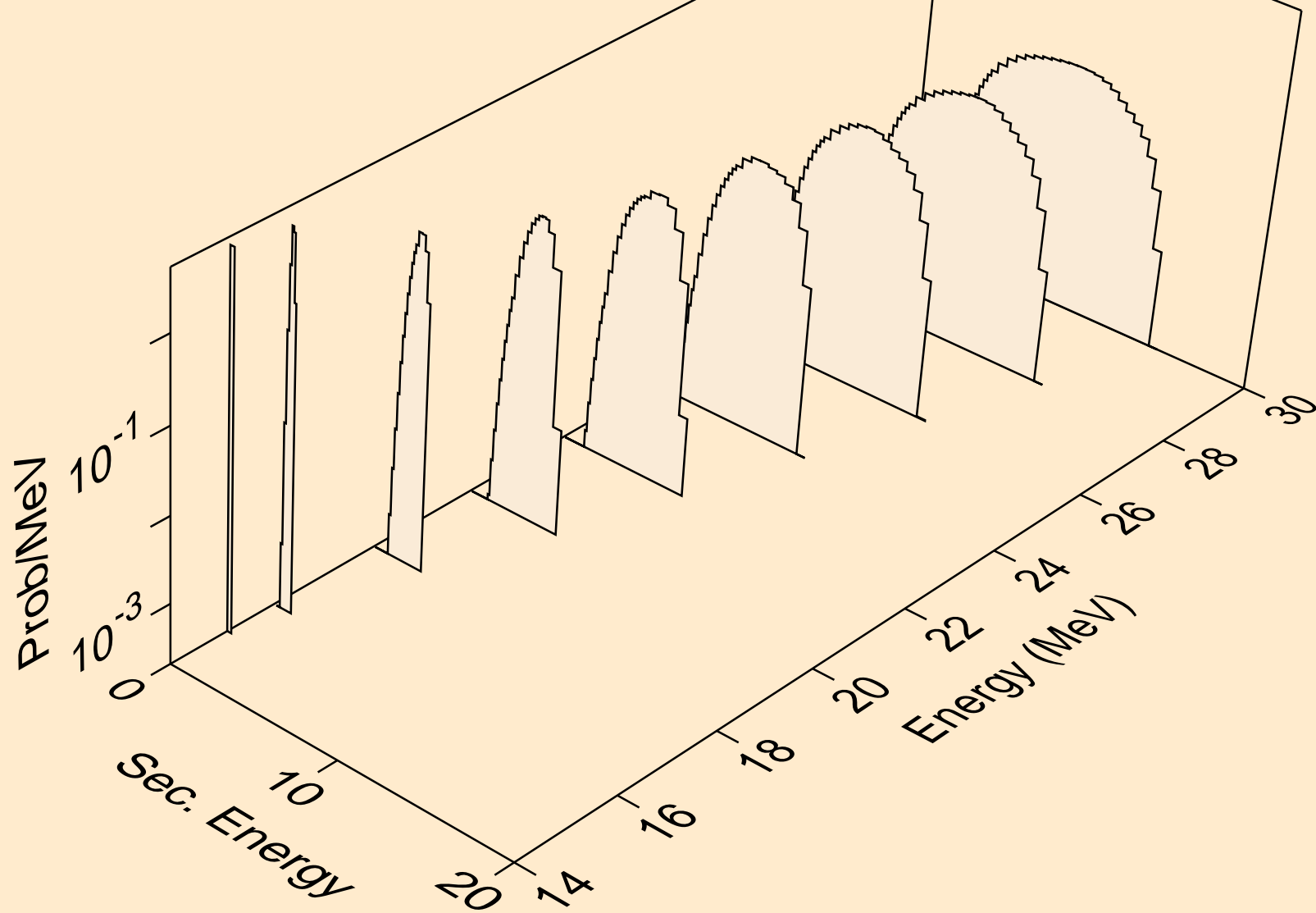

CU070 NEUTRON ACER TENDL-2023 LIBRARY; T=0.K  
protons from (n,3np)

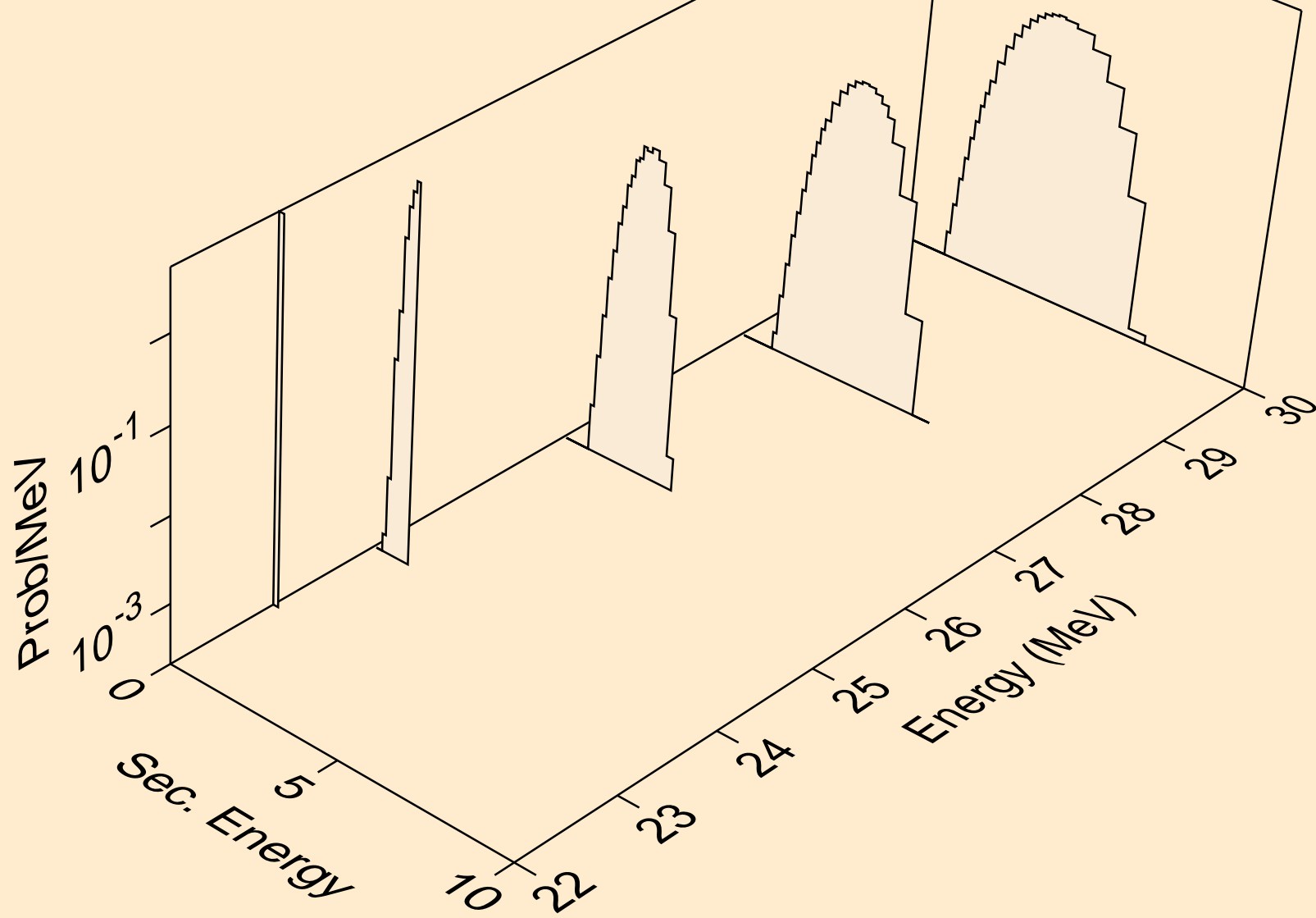

CU070 NEUTRON ACER TENDL-2023 LIBRARY; T=0.K  
protons from (n,p)

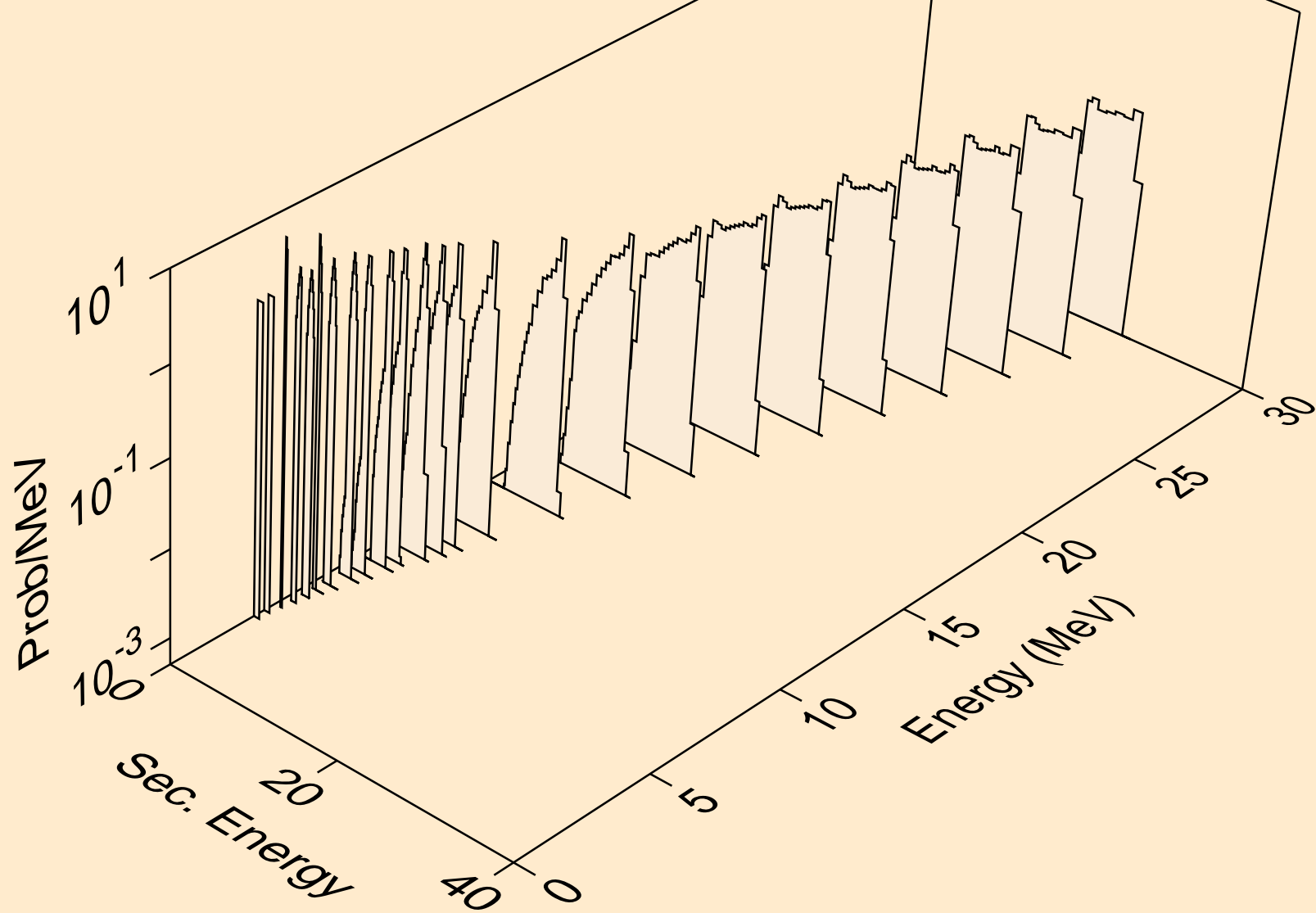

CU070 NEUTRON ACER TENDL-2023 LIBRARY; T=0.K  
protons from (n,2p)

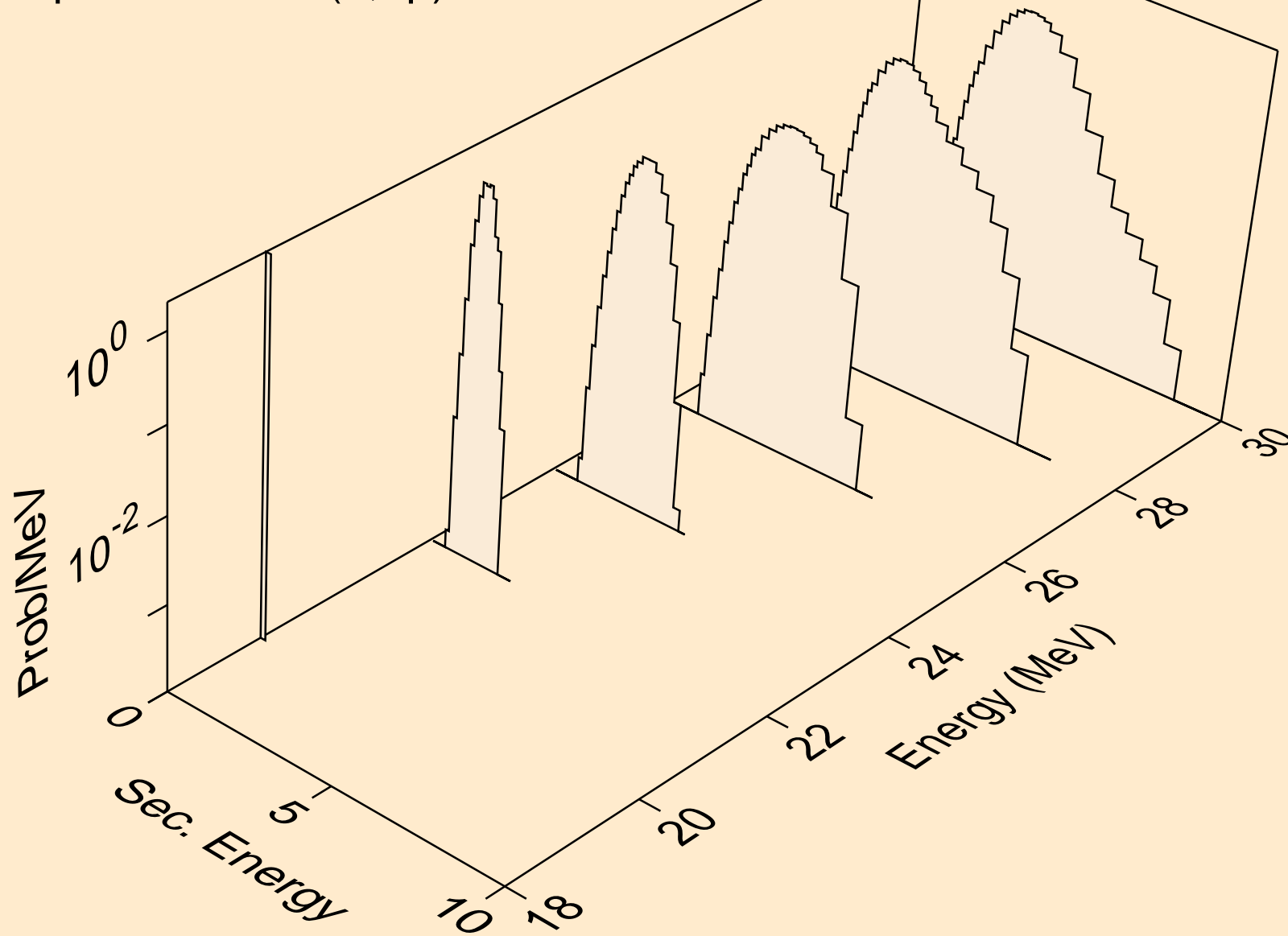

CU070 NEUTRON ACER TENDL-2023 LIBRARY; T=0.K  
protons from (n,p)

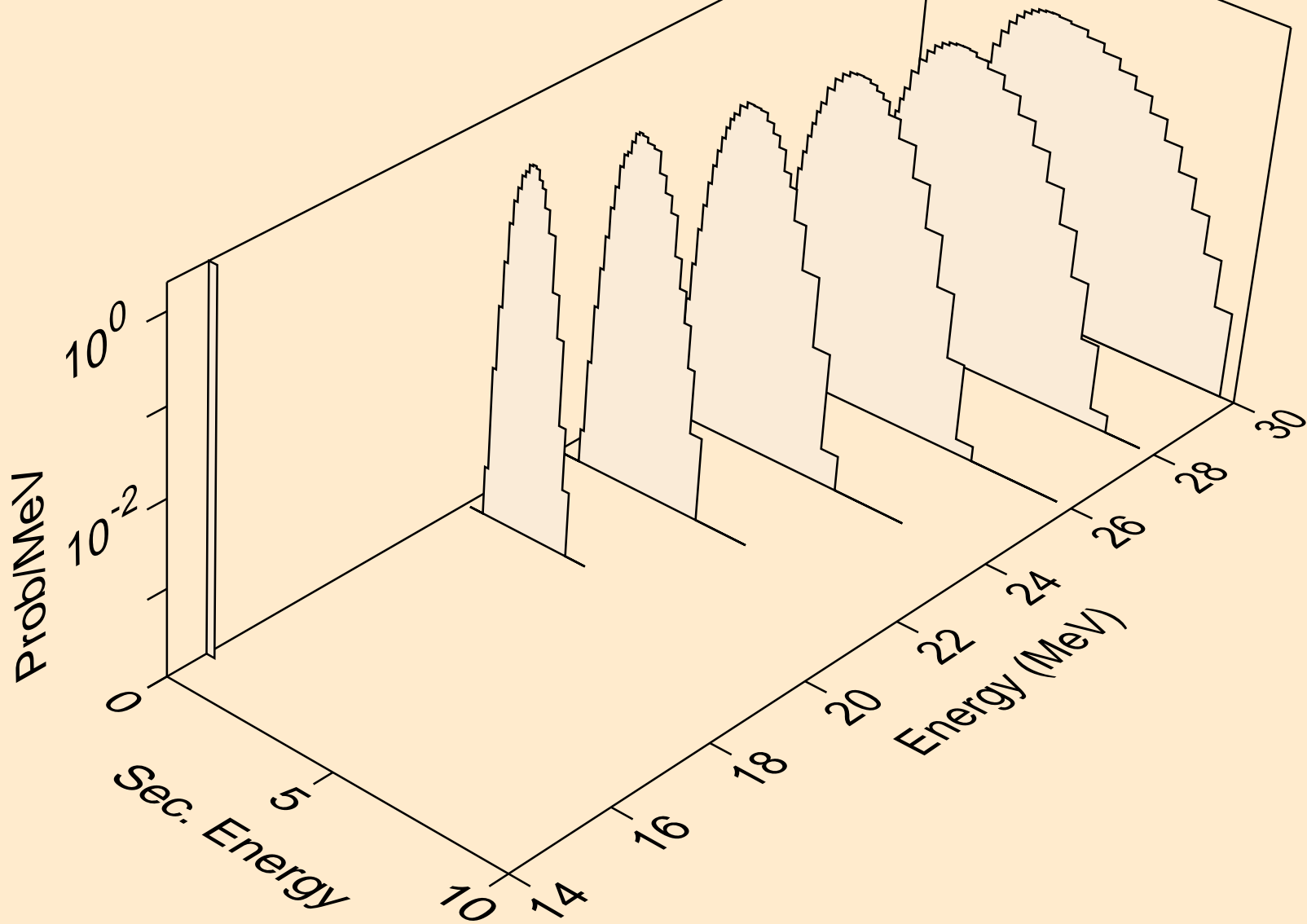

CU070 NEUTRON ACER TENDL-2023 LIBRARY; T=0.K  
deuterons from (n,x)

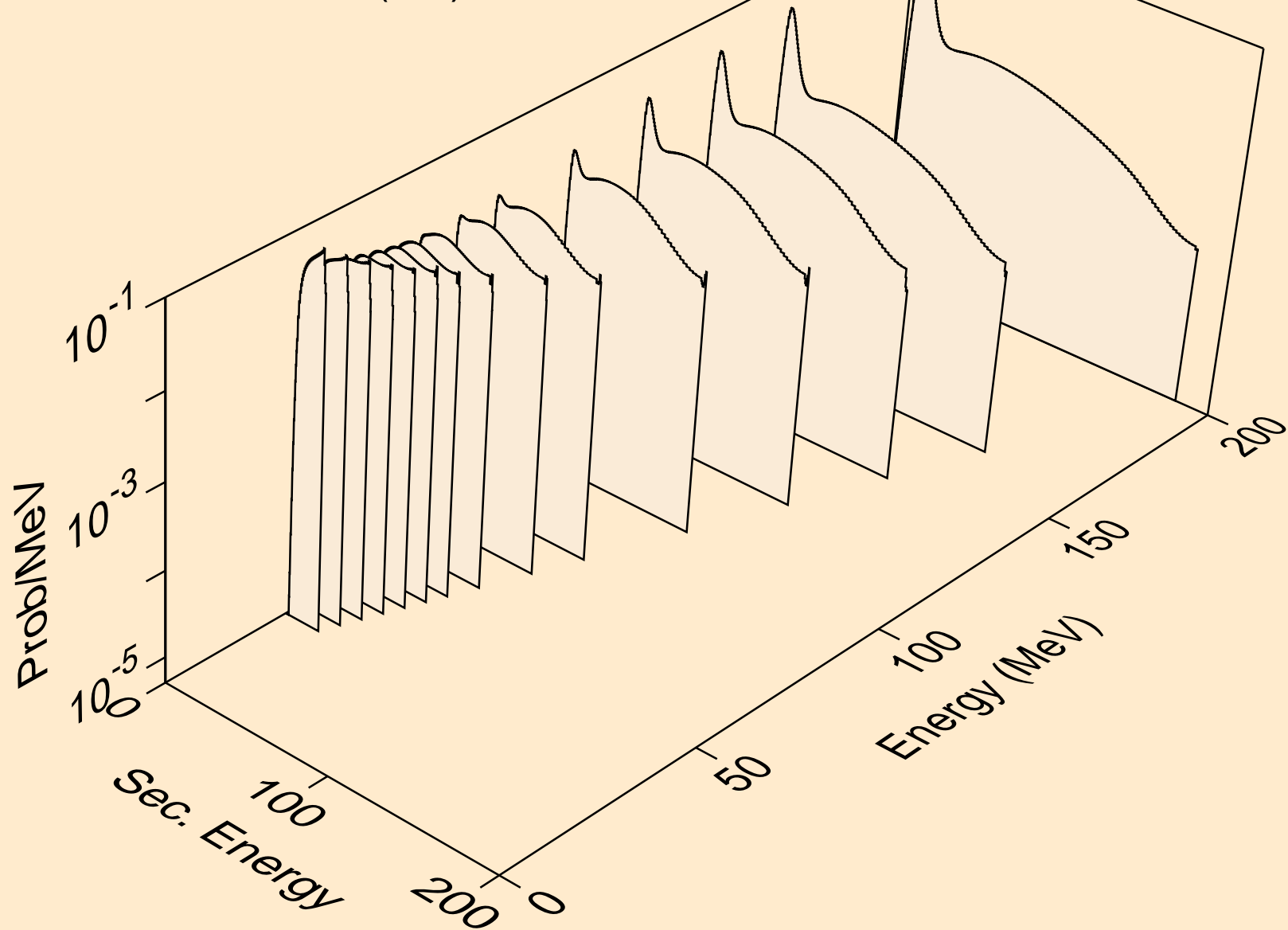

CU070 NEUTRON ACER TENDL-2023 LIBRARY; T=0.K  
deuterons from (n,2nd)

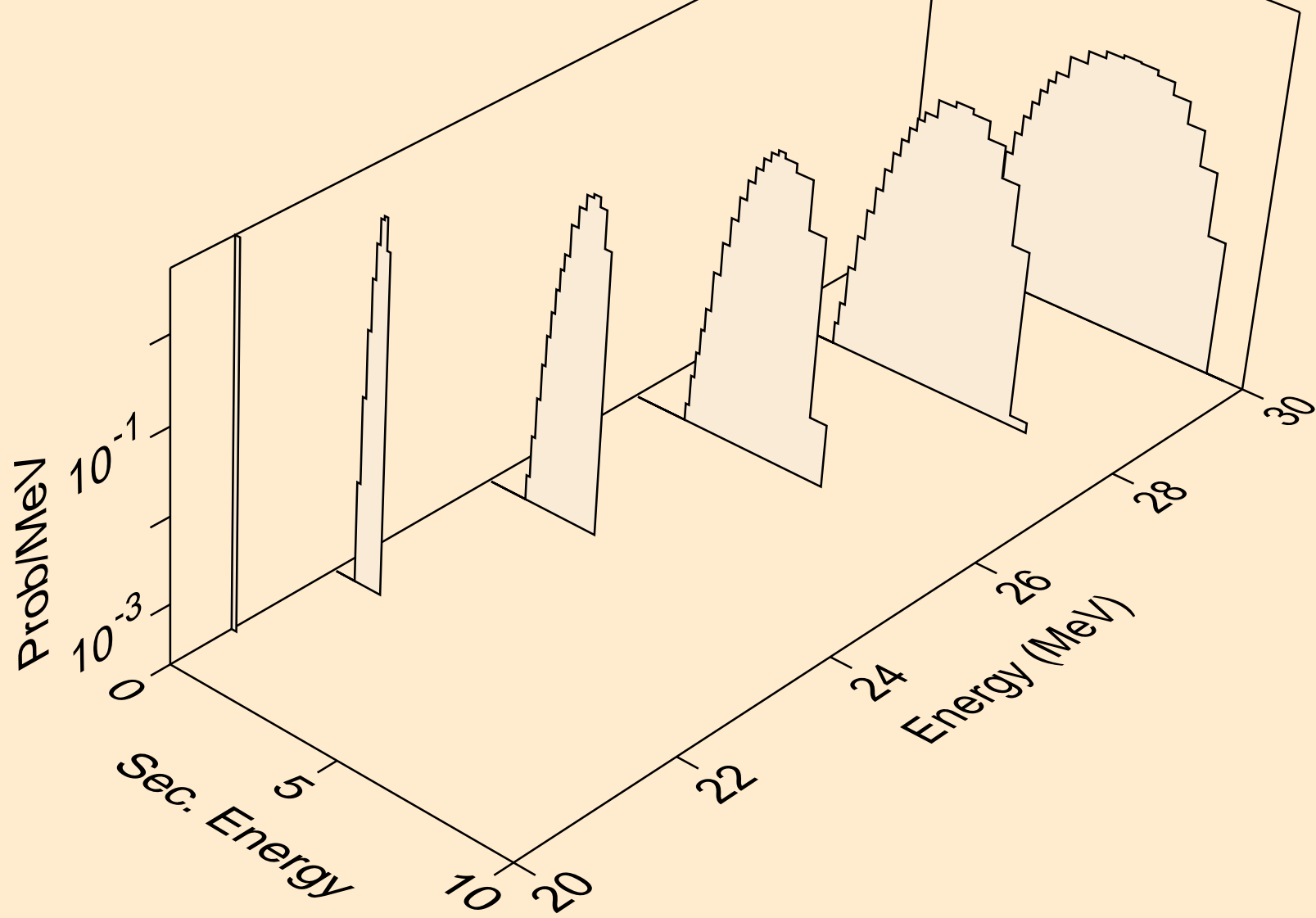

CU070 NEUTRON ACER TENDL-2023 LIBRARY; T=0.K  
deuterons from (n,n\*)d

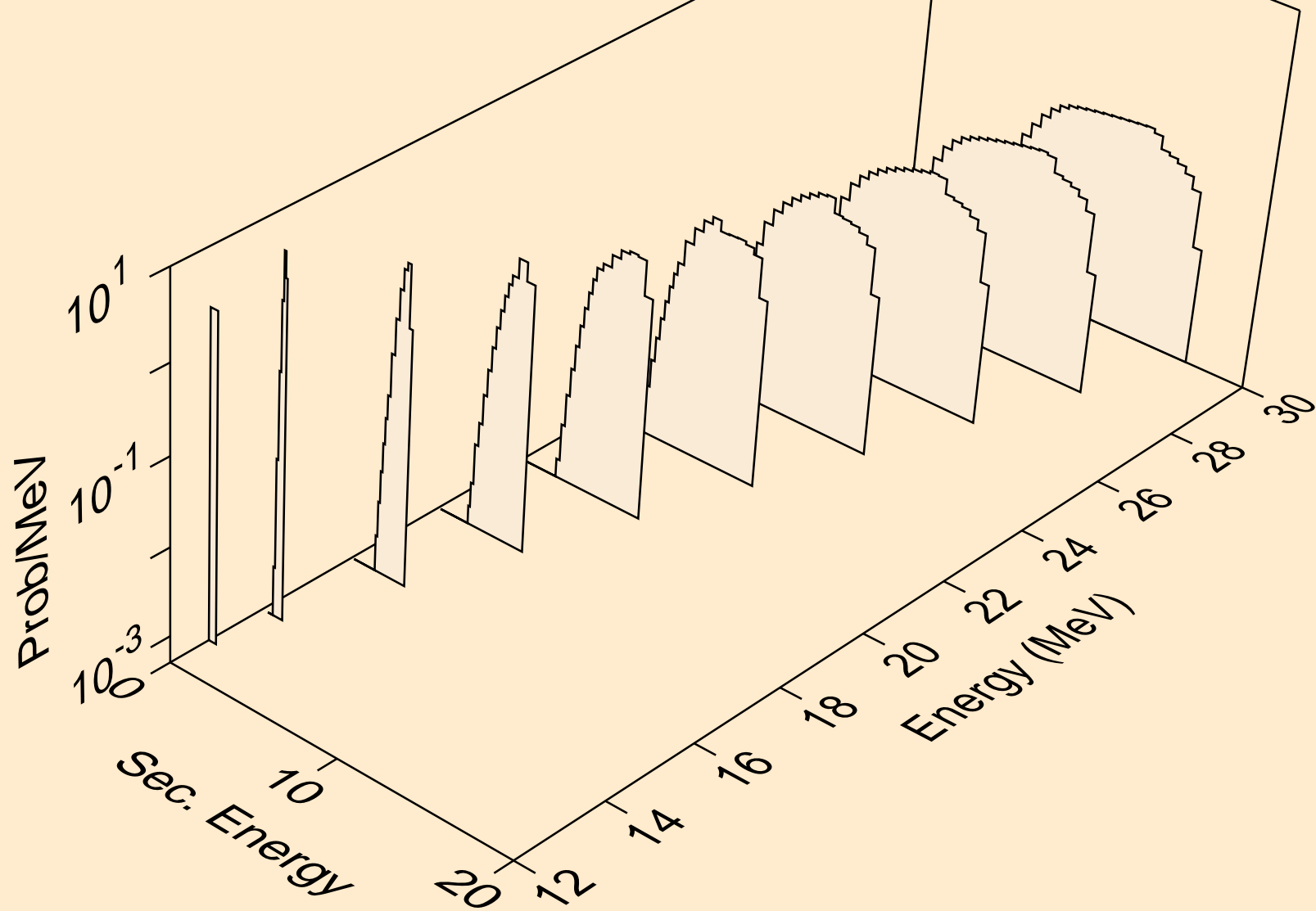



CU070 NEUTRON ACER TENDL-2023 LIBRARY; T=0.K  
deuterons from (n,d)

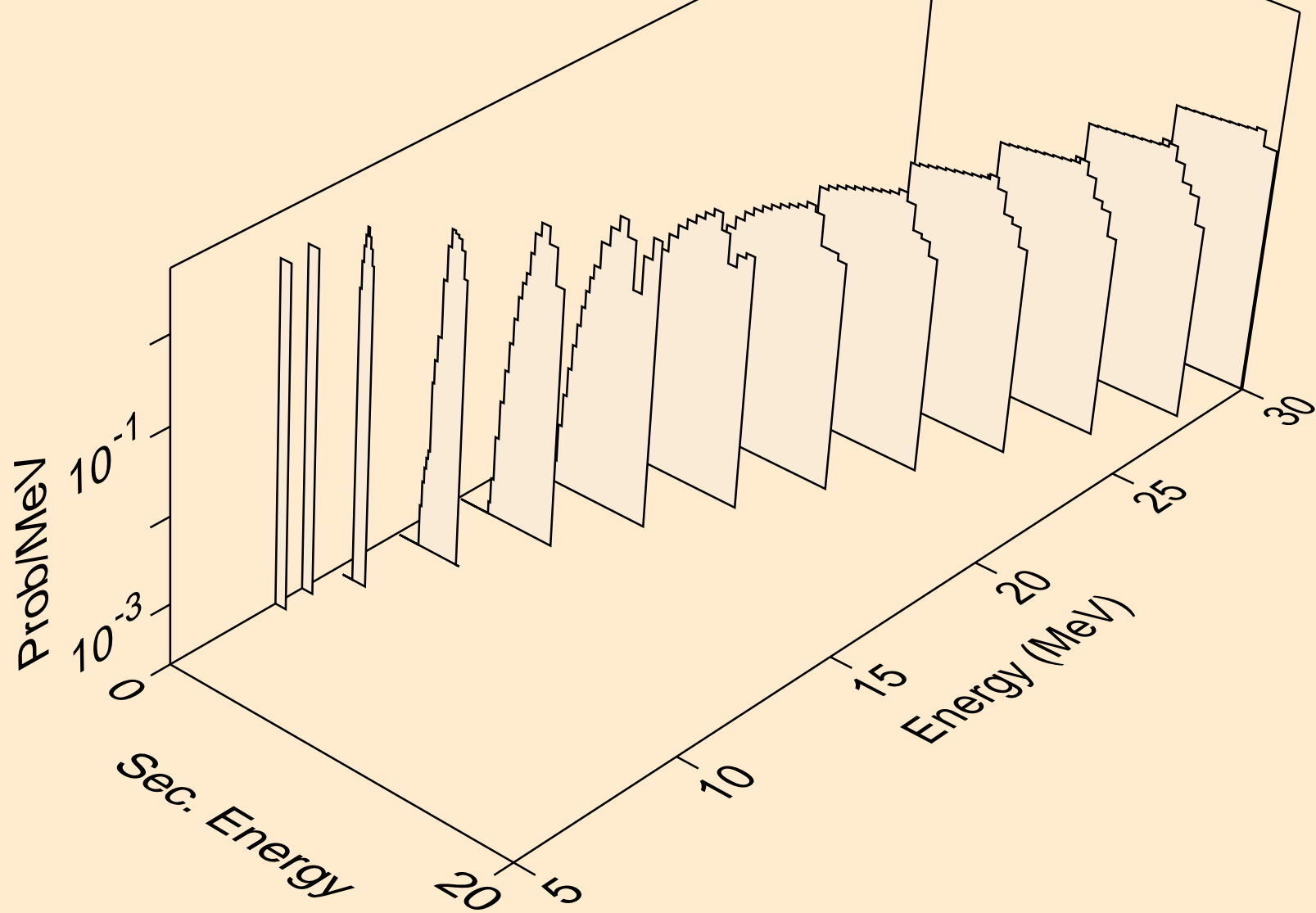

CU070 NEUTRON ACER TENDL-2023 LIBRARY; T=0.K  
tritons from (n,x)

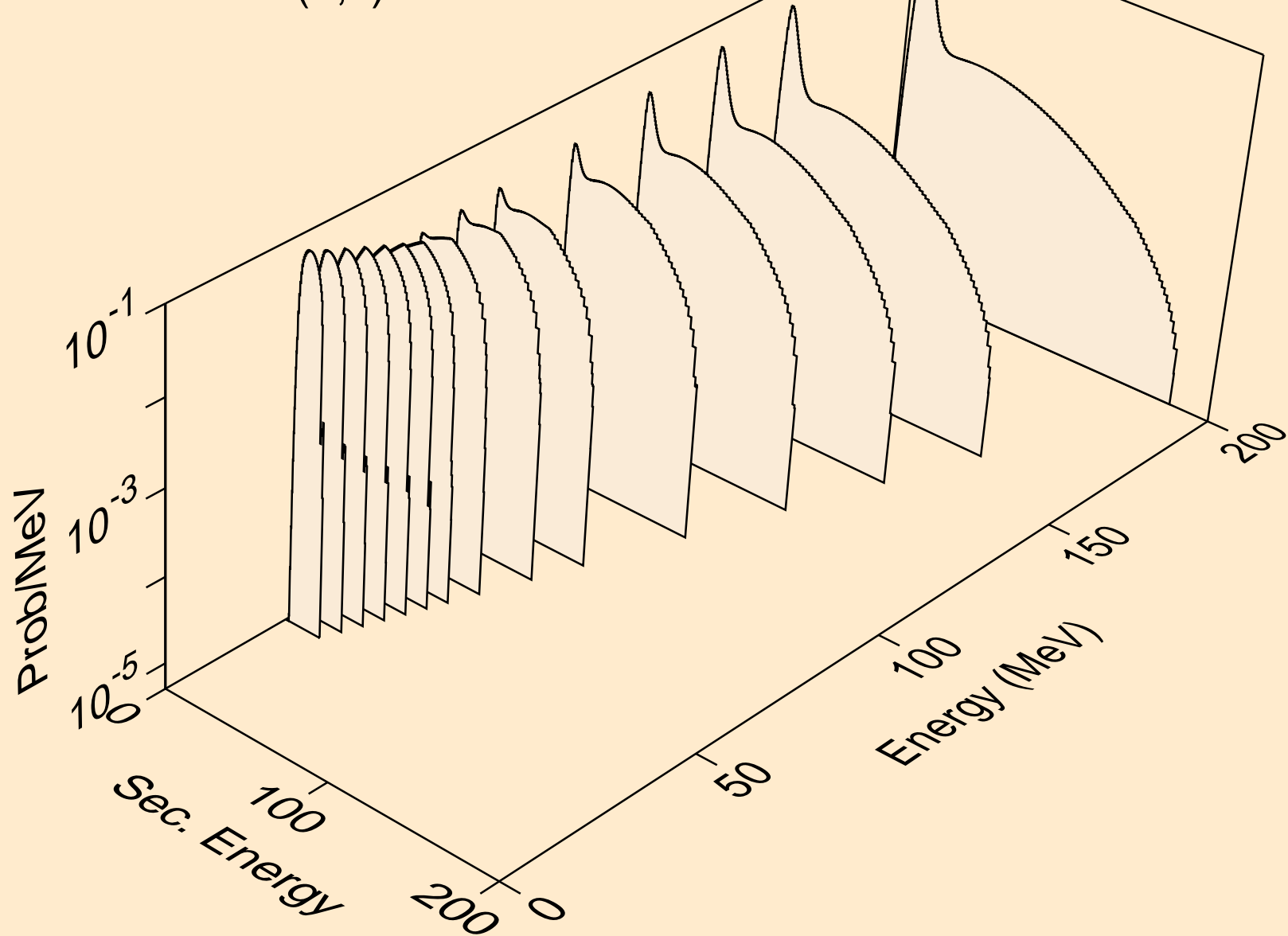

CU070 NEUTRON ACER TENDL-2023 LIBRARY; T=0.K  
tritons from (n,n\*)t

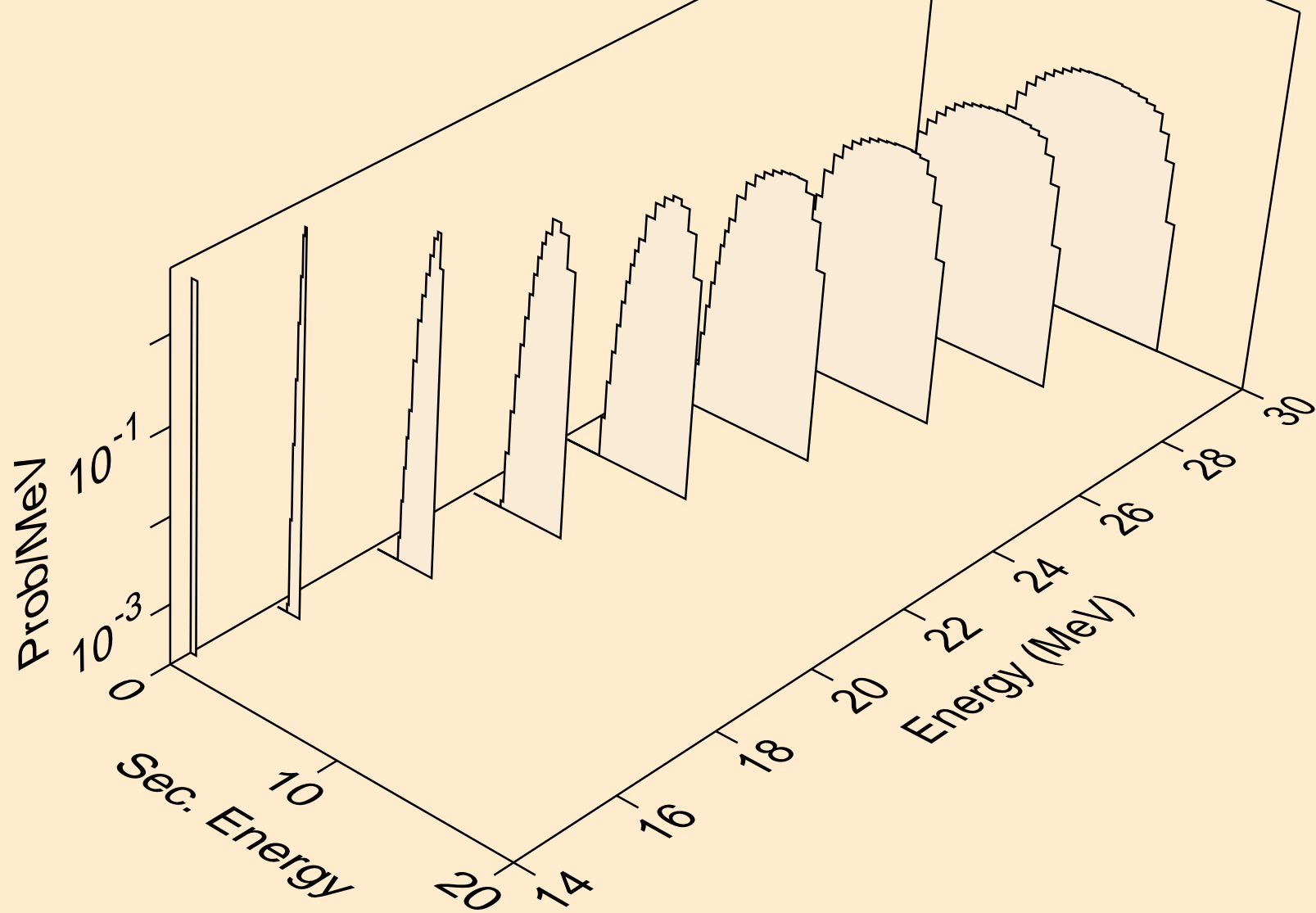

CU070 NEUTRON ACER TENDL-2023 LIBRARY; T=0.K  
tritons from (n,t)

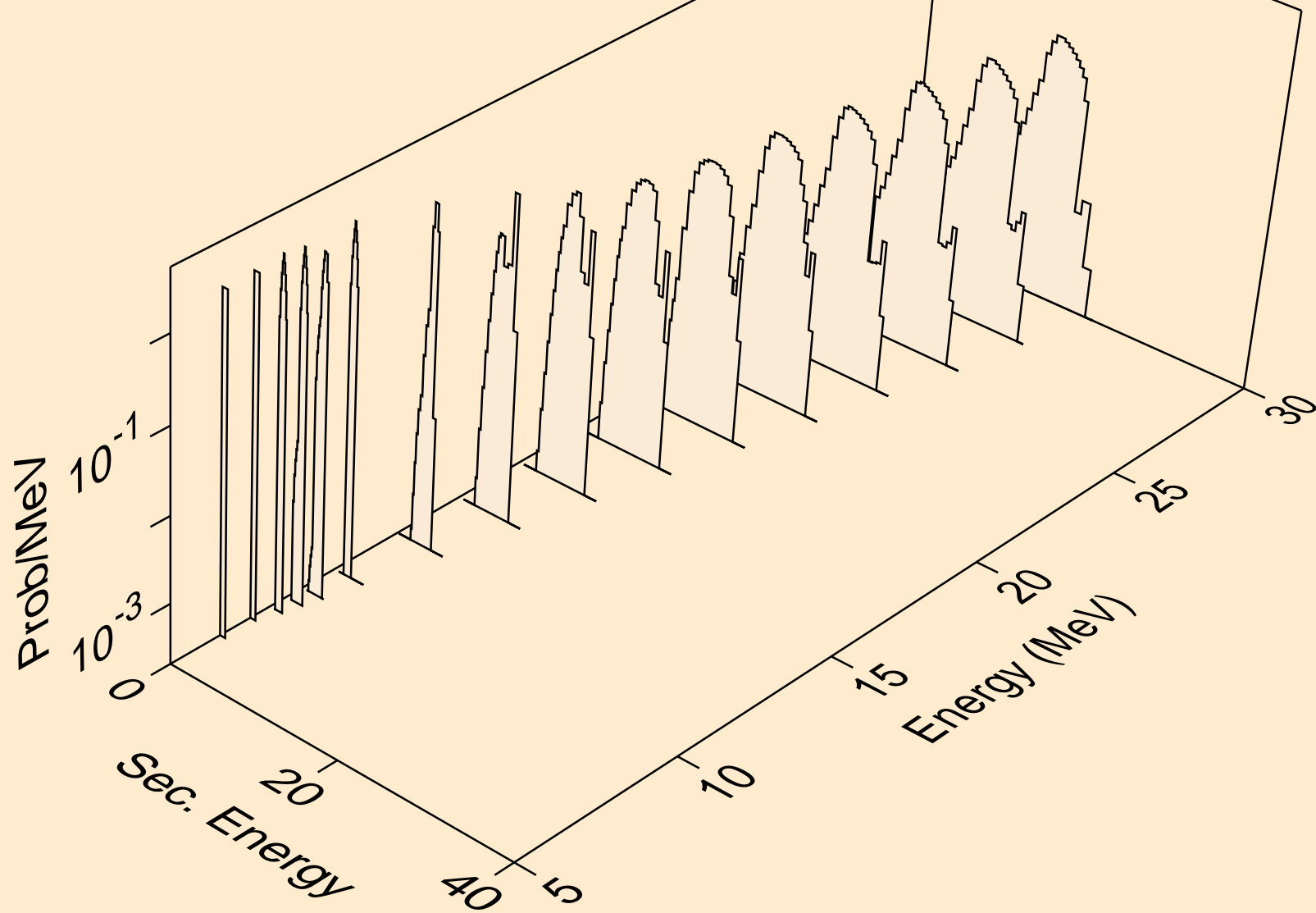

CU070 NEUTRON ACER TENDL-2023 LIBRARY; T=0.K  
he3s from (n,x)

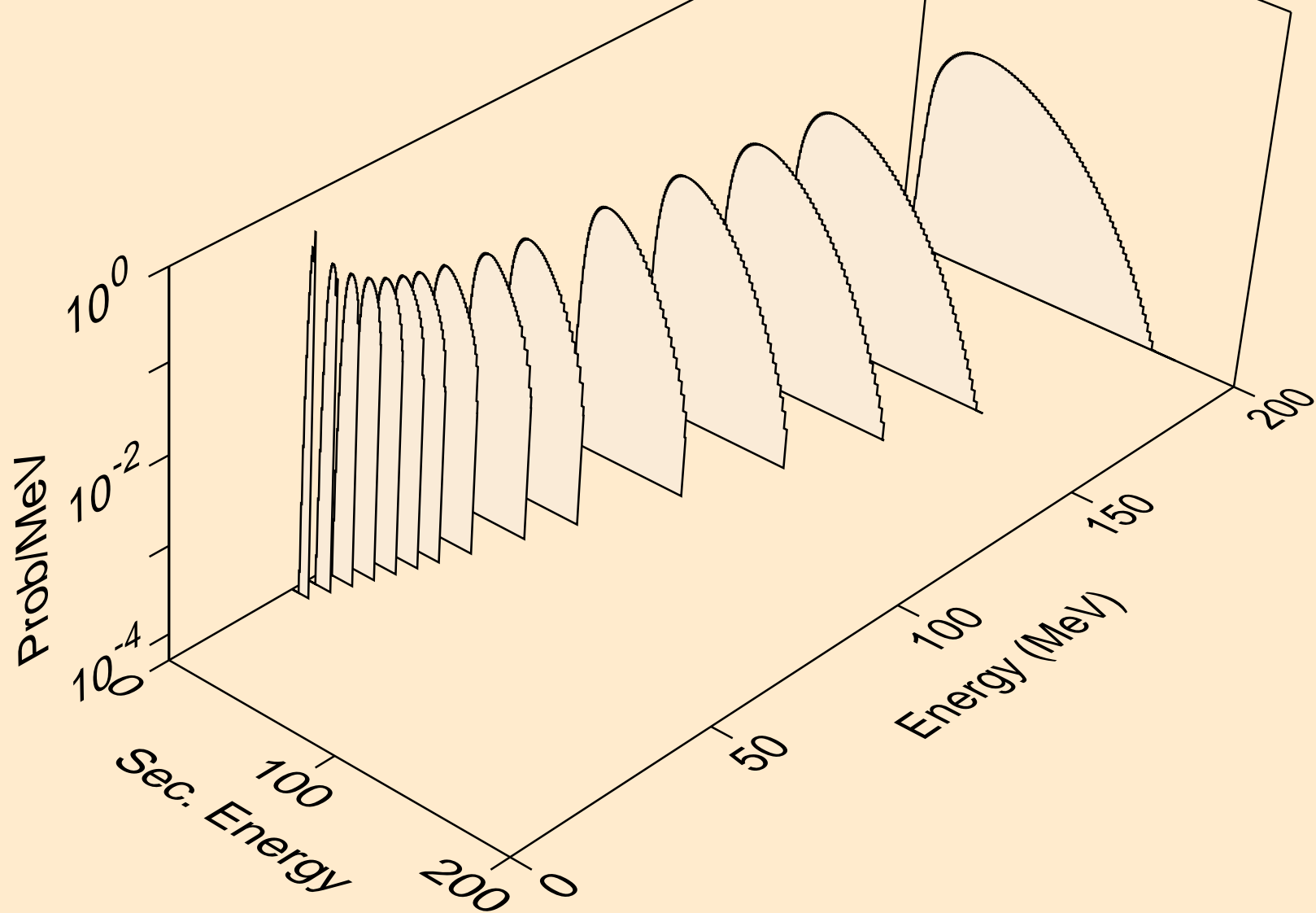

CU070 NEUTRON ACER TENDL-2023 LIBRARY; T=0.K  
he3s from (n,n\*)he3

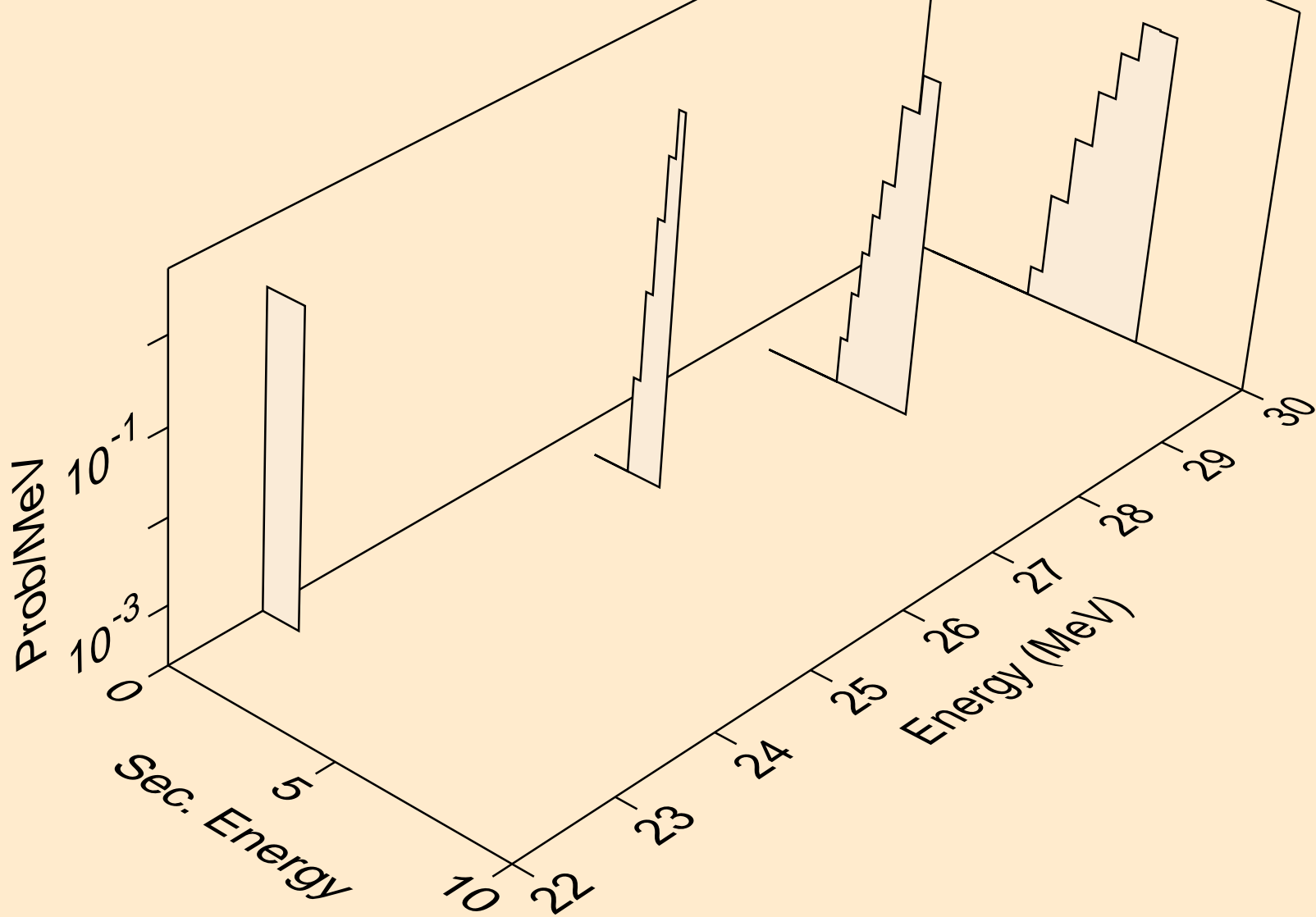

CU070 NEUTRON ACER TENDL-2023 LIBRARY; T=0.K  
he3s from (n,he3)

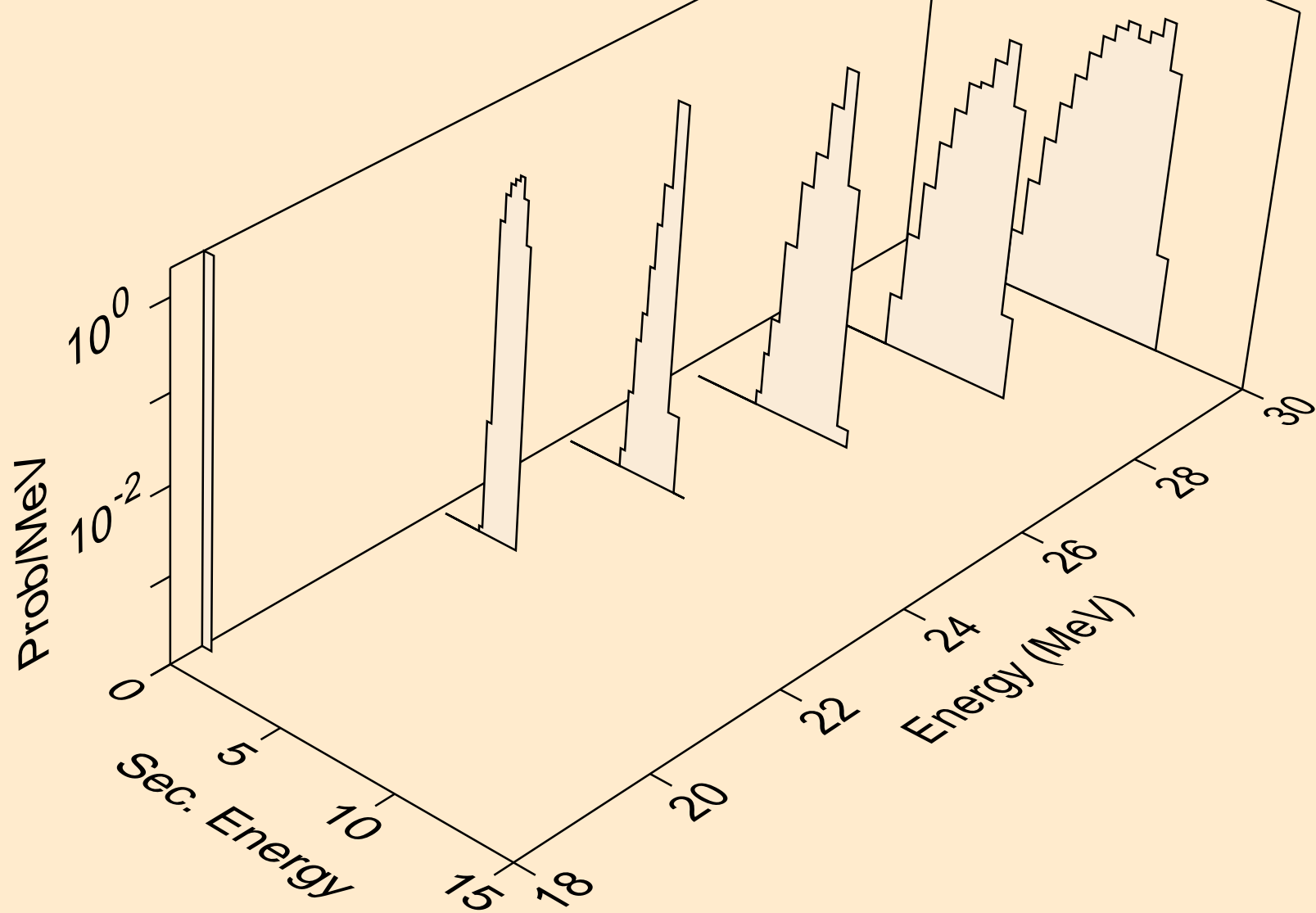

CU070 NEUTRON ACER TENDL-2023 LIBRARY; T=0.K  
alphas from (n,x)

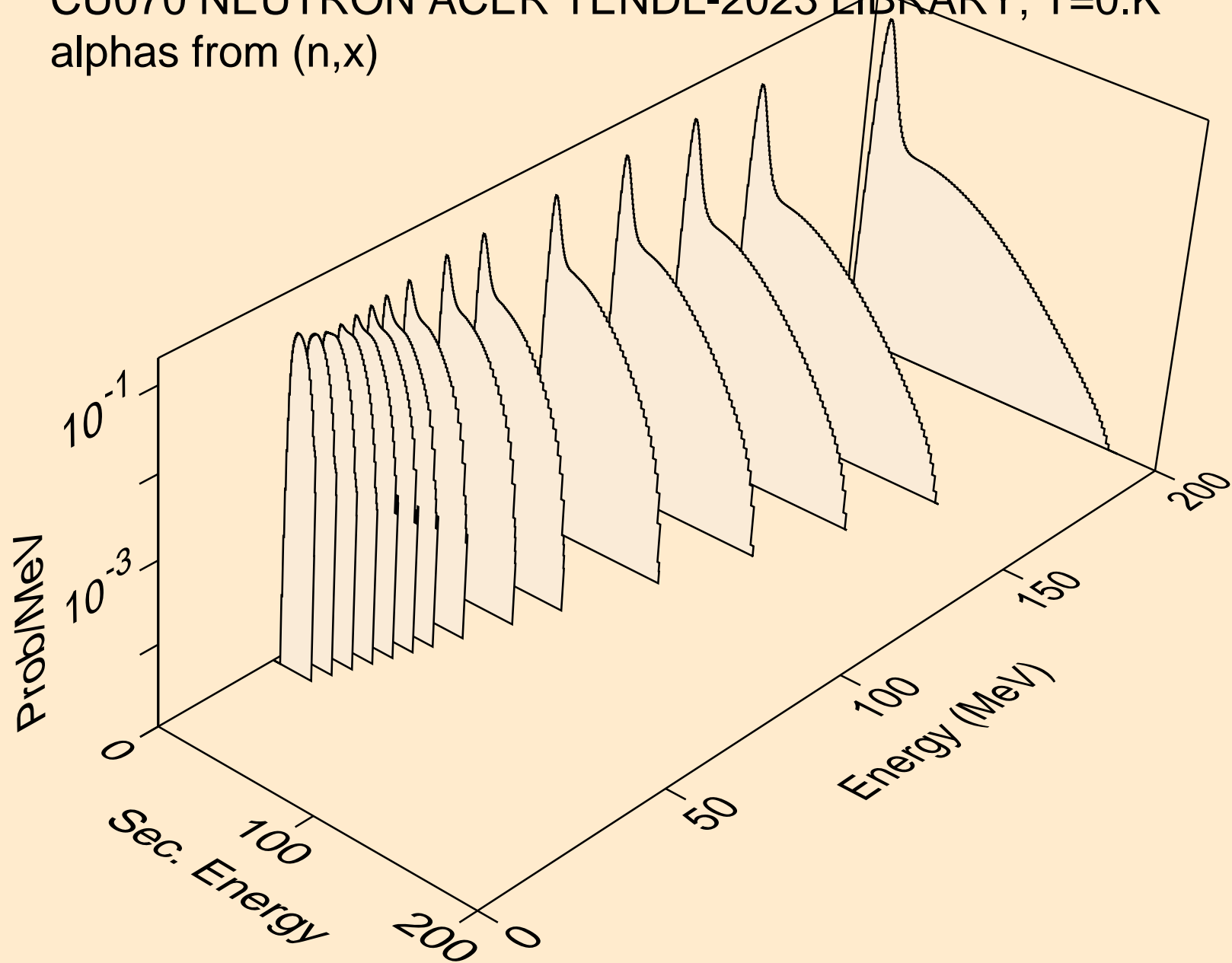



CU070 NEUTRON ACER TENDL-2023 LIBRARY; T=0.K  
alphas from (n,n\*)a

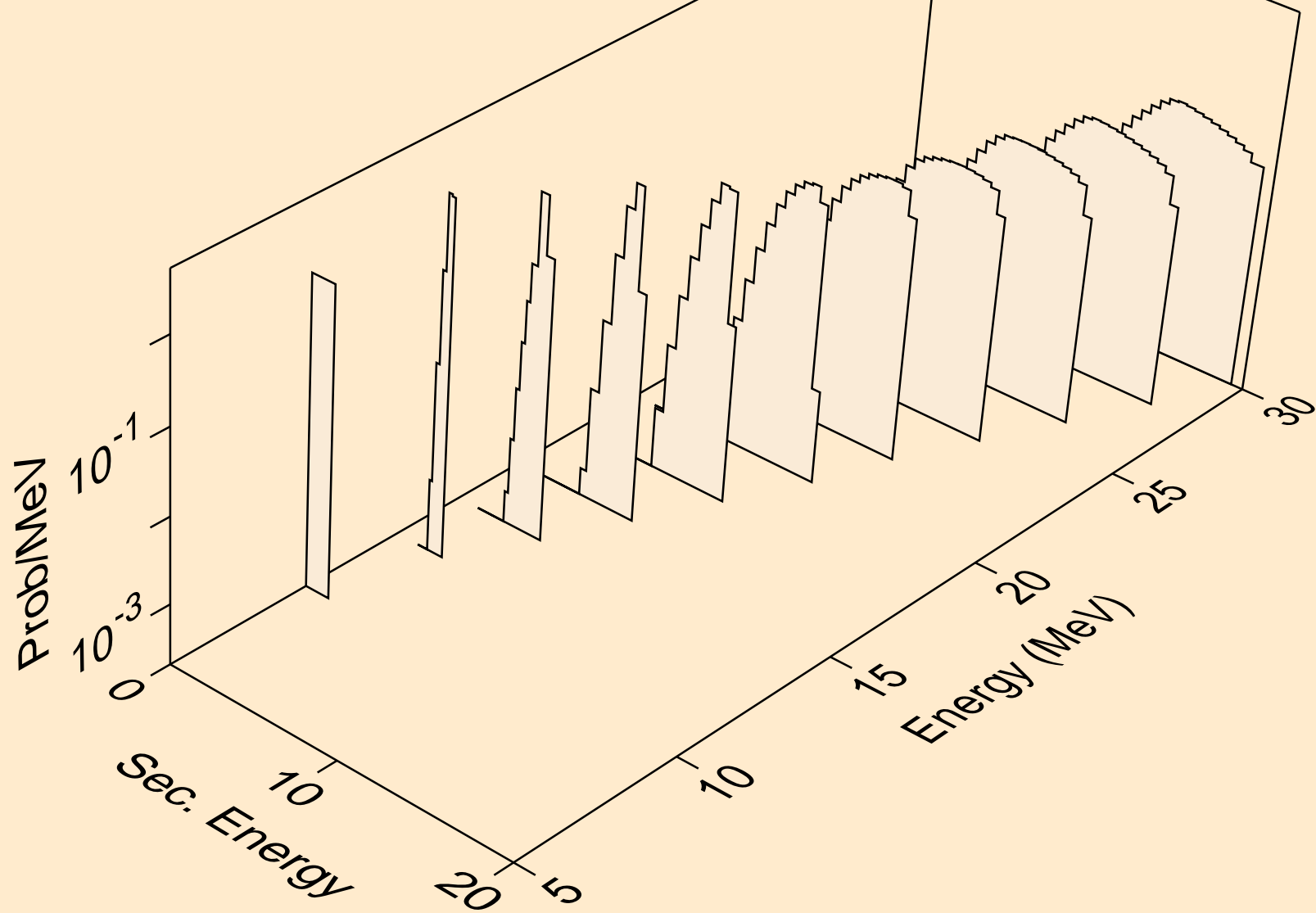

CU070 NEUTRON ACER TENDL-2023 LIBRARY; T=0.K  
alphas from (n,2n)a

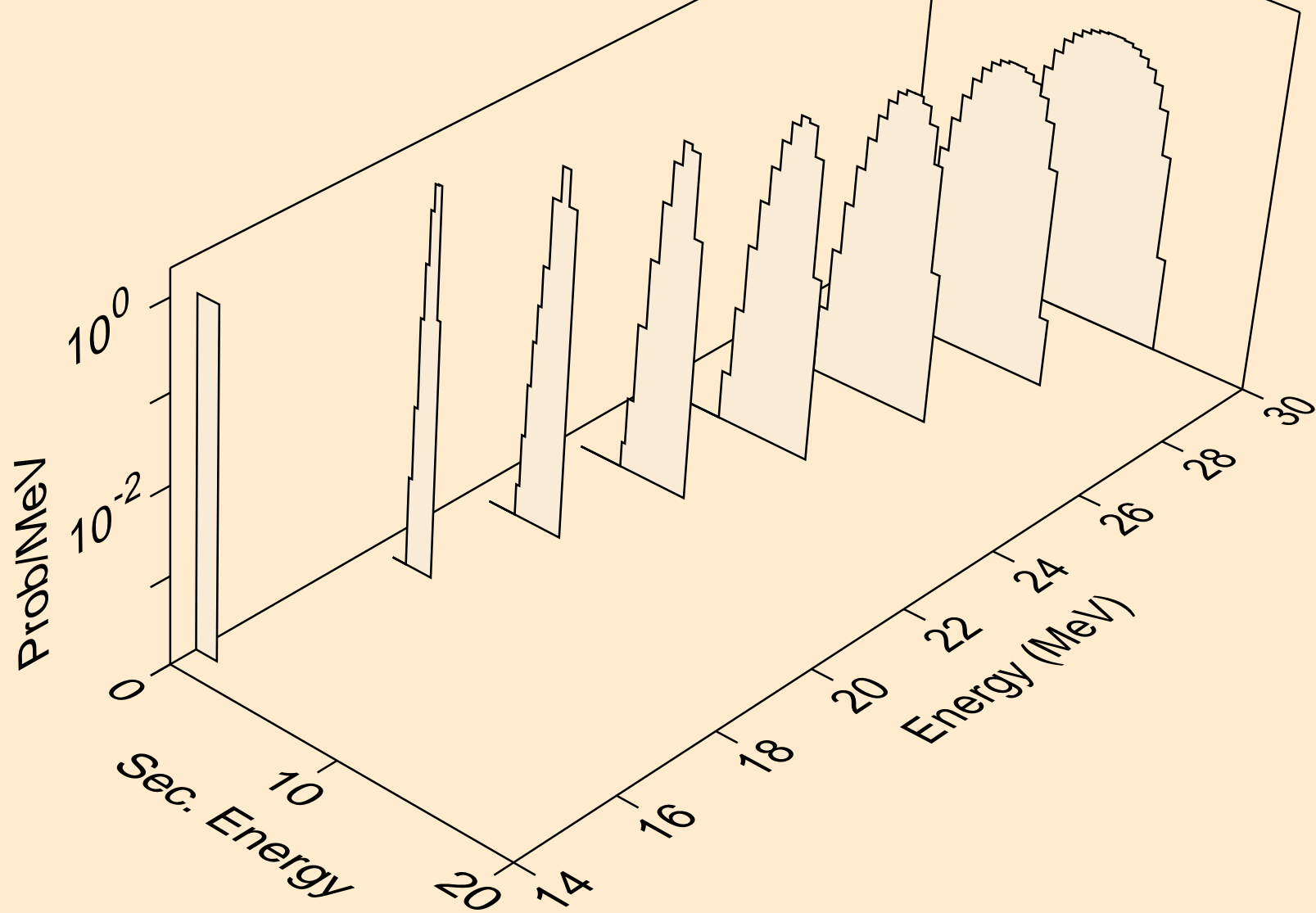

CU070 NEUTRON ACER TENDL-2023 LIBRARY; T=0.K  
alphas from (n,3n)a

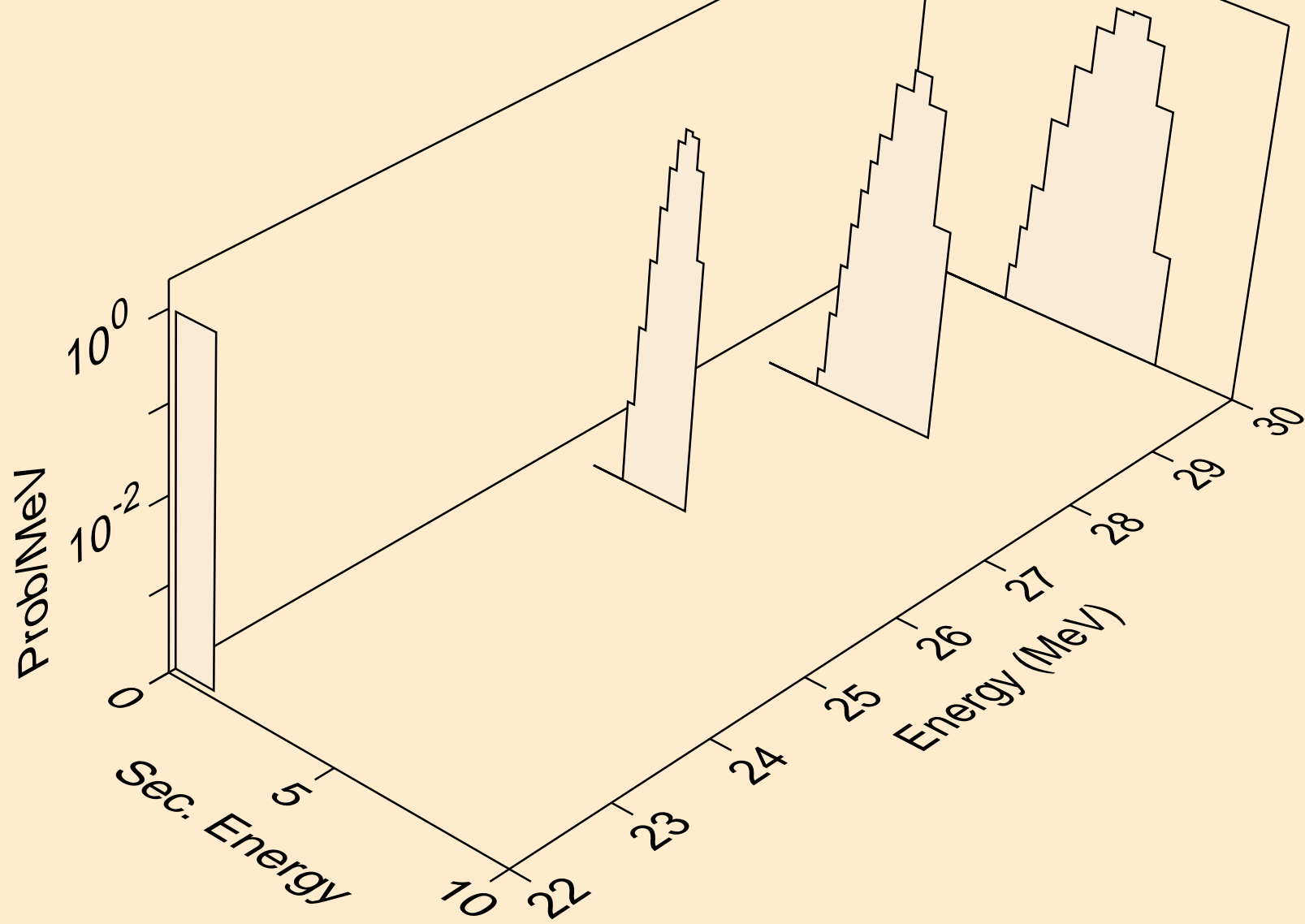

CU070 NEUTRON ACER TENDL-2023 LIBRARY; T=0.K  
alphas from (n,a)

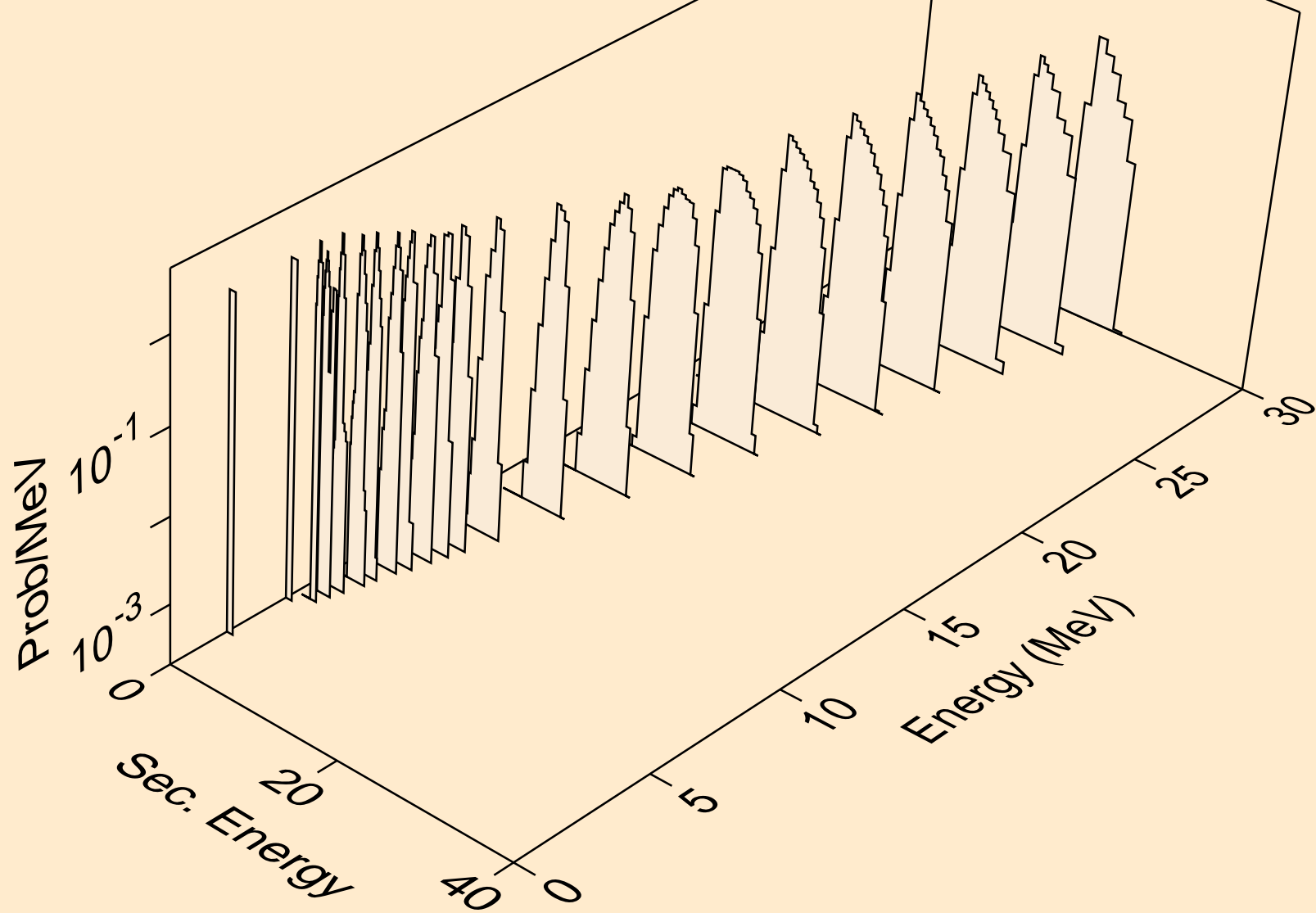

CU070 NEUTRON ACER TENDL-2023 LIBRARY; T=0.K  
alphas from (n,pa)

