

# CU072 NEUTRON ACER TENDL-2023 LIBRARY; T=0.K

## Principal cross sections

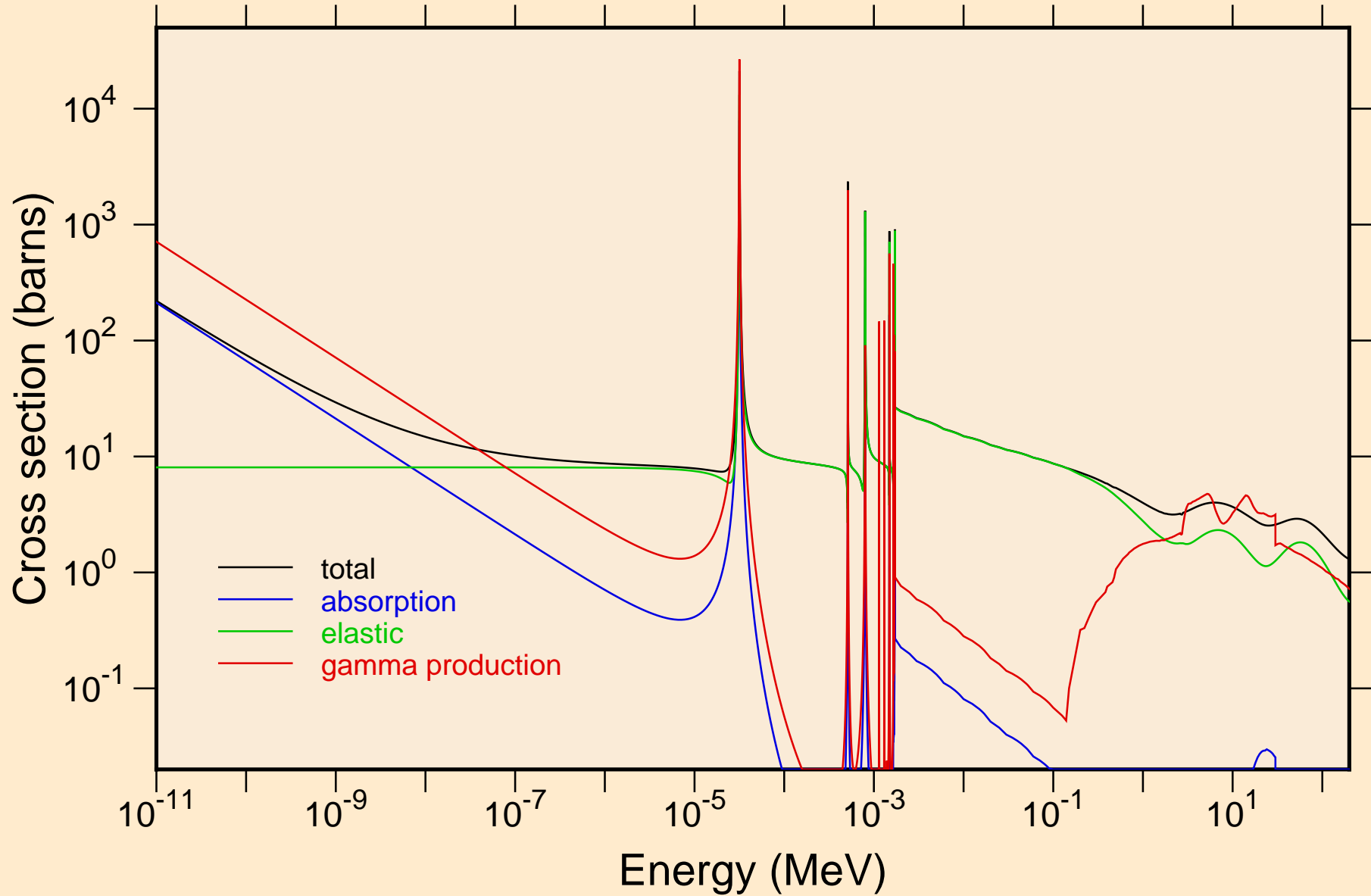

CU072 NEUTRON ACER TENDL-2023 LIBRARY; T=0.K  
resonance total cross section

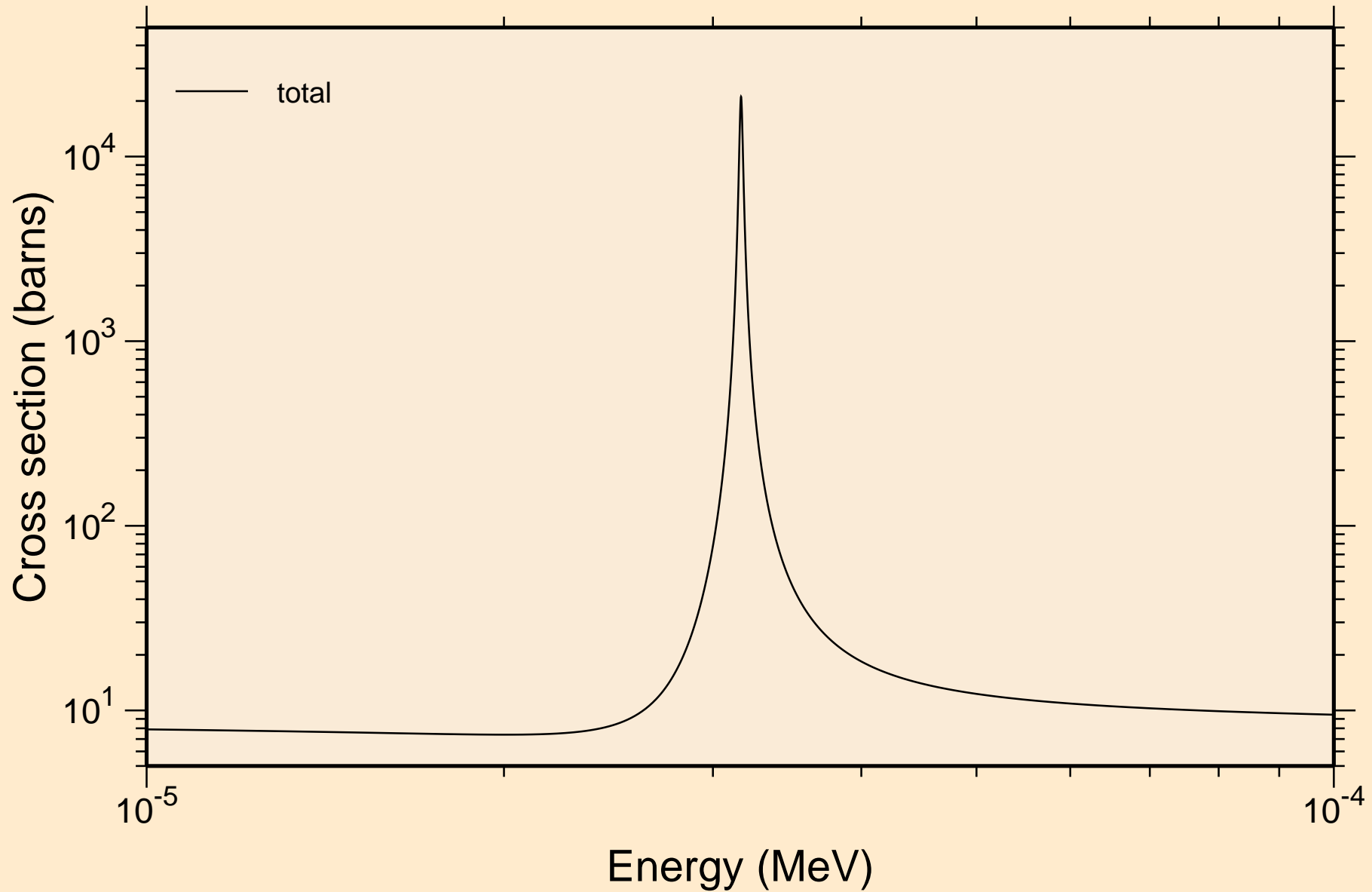

CU072 NEUTRON ACER TENDL-2023 LIBRARY; T=0.K  
resonance total cross section

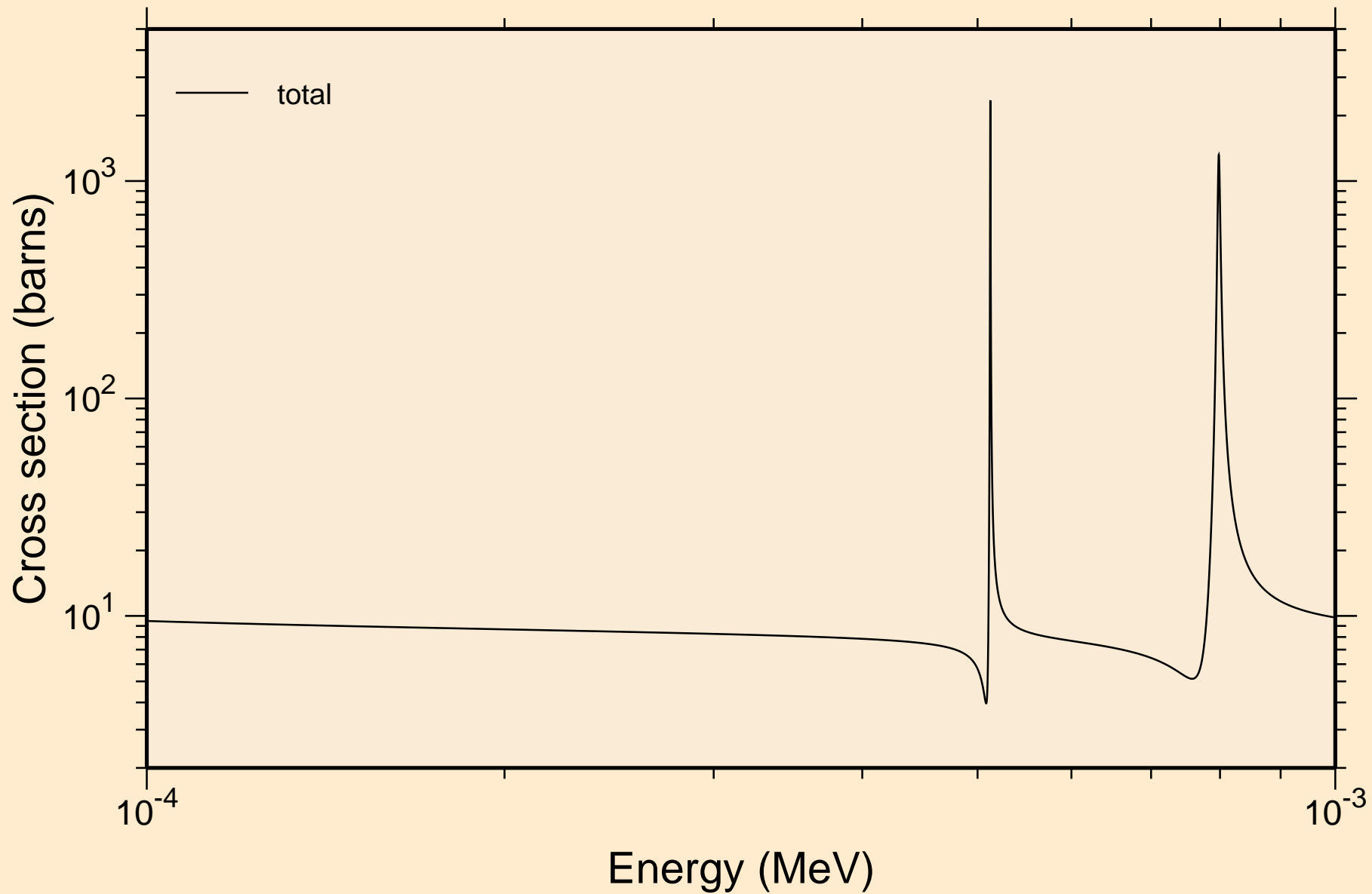

CU072 NEUTRON ACER TENDL-2023 LIBRARY; T=0.K  
resonance total cross section

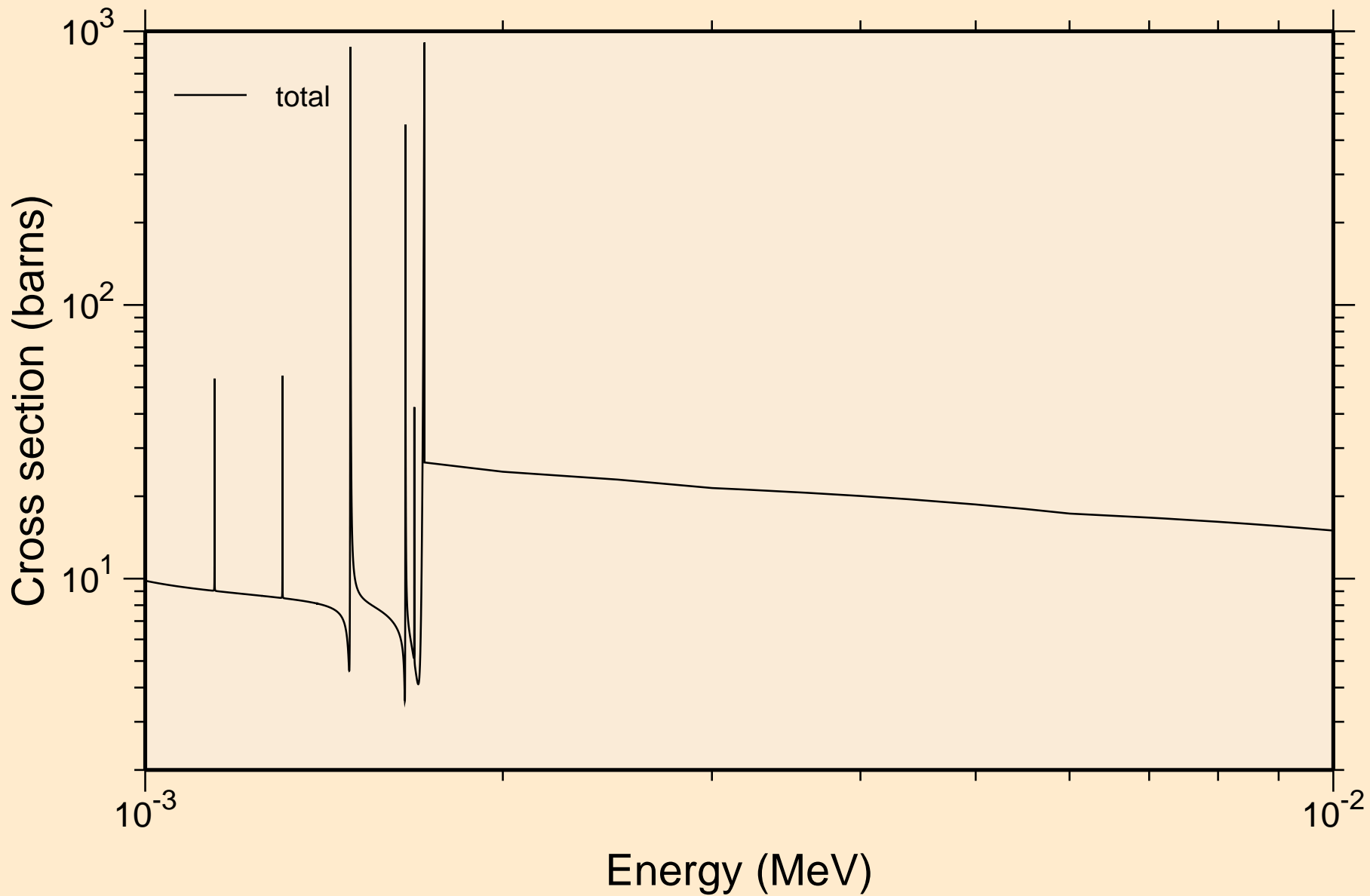

CU072 NEUTRON ACER TENDL-2023 LIBRARY; T=0.K  
resonance total cross section

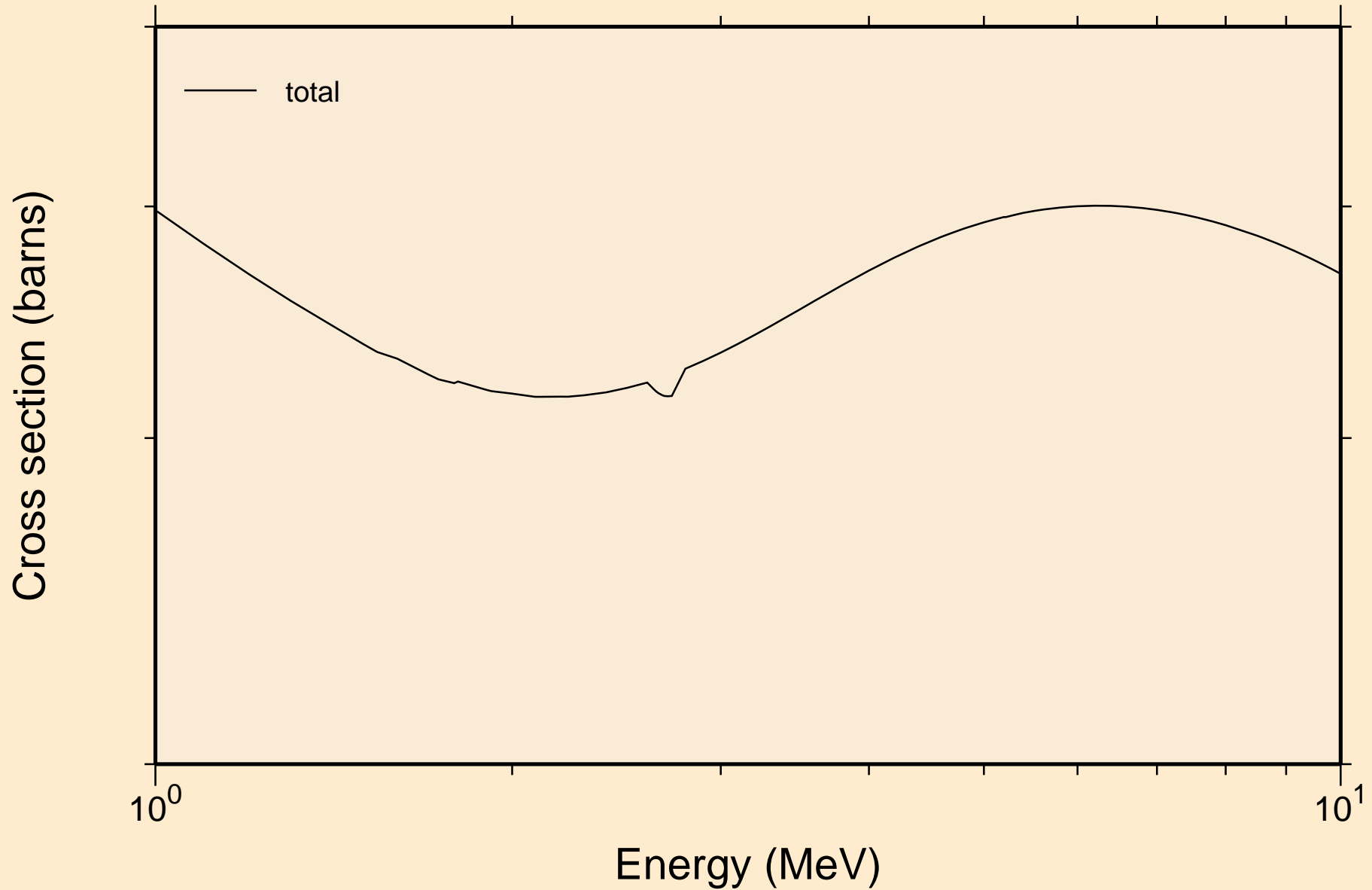

CU072 NEUTRON ACER TENDL-2023 LIBRARY; T=0.K  
resonance absorption cross sections

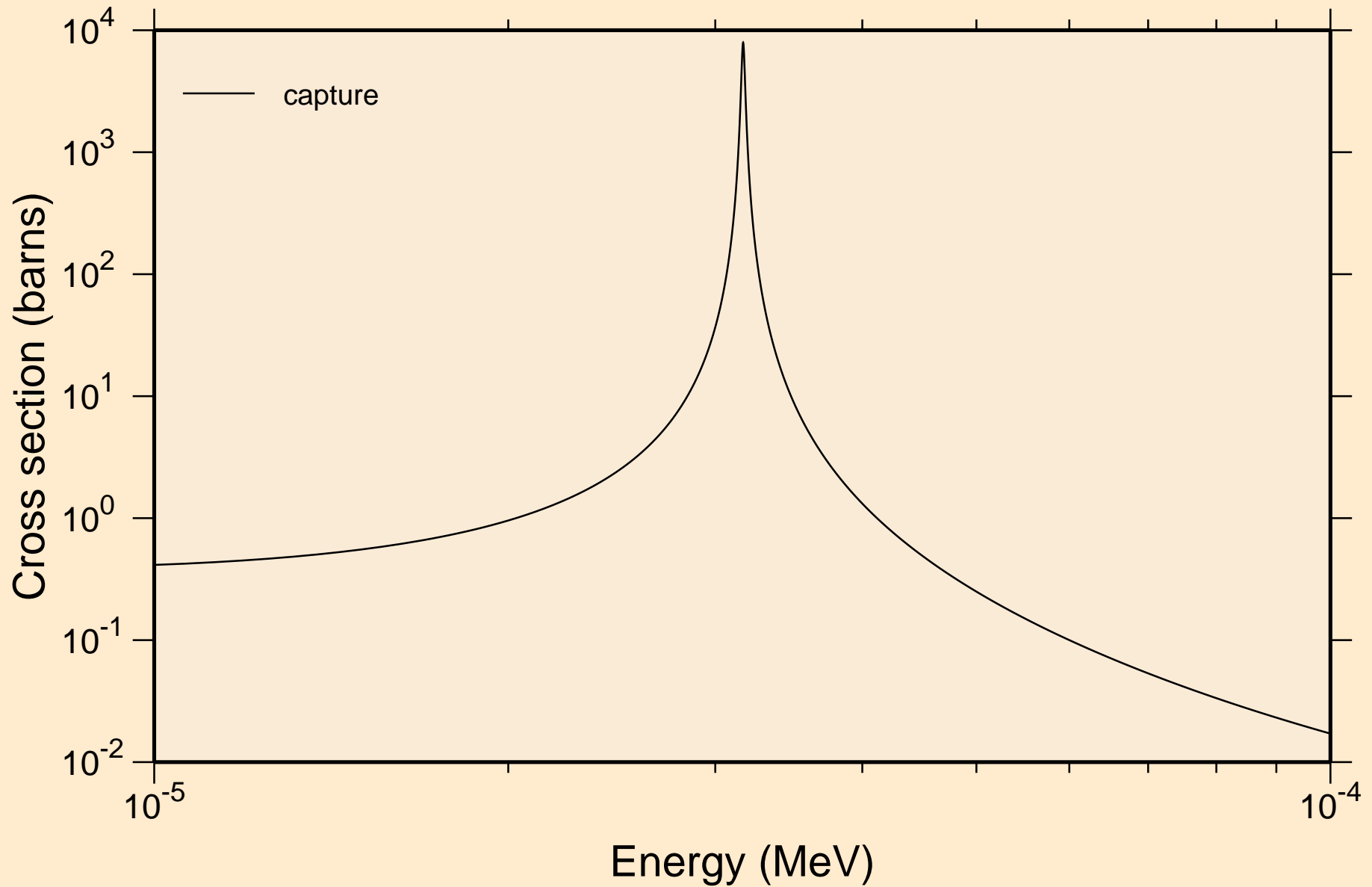

CU072 NEUTRON ACER TENDL-2023 LIBRARY; T=0.K  
resonance absorption cross sections

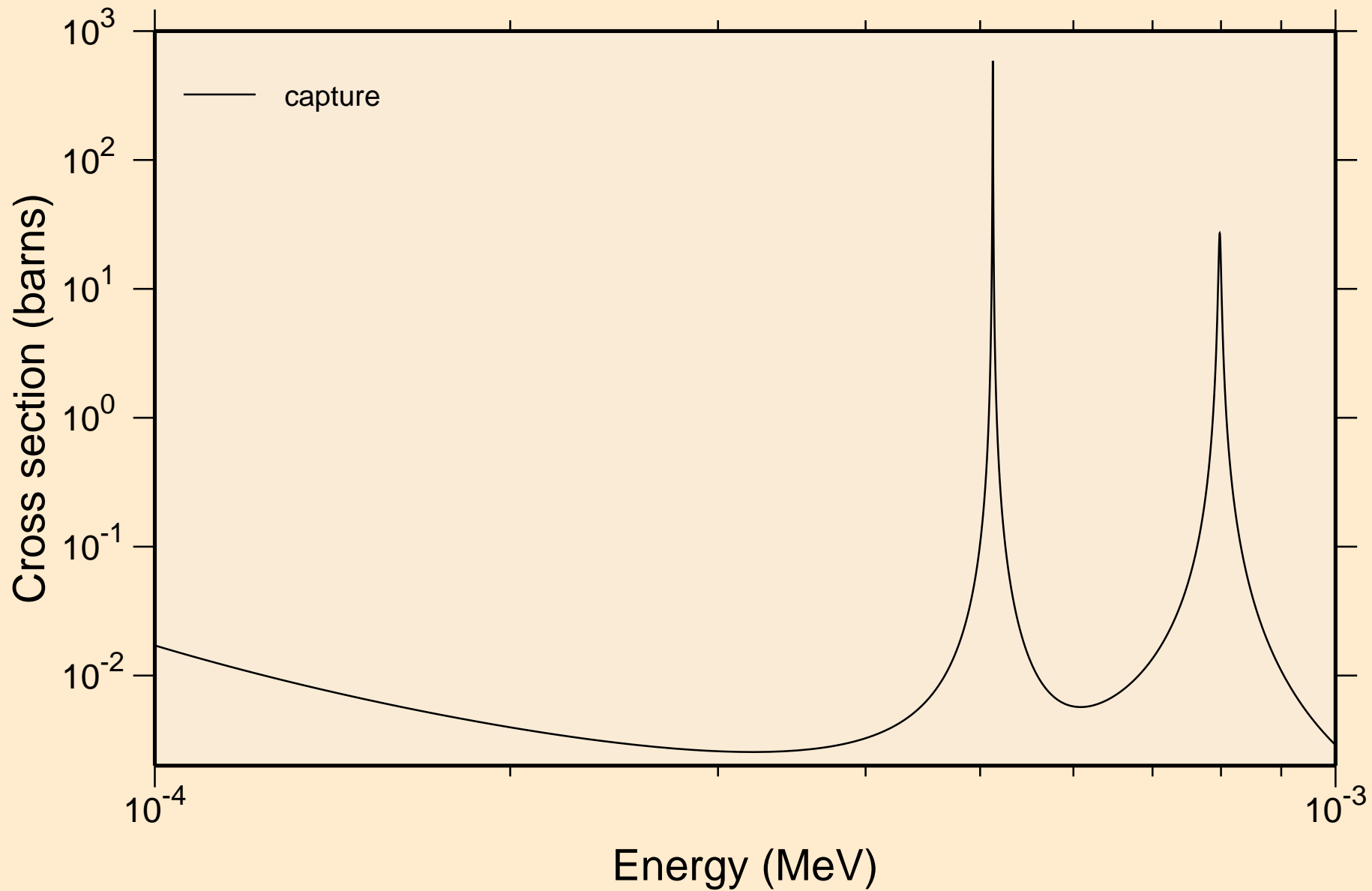

CU072 NEUTRON ACER TENDL-2023 LIBRARY; T=0.K  
resonance absorption cross sections

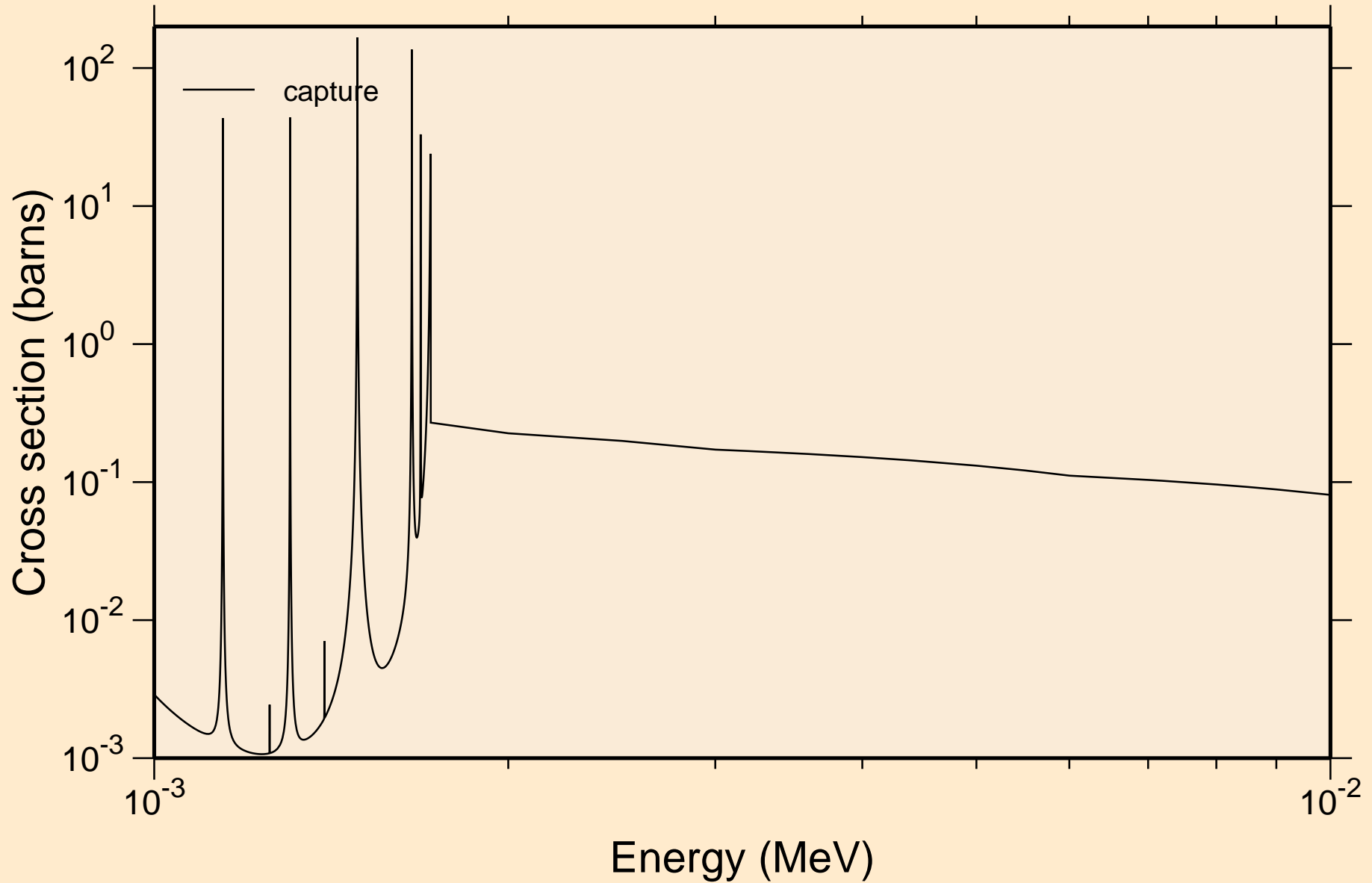



CU072 NEUTRON ACER TENDL-2023 LIBRARY; T=0.K  
resonance absorption cross sections

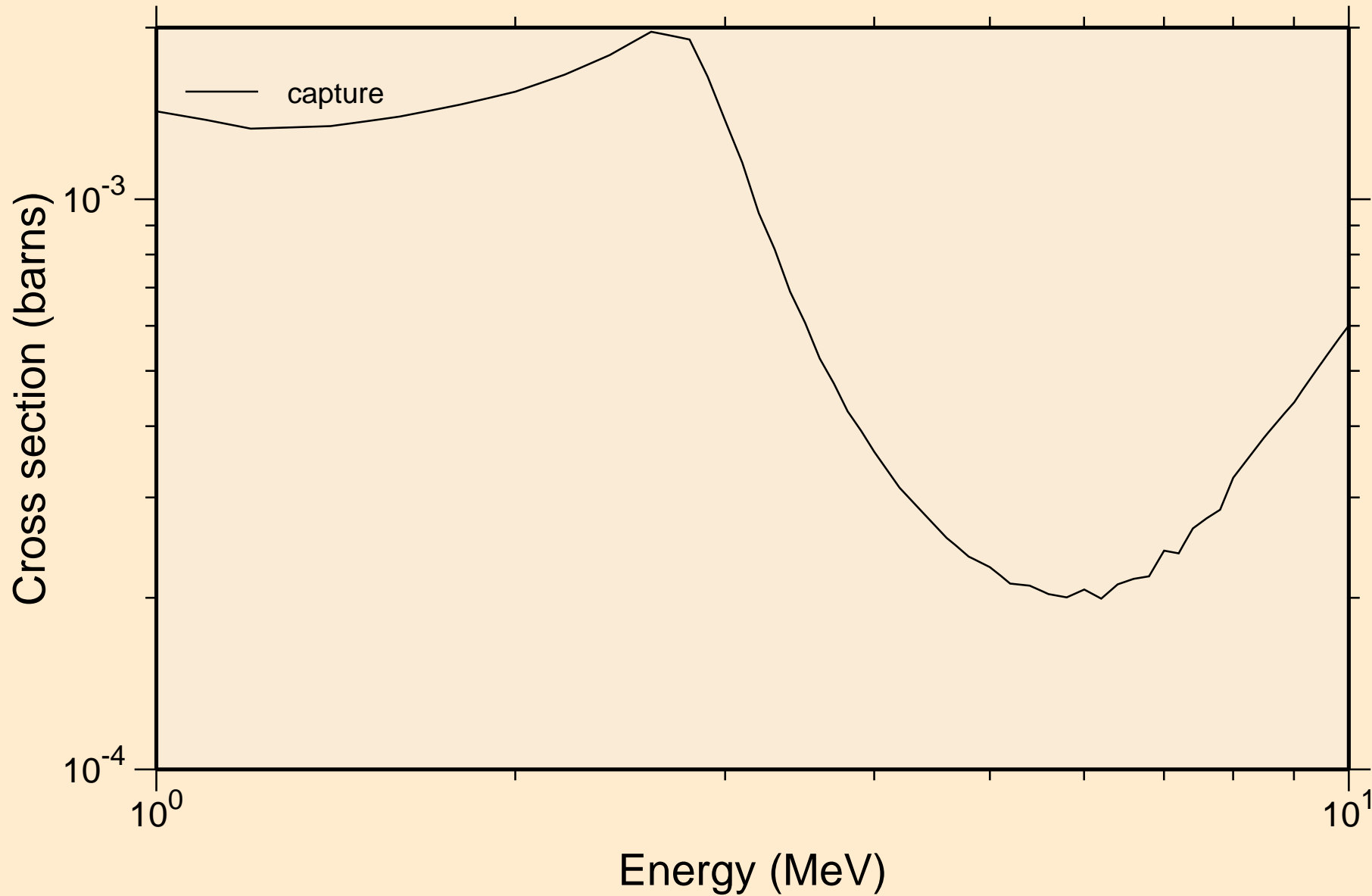

# CU072 NEUTRON ACER TENDL-2023 LIBRARY; T=0.K

## Heating

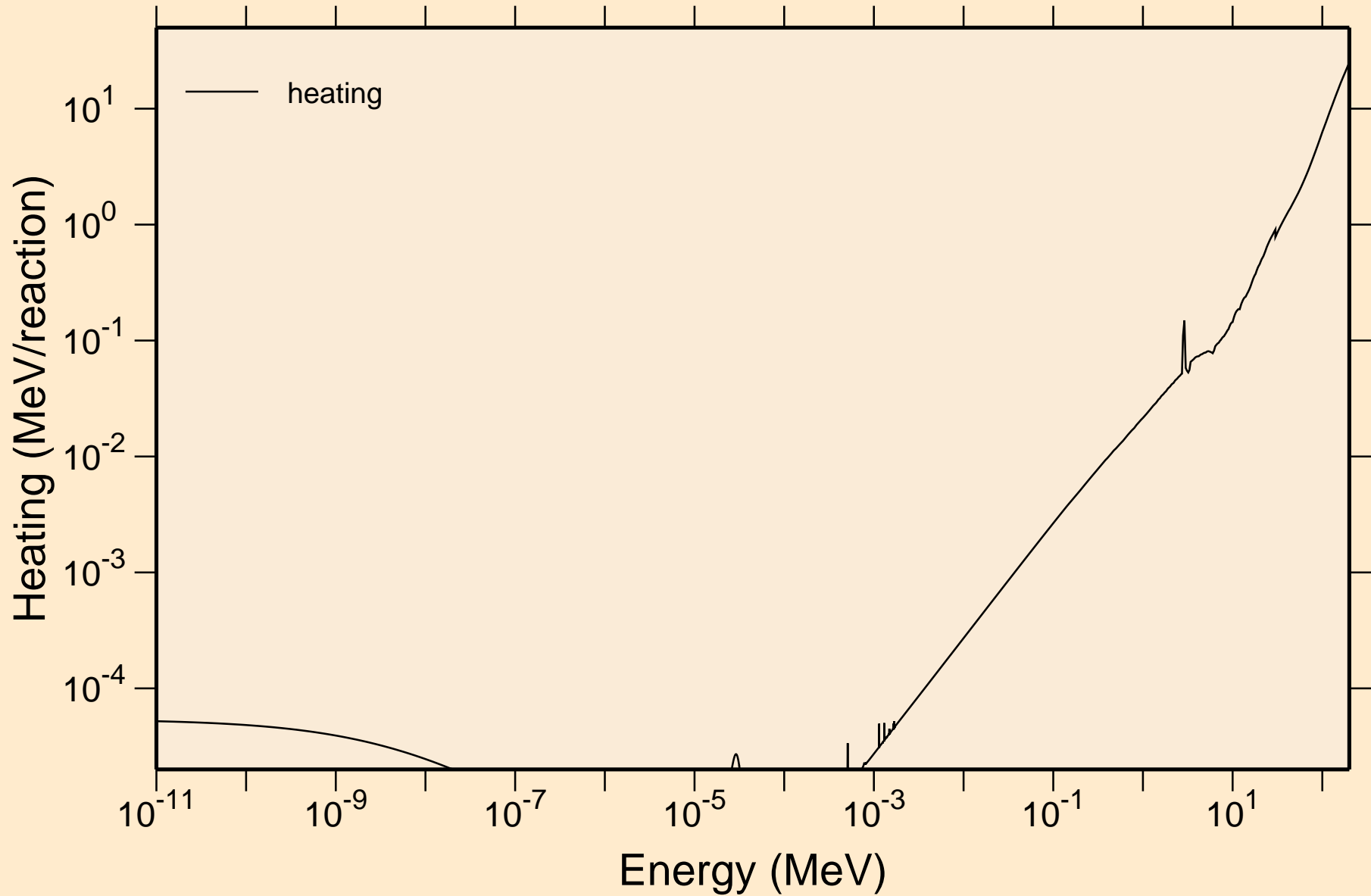

CU072 NEUTRON ACER TENDL-2023 LIBRARY; T=0.K  
Damage

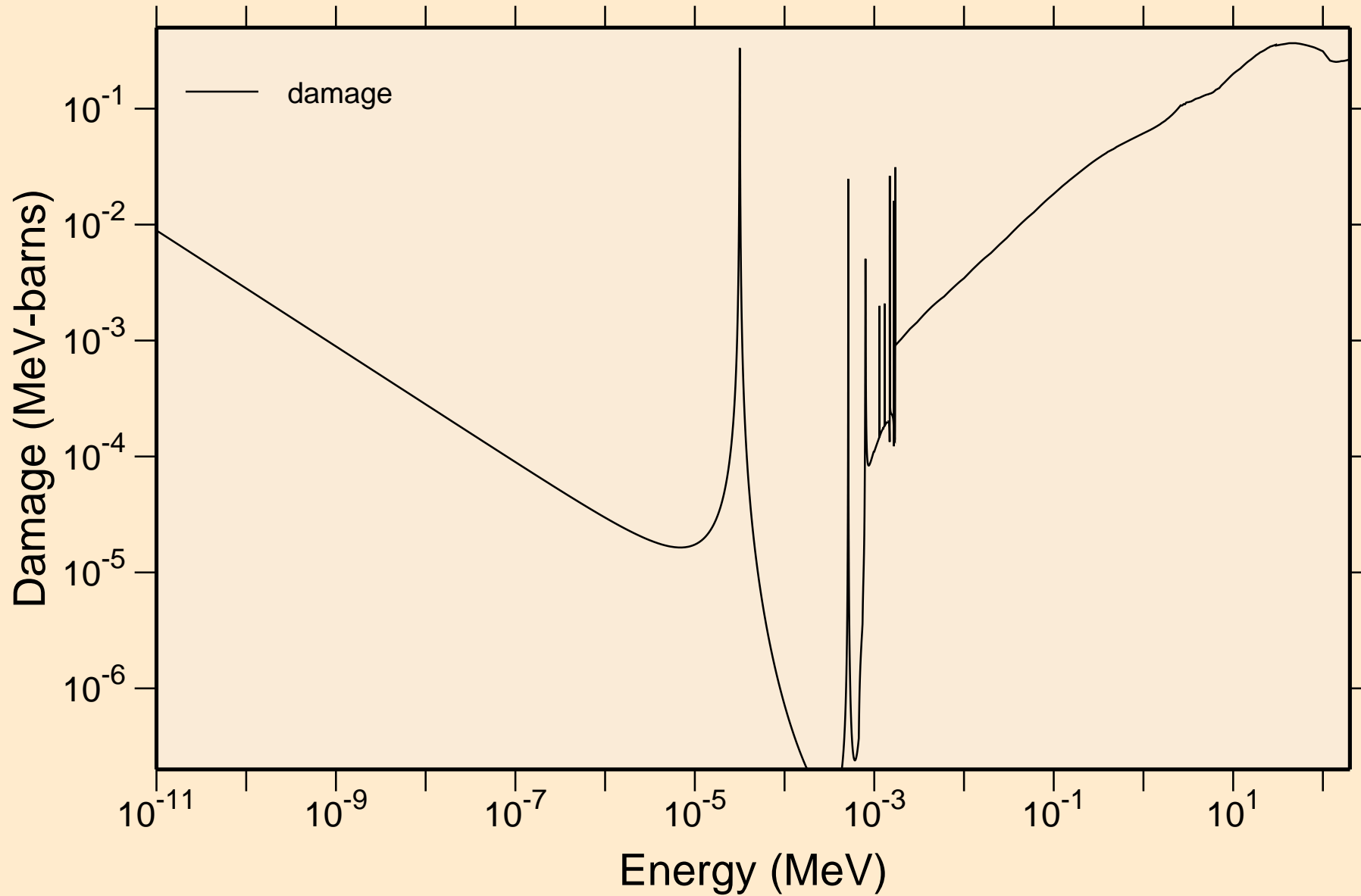

CU072 NEUTRON ACER TENDL-2023 LIBRARY; T=0.K  
Non-threshold reactions

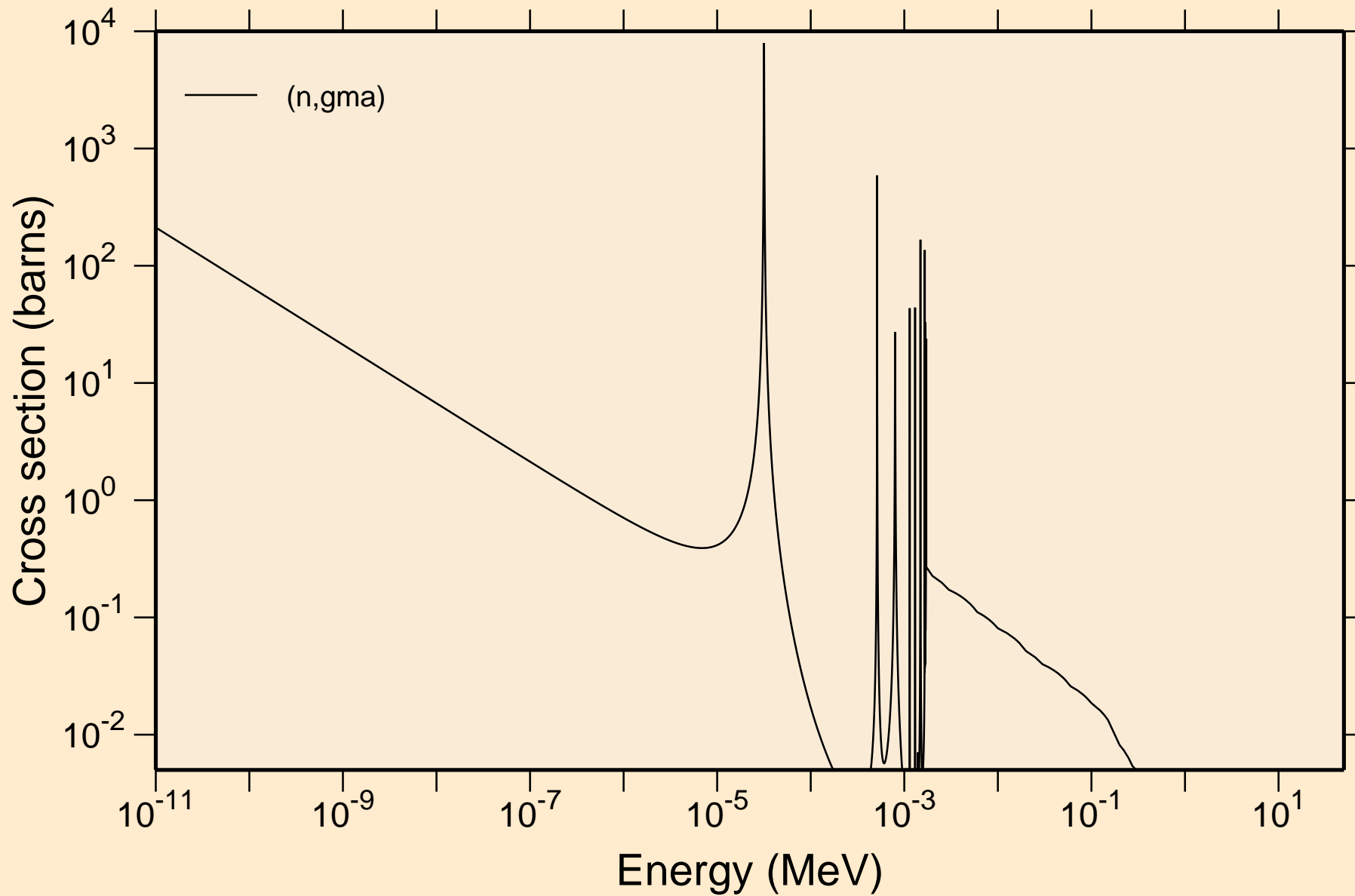

# CU072 NEUTRON ACER TENDL-2023 LIBRARY; T=0.K

## Principal cross sections

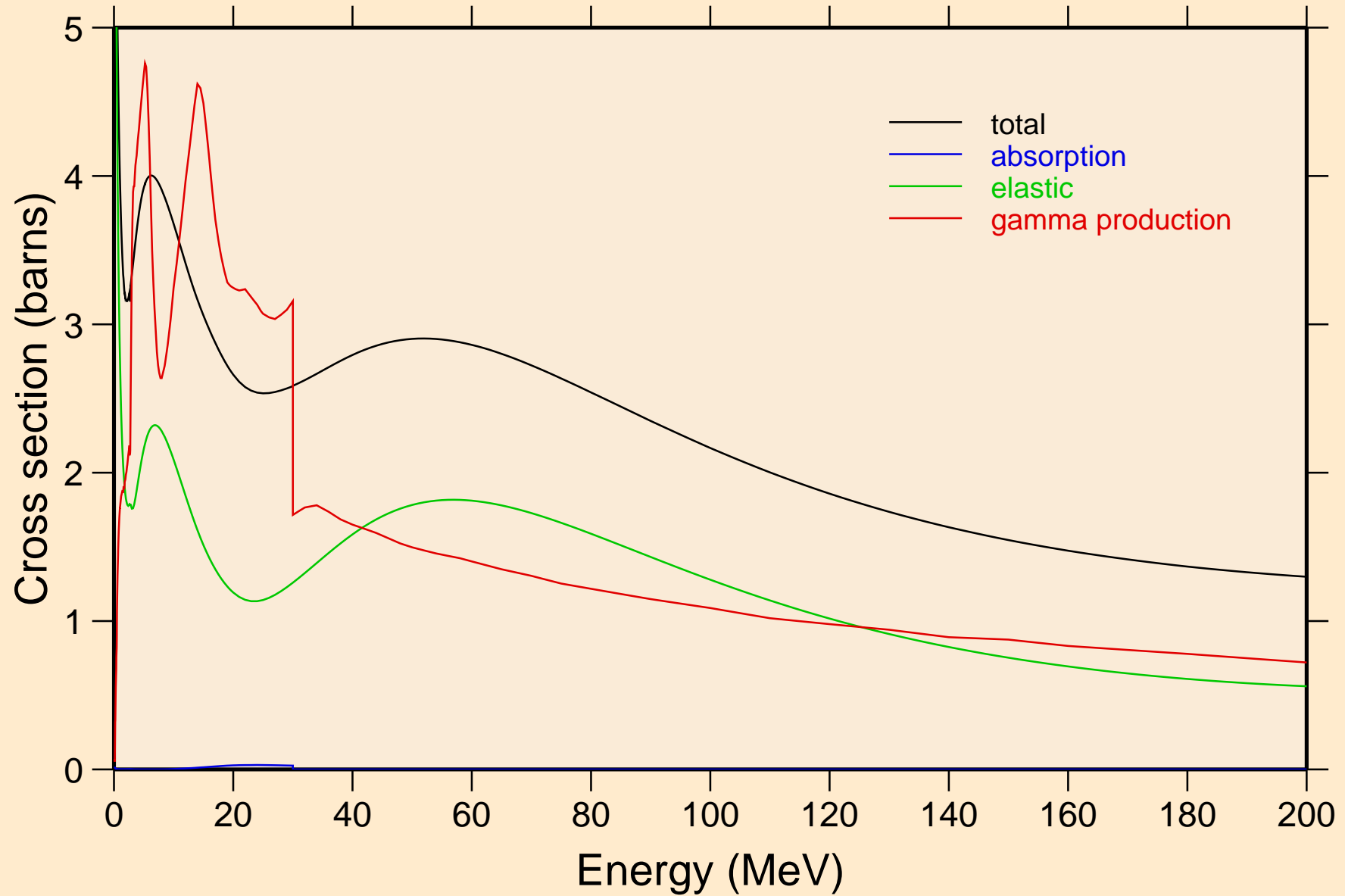

# CU072 NEUTRON ACER TENDL-2023 LIBRARY; T=0.K

## Heating

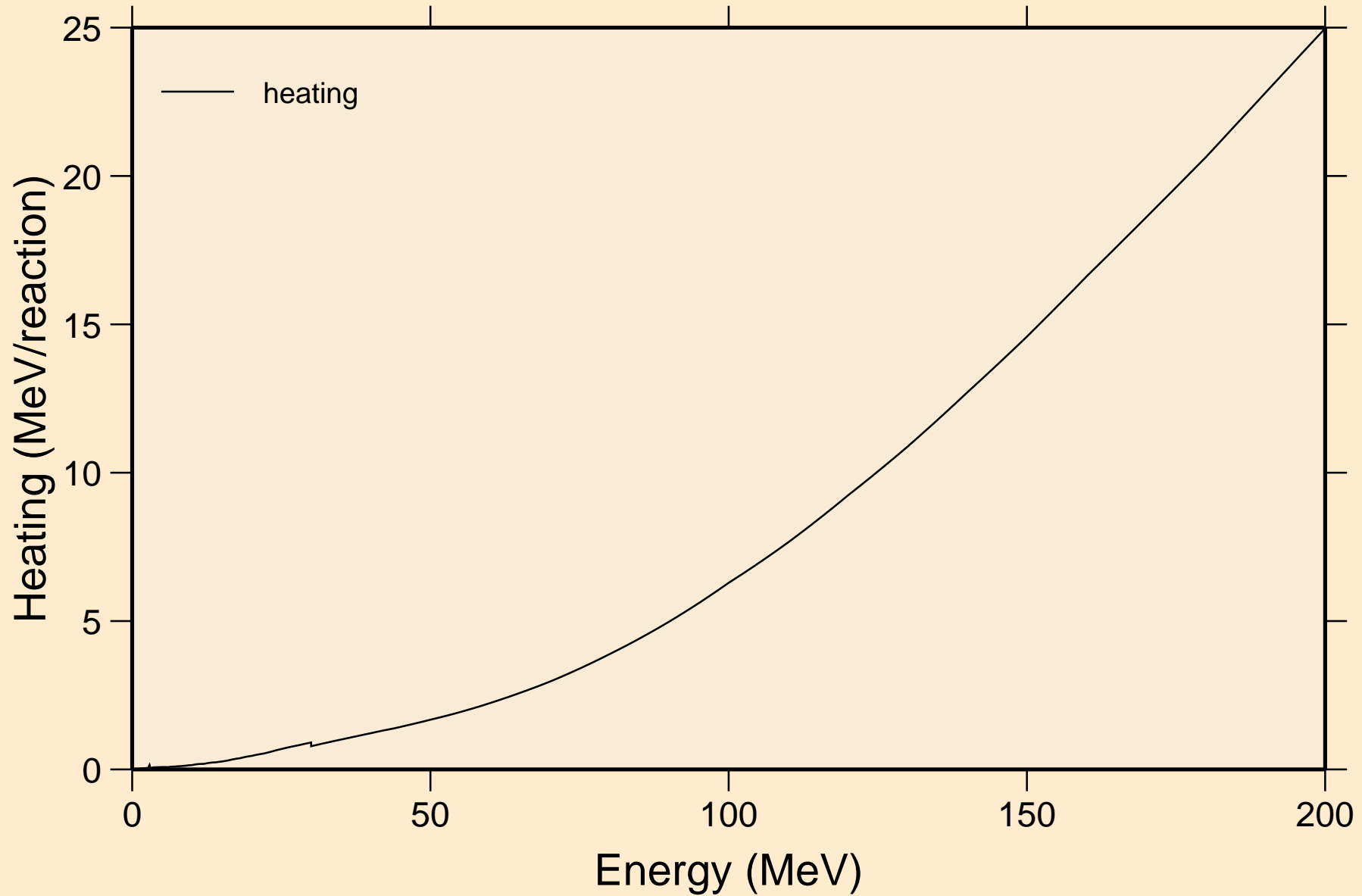

# CU072 NEUTRON ACER TENDL-2023 LIBRARY; T=0.K

## Damage

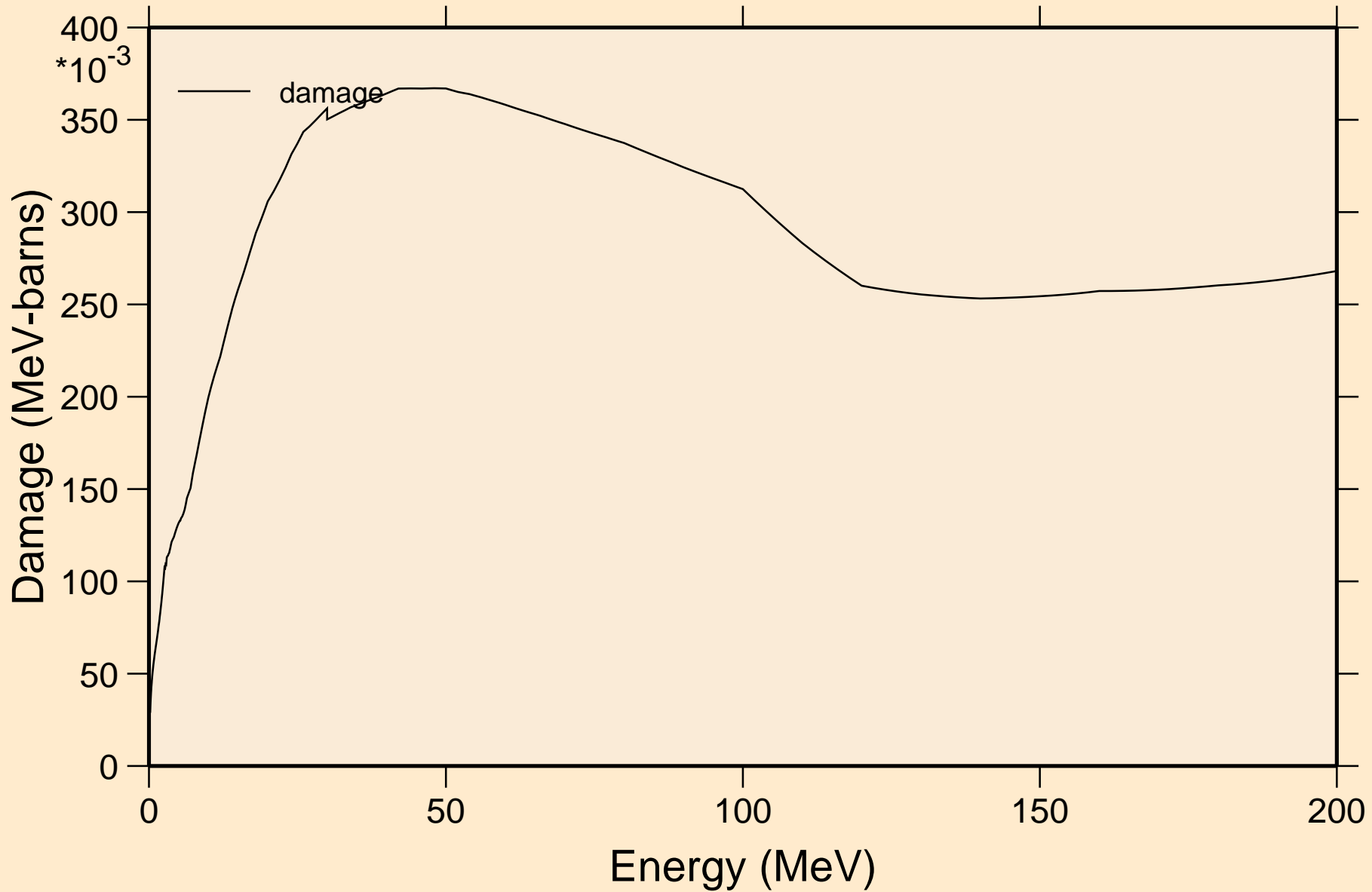

CU072 NEUTRON ACER TENDL-2023 LIBRARY; T=0.K  
Non-threshold reactions

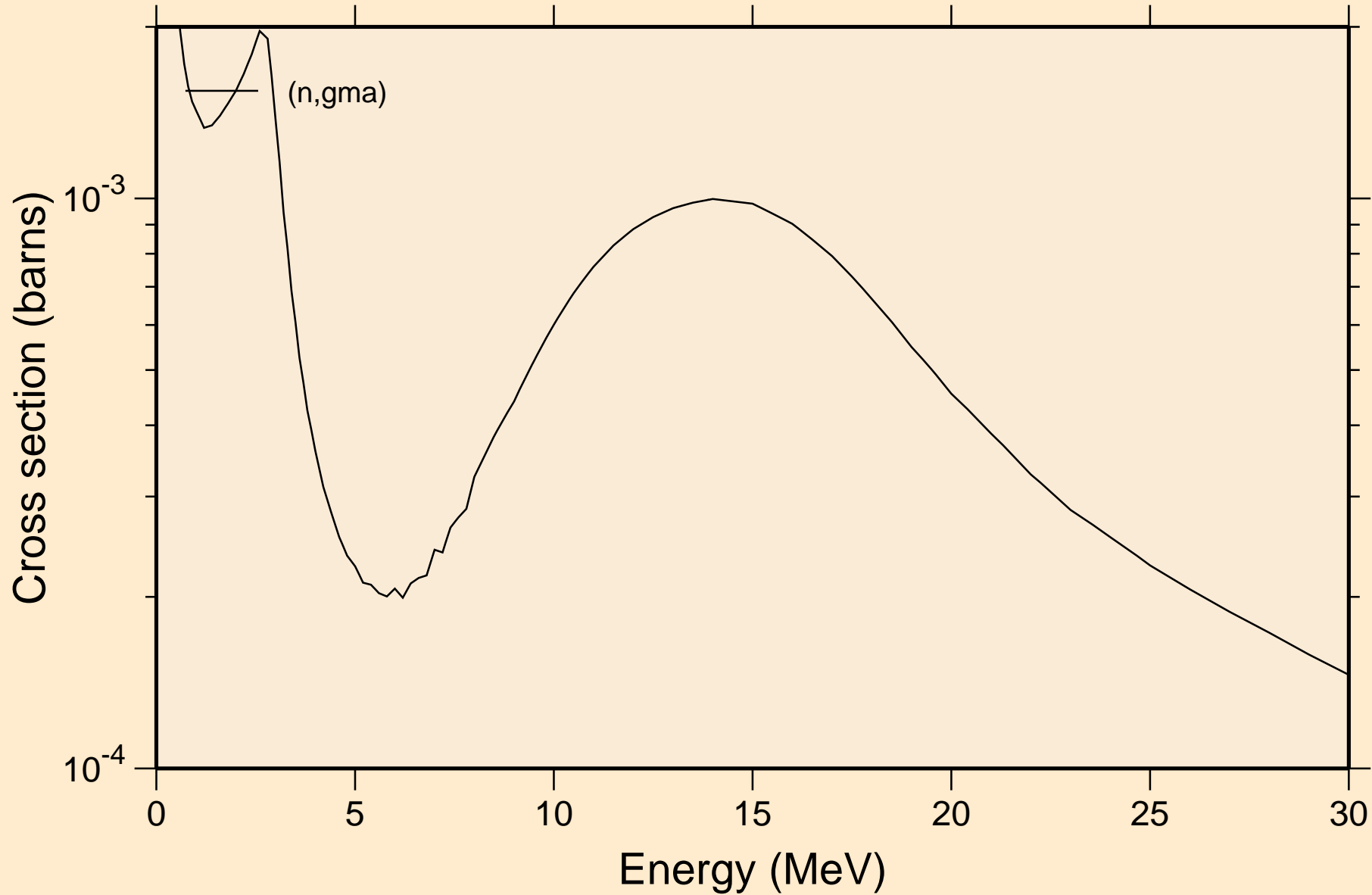



CU072 NEUTRON ACER TENDL-2023 LIBRARY; T=0.K  
Inelastic levels

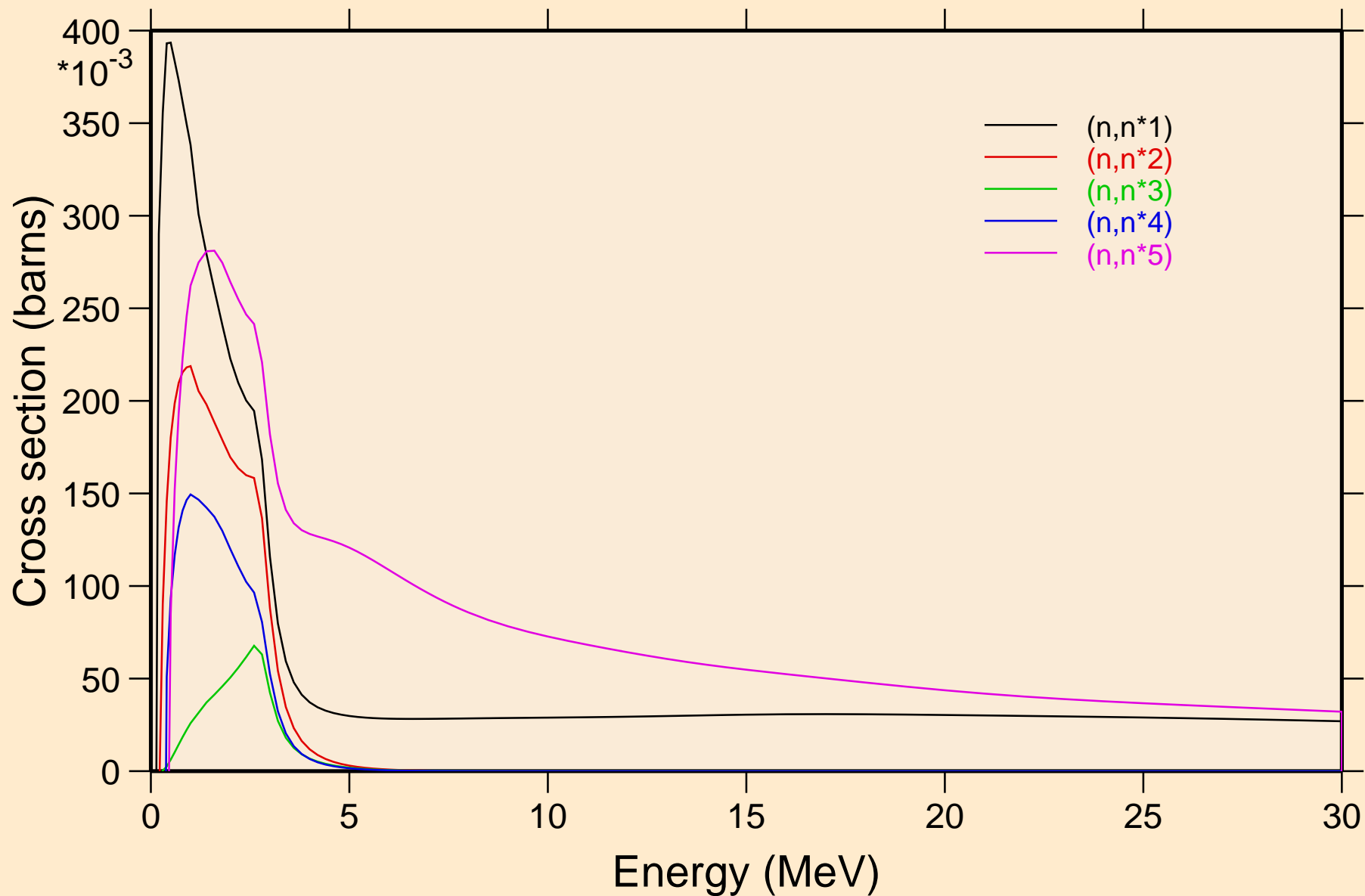

CU072 NEUTRON ACER TENDL-2023 LIBRARY; T=0.K  
Inelastic levels

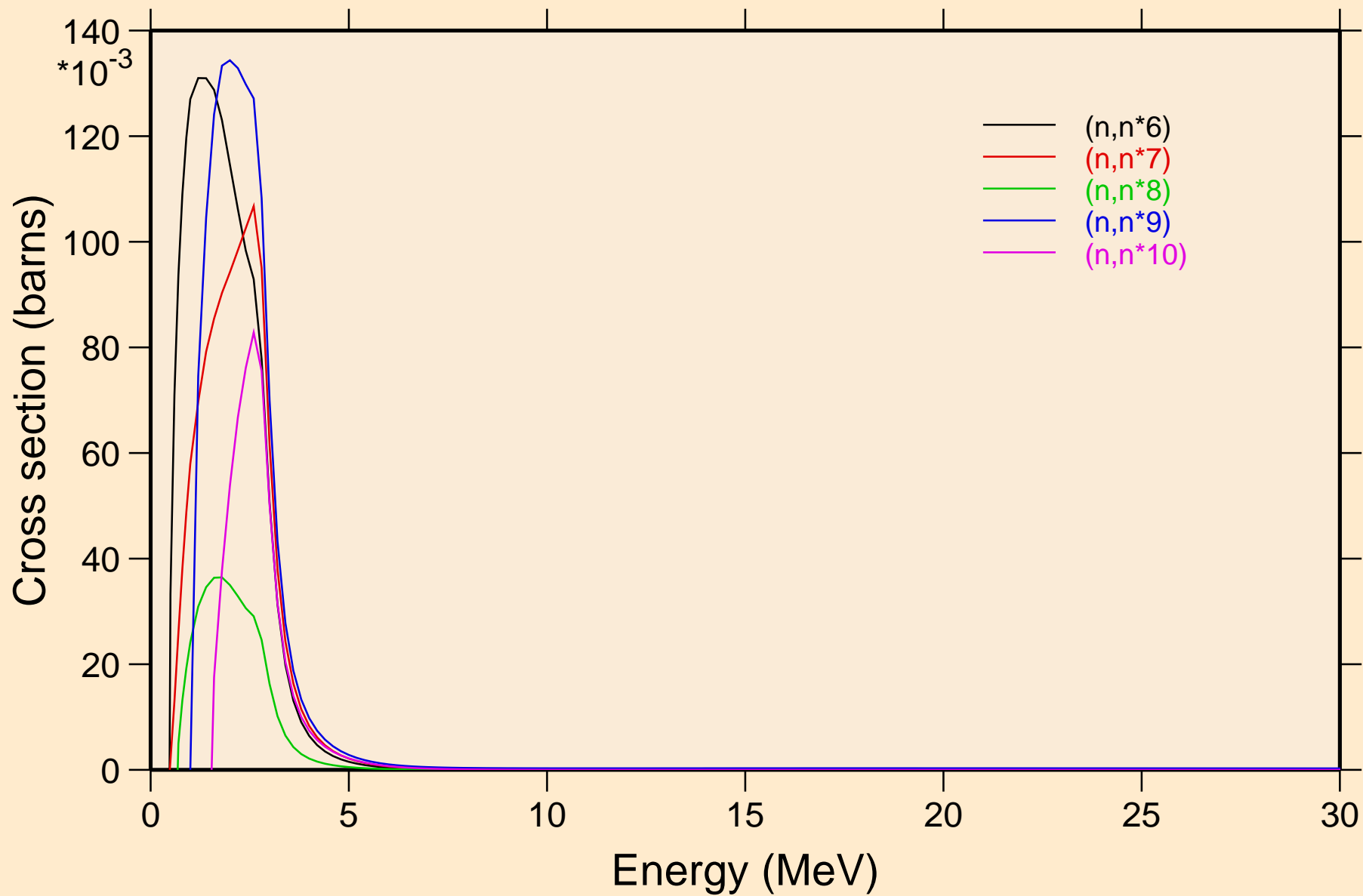

CU072 NEUTRON ACER TENDL-2023 LIBRARY; T=0.K  
Inelastic levels

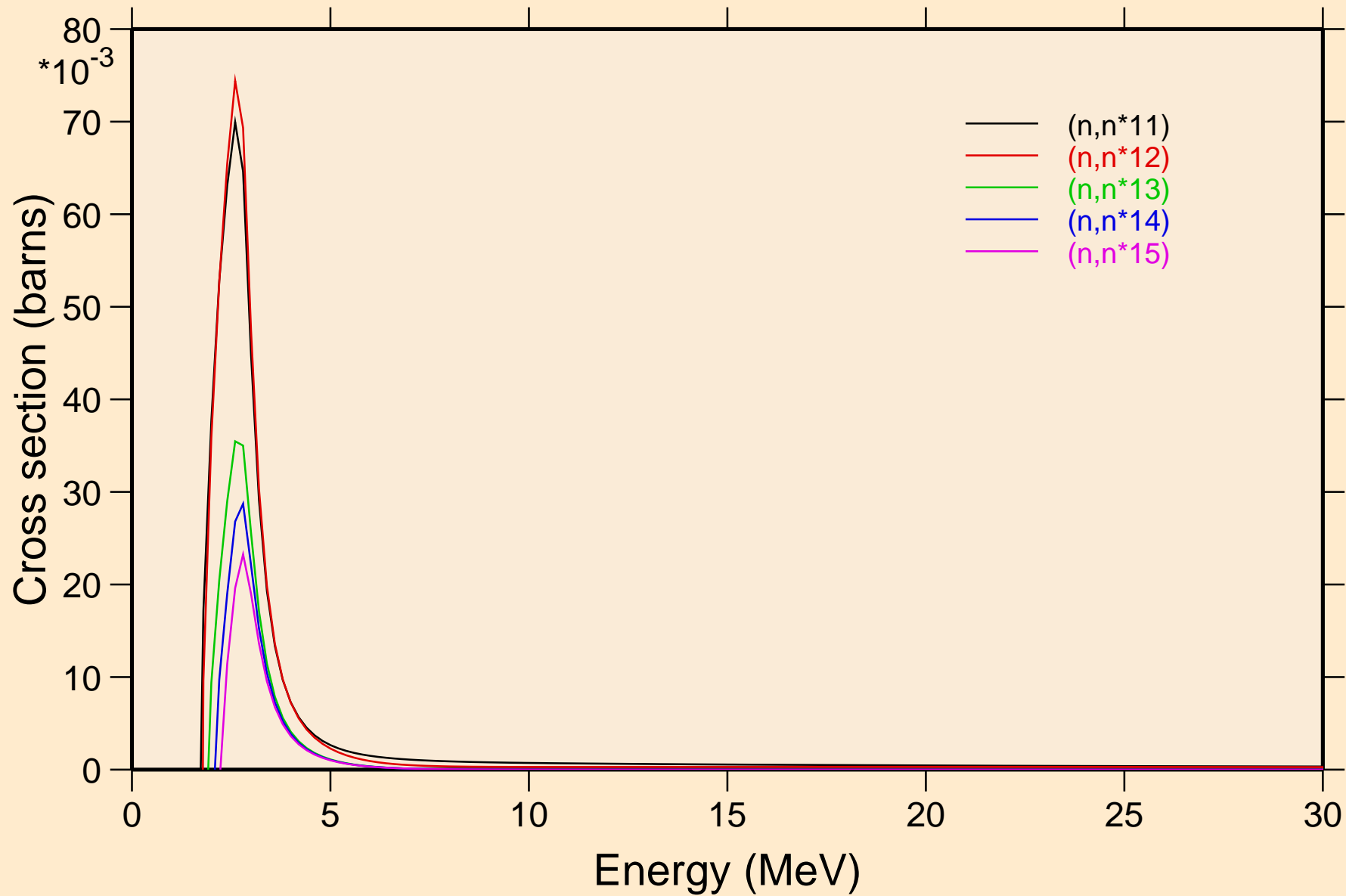

CU072 NEUTRON ACER TENDL-2023 LIBRARY; T=0.K  
Inelastic levels

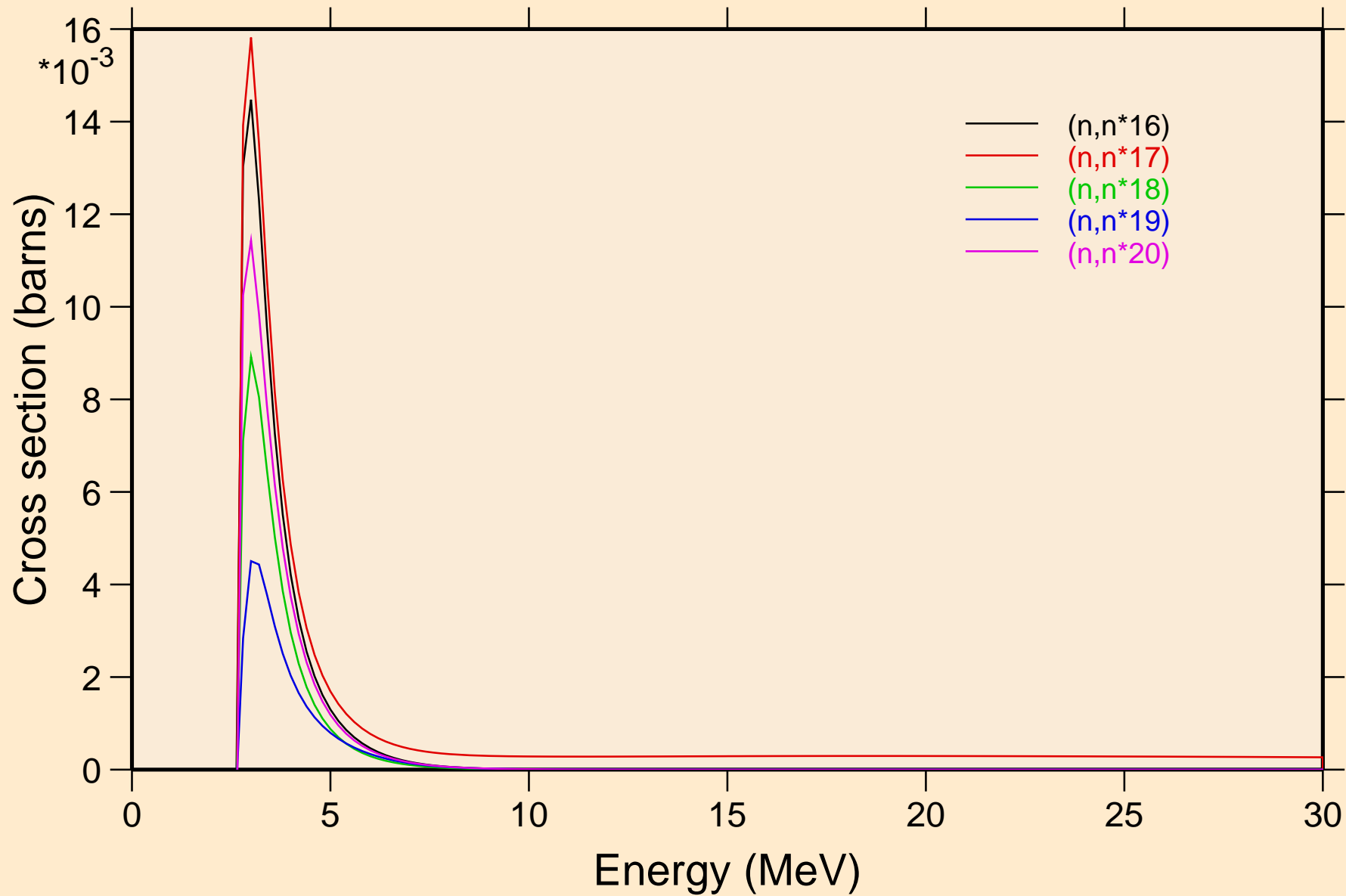

CU072 NEUTRON ACER TENDL-2023 LIBRARY; T=0.K  
Inelastic levels

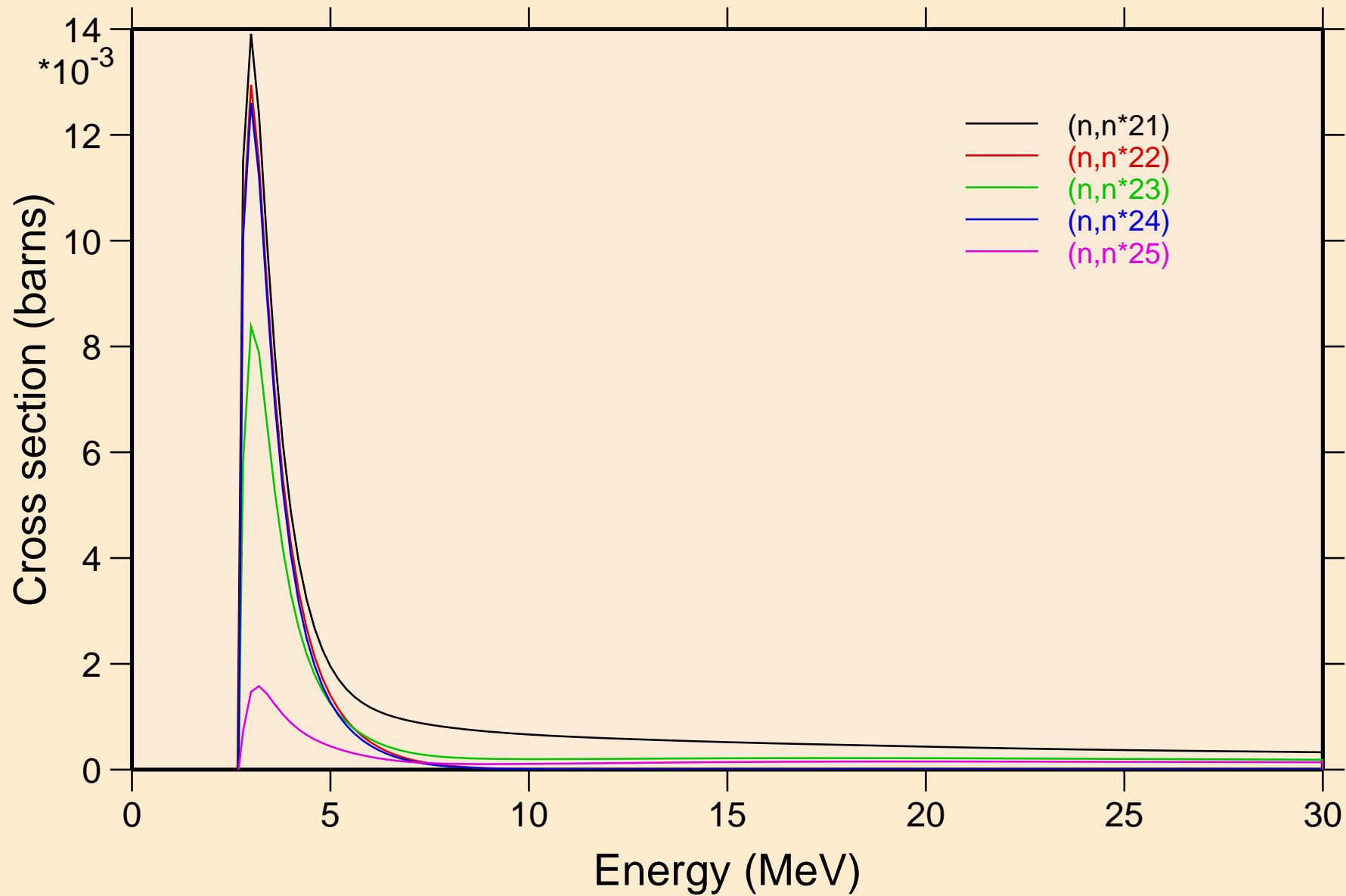

CU072 NEUTRON ACER TENDL-2023 LIBRARY; T=0.K  
Inelastic levels

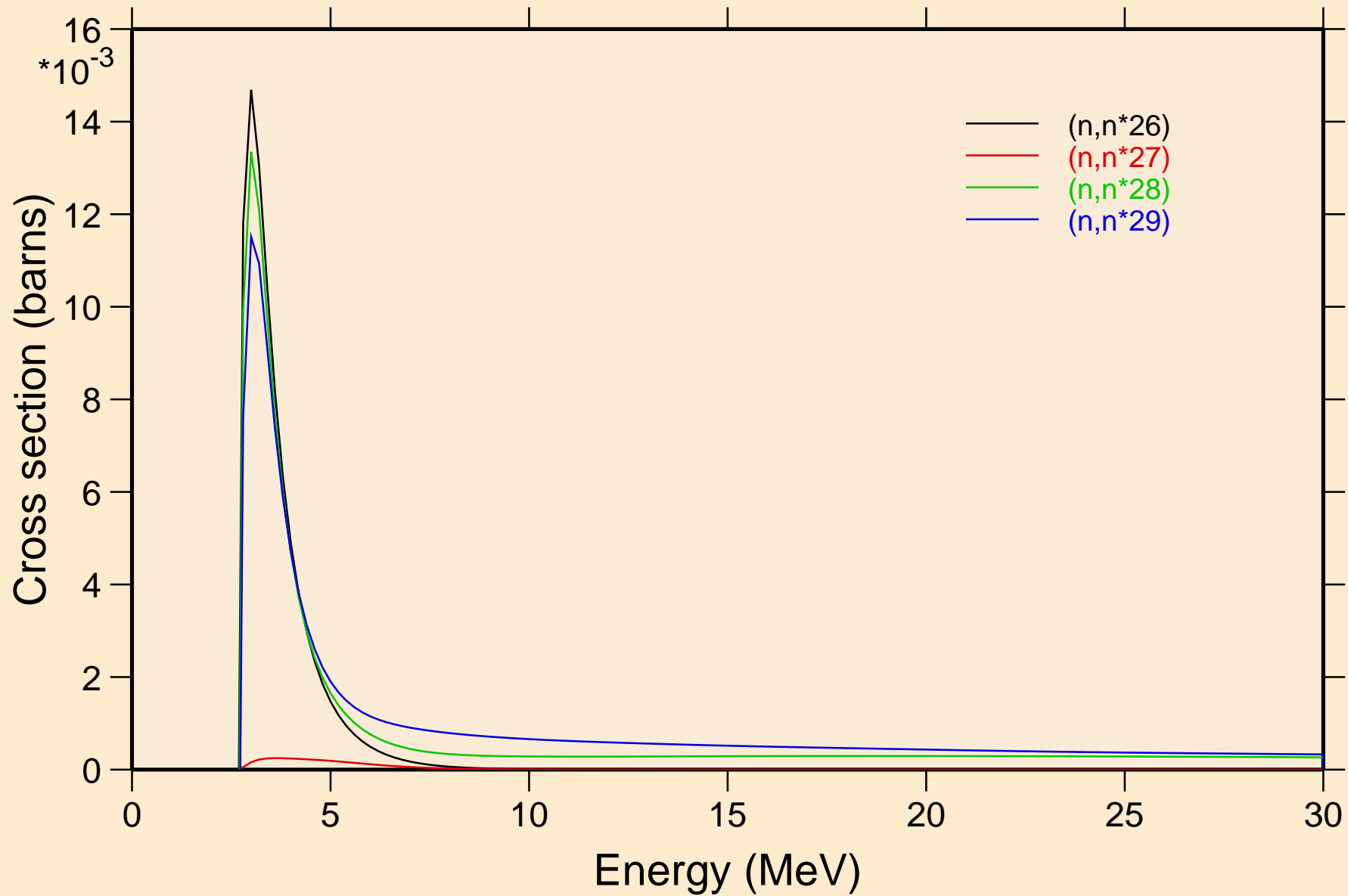

# CU072 NEUTRON ACER TENDL-2023 LIBRARY; T=0.K

## Threshold reactions

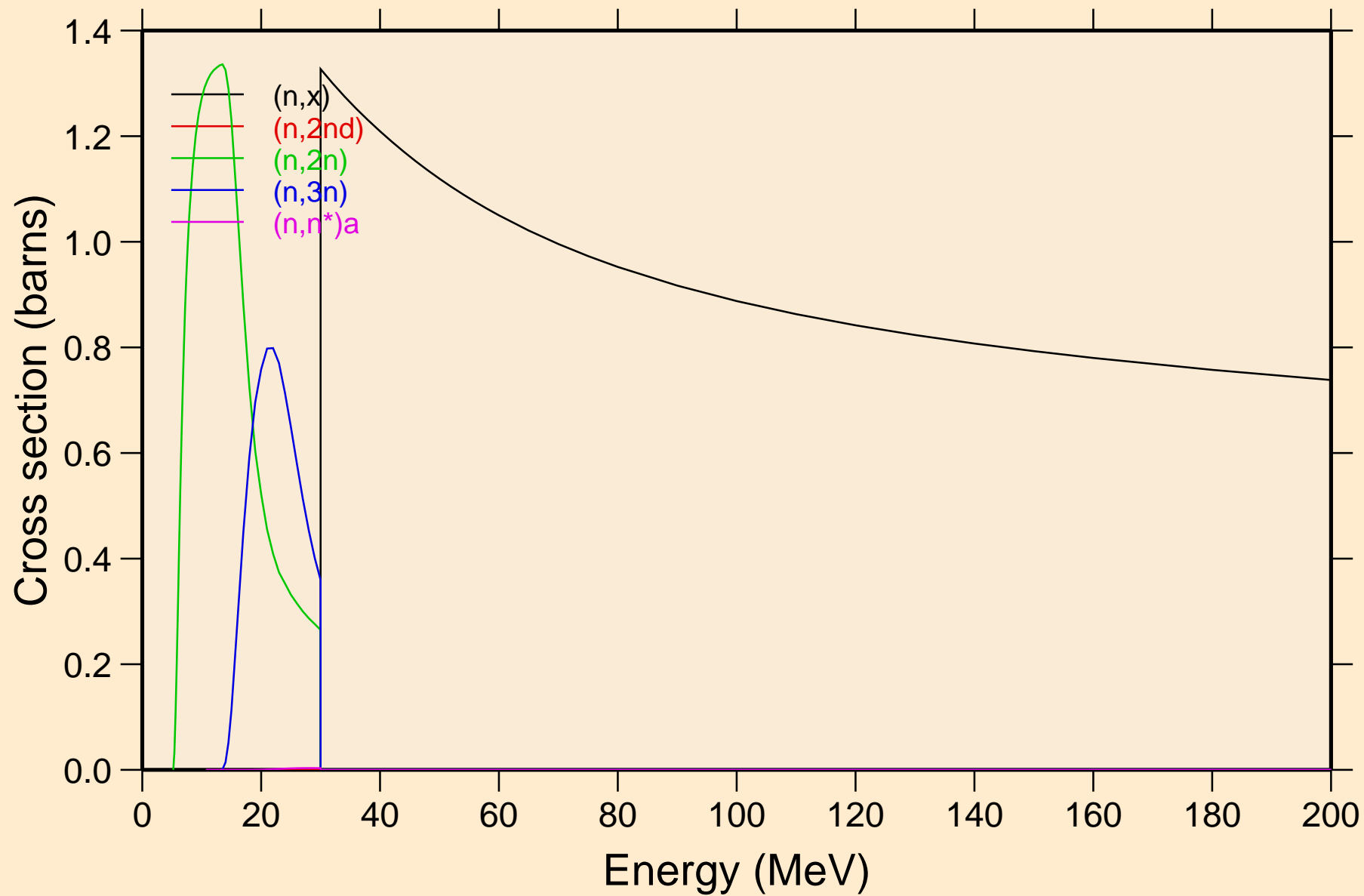

CU072 NEUTRON ACER TENDL-2023 LIBRARY; T=0.K  
Threshold reactions

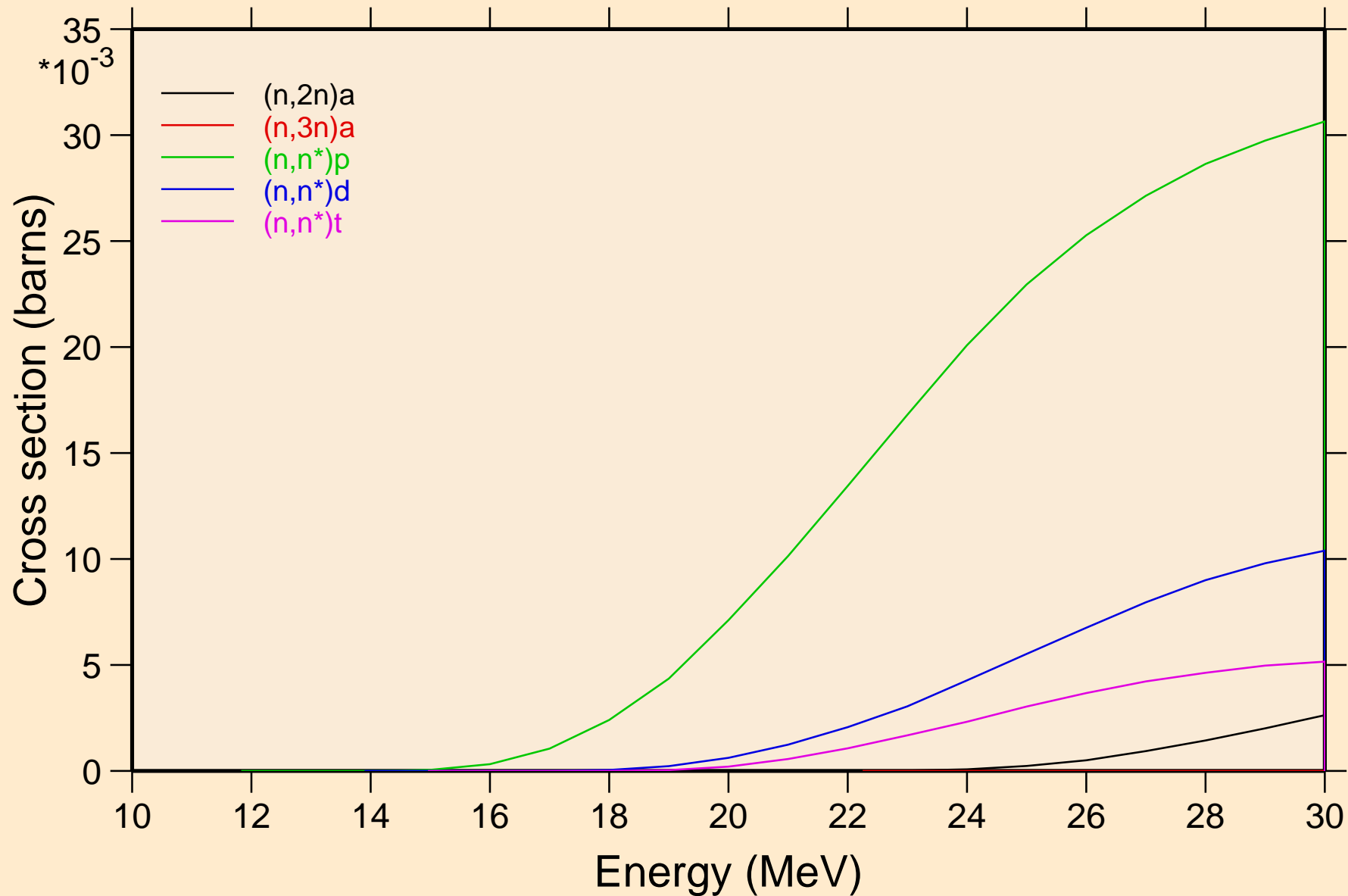



# CU072 NEUTRON ACER TENDL-2023 LIBRARY; T=0.K

## Threshold reactions

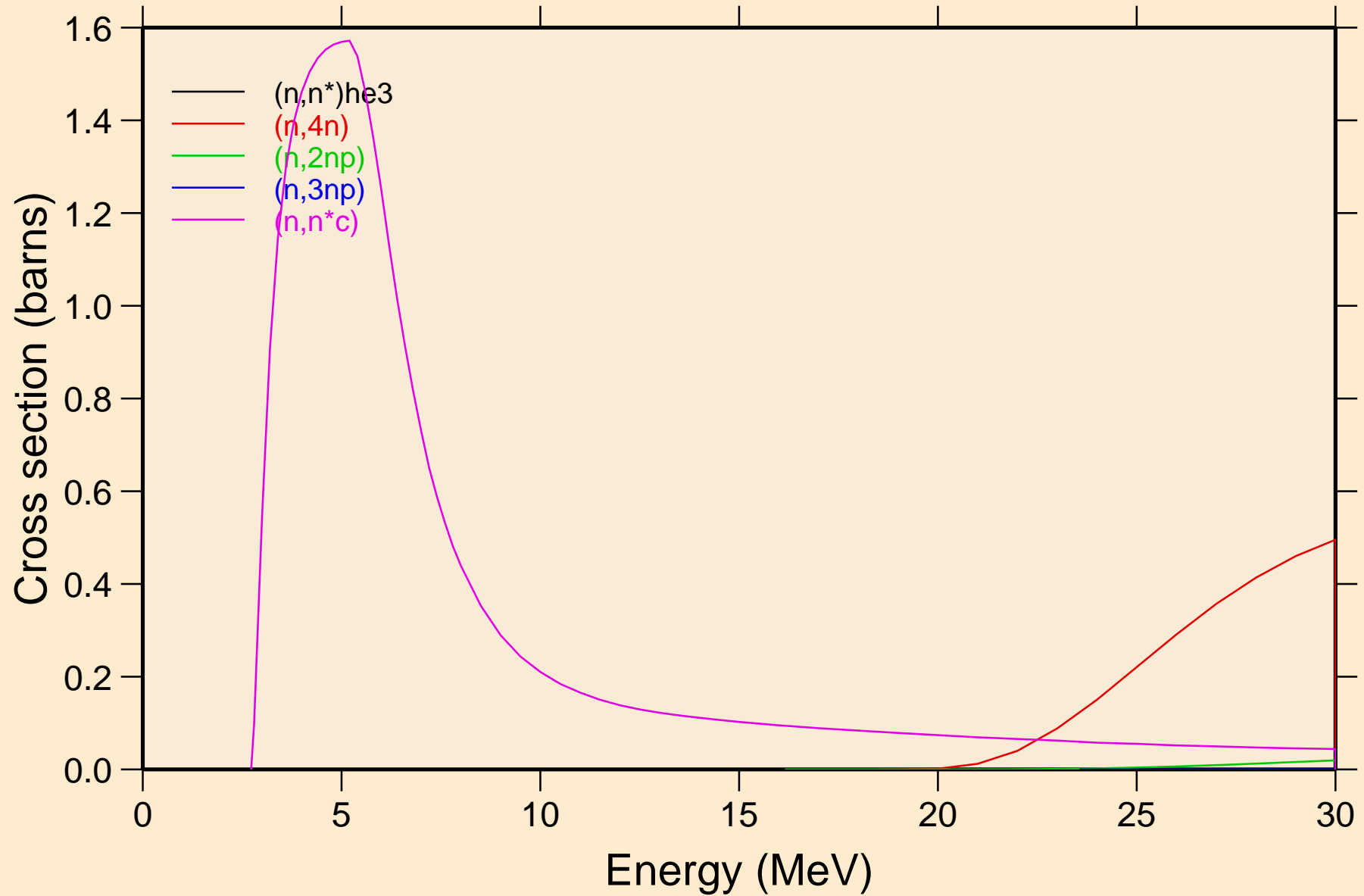

# CU072 NEUTRON ACER TENDL-2023 LIBRARY; T=0.K

## Threshold reactions

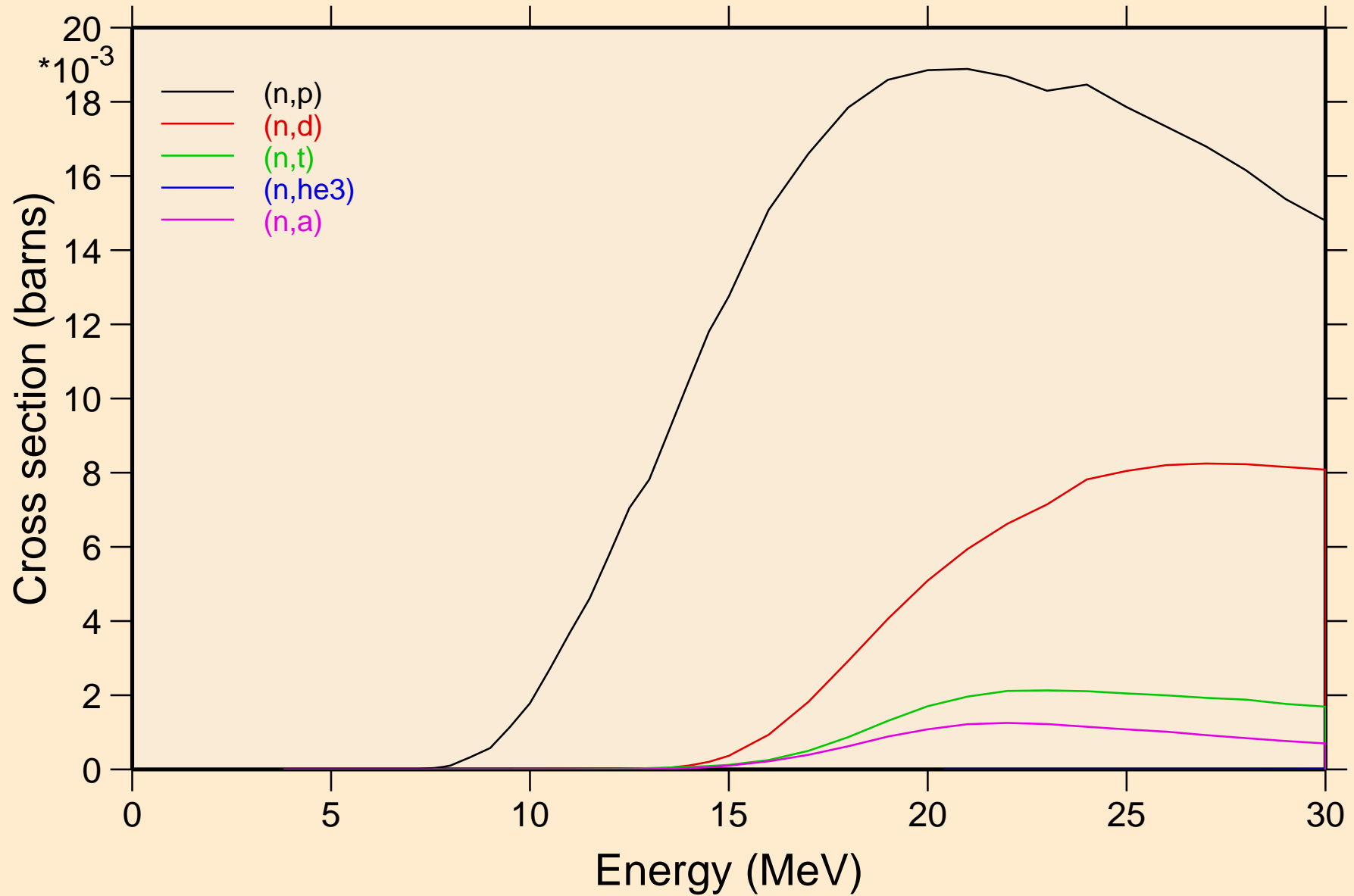

CU072 NEUTRON ACER TENDL-2023 LIBRARY; T=0.K  
Threshold reactions

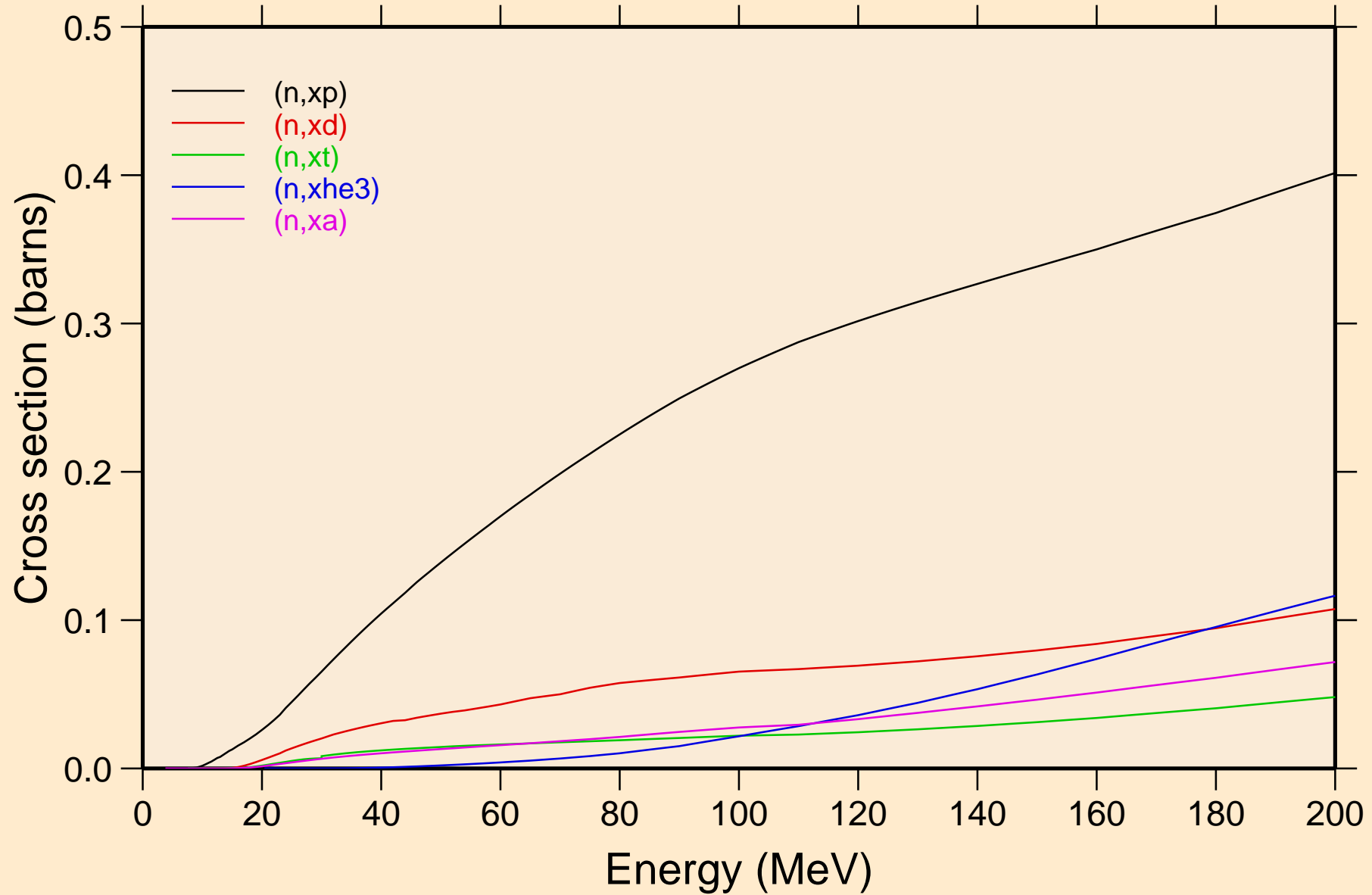

CU072 NEUTRON ACER TENDL-2023 LIBRARY; T=0.K  
angular distribution for elastic

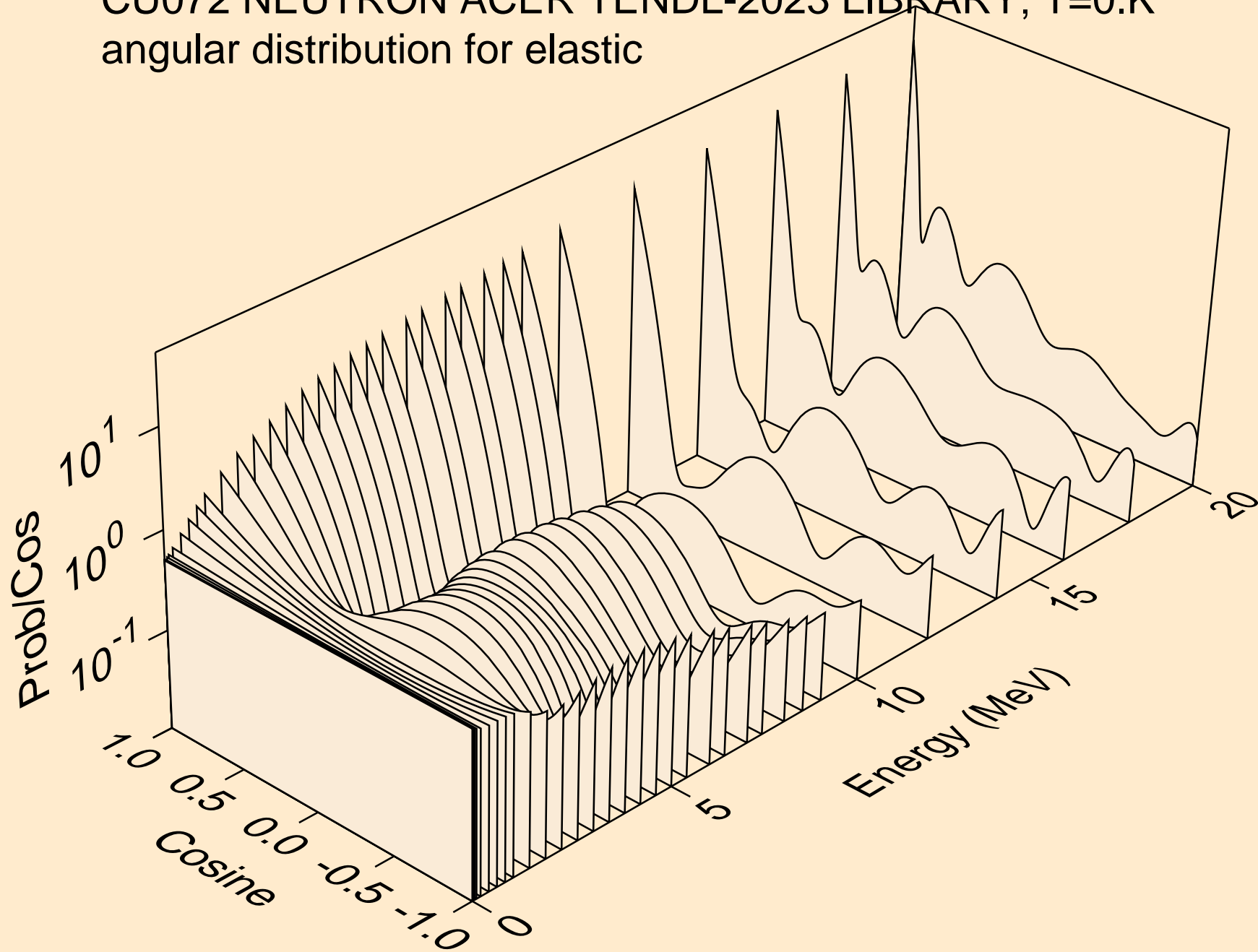

CU072 NEUTRON ACER TENDL-2023 LIBRARY; T=0.K  
angular distribution for elastic

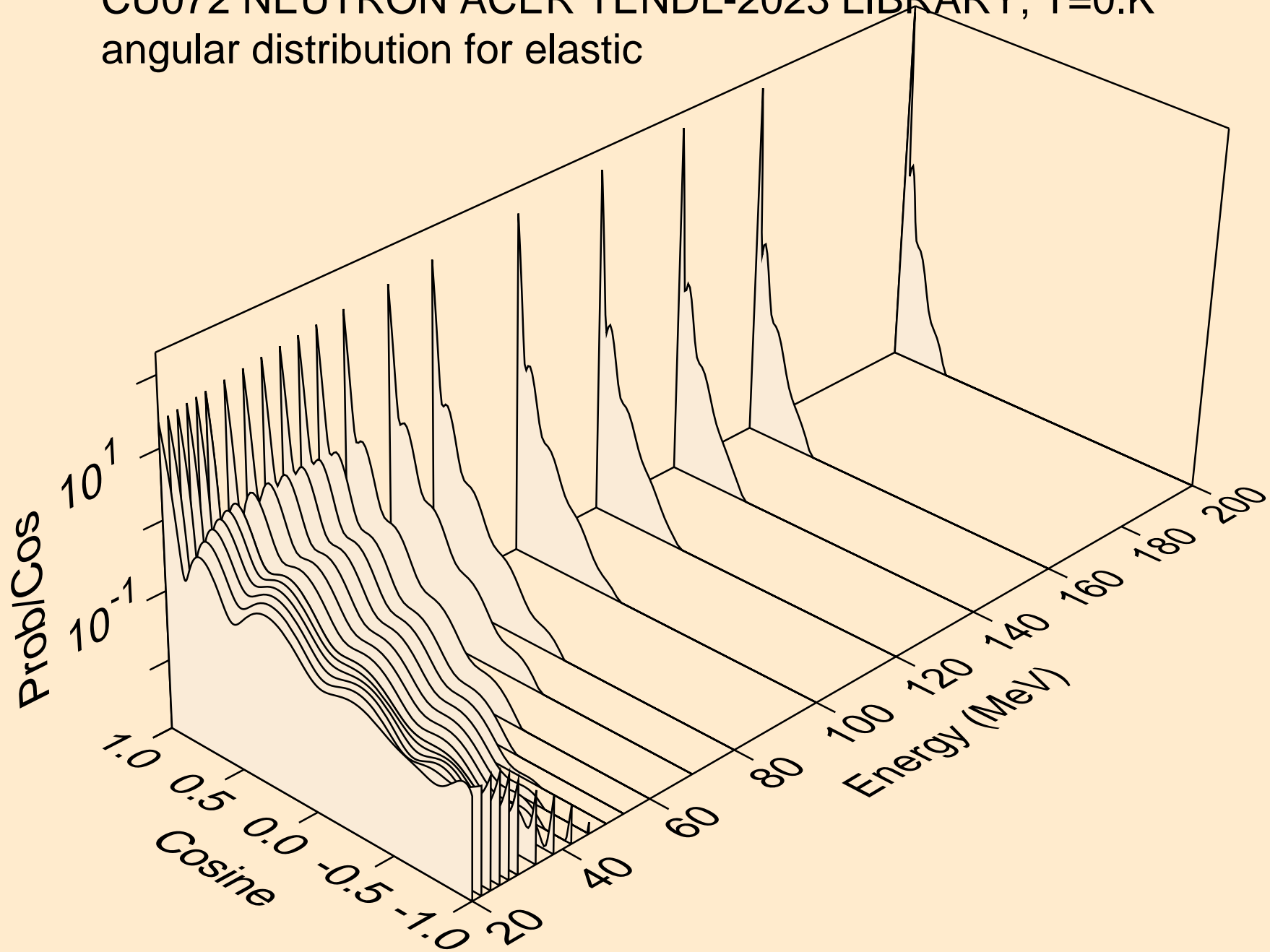

CU072 NEUTRON ACER TENDL-2023 LIBRARY; T=0.K  
angular distribution for (n,n\*1)

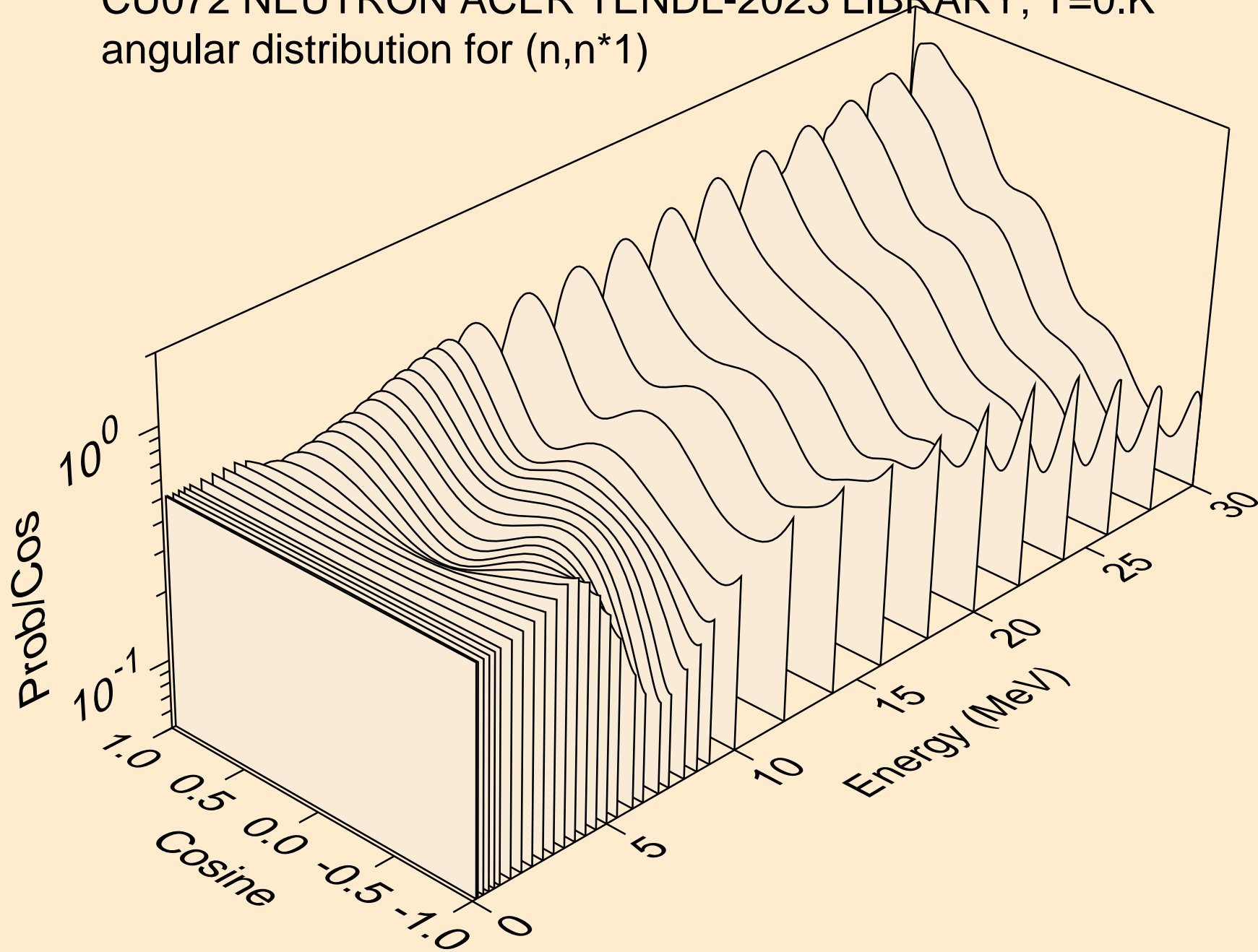

CU072 NEUTRON ACER TENDL-2023 LIBRARY; T=0.K  
angular distribution for (n,n\*2)

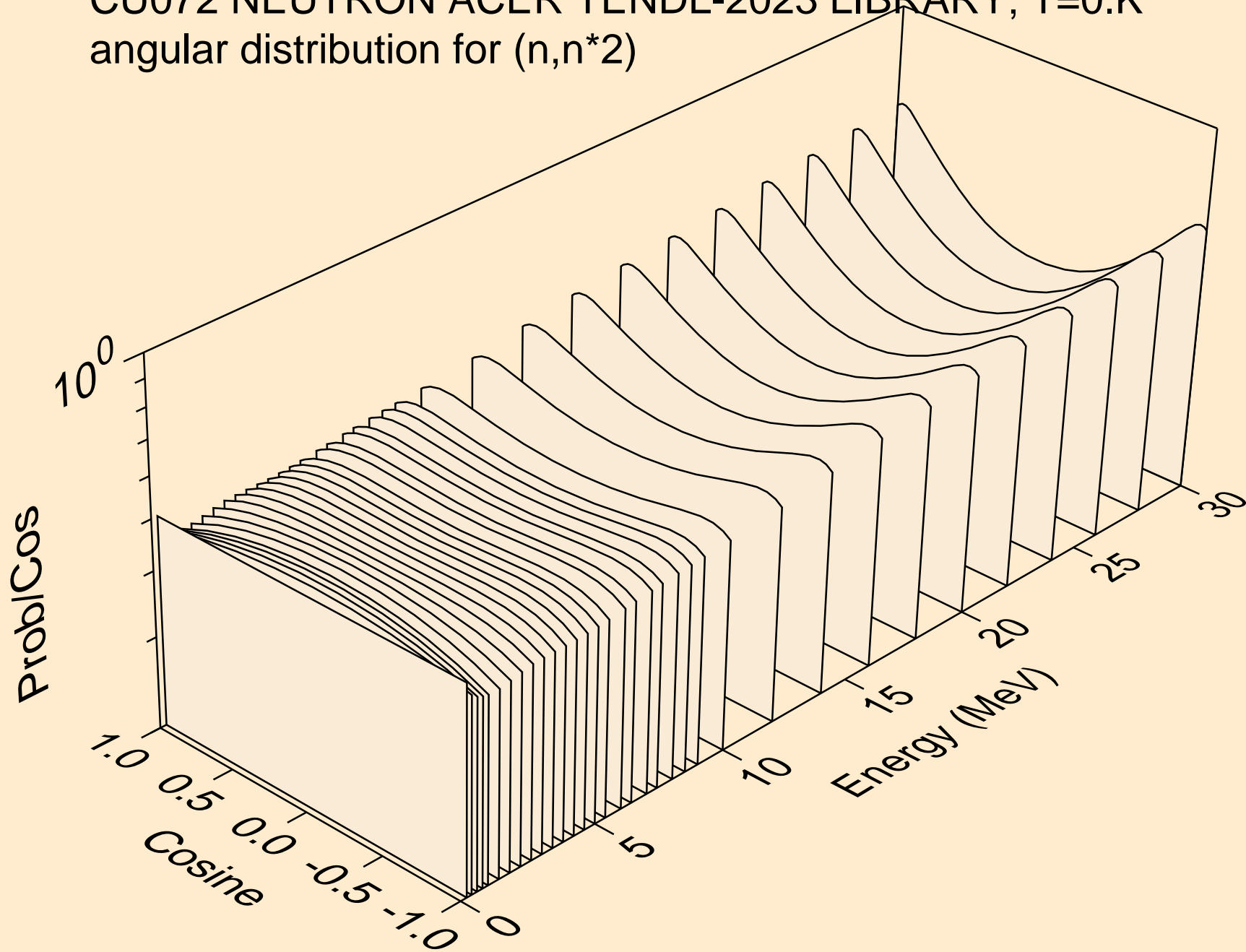

CU072 NEUTRON ACER TENDL-2023 LIBRARY; T=0.K  
angular distribution for (n,n\*3)

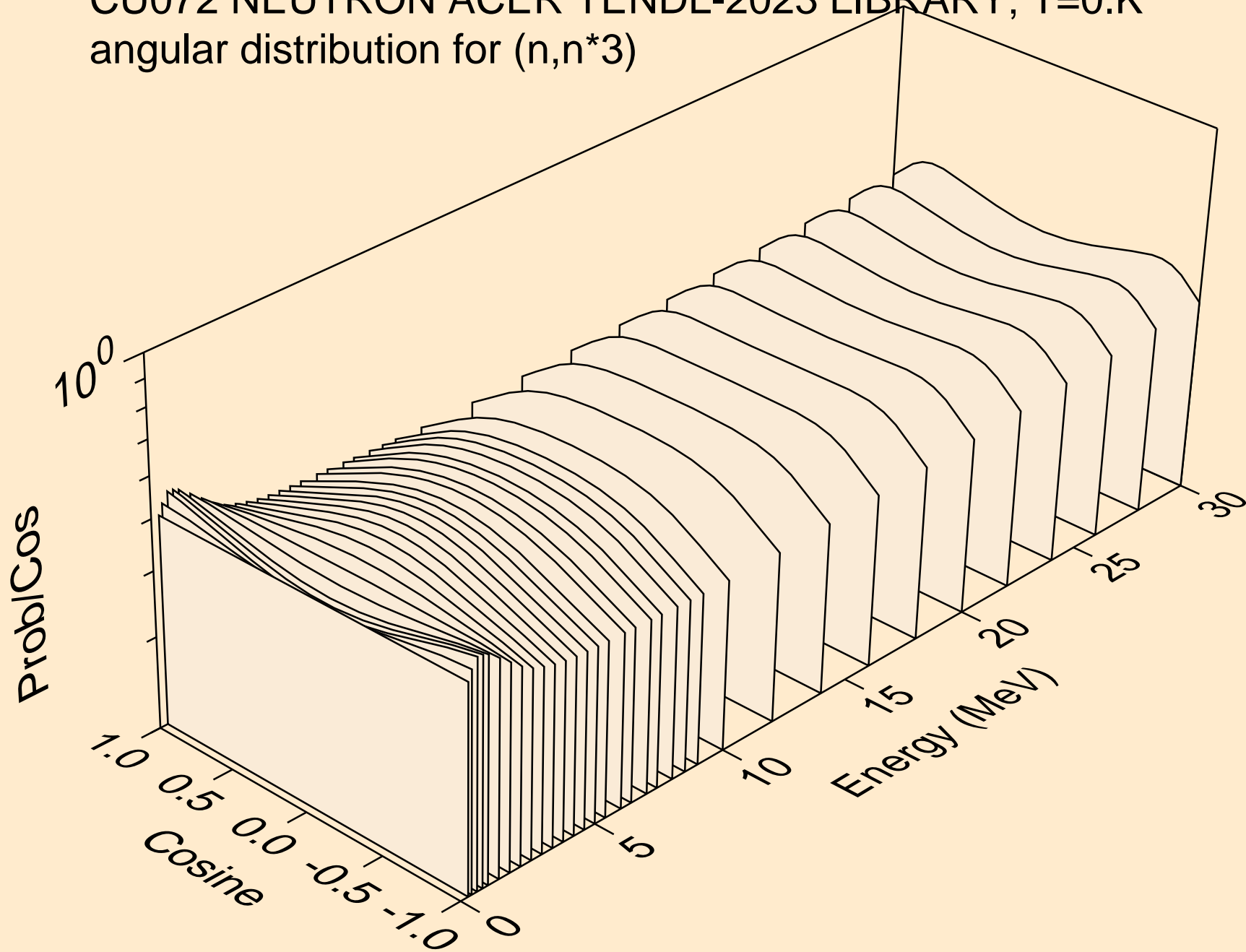



CU072 NEUTRON ACER TENDL-2023 LIBRARY; T=0.K  
angular distribution for (n,n\*4)

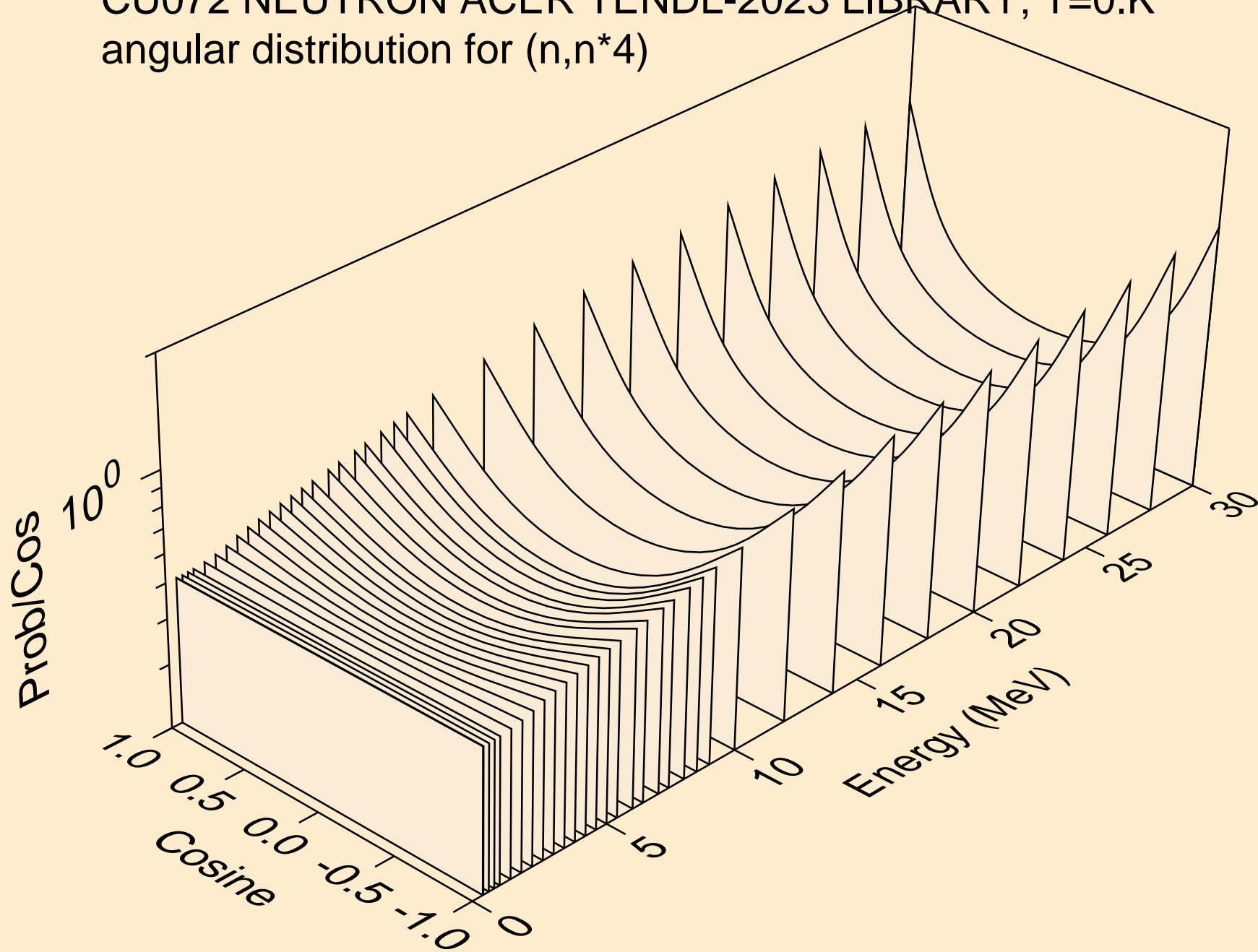

CU072 NEUTRON ACER TENDL-2023 LIBRARY; T=0.K  
angular distribution for (n,n\*5)

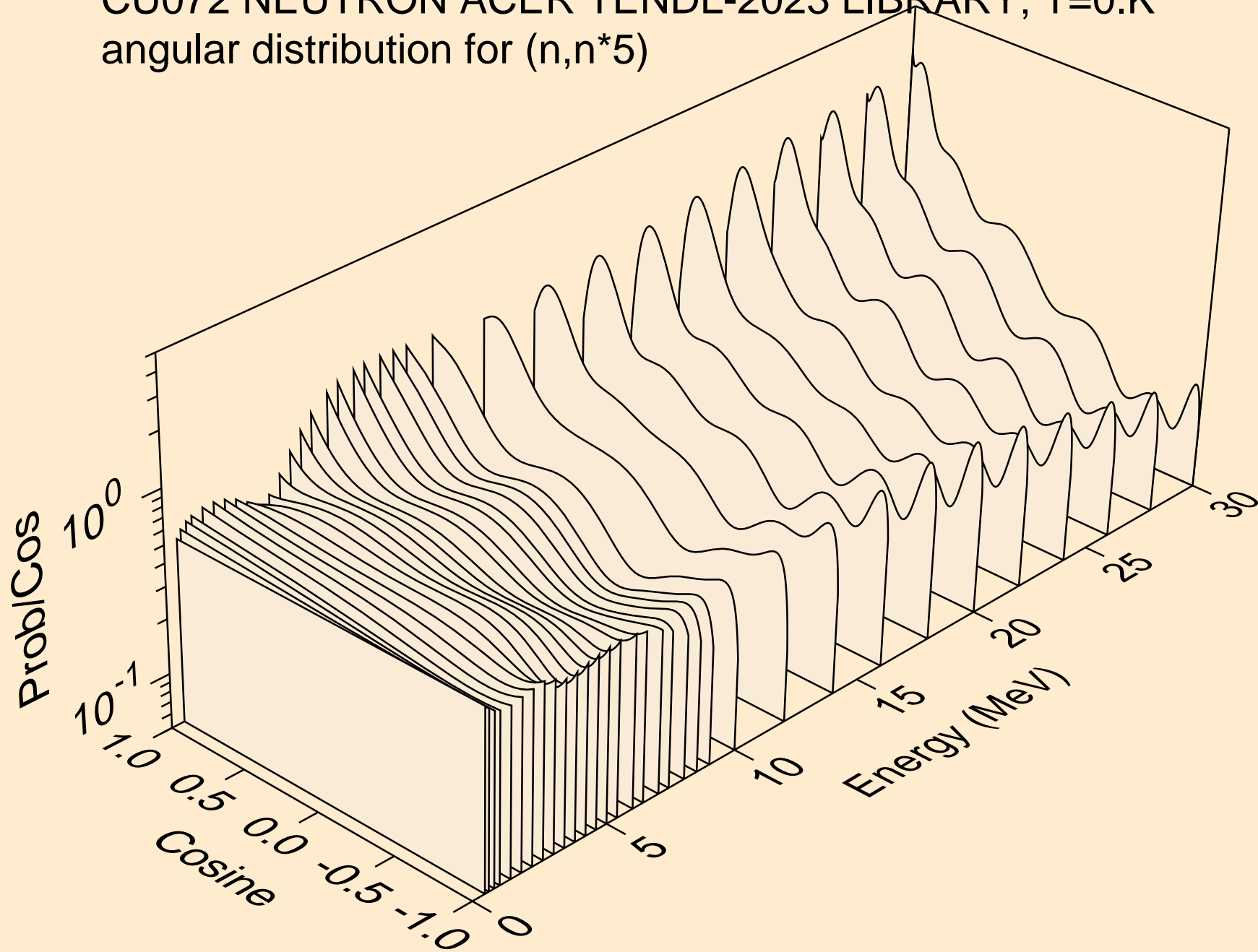

CU072 NEUTRON ACER TENDL-2023 LIBRARY; T=0.K  
angular distribution for (n,n\*6)

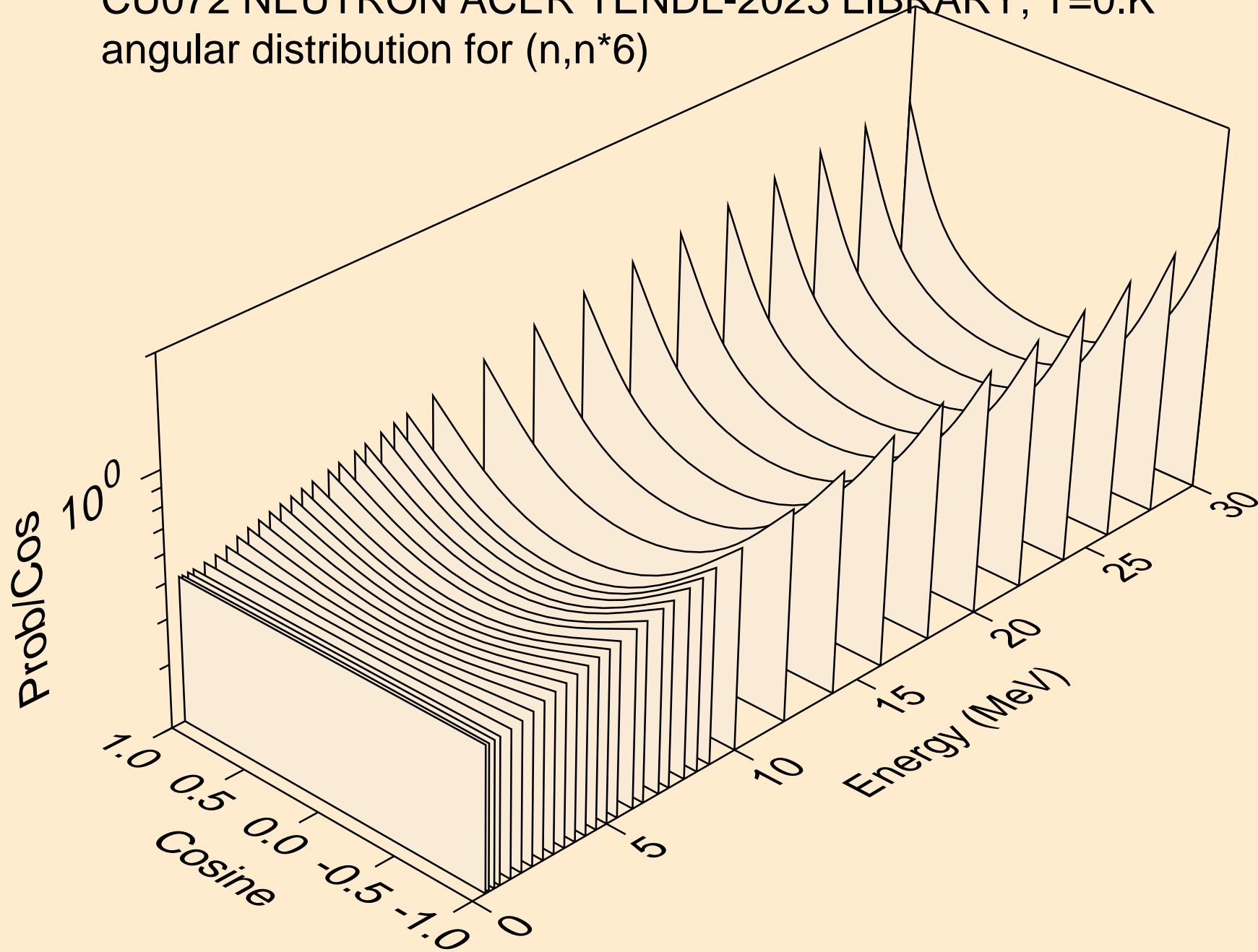

CU072 NEUTRON ACER TENDL-2023 LIBRARY; T=0.K  
angular distribution for (n,n\*7)

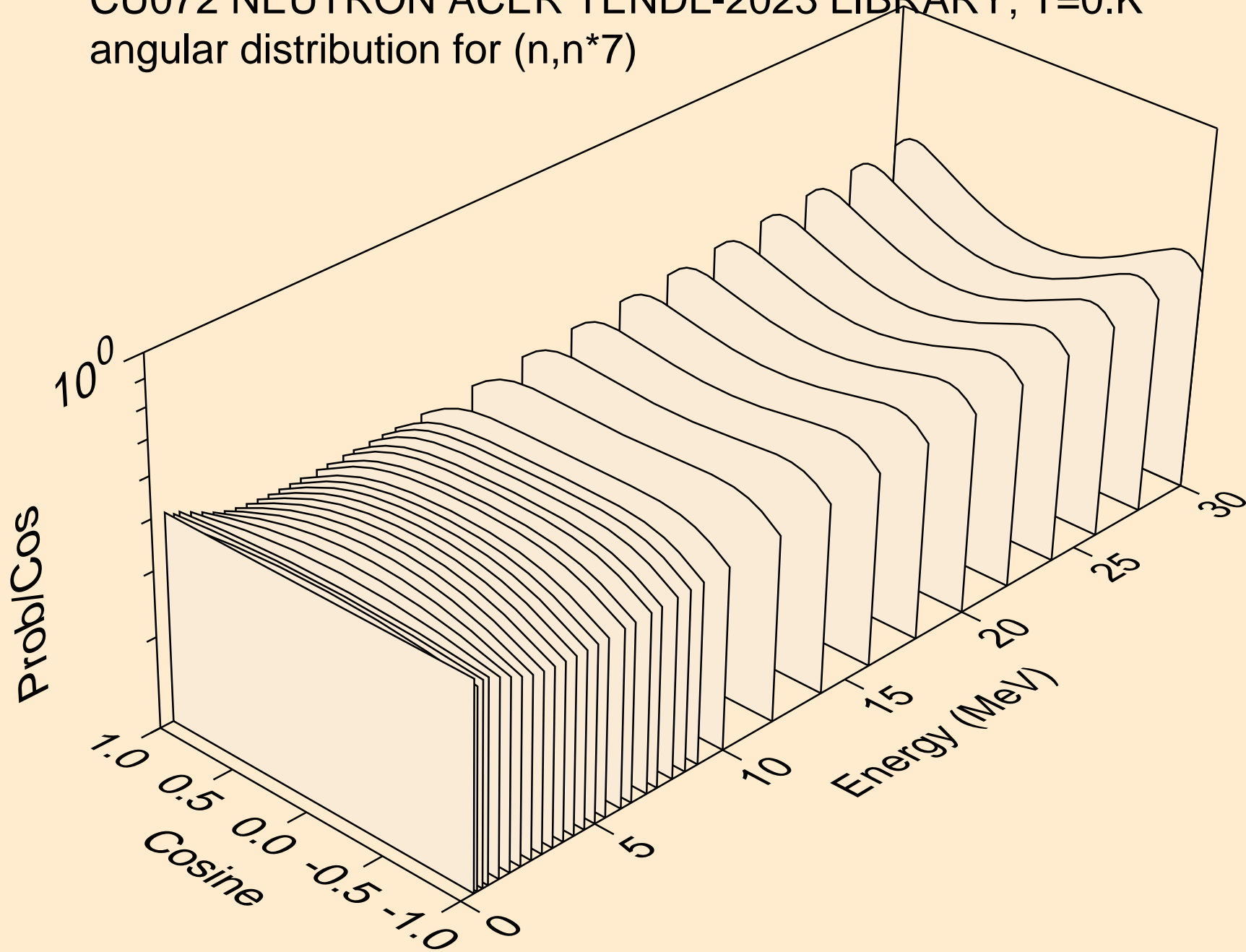

CU072 NEUTRON ACER TENDL-2023 LIBRARY; T=0.K  
angular distribution for (n,n\*8)

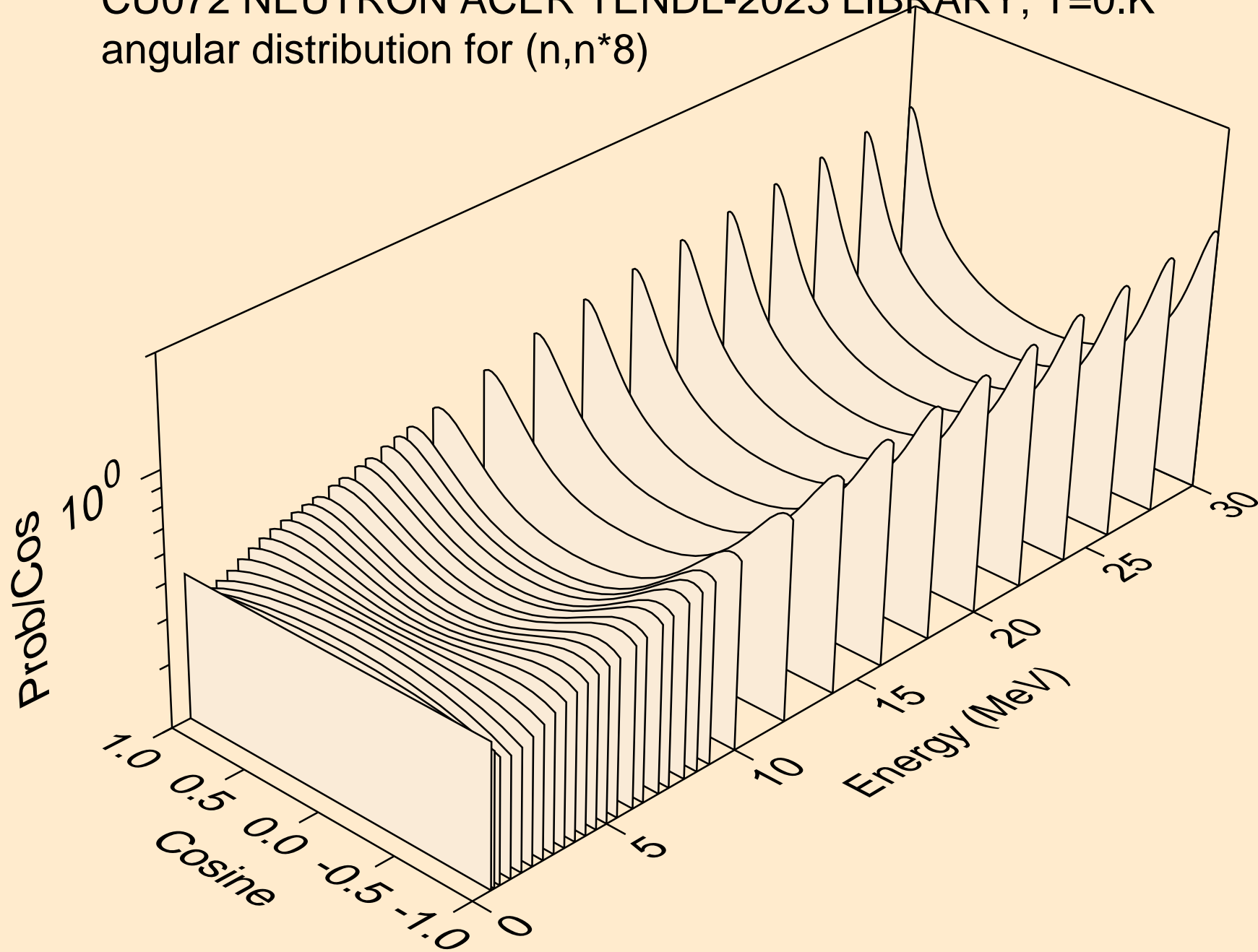

CU072 NEUTRON ACER TENDL-2023 LIBRARY; T=0.K  
angular distribution for (n,n\*9)

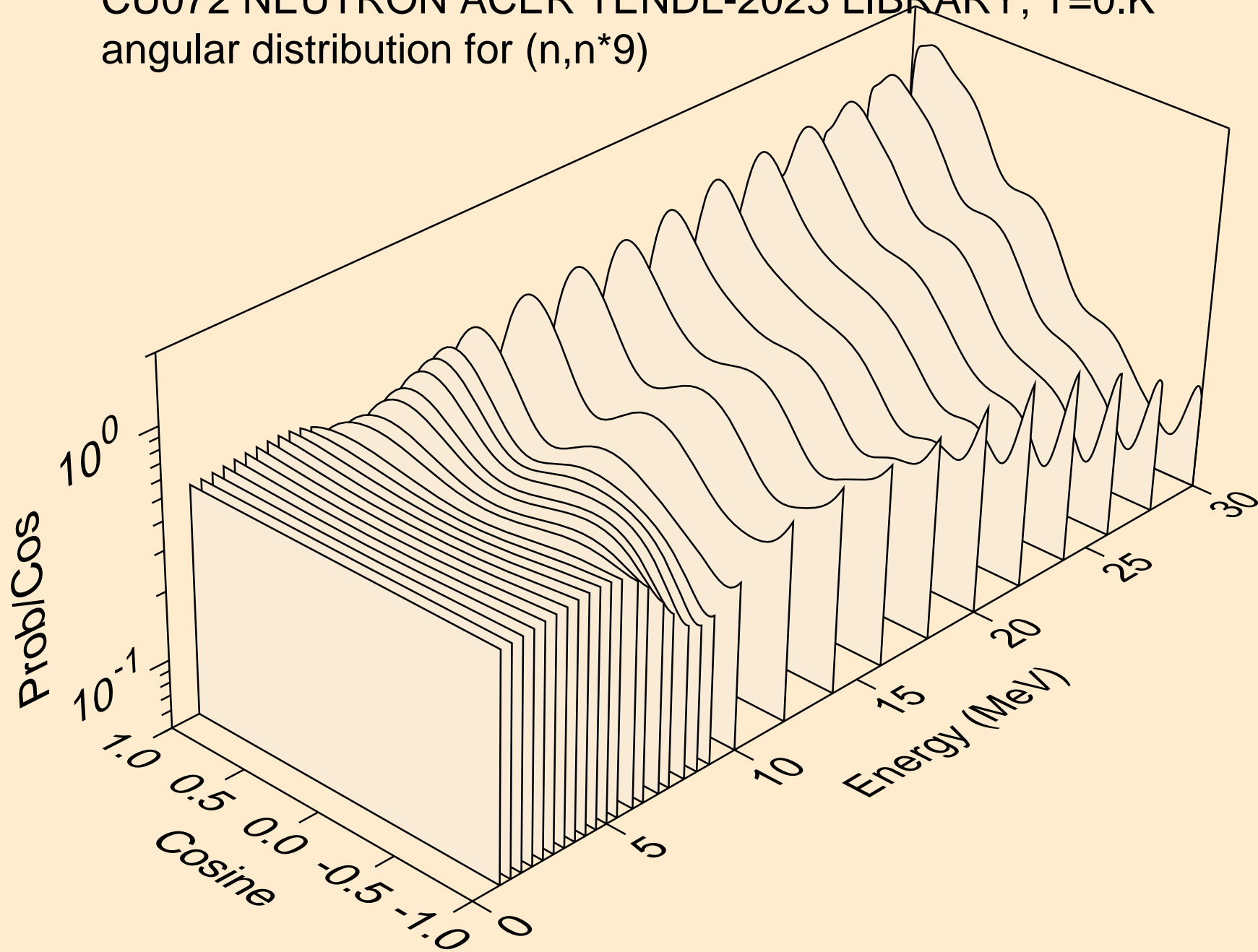

CU072 NEUTRON ACER TENDL-2023 LIBRARY; T=0.K  
angular distribution for (n,n\*10)

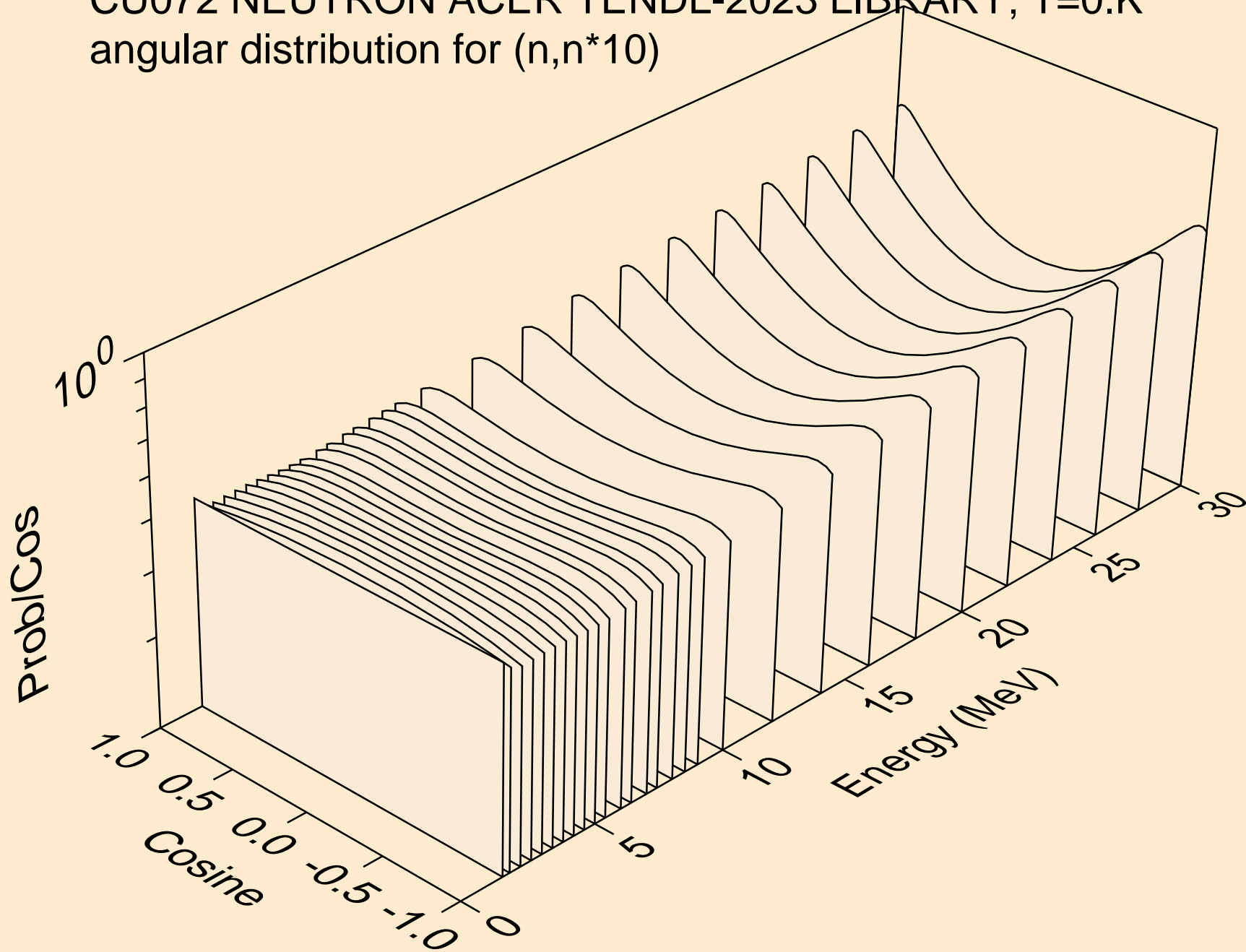

CU072 NEUTRON ACER TENDL-2023 LIBRARY; T=0.K  
angular distribution for (n,n\*11)

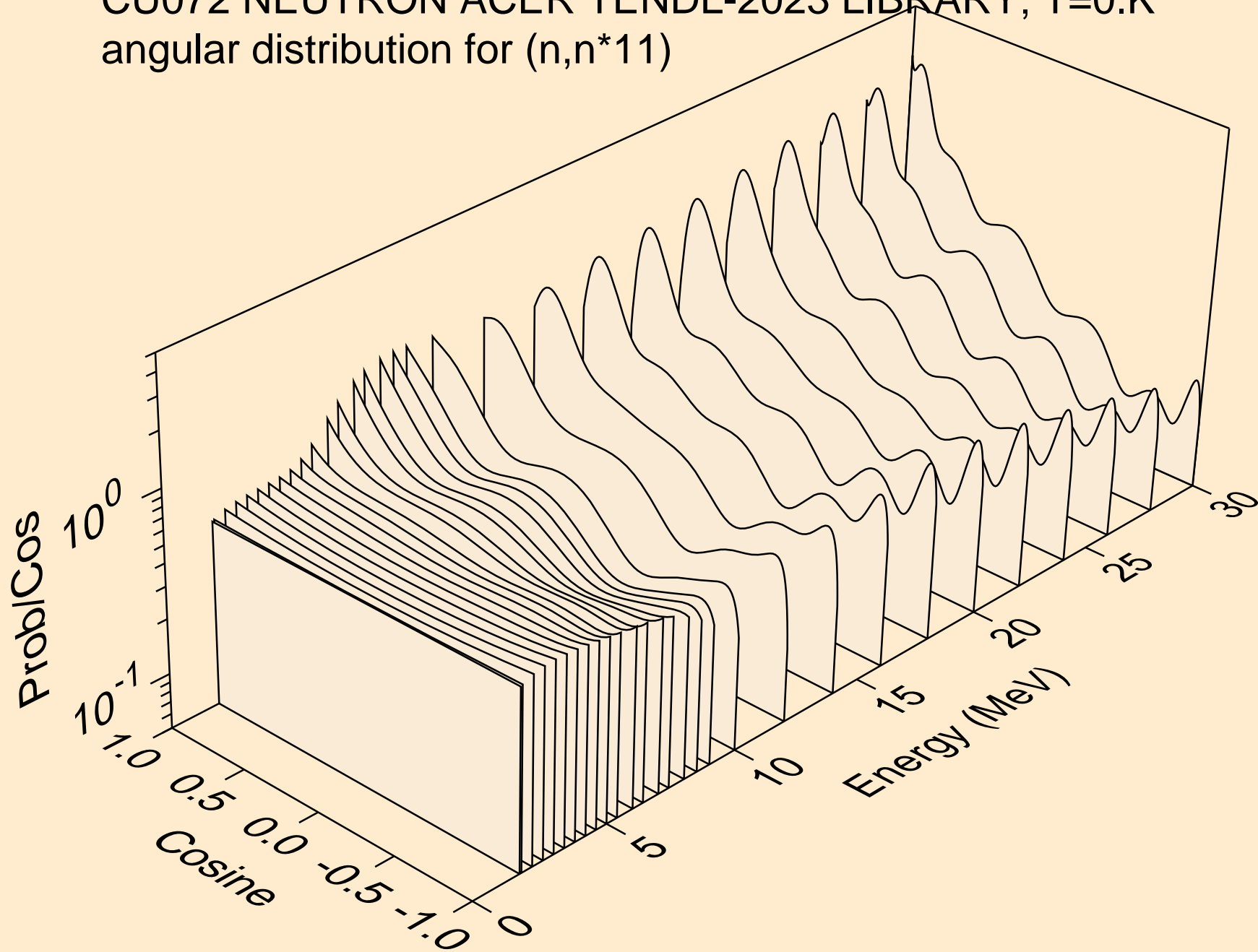



CU072 NEUTRON ACER TENDL-2023 LIBRARY; T=0.K  
angular distribution for (n,n\*12)

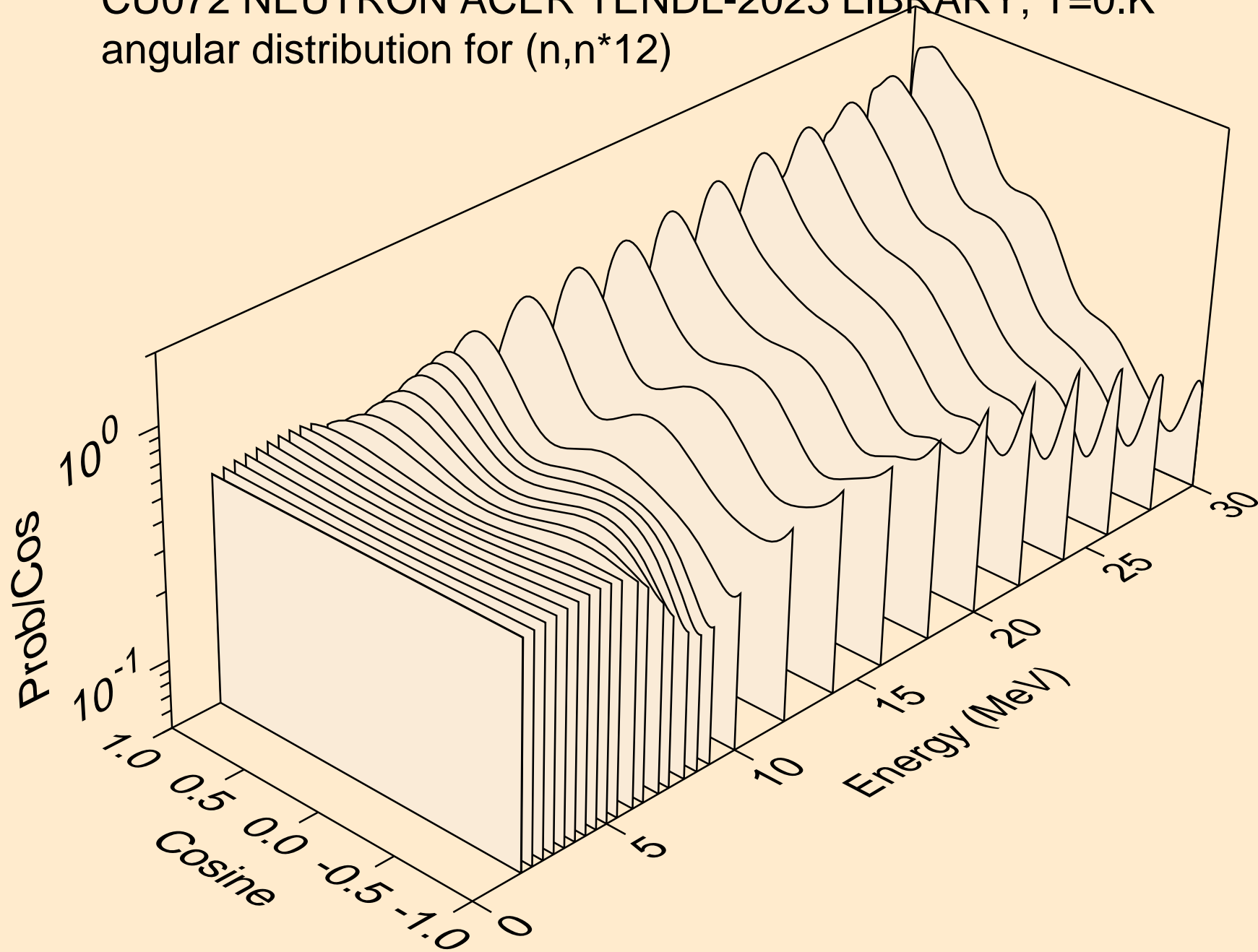

CU072 NEUTRON ACER TENDL-2023 LIBRARY; T=0.K  
angular distribution for (n,n\*13)

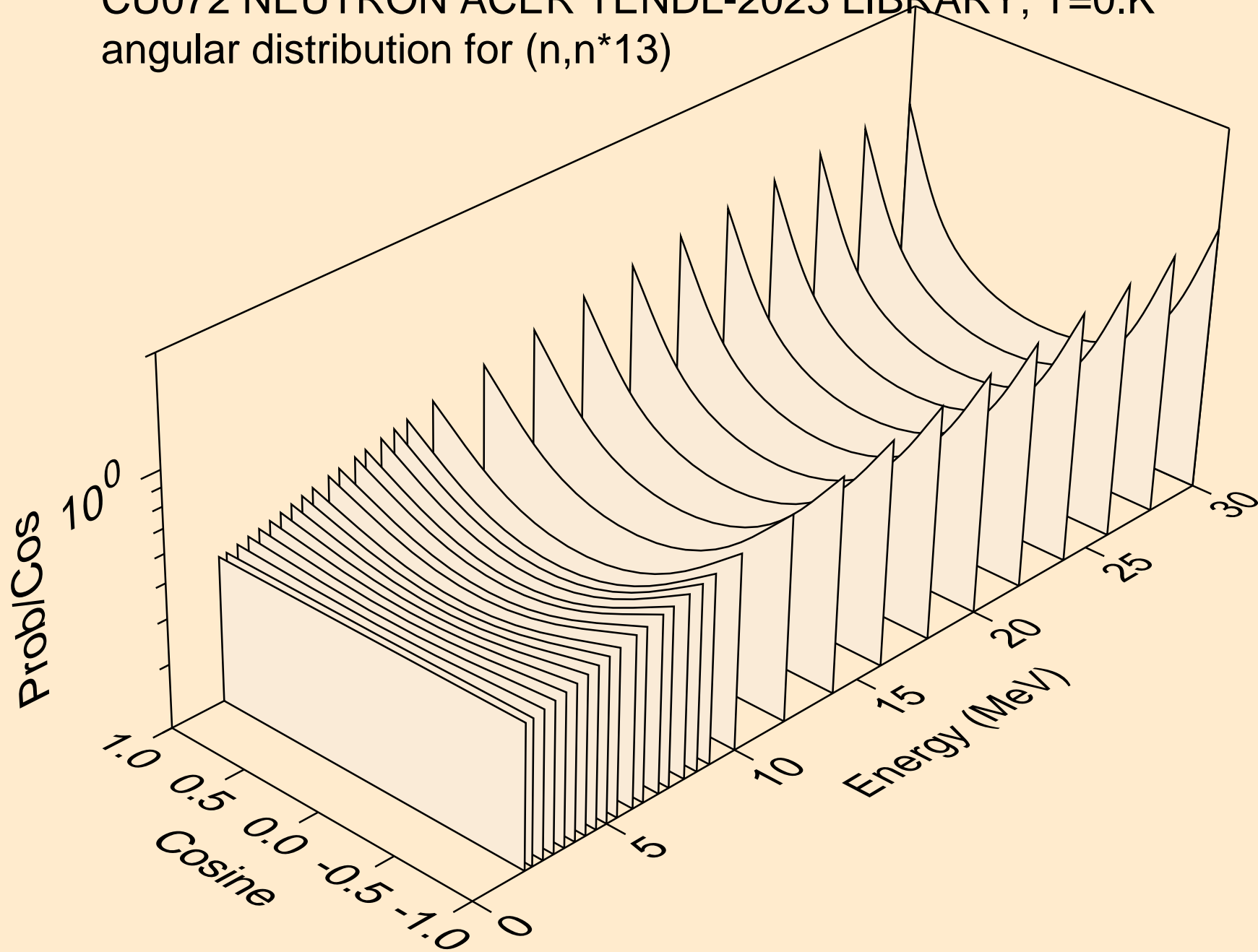

CU072 NEUTRON ACER TENDL-2023 LIBRARY; T=0.K  
angular distribution for (n,n\*14)

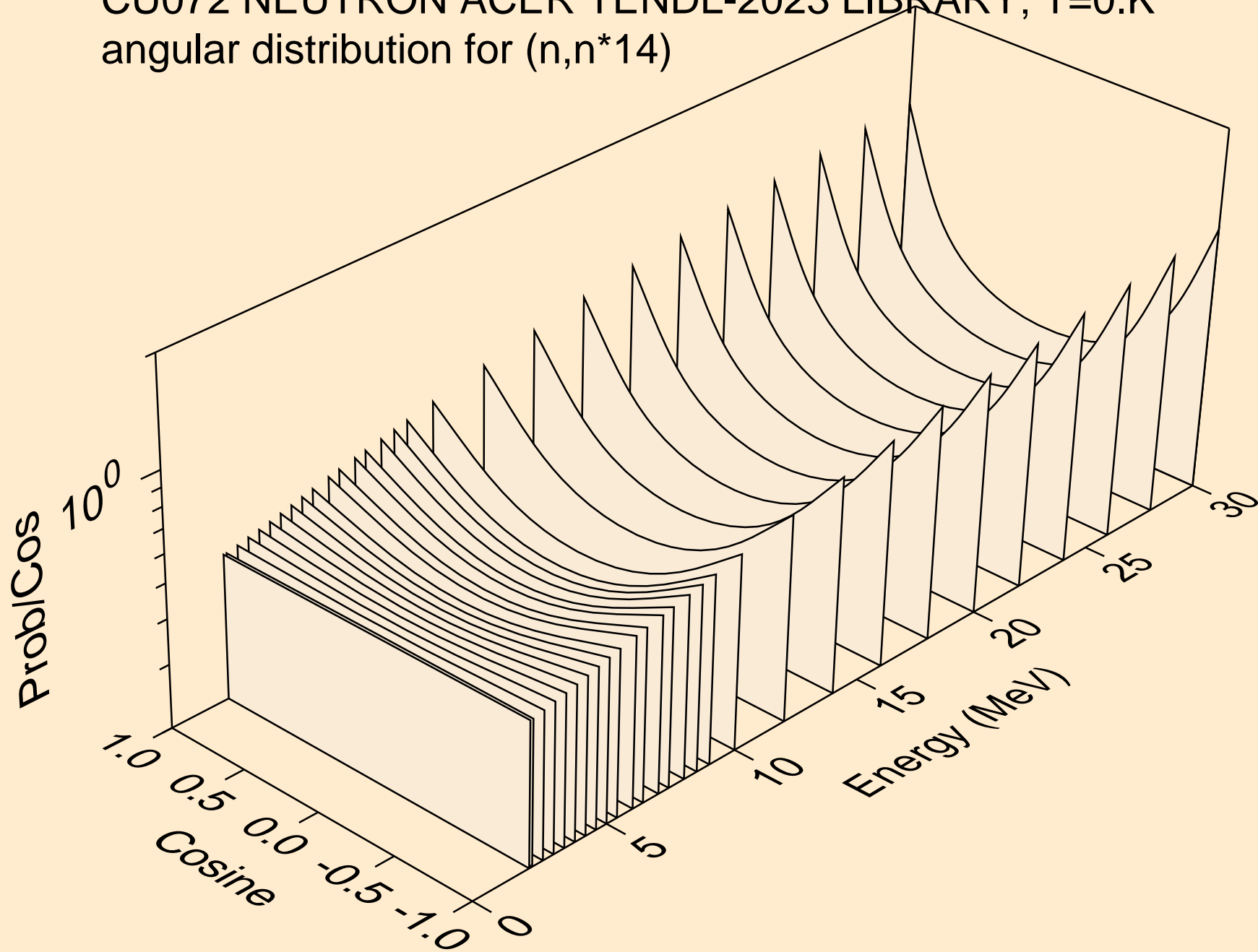

CU072 NEUTRON ACER TENDL-2023 LIBRARY; T=0.K  
angular distribution for (n,n\*15)

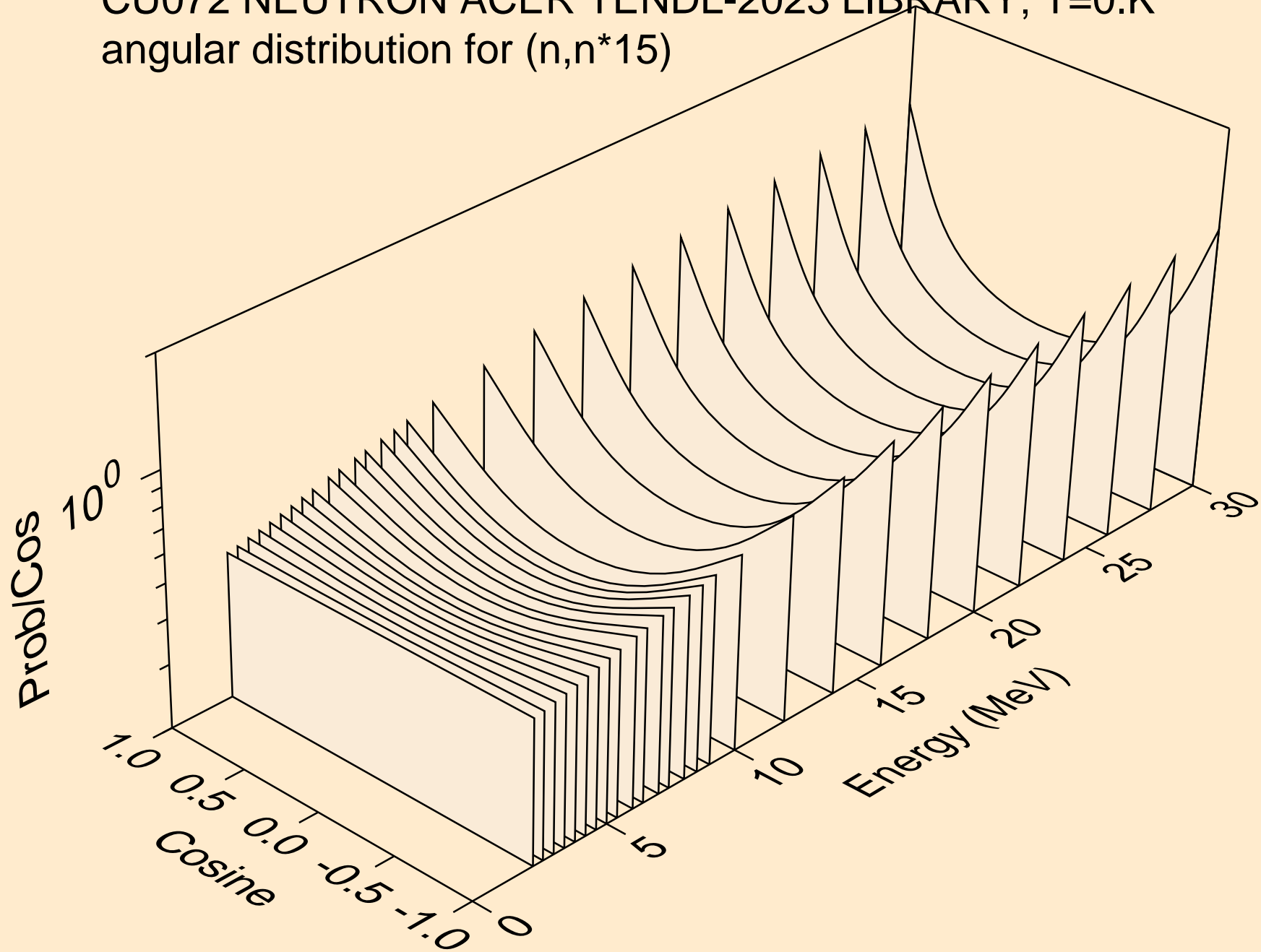

CU072 NEUTRON ACER TENDL-2023 LIBRARY; T=0.K  
angular distribution for (n,n\*16)

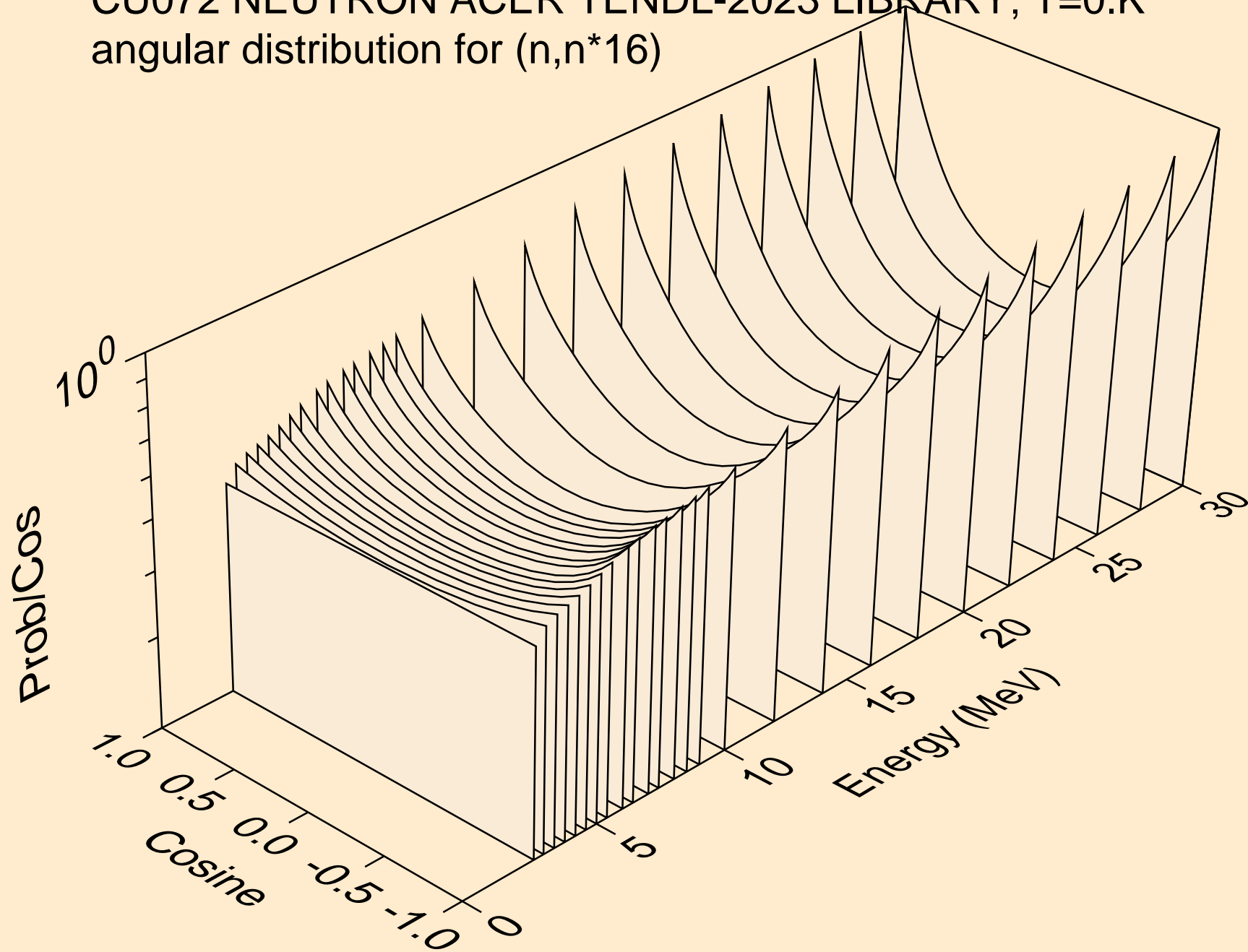

CU072 NEUTRON ACER TENDL-2023 LIBRARY; T=0.K  
angular distribution for (n,n\*17)

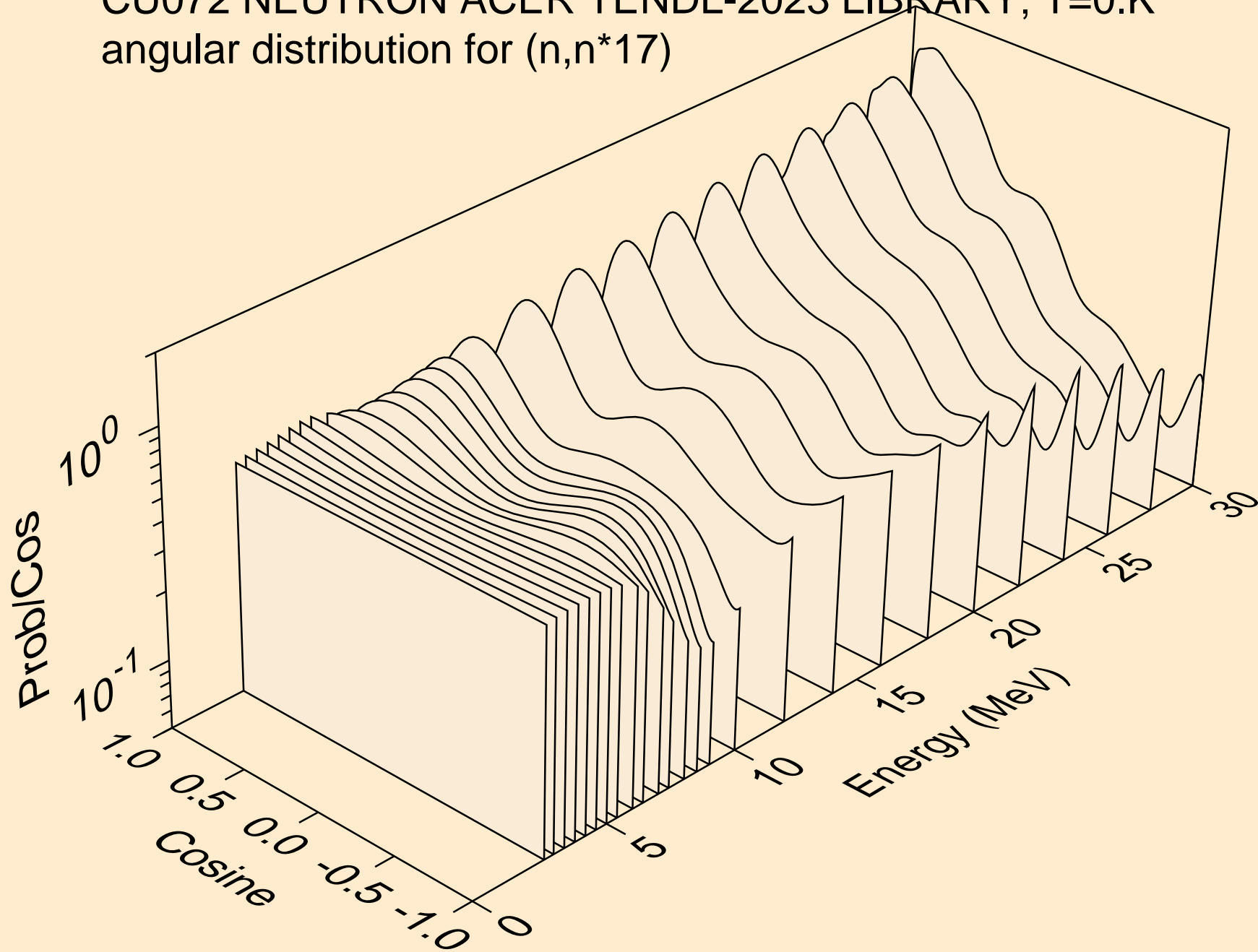

CU072 NEUTRON ACER TENDL-2023 LIBRARY; T=0.K  
angular distribution for (n,n\*18)

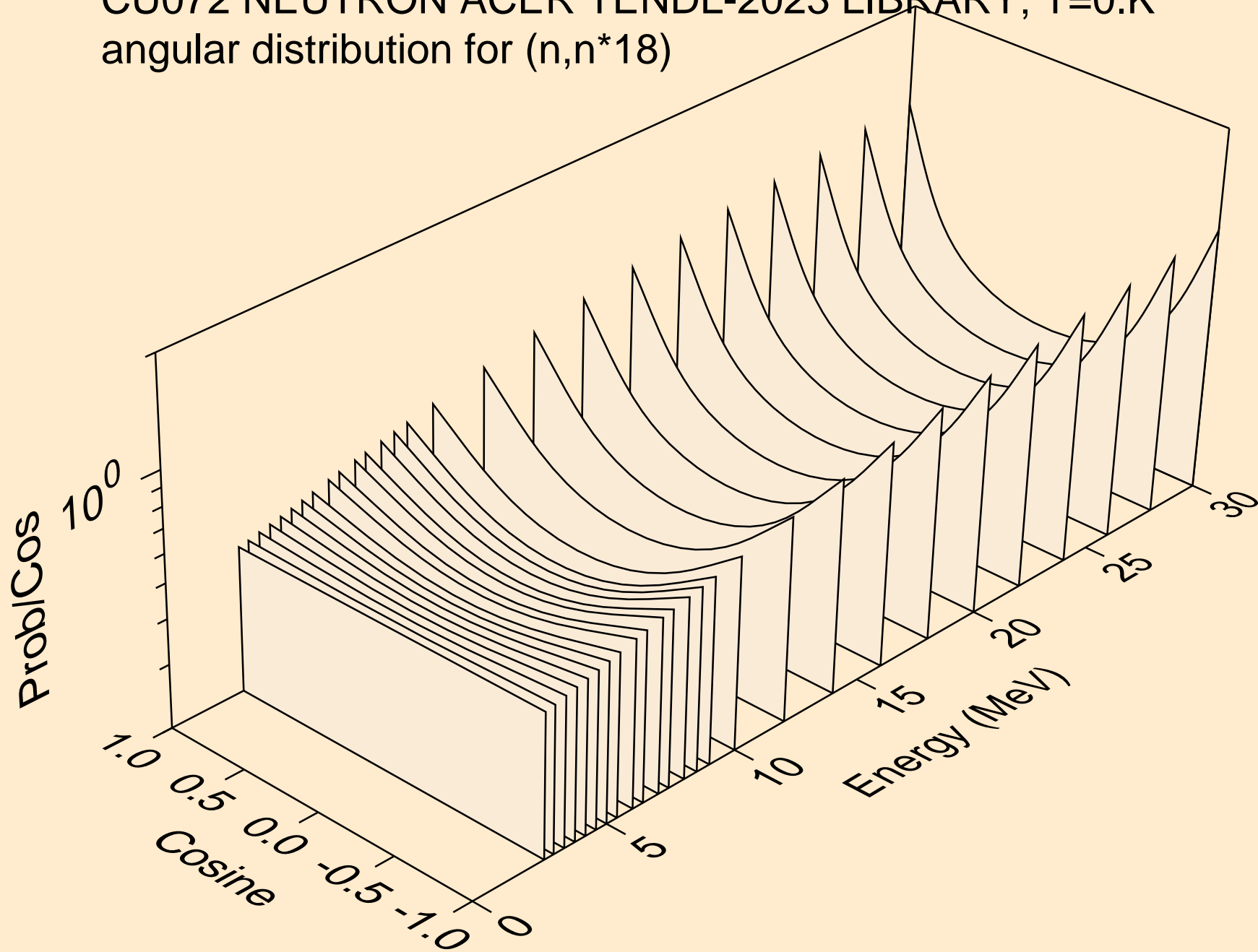

CU072 NEUTRON ACER TENDL-2023 LIBRARY; T=0.K  
angular distribution for (n,n\*19)

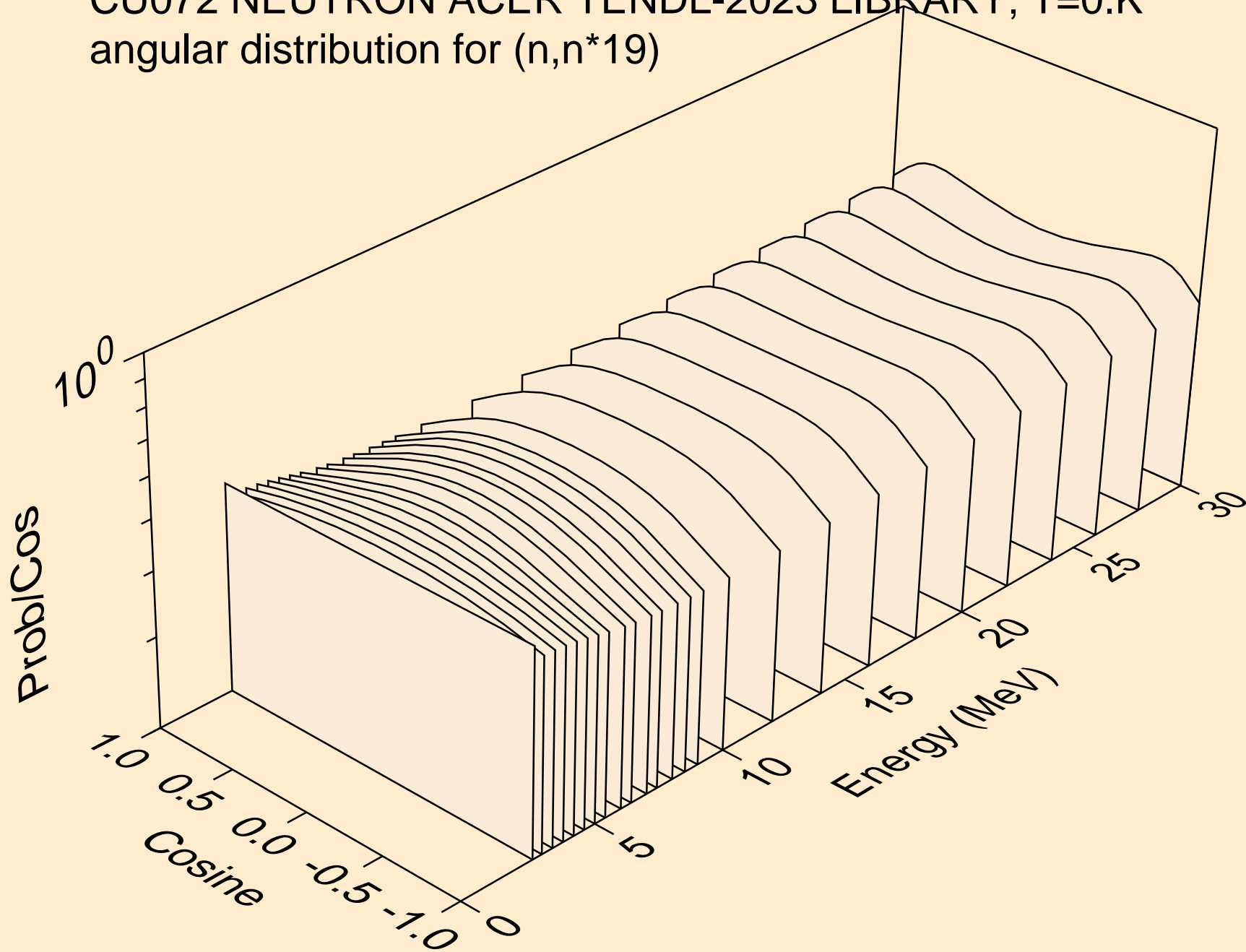



CU072 NEUTRON ACER TENDL-2023 LIBRARY; T=0.K  
angular distribution for (n,n\*20)

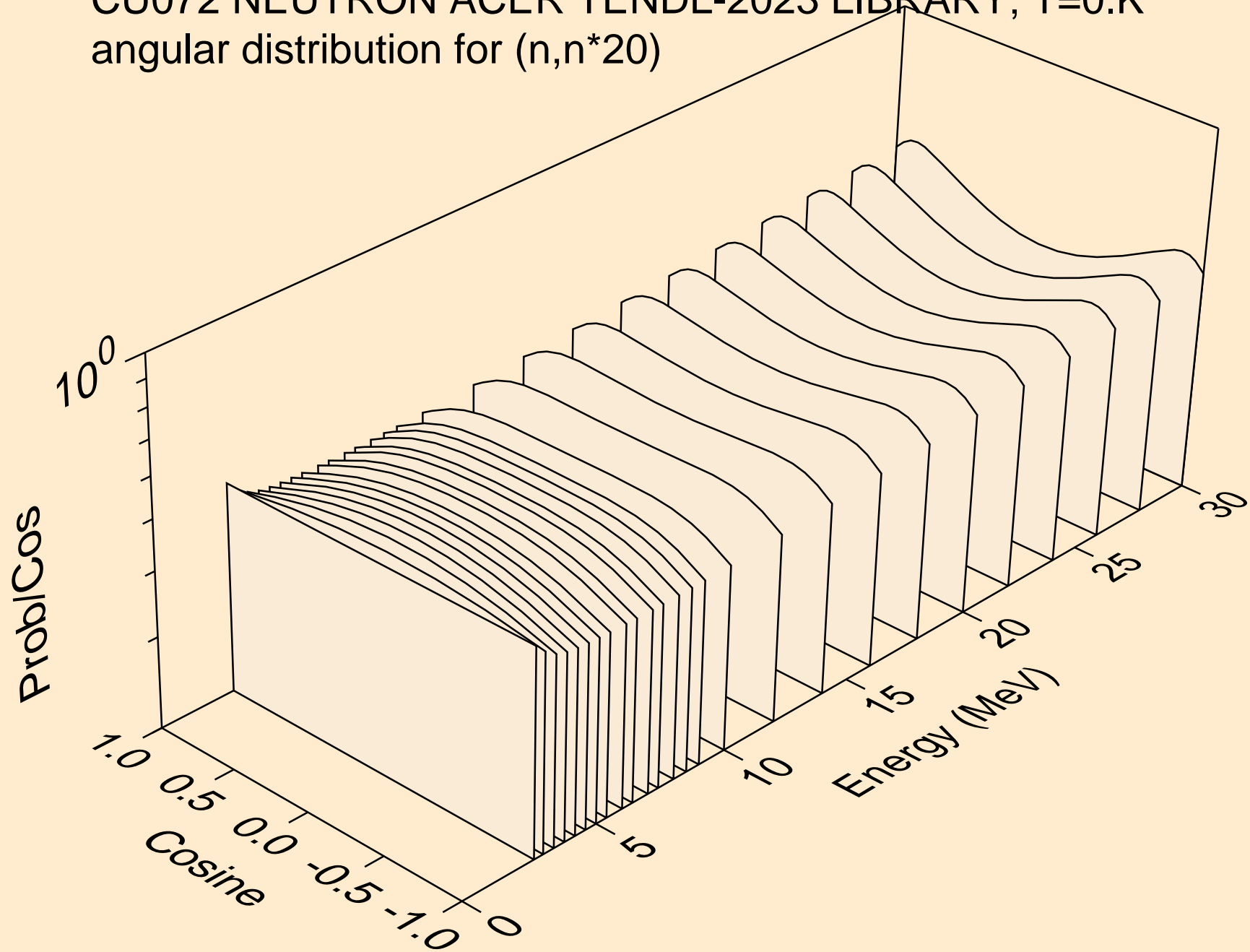

CU072 NEUTRON ACER TENDL-2023 LIBRARY; T=0.K  
angular distribution for (n,n\*21)

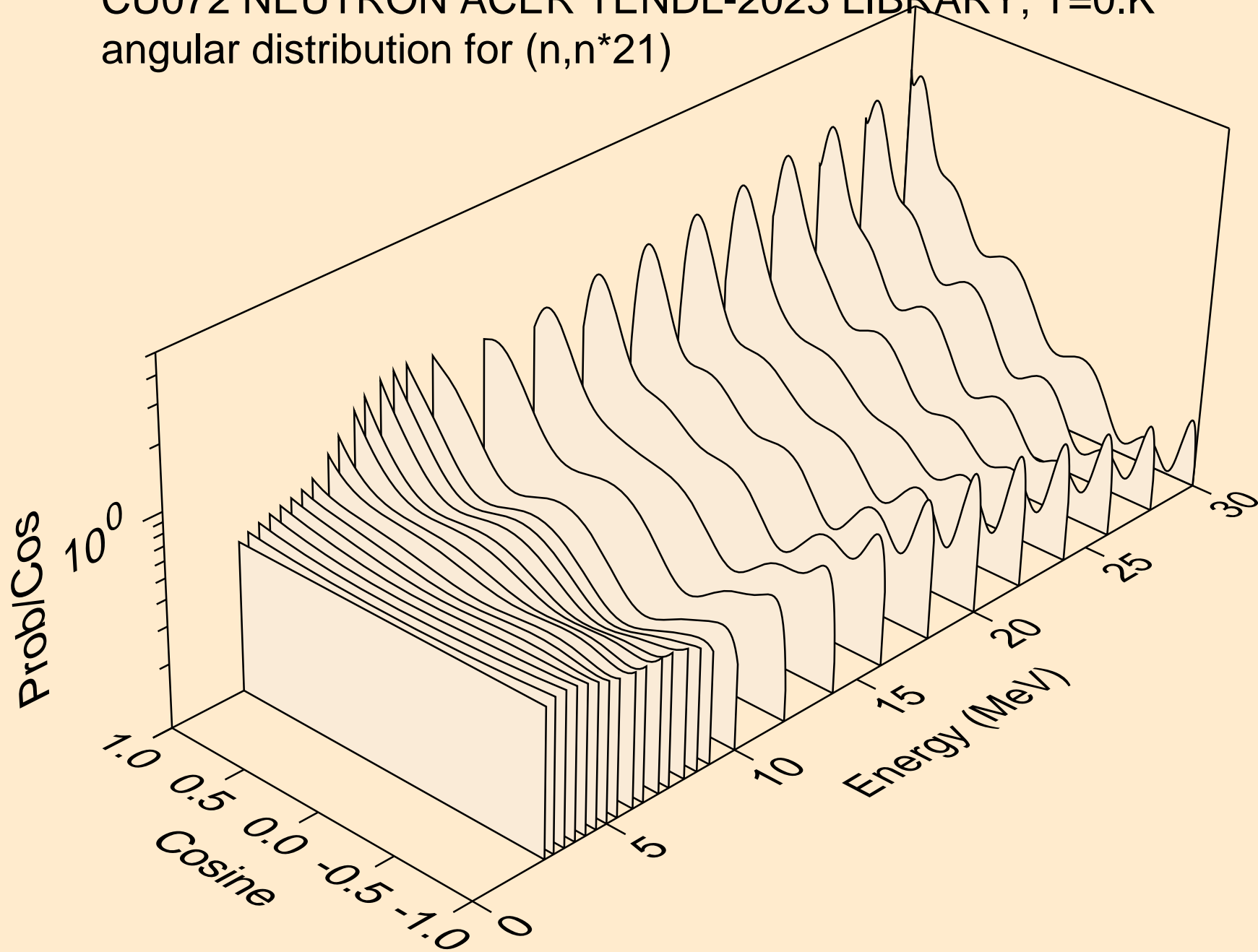

CU072 NEUTRON ACER TENDL-2023 LIBRARY; T=0.K  
angular distribution for (n,n\*22)

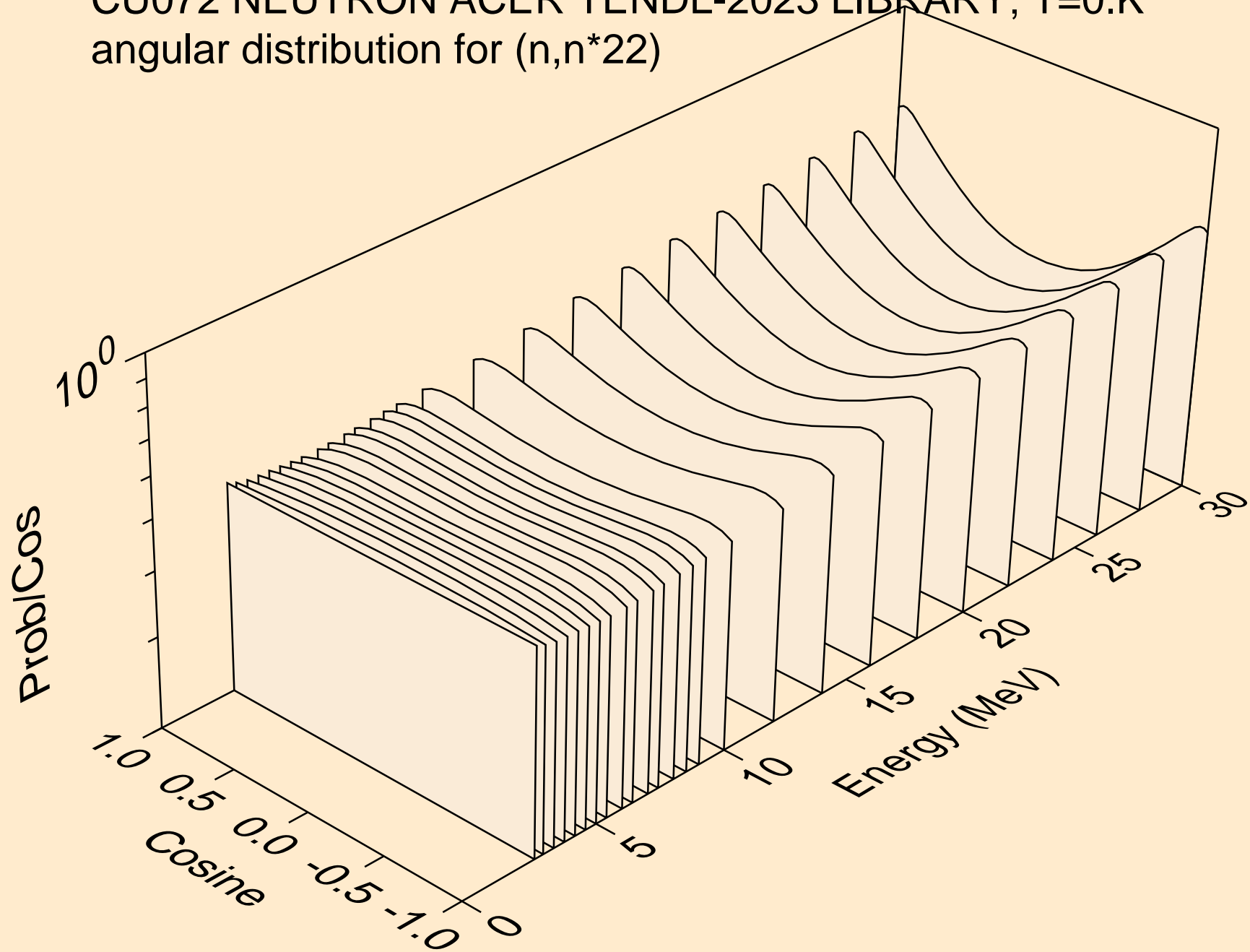

CU072 NEUTRON ACER TENDL-2023 LIBRARY; T=0.K  
angular distribution for (n,n\*23)

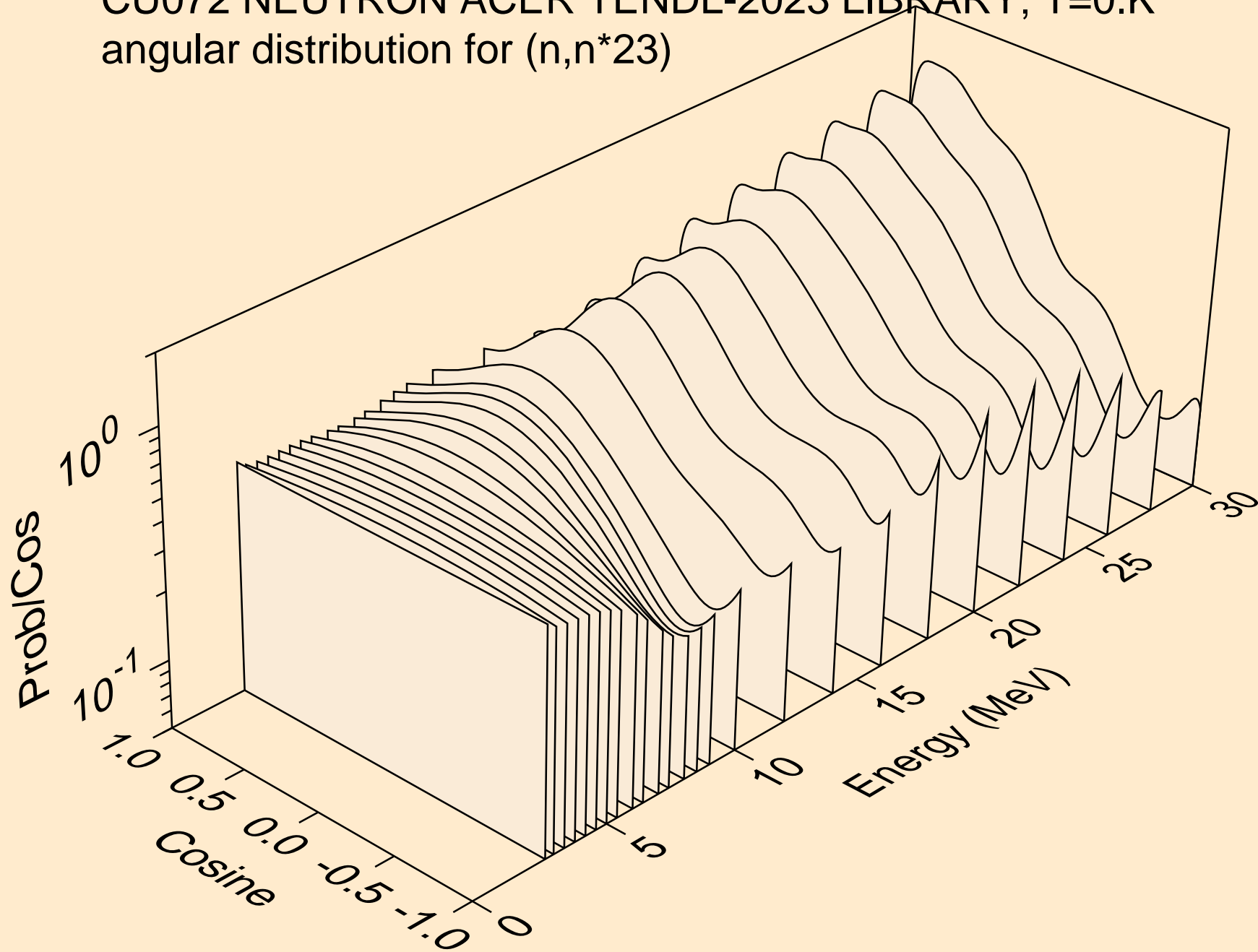

CU072 NEUTRON ACER TENDL-2023 LIBRARY; T=0.K  
angular distribution for (n,n\*24)

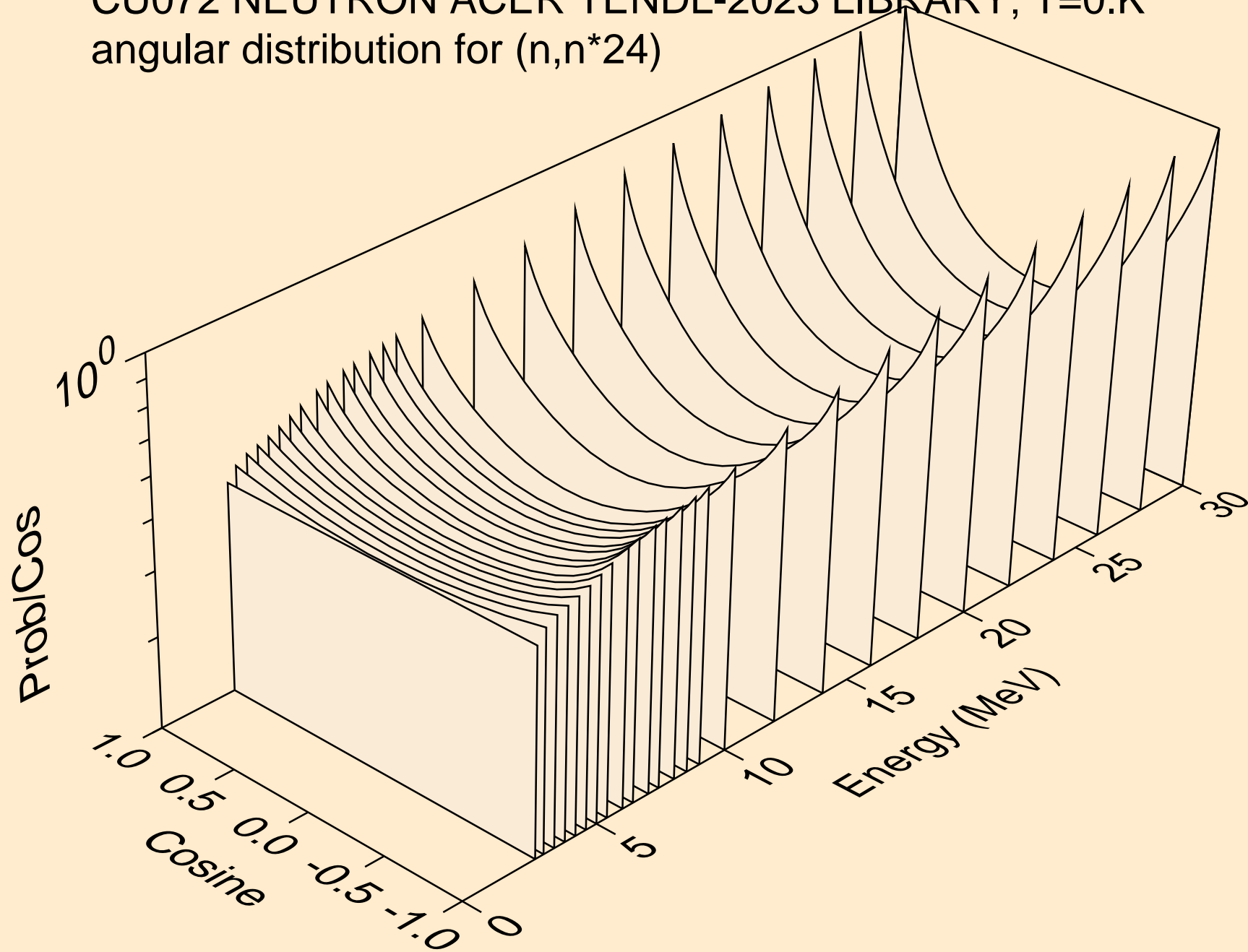

CU072 NEUTRON ACER TENDL-2023 LIBRARY; T=0.K  
angular distribution for (n,n\*25)

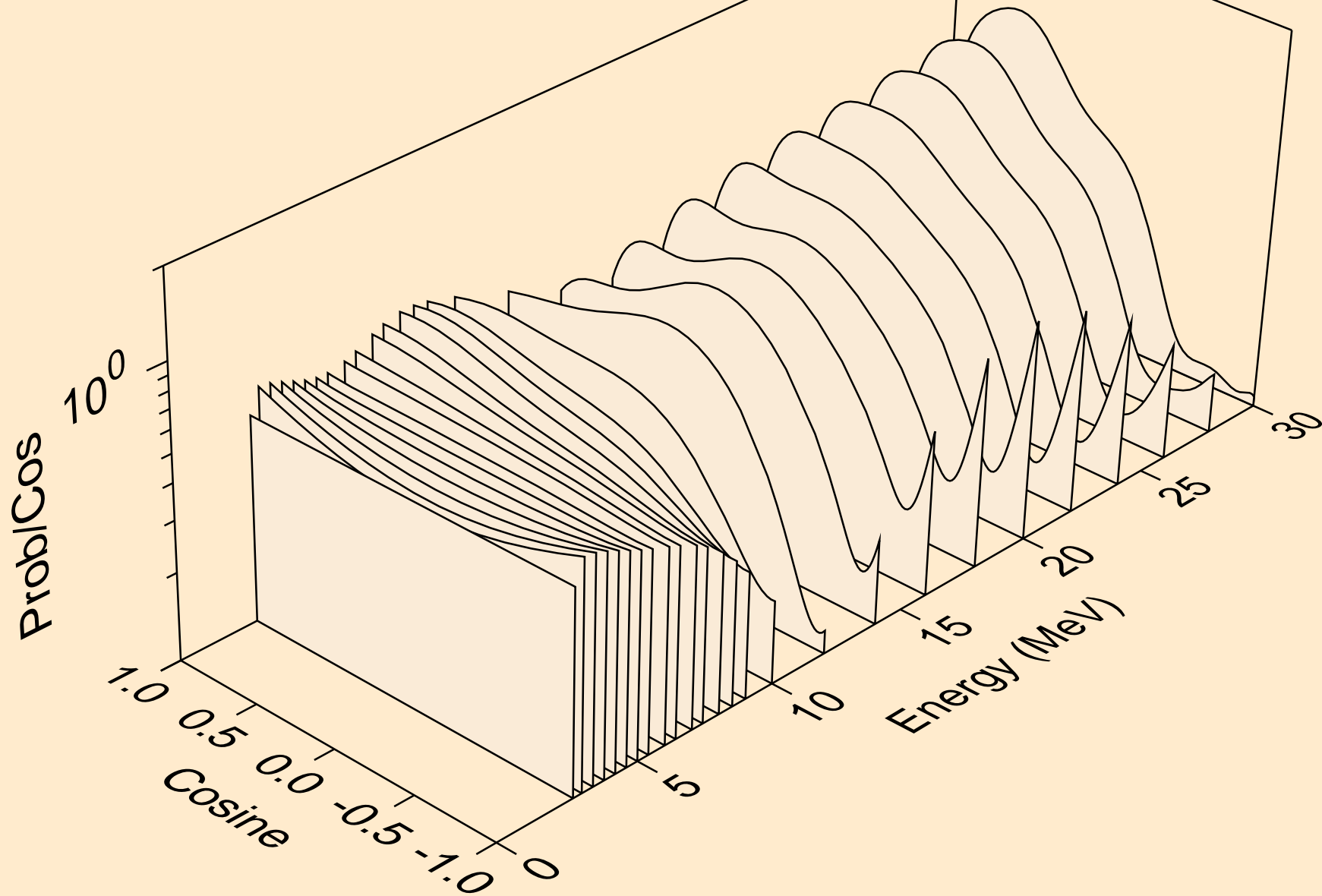

CU072 NEUTRON ACER TENDL-2023 LIBRARY; T=0.K  
angular distribution for (n,n\*26)

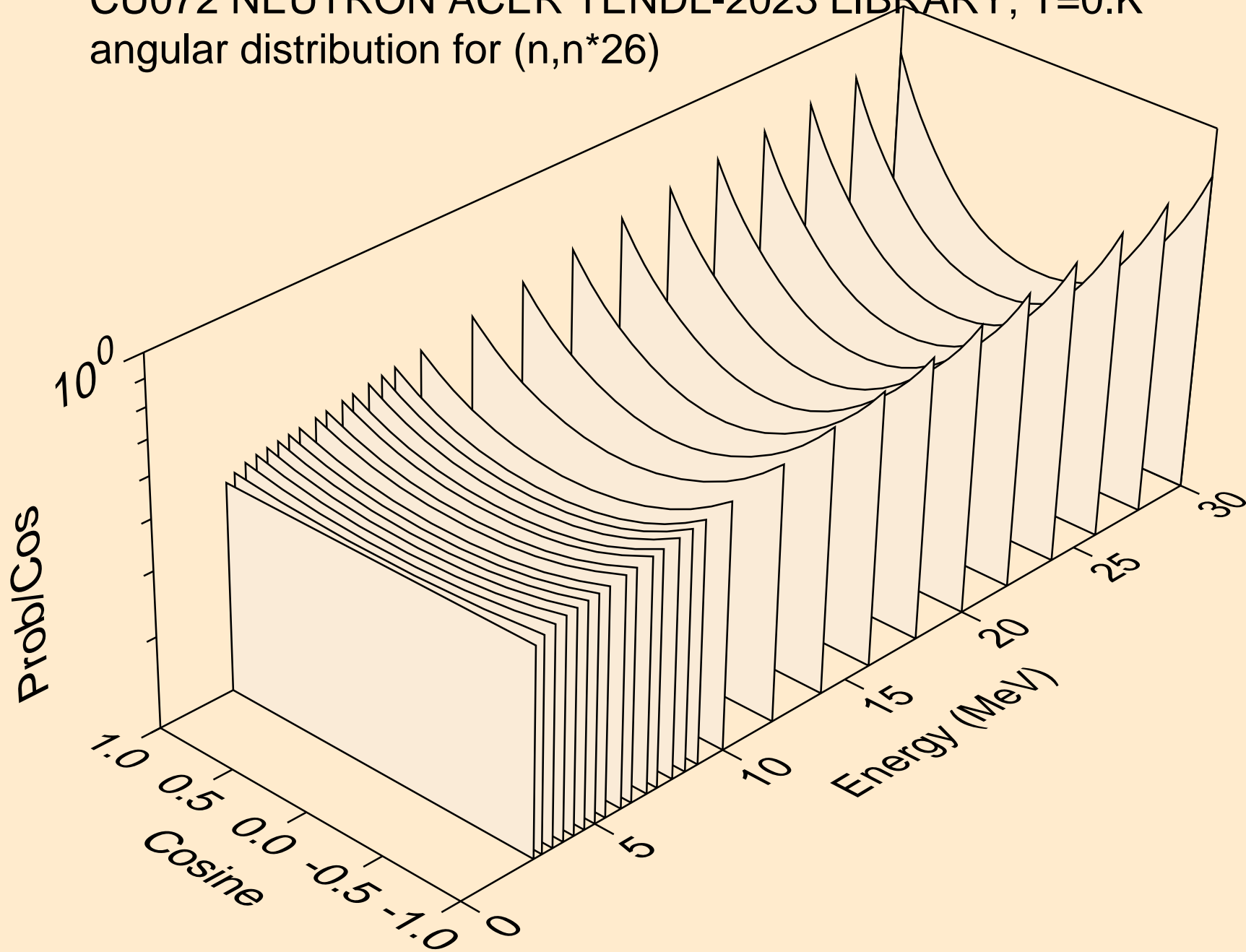

CU072 NEUTRON ACER TENDL-2023 LIBRARY; T=0.K  
angular distribution for (n,n\*27)

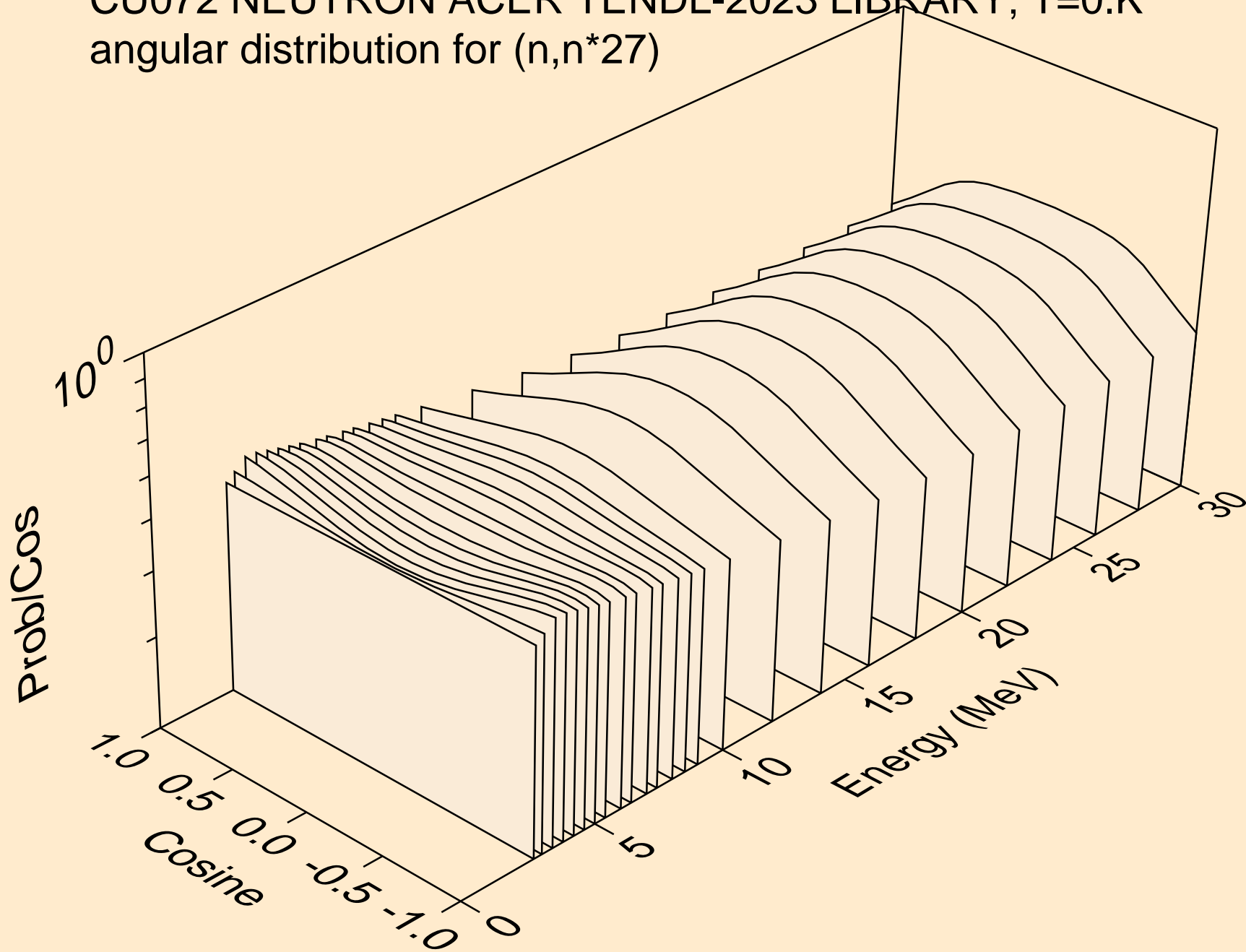



CU072 NEUTRON ACER TENDL-2023 LIBRARY; T=0.K  
angular distribution for (n,n\*28)

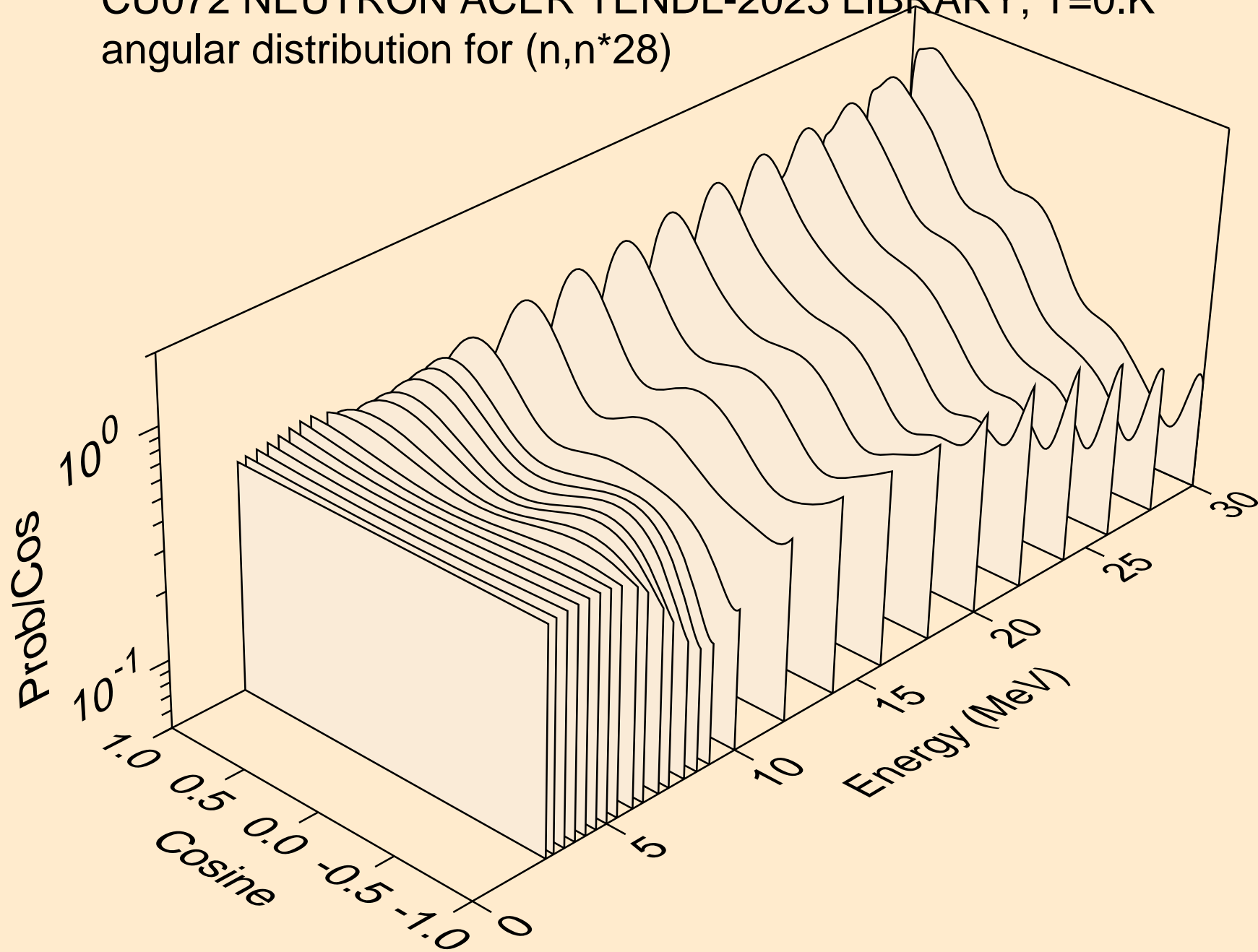

CU072 NEUTRON ACER TENDL-2023 LIBRARY; T=0.K  
angular distribution for (n,n\*29)

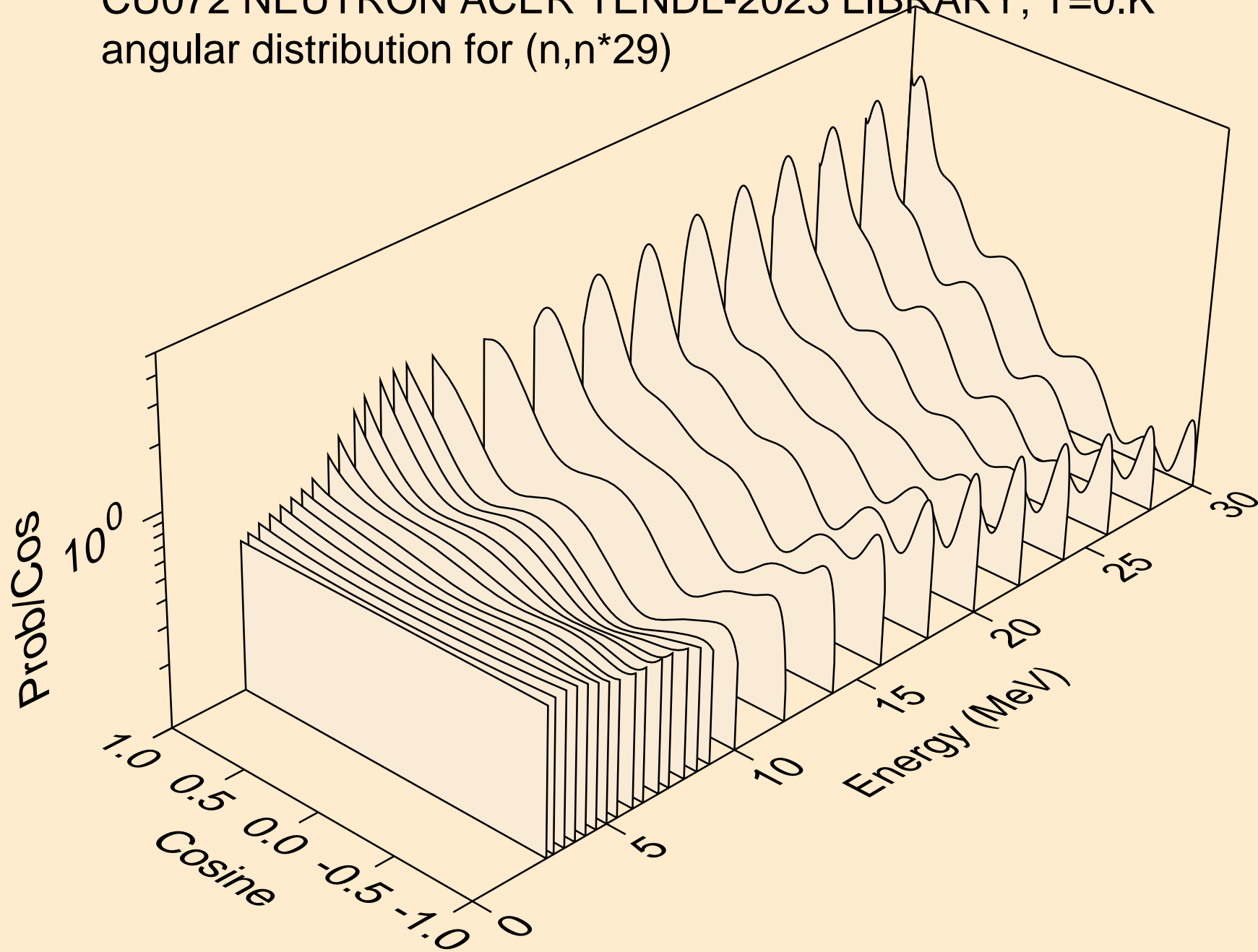

CU072 NEUTRON ACER TENDL-2023 LIBRARY; T=0.K  
Neutron emission for (n,x)

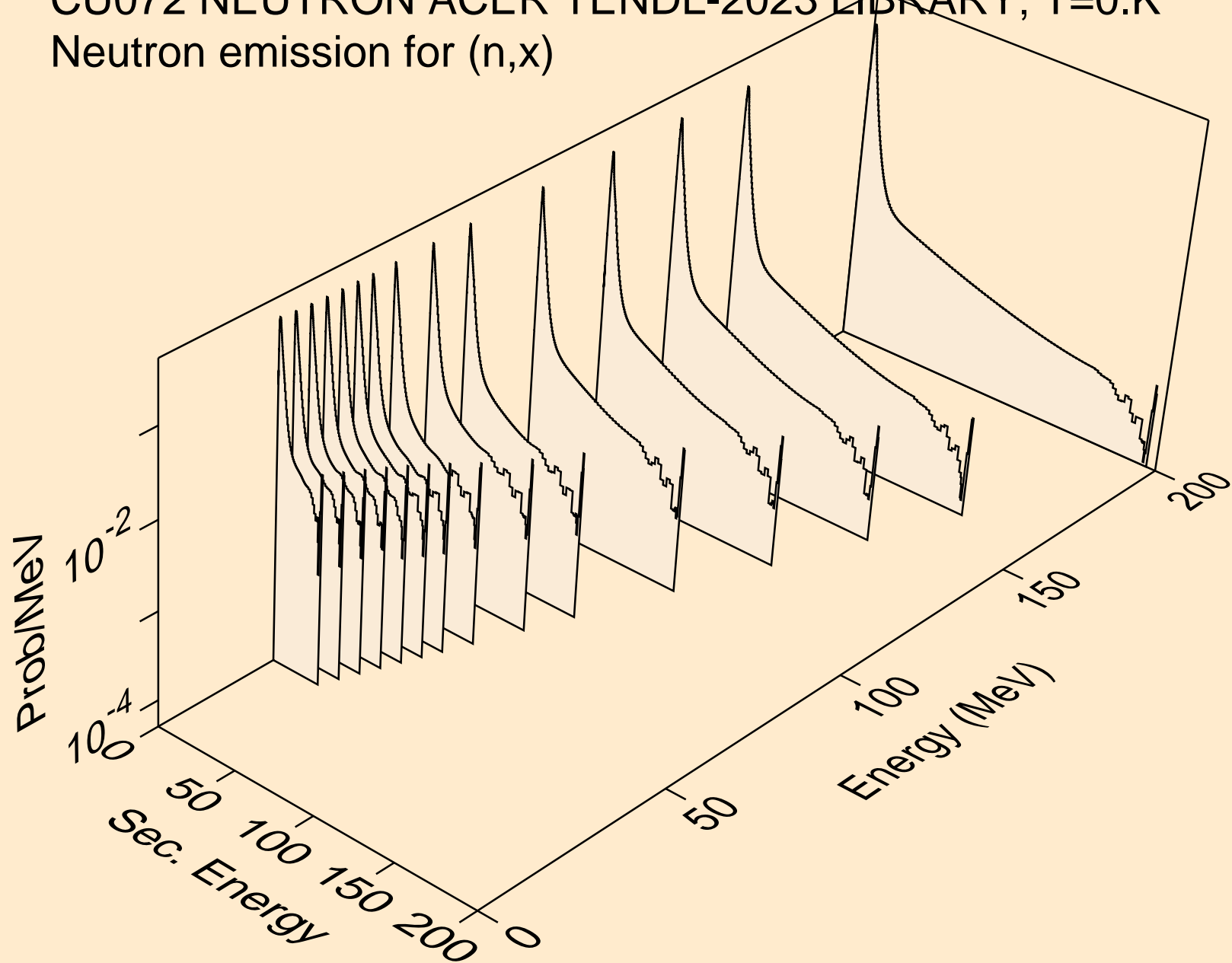

CU072 NEUTRON ACER TENDL-2023 LIBRARY; T=0.K  
Neutron emission for (n,2nd)

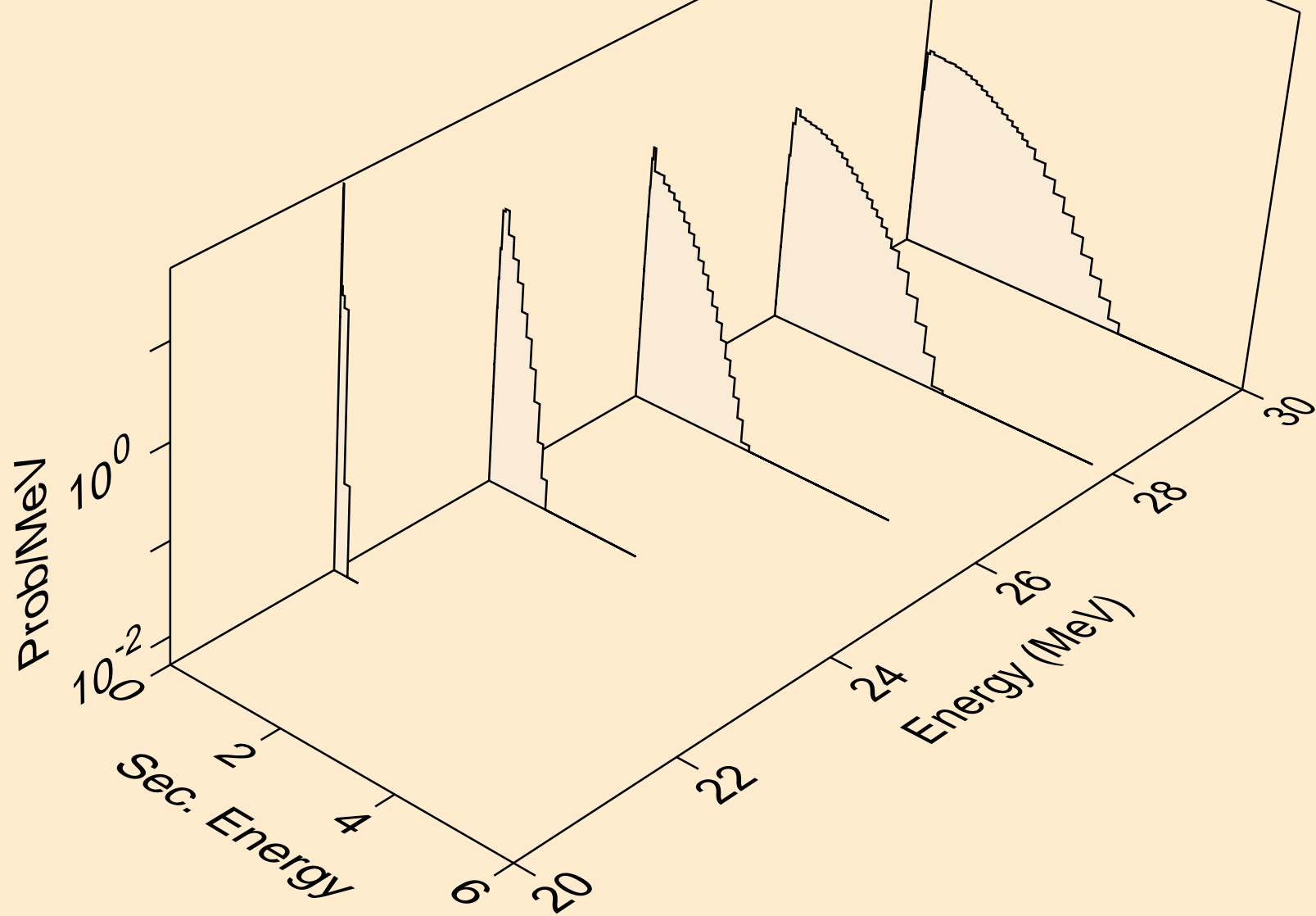

CU072 NEUTRON ACER TENDL-2023 LIBRARY; T=0.K  
Neutron emission for (n,2n)

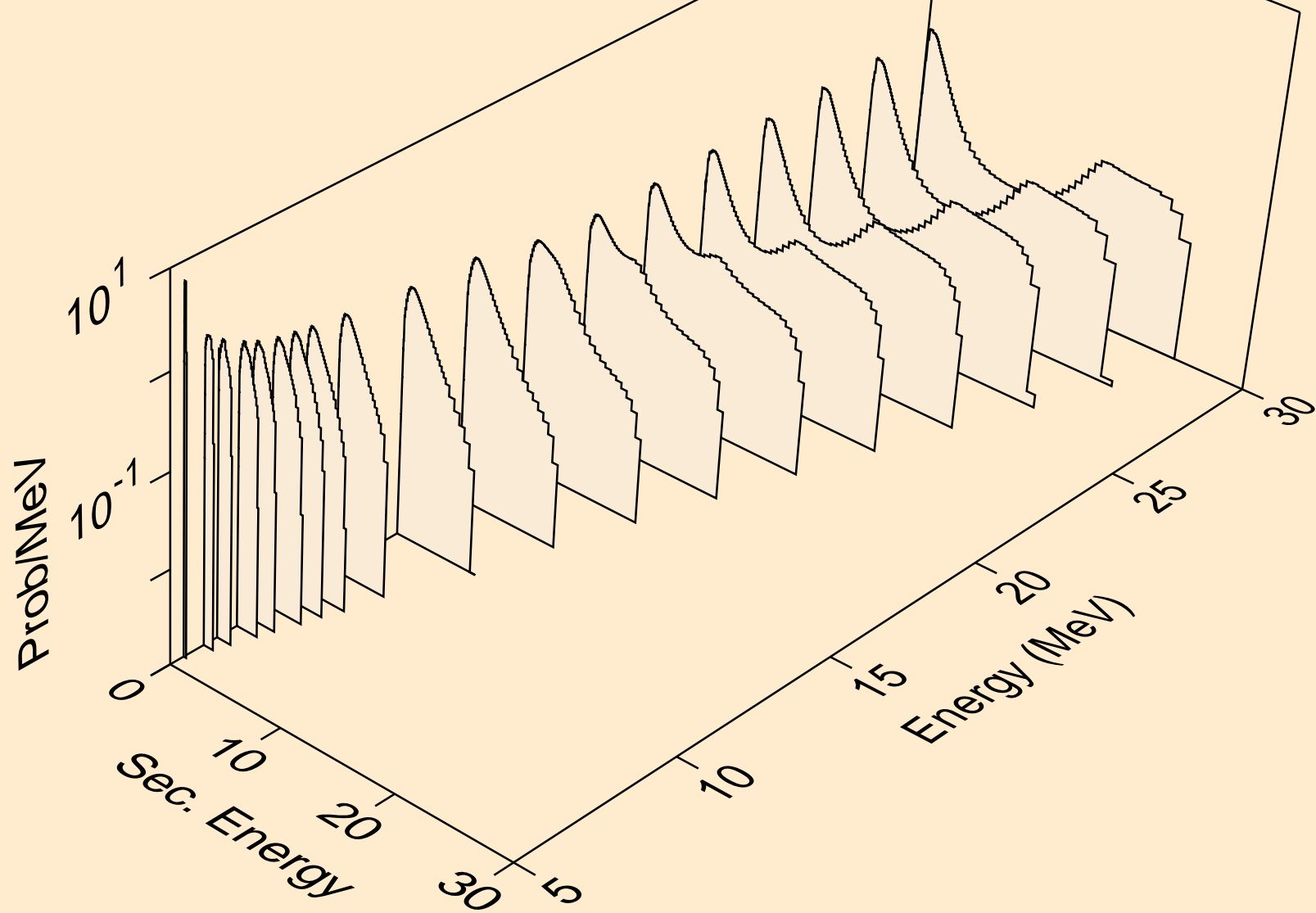

CU072 NEUTRON ACER TENDL-2023 LIBRARY; T=0.K  
Neutron emission for (n,3n)

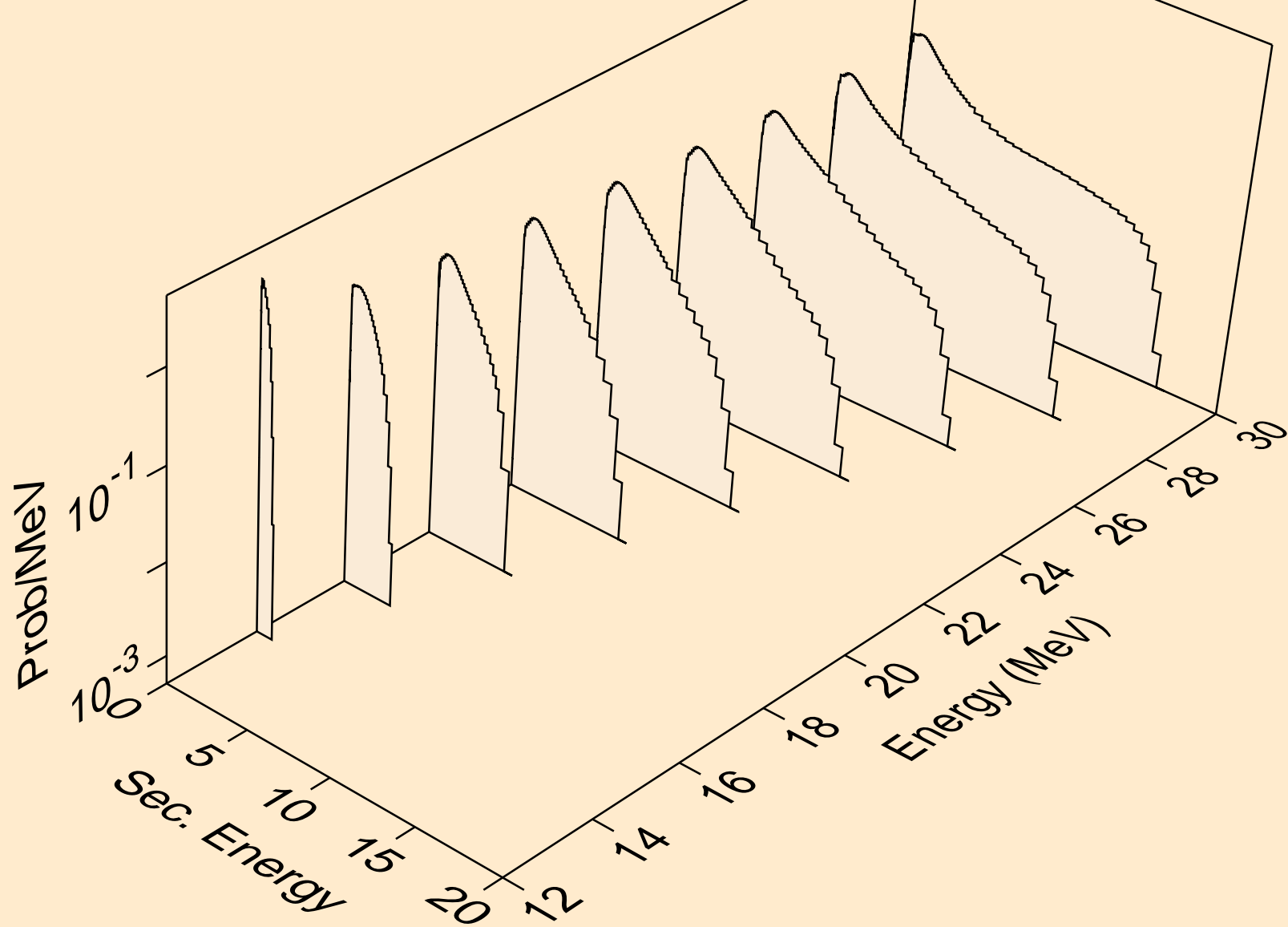

CU072 NEUTRON ACER TENDL-2023 LIBRARY; T=0.K  
Neutron emission for (n,n\*)a

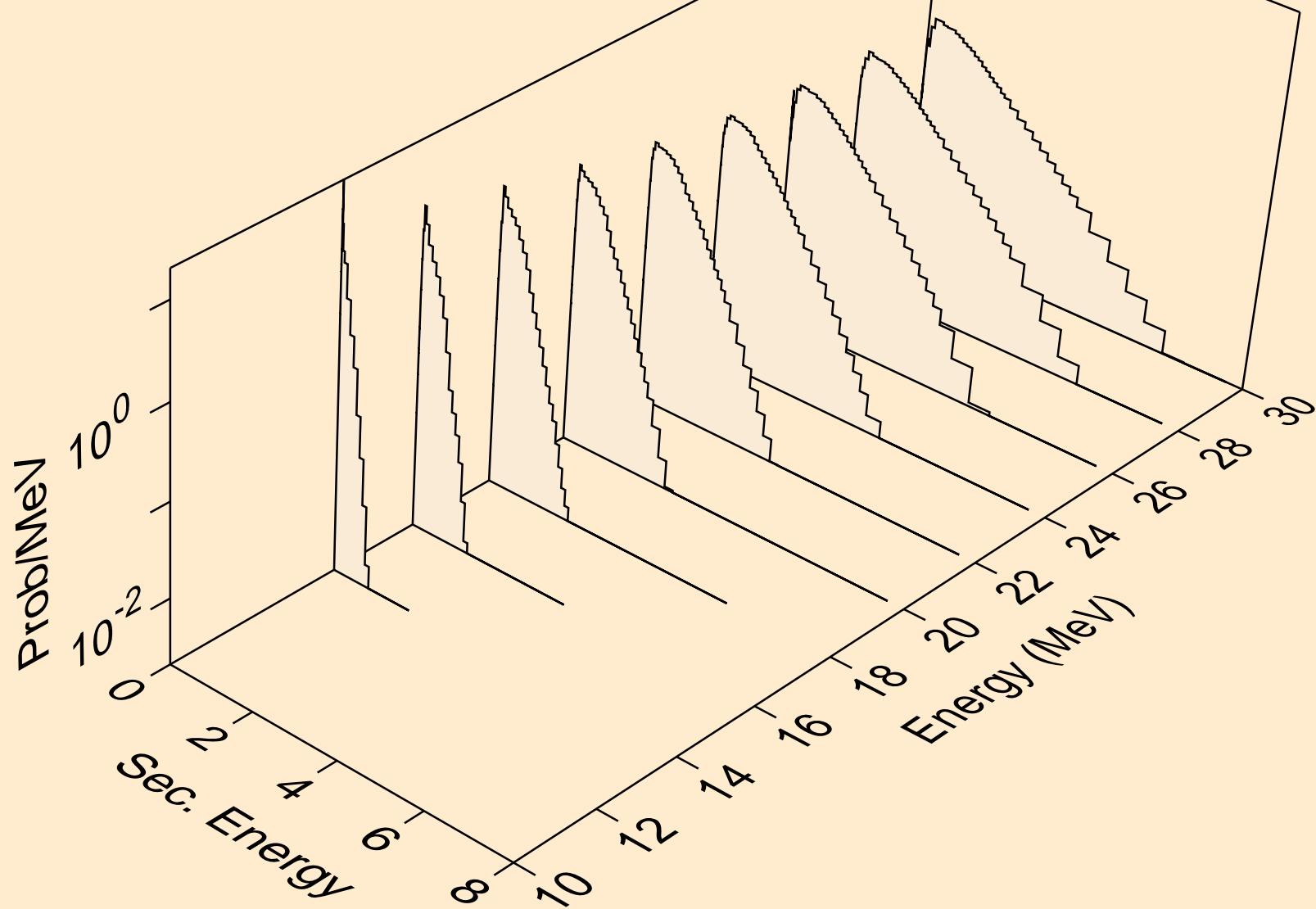

CU072 NEUTRON ACER TENDL-2023 LIBRARY; T=0.K  
Neutron emission for (n,2n)a

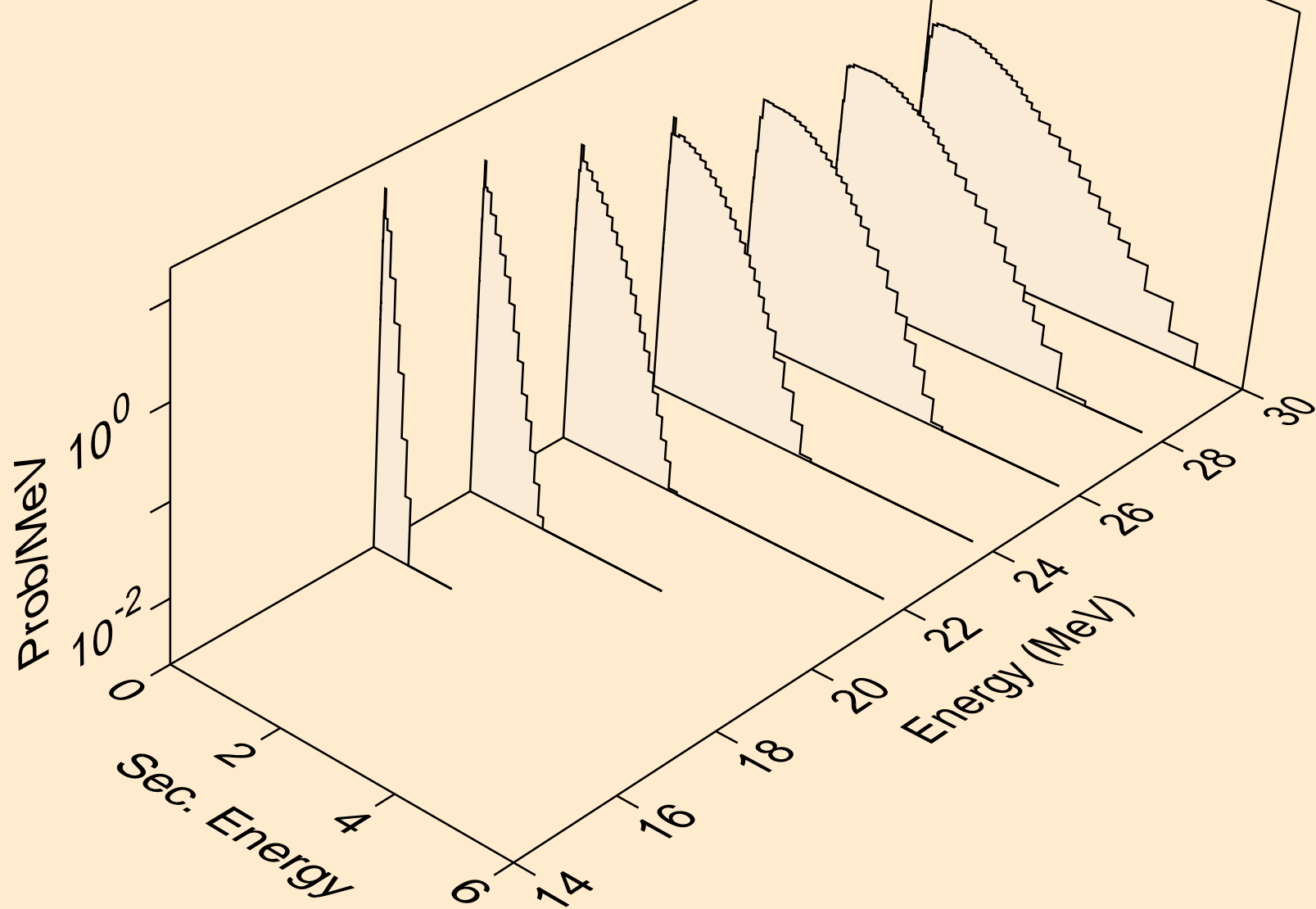



CU072 NEUTRON ACER TENDL-2023 LIBRARY; T=0.K  
Neutron emission for (n,3n)a

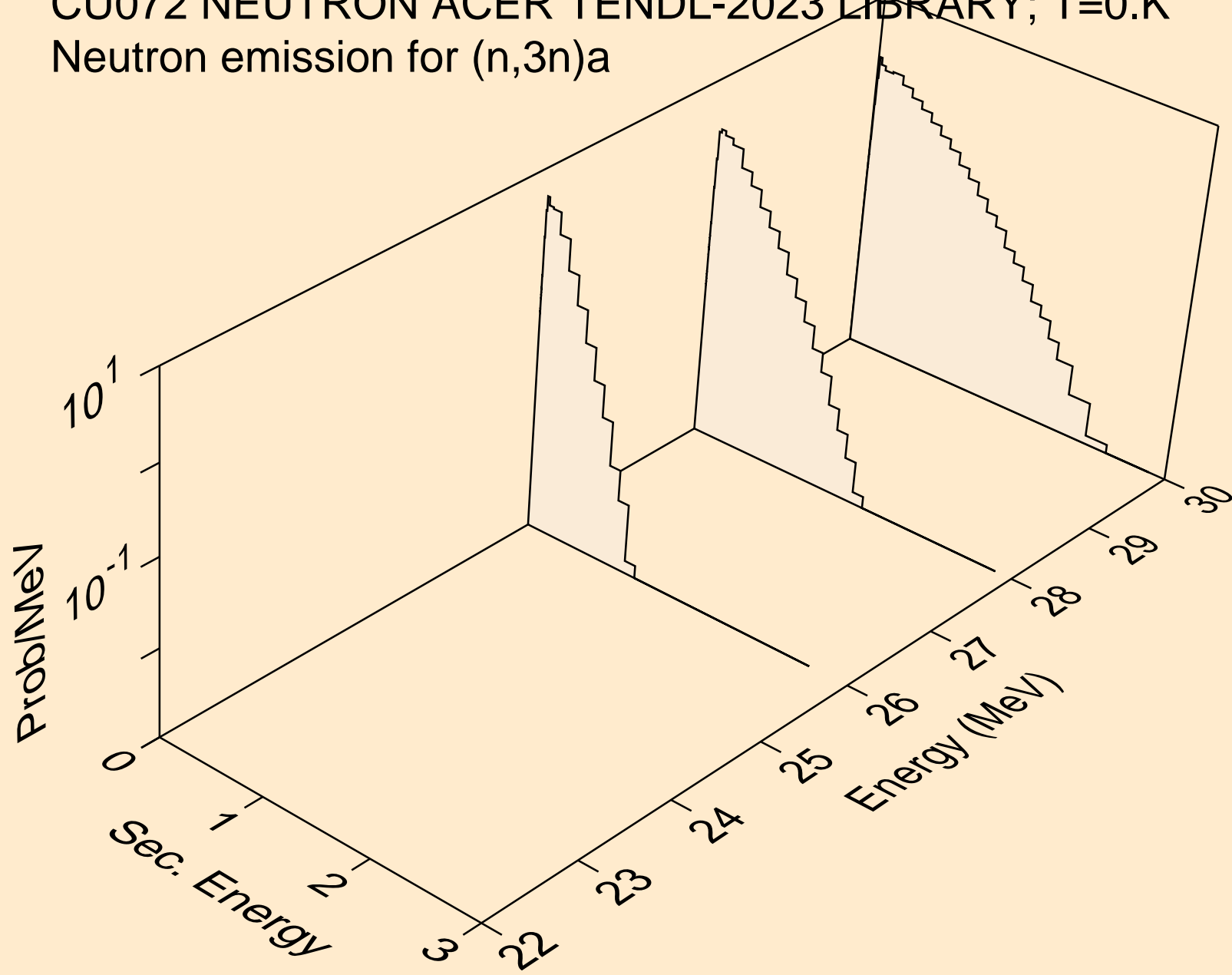

CU072 NEUTRON ACER TENDL-2023 LIBRARY; T=0.K  
Neutron emission for (n,n\*)p

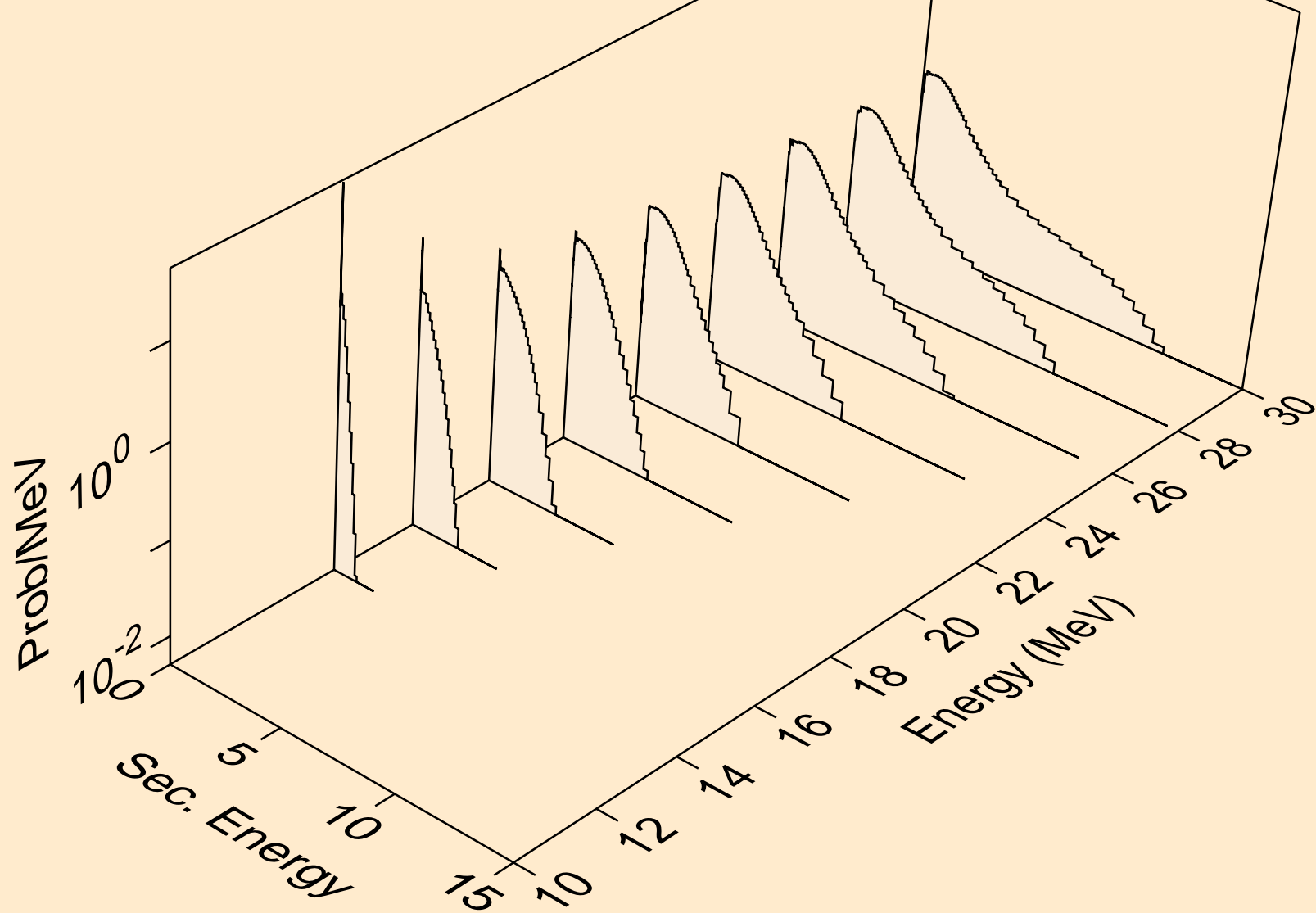

CU072 NEUTRON ACER TENDL-2023 LIBRARY; T=0.K  
Neutron emission for (n,n\*)d

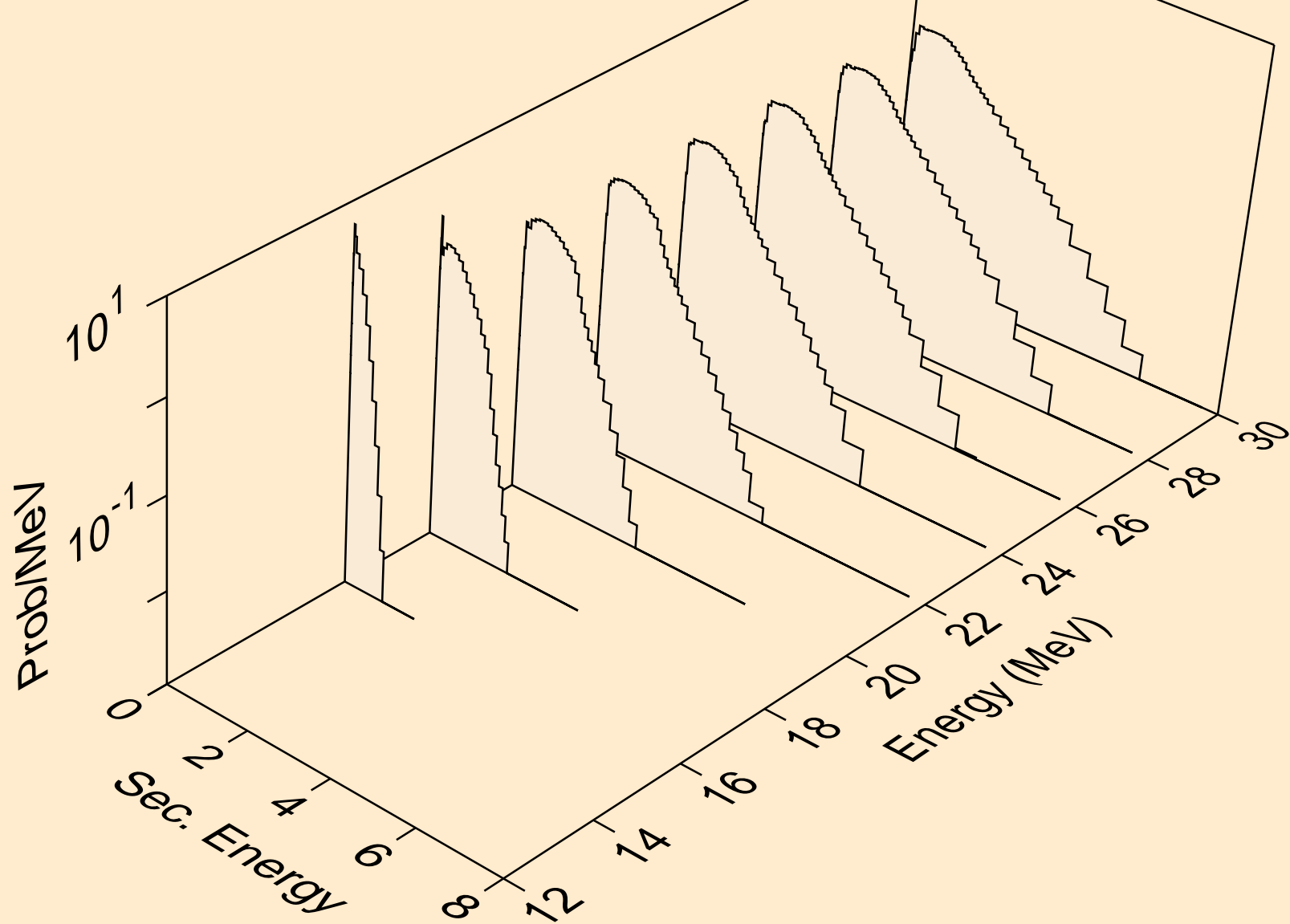

CU072 NEUTRON ACER TENDL-2023 LIBRARY; T=0.K  
Neutron emission for (n,n\*)t

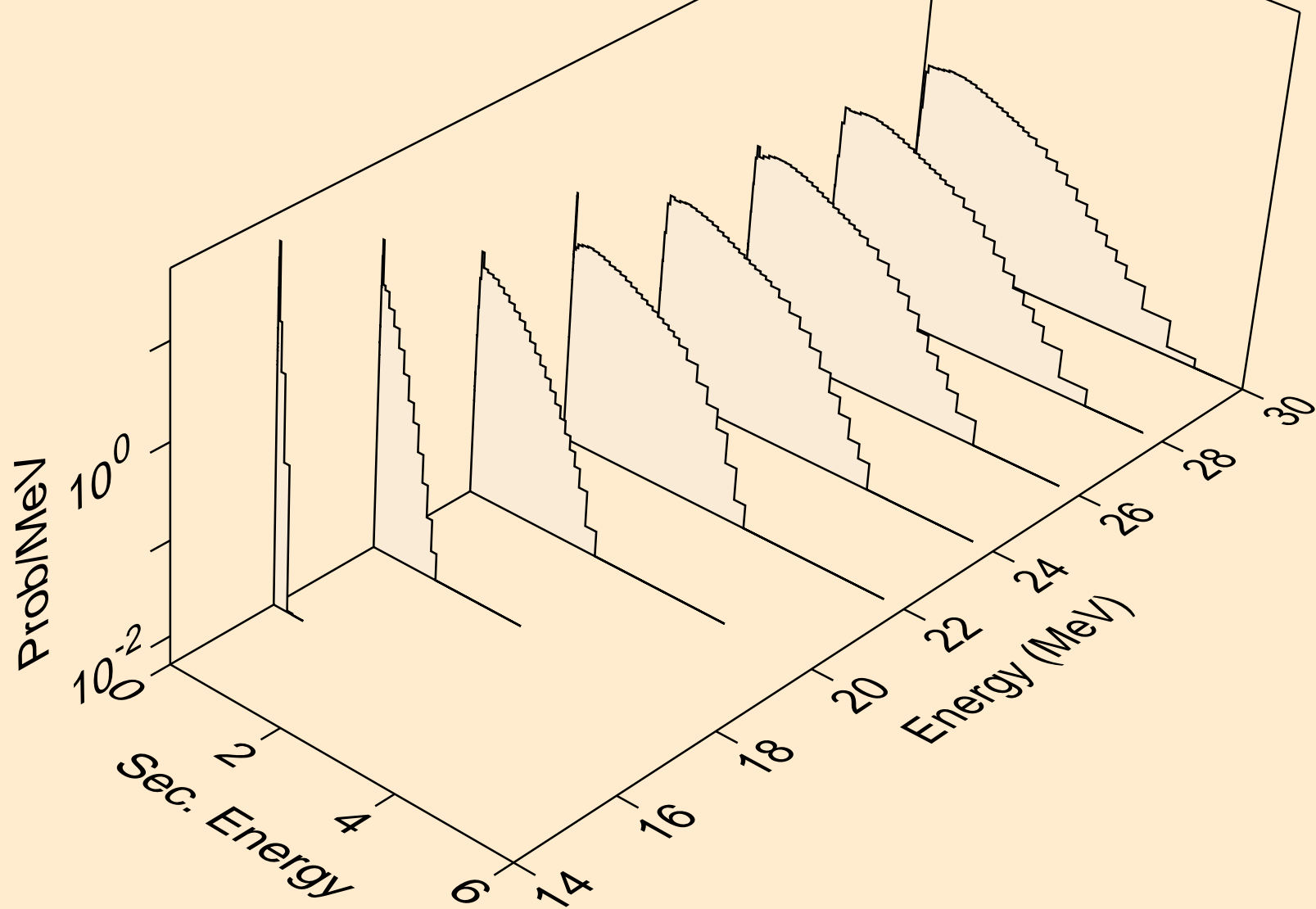

CU072 NEUTRON ACER TENDL-2023 LIBRARY; T=0.K  
Neutron emission for (n,n\*)he3

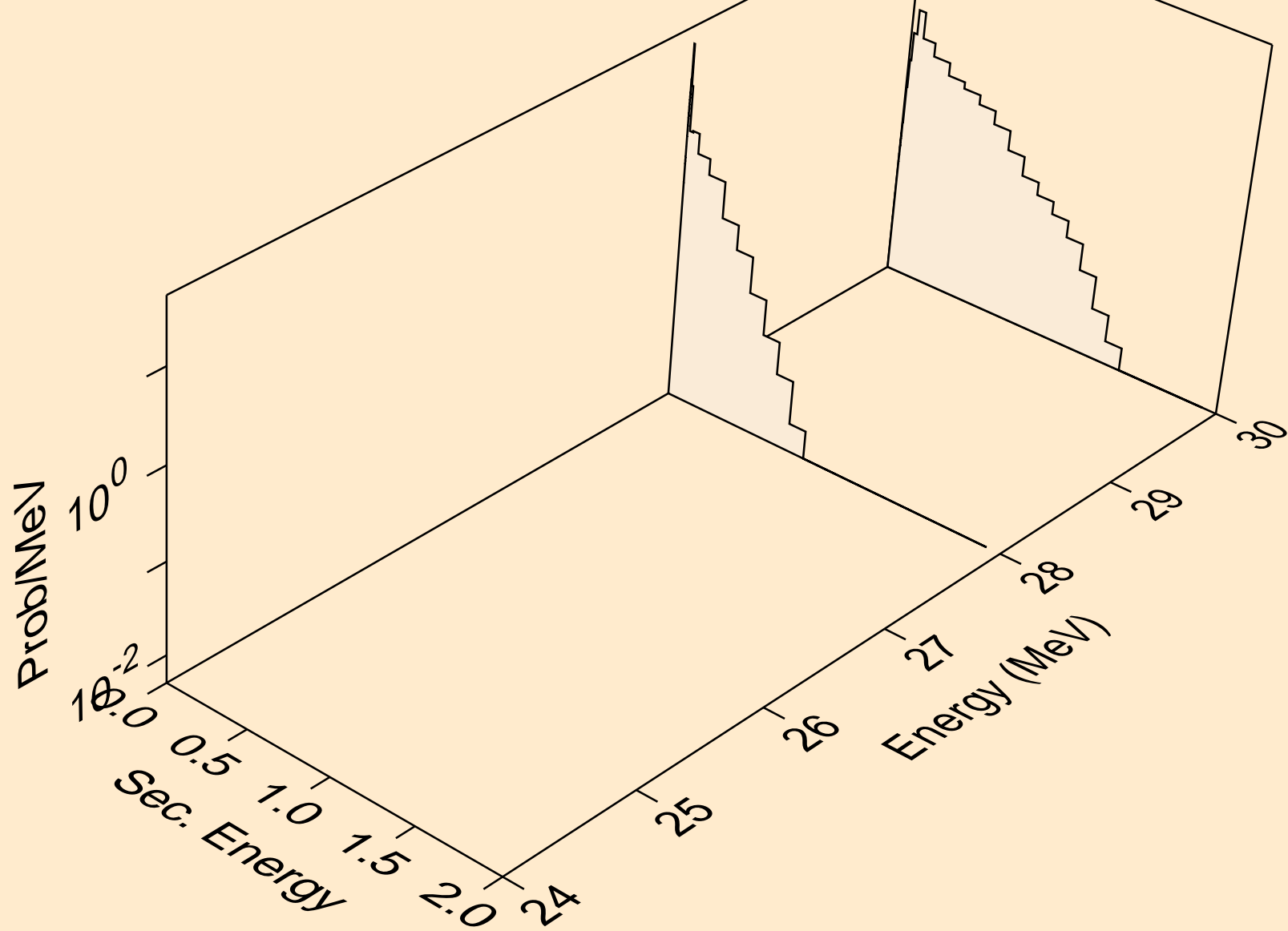

CU072 NEUTRON ACER TENDL-2023 LIBRARY; T=0.K  
Neutron emission for (n,4n)

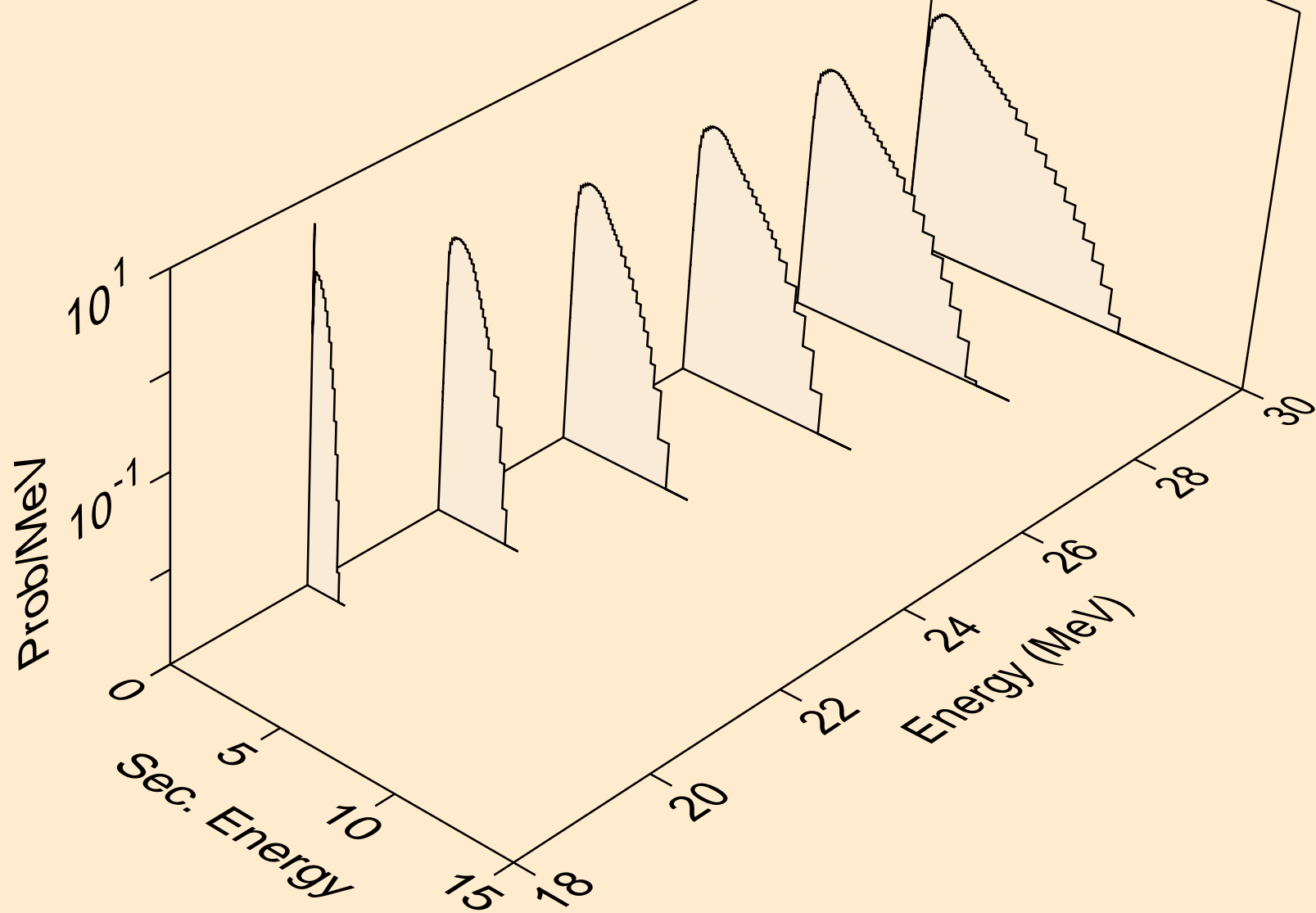

CU072 NEUTRON ACER TENDL-2023 LIBRARY; T=0.K  
Neutron emission for (n,2np)

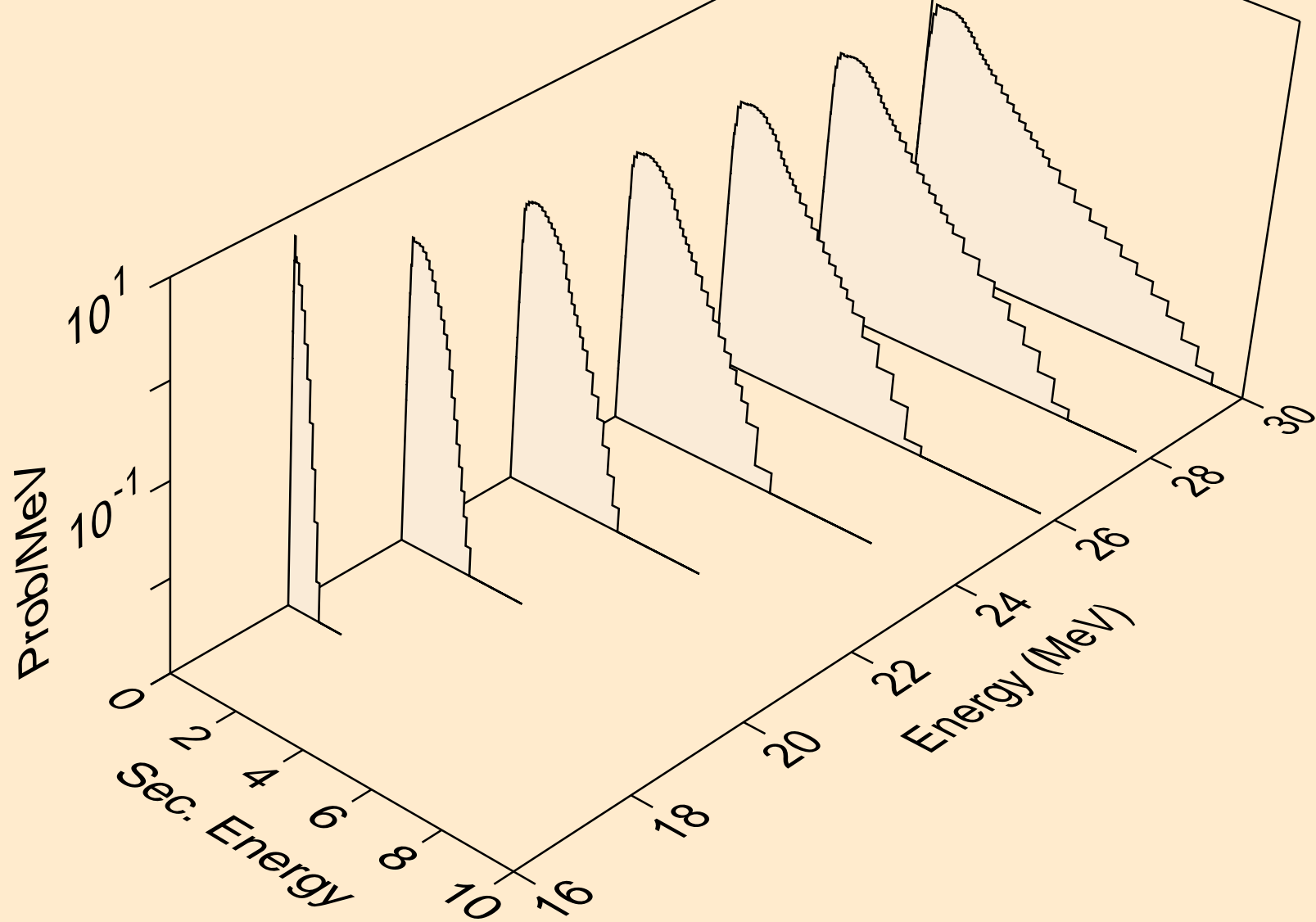

CU072 NEUTRON ACER TENDL-2023 LIBRARY; T=0.K  
Neutron emission for (n,3np)

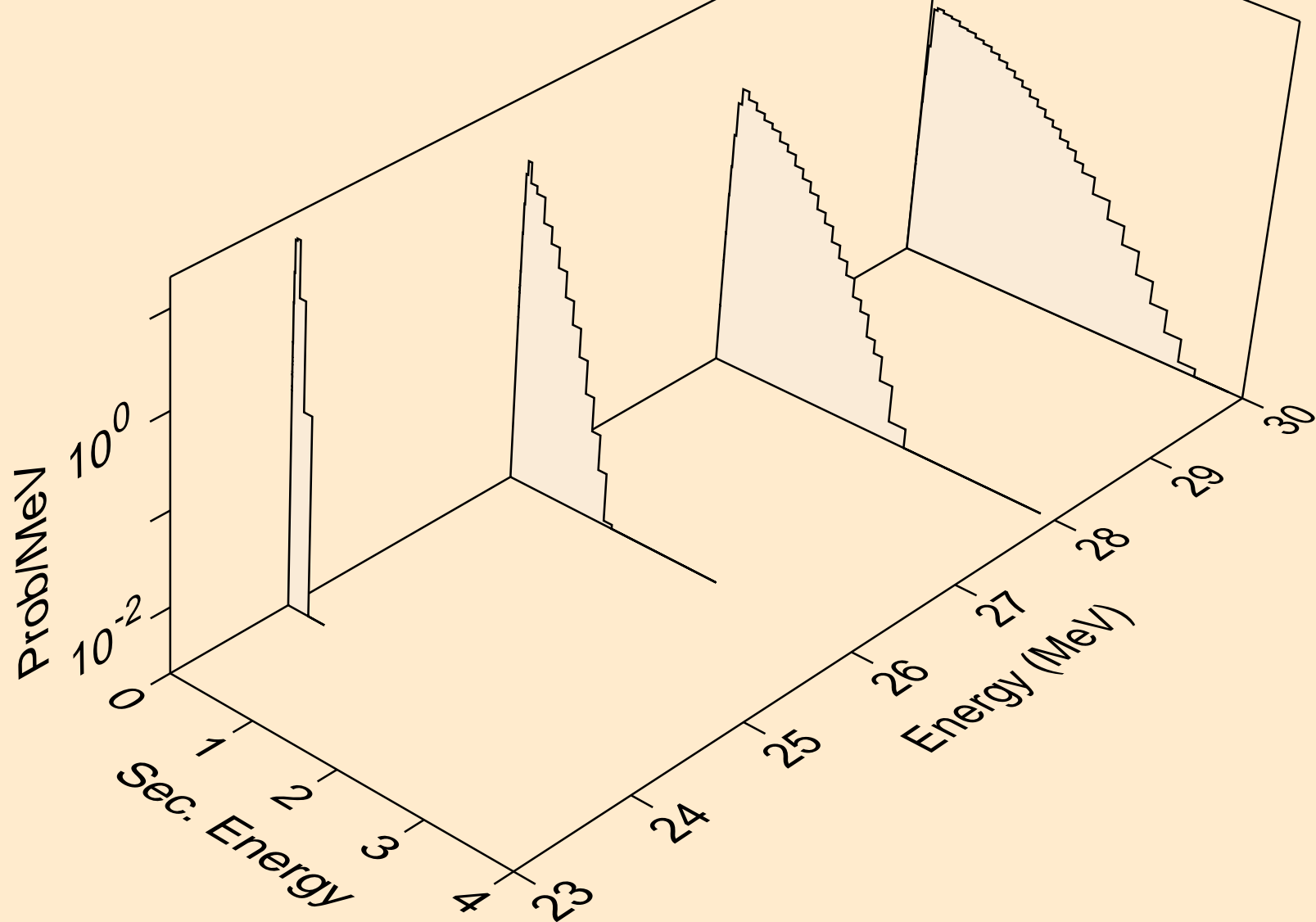



CU072 NEUTRON ACER TENDL-2023 LIBRARY; T=0.K  
Neutron emission for (n,n\*c)

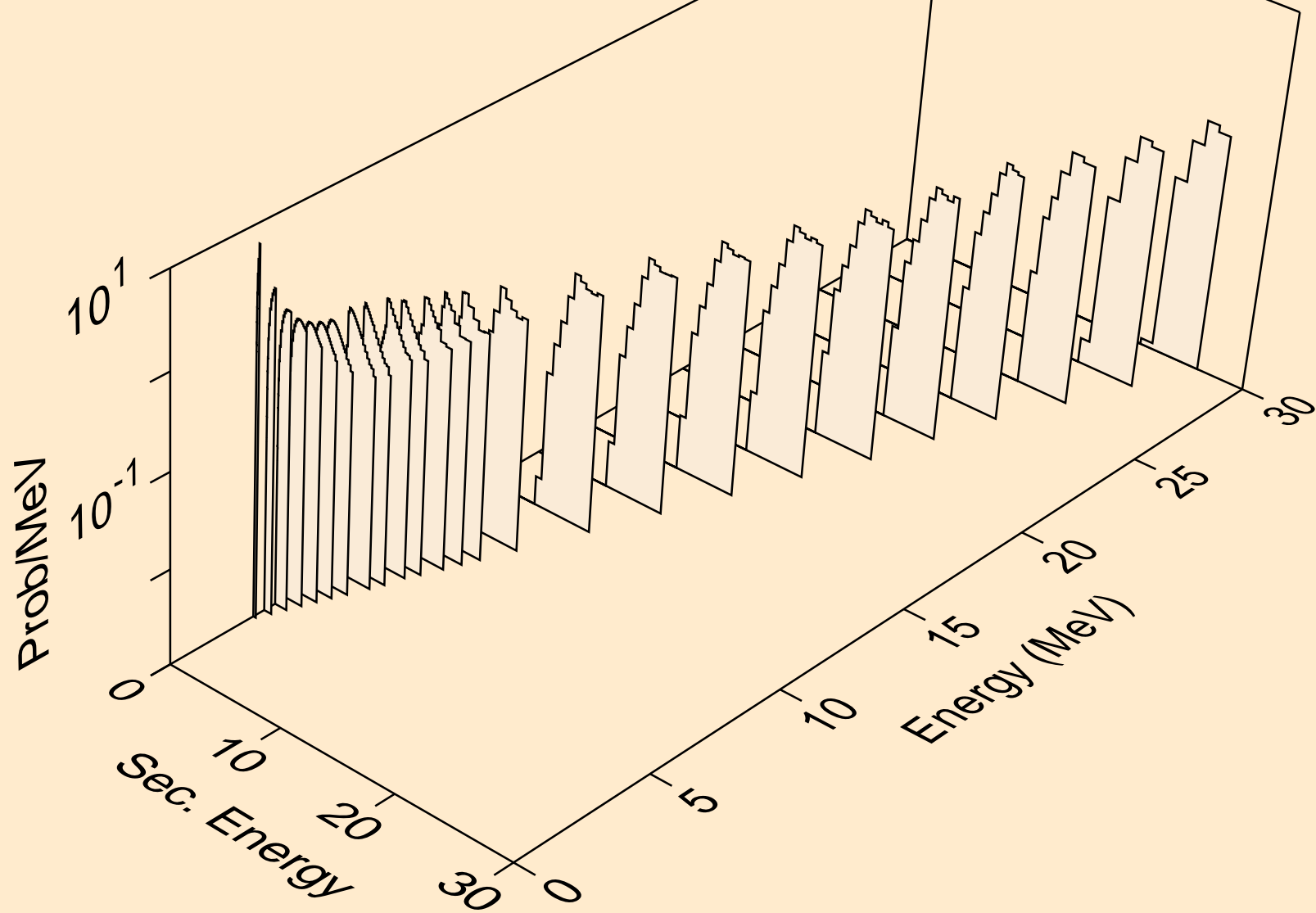

CU072 NEUTRON ACER TENDL-2023 LIBRARY; T=0.K  
Photon emission for (n,x)

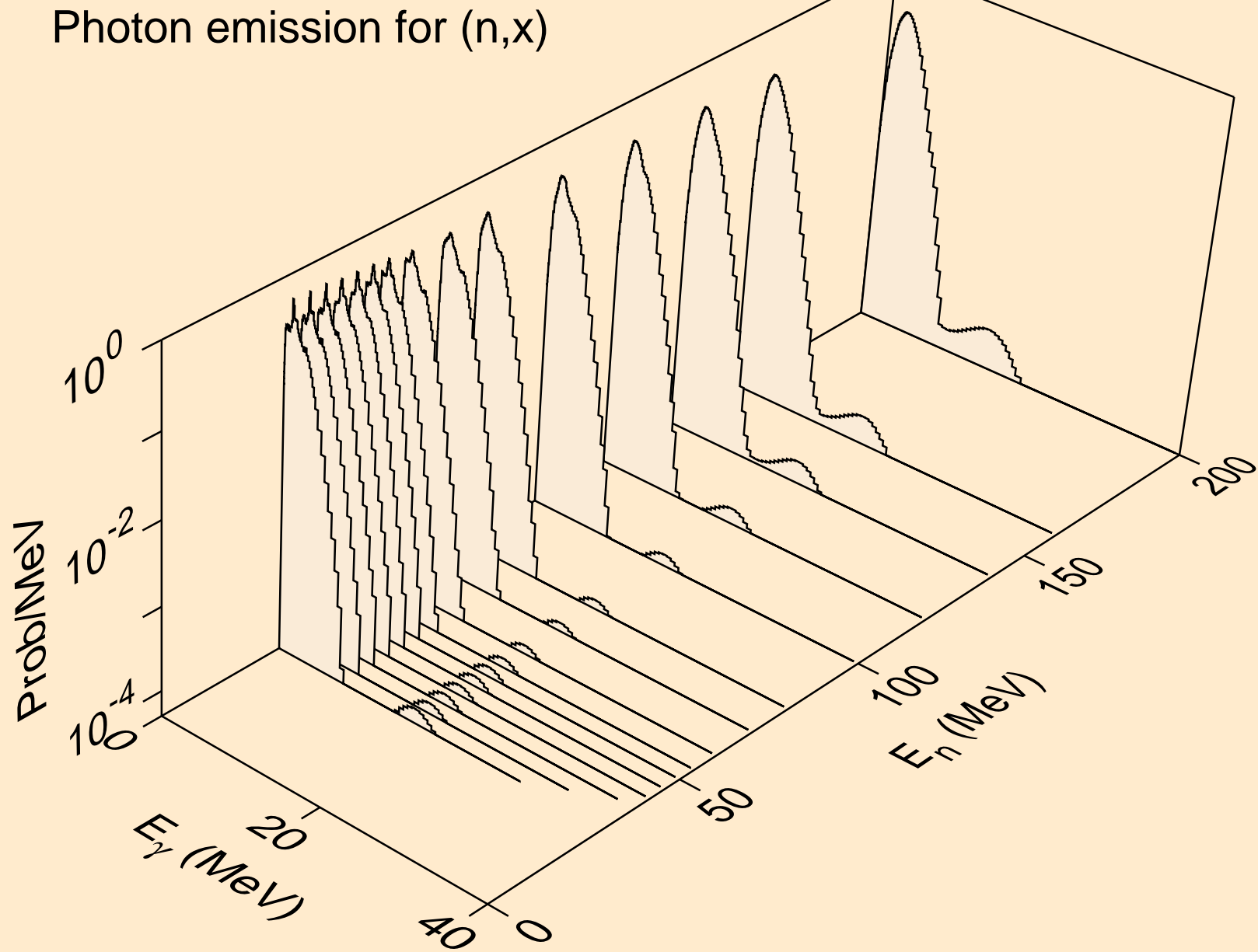

CU072 NEUTRON ACER TENDL-2023 LIBRARY; T=0.K  
Photon emission for (n,2nd)

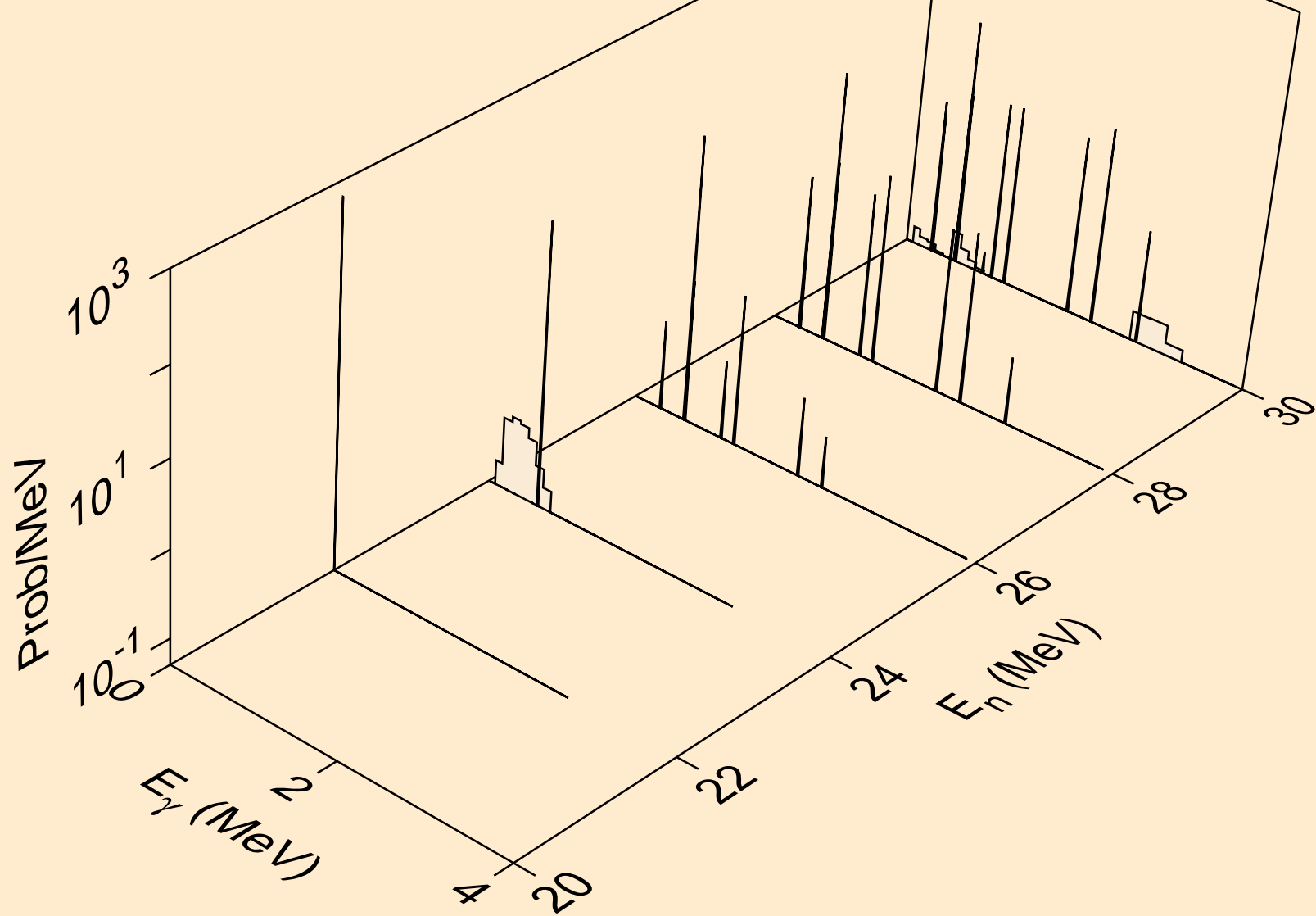

CU072 NEUTRON ACER TENDL-2023 LIBRARY; T=0.K  
Photon emission for (n,2n)

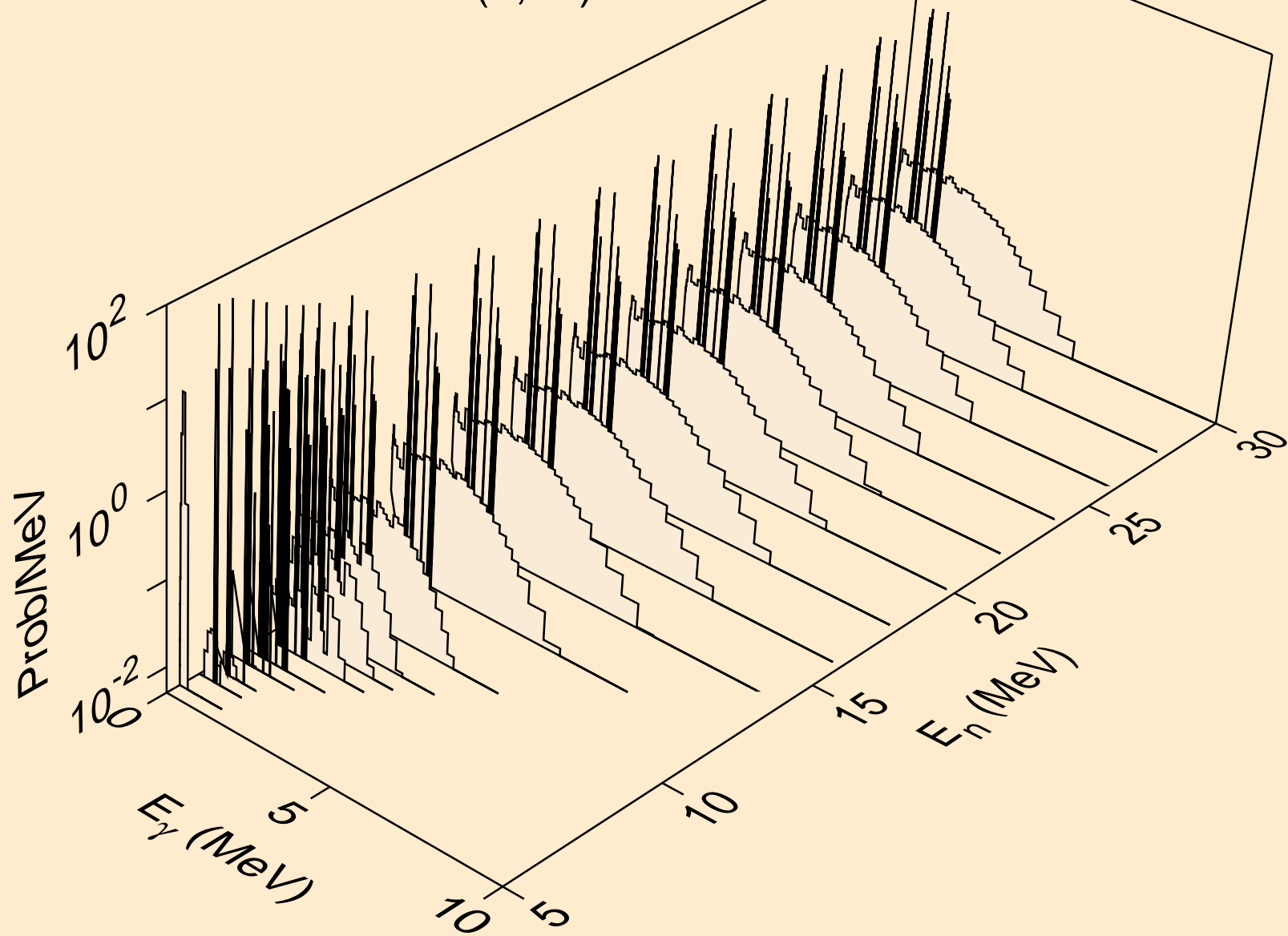

CU072 NEUTRON ACER TENDL-2023 LIBRARY; T=0.K  
Photon emission for (n,3n)

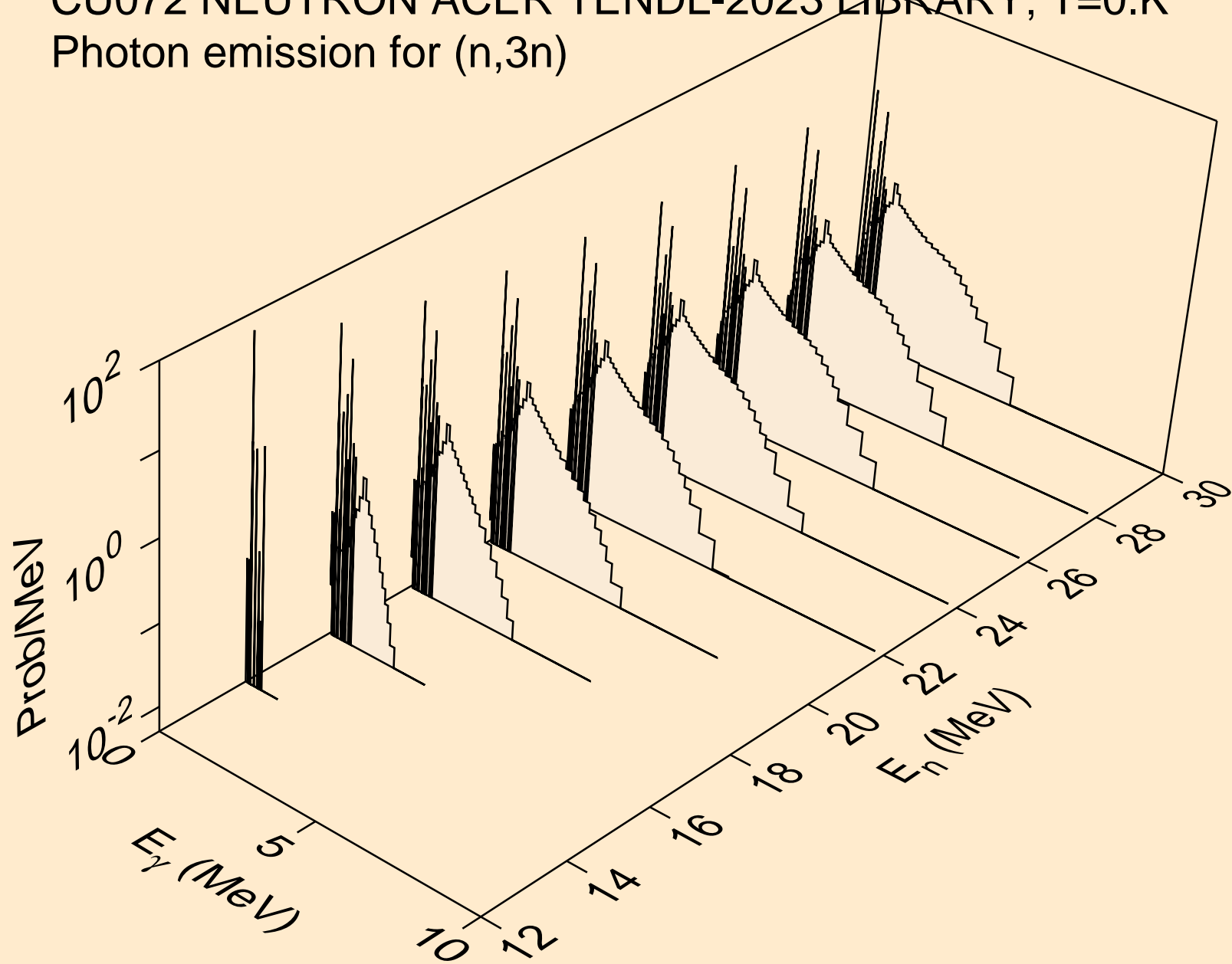

CU072 NEUTRON ACER TENDL-2023 LIBRARY; T=0.K  
Photon emission for (n,n\*)a

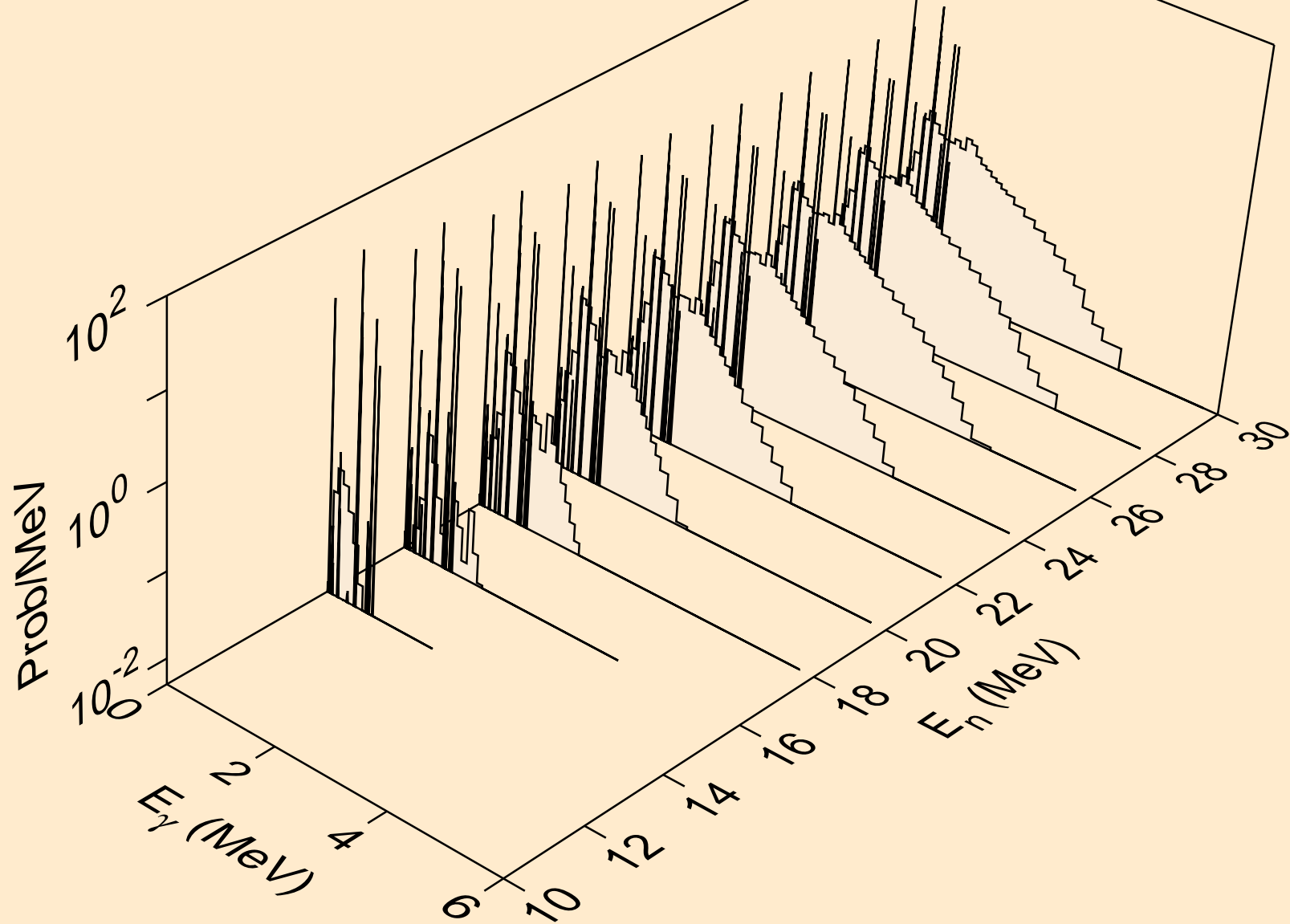

CU072 NEUTRON ACER TENDL-2023 LIBRARY; T=0.K  
Photon emission for (n,2n)a

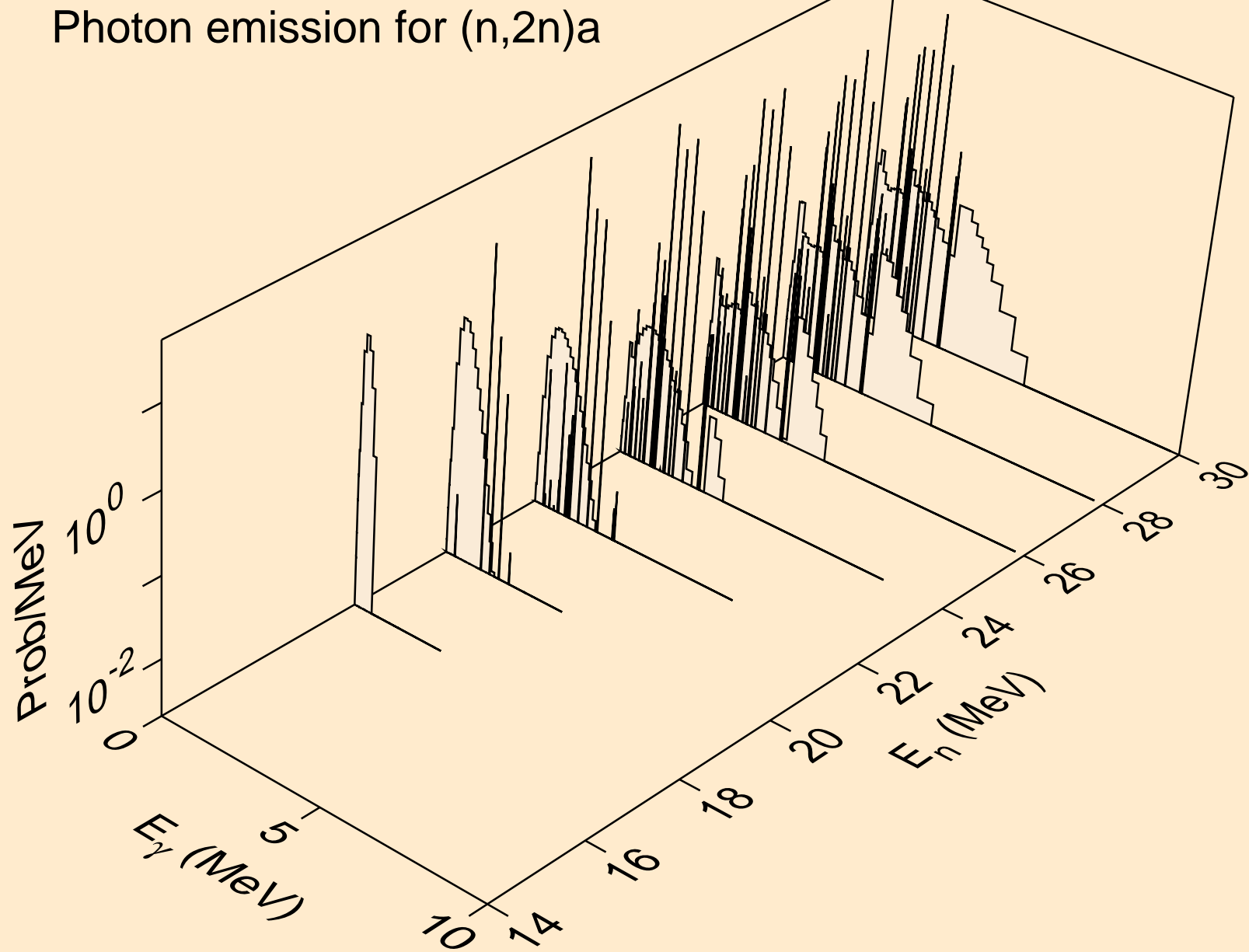

CU072 NEUTRON ACER TENDL-2023 LIBRARY; T=0.K  
Photon emission for (n,3n)a

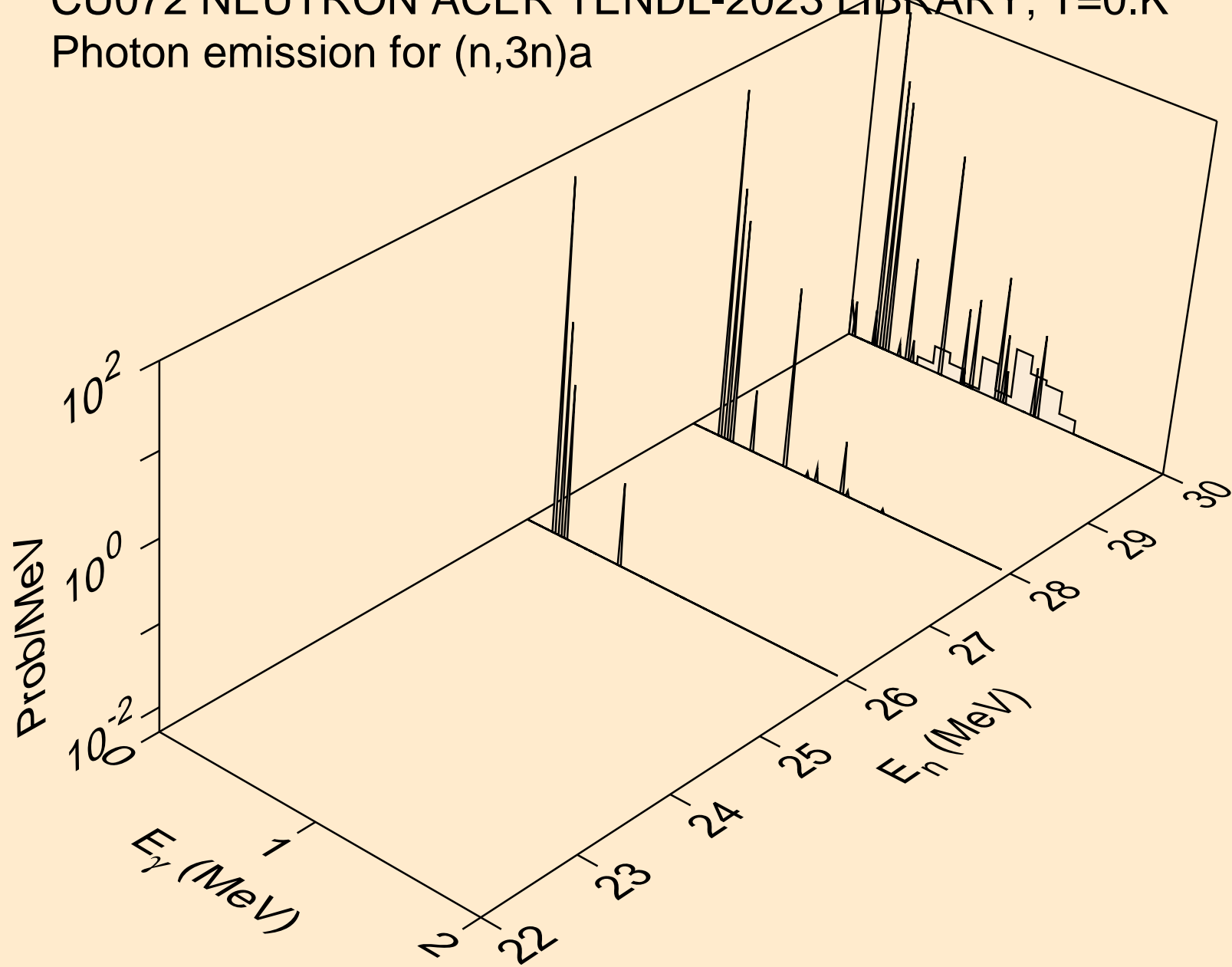



CU072 NEUTRON ACER TENDL-2023 LIBRARY; T=0.K  
Photon emission for (n,n\*)p

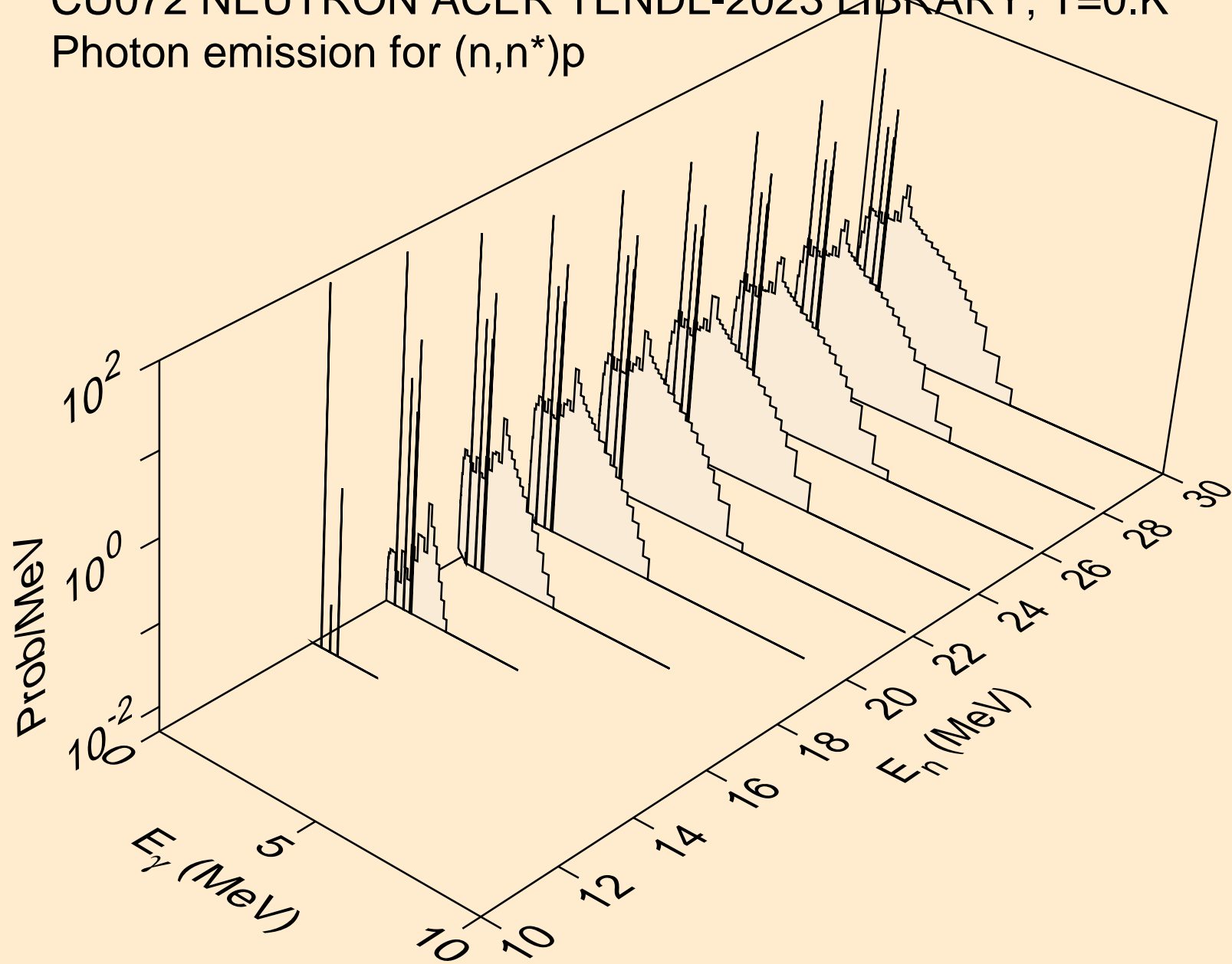

CU072 NEUTRON ACER TENDL-2023 LIBRARY; T=0.K  
Photon emission for (n,n\*)d

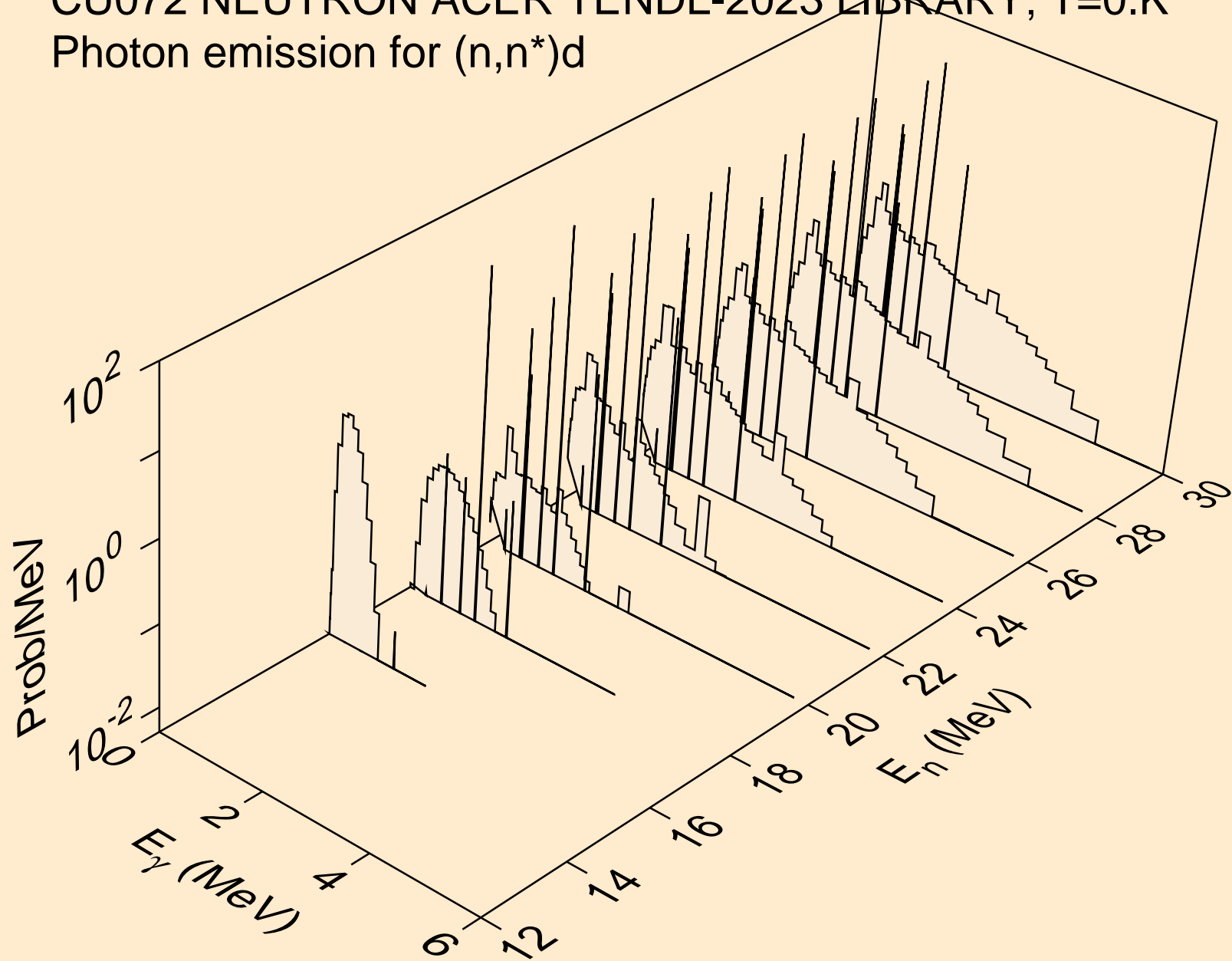

CU072 NEUTRON ACER TENDL-2023 LIBRARY; T=0.K  
Photon emission for (n,n\*)t

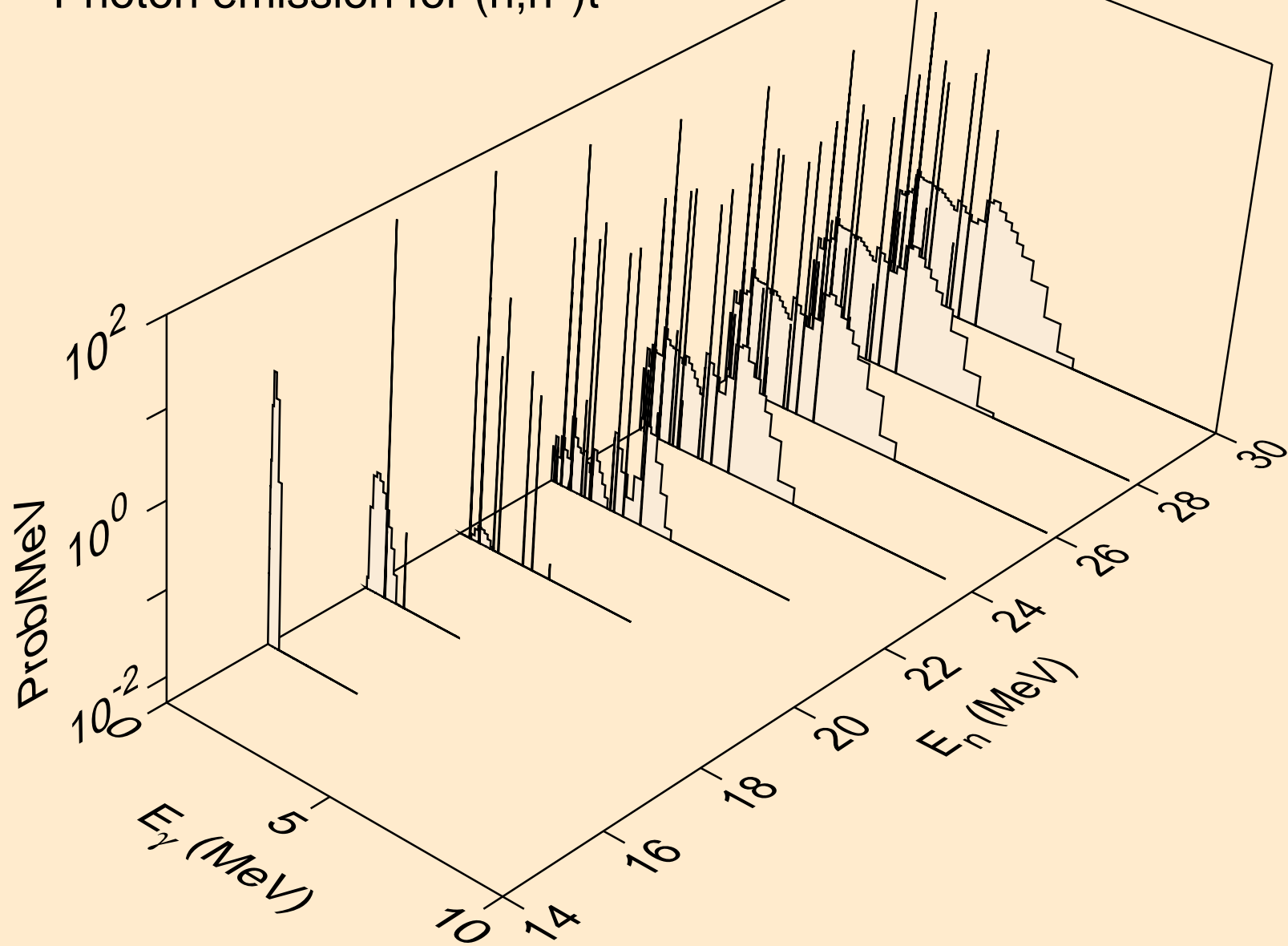

CU072 NEUTRON ACER TENDL-2023 LIBRARY; T=0.K  
Photon emission for (n,n\*)he3

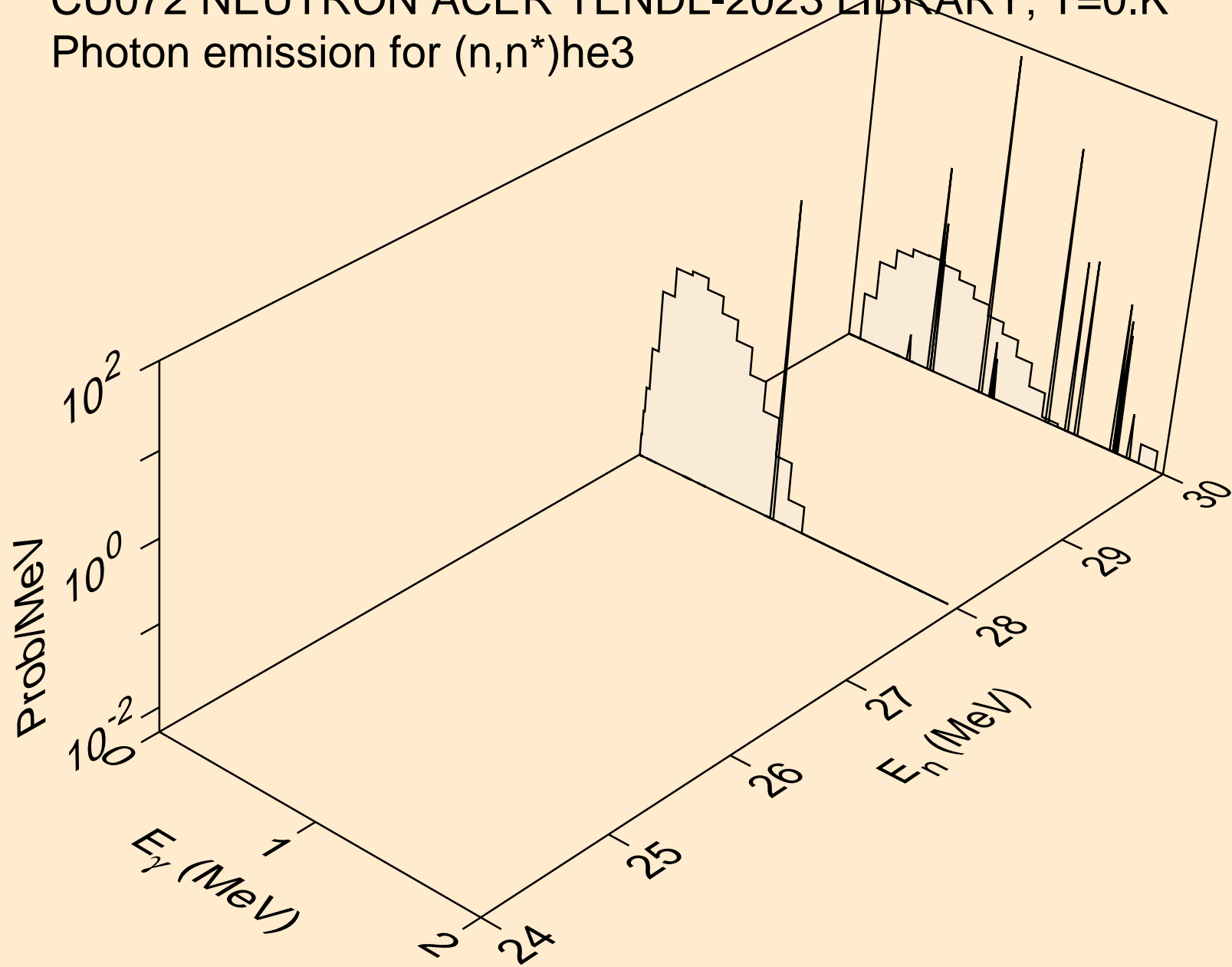

CU072 NEUTRON ACER TENDL-2023 LIBRARY; T=0.K  
Photon emission for (n,4n)

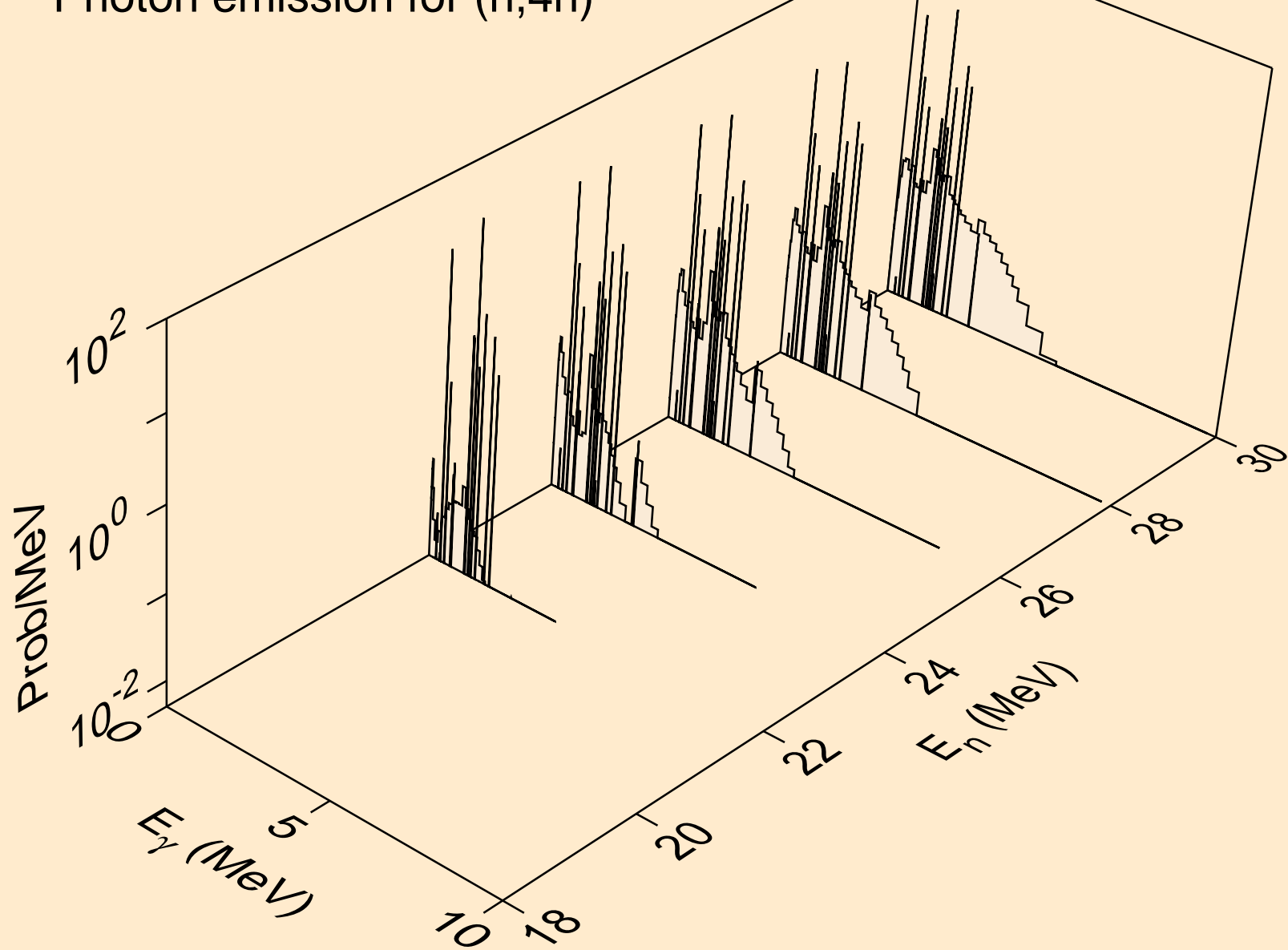

CU072 NEUTRON ACER TENDL-2023 LIBRARY; T=0.K  
Photon emission for (n,2np)

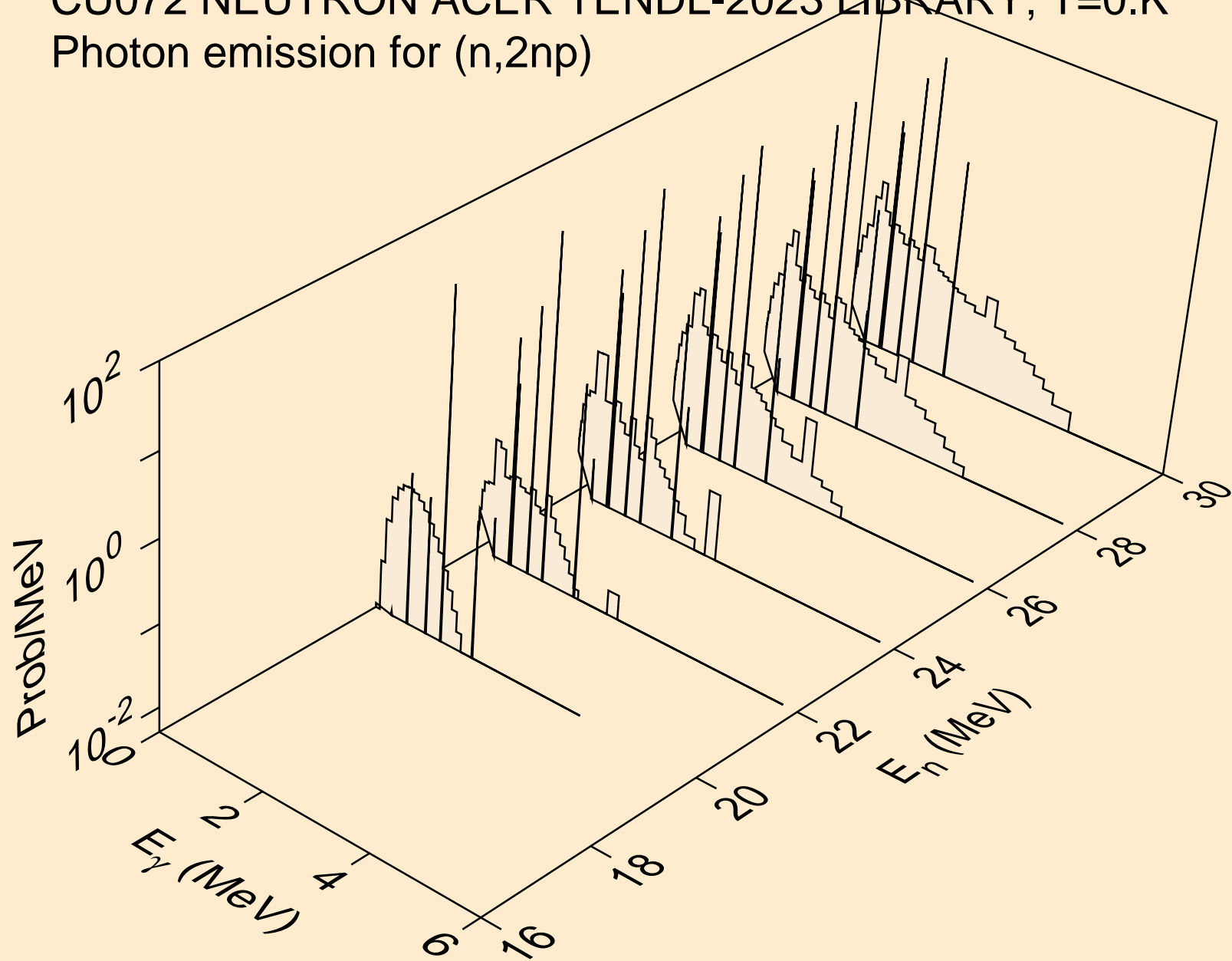

CU072 NEUTRON ACER TENDL-2023 LIBRARY; T=0.K  
Photon emission for (n,3np)

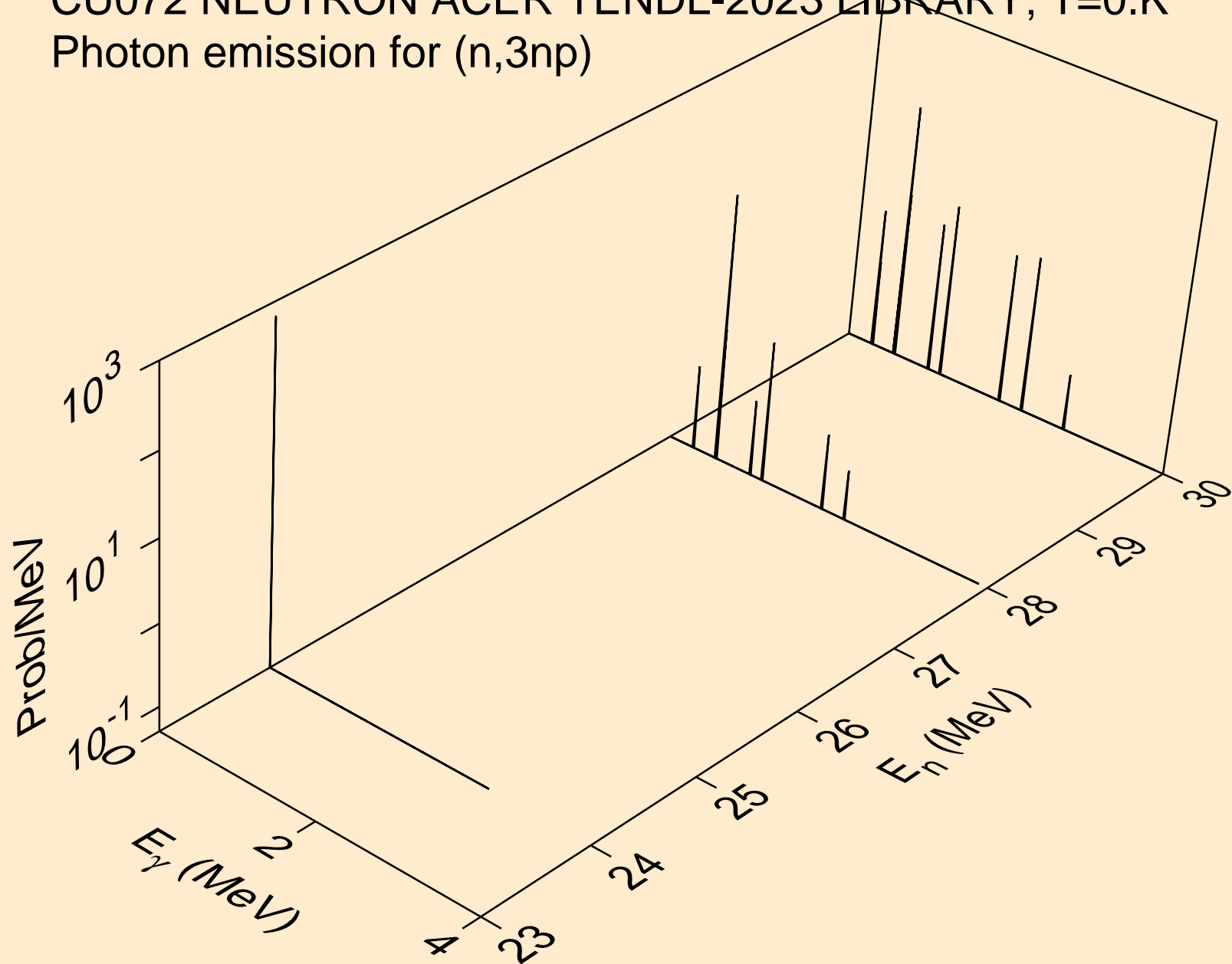

CU072 NEUTRON ACER TENDL-2023 LIBRARY; T=0.K  
Photon emission for (n,n\*c)

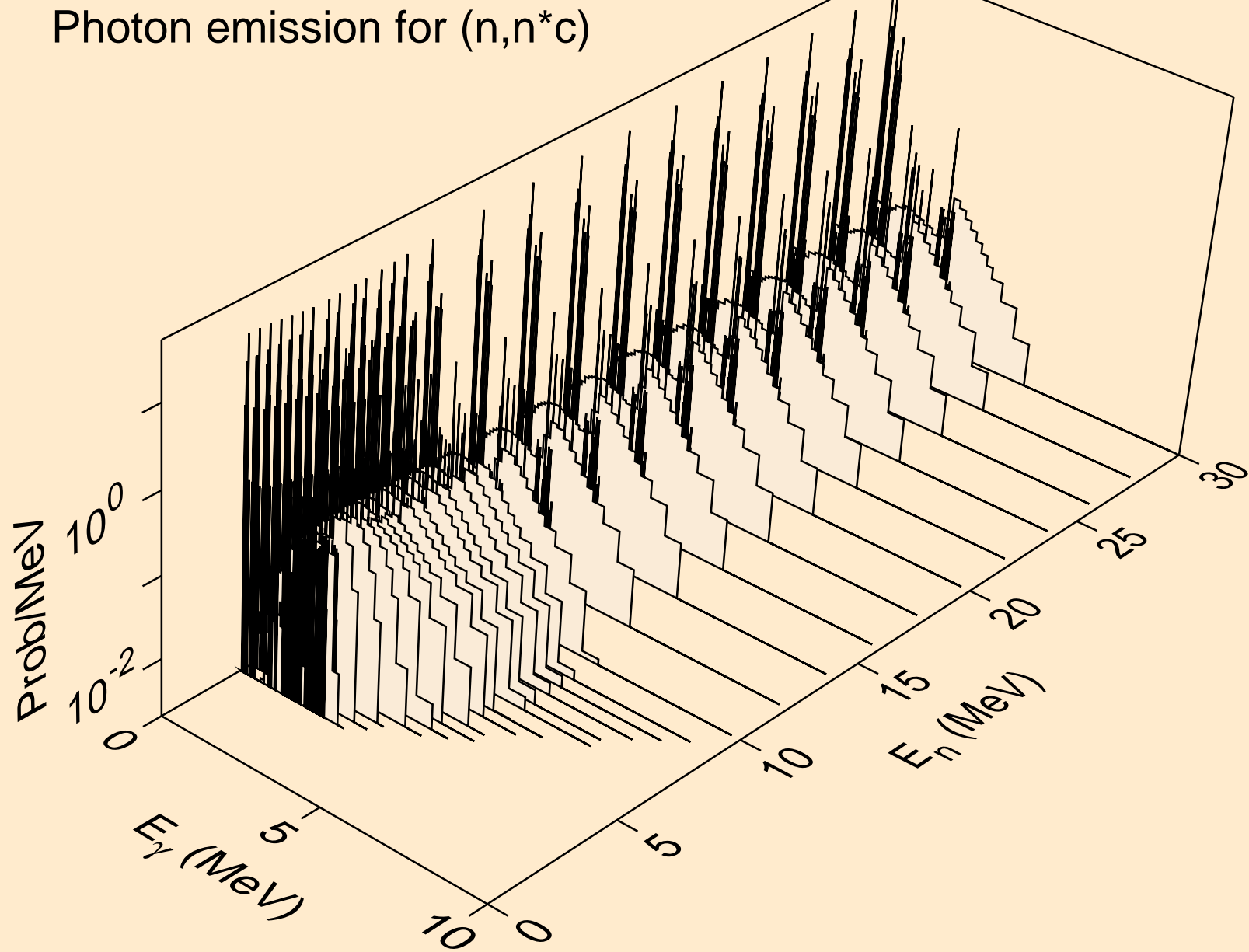



CU072 NEUTRON ACER TENDL-2023 LIBRARY; T=0.K  
Photon emission for (n,gma)

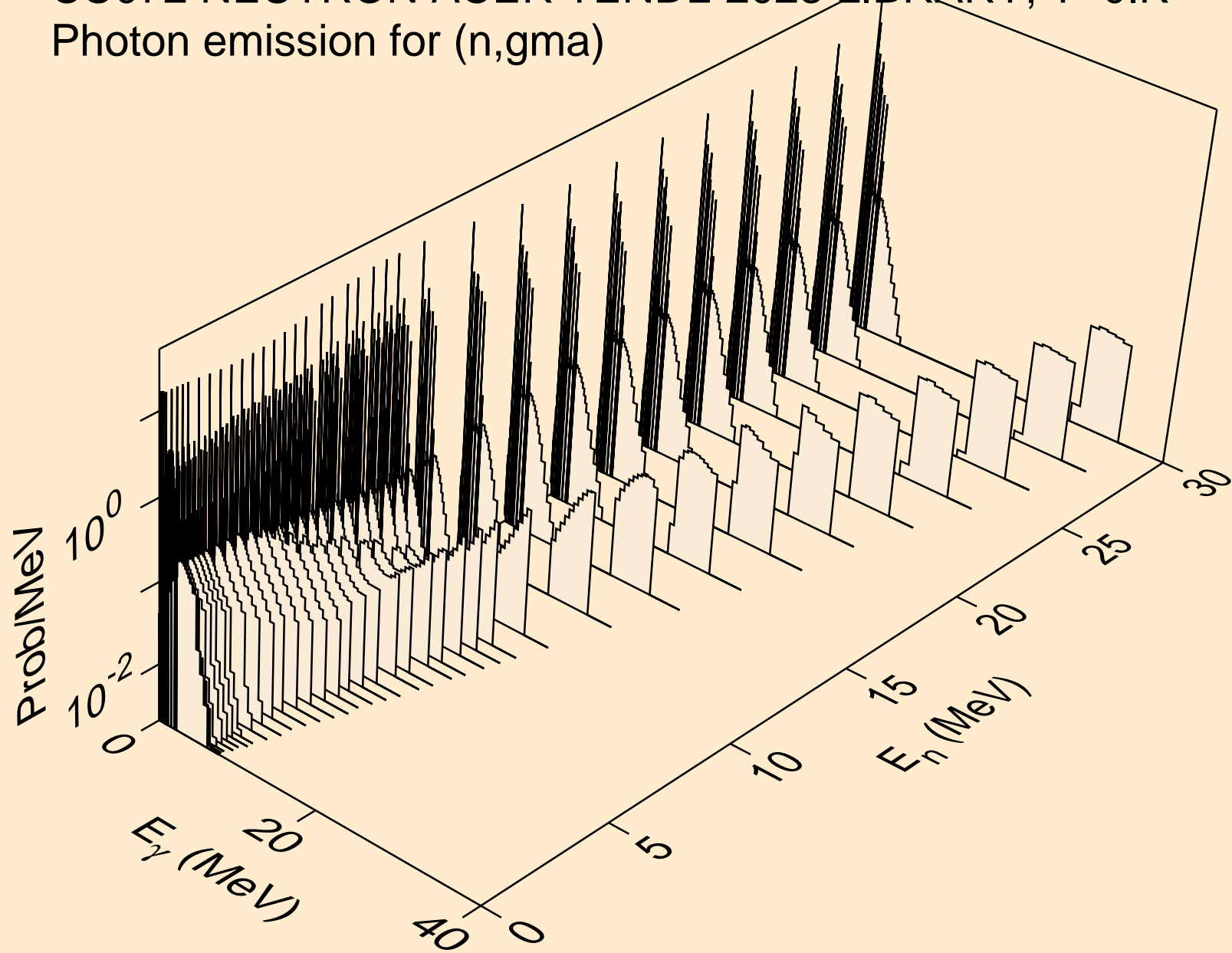

CU072 NEUTRON ACER TENDL-2023 LIBRARY; T=0.K  
Photon emission for (n,p)

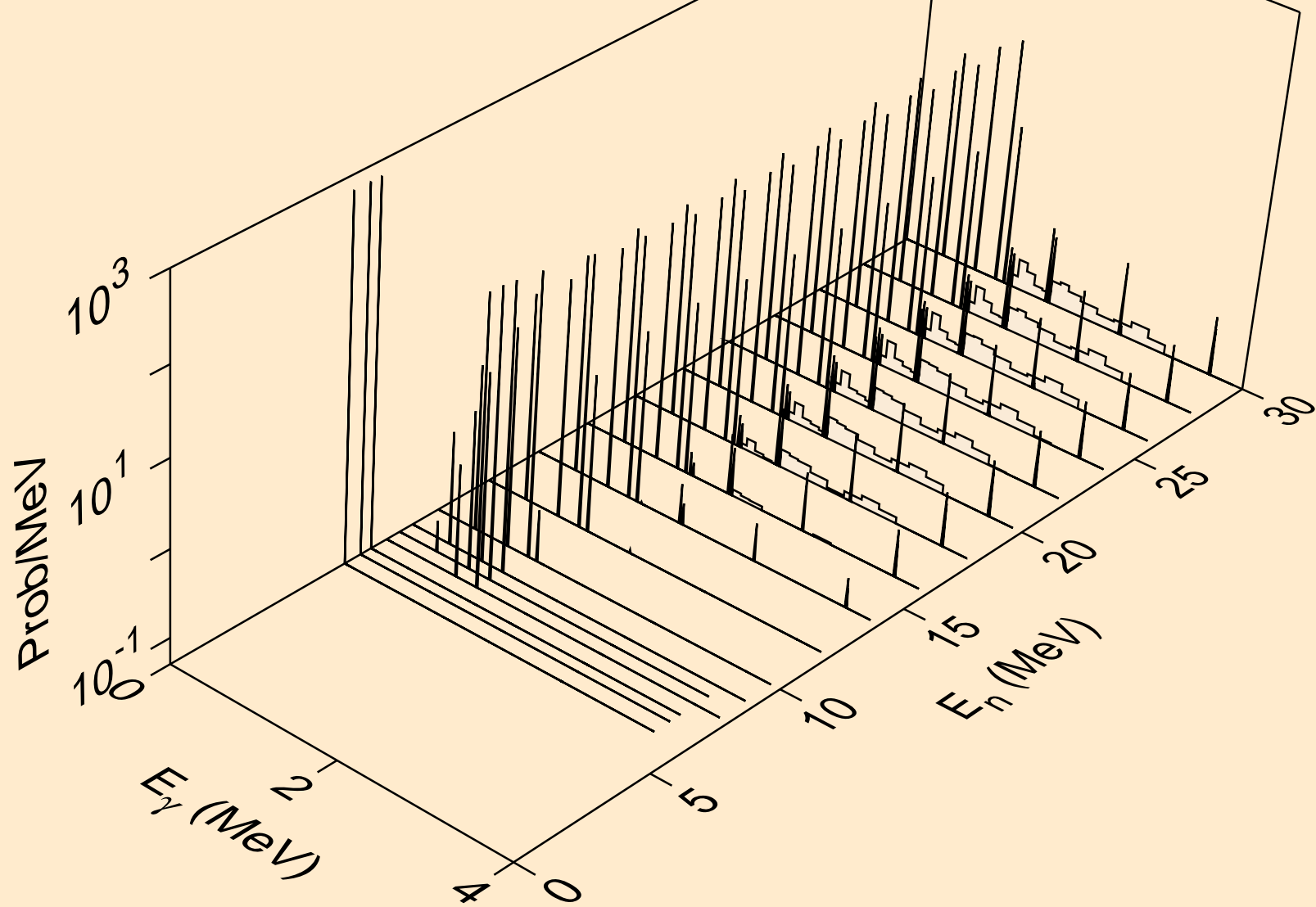

CU072 NEUTRON ACER TENDL-2023 LIBRARY; T=0.K  
Photon emission for (n,d)

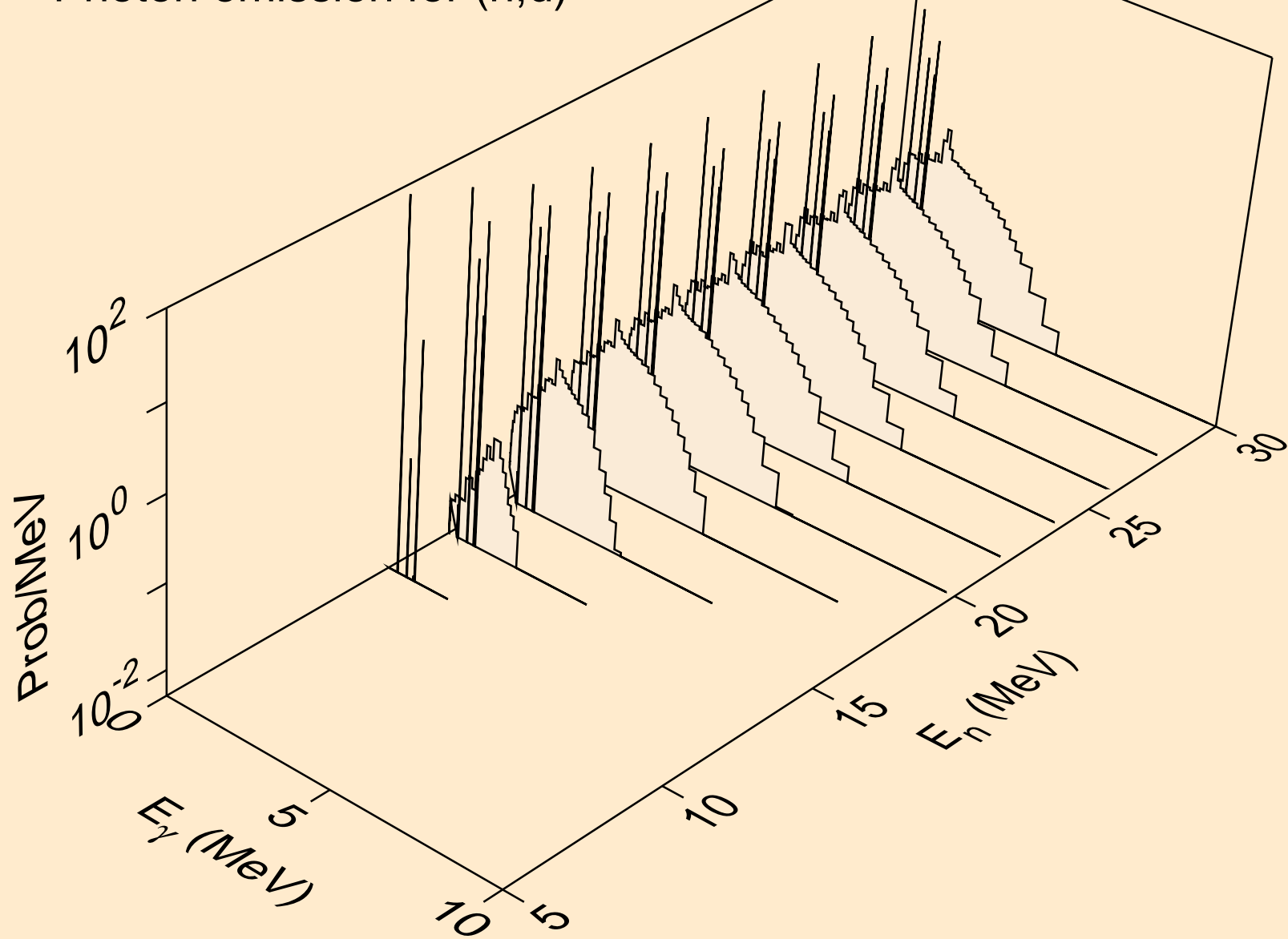

CU072 NEUTRON ACER TENDL-2023 LIBRARY; T=0.K  
Photon emission for (n,t)

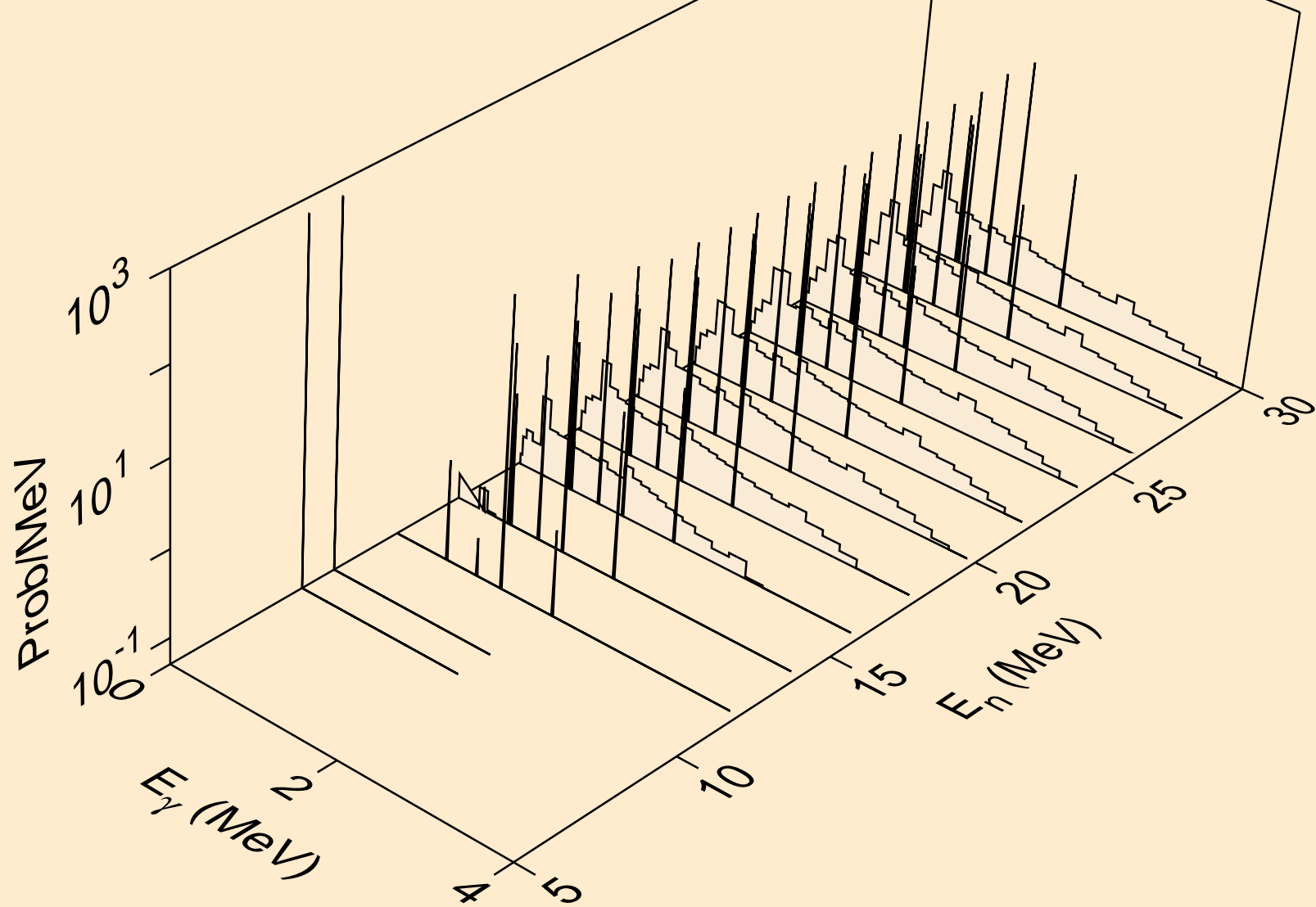

CU072 NEUTRON ACER TENDL-2023 LIBRARY; T=0.K  
Photon emission for (n,he3)

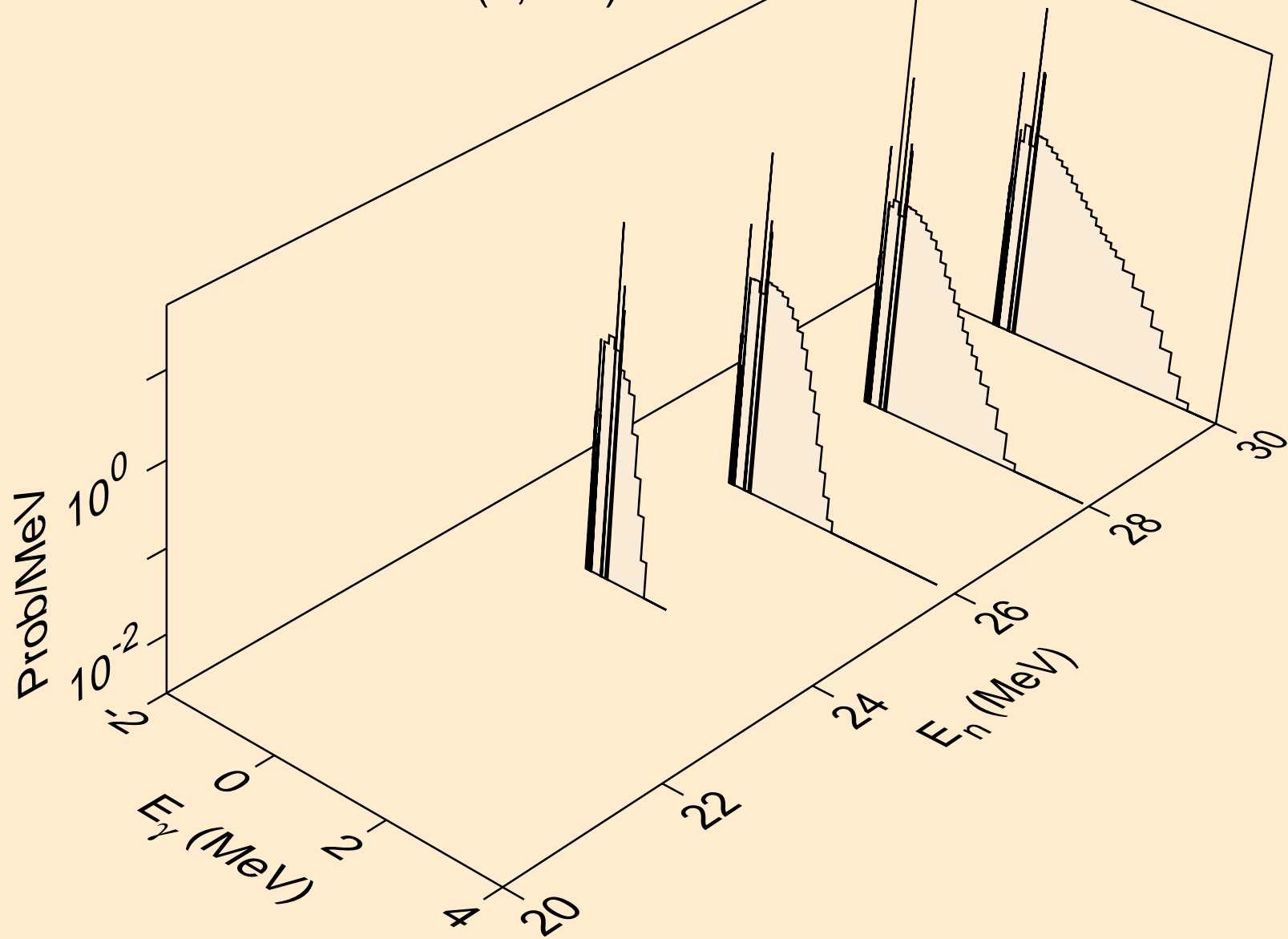

CU072 NEUTRON ACER TENDL-2023 LIBRARY; T=0.K  
Photon emission for (n,a)

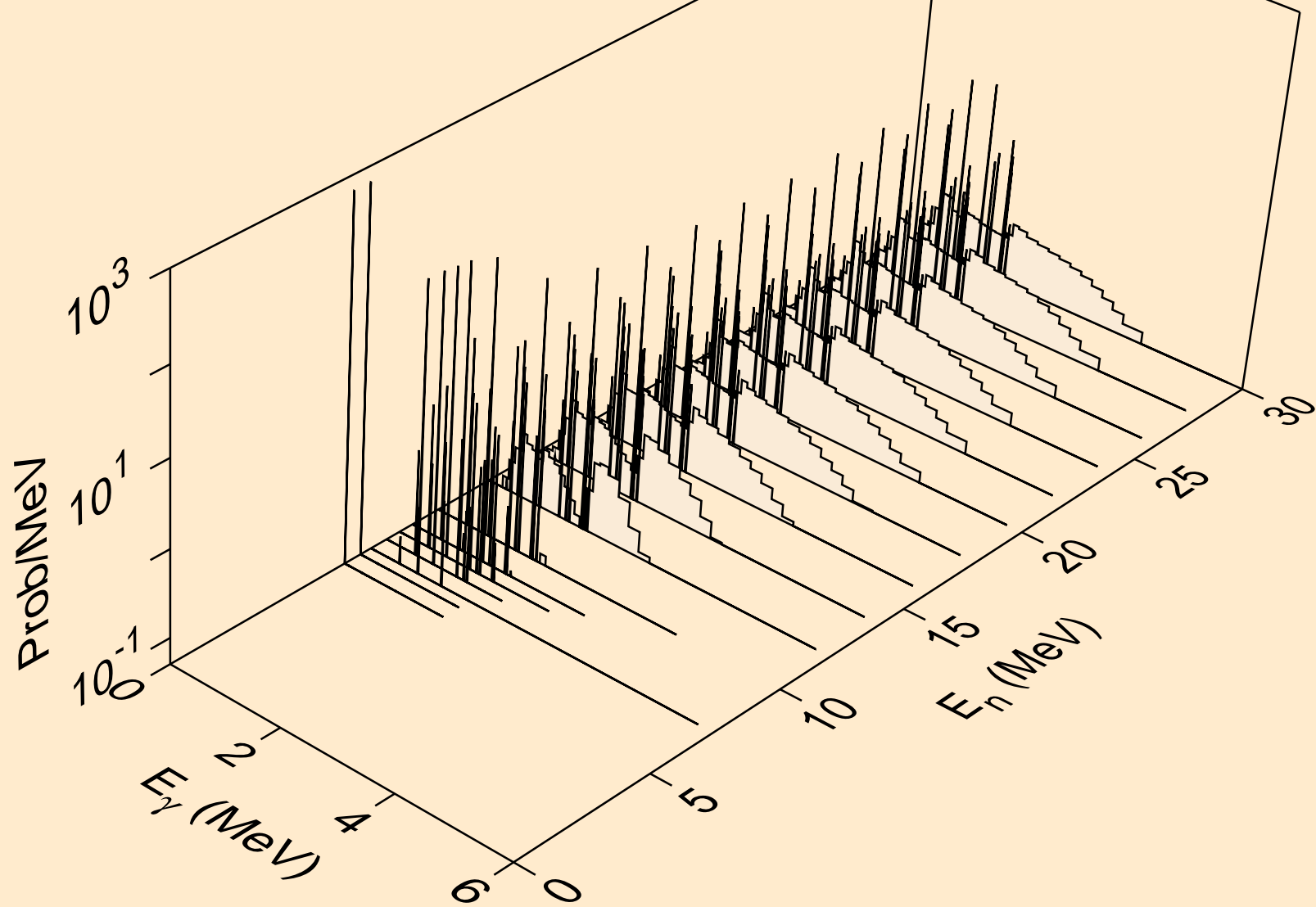

CU072 NEUTRON ACER TENDL-2023 LIBRARY; T=0.K  
thermal capture photon spectrum

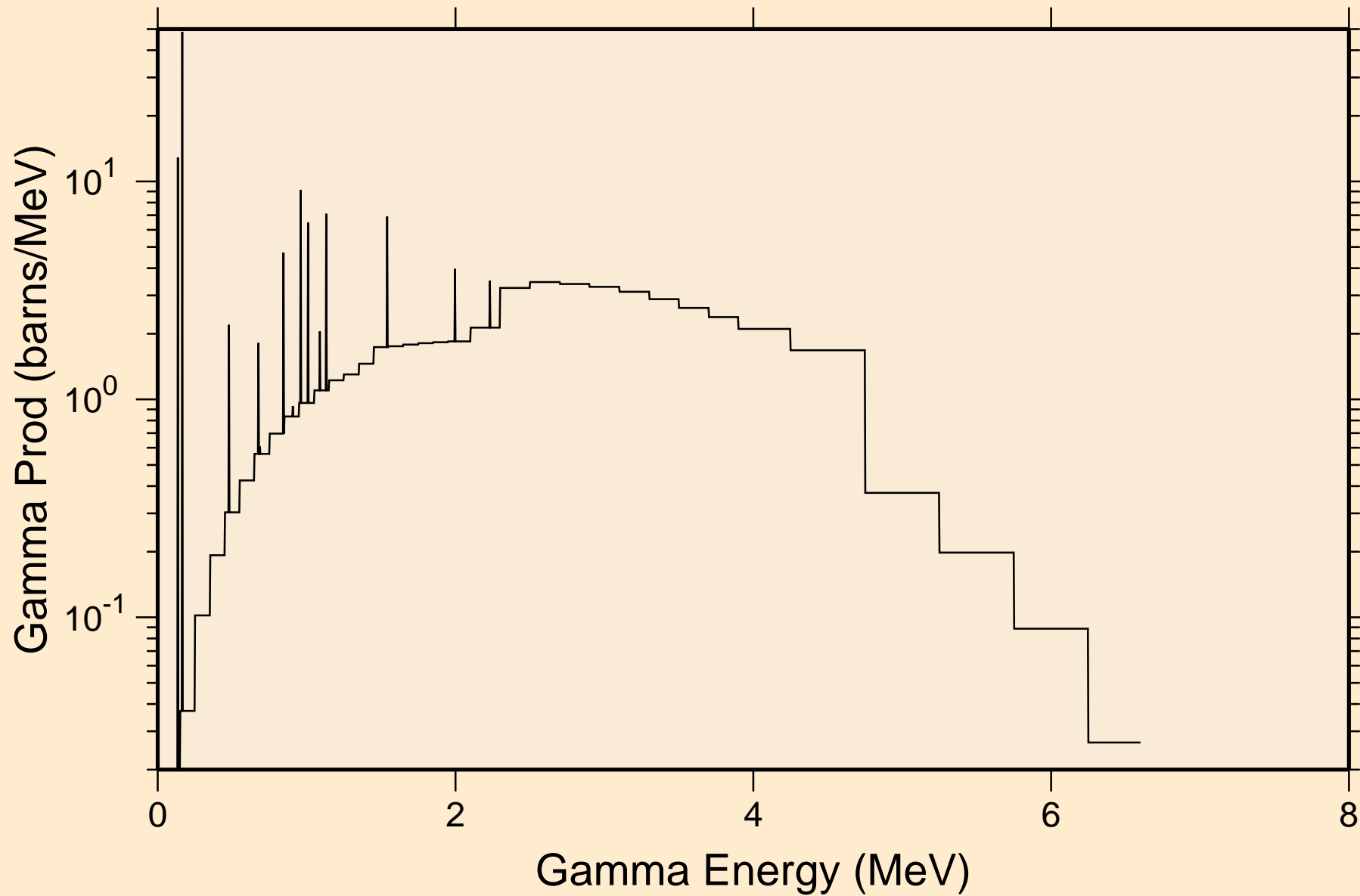

CU072 NEUTRON ACER TENDL-2023 LIBRARY; T=0.K  
14 MeV photon spectrum

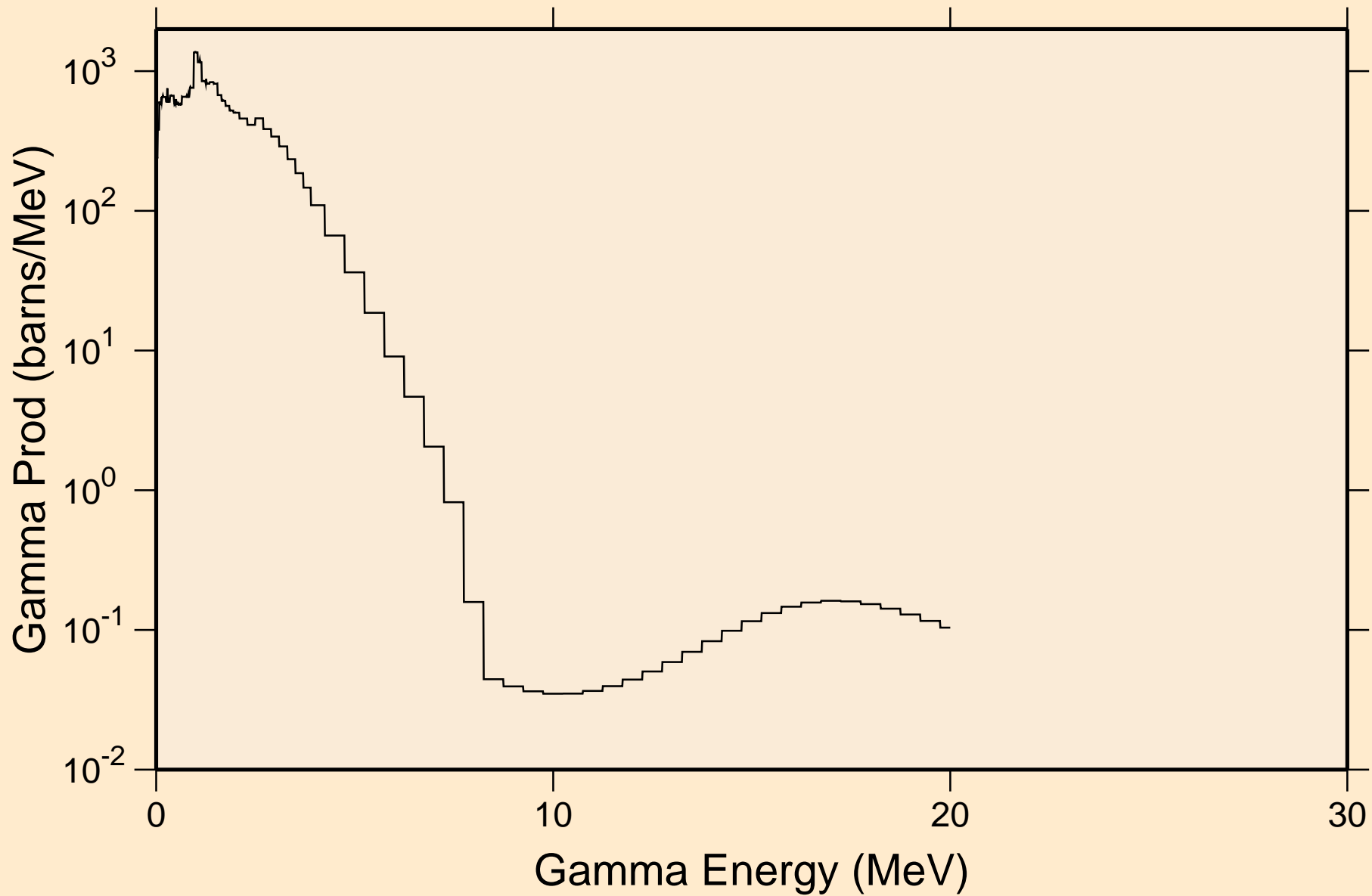



CU072 NEUTRON ACER TENDL-2023 LIBRARY; T=0.K  
Particle heating contributions

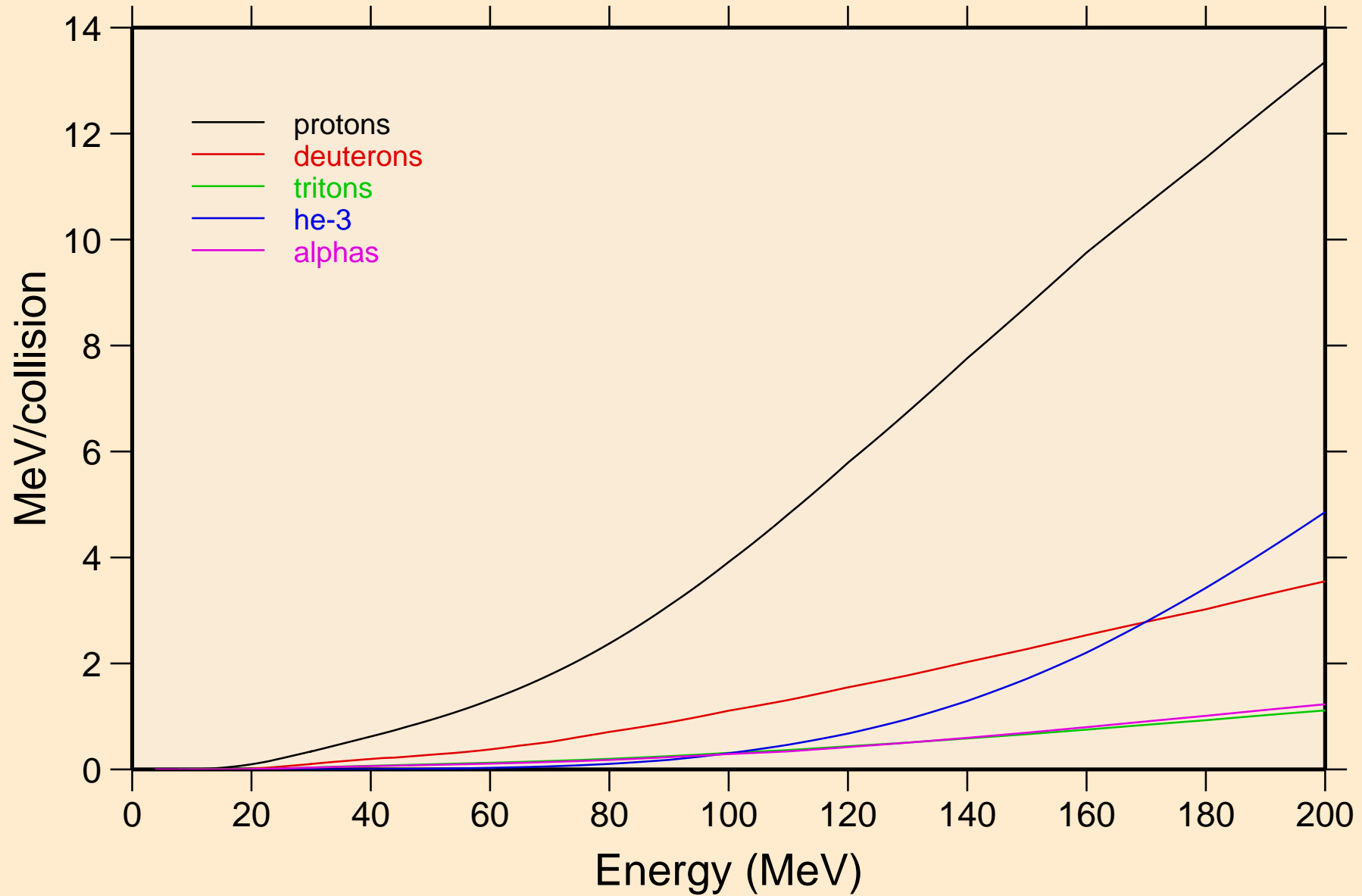

CU072 NEUTRON ACER TENDL-2023 LIBRARY; T=0.K  
Recoil Heating

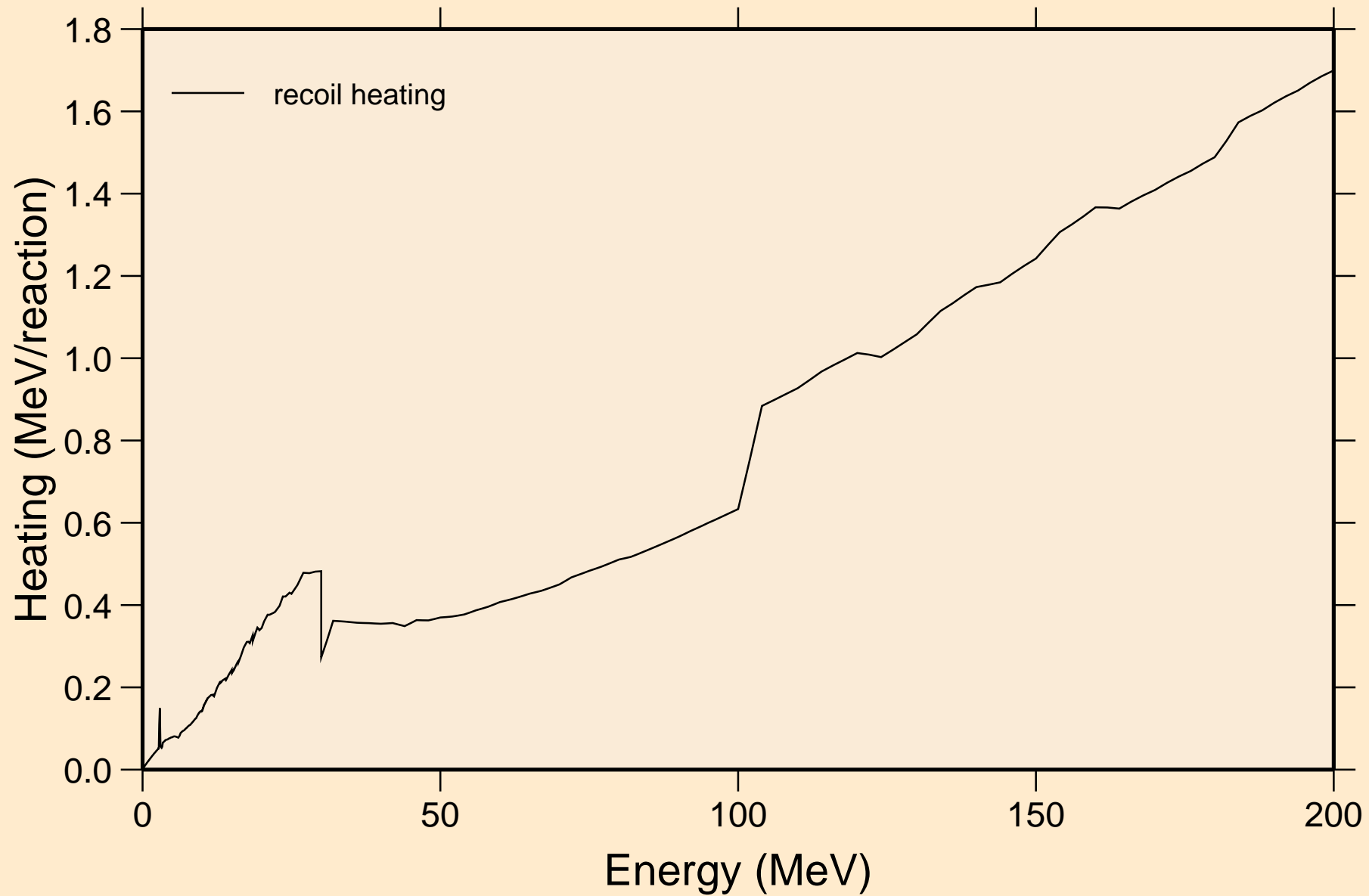

CU072 NEUTRON ACER TENDL-2023 LIBRARY; T=0.K  
Particle production cross sections

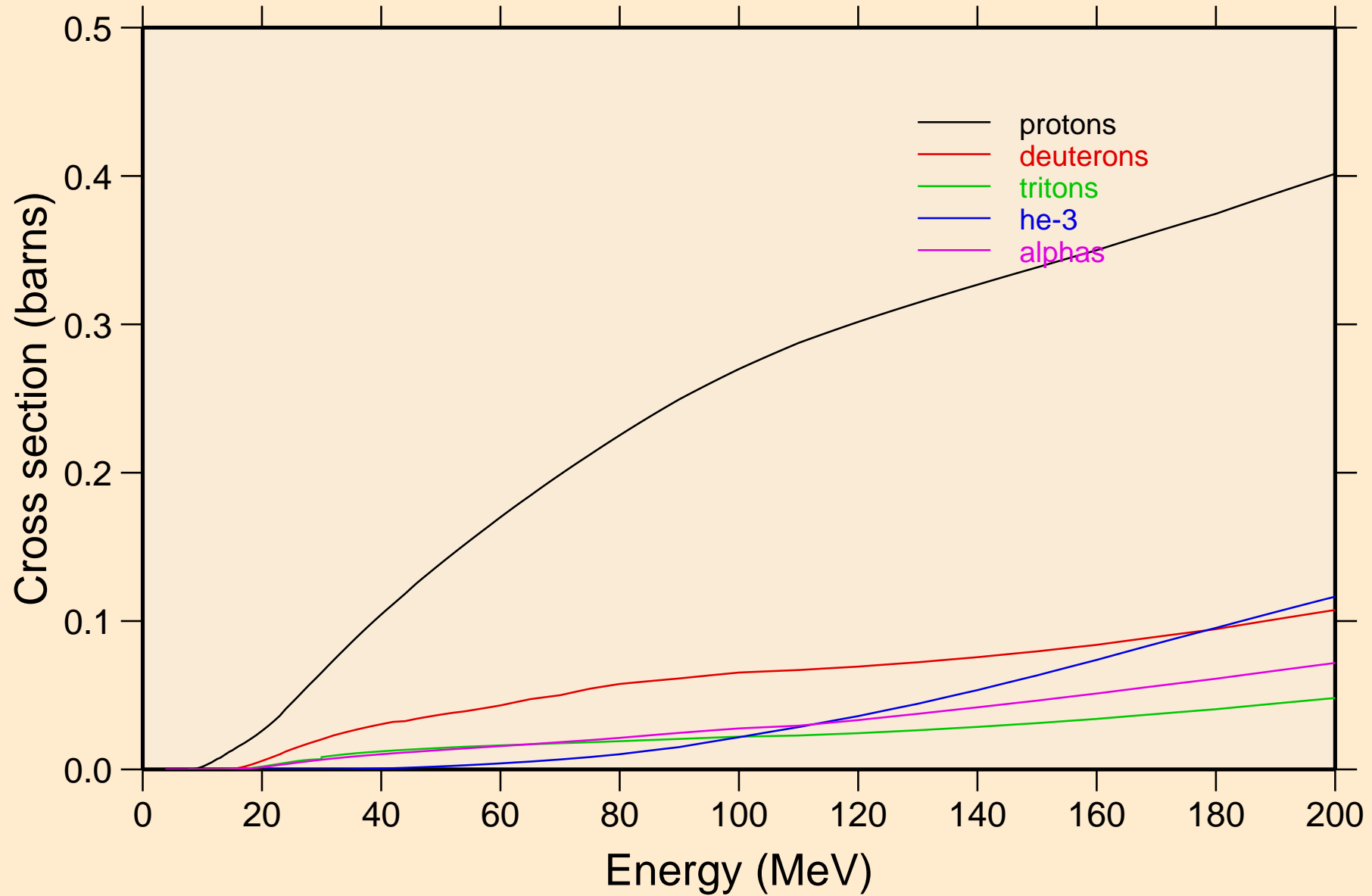

CU072 NEUTRON ACER TENDL-2023 LIBRARY; T=0.K  
protons from (n,x)

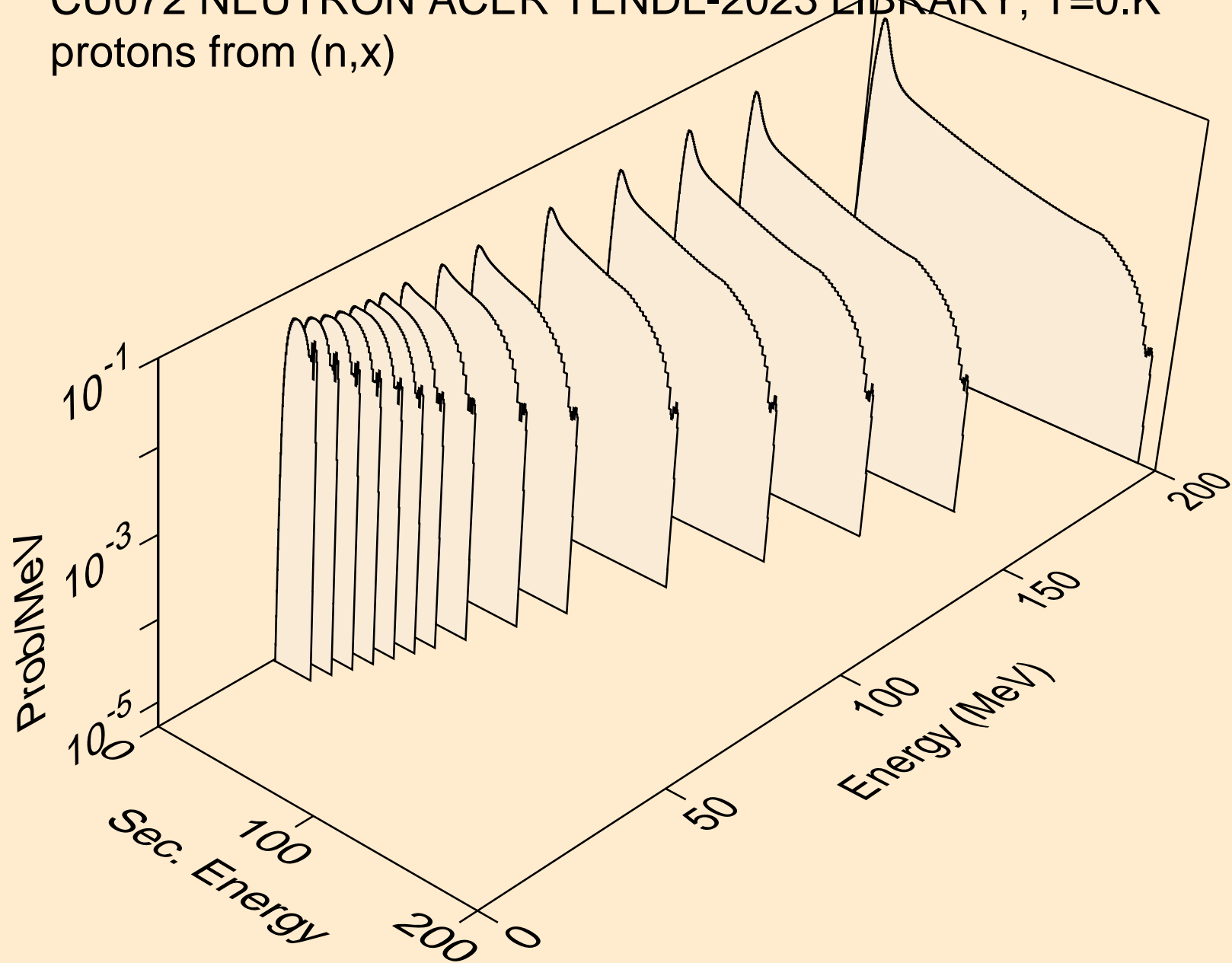

CU072 NEUTRON ACER TENDL-2023 LIBRARY; T=0.K  
protons from (n,n\*)p

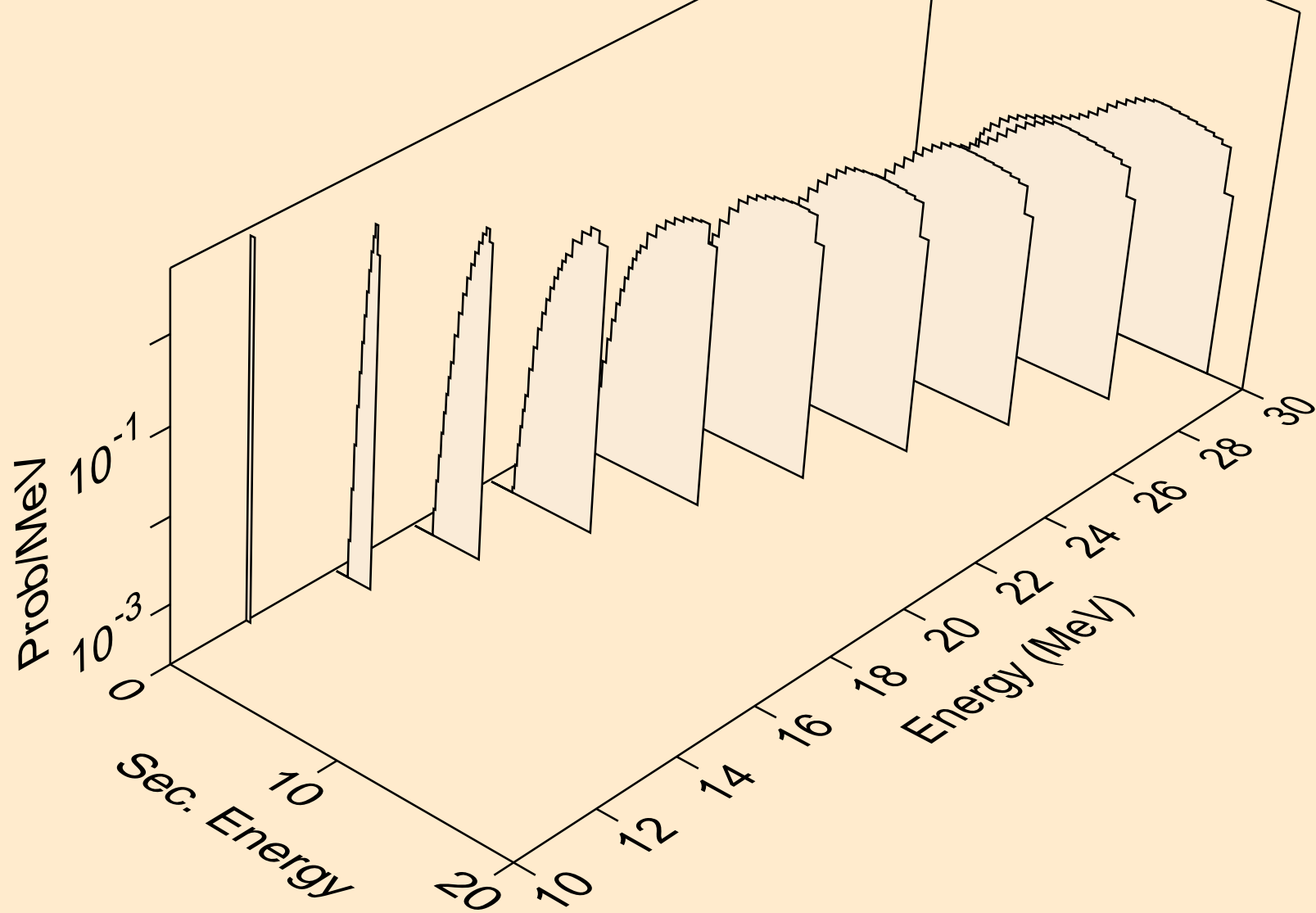

CU072 NEUTRON ACER TENDL-2023 LIBRARY; T=0.K  
protons from (n,2np)

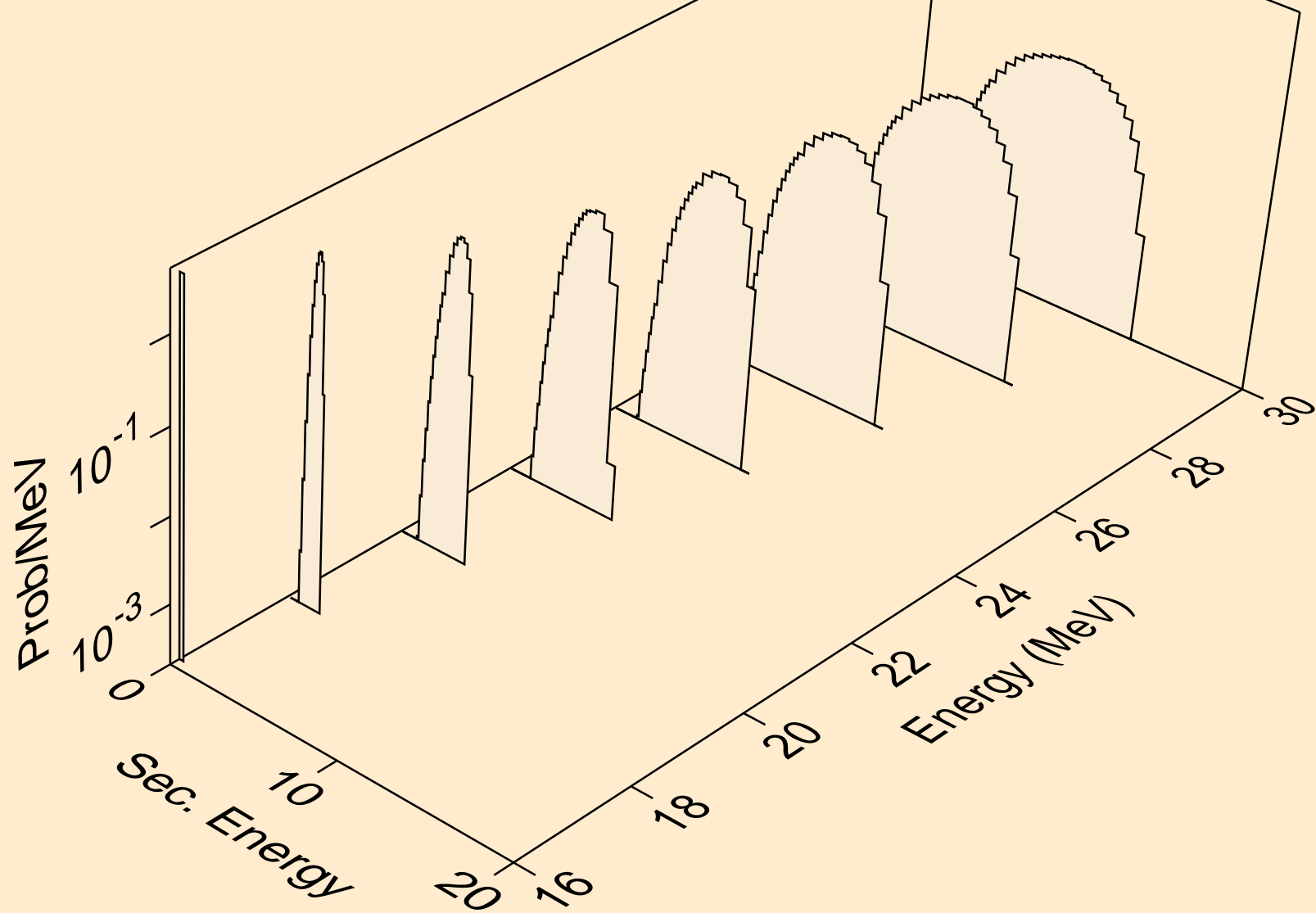

CU072 NEUTRON ACER TENDL-2023 LIBRARY; T=0.K  
protons from (n,3np)

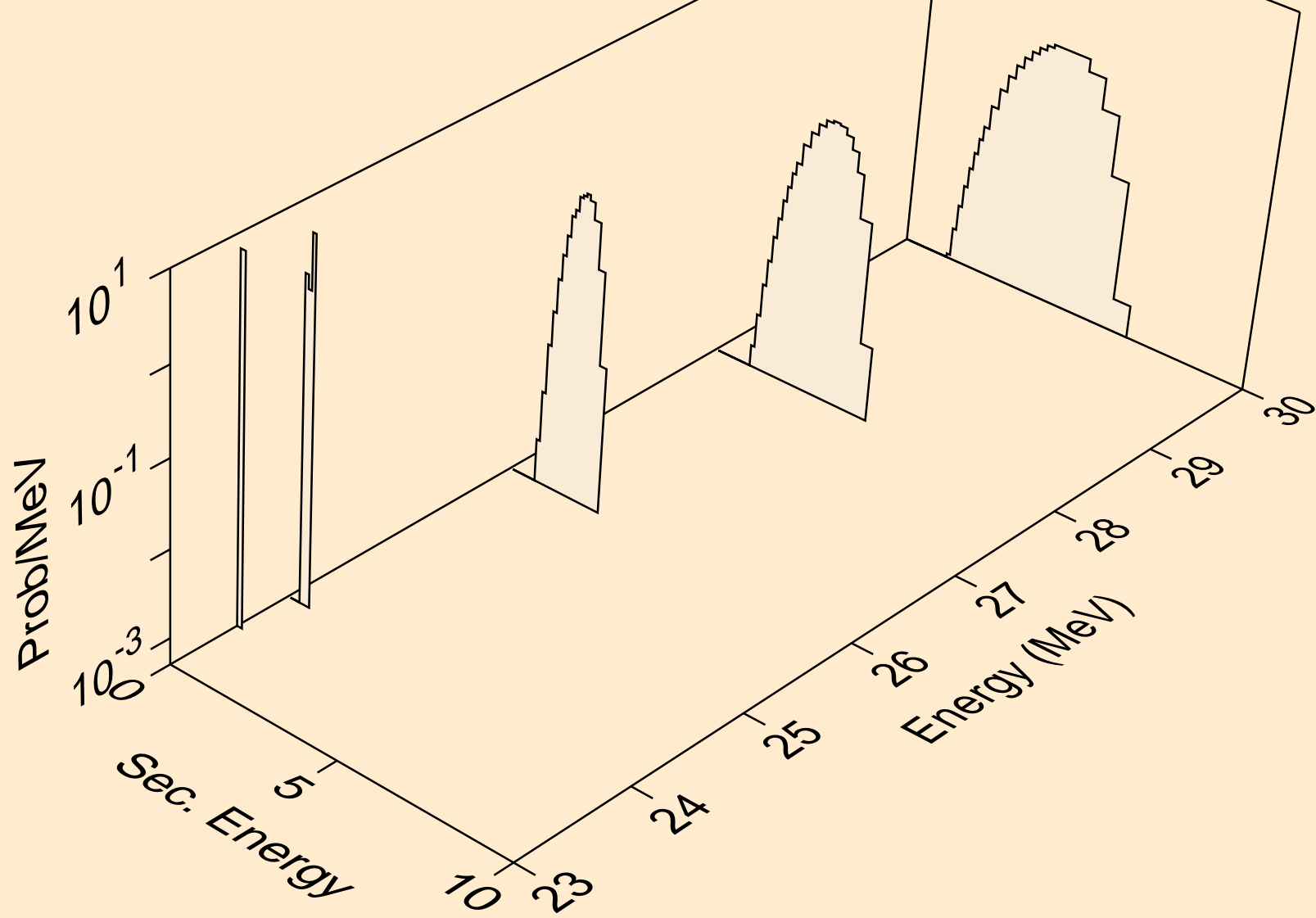

CU072 NEUTRON ACER TENDL-2023 LIBRARY; T=0.K  
protons from (n,p)

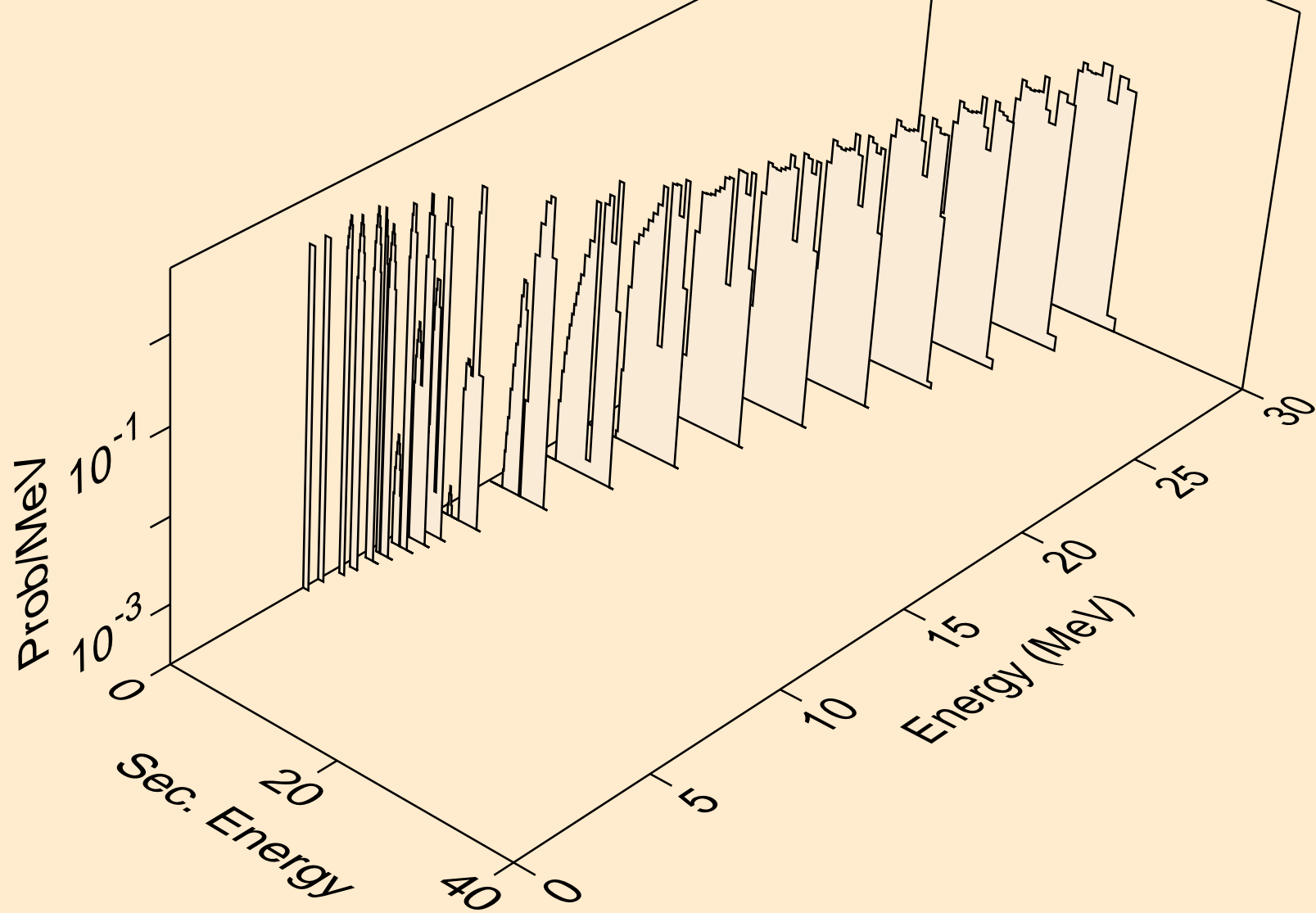



CU072 NEUTRON ACER TENDL-2023 LIBRARY; T=0.K  
deuterons from (n,x)

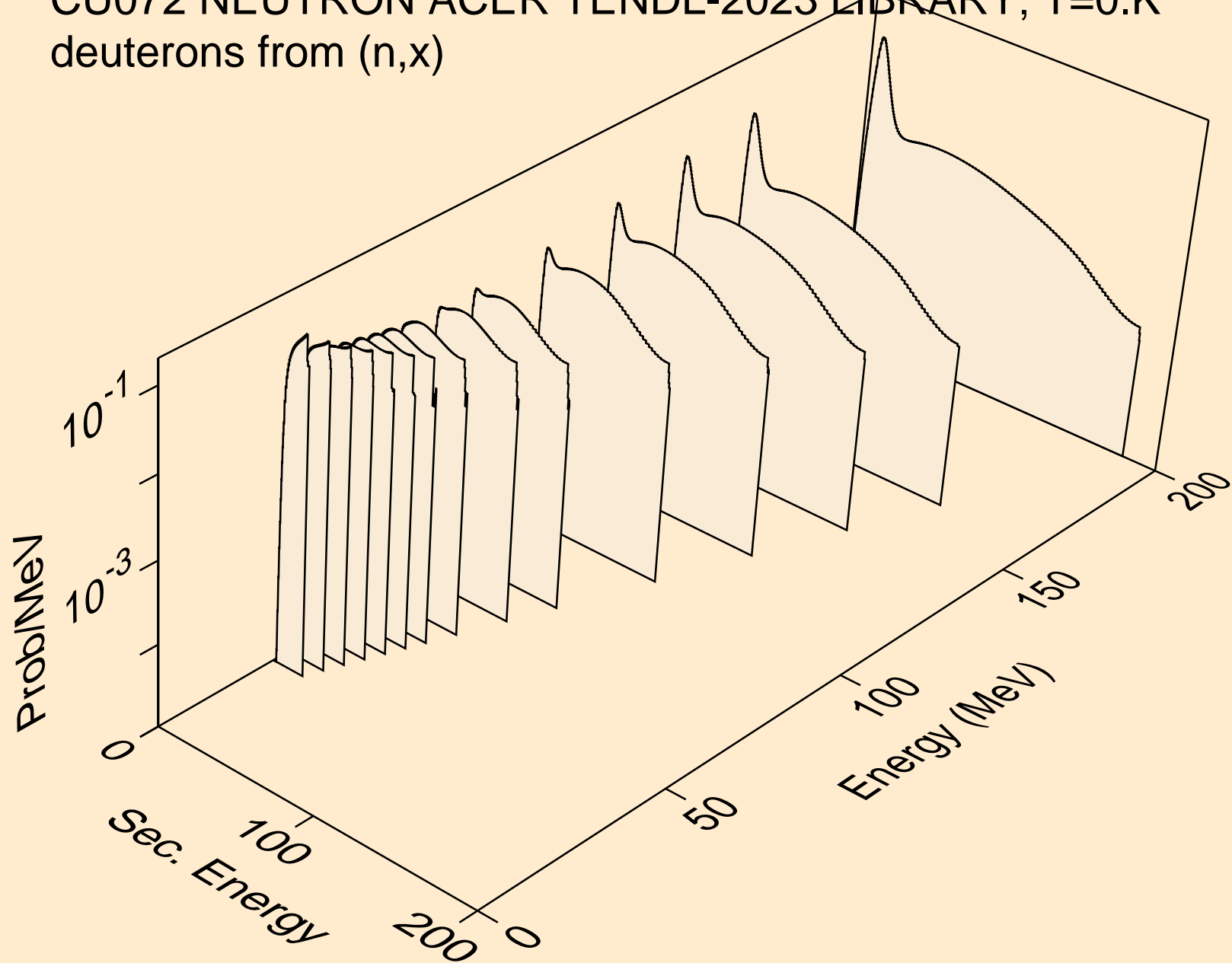

CU072 NEUTRON ACER TENDL-2023 LIBRARY; T=0.K  
deuterons from (n,2nd)

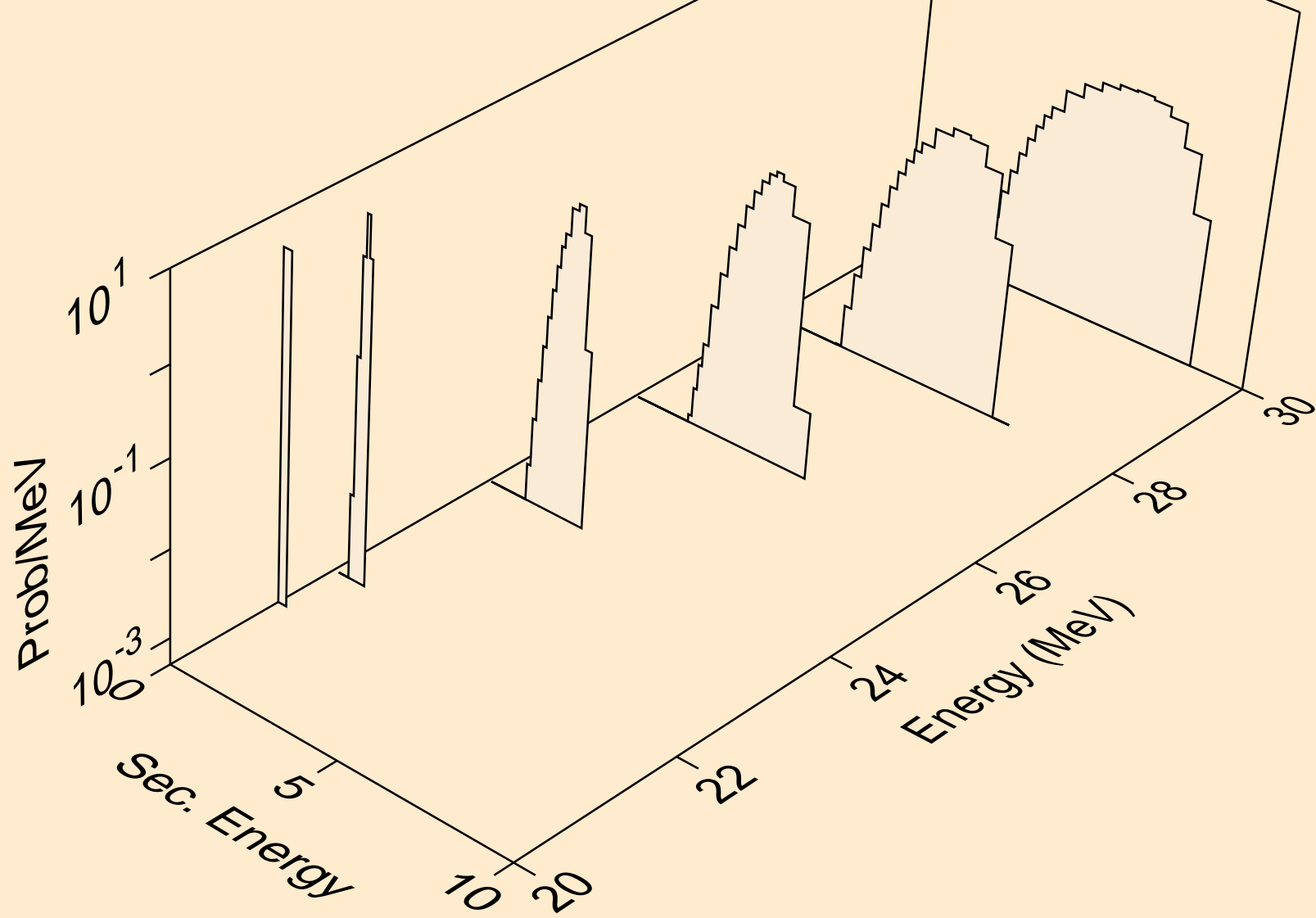

CU072 NEUTRON ACER TENDL-2023 LIBRARY; T=0.K  
deuterons from (n,n\*)d

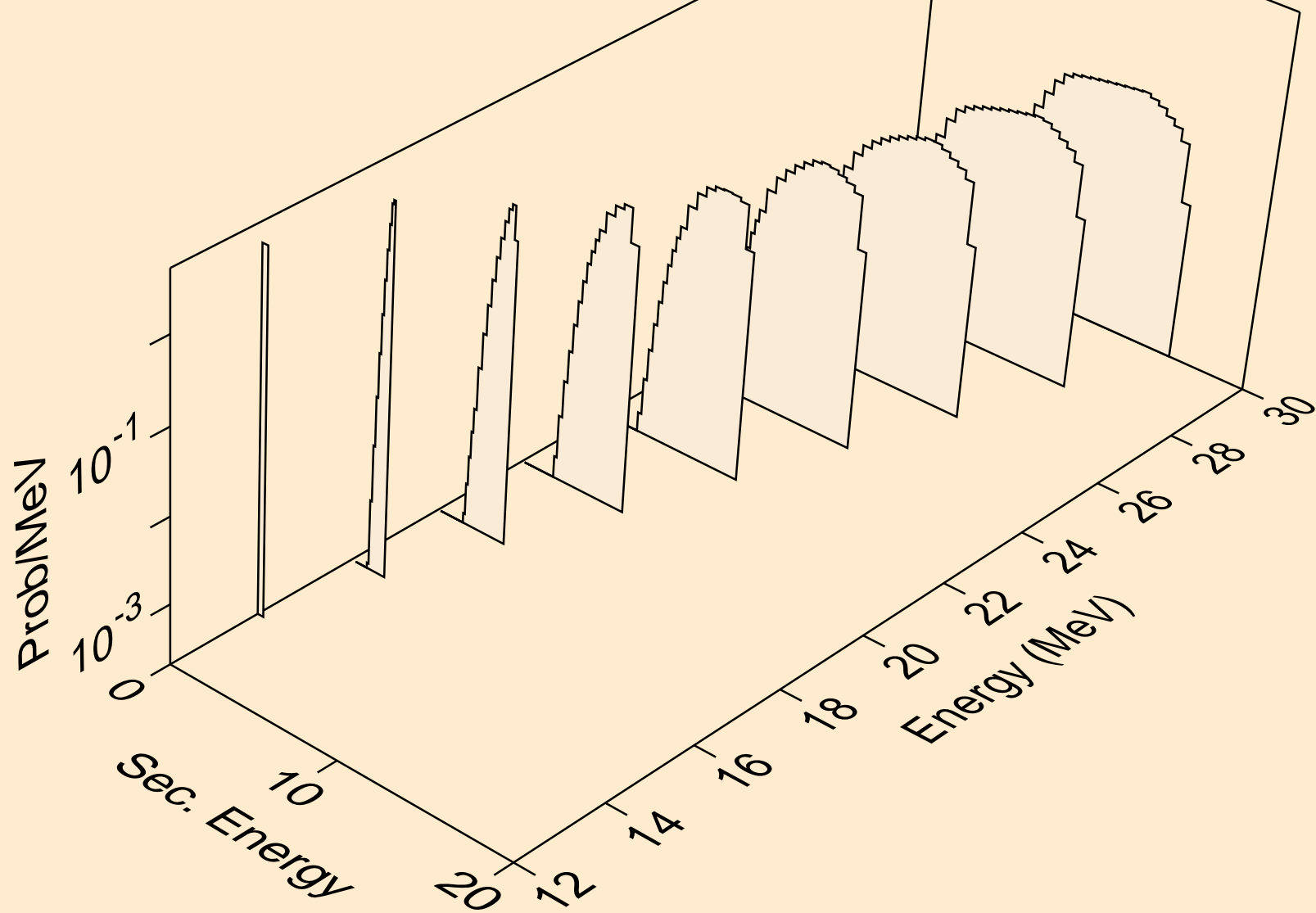

CU072 NEUTRON ACER TENDL-2023 LIBRARY; T=0.K  
deuterons from (n,d)

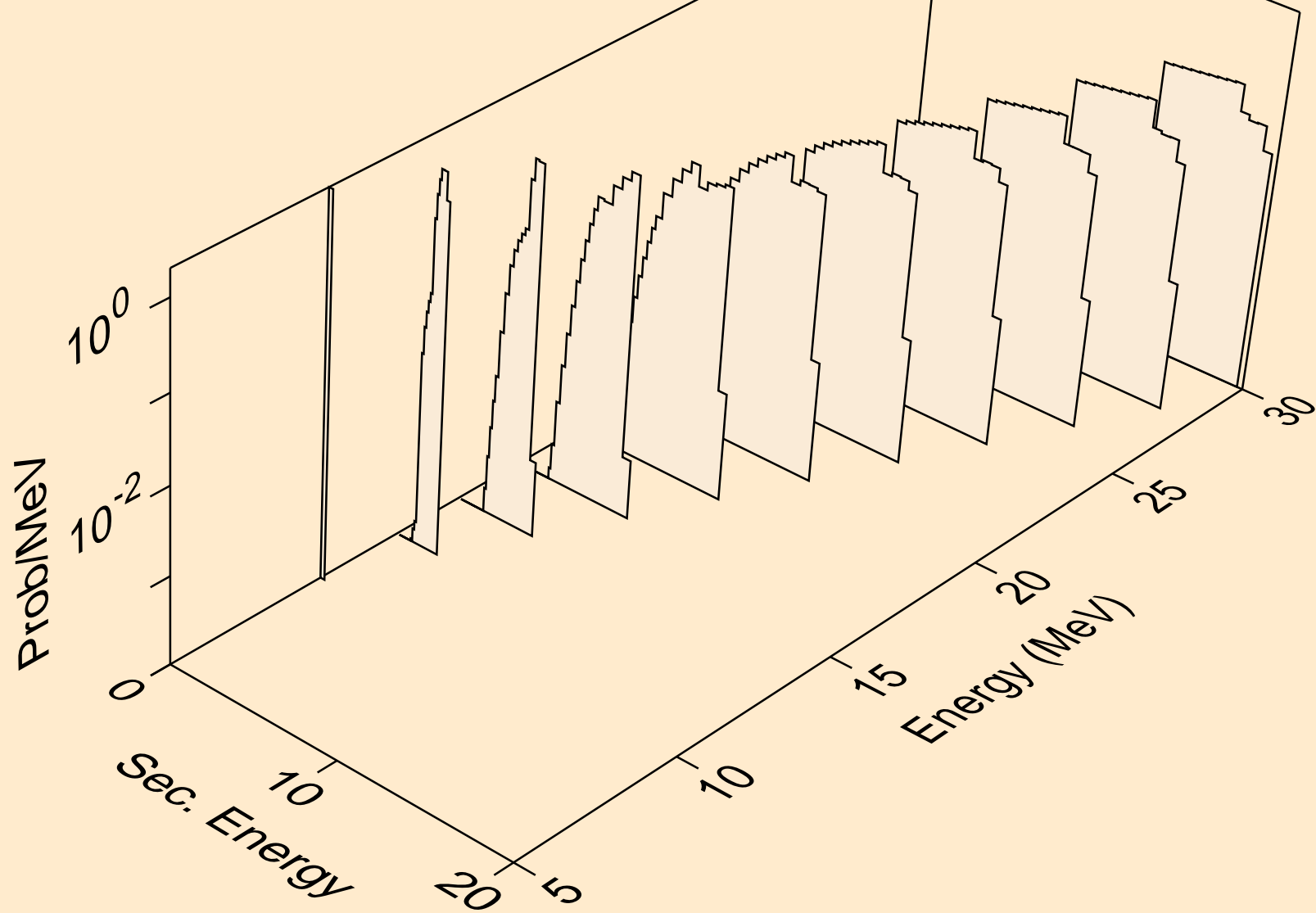

CU072 NEUTRON ACER TENDL-2023 LIBRARY; T=0.K  
tritons from (n,x)

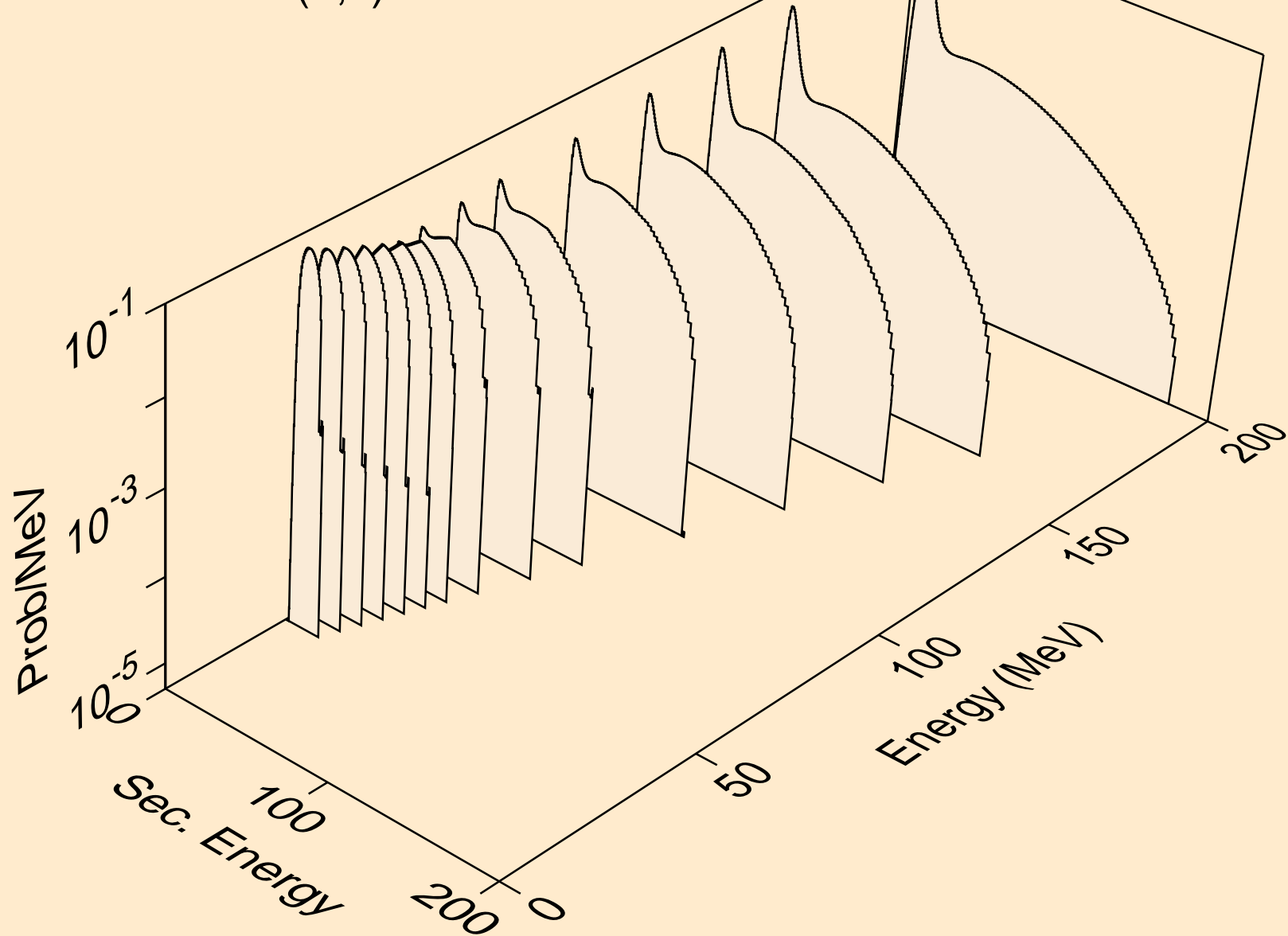

CU072 NEUTRON ACER TENDL-2023 LIBRARY; T=0.K  
tritons from (n,n\*)t

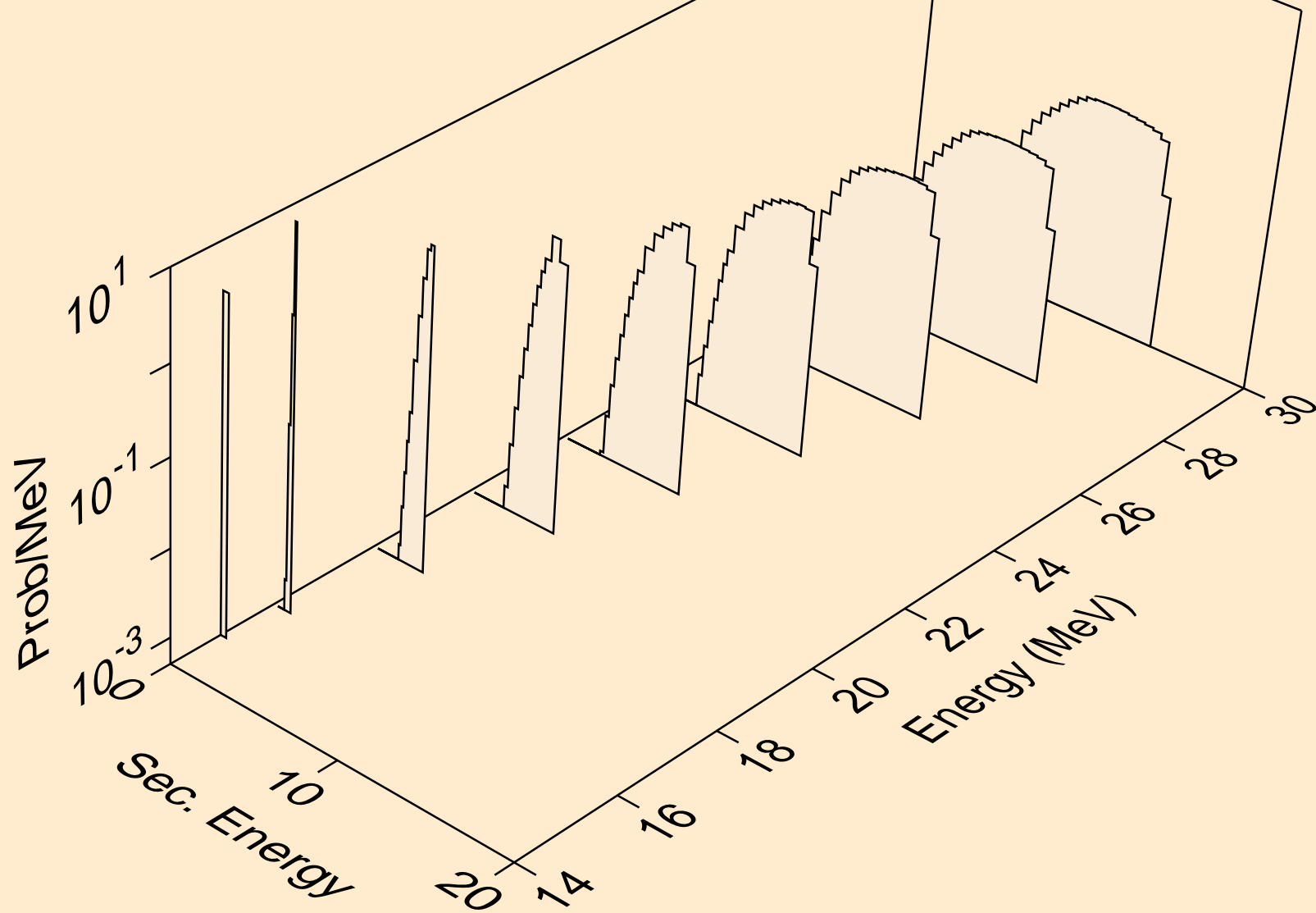

CU072 NEUTRON ACER TENDL-2023 LIBRARY; T=0.K  
tritons from (n,t)

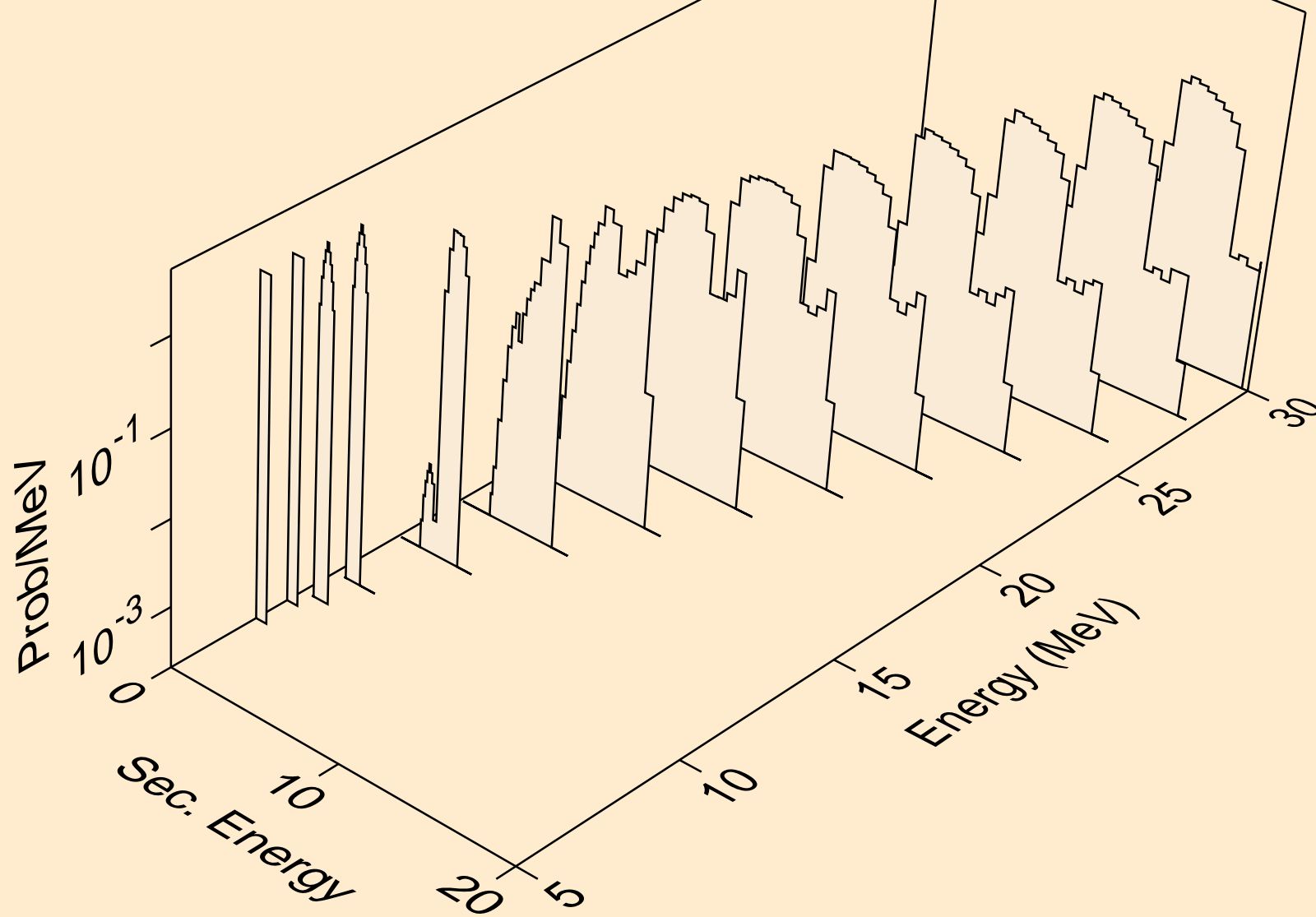

CU072 NEUTRON ACER TENDL-2023 LIBRARY; T=0.K  
he3s from (n,x)

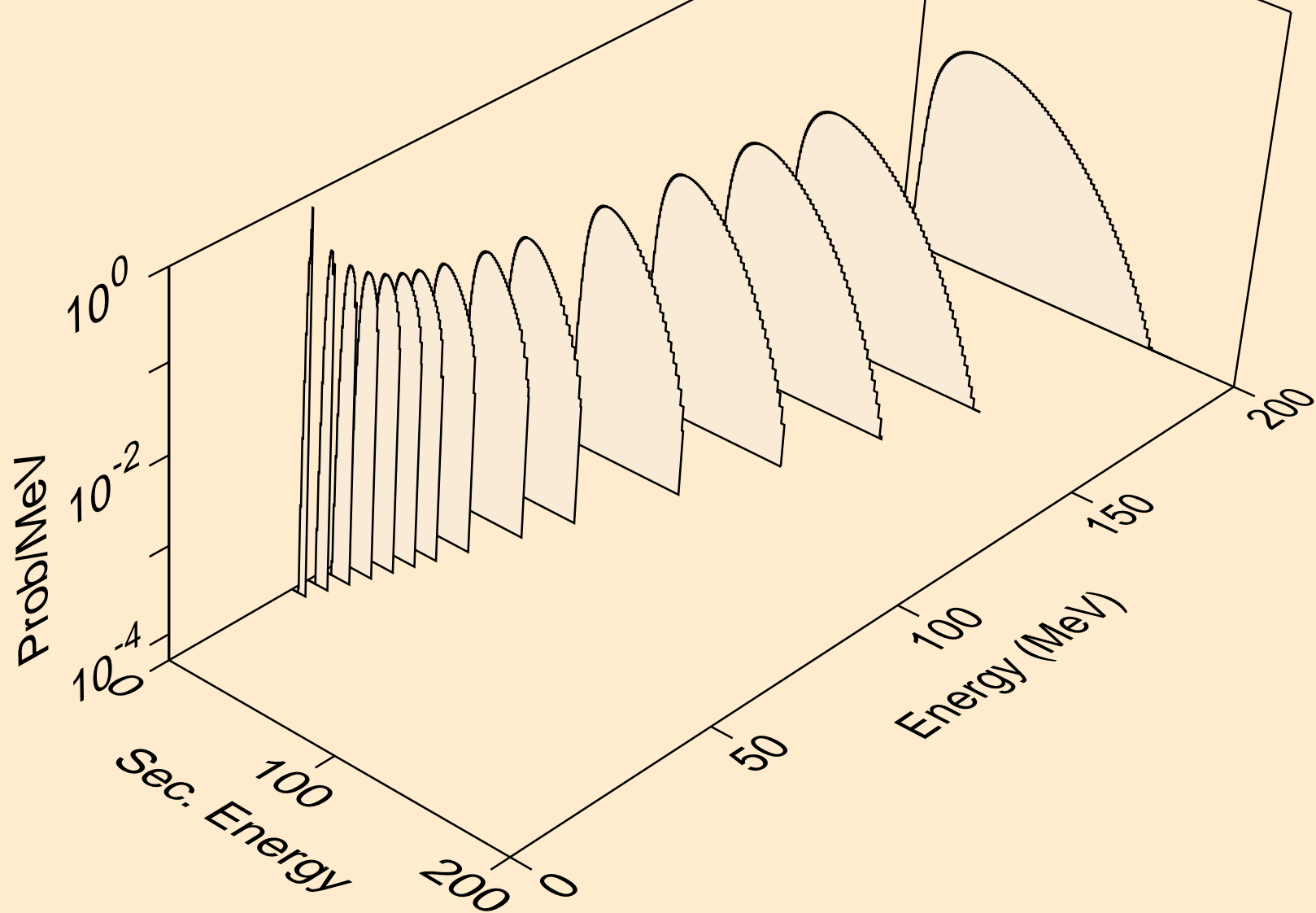



CU072 NEUTRON ACER TENDL-2023 LIBRARY; T=0.K  
he3s from (n,n\*)he3

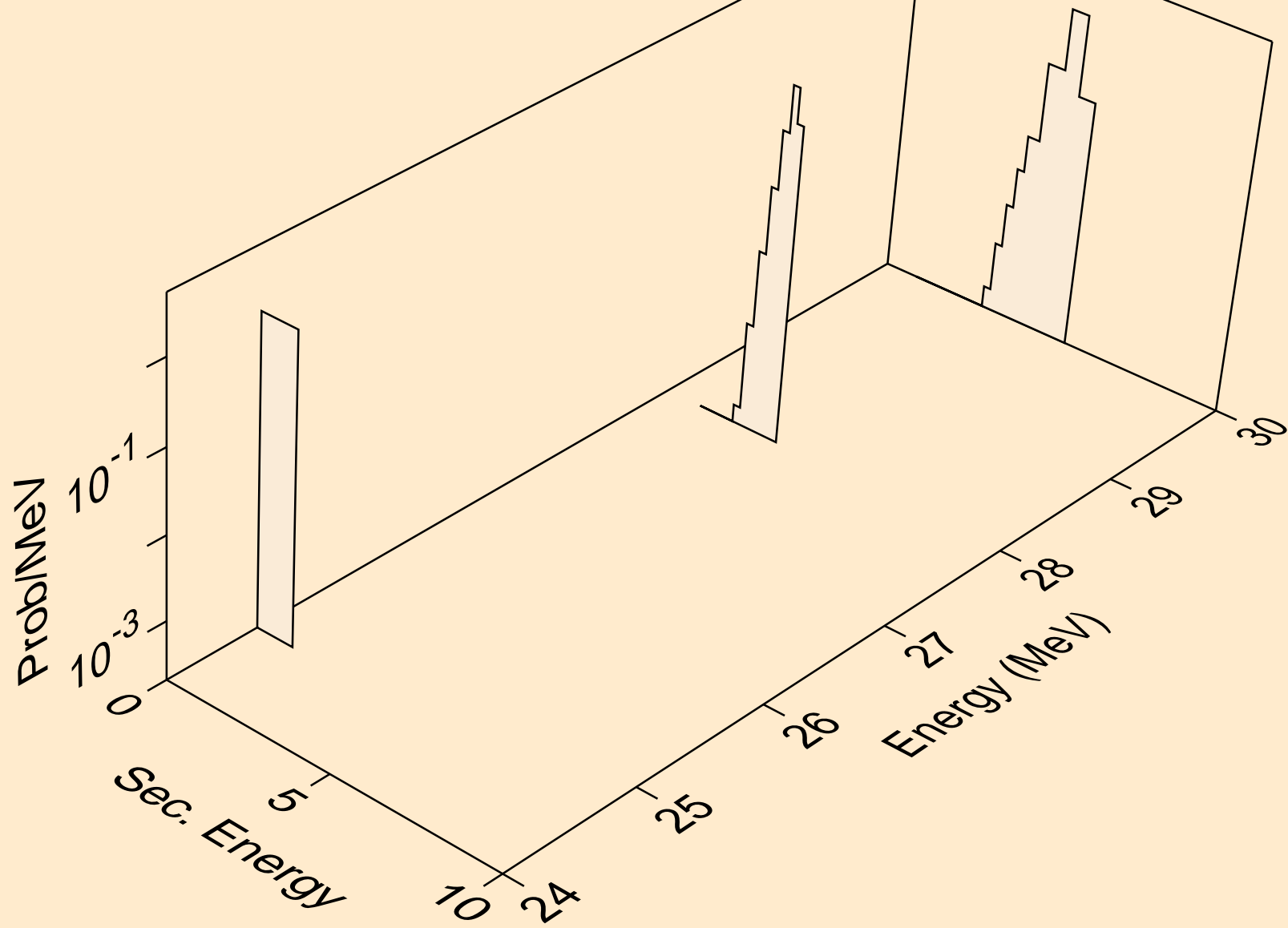

CU072 NEUTRON ACER TENDL-2023 LIBRARY; T=0.K  
he3s from (n,he3)

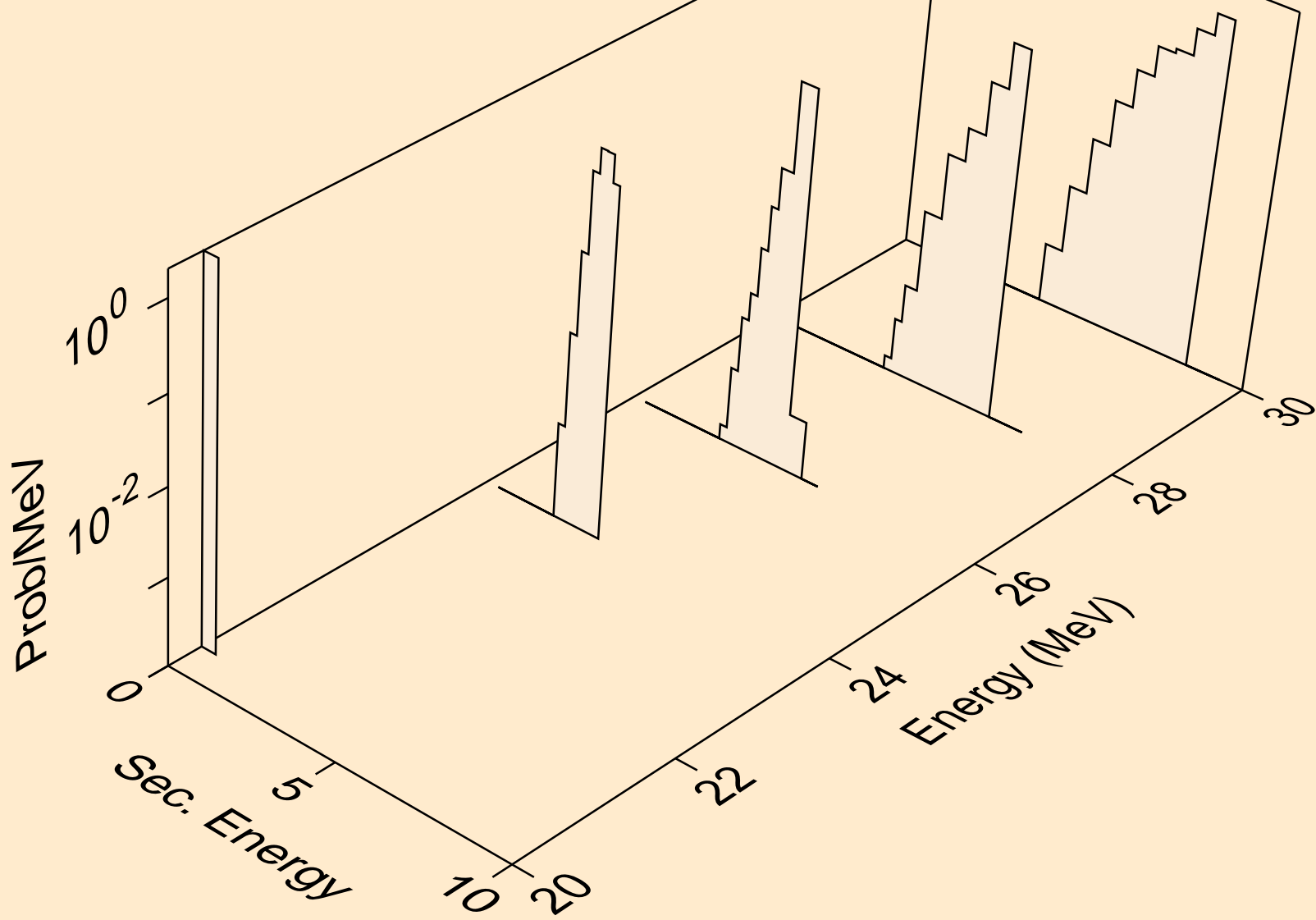

CU072 NEUTRON ACER TENDL-2023 LIBRARY; T=0.K  
alphas from (n,x)

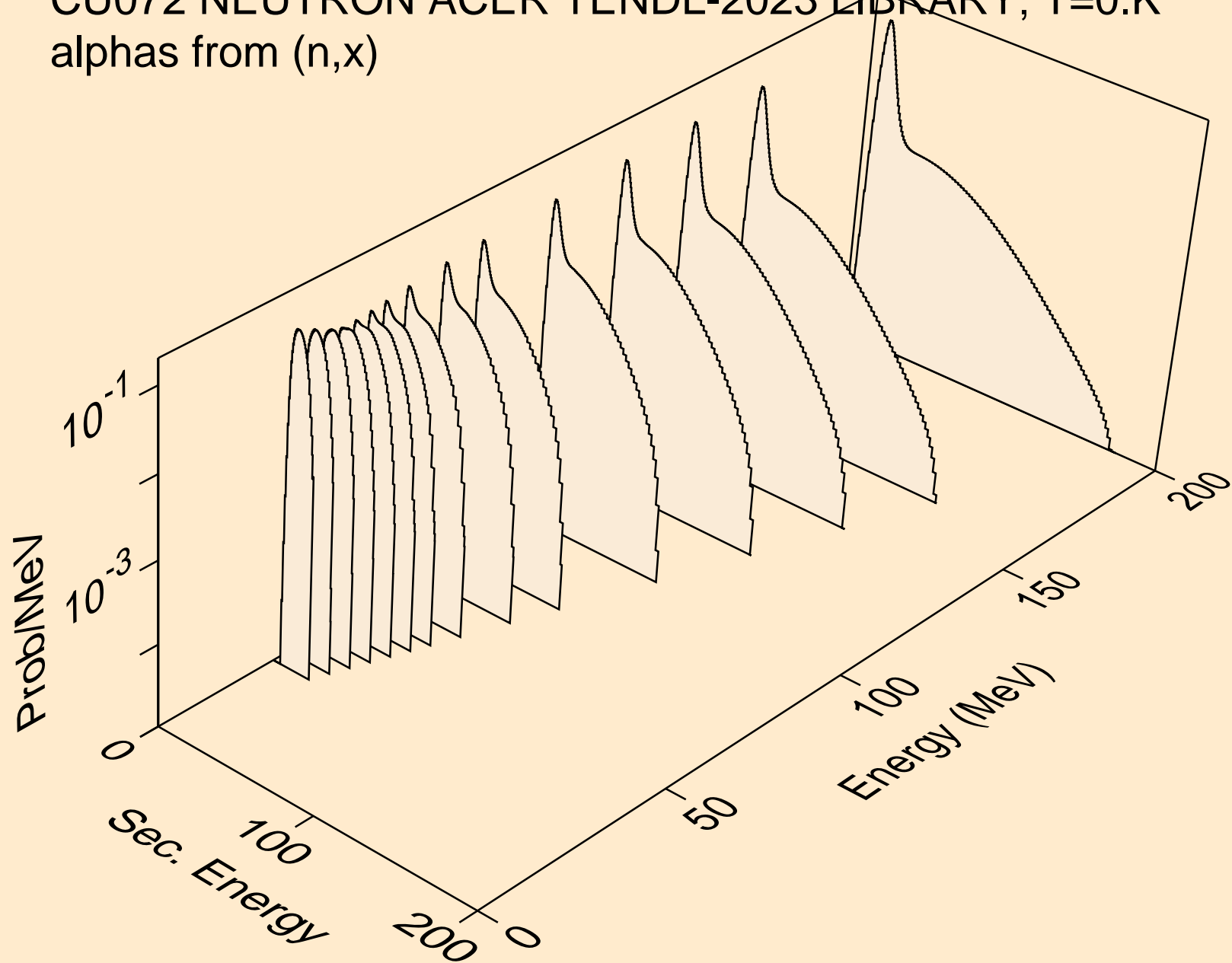

CU072 NEUTRON ACER TENDL-2023 LIBRARY; T=0.K  
alphas from (n,n\*)a

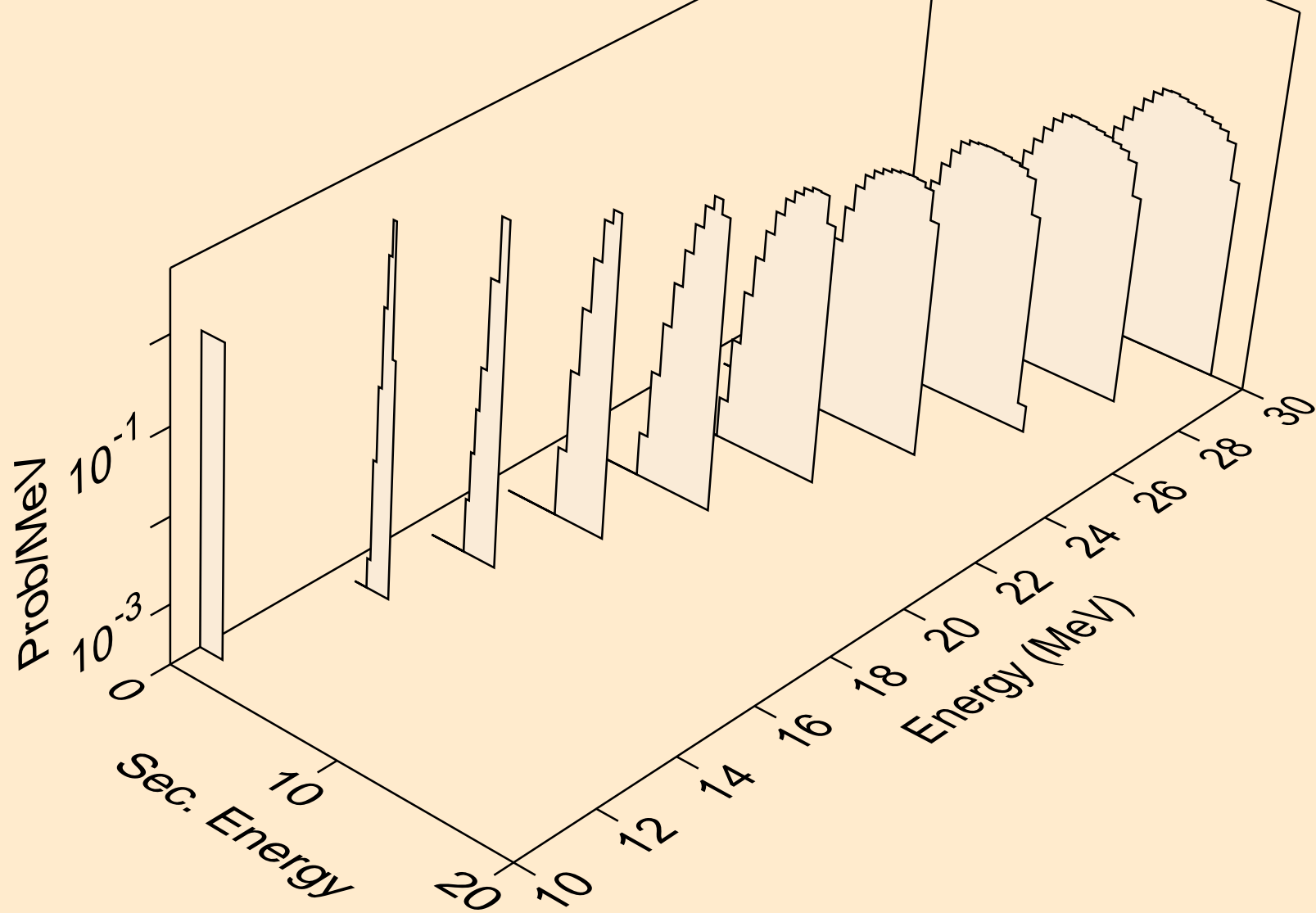

CU072 NEUTRON ACER TENDL-2023 LIBRARY; T=0.K  
alphas from (n,2n)a

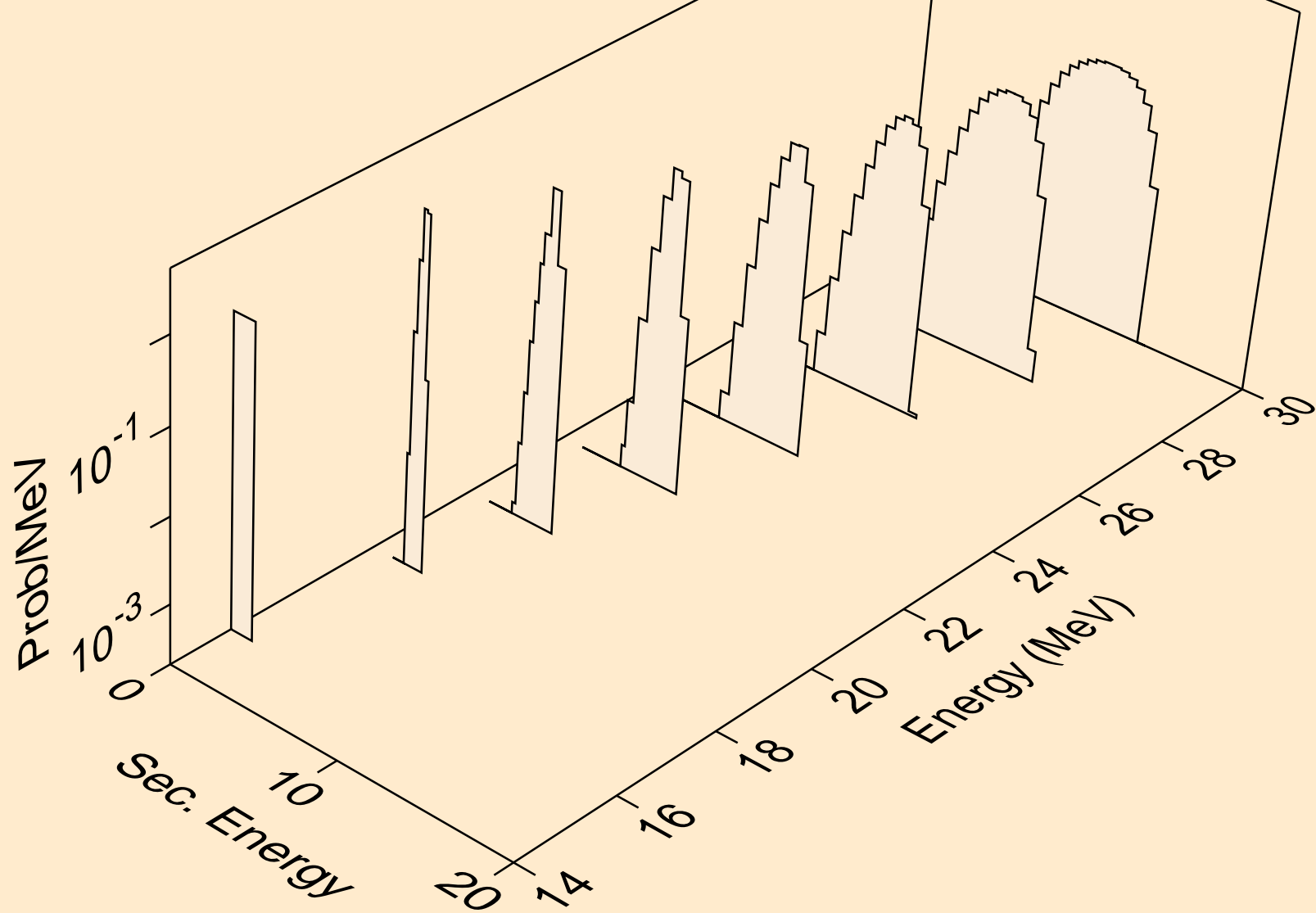

CU072 NEUTRON ACER TENDL-2023 LIBRARY; T=0.K  
alphas from (n,3n)a

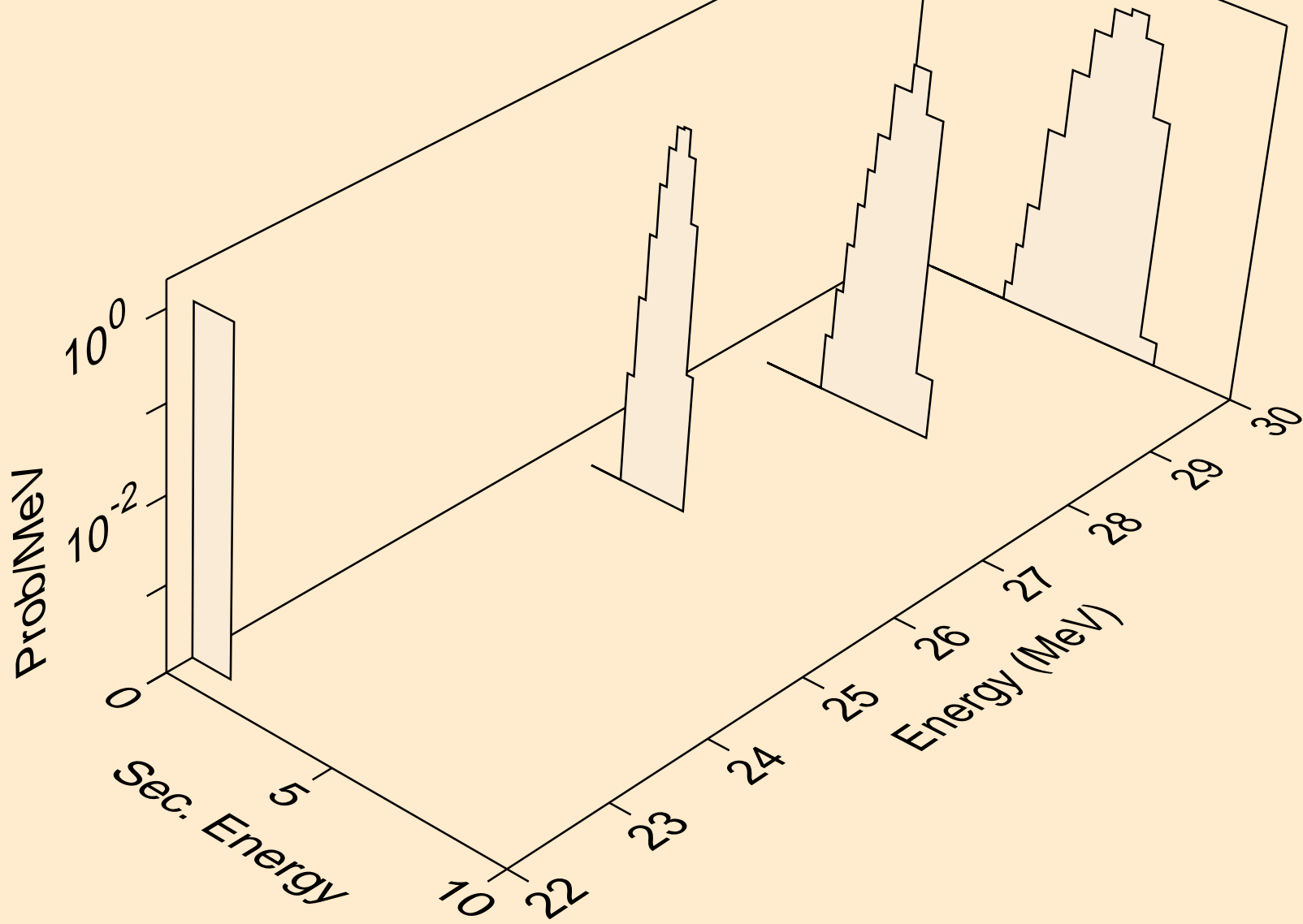

CU072 NEUTRON ACER TENDL-2023 LIBRARY; T=0.K  
alphas from (n,a)

