

# EU148 NEUTRON ACER TENDL-2023 LIBRARY; T=0.K

## Principal cross sections

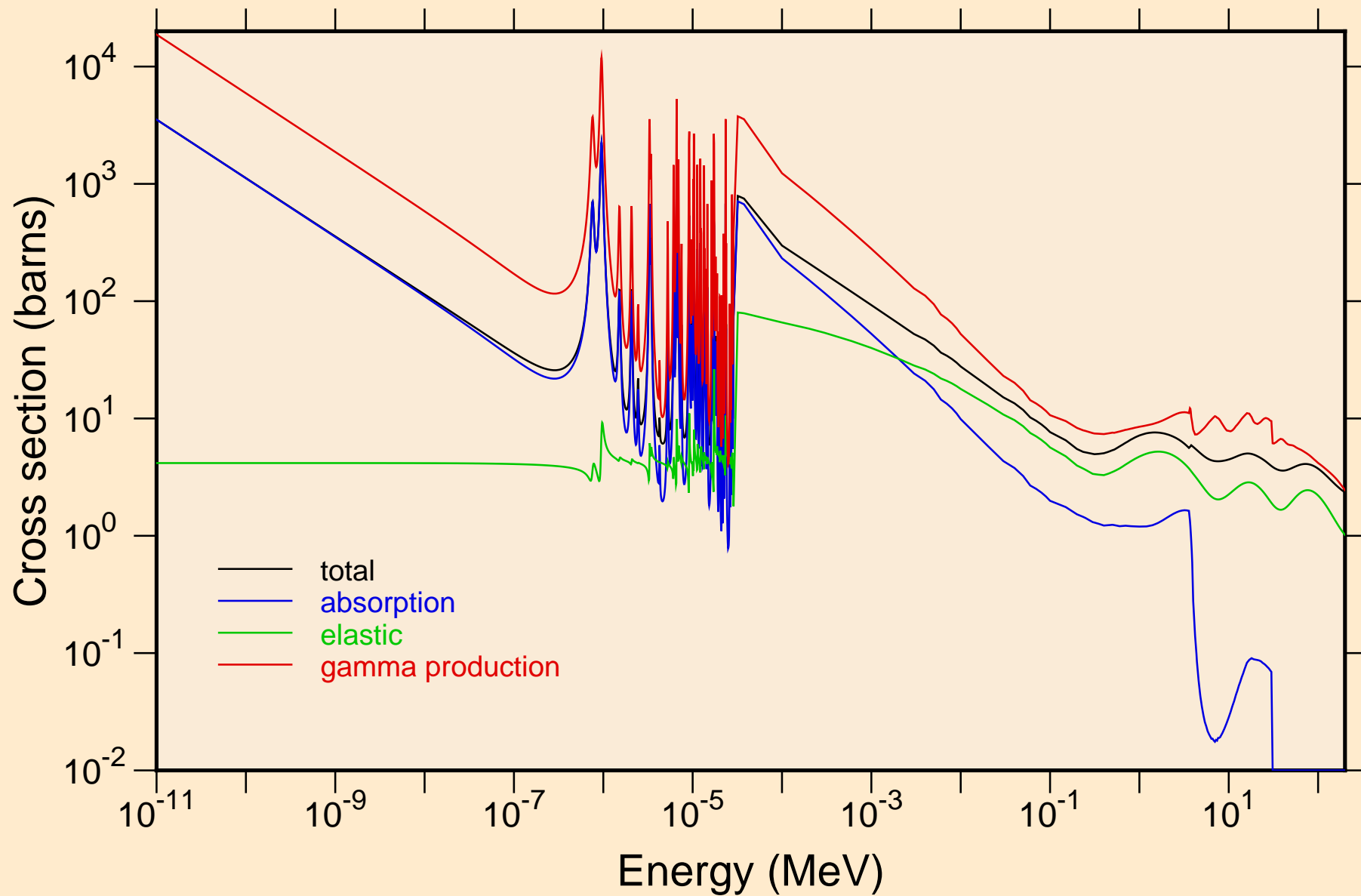

EU148 NEUTRON ACER TENDL-2023 LIBRARY; T=0.K  
resonance total cross section

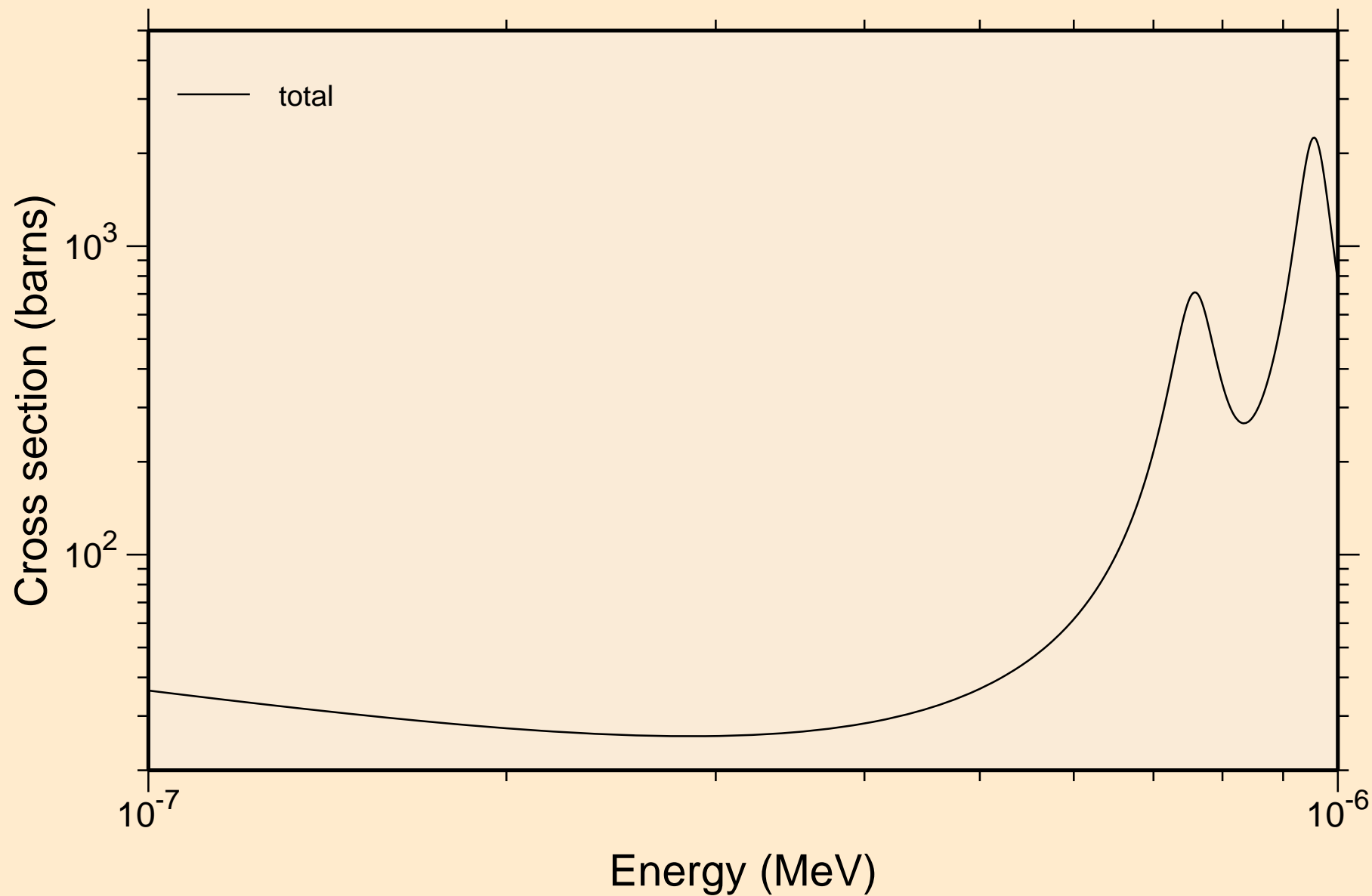

EU148 NEUTRON ACER TENDL-2023 LIBRARY; T=0.K  
resonance total cross section

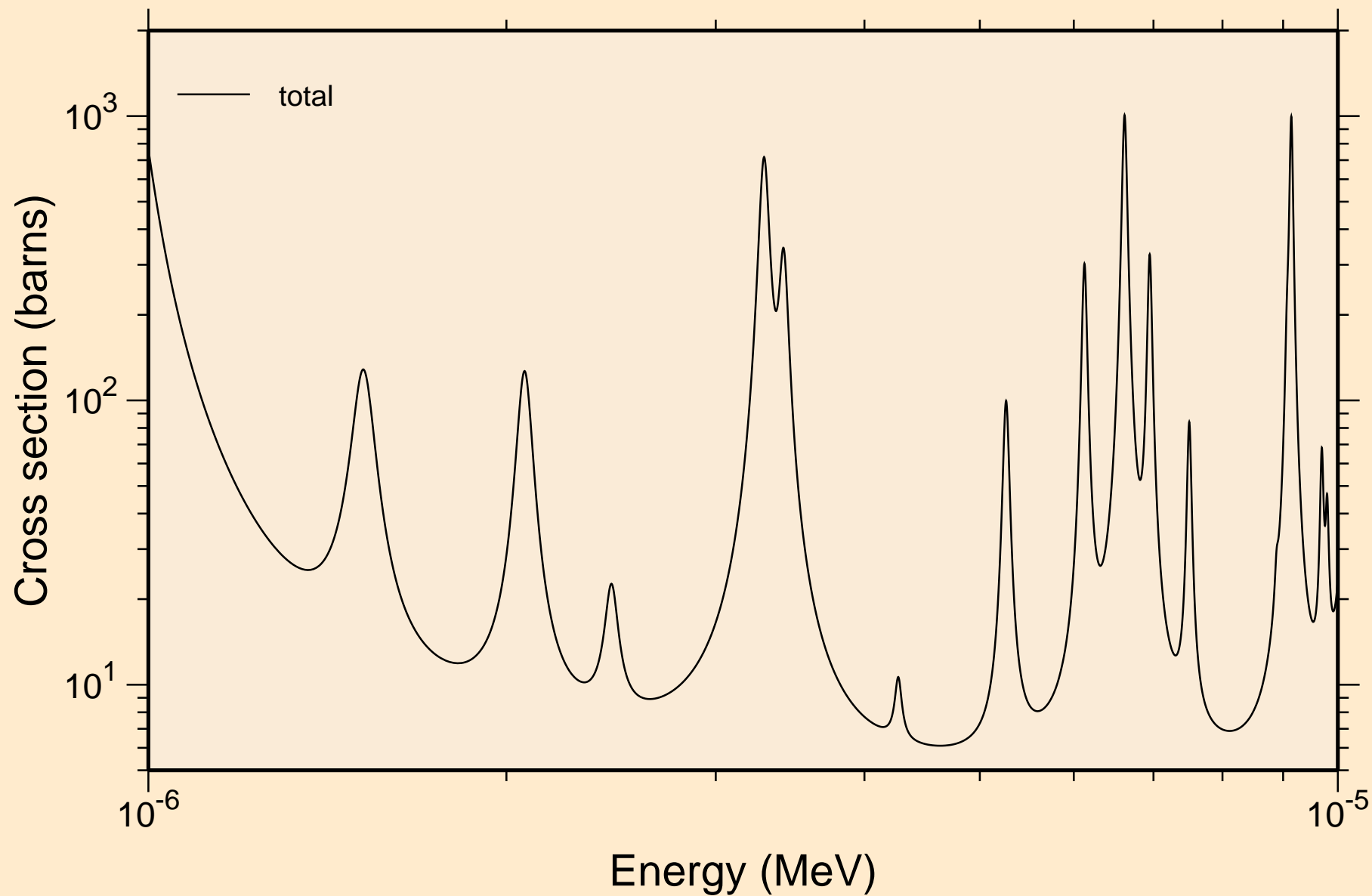

EU148 NEUTRON ACER TENDL-2023 LIBRARY; T=0.K  
resonance total cross section

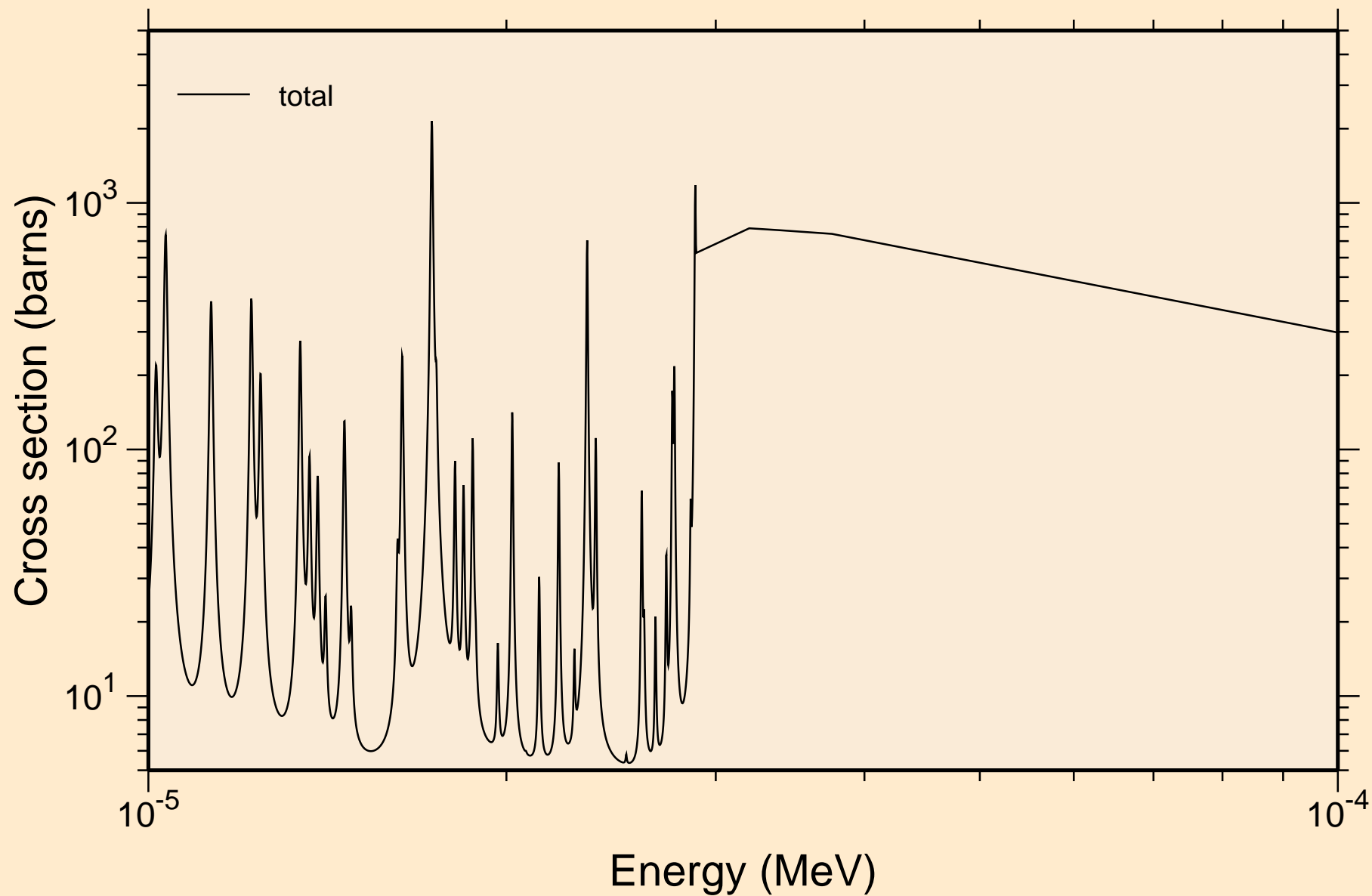

EU148 NEUTRON ACER TENDL-2023 LIBRARY; T=0.K  
resonance total cross section

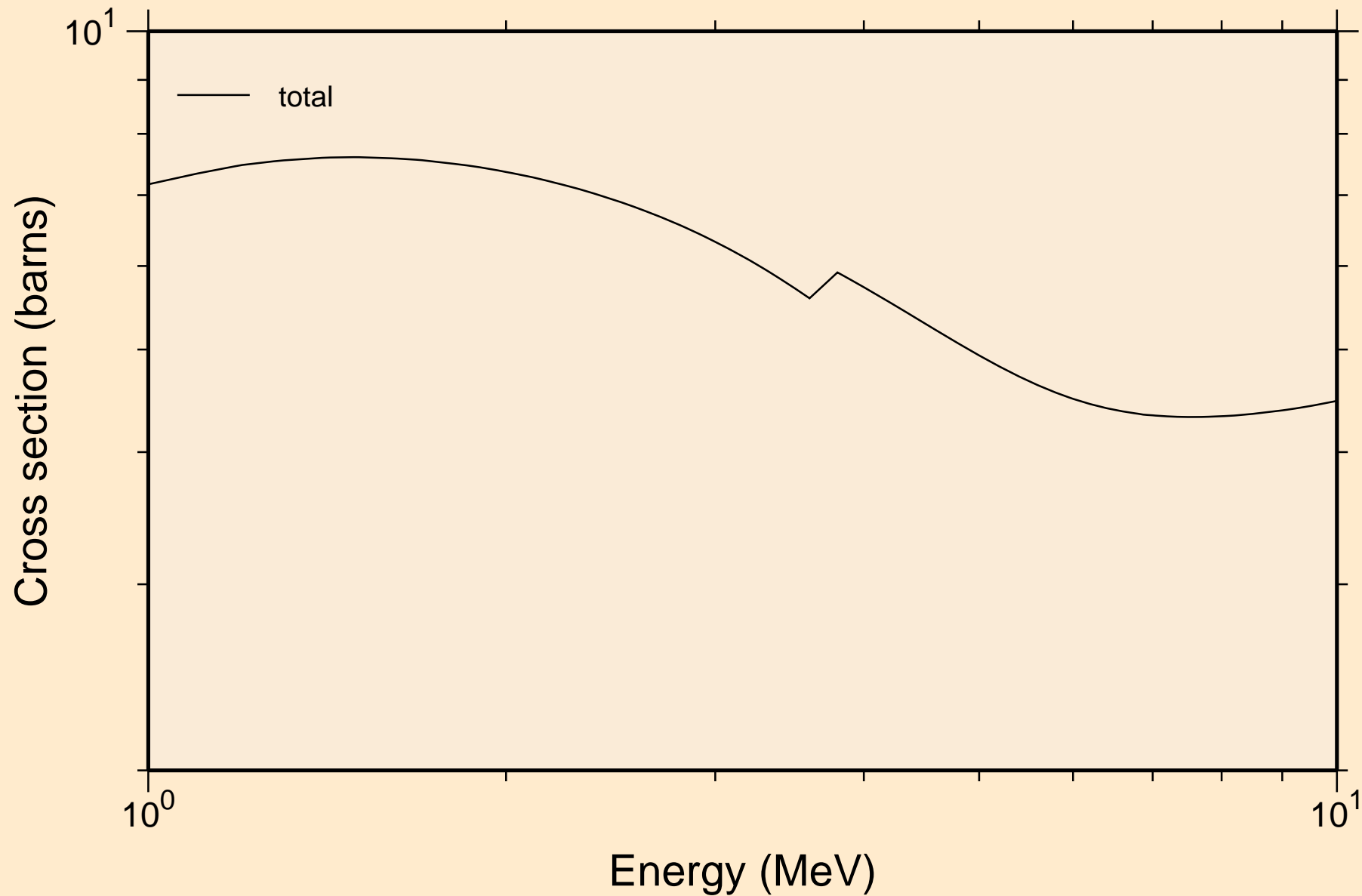

EU148 NEUTRON ACER TENDL-2023 LIBRARY; T=0.K  
resonance absorption cross sections

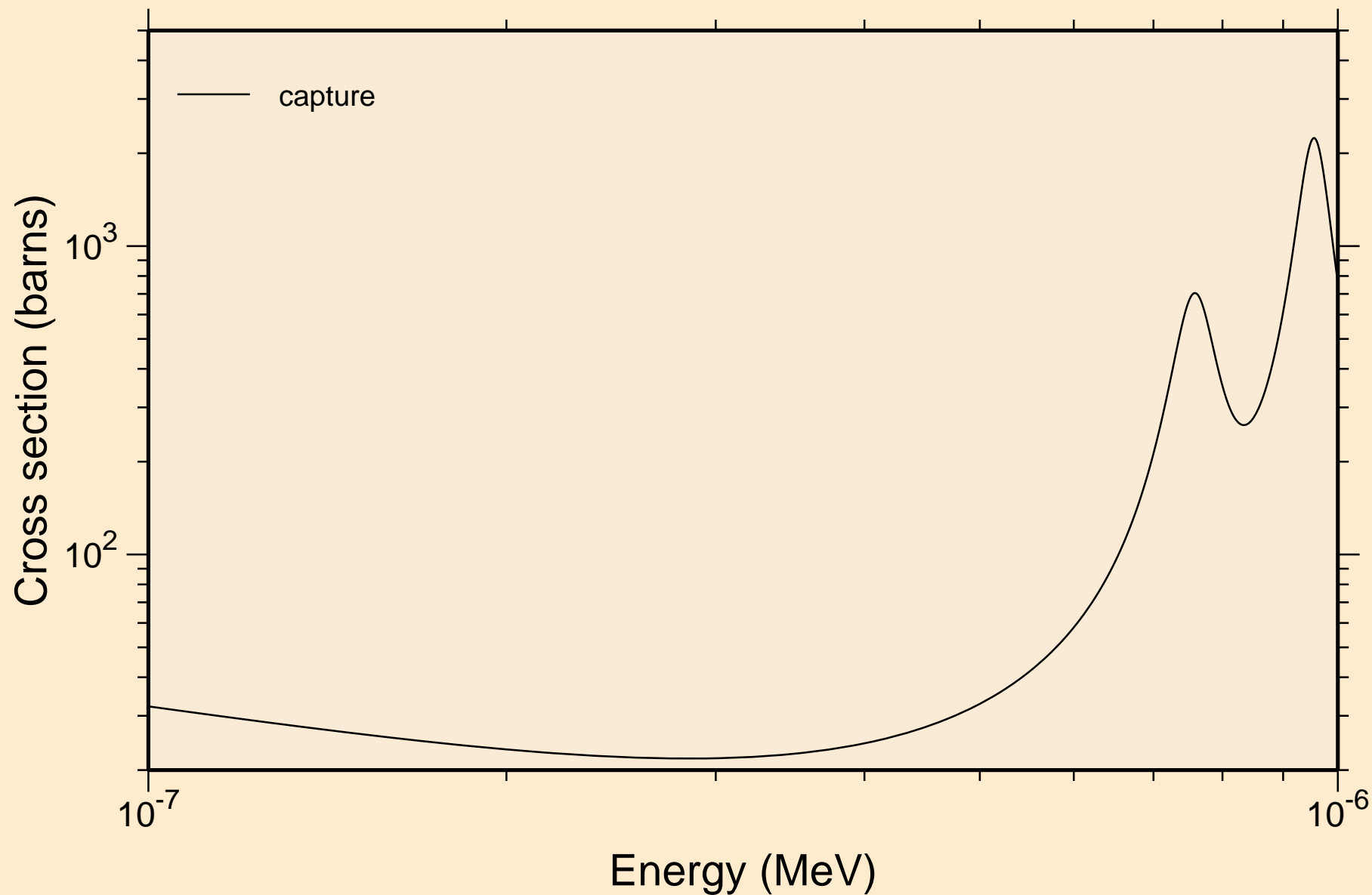

EU148 NEUTRON ACER TENDL-2023 LIBRARY; T=0.K  
resonance absorption cross sections

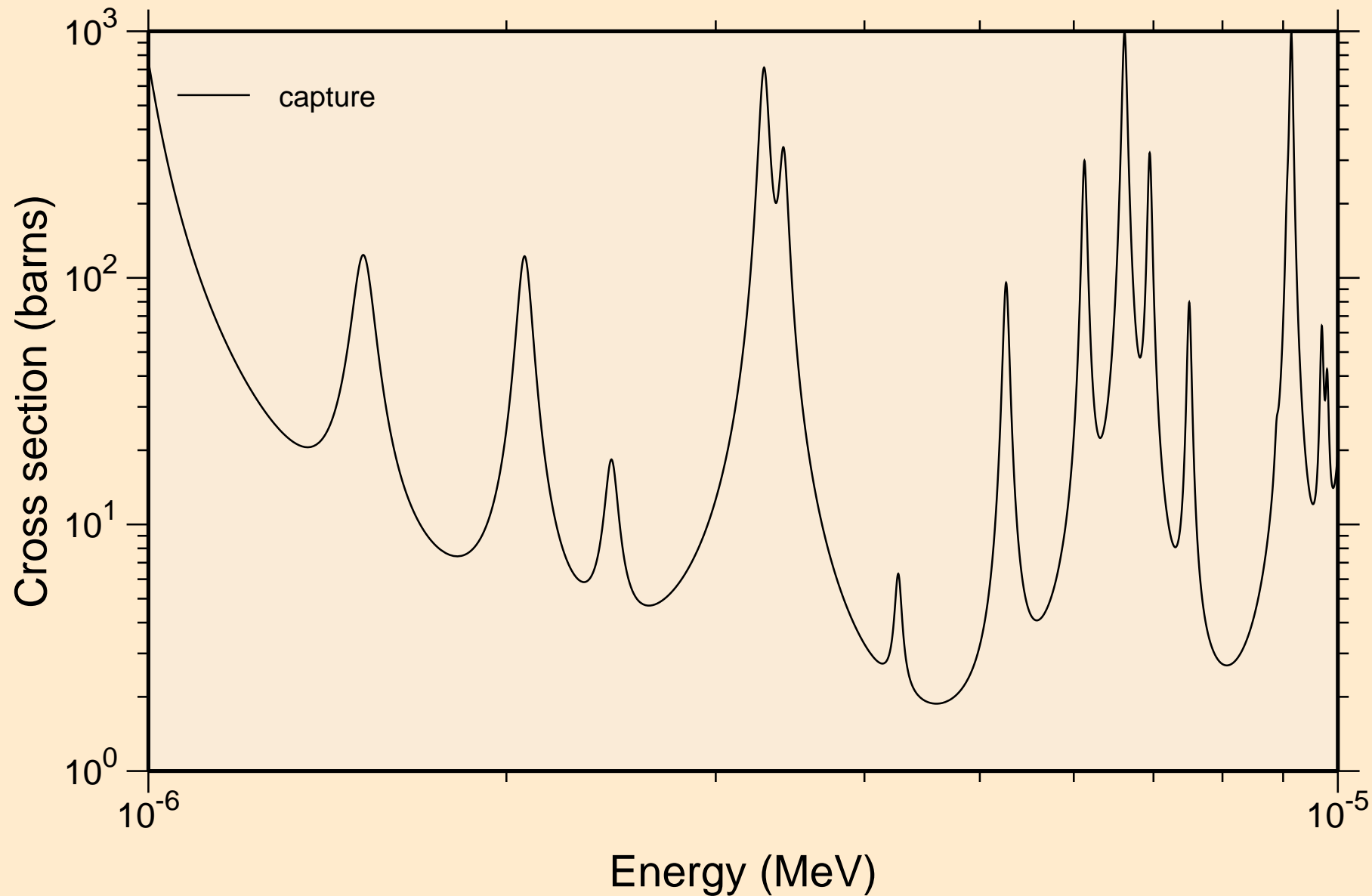

EU148 NEUTRON ACER TENDL-2023 LIBRARY; T=0.K  
resonance absorption cross sections

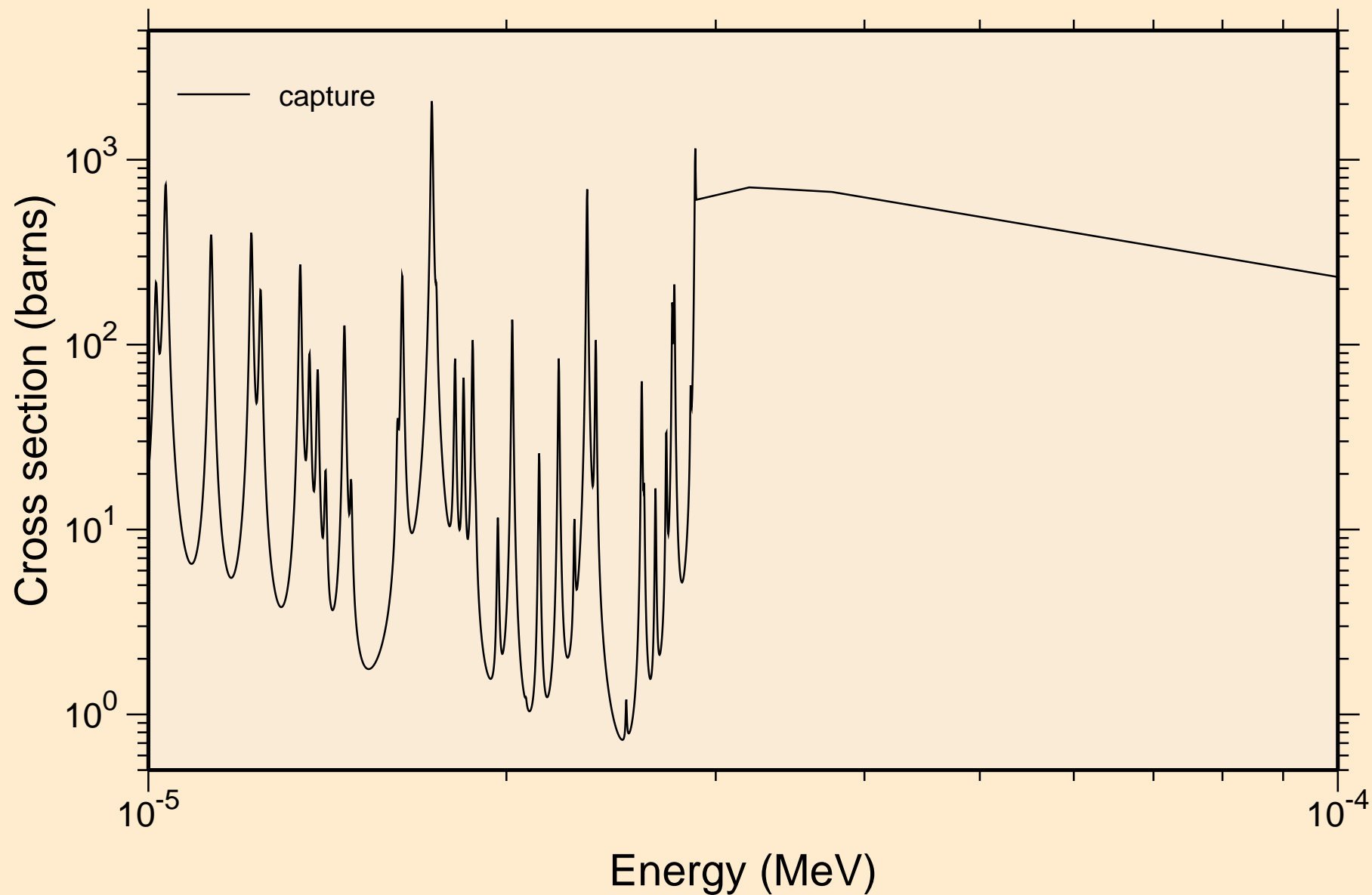



EU148 NEUTRON ACER TENDL-2023 LIBRARY; T=0.K  
resonance absorption cross sections

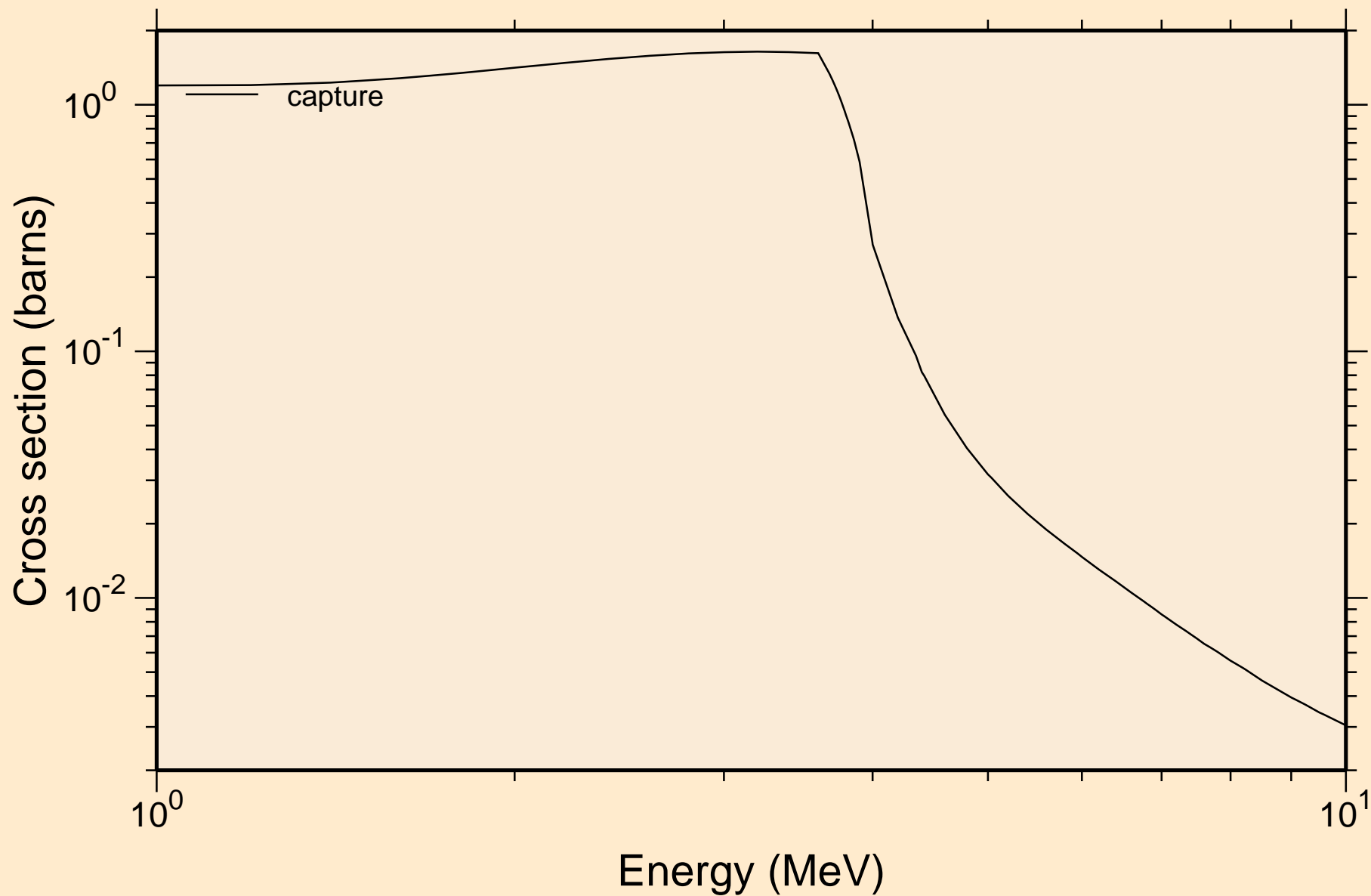

EU148 NEUTRON ACER TENDL-2023 LIBRARY; T=0.K  
Heating

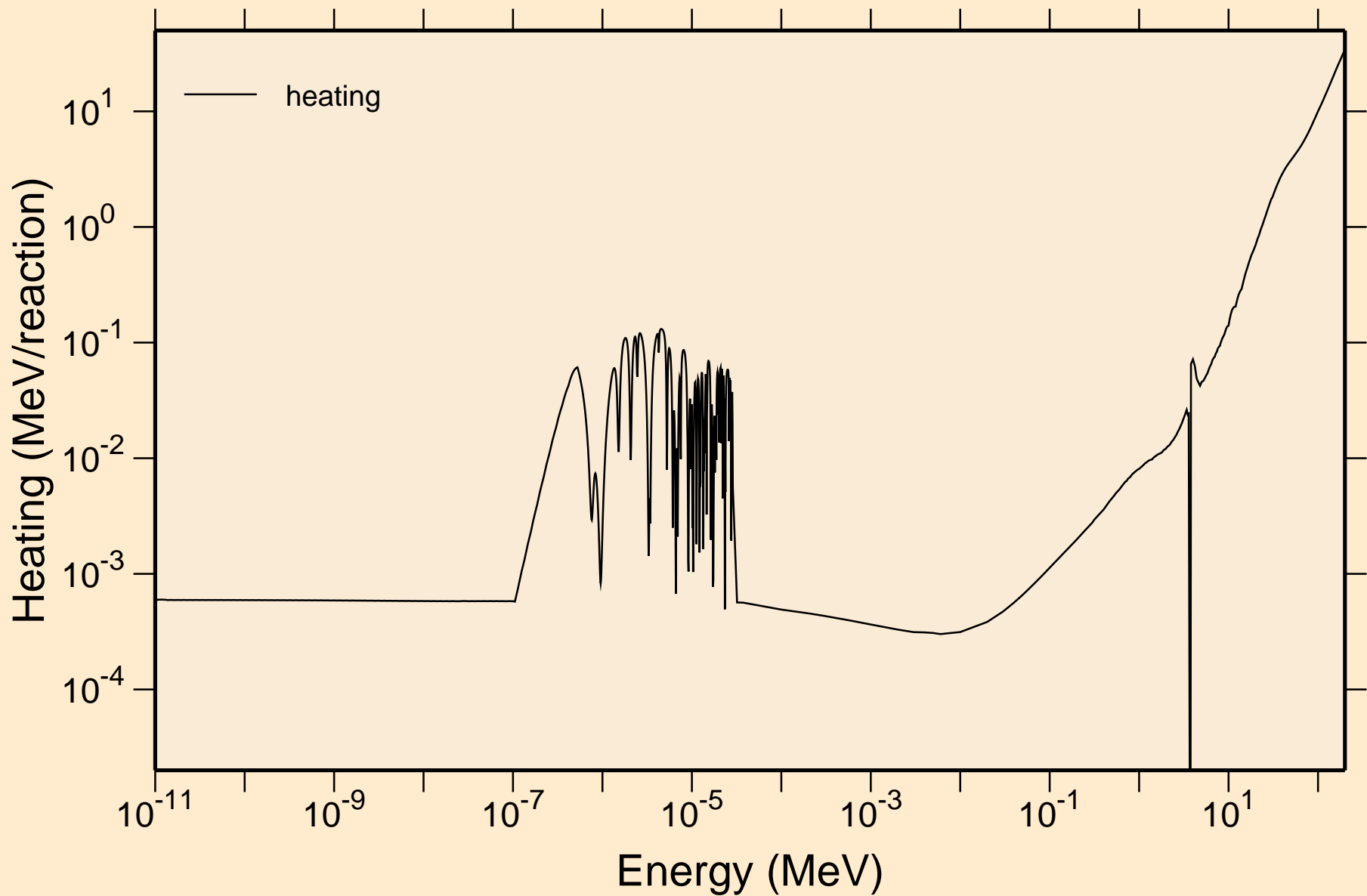

# EU148 NEUTRON ACER TENDL-2023 LIBRARY; T=0.K

## Damage

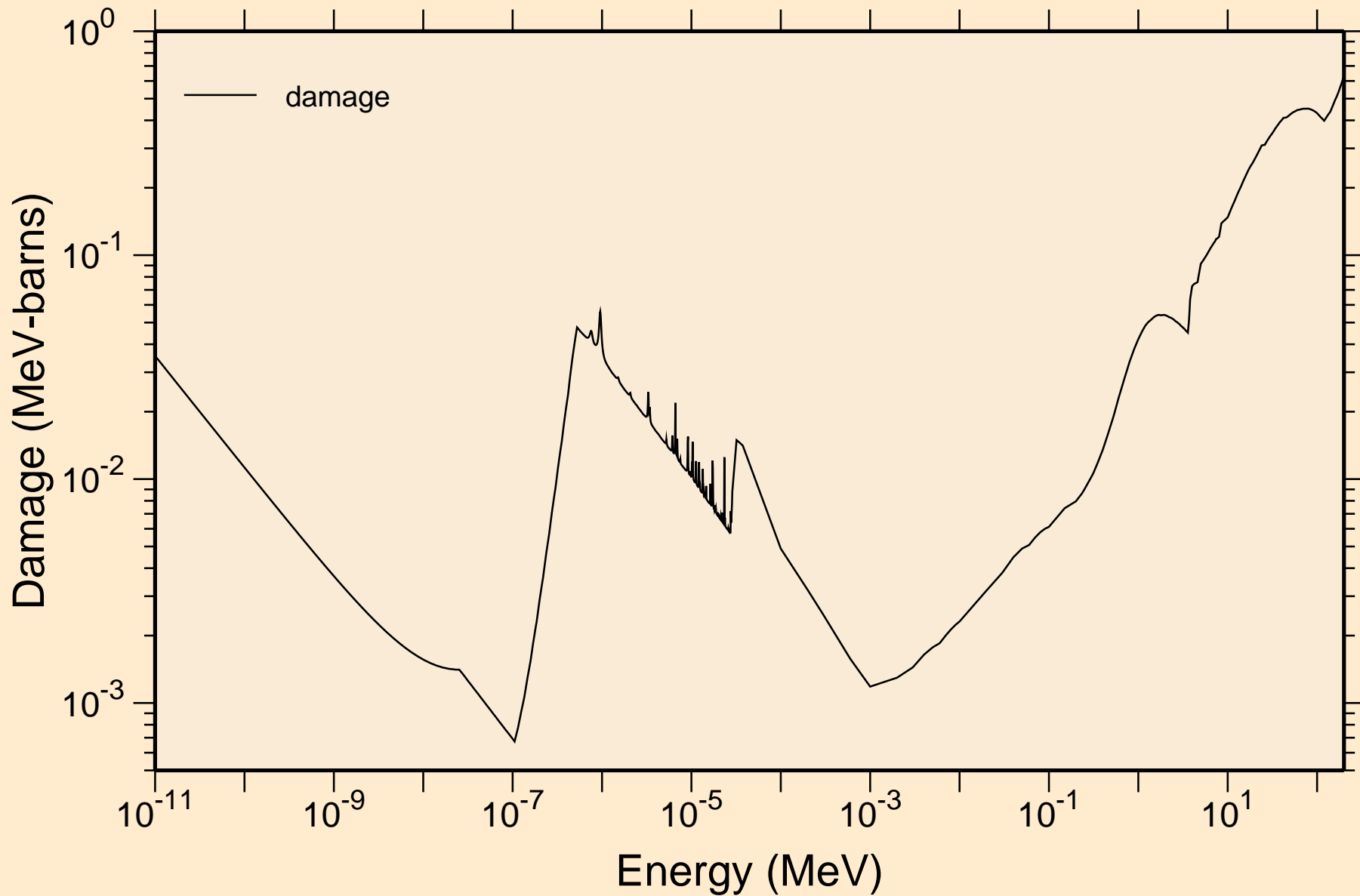

# EU148 NEUTRON ACER TENDL-2023 LIBRARY; T=0.K

## Non-threshold reactions

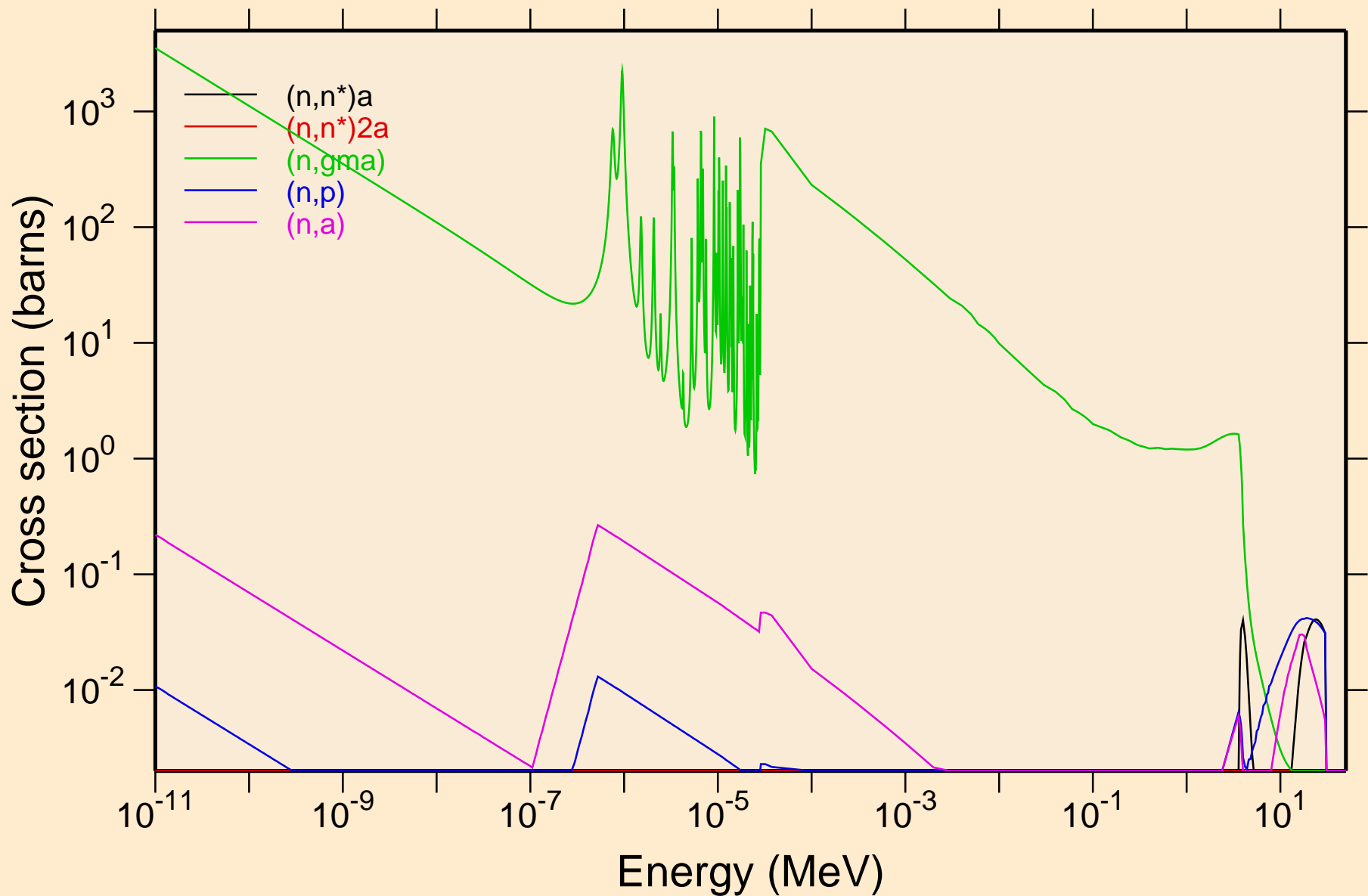

# EU148 NEUTRON ACER TENDL-2023 LIBRARY; T=0.K

## Non-threshold reactions

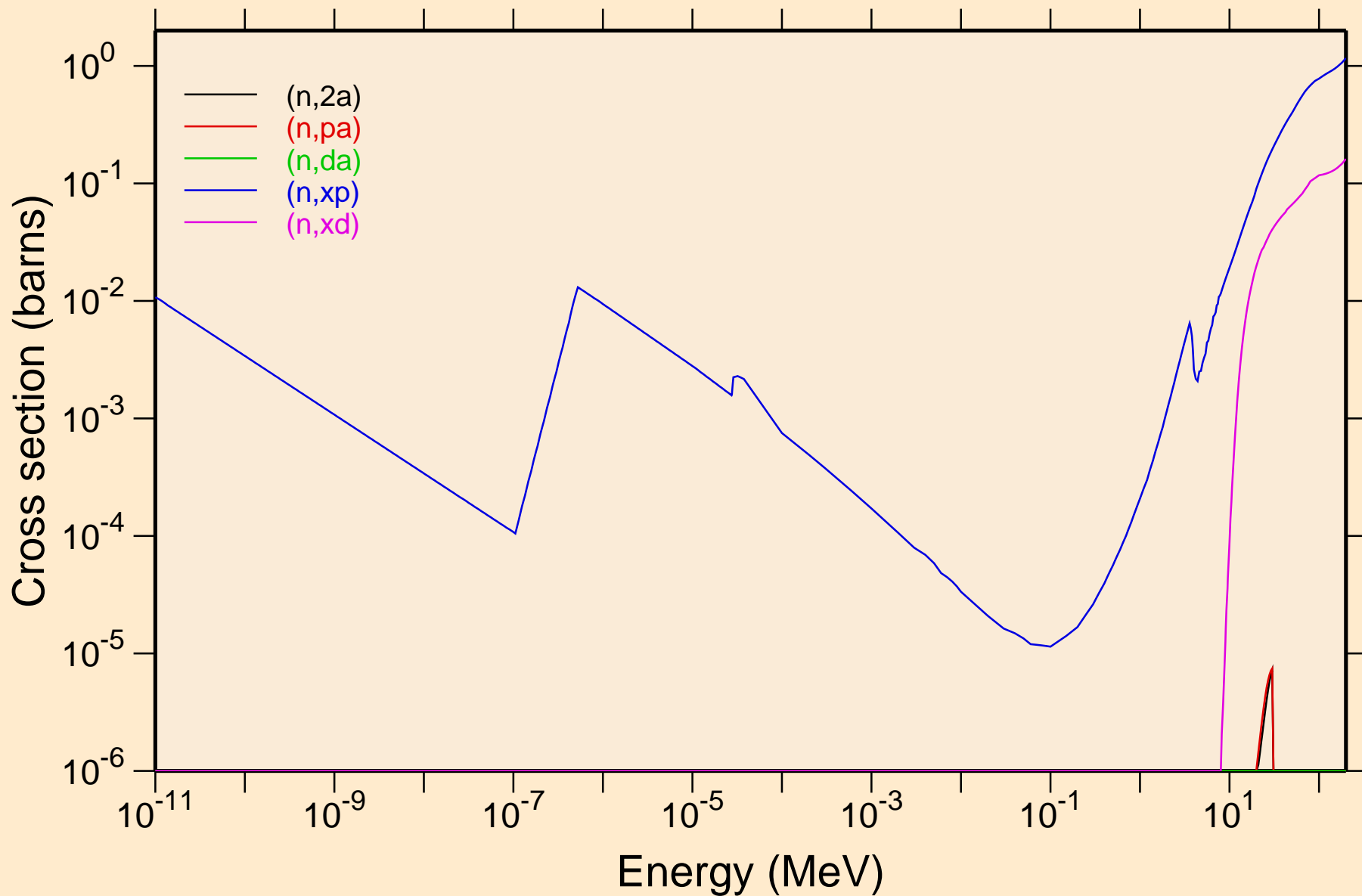

EU148 NEUTRON ACER TENDL-2023 LIBRARY; T=0.K  
Non-threshold reactions

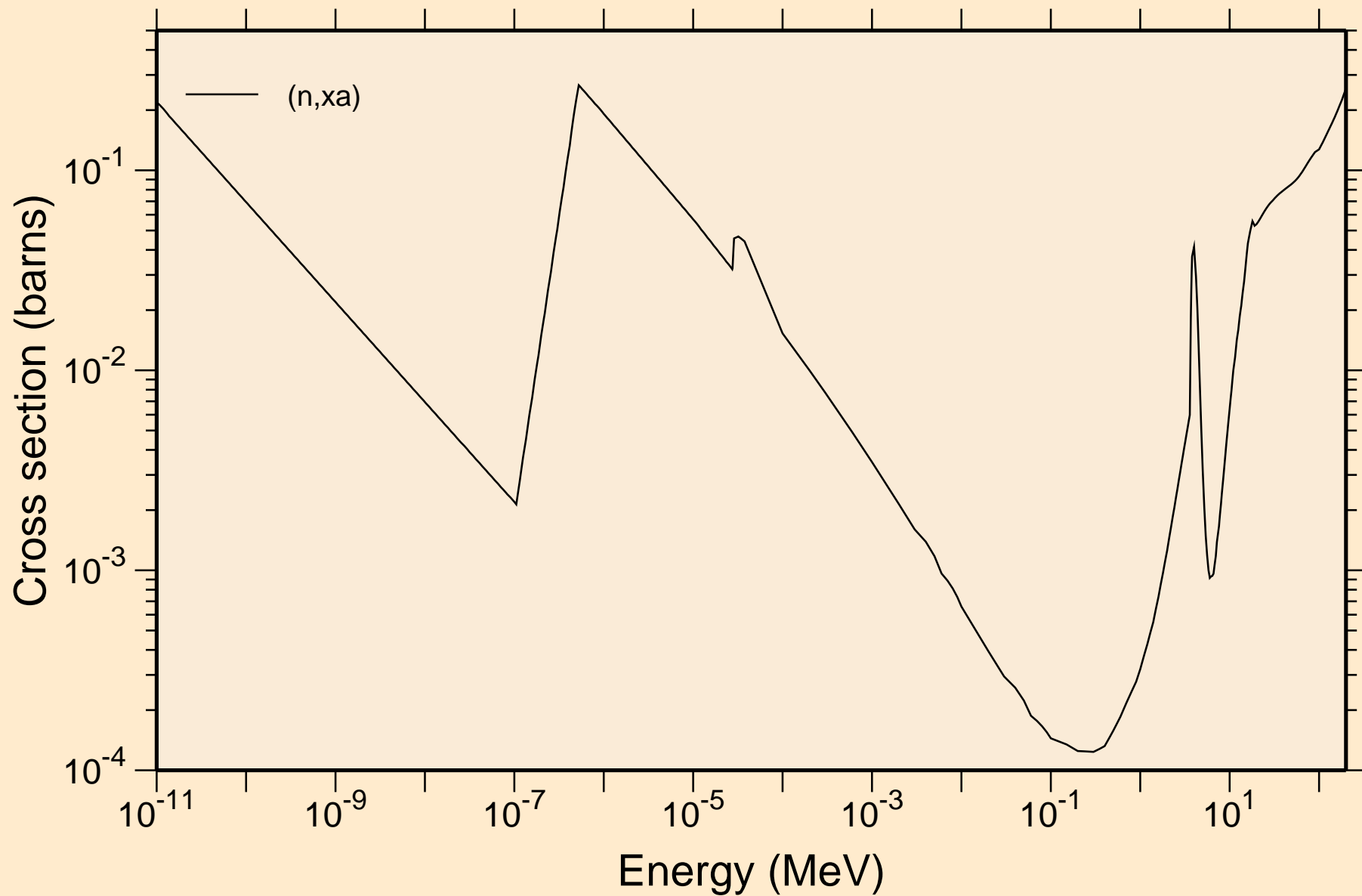

# EU148 NEUTRON ACER TENDL-2023 LIBRARY; T=0.K

## Principal cross sections

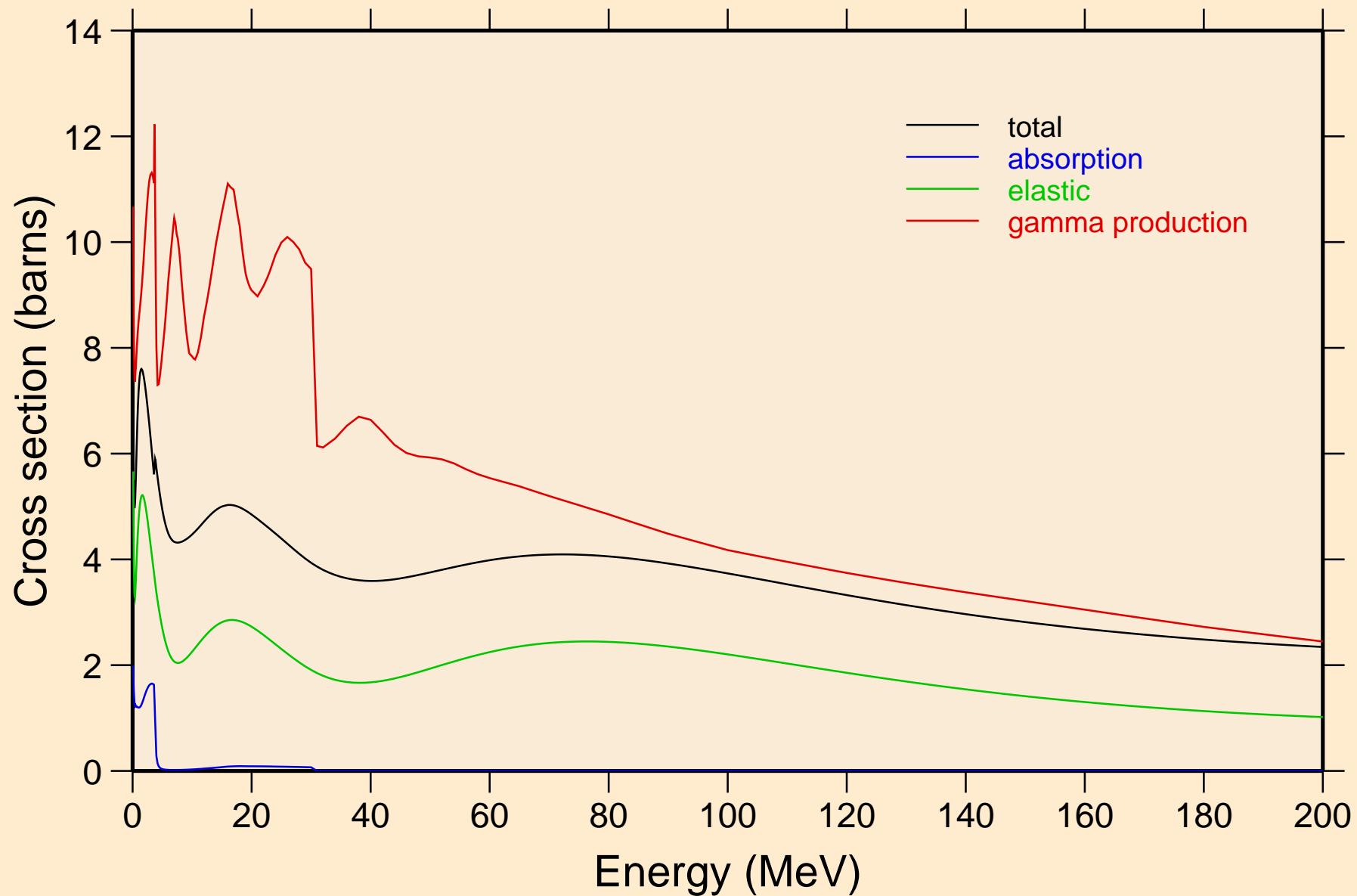

EU148 NEUTRON ACER TENDL-2023 LIBRARY; T=0.K  
Heating

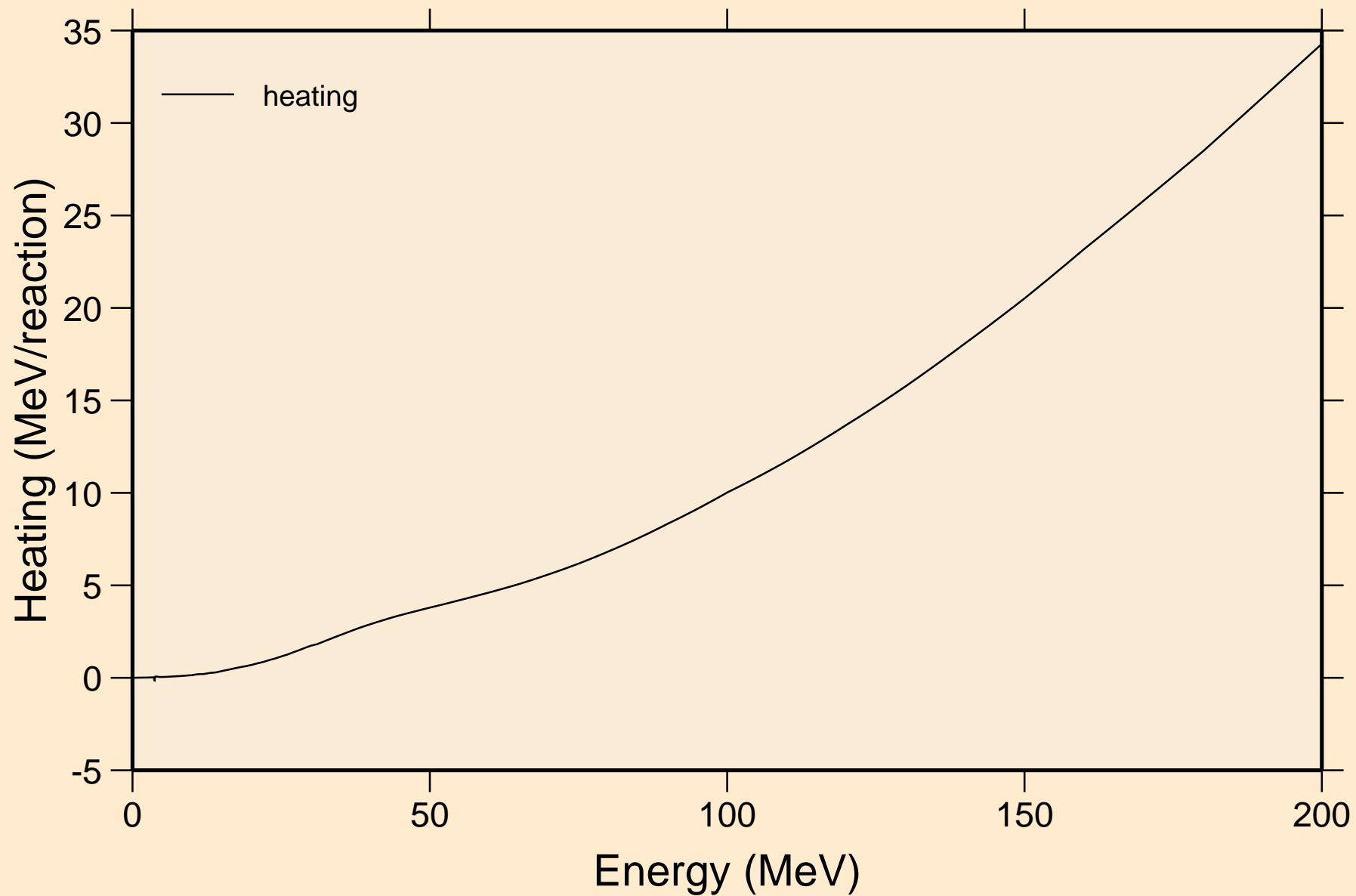



EU148 NEUTRON ACER TENDL-2023 LIBRARY; T=0.K  
Damage

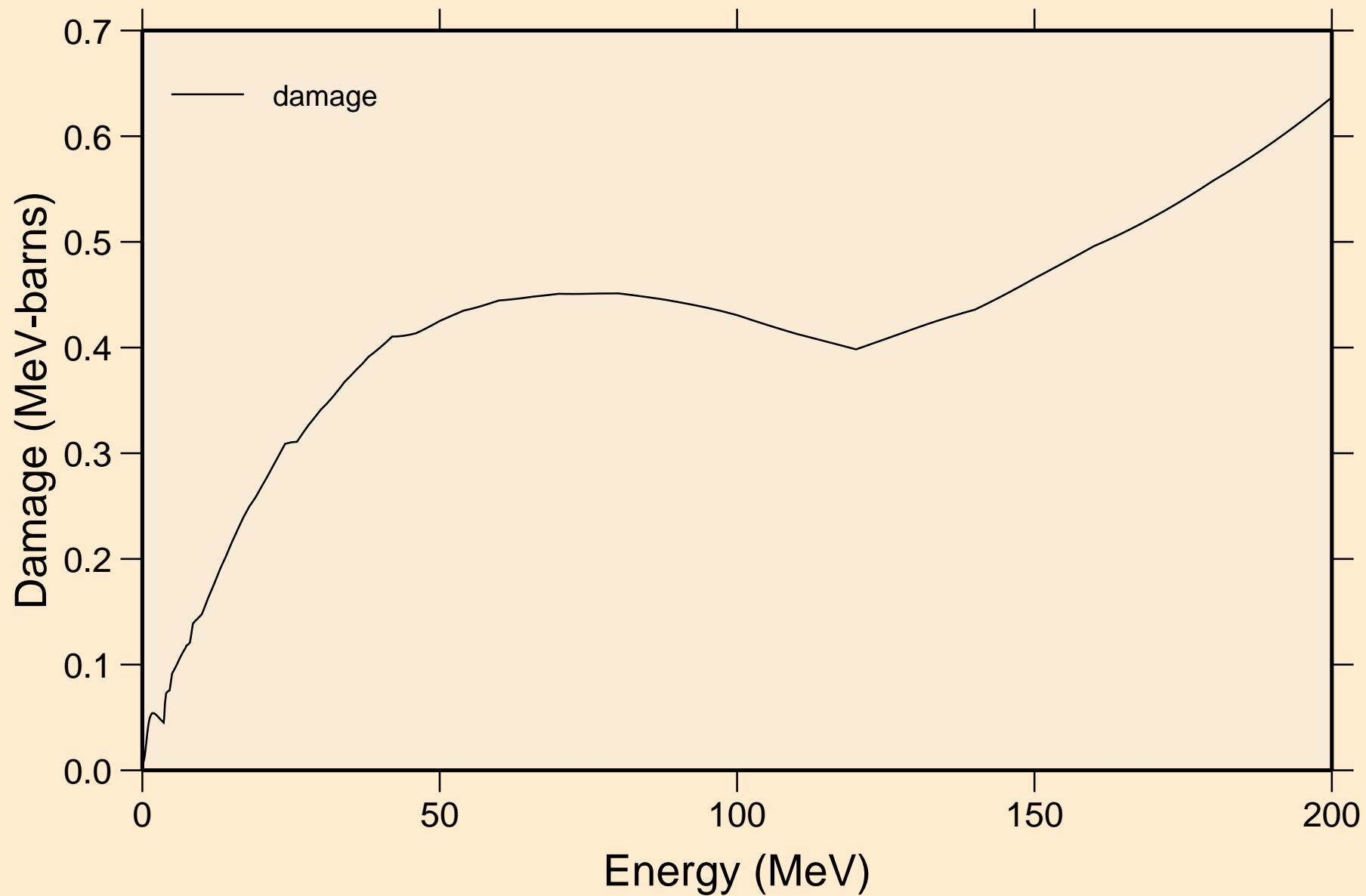

# EU148 NEUTRON ACER TENDL-2023 LIBRARY; T=0.K

## Non-threshold reactions

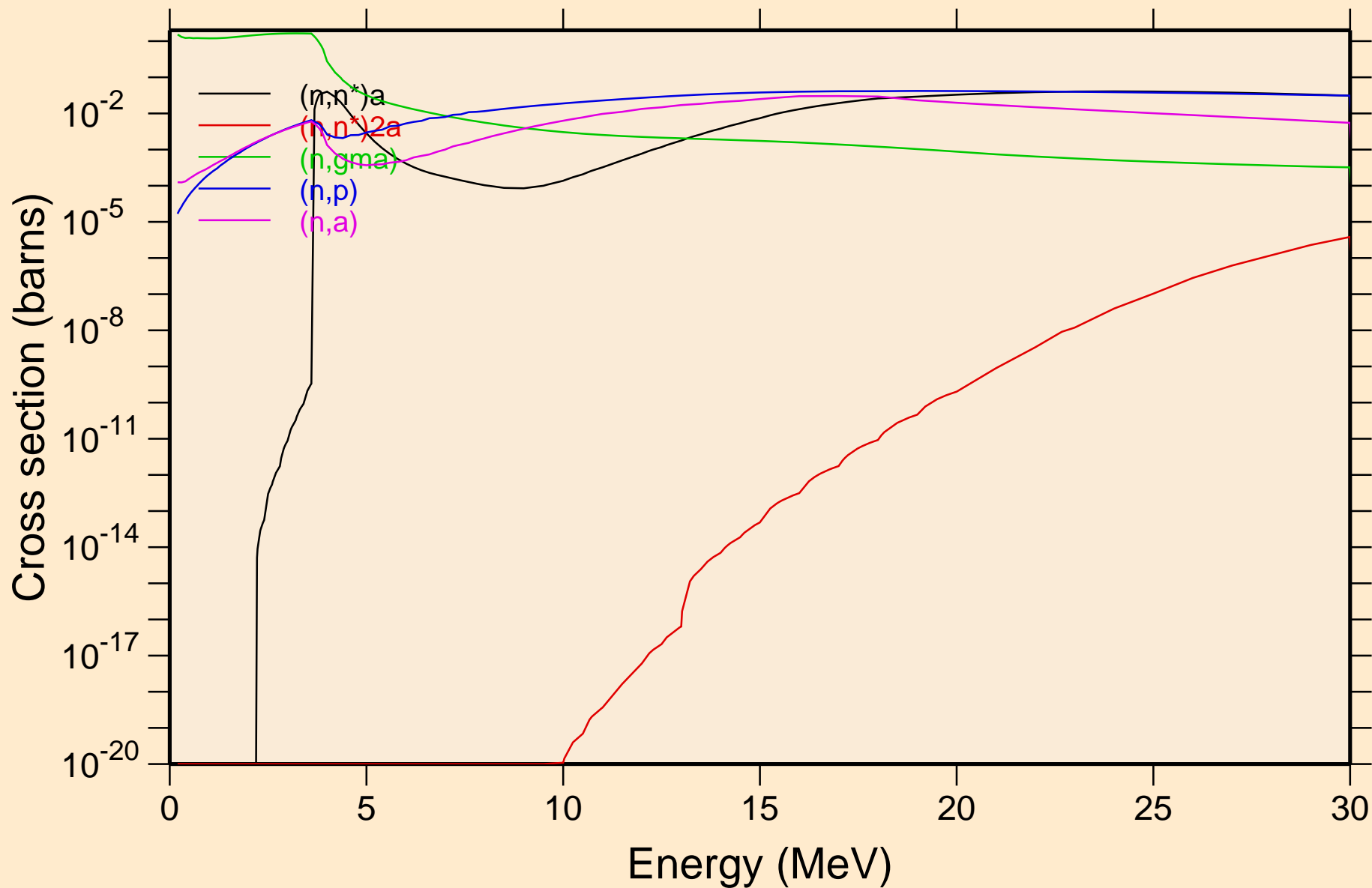

# EU148 NEUTRON ACER TENDL-2023 LIBRARY; T=0.K

## Non-threshold reactions

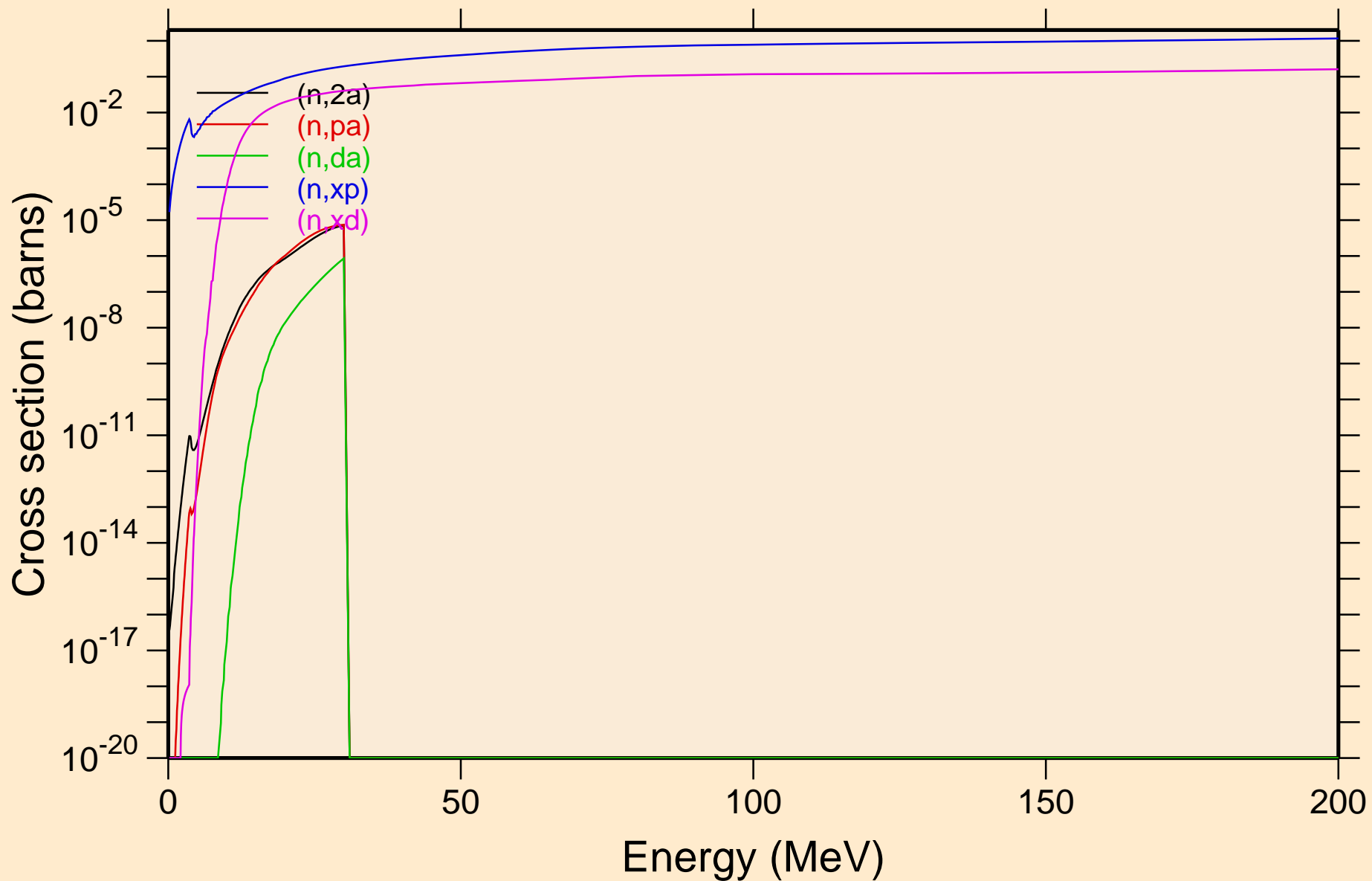

EU148 NEUTRON ACER TENDL-2023 LIBRARY; T=0.K  
Non-threshold reactions

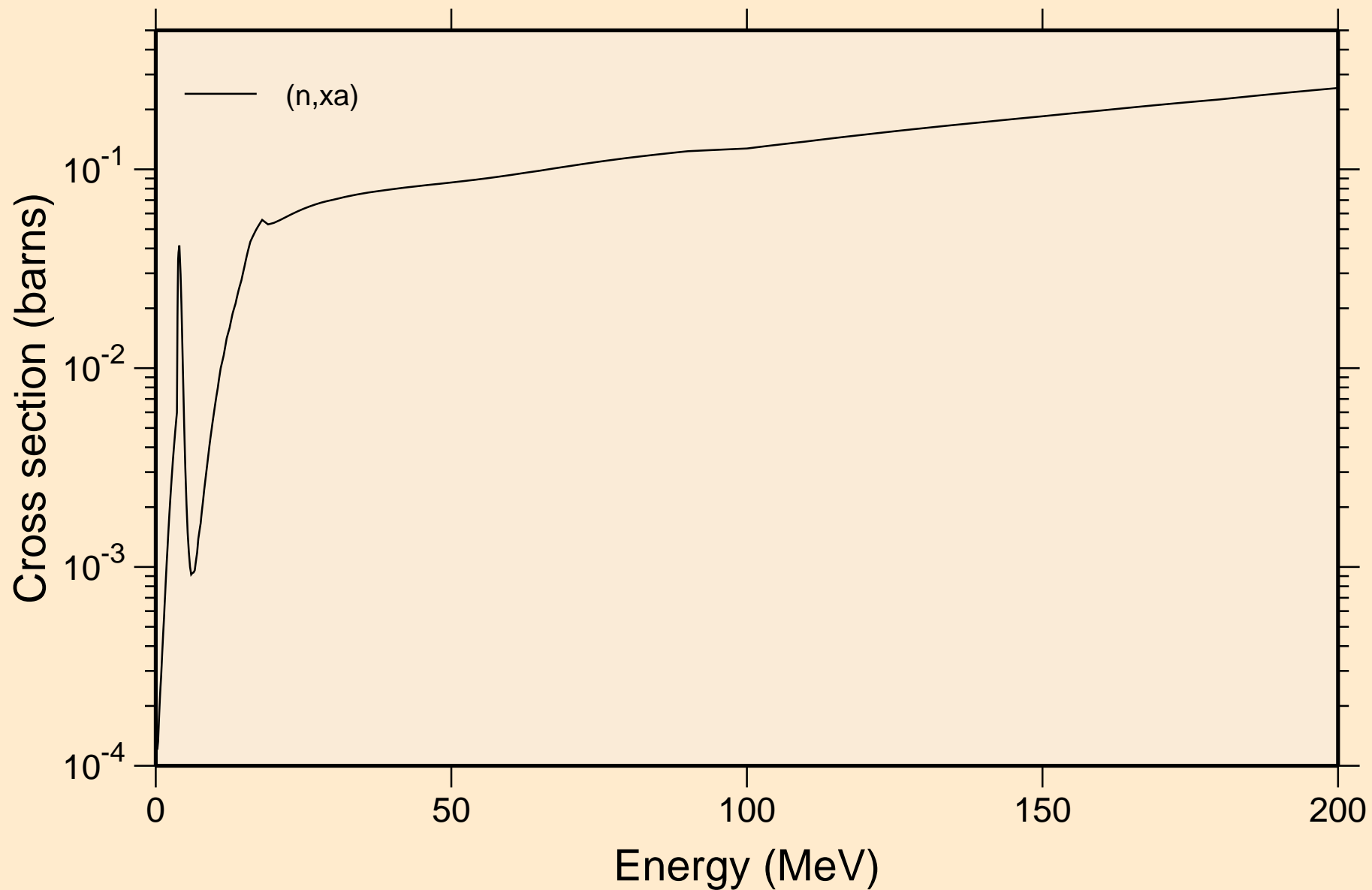

EU148 NEUTRON ACER TENDL-2023 LIBRARY; T=0.K  
Inelastic levels

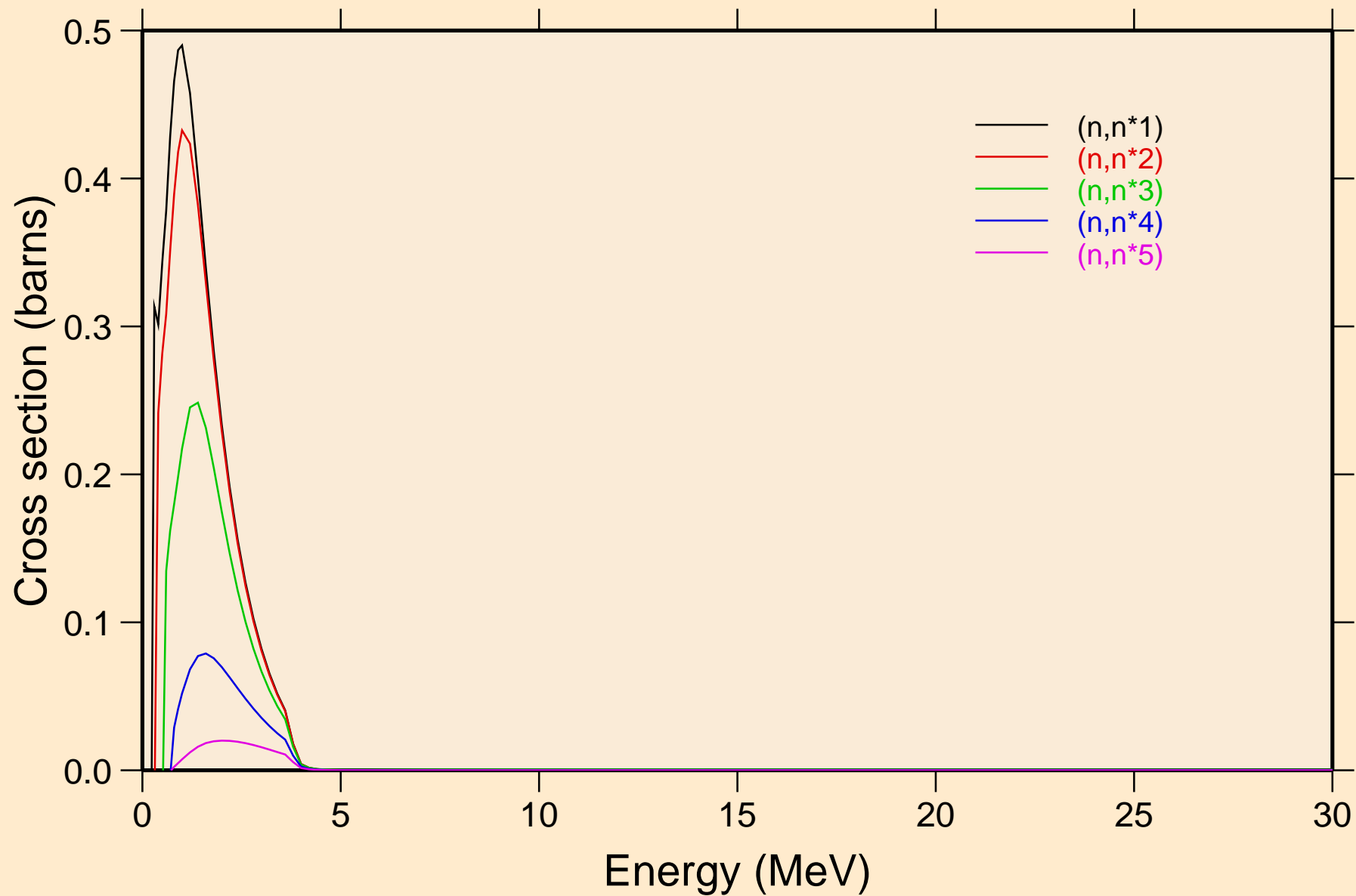

EU148 NEUTRON ACER TENDL-2023 LIBRARY; T=0.K  
Inelastic levels

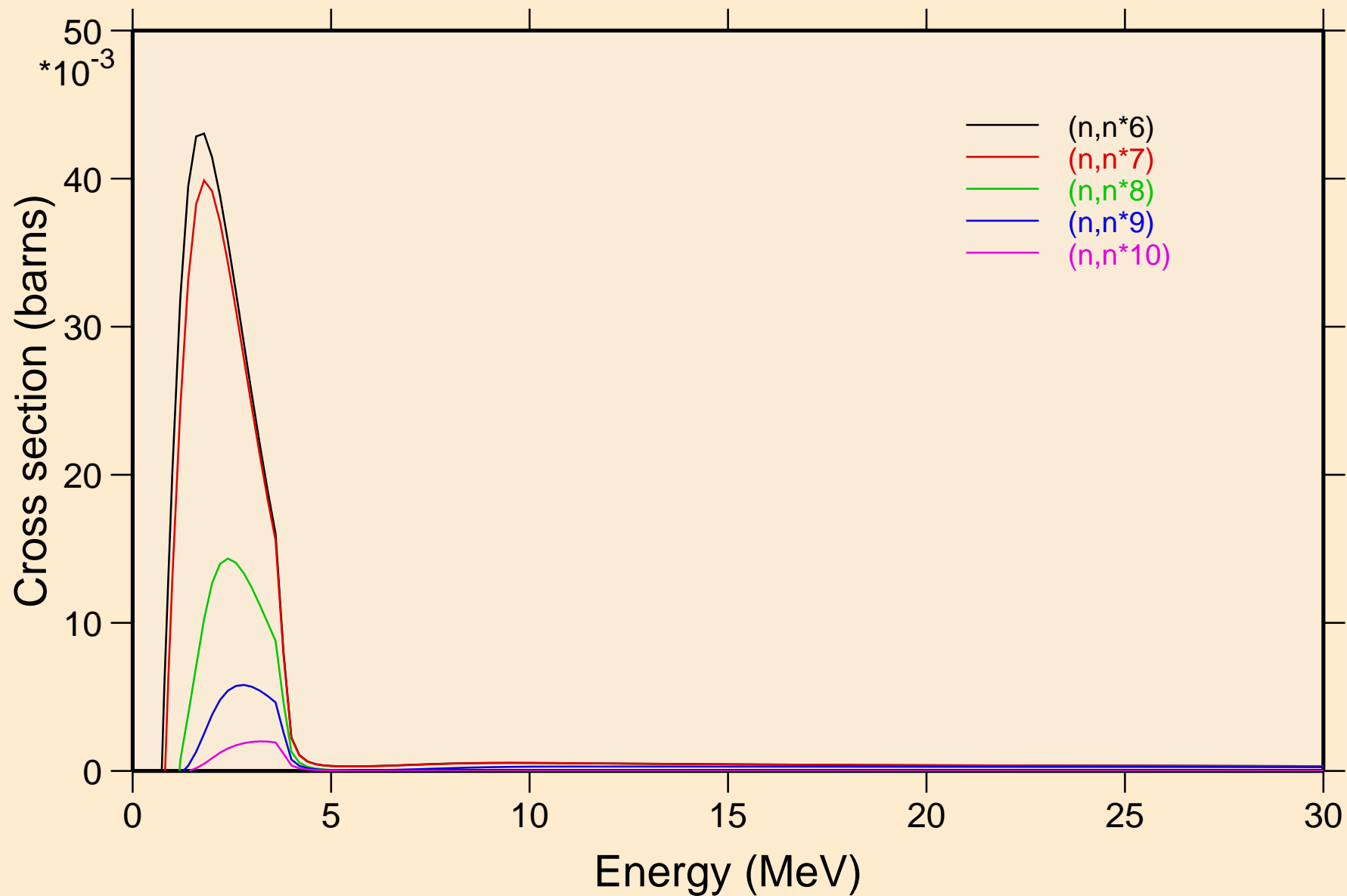

EU148 NEUTRON ACER TENDL-2023 LIBRARY; T=0.K  
Inelastic levels

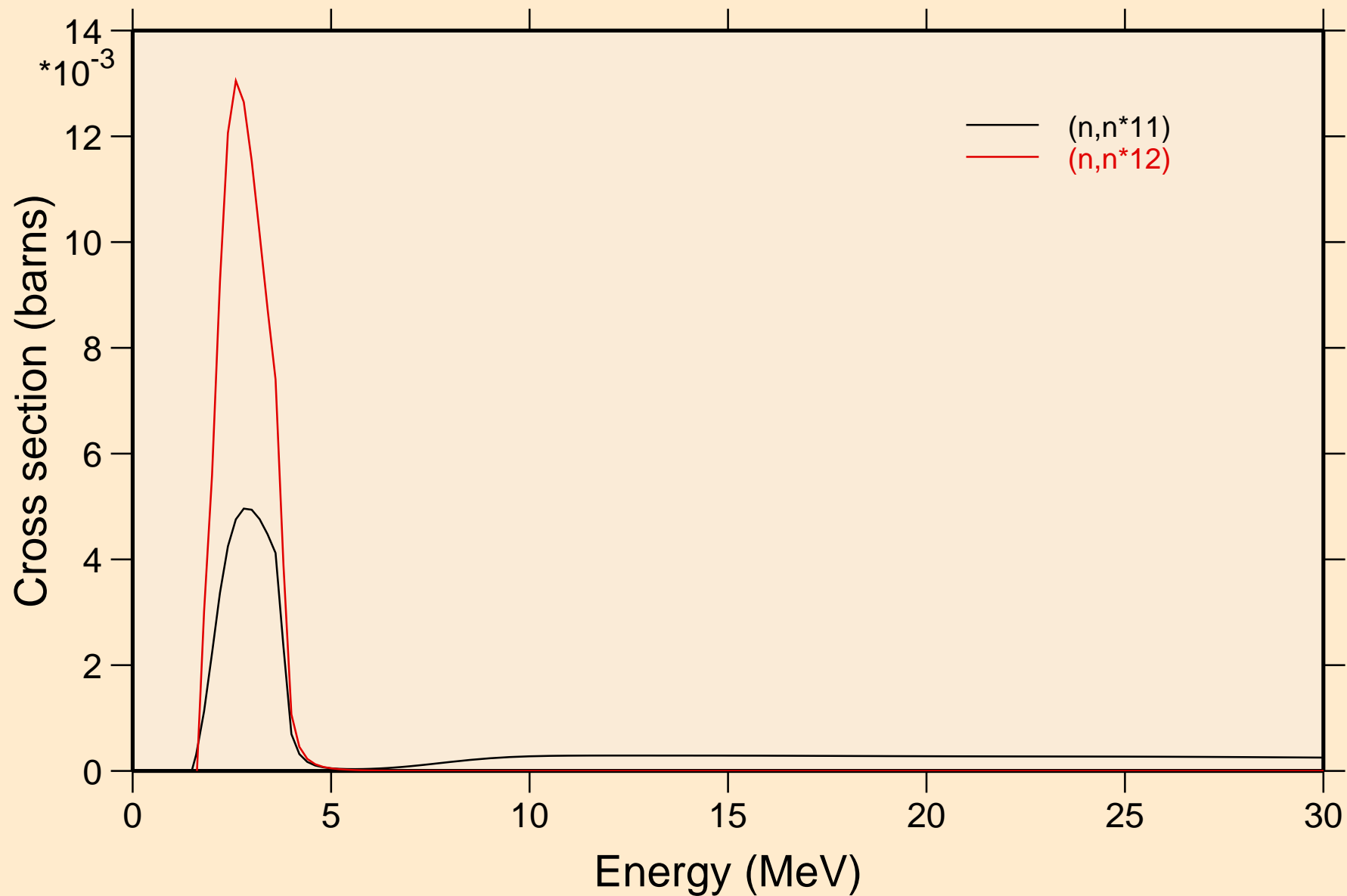

# EU148 NEUTRON ACER TENDL-2023 LIBRARY; T=0.K

## Threshold reactions

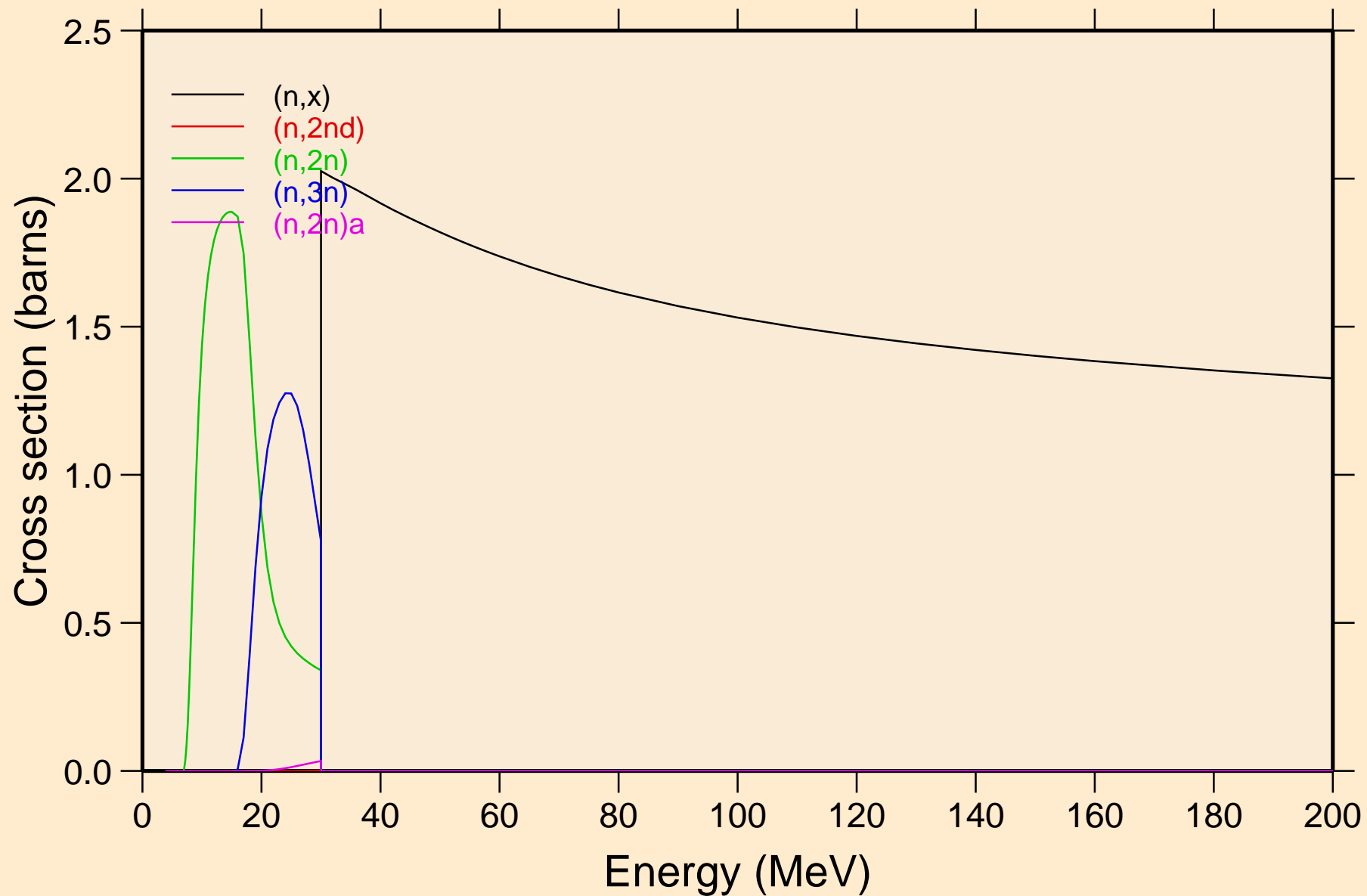



# EU148 NEUTRON ACER TENDL-2023 LIBRARY; T=0.K

## Threshold reactions

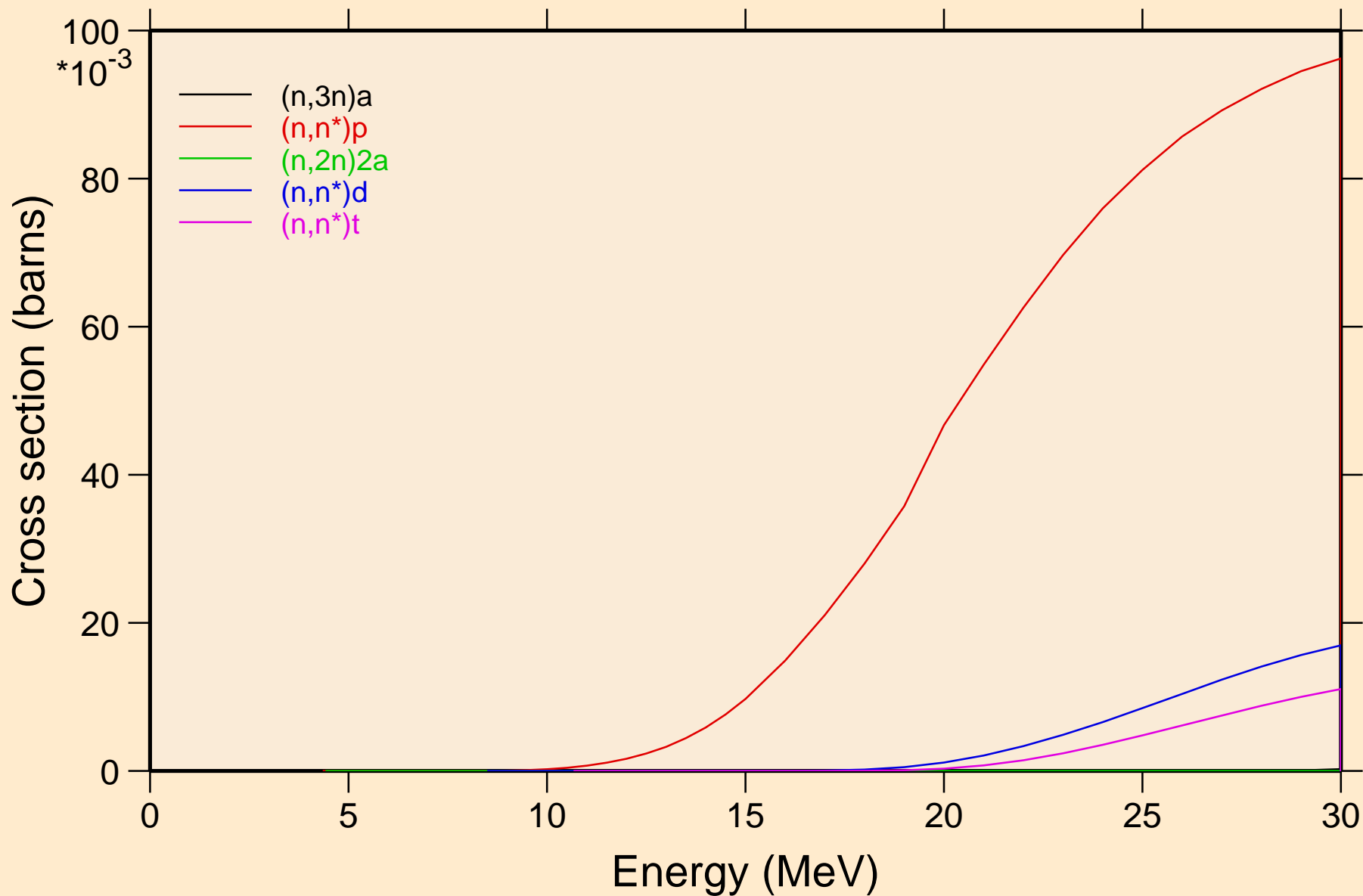

# EU148 NEUTRON ACER TENDL-2023 LIBRARY; T=0.K

## Threshold reactions

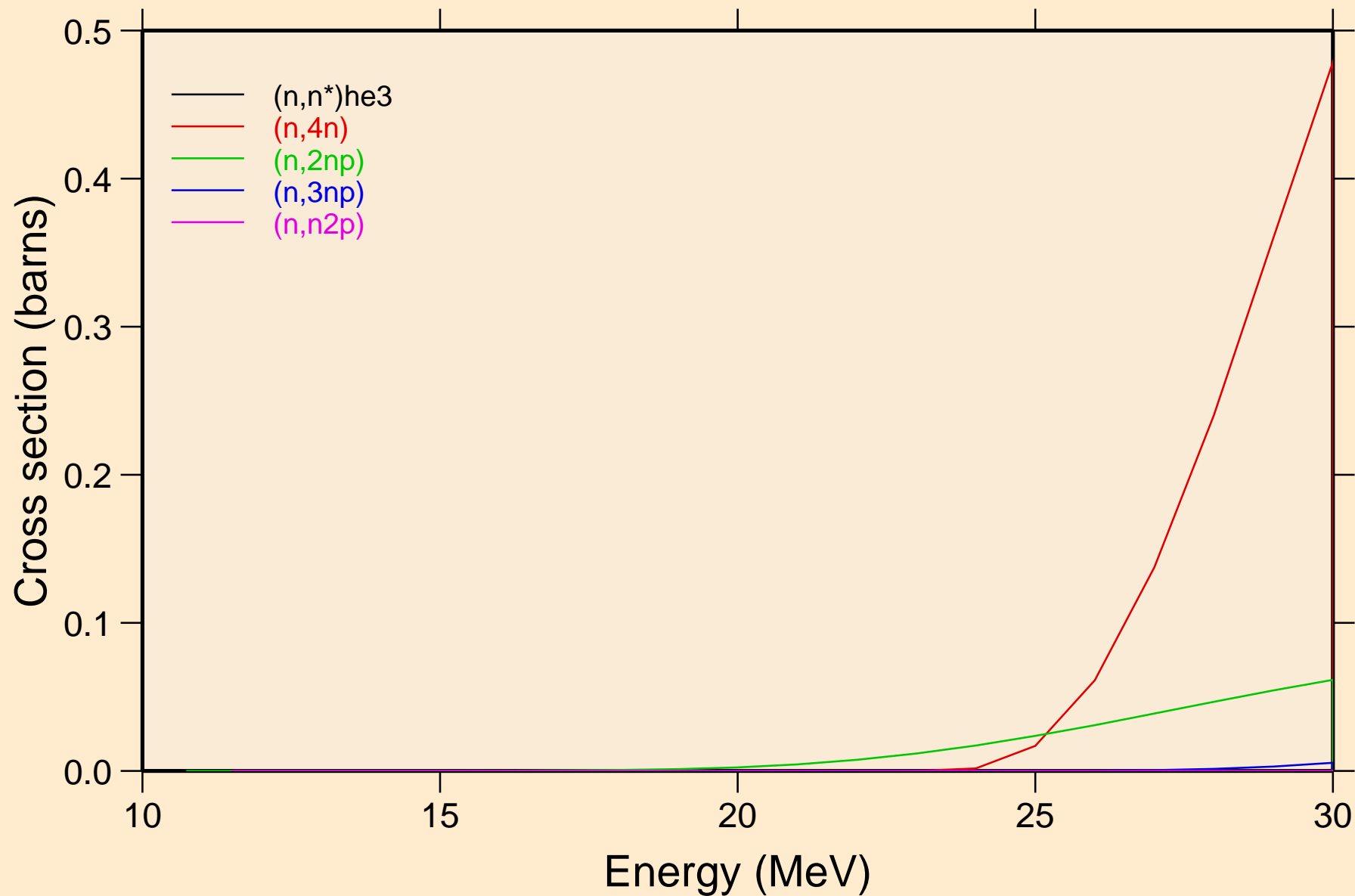

# EU148 NEUTRON ACER TENDL-2023 LIBRARY; T=0.K

## Threshold reactions

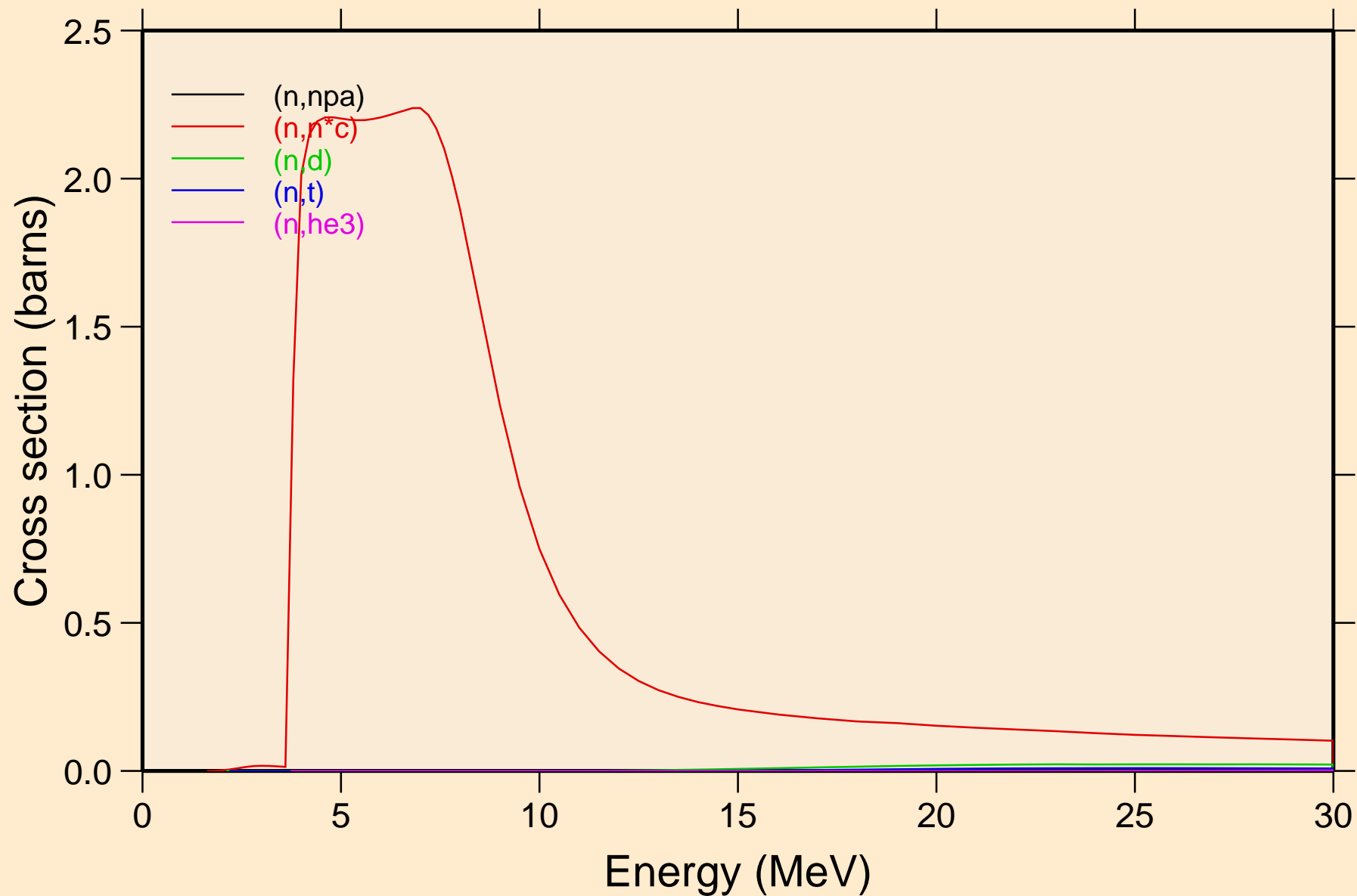

# EU148 NEUTRON ACER TENDL-2023 LIBRARY; T=0.K

## Threshold reactions

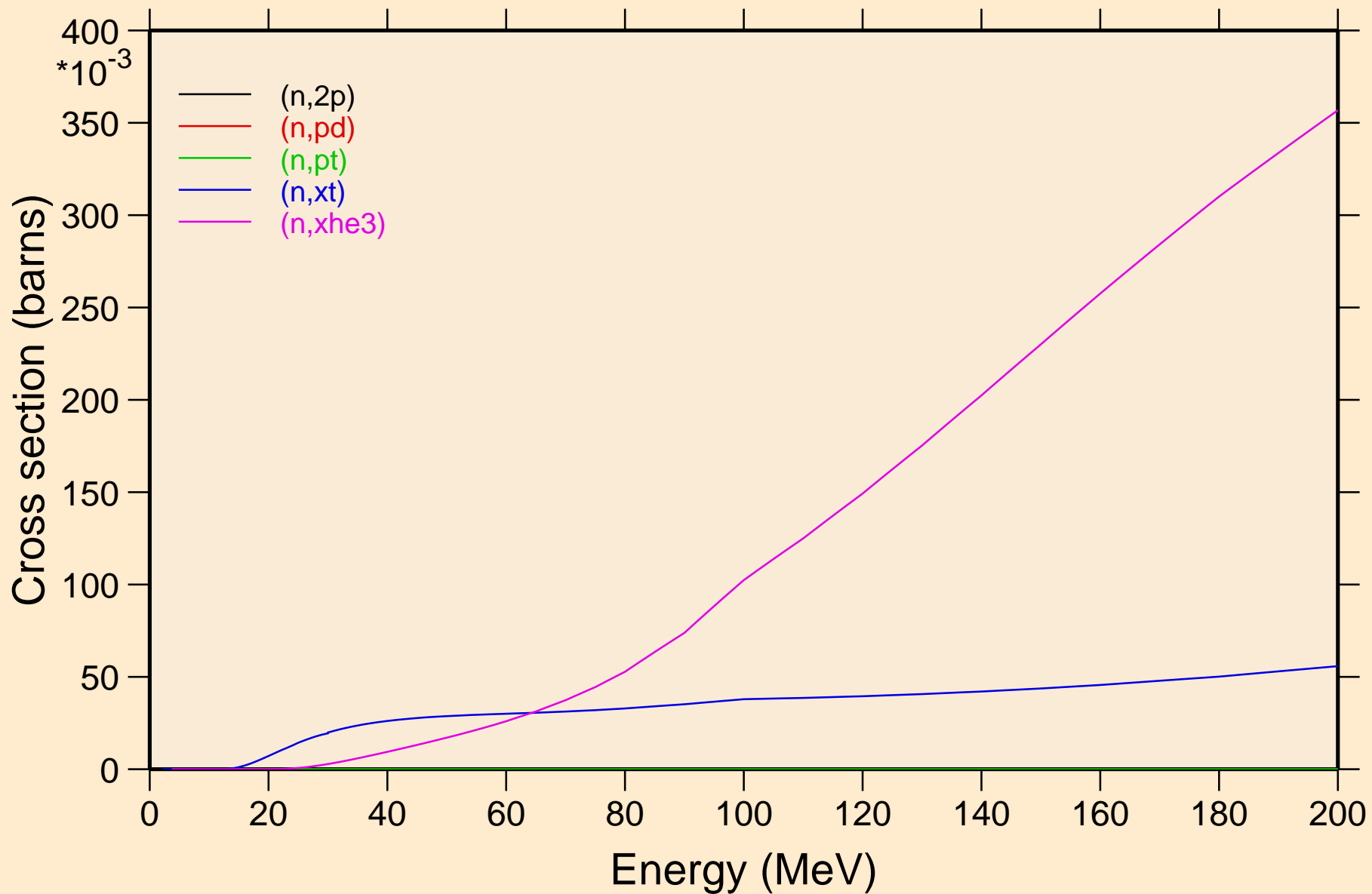

EU148 NEUTRON ACER TENDL-2023 LIBRARY; T=0.K  
angular distribution for elastic

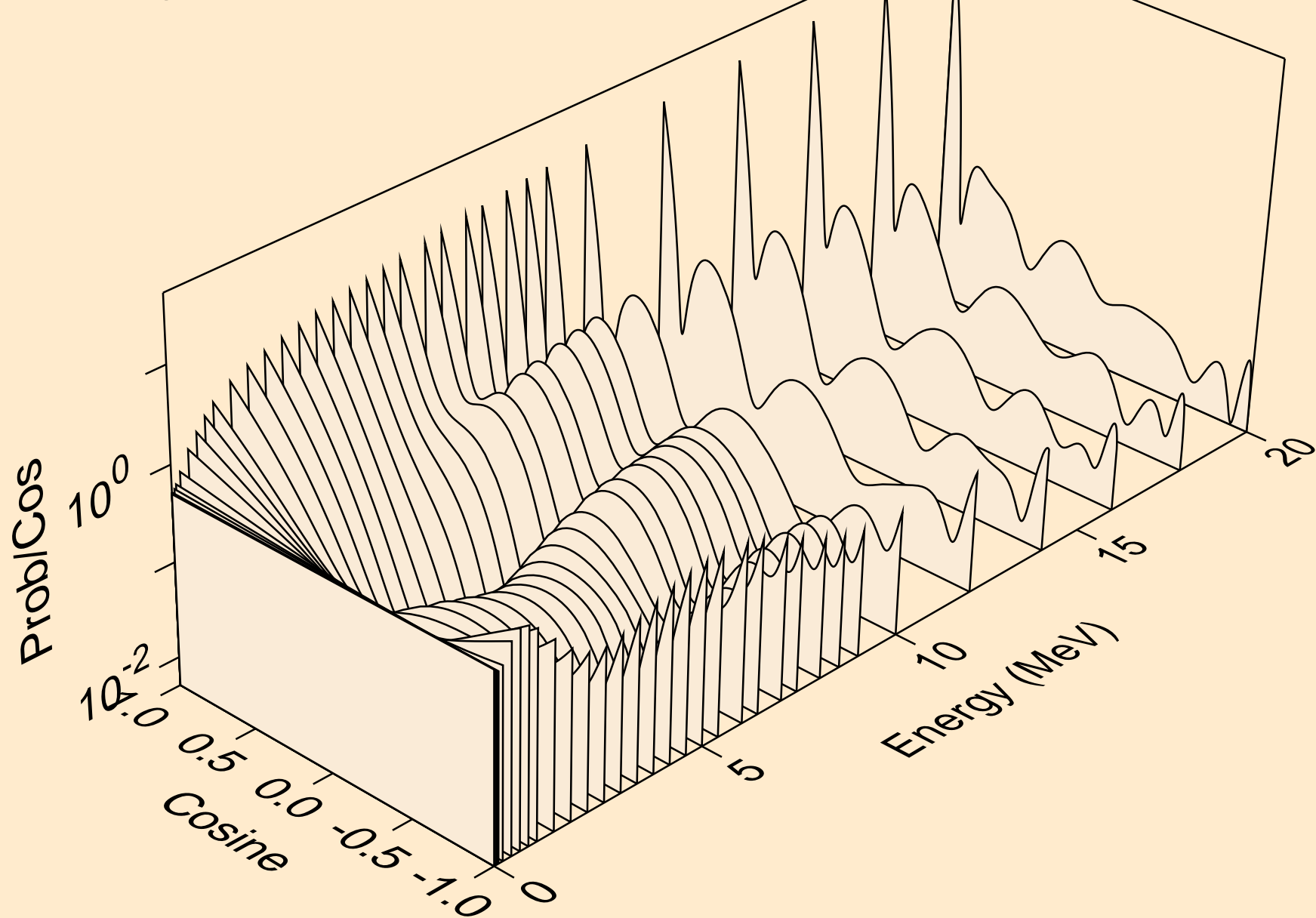

EU148 NEUTRON ACER TENDL-2023 LIBRARY; T=0.K  
angular distribution for elastic

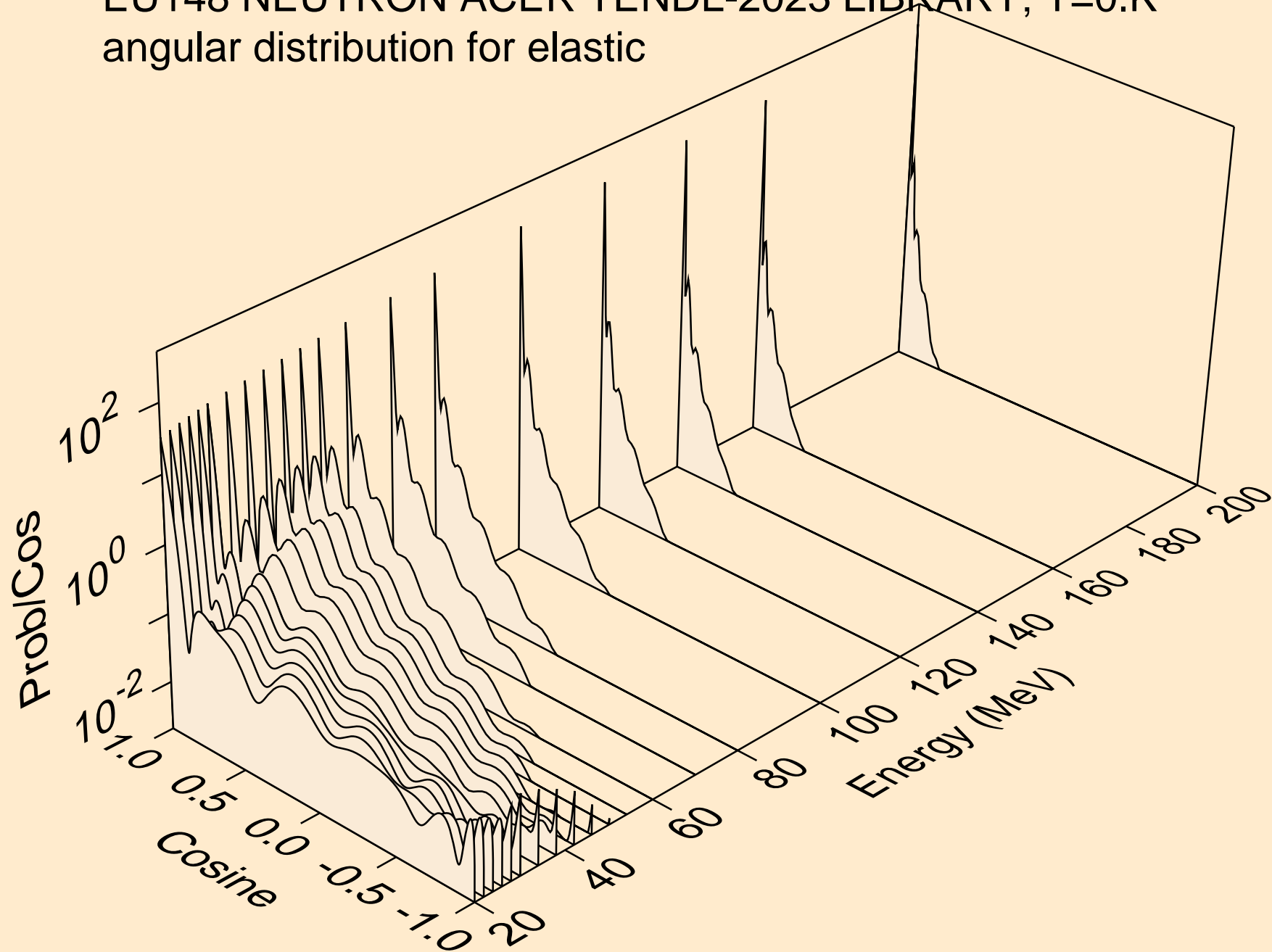

EU148 NEUTRON ACER TENDL-2023 LIBRARY; T=0.K  
angular distribution for (n,n\*1)

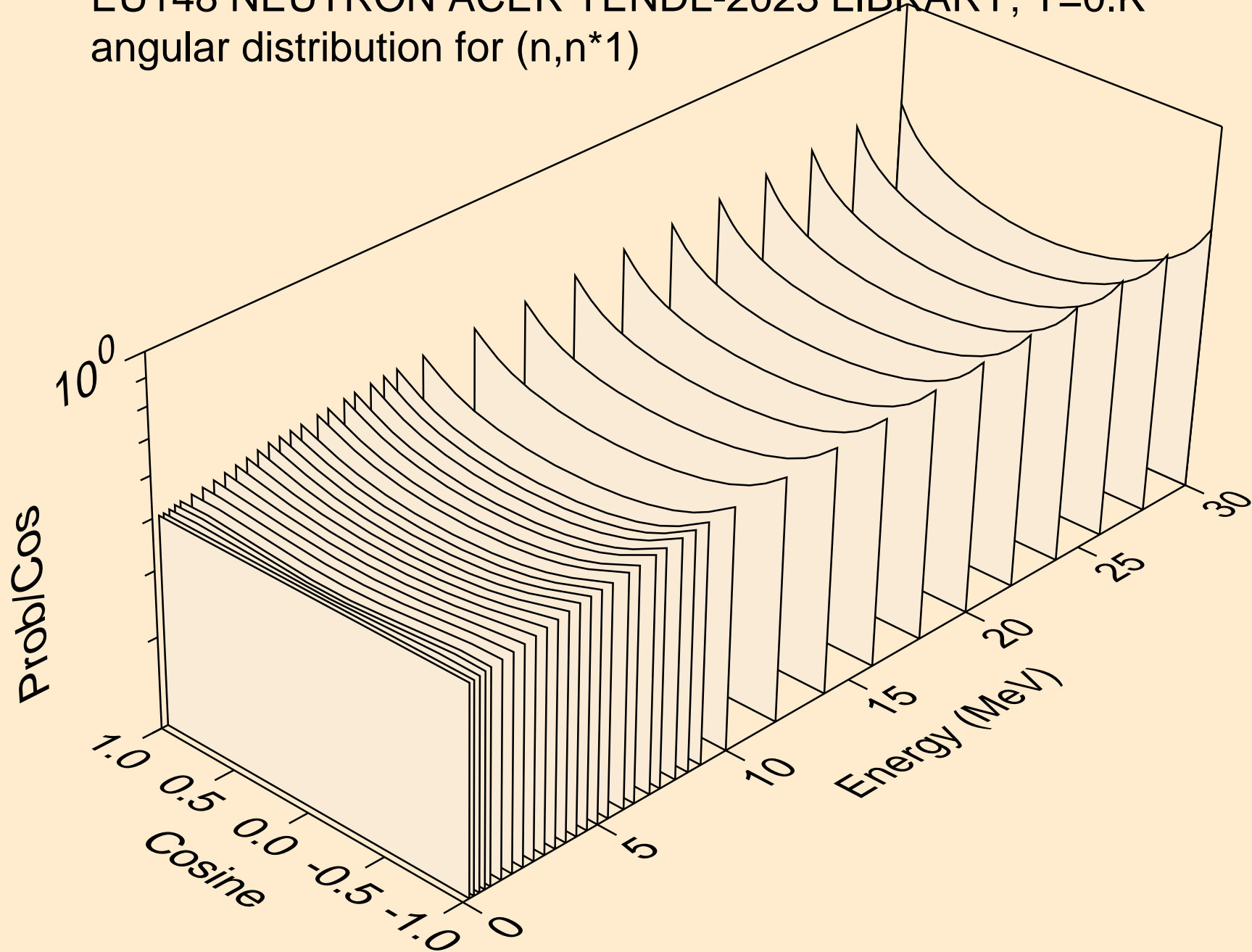

EU148 NEUTRON ACER TENDL-2023 LIBRARY; T=0.K  
angular distribution for (n,n\*2)

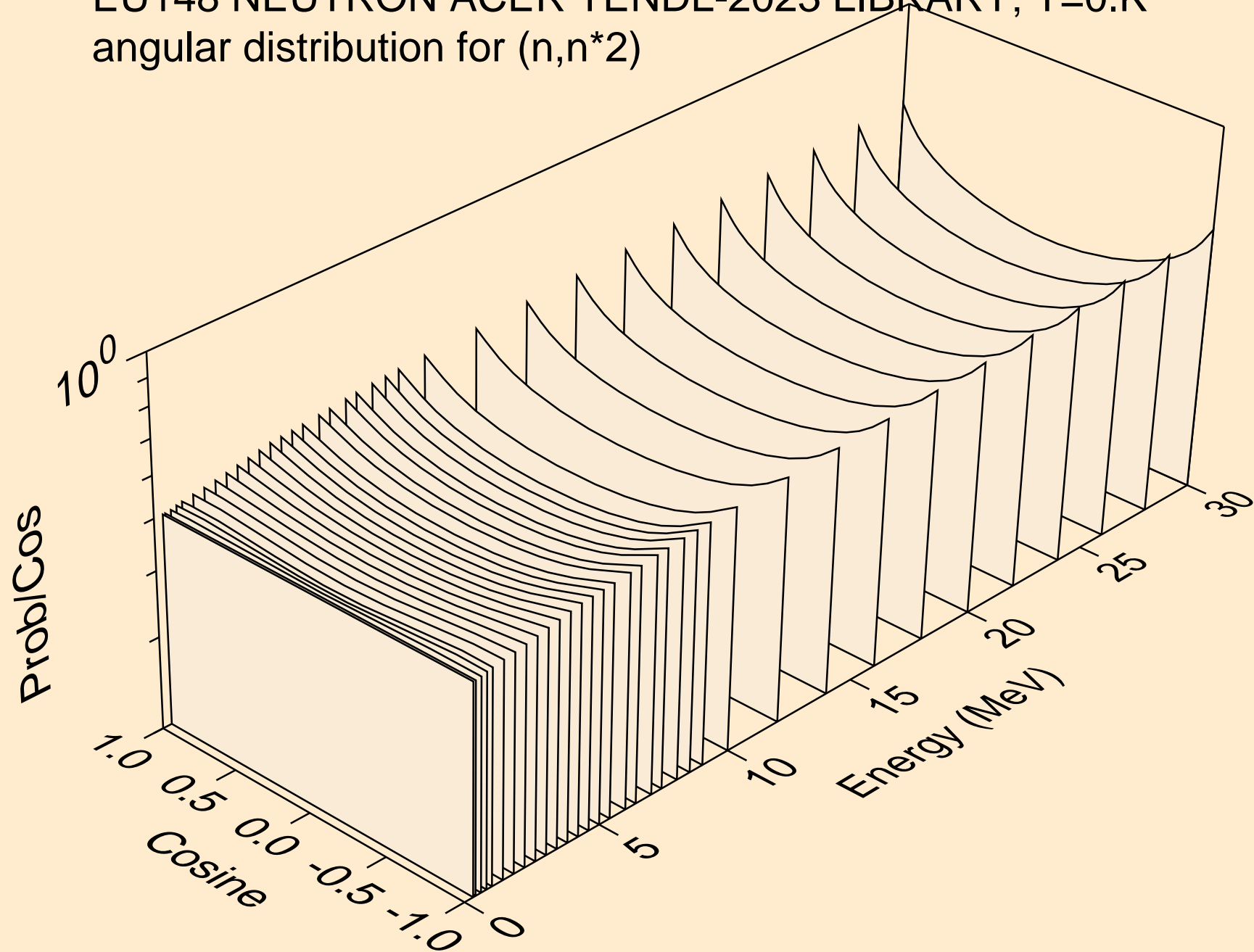



EU148 NEUTRON ACER TENDL-2023 LIBRARY; T=0.K  
angular distribution for (n,n\*3)

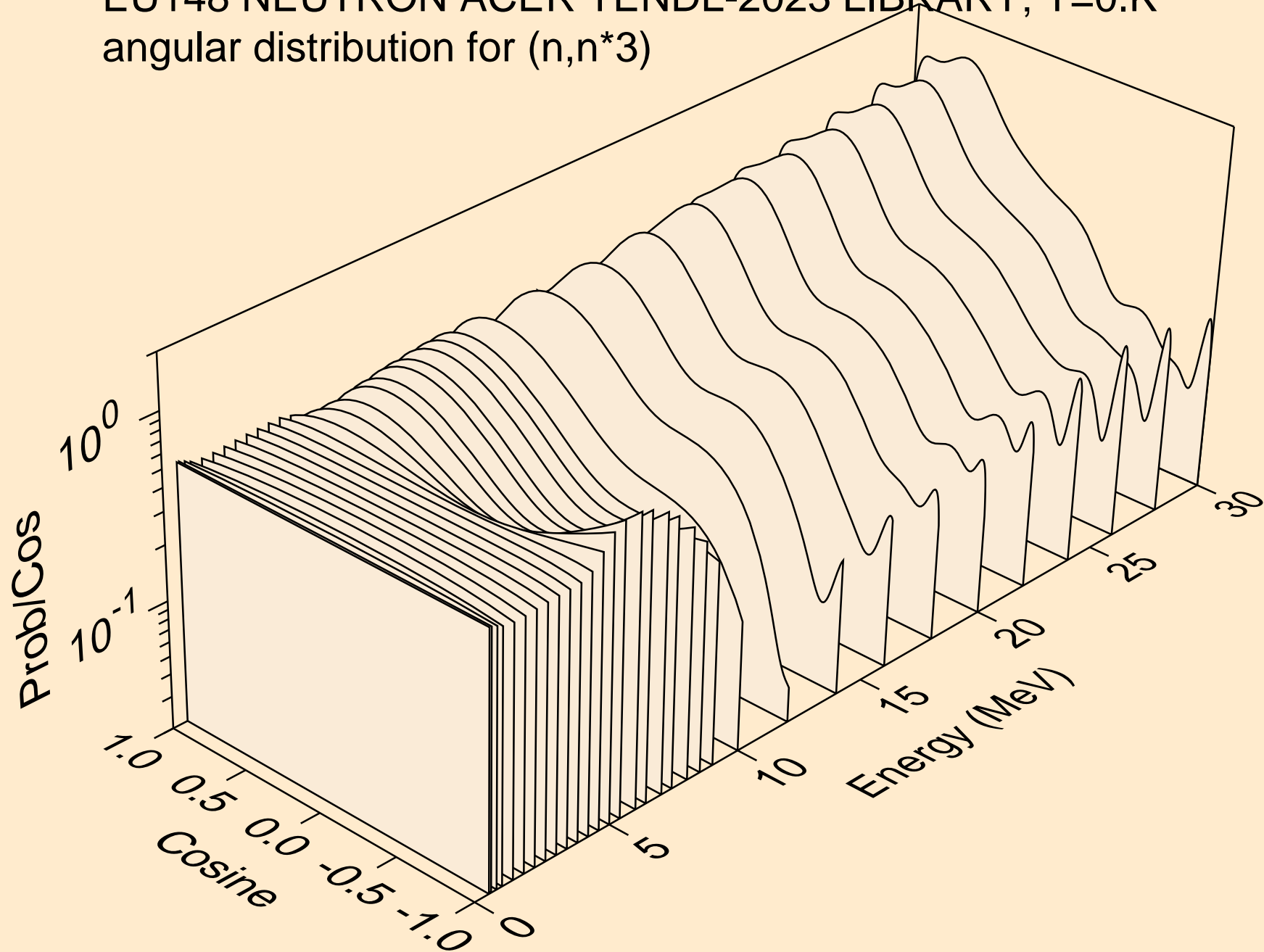

EU148 NEUTRON ACER TENDL-2023 LIBRARY; T=0.K  
angular distribution for (n,n\*4)

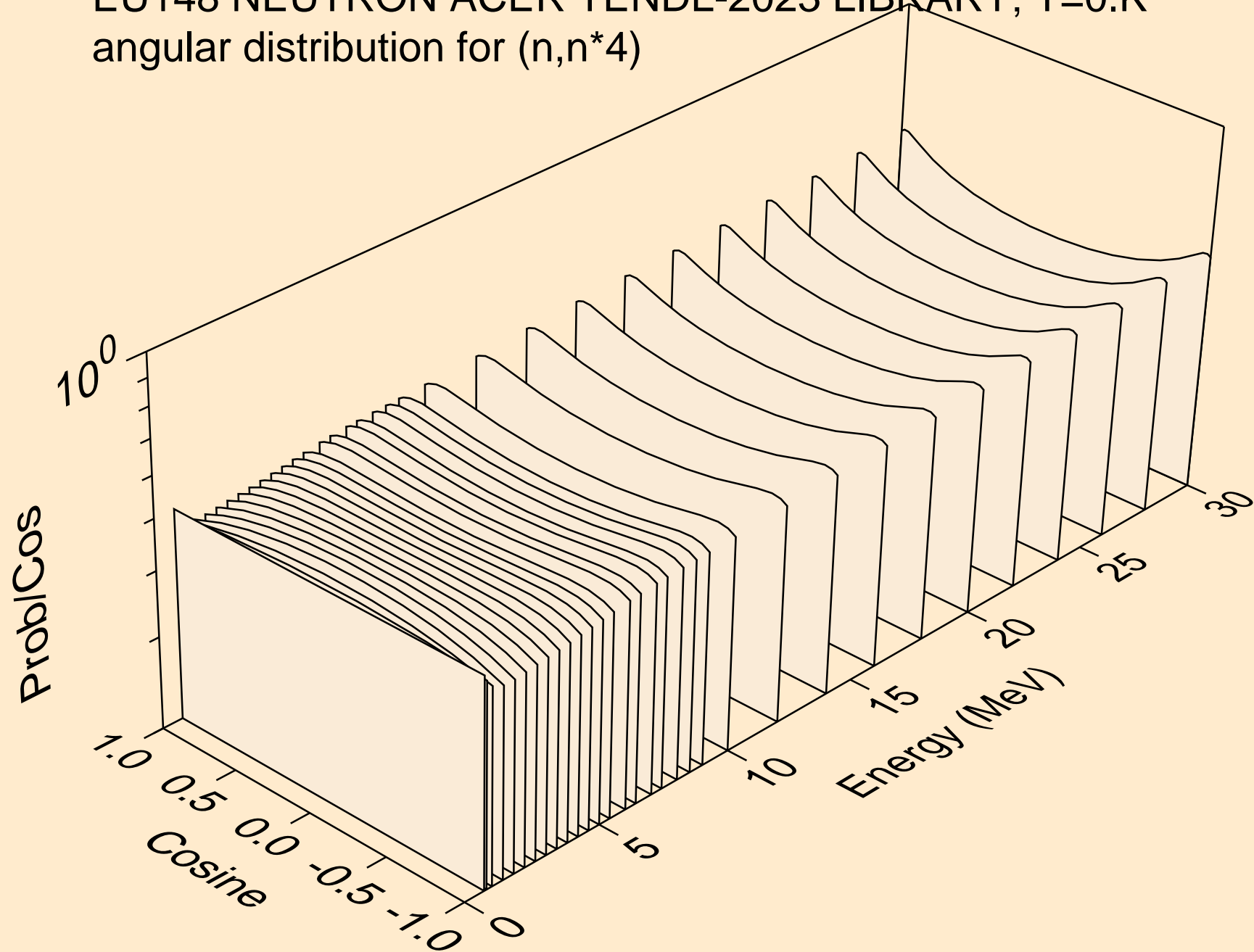

EU148 NEUTRON ACER TENDL-2023 LIBRARY; T=0.K  
angular distribution for (n,n\*5)

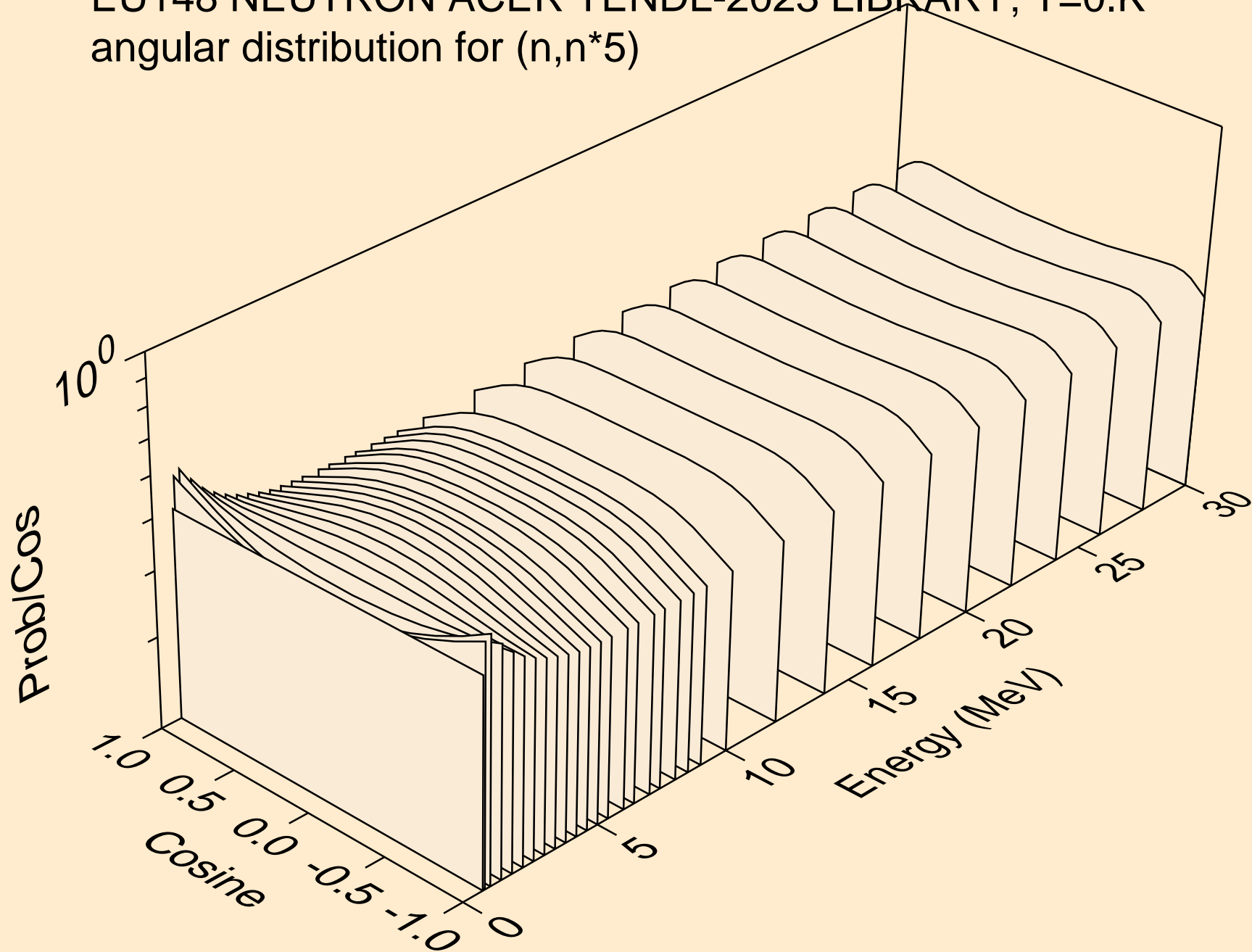

EU148 NEUTRON ACER TENDL-2023 LIBRARY; T=0.K  
angular distribution for (n,n\*6)

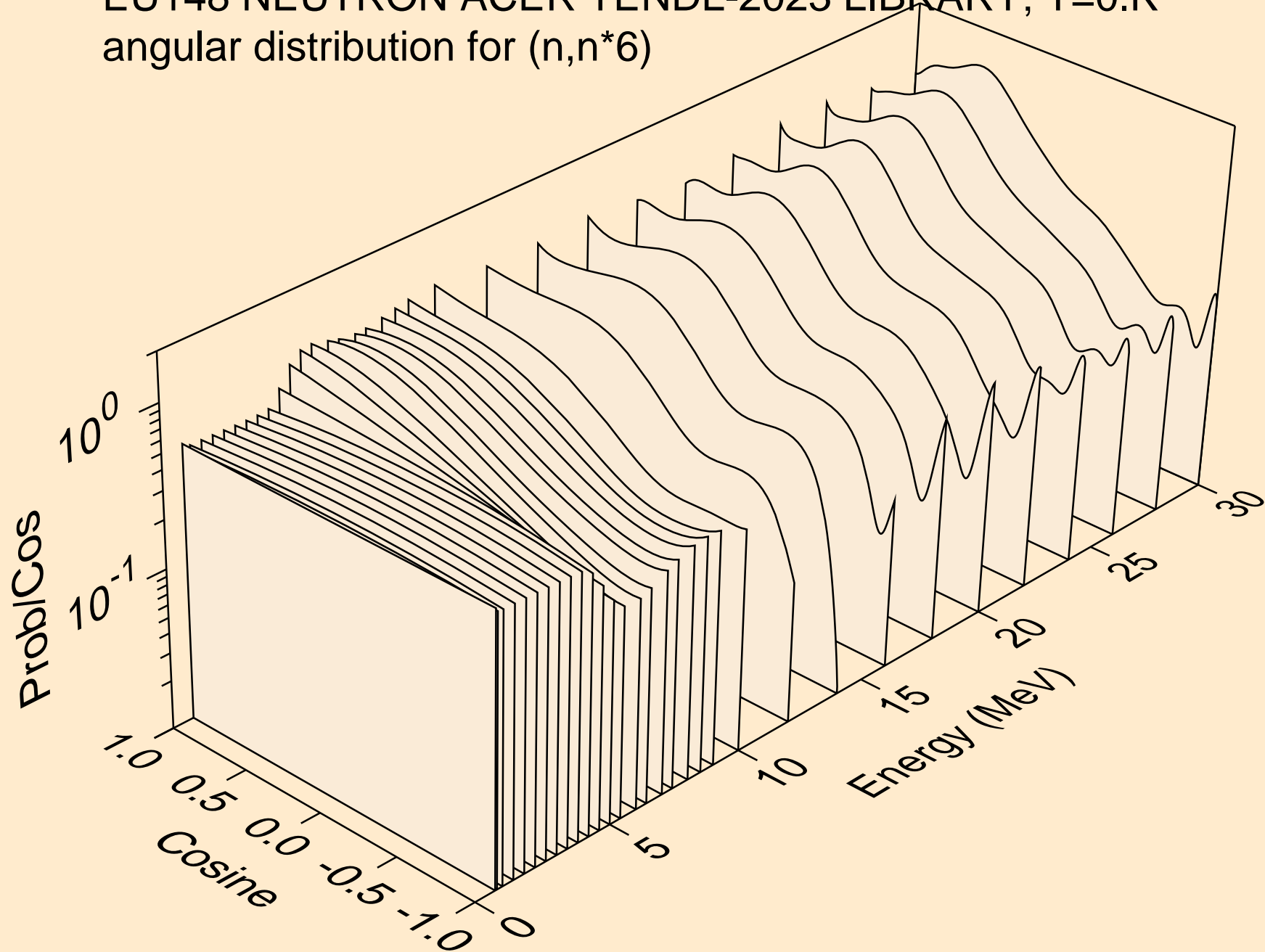

EU148 NEUTRON ACER TENDL-2023 LIBRARY; T=0.K  
angular distribution for (n,n\*7)

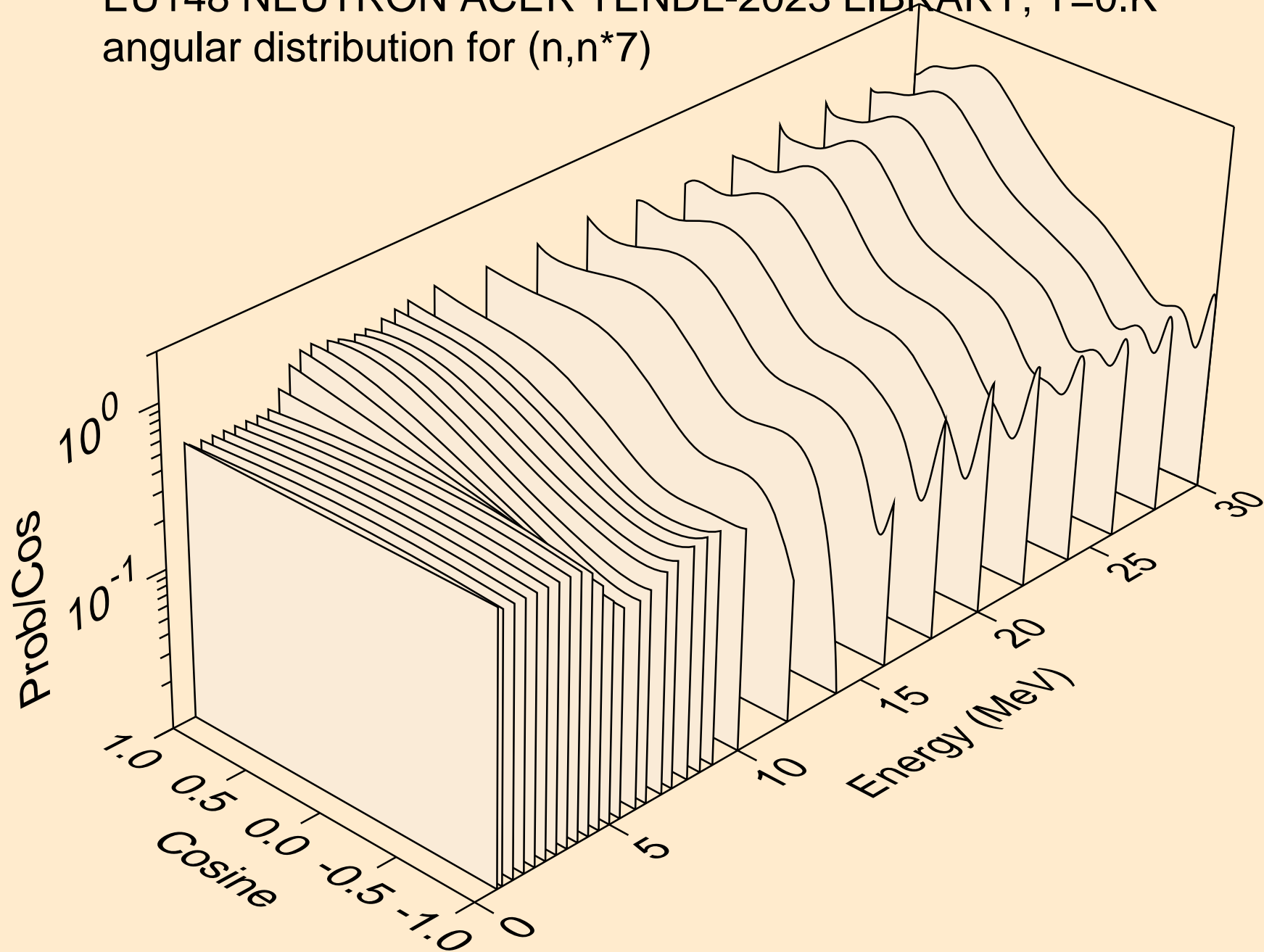

EU148 NEUTRON ACER TENDL-2023 LIBRARY; T=0.K  
angular distribution for (n,n\*8)

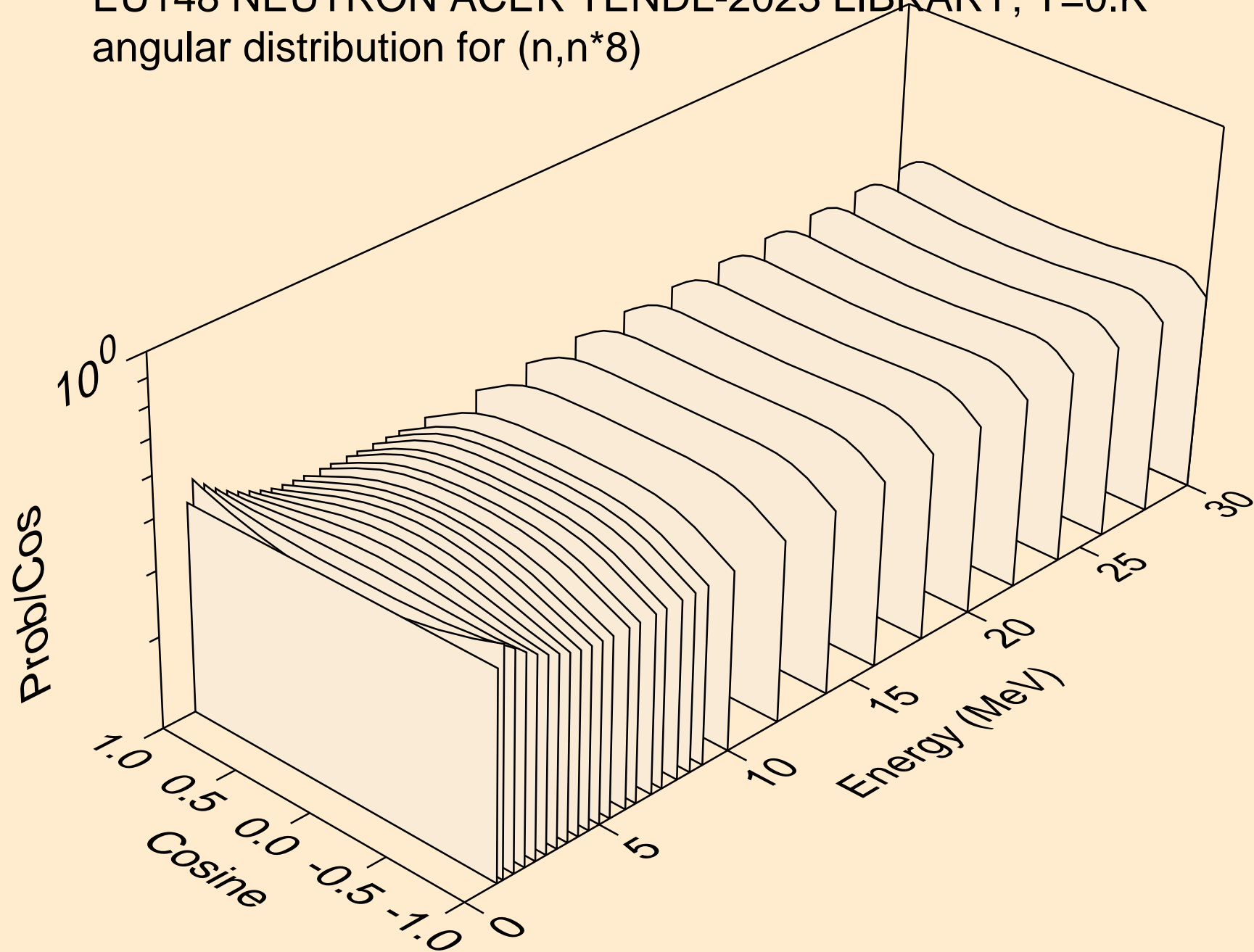

EU148 NEUTRON ACER TENDL-2023 LIBRARY; T=0.K  
angular distribution for (n,n\*9)

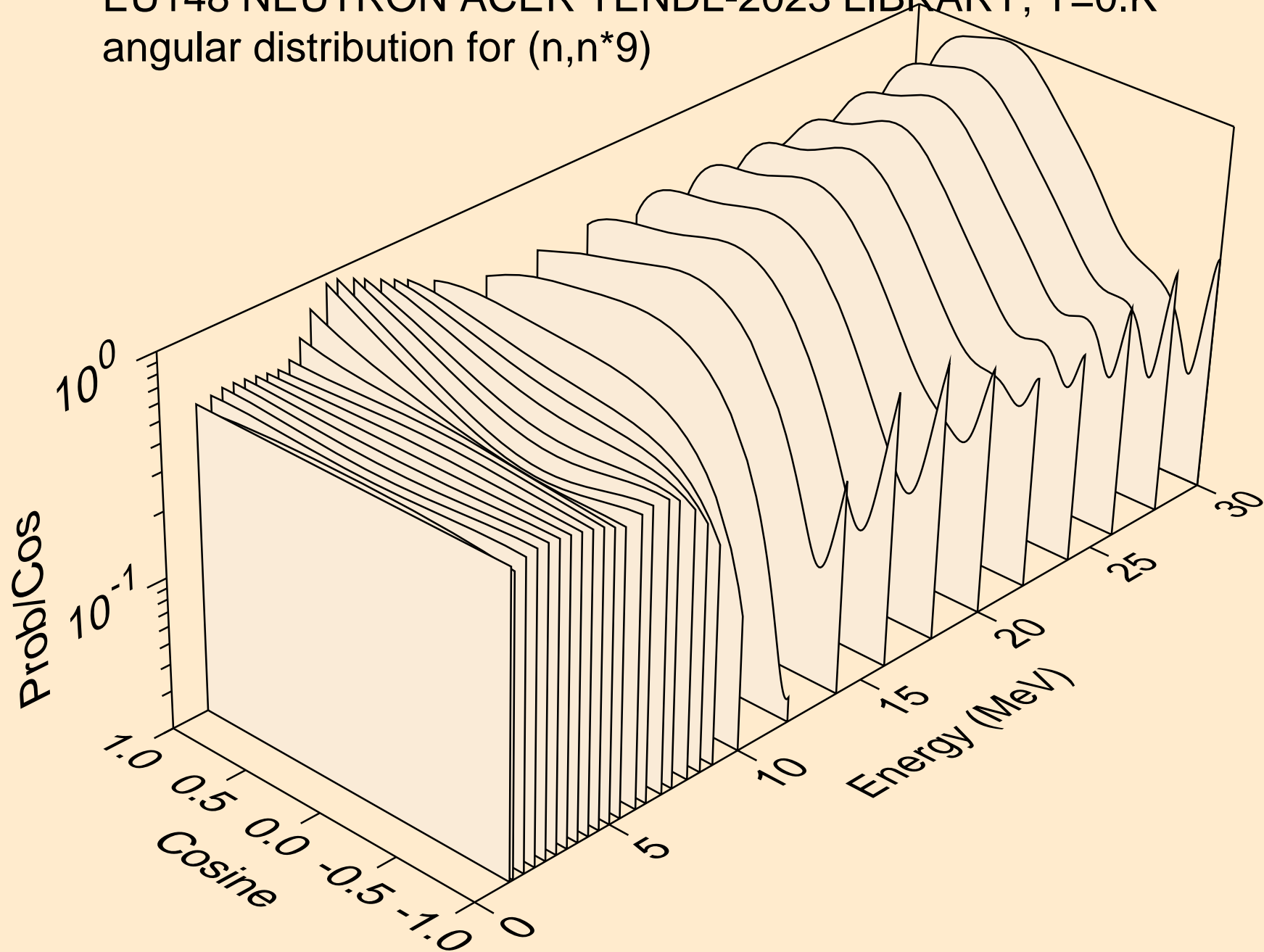

EU148 NEUTRON ACER TENDL-2023 LIBRARY; T=0.K  
angular distribution for (n,n\*10)

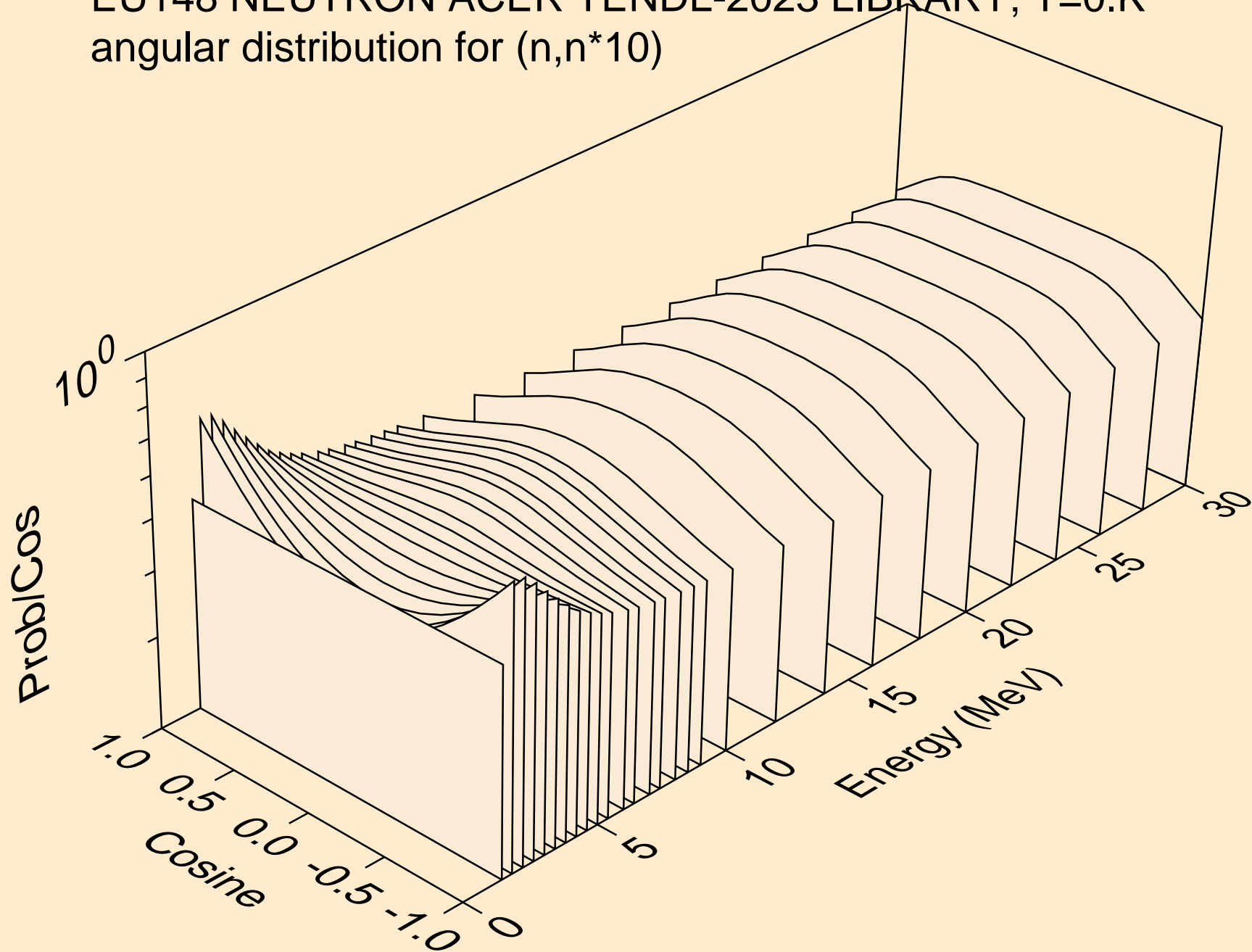



EU148 NEUTRON ACER TENDL-2023 LIBRARY; T=0.K  
angular distribution for (n,n\*11)

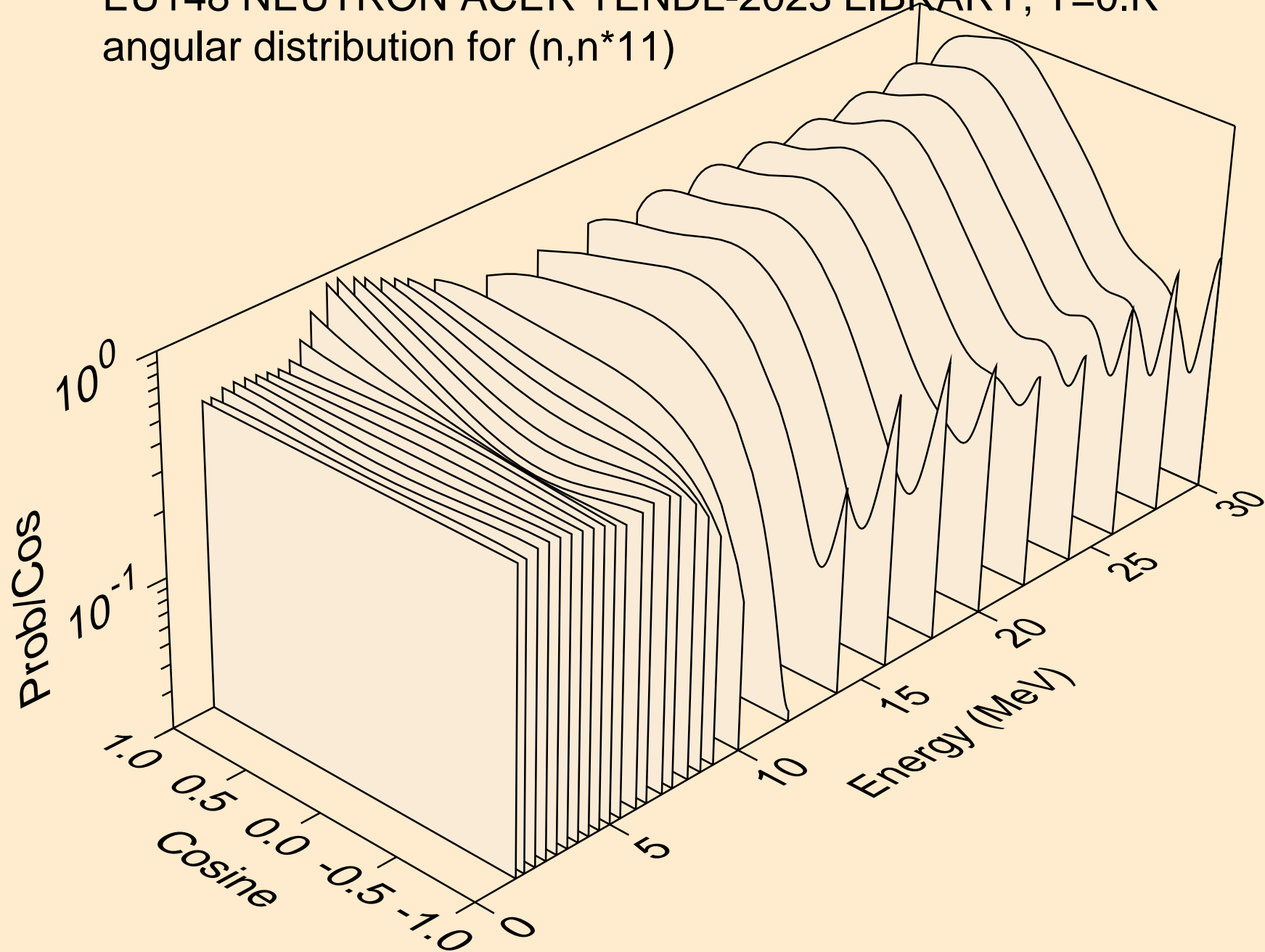

EU148 NEUTRON ACER TENDL-2023 LIBRARY; T=0.K  
angular distribution for (n,n\*12)

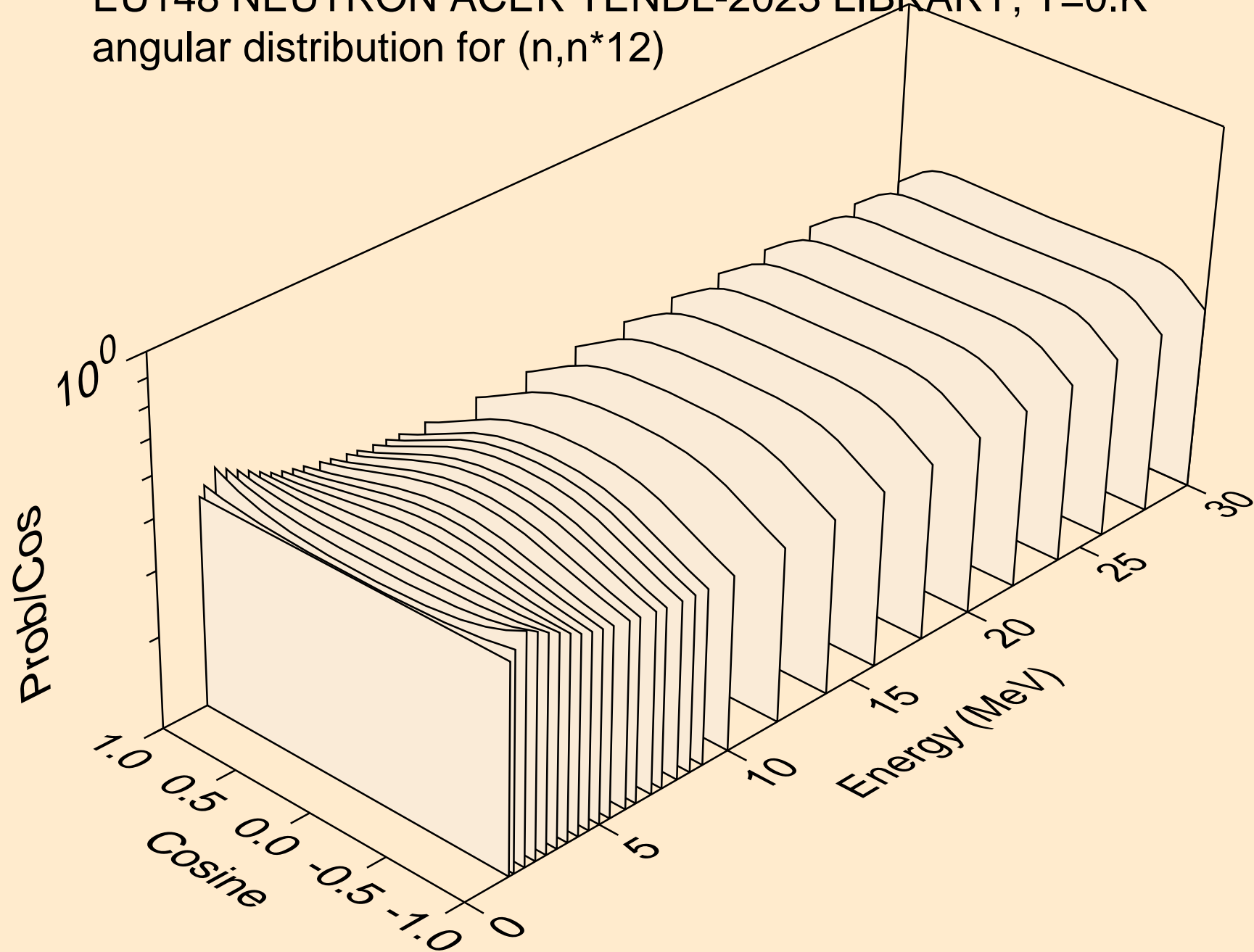

EU148 NEUTRON ACER TENDL-2023 LIBRARY; T=0.K  
Neutron emission for (n,x)

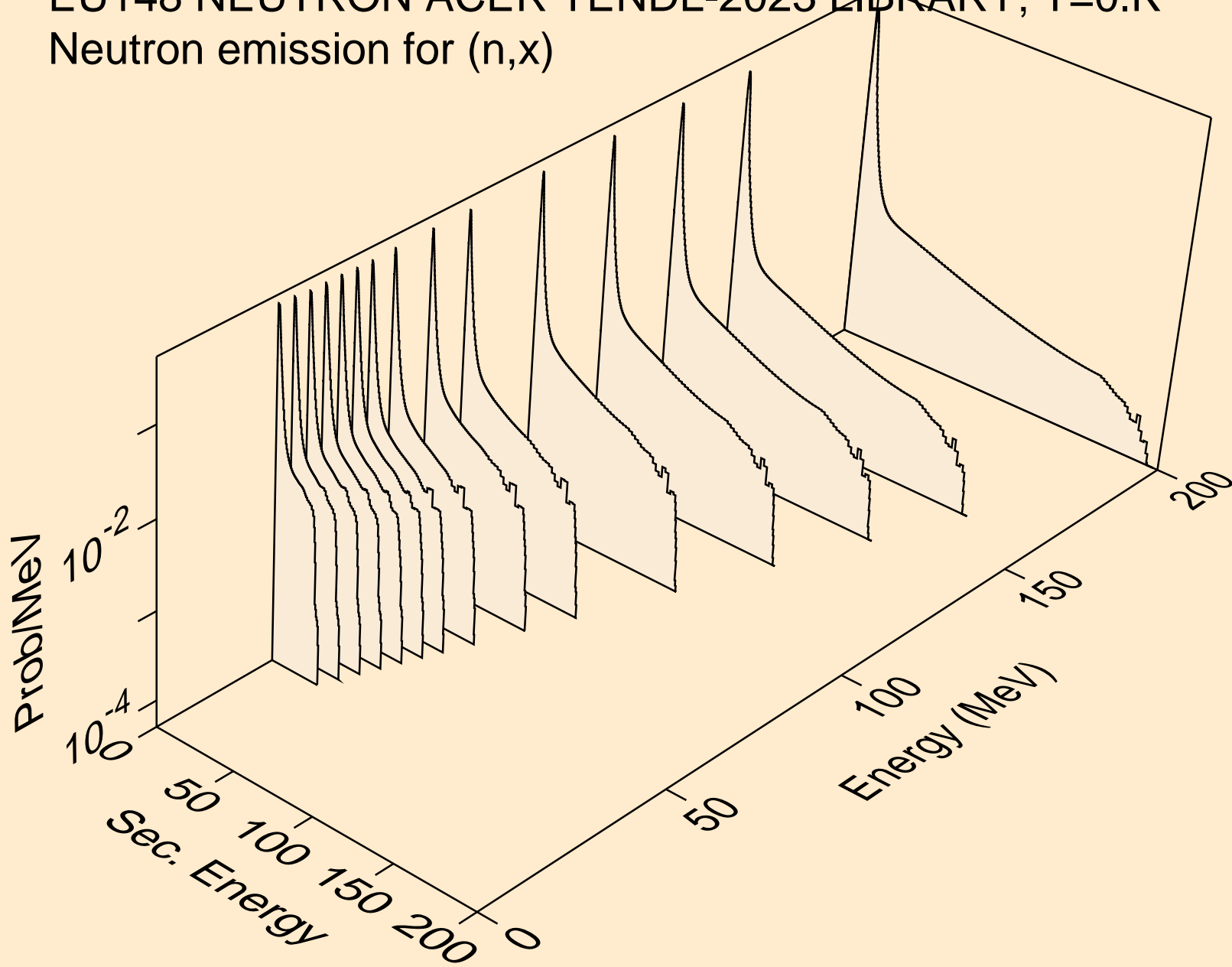

EU148 NEUTRON ACER TENDL-2023 LIBRARY; T=0.K  
Neutron emission for (n,2nd)

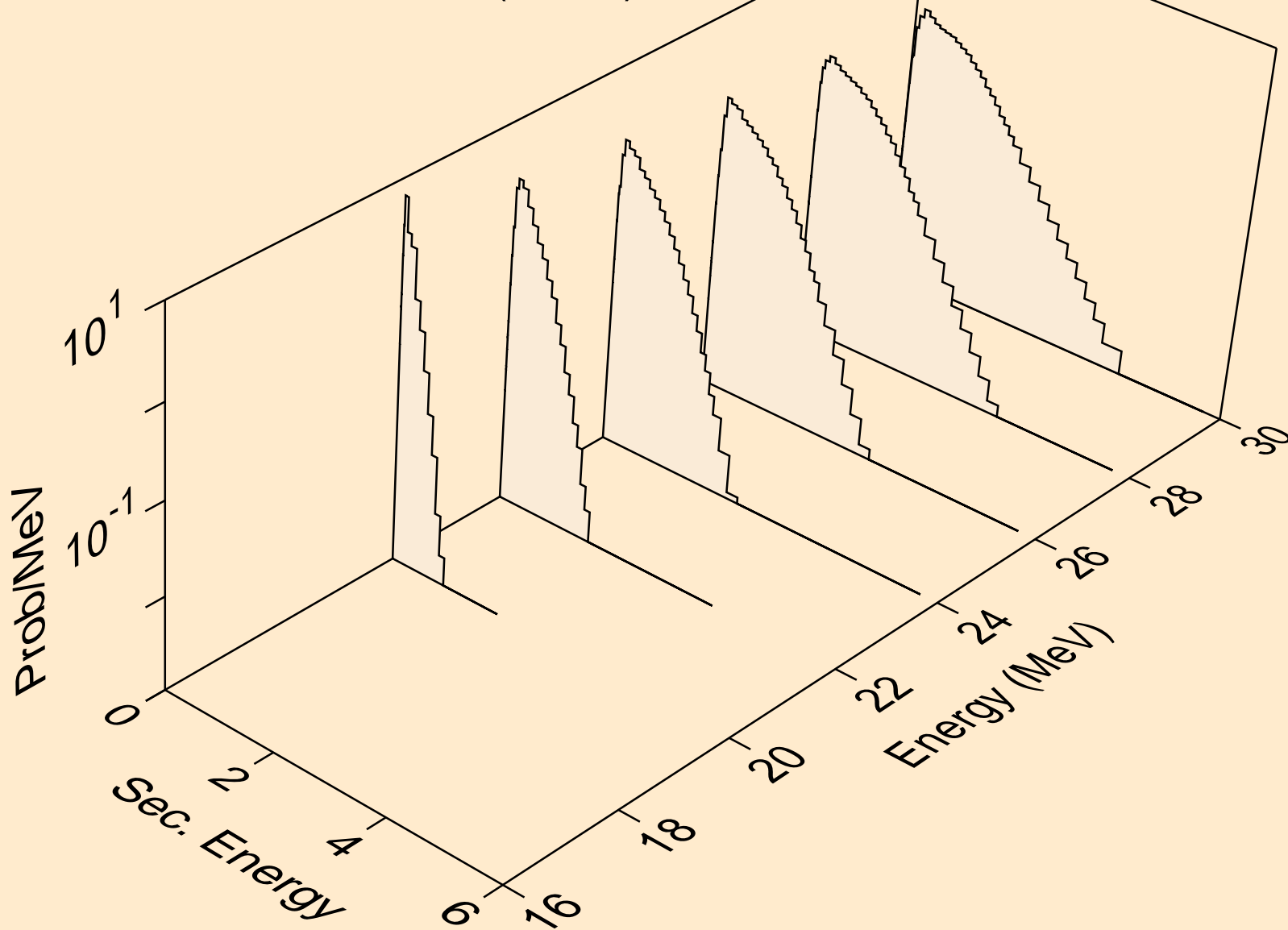

EU148 NEUTRON ACER TENDL-2023 LIBRARY; T=0.K  
Neutron emission for (n,2n)

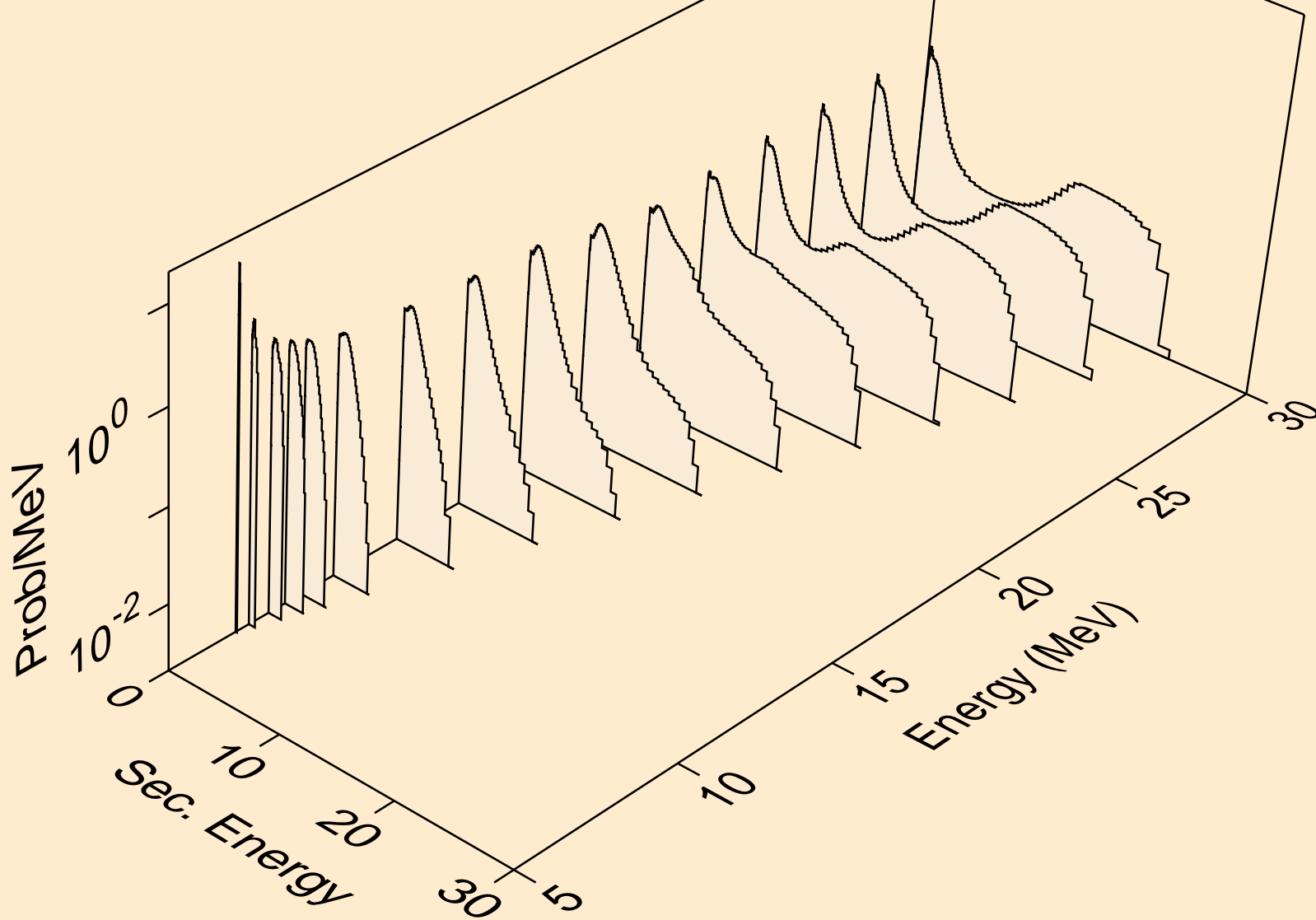

EU148 NEUTRON ACER TENDL-2023 LIBRARY; T=0.K  
Neutron emission for (n,3n)

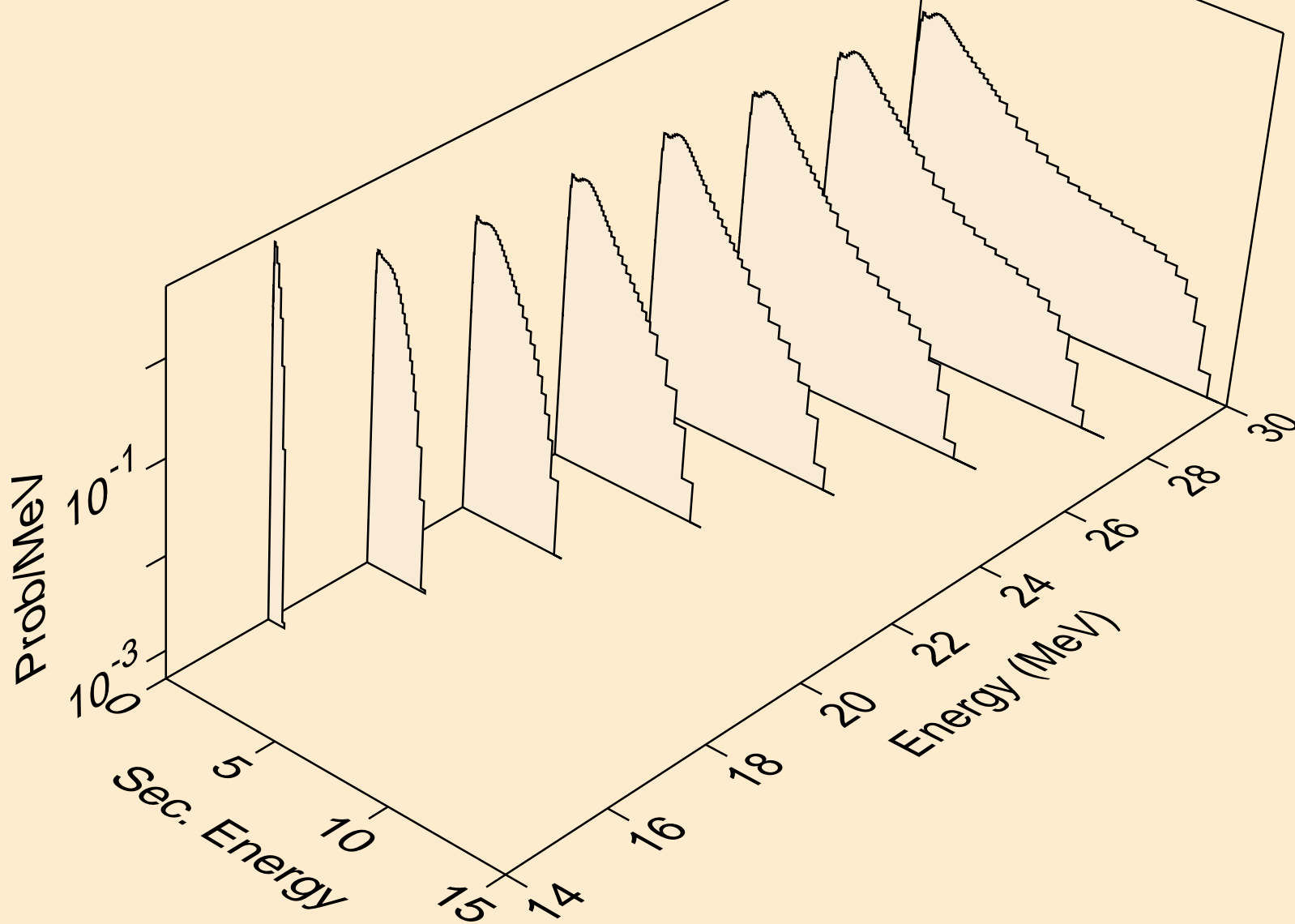

EU148 NEUTRON ACER TENDL-2023 LIBRARY; T=0.K  
Neutron emission for (n,n\*)a

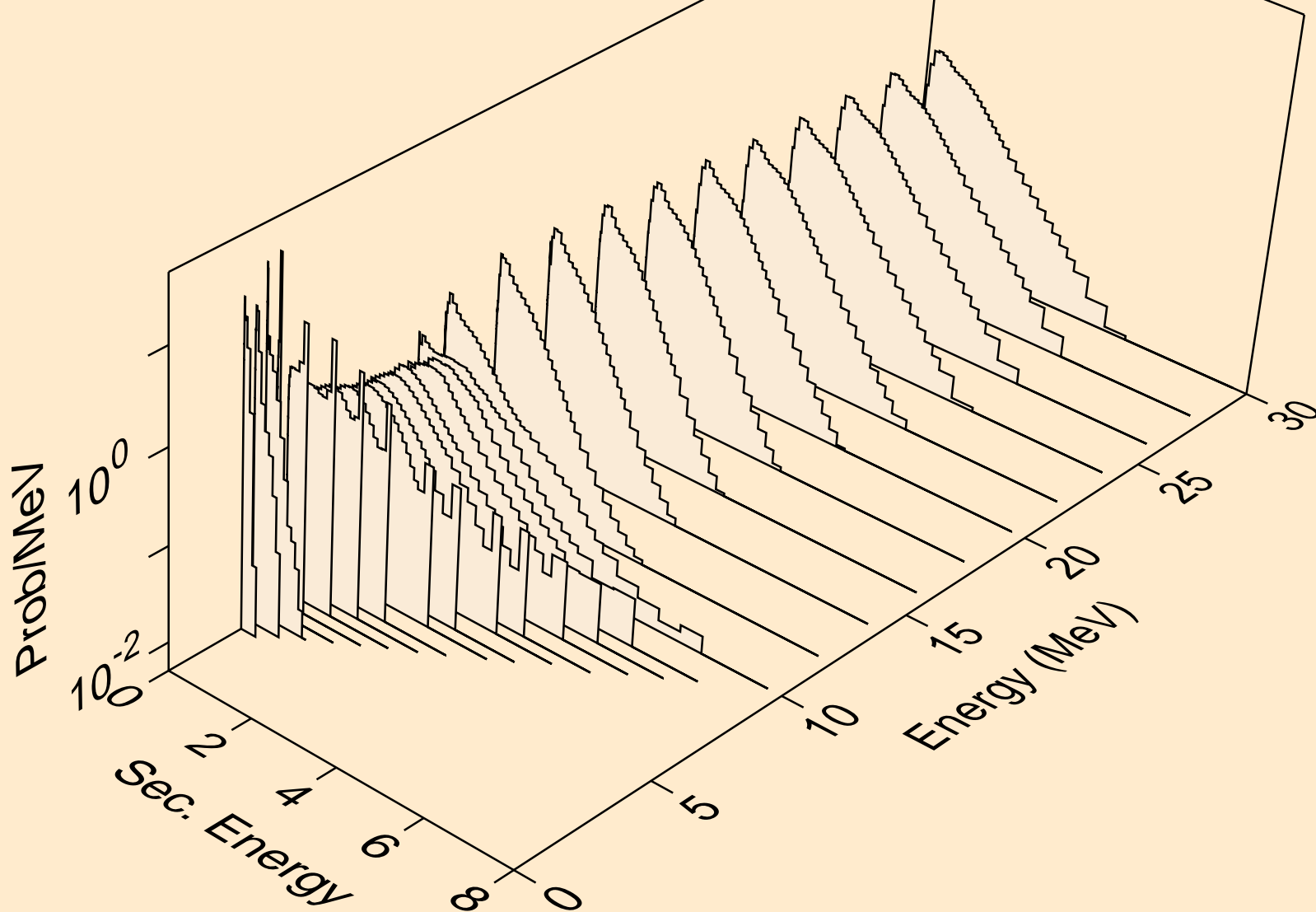

EU148 NEUTRON ACER TENDL-2023 LIBRARY; T=0.K  
Neutron emission for (n,2n)a

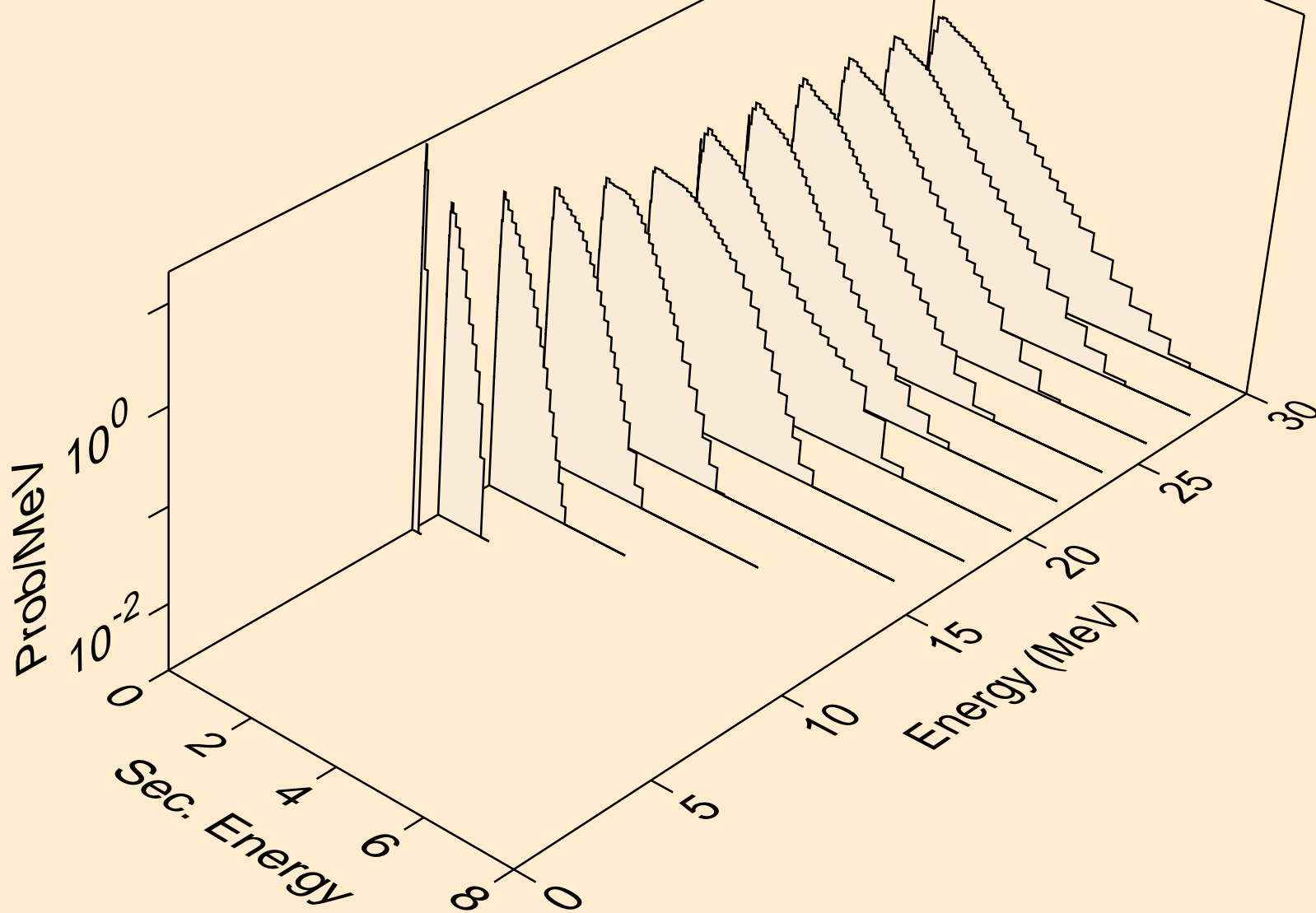



EU148 NEUTRON ACER TENDL-2023 LIBRARY; T=0.K  
Neutron emission for (n,3n)a

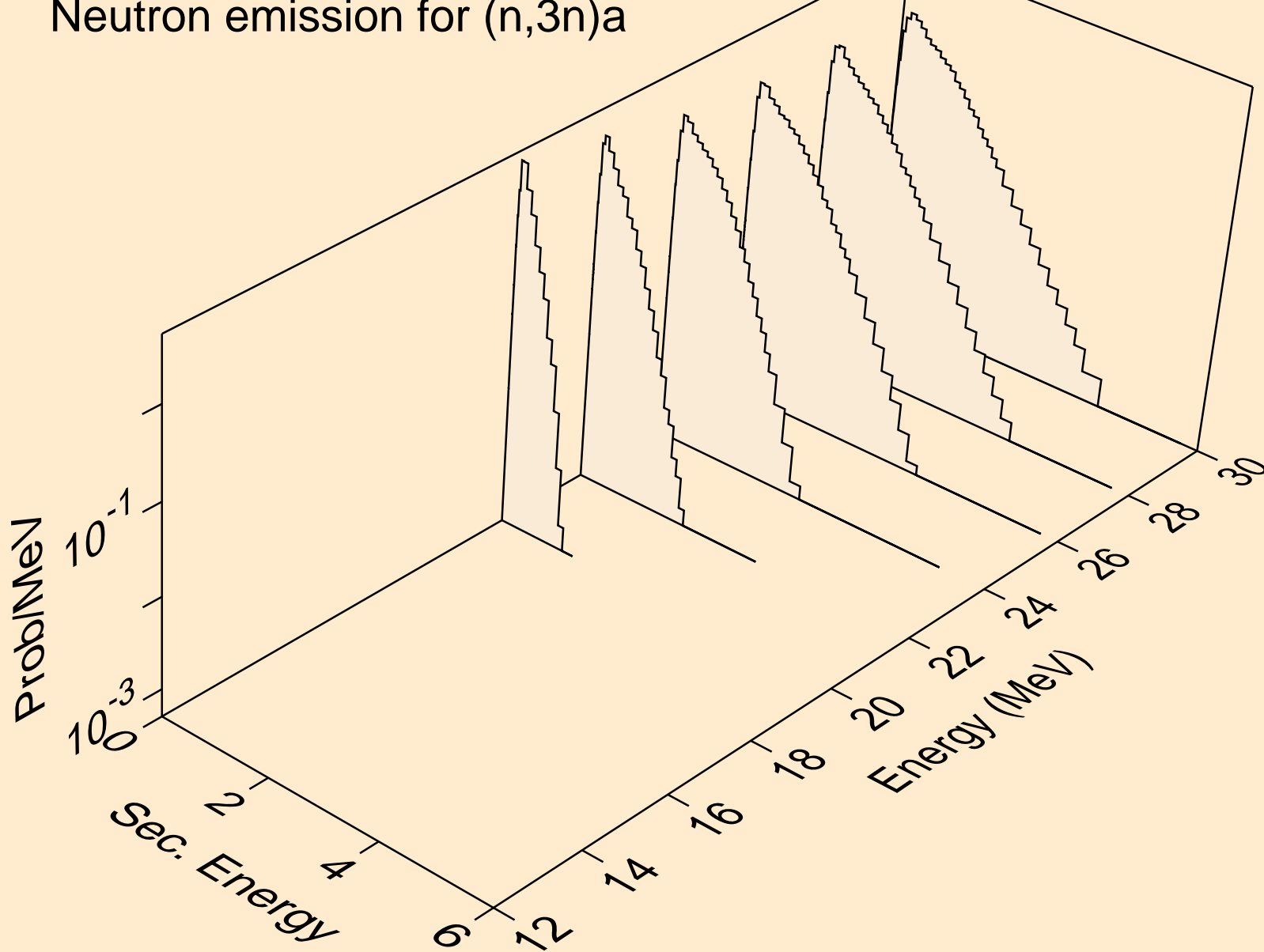

EU148 NEUTRON ACER TENDL-2023 LIBRARY; T=0.K  
Neutron emission for (n,n\*)p

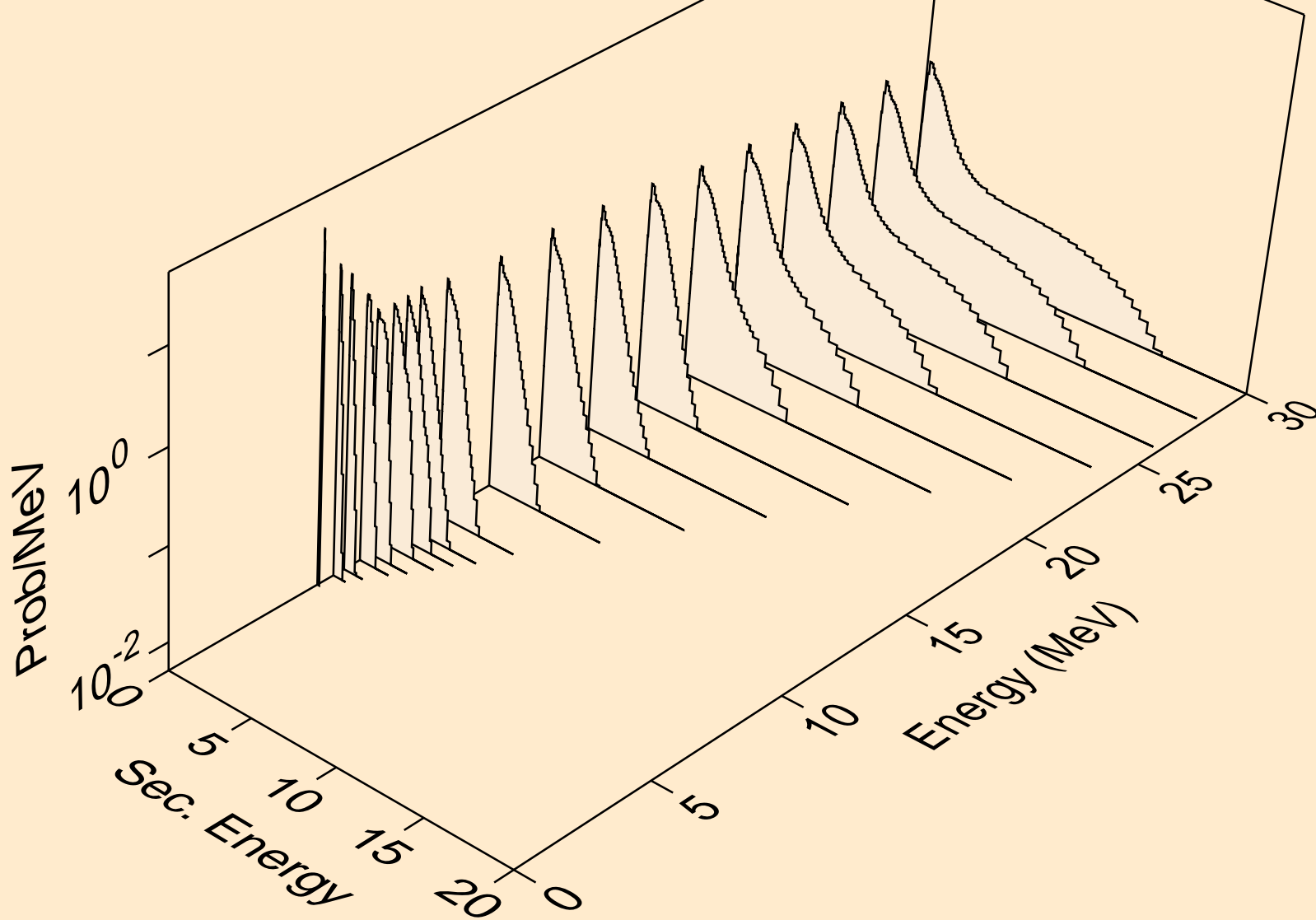

EU148 NEUTRON ACER TENDL-2023 LIBRARY; T=0.K  
Neutron emission for (n,n\*)2a

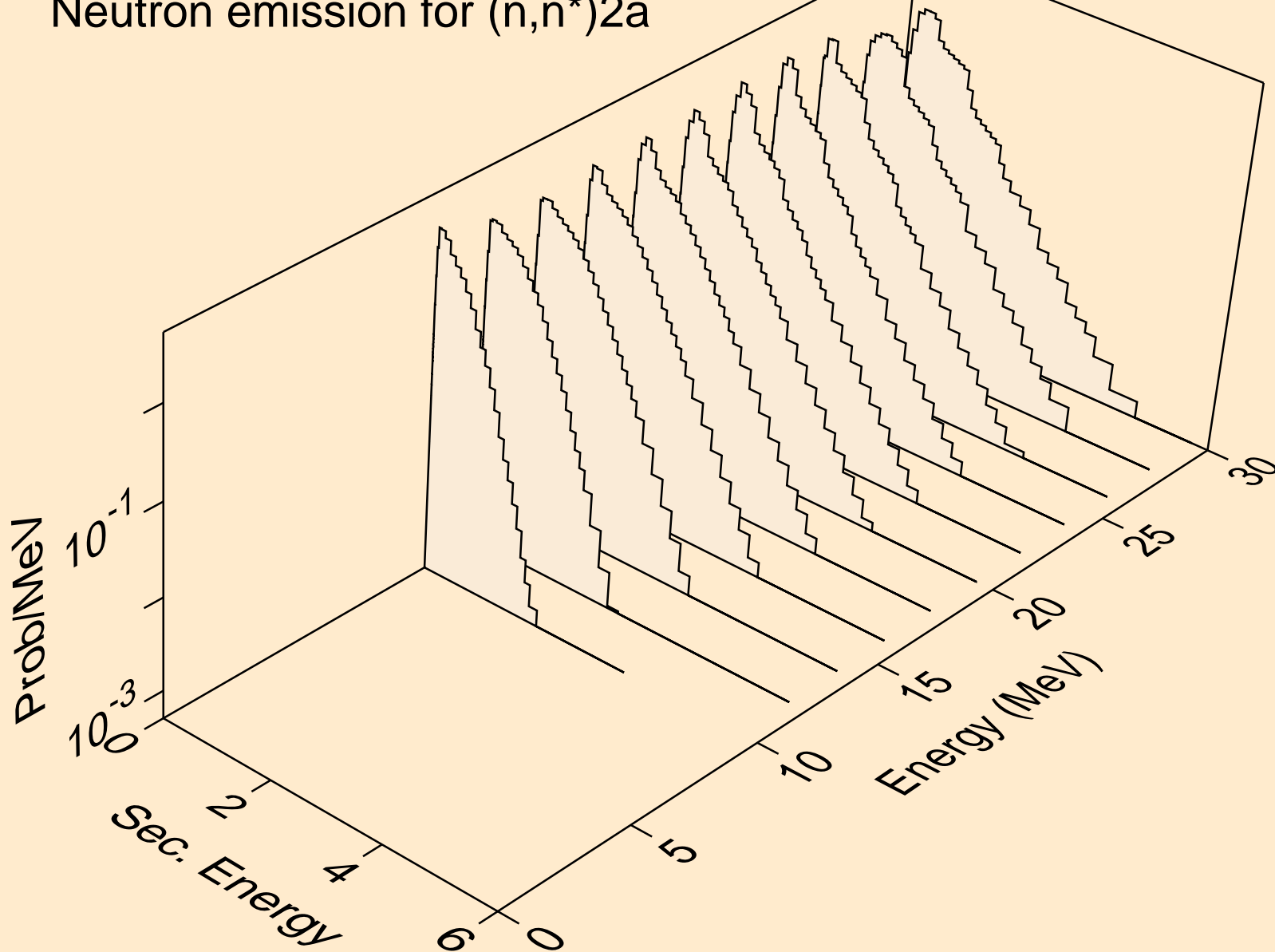

EU148 NEUTRON ACER TENDL-2023 LIBRARY; T=0.K  
Neutron emission for (n,2n)2a

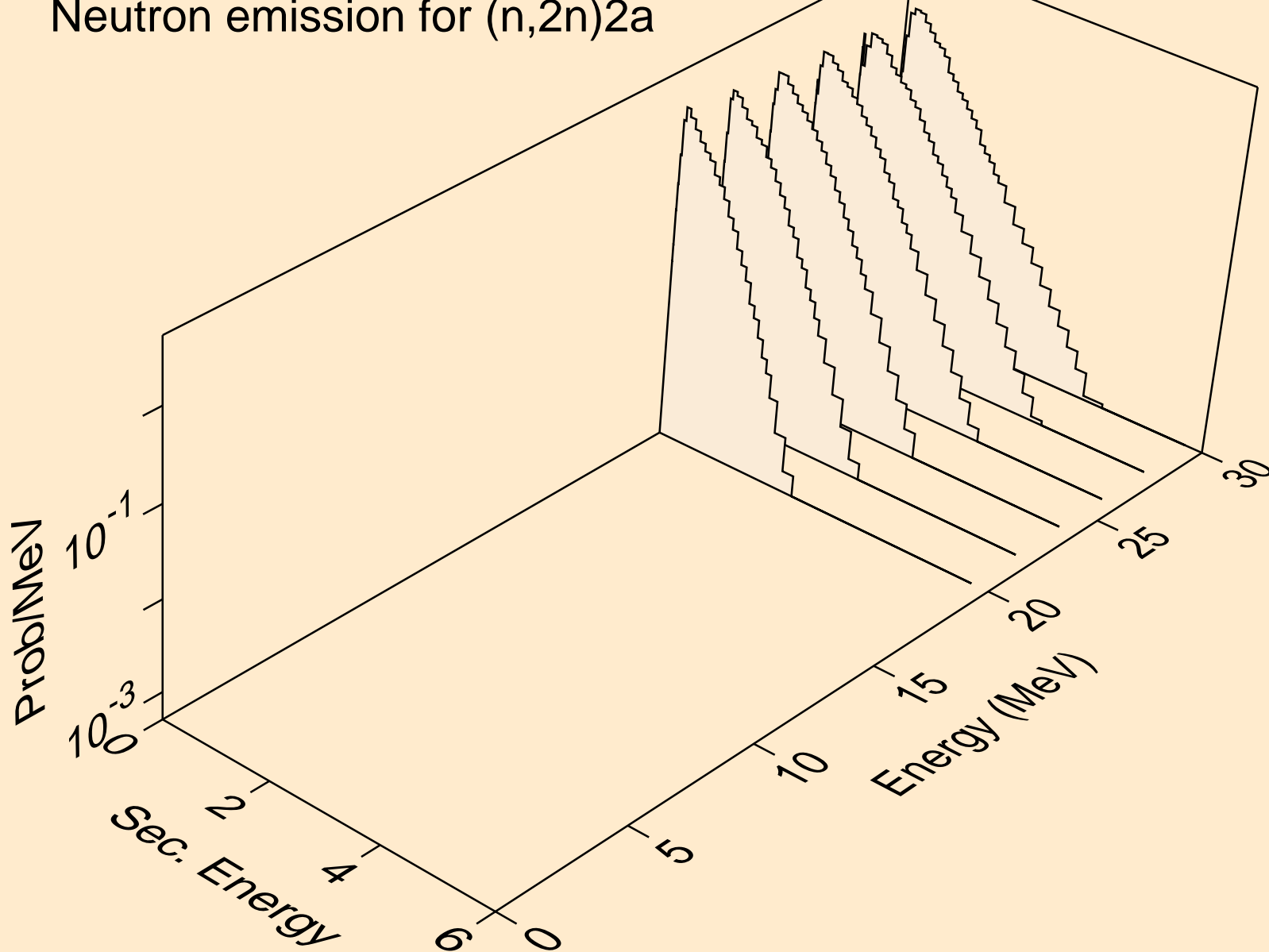

EU148 NEUTRON ACER TENDL-2023 LIBRARY; T=0.K  
Neutron emission for (n,n\*)d

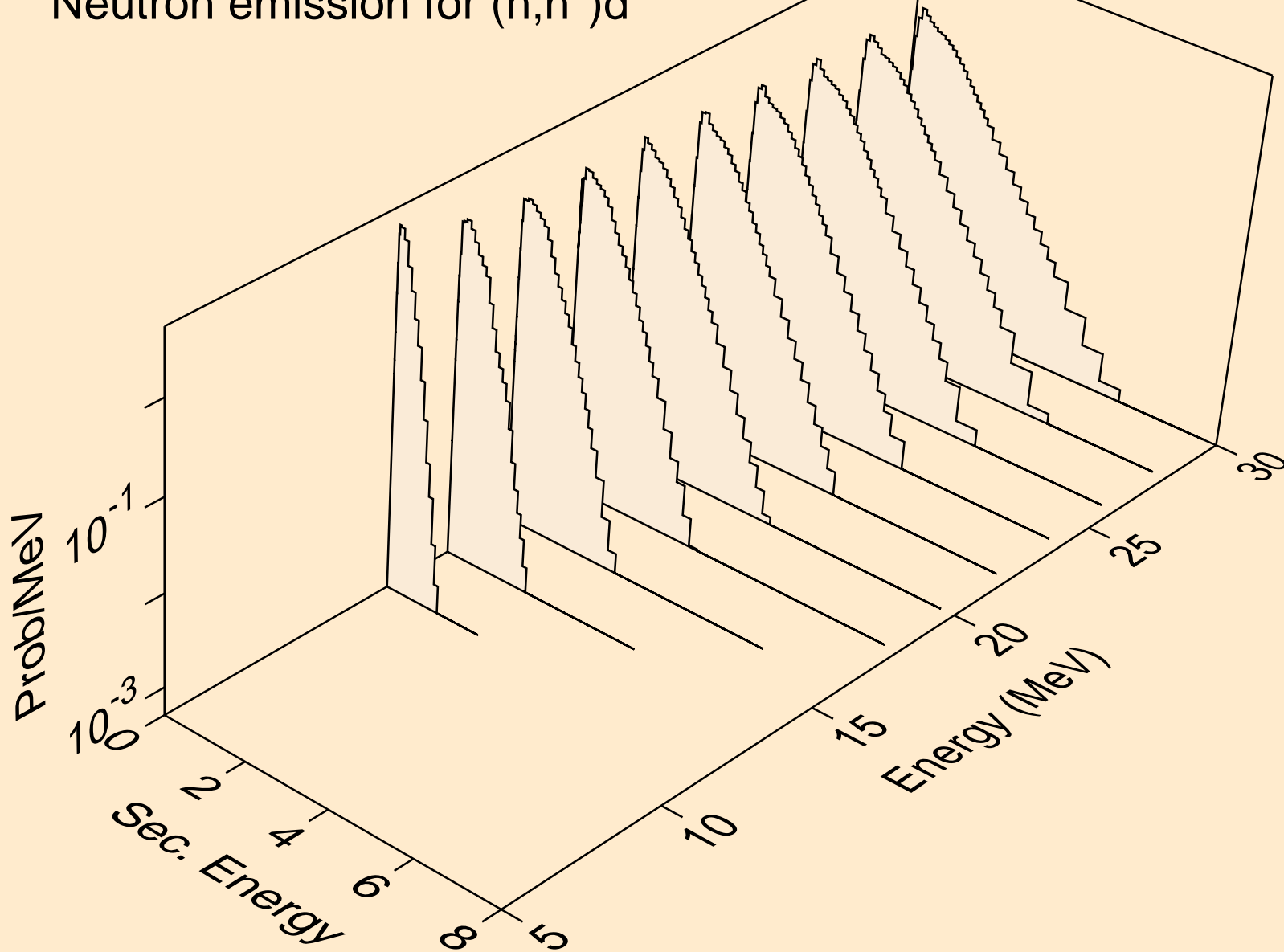

EU148 NEUTRON ACER TENDL-2023 LIBRARY; T=0.K  
Neutron emission for (n,n\*)t

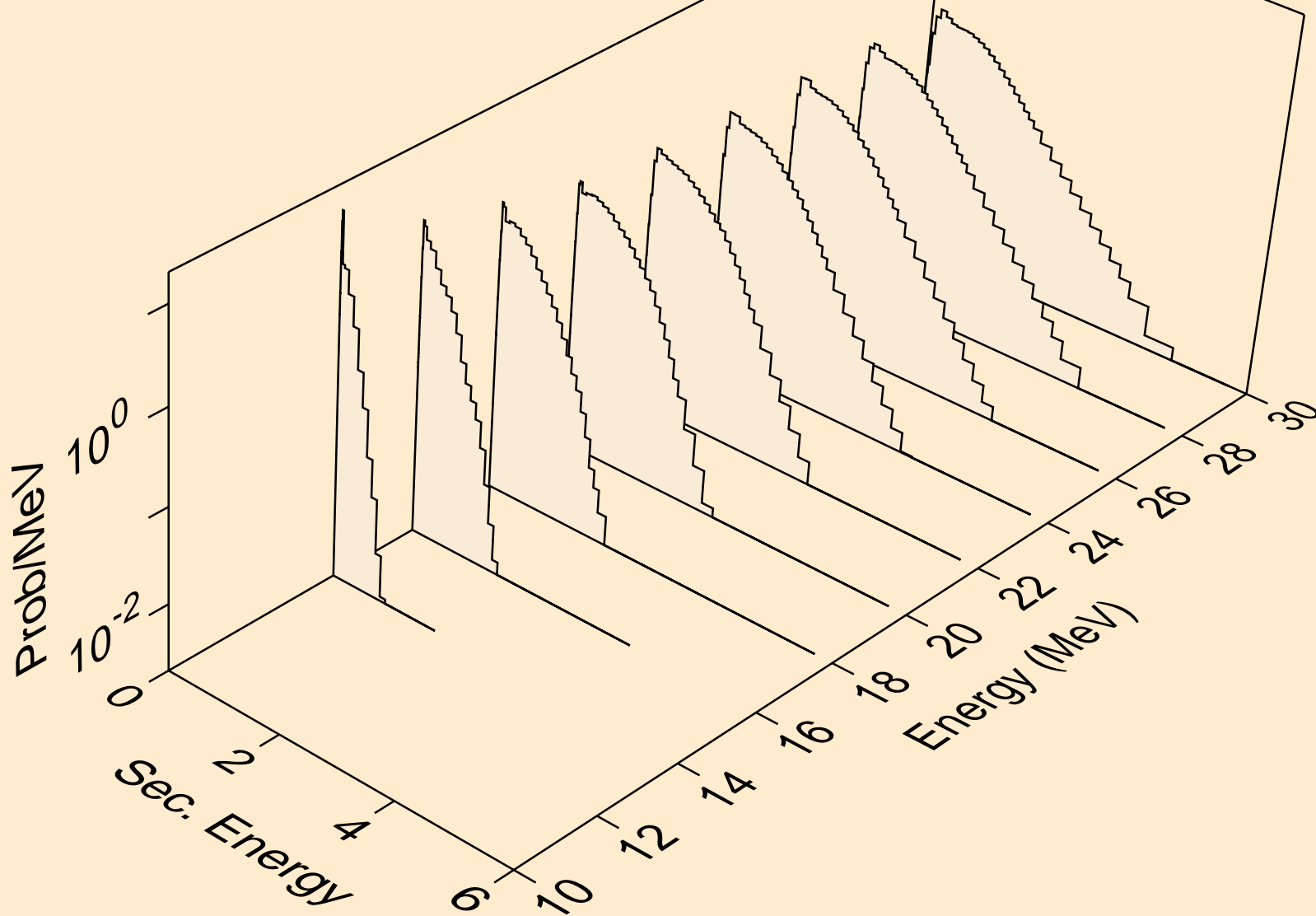

EU148 NEUTRON ACER TENDL-2023 LIBRARY; T=0.K  
Neutron emission for (n,n\*)he3

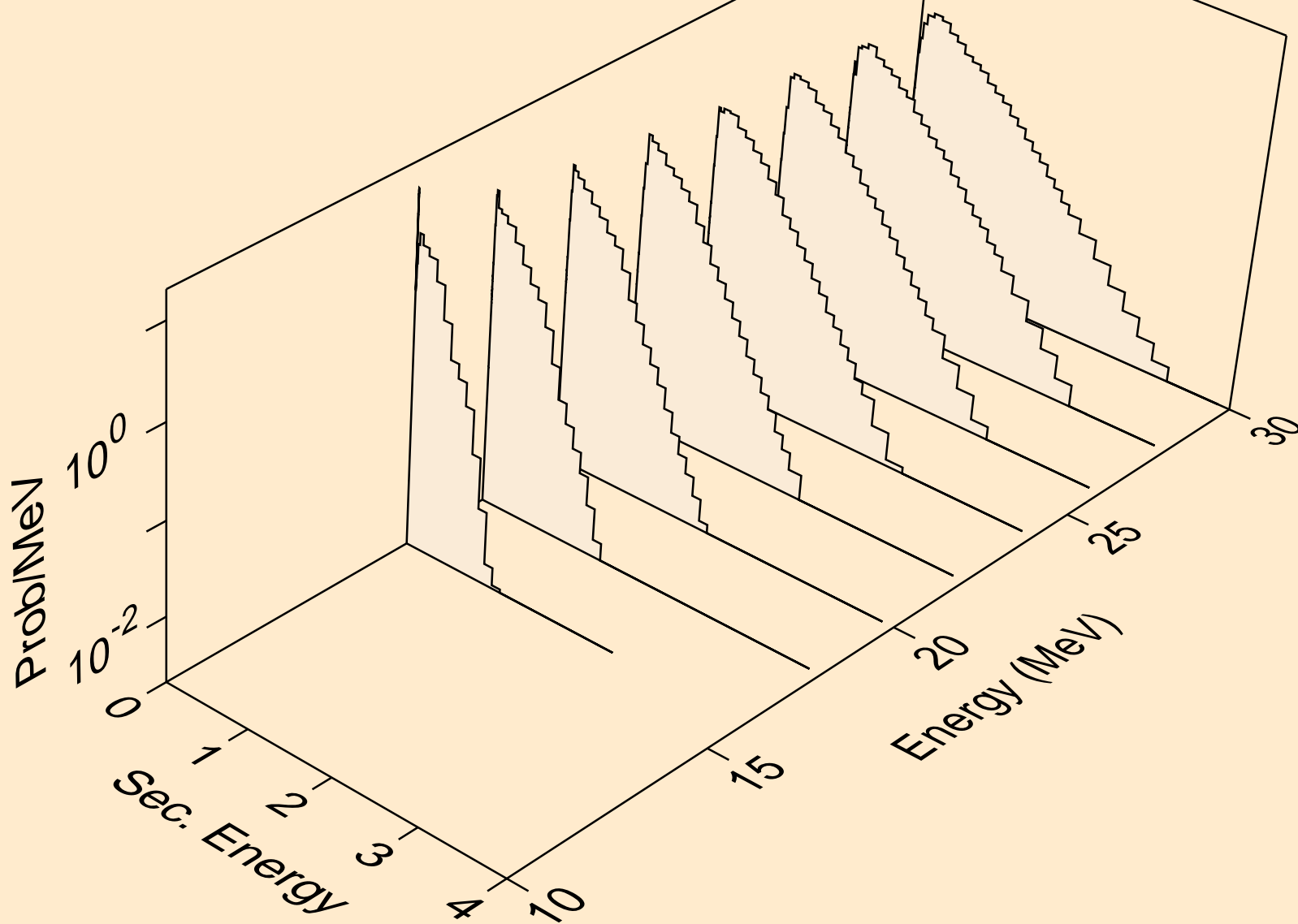

EU148 NEUTRON ACER TENDL-2023 LIBRARY; T=0.K  
Neutron emission for (n,4n)

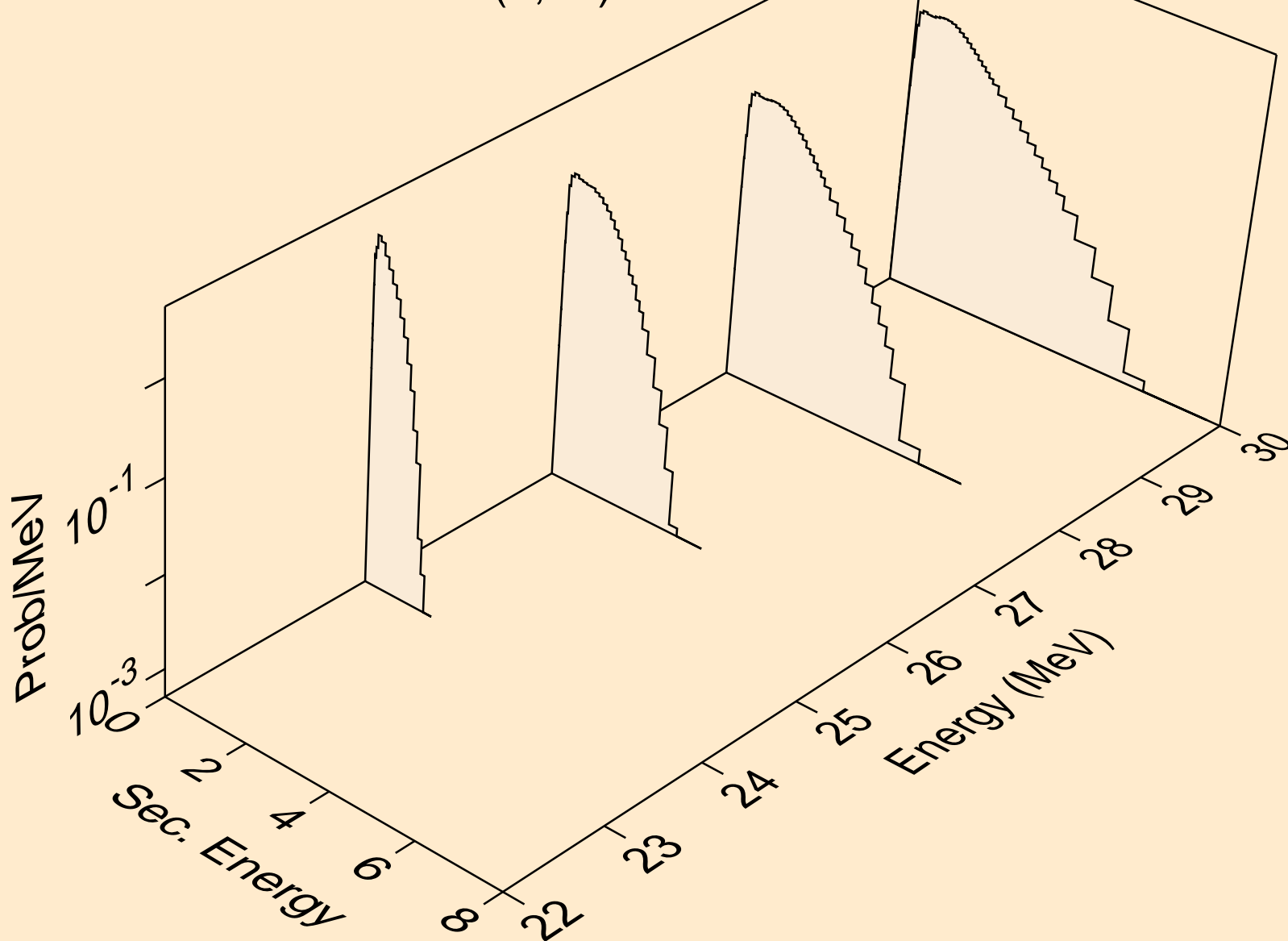



EU148 NEUTRON ACER TENDL-2023 LIBRARY; T=0.K  
Neutron emission for (n,2np)

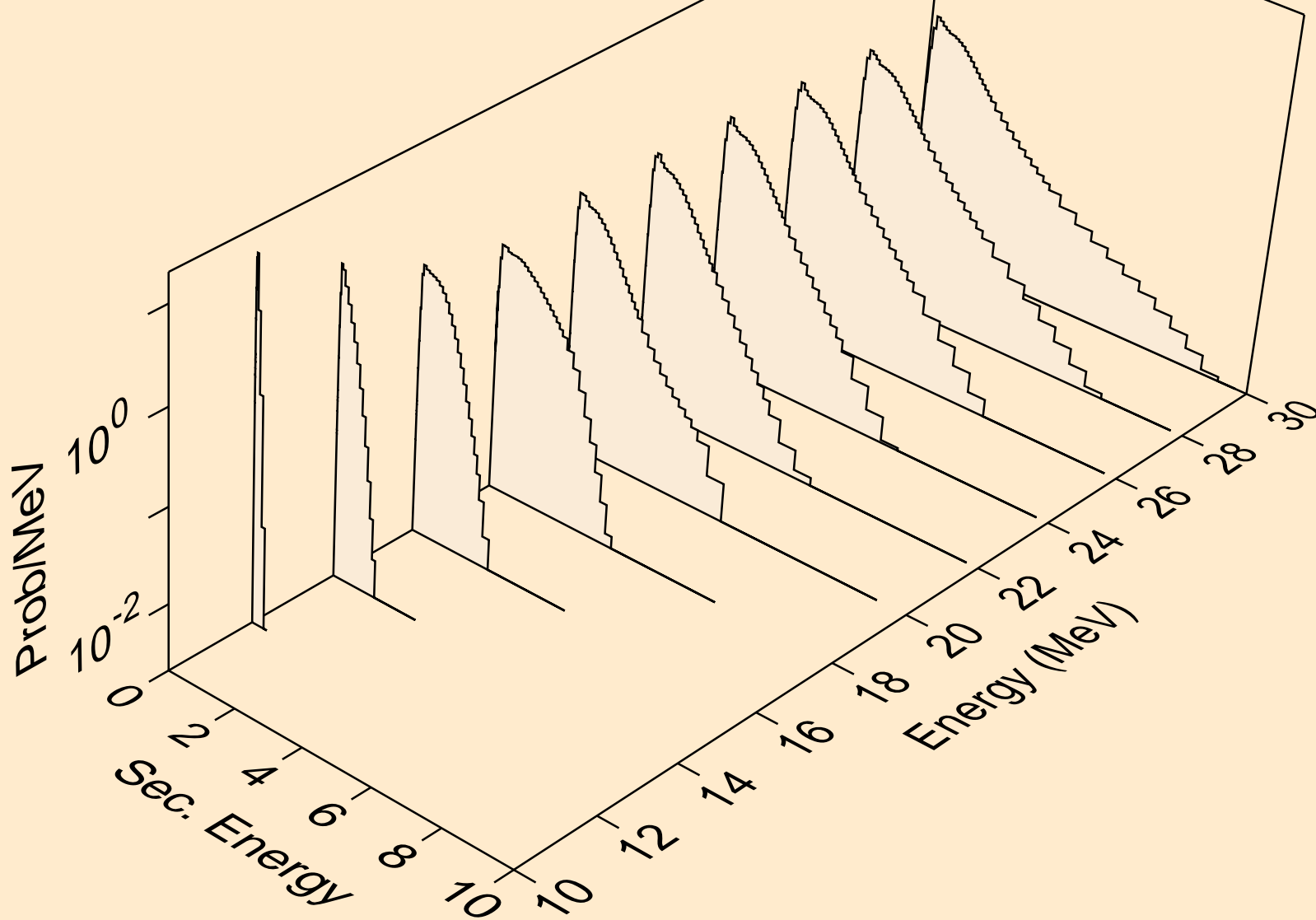

EU148 NEUTRON ACER TENDL-2023 LIBRARY; T=0.K  
Neutron emission for (n,3np)

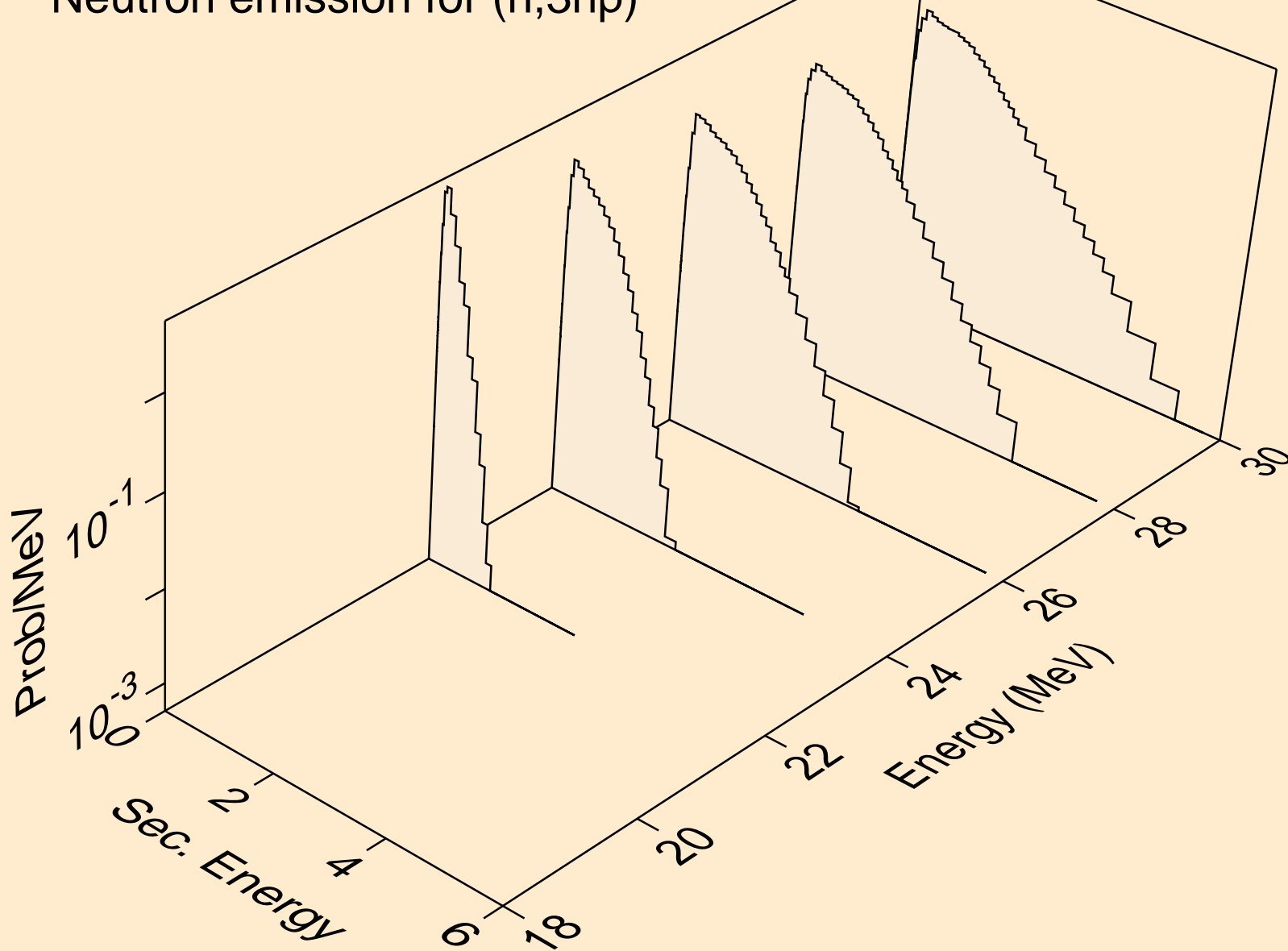

EU148 NEUTRON ACER TENDL-2023 LIBRARY; T=0.K  
Neutron emission for (n,n2p)

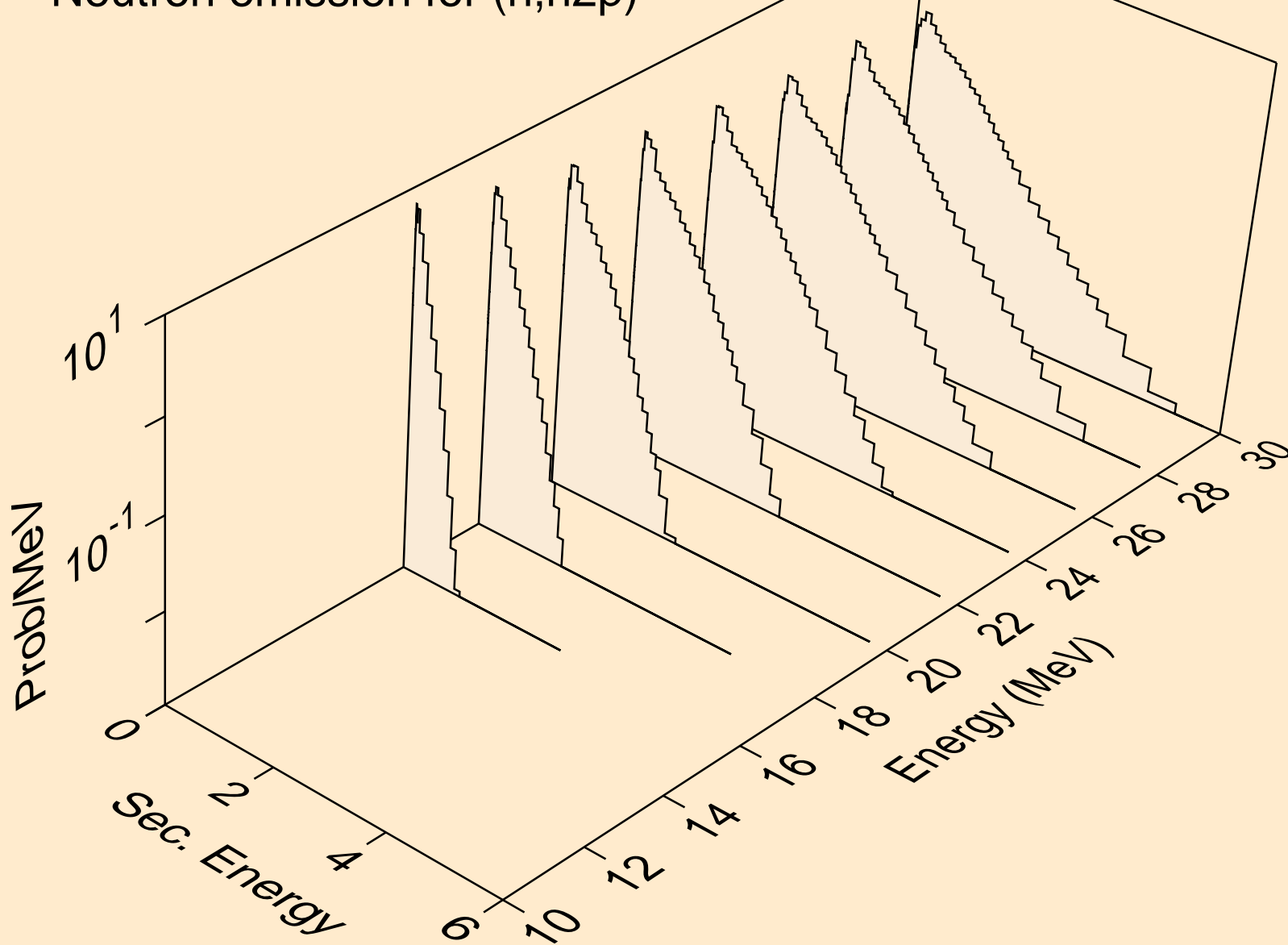

EU148 NEUTRON ACER TENDL-2023 LIBRARY; T=0.K  
Neutron emission for (n,npa)

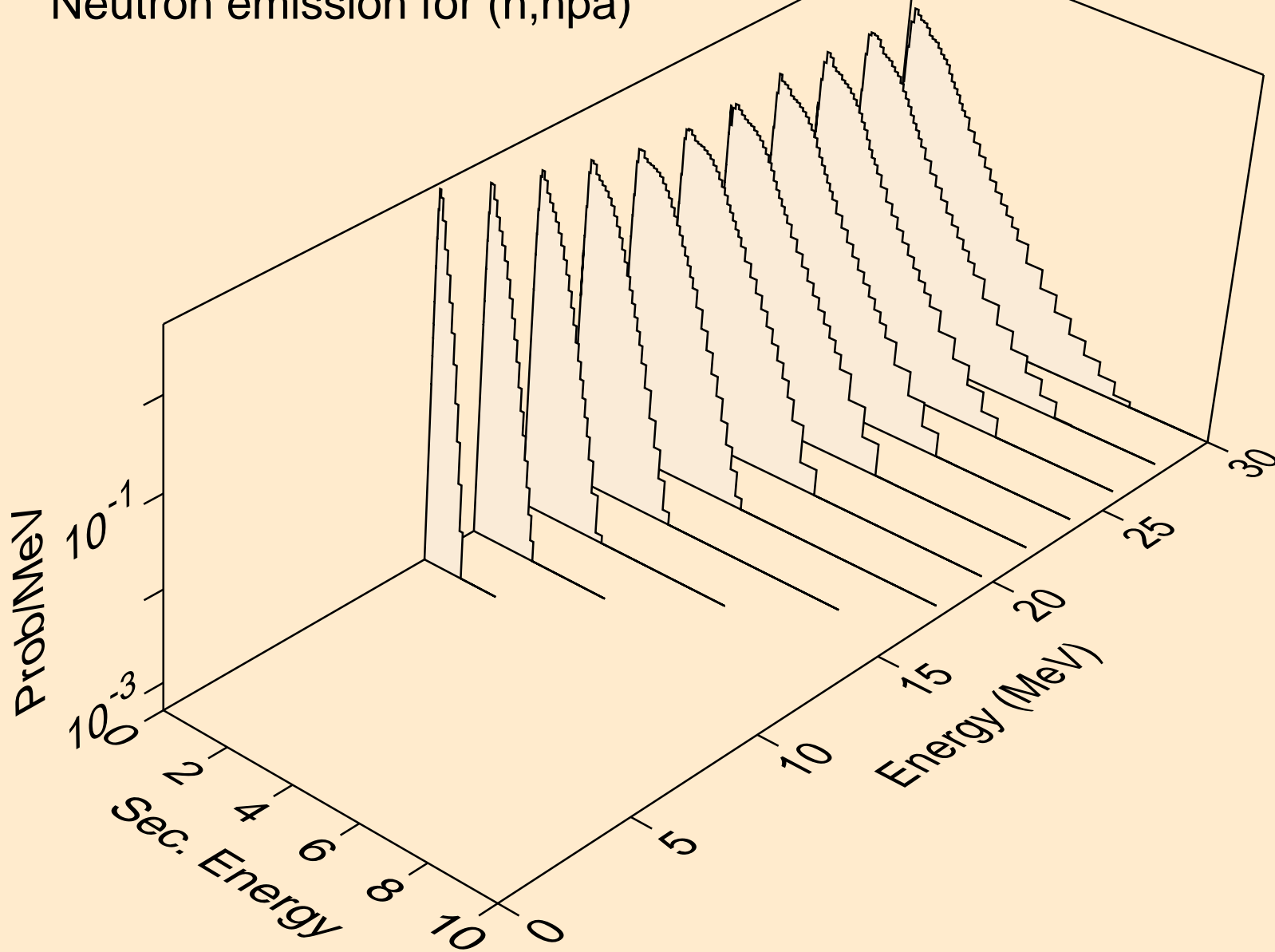

EU148 NEUTRON ACER TENDL-2023 LIBRARY; T=0.K  
Neutron emission for (n,n\*c)

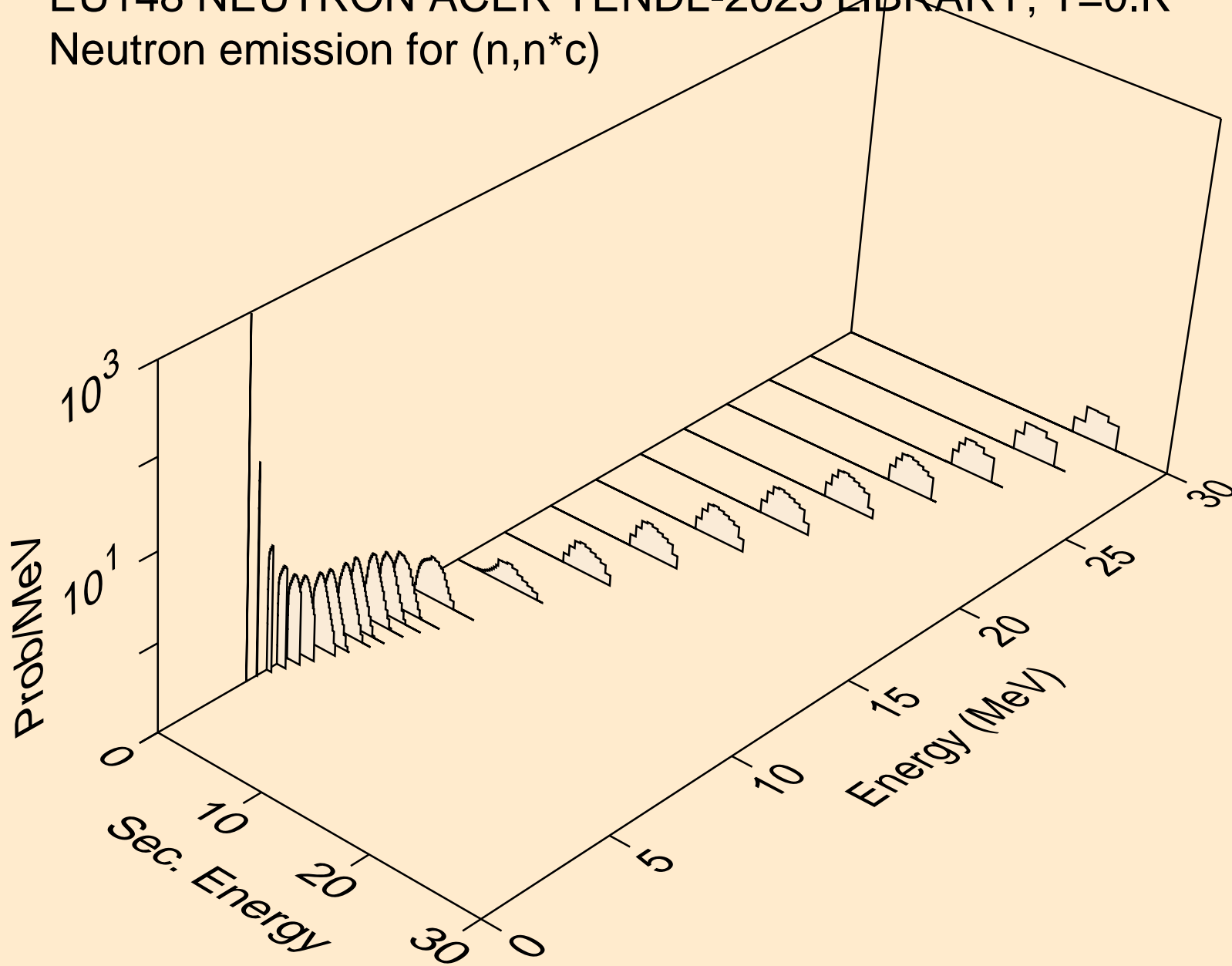

EU148 NEUTRON ACER TENDL-2023 LIBRARY; T=0.K  
Photon emission for (n,x)

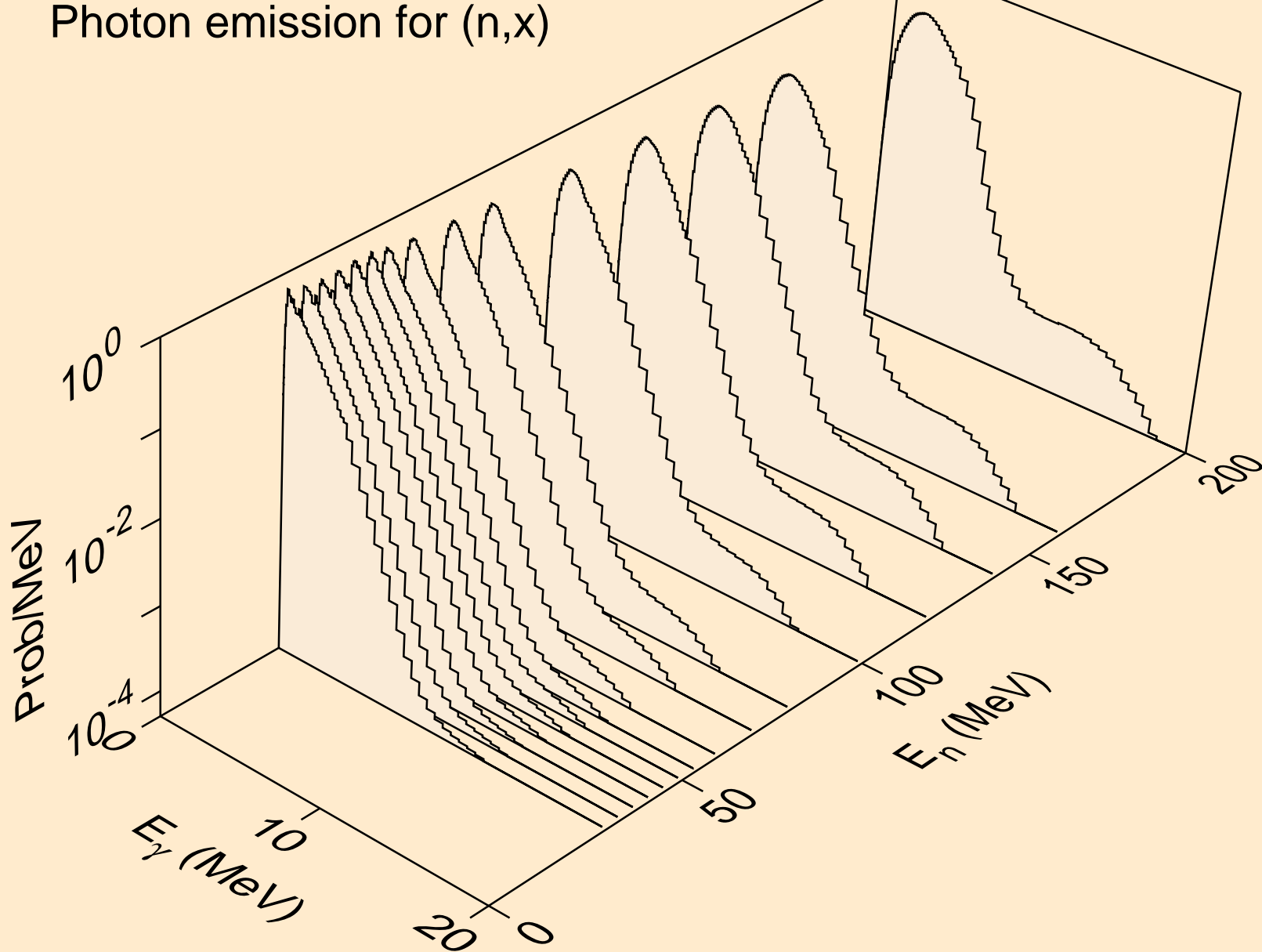

EU148 NEUTRON ACER TENDL-2023 LIBRARY; T=0.K  
Photon emission for (n,2nd)

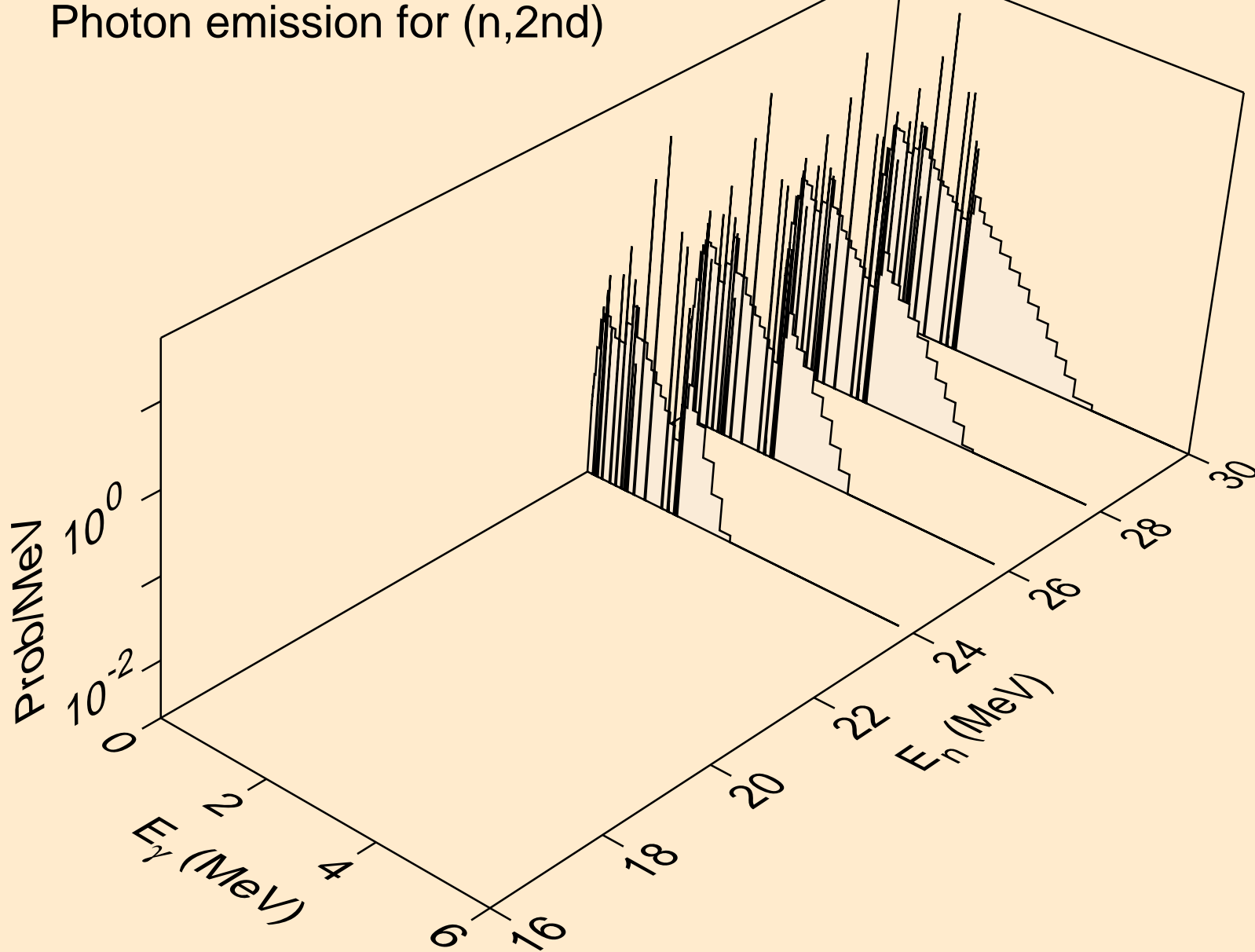

EU148 NEUTRON ACER TENDL-2023 LIBRARY; T=0.K  
Photon emission for (n,2n)

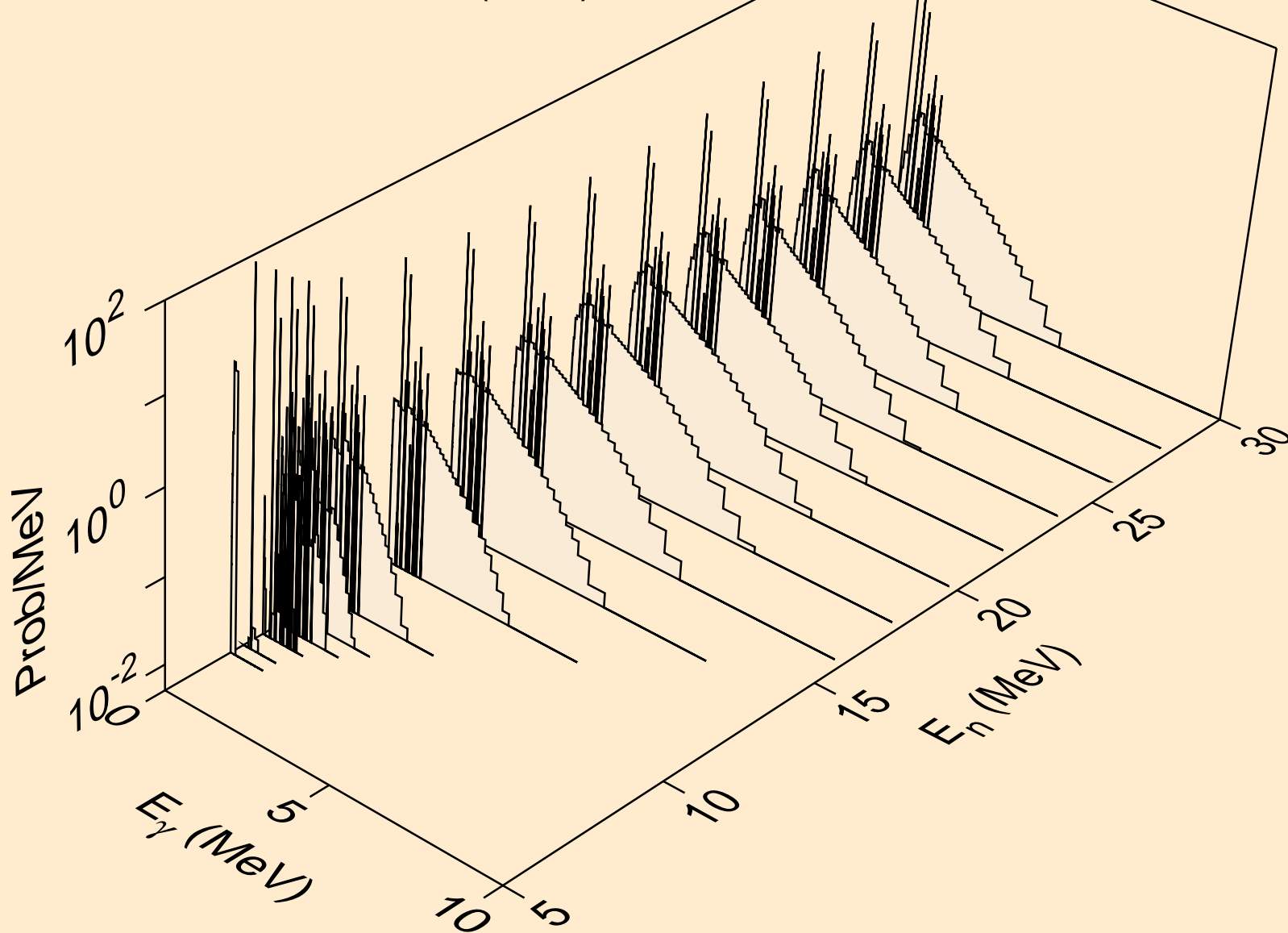



EU148 NEUTRON ACER TENDL-2023 LIBRARY; T=0.K  
Photon emission for (n,3n)

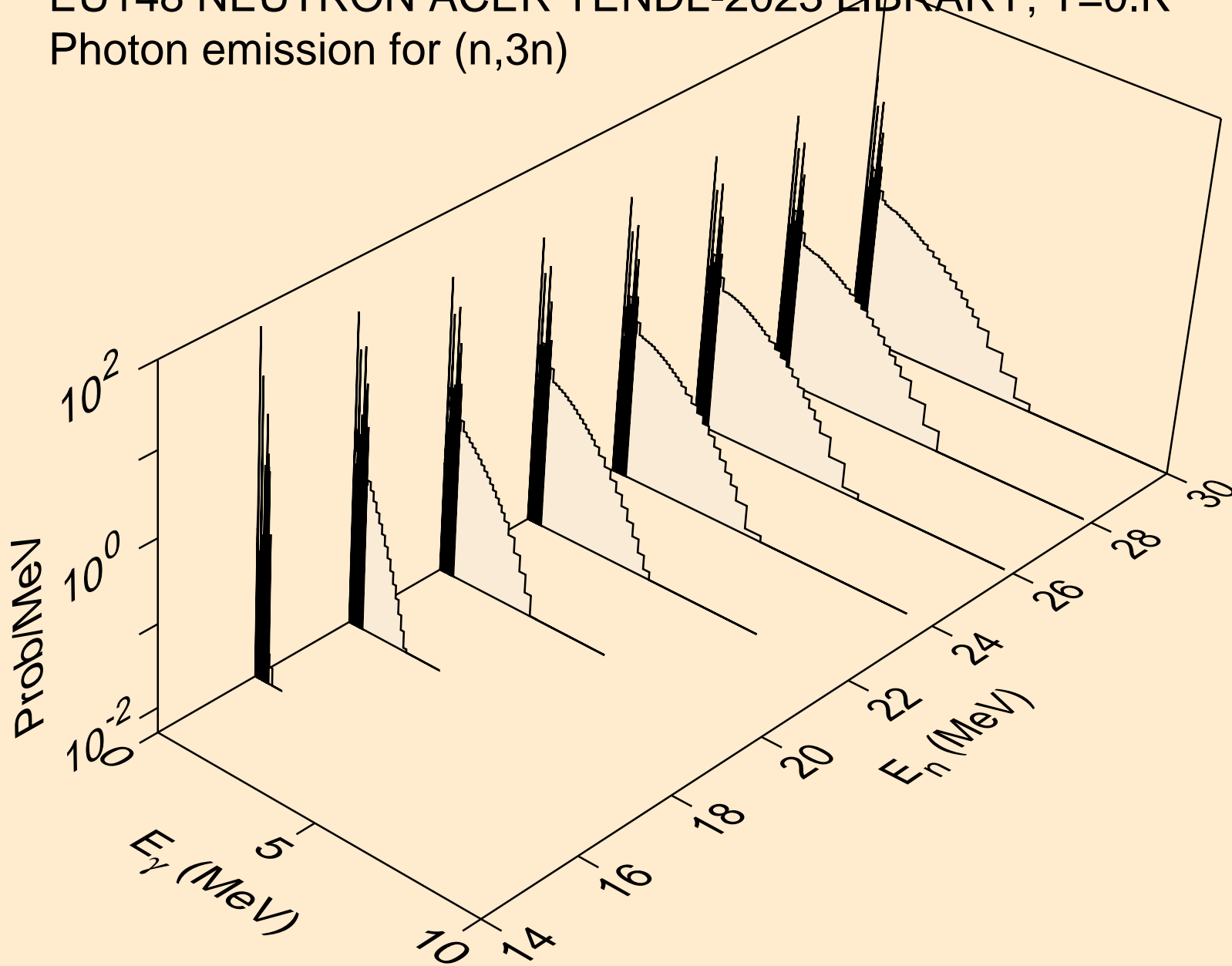

EU148 NEUTRON ACER TENDL-2023 LIBRARY; T=0.K  
Photon emission for (n,n\*)a

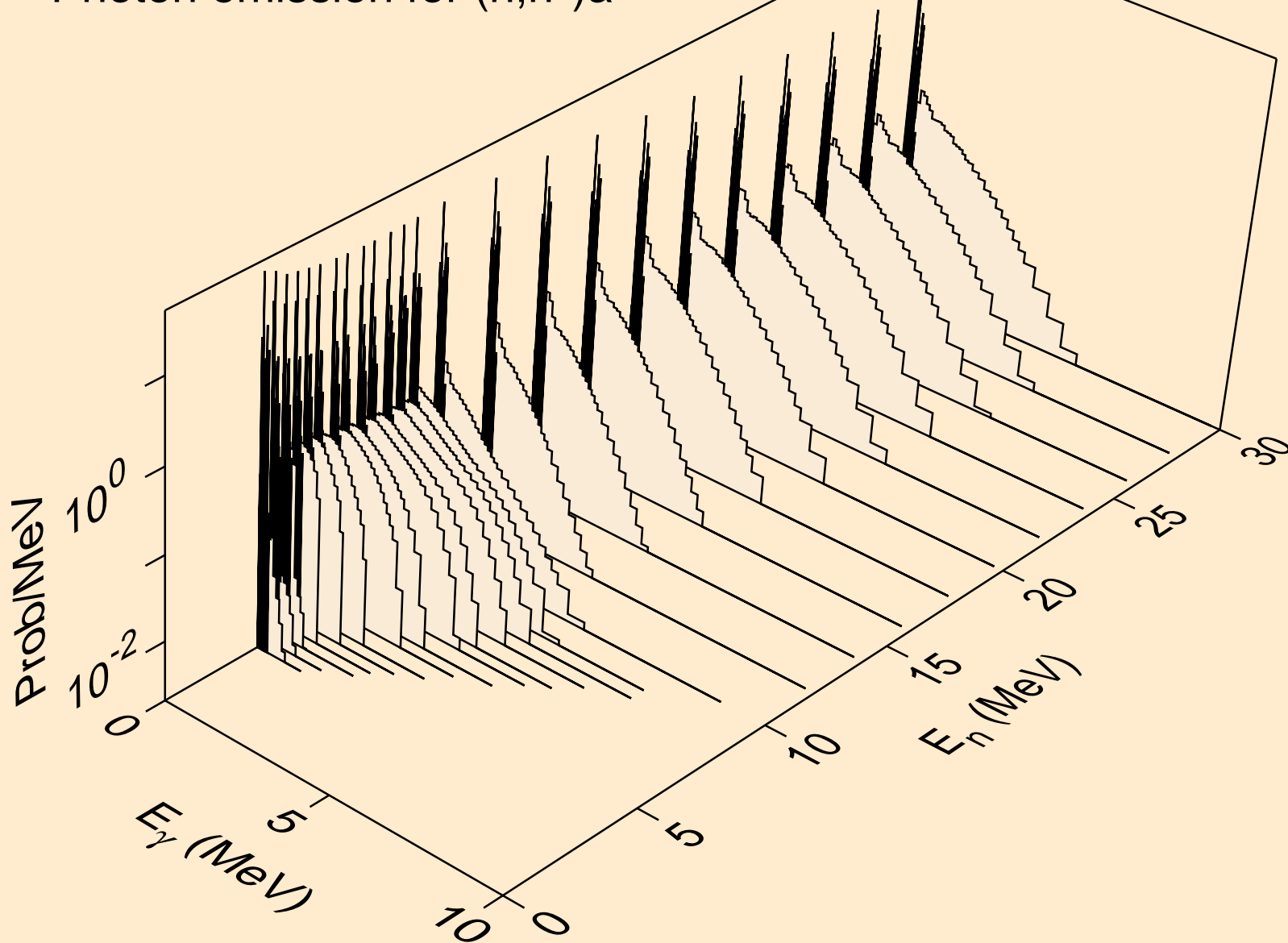

EU148 NEUTRON ACER TENDL-2023 LIBRARY; T=0.K  
Photon emission for (n,2n)a

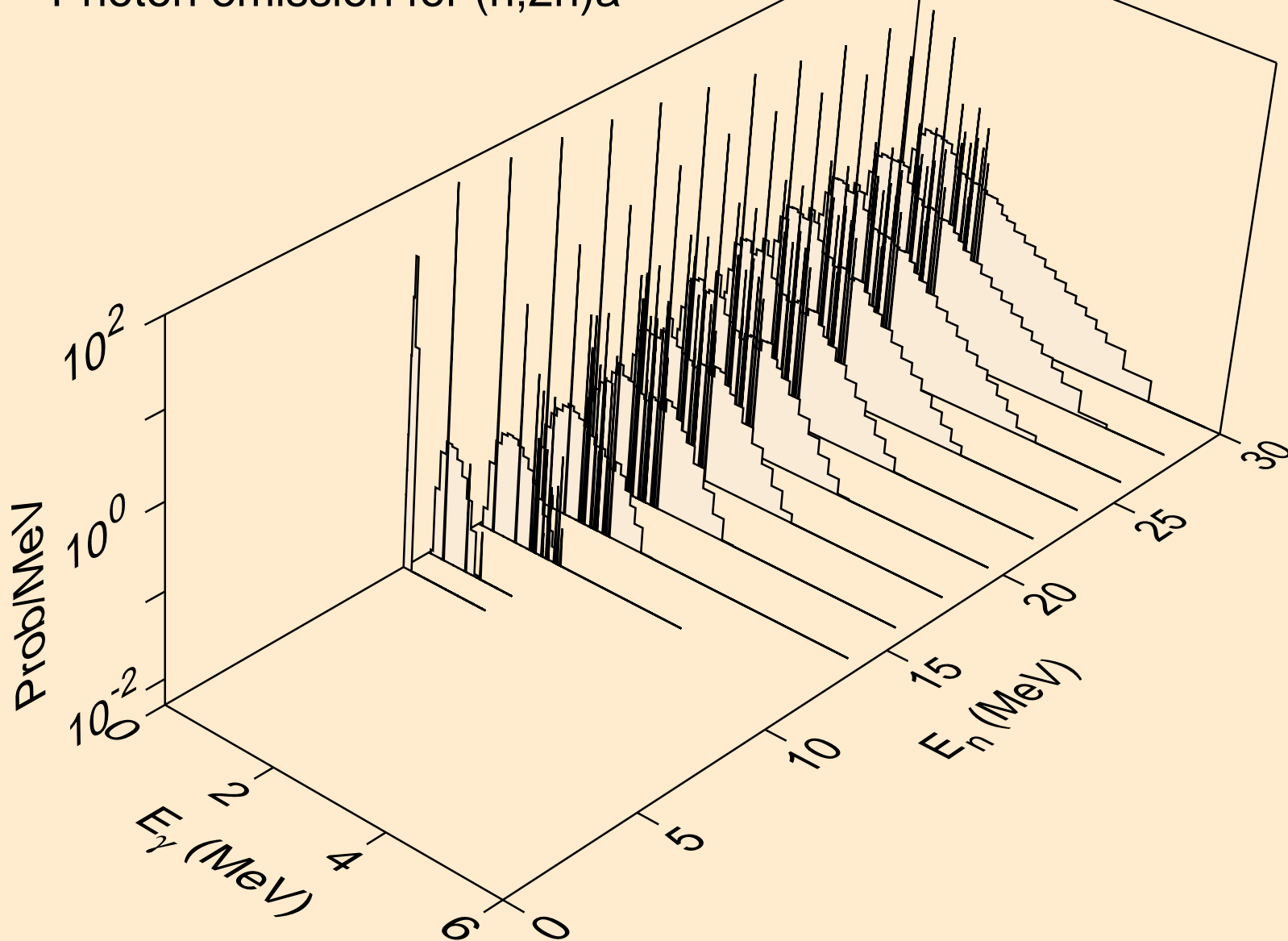

EU148 NEUTRON ACER TENDL-2023 LIBRARY; T=0.K  
Photon emission for (n,3n)a

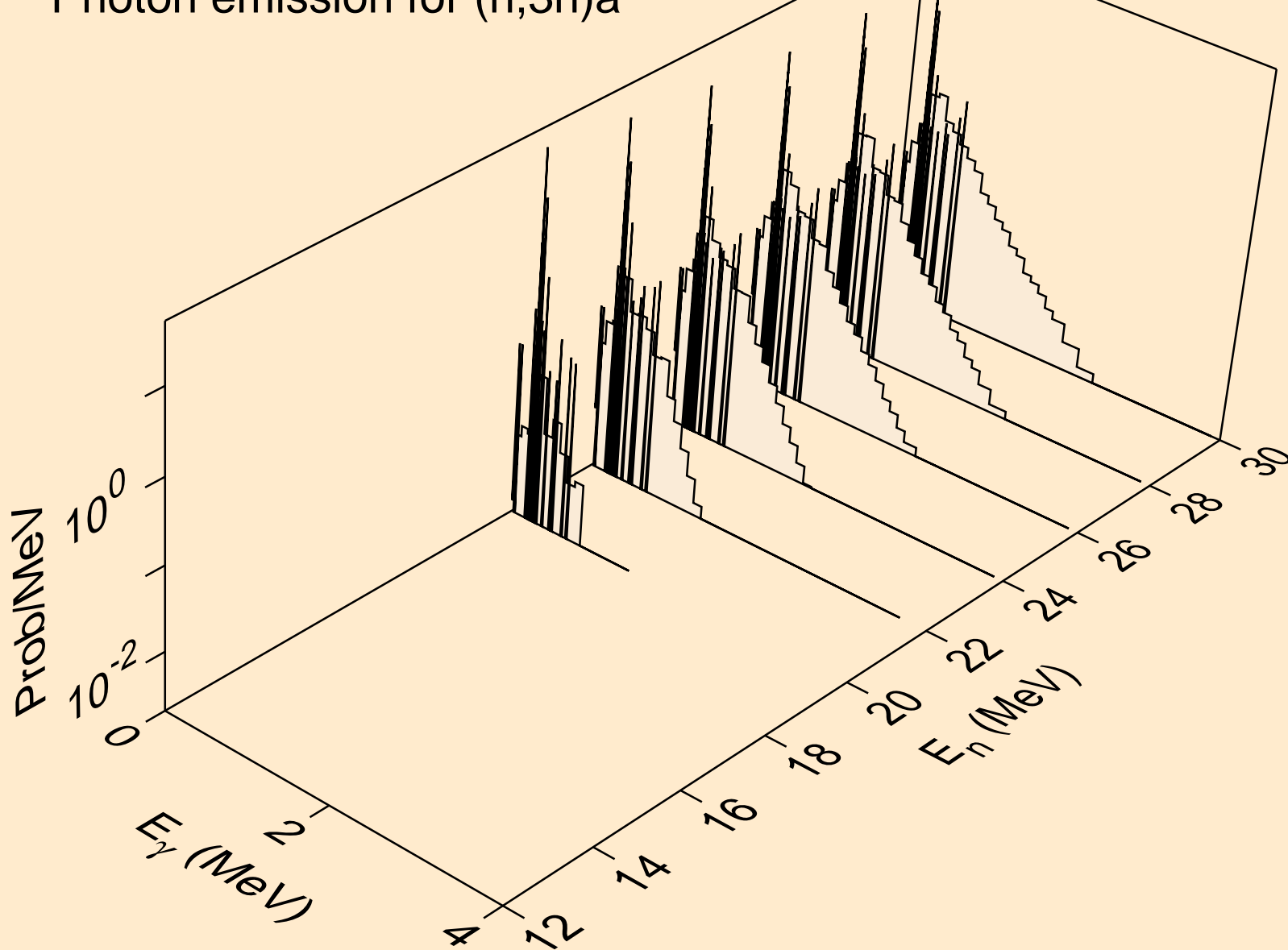

EU148 NEUTRON ACER TENDL-2023 LIBRARY; T=0.K  
Photon emission for (n,n\*)p

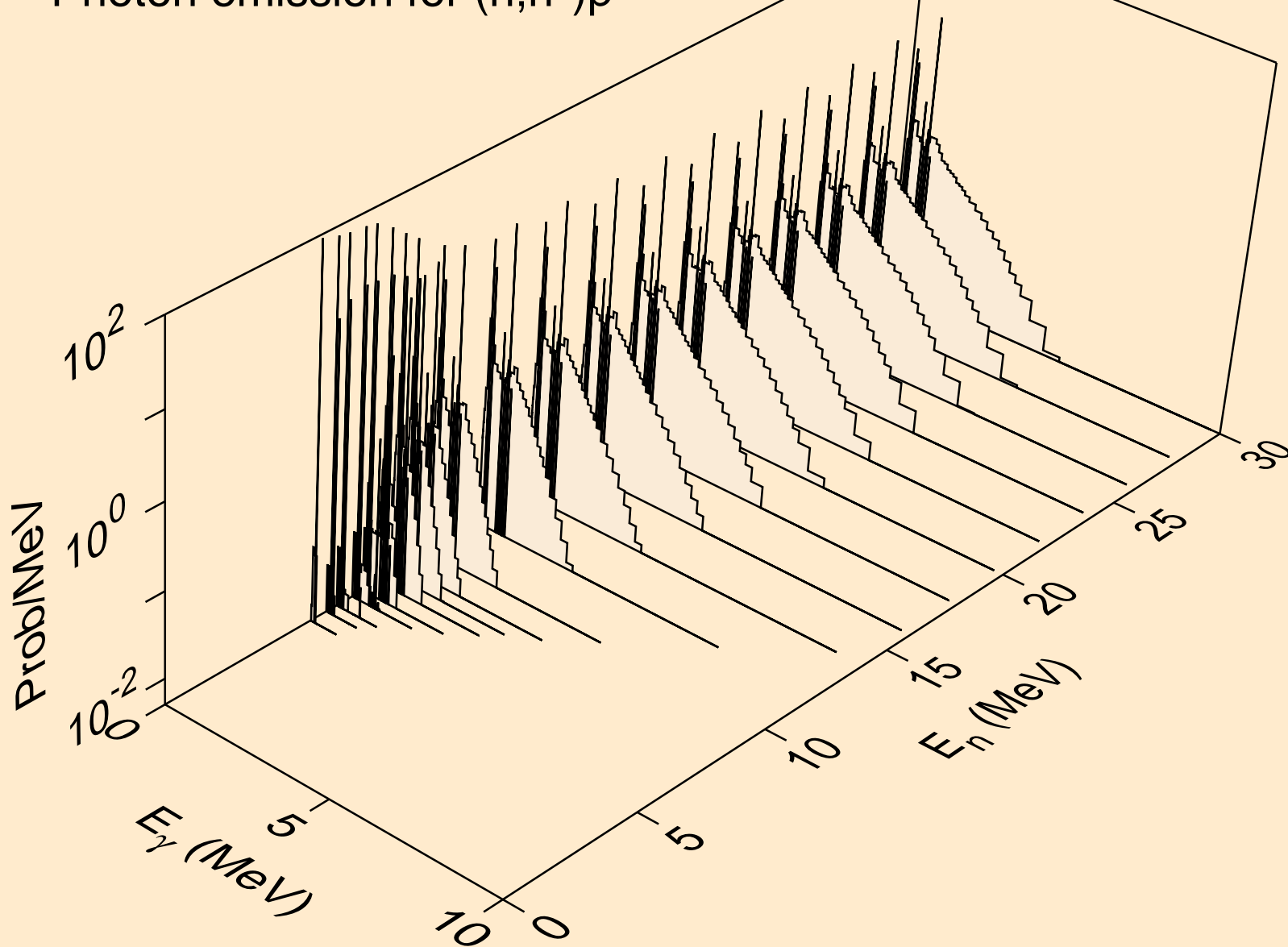

EU148 NEUTRON ACER TENDL-2023 LIBRARY; T=0.K  
Photon emission for (n,n\*)2a

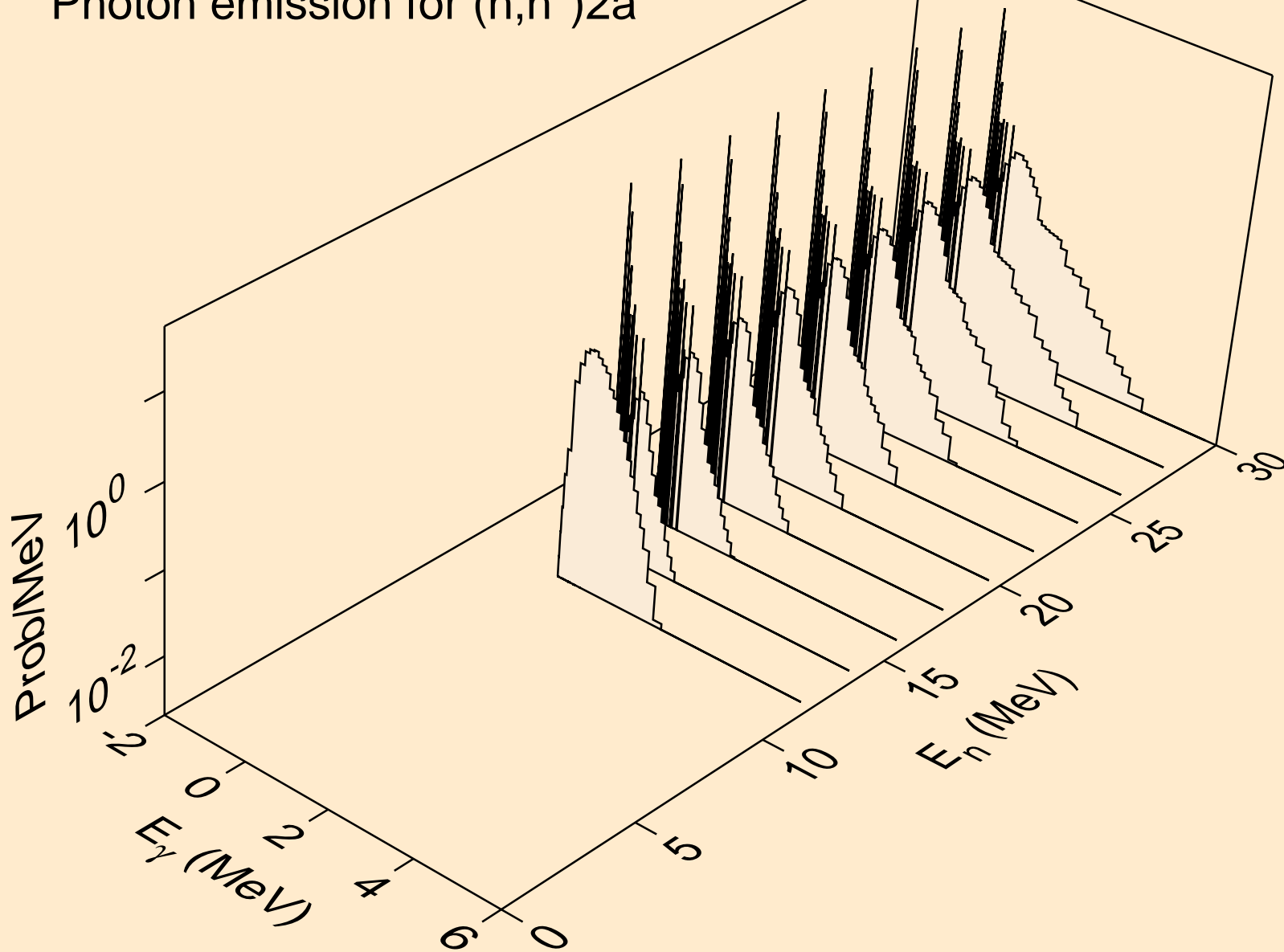

EU148 NEUTRON ACER TENDL-2023 LIBRARY; T=0.K  
Photon emission for (n,2n)2a

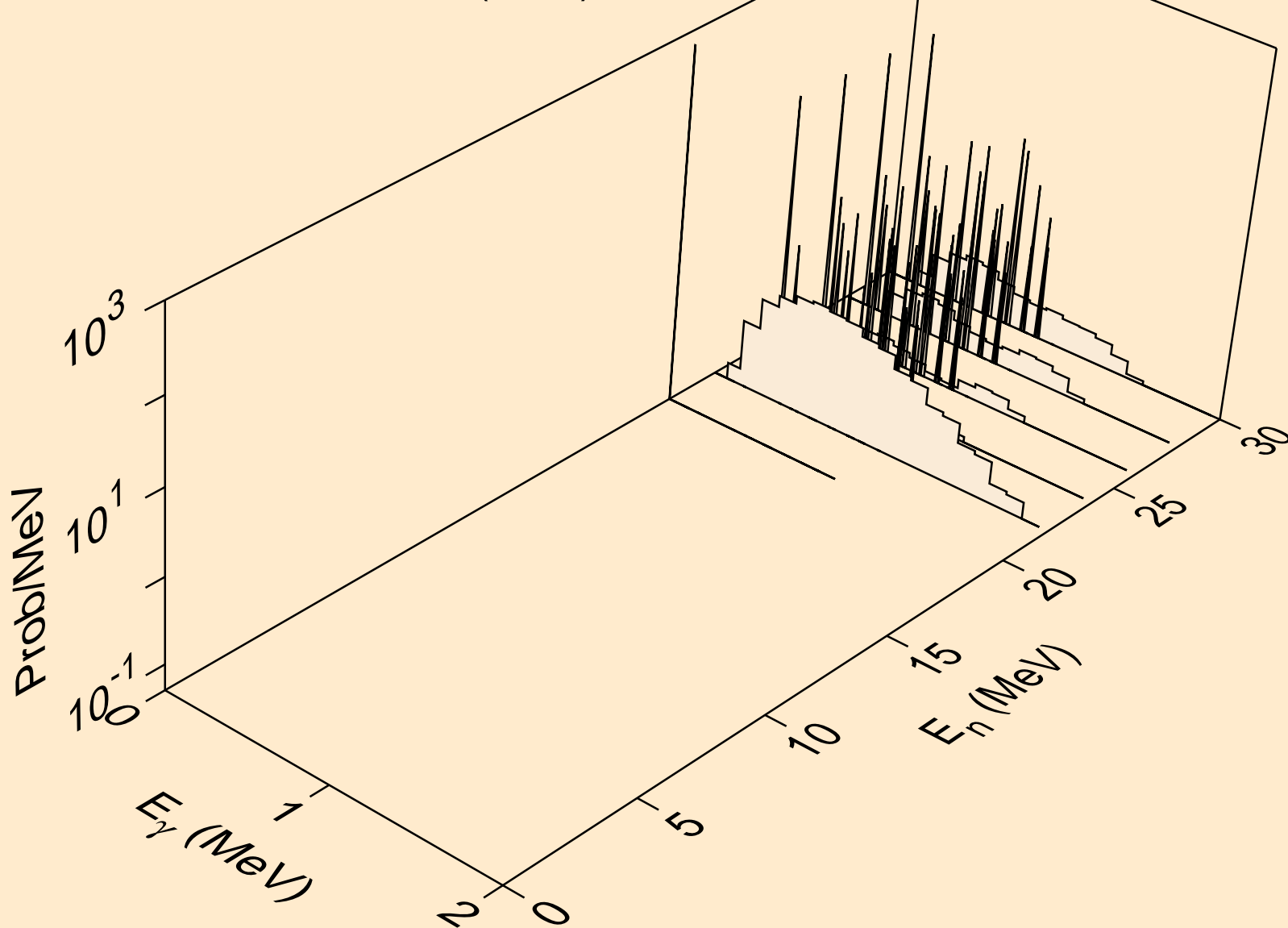

EU148 NEUTRON ACER TENDL-2023 LIBRARY; T=0.K  
Photon emission for (n,n\*)d

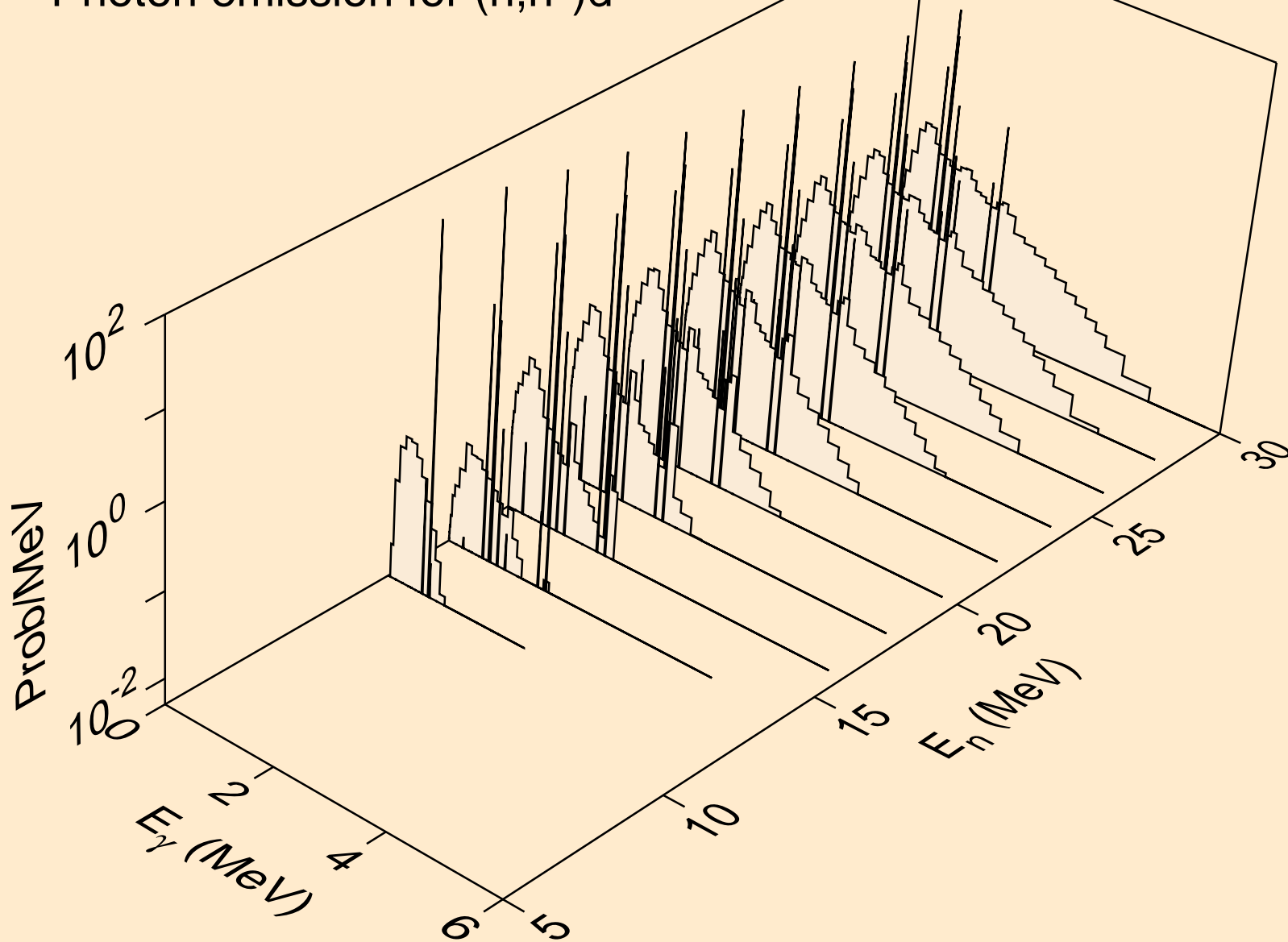



EU148 NEUTRON ACER TENDL-2023 LIBRARY; T=0.K  
Photon emission for (n,n\*)t

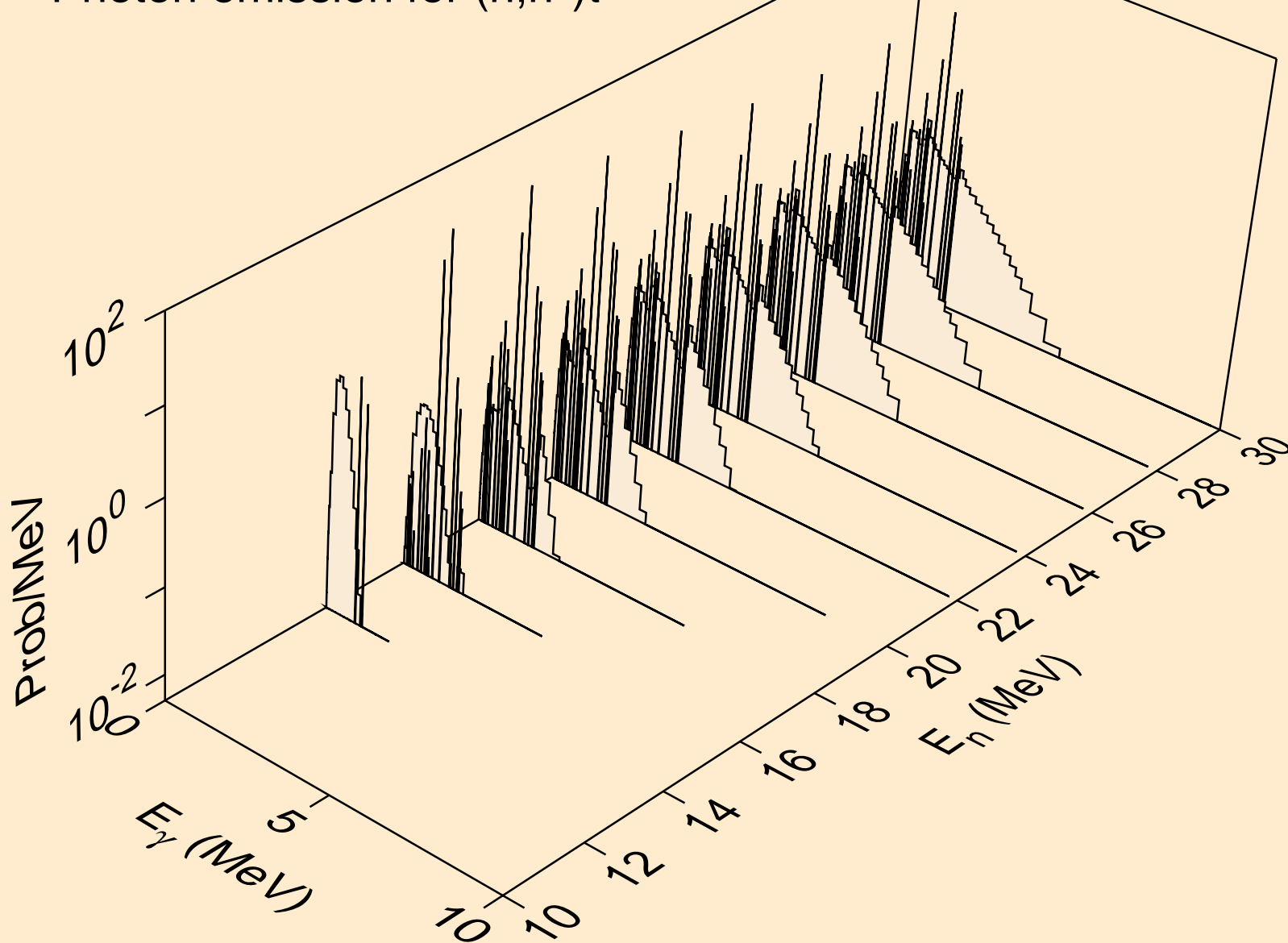

EU148 NEUTRON ACER TENDL-2023 LIBRARY; T=0.K  
Photon emission for (n,n\*)he3

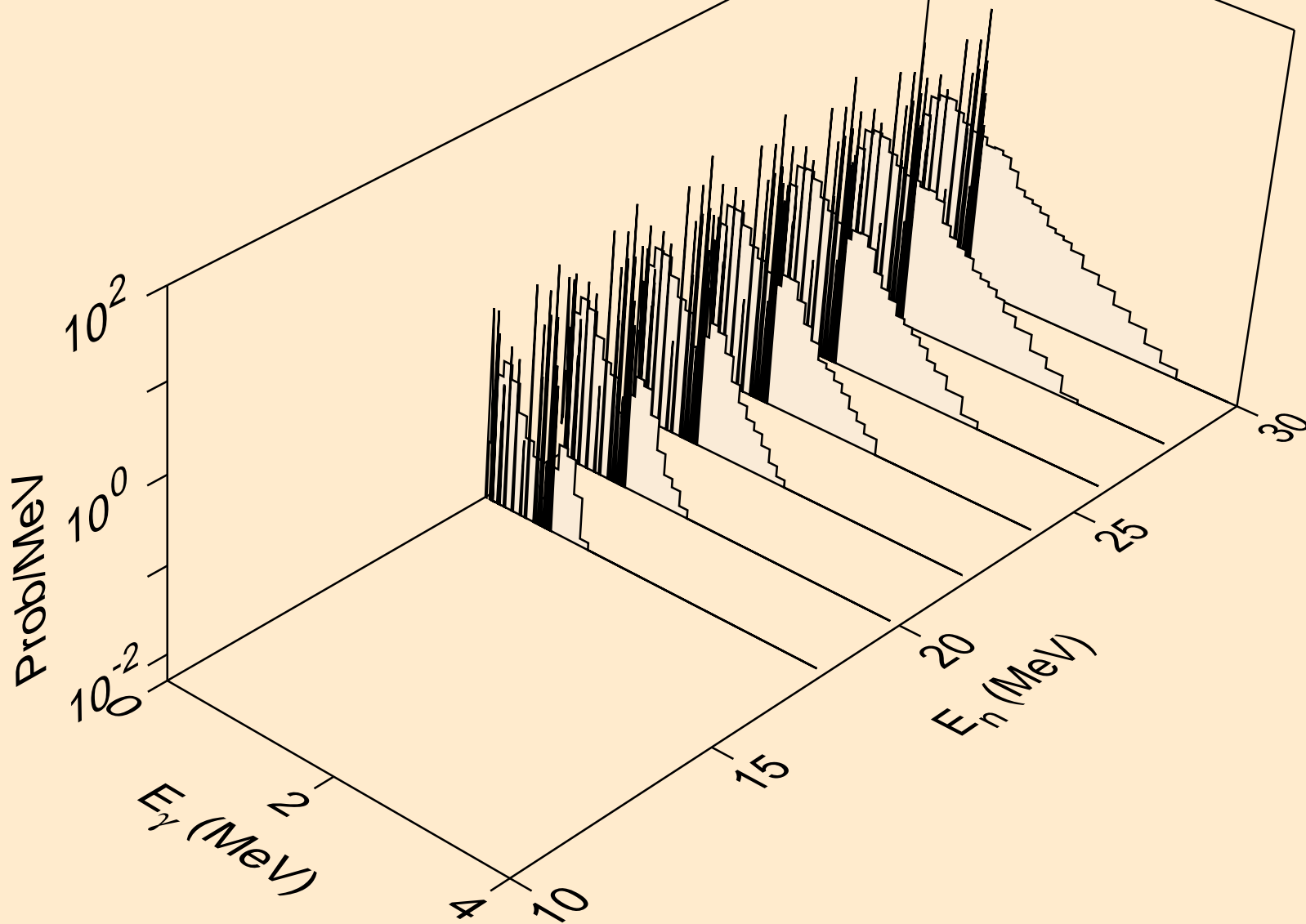

EU148 NEUTRON ACER TENDL-2023 LIBRARY; T=0.K  
Photon emission for (n,4n)

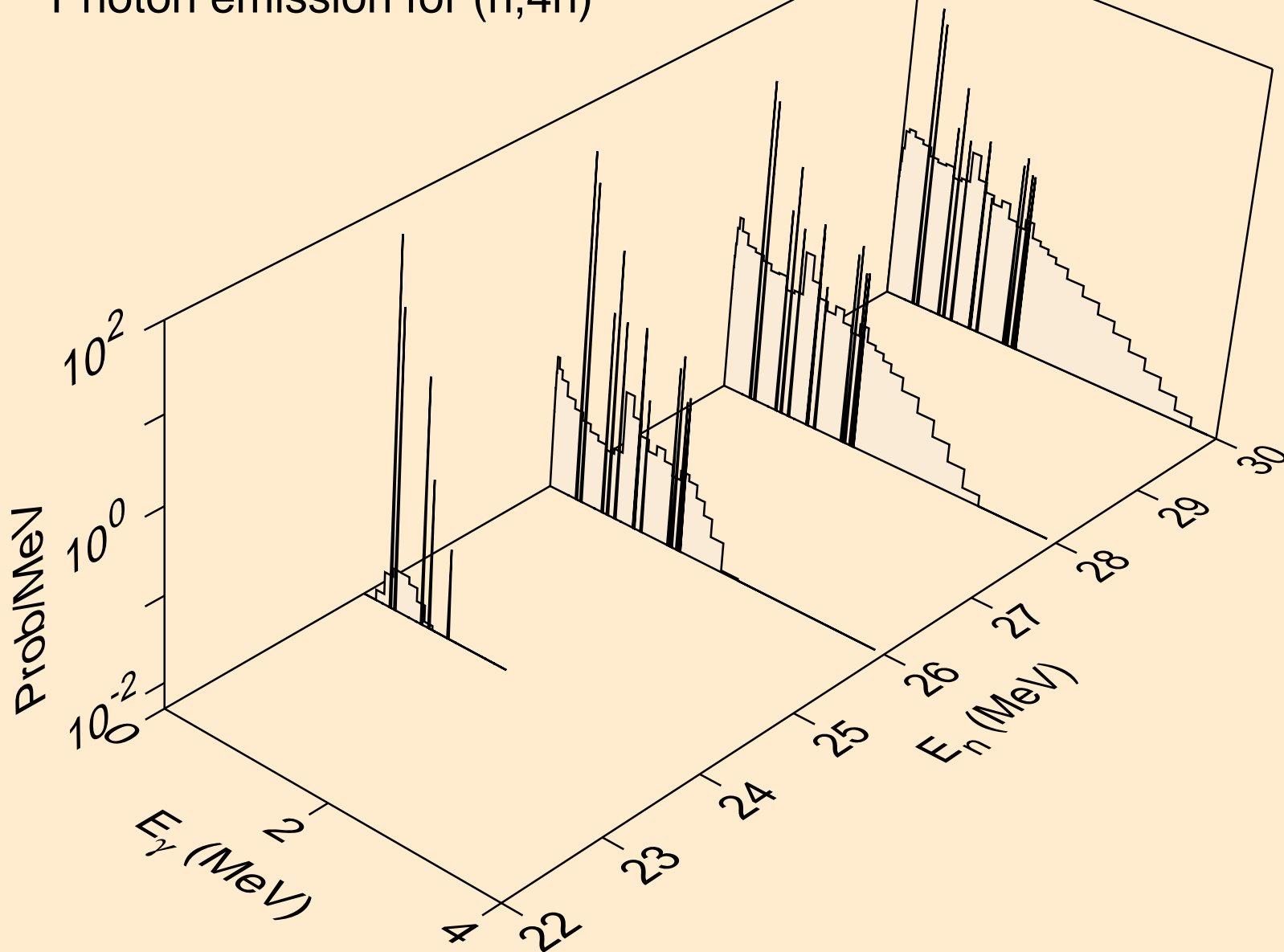

EU148 NEUTRON ACER TENDL-2023 LIBRARY; T=0.K  
Photon emission for (n,2np)

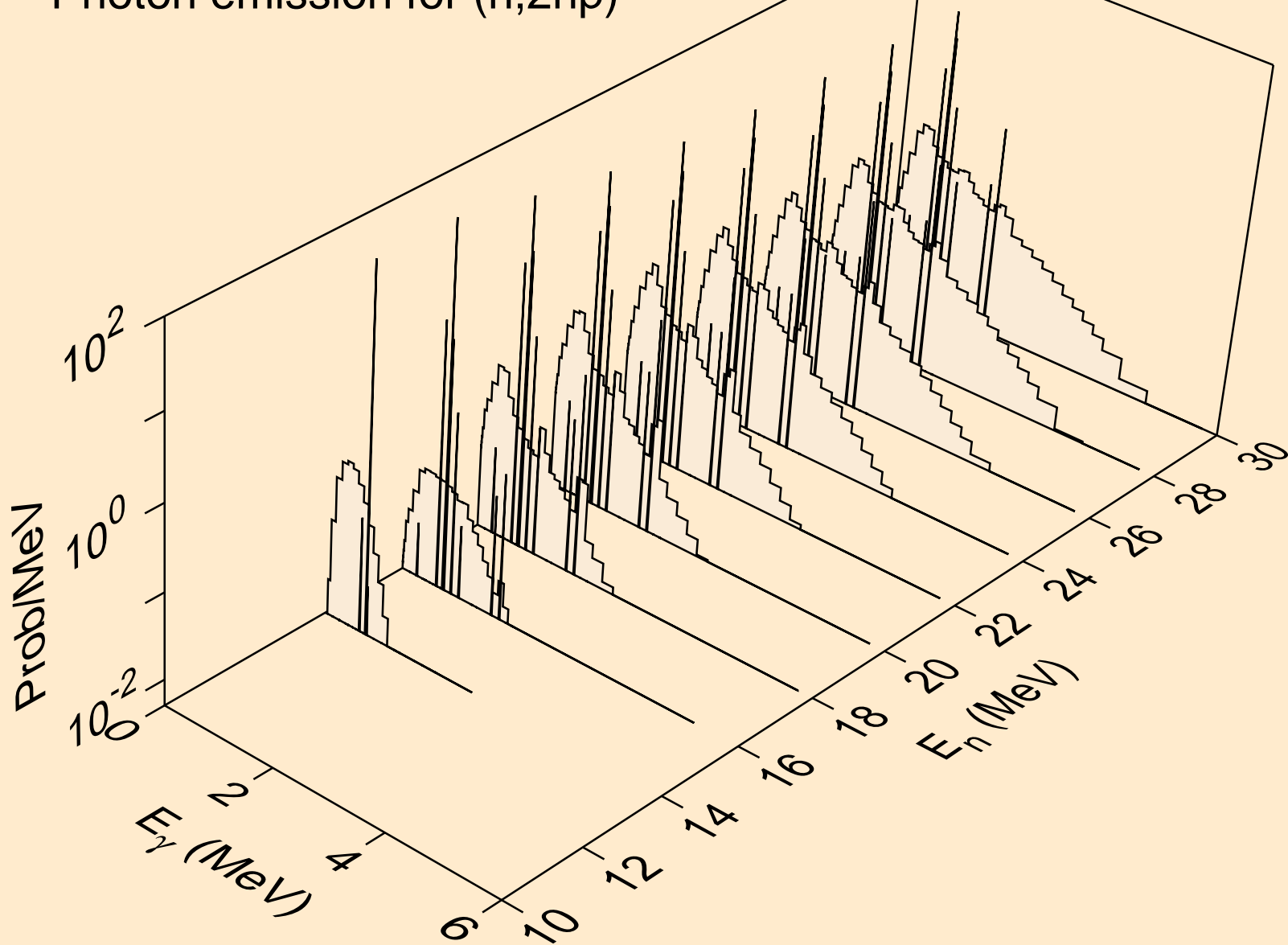

EU148 NEUTRON ACER TENDL-2023 LIBRARY; T=0.K  
Photon emission for (n,3np)

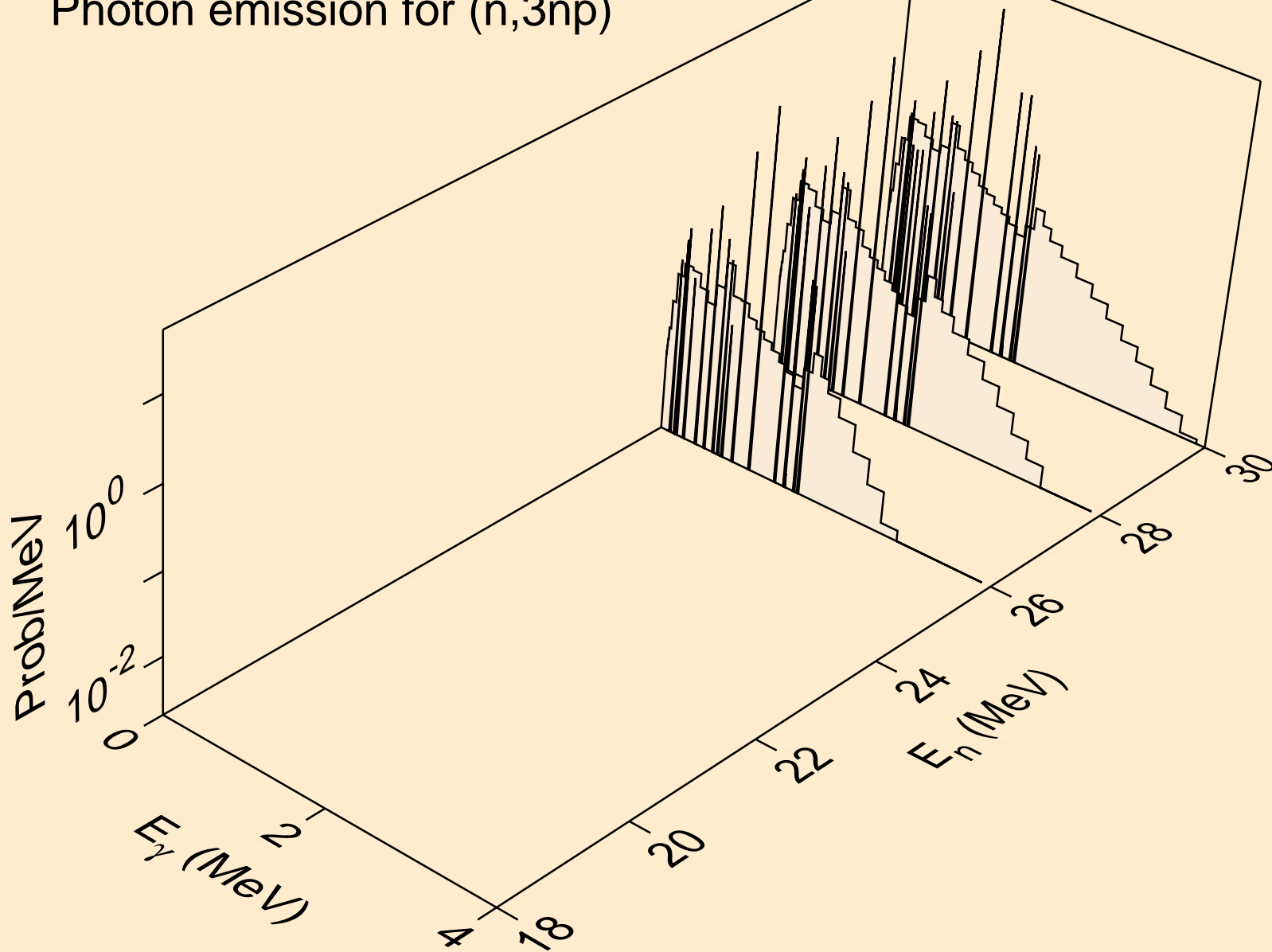

EU148 NEUTRON ACER TENDL-2023 LIBRARY; T=0.K  
Photon emission for (n,n2p)

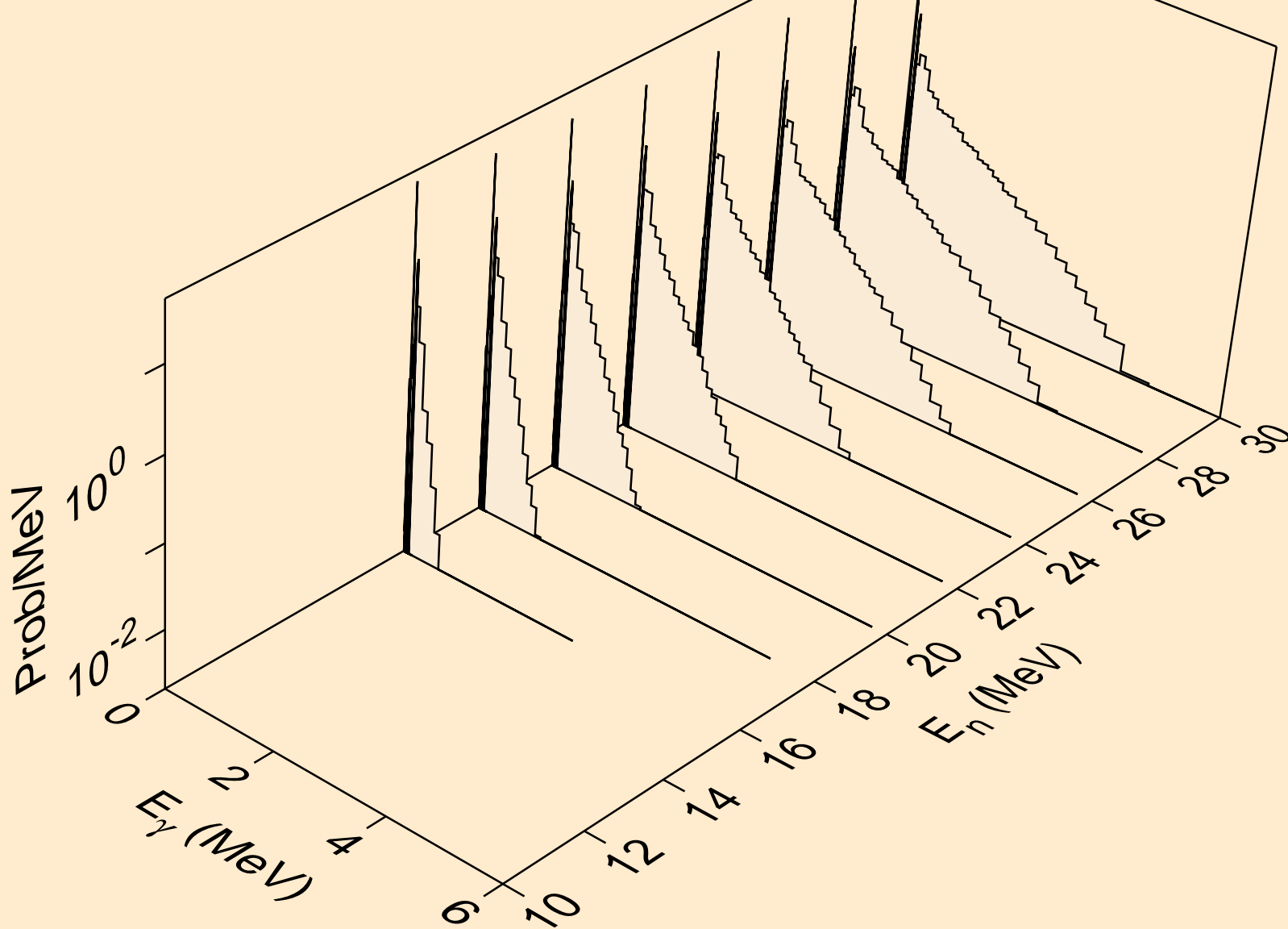

EU148 NEUTRON ACER TENDL-2023 LIBRARY; T=0.K  
Photon emission for (n,npa)

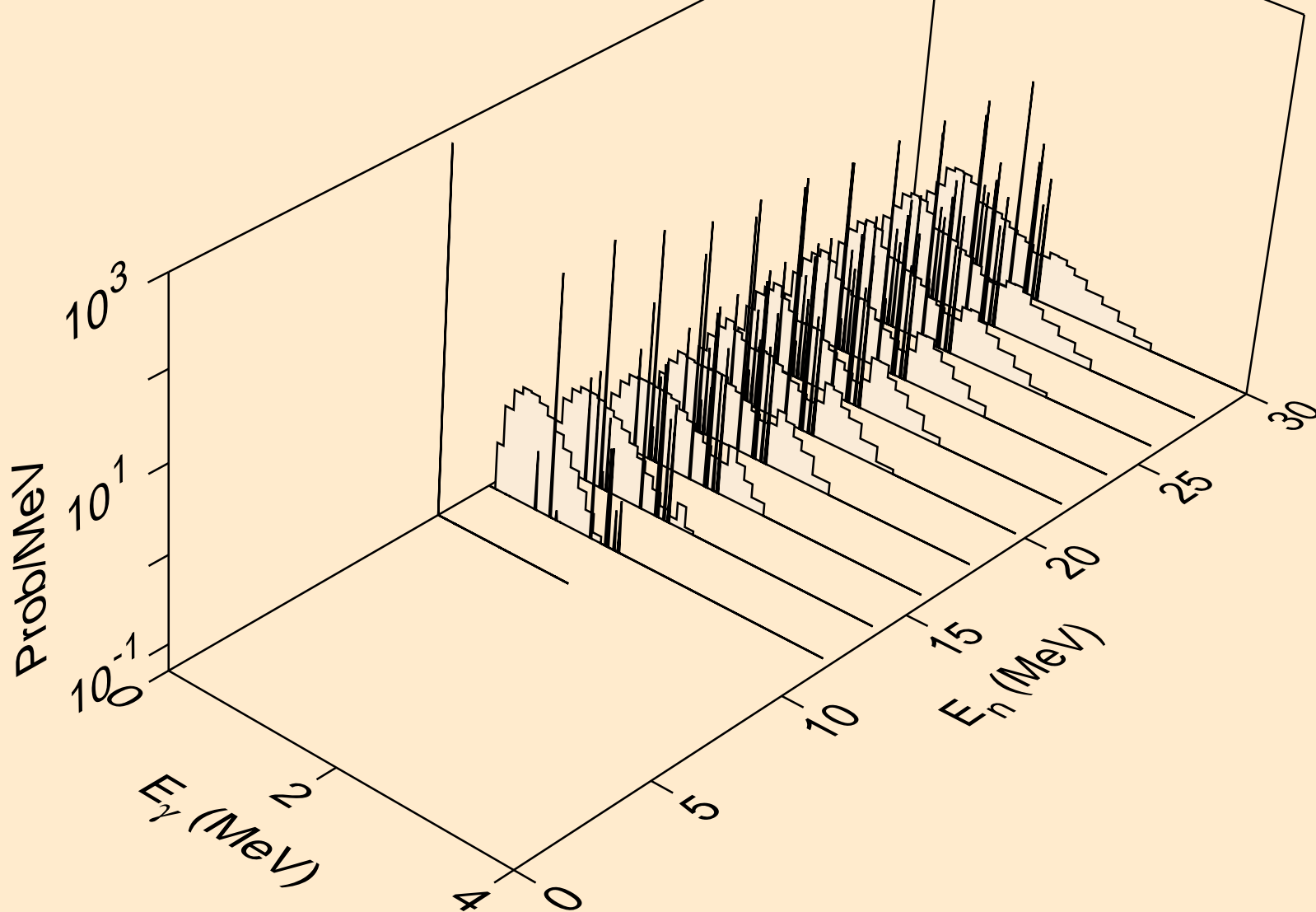

EU148 NEUTRON ACER TENDL-2023 LIBRARY; T=0.K  
Photon emission for (n,n\*c)

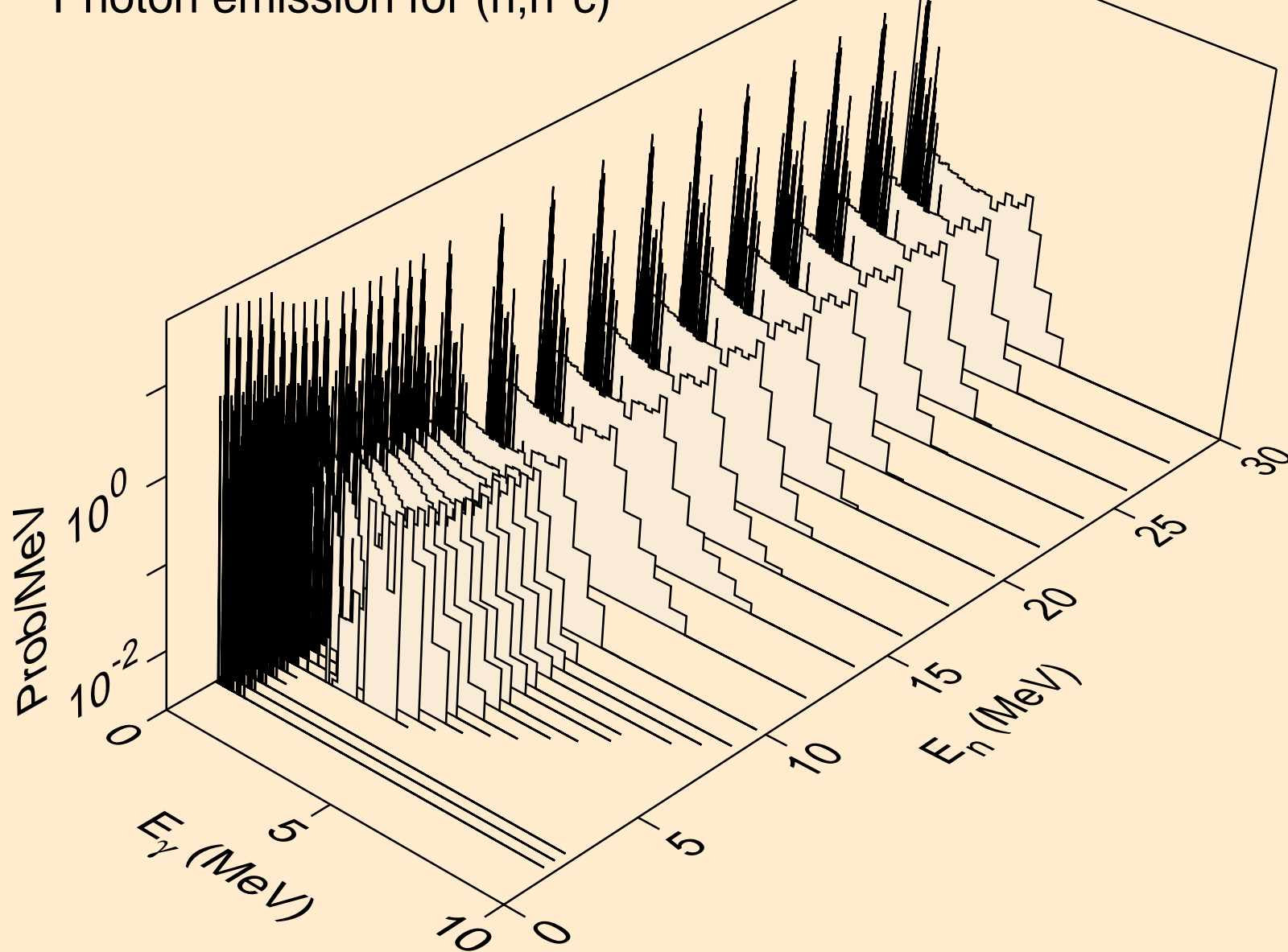



EU148 NEUTRON ACER TENDL-2023 LIBRARY; T=0.K  
Photon emission for (n,gma)

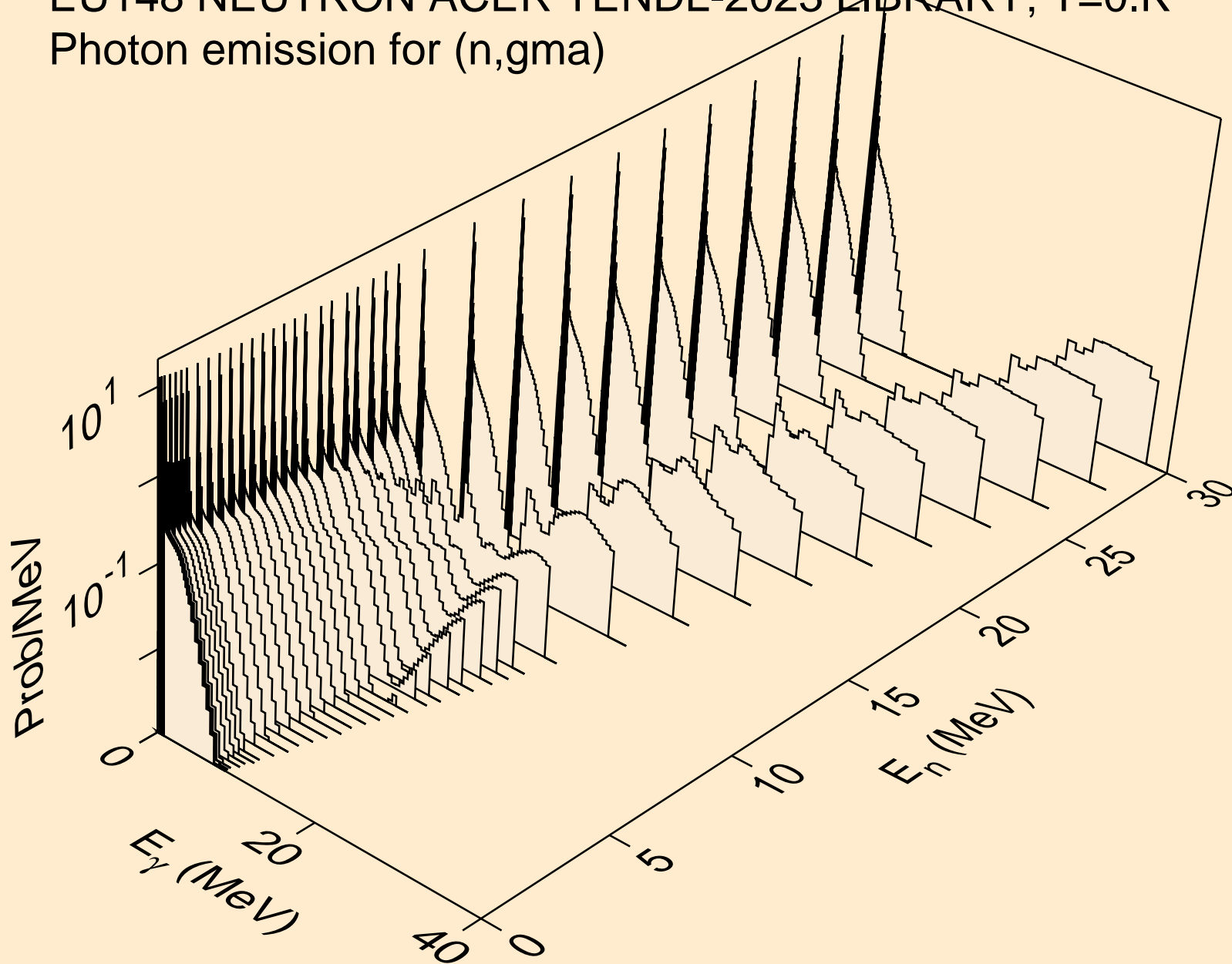

EU148 NEUTRON ACER TENDL-2023 LIBRARY; T=0.K  
Photon emission for (n,p)

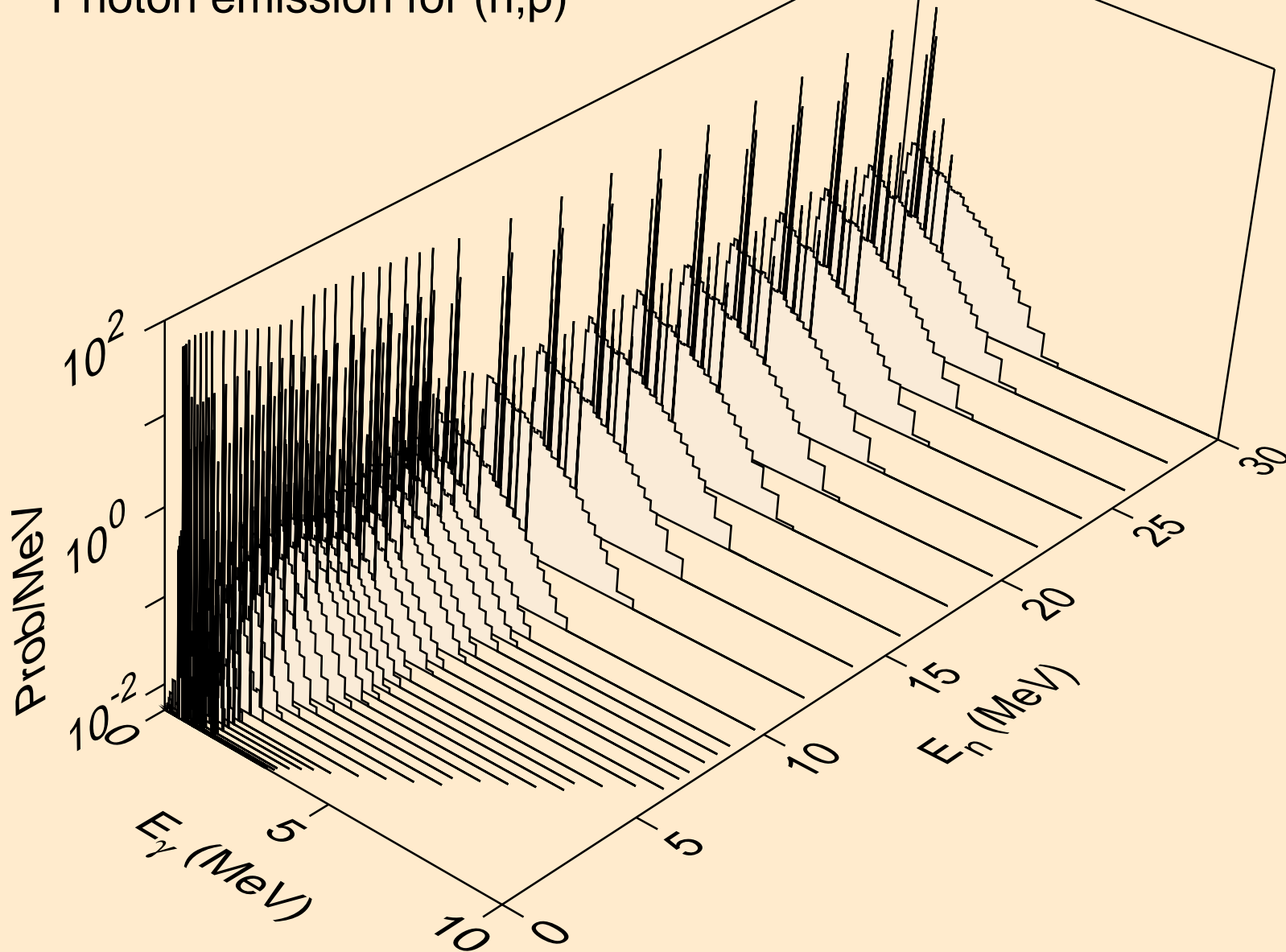

EU148 NEUTRON ACER TENDL-2023 LIBRARY; T=0.K  
Photon emission for (n,d)

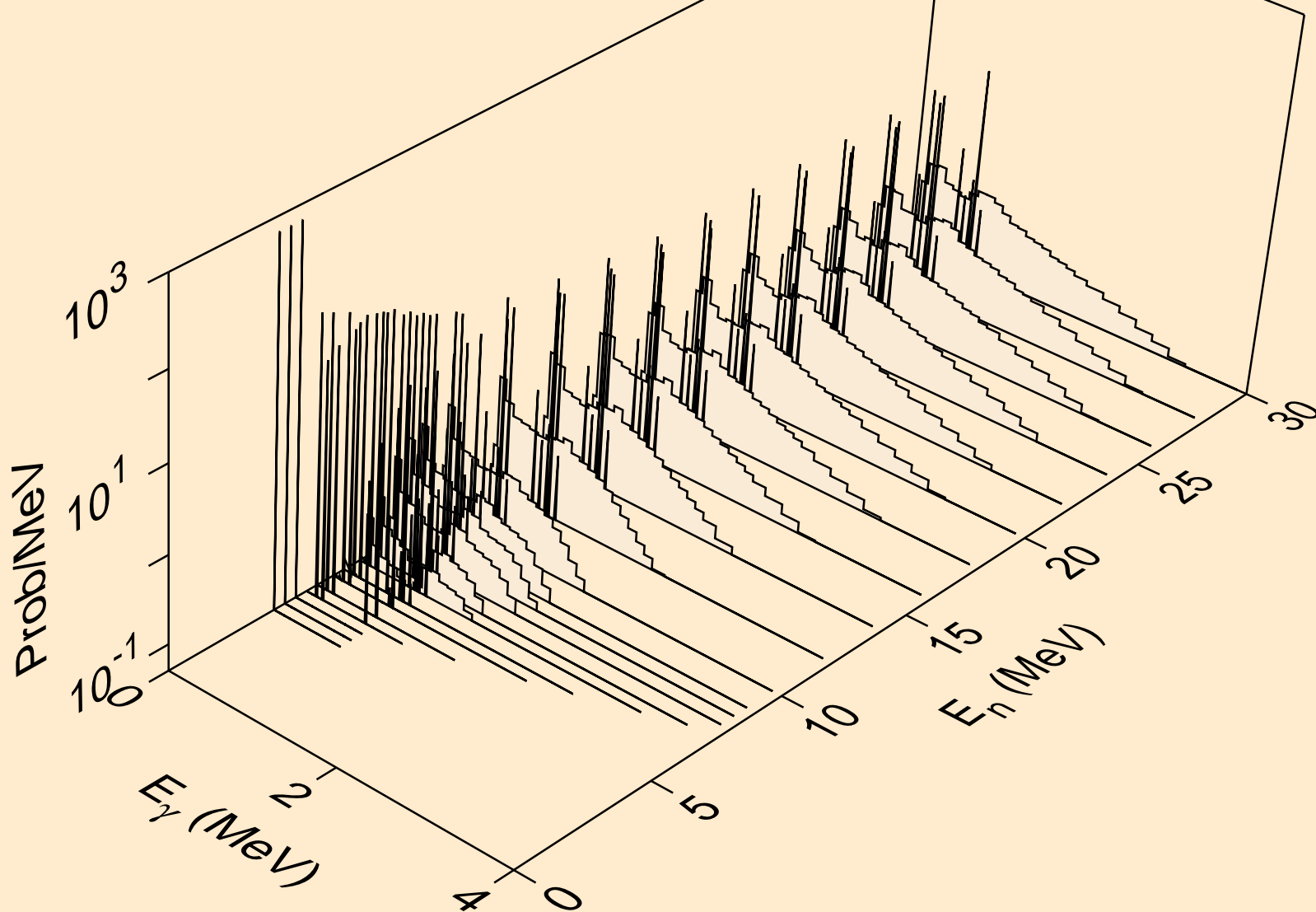

EU148 NEUTRON ACER TENDL-2023 LIBRARY; T=0.K  
Photon emission for (n,t)

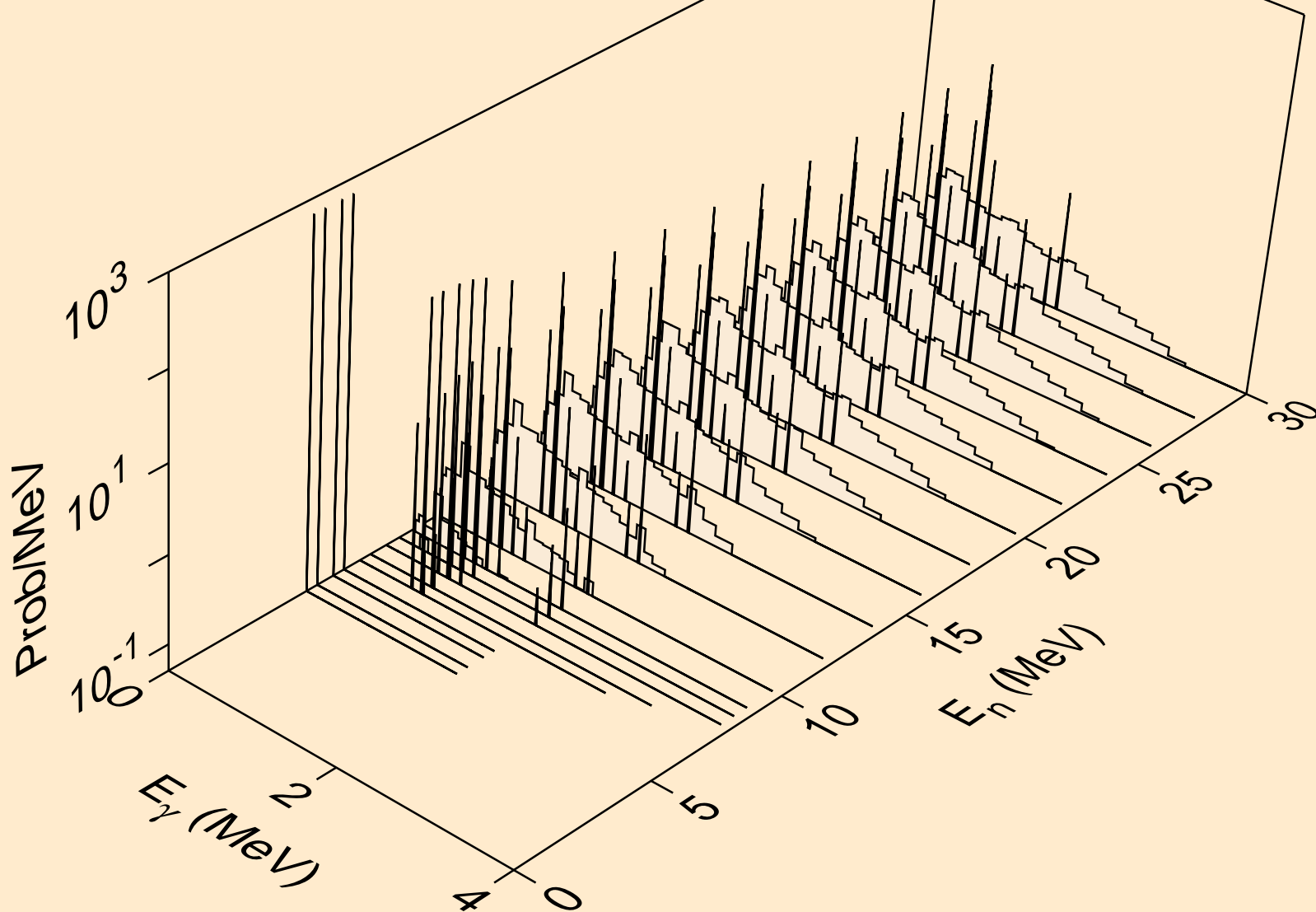

EU148 NEUTRON ACER TENDL-2023 LIBRARY; T=0.K  
Photon emission for (n,he3)

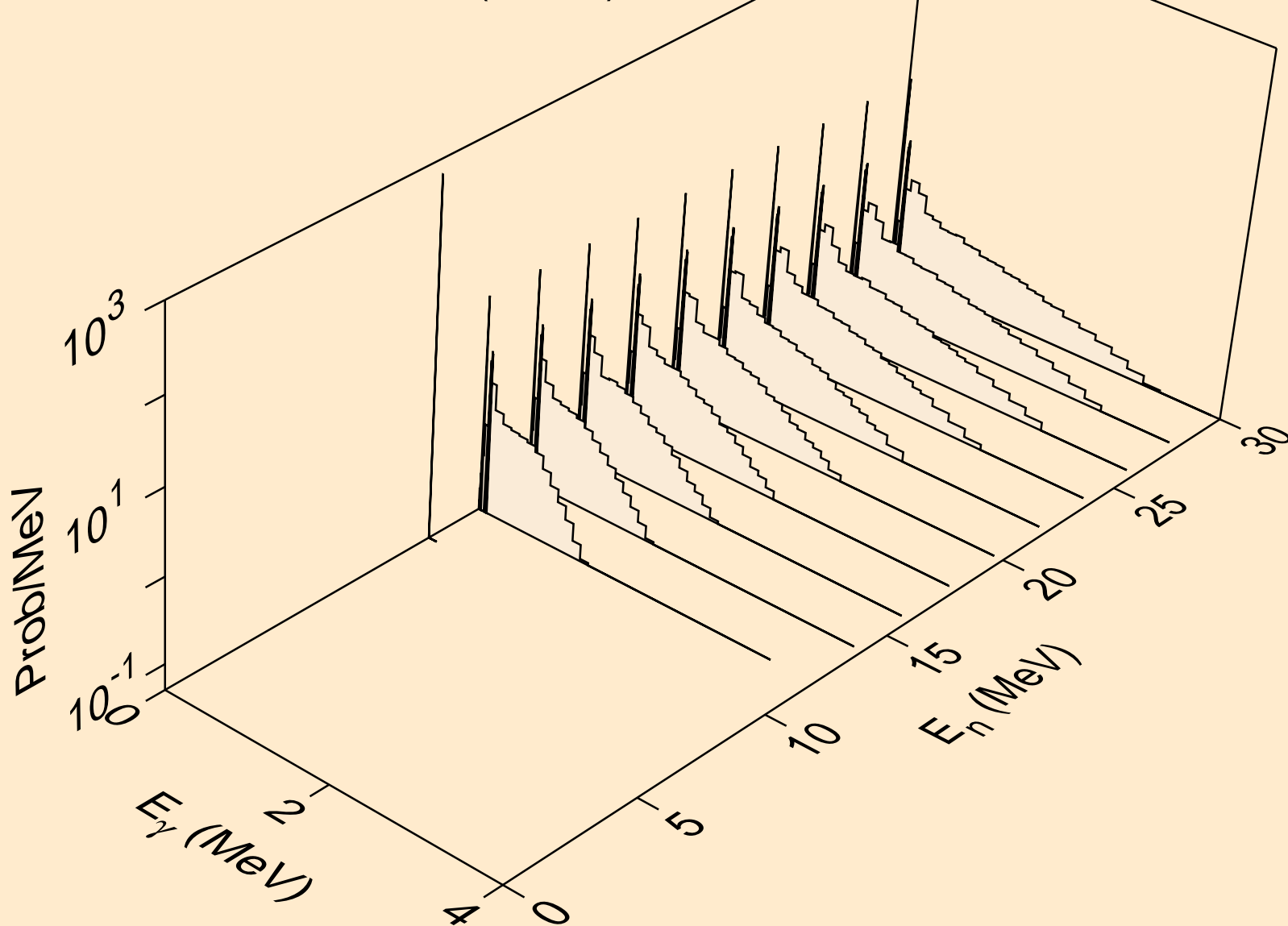

EU148 NEUTRON ACER TENDL-2023 LIBRARY; T=0.K  
Photon emission for (n,a)

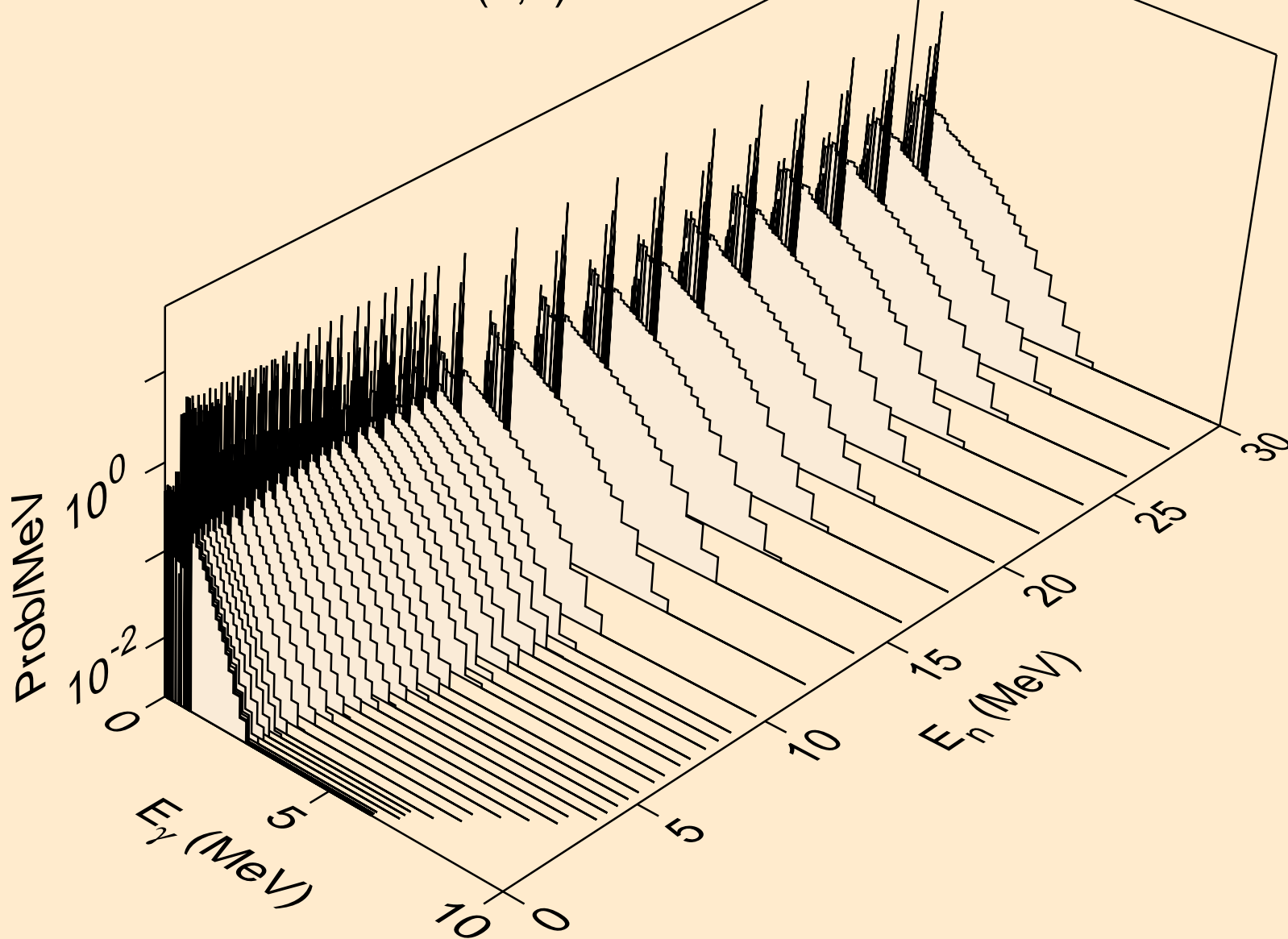

EU148 NEUTRON ACER TENDL-2023 LIBRARY; T=0.K  
Photon emission for (n,2a)

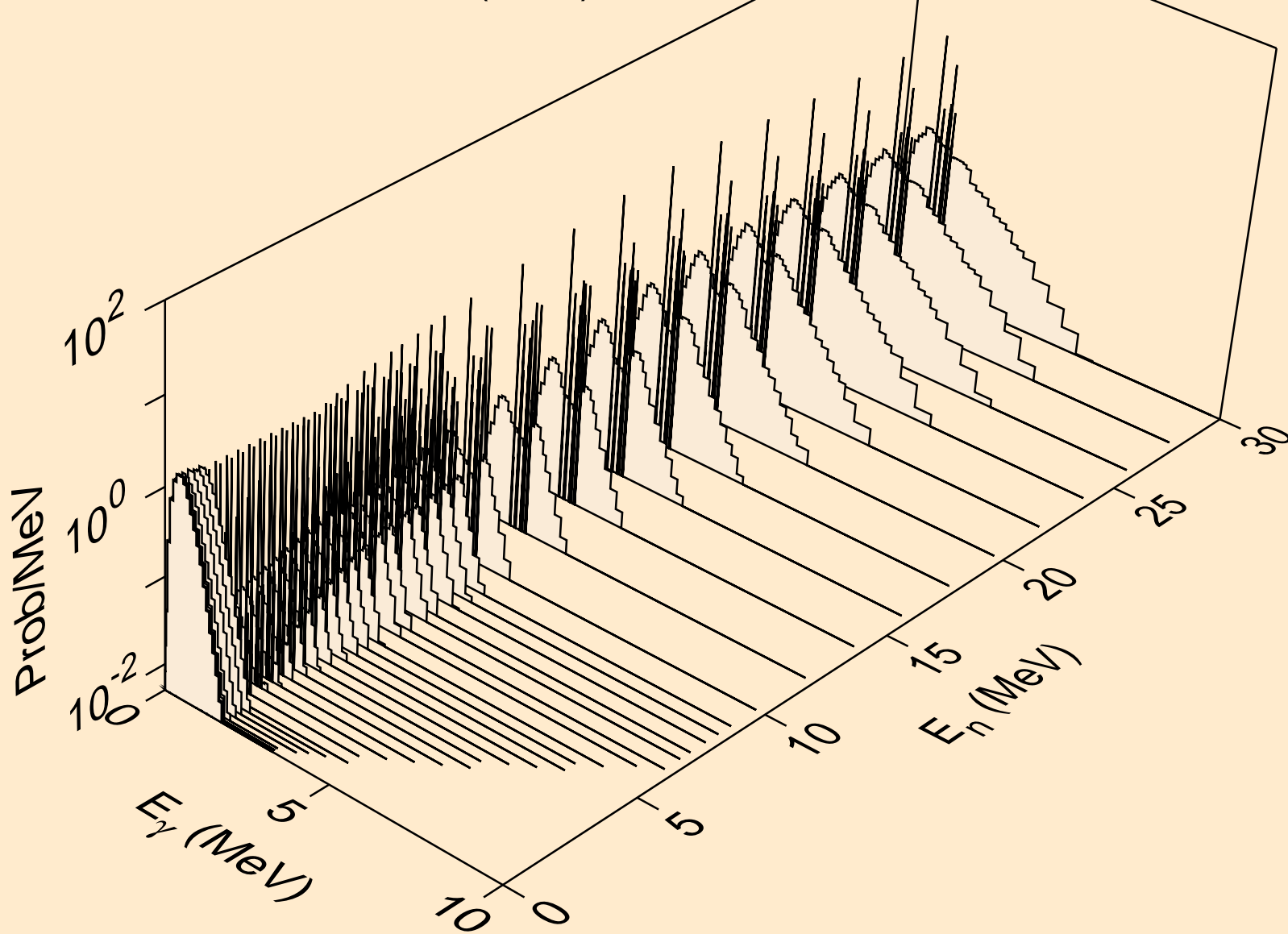

EU148 NEUTRON ACER TENDL-2023 LIBRARY; T=0.K  
Photon emission for (n,2p)

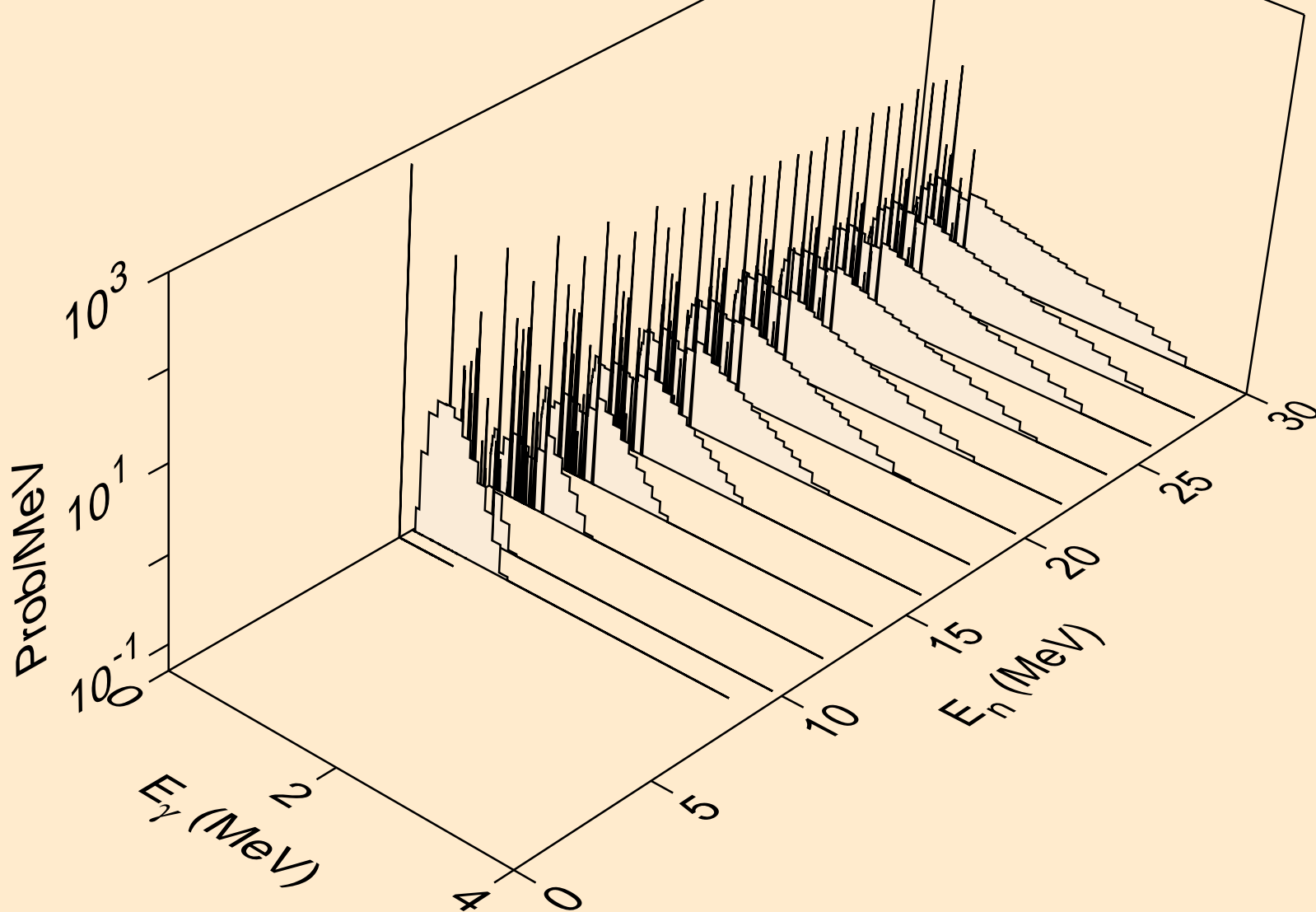



EU148 NEUTRON ACER TENDL-2023 LIBRARY; T=0.K  
Photon emission for (n,p $\alpha$ )

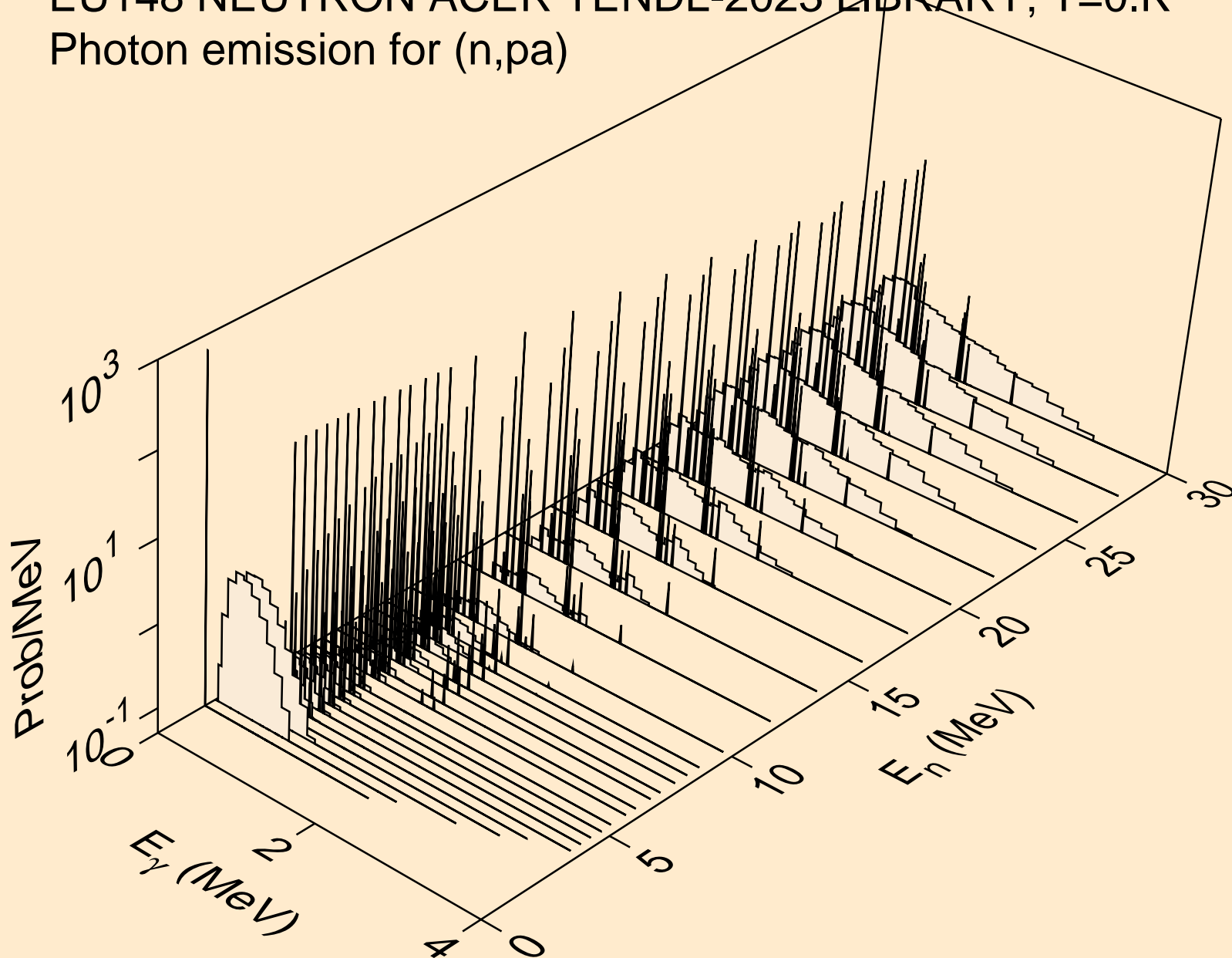

EU148 NEUTRON ACER TENDL-2023 LIBRARY; T=0.K  
Photon emission for (n,pd)

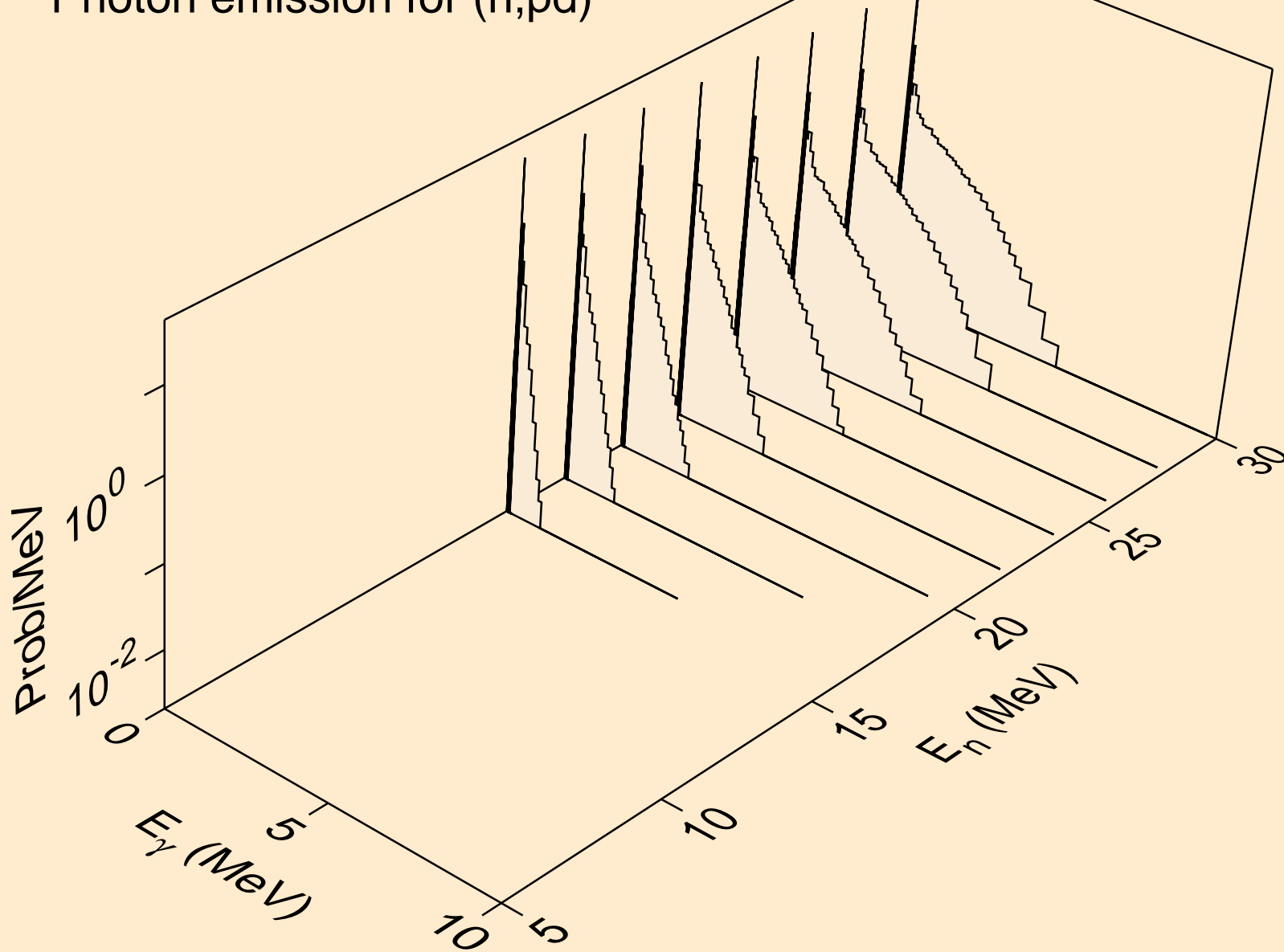

EU148 NEUTRON ACER TENDL-2023 LIBRARY; T=0.K  
Photon emission for (n,pt)

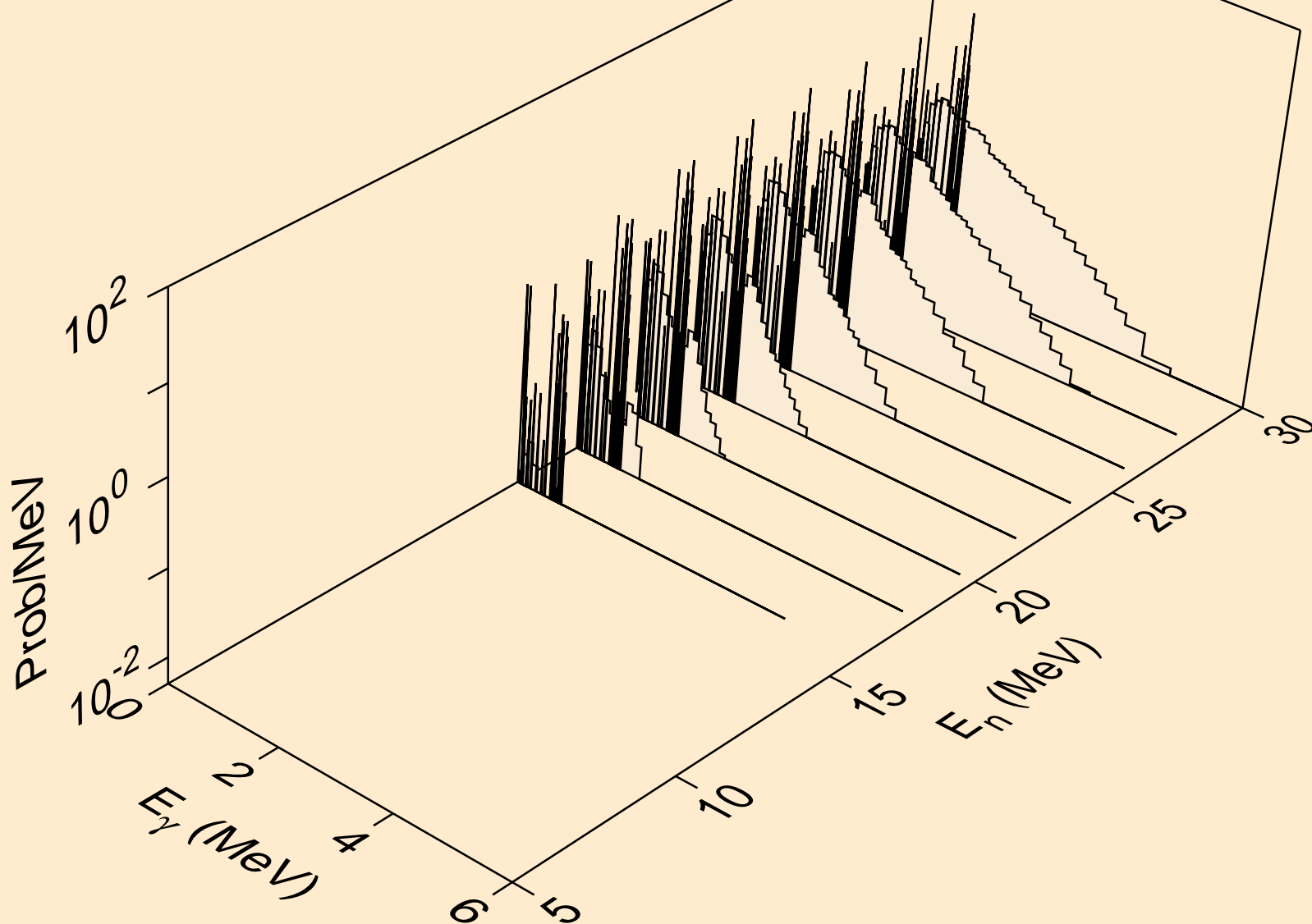

EU148 NEUTRON ACER TENDL-2023 LIBRARY; T=0.K  
Photon emission for (n,da)

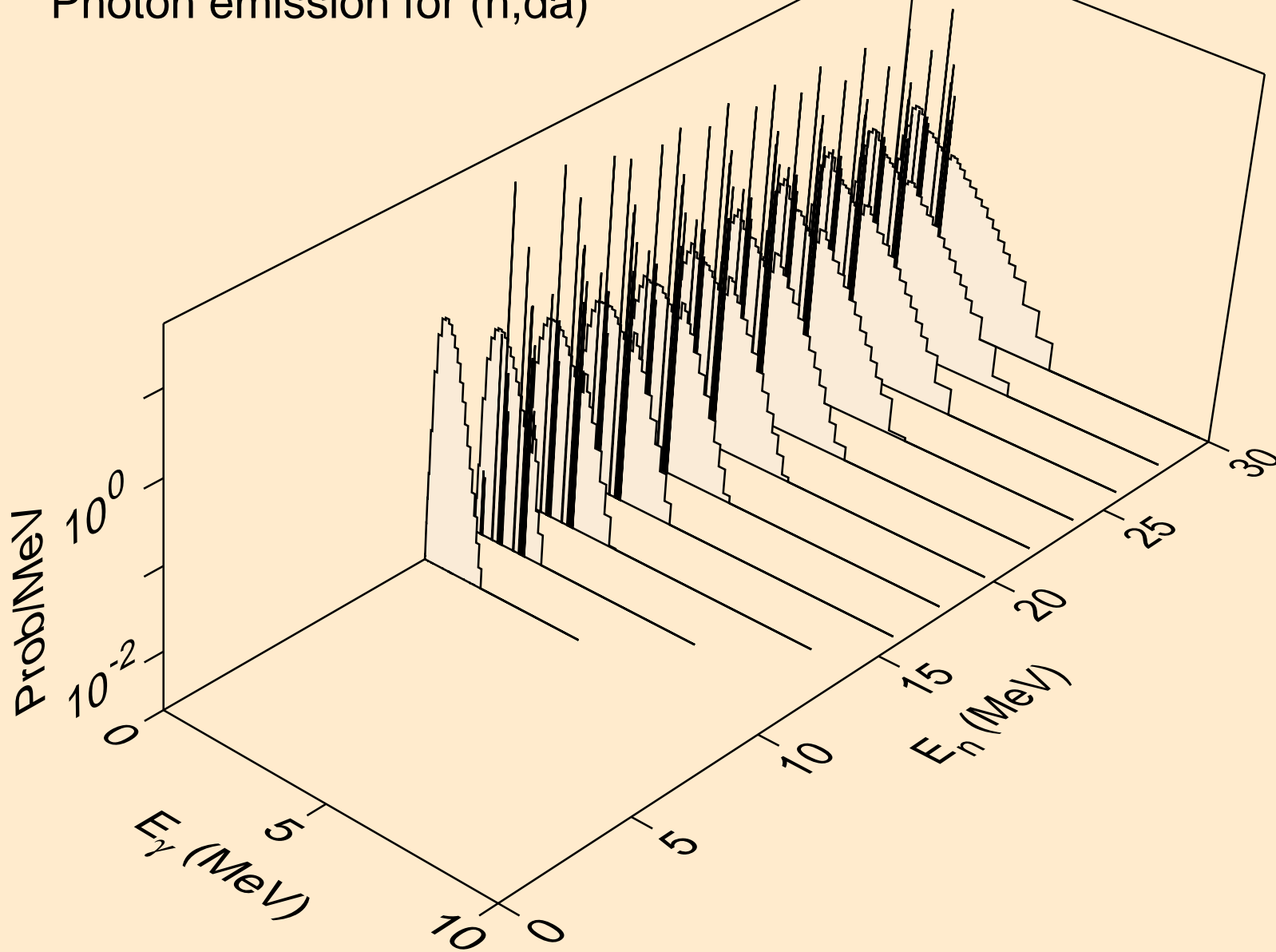

EU148 NEUTRON ACER TENDL-2023 LIBRARY; T=0.K  
thermal capture photon spectrum

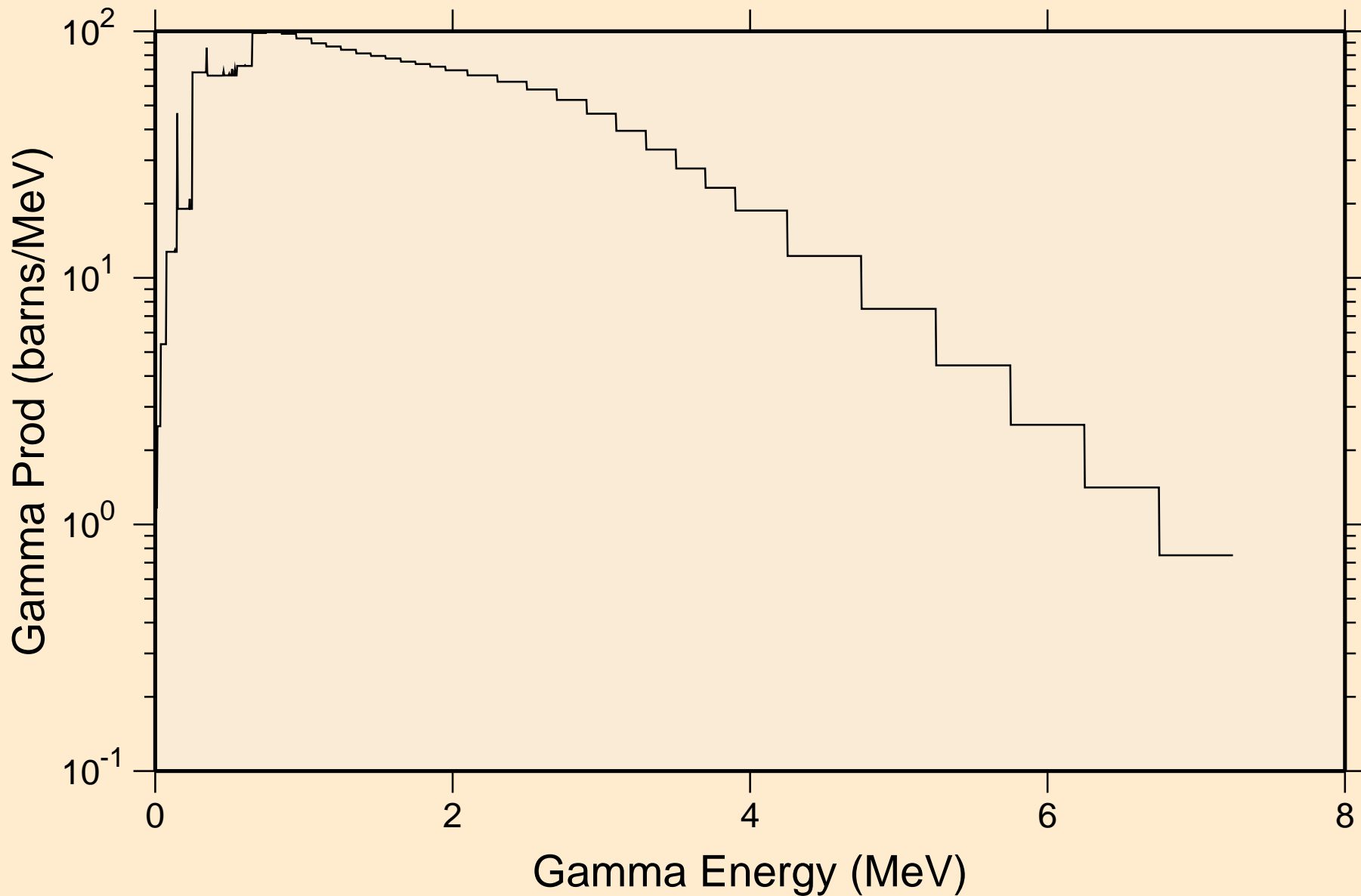

EU148 NEUTRON ACER TENDL-2023 LIBRARY; T=0.K  
14 MeV photon spectrum

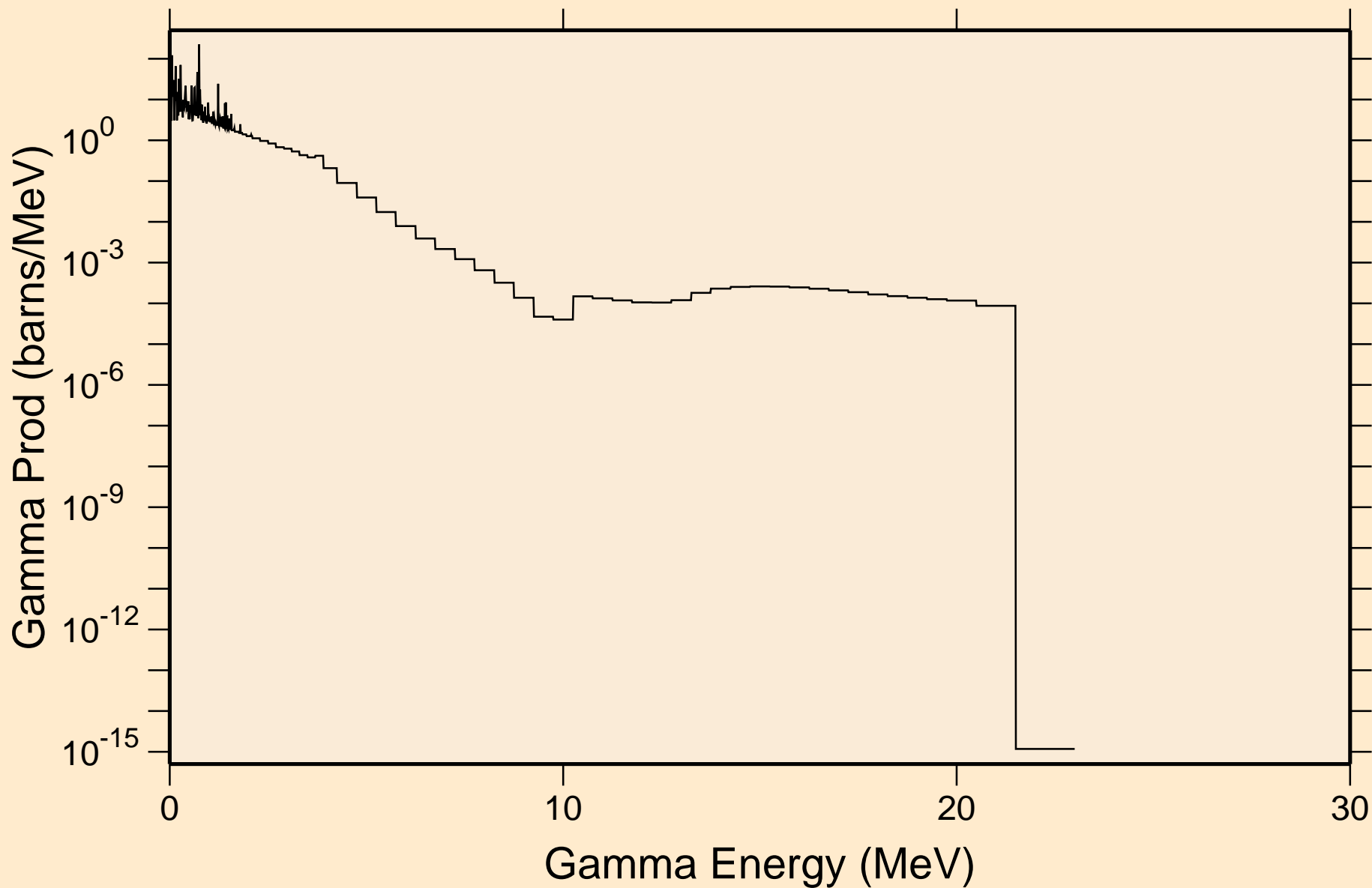

# EU148 NEUTRON ACER TENDL-2023 LIBRARY; T=0.K

## Particle heating contributions

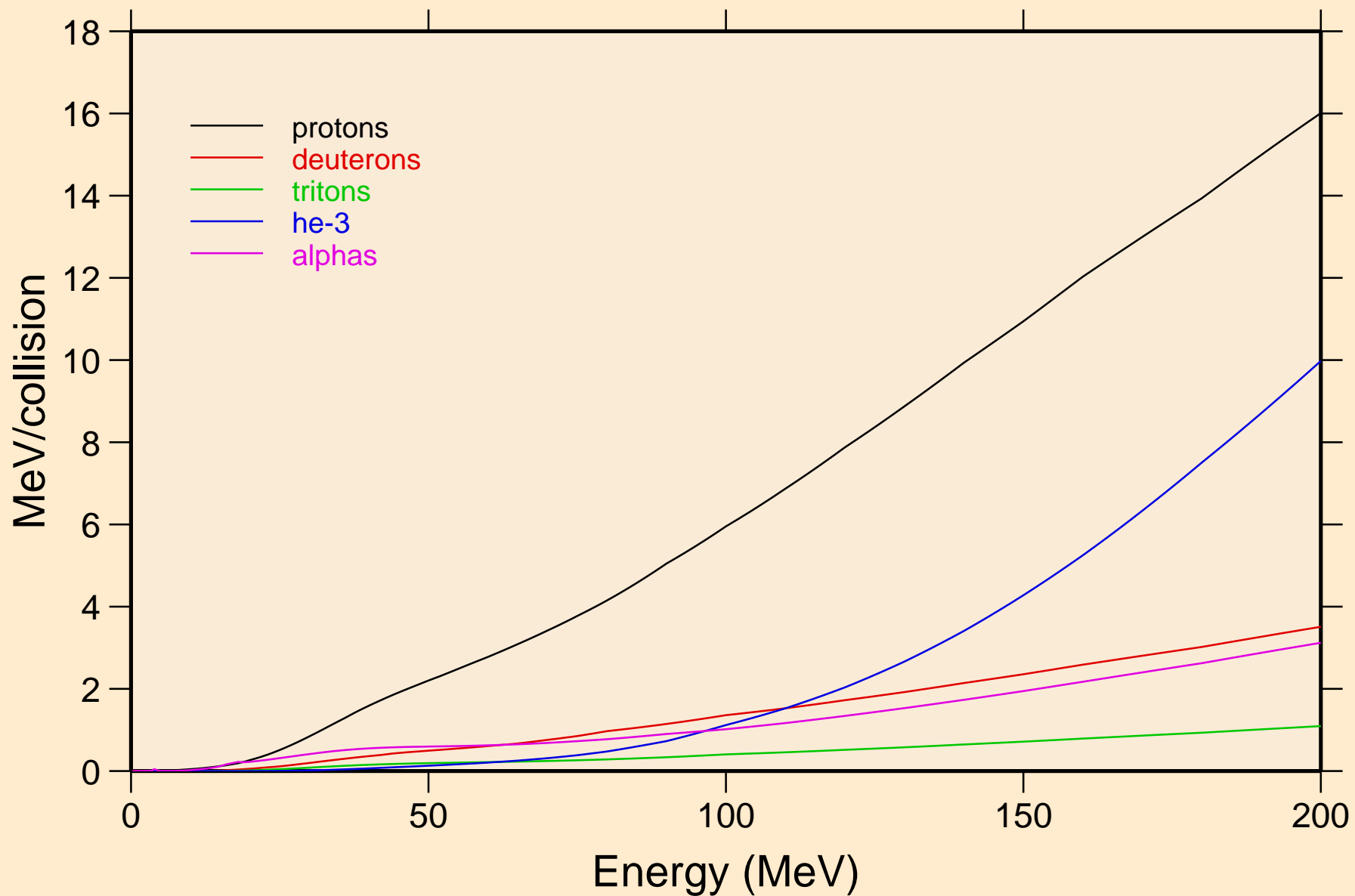

# EU148 NEUTRON ACER TENDL-2023 LIBRARY; T=0.K

## Recoil Heating

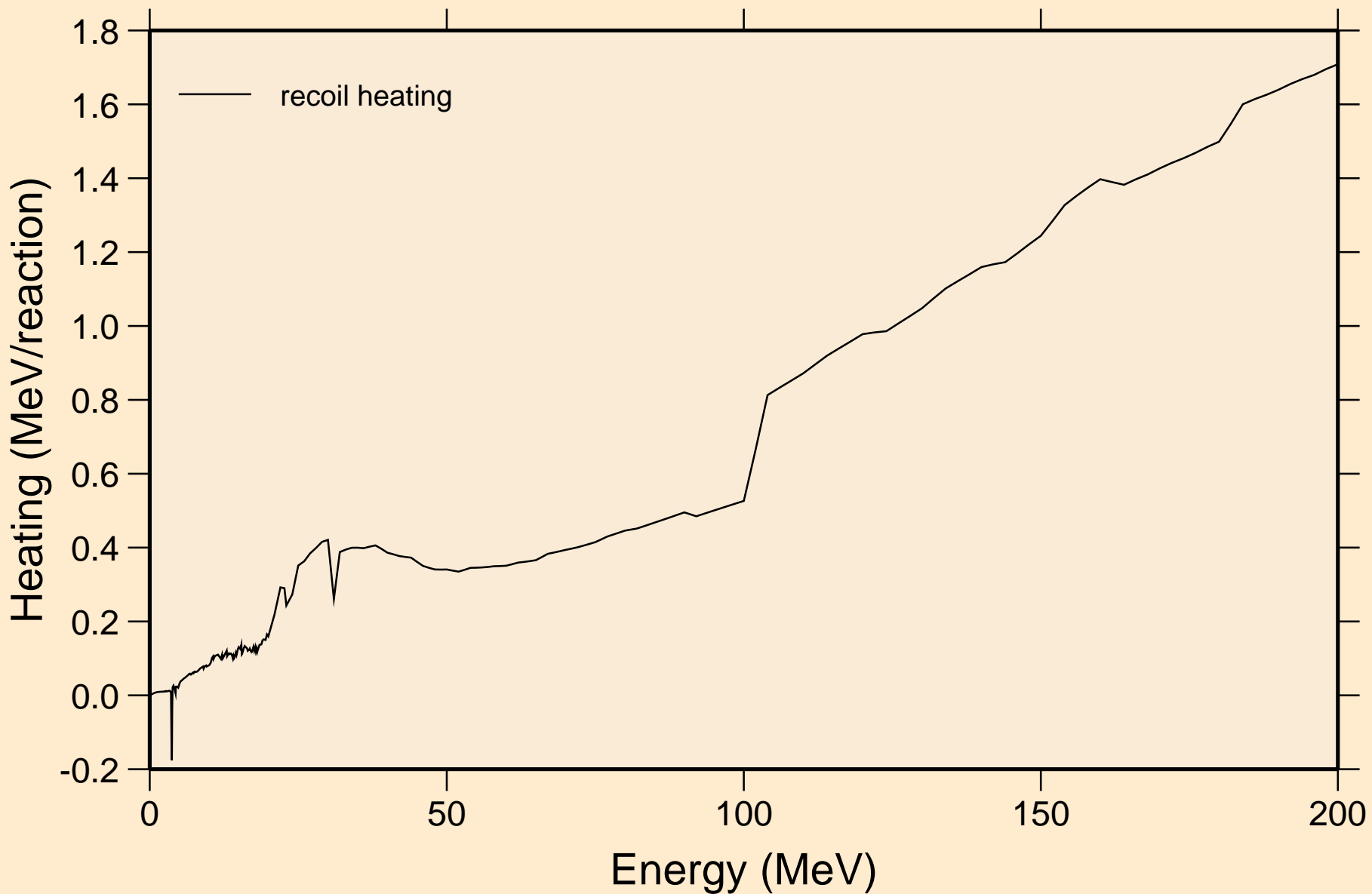



# EU148 NEUTRON ACER TENDL-2023 LIBRARY; T=0.K

## Particle production cross sections

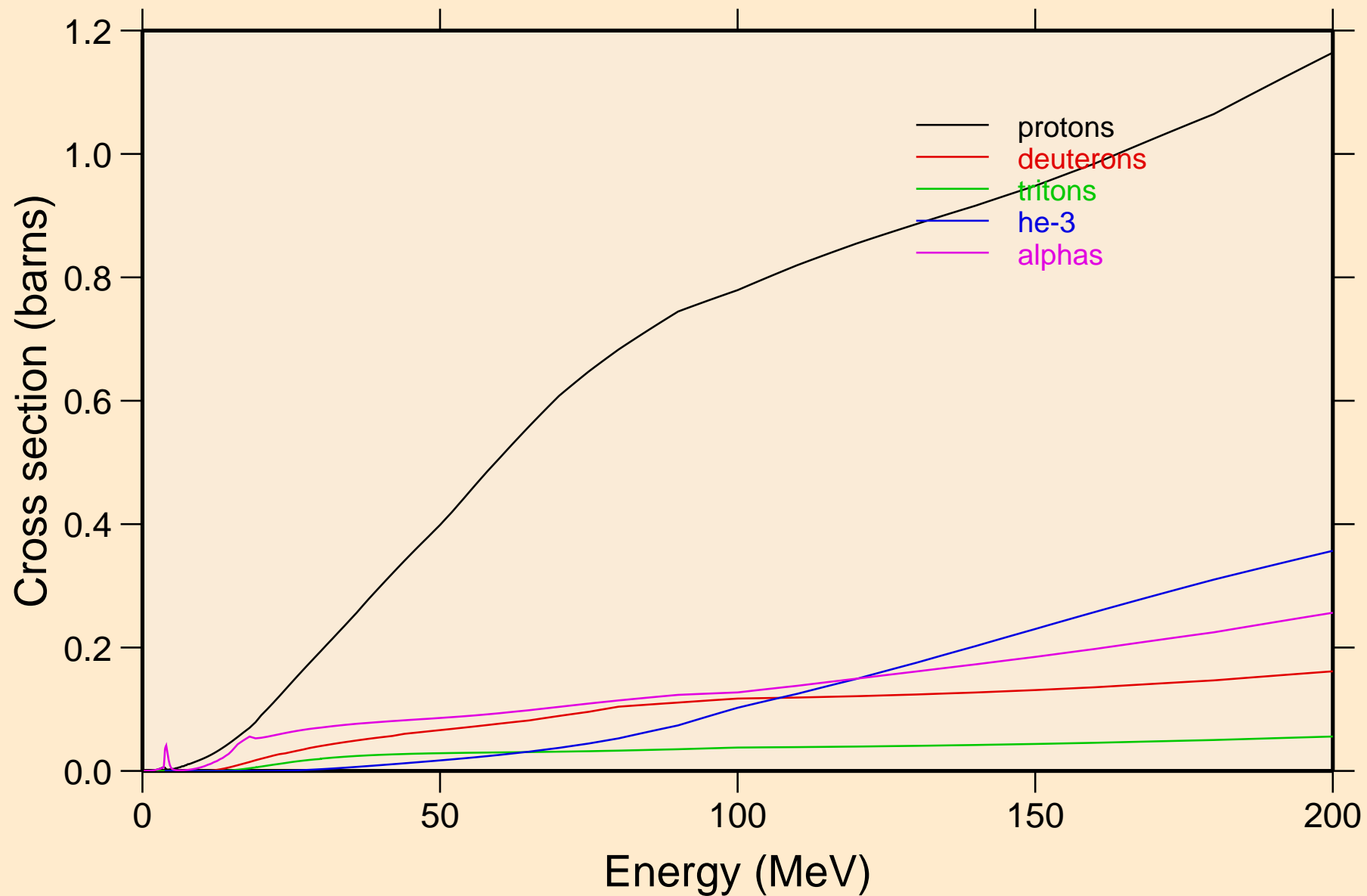

EU148 NEUTRON ACER TENDL-2023 LIBRARY; T=0.K  
protons from (n,x)

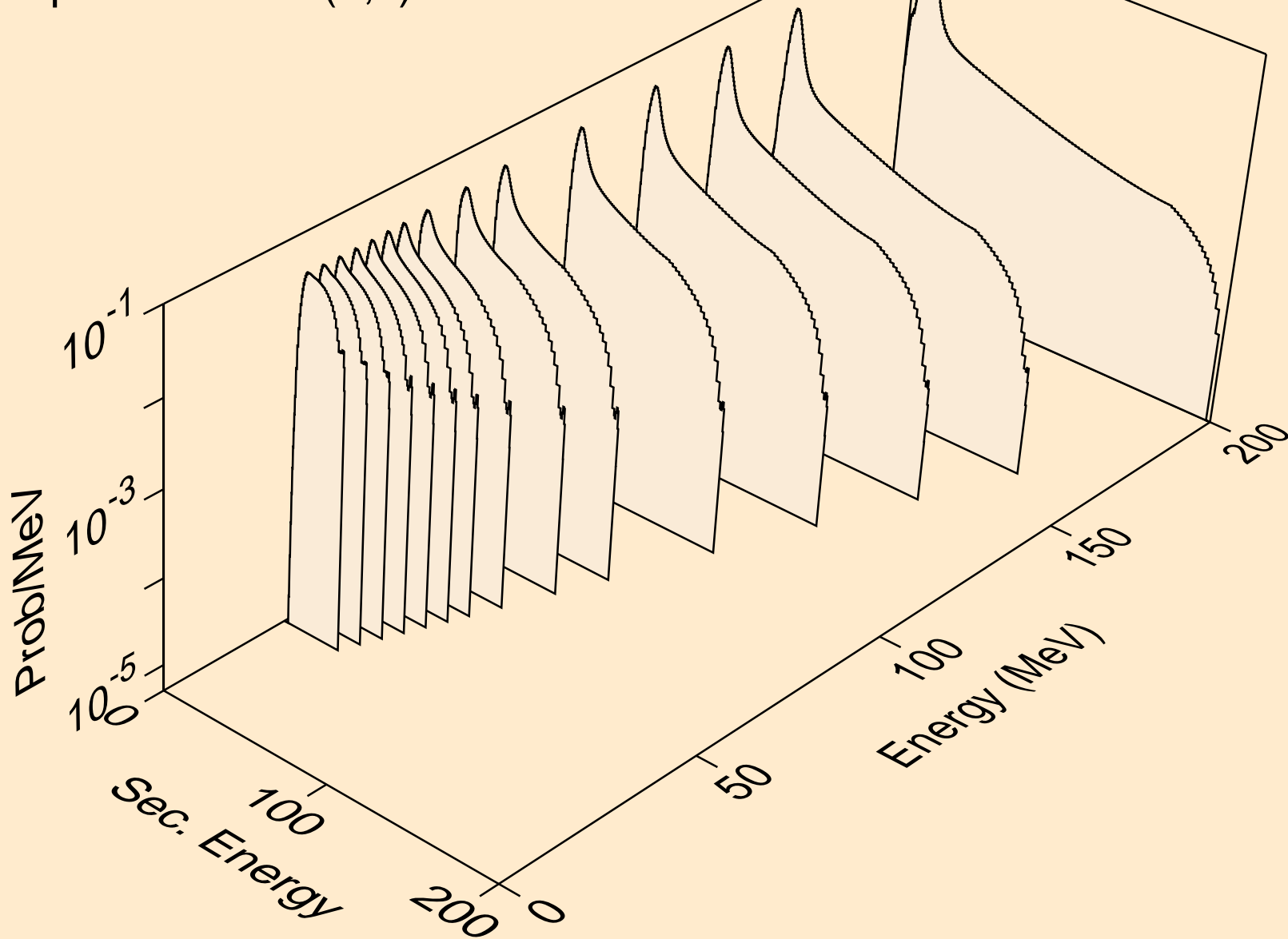

EU148 NEUTRON ACER TENDL-2023 LIBRARY; T=0.K  
protons from (n,n\*)p

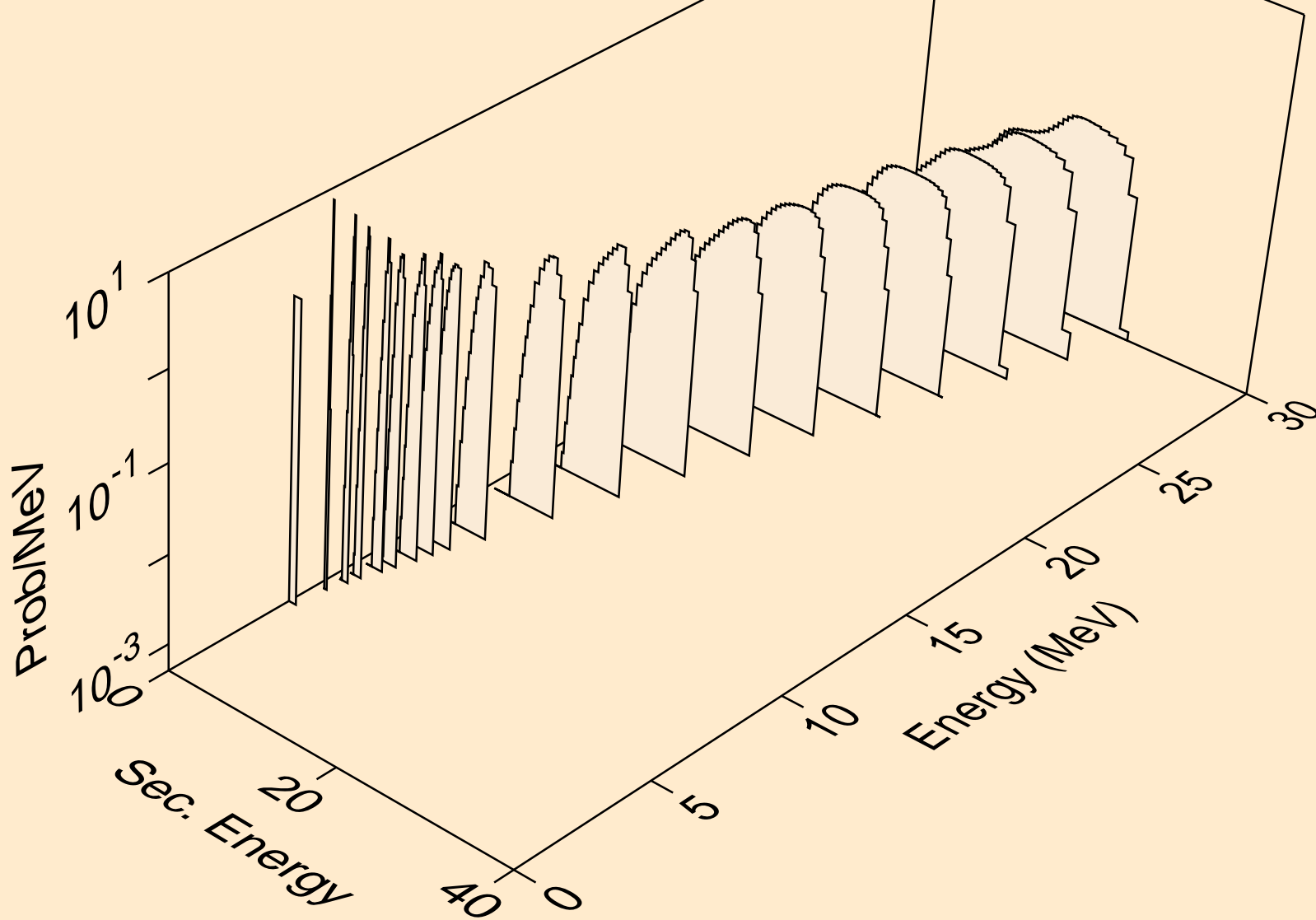

EU148 NEUTRON ACER TENDL-2023 LIBRARY; T=0.K  
protons from (n,2np)

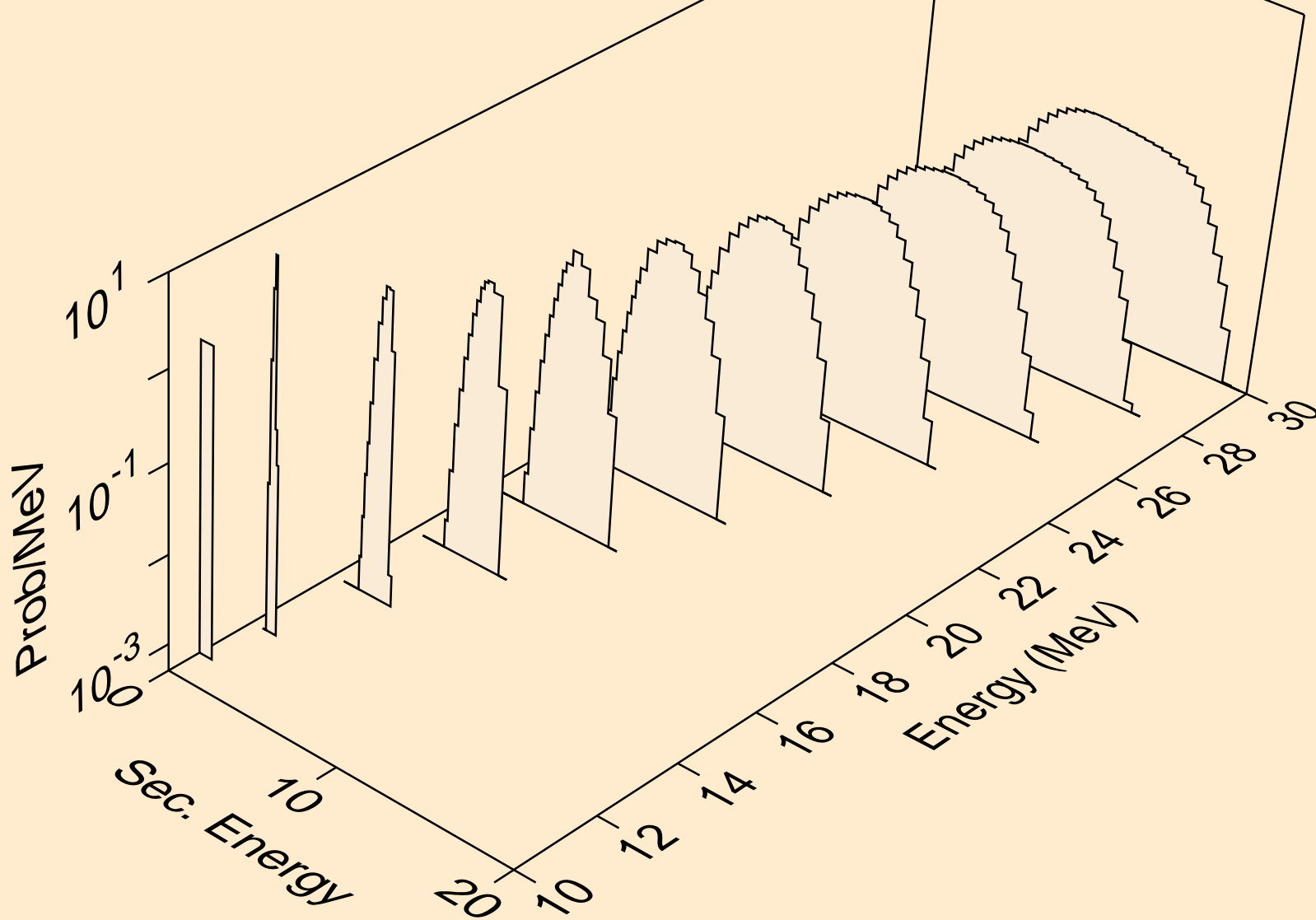

EU148 NEUTRON ACER TENDL-2023 LIBRARY; T=0.K  
protons from (n,3np)

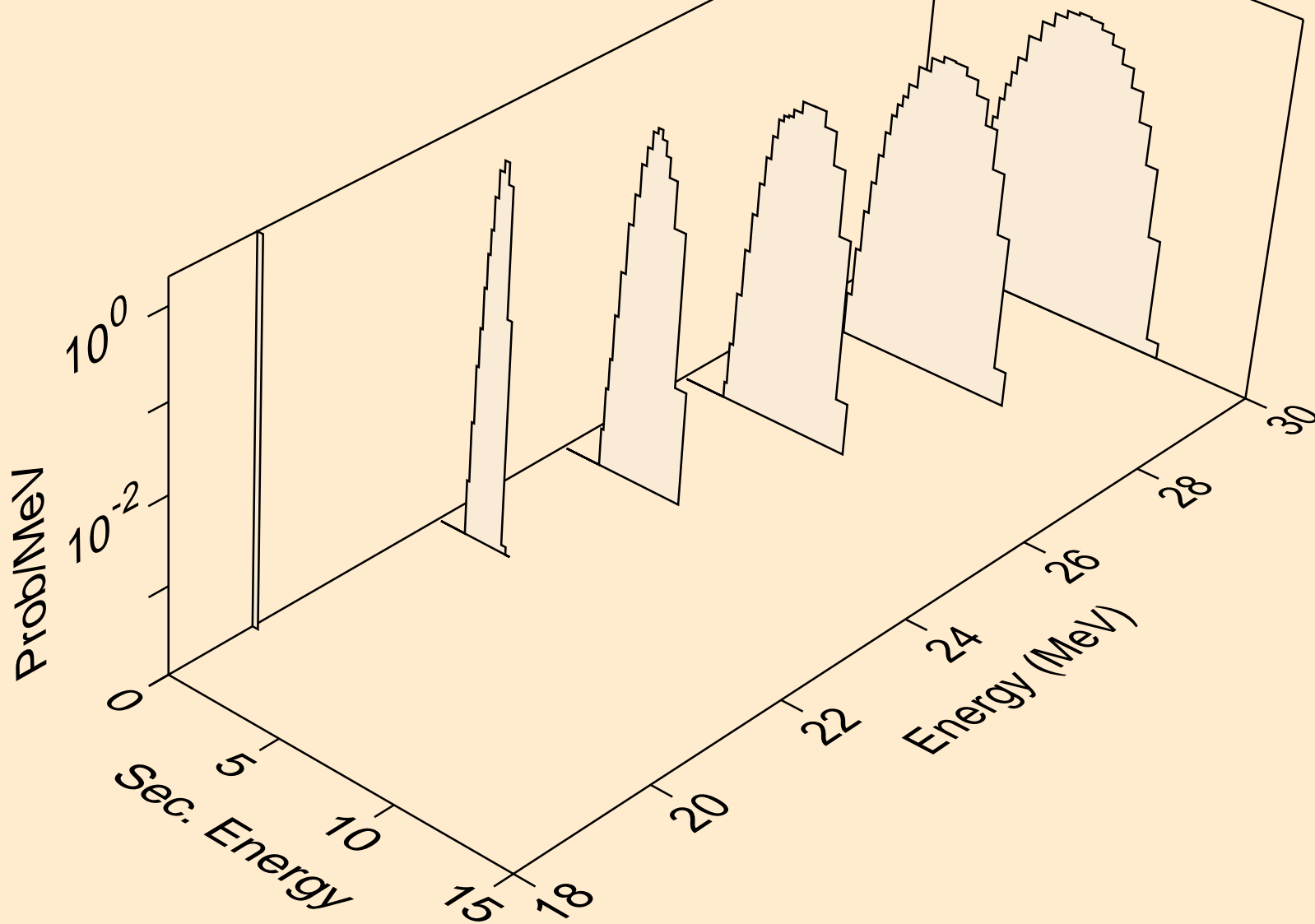

EU148 NEUTRON ACER TENDL-2023 LIBRARY; T=0.K  
protons from (n,n2p)

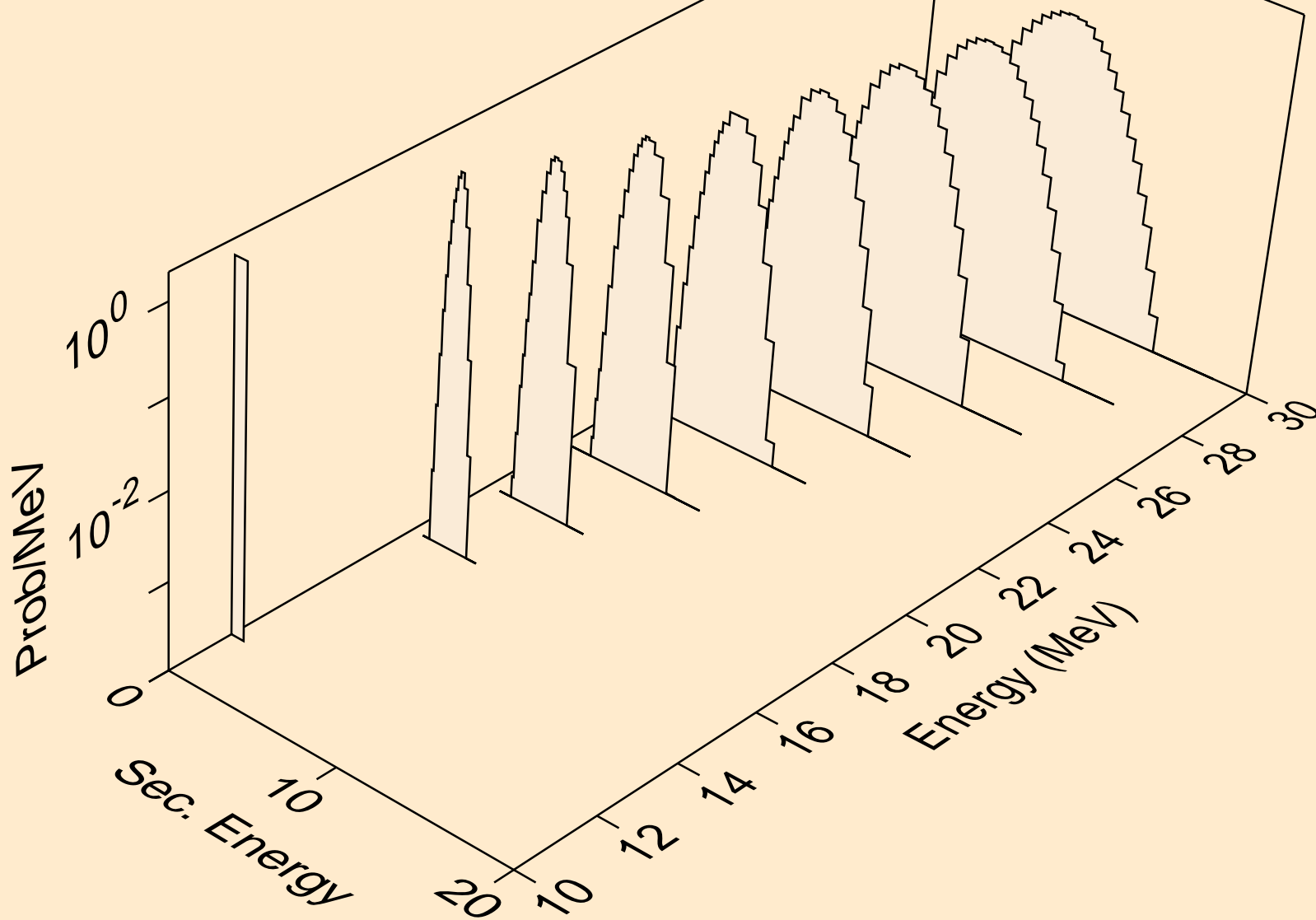

EU148 NEUTRON ACER TENDL-2023 LIBRARY; T=0.K  
protons from (n,npa)

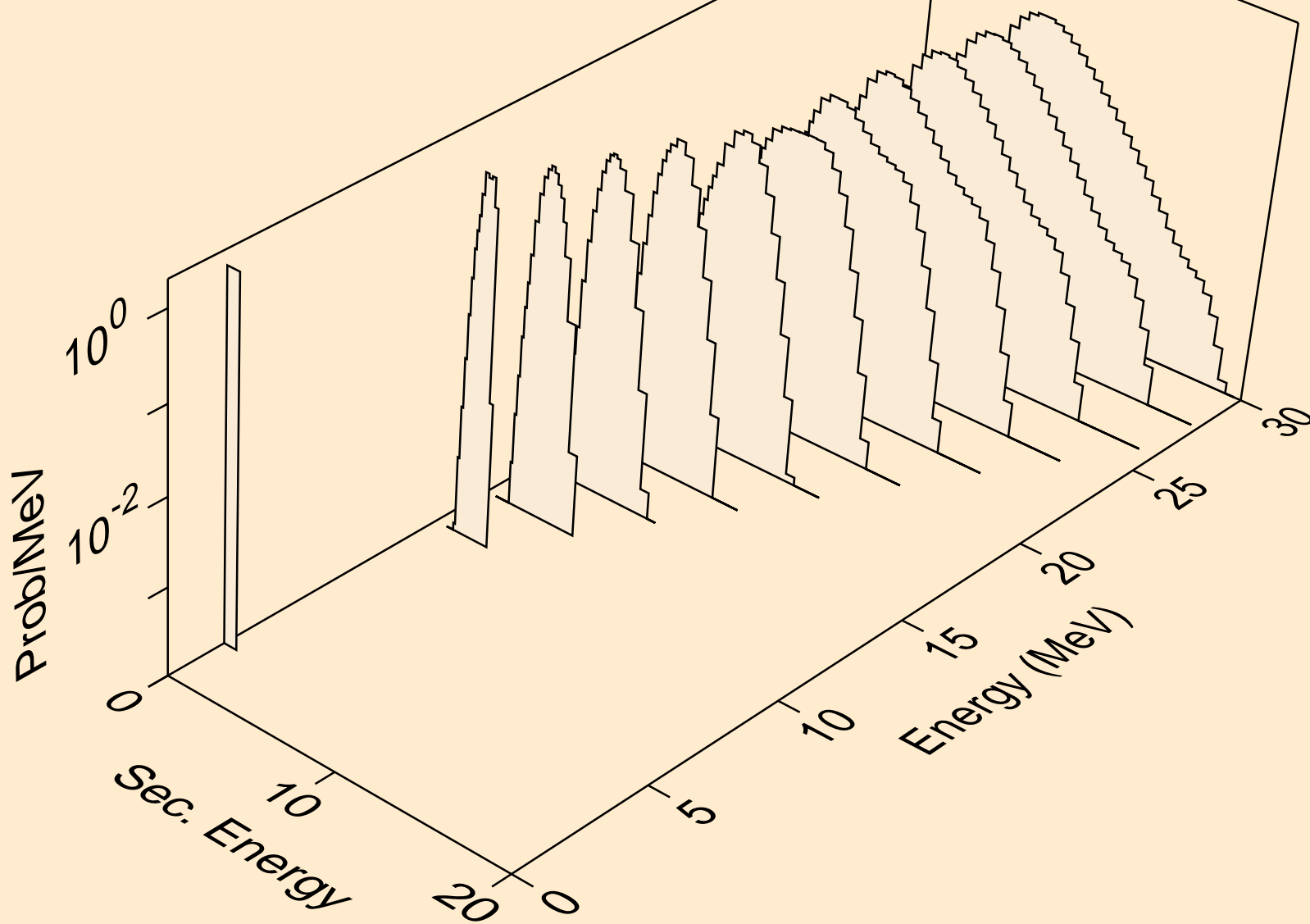

EU148 NEUTRON ACER TENDL-2023 LIBRARY; T=0.K  
protons from (n,p)

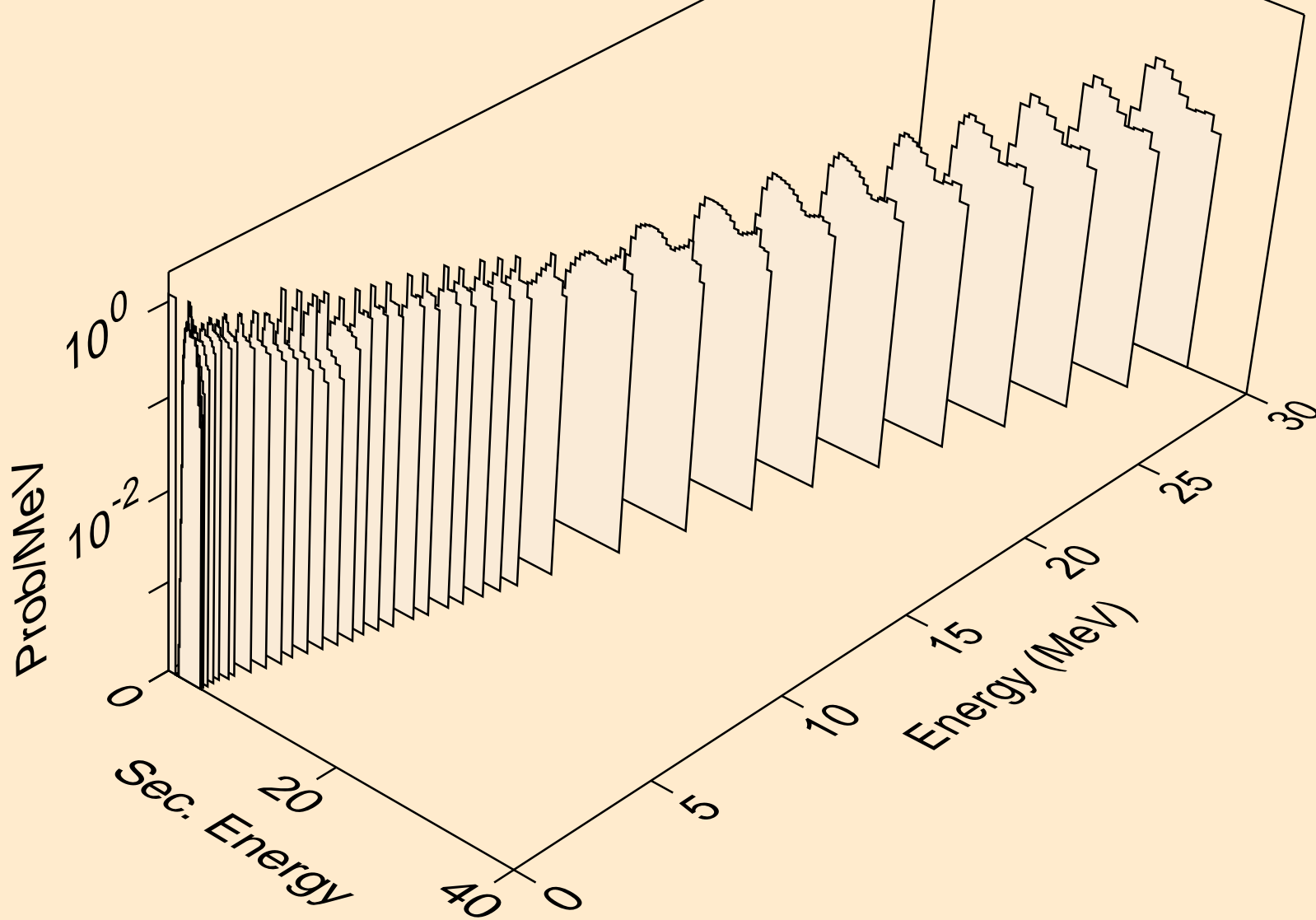



EU148 NEUTRON ACER TENDL-2023 LIBRARY; T=0.K  
protons from (n,2p)

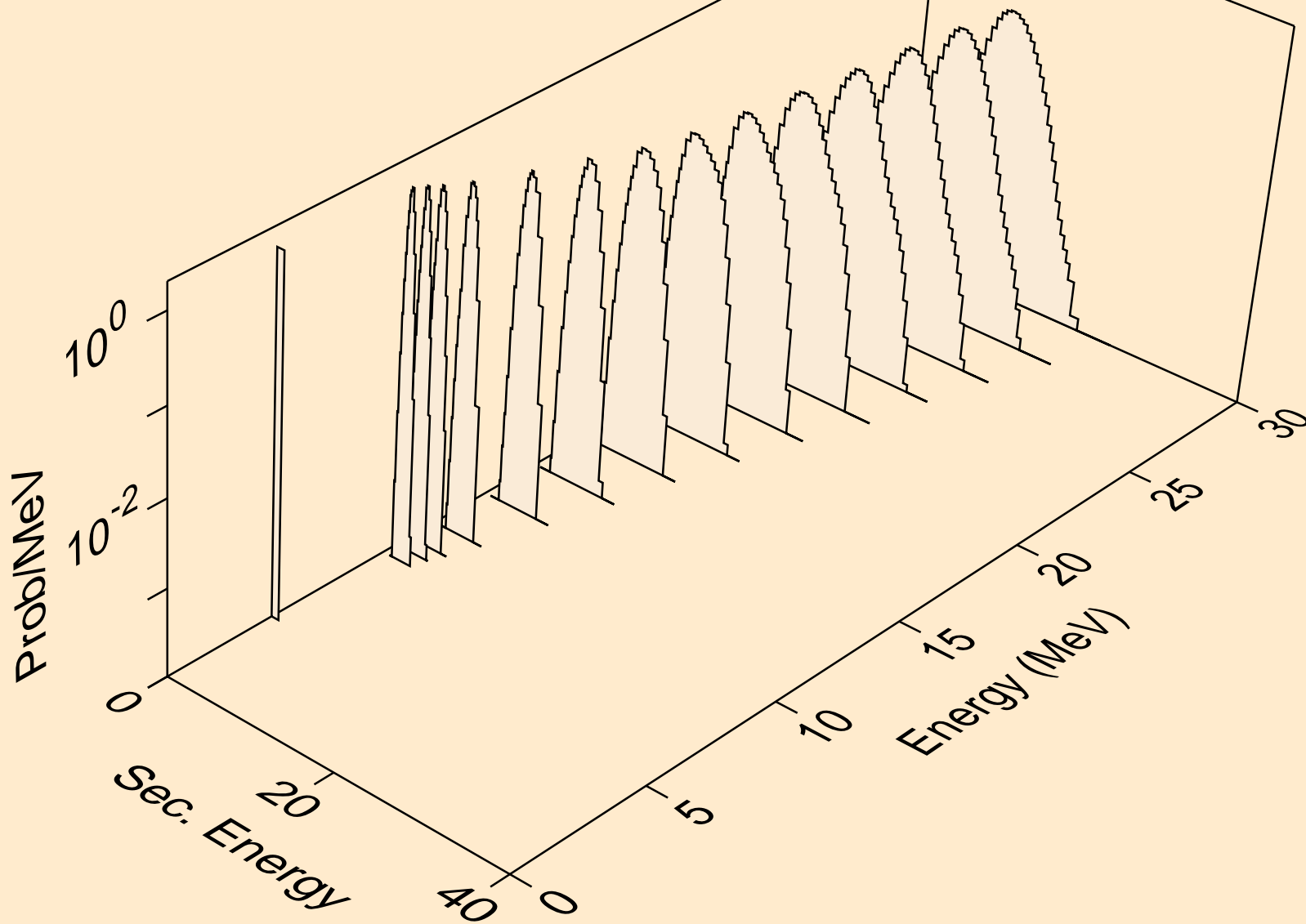

EU148 NEUTRON ACER TENDL-2023 LIBRARY; T=0.K  
protons from (n,p)

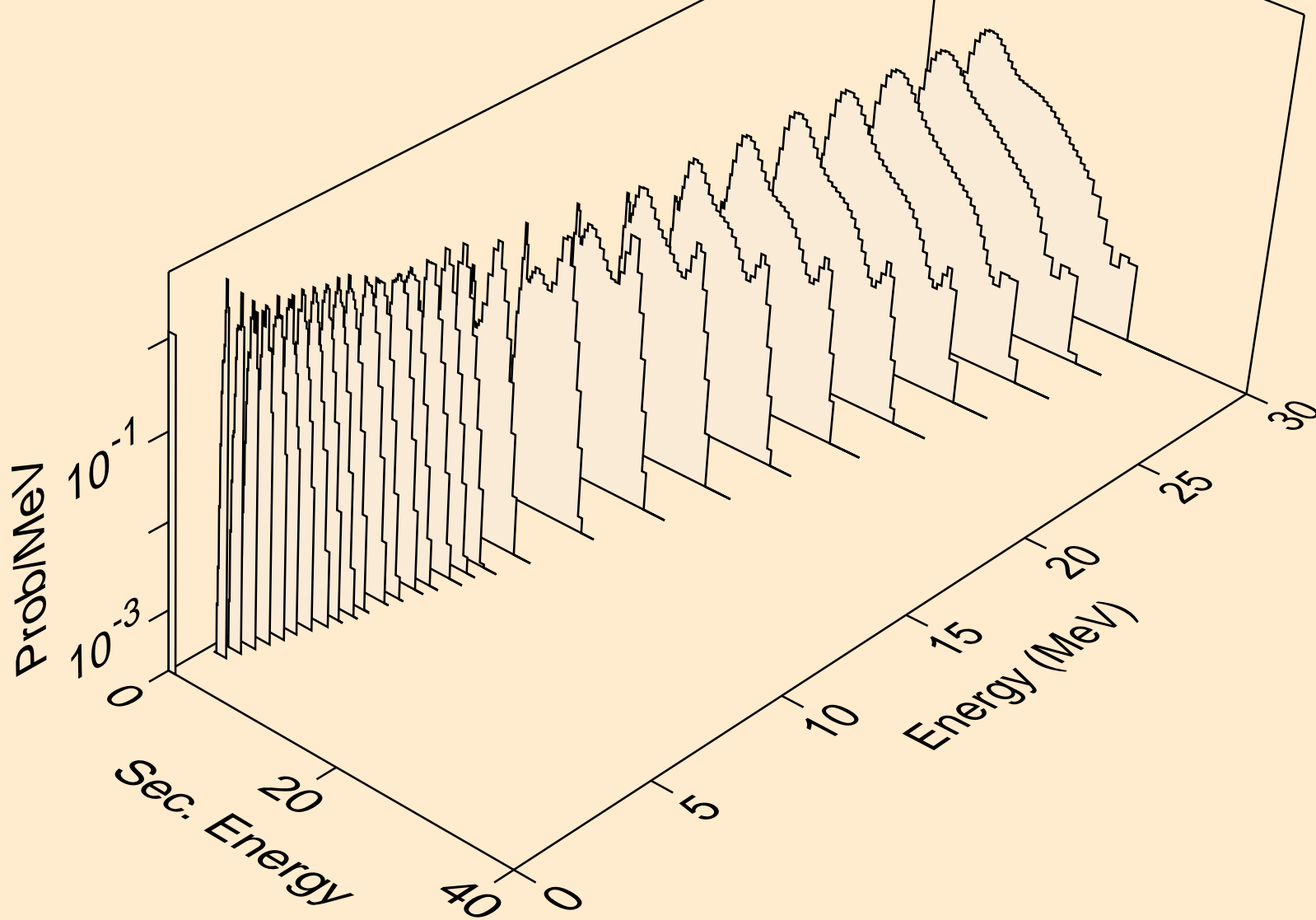

EU148 NEUTRON ACER TENDL-2023 LIBRARY; T=0.K  
protons from (n,pd)

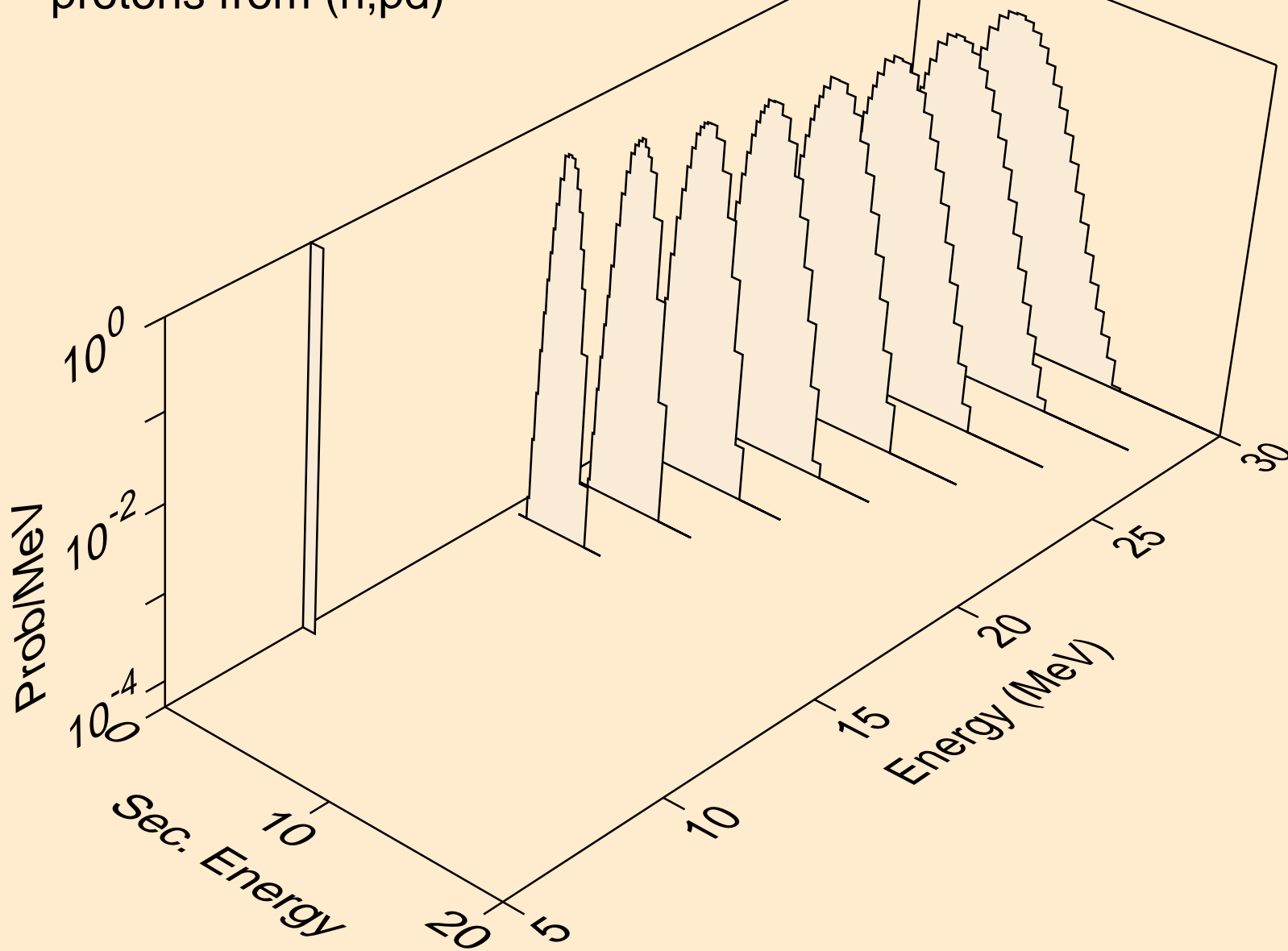

EU148 NEUTRON ACER TENDL-2023 LIBRARY; T=0.K  
protons from (n,pt)

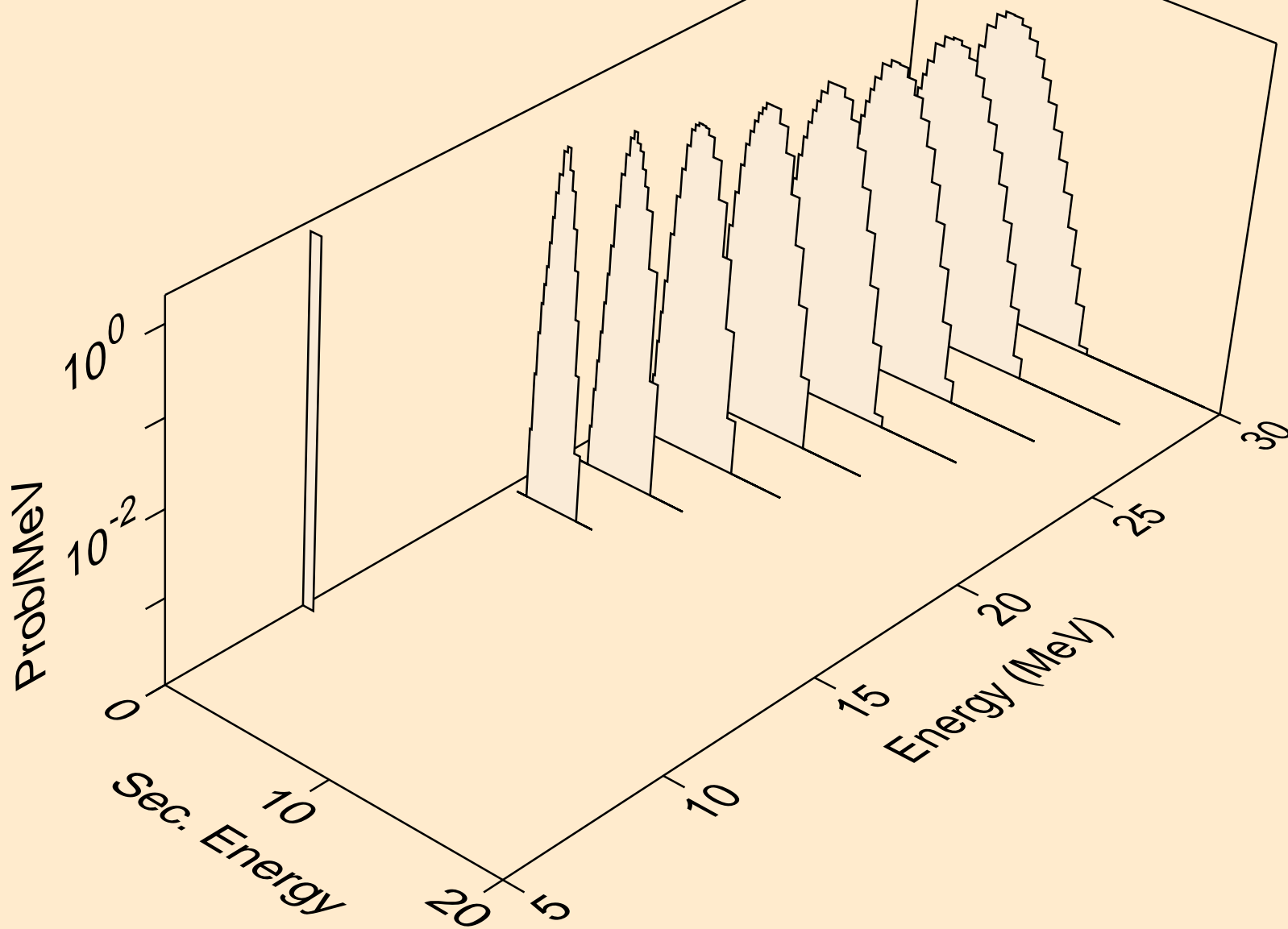

EU148 NEUTRON ACER TENDL-2023 LIBRARY; T=0.K  
deuterons from (n,x)

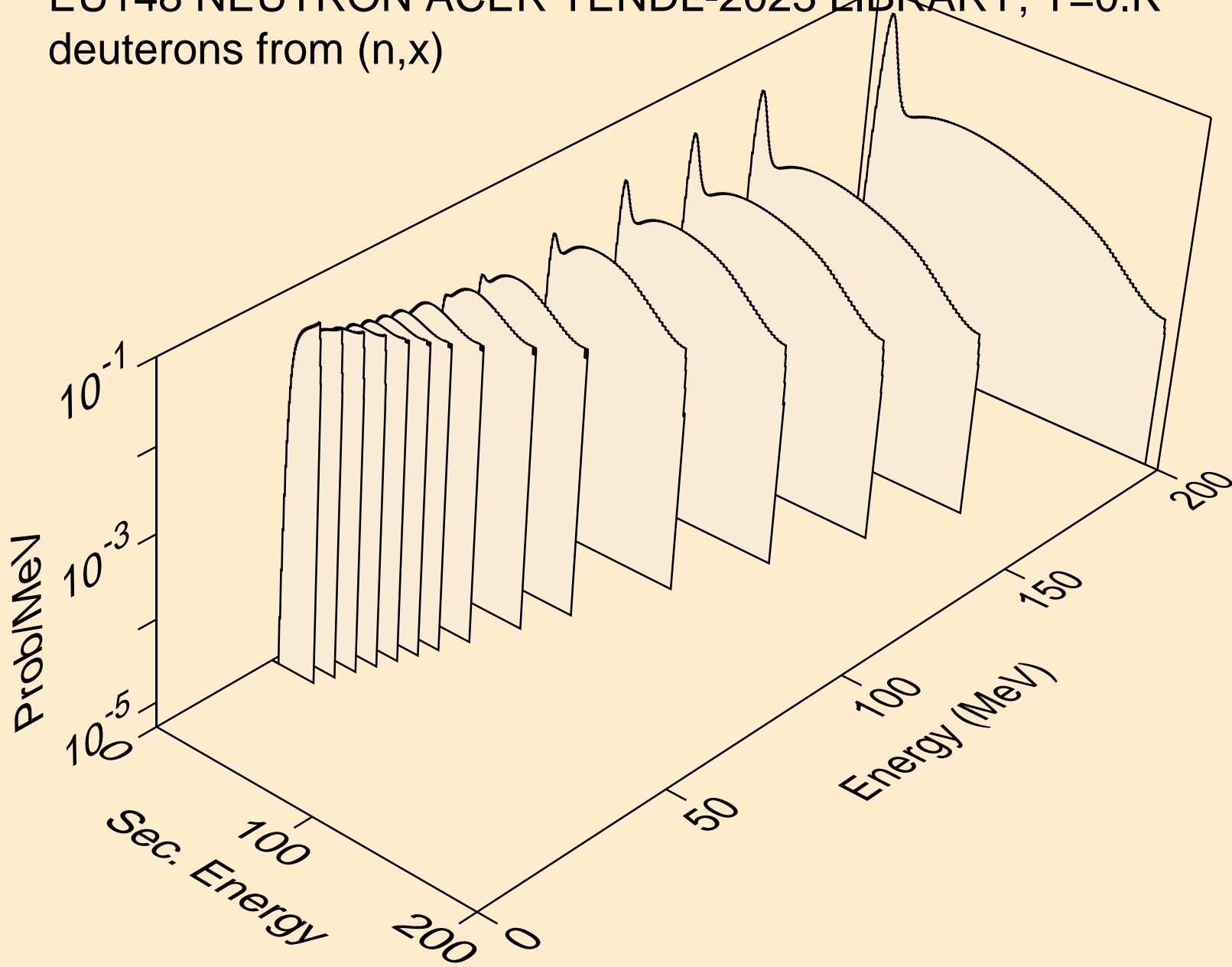

EU148 NEUTRON ACER TENDL-2023 LIBRARY; T=0.K  
deuterons from (n,2nd)

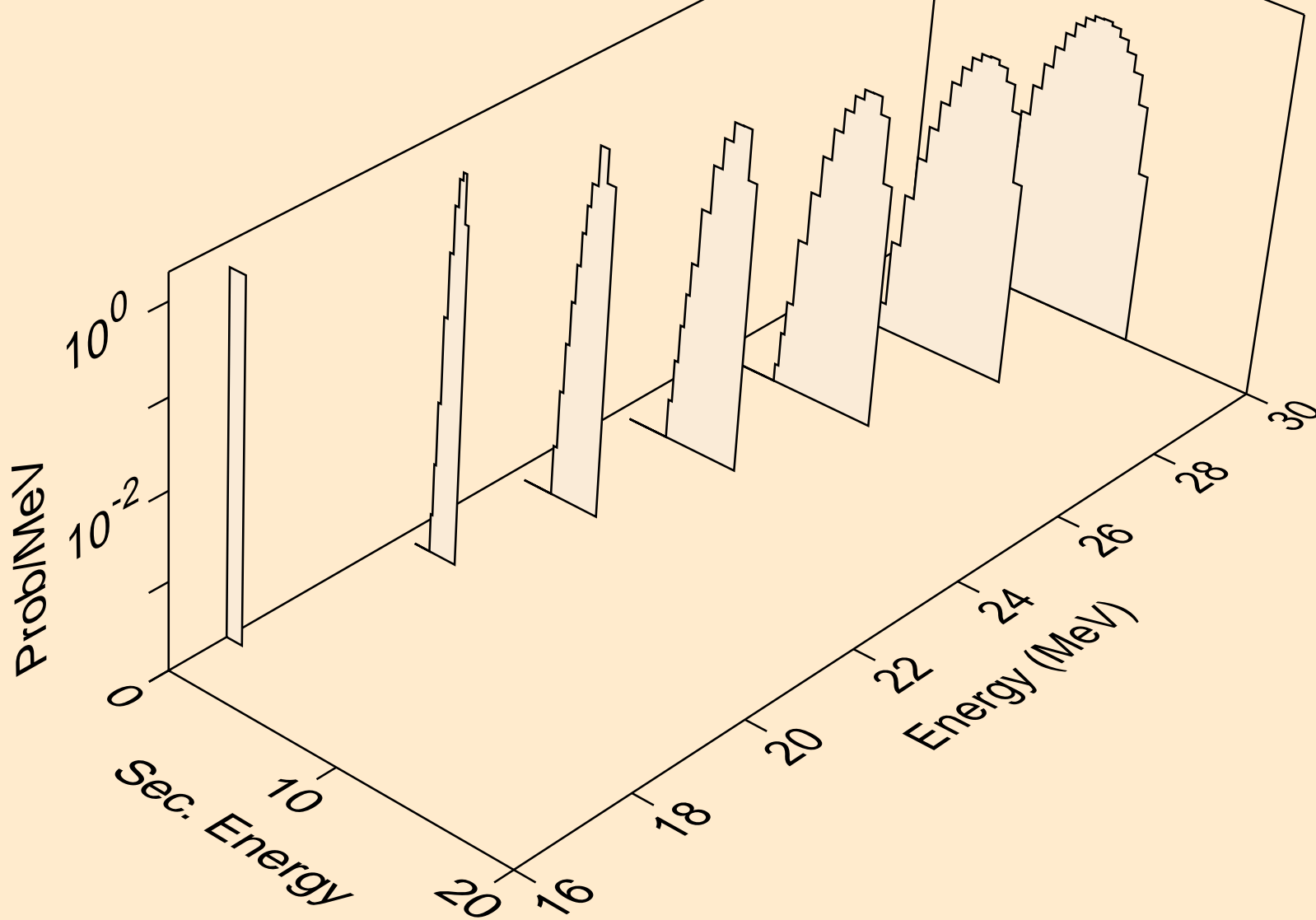

EU148 NEUTRON ACER TENDL-2023 LIBRARY; T=0.K  
deuterons from (n,n\*)d

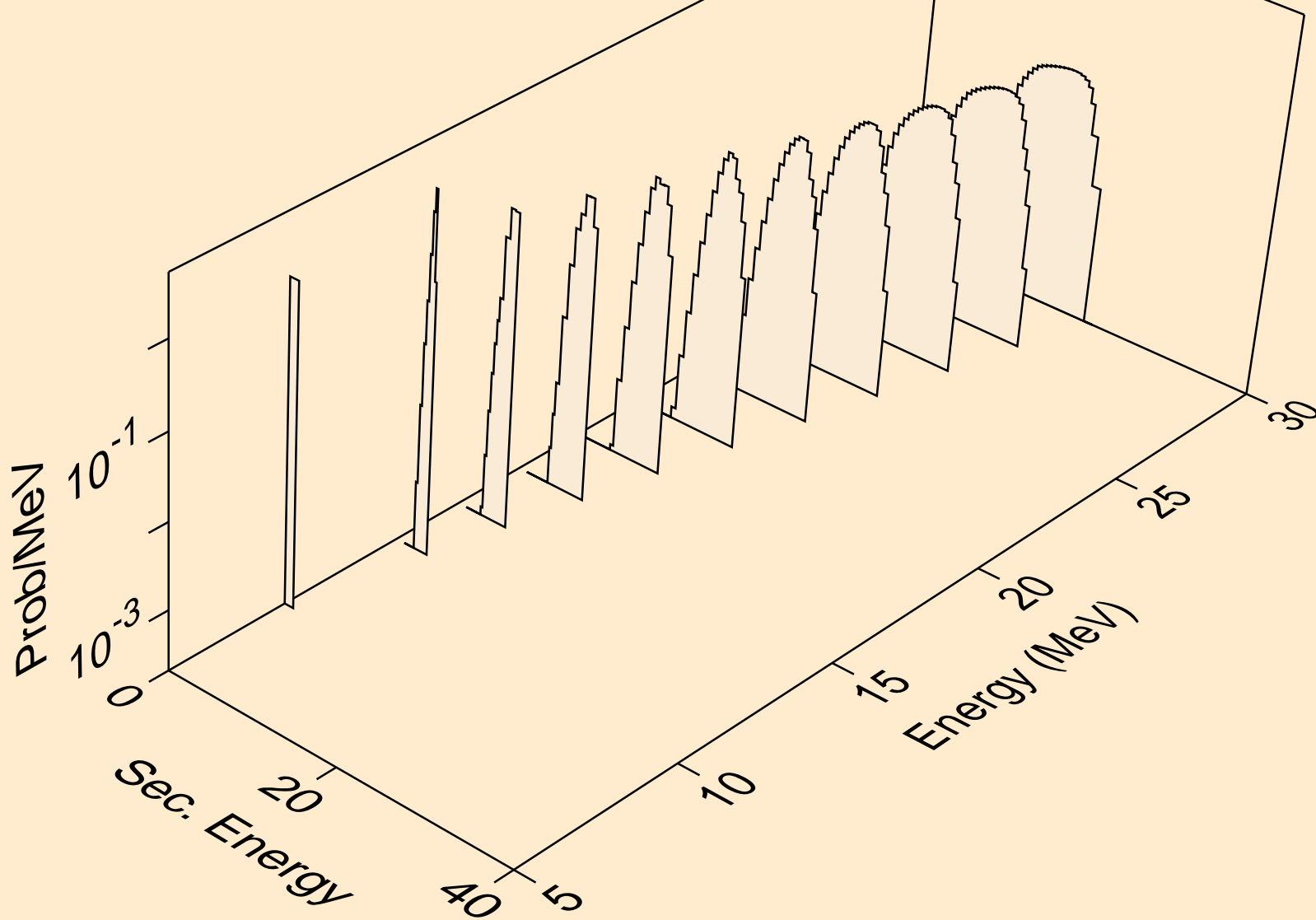

EU148 NEUTRON ACER TENDL-2023 LIBRARY; T=0.K  
deuterons from (n,d)

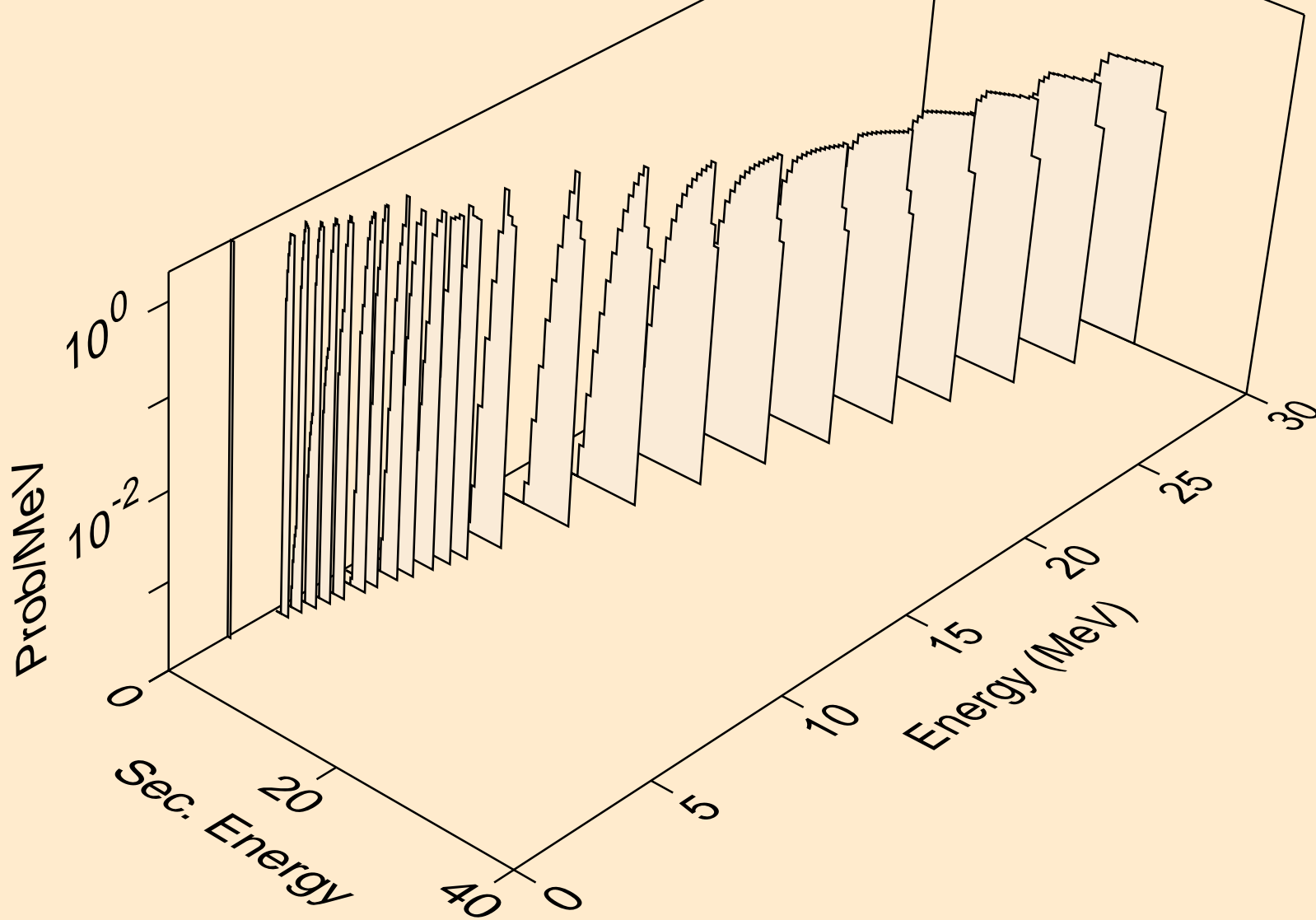



EU148 NEUTRON ACER TENDL-2023 LIBRARY; T=0.K  
deuterons from (n,pd)

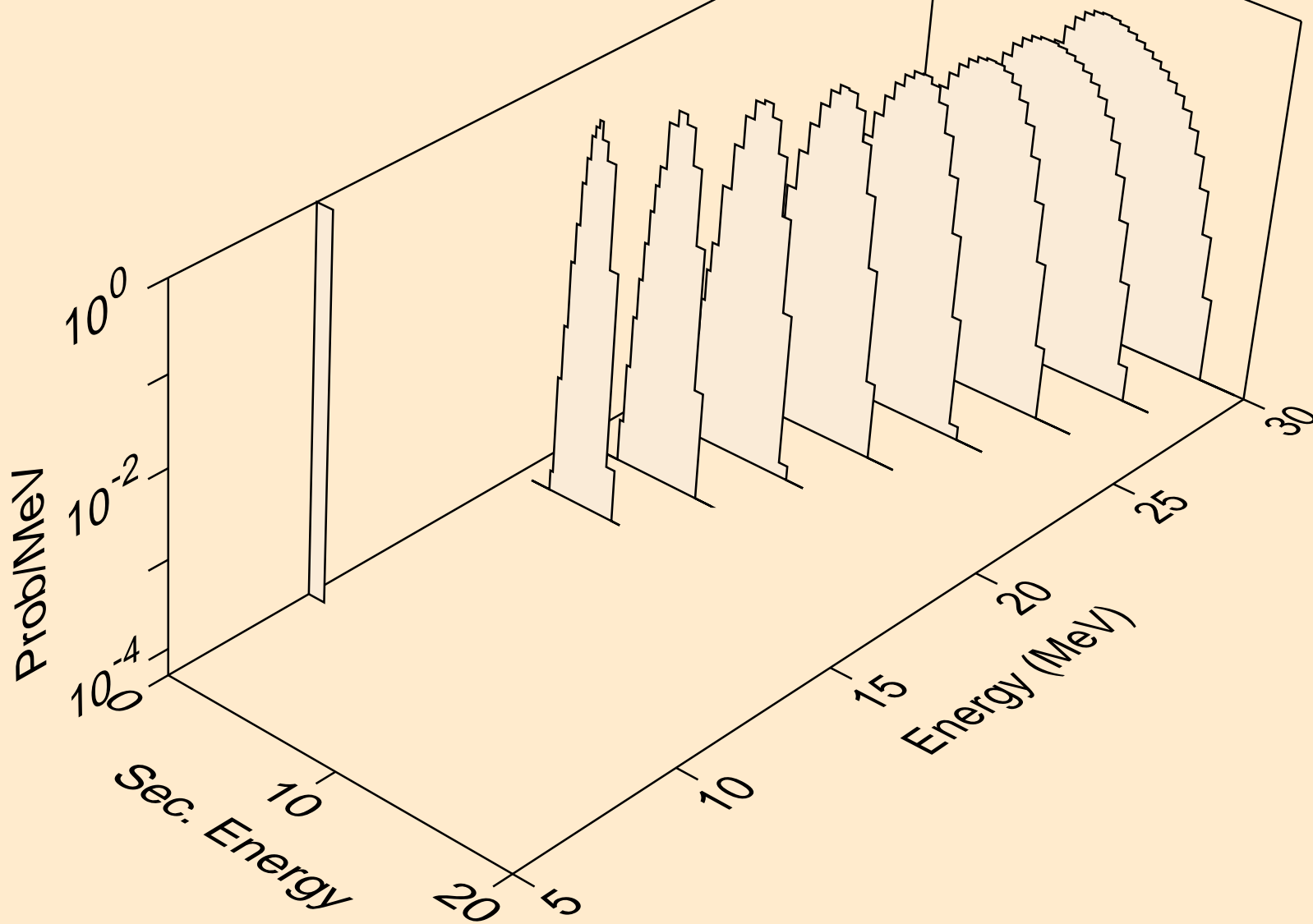

EU148 NEUTRON ACER TENDL-2023 LIBRARY; T=0.K  
deuterons from (n,da)

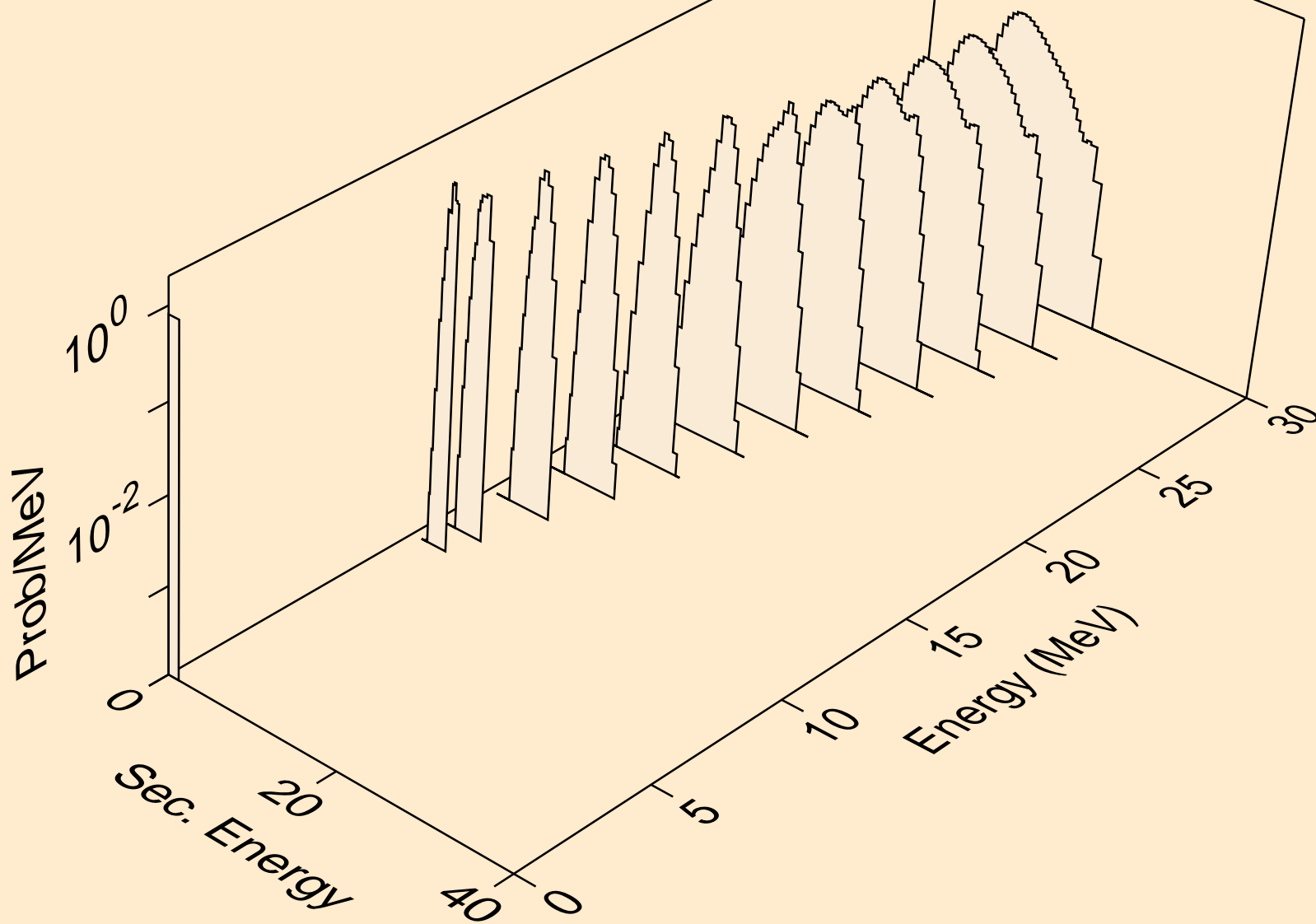

EU148 NEUTRON ACER TENDL-2023 LIBRARY; T=0.K  
tritons from (n,x)

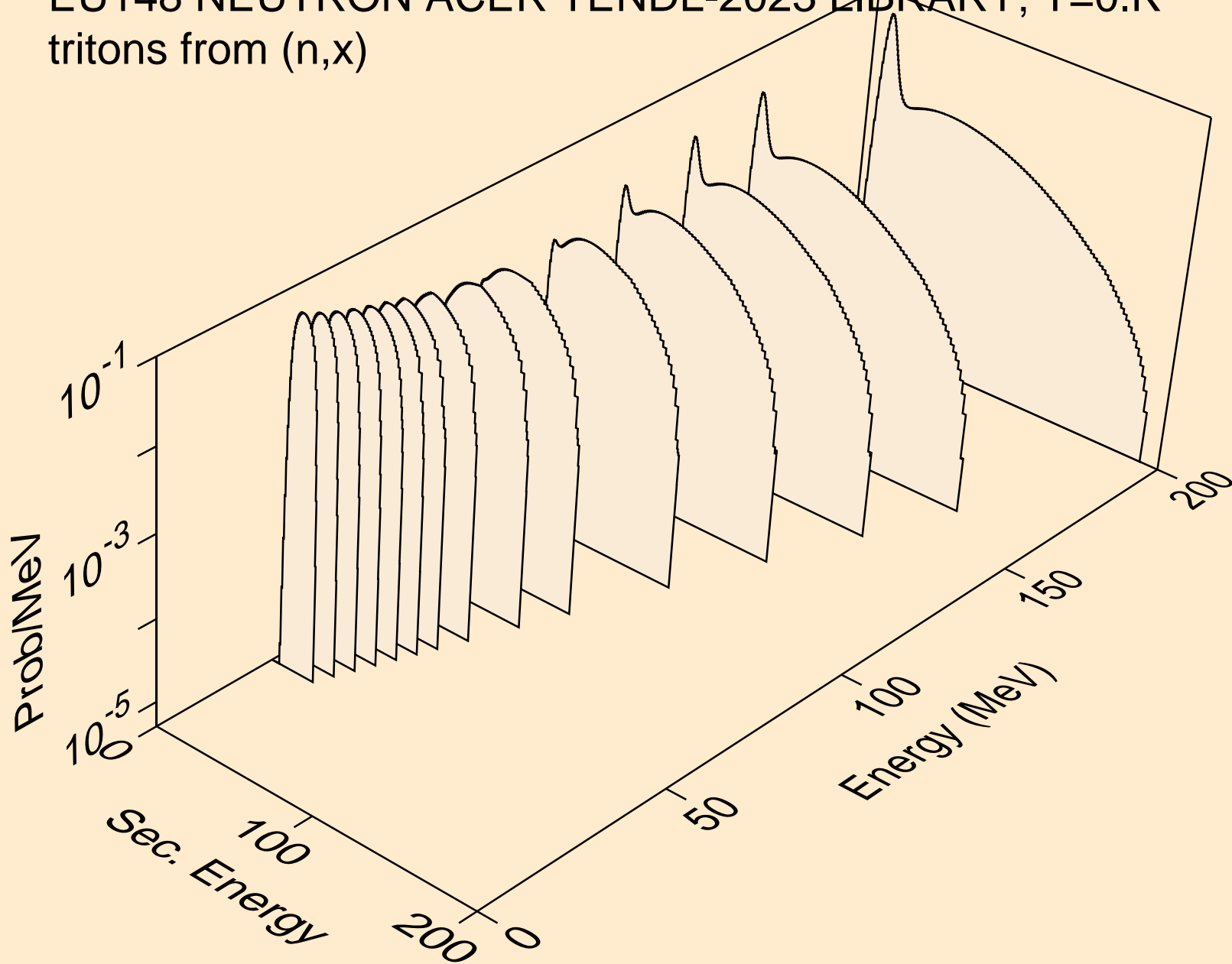

EU148 NEUTRON ACER TENDL-2023 LIBRARY; T=0.K  
tritons from (n,n\*)t

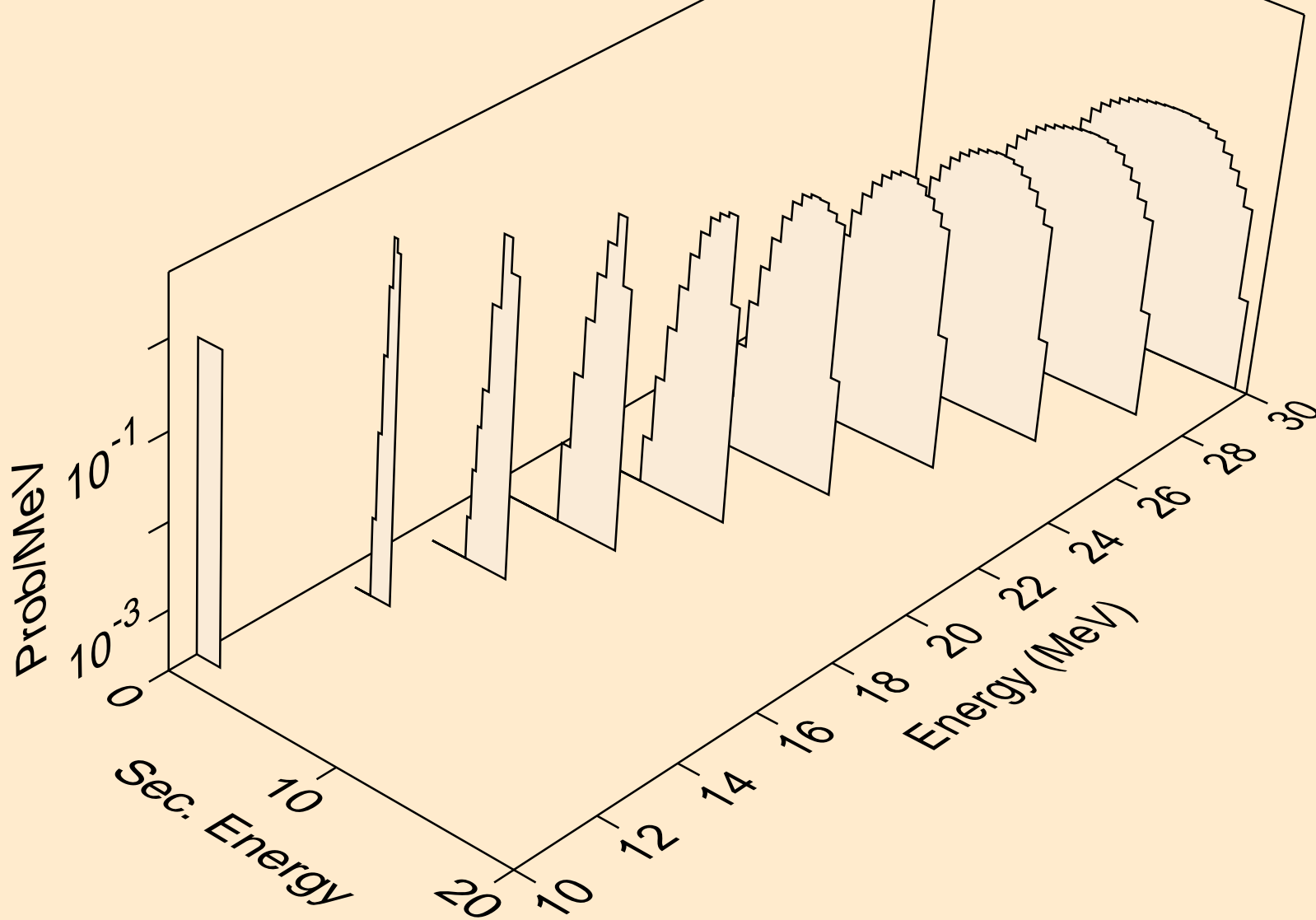

EU148 NEUTRON ACER TENDL-2023 LIBRARY; T=0.K  
tritons from (n,t)

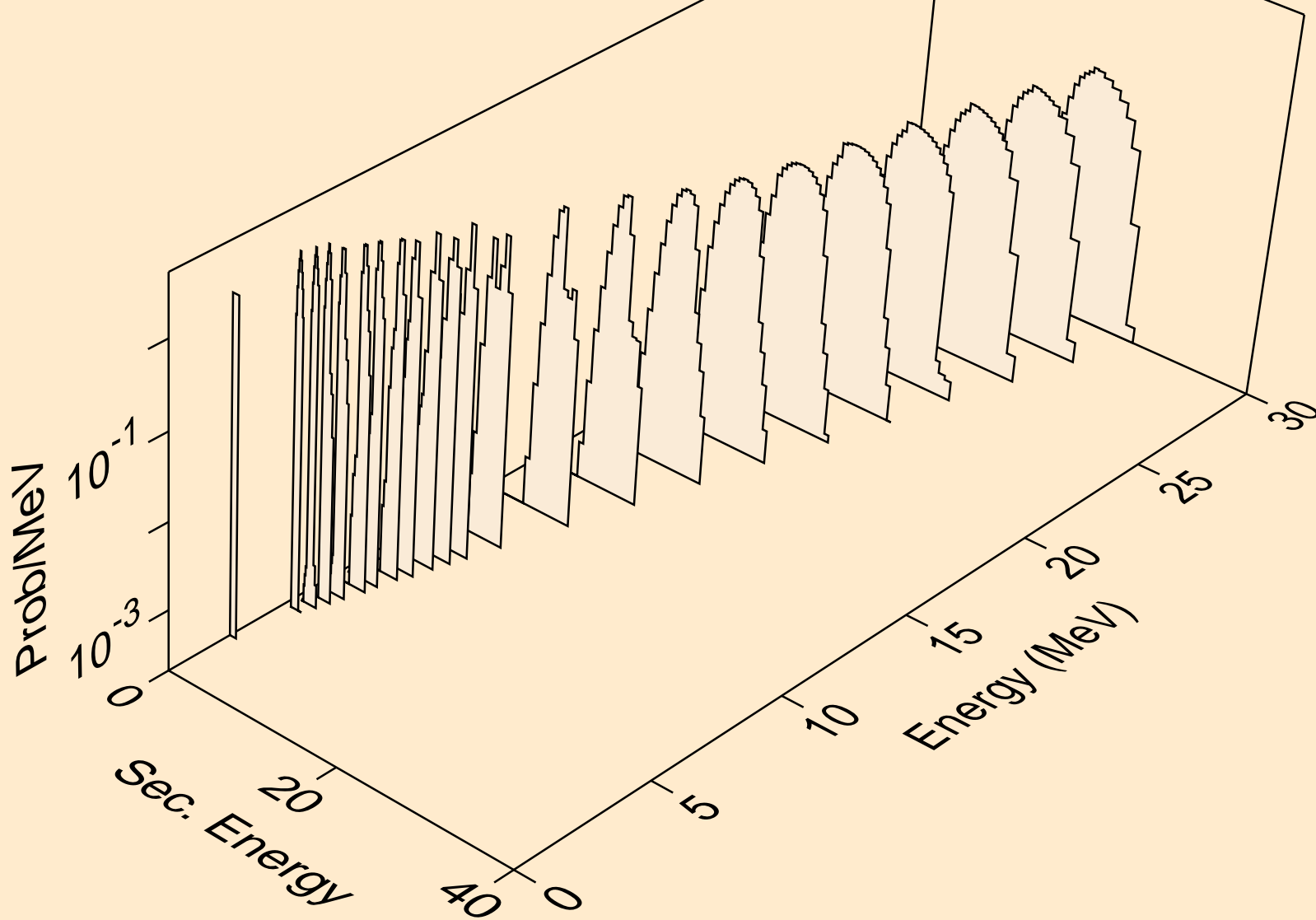

EU148 NEUTRON ACER TENDL-2023 LIBRARY; T=0.K  
tritons from (n,pt)

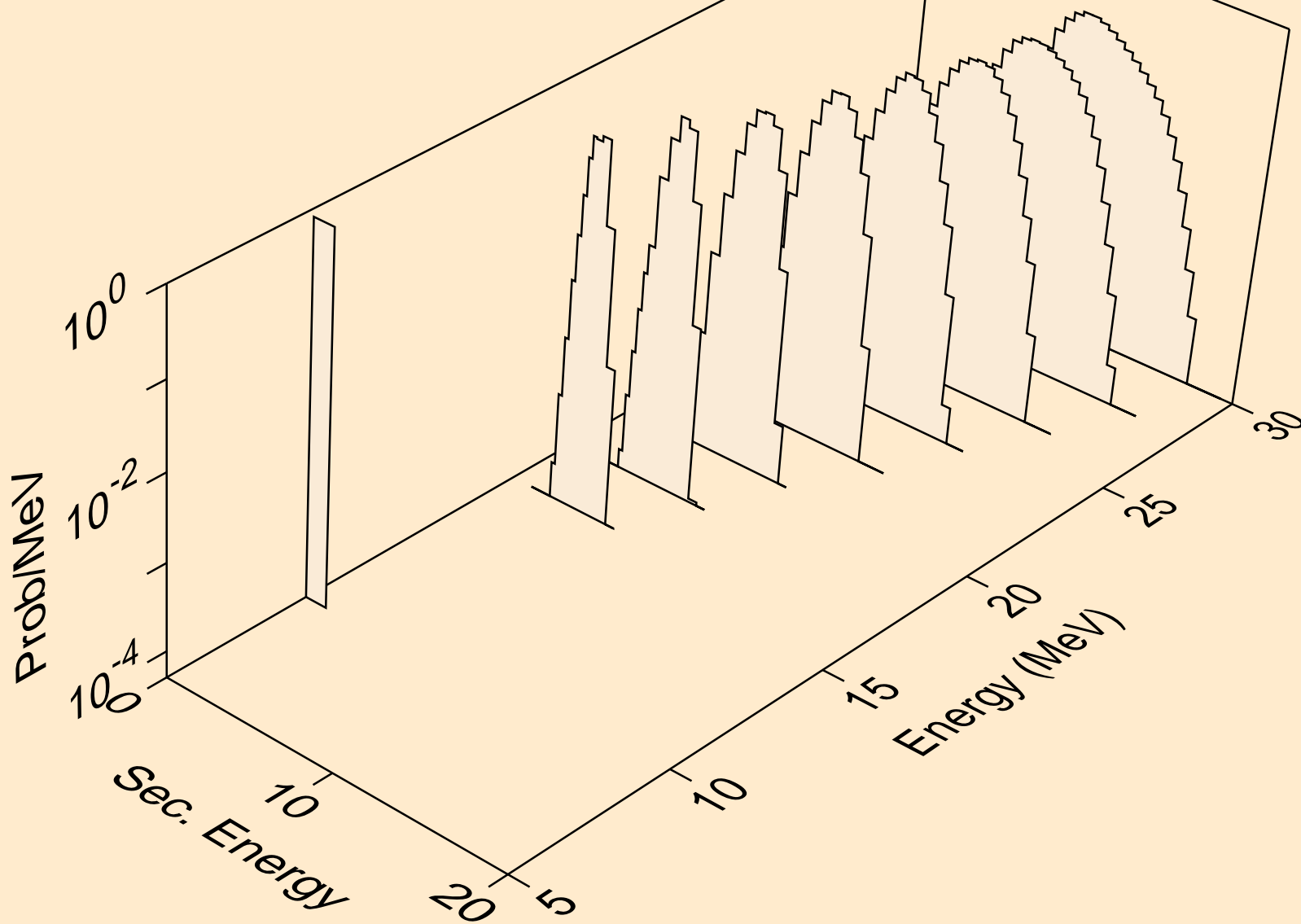

EU148 NEUTRON ACER TENDL-2023 LIBRARY; T=0.K  
he3s from (n,x)

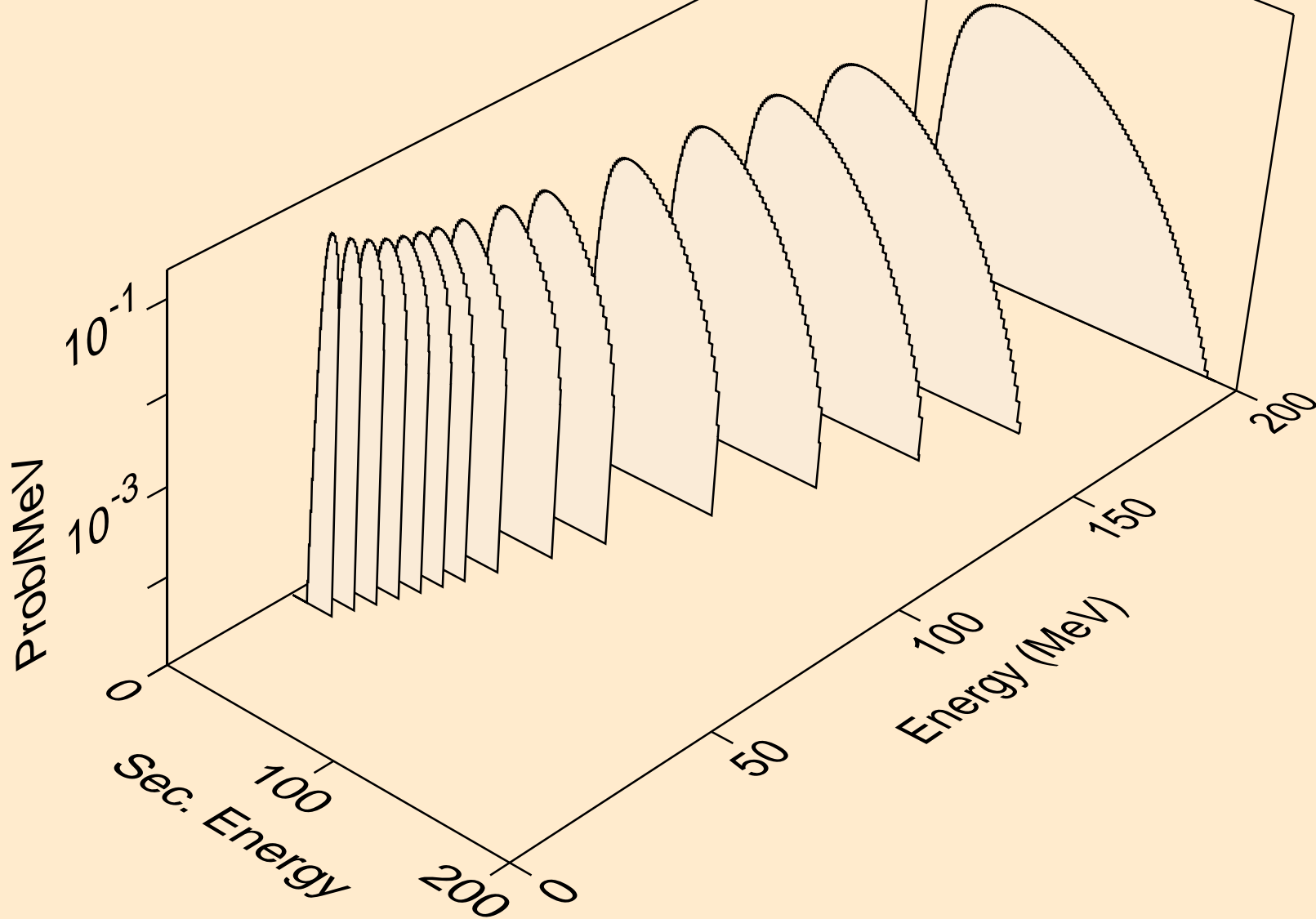

EU148 NEUTRON ACER TENDL-2023 LIBRARY; T=0.K  
he3s from (n,n\*)he3

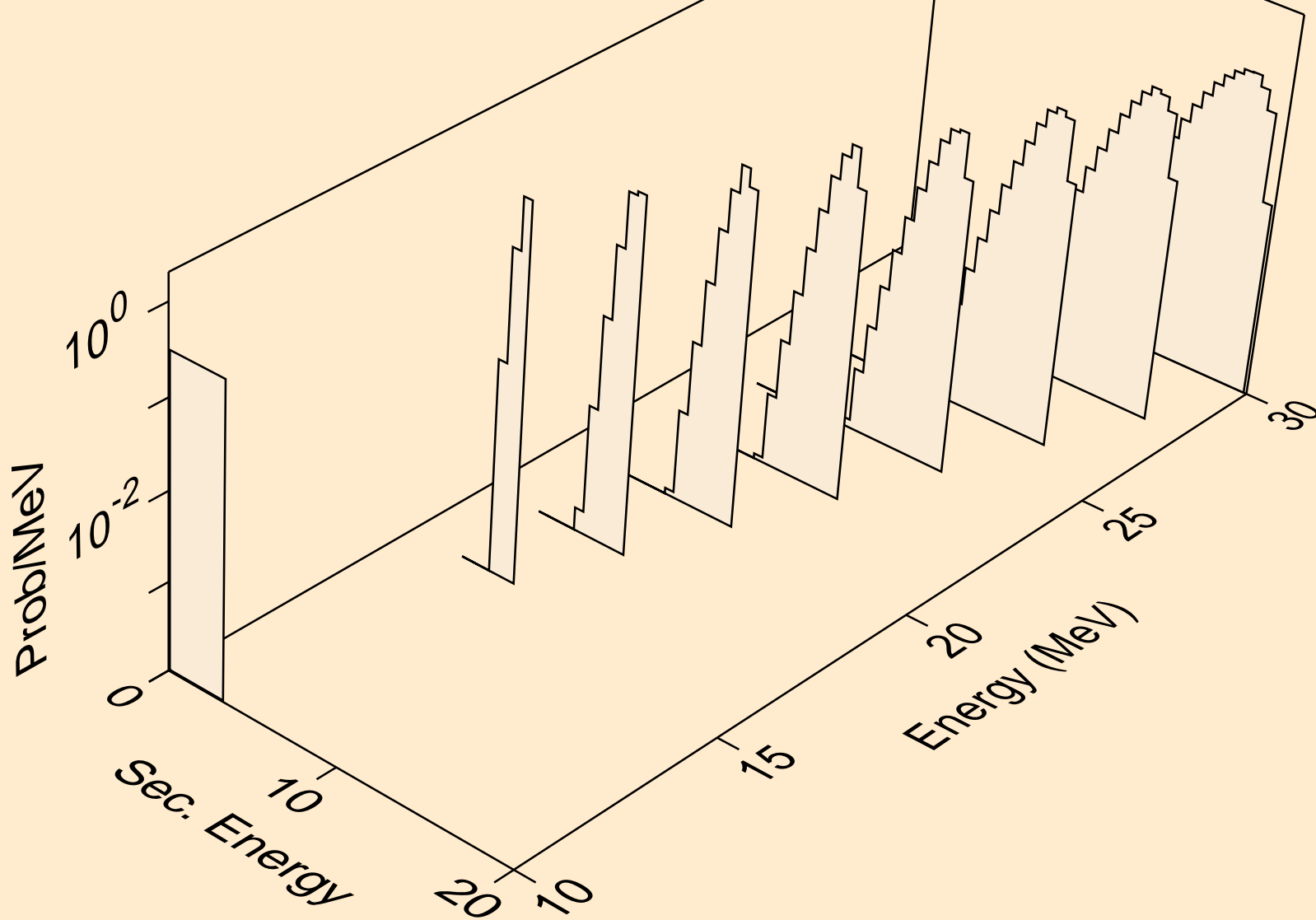



EU148 NEUTRON ACER TENDL-2023 LIBRARY; T=0.K  
he3s from (n,he3)

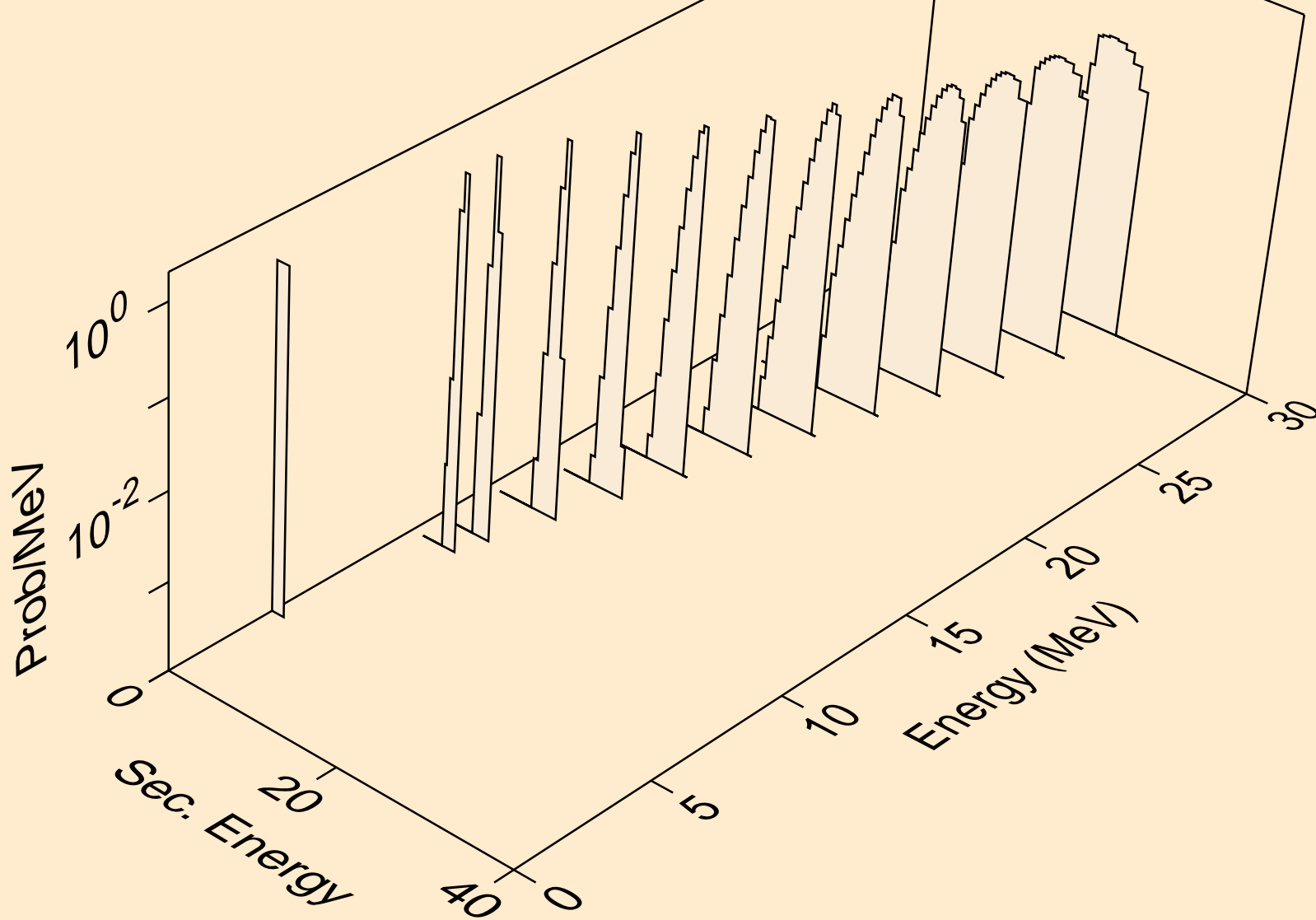

EU148 NEUTRON ACER TENDL-2023 LIBRARY; T=0.K  
alphas from (n,x)

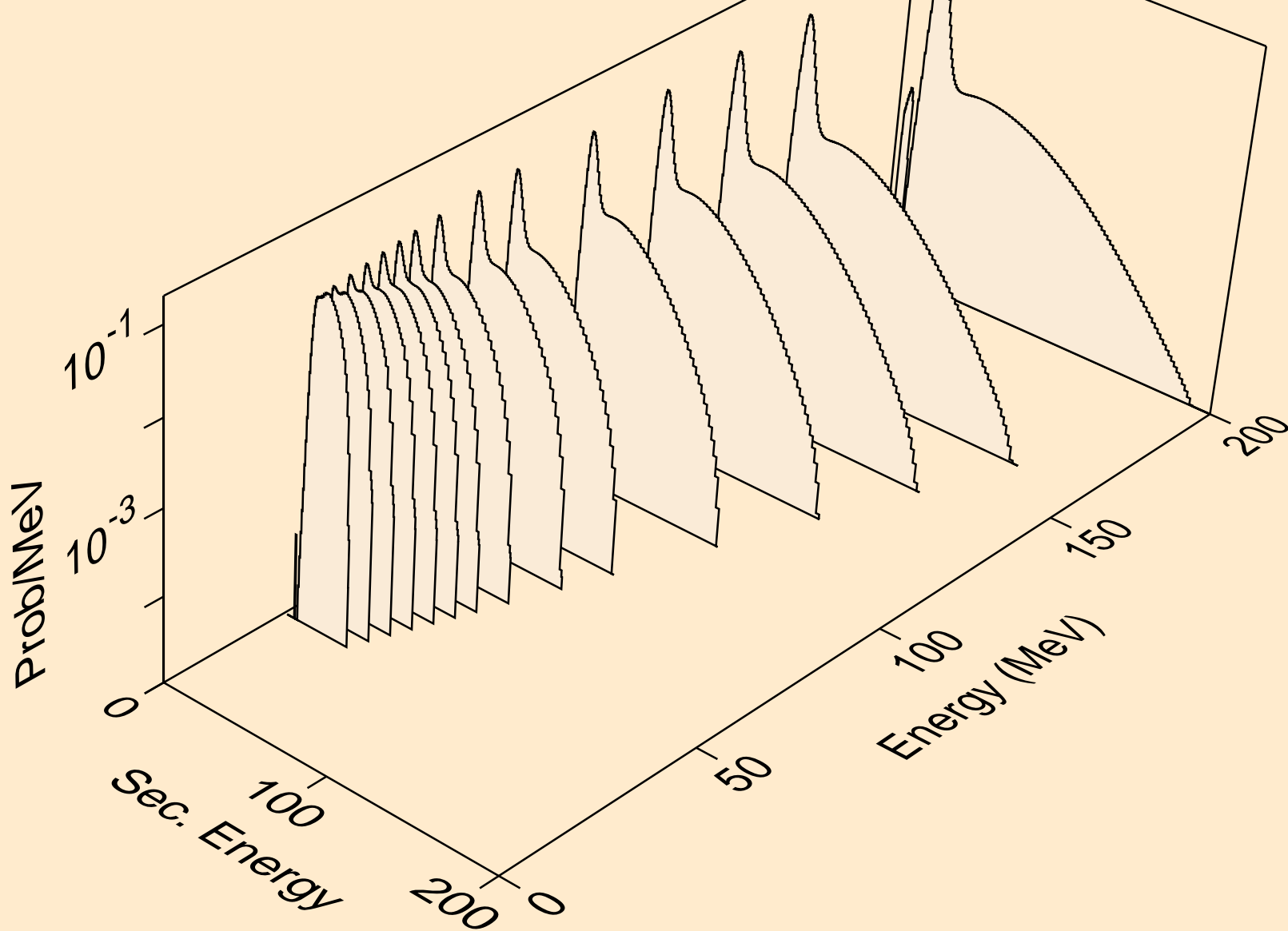

EU148 NEUTRON ACER TENDL-2023 LIBRARY; T=0.K  
alphas from (n,n\*)a

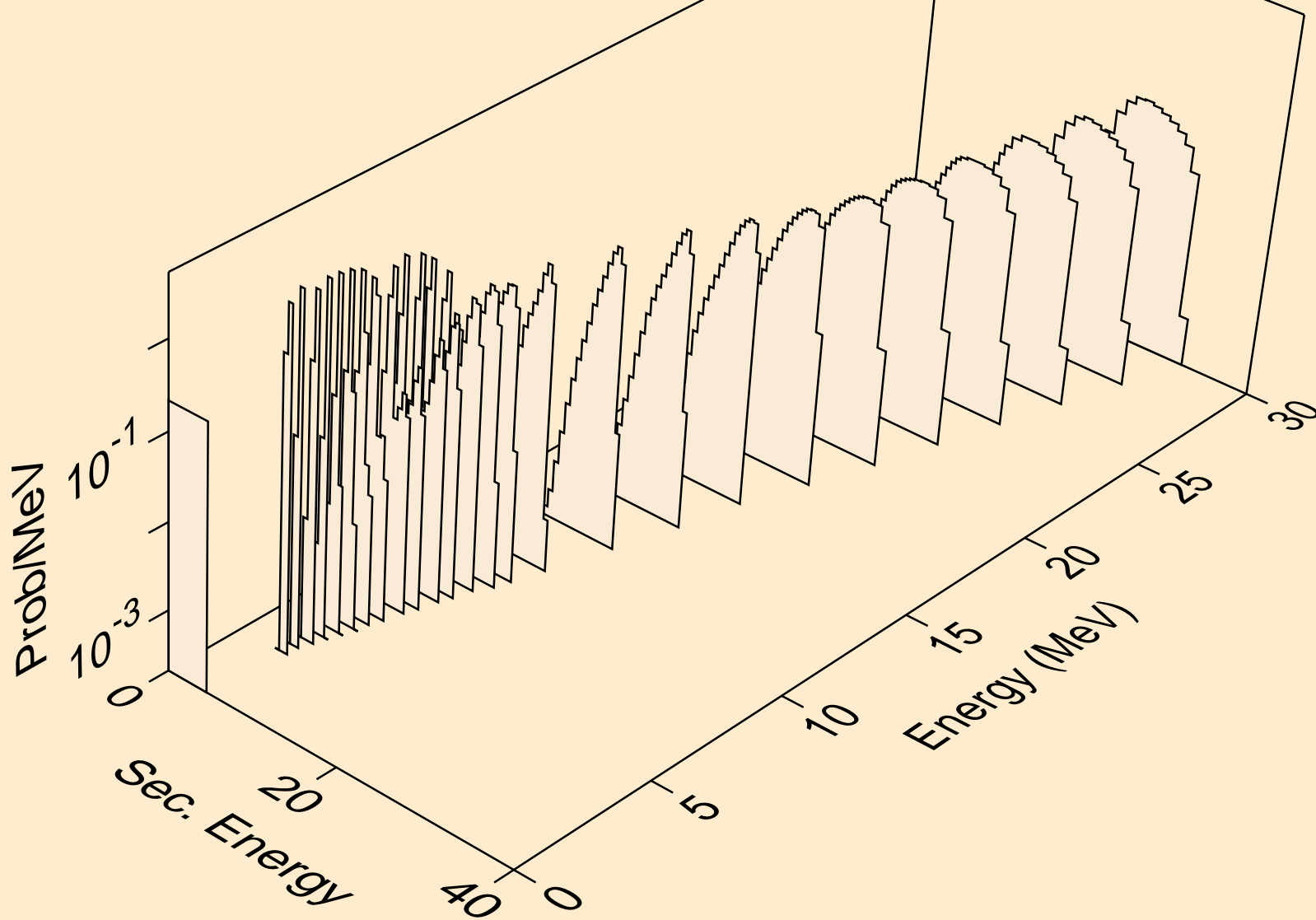

EU148 NEUTRON ACER TENDL-2023 LIBRARY; T=0.K  
alphas from (n,2n)a

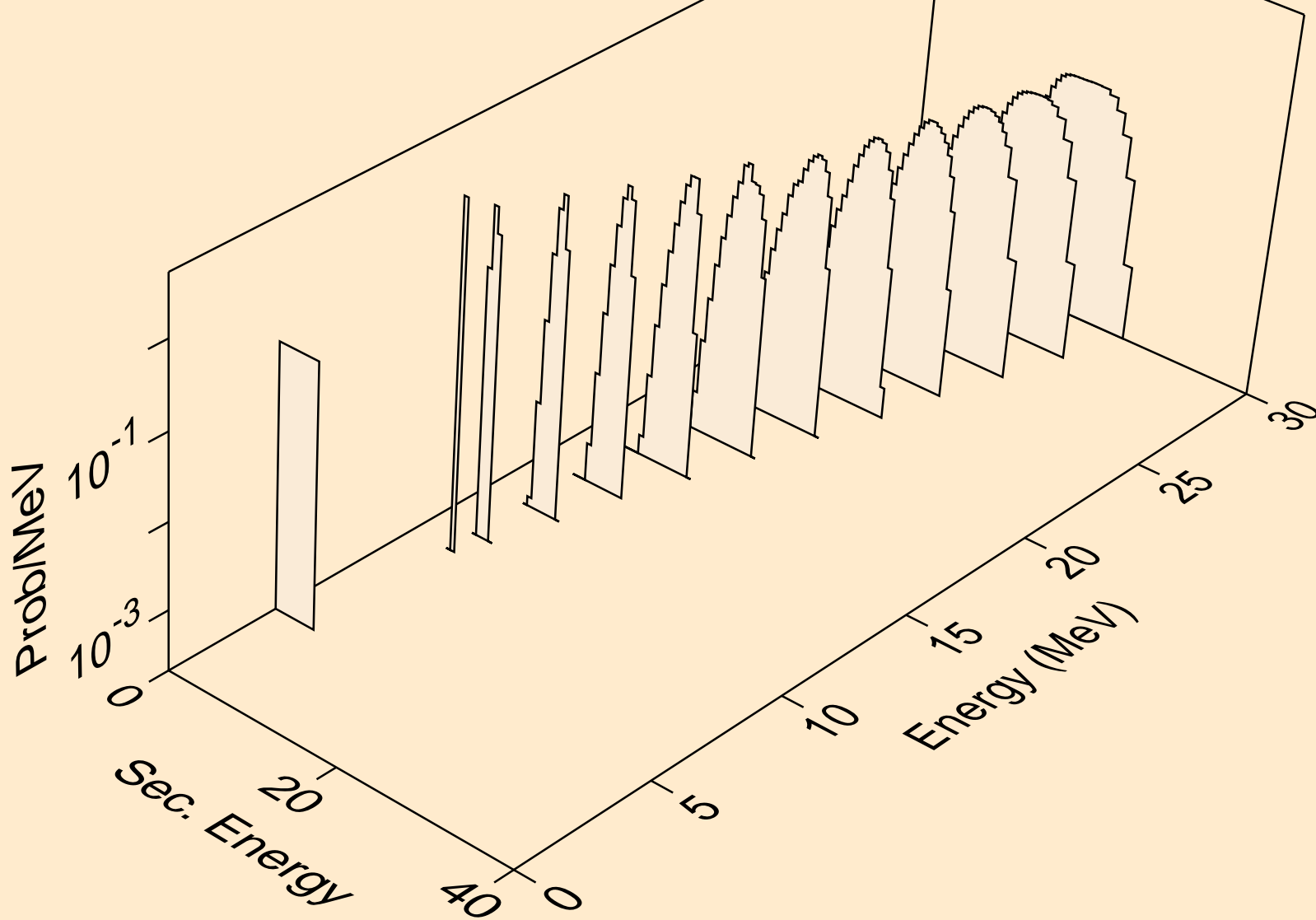

EU148 NEUTRON ACER TENDL-2023 LIBRARY; T=0.K  
alphas from (n,3n)a

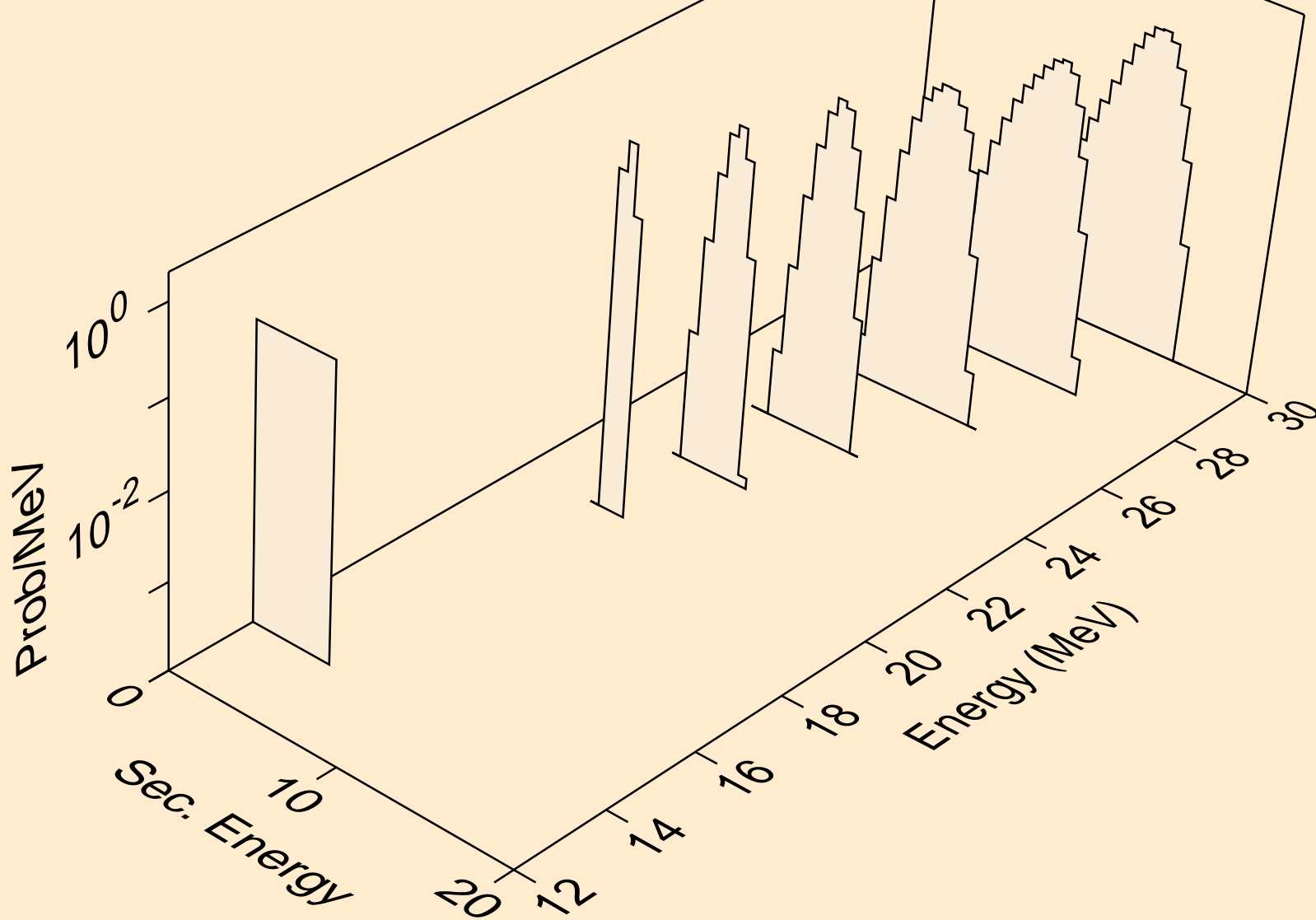

EU148 NEUTRON ACER TENDL-2023 LIBRARY; T=0.K  
alphas from (n,n\*)2a

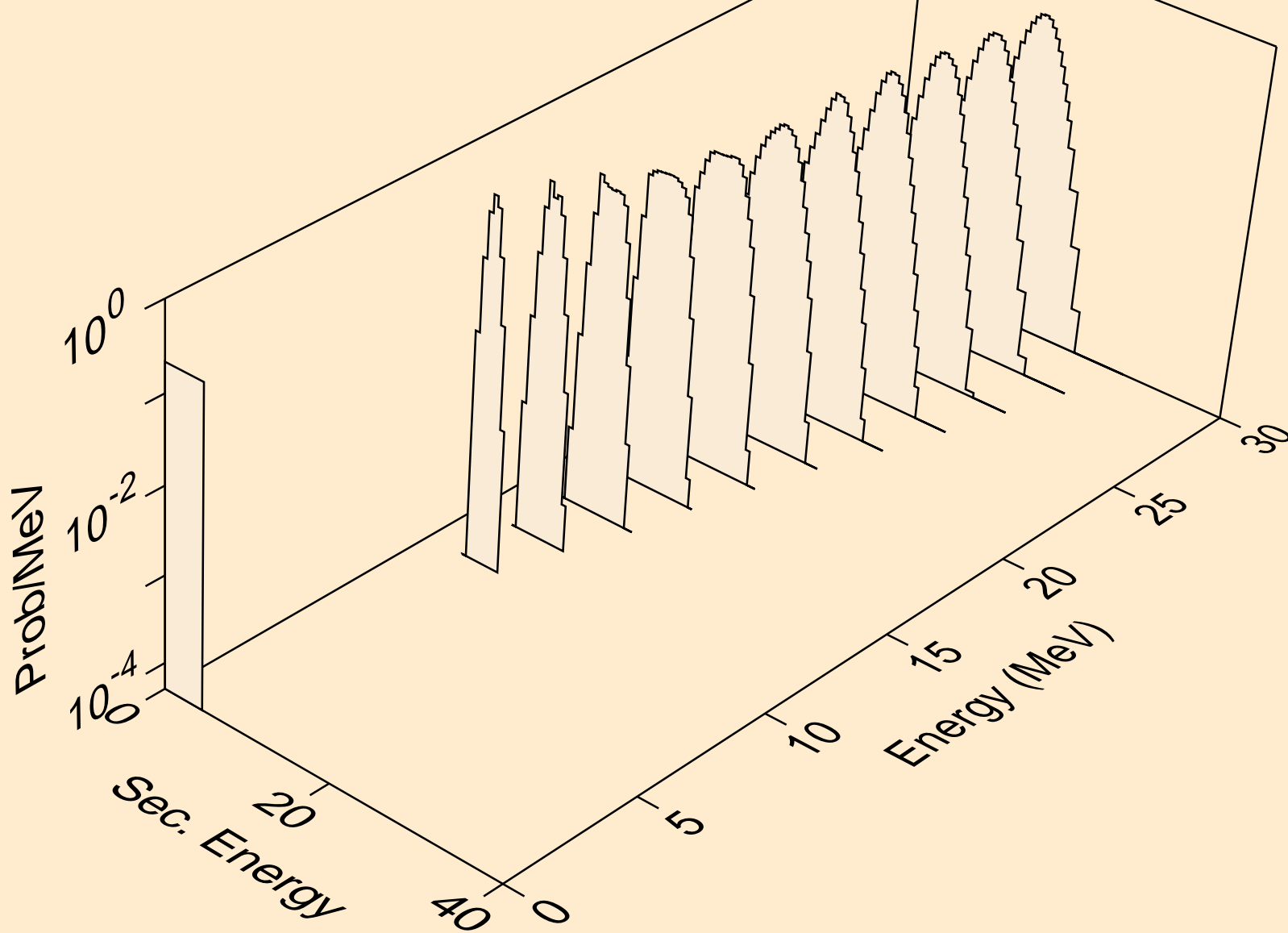

EU148 NEUTRON ACER TENDL-2023 LIBRARY; T=0.K  
alphas from (n,2n)2a

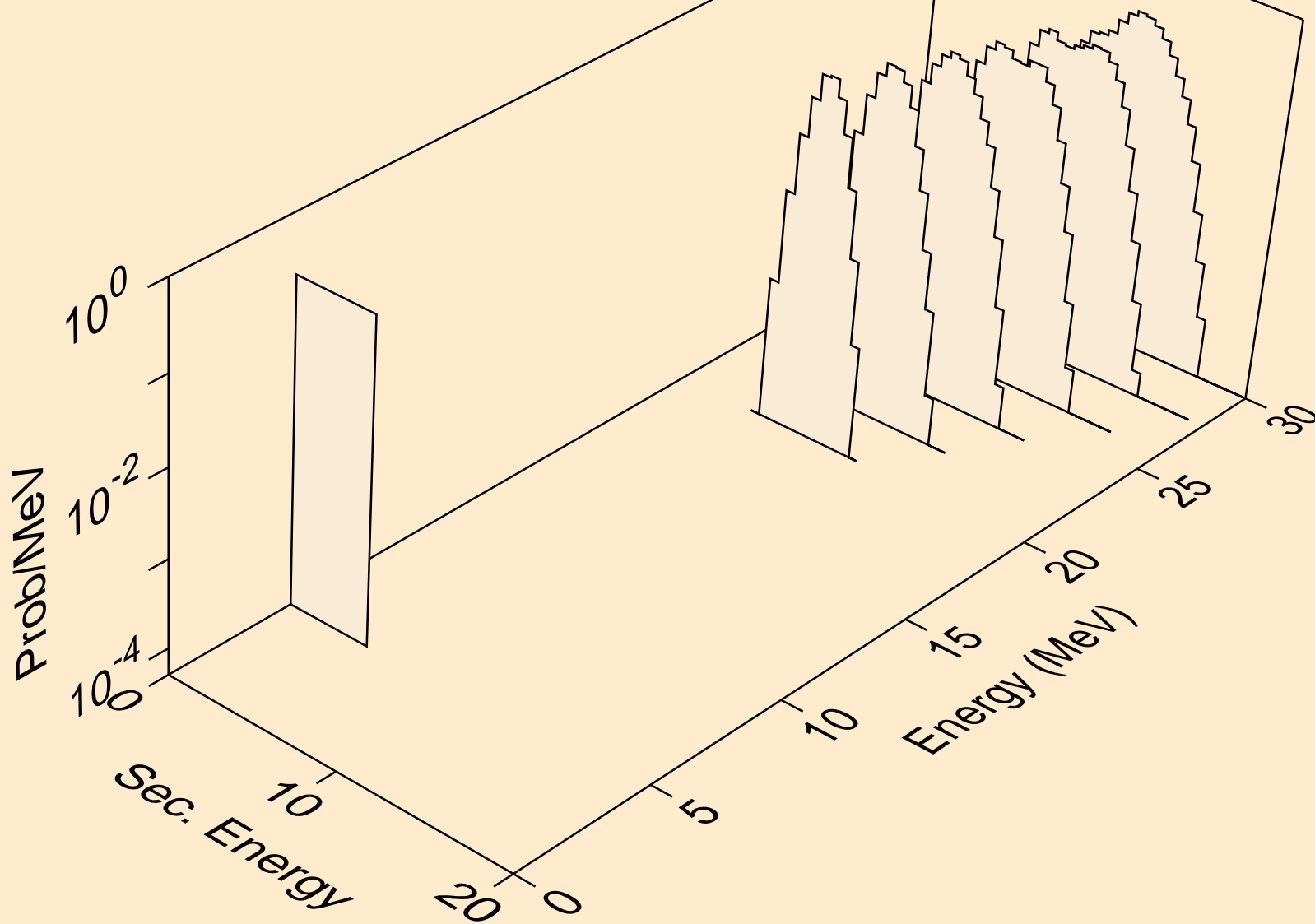

EU148 NEUTRON ACER TENDL-2023 LIBRARY; T=0.K  
alphas from (n,npa)

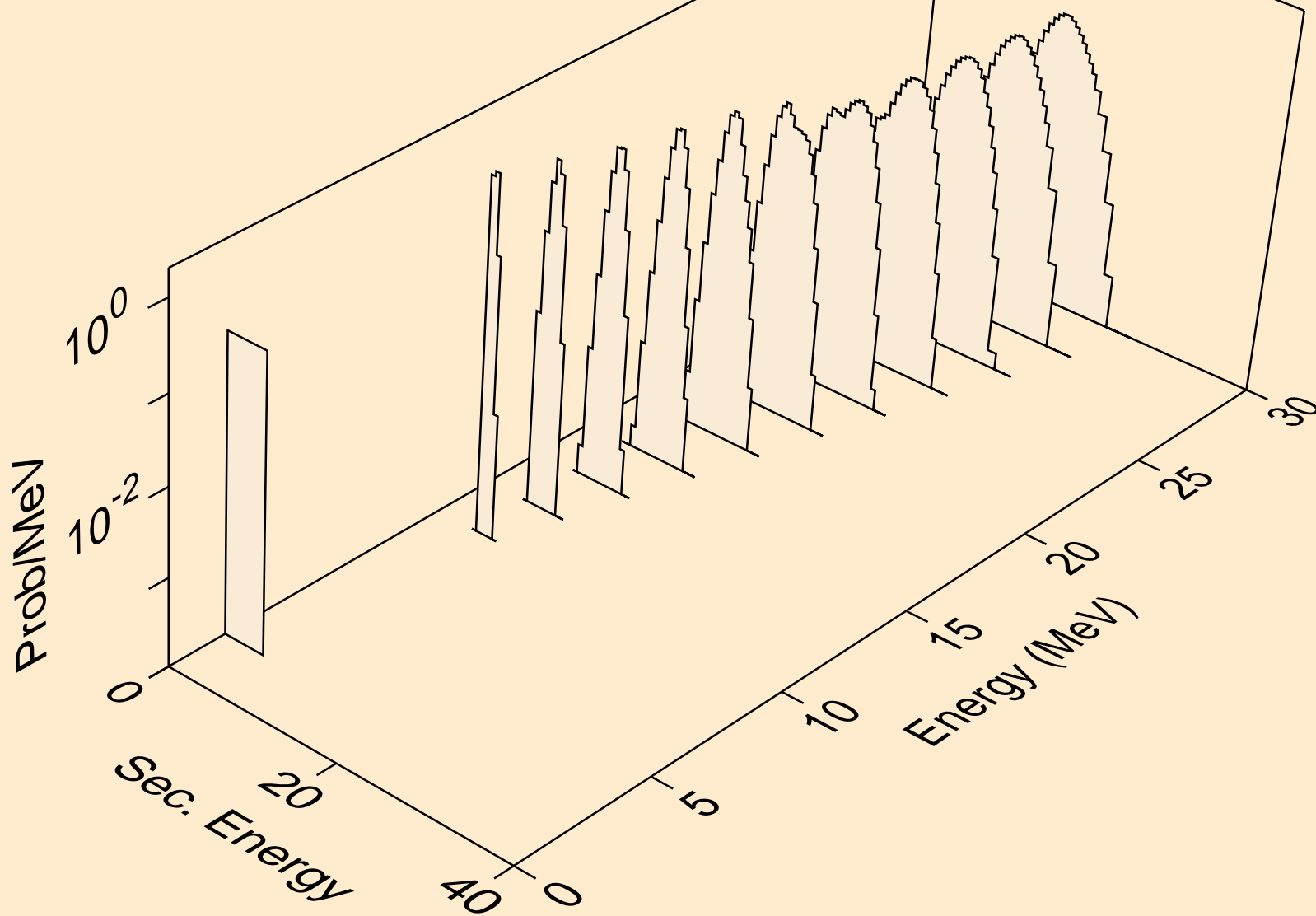



EU148 NEUTRON ACER TENDL-2023 LIBRARY; T=0.K  
alphas from (n,a)

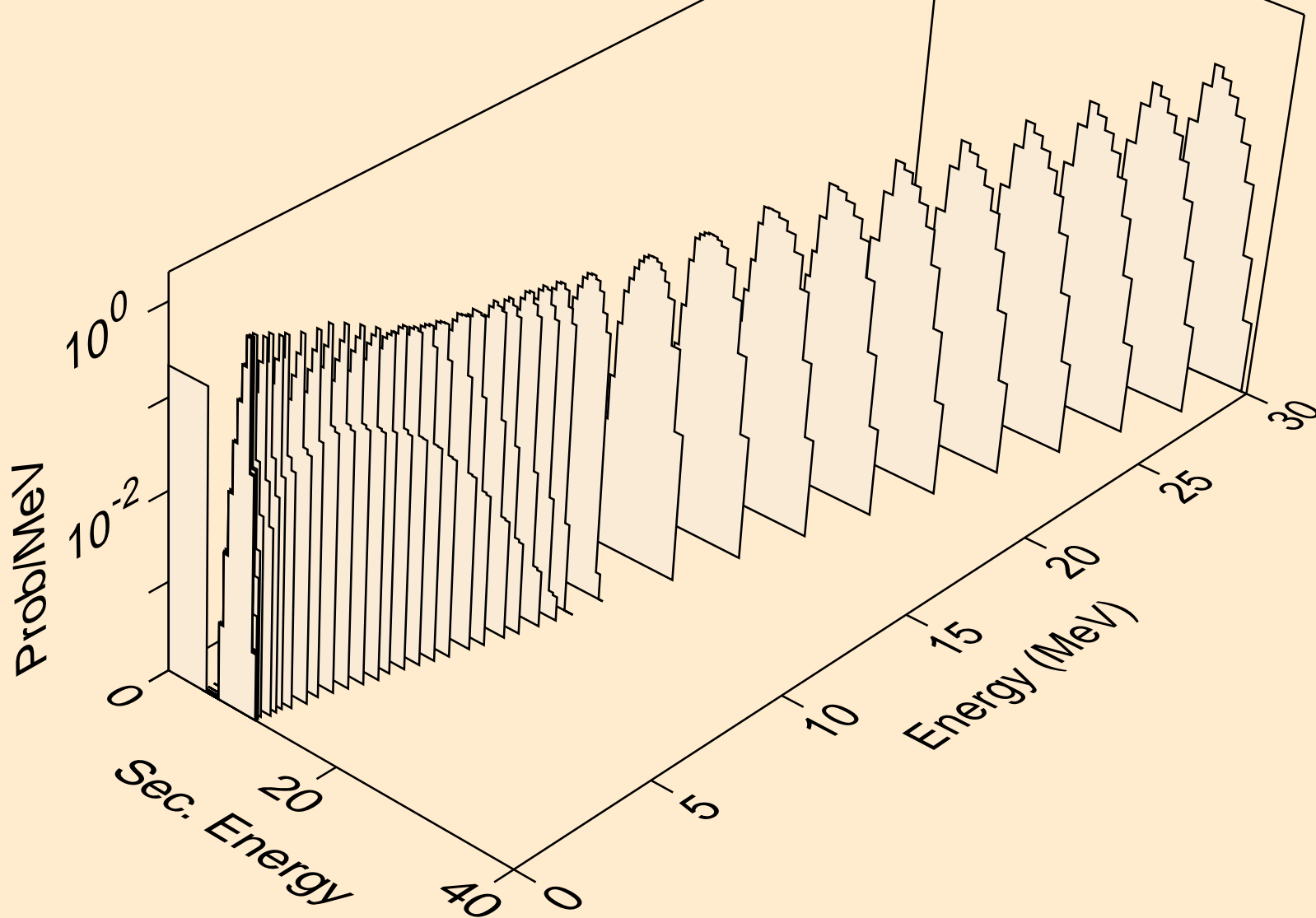

EU148 NEUTRON ACER TENDL-2023 LIBRARY; T=0.K  
alphas from (n,2a)

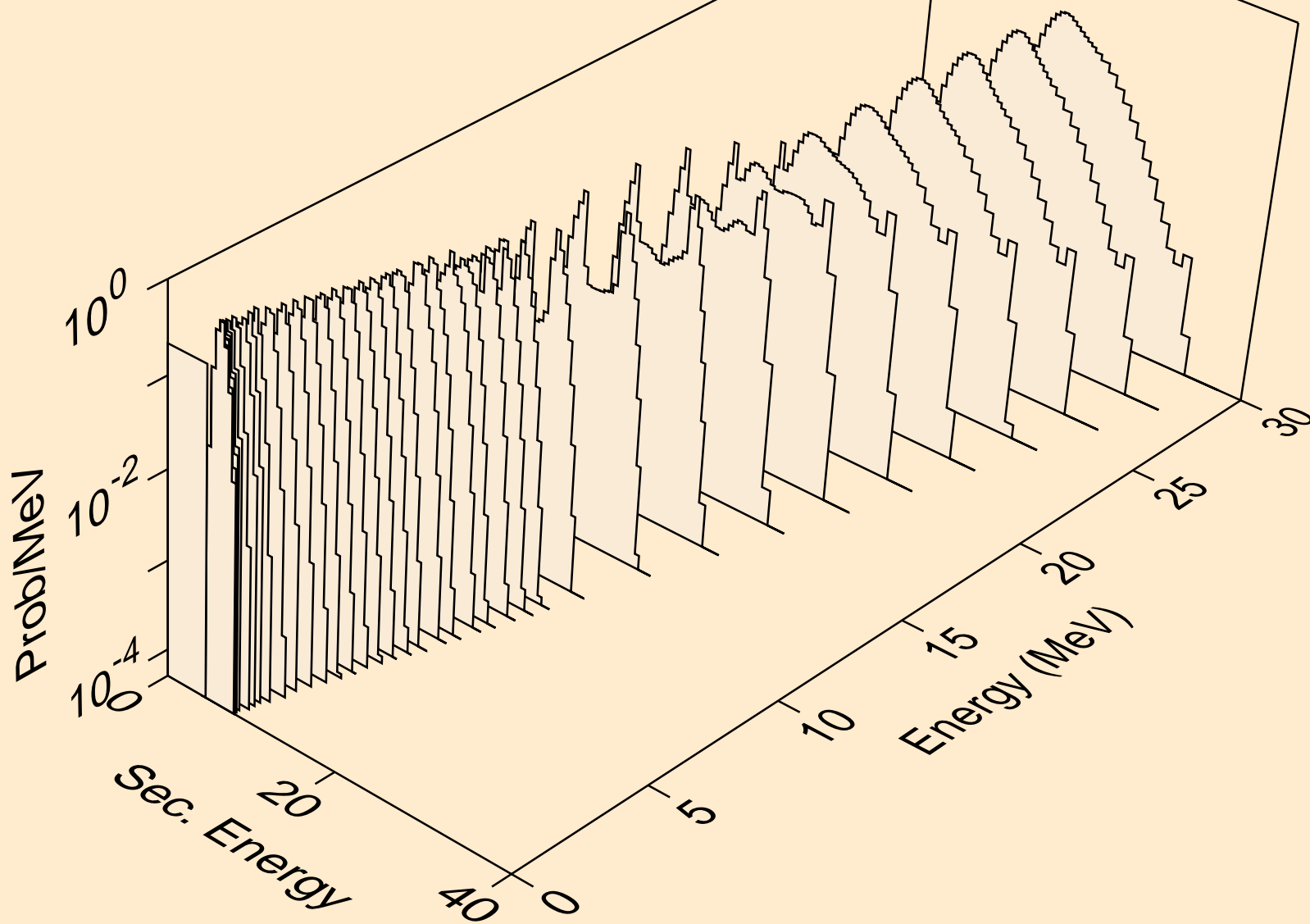

EU148 NEUTRON ACER TENDL-2023 LIBRARY; T=0.K  
alphas from (n,pa)

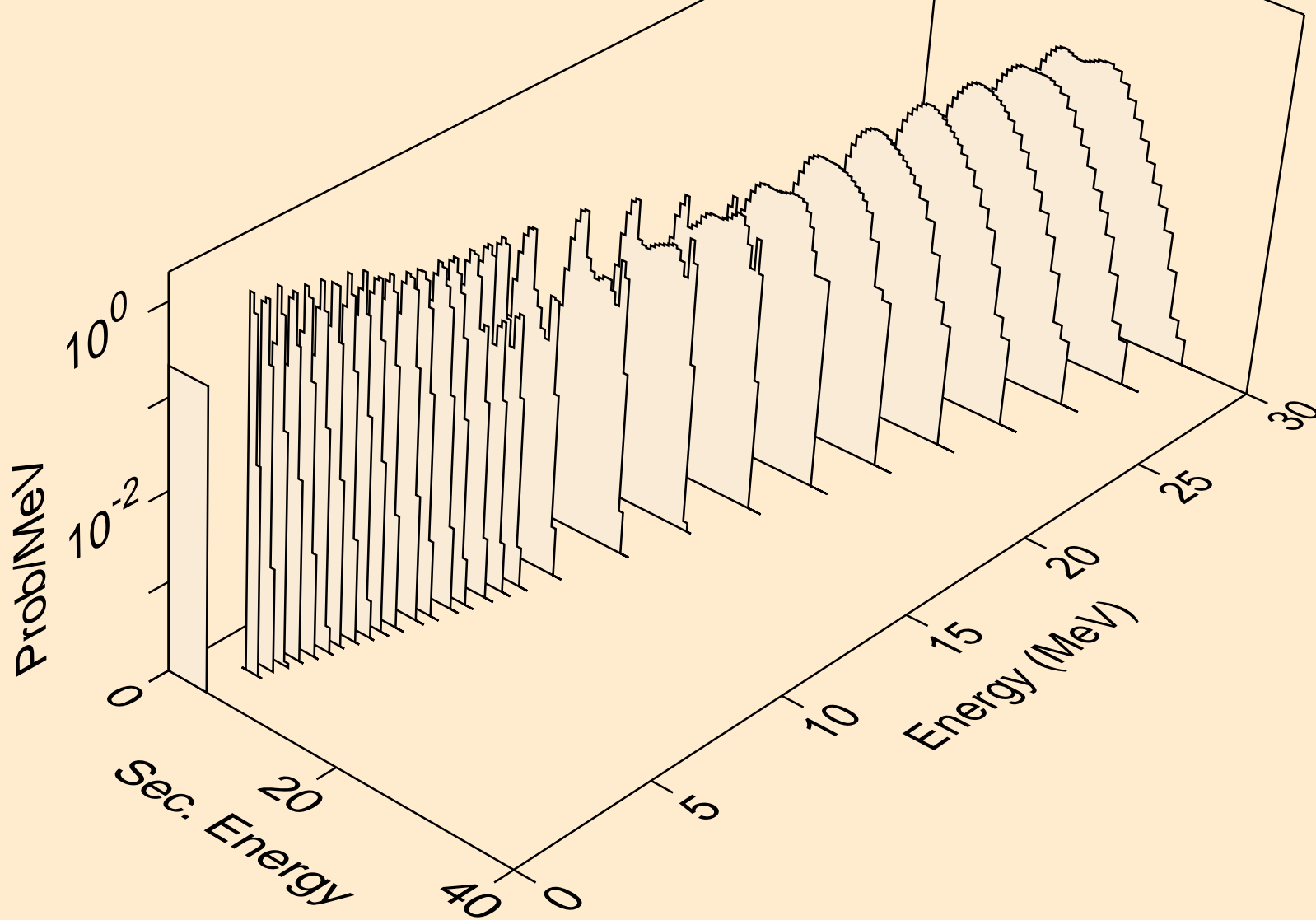

EU148 NEUTRON ACER TENDL-2023 LIBRARY; T=0.K  
alphas from (n,da)

