

GA075 NEUTRON ACER TENDL-2023 LIBRARY; T=0.K

Principal cross sections

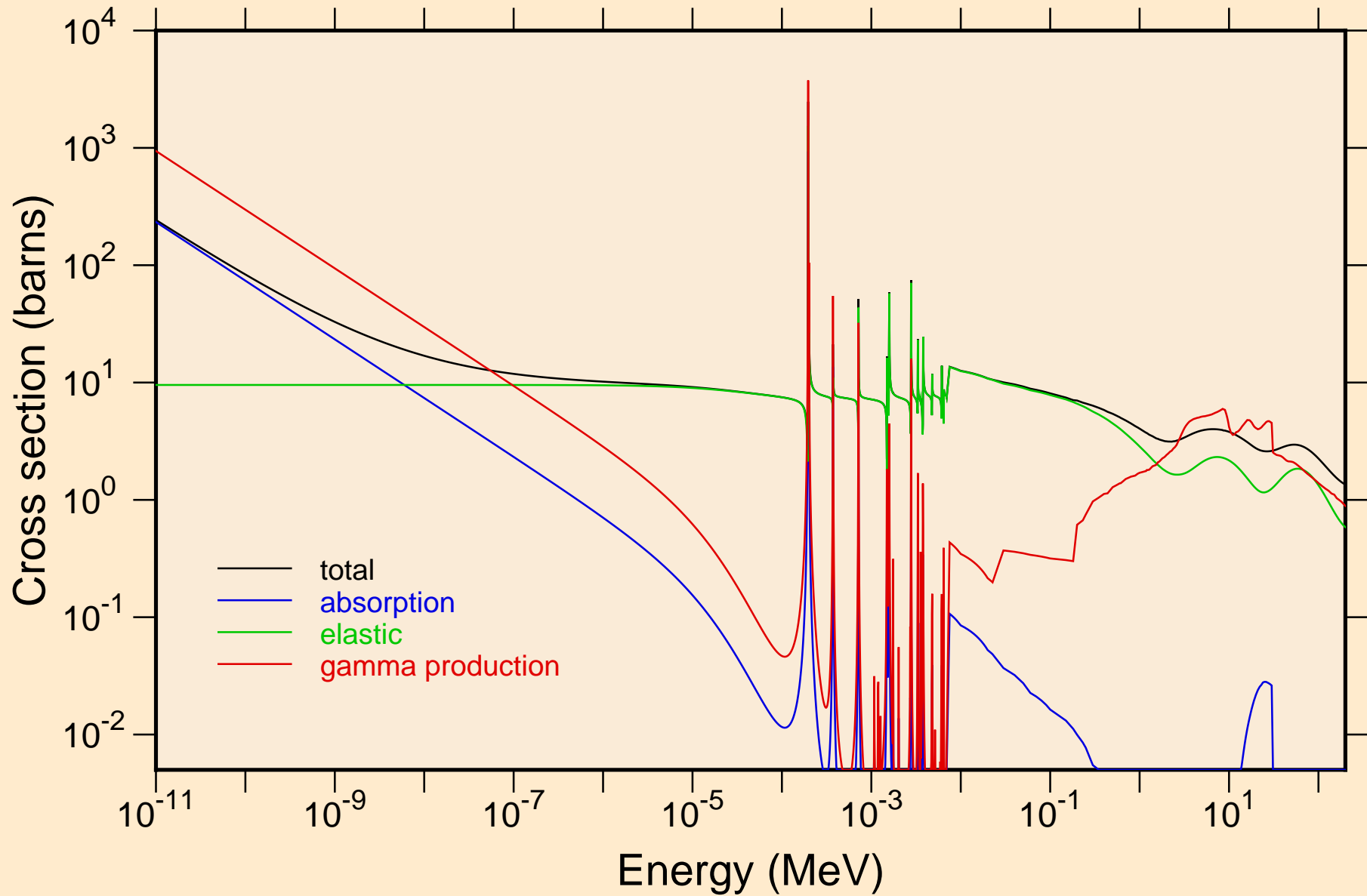

GA075 NEUTRON ACER TENDL-2023 LIBRARY; T=0.K
resonance total cross section

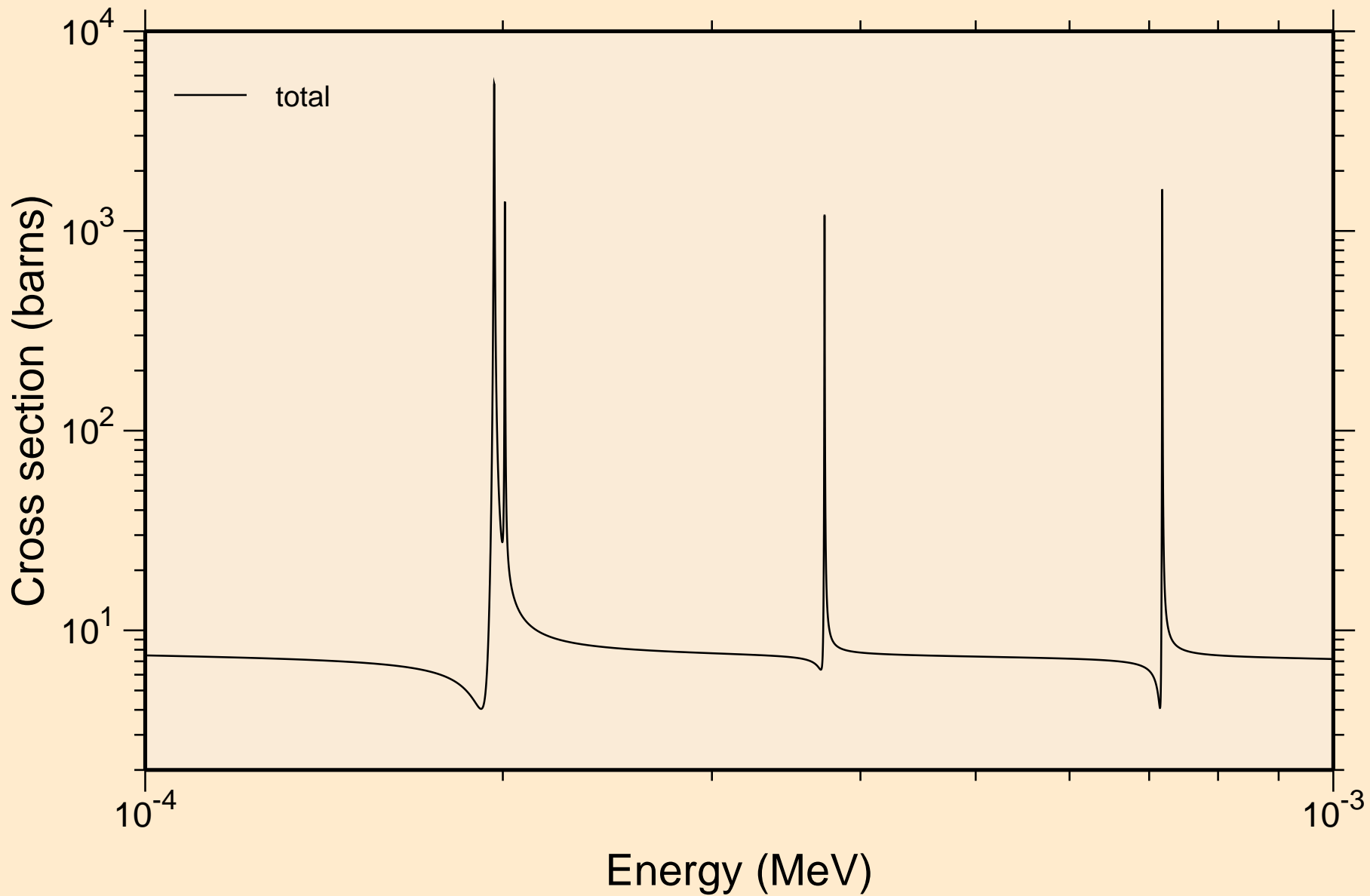

GA075 NEUTRON ACER TENDL-2023 LIBRARY; T=0.K
resonance total cross section

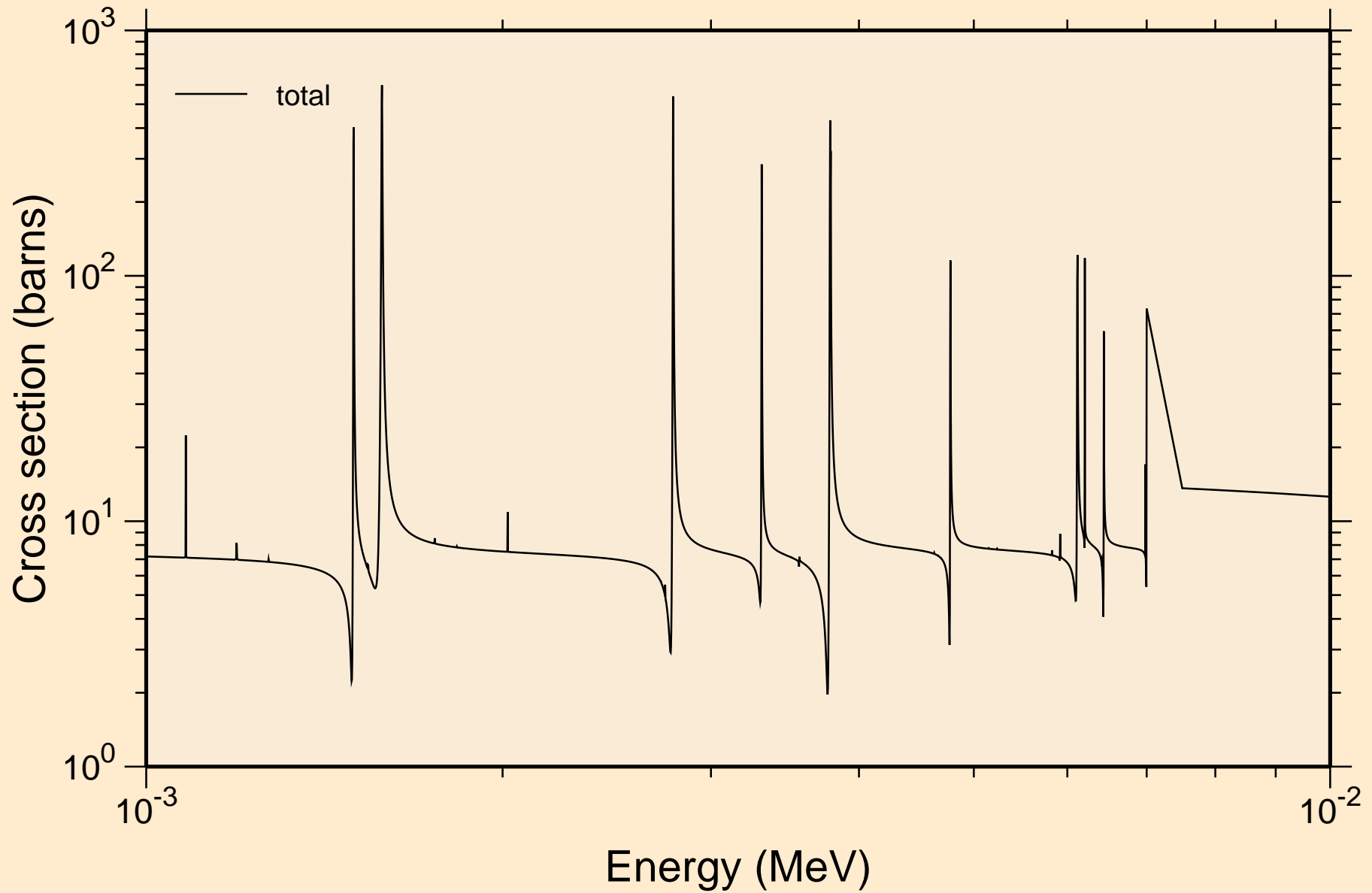

GÄ075 NEUTRON ACER TENDL-2023 LIBRARY; T=0.K
resonance total cross section

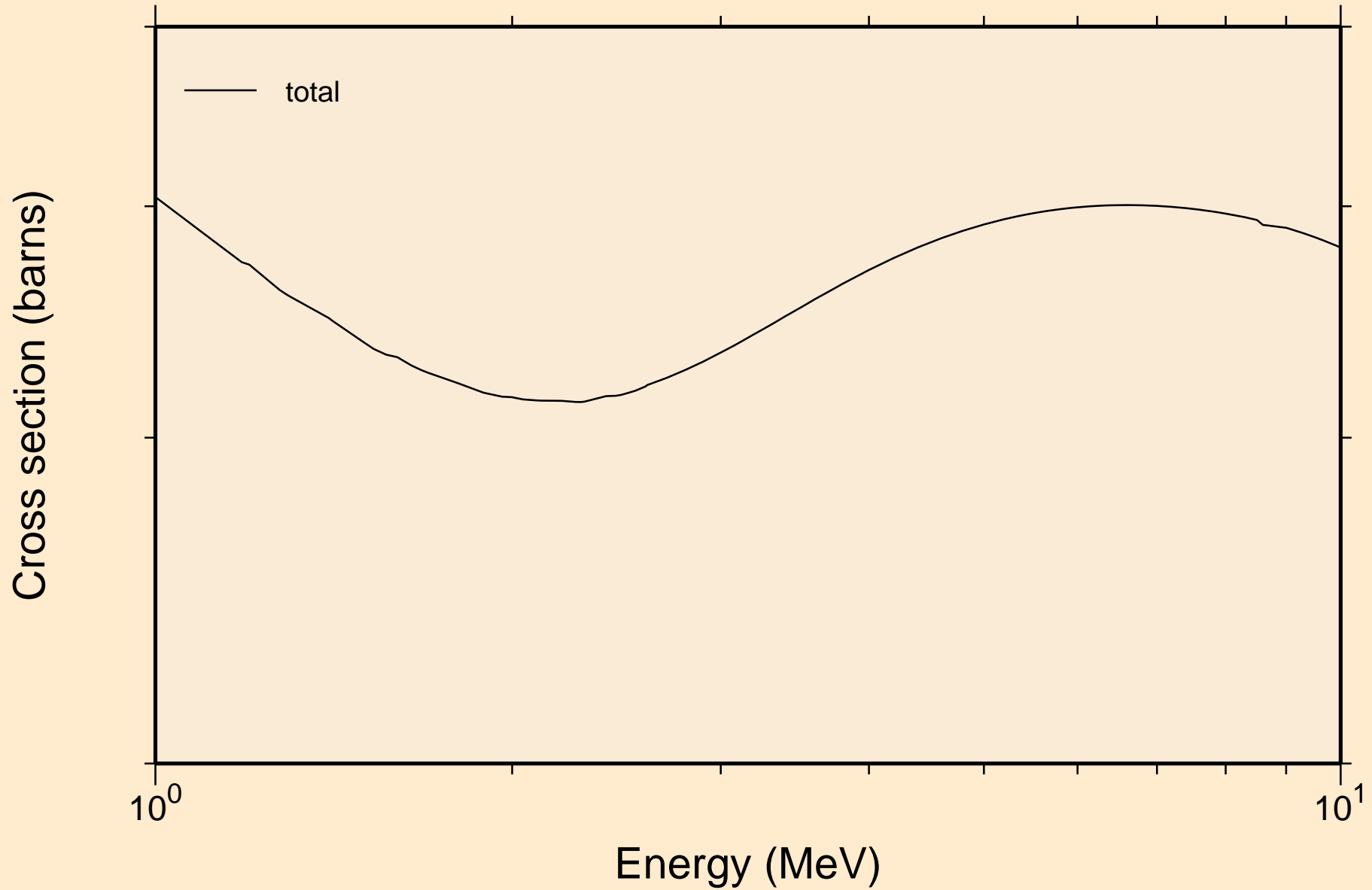

GA075 NEUTRON ACER TENDL-2023 LIBRARY; T=0.K
resonance absorption cross sections

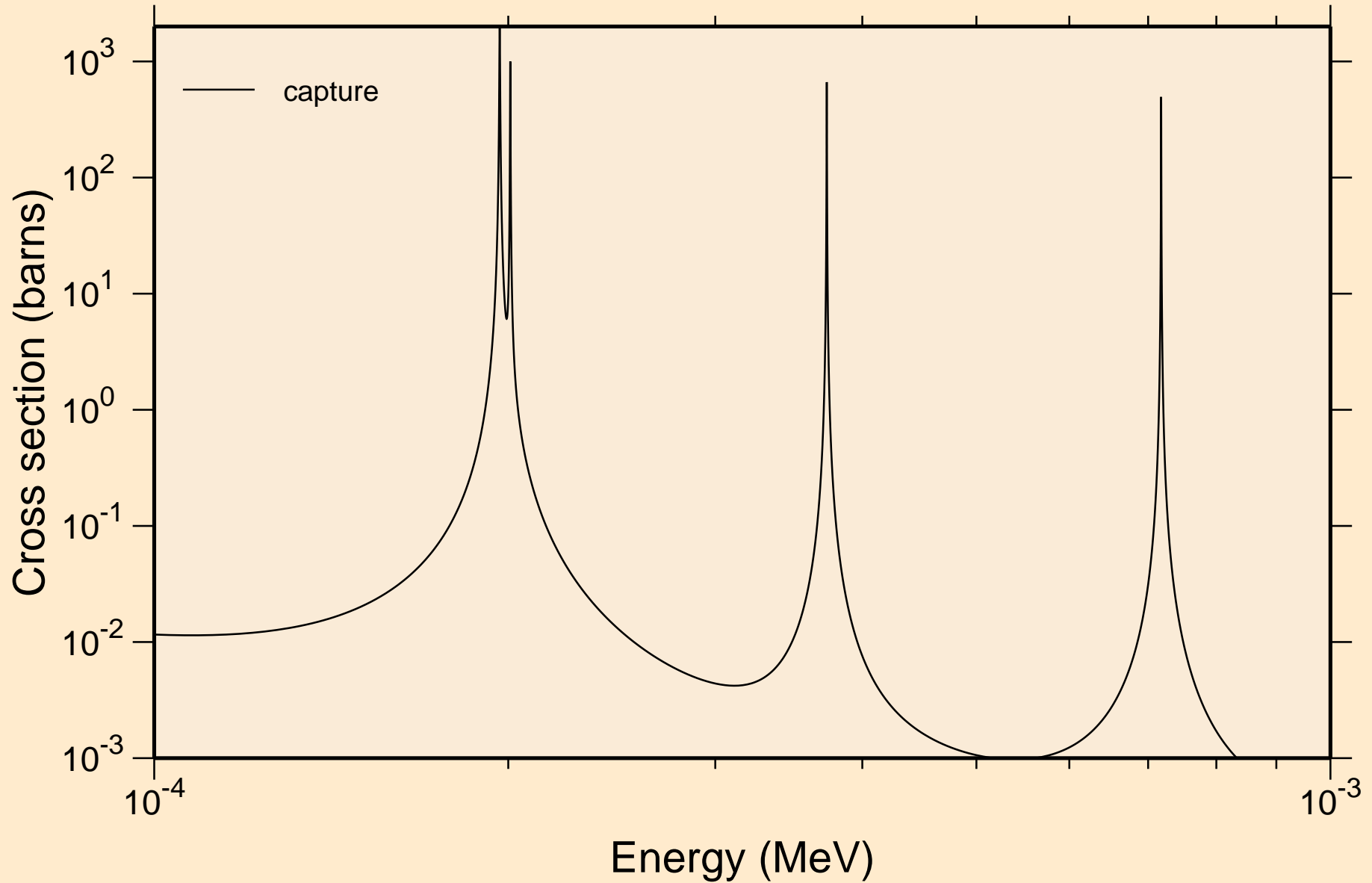

GA075 NEUTRON ACER TENDL-2023 LIBRARY; T=0.K
resonance absorption cross sections

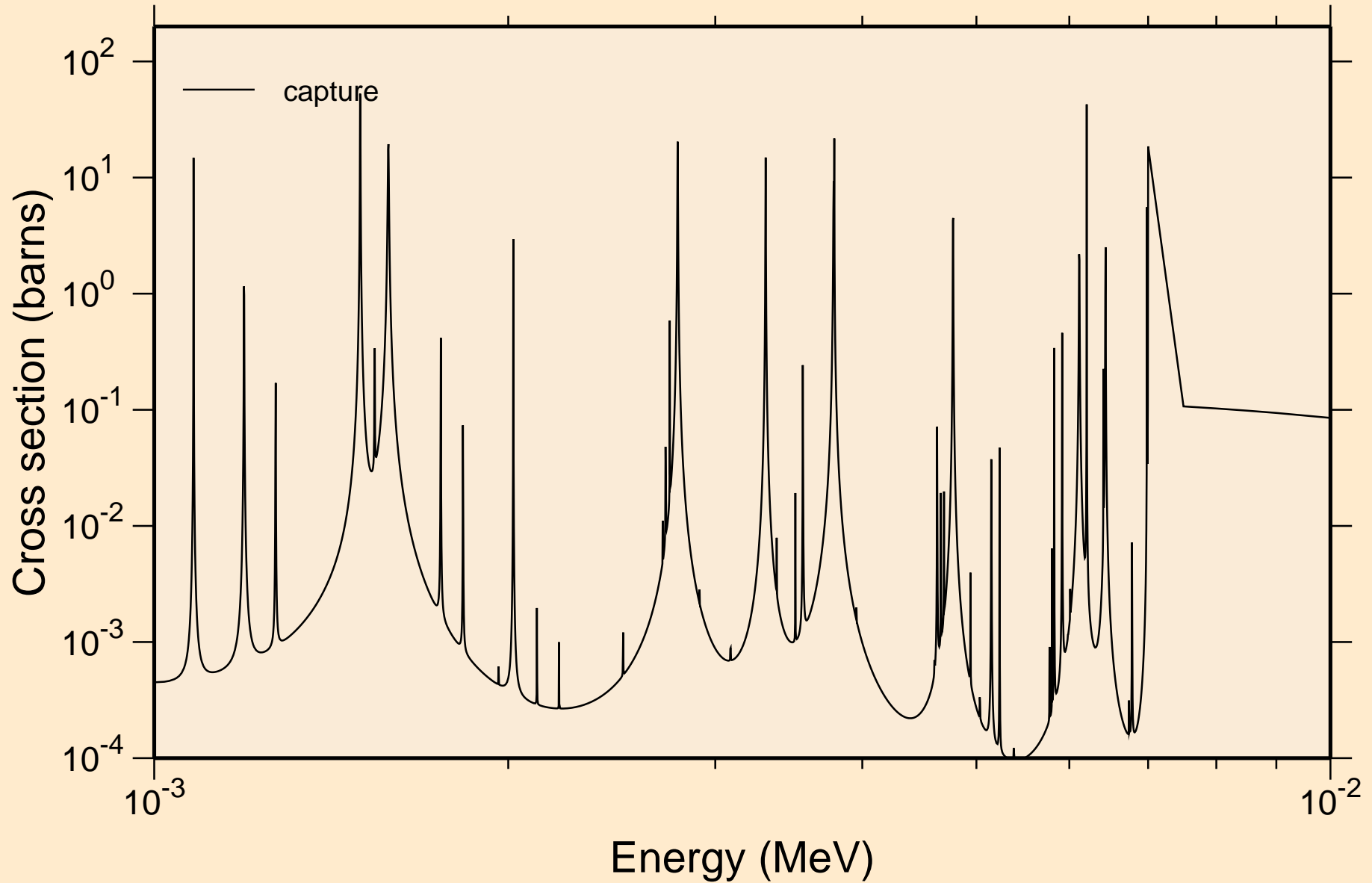

GA075 NEUTRON ACER TENDL-2023 LIBRARY; T=0.K
resonance absorption cross sections

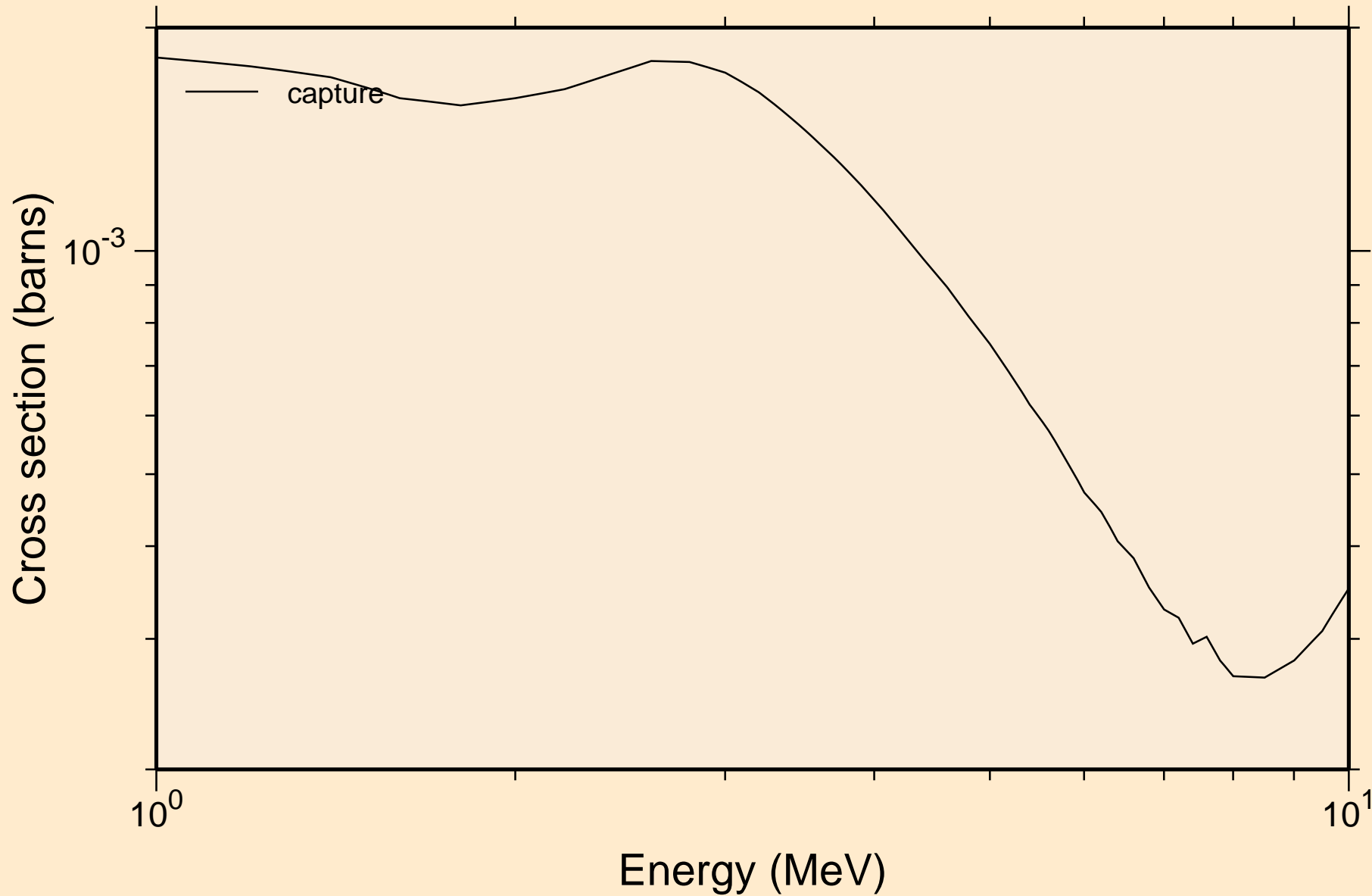

GA075 NEUTRON ACER TENDL-2023 LIBRARY; T=0.K

Heating

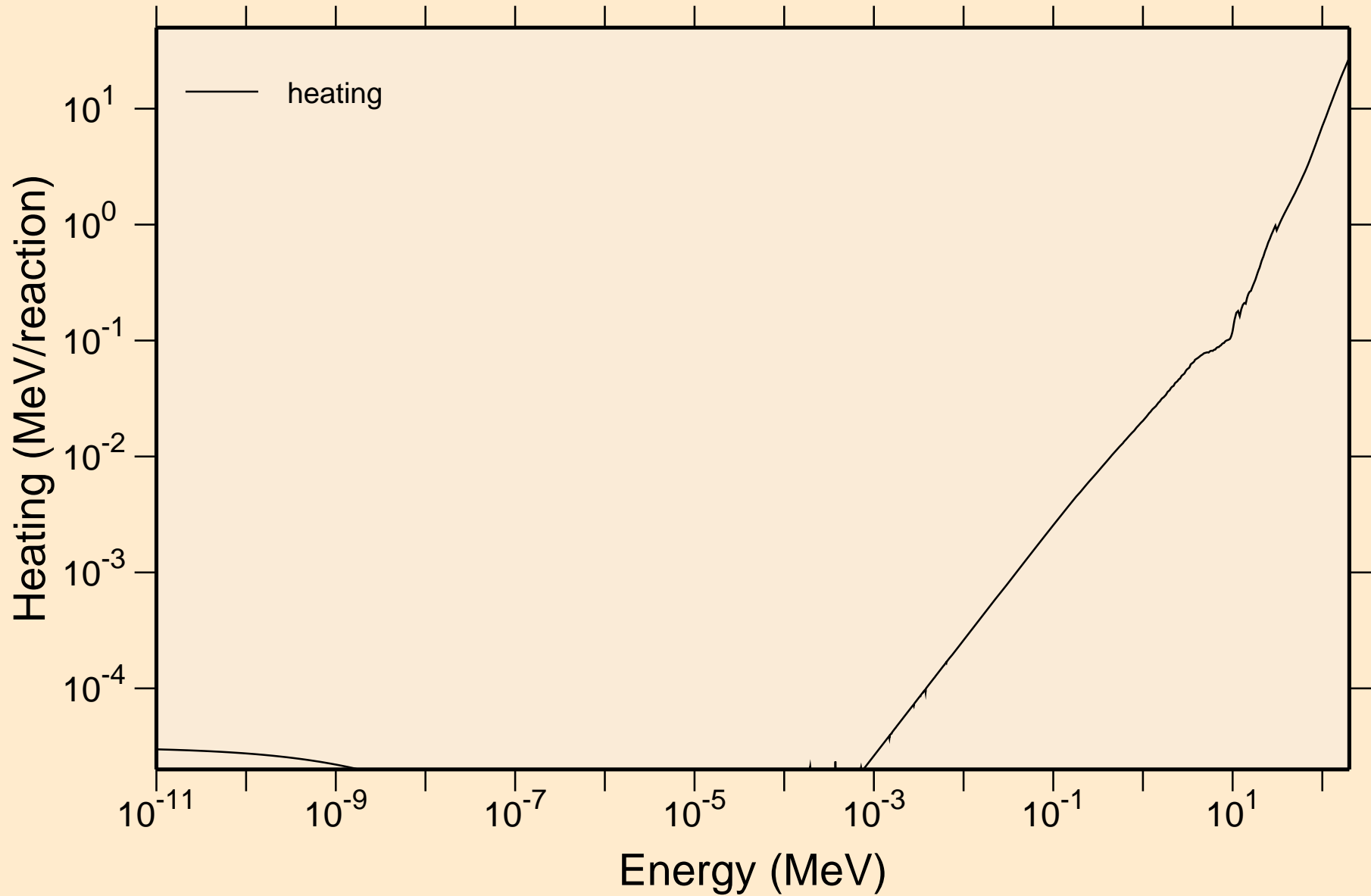

GA075 NEUTRON ACER TENDL-2023 LIBRARY; T=0.K

Damage

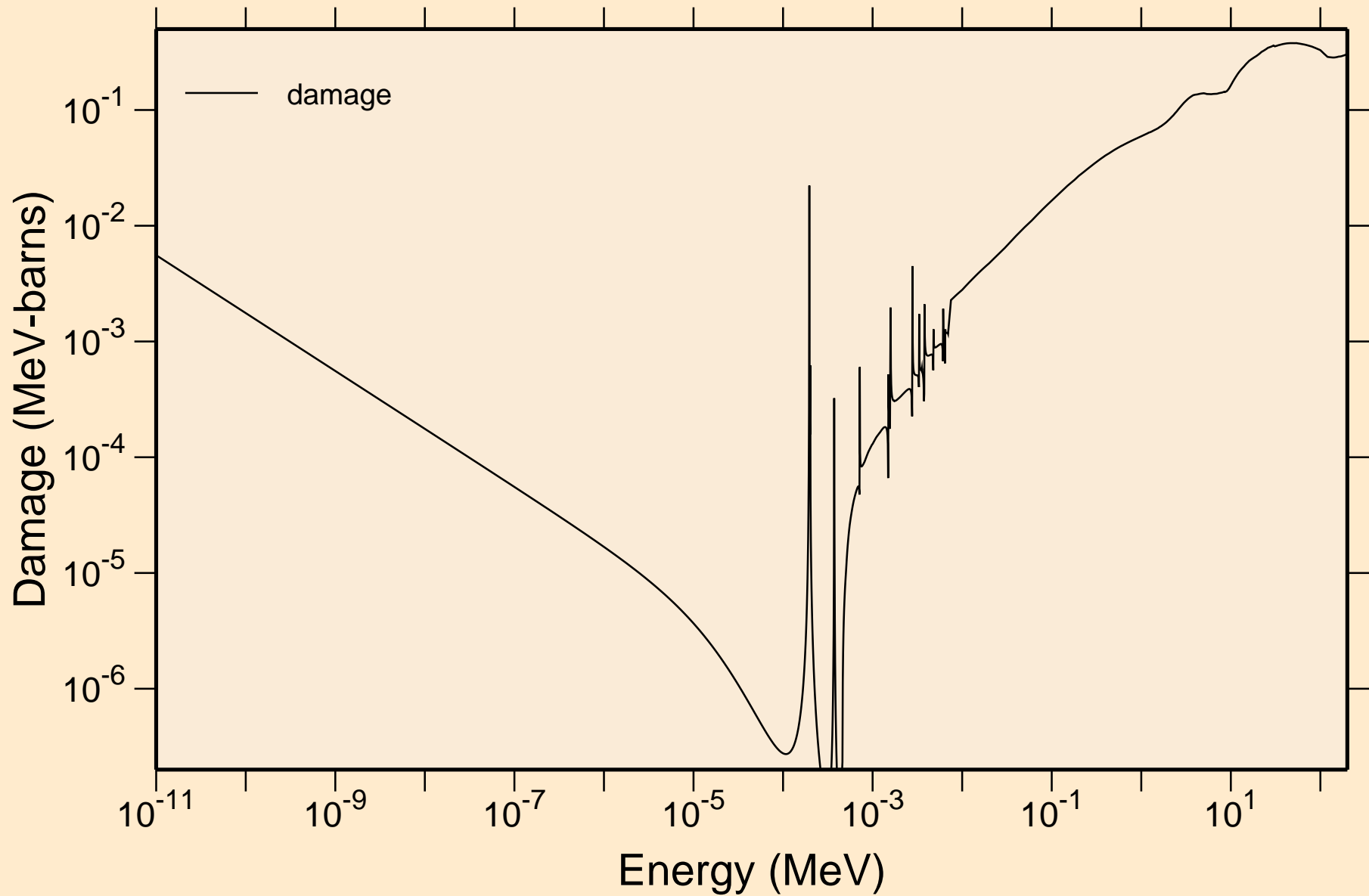

GA075 NEUTRON ACER TENDL-2023 LIBRARY; T=0.K
Non-threshold reactions

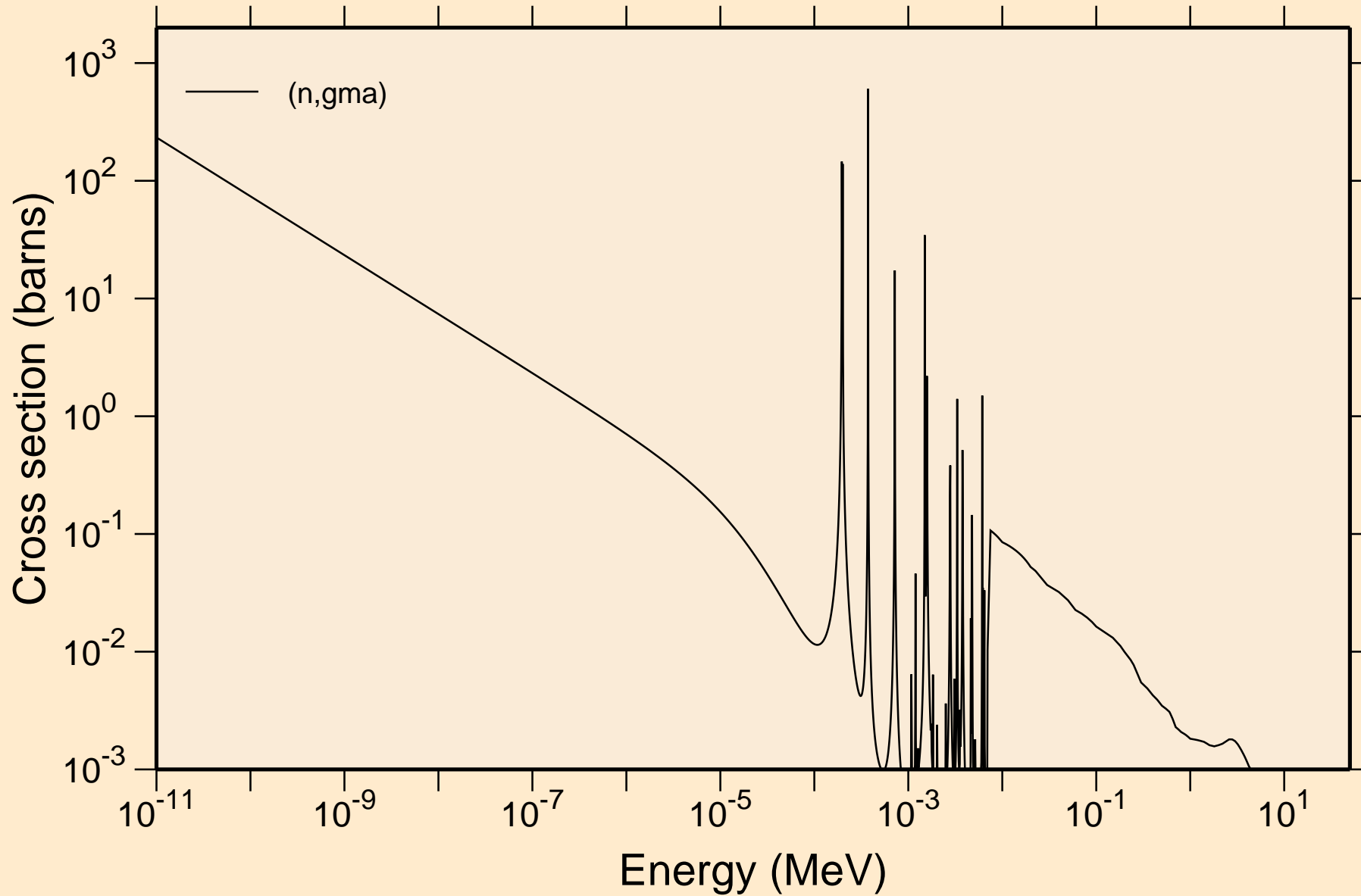

GA075 NEUTRON ACER TENDL-2023 LIBRARY; T=0.K

Principal cross sections

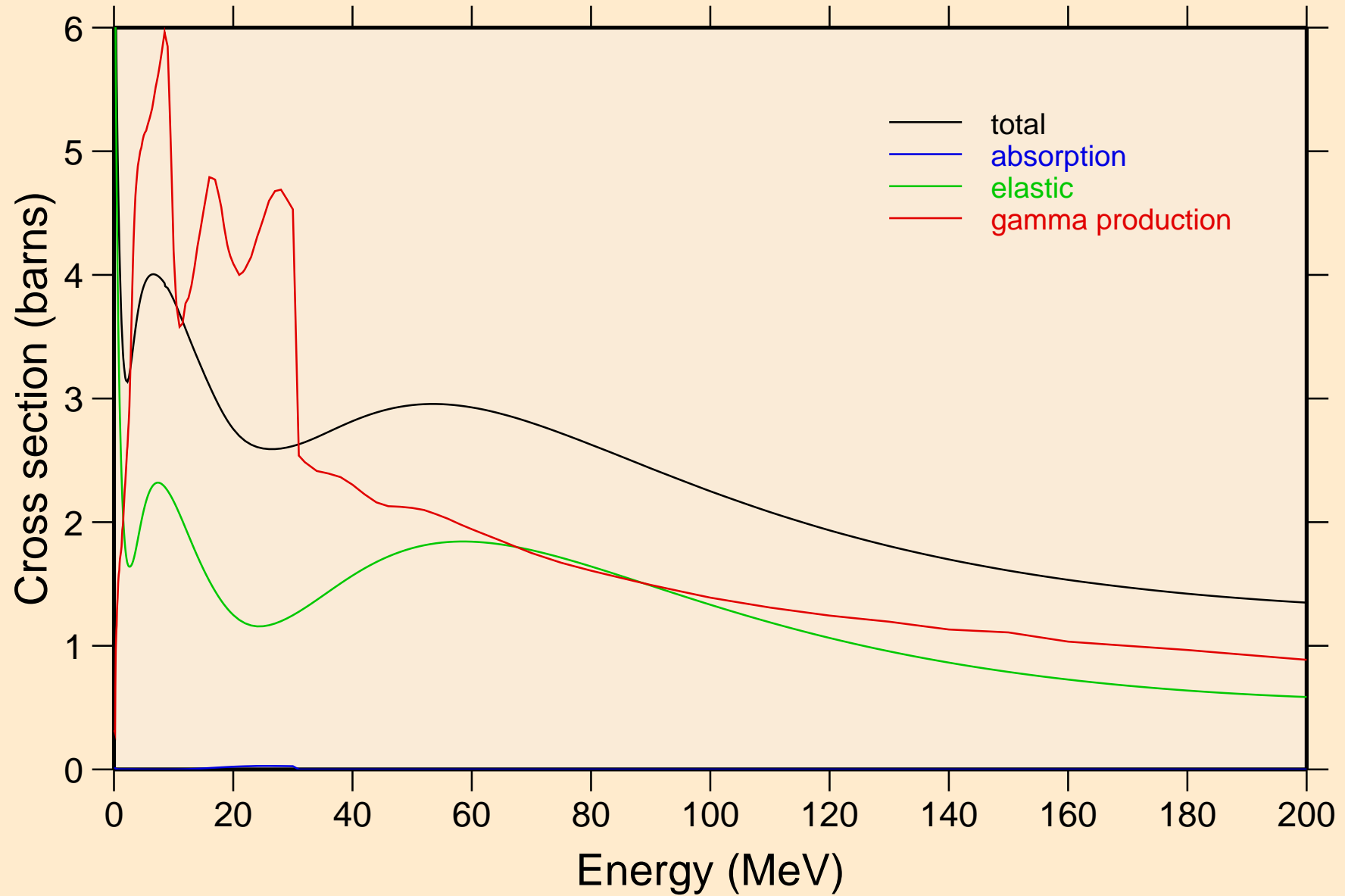

GA075 NEUTRON ACER TENDL-2023 LIBRARY; T=0.K

Heating

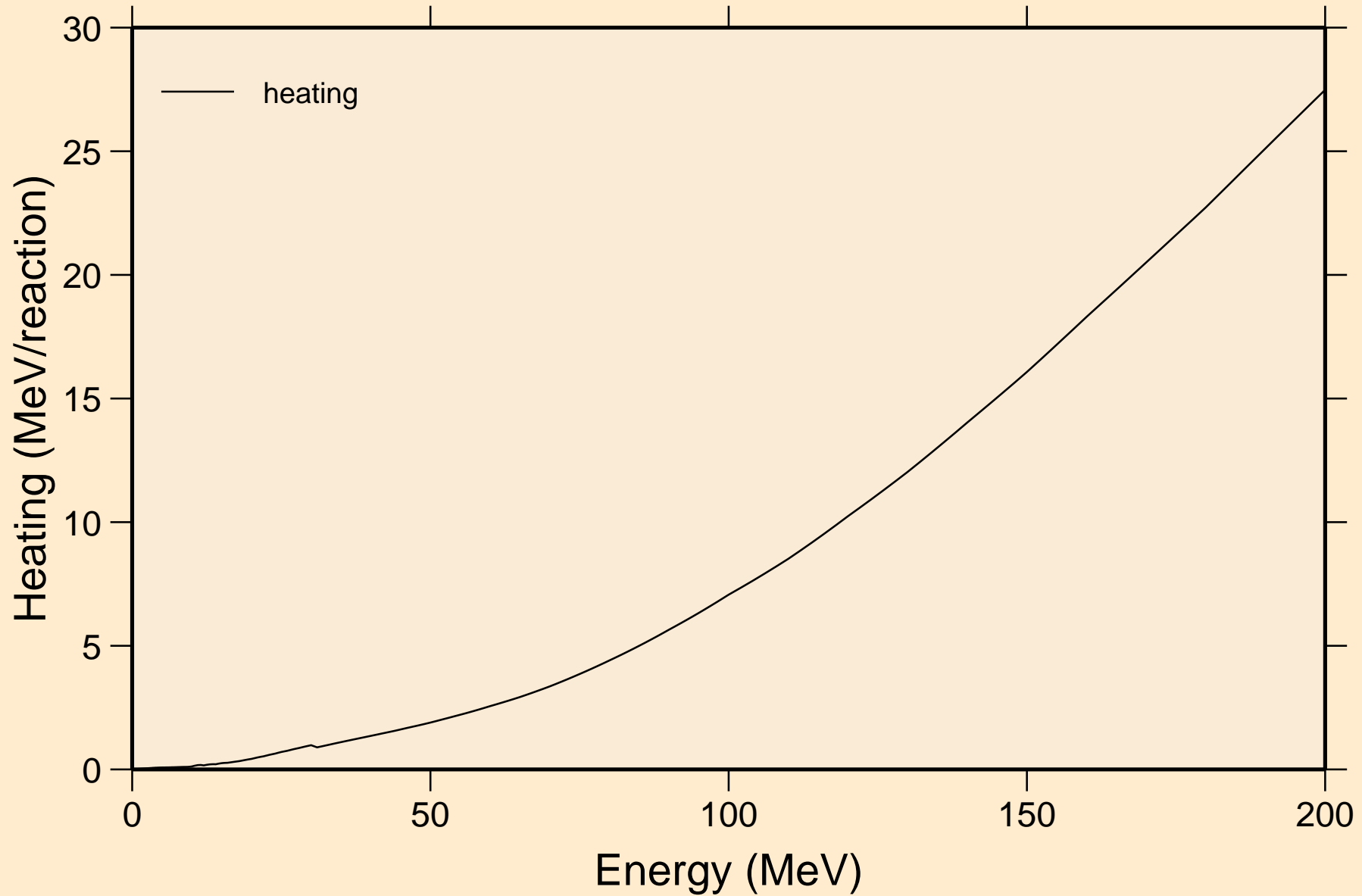

GA075 NEUTRON ACER TENDL-2023 LIBRARY; T=0.K

Damage

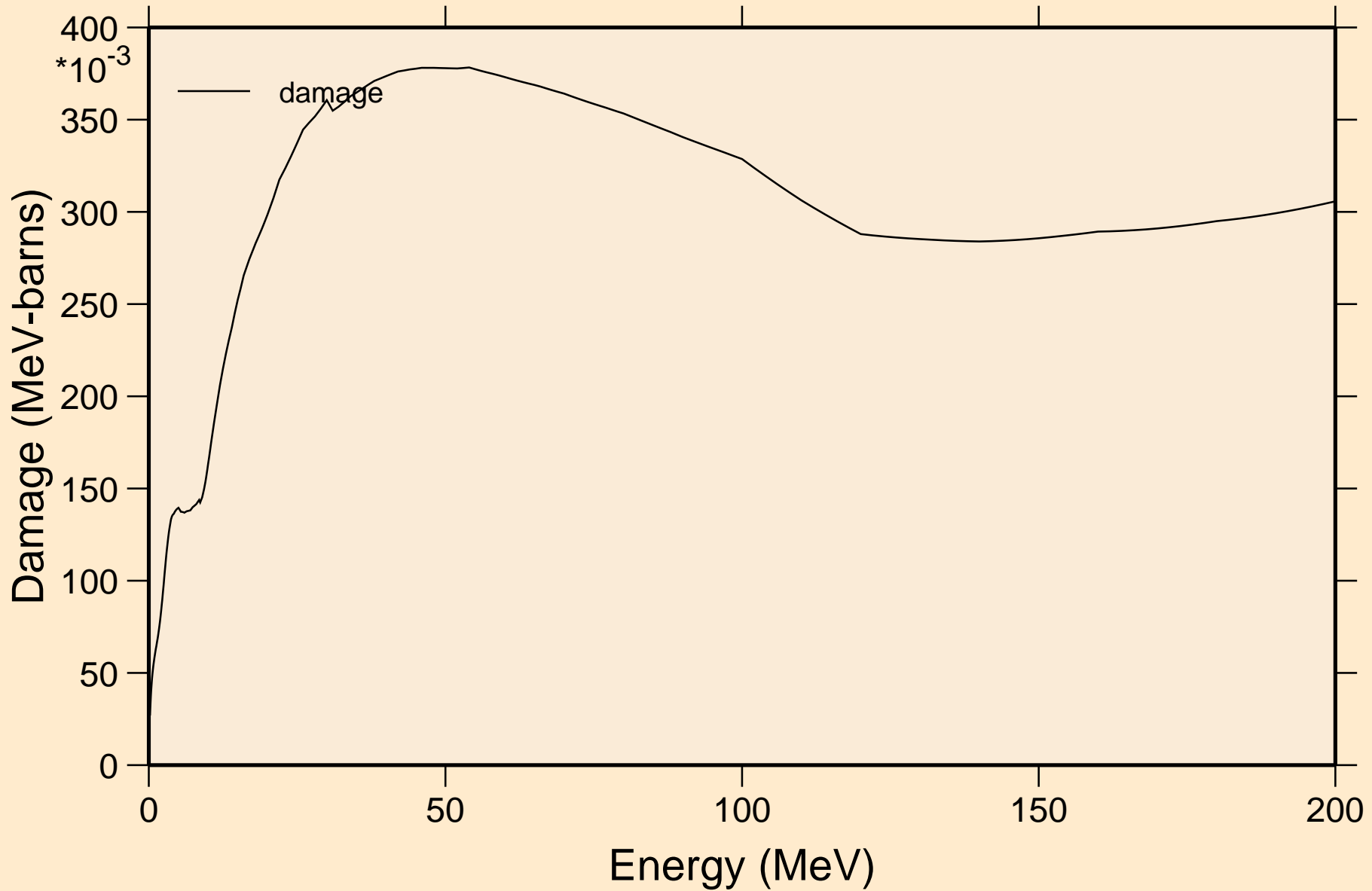

GA075 NEUTRON ACER TENDL-2023 LIBRARY; T=0.K
Non-threshold reactions

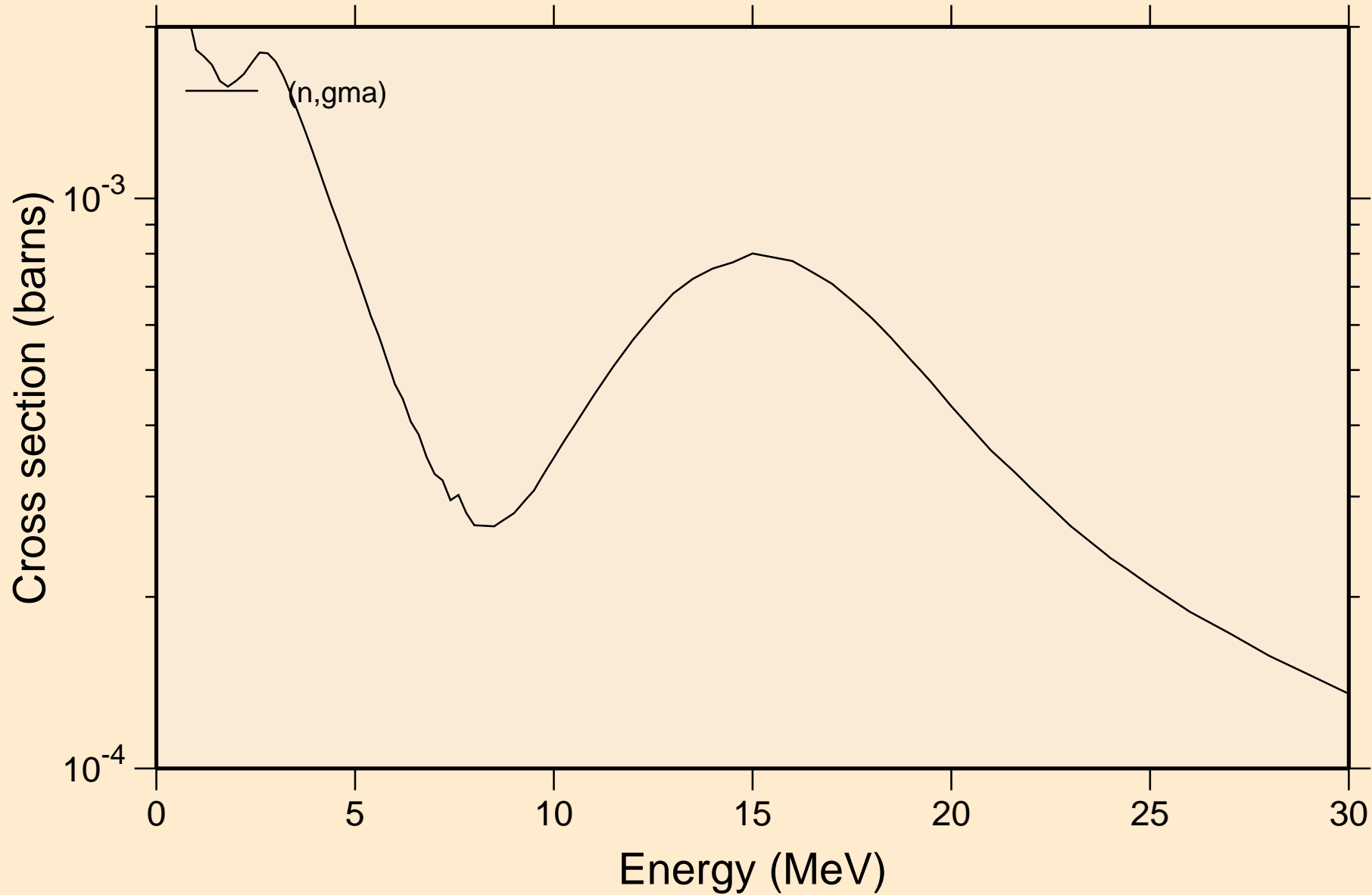

GA075 NEUTRON ACER TENDL-2023 LIBRARY; T=0.K
Inelastic levels

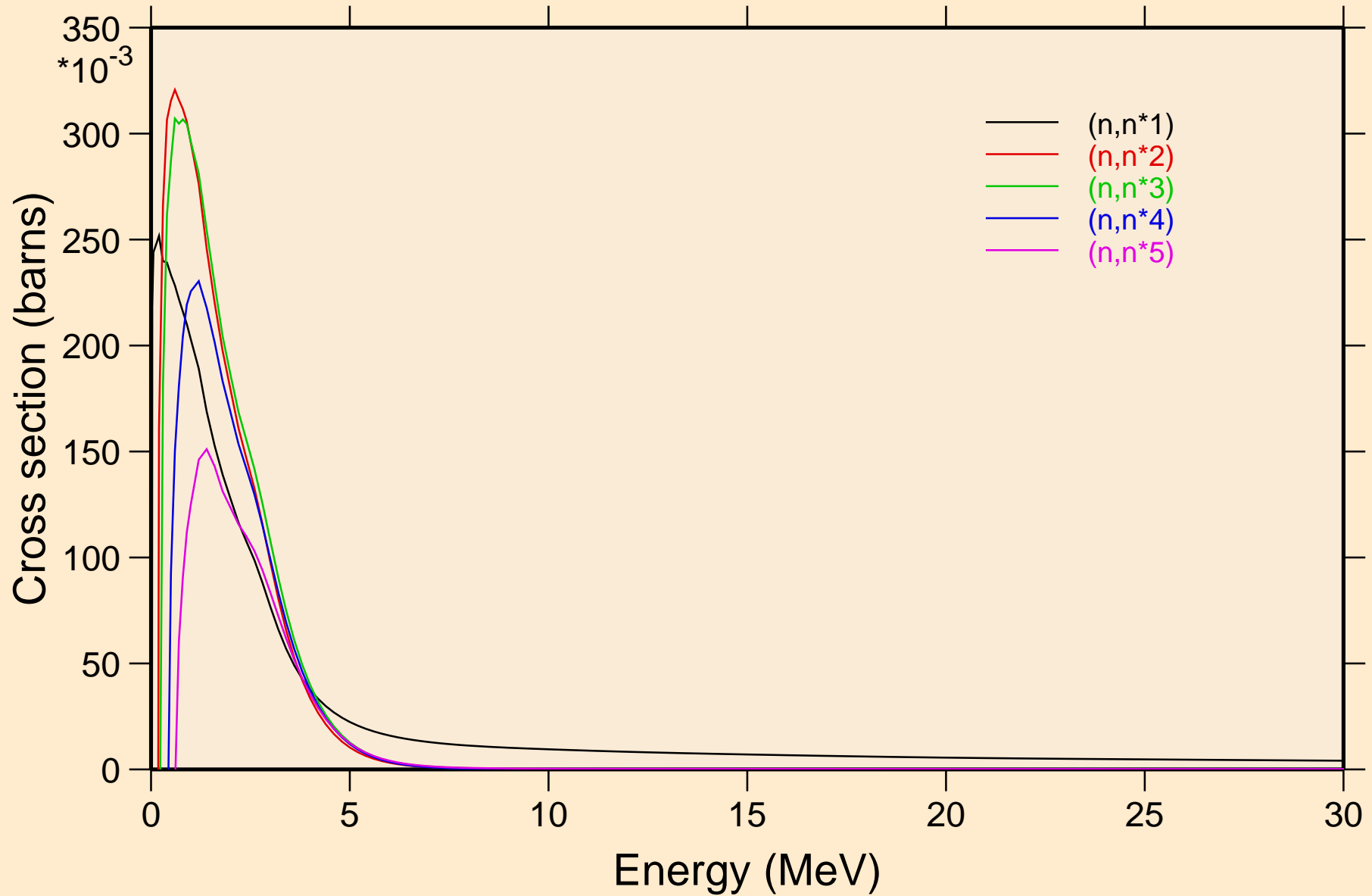

GA075 NEUTRON ACER TENDL-2023 LIBRARY; T=0.K
Inelastic levels

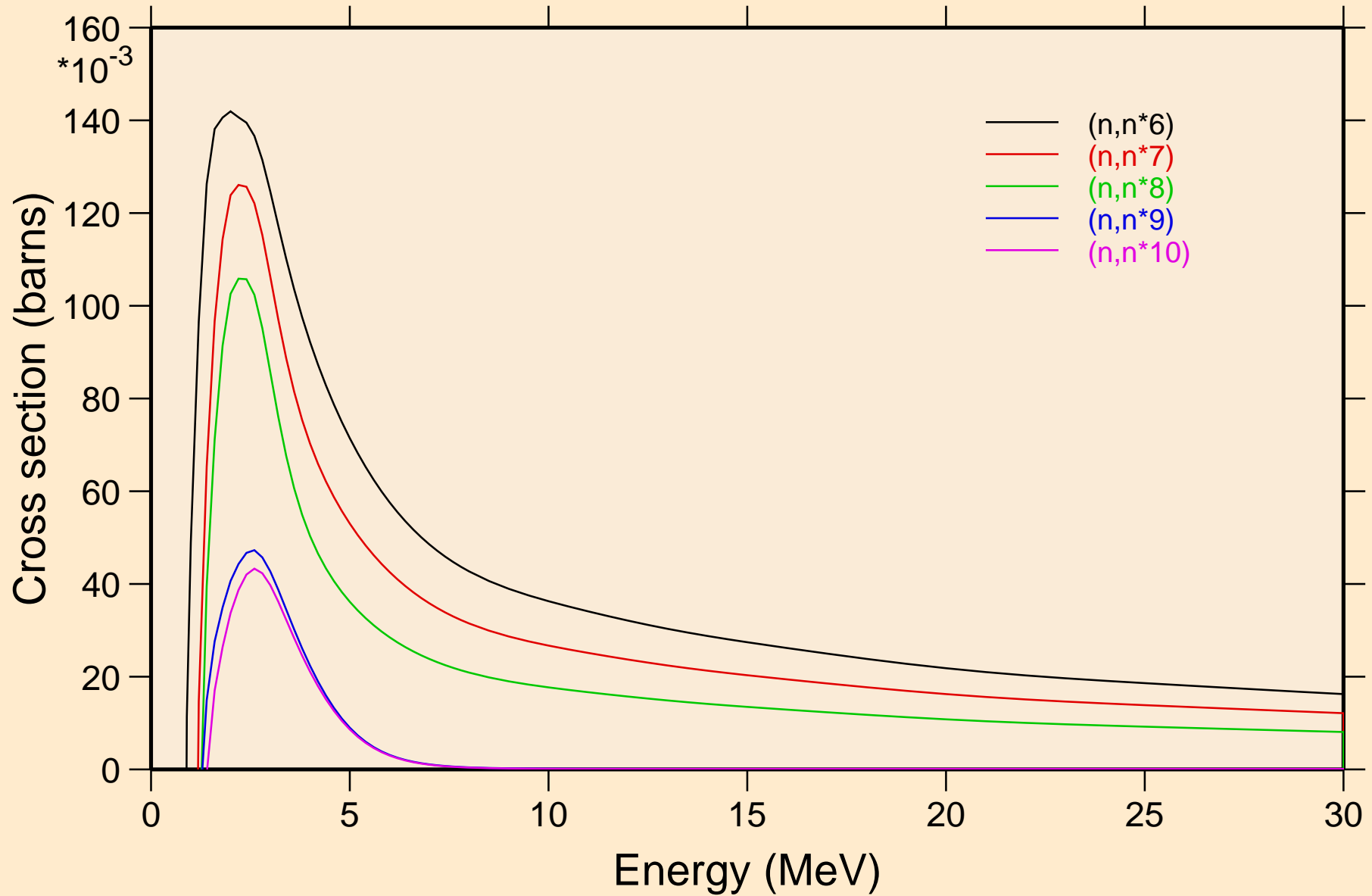

GA075 NEUTRON ACER TENDL-2023 LIBRARY; T=0.K
Inelastic levels

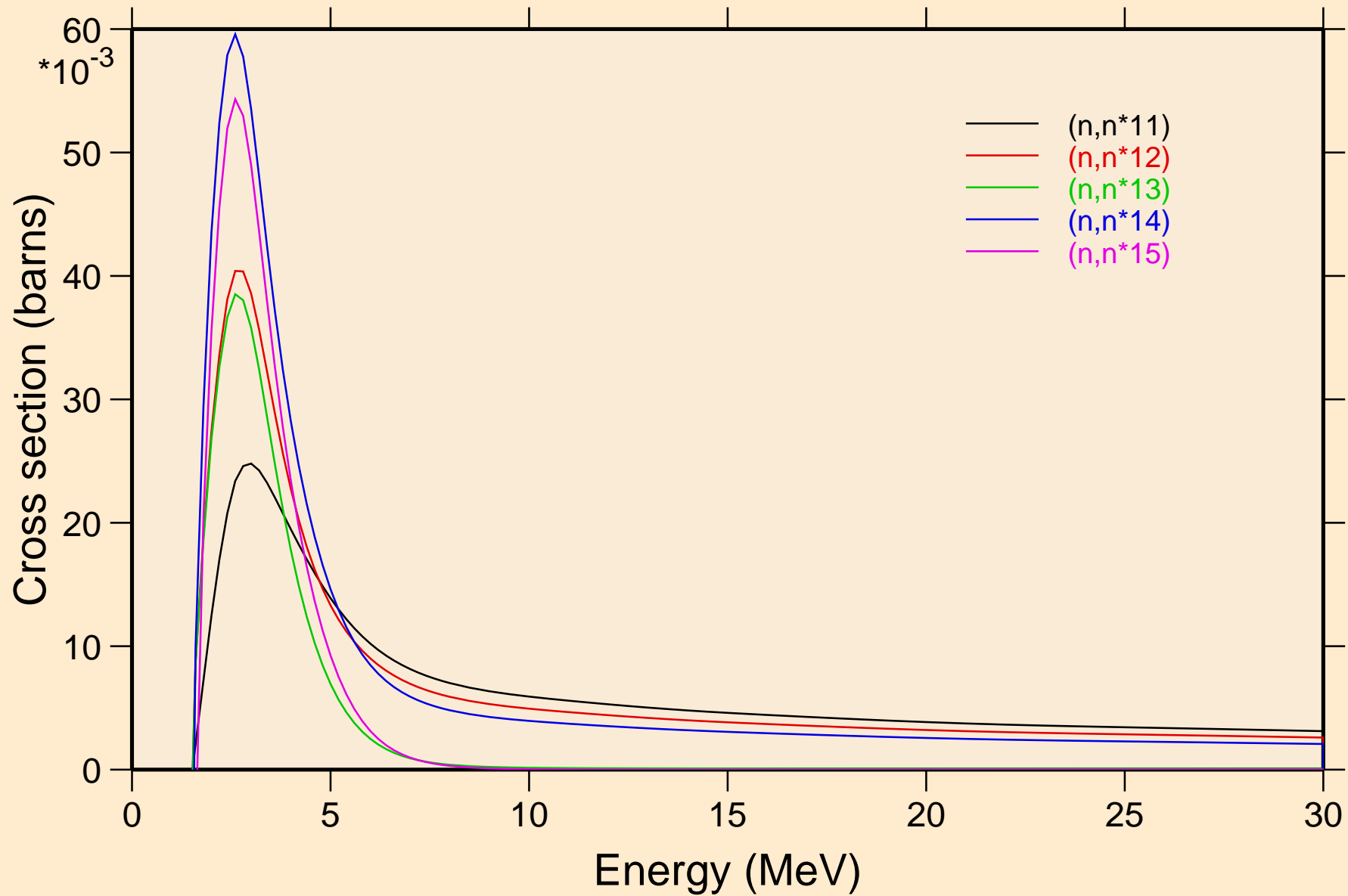

GA075 NEUTRON ACER TENDL-2023 LIBRARY; T=0.K

Inelastic levels

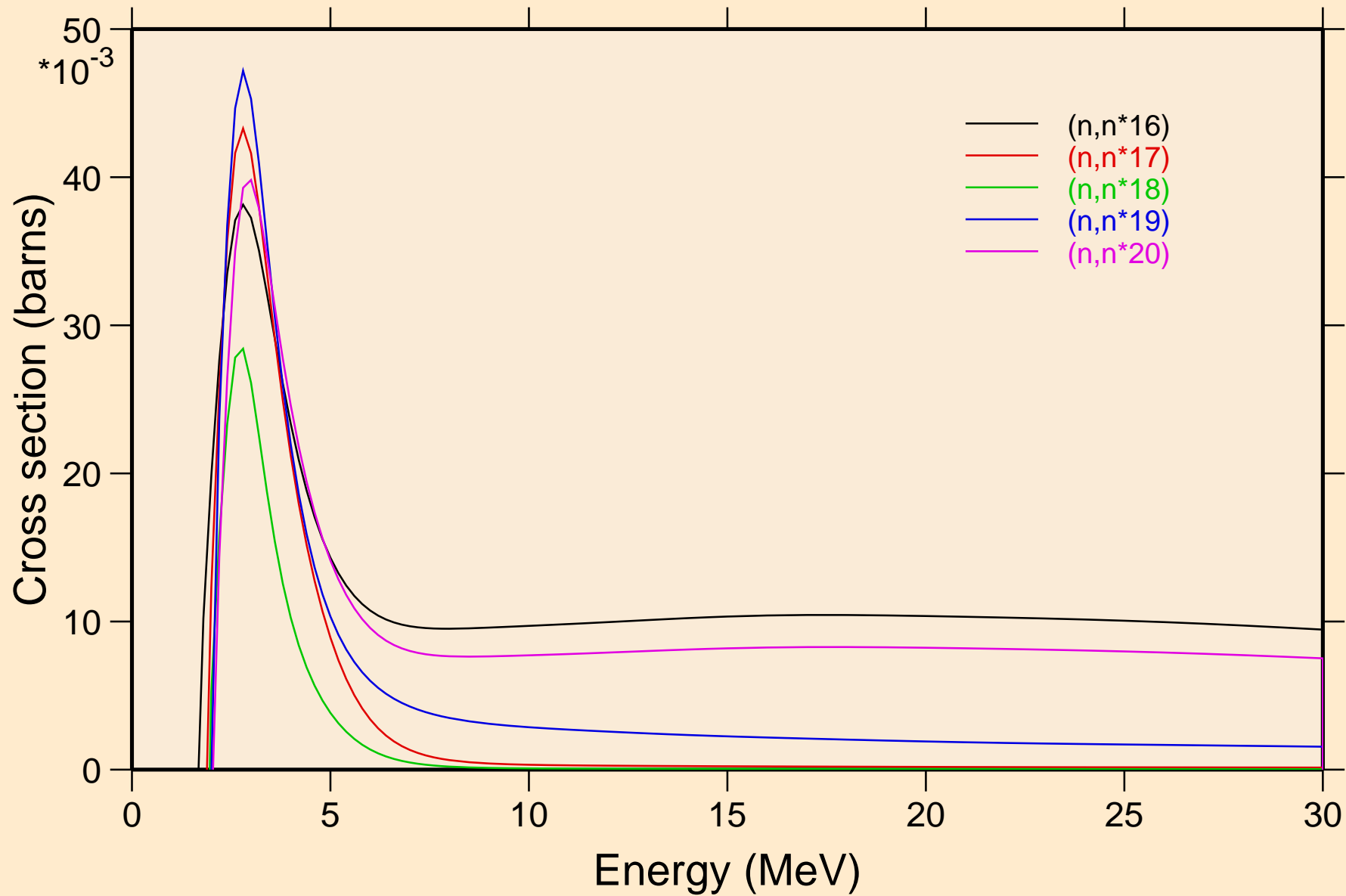

GA075 NEUTRON ACER TENDL-2023 LIBRARY; T=0.K
Inelastic levels

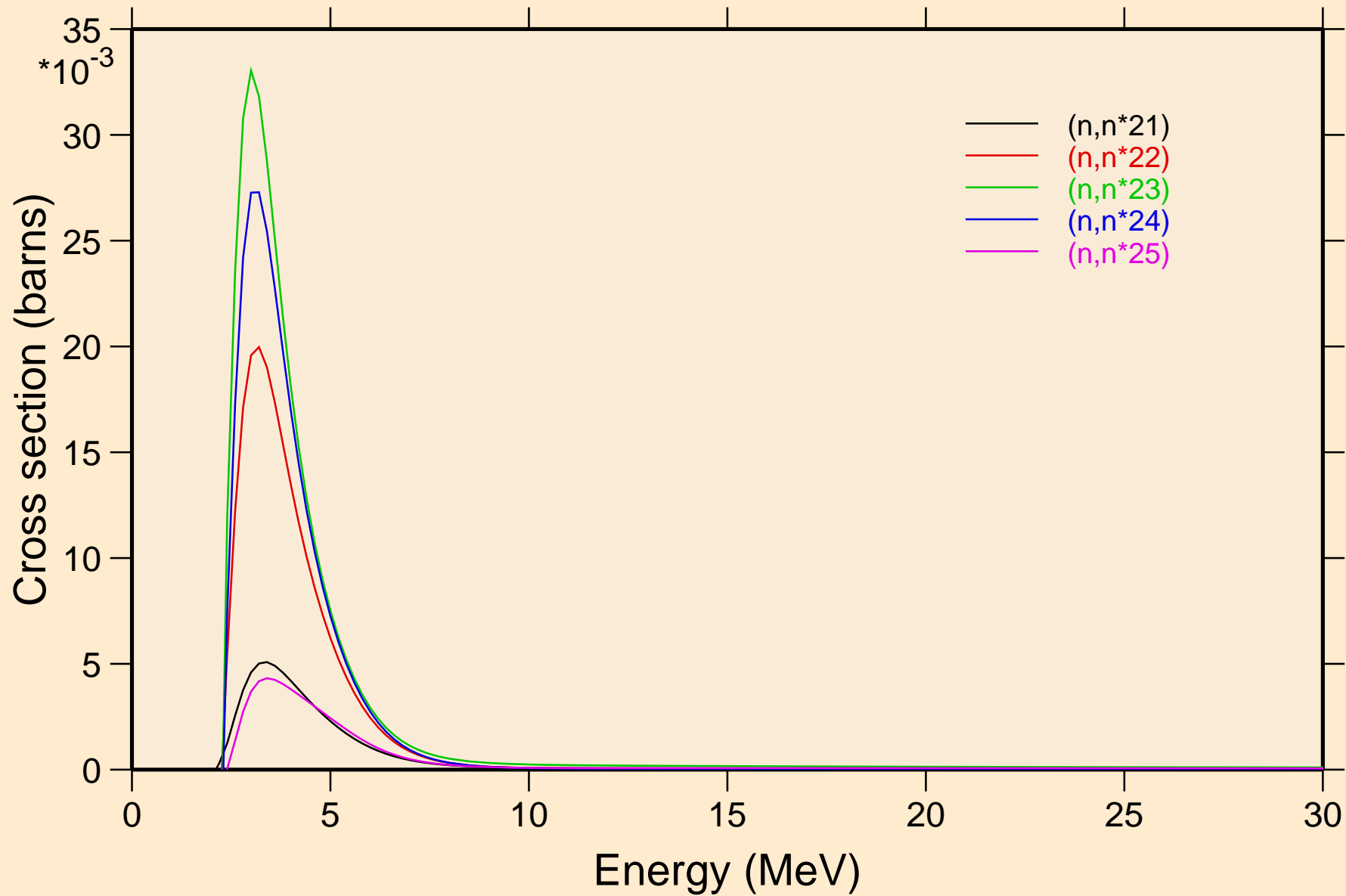

GA075 NEUTRON ACER TENDL-2023 LIBRARY; T=0.K
Inelastic levels

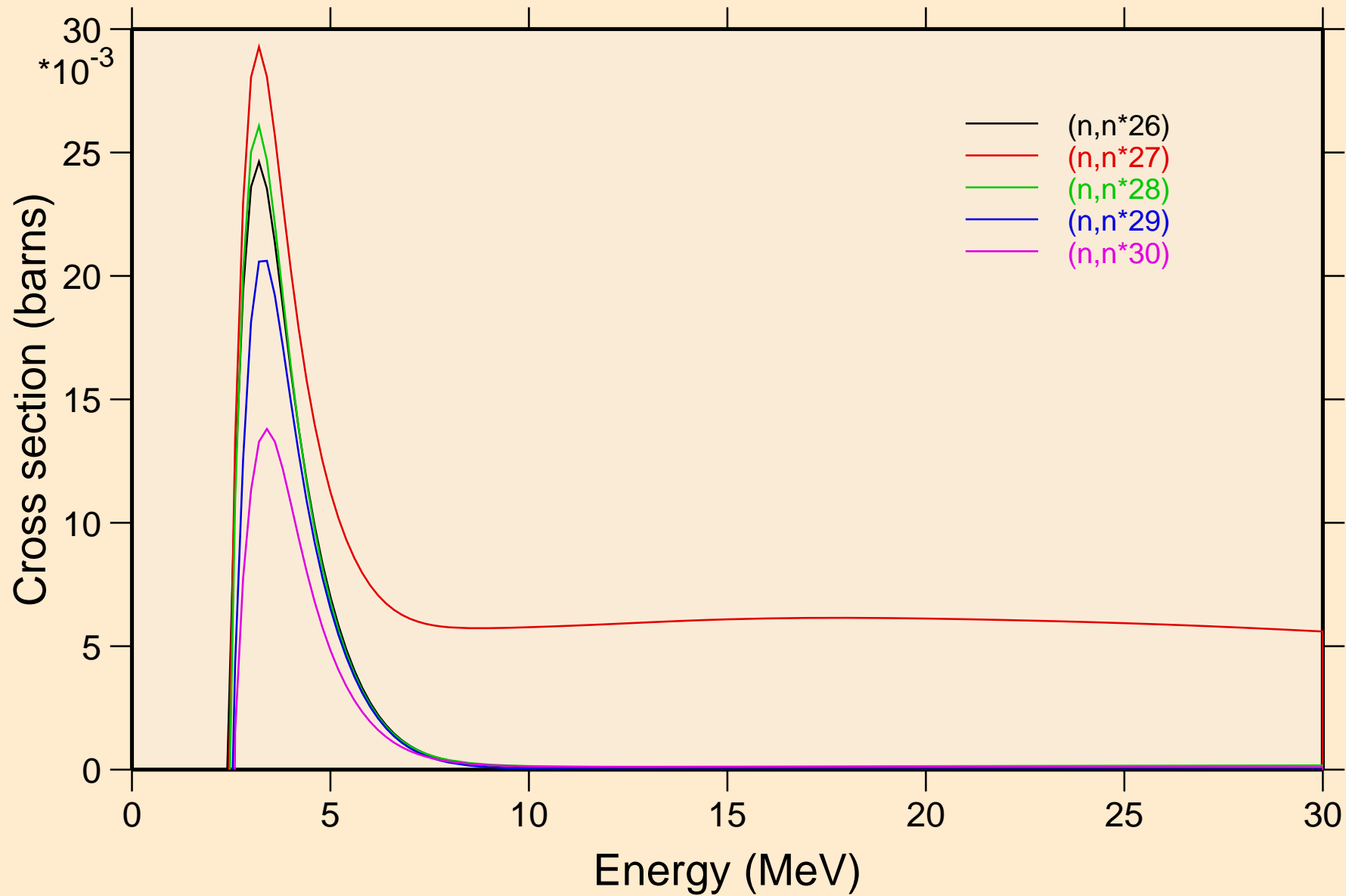

GA075 NEUTRON ACER TENDL-2023 LIBRARY; T=0.K
Threshold reactions

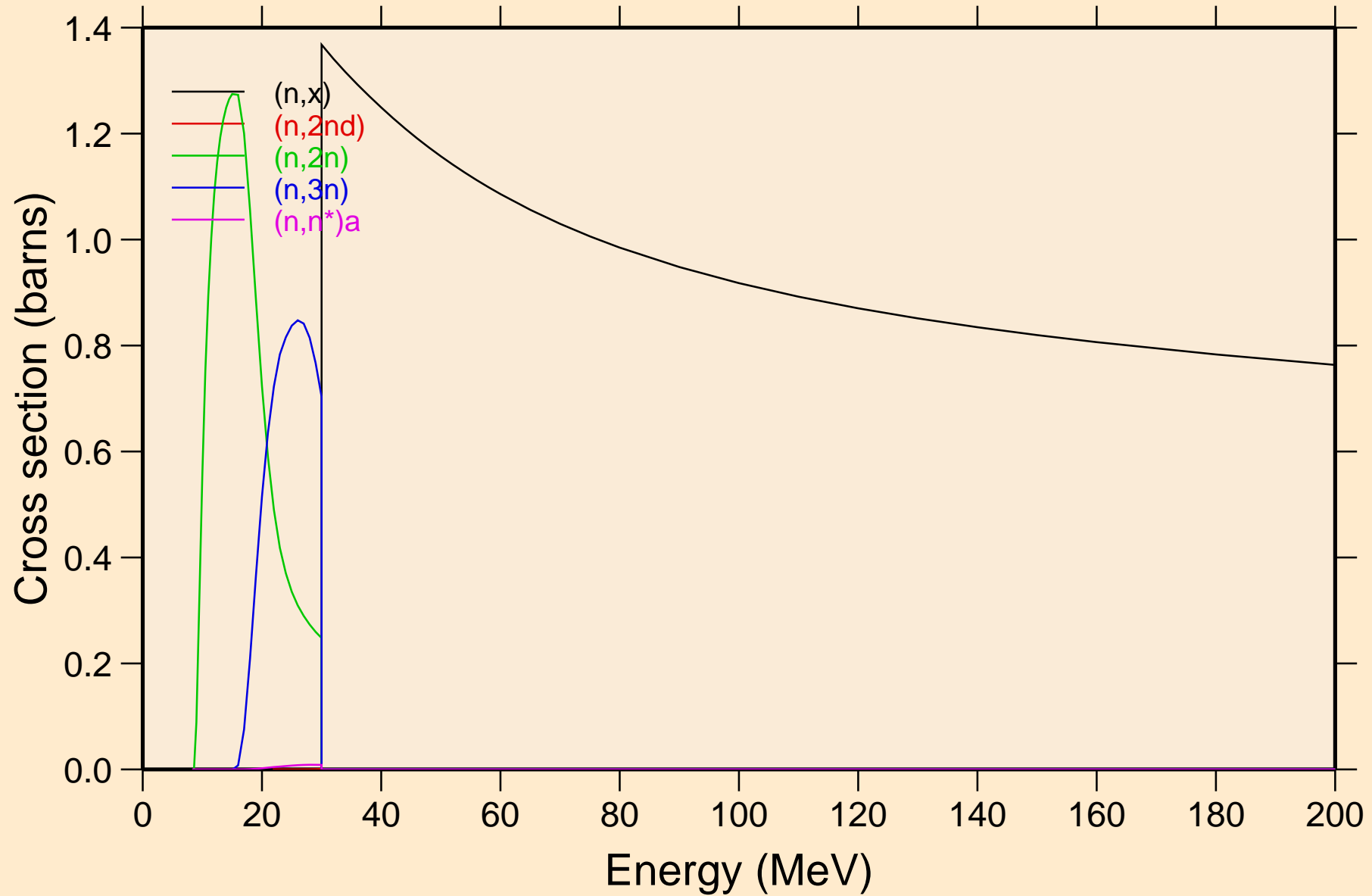

GA075 NEUTRON ACER TENDL-2023 LIBRARY; T=0.K
Threshold reactions

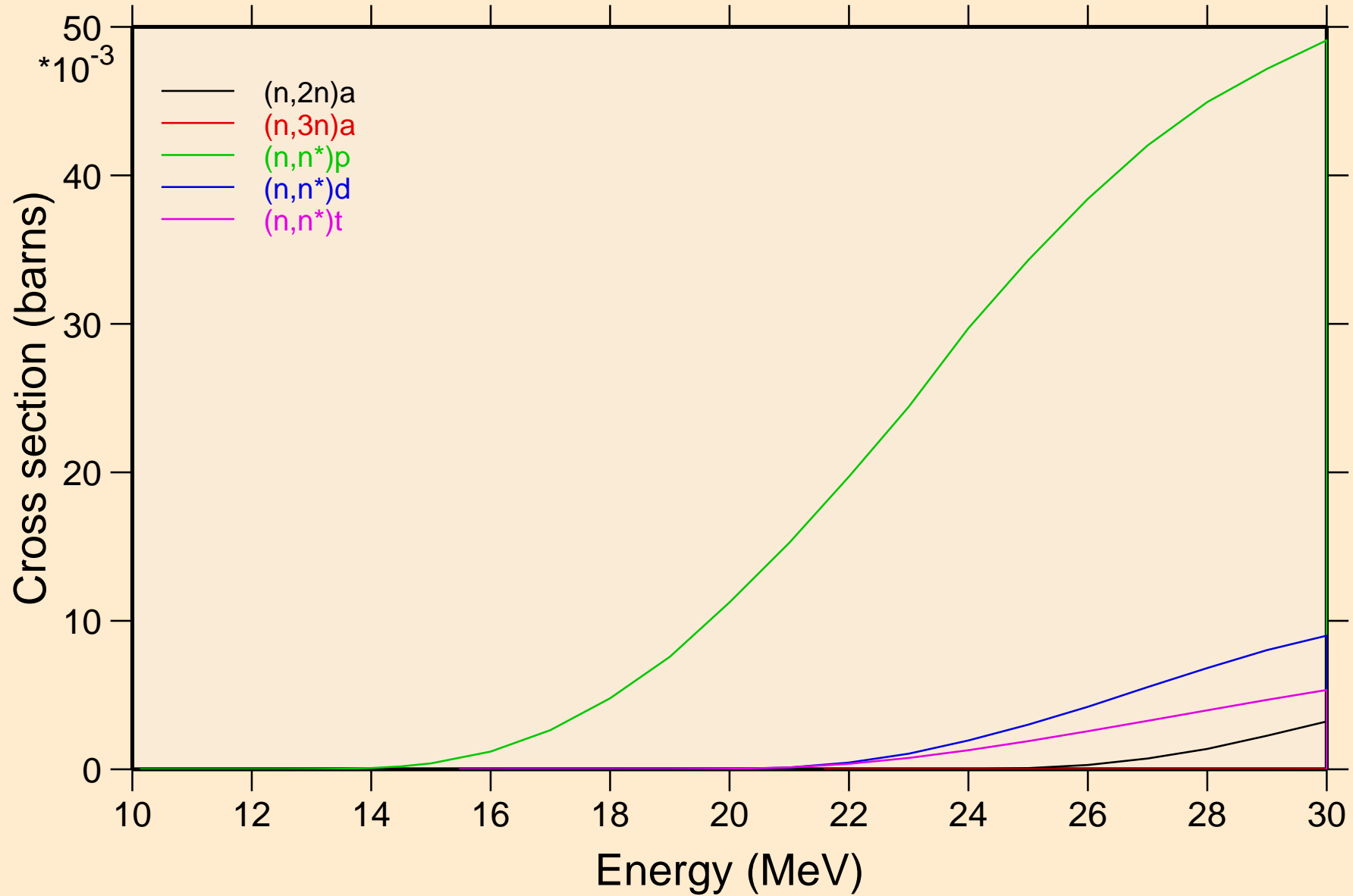

GA075 NEUTRON ACER TENDL-2023 LIBRARY; T=0.K
Threshold reactions

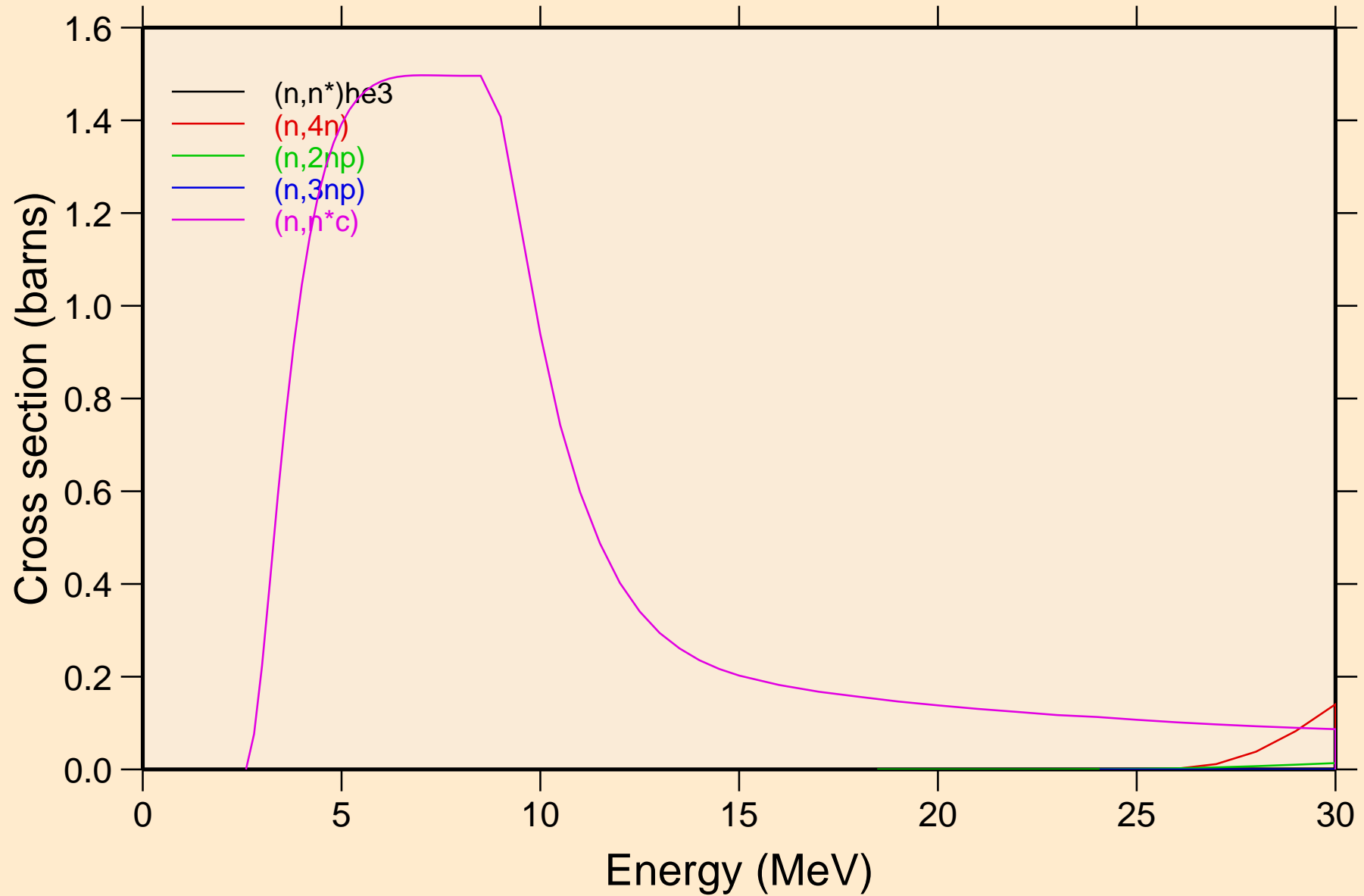

GA075 NEUTRON ACER TENDL-2023 LIBRARY; T=0.K

Threshold reactions

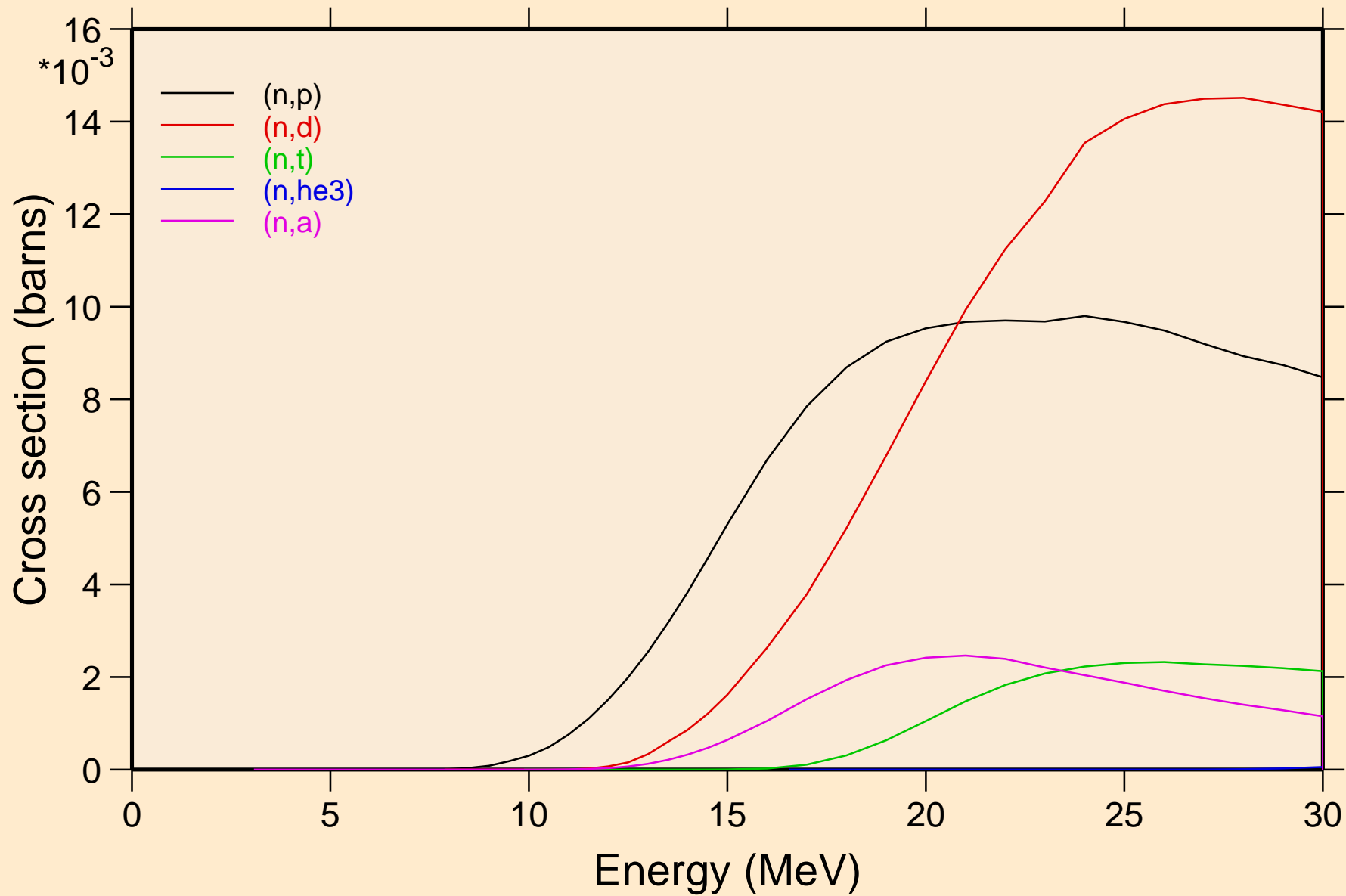

GA075 NEUTRON ACER TENDL-2023 LIBRARY; T=0.K
Threshold reactions

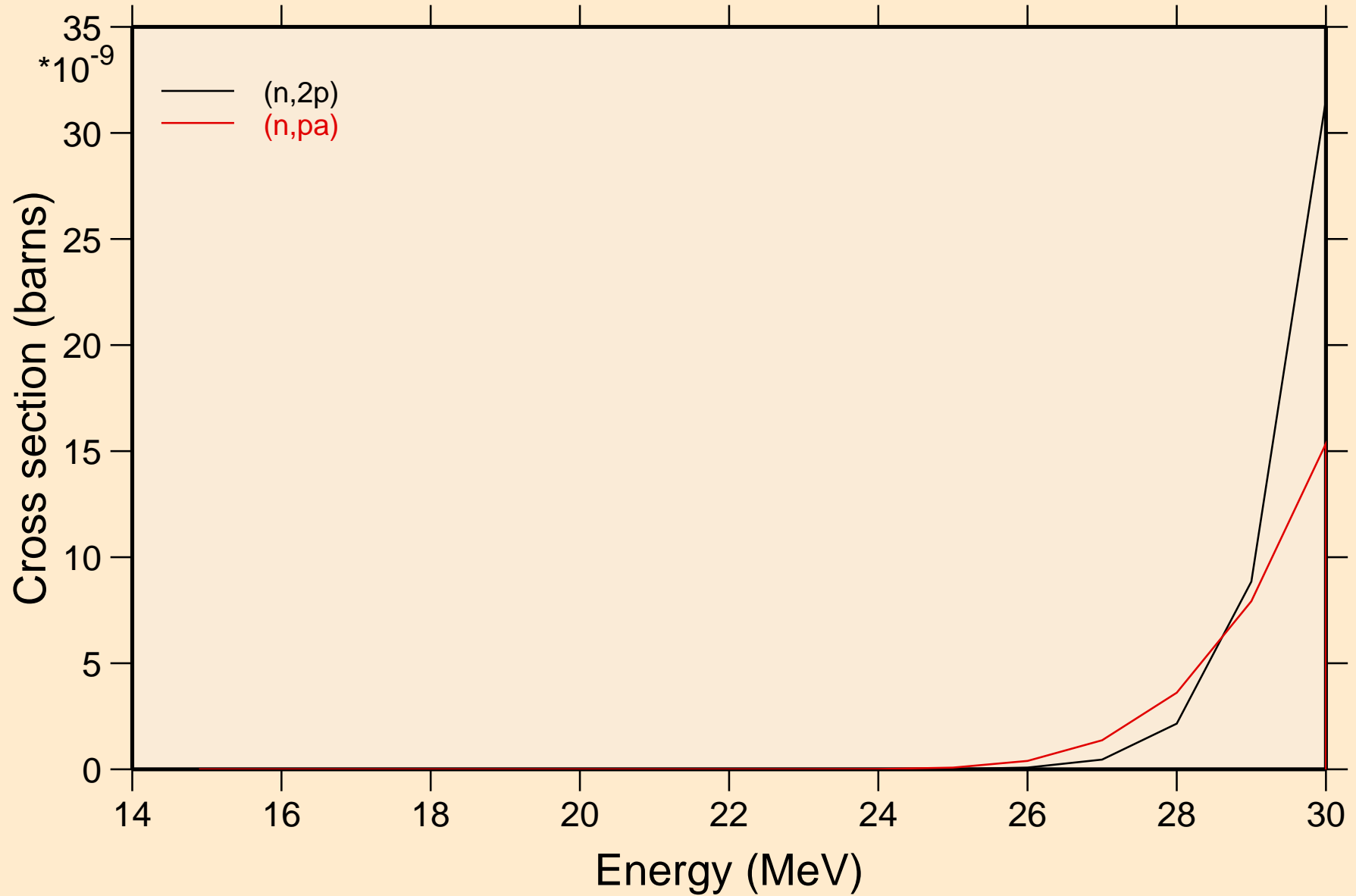

GA075 NEUTRON ACER TENDL-2023 LIBRARY; T=0.K

Threshold reactions

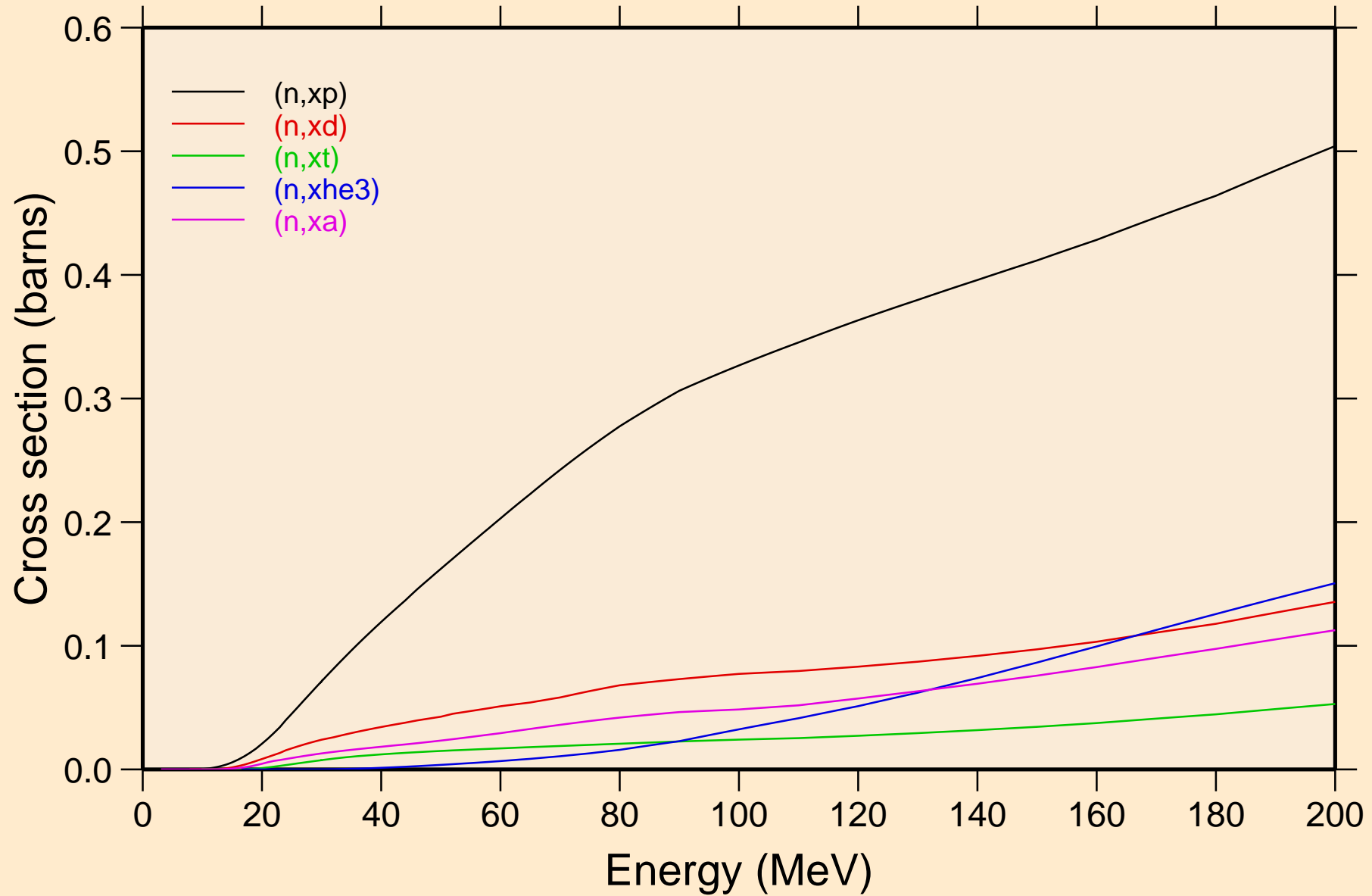

GA075 NEUTRON ACER TENDL-2023 LIBRARY; T=0.K
angular distribution for elastic

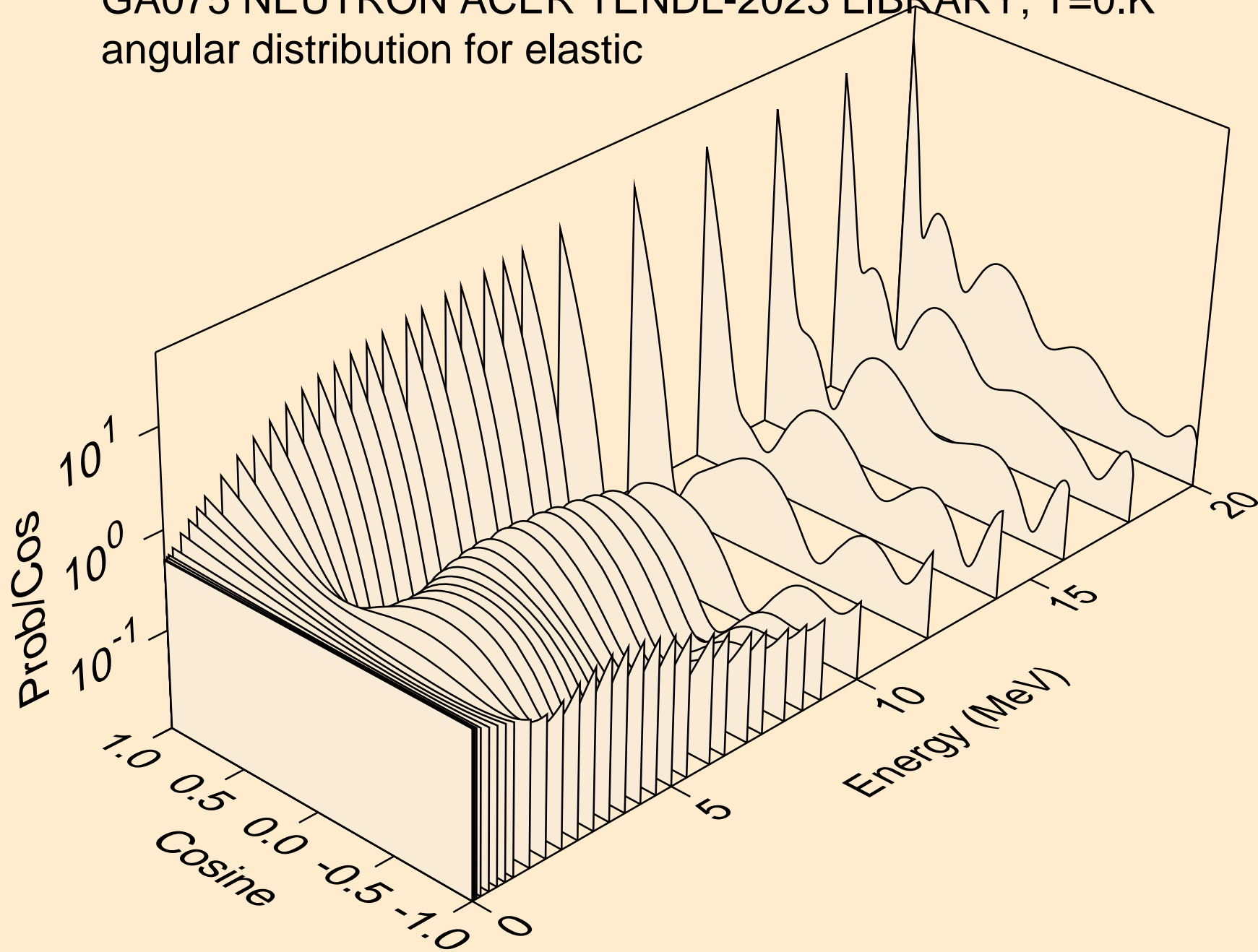

GA075 NEUTRON ACER TENDL-2023 LIBRARY; T=0.K
angular distribution for elastic

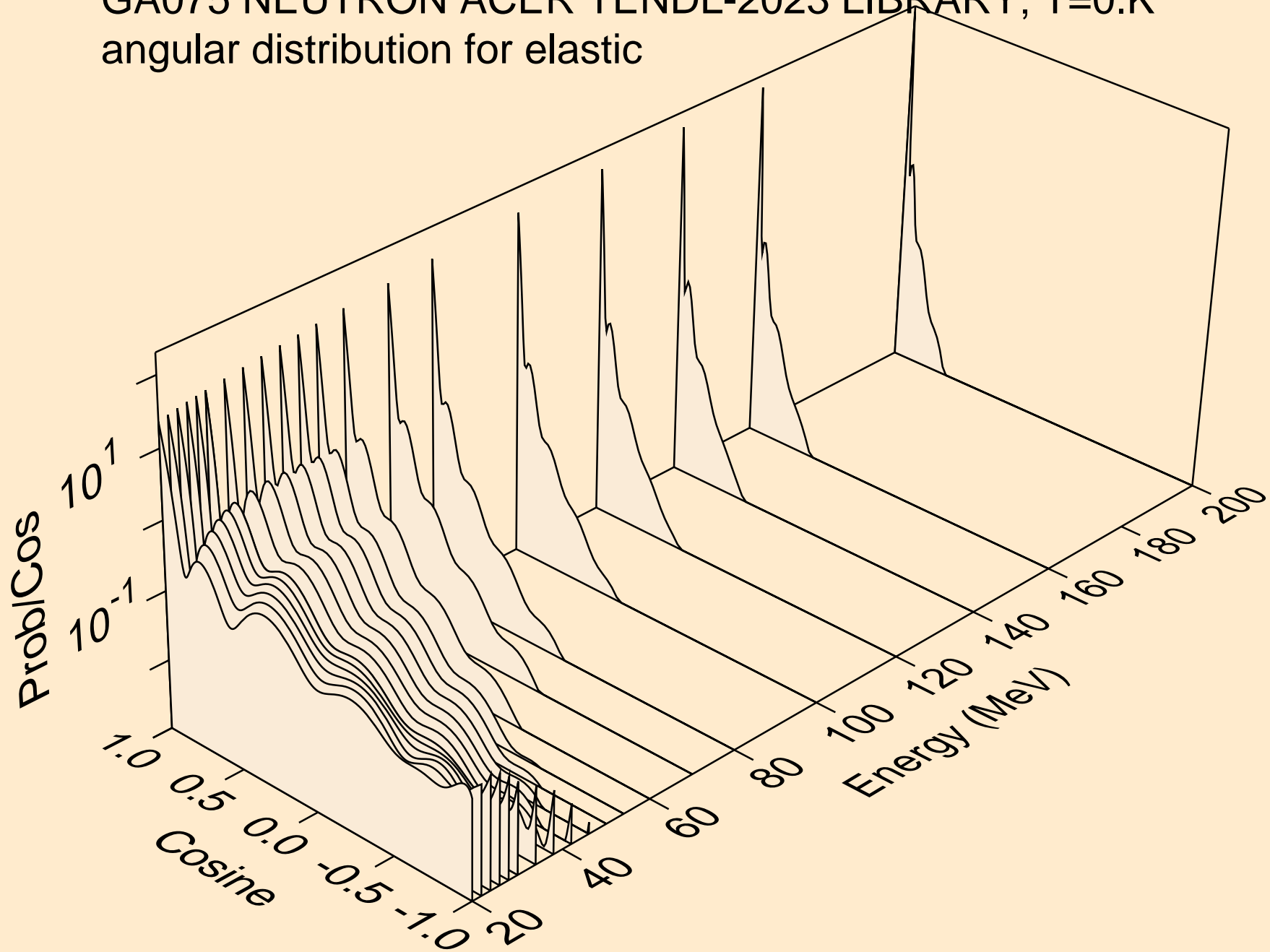

GA075 NEUTRON ACER TENDL-2023 LIBRARY; T=0.K
angular distribution for (n,n*1)

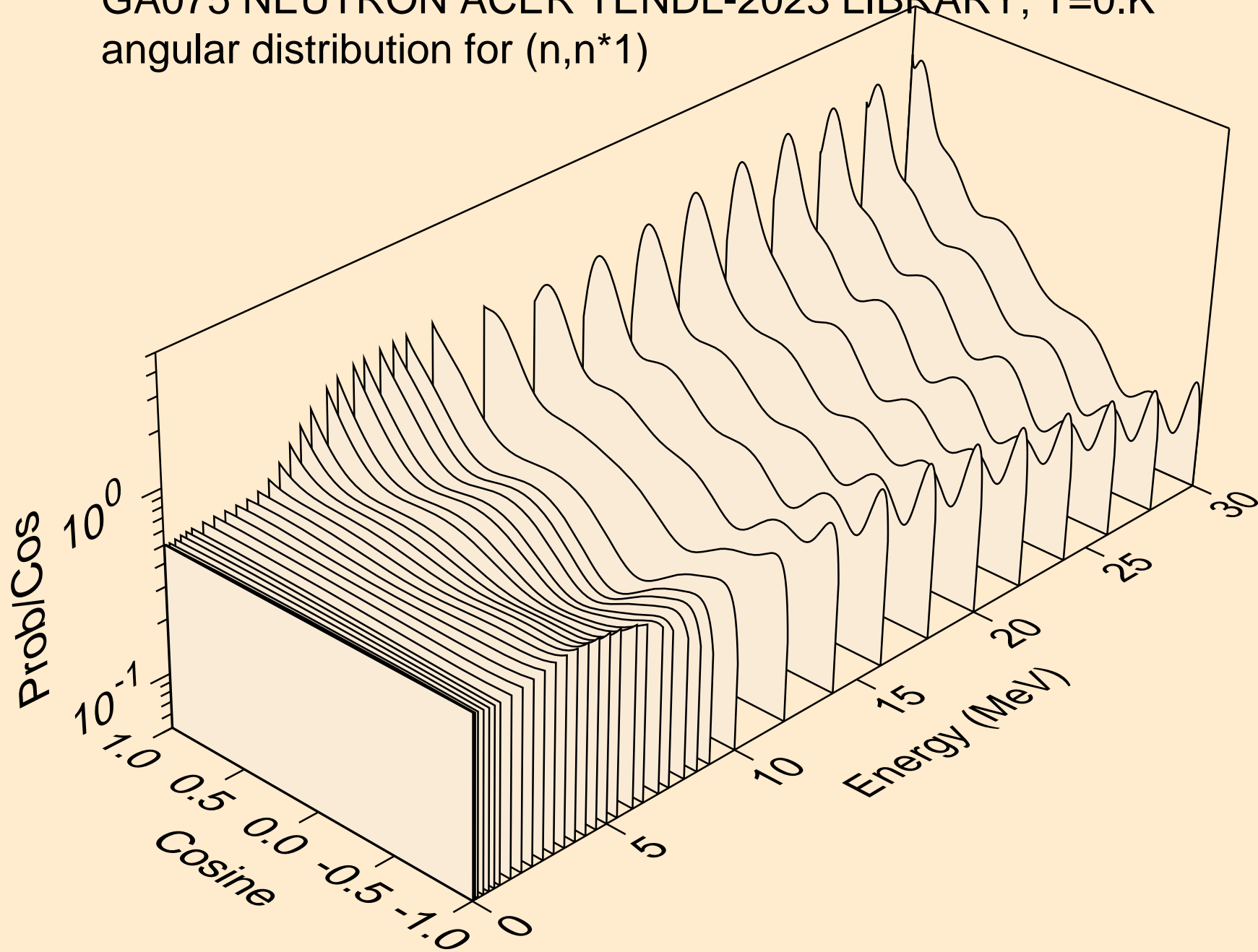

GA075 NEUTRON ACER TENDL-2023 LIBRARY; T=0.K
angular distribution for (n,n*2)

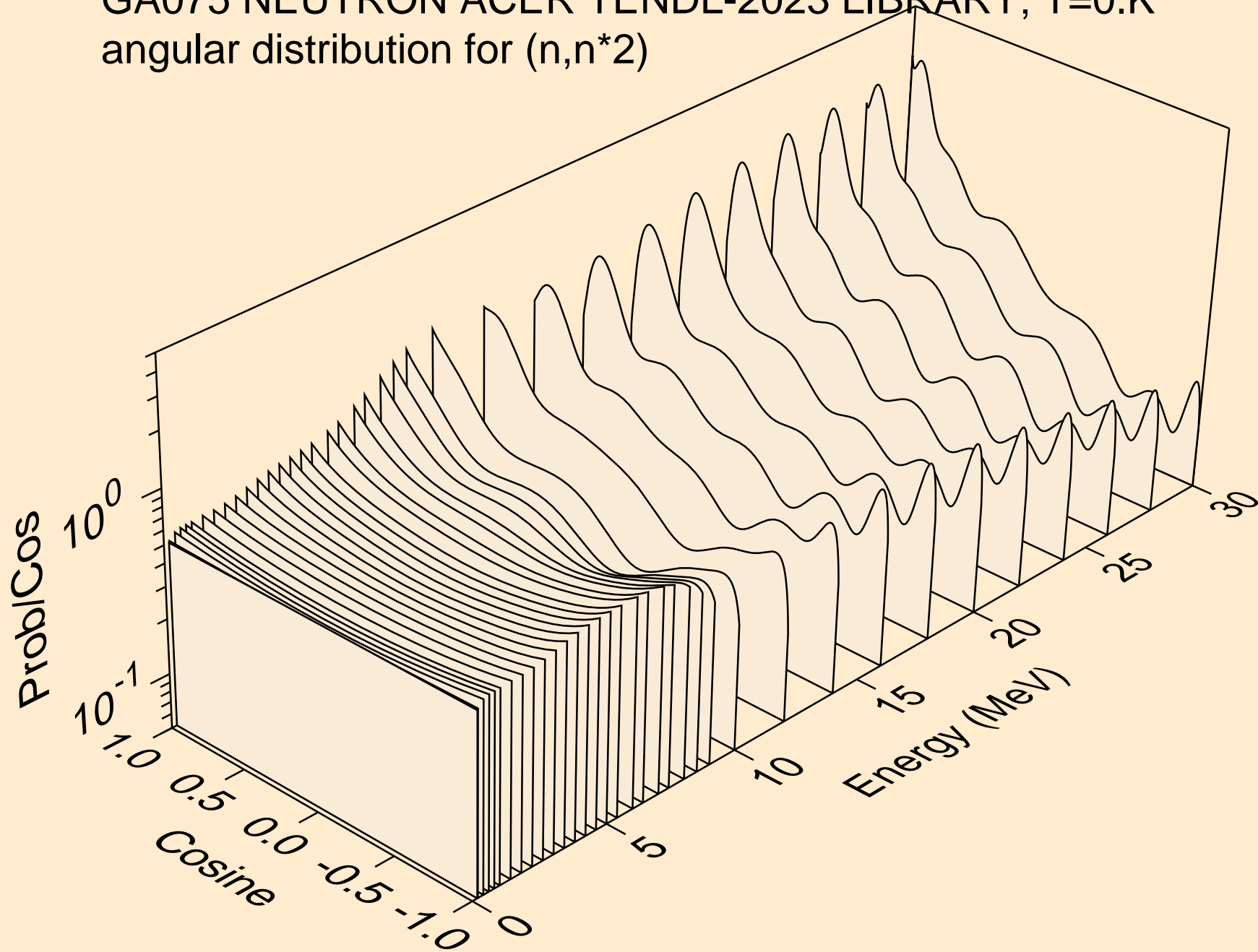

GA075 NEUTRON ACER TENDL-2023 LIBRARY; T=0.K
angular distribution for (n,n*3)

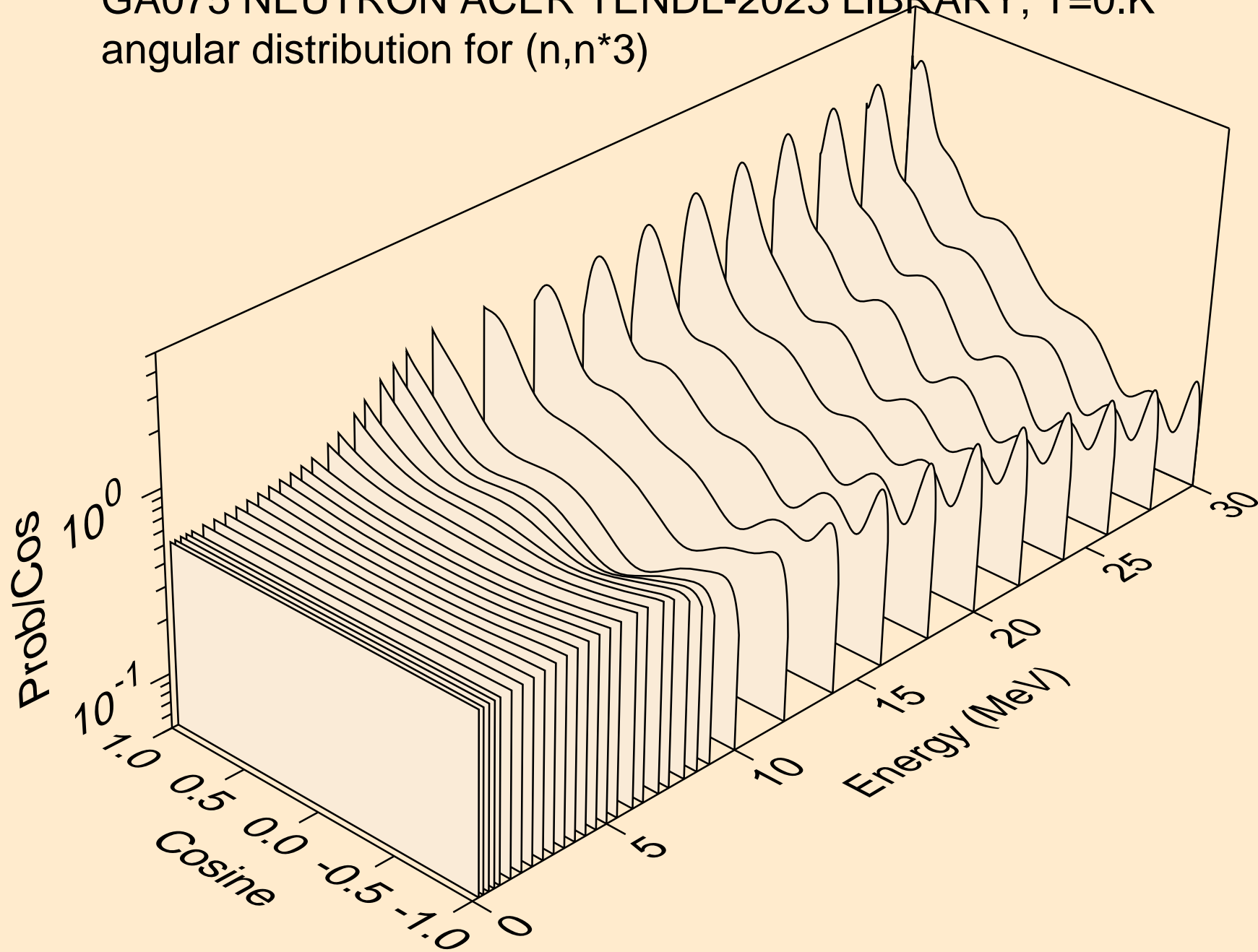

GA075 NEUTRON ACER TENDL-2023 LIBRARY; T=0.K
angular distribution for (n,n*4)

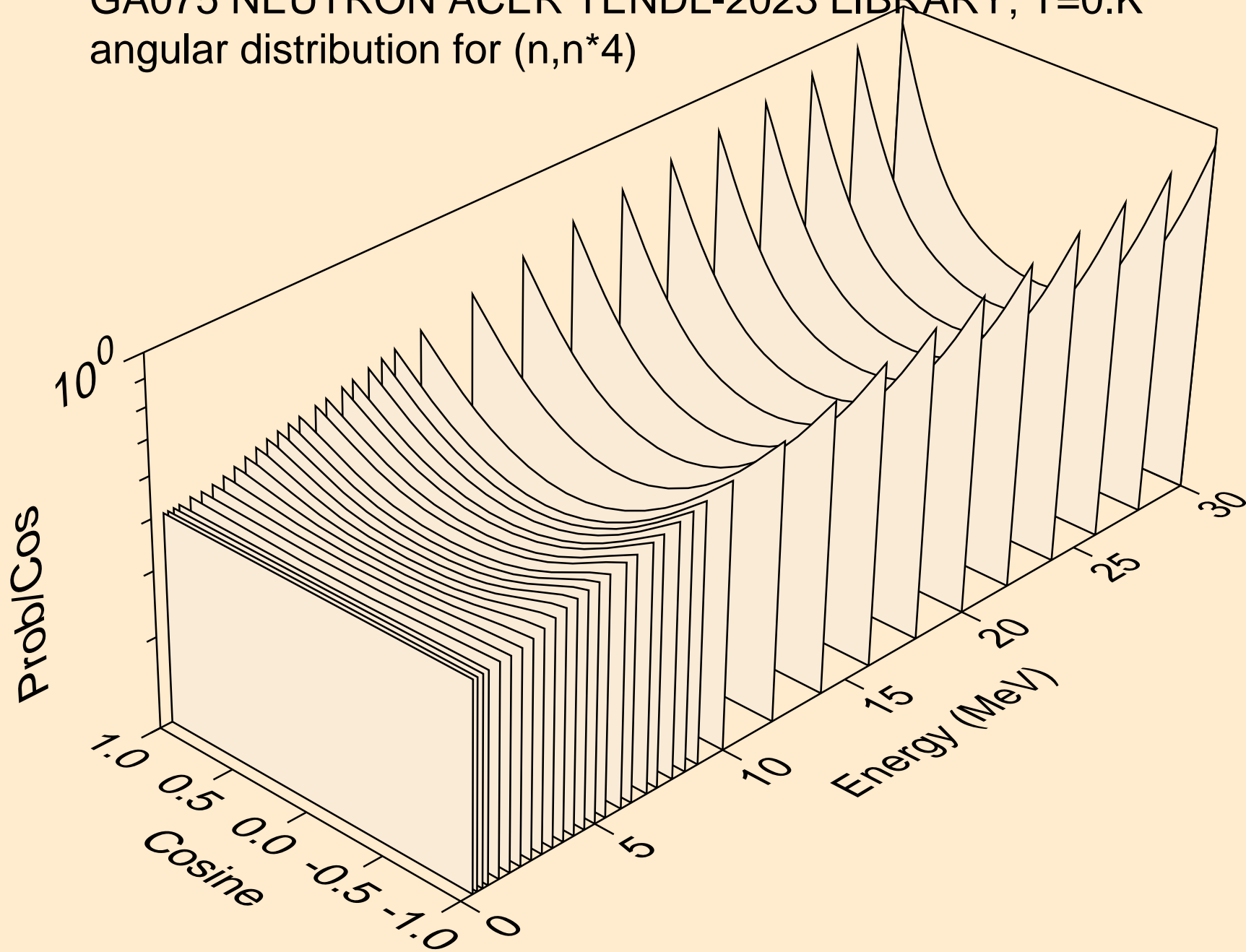

GA075 NEUTRON ACER TENDL-2023 LIBRARY; T=0.K
angular distribution for (n,n*5)

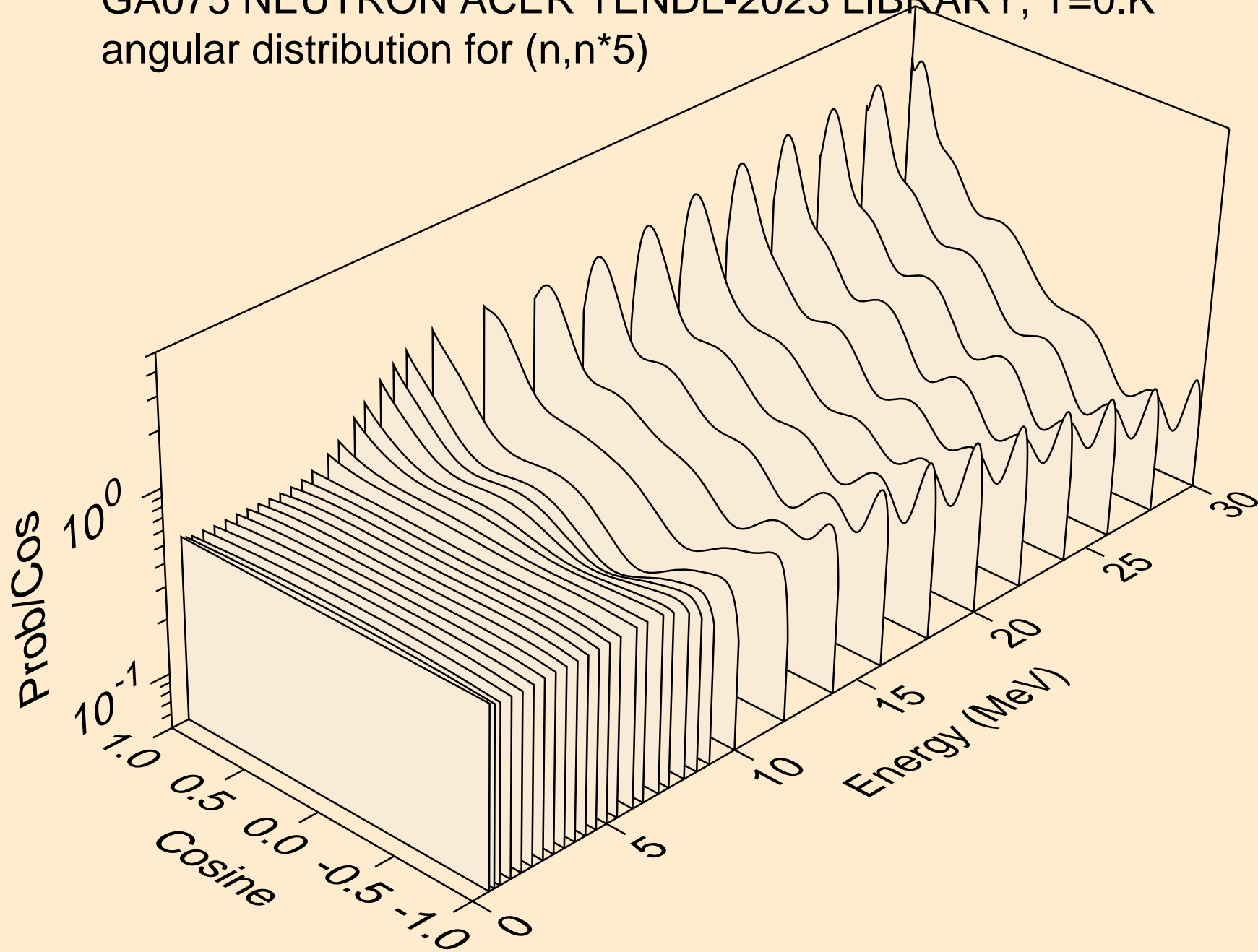

GA075 NEUTRON ACER TENDL-2023 LIBRARY; T=0.K
angular distribution for (n,n*6)

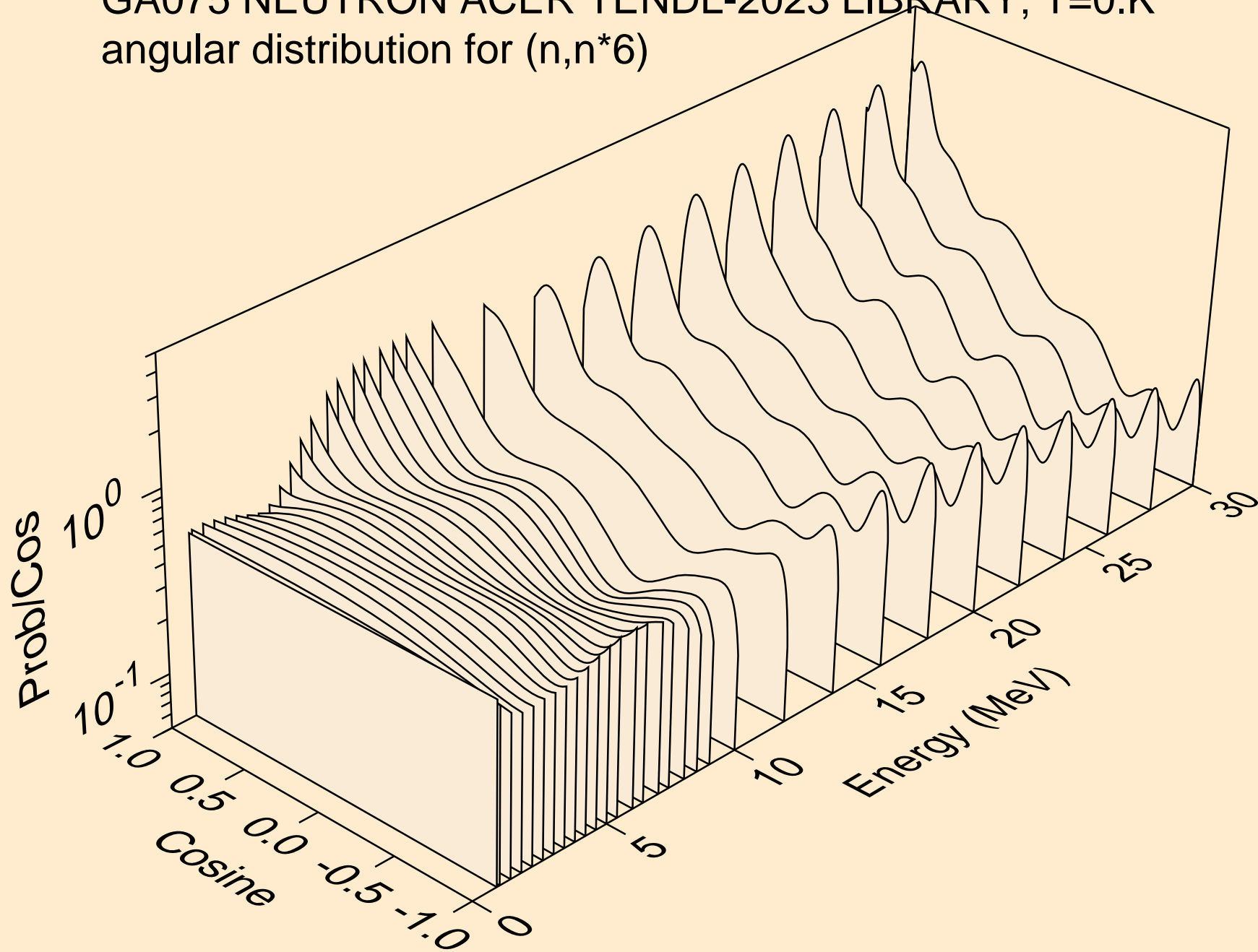

GA075 NEUTRON ACER TENDL-2023 LIBRARY; T=0.K
angular distribution for (n,n*7)

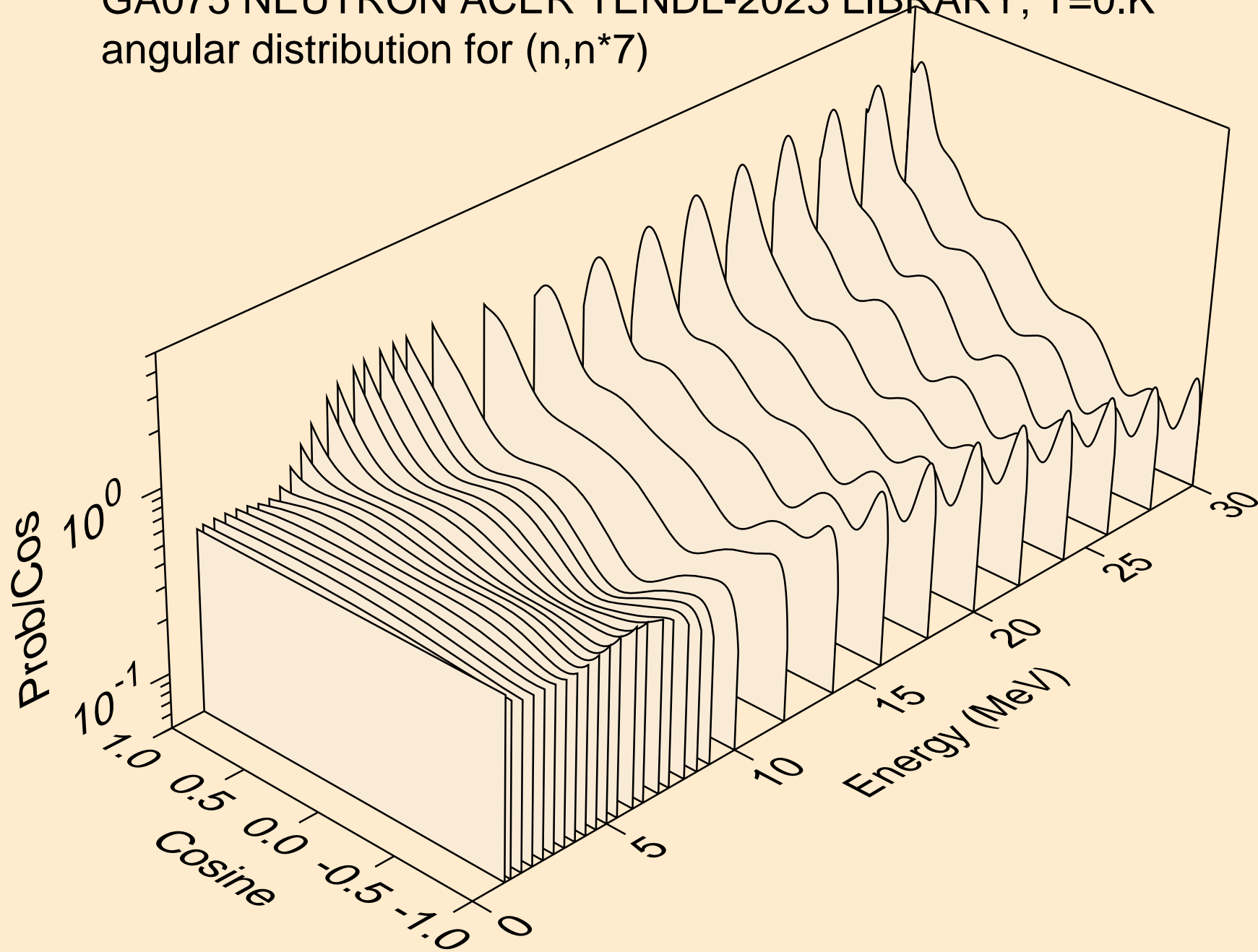

GA075 NEUTRON ACER TENDL-2023 LIBRARY; T=0.K
angular distribution for (n,n*8)

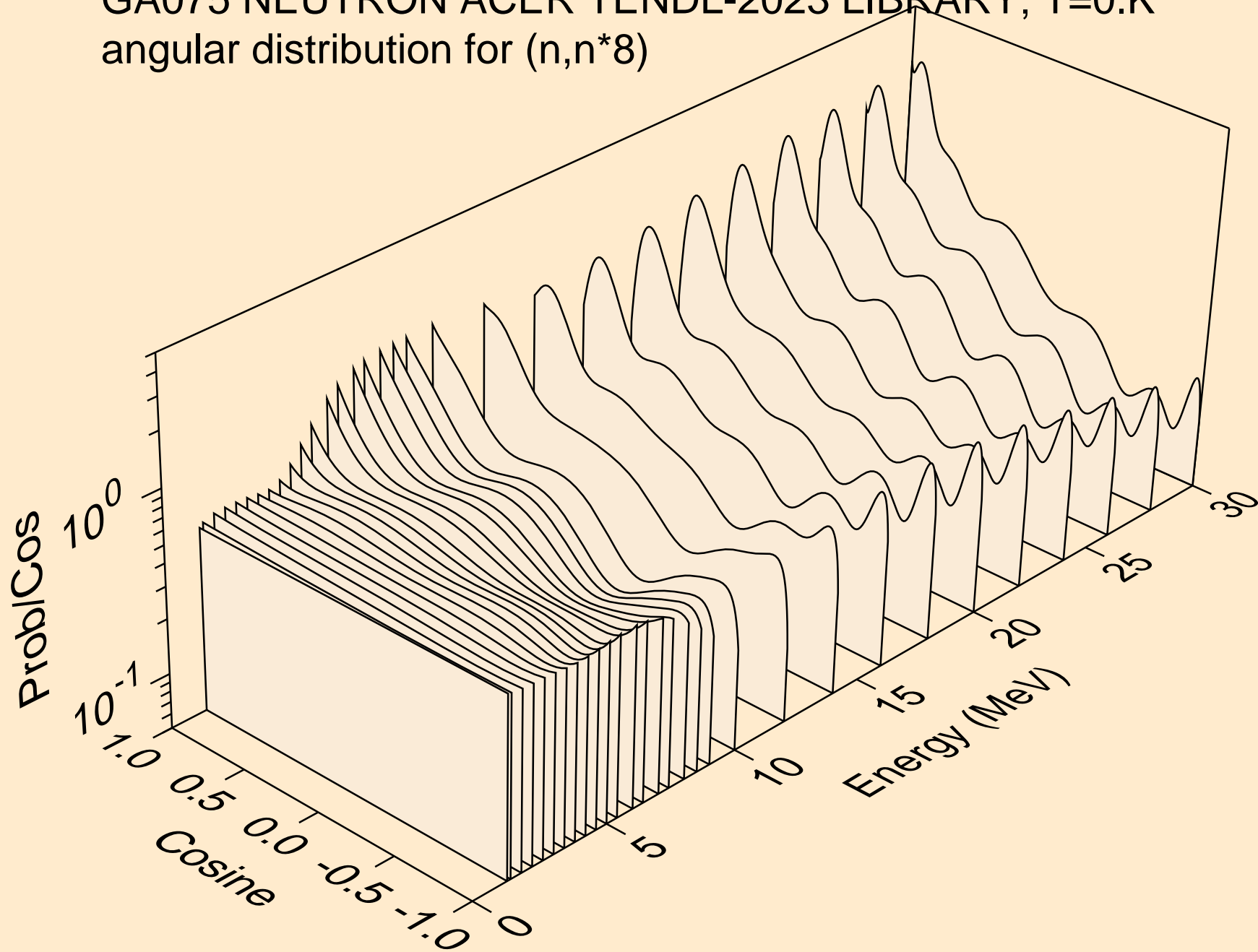

GA075 NEUTRON ACER TENDL-2023 LIBRARY; T=0.K
angular distribution for (n,n*9)

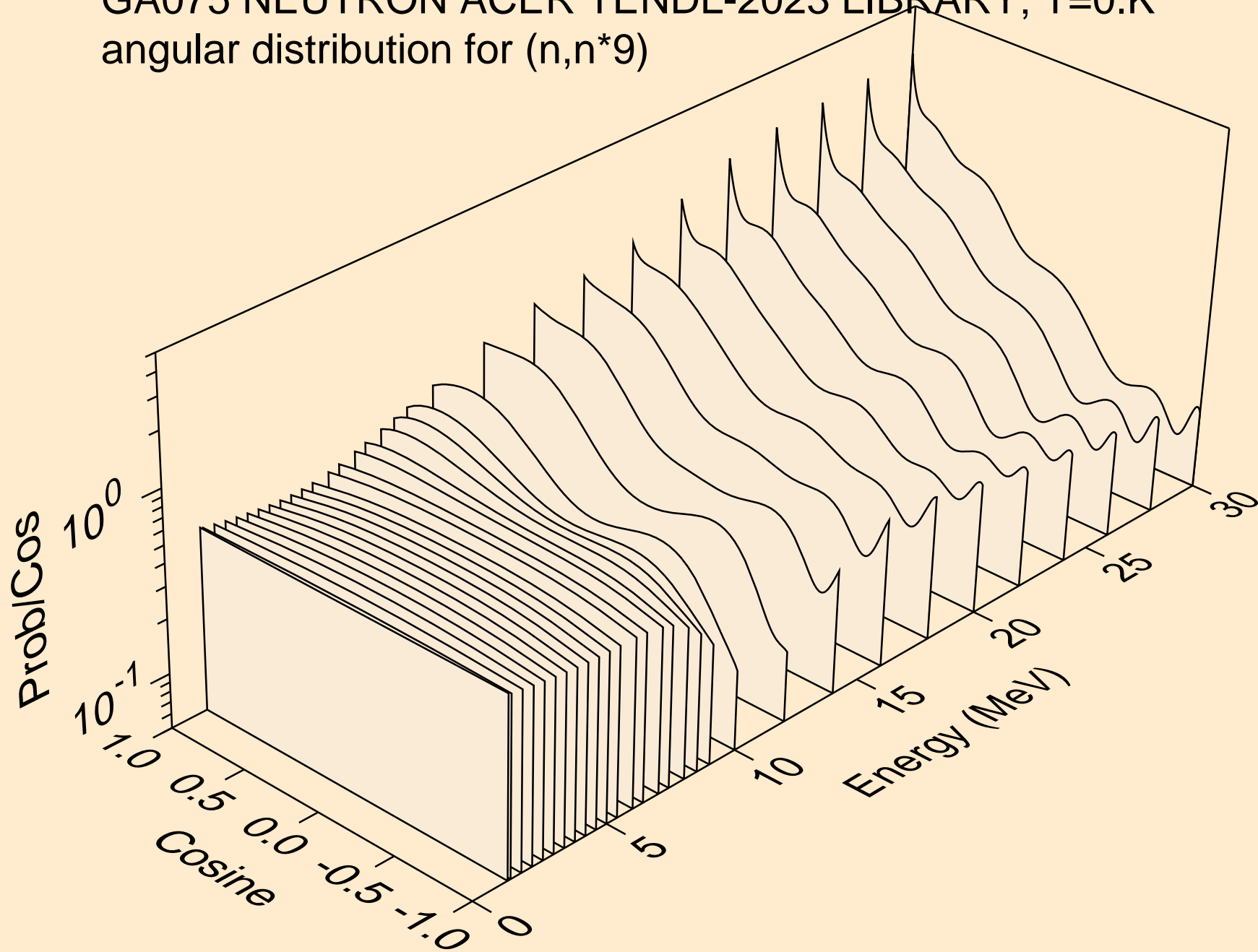

GA075 NEUTRON ACER TENDL-2023 LIBRARY; T=0.K
angular distribution for (n,n*10)

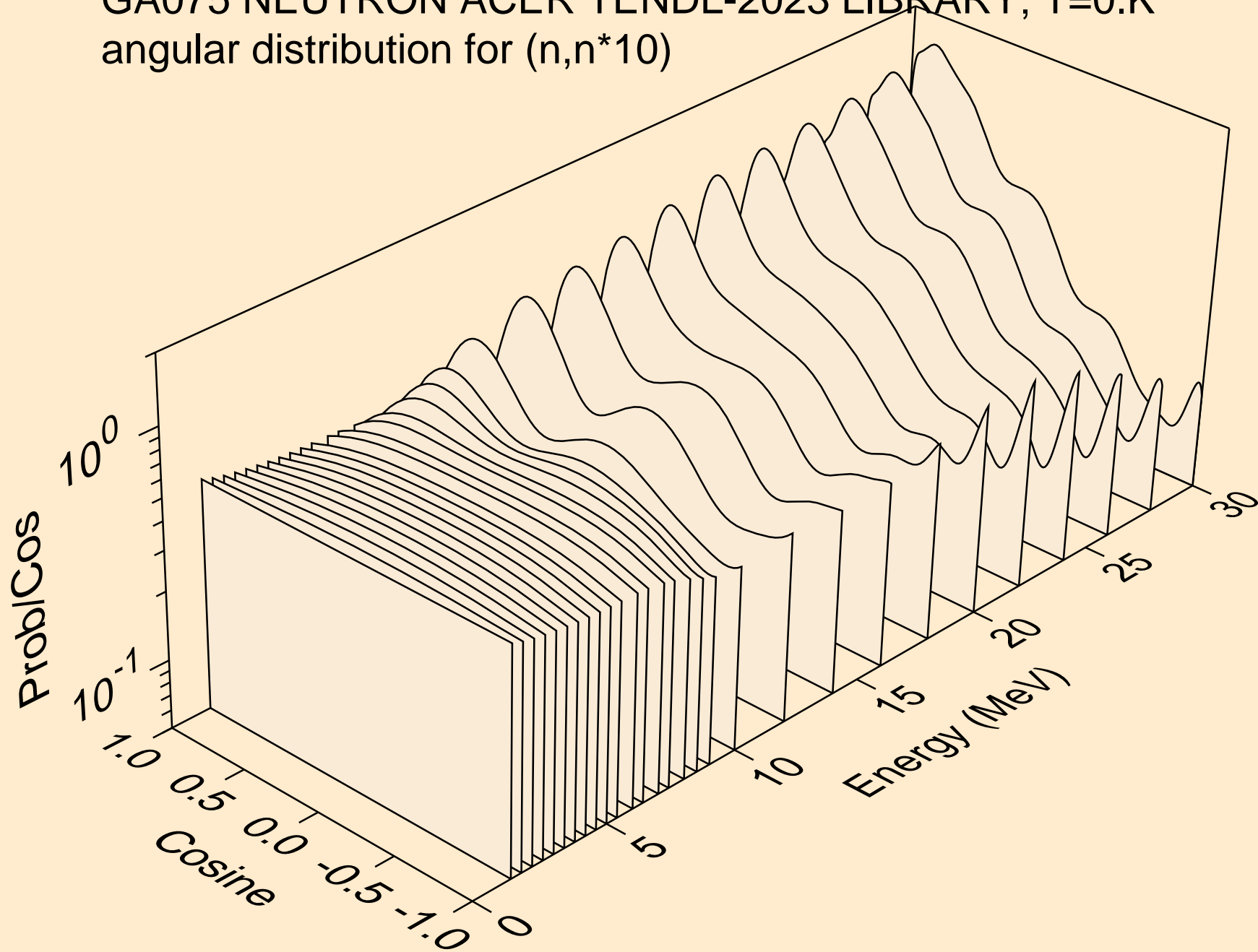

GA075 NEUTRON ACER TENDL-2023 LIBRARY; T=0.K
angular distribution for (n,n*11)

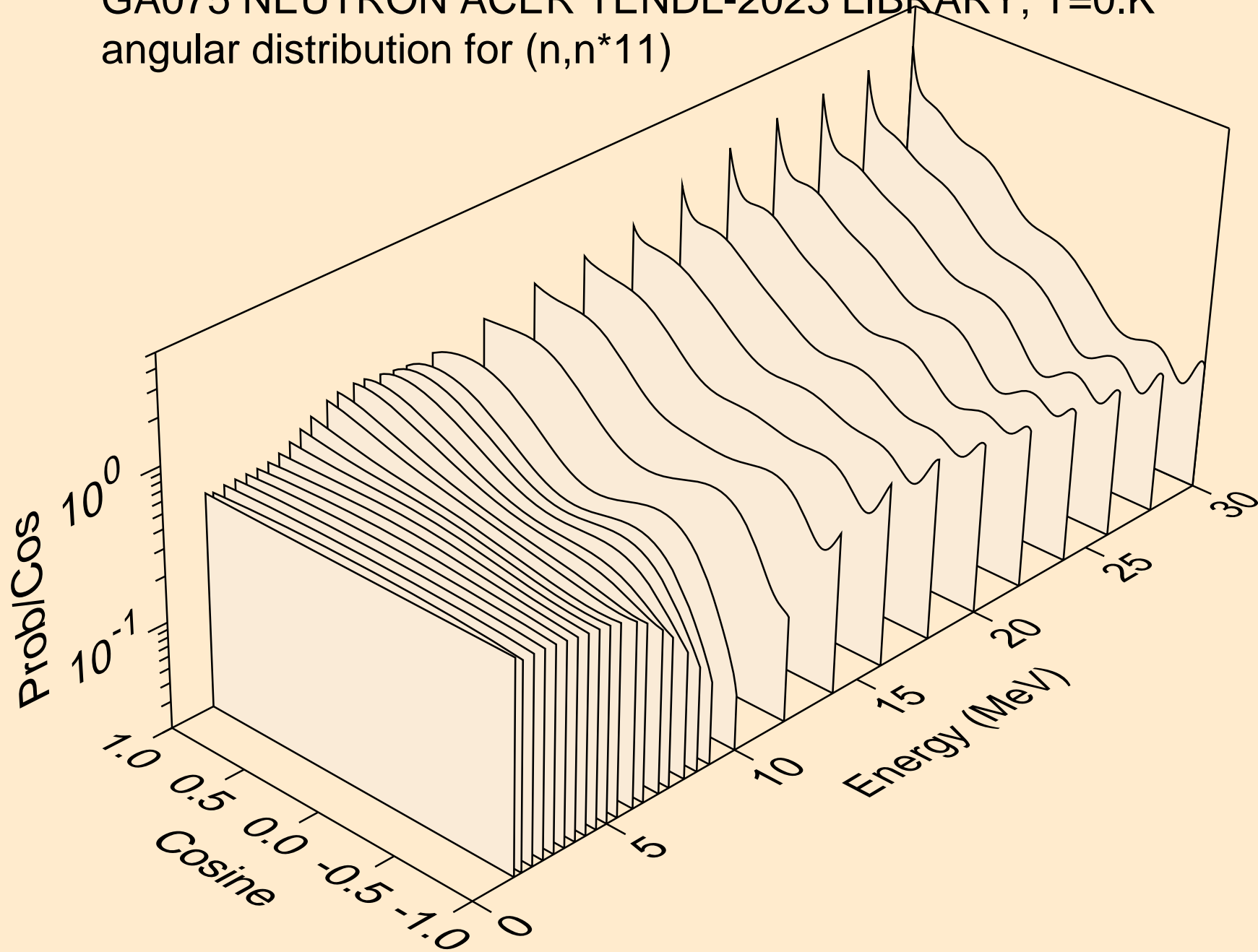

GA075 NEUTRON ACER TENDL-2023 LIBRARY; T=0.K
angular distribution for (n,n*12)

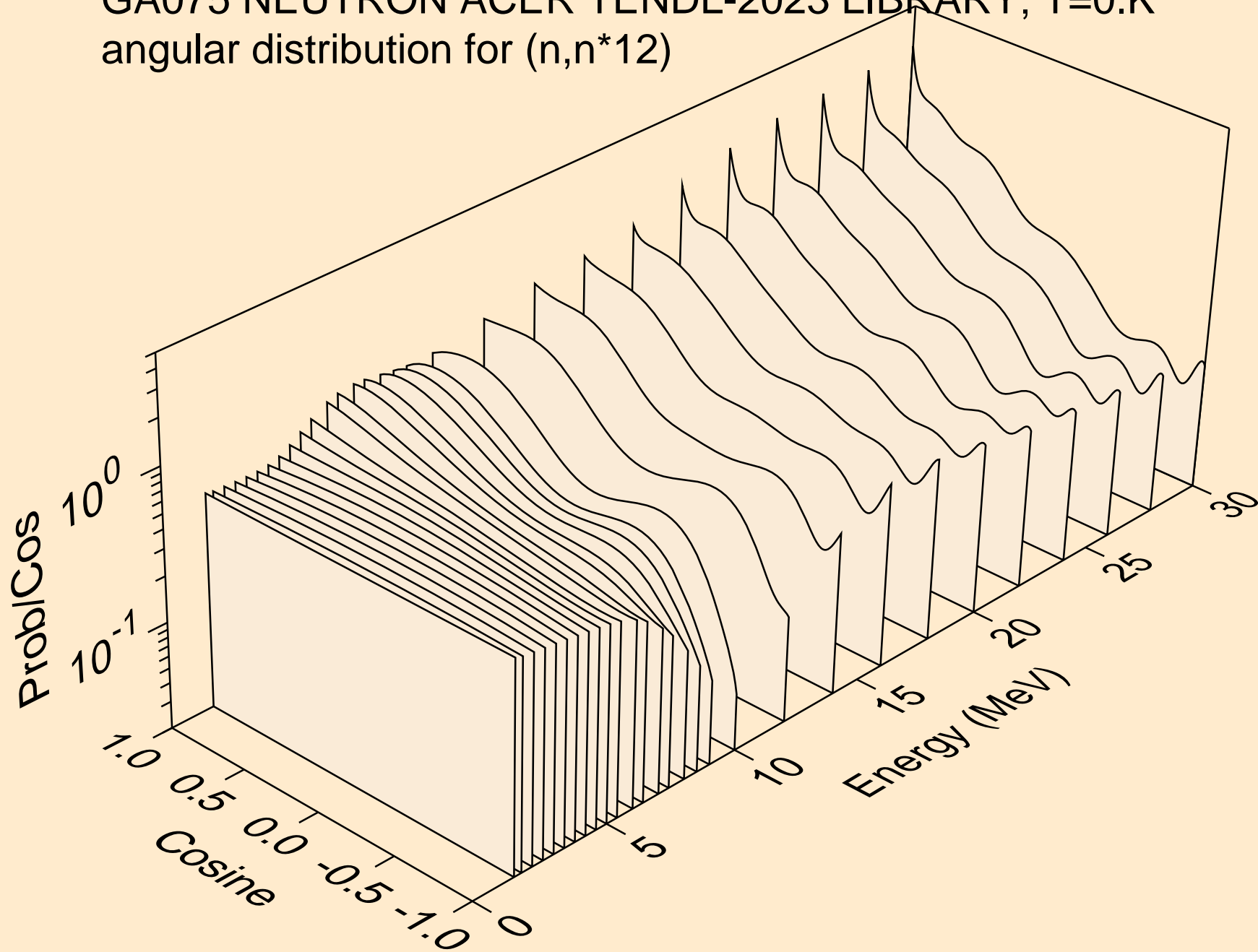

GA075 NEUTRON ACER TENDL-2023 LIBRARY; T=0.K
angular distribution for (n,n*13)

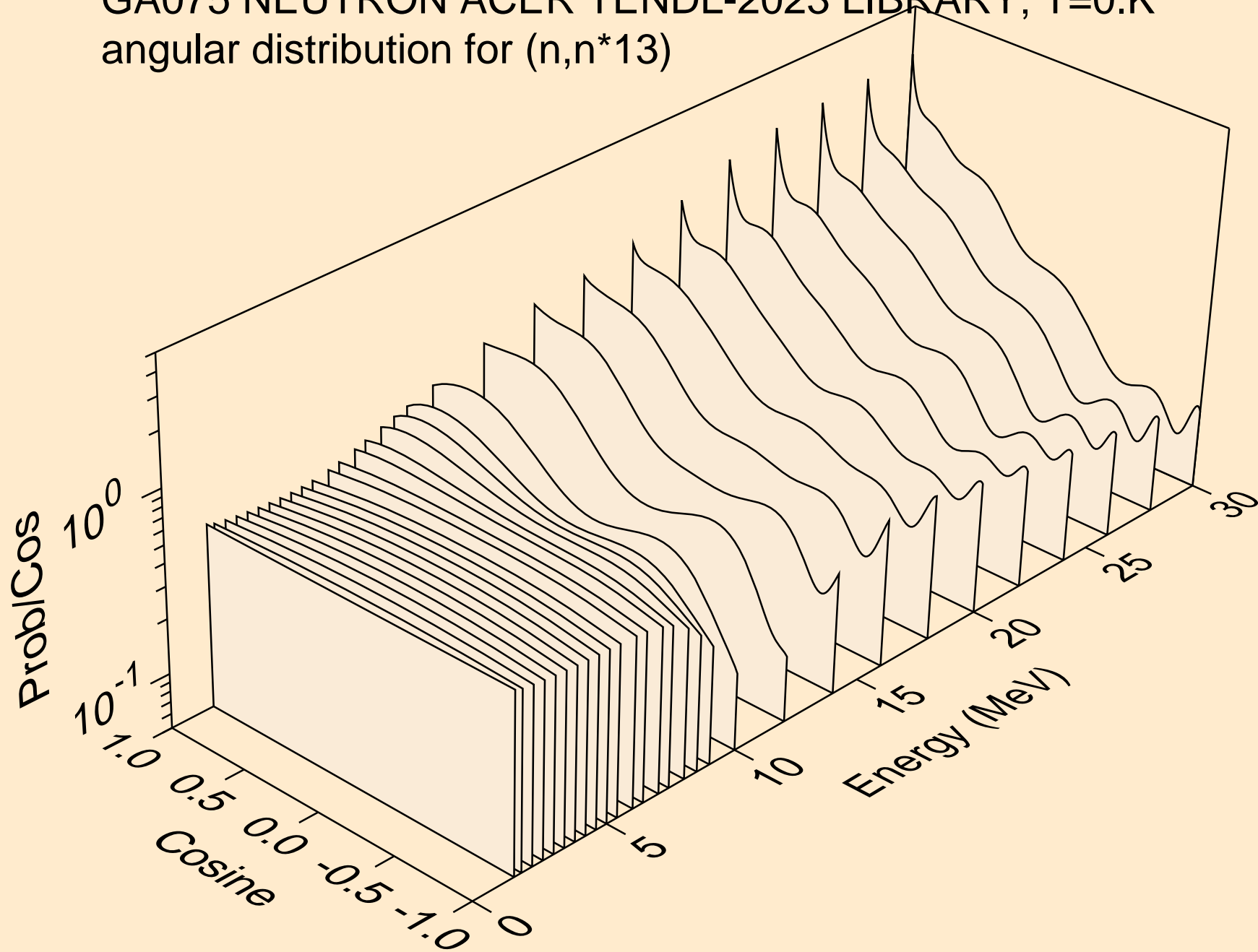

GA075 NEUTRON ACER TENDL-2023 LIBRARY; T=0.K
angular distribution for (n,n*14)

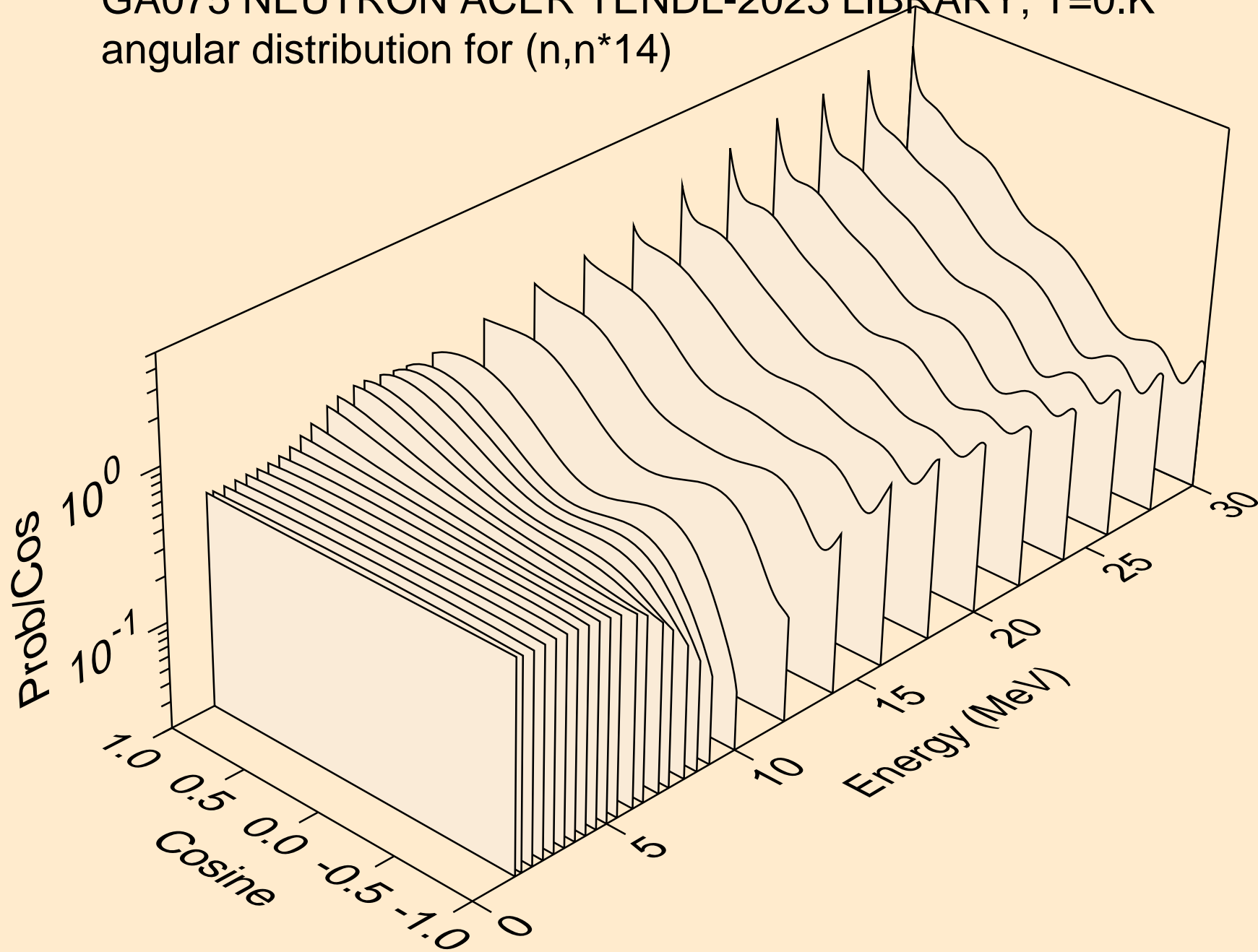

GA075 NEUTRON ACER TENDL-2023 LIBRARY; T=0.K
angular distribution for (n,n*15)

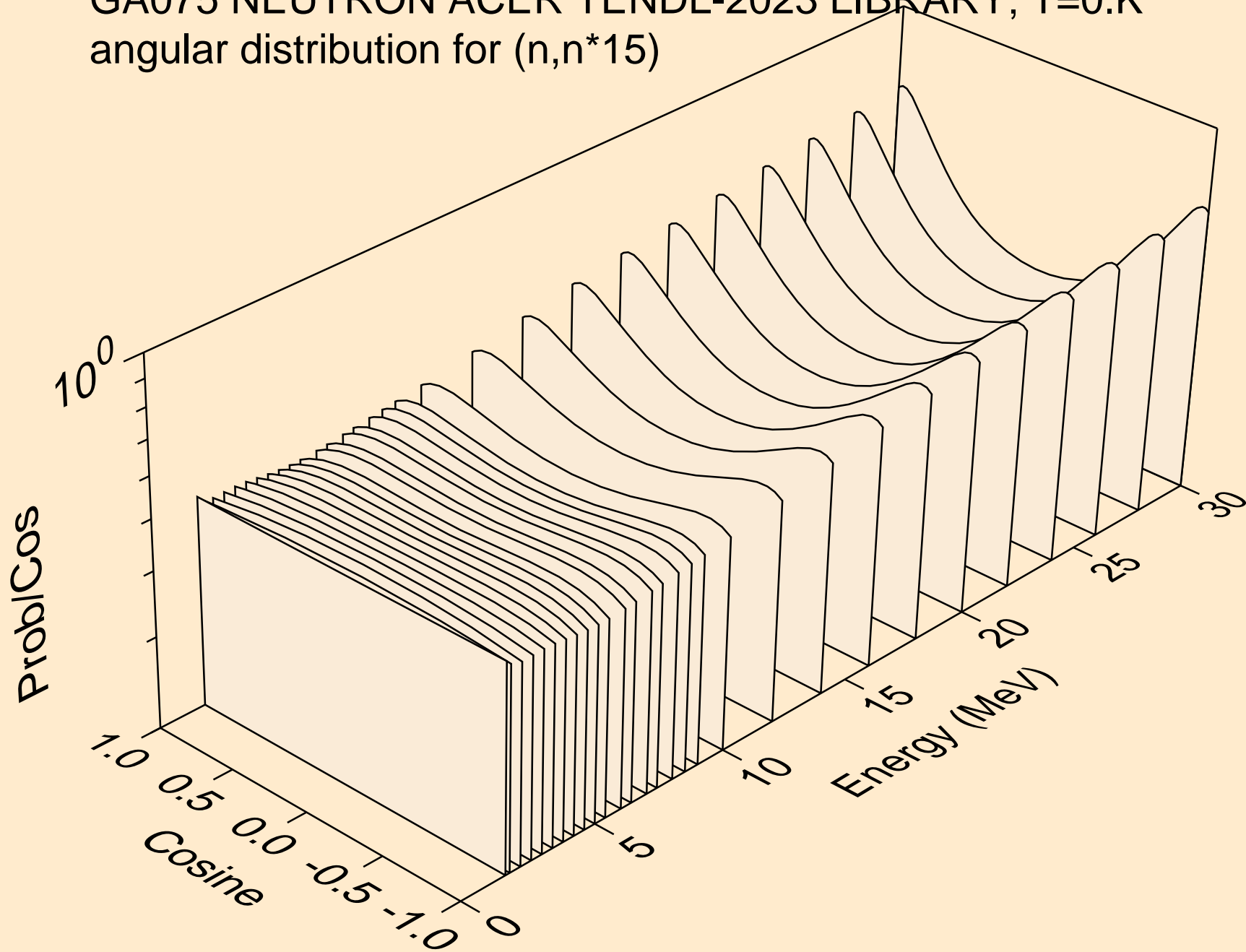

GA075 NEUTRON ACER TENDL-2023 LIBRARY; T=0.K
angular distribution for (n,n*16)

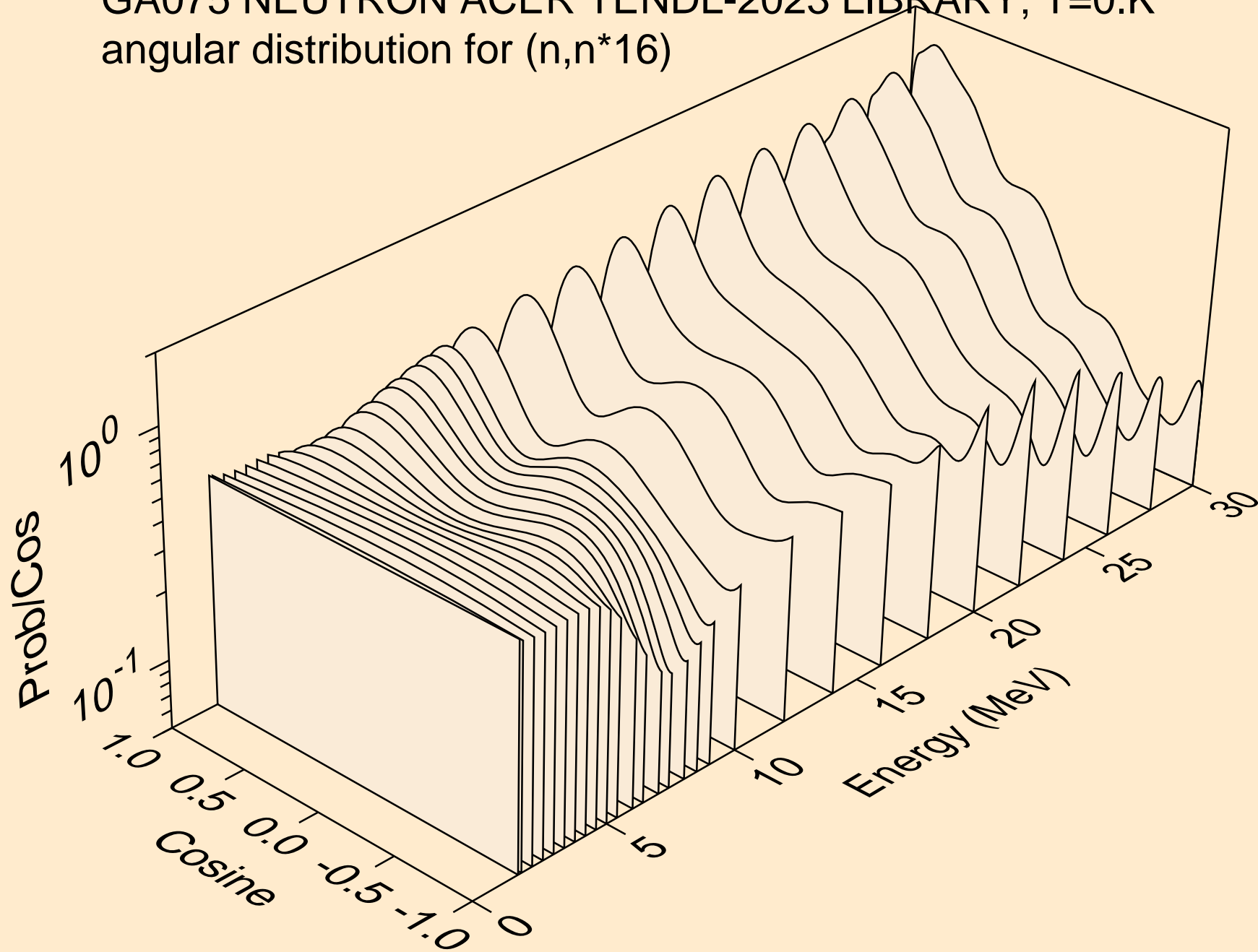

GA075 NEUTRON ACER TENDL-2023 LIBRARY; T=0.K
angular distribution for (n,n*17)

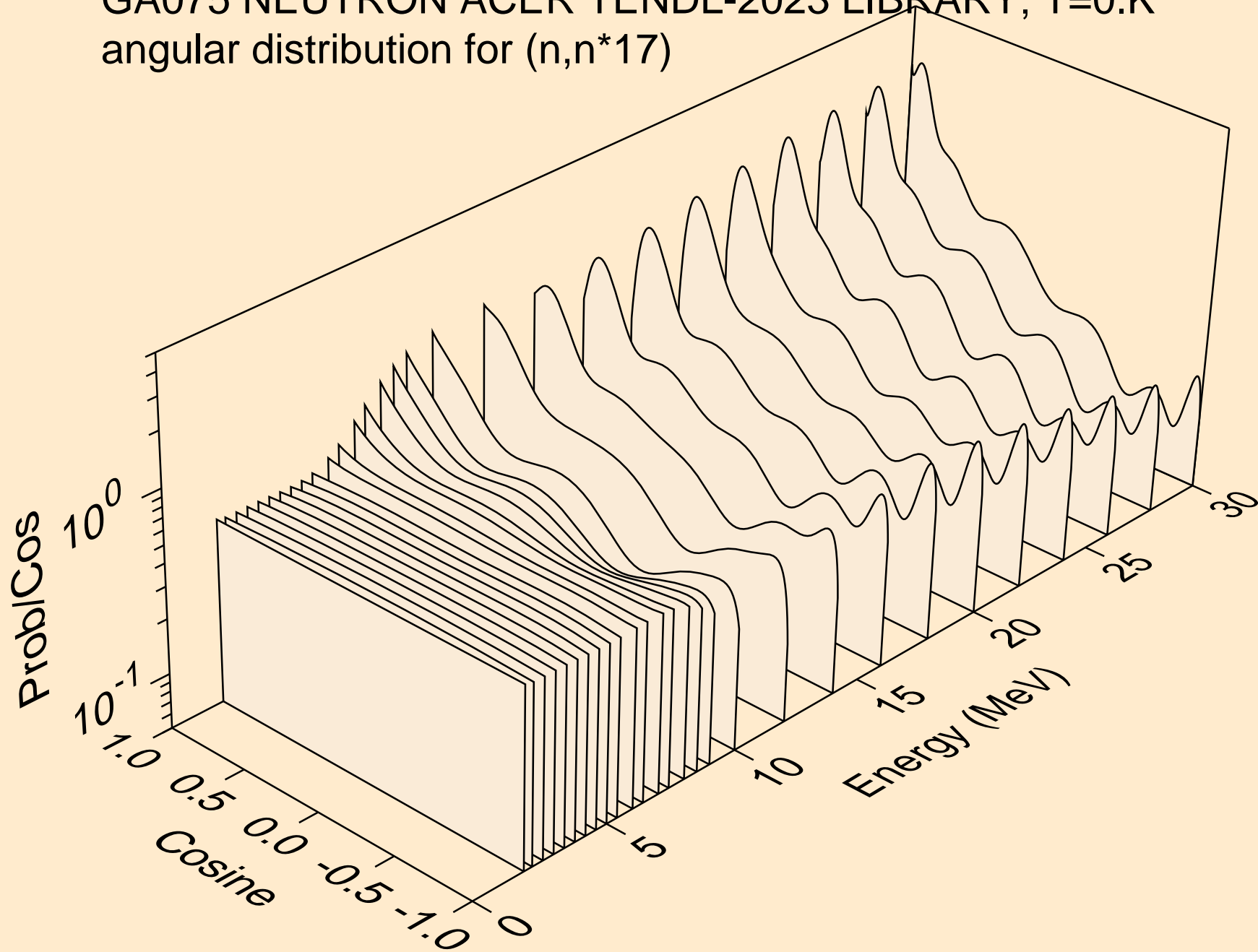

GA075 NEUTRON ACER TENDL-2023 LIBRARY; T=0.K
angular distribution for (n,n*18)

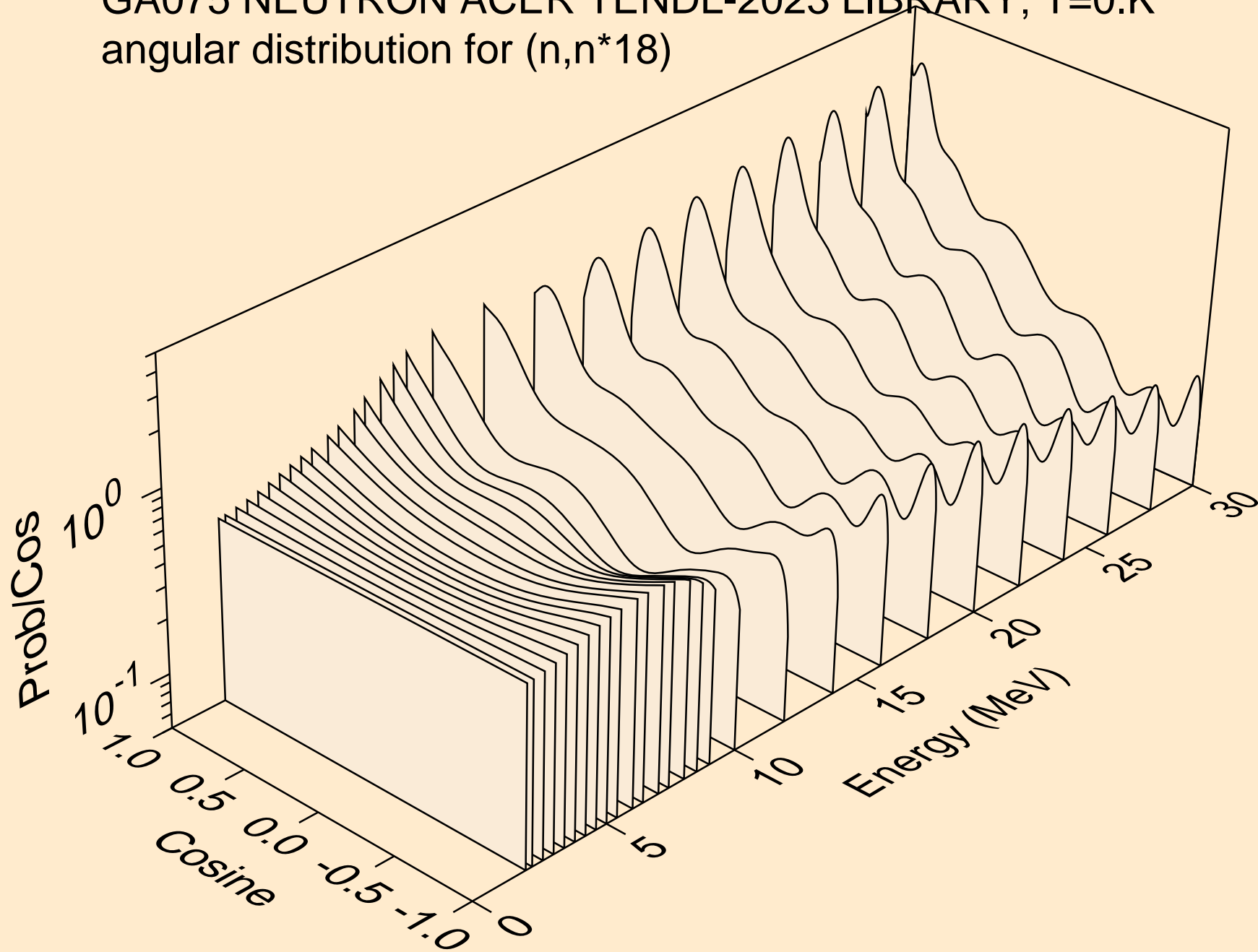

GA075 NEUTRON ACER TENDL-2023 LIBRARY; T=0.K
angular distribution for (n,n*19)

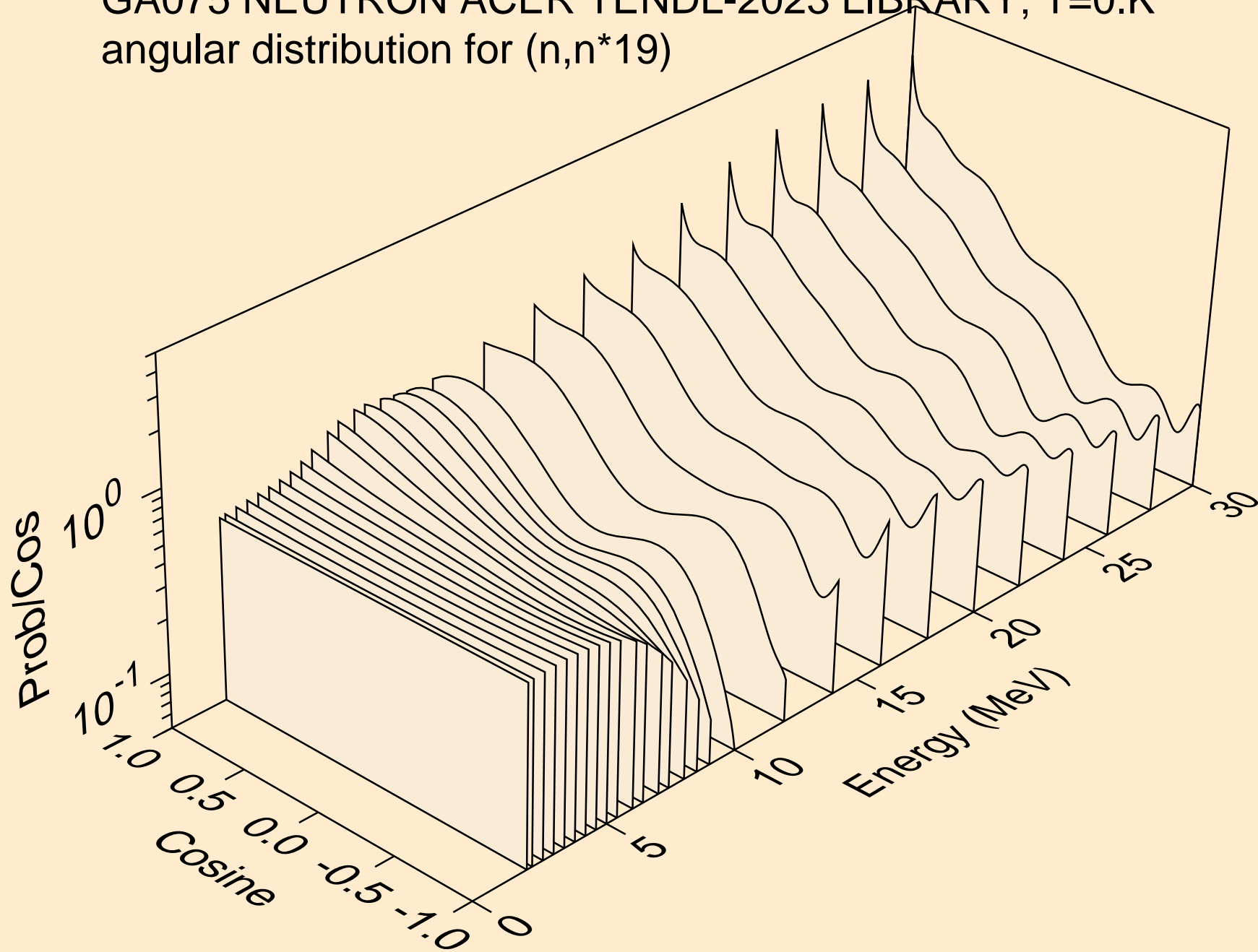

GA075 NEUTRON ACER TENDL-2023 LIBRARY; T=0.K
angular distribution for (n,n*20)

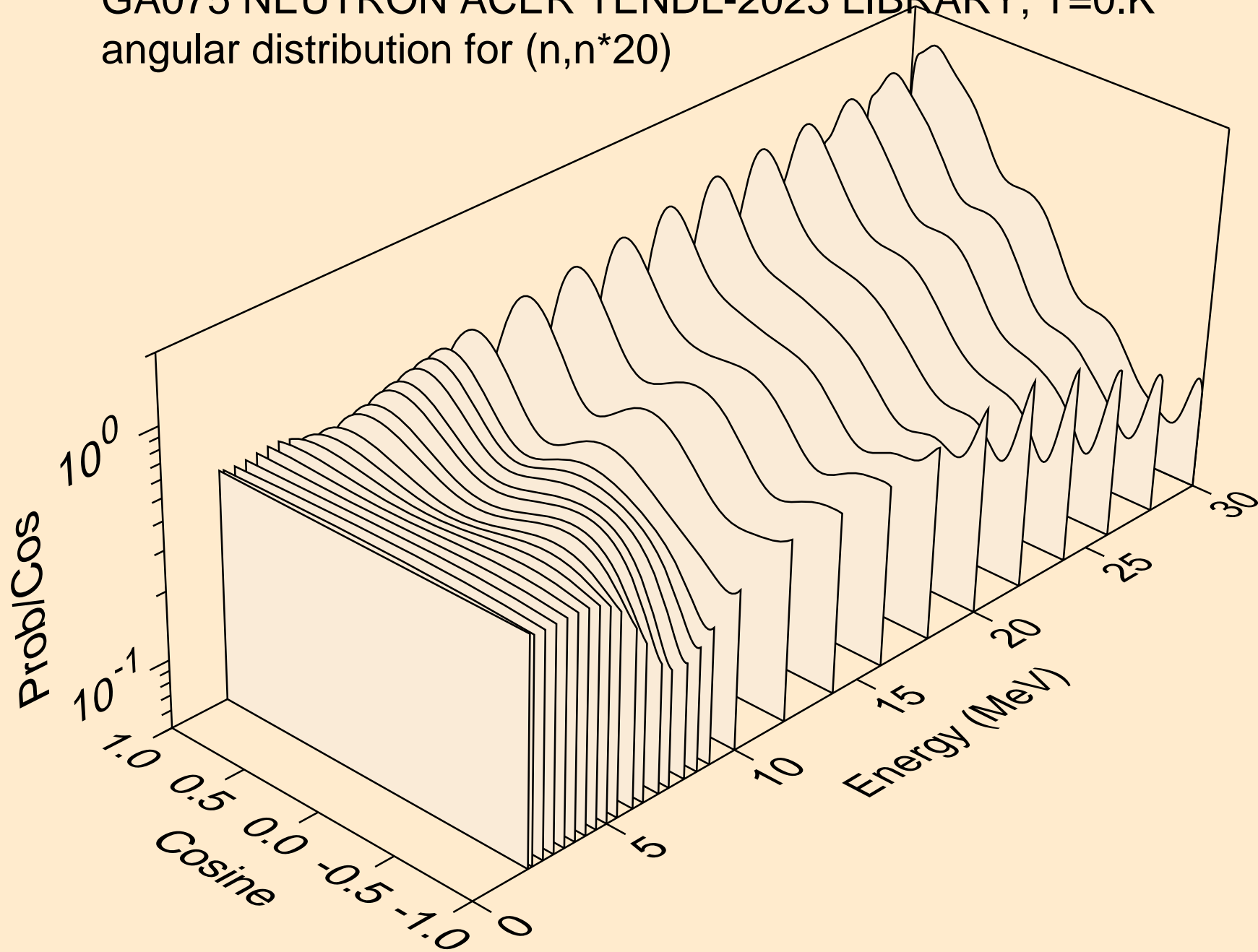

GA075 NEUTRON ACER TENDL-2023 LIBRARY; T=0.K
angular distribution for (n,n*21)

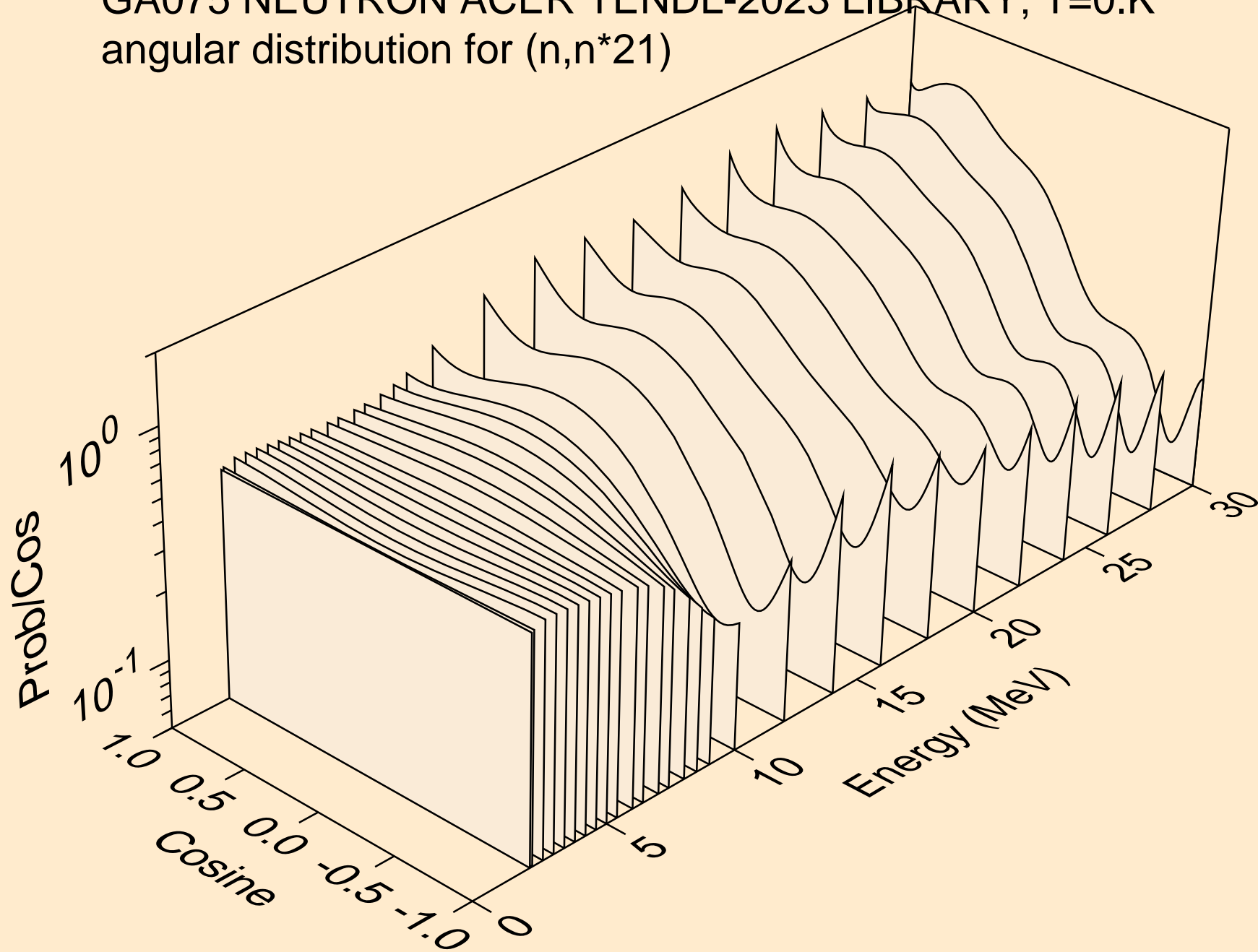

GA075 NEUTRON ACER TENDL-2023 LIBRARY; T=0.K
angular distribution for (n,n*22)

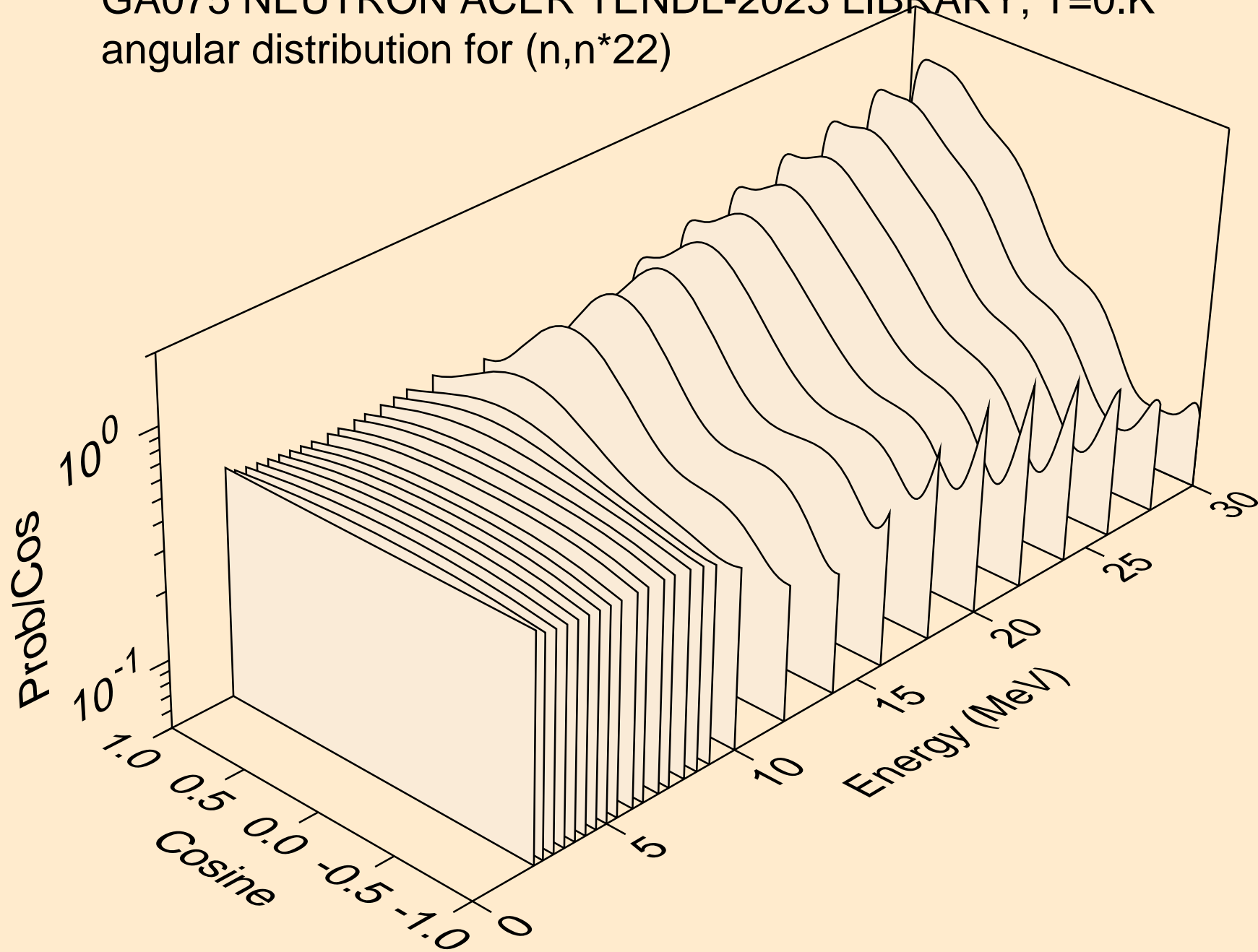

GA075 NEUTRON ACER TENDL-2023 LIBRARY; T=0.K
angular distribution for (n,n*23)

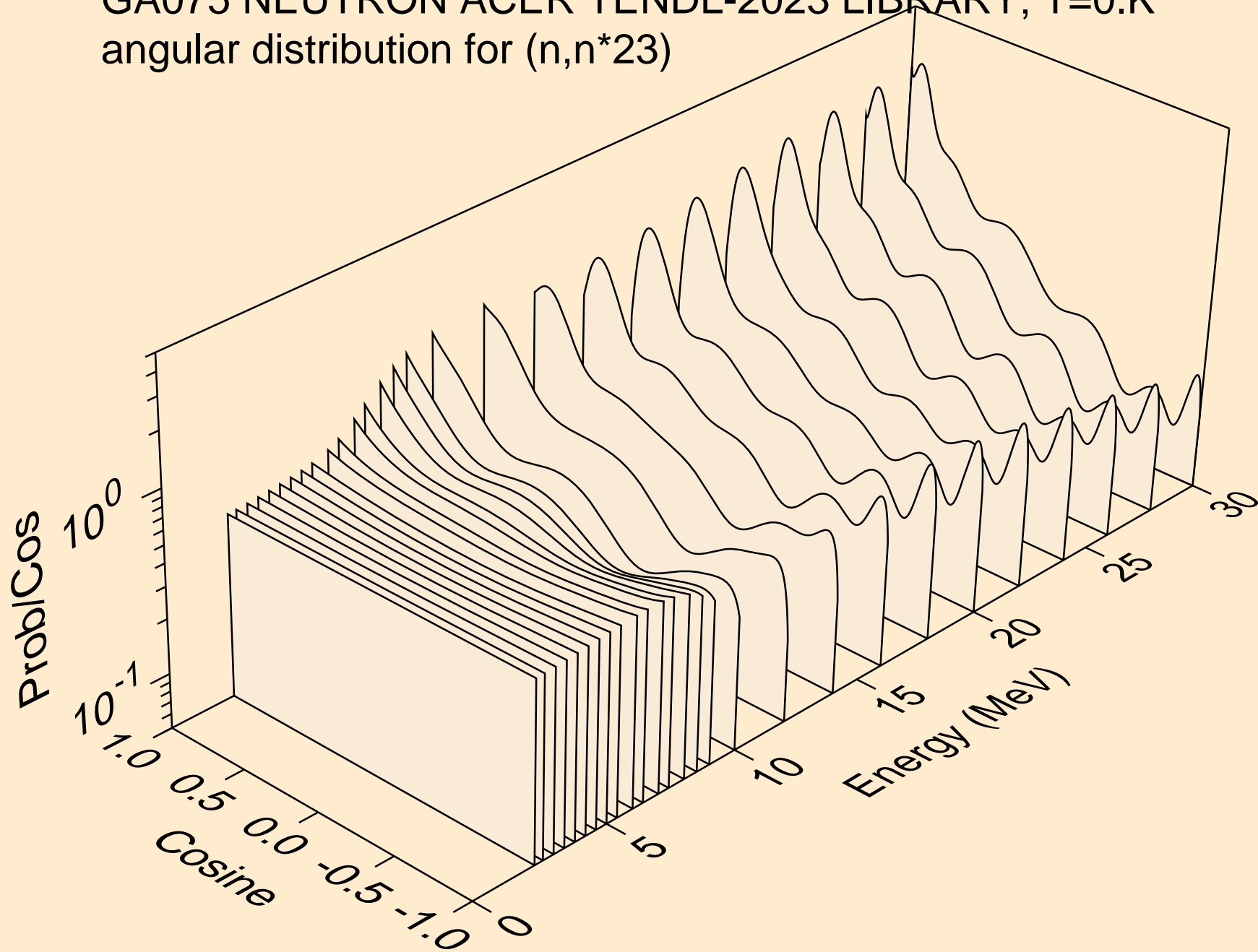

GA075 NEUTRON ACER TENDL-2023 LIBRARY; T=0.K
angular distribution for (n,n*24)

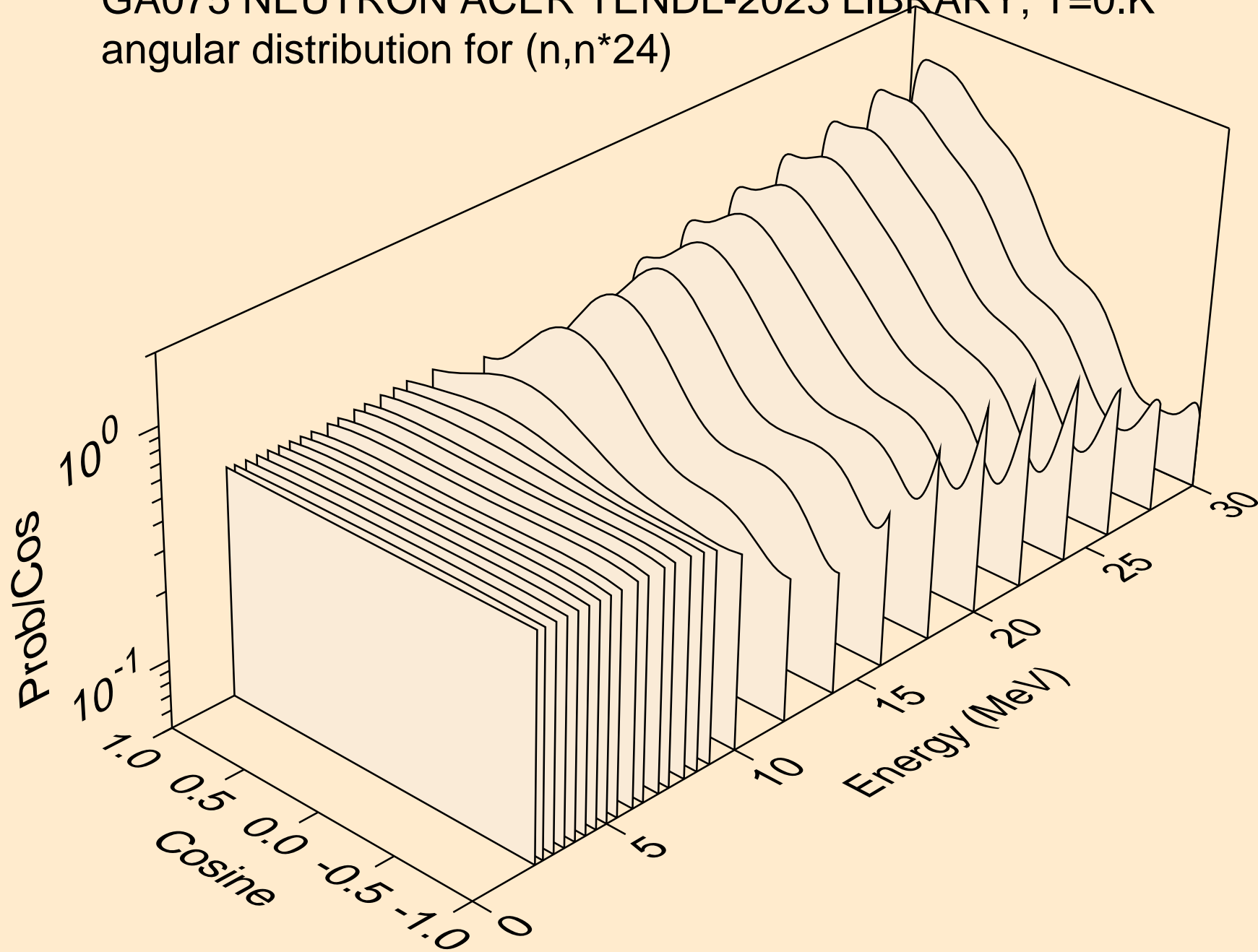

GA075 NEUTRON ACER TENDL-2023 LIBRARY; T=0.K
angular distribution for (n,n*25)

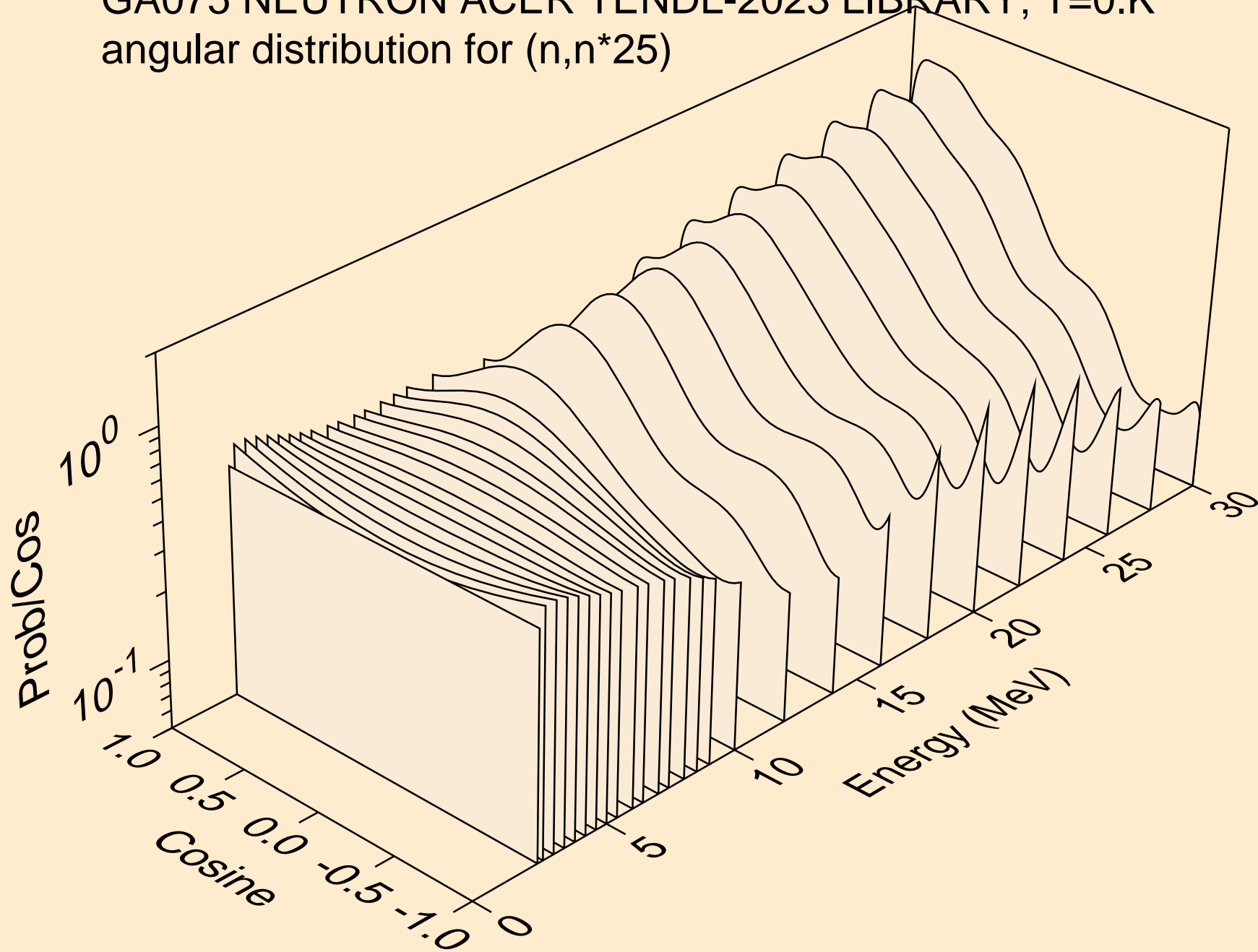

GA075 NEUTRON ACER TENDL-2023 LIBRARY; T=0.K
angular distribution for (n,n*26)

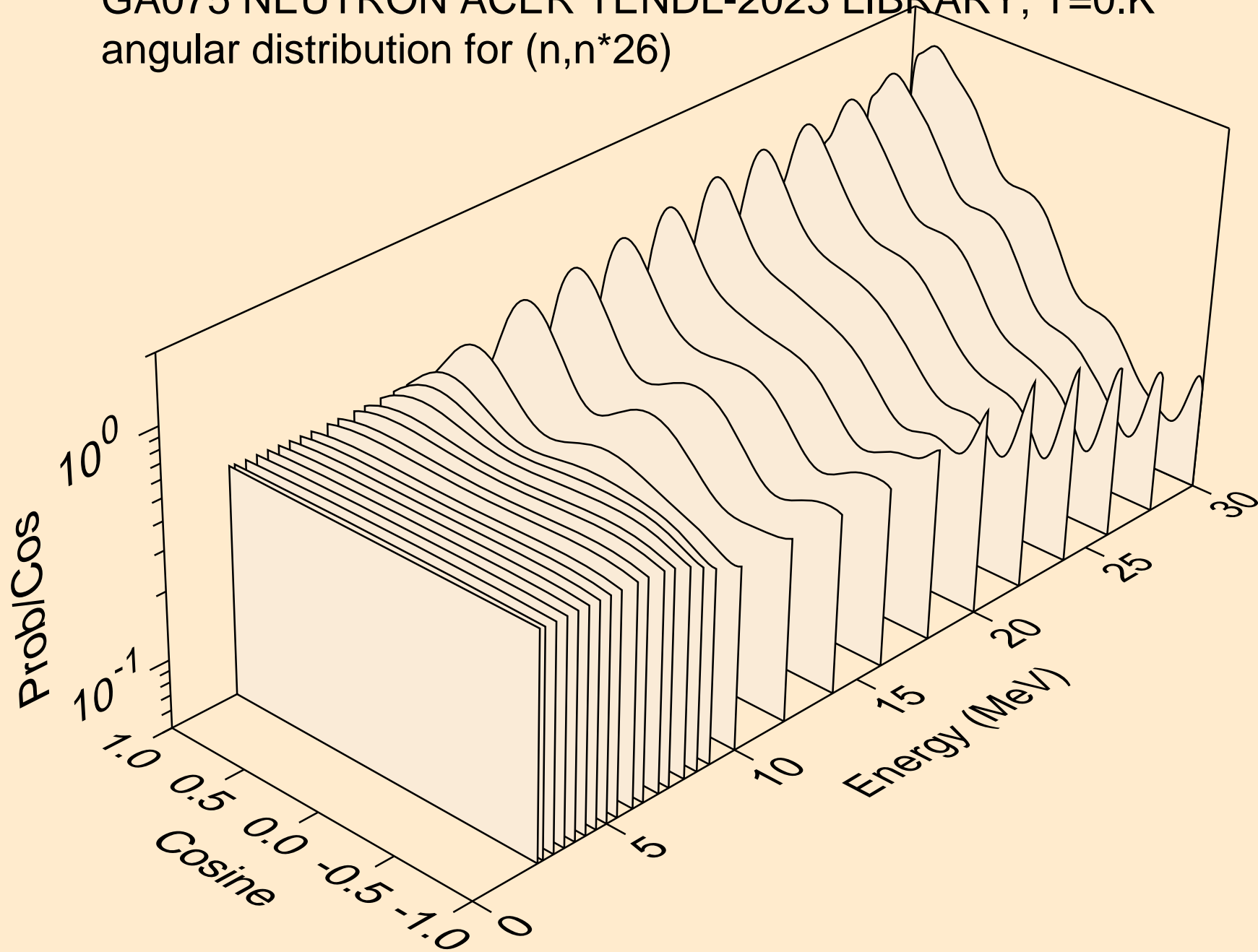

GA075 NEUTRON ACER TENDL-2023 LIBRARY; T=0.K
angular distribution for (n,n*27)

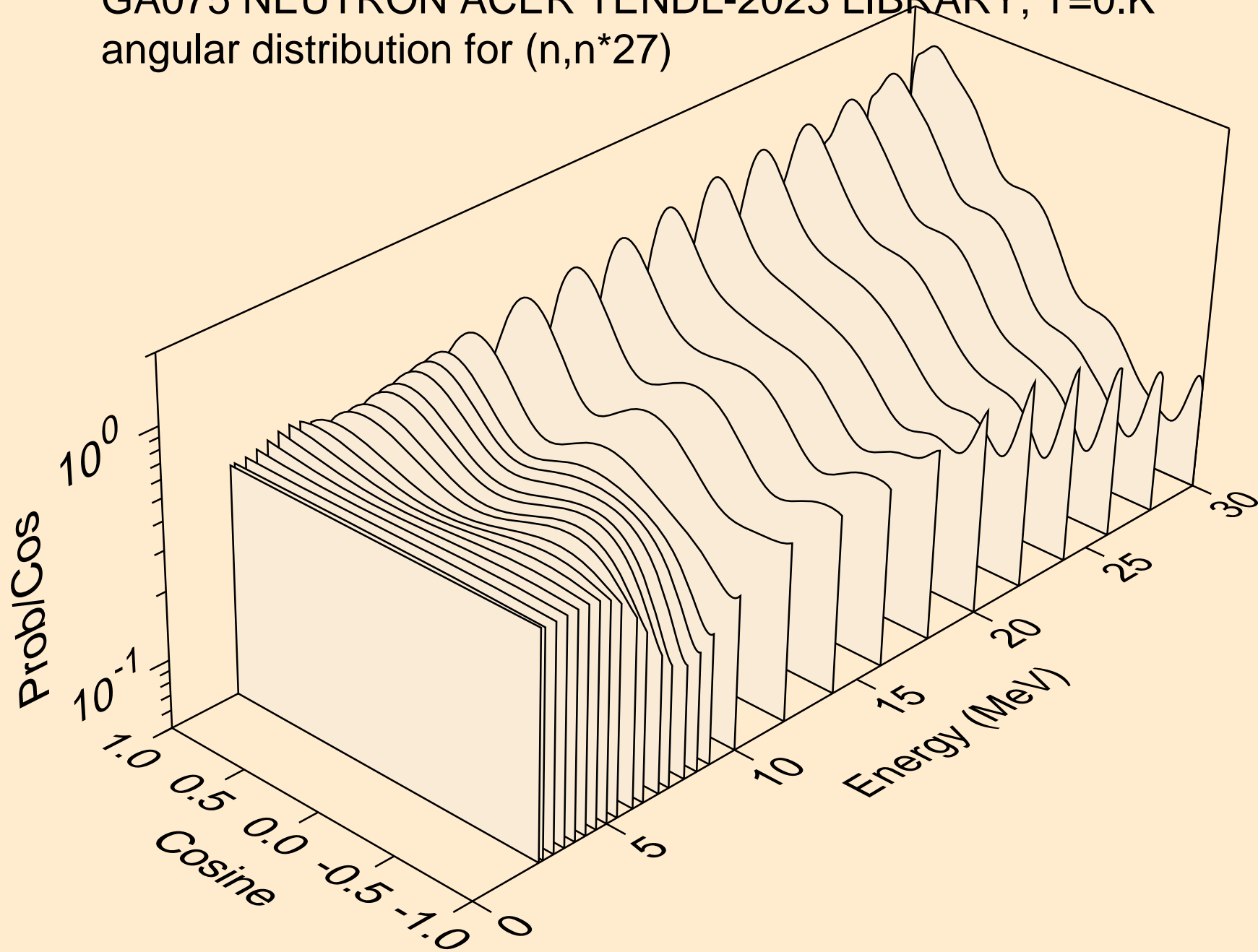

GA075 NEUTRON ACER TENDL-2023 LIBRARY; T=0.K
angular distribution for (n,n*28)

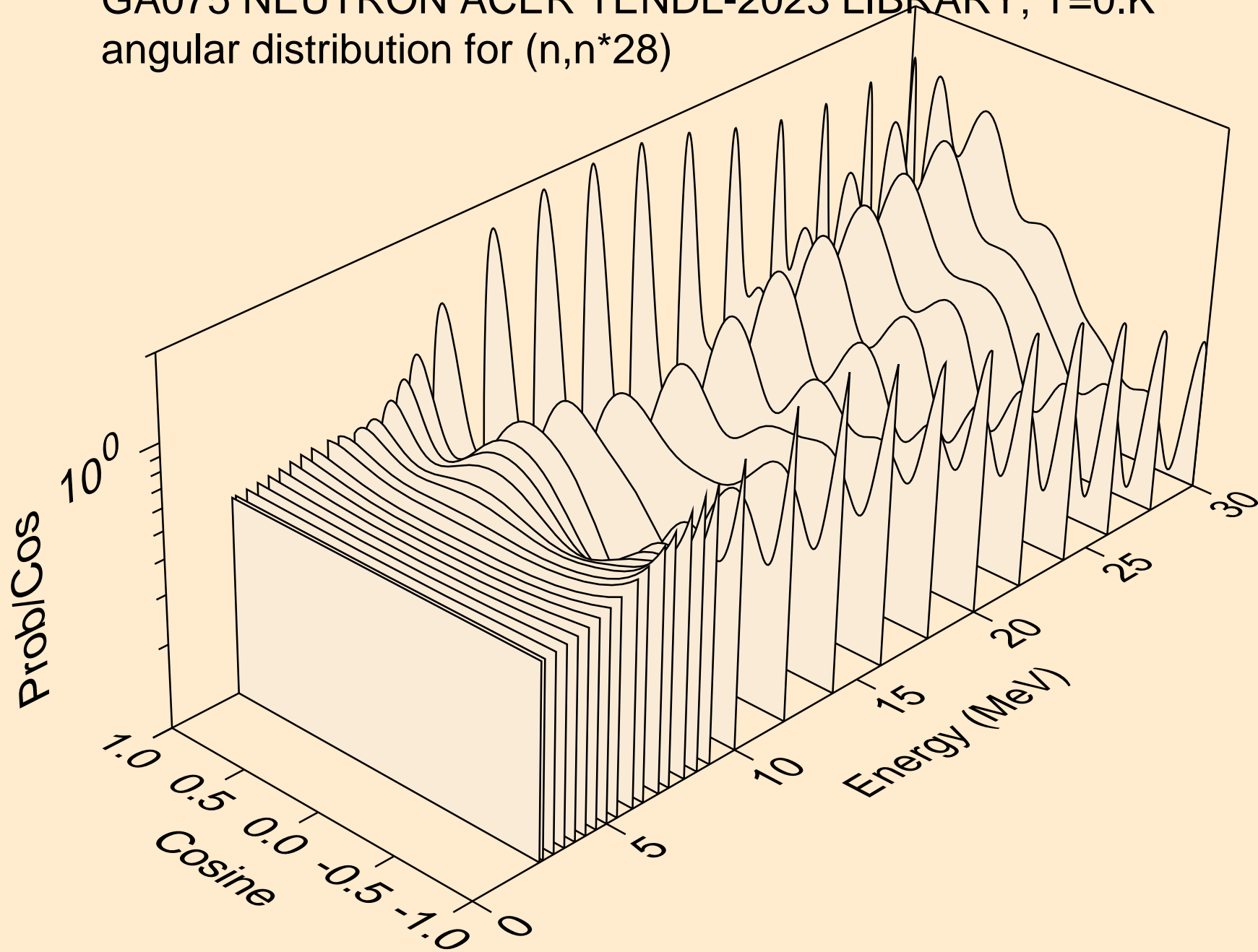

GA075 NEUTRON ACER TENDL-2023 LIBRARY; T=0.K
angular distribution for (n,n*29)

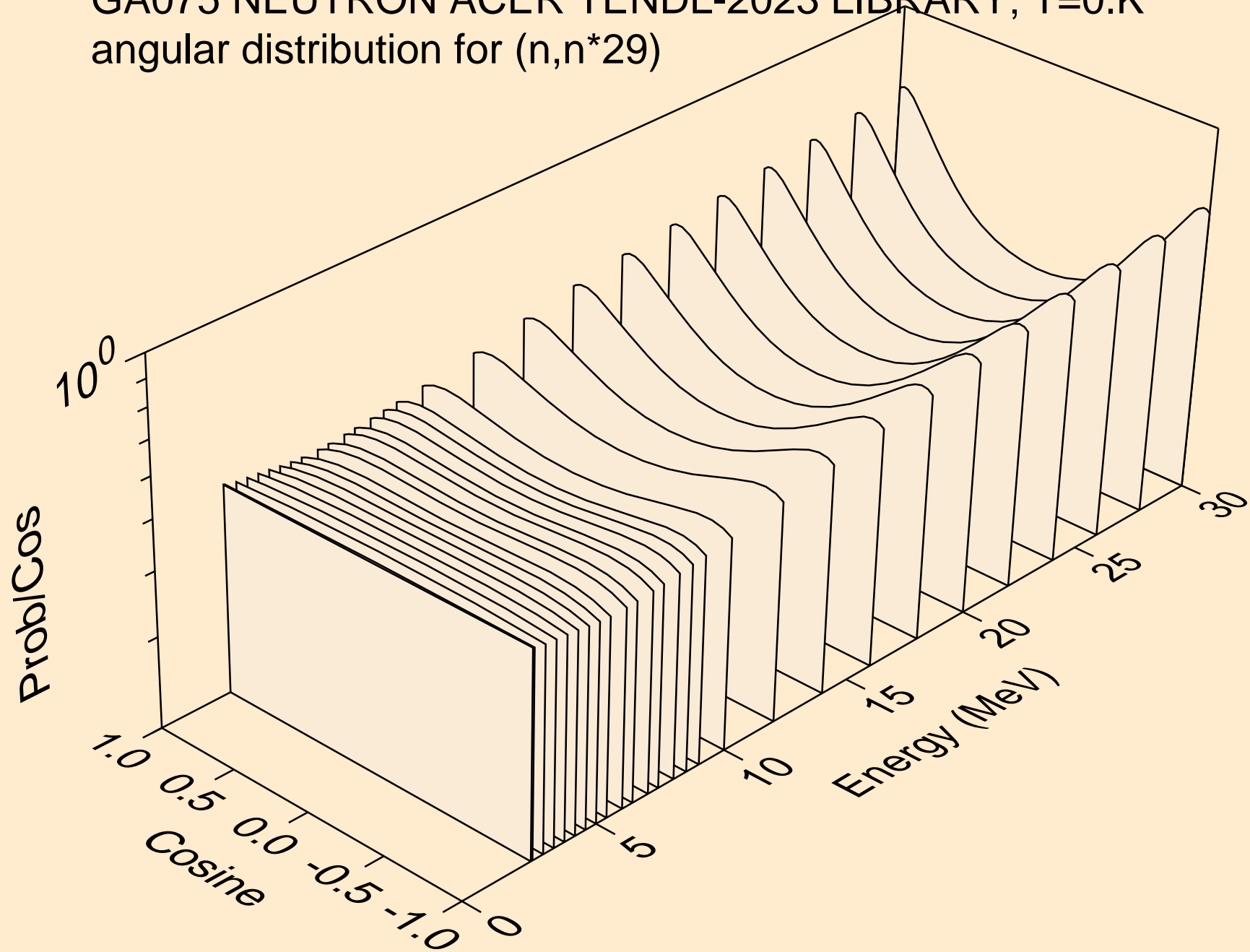

GA075 NEUTRON ACER TENDL-2023 LIBRARY; T=0.K
angular distribution for (n,n*30)

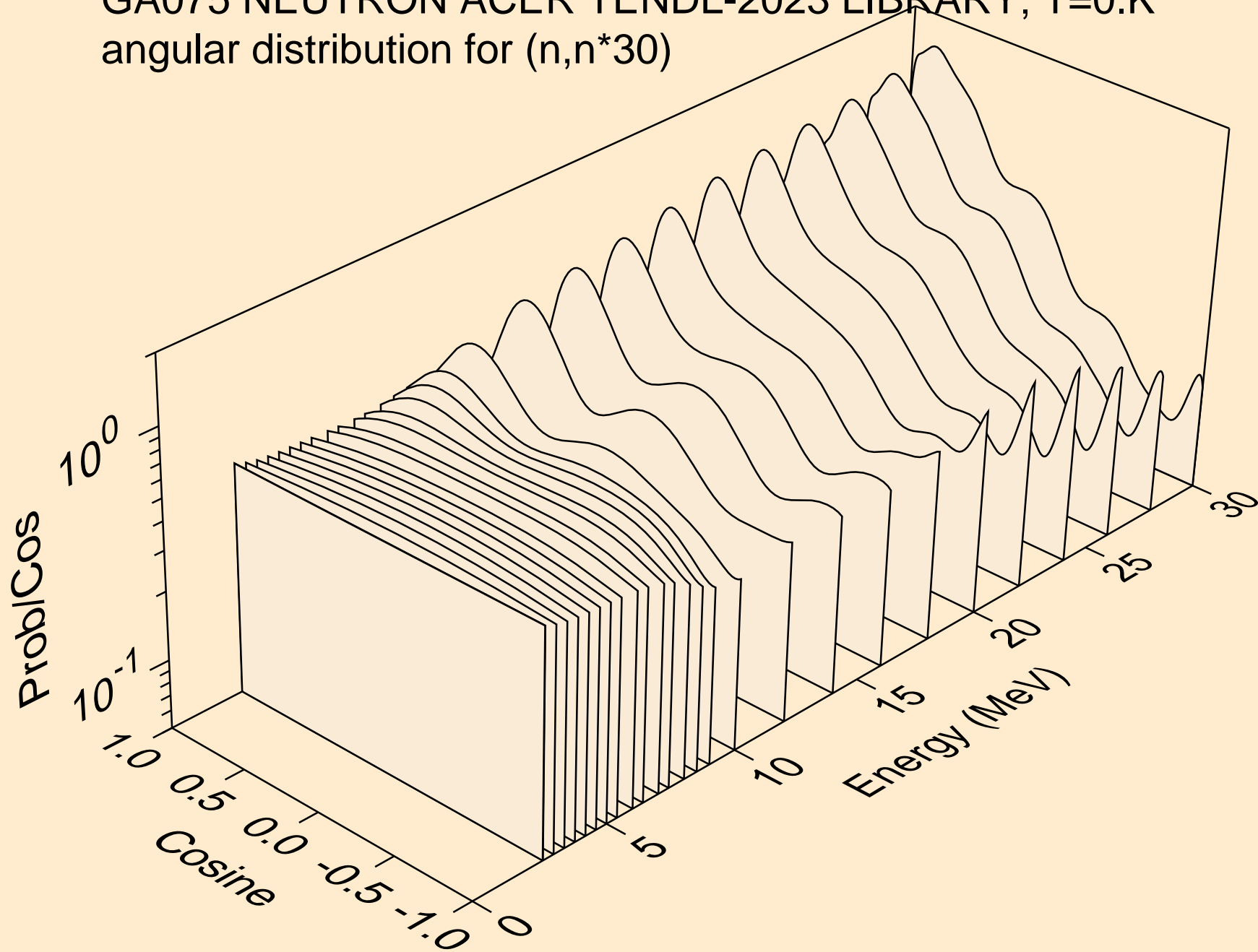

GA075 NEUTRON ACER TENDL-2023 LIBRARY; T=0.K
Neutron emission for (n,x)

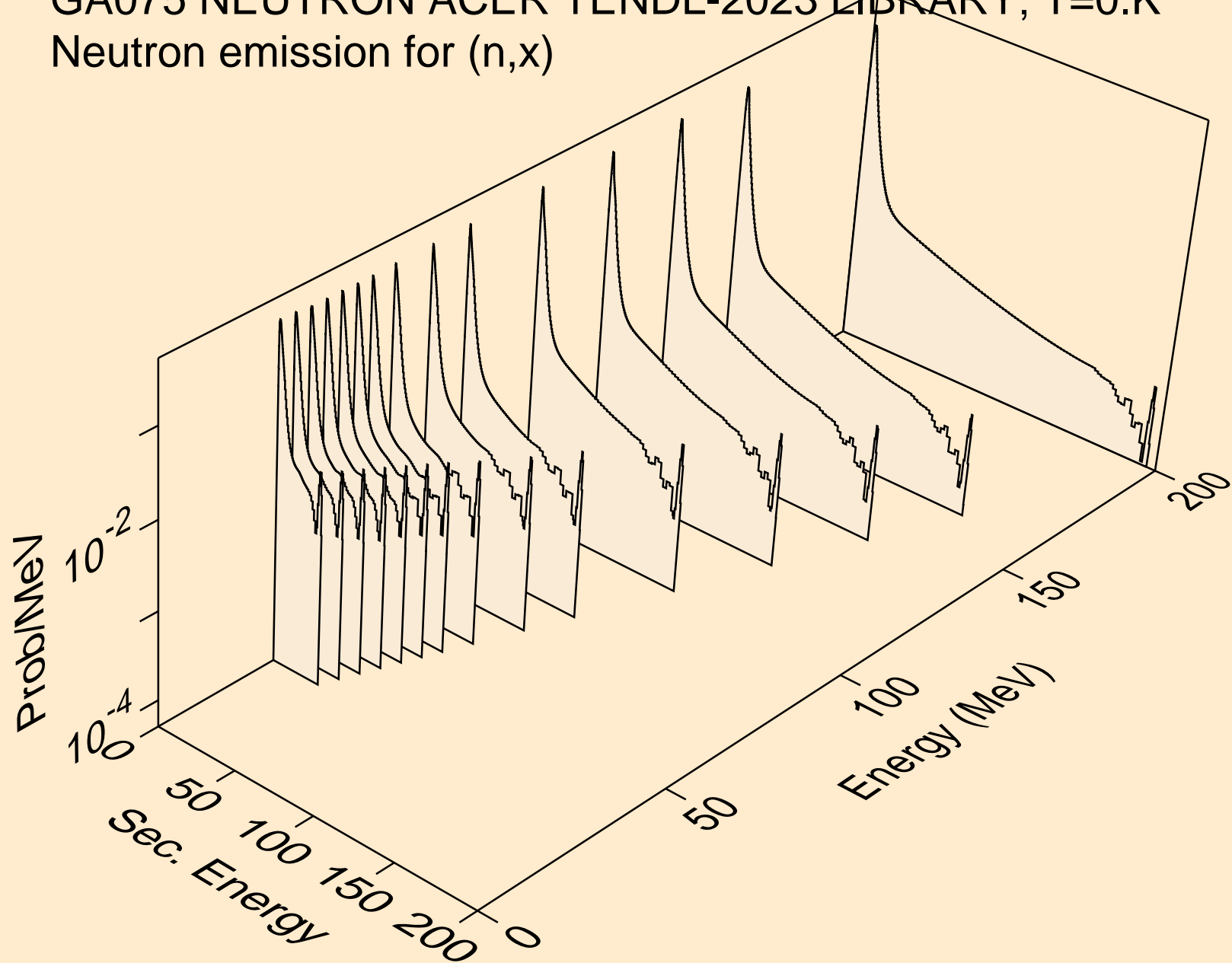

GA075 NEUTRON ACER TENDL-2023 LIBRARY; T=0.K
Neutron emission for (n,2nd)

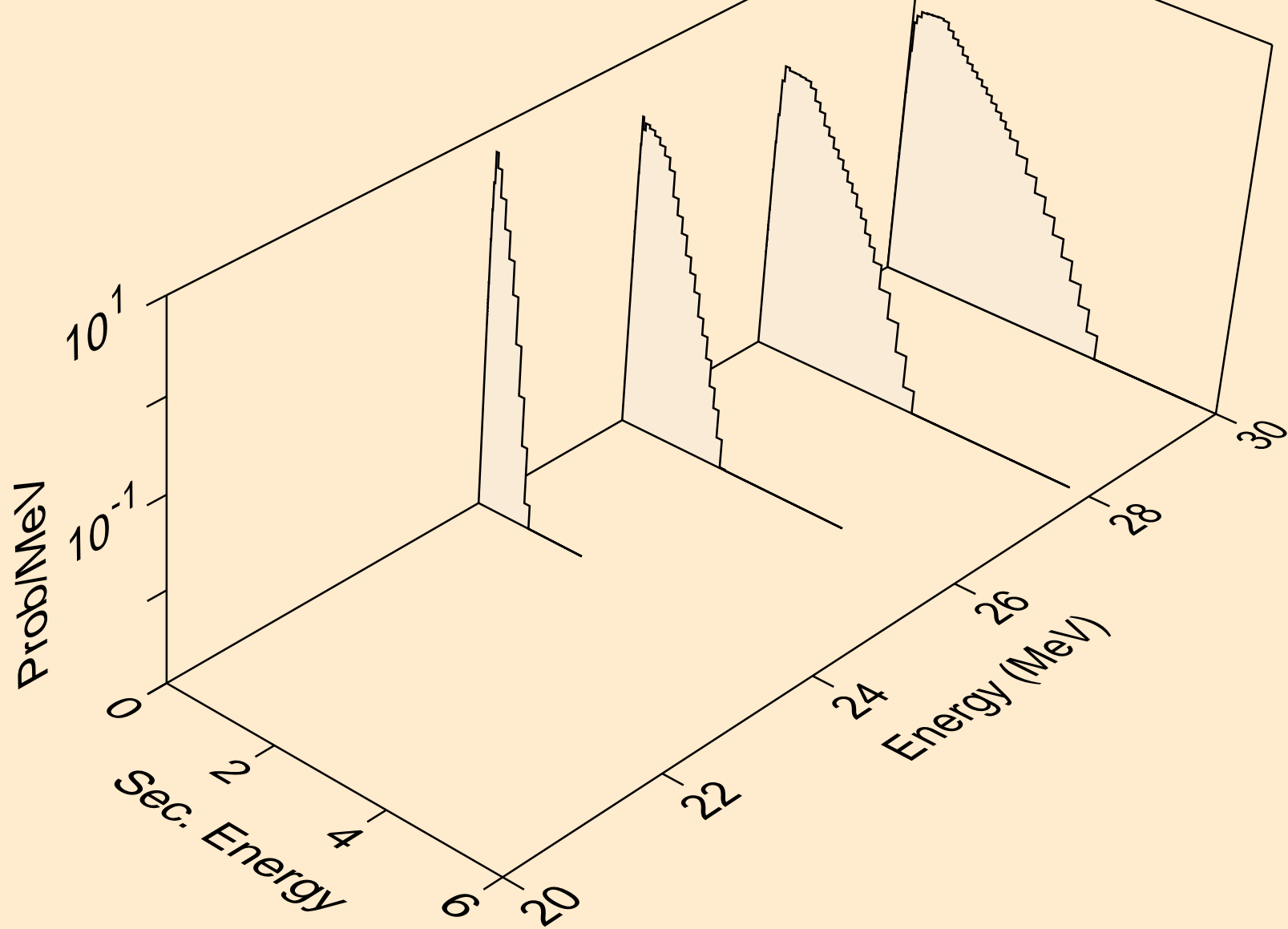

GA075 NEUTRON ACER TENDL-2023 LIBRARY; T=0.K
Neutron emission for (n,2n)

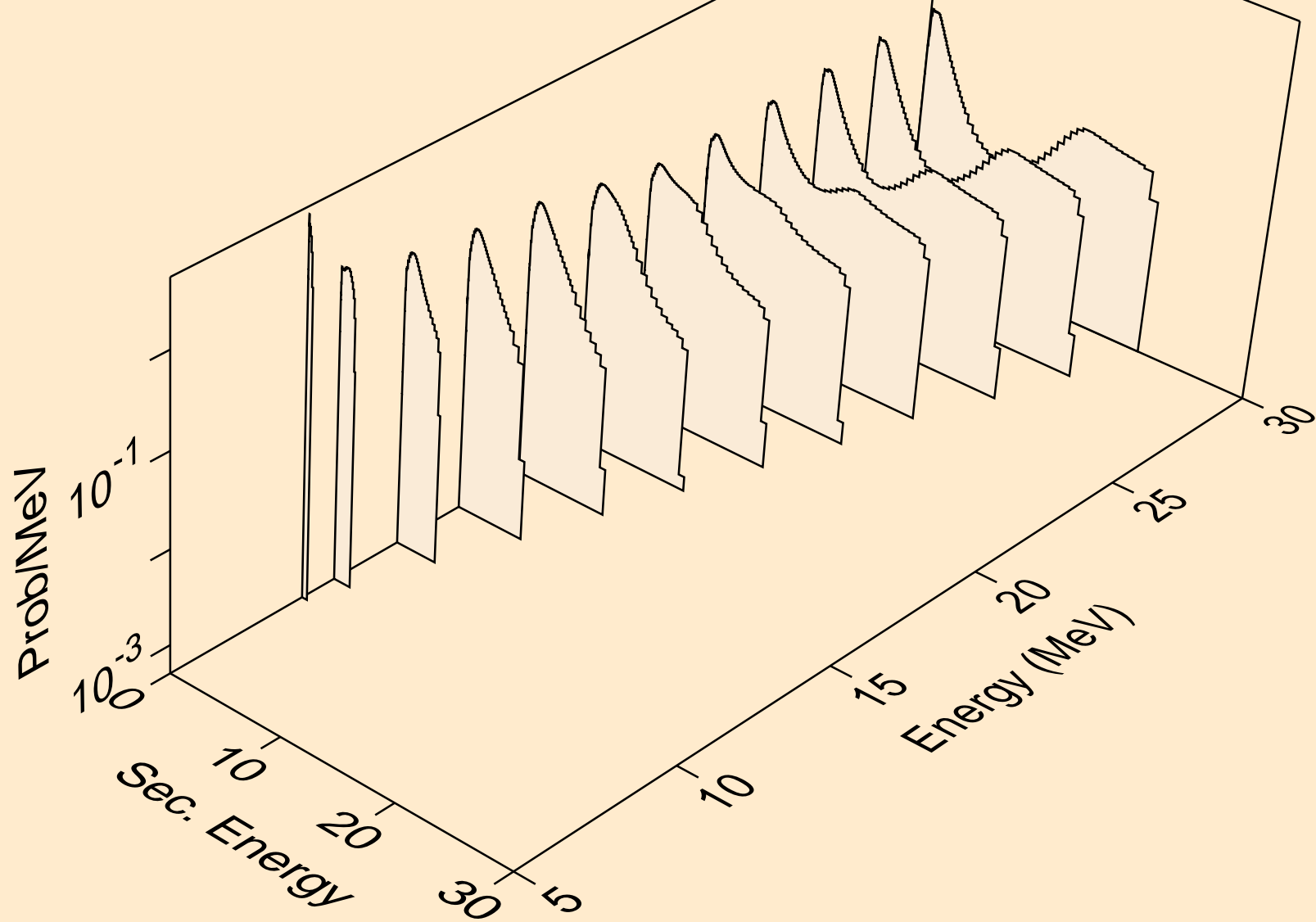

GA075 NEUTRON ACER TENDL-2023 LIBRARY; T=0.K
Neutron emission for (n,3n)

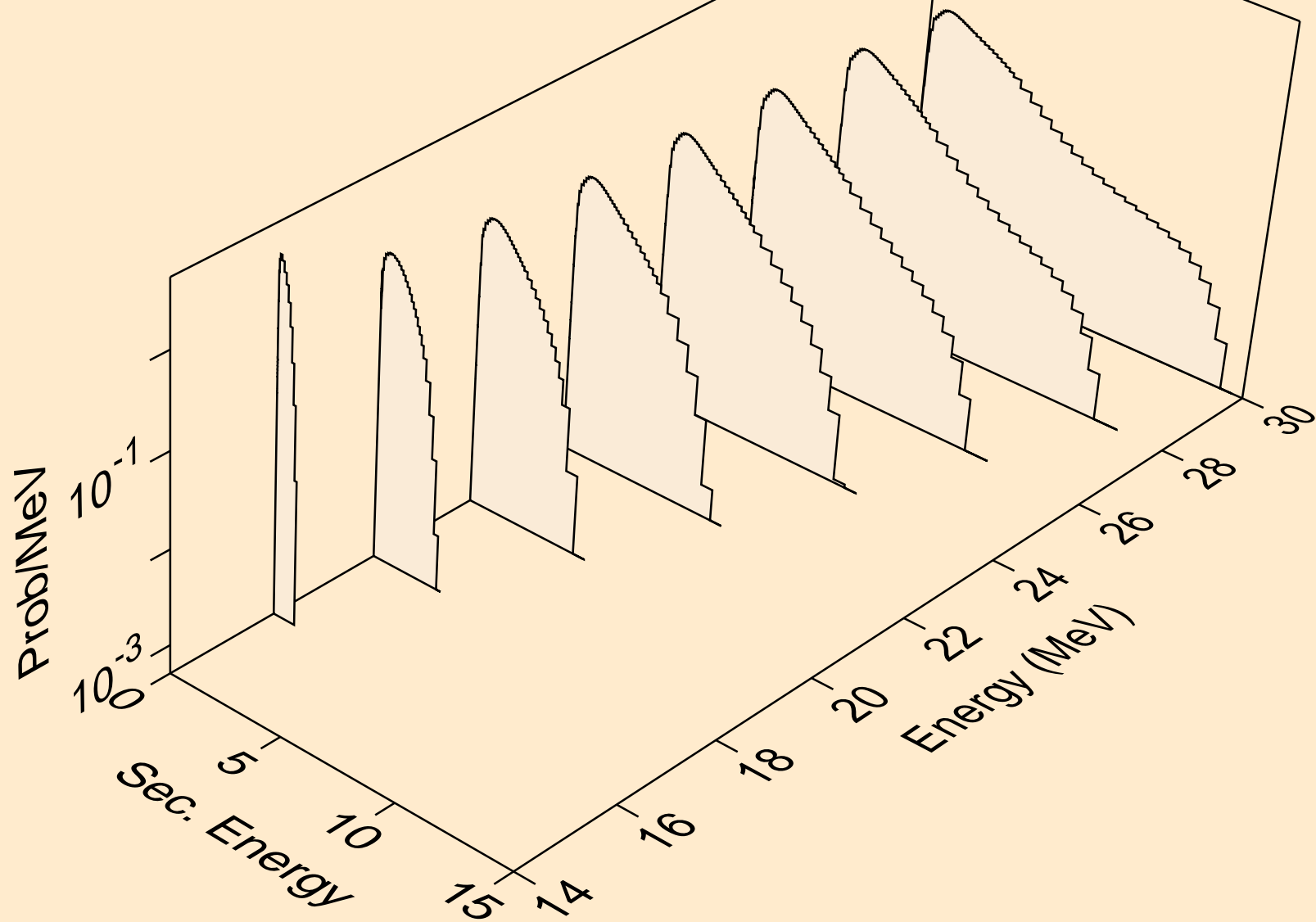

GA075 NEUTRON ACER TENDL-2023 LIBRARY; T=0.K
Neutron emission for (n,n*)a

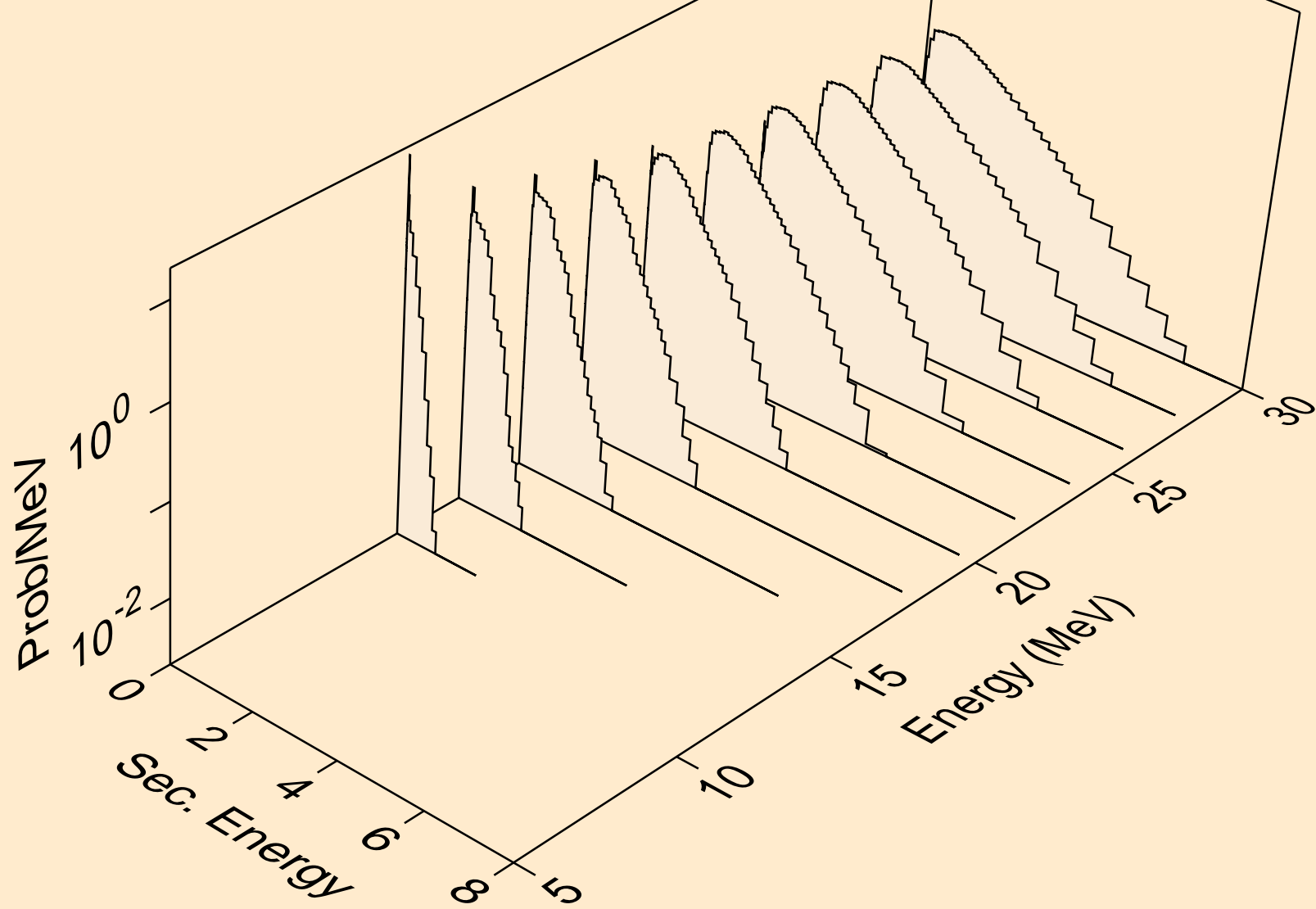

GA075 NEUTRON ACER TENDL-2023 LIBRARY; T=0.K
Neutron emission for (n,2n)a

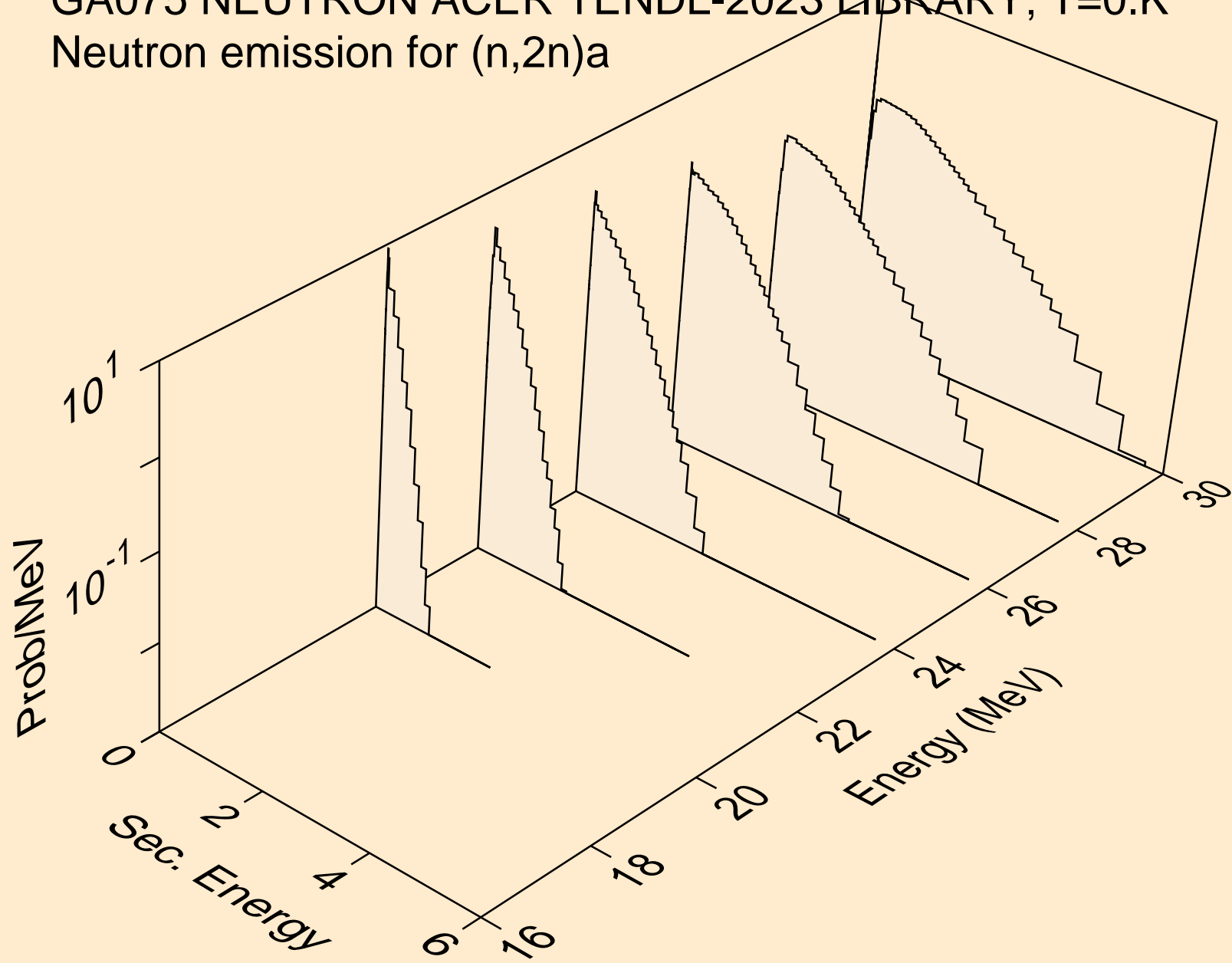

GA075 NEUTRON ACER TENDL-2023 LIBRARY; T=0.K
Neutron emission for (n,3n)a

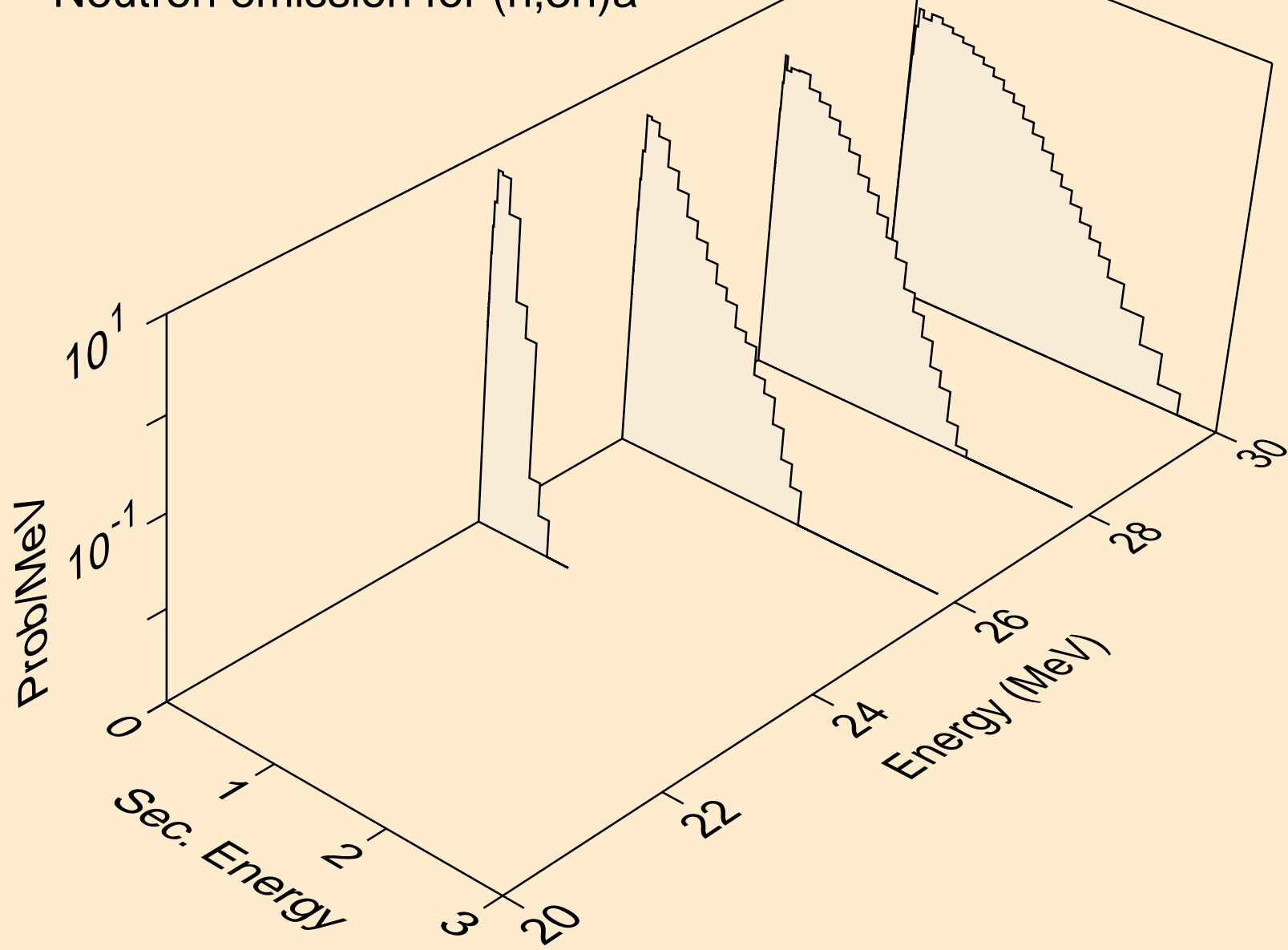

GA075 NEUTRON ACER TENDL-2023 LIBRARY; T=0.K
Neutron emission for (n,n*)p

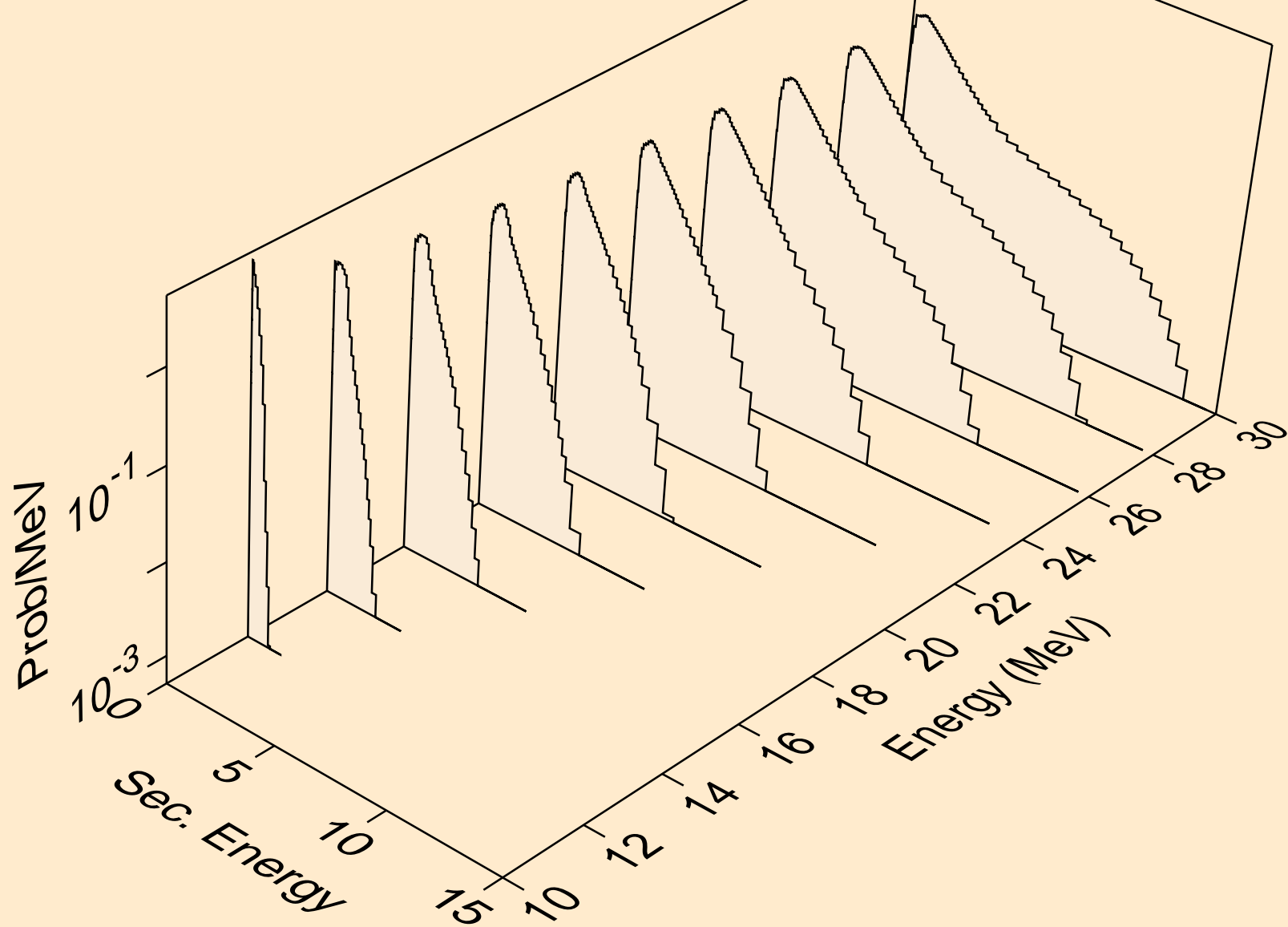

GA075 NEUTRON ACER TENDL-2023 LIBRARY; T=0.K
Neutron emission for (n,n*)d

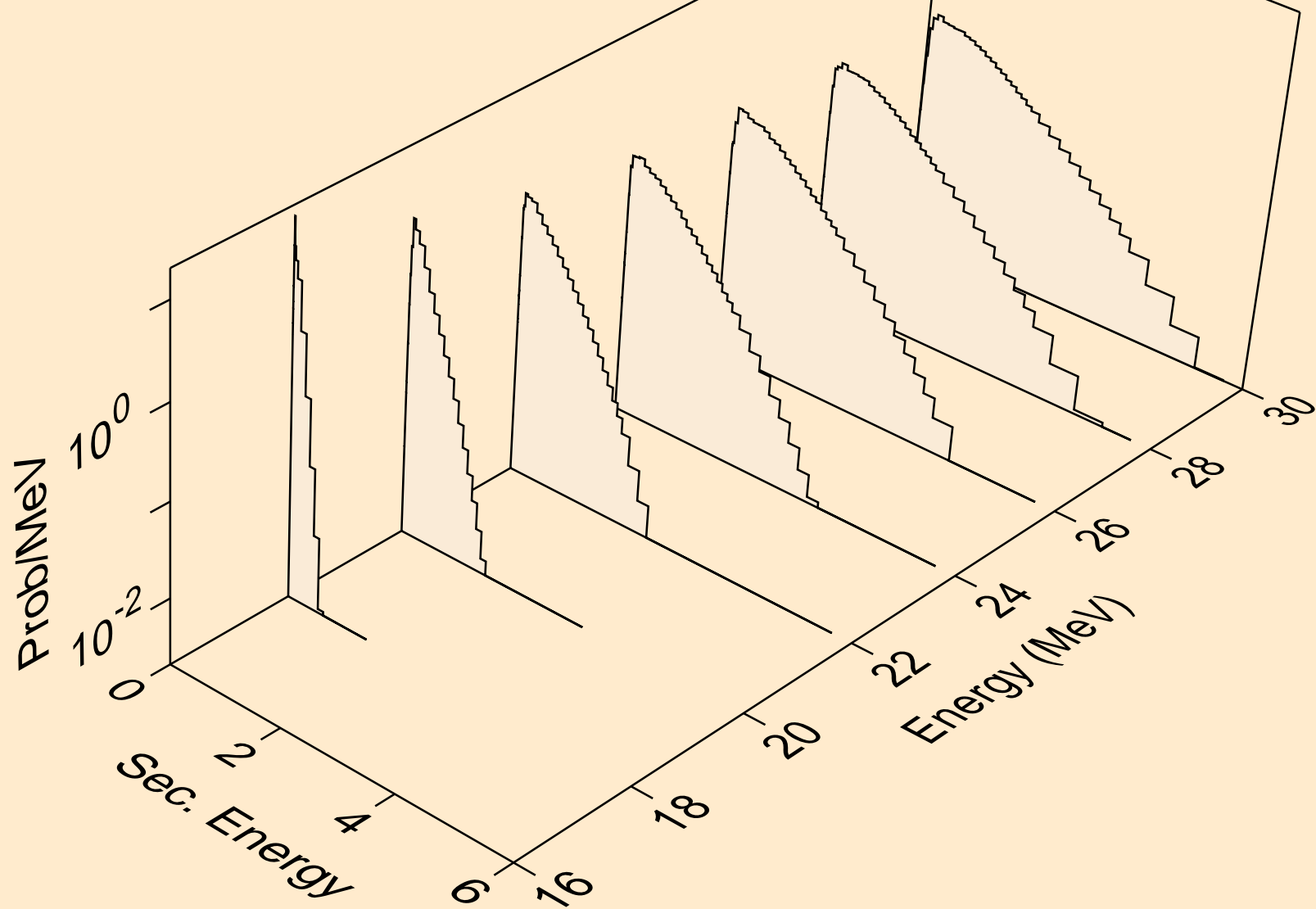

GA075 NEUTRON ACER TENDL-2023 LIBRARY; T=0.K
Neutron emission for (n,n*)t

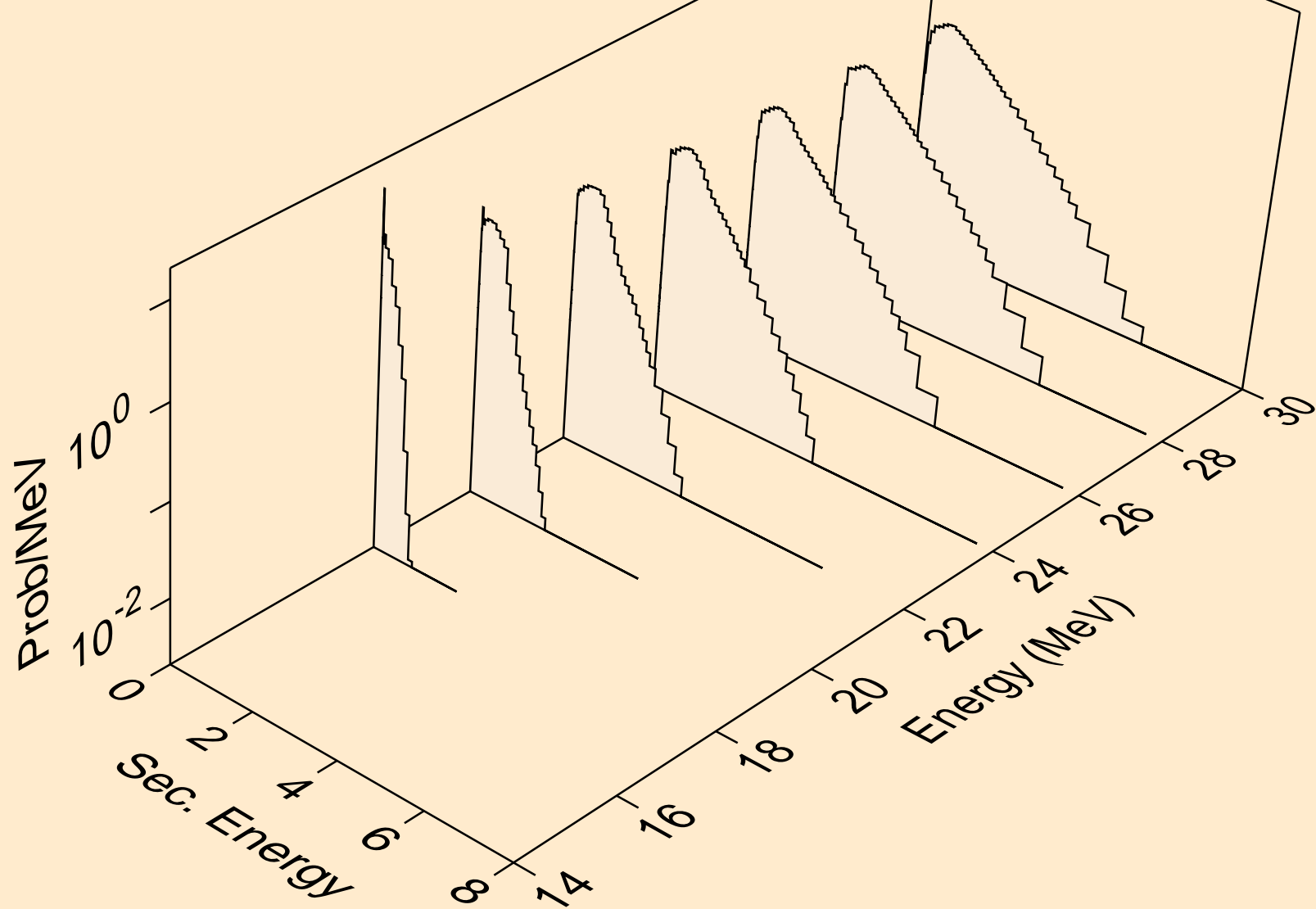

GA075 NEUTRON ACER TENDL-2023 LIBRARY; T=0.K
Neutron emission for (n,n*)he3

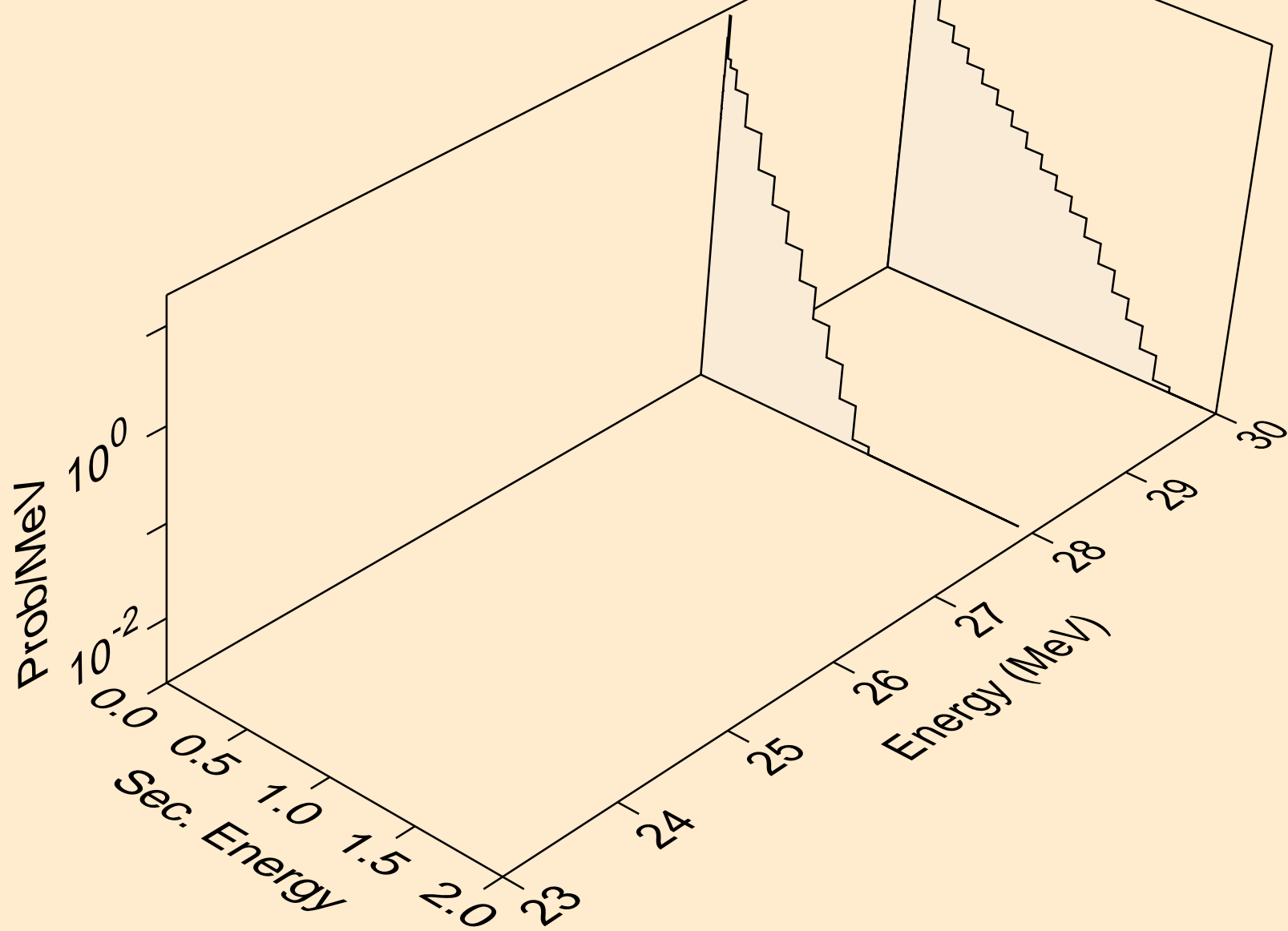

GA075 NEUTRON ACER TENDL-2023 LIBRARY; T=0.K
Neutron emission for (n,4n)

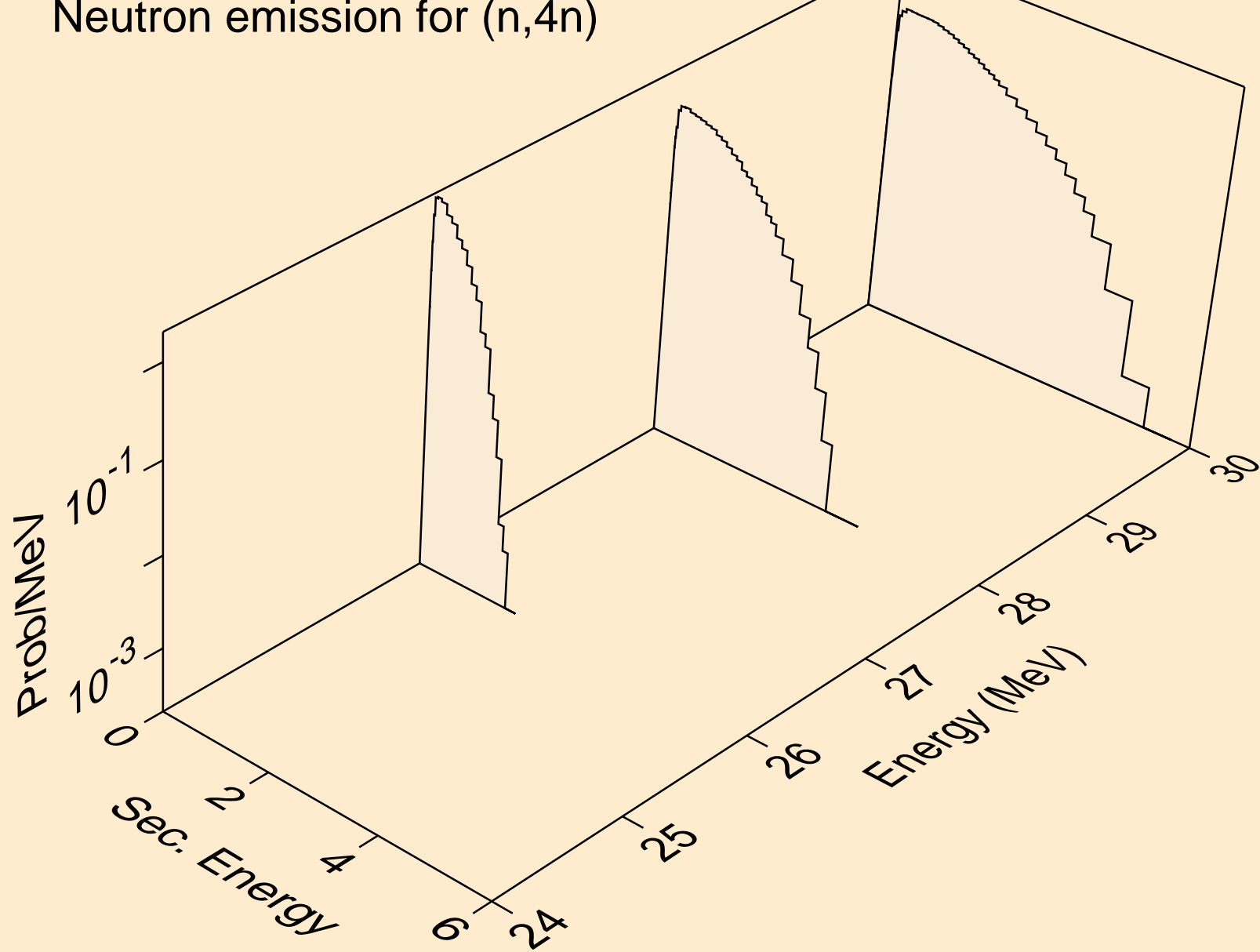

GA075 NEUTRON ACER TENDL-2023 LIBRARY; T=0.K
Neutron emission for (n,2np)

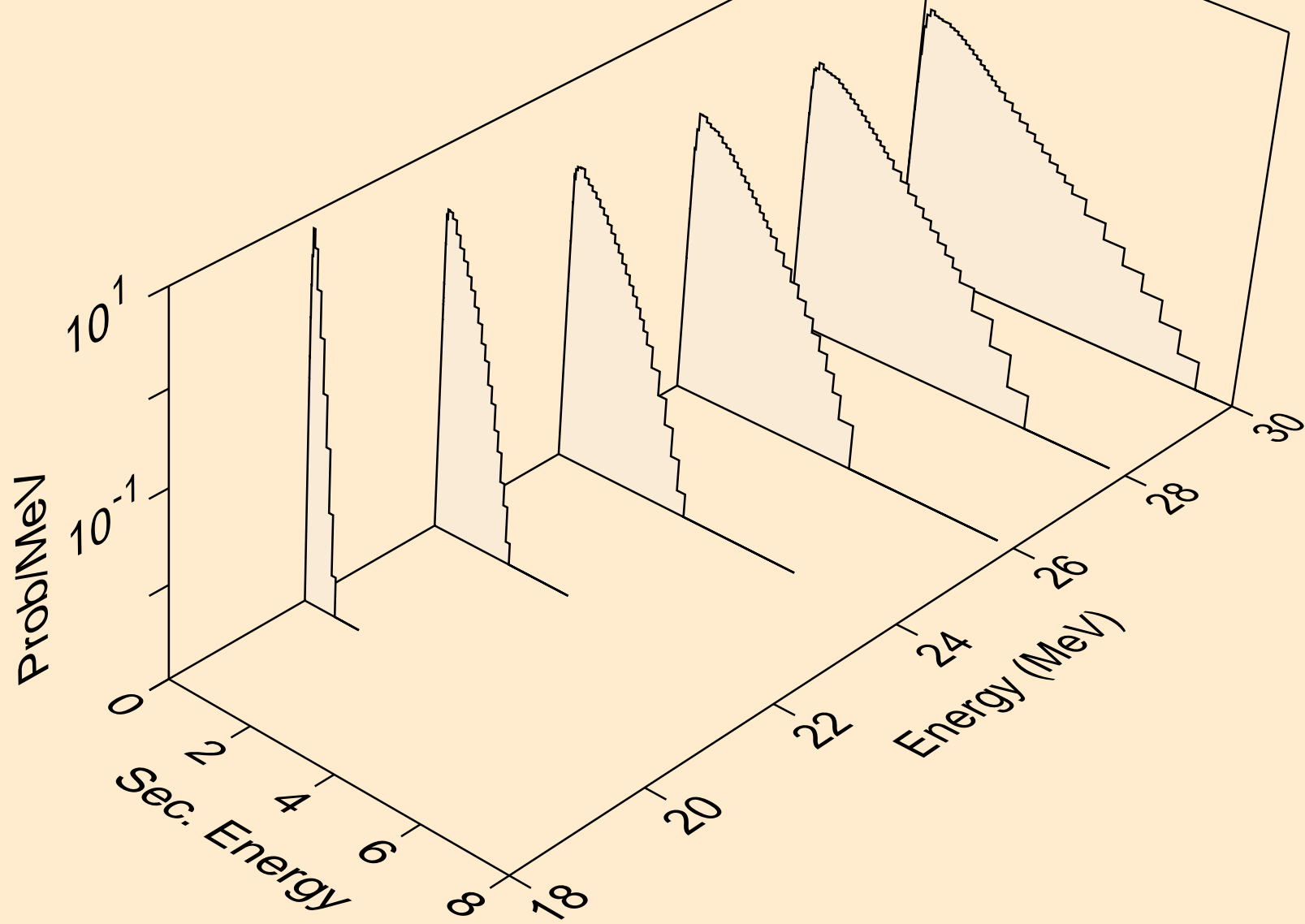

GA075 NEUTRON ACER TENDL-2023 LIBRARY; T=0.K
Neutron emission for (n,3np)

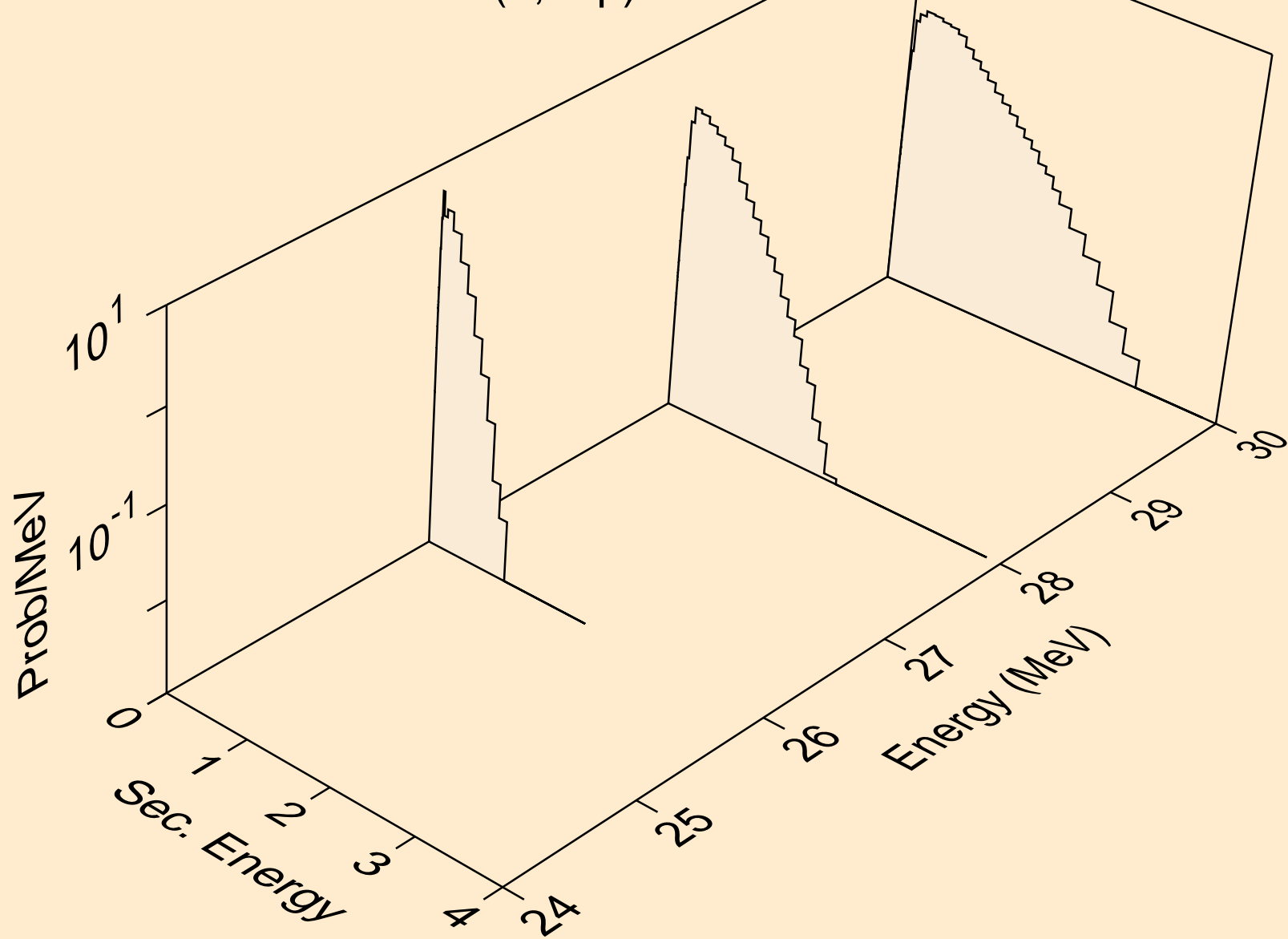

GA075 NEUTRON ACER TENDL-2023 LIBRARY; T=0.K
Neutron emission for (n,n*c)

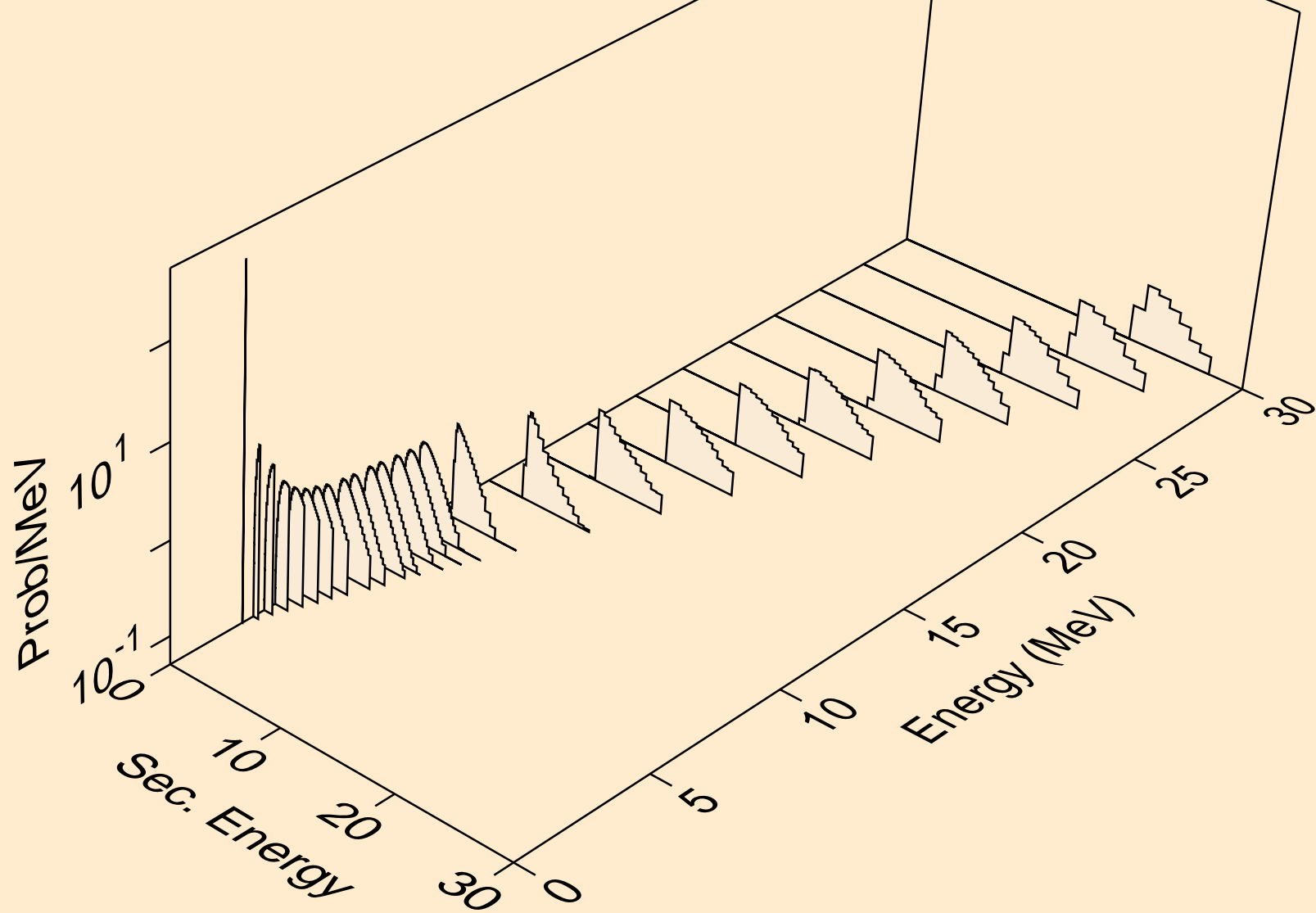

GA075 NEUTRON ACER TENDL-2023 LIBRARY; T=0.K
Photon emission for (n,x)

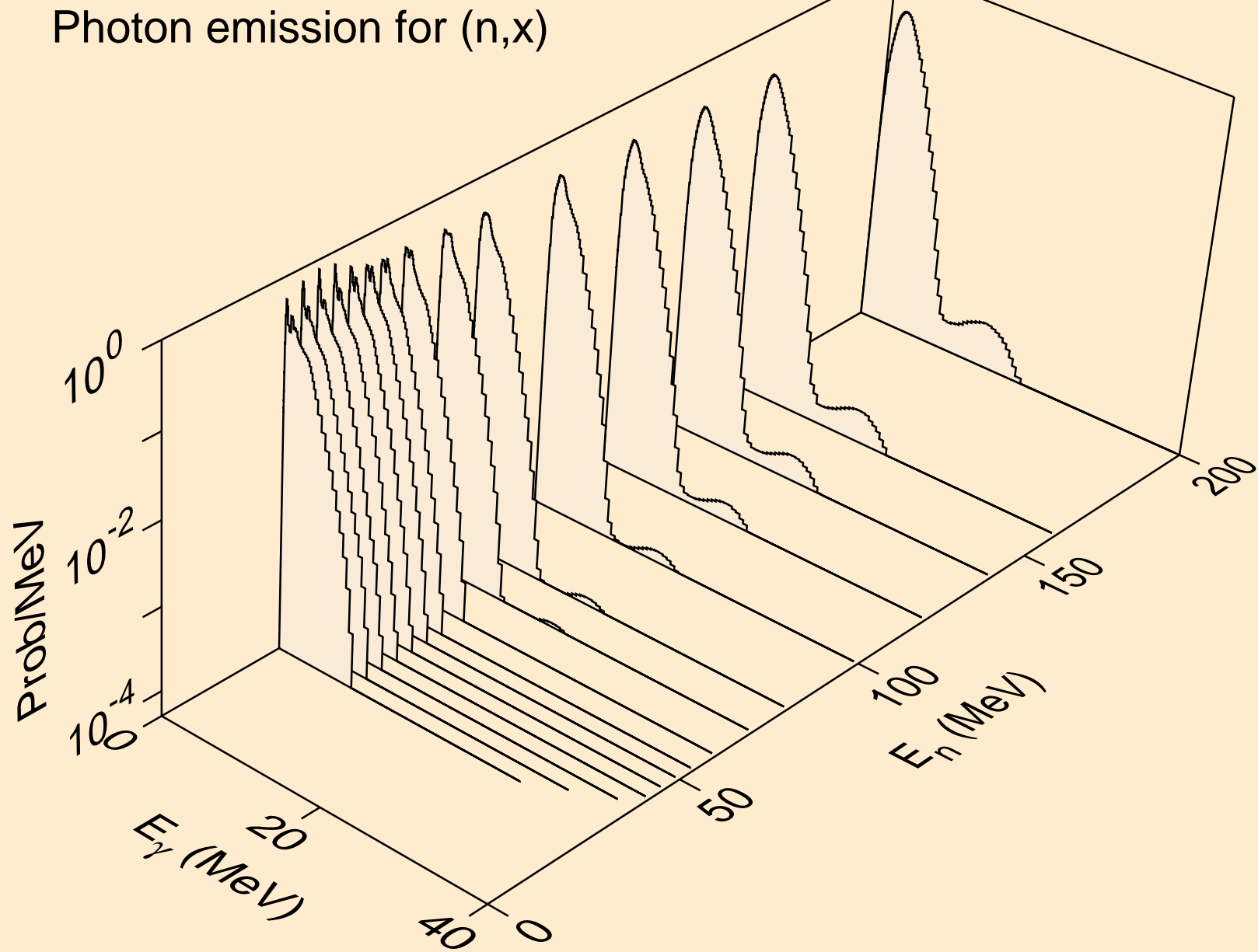

GA075 NEUTRON ACER TENDL-2023 LIBRARY; T=0.K
Photon emission for (n,2nd)

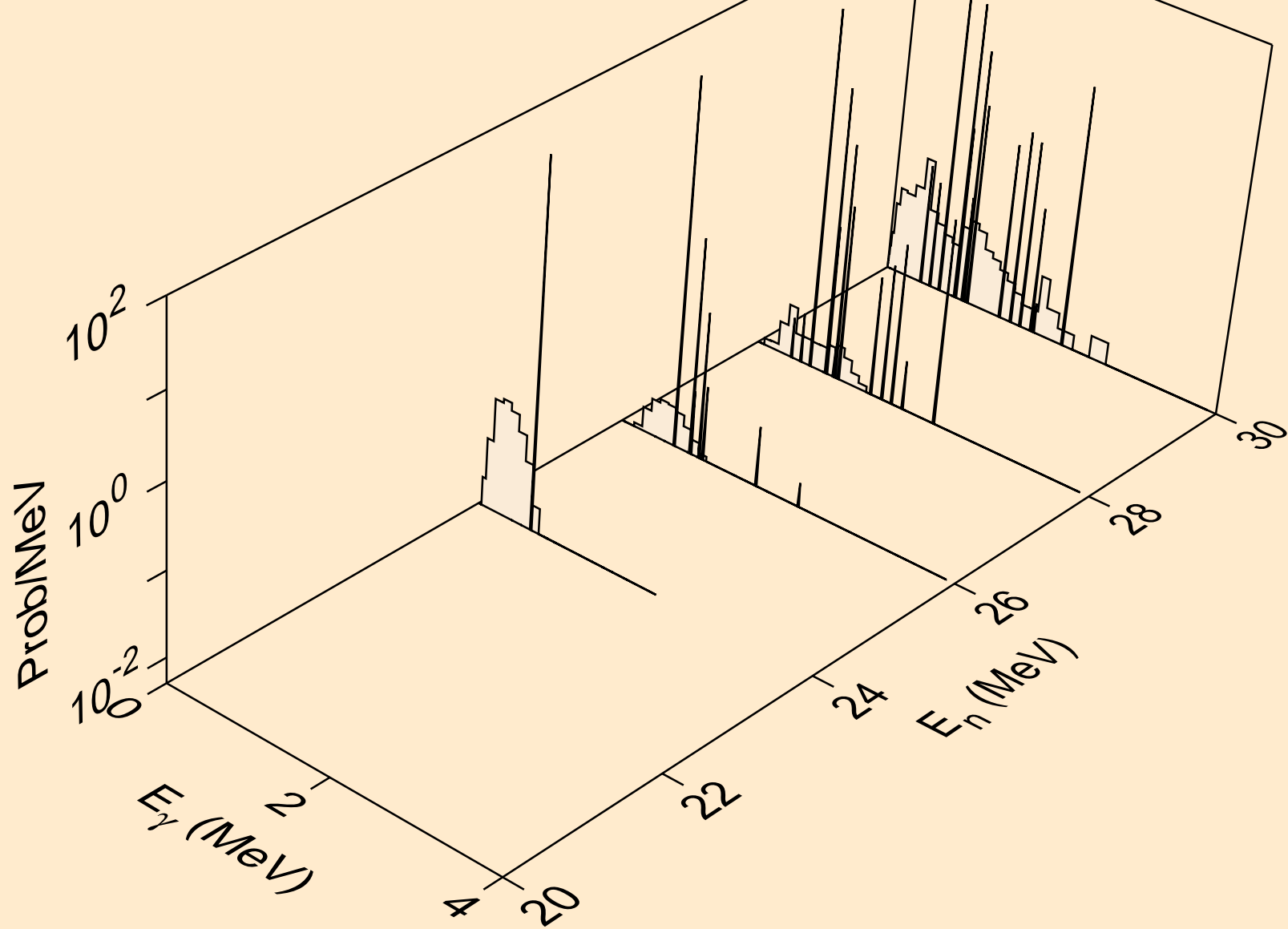

GA075 NEUTRON ACER TENDL-2023 LIBRARY; T=0.K
Photon emission for (n,2n)

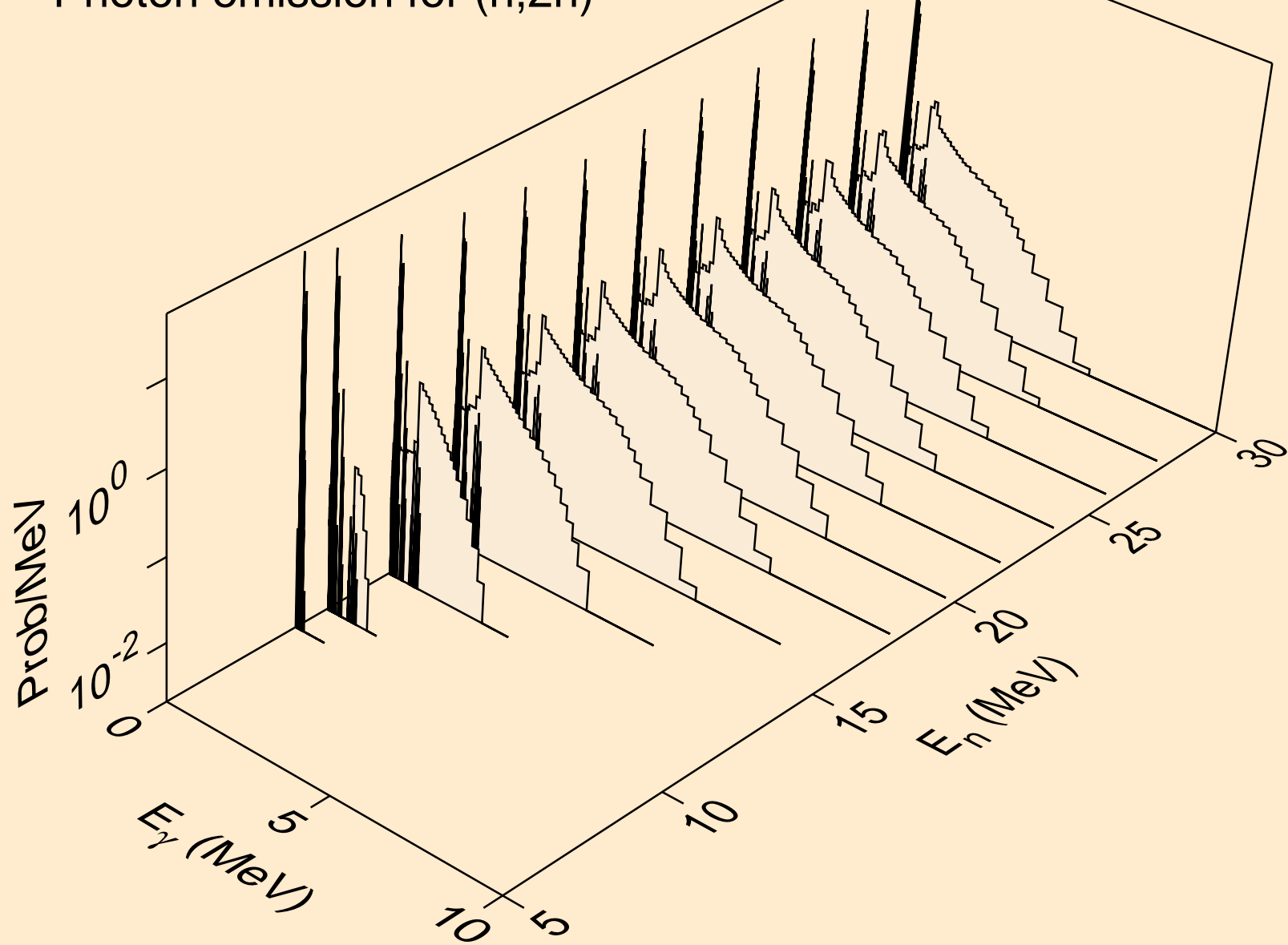

GA075 NEUTRON ACER TENDL-2023 LIBRARY; T=0.K
Photon emission for (n,3n)

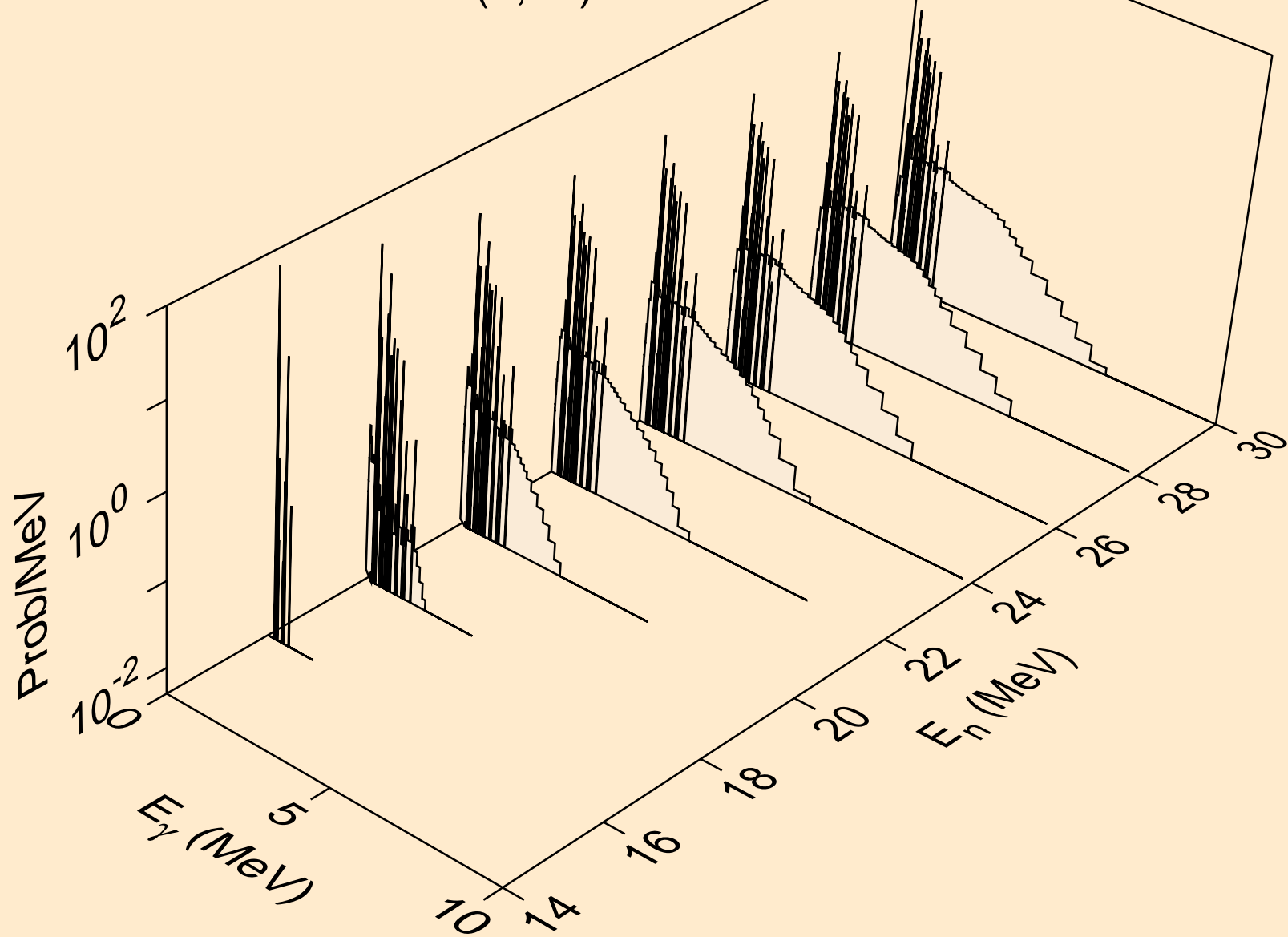

GA075 NEUTRON ACER TENDL-2023 LIBRARY; T=0.K
Photon emission for (n,n*)a

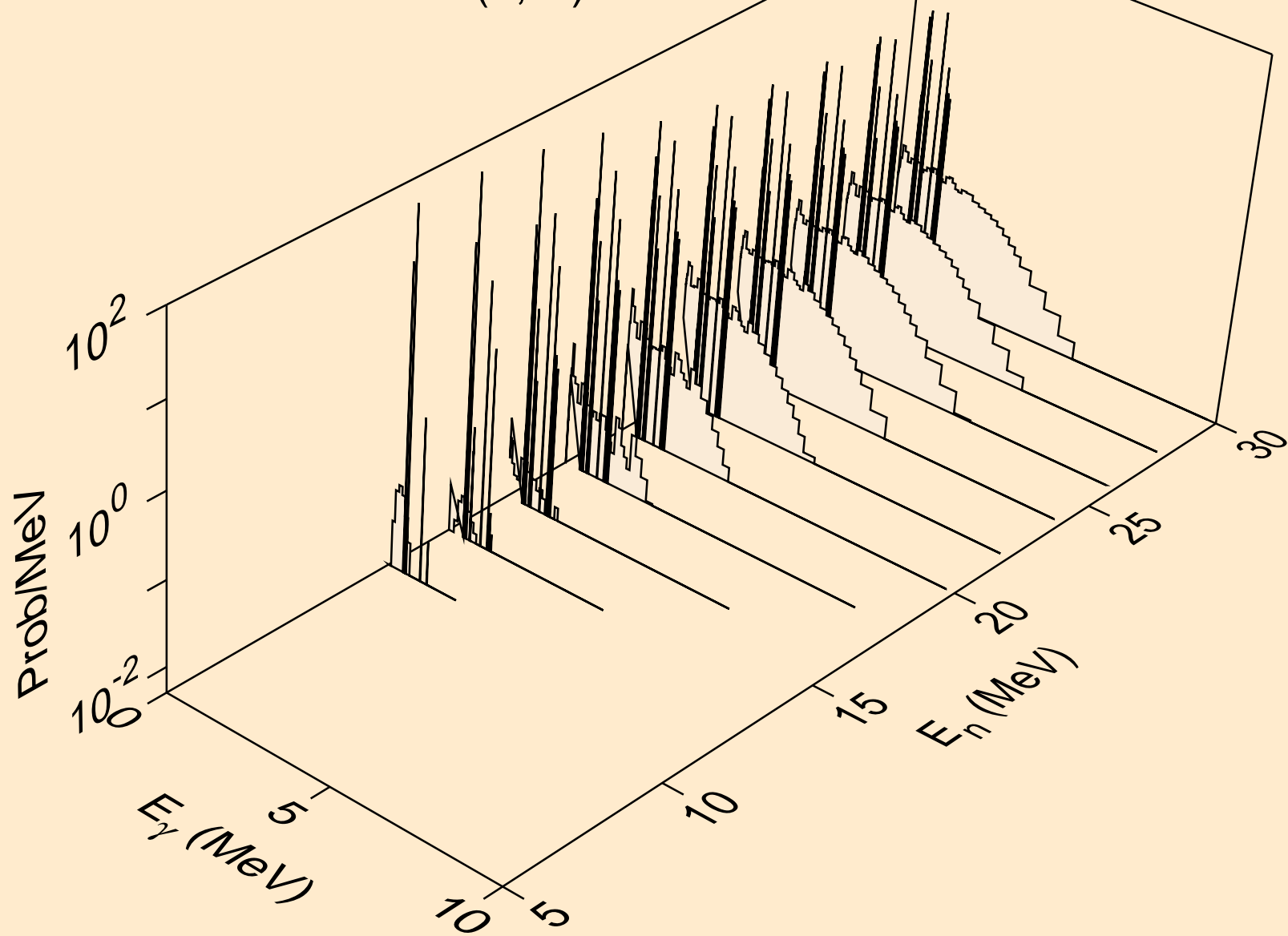

GA075 NEUTRON ACER TENDL-2023 LIBRARY; T=0.K
Photon emission for (n,2n)a

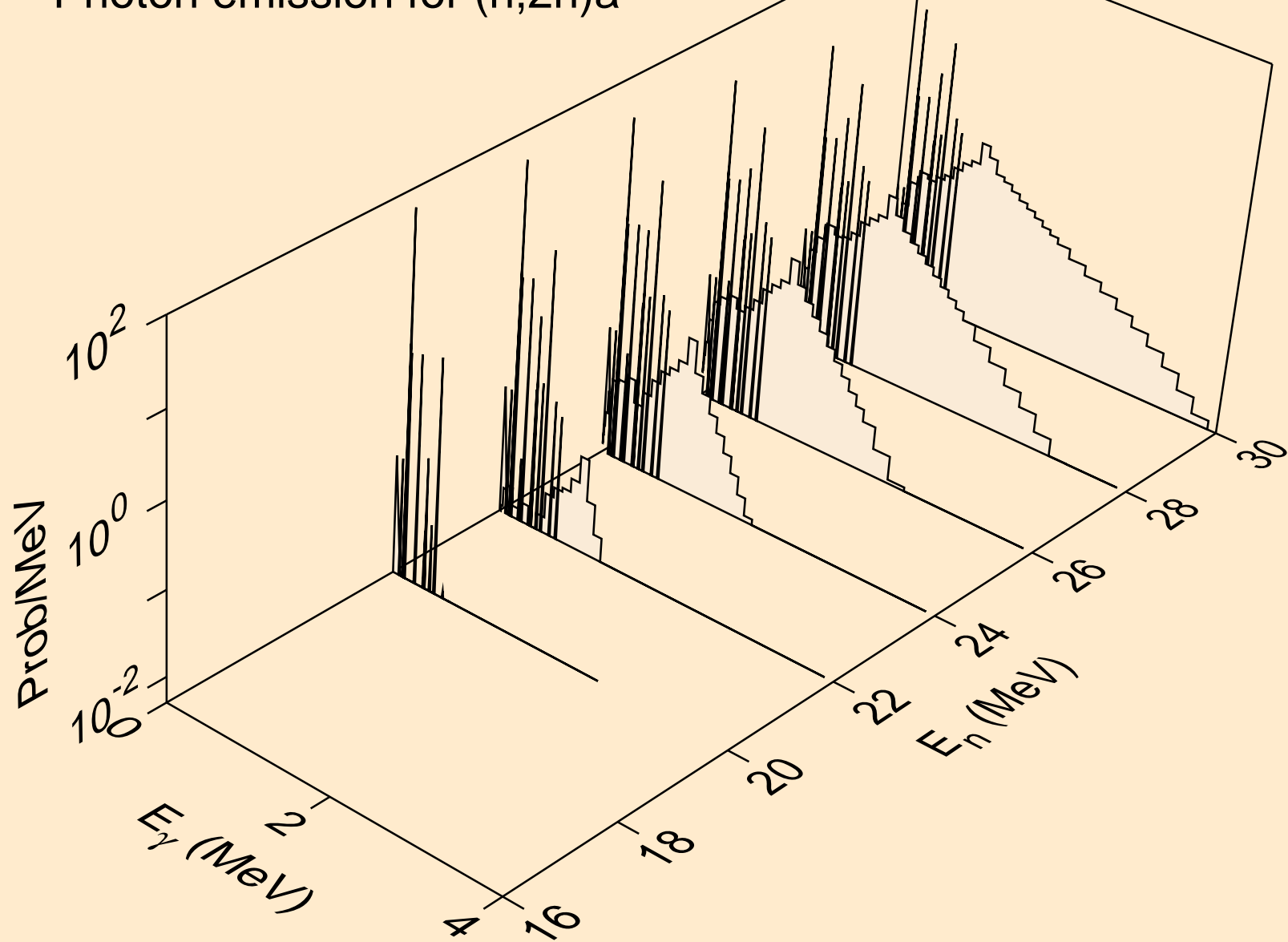

GA075 NEUTRON ACER TENDL-2023 LIBRARY; T=0.K
Photon emission for (n,3n)a

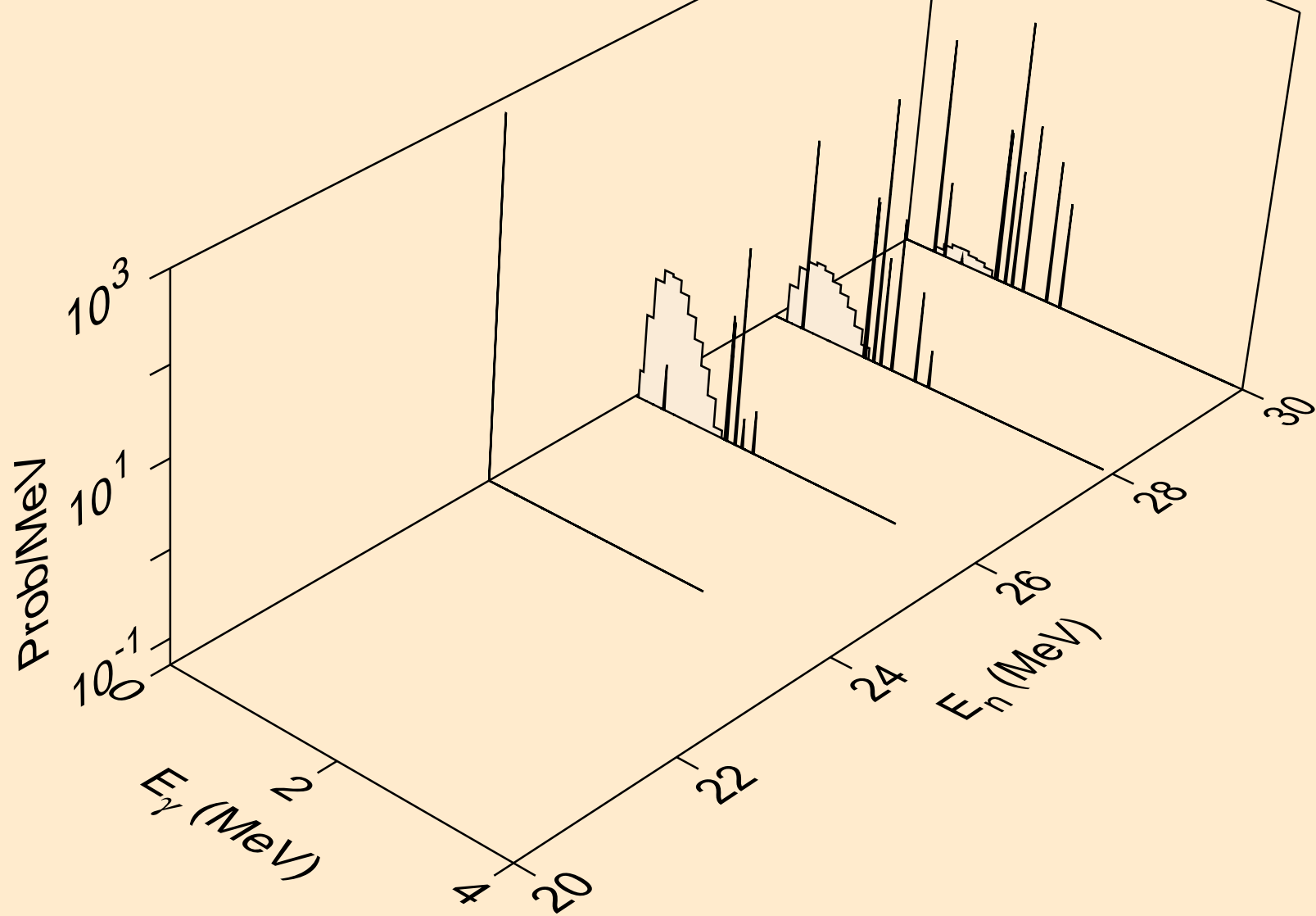

GA075 NEUTRON ACER TENDL-2023 LIBRARY; T=0.K
Photon emission for (n,n*)p

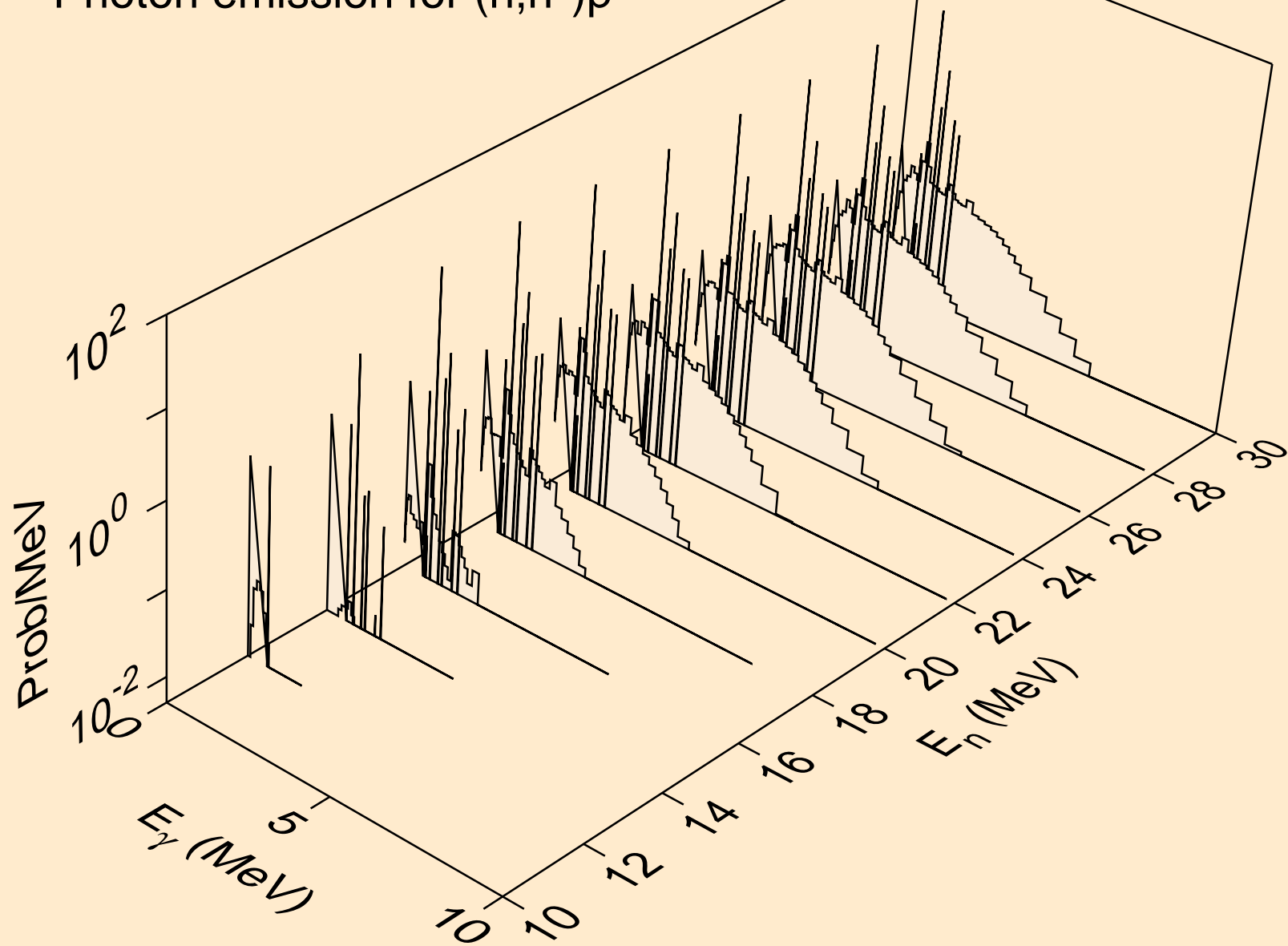

GA075 NEUTRON ACER TENDL-2023 LIBRARY; T=0.K
Photon emission for (n,n*)d

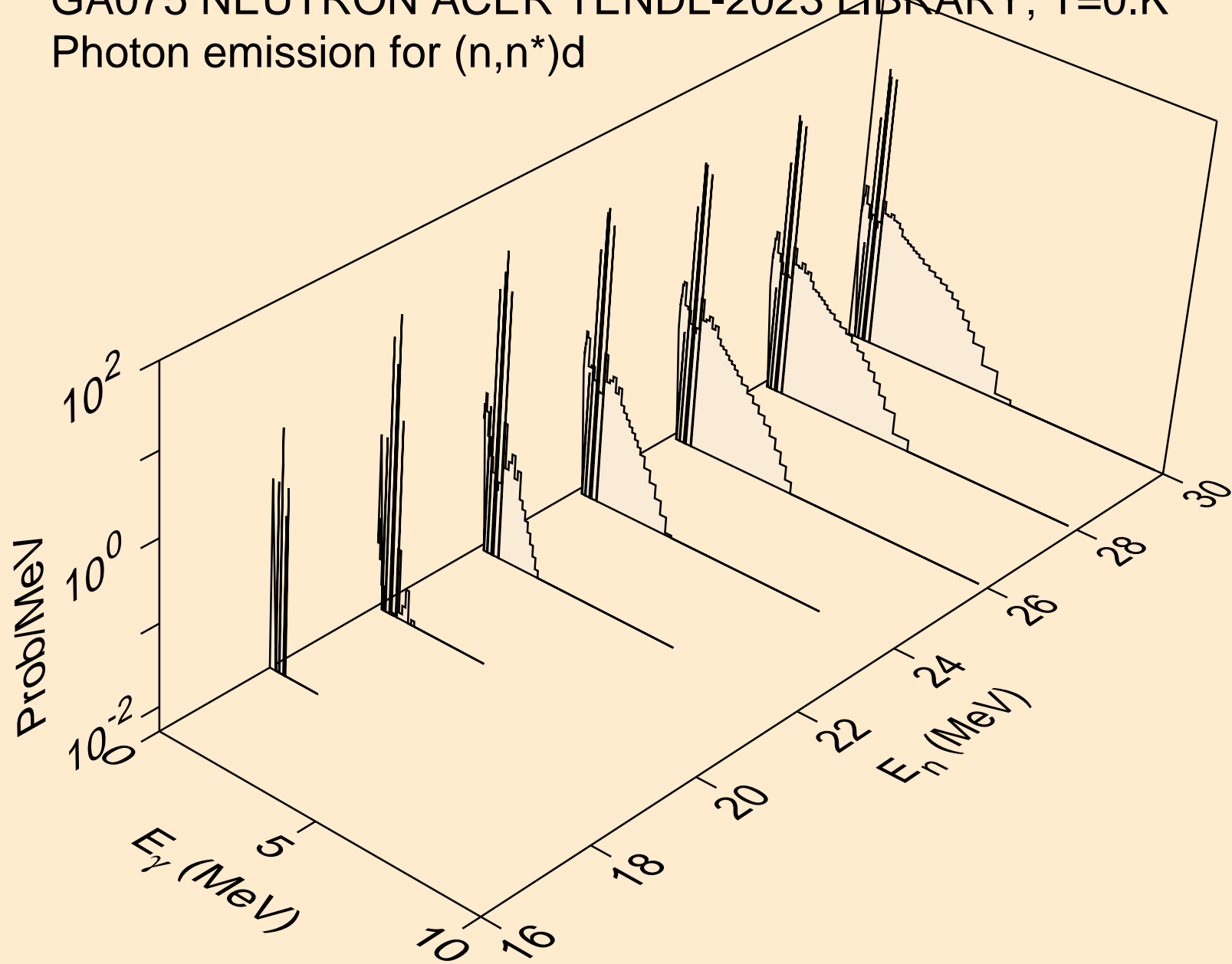

GA075 NEUTRON ACER TENDL-2023 LIBRARY; T=0.K
Photon emission for (n,n*)t

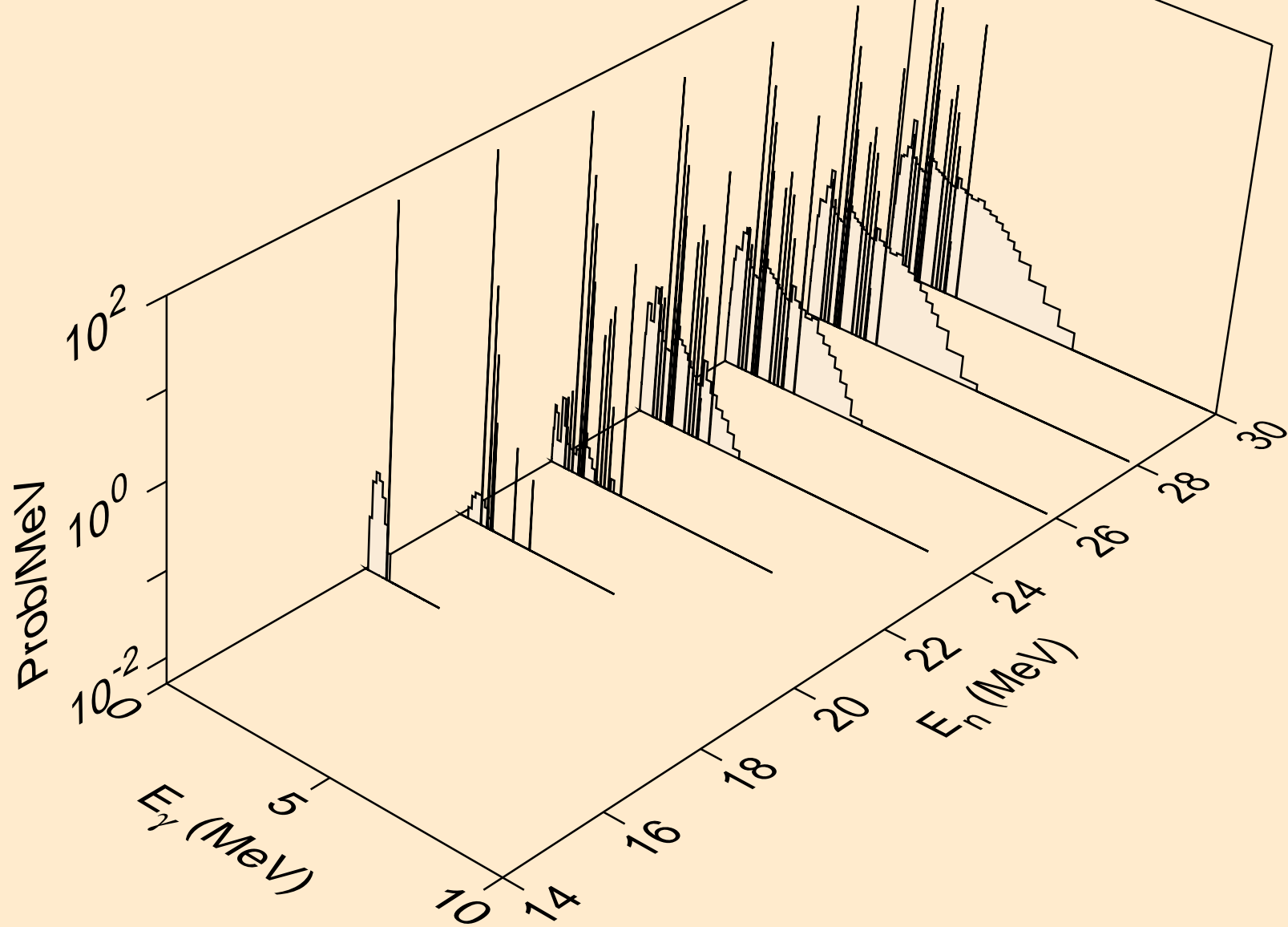

GA075 NEUTRON ACER TENDL-2023 LIBRARY; T=0.K
Photon emission for (n,n*)he3

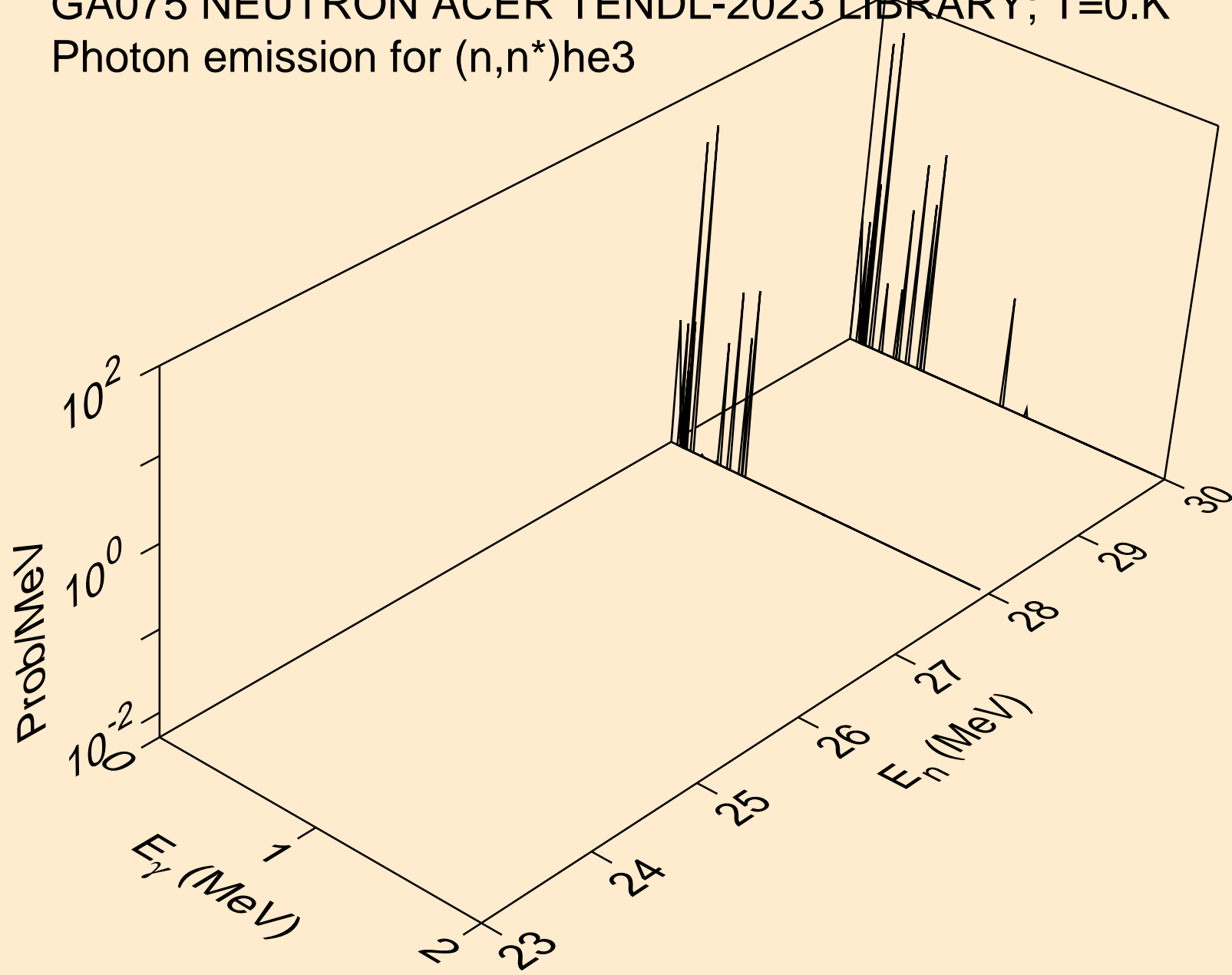

GA075 NEUTRON ACER TENDL-2023 LIBRARY; T=0.K
Photon emission for (n,4n)

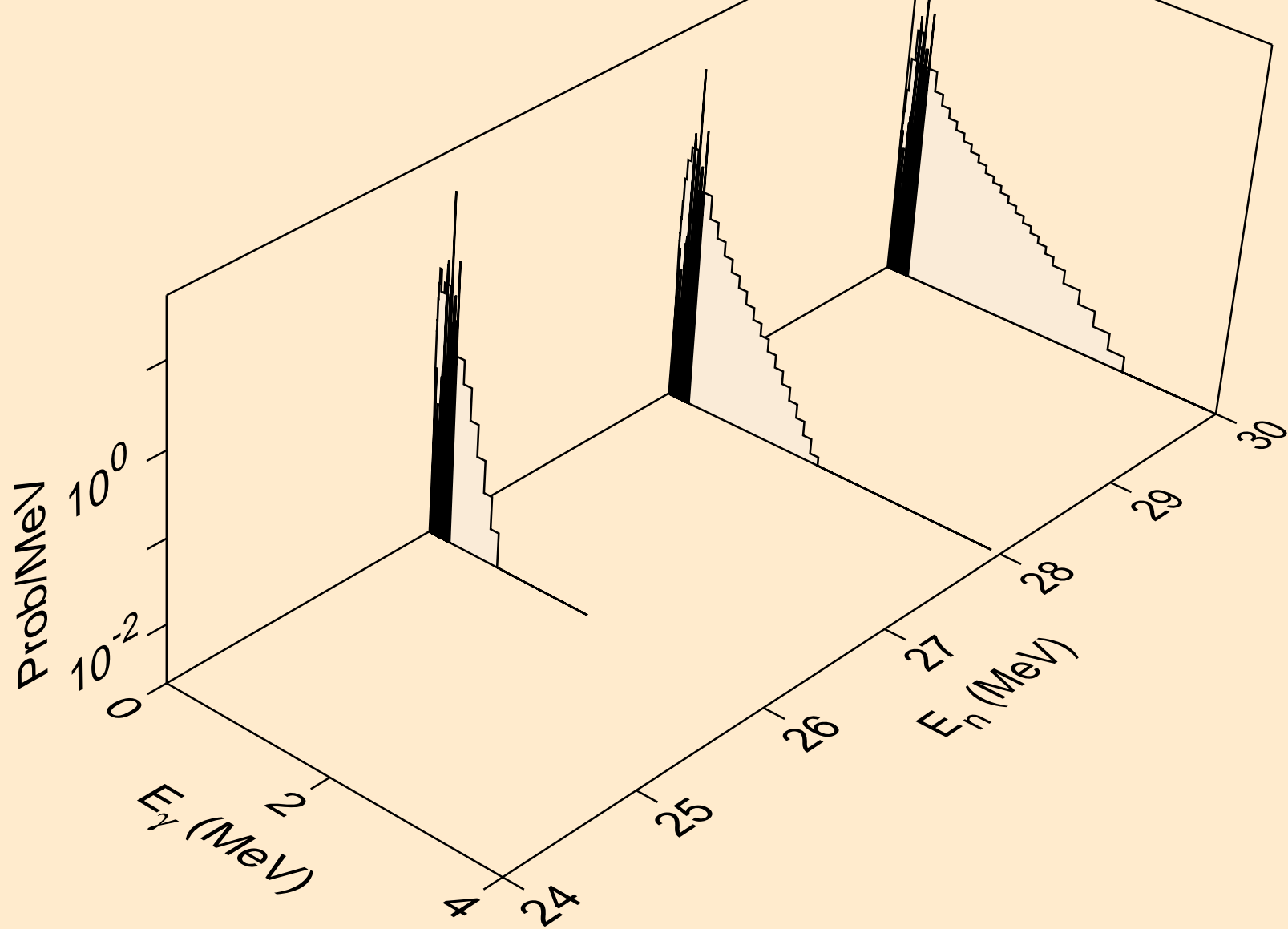

GA075 NEUTRON ACER TENDL-2023 LIBRARY; T=0.K
Photon emission for (n,2np)

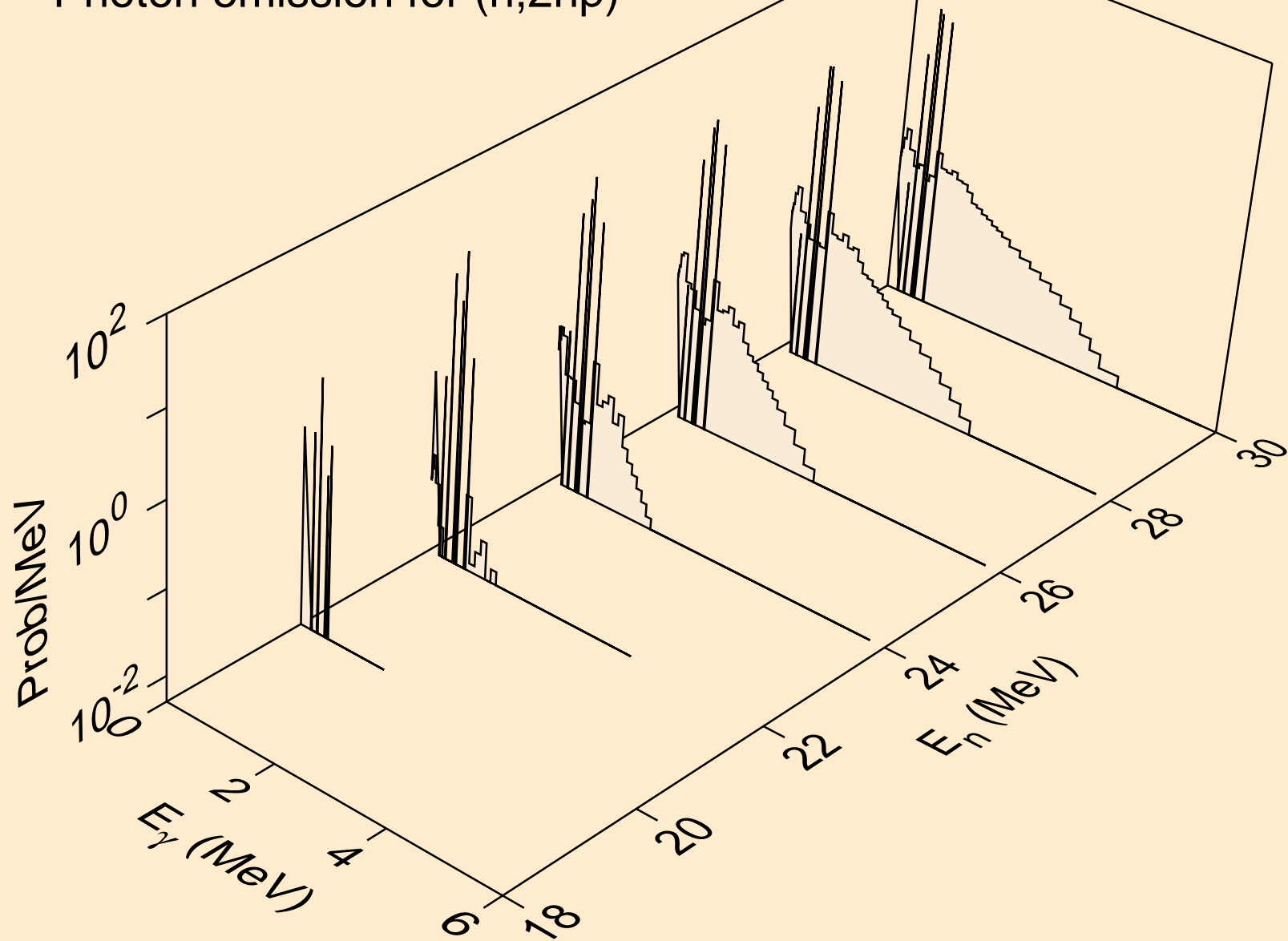

GA075 NEUTRON ACER TENDL-2023 LIBRARY; T=0.K
Photon emission for (n,3np)

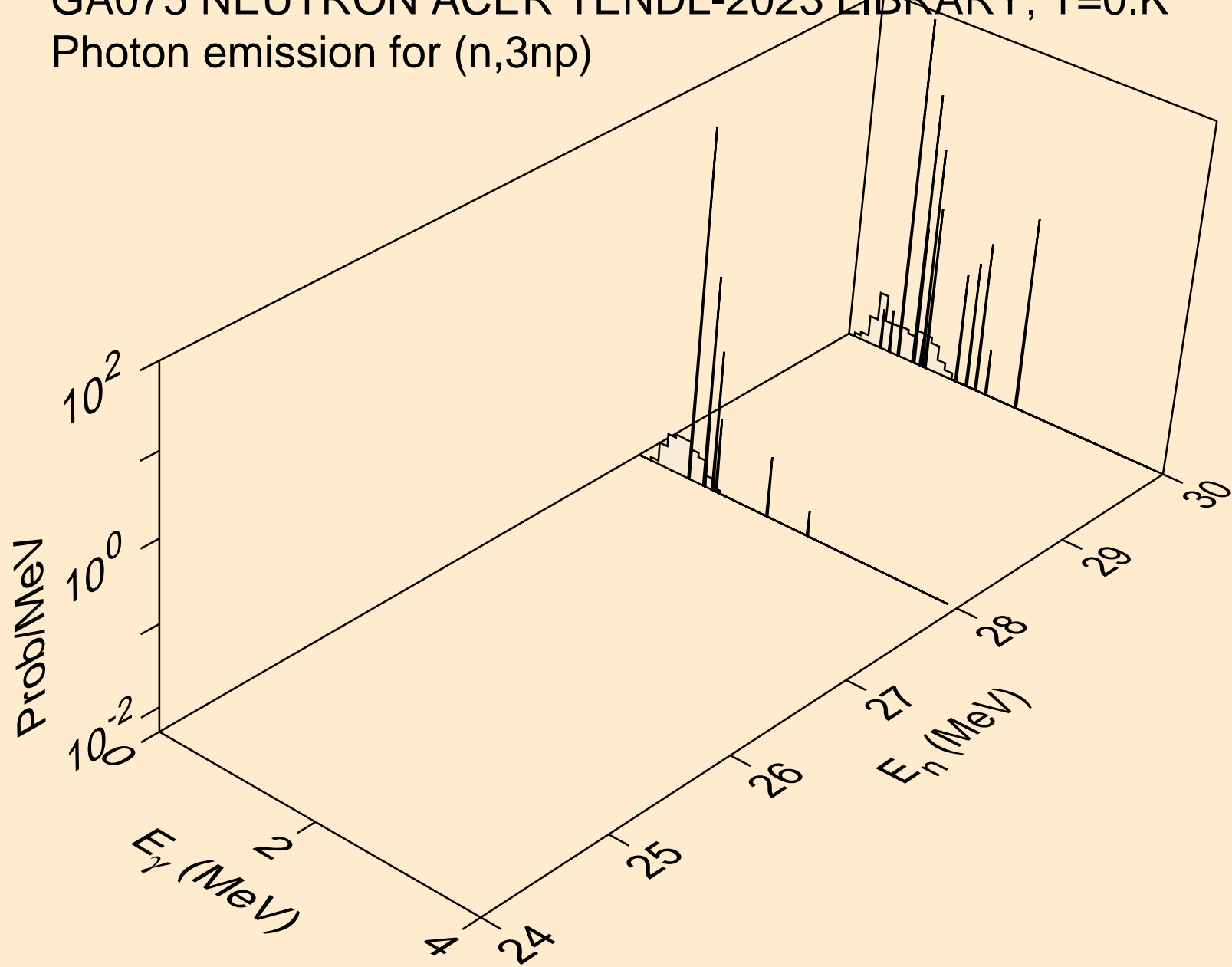

GA075 NEUTRON ACER TENDL-2023 LIBRARY; T=0.K
Photon emission for (n,n*c)

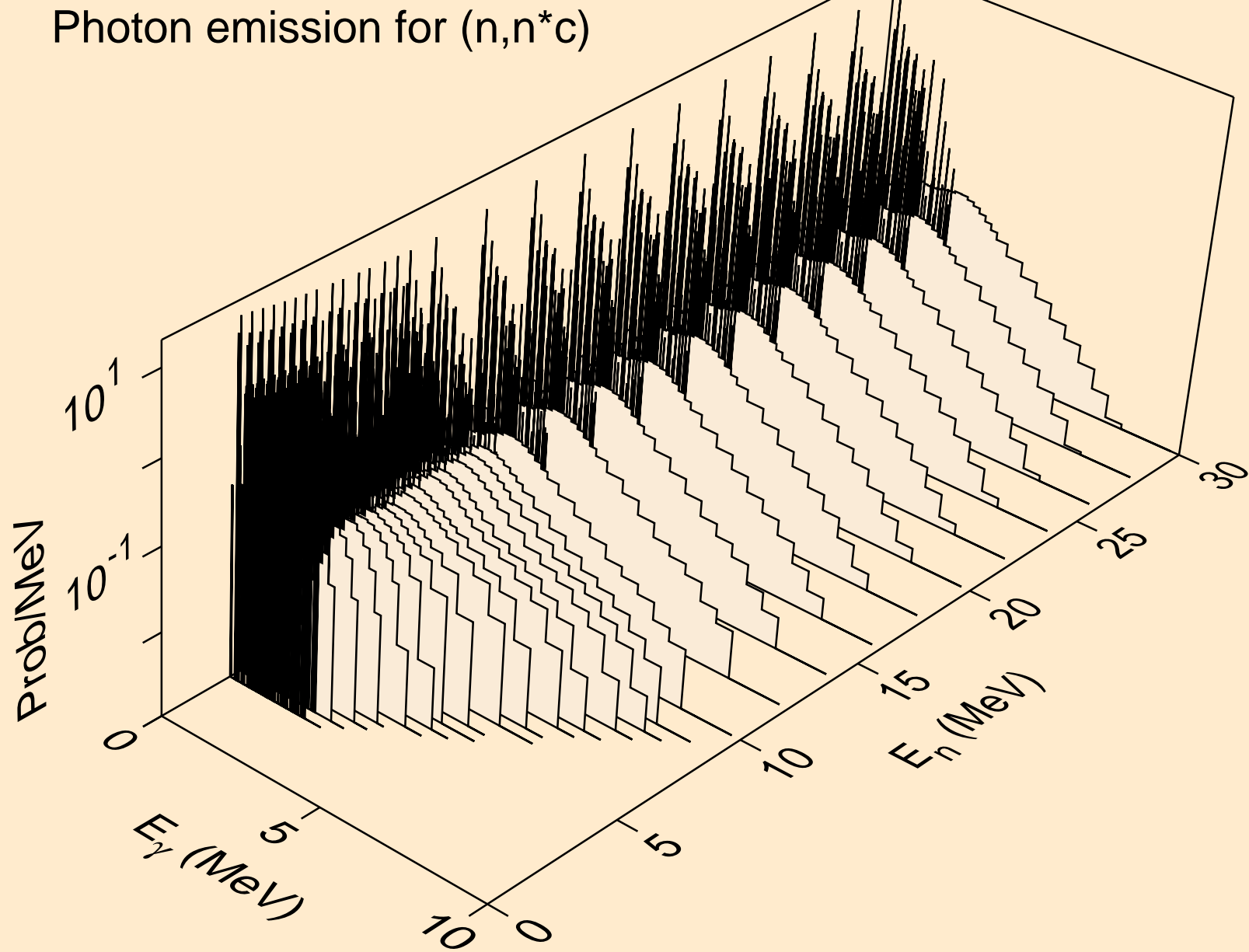

GA075 NEUTRON ACER TENDL-2023 LIBRARY; T=0.K
Photon emission for (n,gma)

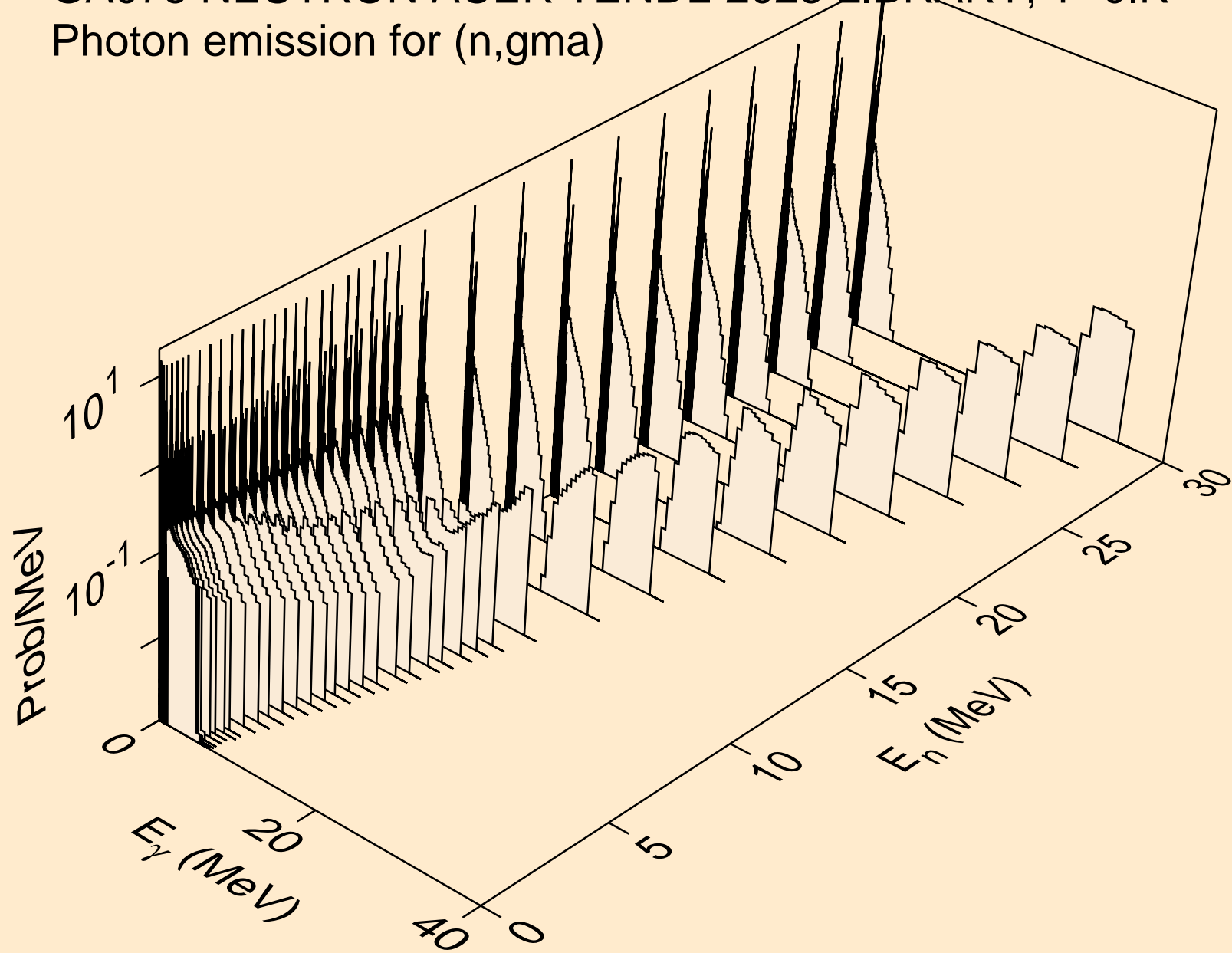

GA075 NEUTRON ACER TENDL-2023 LIBRARY; T=0.K
Photon emission for (n,p)

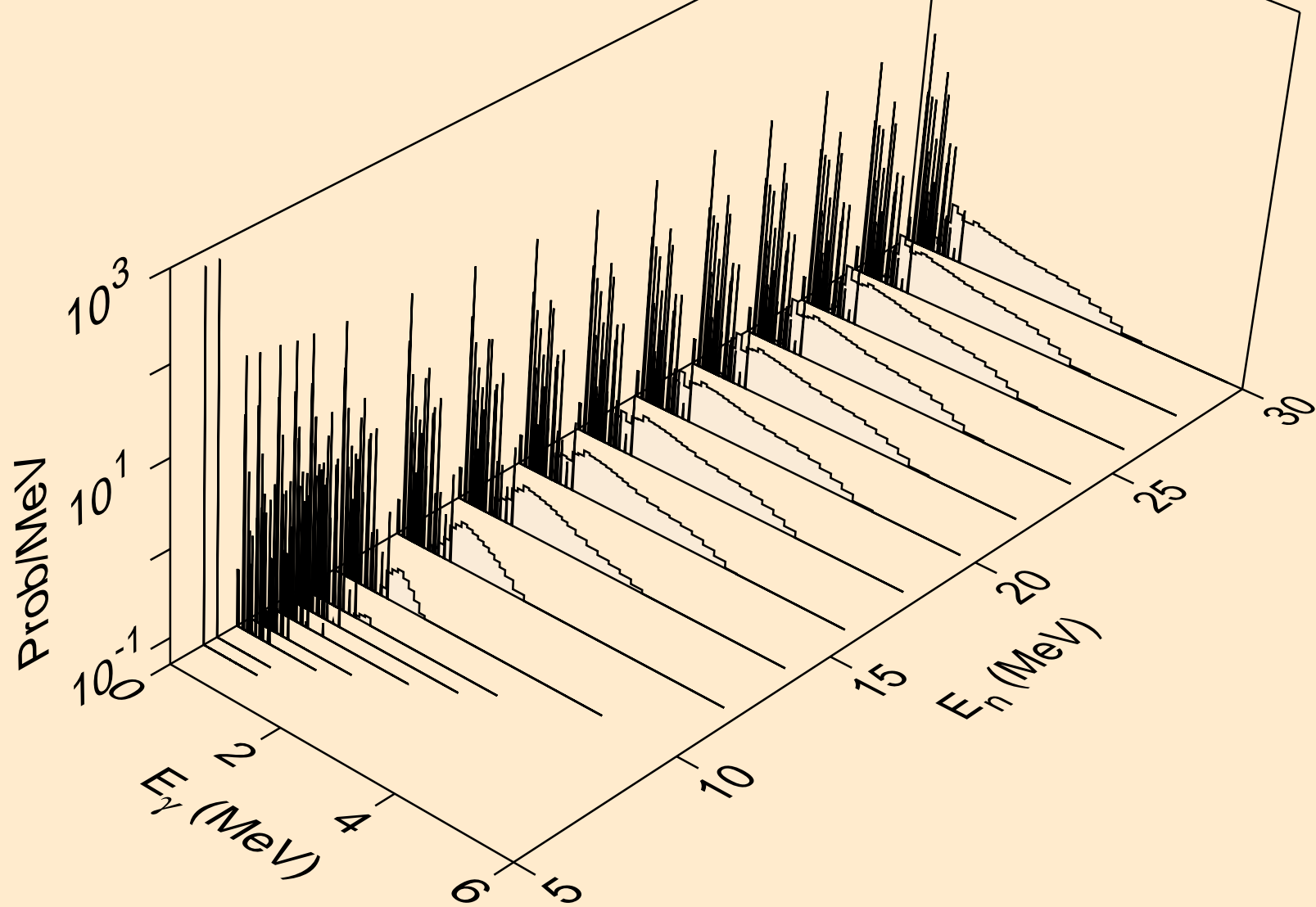

GA075 NEUTRON ACER TENDL-2023 LIBRARY; T=0.K
Photon emission for (n,d)

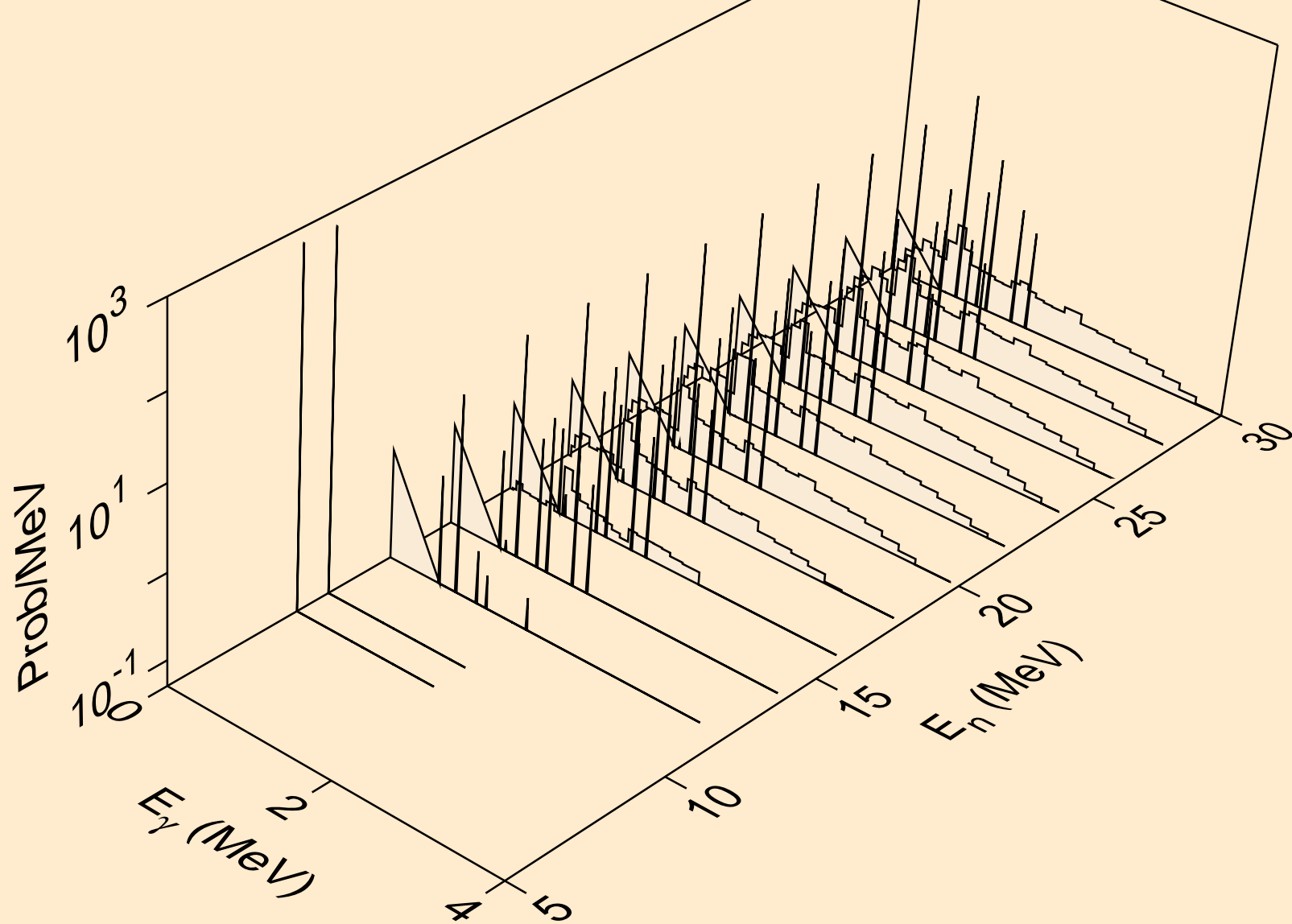

GA075 NEUTRON ACER TENDL-2023 LIBRARY; T=0.K
Photon emission for (n,t)

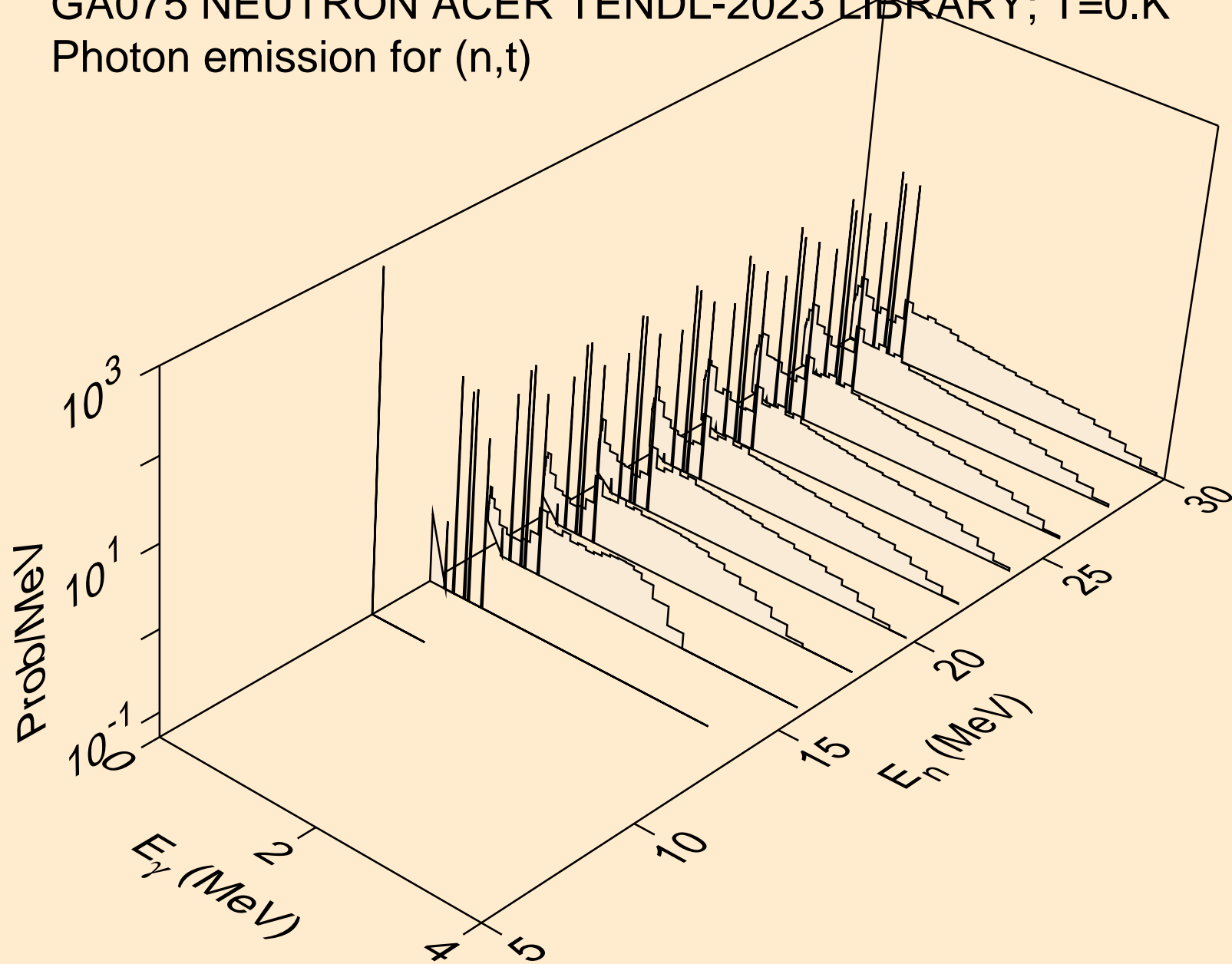

GA075 NEUTRON ACER TENDL-2023 LIBRARY; T=0.K
Photon emission for (n,he3)

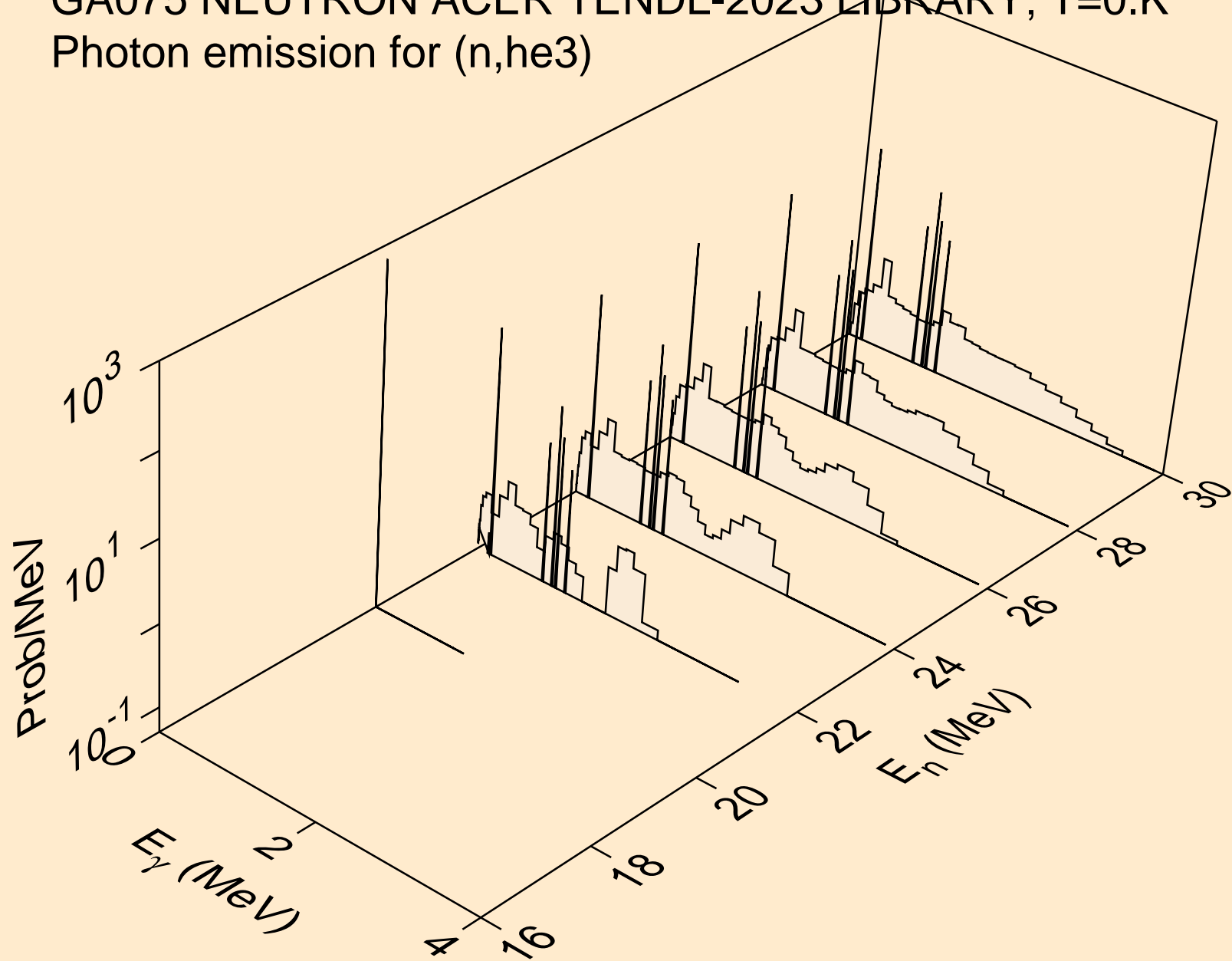

GA075 NEUTRON ACER TENDL-2023 LIBRARY; T=0.K
Photon emission for (n,a)

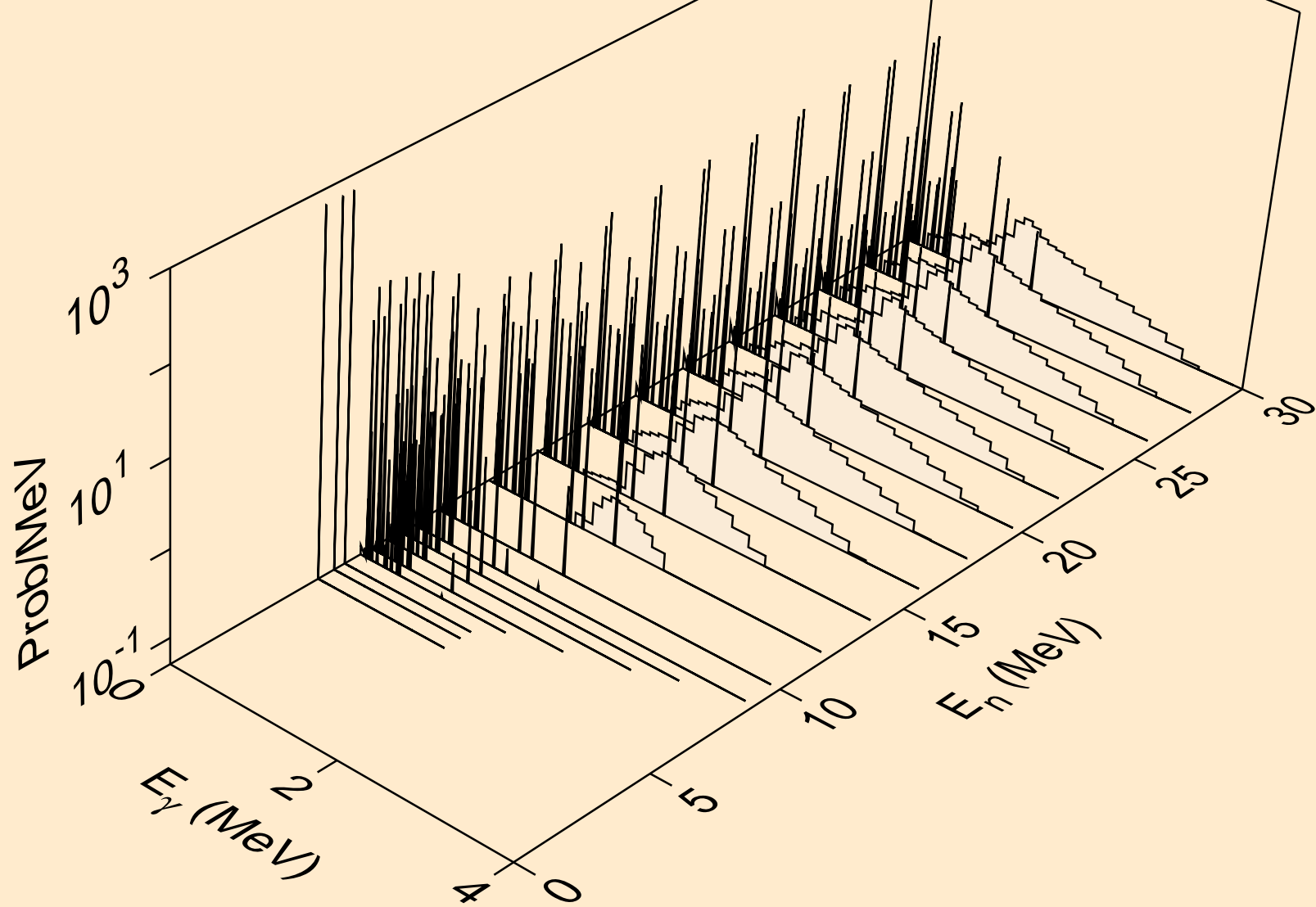

GA075 NEUTRON ACER TENDL-2023 LIBRARY; T=0.K
Photon emission for (n,2p)

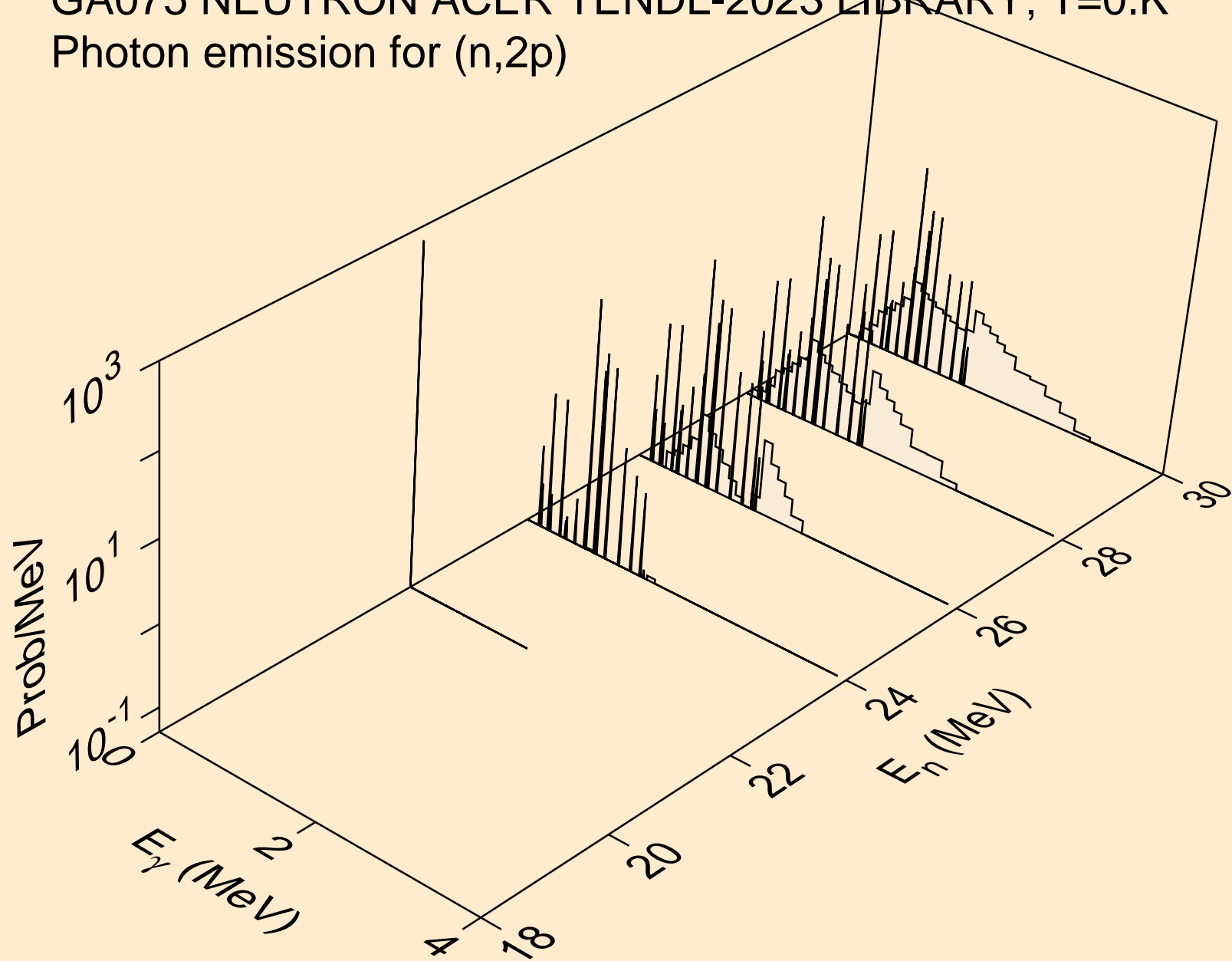

GA075 NEUTRON ACER TENDL-2023 LIBRARY; T=0.K
Photon emission for (n,p)

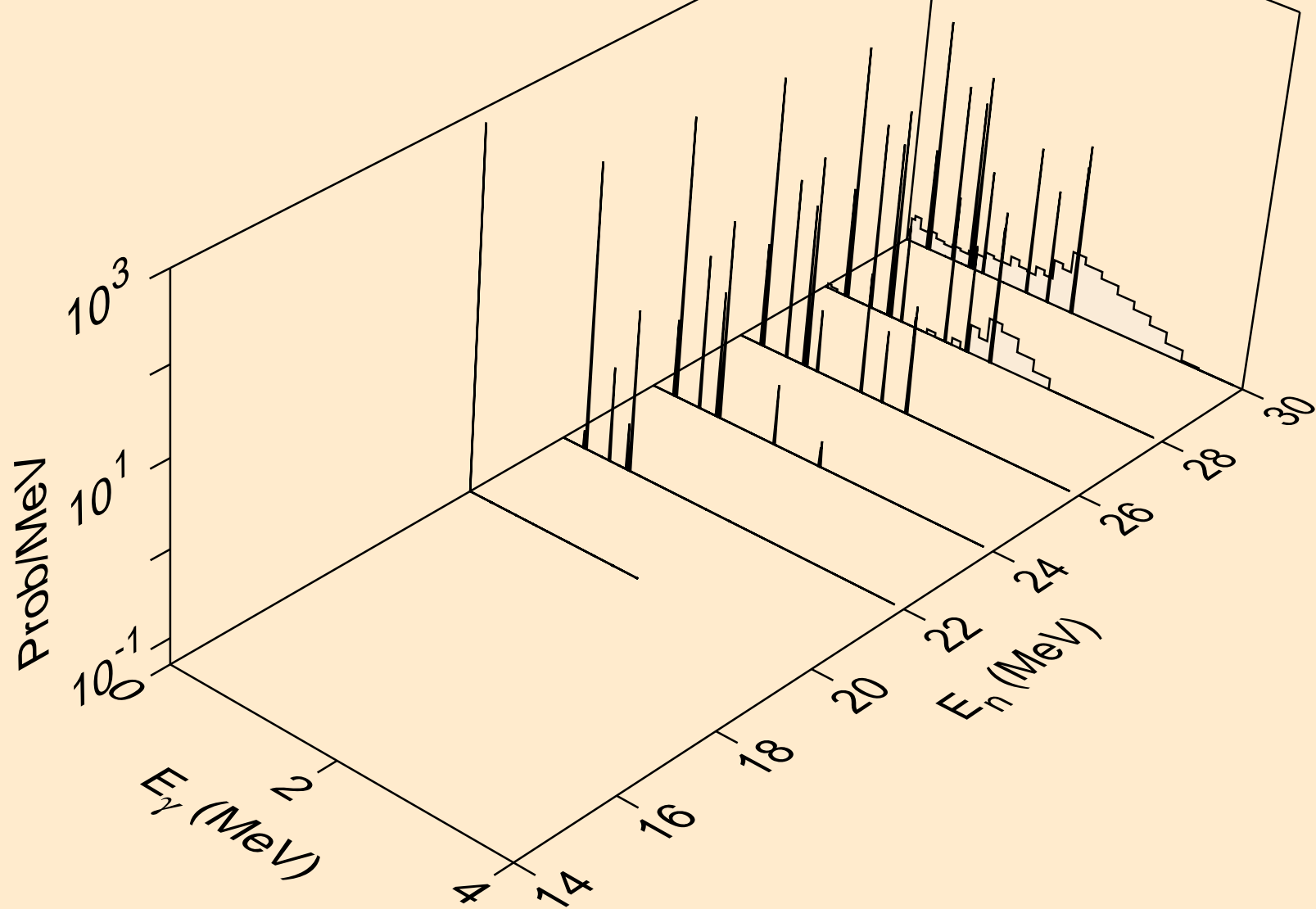

GA075 NEUTRON ACER TENDL-2023 LIBRARY; T=0.K
thermal capture photon spectrum

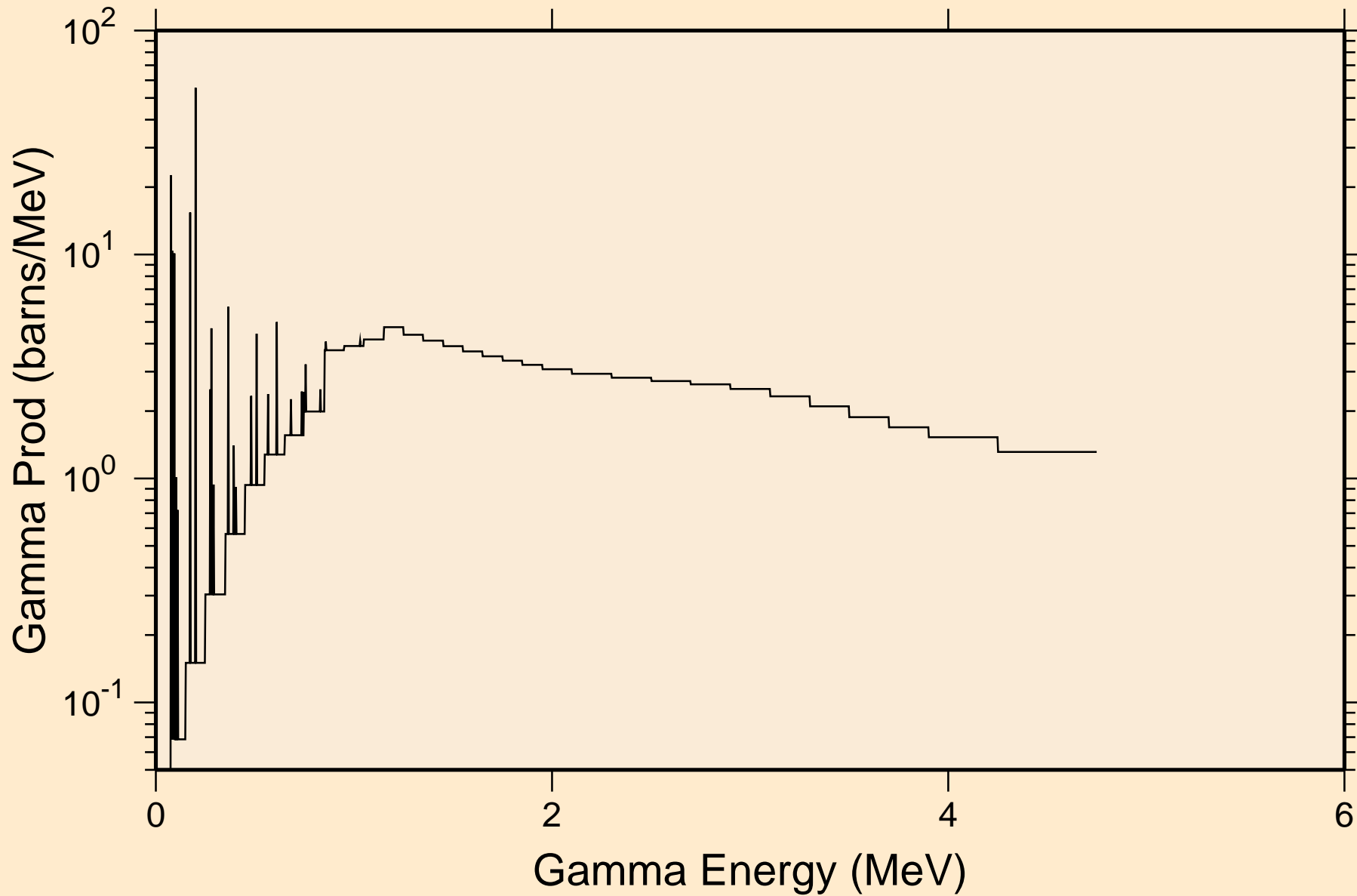

GA075 NEUTRON ACER TENDL-2023 LIBRARY; T=0.K
14 MeV photon spectrum

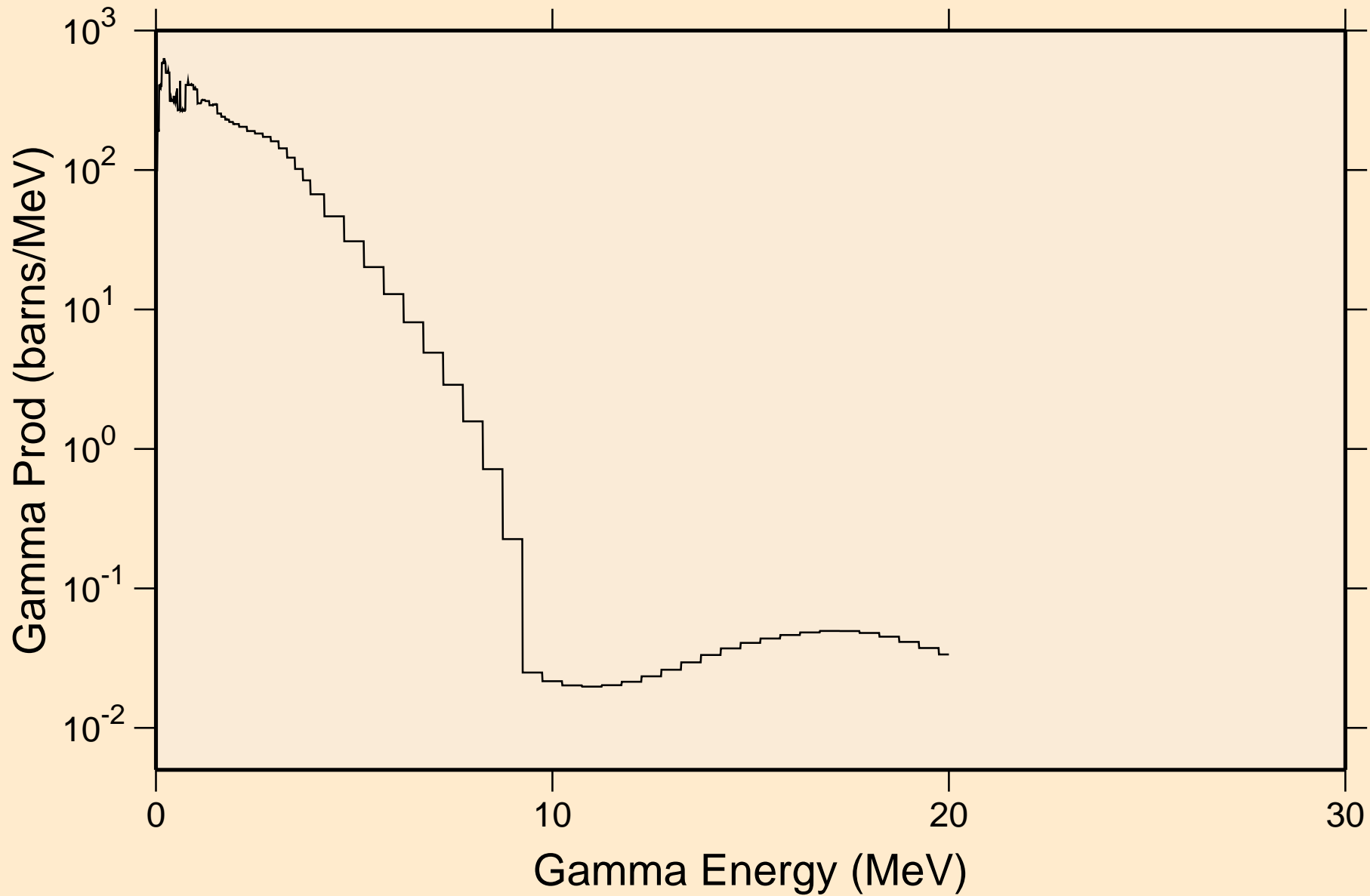

GA075 NEUTRON ACER TENDL-2023 LIBRARY; T=0.K

Particle heating contributions

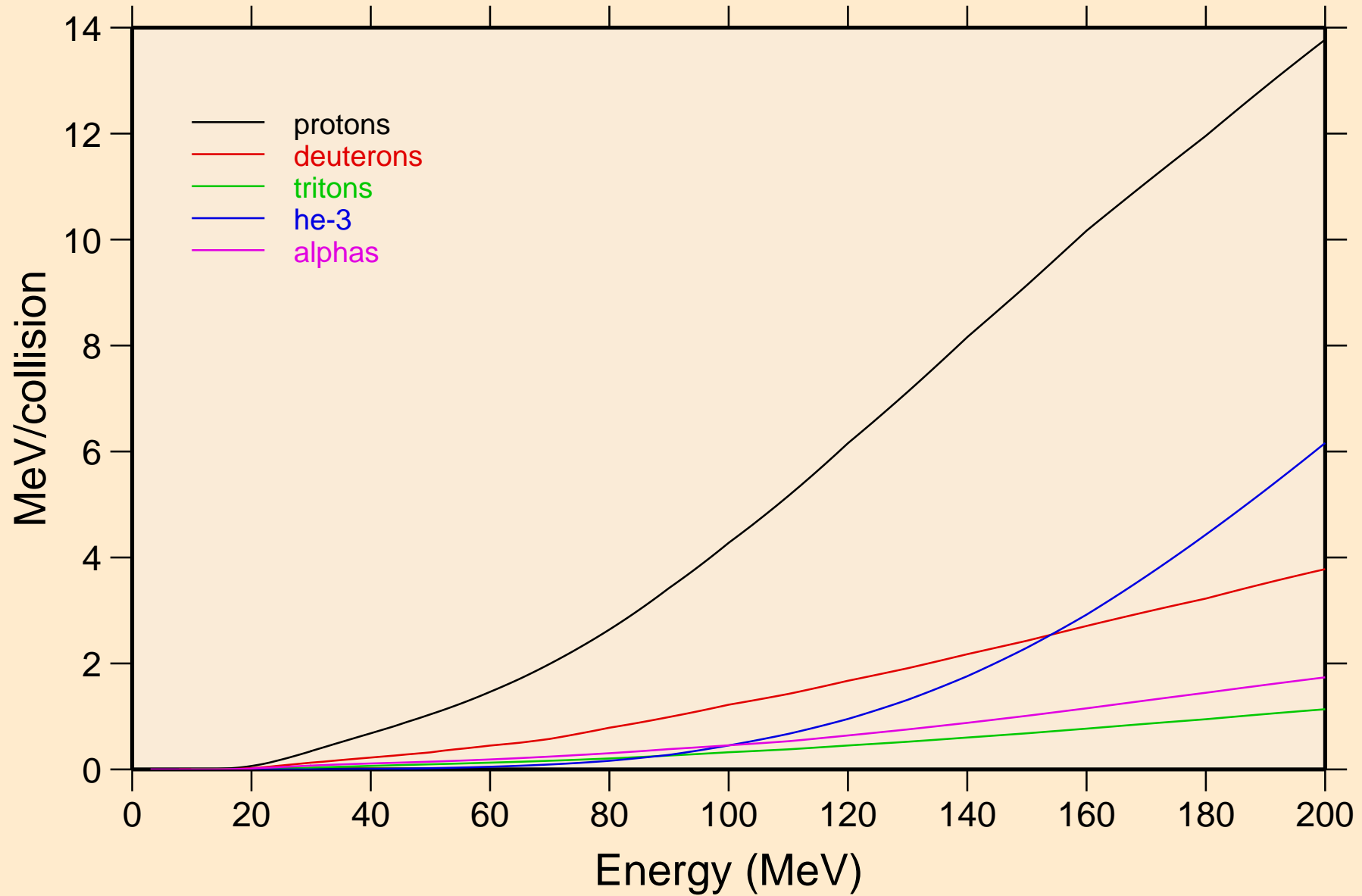

GA075 NEUTRON ACER TENDL-2023 LIBRARY; T=0.K

Recoil Heating

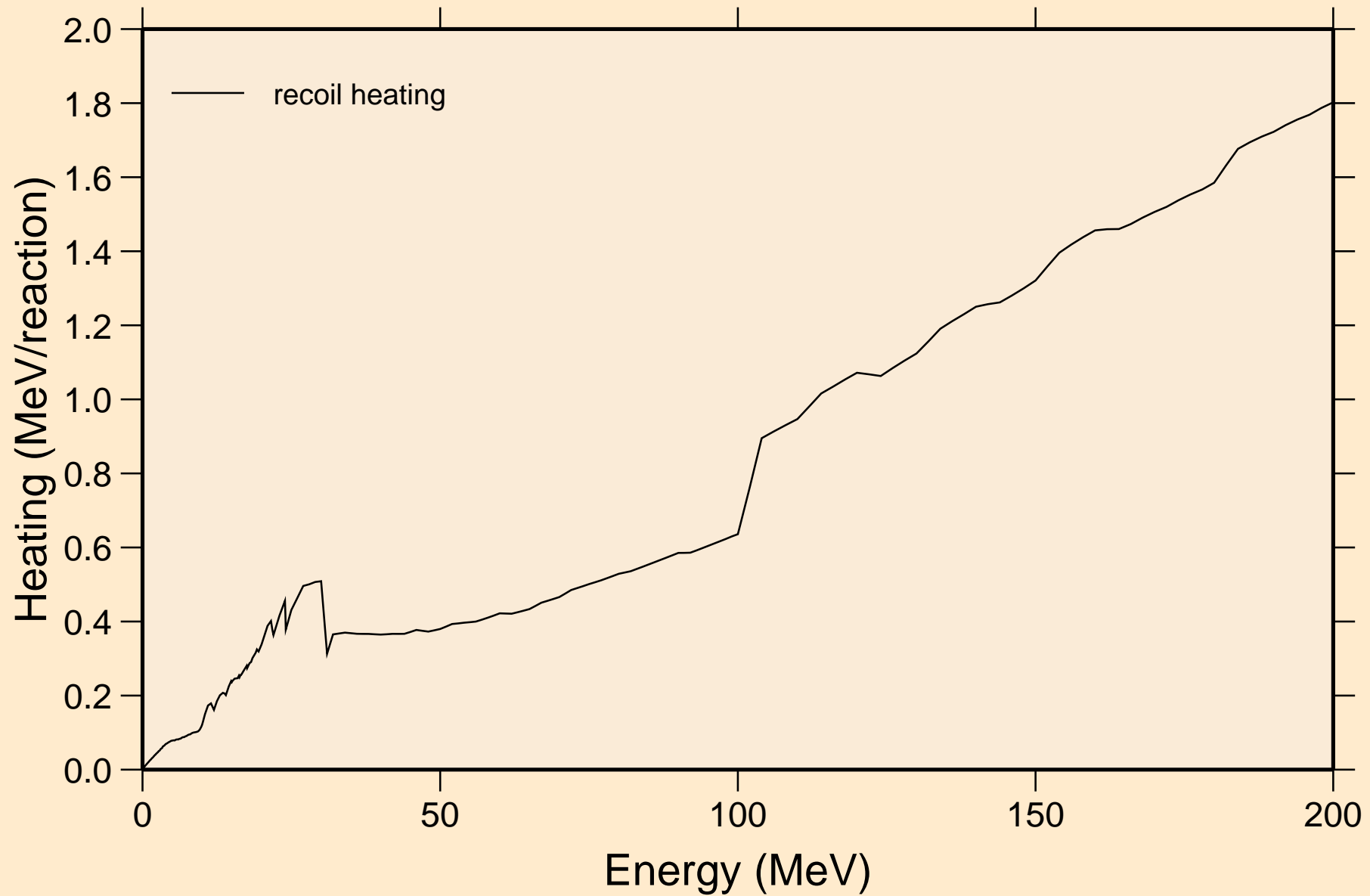

GA075 NEUTRON ACER TENDL-2023 LIBRARY; T=0.K

Particle production cross sections

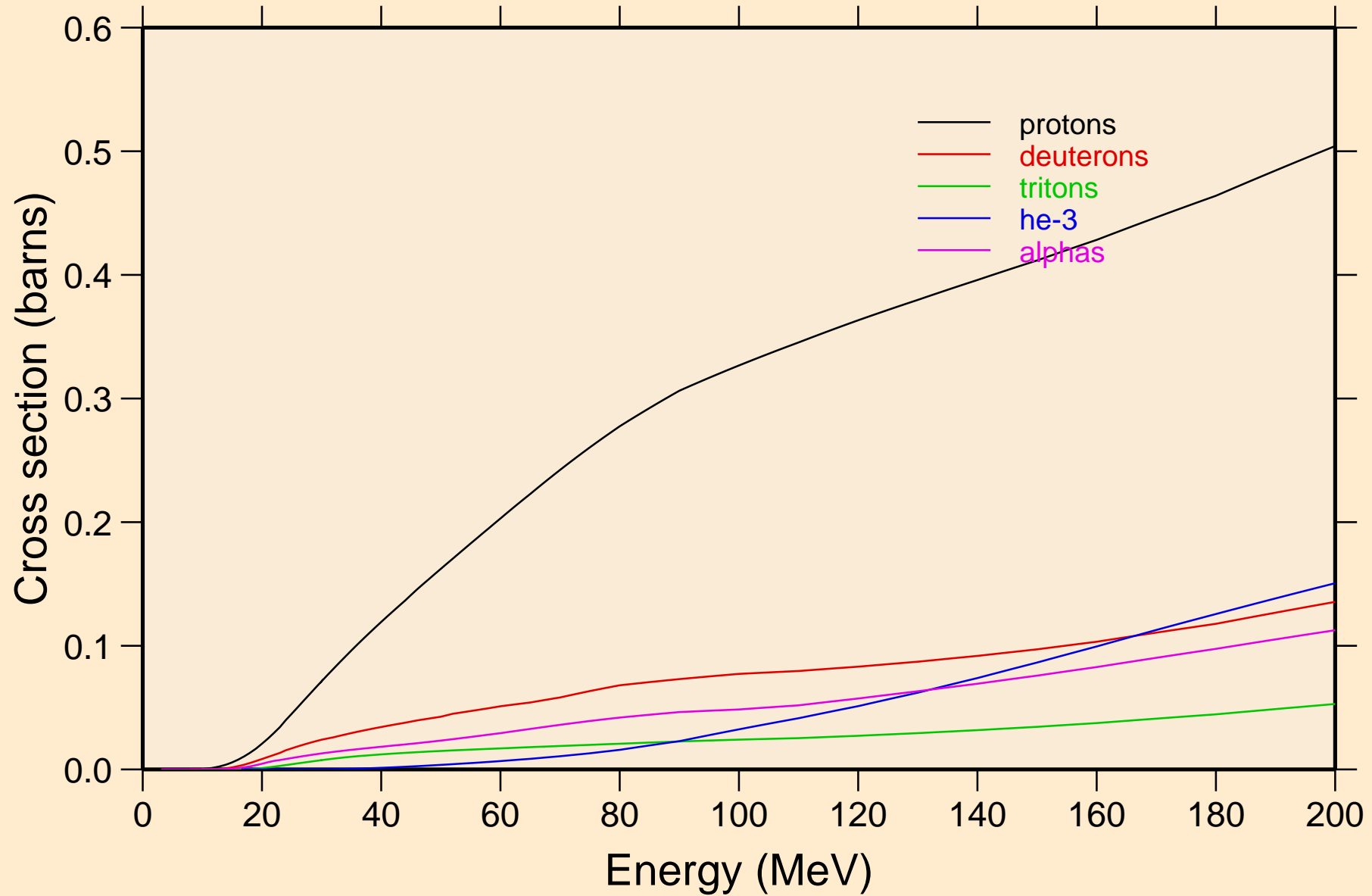

GA075 NEUTRON ACER TENDL-2023 LIBRARY; T=0.K
protons from (n,x)

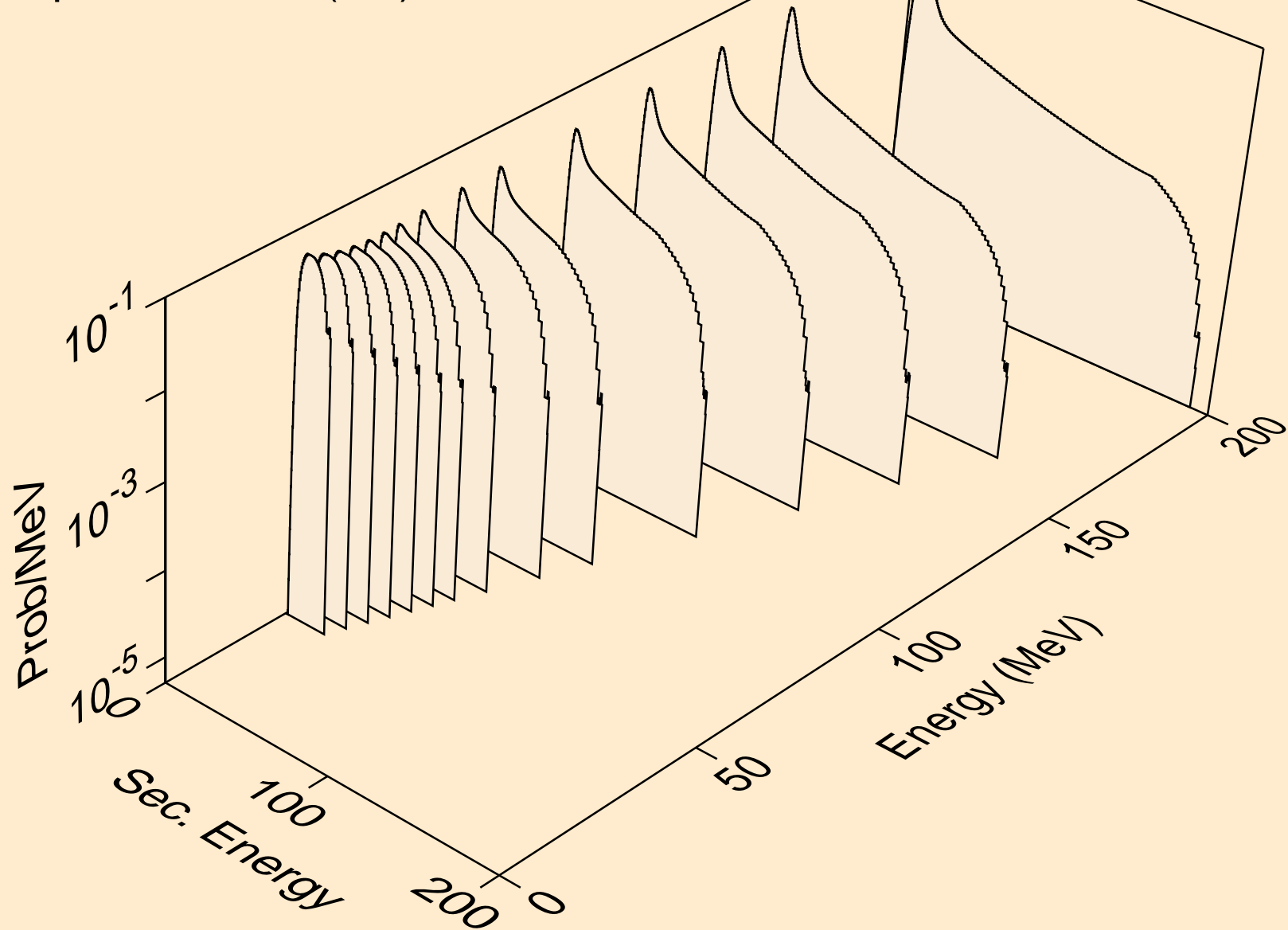

GA075 NEUTRON ACER TENDL-2023 LIBRARY; T=0.K
protons from (n,n*)p

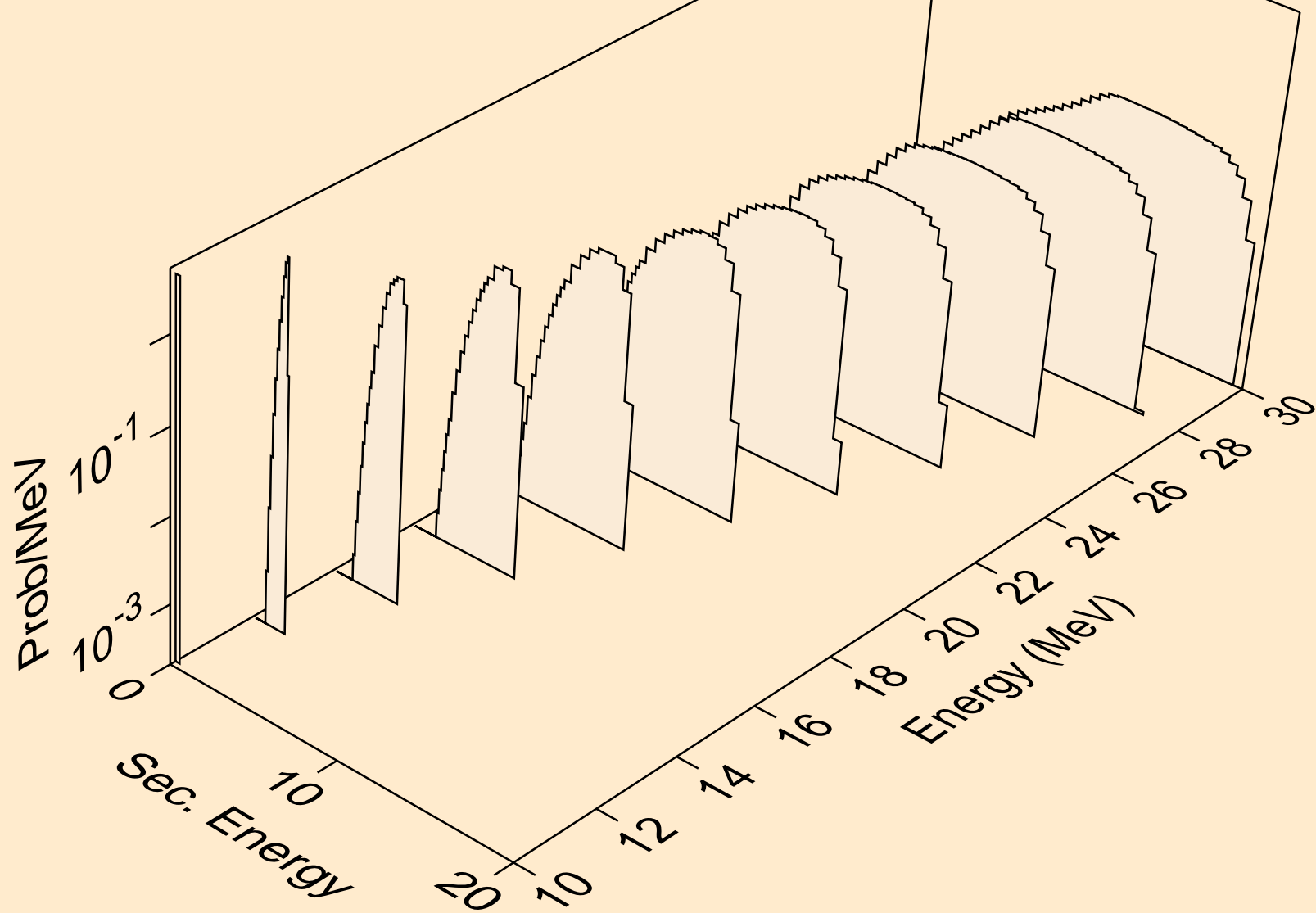

GA075 NEUTRON ACER TENDL-2023 LIBRARY; T=0.K
protons from (n,2np)

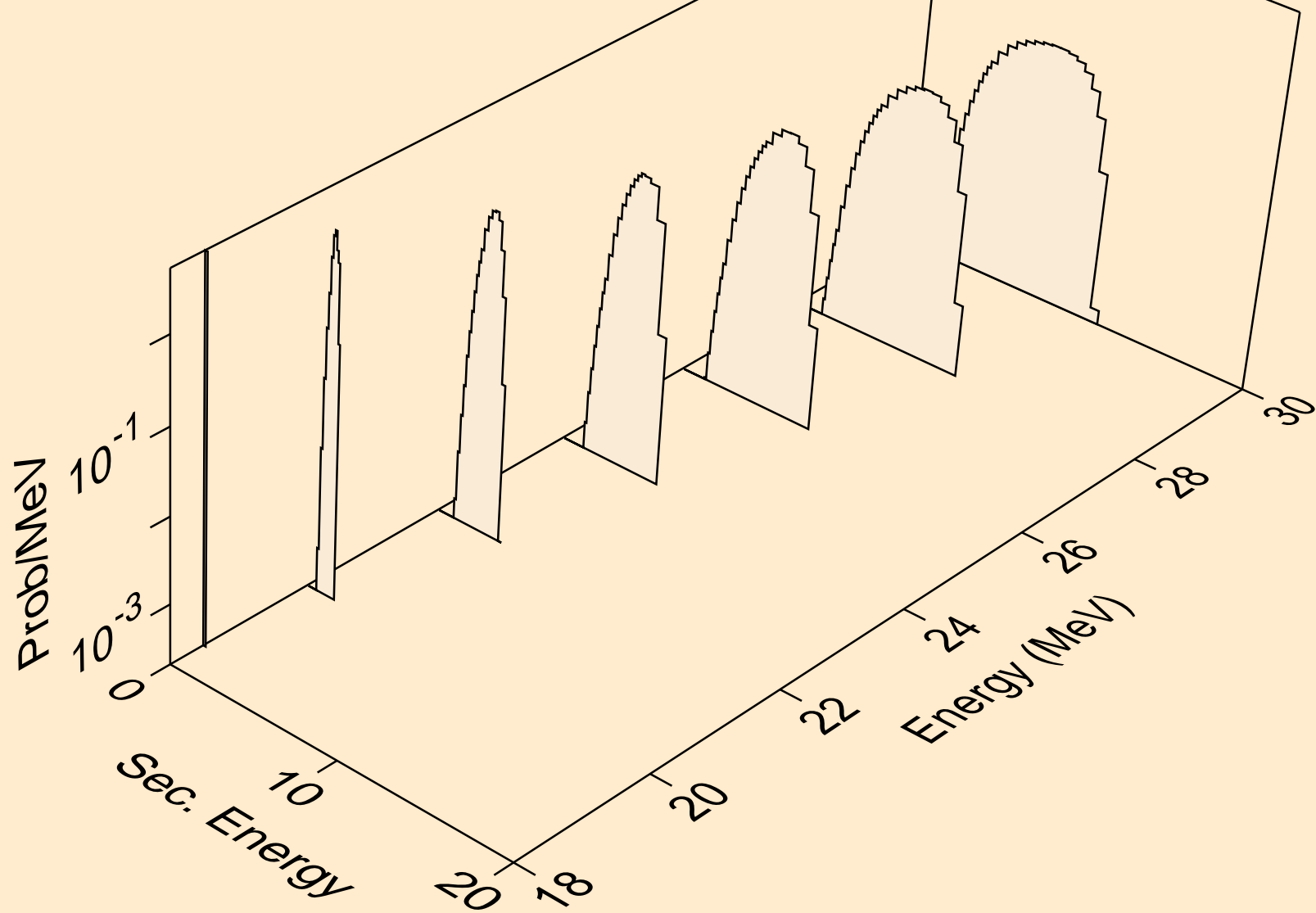

GA075 NEUTRON ACER TENDL-2023 LIBRARY; T=0.K
protons from (n,3np)

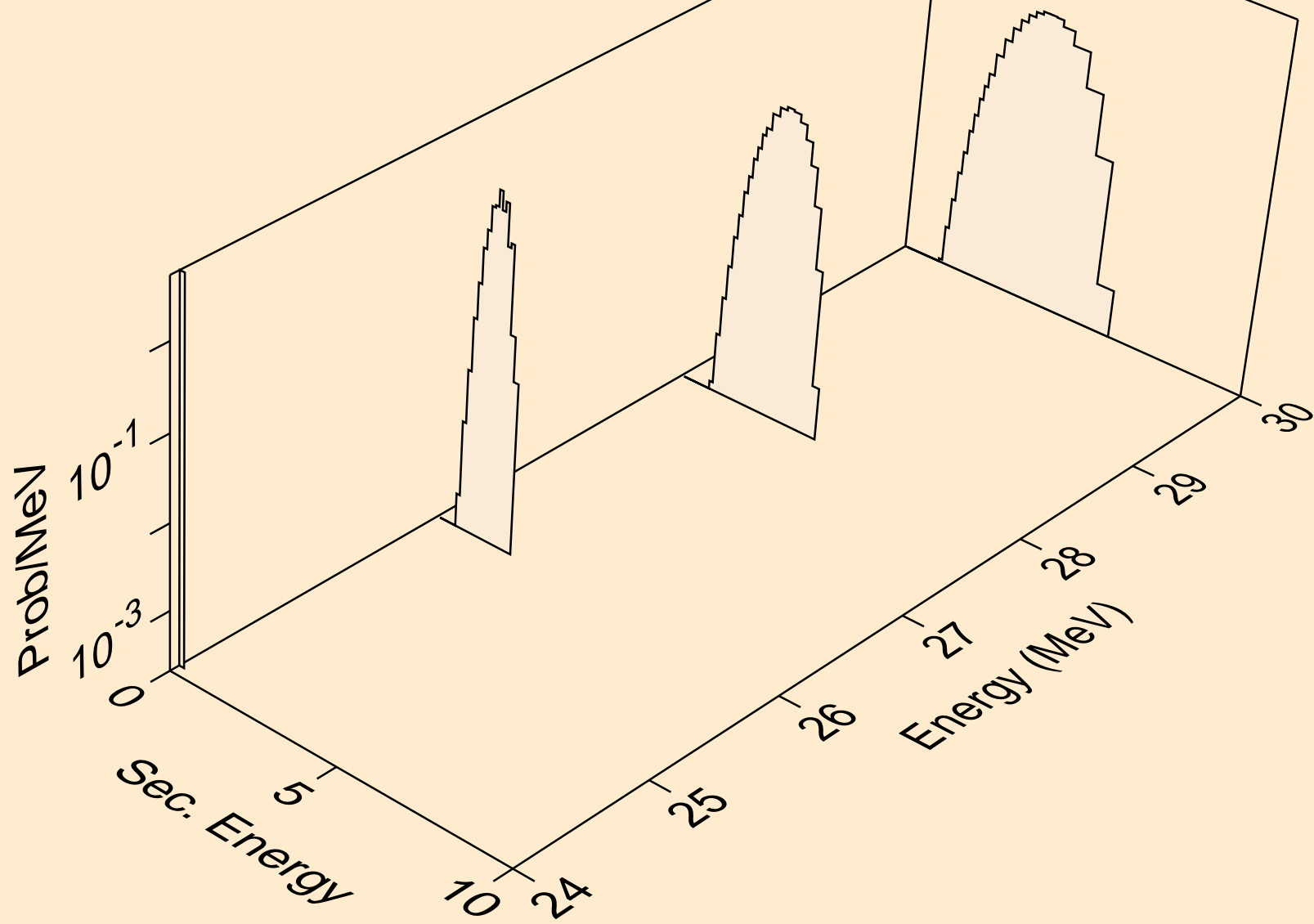

GA075 NEUTRON ACER TENDL-2023 LIBRARY; T=0.K
protons from (n,p)

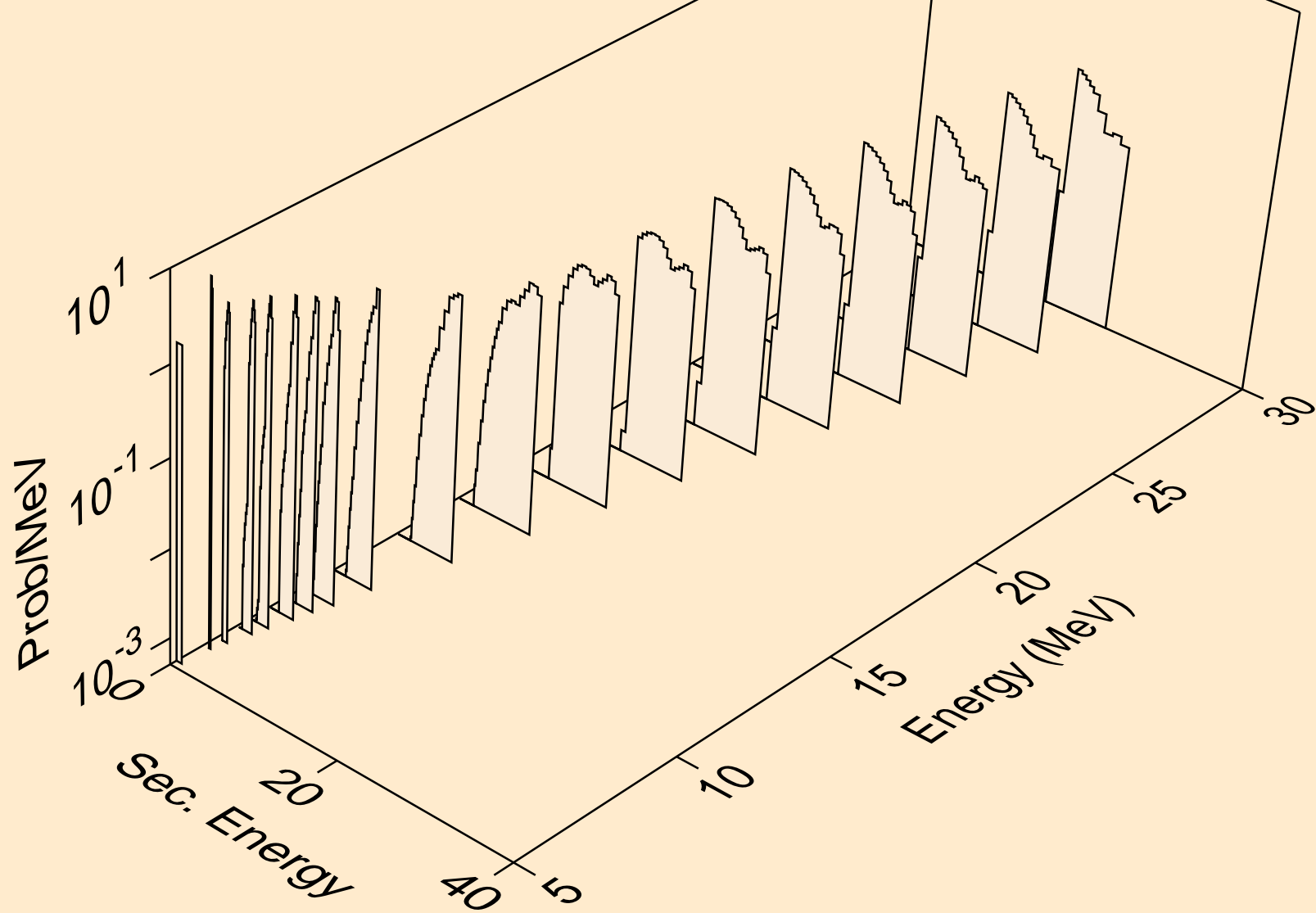

GA075 NEUTRON ACER TENDL-2023 LIBRARY; T=0.K
protons from (n,2p)

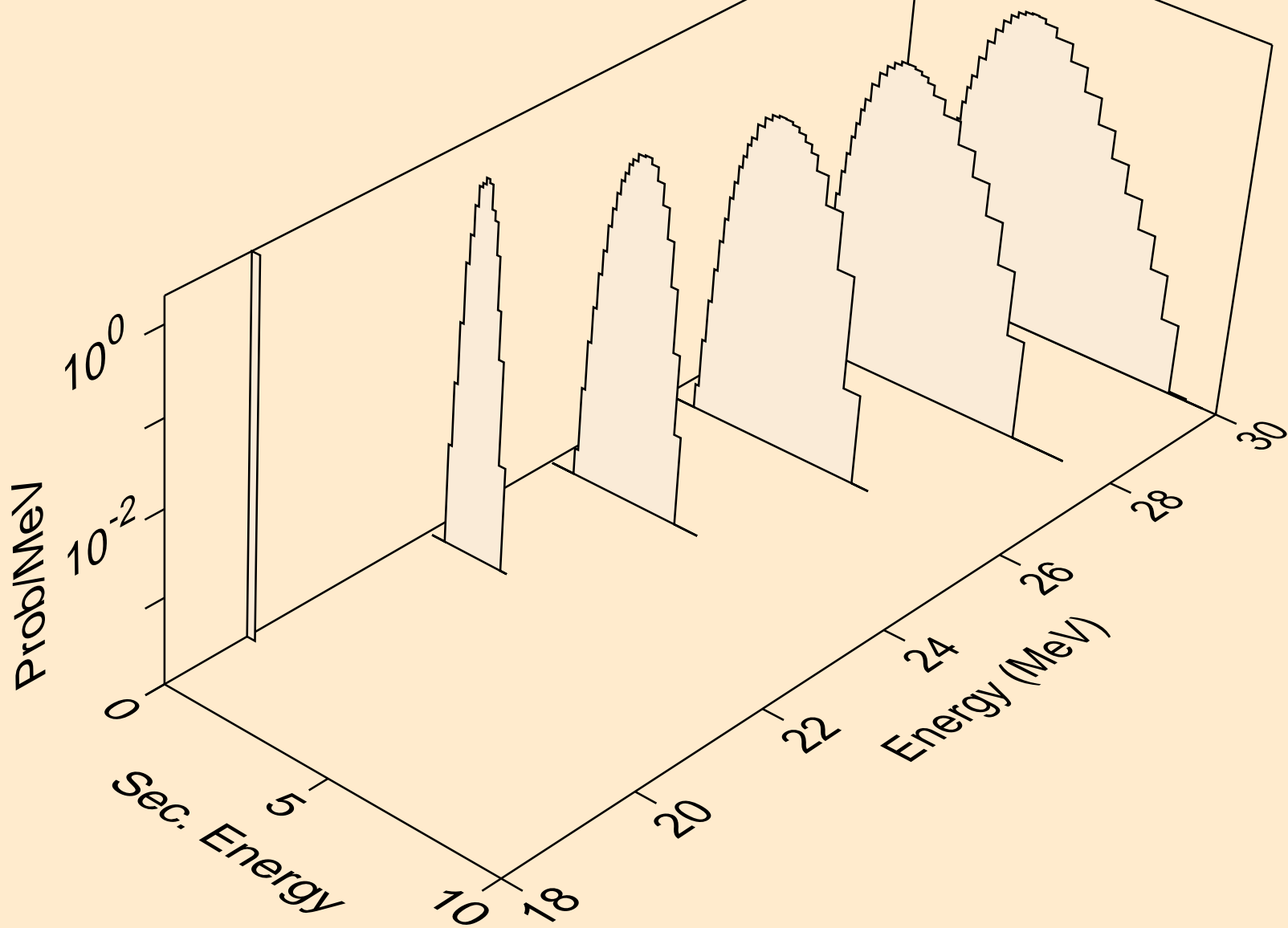

GA075 NEUTRON ACER TENDL-2023 LIBRARY; T=0.K
protons from (n,p)

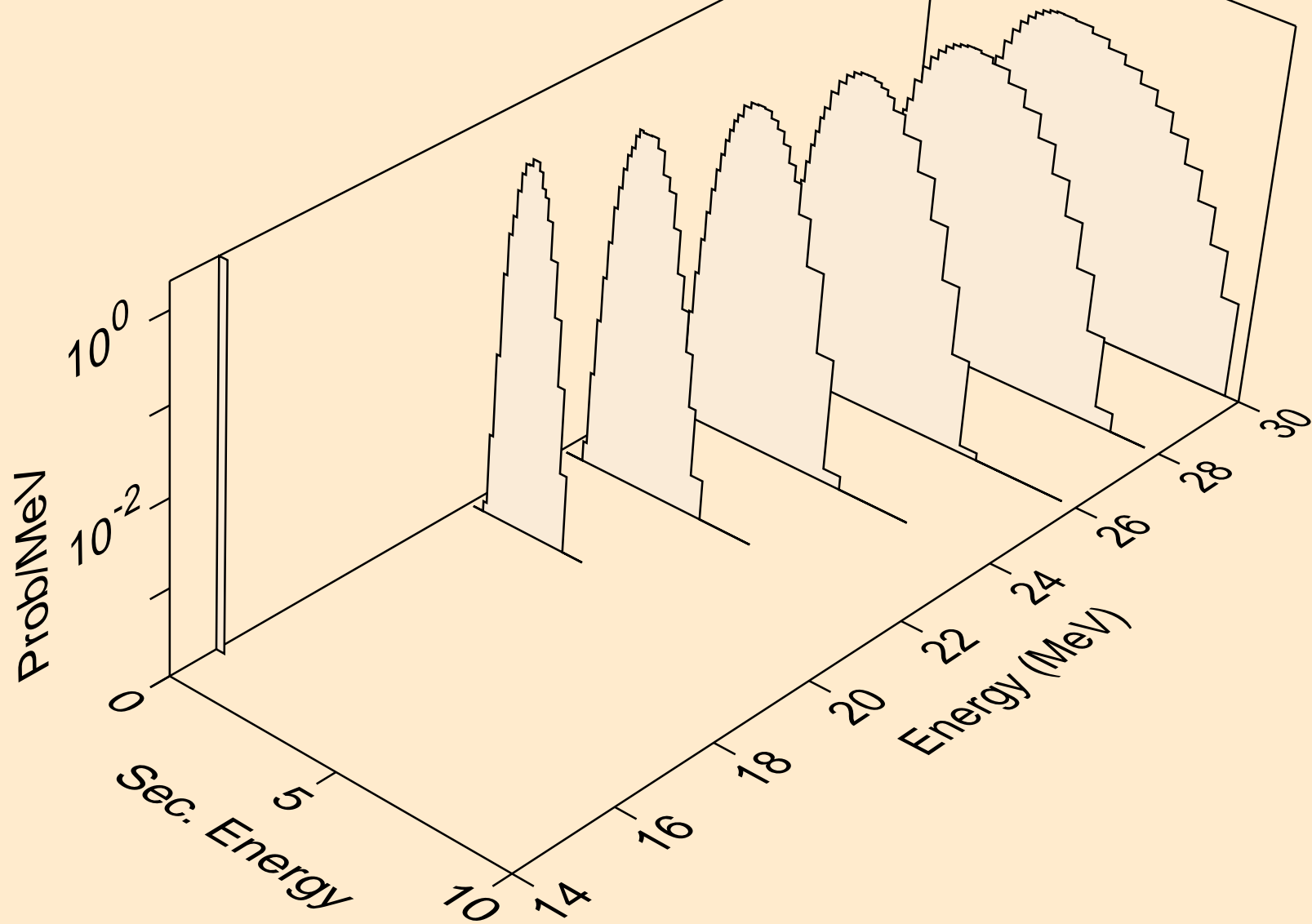

GA075 NEUTRON ACER TENDL-2023 LIBRARY; T=0.K
deuterons from (n,x)

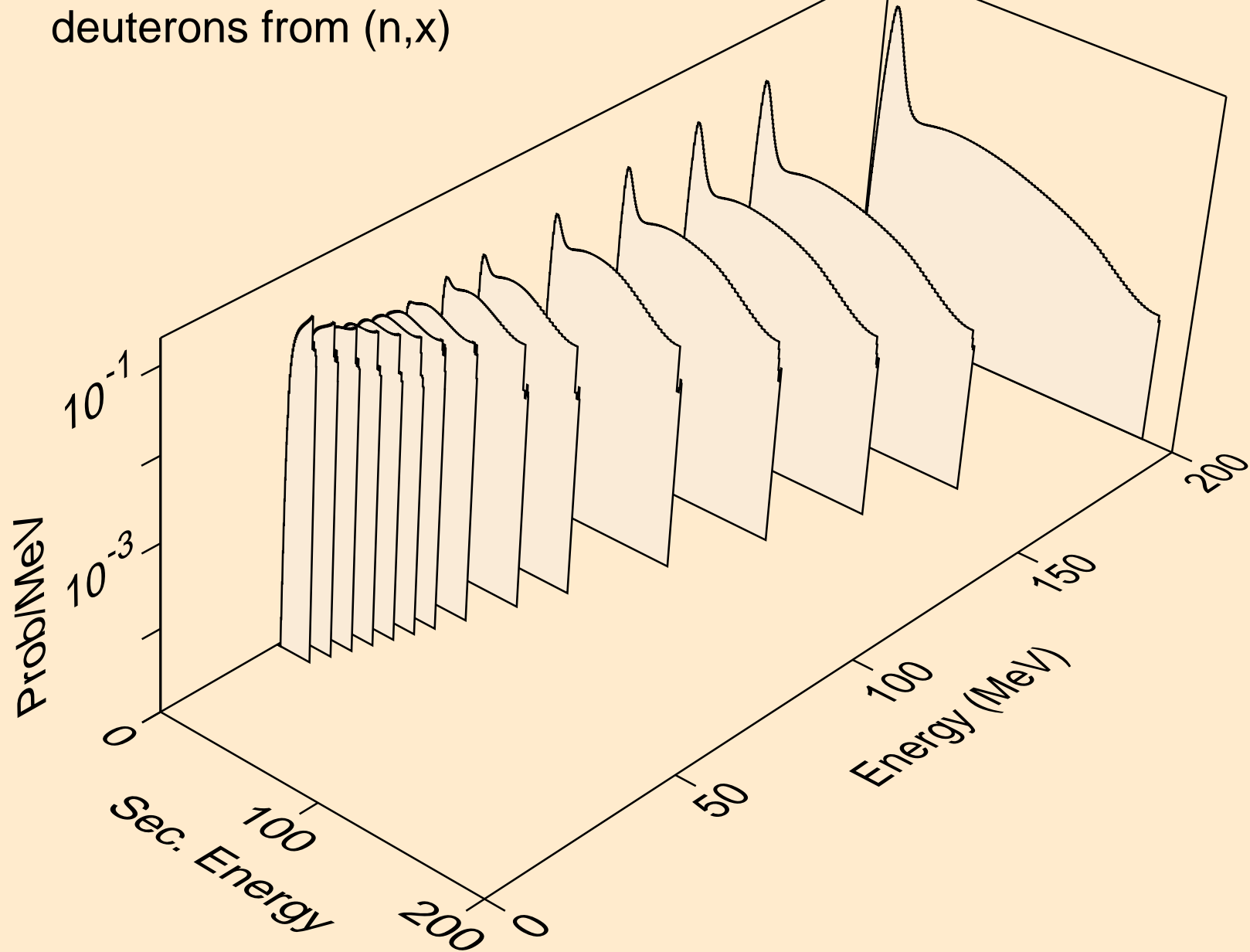

GA075 NEUTRON ACER TENDL-2023 LIBRARY; T=0.K
deuterons from (n,2nd)

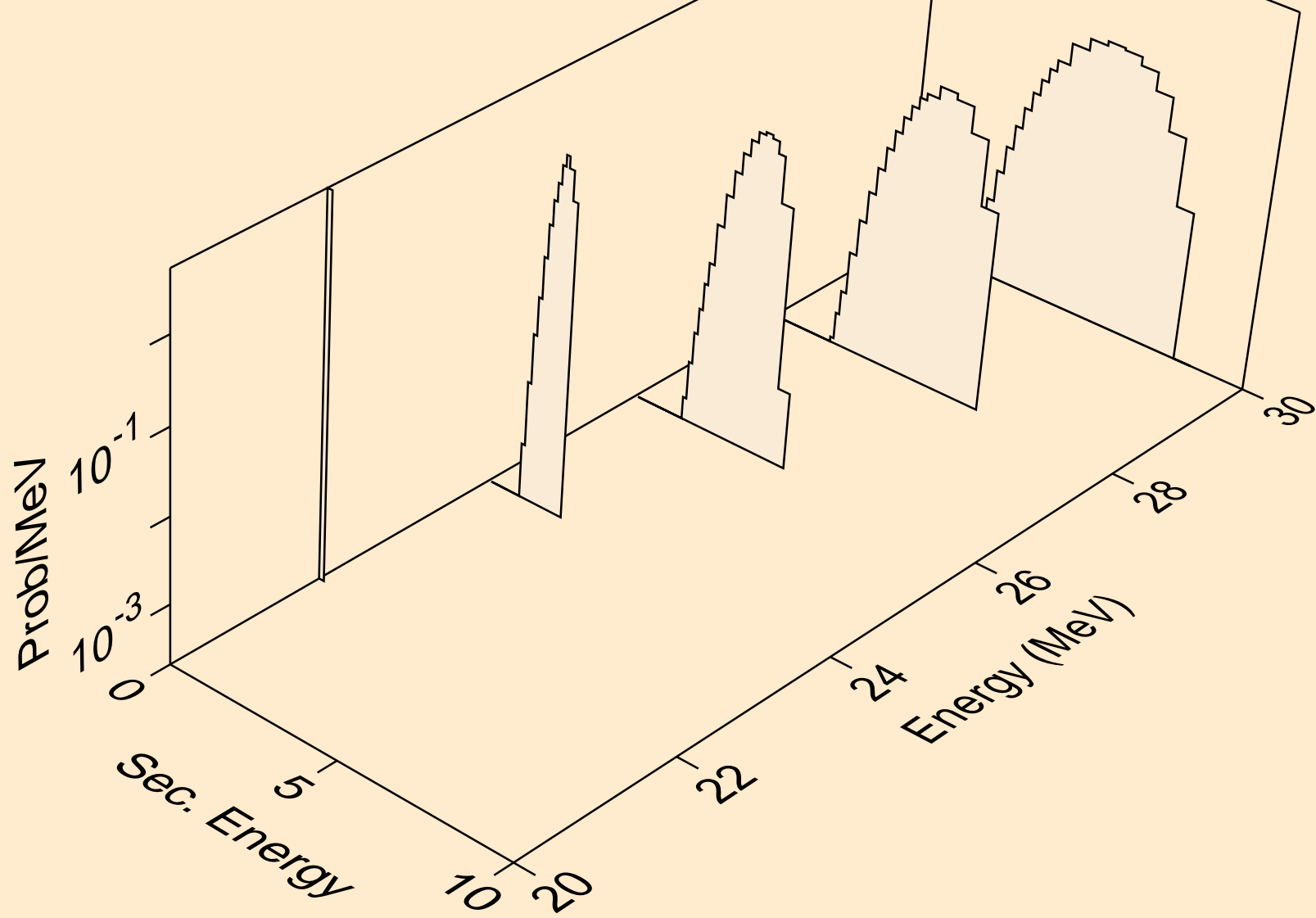

GA075 NEUTRON ACER TENDL-2023 LIBRARY; T=0.K
deuterons from (n,n*)d

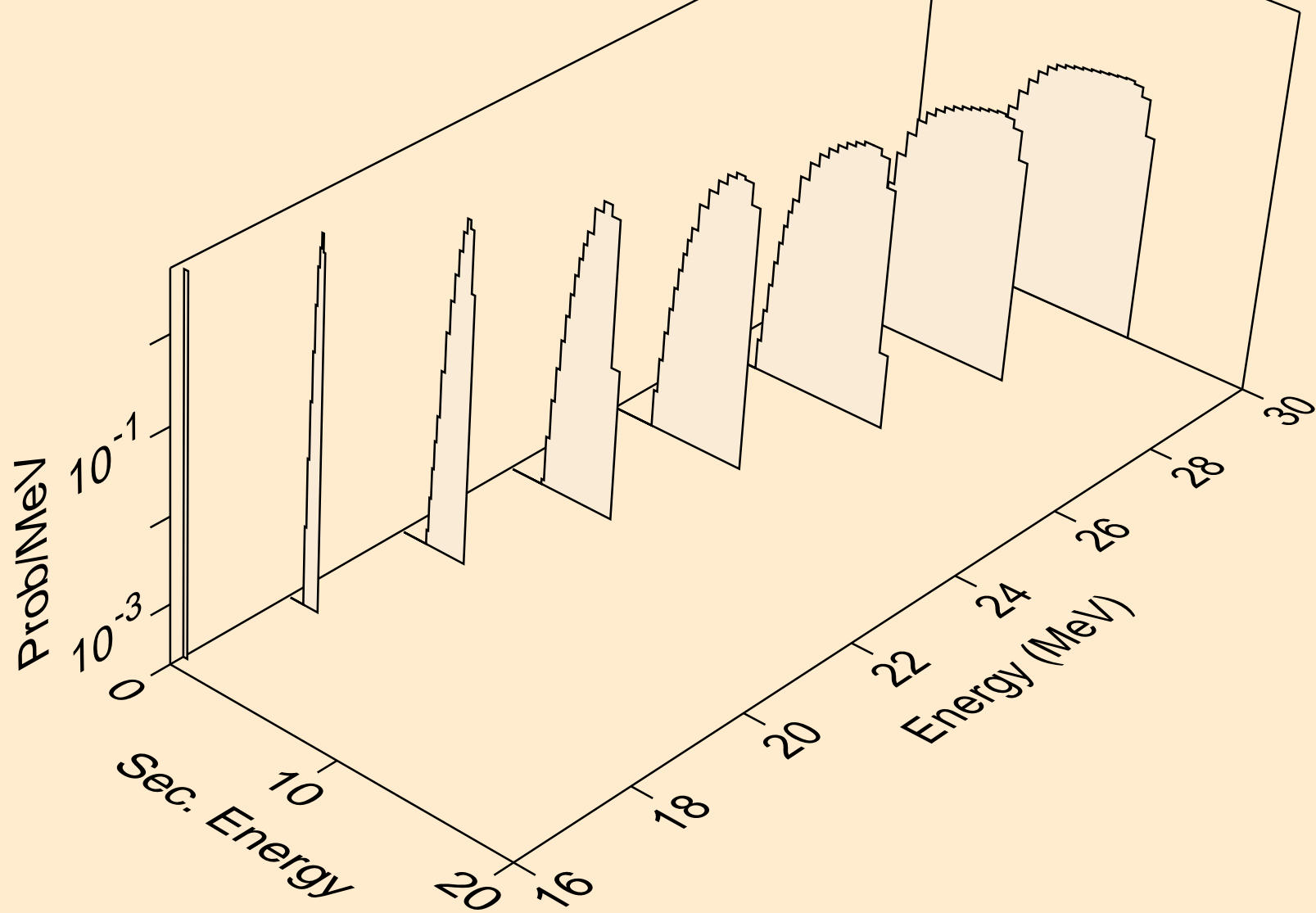

GA075 NEUTRON ACER TENDL-2023 LIBRARY; T=0.K
deuterons from (n,d)

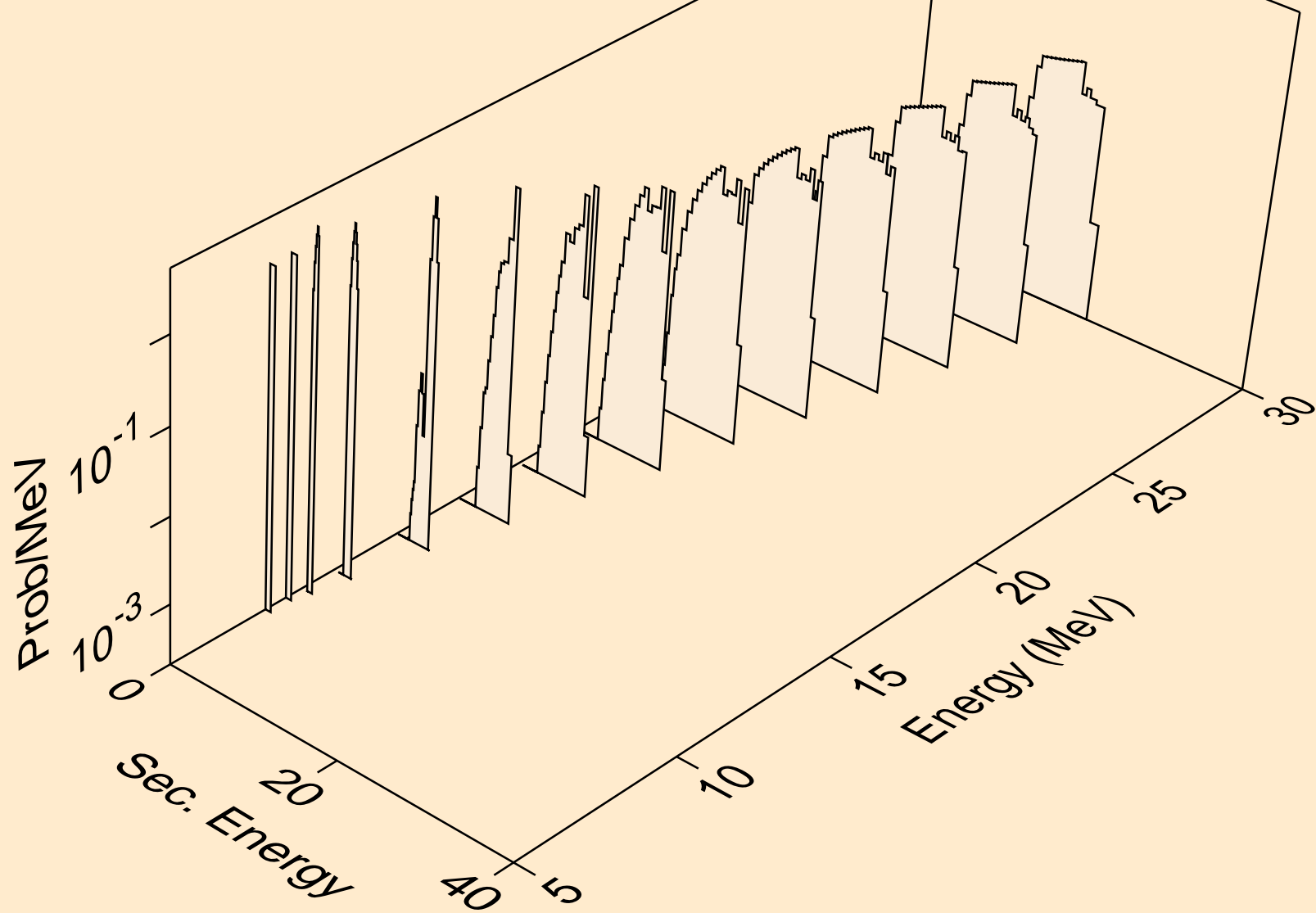

GA075 NEUTRON ACER TENDL-2023 LIBRARY; T=0.K
tritons from (n,x)

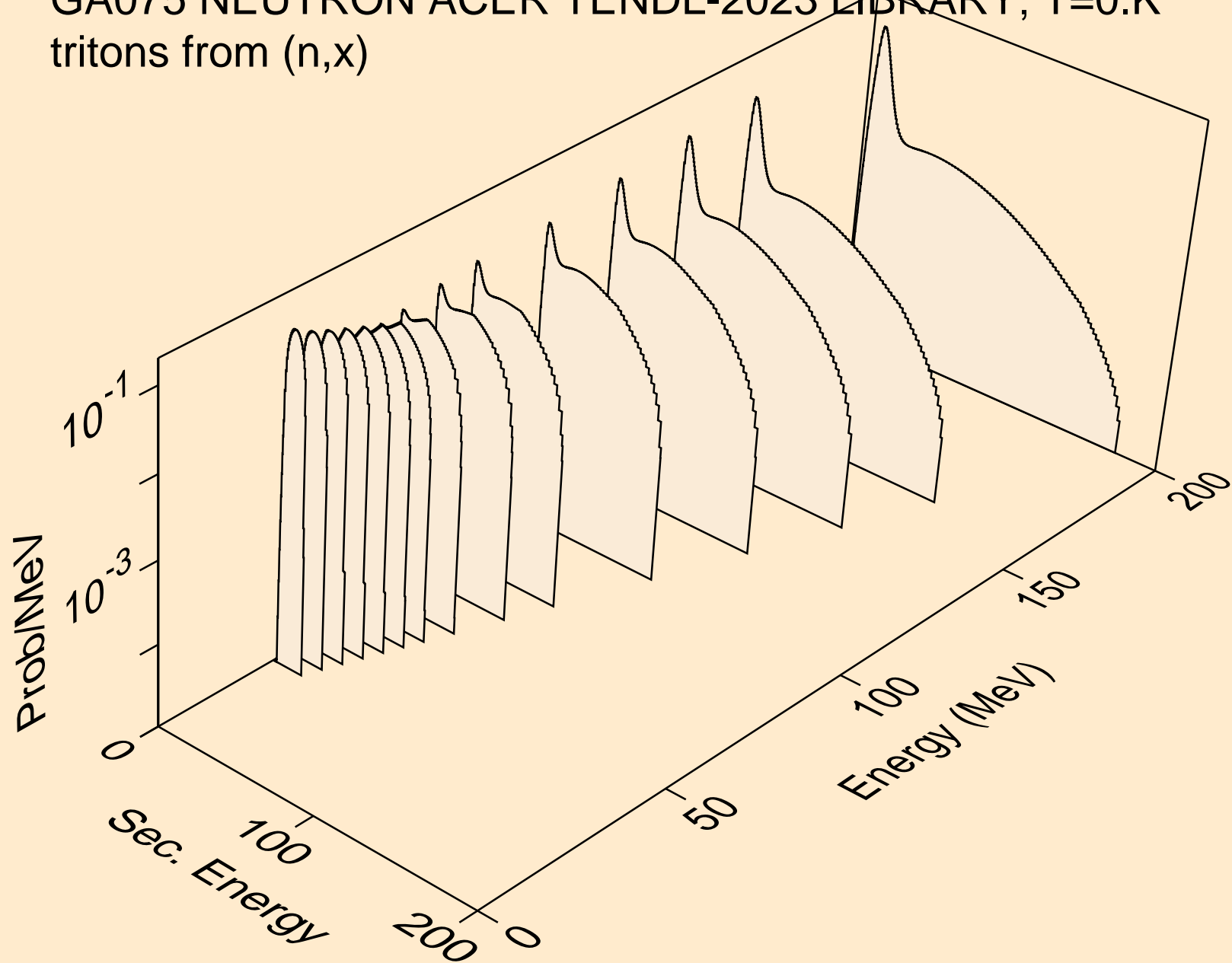

GA075 NEUTRON ACER TENDL-2023 LIBRARY; T=0.K
tritons from (n,n*)t

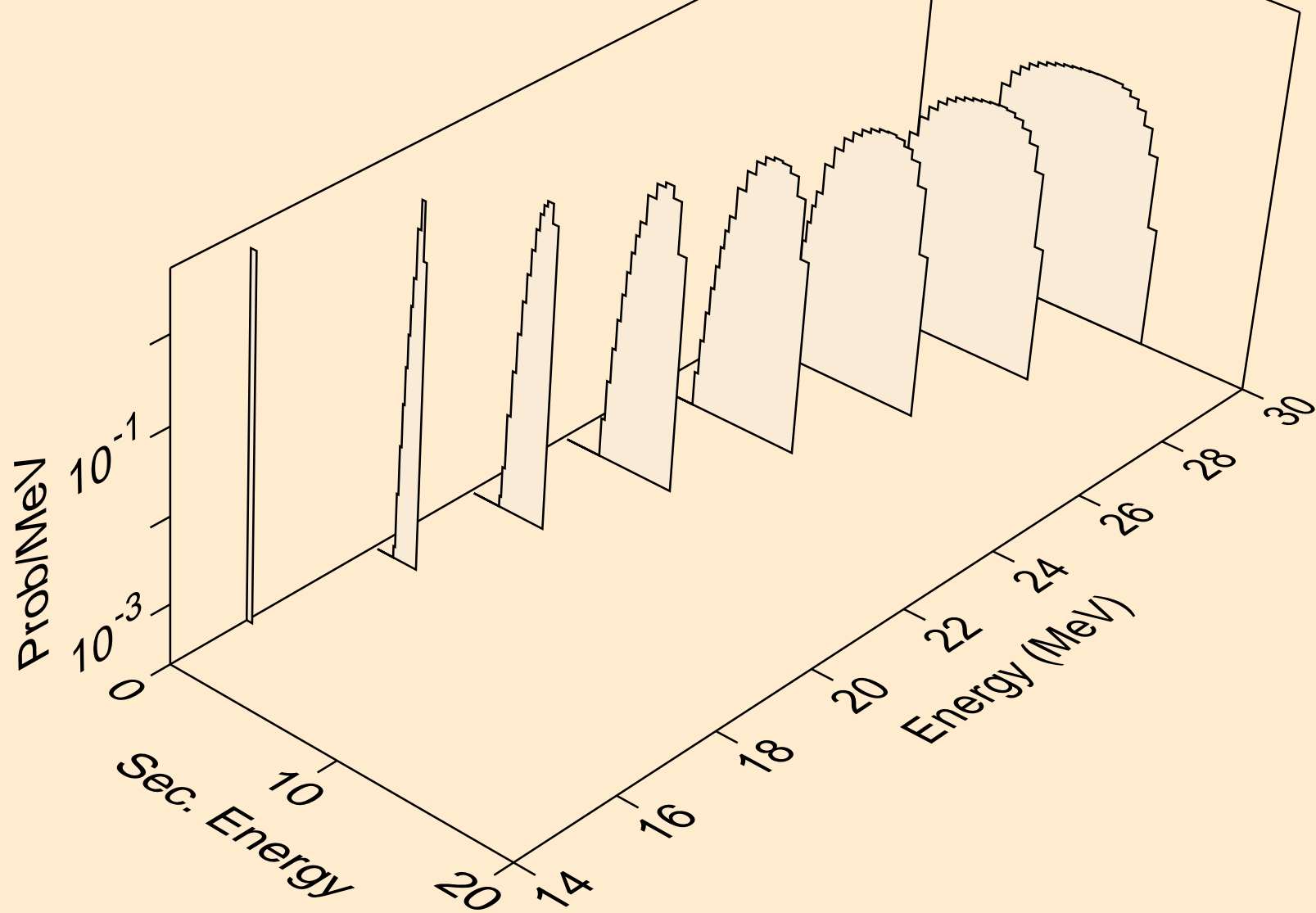

GA075 NEUTRON ACER TENDL-2023 LIBRARY; T=0.K
tritons from (n,t)

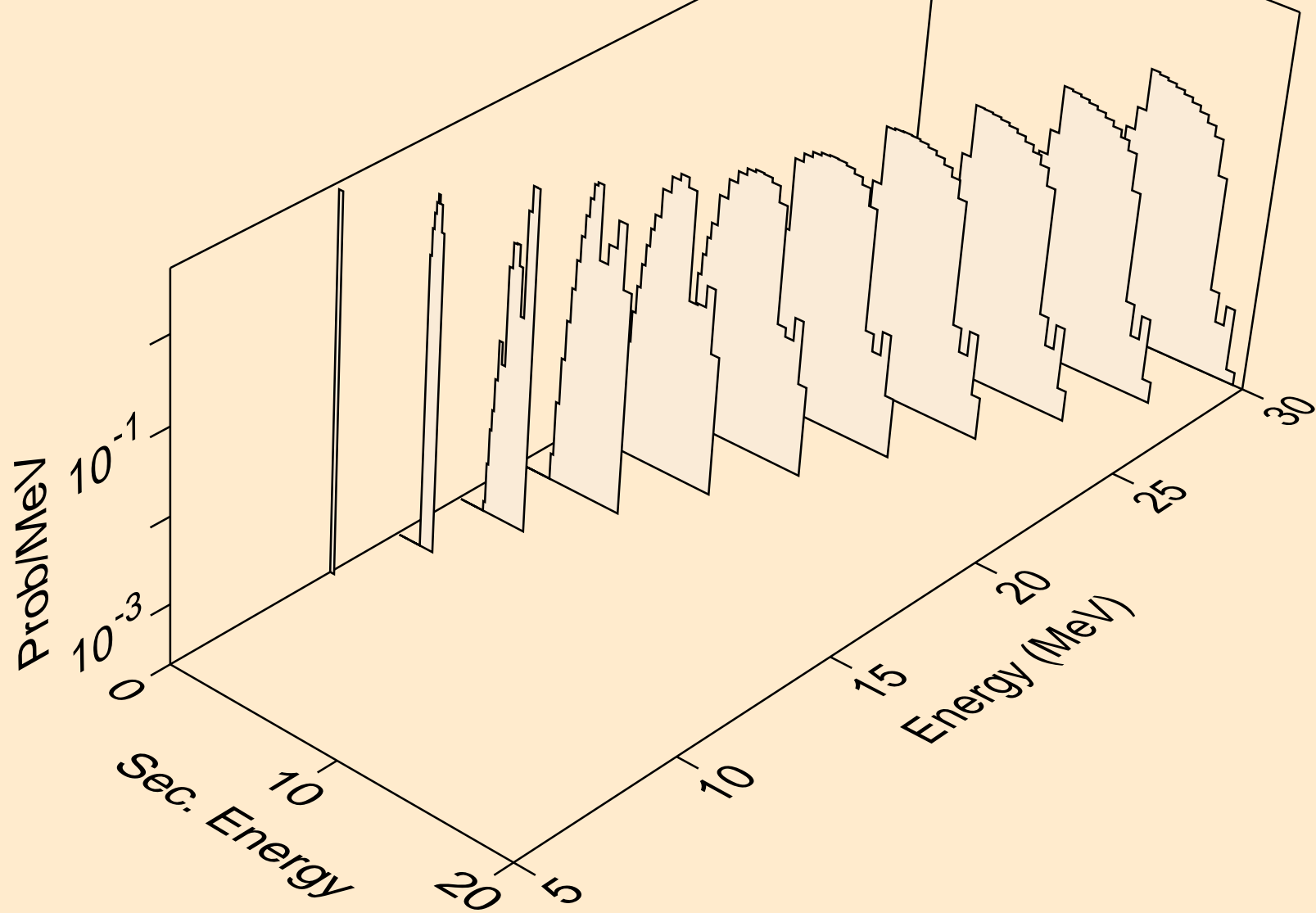

GA075 NEUTRON ACER TENDL-2023 LIBRARY; T=0.K
he3s from (n,x)

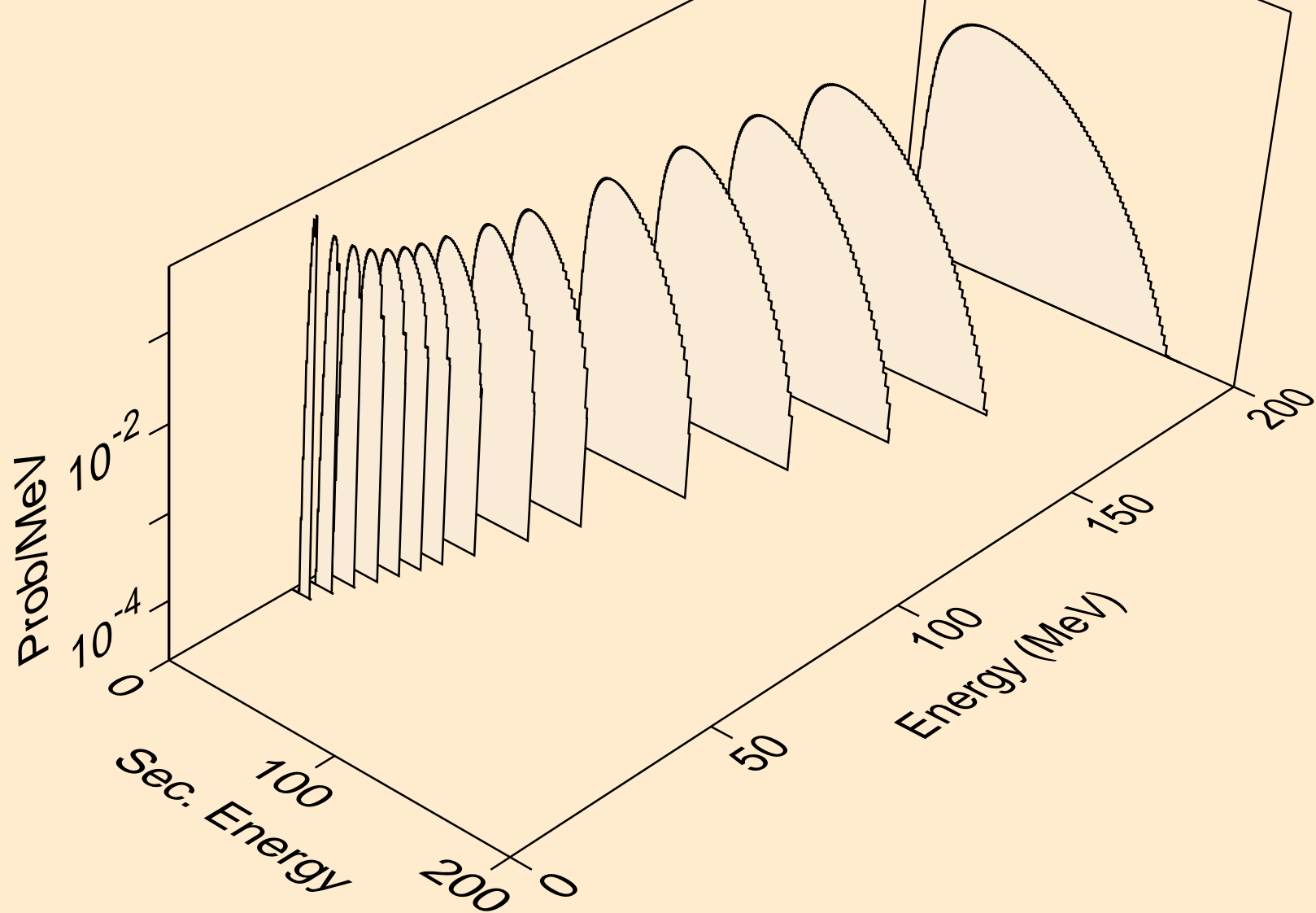

GA075 NEUTRON ACER TENDL-2023 LIBRARY; T=0.K
he3s from (n,n*)he3

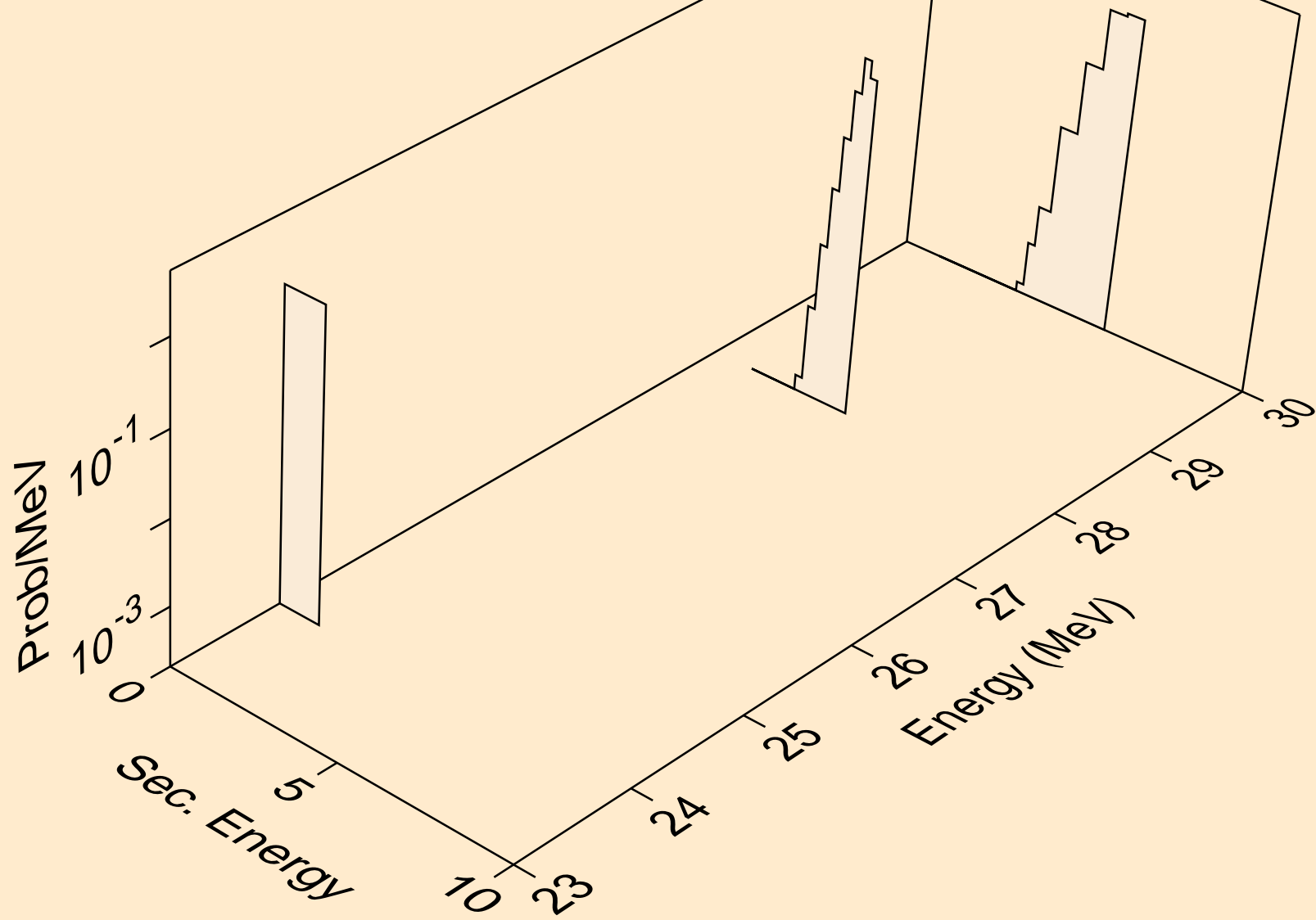

GA075 NEUTRON ACER TENDL-2023 LIBRARY; T=0.K
he3s from (n,he3)

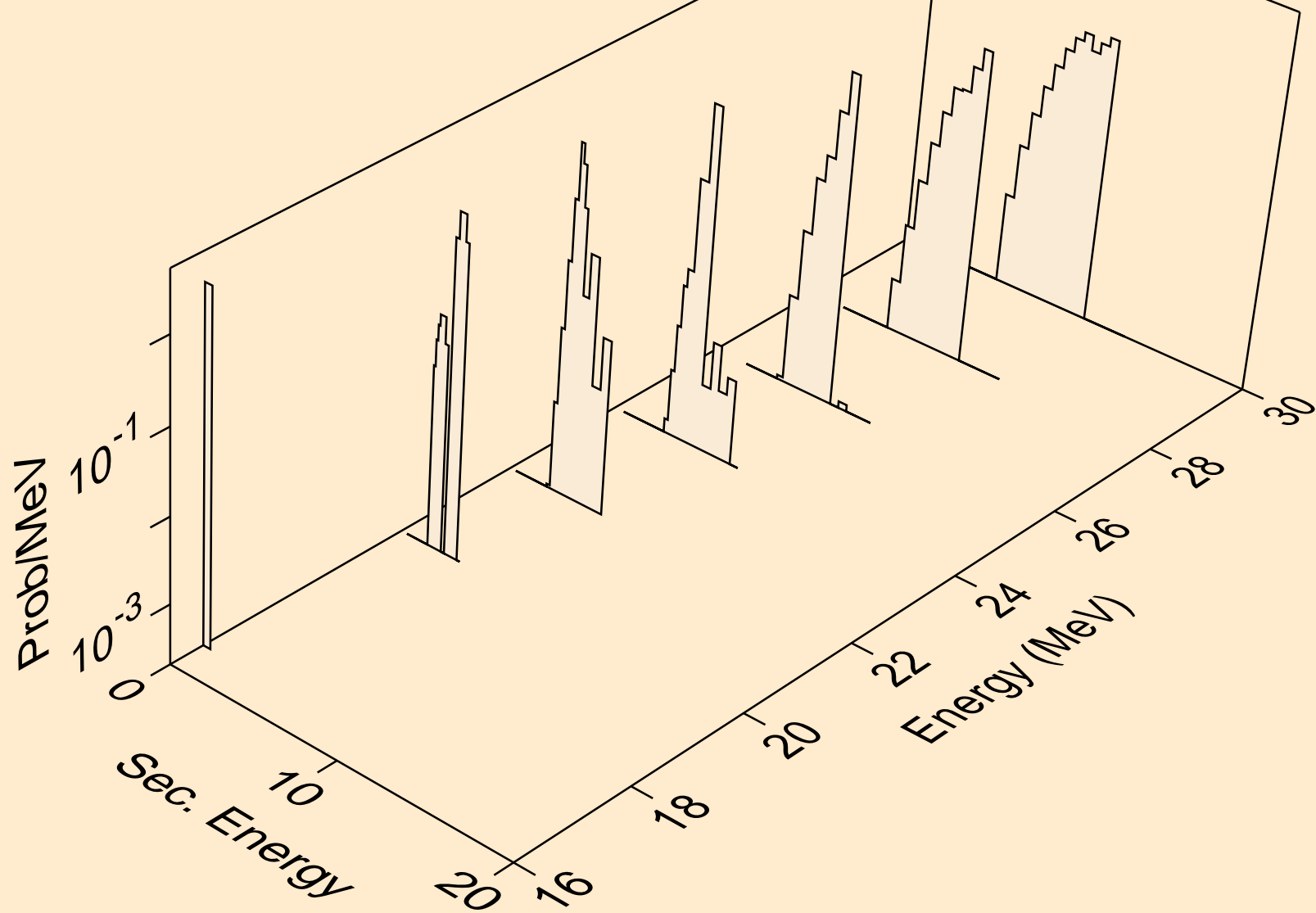

GA075 NEUTRON ACER TENDL-2023 LIBRARY; T=0.K
alphas from (n,x)

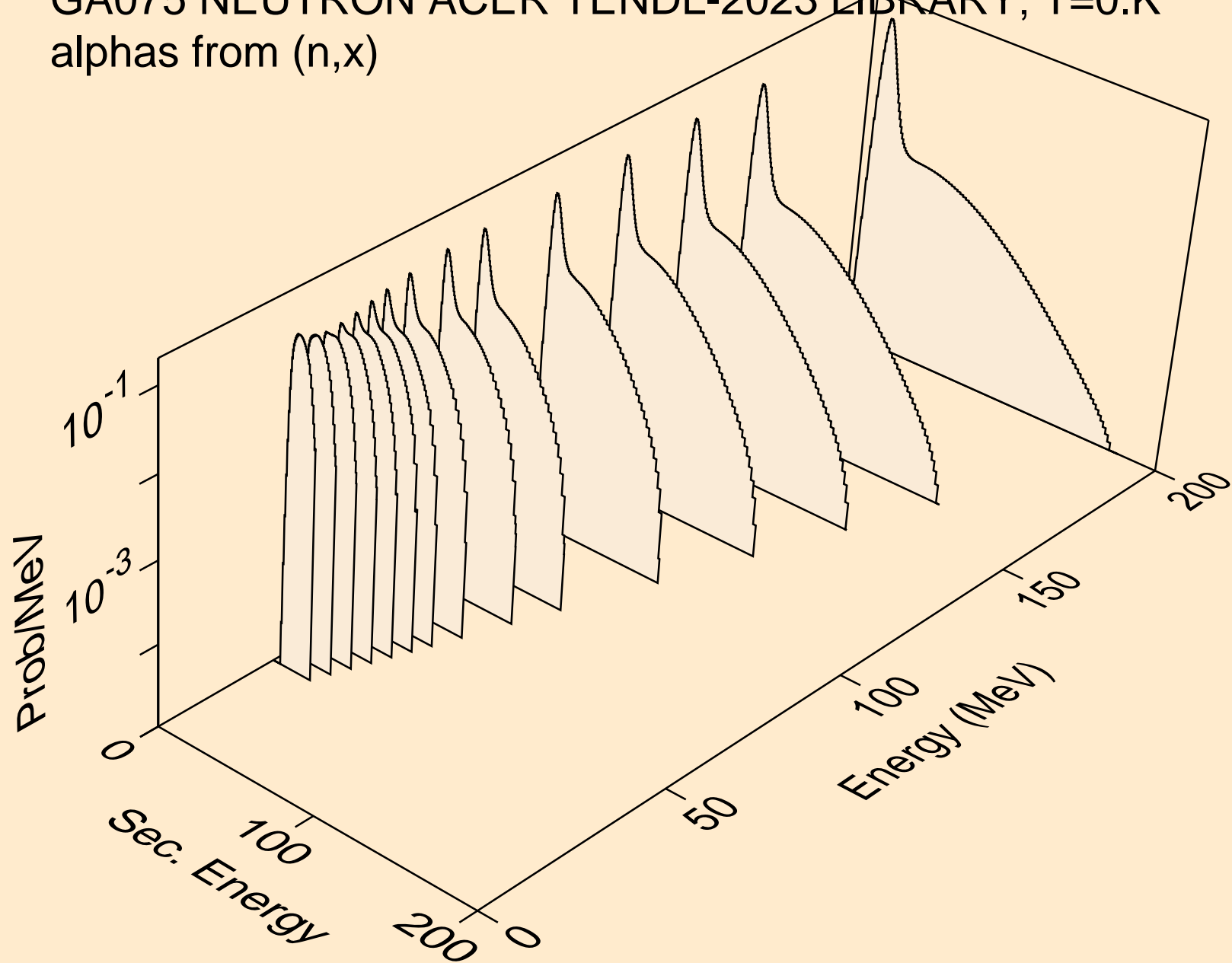

GA075 NEUTRON ACER TENDL-2023 LIBRARY; T=0.K
alphas from (n,n*)a

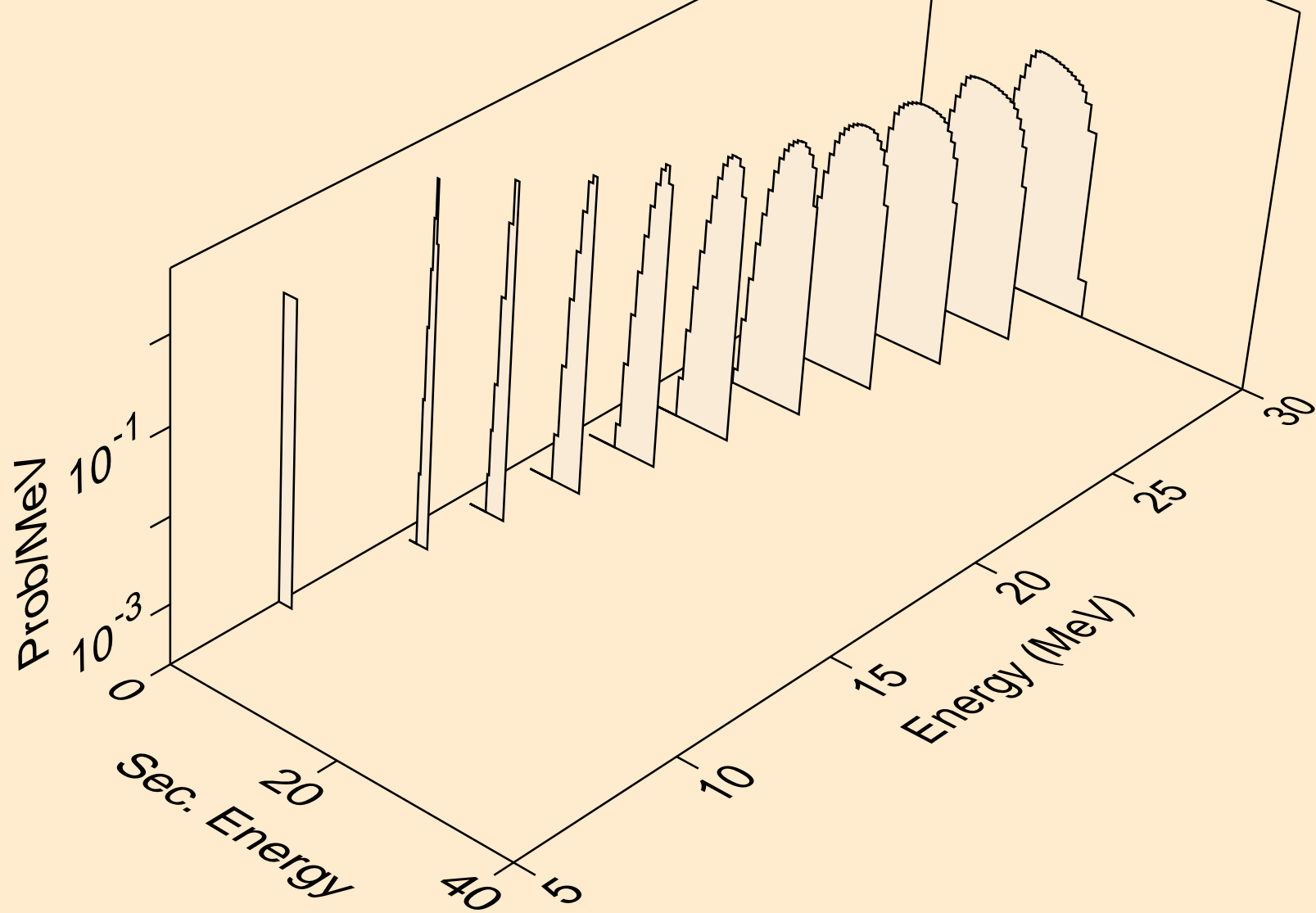

GA075 NEUTRON ACER TENDL-2023 LIBRARY; T=0.K
alphas from (n,2n)a

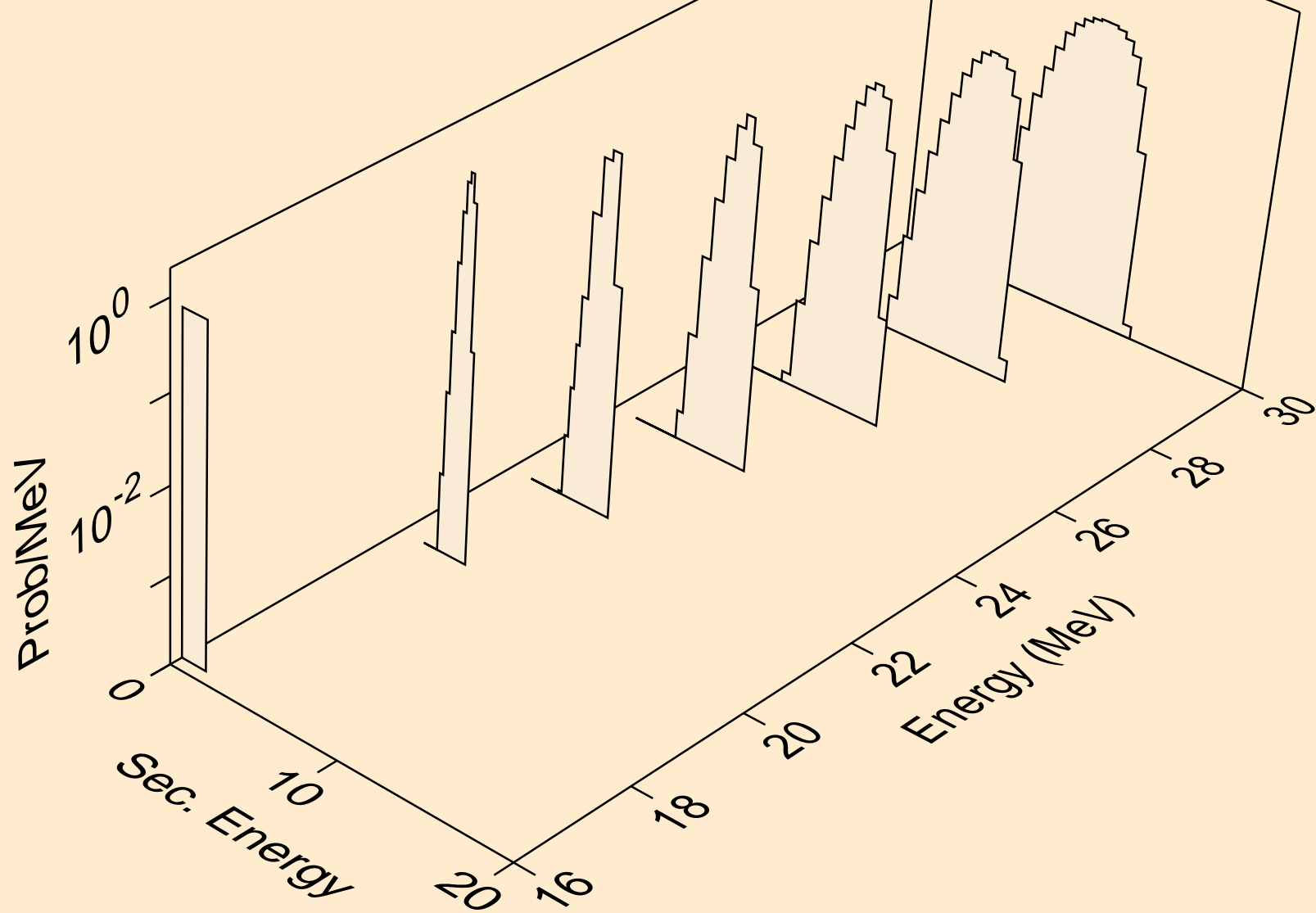

GA075 NEUTRON ACER TENDL-2023 LIBRARY; T=0.K
alphas from (n,3n)a

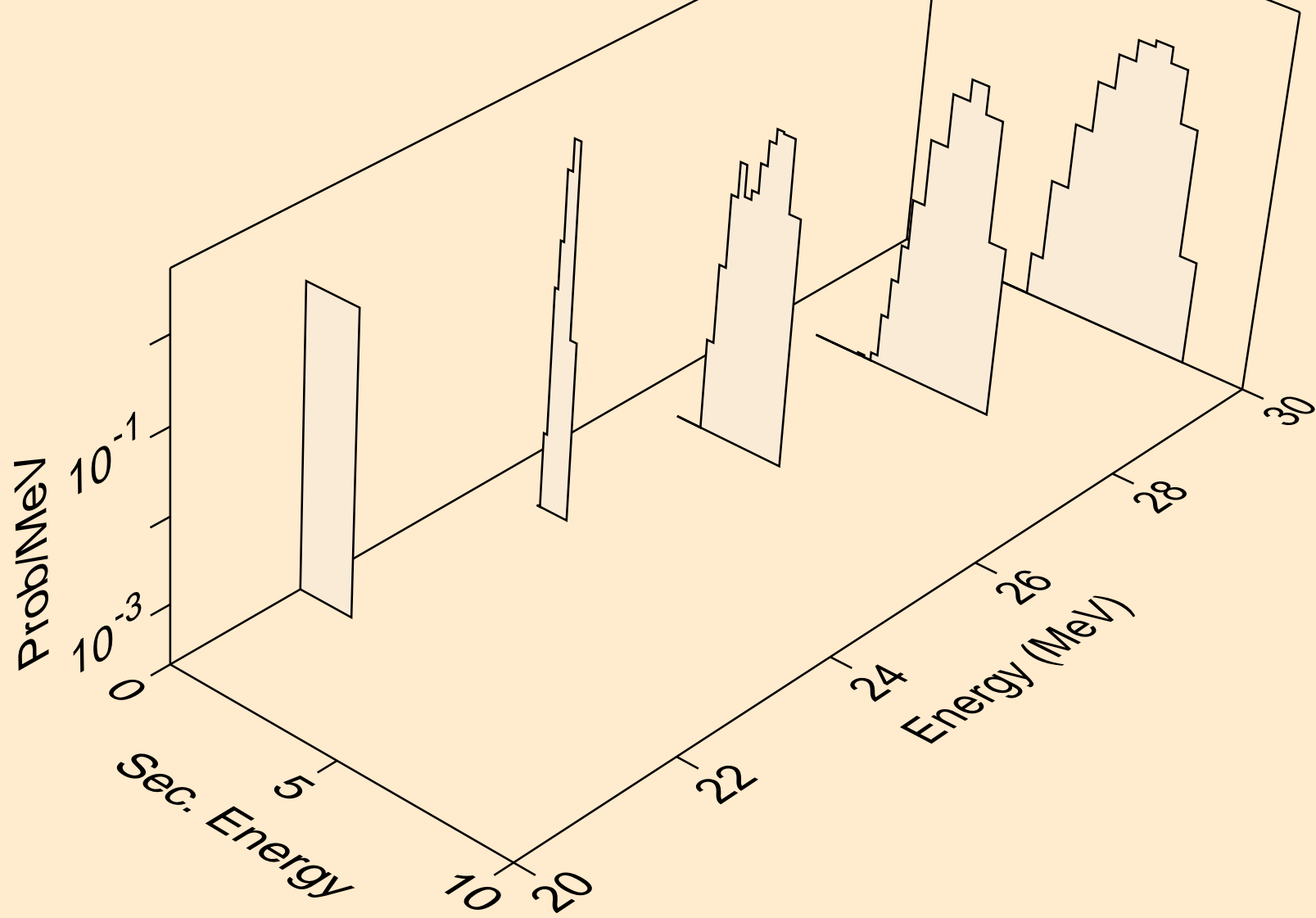

GA075 NEUTRON ACER TENDL-2023 LIBRARY; T=0.K
alphas from (n,a)

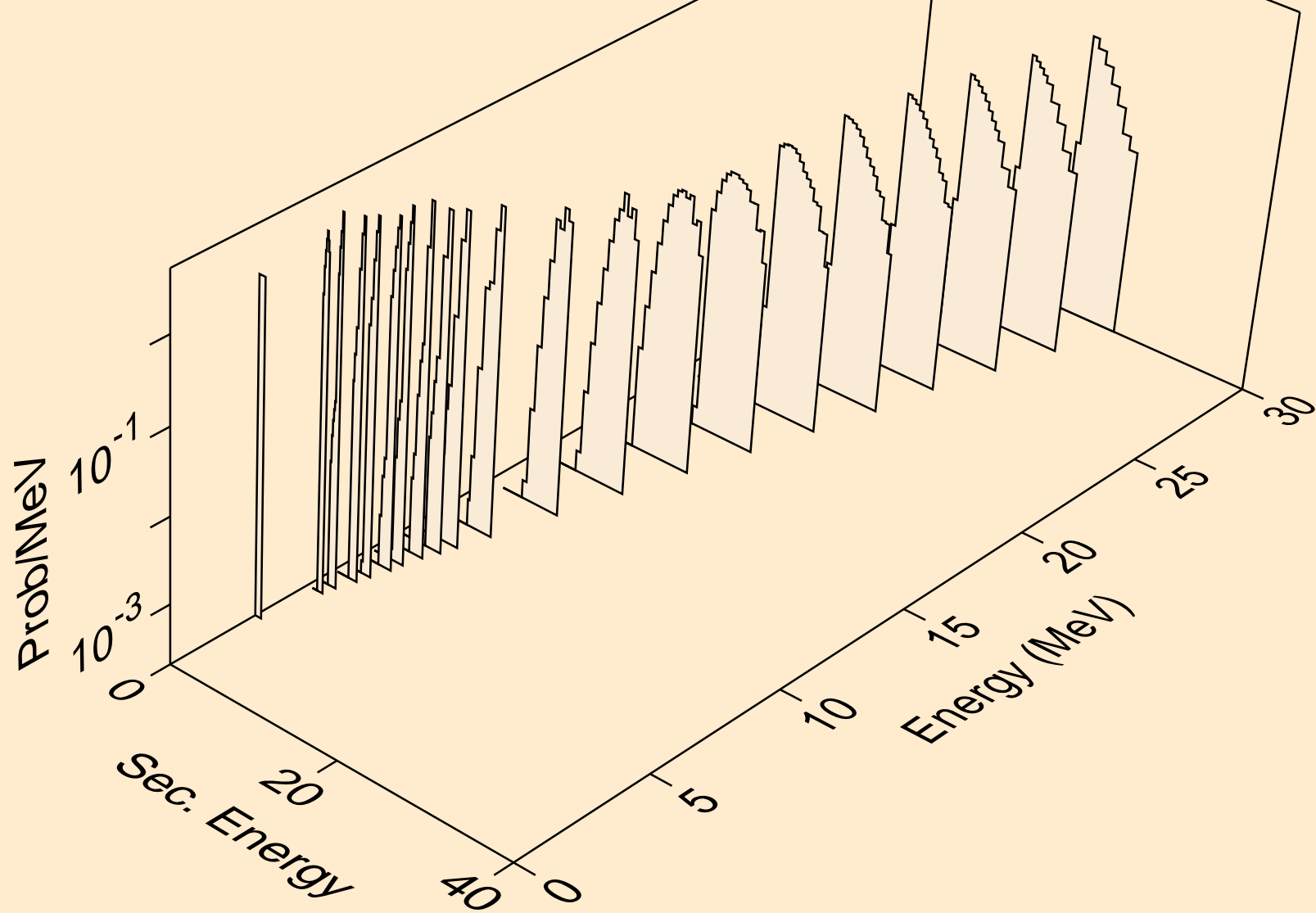

GA075 NEUTRON ACER TENDL-2023 LIBRARY; T=0.K
alphas from (n,pa)

