

# GD137 NEUTRON ACER TENDL-2023 LIBRARY; T=0.K

## Principal cross sections

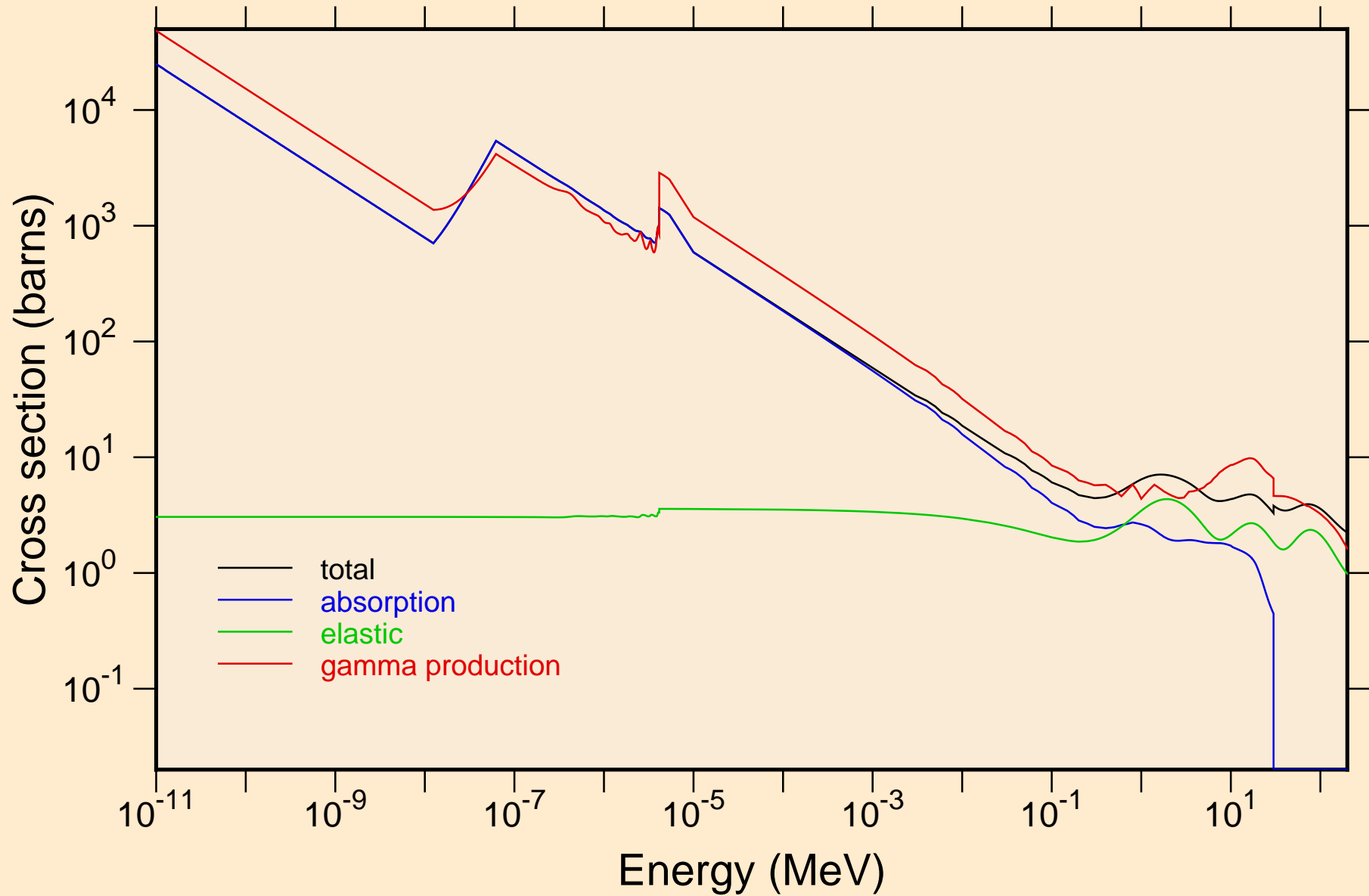

# GD137 NEUTRON ACER TENDL-2023 LIBRARY; T=0.K

## Heating

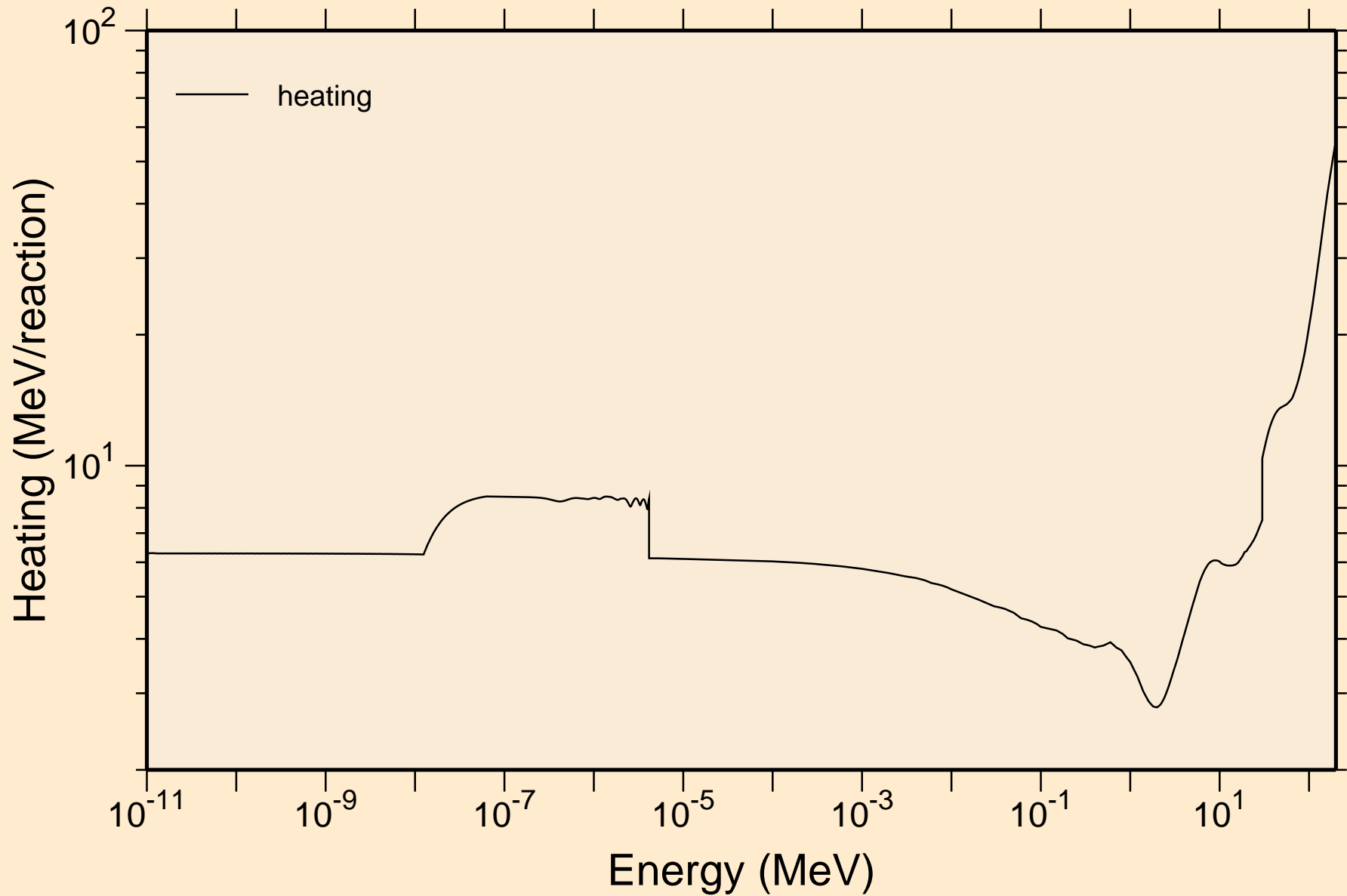

# GD137 NEUTRON ACER TENDL-2023 LIBRARY; T=0.K

## Damage

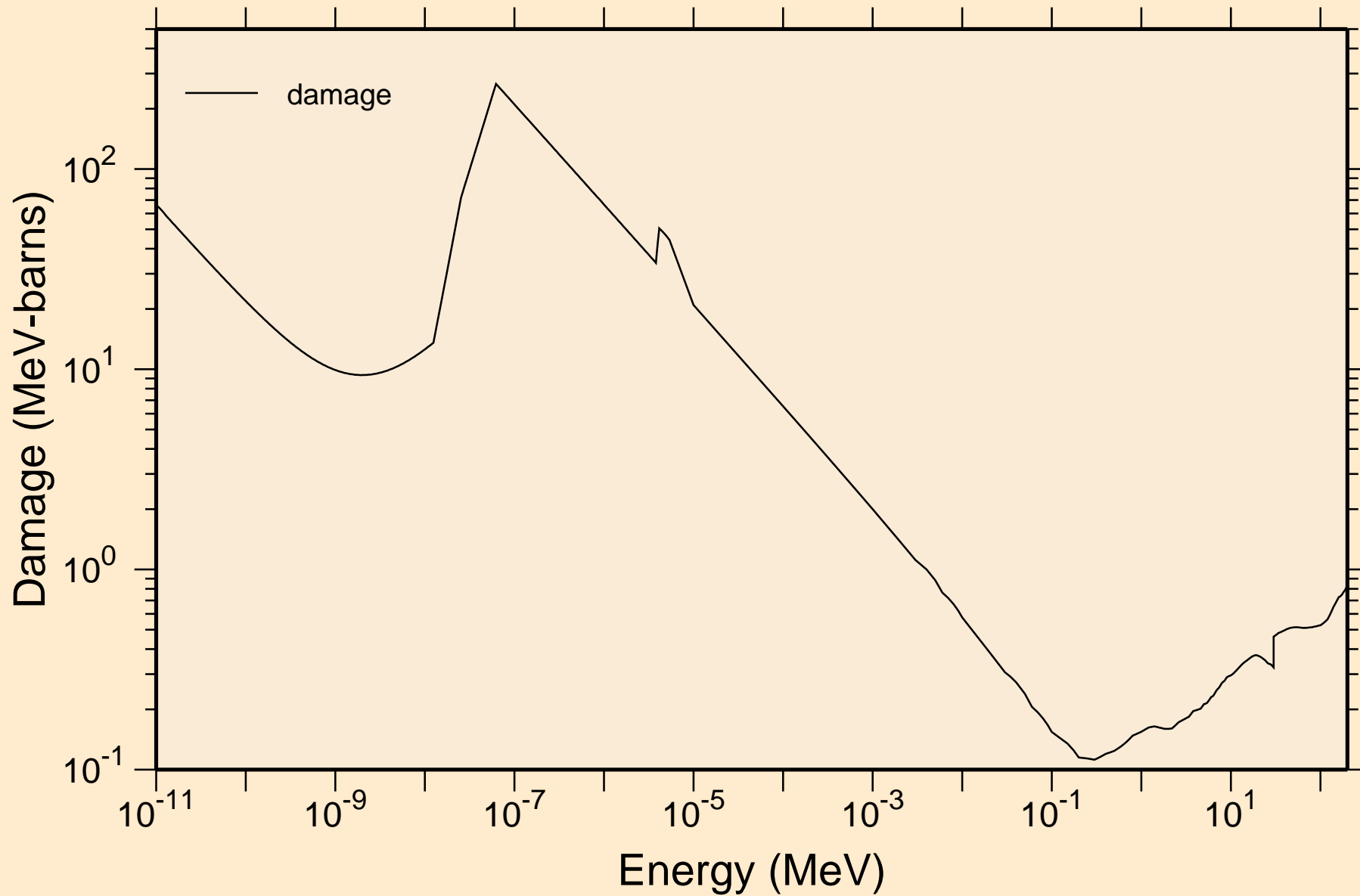

# GD137 NEUTRON ACER TENDL-2023 LIBRARY; T=0.K

## Non-threshold reactions

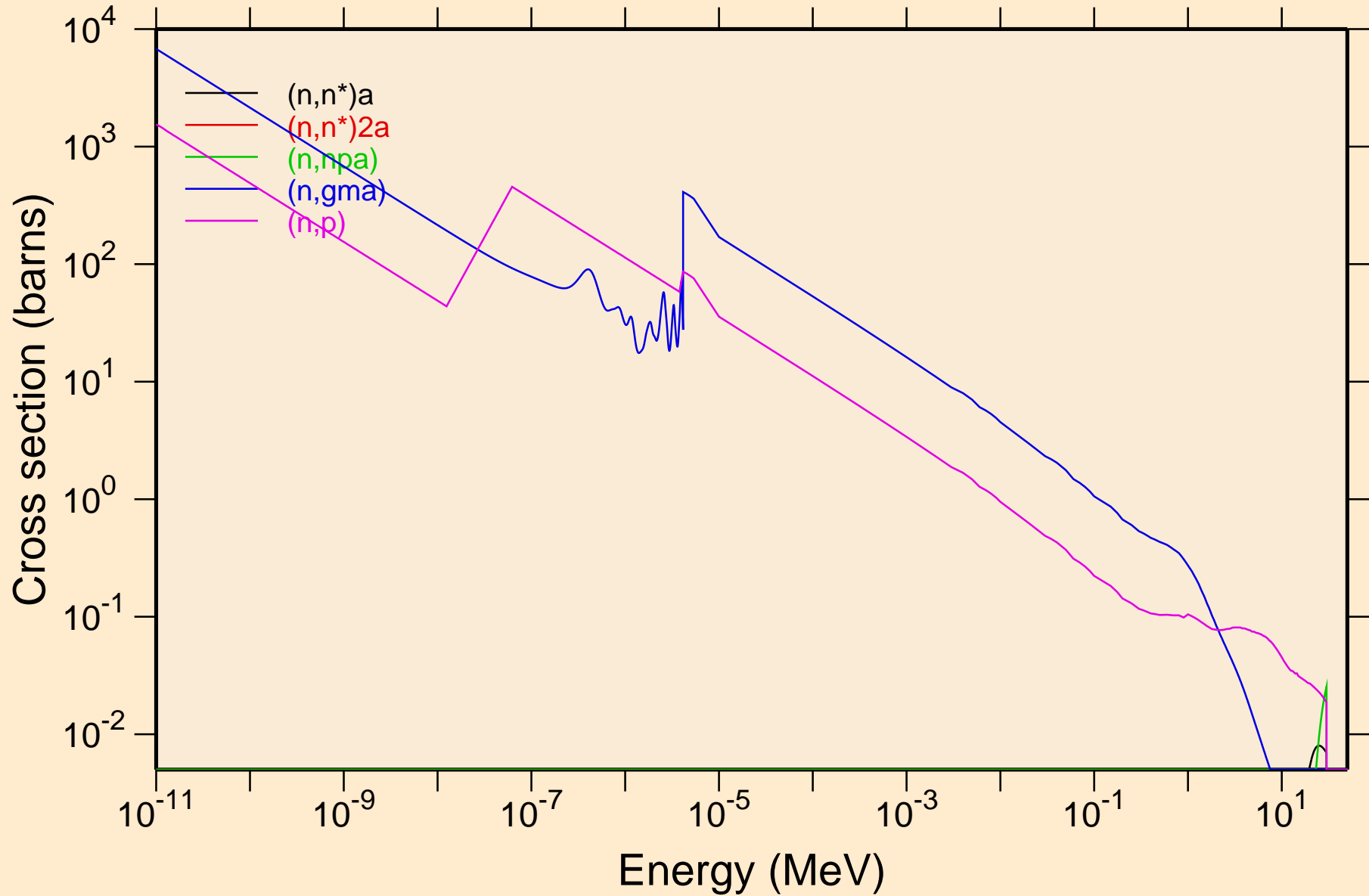

# GD137 NEUTRON ACER TENDL-2023 LIBRARY; T=0.K

## Non-threshold reactions

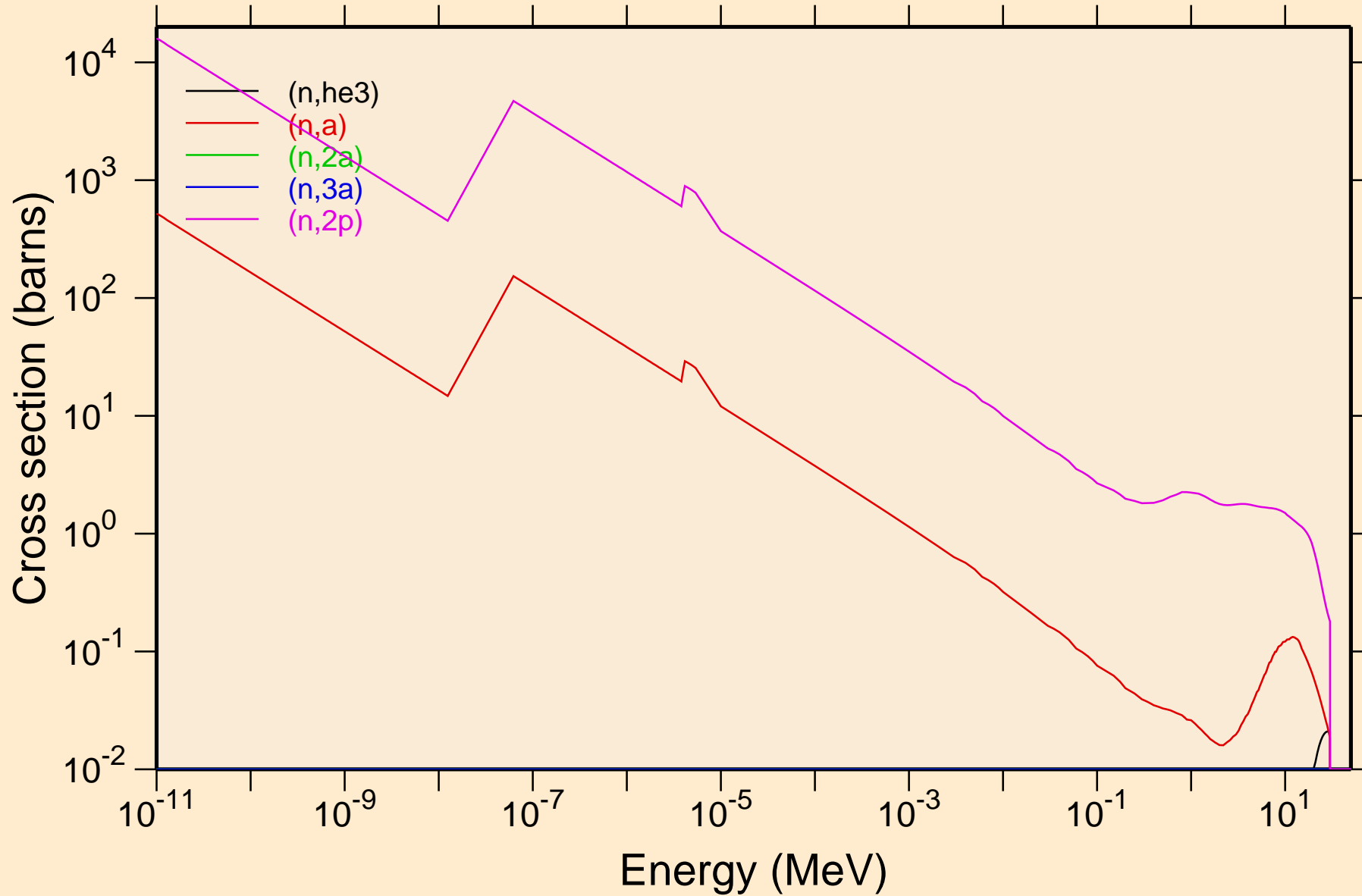

# GD137 NEUTRON ACER TENDL-2023 LIBRARY; T=0.K

## Non-threshold reactions

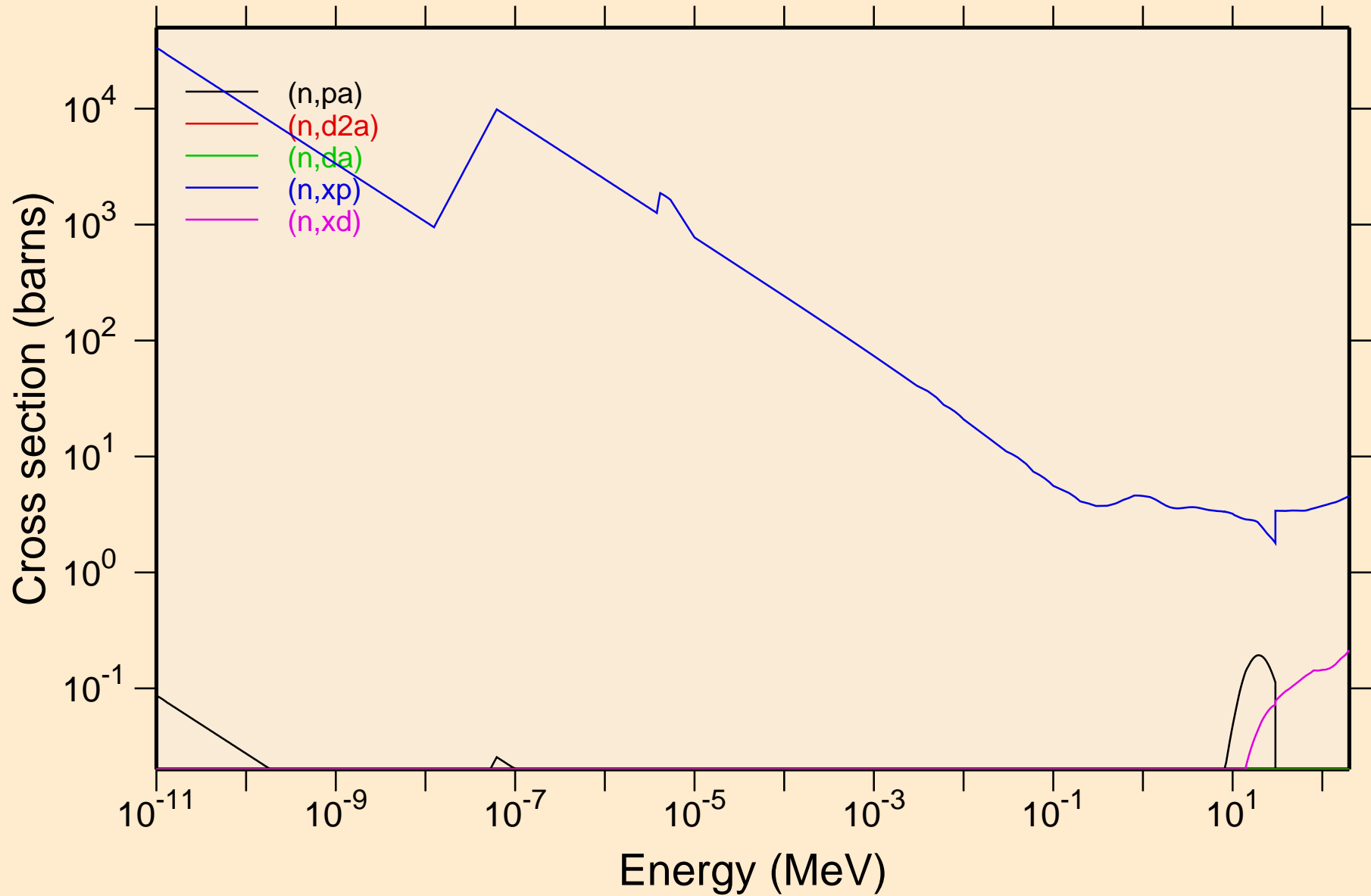

GD137 NEUTRON ACER TENDL-2023 LIBRARY; T=0.K  
Non-threshold reactions

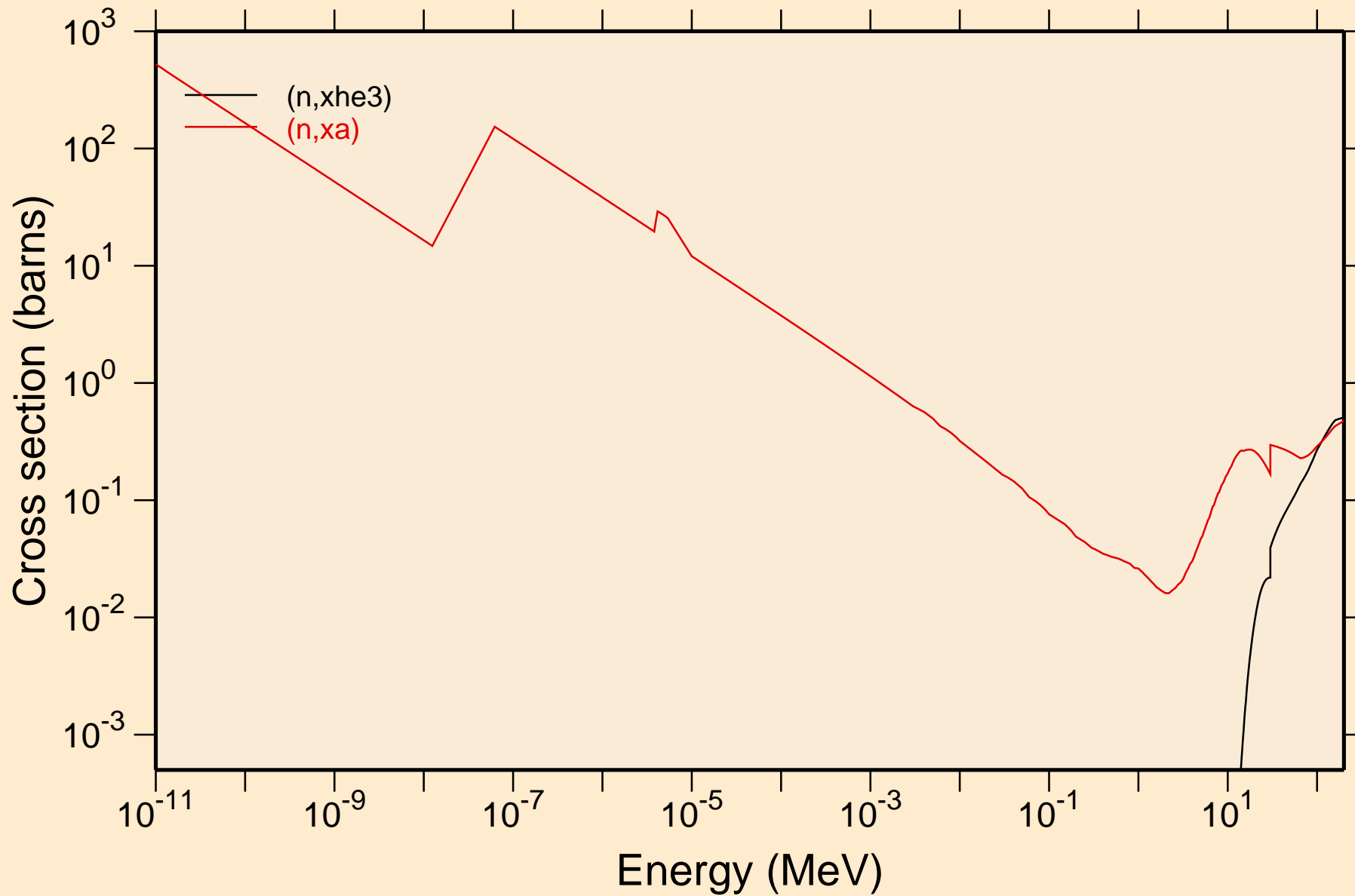

# GD137 NEUTRON ACER TENDL-2023 LIBRARY; T=0.K

## Principal cross sections

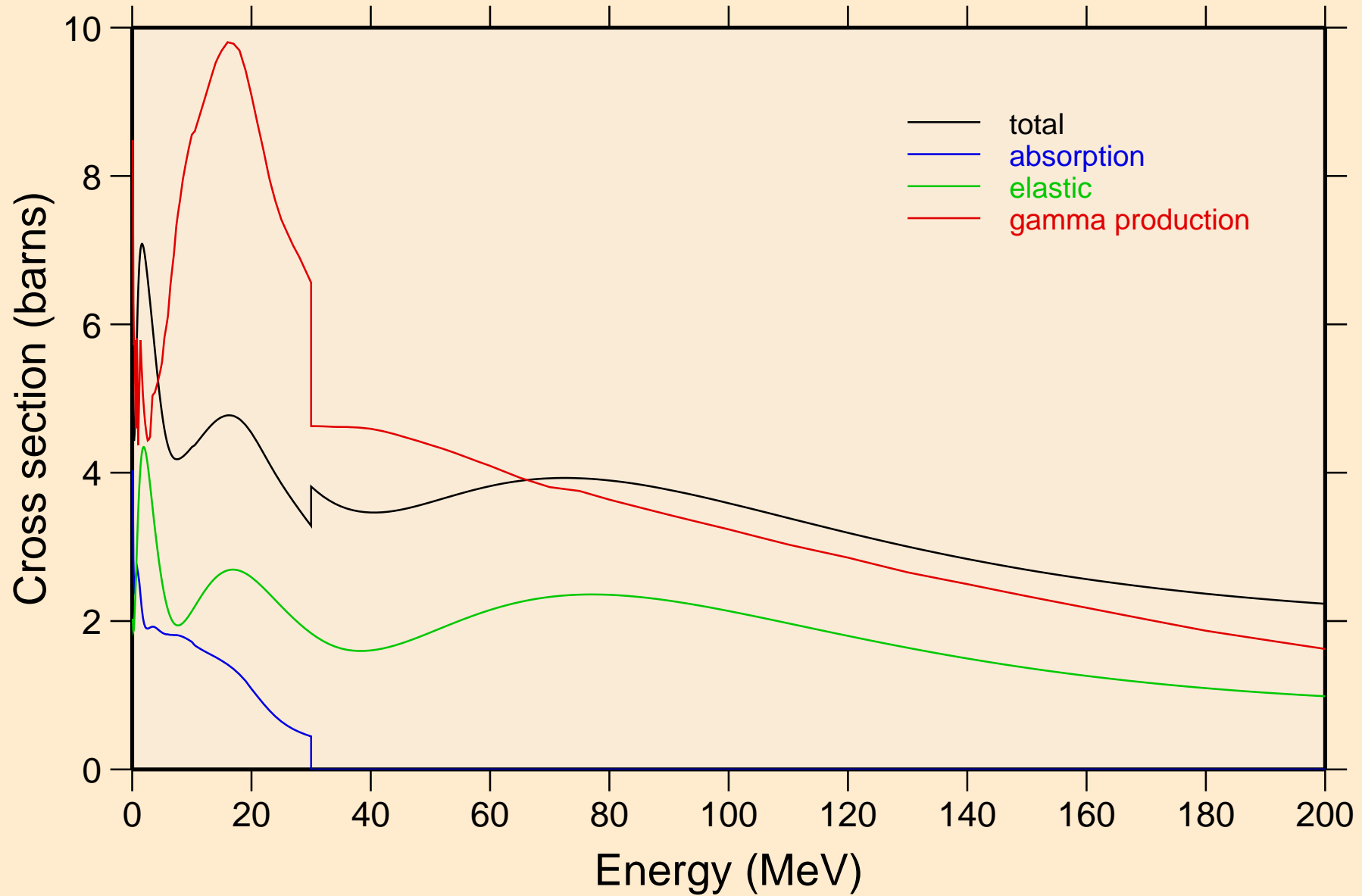



# GD137 NEUTRON ACER TENDL-2023 LIBRARY; T=0.K

## Heating

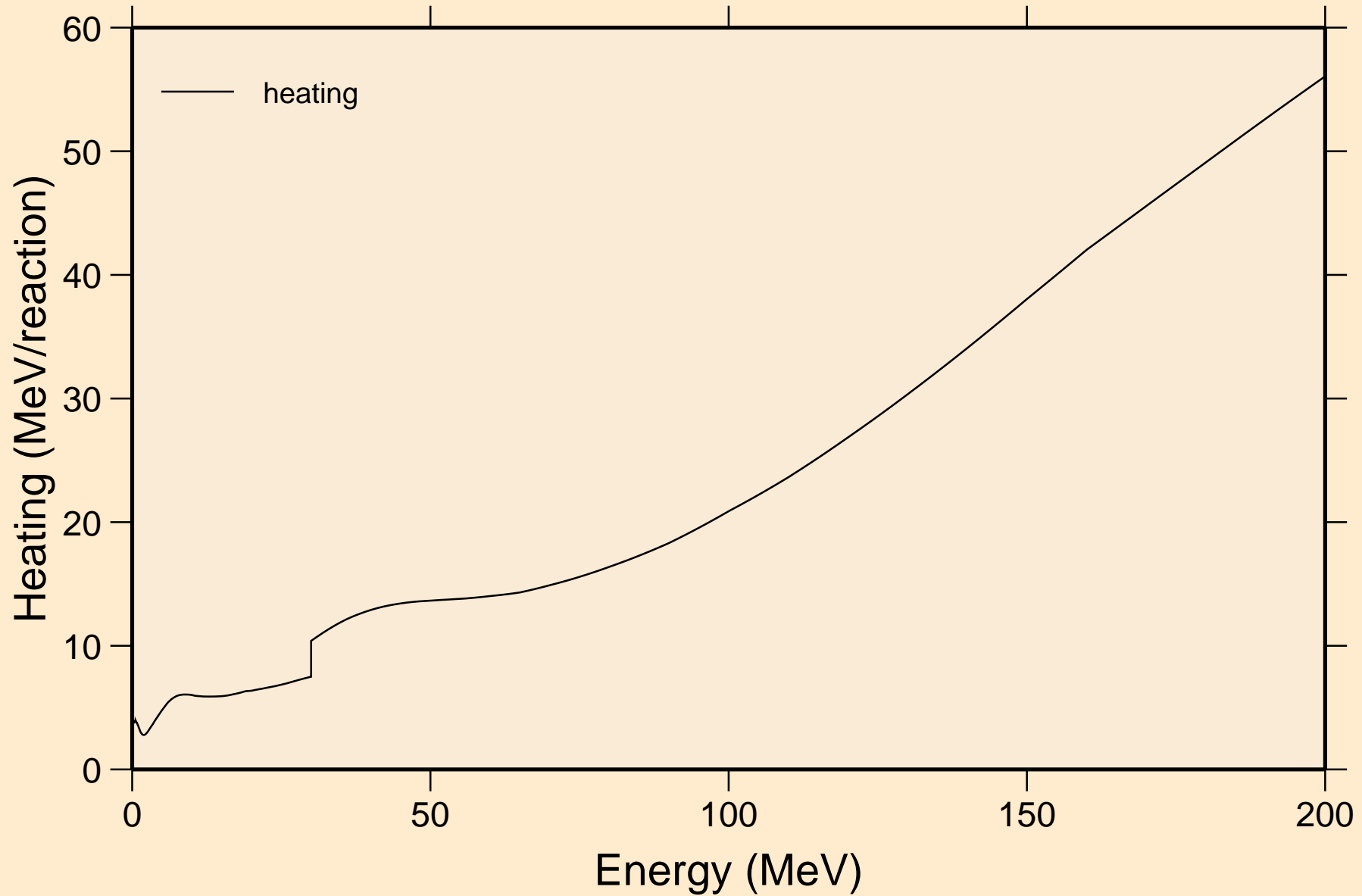

# GD137 NEUTRON ACER TENDL-2023 LIBRARY; T=0.K

## Damage

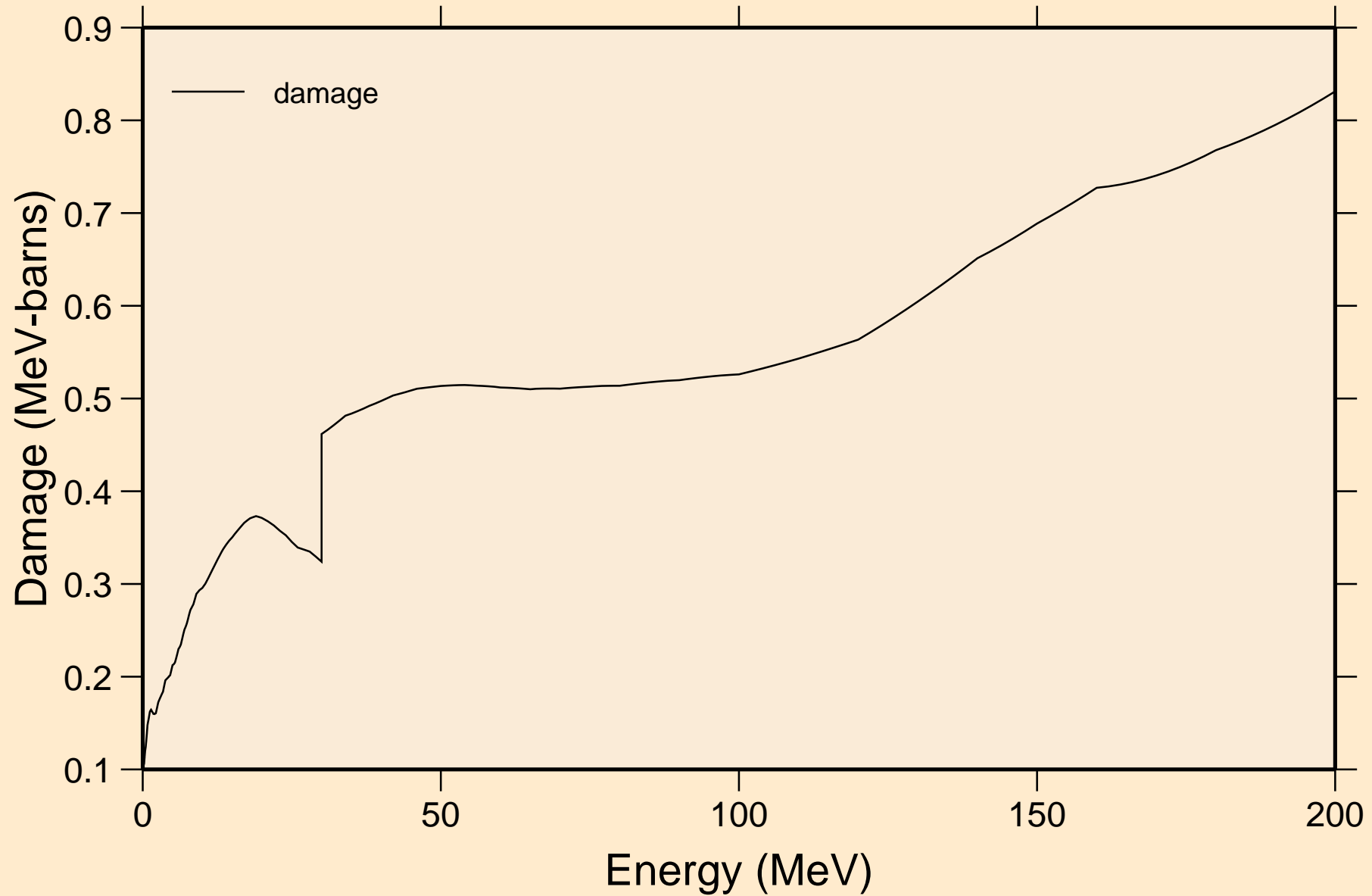

# GD137 NEUTRON ACER TENDL-2023 LIBRARY; T=0.K

## Non-threshold reactions

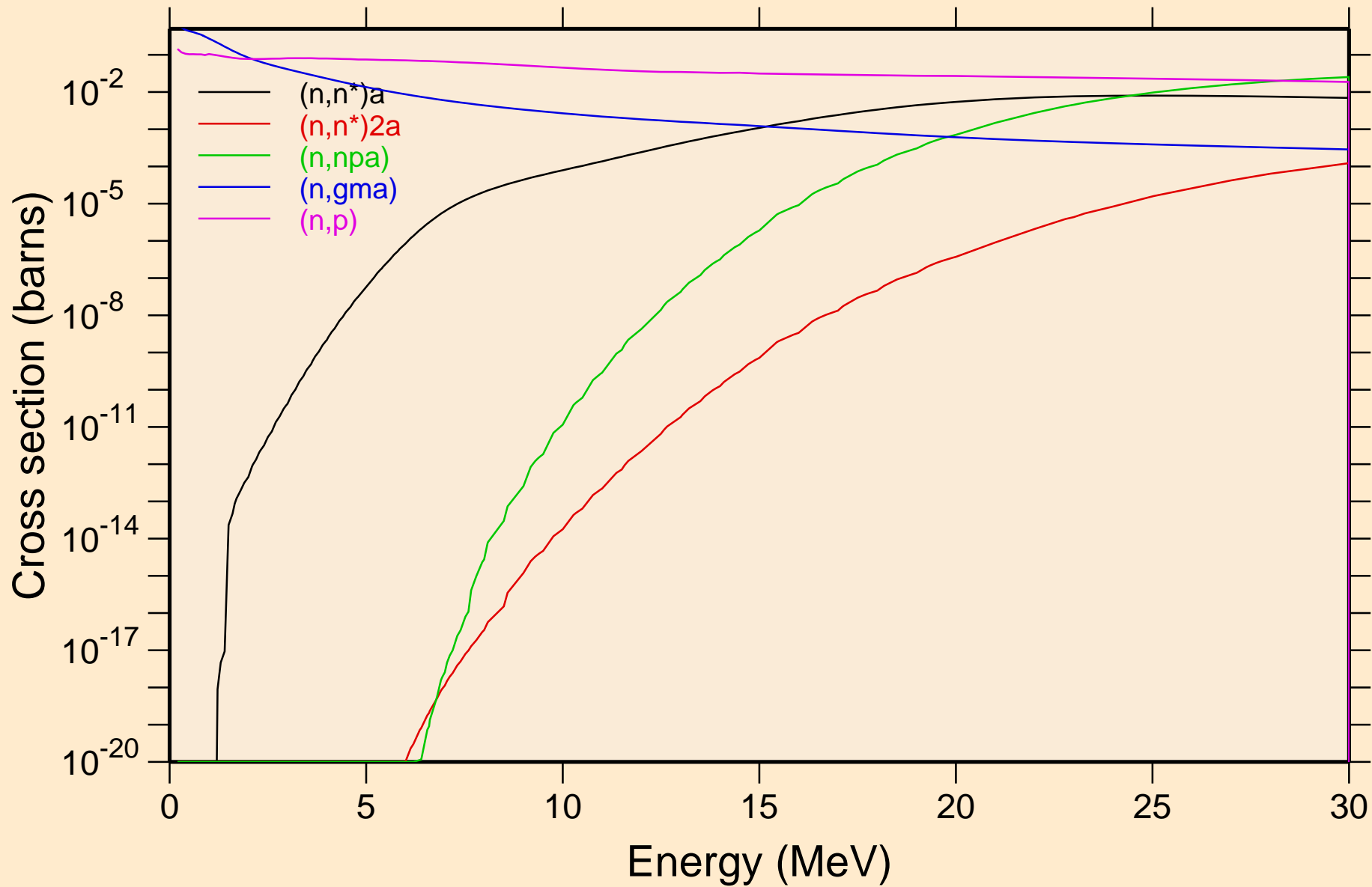

# GD137 NEUTRON ACER TENDL-2023 LIBRARY; T=0.K

## Non-threshold reactions

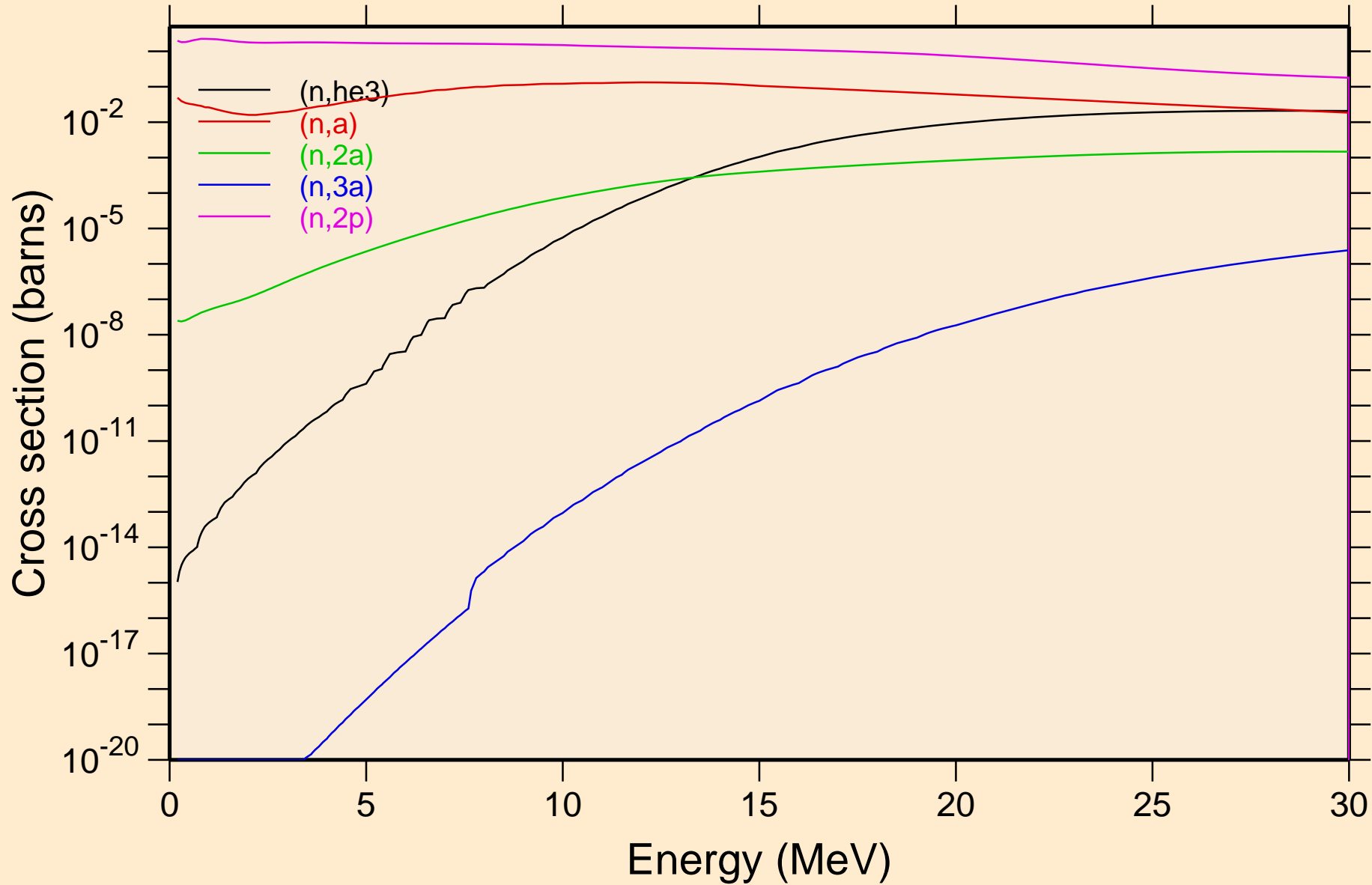

# GD137 NEUTRON ACER TENDL-2023 LIBRARY; T=0.K

## Non-threshold reactions

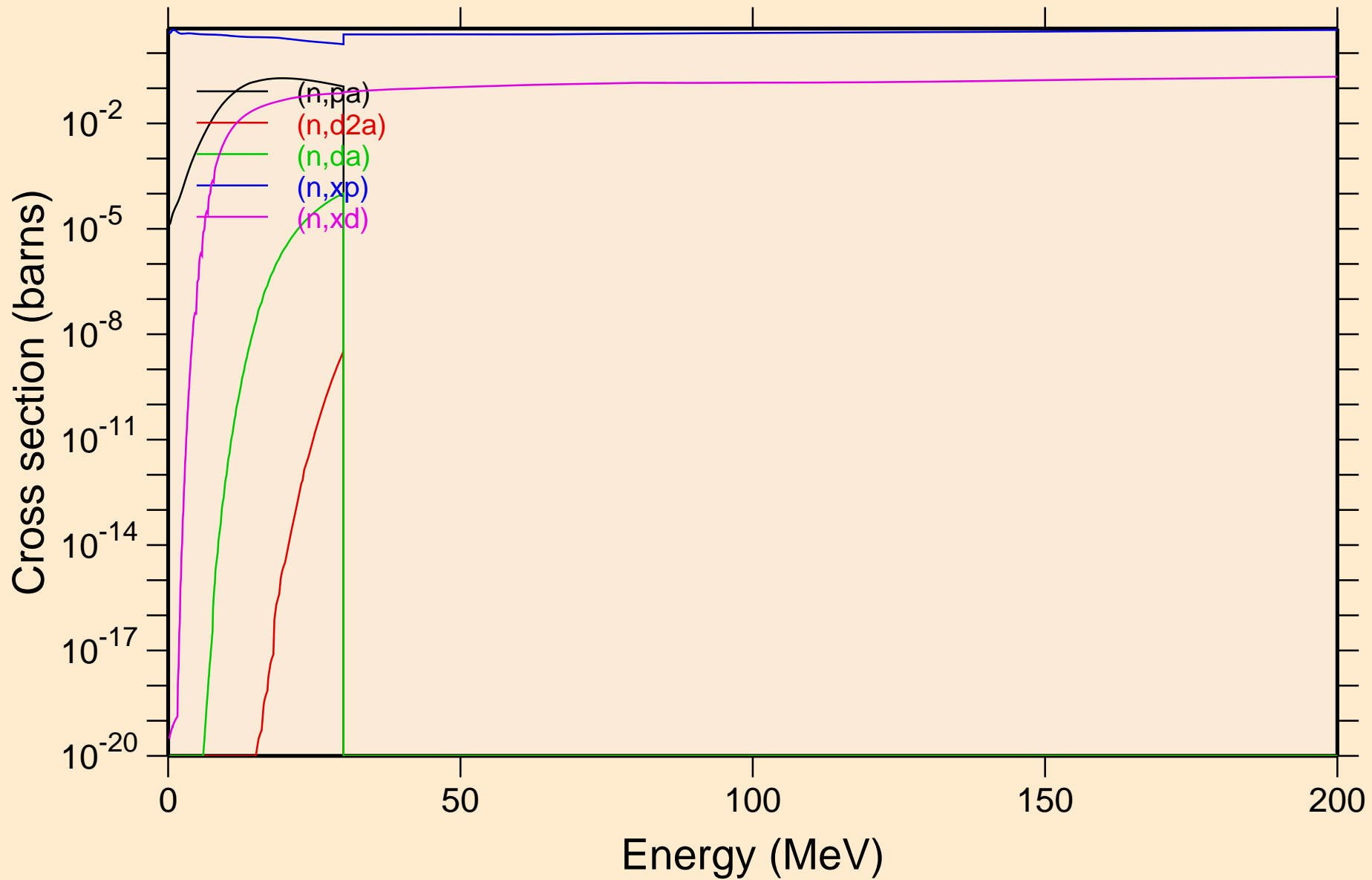

GD137 NEUTRON ACER TENDL-2023 LIBRARY; T=0.K  
Non-threshold reactions

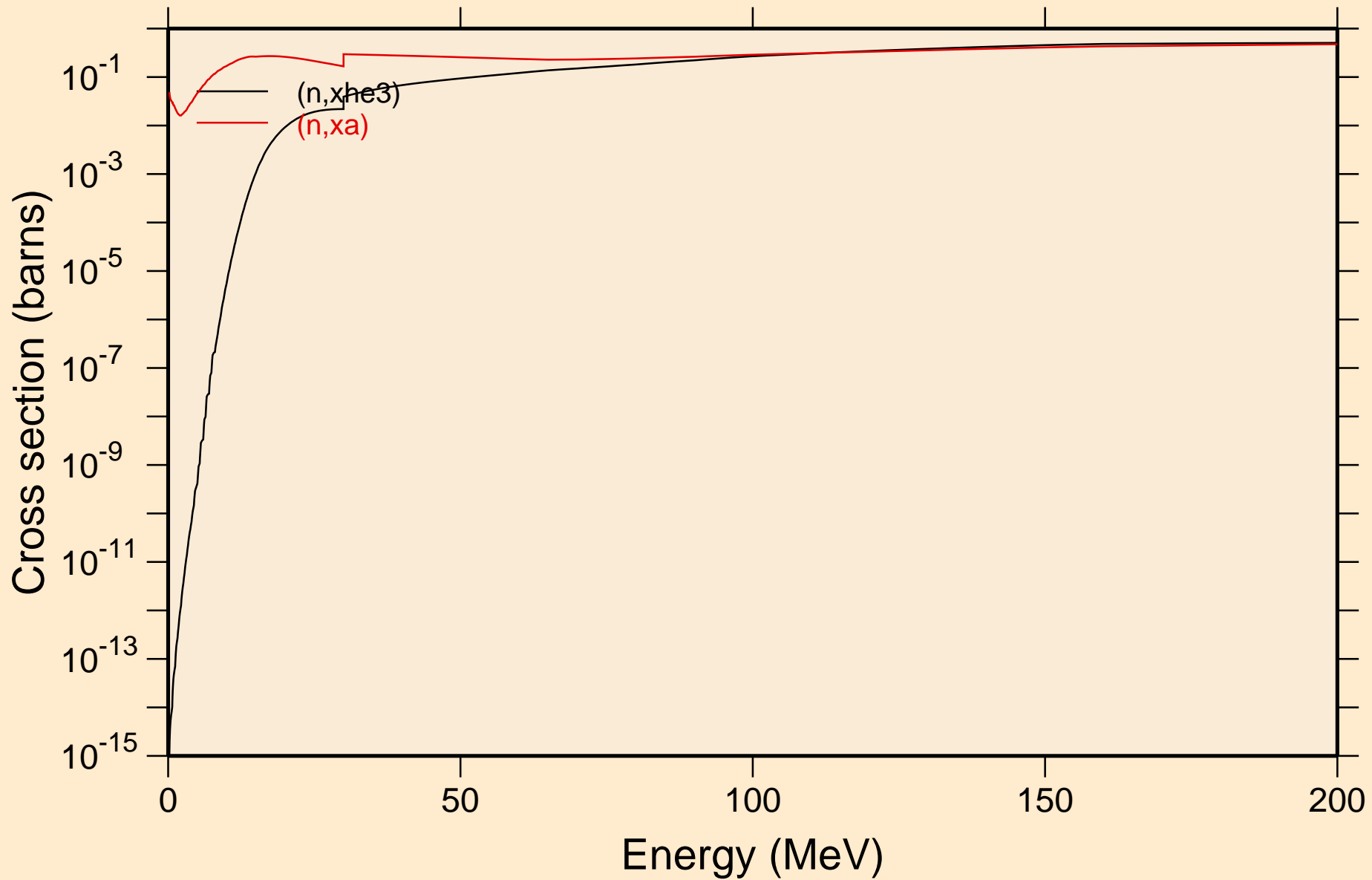

# GD137 NEUTRON ACER TENDL-2023 LIBRARY; T=0.K

## Inelastic levels

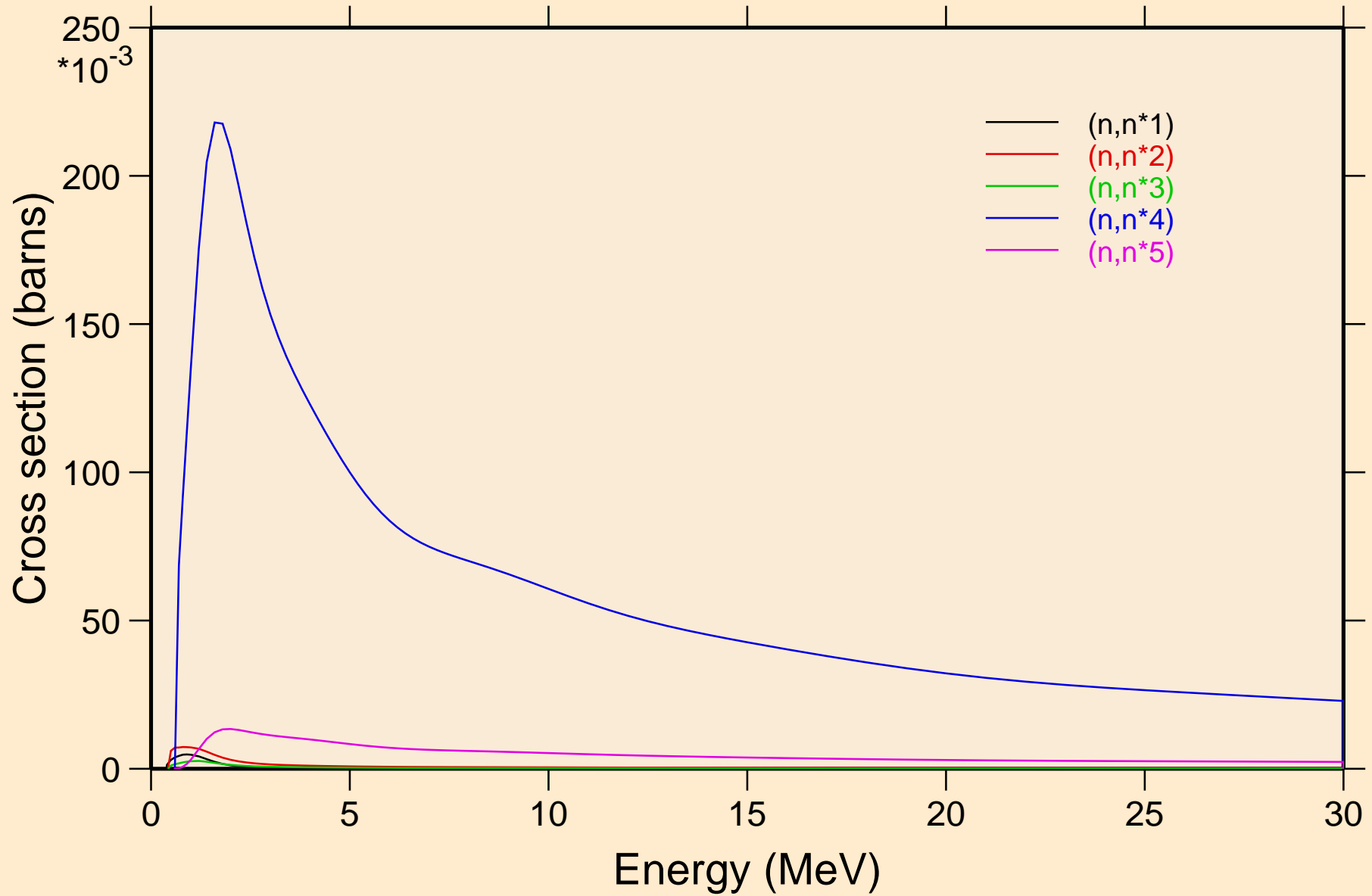

GD137 NEUTRON ACER TENDL-2023 LIBRARY; T=0.K  
Inelastic levels

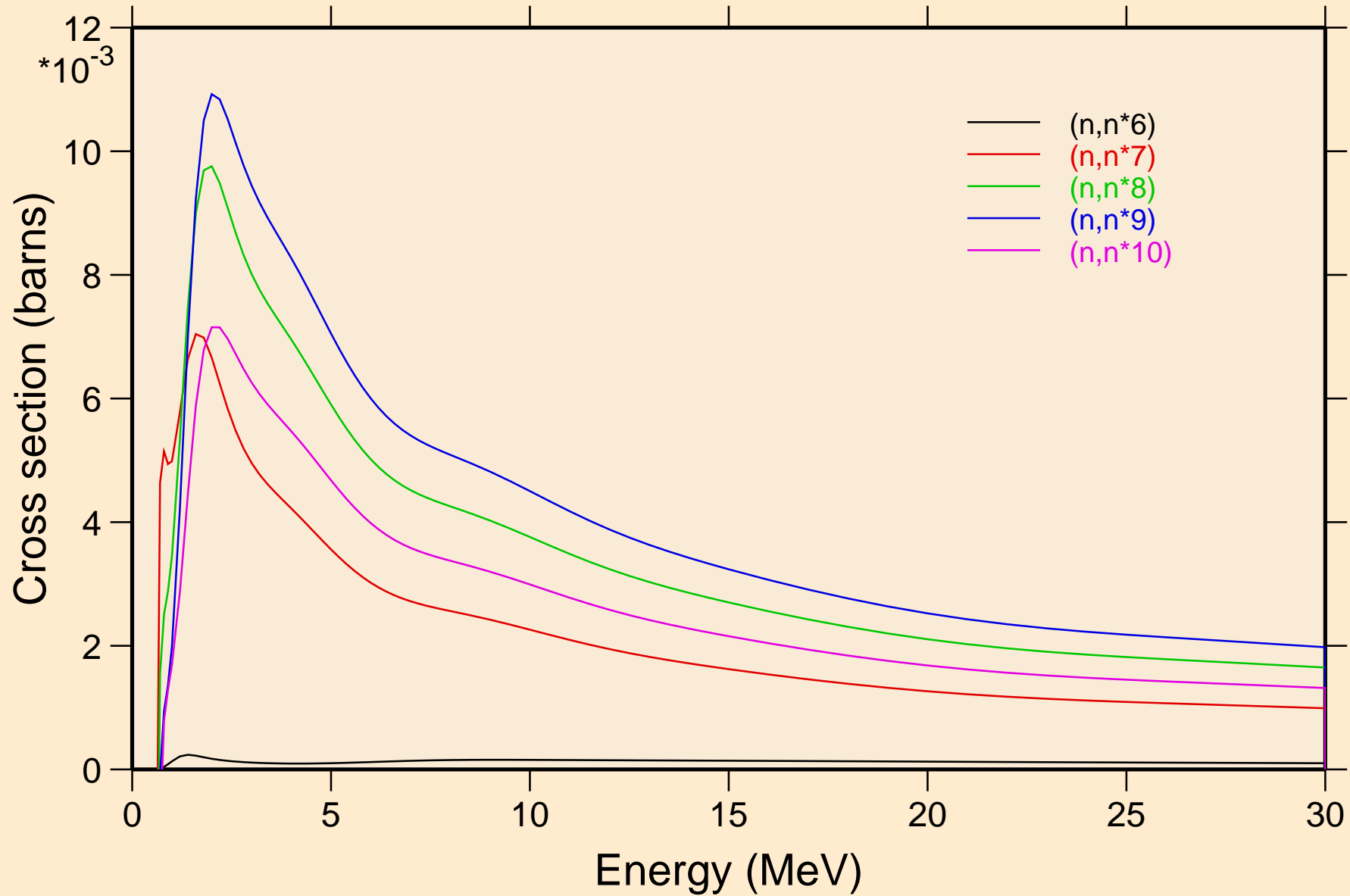



# GD137 NEUTRON ACER TENDL-2023 LIBRARY; T=0.K

## Inelastic levels

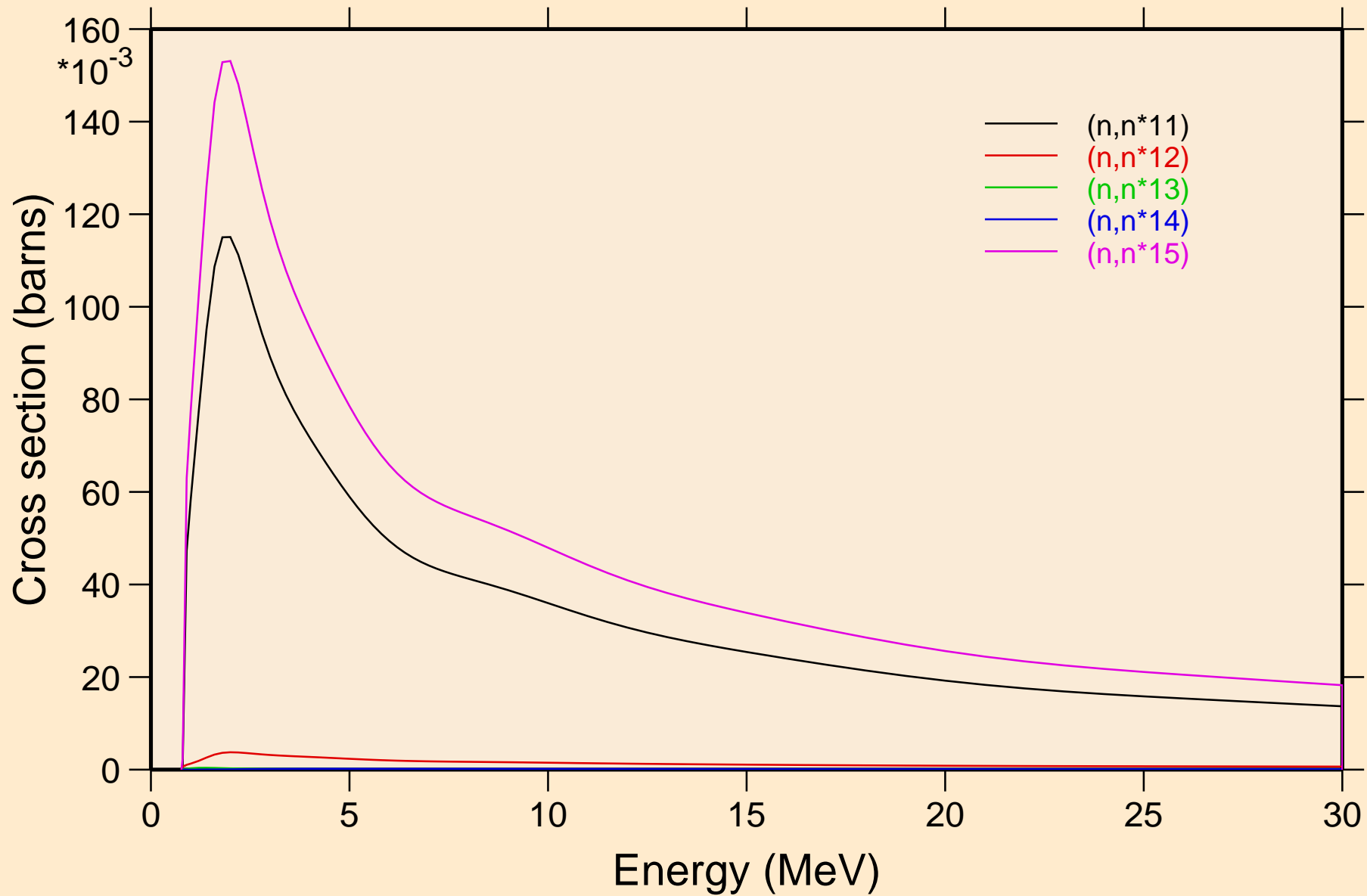

GD137 NEUTRON ACER TENDL-2023 LIBRARY; T=0.K  
Inelastic levels

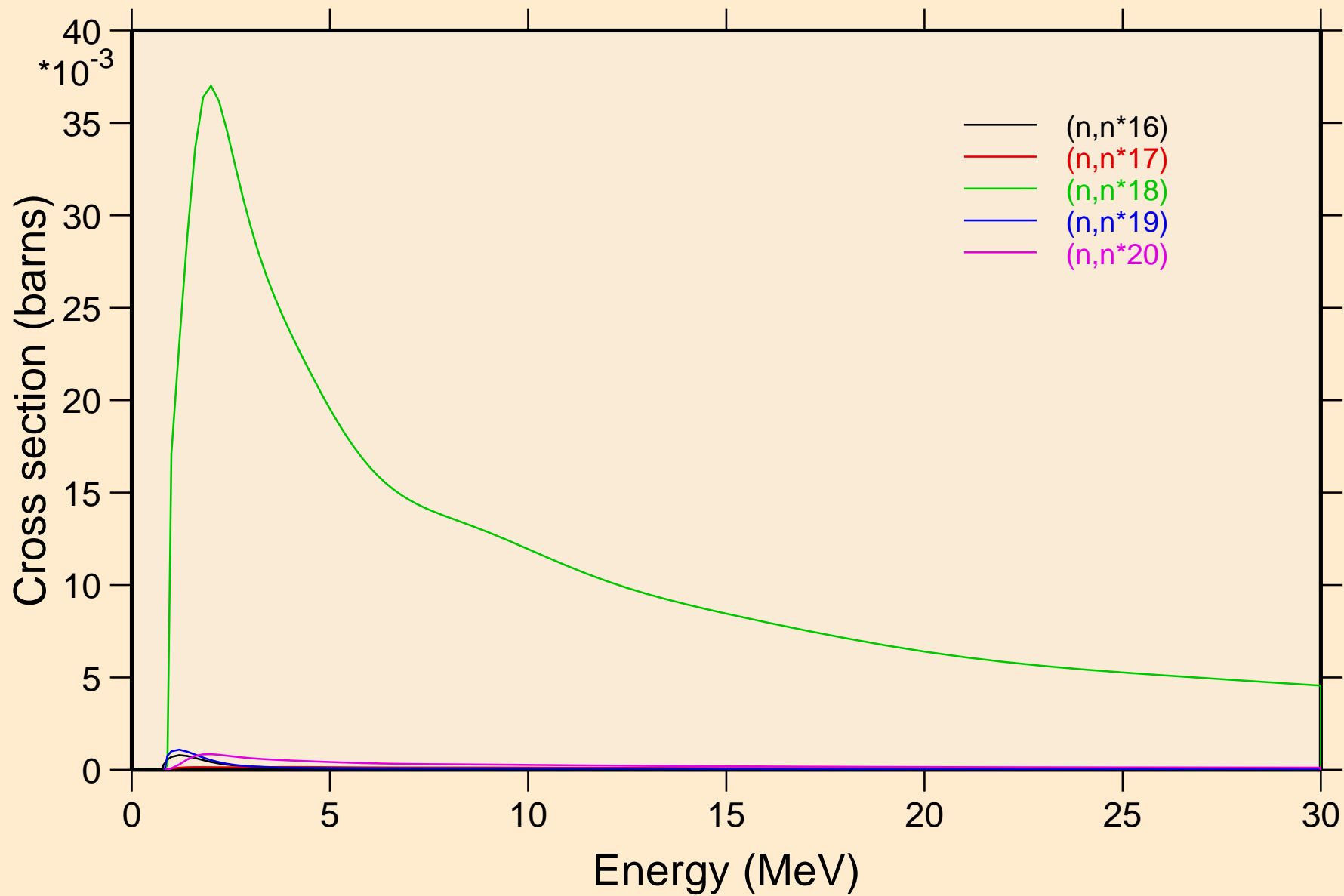

GD137 NEUTRON ACER TENDL-2023 LIBRARY; T=0.K  
Inelastic levels

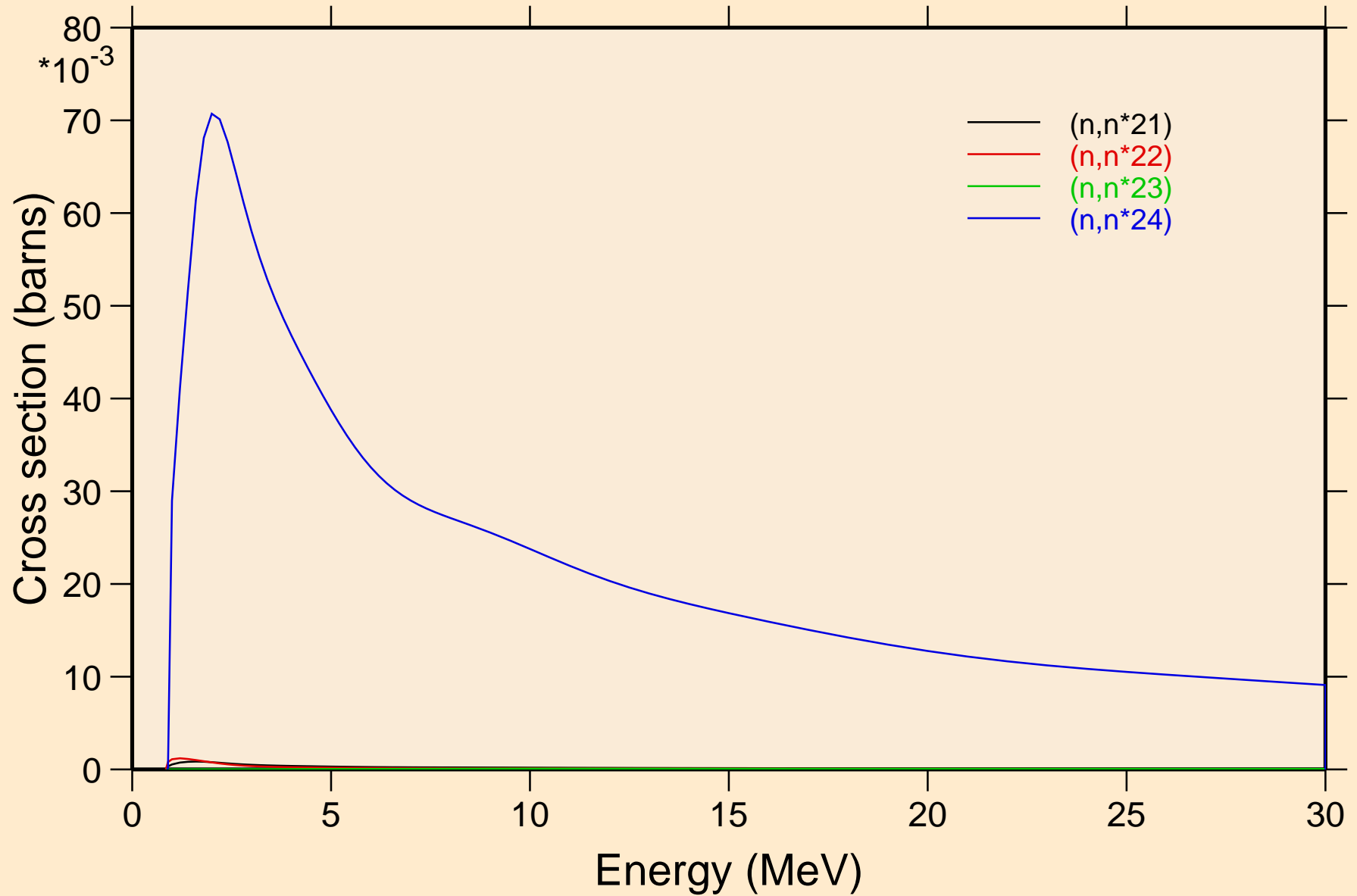

# GD137 NEUTRON ACER TENDL-2023 LIBRARY; T=0.K

## Threshold reactions

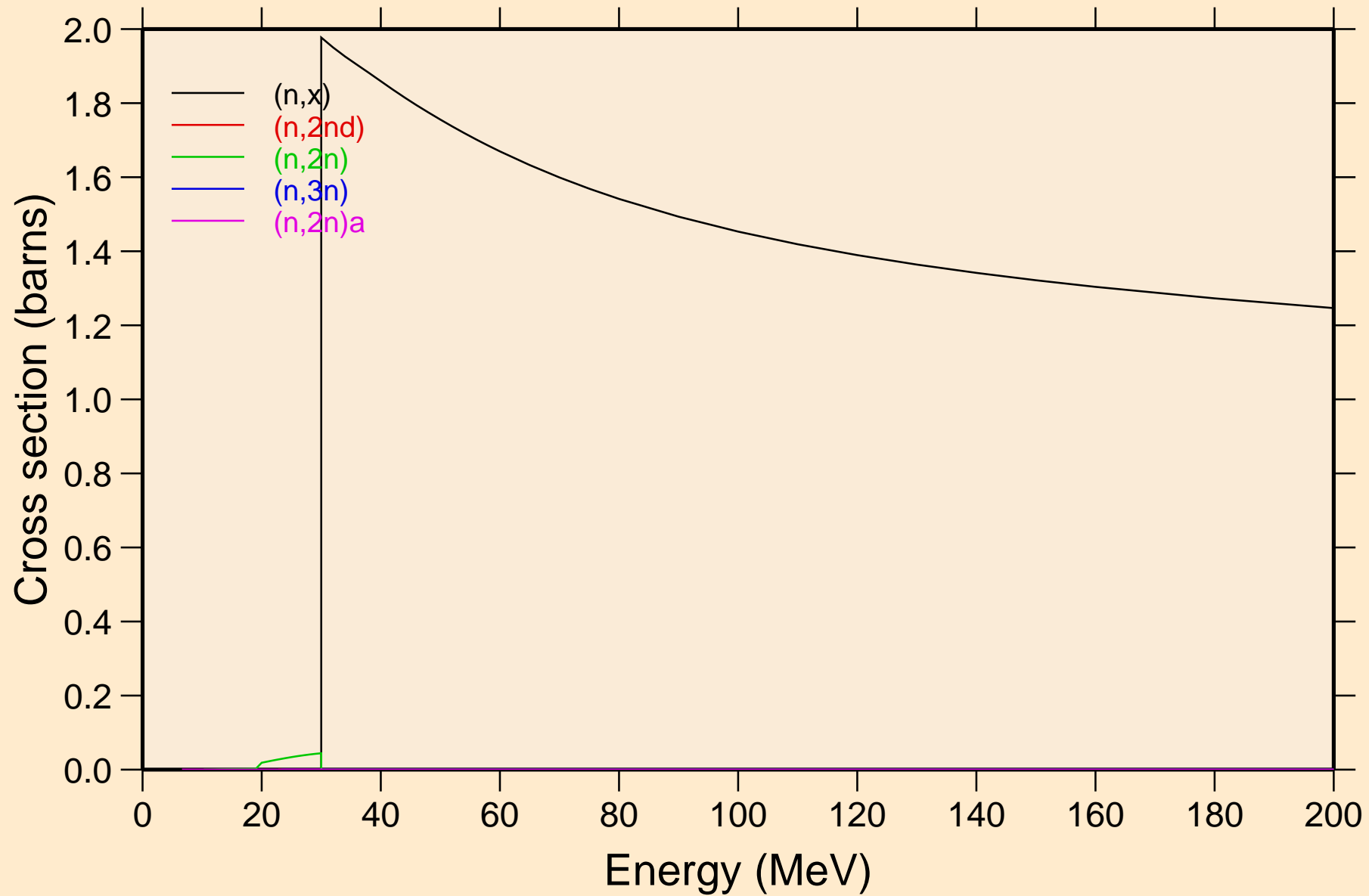

# GD137 NEUTRON ACER TENDL-2023 LIBRARY; T=0.K

## Threshold reactions

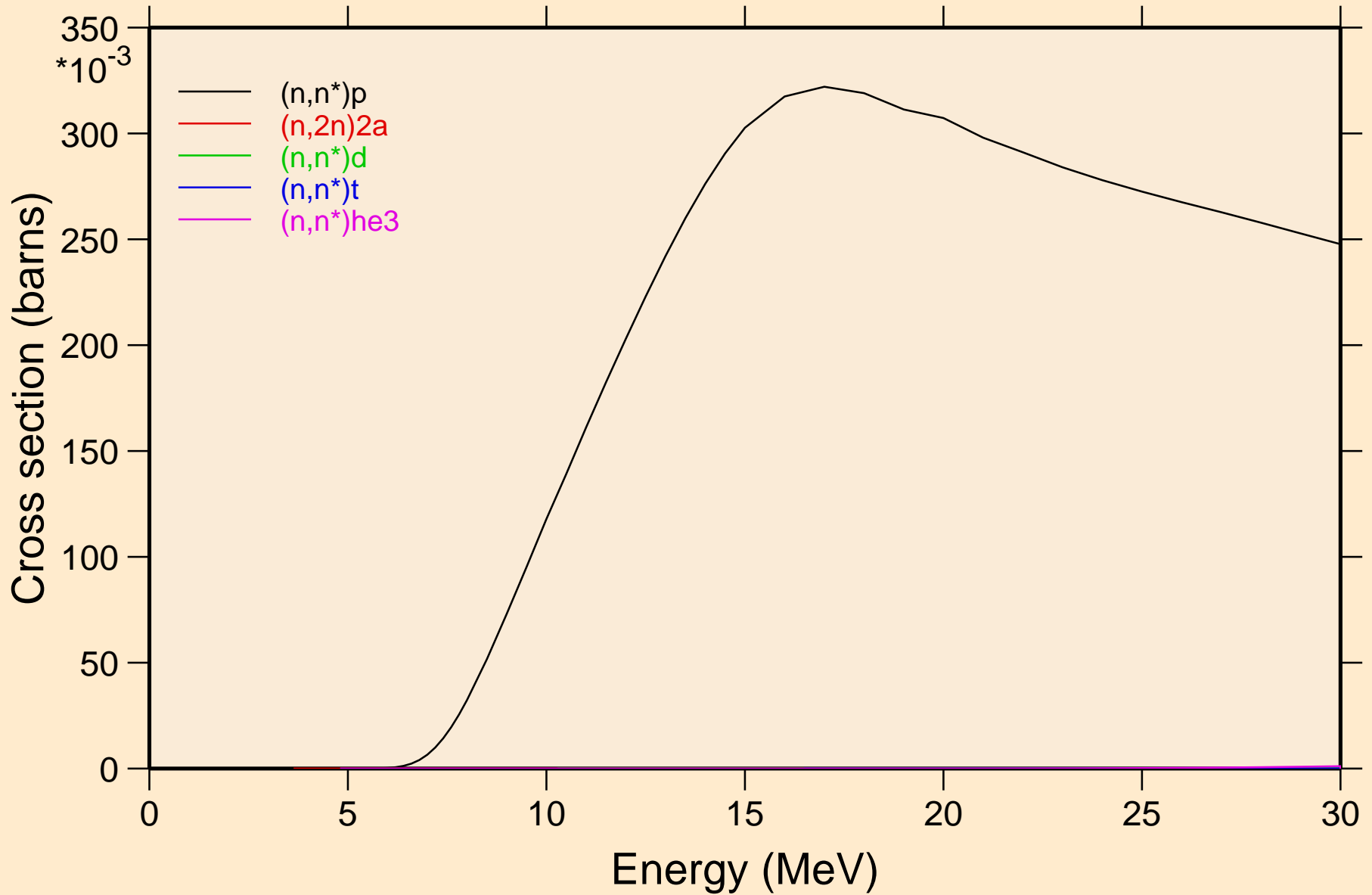

# GD137 NEUTRON ACER TENDL-2023 LIBRARY; T=0.K

## Threshold reactions

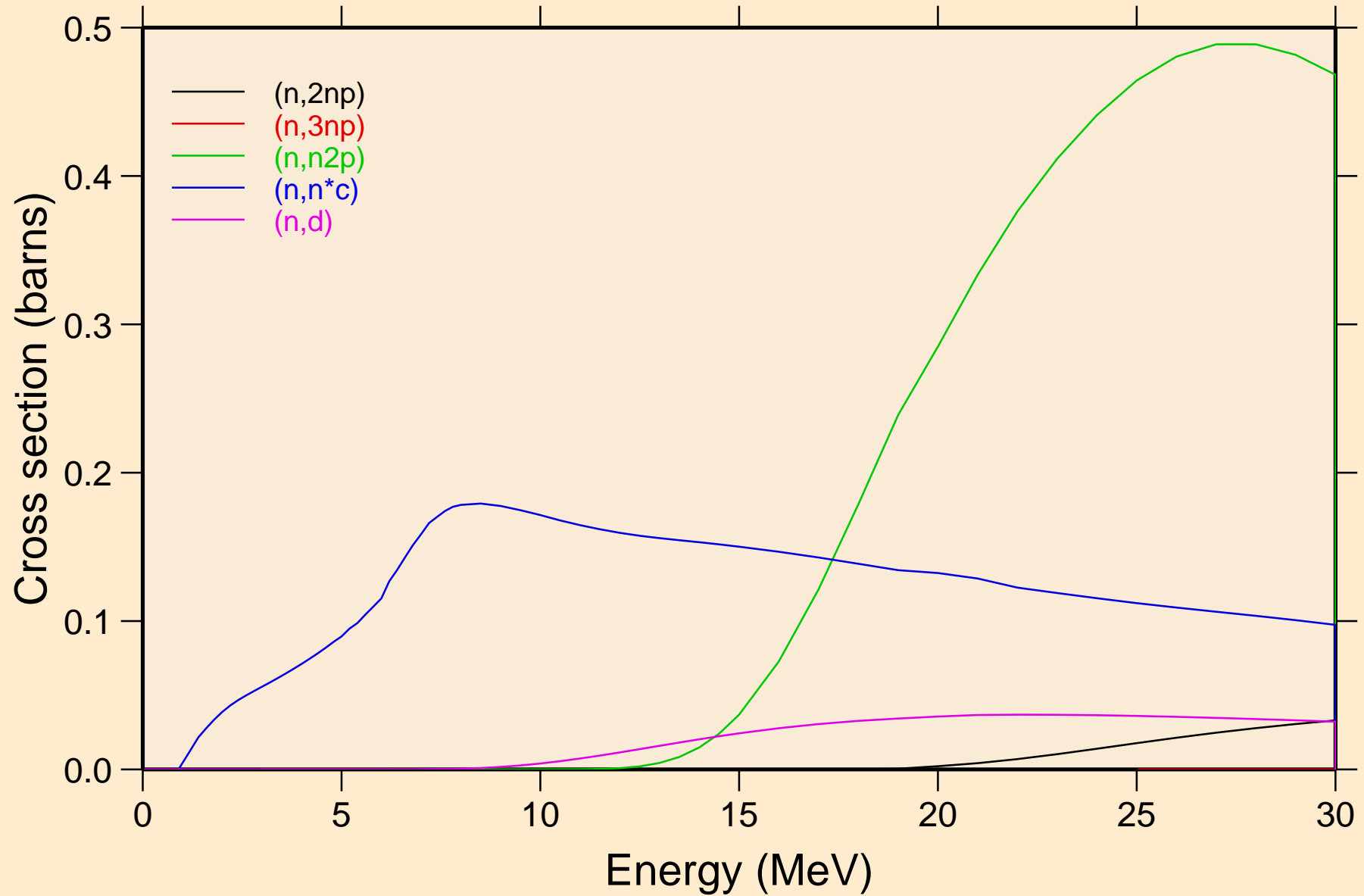

# GD137 NEUTRON ACER TENDL-2023 LIBRARY; T=0.K

## Threshold reactions

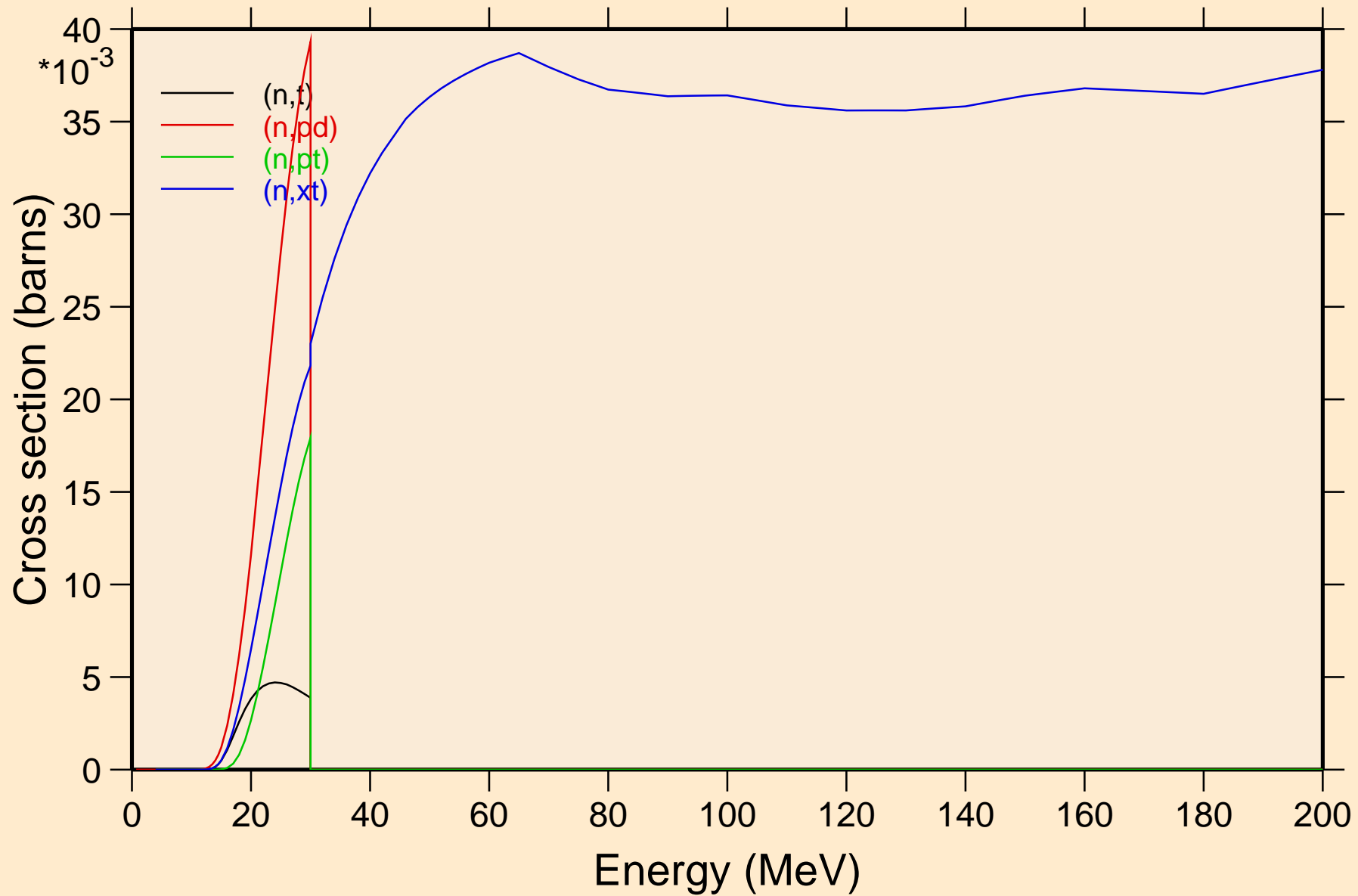

GD137 NEUTRON ACER TENDL-2023 LIBRARY; T=0.K  
angular distribution for elastic

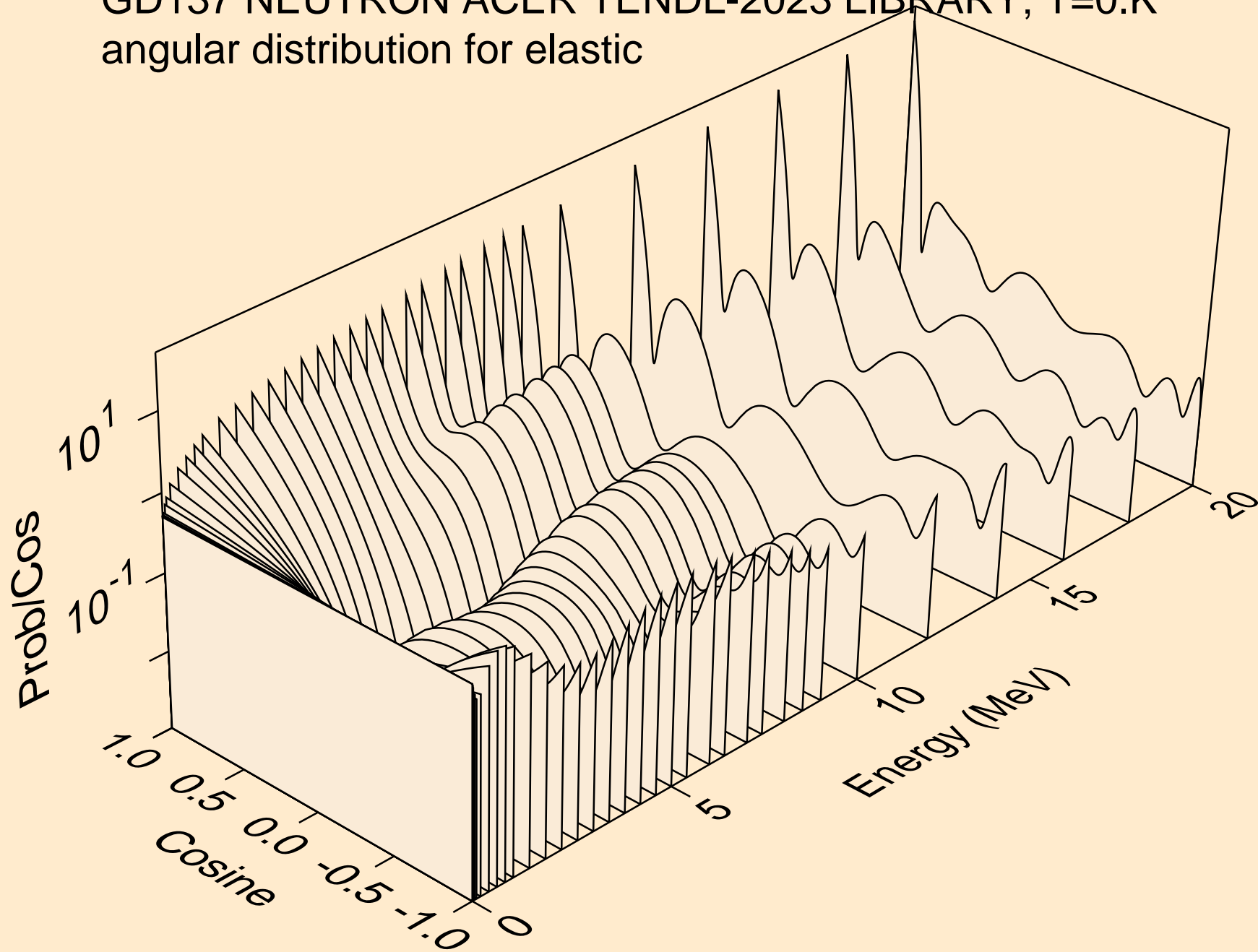



GD137 NEUTRON ACER TENDL-2023 LIBRARY; T=0.K  
angular distribution for elastic

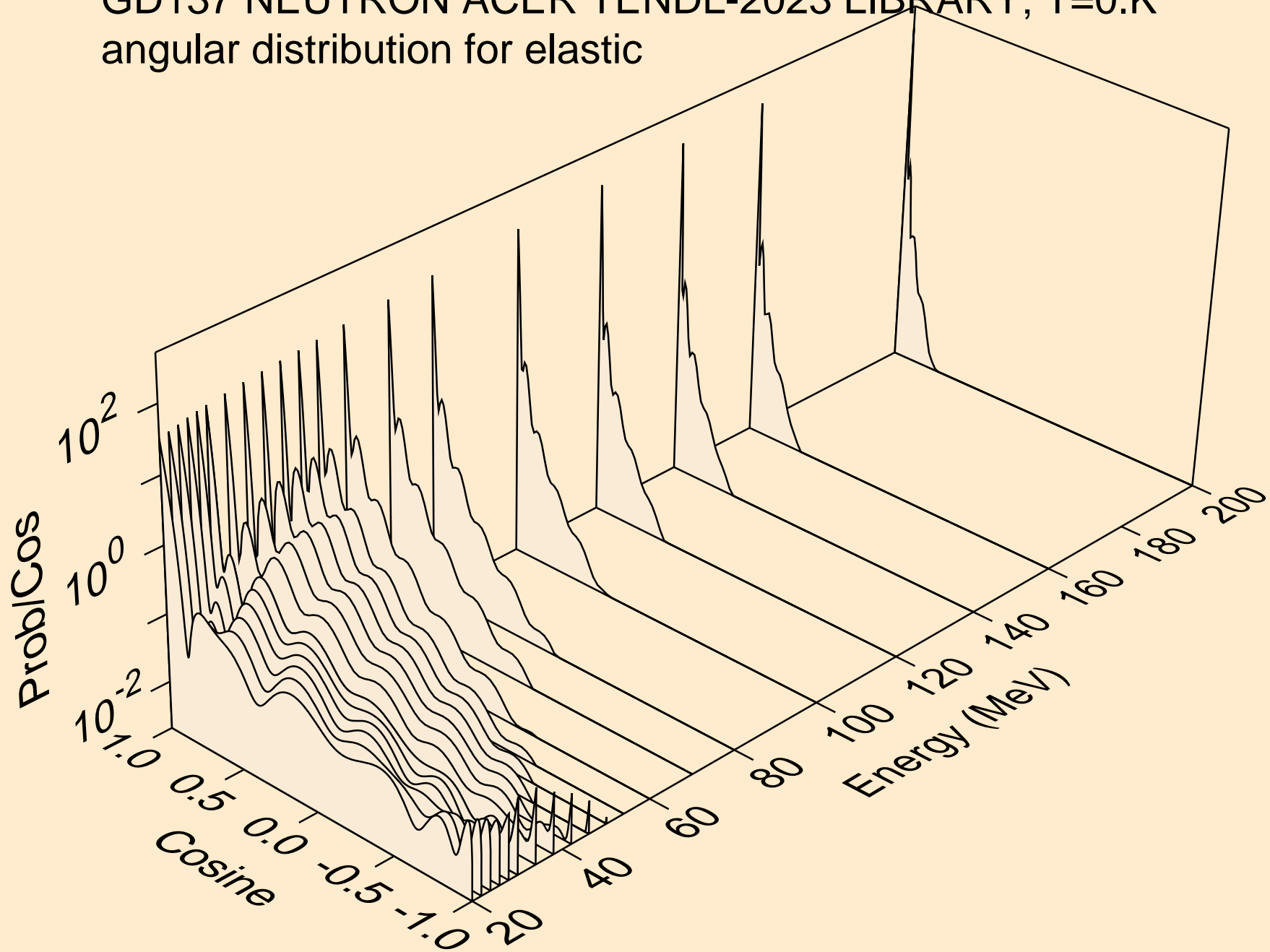

GD137 NEUTRON ACER TENDL-2023 LIBRARY; T=0.K  
angular distribution for (n,n\*1)

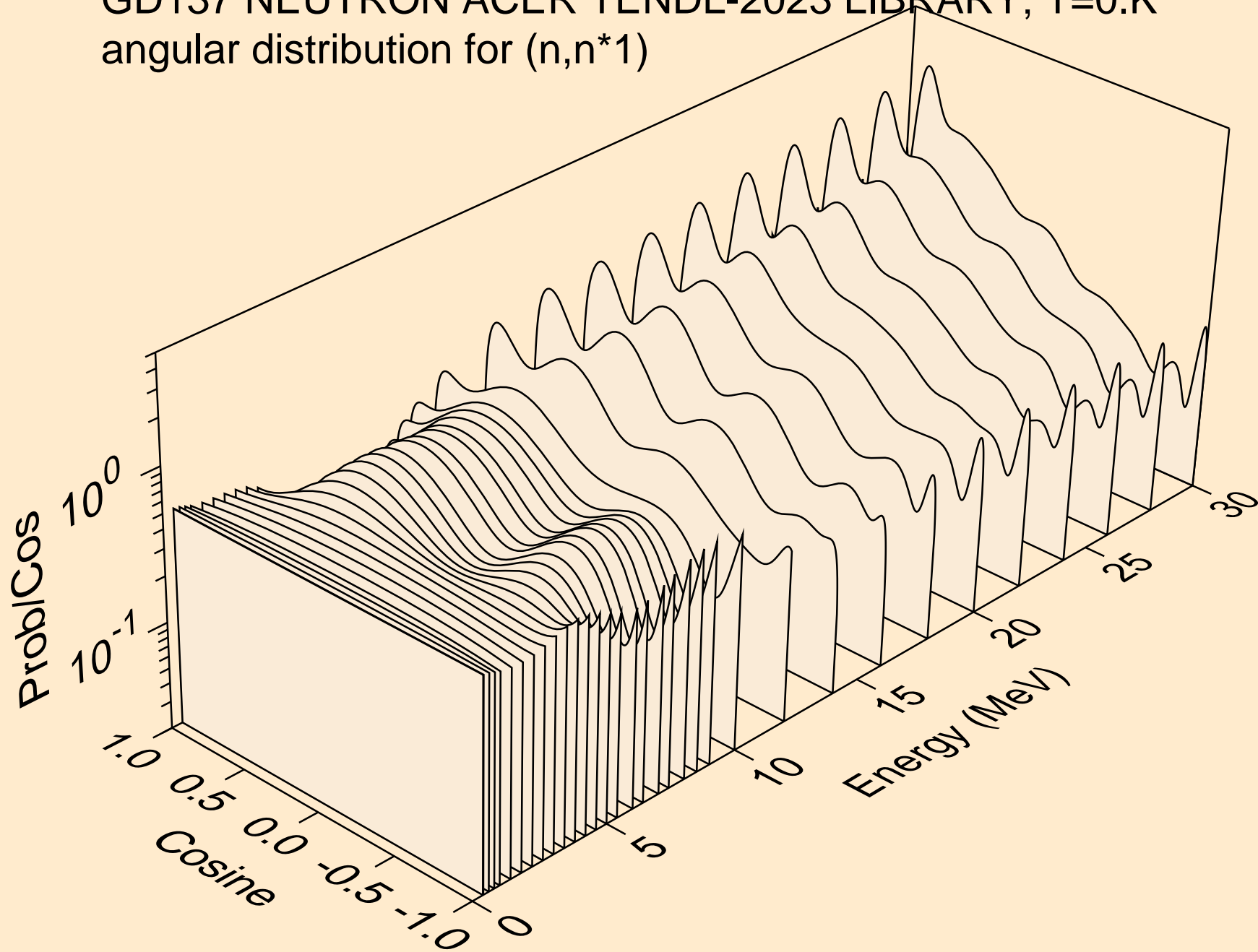

GD137 NEUTRON ACER TENDL-2023 LIBRARY; T=0.K  
angular distribution for (n,n\*2)

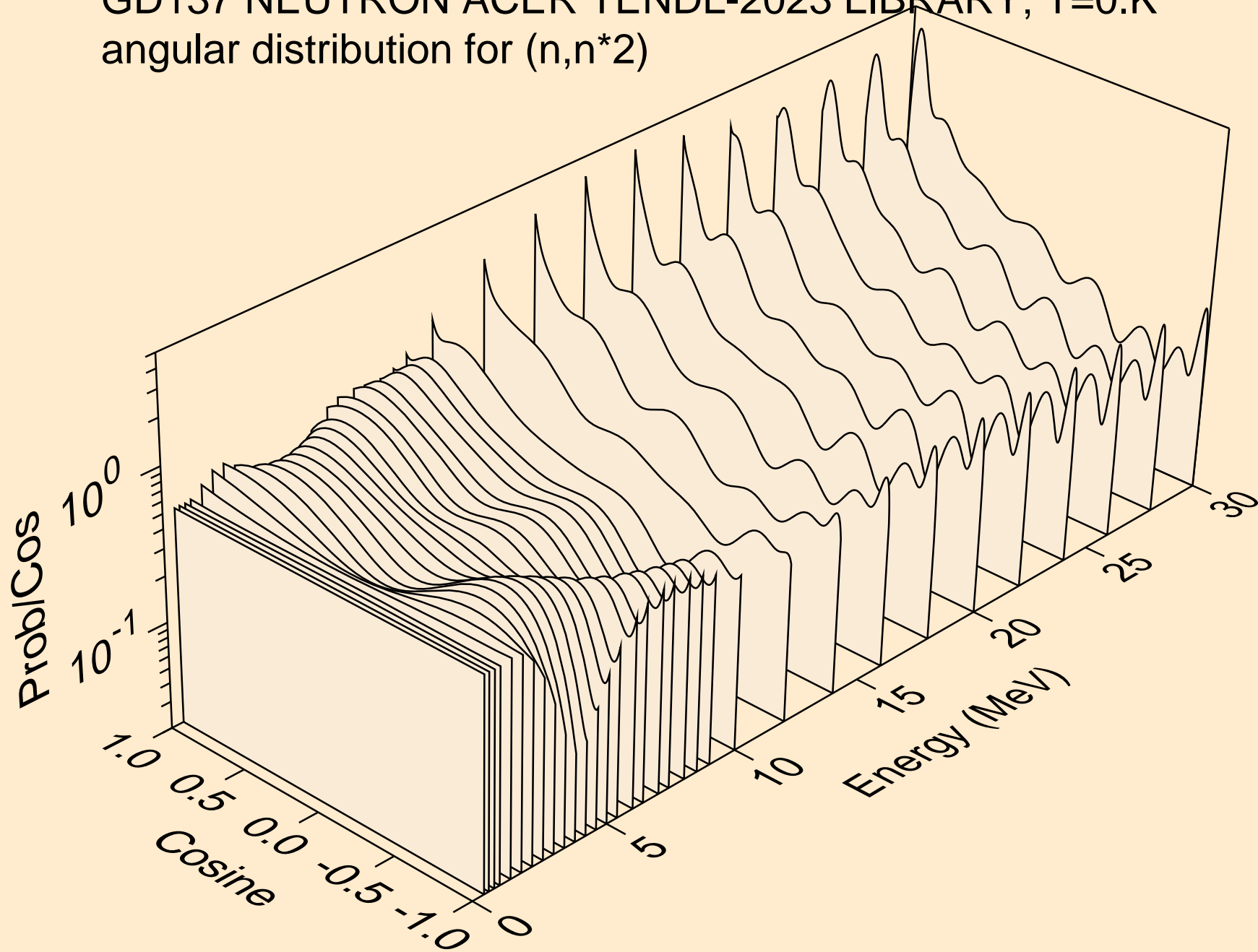

GD137 NEUTRON ACER TENDL-2023 LIBRARY; T=0.K  
angular distribution for (n,n\*3)

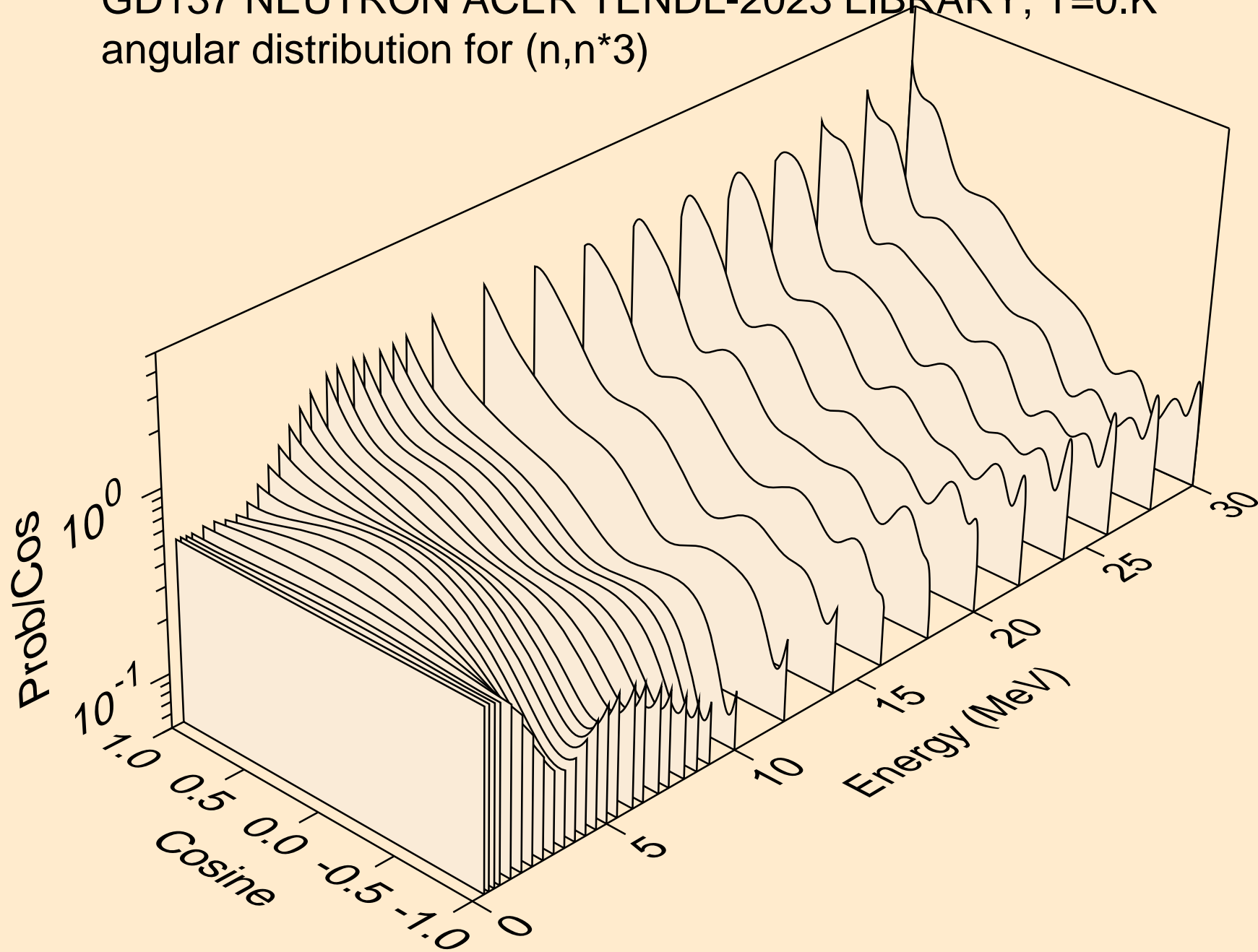

GD137 NEUTRON ACER TENDL-2023 LIBRARY; T=0.K  
angular distribution for (n,n\*4)

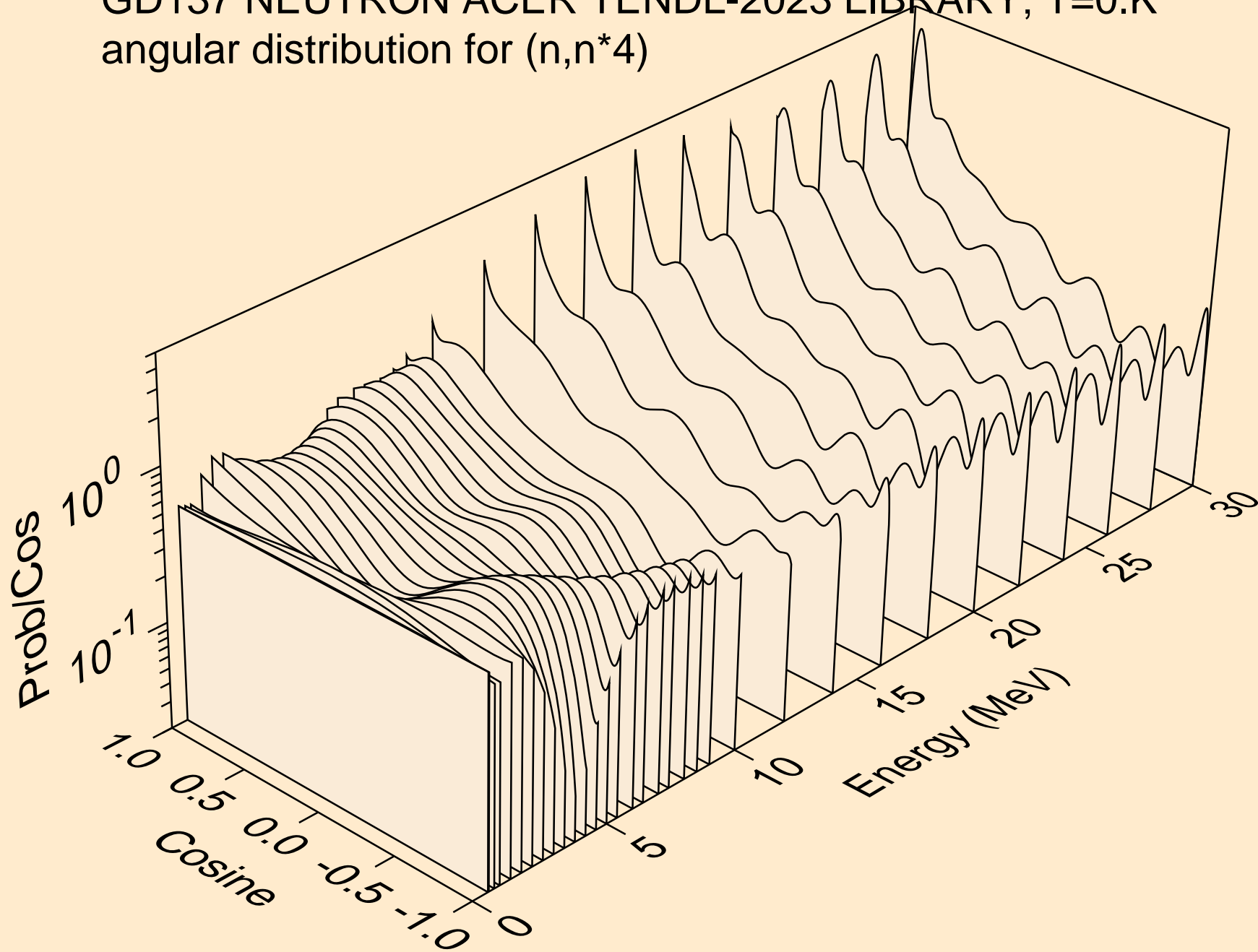

GD137 NEUTRON ACER TENDL-2023 LIBRARY; T=0.K  
angular distribution for (n,n\*5)

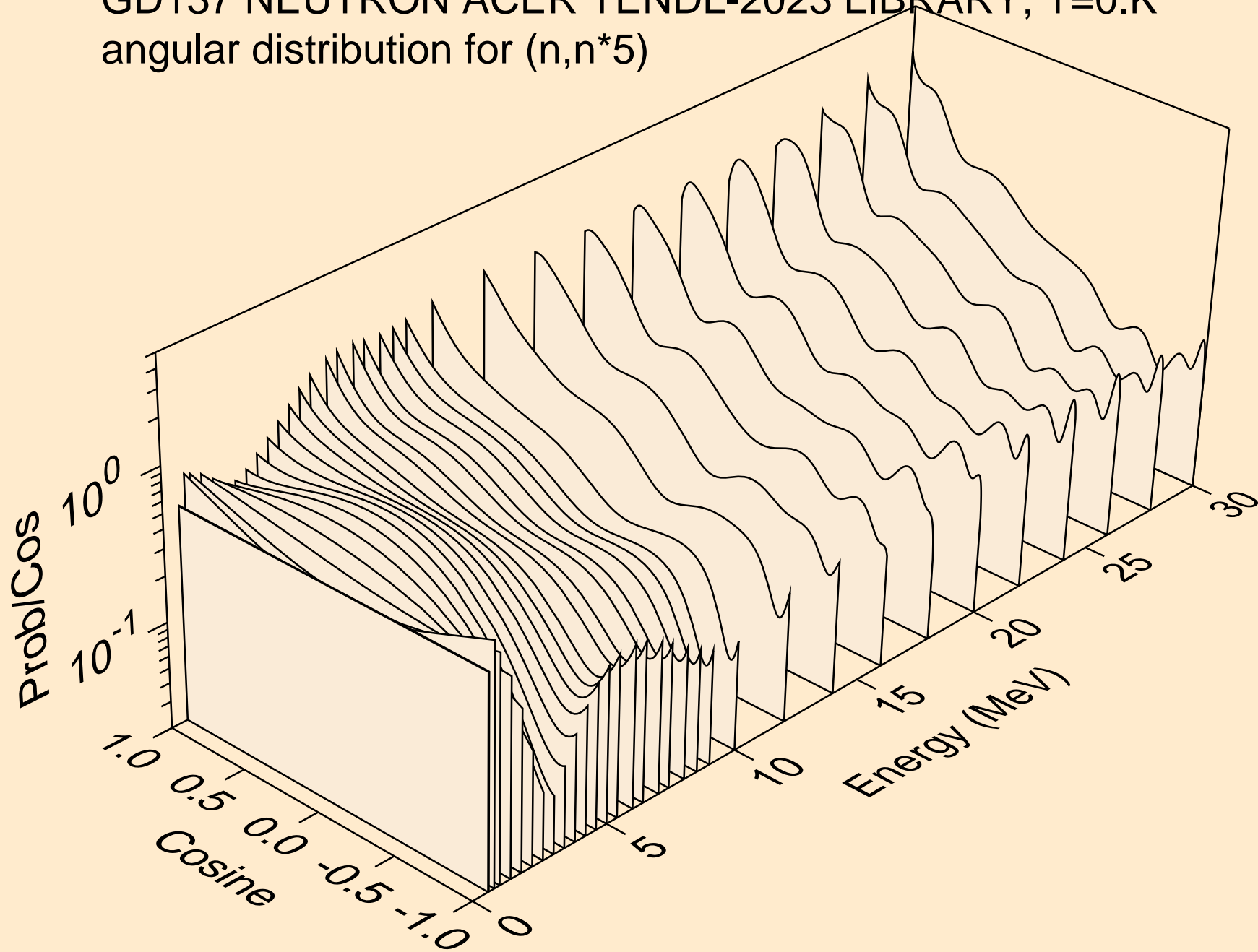

GD137 NEUTRON ACER TENDL-2023 LIBRARY; T=0.K  
angular distribution for (n,n\*6)

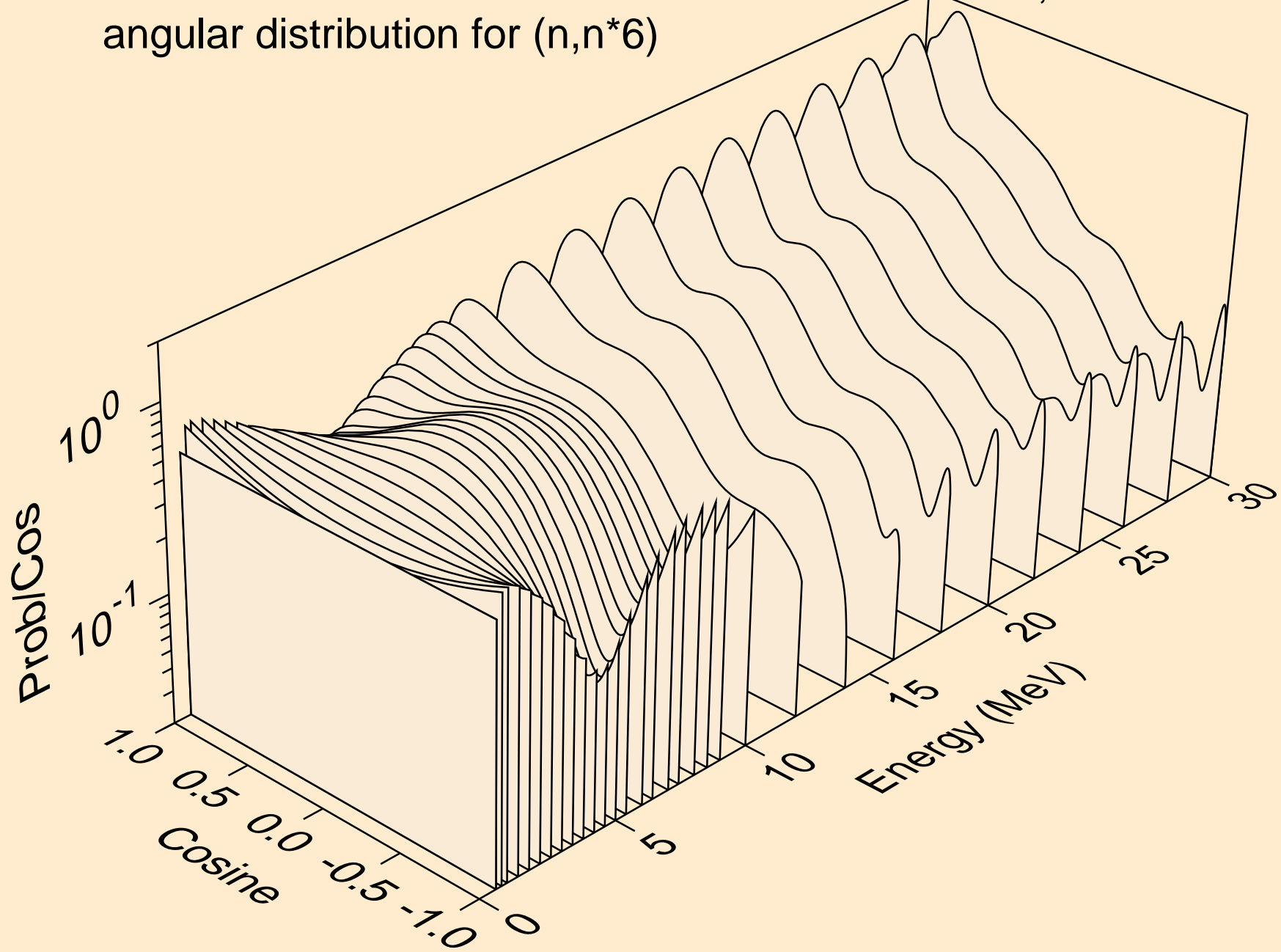

GD137 NEUTRON ACER TENDL-2023 LIBRARY; T=0.K  
angular distribution for (n,n\*7)

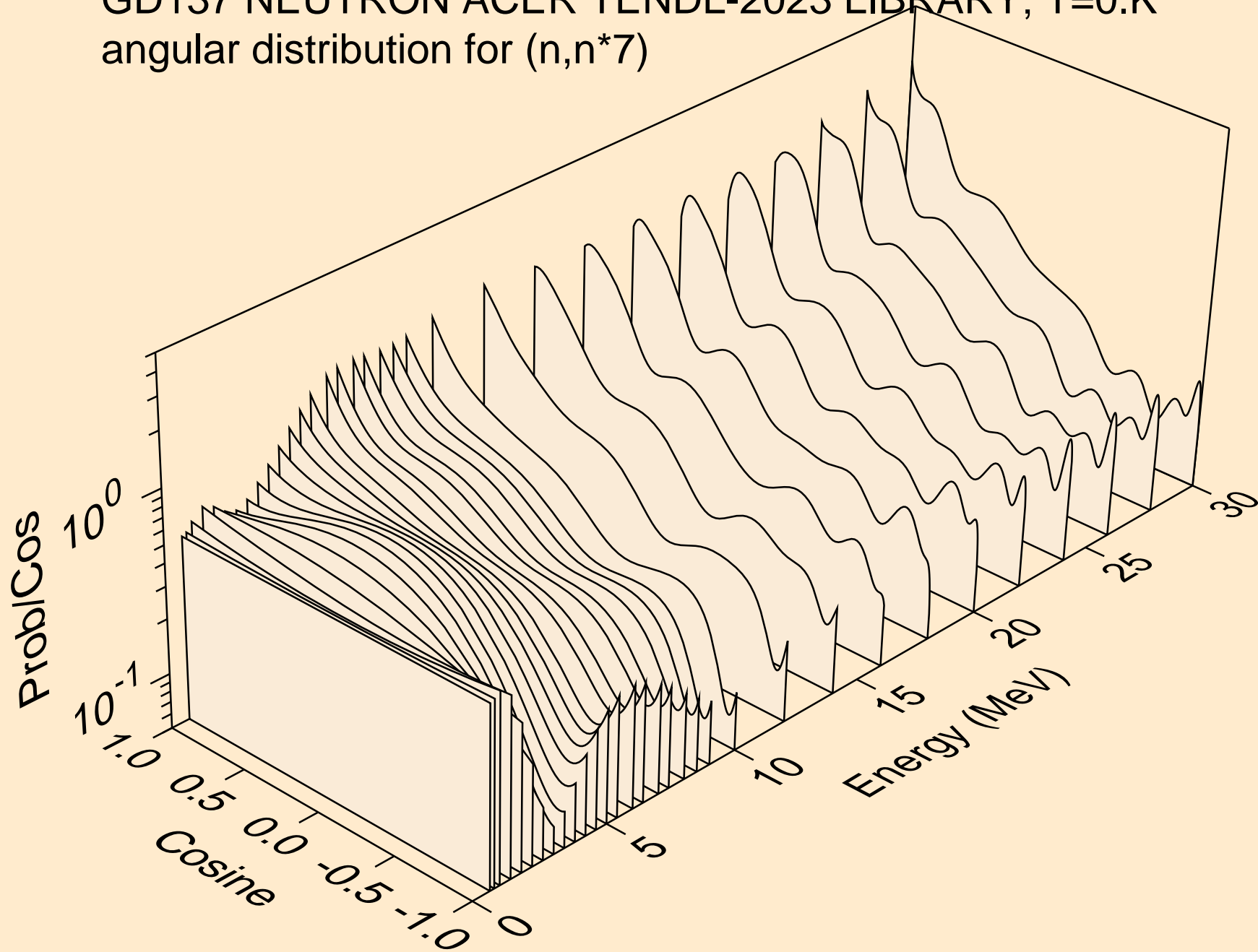



GD137 NEUTRON ACER TENDL-2023 LIBRARY; T=0.K  
angular distribution for (n,n\*8)

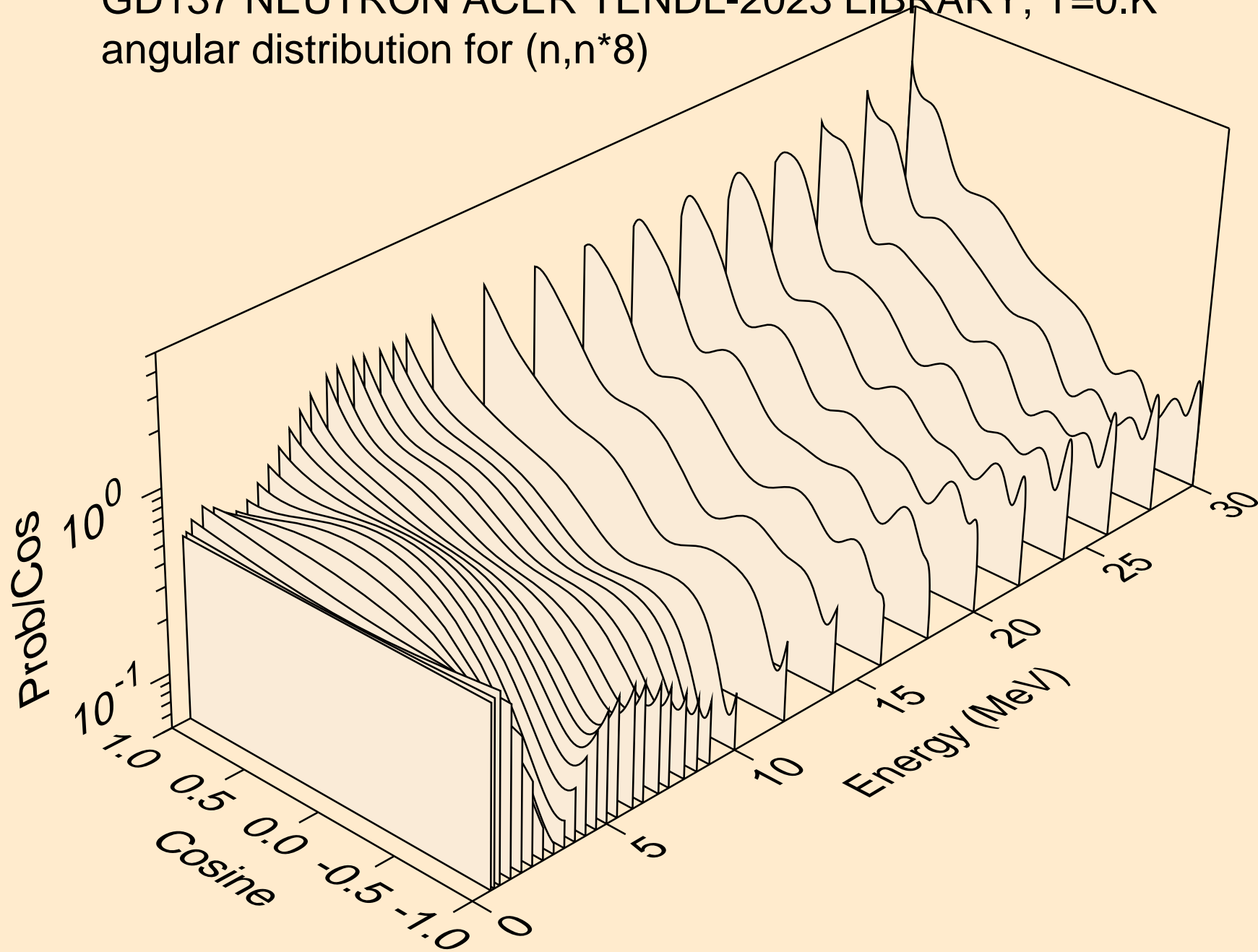

GD137 NEUTRON ACER TENDL-2023 LIBRARY; T=0.K  
angular distribution for (n,n\*9)

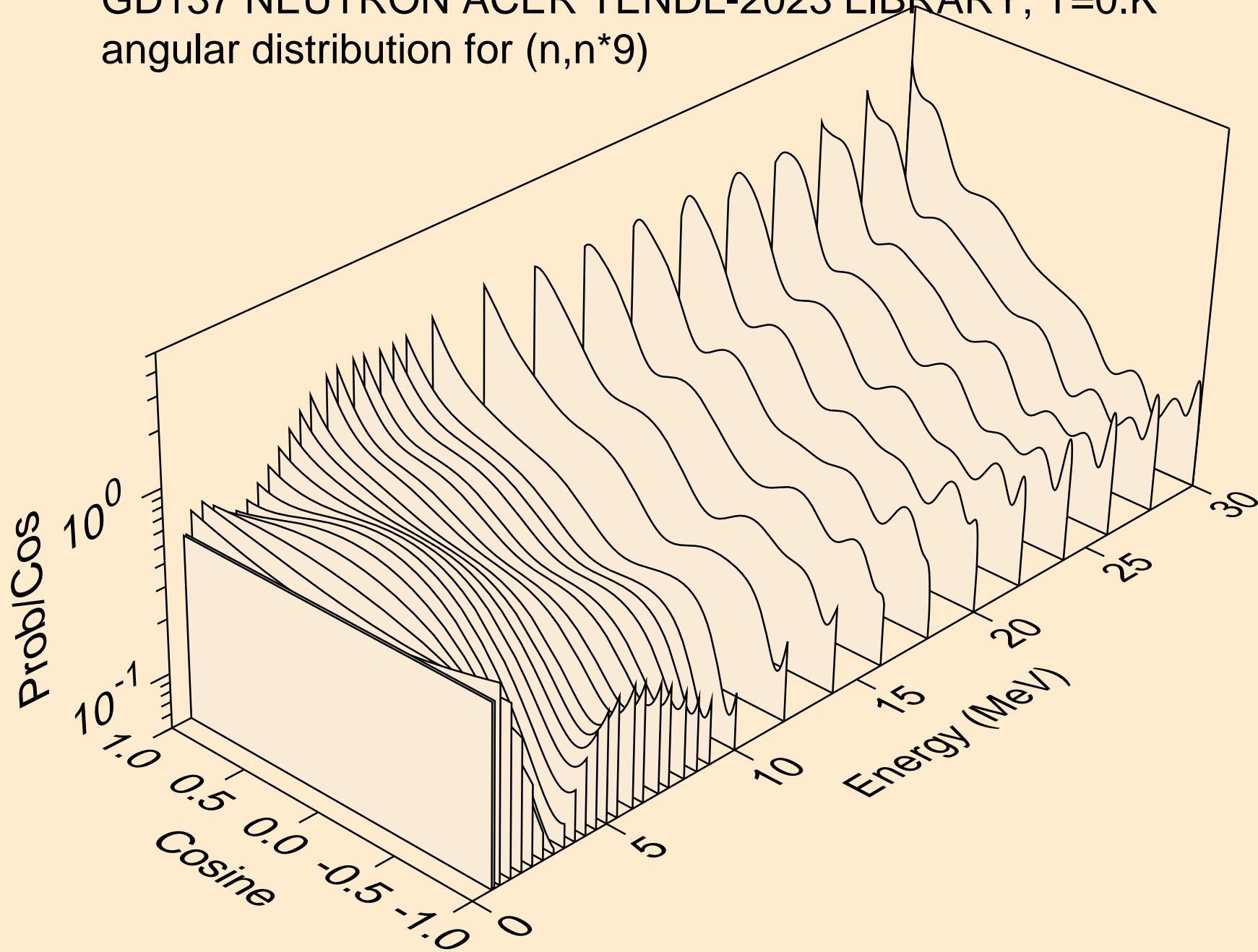

GD137 NEUTRON ACER TENDL-2023 LIBRARY; T=0.K  
angular distribution for (n,n\*10)

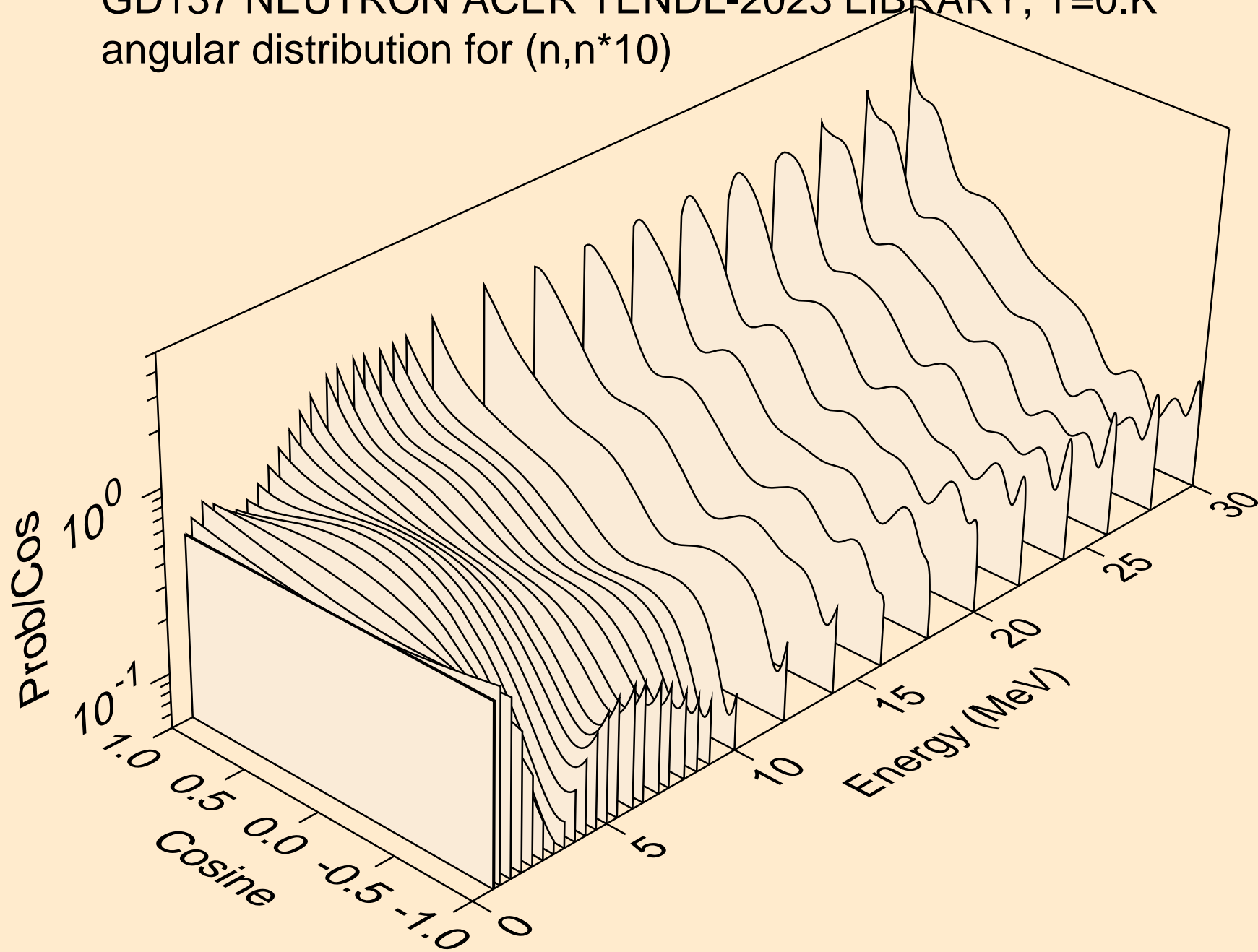

GD137 NEUTRON ACER TENDL-2023 LIBRARY; T=0.K  
angular distribution for (n,n\*11)

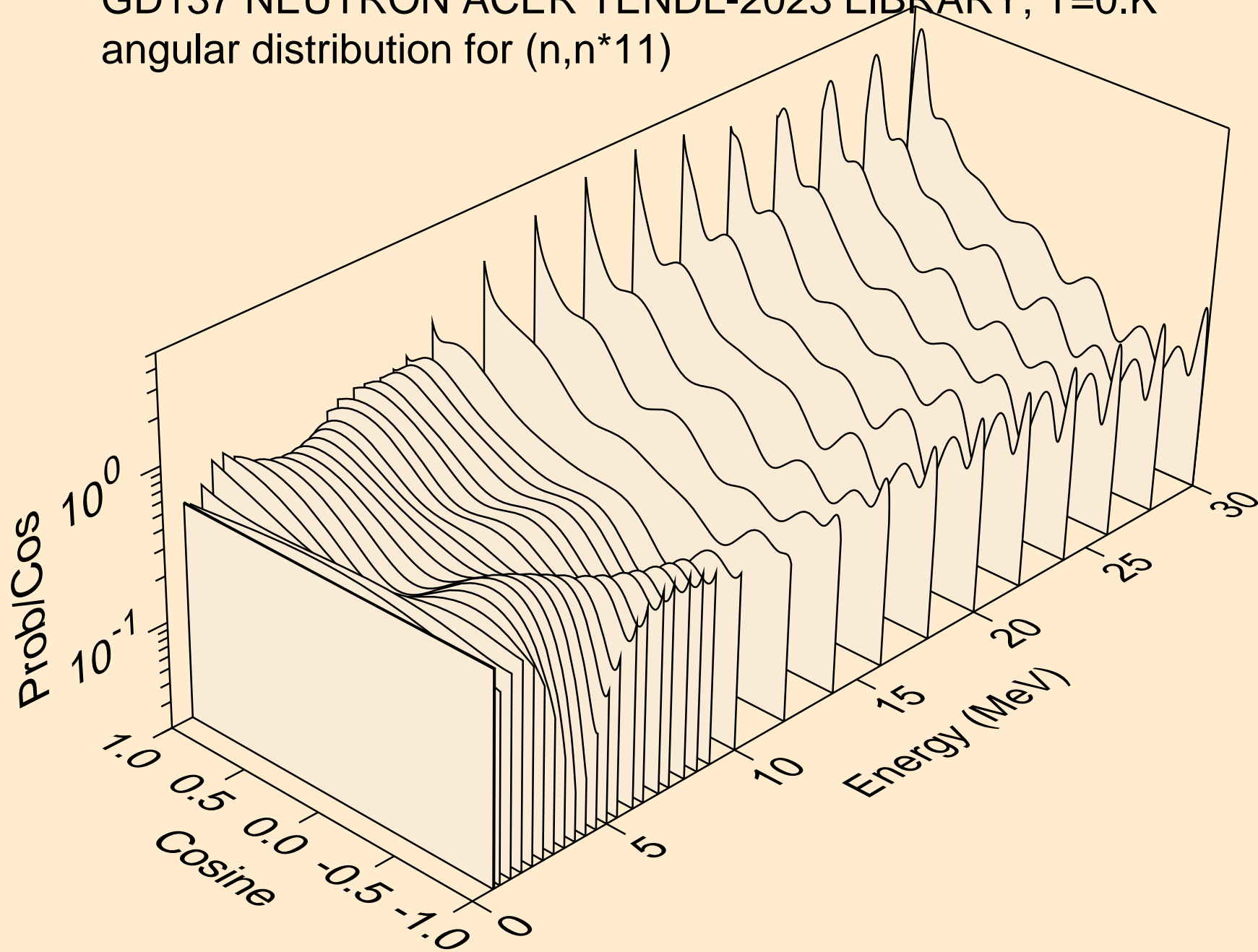

GD137 NEUTRON ACER TENDL-2023 LIBRARY; T=0.K  
angular distribution for (n,n\*12)

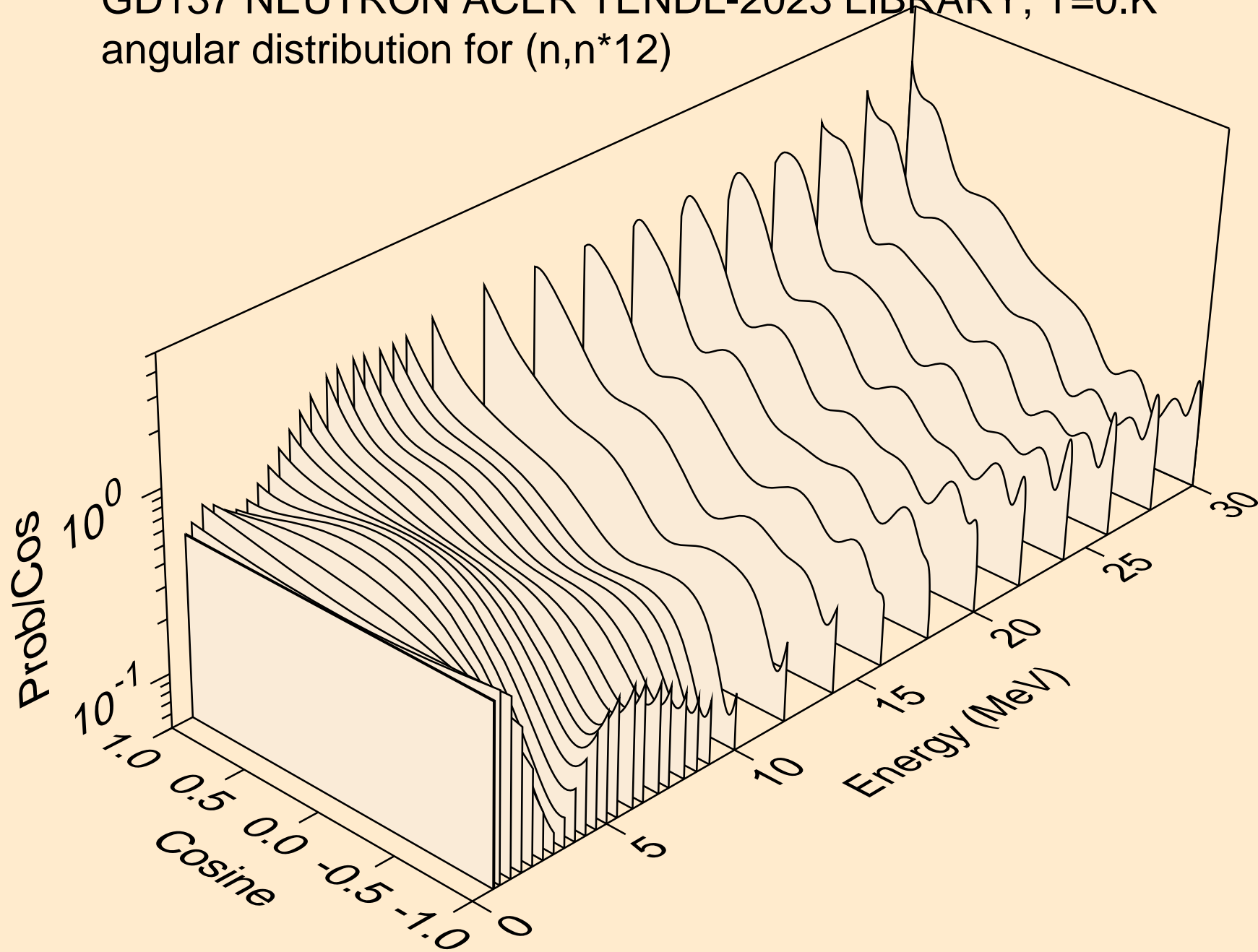

GD137 NEUTRON ACER TENDL-2023 LIBRARY; T=0.K  
angular distribution for (n,n\*13)

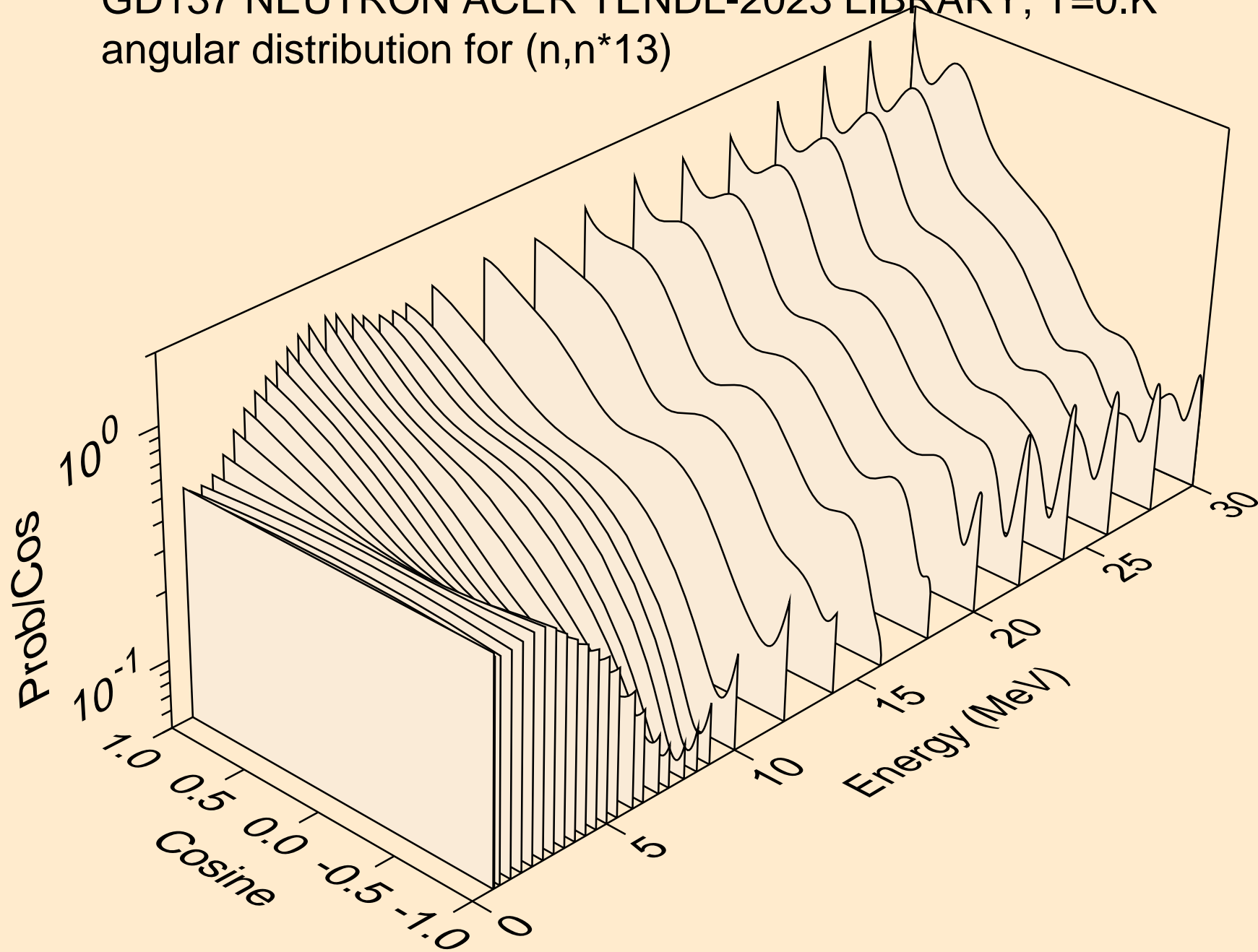

GD137 NEUTRON ACER TENDL-2023 LIBRARY; T=0.K  
angular distribution for (n,n\*14)

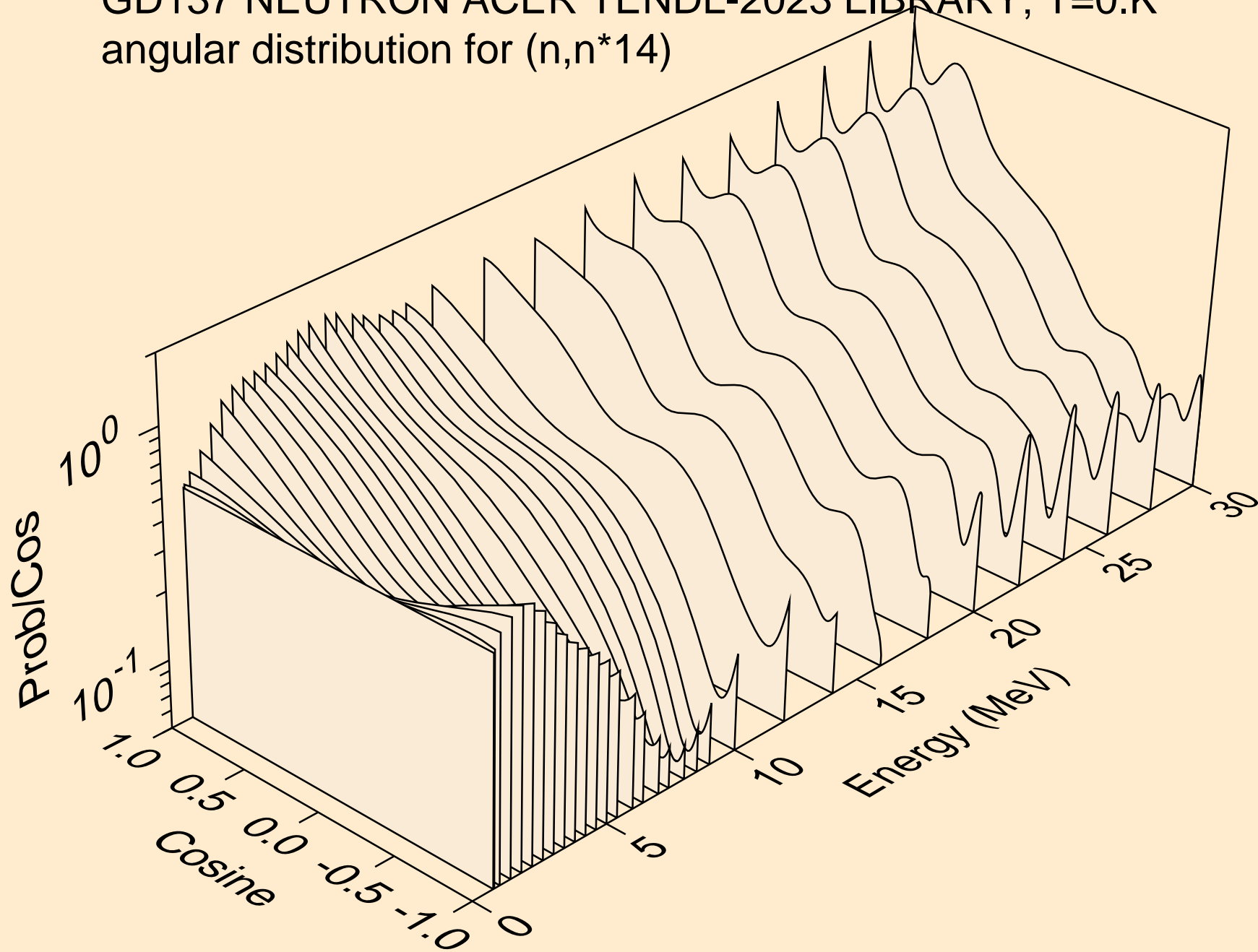

GD137 NEUTRON ACER TENDL-2023 LIBRARY; T=0.K  
angular distribution for (n,n\*15)

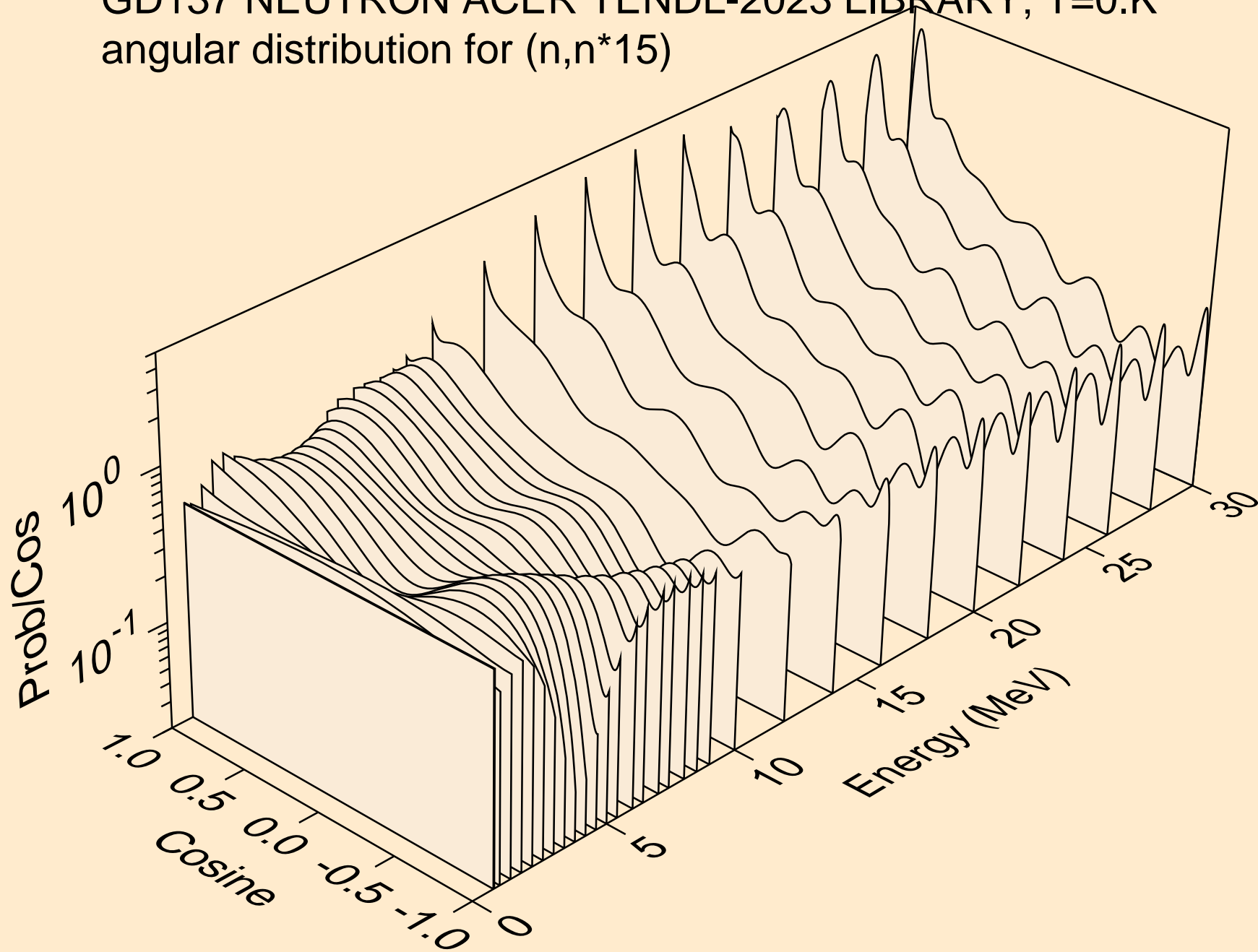



GD137 NEUTRON ACER TENDL-2023 LIBRARY; T=0.K  
angular distribution for (n,n\*16)

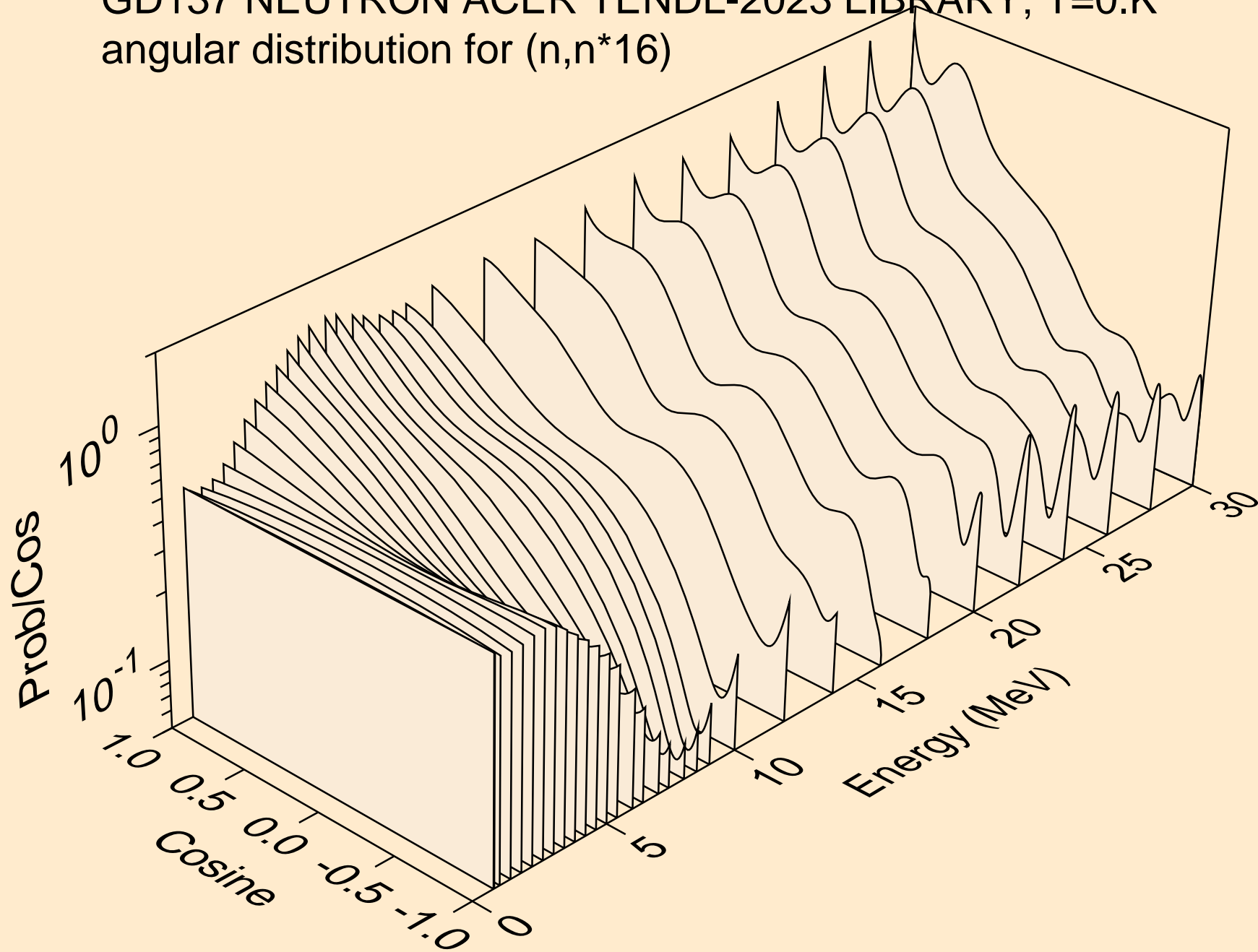

GD137 NEUTRON ACER TENDL-2023 LIBRARY; T=0.K  
angular distribution for (n,n\*17)

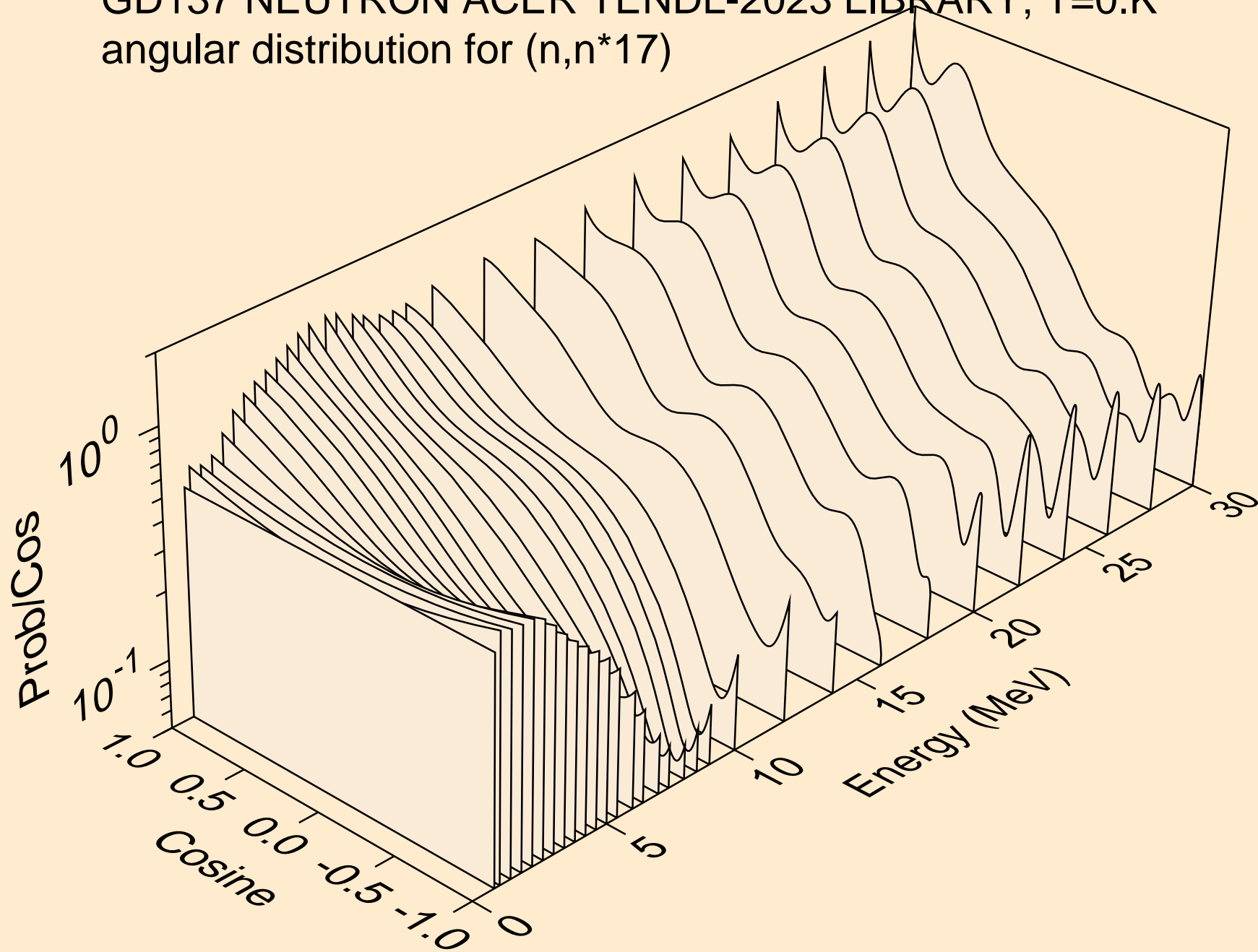

GD137 NEUTRON ACER TENDL-2023 LIBRARY; T=0.K  
angular distribution for (n,n\*18)

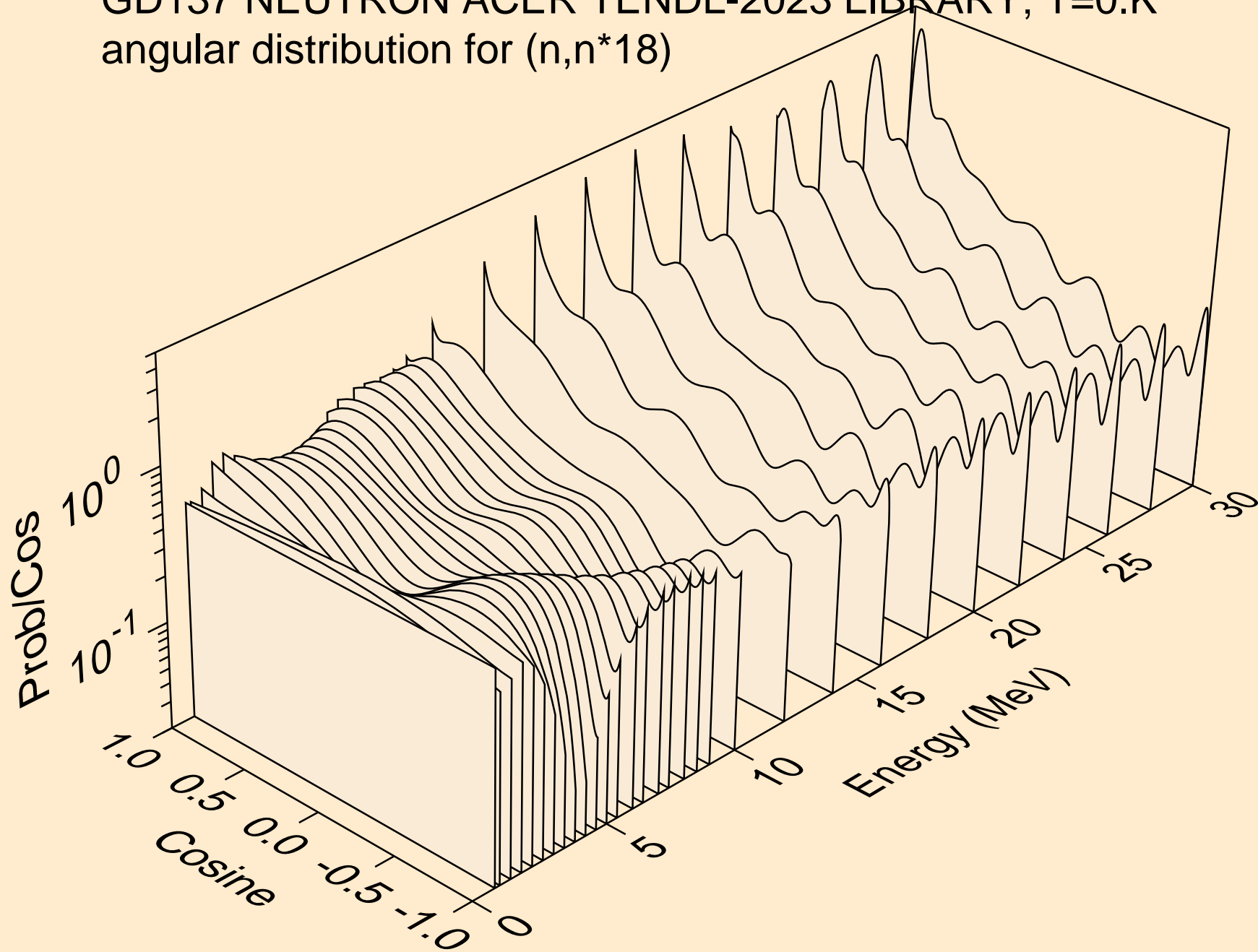

GD137 NEUTRON ACER TENDL-2023 LIBRARY; T=0.K  
angular distribution for (n,n\*19)

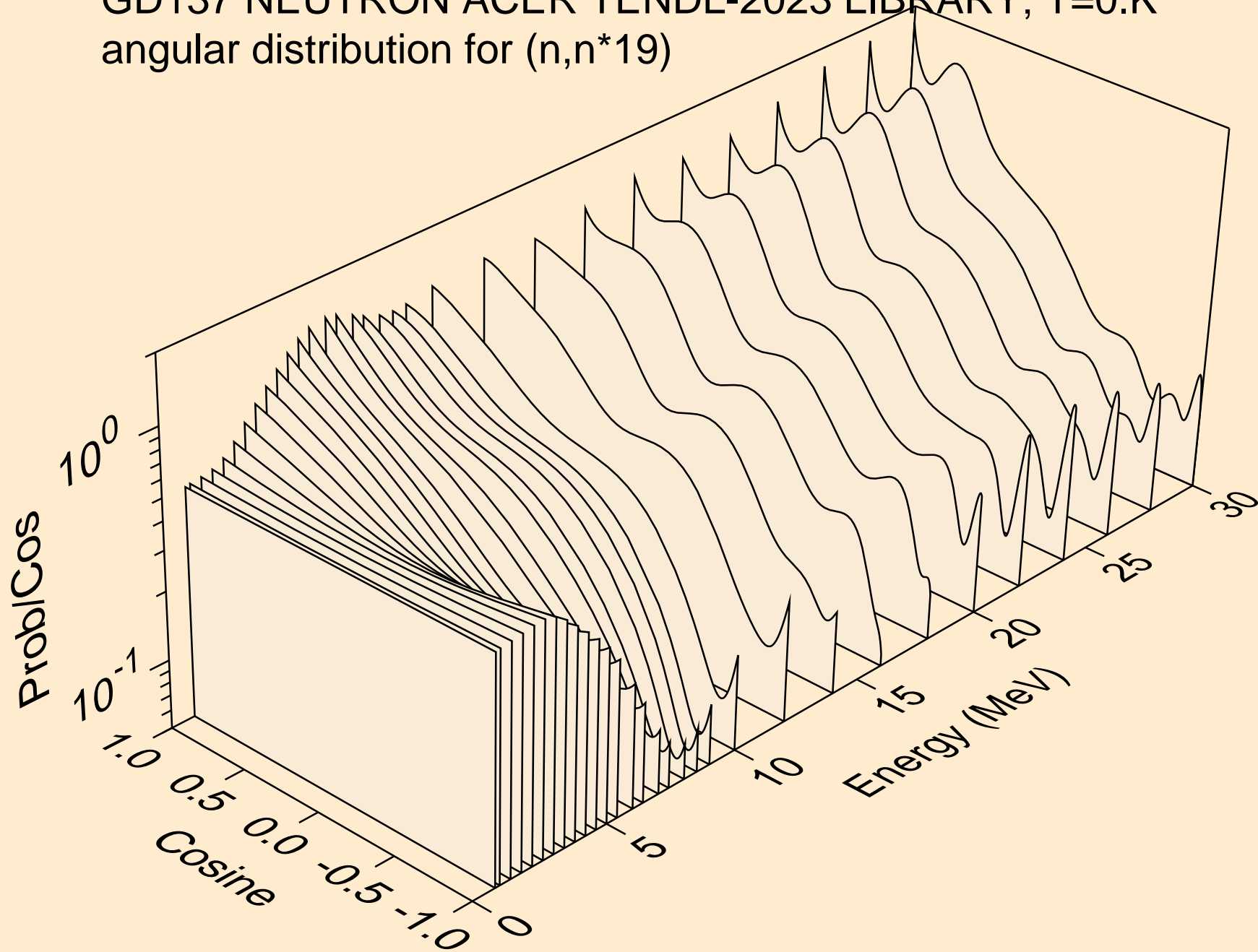

GD137 NEUTRON ACER TENDL-2023 LIBRARY; T=0.K  
angular distribution for (n,n\*20)

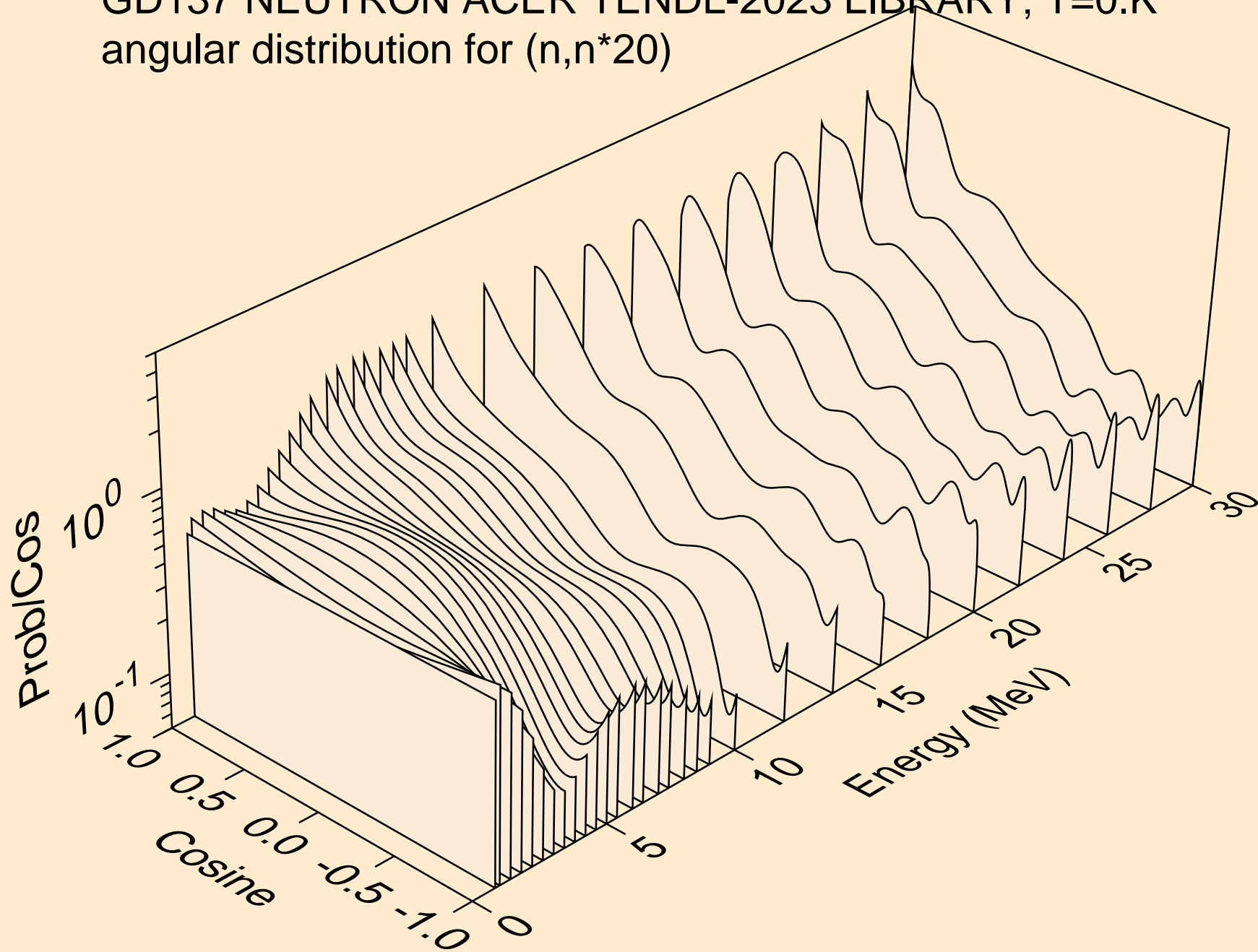

GD137 NEUTRON ACER TENDL-2023 LIBRARY; T=0.K  
angular distribution for (n,n\*21)

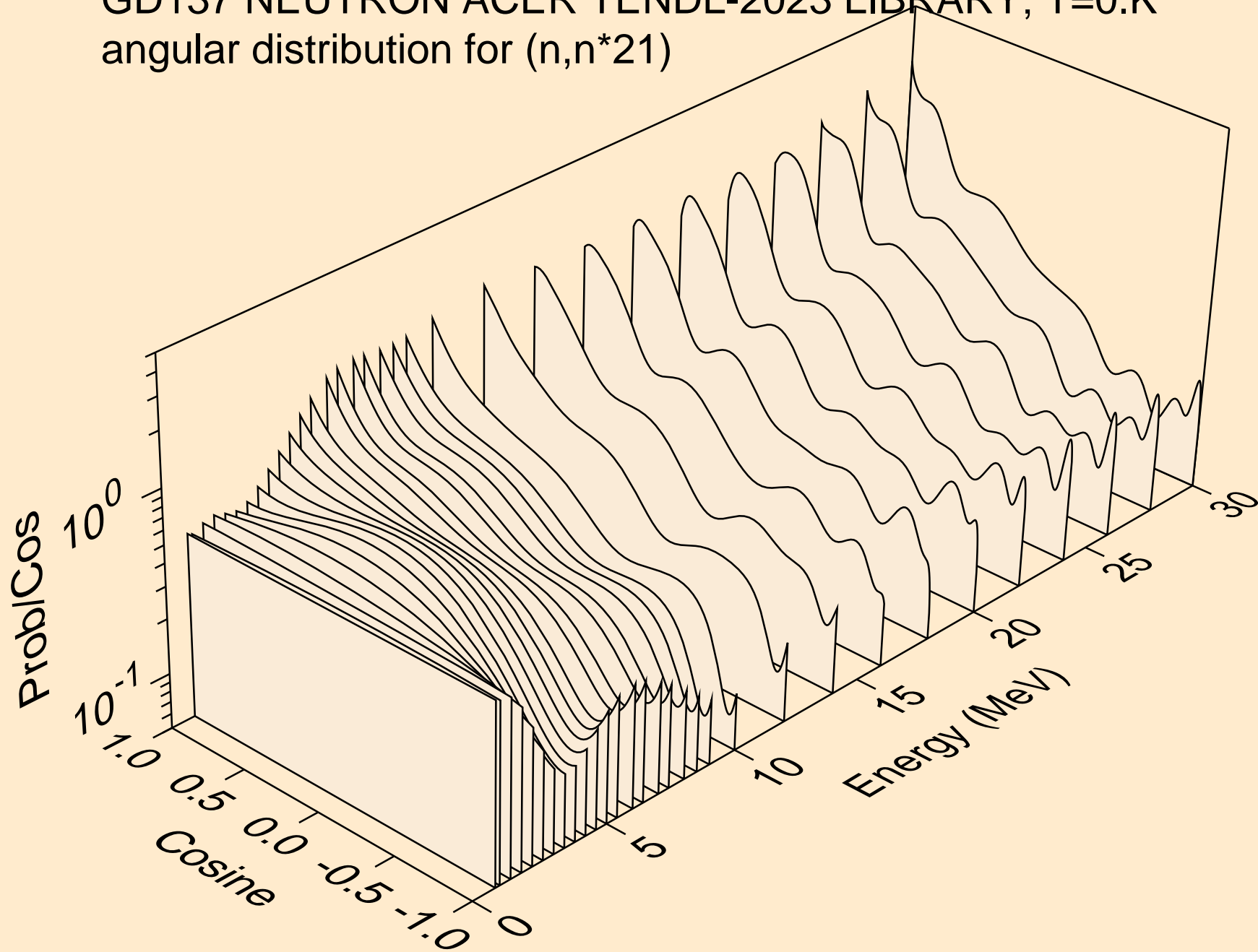

GD137 NEUTRON ACER TENDL-2023 LIBRARY; T=0.K  
angular distribution for (n,n\*22)

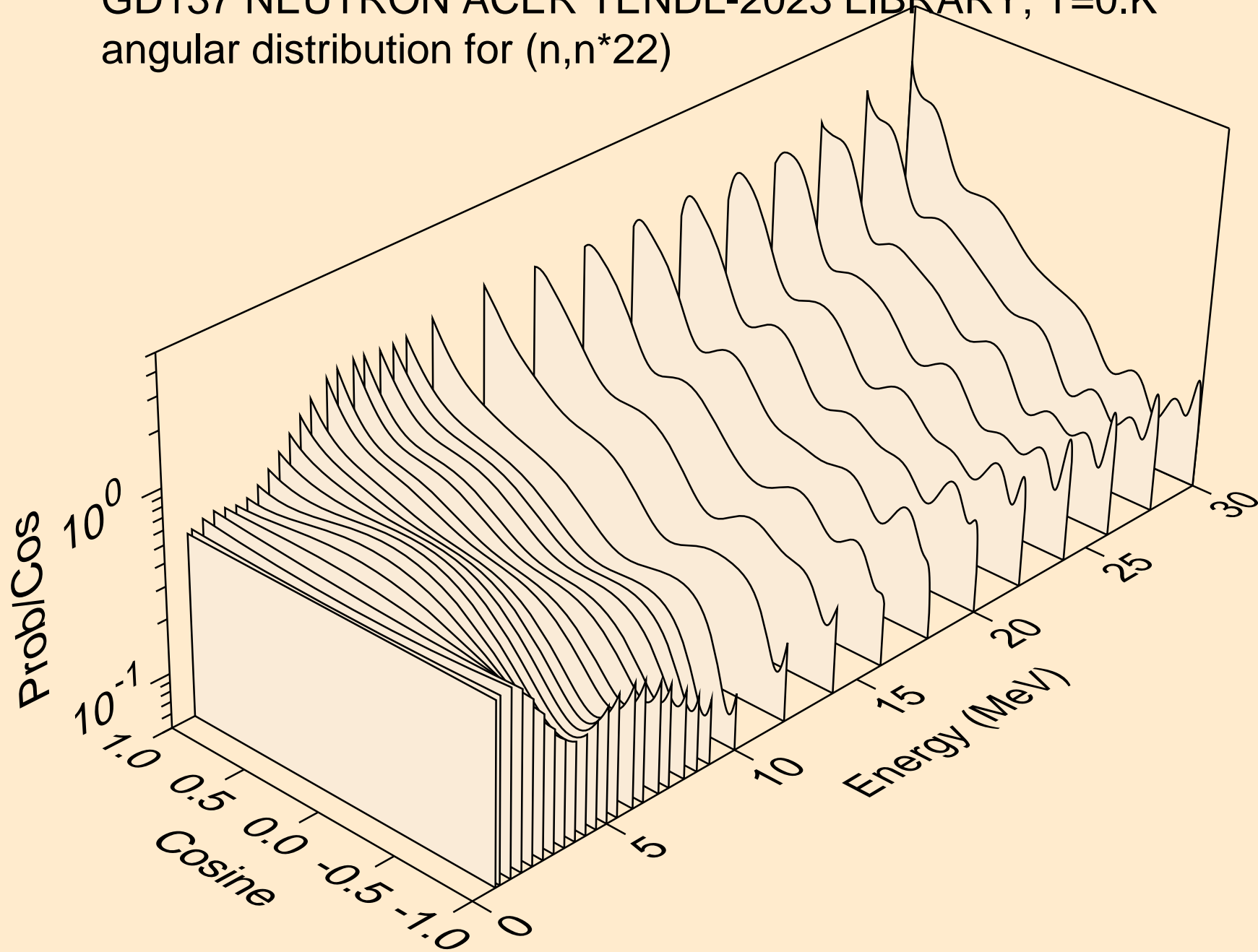

GD137 NEUTRON ACER TENDL-2023 LIBRARY; T=0.K  
angular distribution for (n,n\*23)

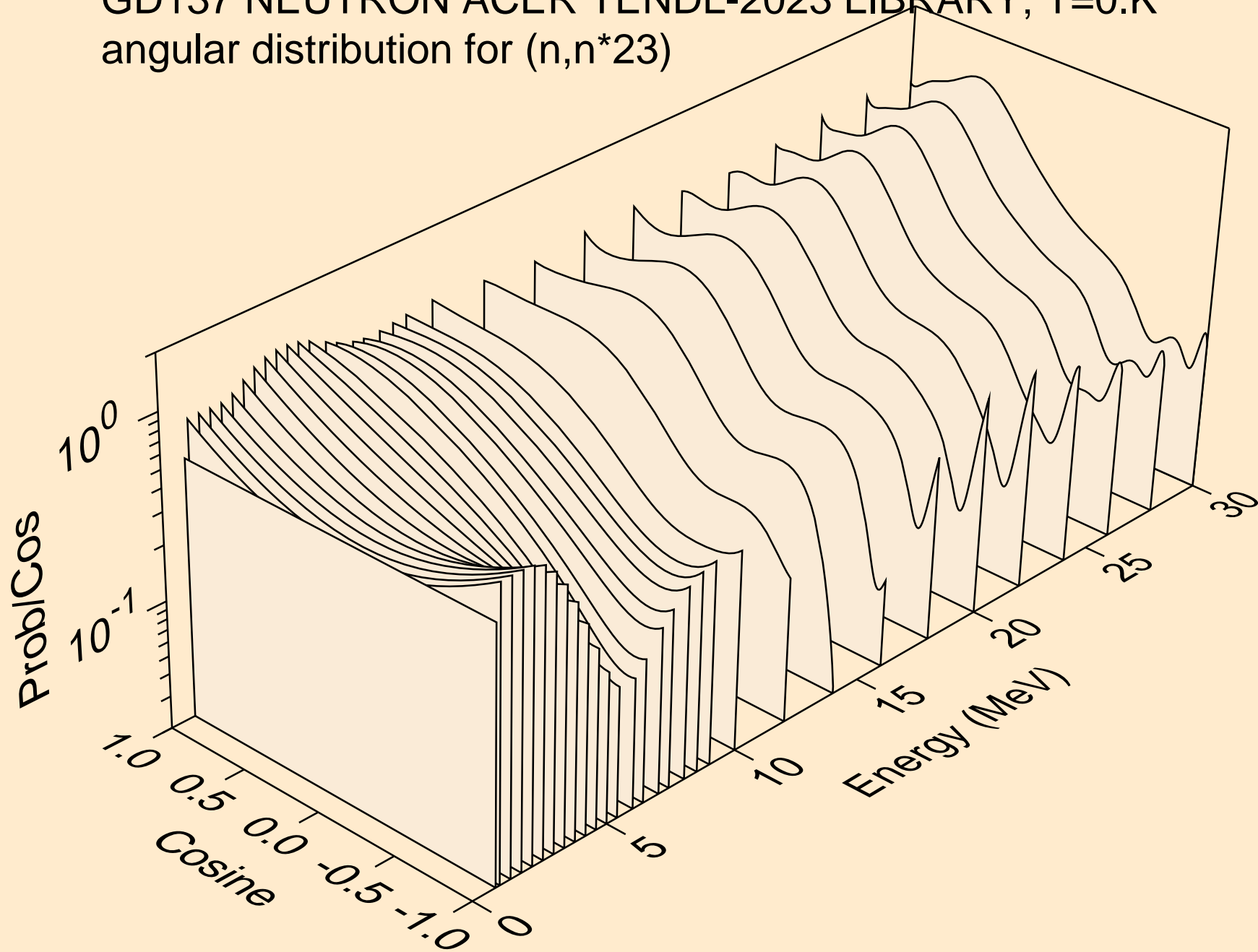



GD137 NEUTRON ACER TENDL-2023 LIBRARY; T=0.K  
angular distribution for (n,n\*24)

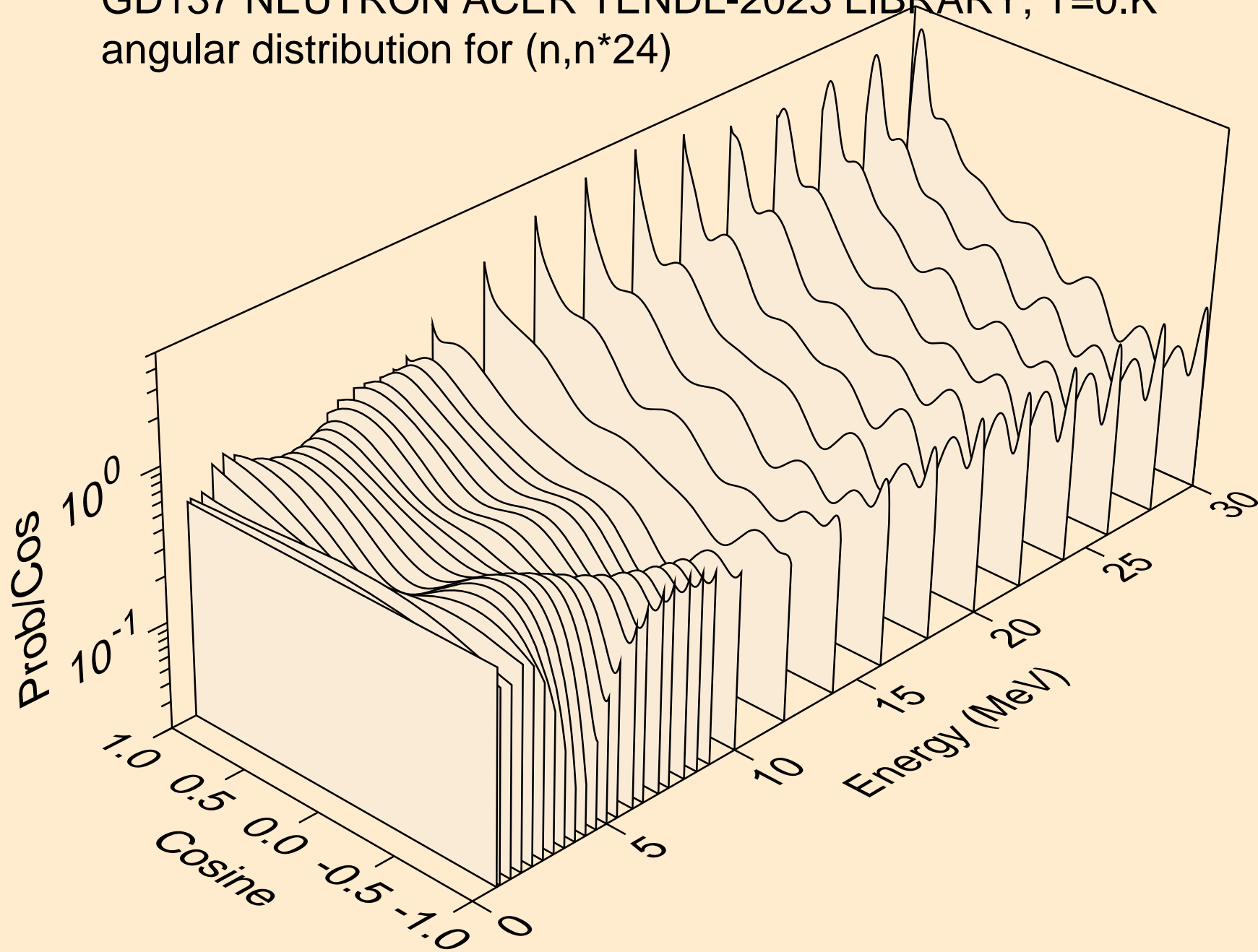

GD137 NEUTRON ACER TENDL-2023 LIBRARY; T=0.K  
Neutron emission for (n,x)

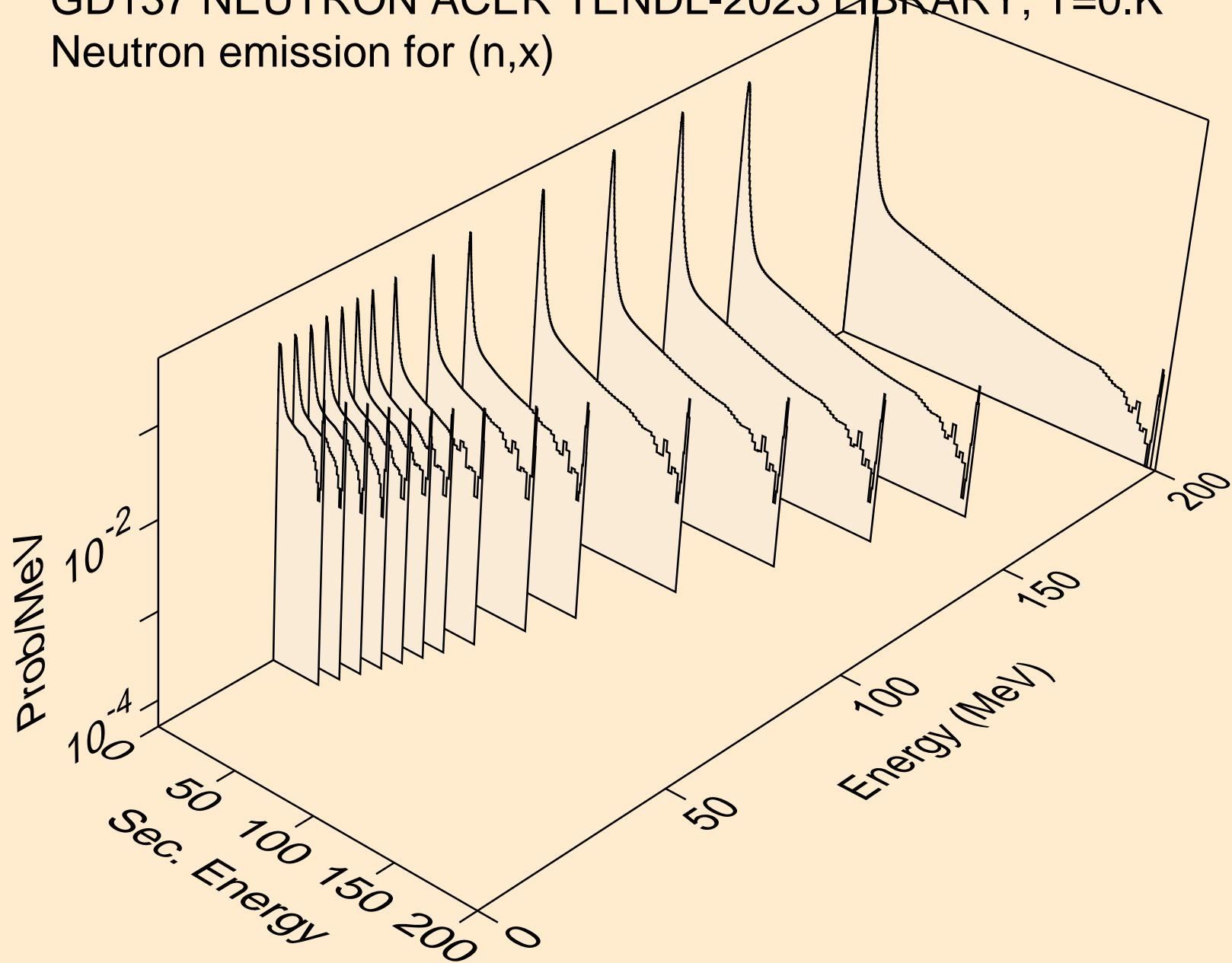

GD137 NEUTRON ACER TENDL-2023 LIBRARY; T=0.K  
Neutron emission for (n,2nd)

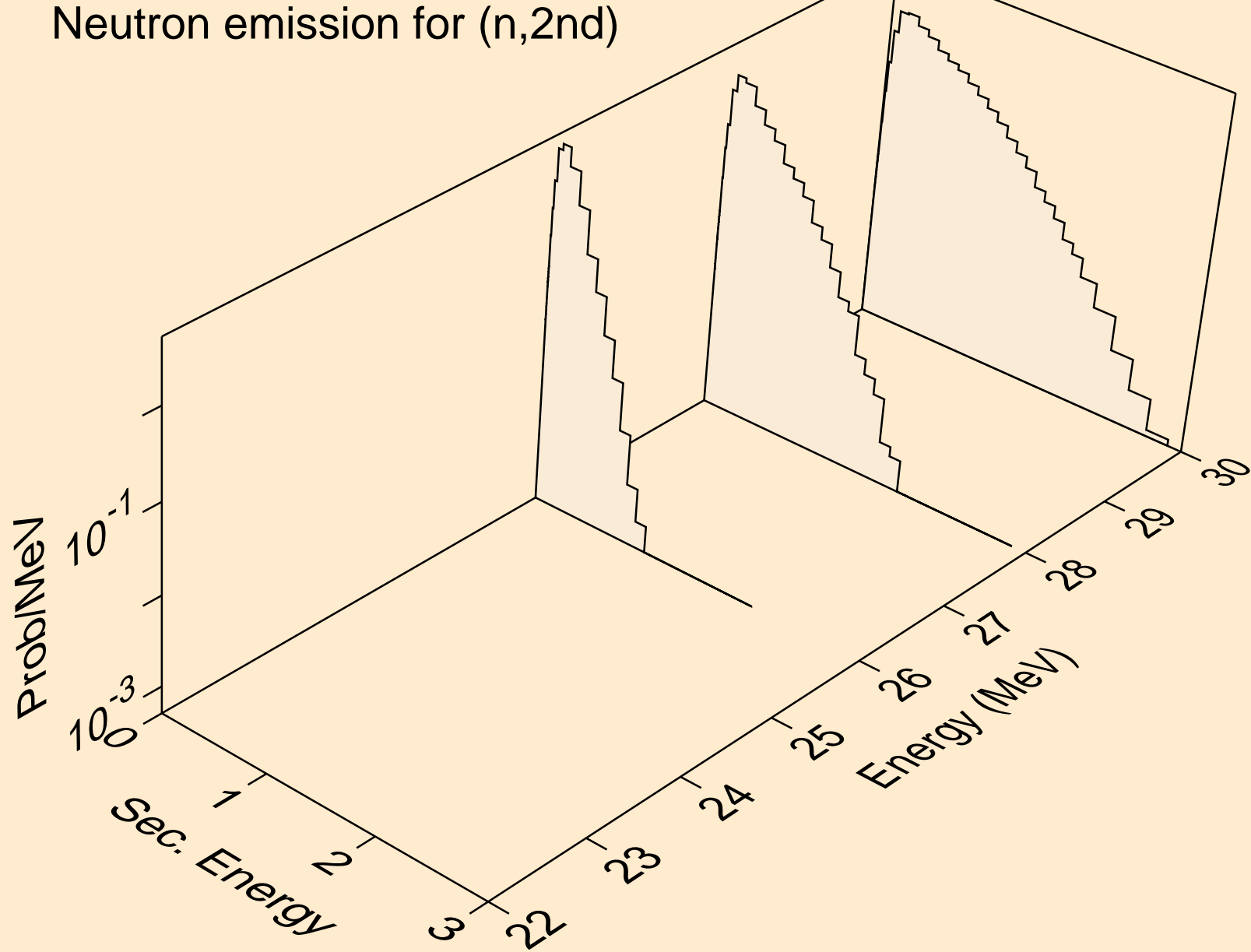

GD137 NEUTRON ACER TENDL-2023 LIBRARY; T=0.K  
Neutron emission for (n,2n)

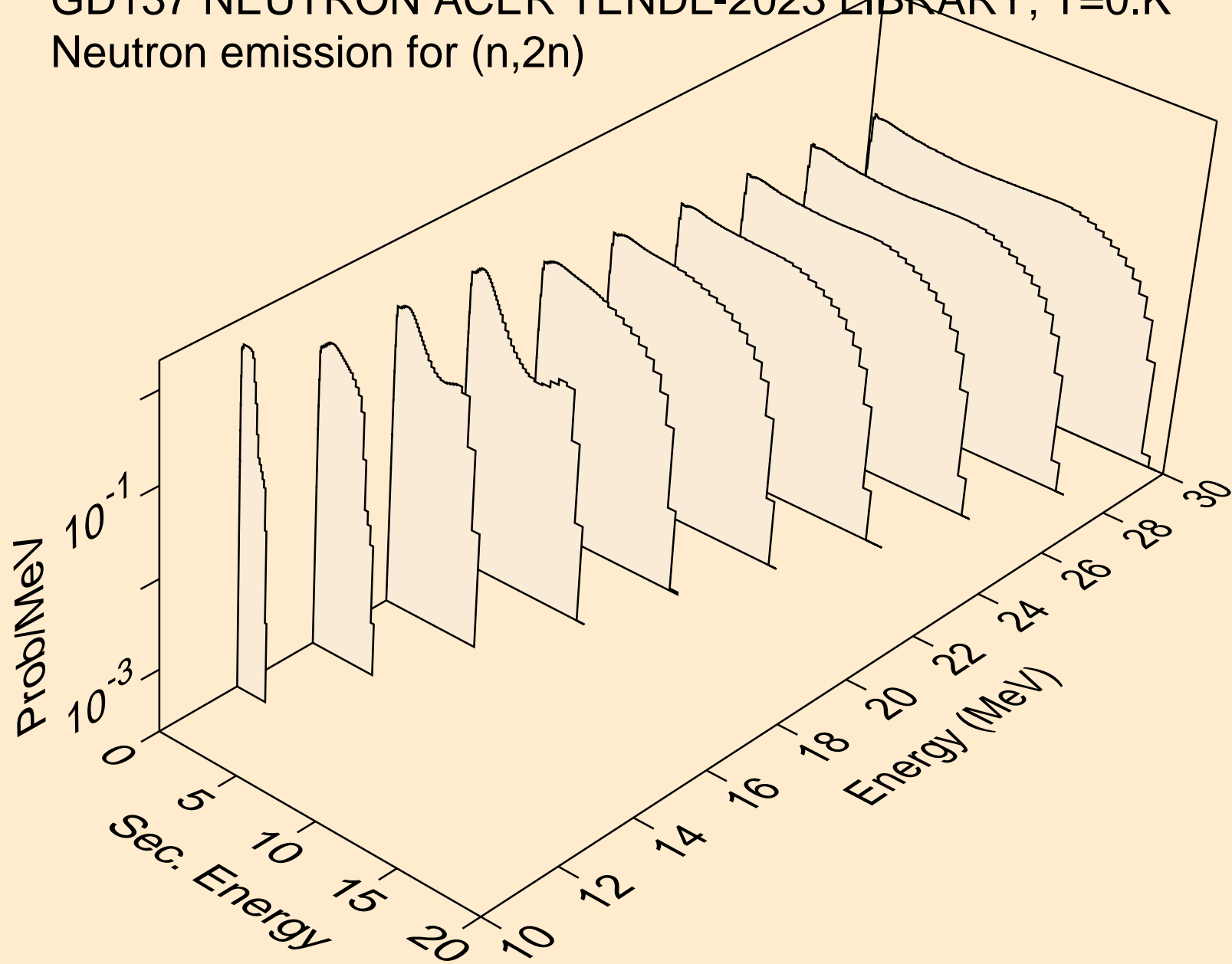

GD137 NEUTRON ACER TENDL-2023 LIBRARY; T=0.K  
Neutron emission for (n,3n)

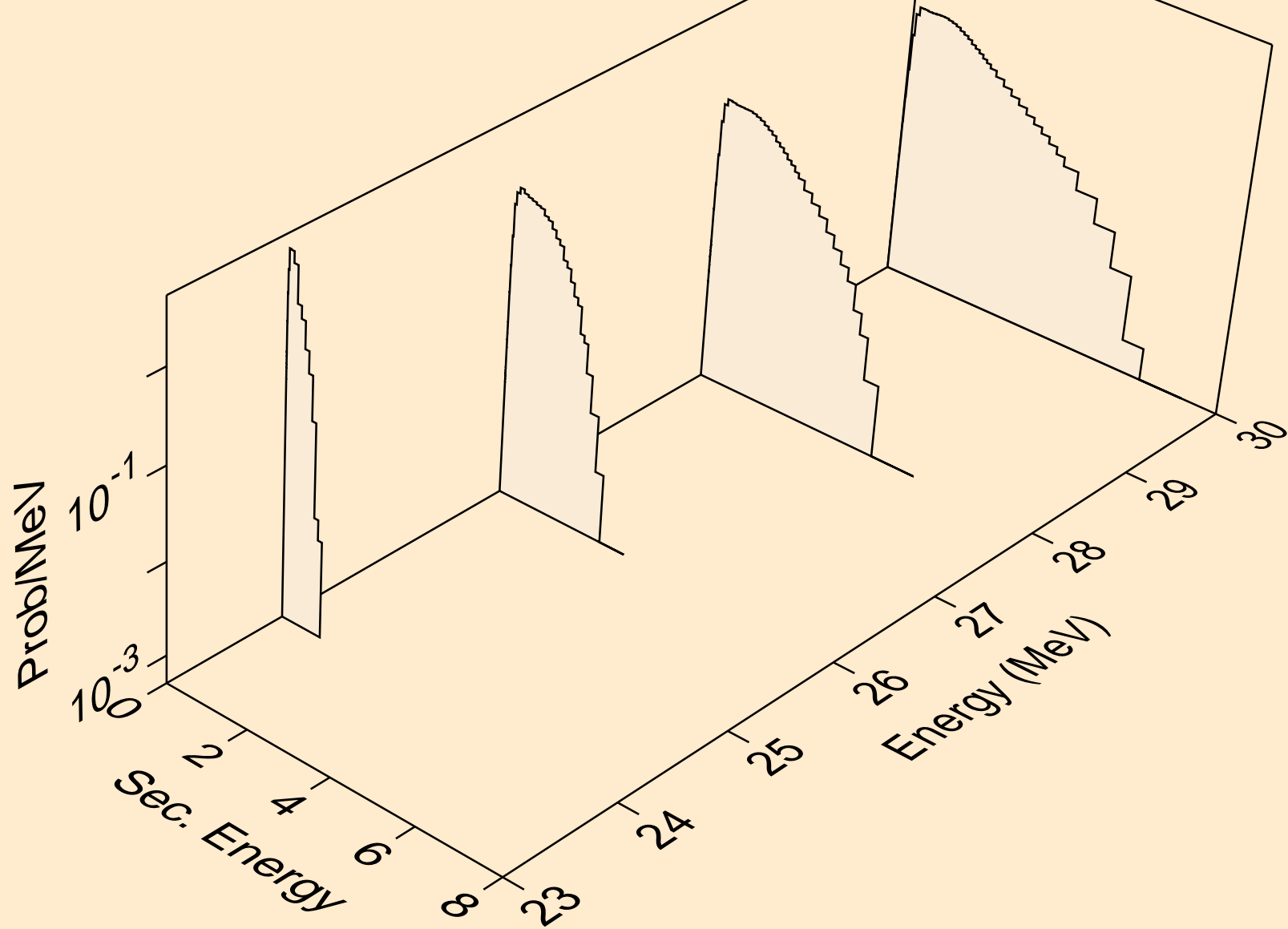

GD137 NEUTRON ACER TENDL-2023 LIBRARY; T=0.K  
Neutron emission for (n,n\*)a

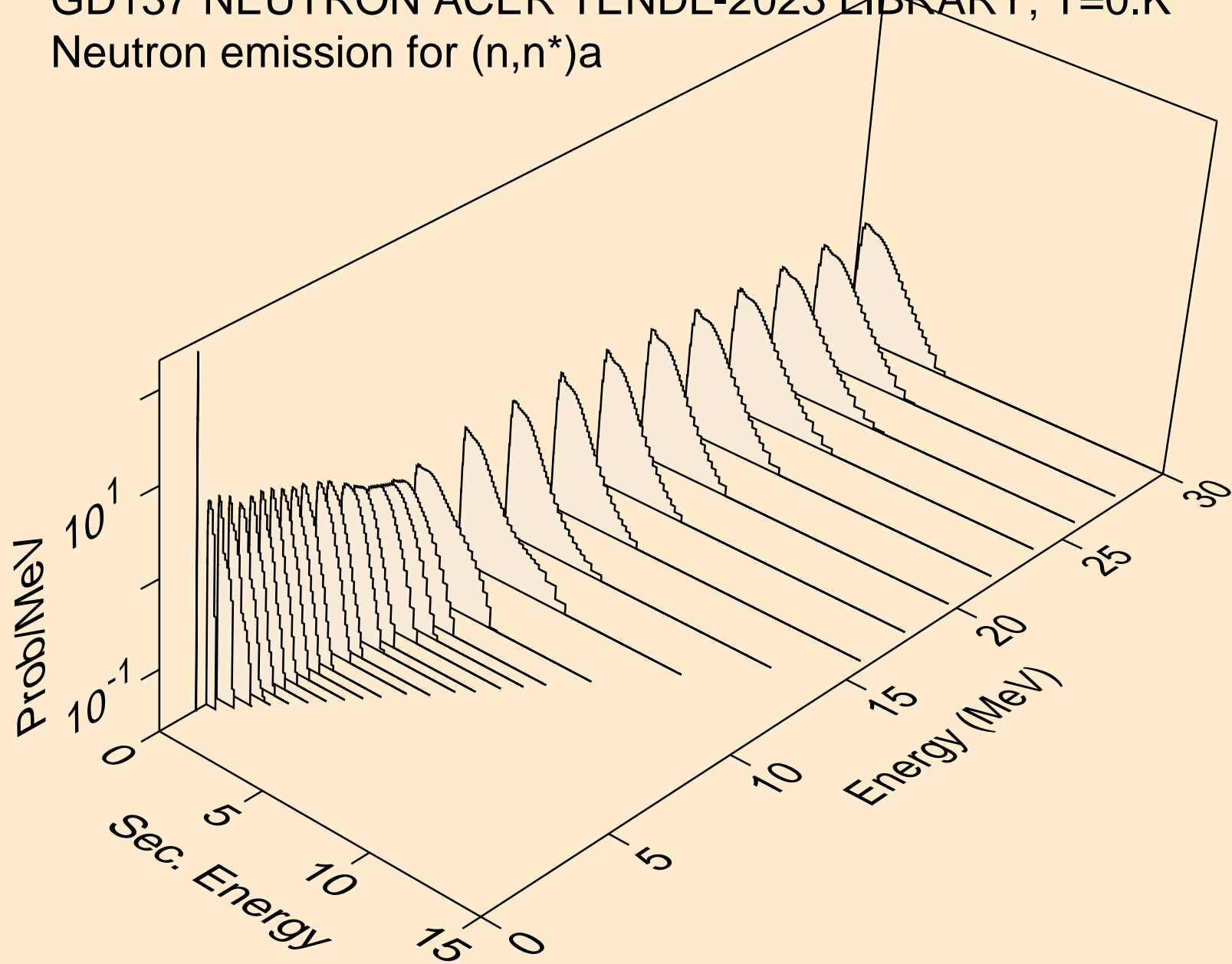

GD137 NEUTRON ACER TENDL-2023 LIBRARY; T=0.K  
Neutron emission for (n,2n)a

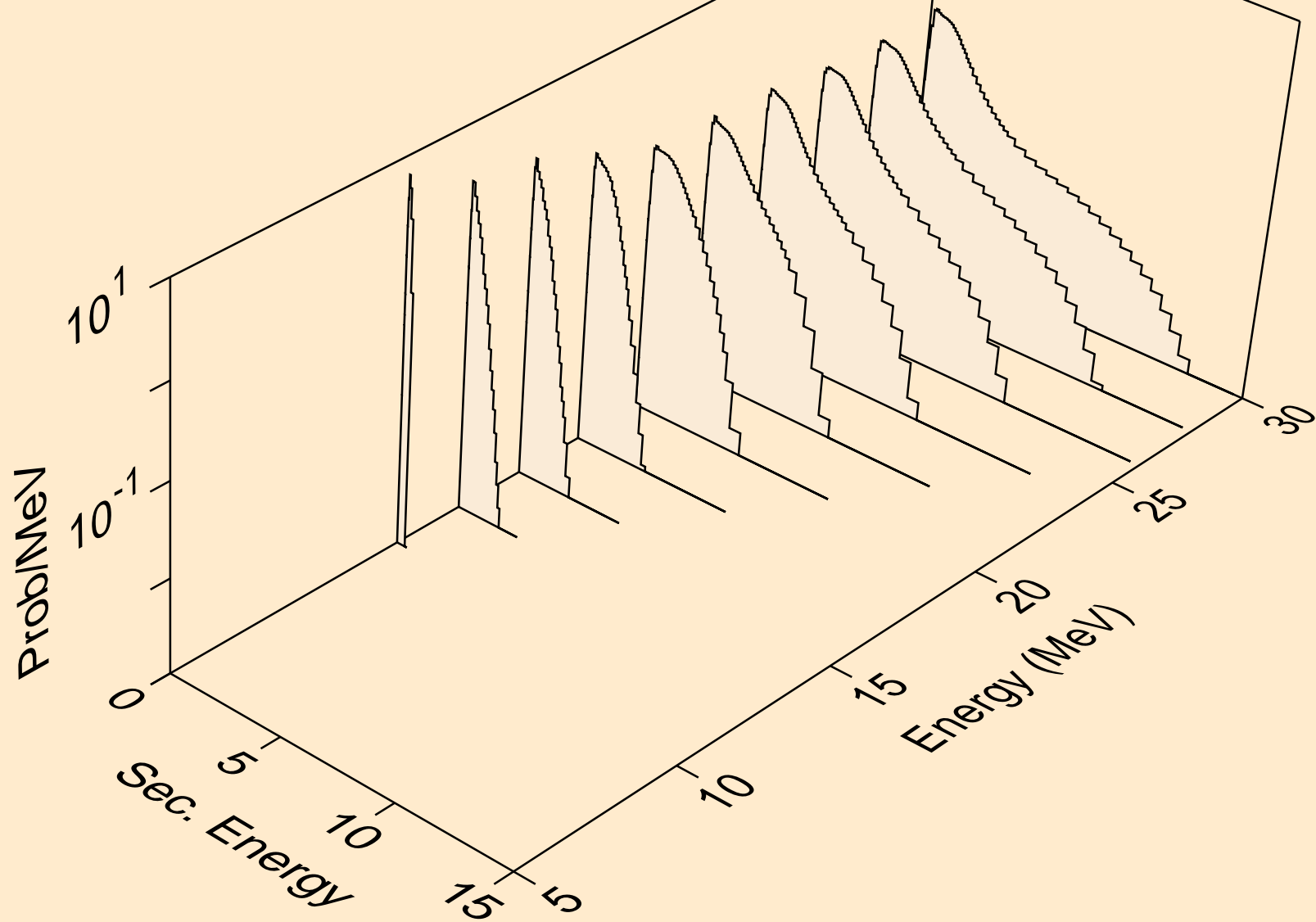

GD137 NEUTRON ACER TENDL-2023 LIBRARY; T=0.K  
Neutron emission for (n,n\*)p

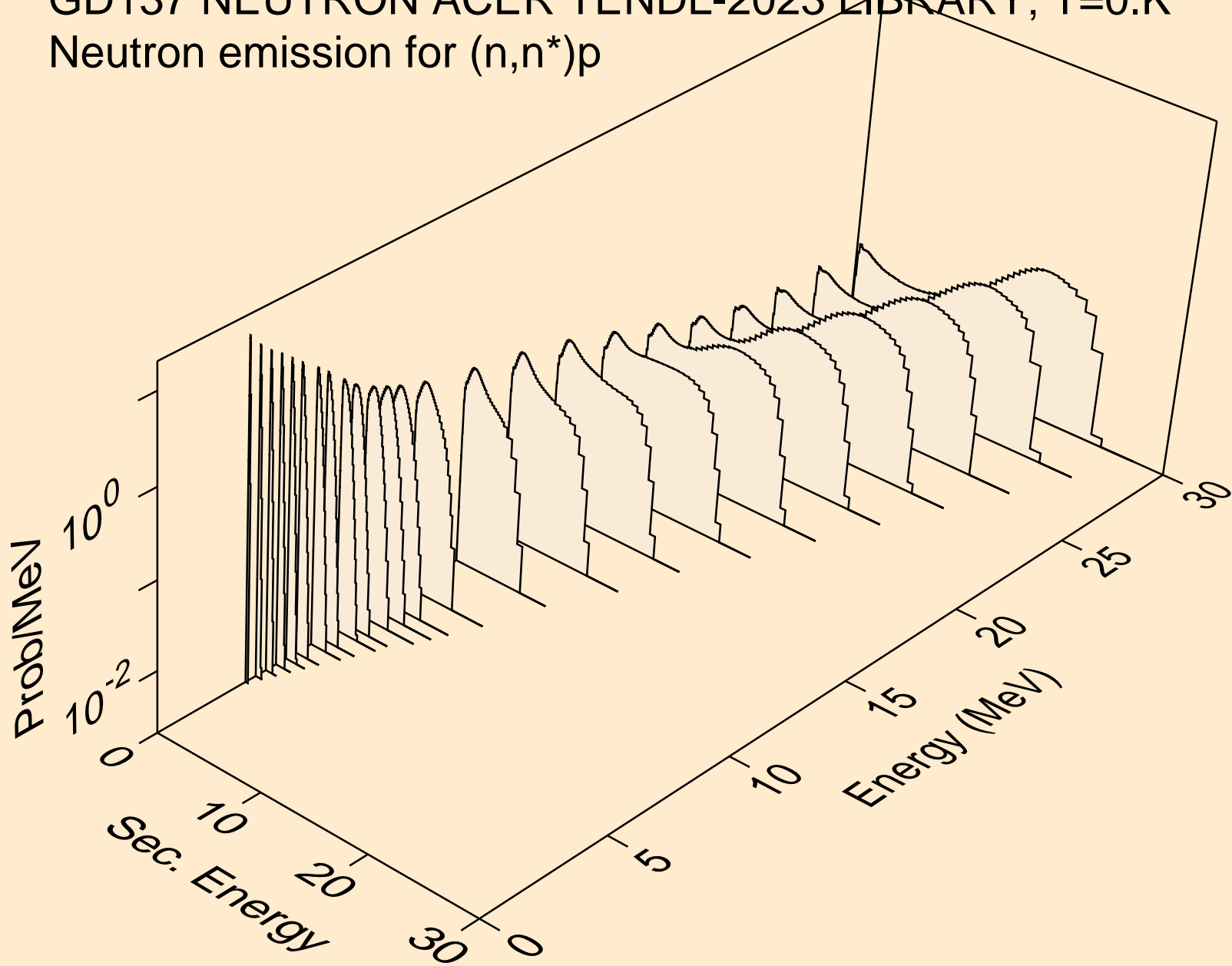



GD137 NEUTRON ACER TENDL-2023 LIBRARY; T=0.K  
Neutron emission for (n,n\*)2a

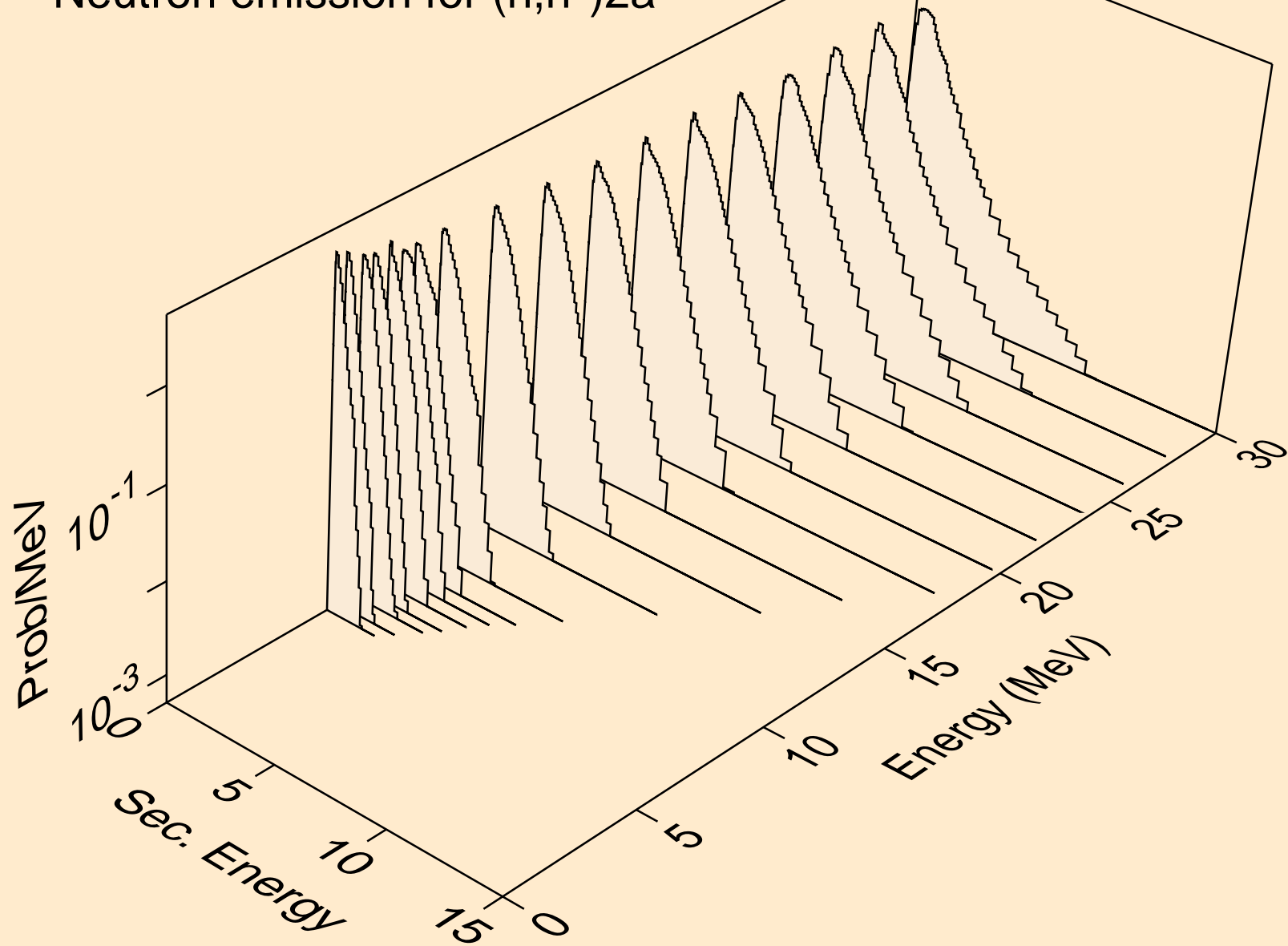

GD137 NEUTRON ACER TENDL-2023 LIBRARY; T=0.K  
Neutron emission for (n,2n)2a

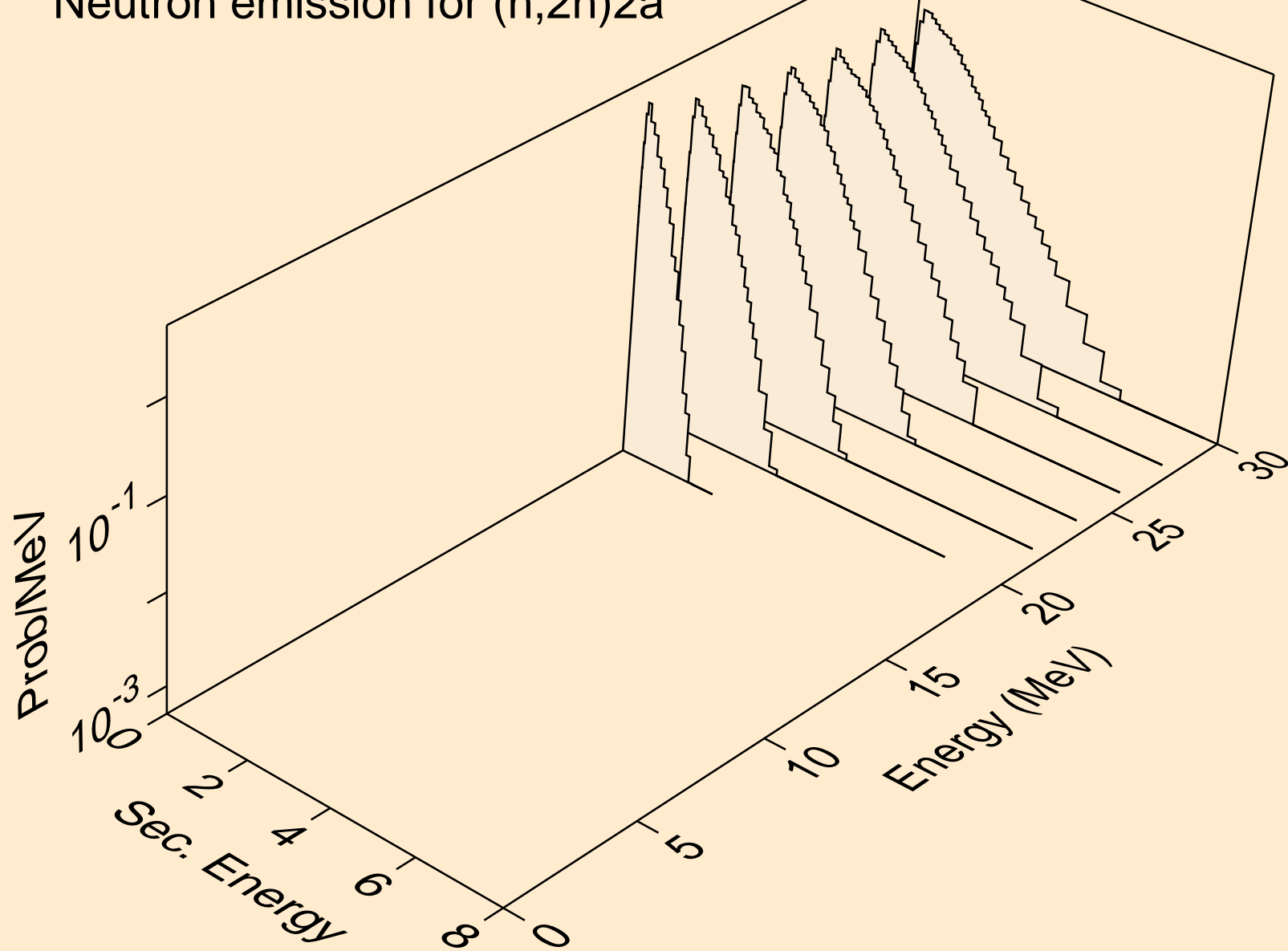

GD137 NEUTRON ACER TENDL-2023 LIBRARY; T=0.K  
Neutron emission for (n,n\*)d

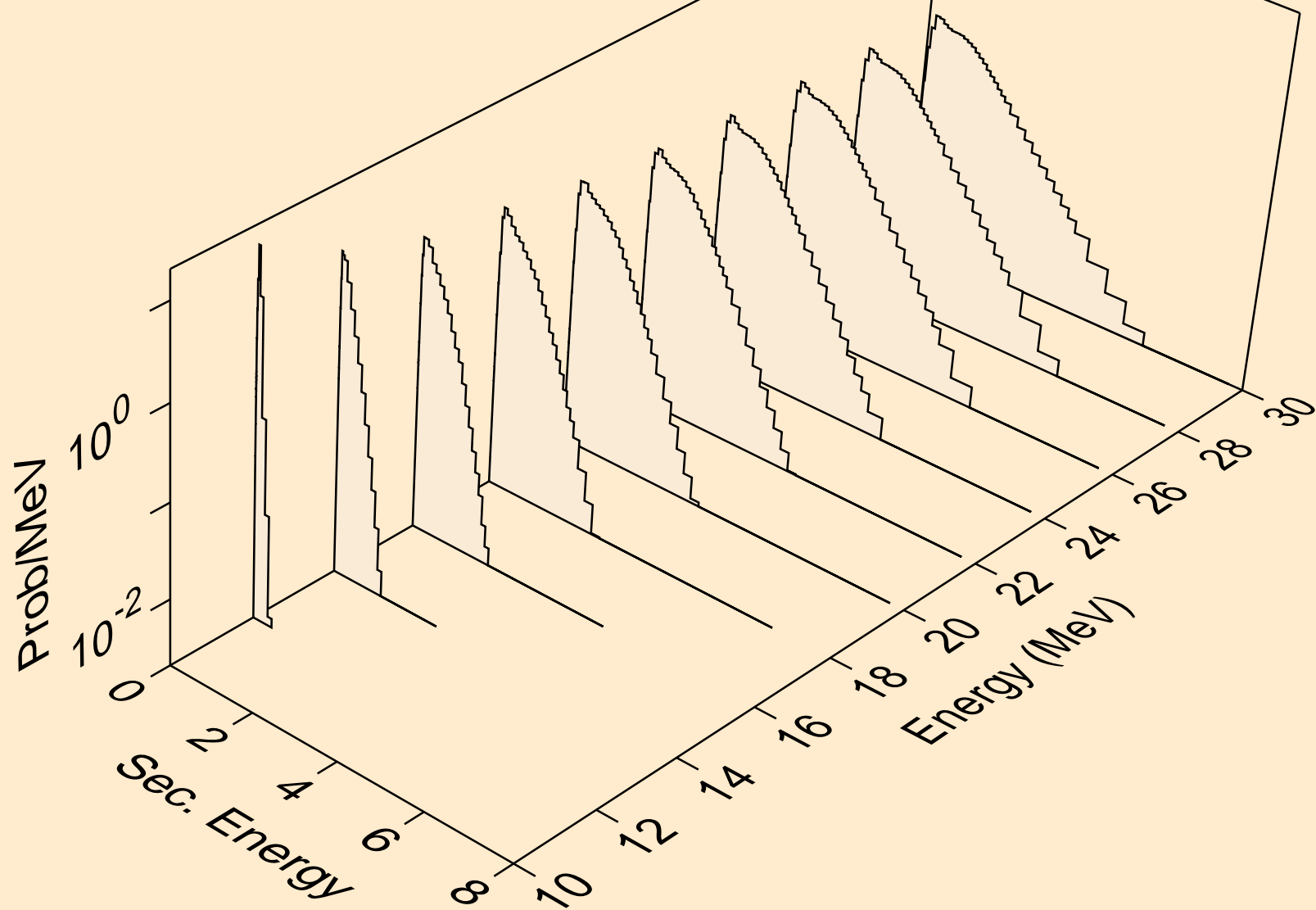

GD137 NEUTRON ACER TENDL-2023 LIBRARY; T=0.K  
Neutron emission for (n,n\*)t

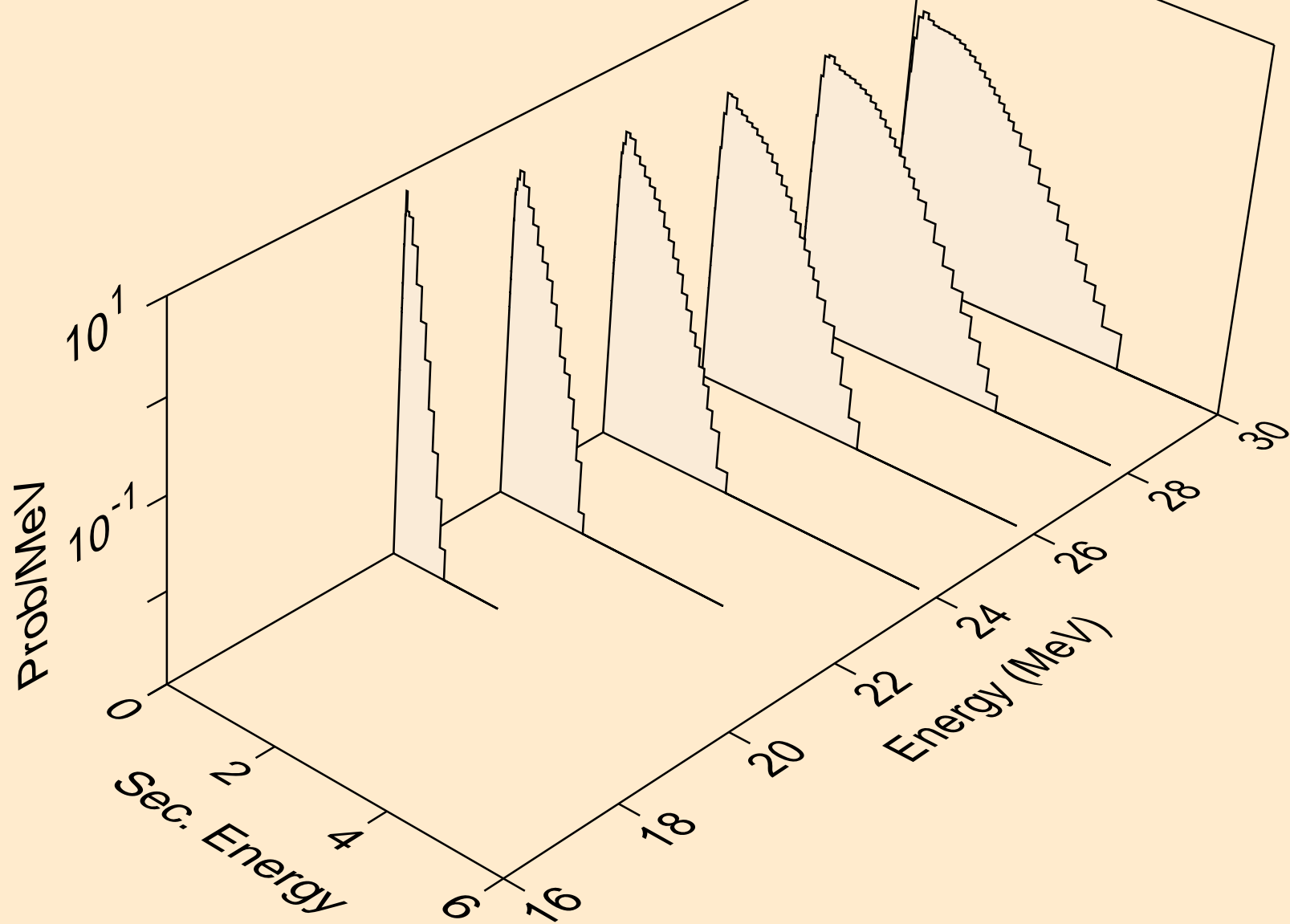

GD137 NEUTRON ACER TENDL-2023 LIBRARY; T=0.K  
Neutron emission for (n,n\*)he3

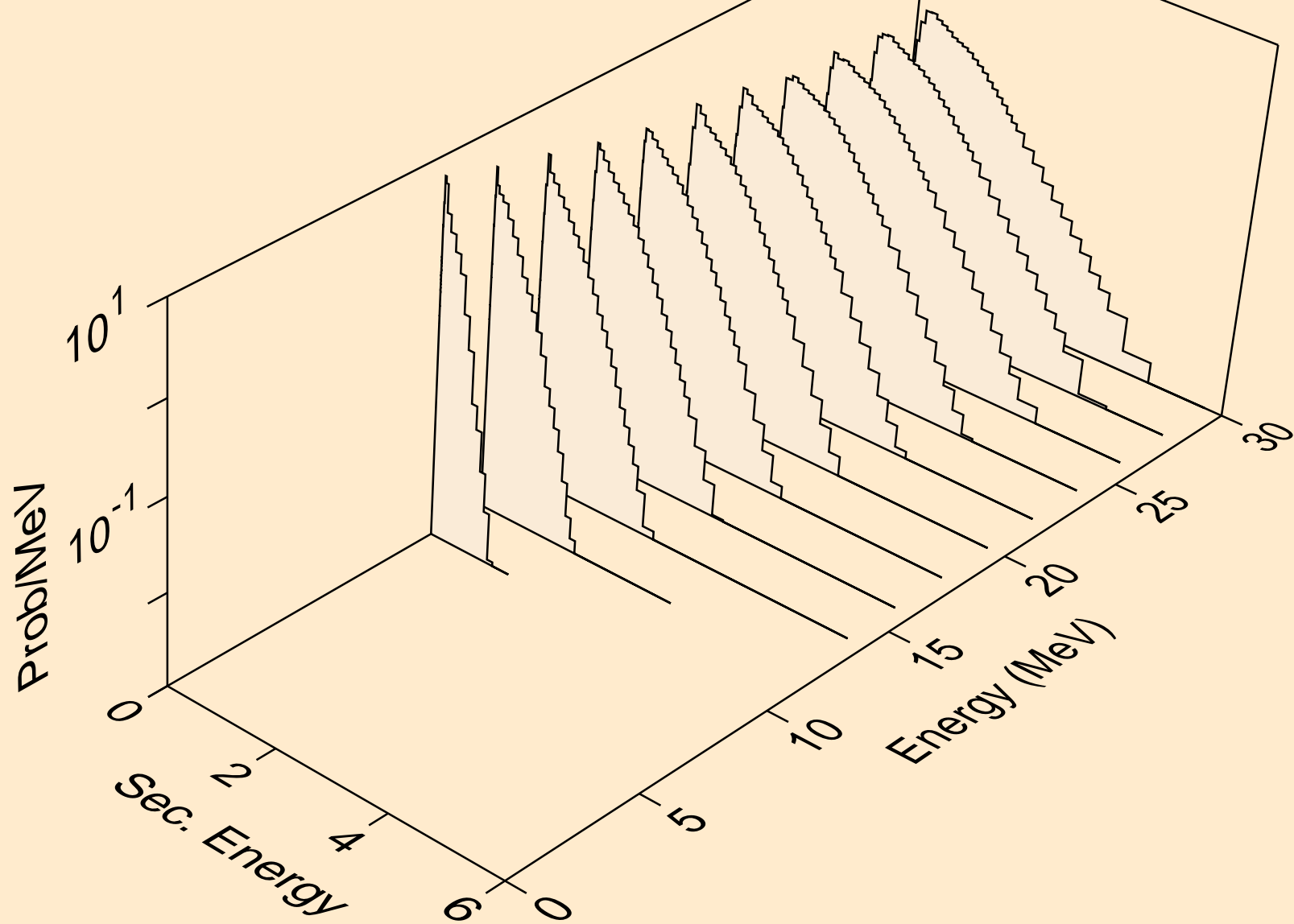

GD137 NEUTRON ACER TENDL-2023 LIBRARY; T=0.K  
Neutron emission for (n,2np)

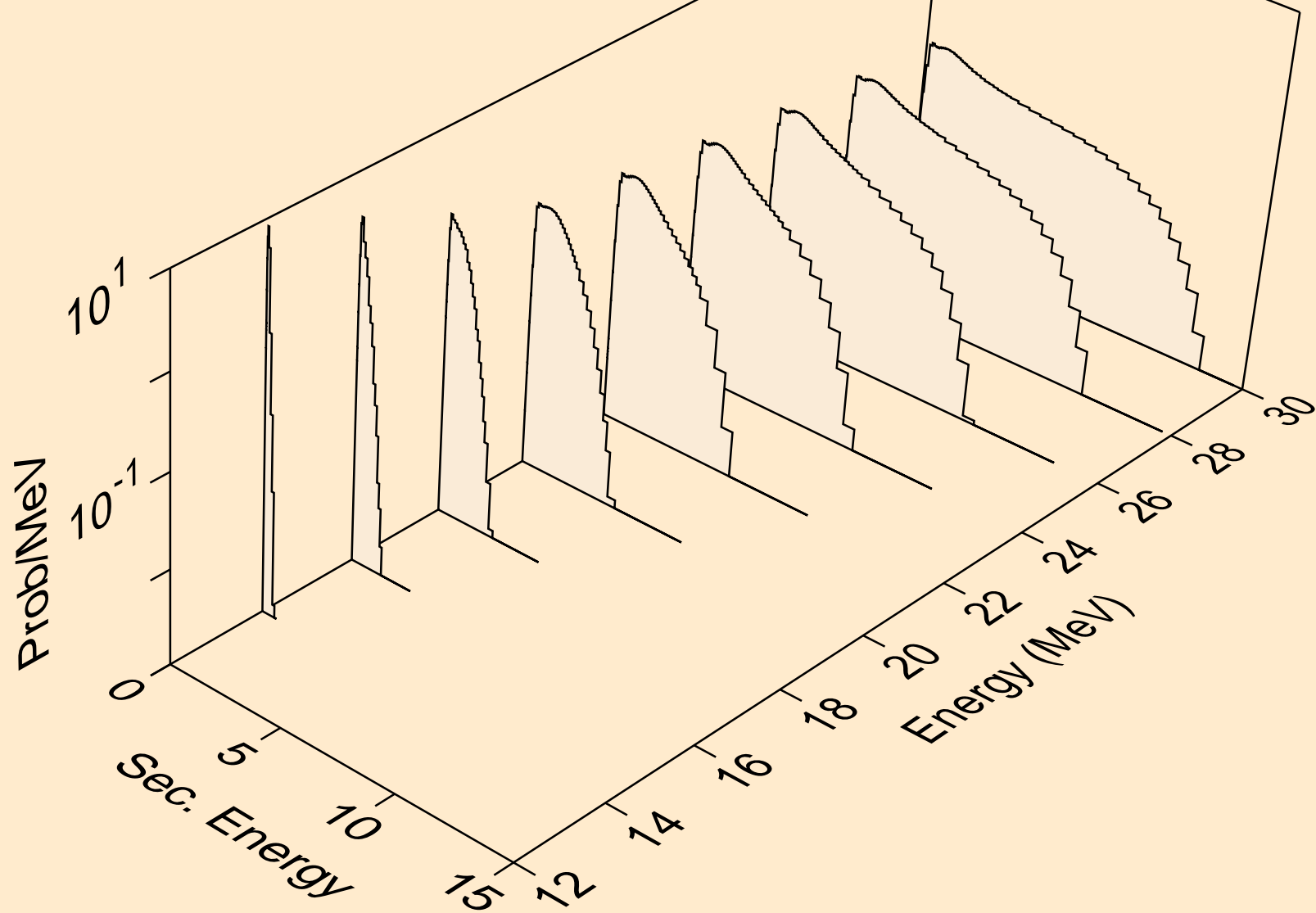

GD137 NEUTRON ACER TENDL-2023 LIBRARY; T=0.K  
Neutron emission for (n,3np)

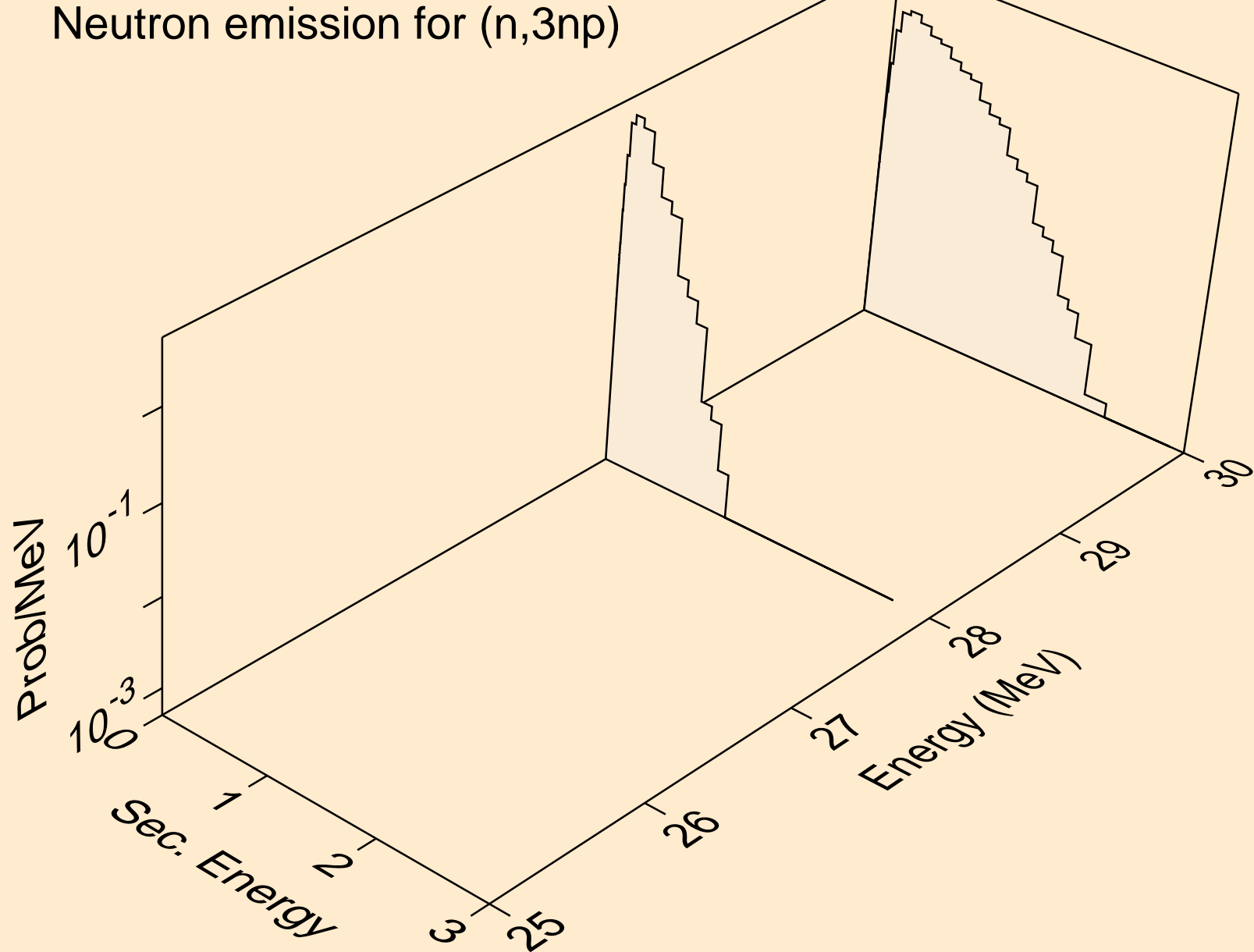

GD137 NEUTRON ACER TENDL-2023 LIBRARY; T=0.K  
Neutron emission for (n,n2p)

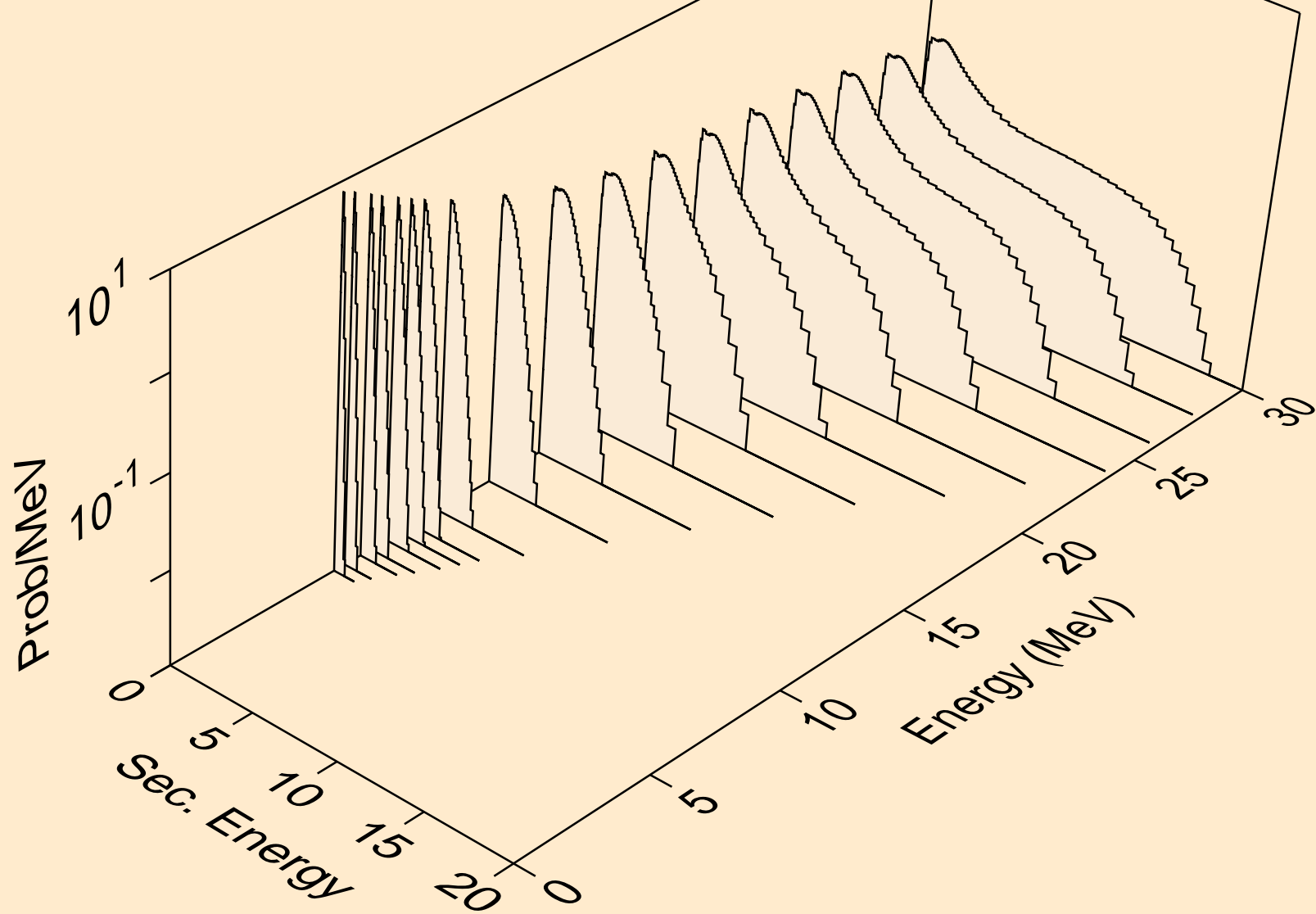



GD137 NEUTRON ACER TENDL-2023 LIBRARY; T=0.K  
Neutron emission for (n,npa)

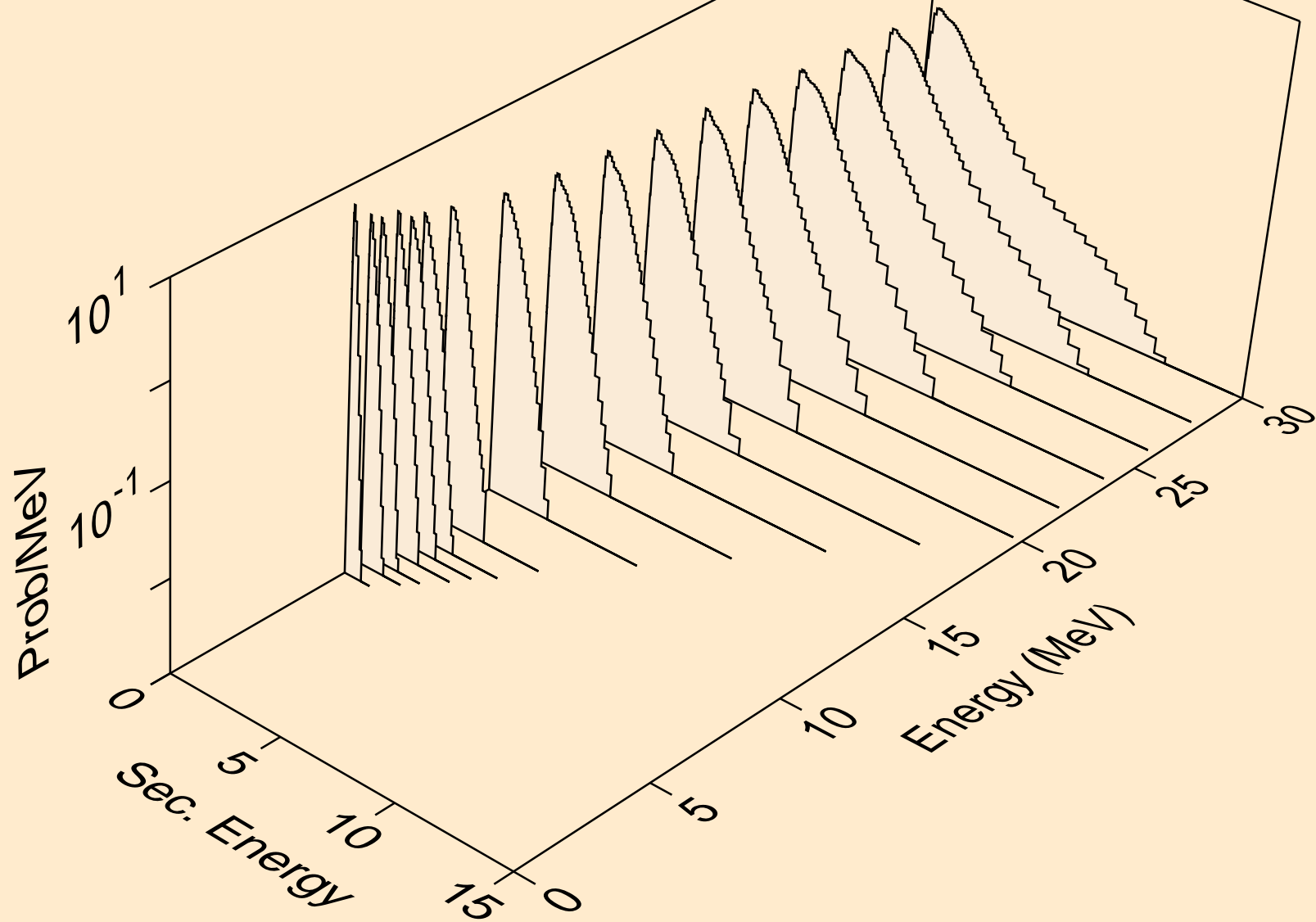

GD137 NEUTRON ACER TENDL-2023 LIBRARY; T=0.K  
Neutron emission for (n,n\*c)

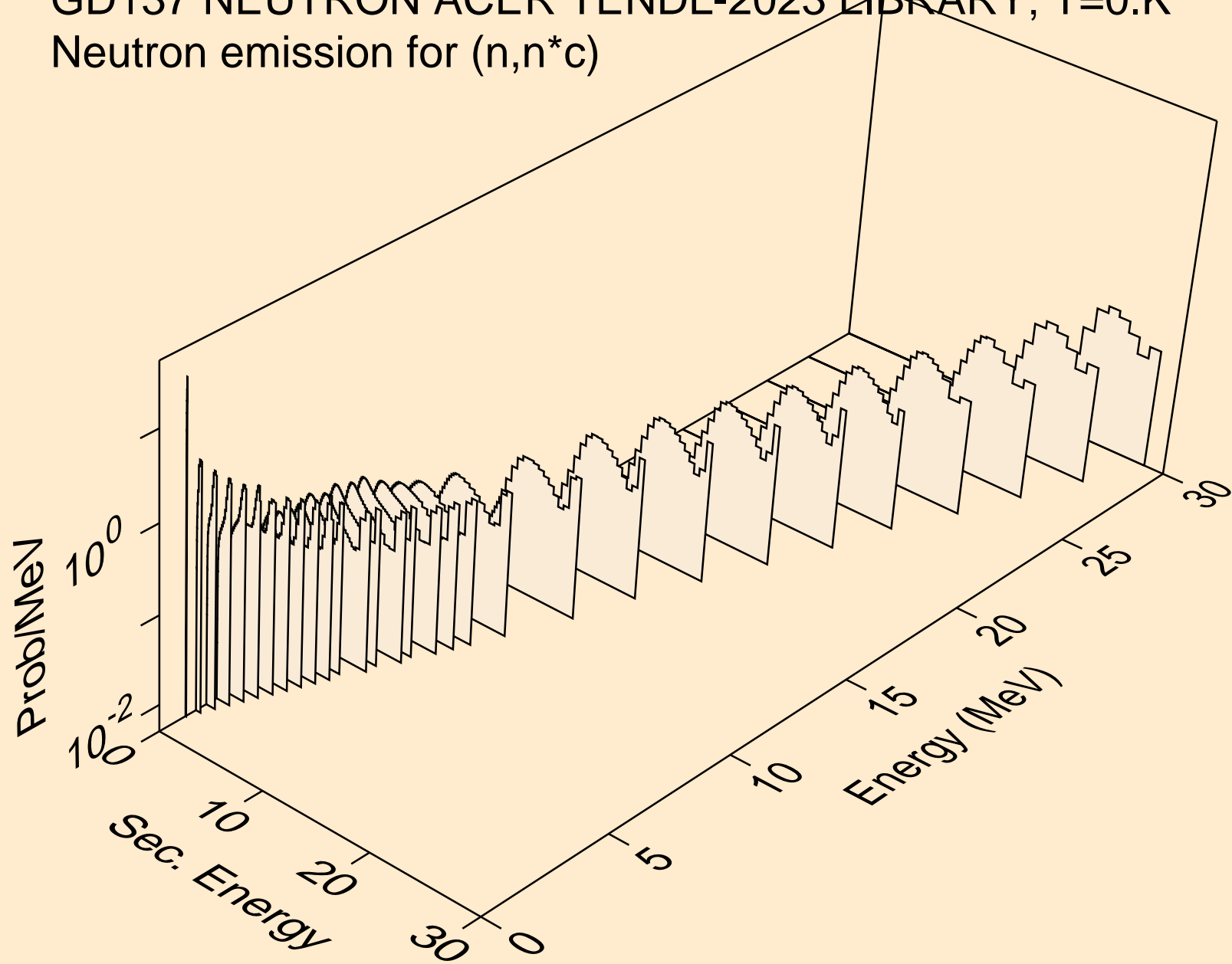

GD137 NEUTRON ACER TENDL-2023 LIBRARY; T=0.K  
Photon emission for (n,x)

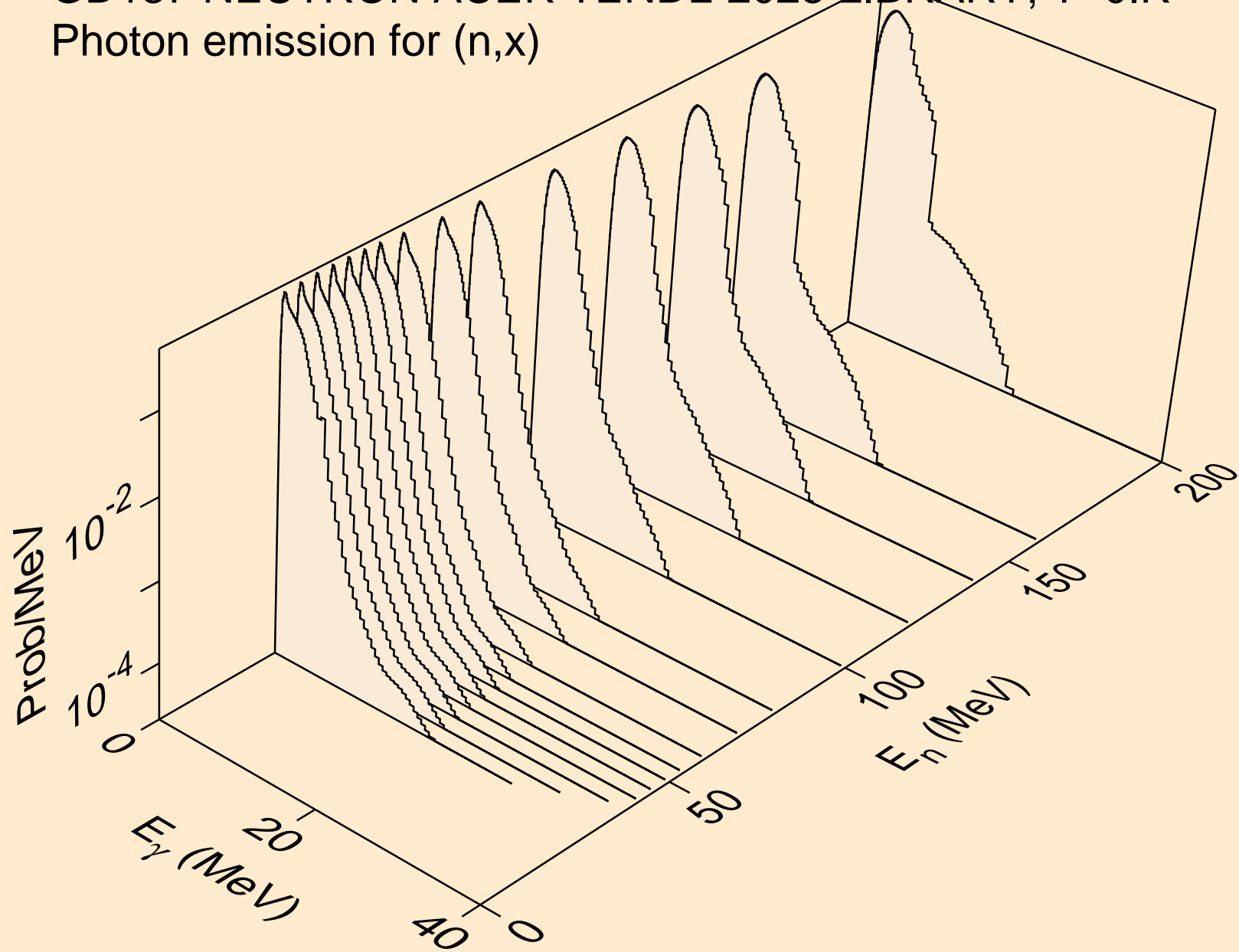

GD137 NEUTRON ACER TENDL-2023 LIBRARY; T=0.K  
Photon emission for (n,2nd)

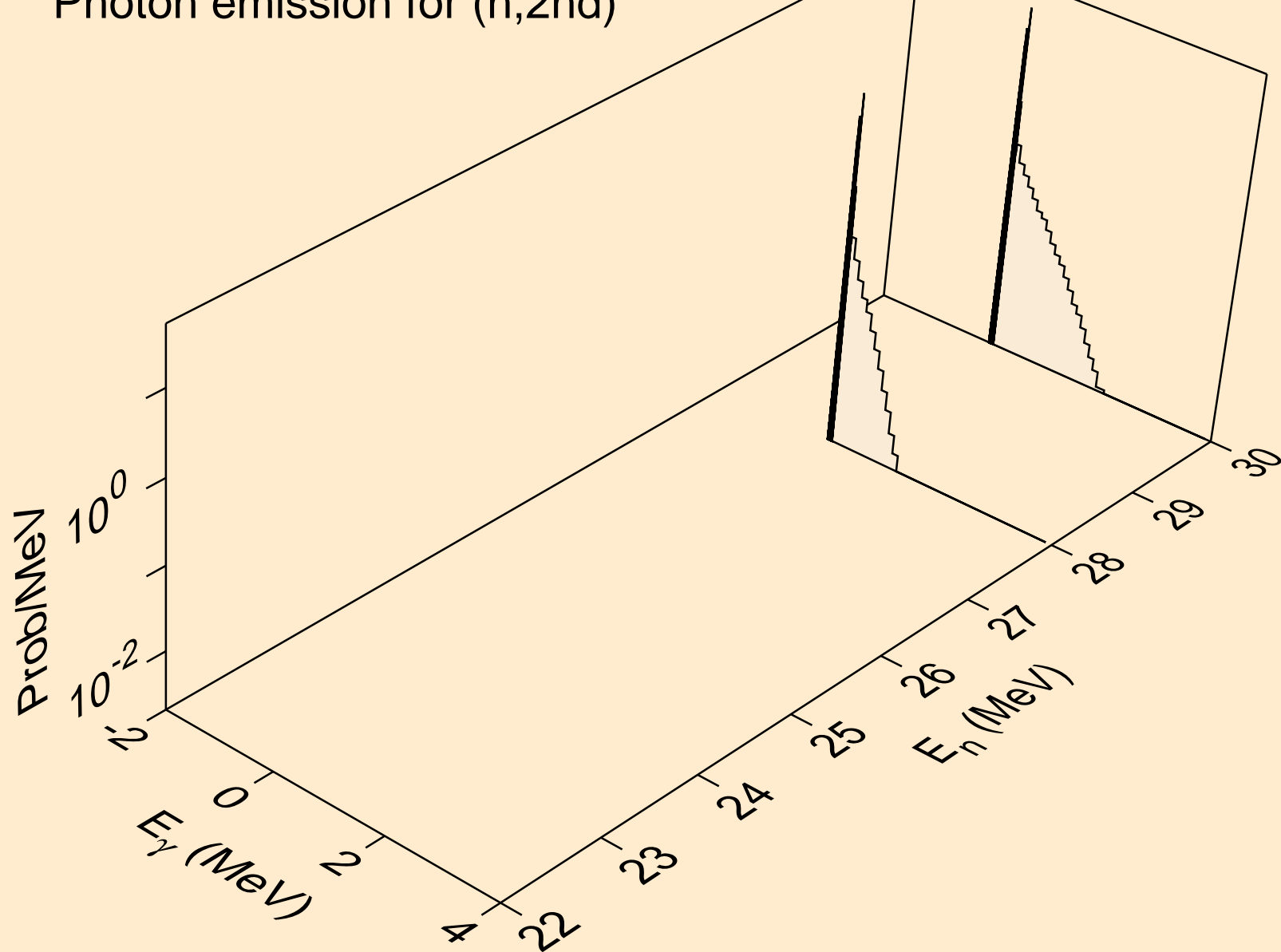

GD137 NEUTRON ACER TENDL-2023 LIBRARY; T=0.K  
Photon emission for (n,2n)

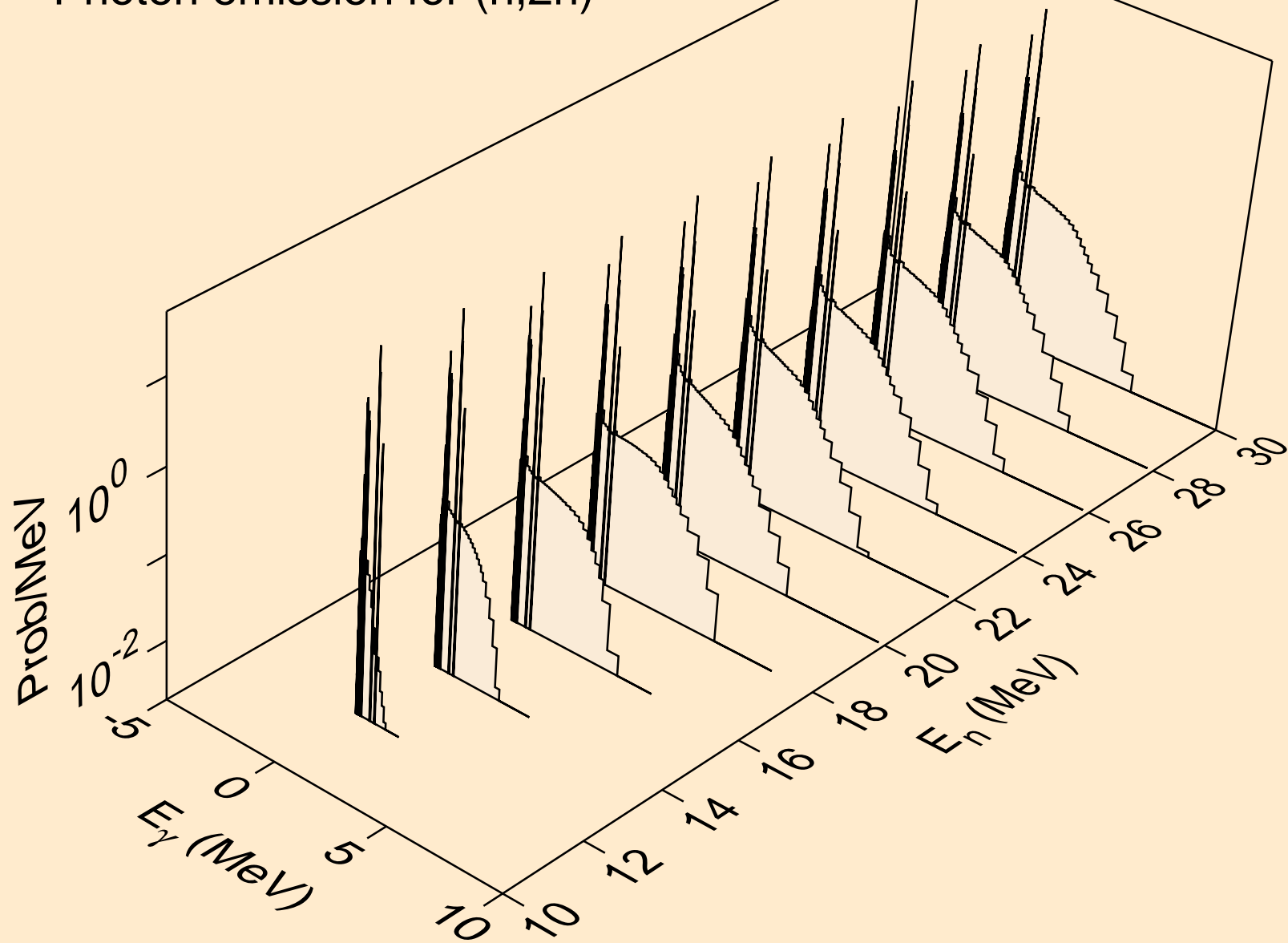

GD137 NEUTRON ACER TENDL-2023 LIBRARY; T=0.K  
Photon emission for (n,3n)

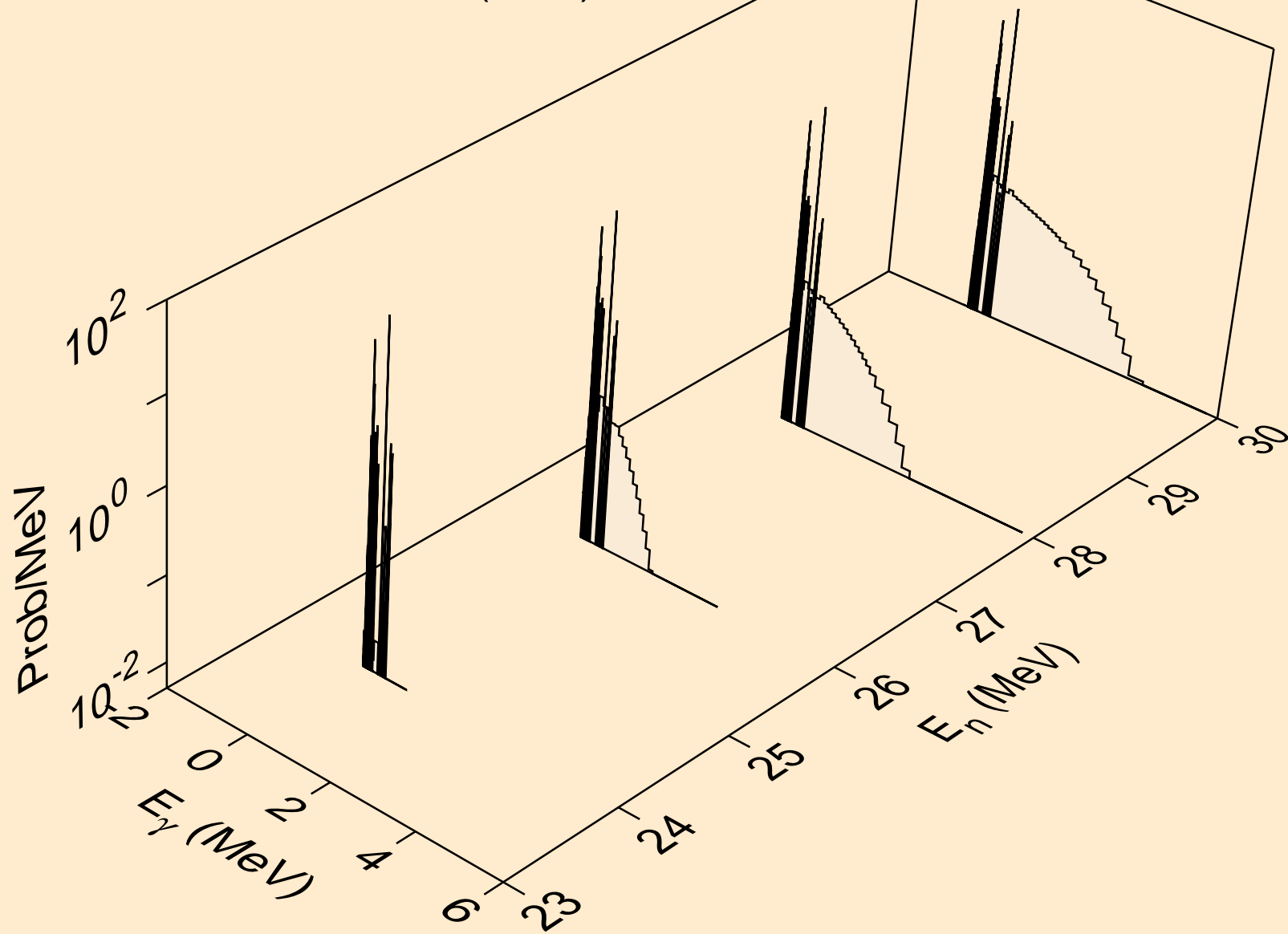

GD137 NEUTRON ACER TENDL-2023 LIBRARY; T=0.K  
Photon emission for (n,n\*)a

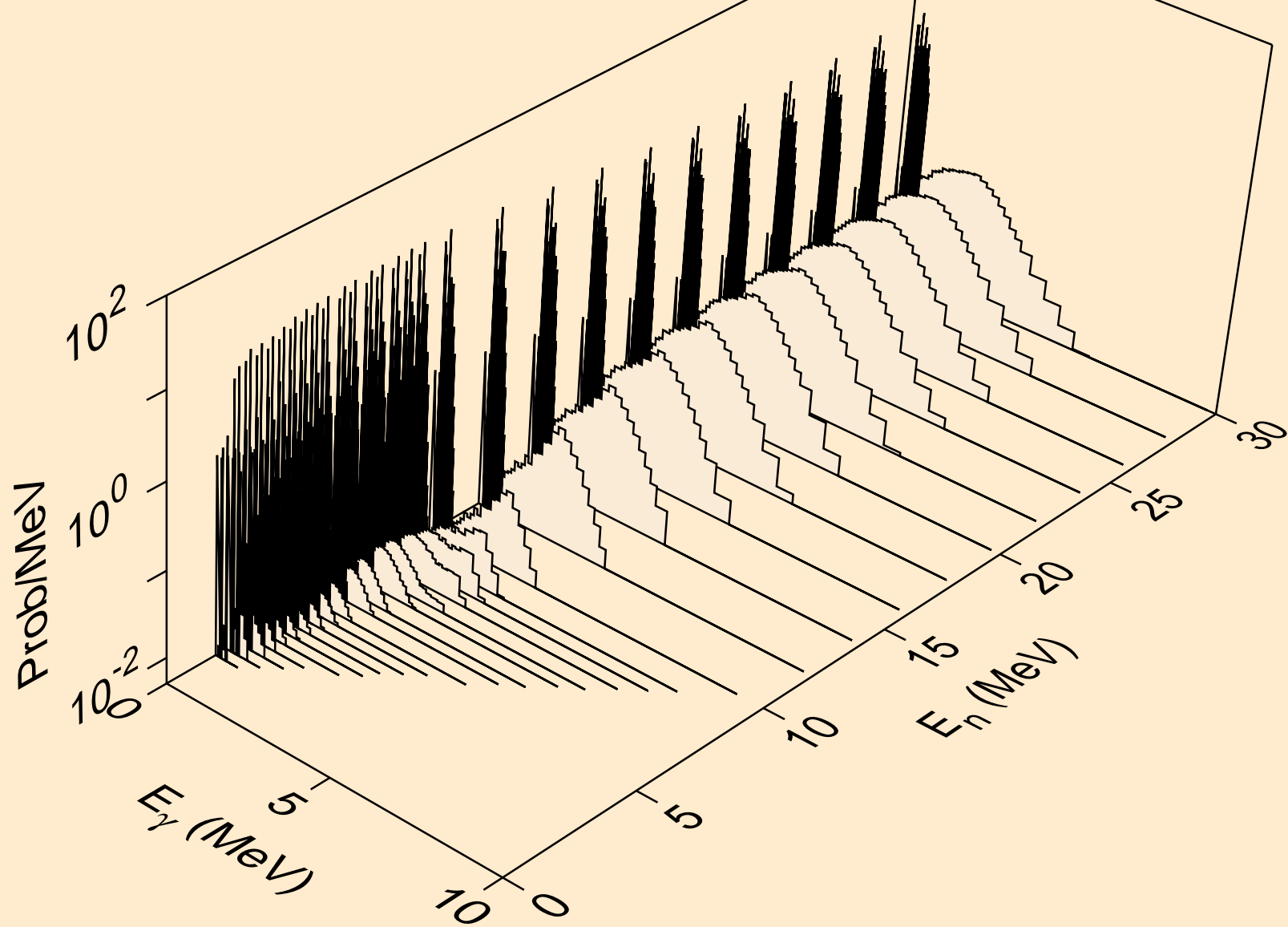

GD137 NEUTRON ACER TENDL-2023 LIBRARY; T=0.K  
Photon emission for (n,2n)a

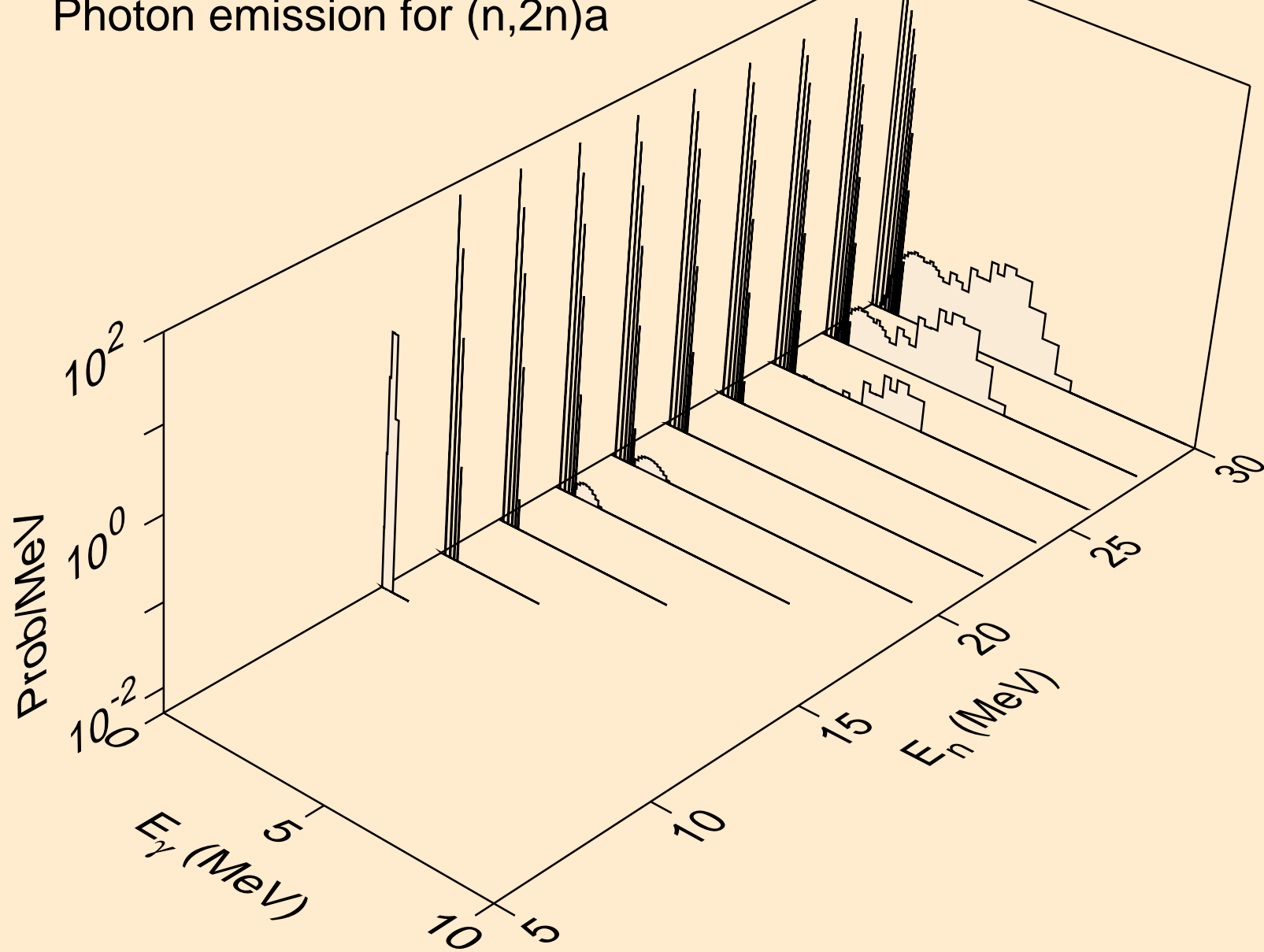



GD137 NEUTRON ACER TENDL-2023 LIBRARY; T=0.K  
Photon emission for (n,n\*)p

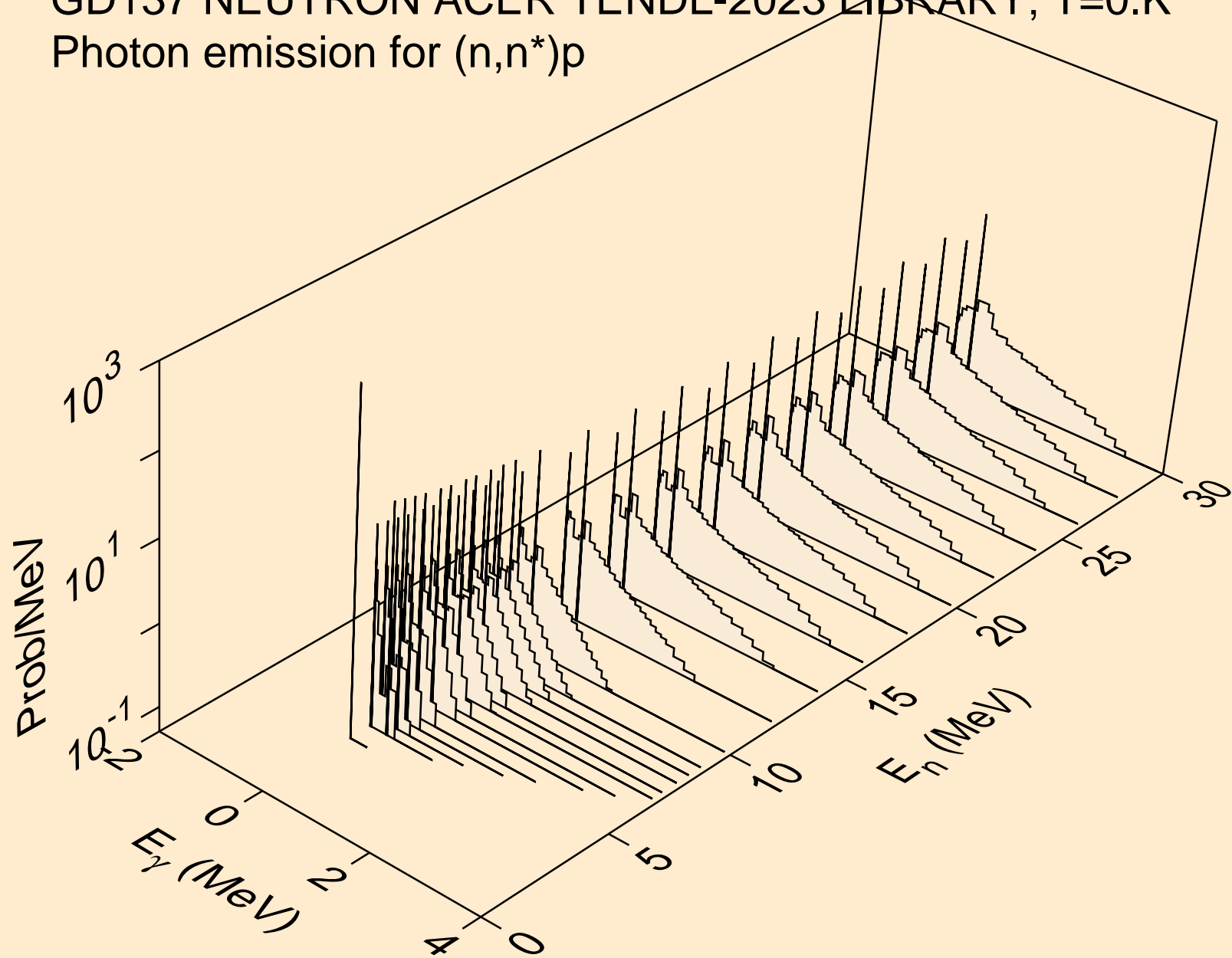

GD137 NEUTRON ACER TENDL-2023 LIBRARY; T=0.K  
Photon emission for (n,n\*)2a

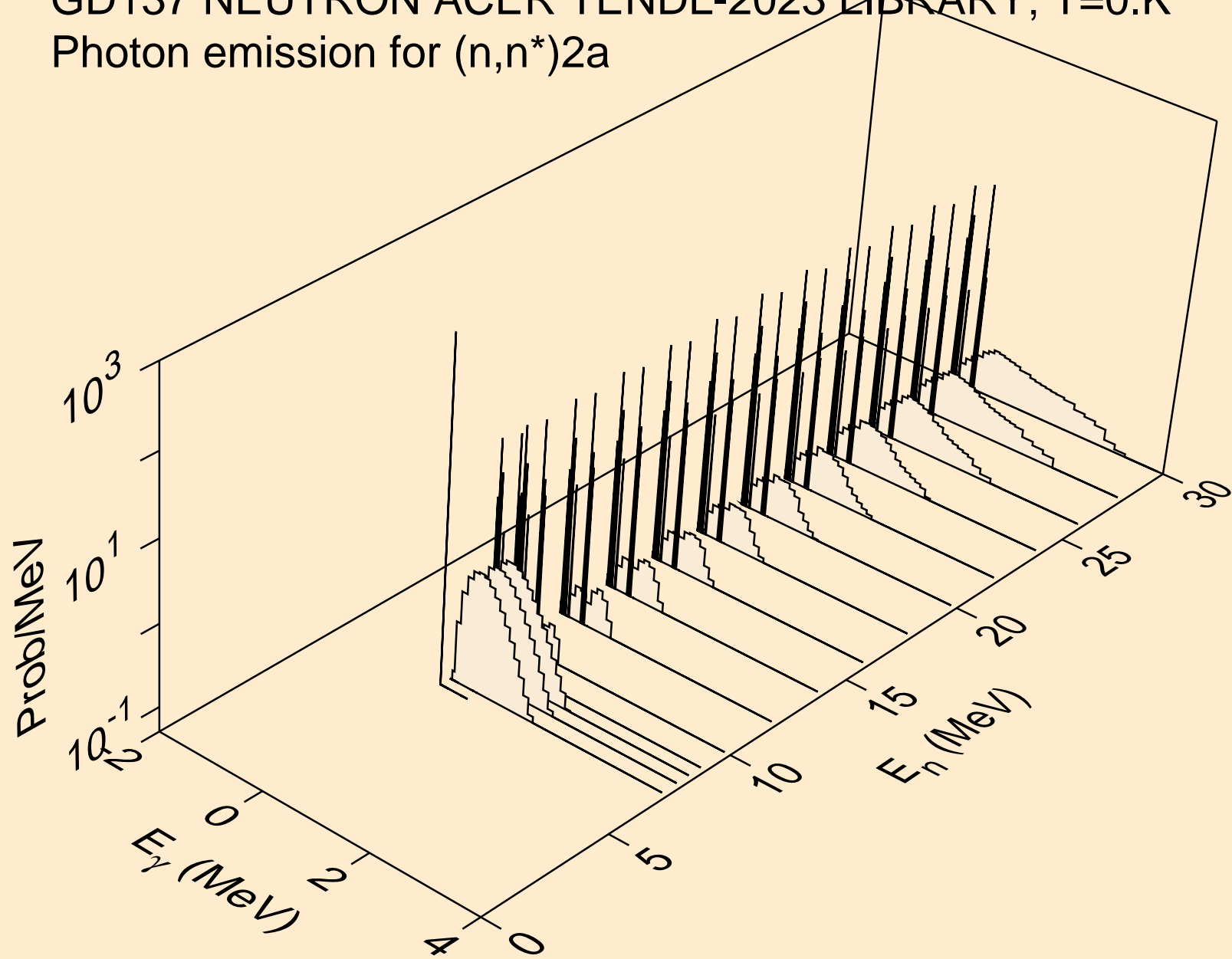

GD137 NEUTRON ACER TENDL-2023 LIBRARY; T=0.K  
Photon emission for (n,2n)2a

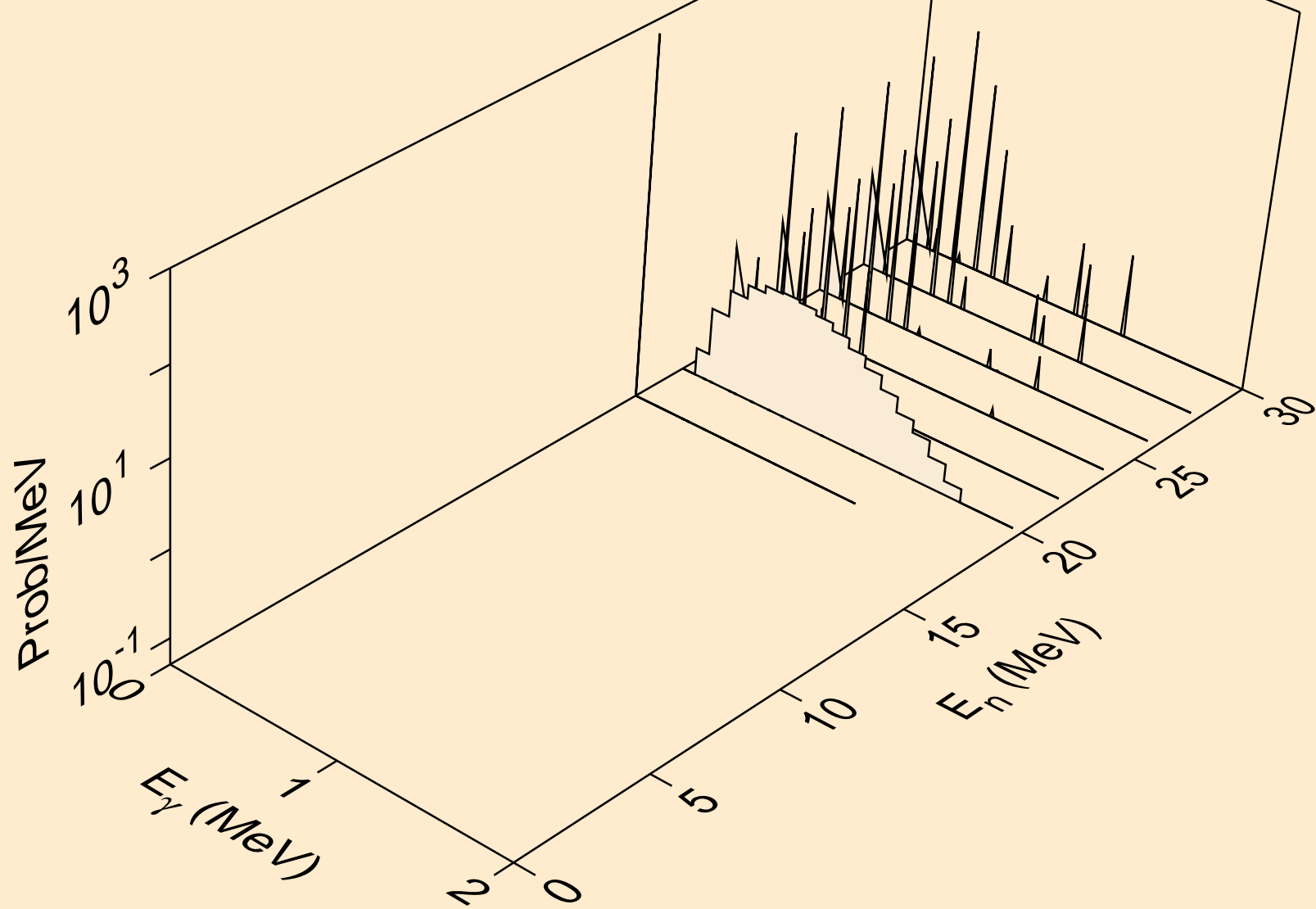

GD137 NEUTRON ACER TENDL-2023 LIBRARY; T=0.K  
Photon emission for (n,n\*)d

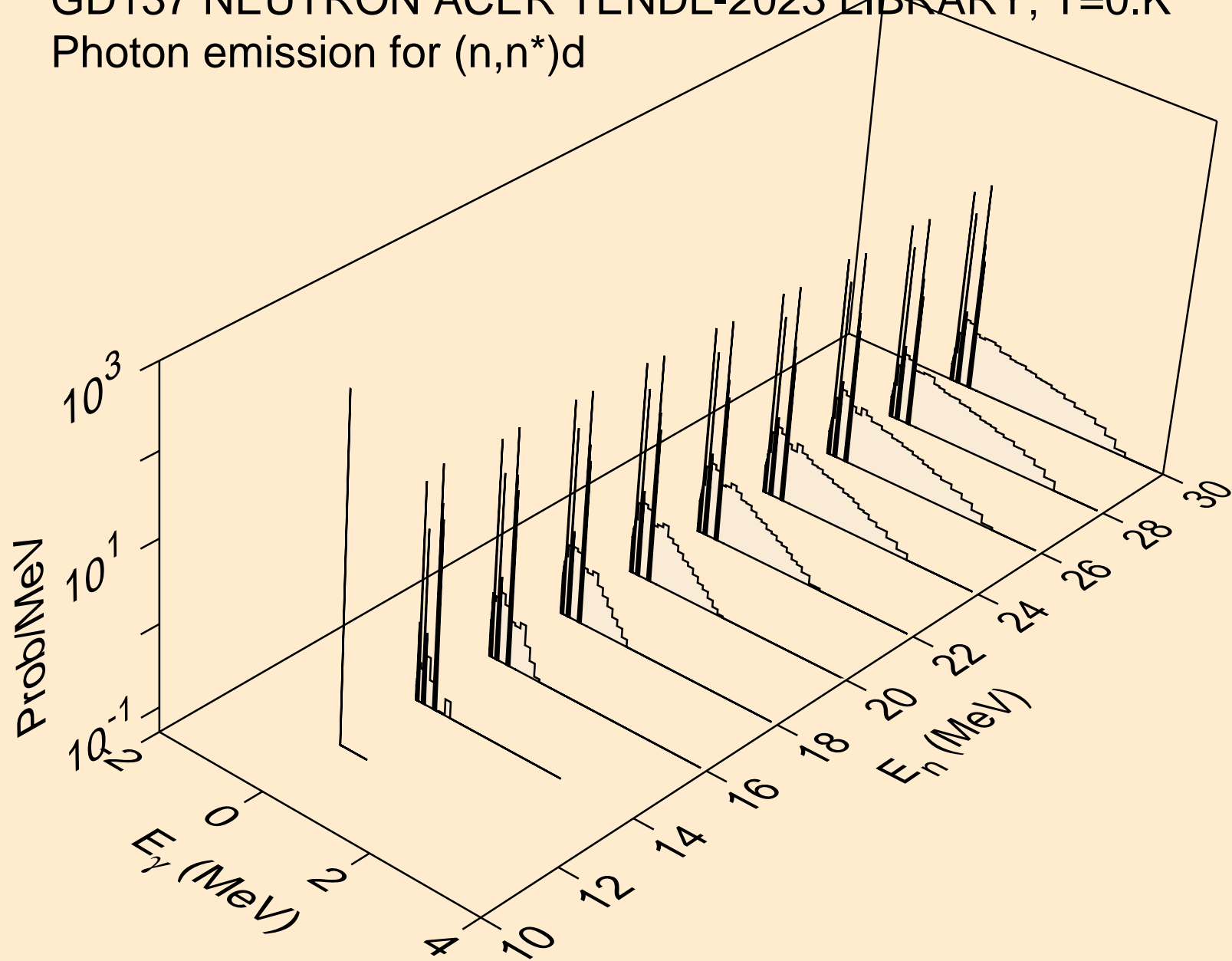

GD137 NEUTRON ACER TENDL-2023 LIBRARY; T=0.K  
Photon emission for (n,n\*)t

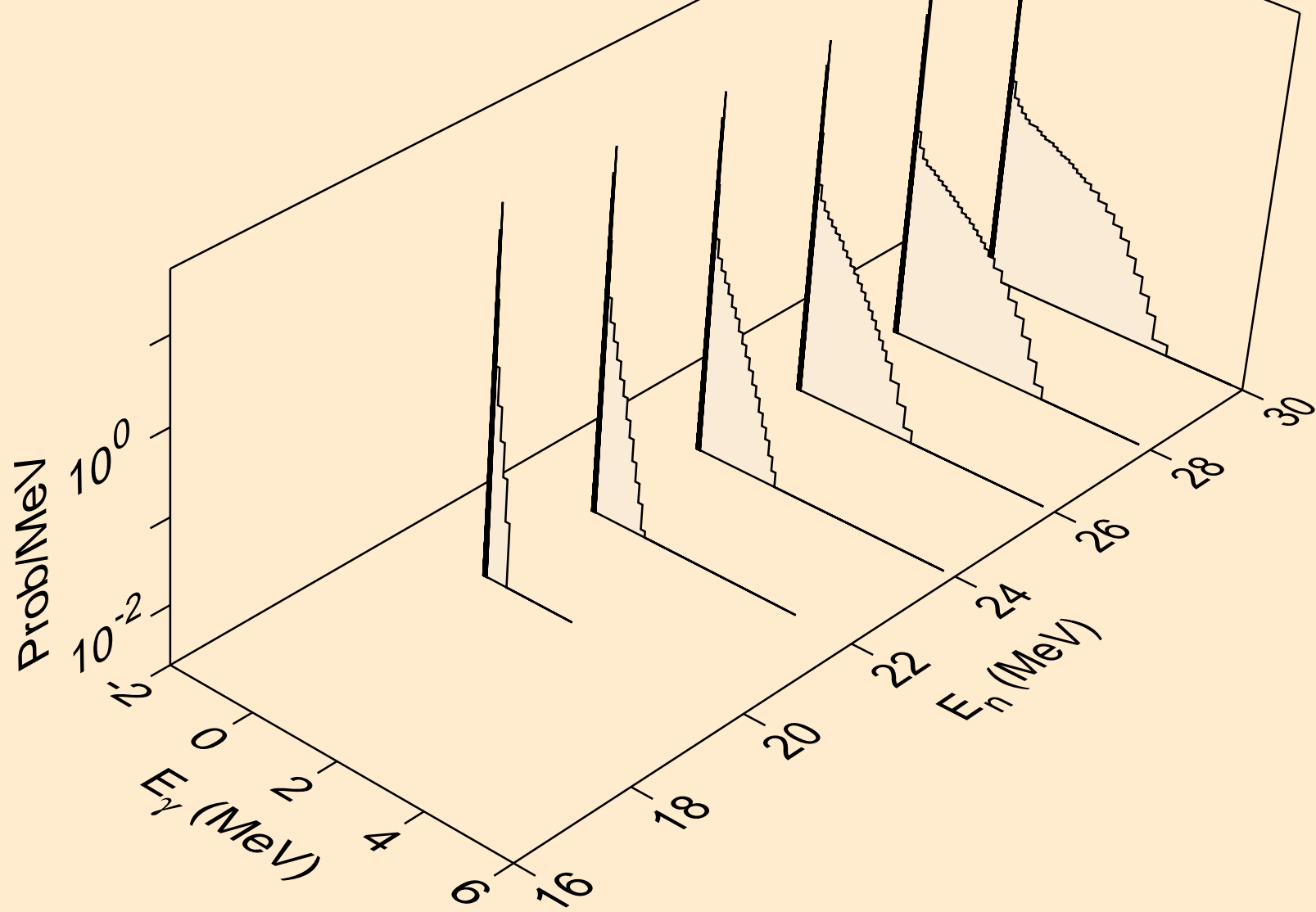

GD137 NEUTRON ACER TENDL-2023 LIBRARY; T=0.K  
Photon emission for (n,n\*)he3

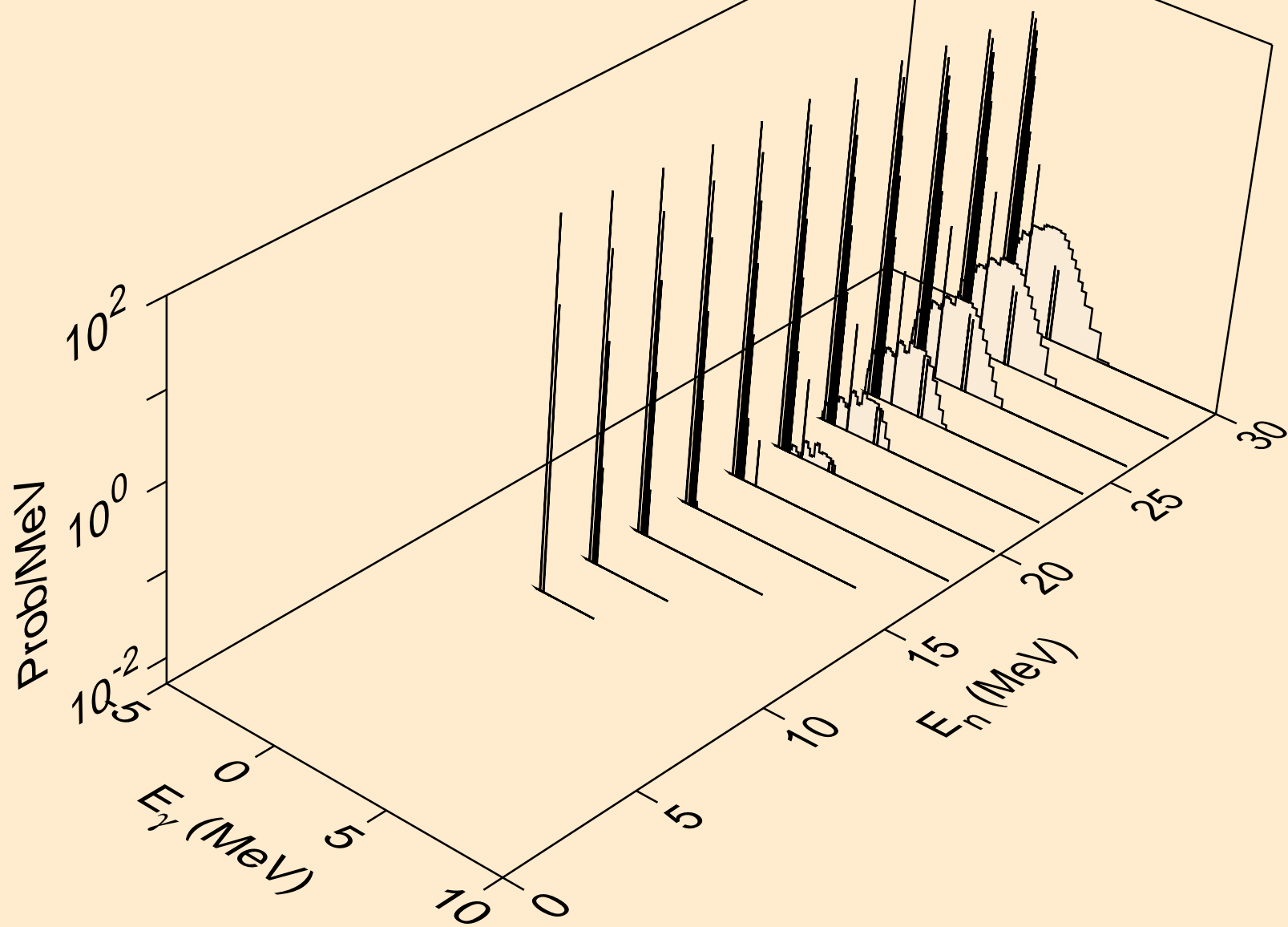

GD137 NEUTRON ACER TENDL-2023 LIBRARY; T=0.K  
Photon emission for (n,2np)

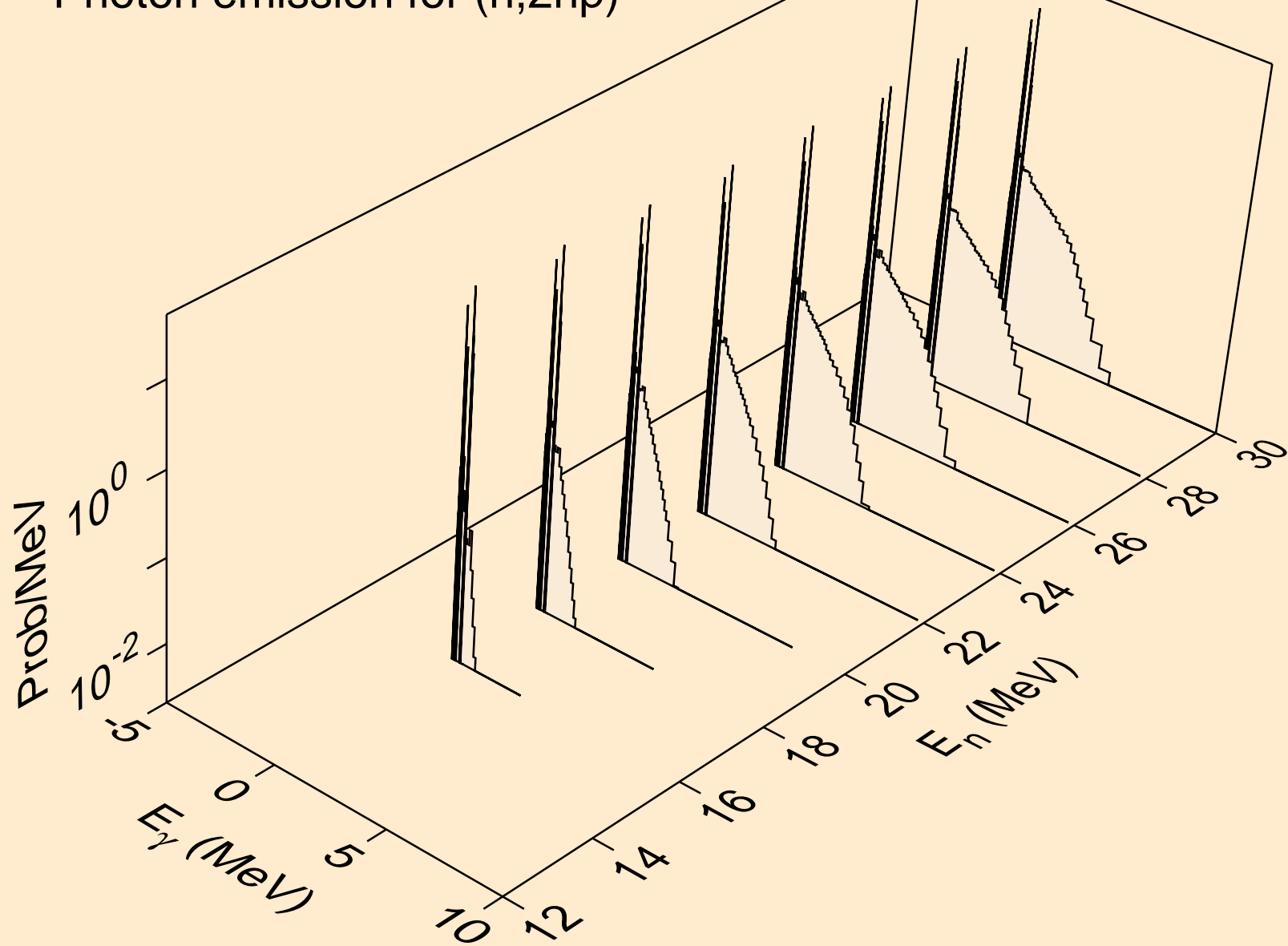

GD137 NEUTRON ACER TENDL-2023 LIBRARY; T=0.K  
Photon emission for (n,3np)

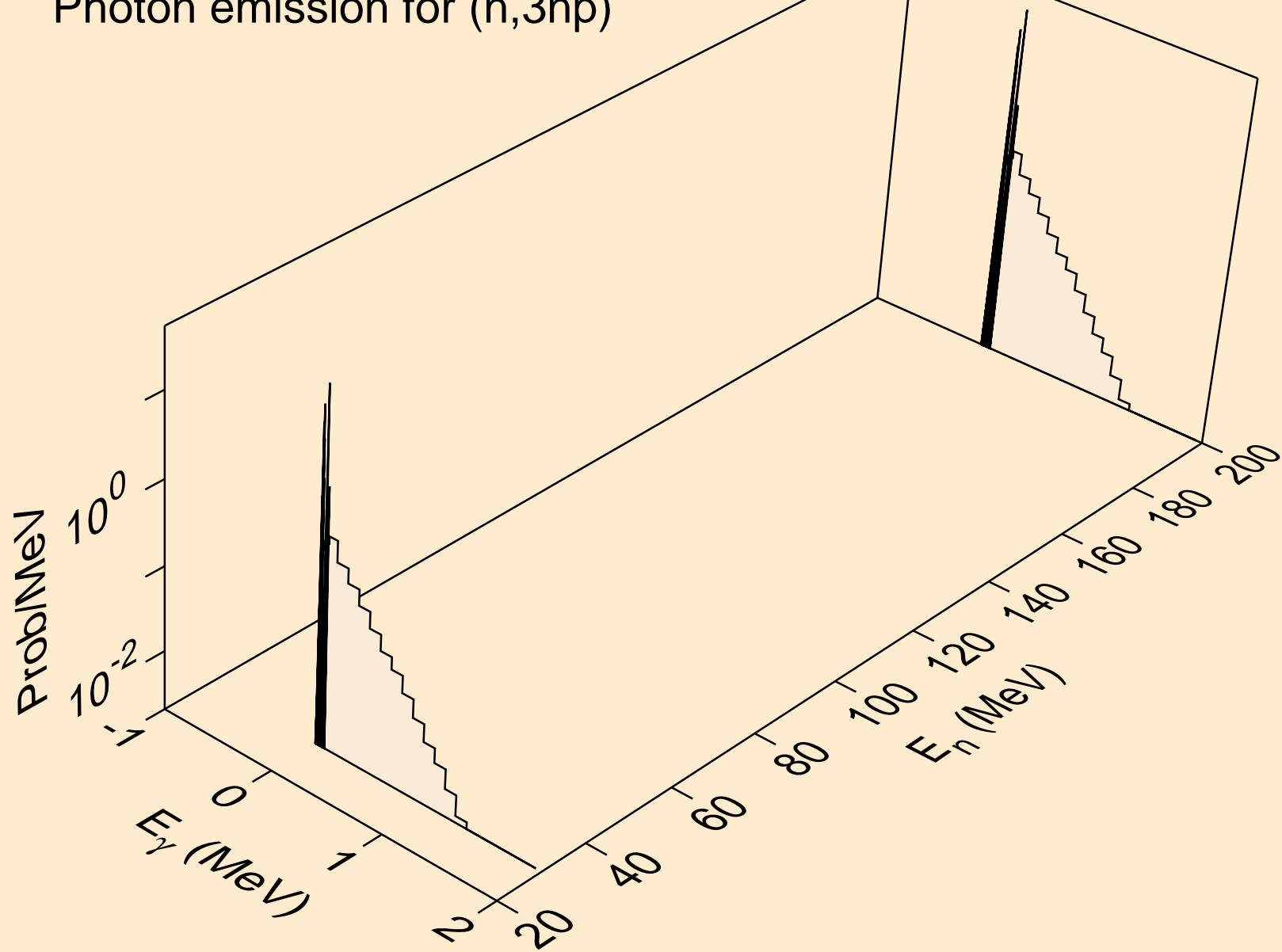



GD137 NEUTRON ACER TENDL-2023 LIBRARY; T=0.K  
Photon emission for (n,n2p)

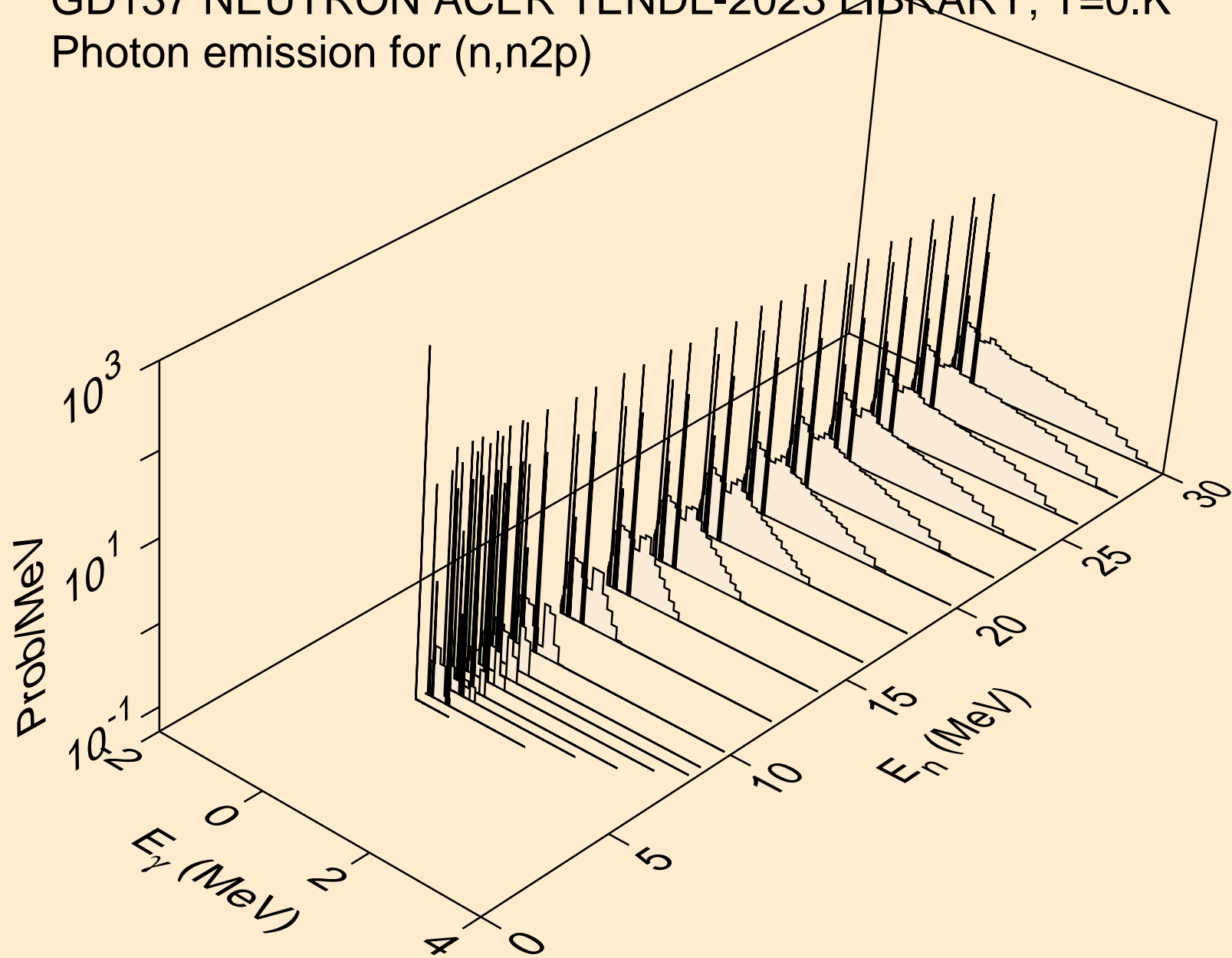

GD137 NEUTRON ACER TENDL-2023 LIBRARY; T=0.K  
Photon emission for (n,npa)

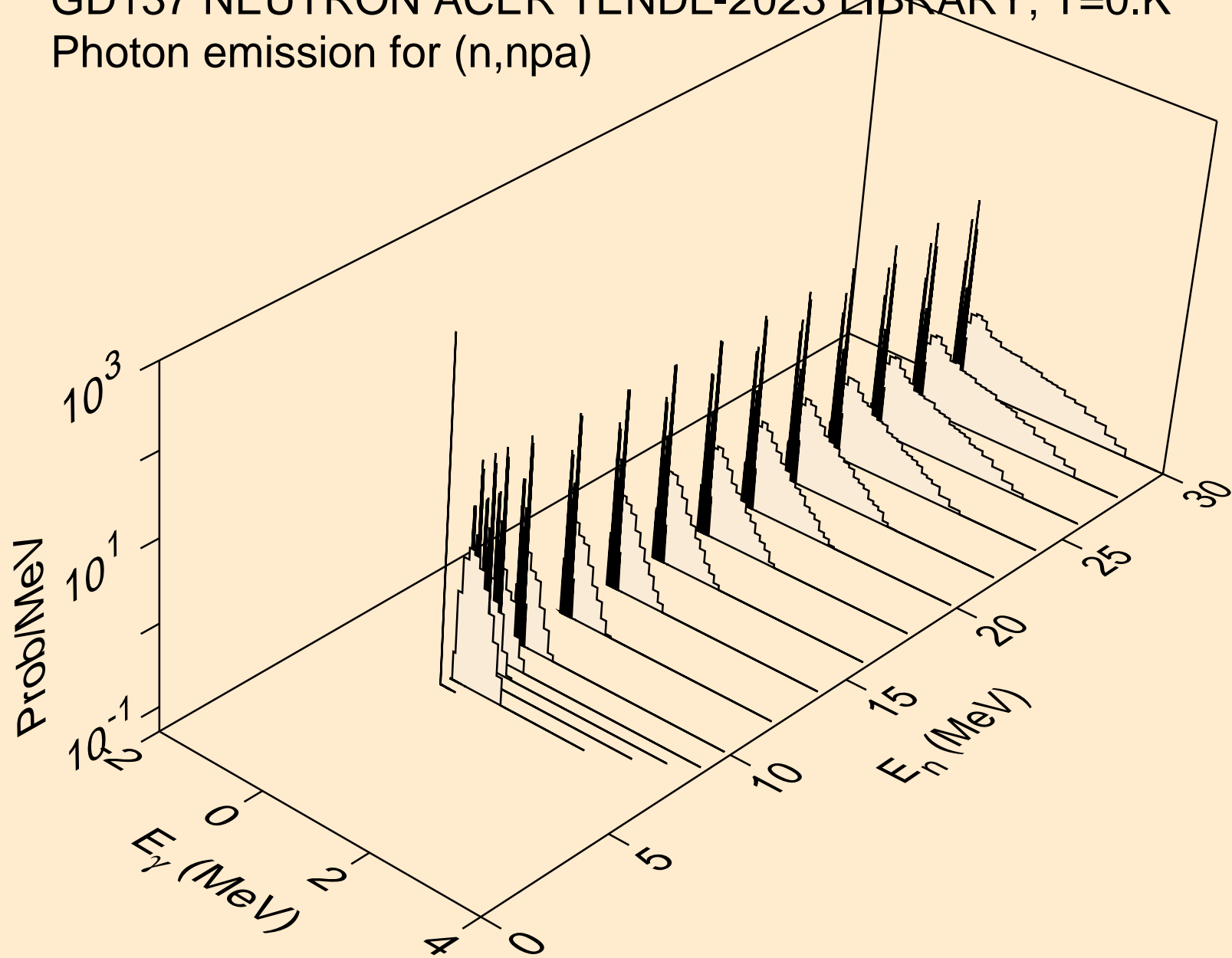

GD137 NEUTRON ACER TENDL-2023 LIBRARY; T=0.K  
Photon emission for (n,n\*c)

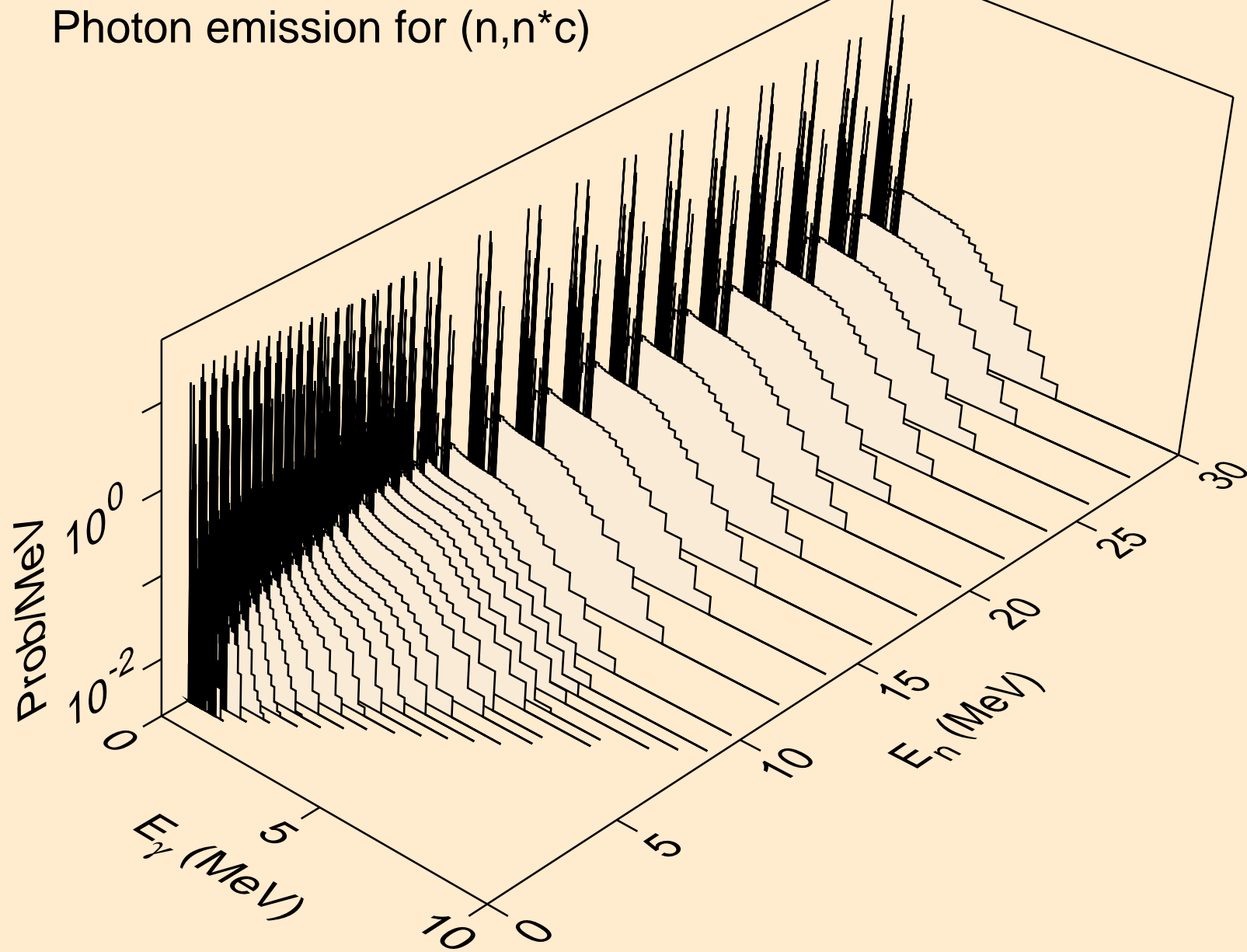

GD137 NEUTRON ACER TENDL-2023 LIBRARY; T=0.K  
Photon emission for (n,gma)

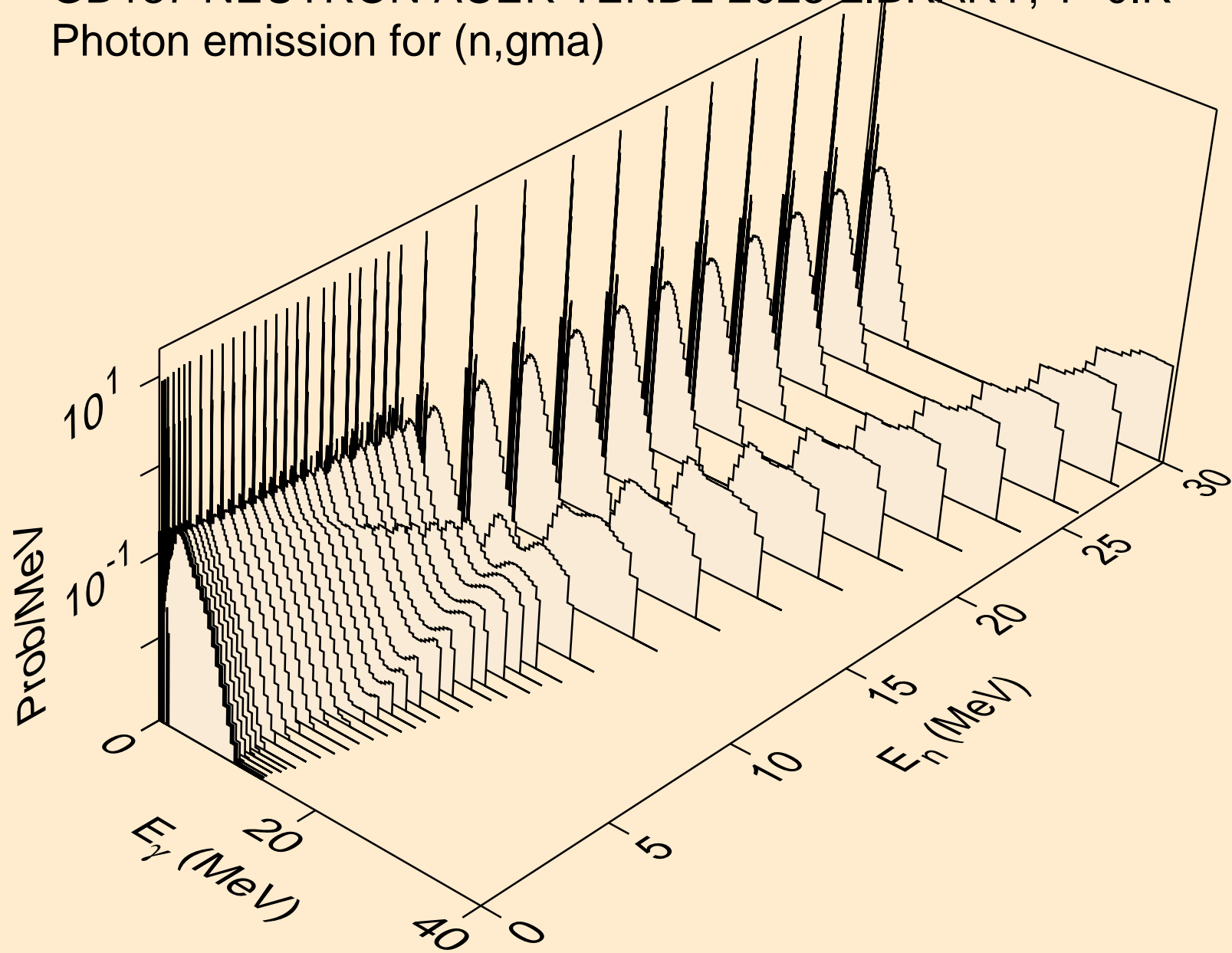

GD137 NEUTRON ACER TENDL-2023 LIBRARY; T=0.K  
Photon emission for (n,p)

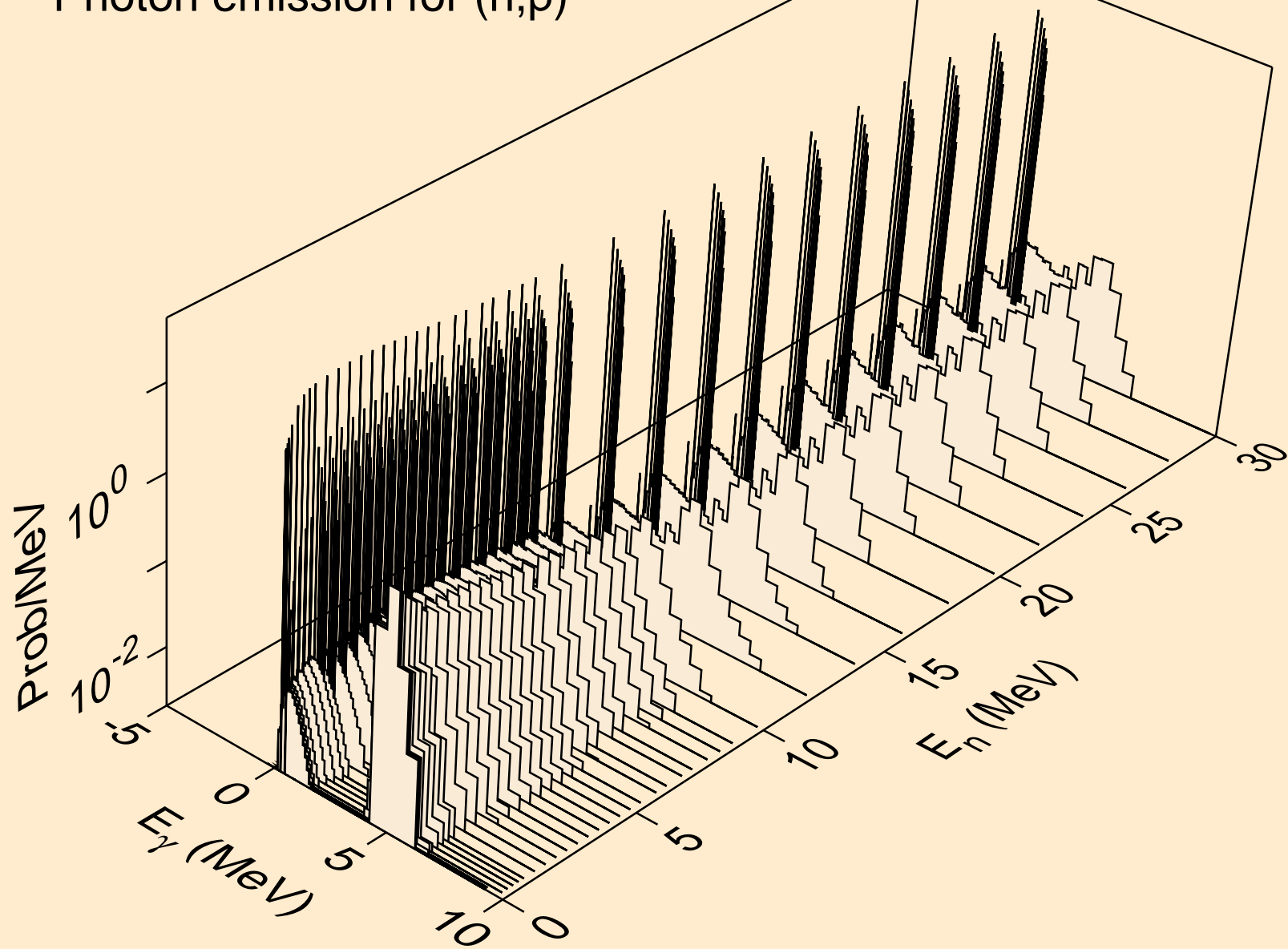

GD137 NEUTRON ACER TENDL-2023 LIBRARY; T=0.K  
Photon emission for (n,d)

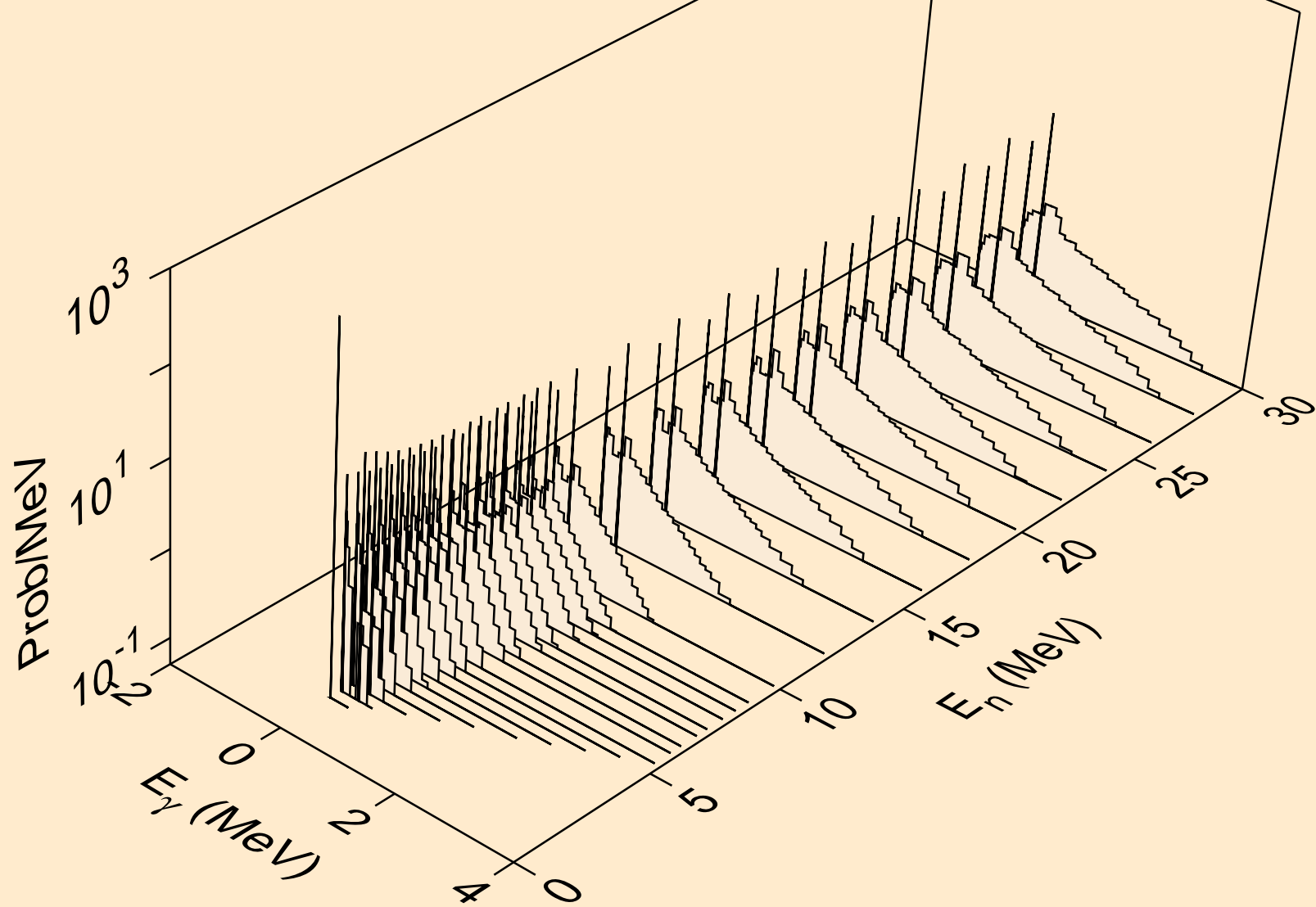

GD137 NEUTRON ACER TENDL-2023 LIBRARY; T=0.K  
Photon emission for (n,t)

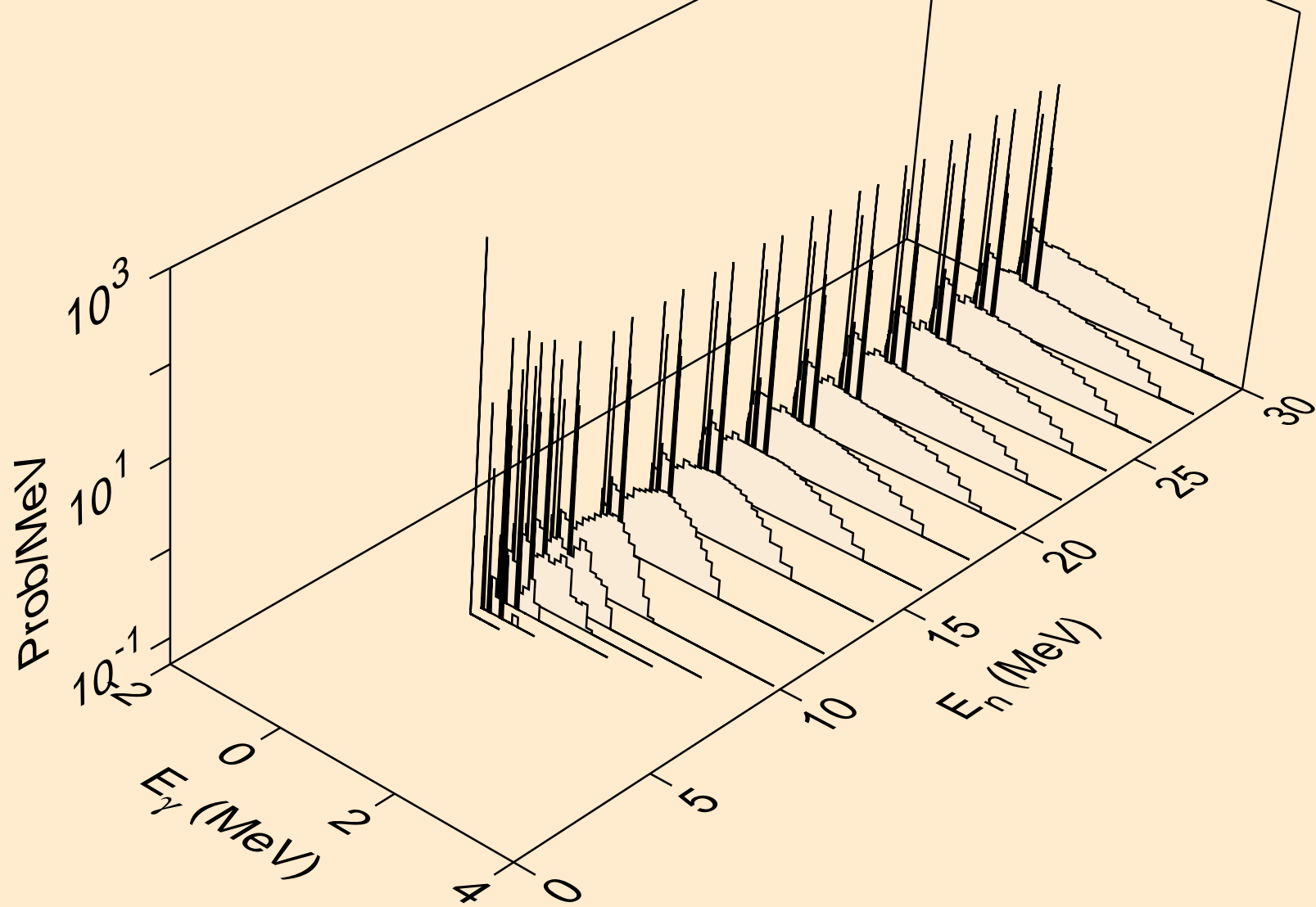

GD137 NEUTRON ACER TENDL-2023 LIBRARY; T=0.K  
Photon emission for (n,he3)

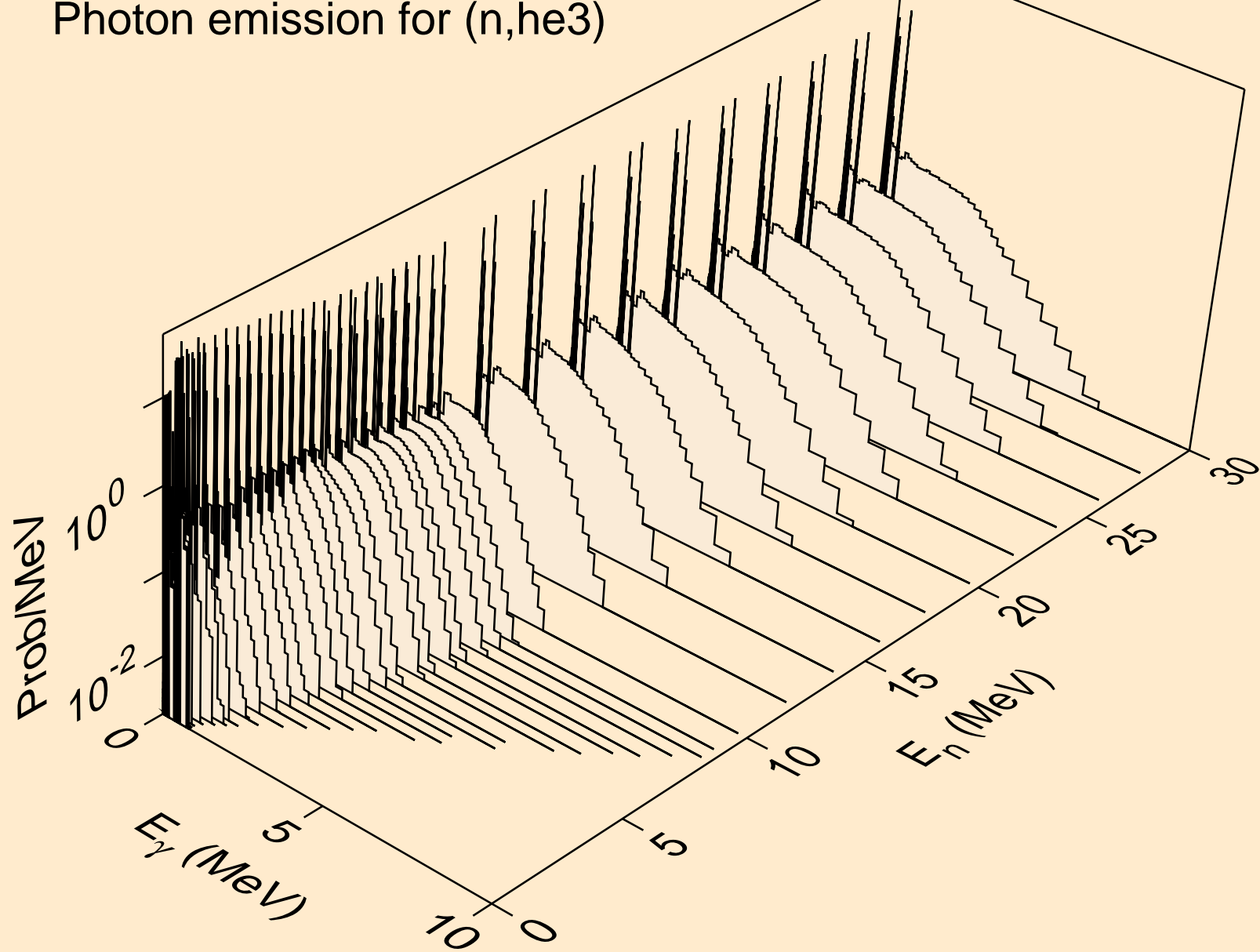



GD137 NEUTRON ACER TENDL-2023 LIBRARY; T=0.K  
Photon emission for (n,a)

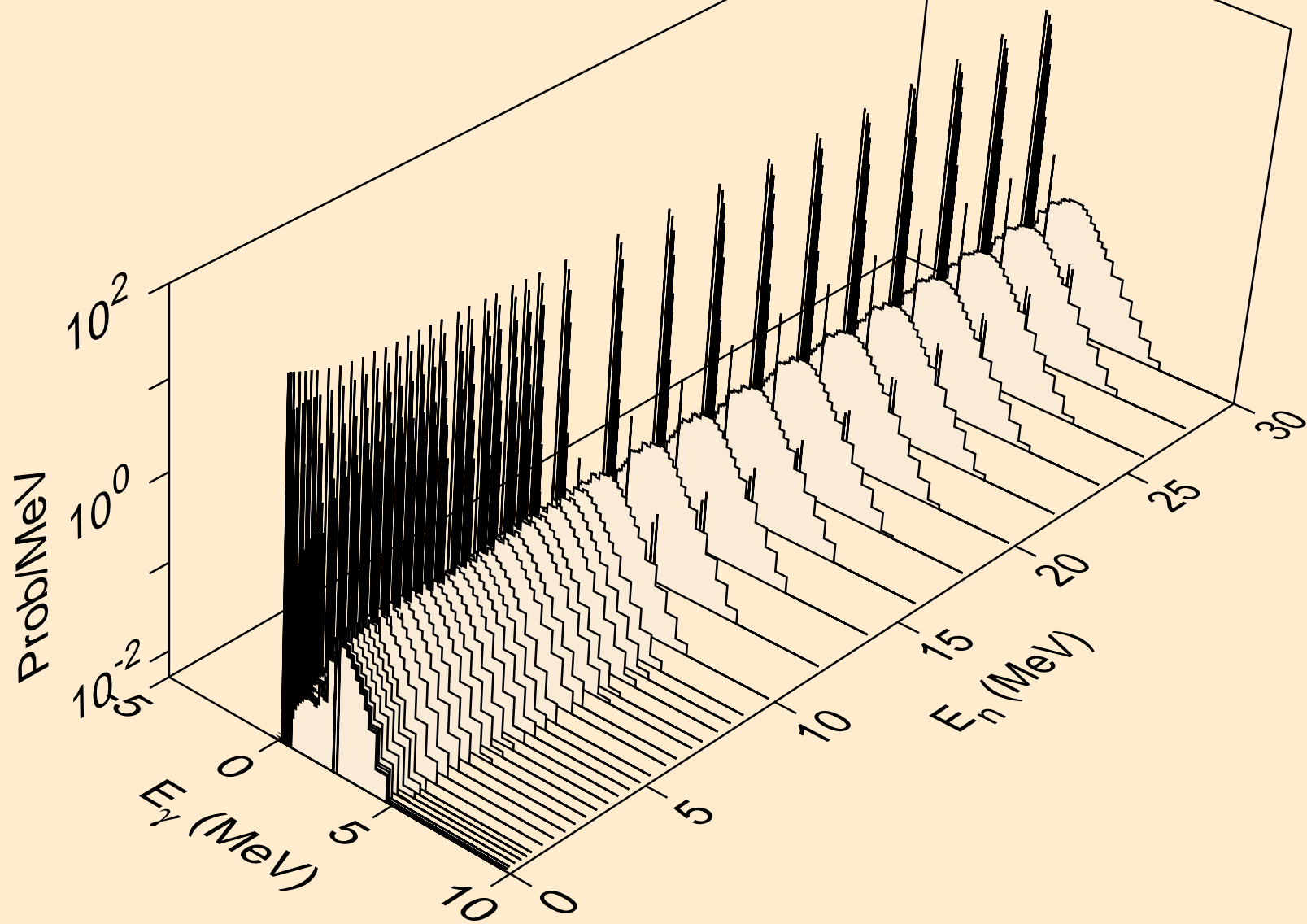

GD137 NEUTRON ACER TENDL-2023 LIBRARY; T=0.K  
Photon emission for (n,2a)

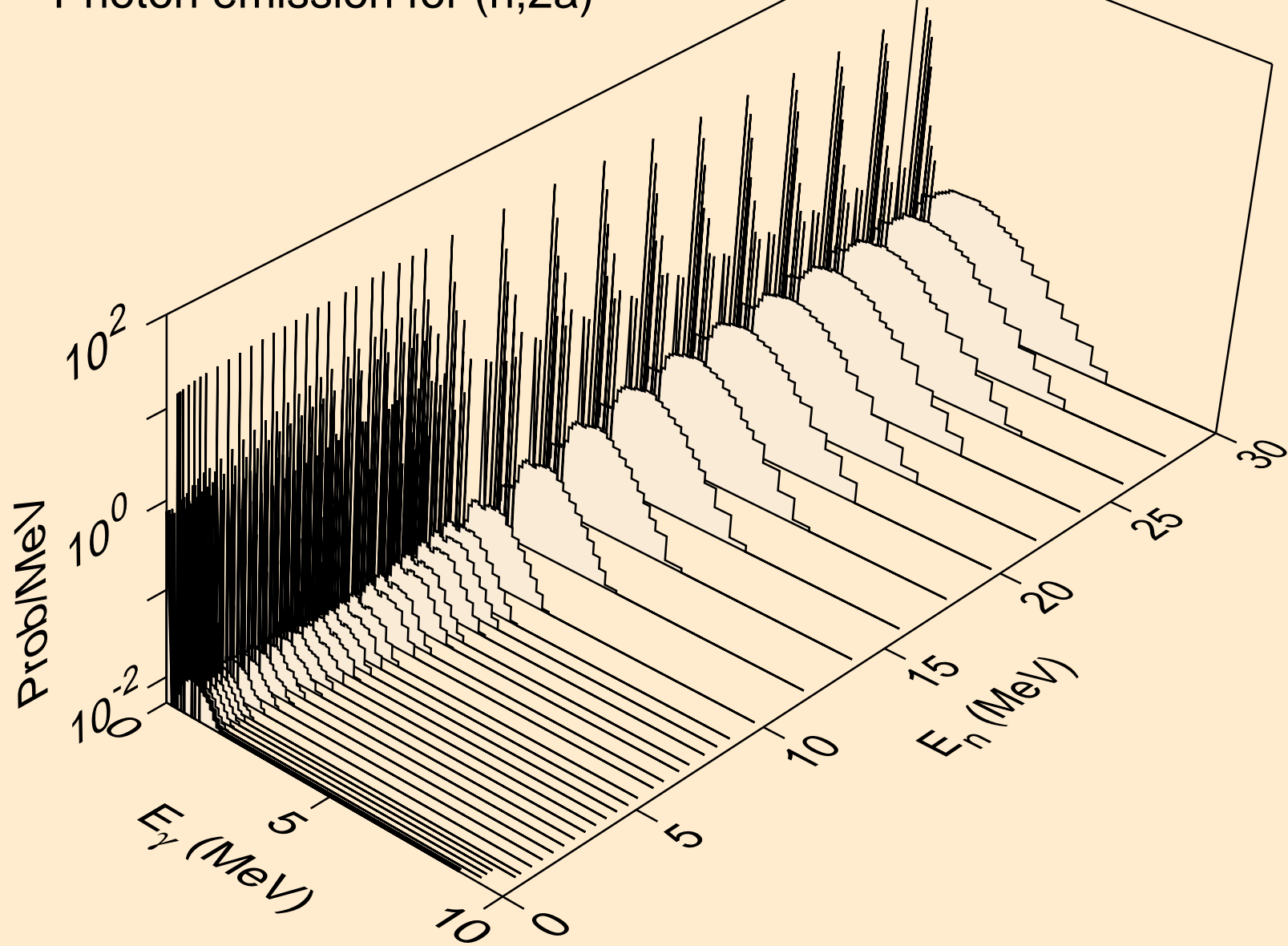

GD137 NEUTRON ACER TENDL-2023 LIBRARY; T=0.K  
Photon emission for (n,3a)

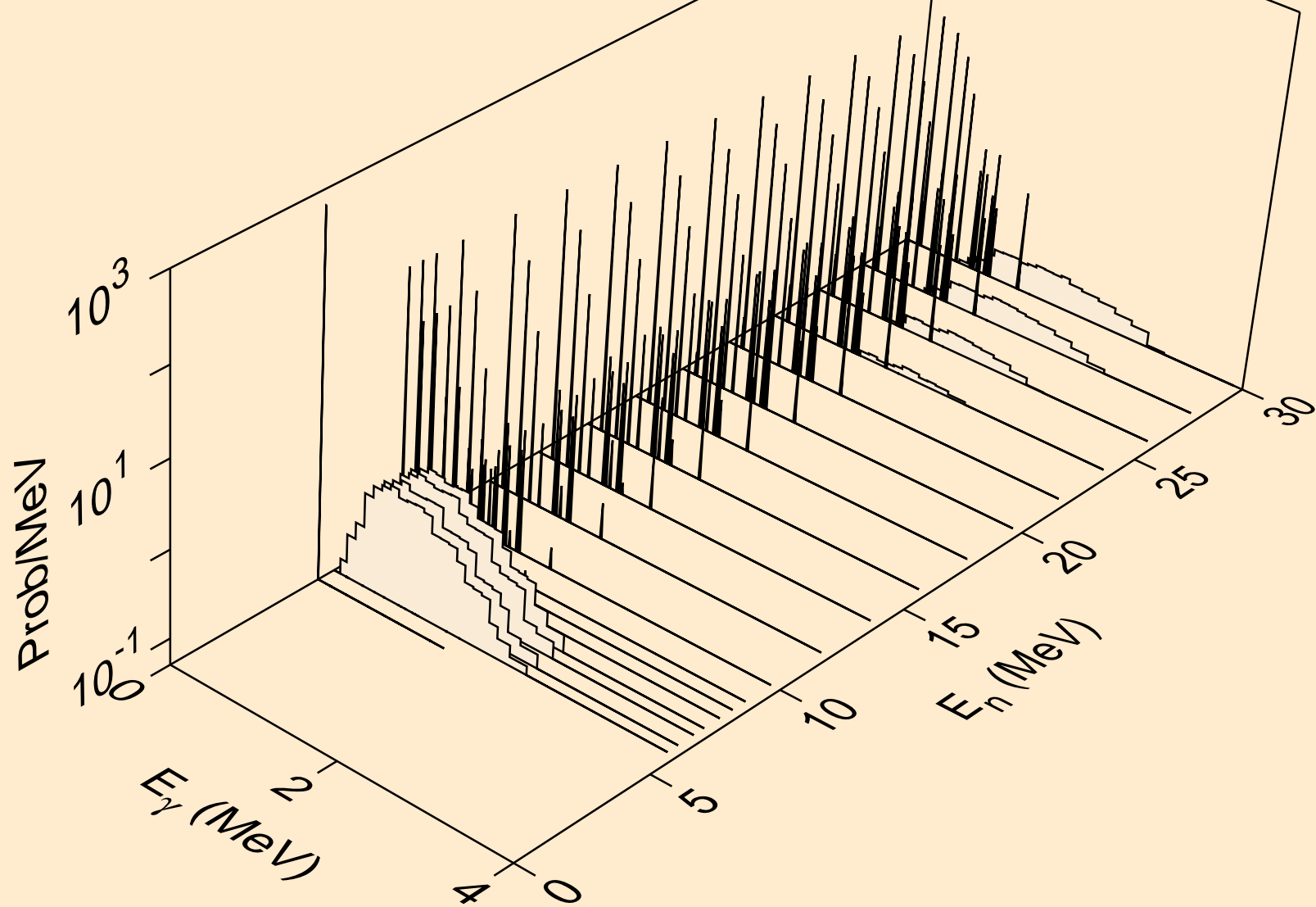

GD137 NEUTRON ACER TENDL-2023 LIBRARY; T=0.K  
Photon emission for (n,2p)

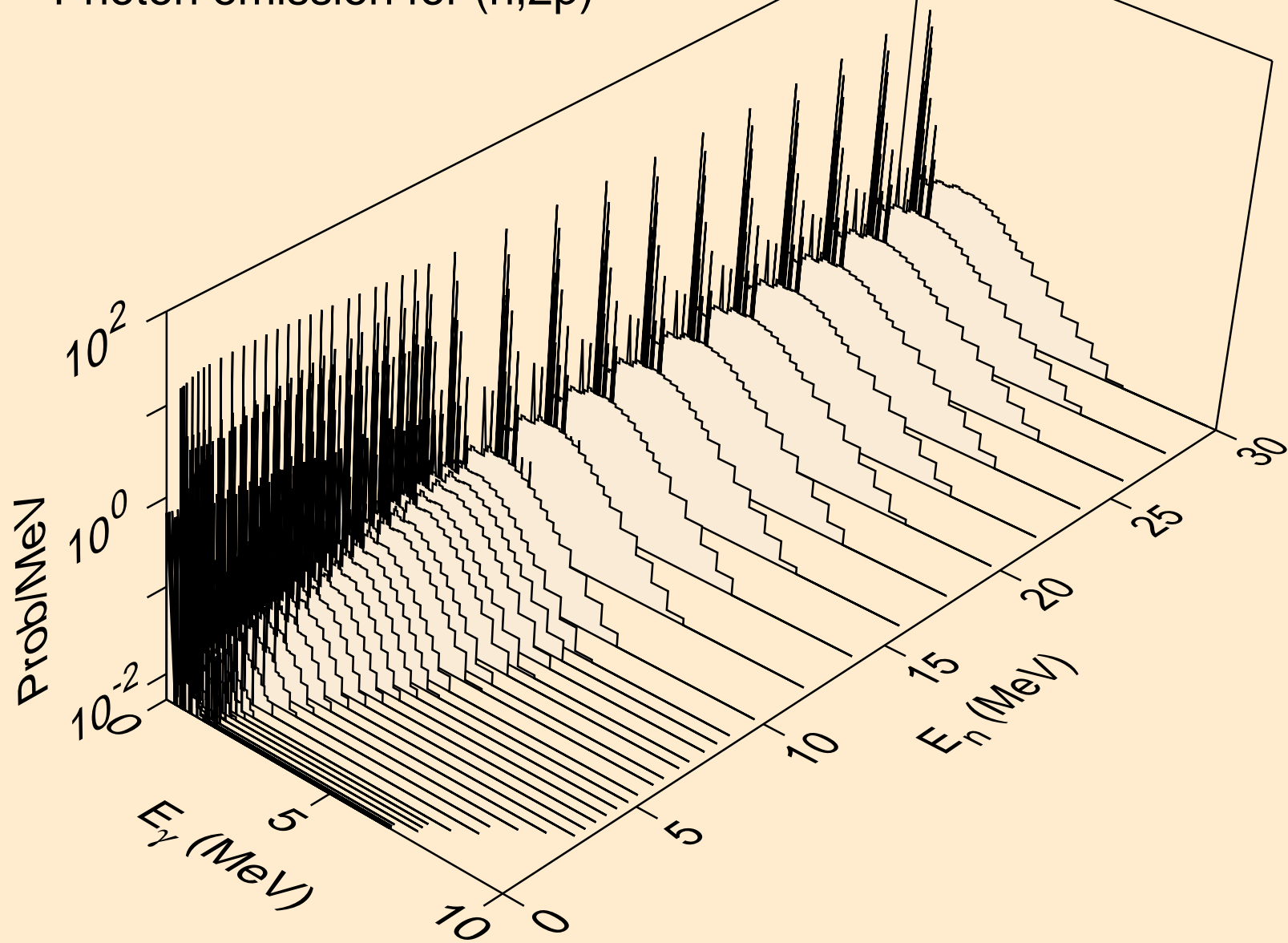

GD137 NEUTRON ACER TENDL-2023 LIBRARY; T=0.K  
Photon emission for (n,p $\alpha$ )

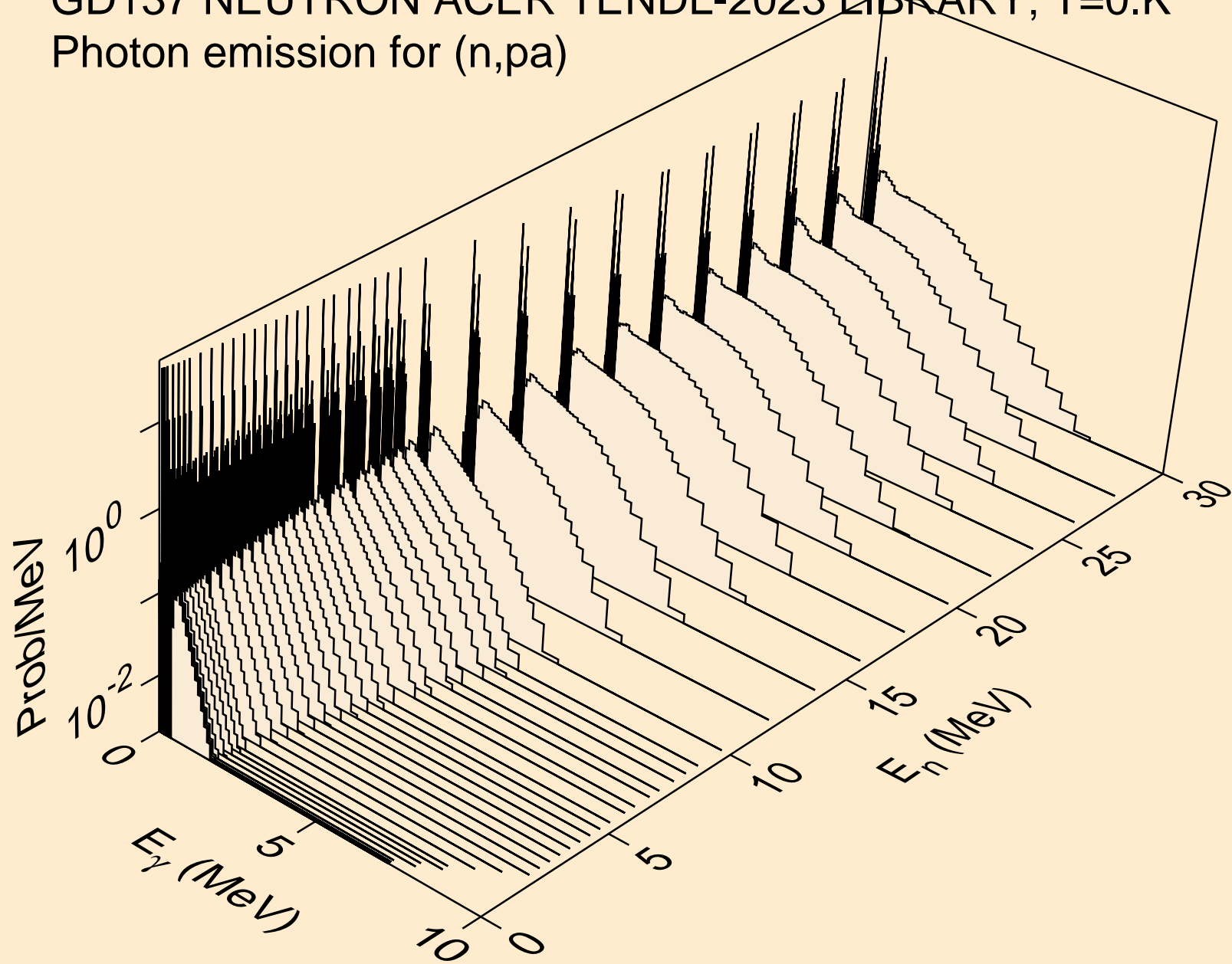

GD137 NEUTRON ACER TENDL-2023 LIBRARY; T=0.K  
Photon emission for (n,d2a)

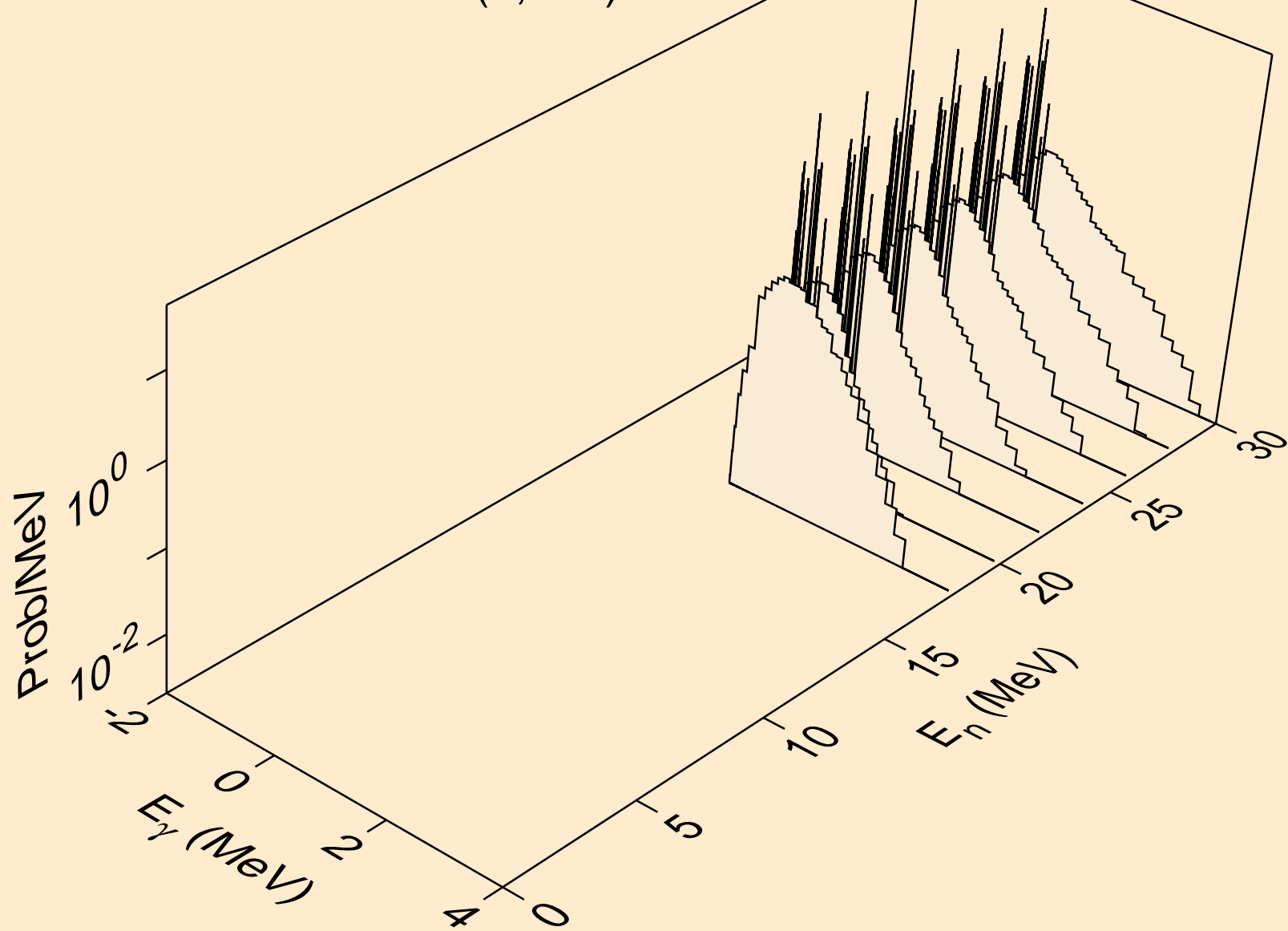

GD137 NEUTRON ACER TENDL-2023 LIBRARY; T=0.K  
Photon emission for (n,pd)

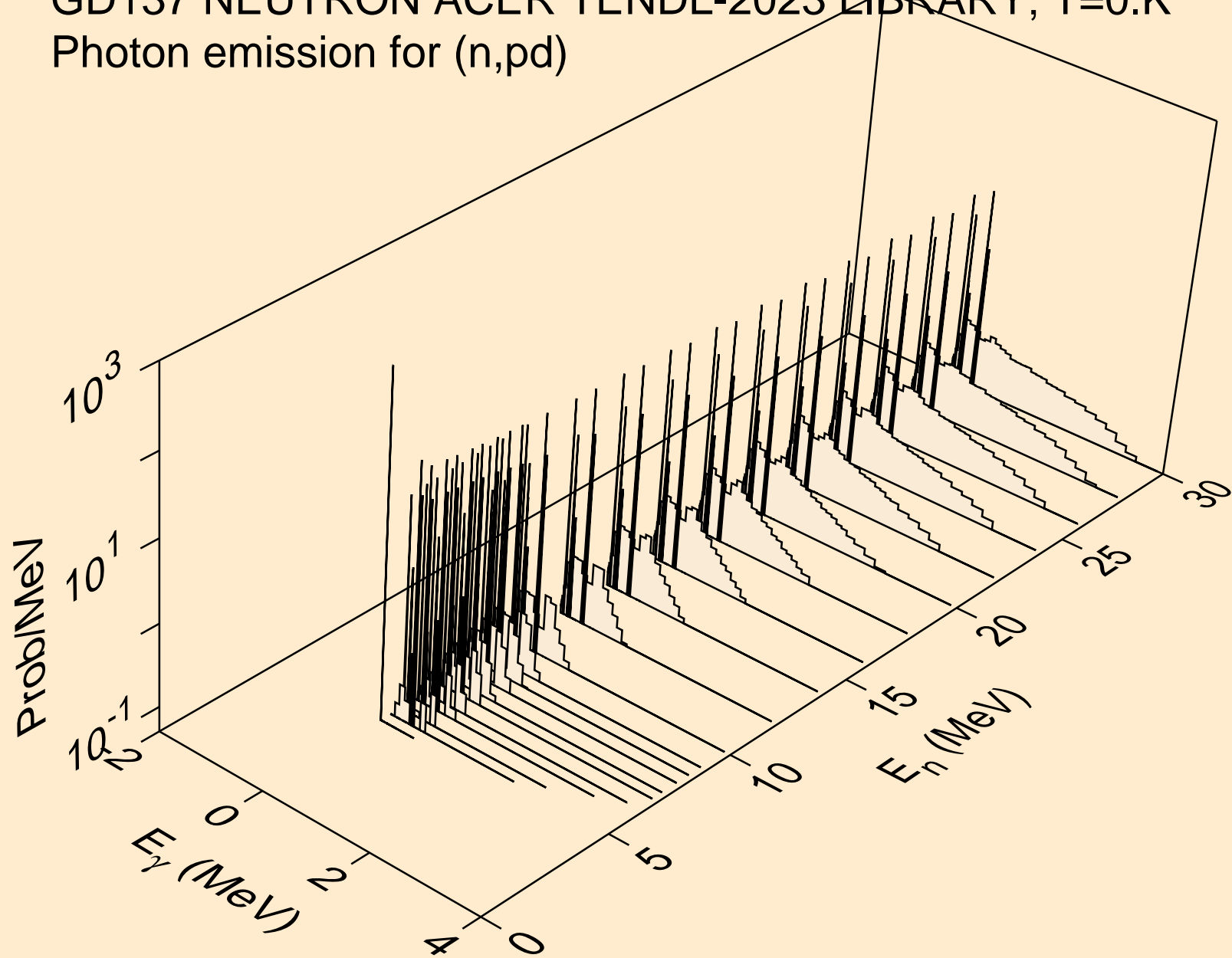

GD137 NEUTRON ACER TENDL-2023 LIBRARY; T=0.K  
Photon emission for (n,pt)

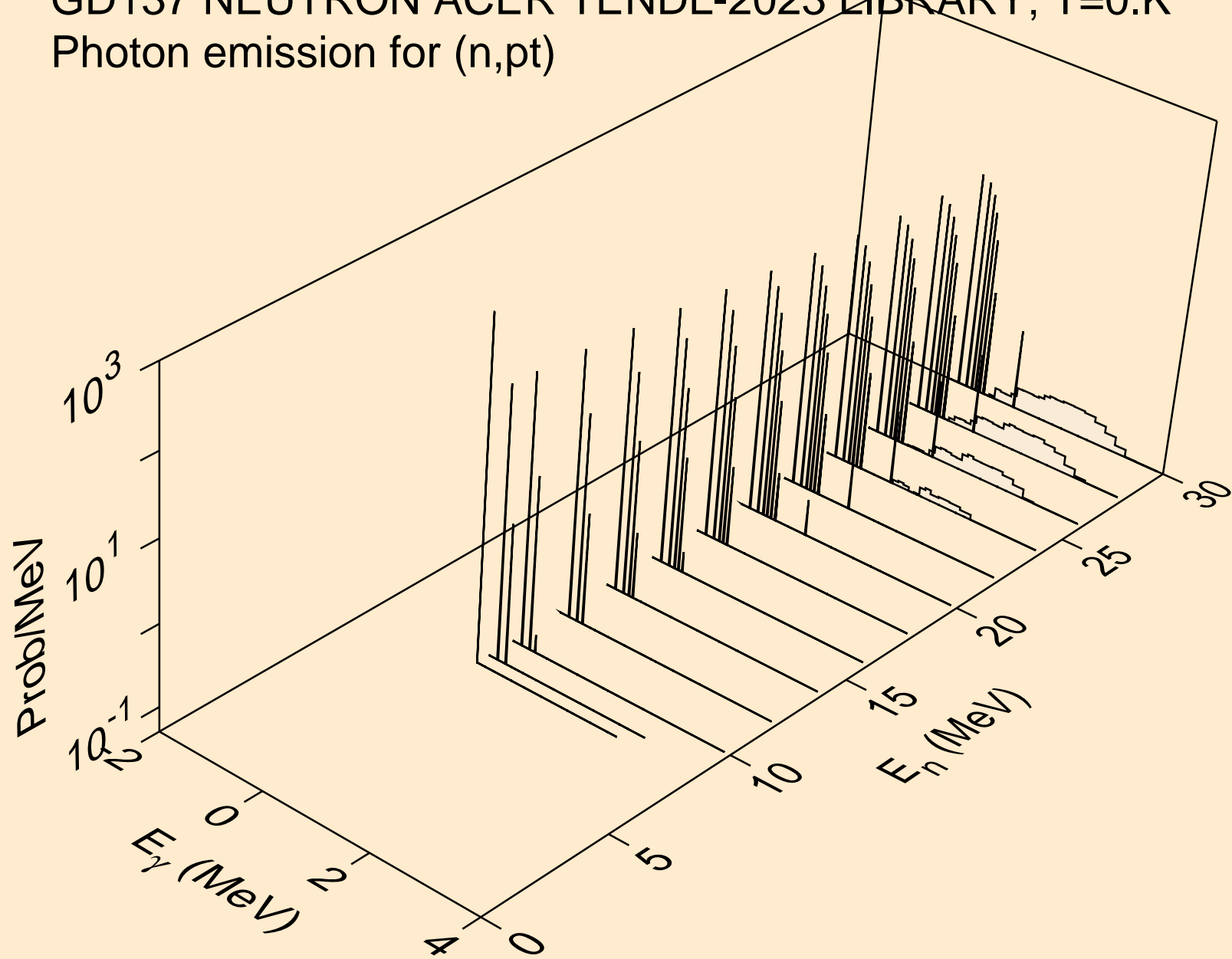



GD137 NEUTRON ACER TENDL-2023 LIBRARY; T=0.K  
Photon emission for (n,da)

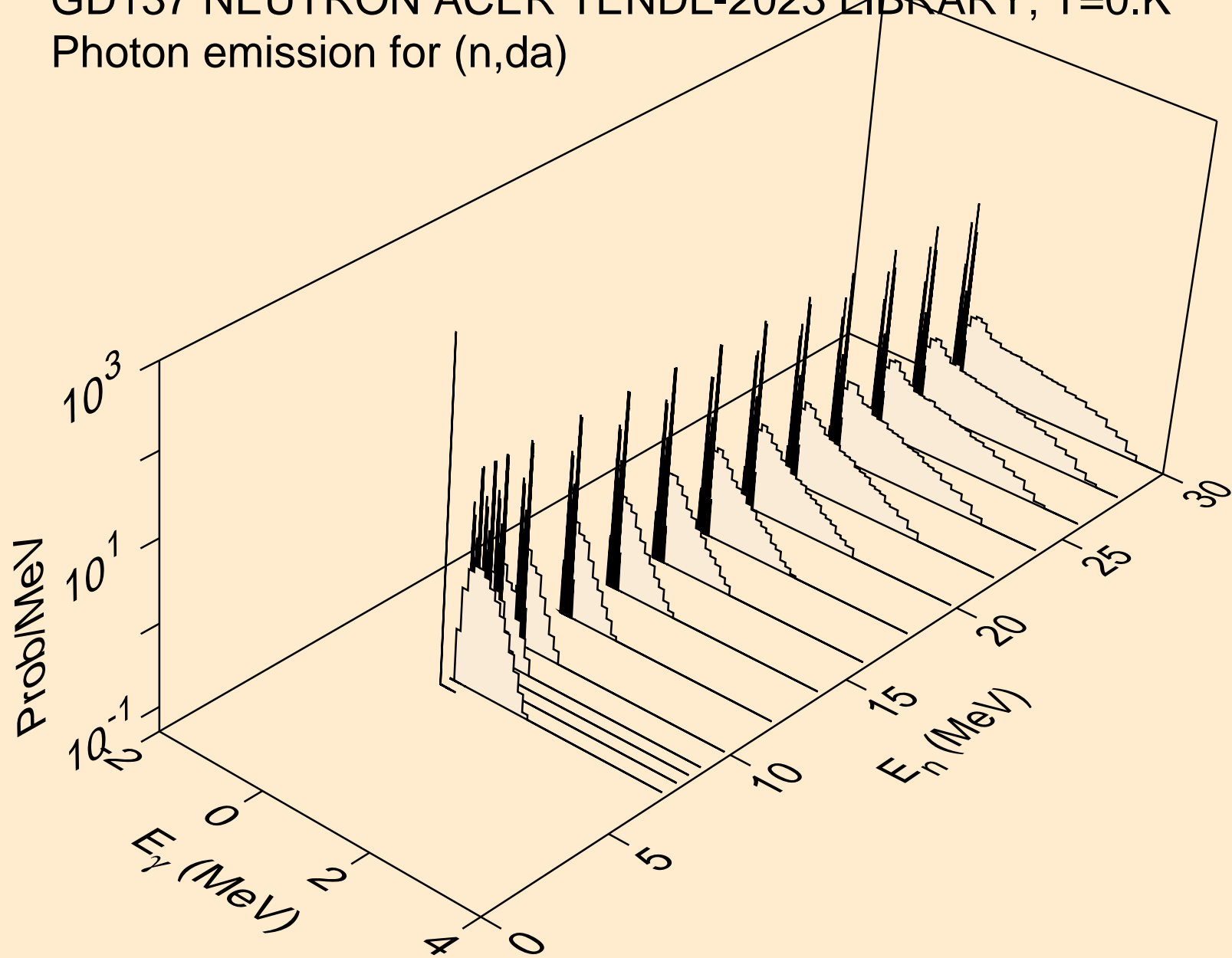

GD137 NEUTRON ACER TENDL-2023 LIBRARY; T=0.K  
thermal capture photon spectrum

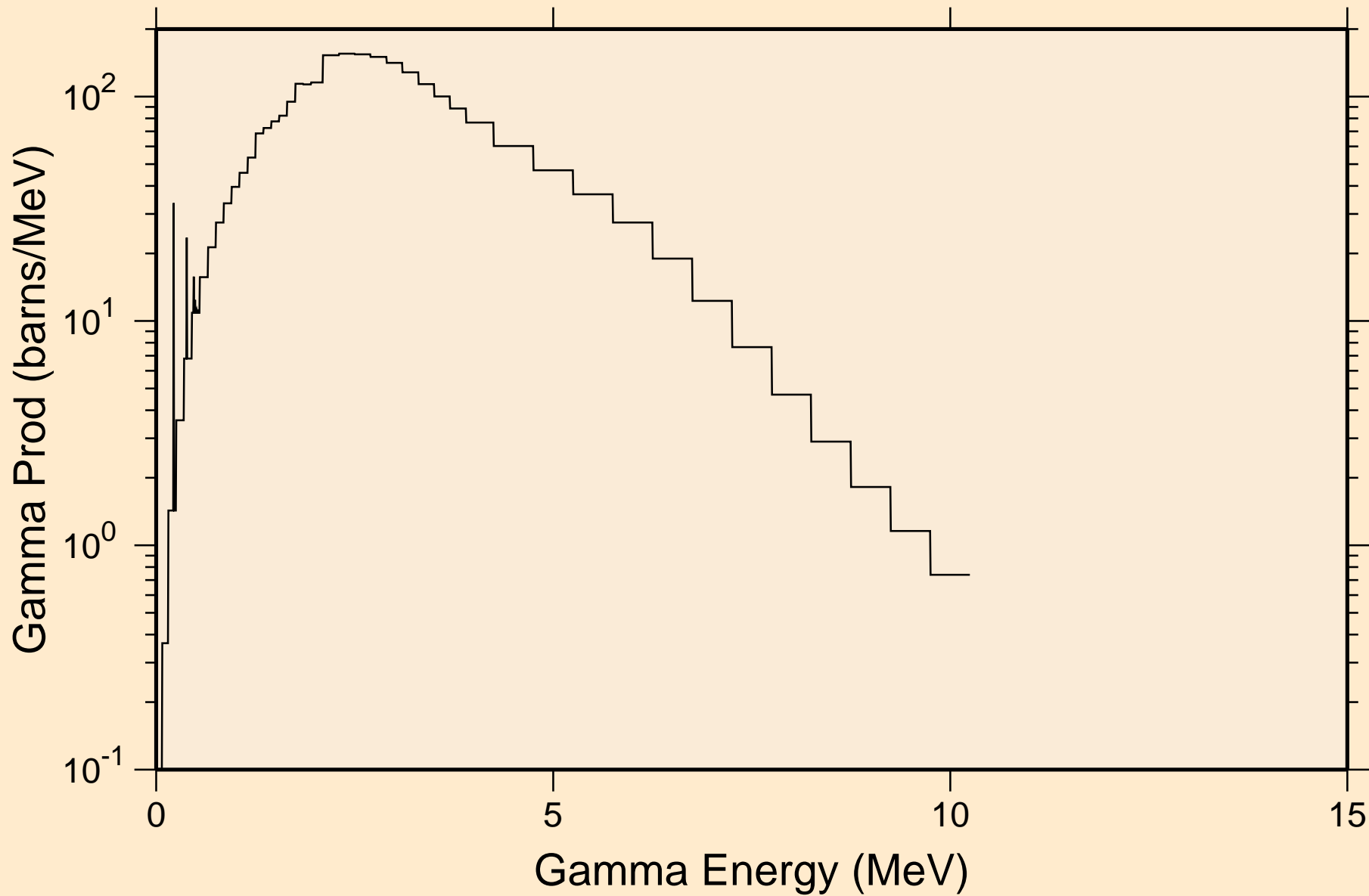

GD137 NEUTRON ACER TENDL-2023 LIBRARY; T=0.K  
14 MeV photon spectrum

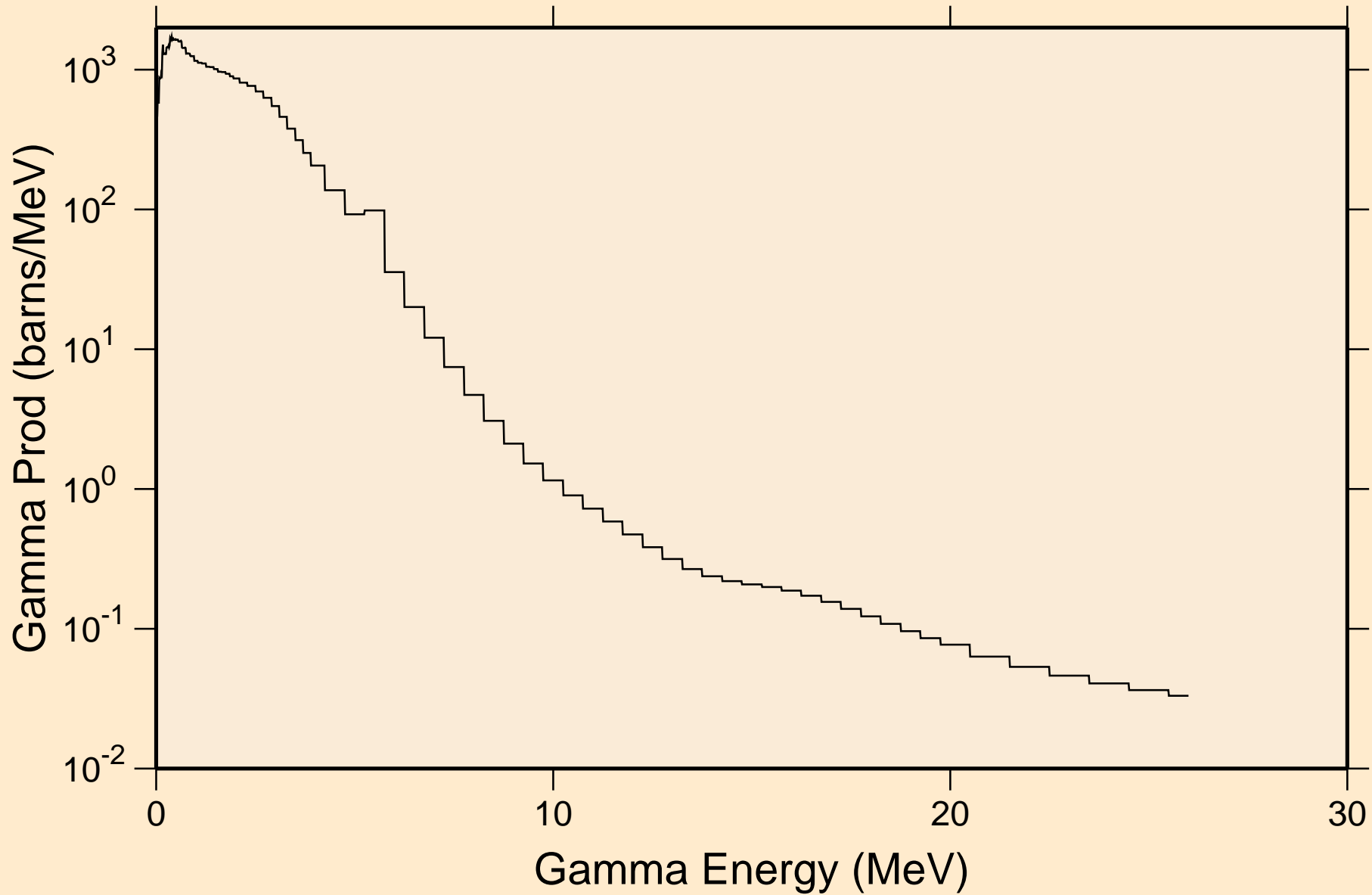

# GD137 NEUTRON ACER TENDL-2023 LIBRARY; T=0.K

## Particle heating contributions

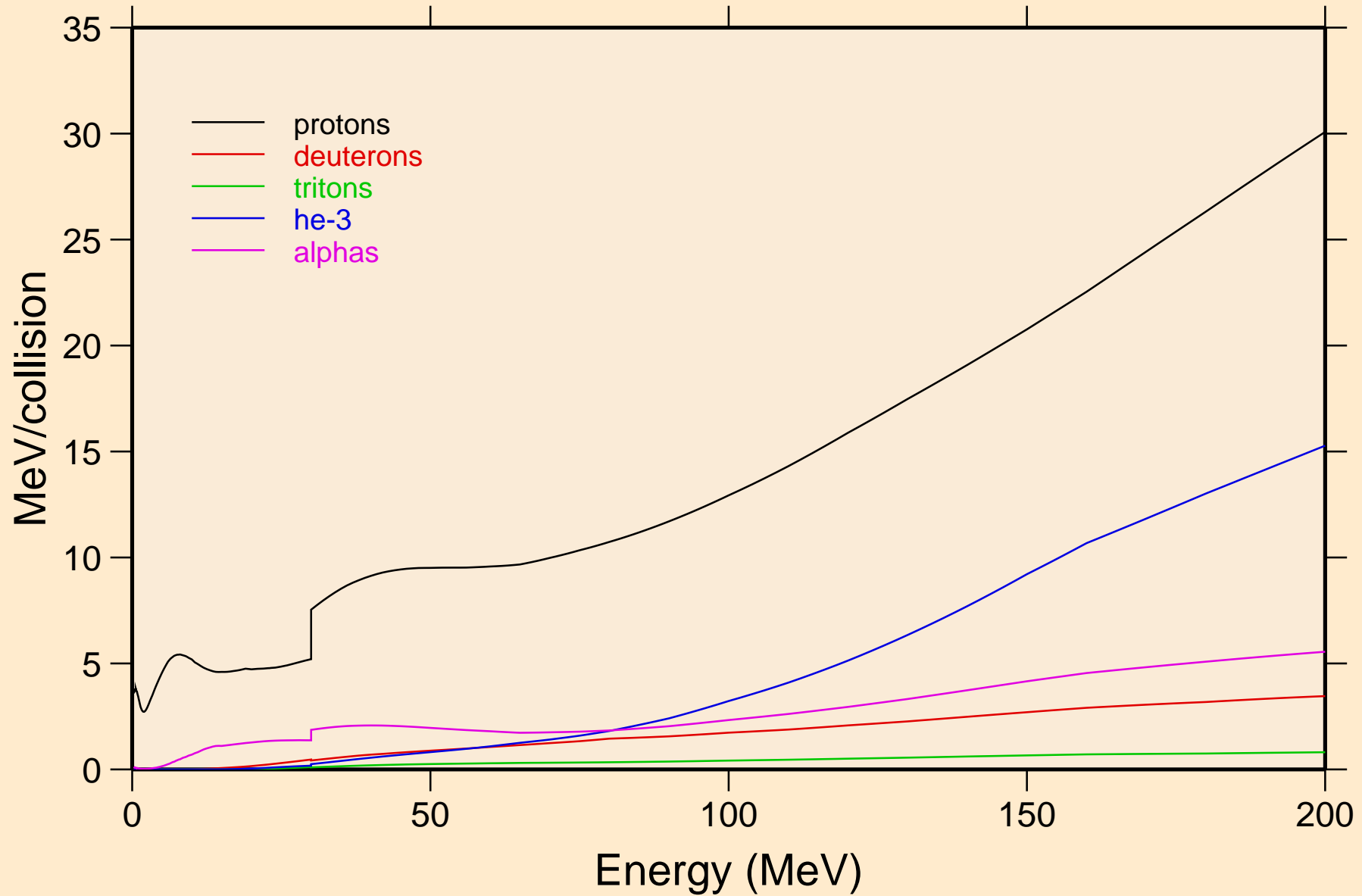

# GD137 NEUTRON ACER TENDL-2023 LIBRARY; T=0.K

## Recoil Heating

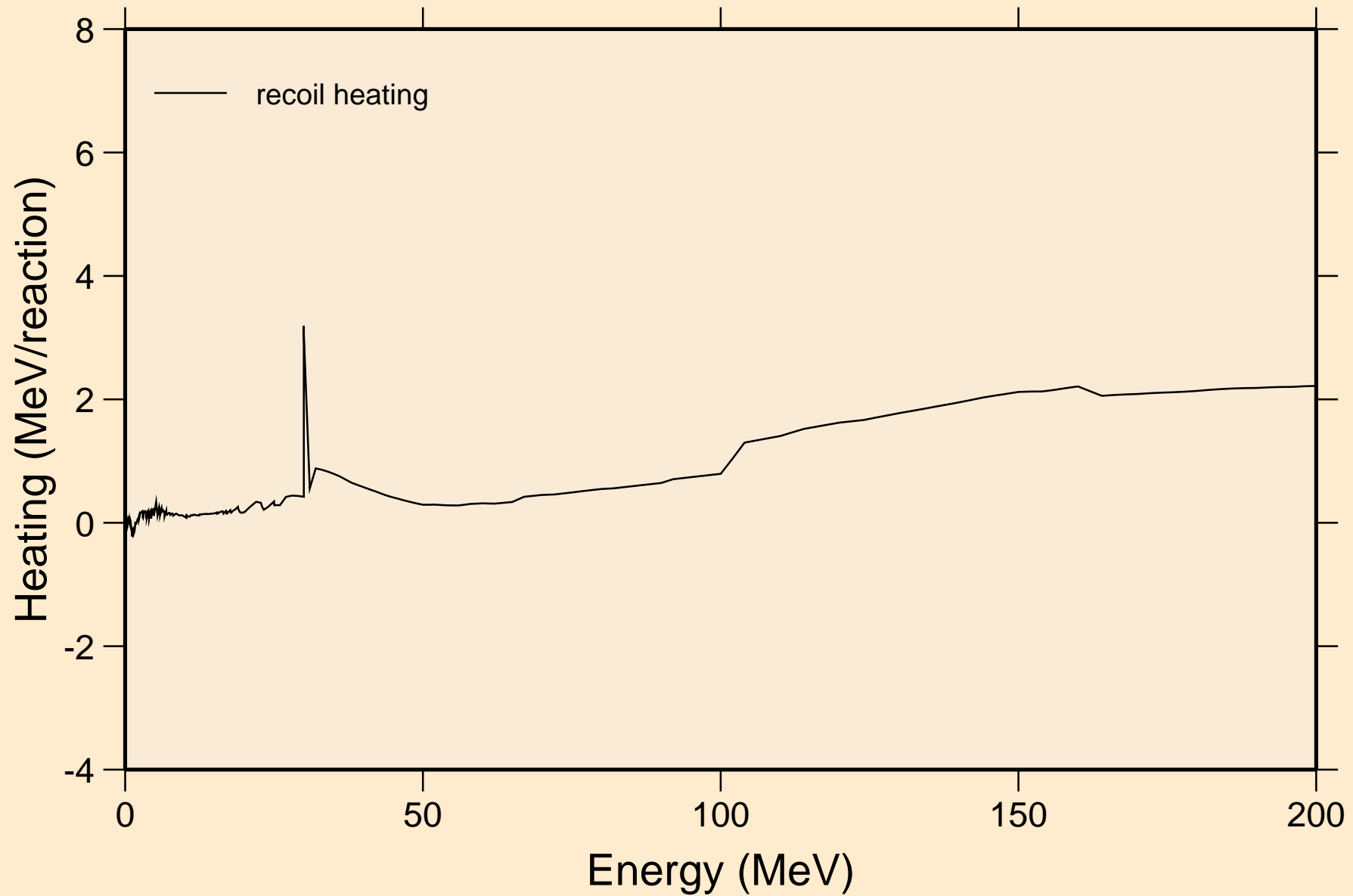

# GD137 NEUTRON ACER TENDL-2023 LIBRARY; T=0.K

## Particle production cross sections

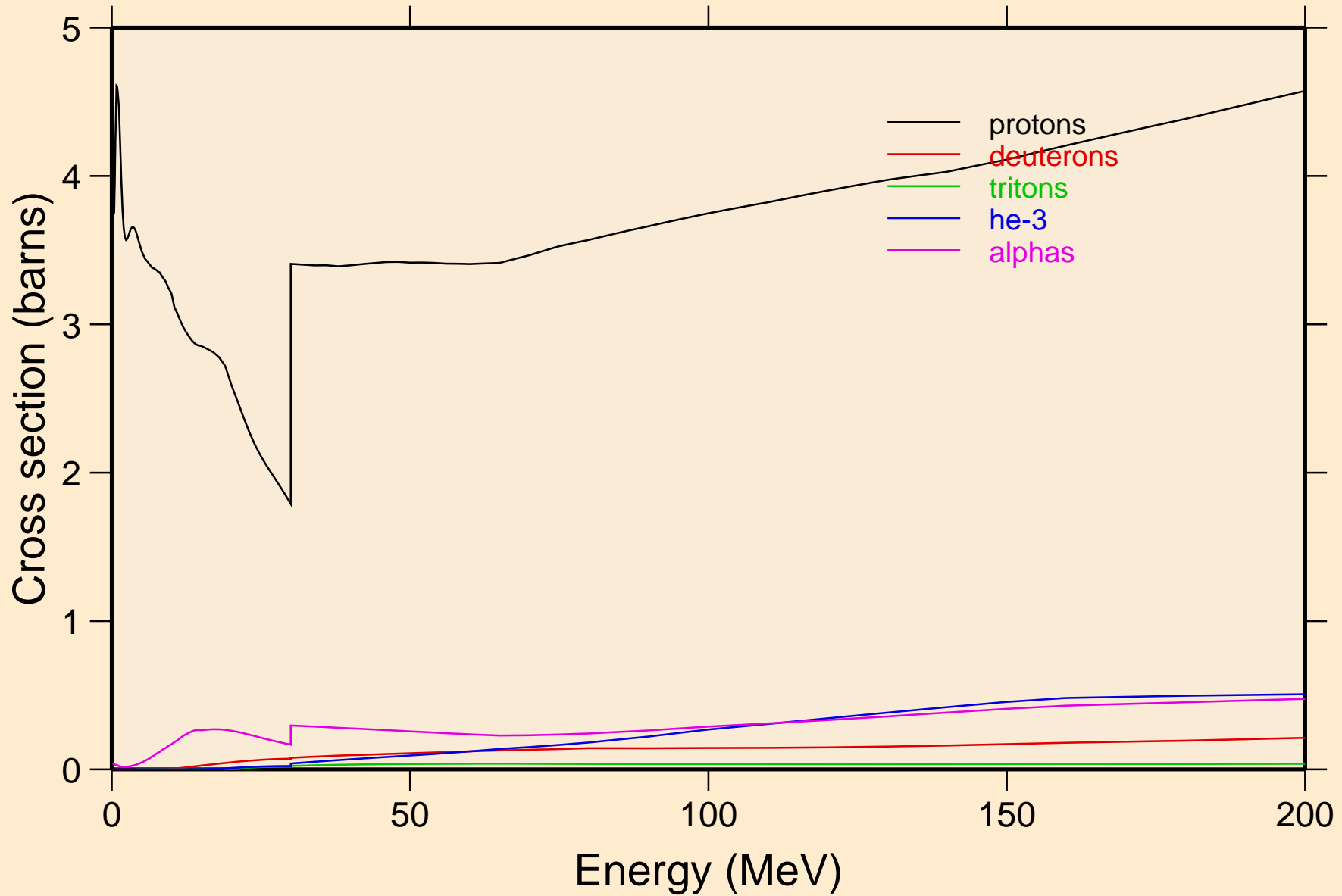

GD137 NEUTRON ACER TENDL-2023 LIBRARY; T=0.K  
protons from (n,x)

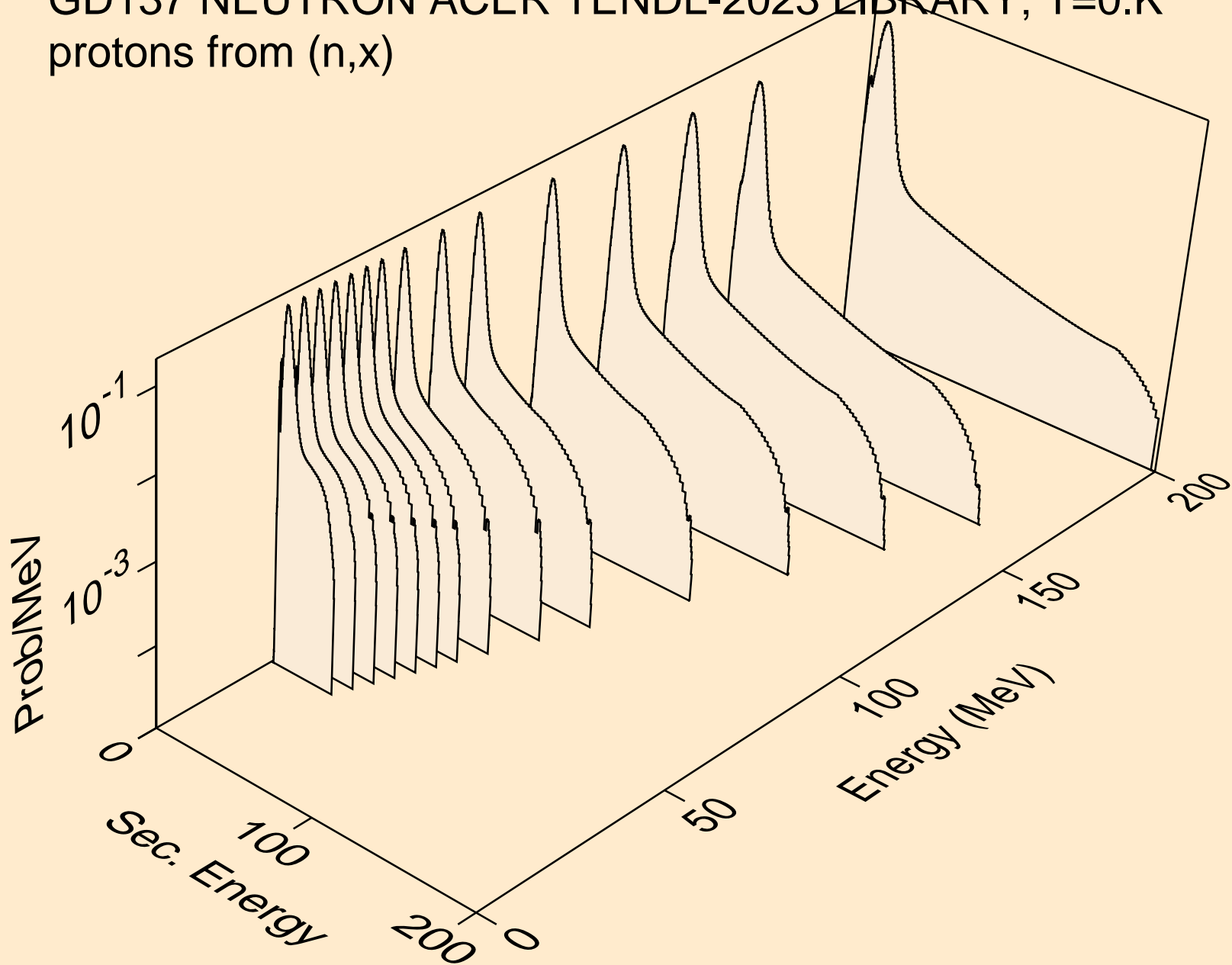

GD137 NEUTRON ACER TENDL-2023 LIBRARY; T=0.K  
protons from (n,n\*)p

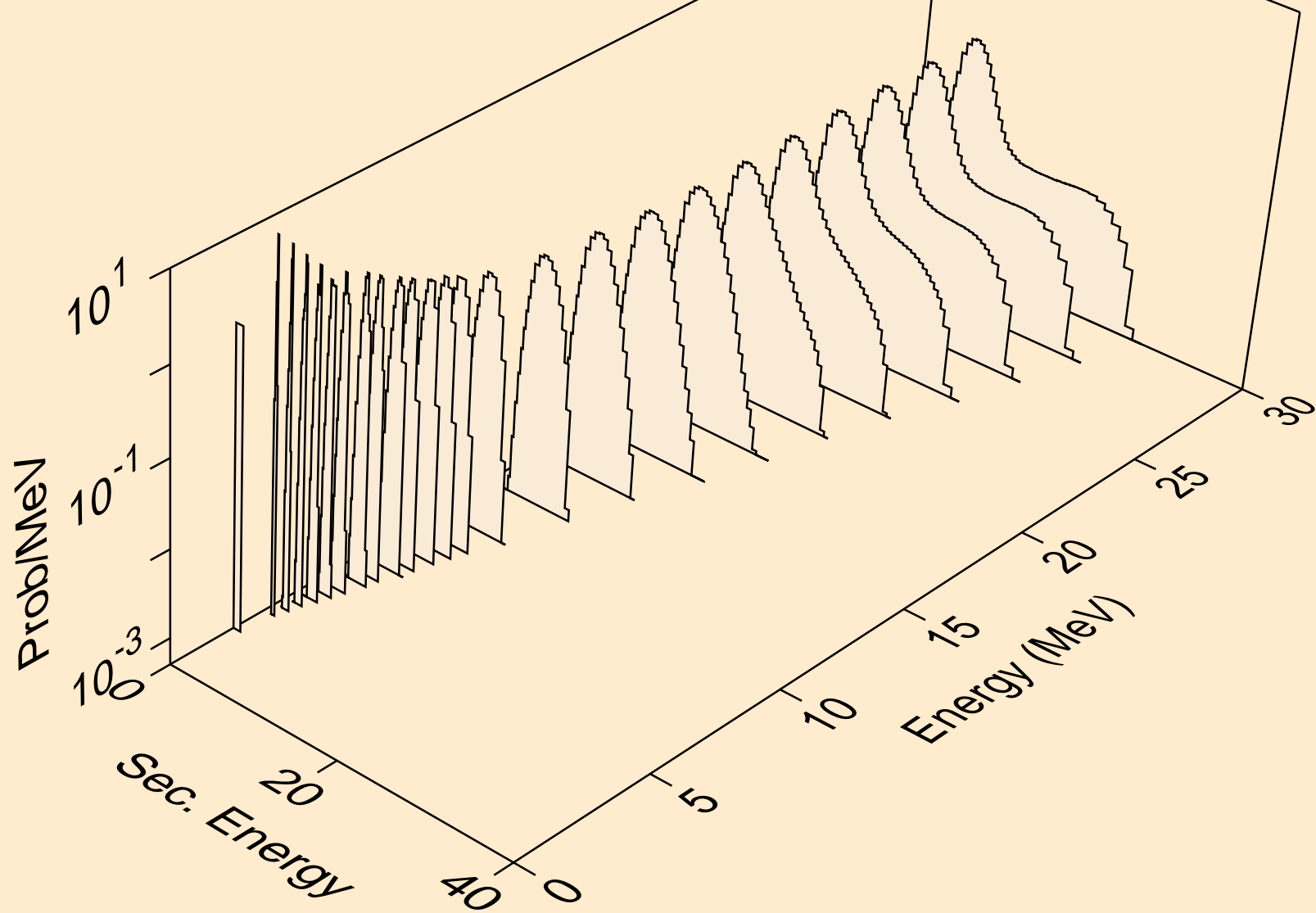



GD137 NEUTRON ACER TENDL-2023 LIBRARY; T=0.K  
protons from (n,2np)

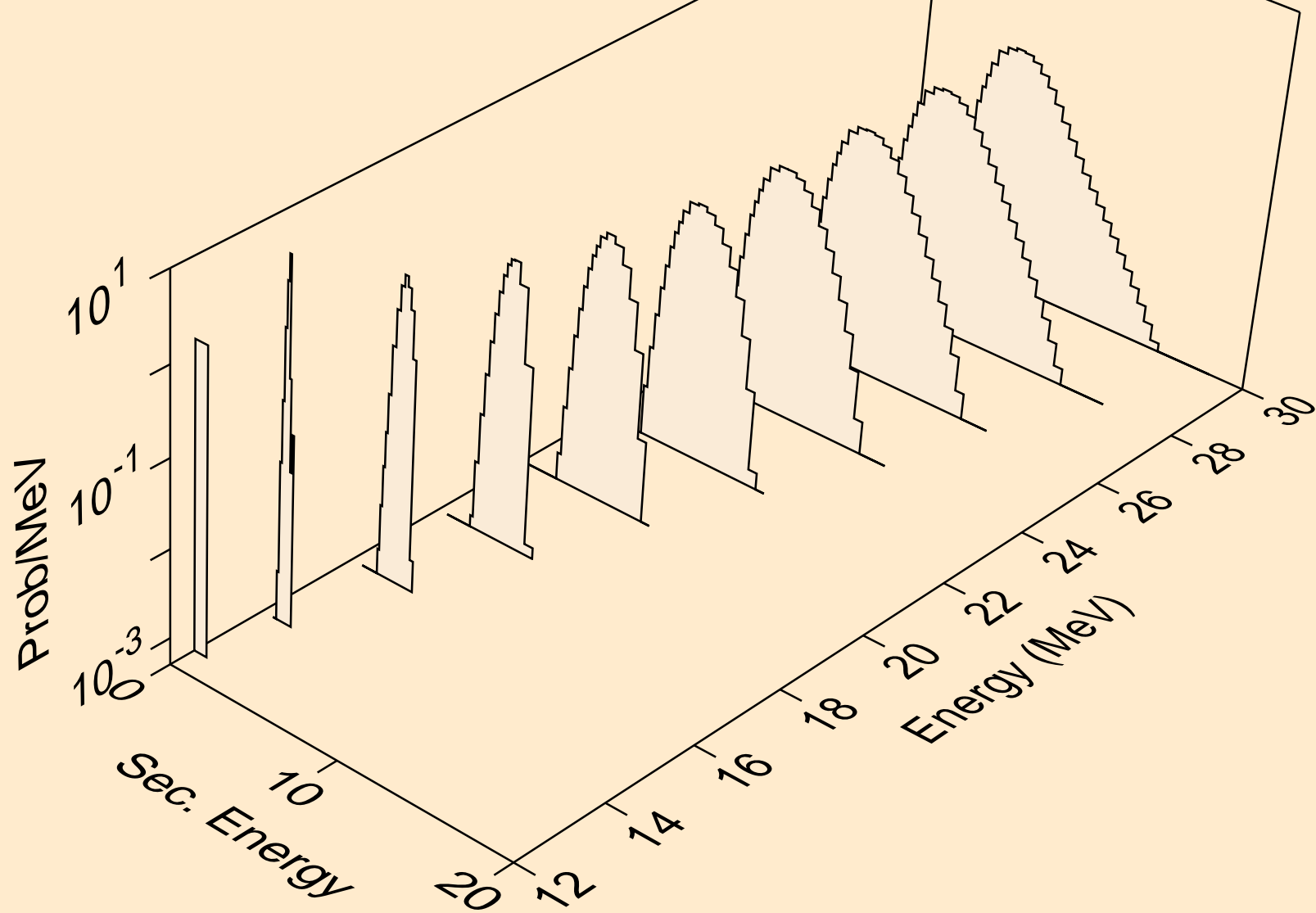

GD137 NEUTRON ACER TENDL-2023 LIBRARY; T=0.K  
protons from (n,3np)

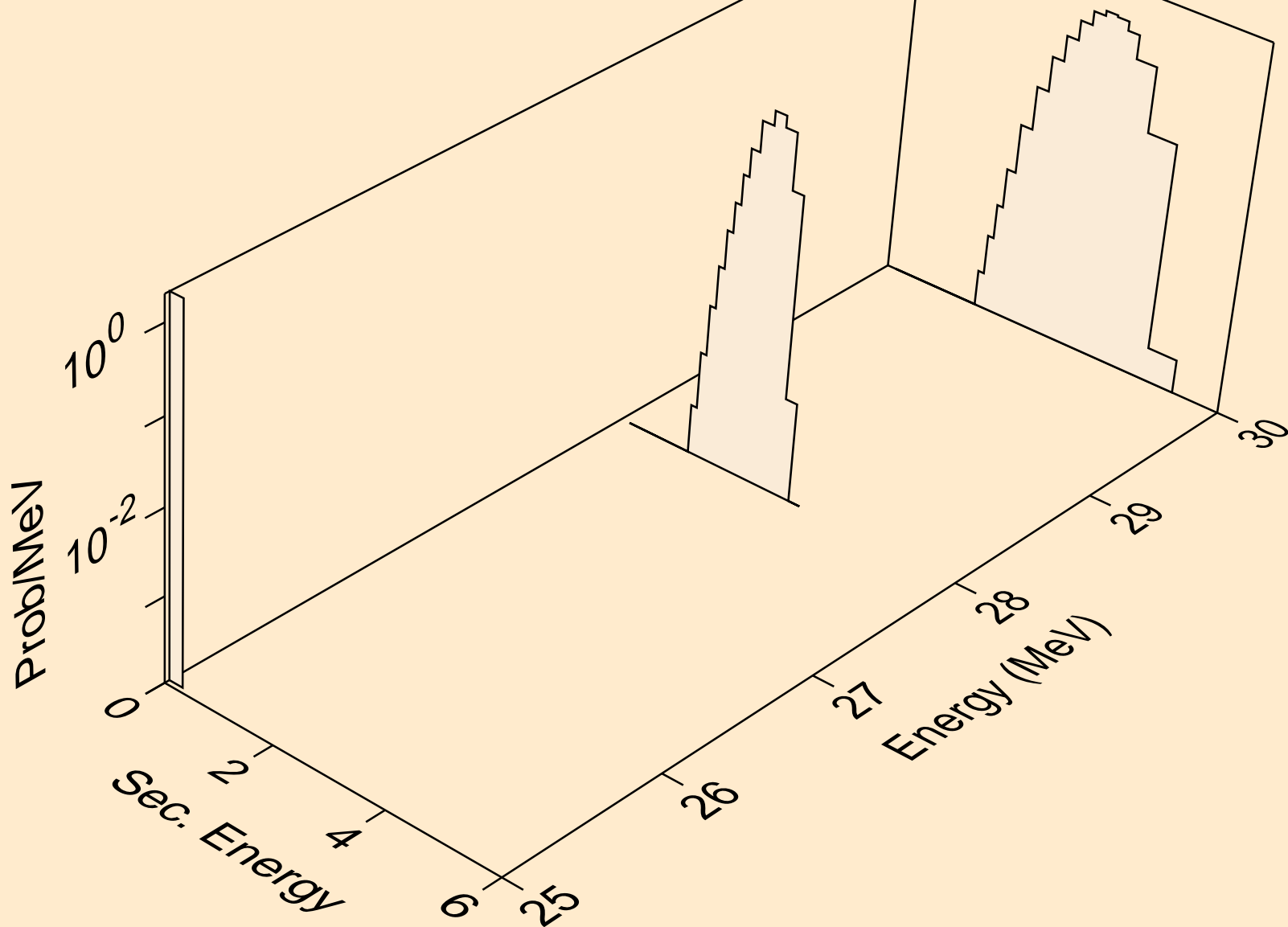

GD137 NEUTRON ACER TENDL-2023 LIBRARY; T=0.K  
protons from (n,n2p)

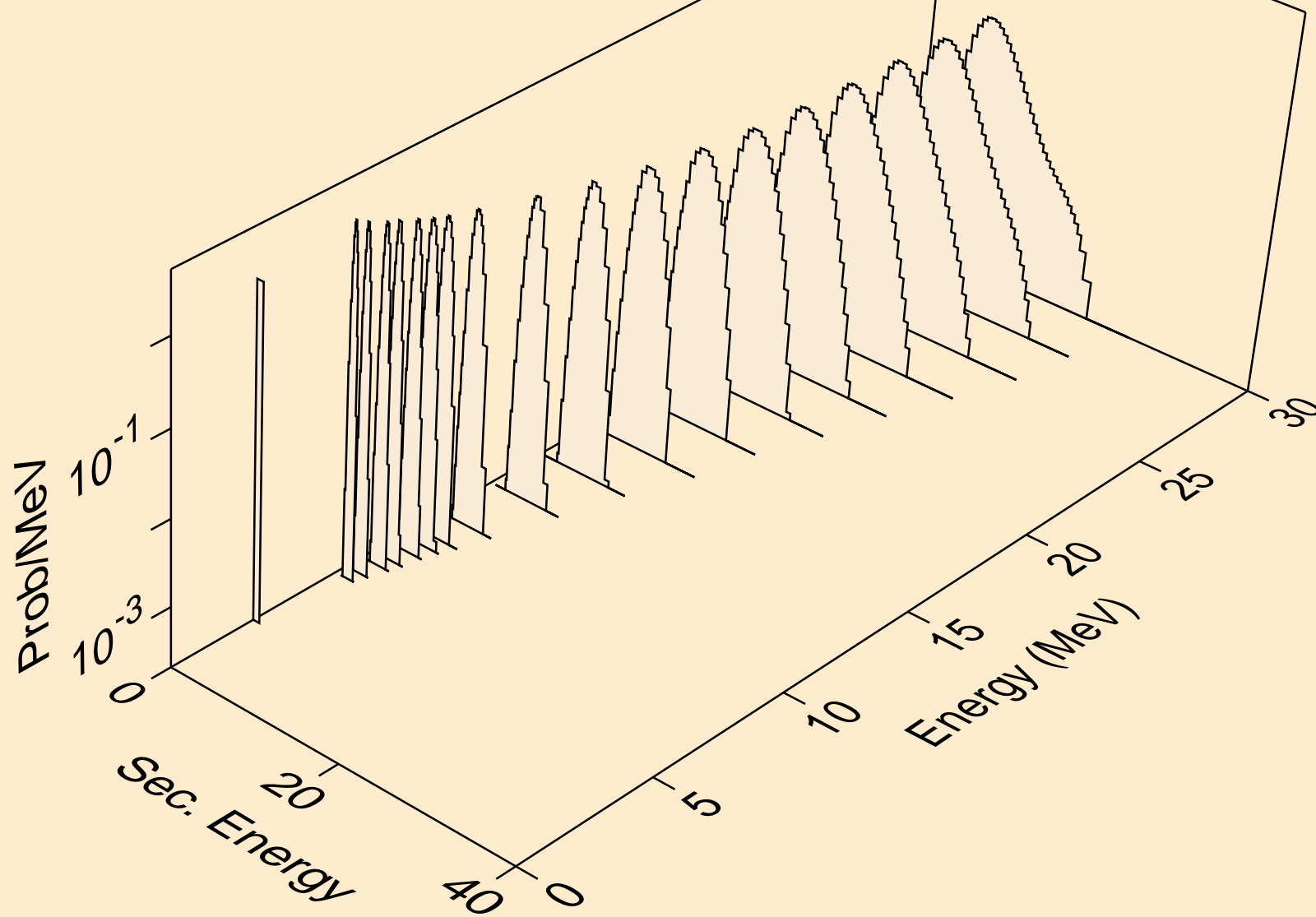

GD137 NEUTRON ACER TENDL-2023 LIBRARY; T=0.K  
protons from (n,npa)

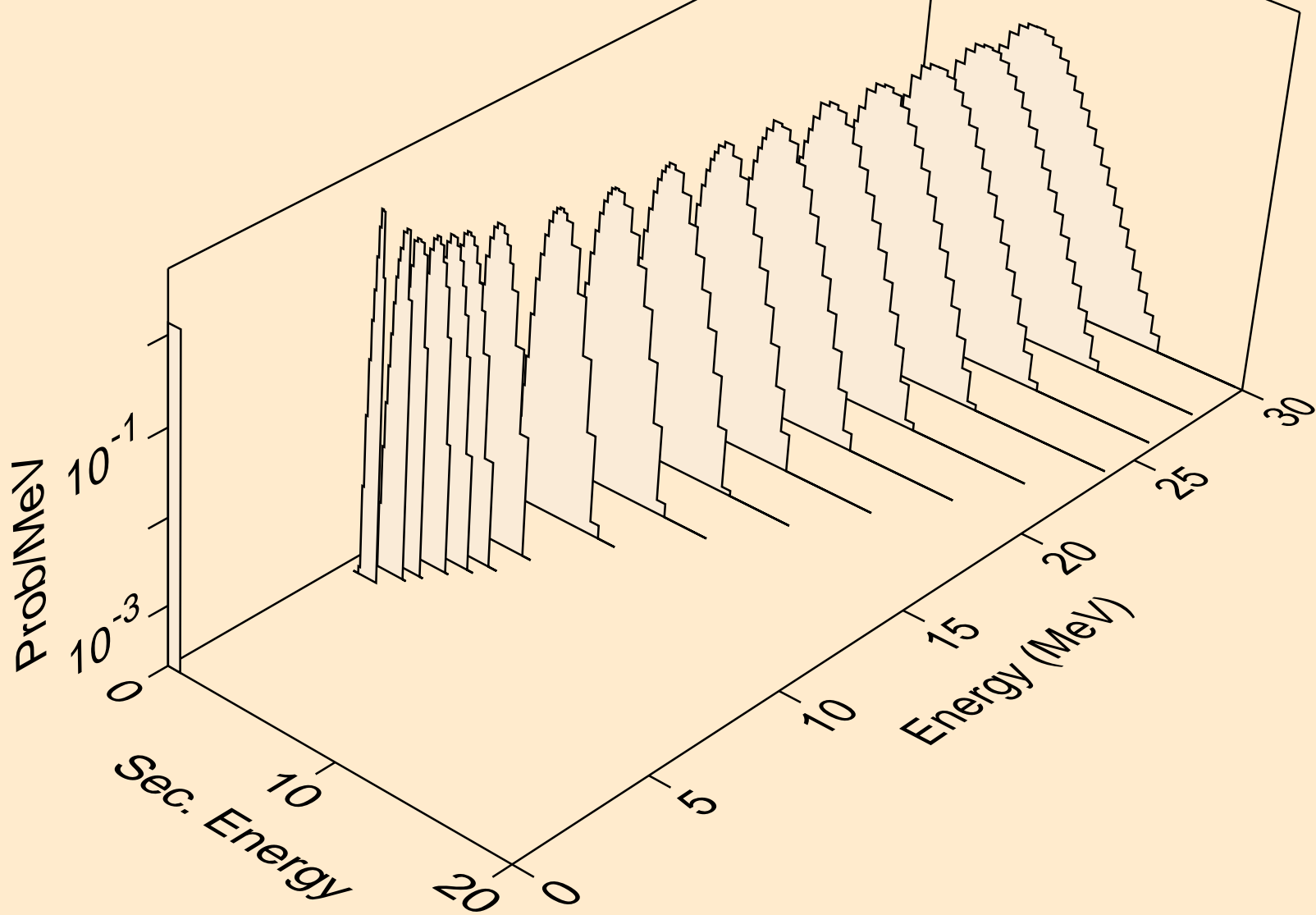

GD137 NEUTRON ACER TENDL-2023 LIBRARY; T=0.K  
protons from (n,p)

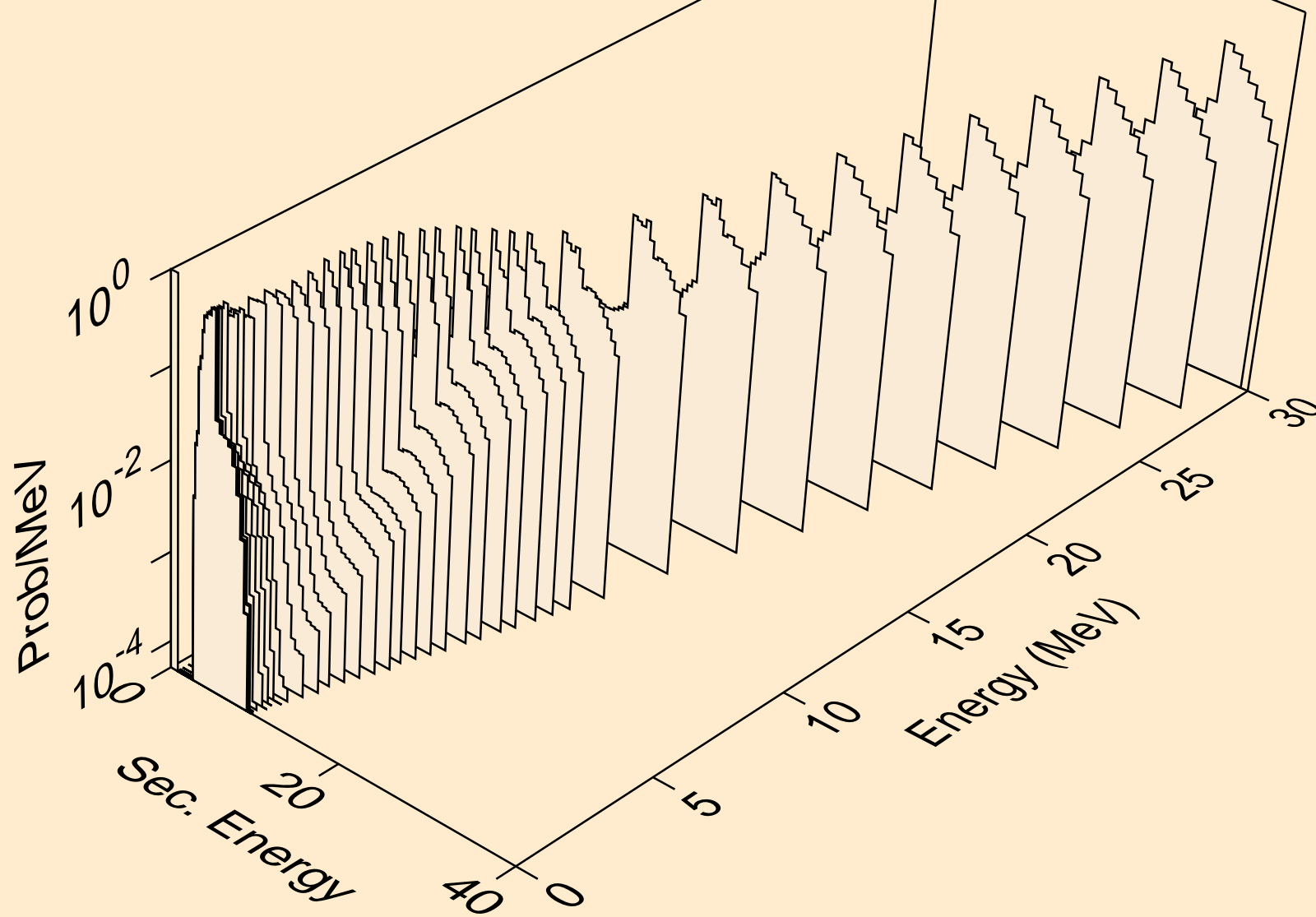

GD137 NEUTRON ACER TENDL-2023 LIBRARY; T=0.K  
protons from (n,2p)

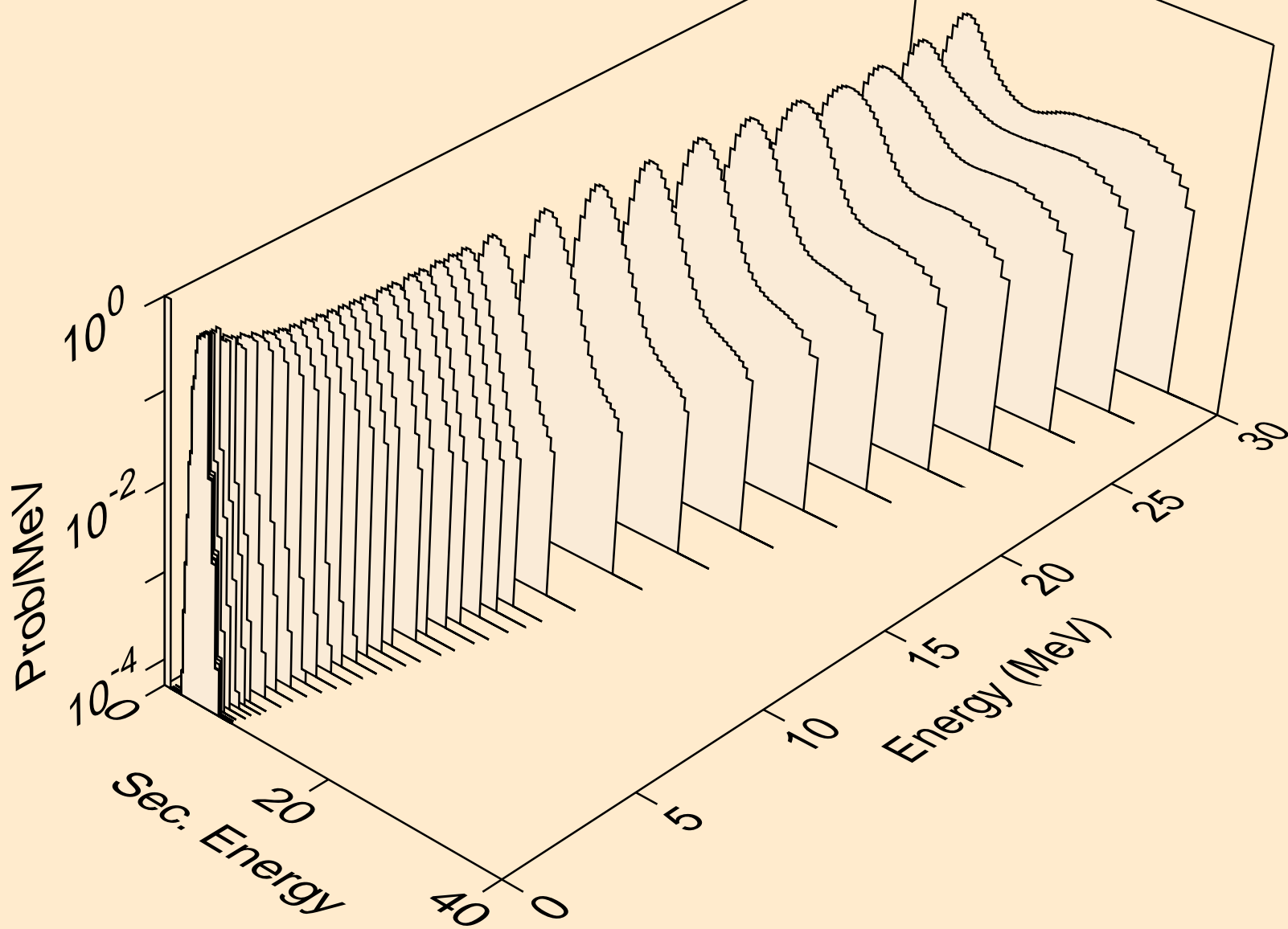

GD137 NEUTRON ACER TENDL-2023 LIBRARY; T=0.K  
protons from (n,p)

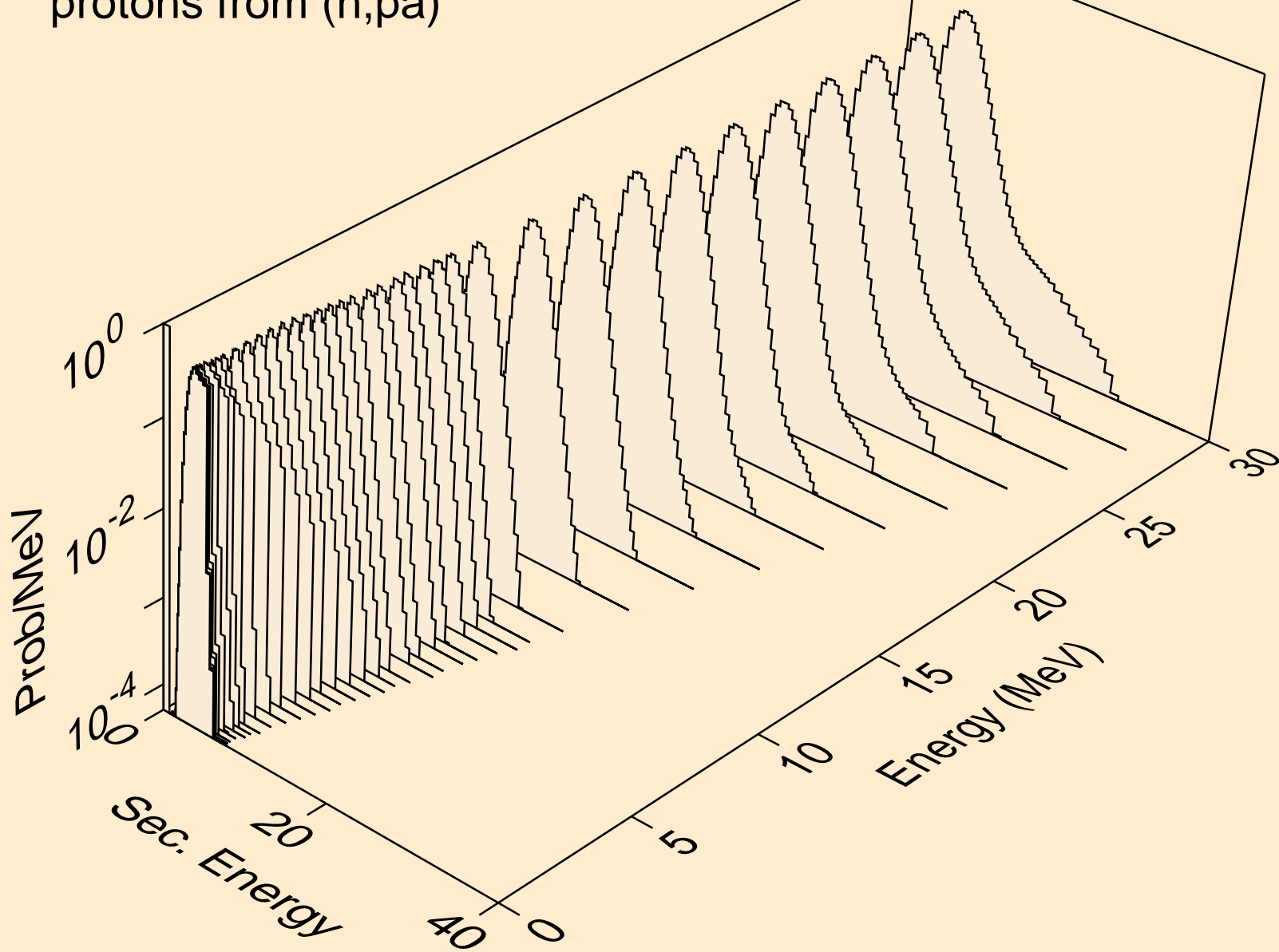

GD137 NEUTRON ACER TENDL-2023 LIBRARY; T=0.K  
protons from (n,pd)

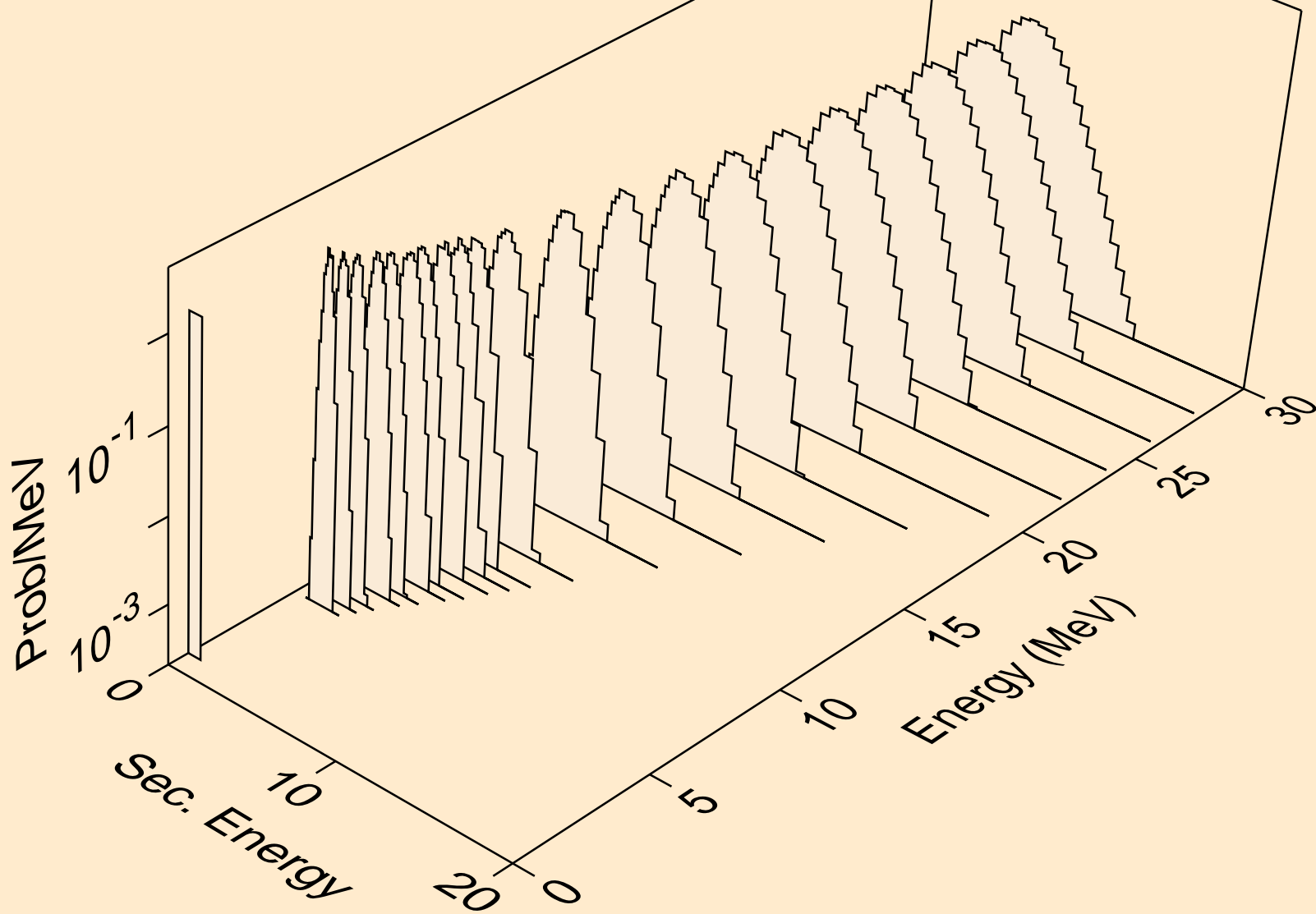



GD137 NEUTRON ACER TENDL-2023 LIBRARY; T=0.K  
protons from (n,pt)

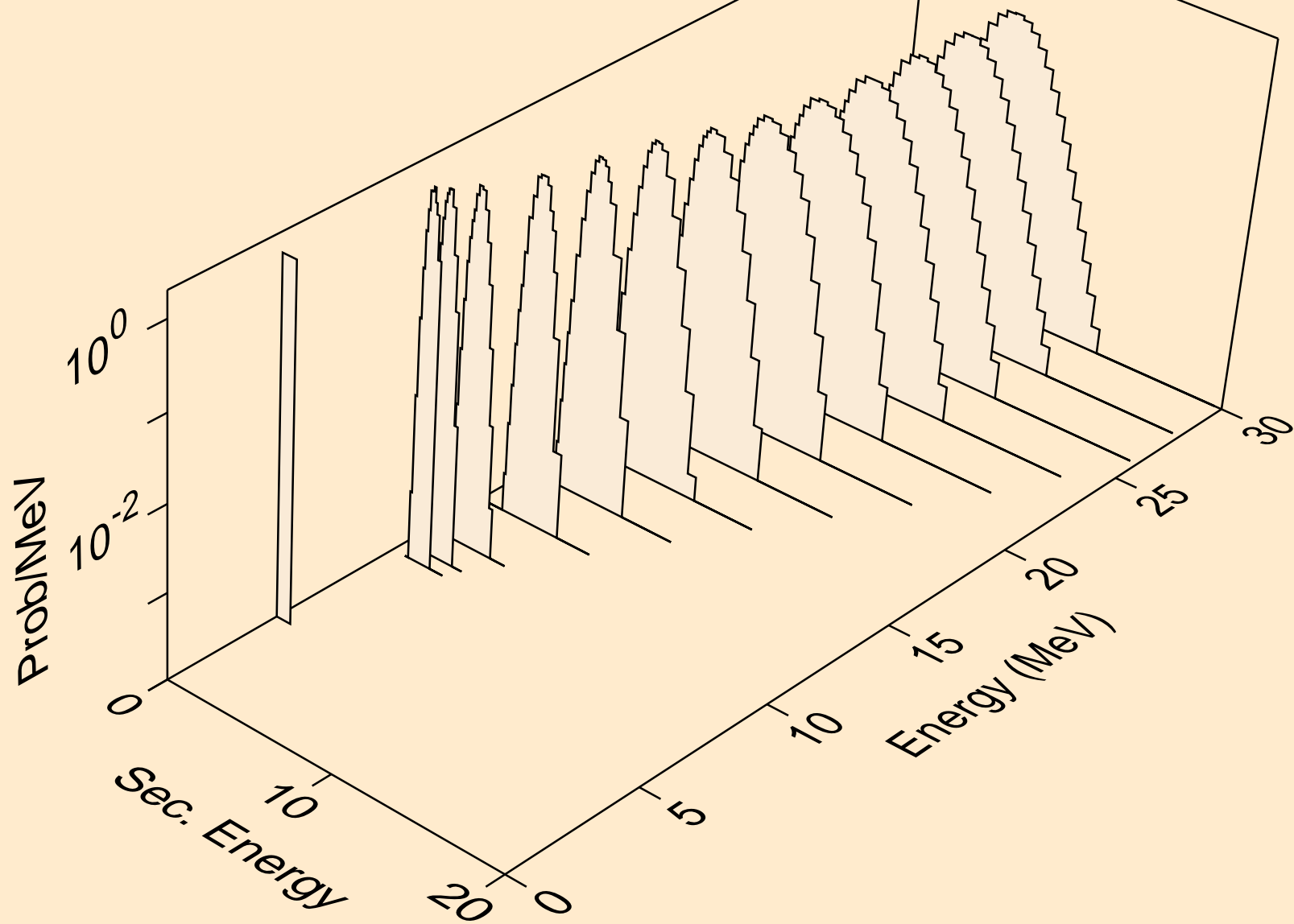

GD137 NEUTRON ACER TENDL-2023 LIBRARY; T=0.K  
deuterons from (n,x)

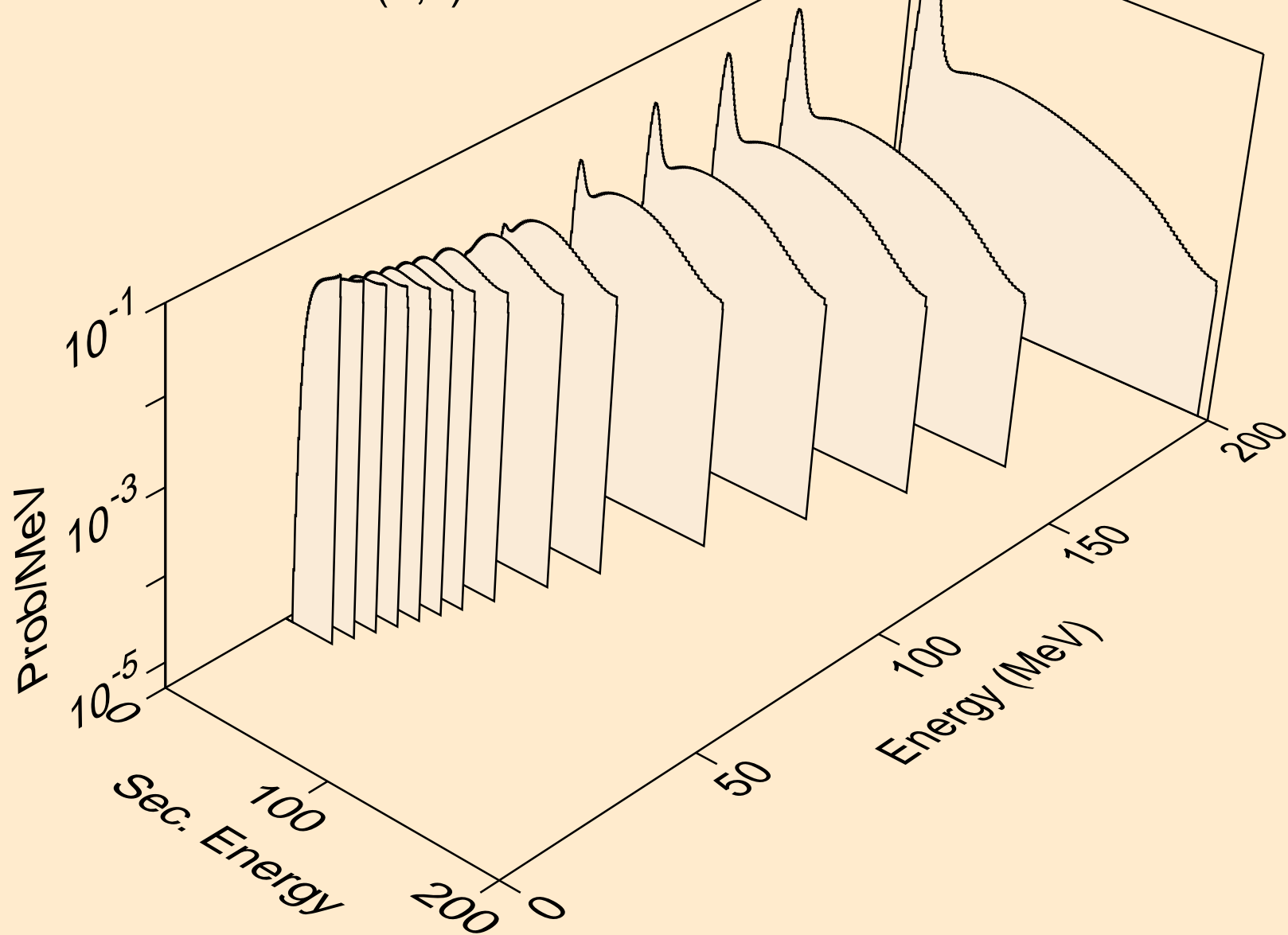

GD137 NEUTRON ACER TENDL-2023 LIBRARY; T=0.K  
deuterons from (n,2nd)

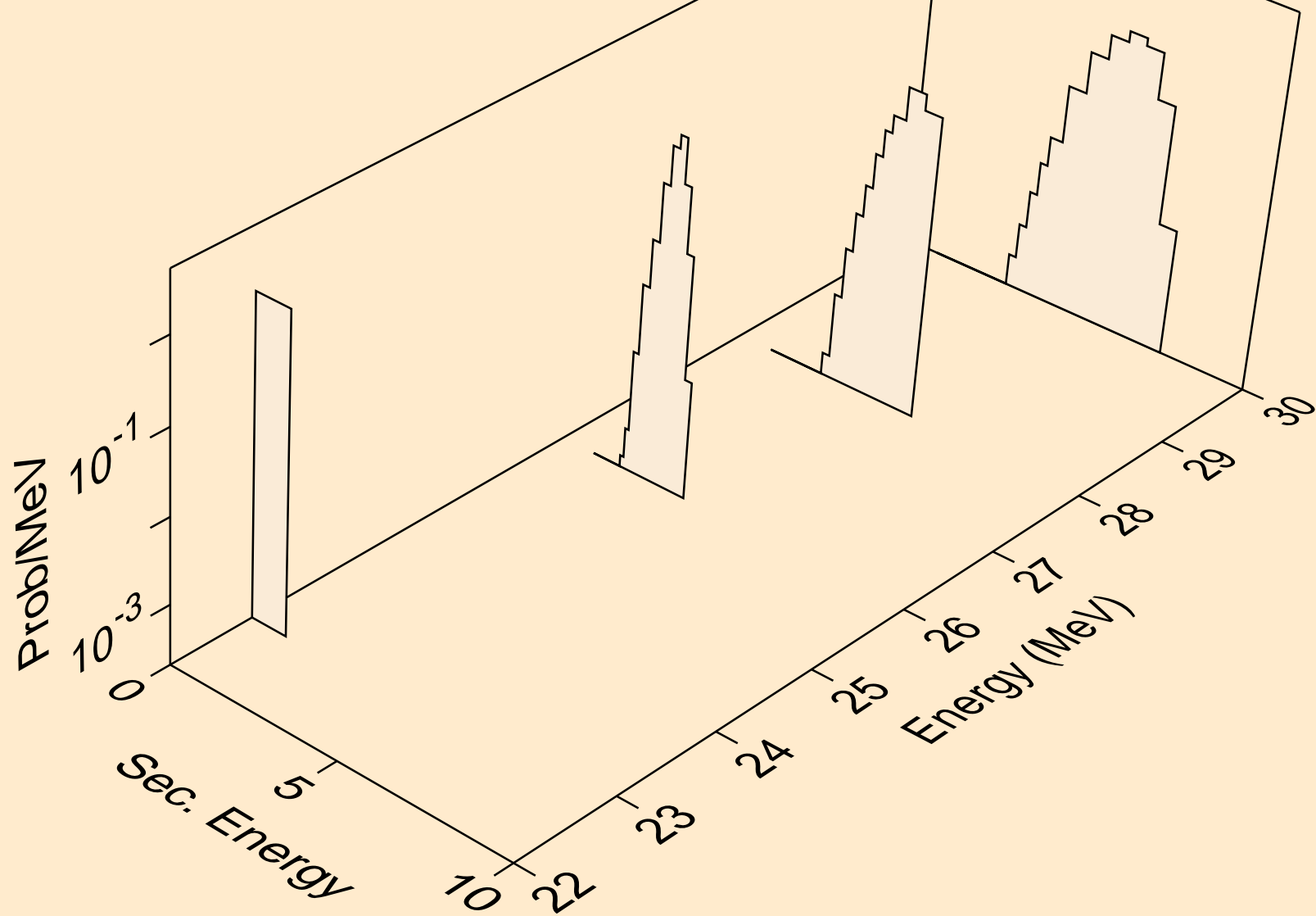

GD137 NEUTRON ACER TENDL-2023 LIBRARY; T=0.K  
deuterons from (n,n\*)d

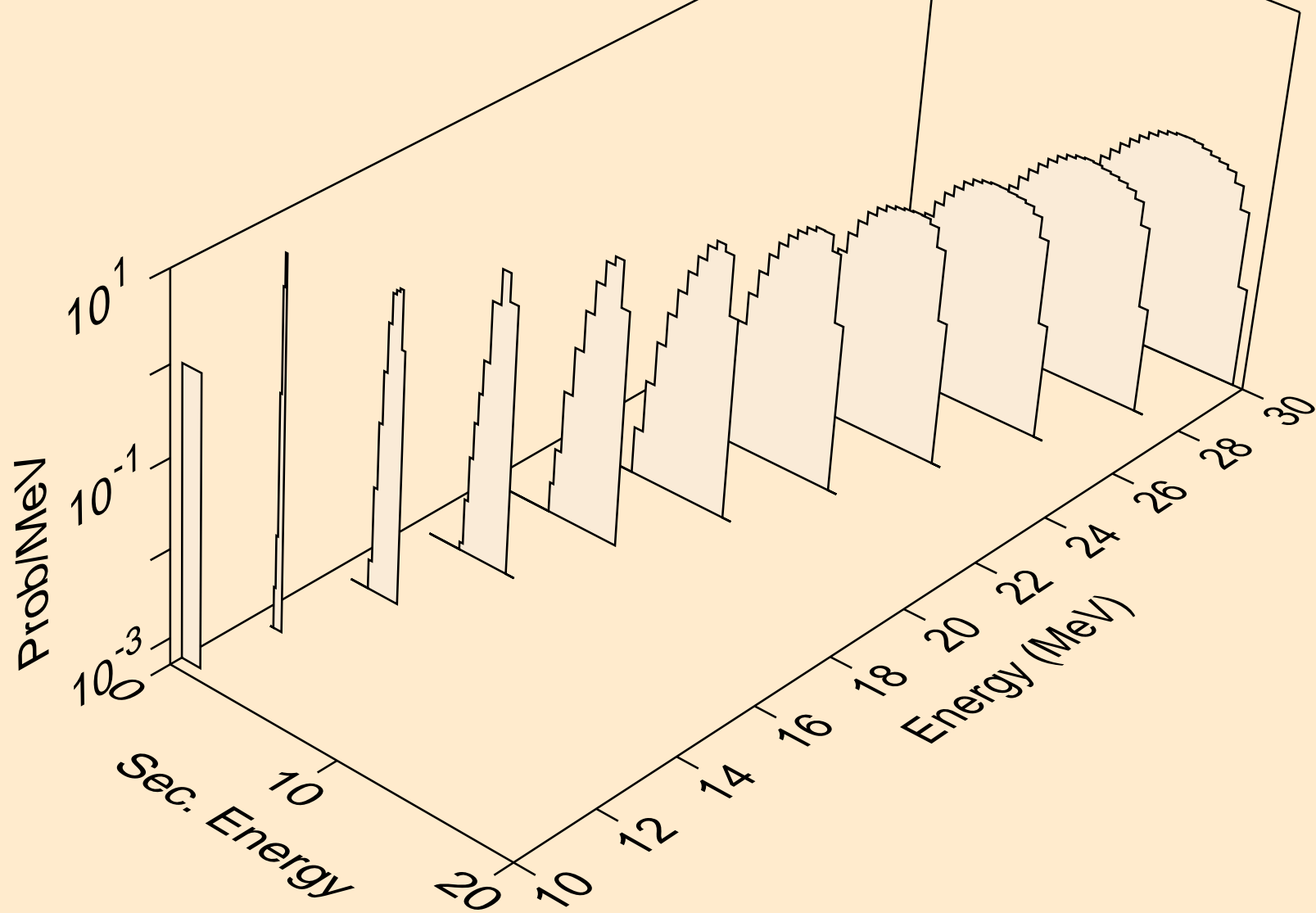

GD137 NEUTRON ACER TENDL-2023 LIBRARY; T=0.K  
deuterons from (n,d)

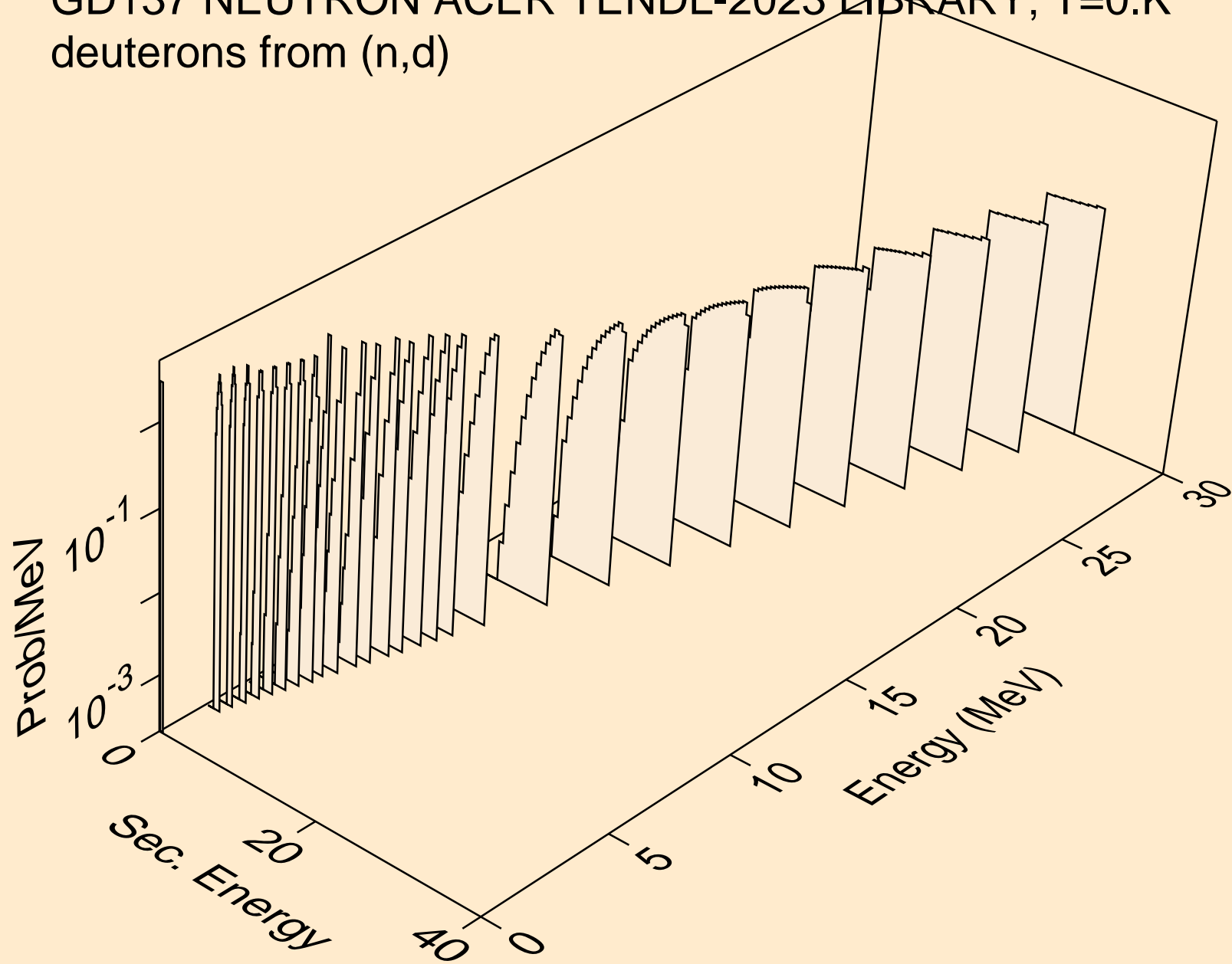

GD137 NEUTRON ACER TENDL-2023 LIBRARY; T=0.K  
deuterons from (n,d2a)

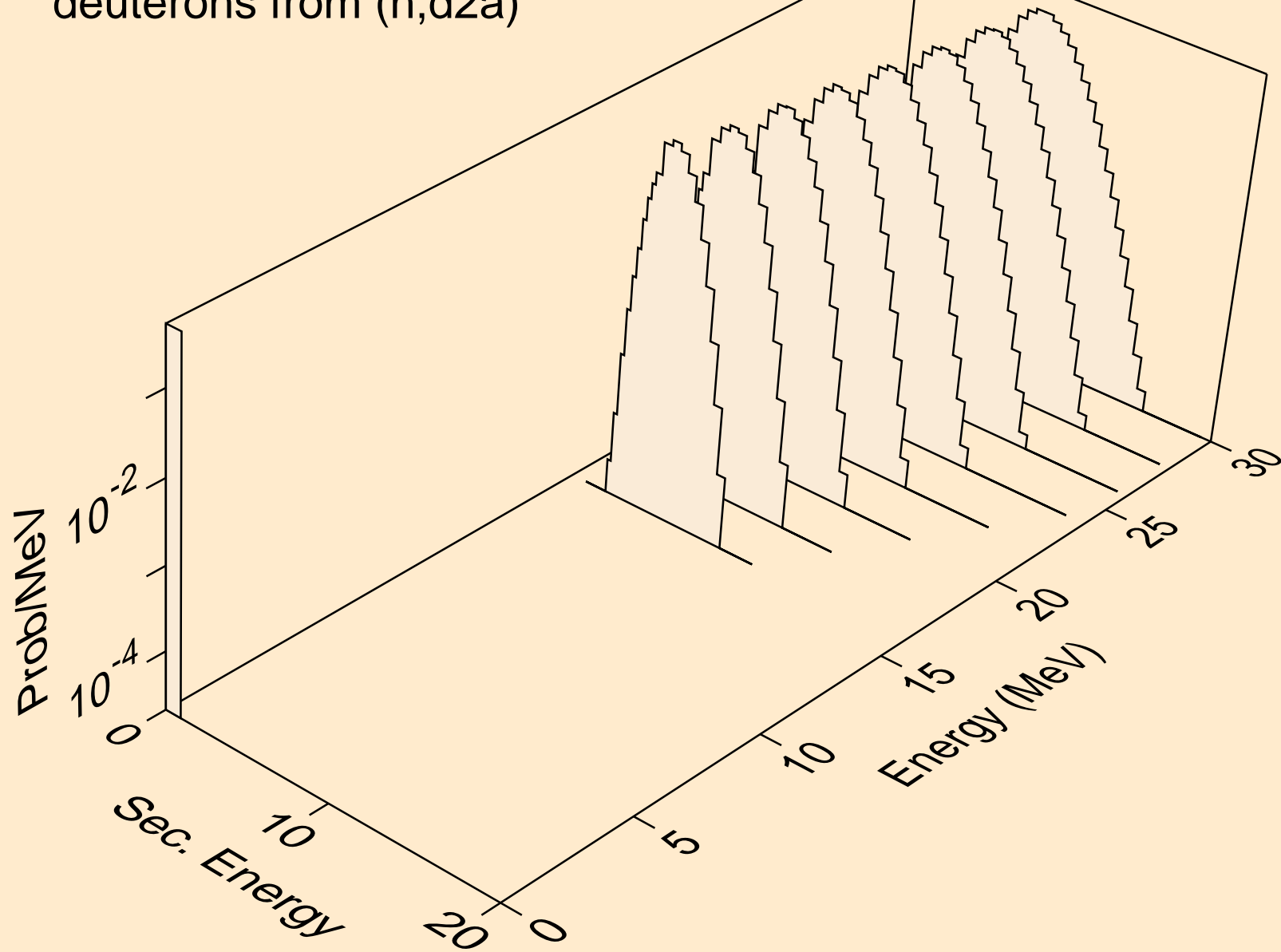

GD137 NEUTRON ACER TENDL-2023 LIBRARY; T=0.K  
deuterons from (n,pd)

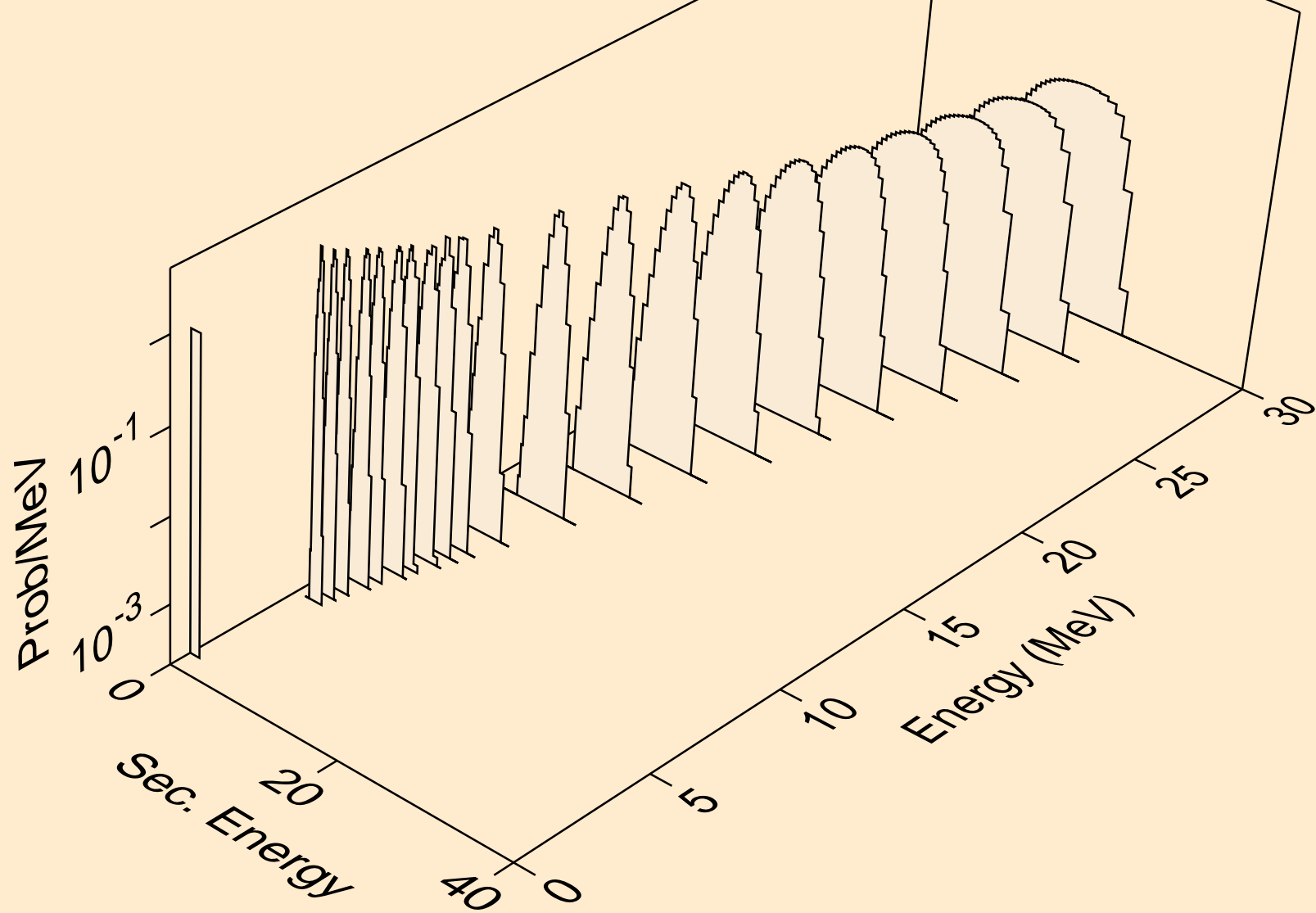

GD137 NEUTRON ACER TENDL-2023 LIBRARY; T=0.K  
deuterons from (n,da)

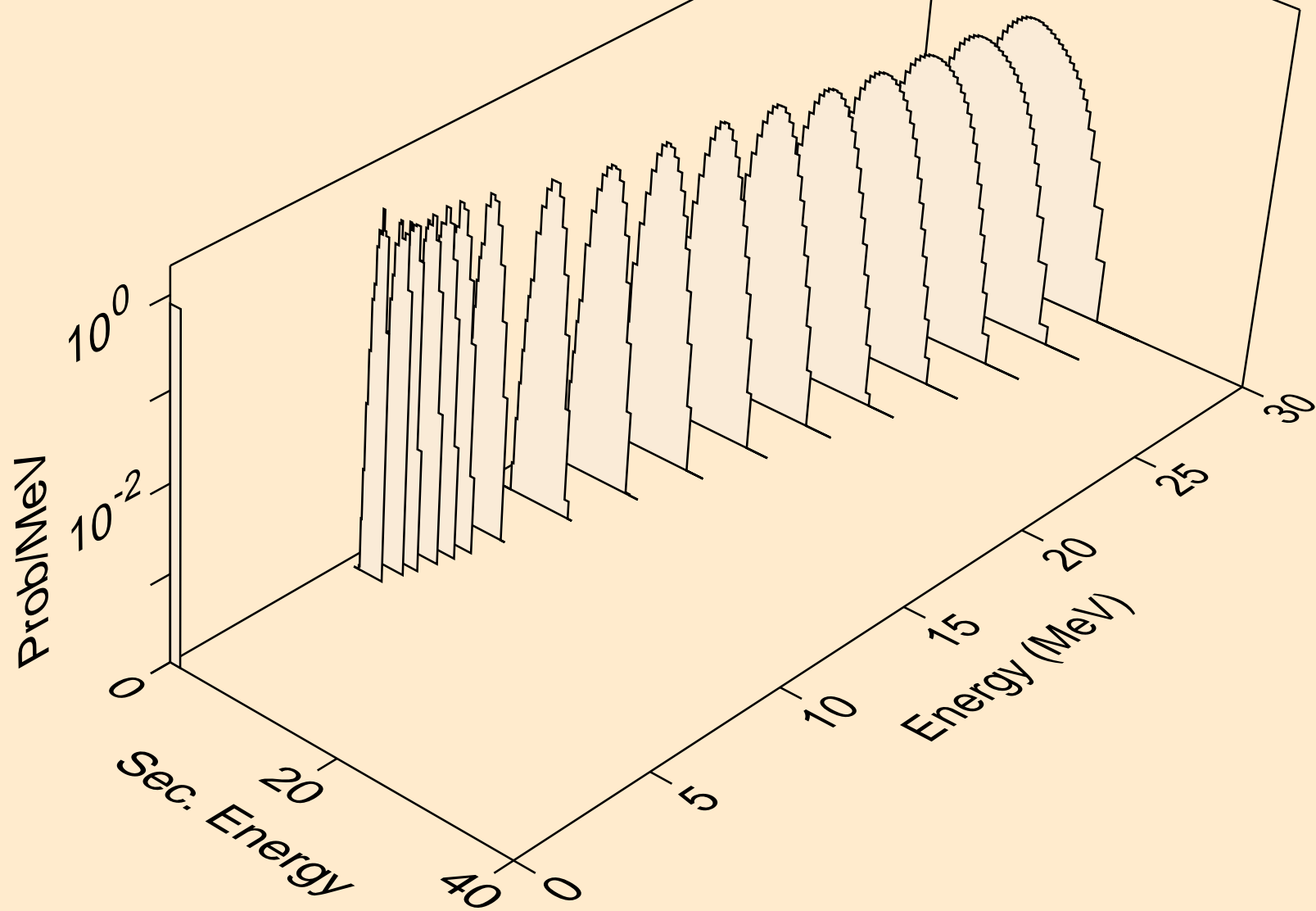



GD137 NEUTRON ACER TENDL-2023 LIBRARY; T=0.K  
tritons from (n,x)

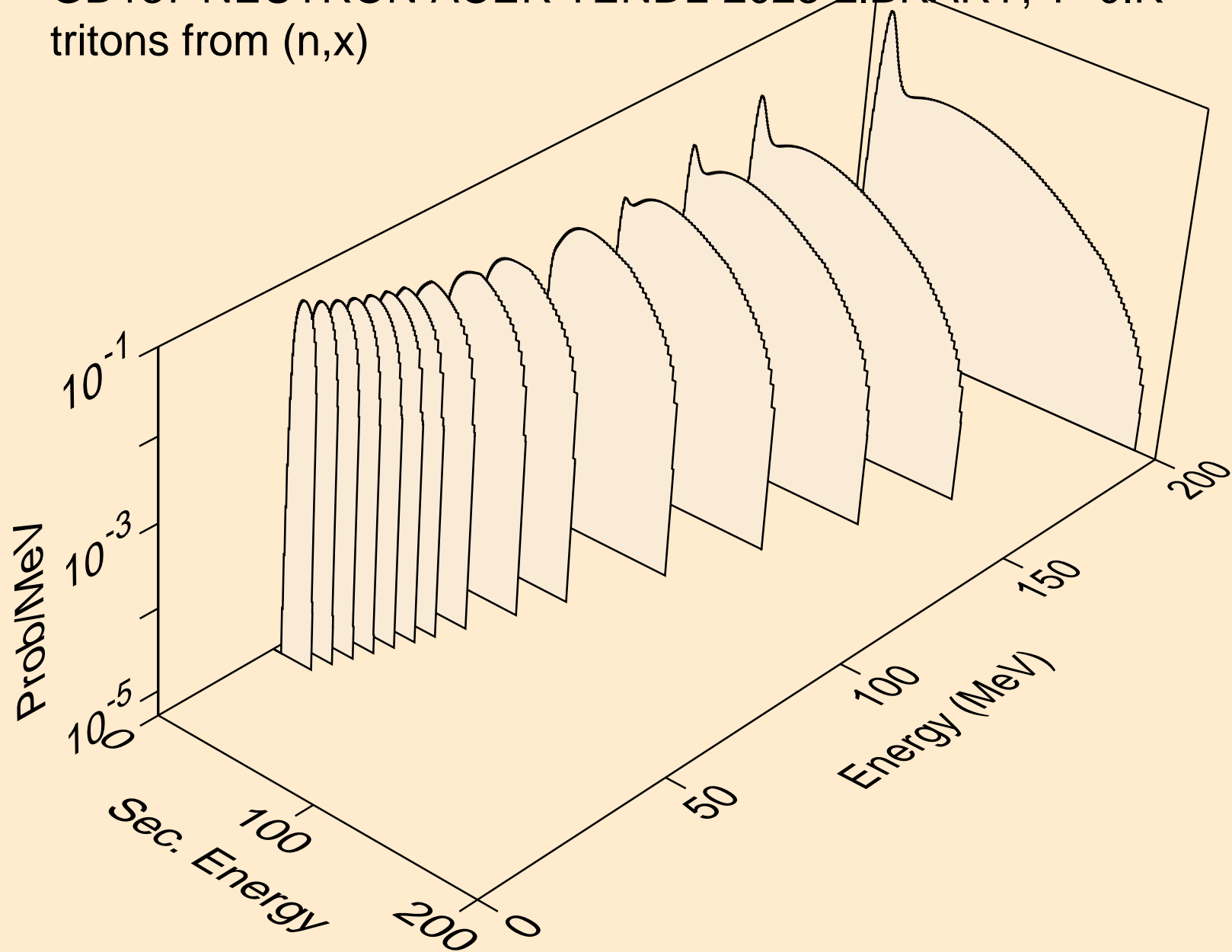

GD137 NEUTRON ACER TENDL-2023 LIBRARY; T=0.K  
tritons from (n,n\*)t

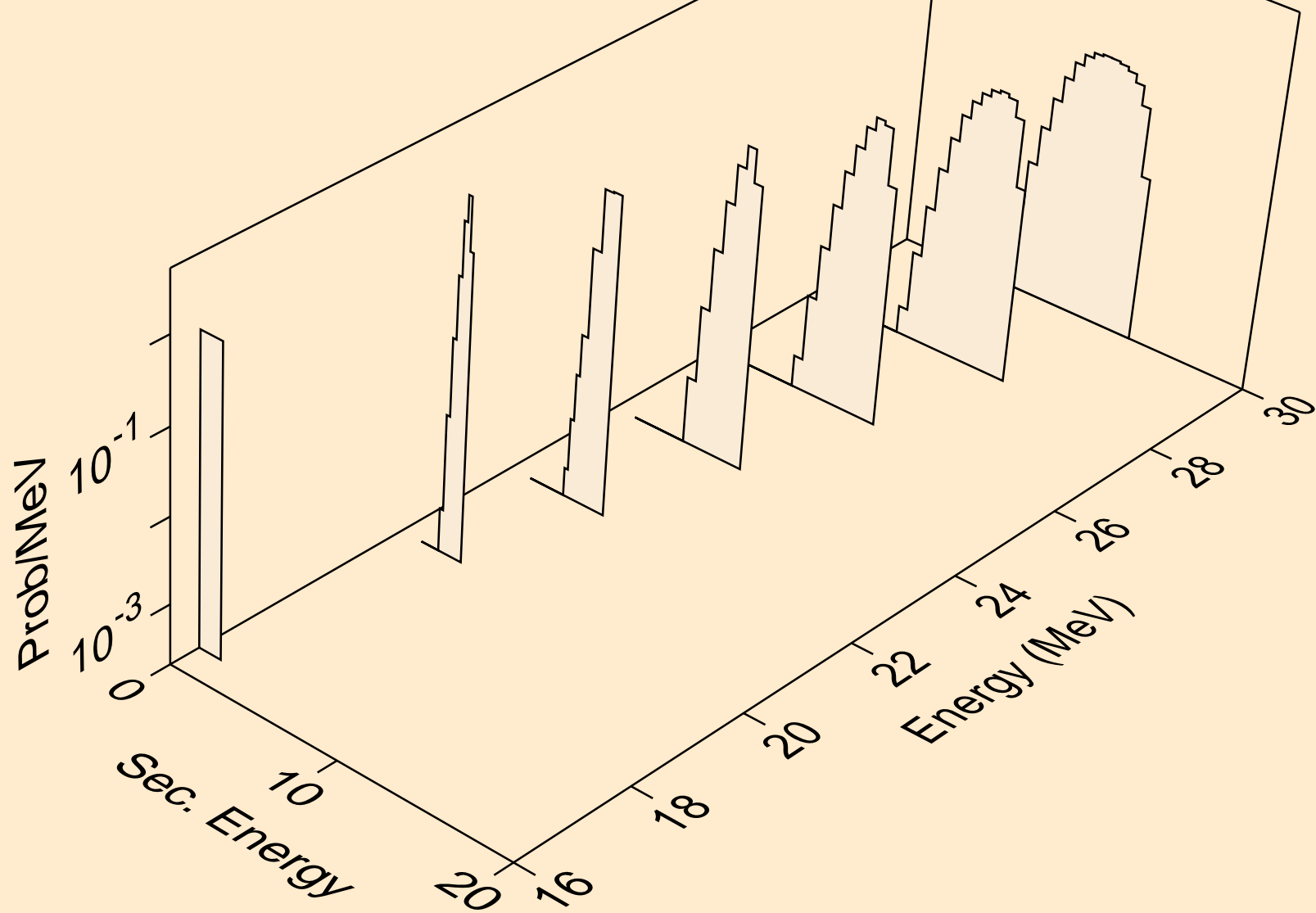

GD137 NEUTRON ACER TENDL-2023 LIBRARY; T=0.K  
tritons from (n,t)

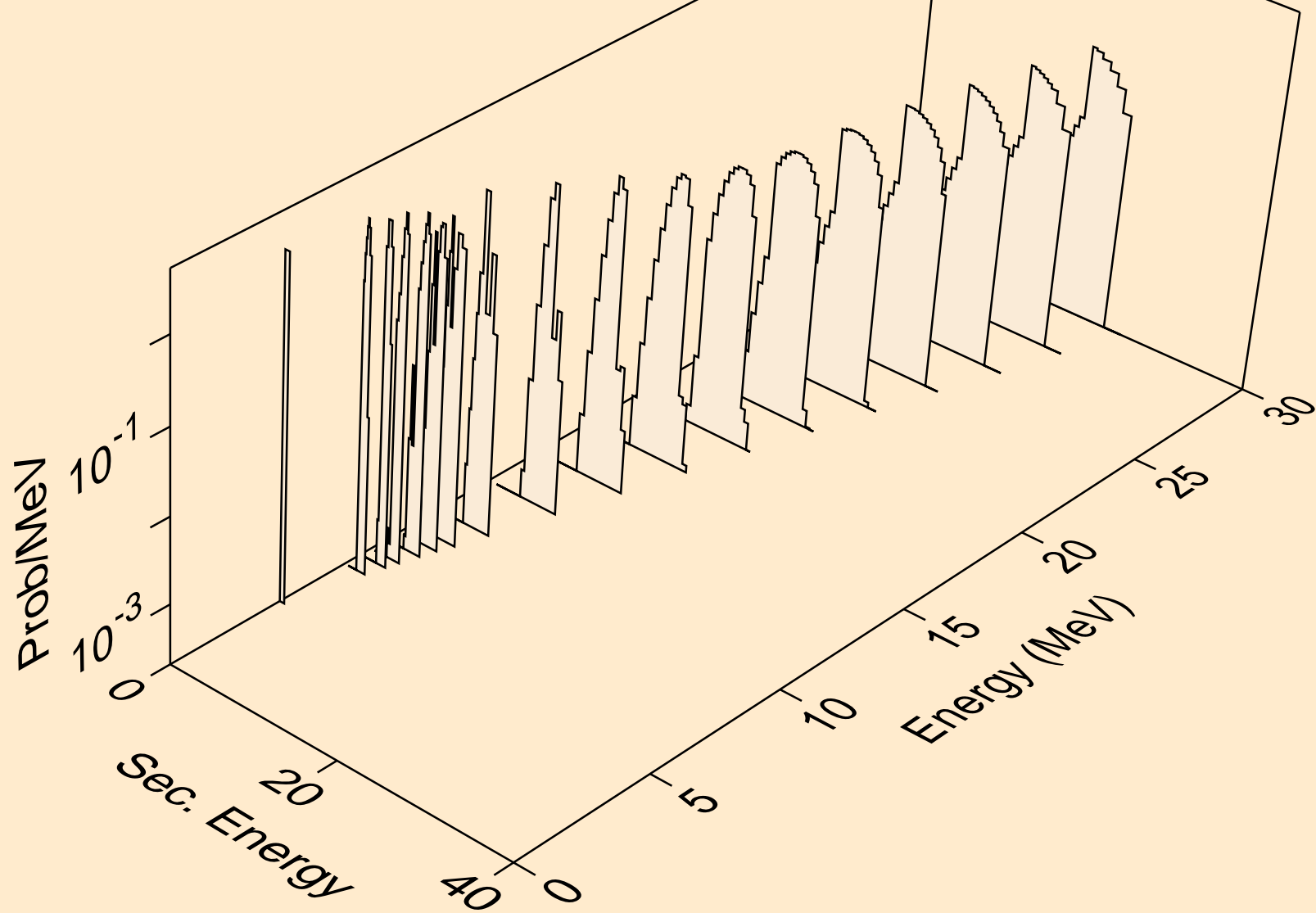

GD137 NEUTRON ACER TENDL-2023 LIBRARY; T=0.K  
tritons from (n,pt)

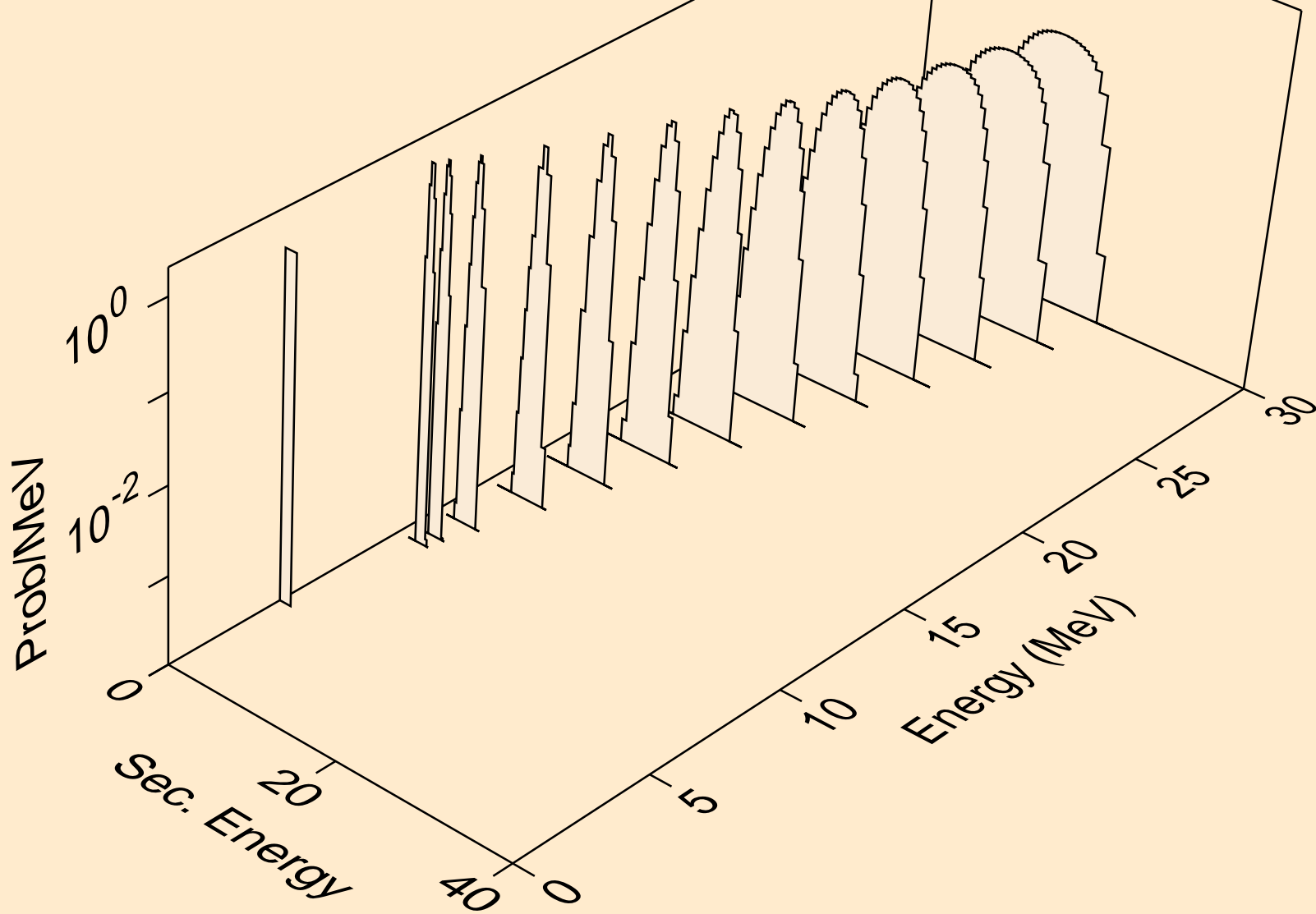

GD137 NEUTRON ACER TENDL-2023 LIBRARY; T=0.K  
he3s from (n,x)

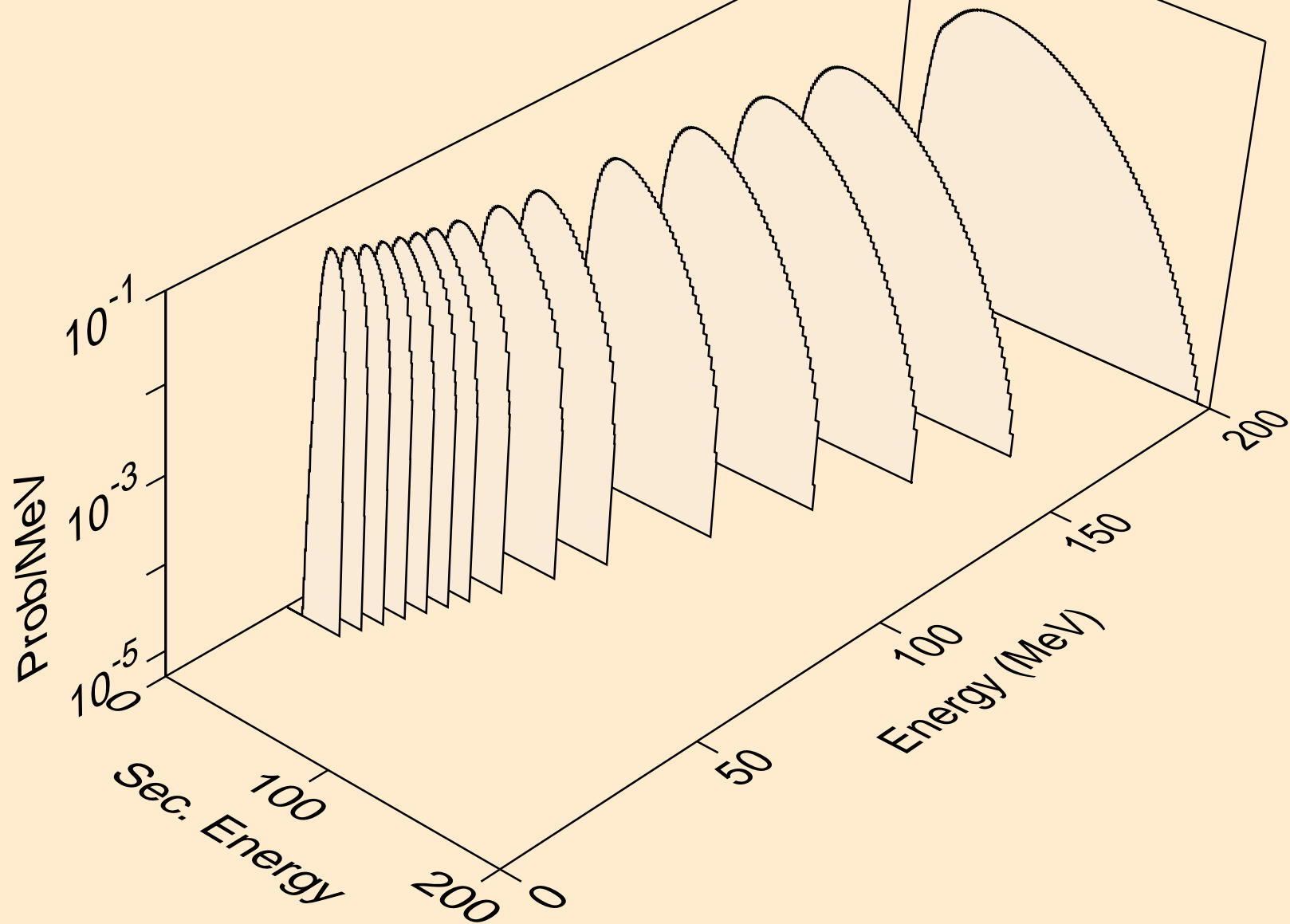

GD137 NEUTRON ACER TENDL-2023 LIBRARY; T=0.K  
he3s from (n,n\*)he3

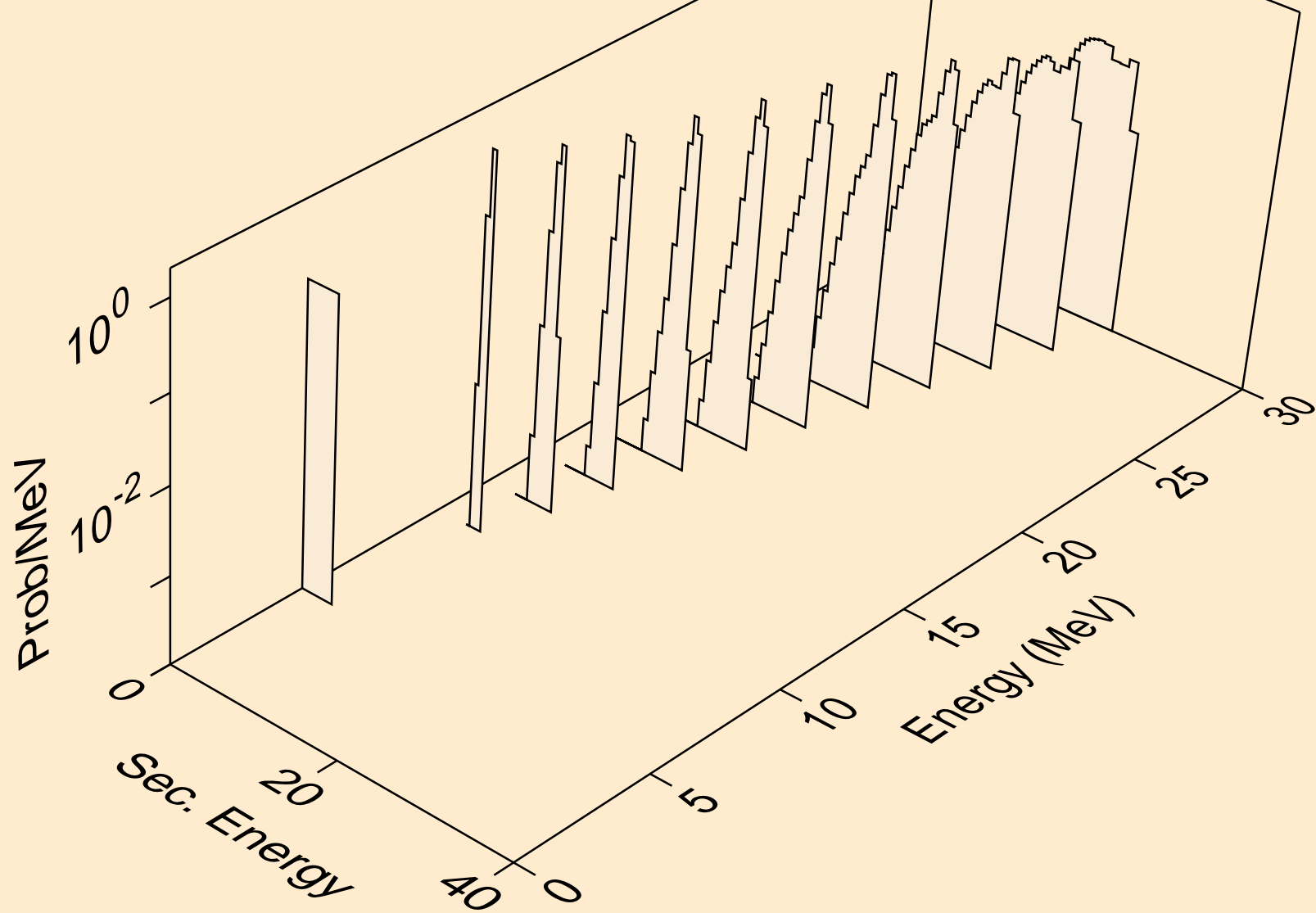

GD137 NEUTRON ACER TENDL-2023 LIBRARY; T=0.K  
he3s from (n,he3)

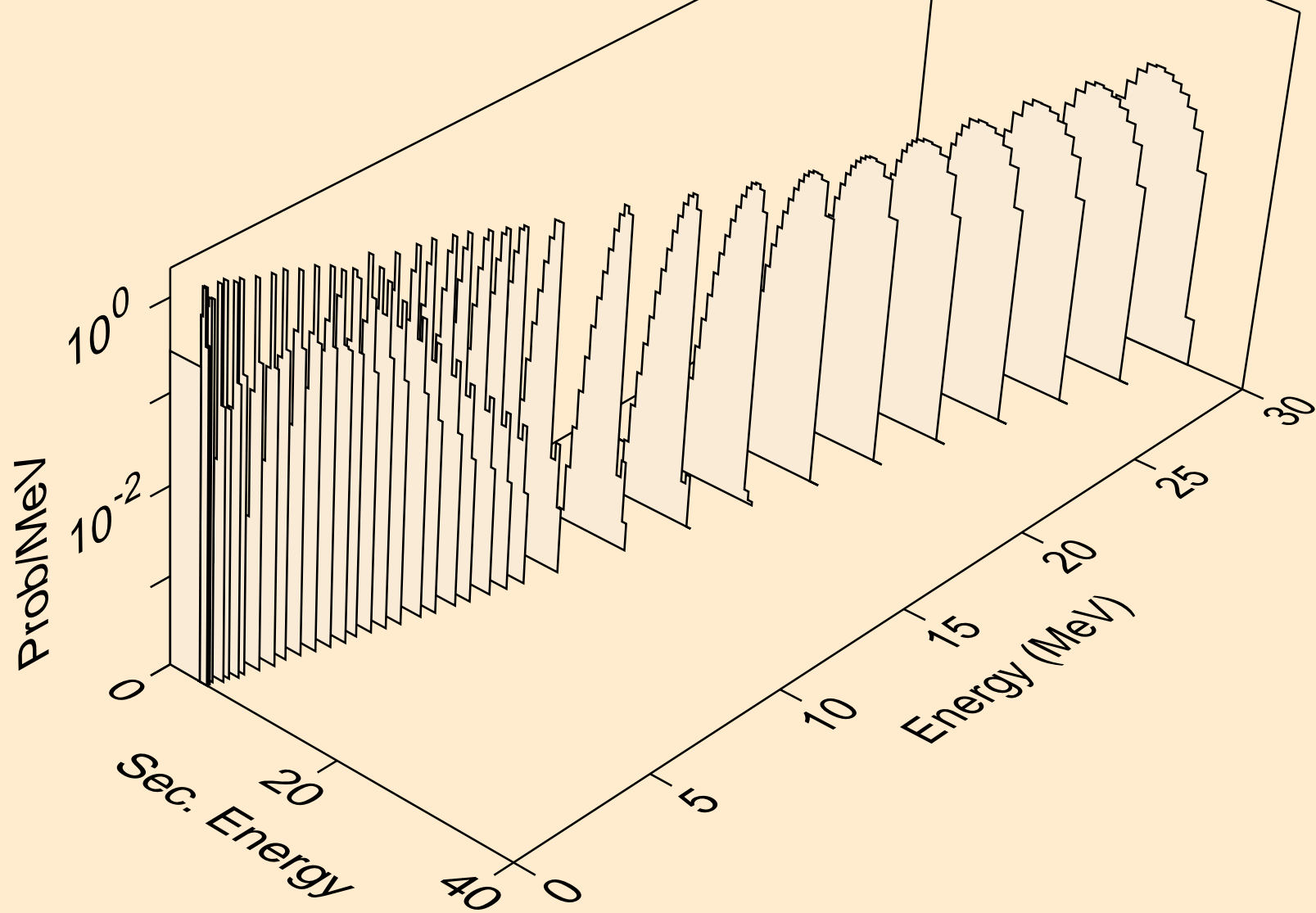

GD137 NEUTRON ACER TENDL-2023 LIBRARY; T=0.K  
alphas from (n,x)

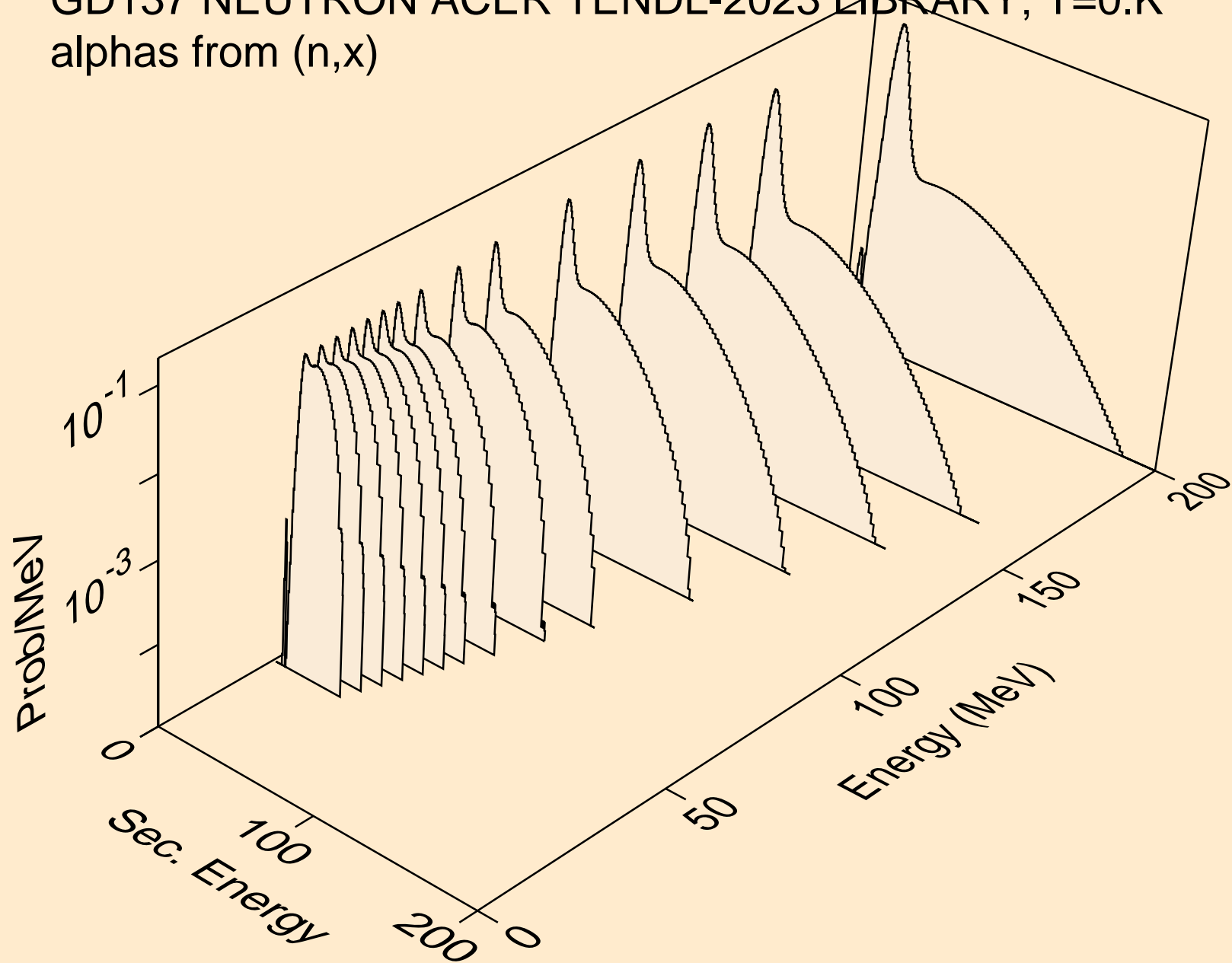



GD137 NEUTRON ACER TENDL-2023 LIBRARY; T=0.K  
alphas from (n,n\*)a

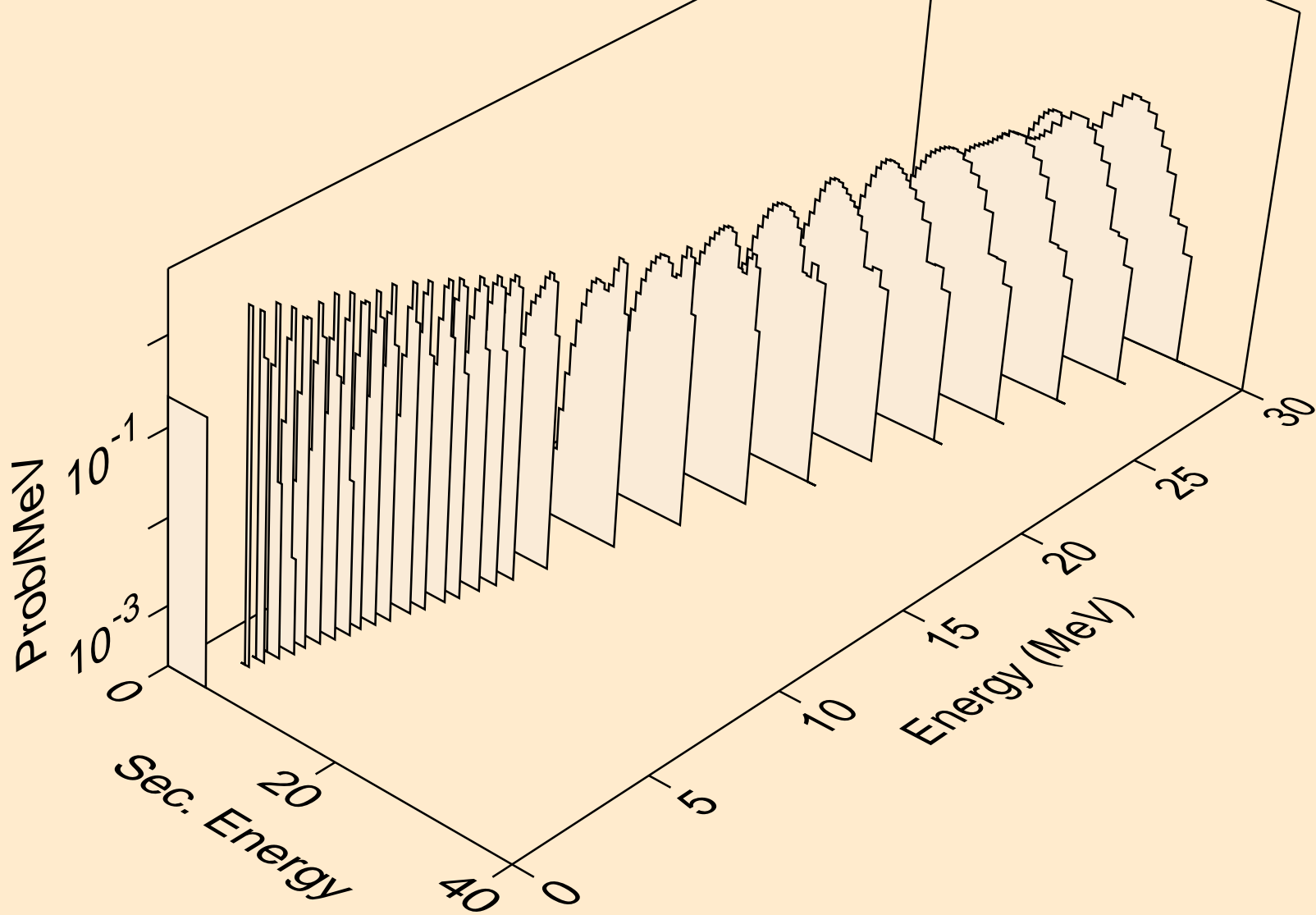

GD137 NEUTRON ACER TENDL-2023 LIBRARY; T=0.K  
alphas from (n,2n)a

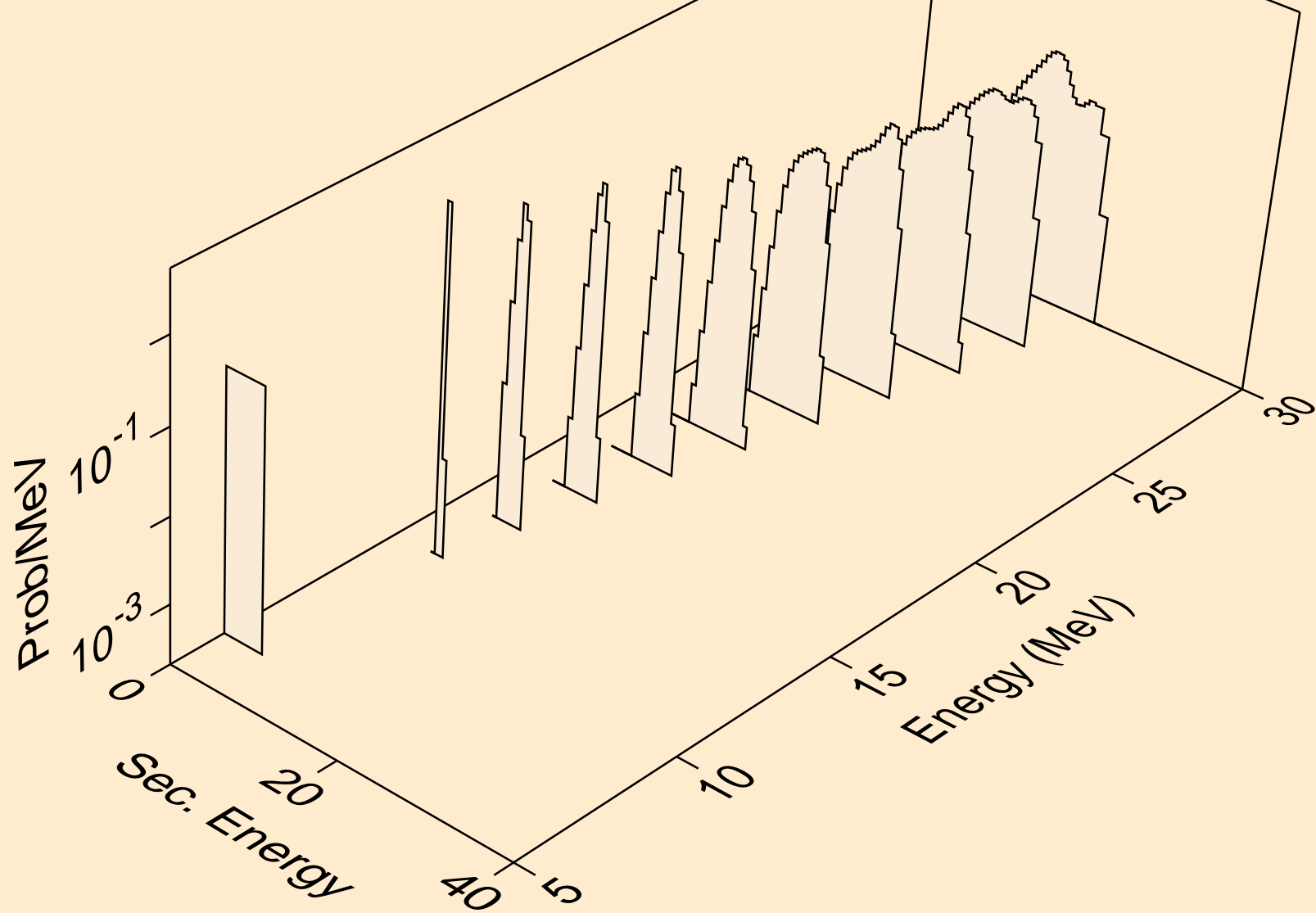

GD137 NEUTRON ACER TENDL-2023 LIBRARY; T=0.K  
alphas from (n,n\*)2a

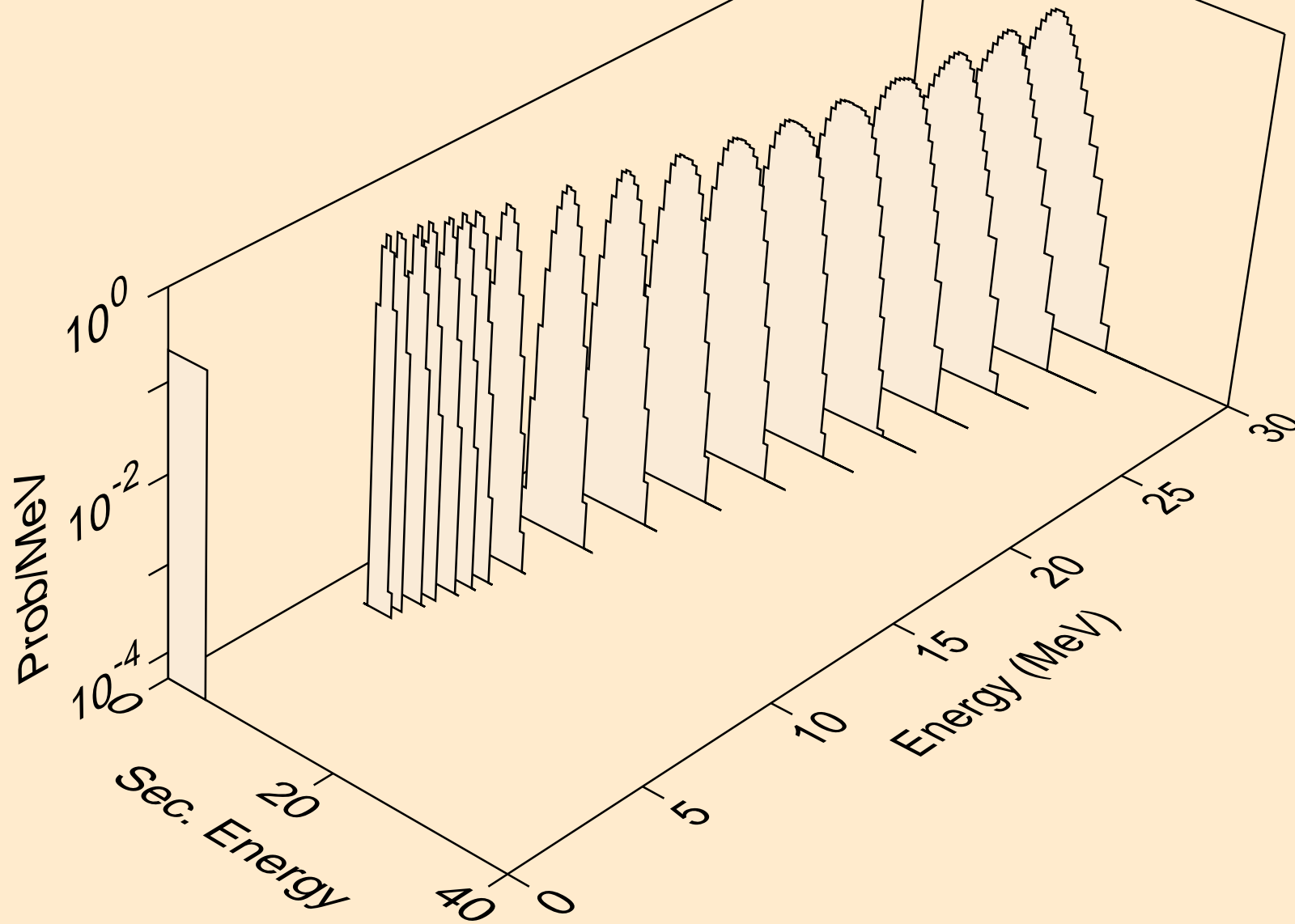

GD137 NEUTRON ACER TENDL-2023 LIBRARY; T=0.K  
alphas from (n,2n)2a

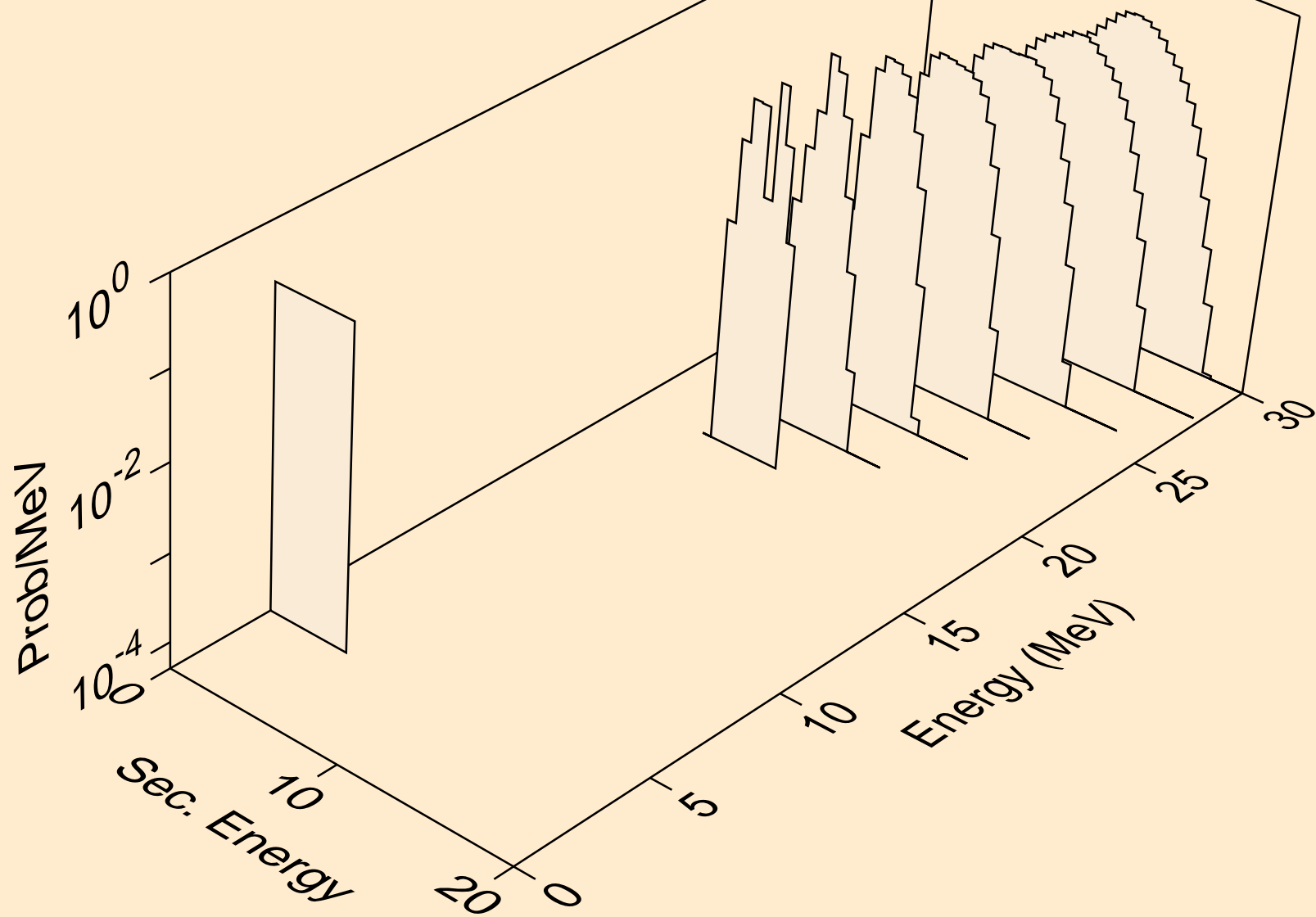

GD137 NEUTRON ACER TENDL-2023 LIBRARY; T=0.K  
alphas from (n,npa)

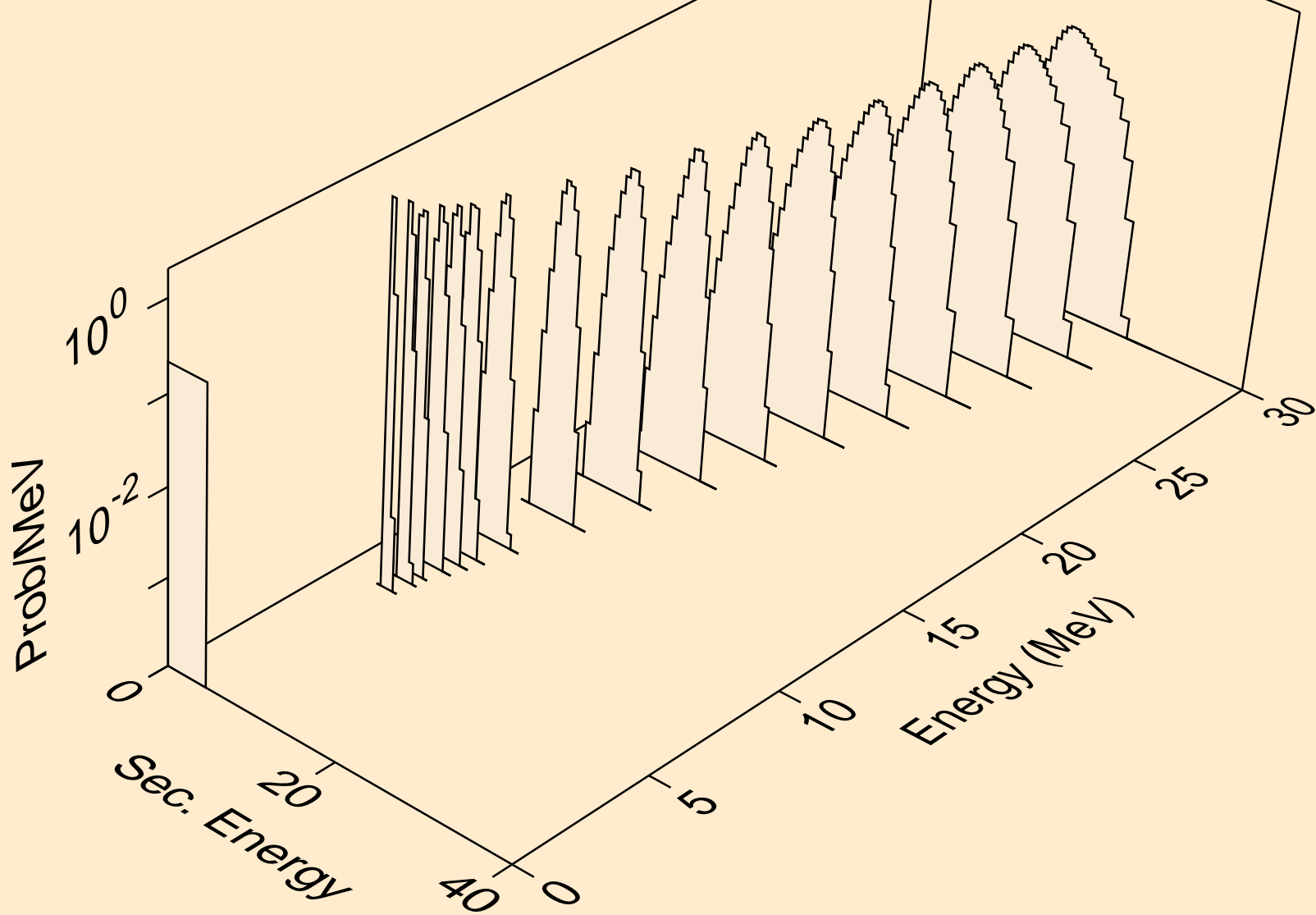

GD137 NEUTRON ACER TENDL-2023 LIBRARY; T=0.K  
alphas from (n,a)

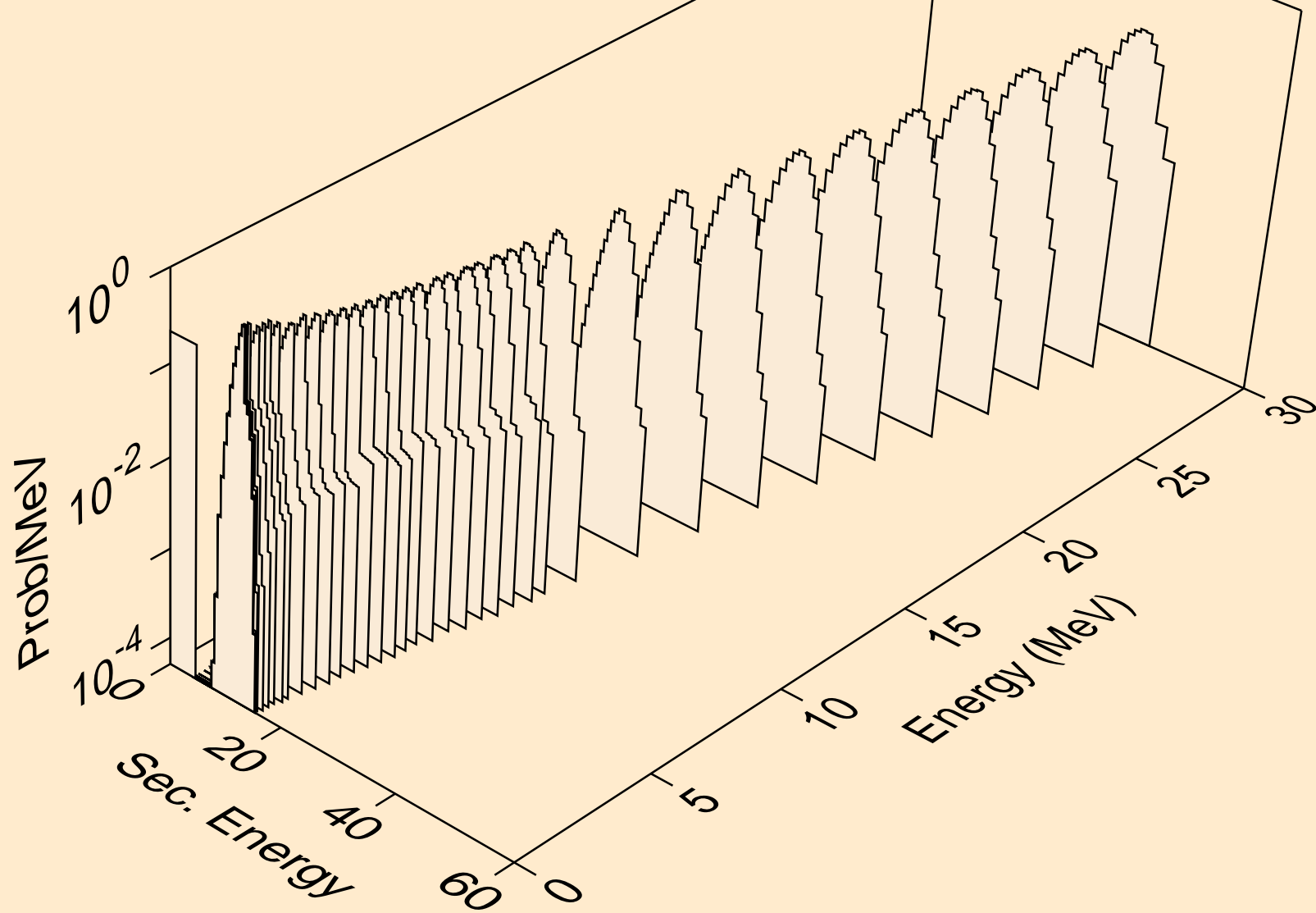

GD137 NEUTRON ACER TENDL-2023 LIBRARY; T=0.K  
alphas from (n,2a)

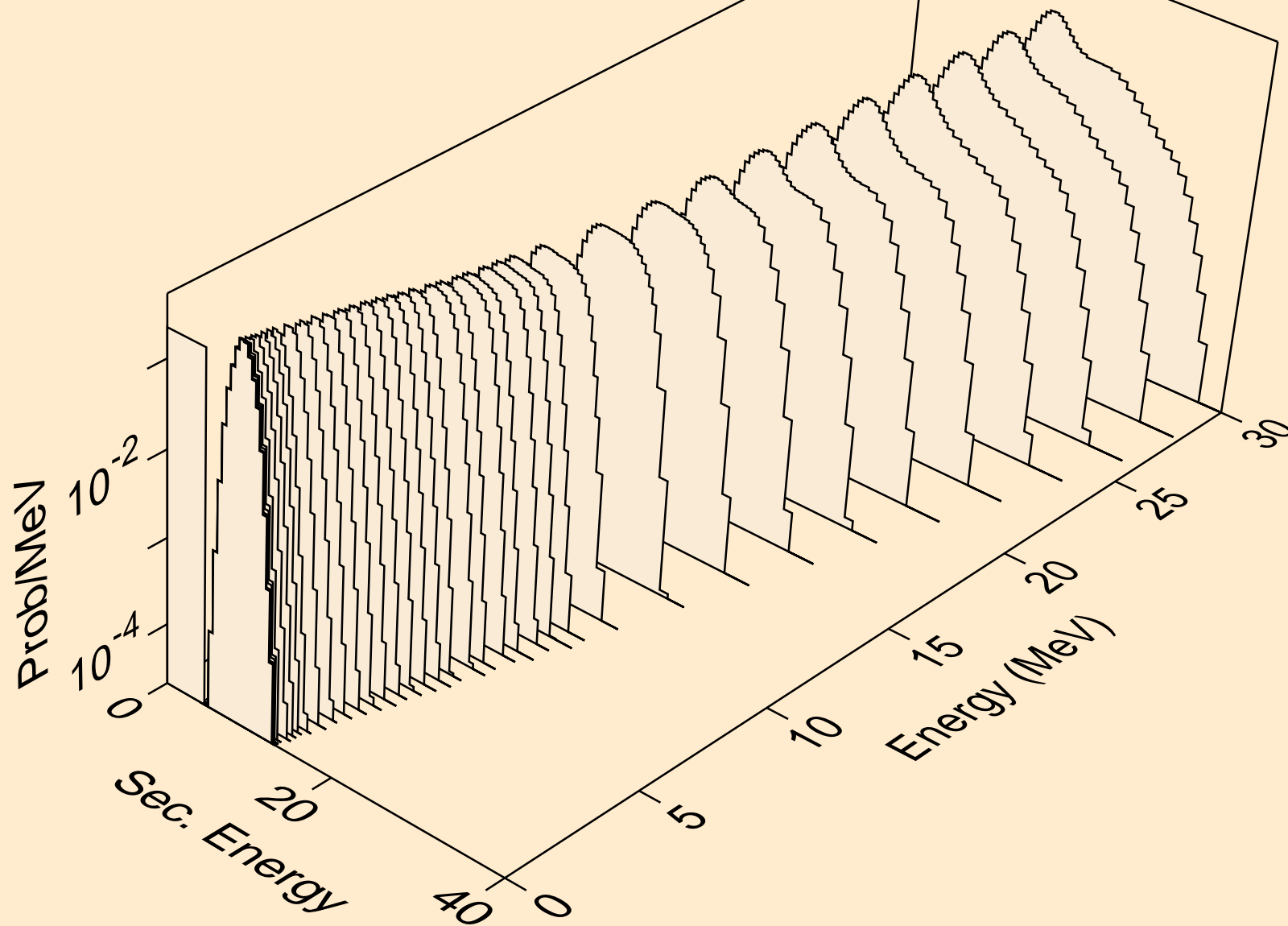

GD137 NEUTRON ACER TENDL-2023 LIBRARY; T=0.K  
alphas from (n,3a)

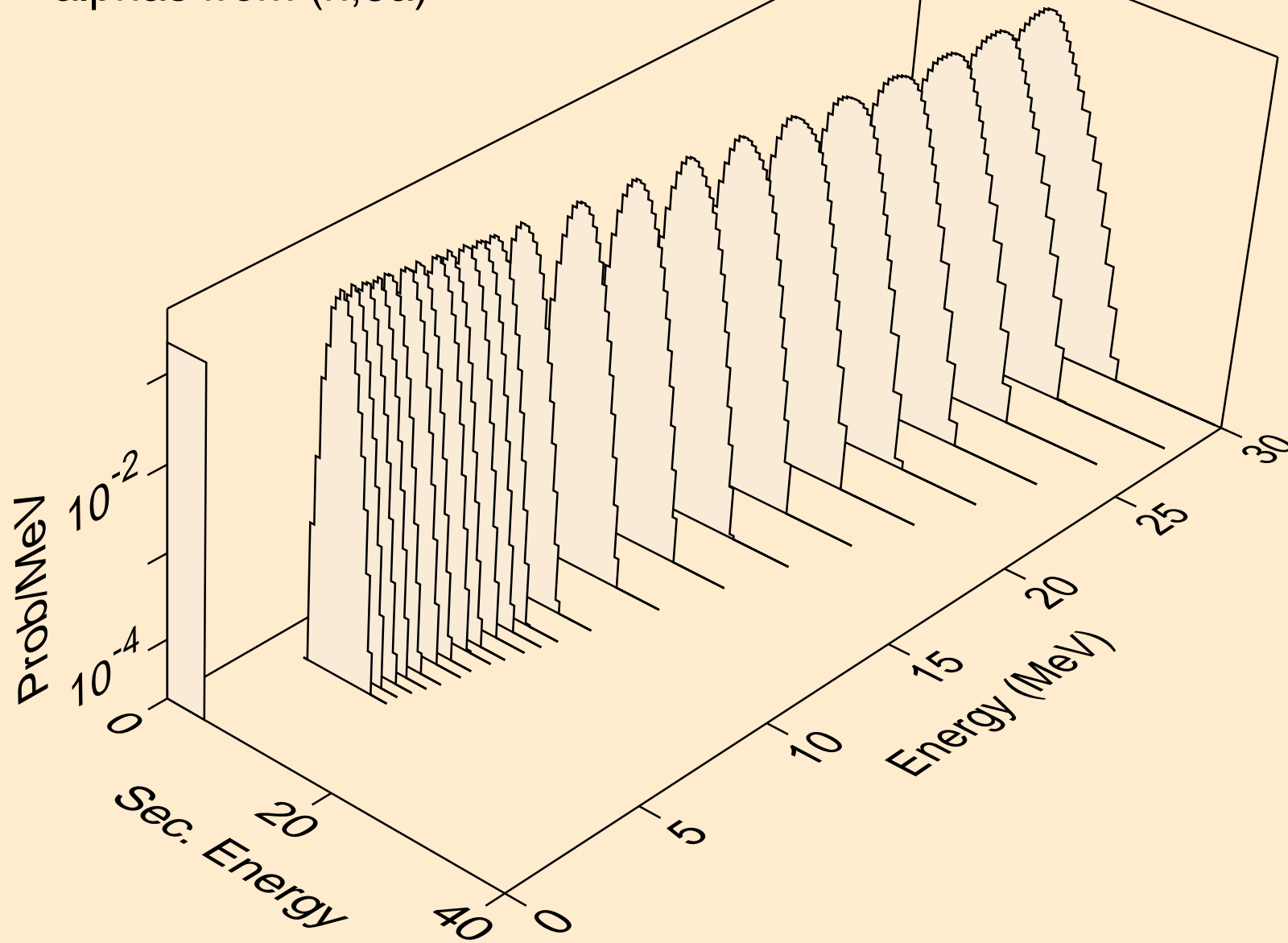



GD137 NEUTRON ACER TENDL-2023 LIBRARY; T=0.K  
alphas from (n,pa)

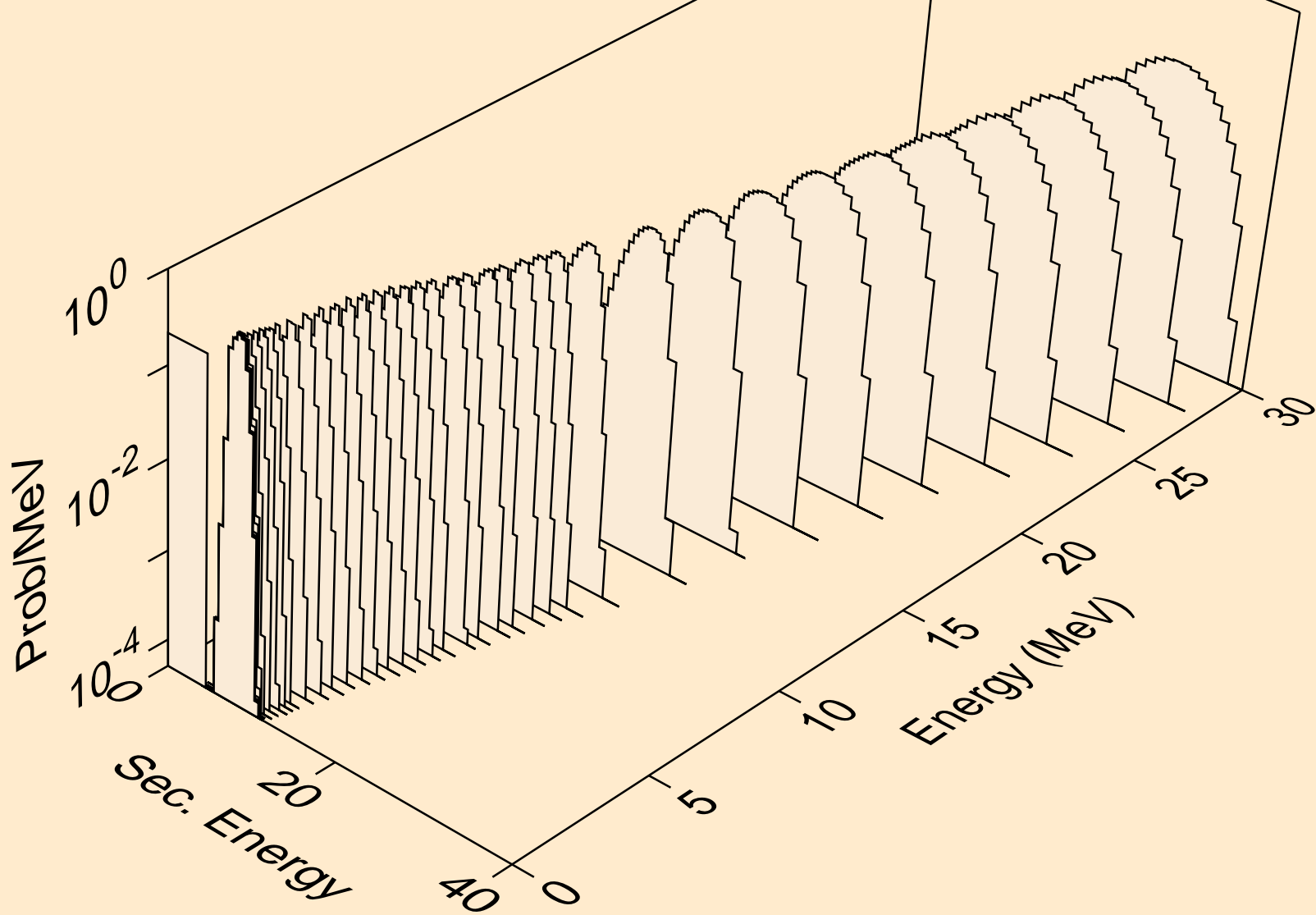

GD137 NEUTRON ACER TENDL-2023 LIBRARY; T=0.K  
alphas from (n,d2a)

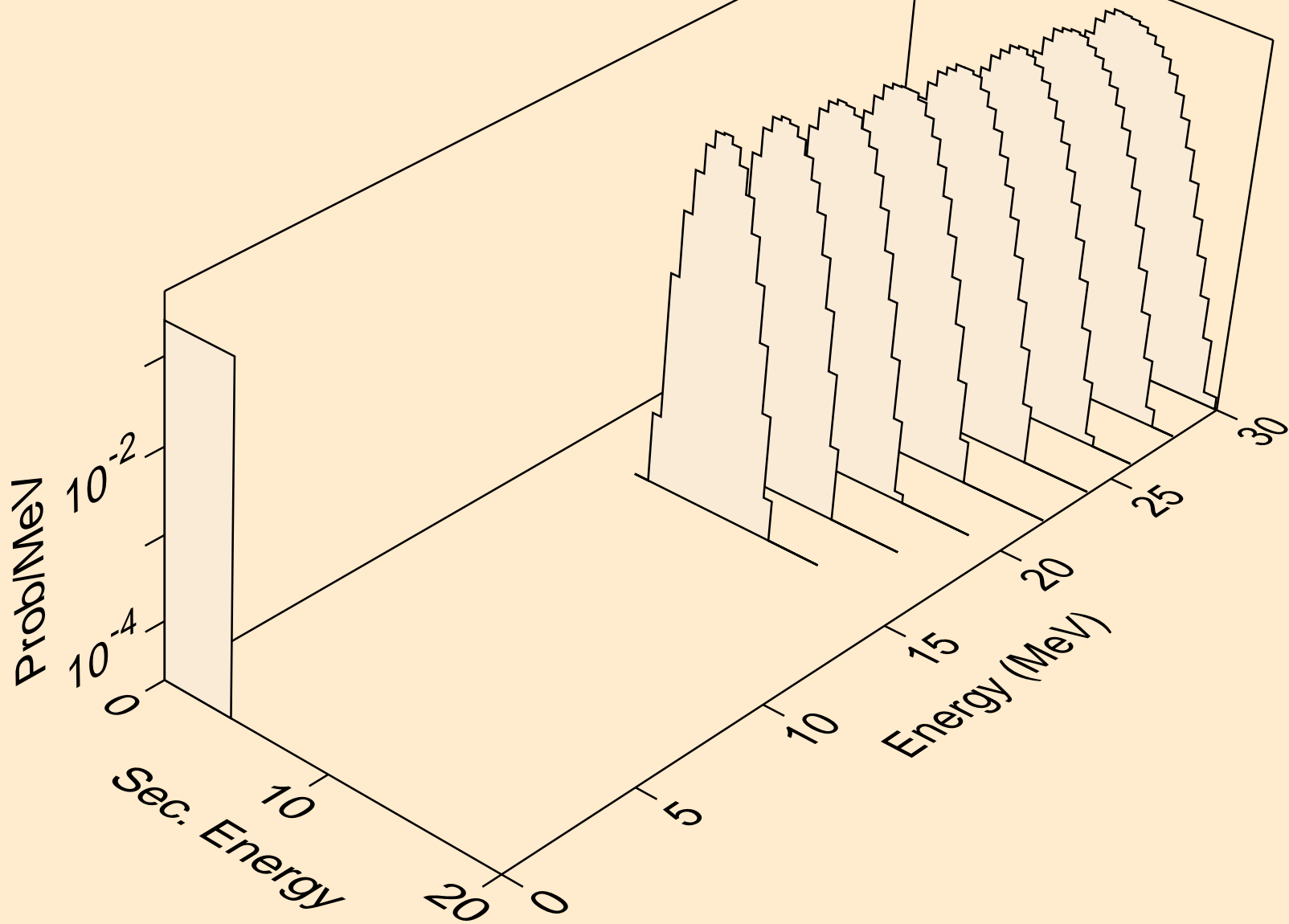

GD137 NEUTRON ACER TENDL-2023 LIBRARY; T=0.K  
alphas from (n,da)

