

HS277M NEUTRON ACER TENDL-2023 LIBRARY; T=0.K

Principal cross sections

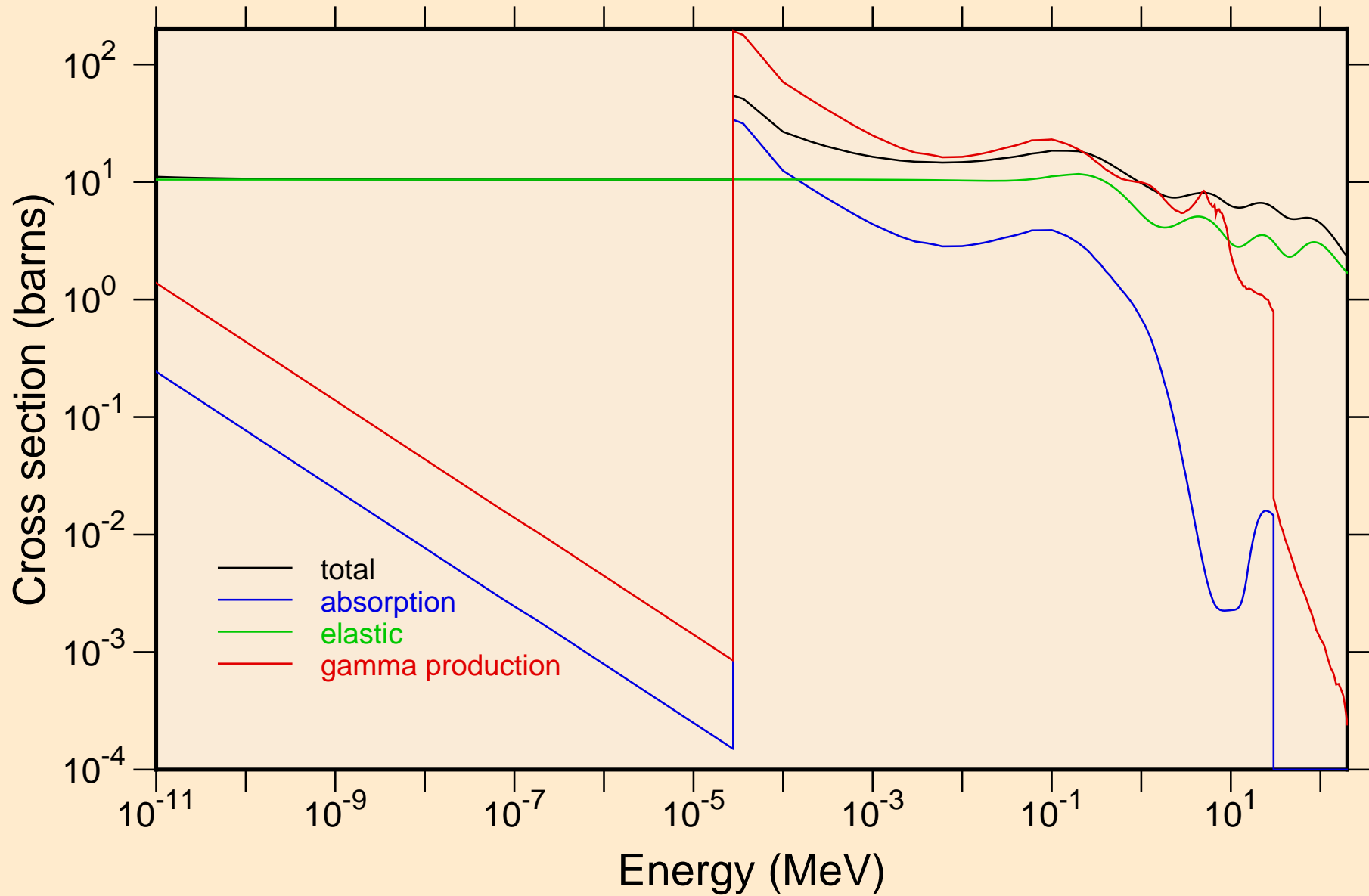

HS277M NEUTRON ACER TENDL-2023 LIBRARY; T=0.K

Heating

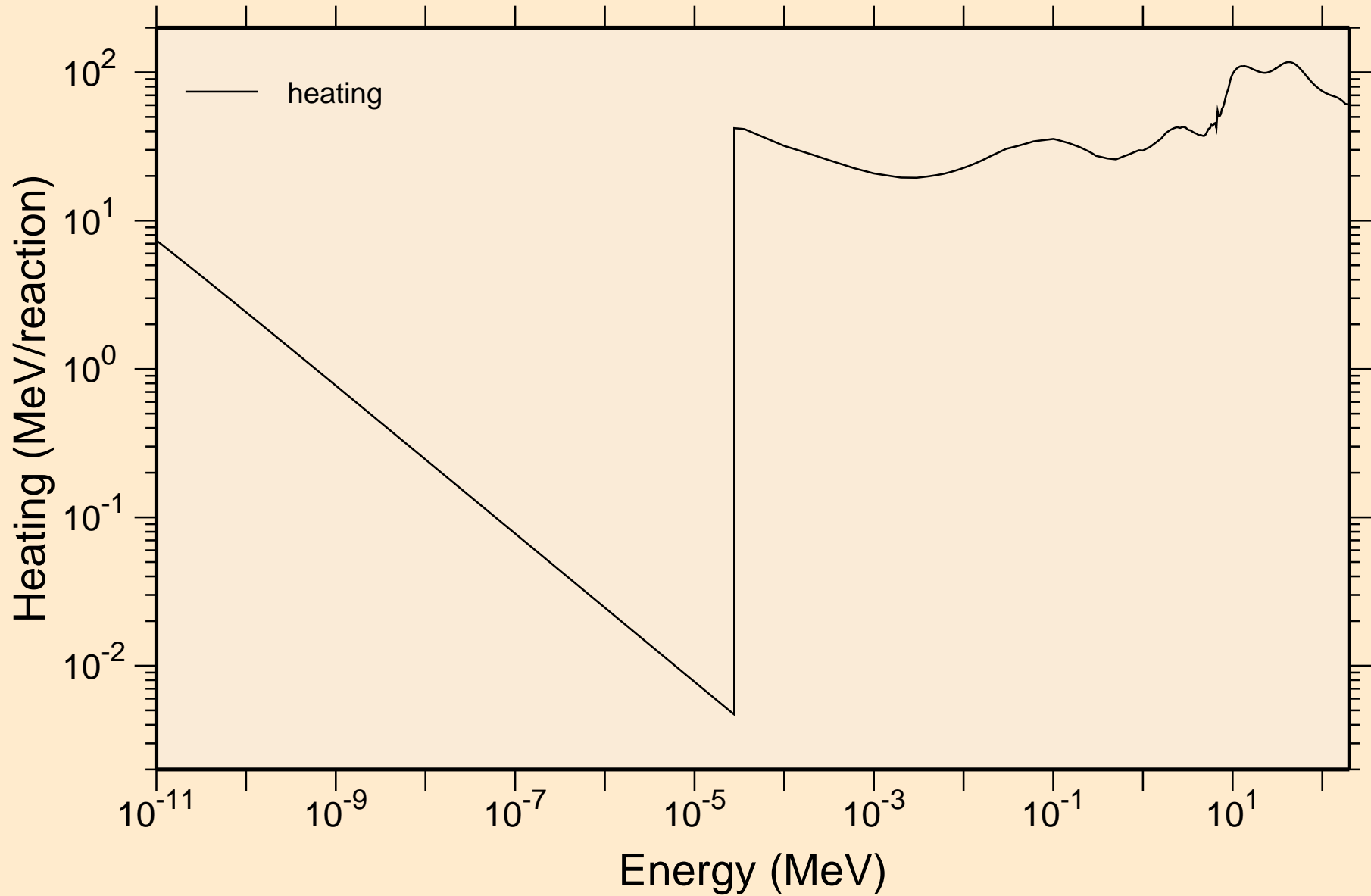

HS277M NEUTRON ACER TENDL-2023 LIBRARY; T=0.K

Damage

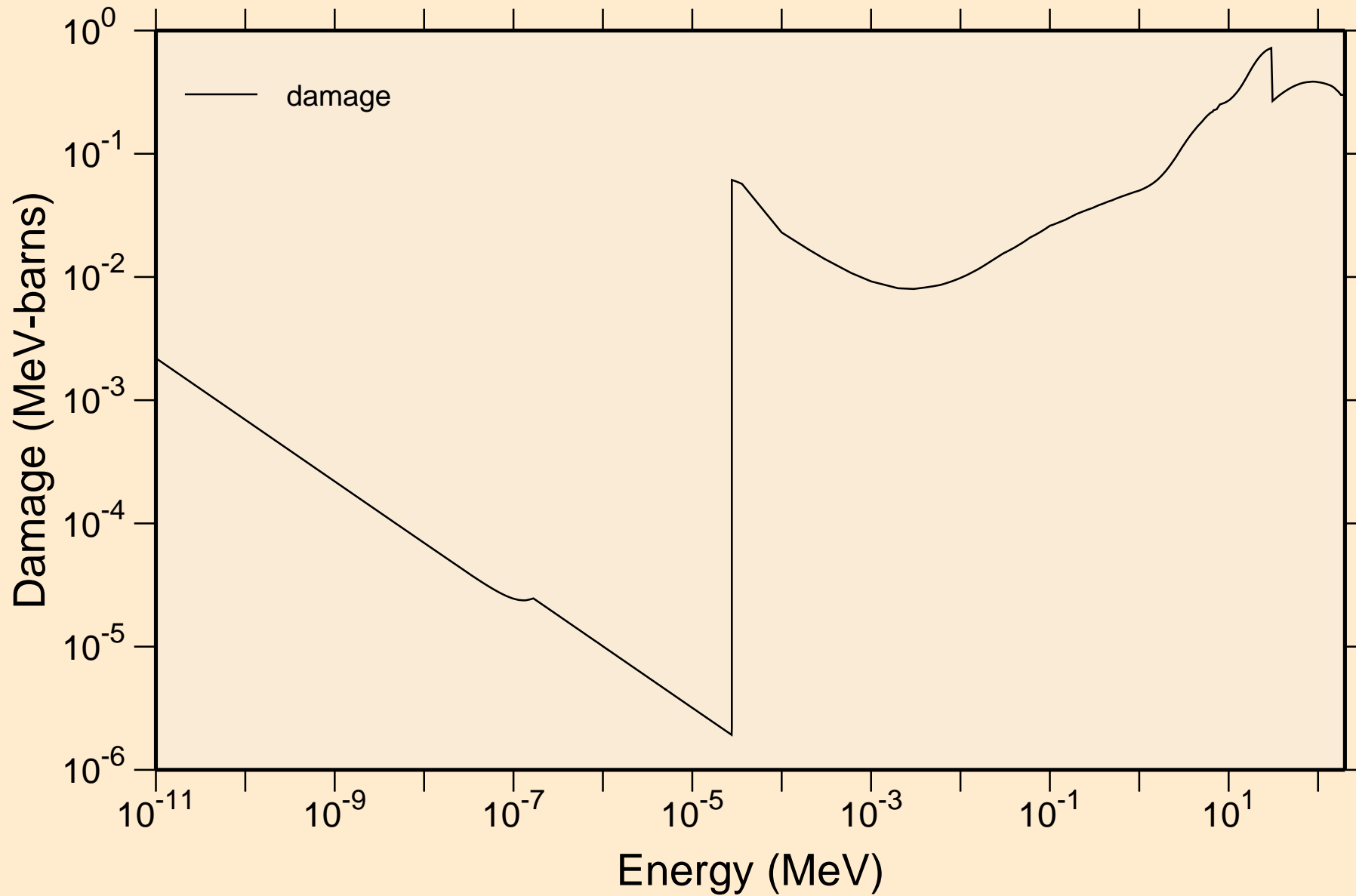

HS277M NEUTRON ACER TENDL-2023 LIBRARY; T=0.K

Non-threshold reactions

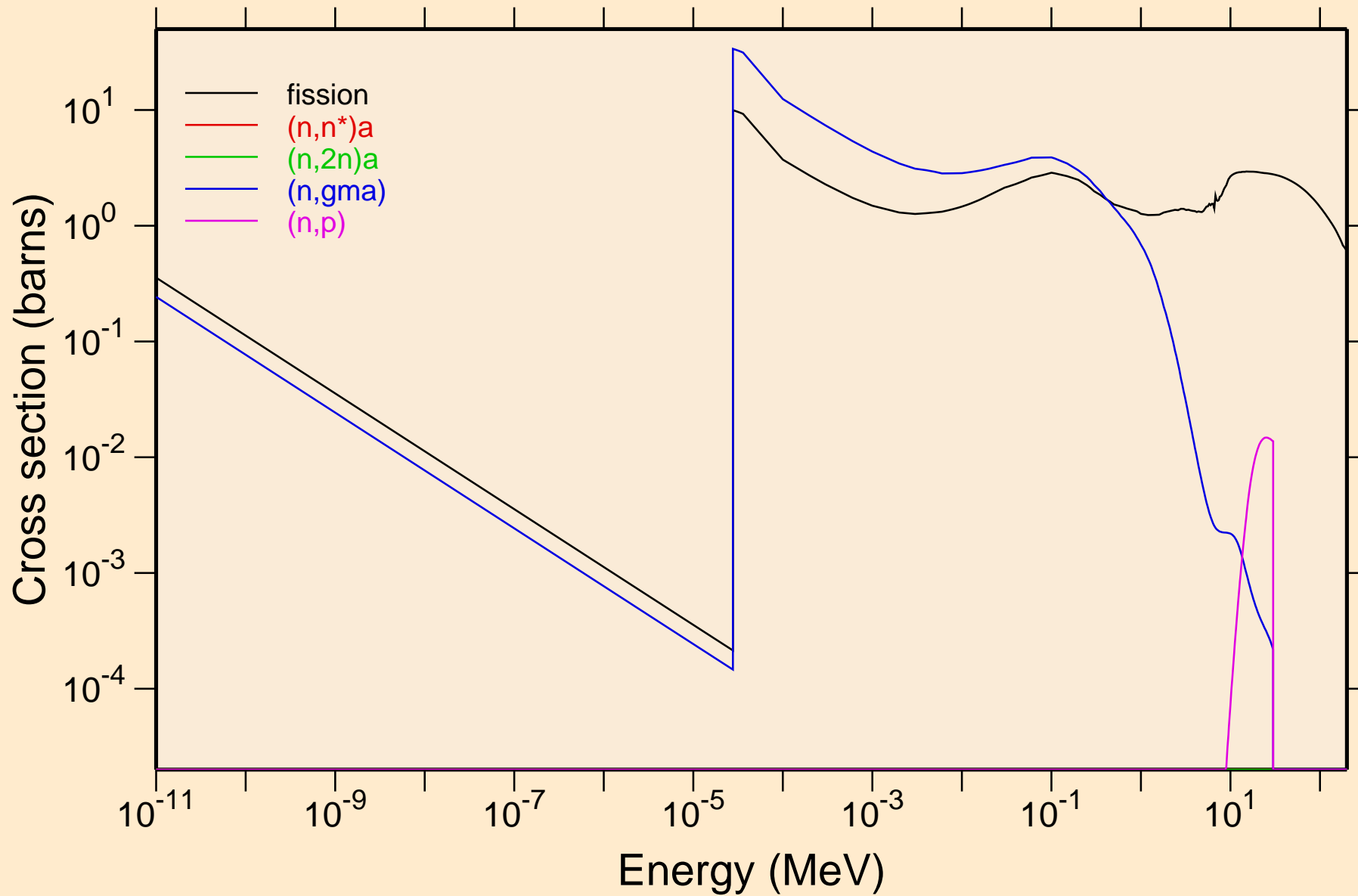

HS277M NEUTRON ACER TENDL-2023 LIBRARY; T=0.K

Non-threshold reactions

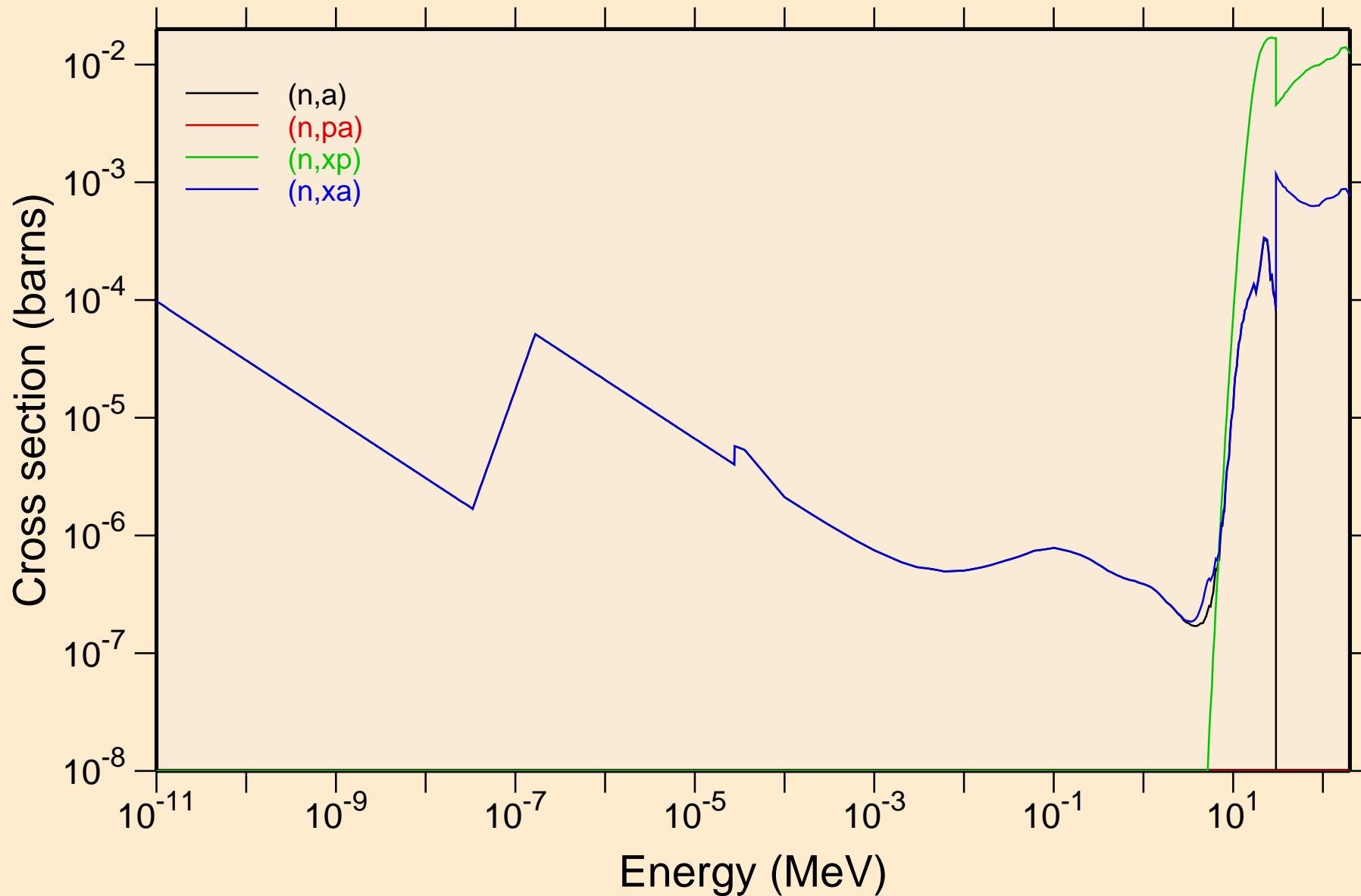

HS277M NEUTRON ACER TENDL-2023 LIBRARY; T=0.K

Principal cross sections

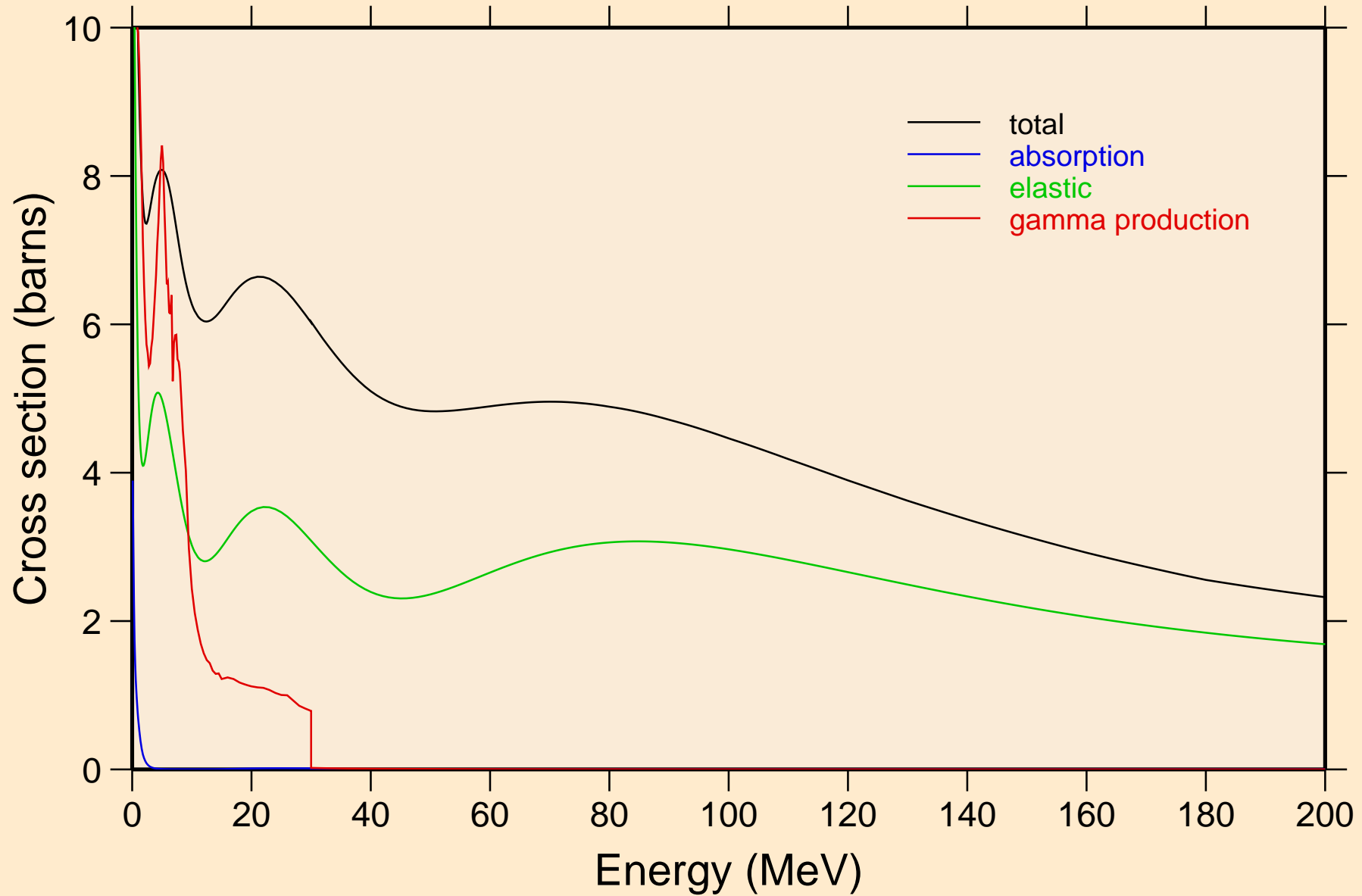

HS277M NEUTRON ACER TENDL-2023 LIBRARY; T=0.K

Heating

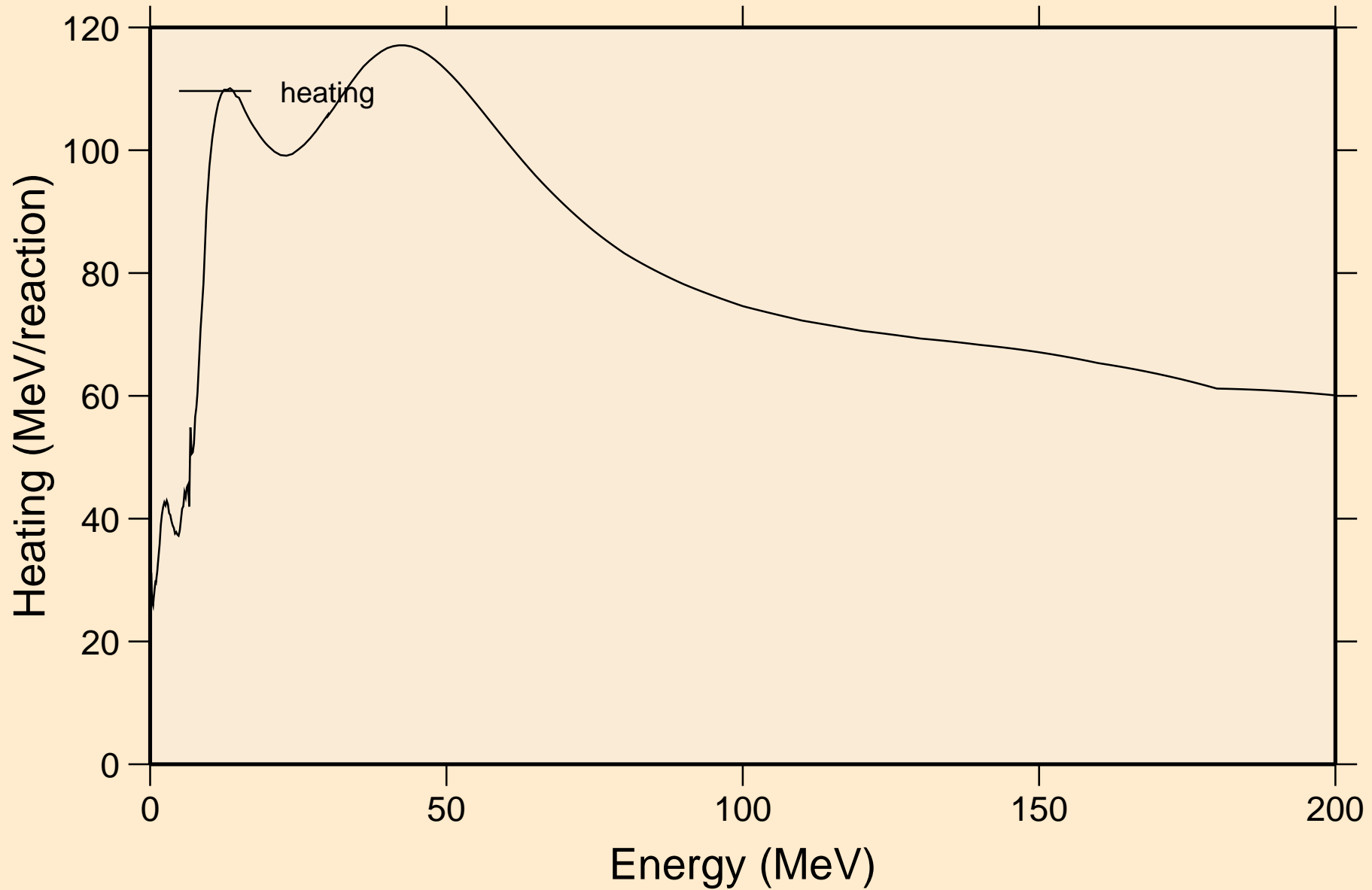

HS277M NEUTRON ACER TENDL-2023 LIBRARY; T=0.K

Damage

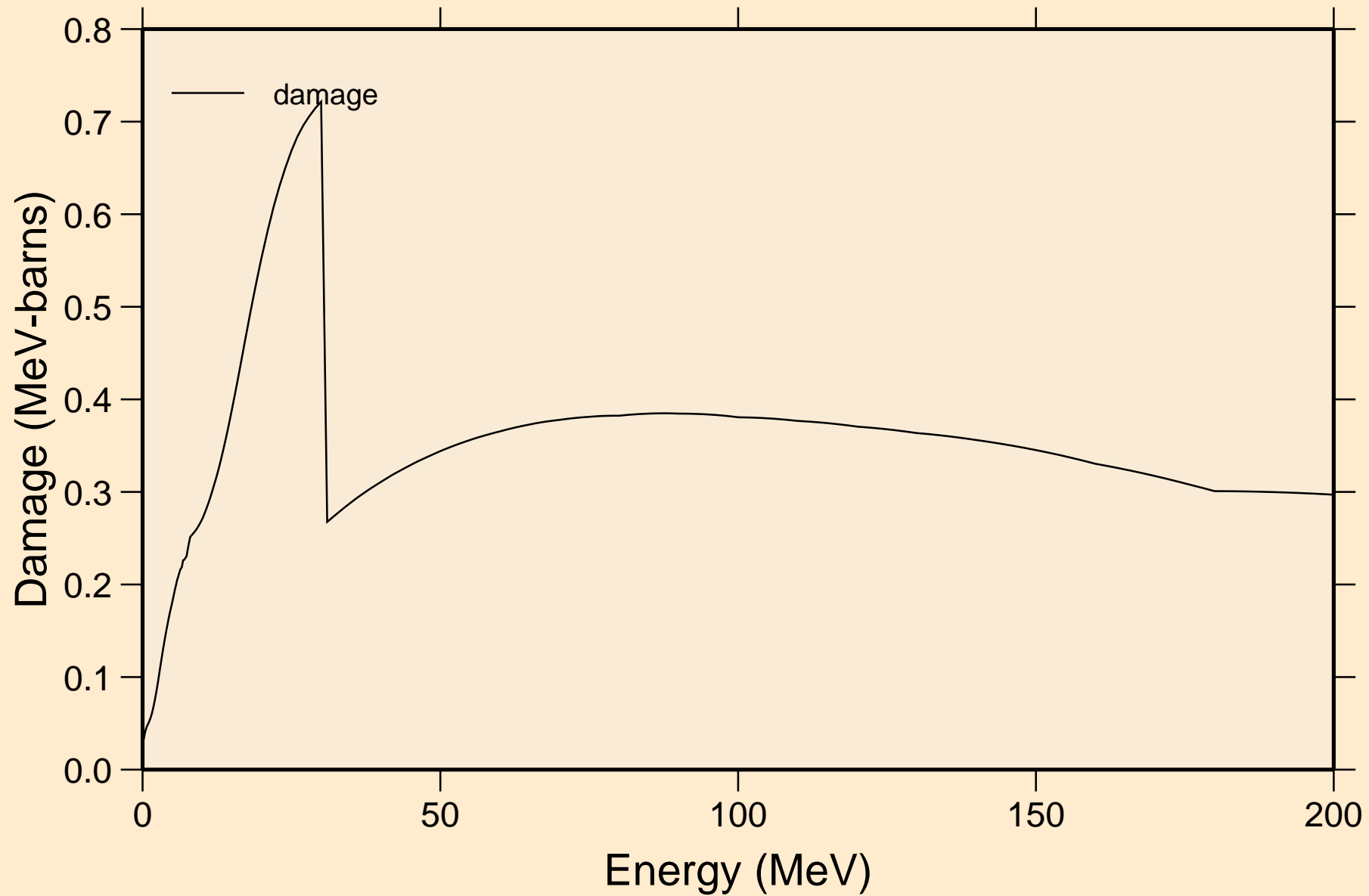

HS277M NEUTRON ACER TENDL-2023 LIBRARY; T=0.K

Non-threshold reactions

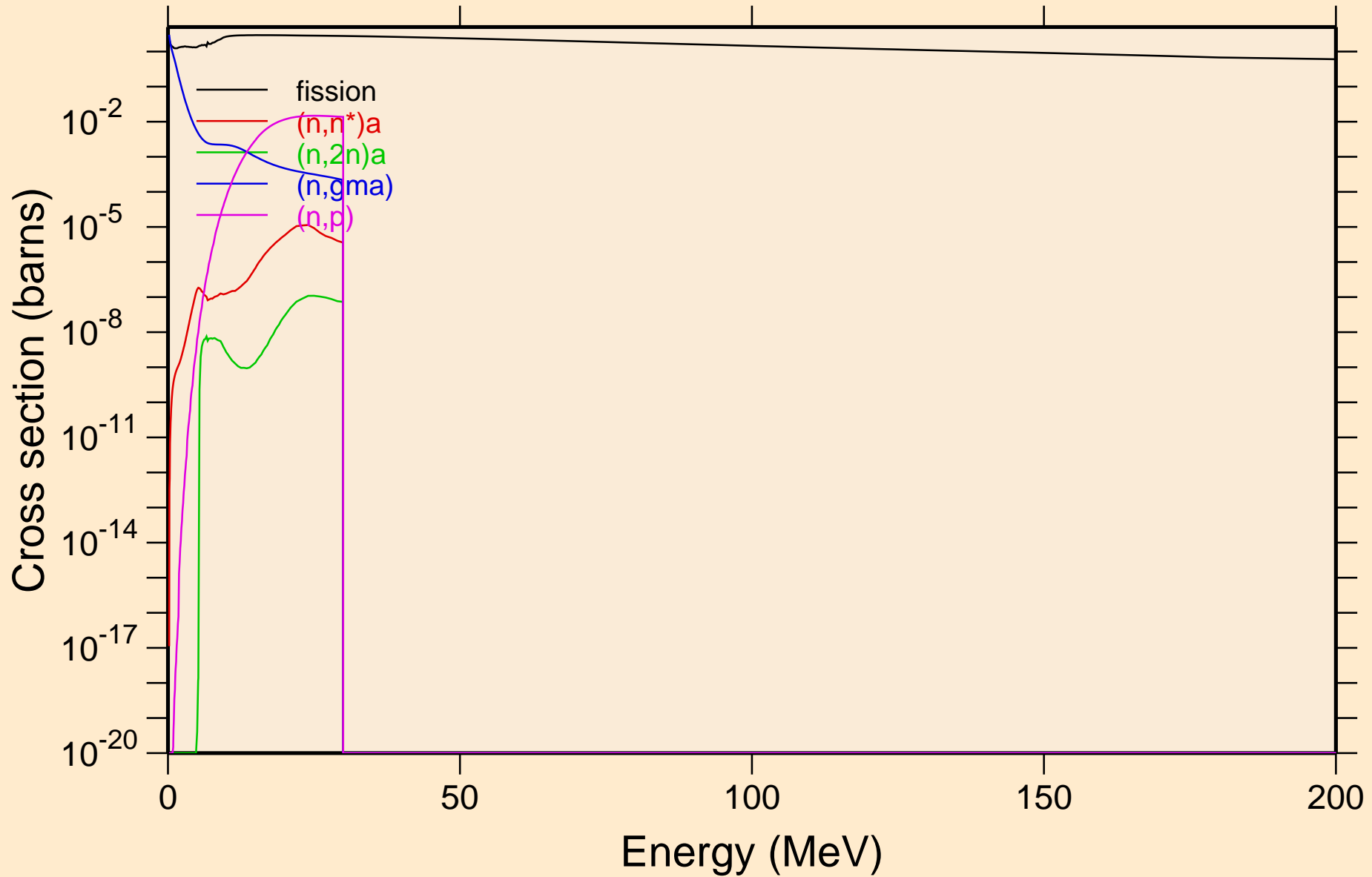

HS277M NEUTRON ACER TENDL-2023 LIBRARY; T=0.K

Non-threshold reactions

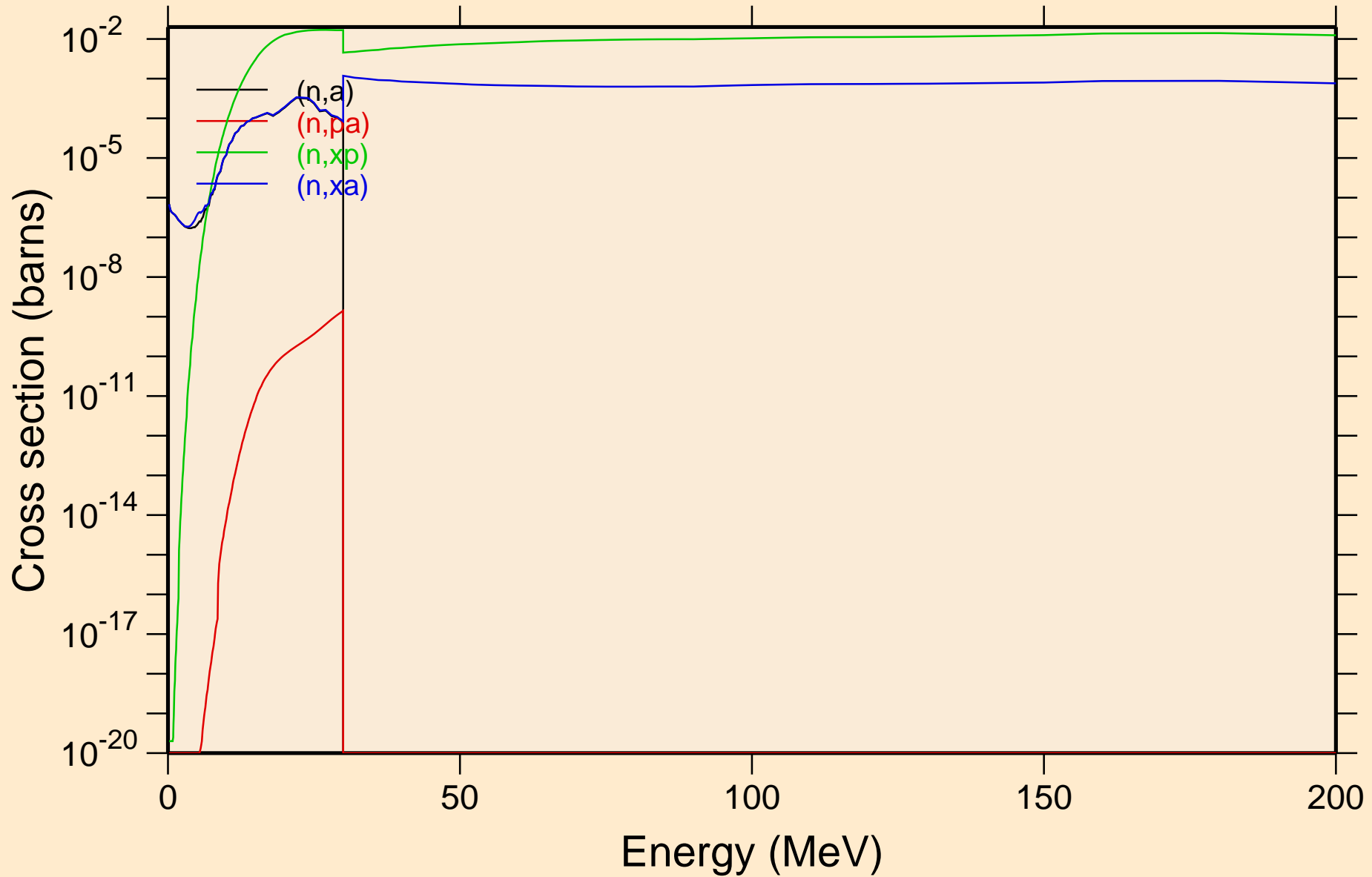

HS277M NEUTRON ACER TENDL-2023 LIBRARY; T=0.K
Inelastic levels

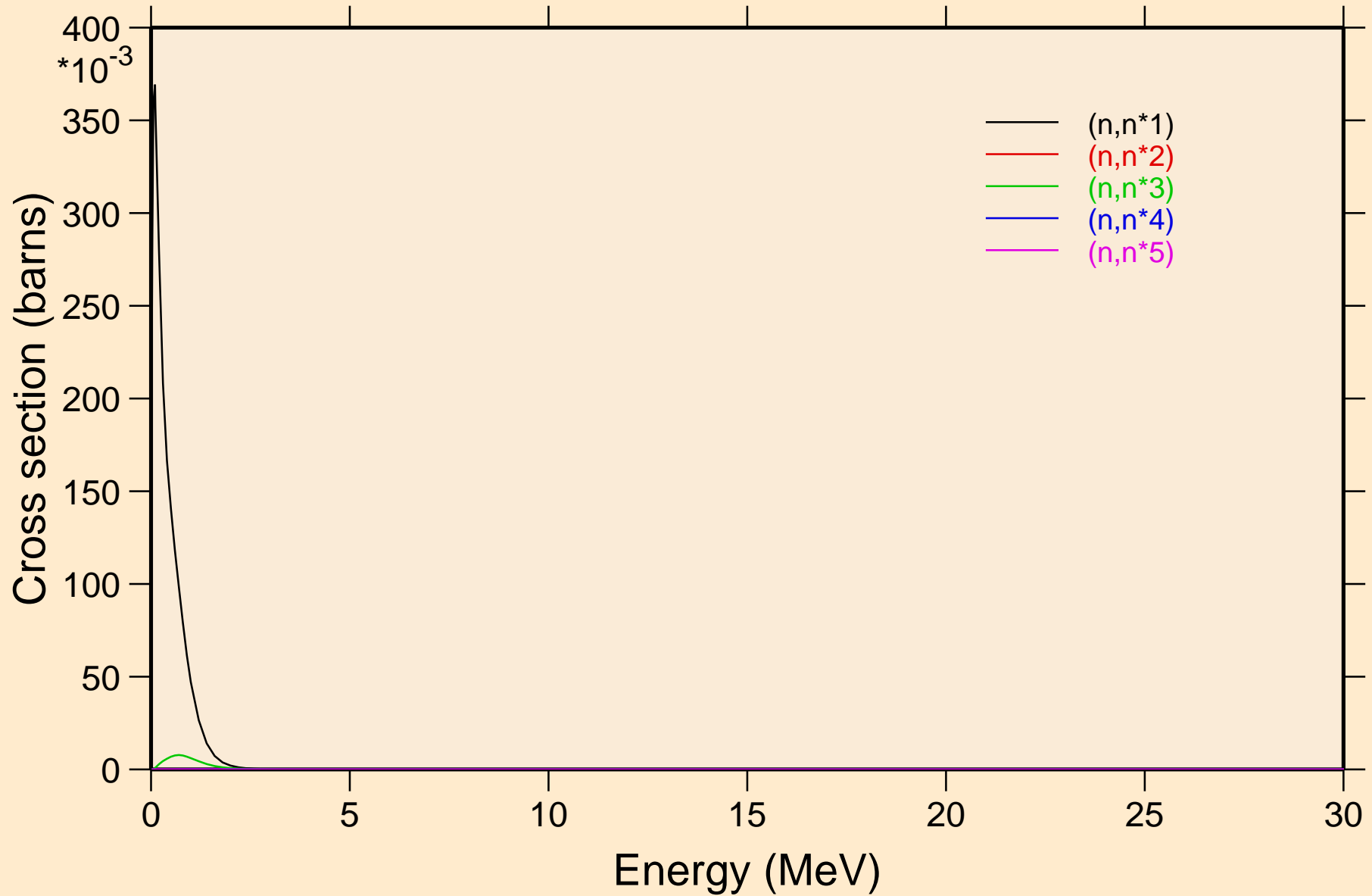

HS277M NEUTRON ACER TENDL-2023 LIBRARY; T=0.K

Inelastic levels

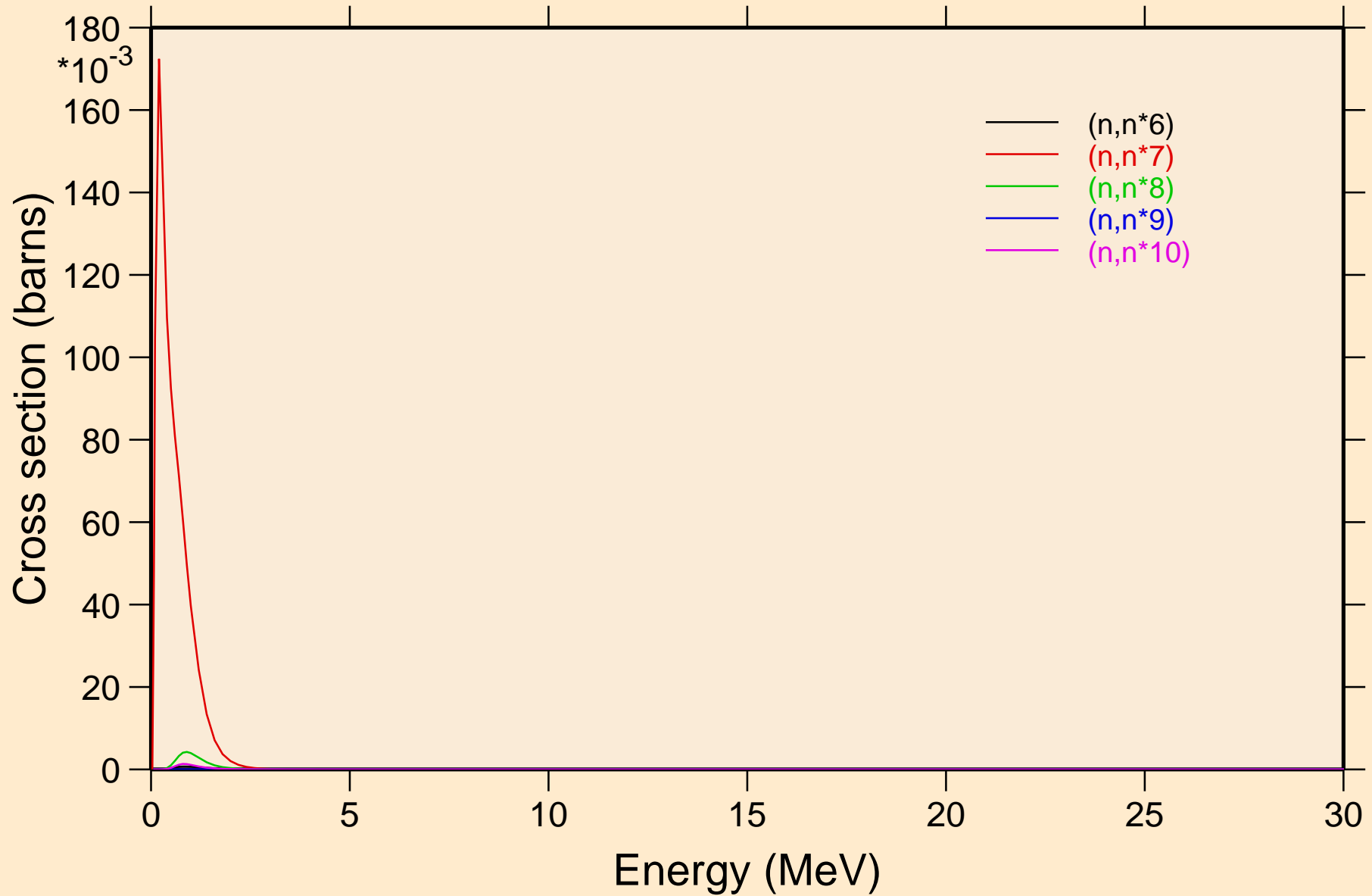

HS277M NEUTRON ACER TENDL-2023 LIBRARY; T=0.K
Inelastic levels

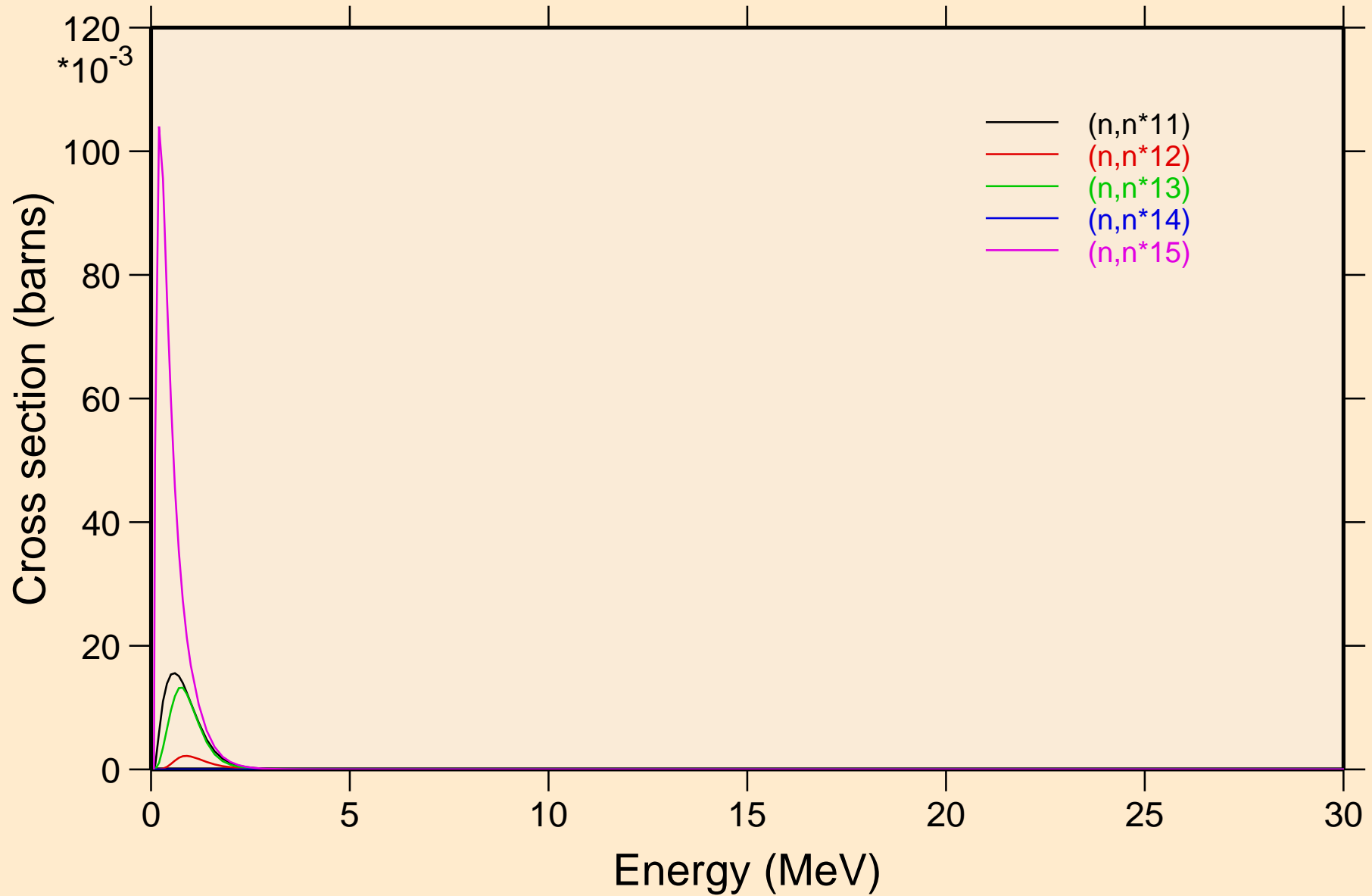

HS277M NEUTRON ACER TENDL-2023 LIBRARY; T=0.K

Inelastic levels

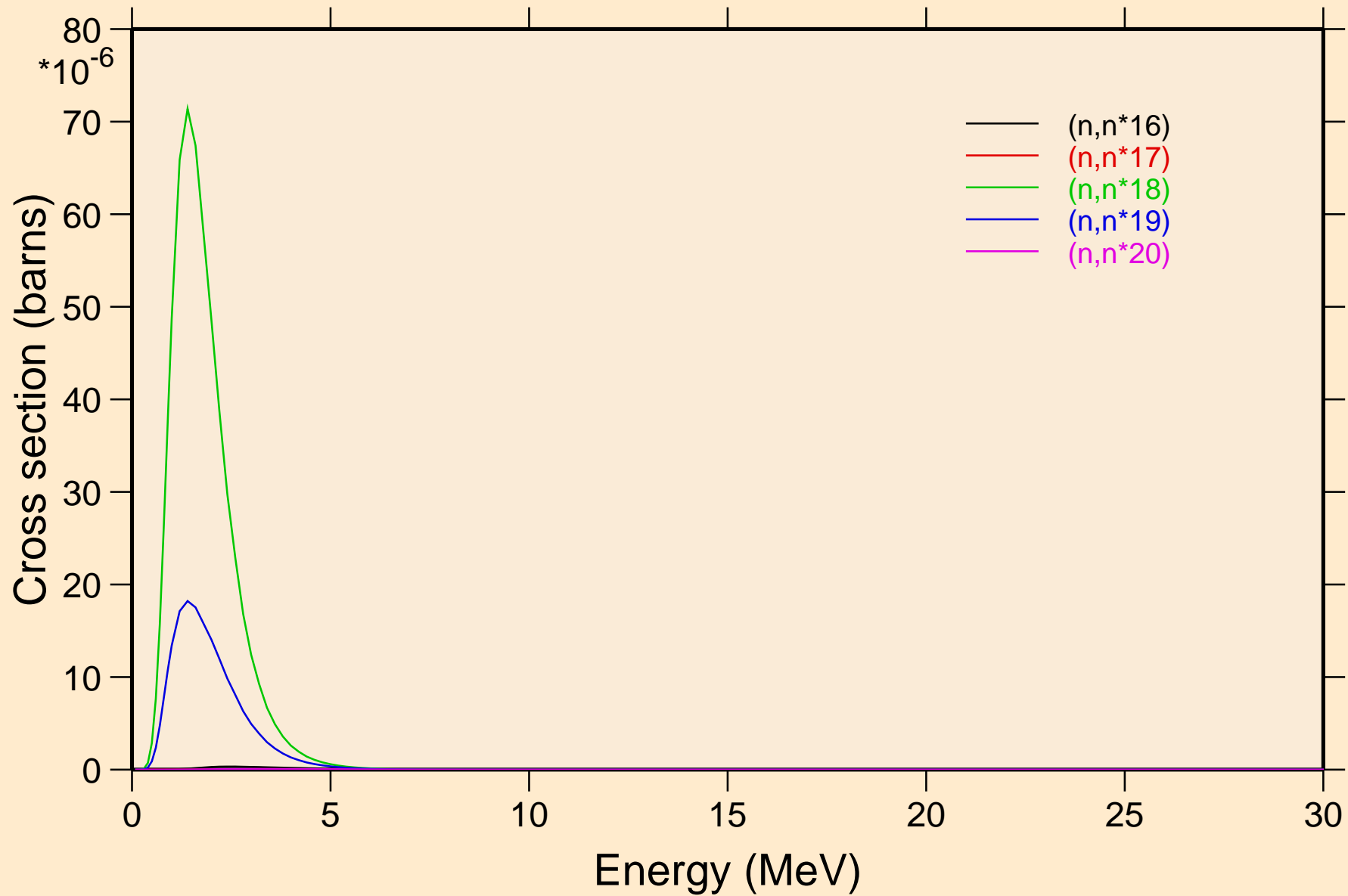

HS277M NEUTRON ACER TENDL-2023 LIBRARY; T=0.K

Inelastic levels

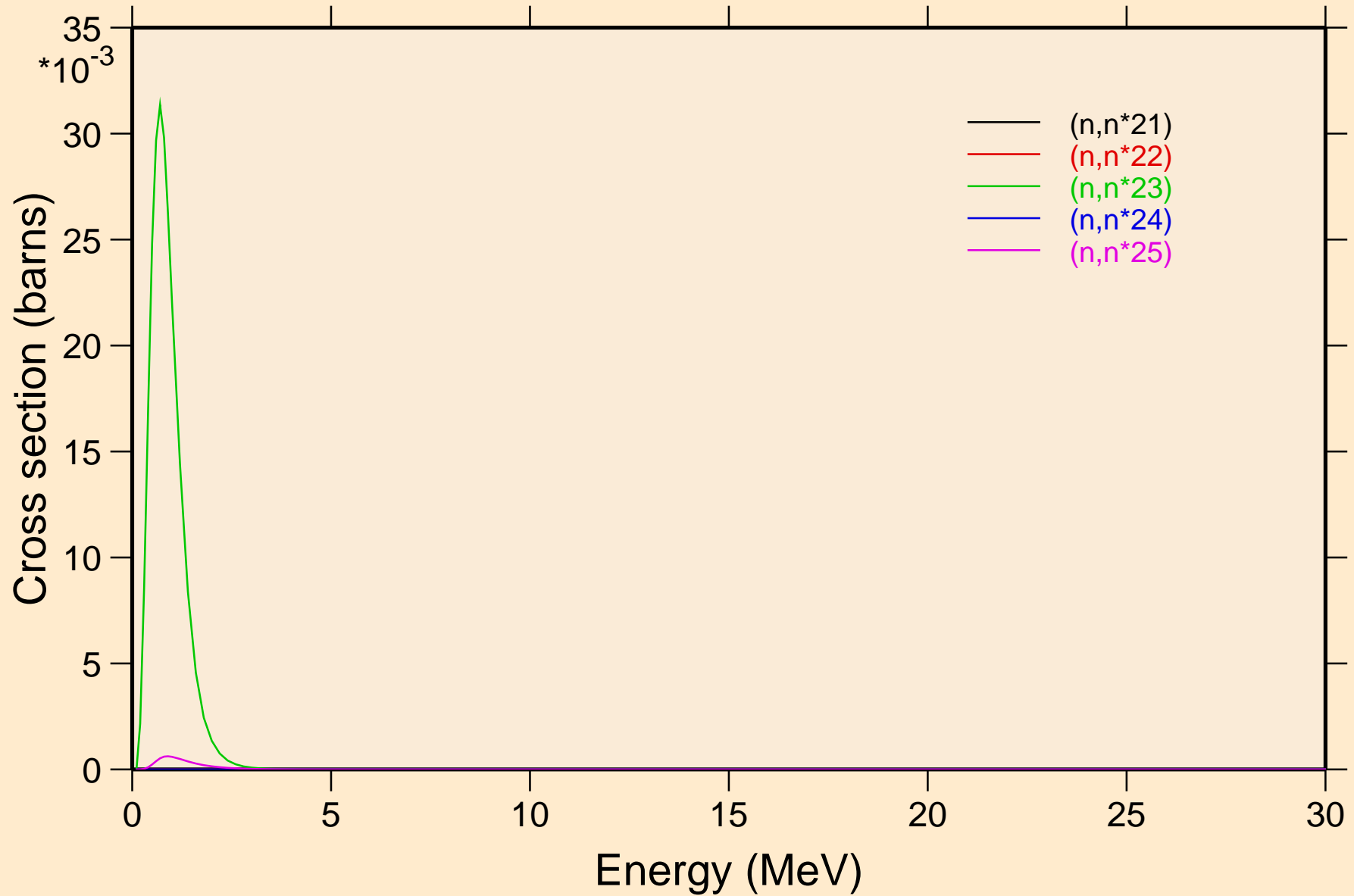

HS277M NEUTRON ACER TENDL-2023 LIBRARY; T=0.K
Inelastic levels

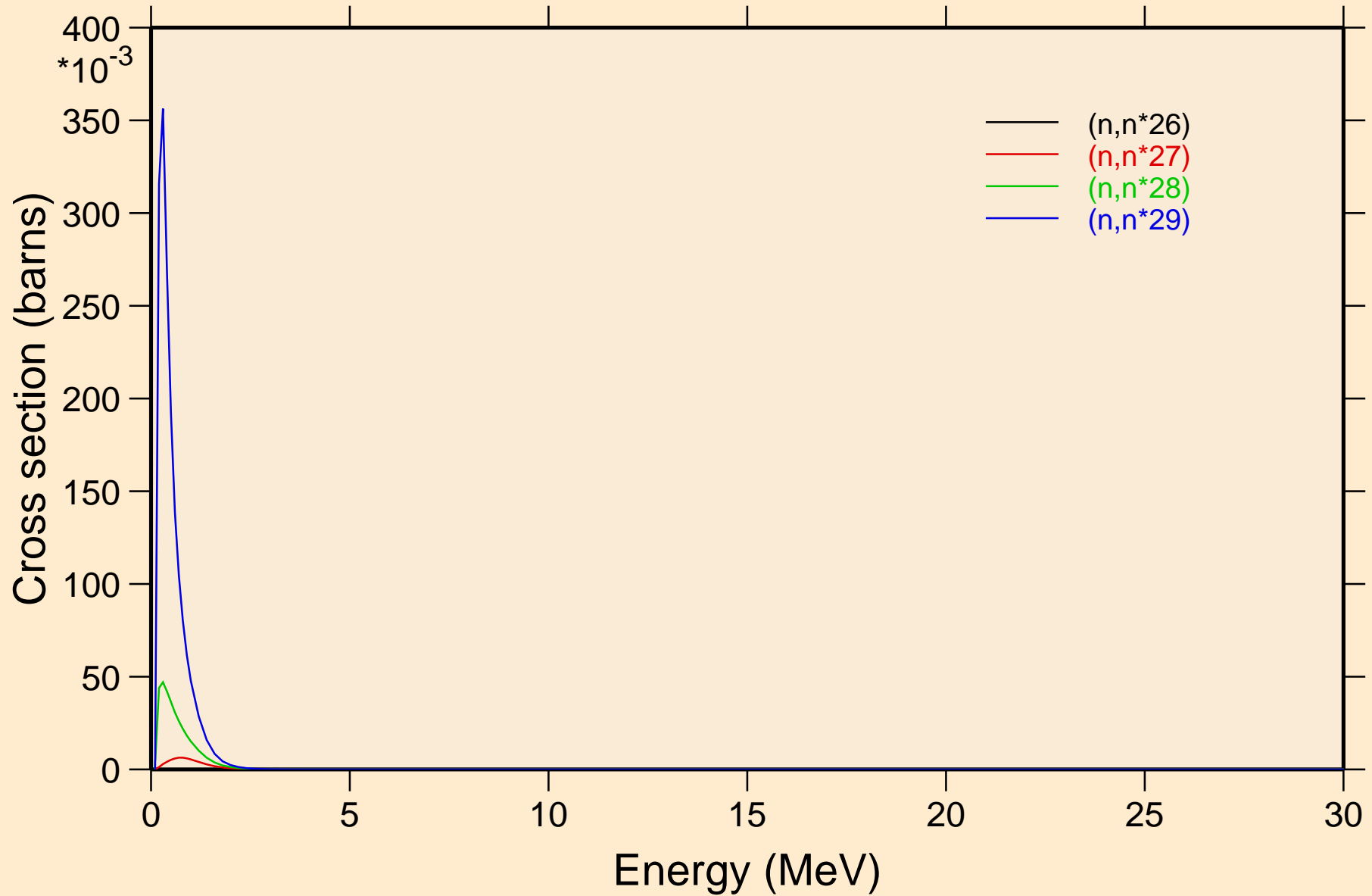

HS277M NEUTRON ACER TENDL-2023 LIBRARY; T=0.K

Threshold reactions

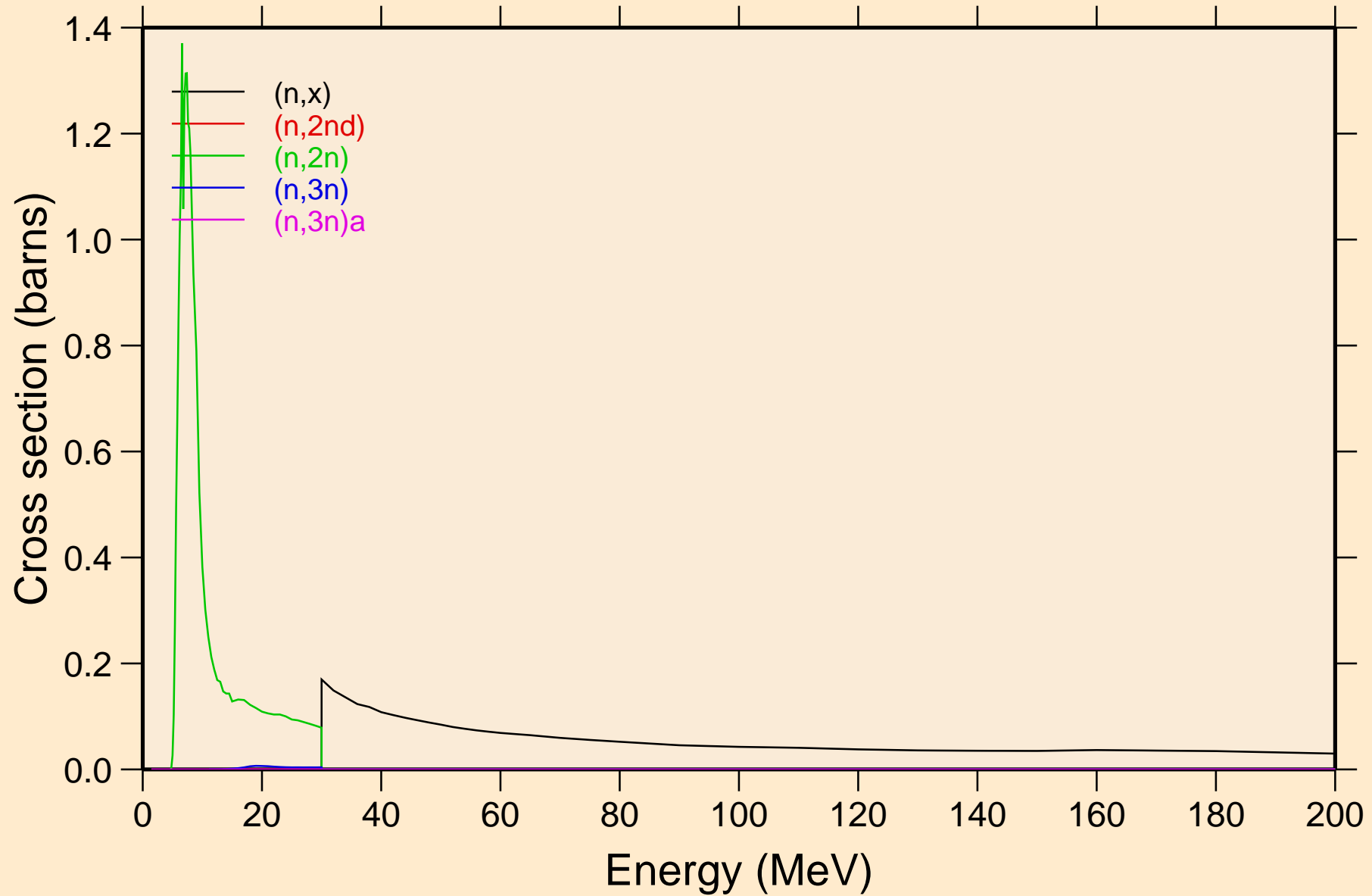

HS277M NEUTRON ACER TENDL-2023 LIBRARY; T=0.K

Threshold reactions

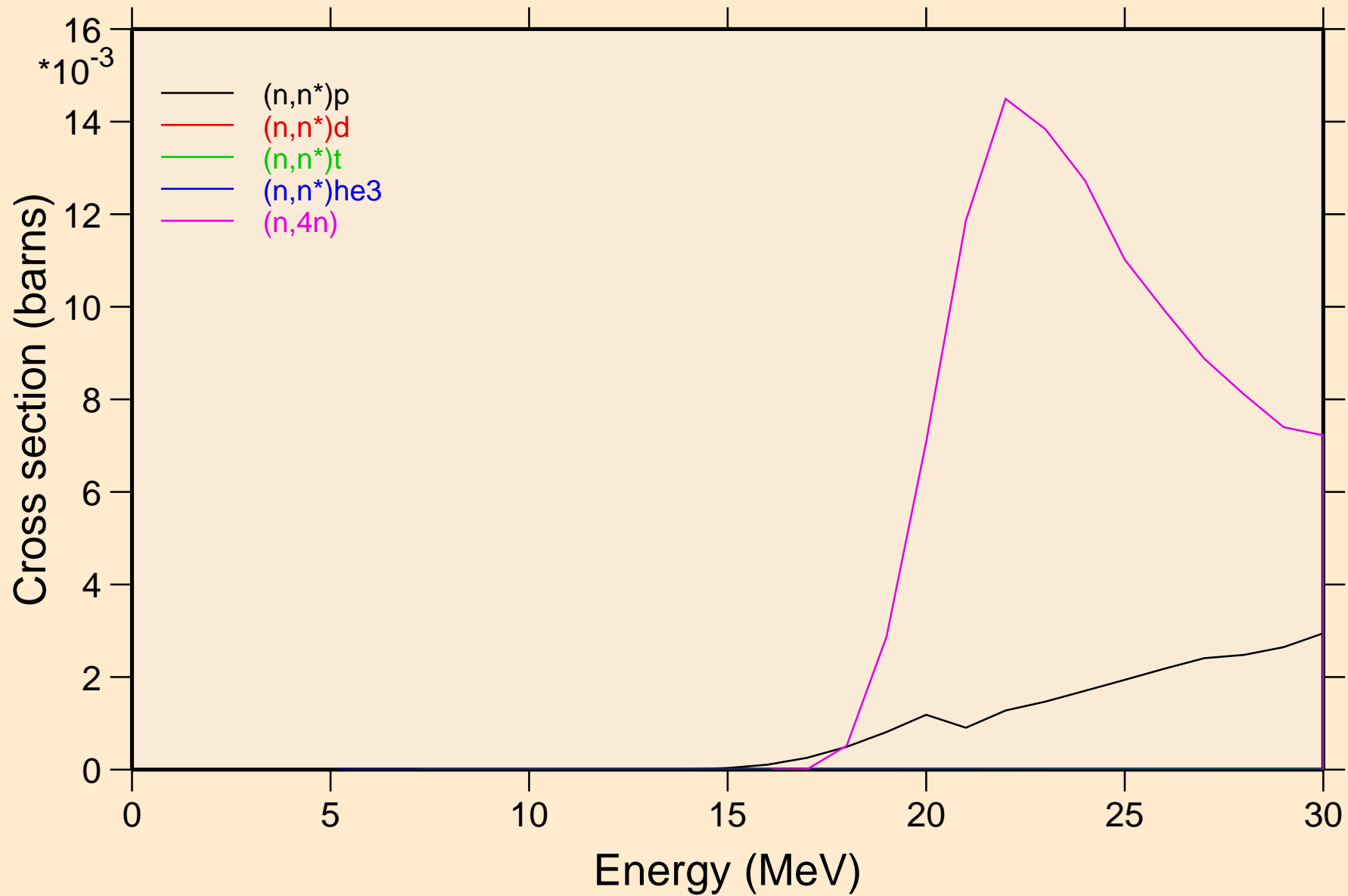

HS277M NEUTRON ACER TENDL-2023 LIBRARY; T=0.K

Threshold reactions

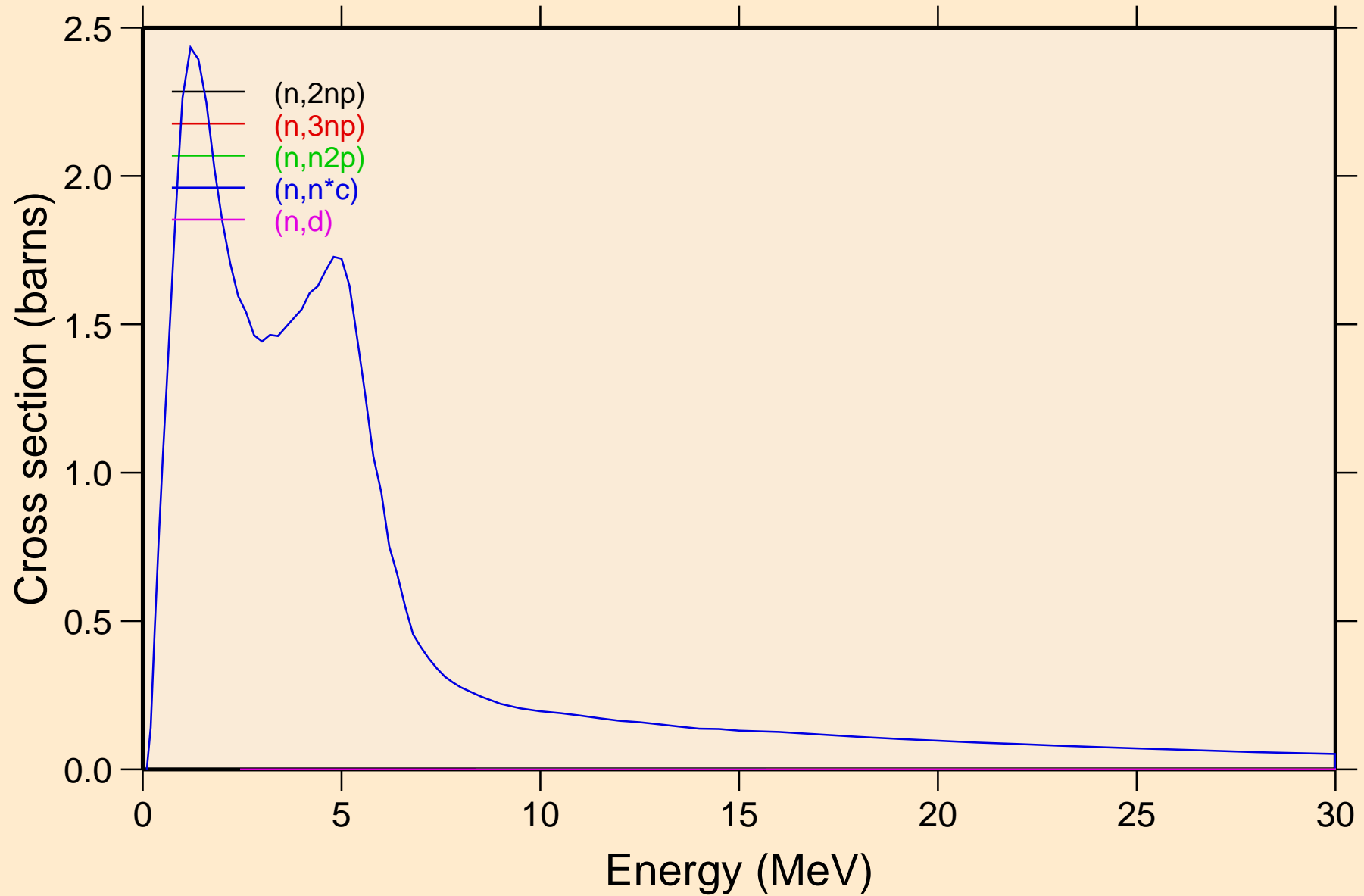

HS277M NEUTRON ACER TENDL-2023 LIBRARY; T=0.K

Threshold reactions

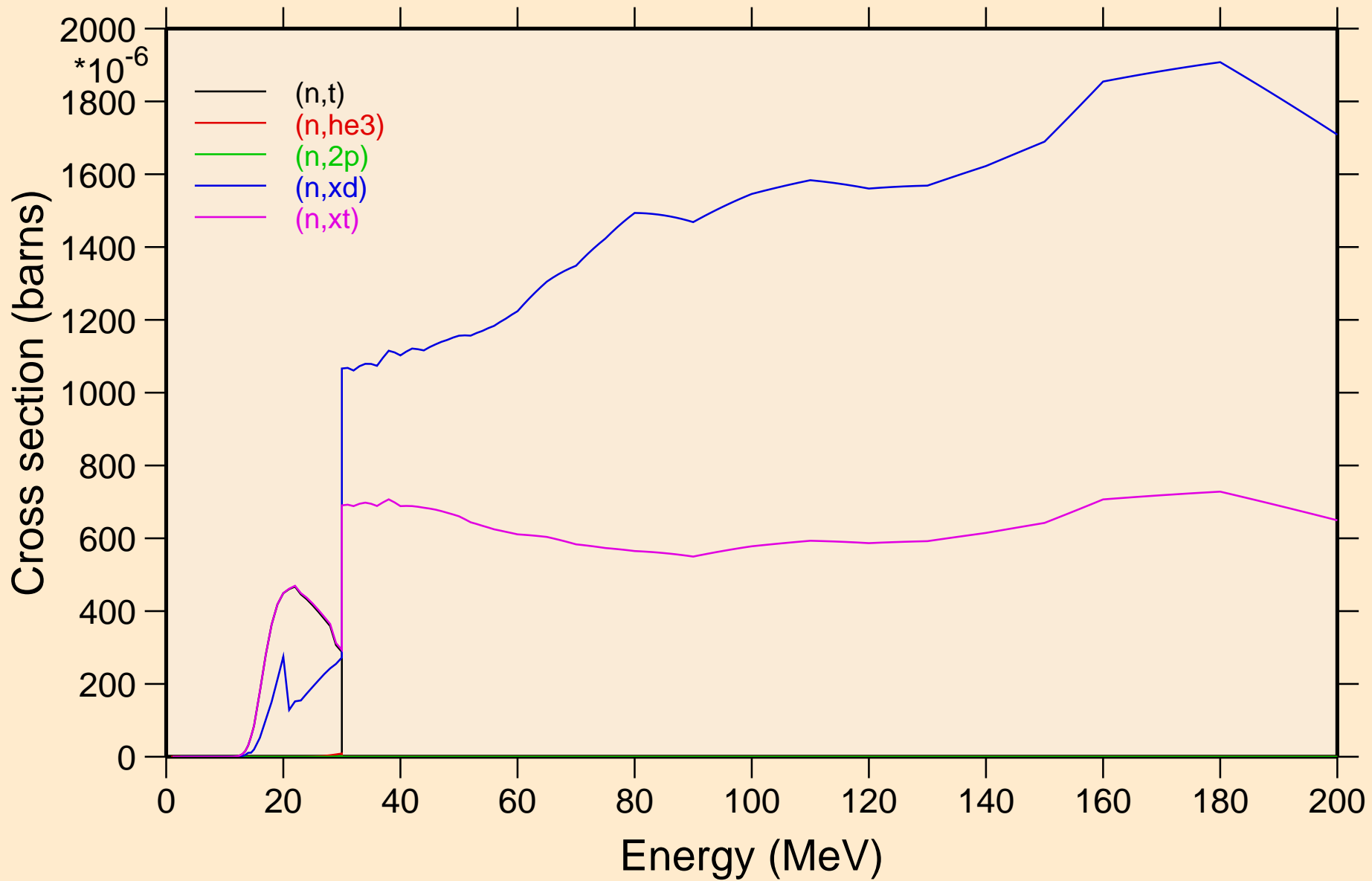

HS277M NEUTRON ACER TENDL-2023 LIBRARY; T=0.K

Threshold reactions

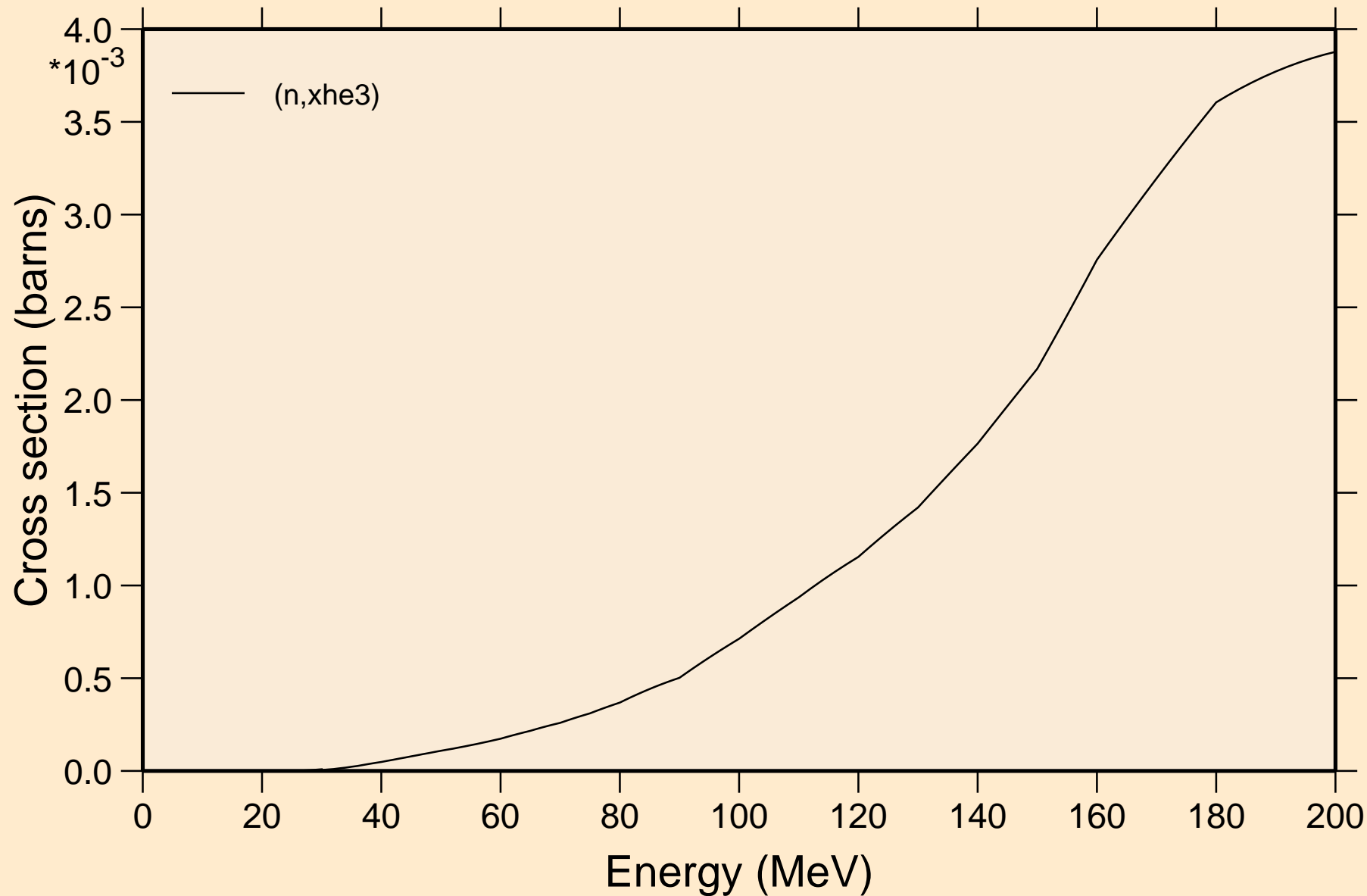

HS277M NEUTRON ACER TENDL-2023 LIBRARY; T=0.K
angular distribution for elastic

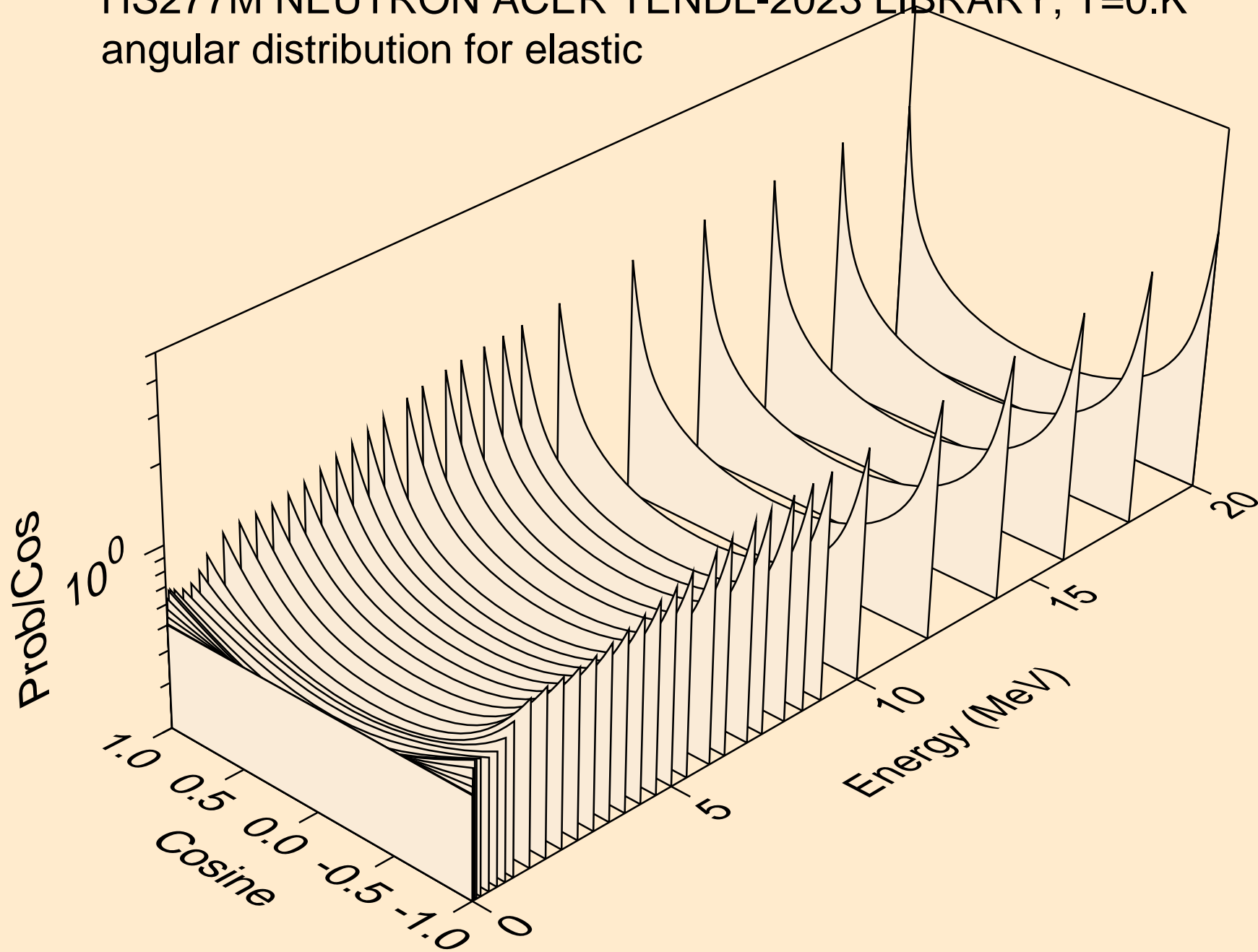

HS277M NEUTRON ACER TENDL-2023 LIBRARY; T=0.K
angular distribution for elastic

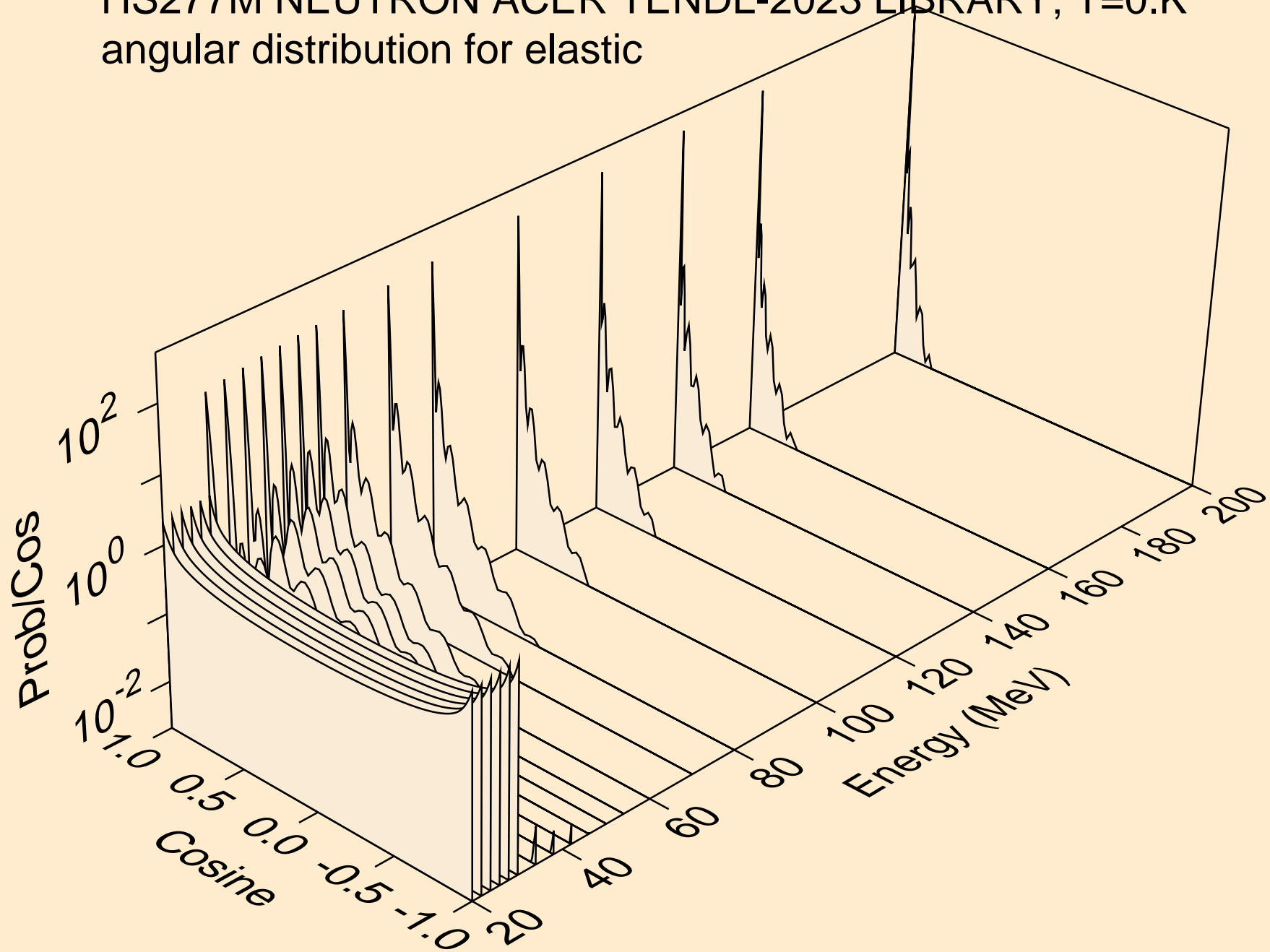

HS277M NEUTRON ACER TENDL-2023 LIBRARY; T=0.K
angular distribution for (n,n*1)

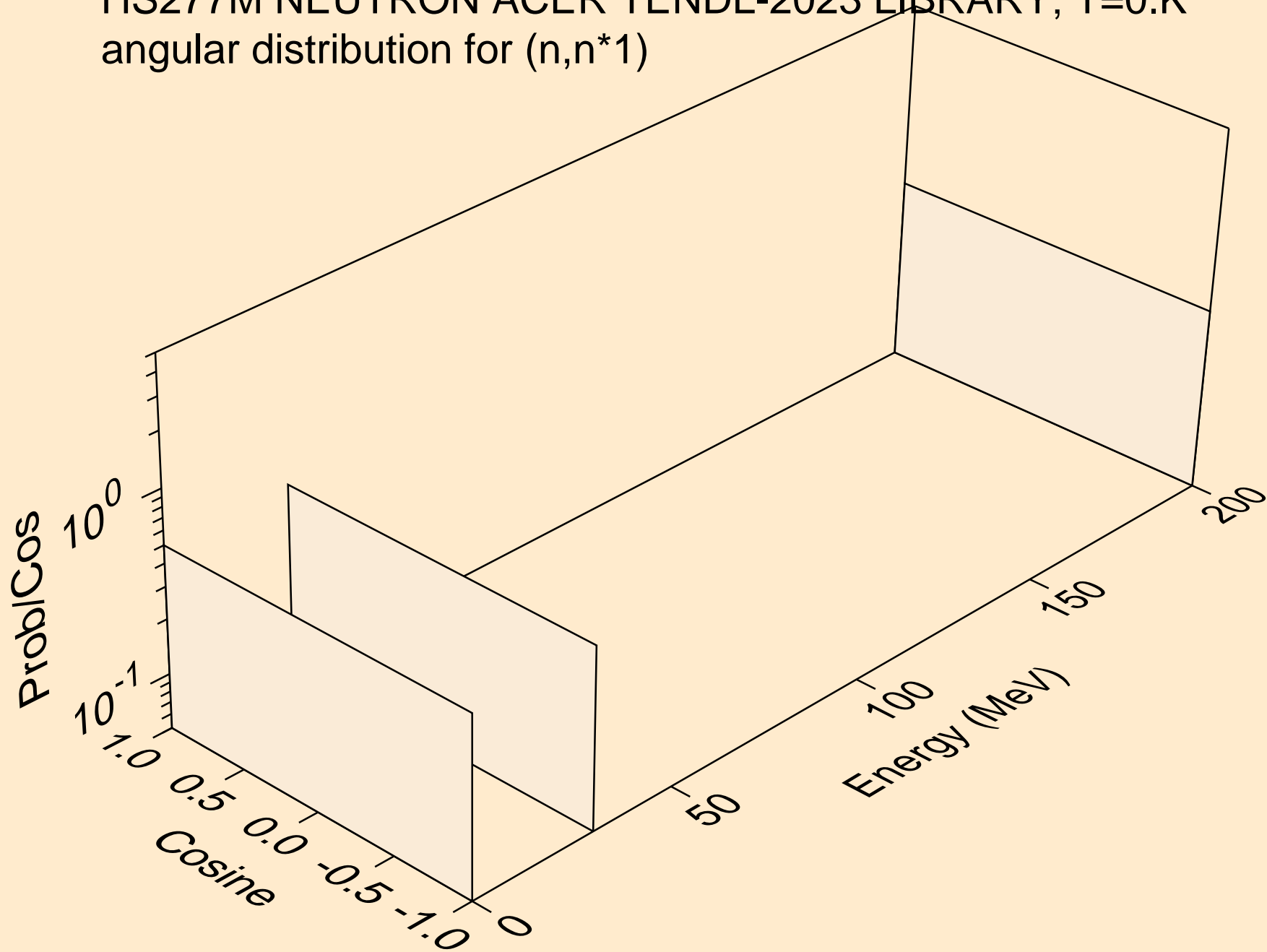

HS277M NEUTRON ACER TENDL-2023 LIBRARY; T=0.K
angular distribution for (n,n*2)

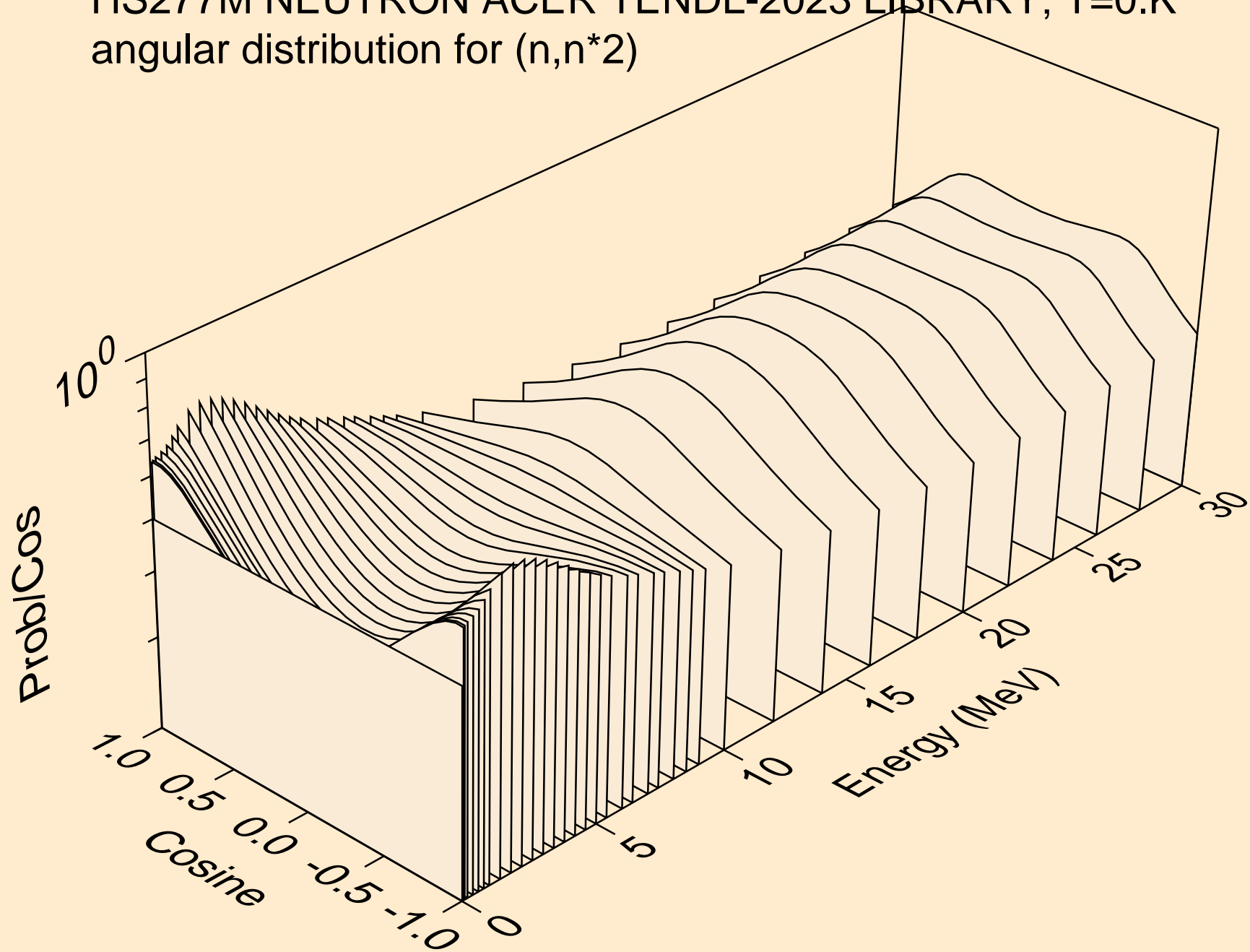

HS277M NEUTRON ACER TENDL-2023 LIBRARY; T=0.K
angular distribution for (n,n*3)

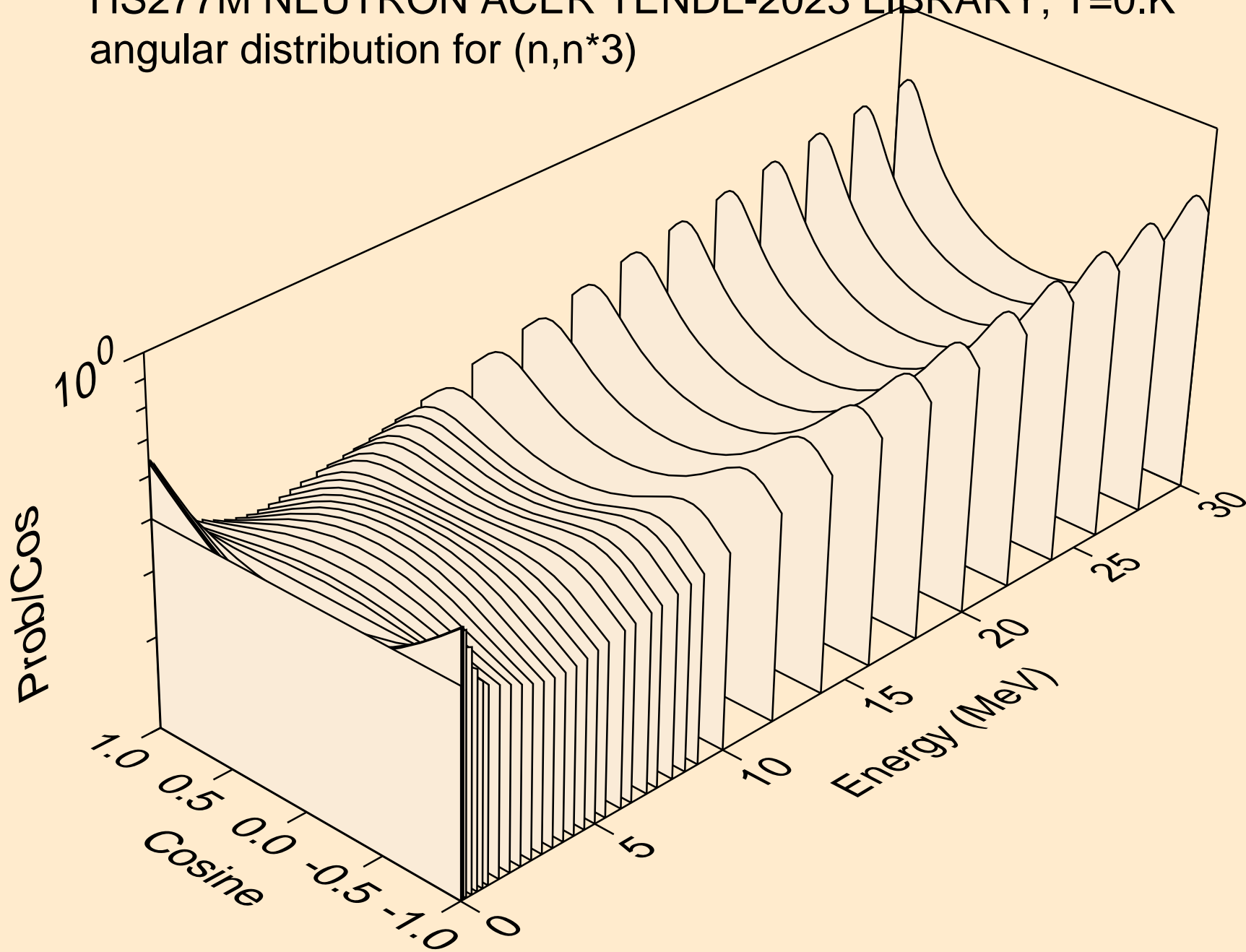

HS277M NEUTRON ACER TENDL-2023 LIBRARY; T=0.K
angular distribution for (n,n*4)

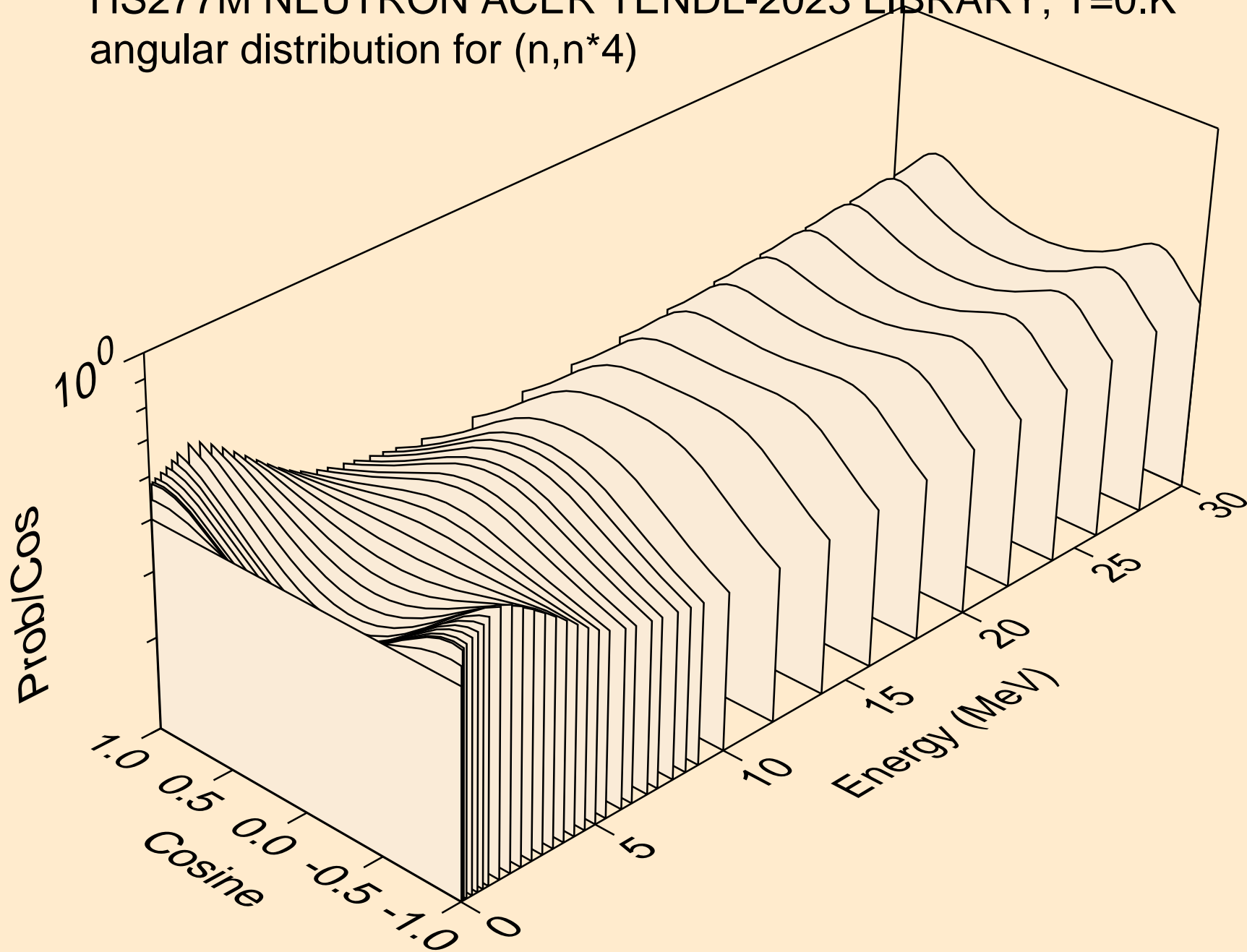

HS277M NEUTRON ACER TENDL-2023 LIBRARY; T=0.K
angular distribution for (n,n*5)

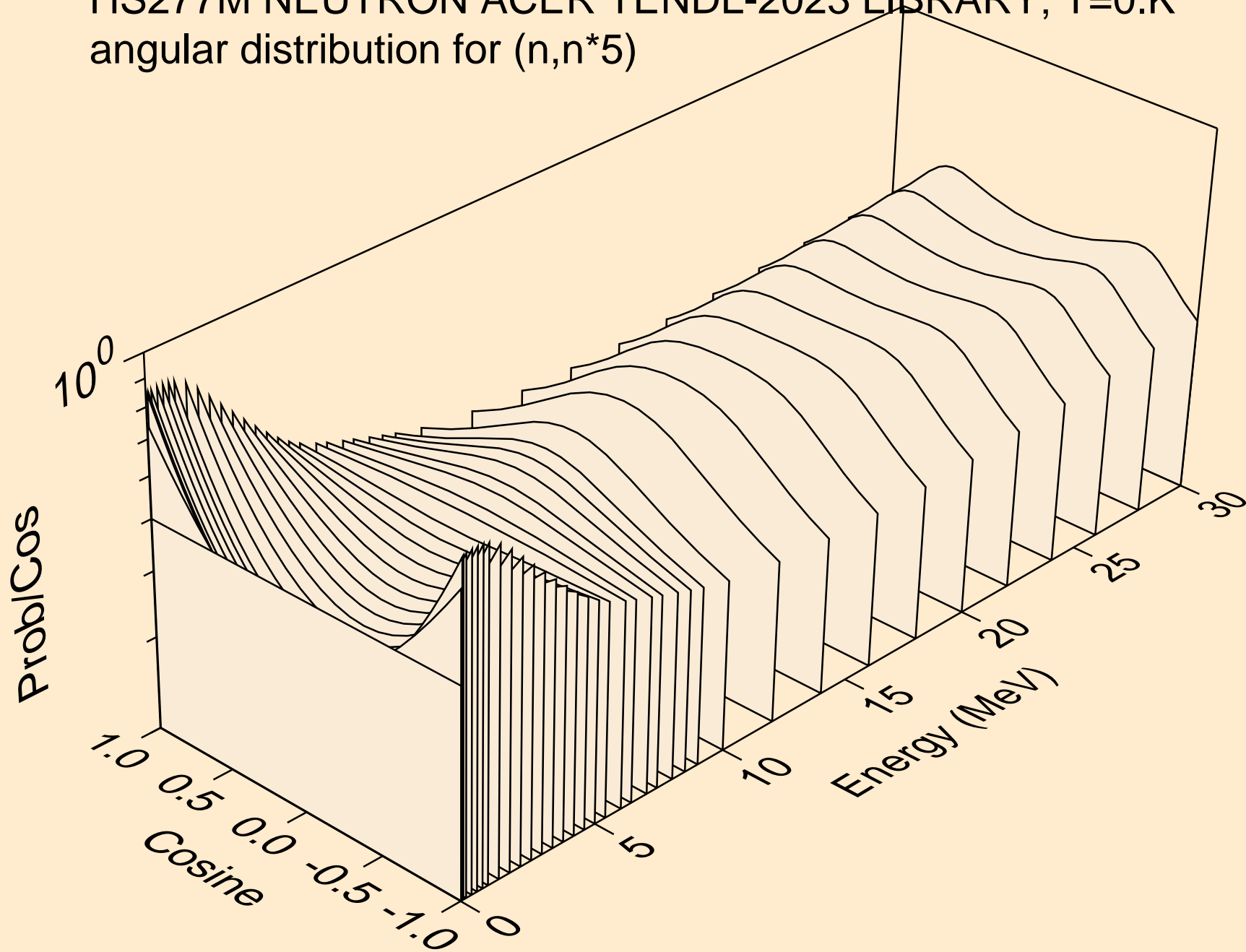

HS277M NEUTRON ACER TENDL-2023 LIBRARY; T=0.K
angular distribution for (n,n*6)

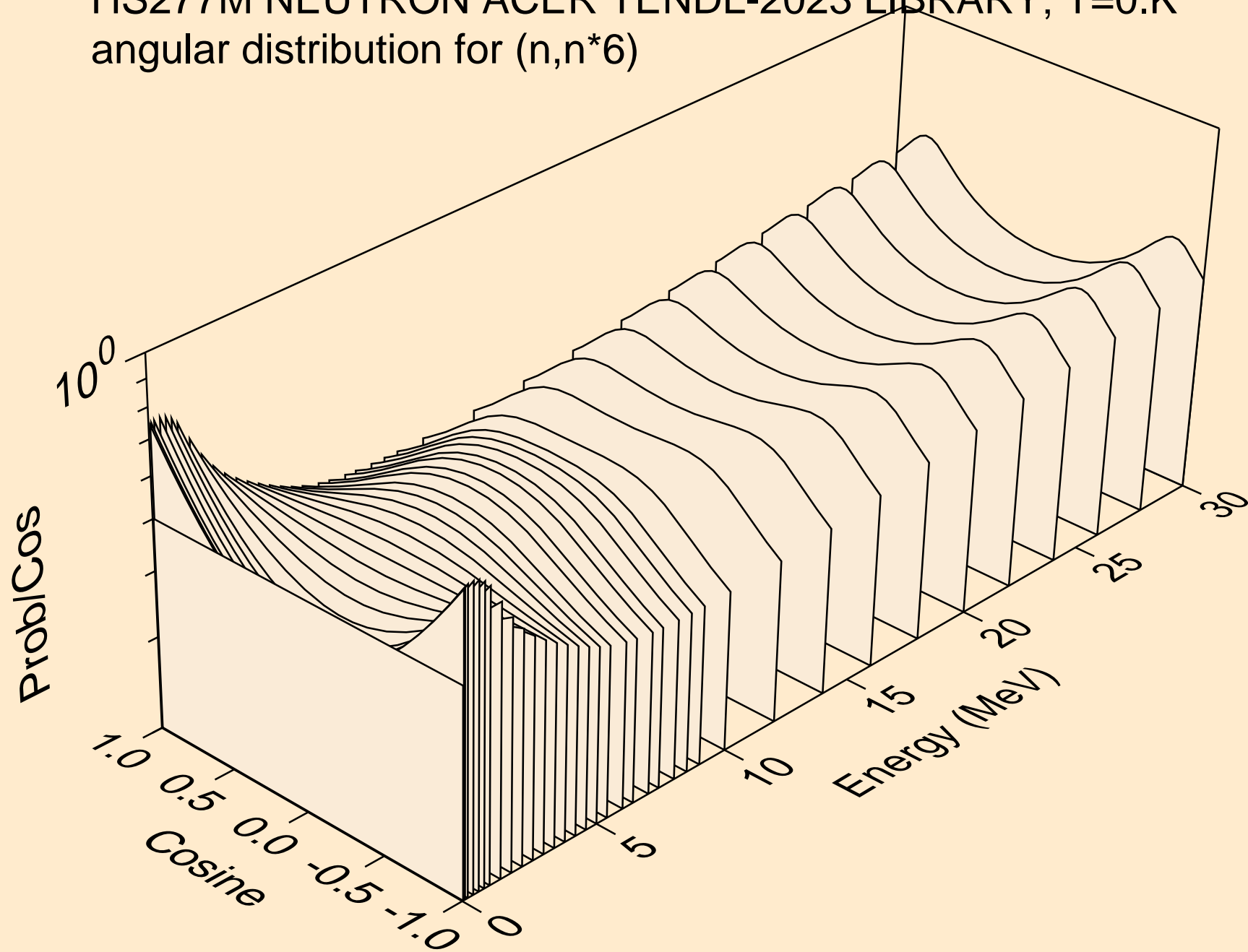

HS277M NEUTRON ACER TENDL-2023 LIBRARY; T=0.K
angular distribution for (n,n*7)

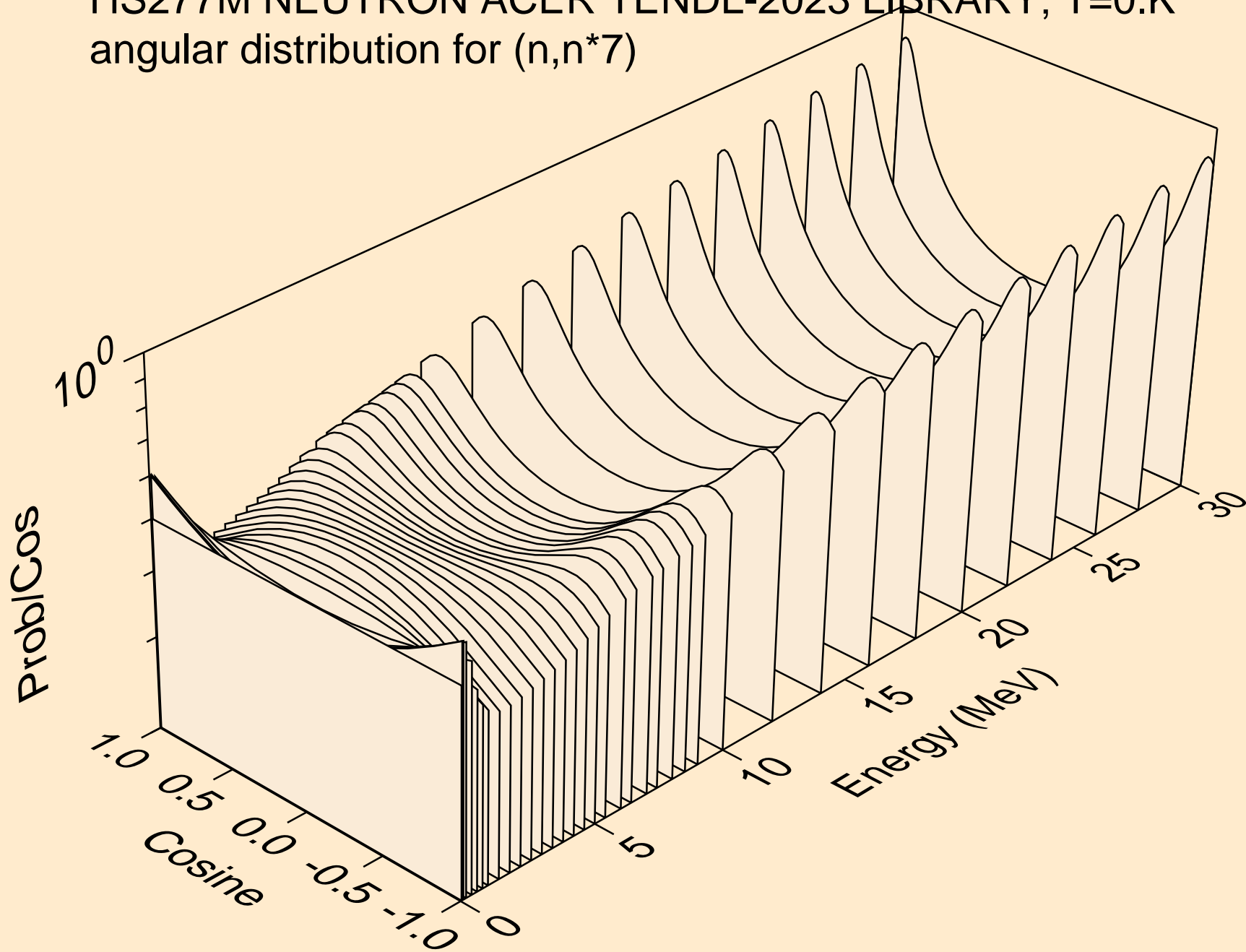

HS277M NEUTRON ACER TENDL-2023 LIBRARY; T=0.K
angular distribution for (n,n*8)

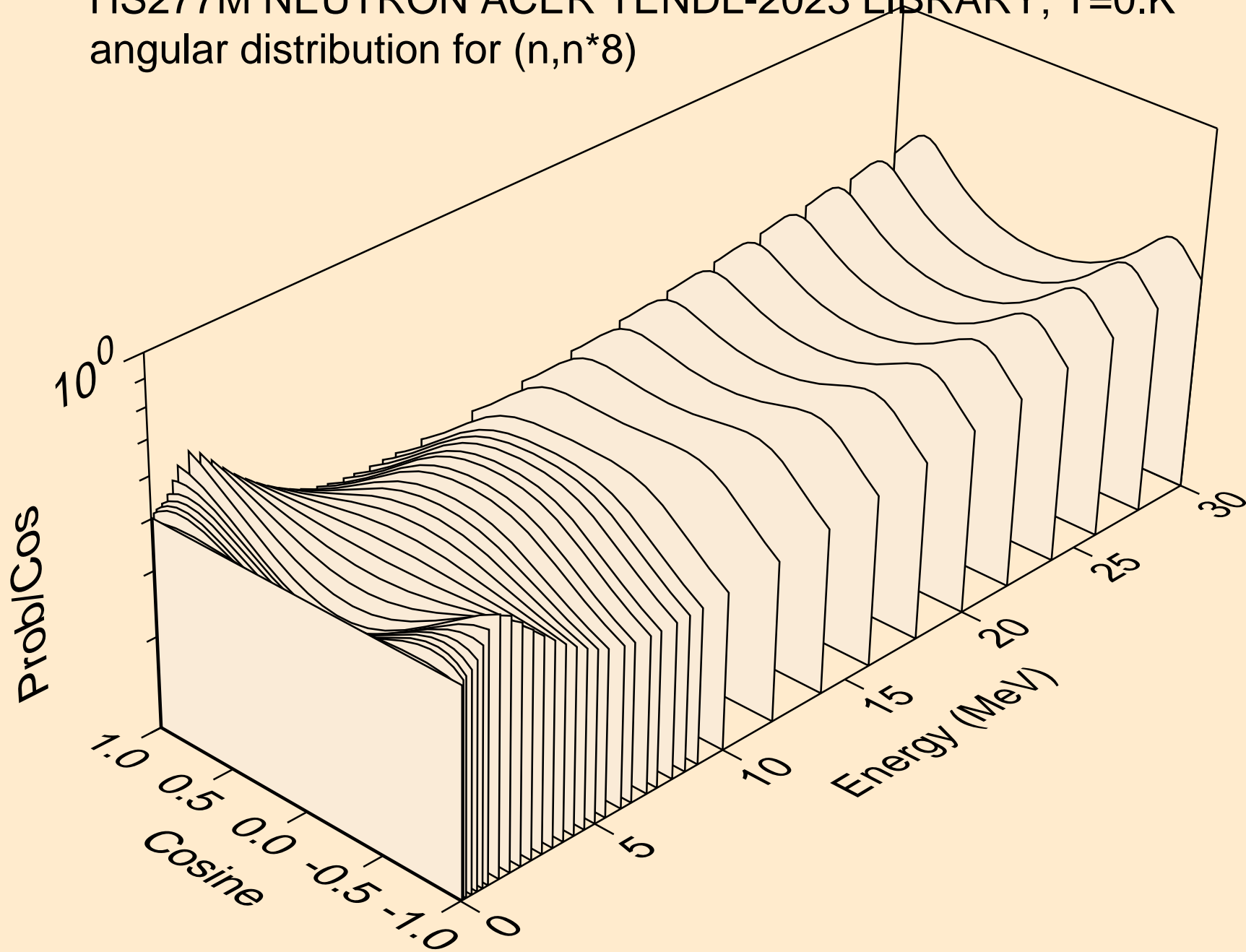

HS277M NEUTRON ACER TENDL-2023 LIBRARY; T=0.K
angular distribution for (n,n*9)

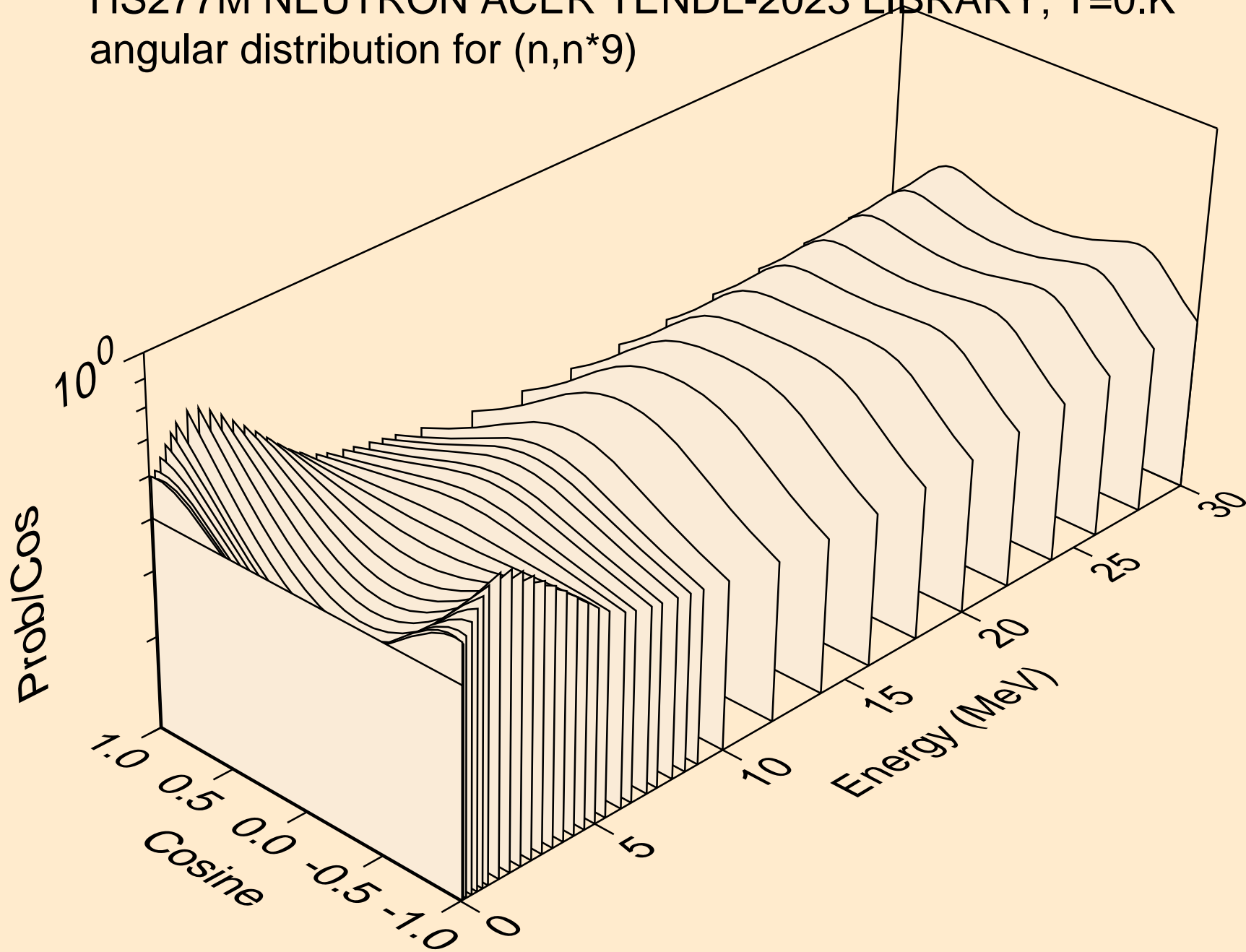

HS277M NEUTRON ACER TENDL-2023 LIBRARY; T=0.K
angular distribution for (n,n*10)

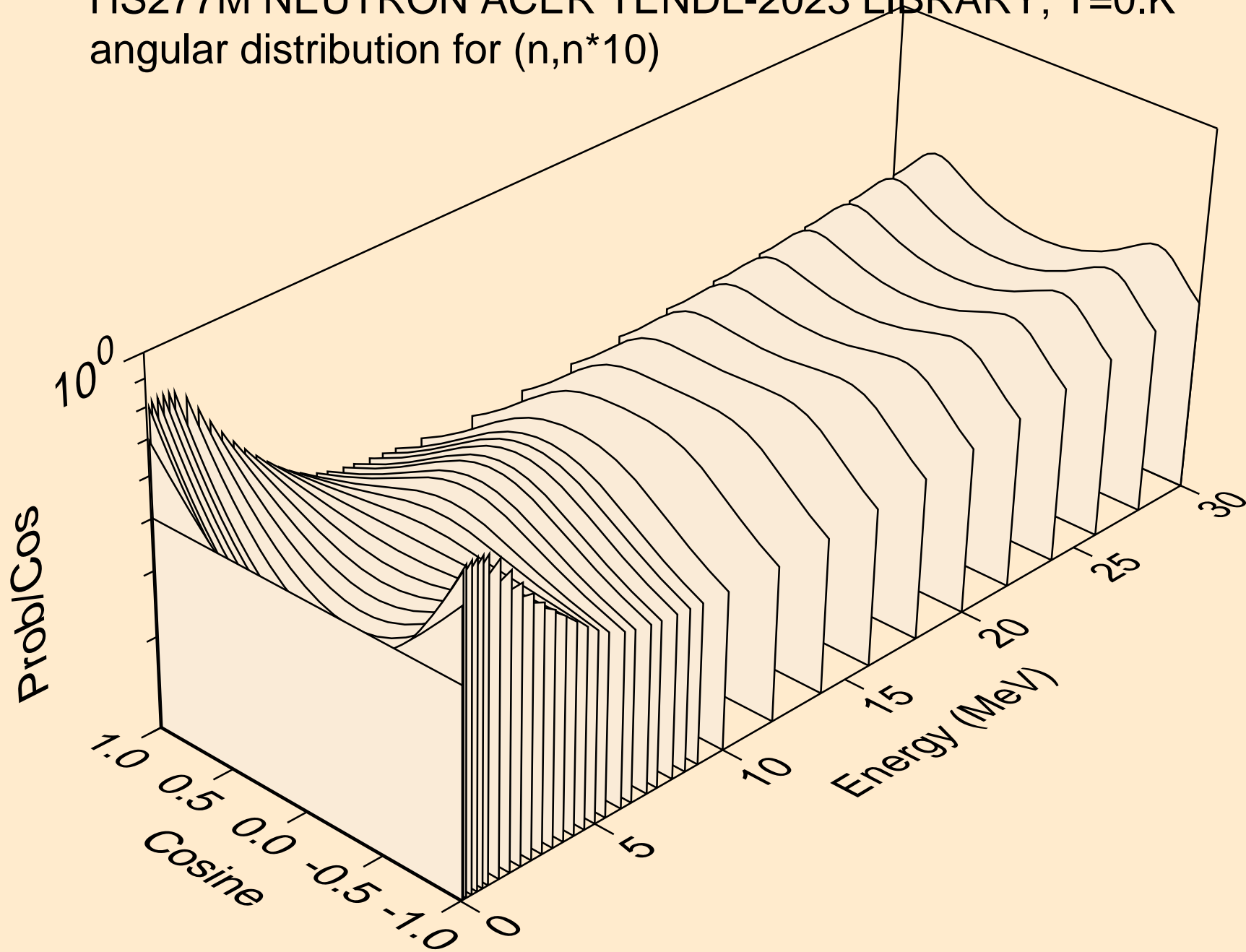

HS277M NEUTRON ACER TENDL-2023 LIBRARY; T=0.K
angular distribution for (n,n*11)

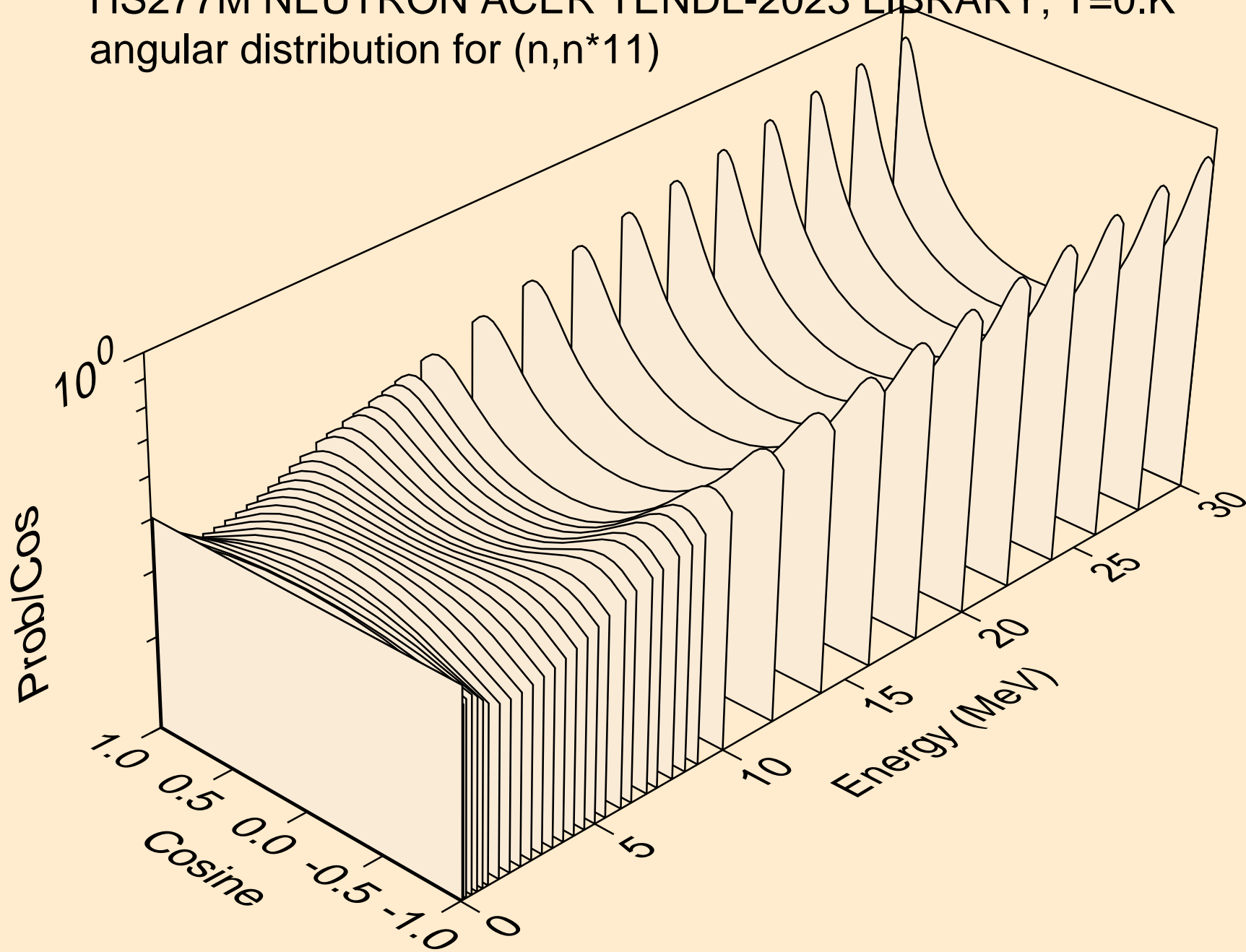

HS277M NEUTRON ACER TENDL-2023 LIBRARY; T=0.K
angular distribution for (n,n*12)

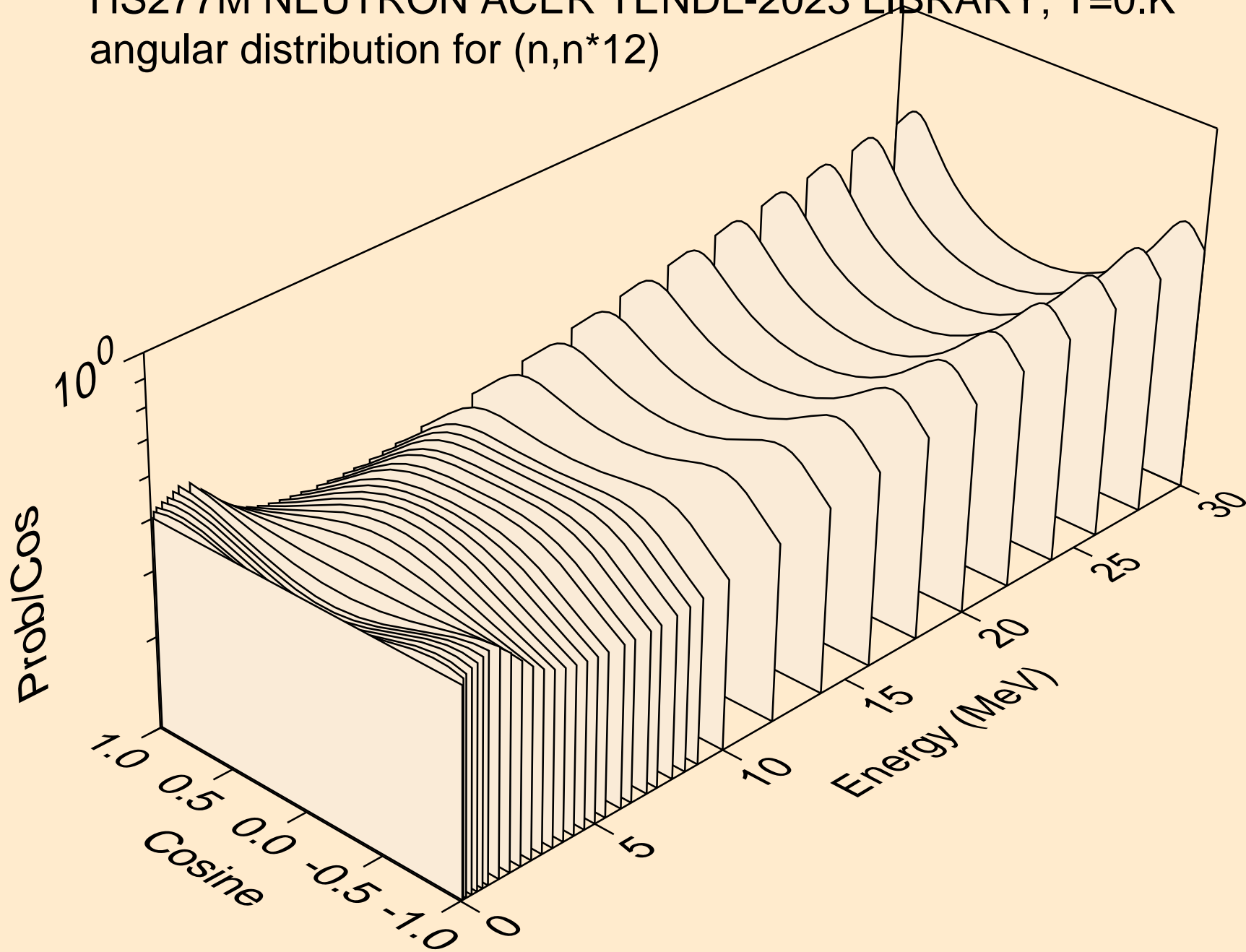

HS277M NEUTRON ACER TENDL-2023 LIBRARY; T=0.K
angular distribution for (n,n*13)

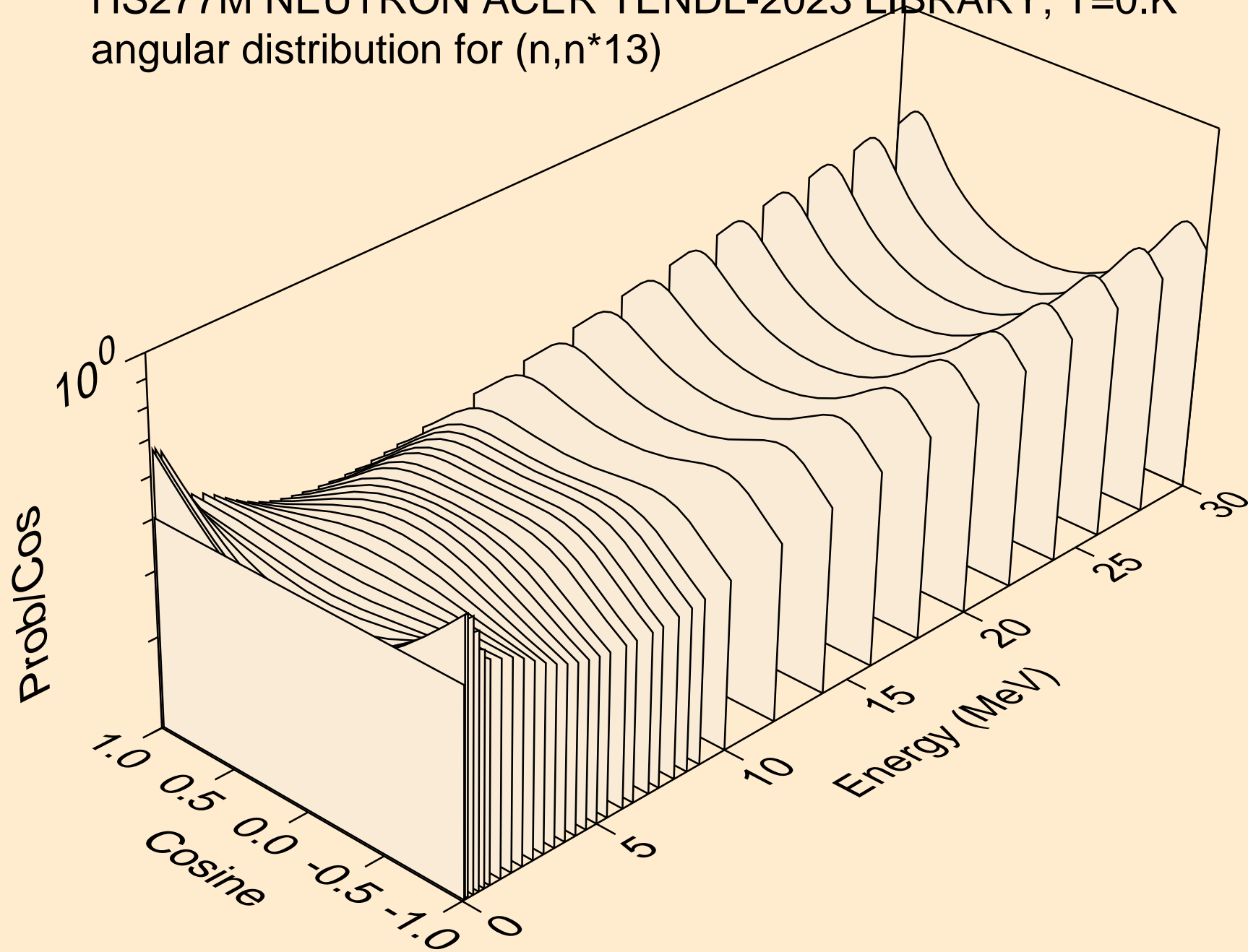

HS277M NEUTRON ACER TENDL-2023 LIBRARY; T=0.K
angular distribution for (n,n*14)

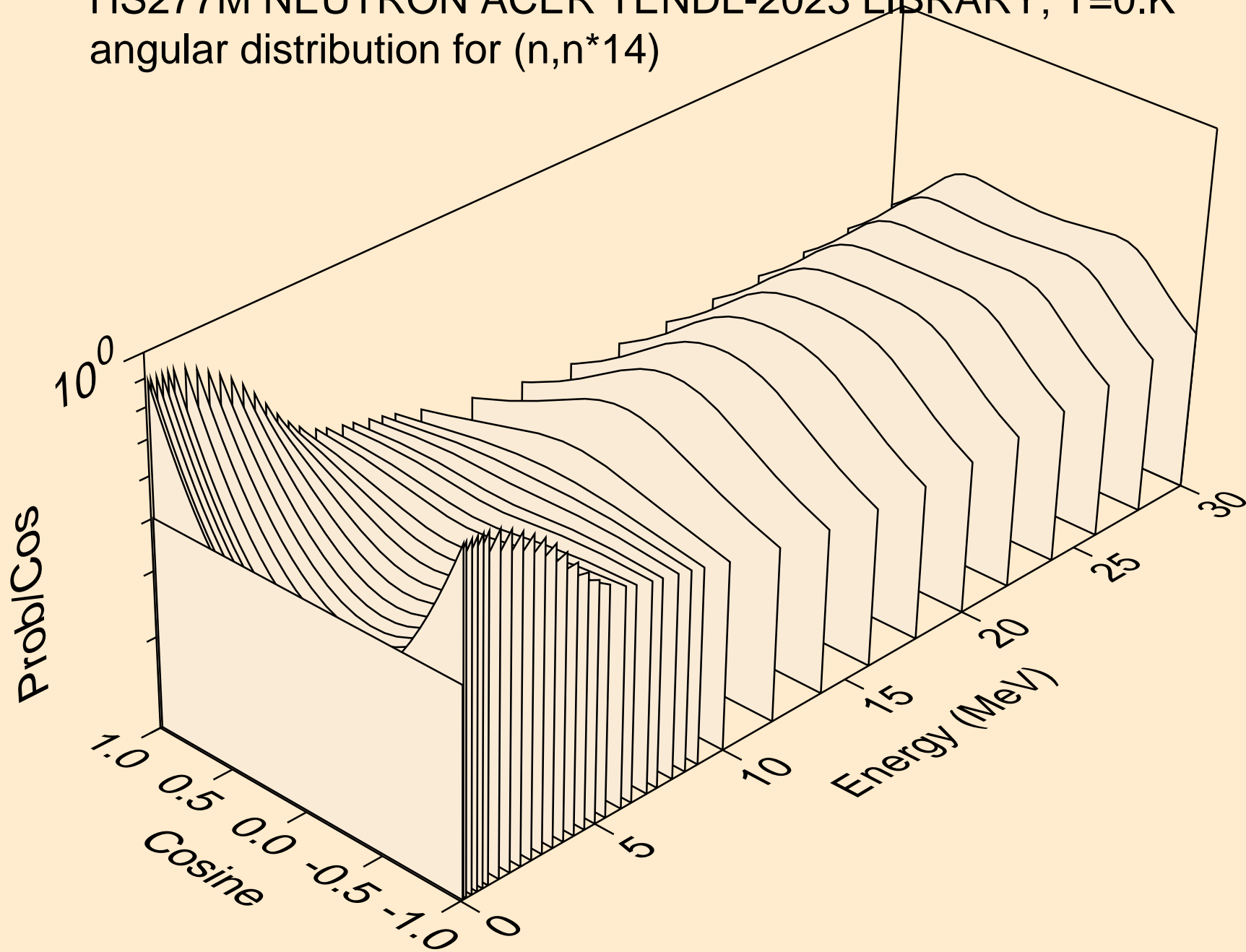

HS277M NEUTRON ACER TENDL-2023 LIBRARY; T=0.K
angular distribution for (n,n*15)

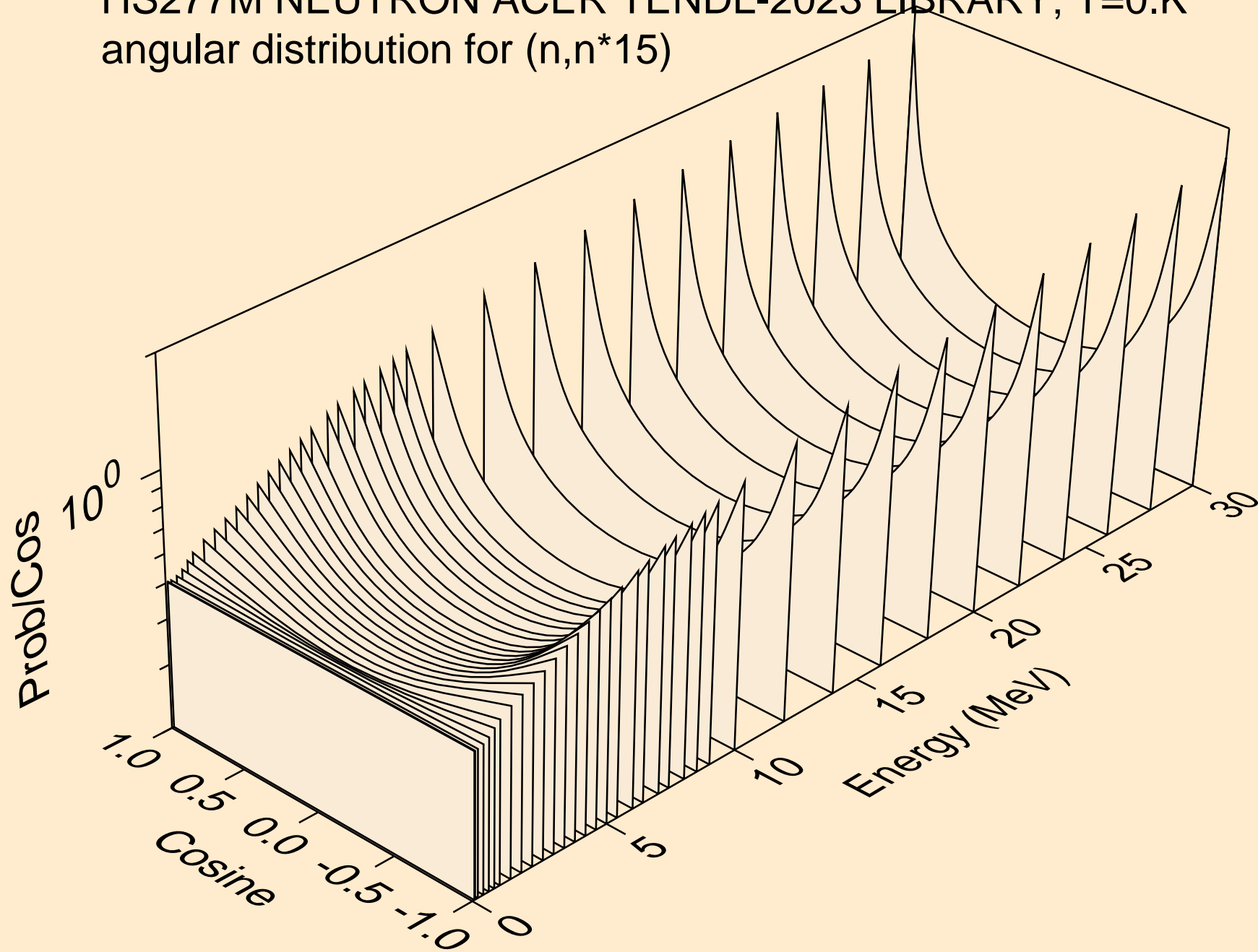

HS277M NEUTRON ACER TENDL-2023 LIBRARY; T=0.K
angular distribution for (n,n*16)

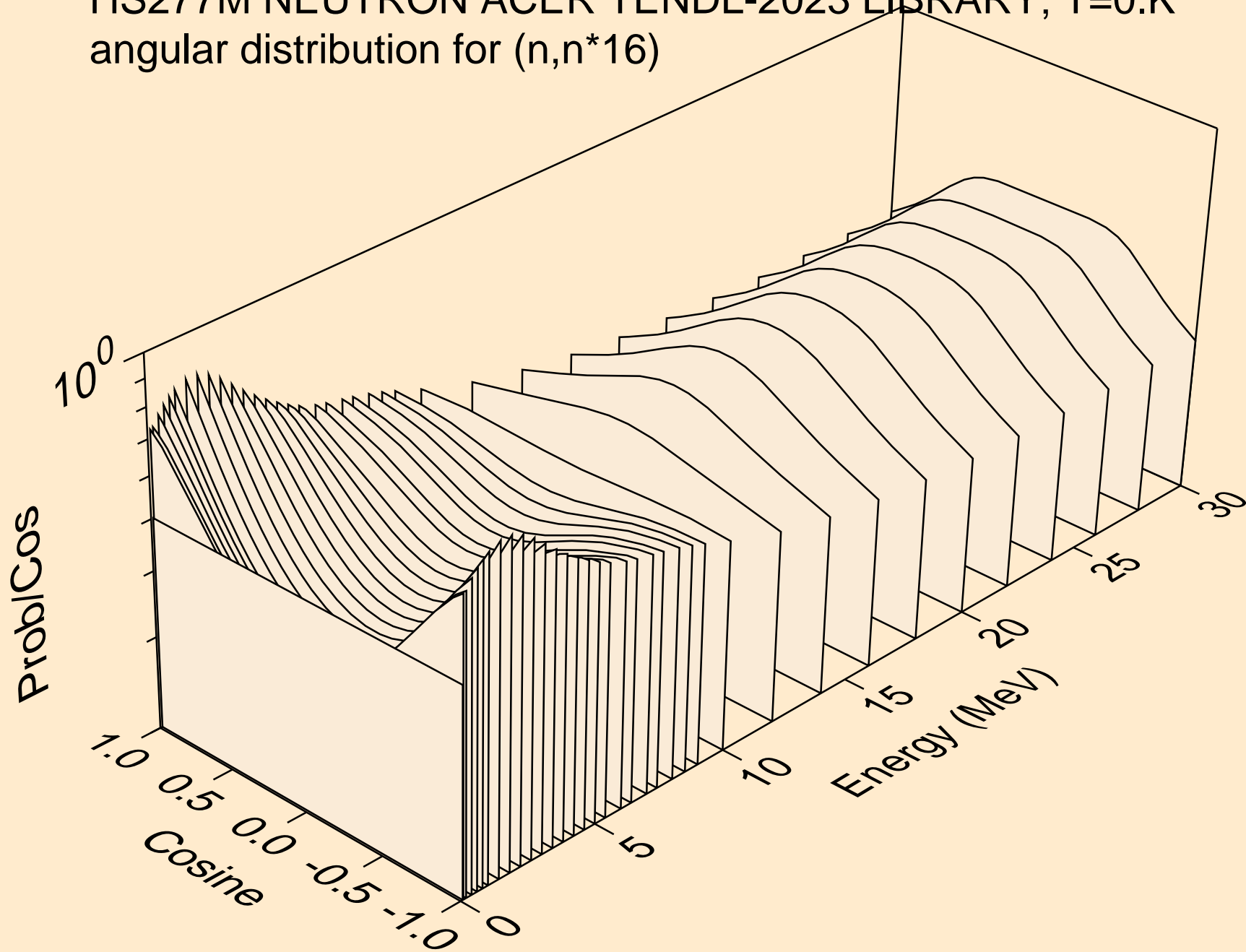

HS277M NEUTRON ACER TENDL-2023 LIBRARY; T=0.K
angular distribution for (n,n*17)

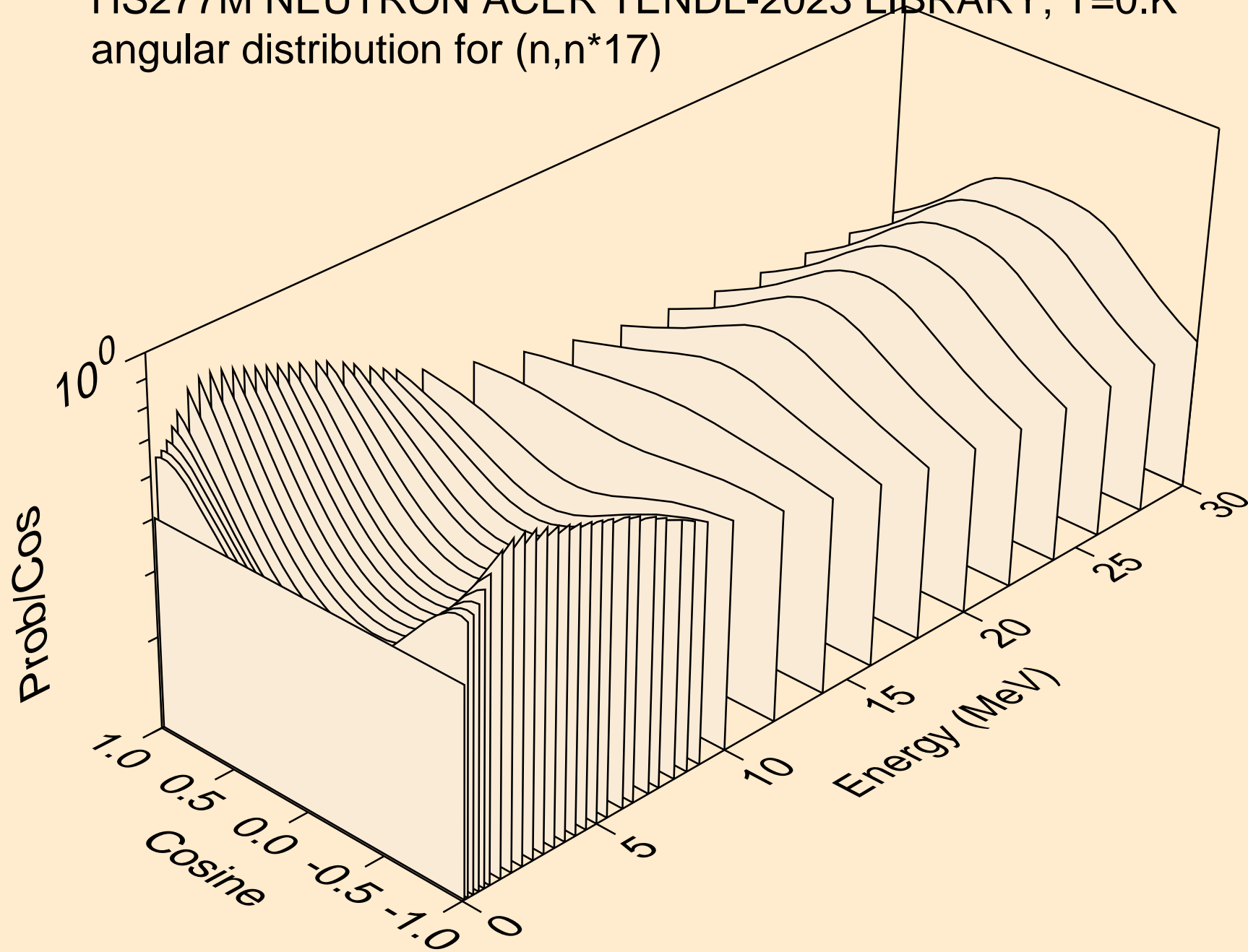

HS277M NEUTRON ACER TENDL-2023 LIBRARY; T=0.K
angular distribution for (n,n*18)

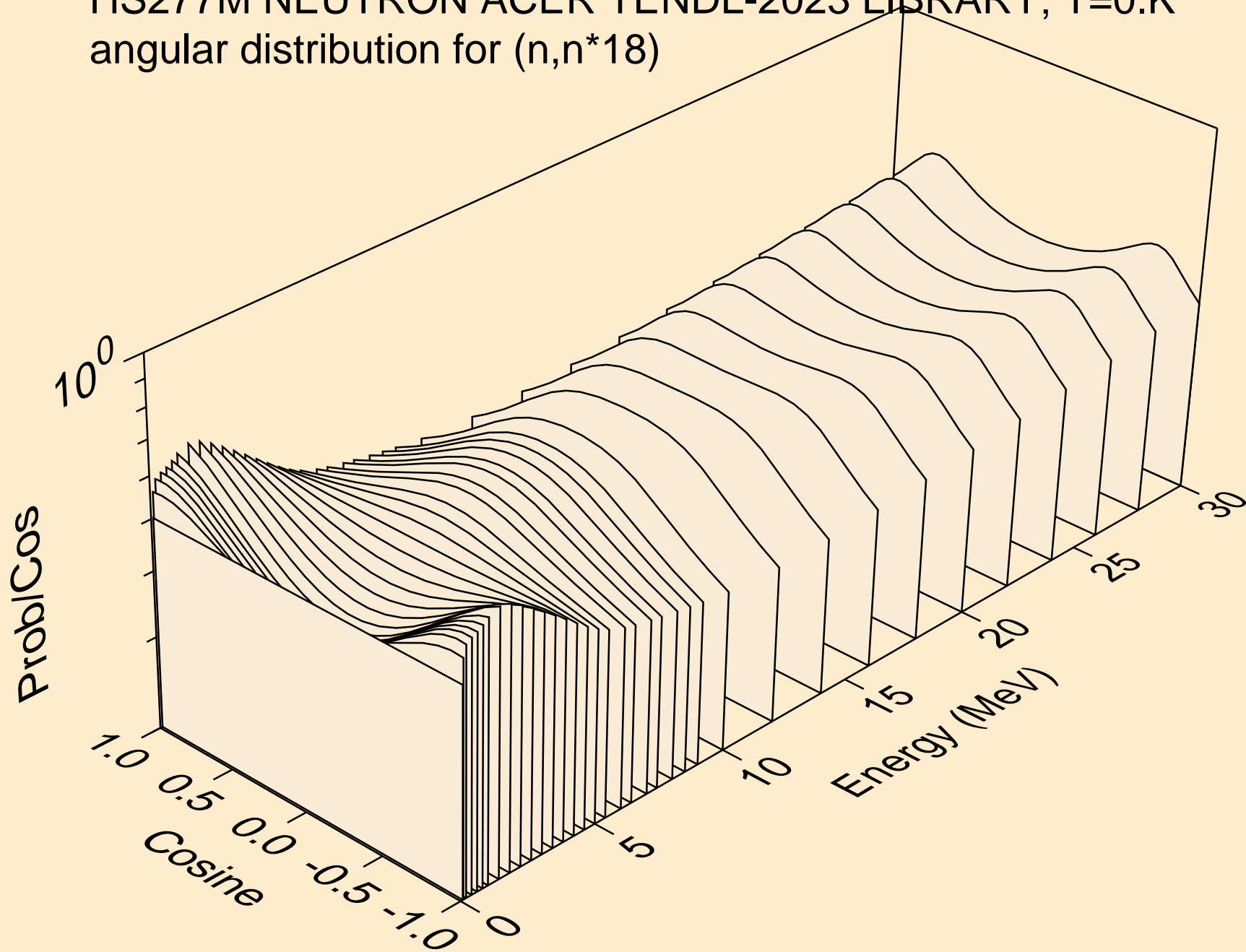

HS277M NEUTRON ACER TENDL-2023 LIBRARY; T=0.K
angular distribution for (n,n*19)

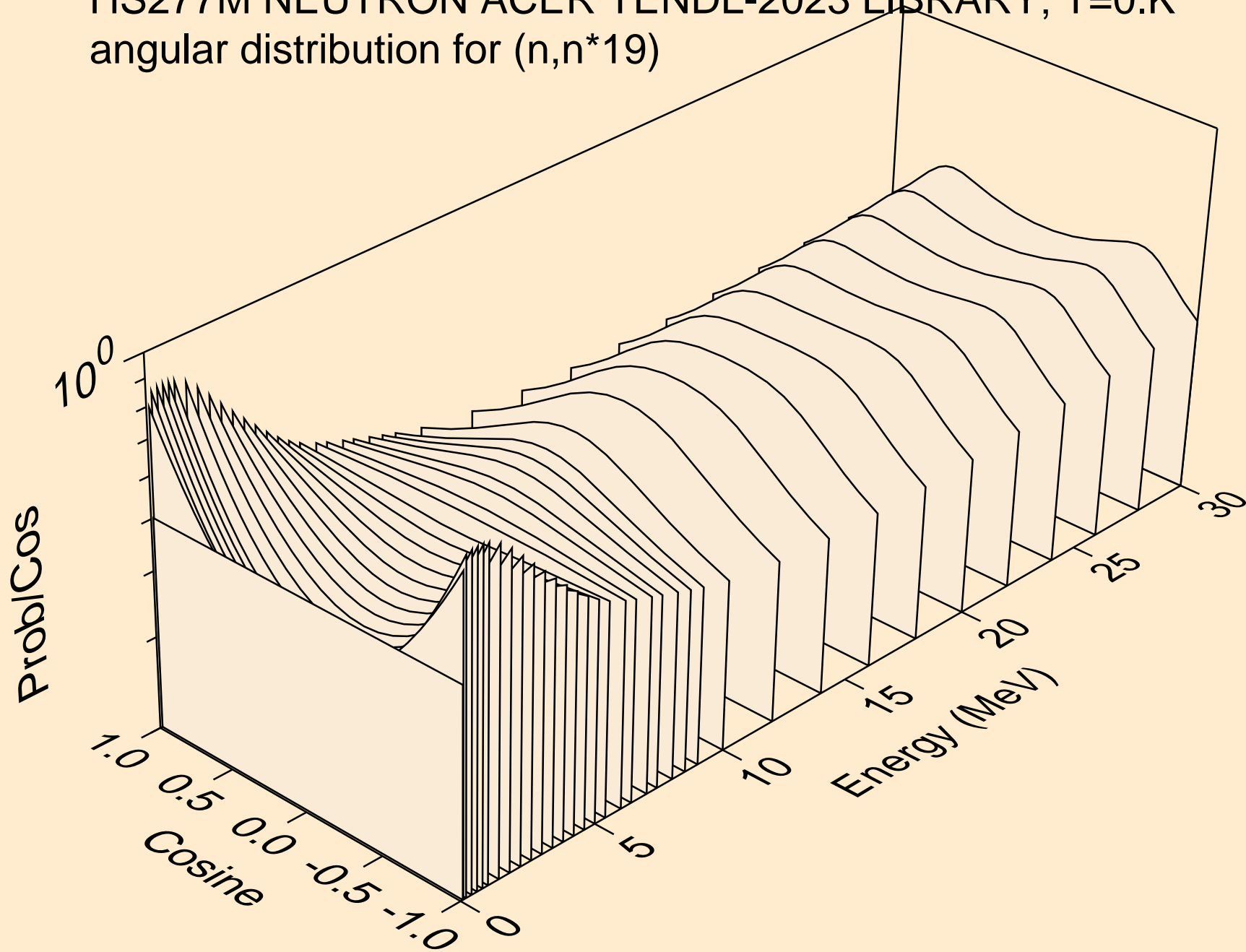

HS277M NEUTRON ACER TENDL-2023 LIBRARY; T=0.K
angular distribution for (n,n*20)

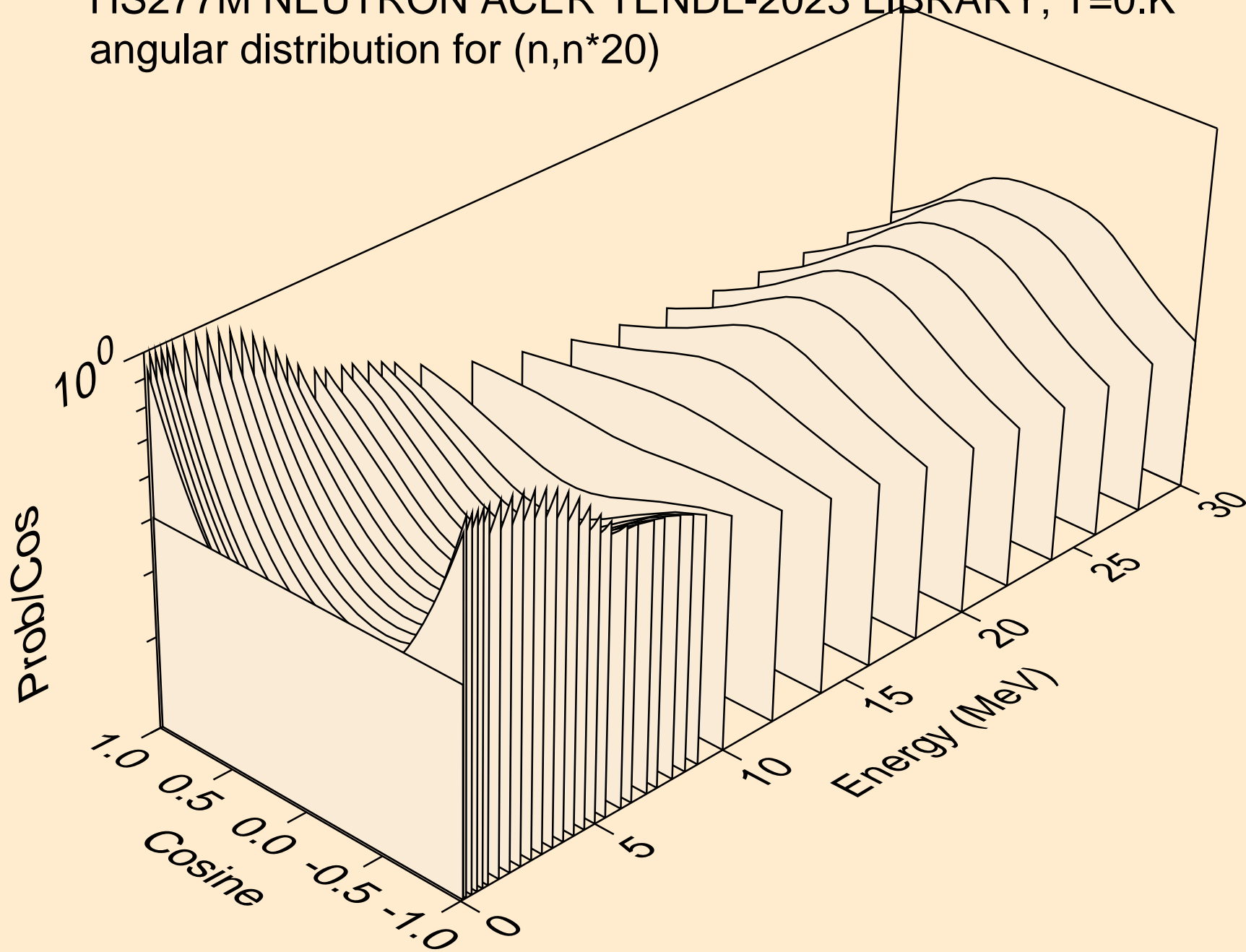

HS277M NEUTRON ACER TENDL-2023 LIBRARY; T=0.K
angular distribution for (n,n*21)

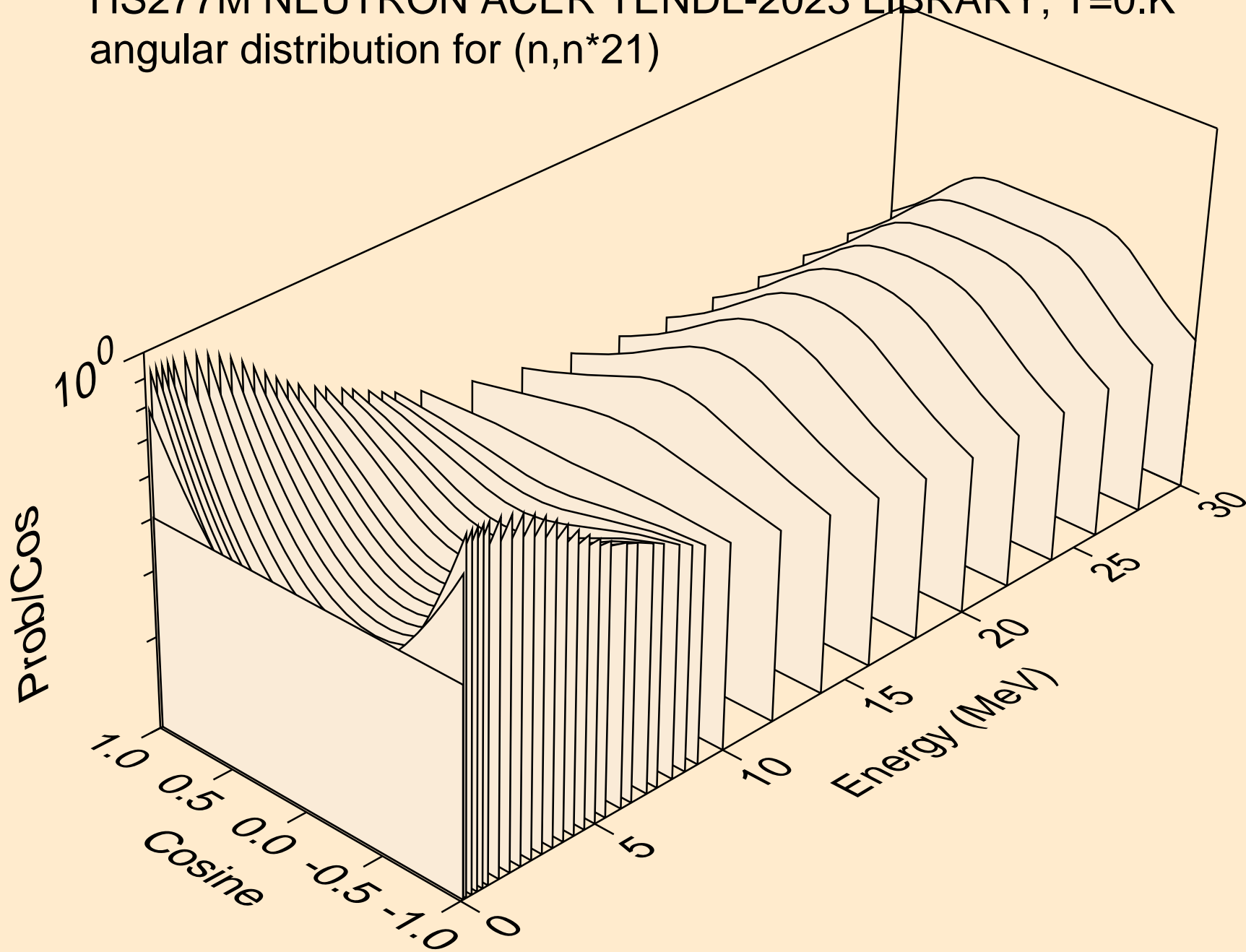

HS277M NEUTRON ACER TENDL-2023 LIBRARY; T=0.K
angular distribution for (n,n*22)

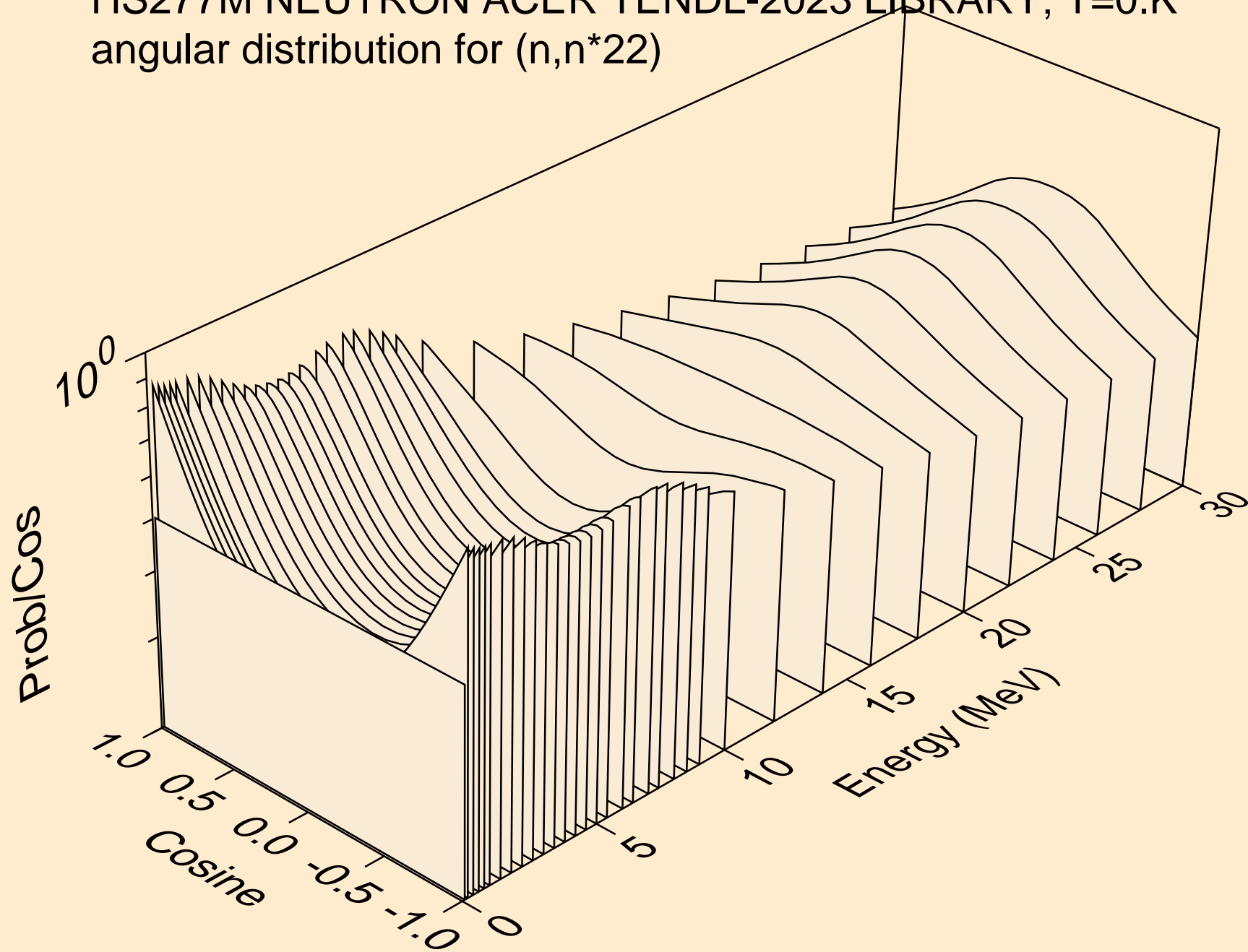

HS277M NEUTRON ACER TENDL-2023 LIBRARY; T=0.K
angular distribution for (n,n*23)

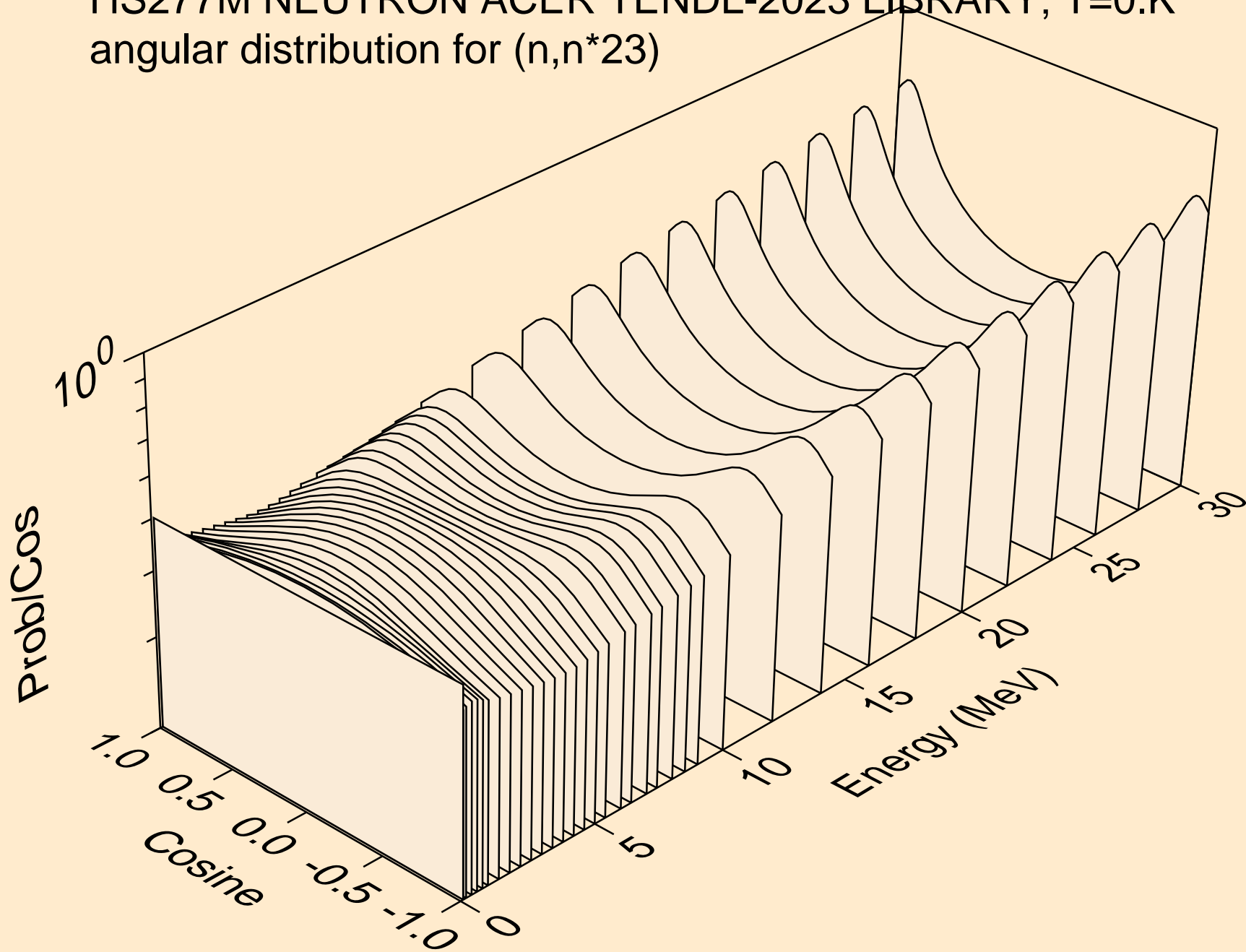

HS277M NEUTRON ACER TENDL-2023 LIBRARY; T=0.K
angular distribution for (n,n*24)

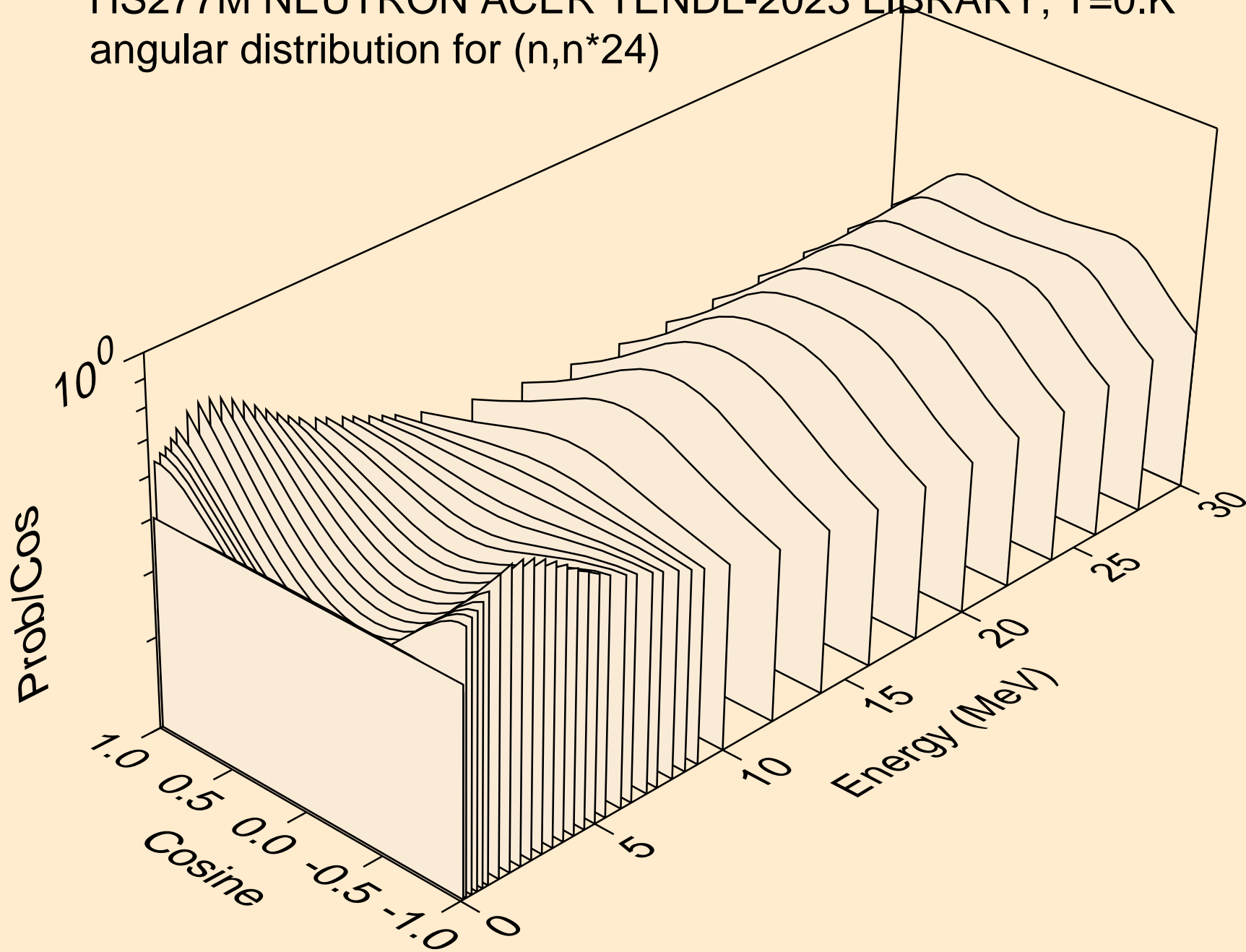

HS277M NEUTRON ACER TENDL-2023 LIBRARY; T=0.K
angular distribution for (n,n*25)

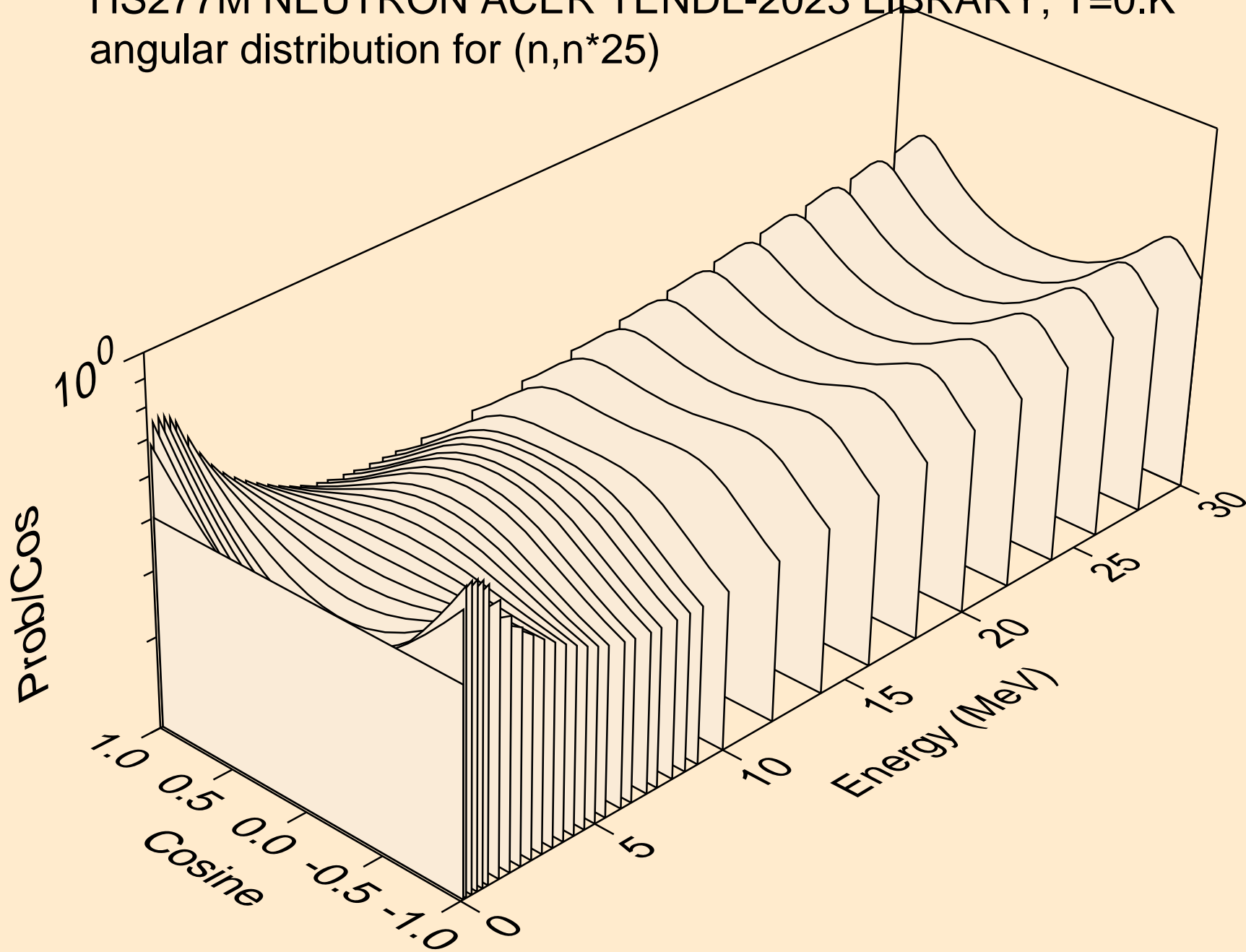

HS277M NEUTRON ACER TENDL-2023 LIBRARY; T=0.K
angular distribution for (n,n*26)

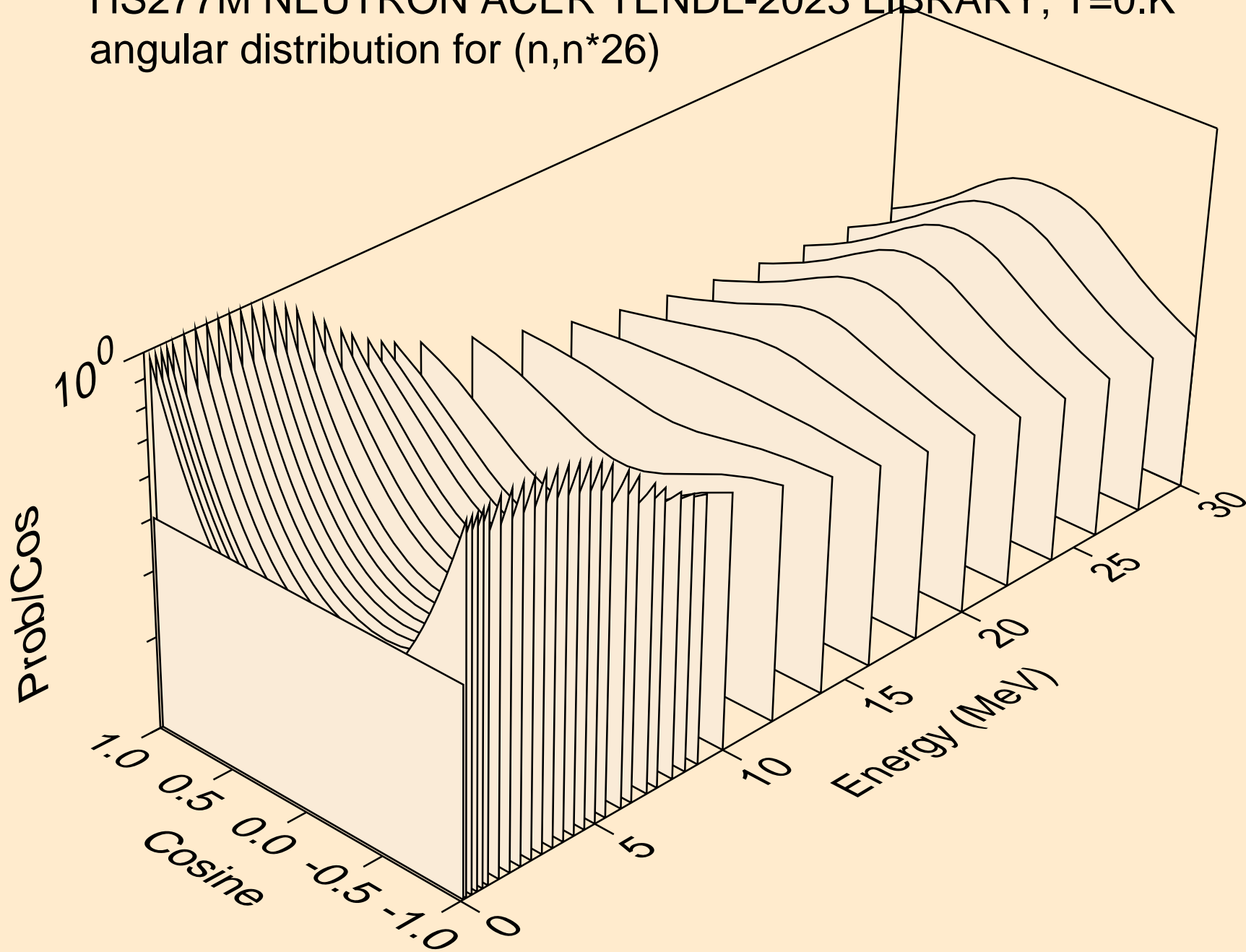

HS277M NEUTRON ACER TENDL-2023 LIBRARY; T=0.K
angular distribution for (n,n*27)

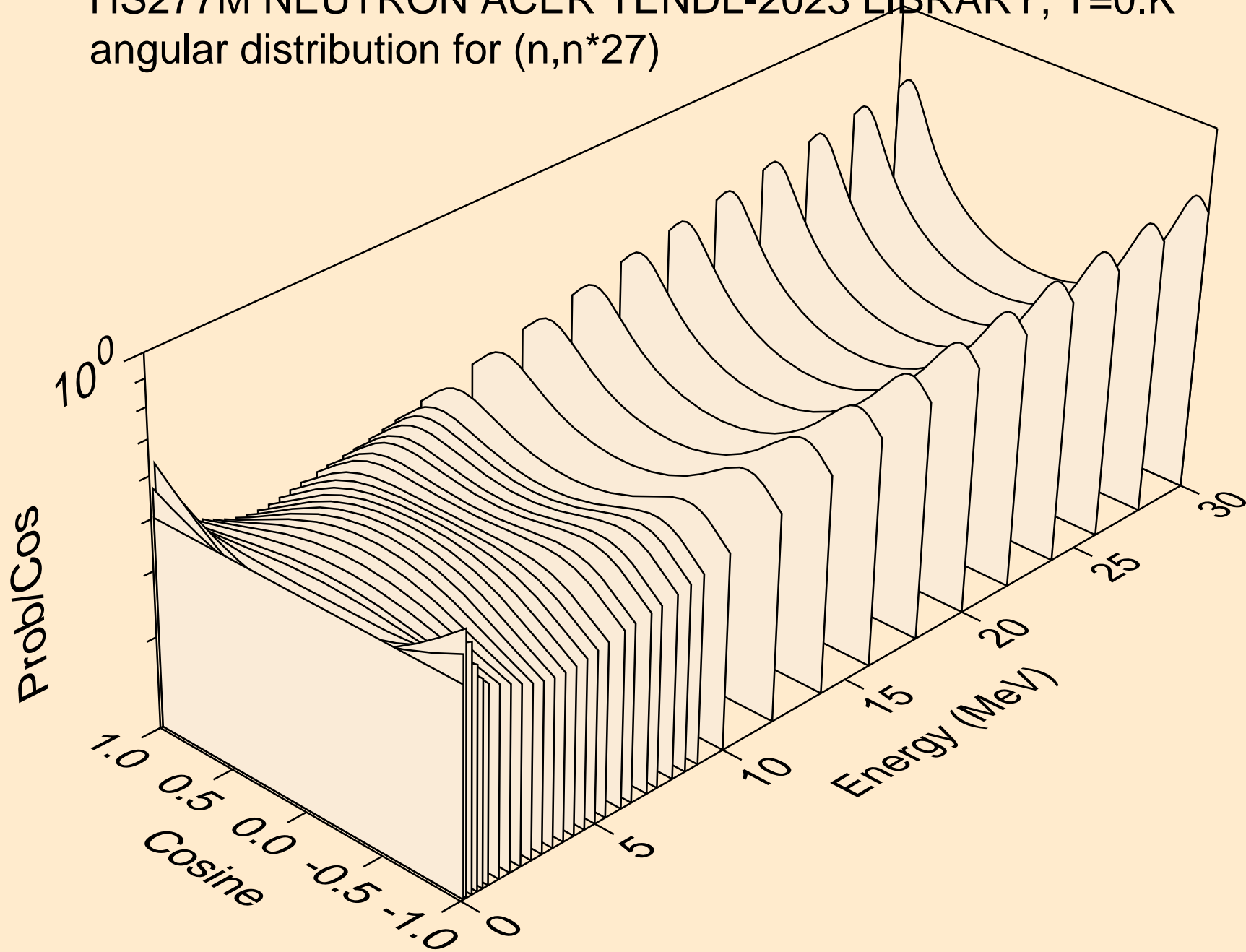

HS277M NEUTRON ACER TENDL-2023 LIBRARY; T=0.K
angular distribution for (n,n*28)

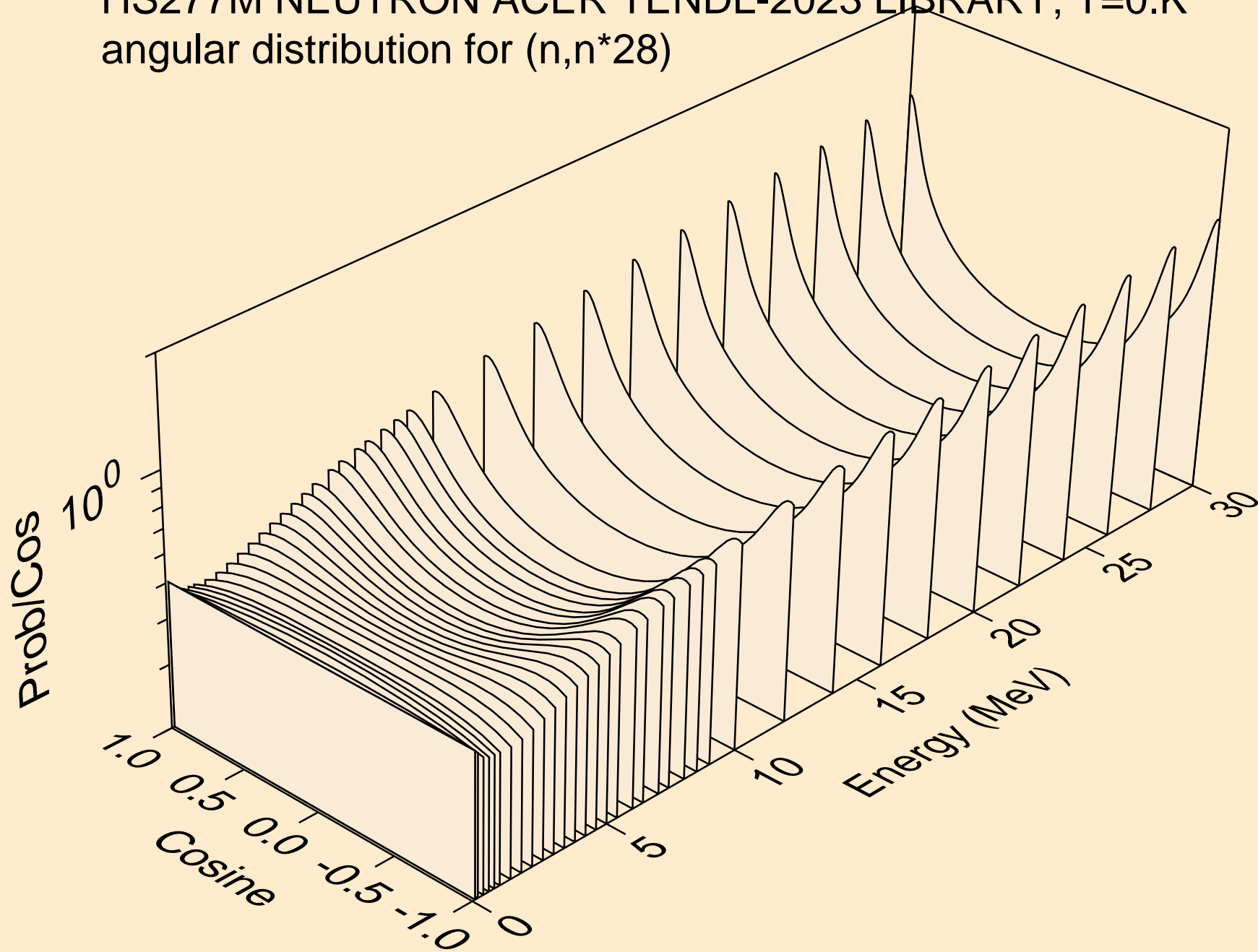

HS277M NEUTRON ACER TENDL-2023 LIBRARY; T=0.K
angular distribution for (n,n*29)

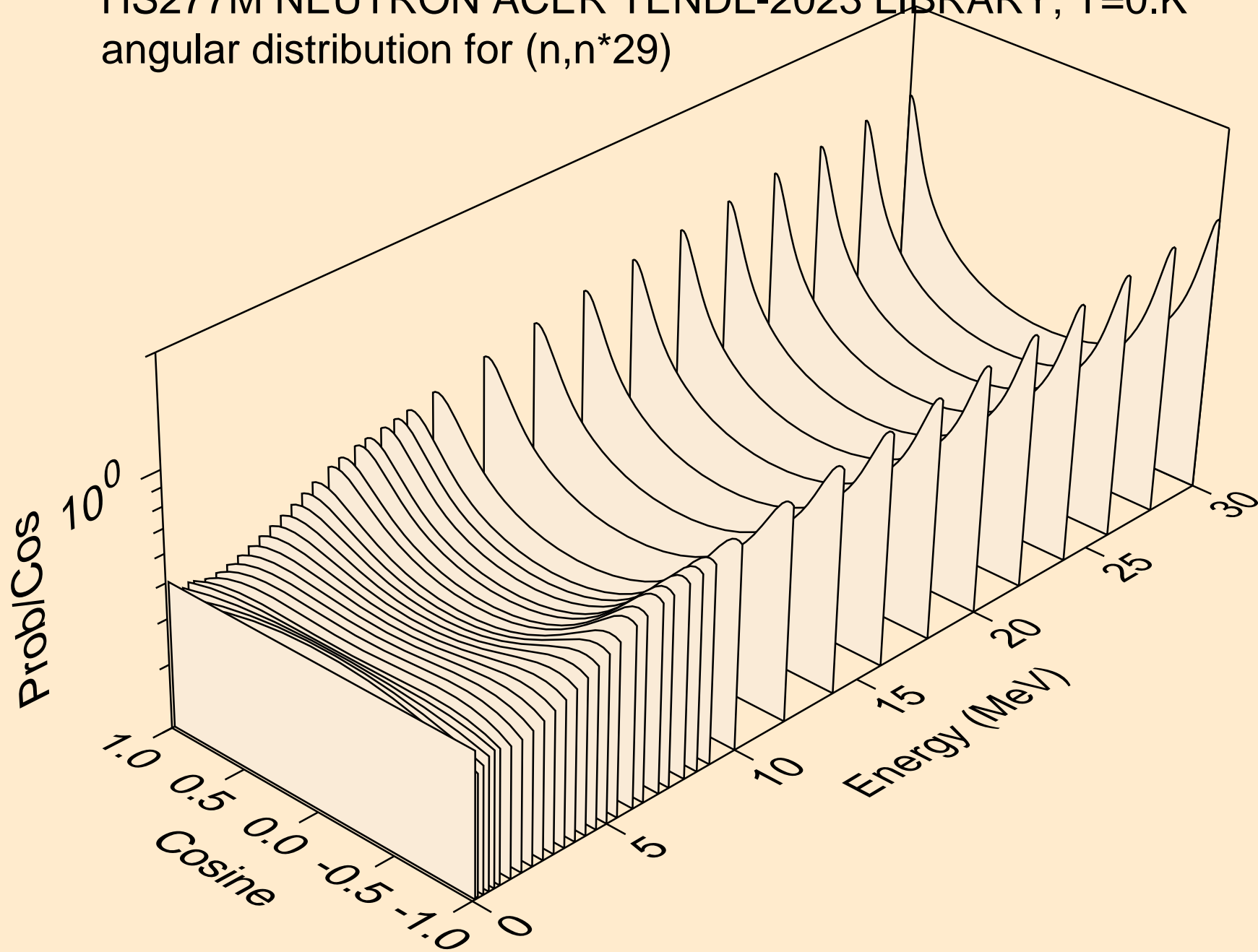

HS277M NEUTRON ACER TENDL-2023 LIBRARY; T=0.K
Total fission nubar

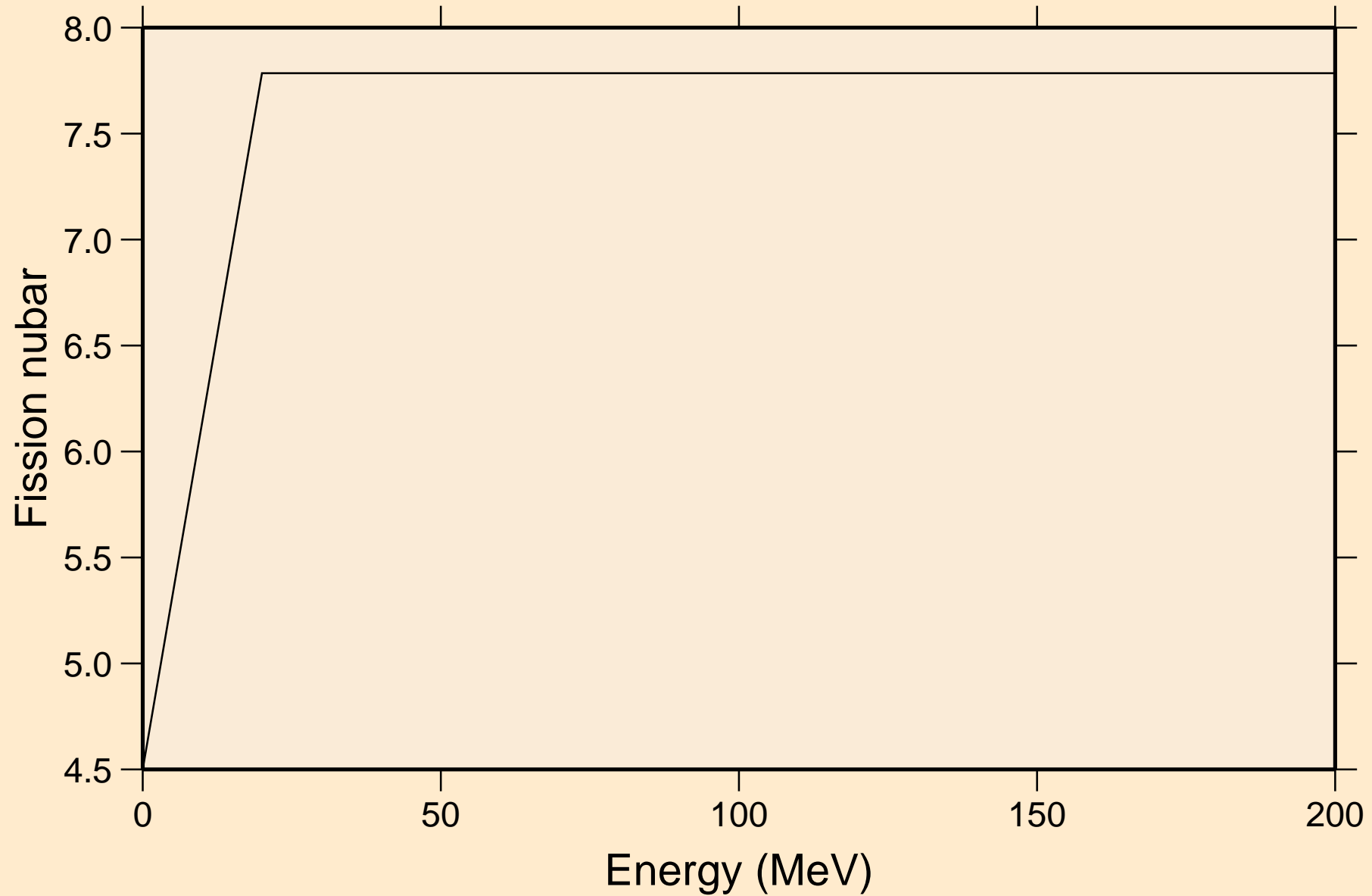

HS277M NEUTRON ACER TENDL-2023 LIBRARY; T=0.K
Neutron emission for (n,x)

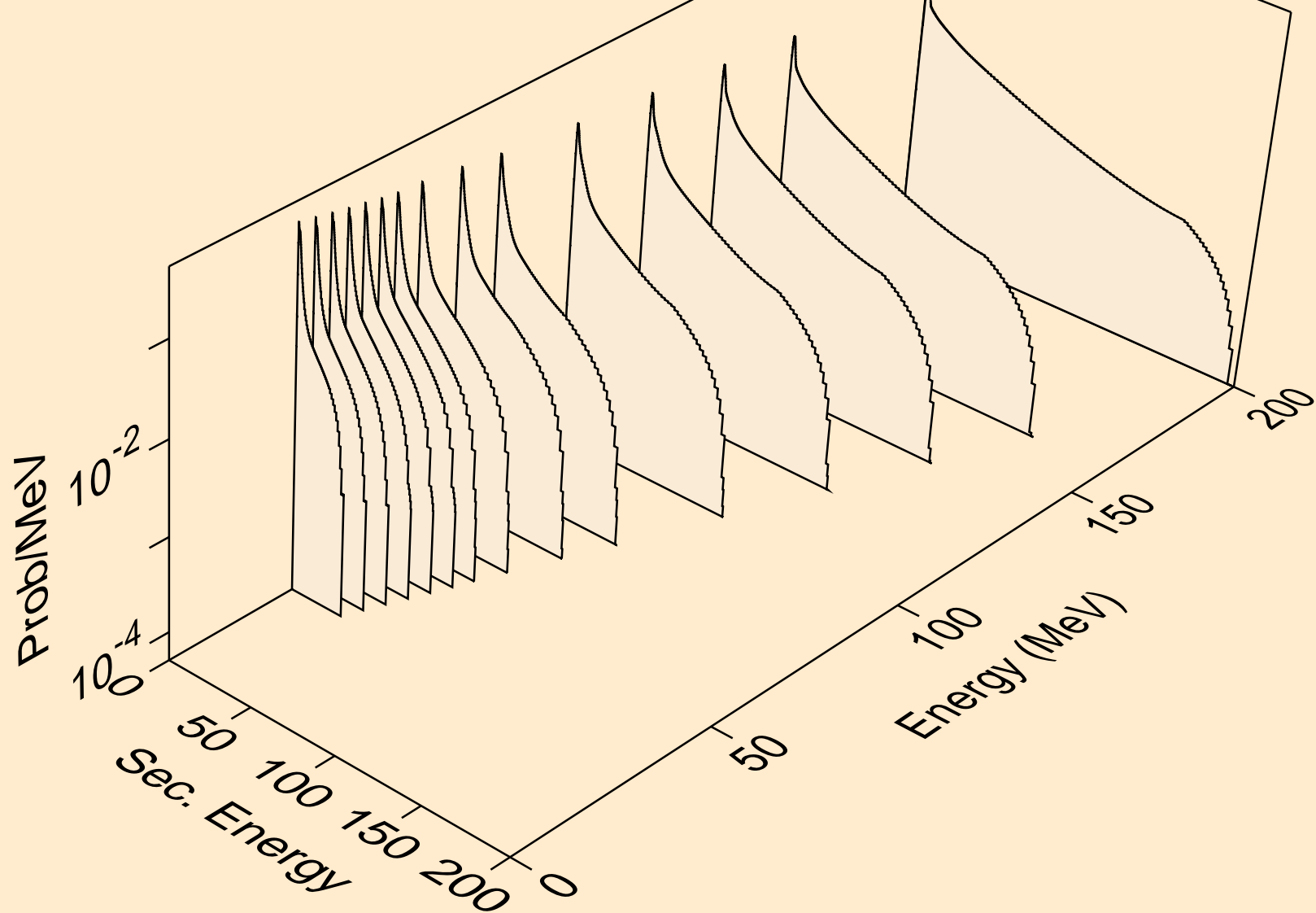

HS277M NEUTRON ACER TENDL-2023 LIBRARY; T=0.K
Neutron emission for (n,2nd)

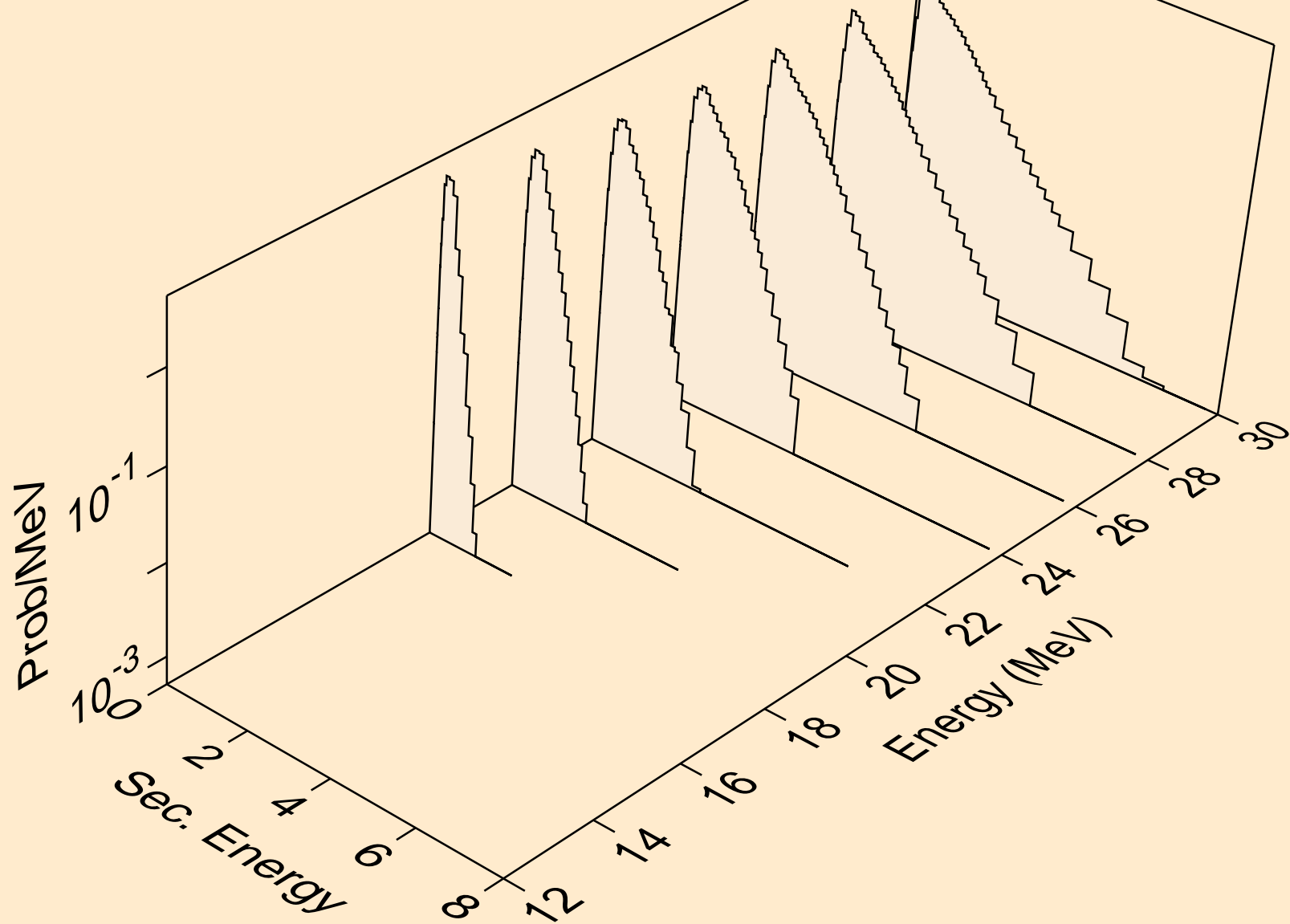

HS277M NEUTRON ACER TENDL-2023 LIBRARY; T=0.K
Neutron emission for (n,2n)

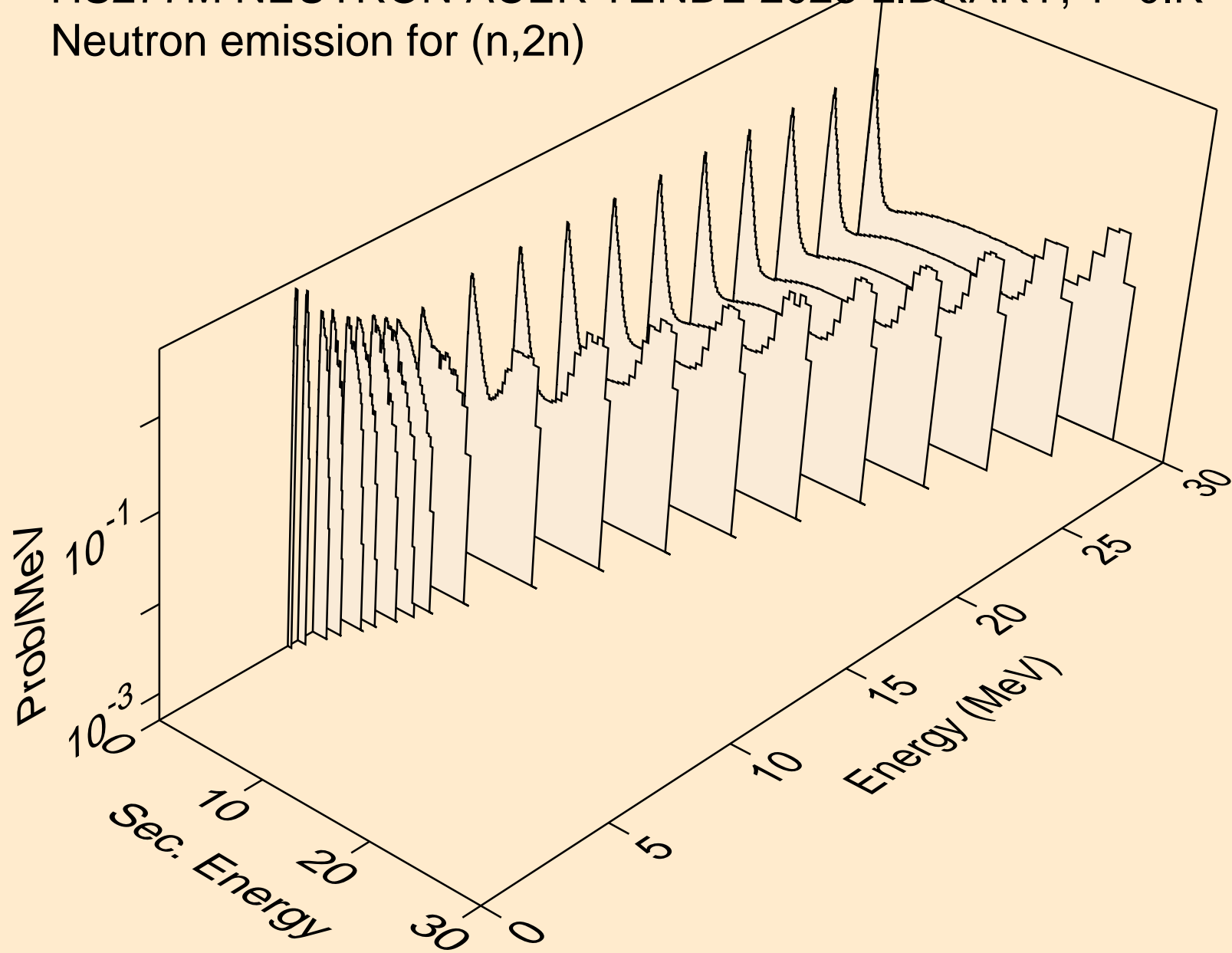

HS277M NEUTRON ACER TENDL-2023 LIBRARY; T=0.K
Neutron emission for (n,3n)

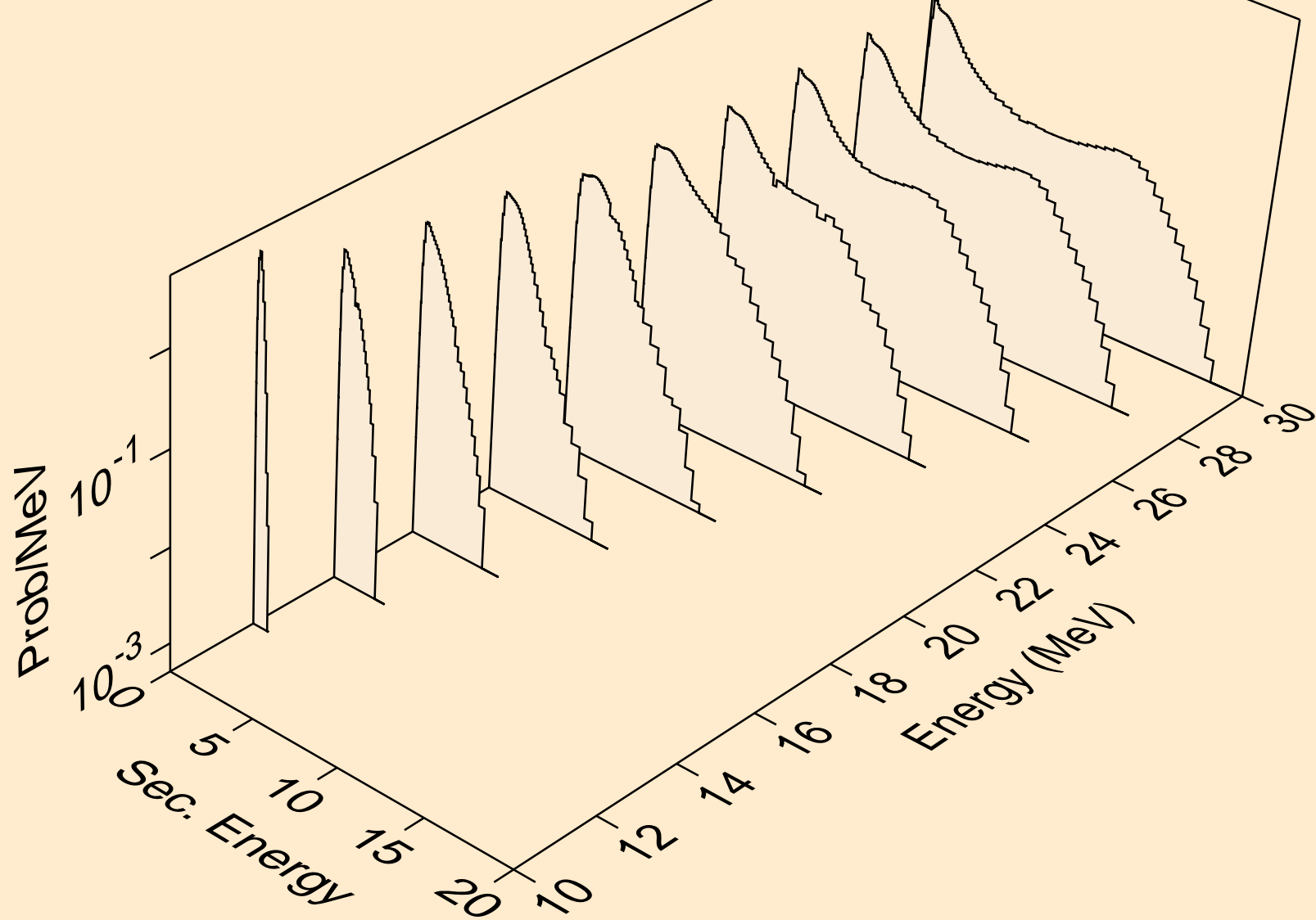

HS277M NEUTRON ACER TENDL-2023 LIBRARY; T=0.K
Neutron emission for fission

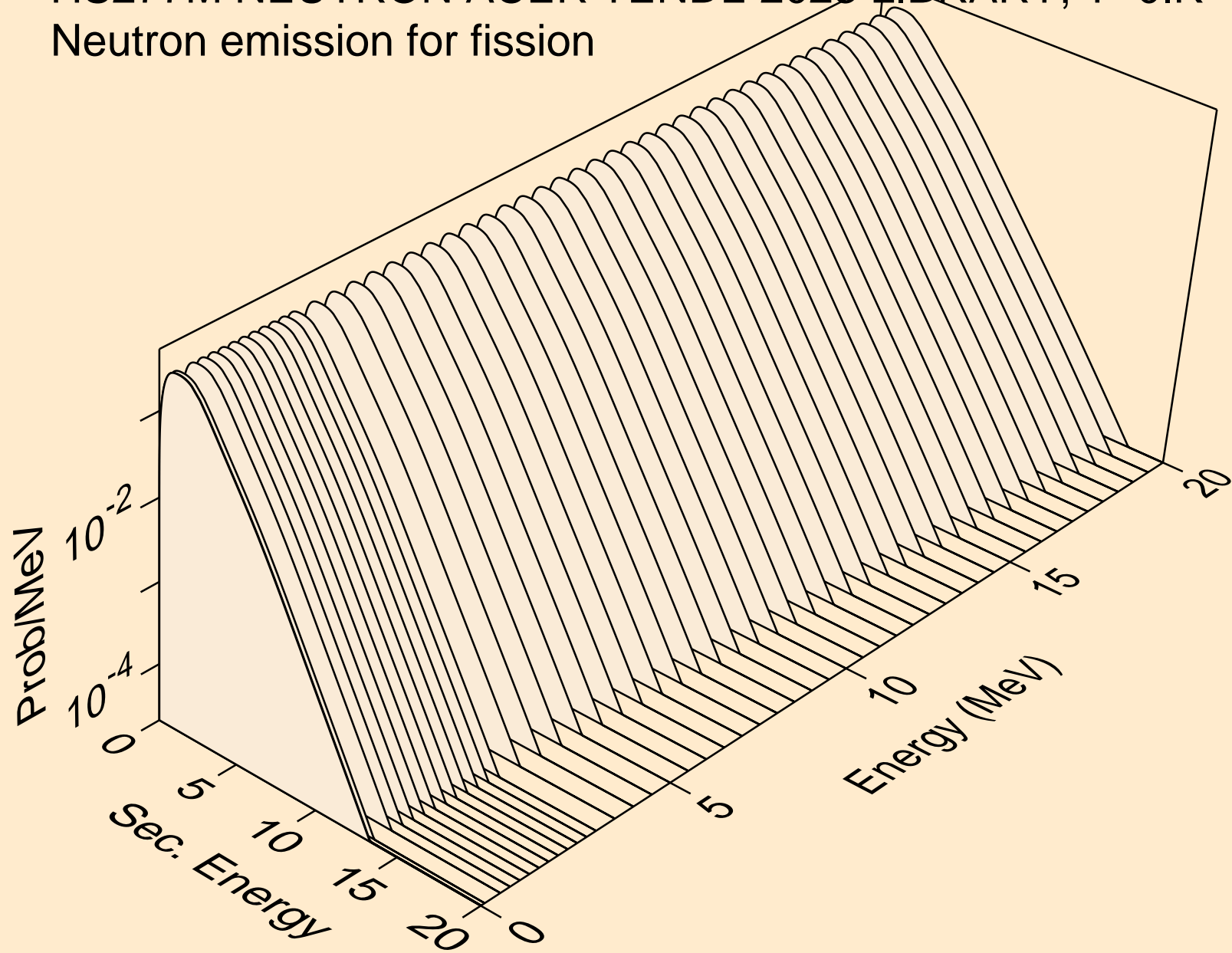

HS277M NEUTRON ACER TENDL-2023 LIBRARY; T=0.K
Neutron emission for (n,n*)a

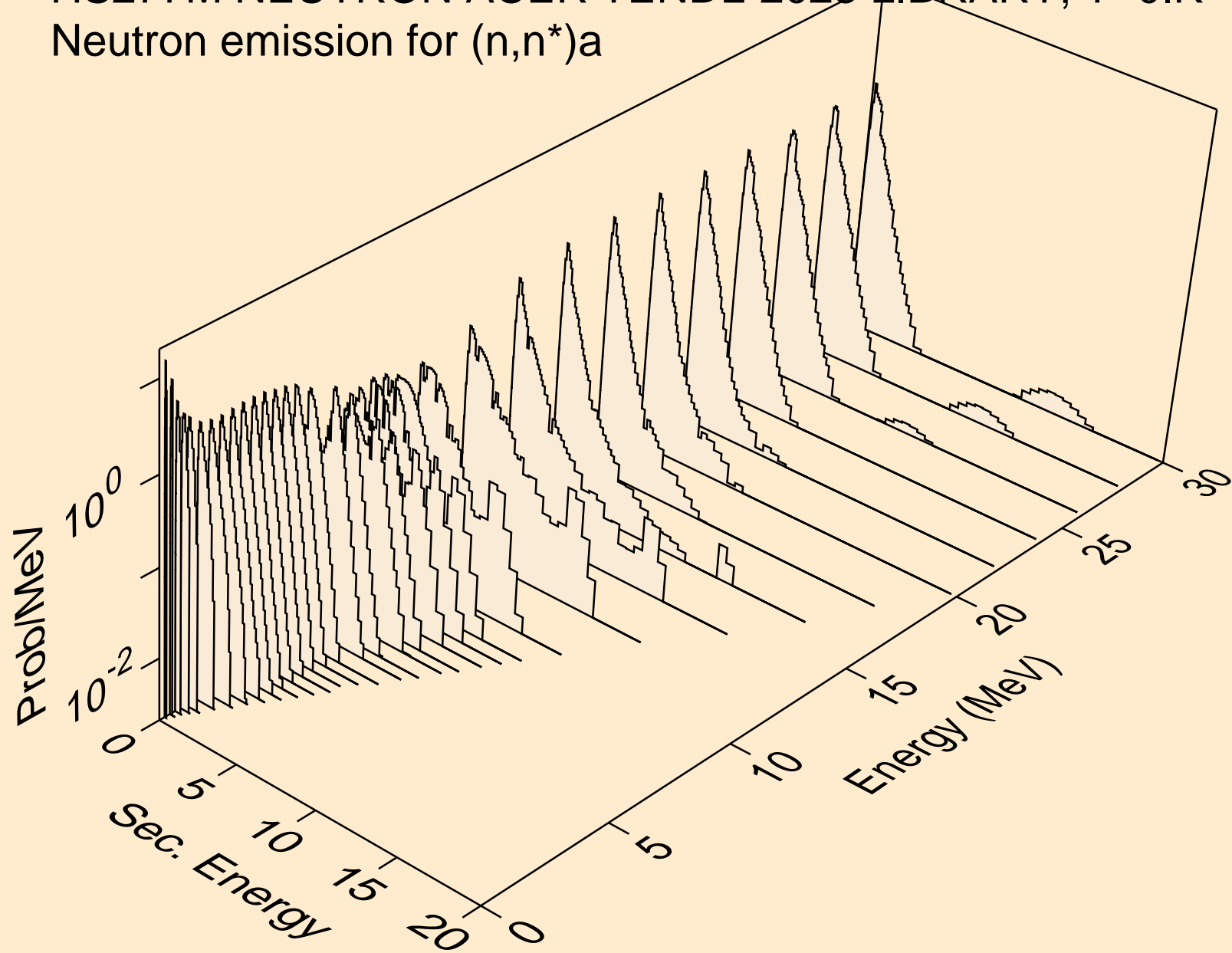

HS277M NEUTRON ACER TENDL-2023 LIBRARY; T=0.K
Neutron emission for (n,2n)a

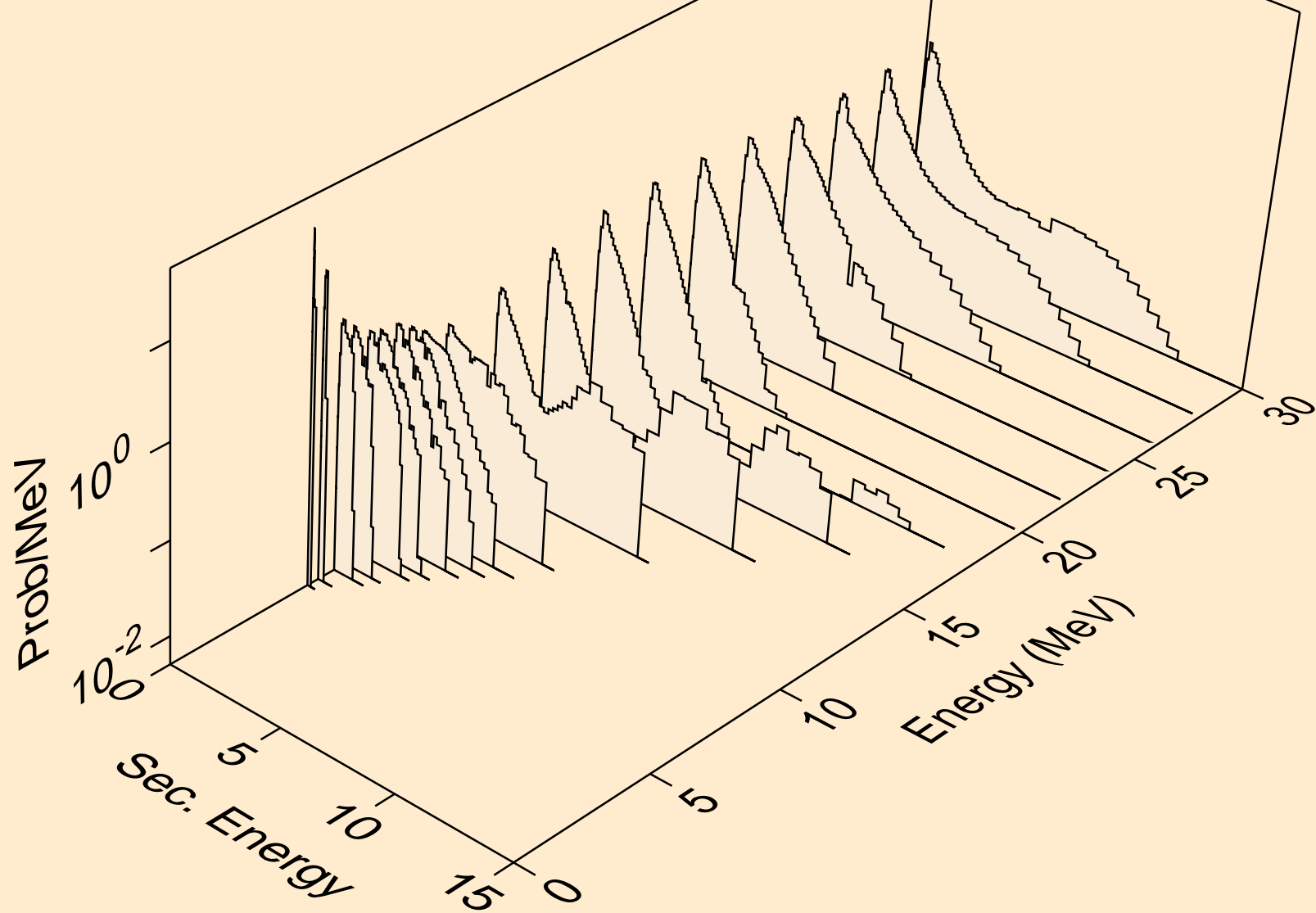

HS277M NEUTRON ACER TENDL-2023 LIBRARY; T=0.K
Neutron emission for (n,3n)a

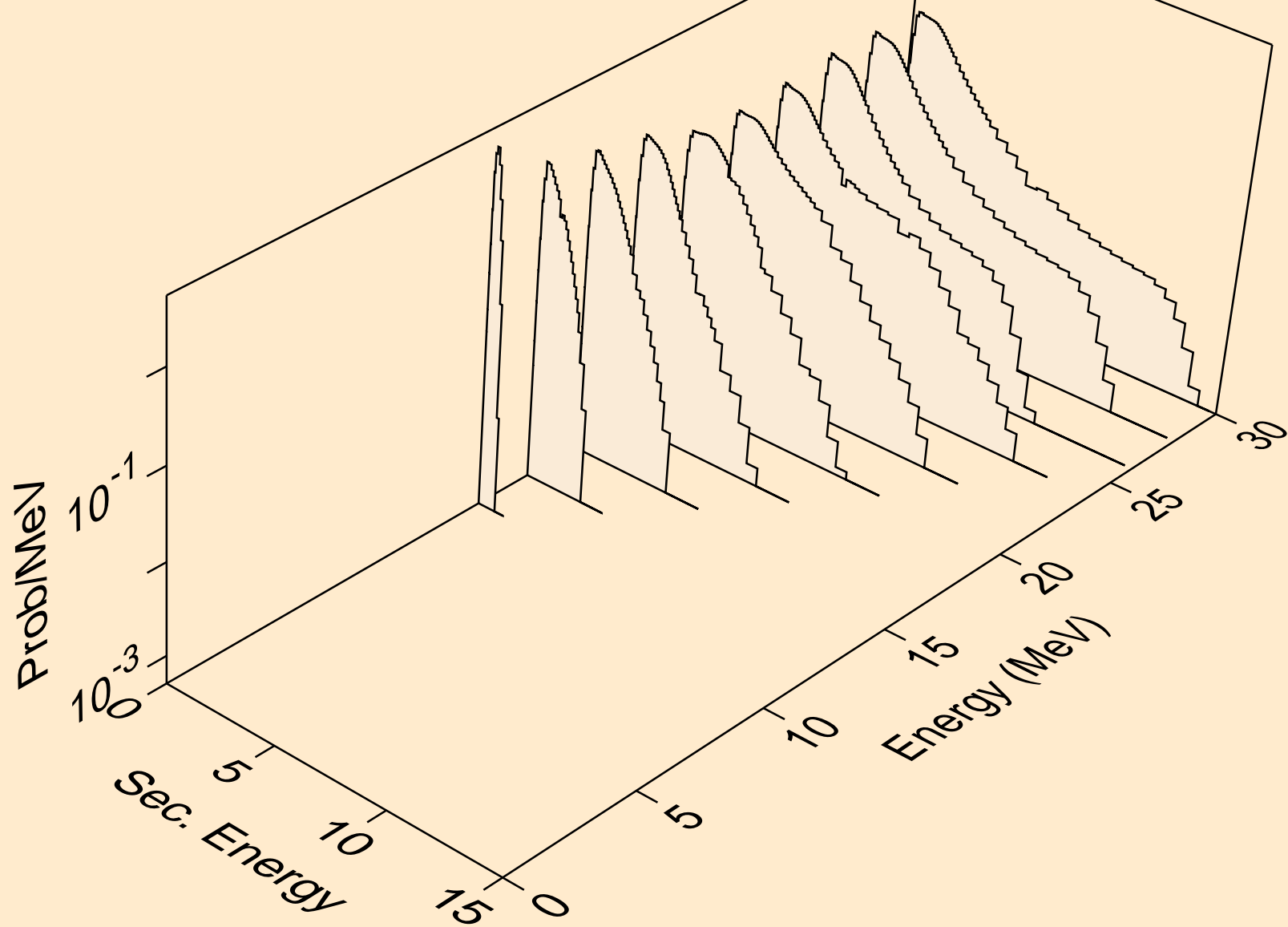

HS277M NEUTRON ACER TENDL-2023 LIBRARY; T=0.K
Neutron emission for (n,n*)p

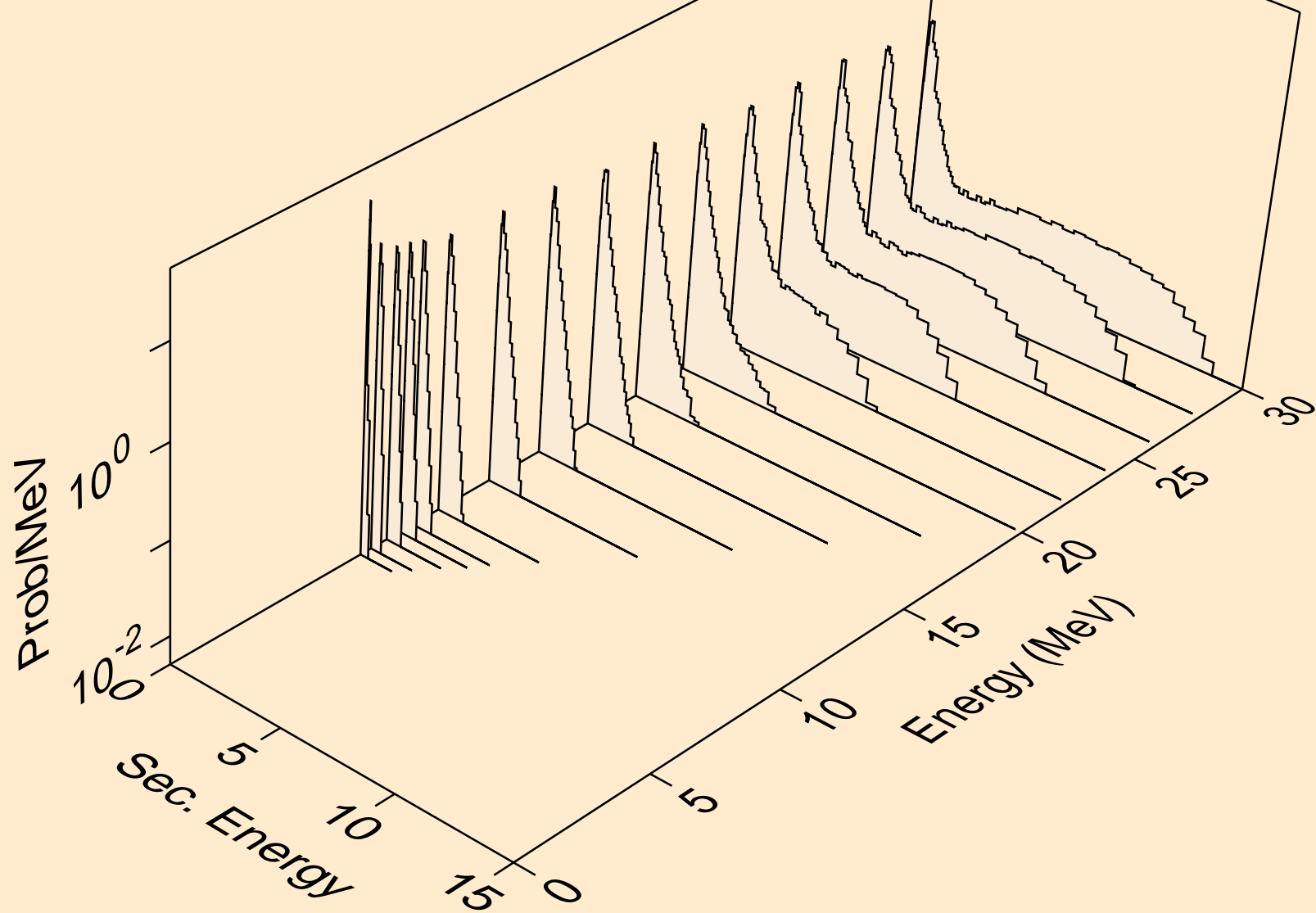

HS277M NEUTRON ACER TENDL-2023 LIBRARY; T=0.K
Neutron emission for (n,n*)d

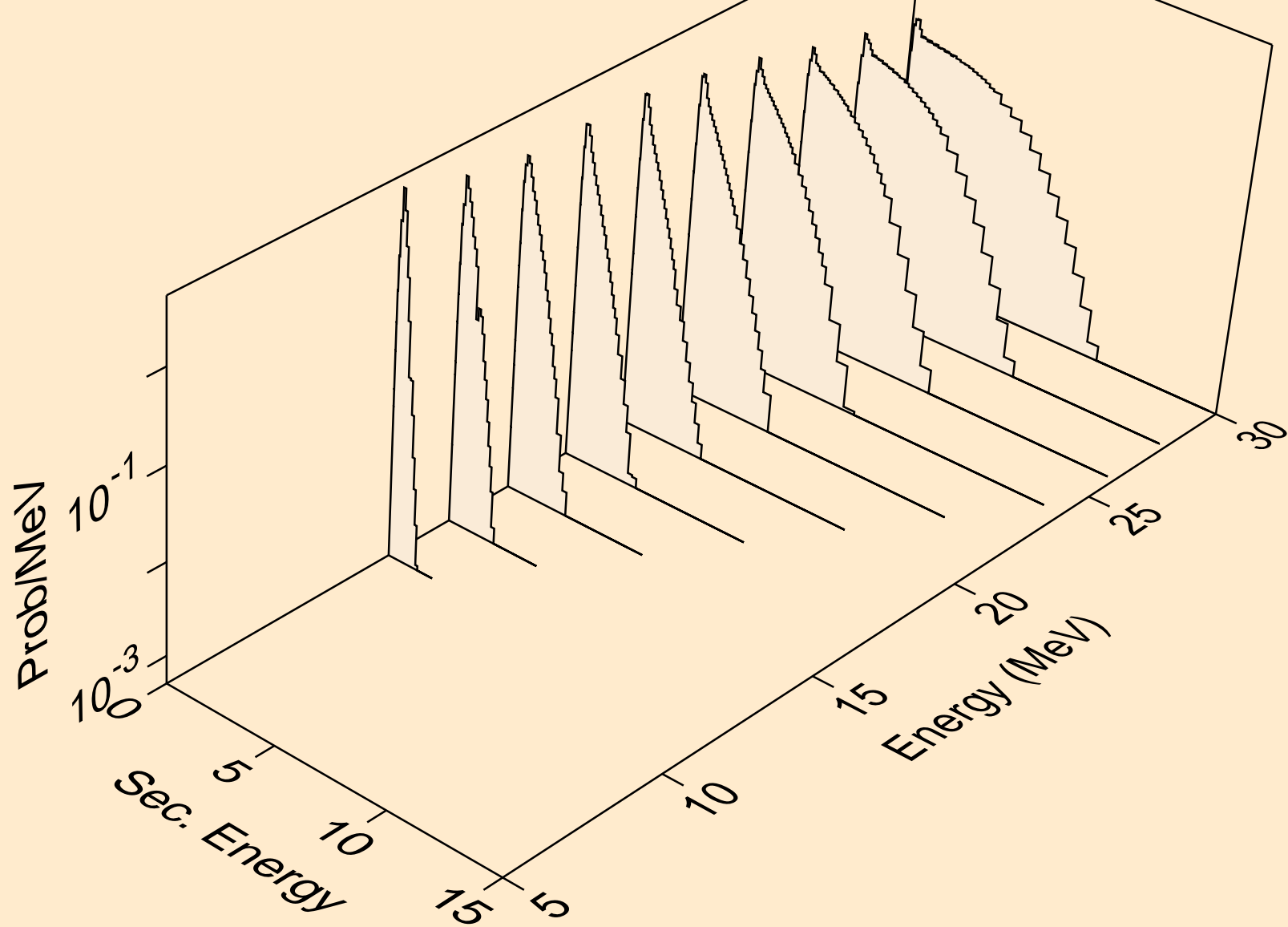

HS277M NEUTRON ACER TENDL-2023 LIBRARY; T=0.K
Neutron emission for (n,n*)t

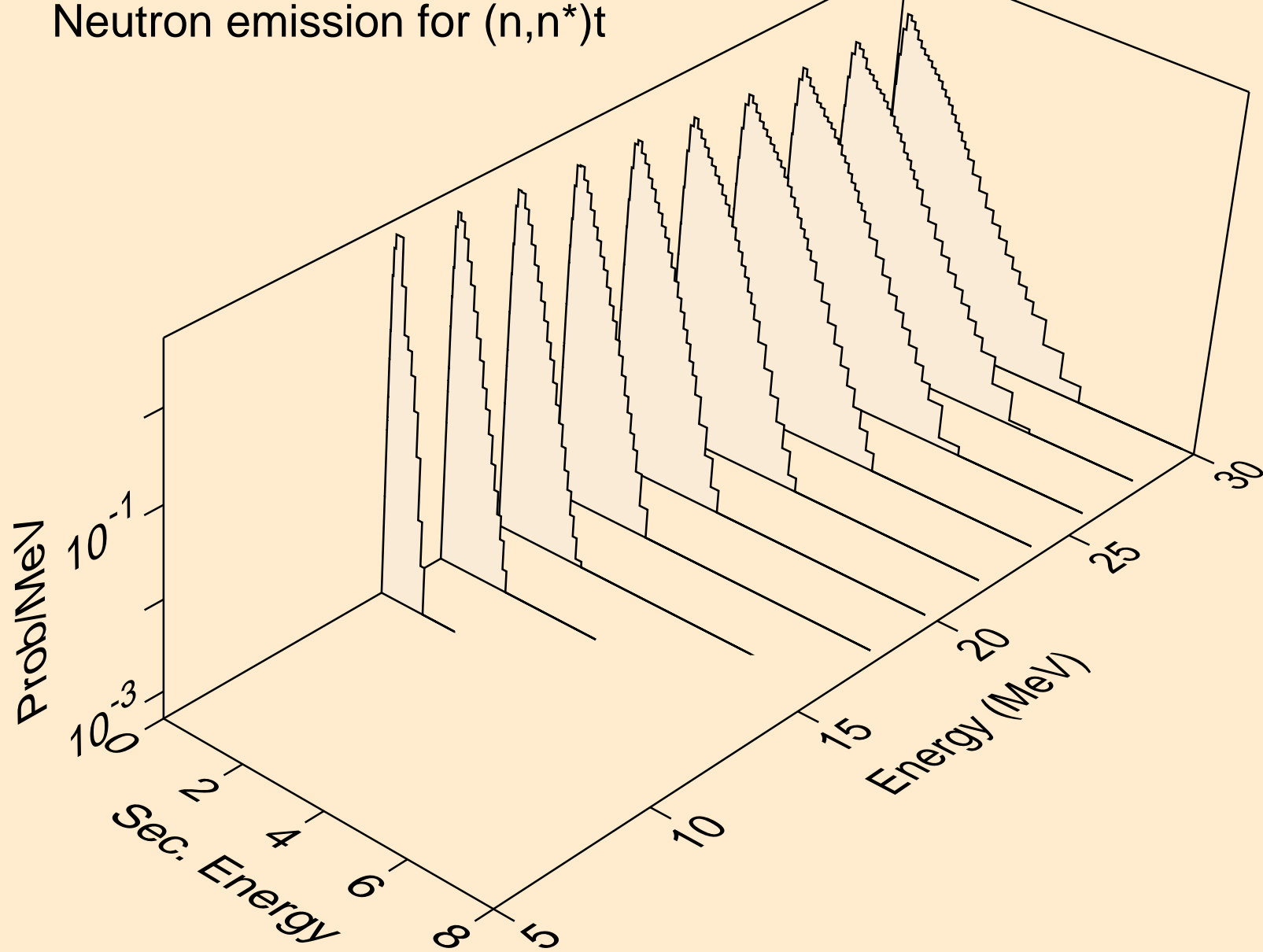

HS277M NEUTRON ACER TENDL-2023 LIBRARY; T=0.K
Neutron emission for (n,n*)he3

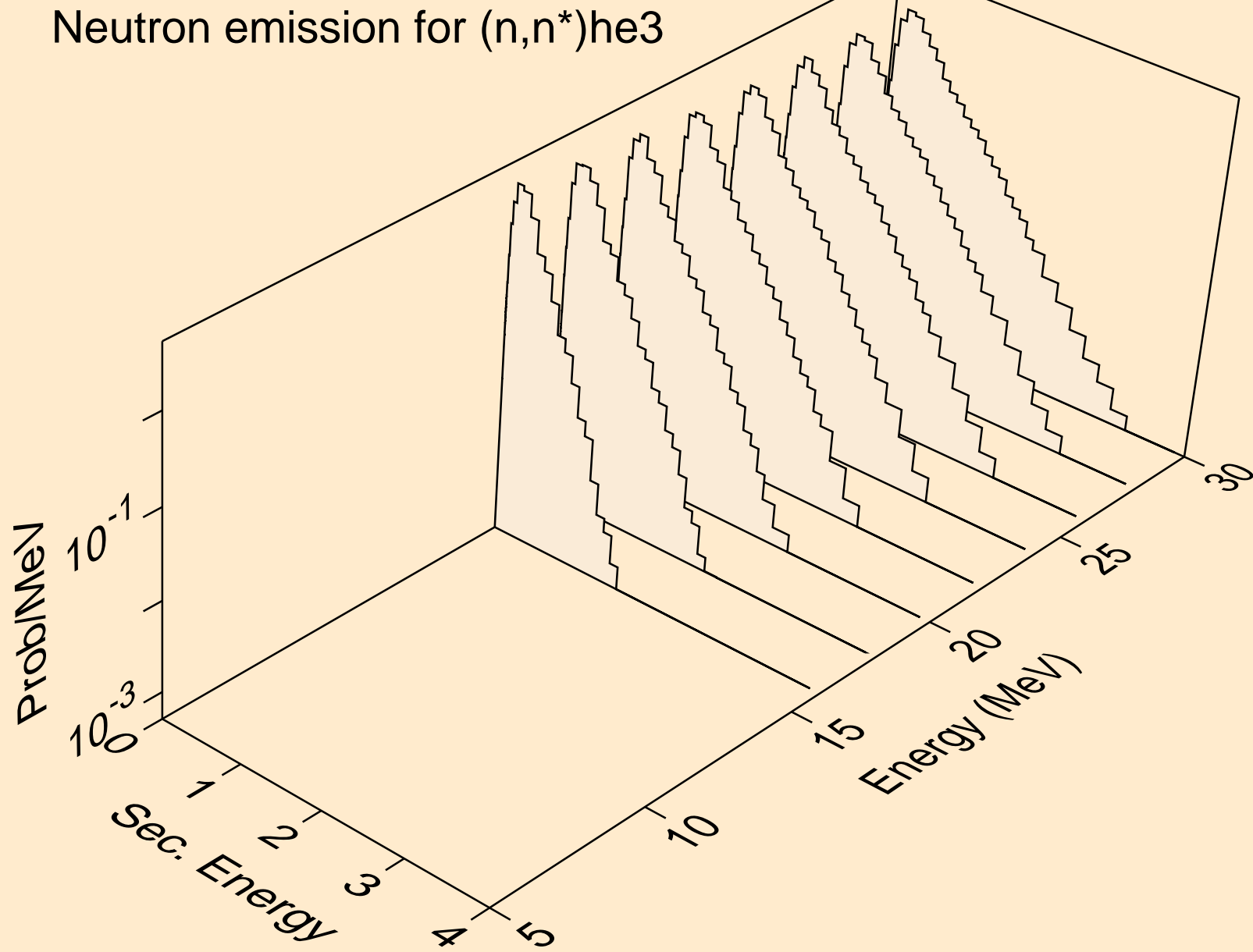

HS277M NEUTRON ACER TENDL-2023 LIBRARY; T=0.K
Neutron emission for (n,4n)

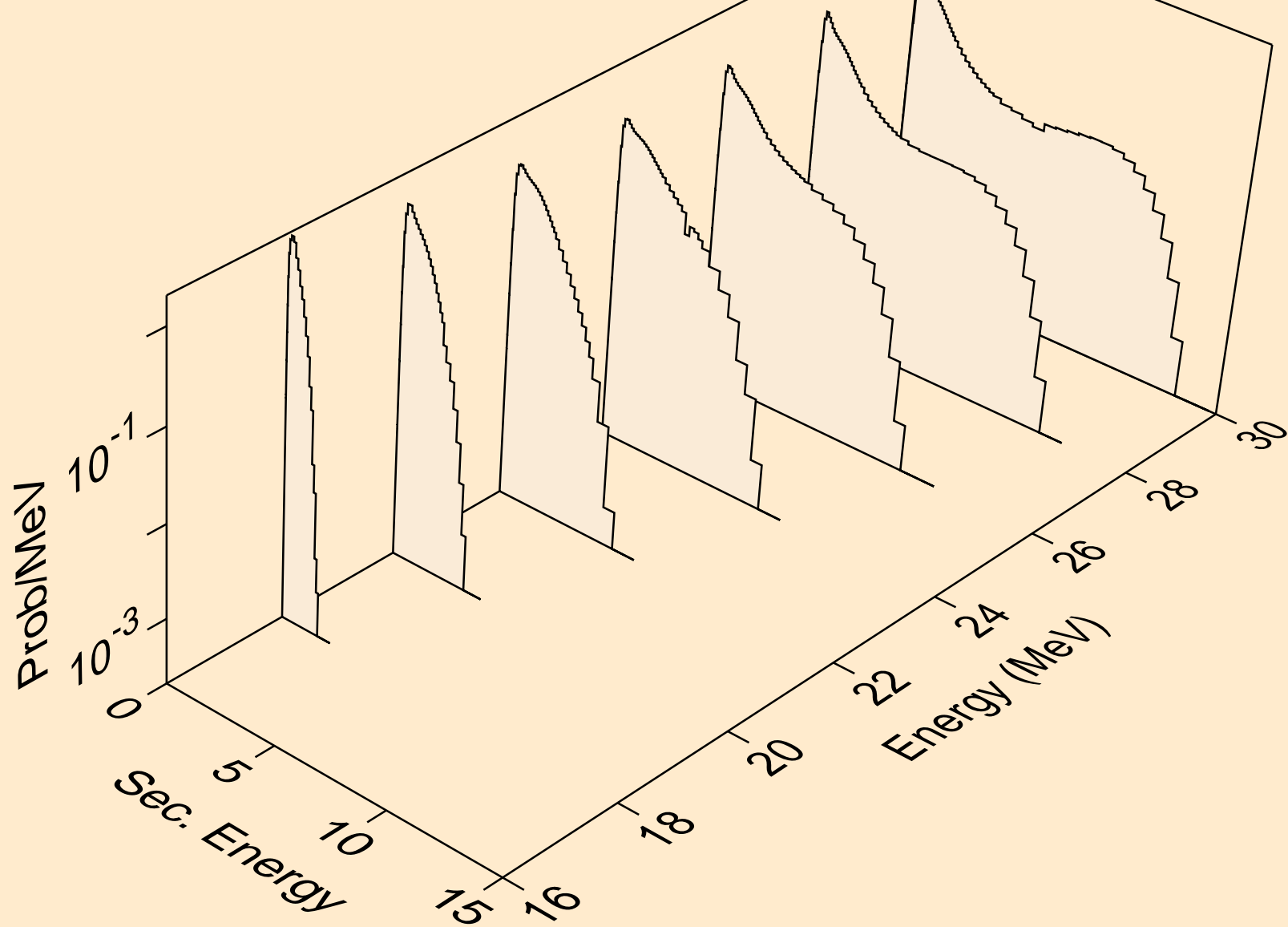

HS277M NEUTRON ACER TENDL-2023 LIBRARY; T=0.K
Neutron emission for (n,2np)

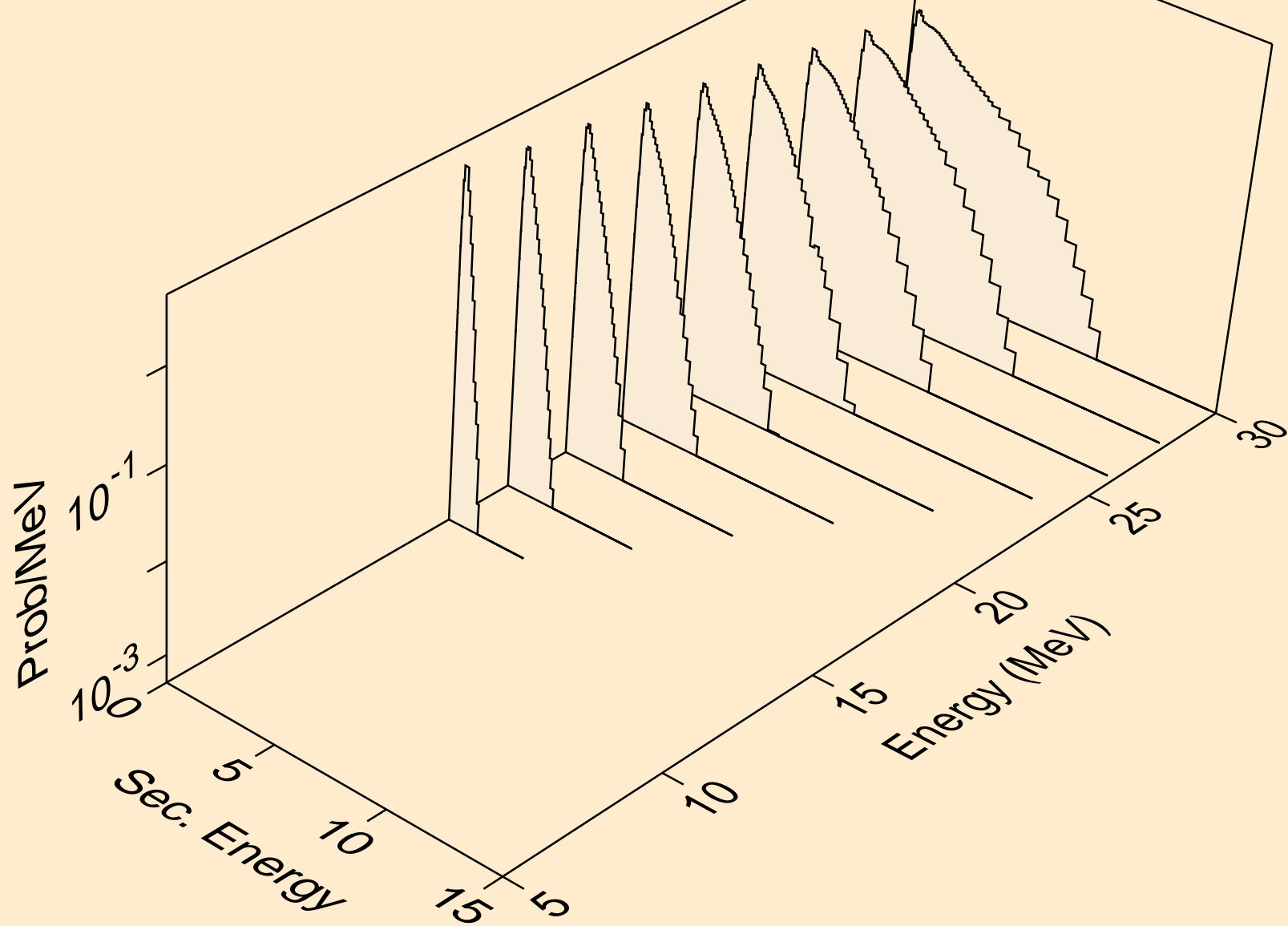

HS277M NEUTRON ACER TENDL-2023 LIBRARY; T=0.K
Neutron emission for (n,3np)

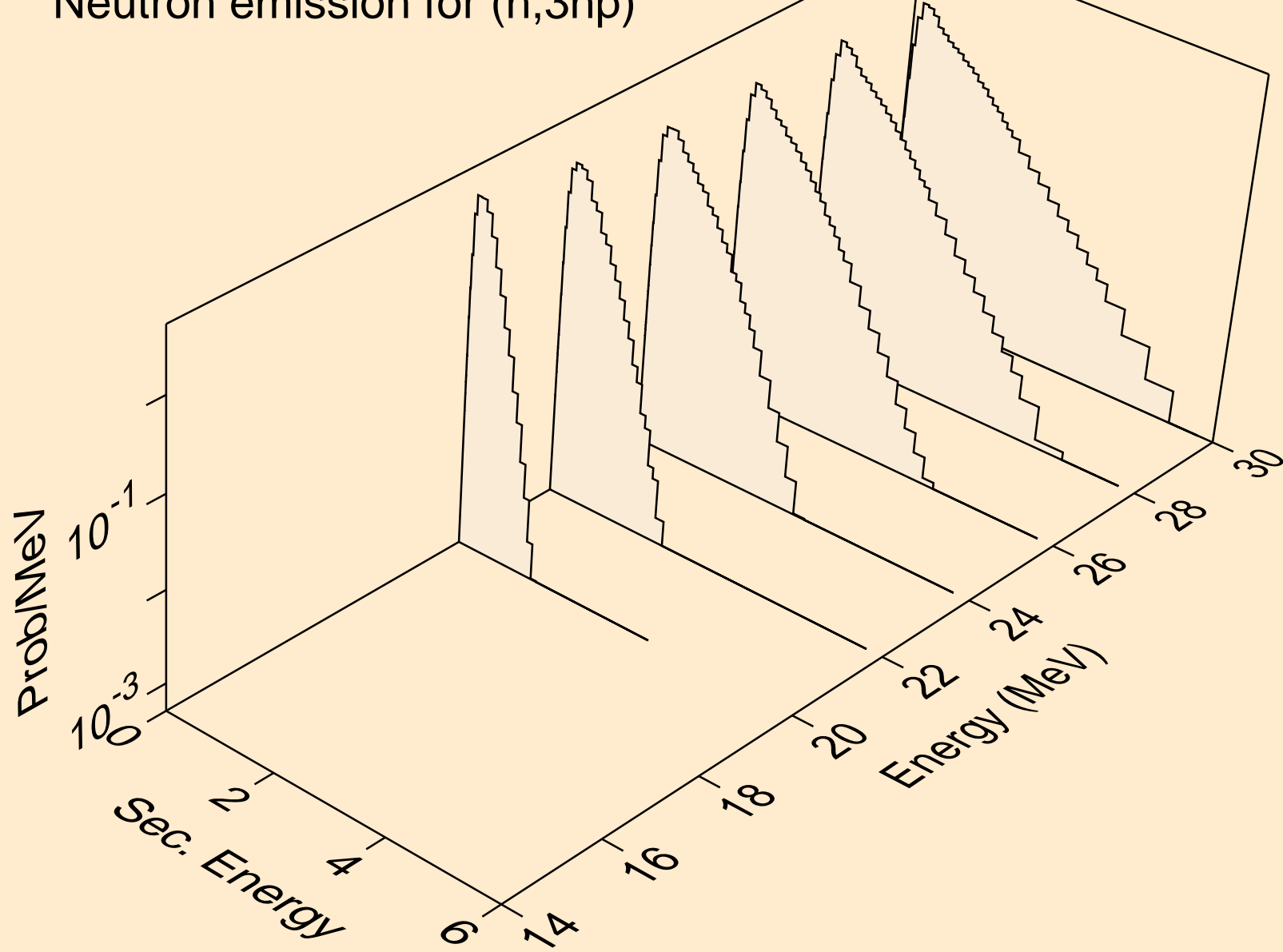

HS277M NEUTRON ACER TENDL-2023 LIBRARY; T=0.K
Neutron emission for (n,n2p)

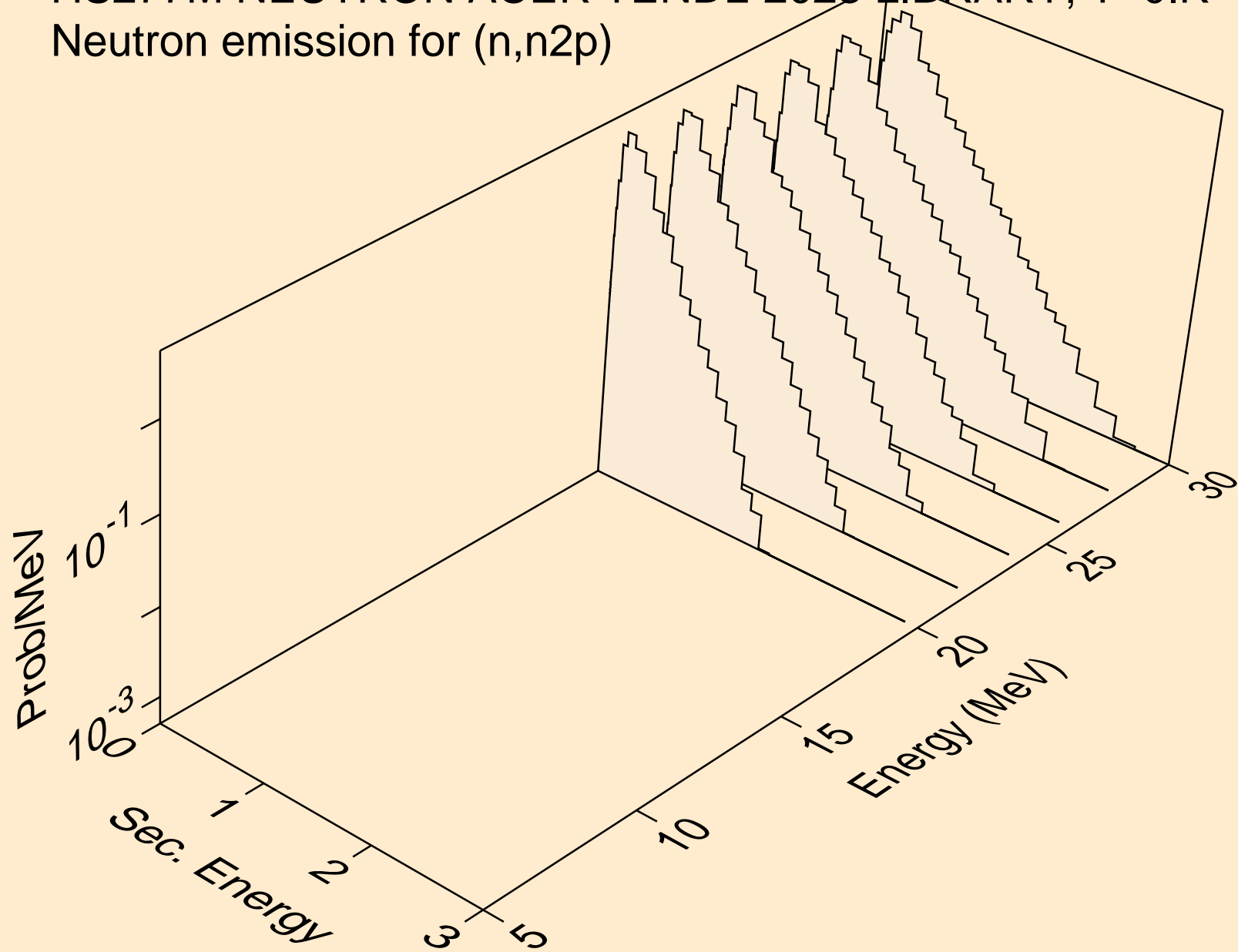

HS277M NEUTRON ACER TENDL-2023 LIBRARY; T=0.K
Neutron emission for (n,n*c)

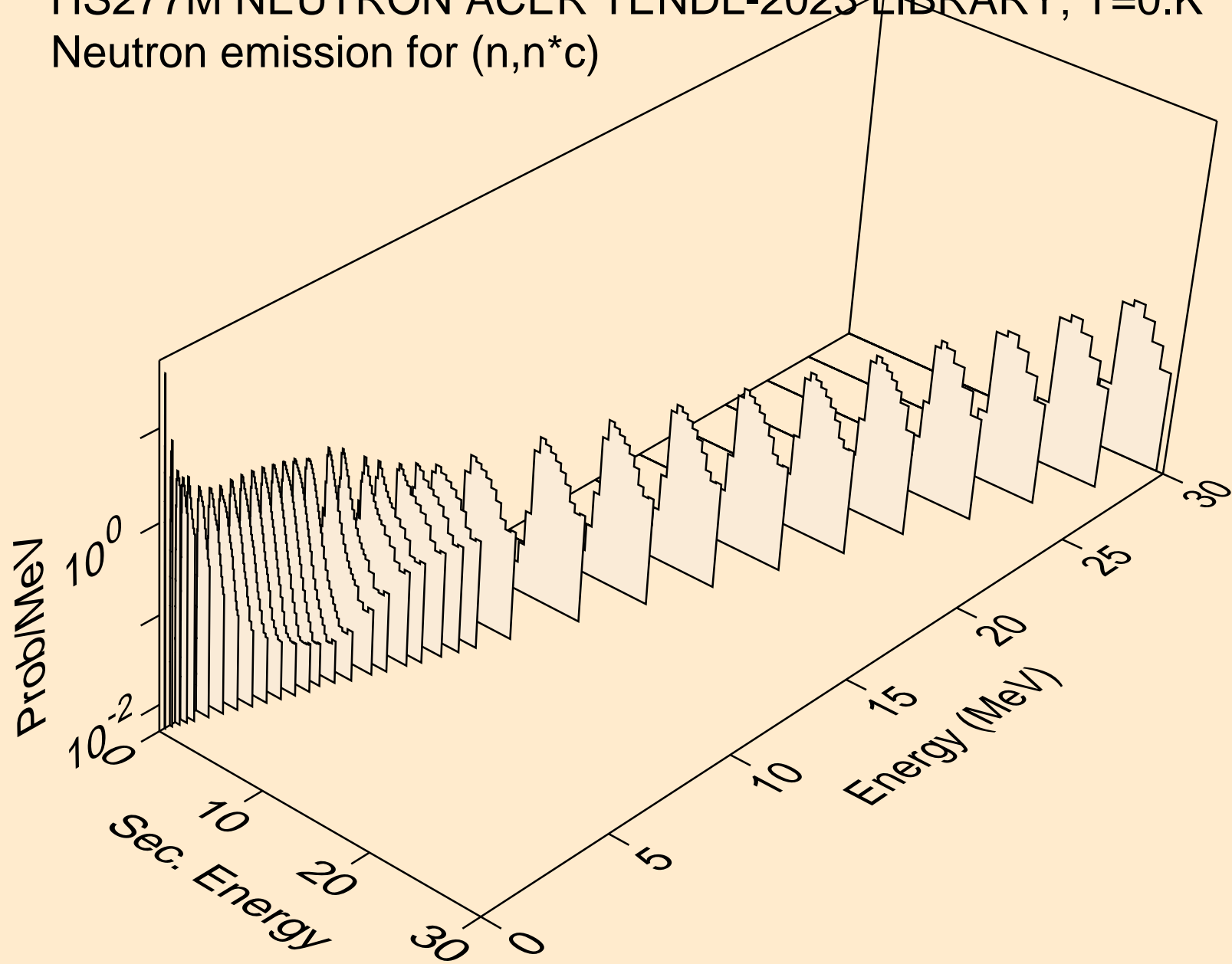

HS277M NEUTRON ACER TENDL-2023 LIBRARY; T=0.K

Delayed nubar

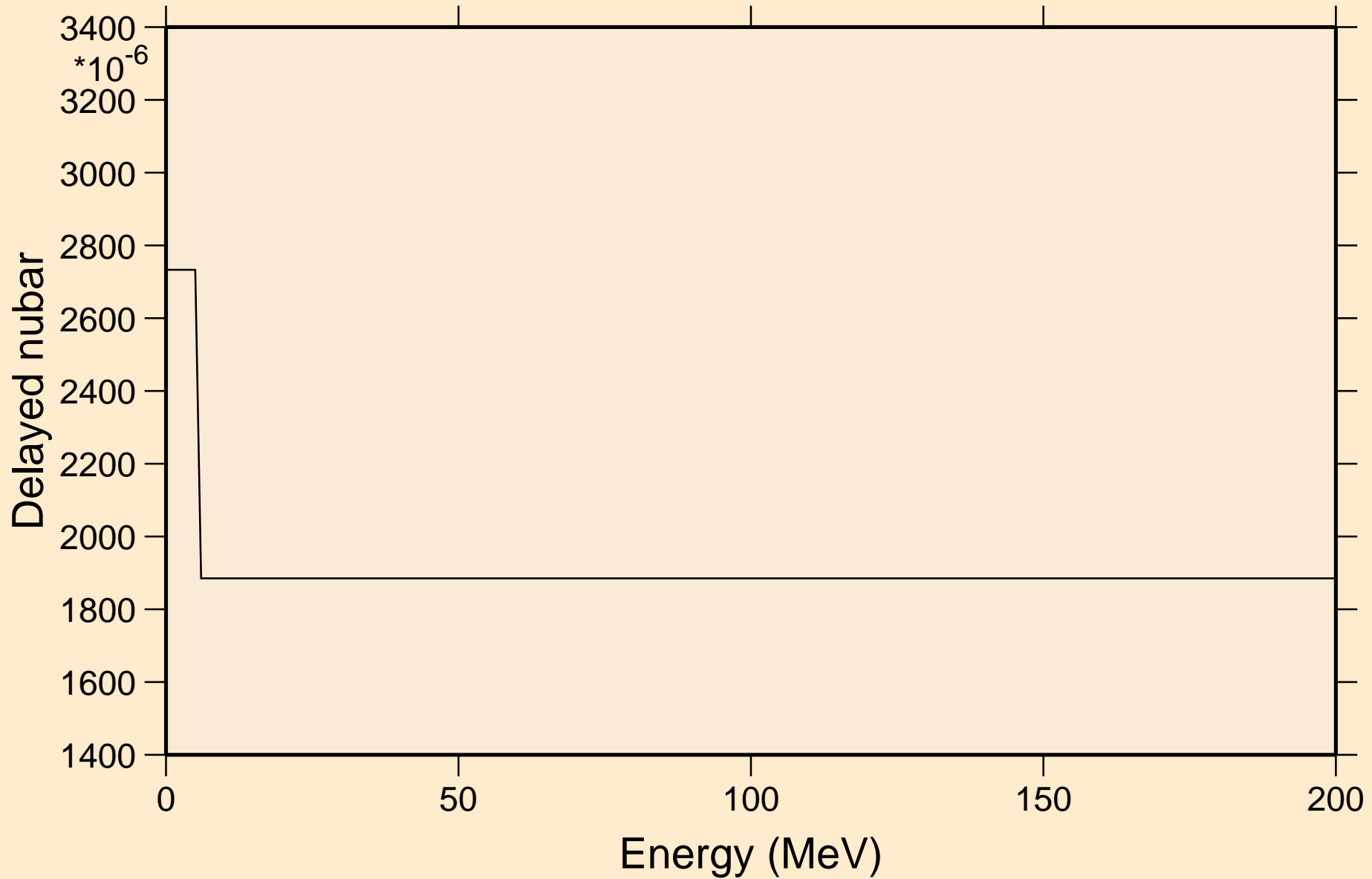

HS277M NEUTRON ACER TENDL-2023 LIBRARY; T=0.K

Delayed neutron spectra

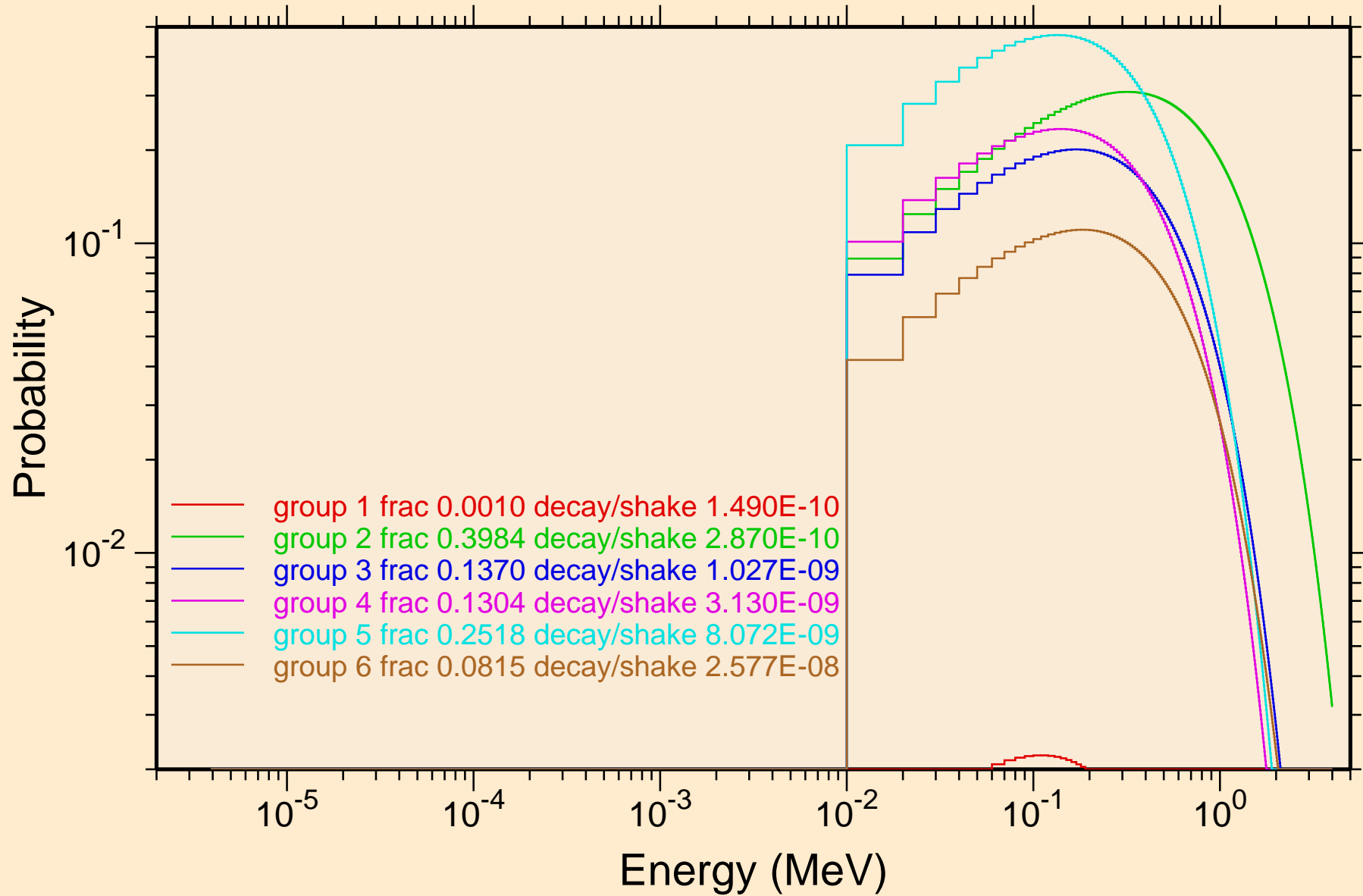

HS277M NEUTRON ACER TENDL-2023 LIBRARY; T=0.K
Photon emission for (n,x)

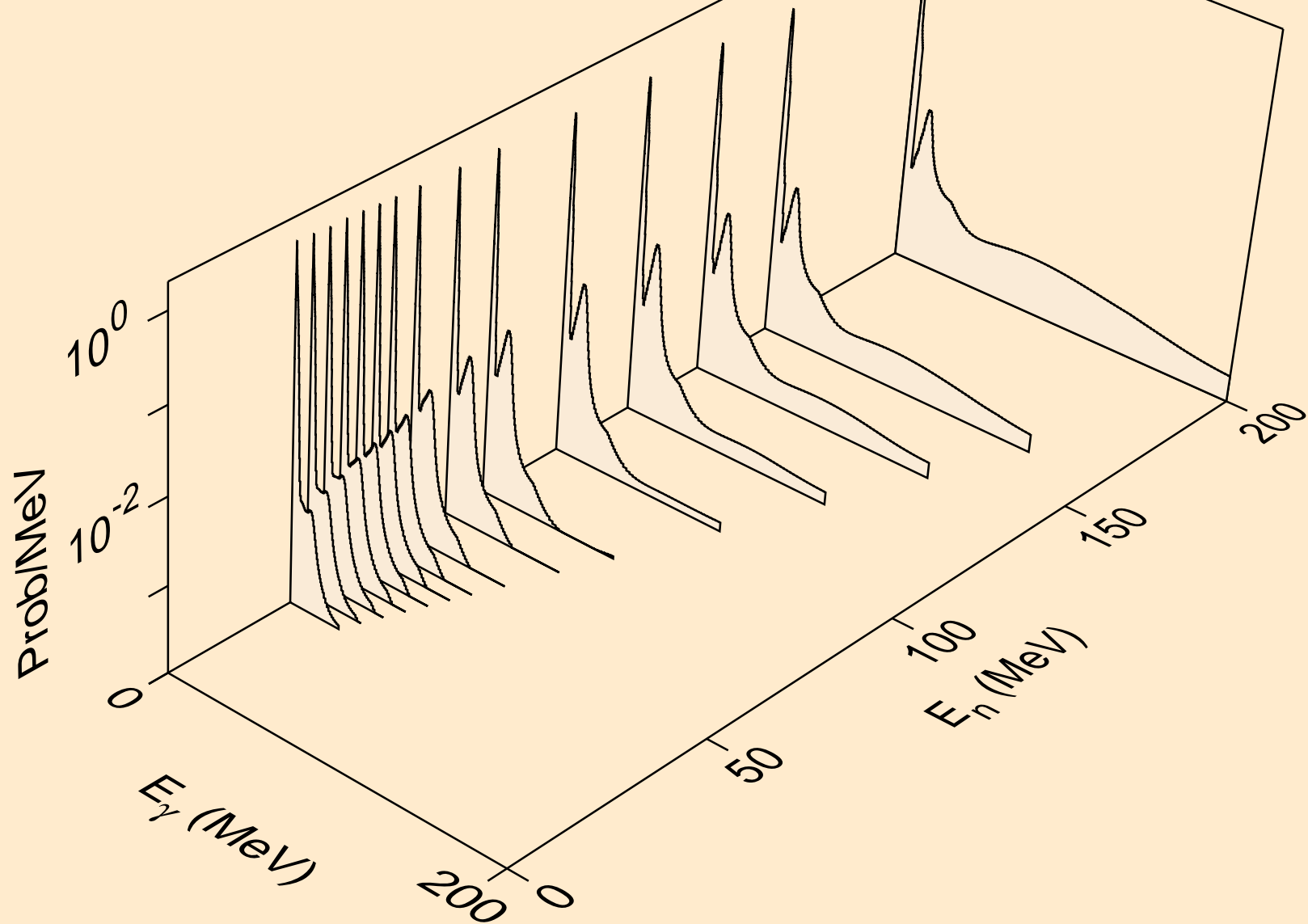

HS277M NEUTRON ACER TENDL-2023 LIBRARY; T=0.K
Photon emission for (n,2nd)

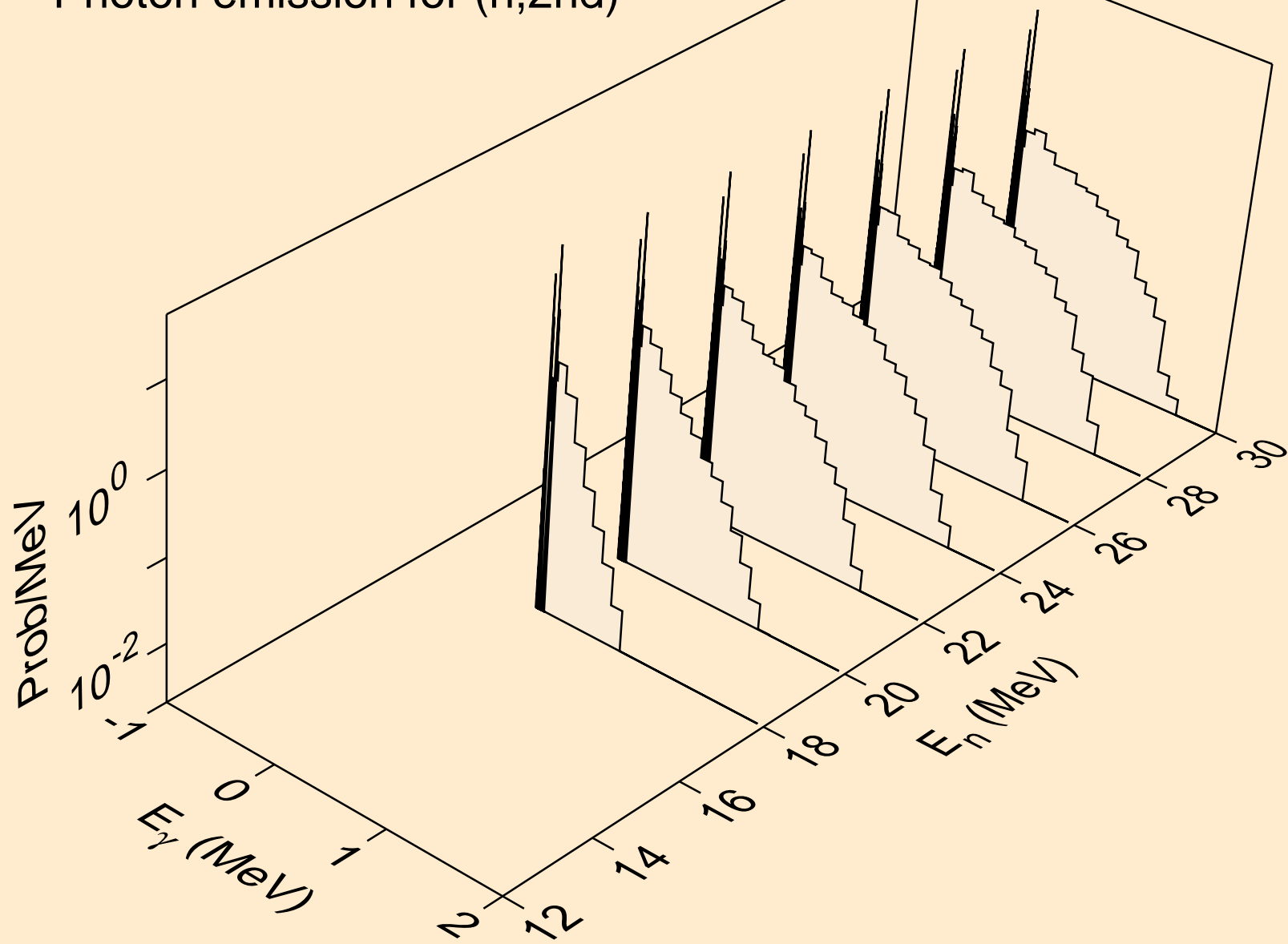

HS277M NEUTRON ACER TENDL-2023 LIBRARY; T=0.K
Photon emission for (n,2n)

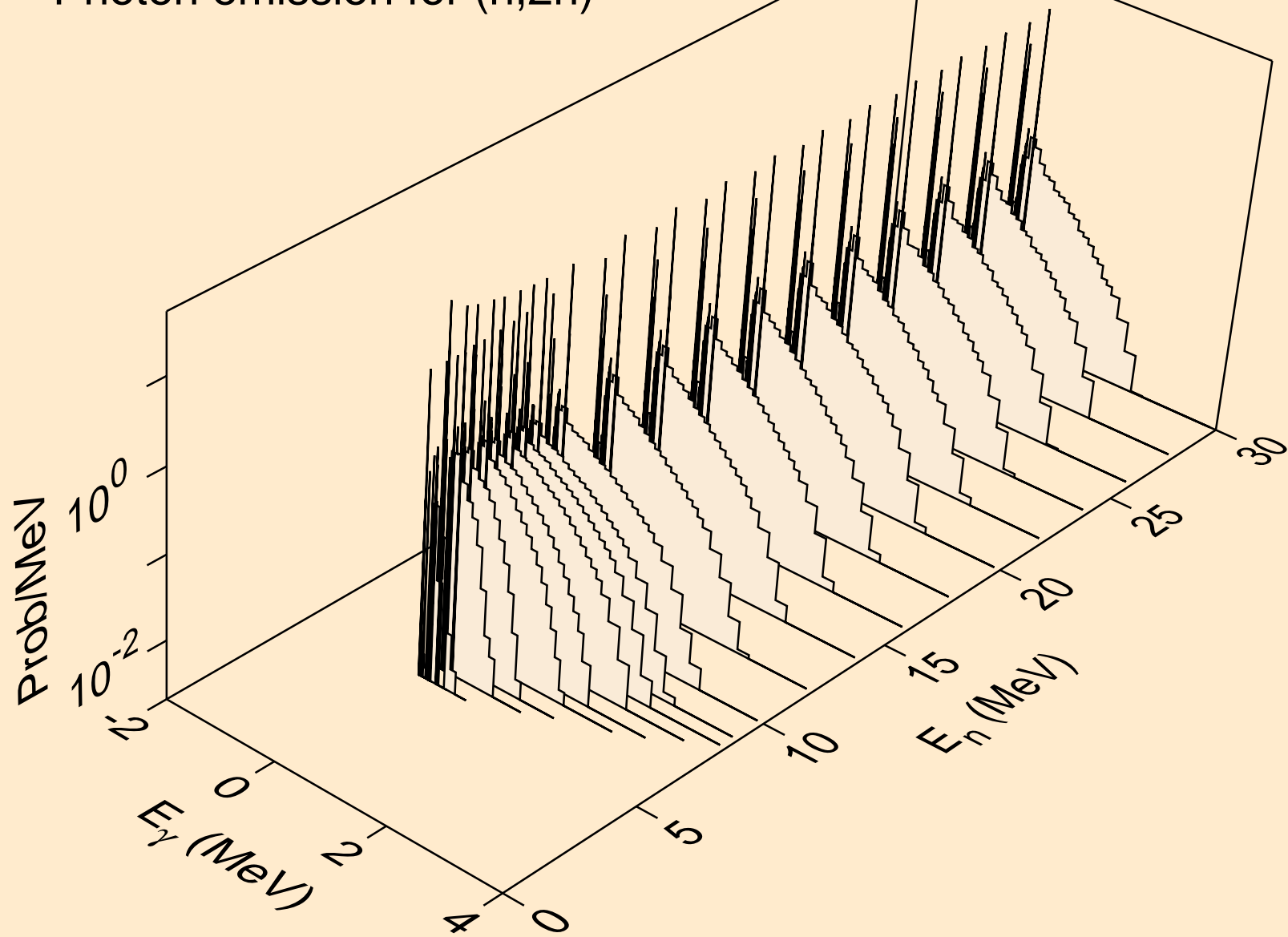

HS277M NEUTRON ACER TENDL-2023 LIBRARY; T=0.K
Photon emission for (n,3n)

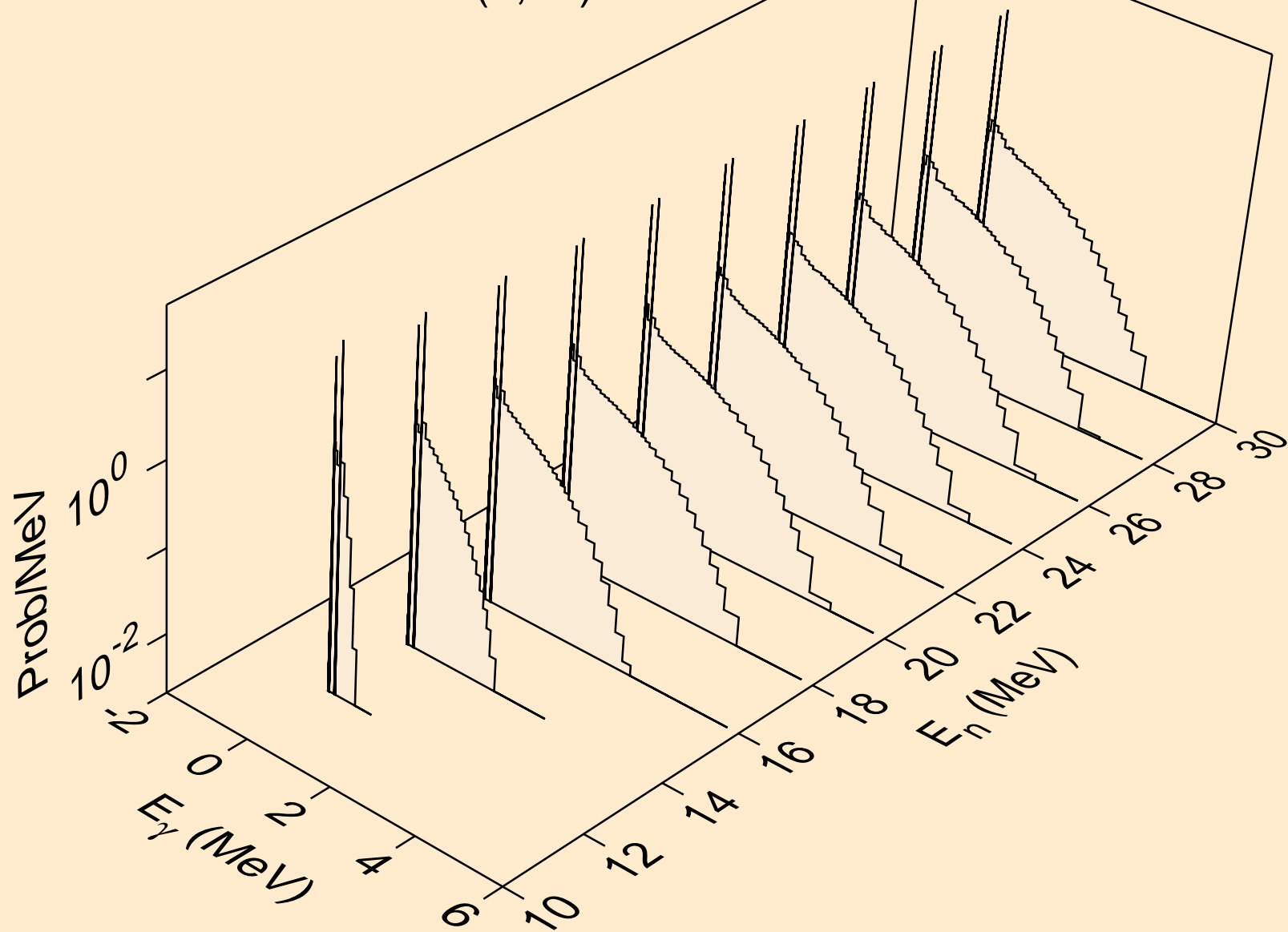

HS277M NEUTRON ACER TENDL-2023 LIBRARY; T=0.K
Photon emission for (n,n*)a

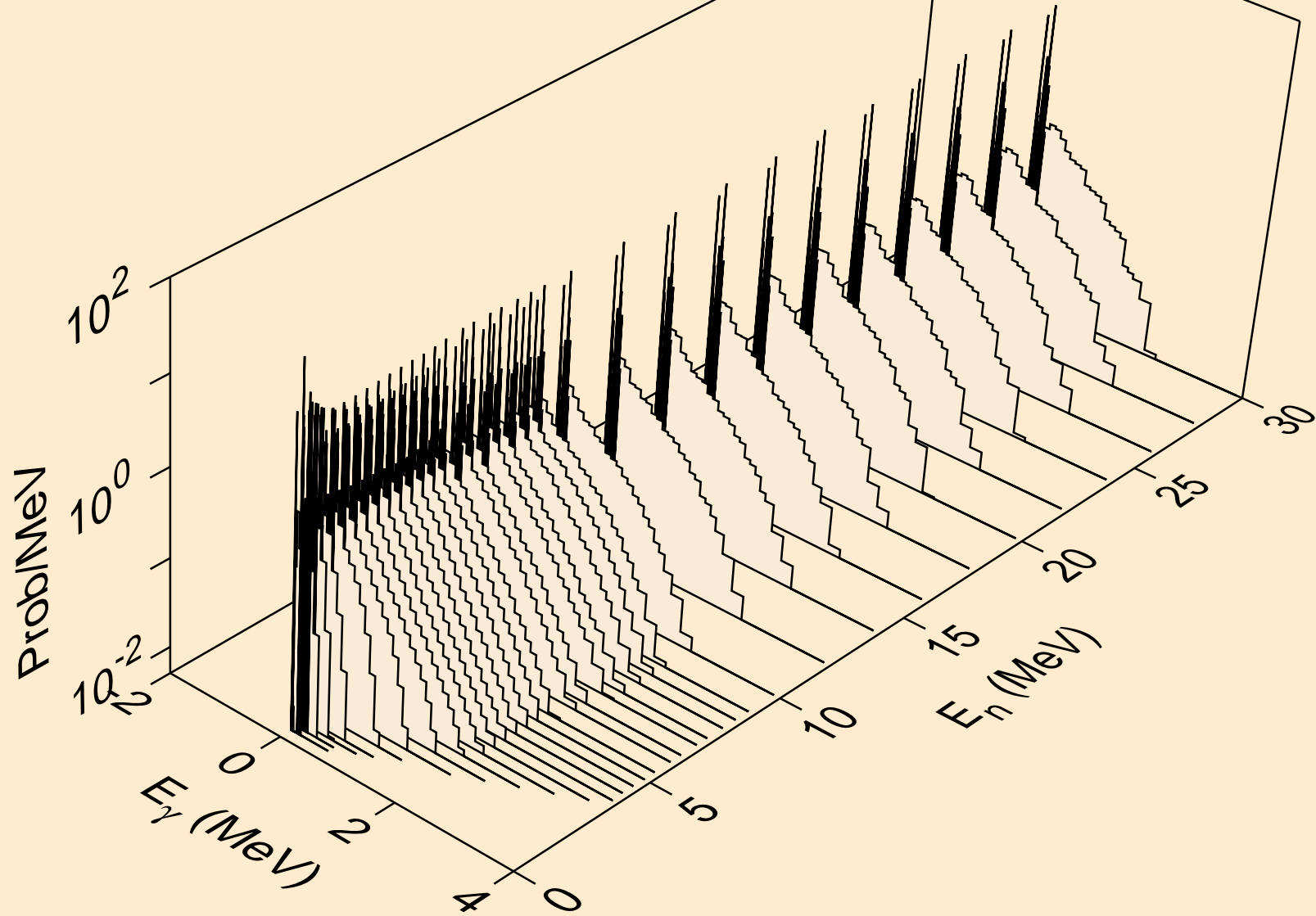

HS277M NEUTRON ACER TENDL-2023 LIBRARY; T=0.K
Photon emission for (n,2n)a

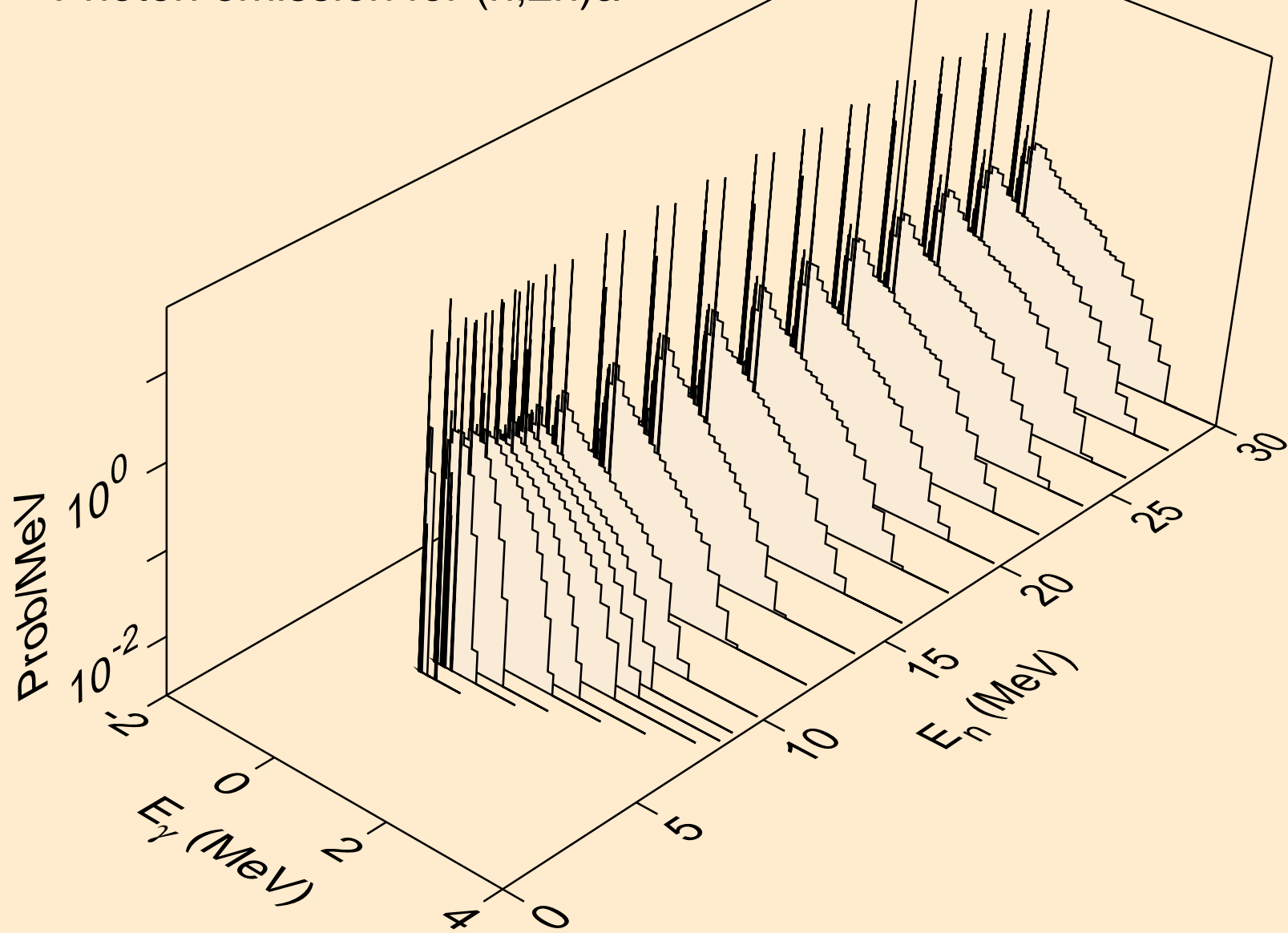

HS277M NEUTRON ACER TENDL-2023 LIBRARY; T=0.K
Photon emission for (n,3n)a

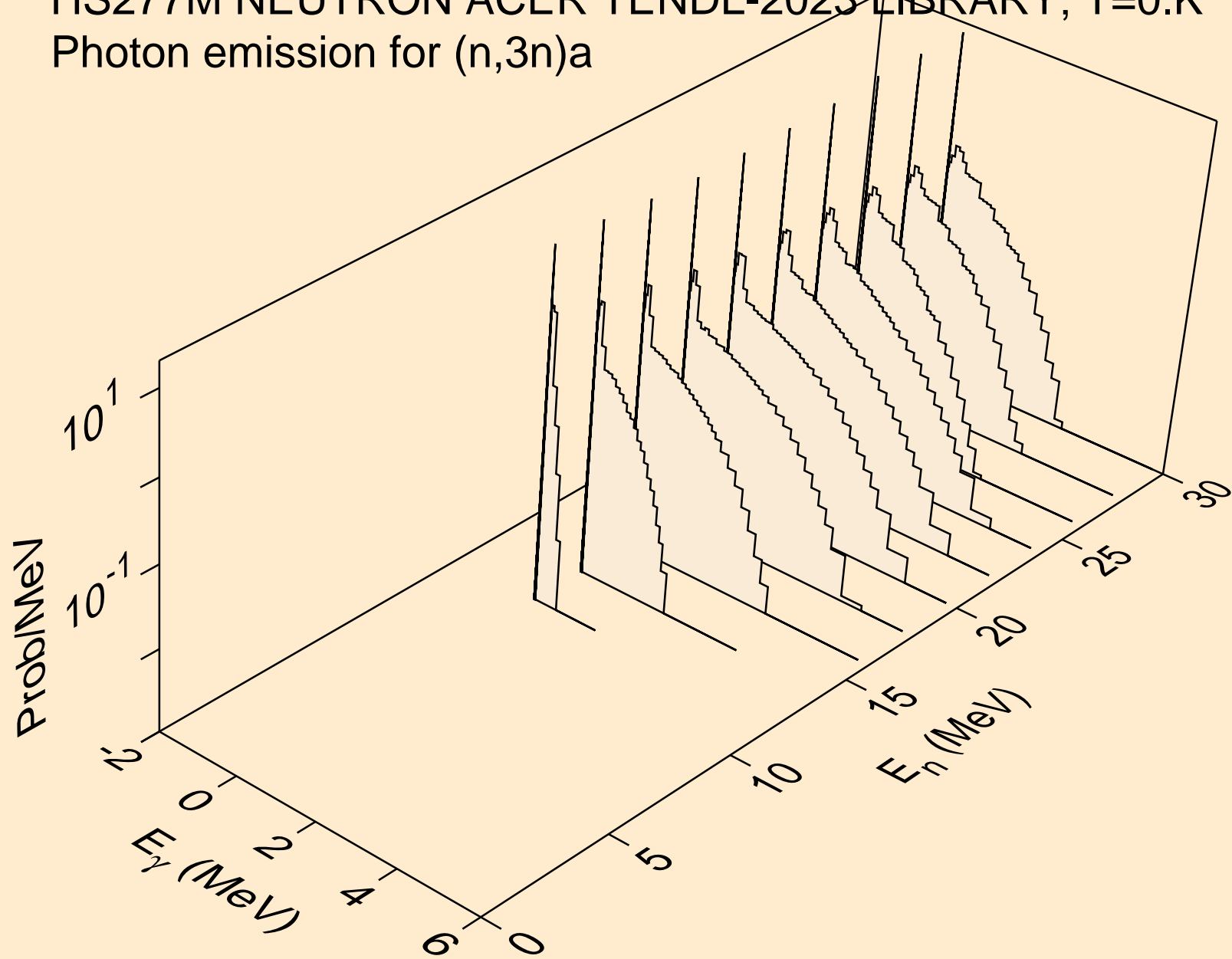

HS277M NEUTRON ACER TENDL-2023 LIBRARY; T=0.K
Photon emission for (n,n*)p

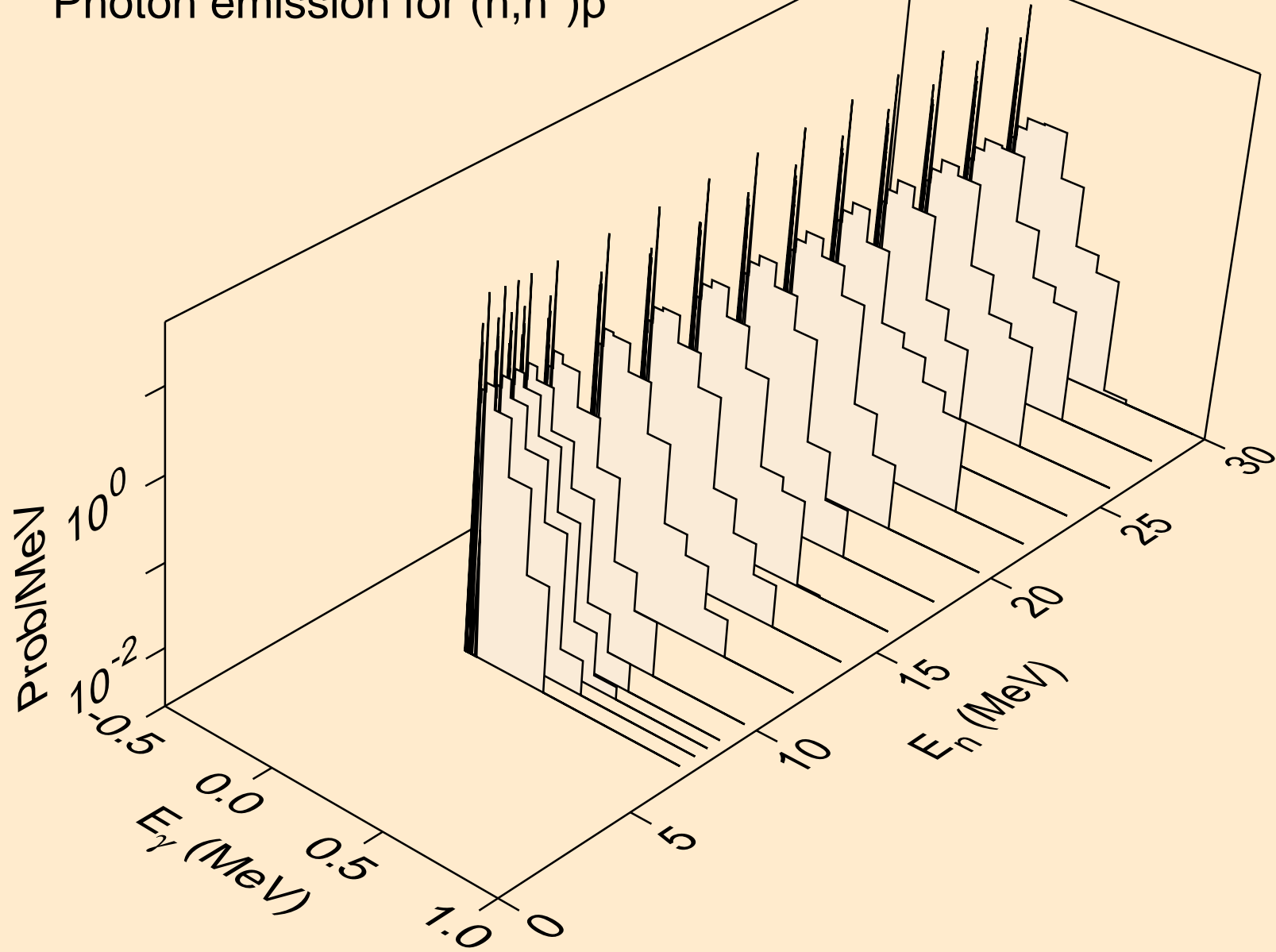

HS277M NEUTRON ACER TENDL-2023 LIBRARY; T=0.K
Photon emission for (n,n*)d

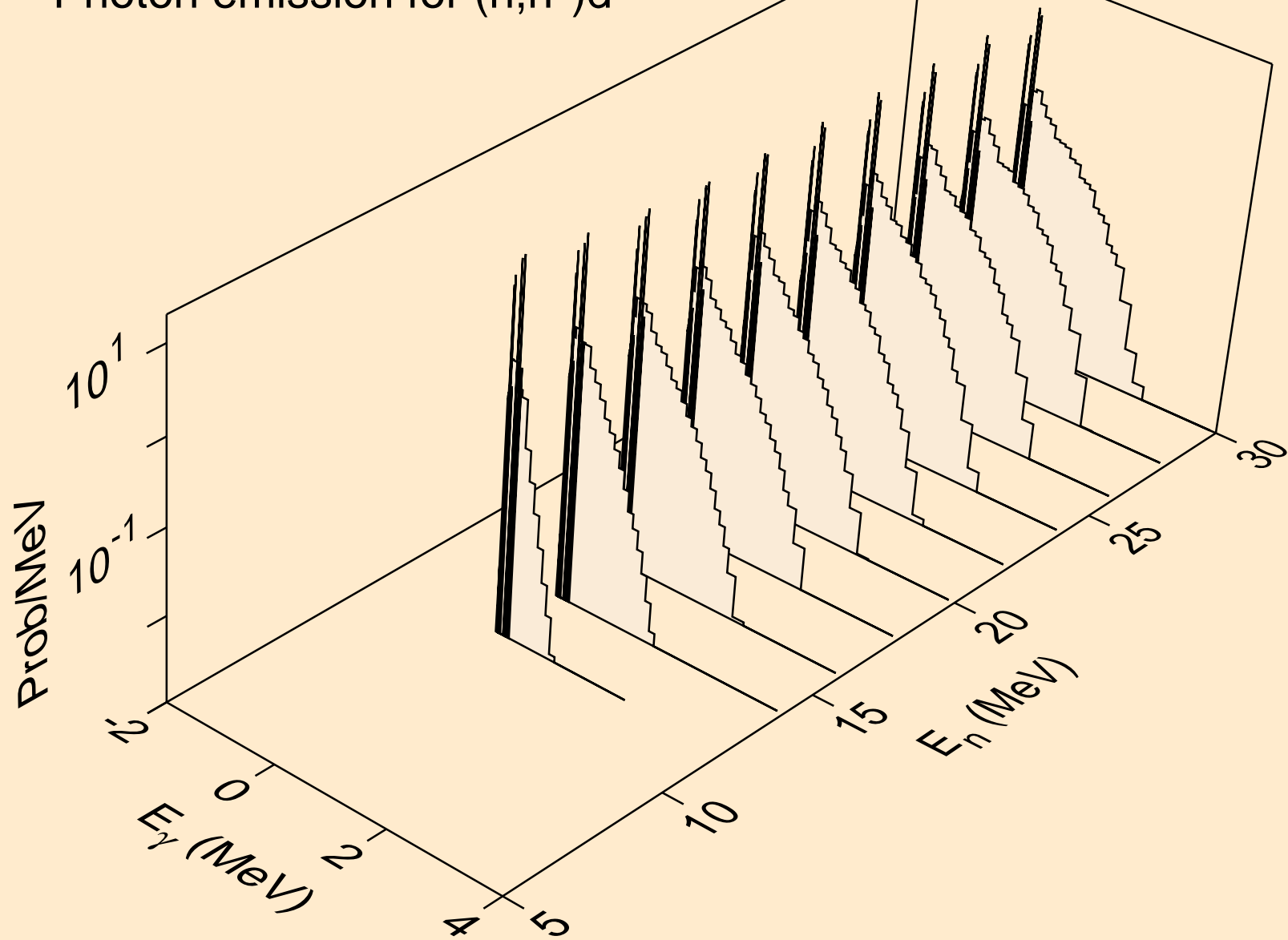

HS277M NEUTRON ACER TENDL-2023 LIBRARY; T=0.K
Photon emission for (n,n*)t

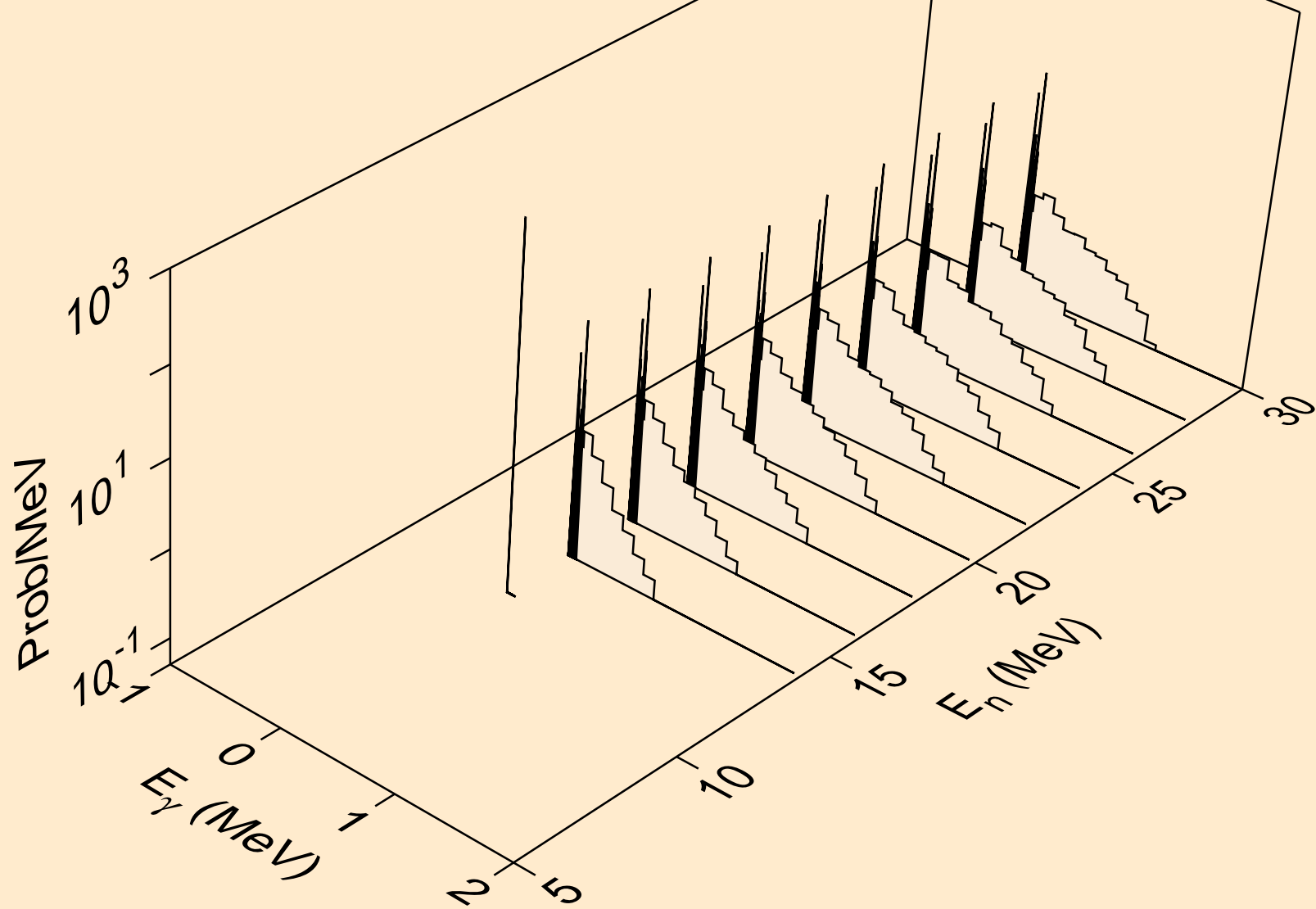

HS277M NEUTRON ACER TENDL-2023 LIBRARY; T=0.K
Photon emission for (n,n*)he3

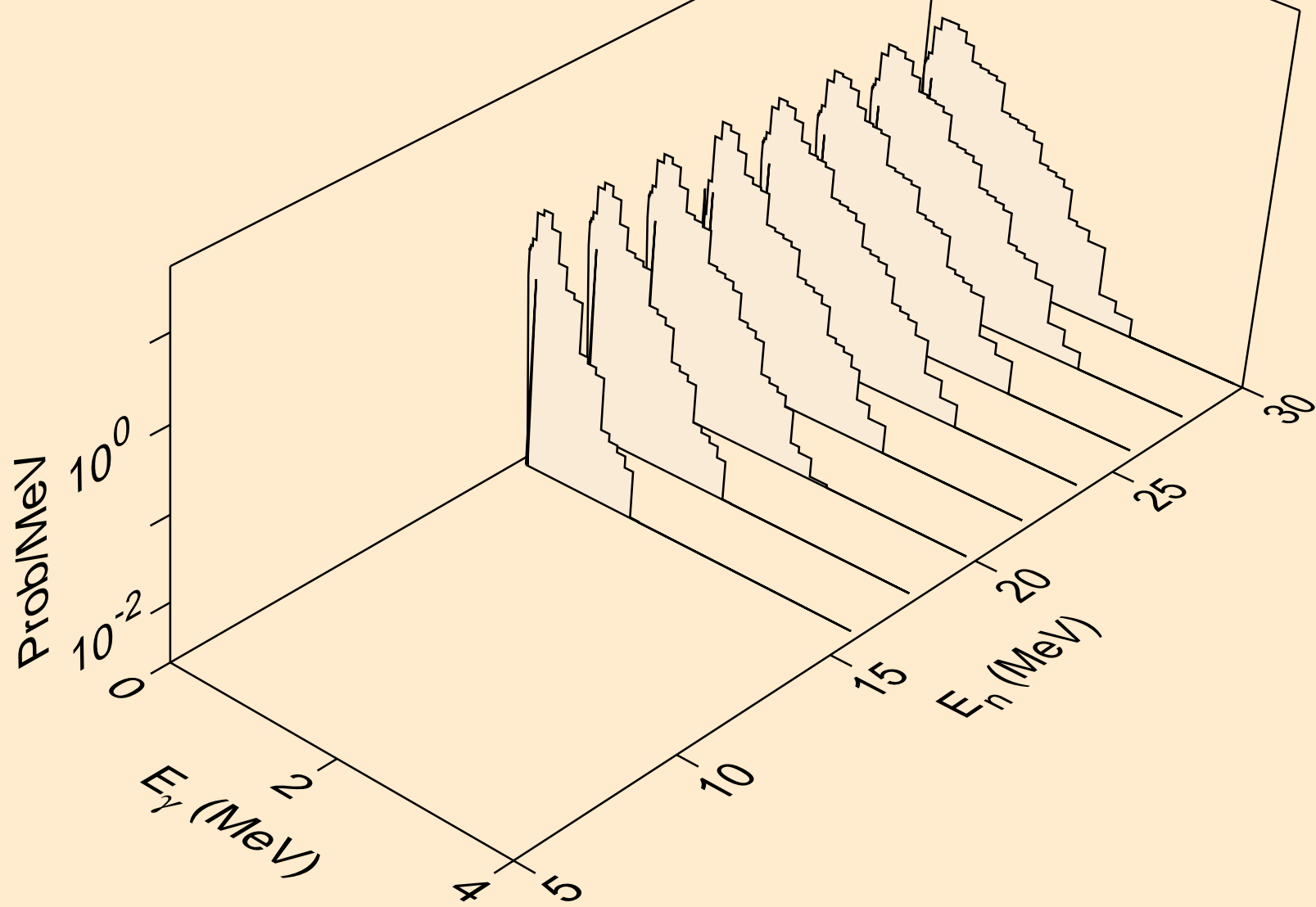

HS277M NEUTRON ACER TENDL-2023 LIBRARY; T=0.K
Photon emission for (n,4n)

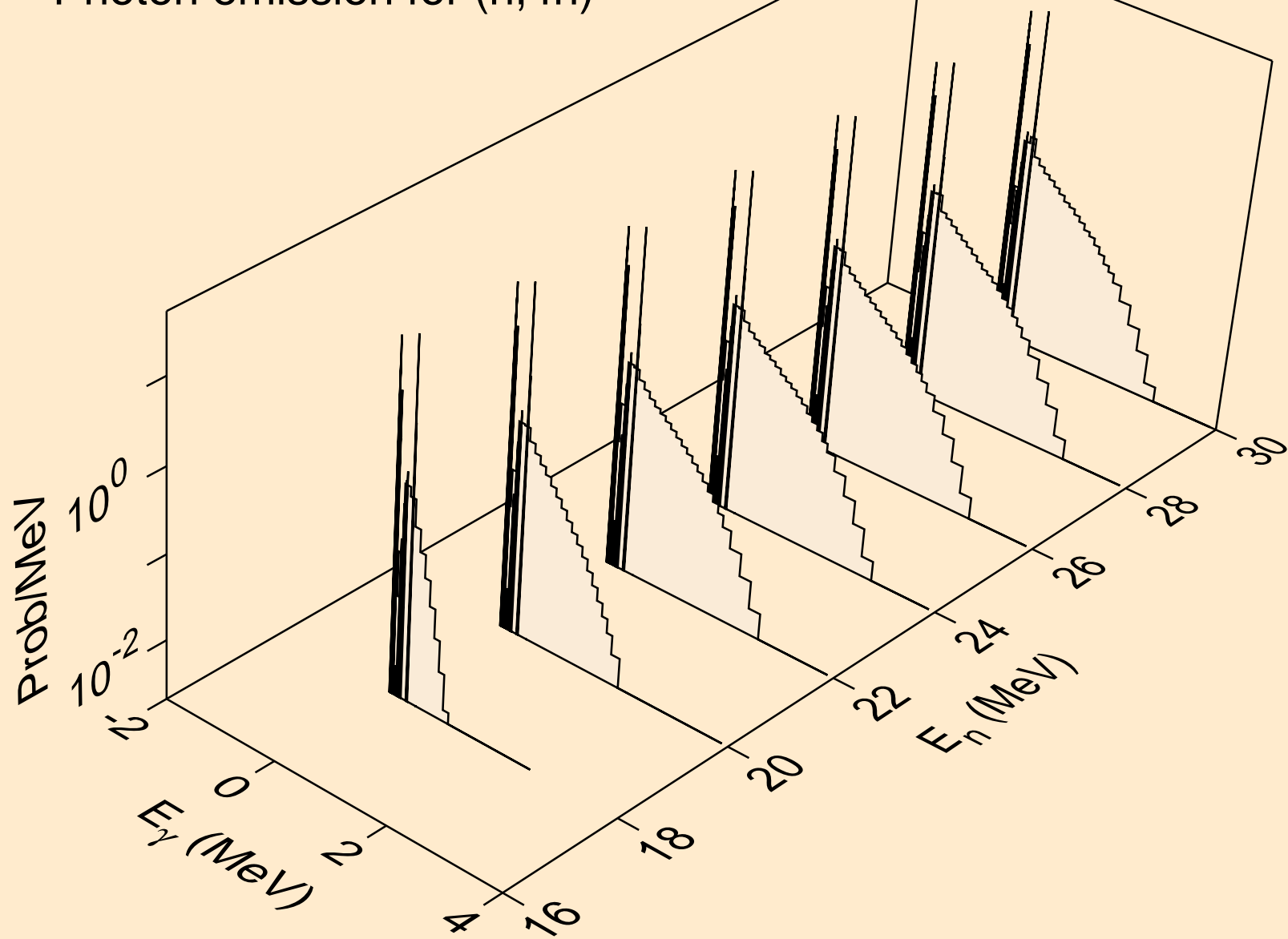

HS277M NEUTRON ACER TENDL-2023 LIBRARY; T=0.K
Photon emission for (n,2np)

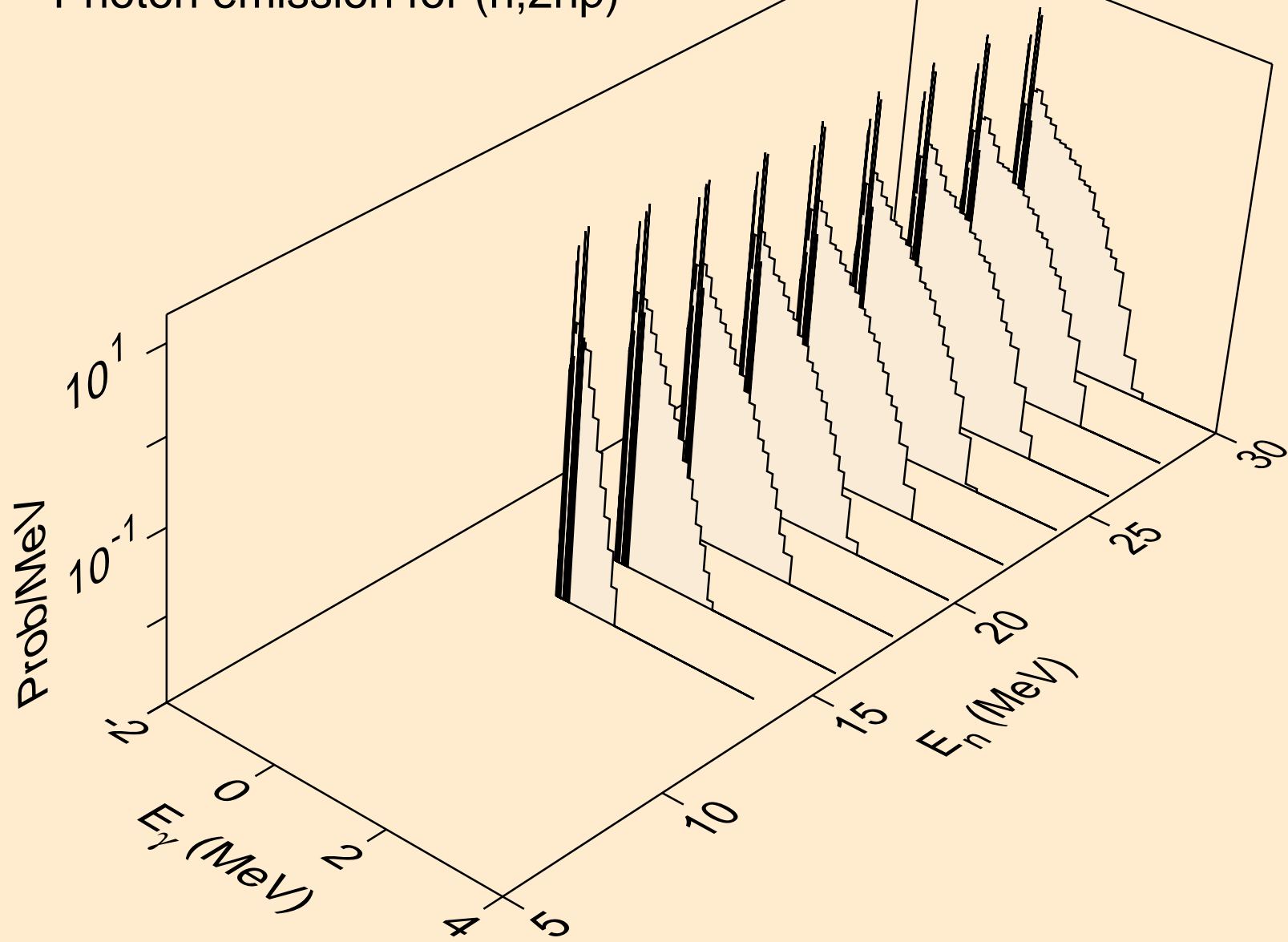

HS277M NEUTRON ACER TENDL-2023 LIBRARY; T=0.K
Photon emission for (n,3np)

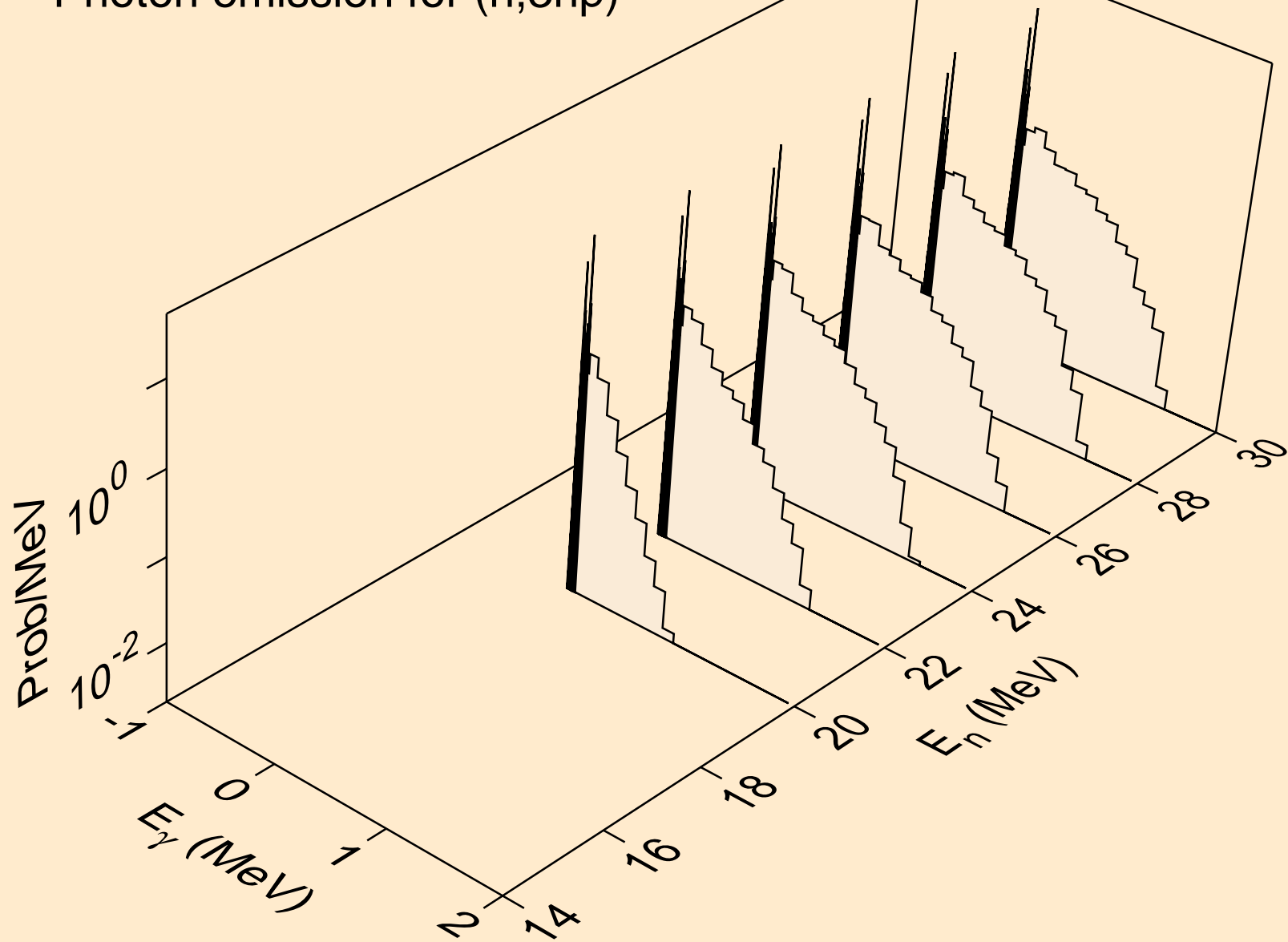

HS277M NEUTRON ACER TENDL-2023 LIBRARY; T=0.K
Photon emission for (n,n2p)

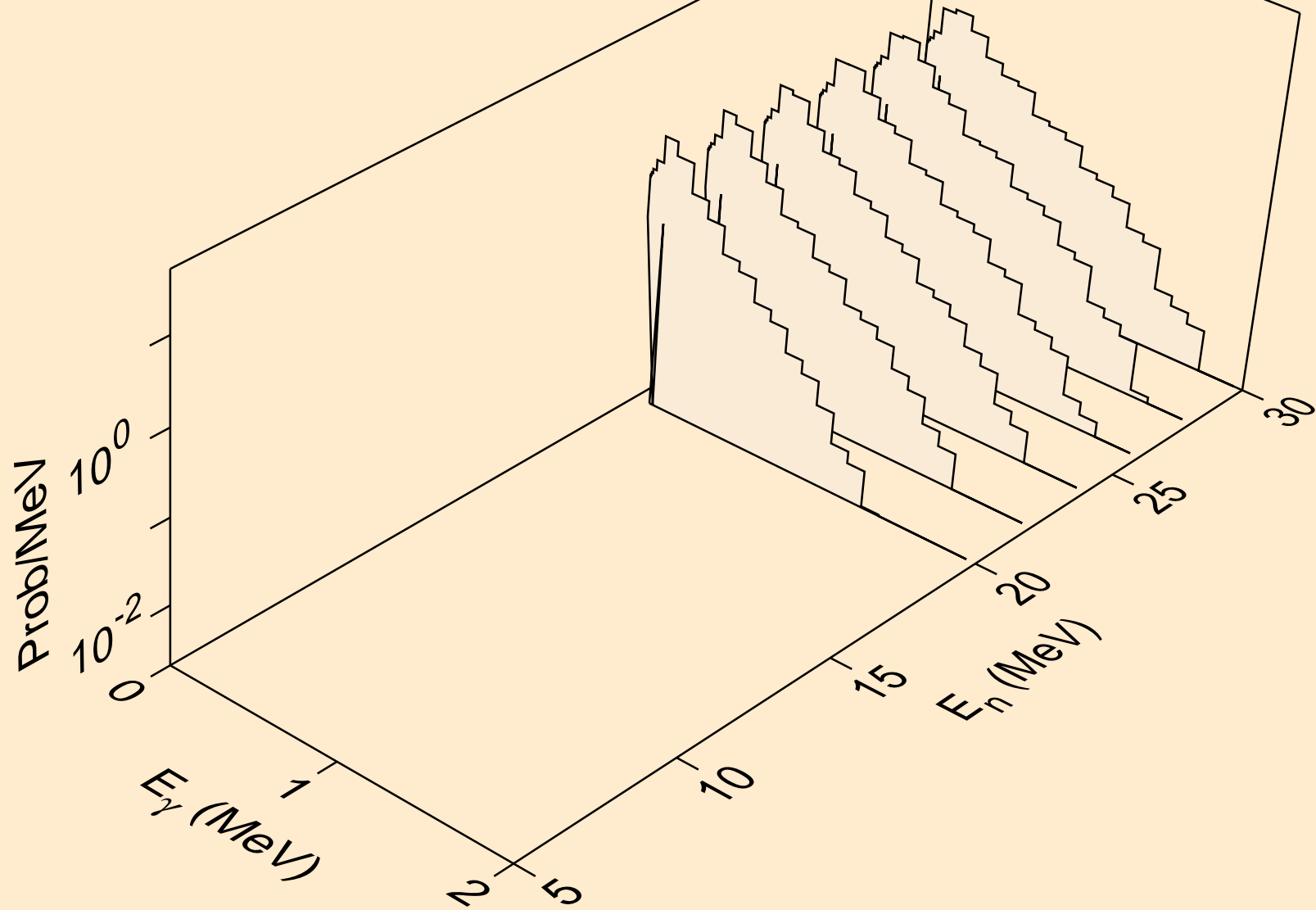

HS277M NEUTRON ACER TENDL-2023 LIBRARY; T=0.K
Photon emission for (n,n*2)

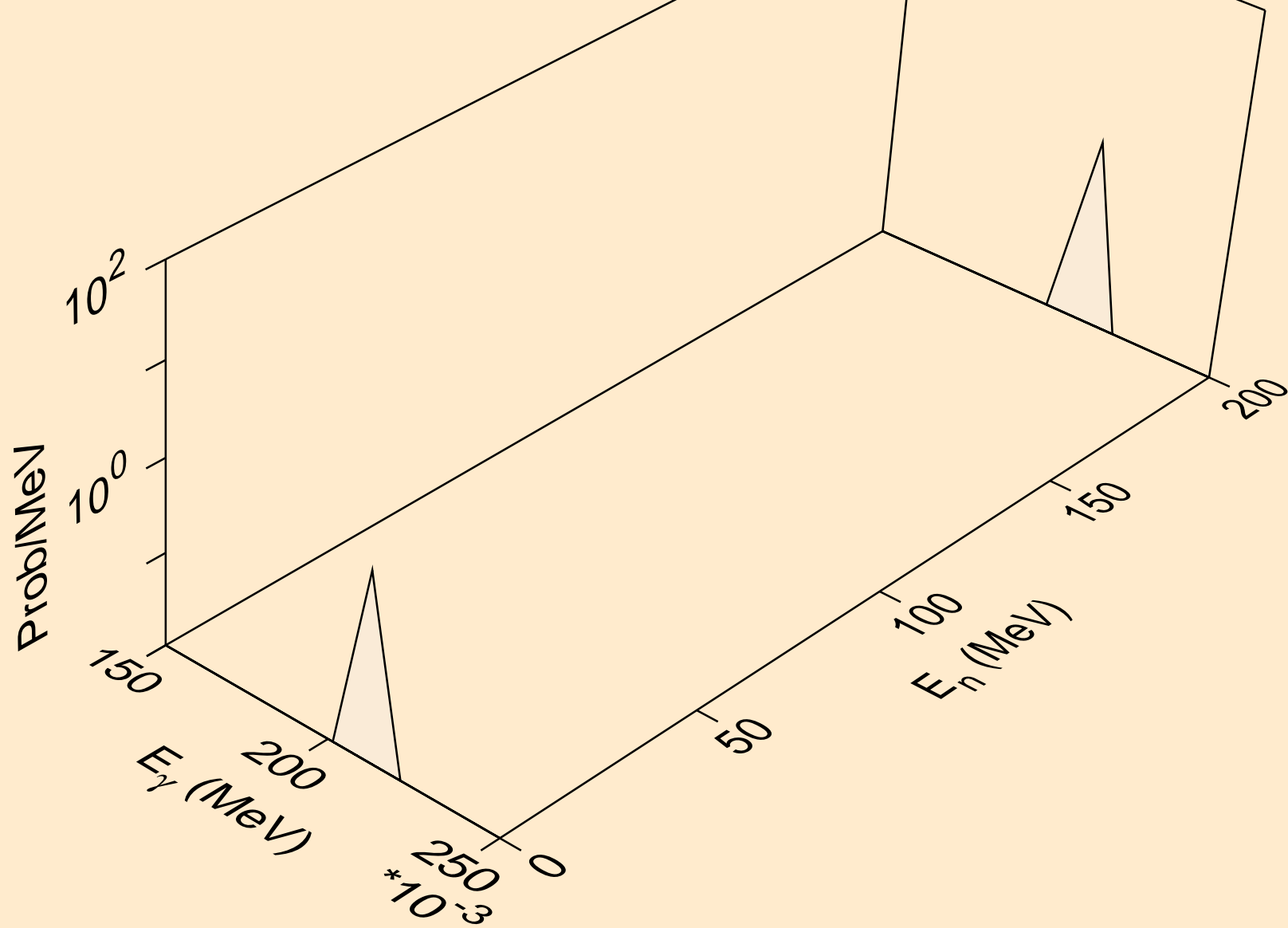

HS277M NEUTRON ACER TENDL-2023 LIBRARY; T=0.K
Photon emission for (n,n*3)

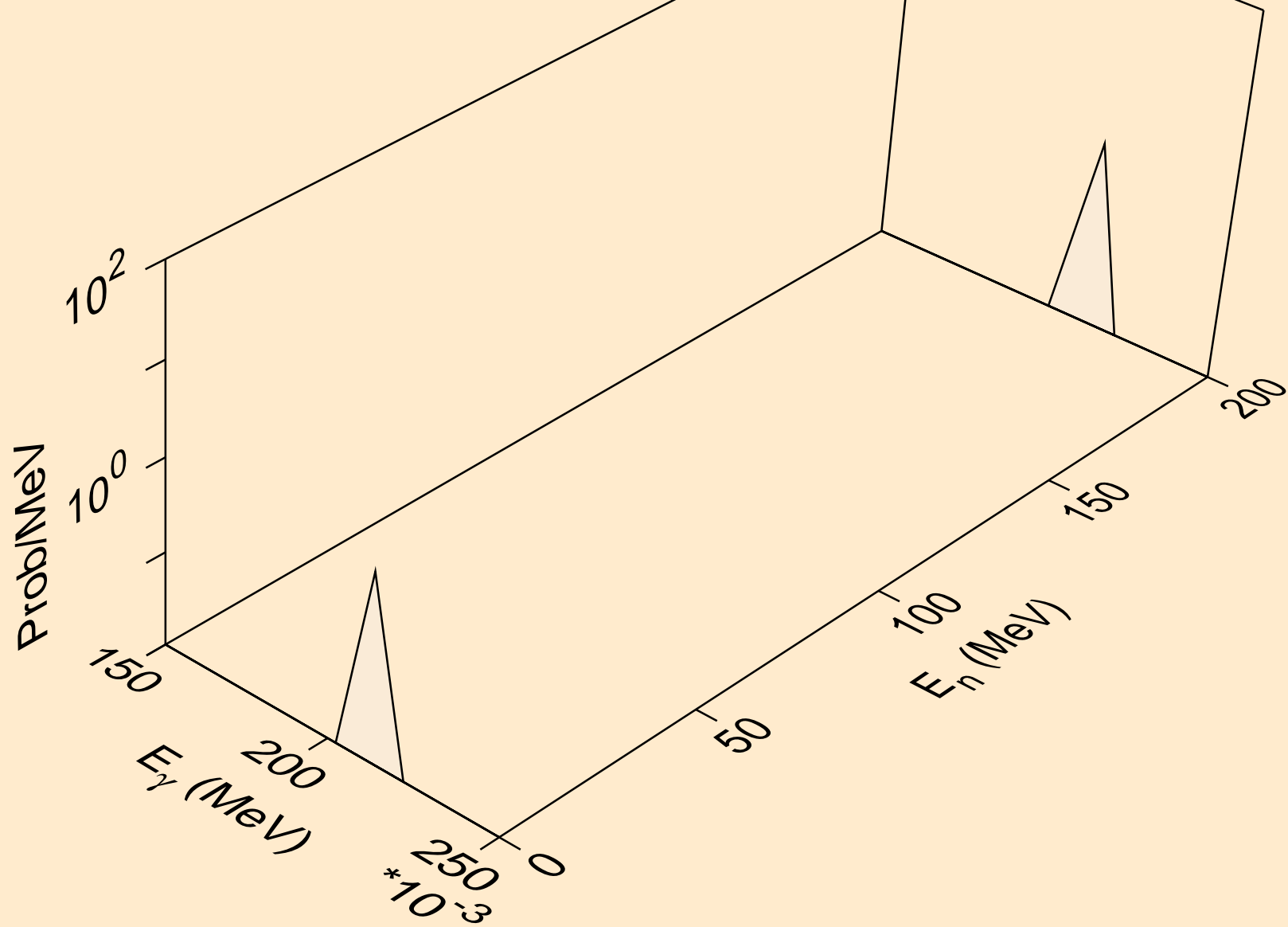

HS277M NEUTRON ACER TENDL-2023 LIBRARY; T=0.K
Photon emission for (n,n*4)

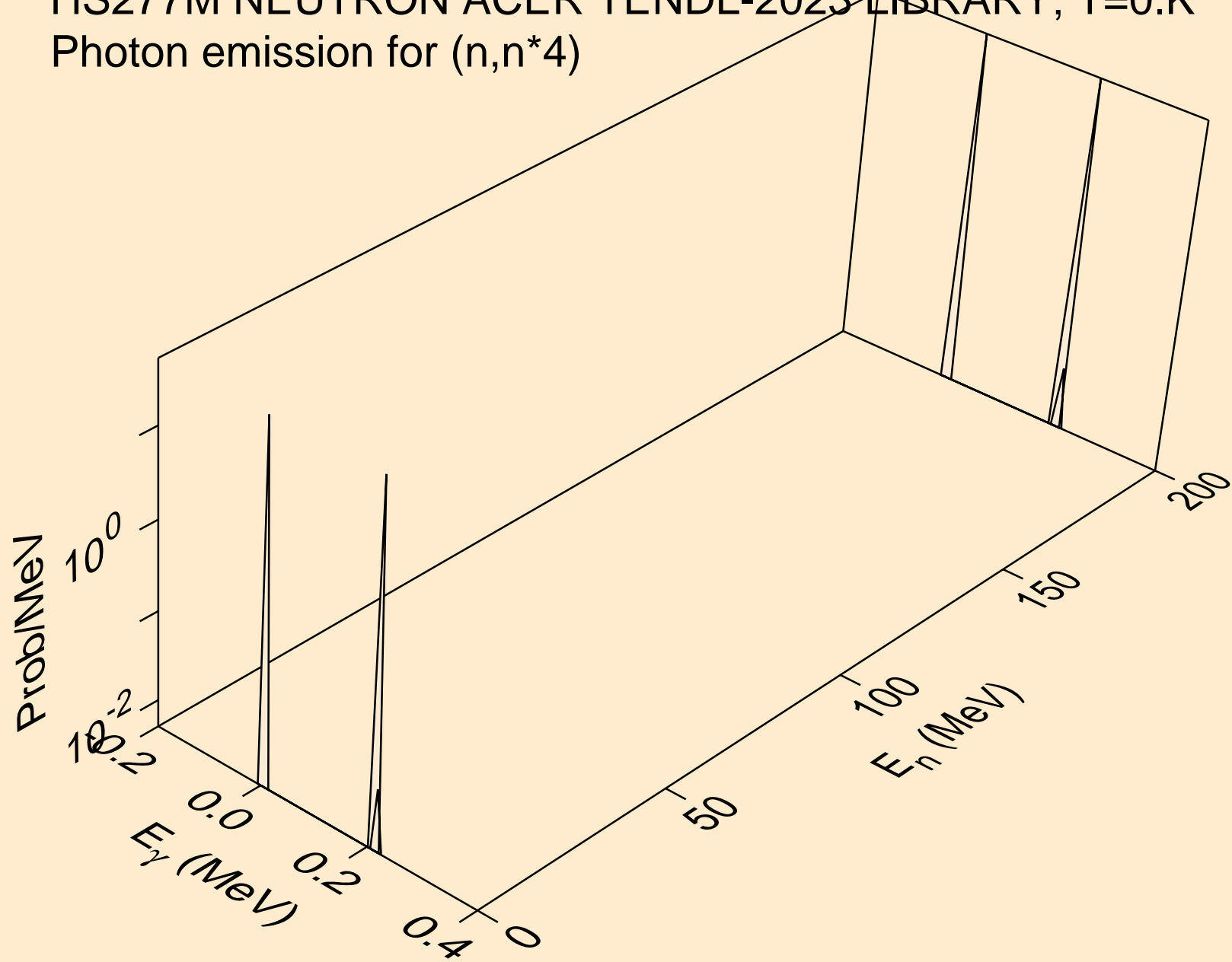

HS277M NEUTRON ACER TENDL-2023 LIBRARY; T=0.K
Photon emission for (n,n*5)

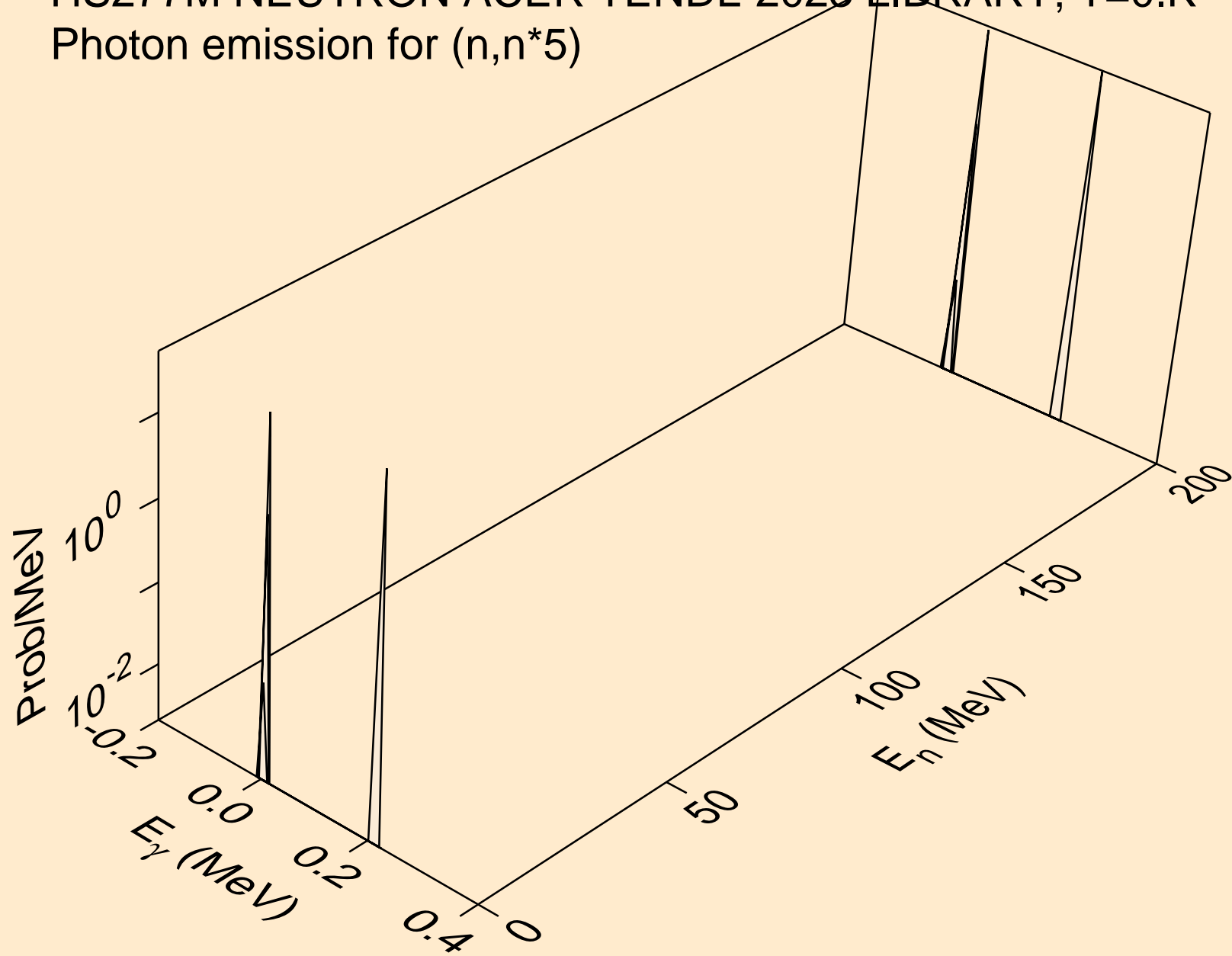

HS277M NEUTRON ACER TENDL-2023 LIBRARY; T=0.K
Photon emission for (n,n*6)

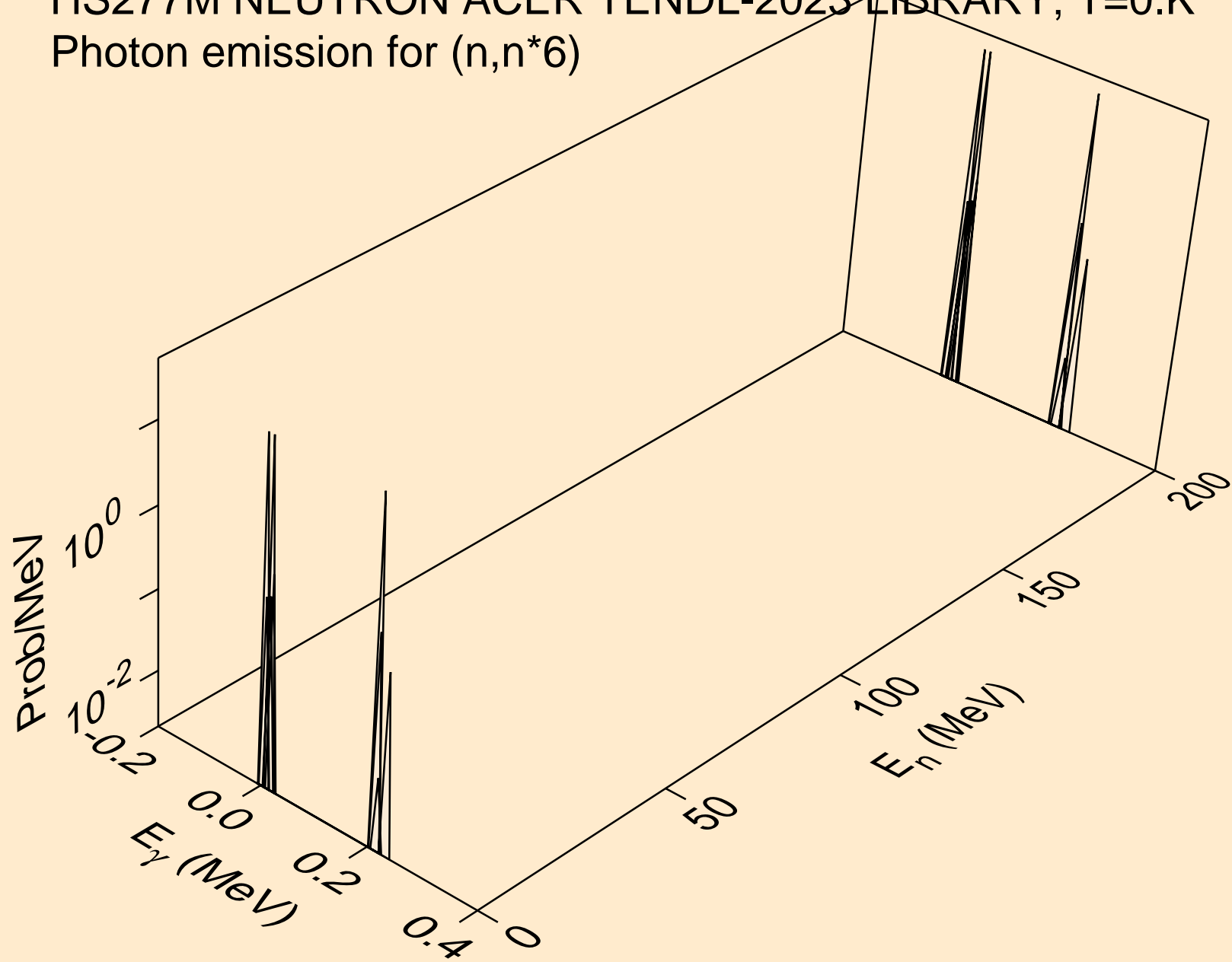

HS277M NEUTRON ACER TENDL-2023 LIBRARY; T=0.K
Photon emission for (n,n*7)

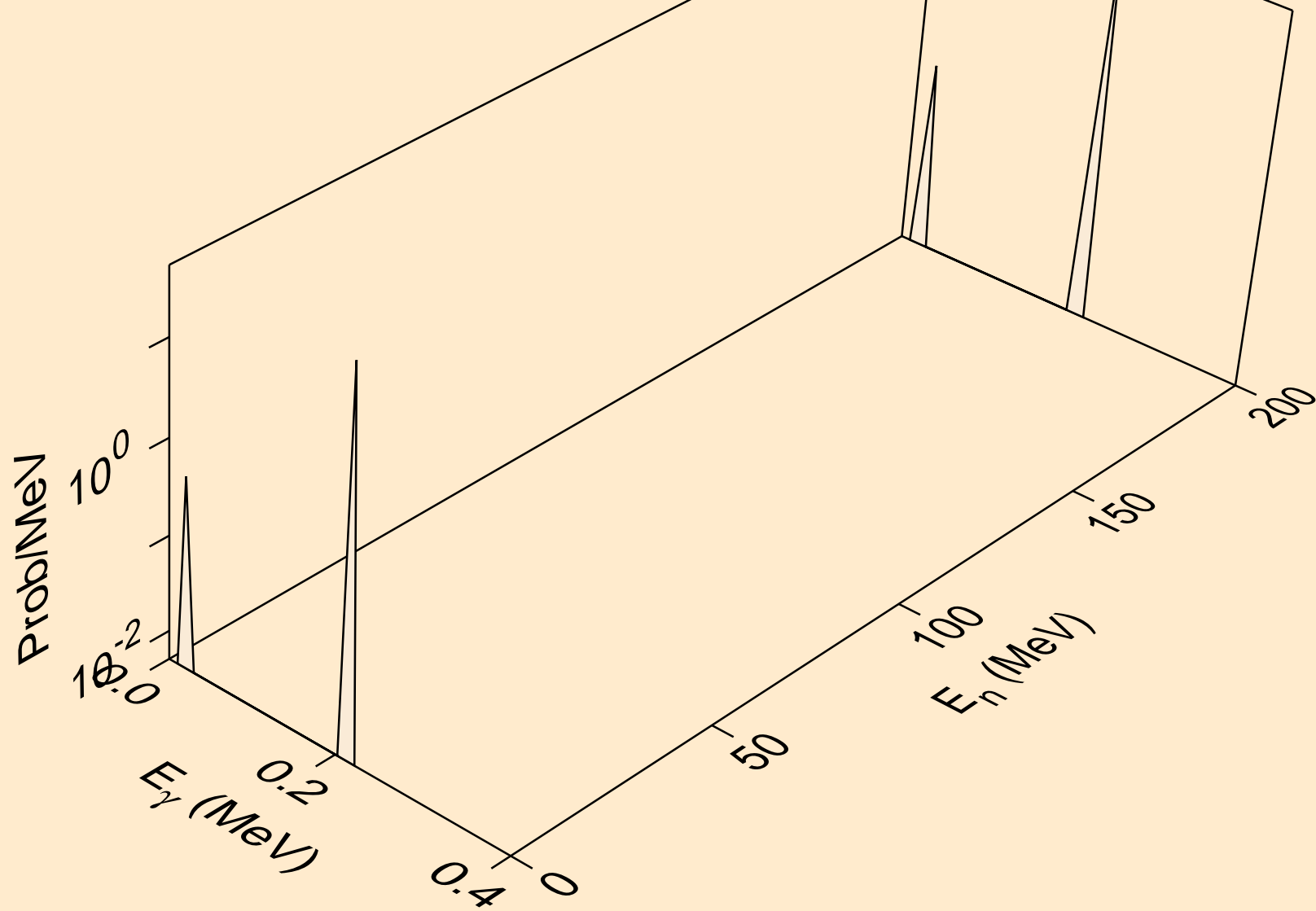

HS277M NEUTRON ACER TENDL-2023 LIBRARY; T=0.K
Photon emission for (n,n*8)

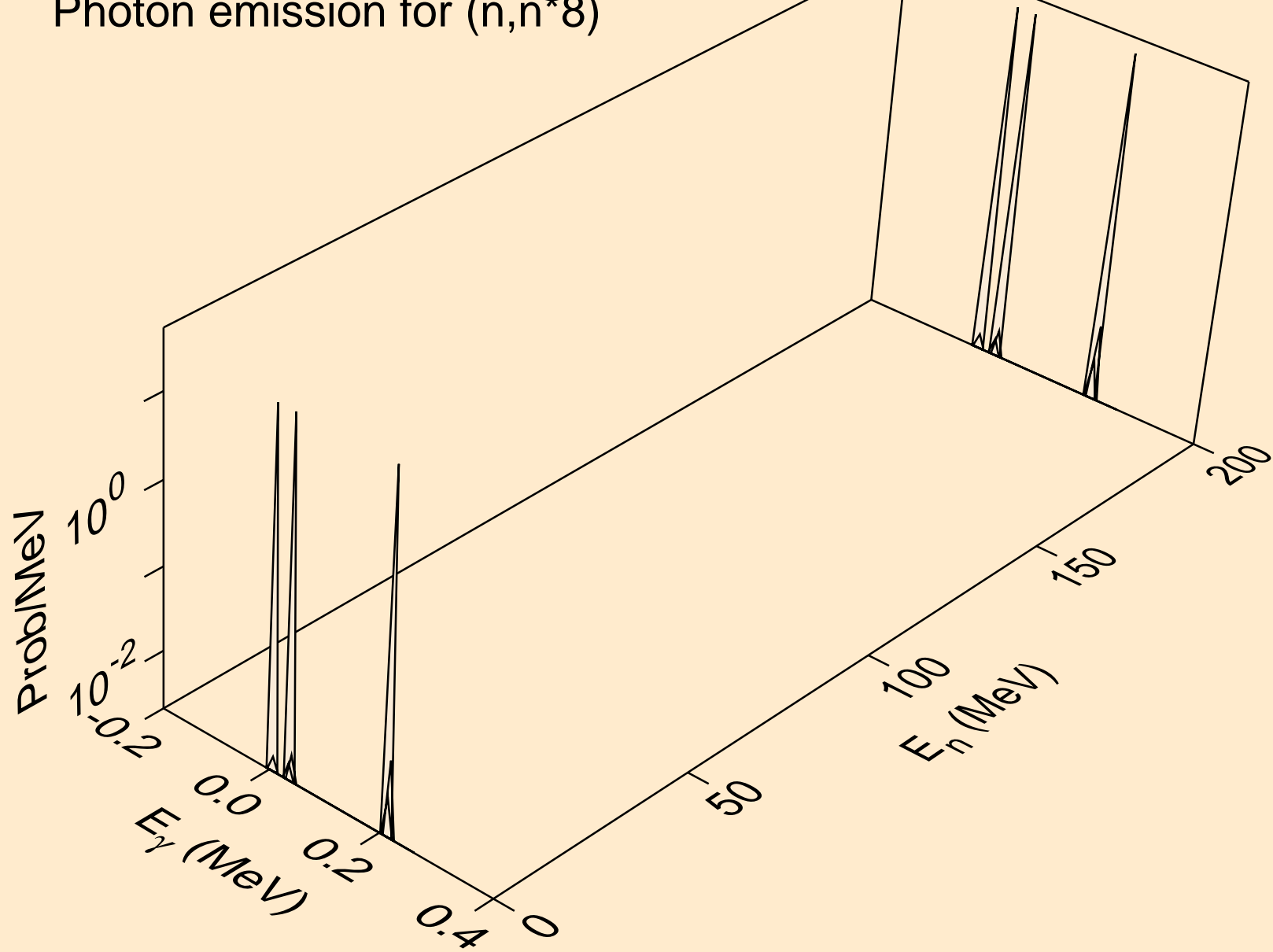

HS277M NEUTRON ACER TENDL-2023 LIBRARY; T=0.K
Photon emission for (n,n*9)

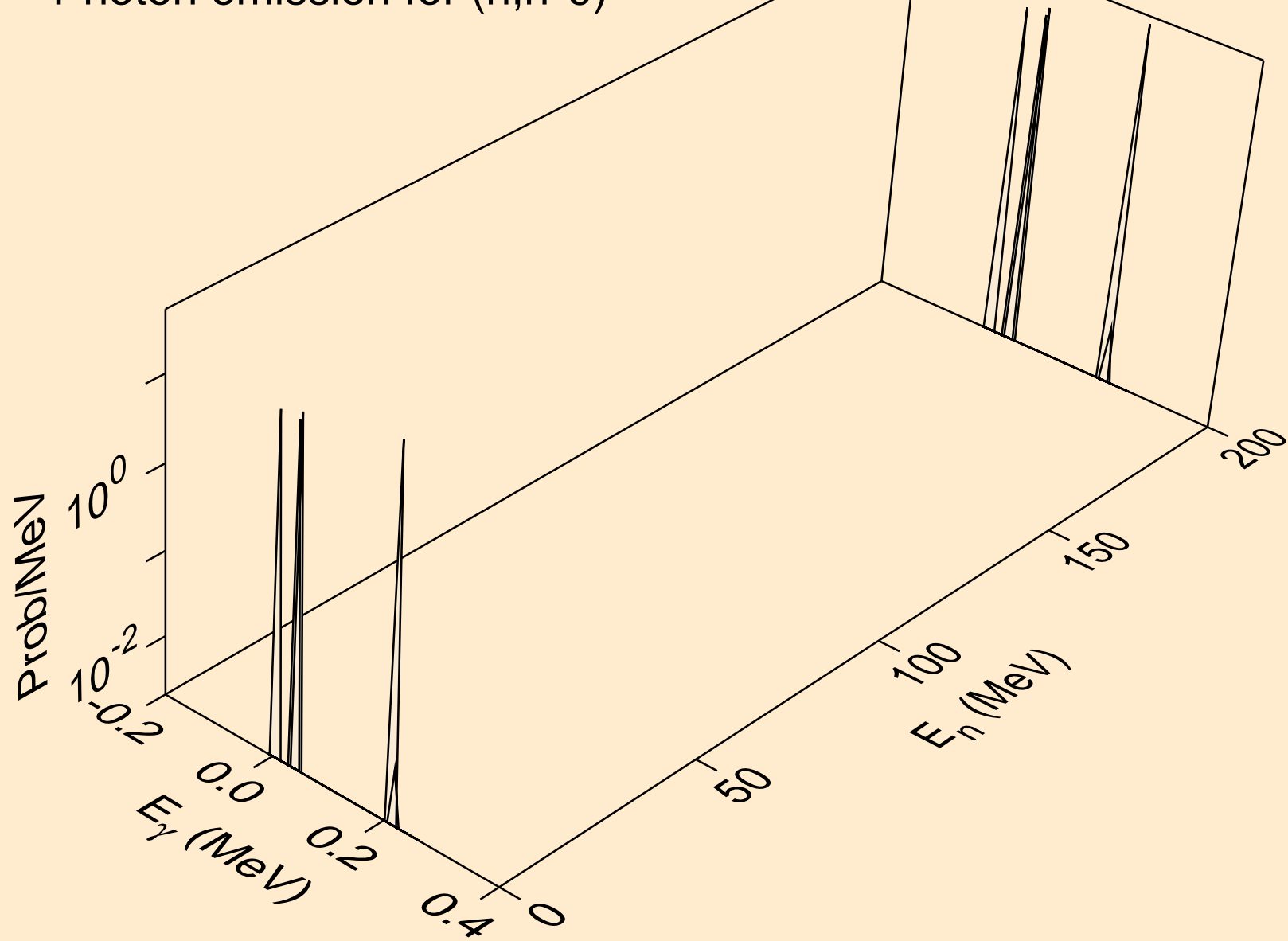

HS277M NEUTRON ACER TENDL-2023 LIBRARY; T=0.K
Photon emission for (n,n*10)

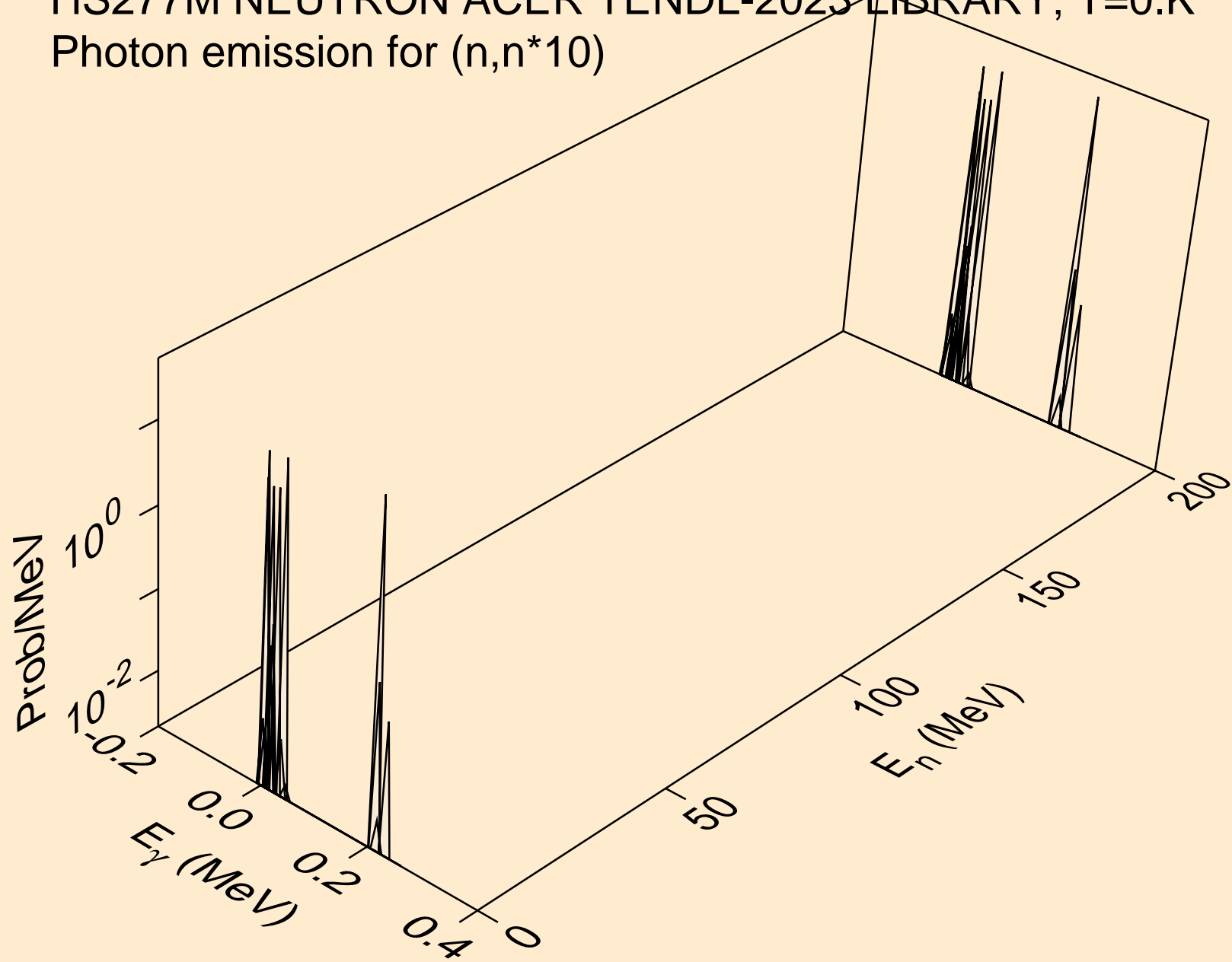

HS277M NEUTRON ACER TENDL-2023 LIBRARY; T=0.K
Photon emission for (n,n*11)

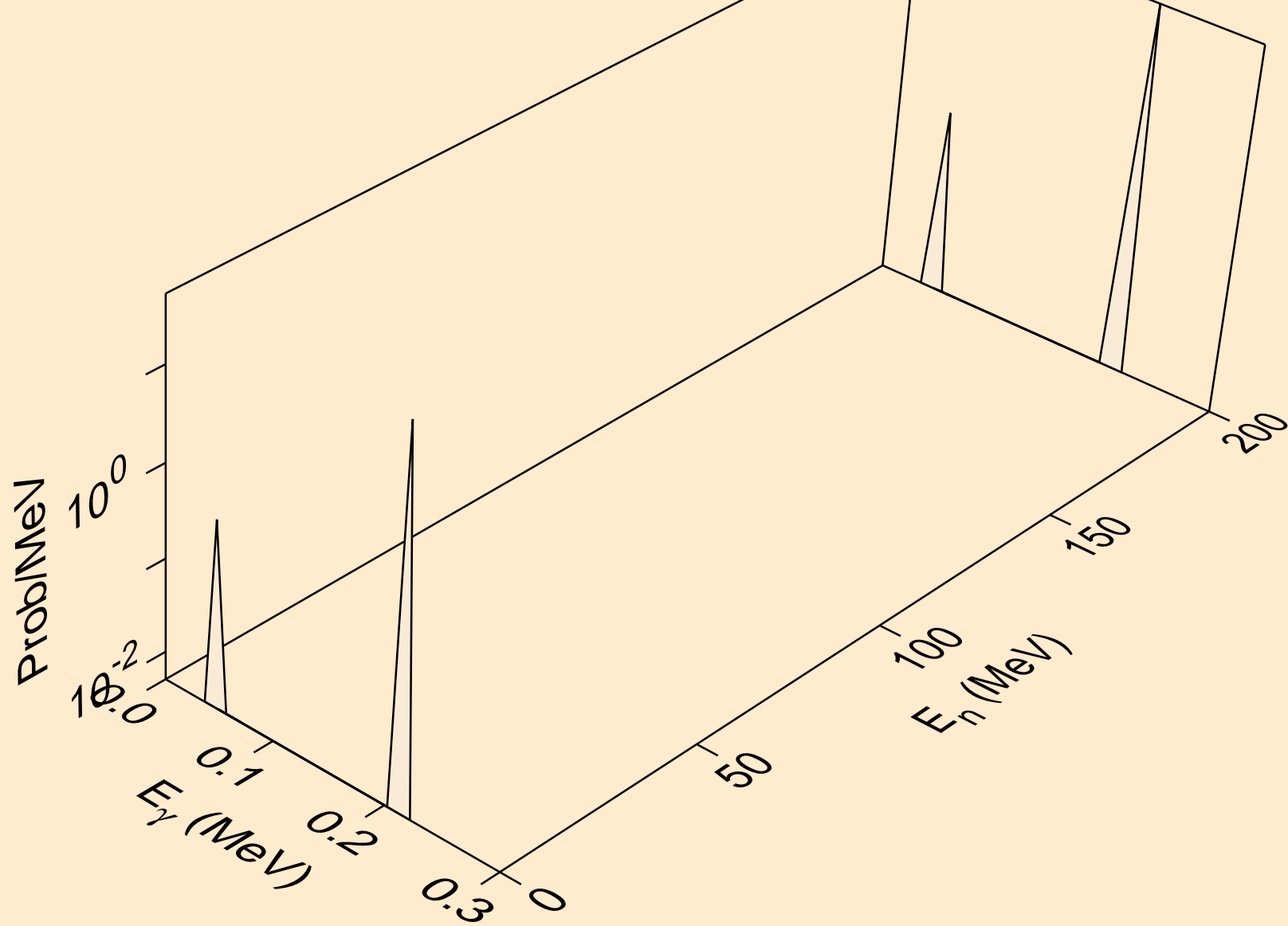

HS277M NEUTRON ACER TENDL-2023 LIBRARY; T=0.K
Photon emission for (n,n*12)

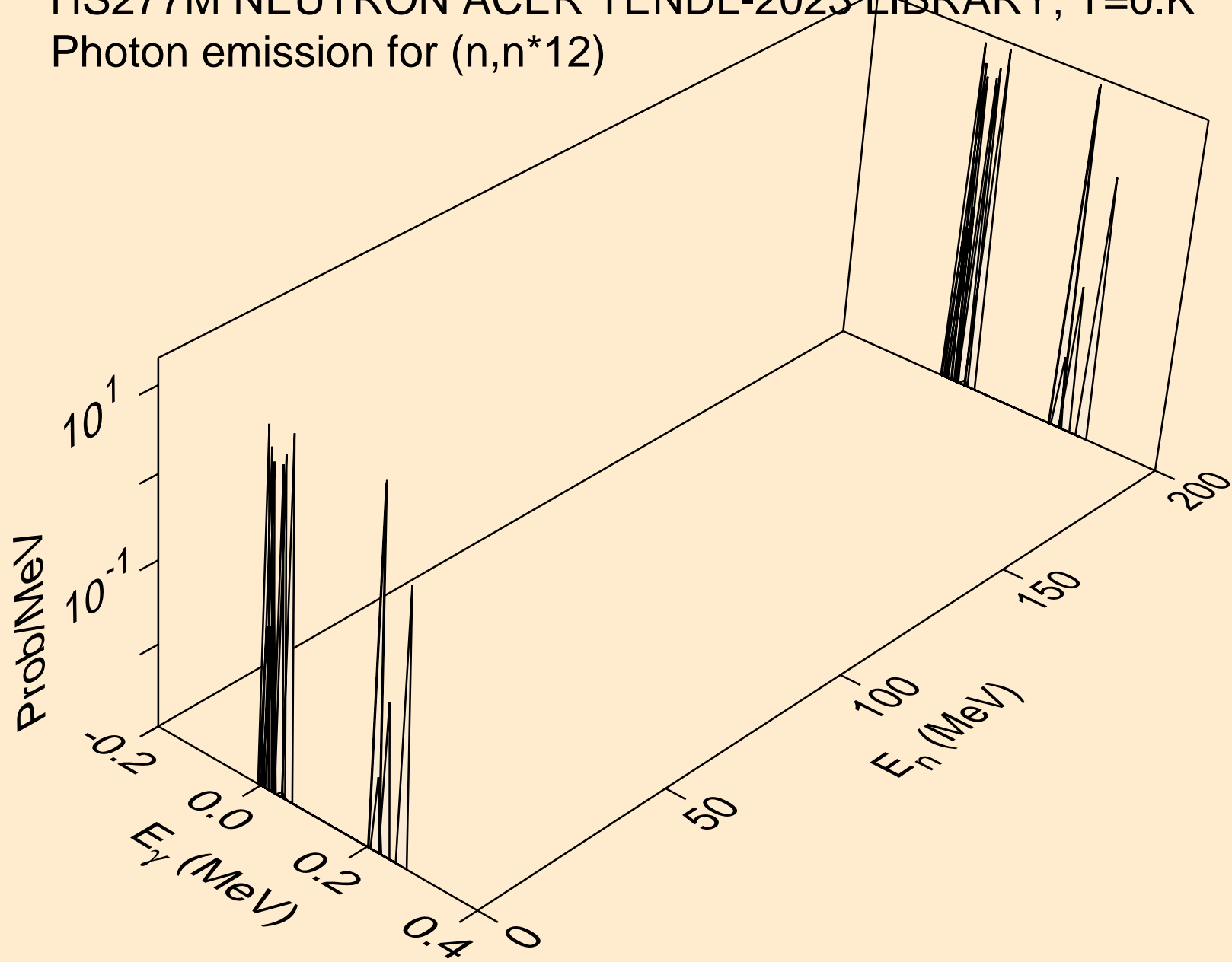

HS277M NEUTRON ACER TENDL-2023 LIBRARY; T=0.K
Photon emission for (n,n*13)

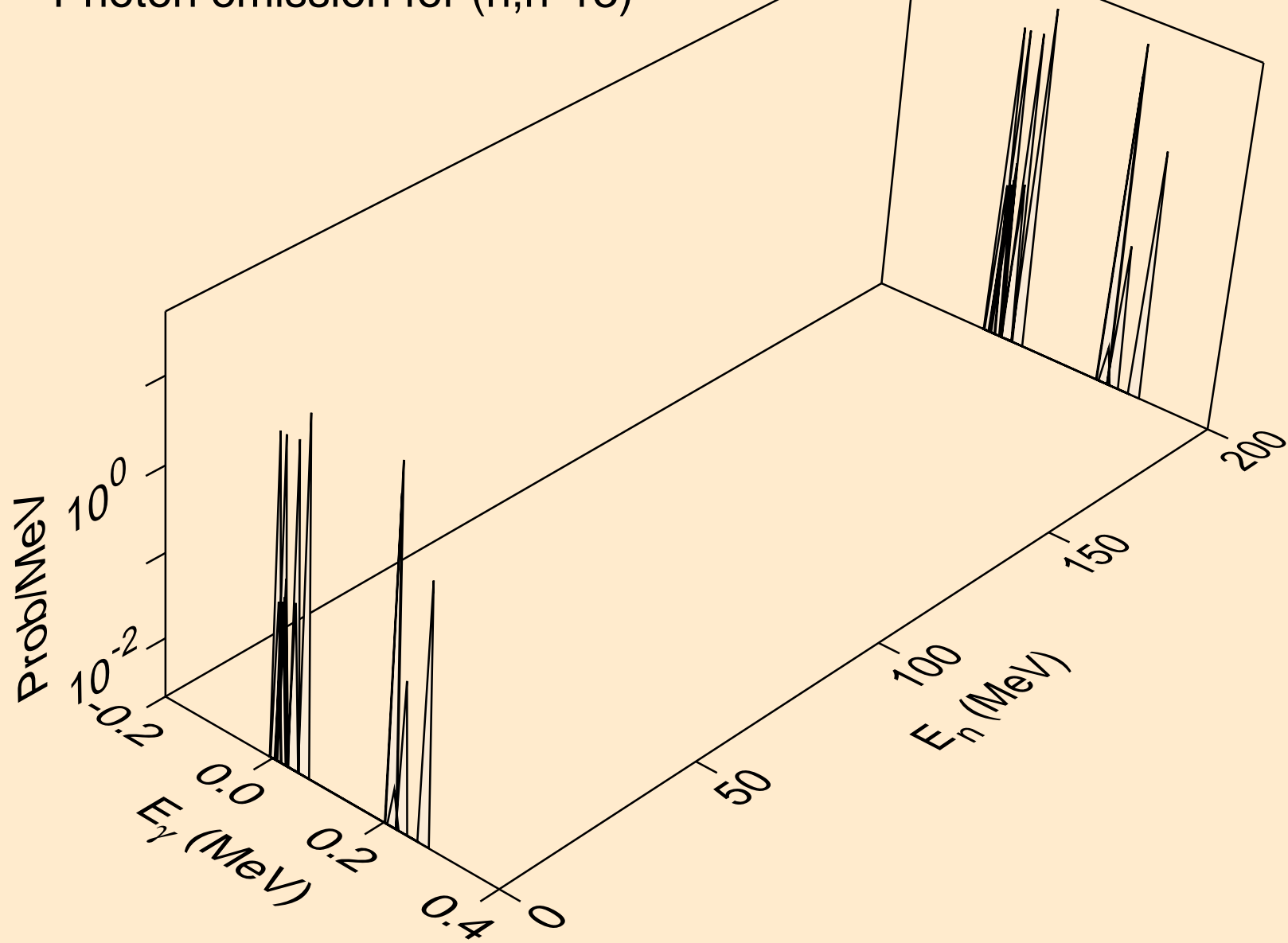

HS277M NEUTRON ACER TENDL-2023 LIBRARY; T=0.K
Photon emission for (n,n*14)

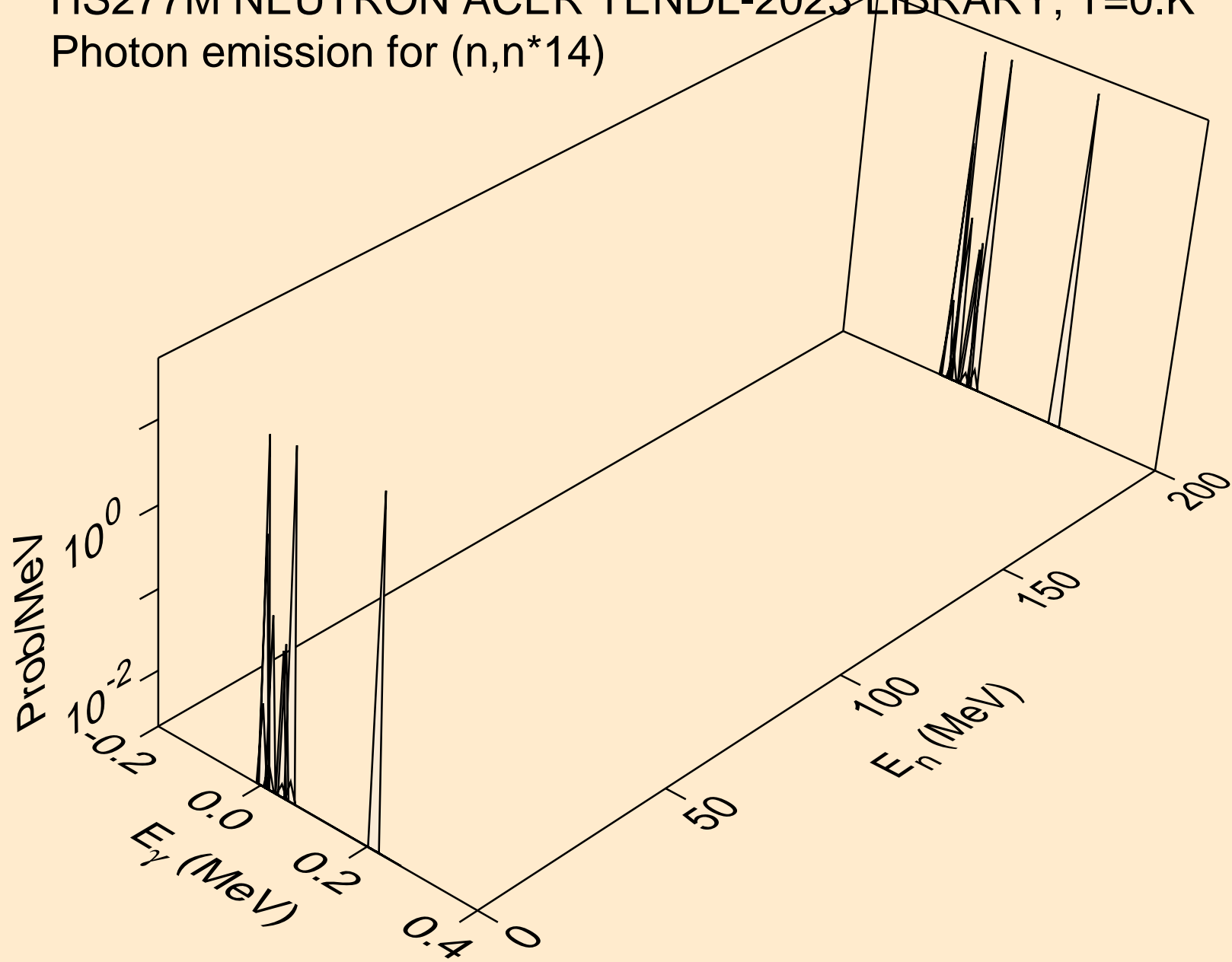

HS277M NEUTRON ACER TENDL-2023 LIBRARY; T=0.K
Photon emission for (n,n*15)

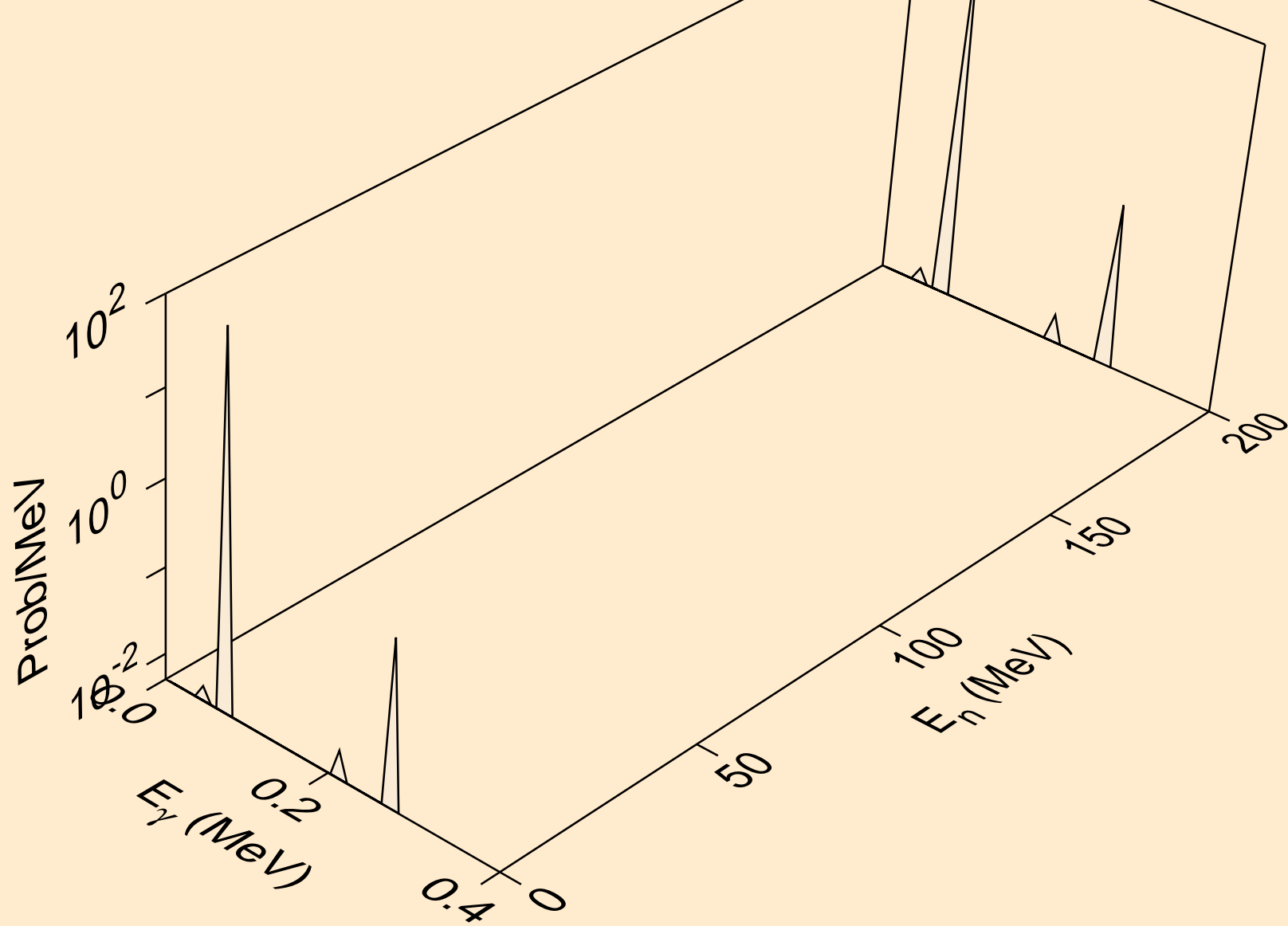

HS277M NEUTRON ACER TENDL-2023 LIBRARY; T=0.K
Photon emission for (n,n*16)

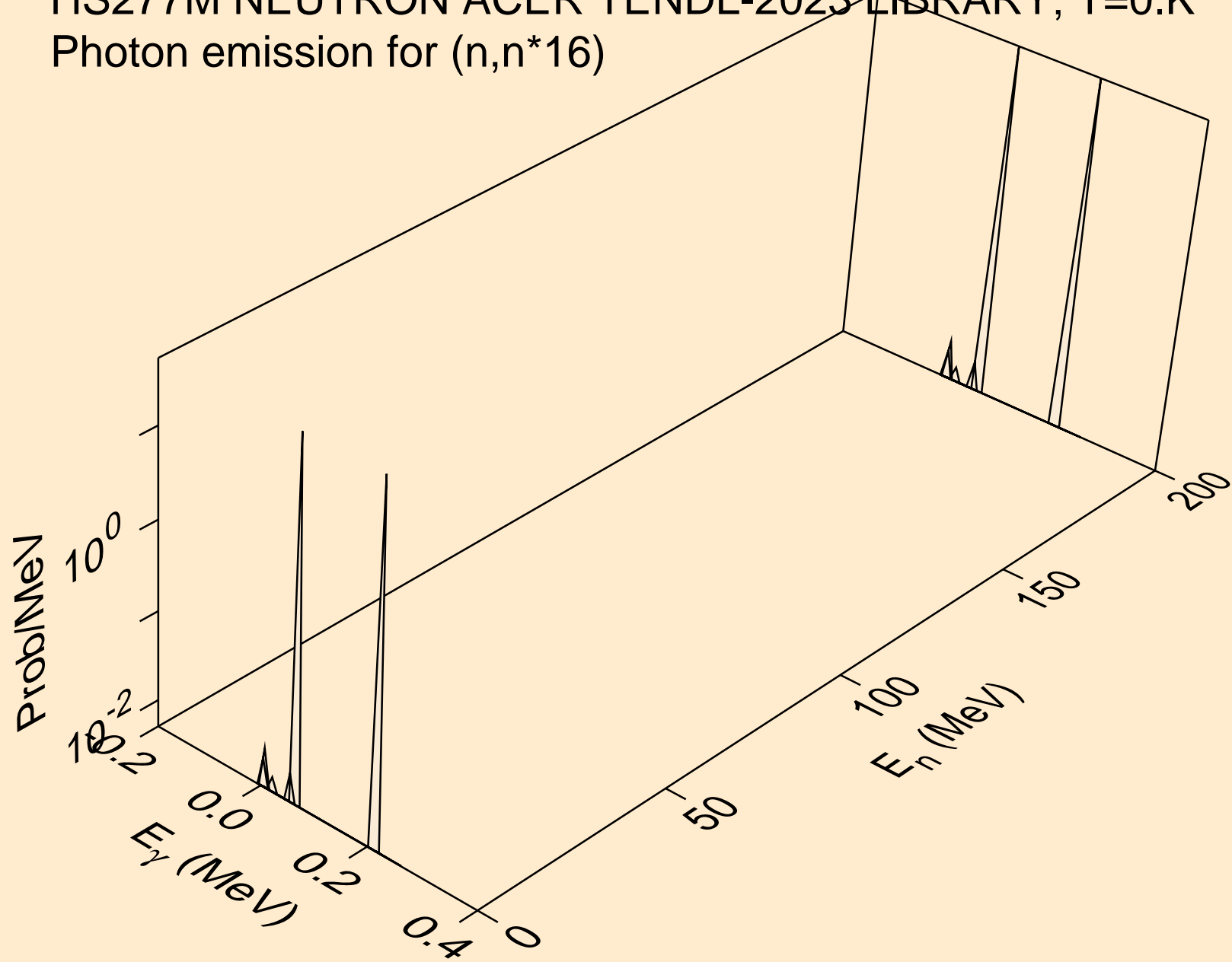

HS277M NEUTRON ACER TENDL-2023 LIBRARY; T=0.K
Photon emission for (n,n*17)

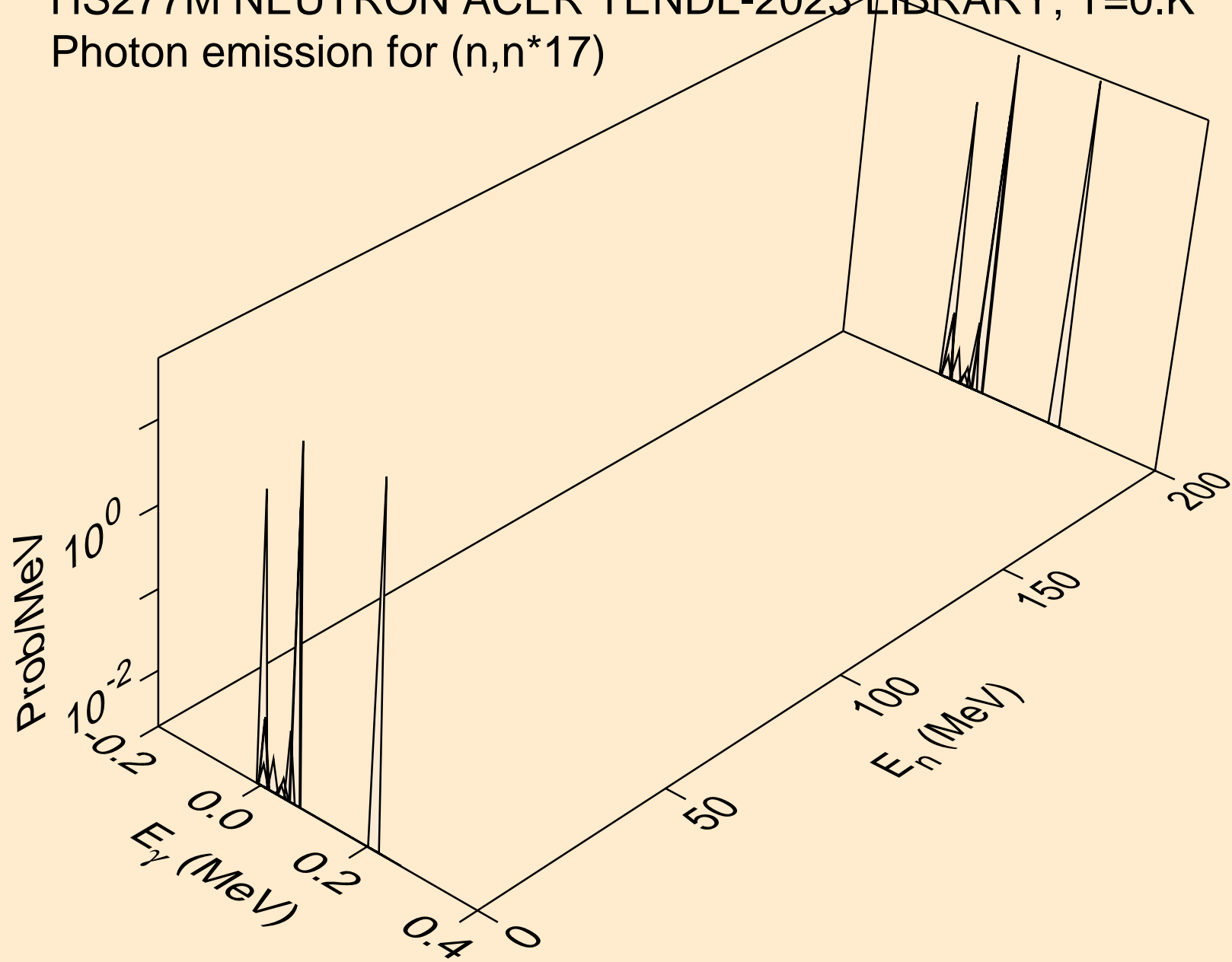

HS277M NEUTRON ACER TENDL-2023 LIBRARY; T=0.K
Photon emission for (n,n*18)

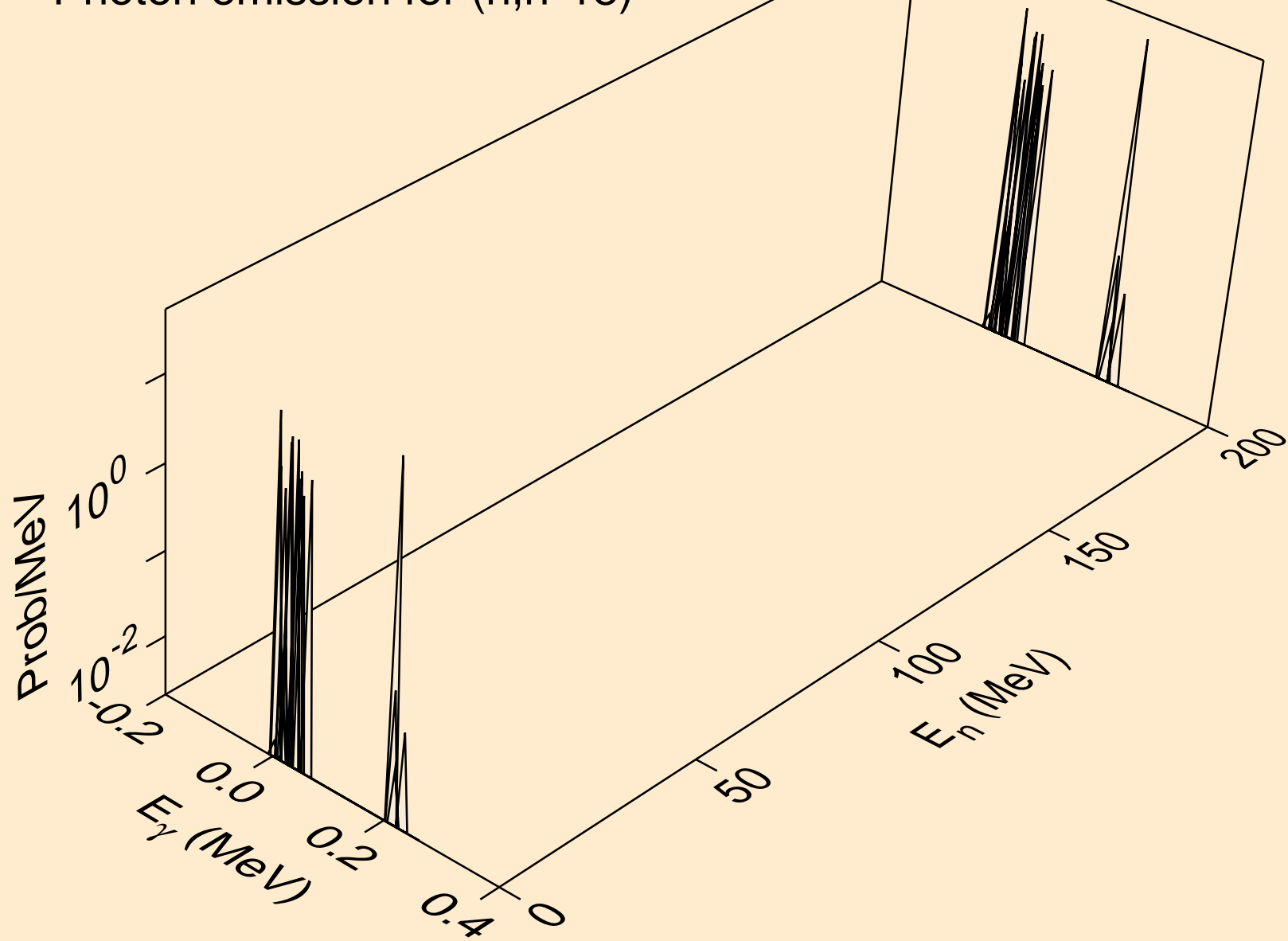

HS277M NEUTRON ACER TENDL-2023 LIBRARY; T=0.K
Photon emission for (n,n*19)

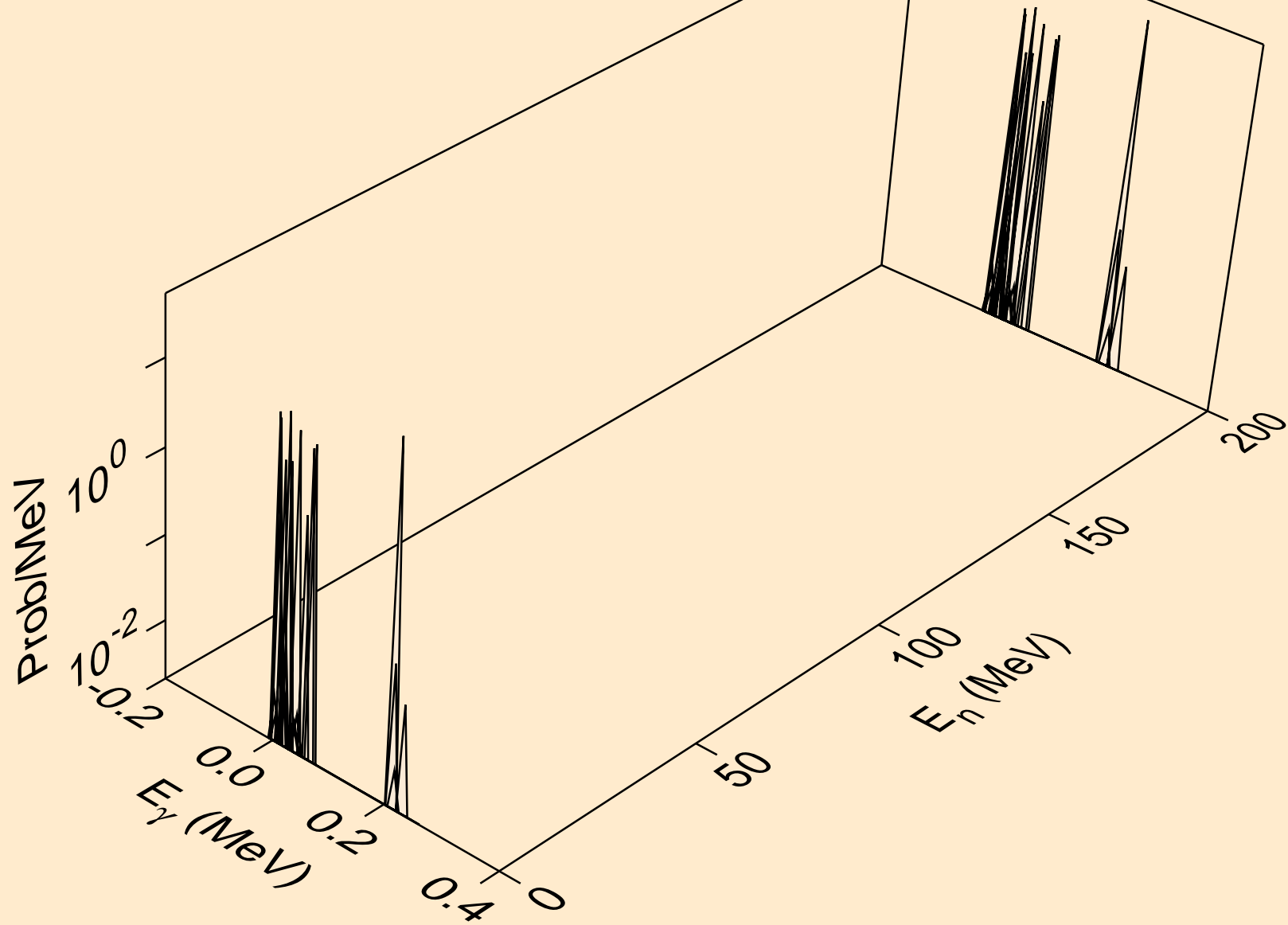

HS277M NEUTRON ACER TENDL-2023 LIBRARY; T=0.K
Photon emission for (n,n*20)

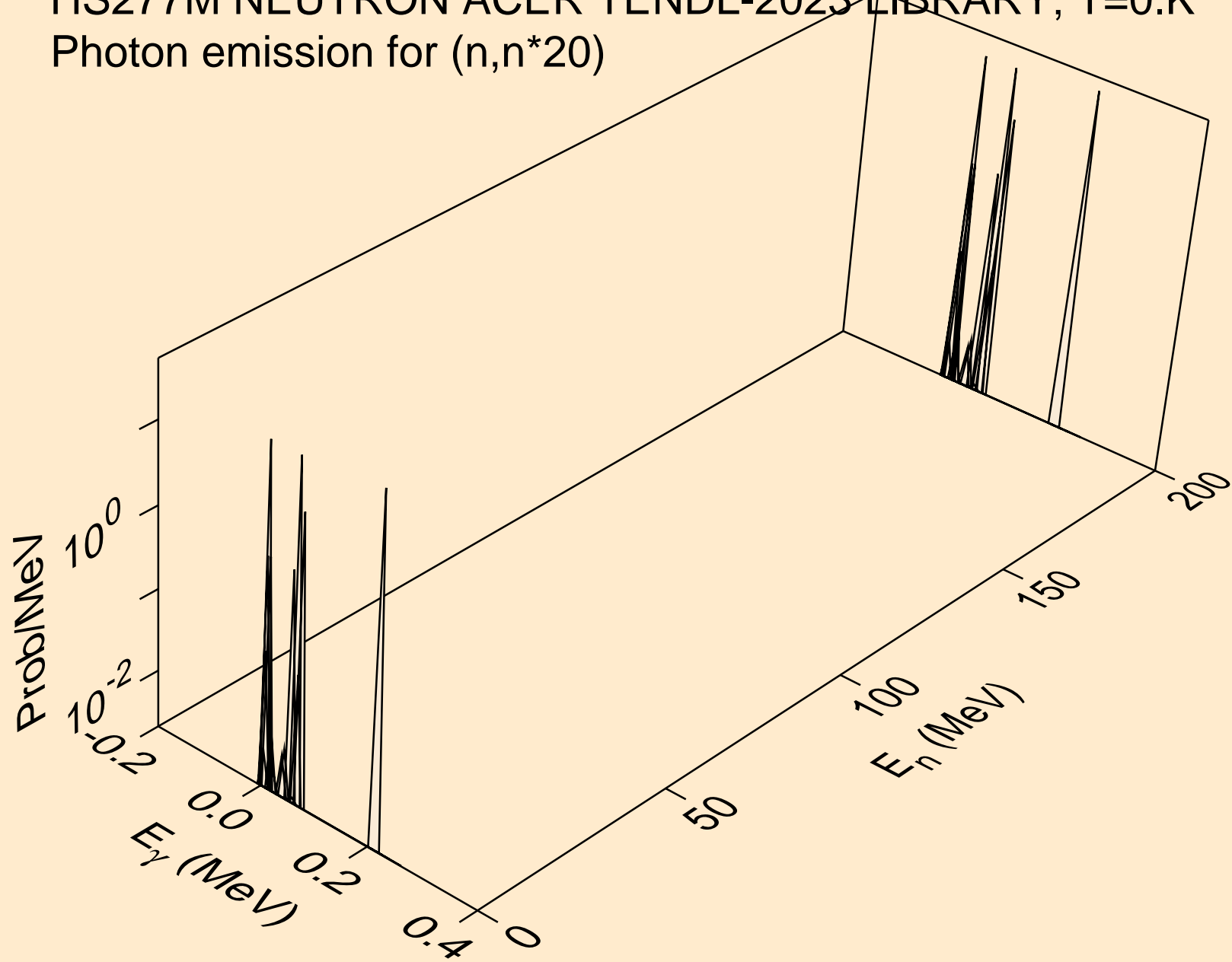

HS277M NEUTRON ACER TENDL-2023 LIBRARY; T=0.K
Photon emission for (n,n*21)

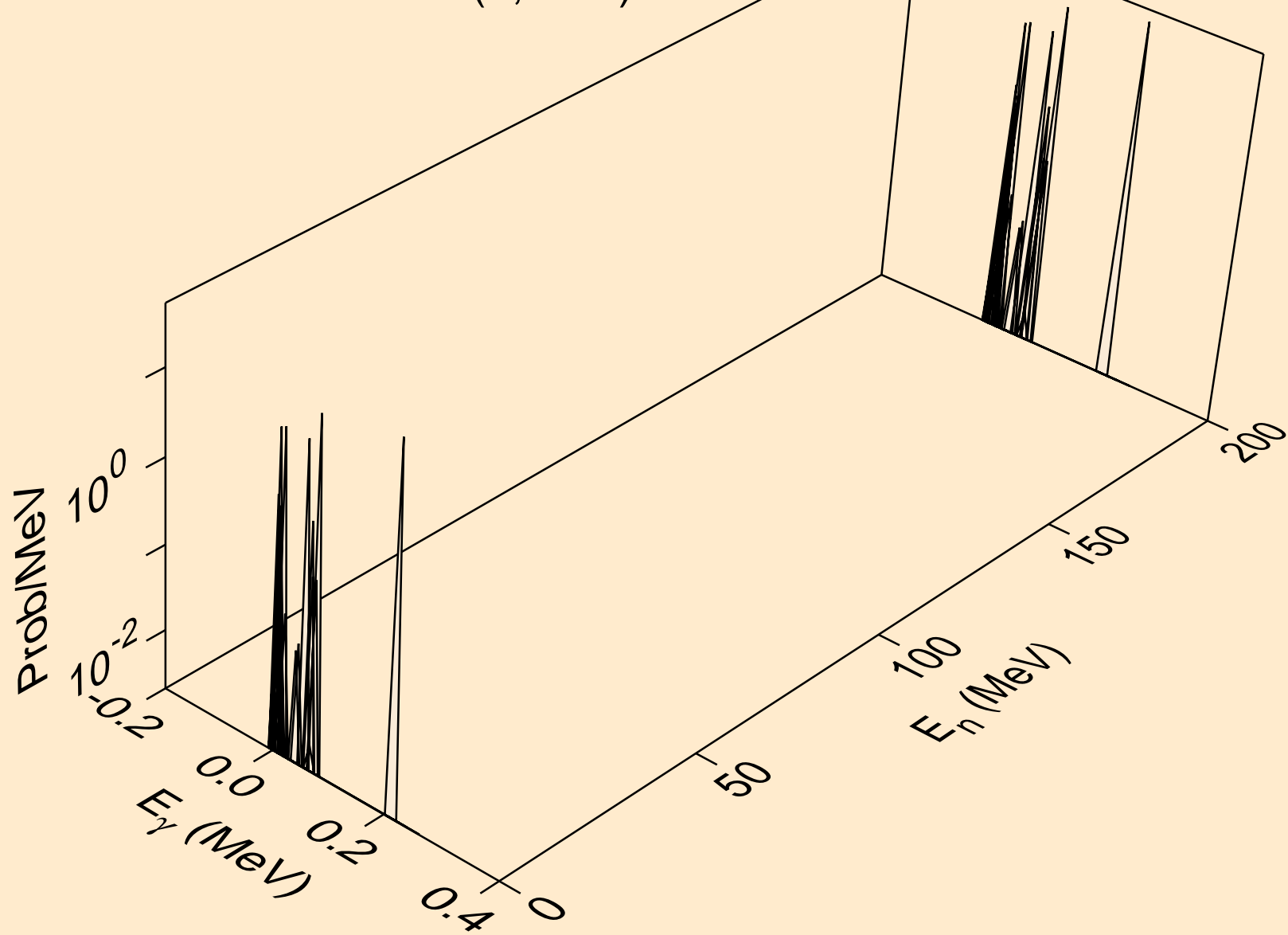

HS277M NEUTRON ACER TENDL-2023 LIBRARY; T=0.K
Photon emission for (n,n*22)

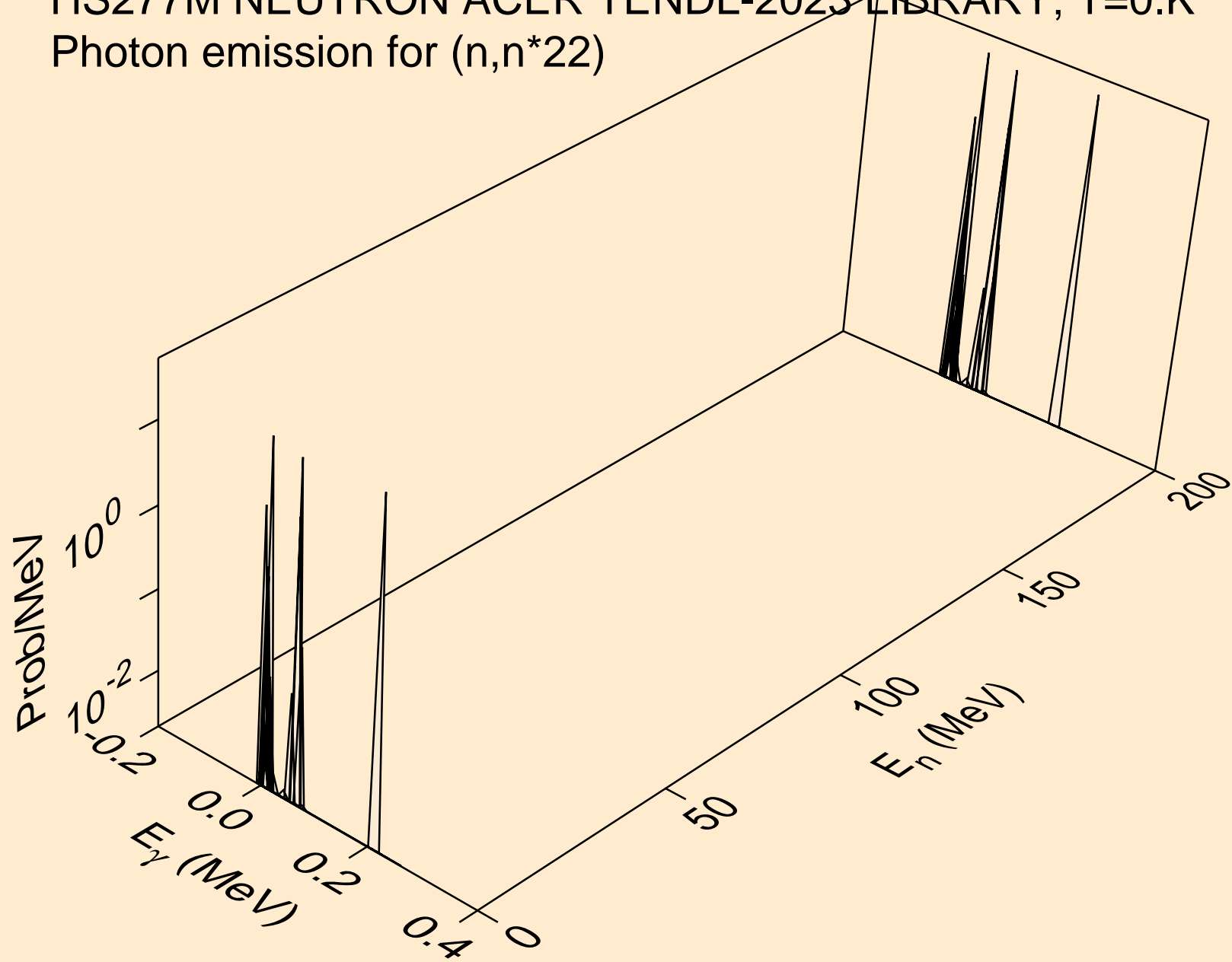

HS277M NEUTRON ACER TENDL-2023 LIBRARY; T=0.K
Photon emission for (n,n*23)

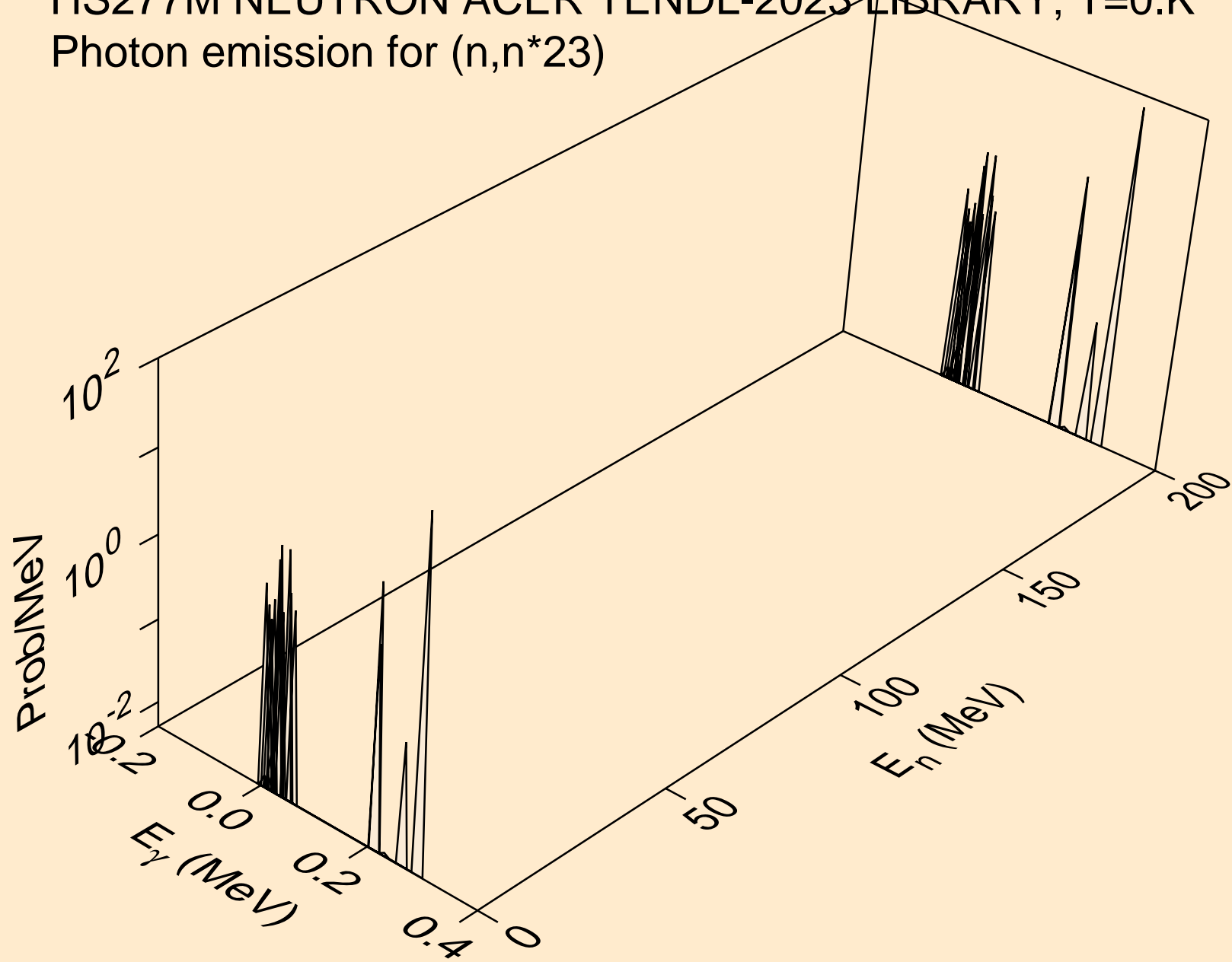

HS277M NEUTRON ACER TENDL-2023 LIBRARY; T=0.K
Photon emission for (n,n*24)

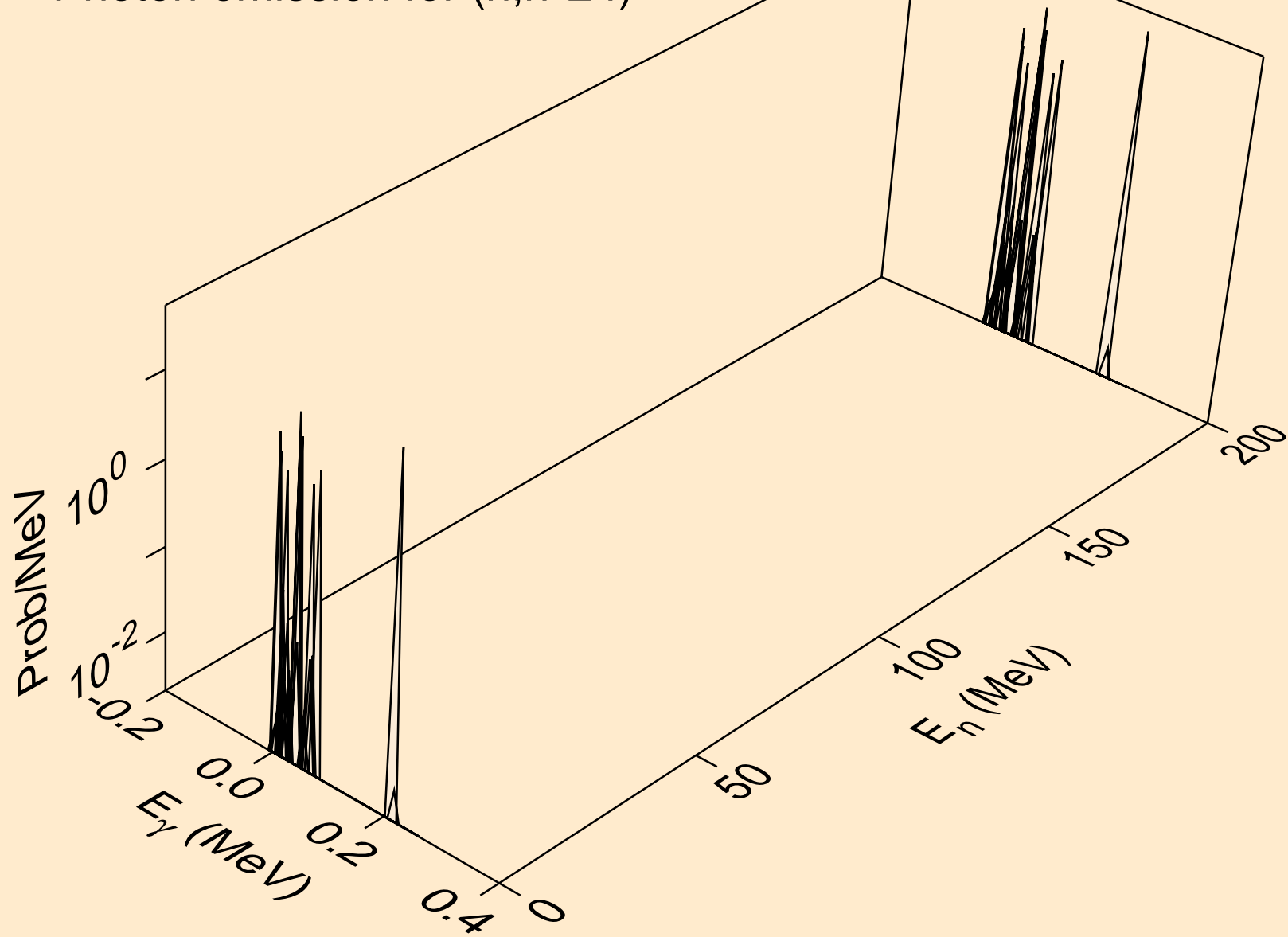

HS277M NEUTRON ACER TENDL-2023 LIBRARY; T=0.K
Photon emission for (n,n*25)

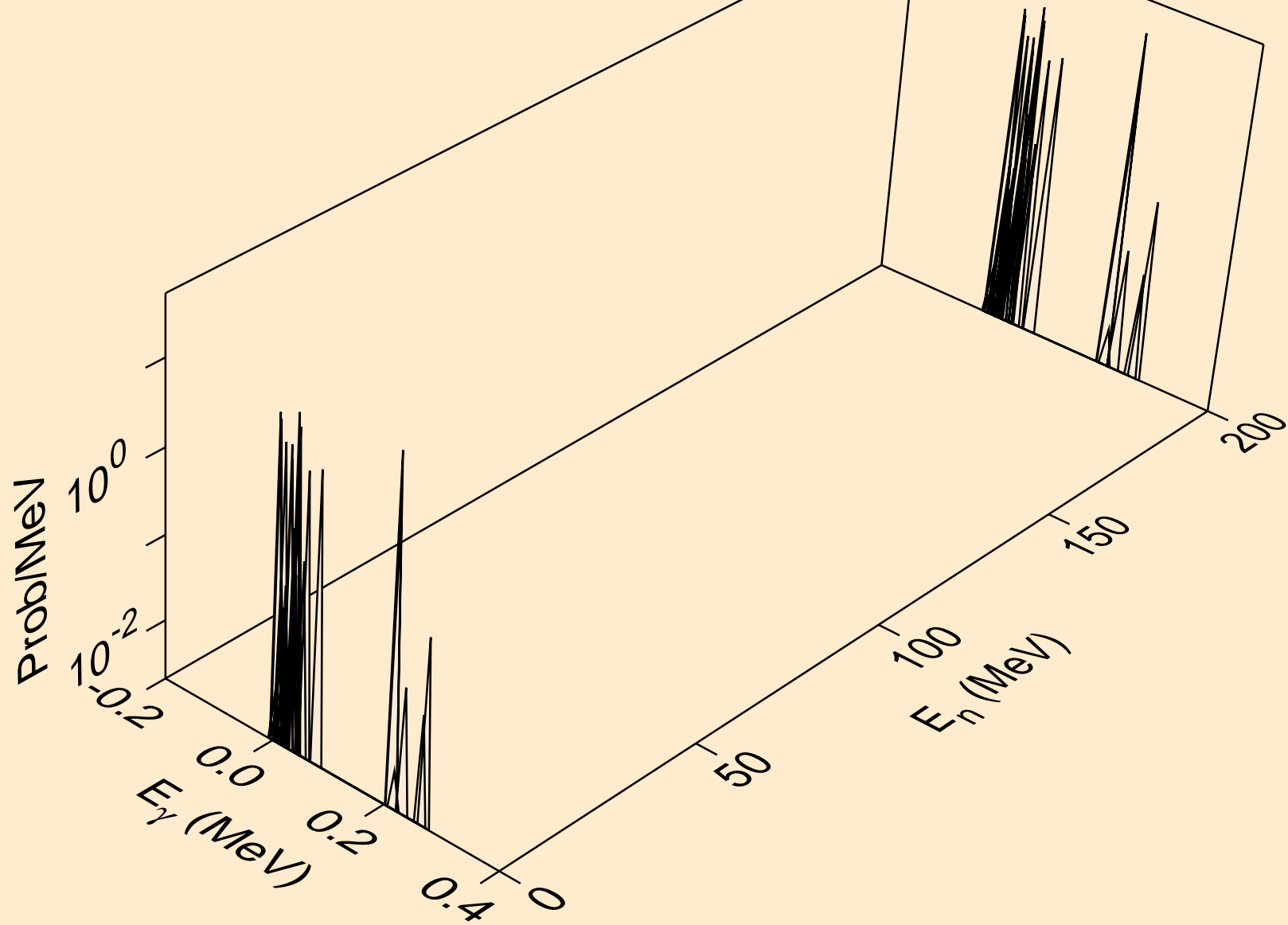

HS277M NEUTRON ACER TENDL-2023 LIBRARY; T=0.K
Photon emission for (n,n*26)

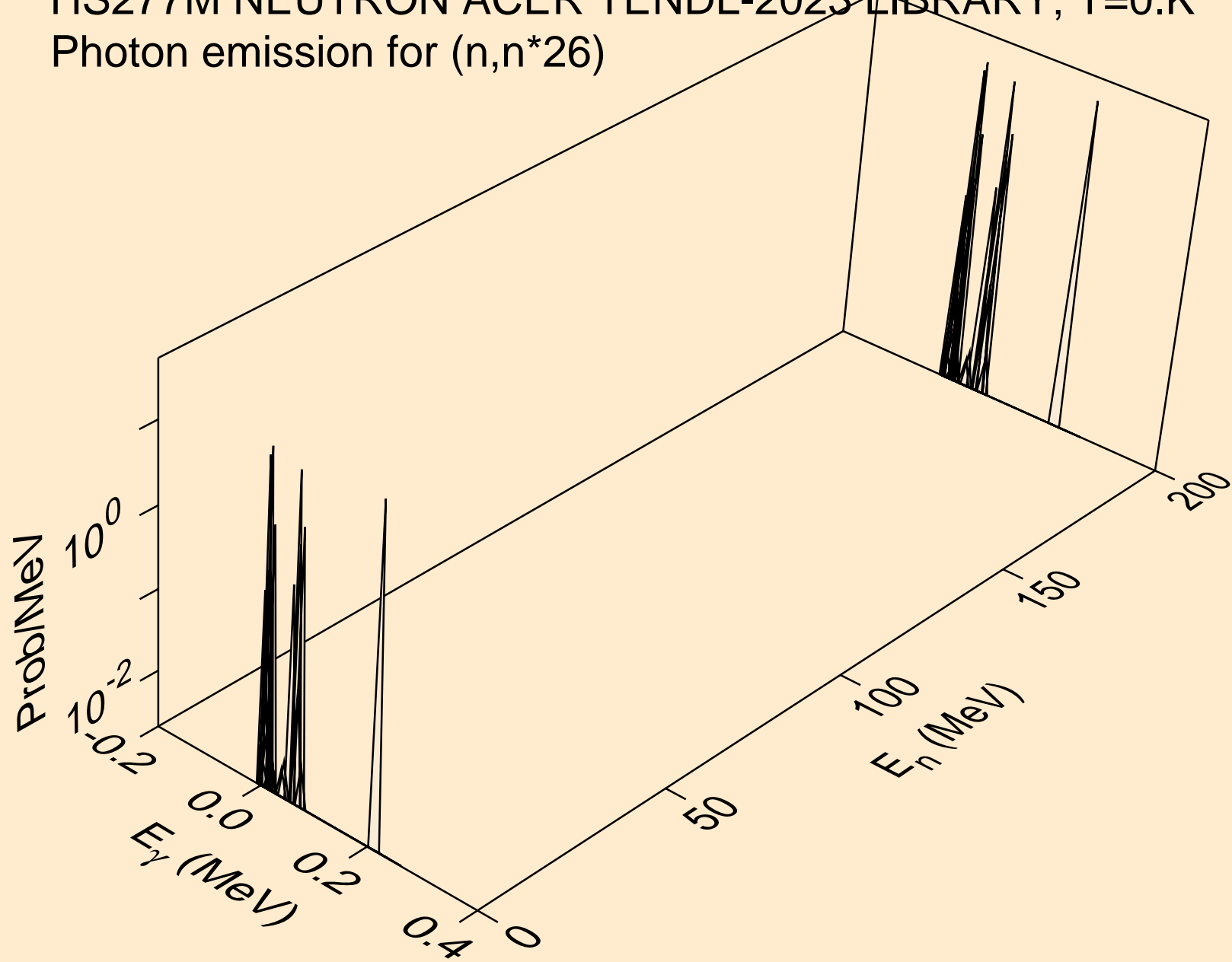

HS277M NEUTRON ACER TENDL-2023 LIBRARY; T=0.K
Photon emission for (n,n*27)

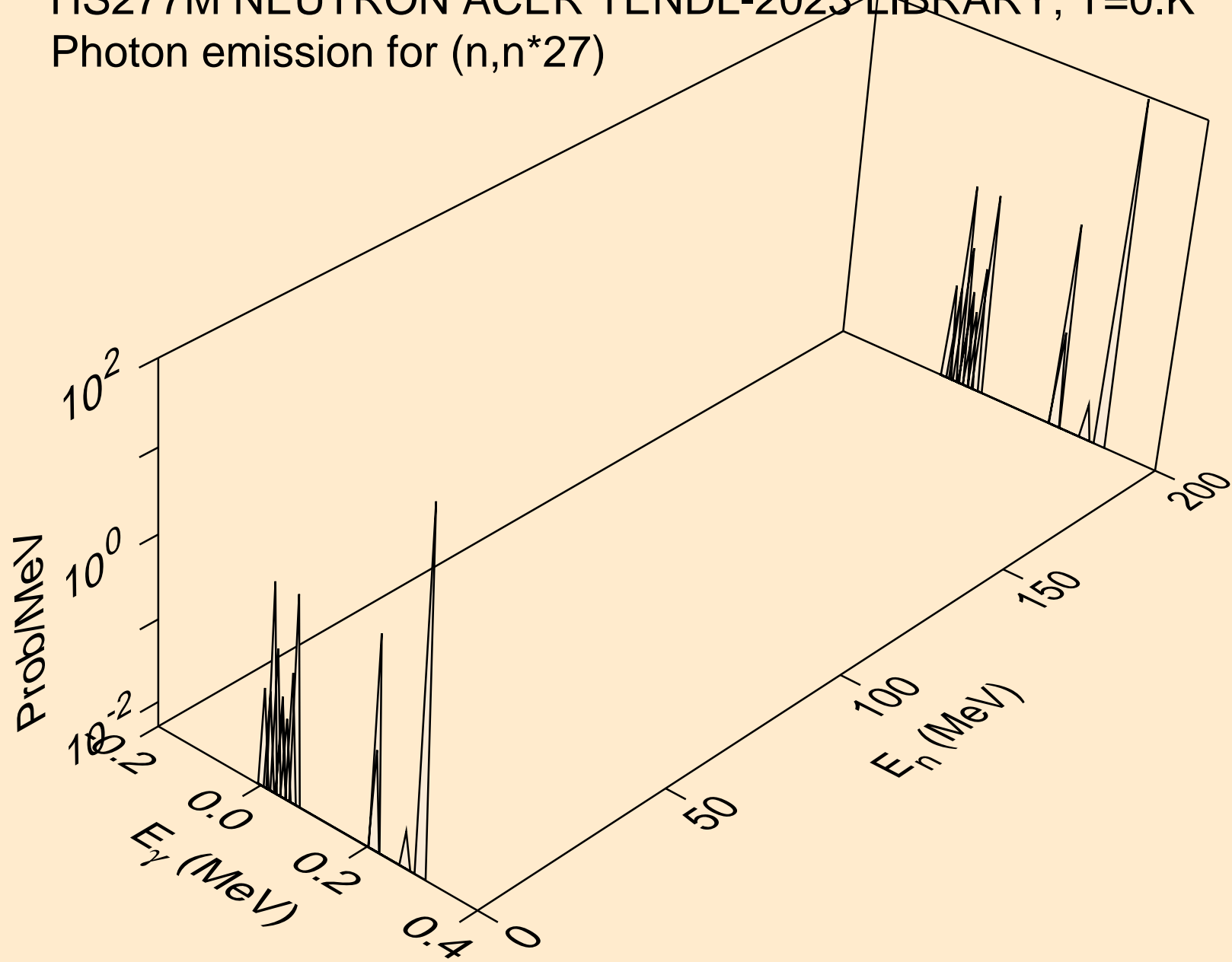

HS277M NEUTRON ACER TENDL-2023 LIBRARY; T=0.K
Photon emission for (n,n*28)

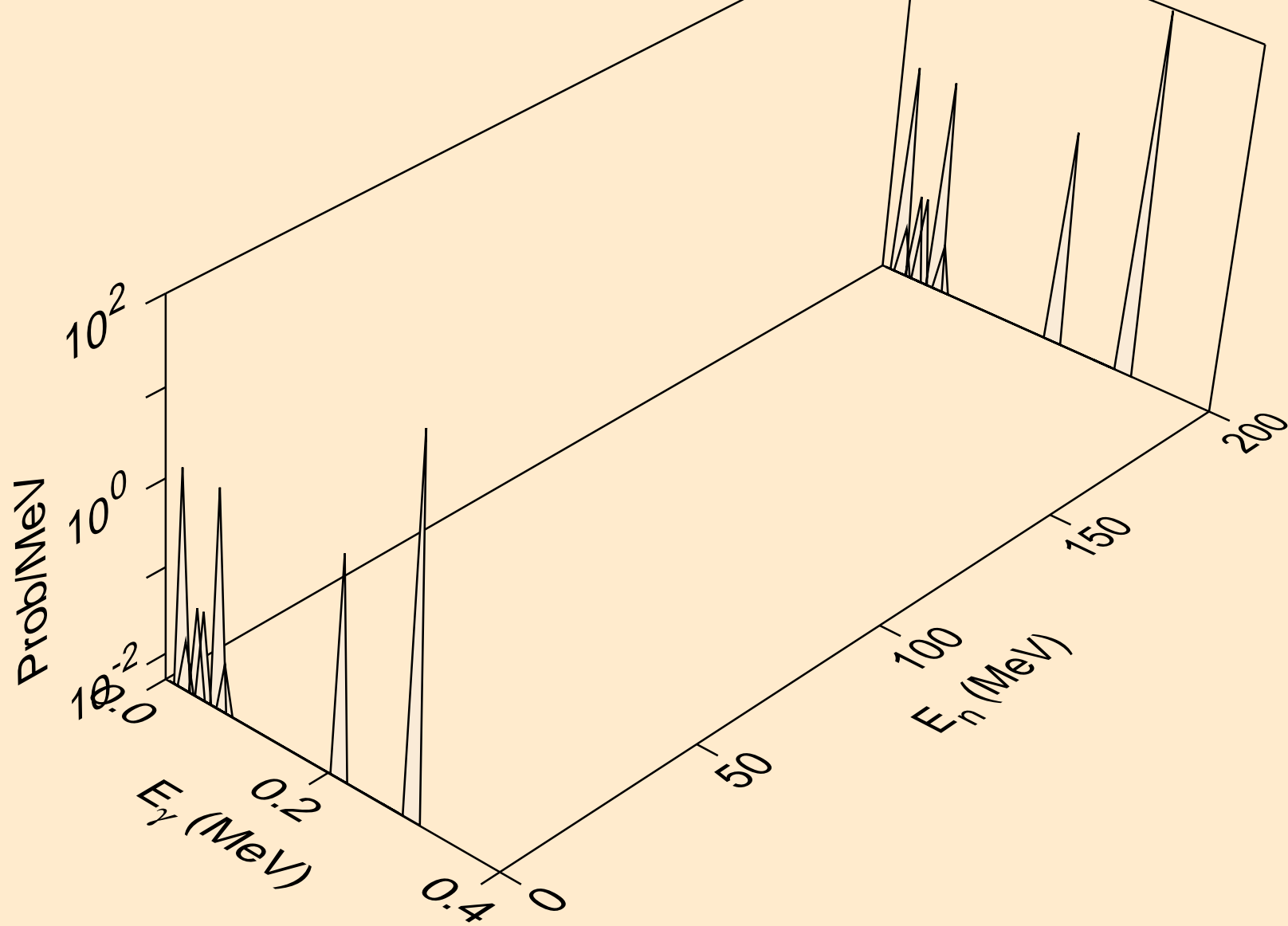

HS277M NEUTRON ACER TENDL-2023 LIBRARY; T=0.K
Photon emission for (n,n*29)

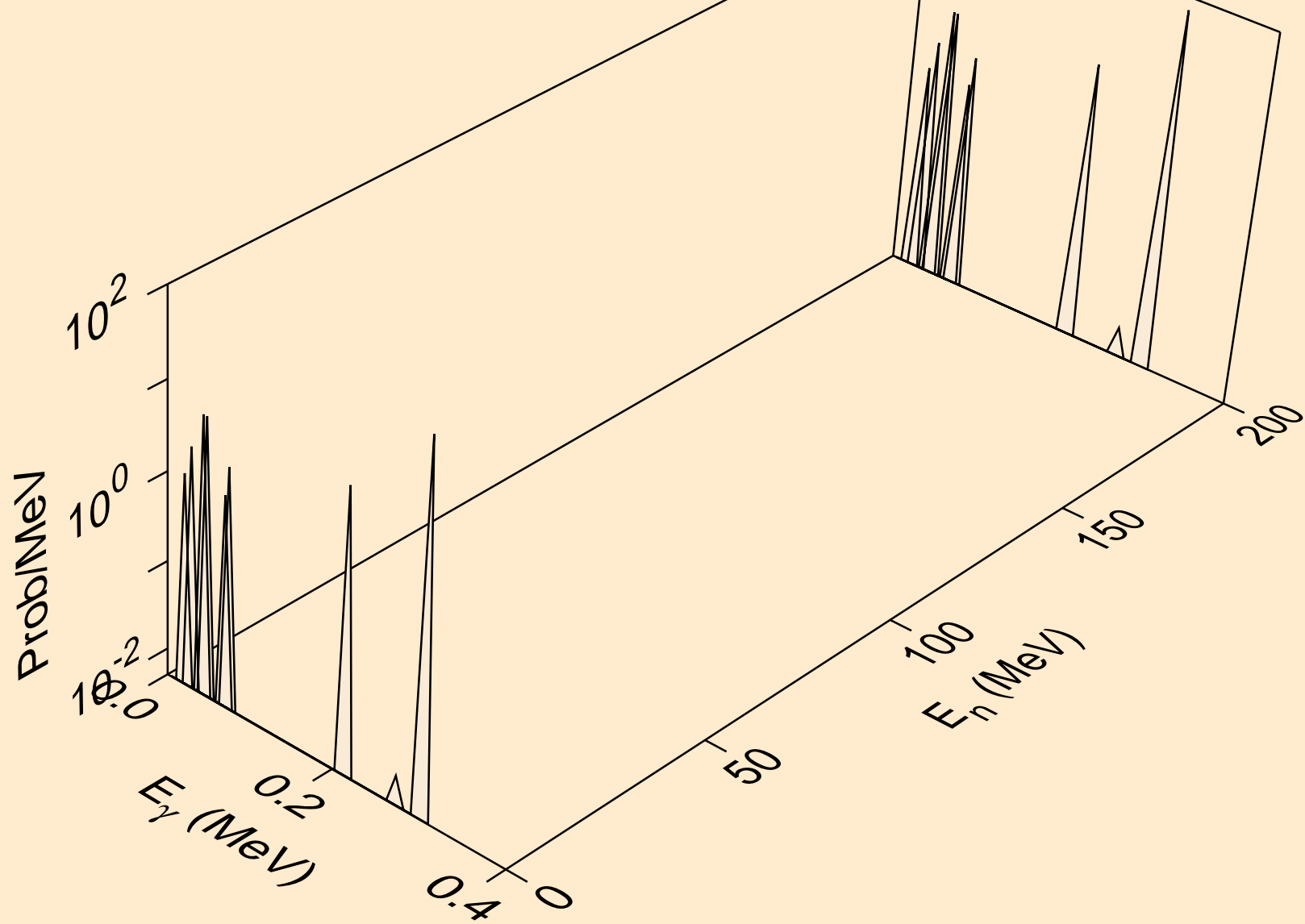

HS277M NEUTRON ACER TENDL-2023 LIBRARY; T=0.K
Photon emission for (n,n*c)

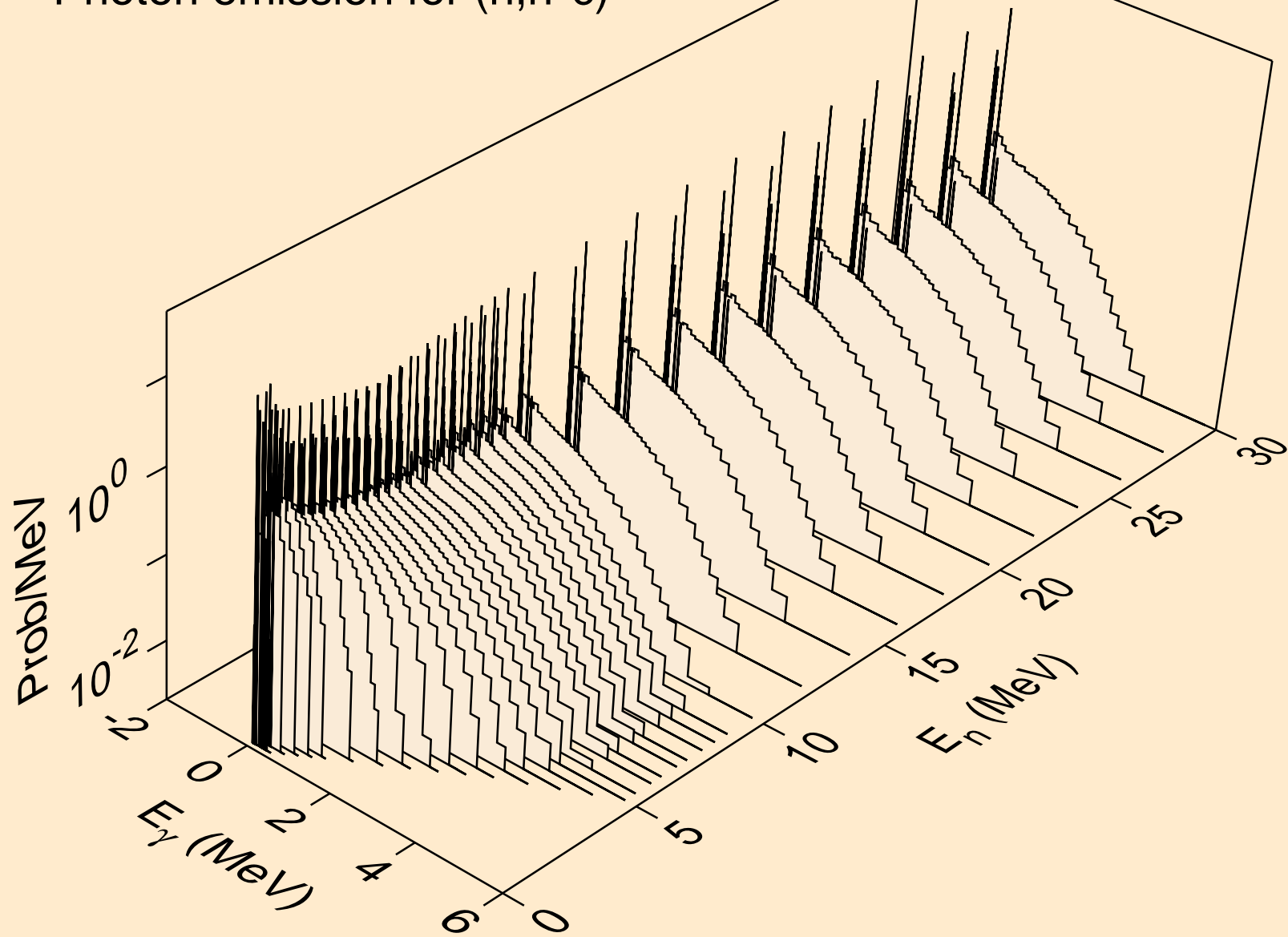

HS277M NEUTRON ACER TENDL-2023 LIBRARY; T=0.K
Photon emission for (n,gma)

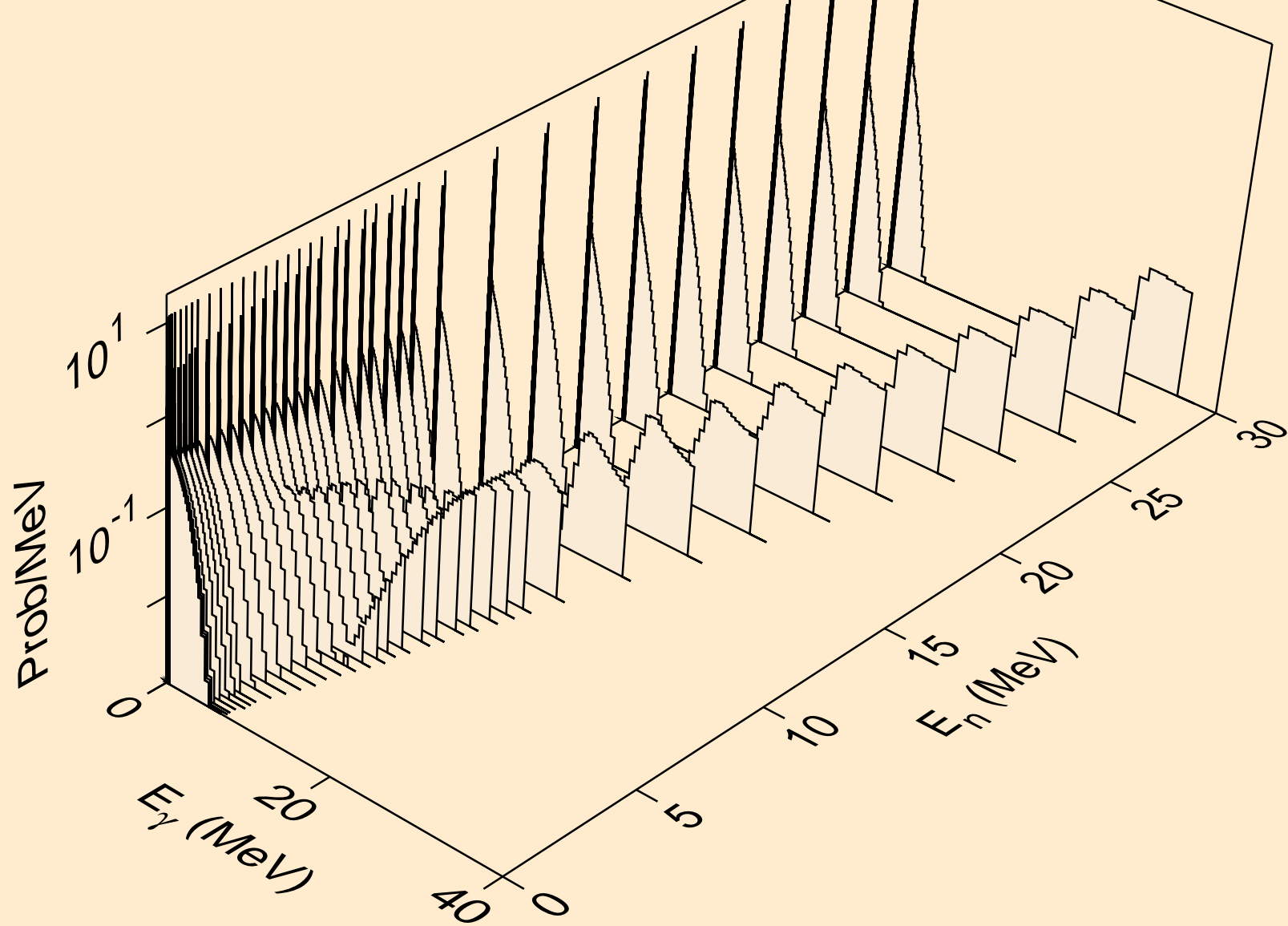

HS277M NEUTRON ACER TENDL-2023 LIBRARY; T=0.K
Photon emission for (n,p)

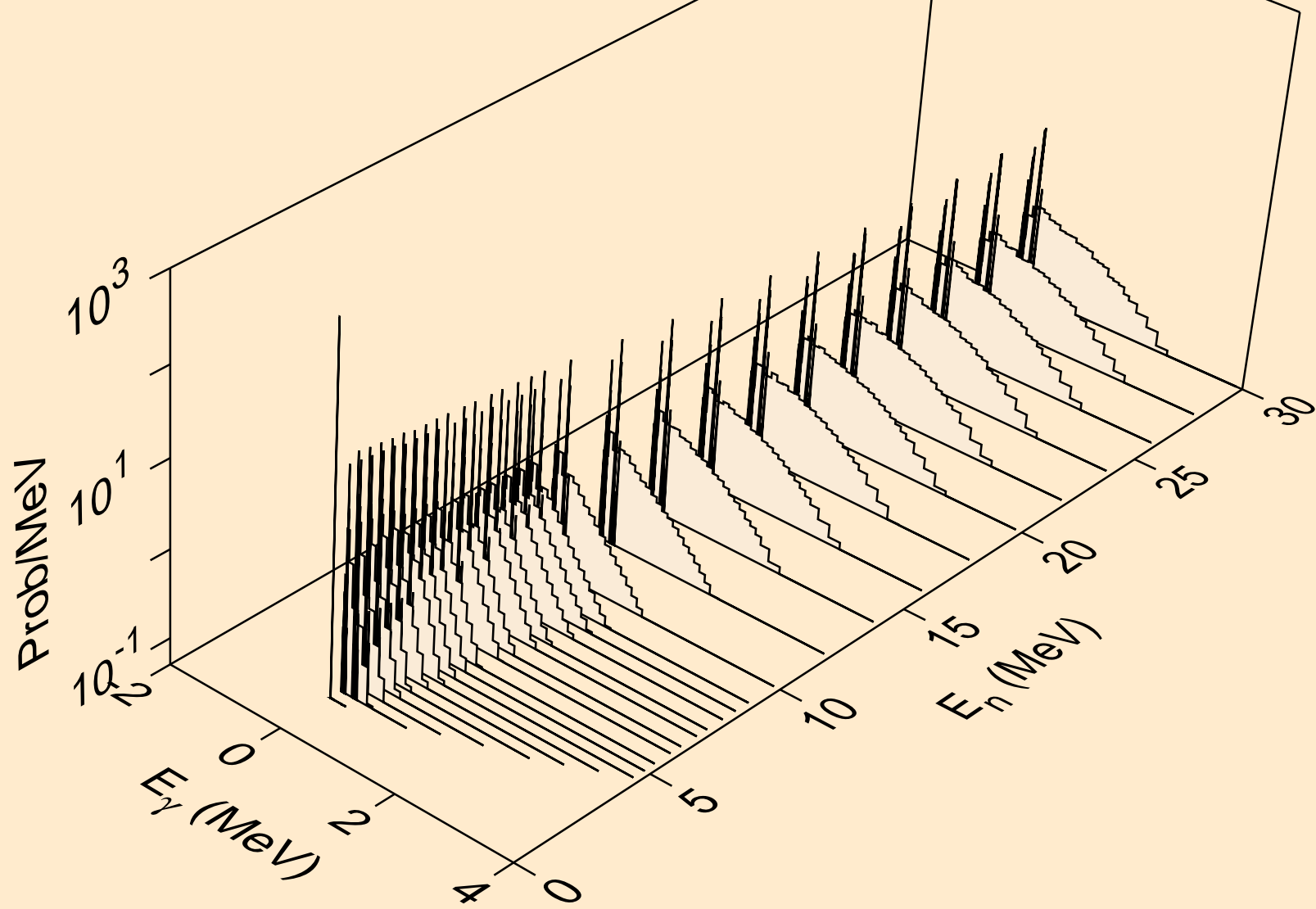

HS277M NEUTRON ACER TENDL-2023 LIBRARY; T=0.K
Photon emission for (n,d)

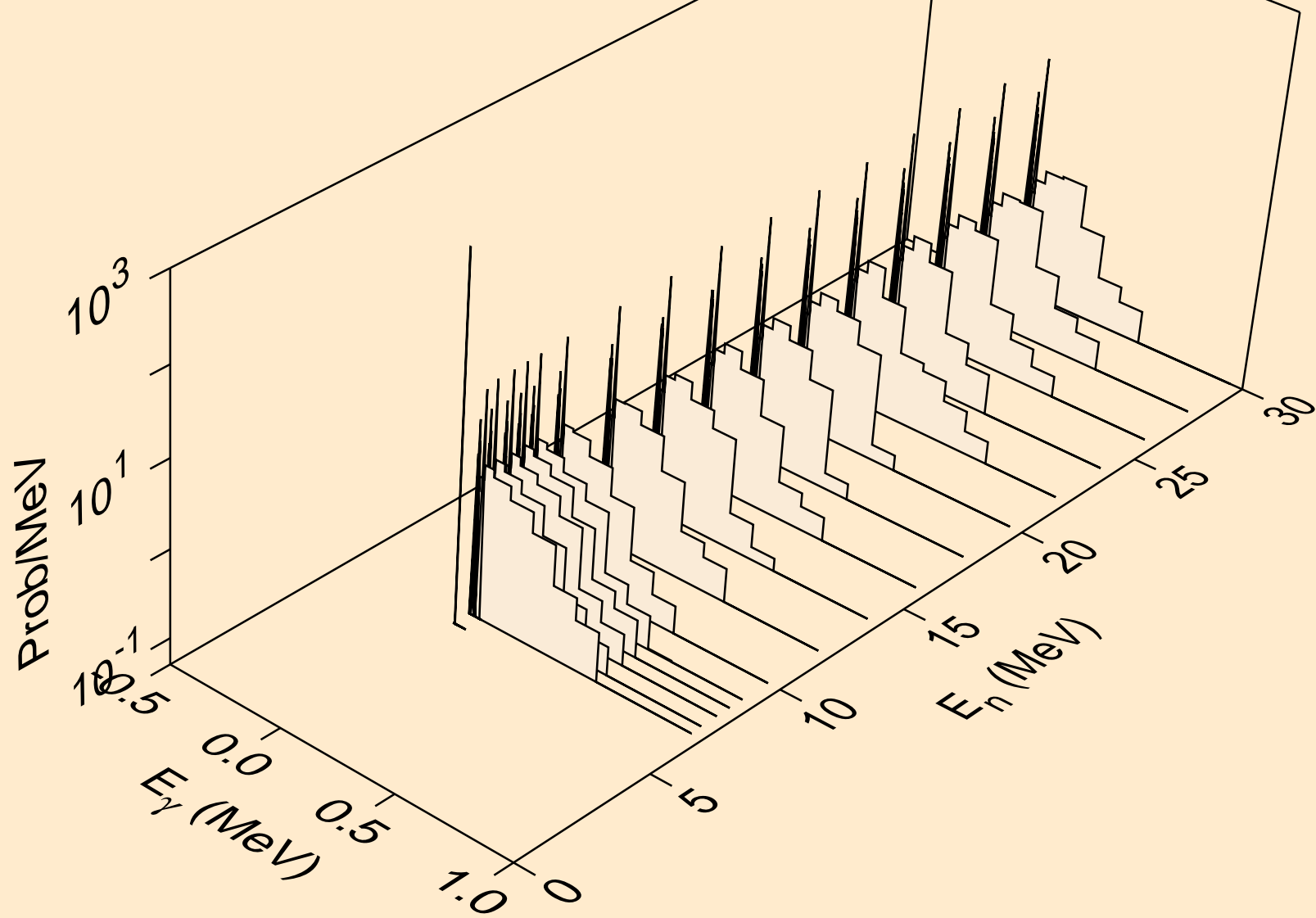

HS277M NEUTRON ACER TENDL-2023 LIBRARY; T=0.K
Photon emission for (n,t)

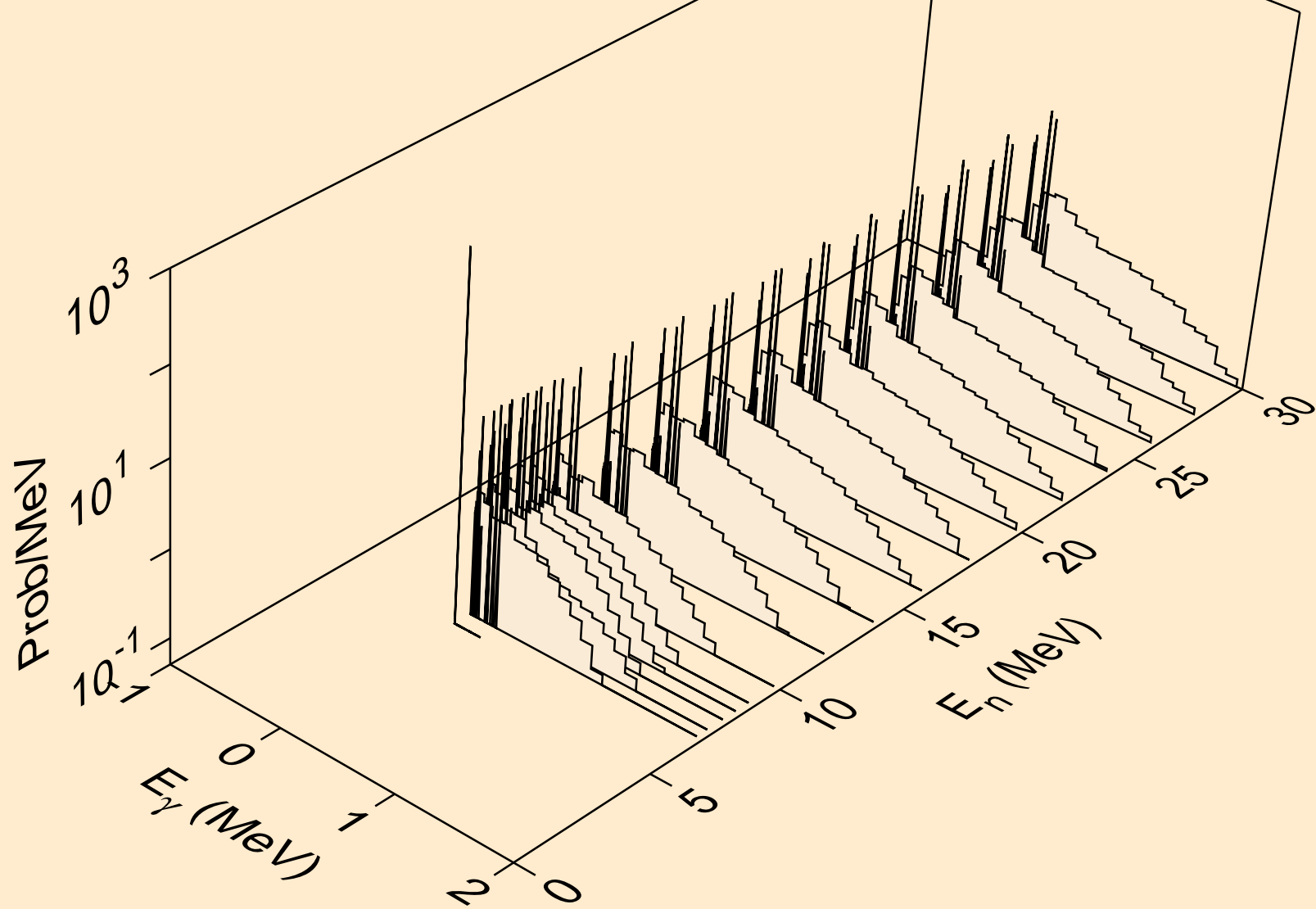

HS277M NEUTRON ACER TENDL-2023 LIBRARY; T=0.K
Photon emission for (n,he3)

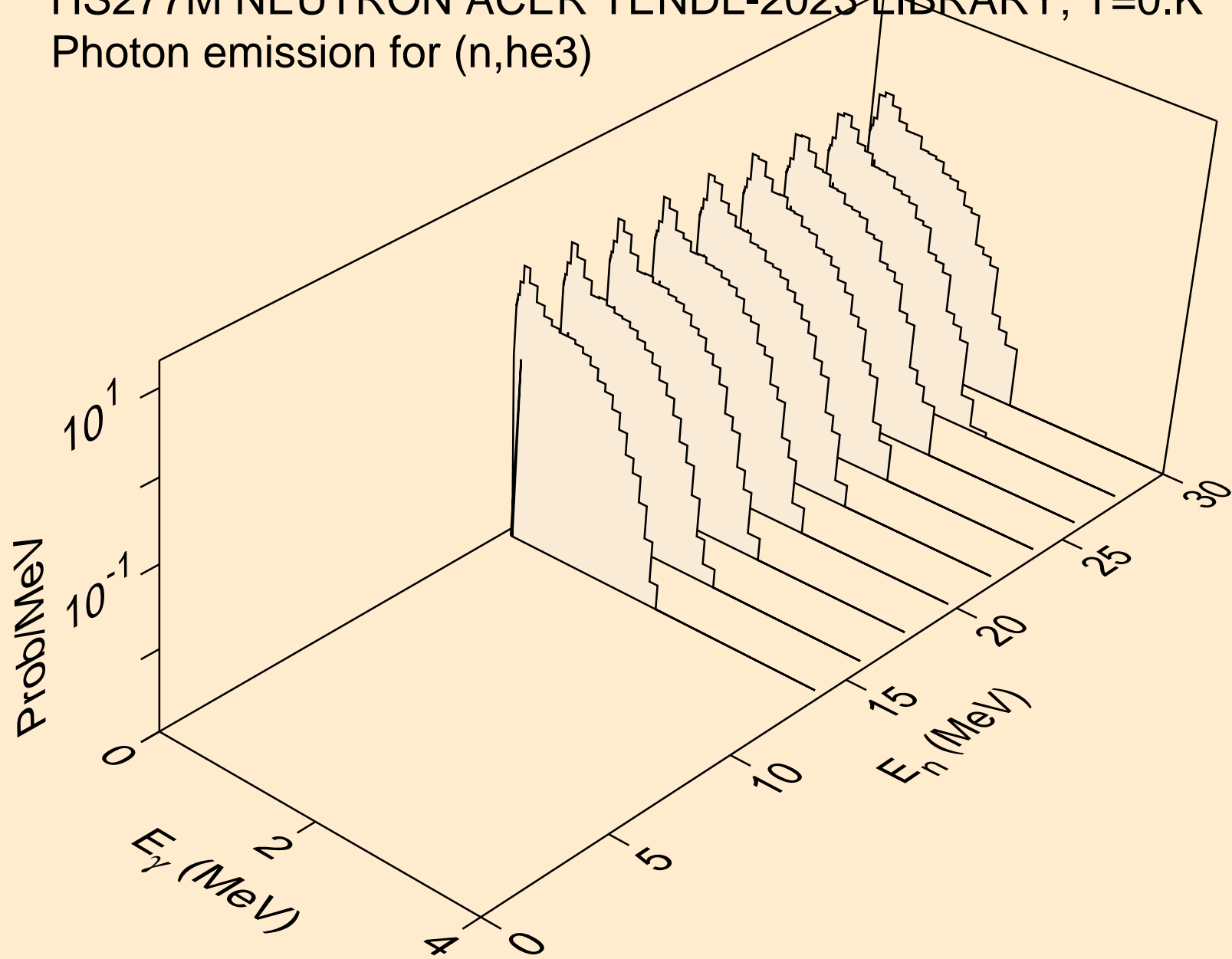

HS277M NEUTRON ACER TENDL-2023 LIBRARY; T=0.K
Photon emission for (n,a)

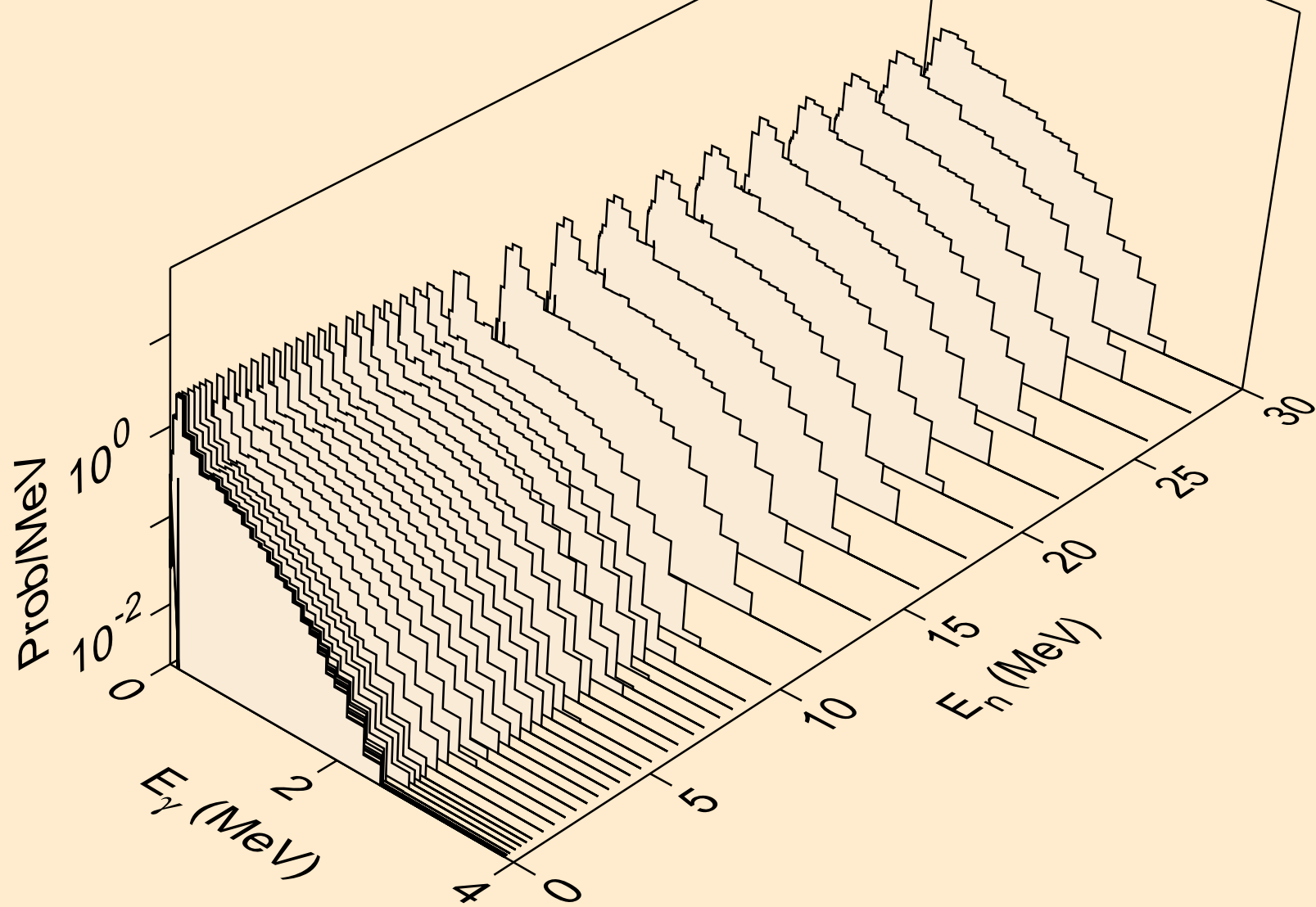

HS277M NEUTRON ACER TENDL-2023 LIBRARY; T=0.K
Photon emission for (n,2p)

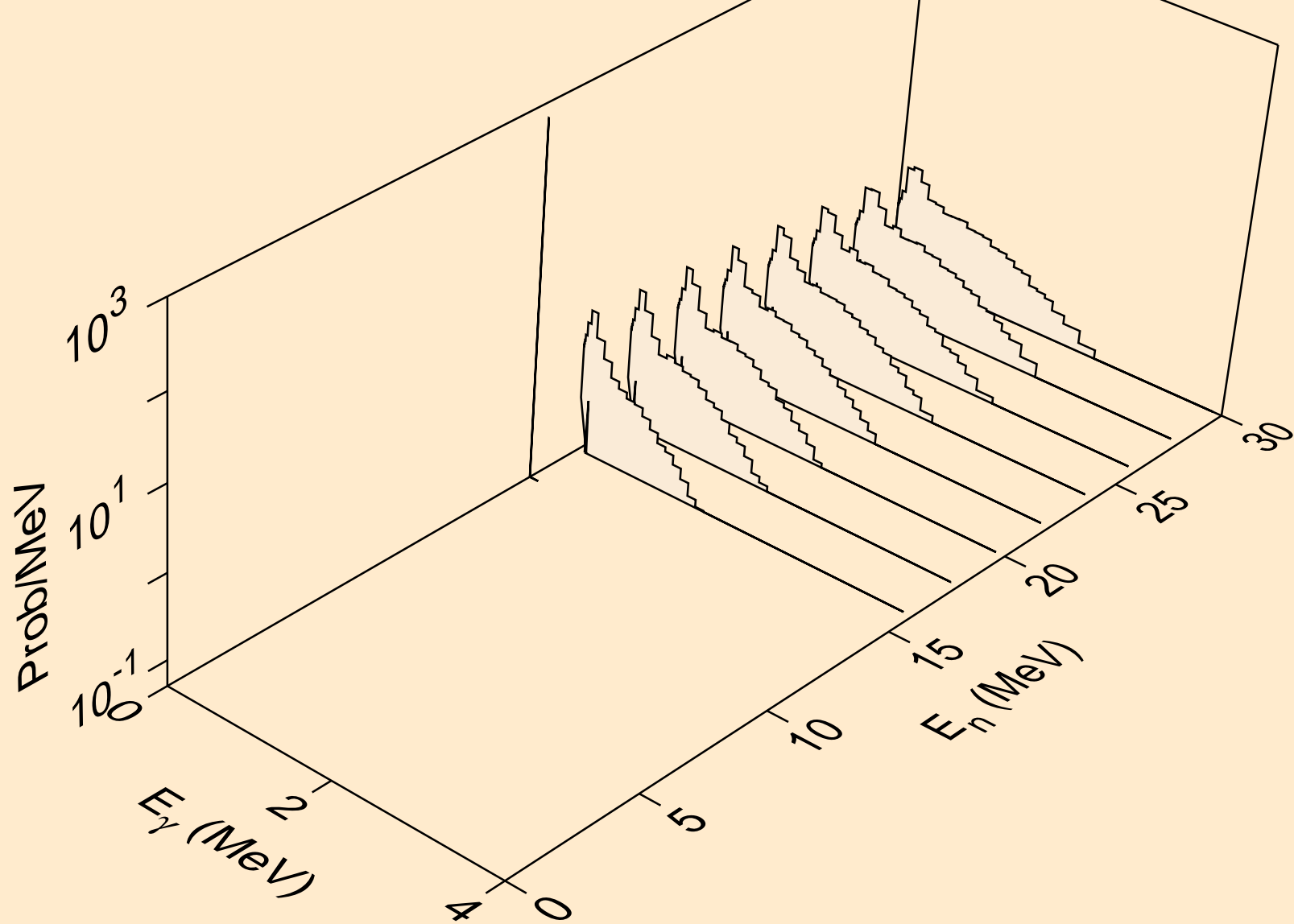

HS277M NEUTRON ACER TENDL-2023 LIBRARY; T=0.K
Photon emission for (n,p)

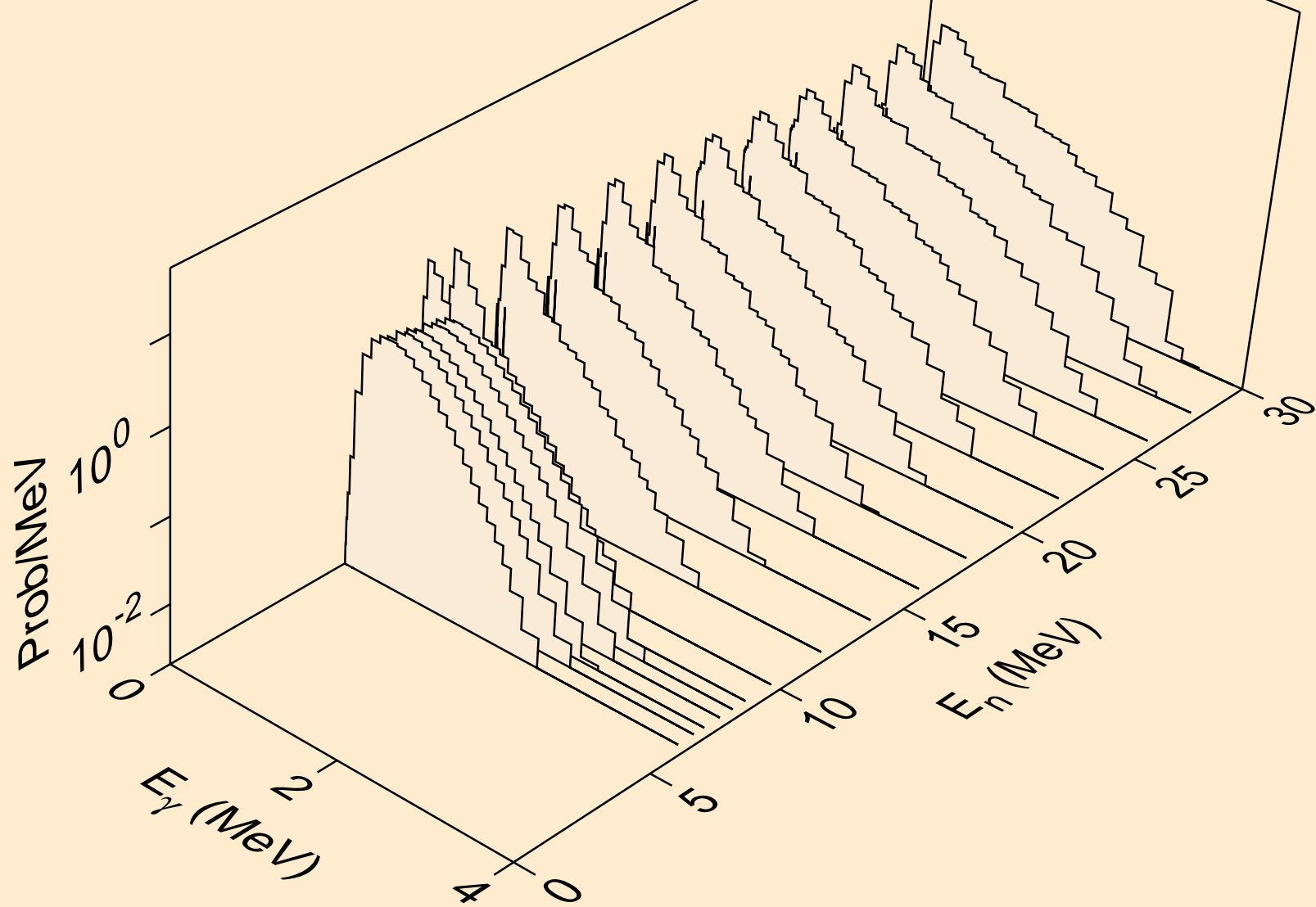

HS277M NEUTRON ACER TENDL-2023 LIBRARY; T=0.K
thermal capture photon spectrum

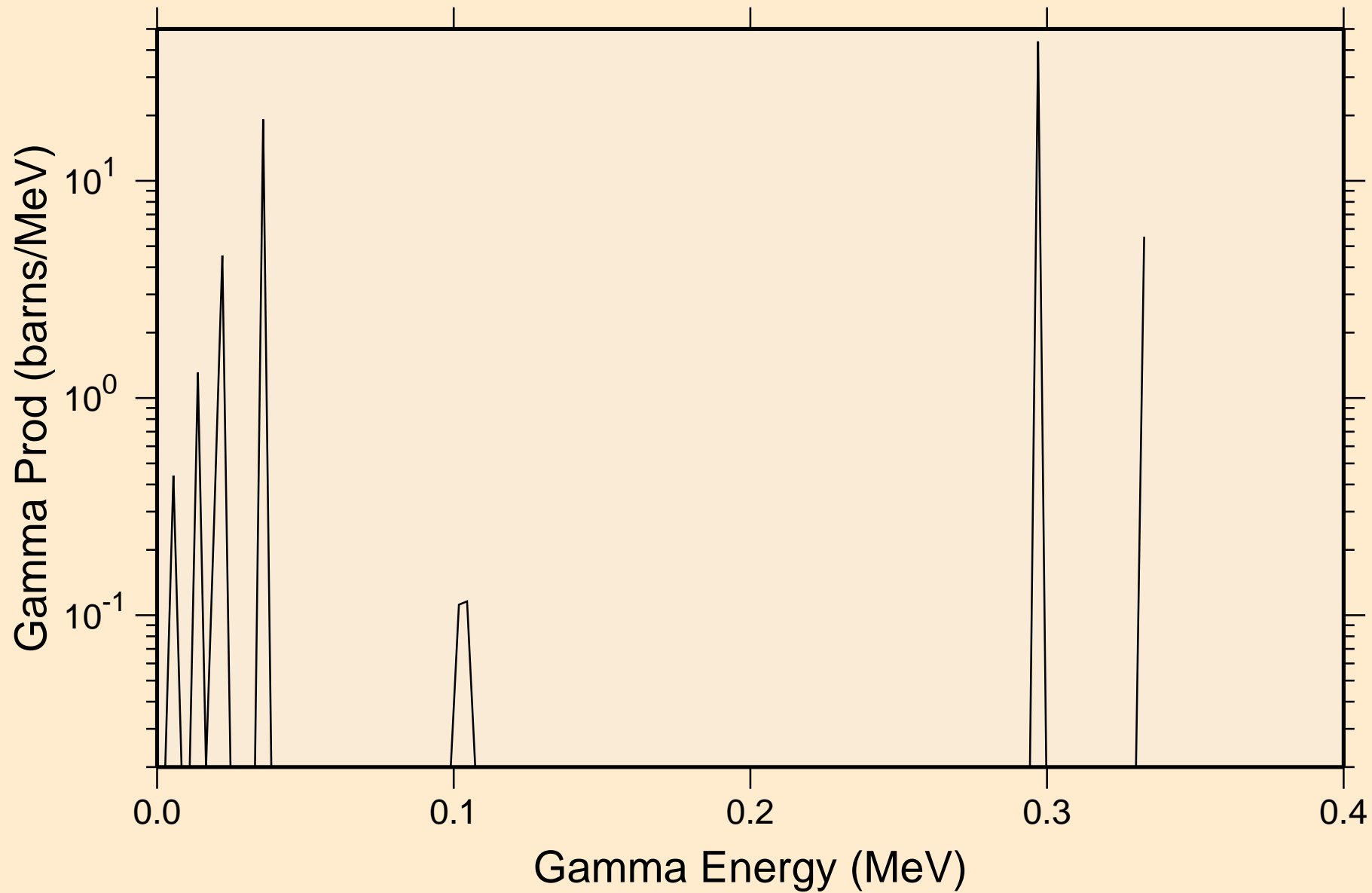

HS277M NEUTRON ACER TENDL-2023 LIBRARY; T=0.K
14 MeV photon spectrum

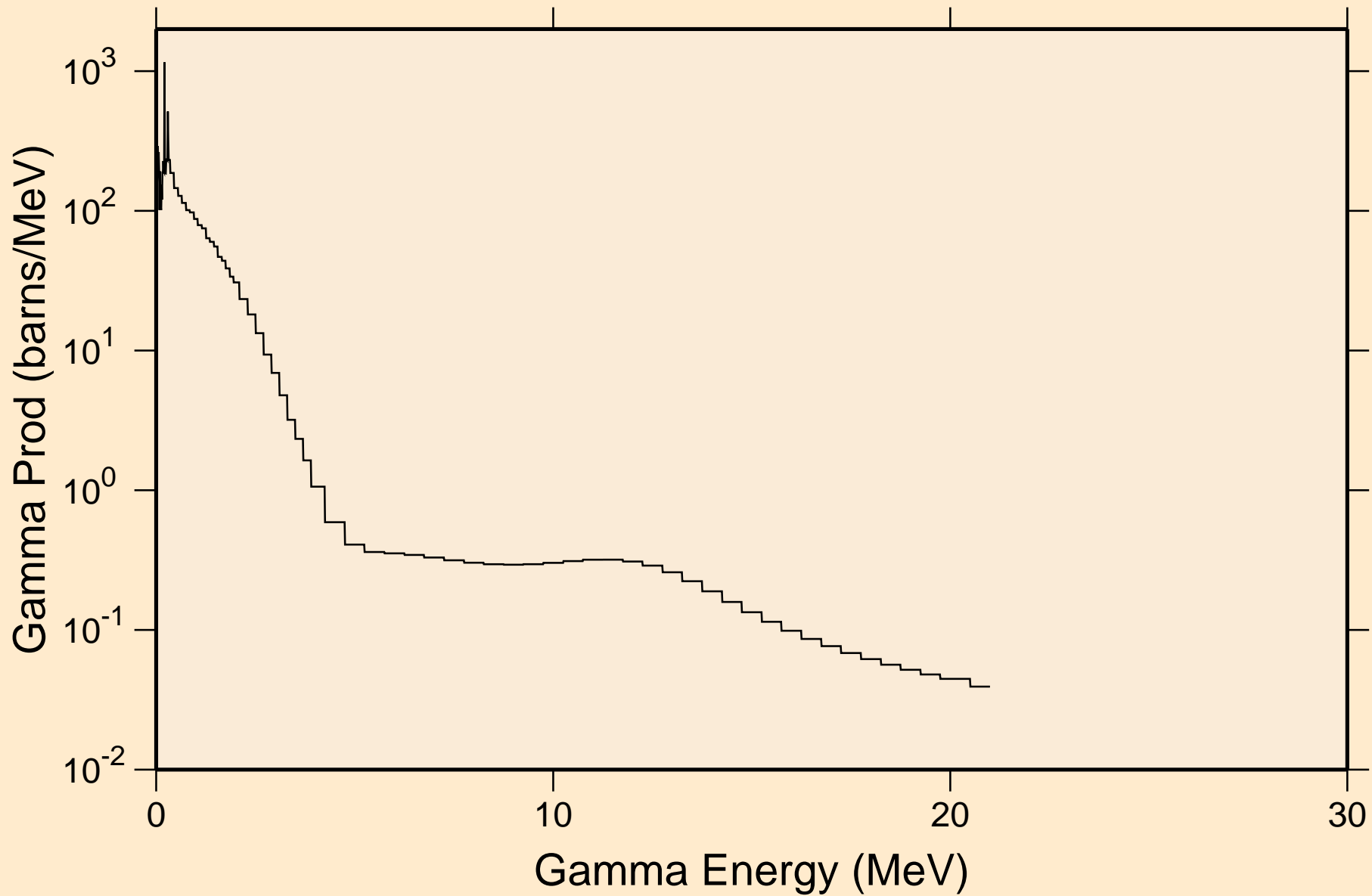

HS277M NEUTRON ACER TENDL-2023 LIBRARY; T=0.K

Particle heating contributions

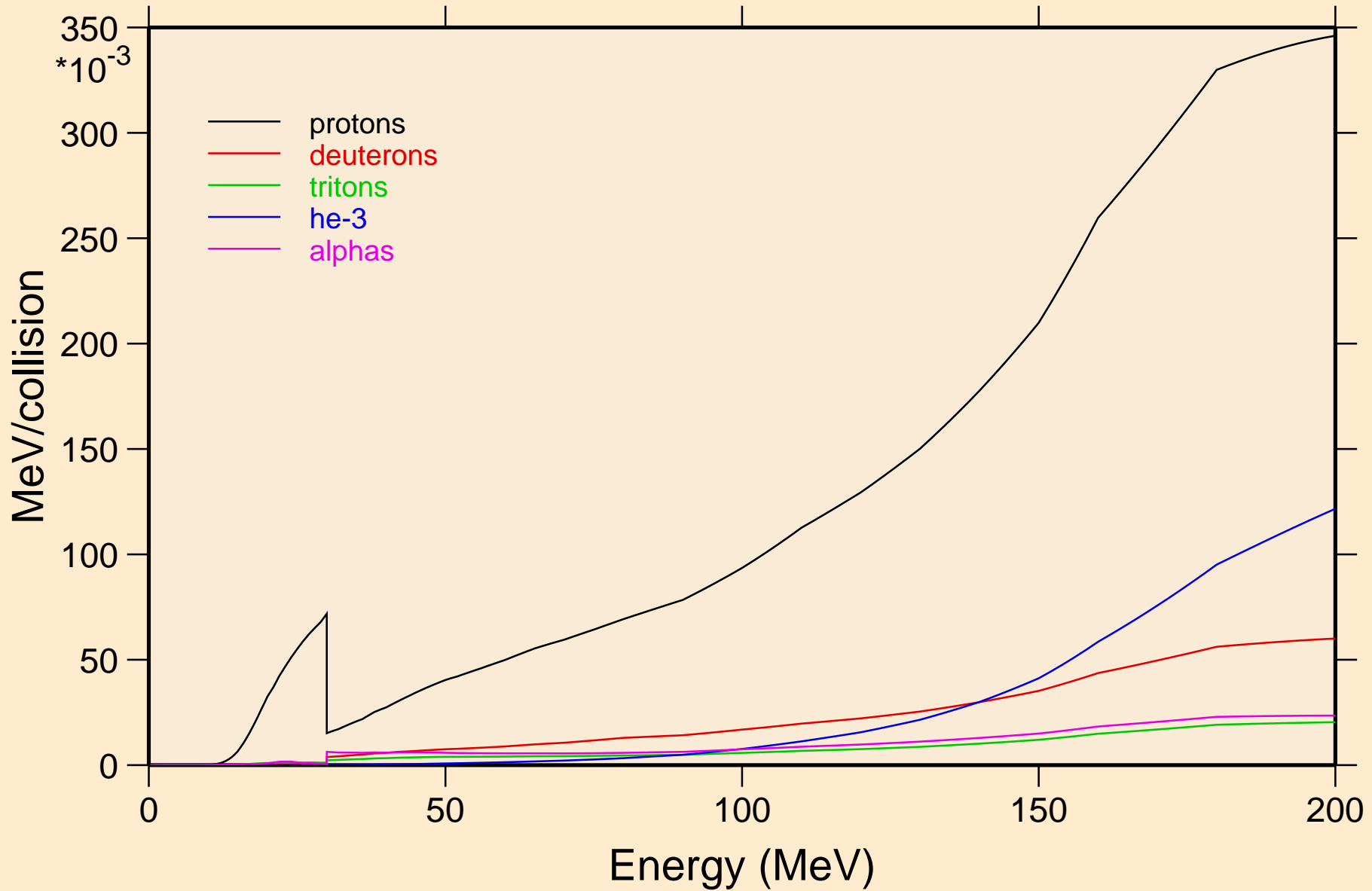

HS277M NEUTRON ACER TENDL-2023 LIBRARY; T=0.K
Recoil Heating

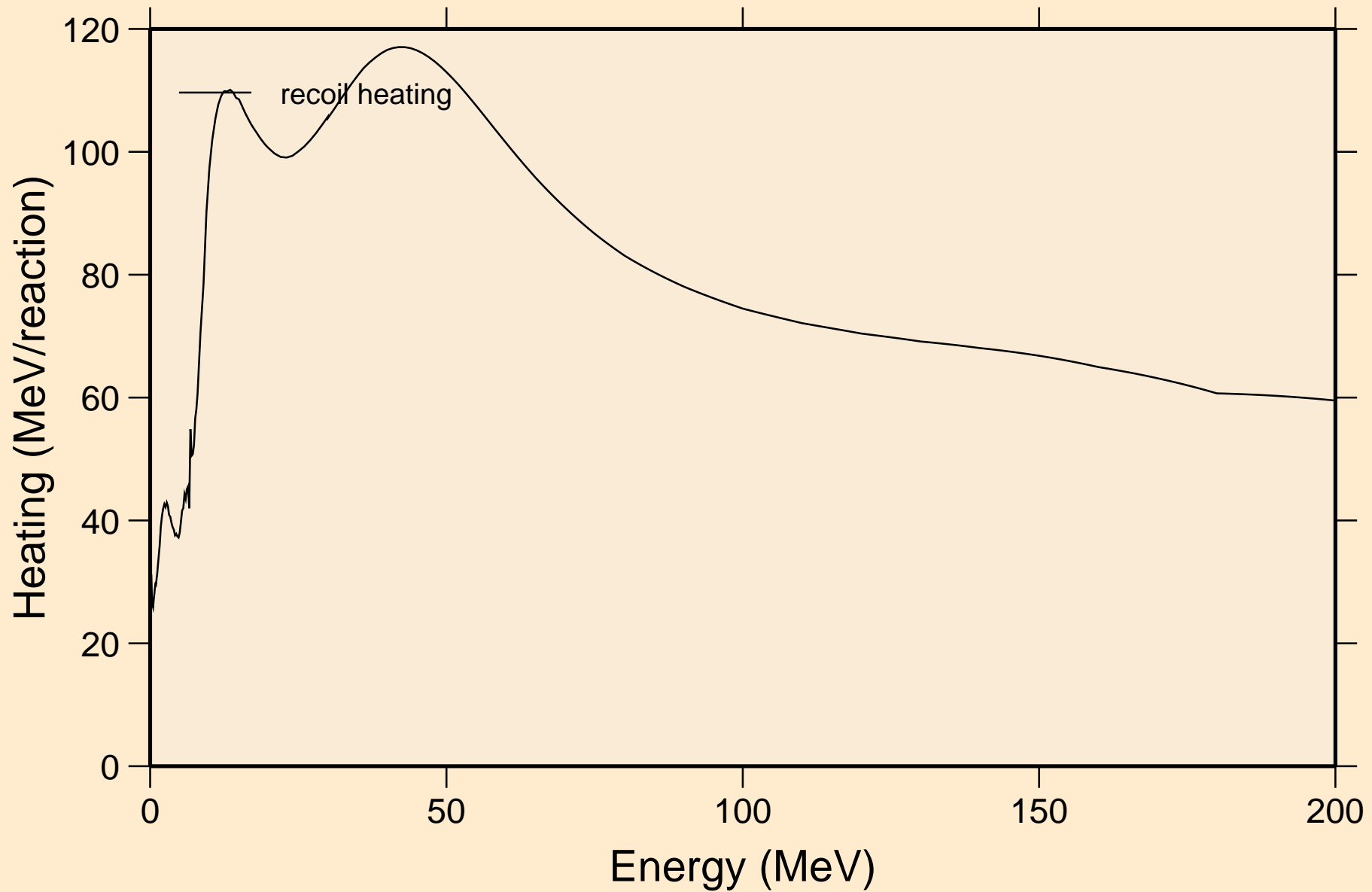

HS277M NEUTRON ACER TENDL-2023 LIBRARY; T=0.K

Particle production cross sections

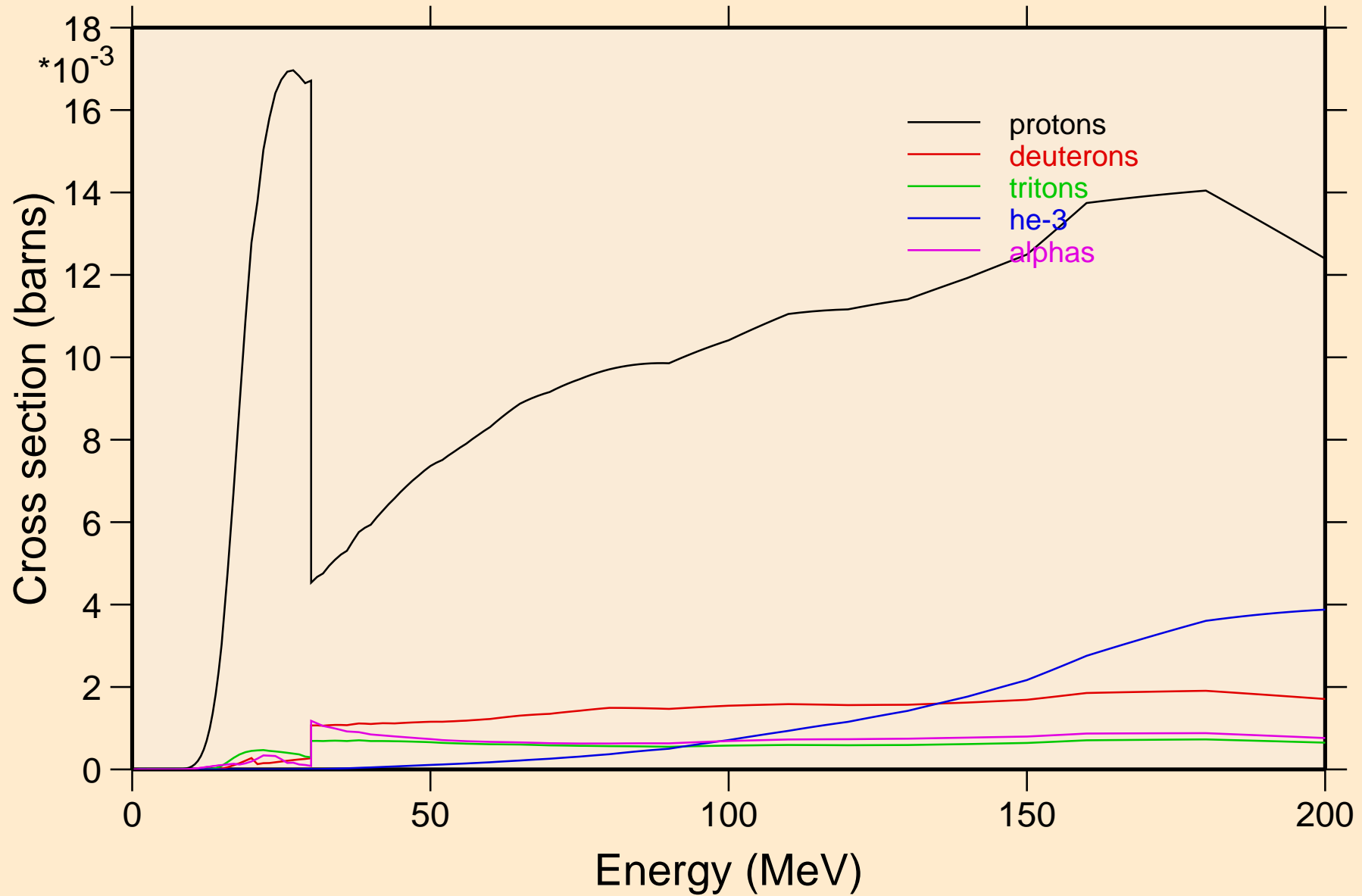

HS277M NEUTRON ACER TENDL-2023 LIBRARY; T=0.K
protons from (n,x)

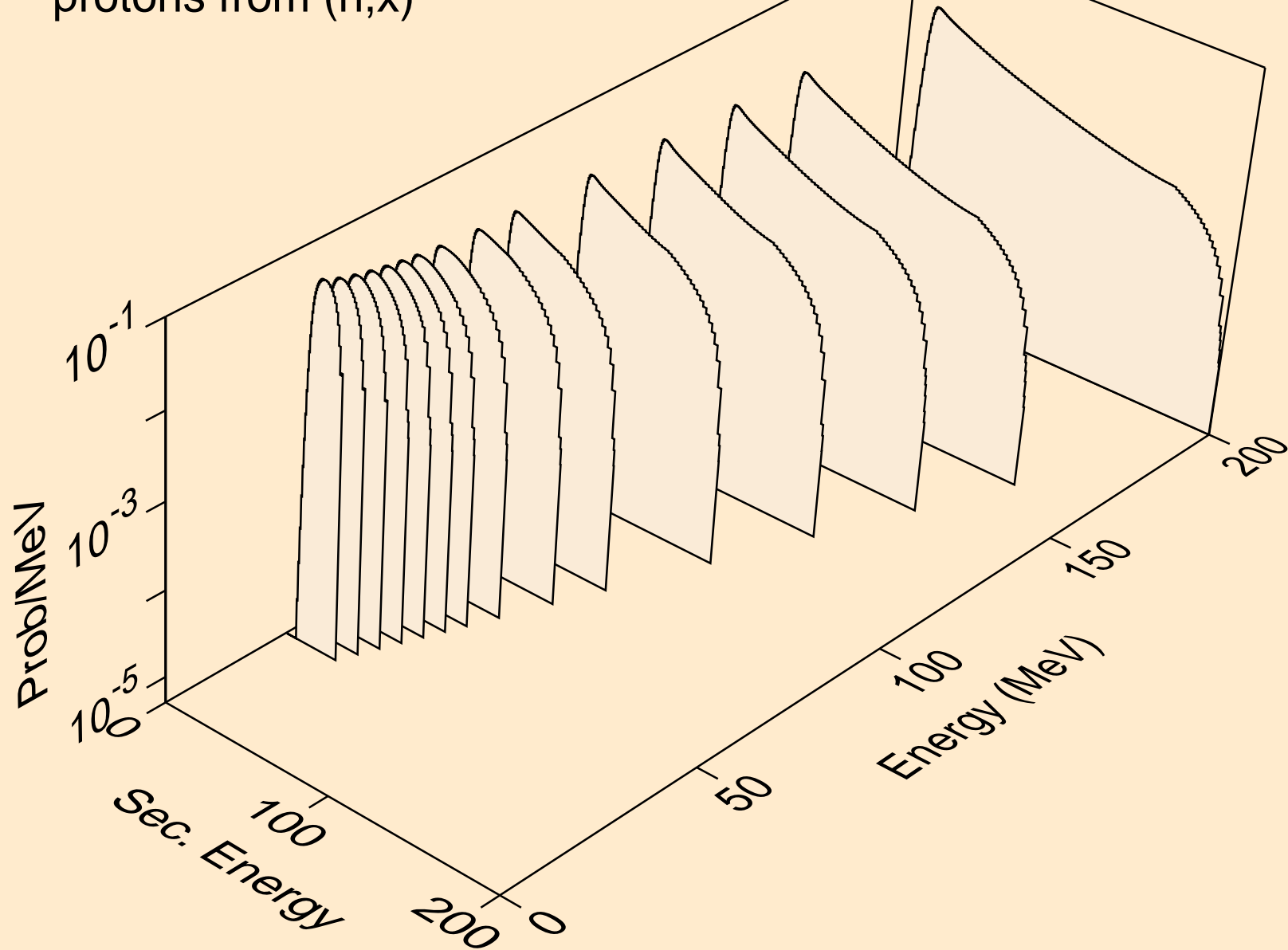

HS277M NEUTRON ACER TENDL-2023 LIBRARY; T=0.K
protons from (n,n*)p

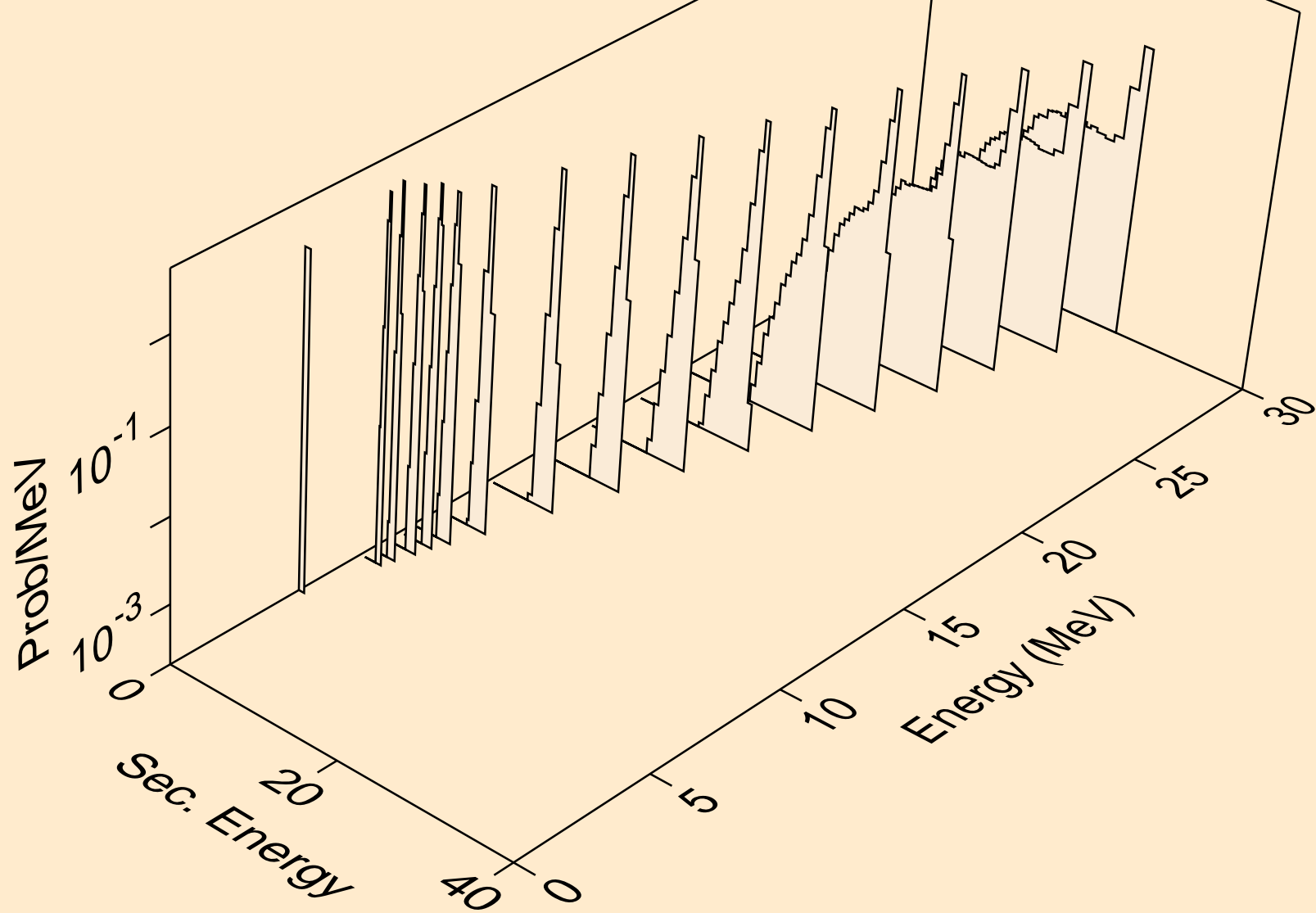

HS277M NEUTRON ACER TENDL-2023 LIBRARY; T=0.K
protons from (n,2np)

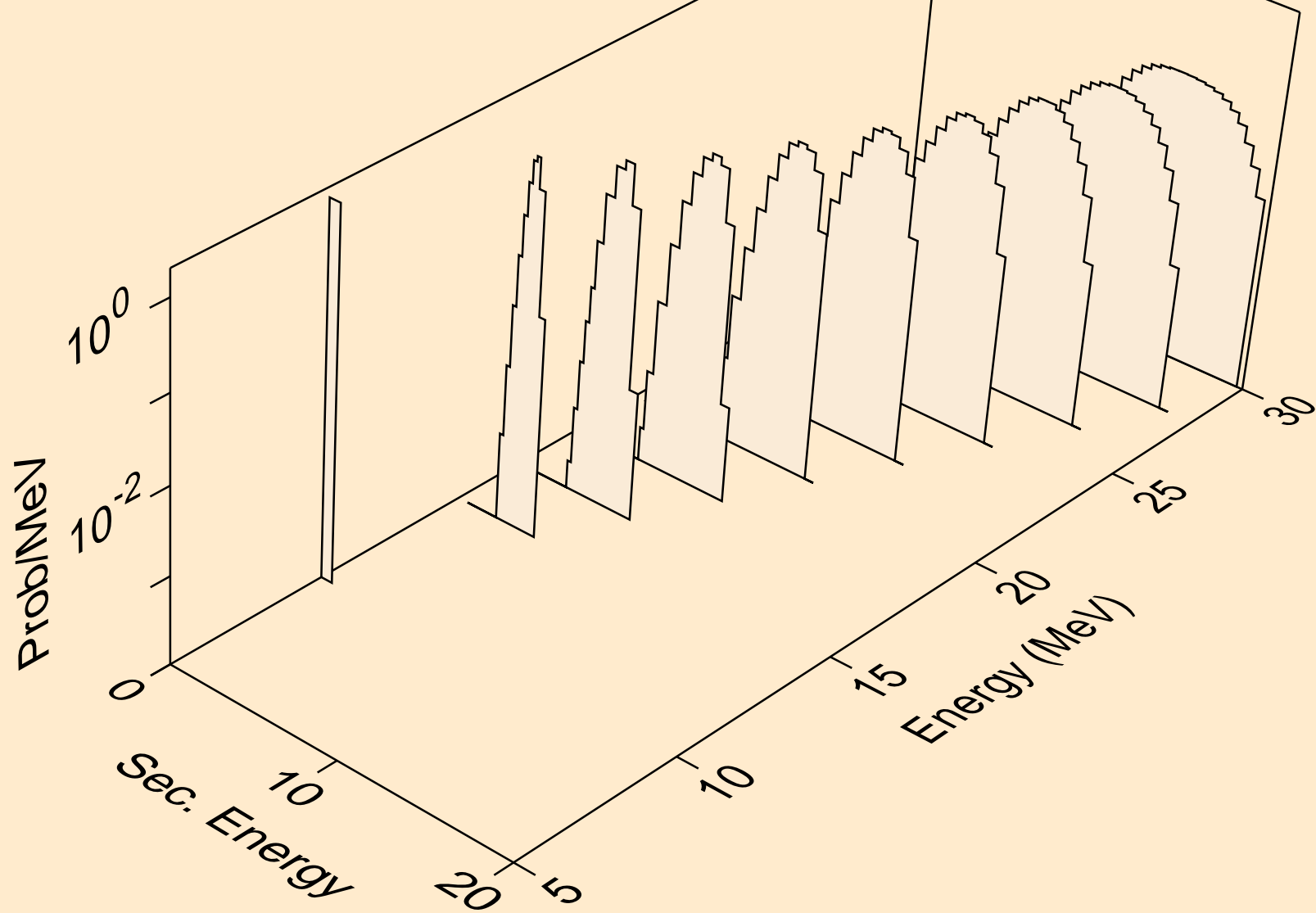

HS277M NEUTRON ACER TENDL-2023 LIBRARY; T=0.K
protons from (n,3np)

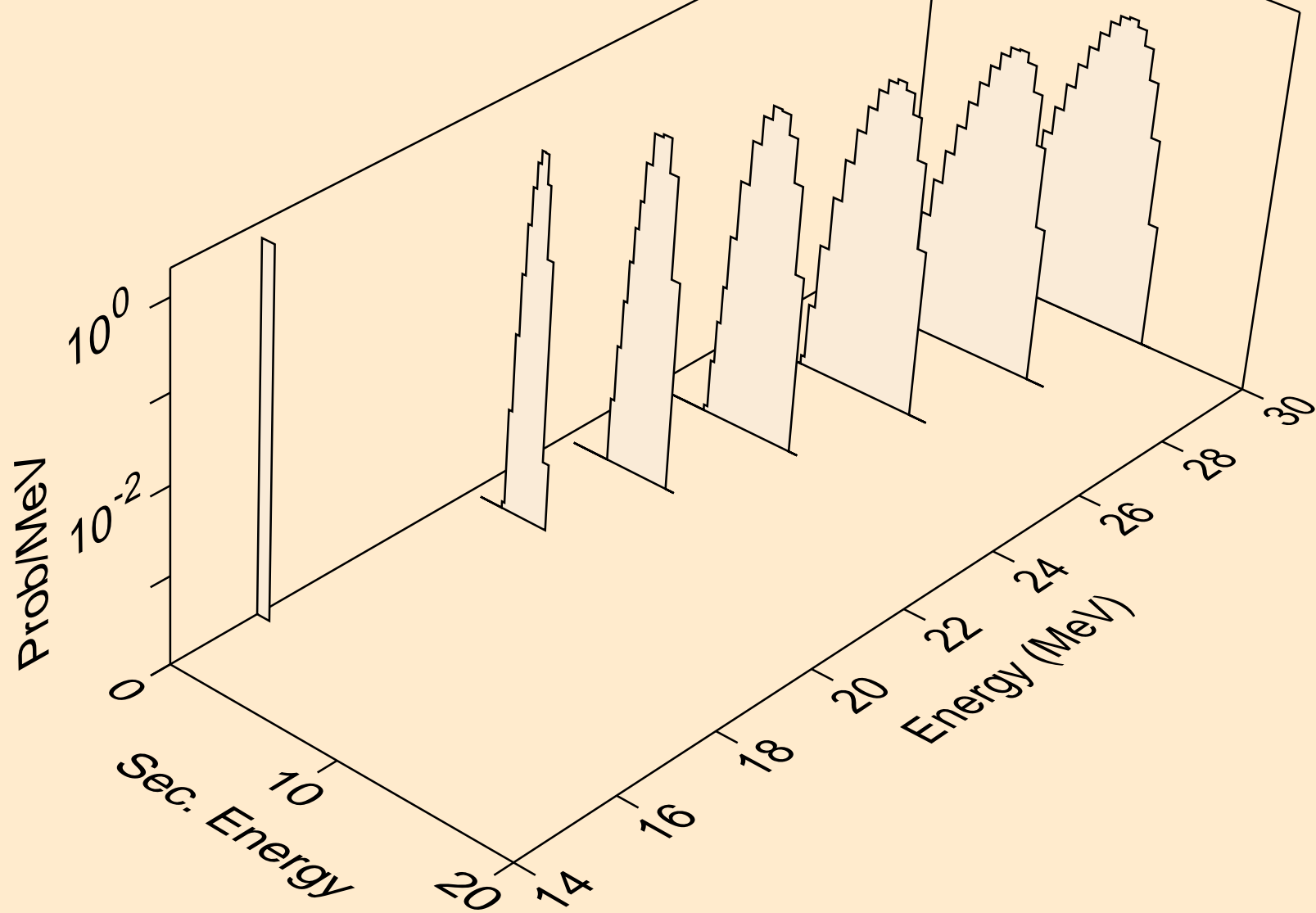

HS277M NEUTRON ACER TENDL-2023 LIBRARY; T=0.K
protons from (n,n2p)

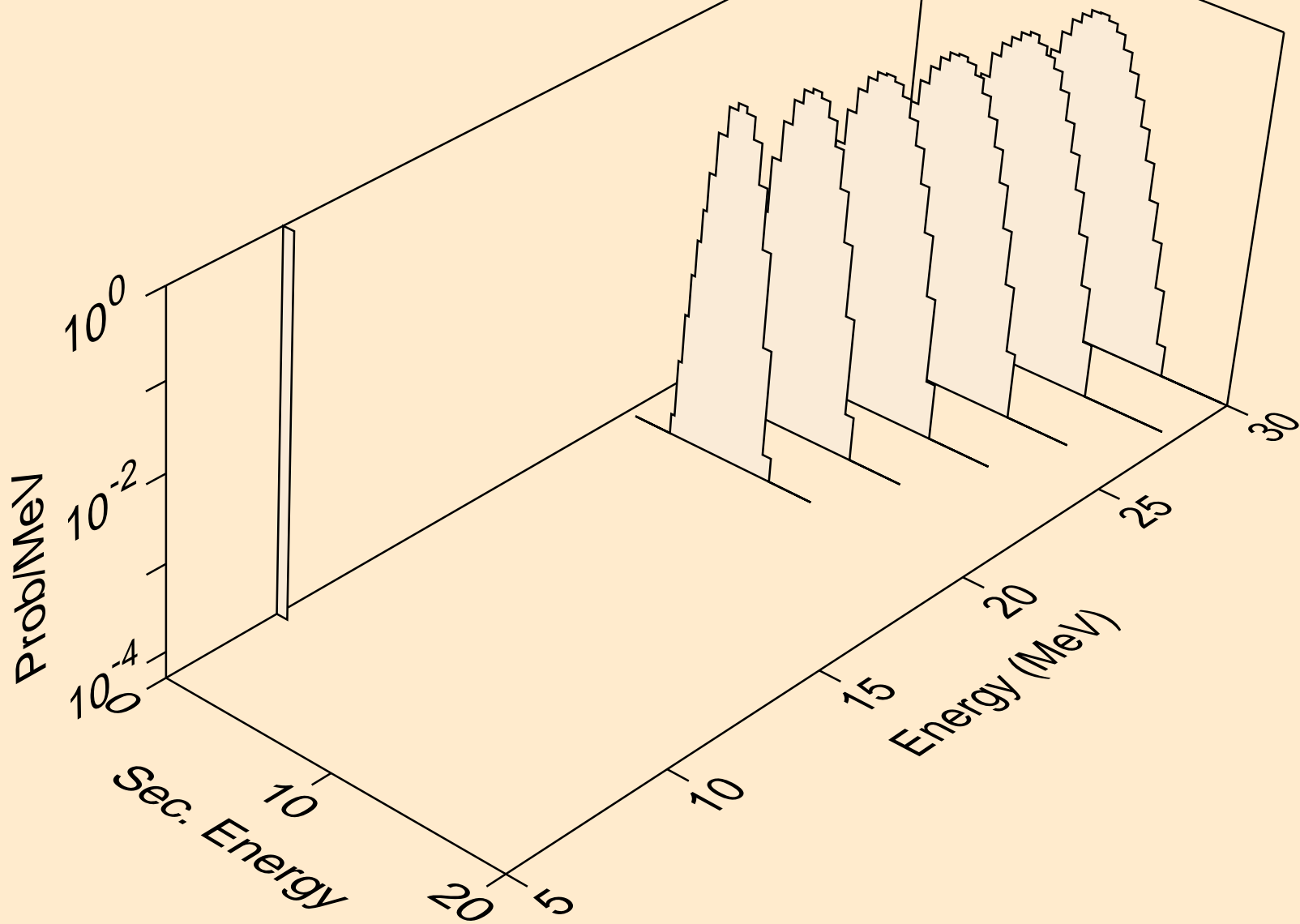

HS277M NEUTRON ACER TENDL-2023 LIBRARY; T=0.K
protons from (n,p)

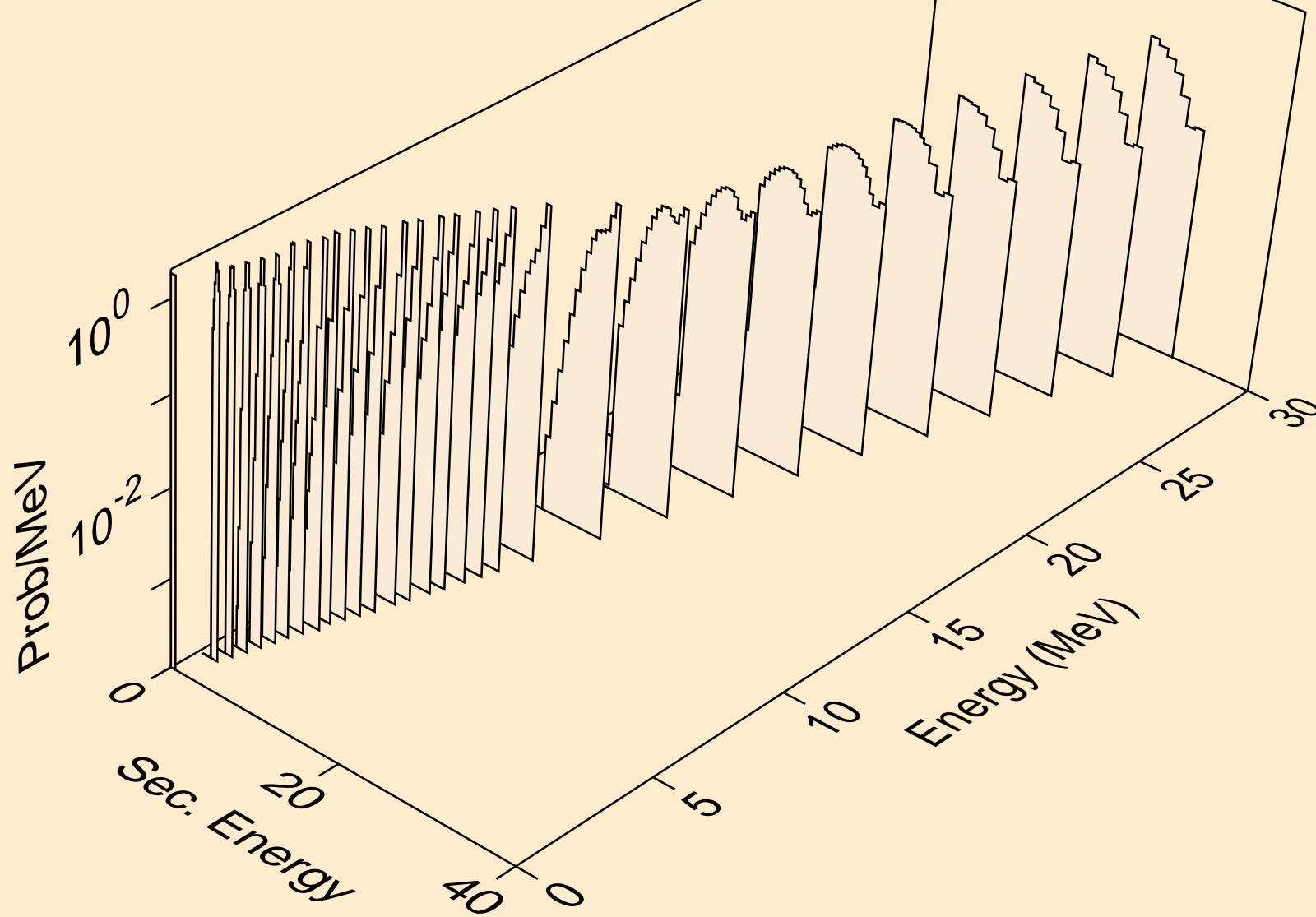

HS277M NEUTRON ACER TENDL-2023 LIBRARY; T=0.K
protons from (n,2p)

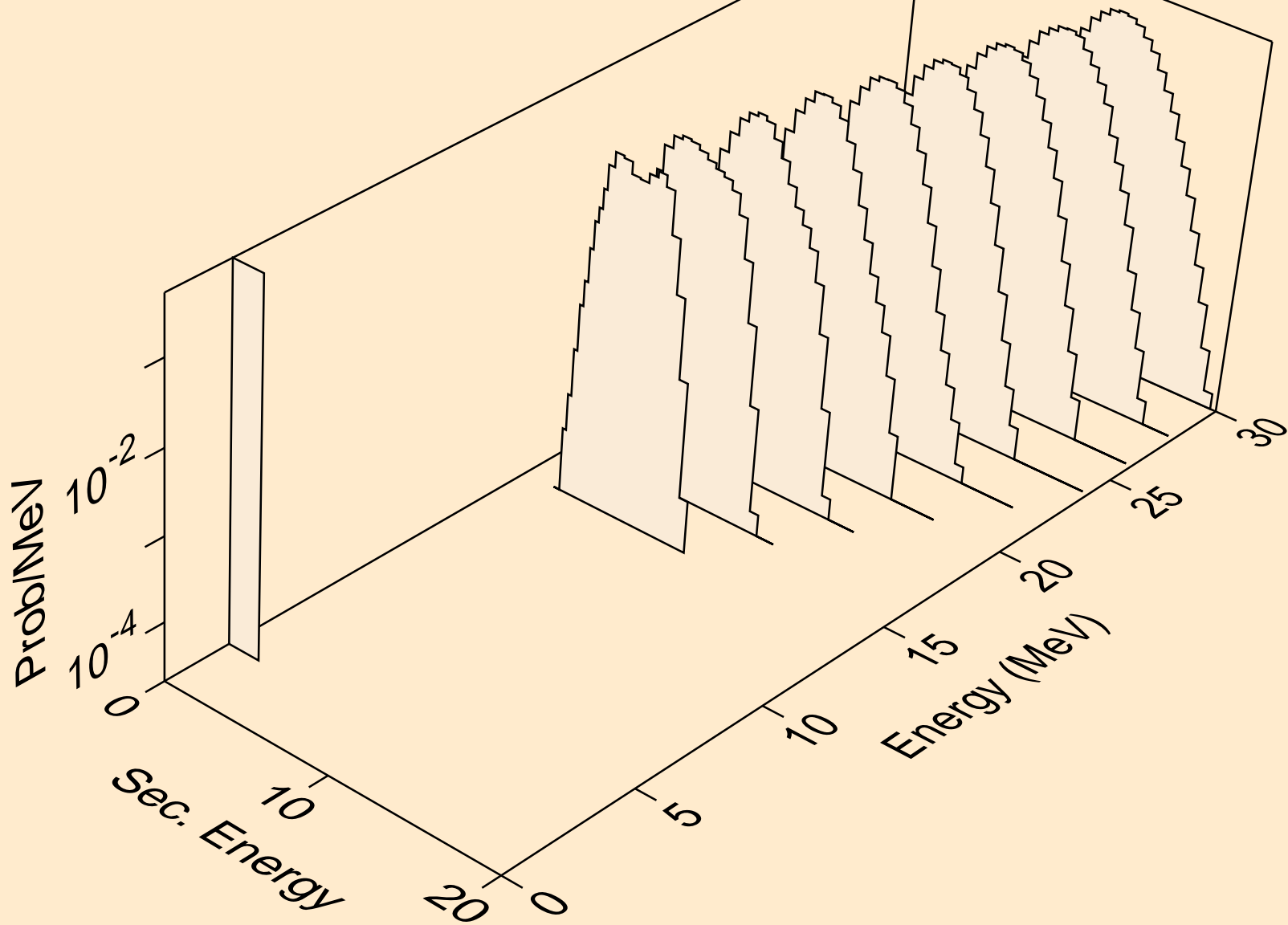

HS277M NEUTRON ACER TENDL-2023 LIBRARY; T=0.K
protons from (n,p)

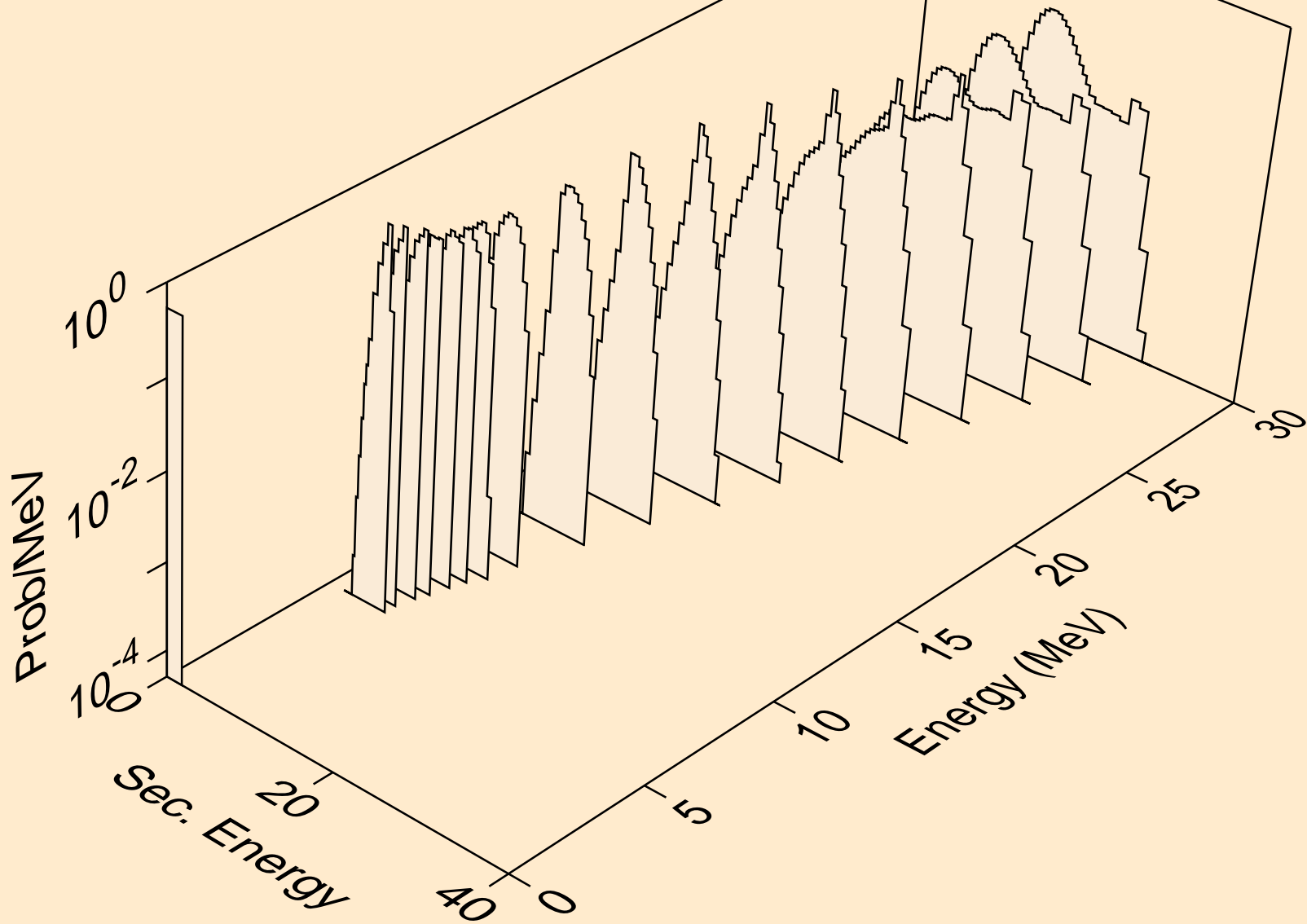

HS277M NEUTRON ACER TENDL-2023 LIBRARY; T=0.K
deuterons from (n,x)

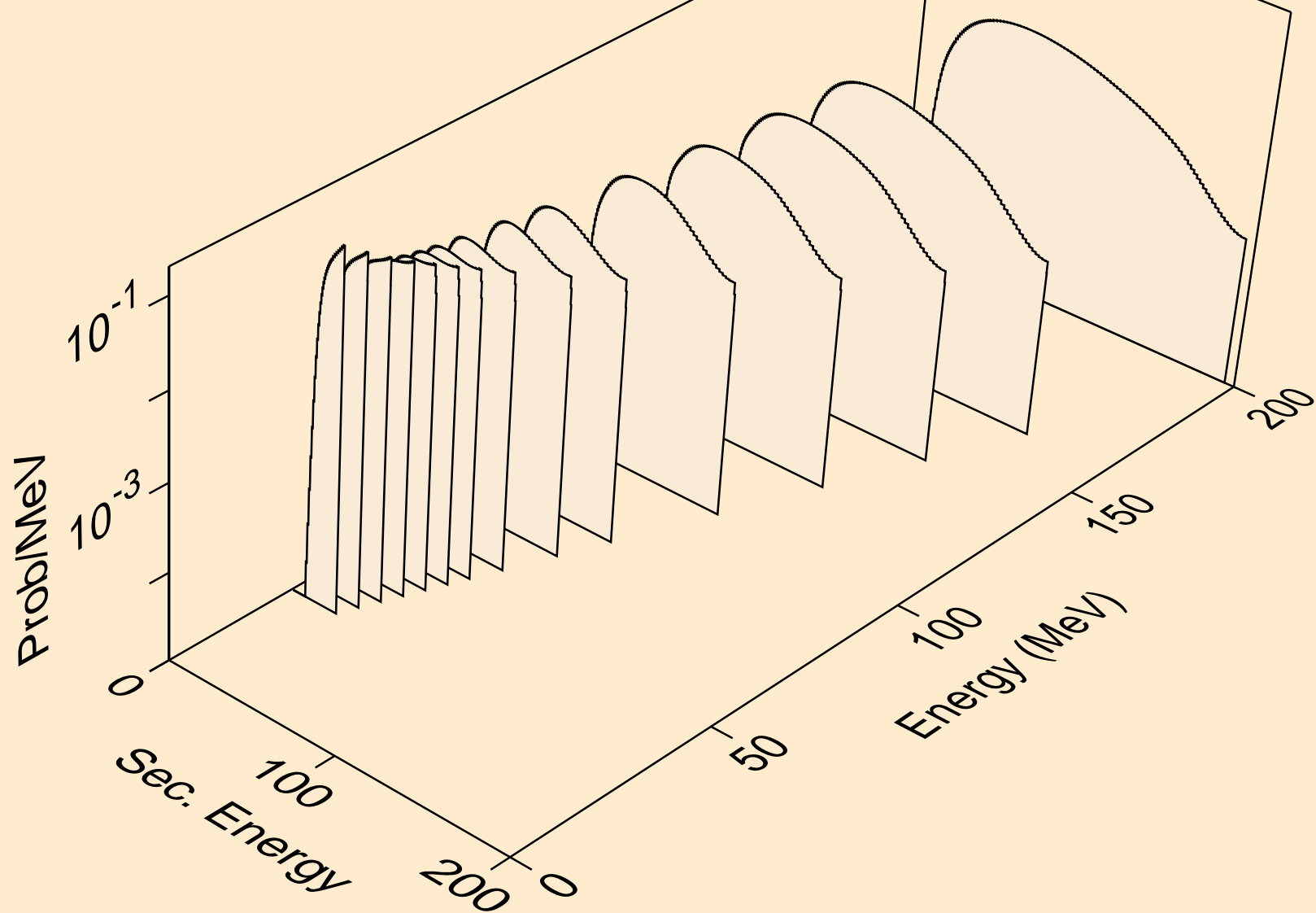

HS277M NEUTRON ACER TENDL-2023 LIBRARY; T=0.K
deuterons from (n,2nd)

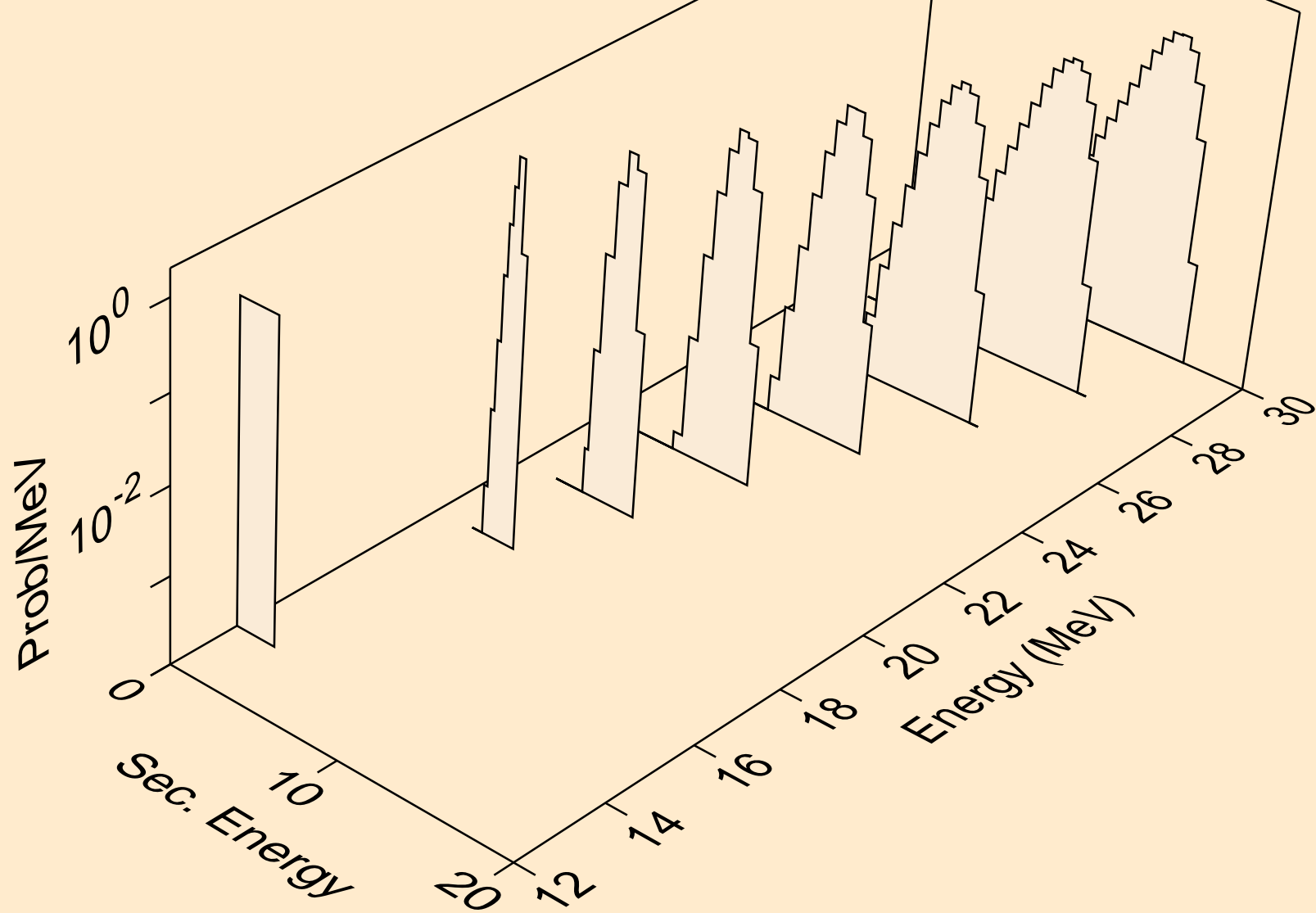

HS277M NEUTRON ACER TENDL-2023 LIBRARY; T=0.K
deuterons from (n,n*)d

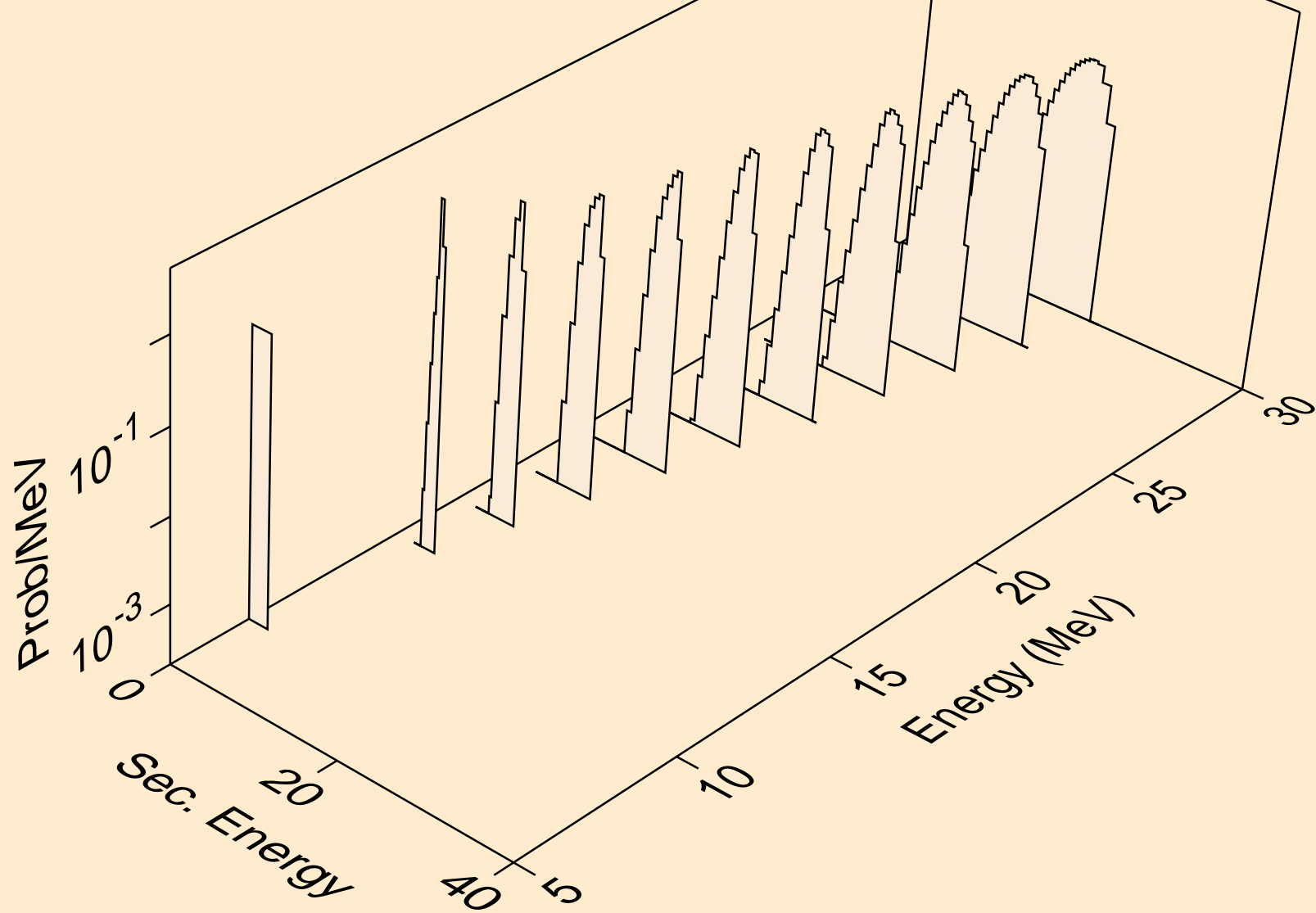

HS277M NEUTRON ACER TENDL-2023 LIBRARY; T=0.K
deuterons from (n,d)

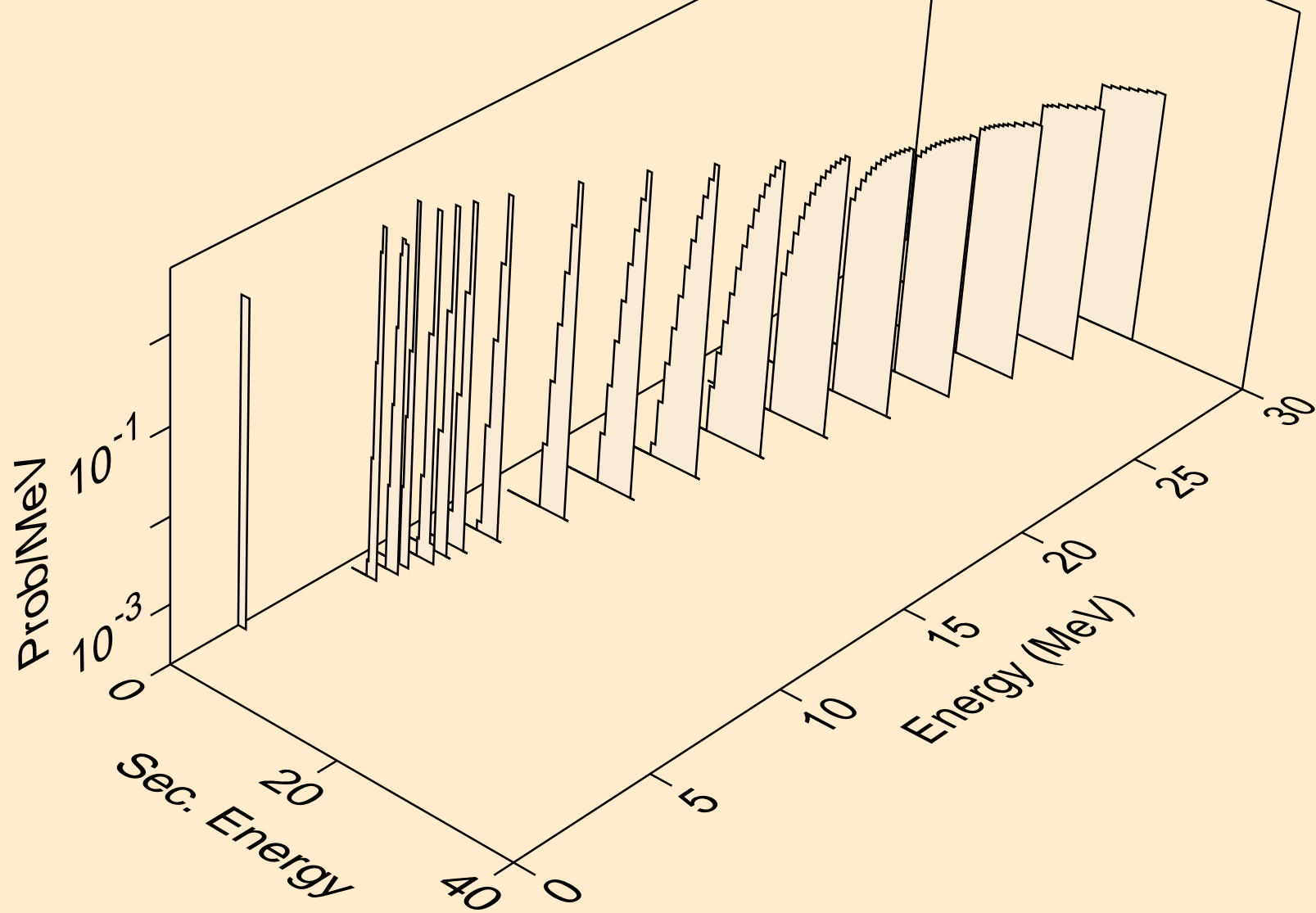

HS277M NEUTRON ACER TENDL-2023 LIBRARY; T=0.K
tritons from (n,x)

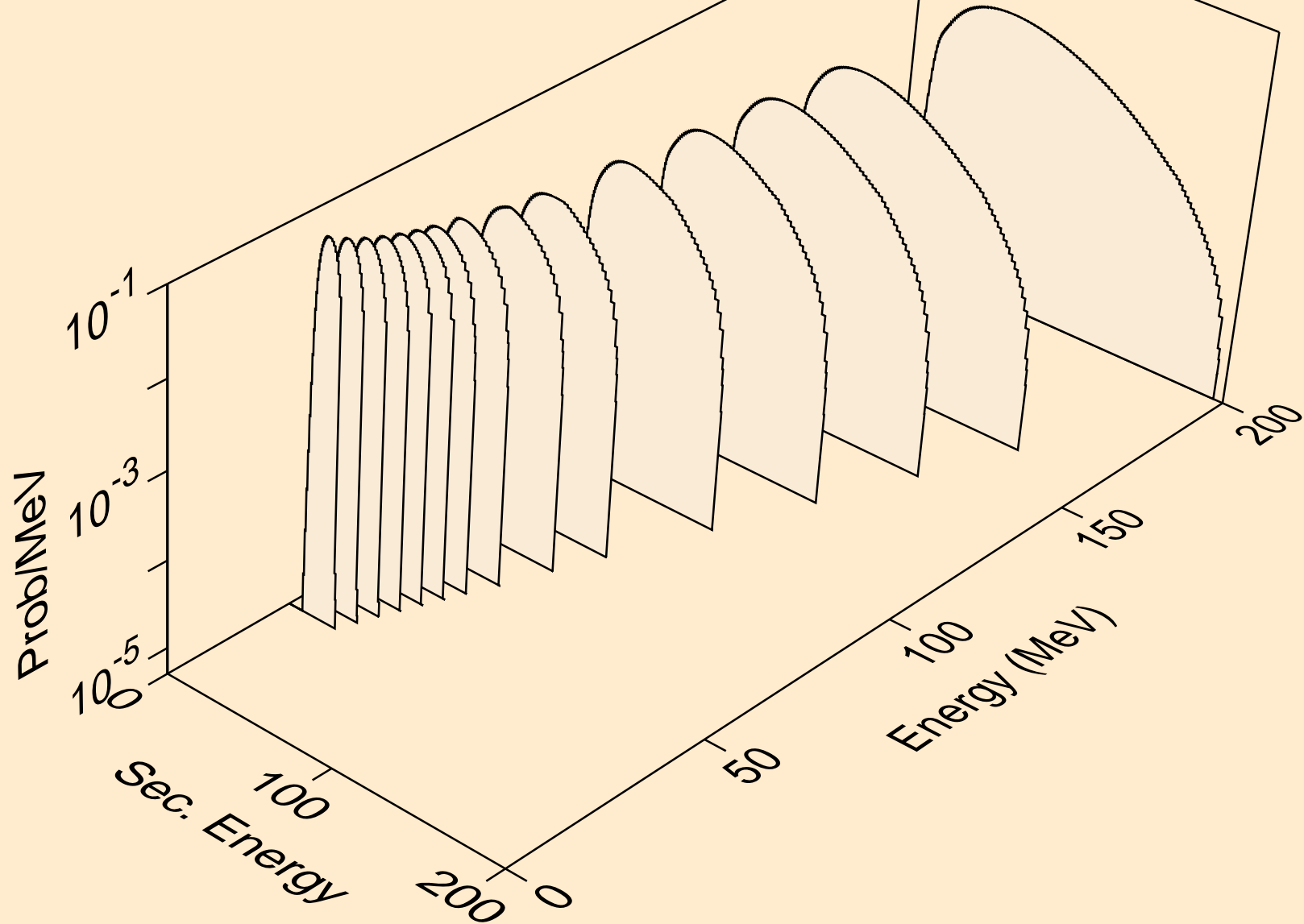

HS277M NEUTRON ACER TENDL-2023 LIBRARY; T=0.K
tritons from (n,n*)t

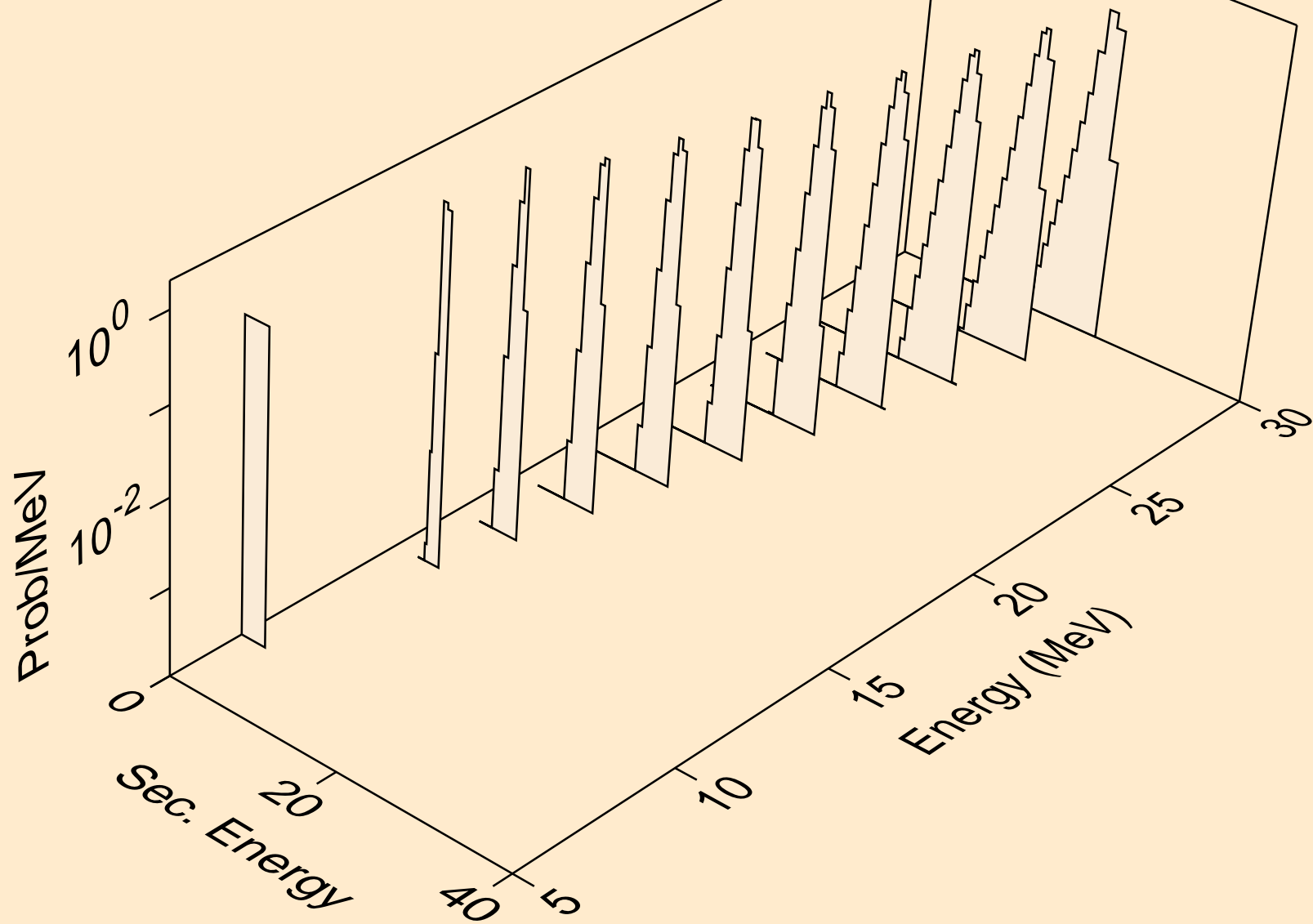

HS277M NEUTRON ACER TENDL-2023 LIBRARY; T=0.K
tritons from (n,t)

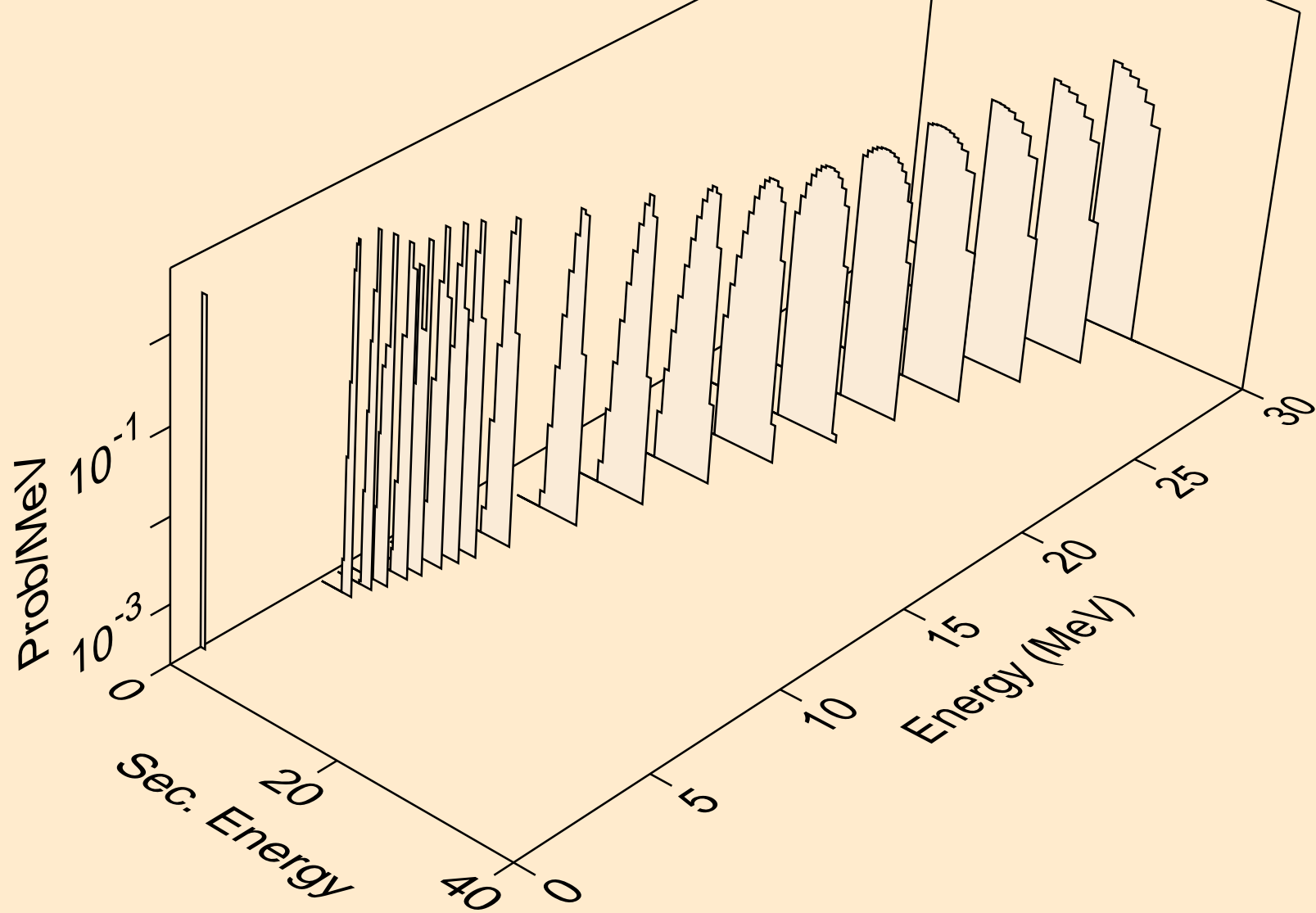

HS277M NEUTRON ACER TENDL-2023 LIBRARY; T=0.K
he3s from (n,x)

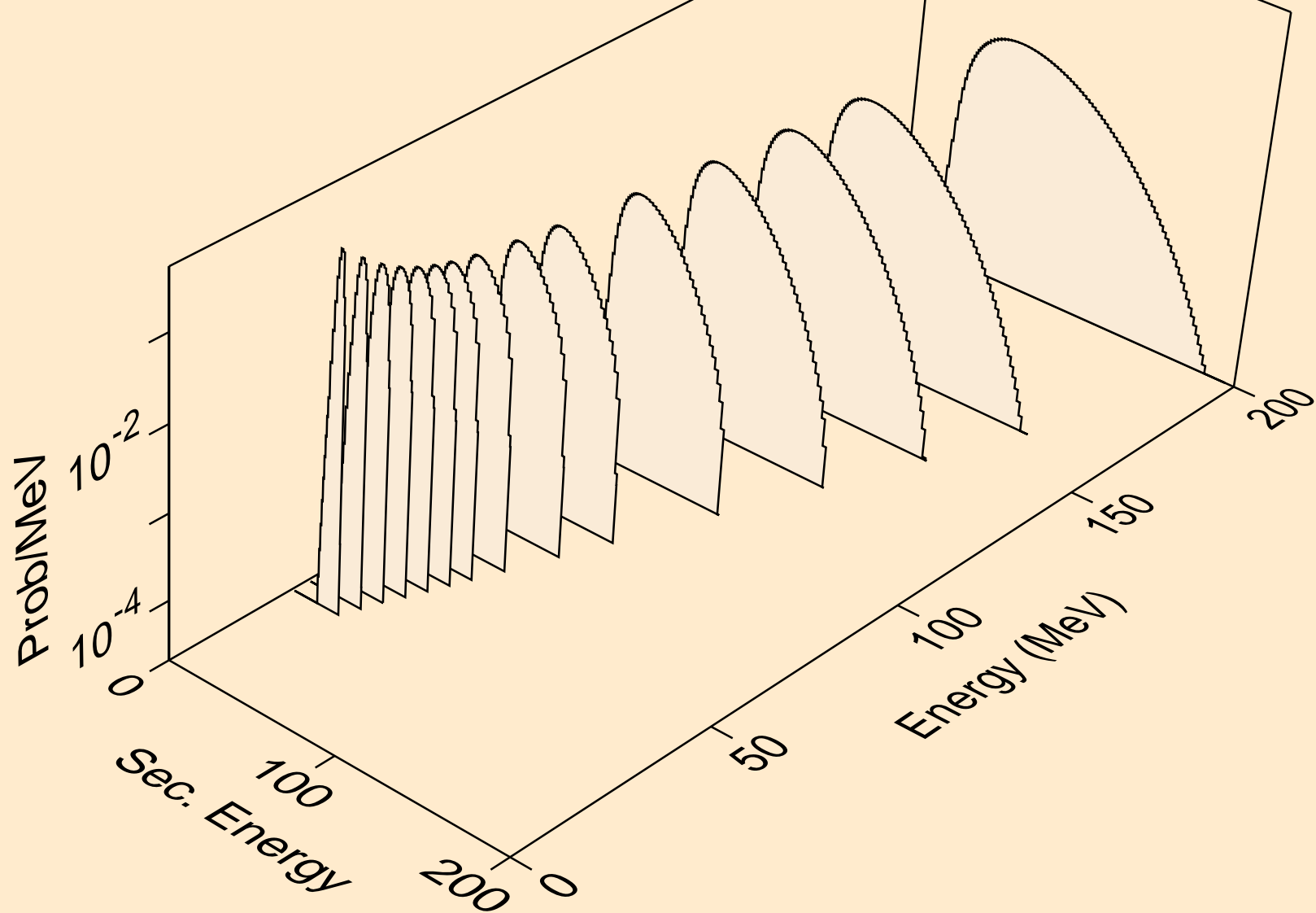

HS277M NEUTRON ACER TENDL-2023 LIBRARY; T=0.K
he3s from (n,n*)he3

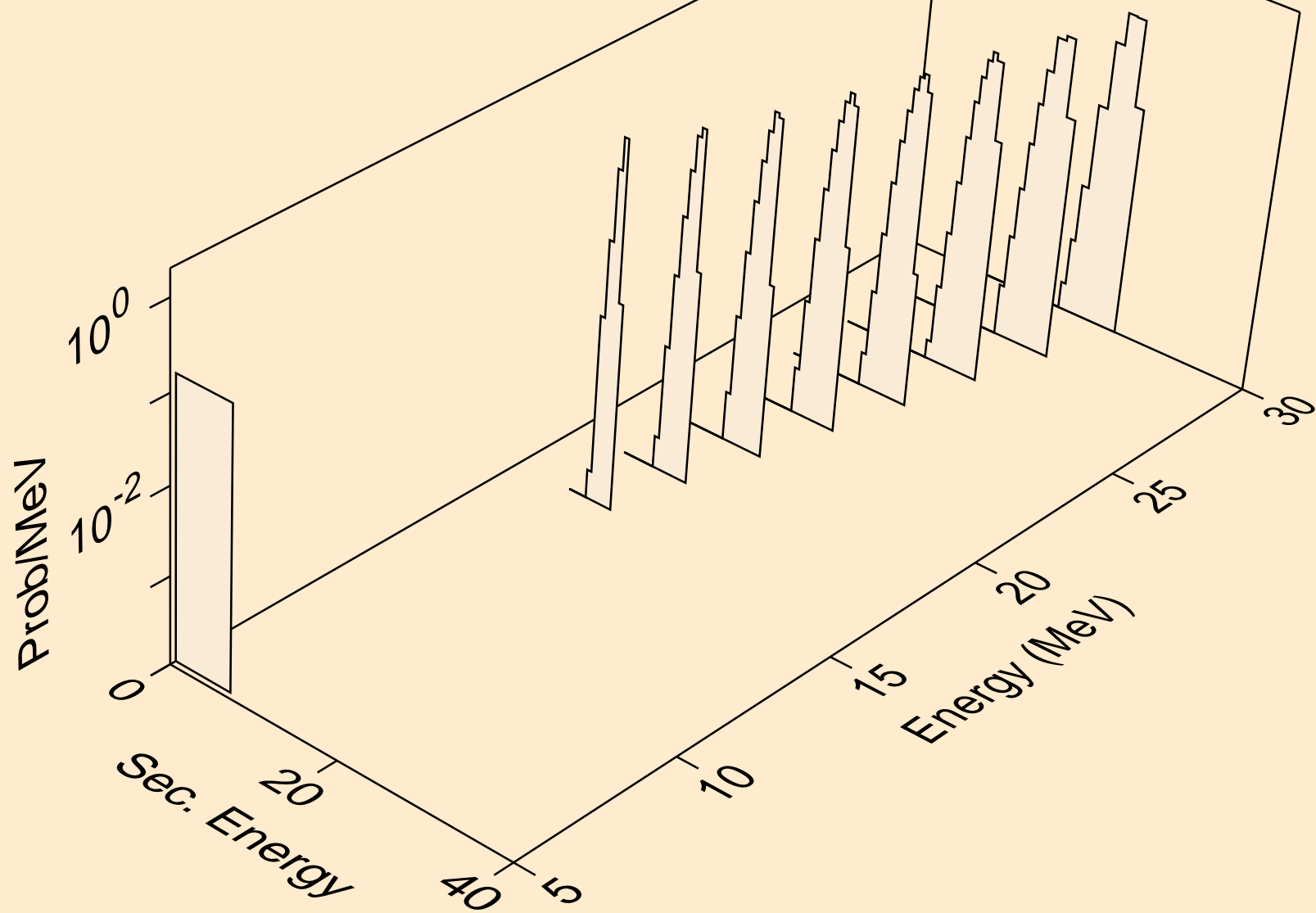

HS277M NEUTRON ACER TENDL-2023 LIBRARY; T=0.K
he3s from (n,he3)

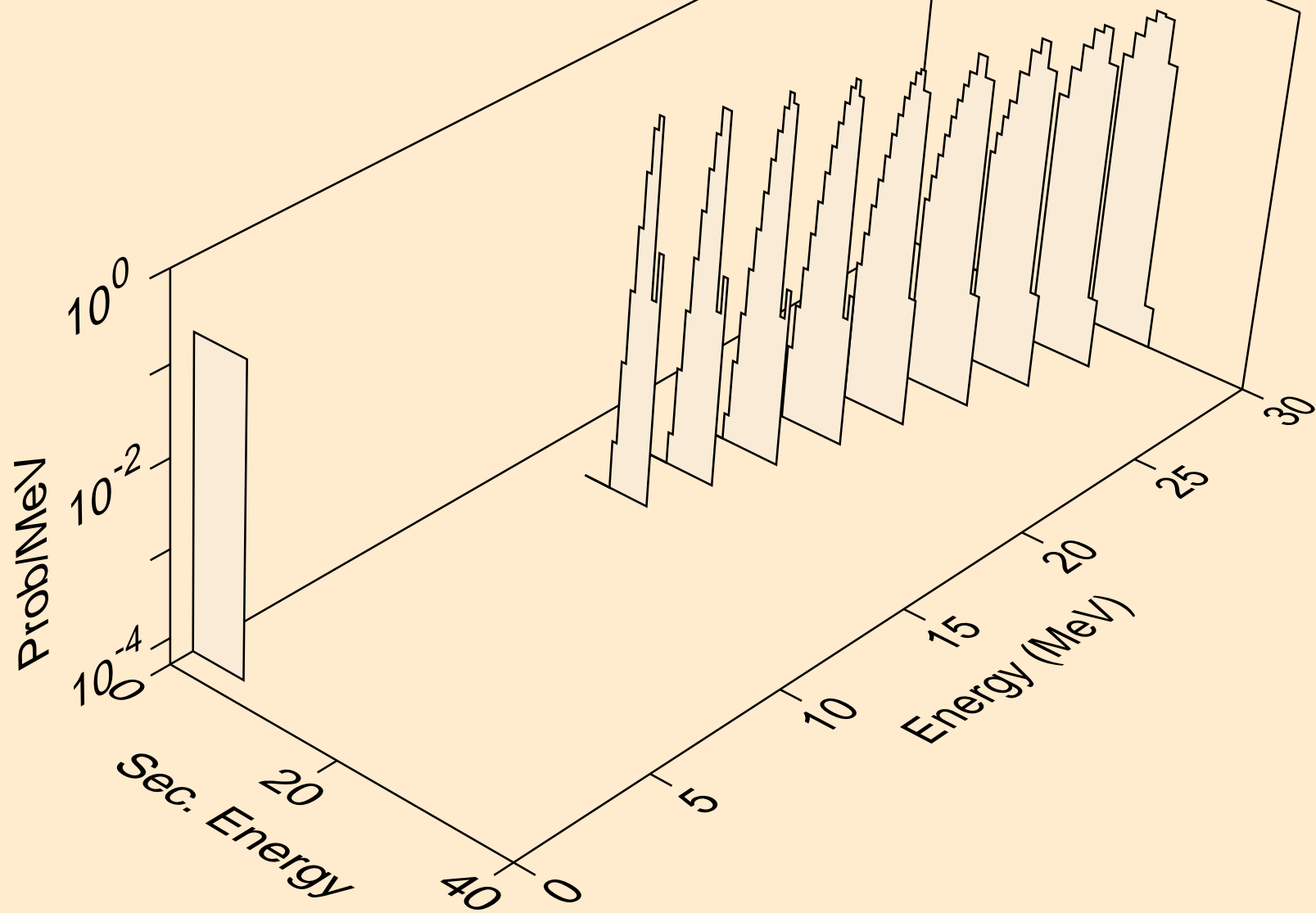

HS277M NEUTRON ACER TENDL-2023 LIBRARY; T=0.K
alphas from (n,x)

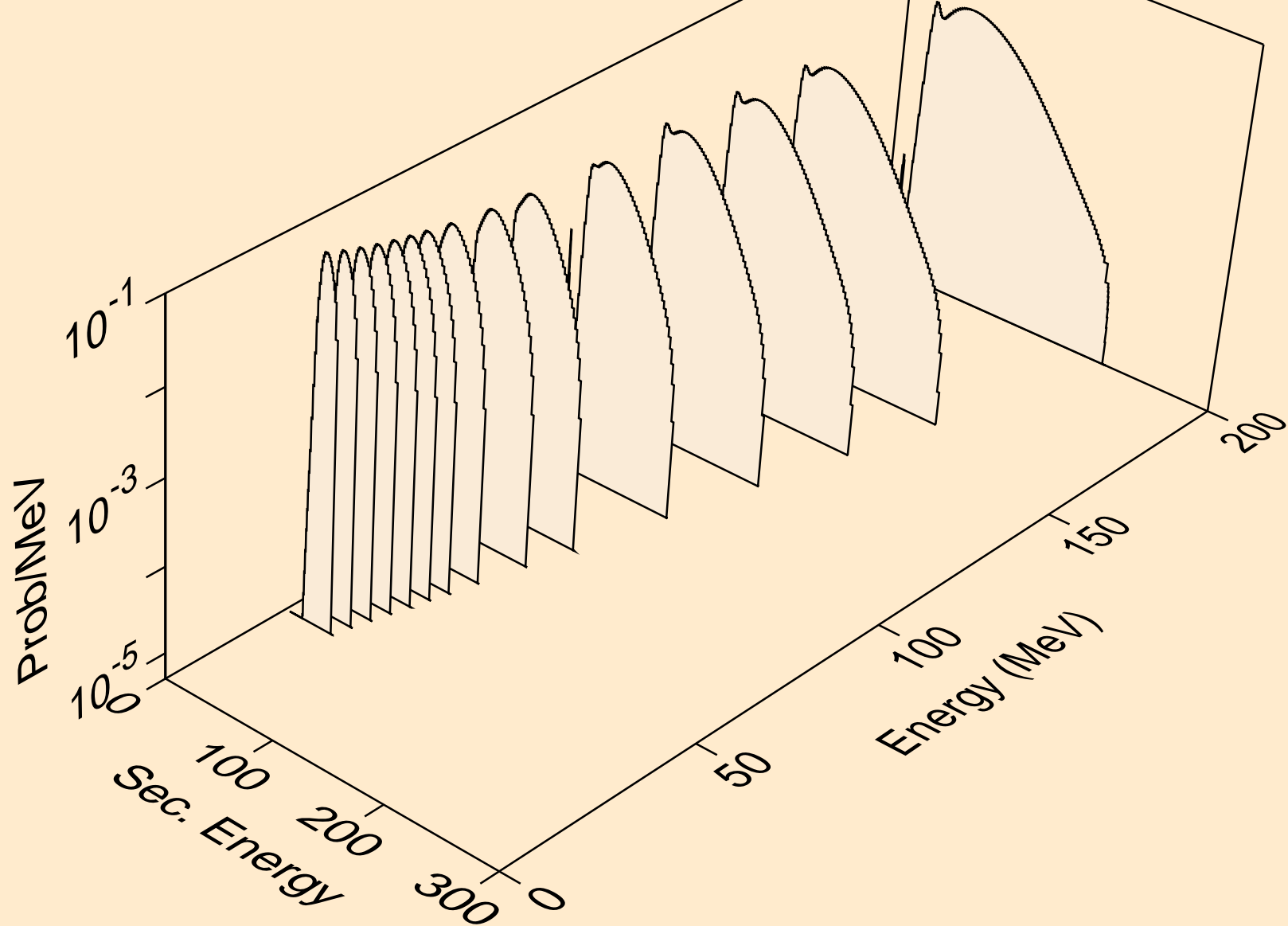

HS277M NEUTRON ACER TENDL-2023 LIBRARY; T=0.K
alphas from (n,n*)a

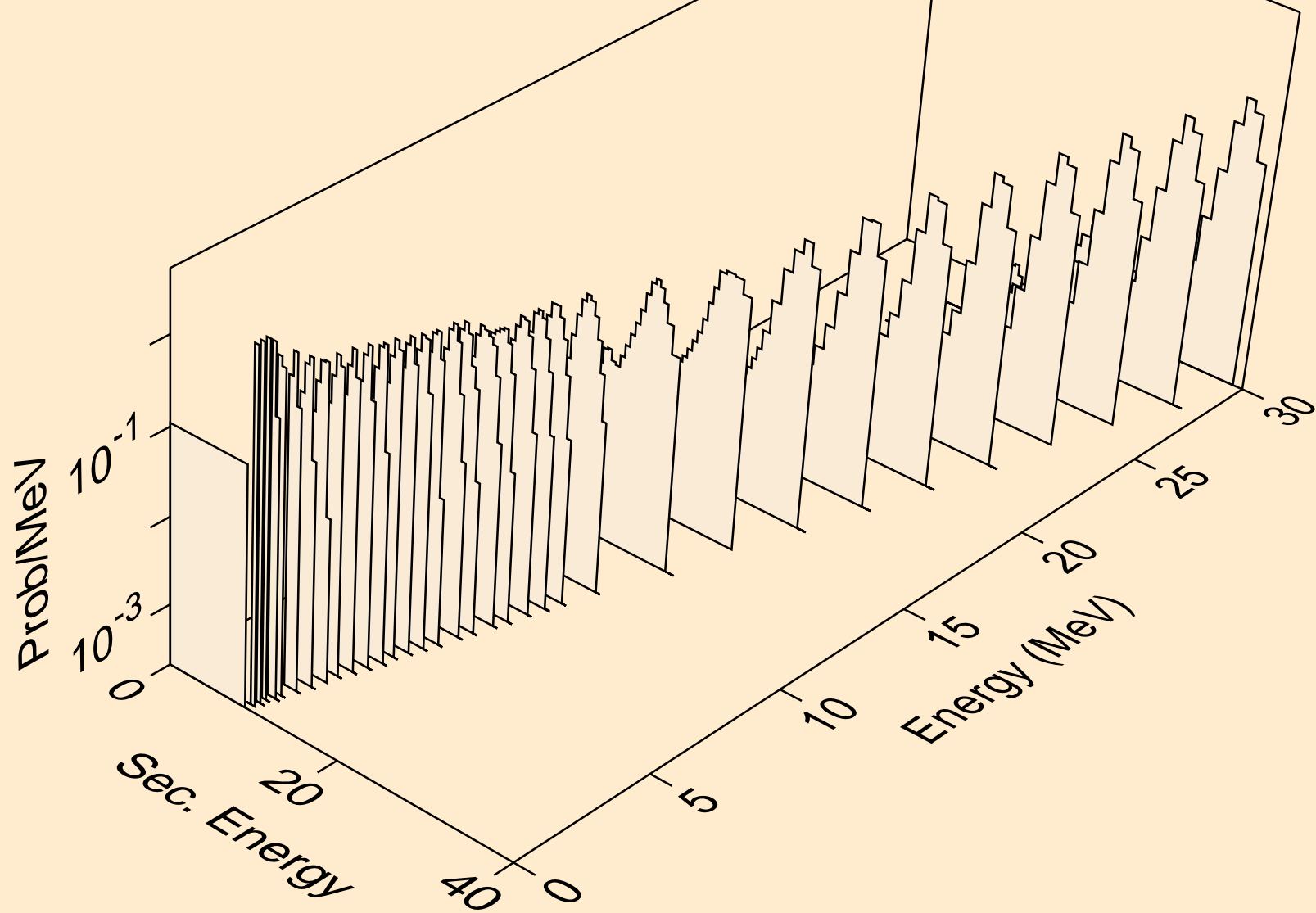

HS277M NEUTRON ACER TENDL-2023 LIBRARY; T=0.K
alphas from (n,2n)a

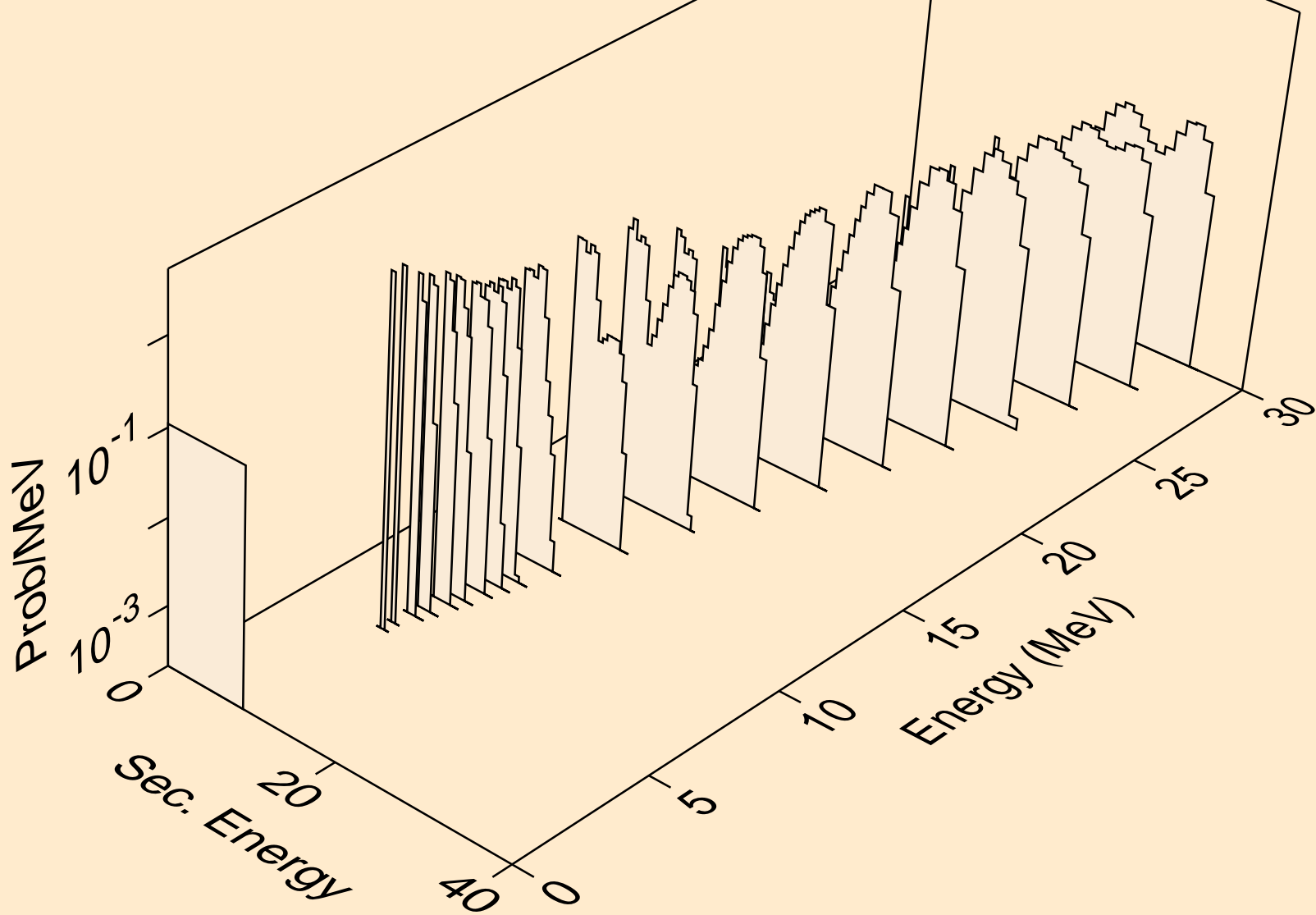

HS277M NEUTRON ACER TENDL-2023 LIBRARY; T=0.K
alphas from (n,3n)a

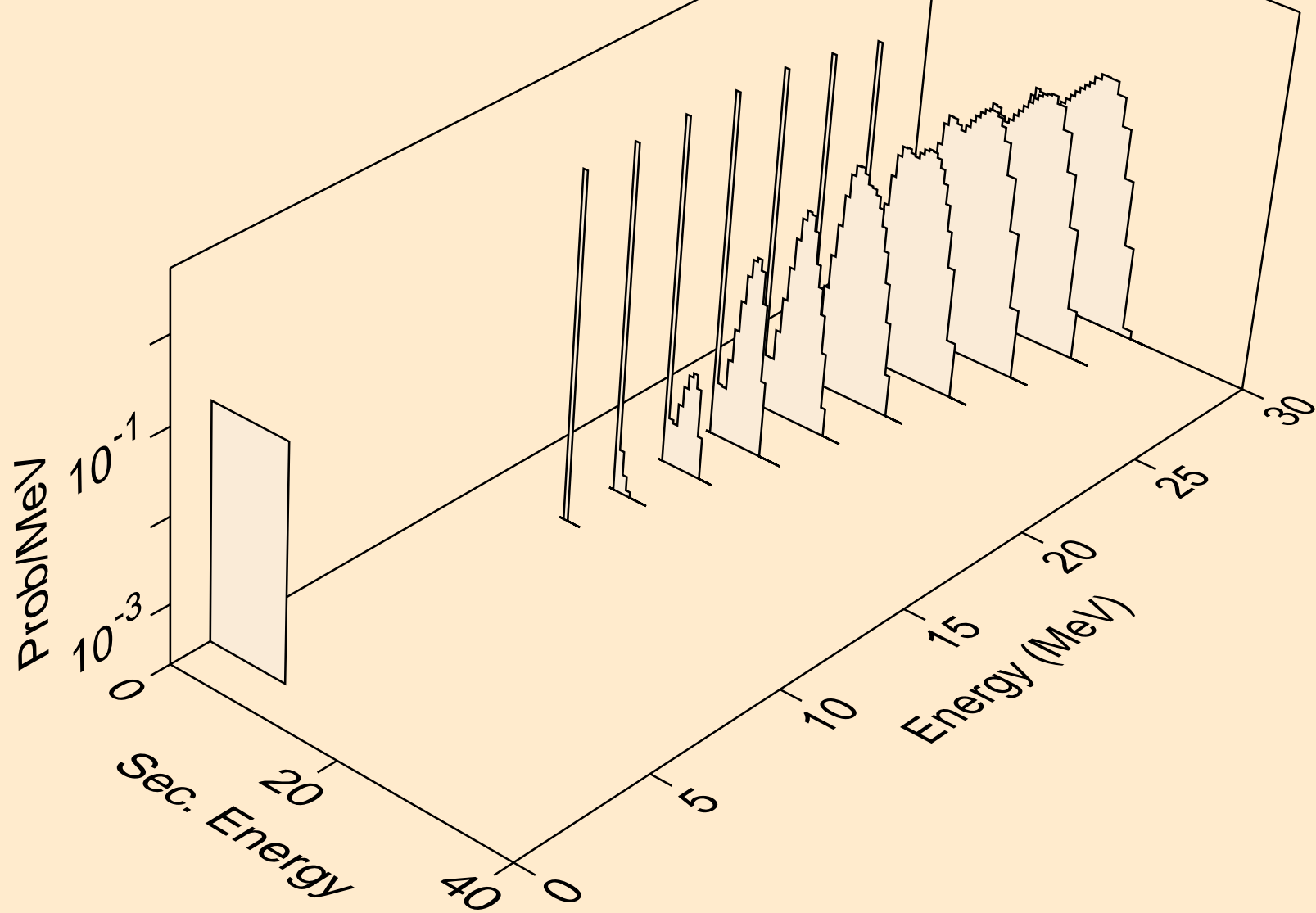

HS277M NEUTRON ACER TENDL-2023 LIBRARY; T=0.K
alphas from (n,a)

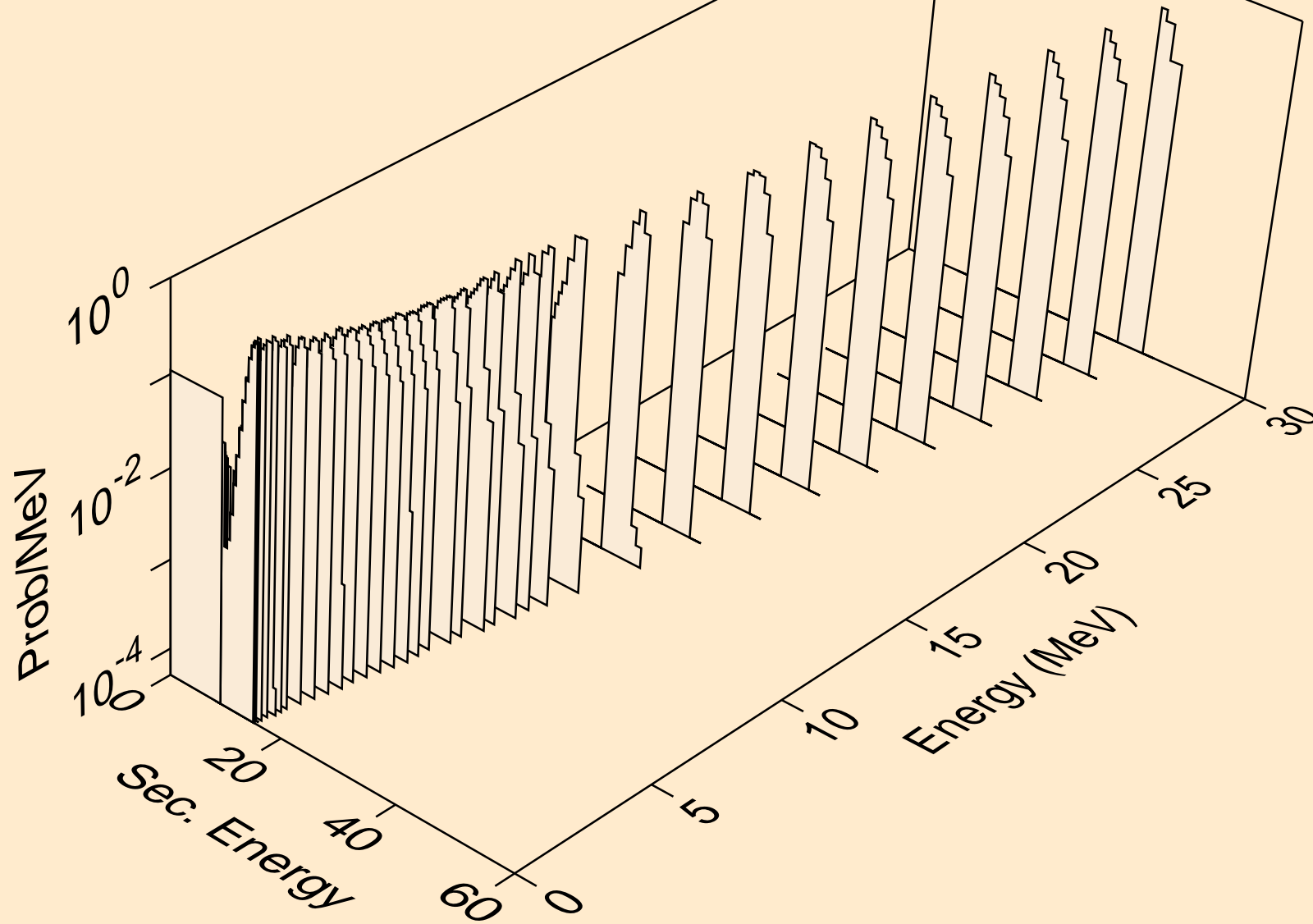

HS277M NEUTRON ACER TENDL-2023 LIBRARY; T=0.K
alphas from (n,pa)

