

# LA132 NEUTRON ACER TENDL-2023 LIBRARY; T=0.K

## Principal cross sections

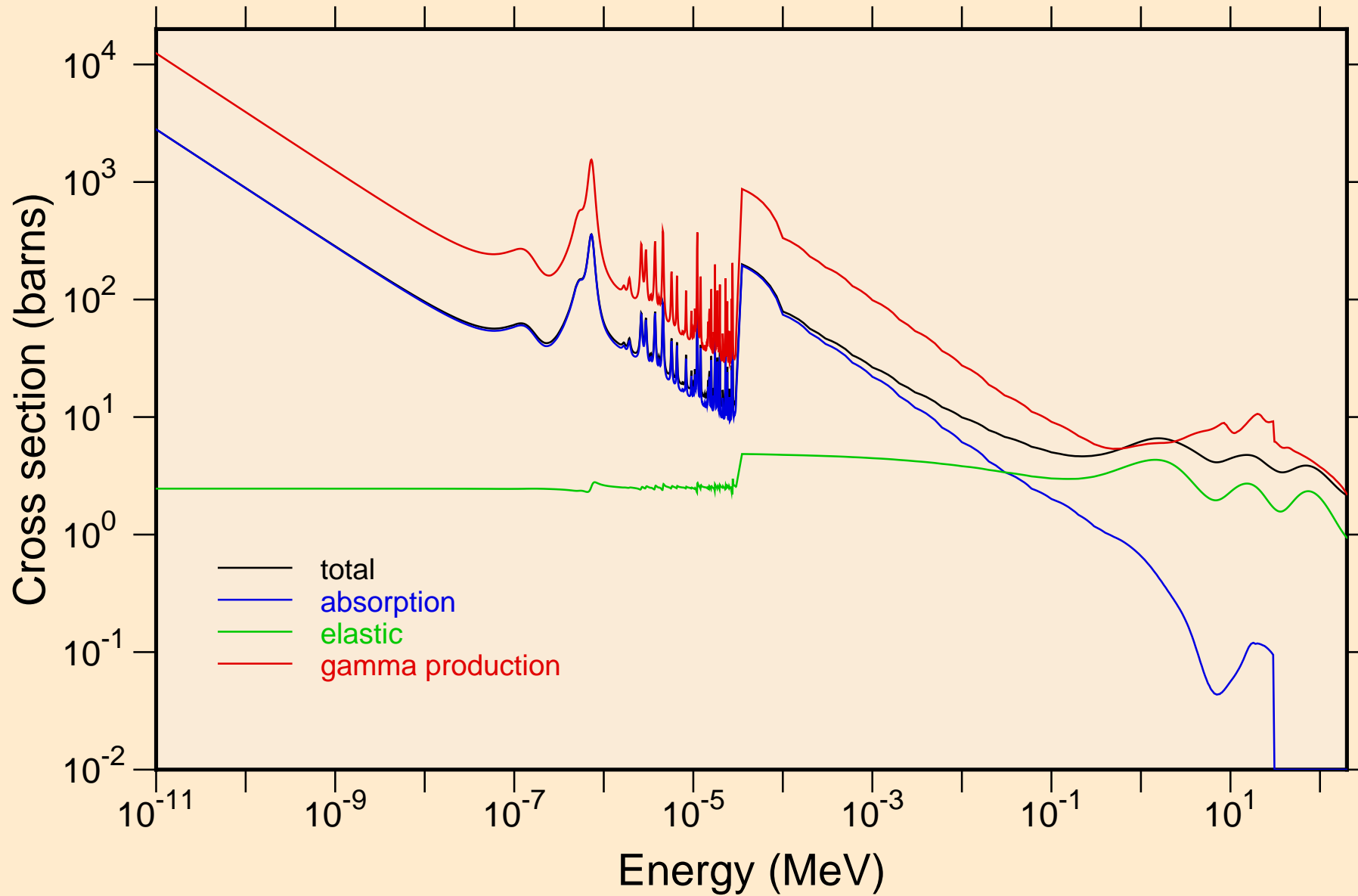

LA132 NEUTRON ACER TENDL-2023 LIBRARY; T=0.K  
resonance total cross section

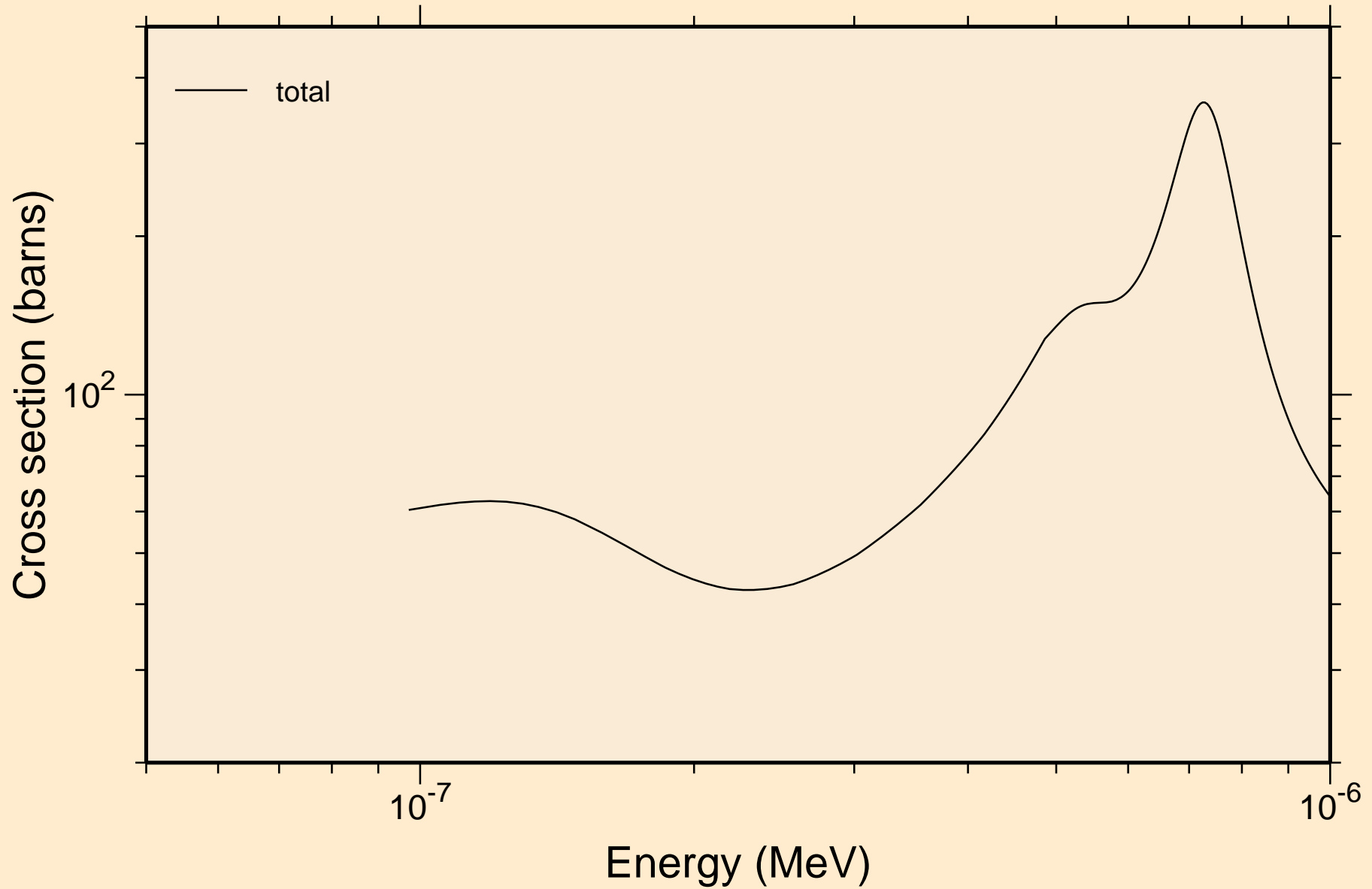

LA132 NEUTRON ACER TENDL-2023 LIBRARY; T=0.K  
resonance total cross section

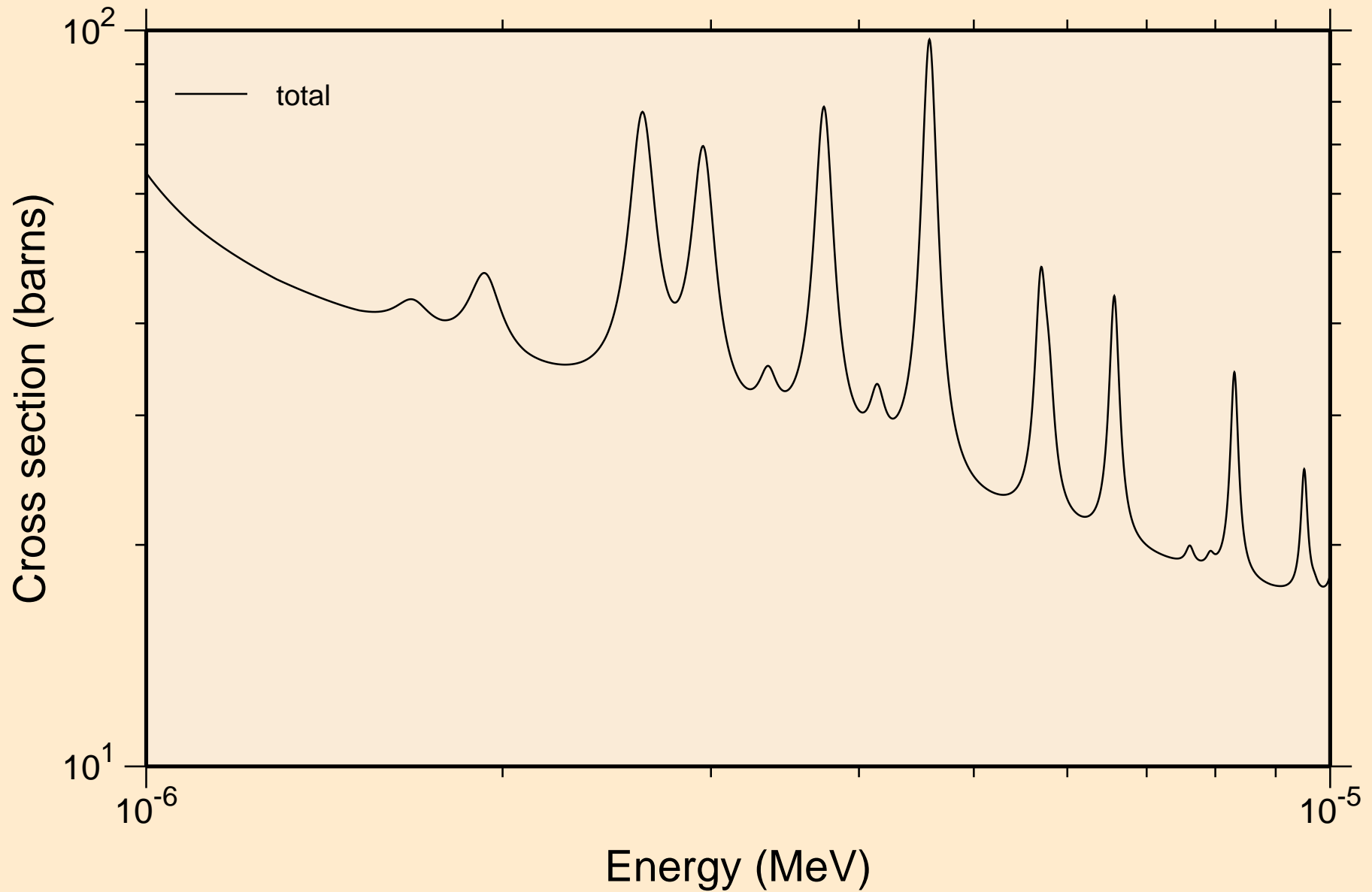

LA132 NEUTRON ACER TENDL-2023 LIBRARY; T=0.K  
resonance total cross section

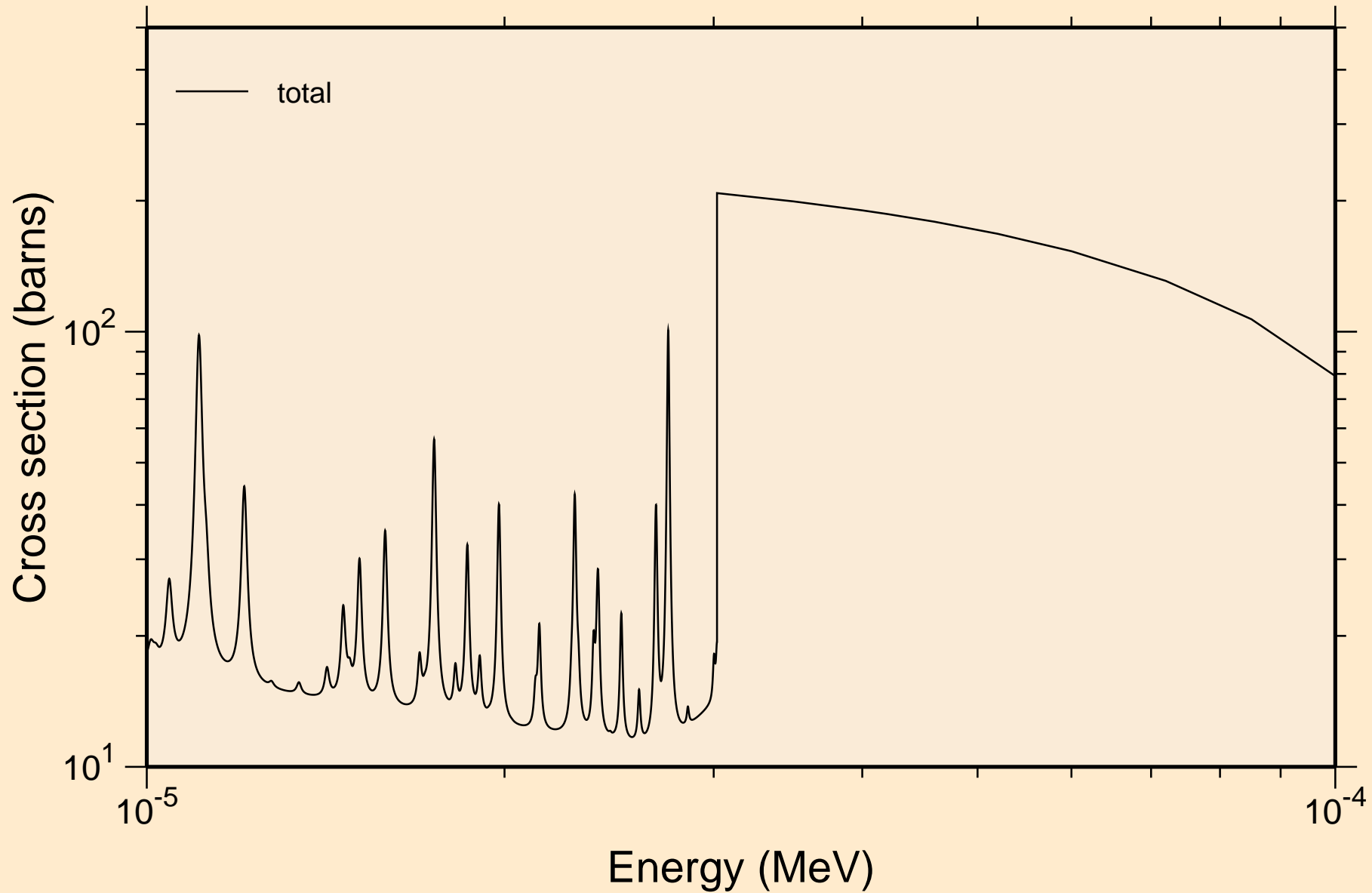

L̄A132 NEUTRON ACER TENDL-2023 LIBRARY; T=0.K  
resonance total cross section

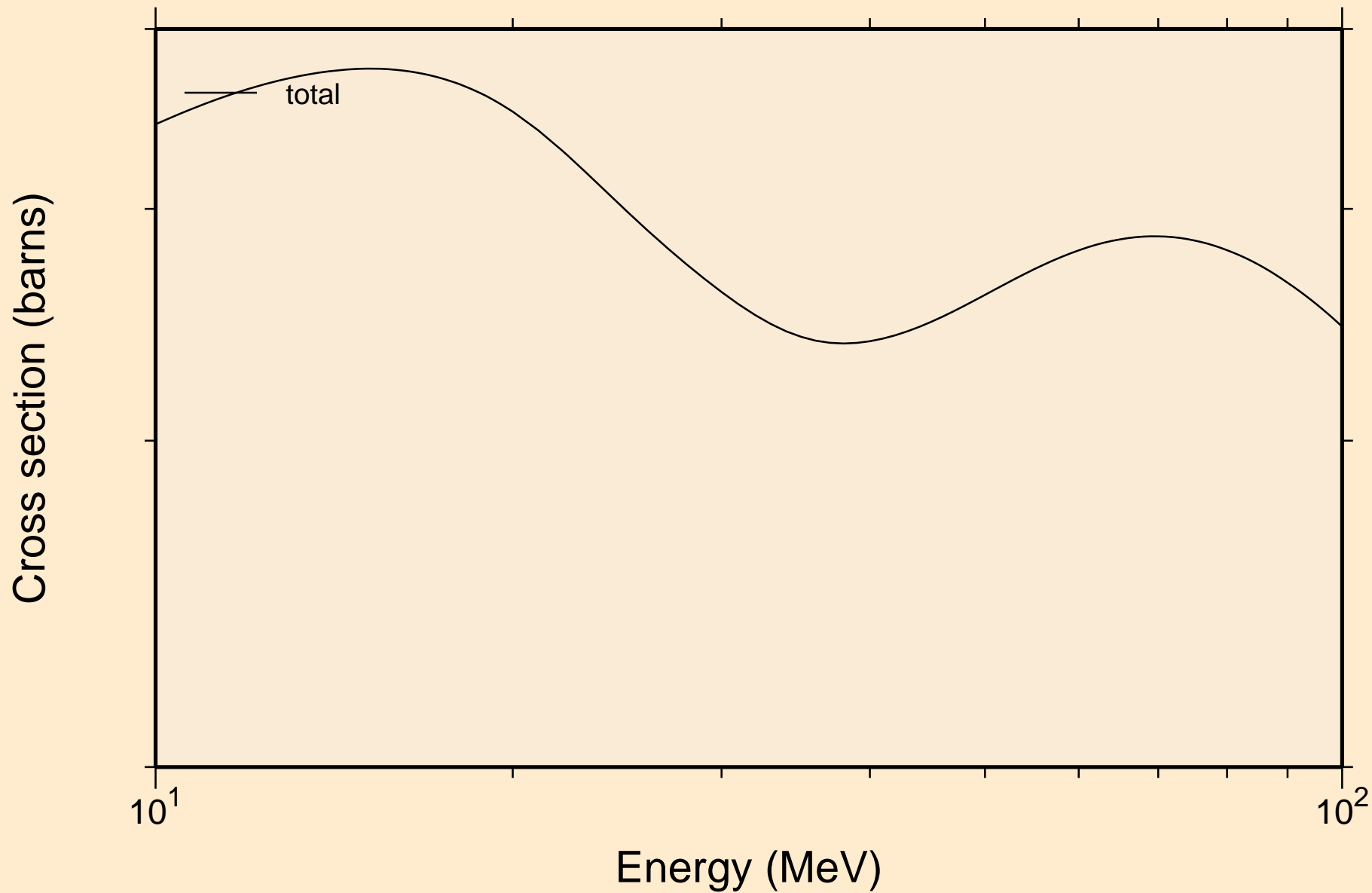

LA132 NEUTRON ACER TENDL-2023 LIBRARY; T=0.K  
resonance absorption cross sections

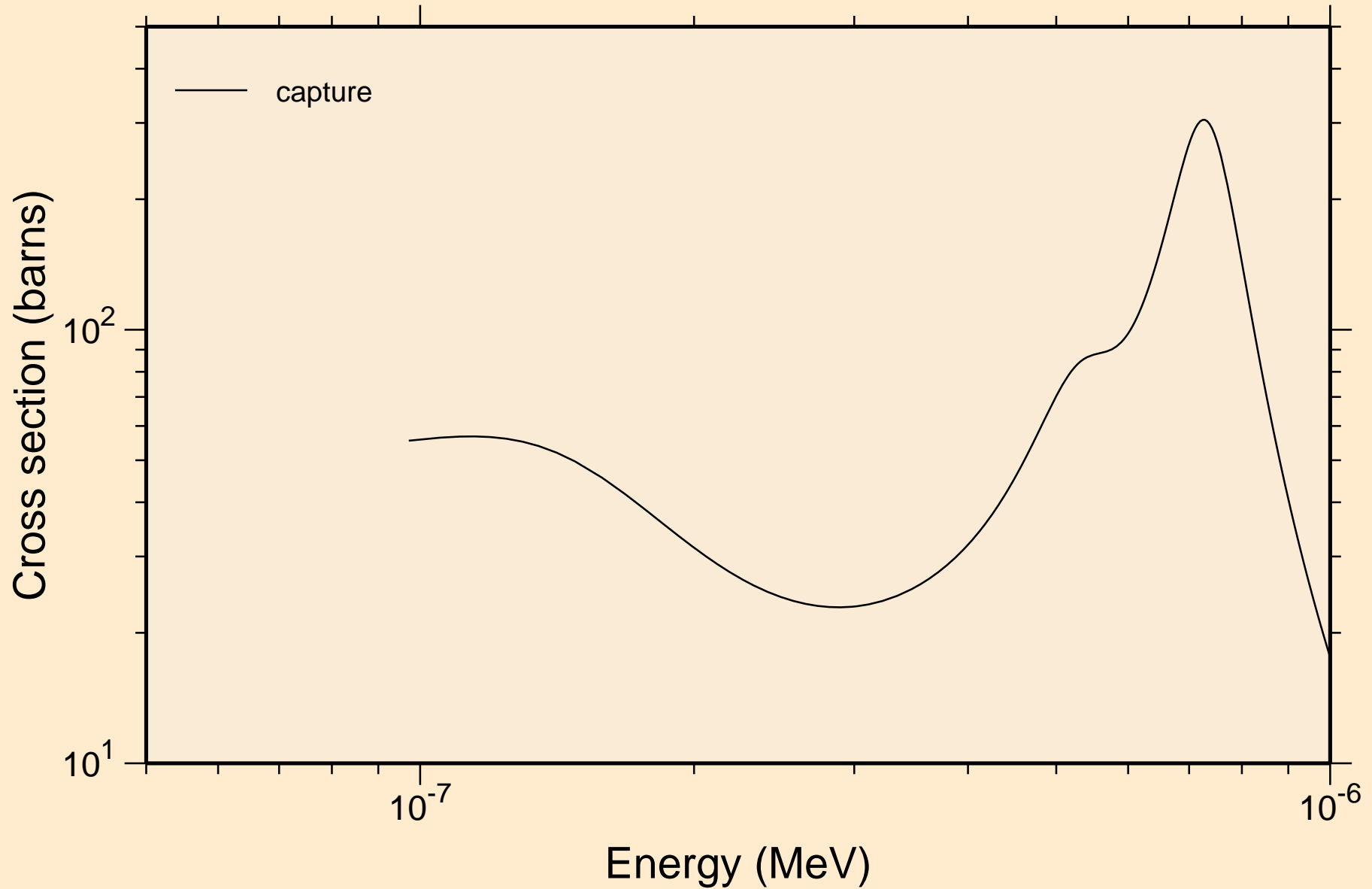

LA132 NEUTRON ACER TENDL-2023 LIBRARY; T=0.K  
resonance absorption cross sections

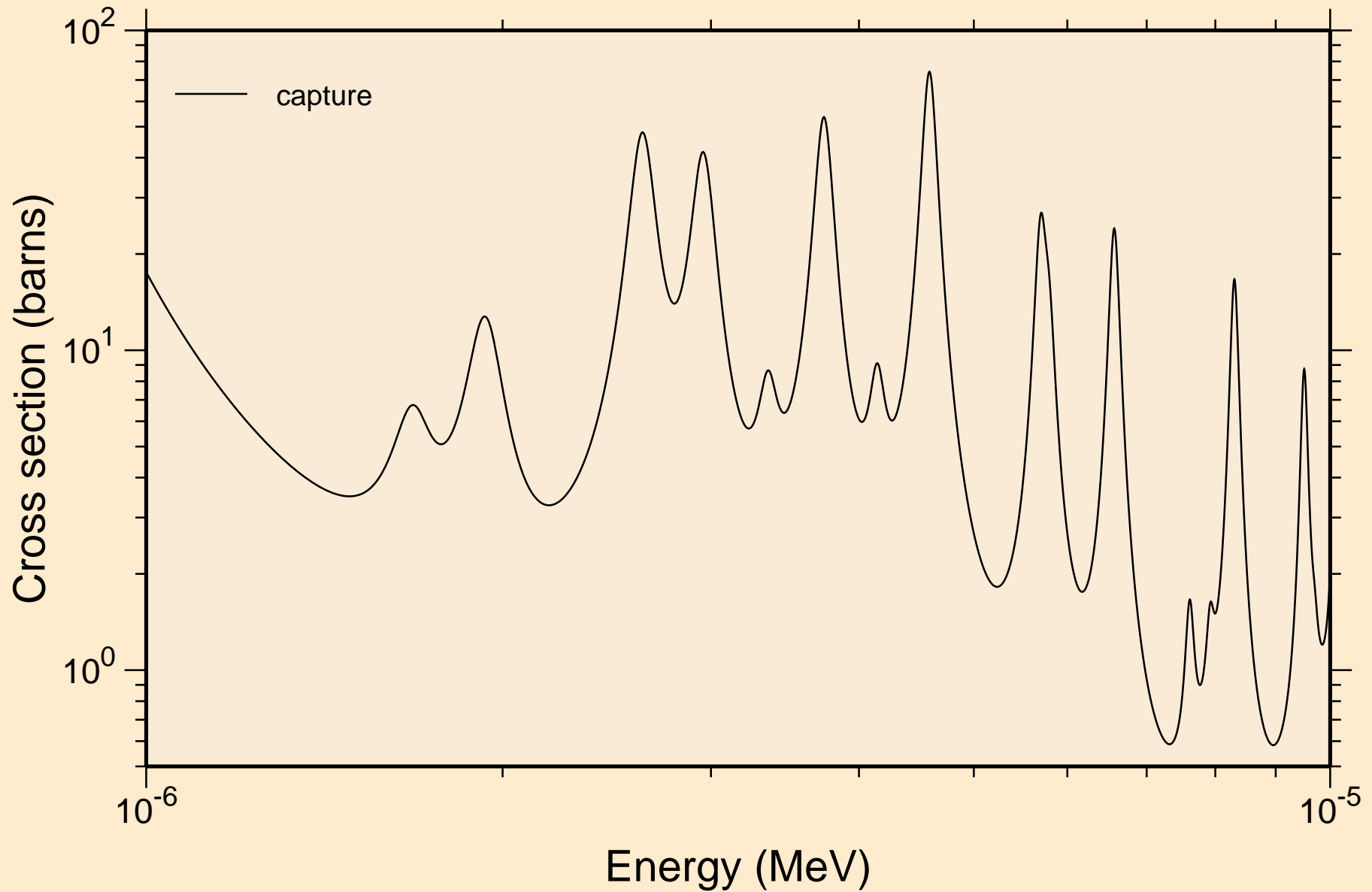

LA132 NEUTRON ACER TENDL-2023 LIBRARY; T=0.K  
resonance absorption cross sections

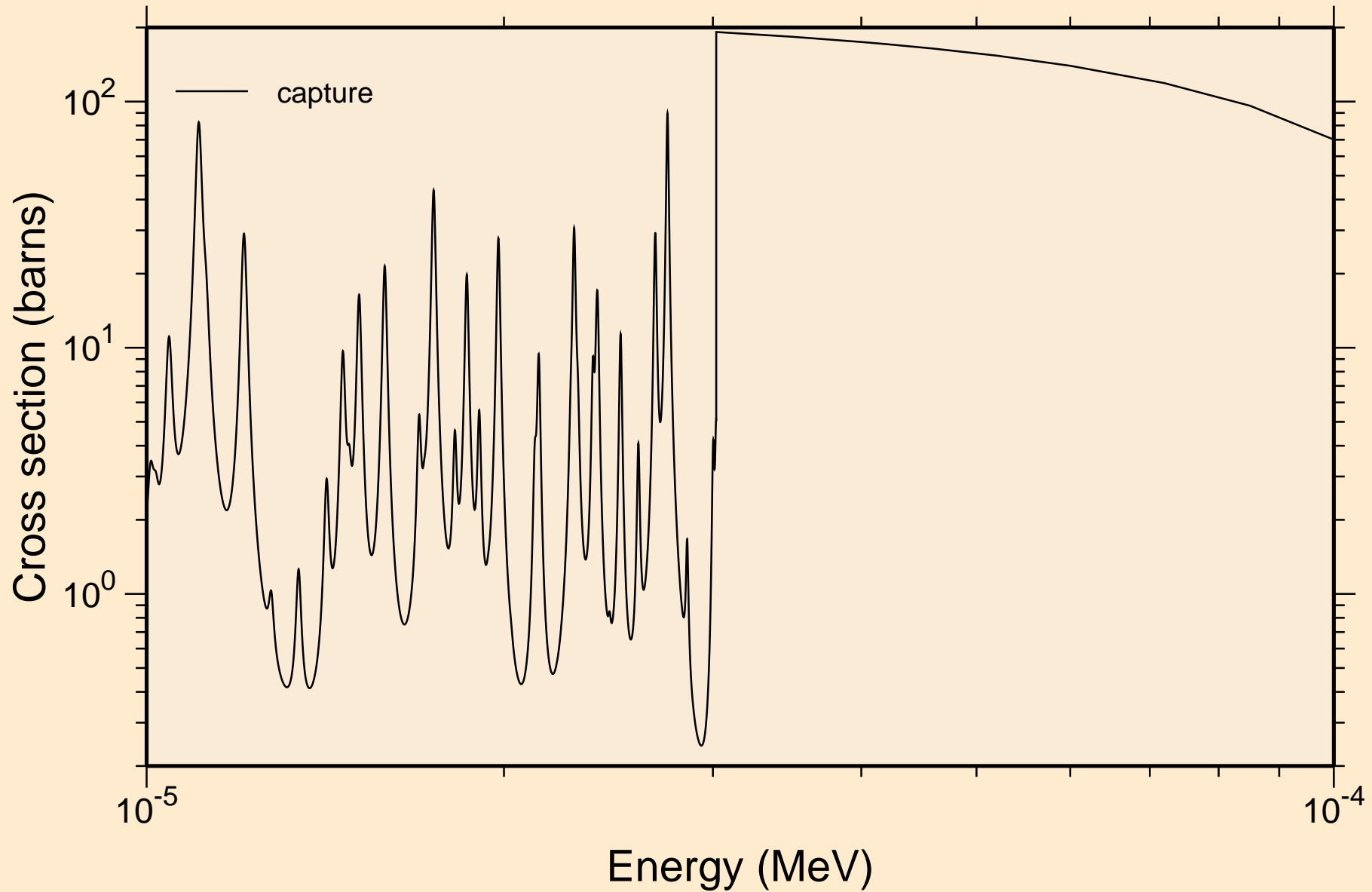



LA132 NEUTRON ACER TENDL-2023 LIBRARY; T=0.K  
resonance absorption cross sections

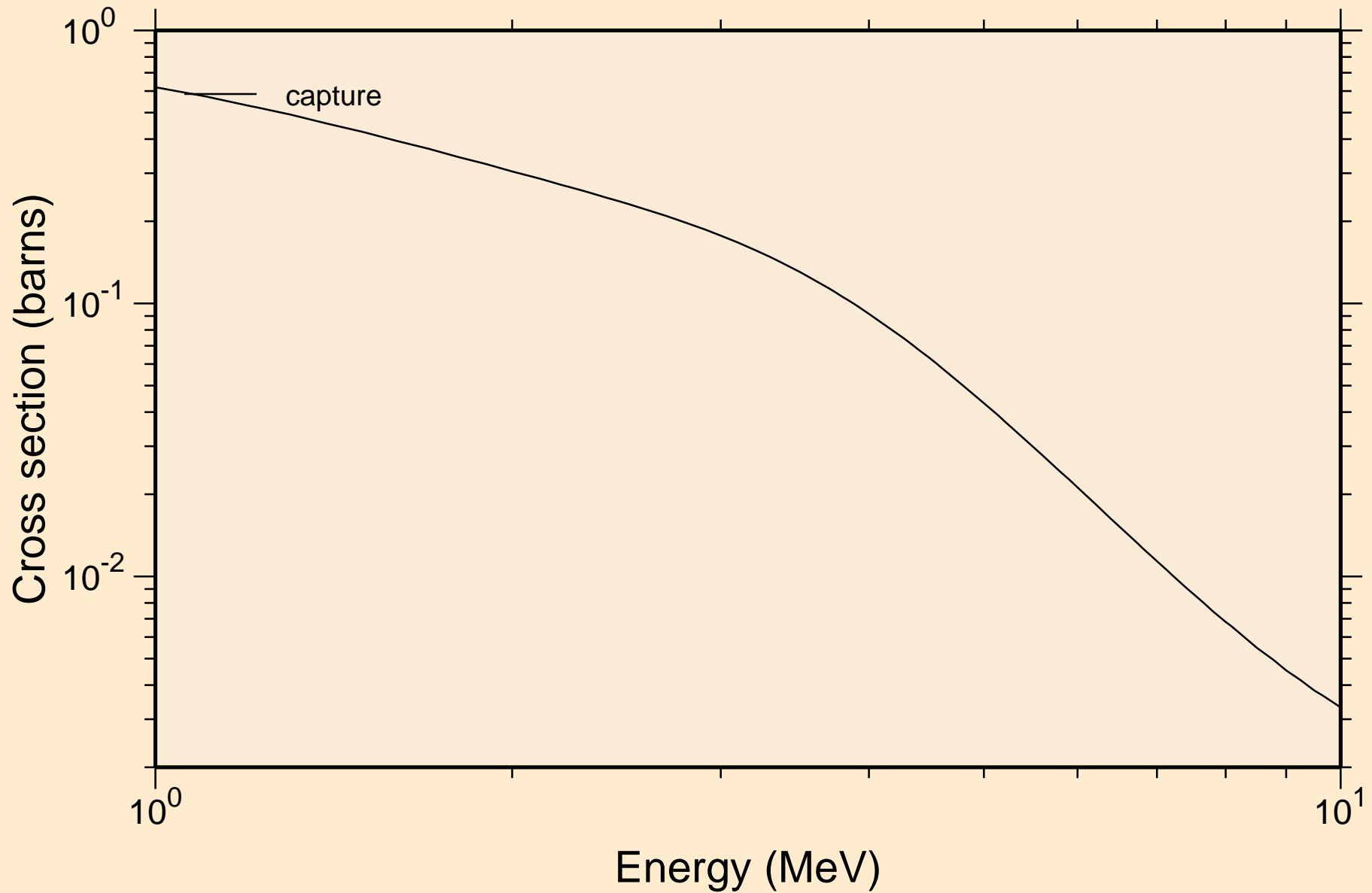

# LA132 NEUTRON ACER TENDL-2023 LIBRARY; T=0.K

## Heating

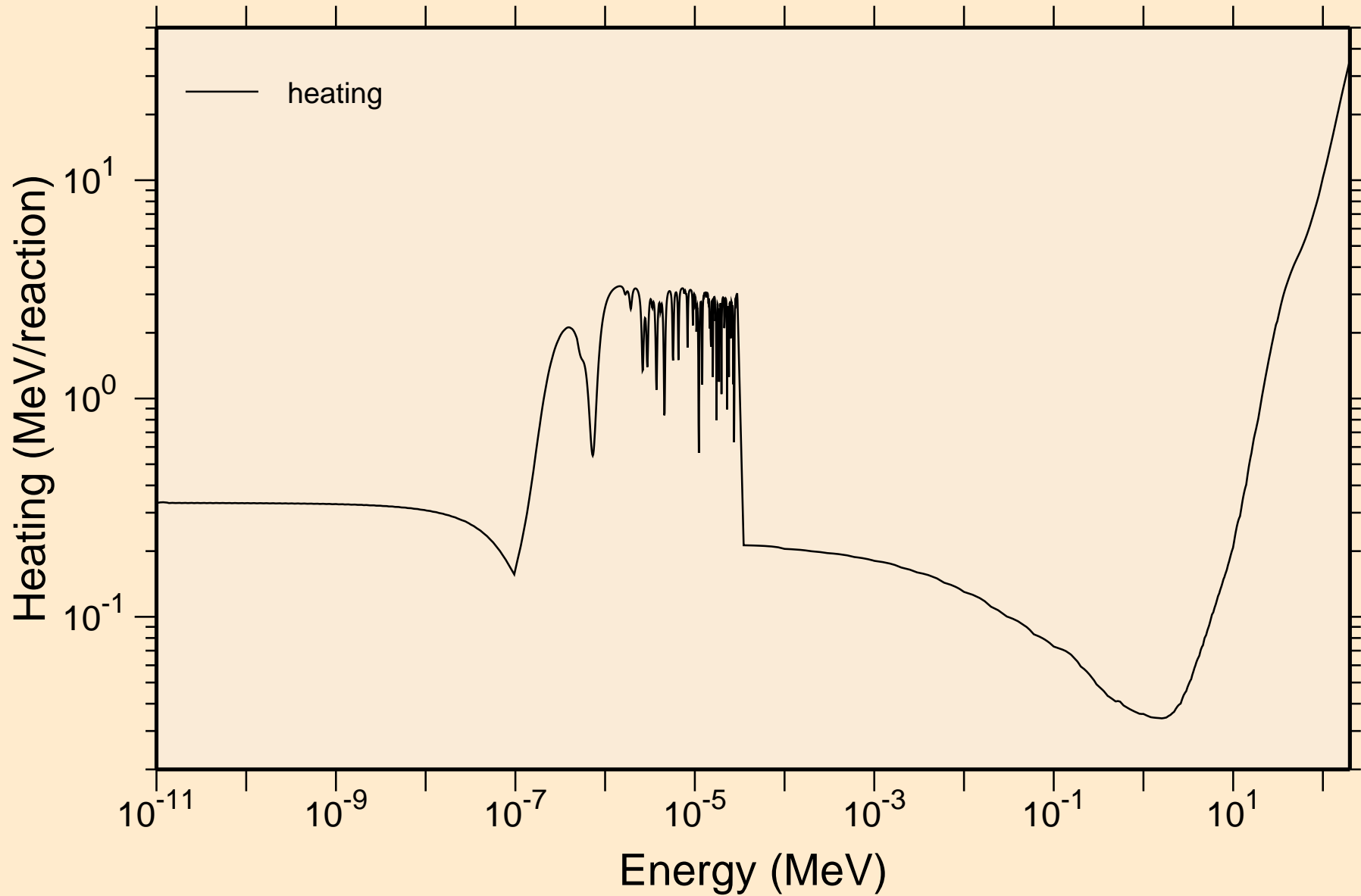

LA132 NEUTRON ACER TENDL-2023 LIBRARY; T=0.K  
Damage

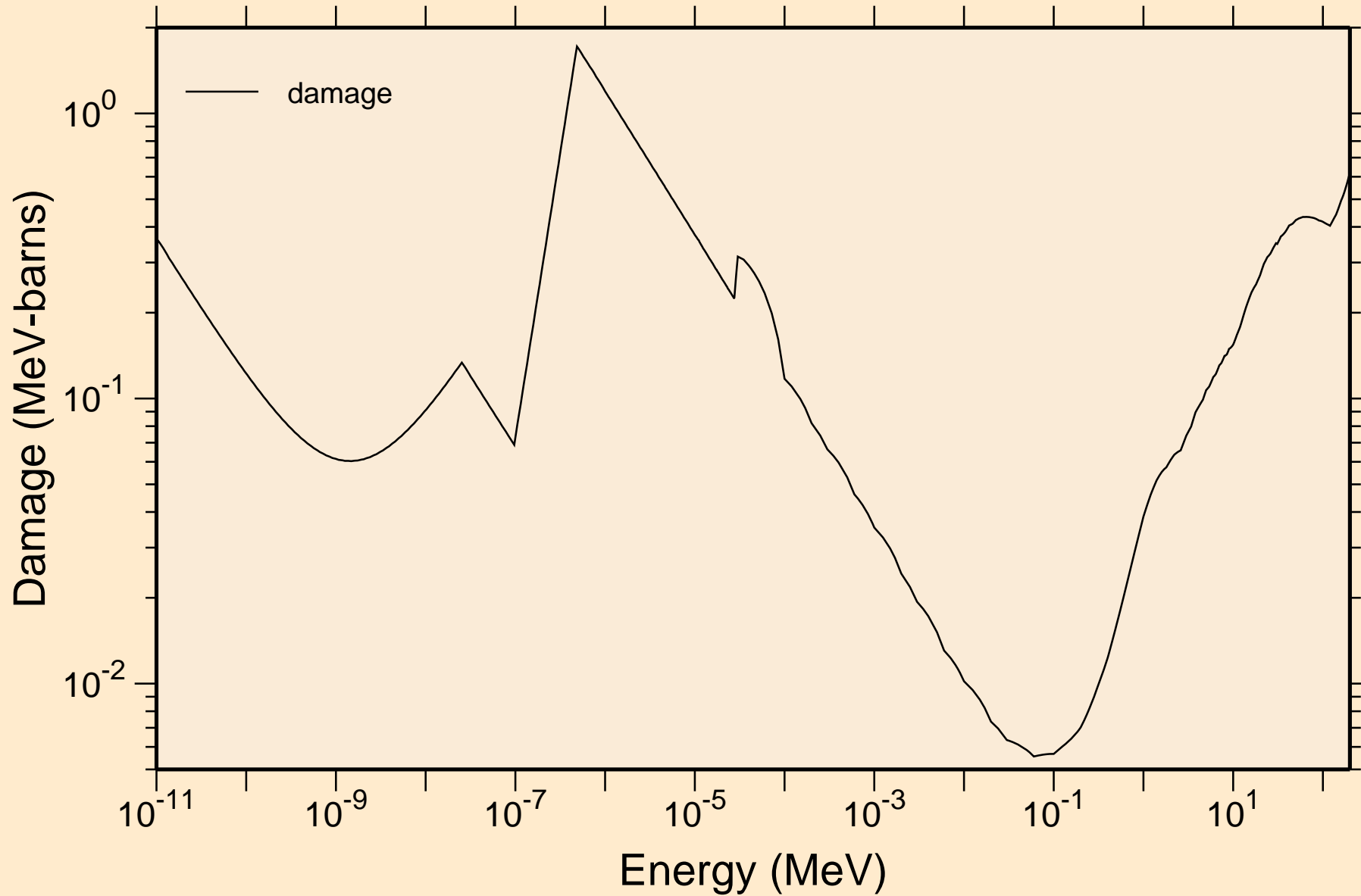

LA132 NEUTRON ACER TENDL-2023 LIBRARY; T=0.K  
Non-threshold reactions

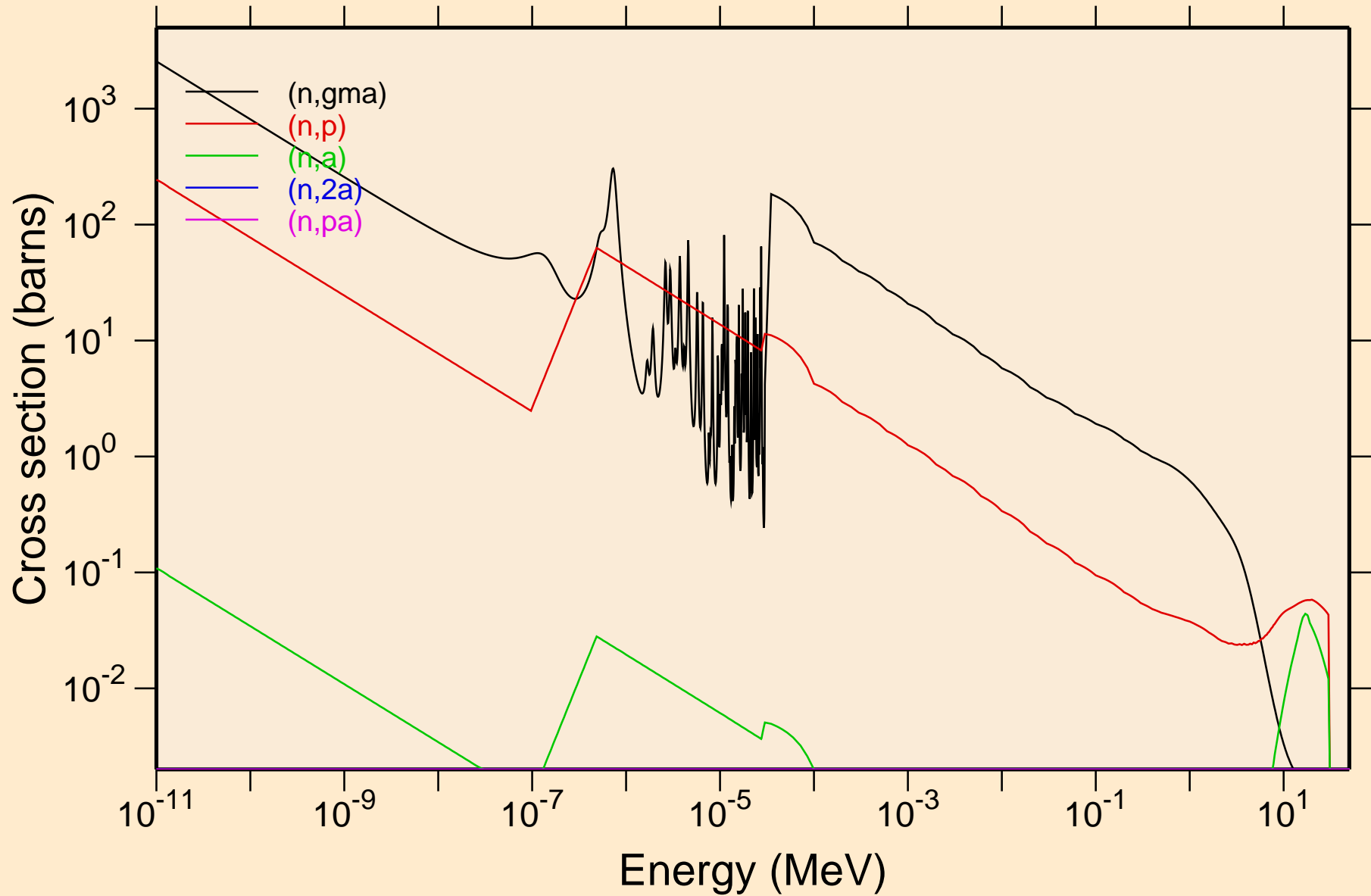

LA132 NEUTRON ACER TENDL-2023 LIBRARY; T=0.K  
Non-threshold reactions

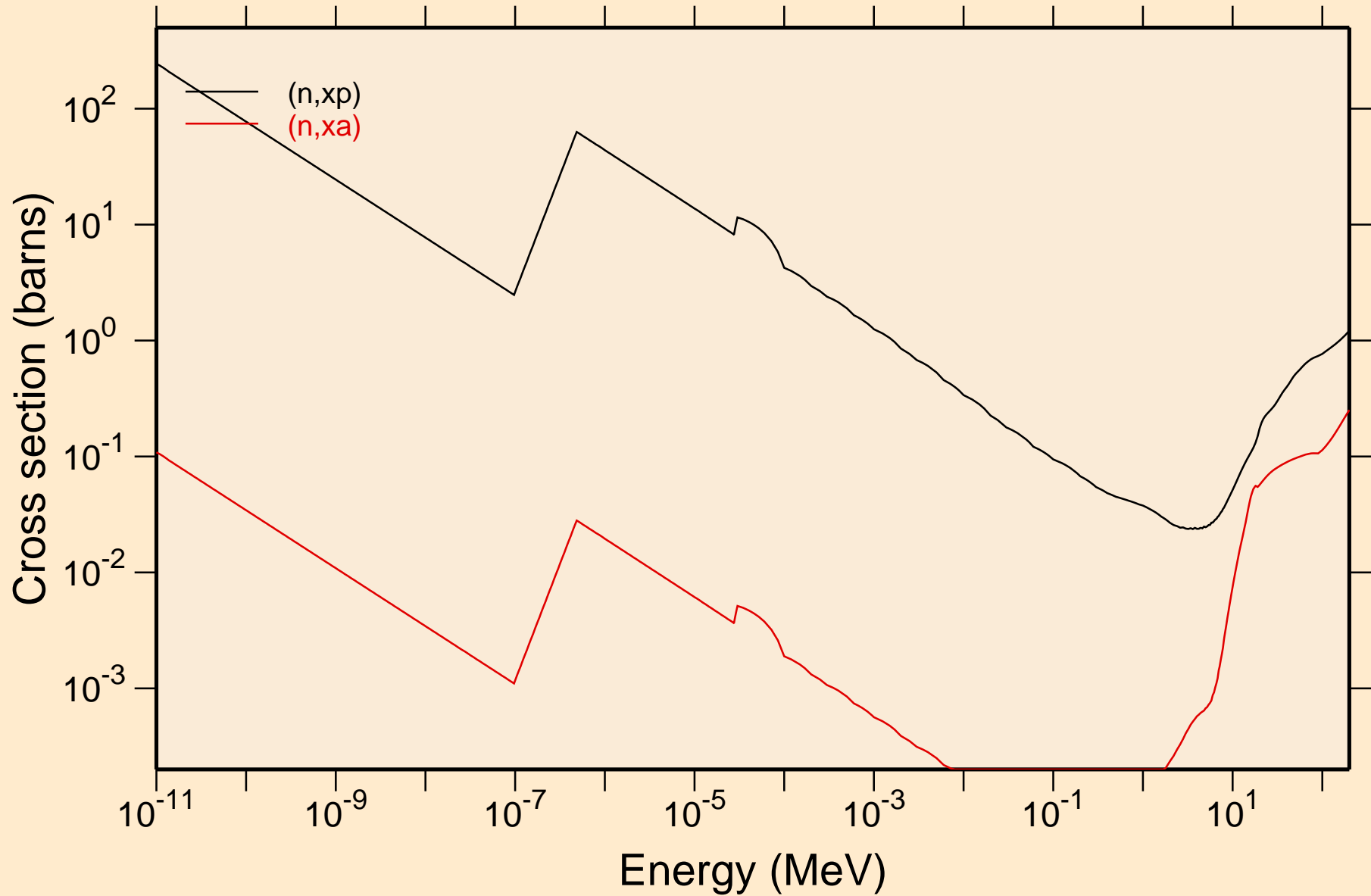

# LA132 NEUTRON ACER TENDL-2023 LIBRARY; T=0.K

## Principal cross sections

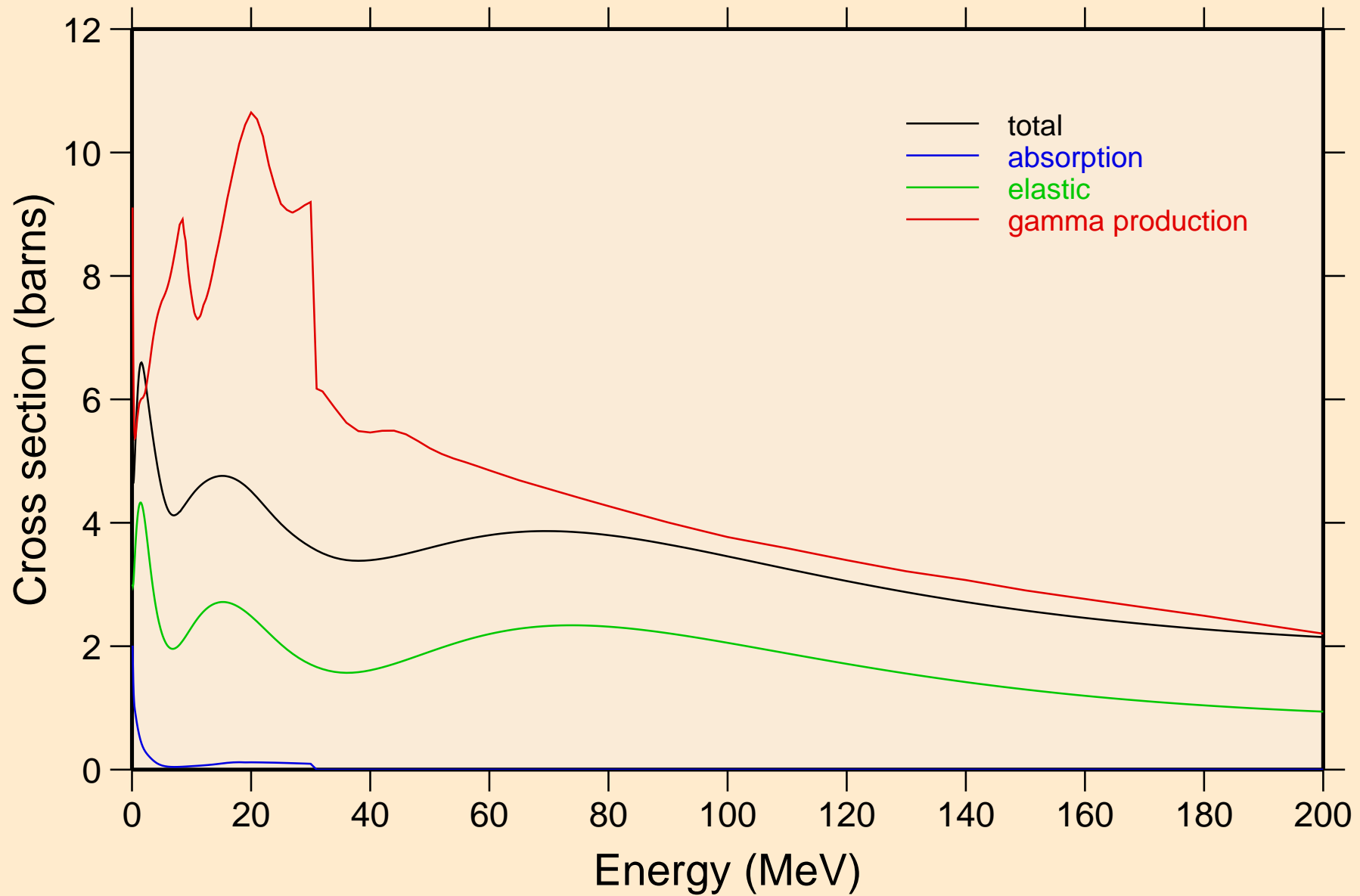

LA132 NEUTRON ACER TENDL-2023 LIBRARY; T=0.K

Heating

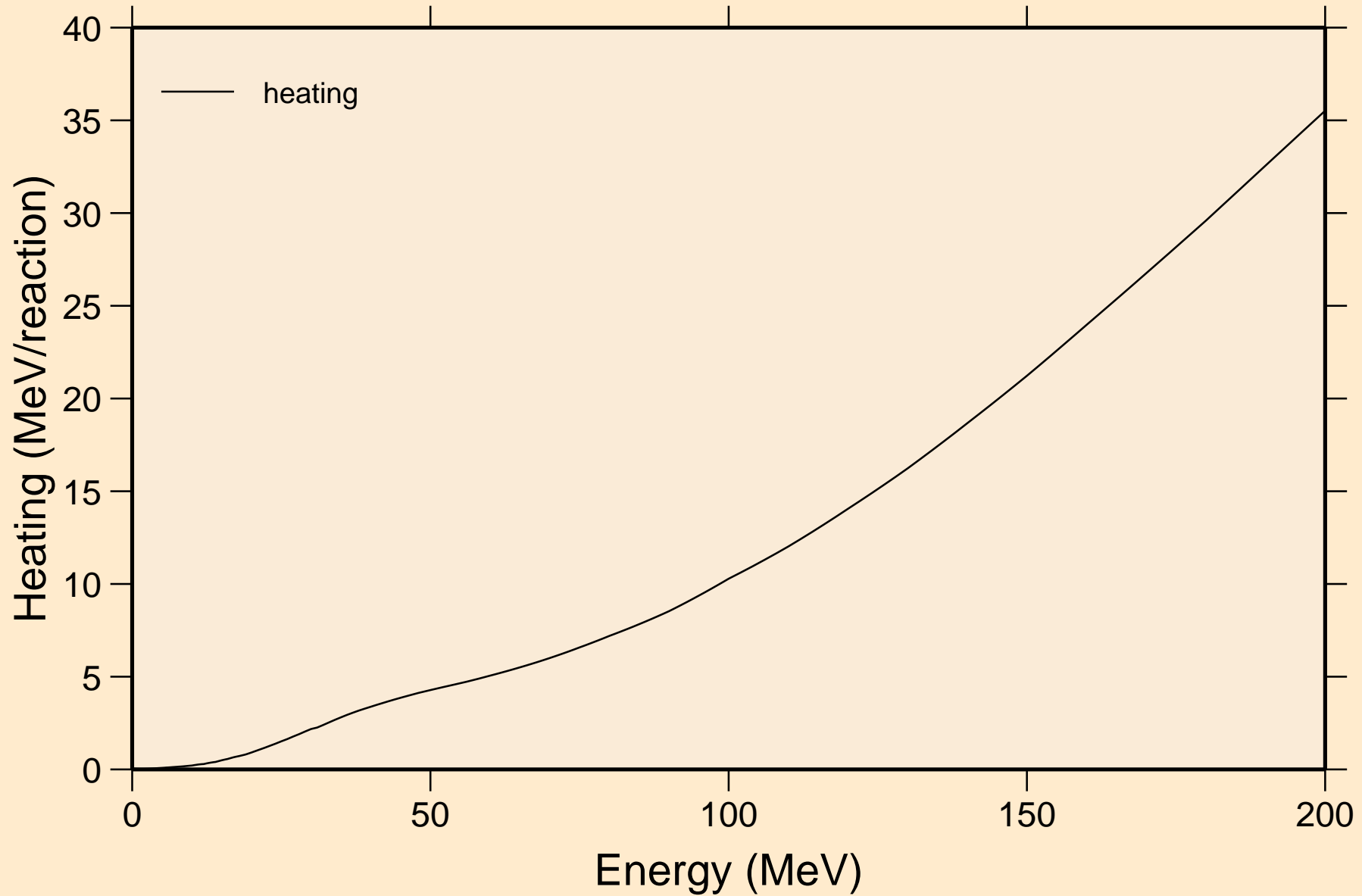

# LA132 NEUTRON ACER TENDL-2023 LIBRARY; T=0.K

## Damage

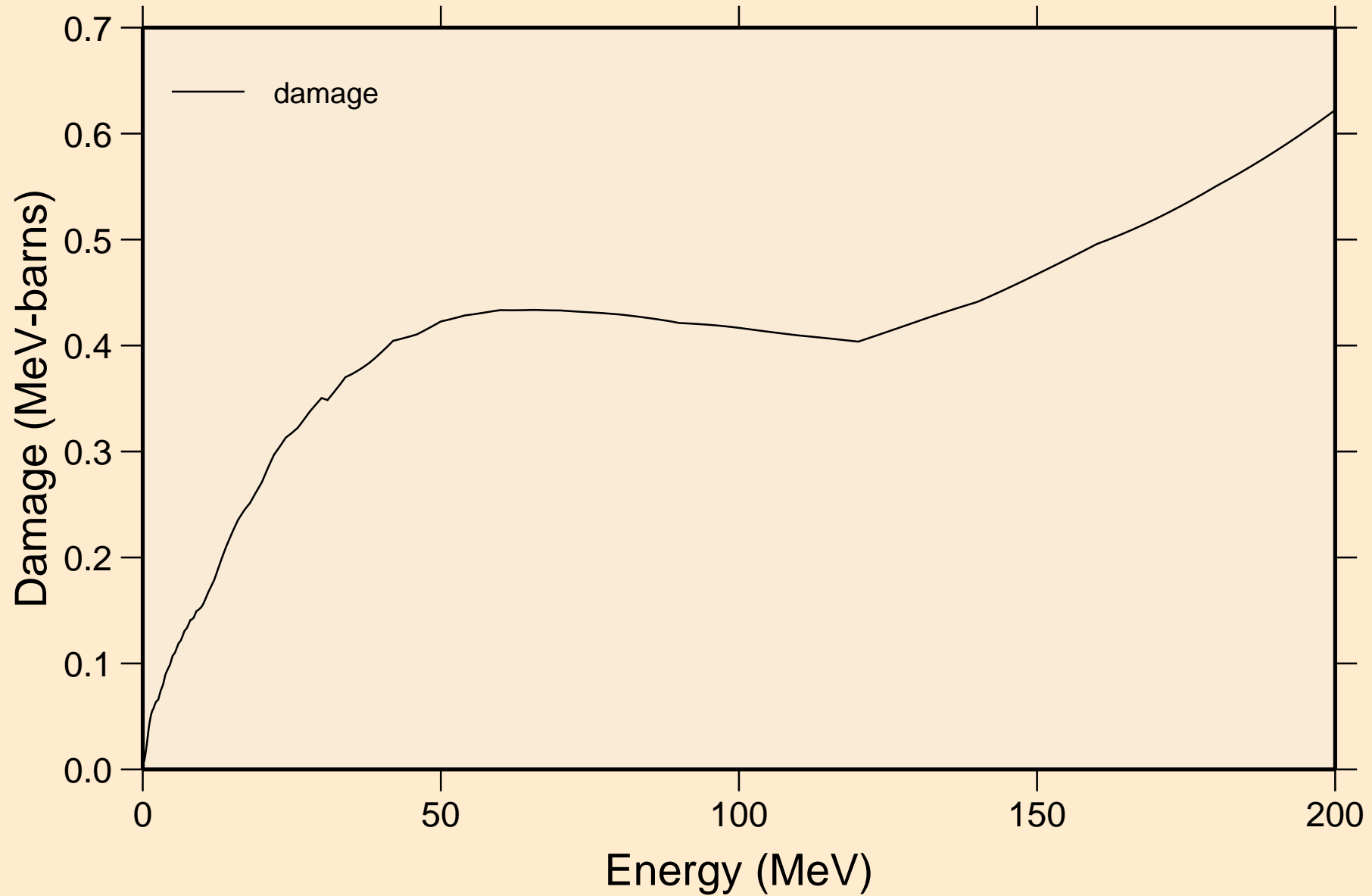



LA132 NEUTRON ACER TENDL-2023 LIBRARY; T=0.K  
Non-threshold reactions

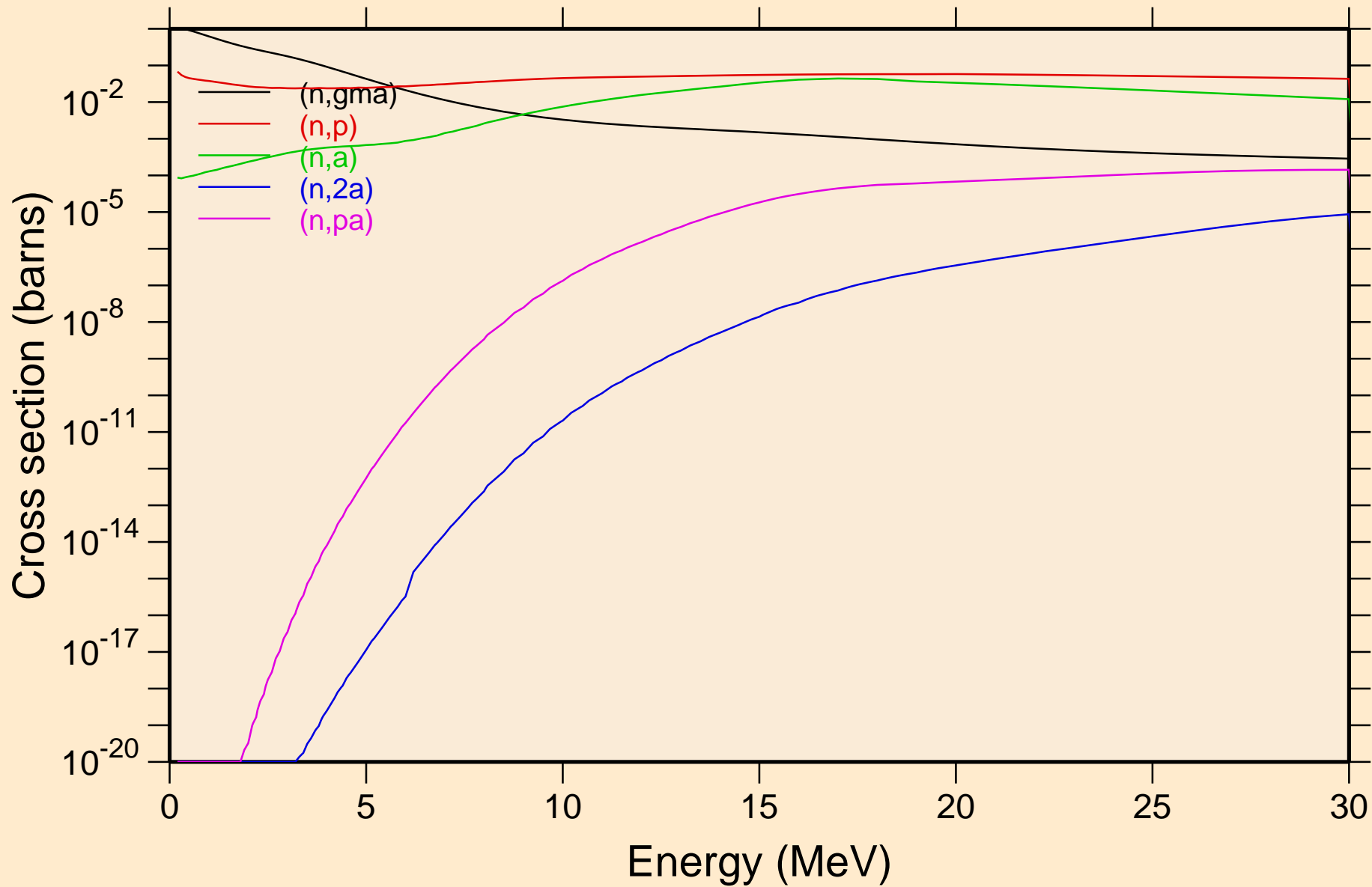

LA132 NEUTRON ACER TENDL-2023 LIBRARY; T=0.K  
Non-threshold reactions

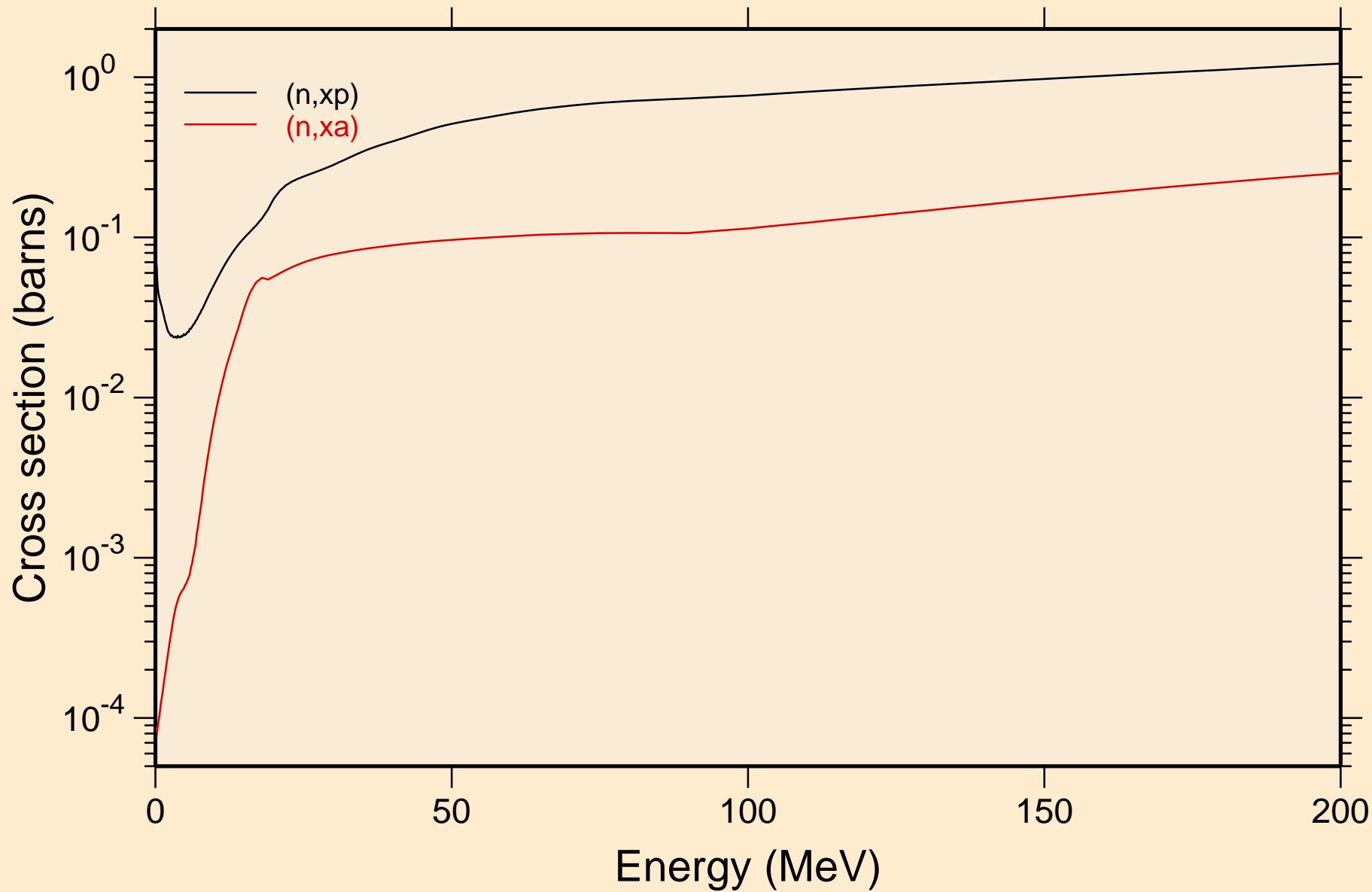

LA132 NEUTRON ACER TENDL-2023 LIBRARY; T=0.K  
Inelastic levels

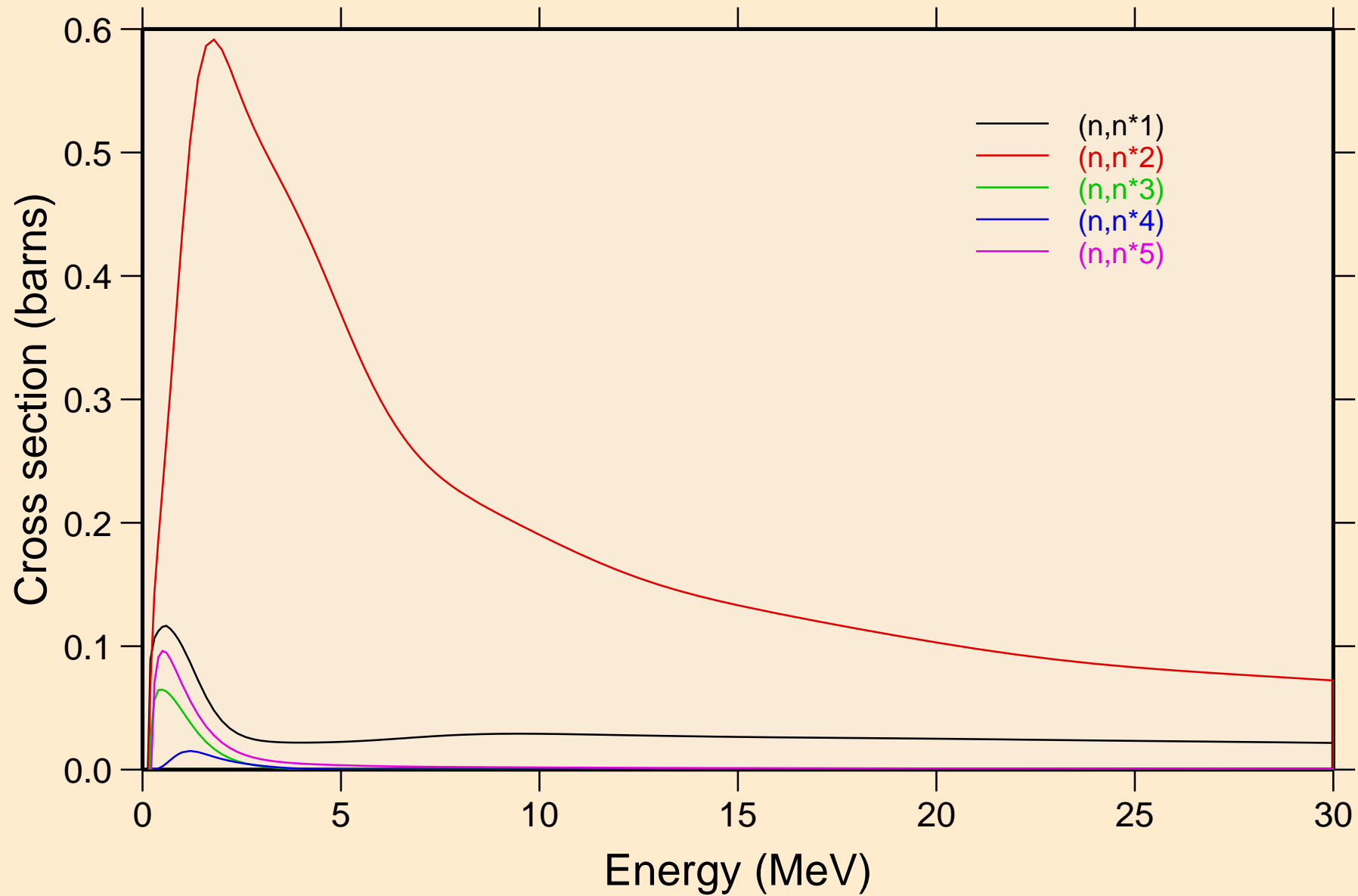

LA132 NEUTRON ACER TENDL-2023 LIBRARY; T=0.K  
Inelastic levels

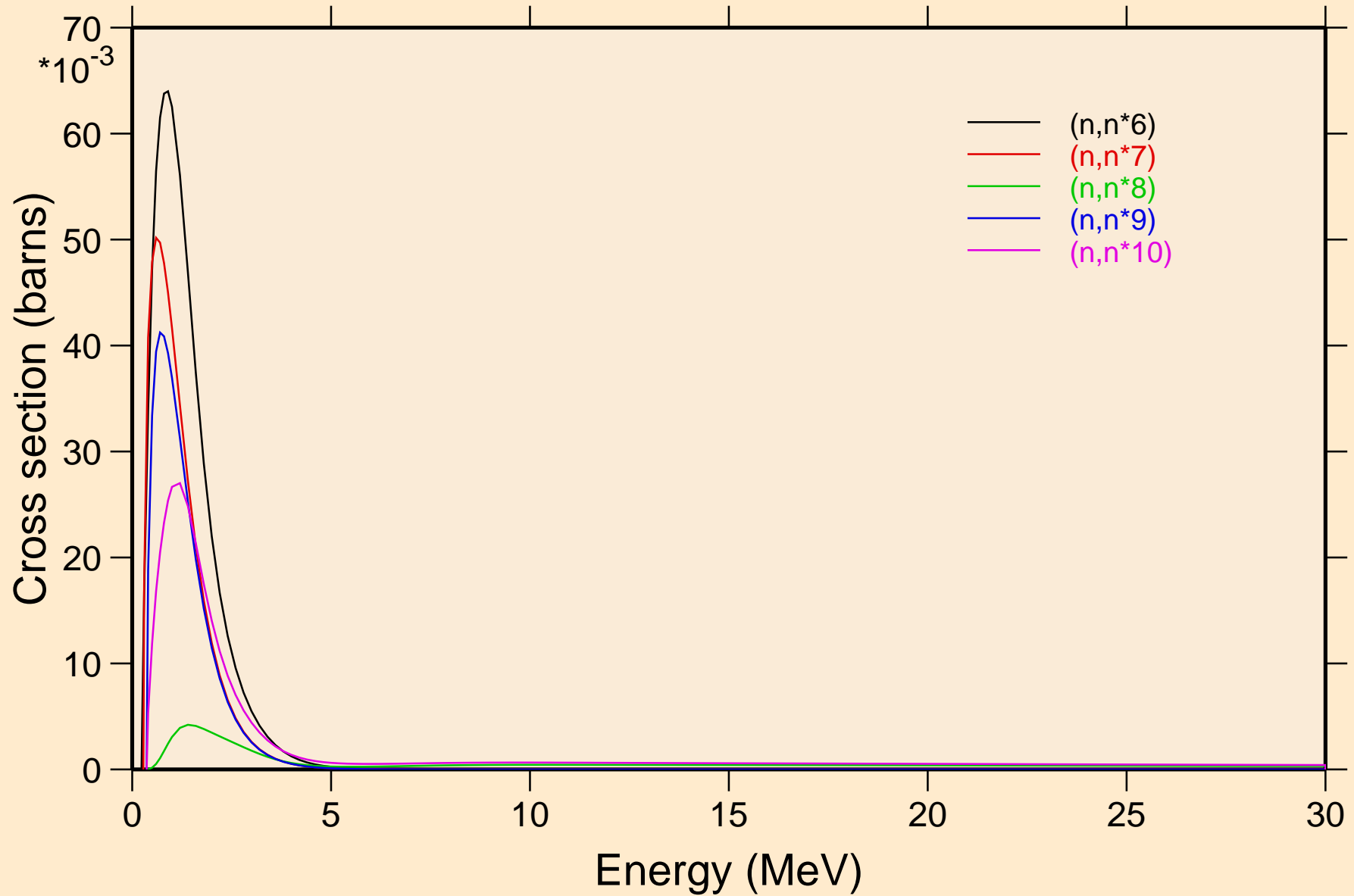

LA132 NEUTRON ACER TENDL-2023 LIBRARY; T=0.K  
Inelastic levels

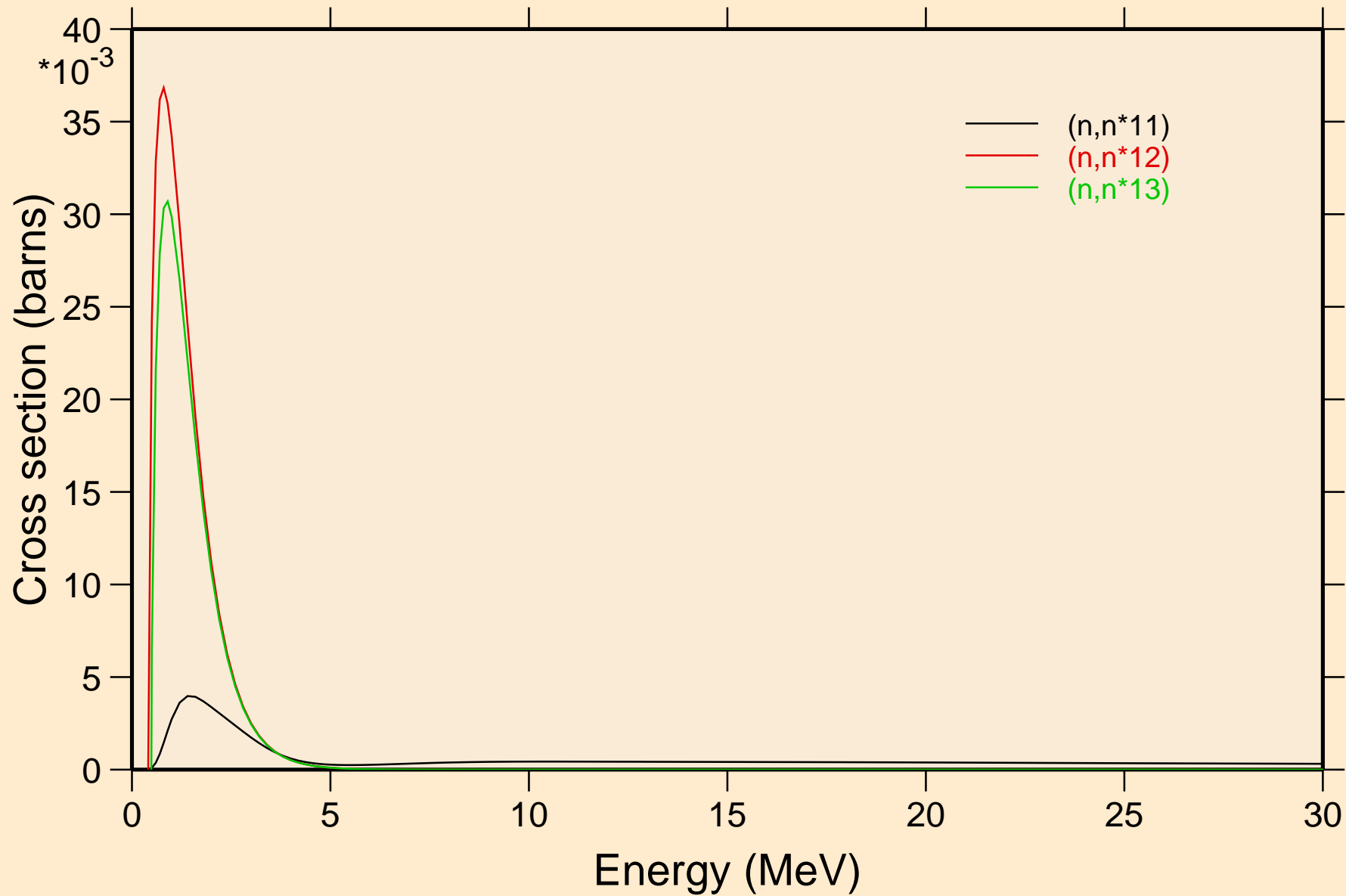

LA132 NEUTRON ACER TENDL-2023 LIBRARY; T=0.K  
Threshold reactions

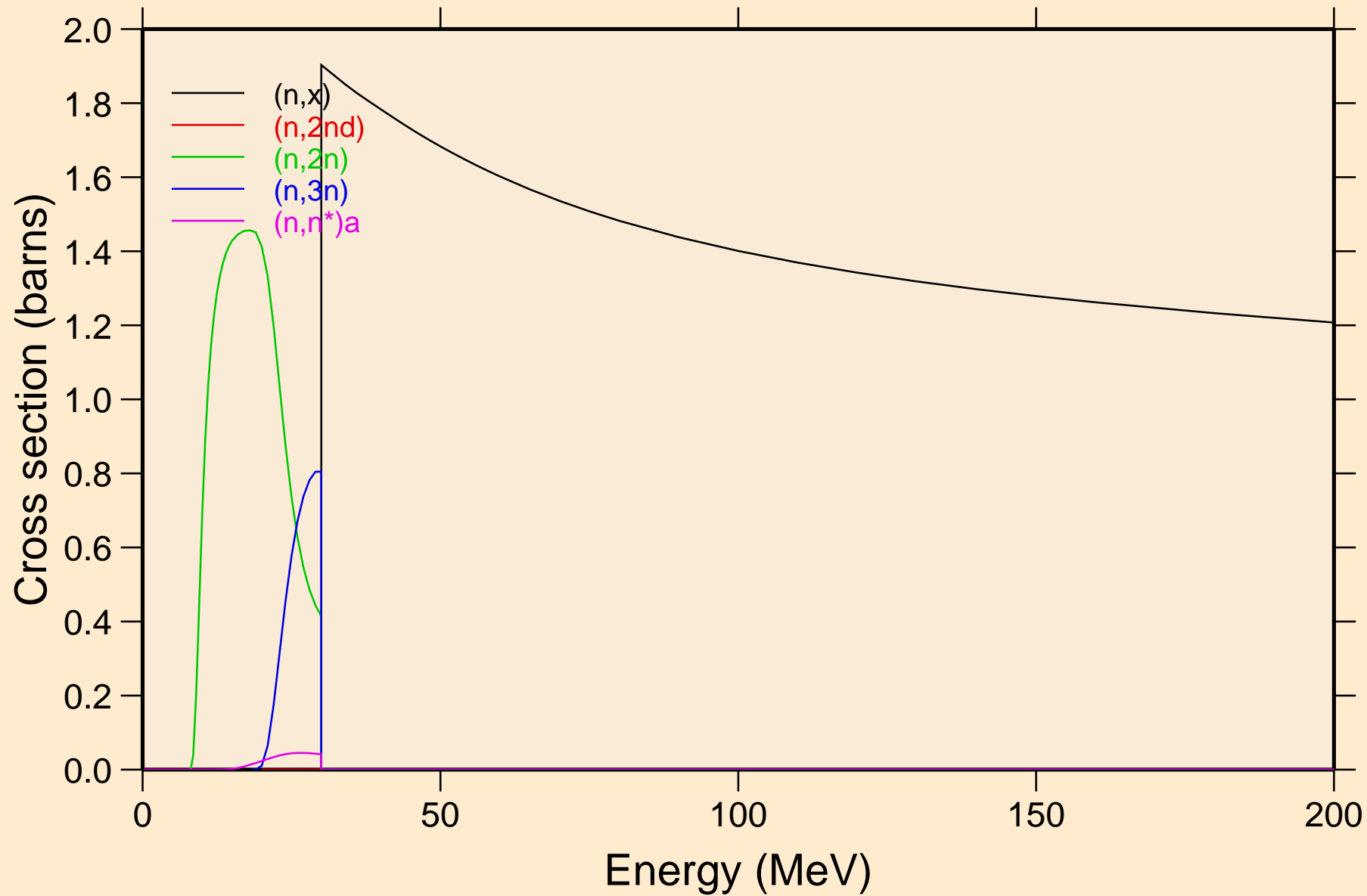

LA132 NEUTRON ACER TENDL-2023 LIBRARY; T=0.K  
Threshold reactions

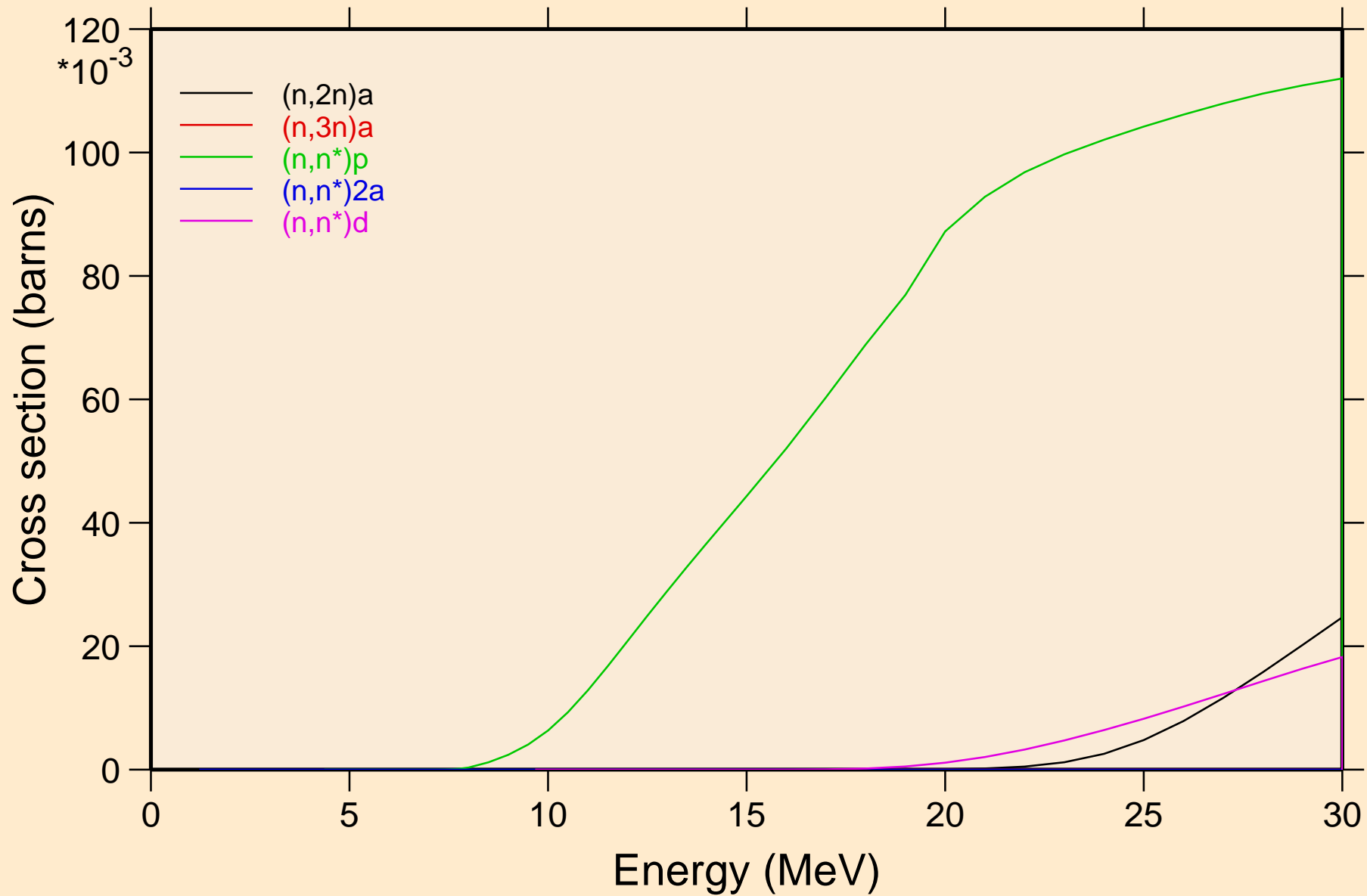

LA132 NEUTRON ACER TENDL-2023 LIBRARY; T=0.K  
Threshold reactions

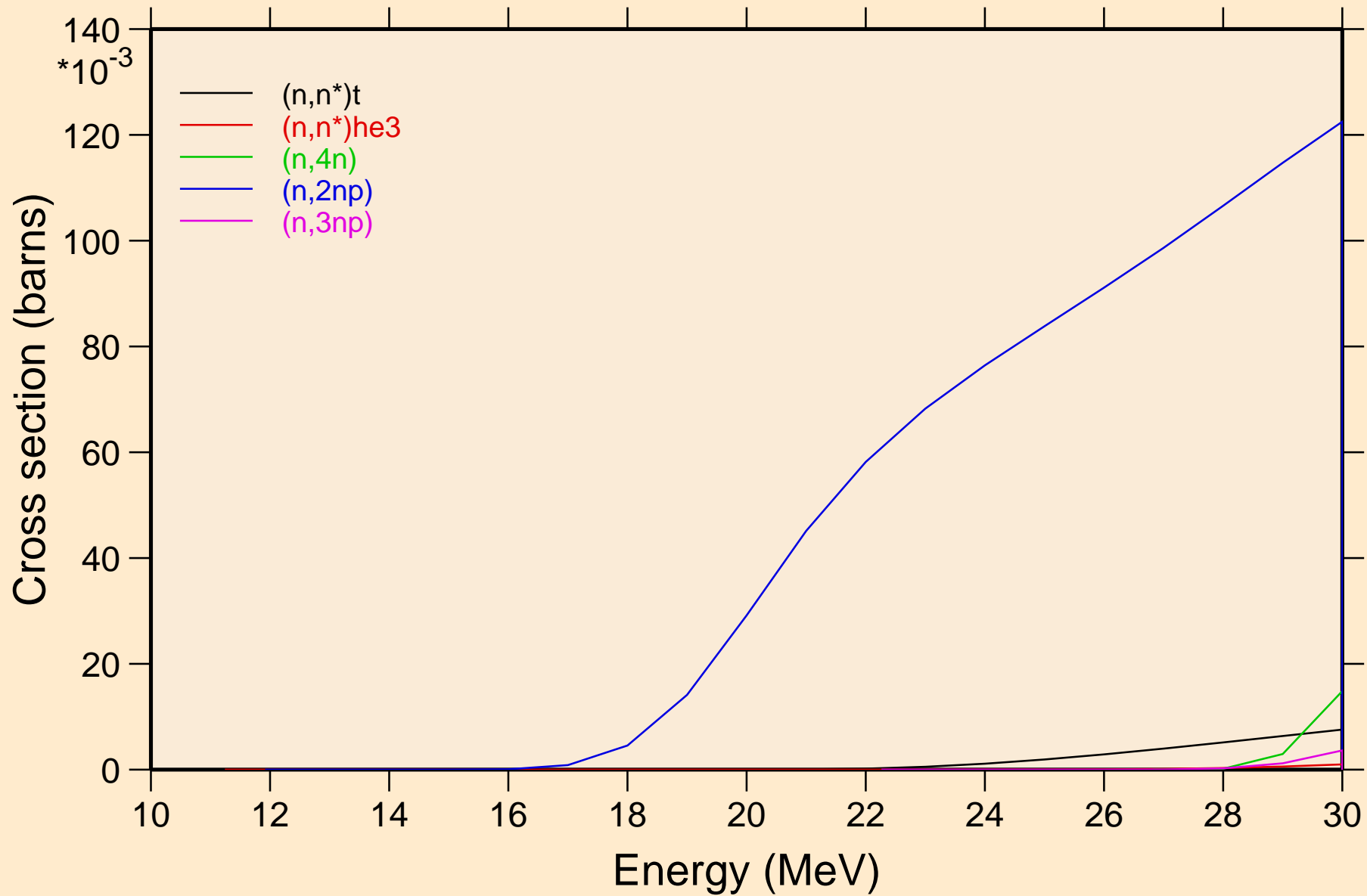



LA132 NEUTRON ACER TENDL-2023 LIBRARY; T=0.K  
Threshold reactions

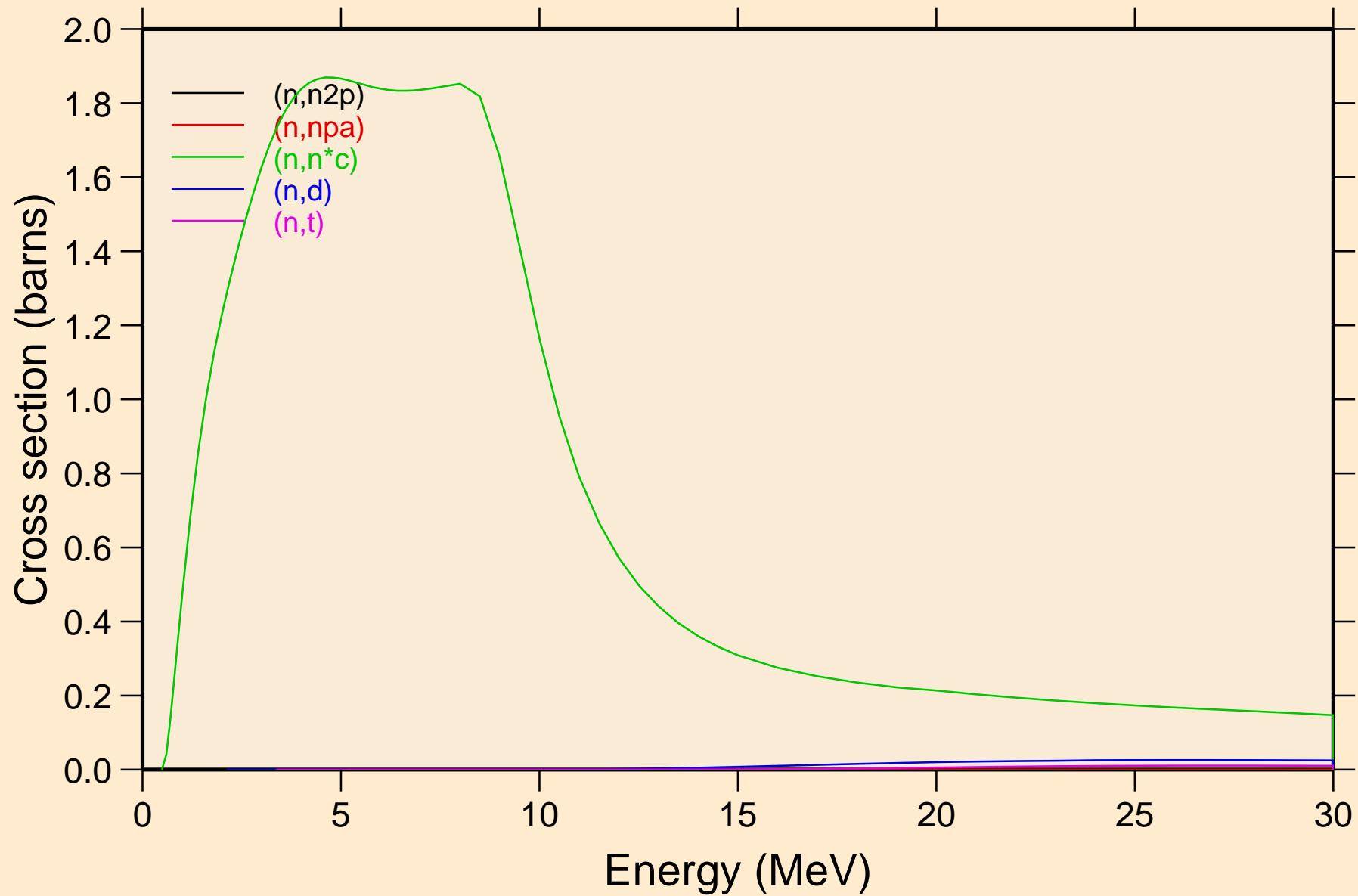

LA132 NEUTRON ACER TENDL-2023 LIBRARY; T=0.K  
Threshold reactions

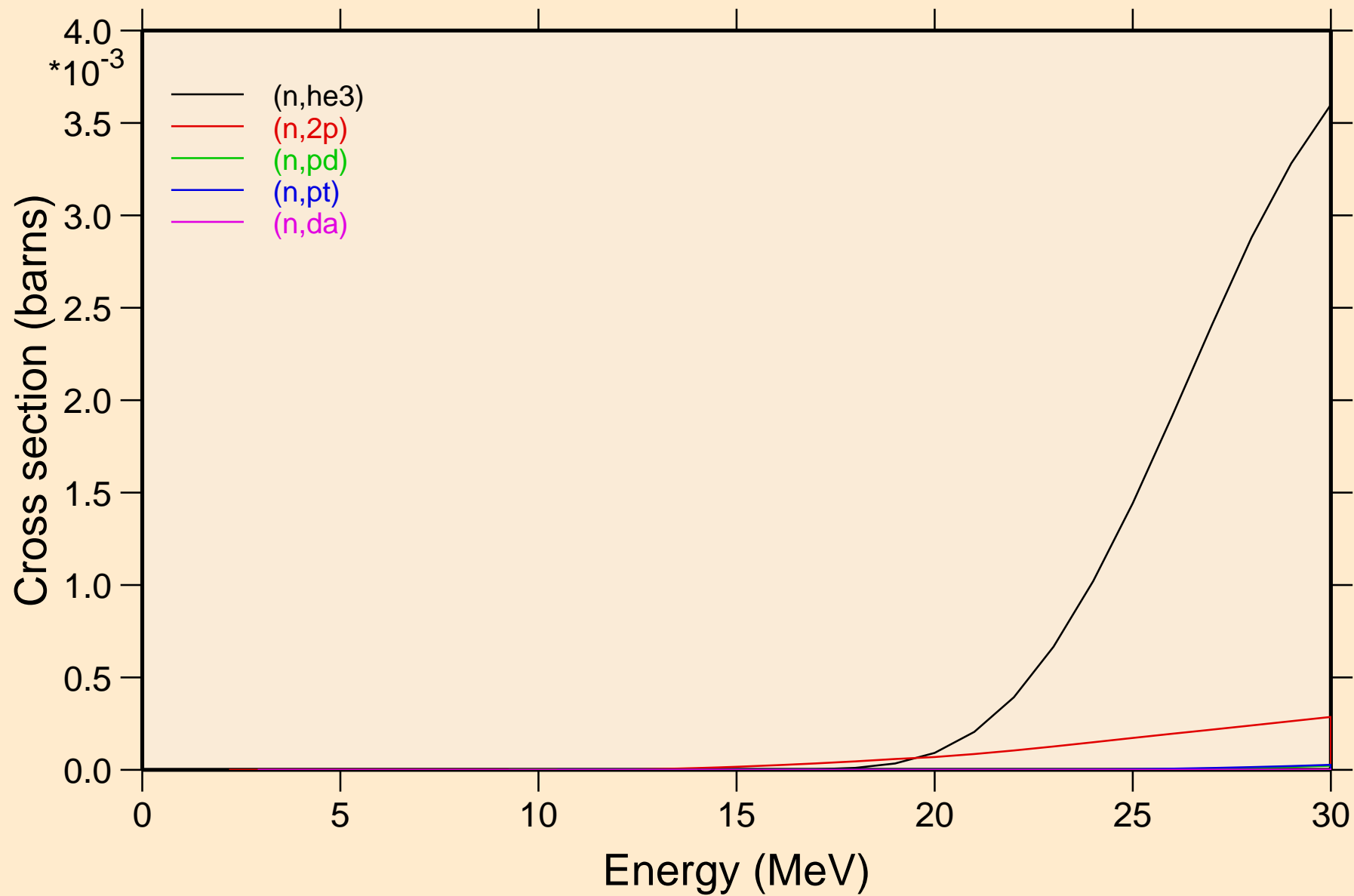

LA132 NEUTRON ACER TENDL-2023 LIBRARY; T=0.K  
Threshold reactions

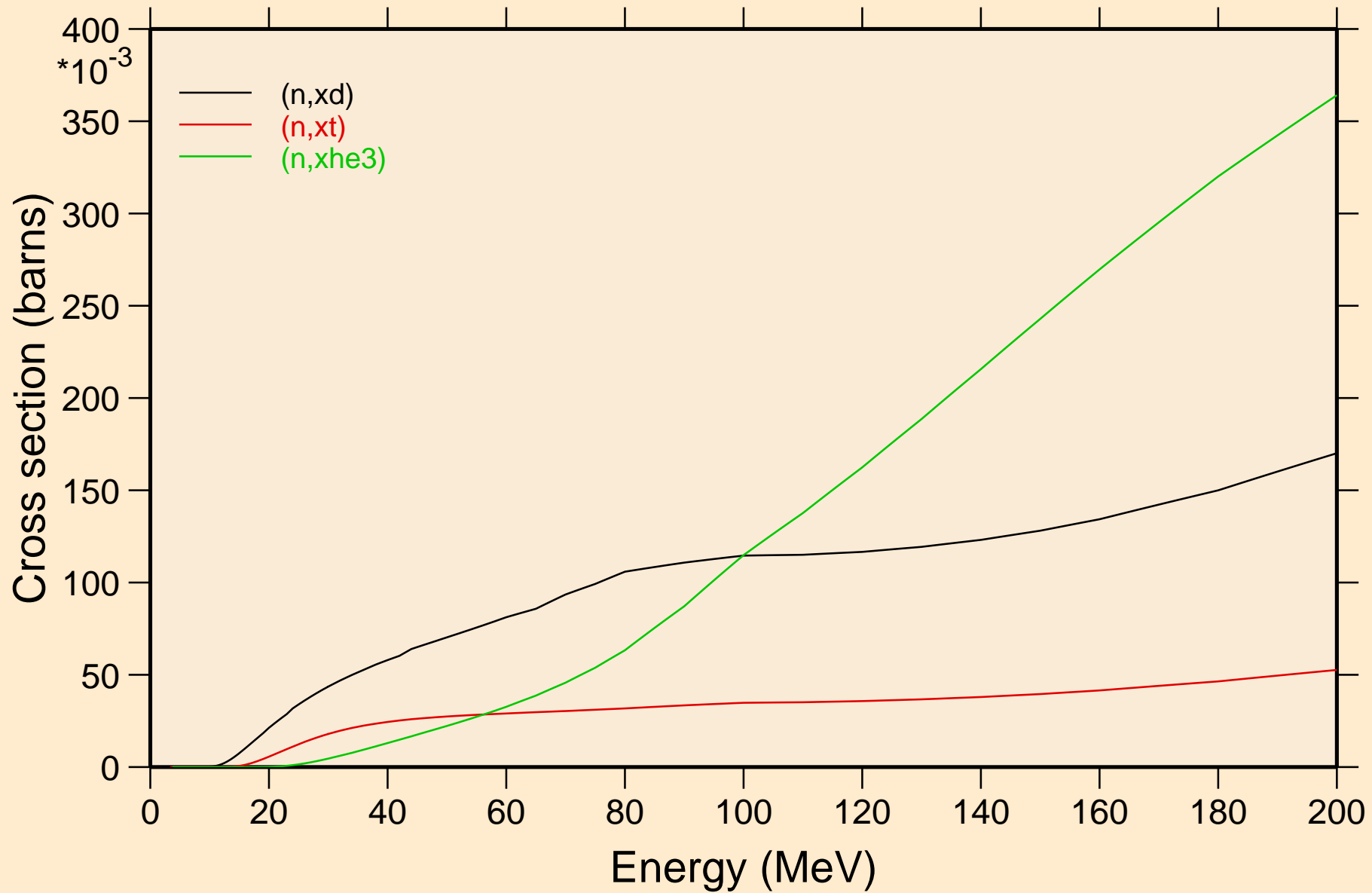

LA132 NEUTRON ACER TENDL-2023 LIBRARY; T=0.K  
angular distribution for elastic

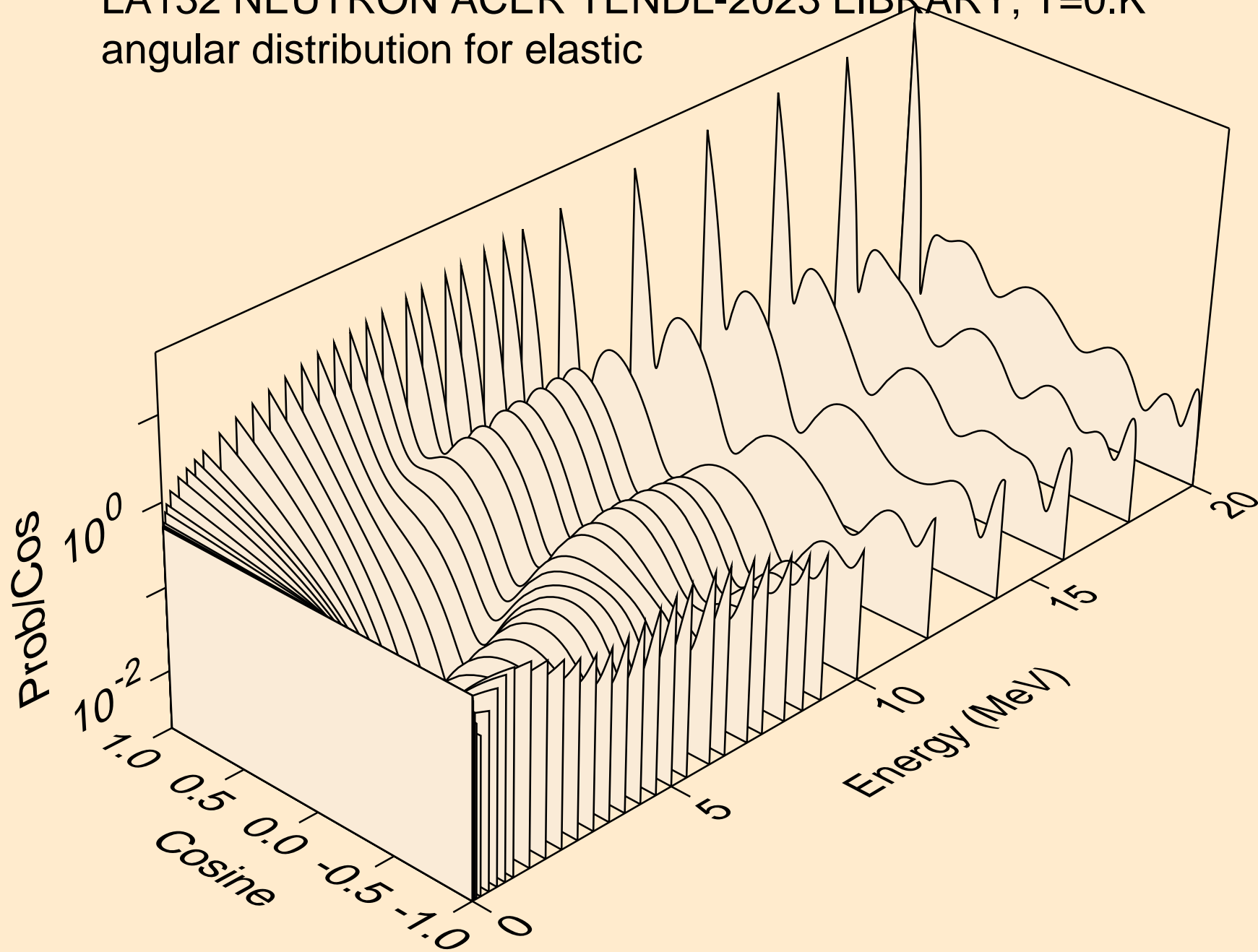

LA132 NEUTRON ACER TENDL-2023 LIBRARY; T=0.K  
angular distribution for elastic

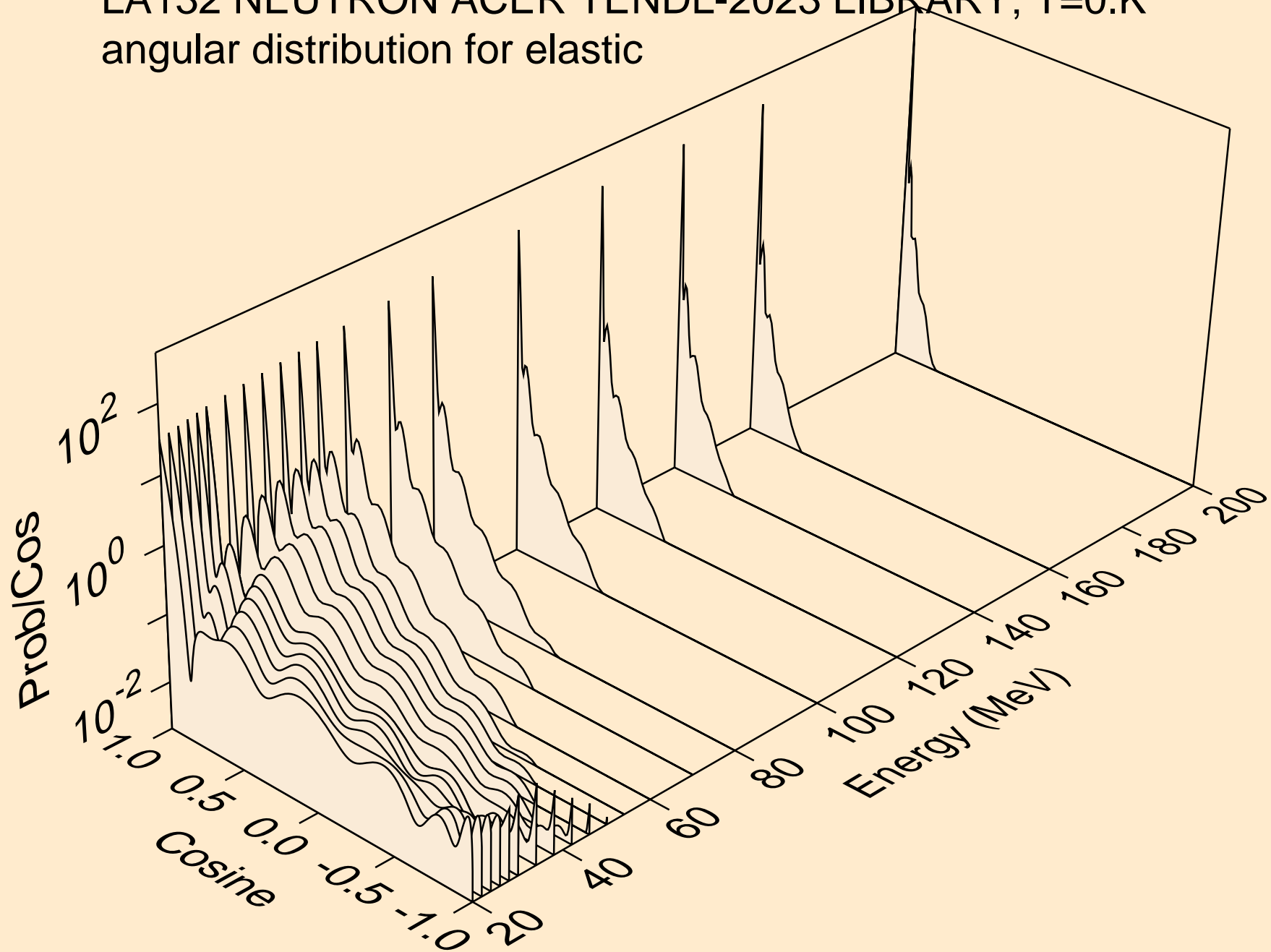

LA132 NEUTRON ACER TENDL-2023 LIBRARY; T=0.K  
angular distribution for (n,n\*1)

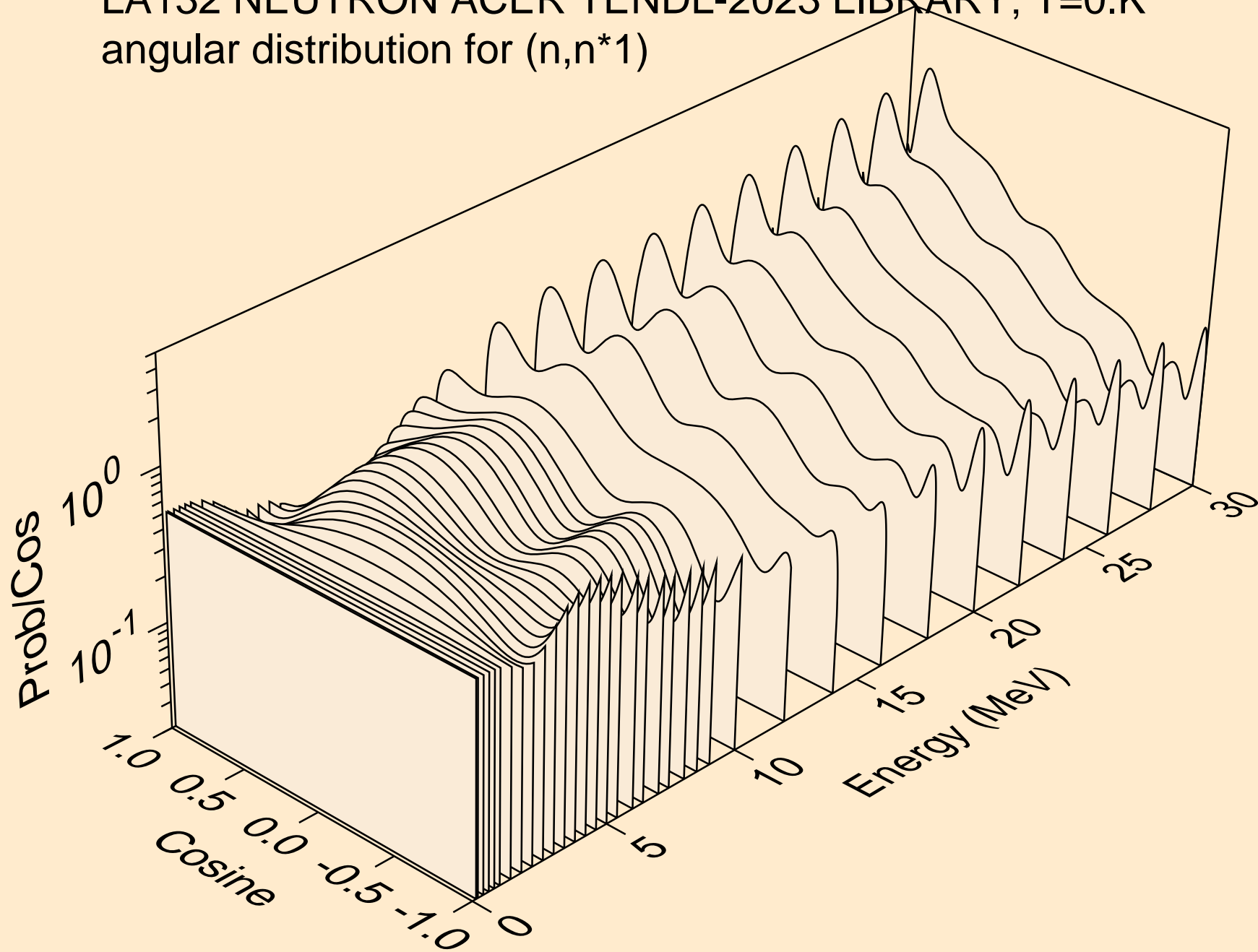

LA132 NEUTRON ACER TENDL-2023 LIBRARY; T=0.K  
angular distribution for (n,n\*2)

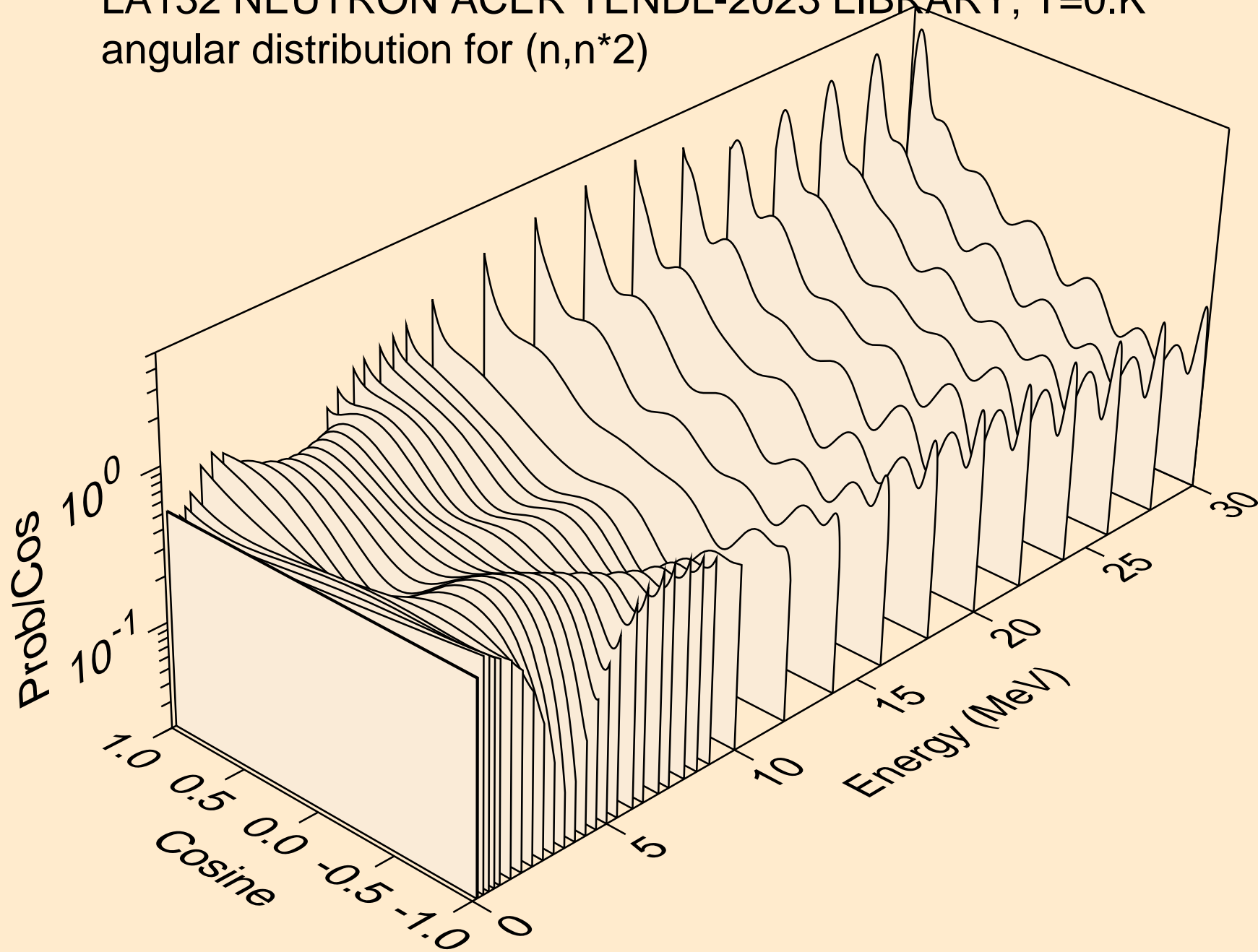

LA132 NEUTRON ACER TENDL-2023 LIBRARY; T=0.K  
angular distribution for (n,n\*3)

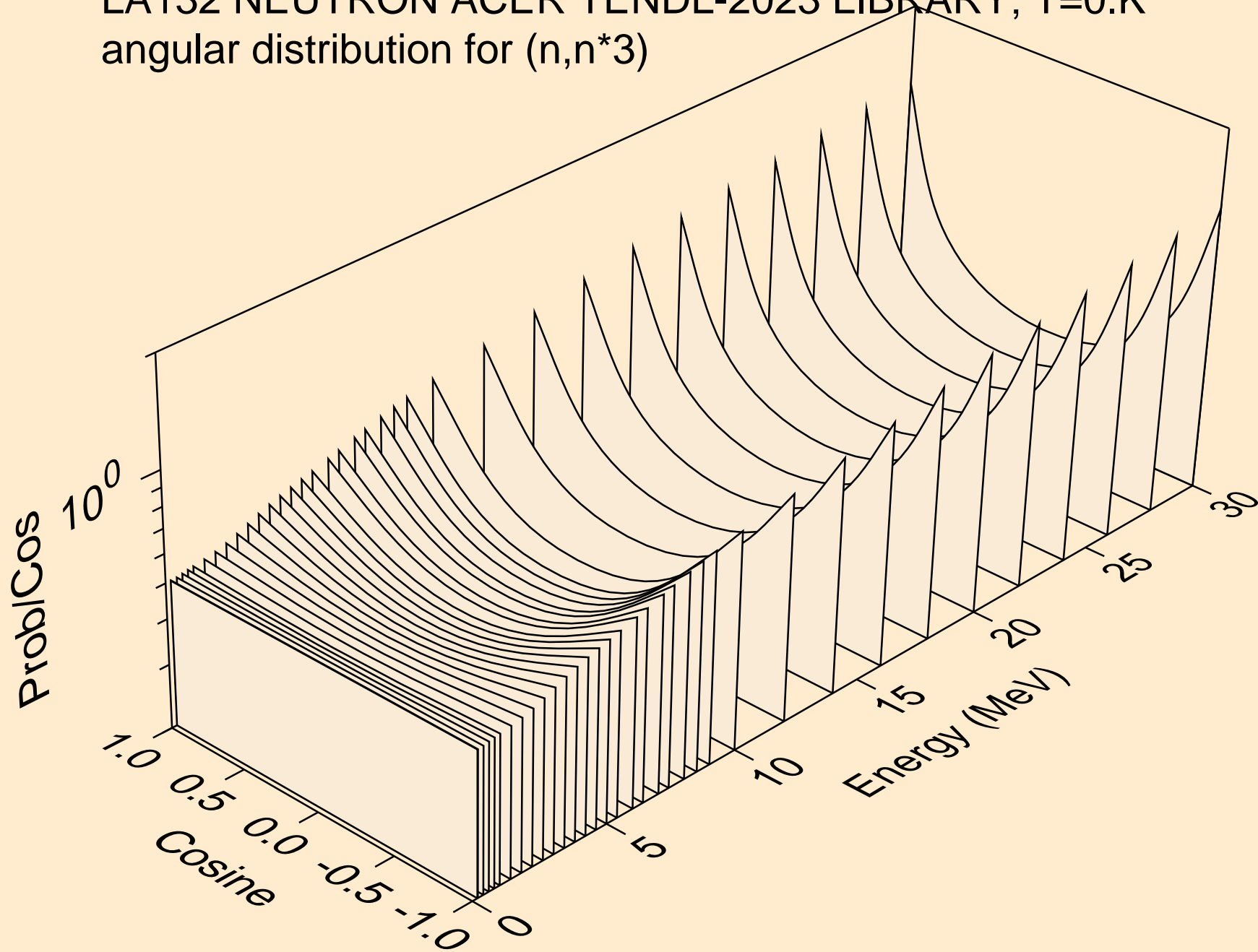



LA132 NEUTRON ACER TENDL-2023 LIBRARY; T=0.K  
angular distribution for (n,n\*4)

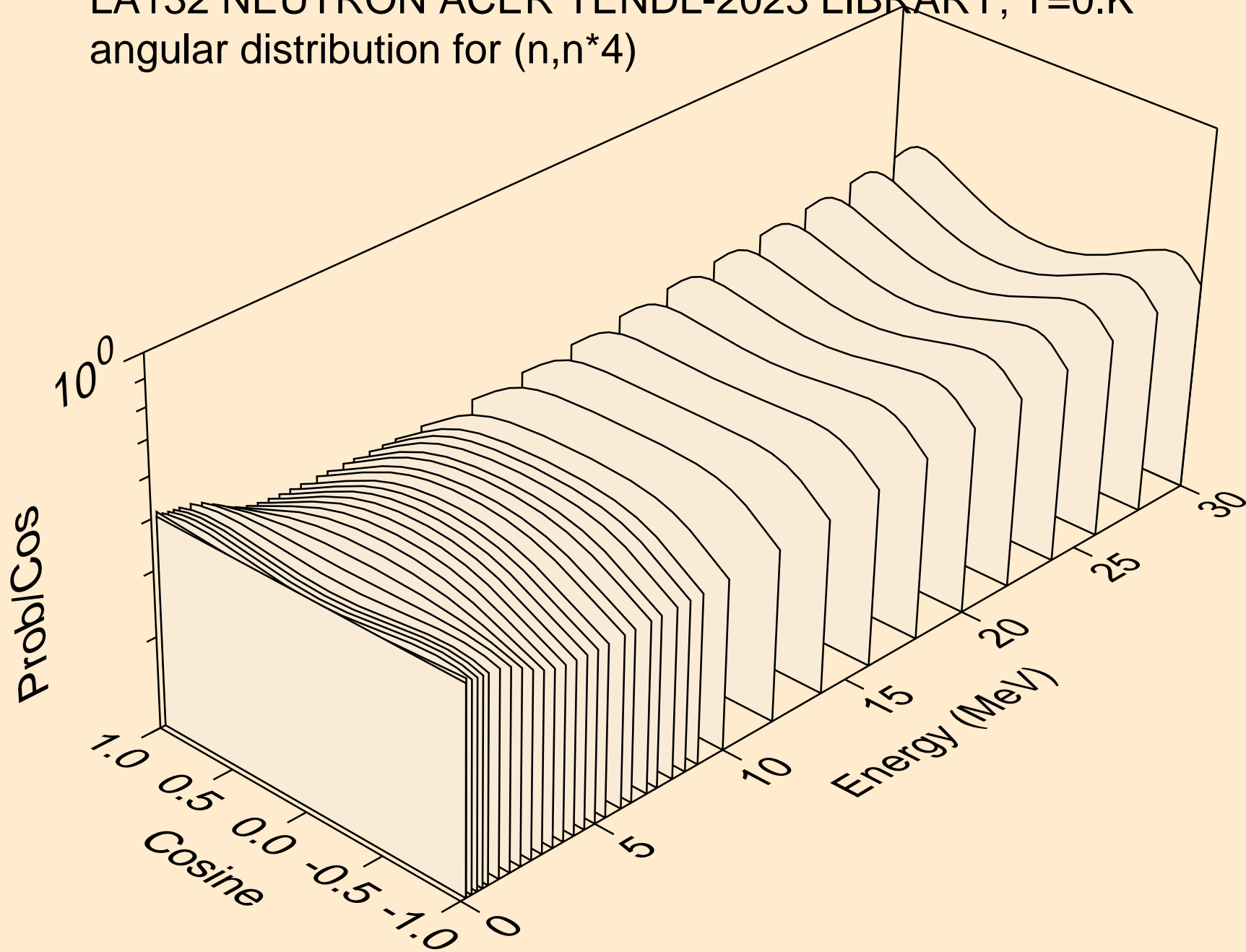

LA132 NEUTRON ACER TENDL-2023 LIBRARY; T=0.K  
angular distribution for (n,n\*5)

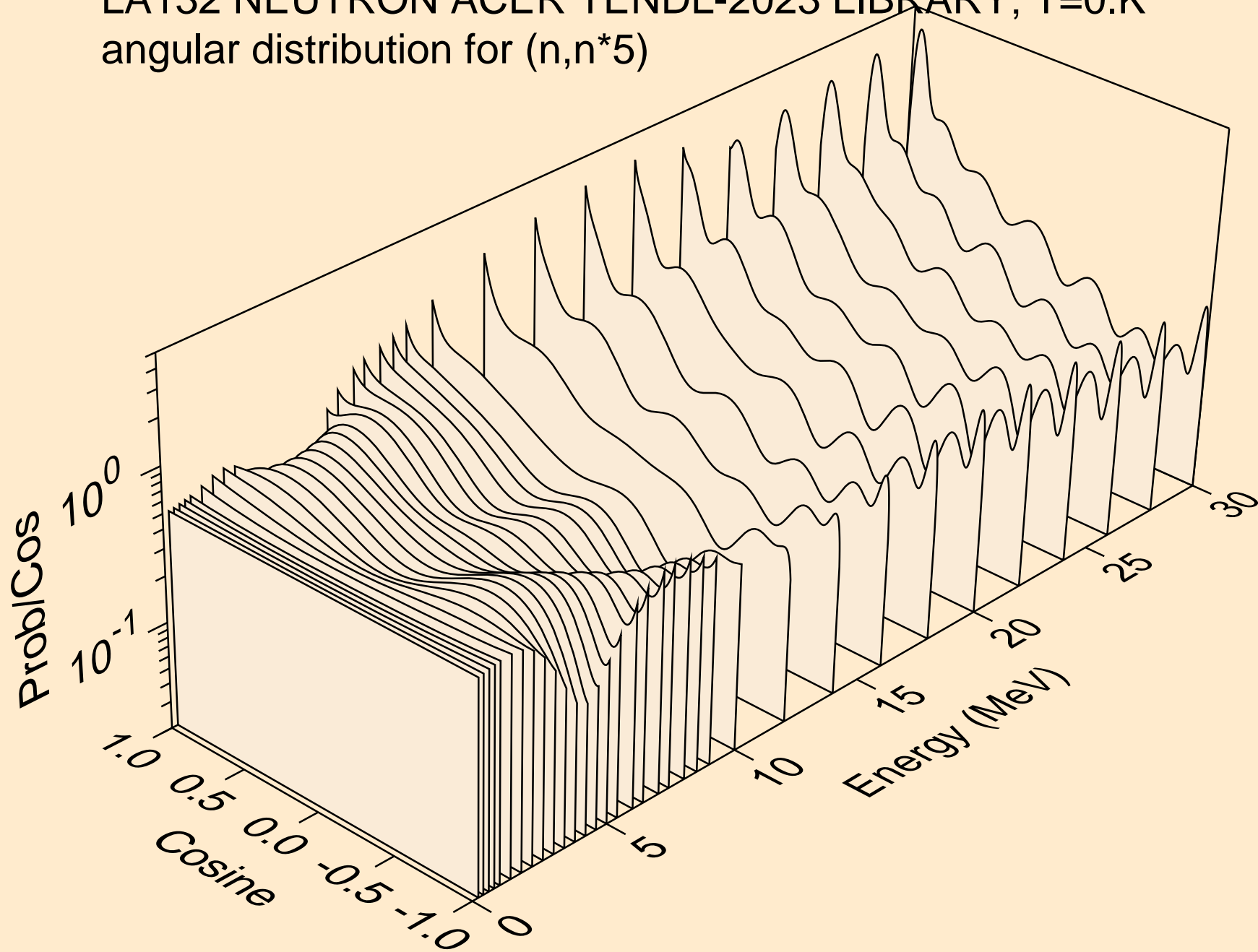

LA132 NEUTRON ACER TENDL-2023 LIBRARY; T=0.K  
angular distribution for (n,n\*6)

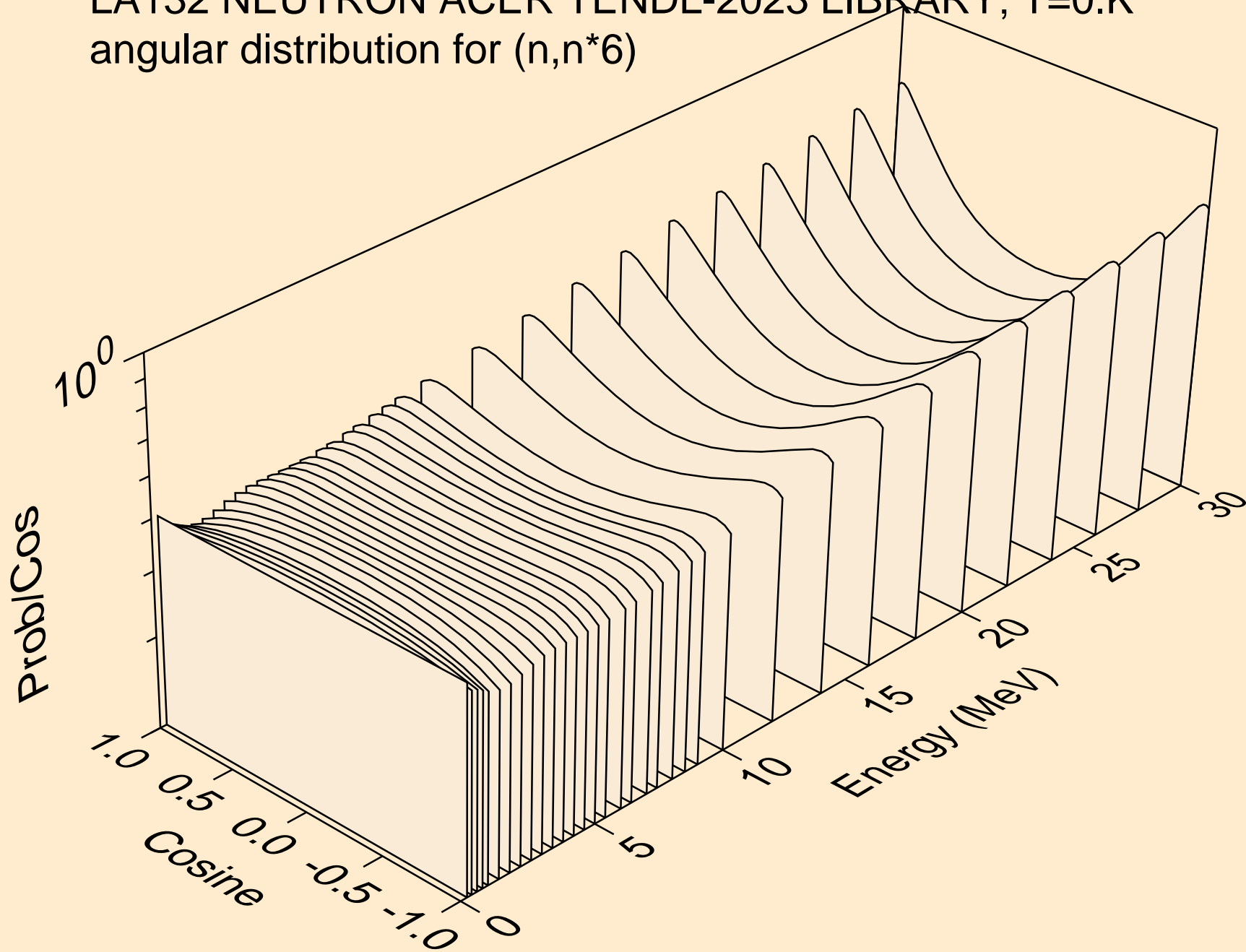

LA132 NEUTRON ACER TENDL-2023 LIBRARY; T=0.K  
angular distribution for (n,n\*7)

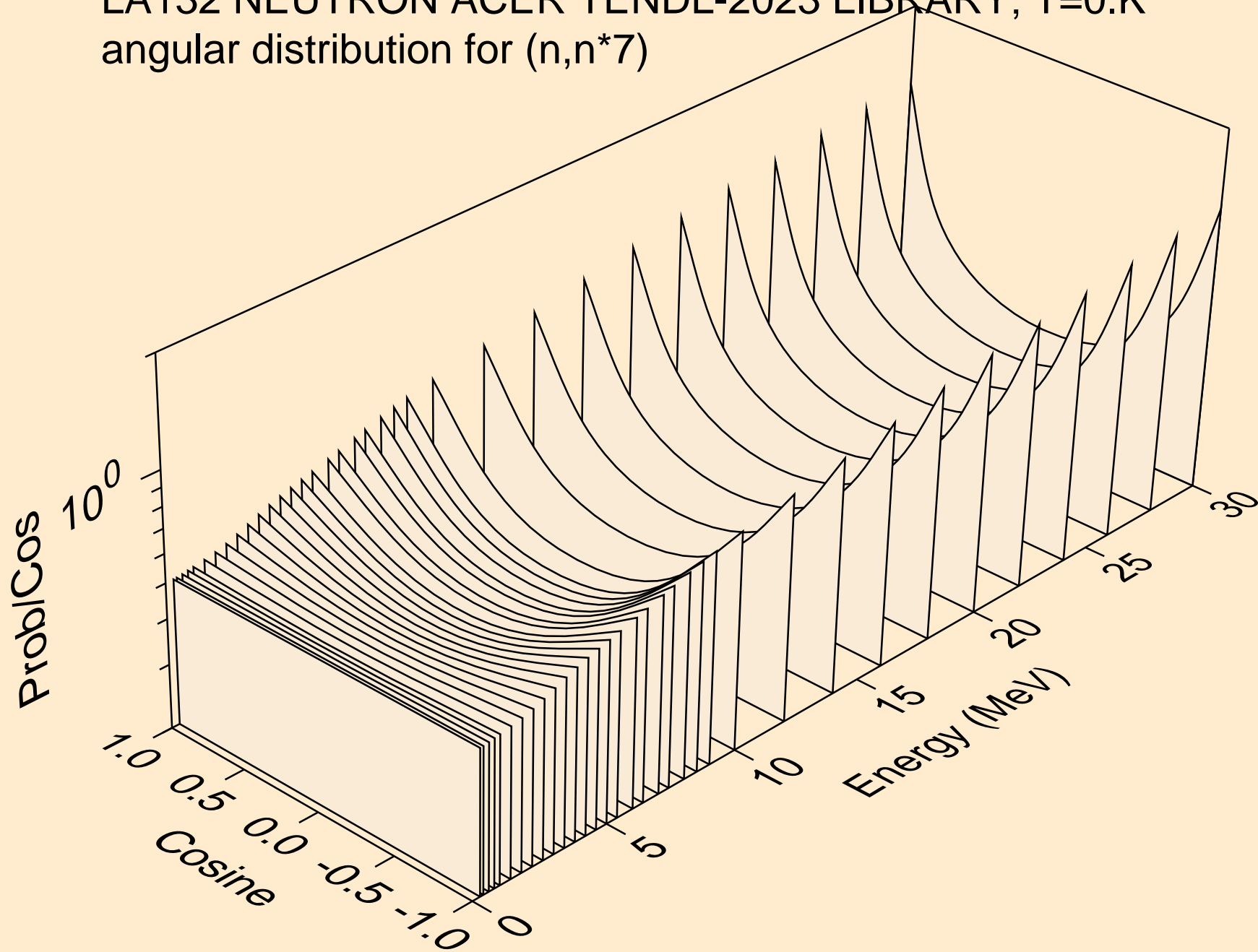

LA132 NEUTRON ACER TENDL-2023 LIBRARY; T=0.K  
angular distribution for (n,n\*8)

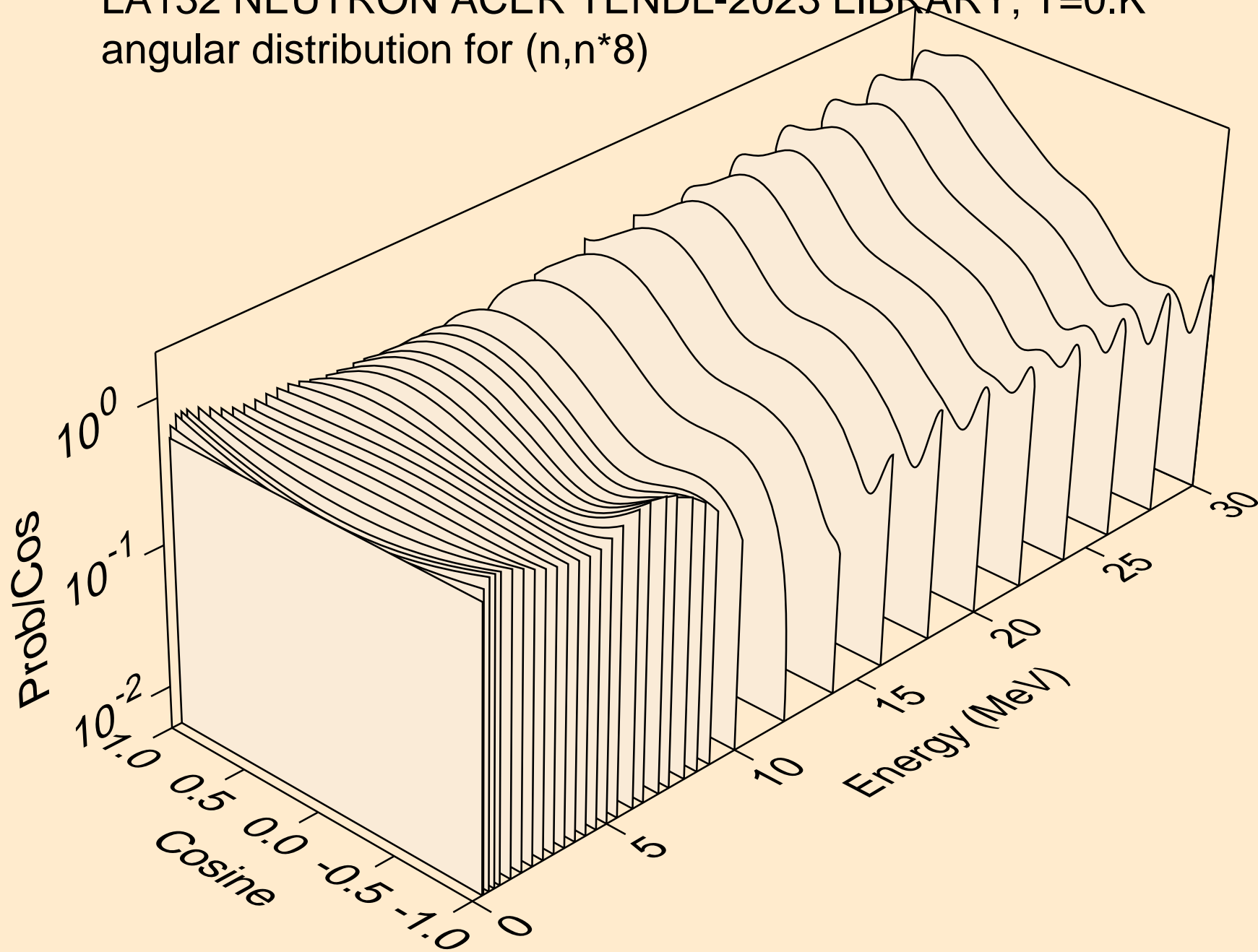

LA132 NEUTRON ACER TENDL-2023 LIBRARY; T=0.K  
angular distribution for (n,n\*9)

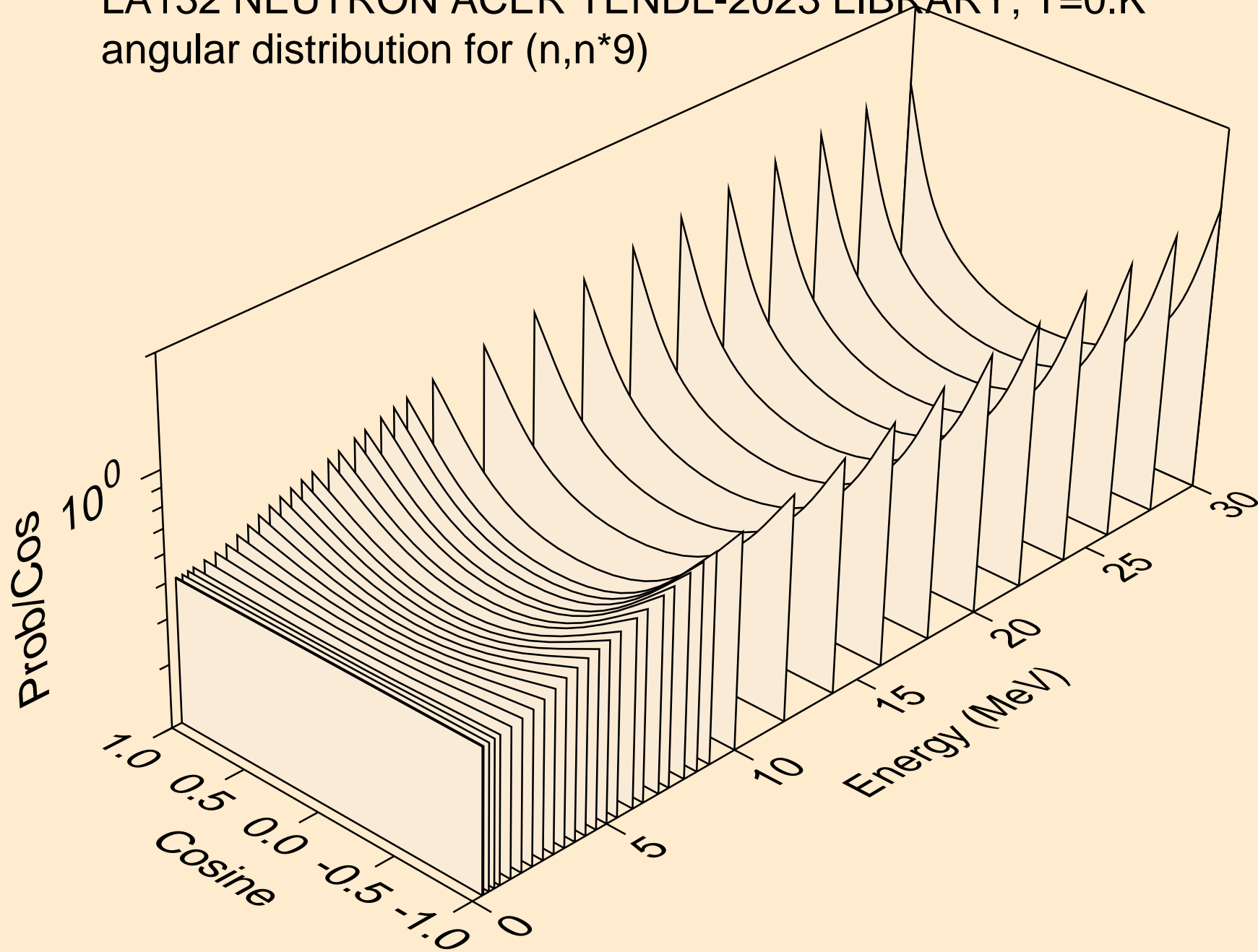

LA132 NEUTRON ACER TENDL-2023 LIBRARY; T=0.K  
angular distribution for (n,n\*10)

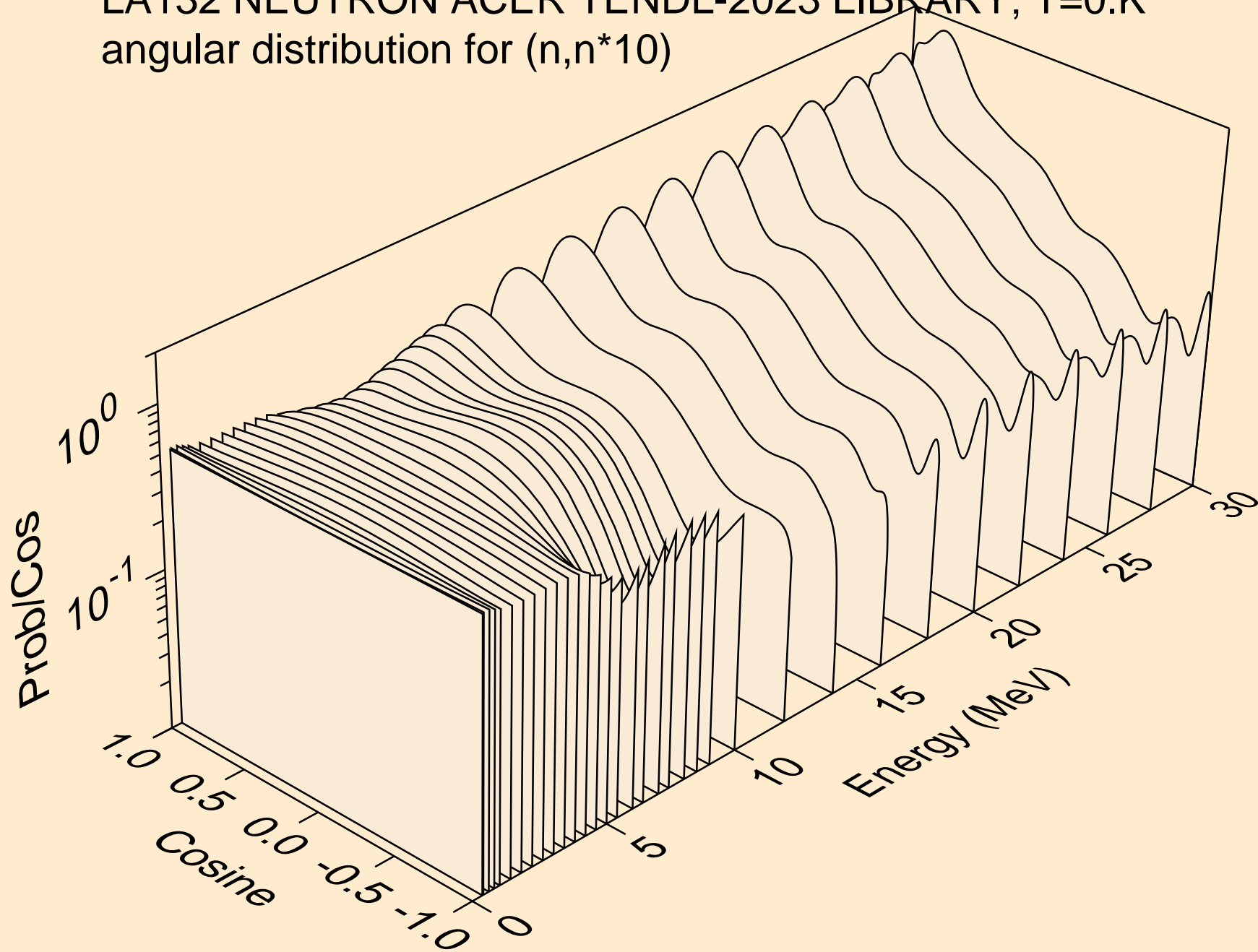

LA132 NEUTRON ACER TENDL-2023 LIBRARY; T=0.K  
angular distribution for (n,n\*11)

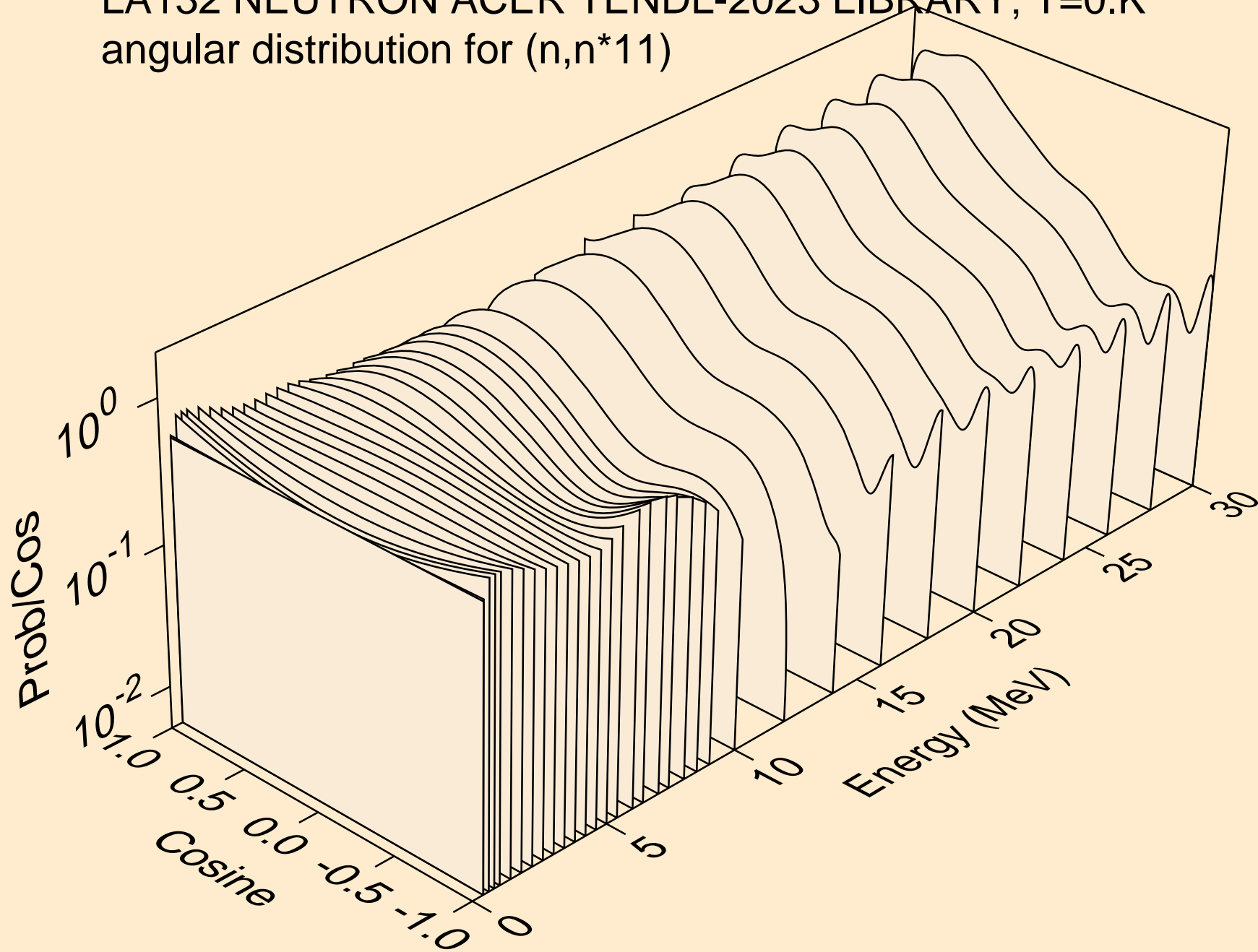



LA132 NEUTRON ACER TENDL-2023 LIBRARY; T=0.K  
angular distribution for (n,n\*12)

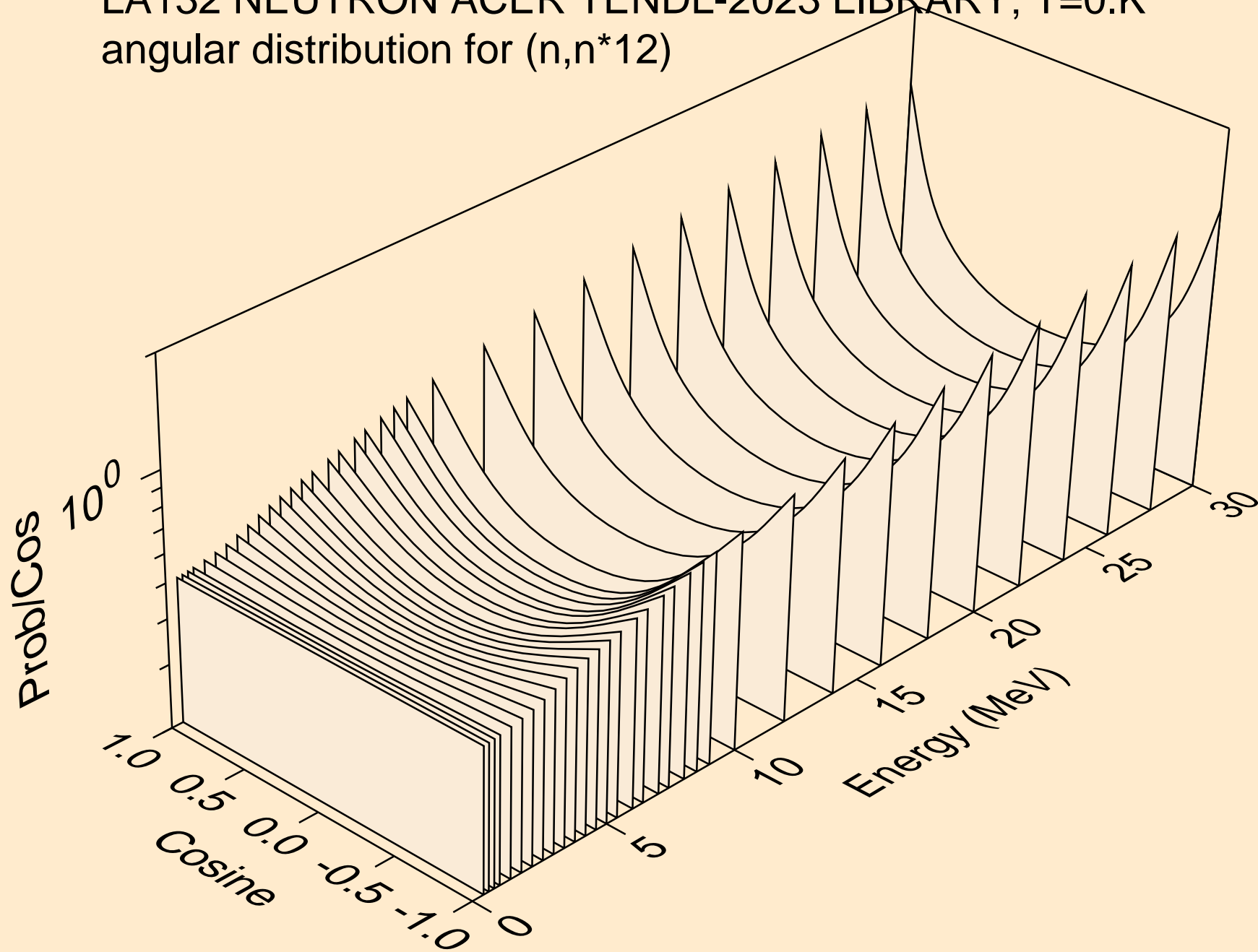

LA132 NEUTRON ACER TENDL-2023 LIBRARY; T=0.K  
angular distribution for (n,n\*13)

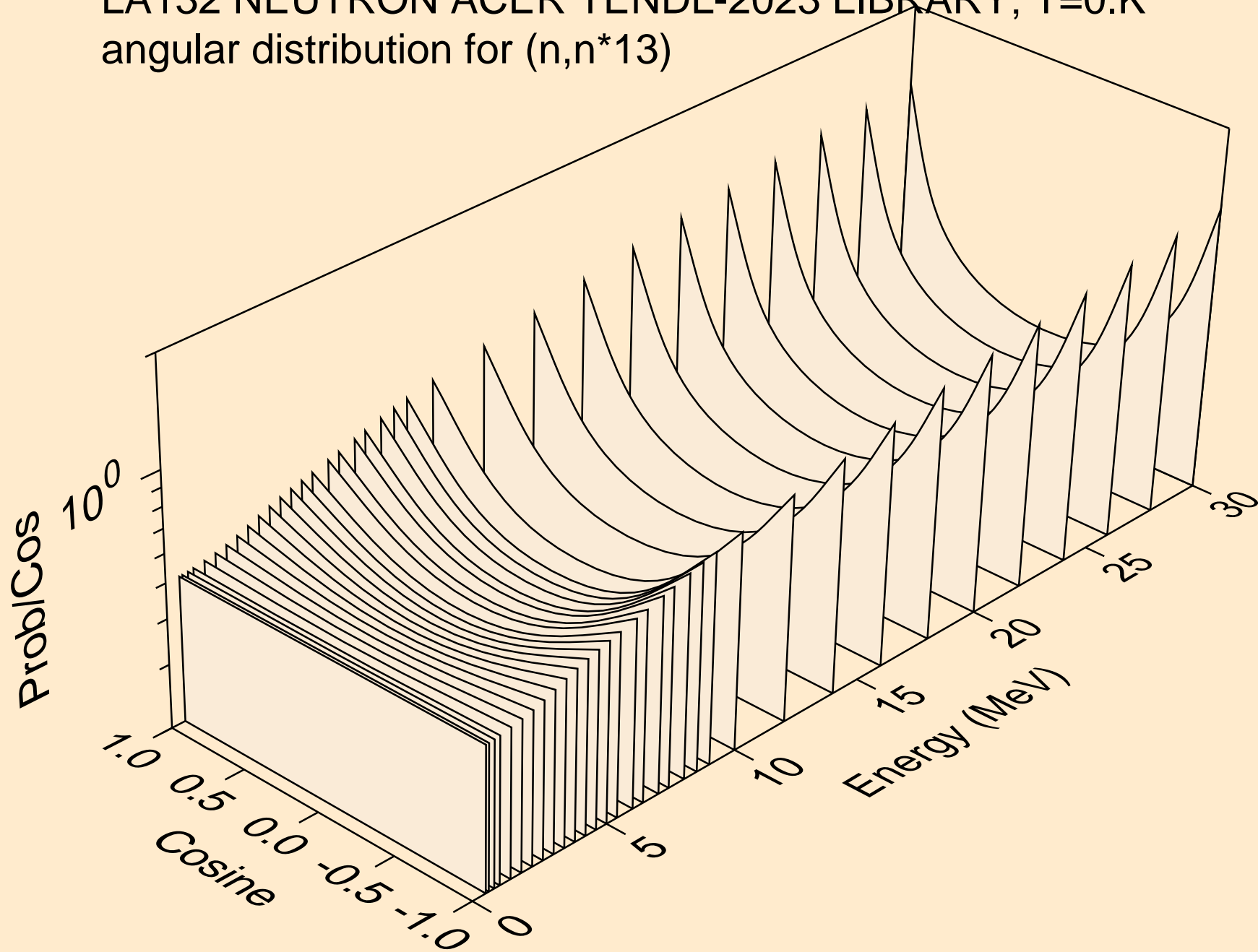

LA132 NEUTRON ACER TENDL-2023 LIBRARY; T=0.K  
Neutron emission for (n,x)

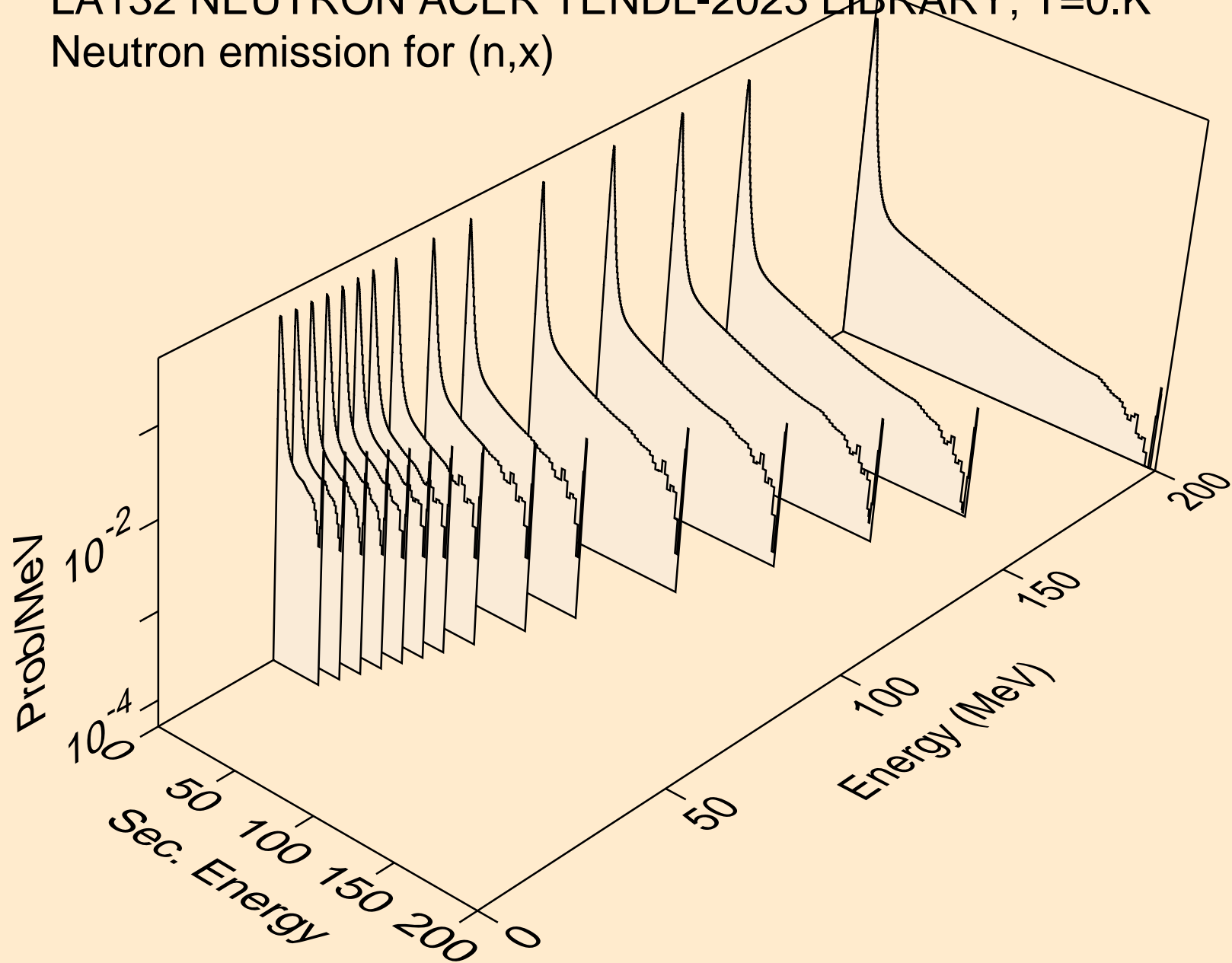

LA132 NEUTRON ACER TENDL-2023 LIBRARY; T=0.K  
Neutron emission for (n,2nd)

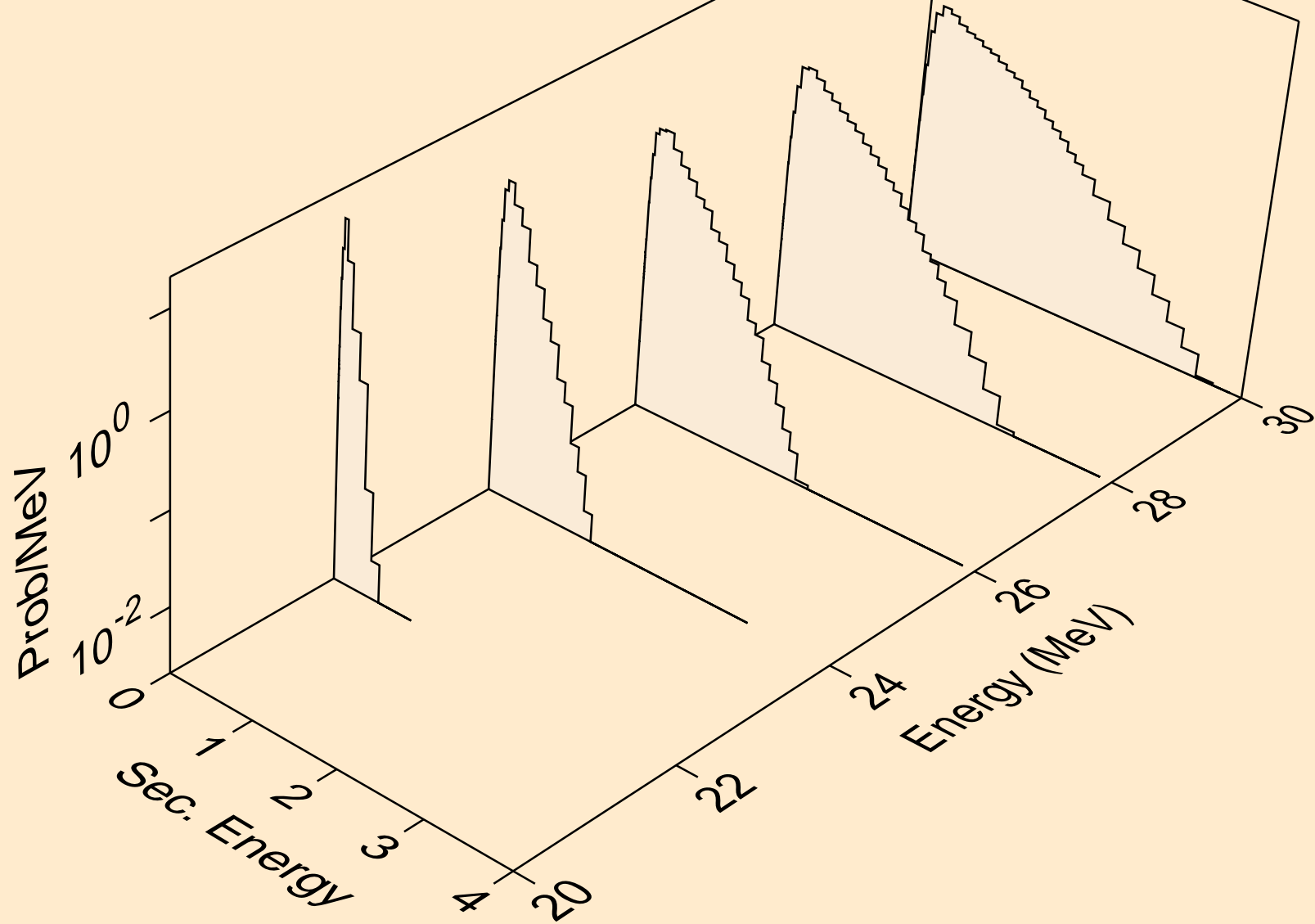

LA132 NEUTRON ACER TENDL-2023 LIBRARY; T=0.K  
Neutron emission for (n,2n)

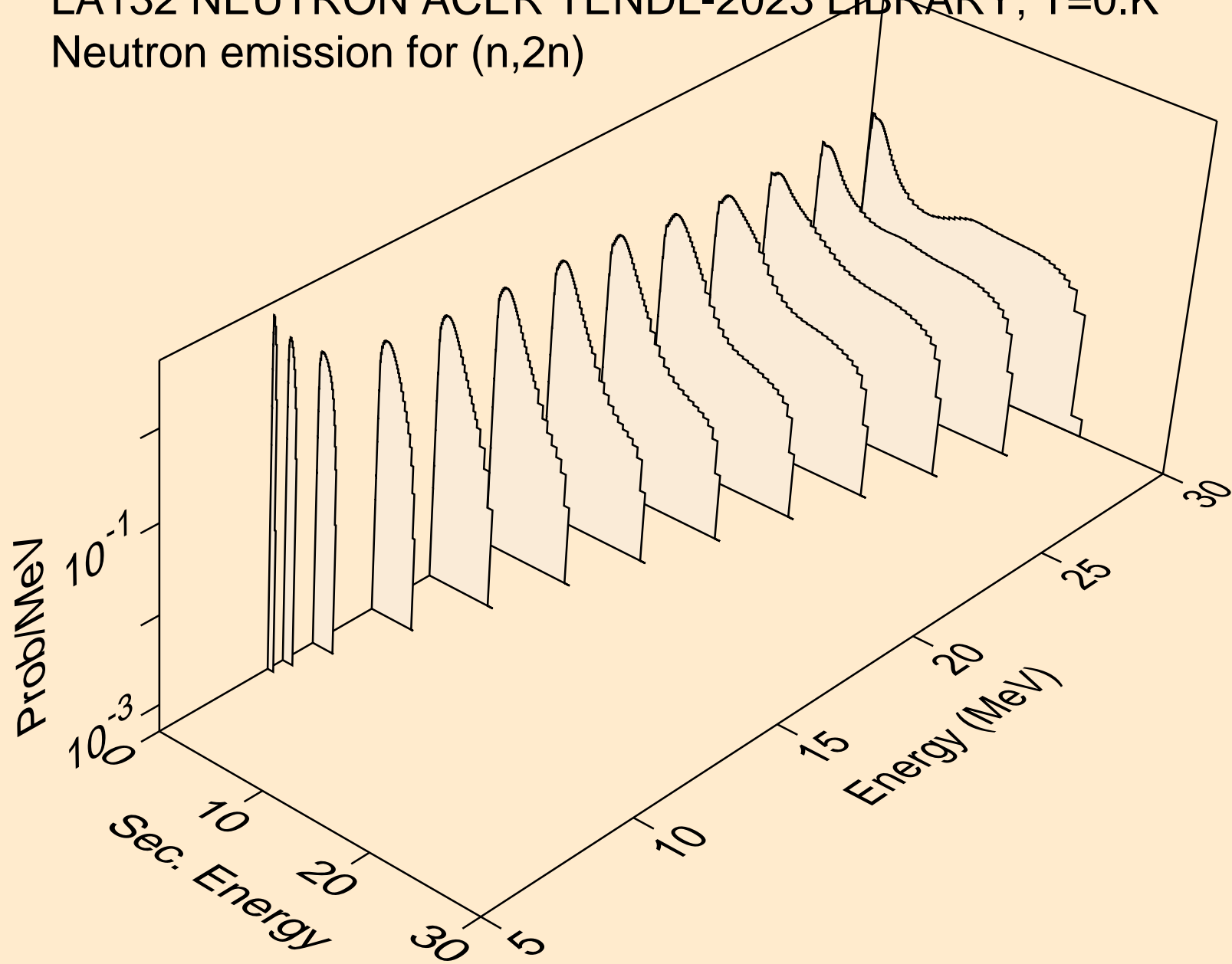

LA132 NEUTRON ACER TENDL-2023 LIBRARY; T=0.K  
Neutron emission for (n,3n)

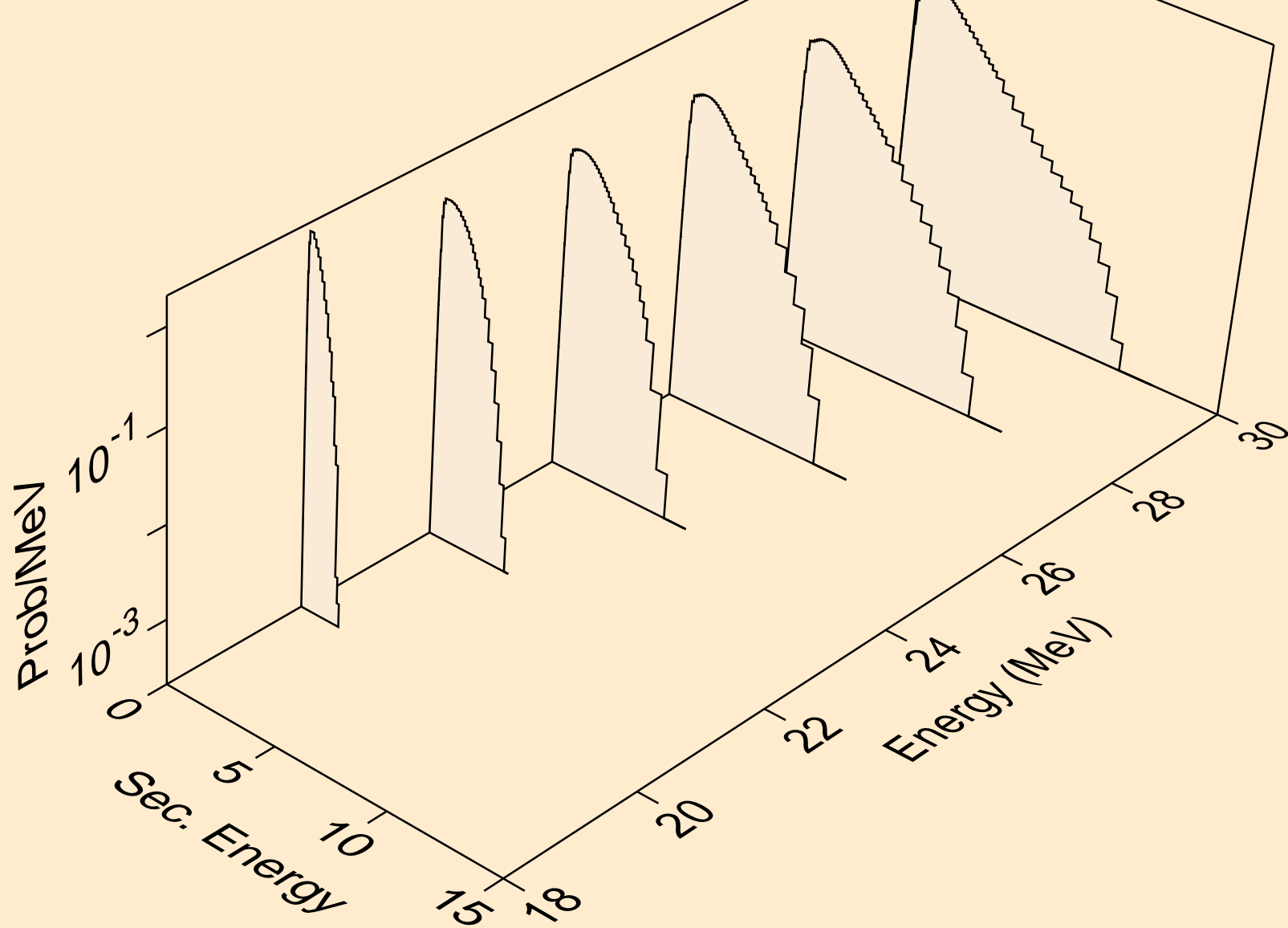

LA132 NEUTRON ACER TENDL-2023 LIBRARY; T=0.K  
Neutron emission for (n,n\*)a

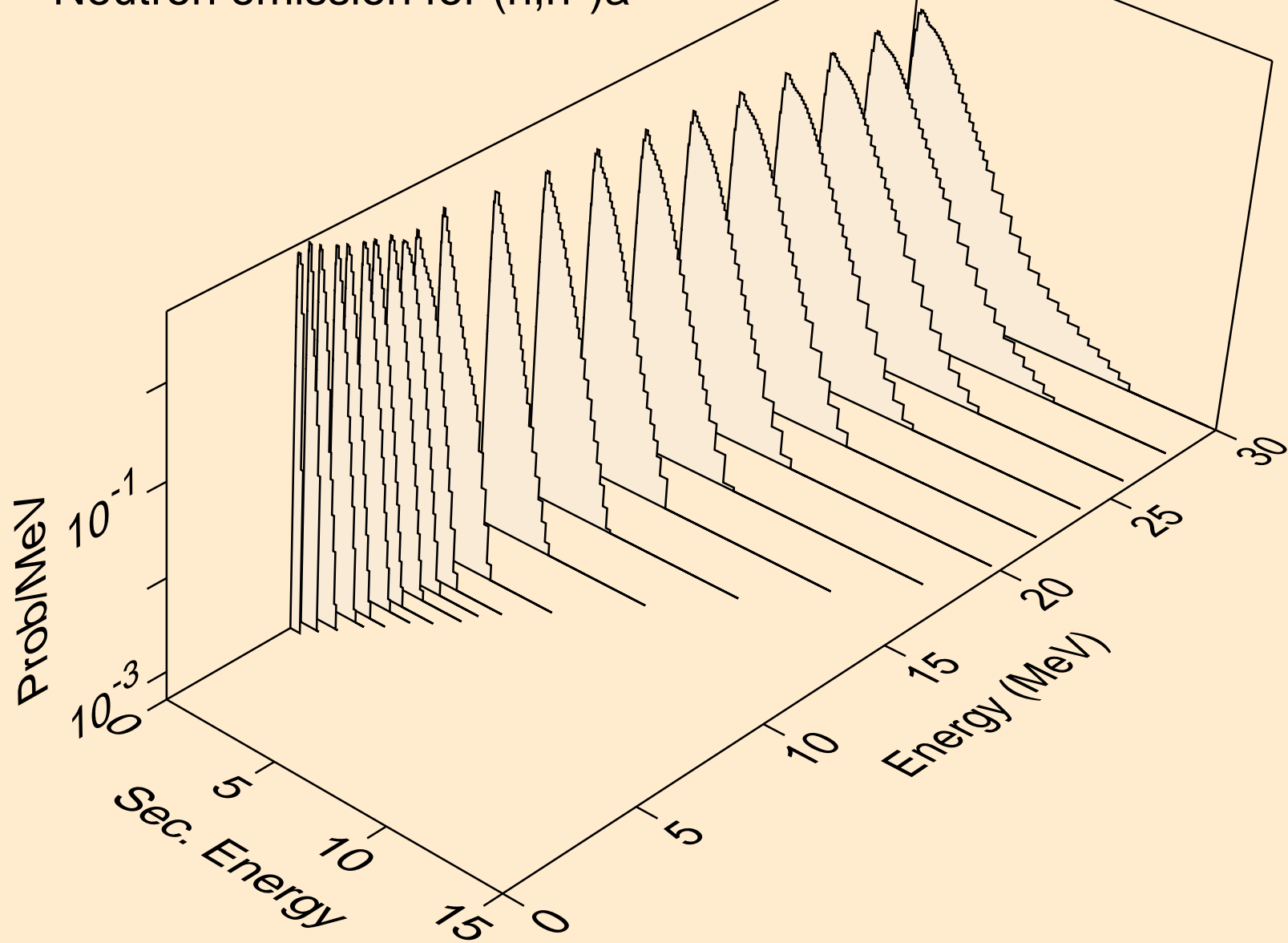

LA132 NEUTRON ACER TENDL-2023 LIBRARY; T=0.K  
Neutron emission for (n,2n)a

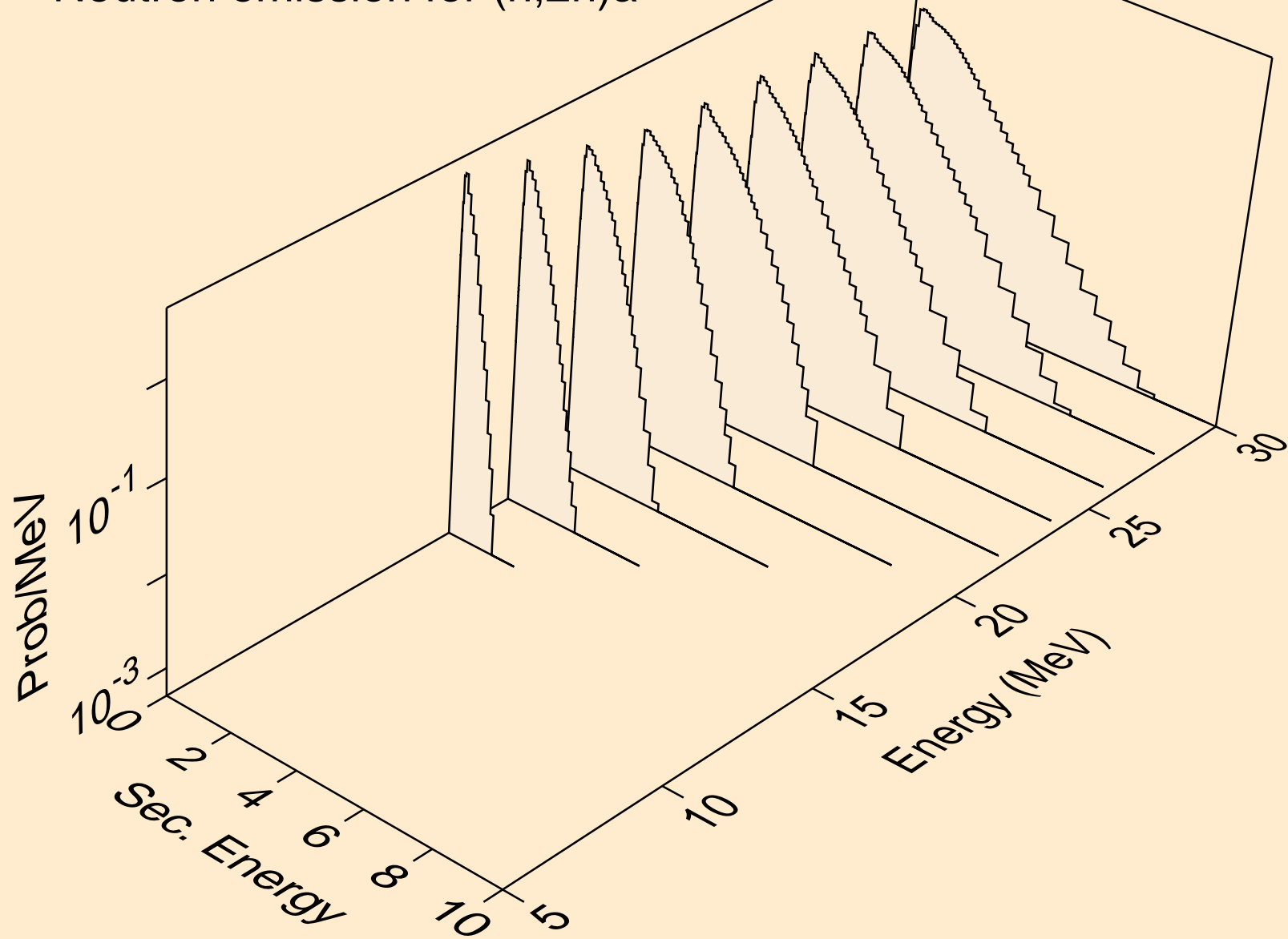



LA132 NEUTRON ACER TENDL-2023 LIBRARY; T=0.K  
Neutron emission for (n,3n)a

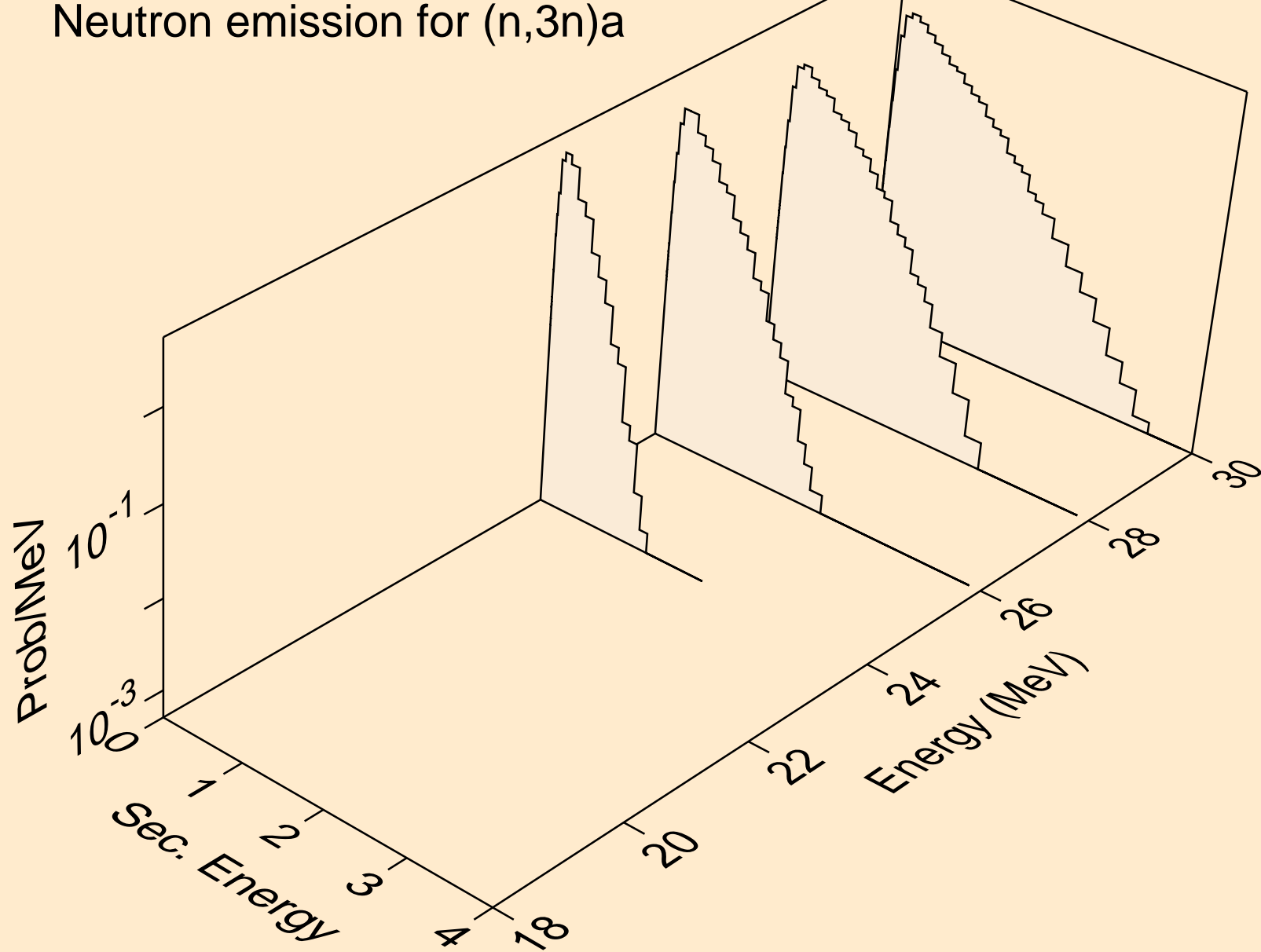

LA132 NEUTRON ACER TENDL-2023 LIBRARY; T=0.K  
Neutron emission for (n,n\*)p

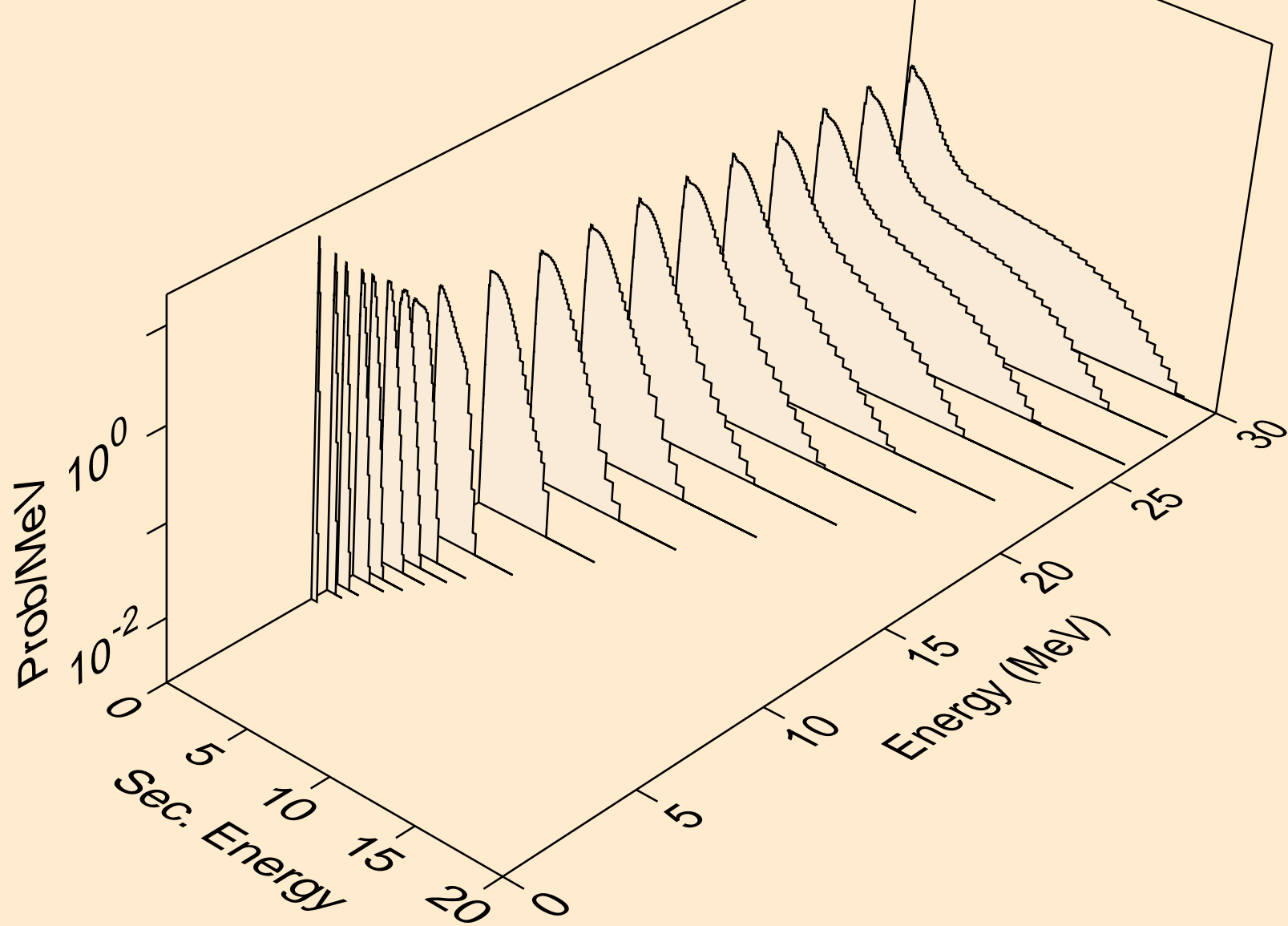

LA132 NEUTRON ACER TENDL-2023 LIBRARY; T=0.K  
Neutron emission for (n,n\*)2a

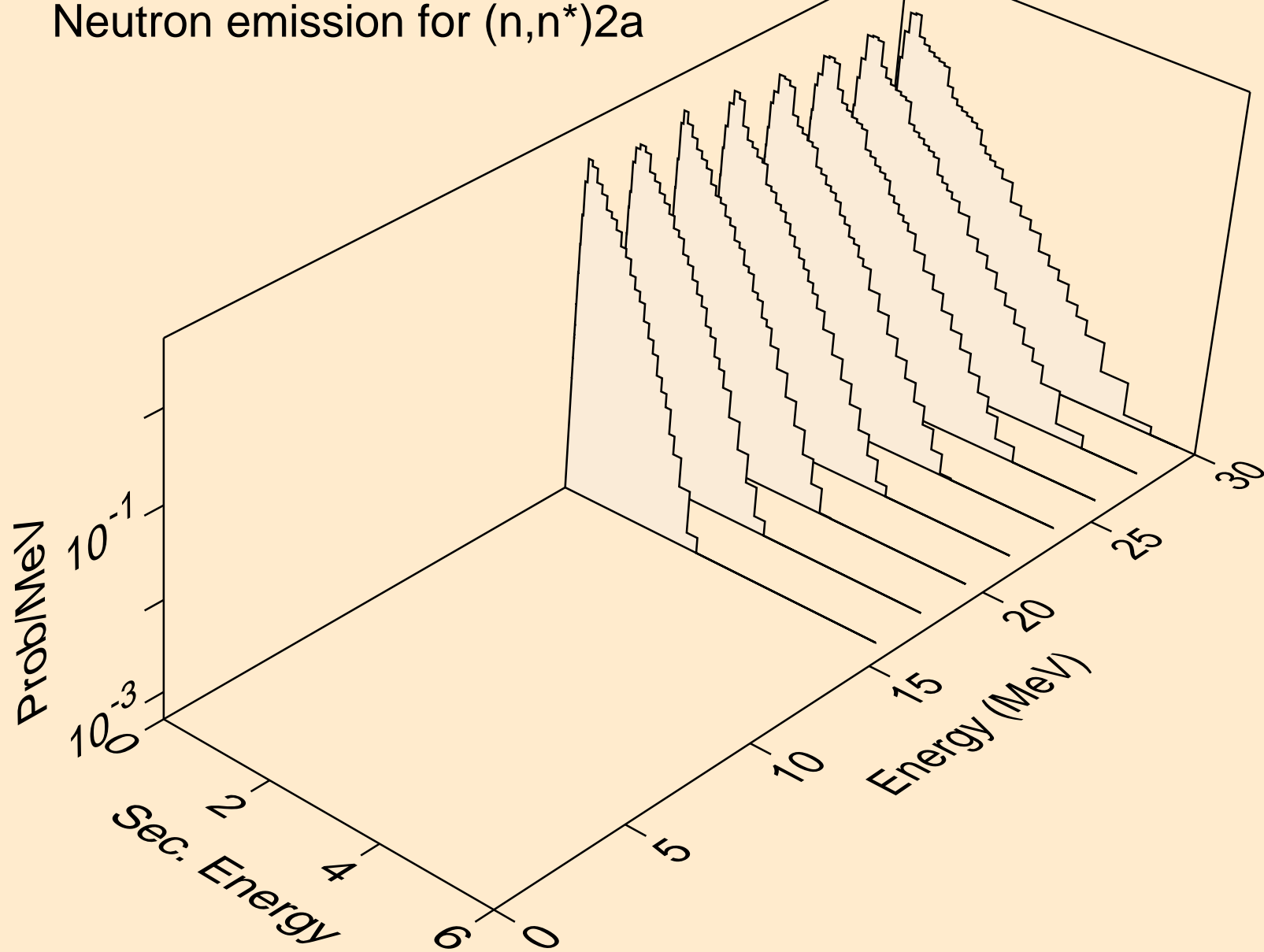

LA132 NEUTRON ACER TENDL-2023 LIBRARY; T=0.K  
Neutron emission for (n,n\*)d

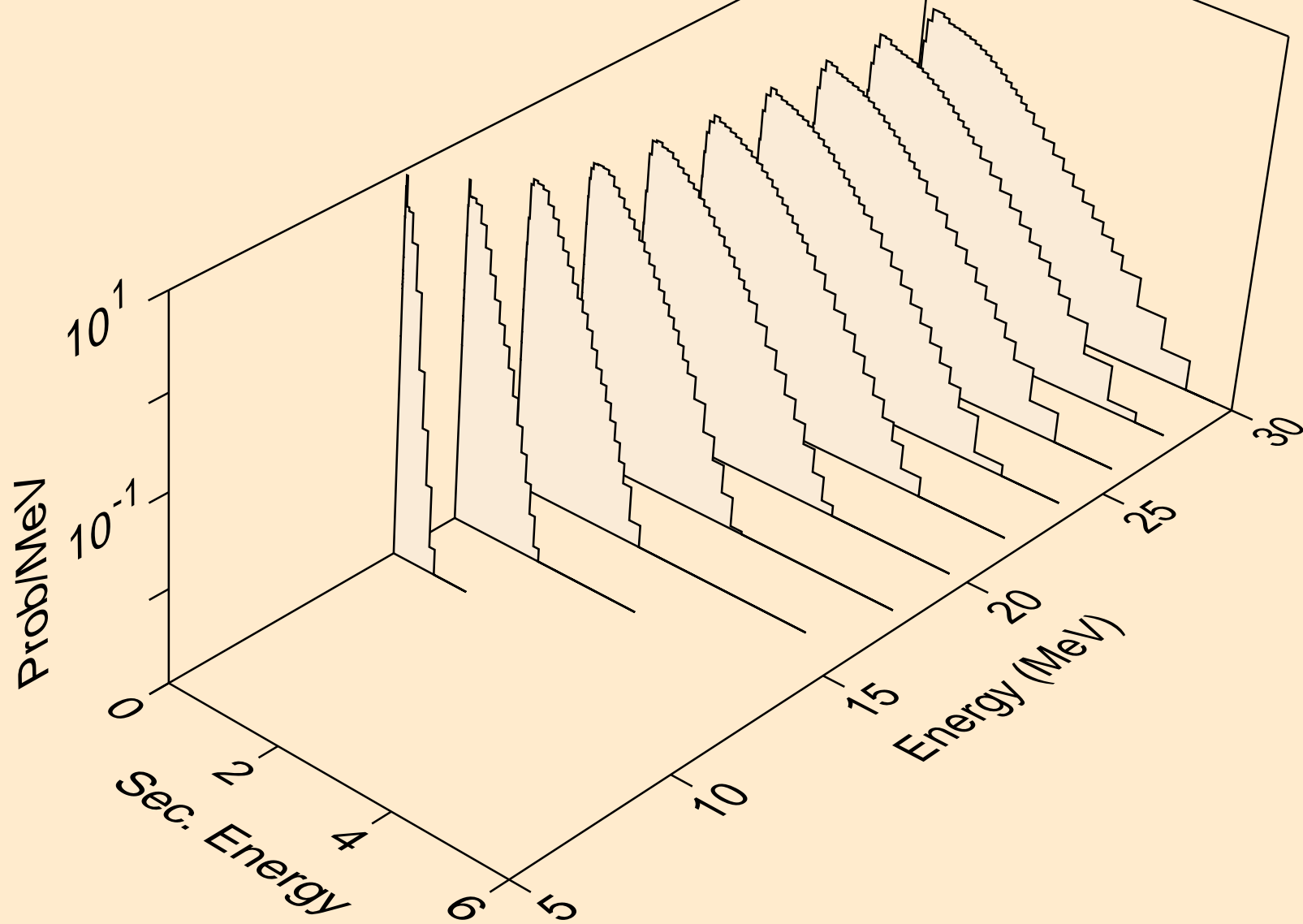

LA132 NEUTRON ACER TENDL-2023 LIBRARY; T=0.K  
Neutron emission for (n,n\*)t

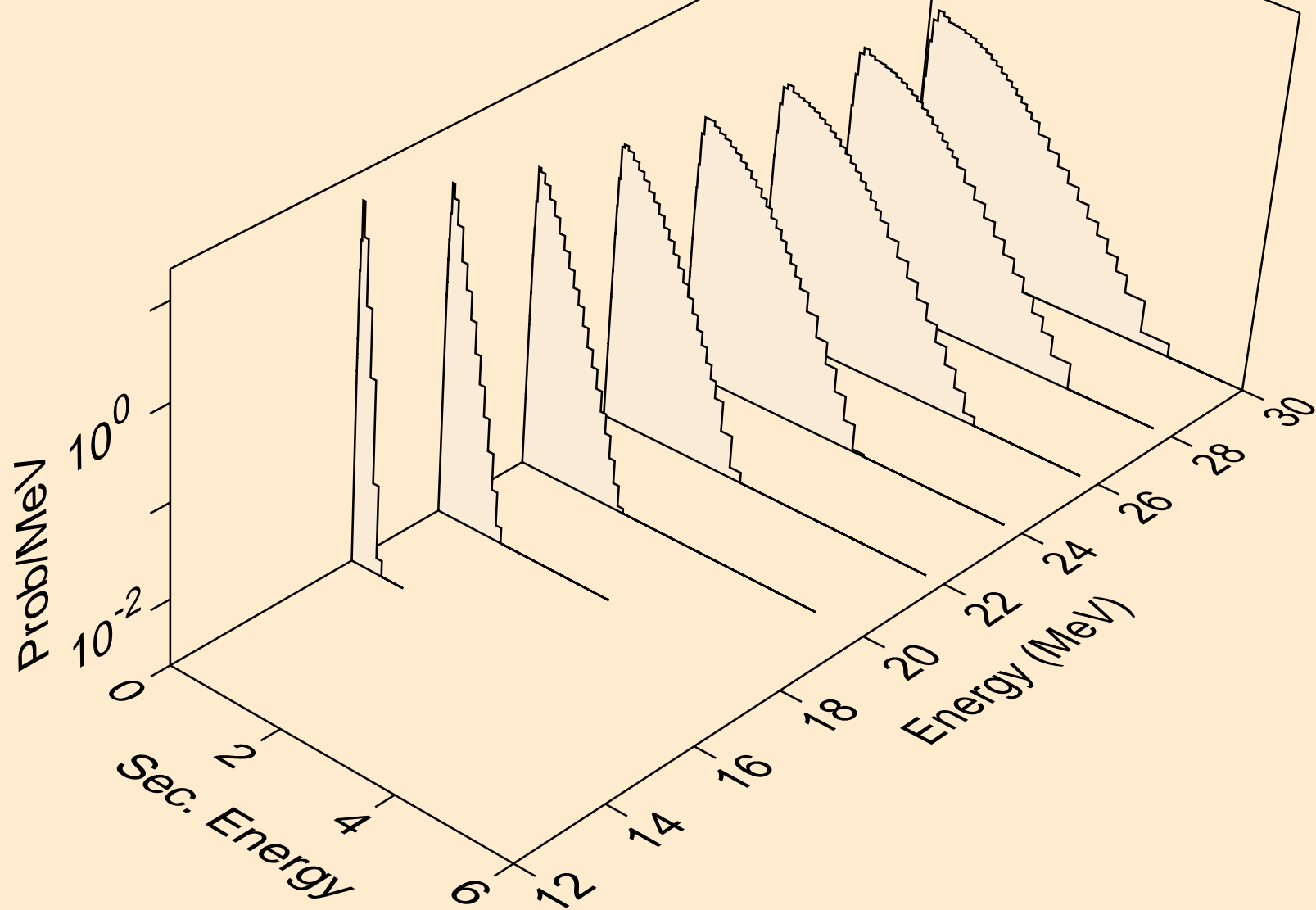

LA132 NEUTRON ACER TENDL-2023 LIBRARY; T=0.K  
Neutron emission for (n,n\*)he3

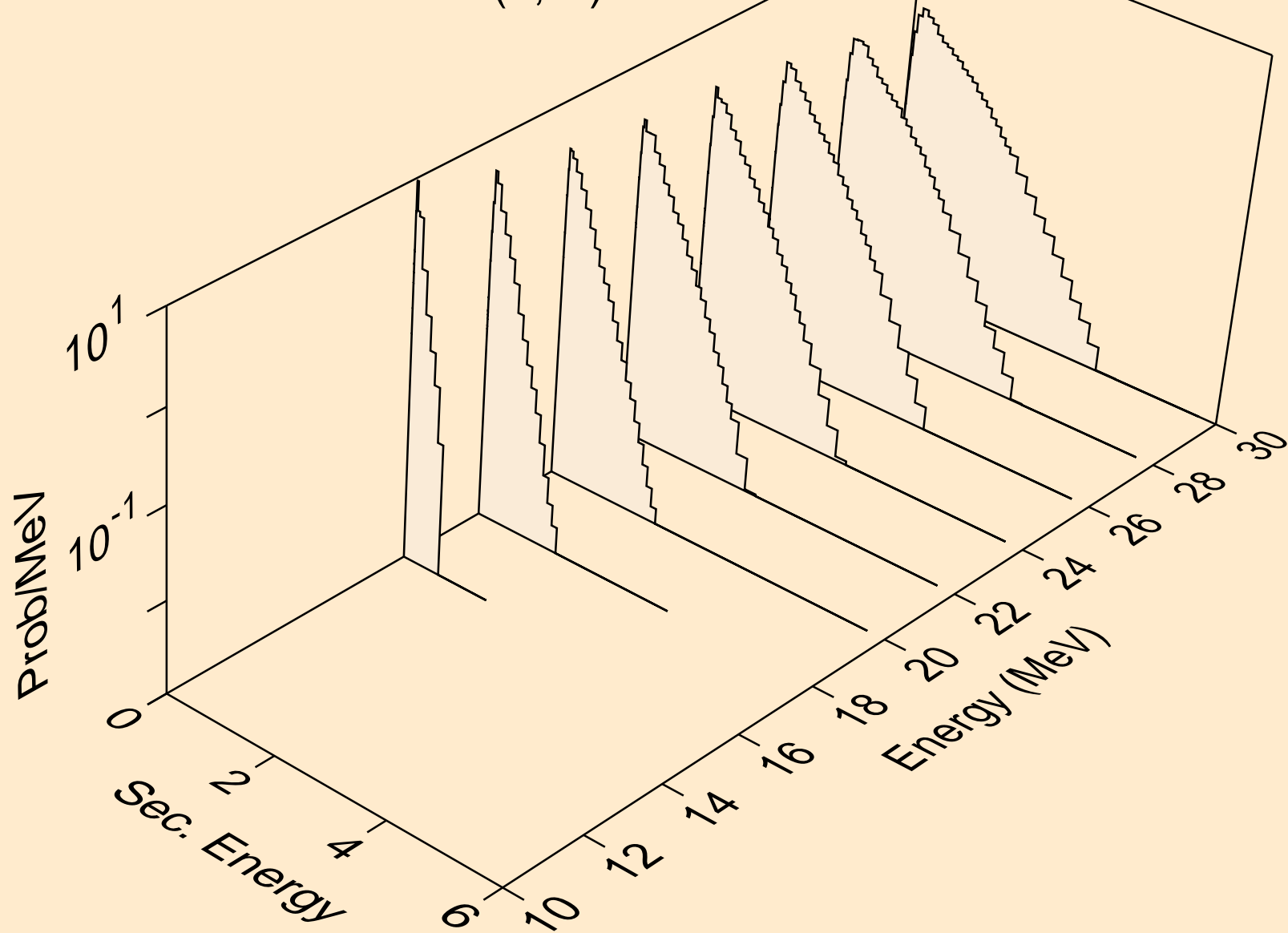

LA132 NEUTRON ACER TENDL-2023 LIBRARY; T=0.K  
Neutron emission for (n,4n)

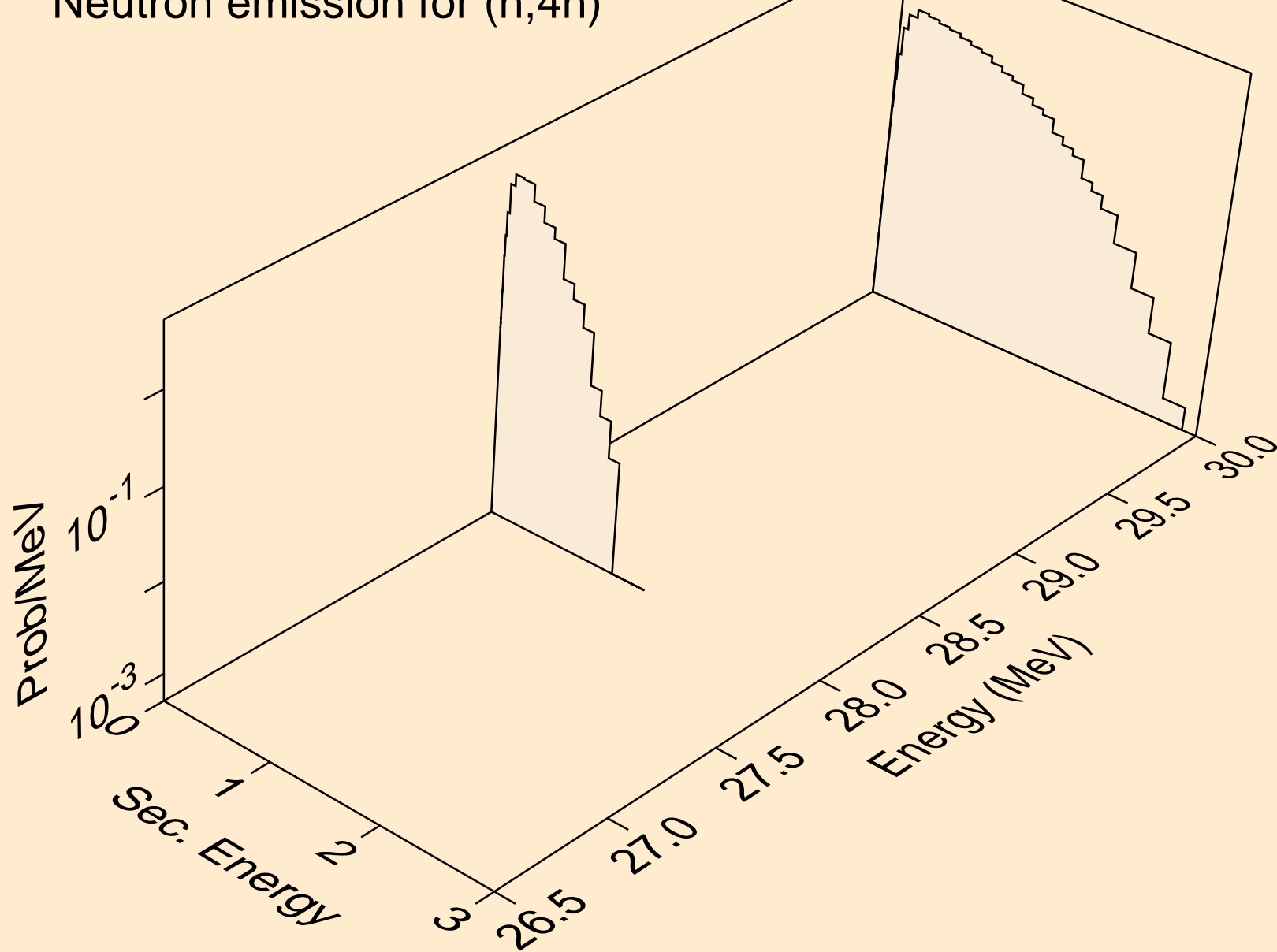

LA132 NEUTRON ACER TENDL-2023 LIBRARY; T=0.K  
Neutron emission for (n,2np)

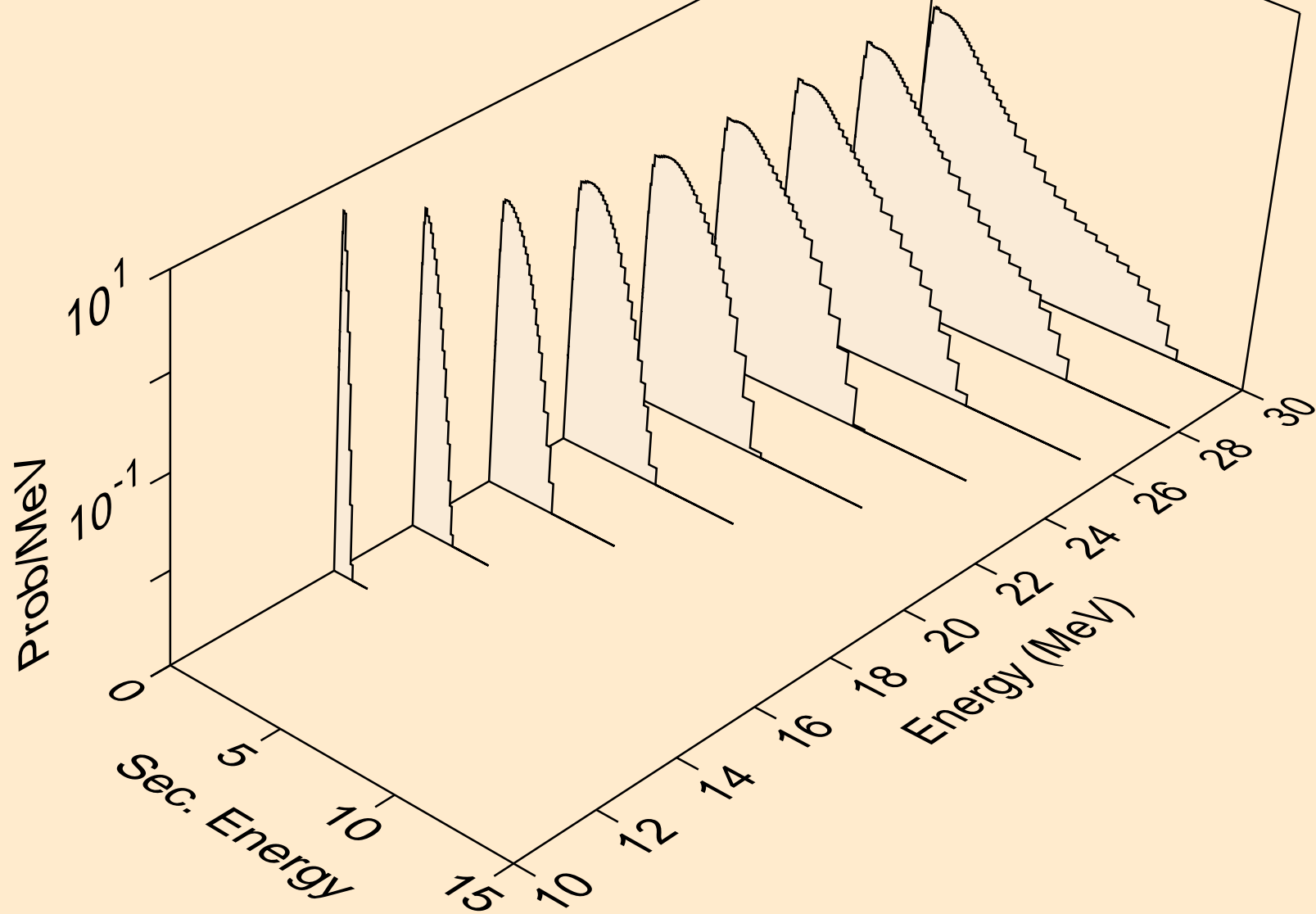



LA132 NEUTRON ACER TENDL-2023 LIBRARY; T=0.K  
Neutron emission for (n,3np)

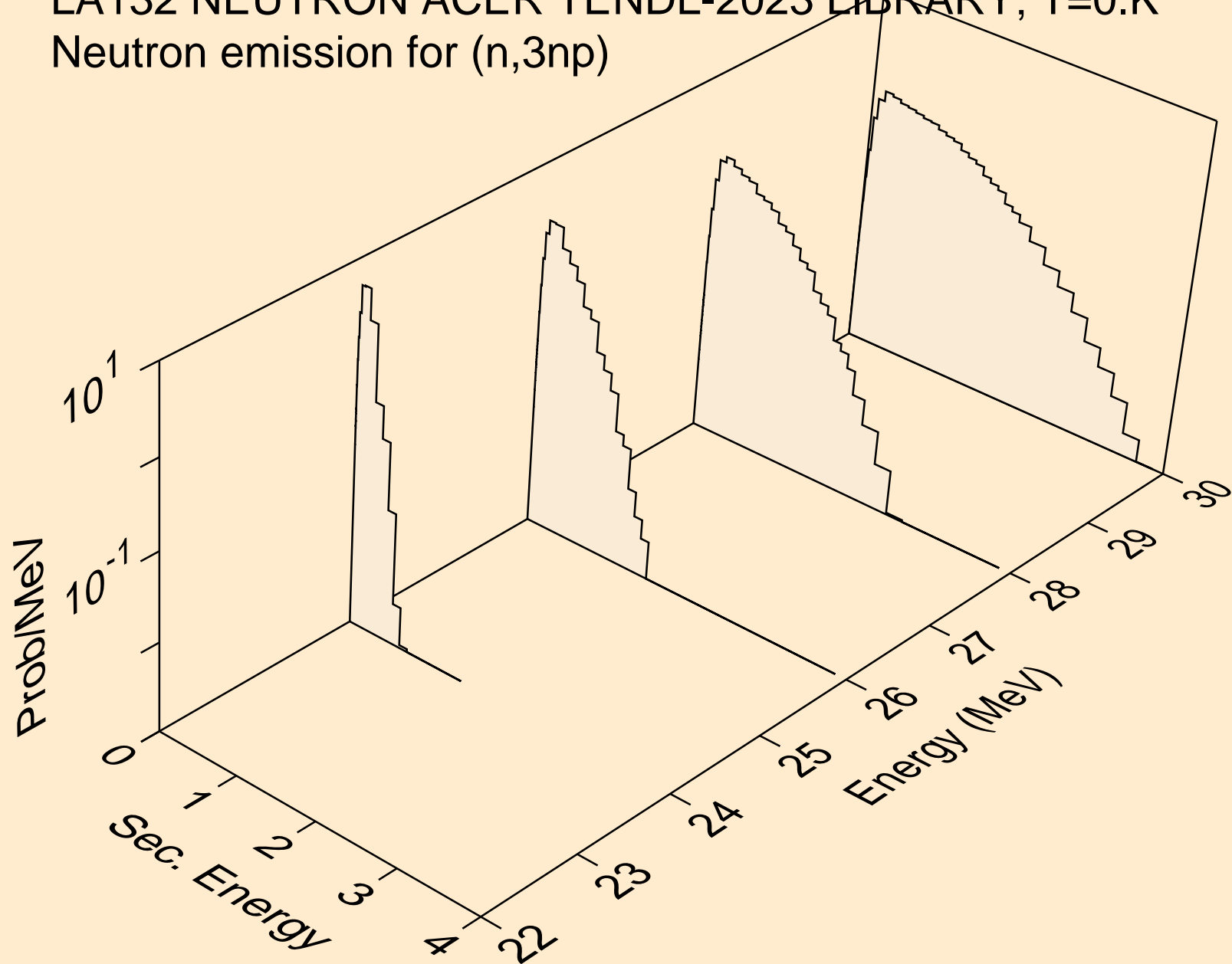

LA132 NEUTRON ACER TENDL-2023 LIBRARY; T=0.K  
Neutron emission for (n,n2p)

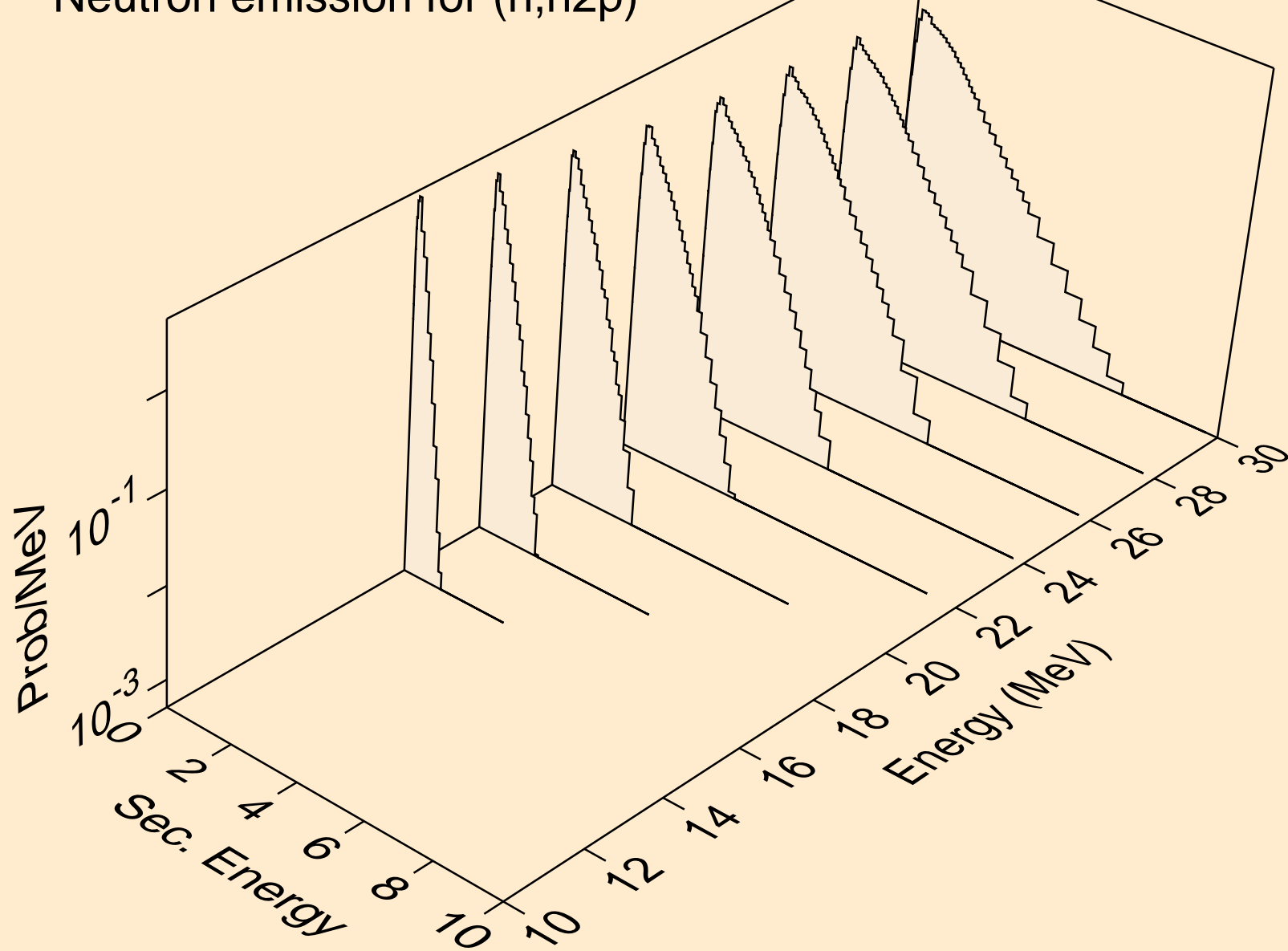

LA132 NEUTRON ACER TENDL-2023 LIBRARY; T=0.K  
Neutron emission for (n,npa)

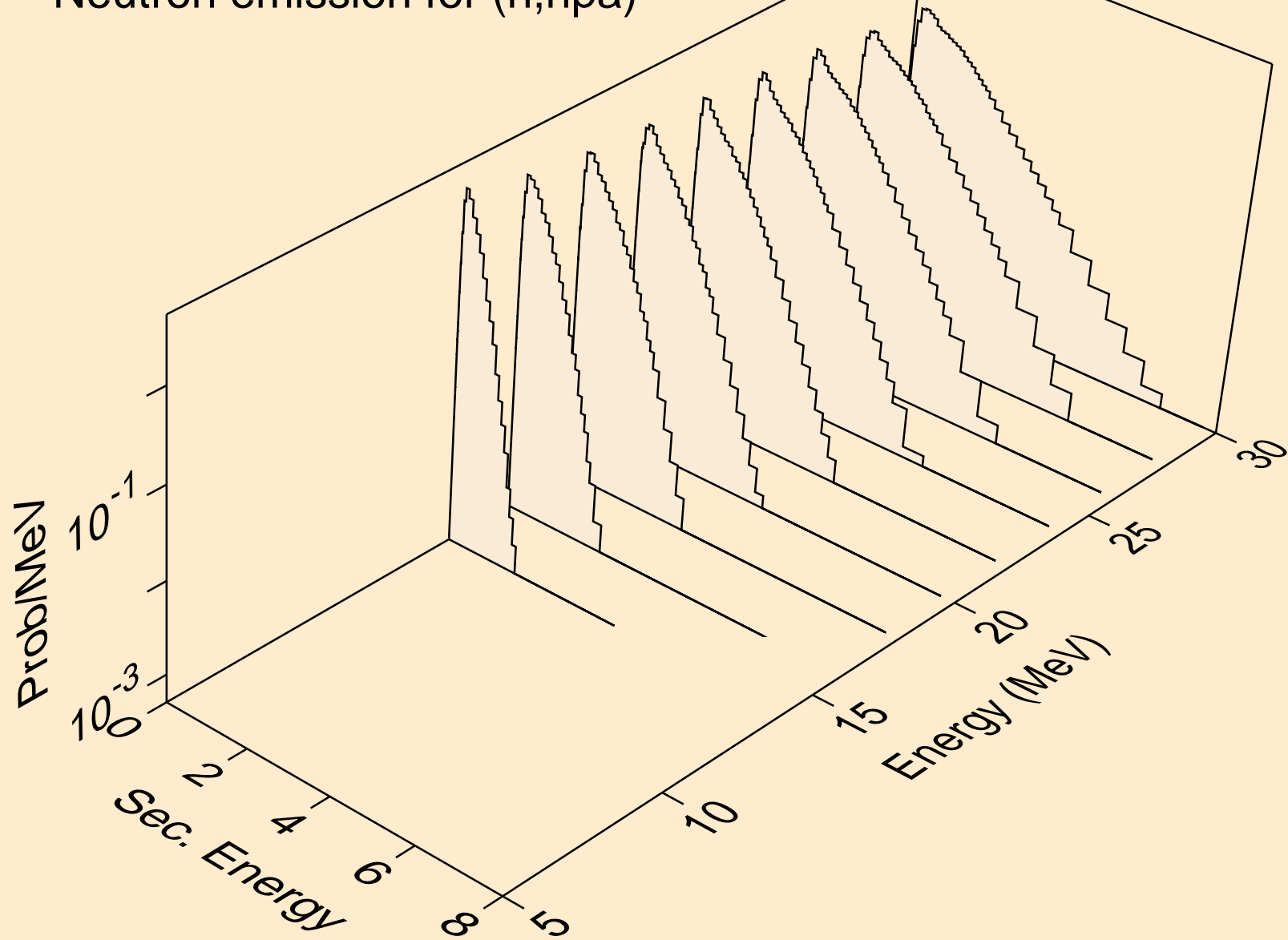

LA132 NEUTRON ACER TENDL-2023 LIBRARY; T=0.K  
Neutron emission for (n,n\*c)

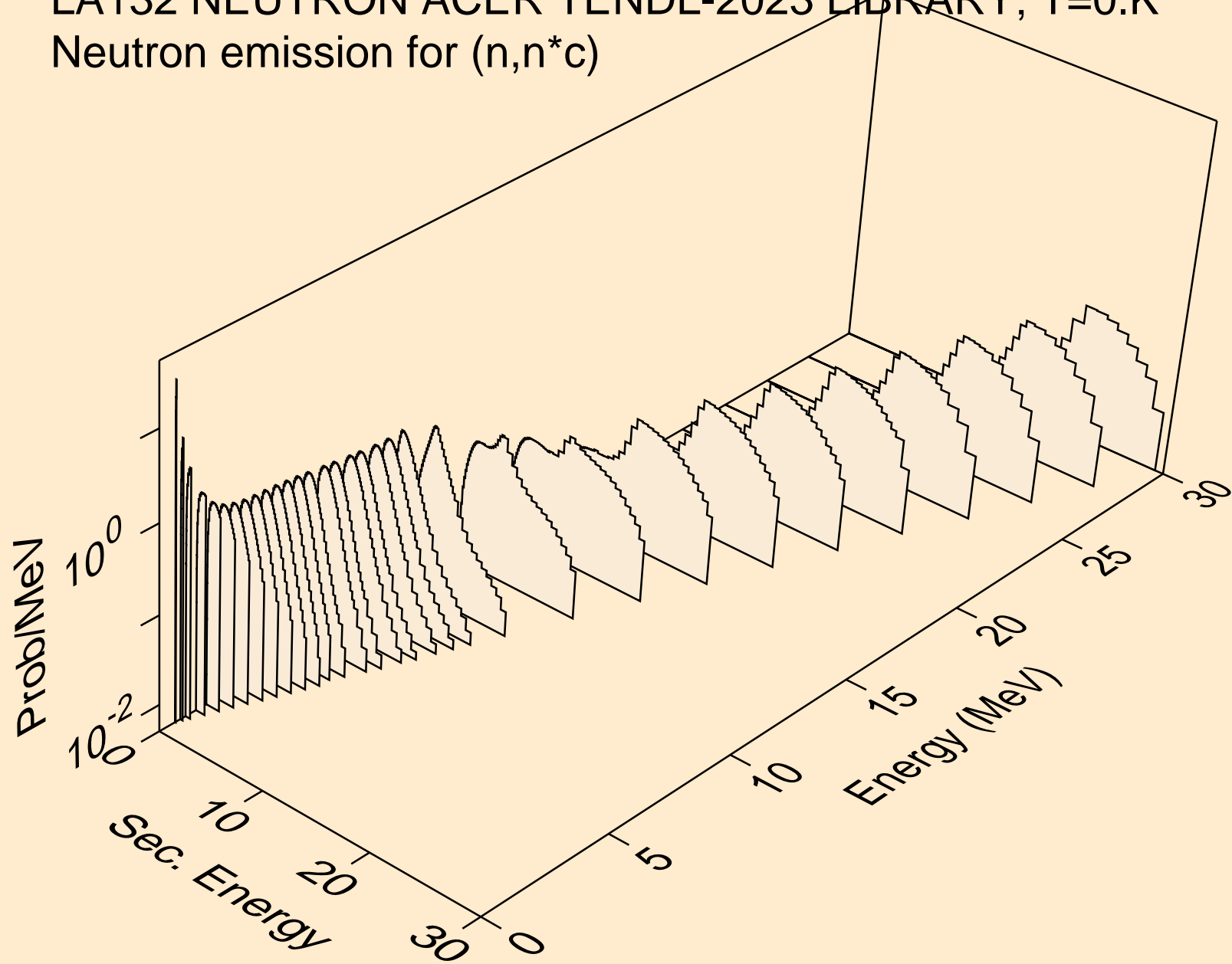

LA132 NEUTRON ACER TENDL-2023 LIBRARY; T=0.K  
Photon emission for (n,x)

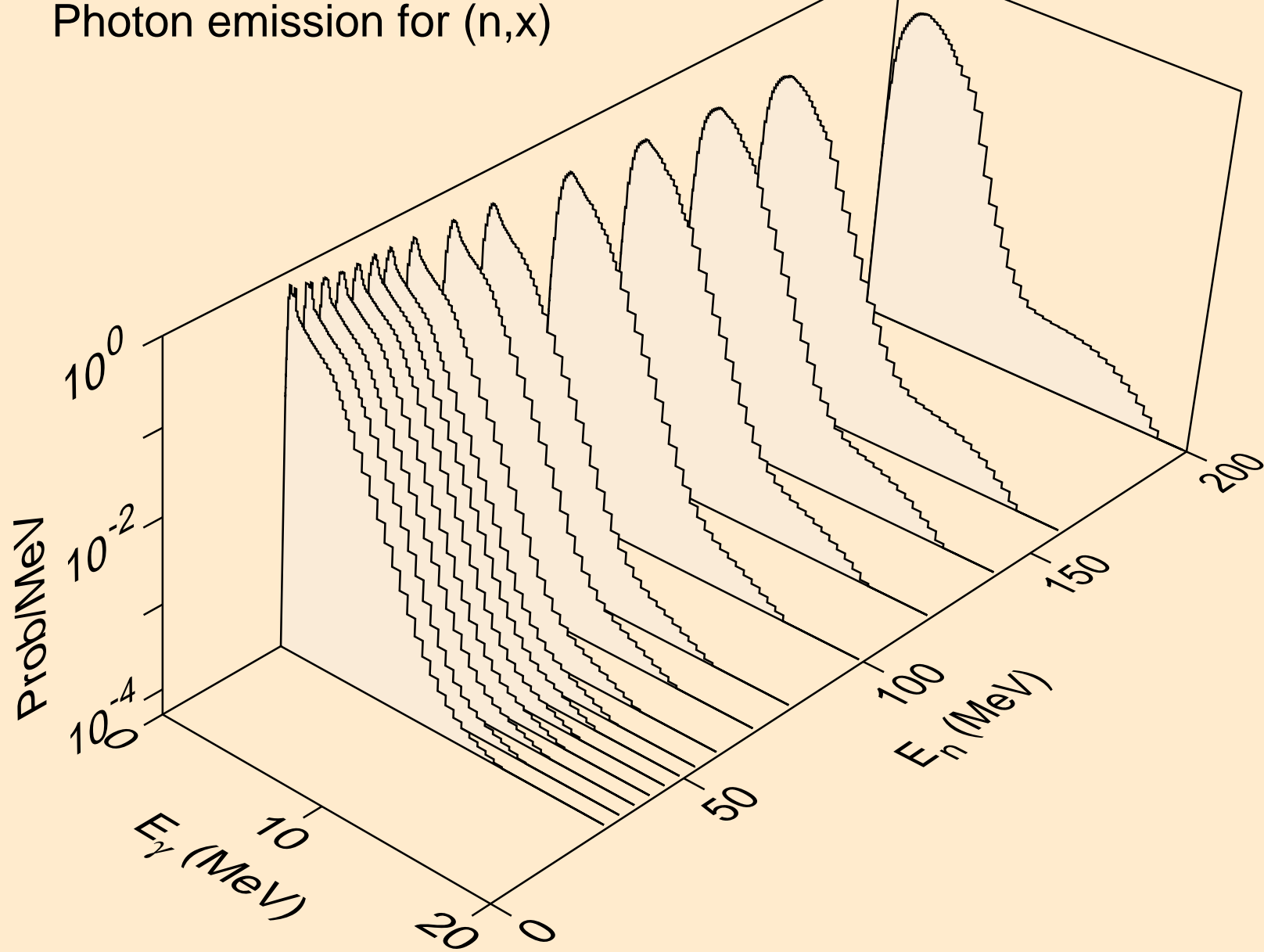

LA132 NEUTRON ACER TENDL-2023 LIBRARY; T=0.K  
Photon emission for (n,2nd)

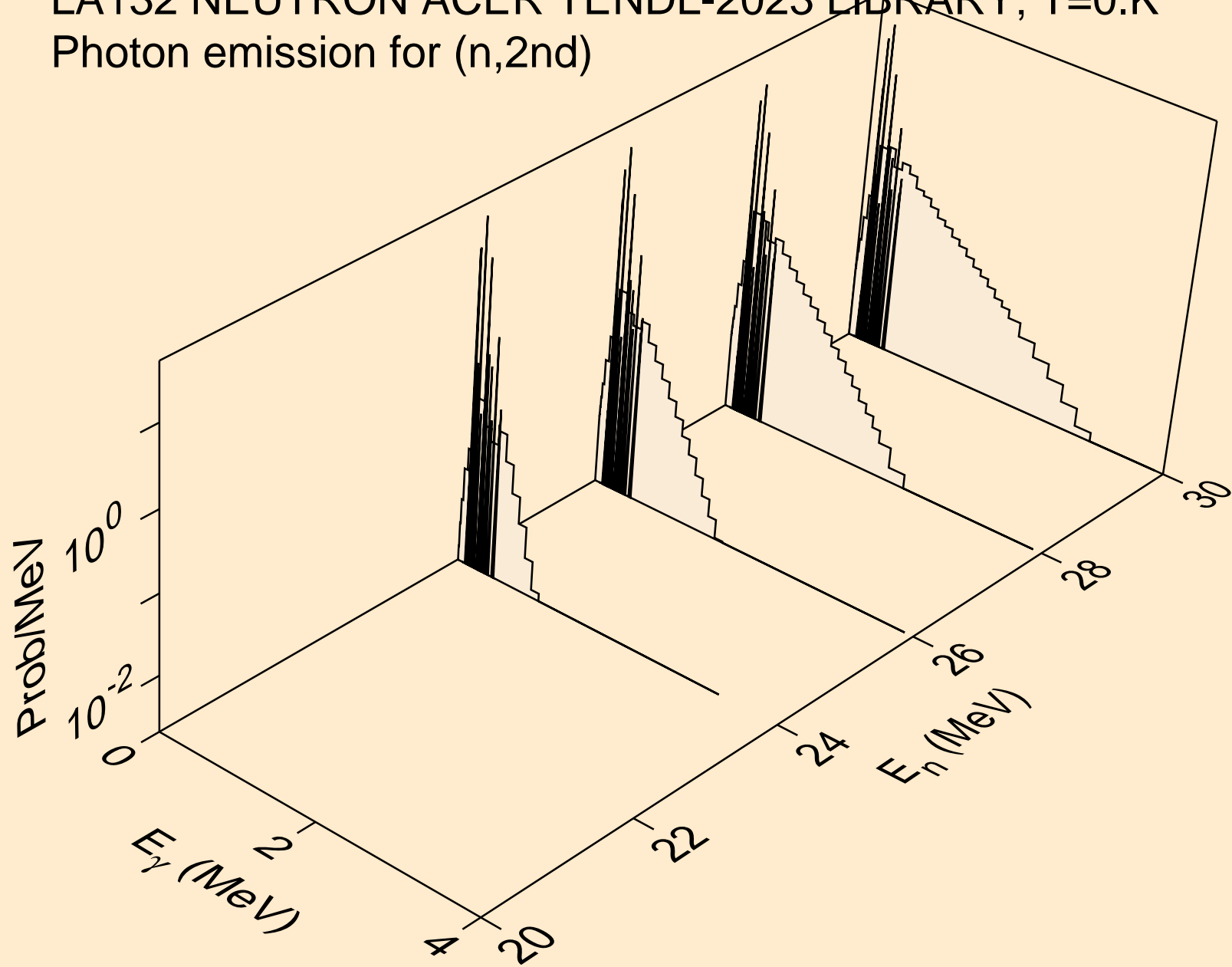

LA132 NEUTRON ACER TENDL-2023 LIBRARY; T=0.K  
Photon emission for (n,2n)

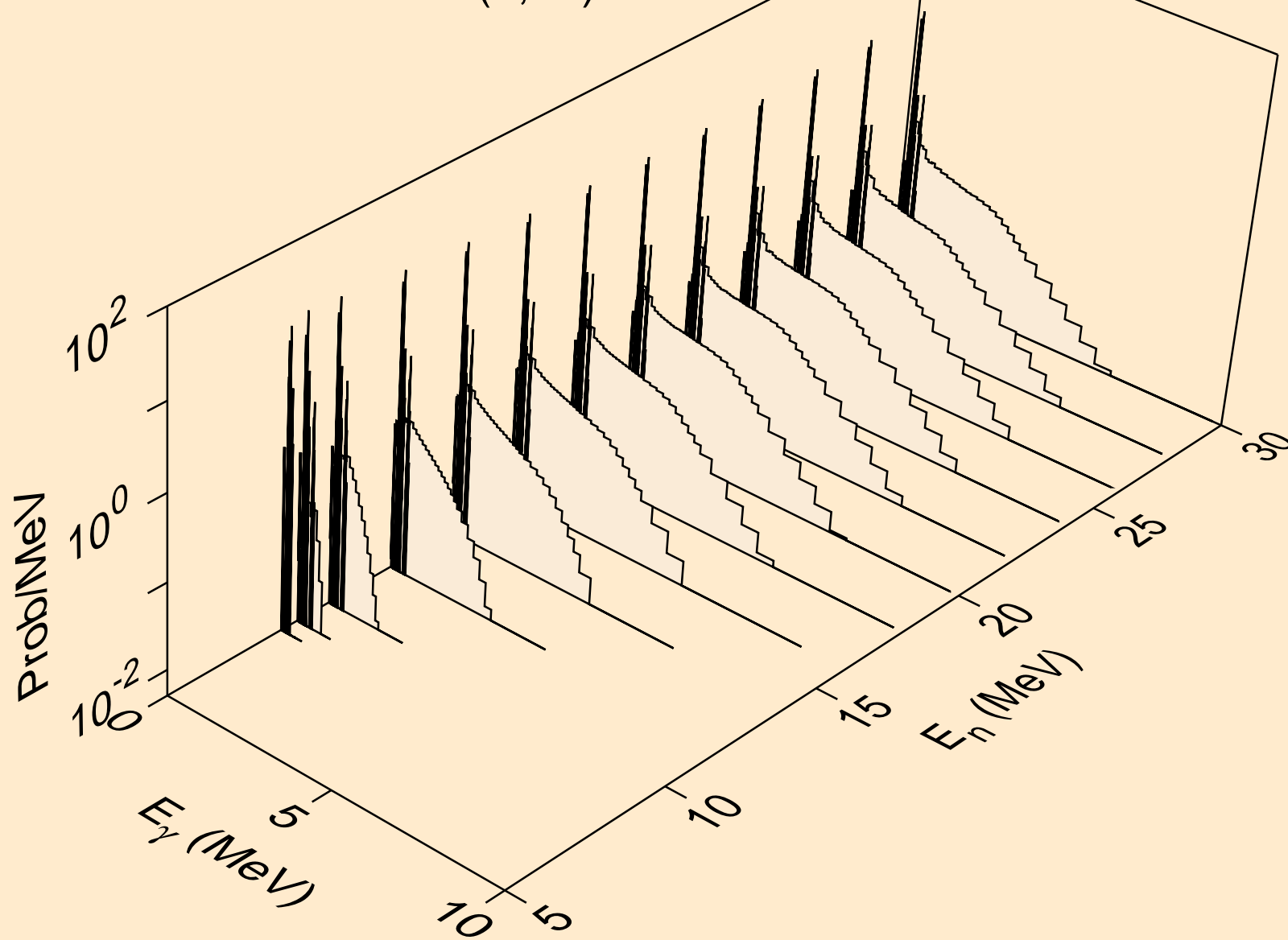

LA132 NEUTRON ACER TENDL-2023 LIBRARY; T=0.K  
Photon emission for (n,3n)

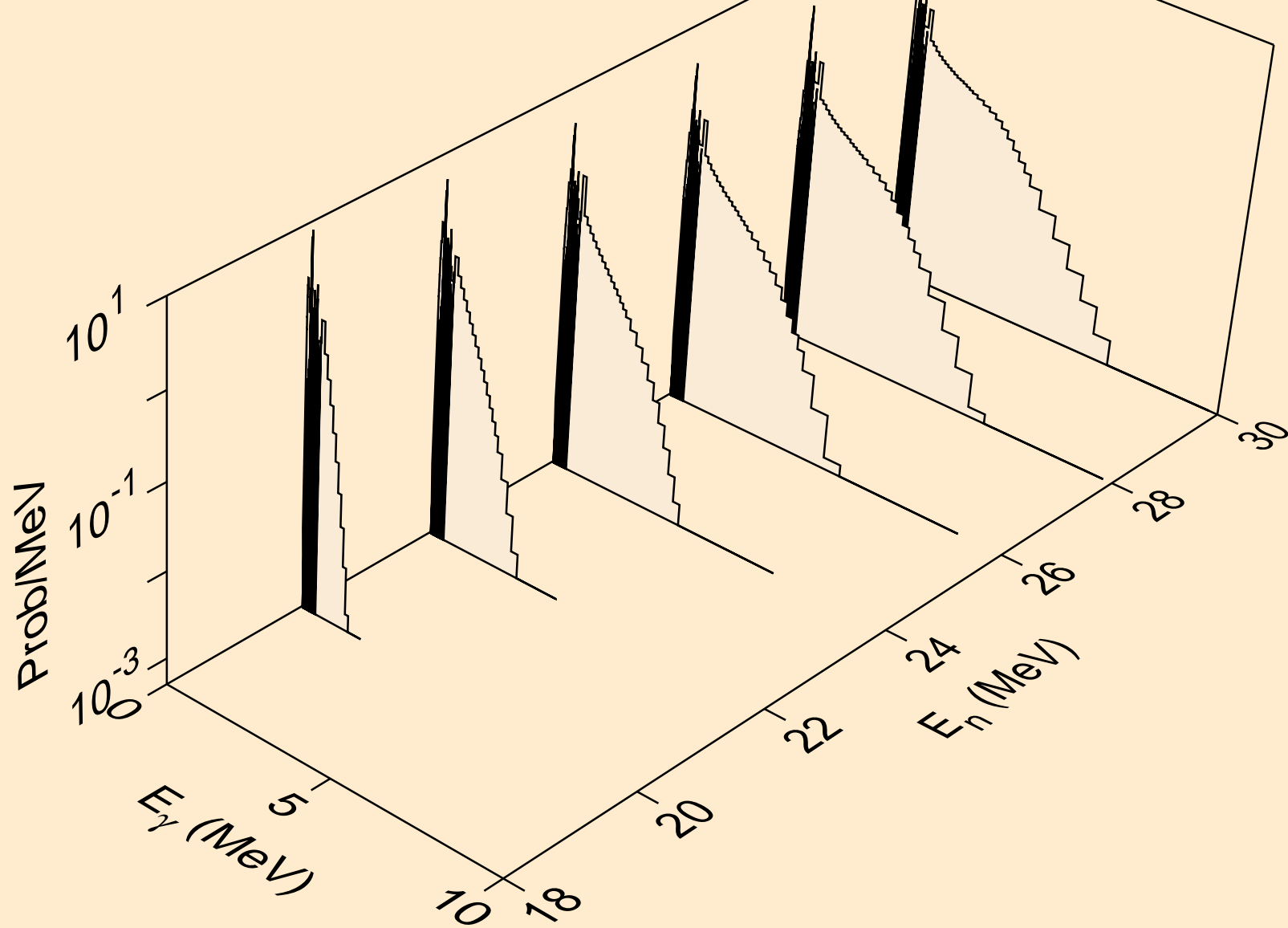



LA132 NEUTRON ACER TENDL-2023 LIBRARY; T=0.K  
Photon emission for (n,n\*)a

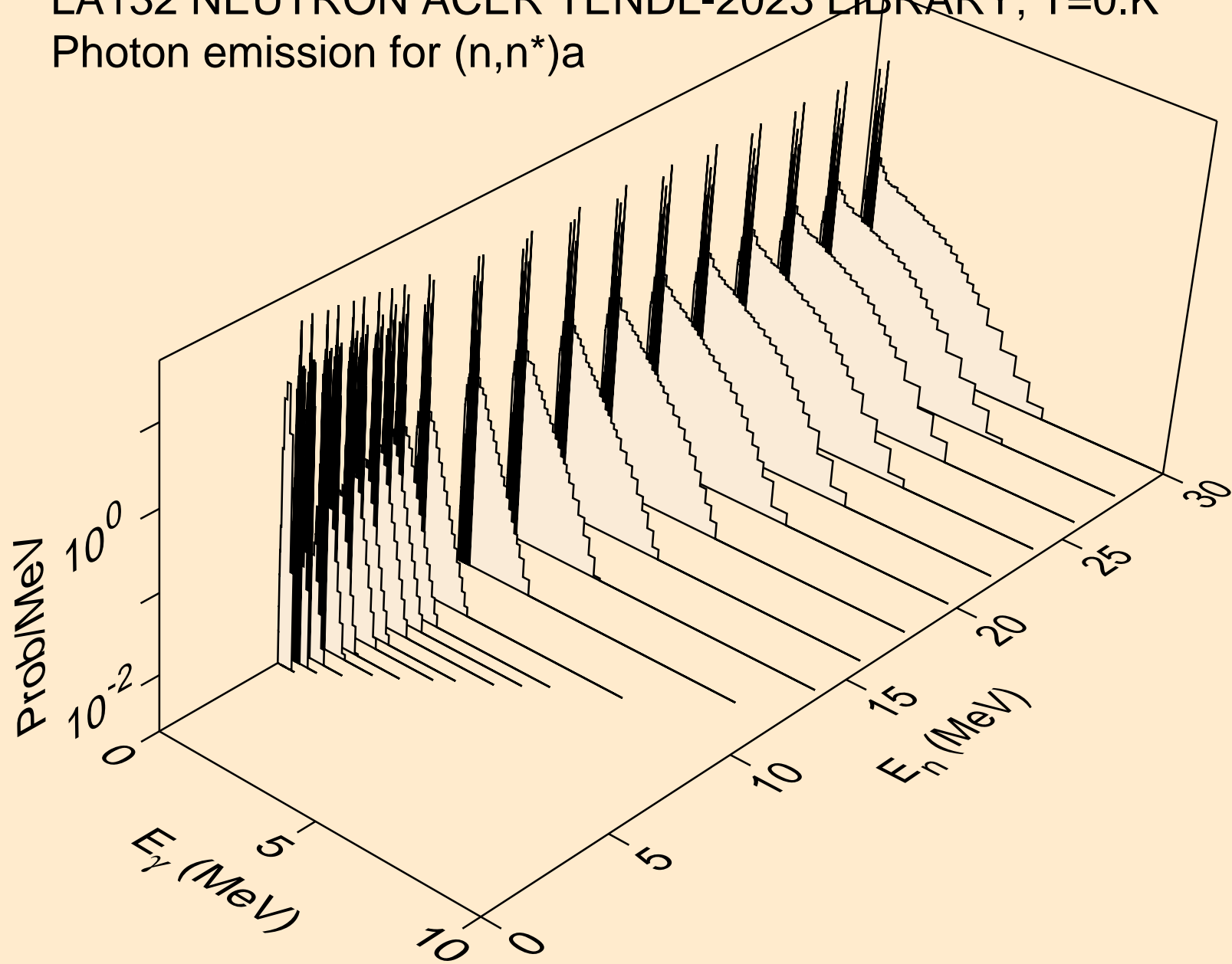

LA132 NEUTRON ACER TENDL-2023 LIBRARY; T=0.K  
Photon emission for (n,2n)a

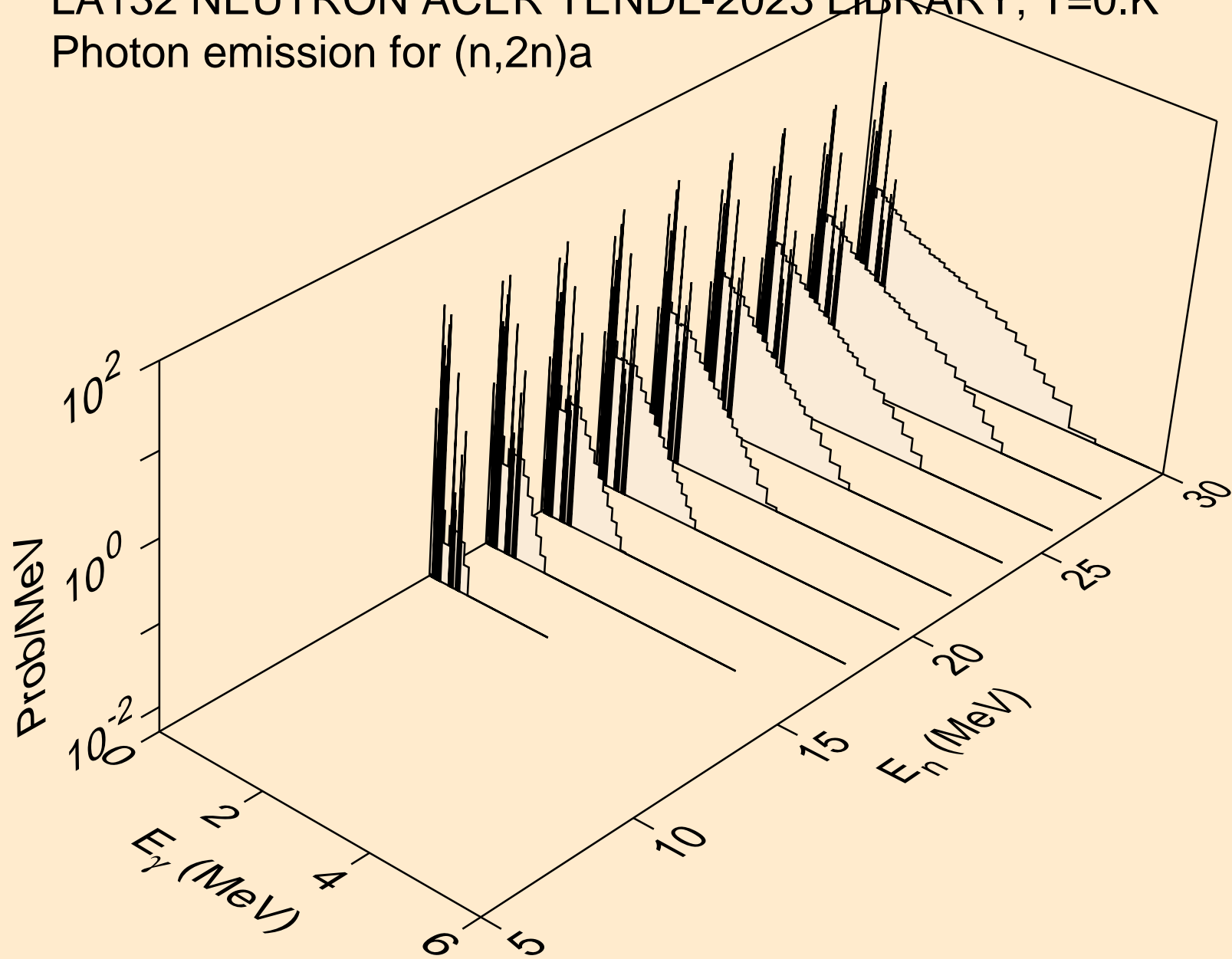

LA132 NEUTRON ACER TENDL-2023 LIBRARY; T=0.K  
Photon emission for (n,3n)a

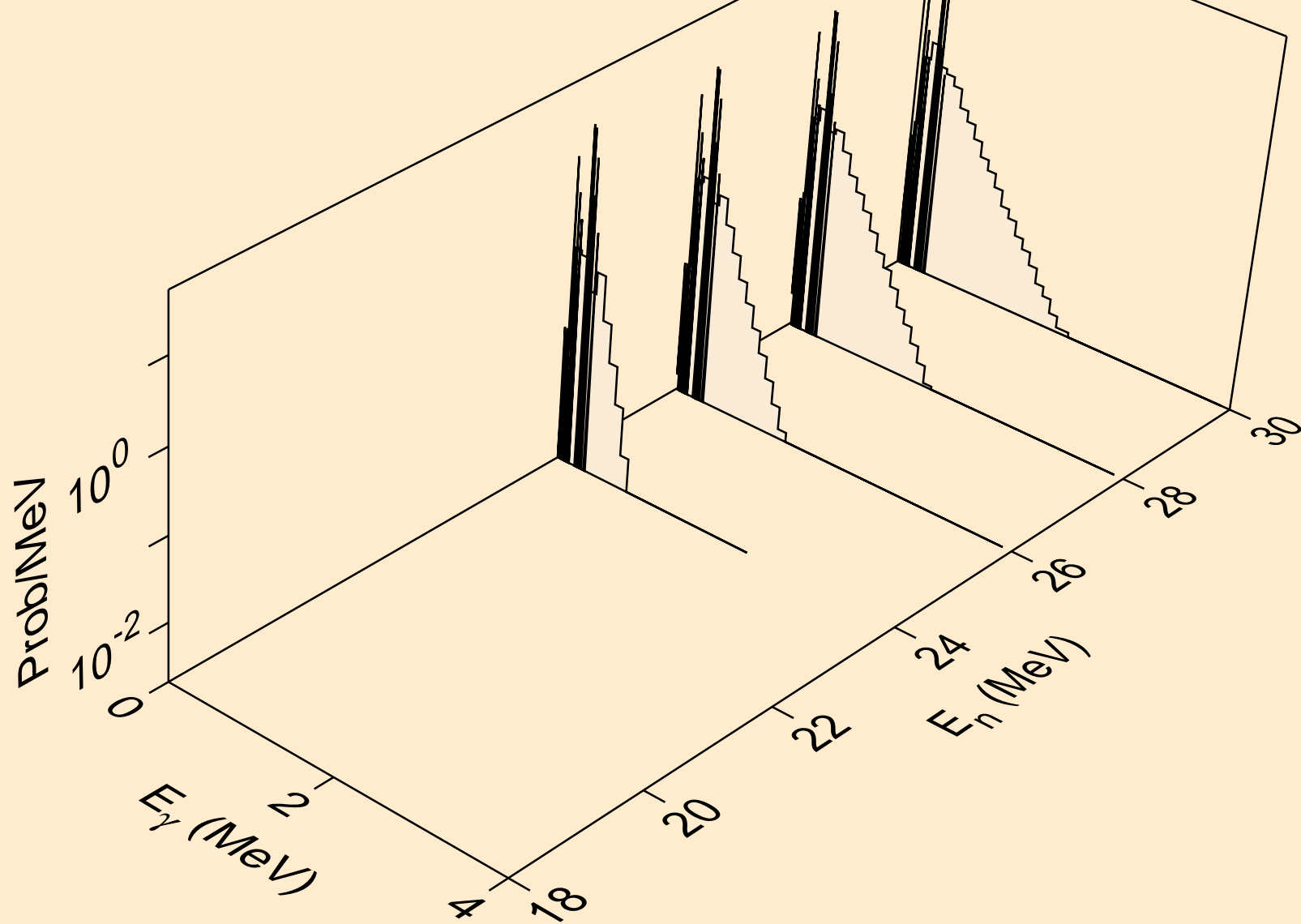

LA132 NEUTRON ACER TENDL-2023 LIBRARY; T=0.K  
Photon emission for (n,n\*)p

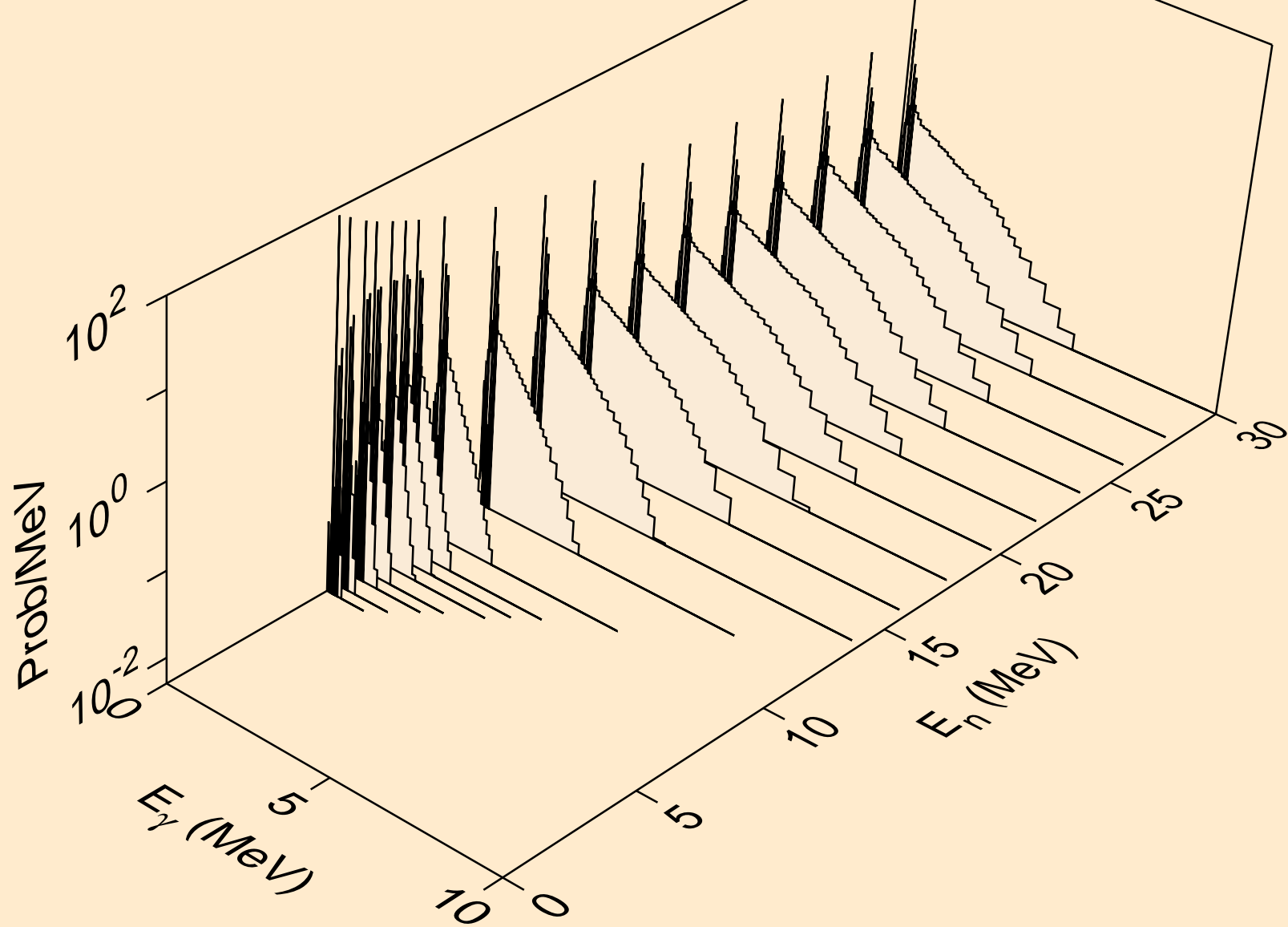

LA132 NEUTRON ACER TENDL-2023 LIBRARY; T=0.K  
Photon emission for (n,n\*)2a

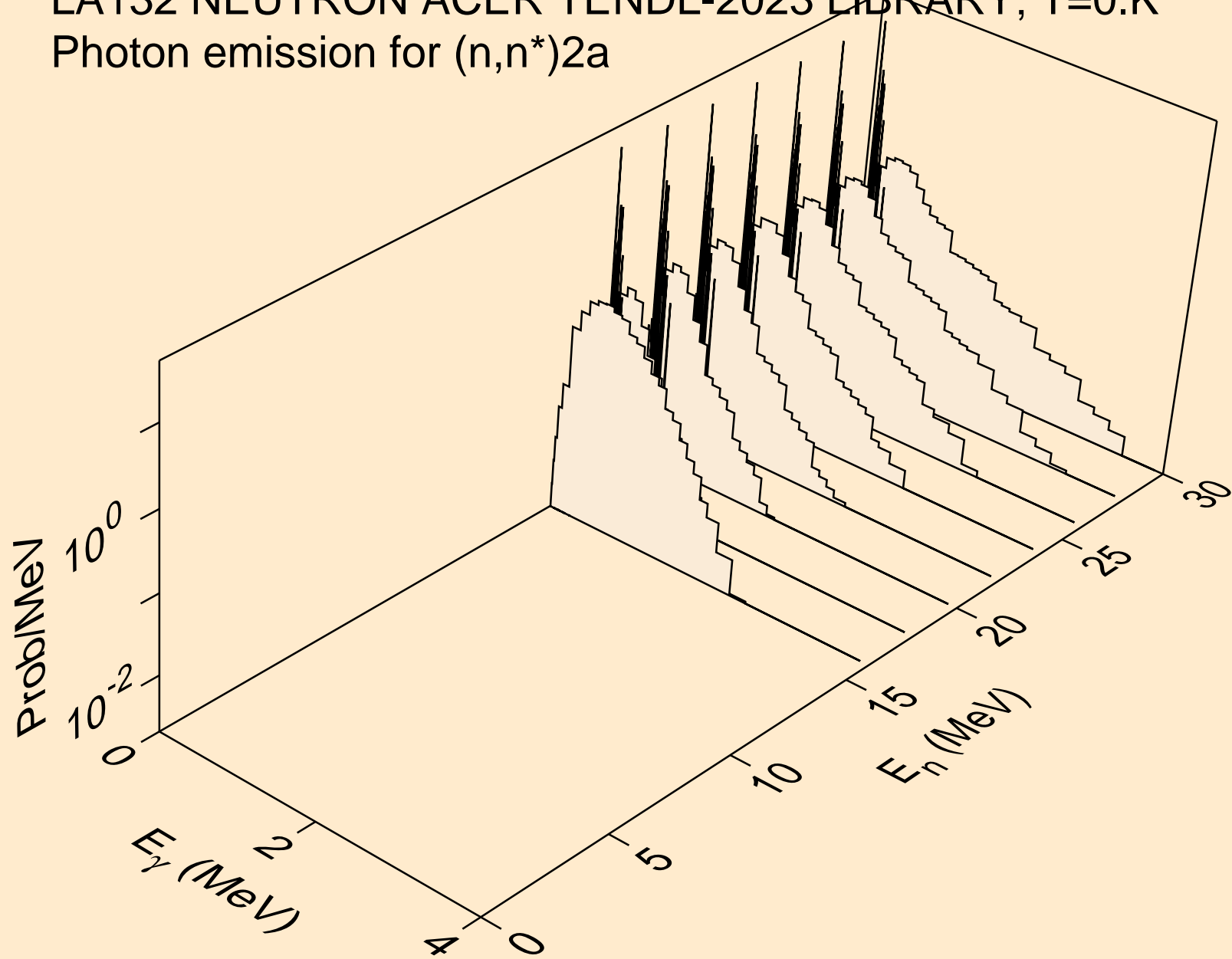

LA132 NEUTRON ACER TENDL-2023 LIBRARY; T=0.K  
Photon emission for (n,n\*)d

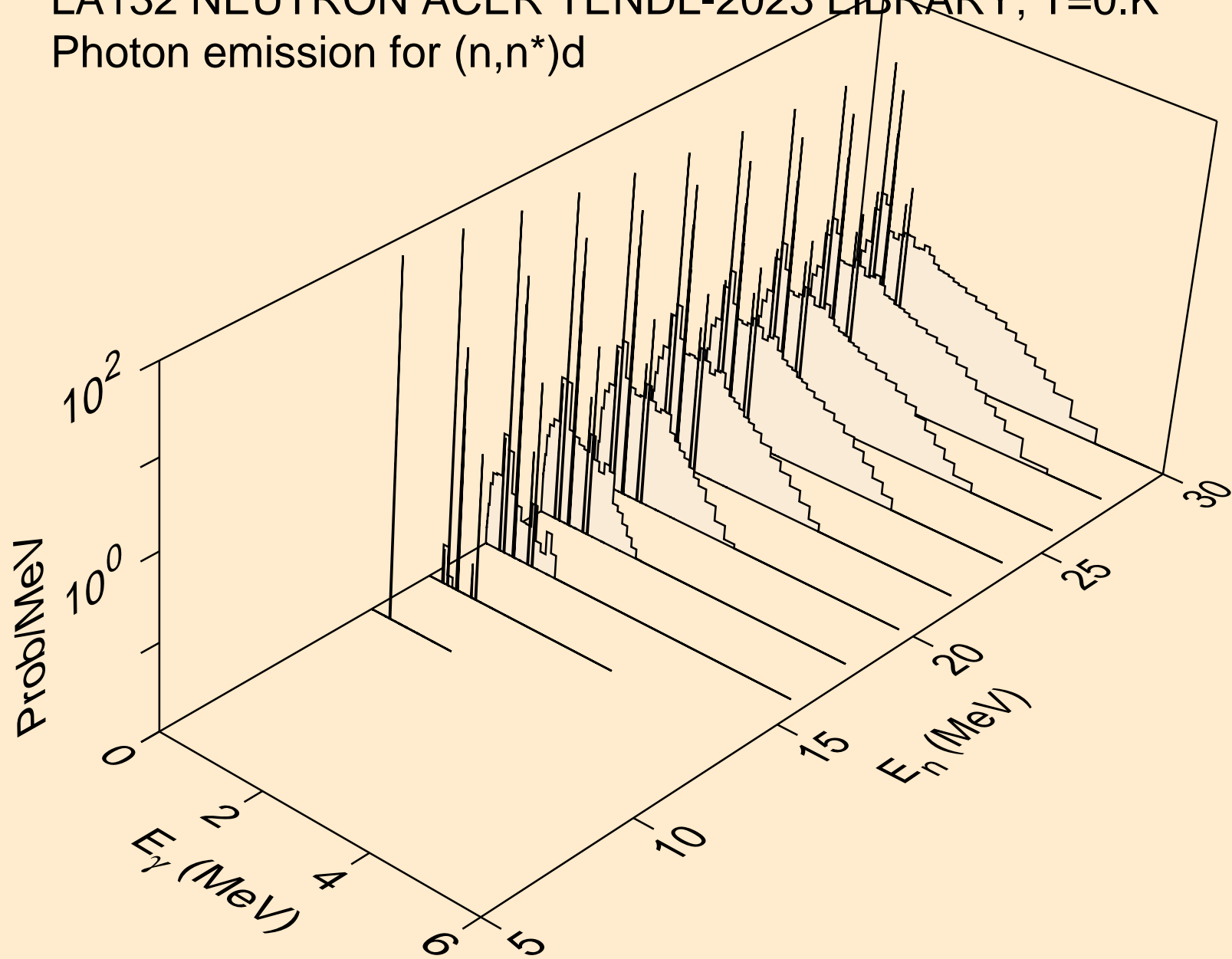

LA132 NEUTRON ACER TENDL-2023 LIBRARY; T=0.K  
Photon emission for (n,n\*)t

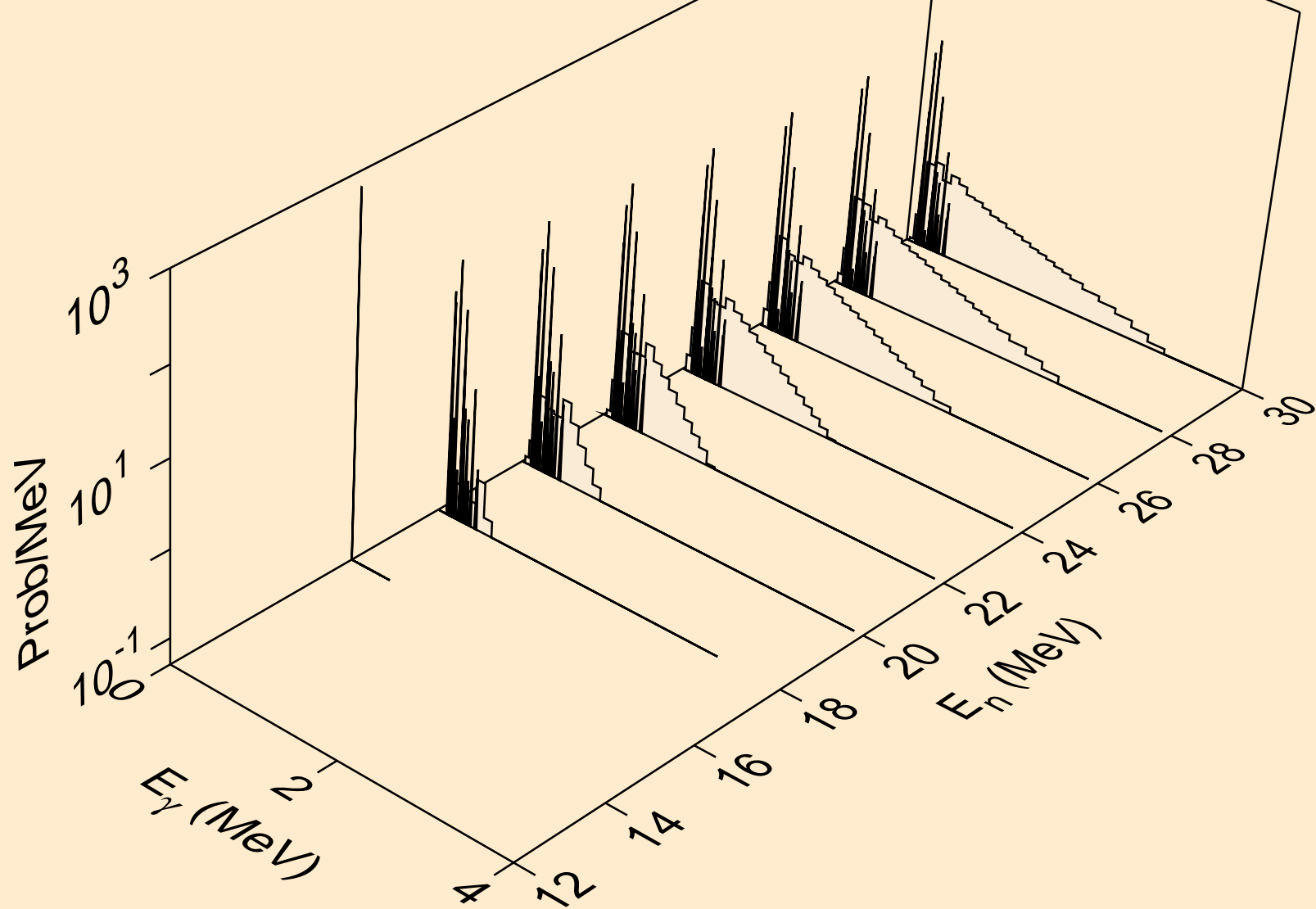

LA132 NEUTRON ACER TENDL-2023 LIBRARY; T=0.K  
Photon emission for (n,n\*)he3

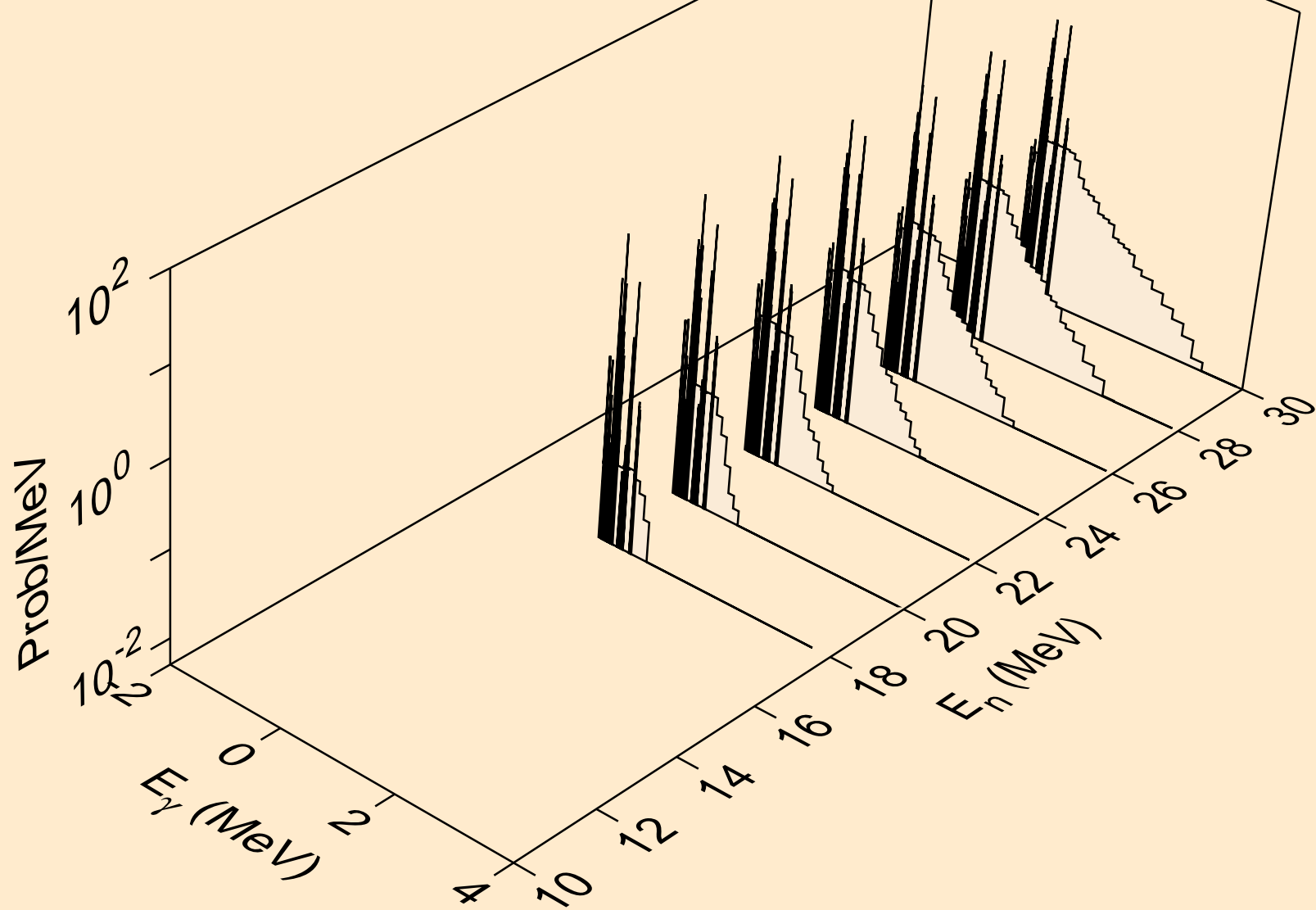



LA132 NEUTRON ACER TENDL-2023 LIBRARY; T=0.K  
Photon emission for (n,4n)

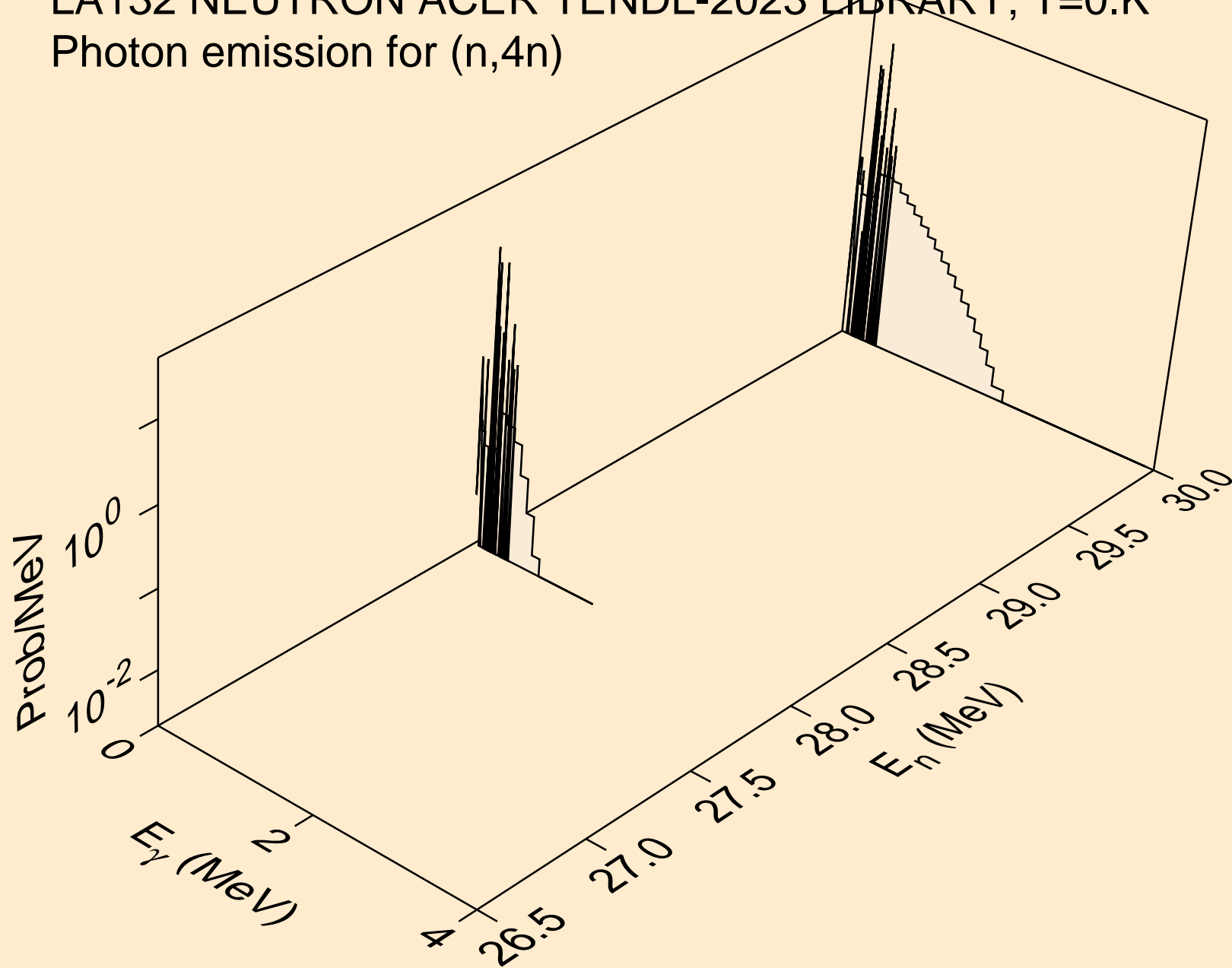

LA132 NEUTRON ACER TENDL-2023 LIBRARY; T=0.K  
Photon emission for (n,2np)

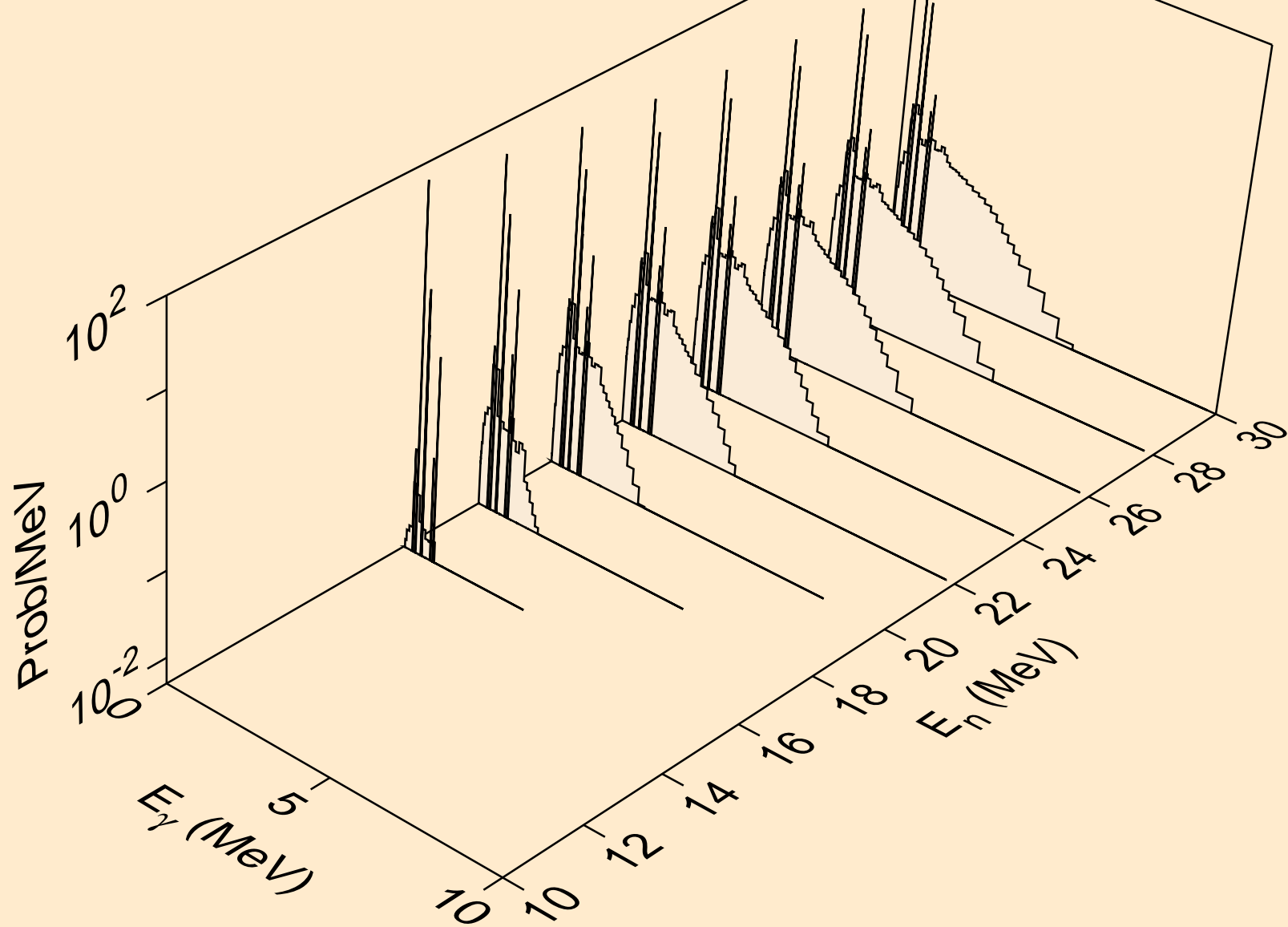

LA132 NEUTRON ACER TENDL-2023 LIBRARY; T=0.K  
Photon emission for (n,3np)

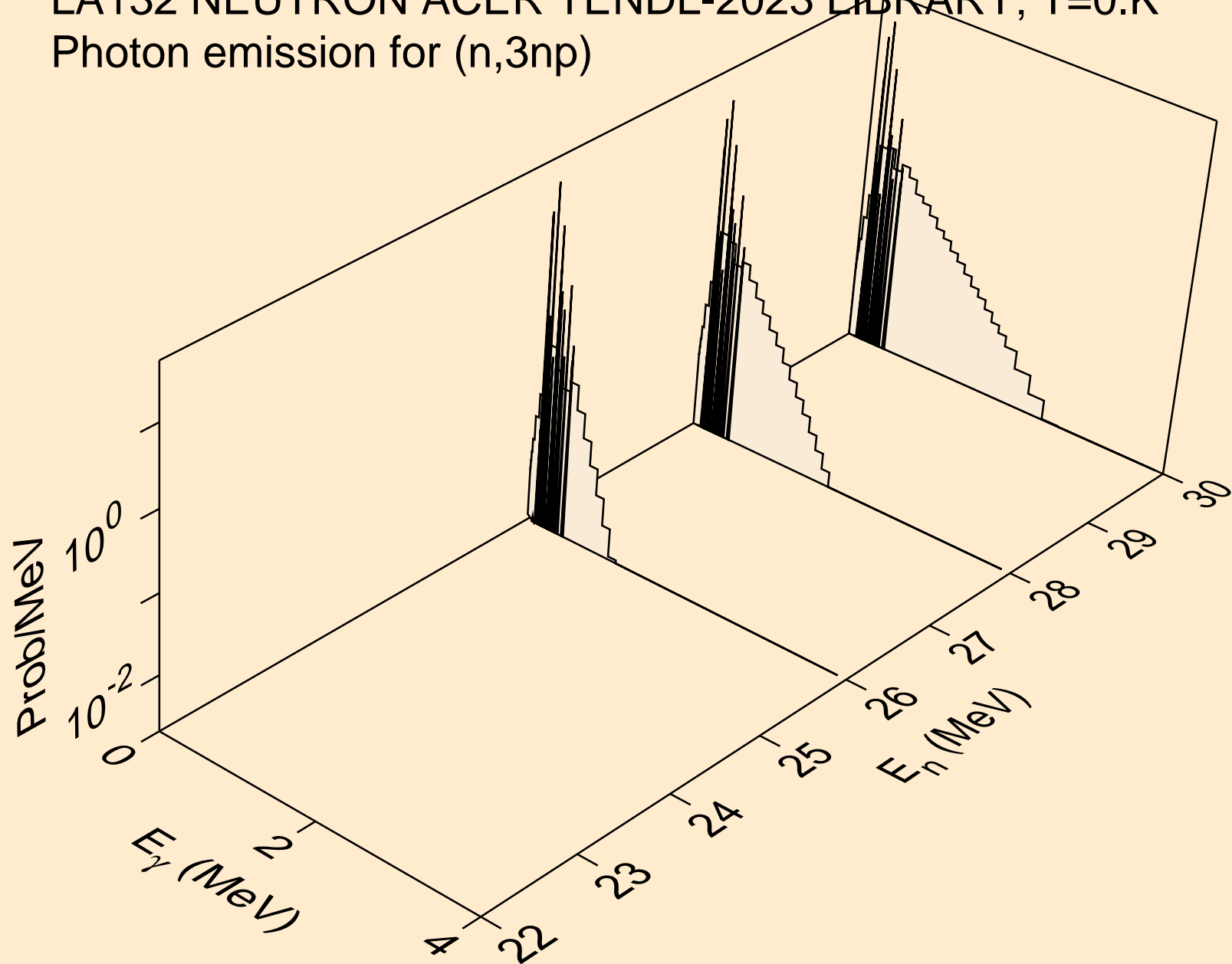

LA132 NEUTRON ACER TENDL-2023 LIBRARY; T=0.K  
Photon emission for (n,n2p)

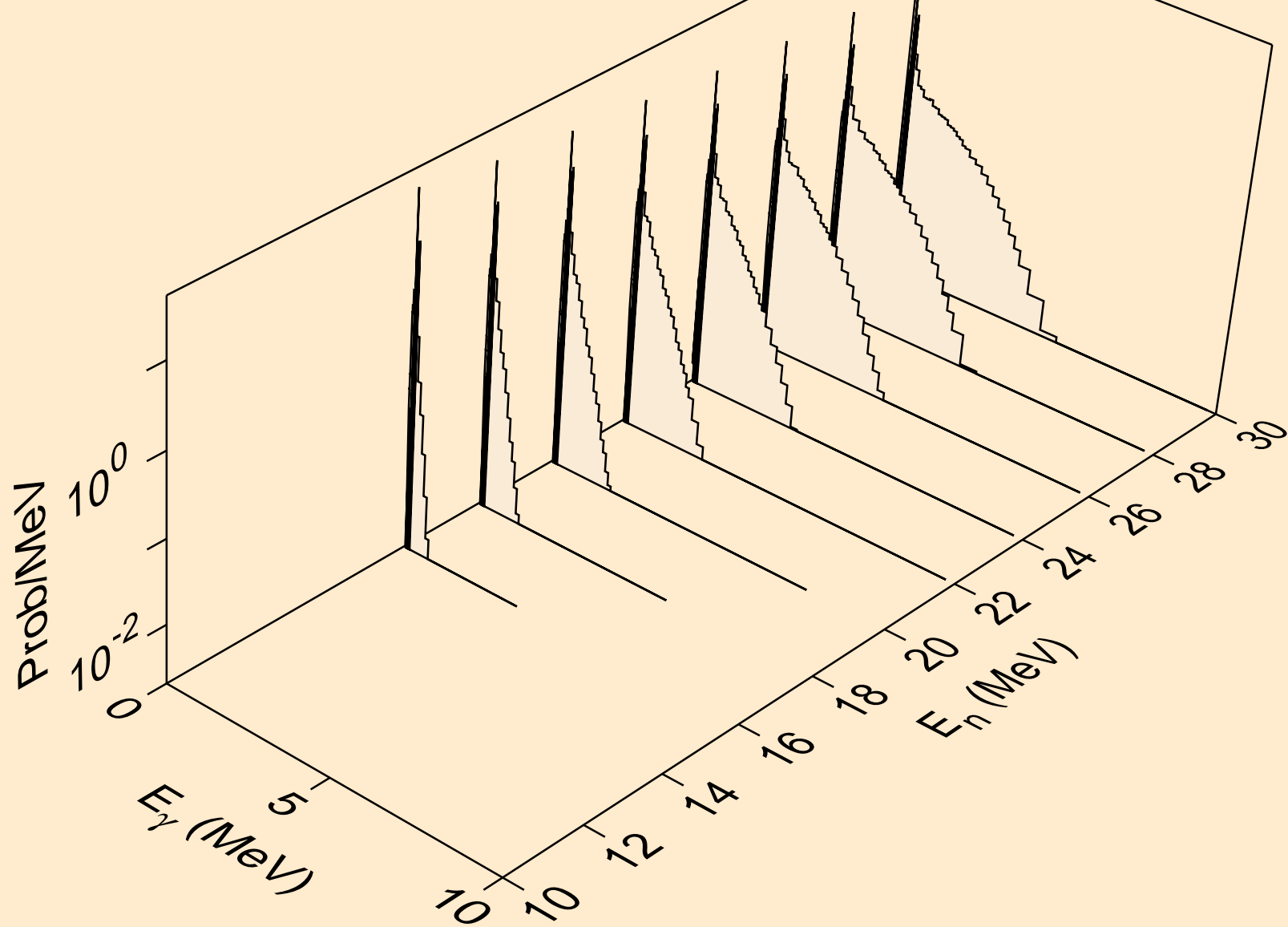

LA132 NEUTRON ACER TENDL-2023 LIBRARY; T=0.K  
Photon emission for (n,npa)

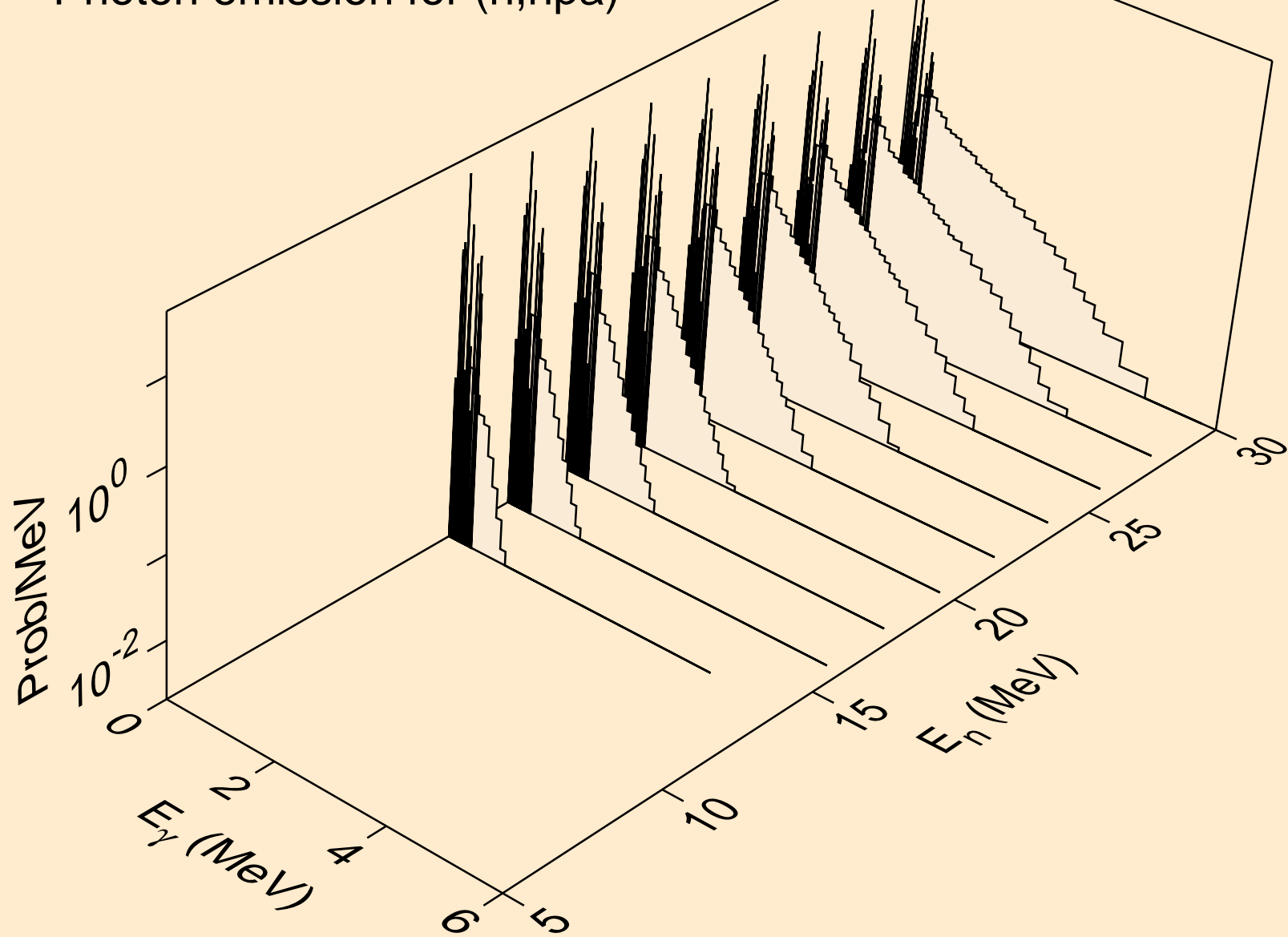

LA132 NEUTRON ACER TENDL-2023 LIBRARY; T=0.K  
Photon emission for (n,n\*c)

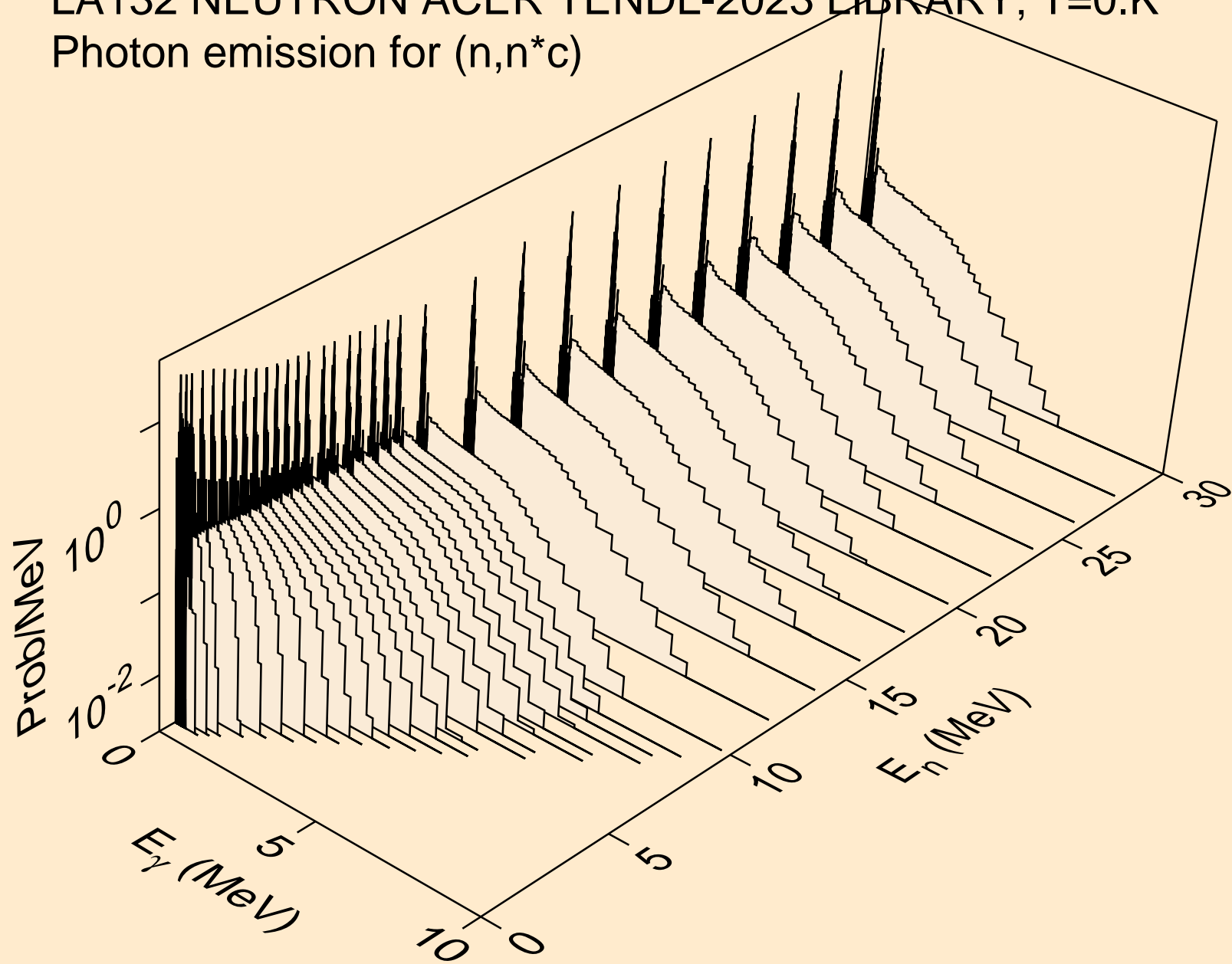

LA132 NEUTRON ACER TENDL-2023 LIBRARY; T=0.K  
Photon emission for (n,gma)

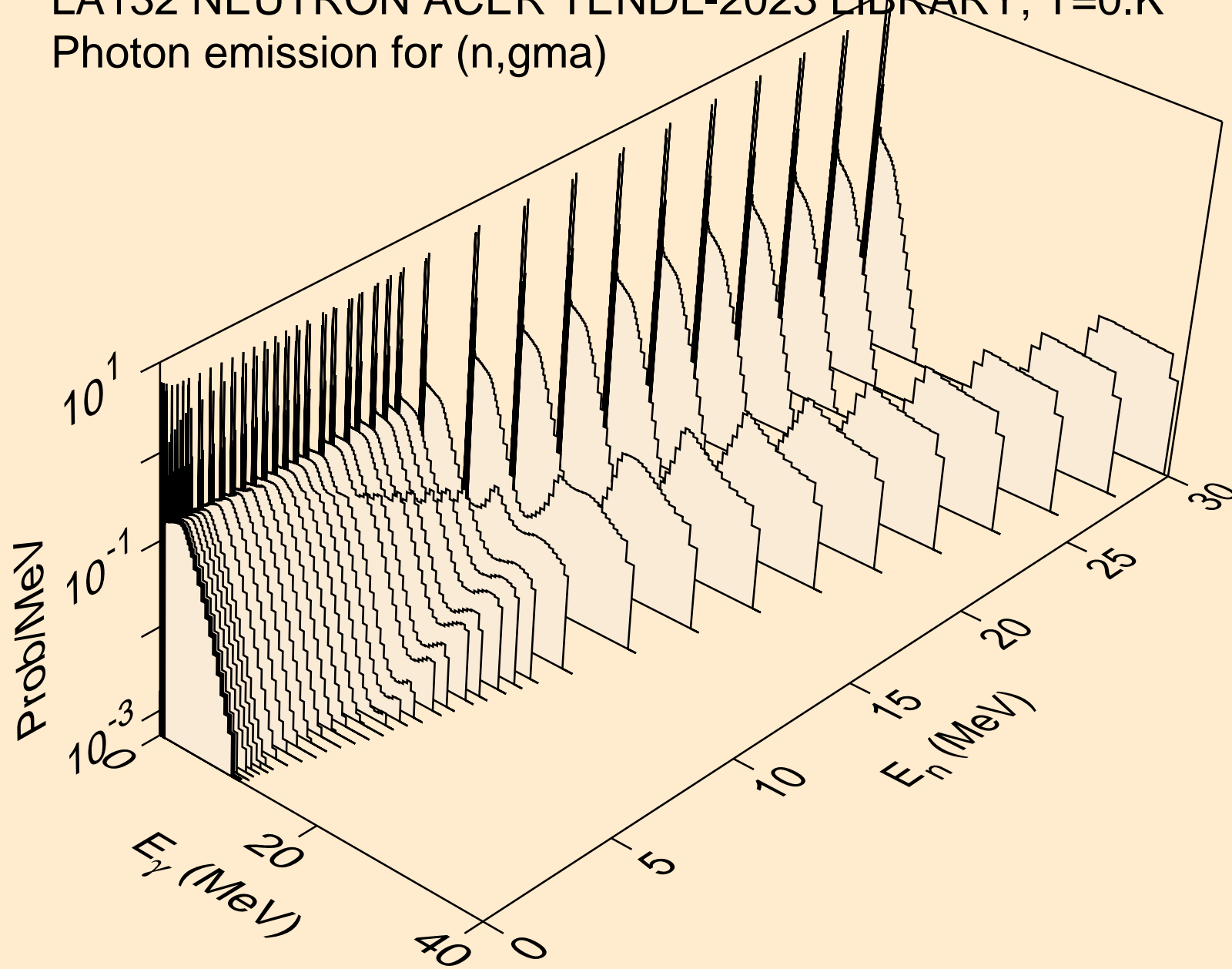

LA132 NEUTRON ACER TENDL-2023 LIBRARY; T=0.K  
Photon emission for (n,p)

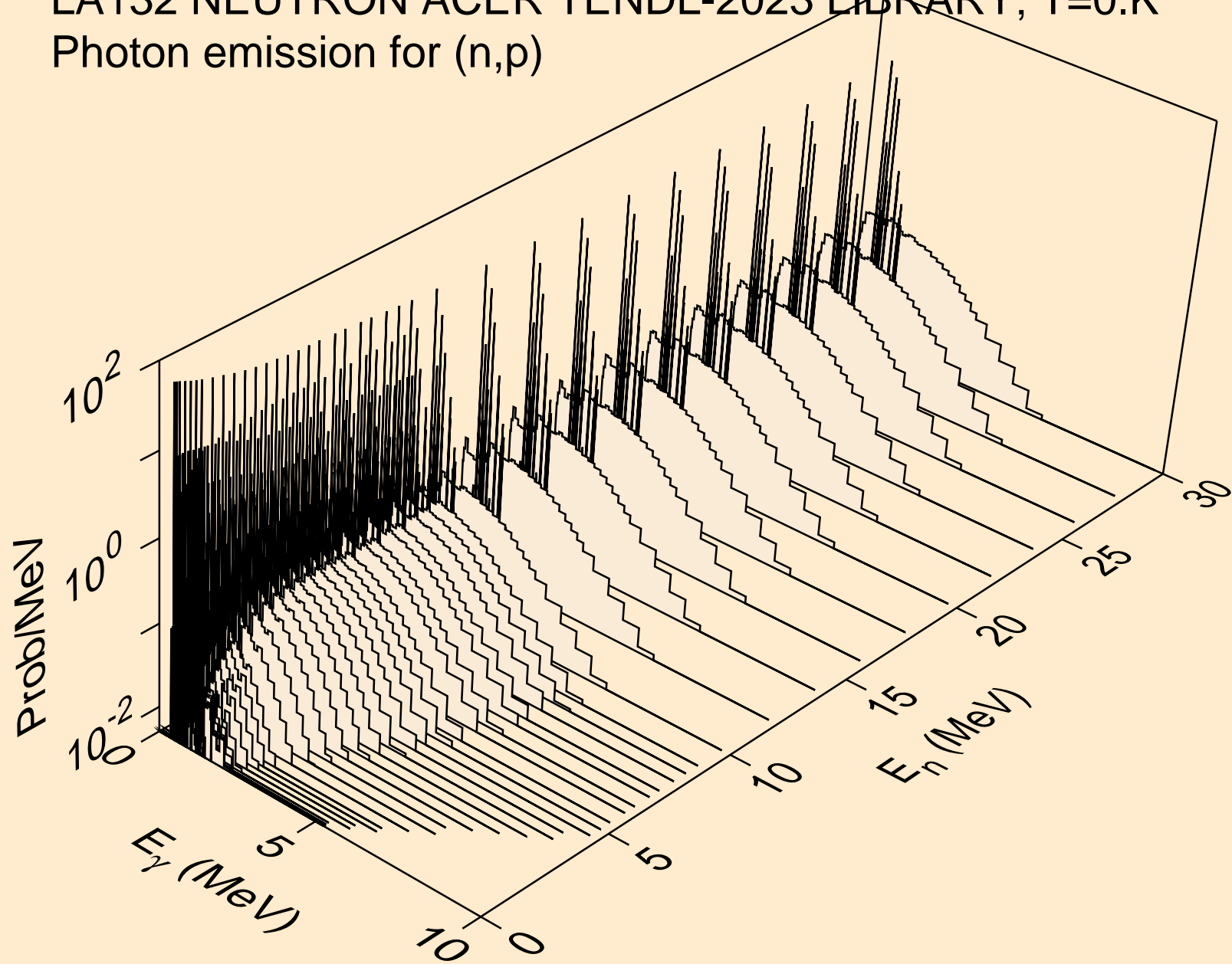



LA132 NEUTRON ACER TENDL-2023 LIBRARY; T=0.K  
Photon emission for (n,d)

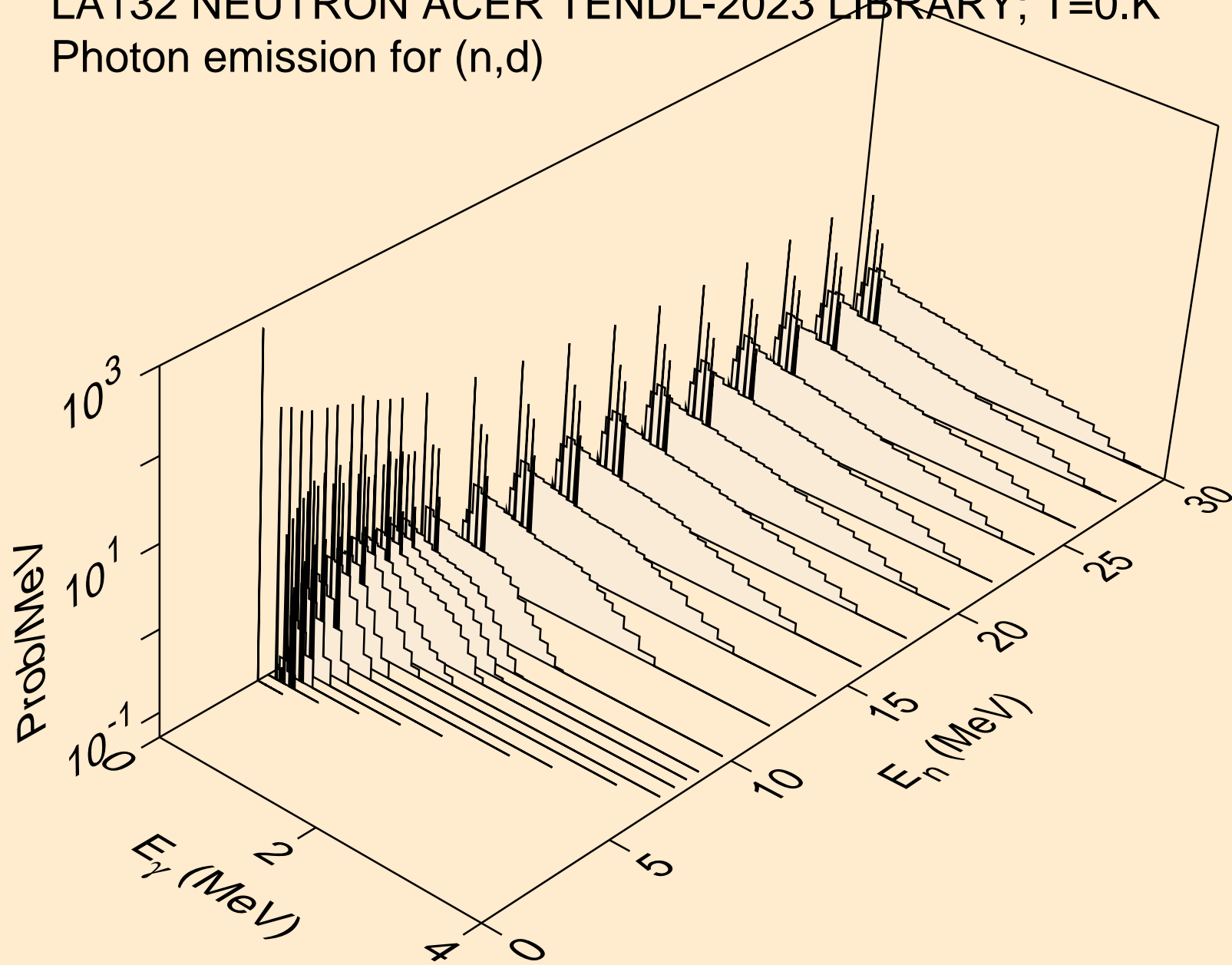

LA132 NEUTRON ACER TENDL-2023 LIBRARY; T=0.K  
Photon emission for (n,t)

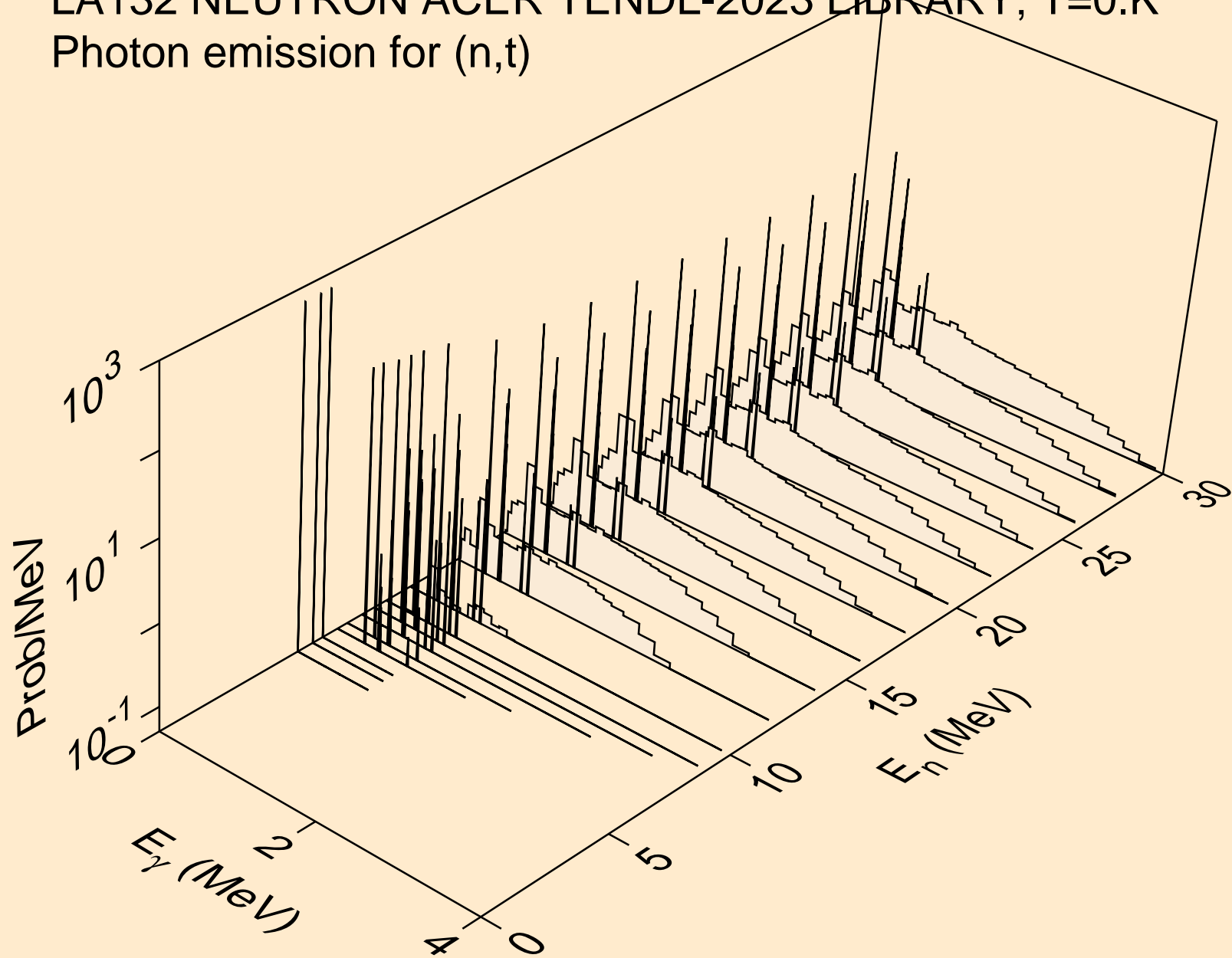

LA132 NEUTRON ACER TENDL-2023 LIBRARY; T=0.K  
Photon emission for (n,he3)

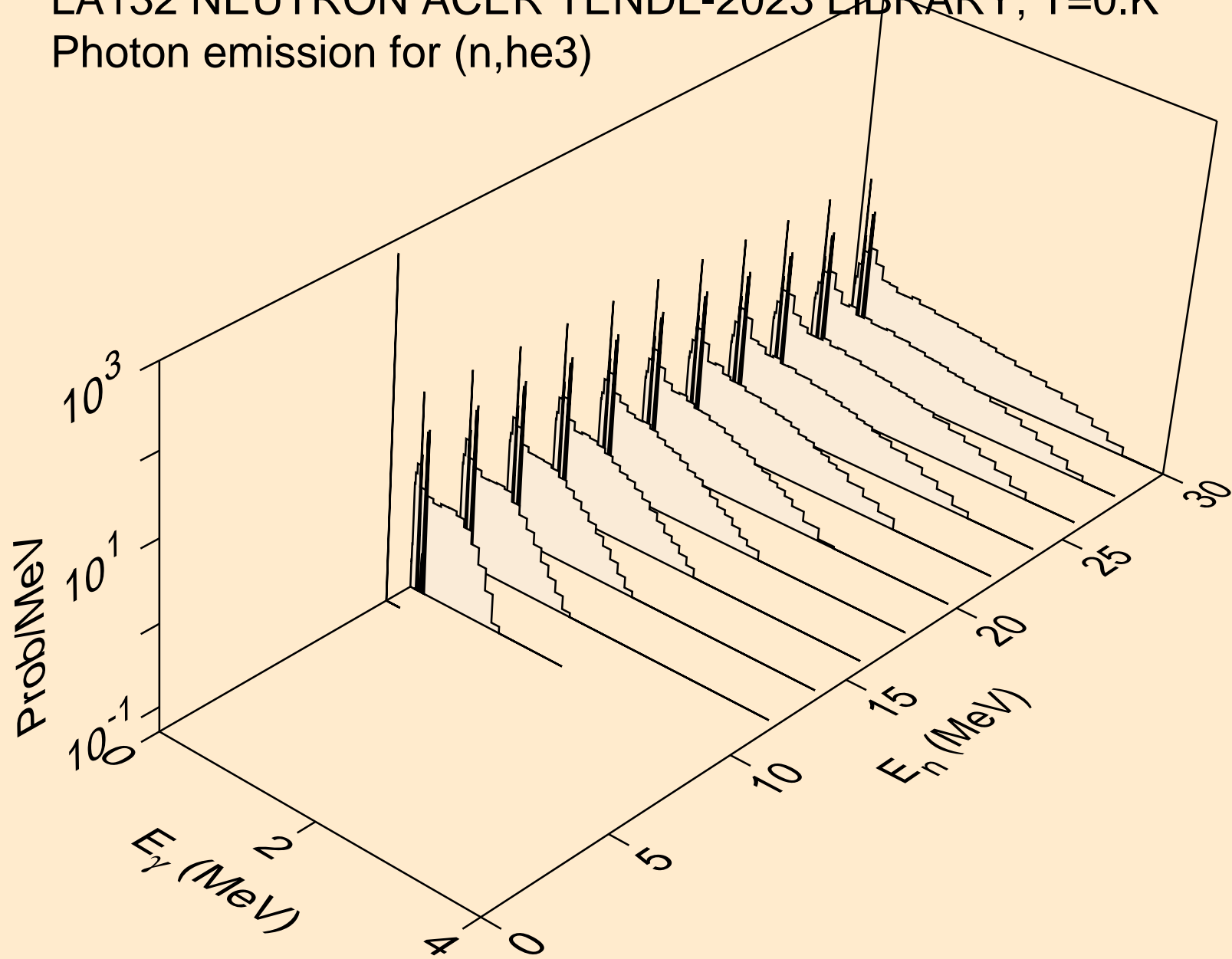

LA132 NEUTRON ACER TENDL-2023 LIBRARY; T=0.K  
Photon emission for (n,a)

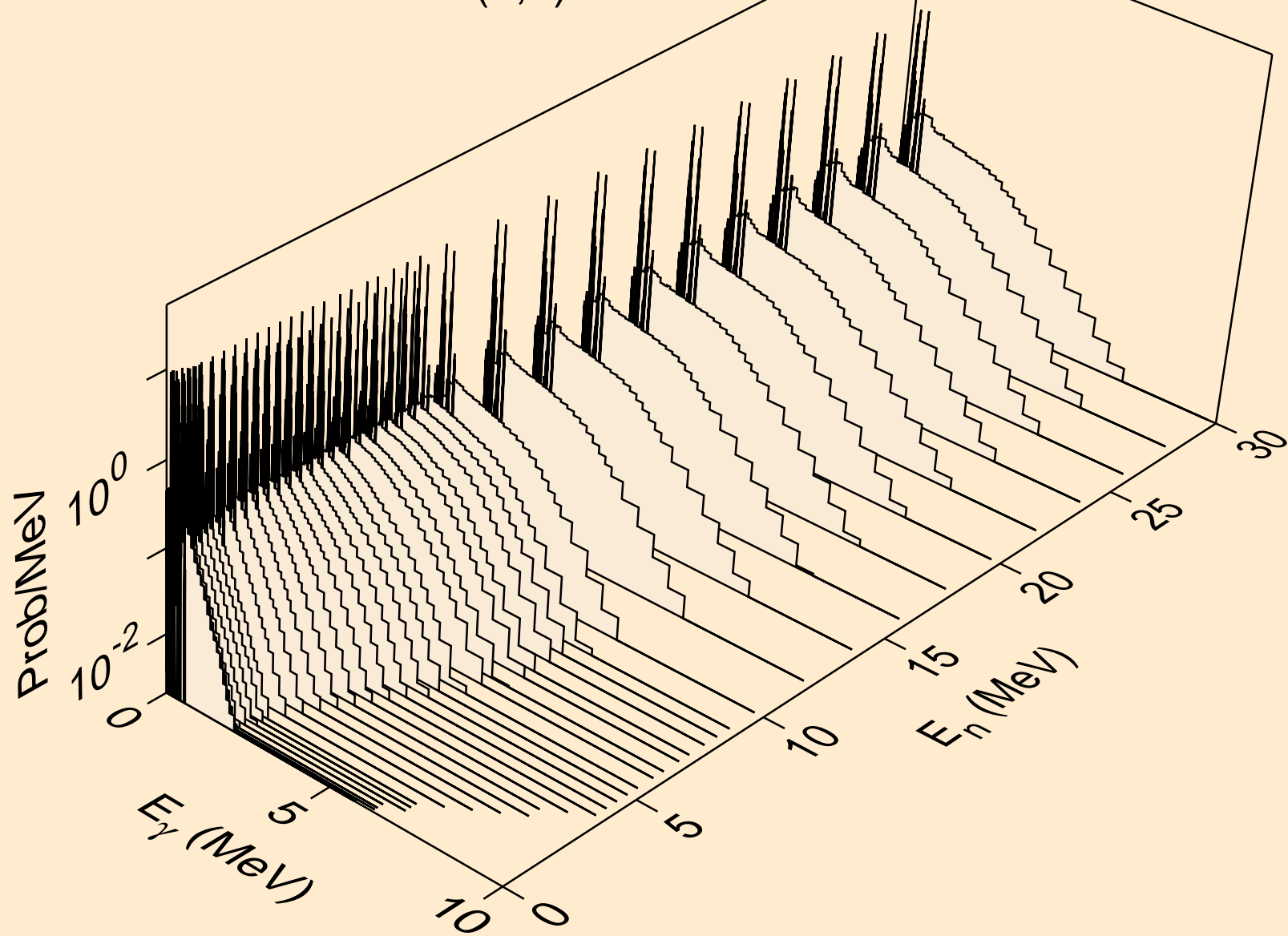

LA132 NEUTRON ACER TENDL-2023 LIBRARY; T=0.K  
Photon emission for (n,2a)

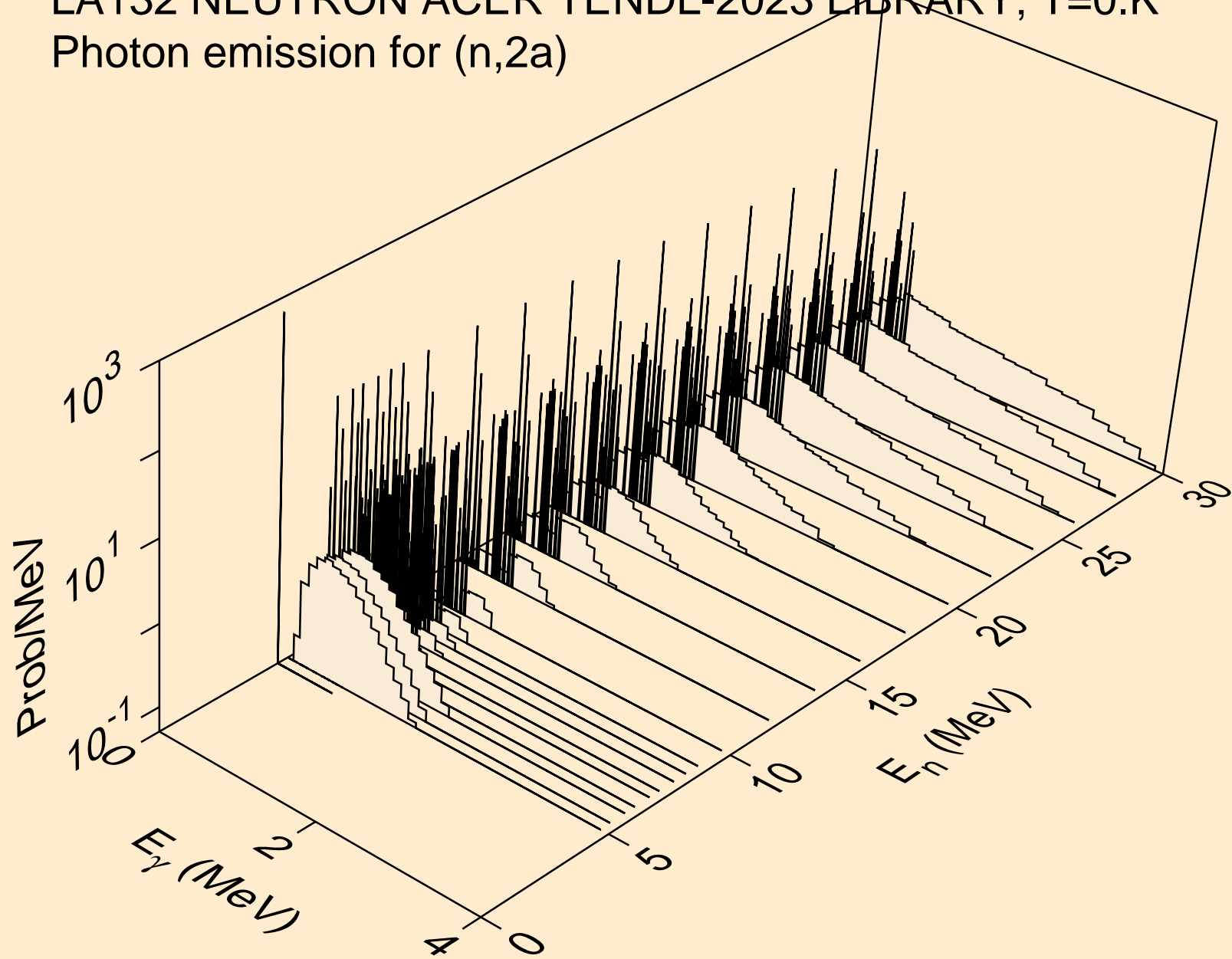

LA132 NEUTRON ACER TENDL-2023 LIBRARY; T=0.K  
Photon emission for (n,2p)

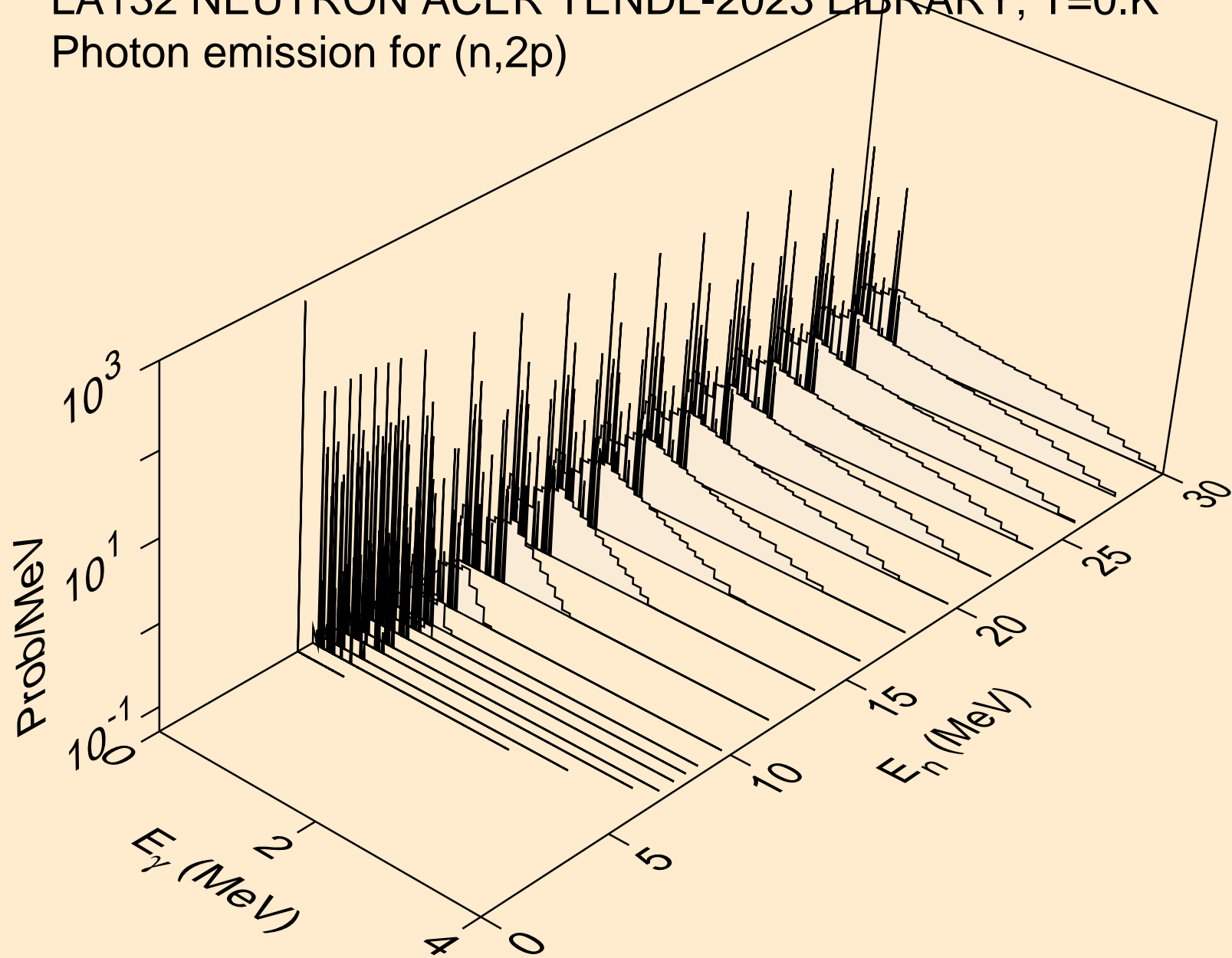

LA132 NEUTRON ACER TENDL-2023 LIBRARY; T=0.K  
Photon emission for (n,p)

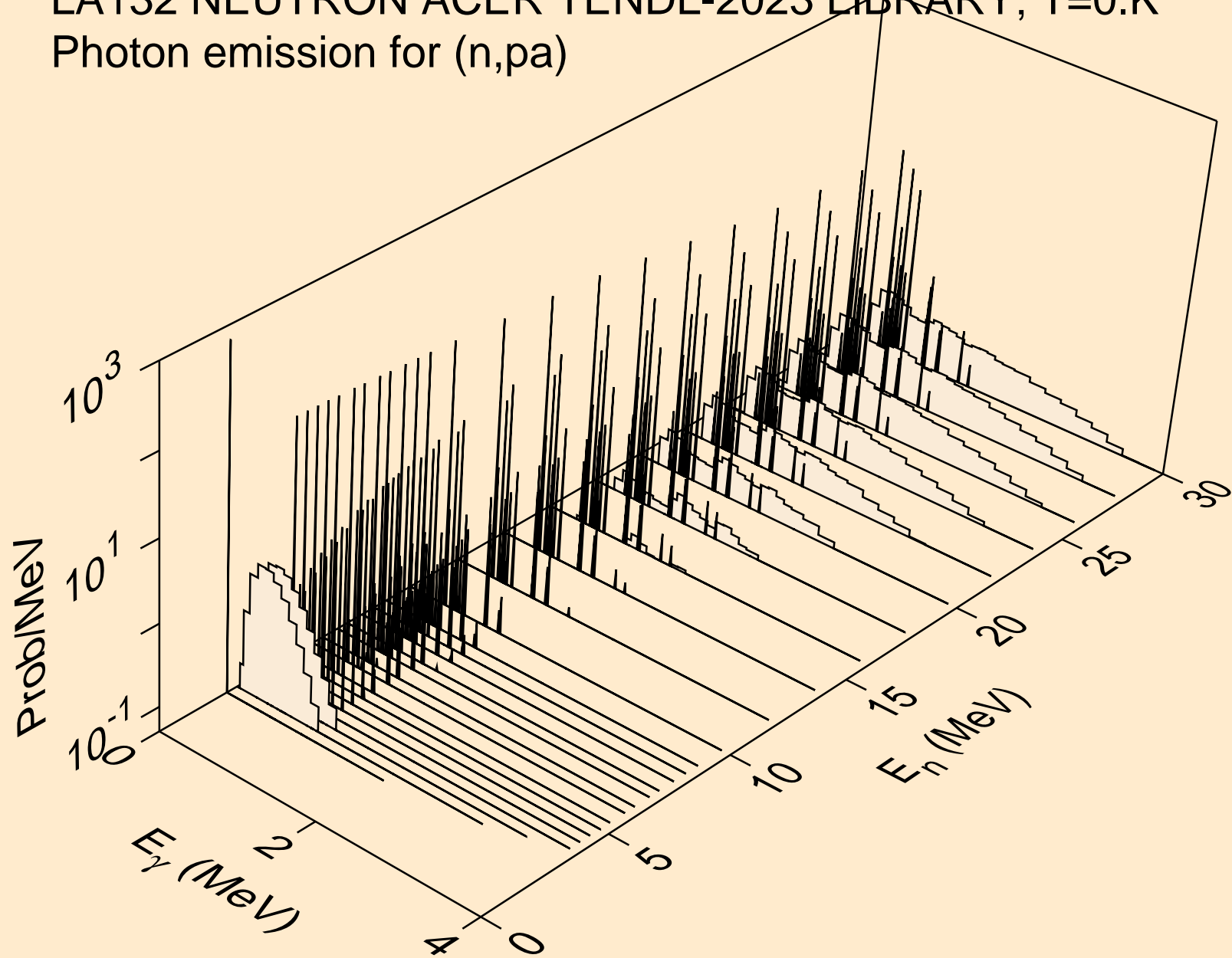

LA132 NEUTRON ACER TENDL-2023 LIBRARY; T=0.K  
Photon emission for (n,pd)

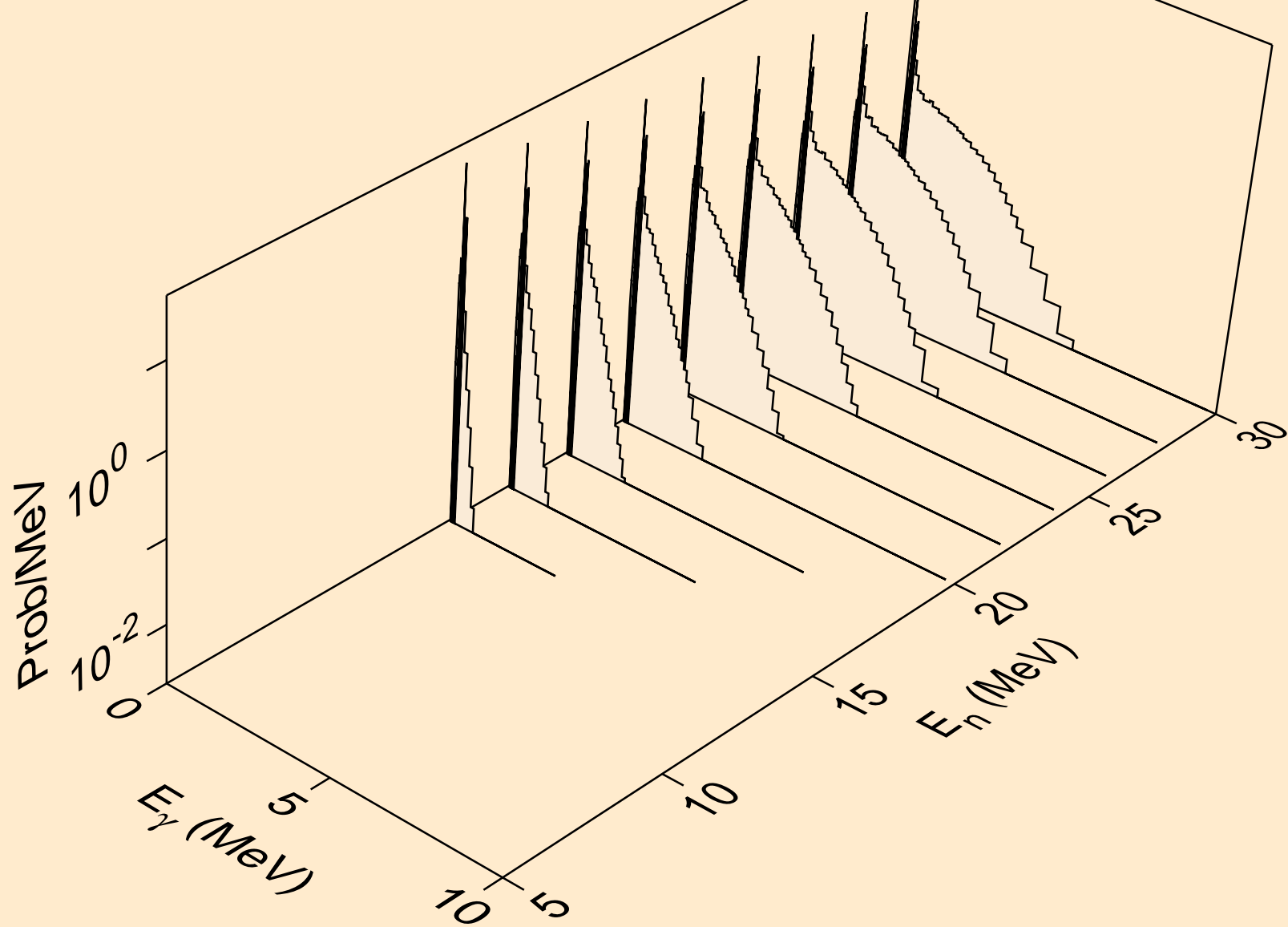



LA132 NEUTRON ACER TENDL-2023 LIBRARY; T=0.K  
Photon emission for (n,pt)

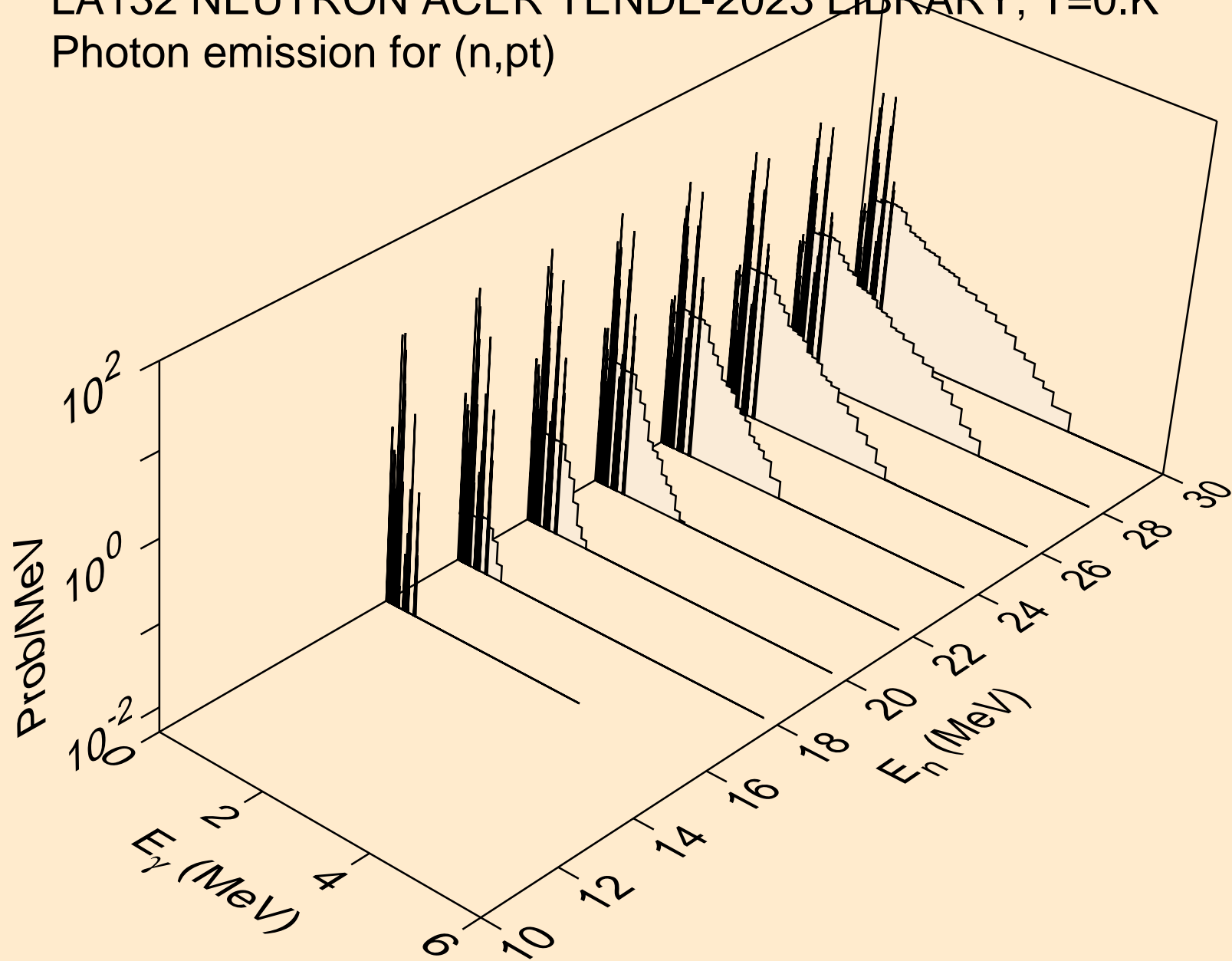

LA132 NEUTRON ACER TENDL-2023 LIBRARY; T=0.K  
Photon emission for (n,da)

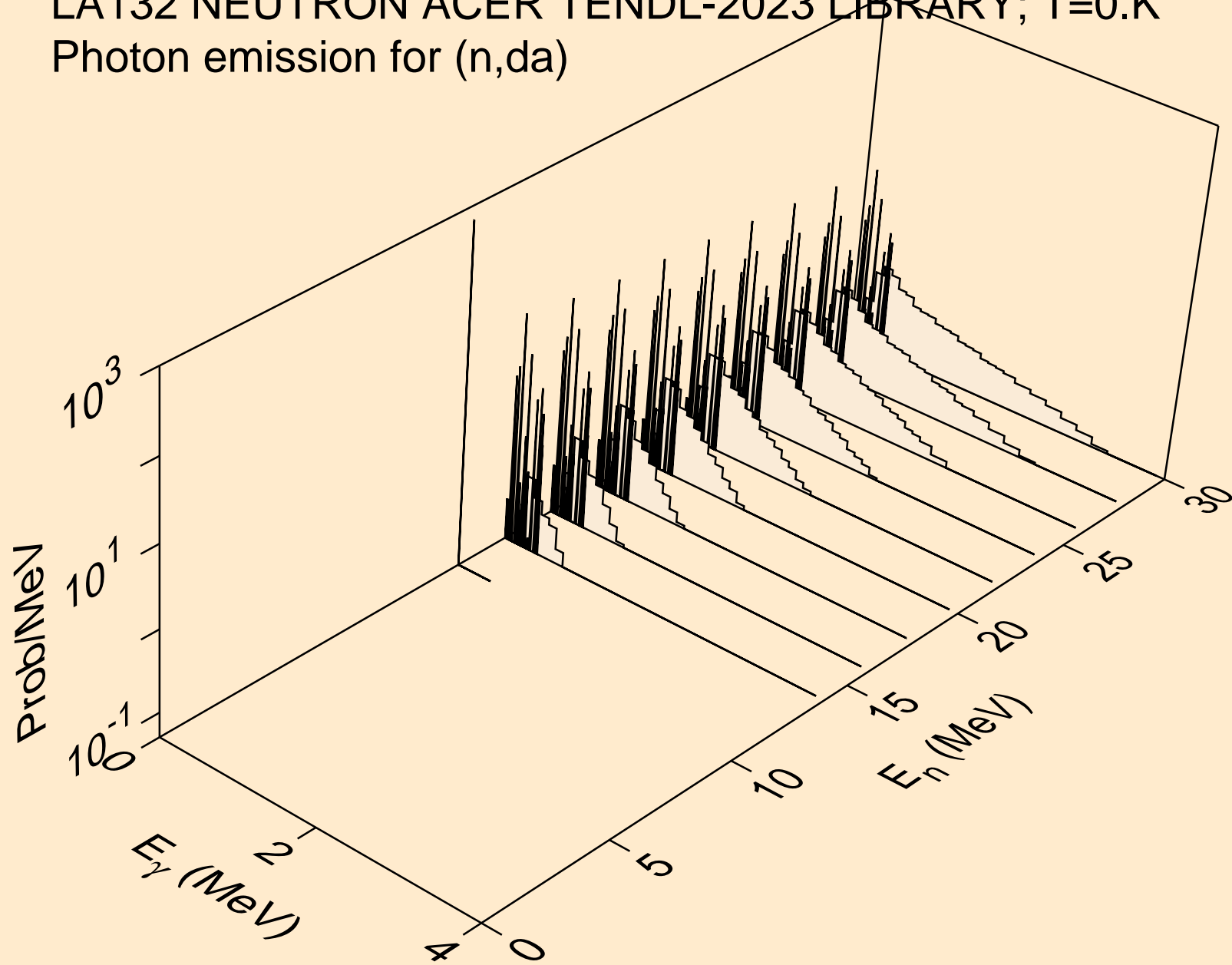

LA132 NEUTRON ACER TENDL-2023 LIBRARY; T=0.K  
thermal capture photon spectrum

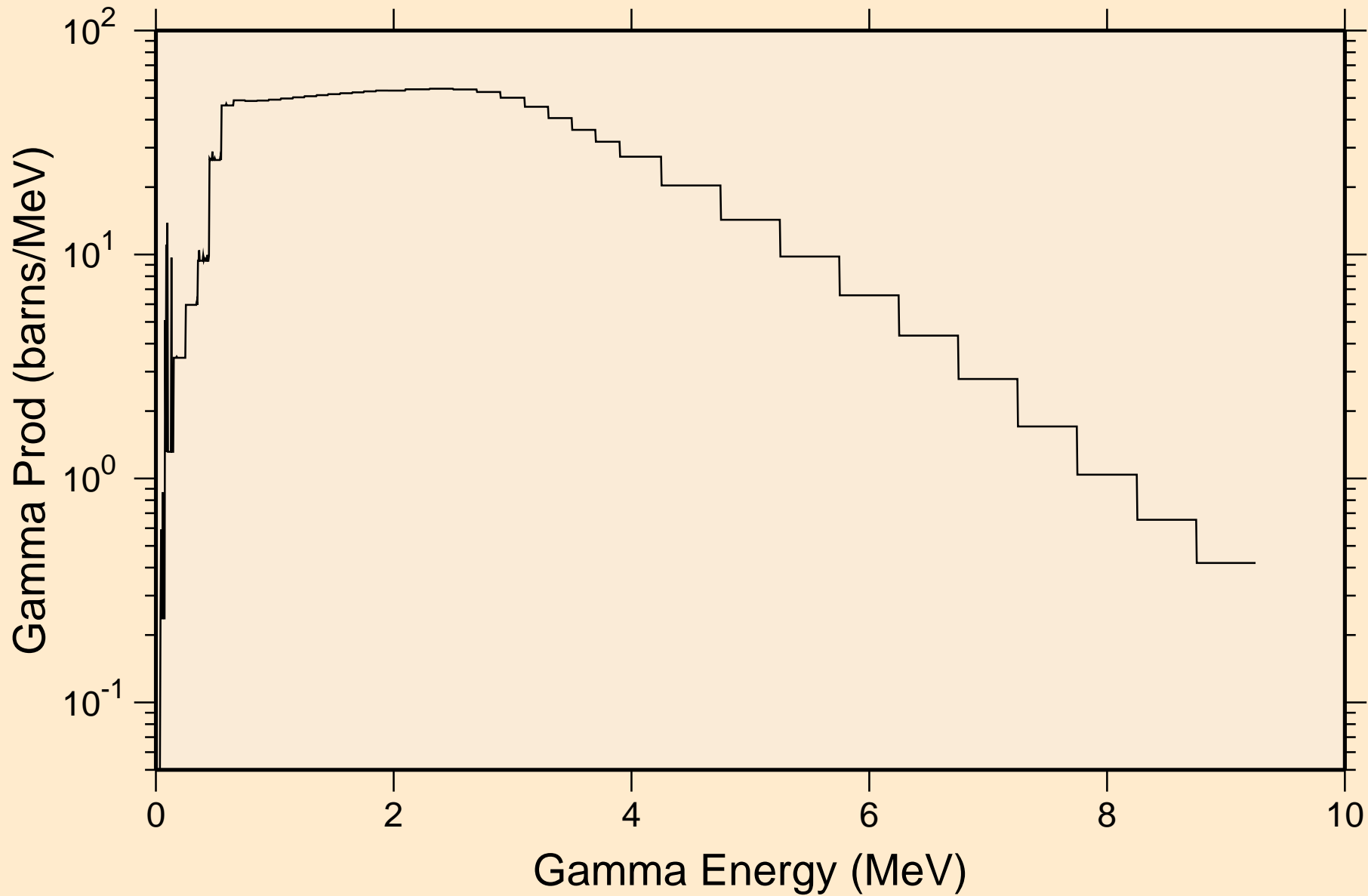

LA132 NEUTRON ACER TENDL-2023 LIBRARY; T=0.K  
14 MeV photon spectrum

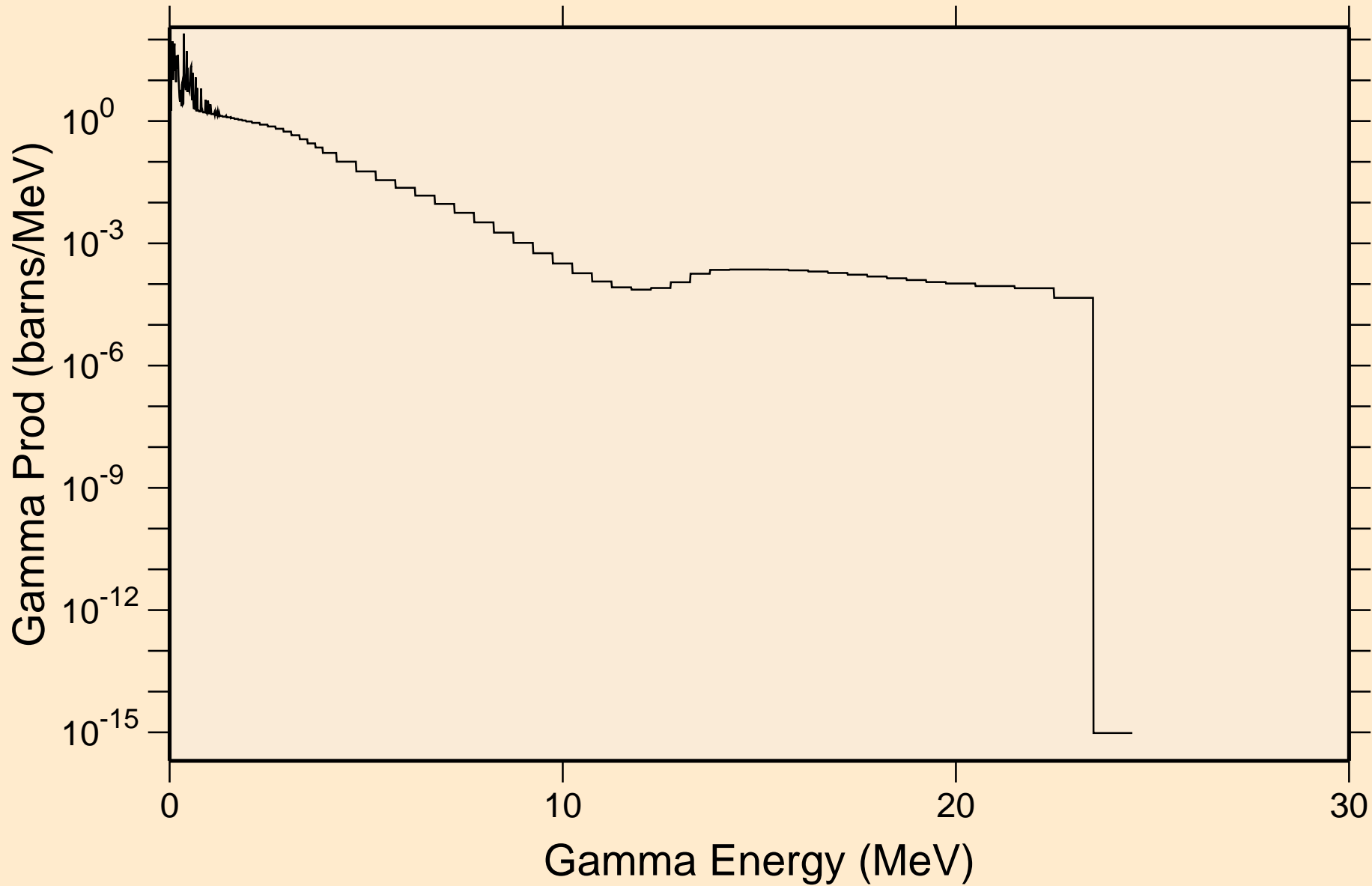

LA132 NEUTRON ACER TENDL-2023 LIBRARY; T=0.K  
Particle heating contributions

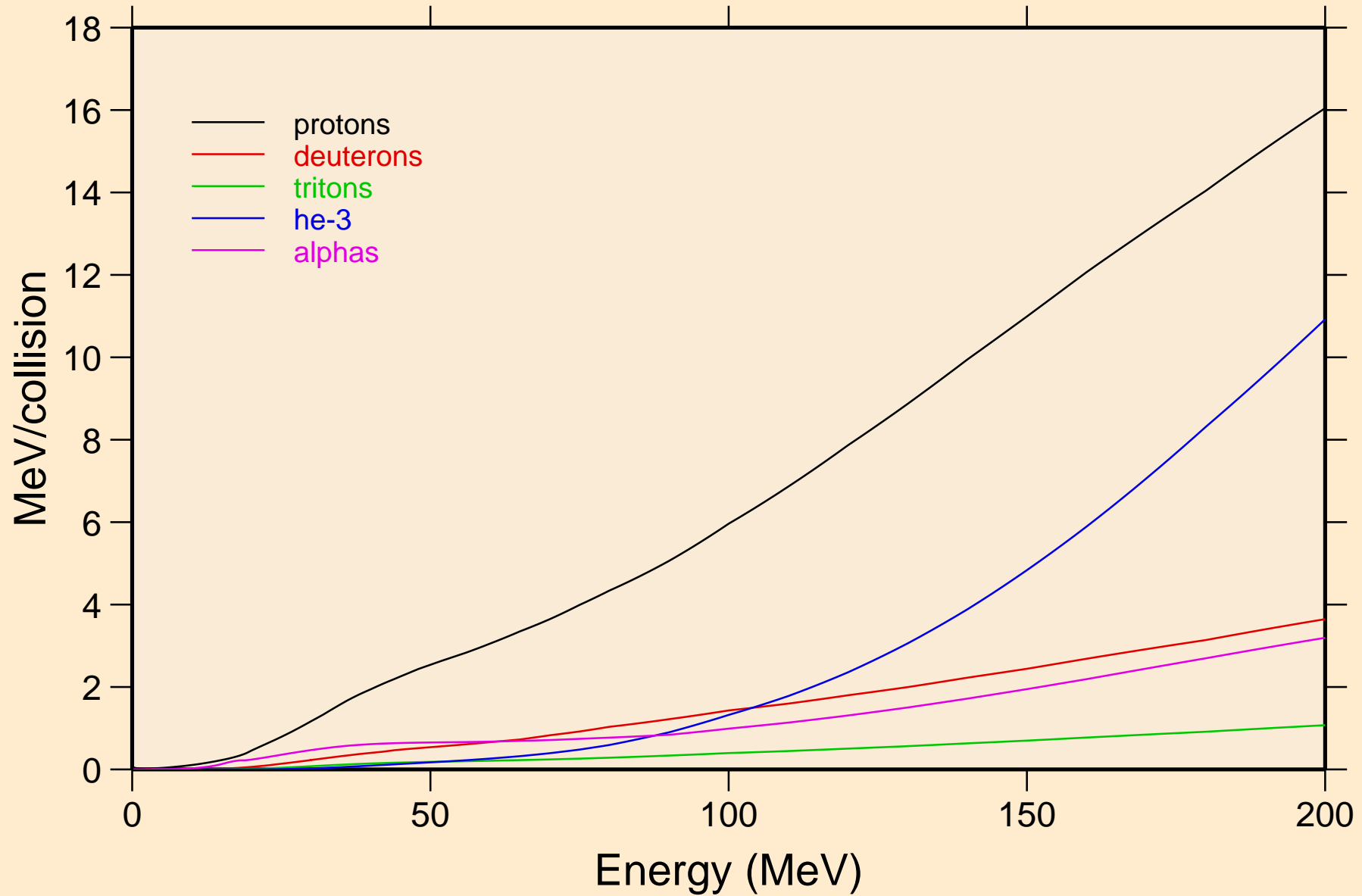

LA132 NEUTRON ACER TENDL-2023 LIBRARY; T=0.K  
Recoil Heating

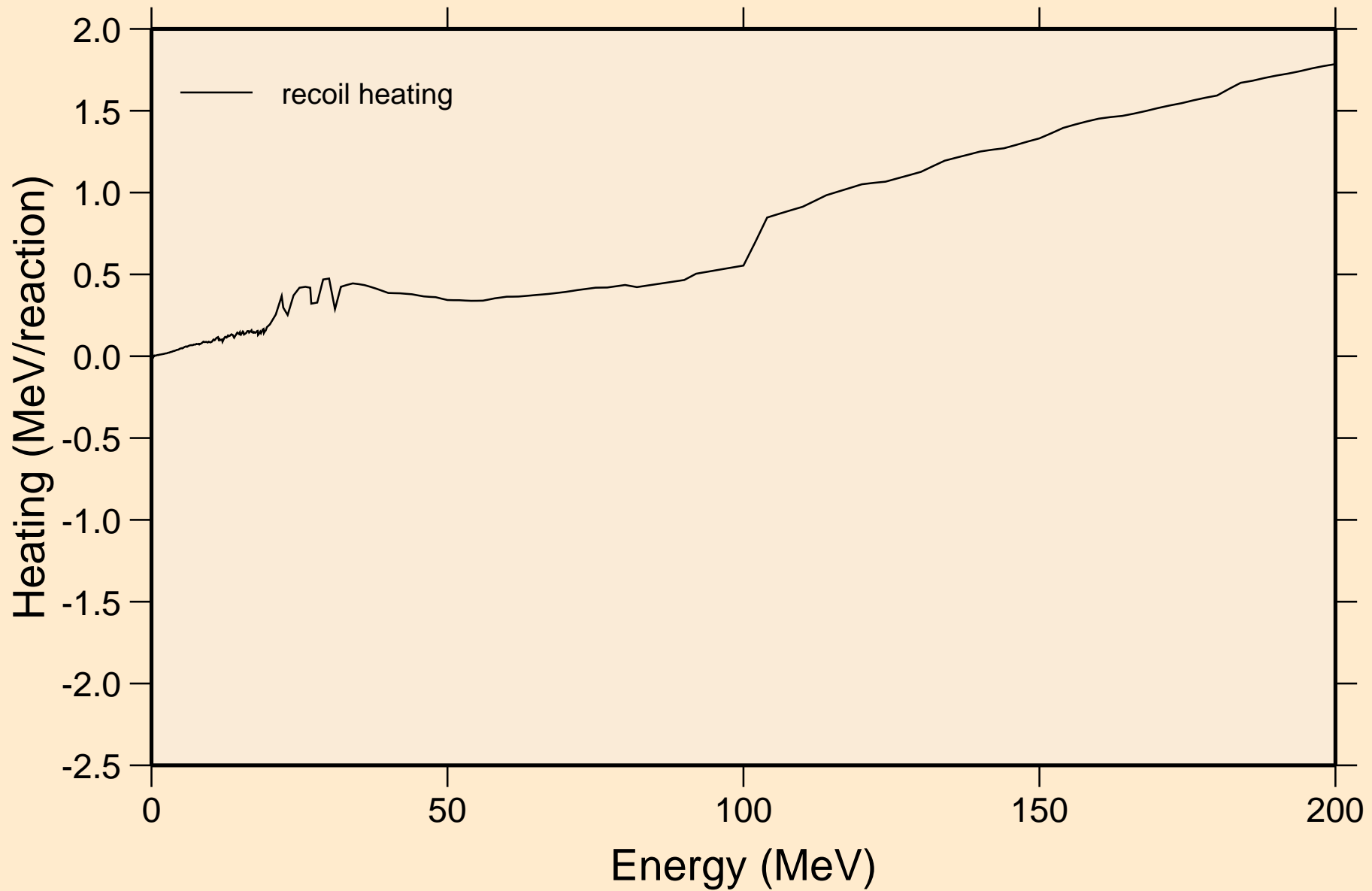

# LA132 NEUTRON ACER TENDL-2023 LIBRARY; T=0.K

## Particle production cross sections

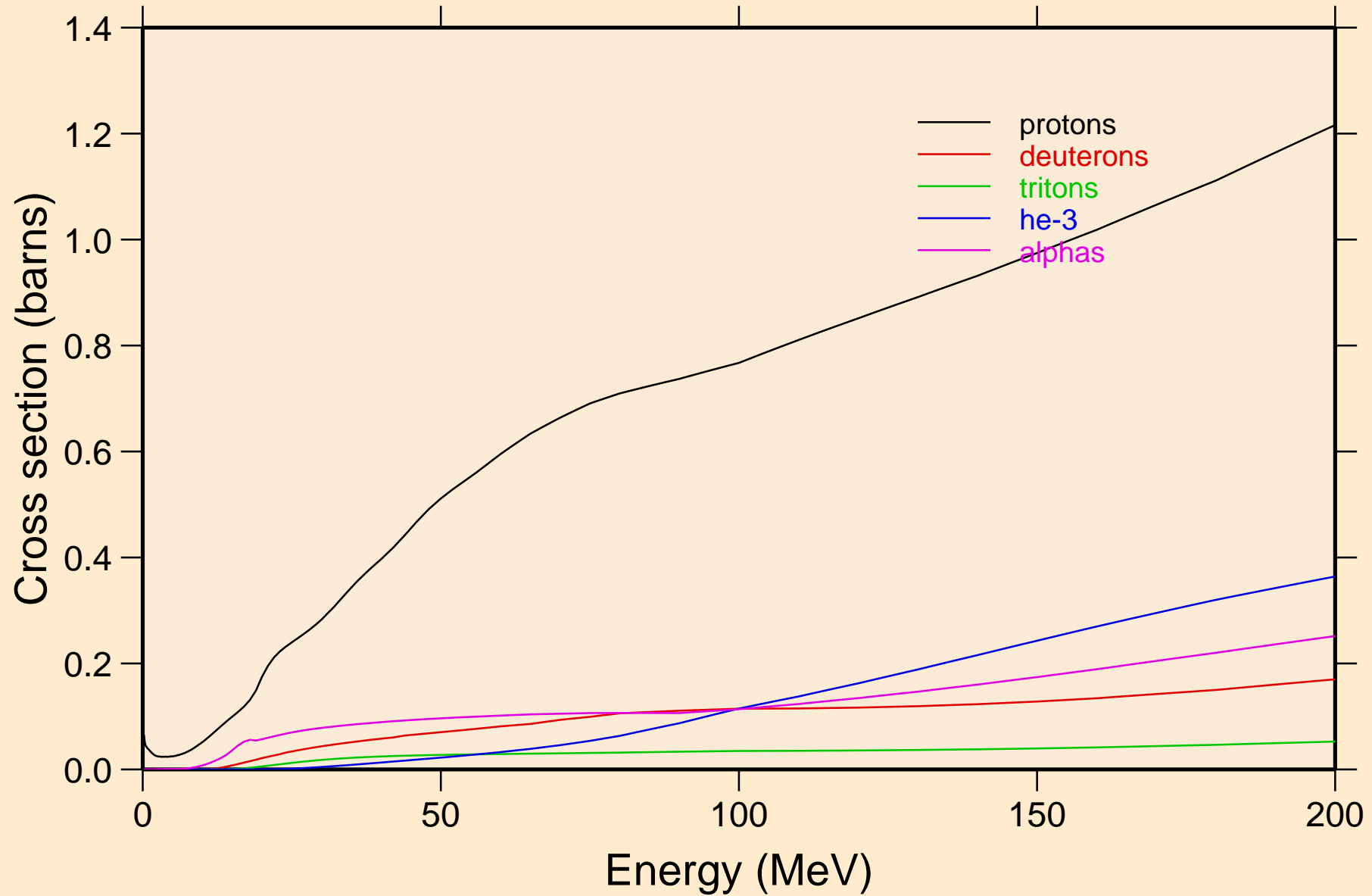

LA132 NEUTRON ACER TENDL-2023 LIBRARY; T=0.K  
protons from (n,x)

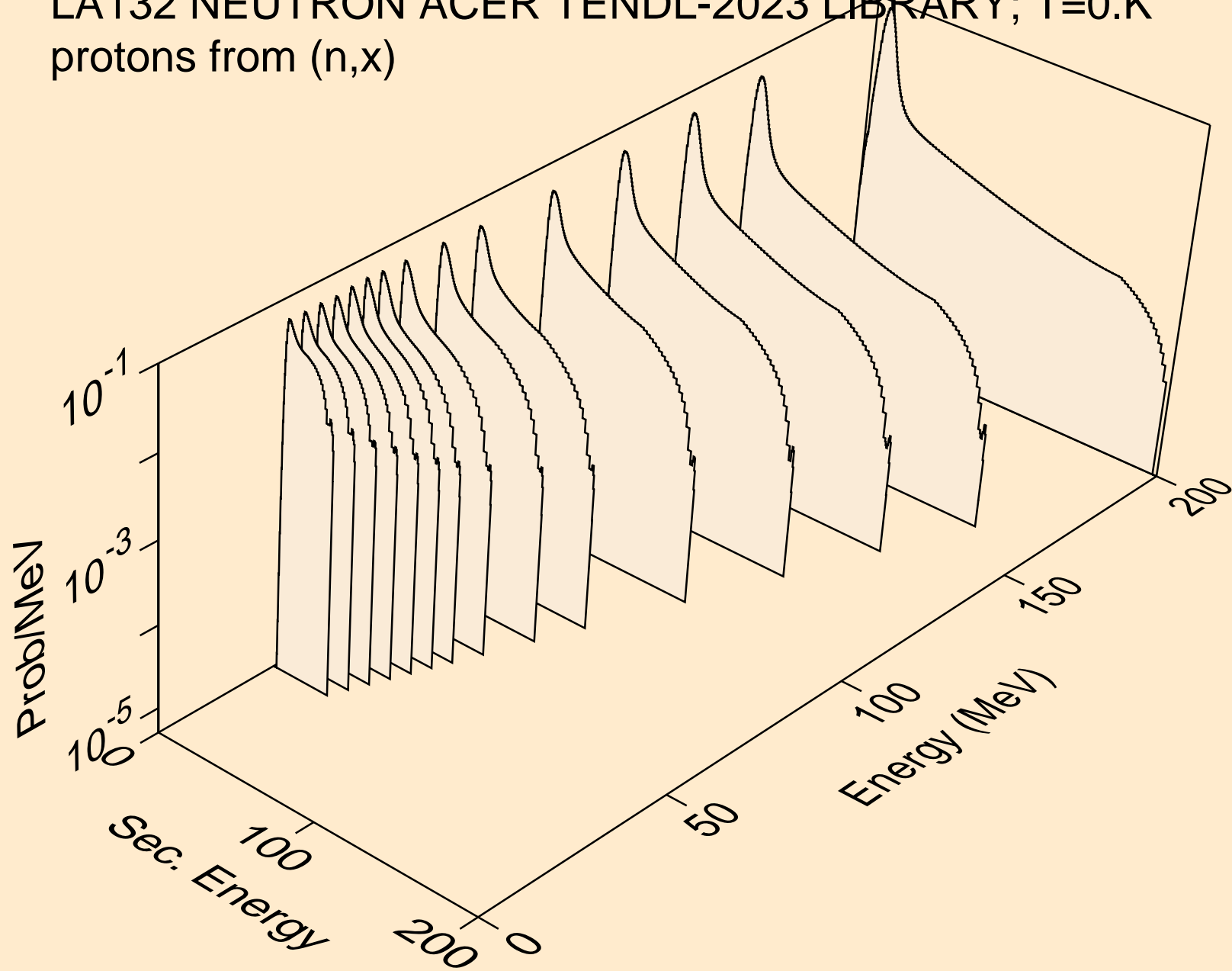



LA132 NEUTRON ACER TENDL-2023 LIBRARY; T=0.K  
protons from (n,n\*)p

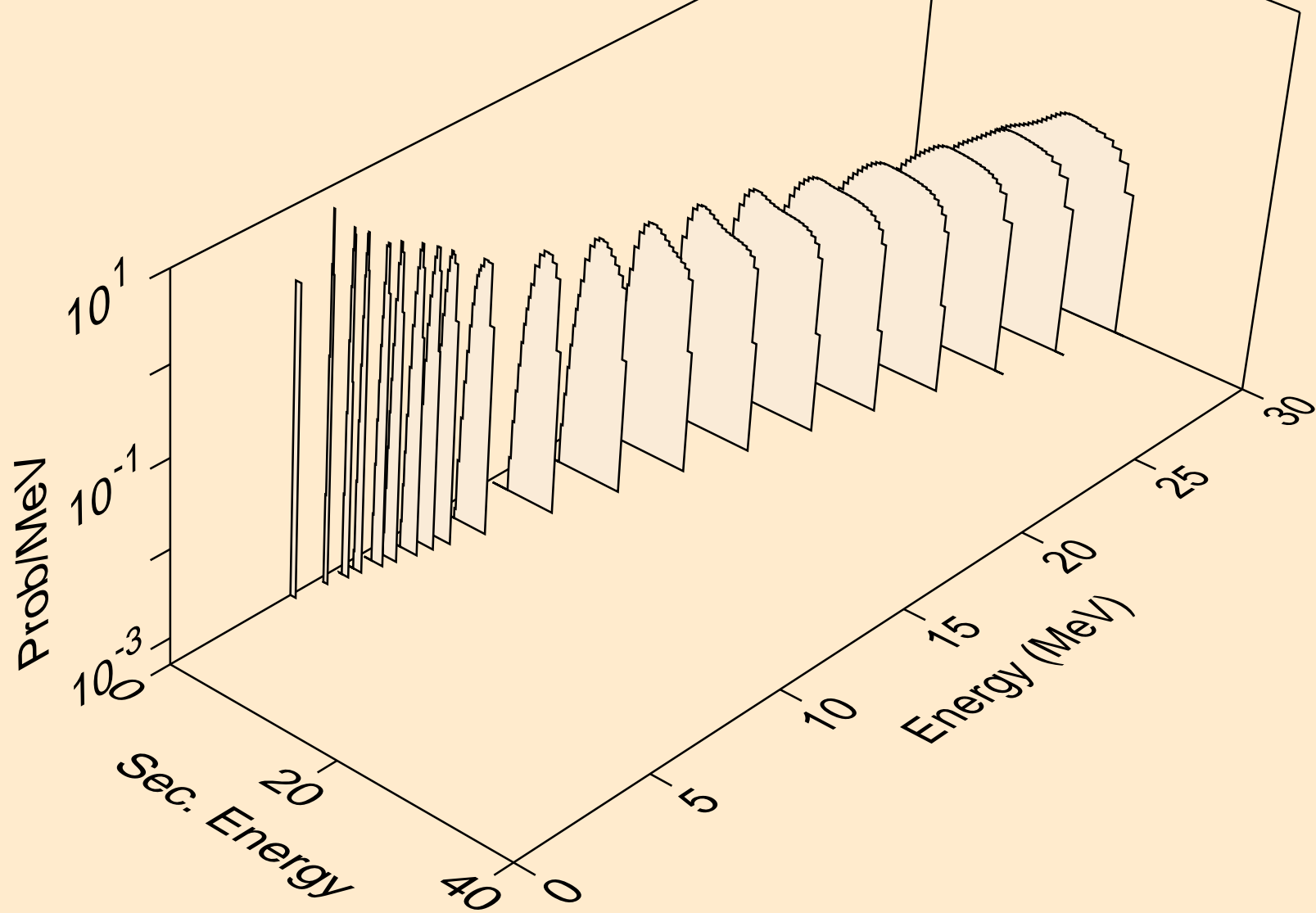

LA132 NEUTRON ACER TENDL-2023 LIBRARY; T=0.K  
protons from (n,2np)

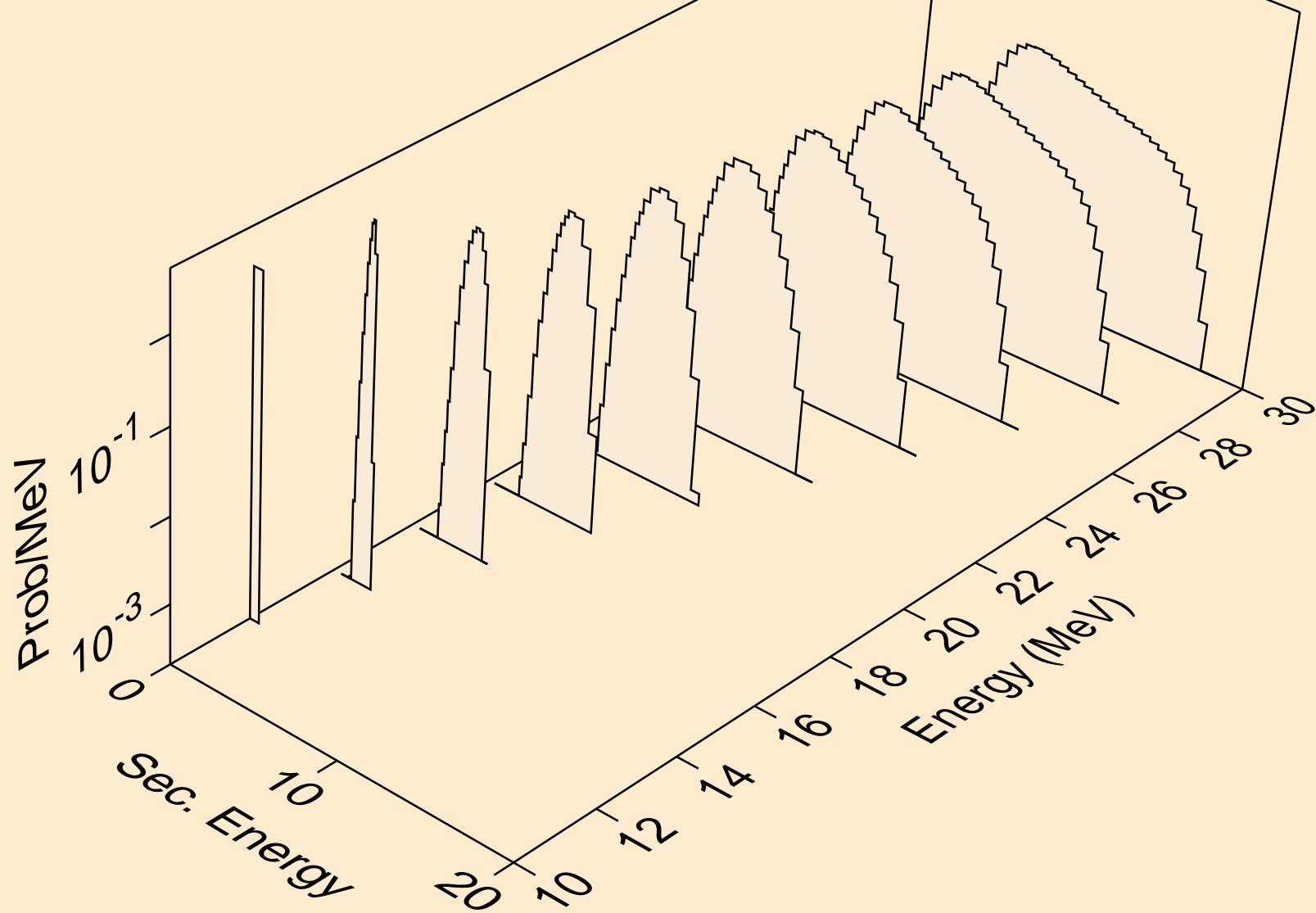

LA132 NEUTRON ACER TENDL-2023 LIBRARY; T=0.K  
protons from (n,3np)

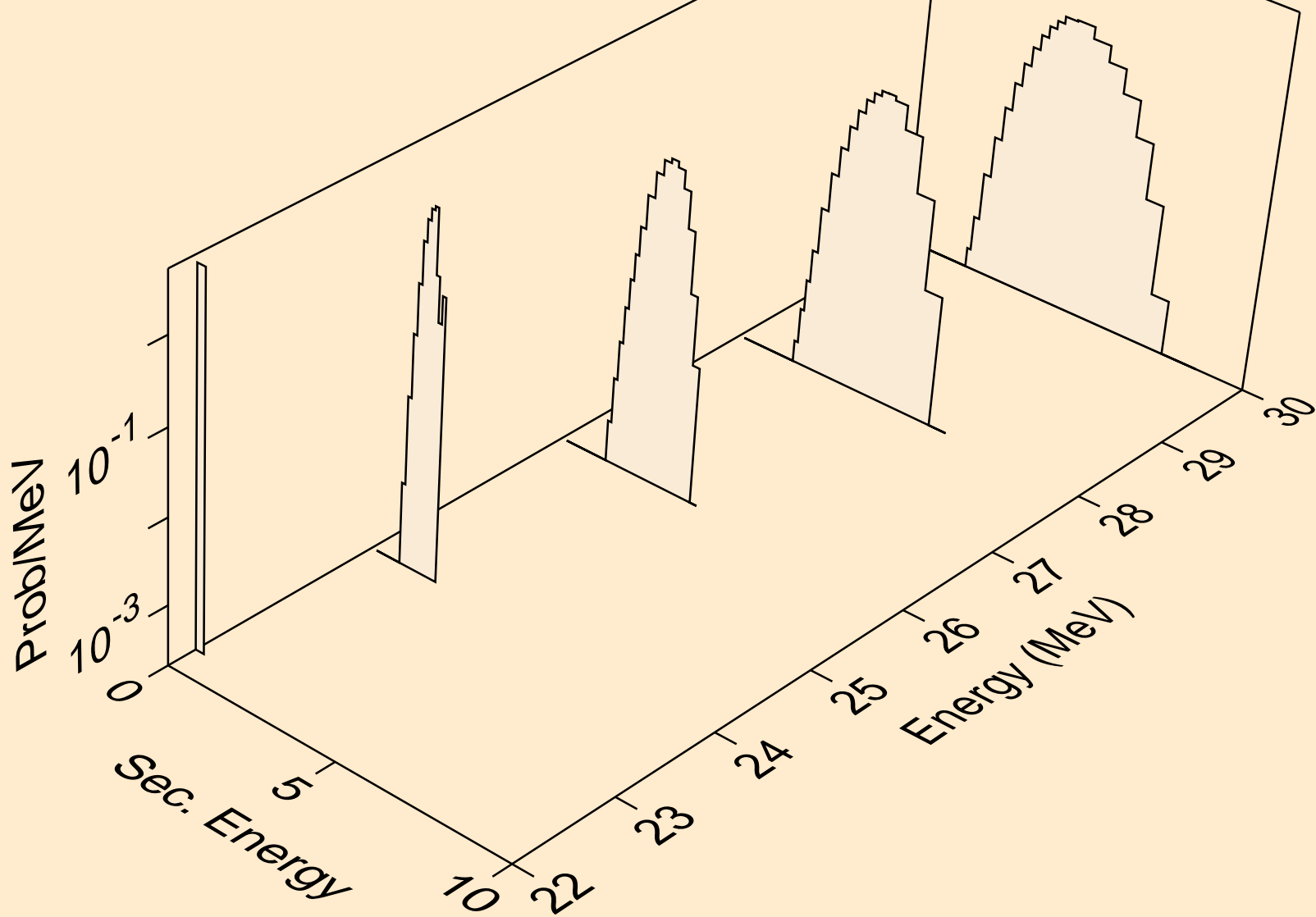

LA132 NEUTRON ACER TENDL-2023 LIBRARY; T=0.K  
protons from (n,n2p)

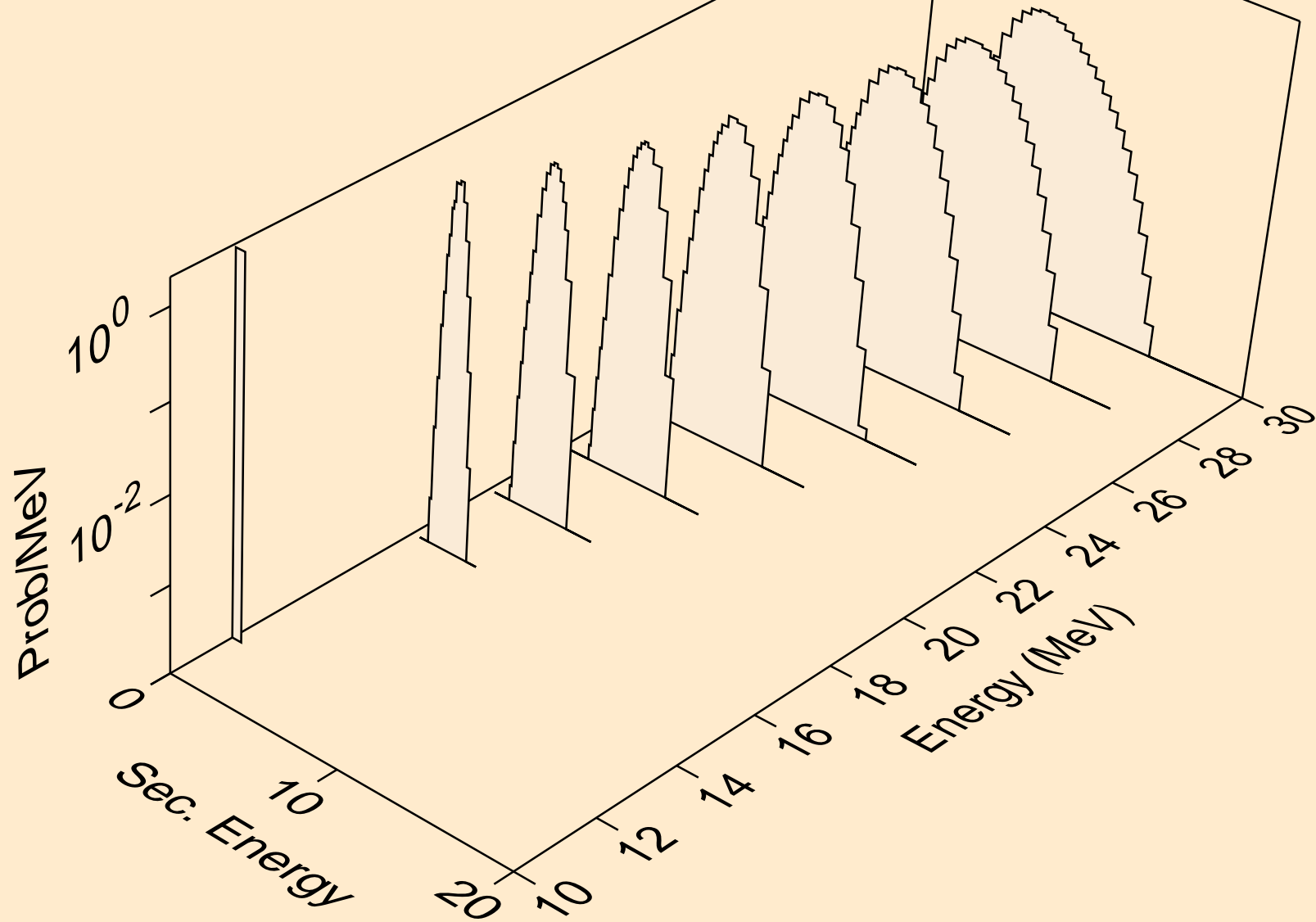

LA132 NEUTRON ACER TENDL-2023 LIBRARY; T=0.K  
protons from (n,npa)

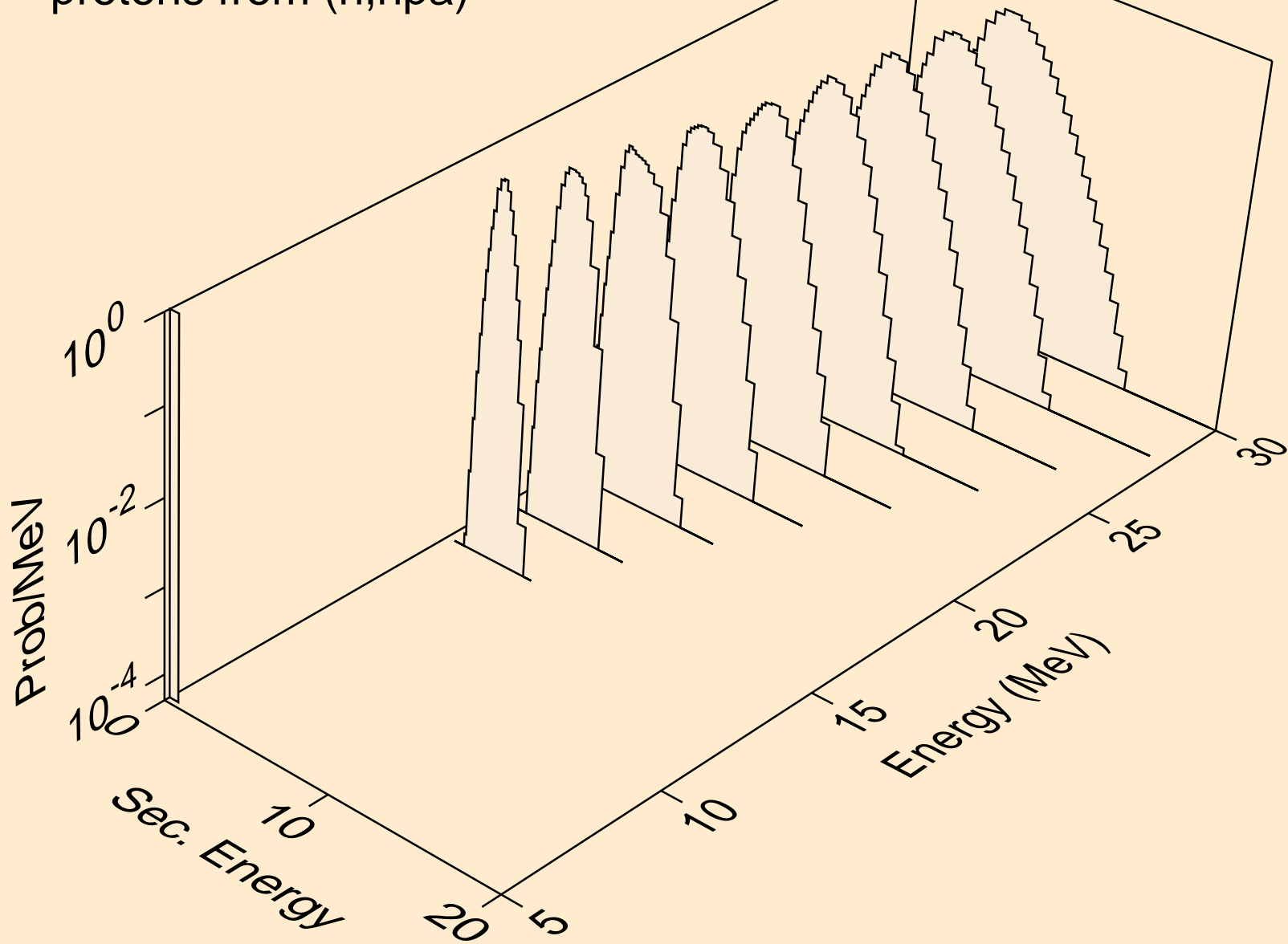

LA132 NEUTRON ACER TENDL-2023 LIBRARY; T=0.K  
protons from (n,p)

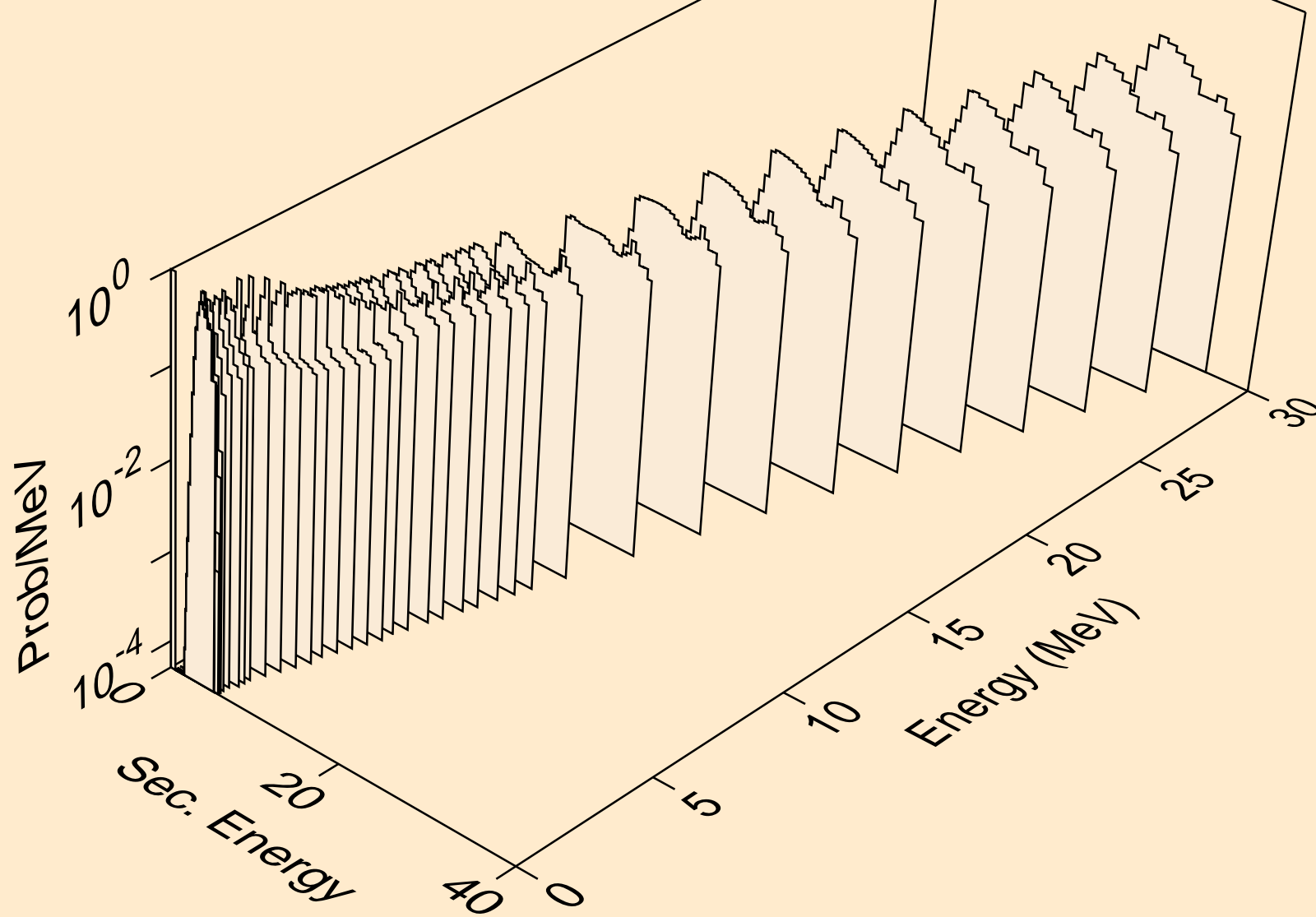

LA132 NEUTRON ACER TENDL-2023 LIBRARY; T=0.K  
protons from (n,2p)

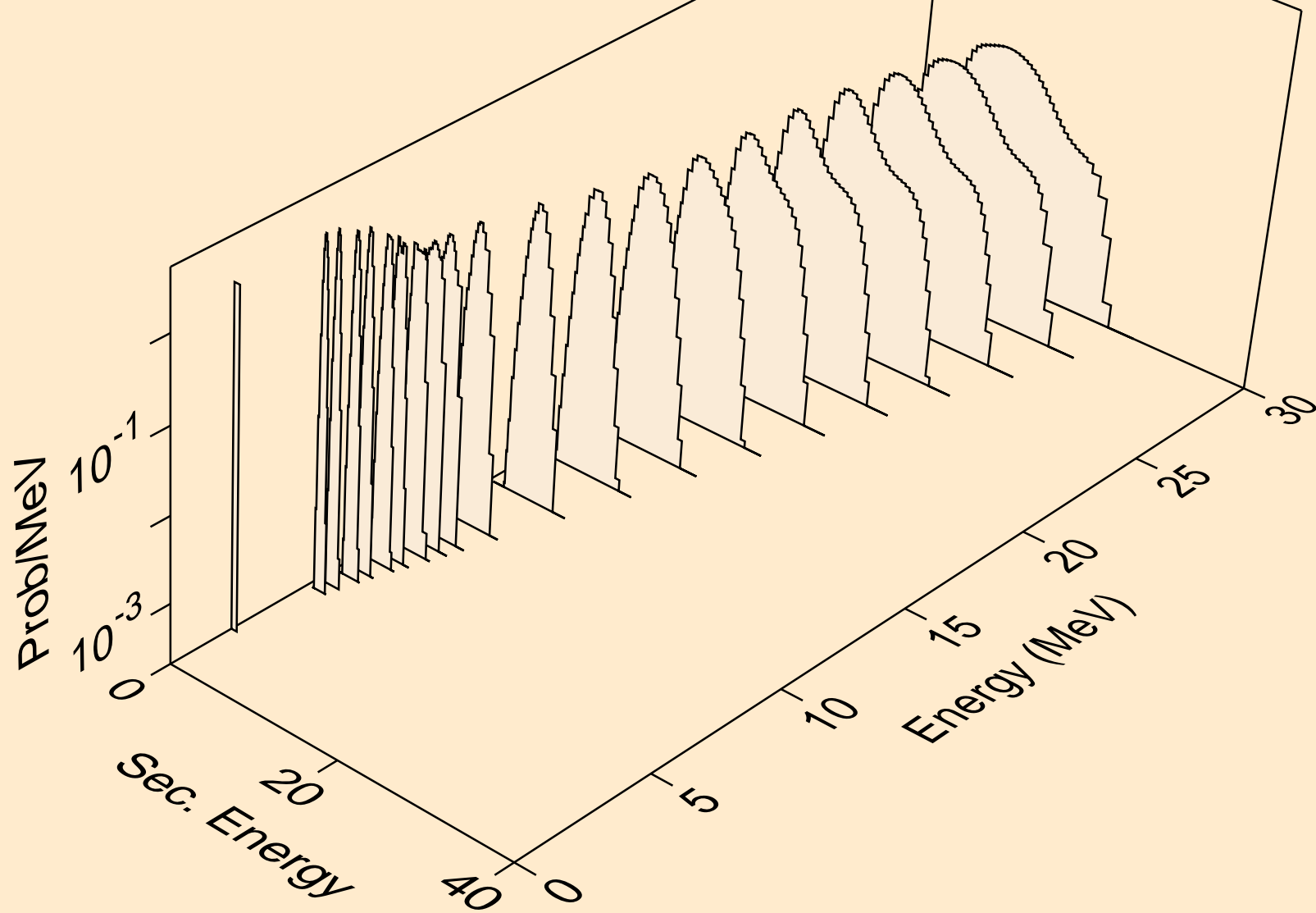

LA132 NEUTRON ACER TENDL-2023 LIBRARY; T=0.K  
protons from (n,p)

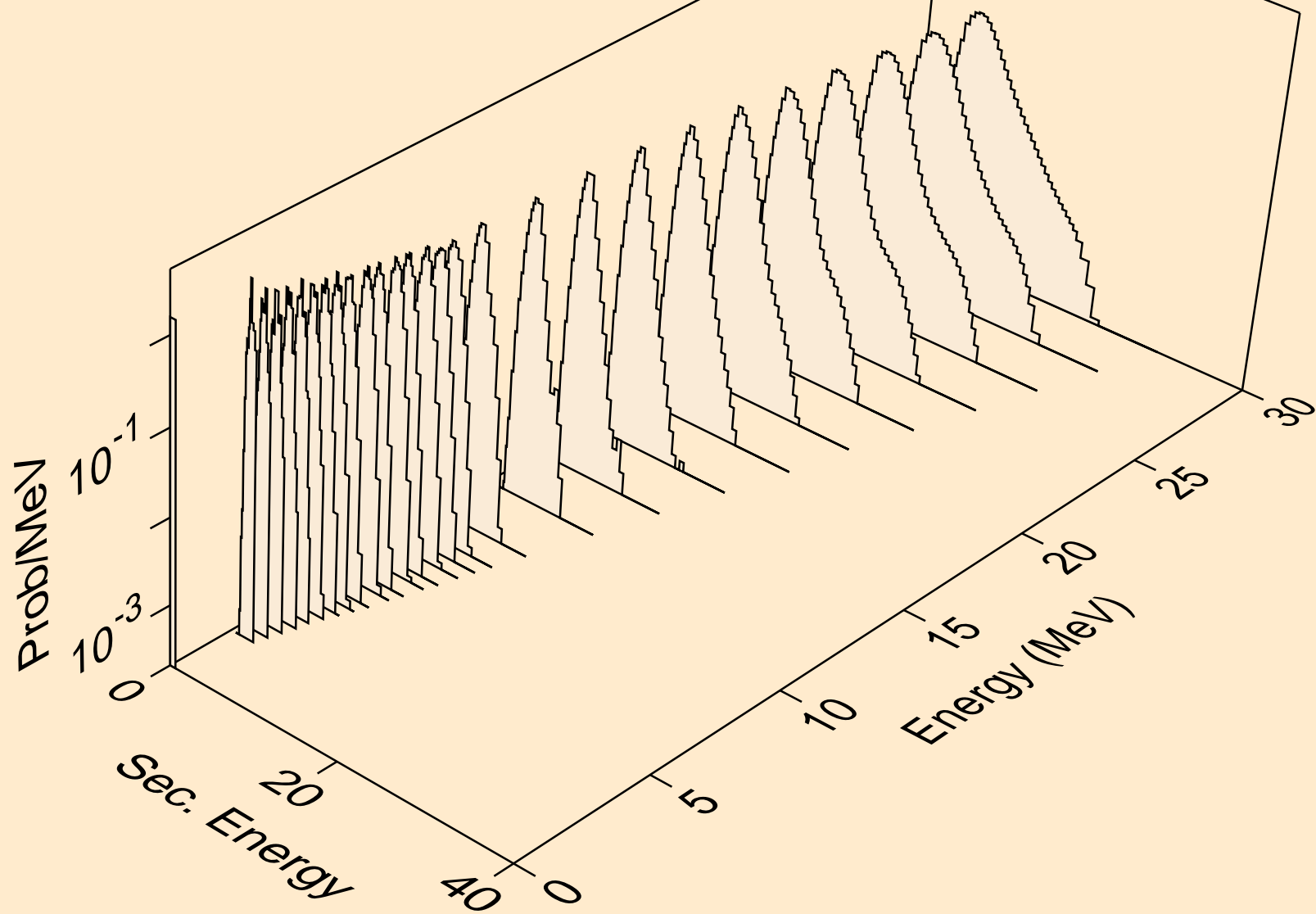



LA132 NEUTRON ACER TENDL-2023 LIBRARY; T=0.K  
protons from (n,pd)

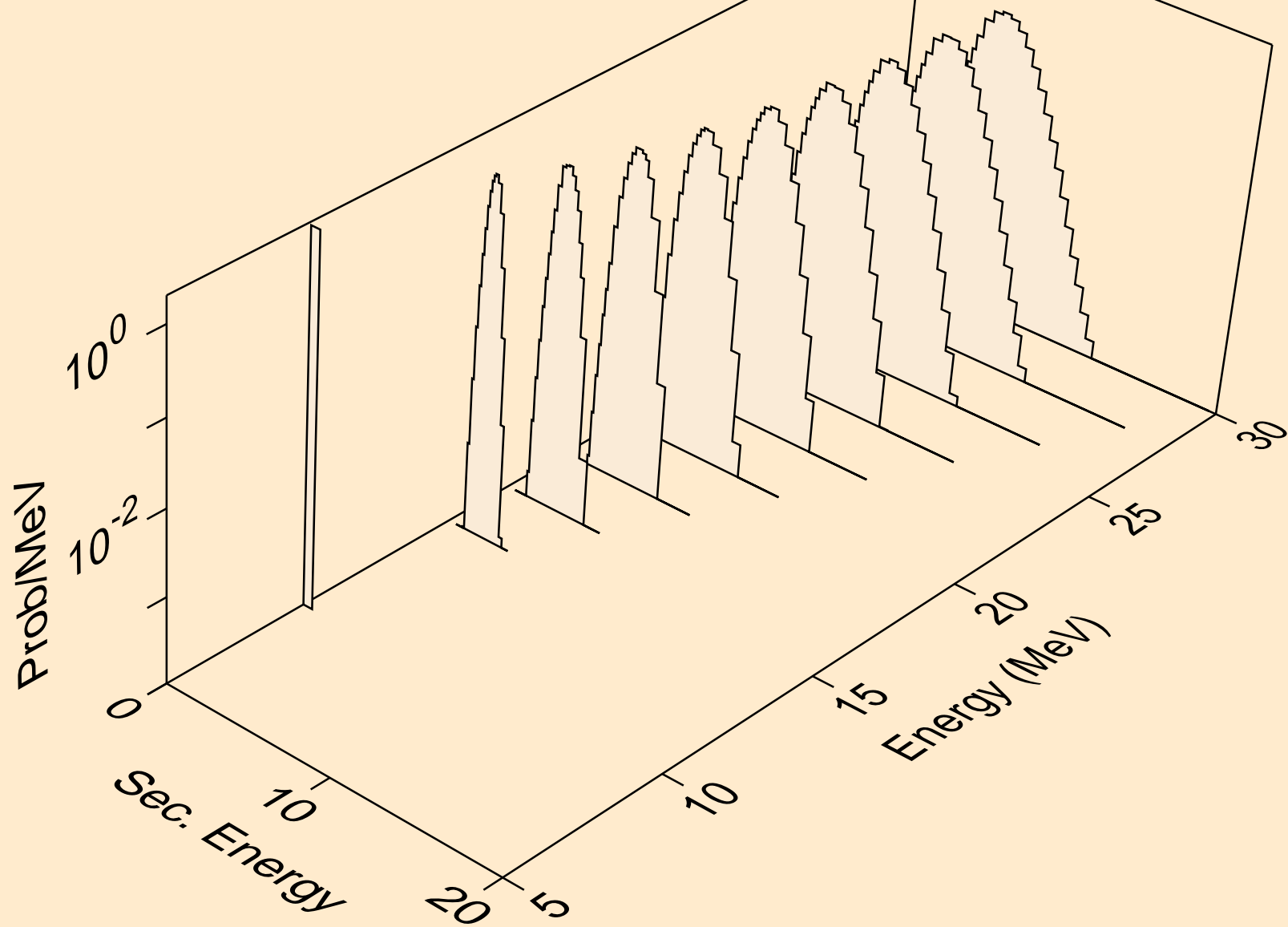

LA132 NEUTRON ACER TENDL-2023 LIBRARY; T=0.K  
protons from (n,pt)

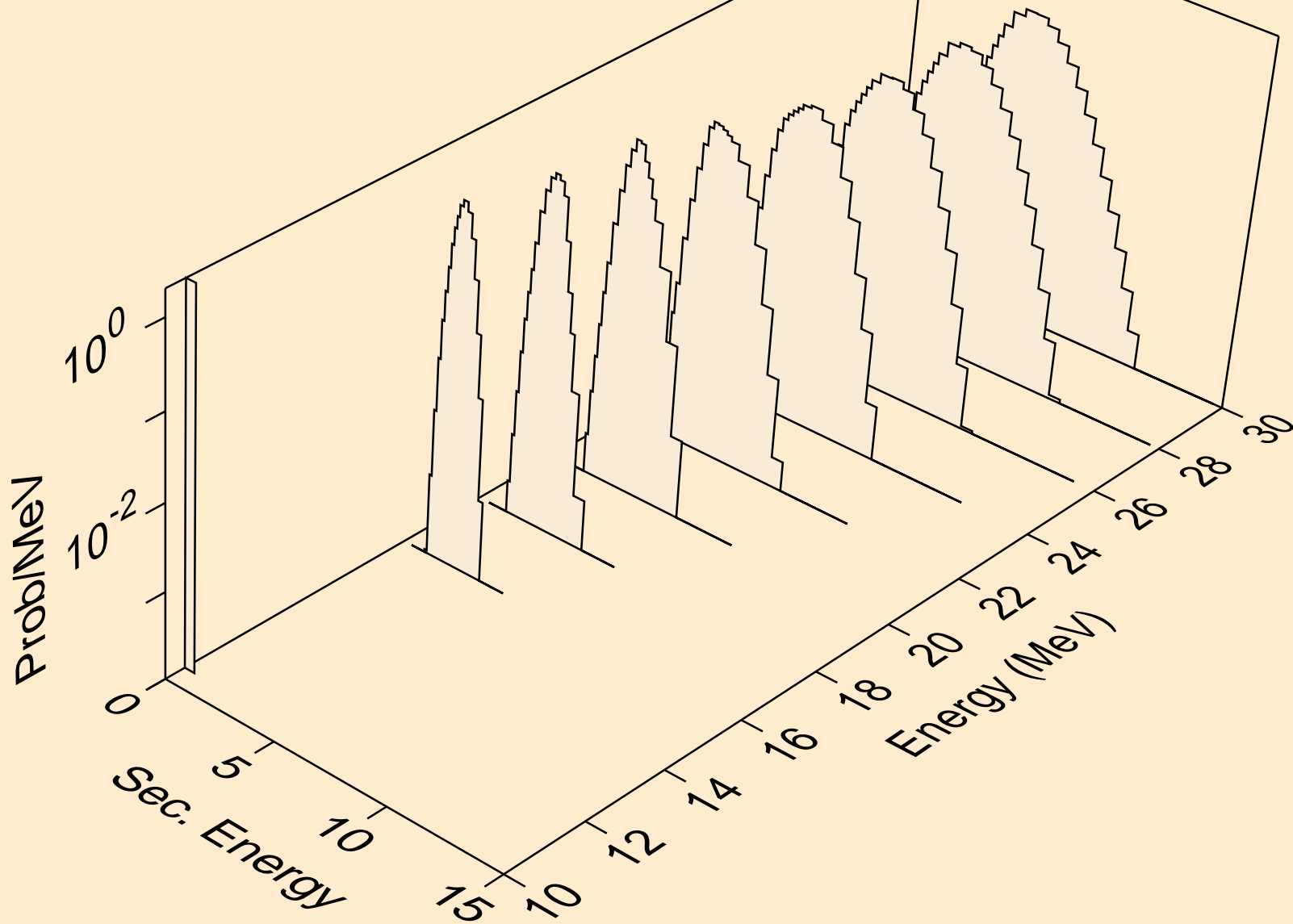

LA132 NEUTRON ACER TENDL-2023 LIBRARY; T=0.K  
deuterons from (n,x)

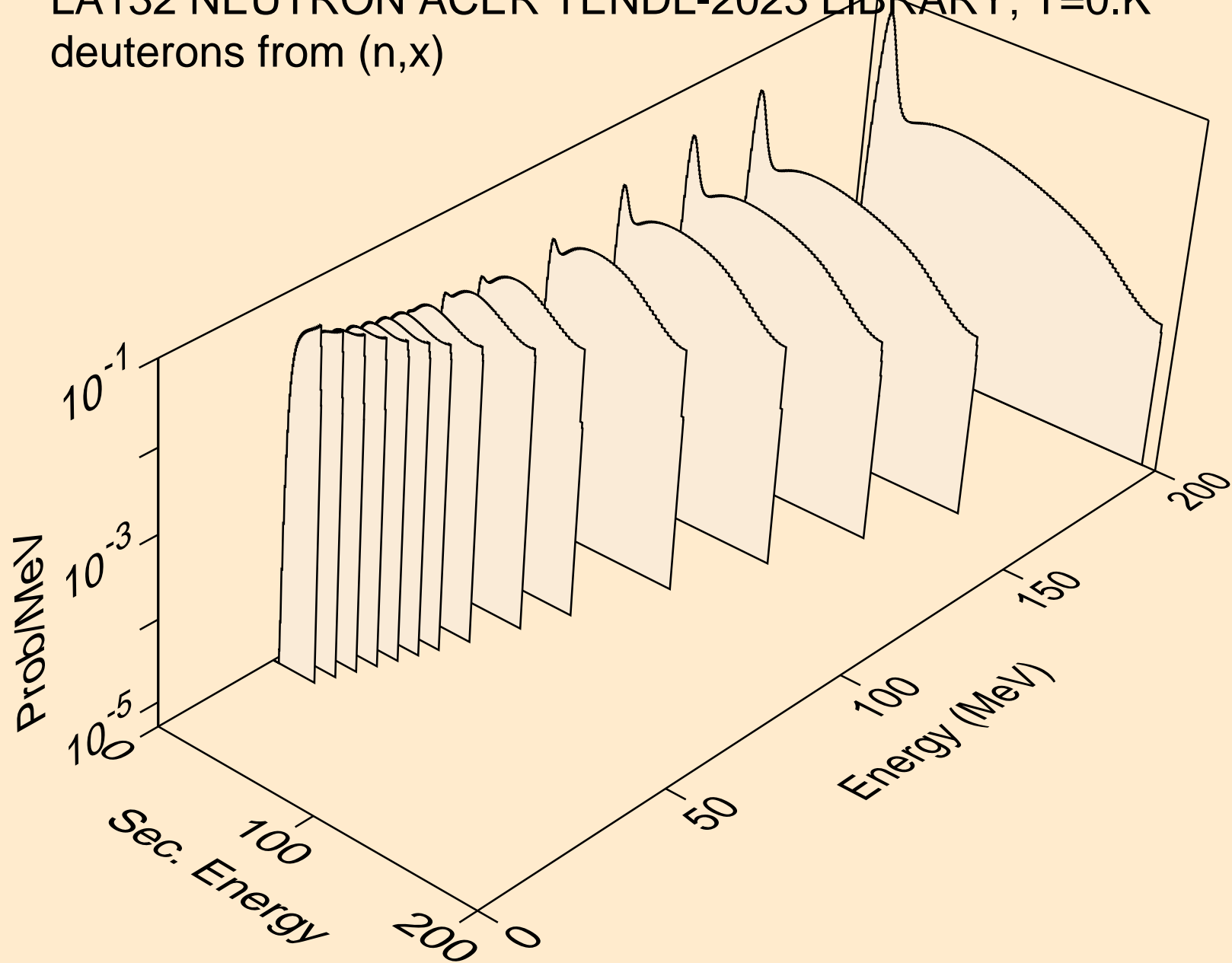

LA132 NEUTRON ACER TENDL-2023 LIBRARY; T=0.K  
deuterons from (n,2nd)

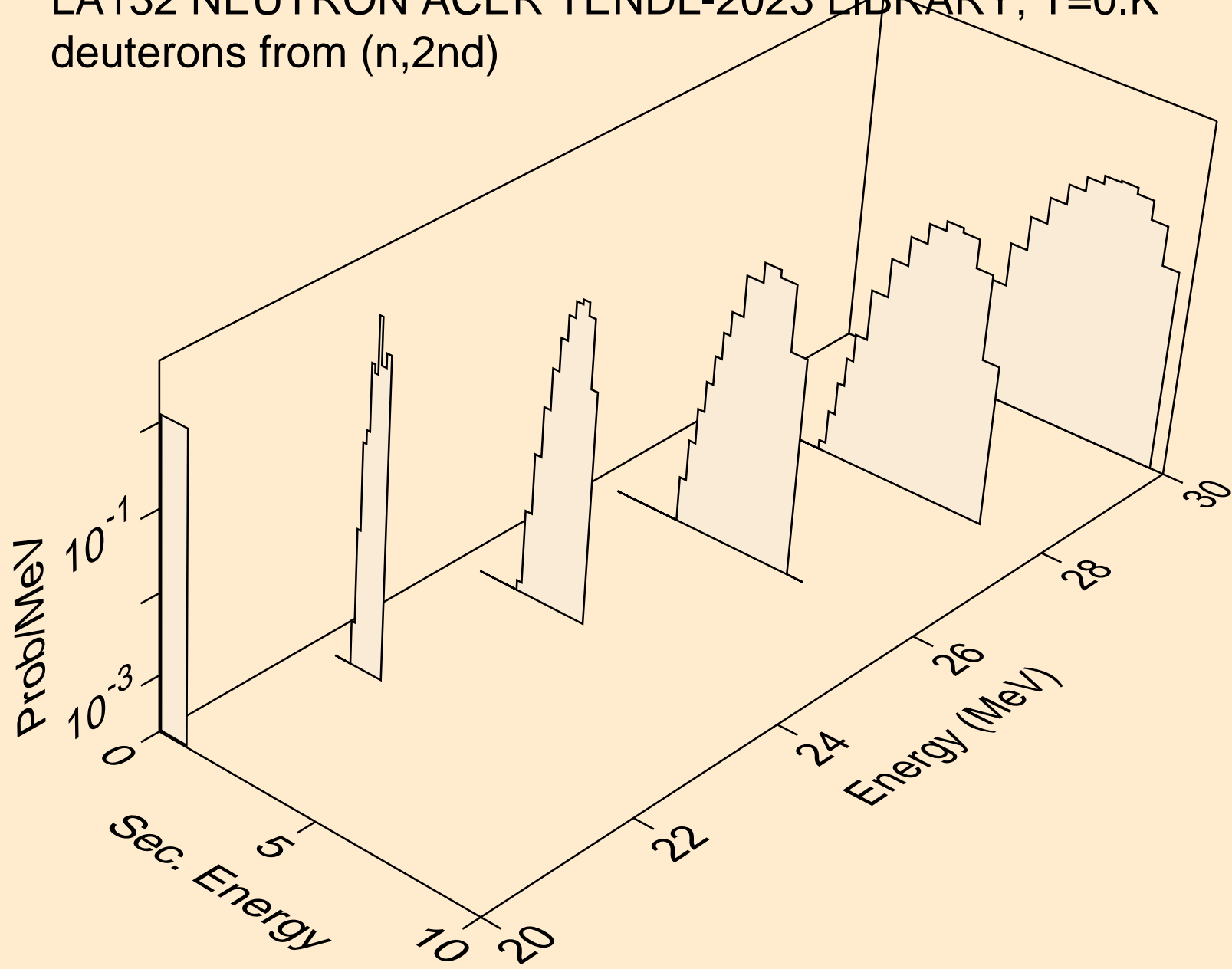

LA132 NEUTRON ACER TENDL-2023 LIBRARY; T=0.K  
deuterons from (n,n\*)d

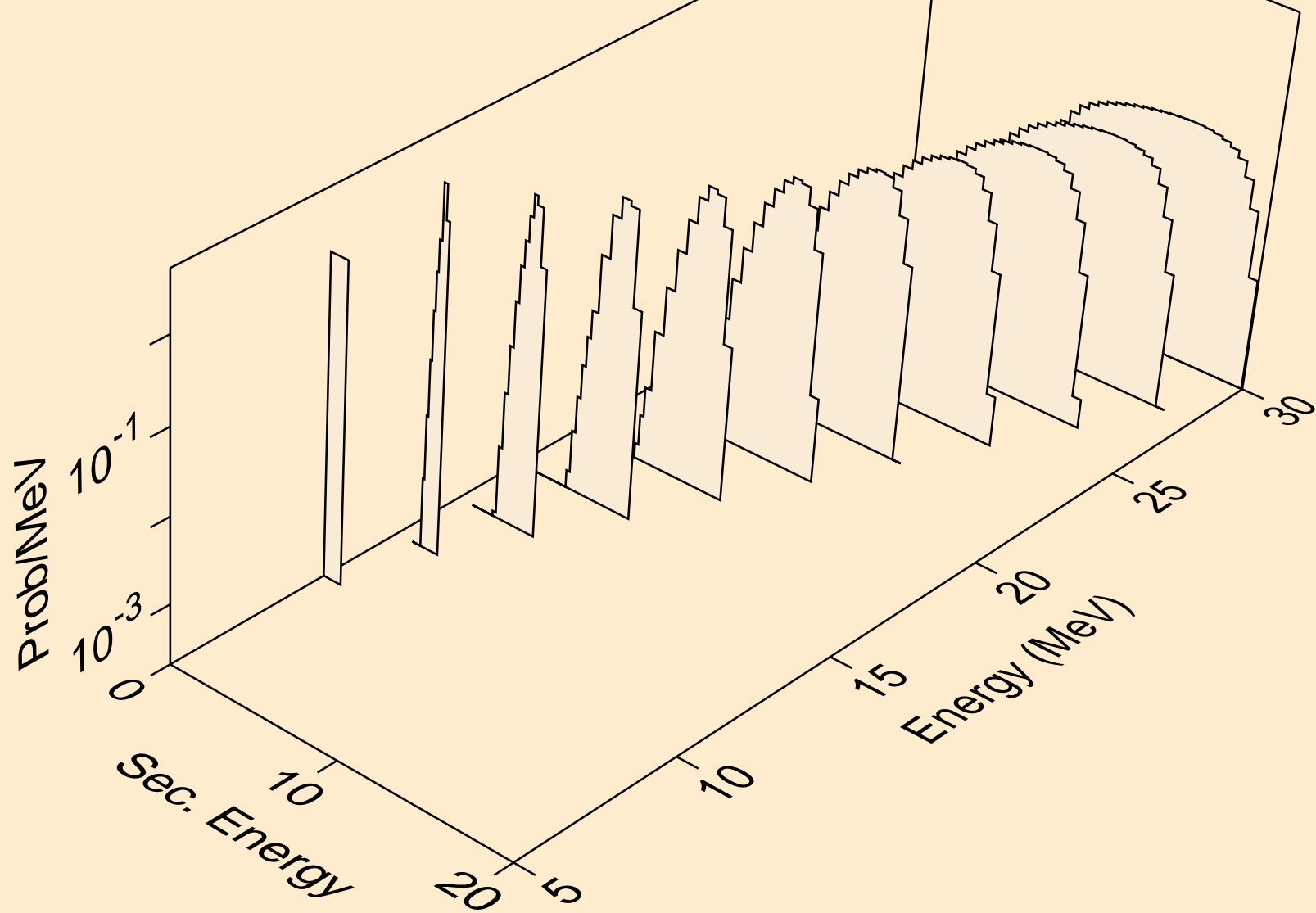

LA132 NEUTRON ACER TENDL-2023 LIBRARY; T=0.K  
deuterons from (n,d)

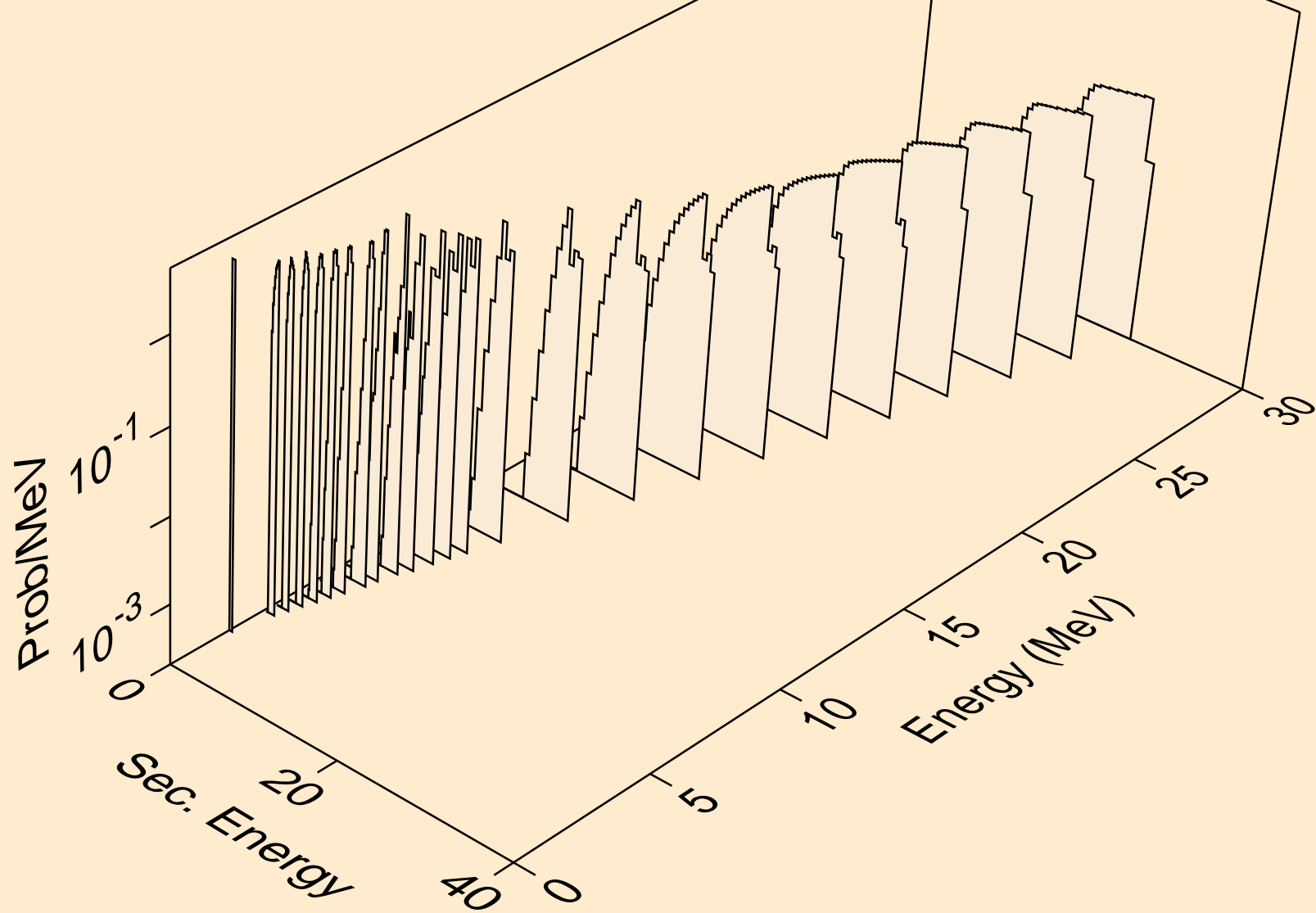

LA132 NEUTRON ACER TENDL-2023 LIBRARY; T=0.K  
deuterons from (n,pd)

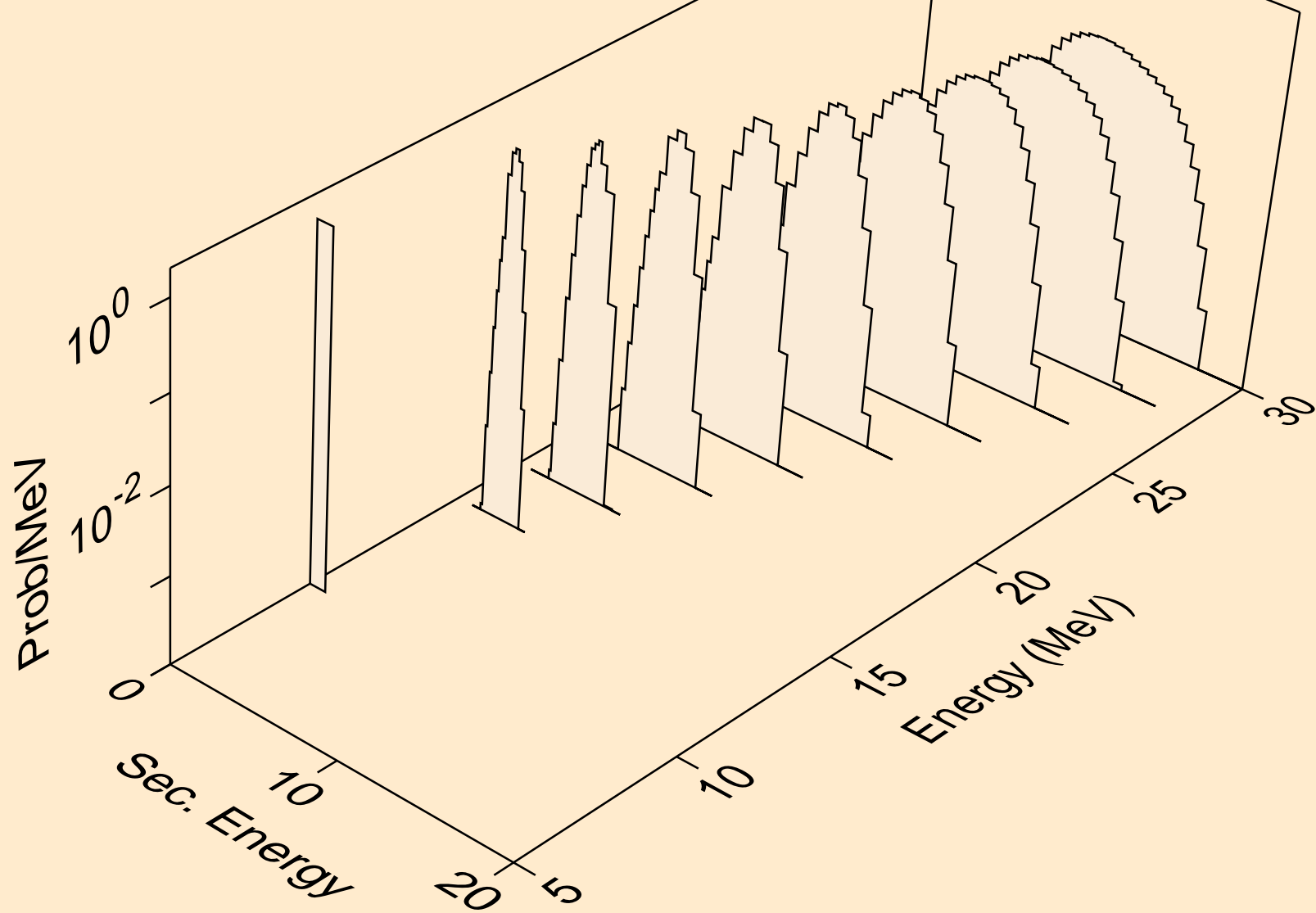

LA132 NEUTRON ACER TENDL-2023 LIBRARY; T=0.K  
deuterons from (n,da)

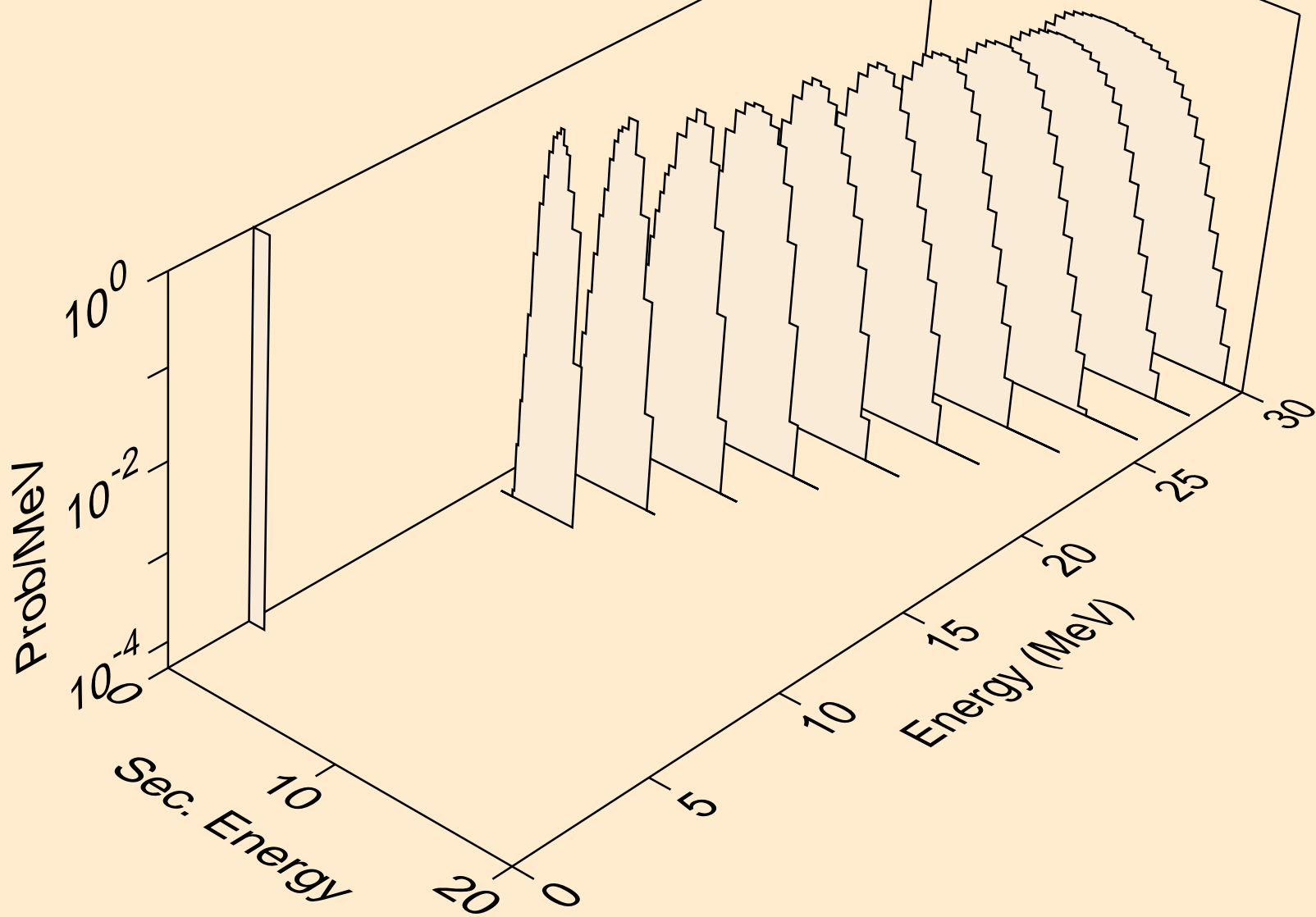



LA132 NEUTRON ACER TENDL-2023 LIBRARY; T=0.K  
tritons from (n,x)

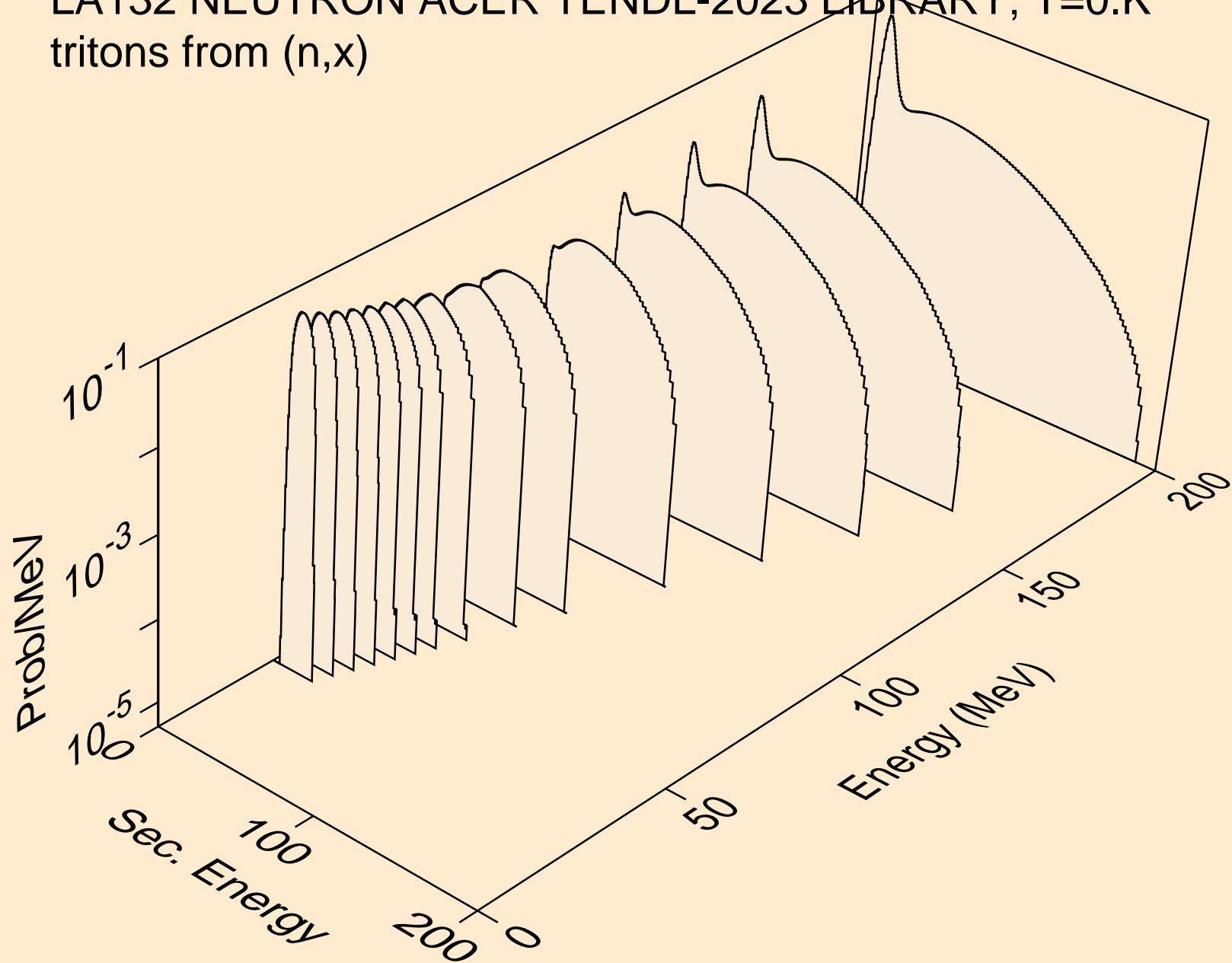

LA132 NEUTRON ACER TENDL-2023 LIBRARY; T=0.K  
tritons from (n,n\*)t

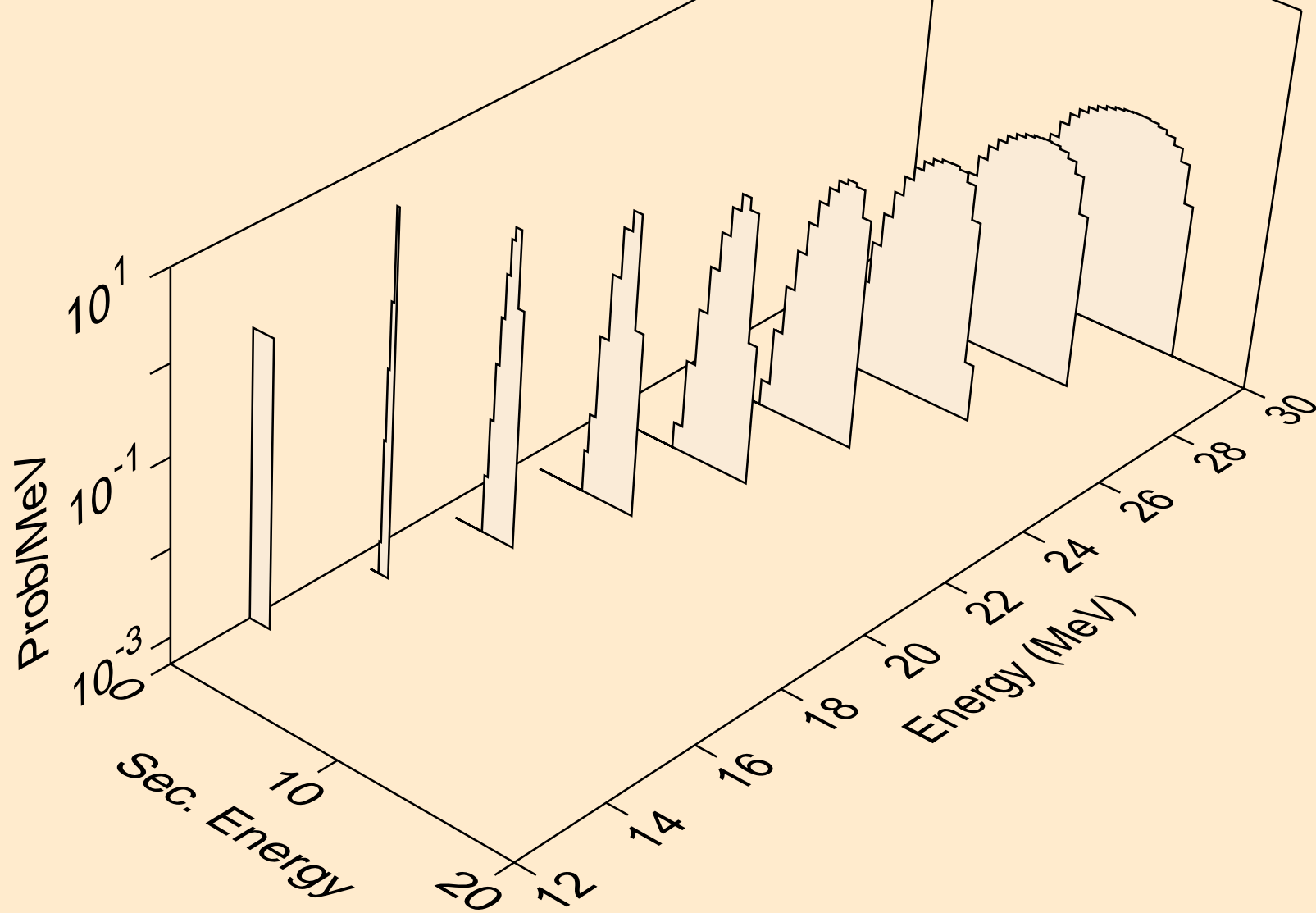

LA132 NEUTRON ACER TENDL-2023 LIBRARY; T=0.K  
tritons from (n,t)

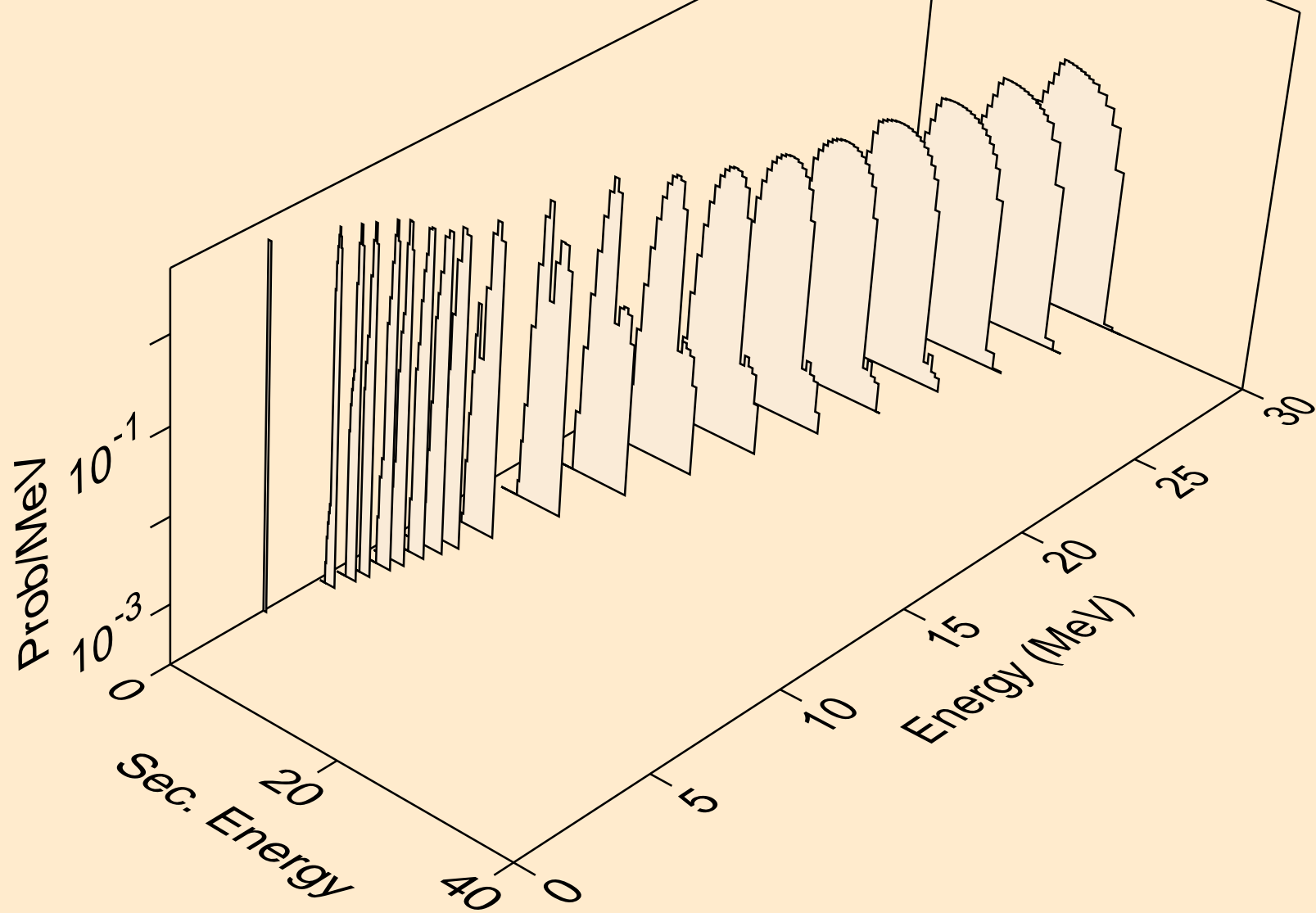

LA132 NEUTRON ACER TENDL-2023 LIBRARY; T=0.K  
tritons from (n,pt)

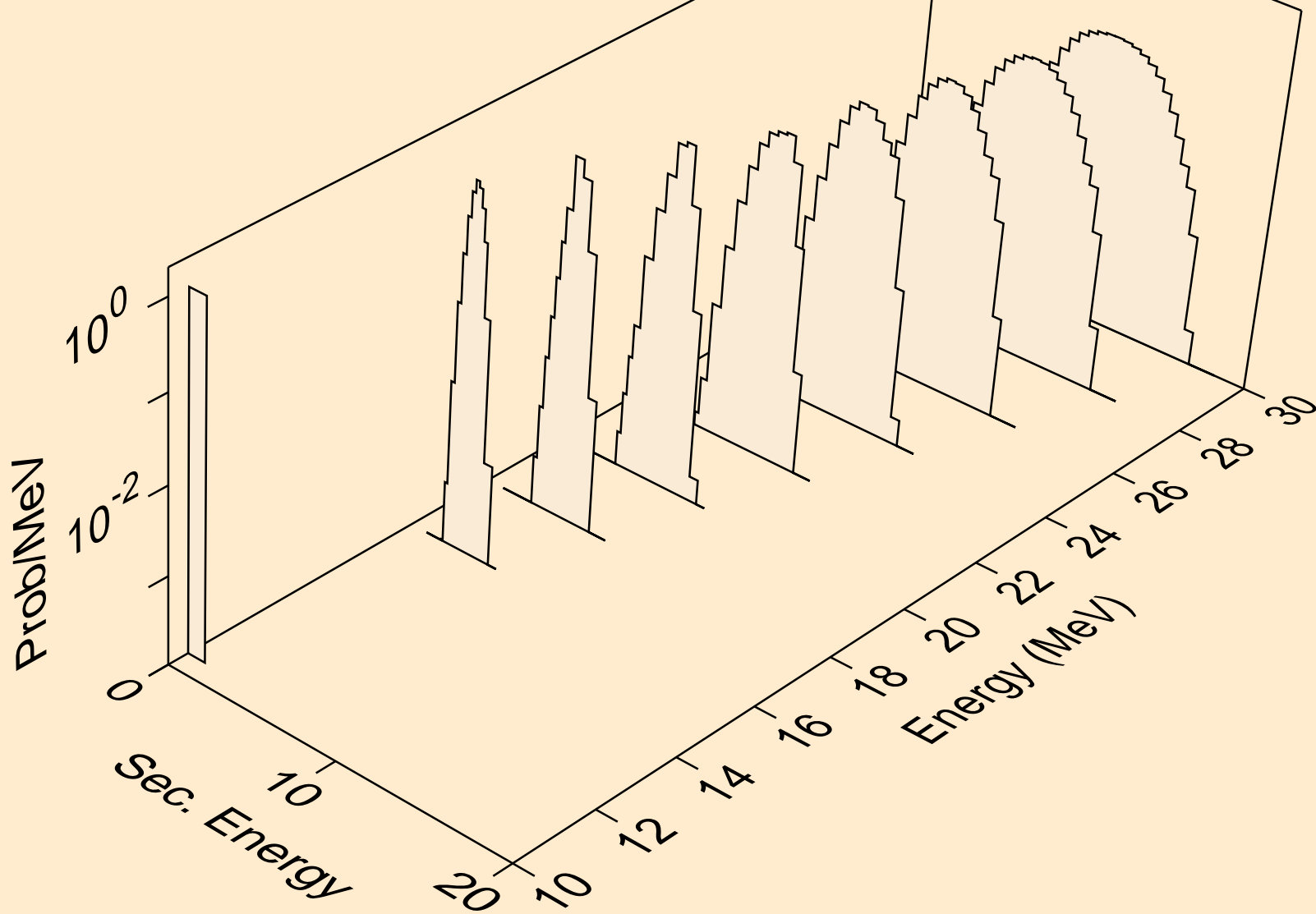

LA132 NEUTRON ACER TENDL-2023 LIBRARY; T=0.K  
he3s from (n,x)

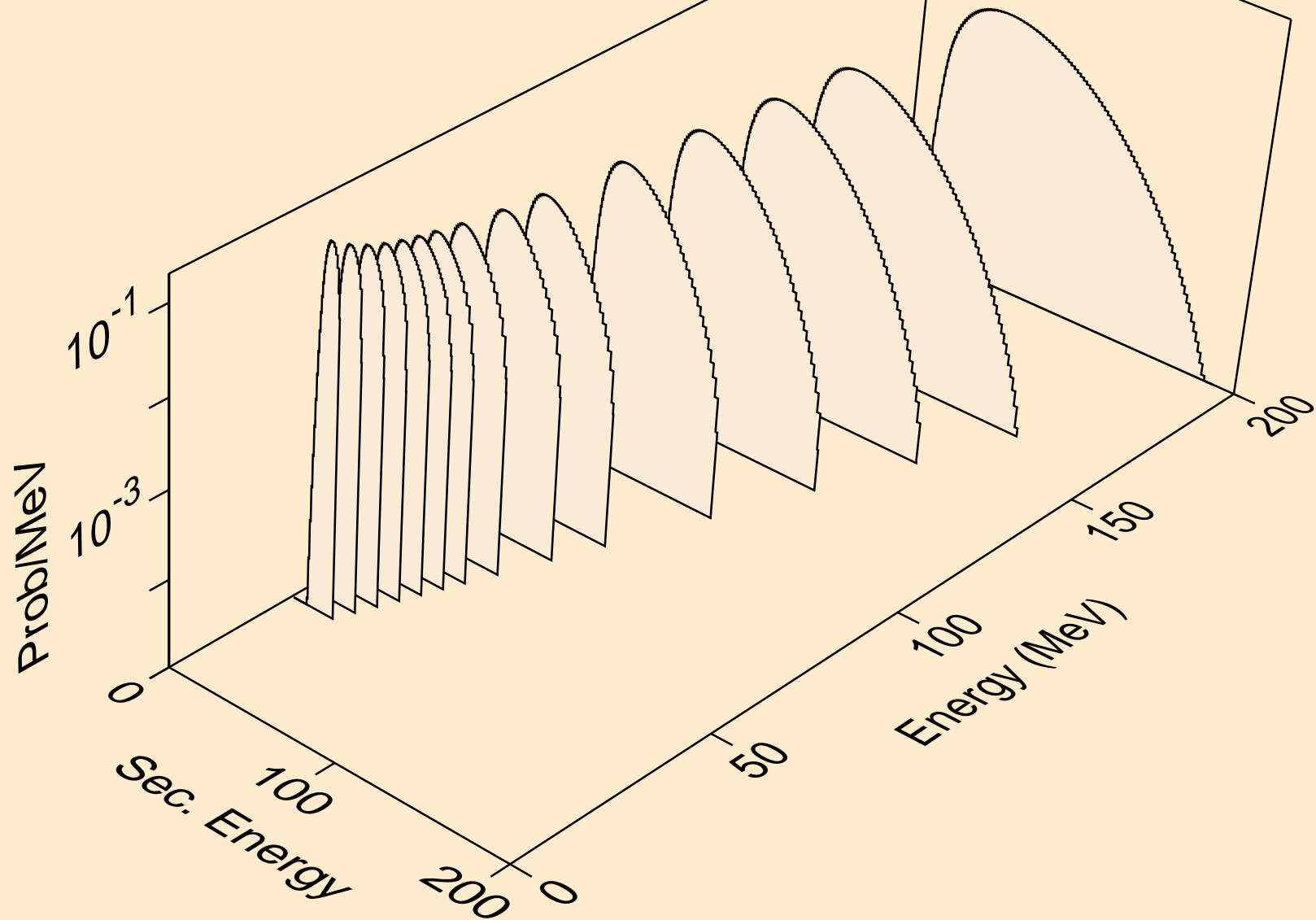

LA132 NEUTRON ACER TENDL-2023 LIBRARY; T=0.K  
he3s from (n,n\*)he3

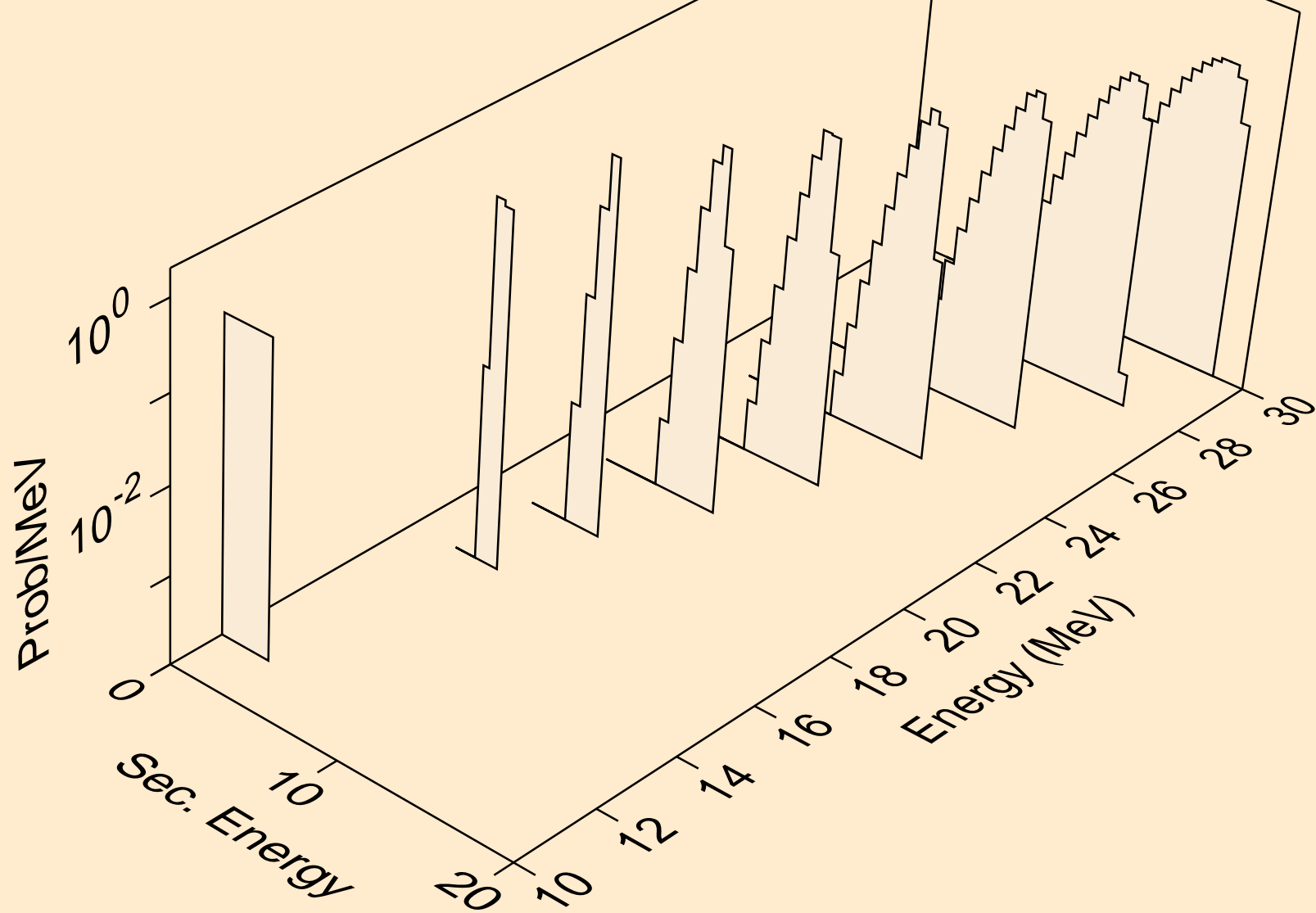

LA132 NEUTRON ACER TENDL-2023 LIBRARY; T=0.K  
he3s from (n,he3)

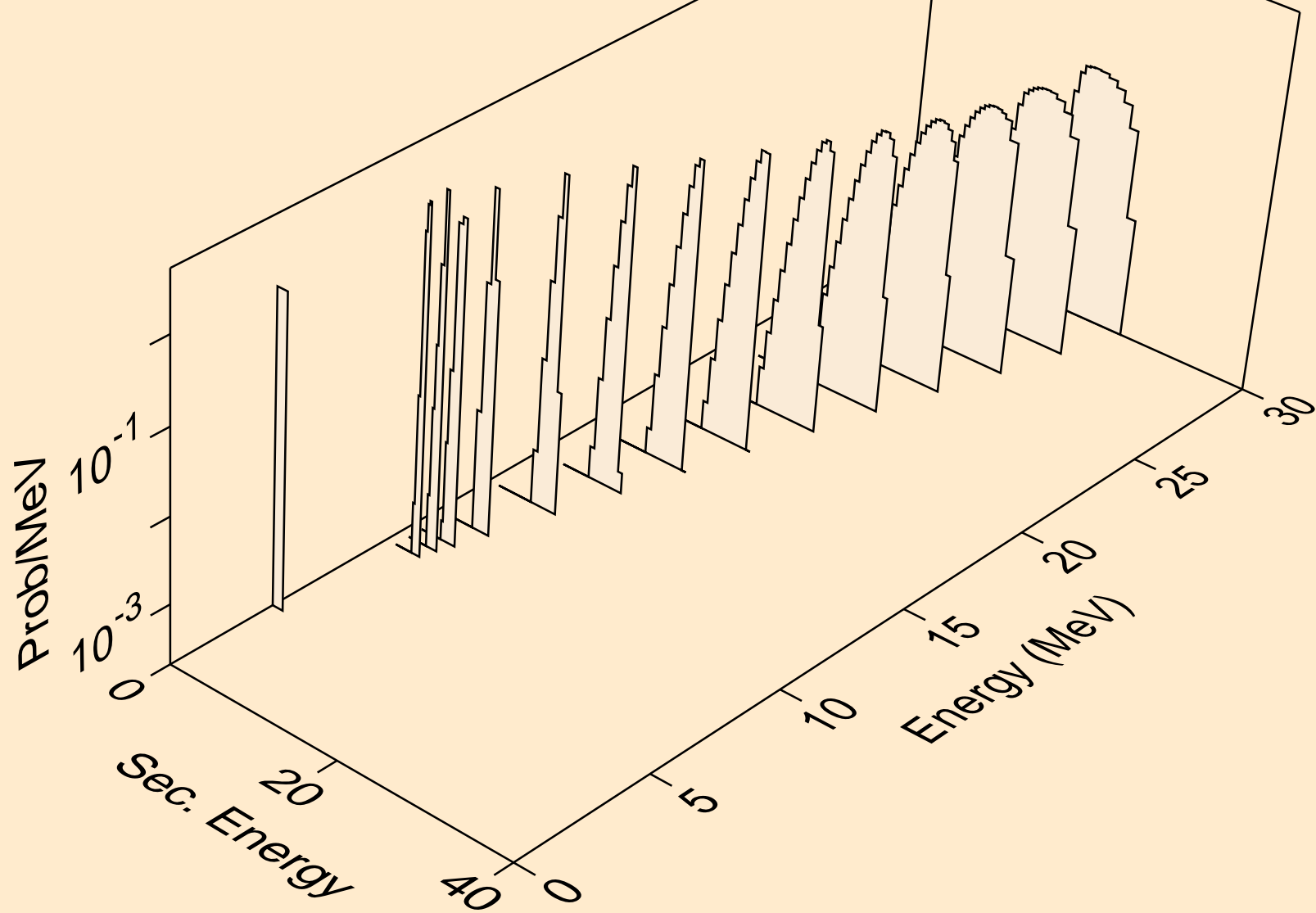

LA132 NEUTRON ACER TENDL-2023 LIBRARY; T=0.K  
alphas from (n,x)

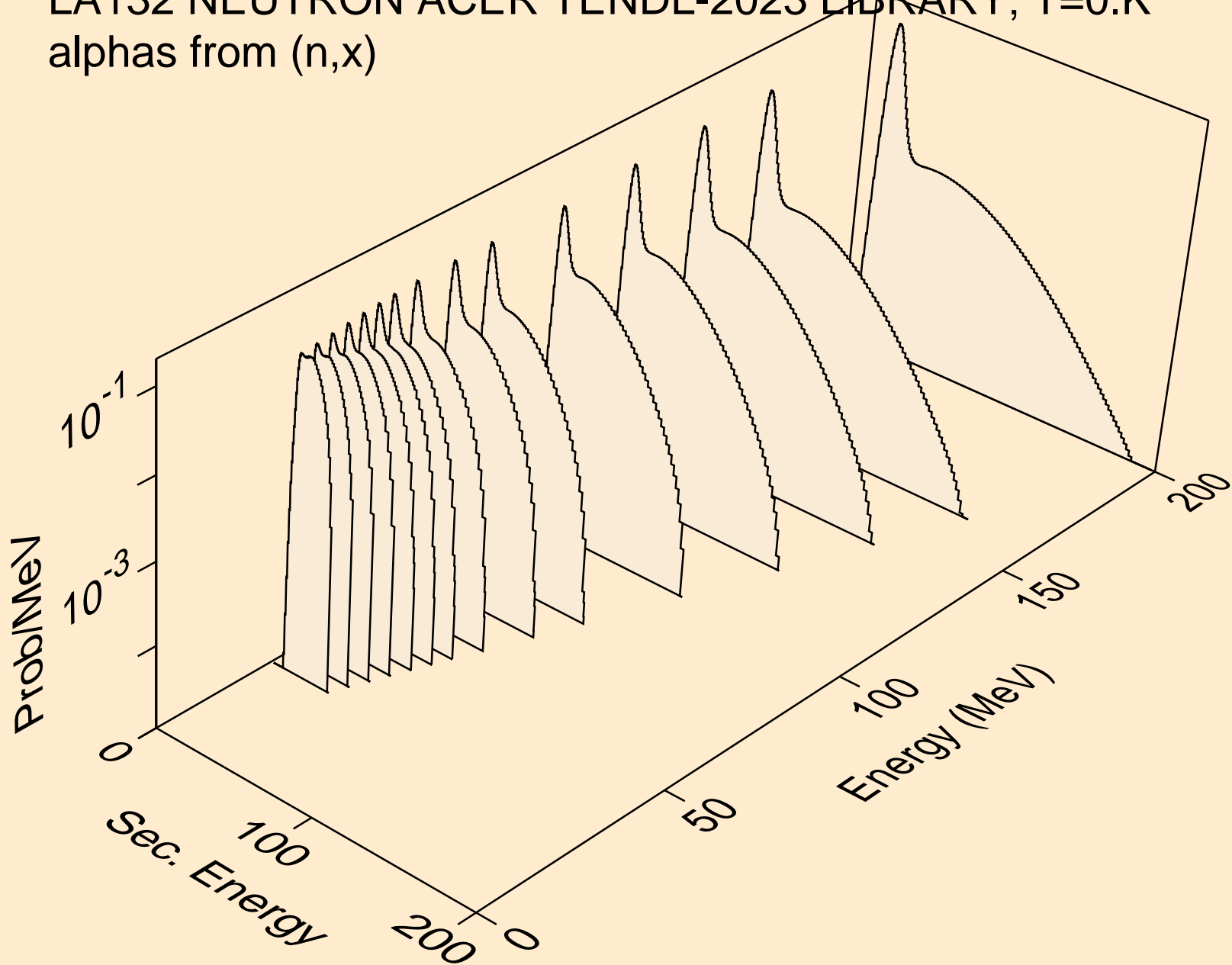



LA132 NEUTRON ACER TENDL-2023 LIBRARY; T=0.K  
alphas from (n,n\*)a

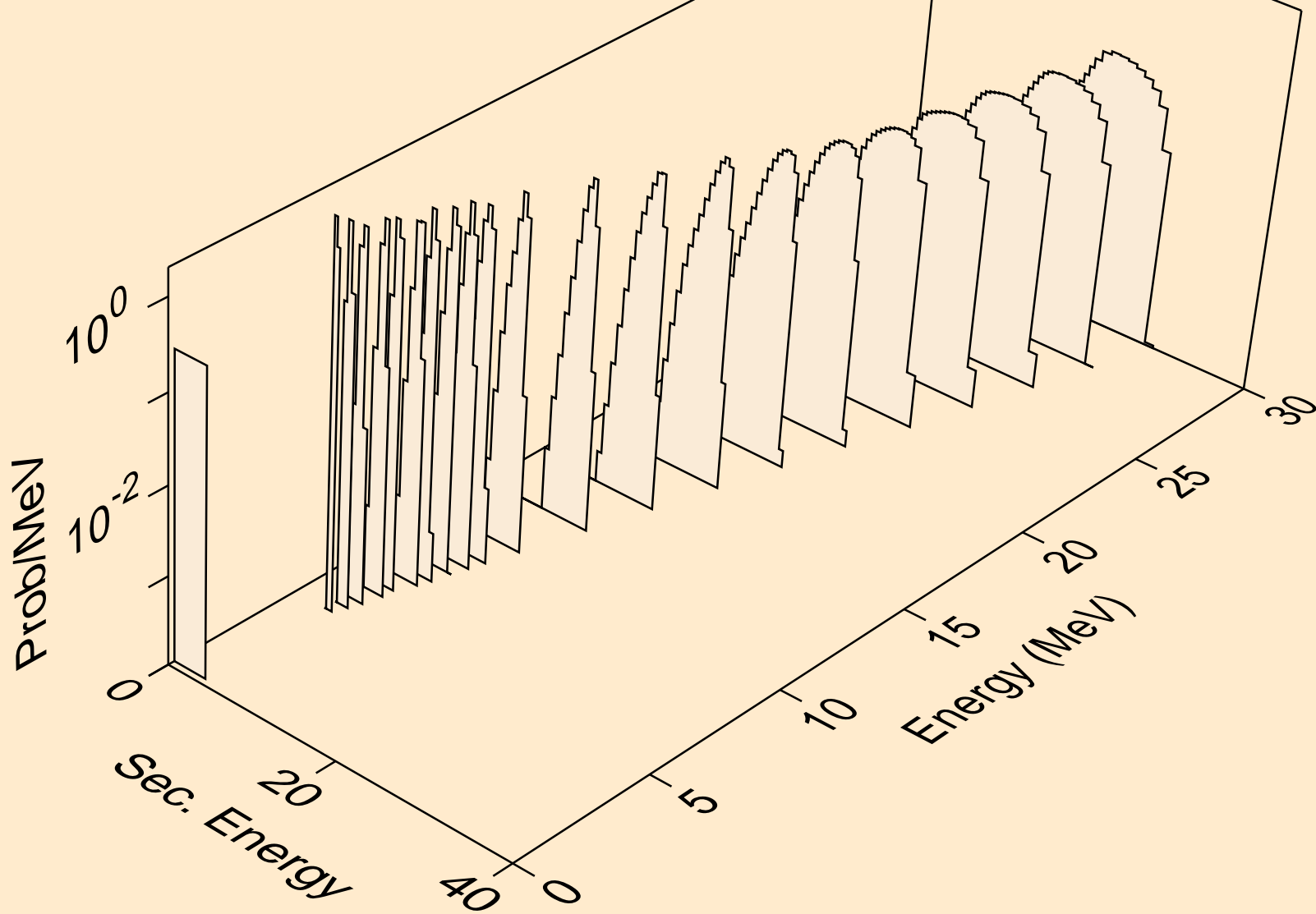

LA132 NEUTRON ACER TENDL-2023 LIBRARY; T=0.K  
alphas from (n,2n)a

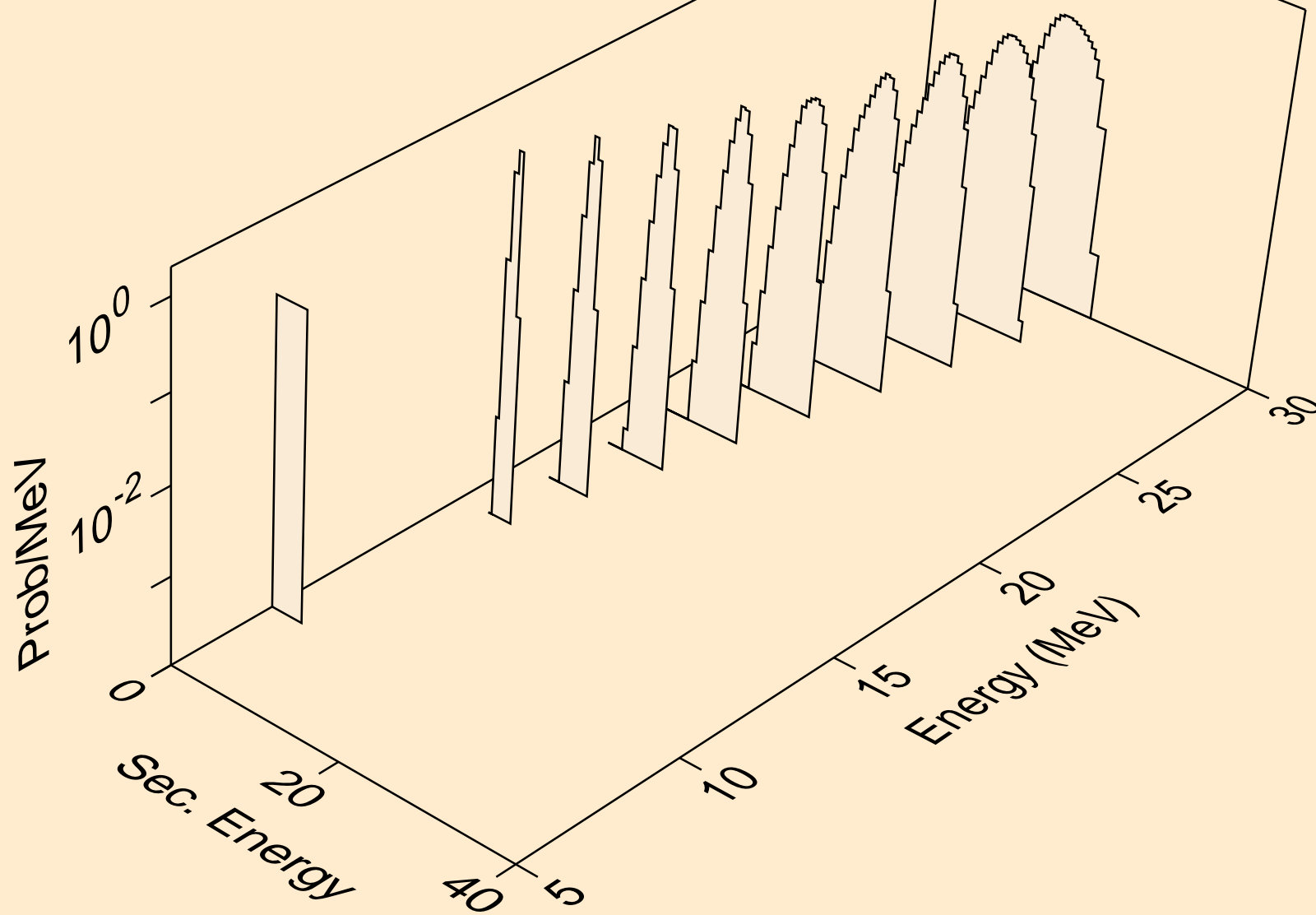

LA132 NEUTRON ACER TENDL-2023 LIBRARY; T=0.K  
alphas from (n,3n)a

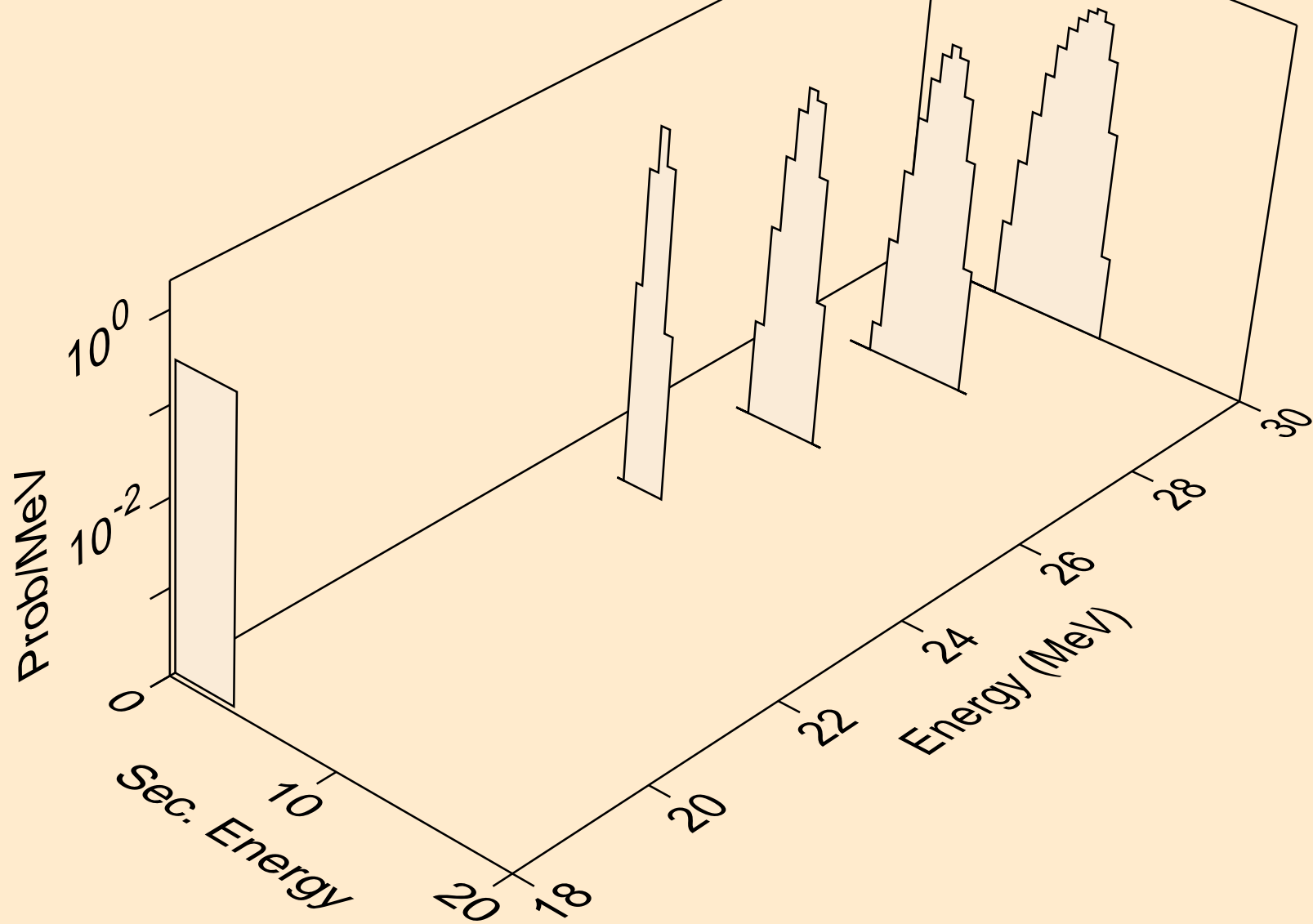

LA132 NEUTRON ACER TENDL-2023 LIBRARY; T=0.K  
alphas from (n,n\*)2a

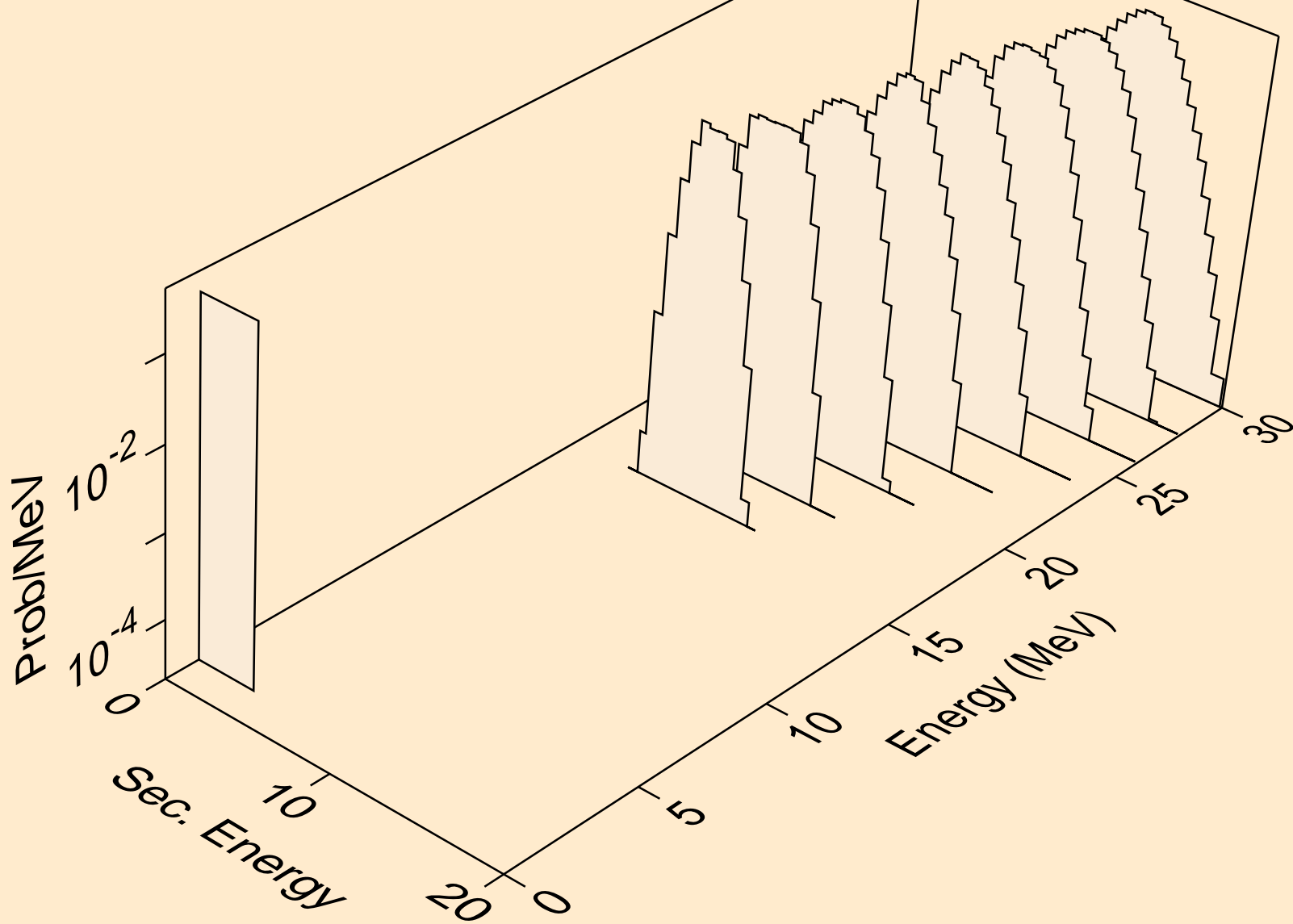

LA132 NEUTRON ACER TENDL-2023 LIBRARY; T=0.K  
alphas from (n,npa)

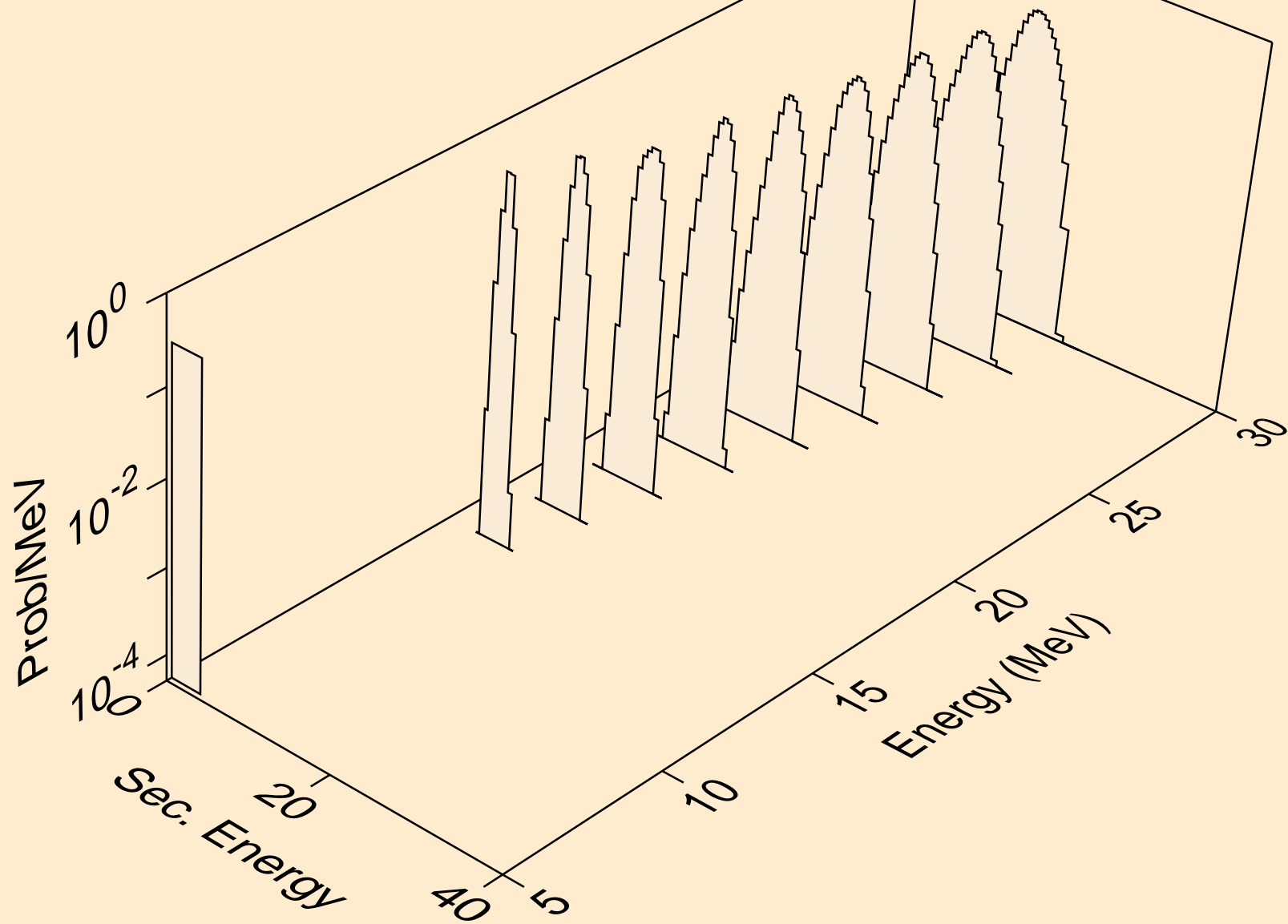

LA132 NEUTRON ACER TENDL-2023 LIBRARY; T=0.K  
alphas from (n,a)

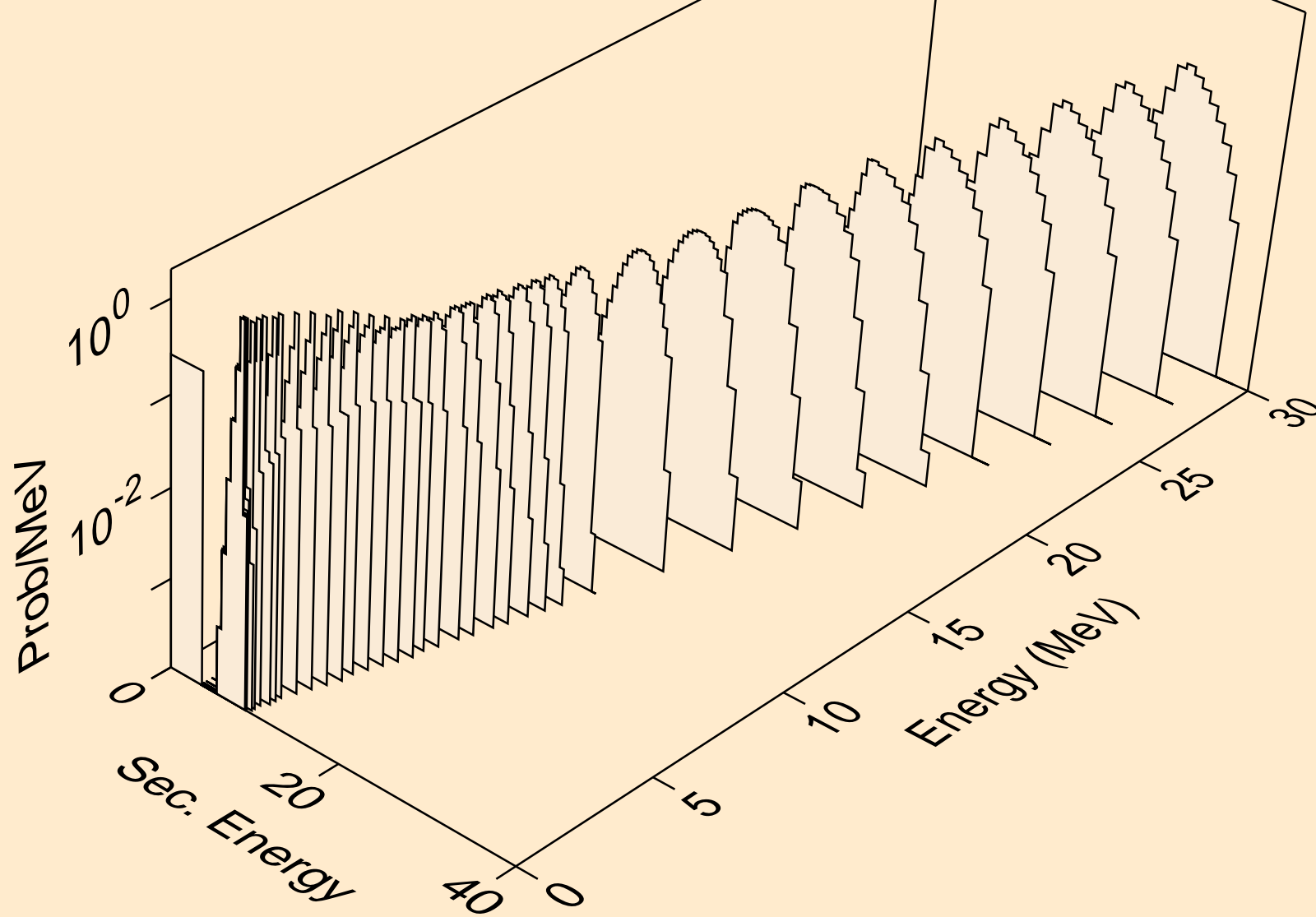

LA132 NEUTRON ACER TENDL-2023 LIBRARY; T=0.K  
alphas from (n,2a)

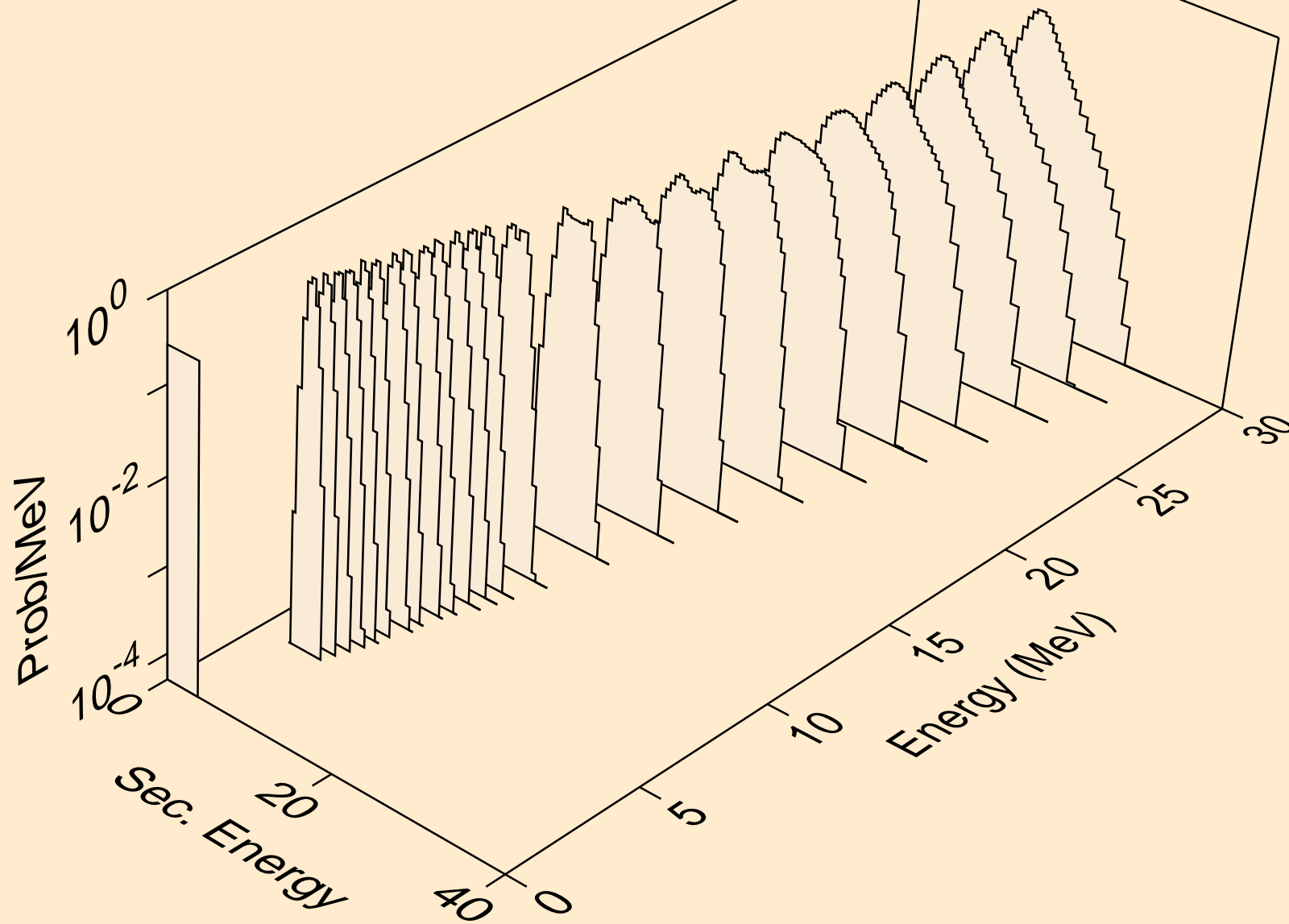

LA132 NEUTRON ACER TENDL-2023 LIBRARY; T=0.K  
alphas from (n,pa)

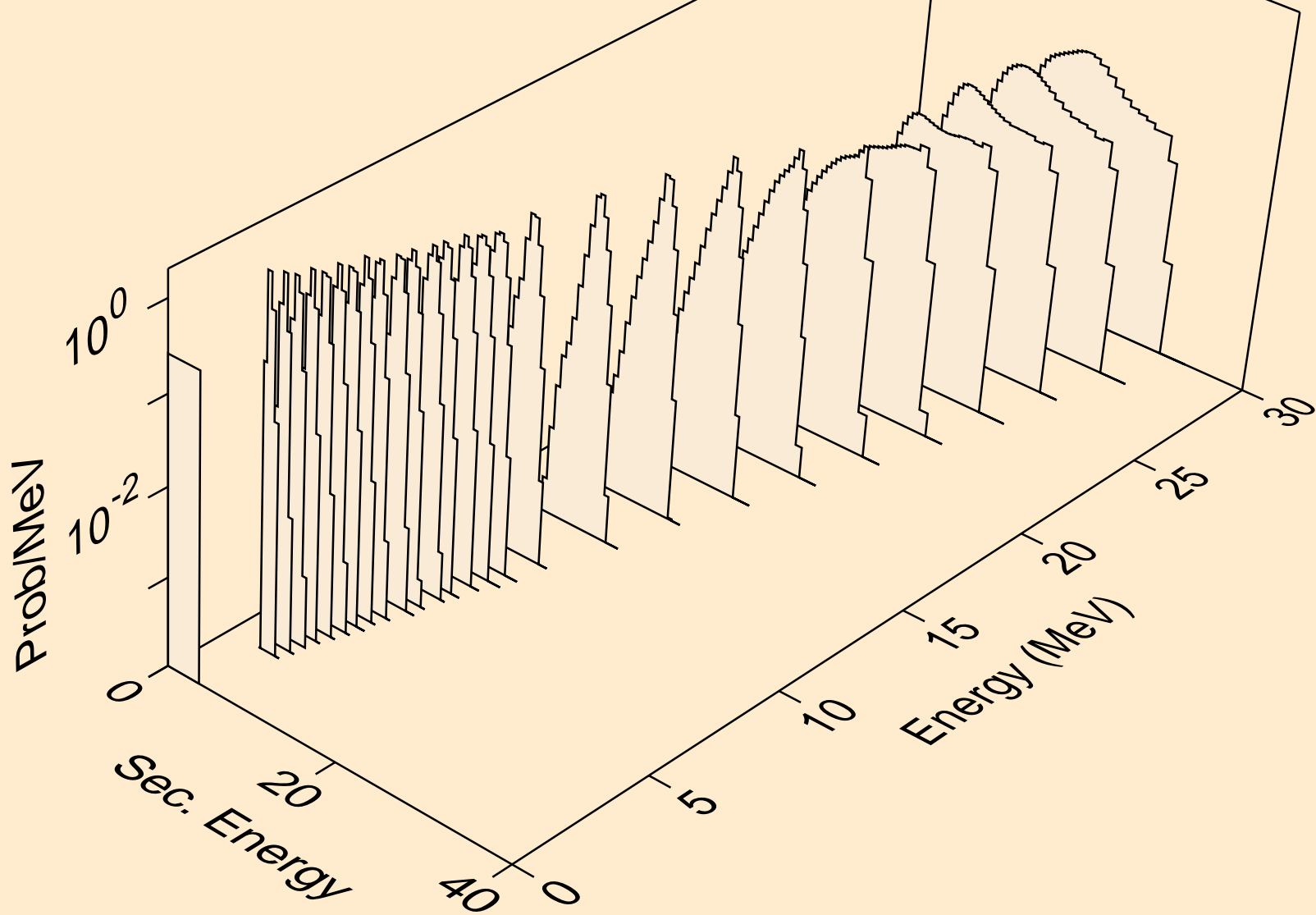



LA132 NEUTRON ACER TENDL-2023 LIBRARY; T=0.K  
alphas from (n,da)

