

# MT280 NEUTRON ACER TENDL-2023 LIBRARY; T=0.K

## Principal cross sections

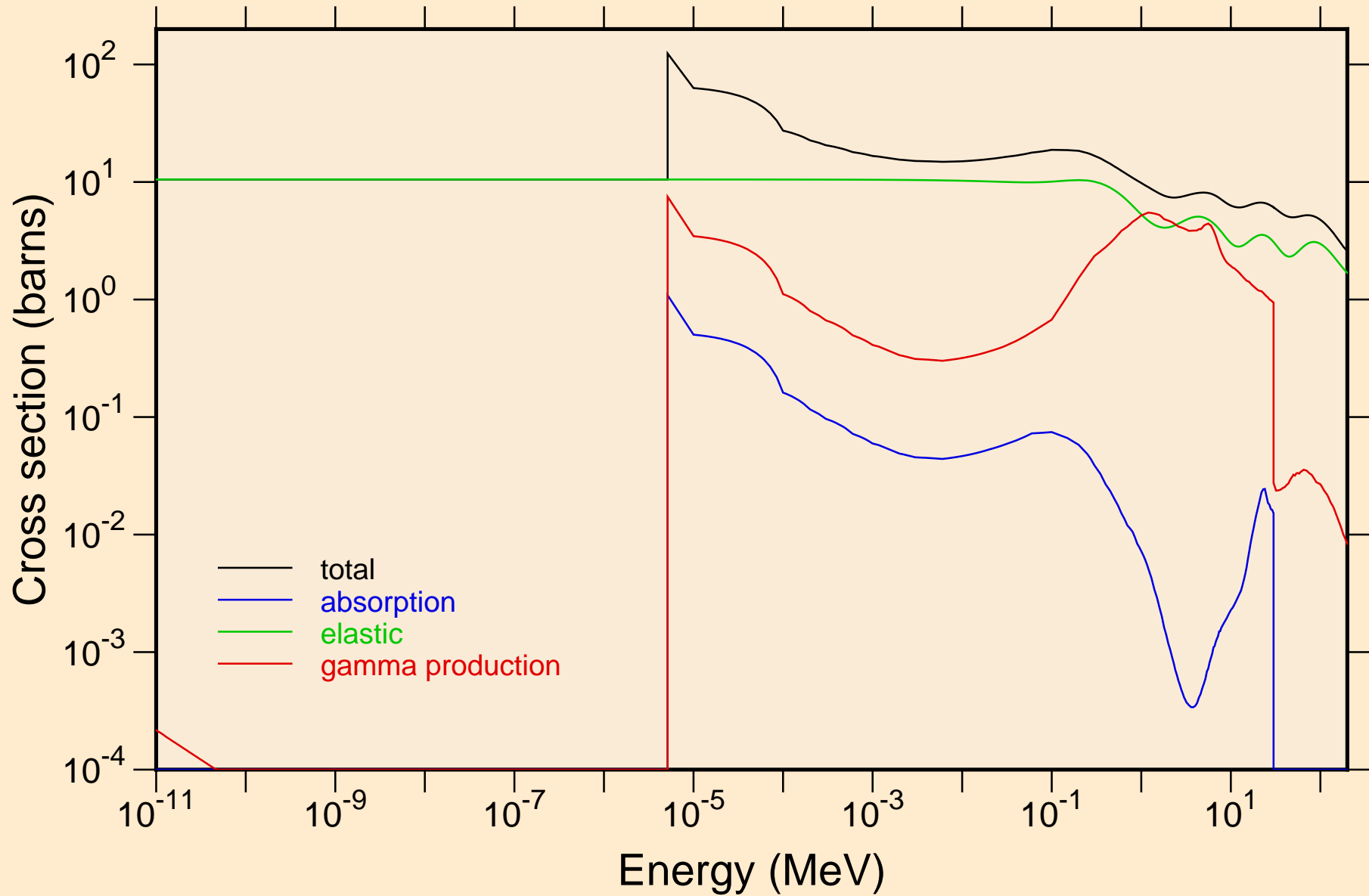

MT280 NEUTRON ACER TENDL-2023 LIBRARY; T=0.K  
Heating

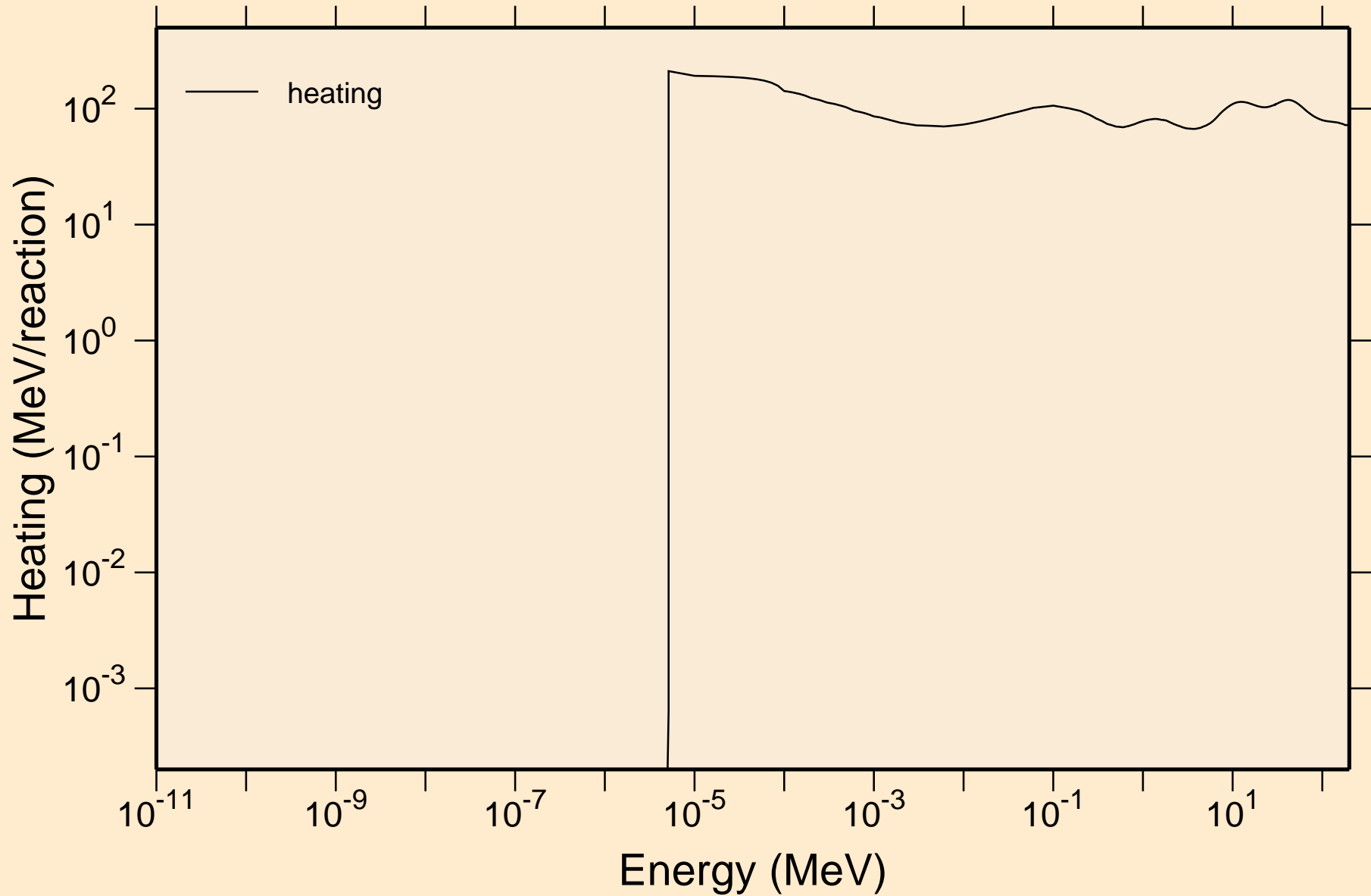

MT280 NEUTRON ACER TENDL-2023 LIBRARY; T=0.K  
Damage

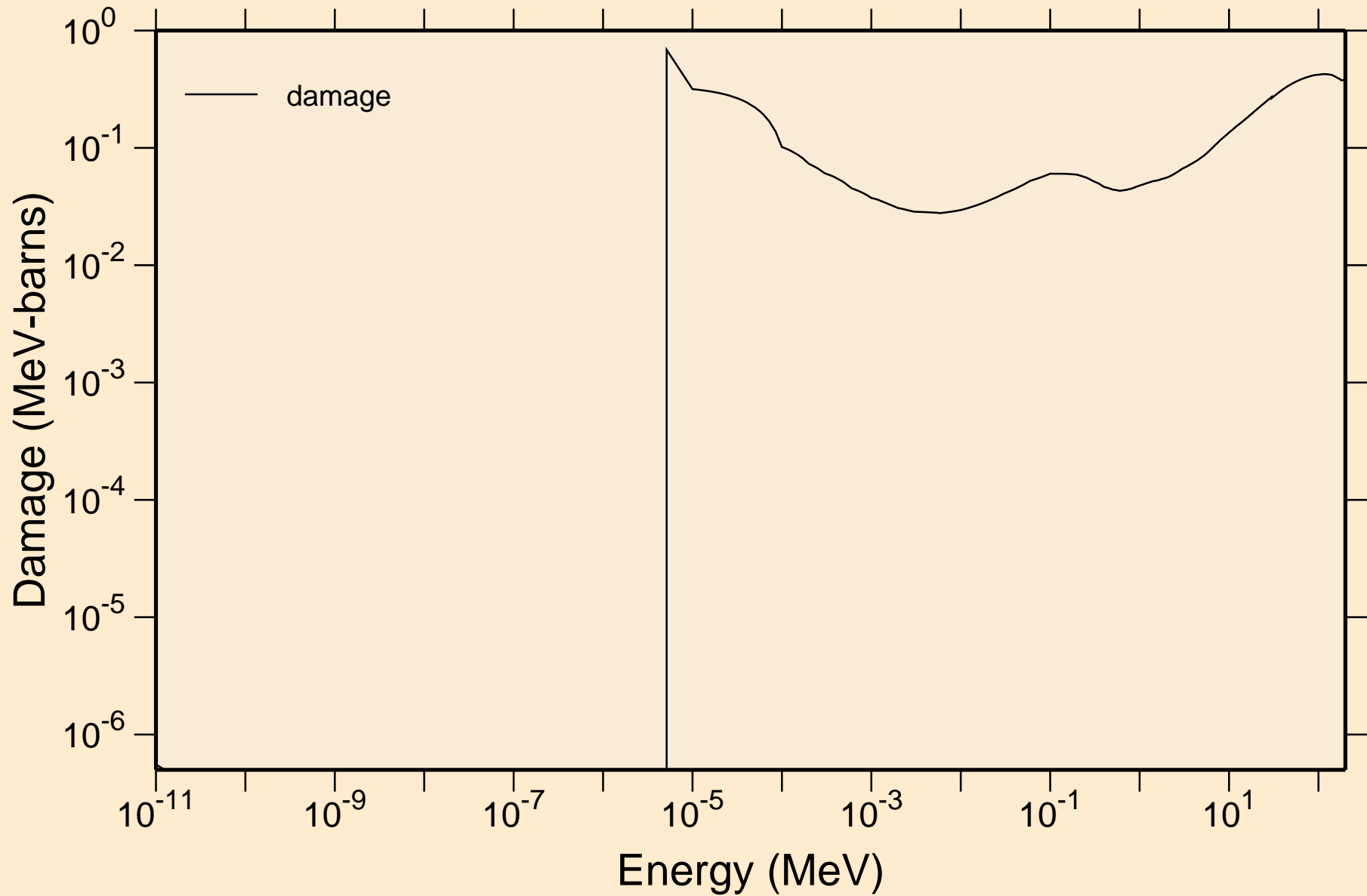

MT280 NEUTRON ACER TENDL-2023 LIBRARY; T=0.K  
Non-threshold reactions

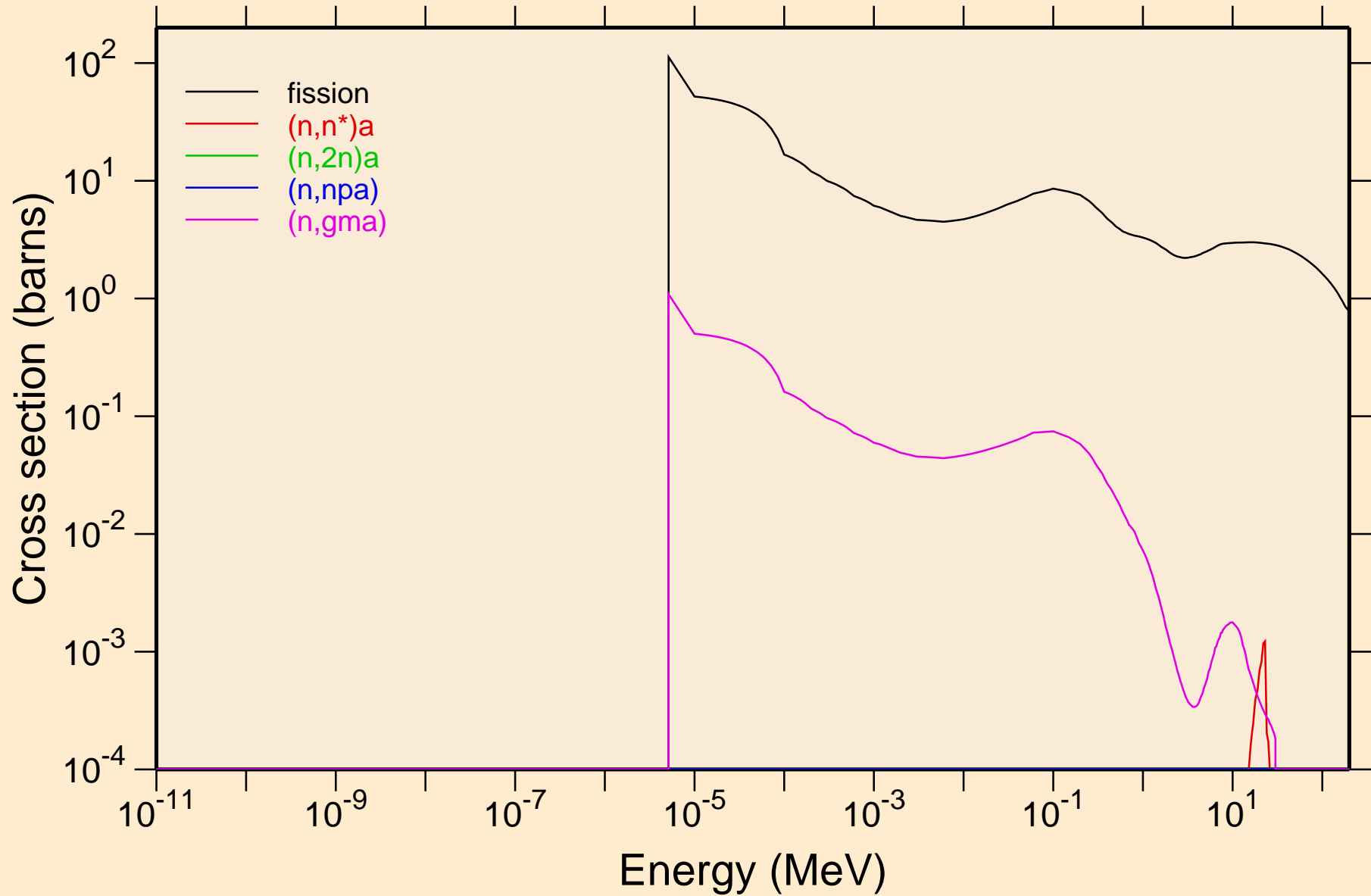

MT280 NEUTRON ACER TENDL-2023 LIBRARY; T=0.K  
Non-threshold reactions

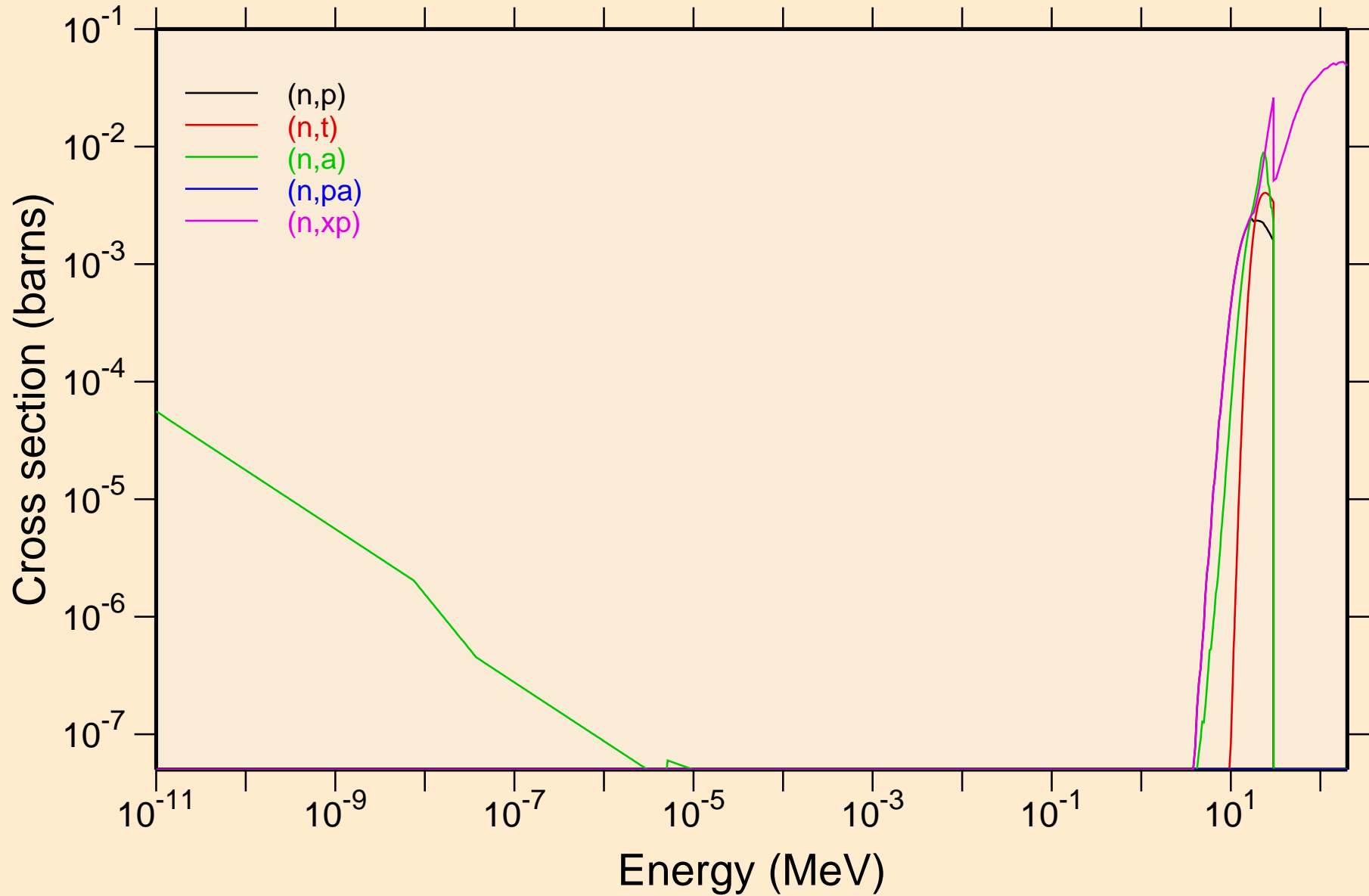

MT280 NEUTRON ACER TENDL-2023 LIBRARY; T=0.K  
Non-threshold reactions

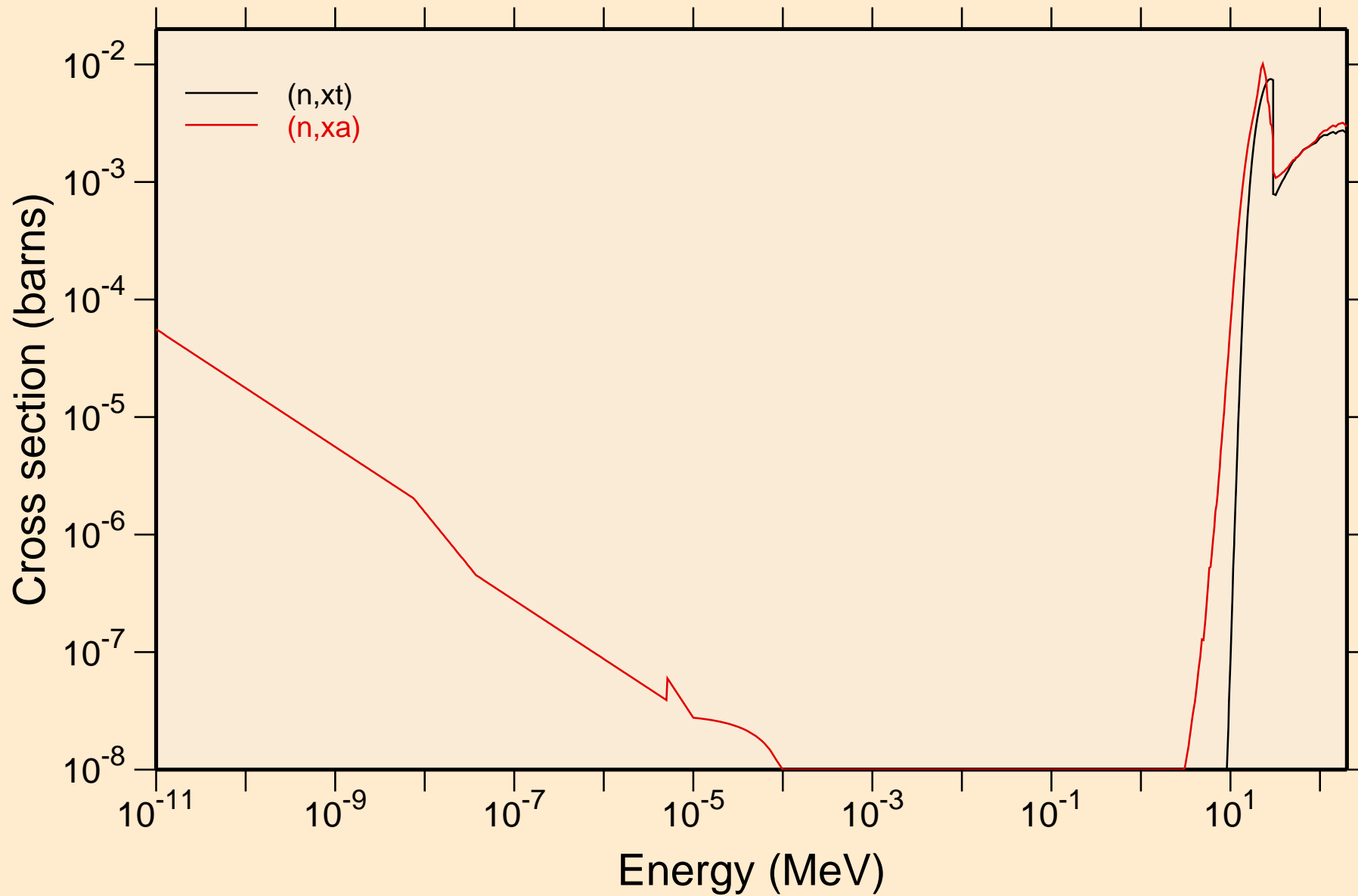

# MT280 NEUTRON ACER TENDL-2023 LIBRARY; T=0.K

## Principal cross sections

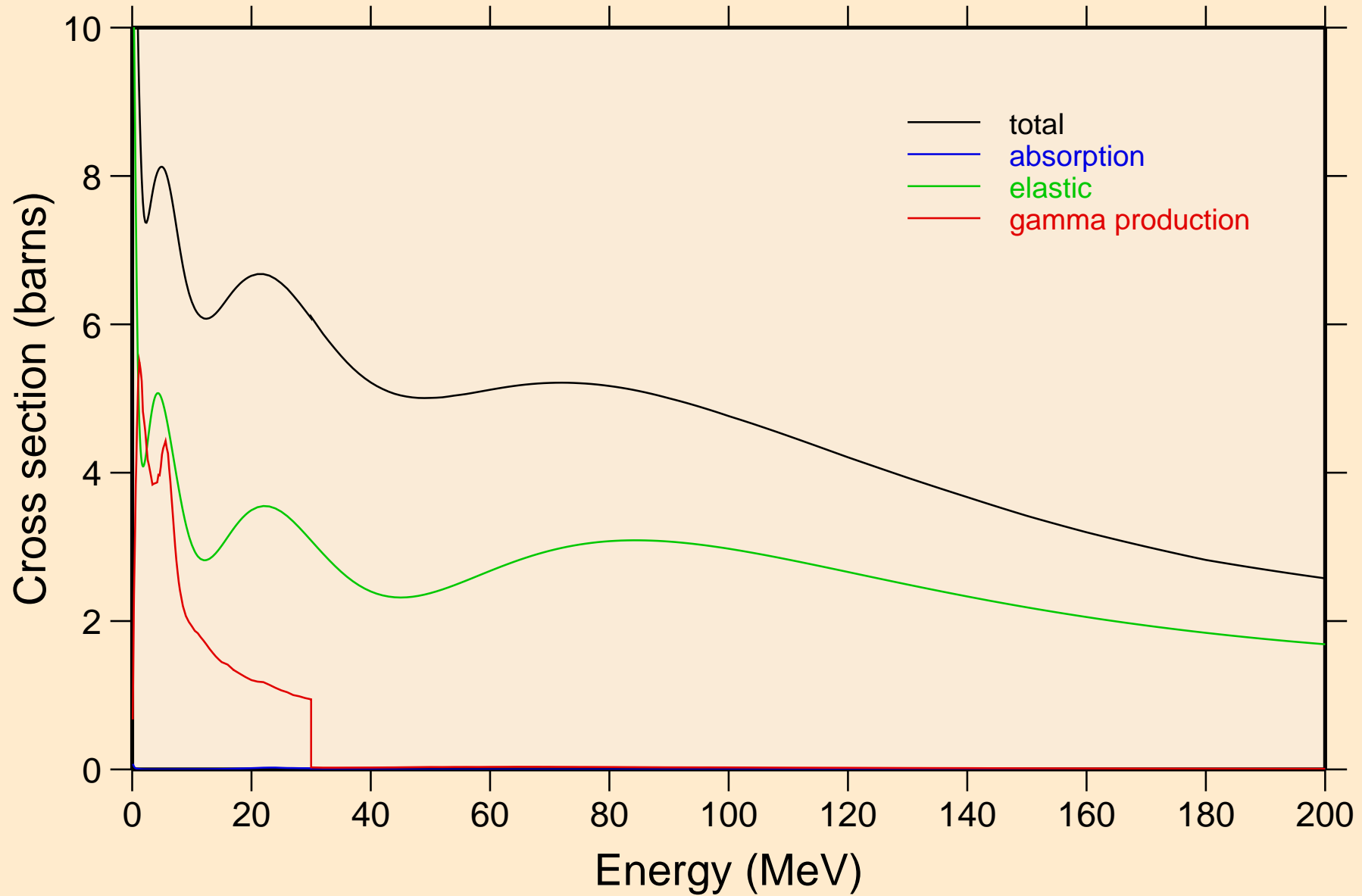

# MT280 NEUTRON ACER TENDL-2023 LIBRARY; T=0.K

## Heating

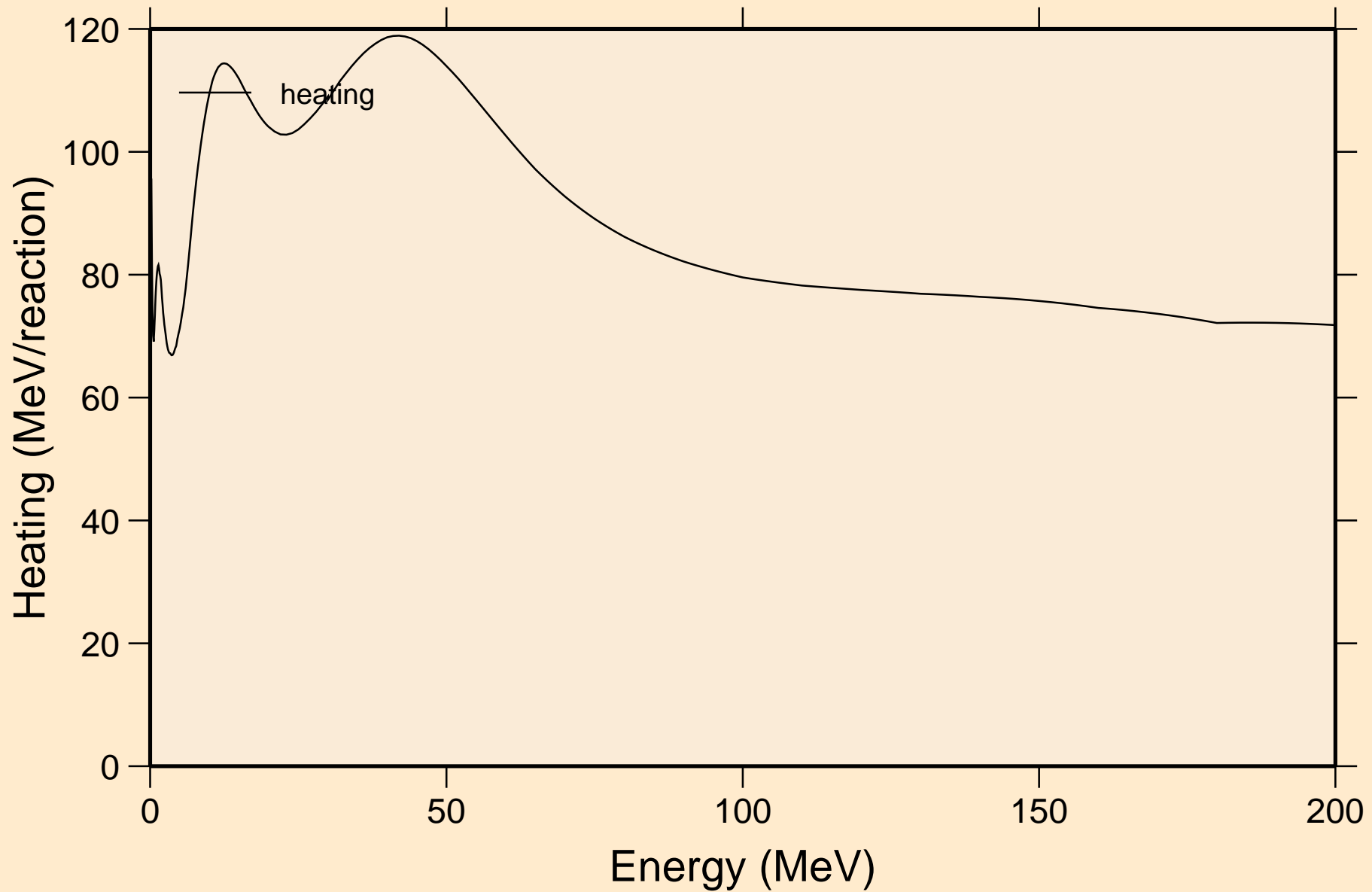



MT280 NEUTRON ACER TENDL-2023 LIBRARY; T=0.K  
Damage

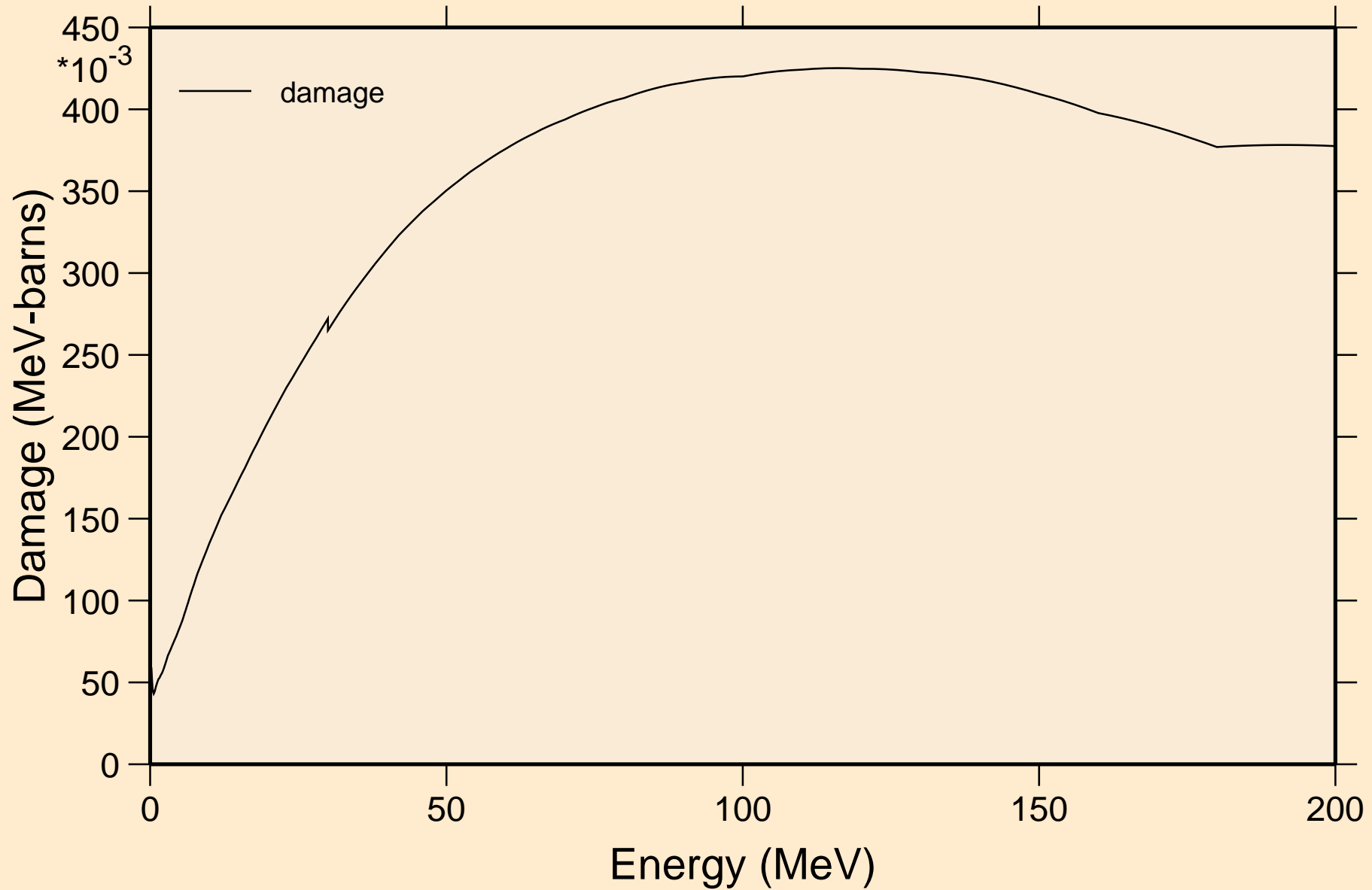

# MT280 NEUTRON ACER TENDL-2023 LIBRARY; T=0.K

## Non-threshold reactions

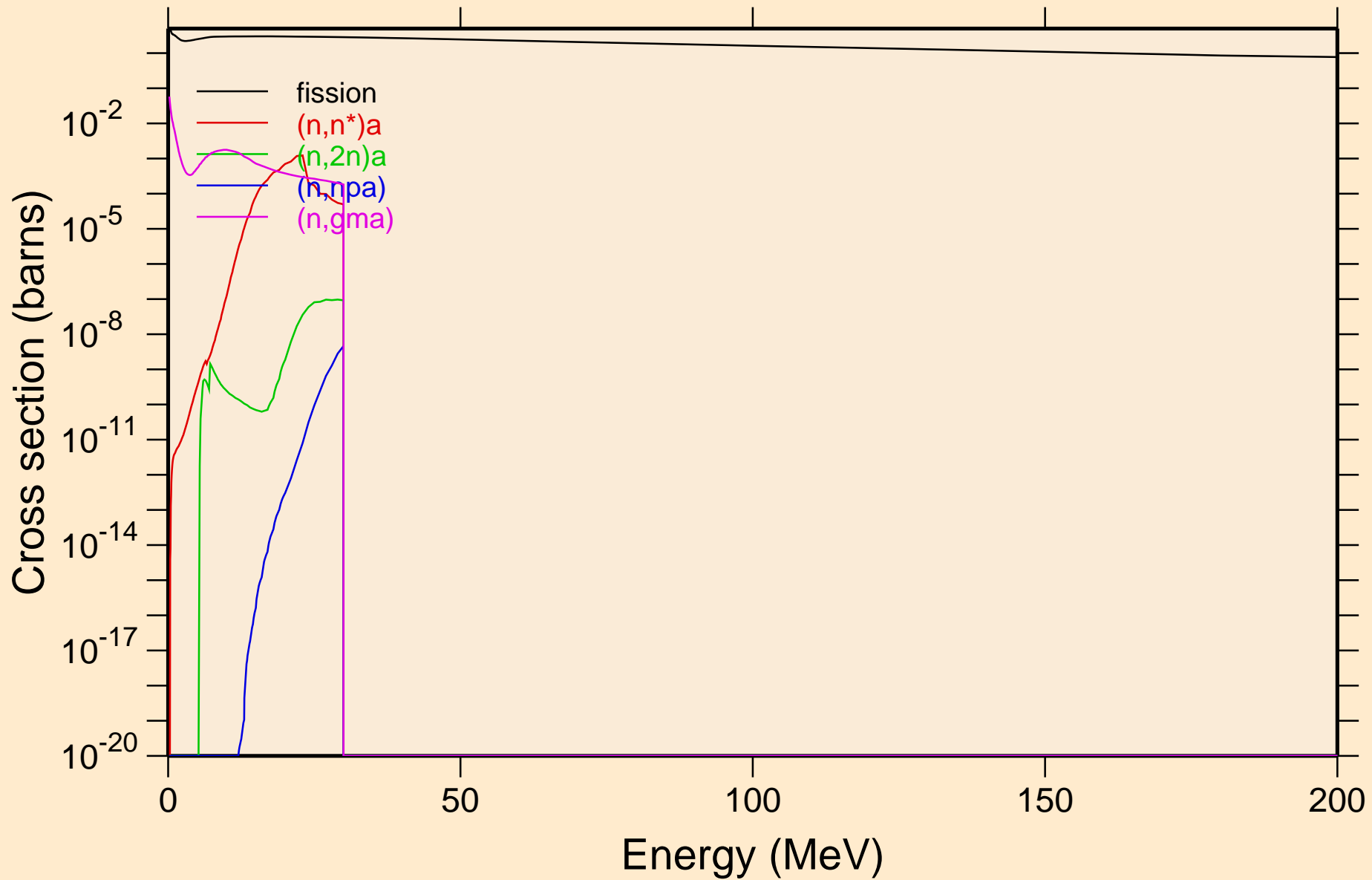

MT280 NEUTRON ACER TENDL-2023 LIBRARY; T=0.K  
Non-threshold reactions

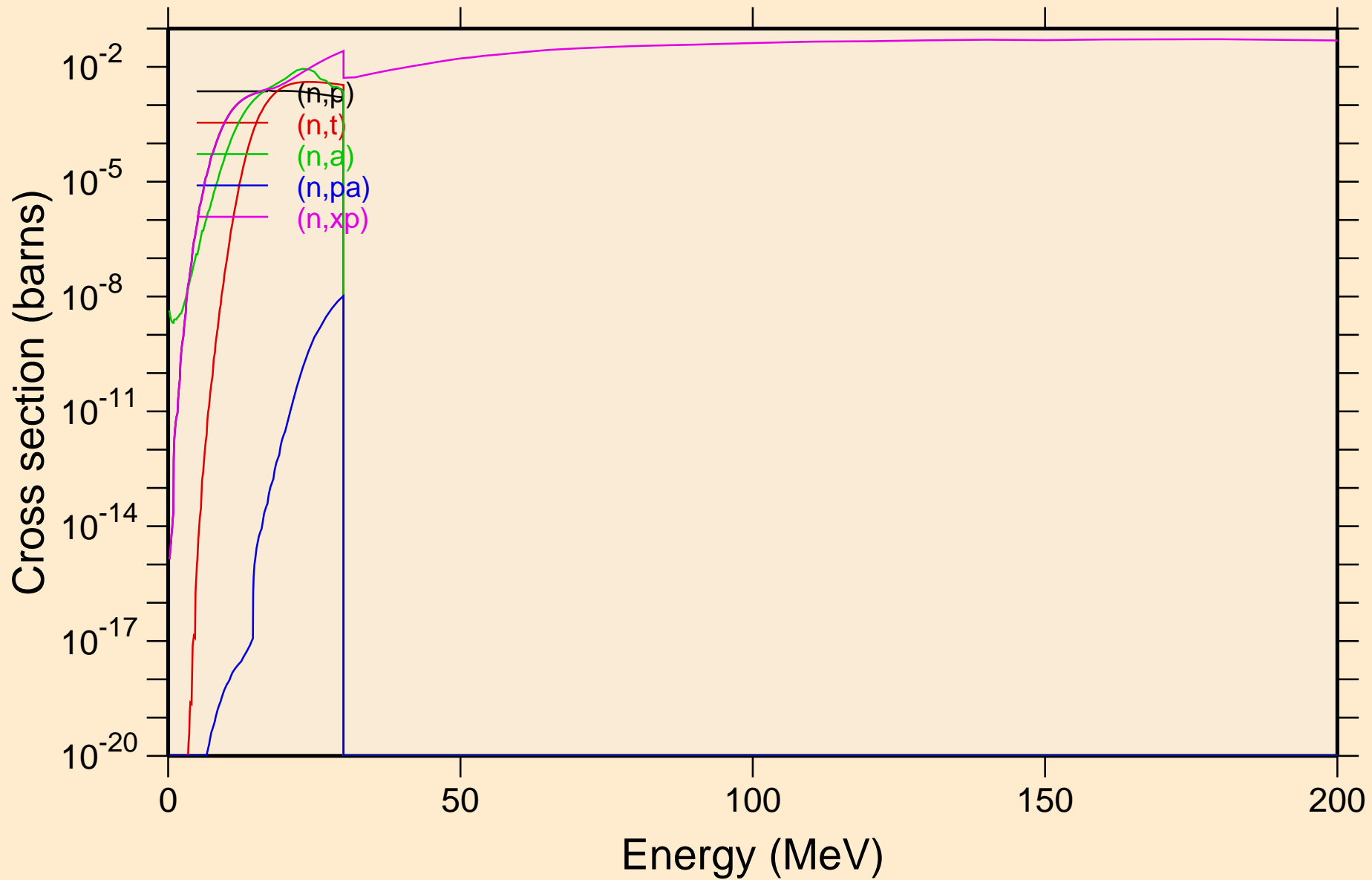

MT280 NEUTRON ACER TENDL-2023 LIBRARY; T=0.K  
Non-threshold reactions

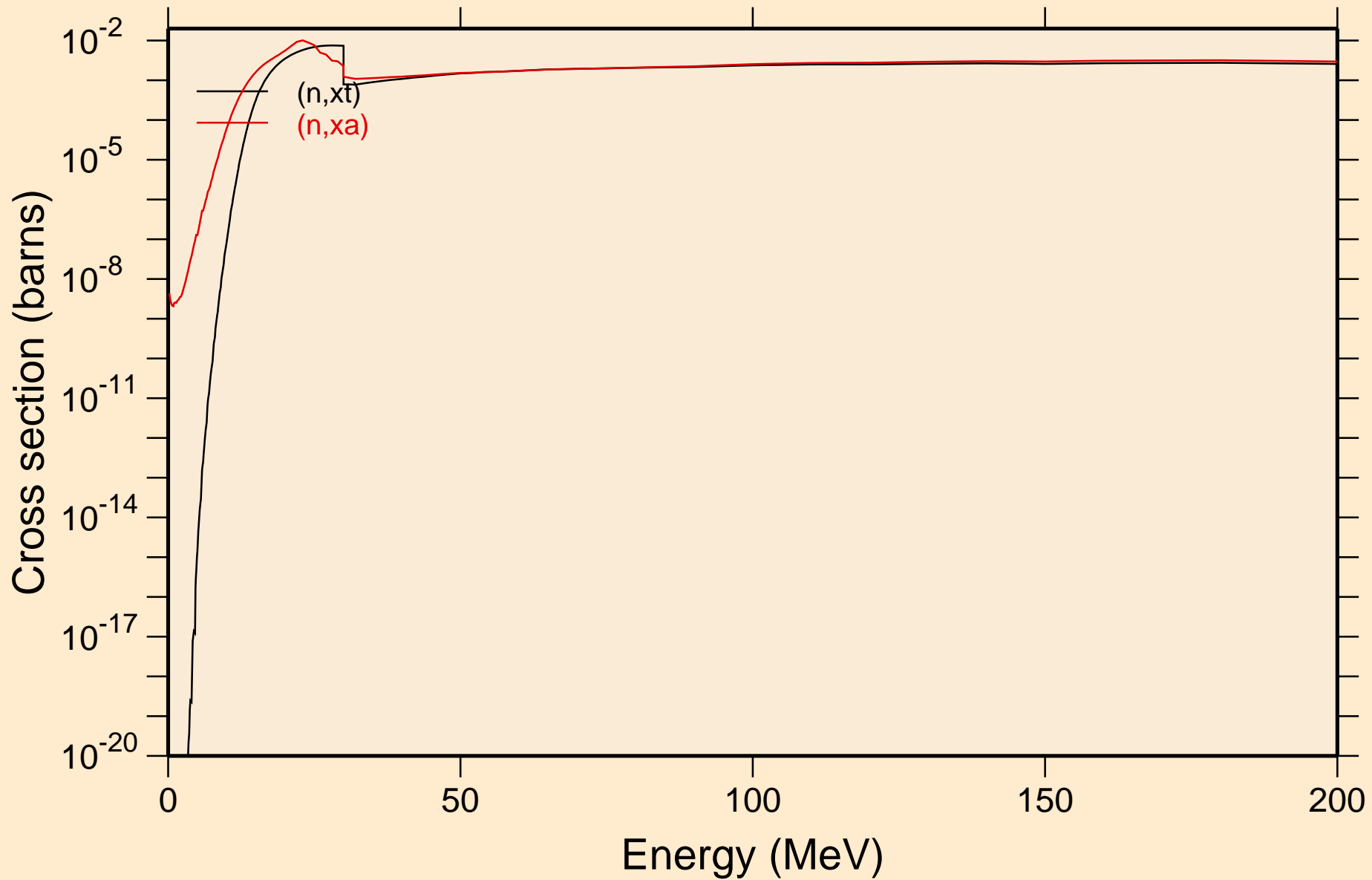

MT280 NEUTRON ACER TENDL-2023 LIBRARY; T=0.K  
Inelastic levels

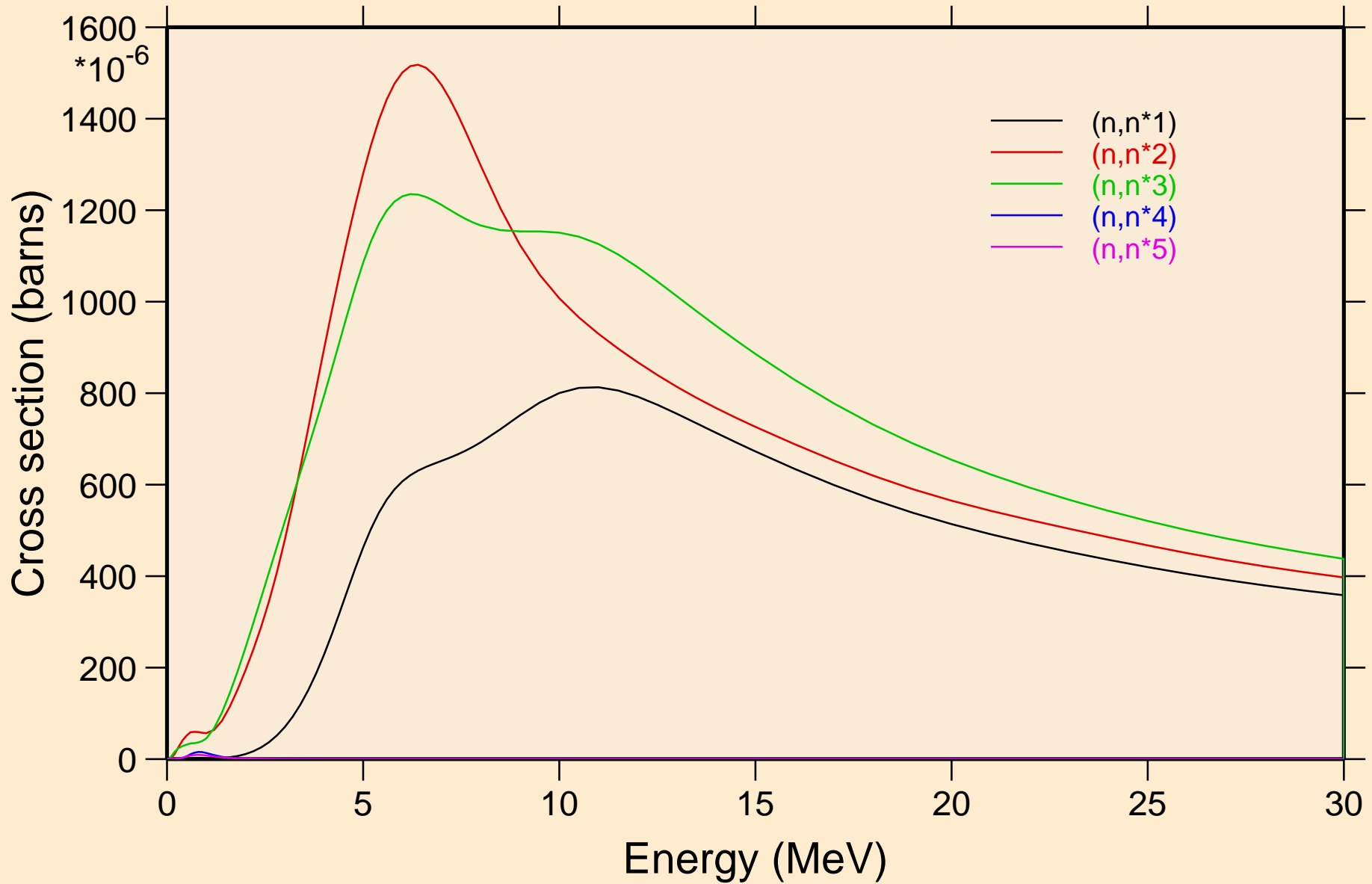

MT280 NEUTRON ACER TENDL-2023 LIBRARY; T=0.K  
Inelastic levels

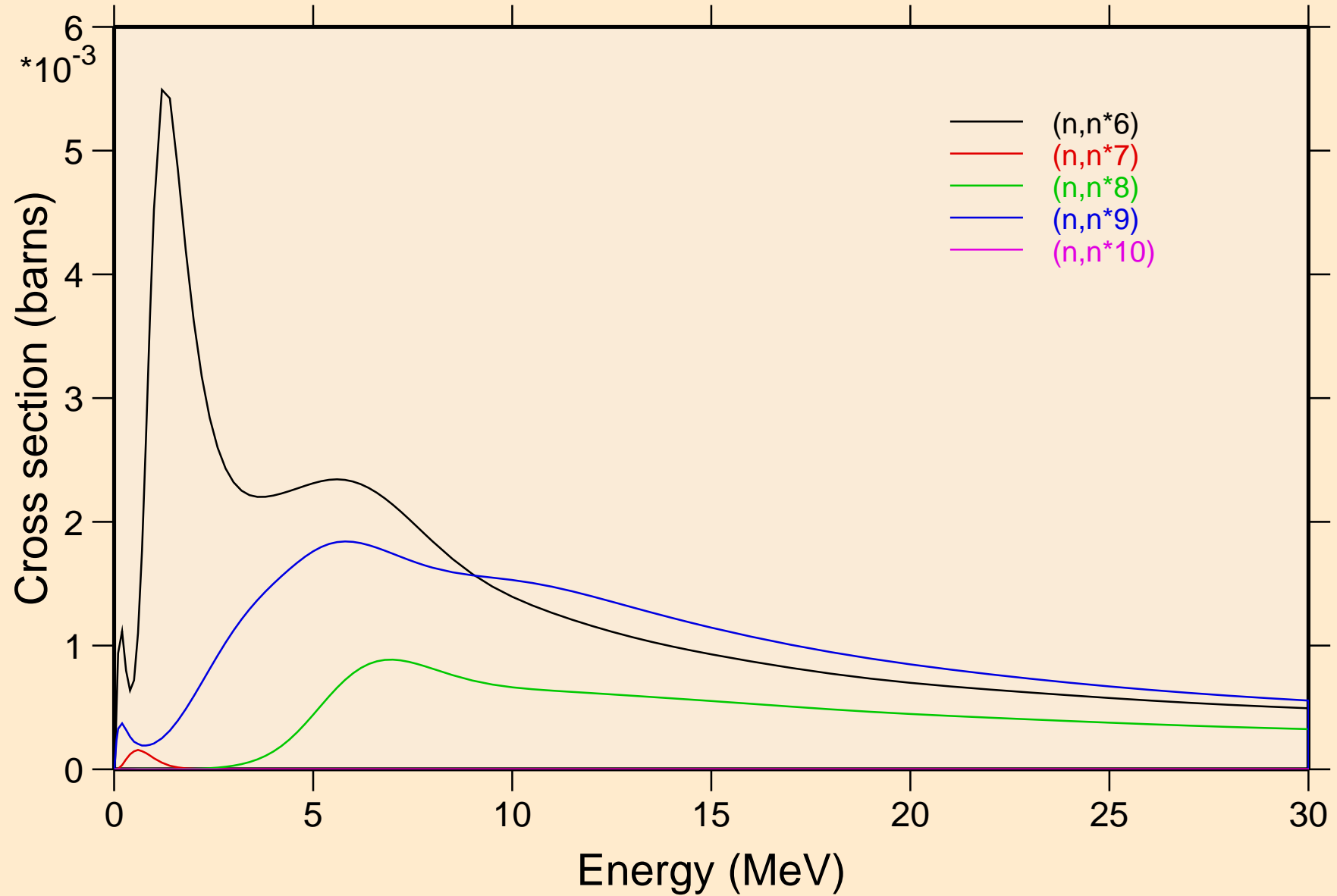

MT280 NEUTRON ACER TENDL-2023 LIBRARY; T=0.K  
Inelastic levels

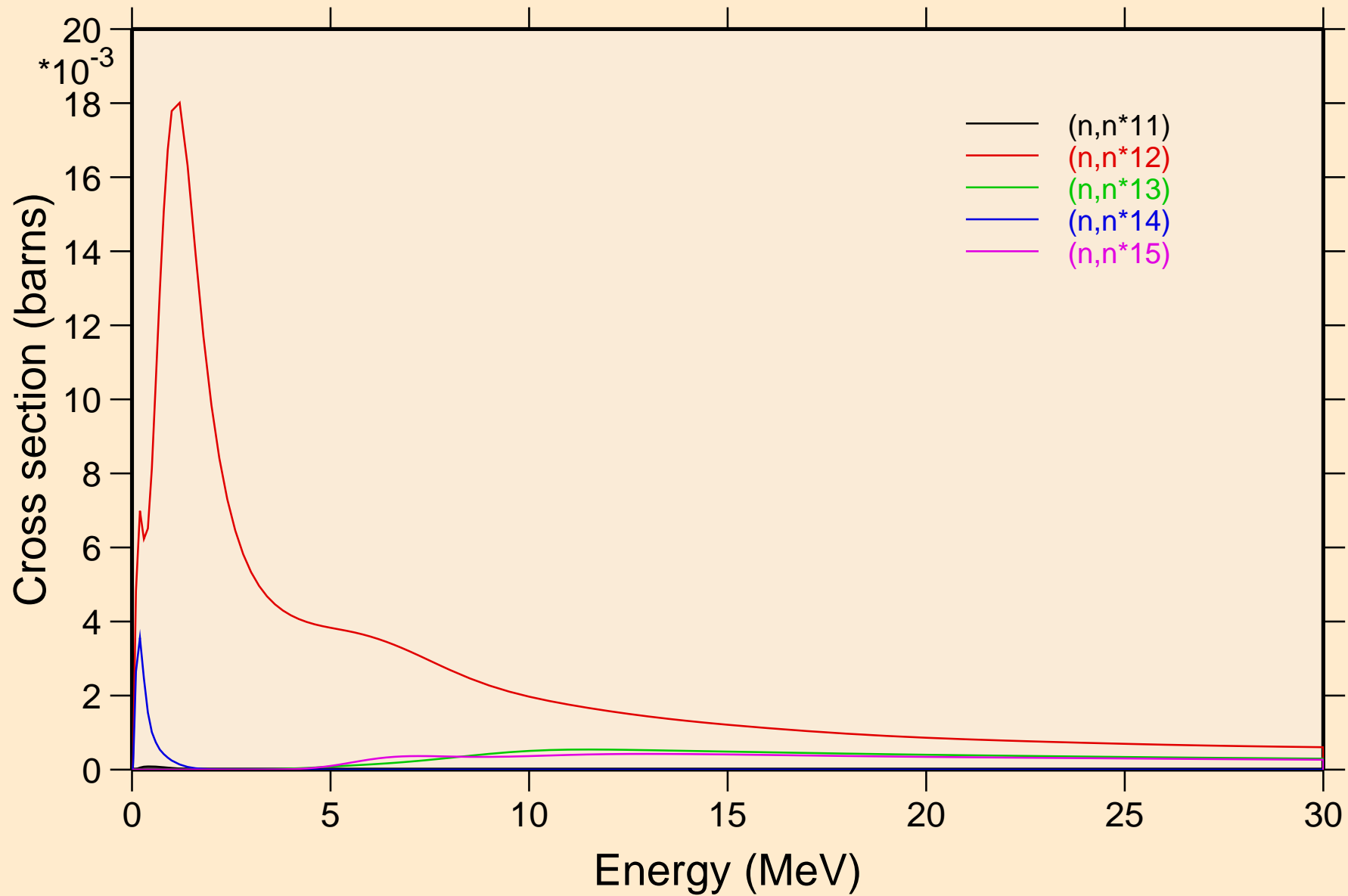

MT280 NEUTRON ACER TENDL-2023 LIBRARY; T=0.K  
Inelastic levels

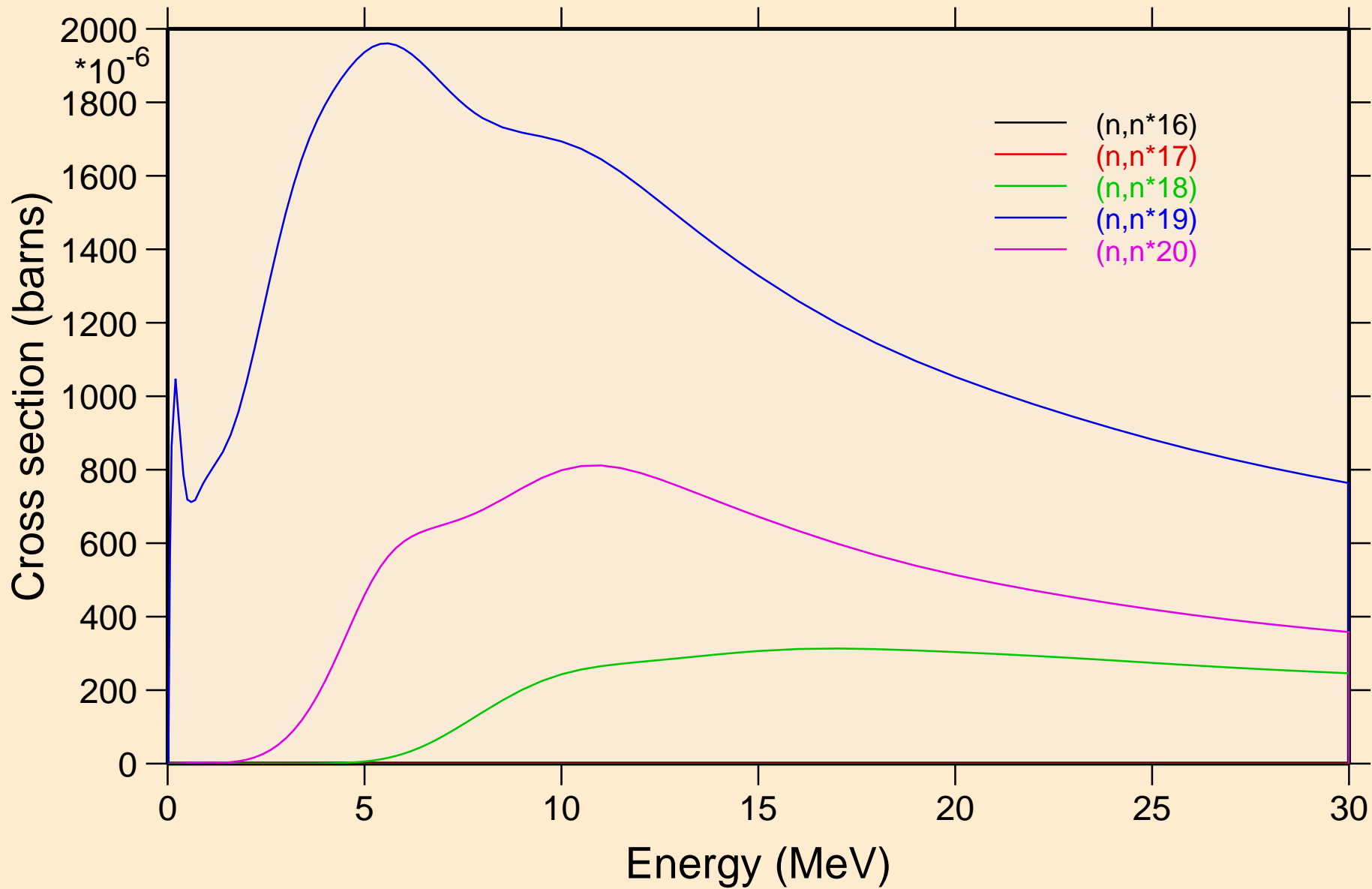



MT280 NEUTRON ACER TENDL-2023 LIBRARY; T=0.K  
Inelastic levels

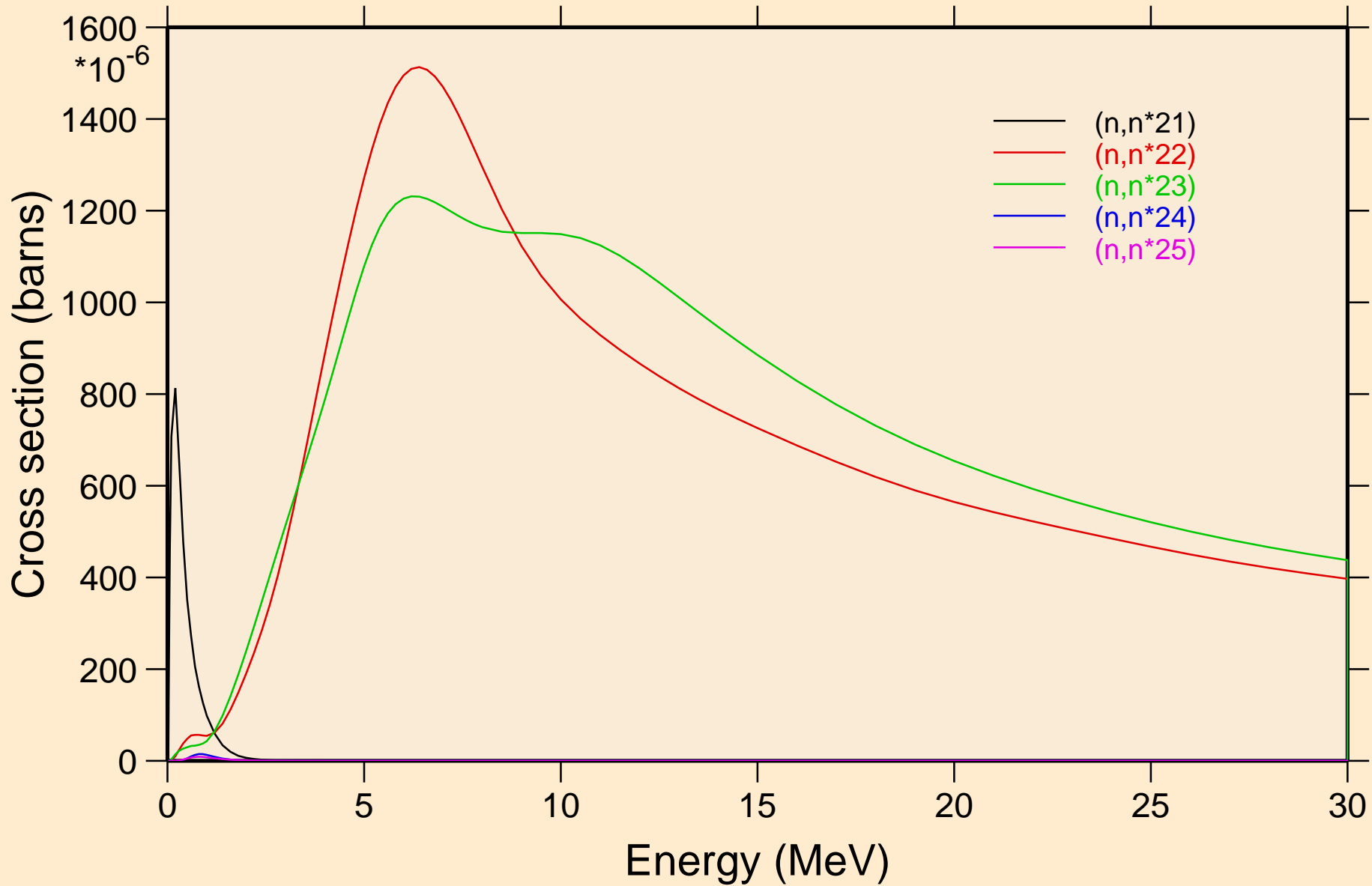

MT280 NEUTRON ACER TENDL-2023 LIBRARY; T=0.K  
Inelastic levels

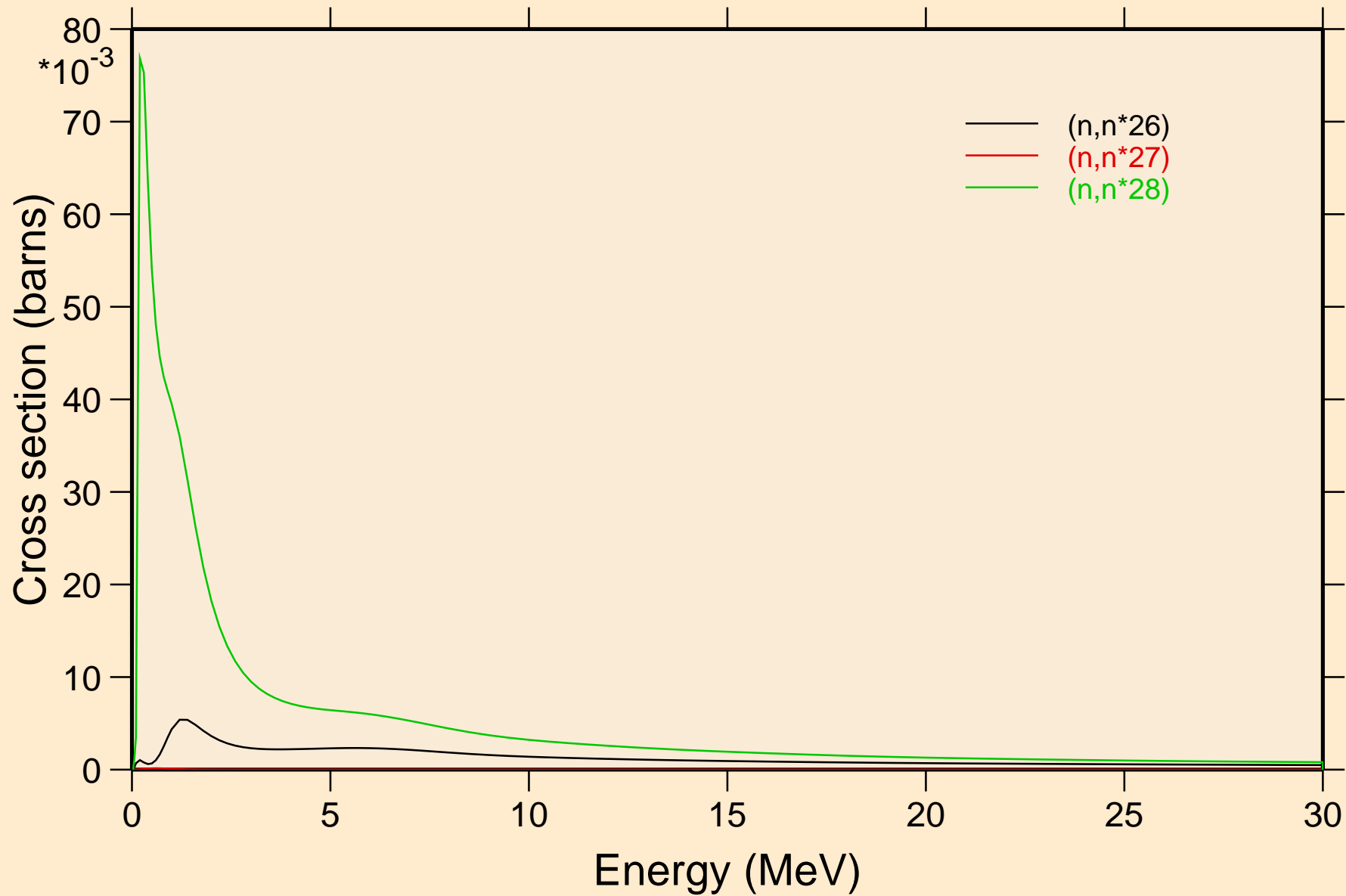

# MT280 NEUTRON ACER TENDL-2023 LIBRARY; T=0.K

## Threshold reactions

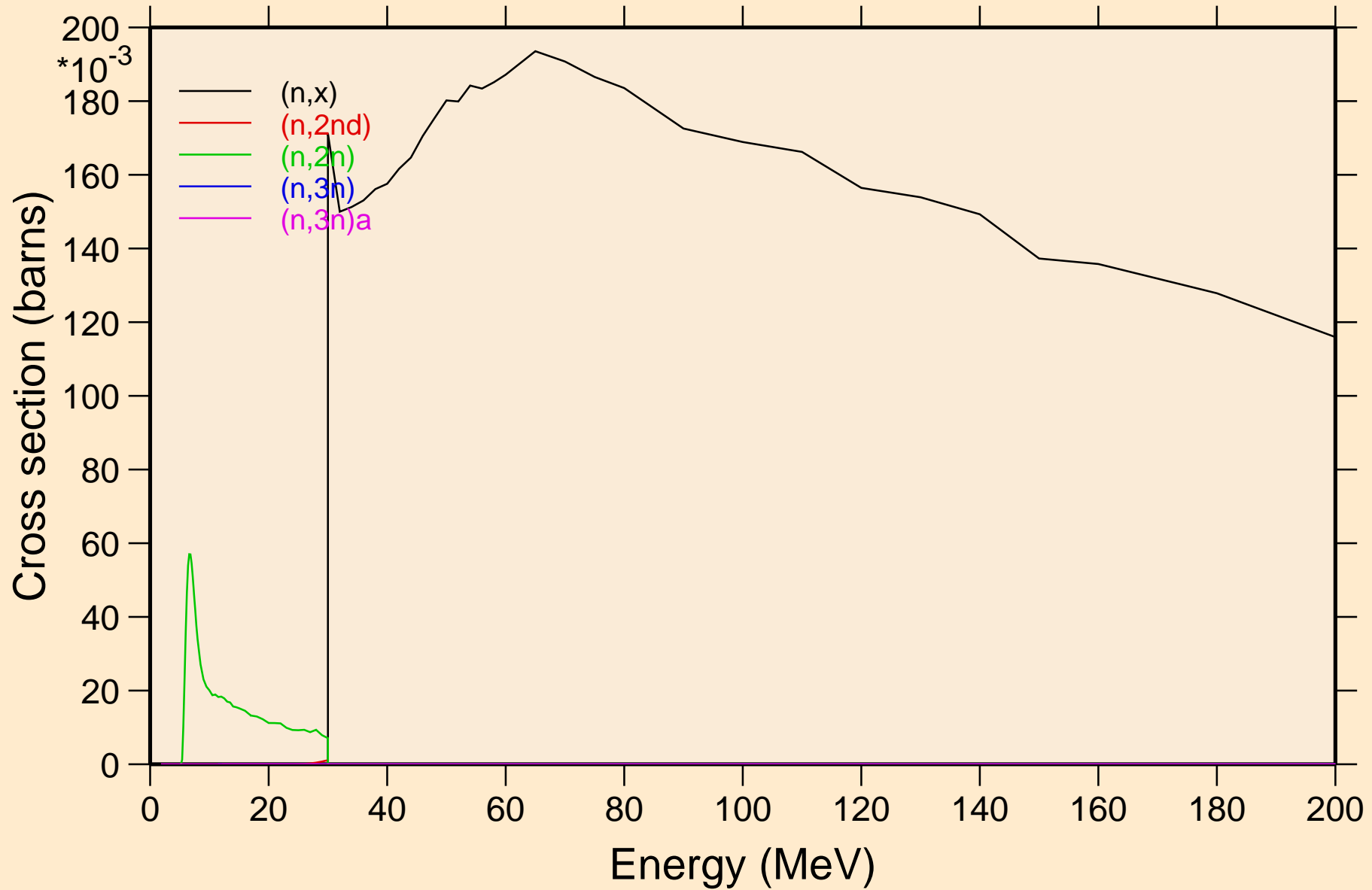

MT280 NEUTRON ACER TENDL-2023 LIBRARY; T=0.K  
Threshold reactions

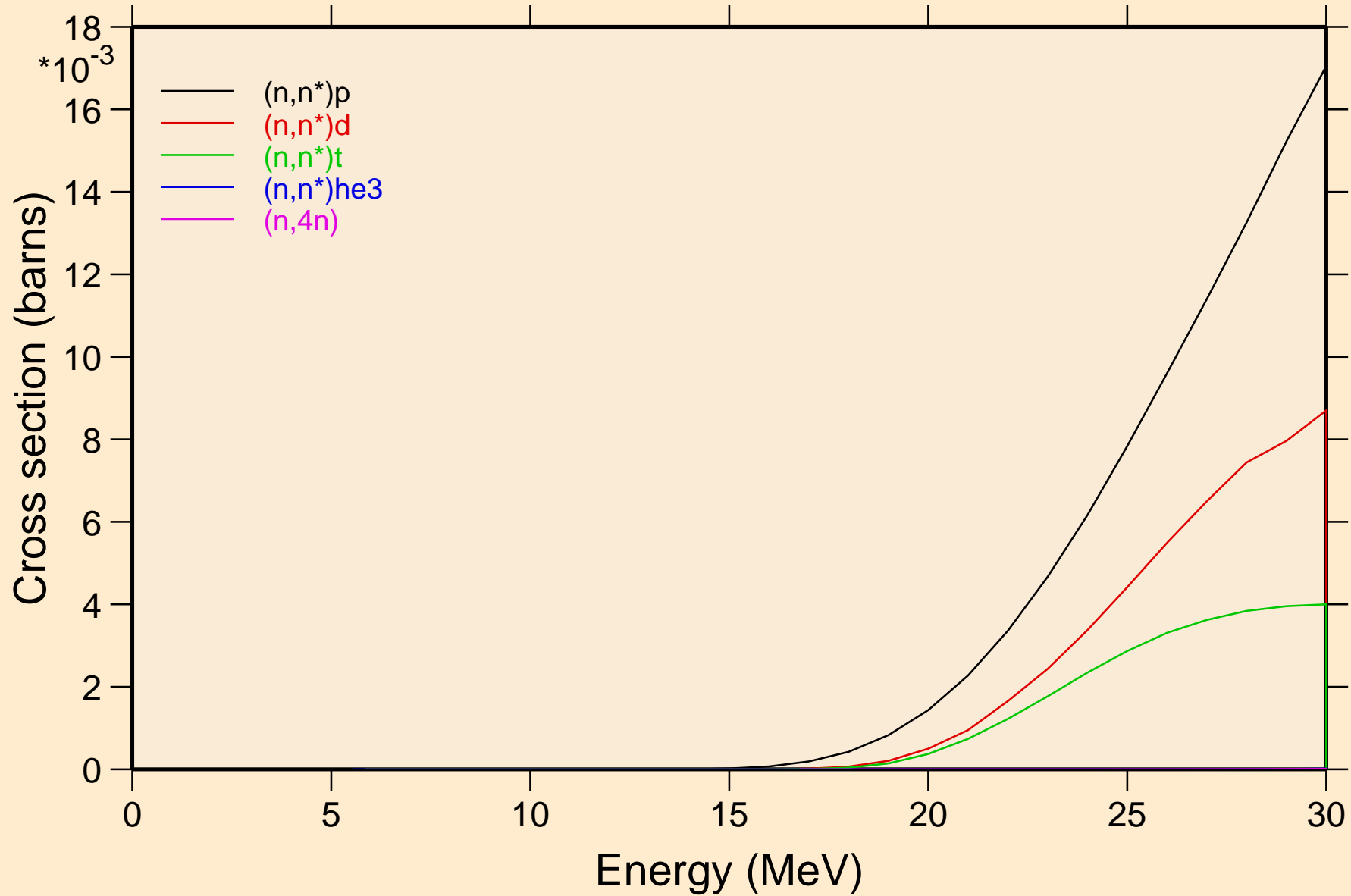

MT280 NEUTRON ACER TENDL-2023 LIBRARY; T=0.K  
Threshold reactions

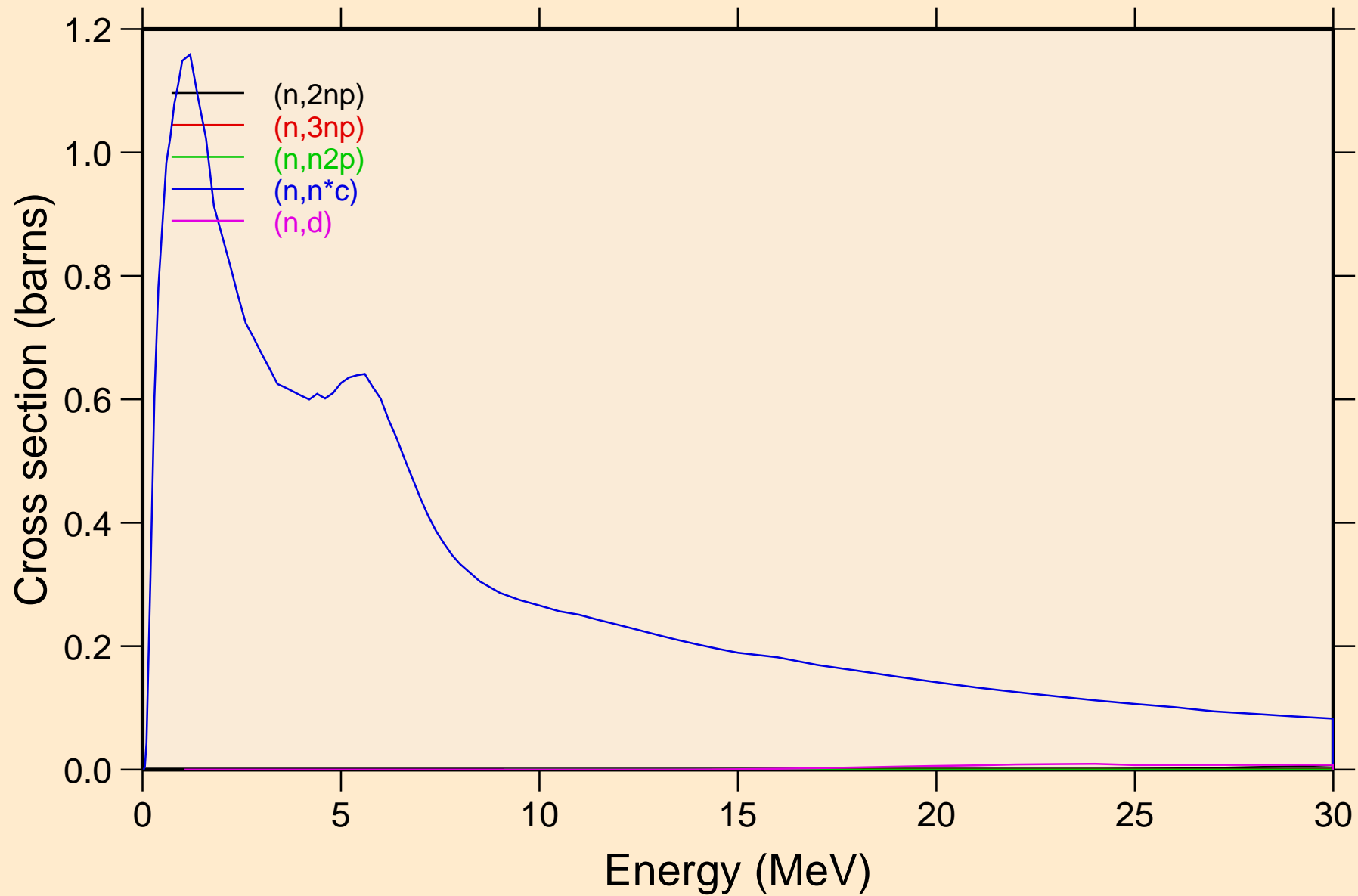

MT280 NEUTRON ACER TENDL-2023 LIBRARY; T=0.K  
Threshold reactions

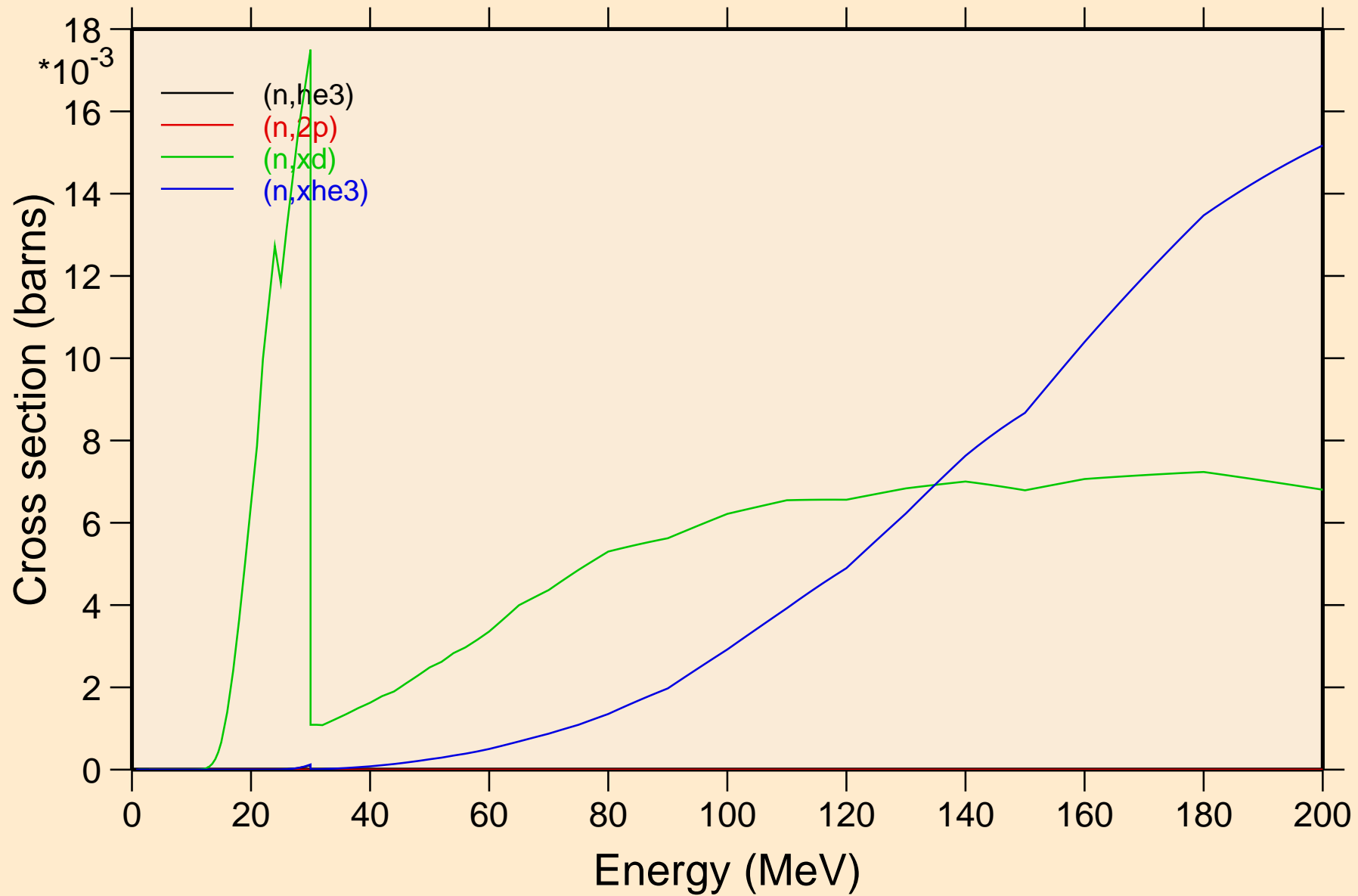

MT280 NEUTRON ACER TENDL-2023 LIBRARY; T=0.K  
angular distribution for elastic

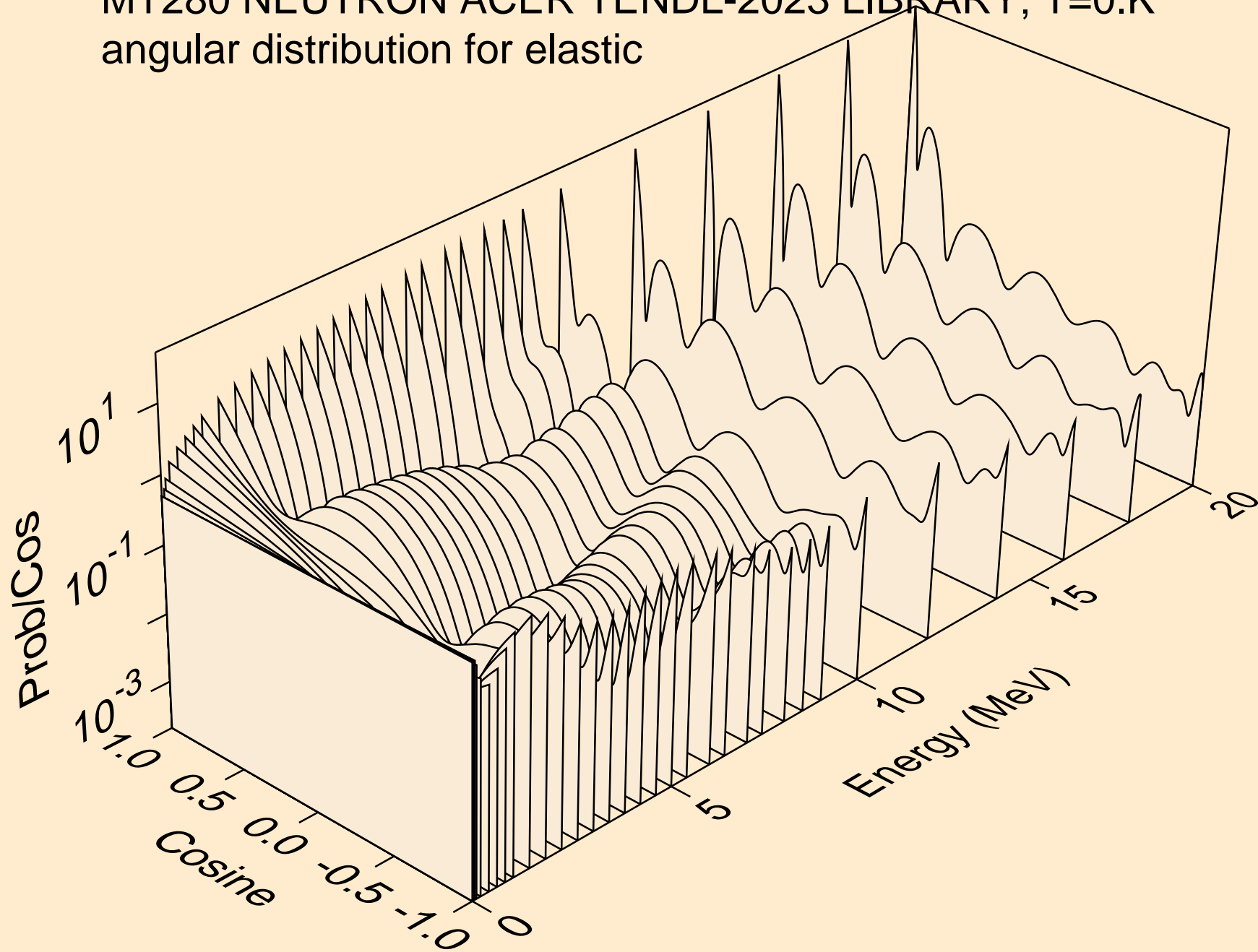

MT280 NEUTRON ACER TENDL-2023 LIBRARY; T=0.K  
angular distribution for elastic

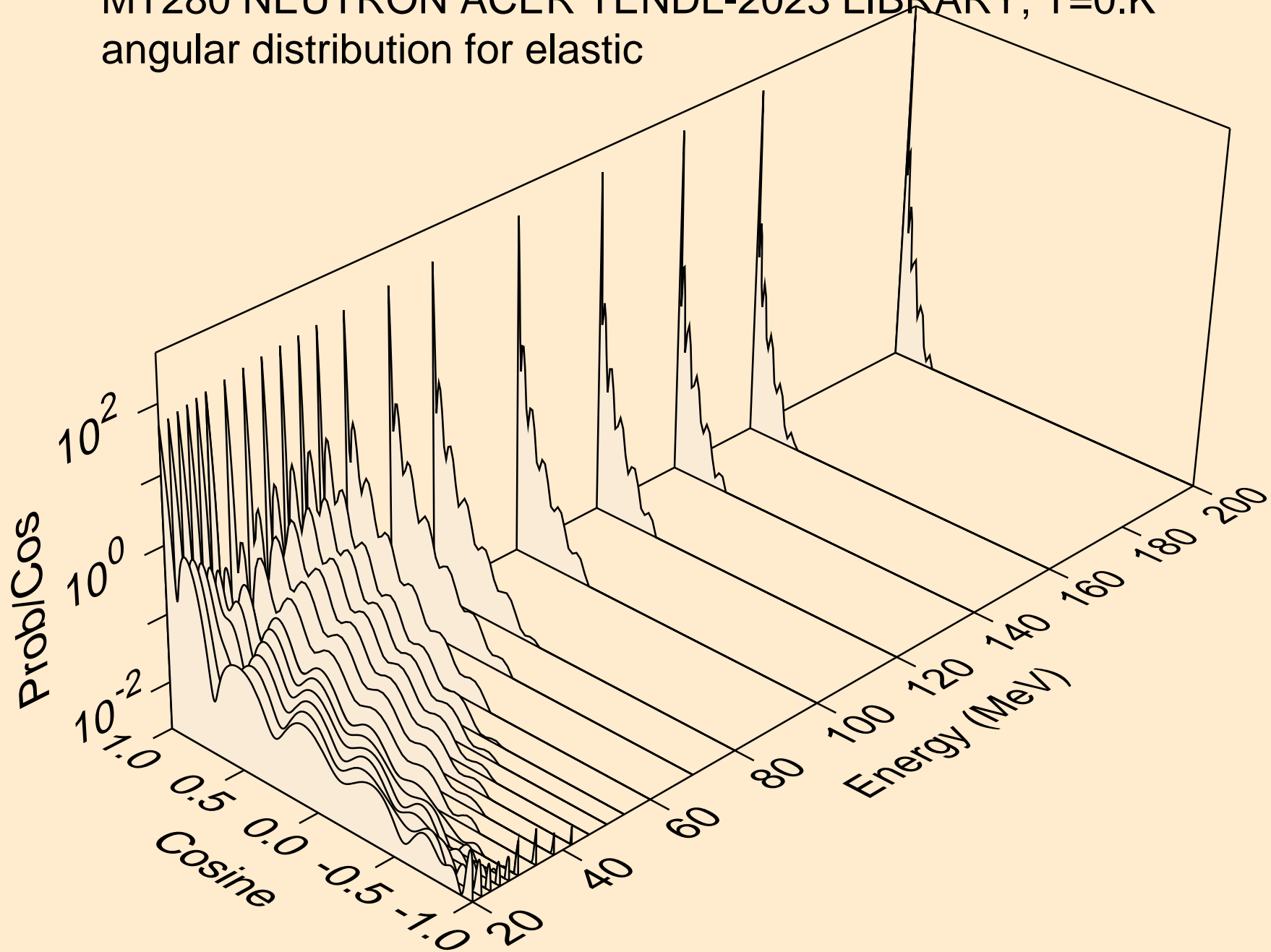



MT280 NEUTRON ACER TENDL-2023 LIBRARY; T=0.K  
angular distribution for (n,n\*1)

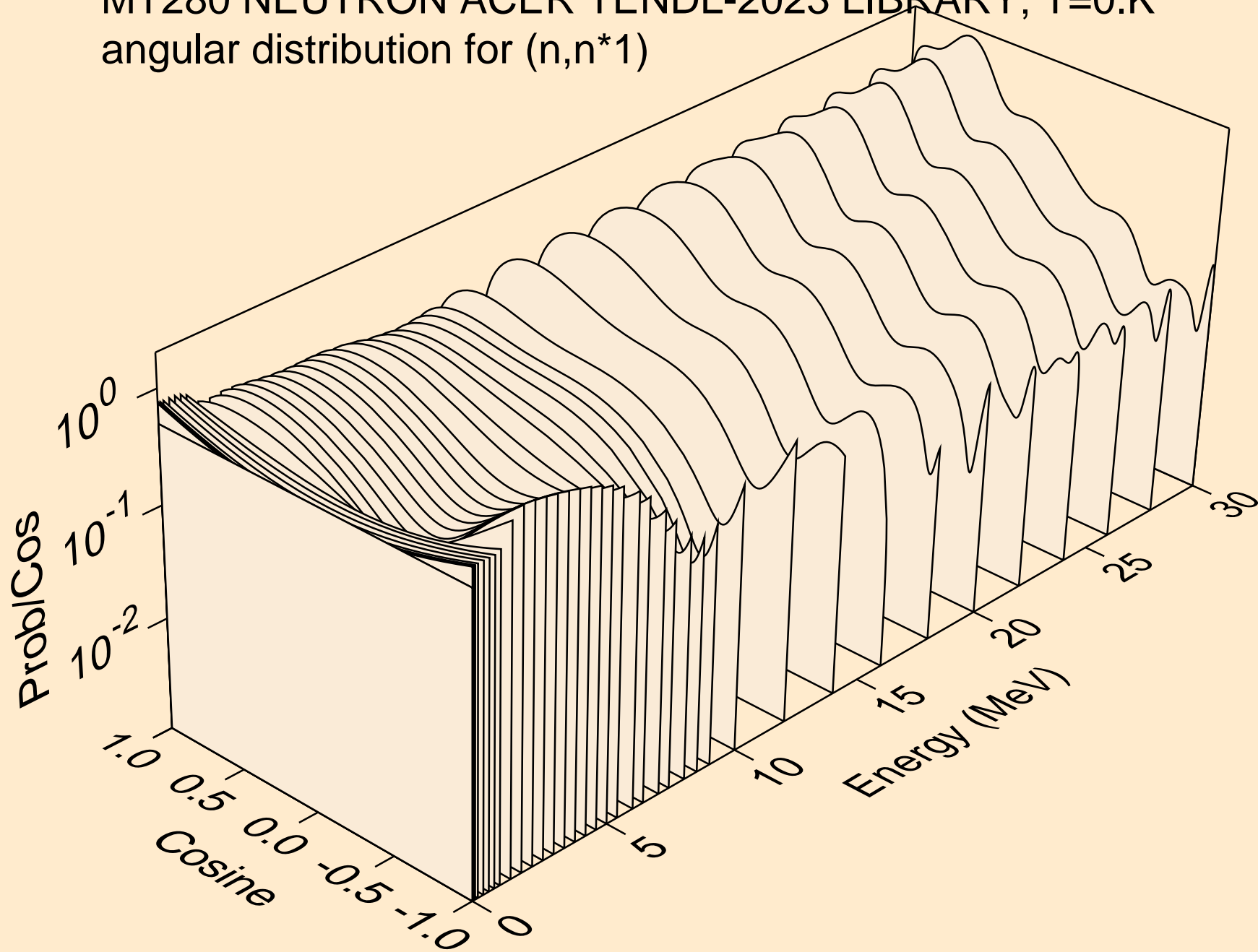

MT280 NEUTRON ACER TENDL-2023 LIBRARY; T=0.K  
angular distribution for (n,n\*2)

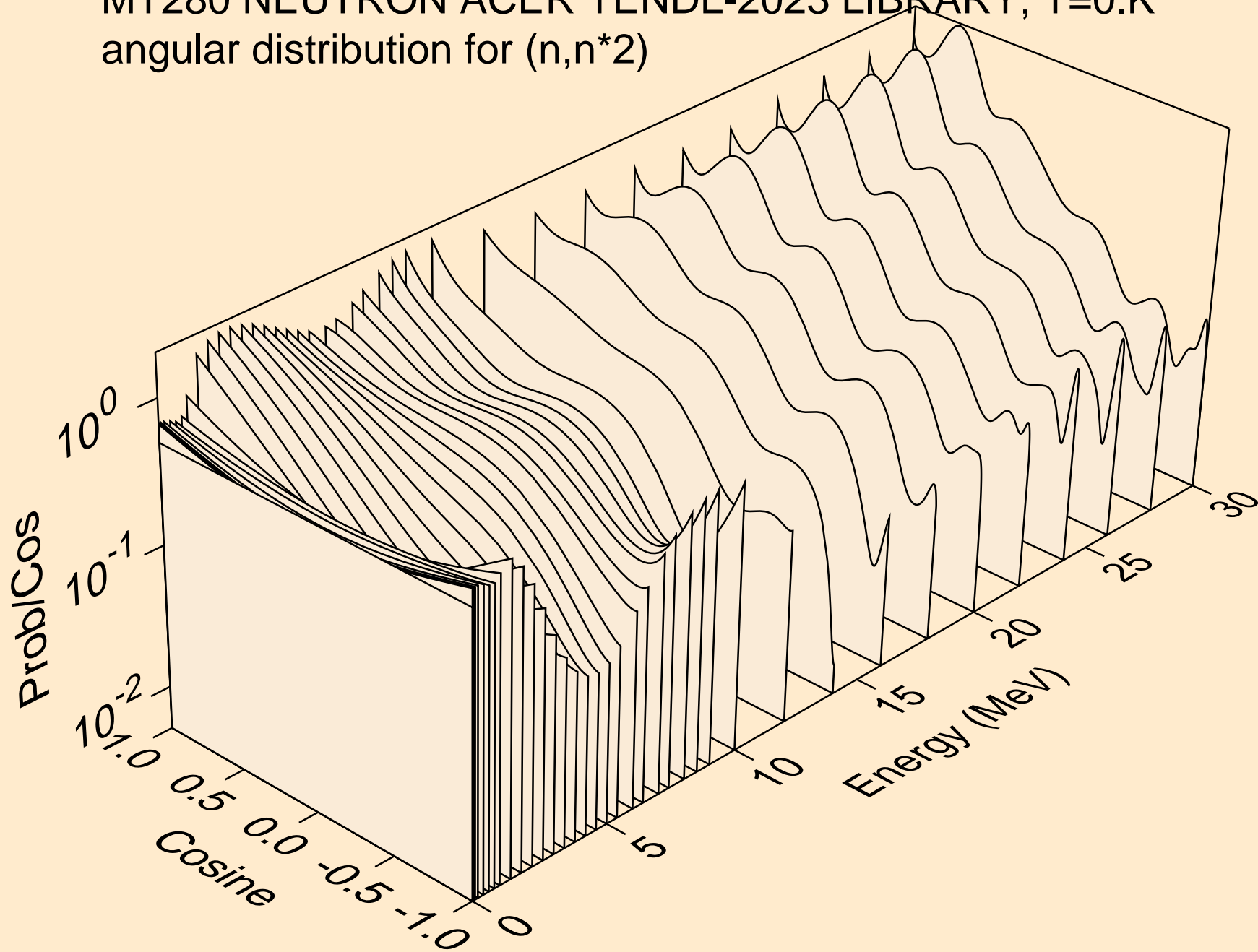

MT280 NEUTRON ACER TENDL-2023 LIBRARY; T=0.K  
angular distribution for (n,n\*3)

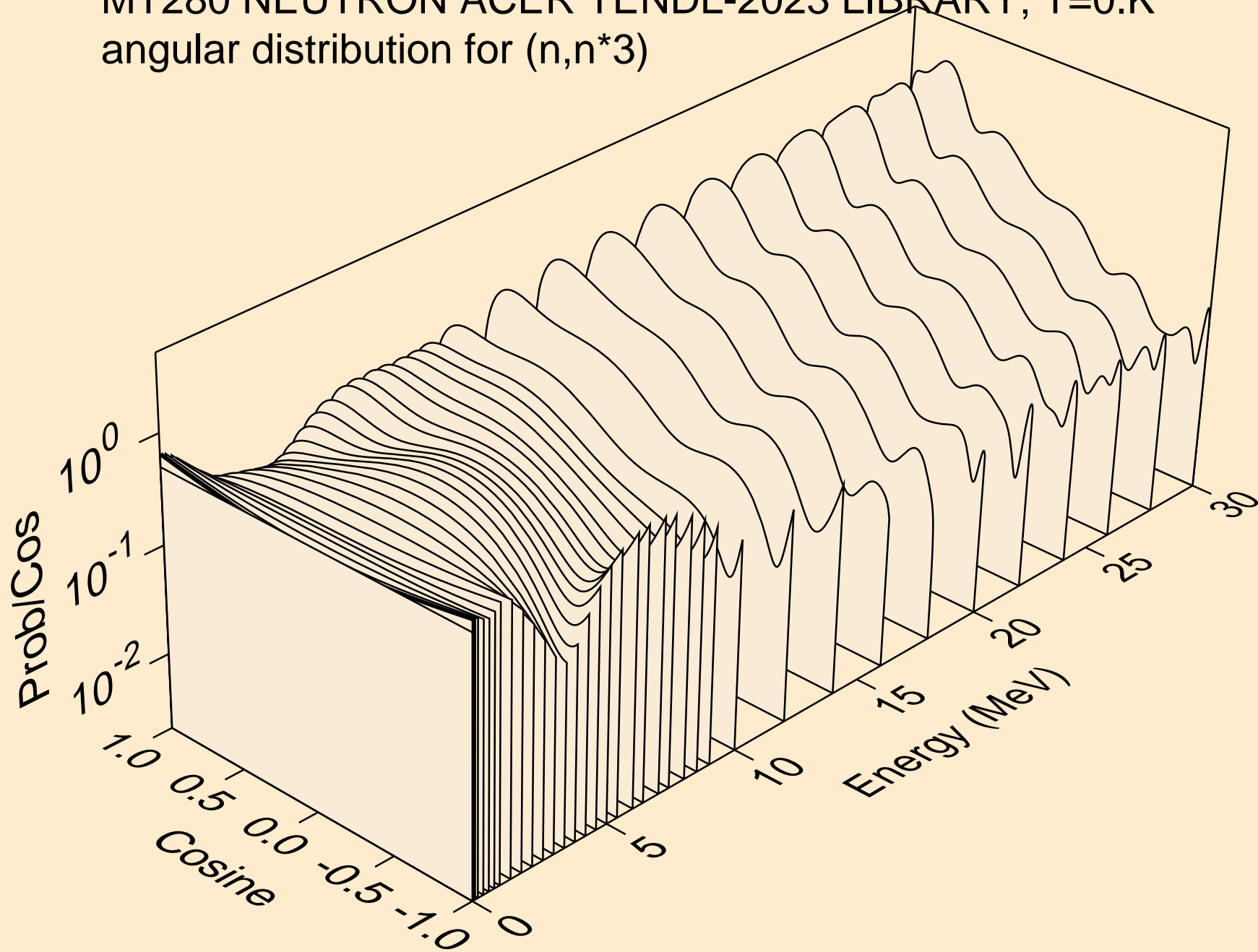

MT280 NEUTRON ACER TENDL-2023 LIBRARY; T=0.K  
angular distribution for (n,n\*4)

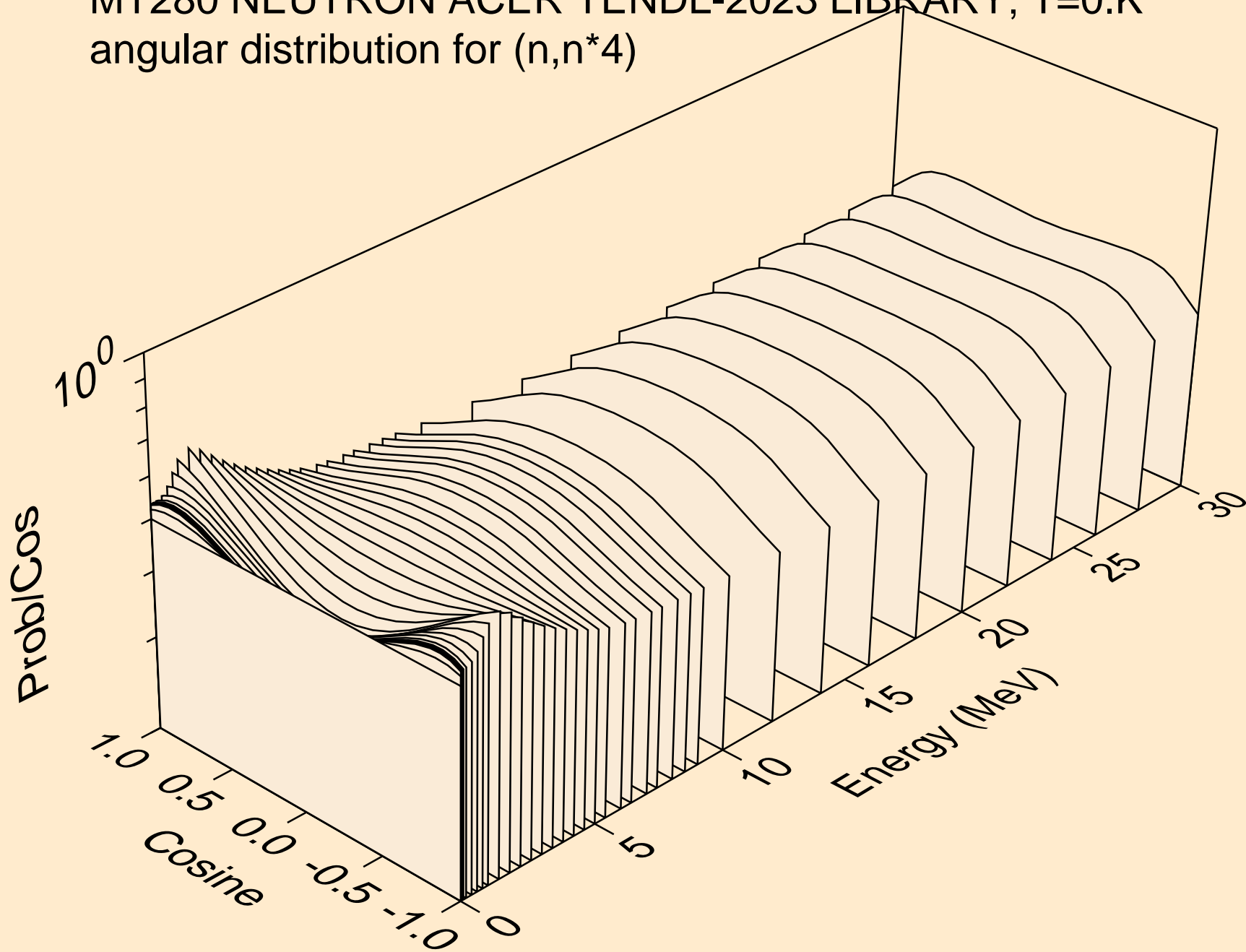

MT280 NEUTRON ACER TENDL-2023 LIBRARY; T=0.K  
angular distribution for (n,n\*5)

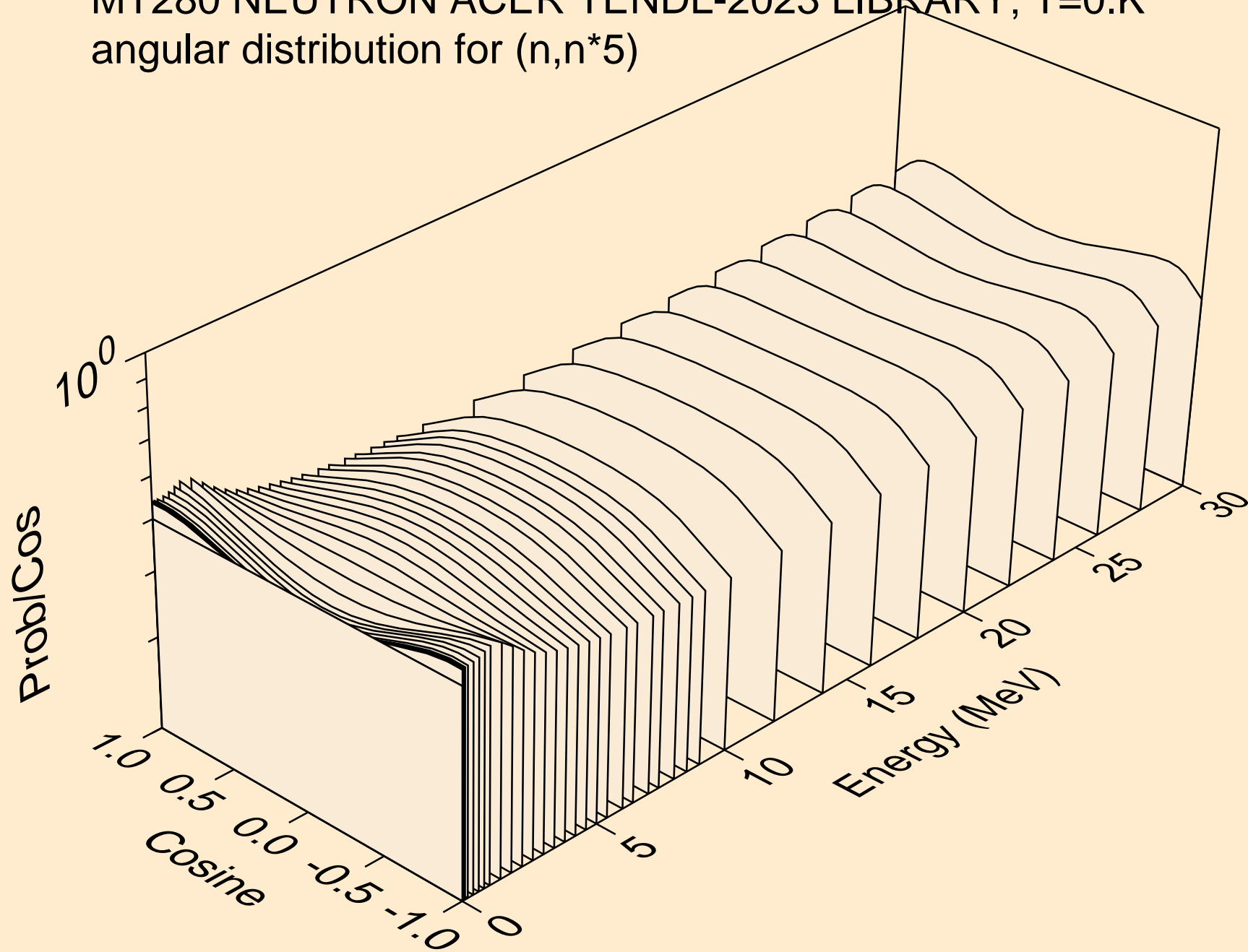

MT280 NEUTRON ACER TENDL-2023 LIBRARY; T=0.K  
angular distribution for (n,n\*6)

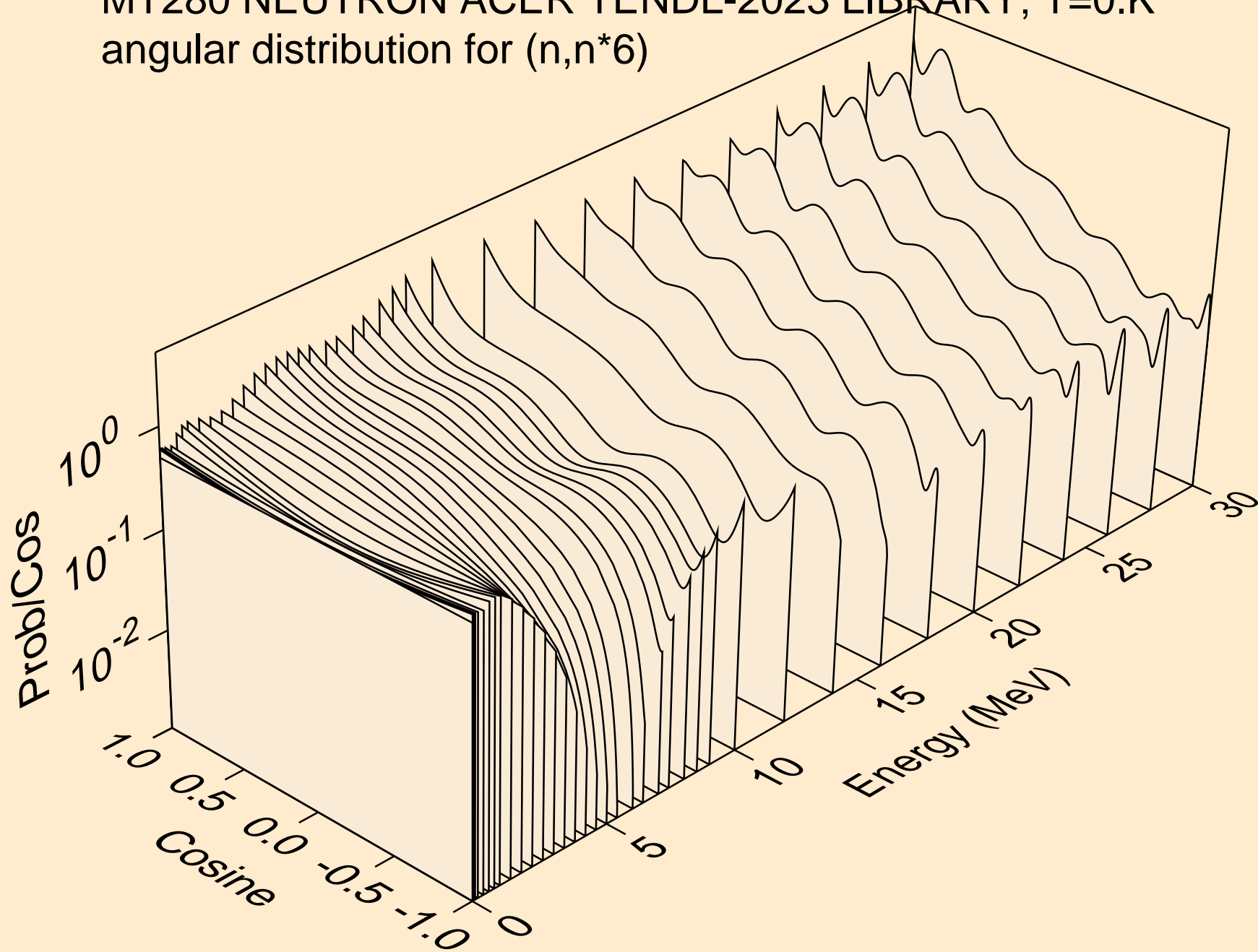

MT280 NEUTRON ACER TENDL-2023 LIBRARY; T=0.K  
angular distribution for (n,n\*7)

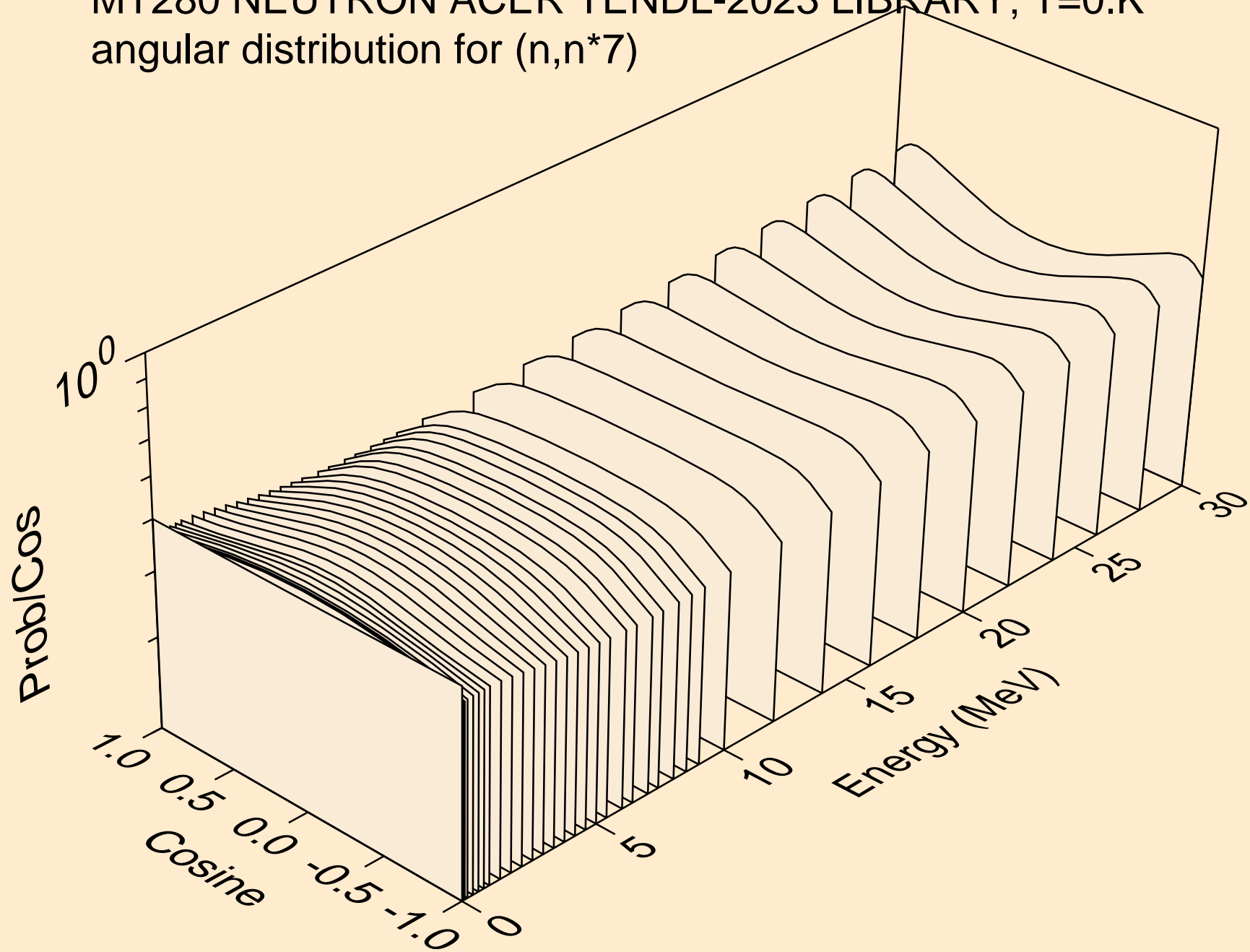

MT280 NEUTRON ACER TENDL-2023 LIBRARY; T=0.K  
angular distribution for (n,n\*8)

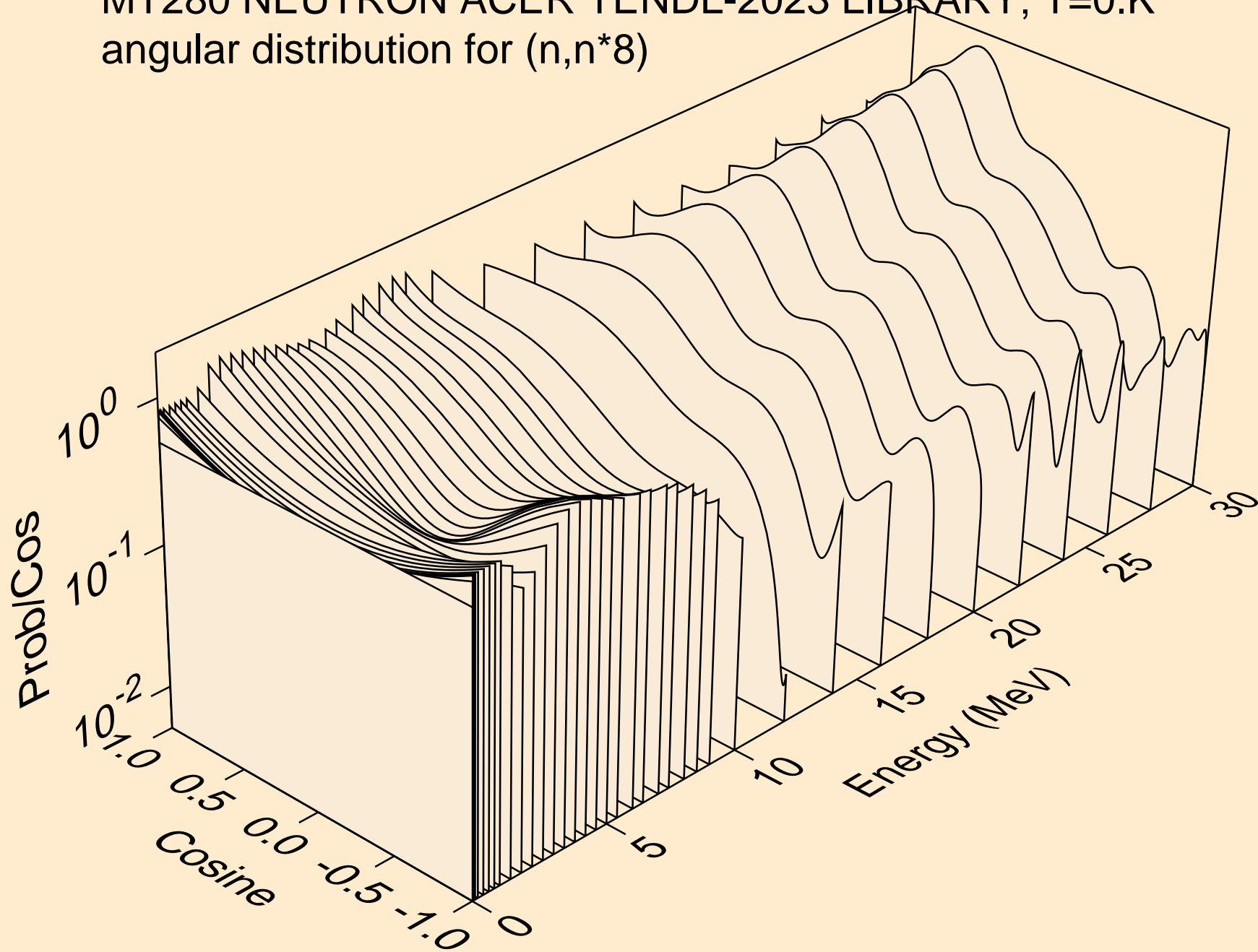



MT280 NEUTRON ACER TENDL-2023 LIBRARY; T=0.K  
angular distribution for (n,n\*9)

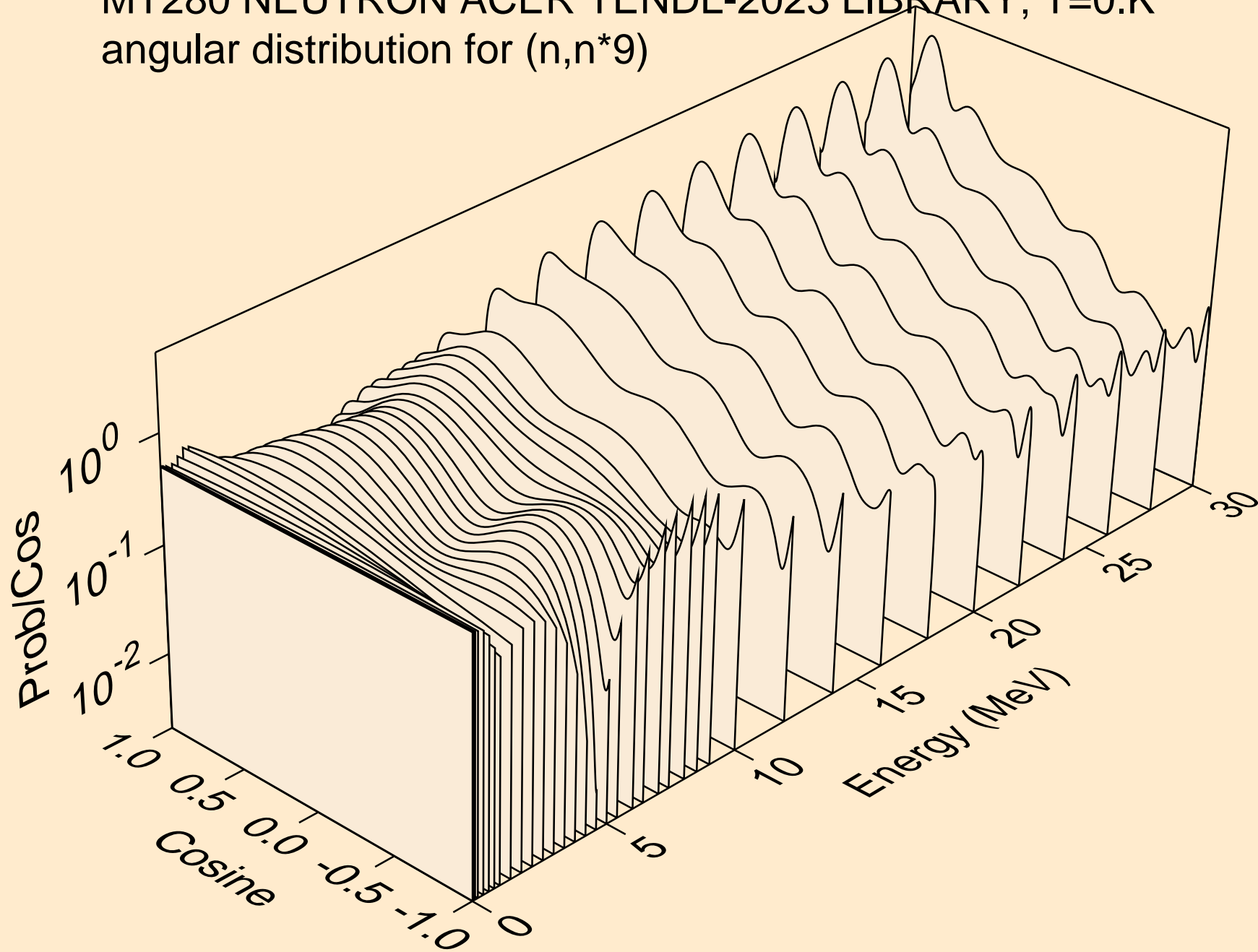

MT280 NEUTRON ACER TENDL-2023 LIBRARY; T=0.K  
angular distribution for (n,n\*10)

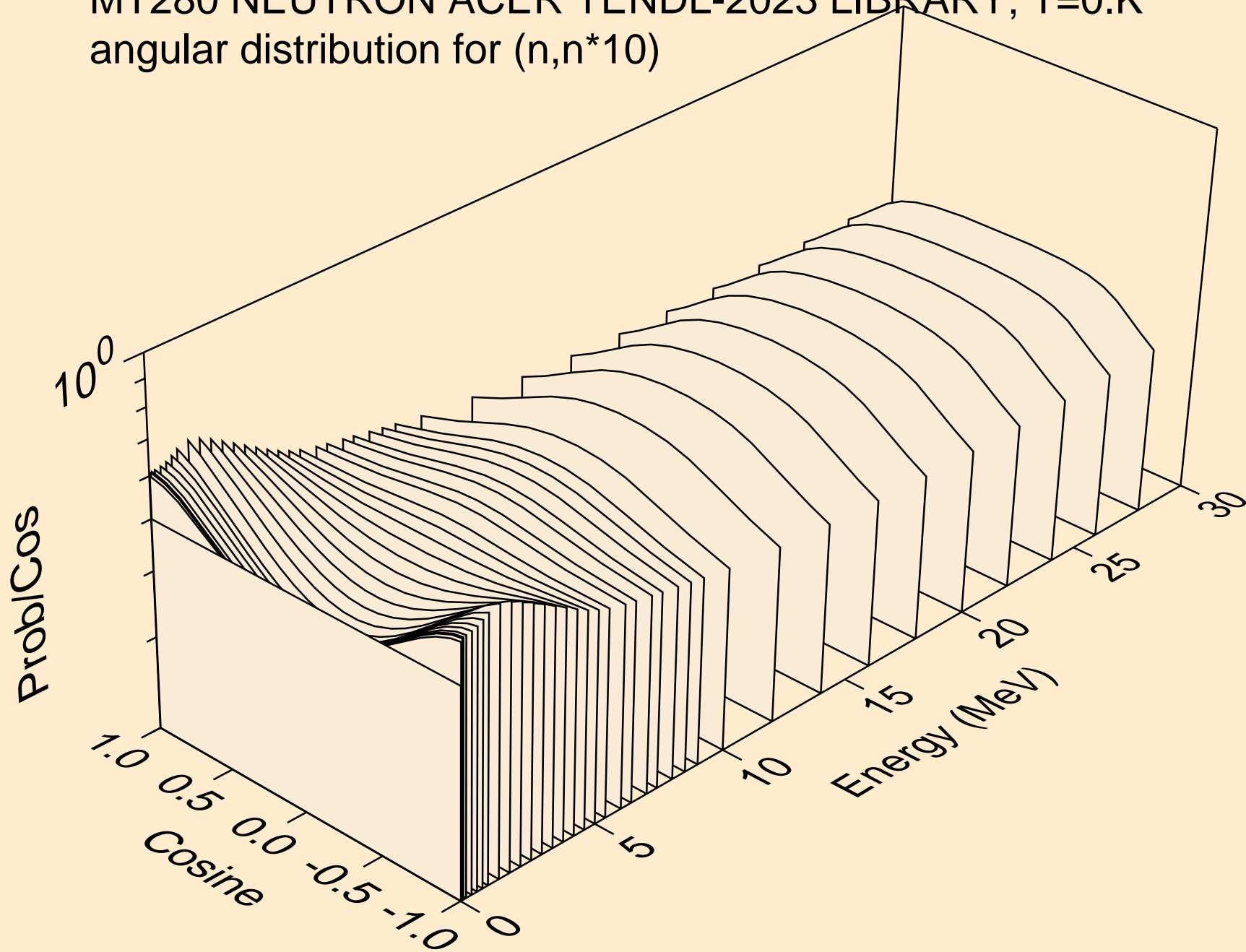

MT280 NEUTRON ACER TENDL-2023 LIBRARY; T=0.K  
angular distribution for (n,n\*11)

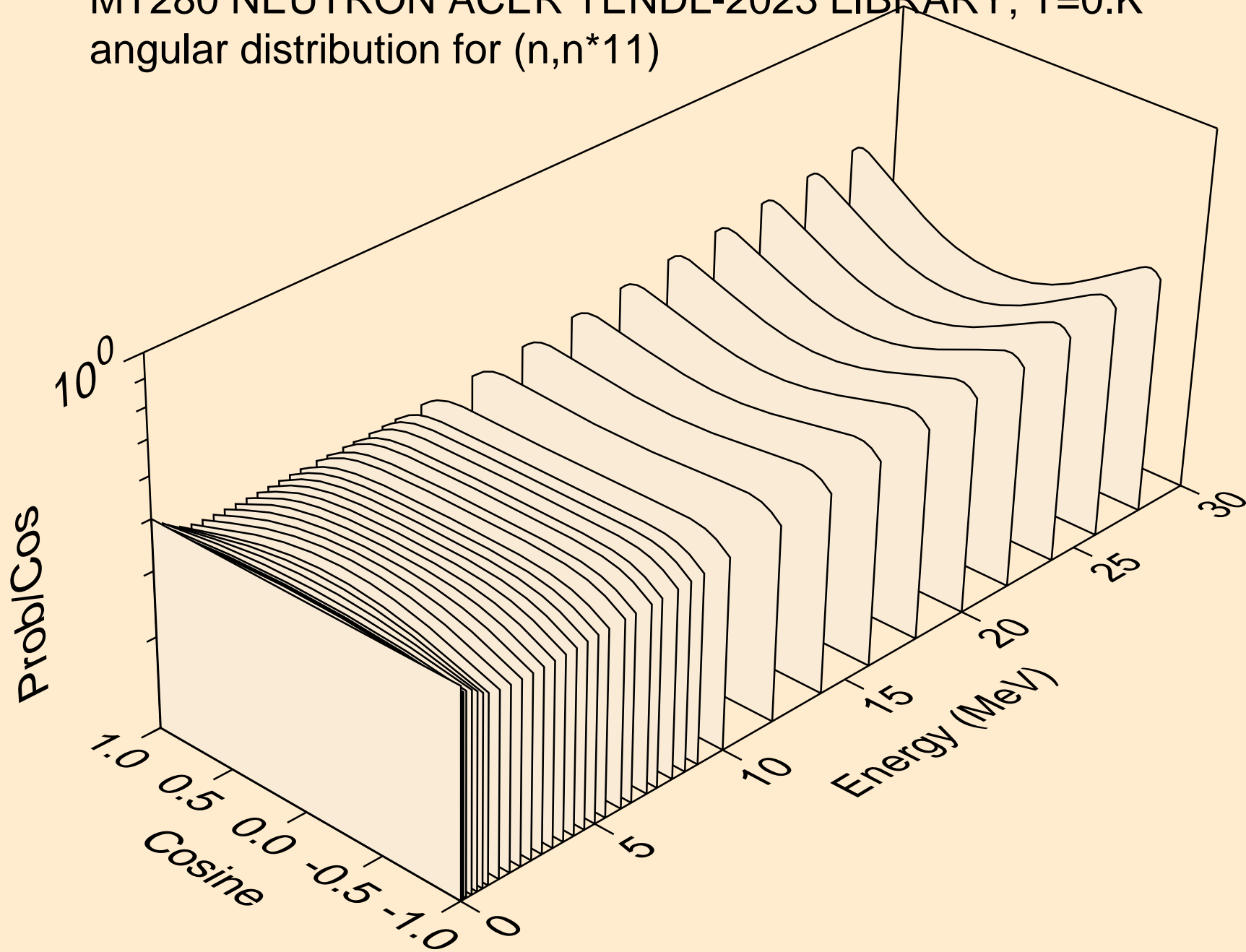

MT280 NEUTRON ACER TENDL-2023 LIBRARY; T=0.K  
angular distribution for (n,n\*12)

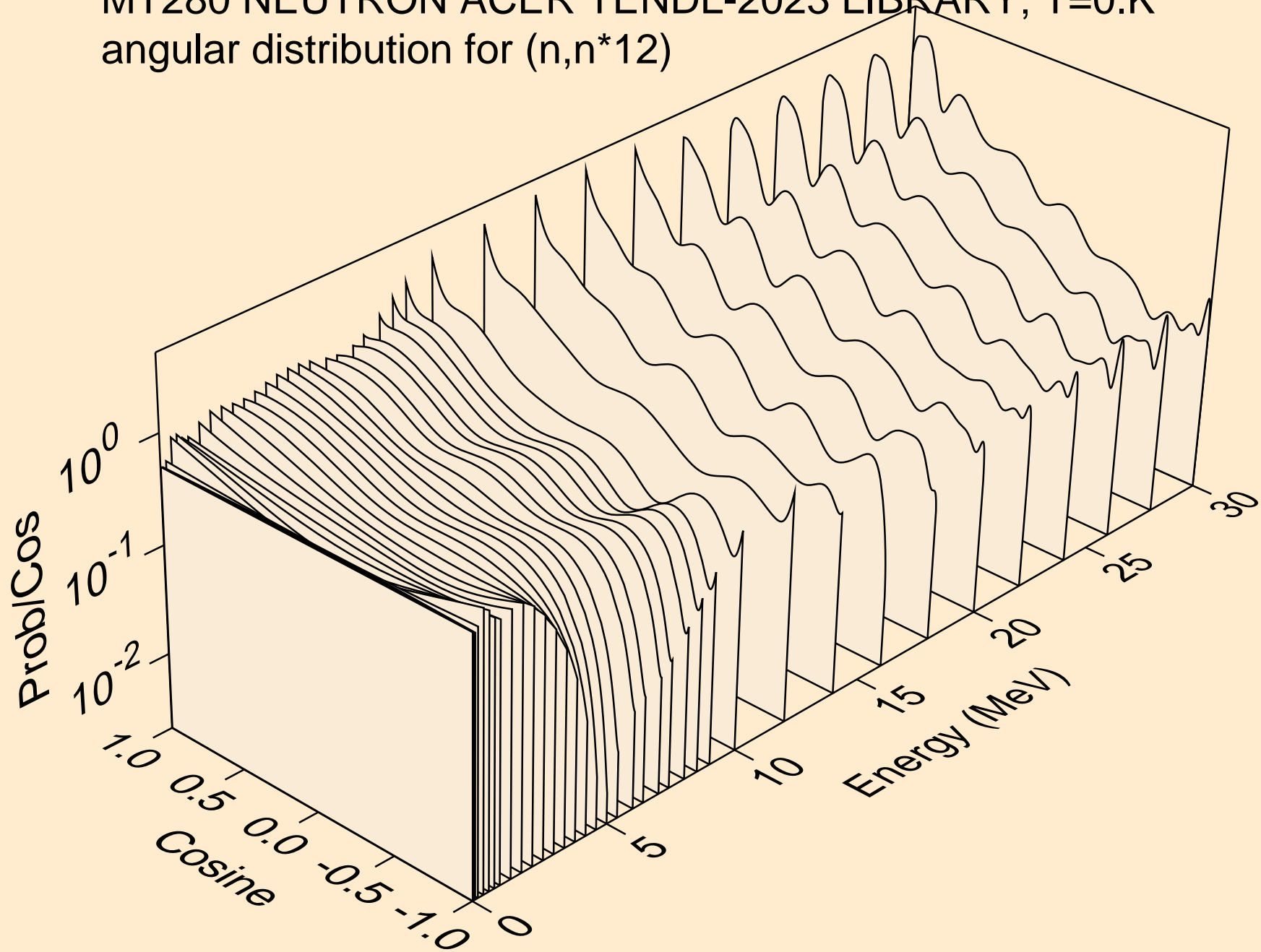

MT280 NEUTRON ACER TENDL-2023 LIBRARY; T=0.K  
angular distribution for (n,n\*13)

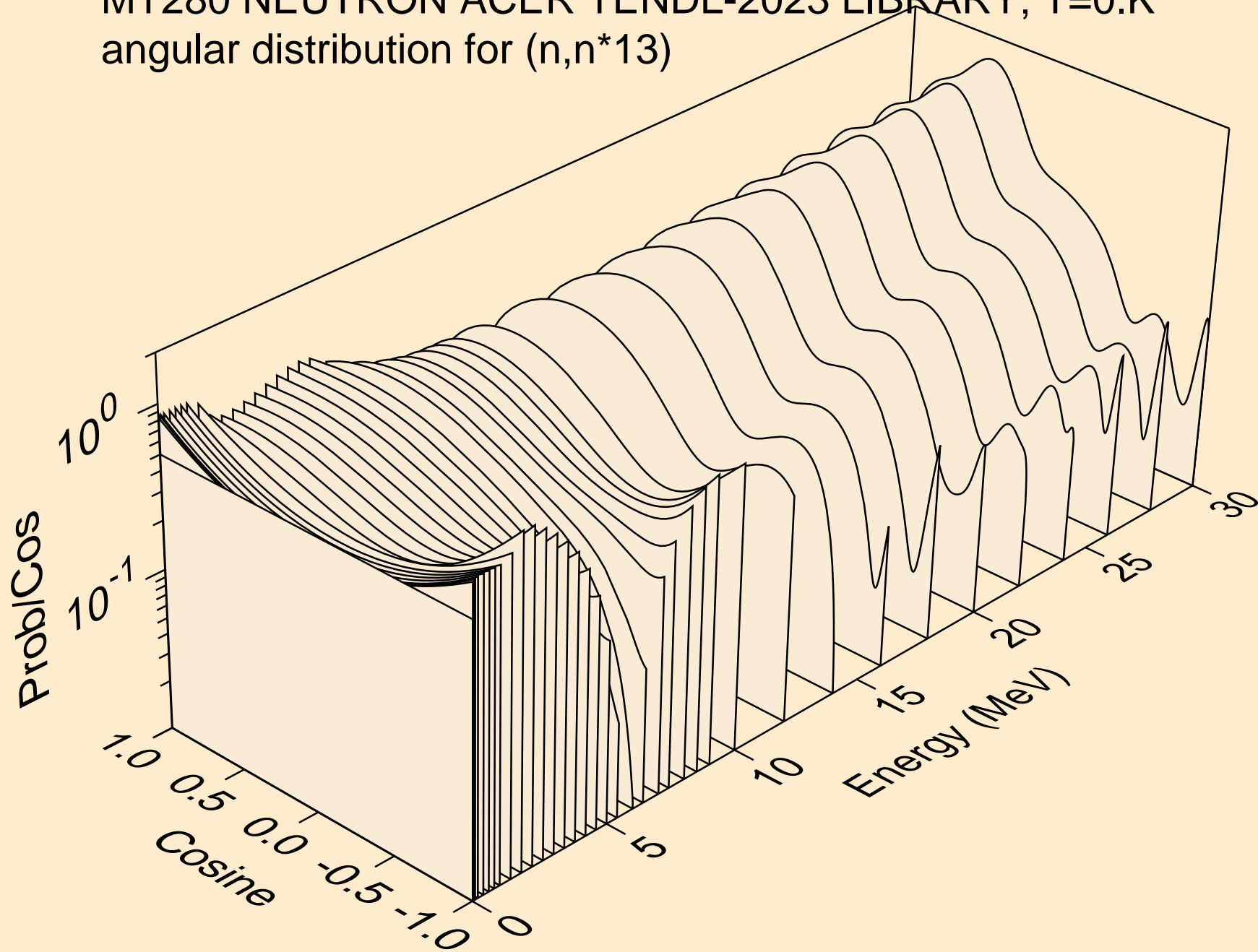

MT280 NEUTRON ACER TENDL-2023 LIBRARY; T=0.K  
angular distribution for (n,n\*14)

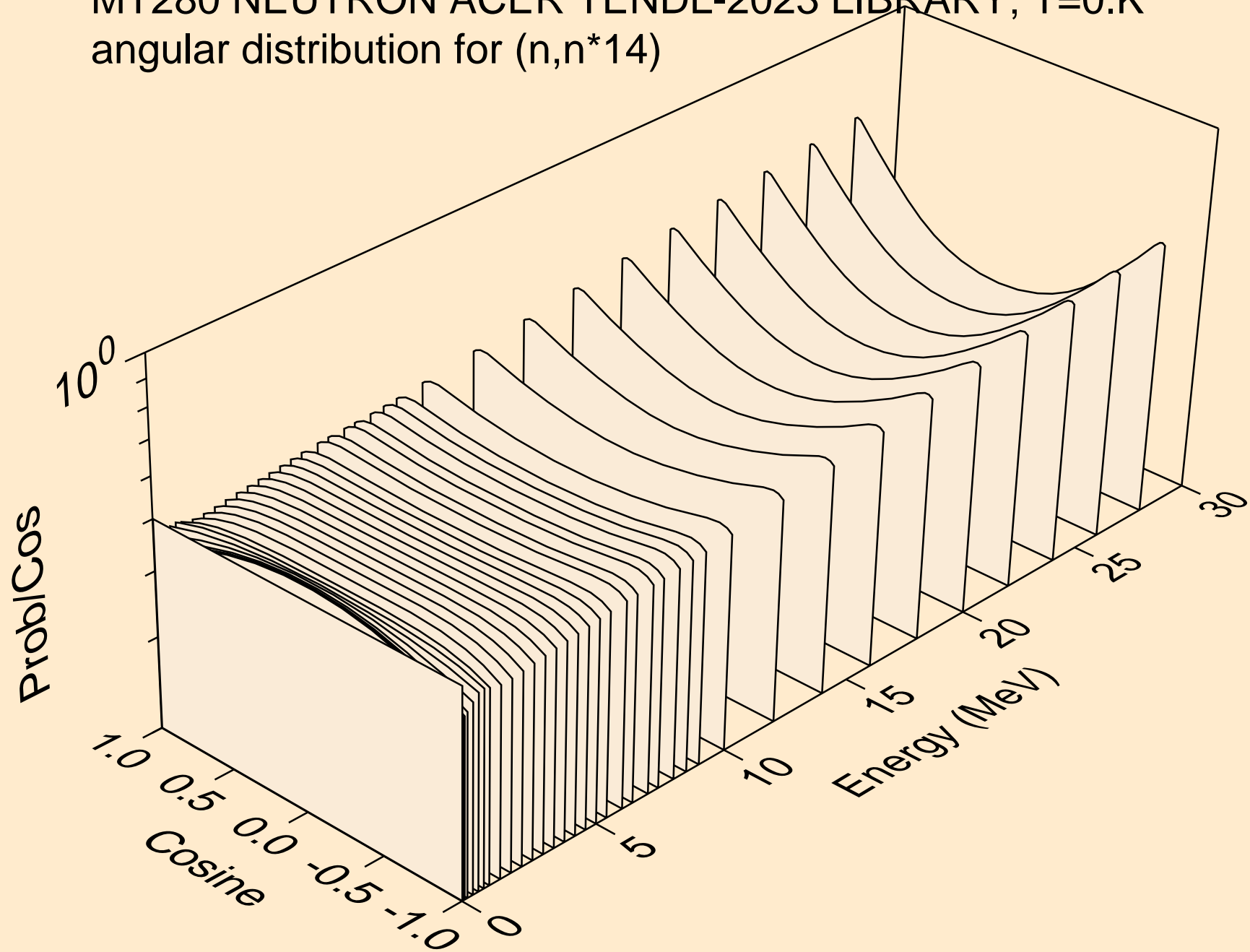

MT280 NEUTRON ACER TENDL-2023 LIBRARY; T=0.K  
angular distribution for (n,n\*15)

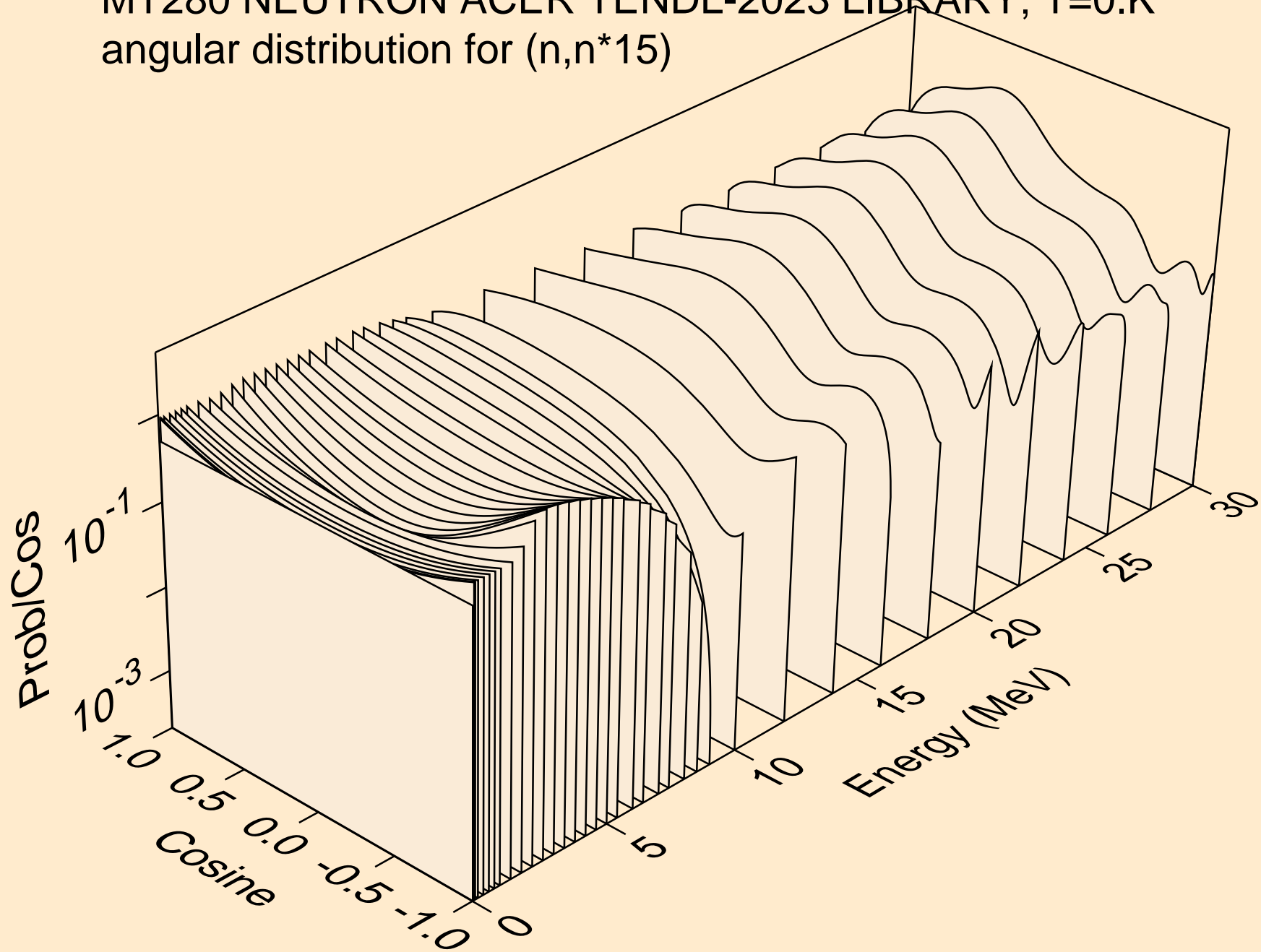

MT280 NEUTRON ACER TENDL-2023 LIBRARY; T=0.K  
angular distribution for (n,n\*16)

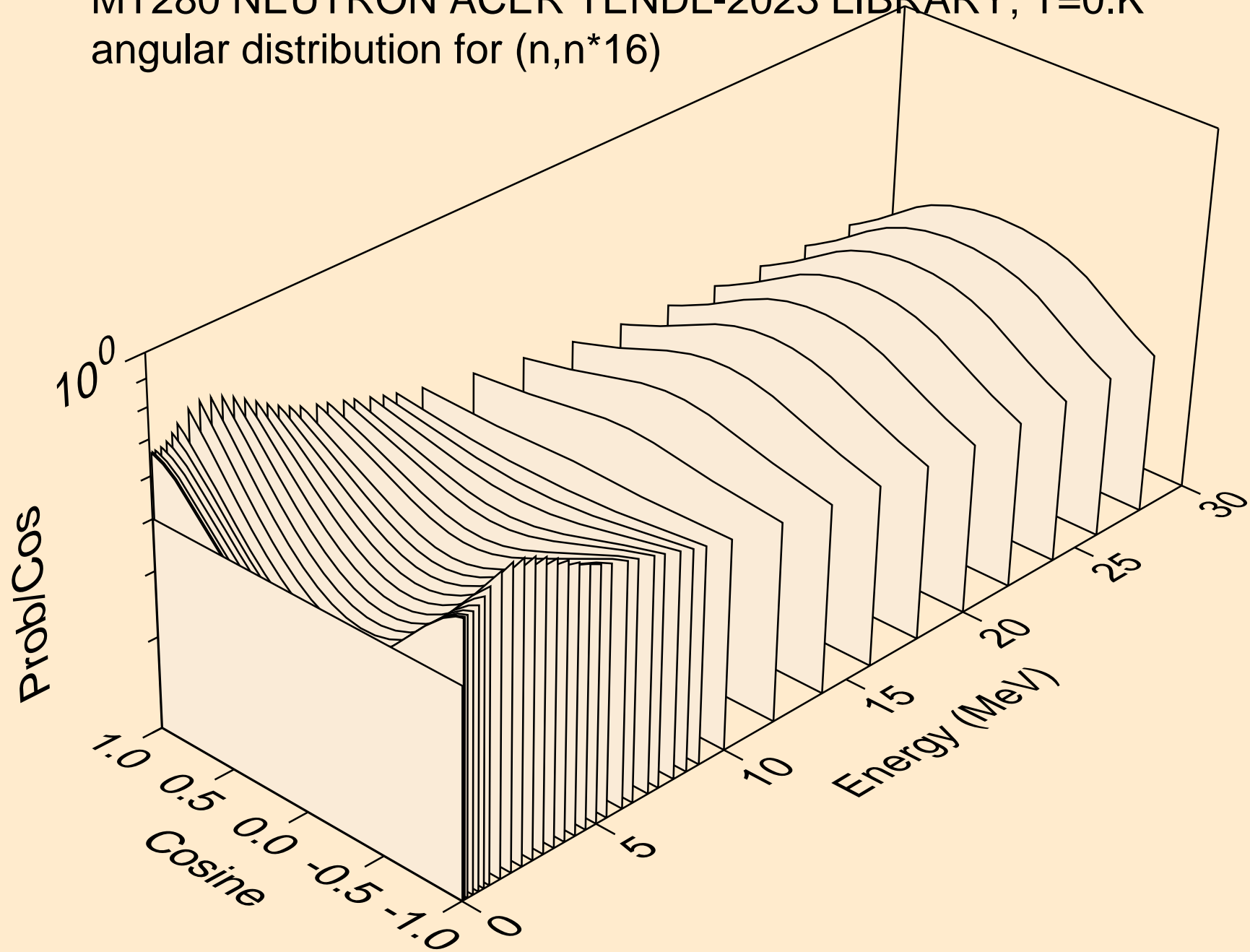



MT280 NEUTRON ACER TENDL-2023 LIBRARY; T=0.K  
angular distribution for (n,n\*17)

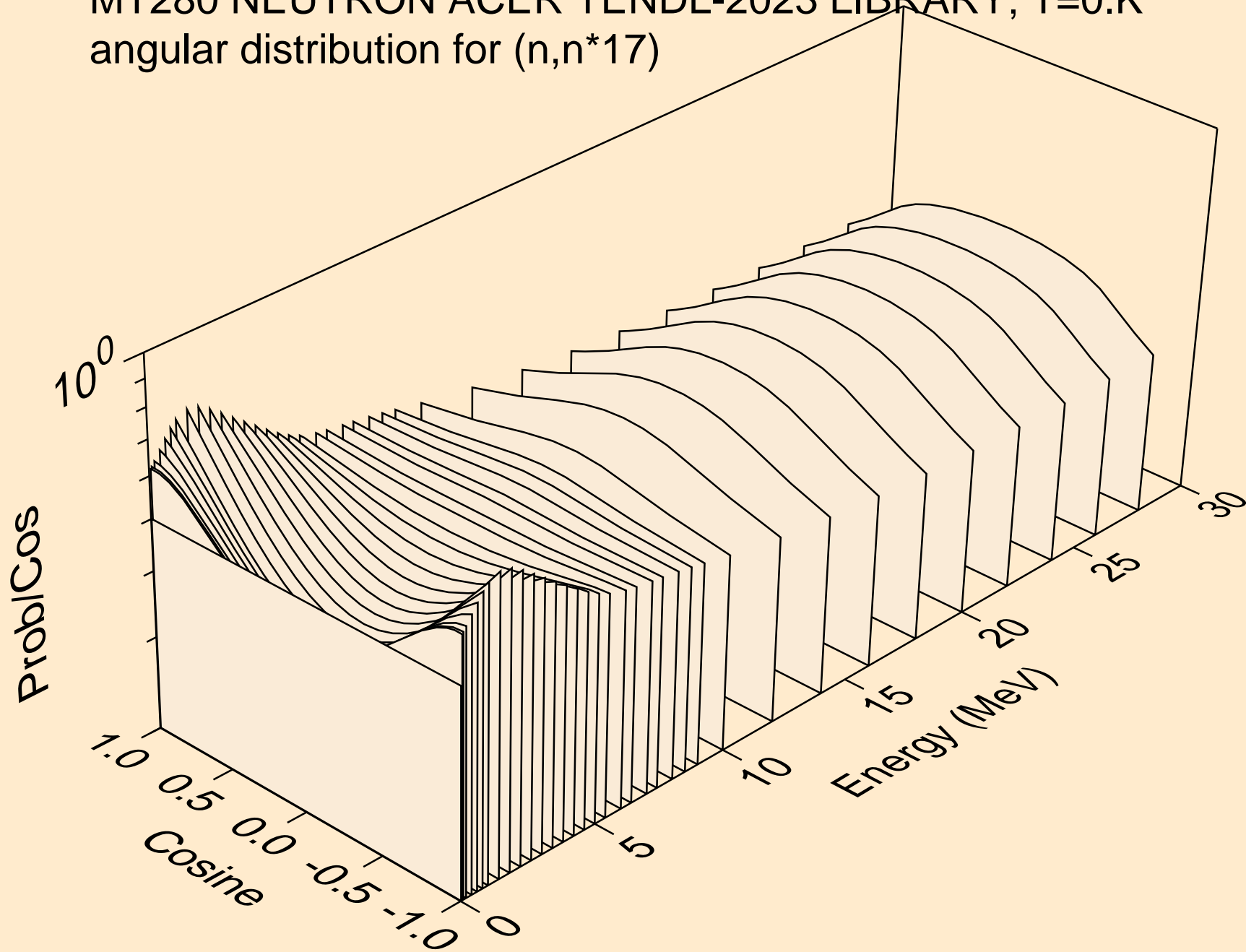

MT280 NEUTRON ACER TENDL-2023 LIBRARY; T=0.K  
angular distribution for (n,n\*18)

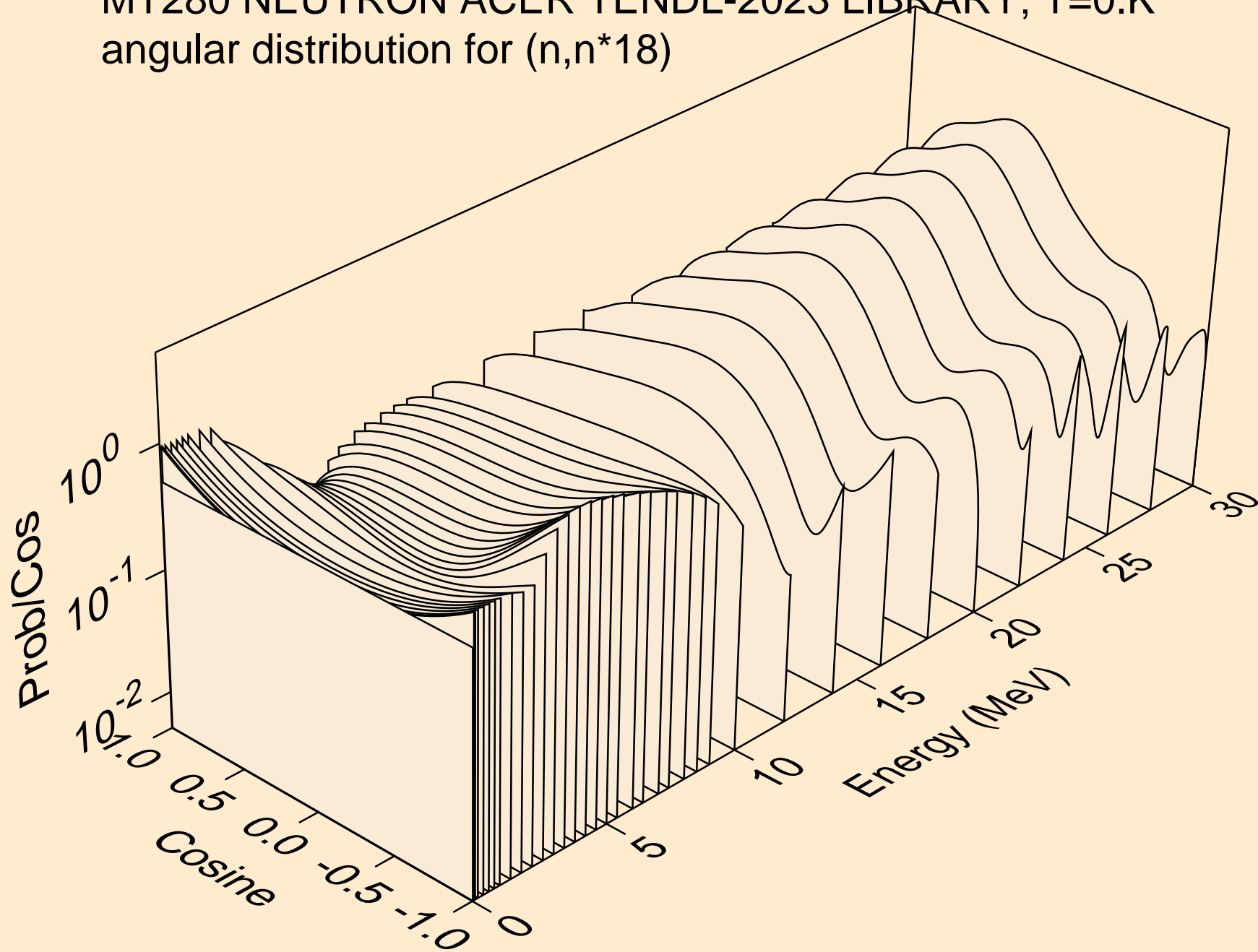

MT280 NEUTRON ACER TENDL-2023 LIBRARY; T=0.K  
angular distribution for (n,n\*19)

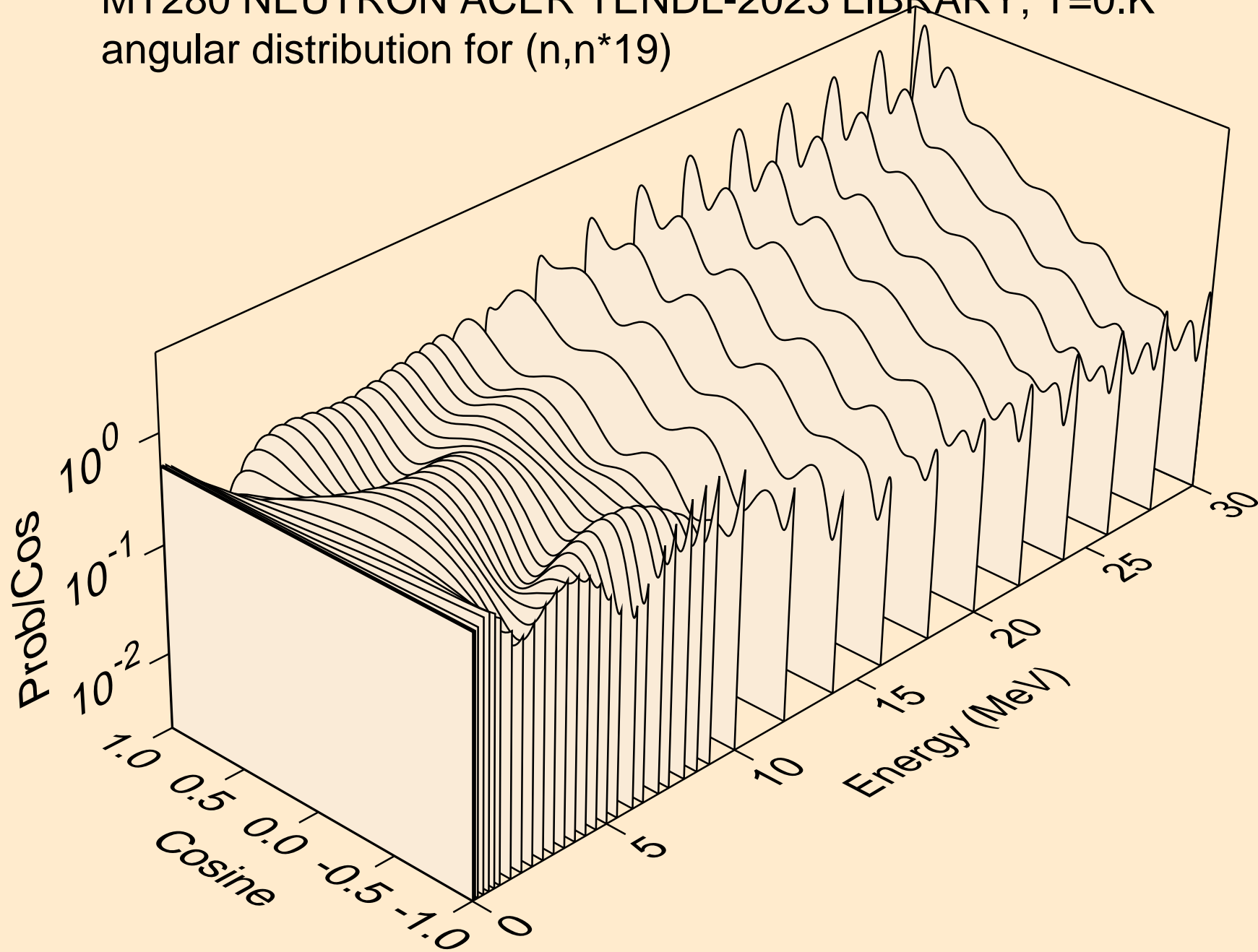

MT280 NEUTRON ACER TENDL-2023 LIBRARY; T=0.K  
angular distribution for (n,n\*20)

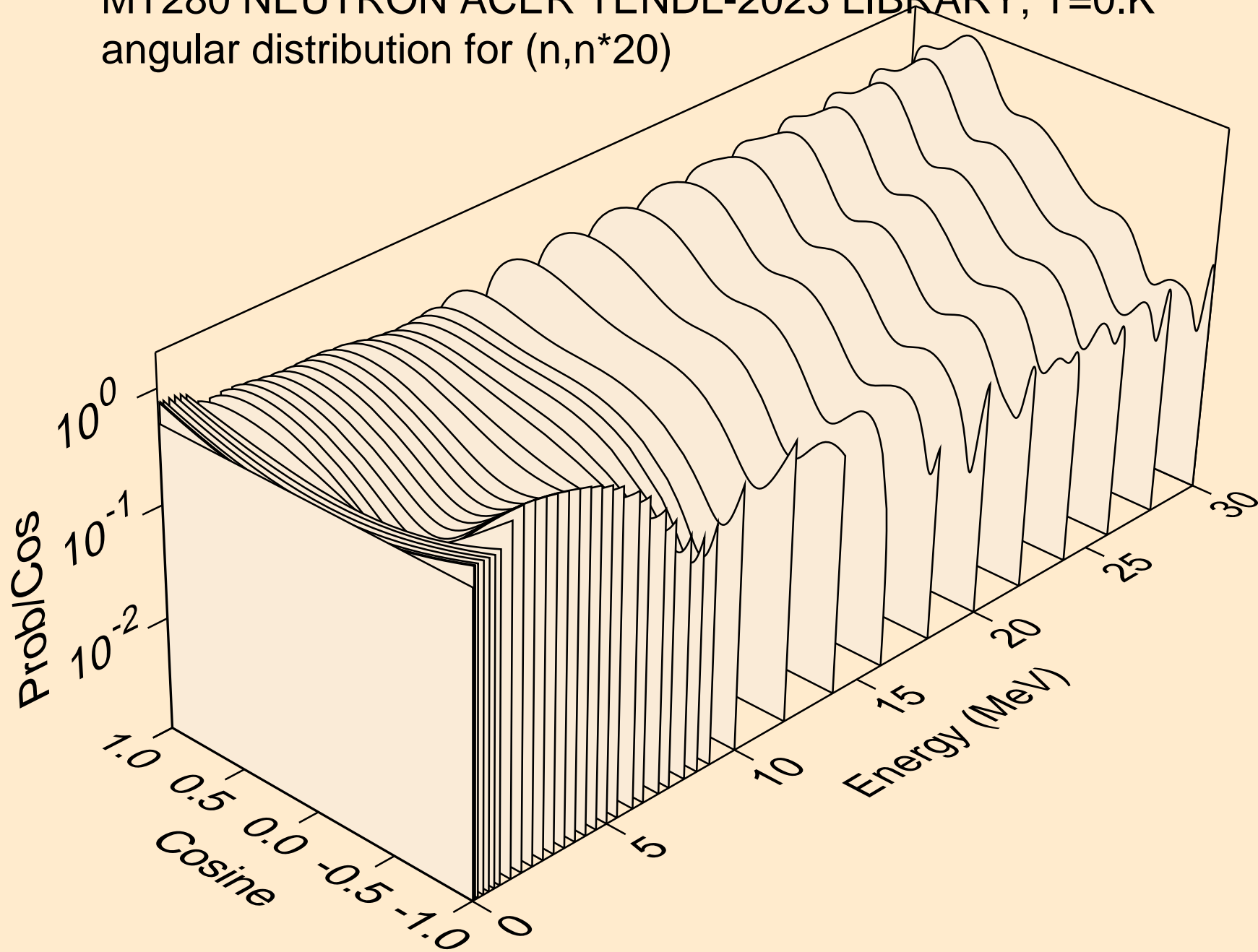

MT280 NEUTRON ACER TENDL-2023 LIBRARY; T=0.K  
angular distribution for (n,n\*21)

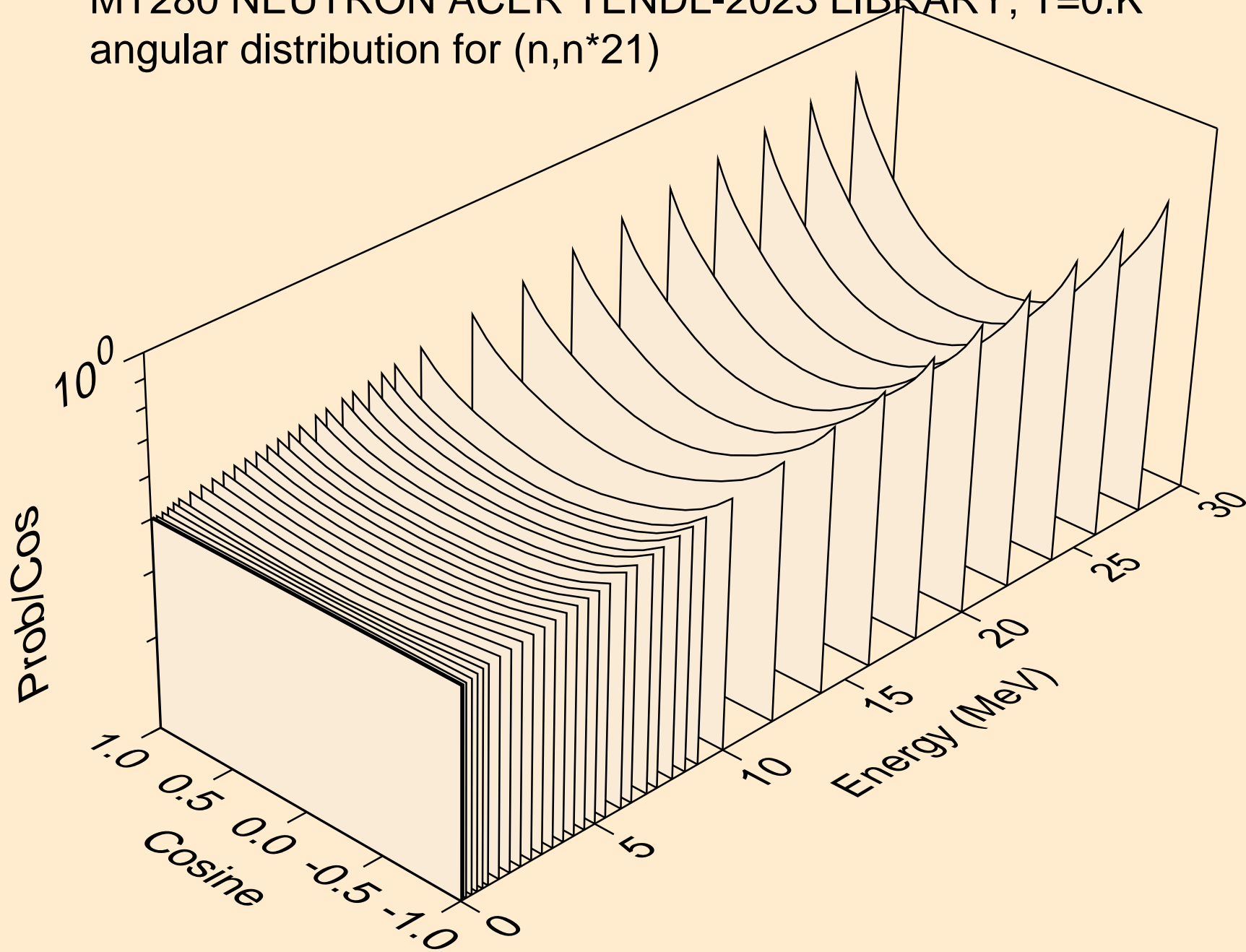

MT280 NEUTRON ACER TENDL-2023 LIBRARY; T=0.K  
angular distribution for (n,n\*22)

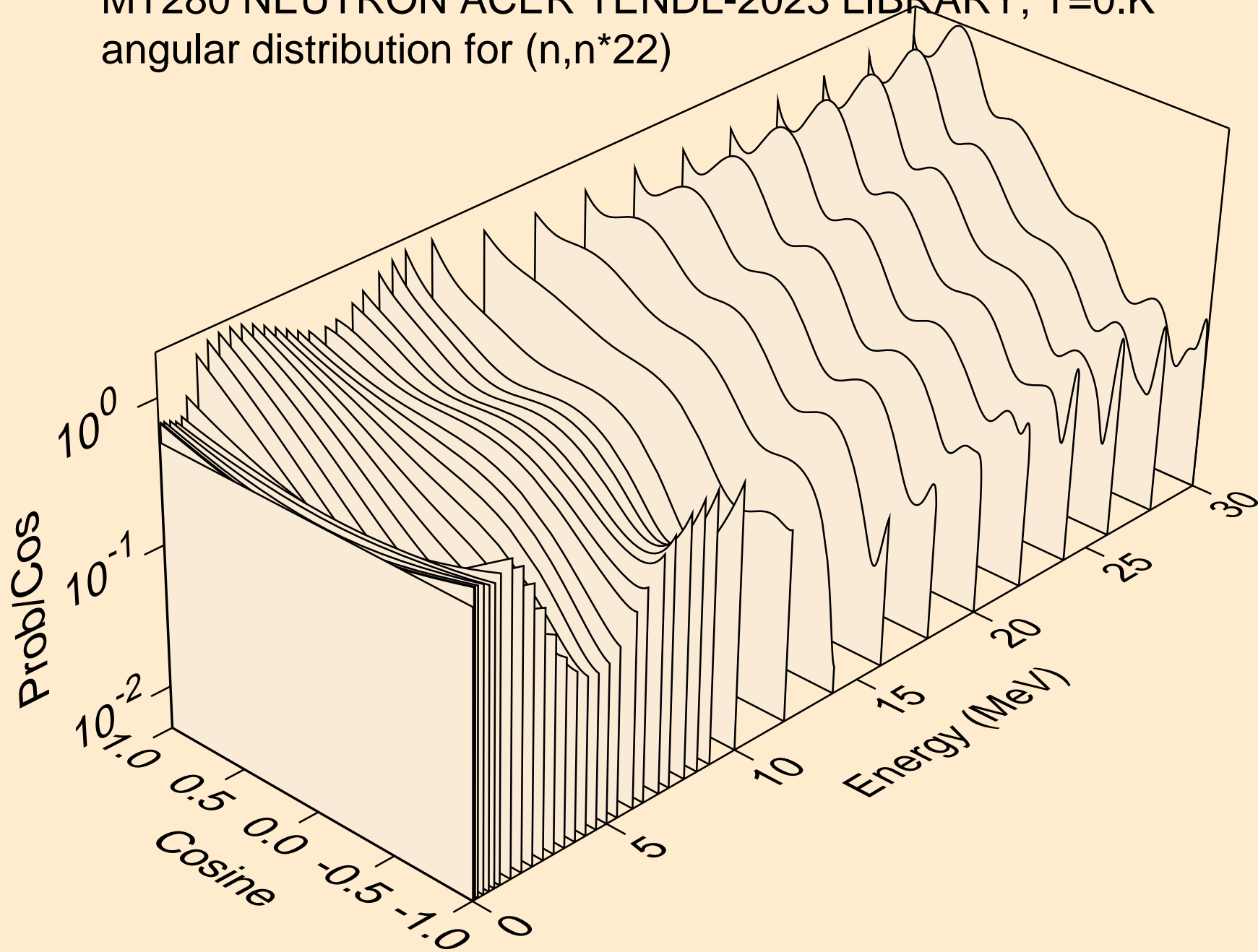

MT280 NEUTRON ACER TENDL-2023 LIBRARY; T=0.K  
angular distribution for (n,n\*23)

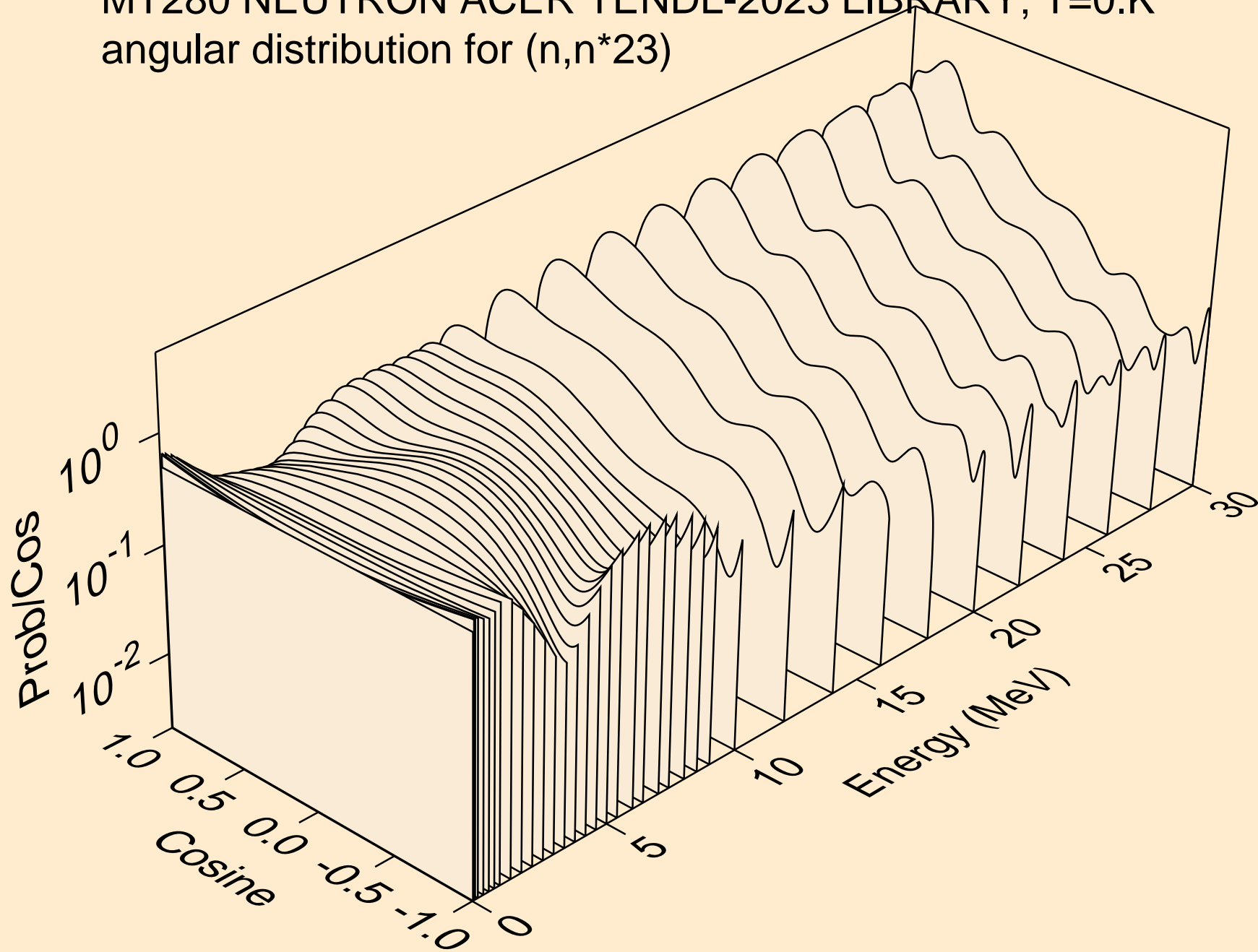

MT280 NEUTRON ACER TENDL-2023 LIBRARY; T=0.K  
angular distribution for (n,n\*24)

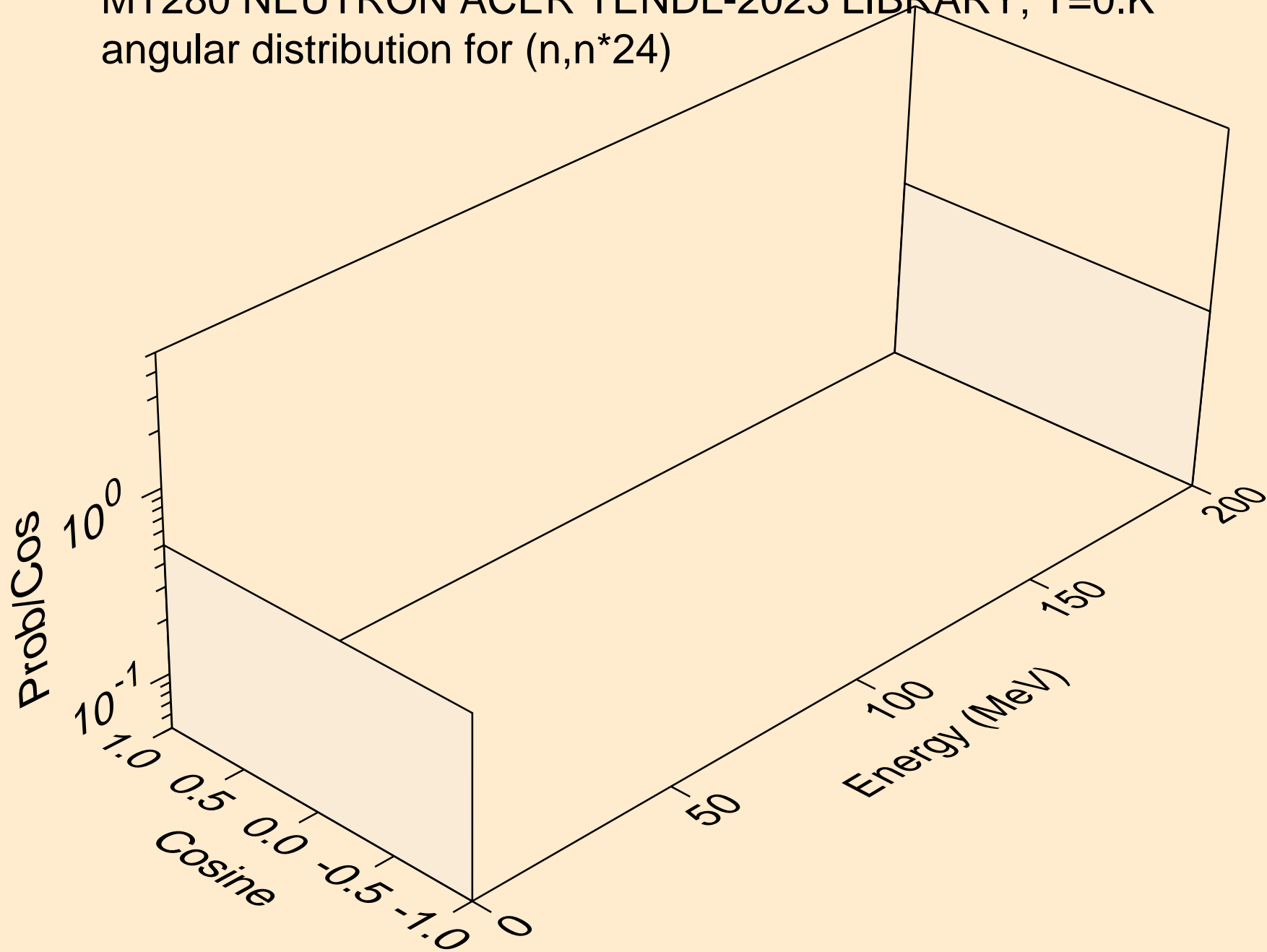



MT280 NEUTRON ACER TENDL-2023 LIBRARY; T=0.K  
angular distribution for (n,n\*25)

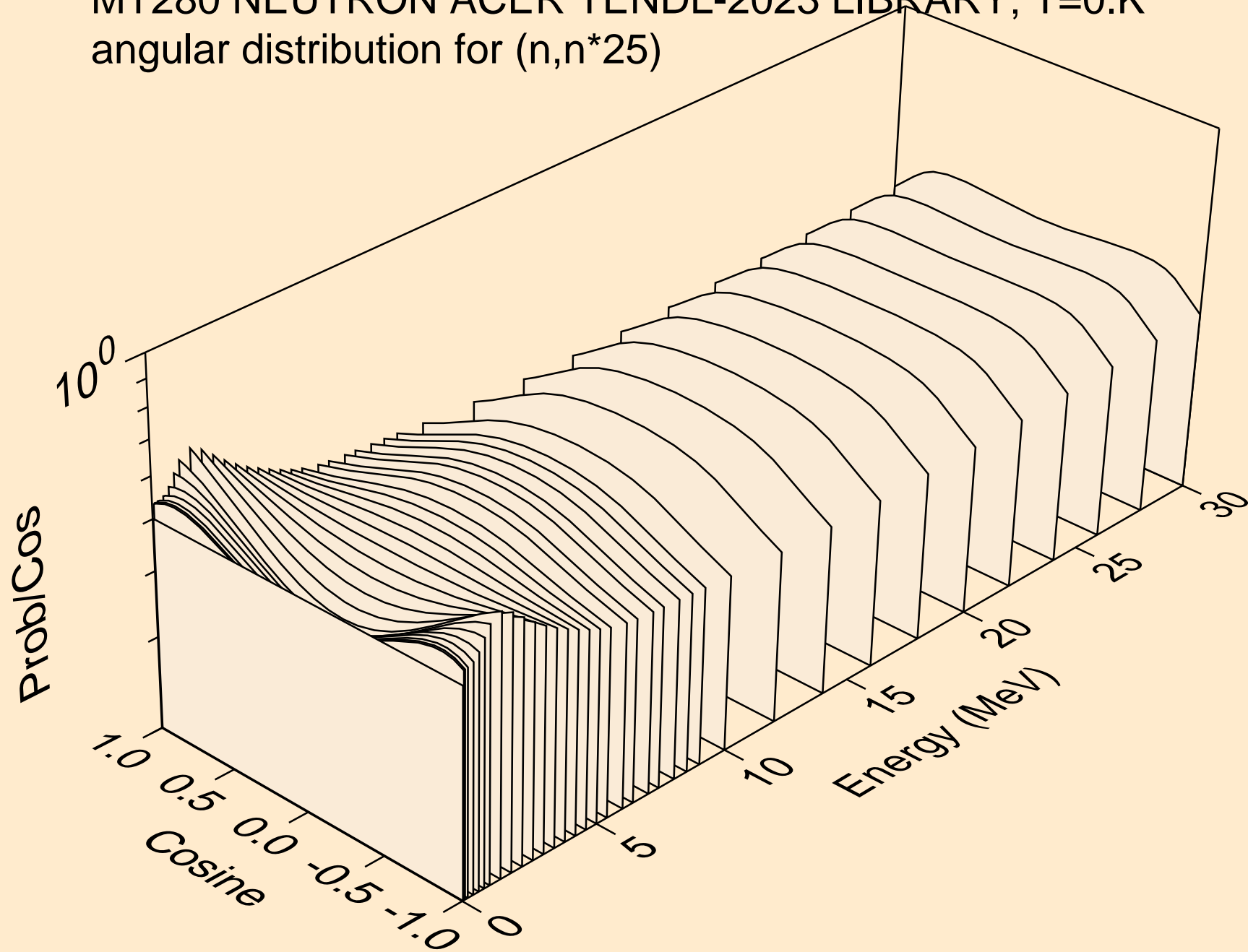

MT280 NEUTRON ACER TENDL-2023 LIBRARY; T=0.K  
angular distribution for (n,n\*26)

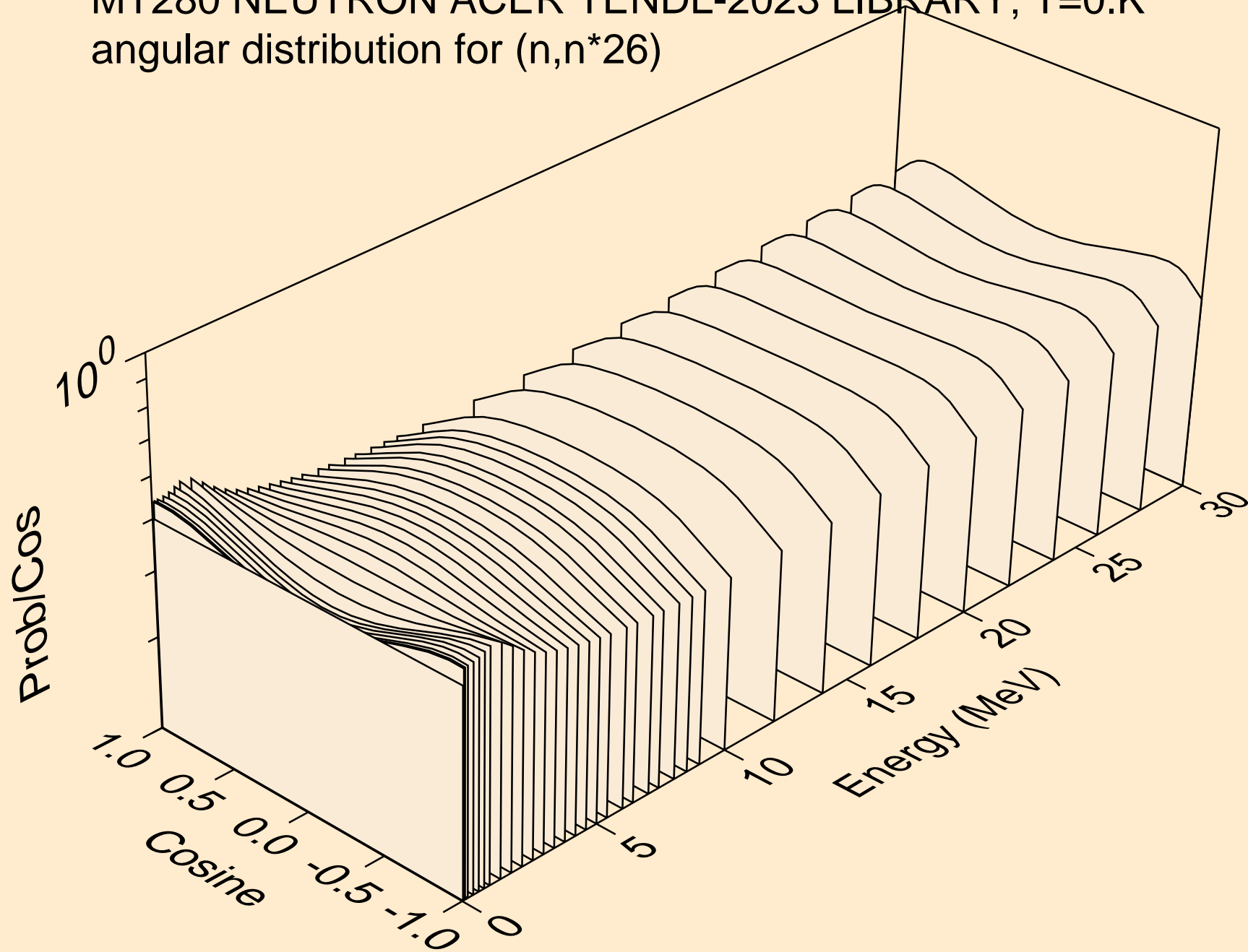

MT280 NEUTRON ACER TENDL-2023 LIBRARY; T=0.K  
angular distribution for (n,n\*27)

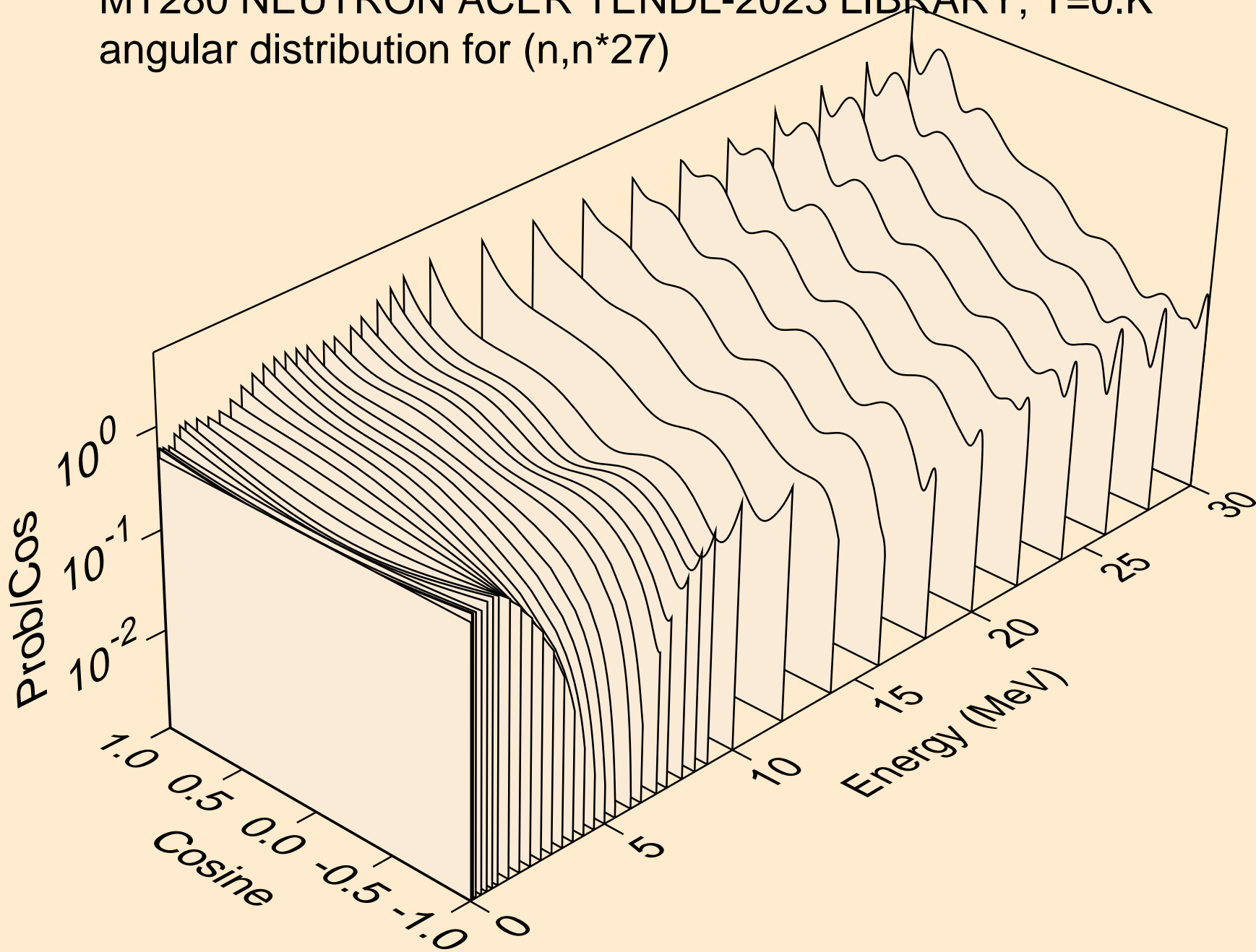

MT280 NEUTRON ACER TENDL-2023 LIBRARY; T=0.K  
angular distribution for (n,n\*28)

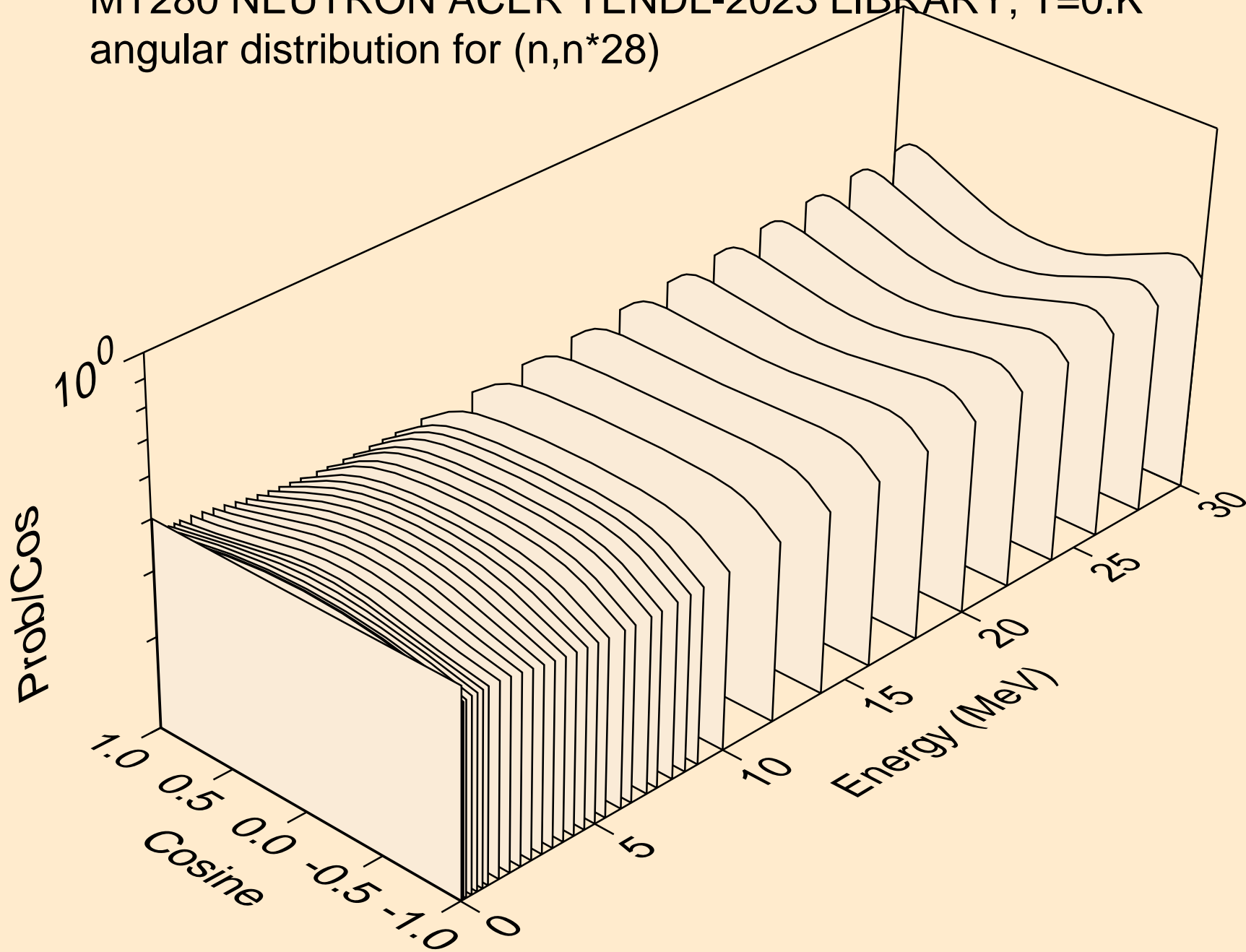

MT280 NEUTRON ACER TENDL-2023 LIBRARY; T=0.K

Total fission nubar

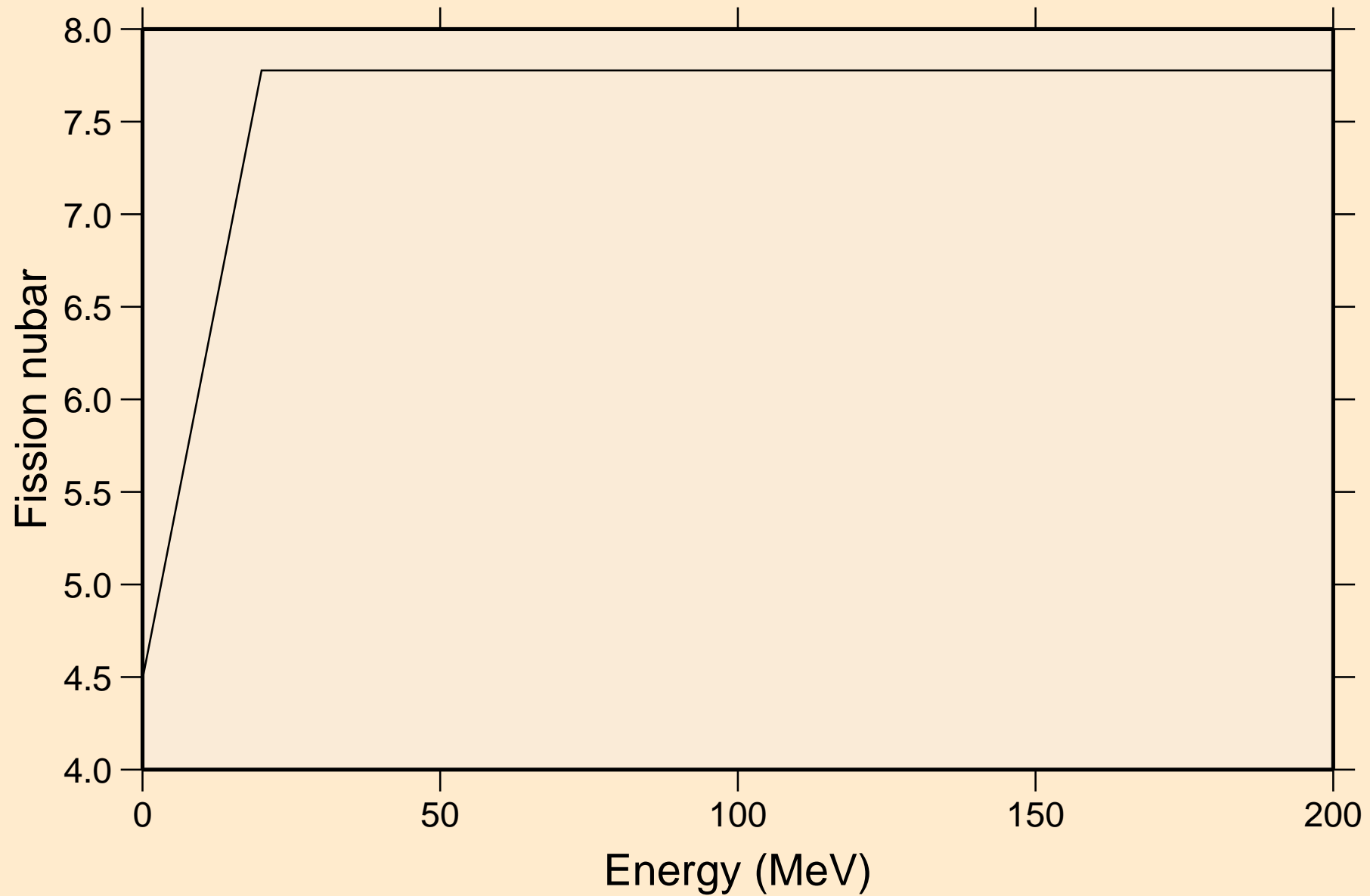

MT280 NEUTRON ACER TENDL-2023 LIBRARY; T=0.K  
Neutron emission for (n,x)

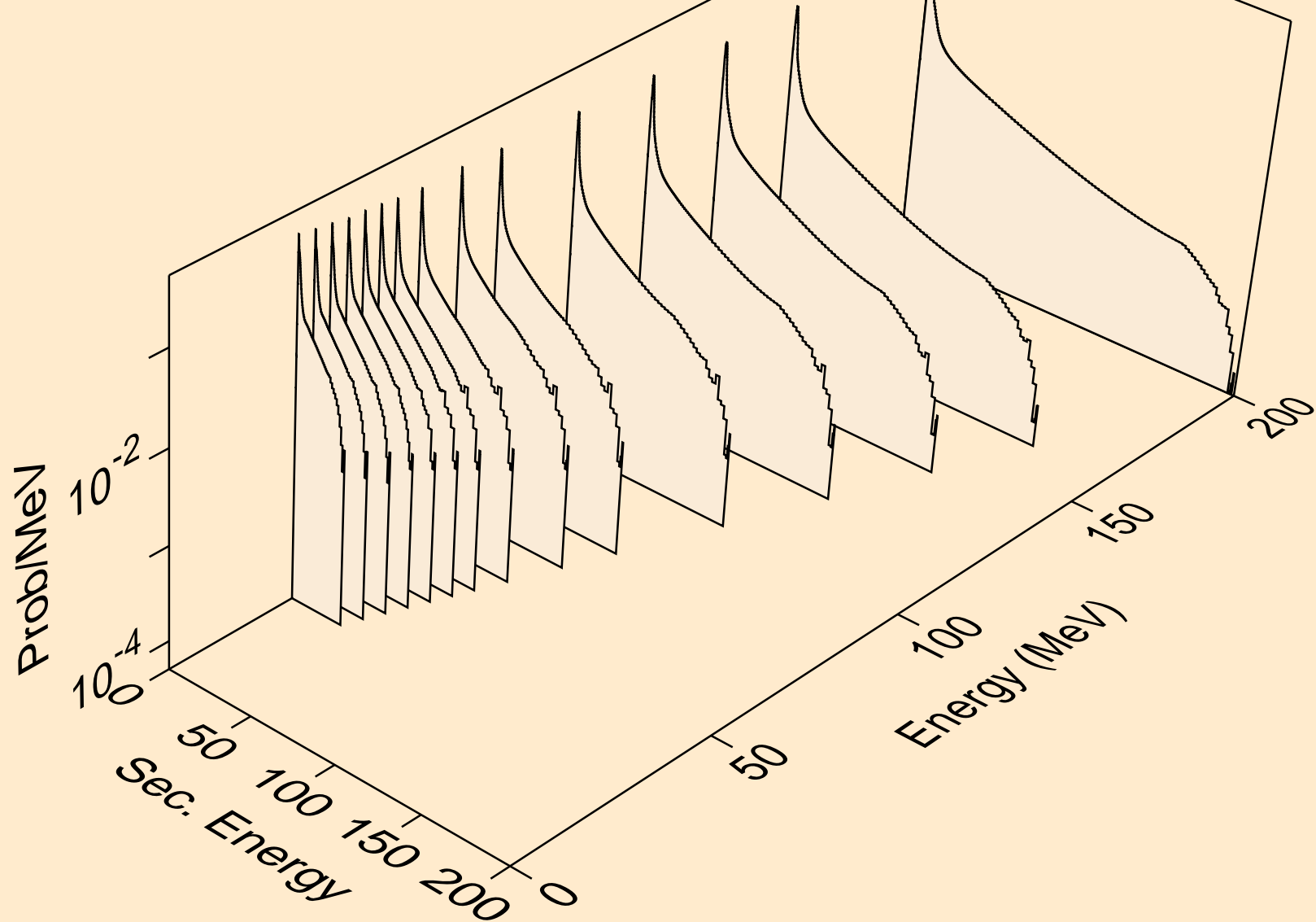

MT280 NEUTRON ACER TENDL-2023 LIBRARY; T=0.K  
Neutron emission for (n,2nd)

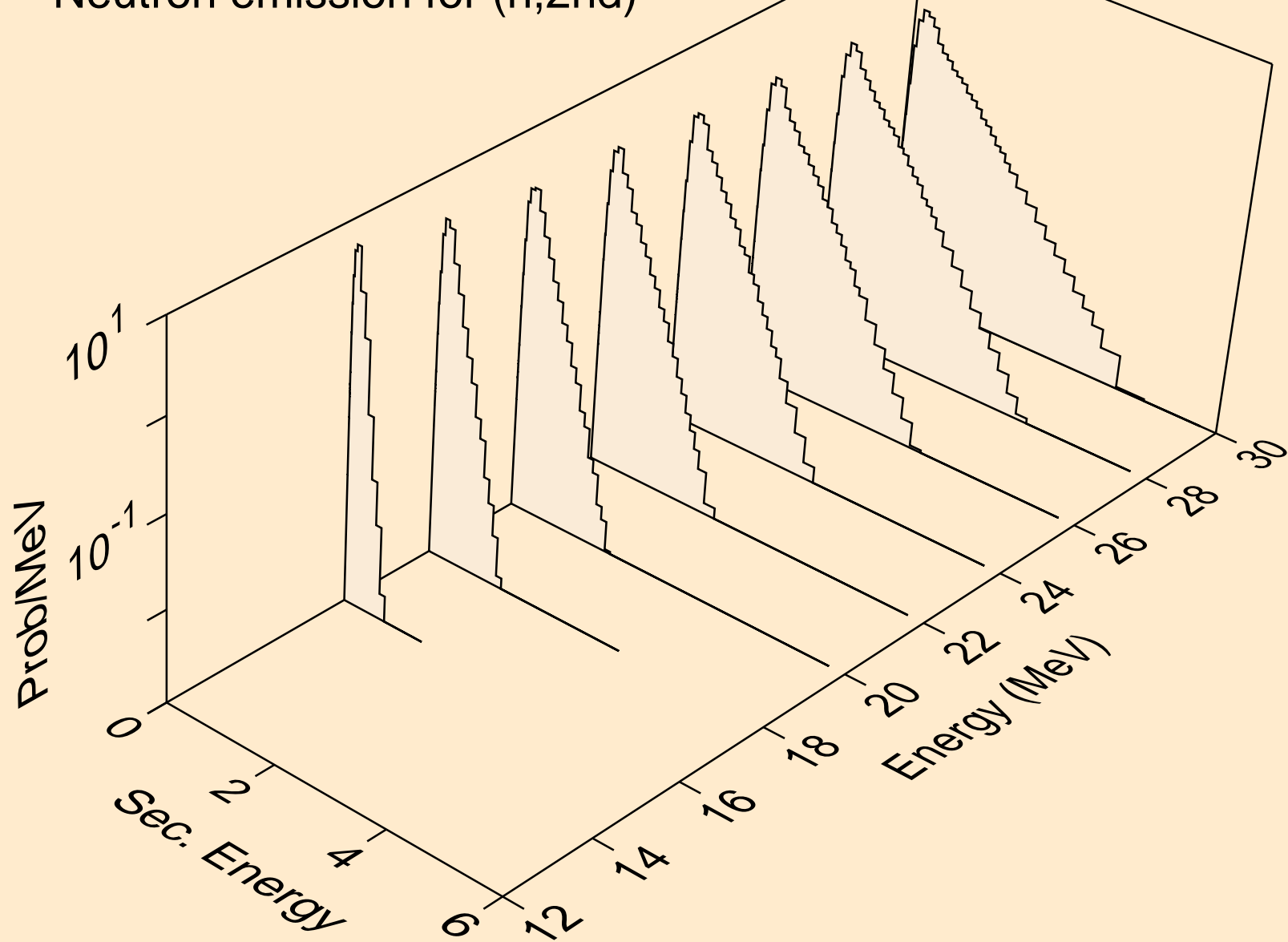

MT280 NEUTRON ACER TENDL-2023 LIBRARY; T=0.K  
Neutron emission for (n,2n)

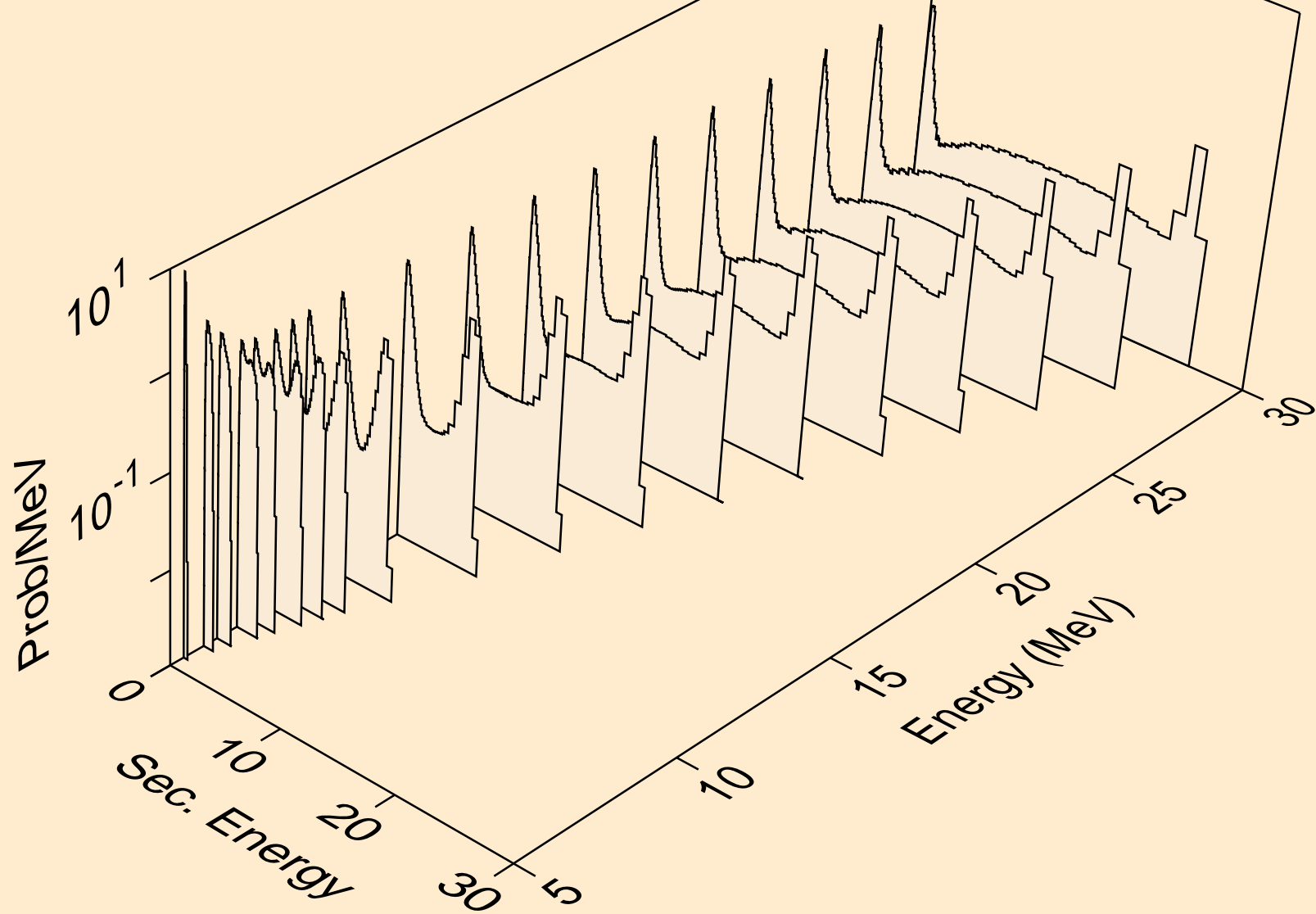



MT280 NEUTRON ACER TENDL-2023 LIBRARY; T=0.K  
Neutron emission for (n,3n)

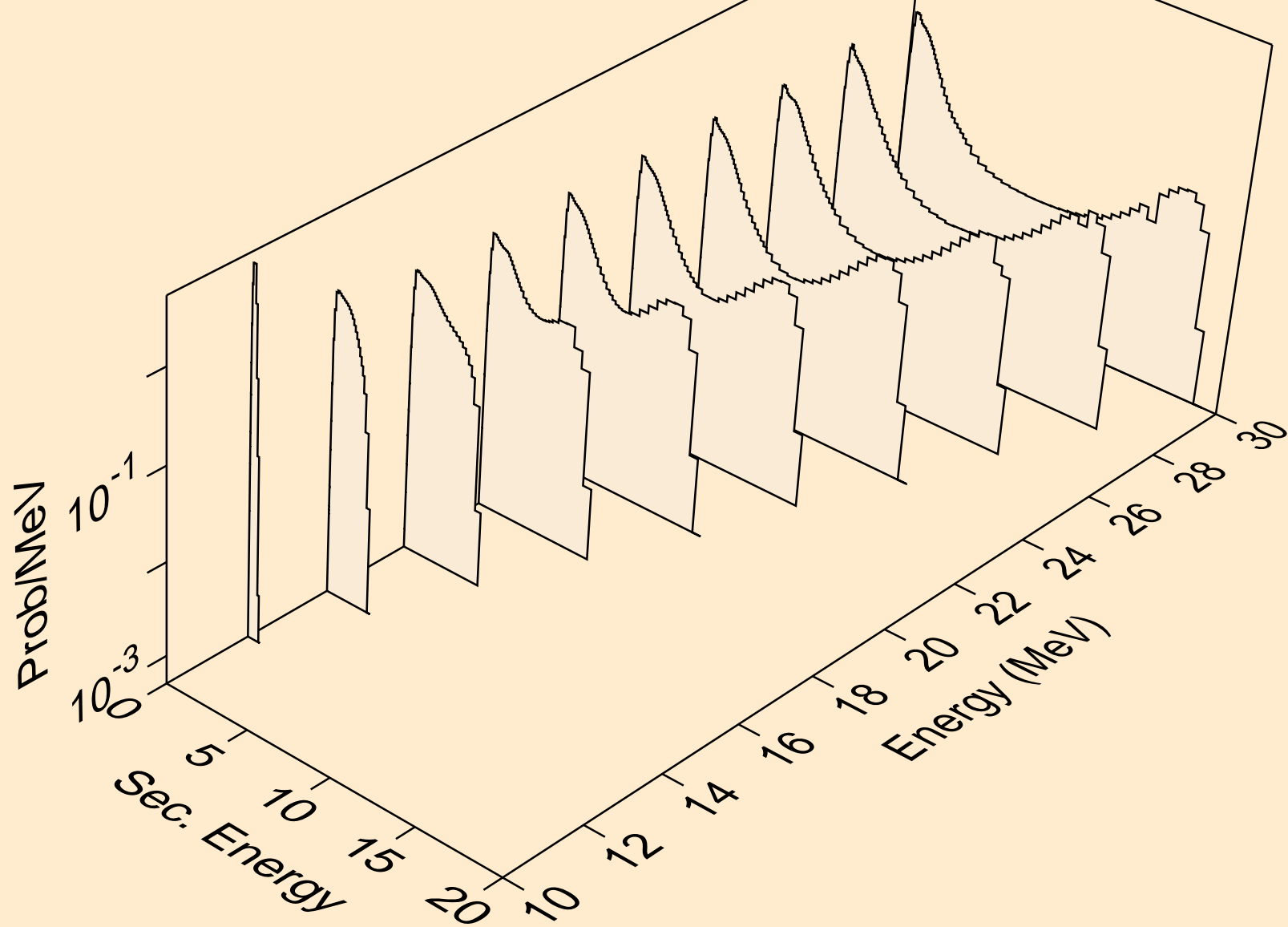

MT280 NEUTRON ACER TENDL-2023 LIBRARY; T=0.K  
Neutron emission for fission

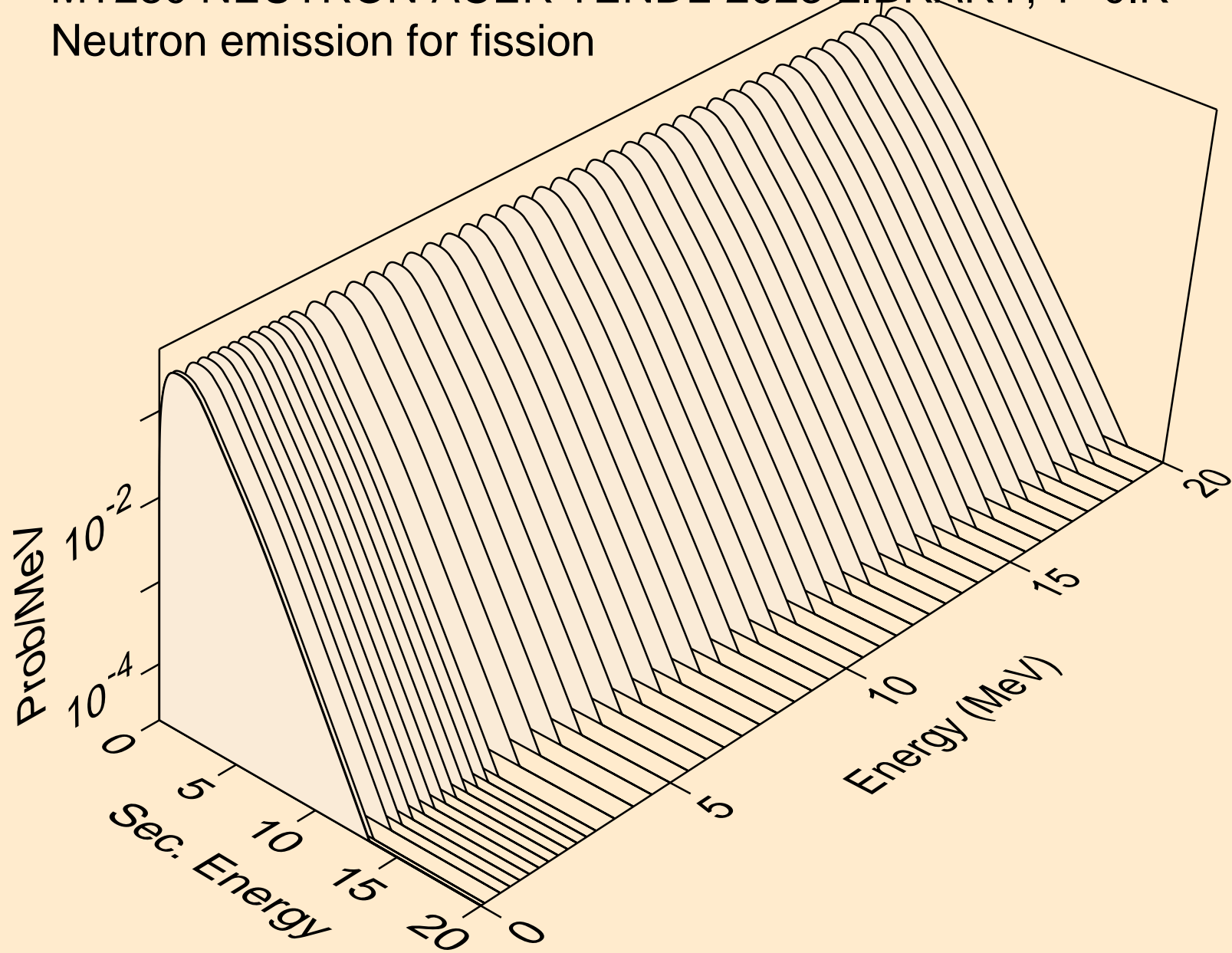

MT280 NEUTRON ACER TENDL-2023 LIBRARY; T=0.K  
Neutron emission for (n,n\*)a

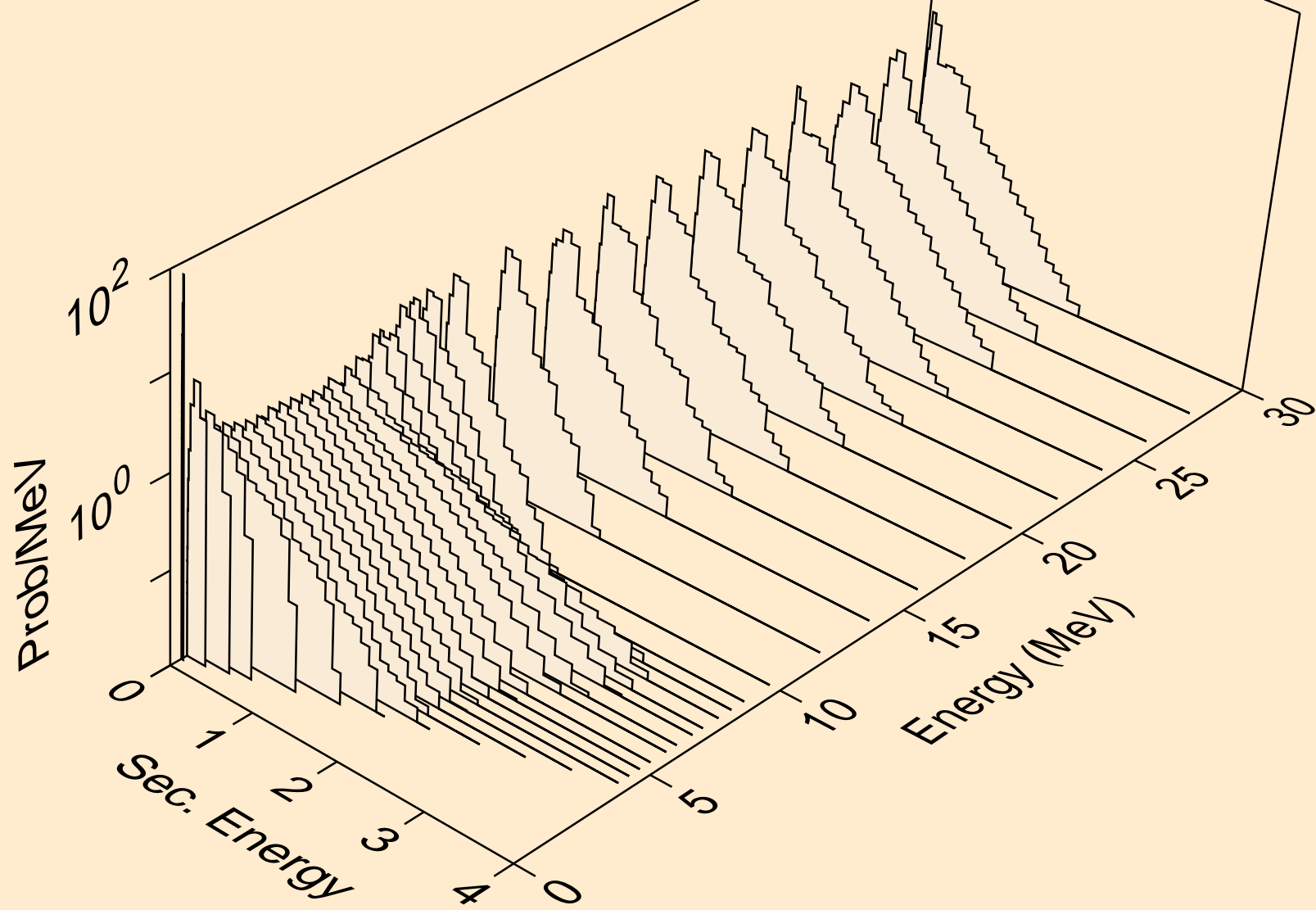

MT280 NEUTRON ACER TENDL-2023 LIBRARY; T=0.K  
Neutron emission for (n,2n)a

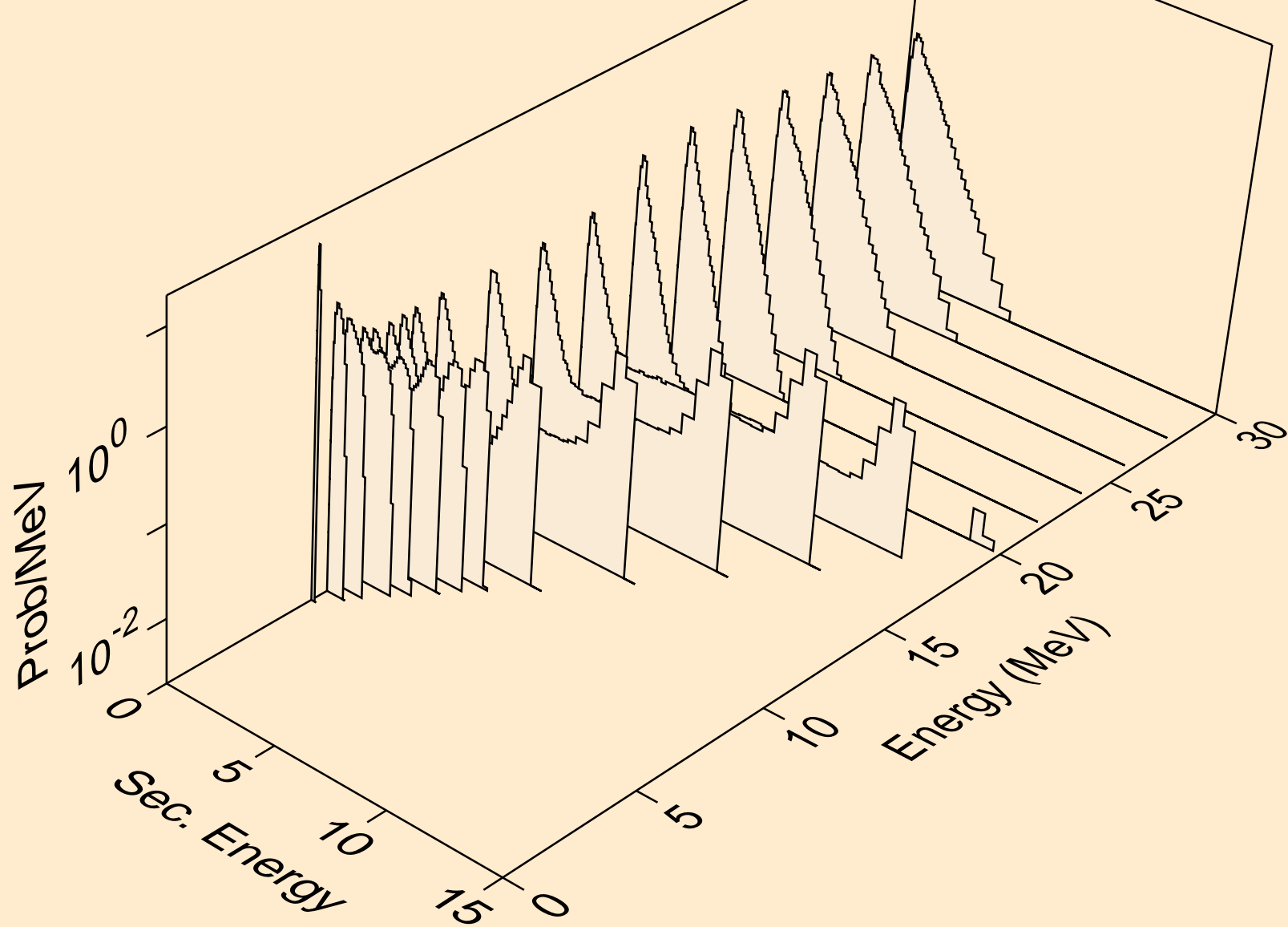

MT280 NEUTRON ACER TENDL-2023 LIBRARY; T=0.K  
Neutron emission for (n,3n)a

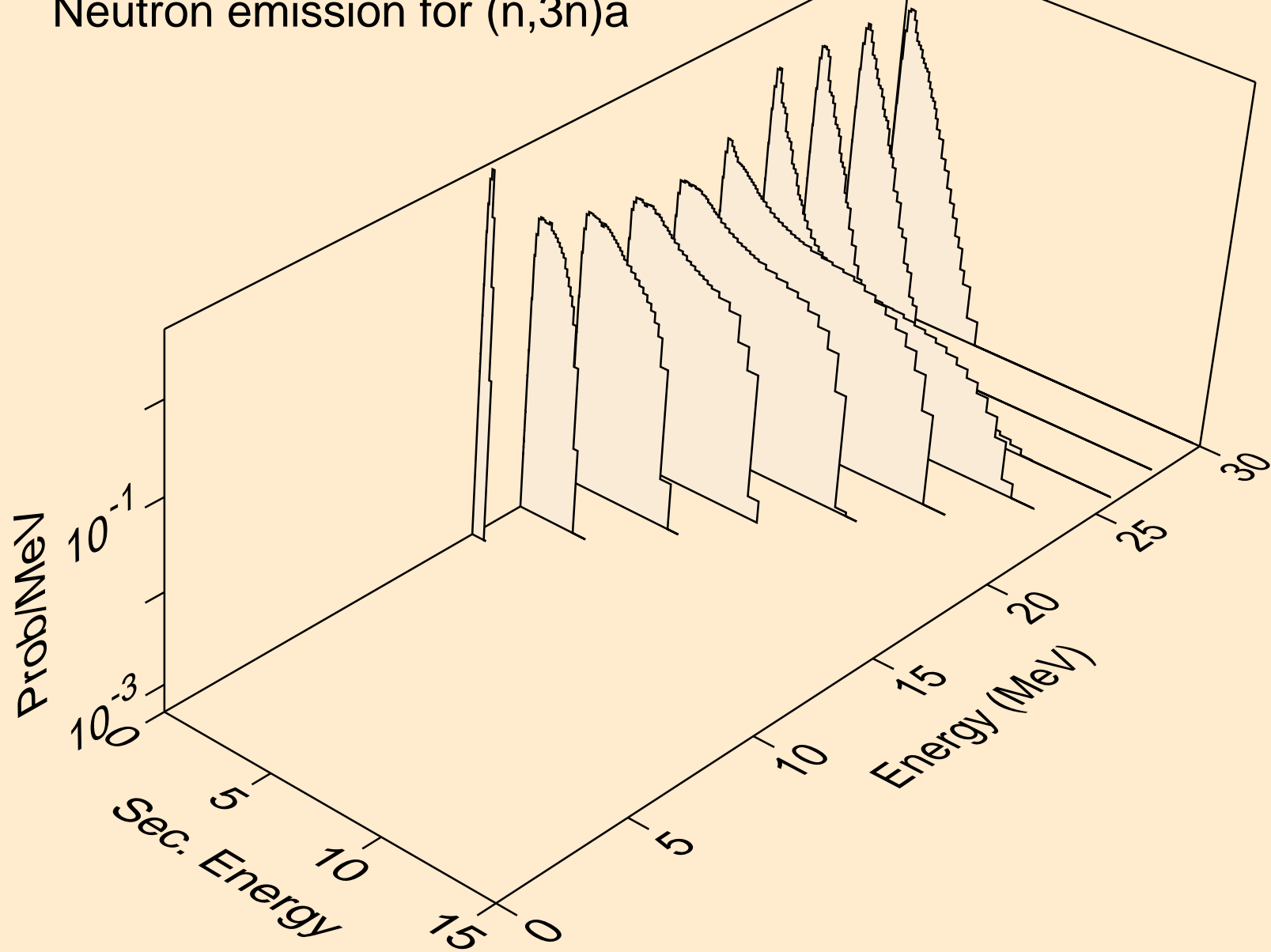

MT280 NEUTRON ACER TENDL-2023 LIBRARY; T=0.K  
Neutron emission for (n,n\*)p

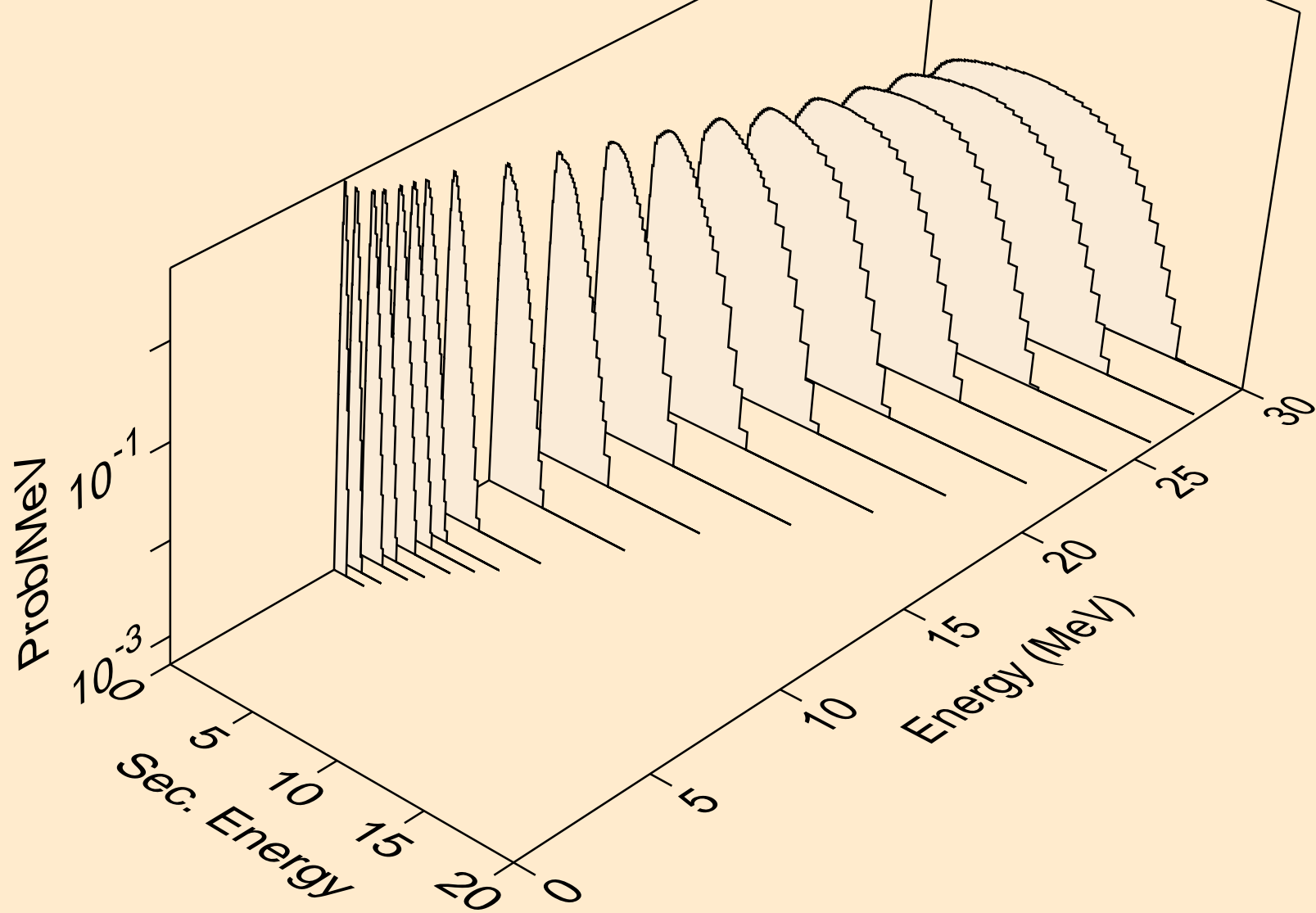

MT280 NEUTRON ACER TENDL-2023 LIBRARY; T=0.K  
Neutron emission for (n,n\*)d

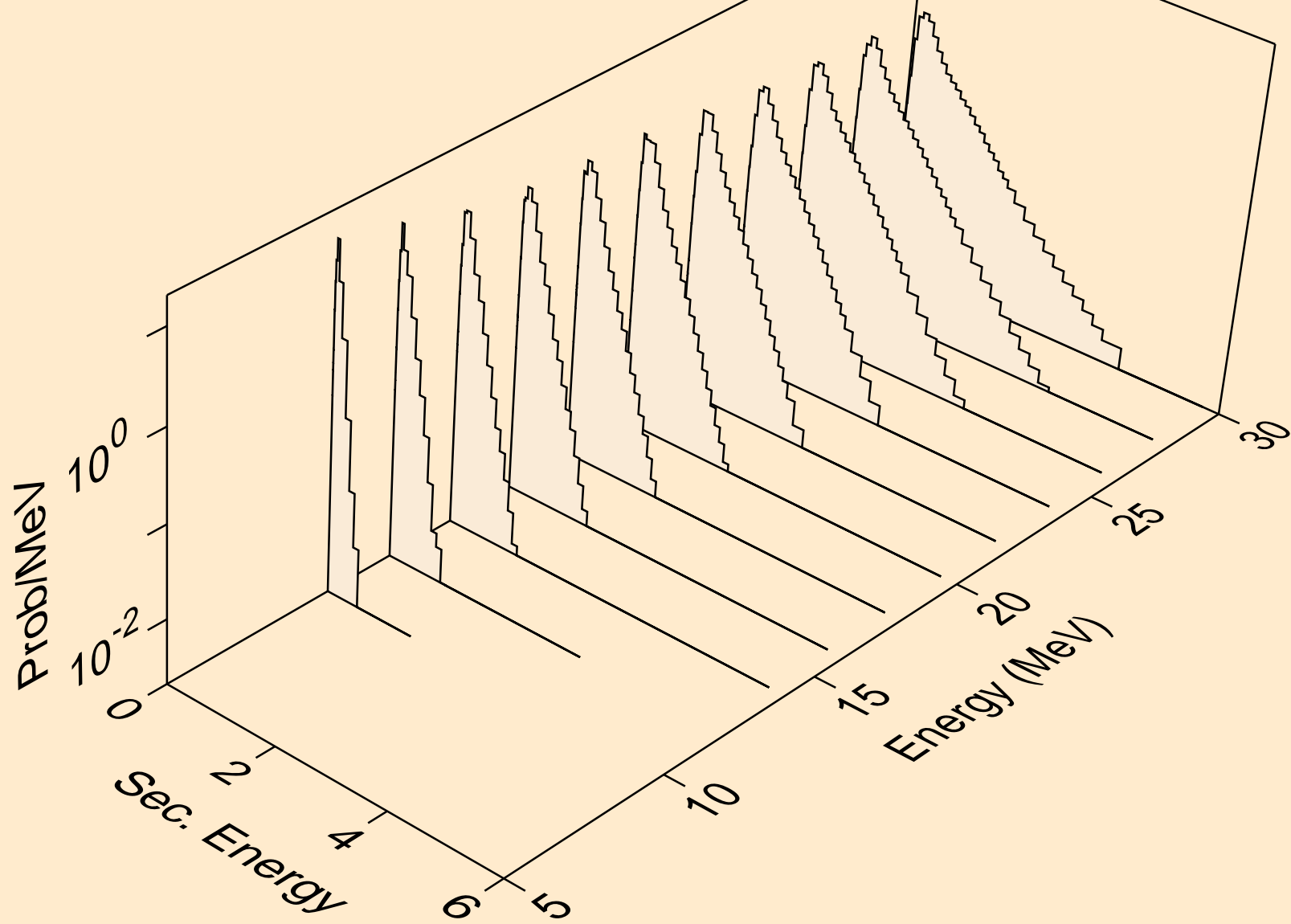

MT280 NEUTRON ACER TENDL-2023 LIBRARY; T=0.K  
Neutron emission for (n,n\*)t

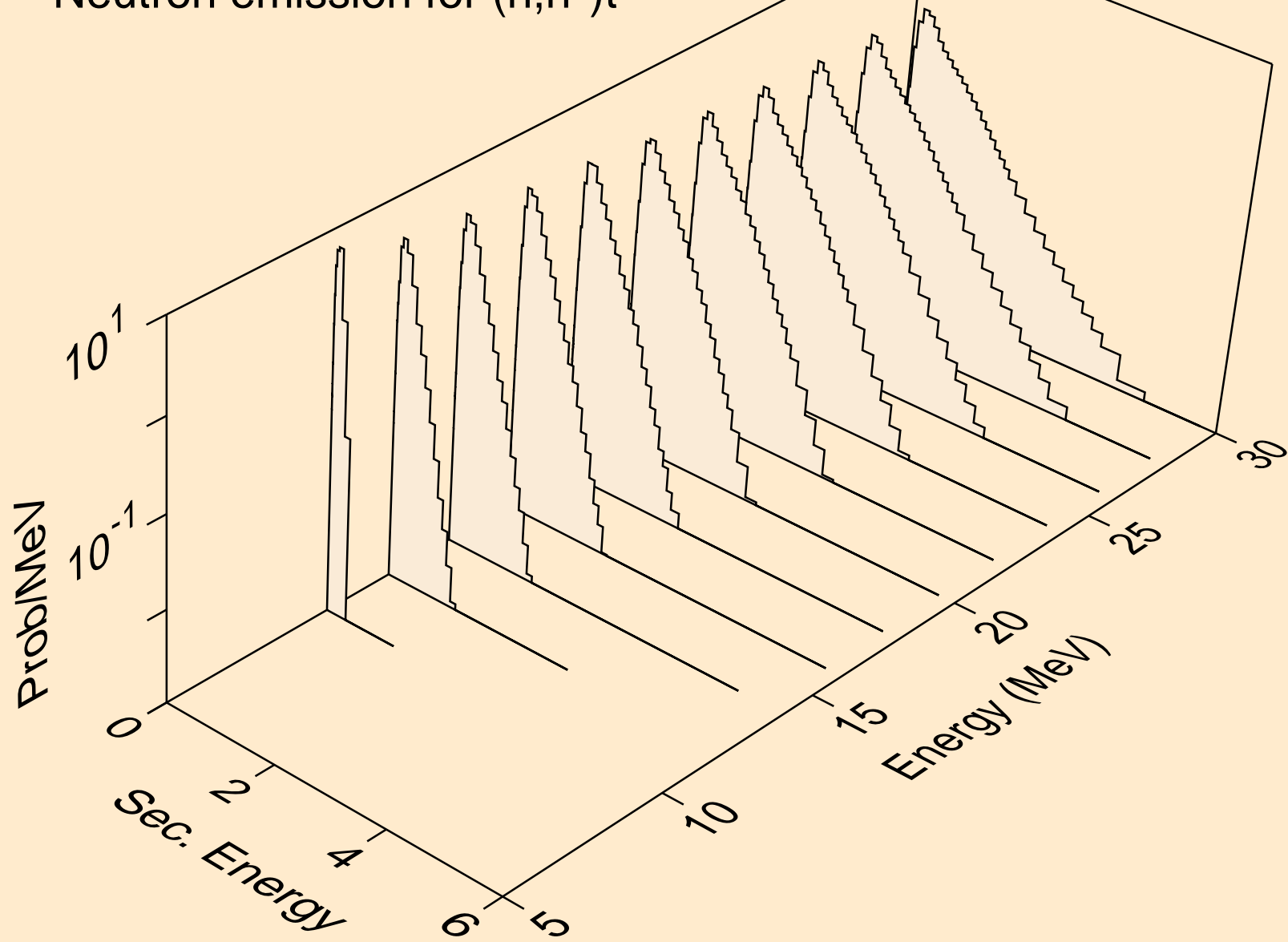



MT280 NEUTRON ACER TENDL-2023 LIBRARY; T=0.K  
Neutron emission for (n,n\*)he3

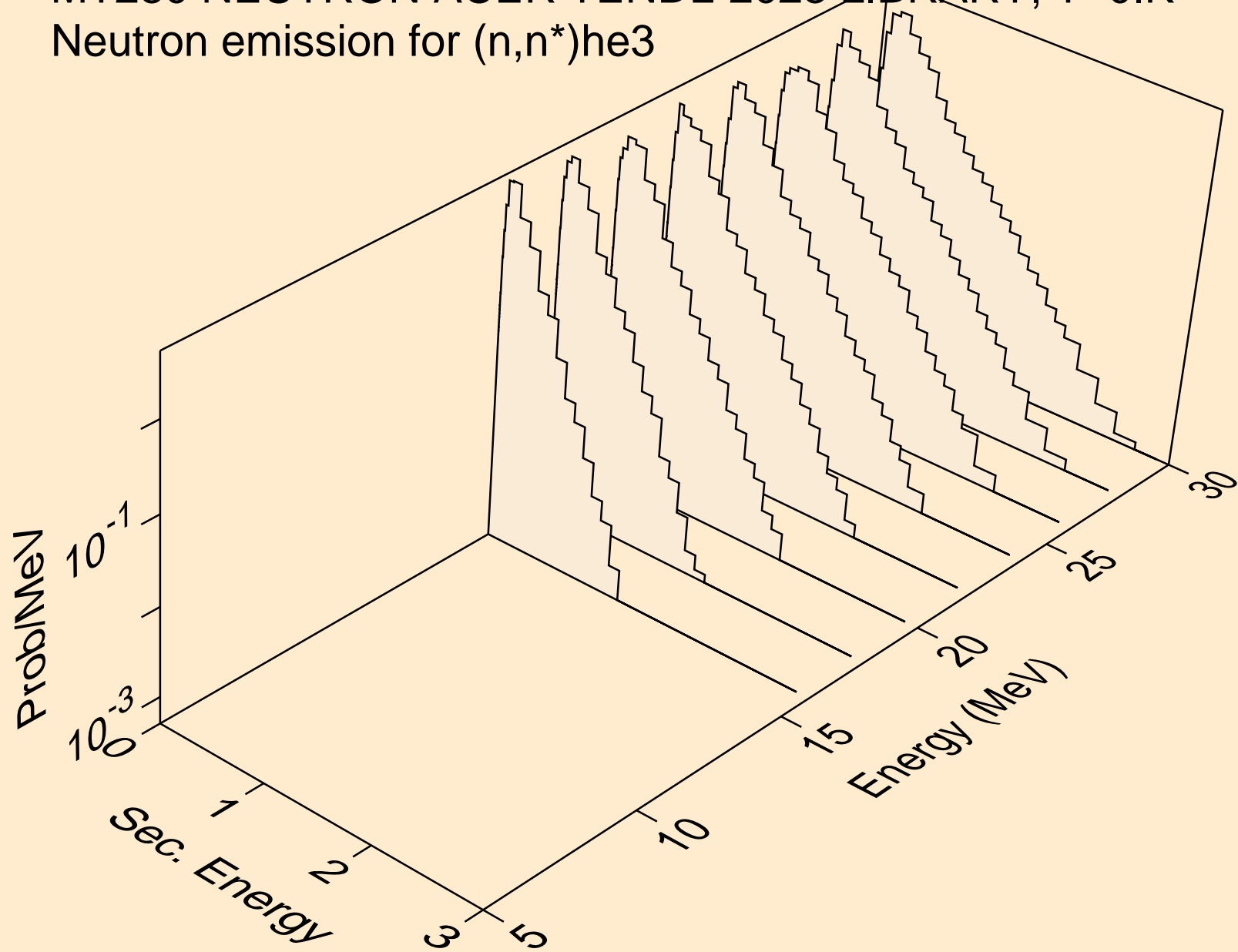

MT280 NEUTRON ACER TENDL-2023 LIBRARY; T=0.K  
Neutron emission for (n,4n)

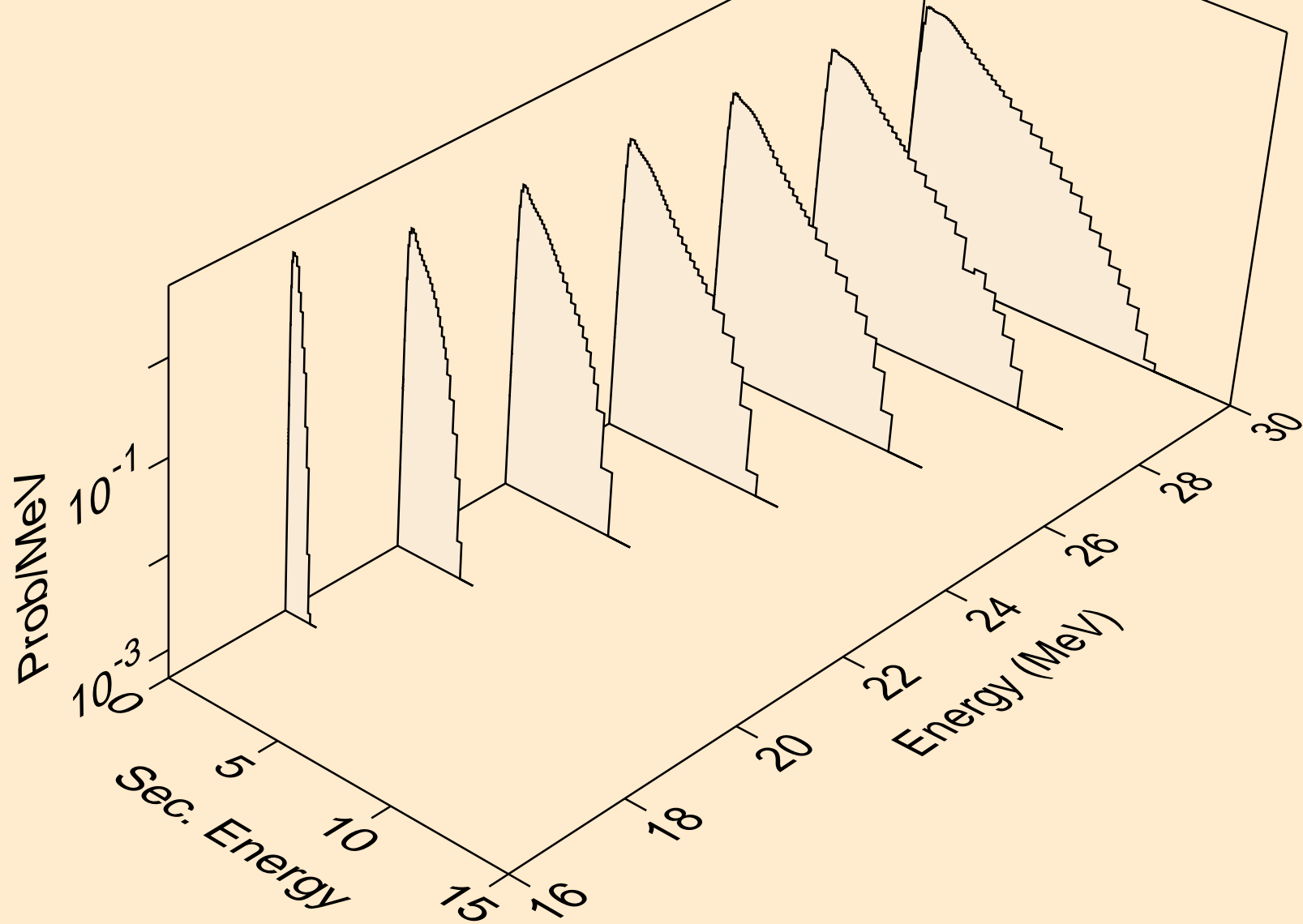

MT280 NEUTRON ACER TENDL-2023 LIBRARY; T=0.K  
Neutron emission for (n,2np)

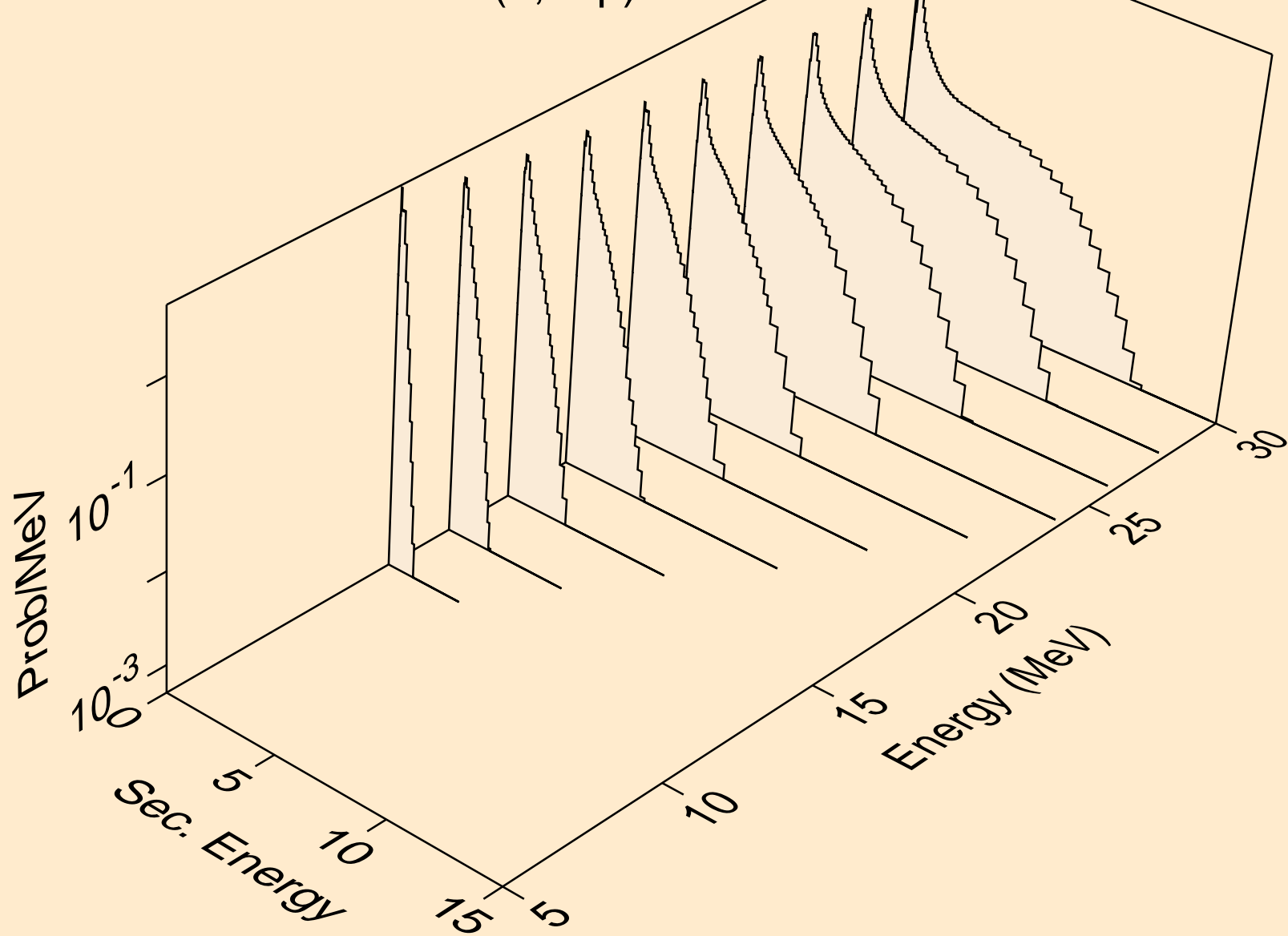

MT280 NEUTRON ACER TENDL-2023 LIBRARY; T=0.K  
Neutron emission for (n,3np)

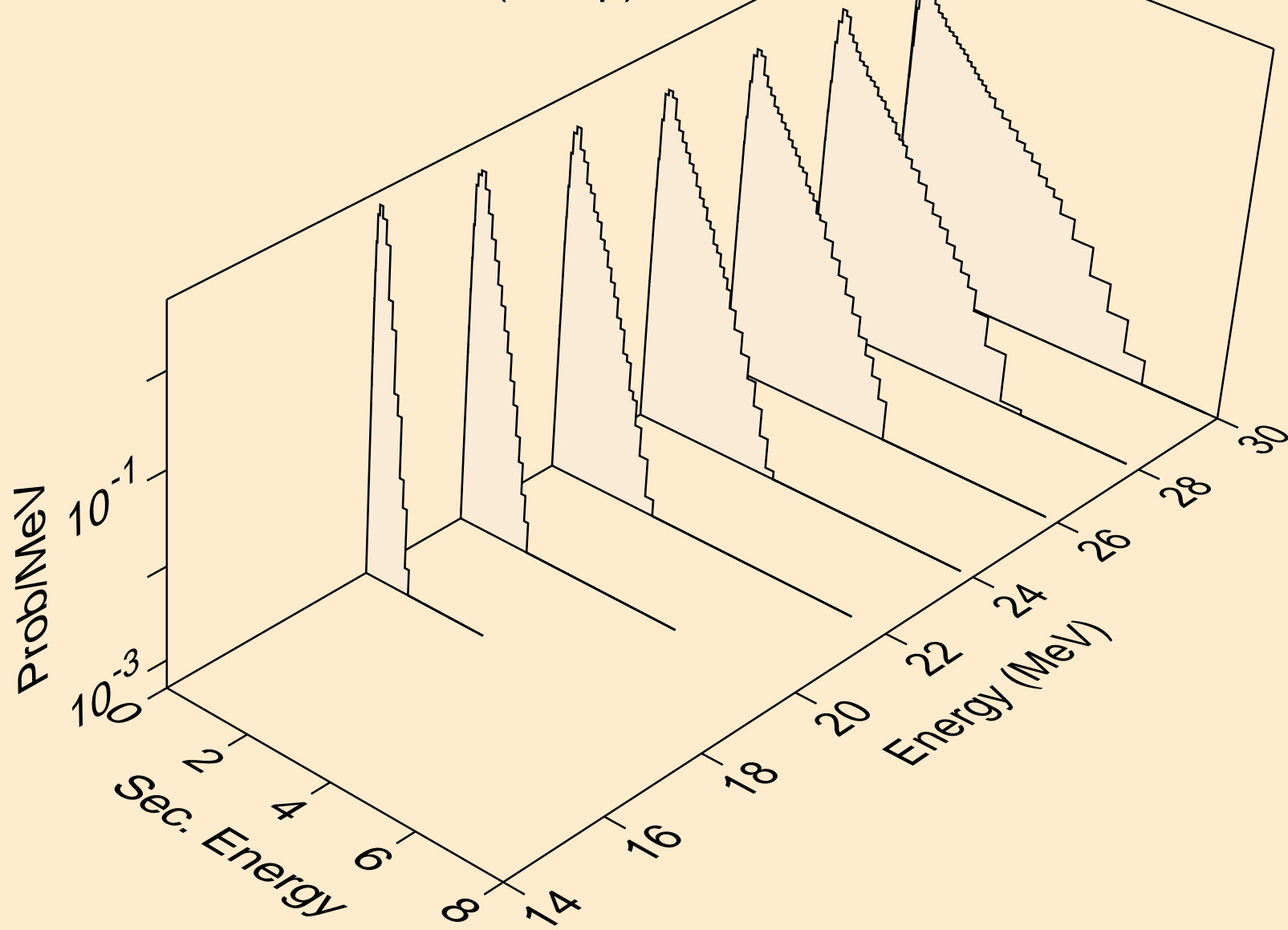

MT280 NEUTRON ACER TENDL-2023 LIBRARY; T=0.K  
Neutron emission for (n,n2p)

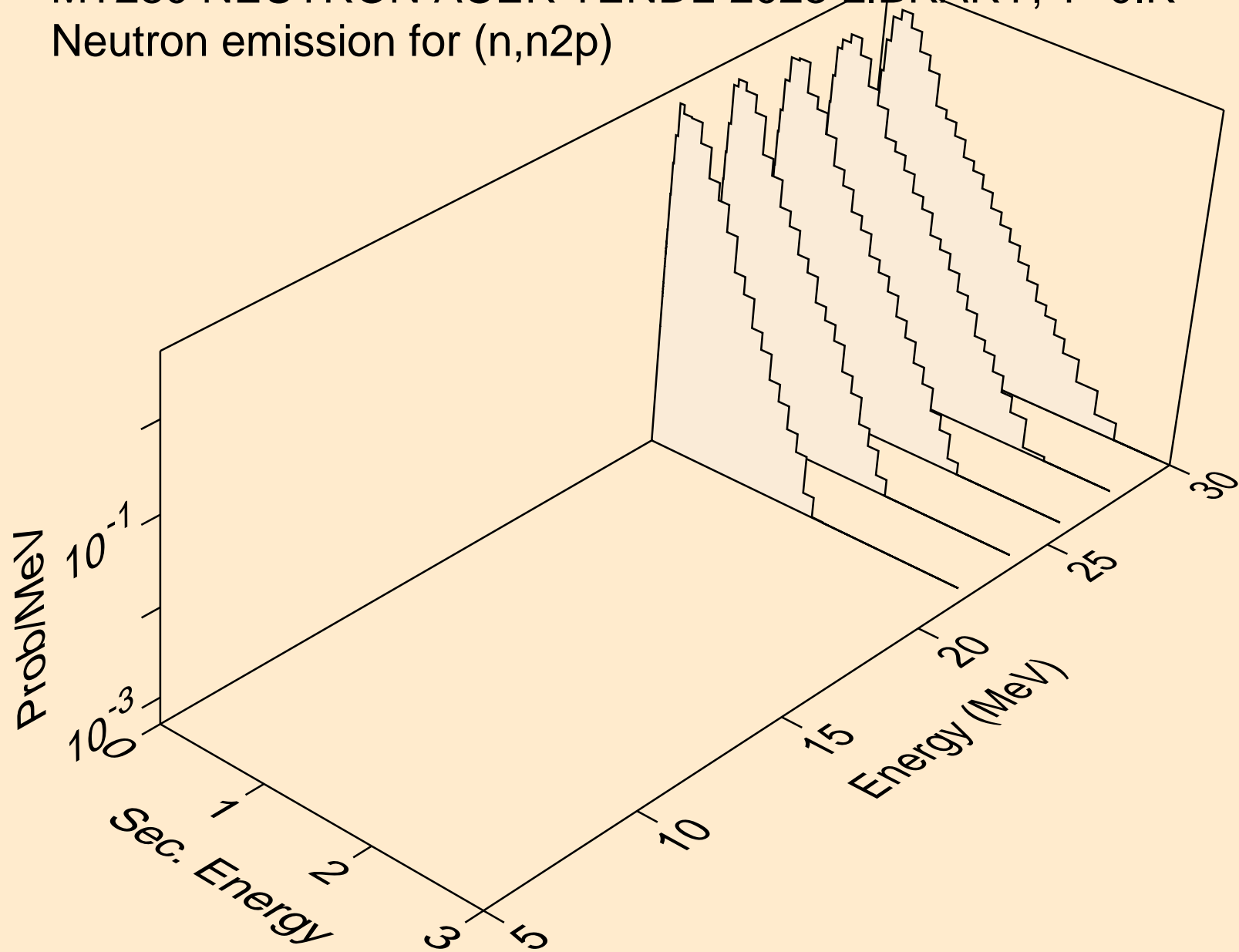

MT280 NEUTRON ACER TENDL-2023 LIBRARY; T=0.K  
Neutron emission for (n,npa)

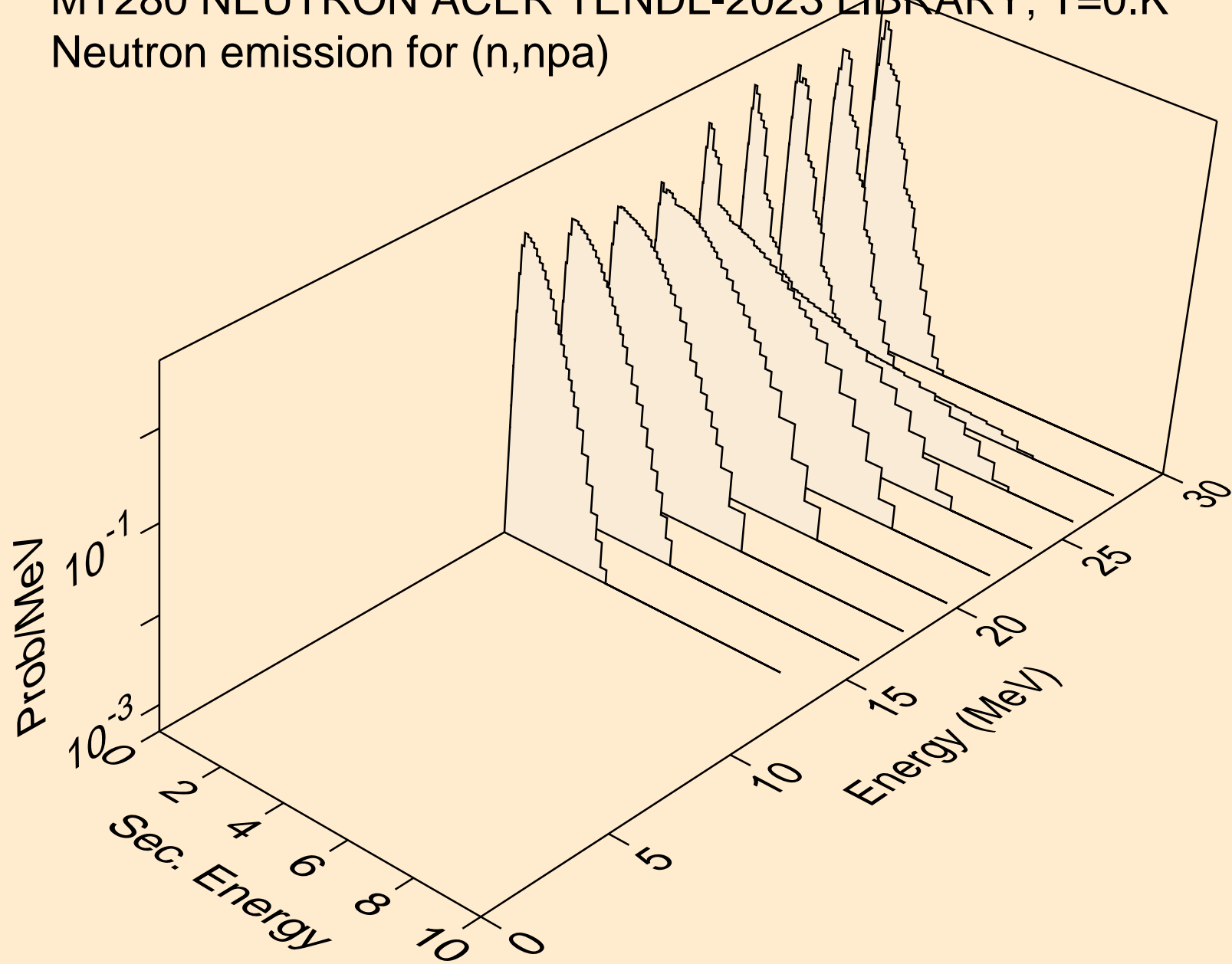

MT280 NEUTRON ACER TENDL-2023 LIBRARY; T=0.K  
Neutron emission for (n,n\*c)

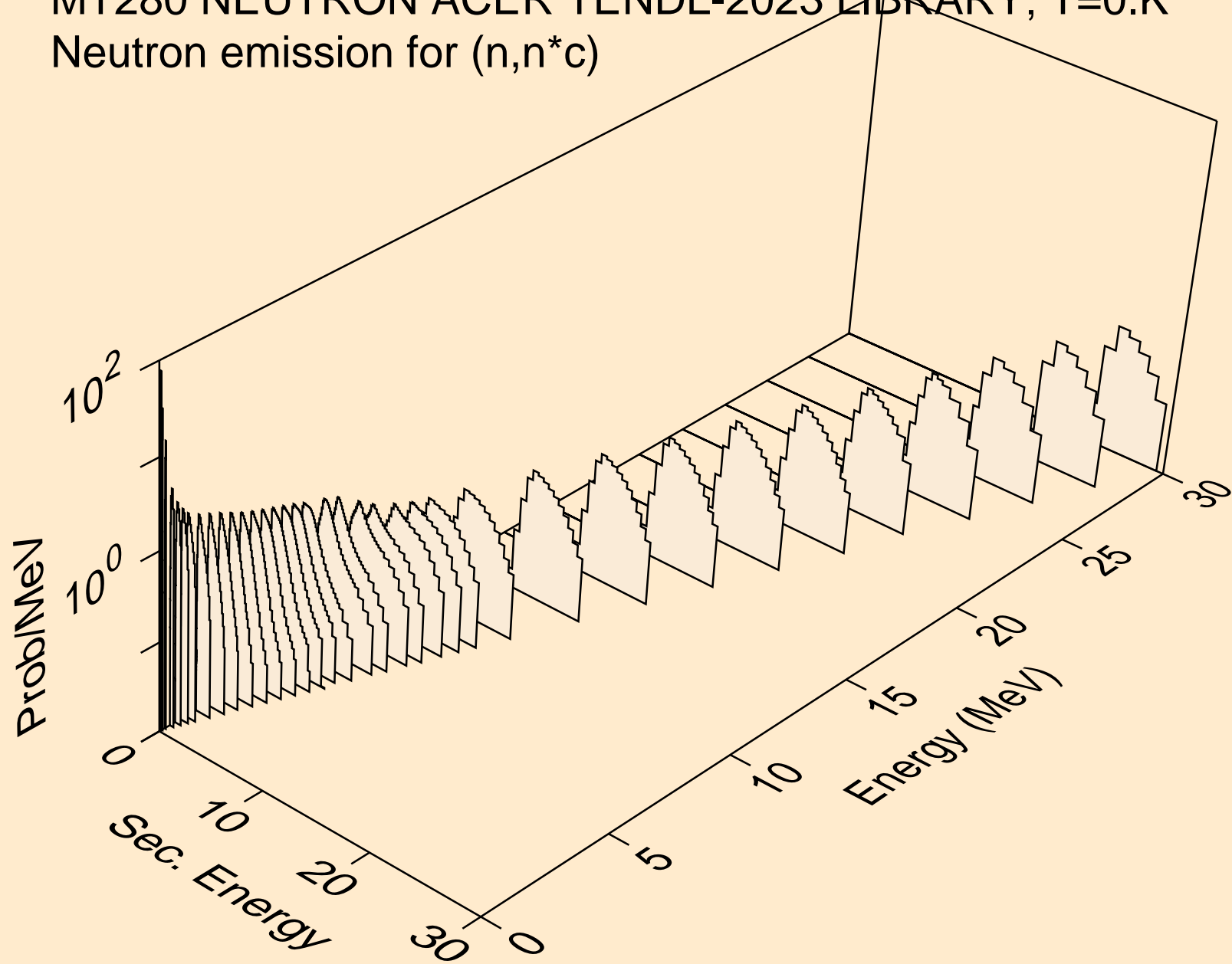

# MT280 NEUTRON ACER TENDL-2023 LIBRARY; T=0.K

## Delayed nubar

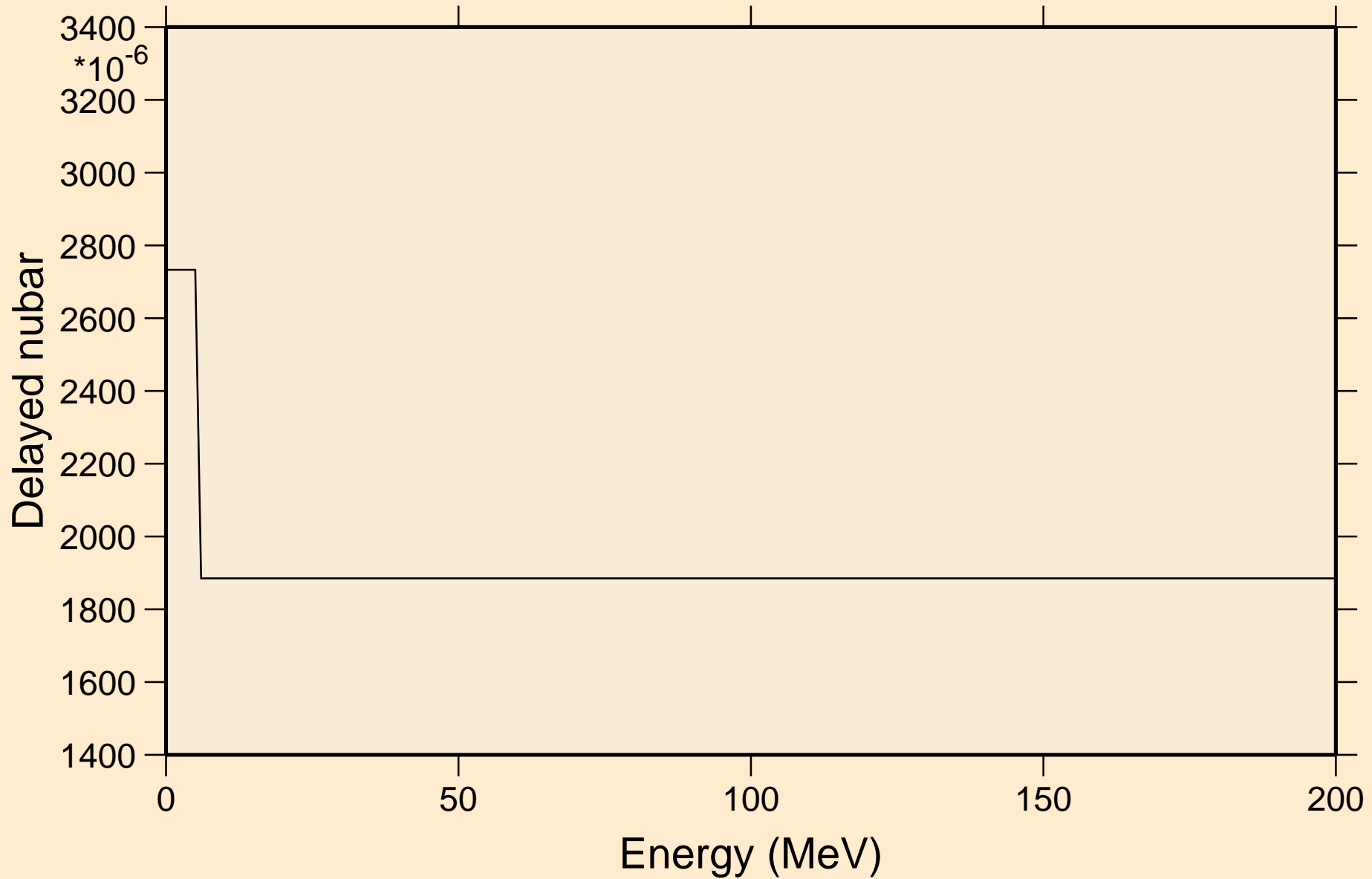



# MT280 NEUTRON ACER TENDL-2023 LIBRARY; T=0.K

## Delayed neutron spectra

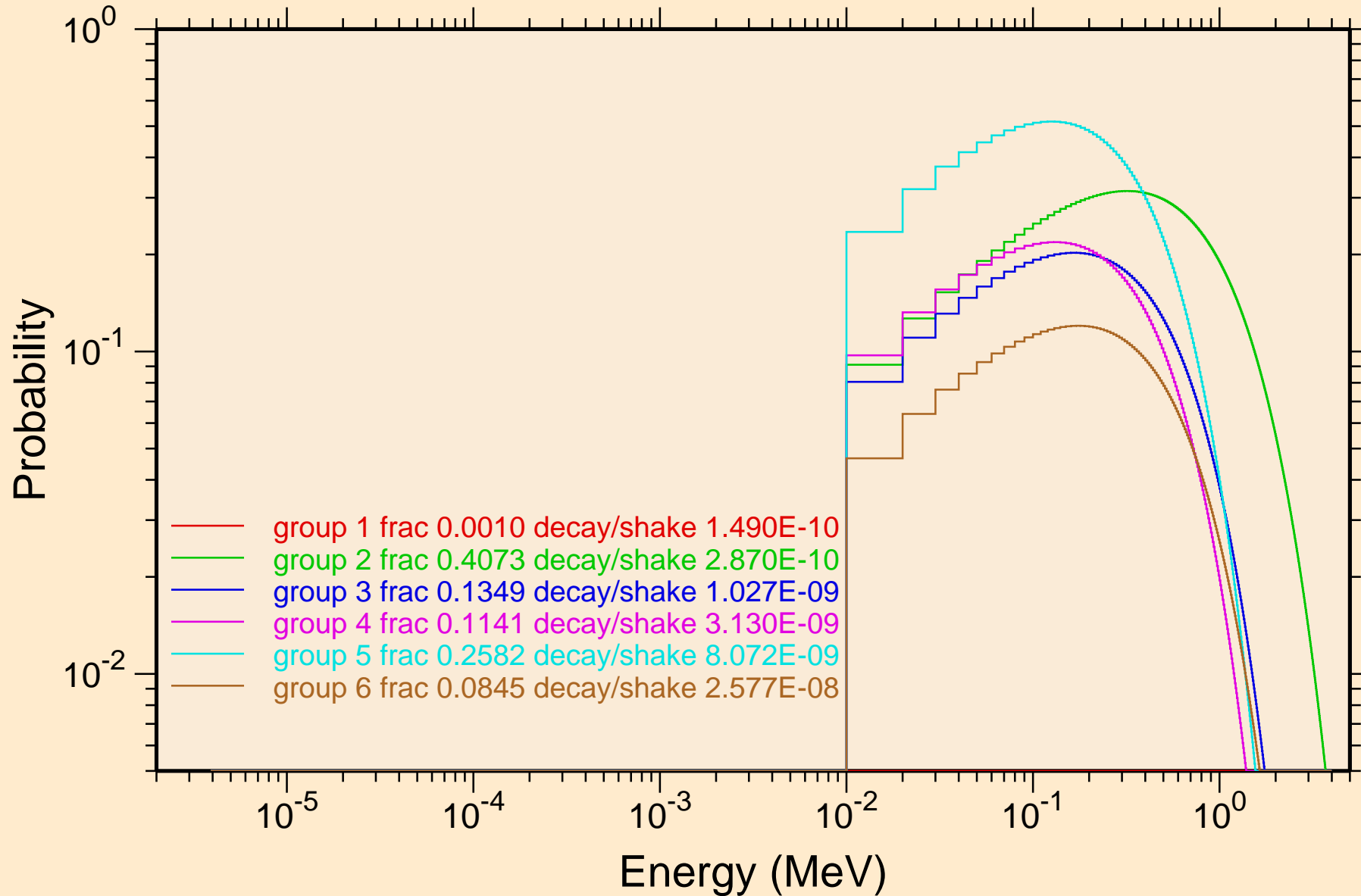

MT280 NEUTRON ACER TENDL-2023 LIBRARY; T=0.K  
Photon emission for (n,x)

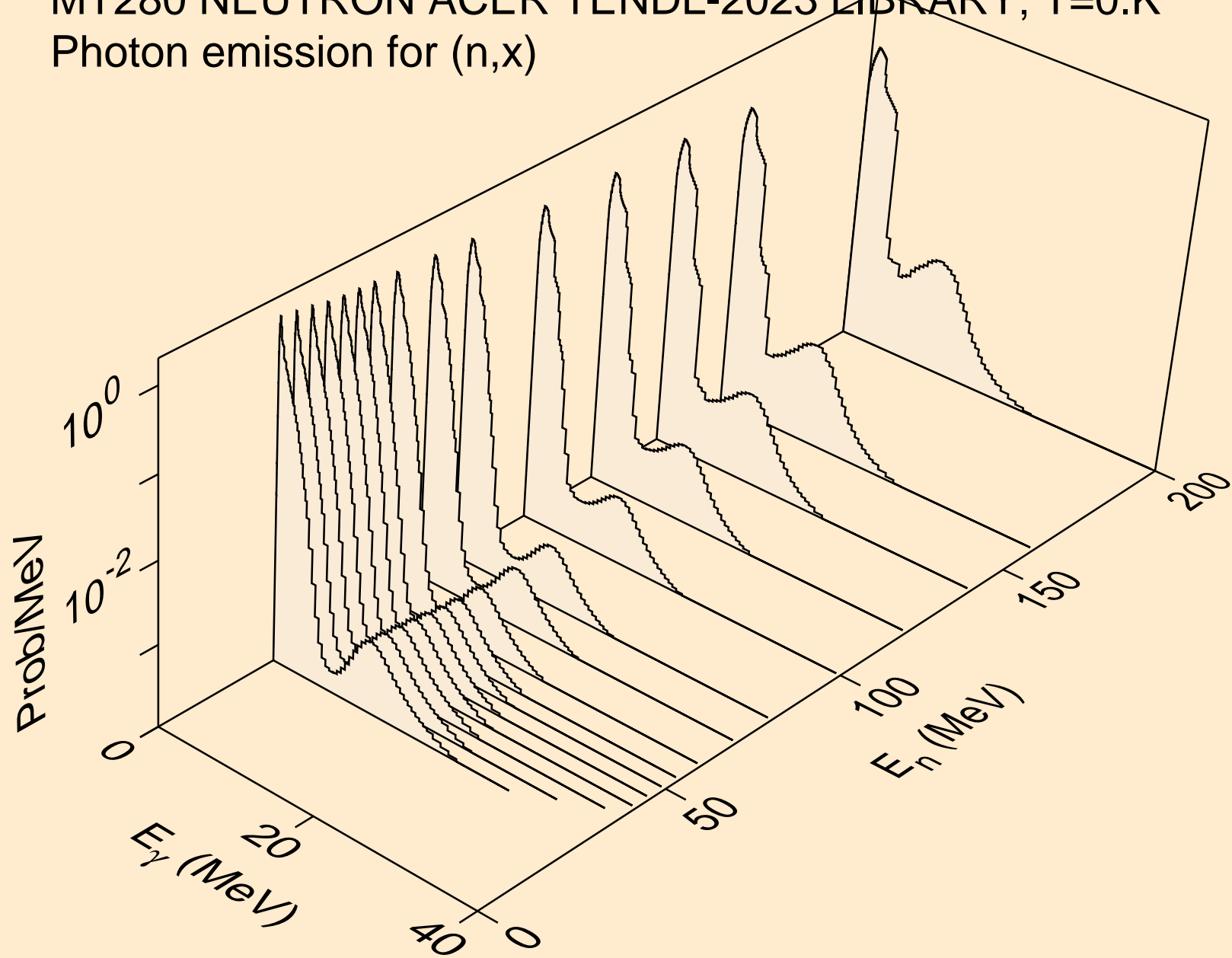

MT280 NEUTRON ACER TENDL-2023 LIBRARY; T=0.K  
Photon emission for (n,2nd)

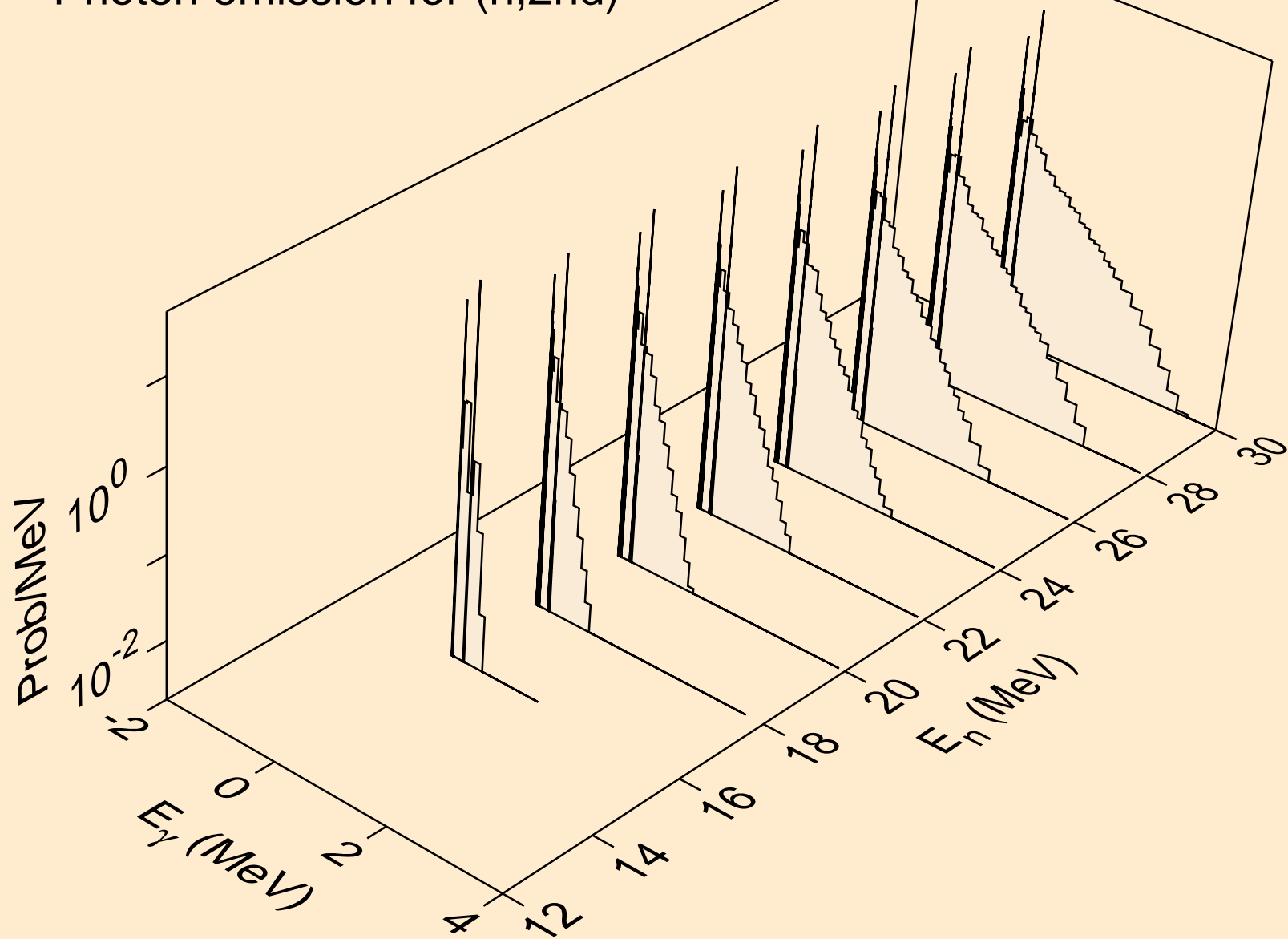

MT280 NEUTRON ACER TENDL-2023 LIBRARY; T=0.K  
Photon emission for (n,2n)

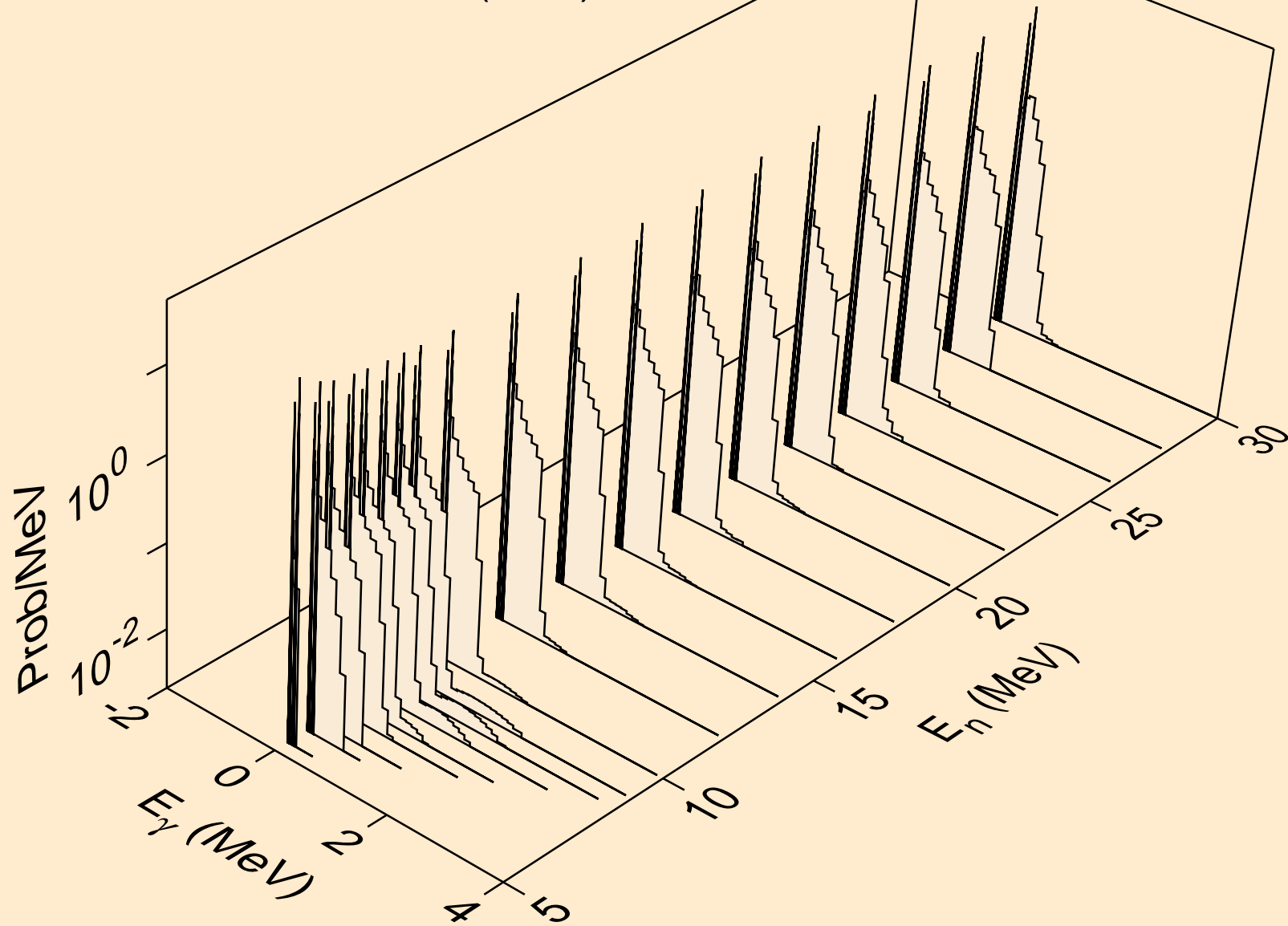

MT280 NEUTRON ACER TENDL-2023 LIBRARY; T=0.K  
Photon emission for (n,3n)

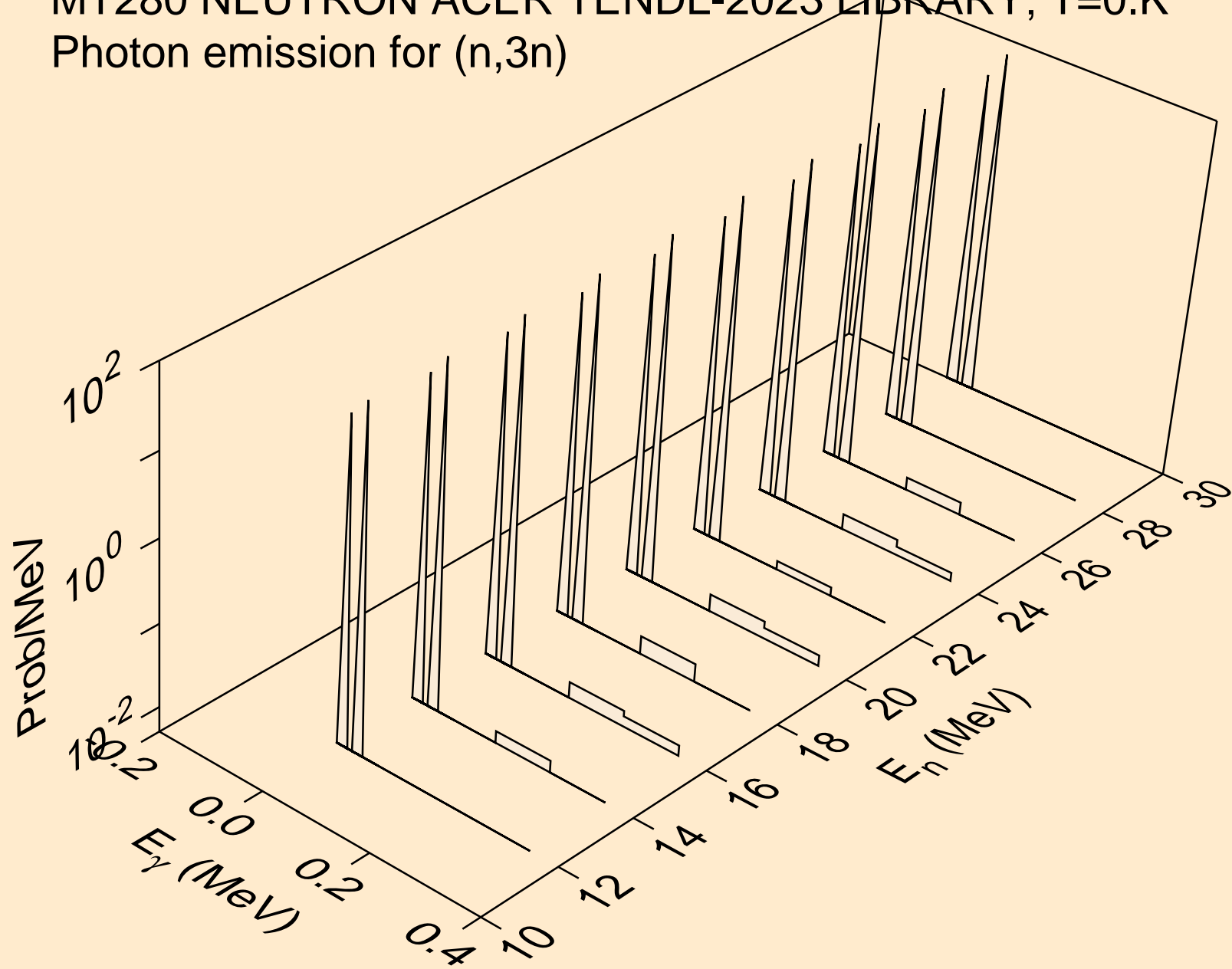

MT280 NEUTRON ACER TENDL-2023 LIBRARY; T=0.K  
Photon emission for (n,n\*)a

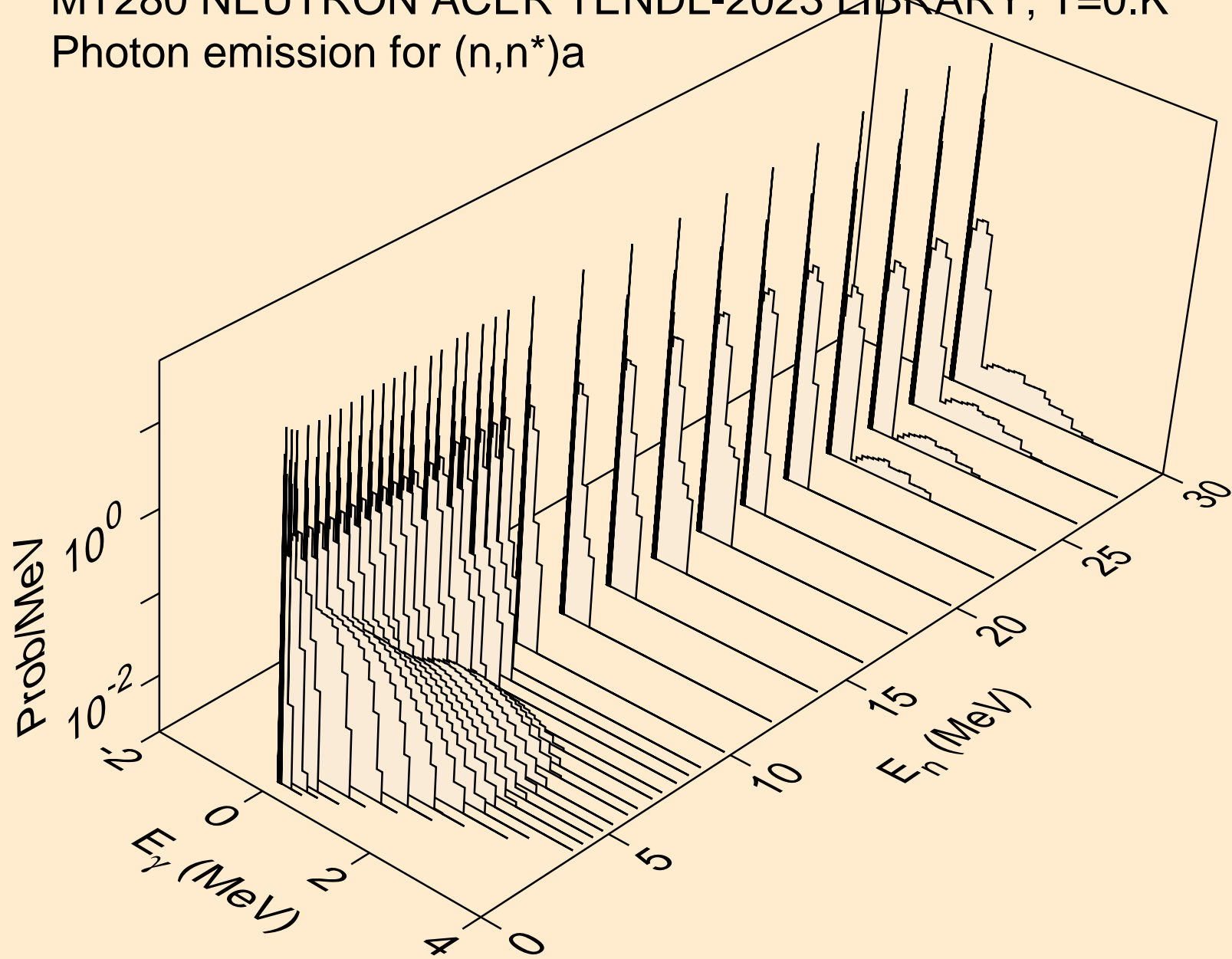

MT280 NEUTRON ACER TENDL-2023 LIBRARY; T=0.K  
Photon emission for (n,2n)a

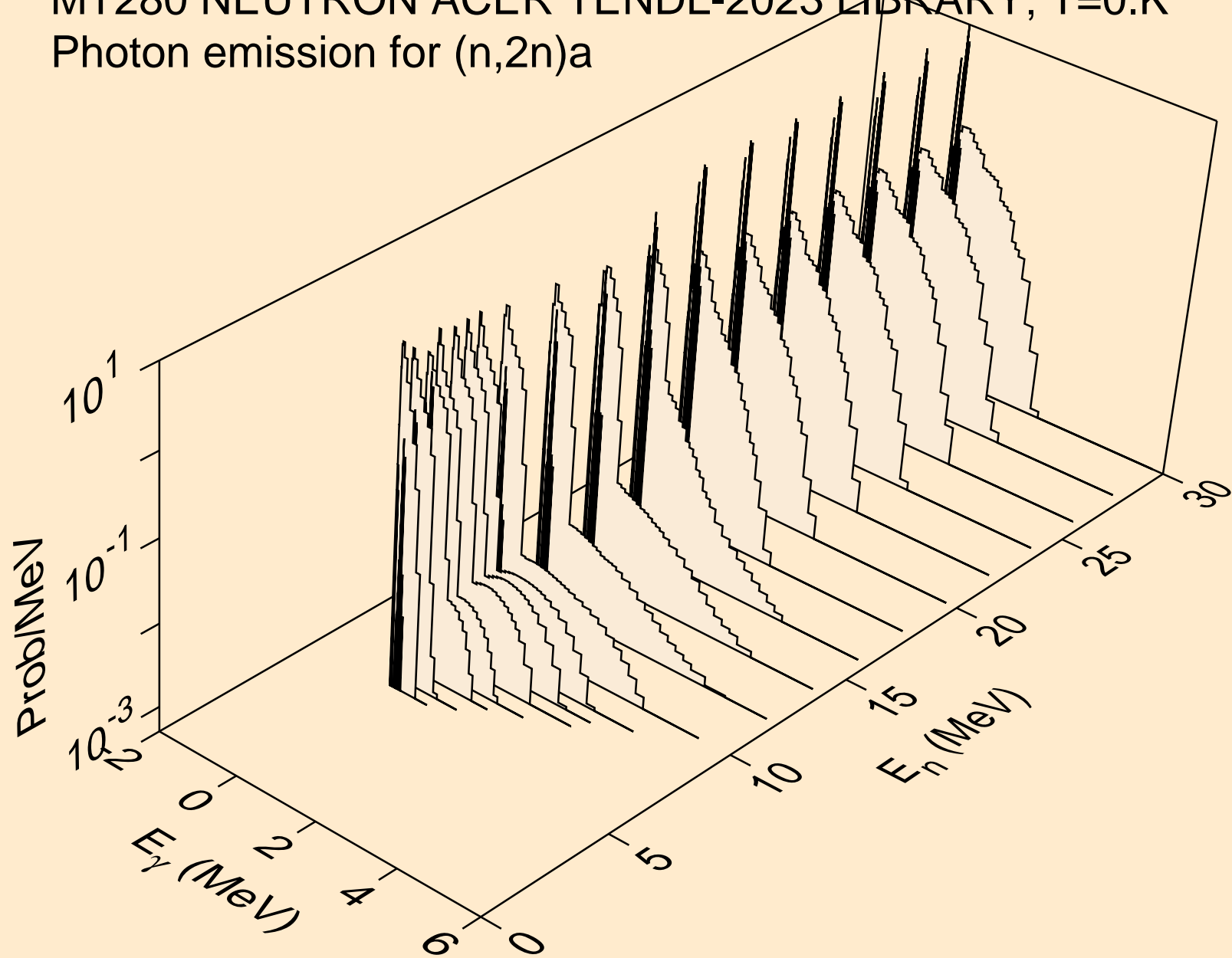

MT280 NEUTRON ACER TENDL-2023 LIBRARY; T=0.K  
Photon emission for (n,3n)a

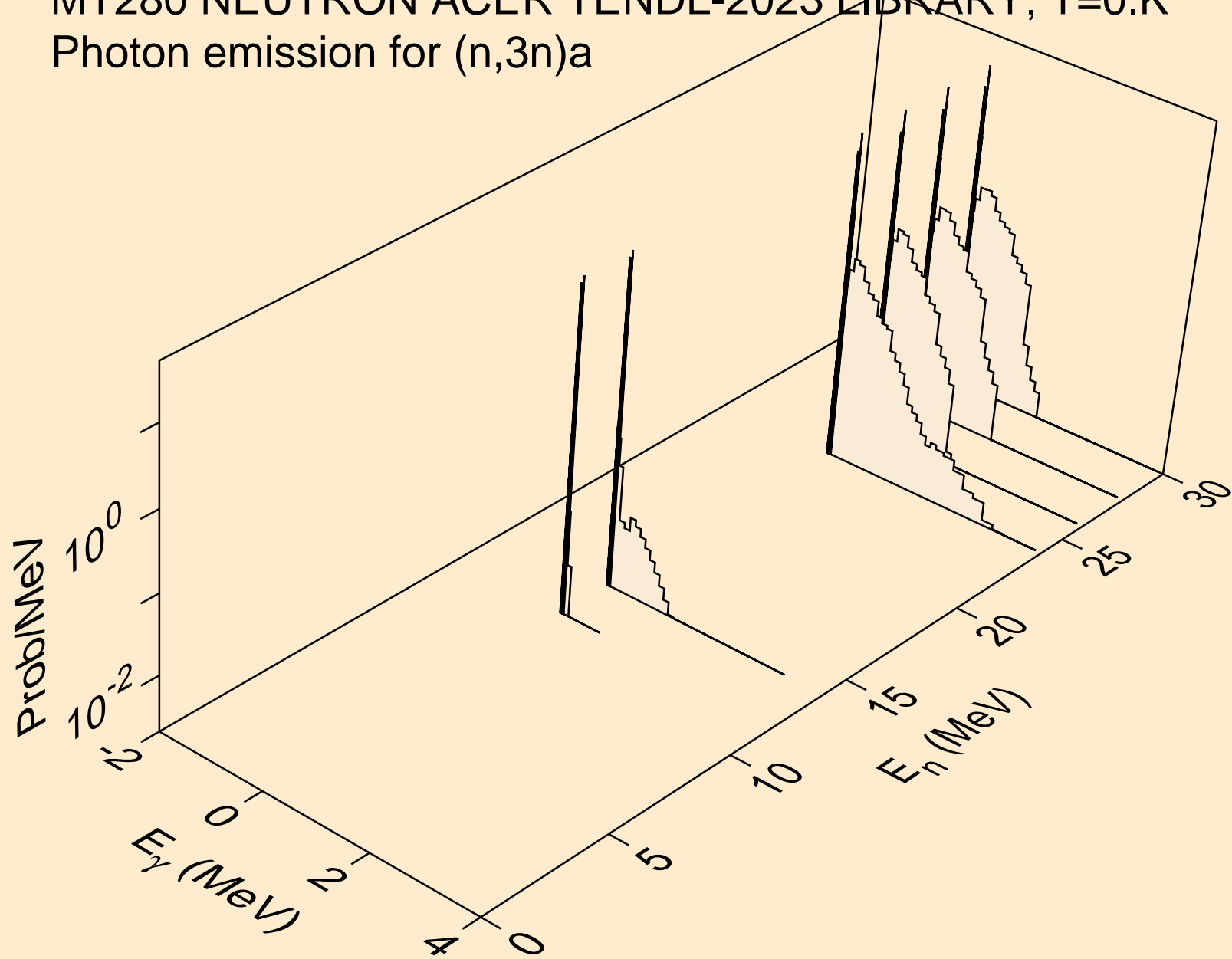



MT280 NEUTRON ACER TENDL-2023 LIBRARY; T=0.K  
Photon emission for (n,n\*)p

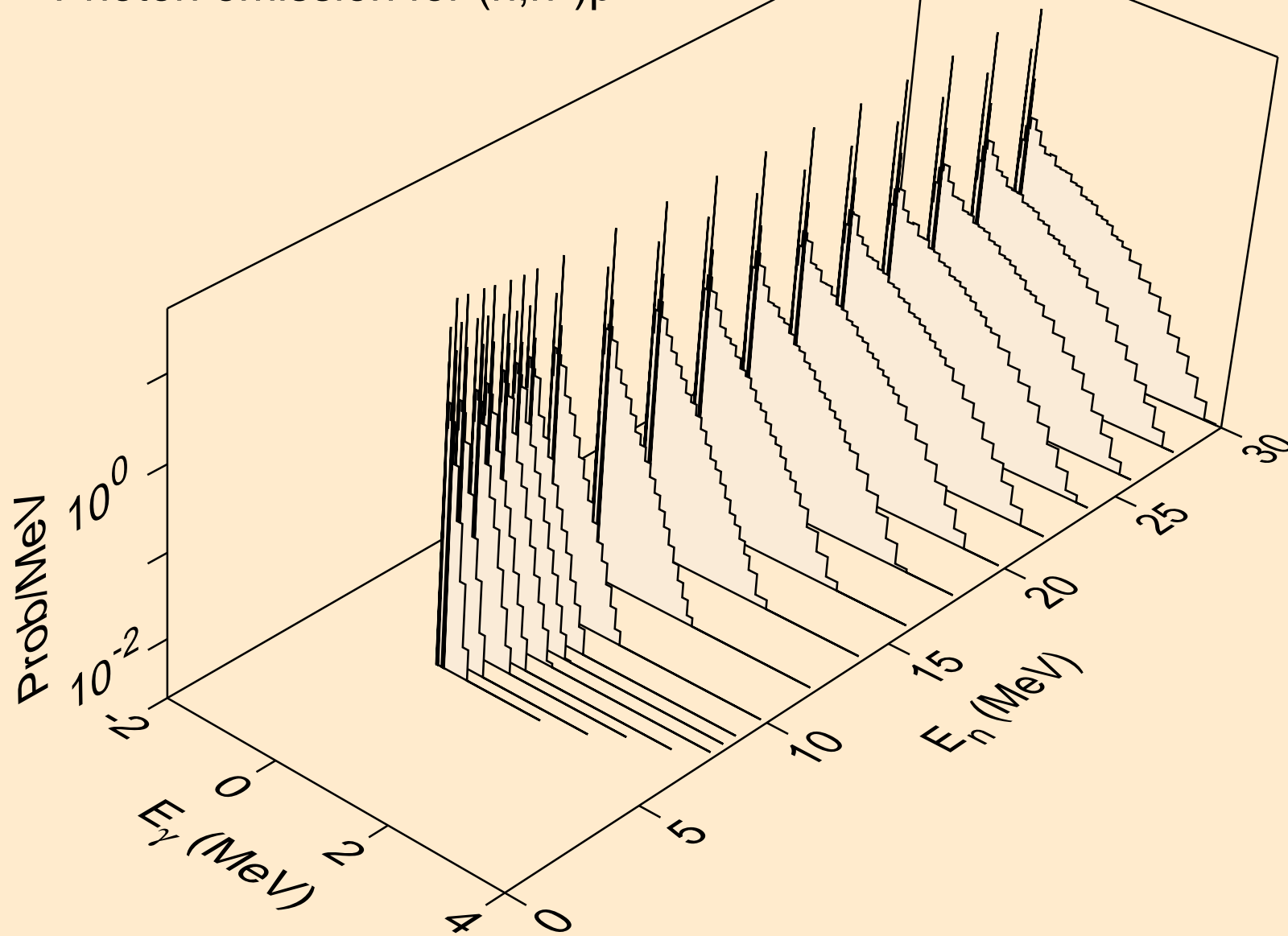

MT280 NEUTRON ACER TENDL-2023 LIBRARY; T=0.K  
Photon emission for (n,n\*)d

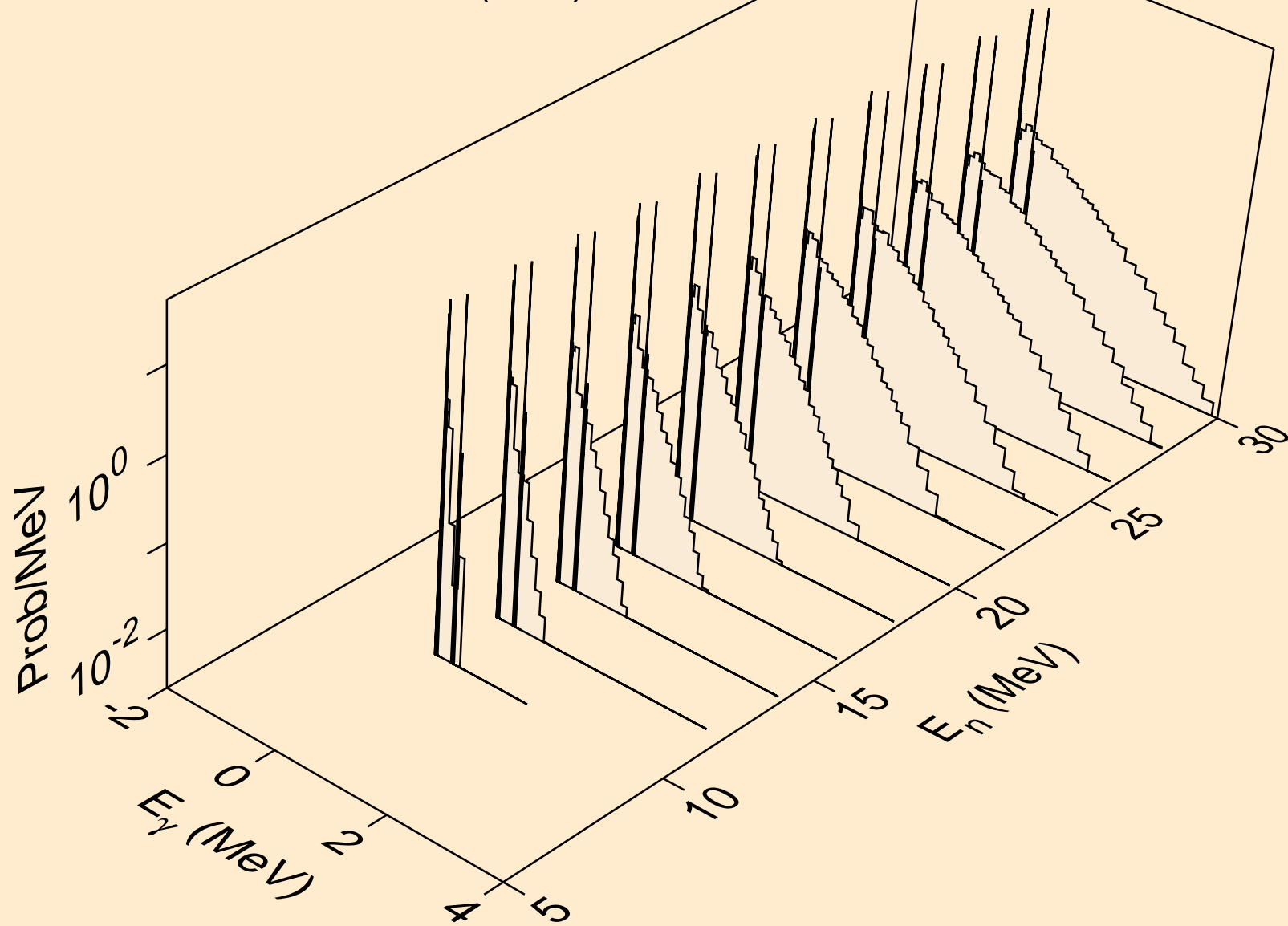

MT280 NEUTRON ACER TENDL-2023 LIBRARY; T=0.K  
Photon emission for (n,n\*)t

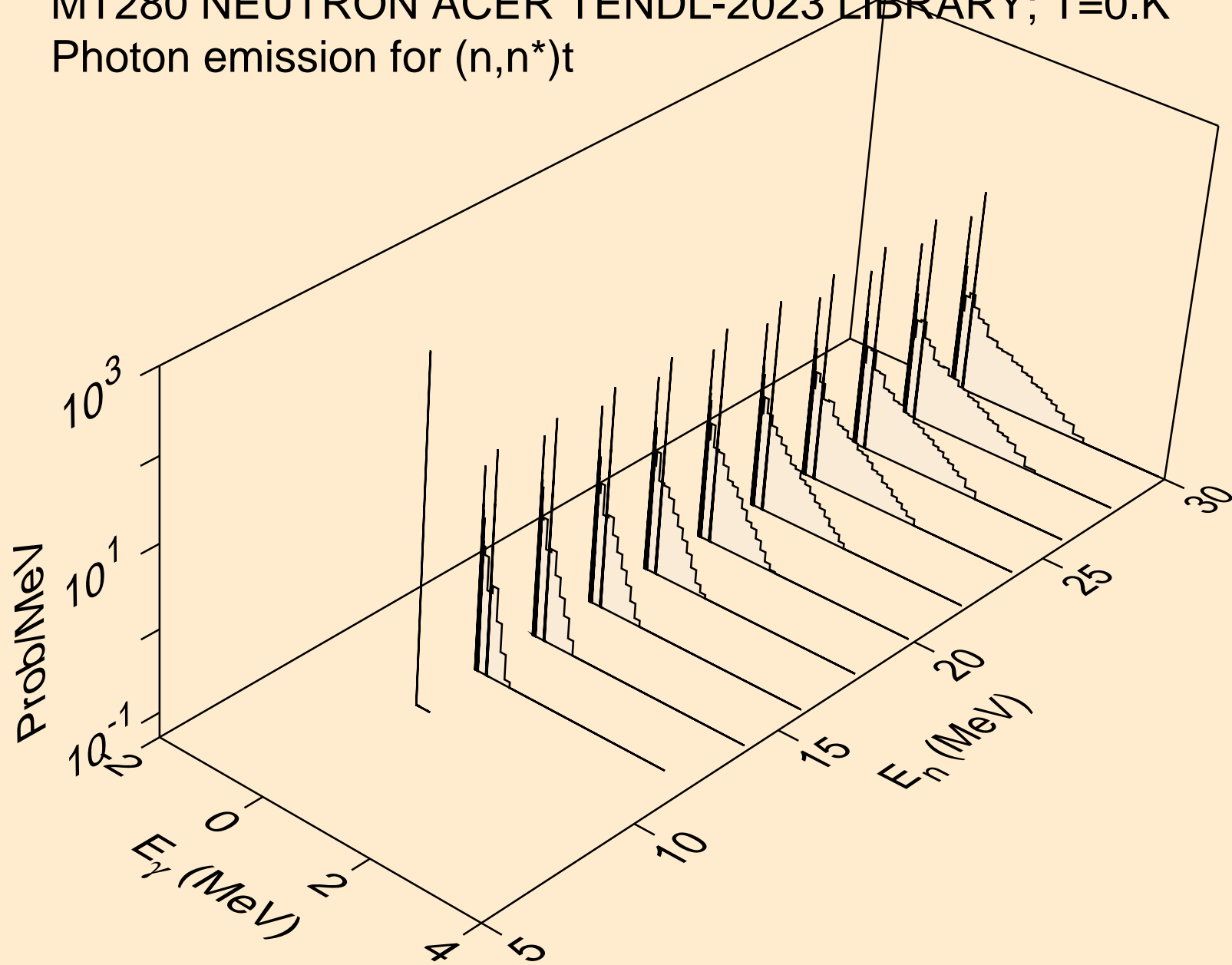

MT280 NEUTRON ACER TENDL-2023 LIBRARY; T=0.K  
Photon emission for (n,n\*)he3

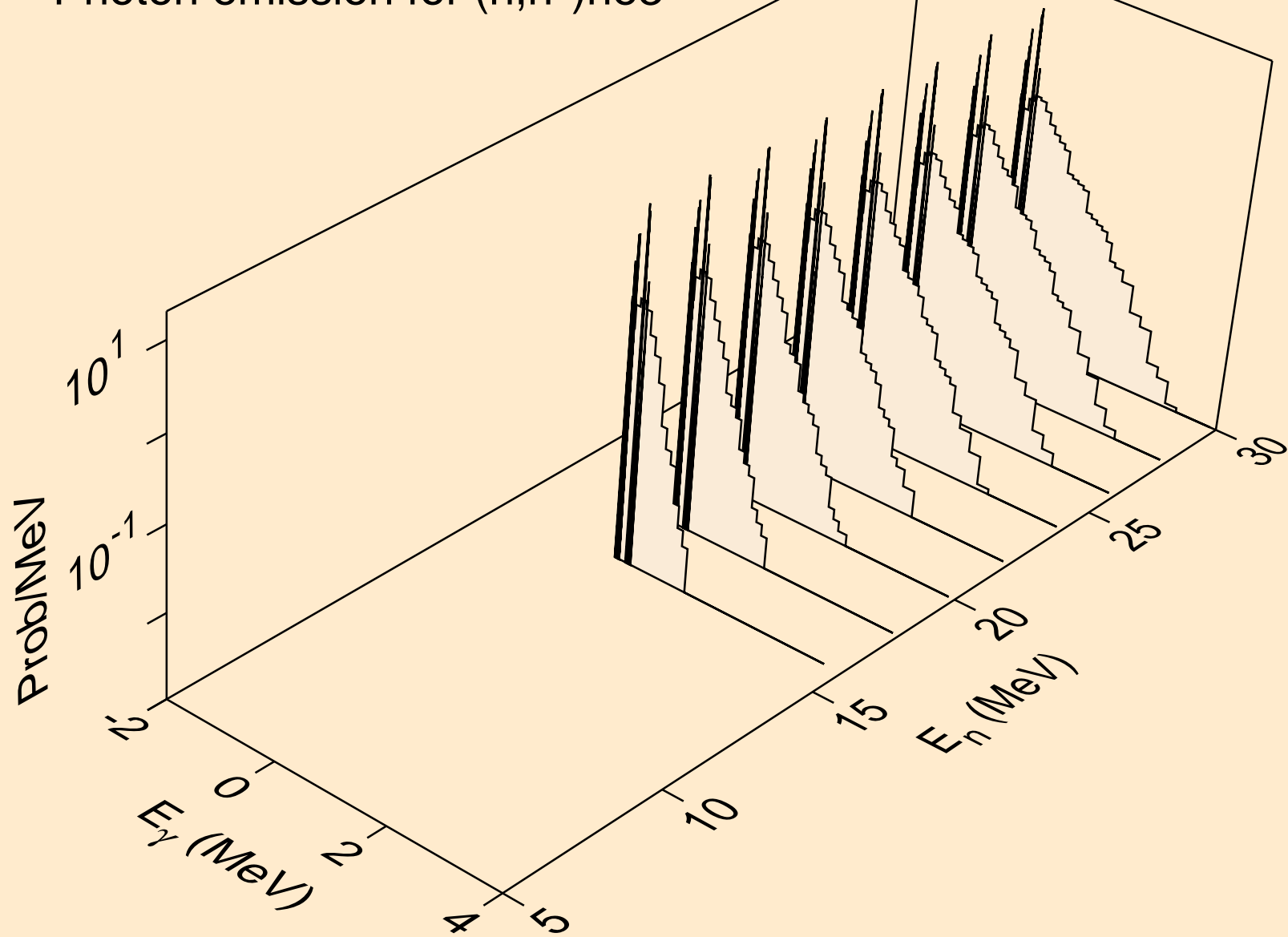

MT280 NEUTRON ACER TENDL-2023 LIBRARY; T=0.K  
Photon emission for (n,4n)

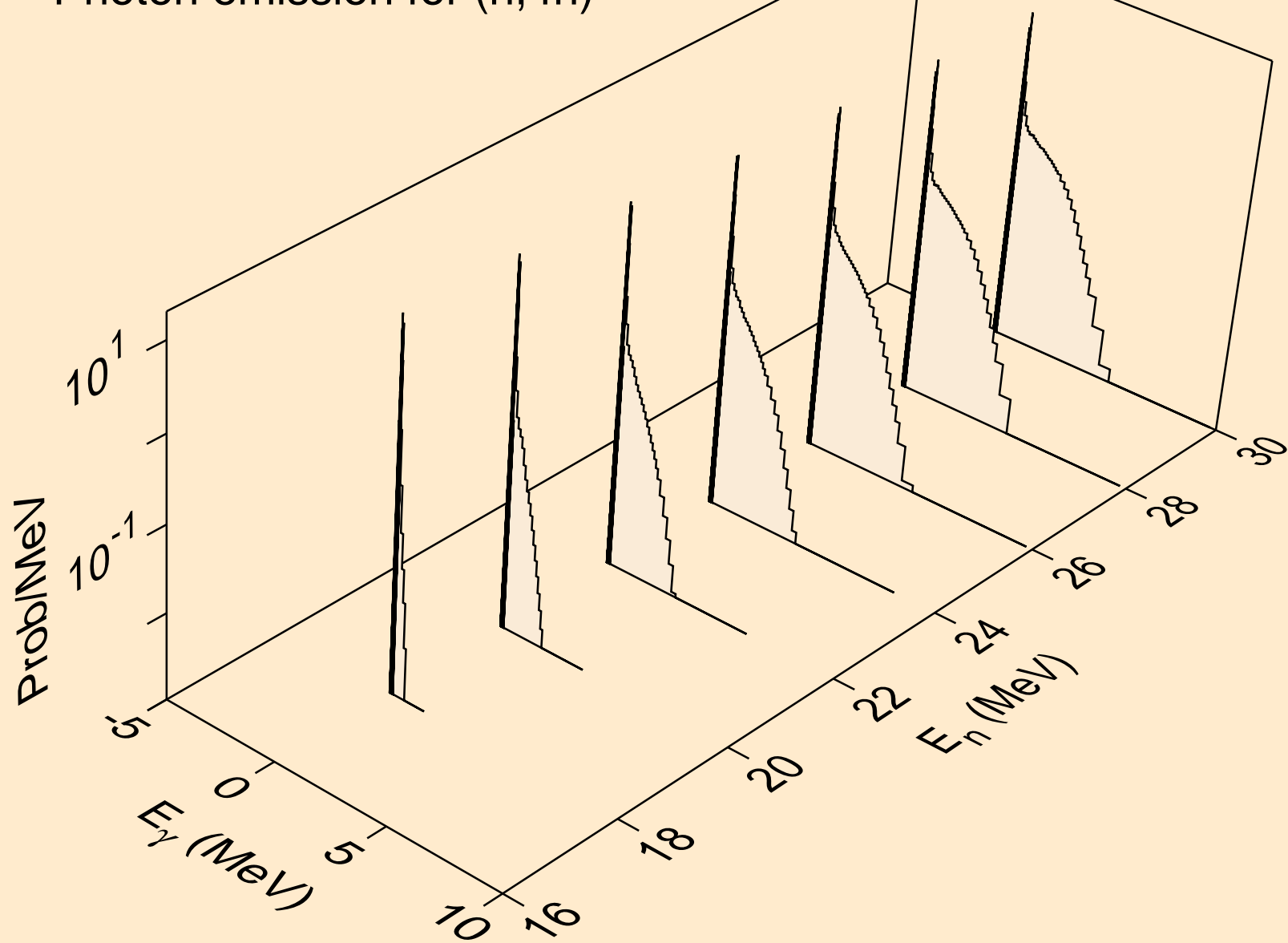

MT280 NEUTRON ACER TENDL-2023 LIBRARY; T=0.K  
Photon emission for (n,2np)

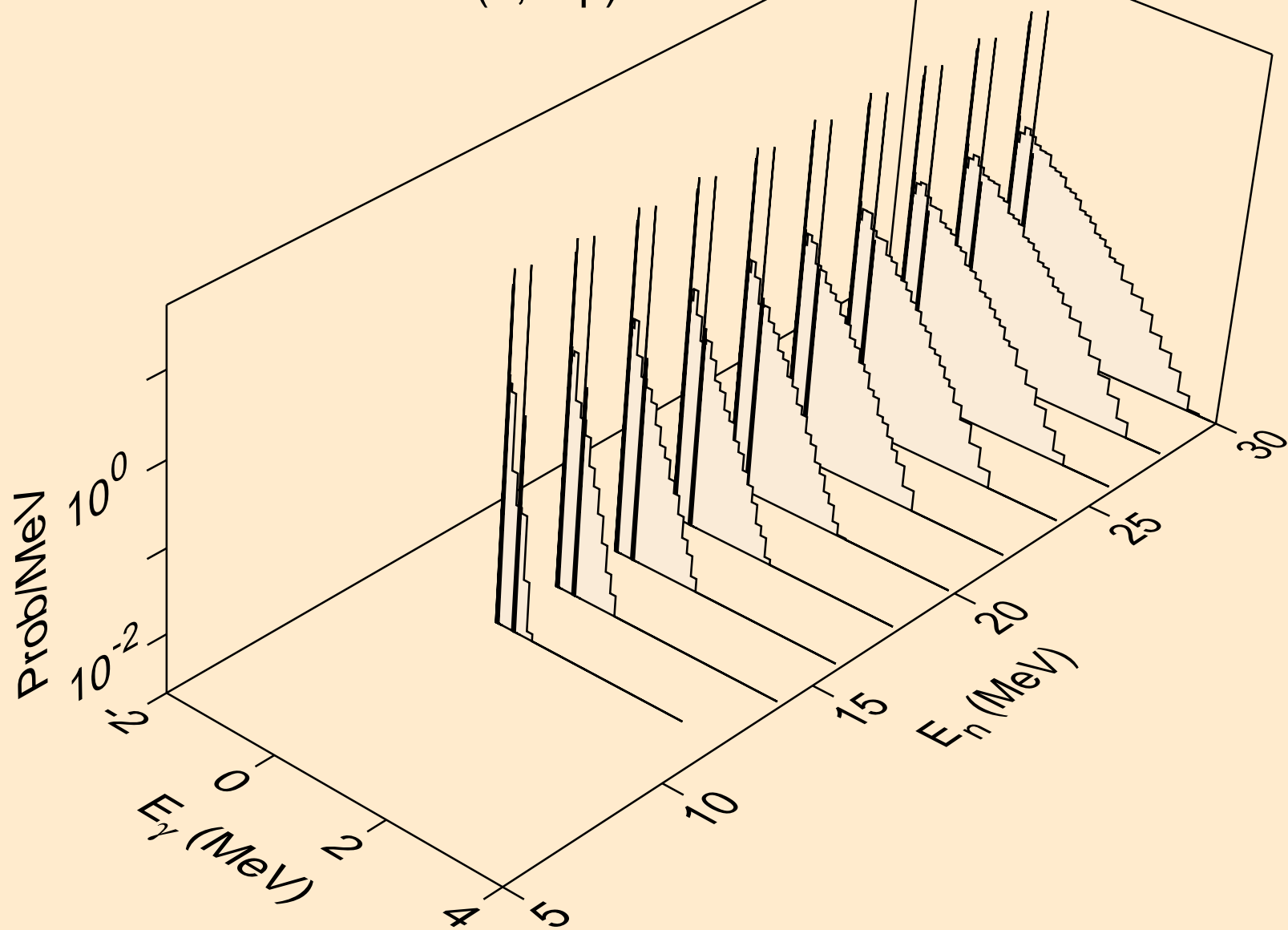

MT280 NEUTRON ACER TENDL-2023 LIBRARY; T=0.K  
Photon emission for (n,3np)

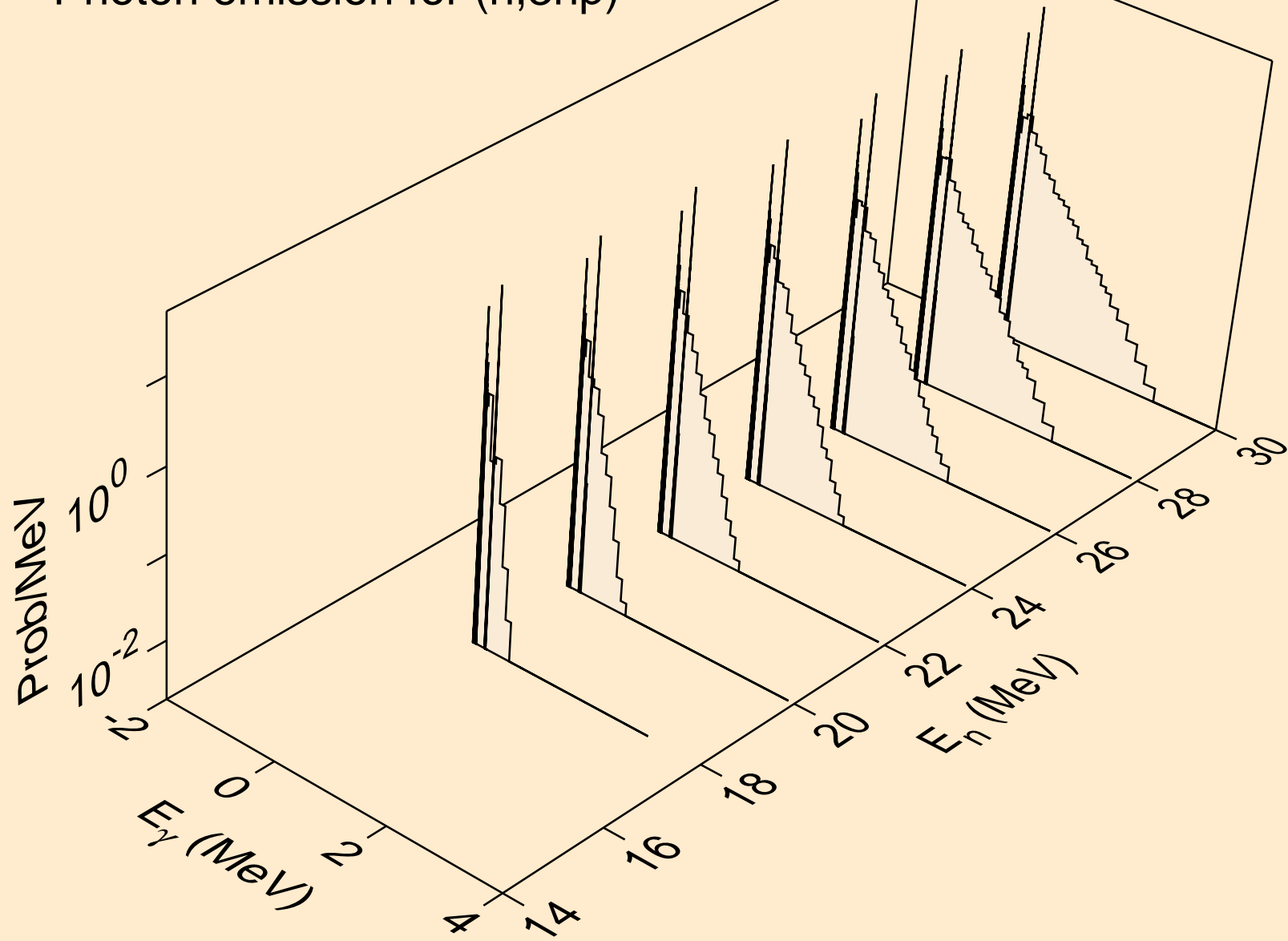

MT280 NEUTRON ACER TENDL-2023 LIBRARY; T=0.K  
Photon emission for (n,n2p)

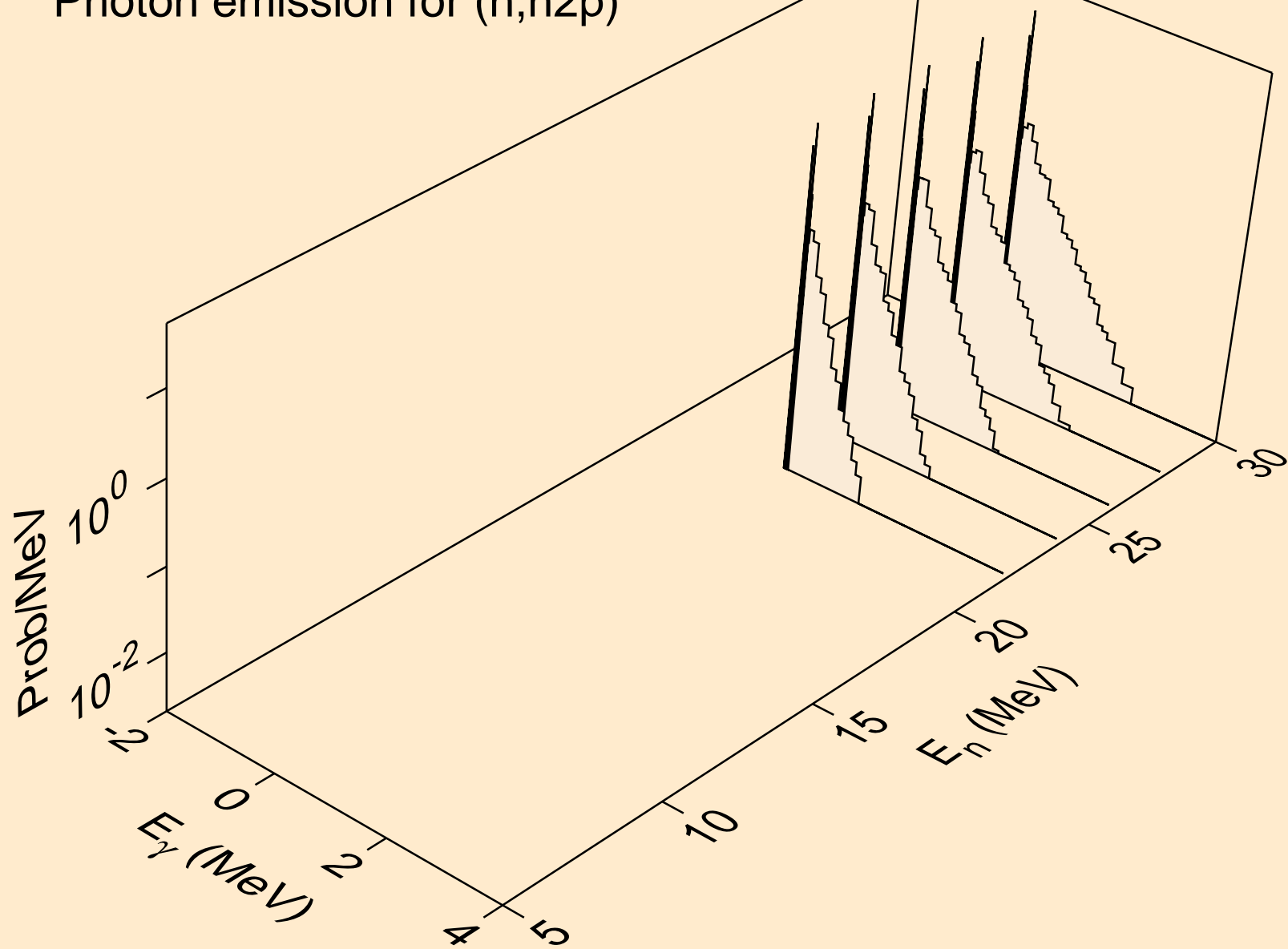



MT280 NEUTRON ACER TENDL-2023 LIBRARY; T=0.K  
Photon emission for (n,npa)

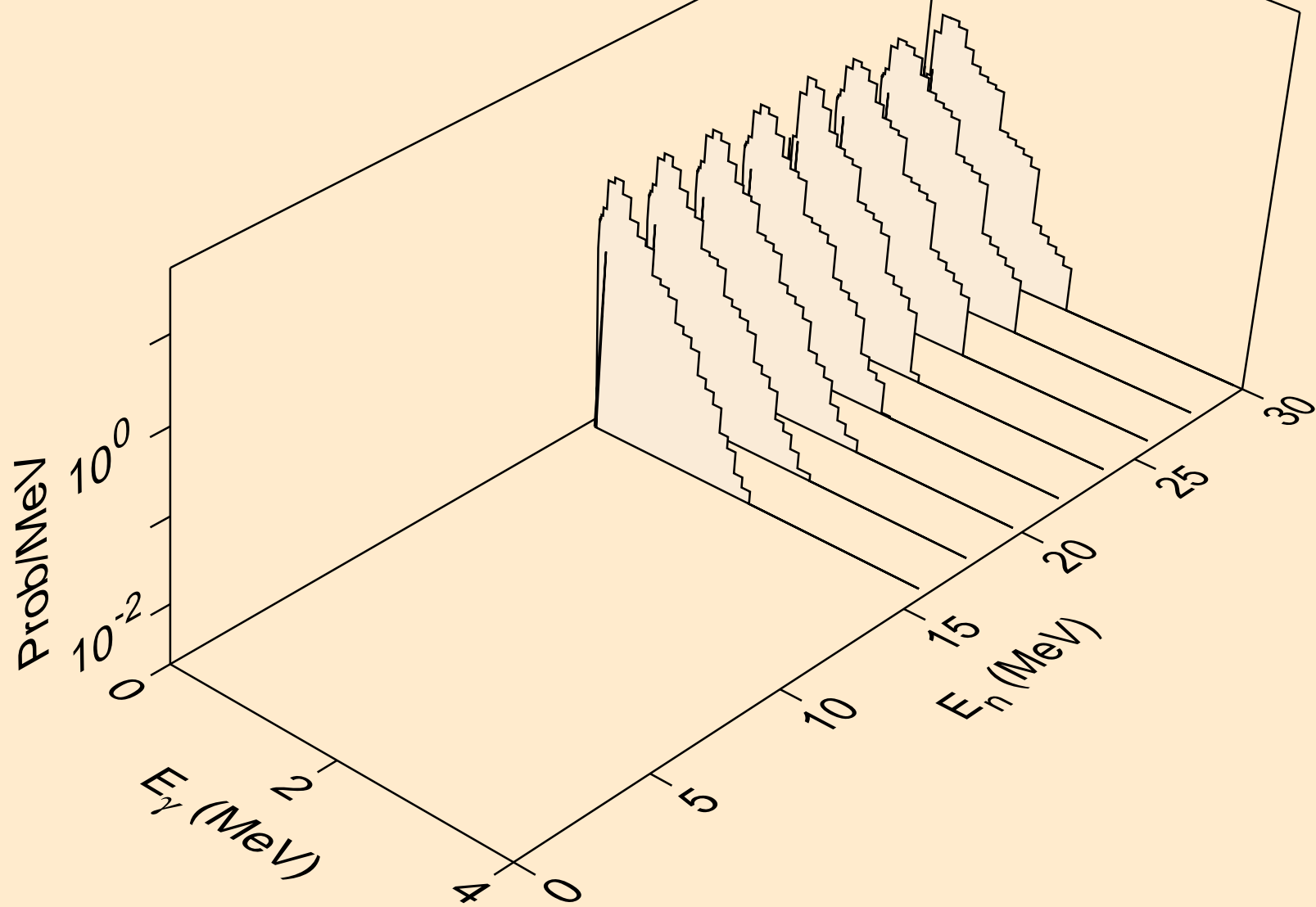

MT280 NEUTRON ACER TENDL-2023 LIBRARY; T=0.K  
Photon emission for (n,n\*c)

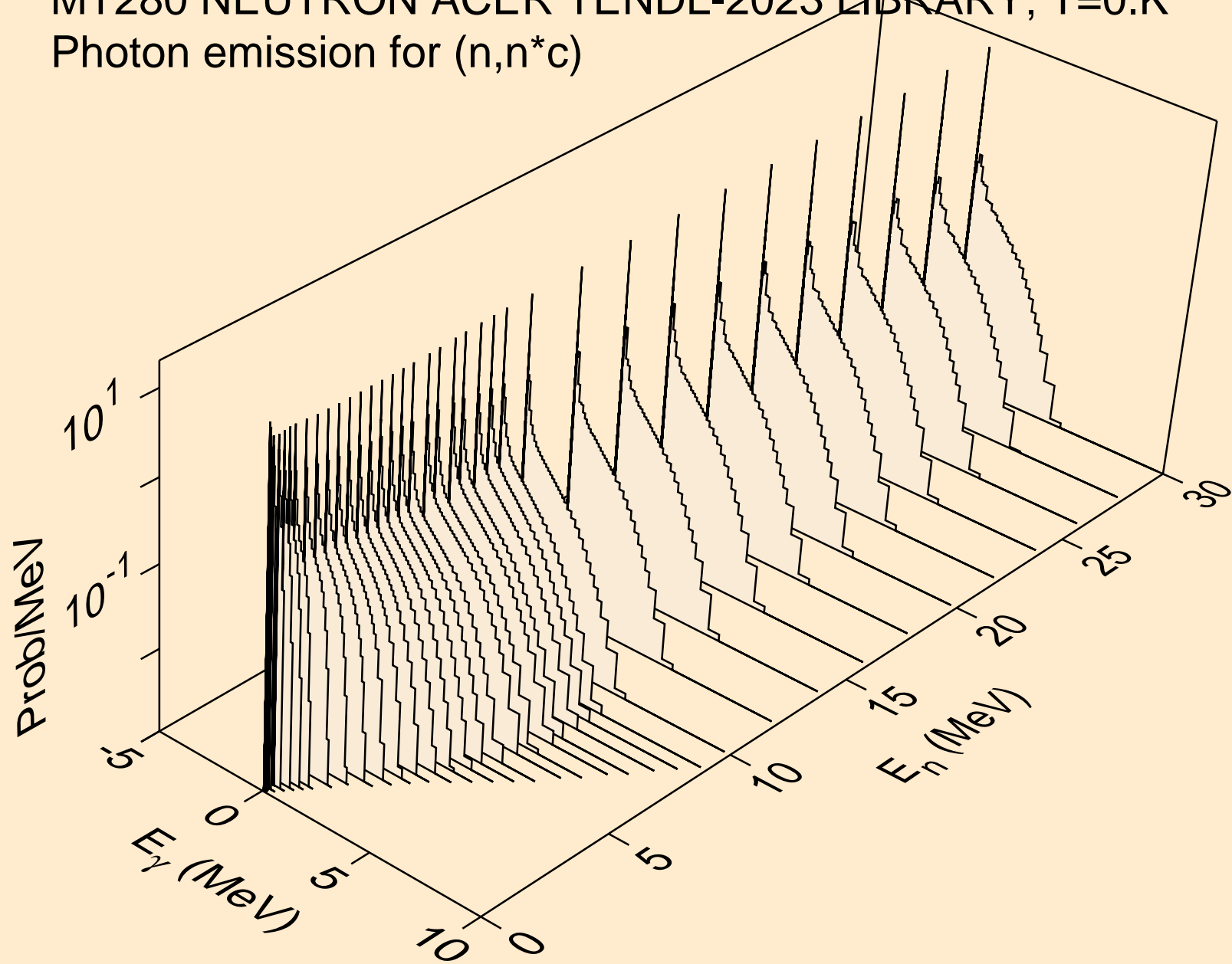

MT280 NEUTRON ACER TENDL-2023 LIBRARY; T=0.K  
Photon emission for (n,gma)

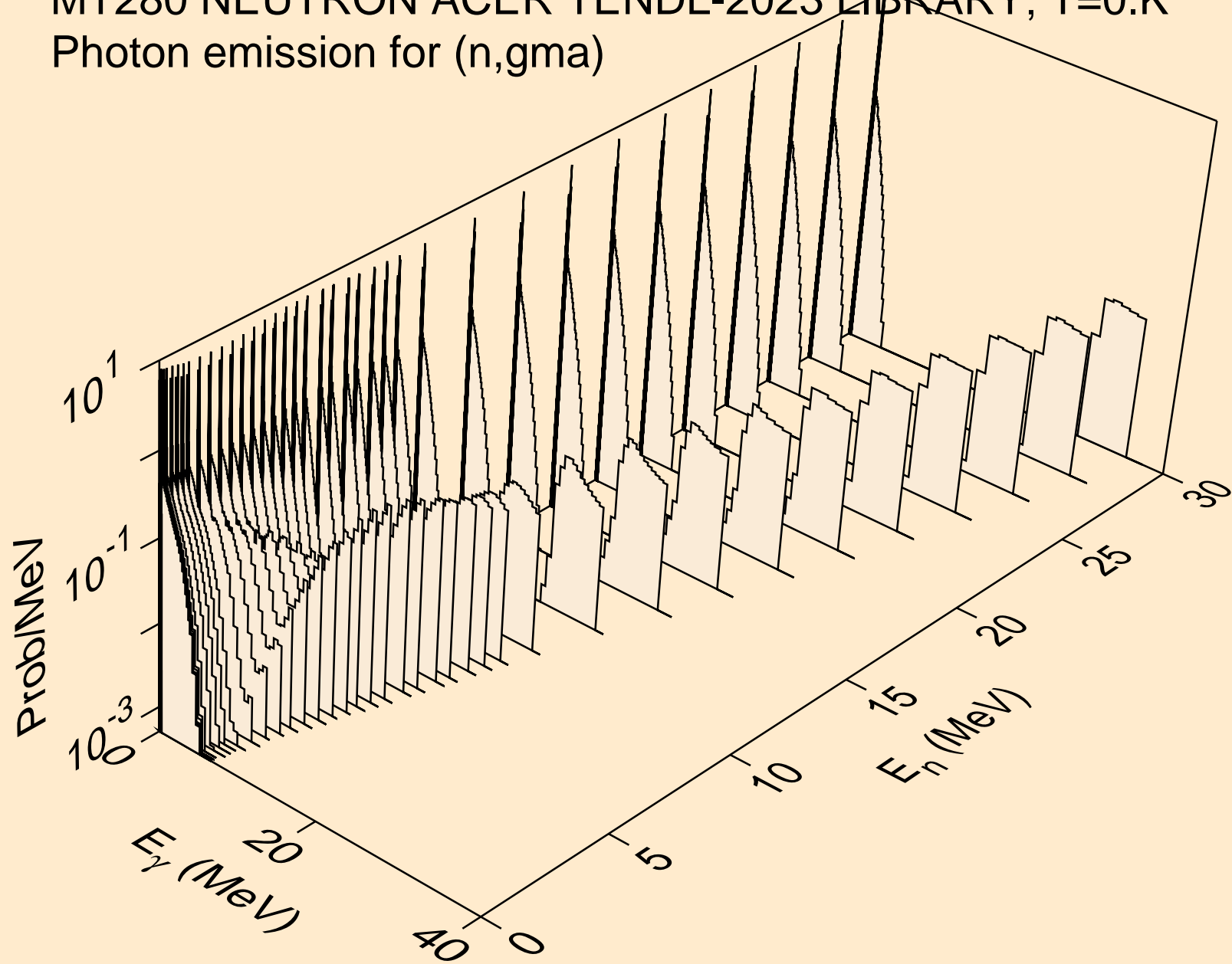

MT280 NEUTRON ACER TENDL-2023 LIBRARY; T=0.K  
Photon emission for (n,p)

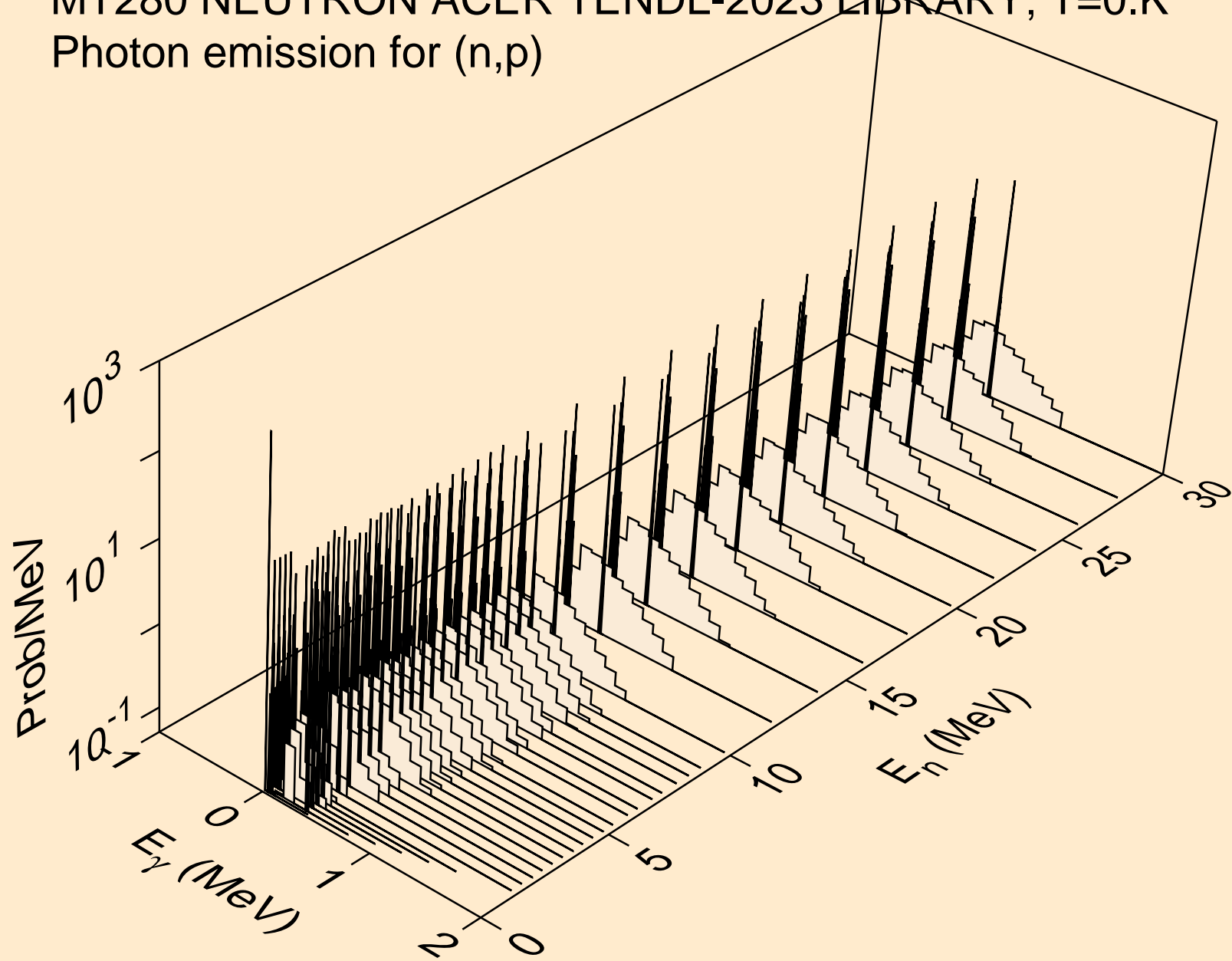

MT280 NEUTRON ACER TENDL-2023 LIBRARY; T=0.K  
Photon emission for (n,d)

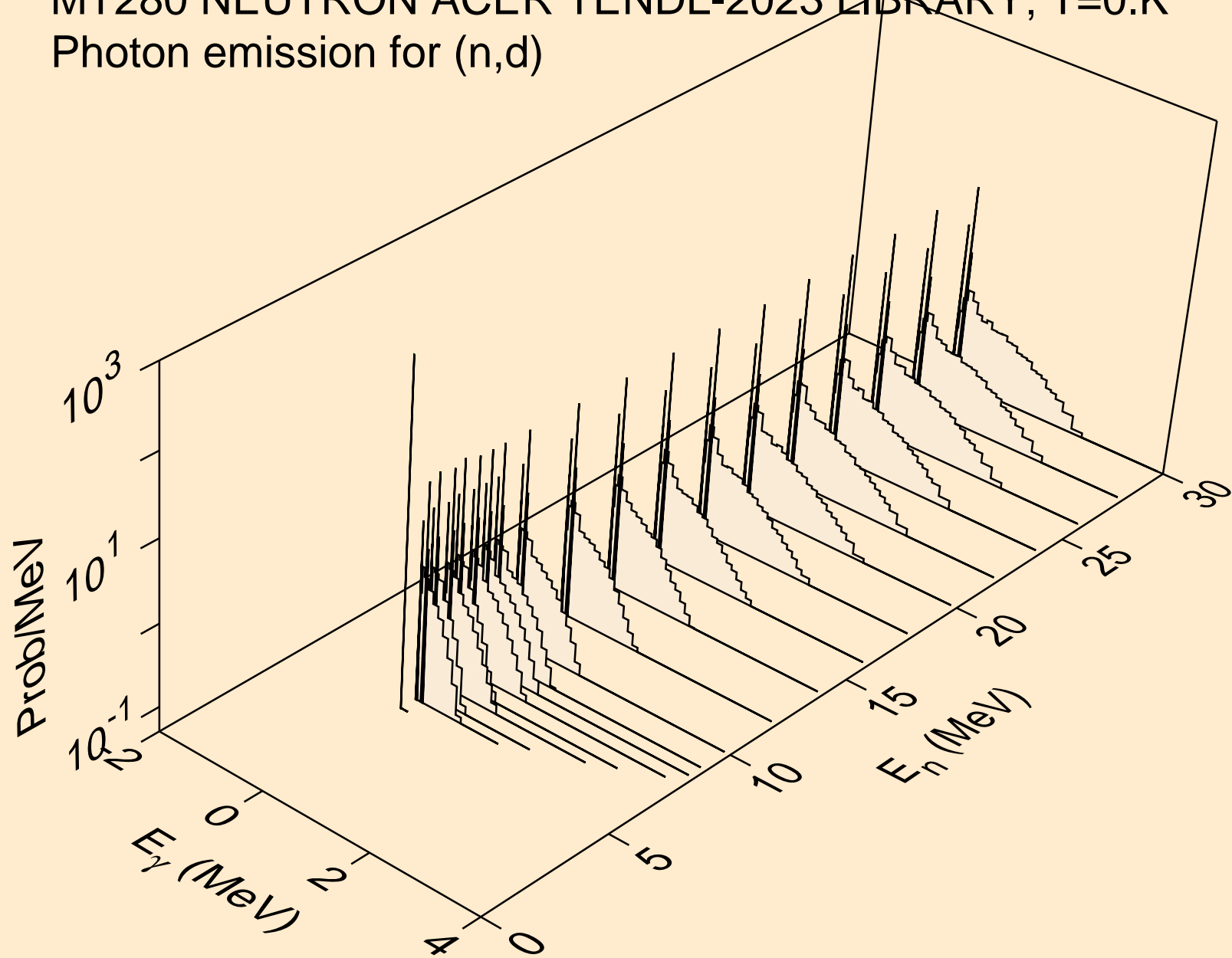

MT280 NEUTRON ACER TENDL-2023 LIBRARY; T=0.K  
Photon emission for (n,t)

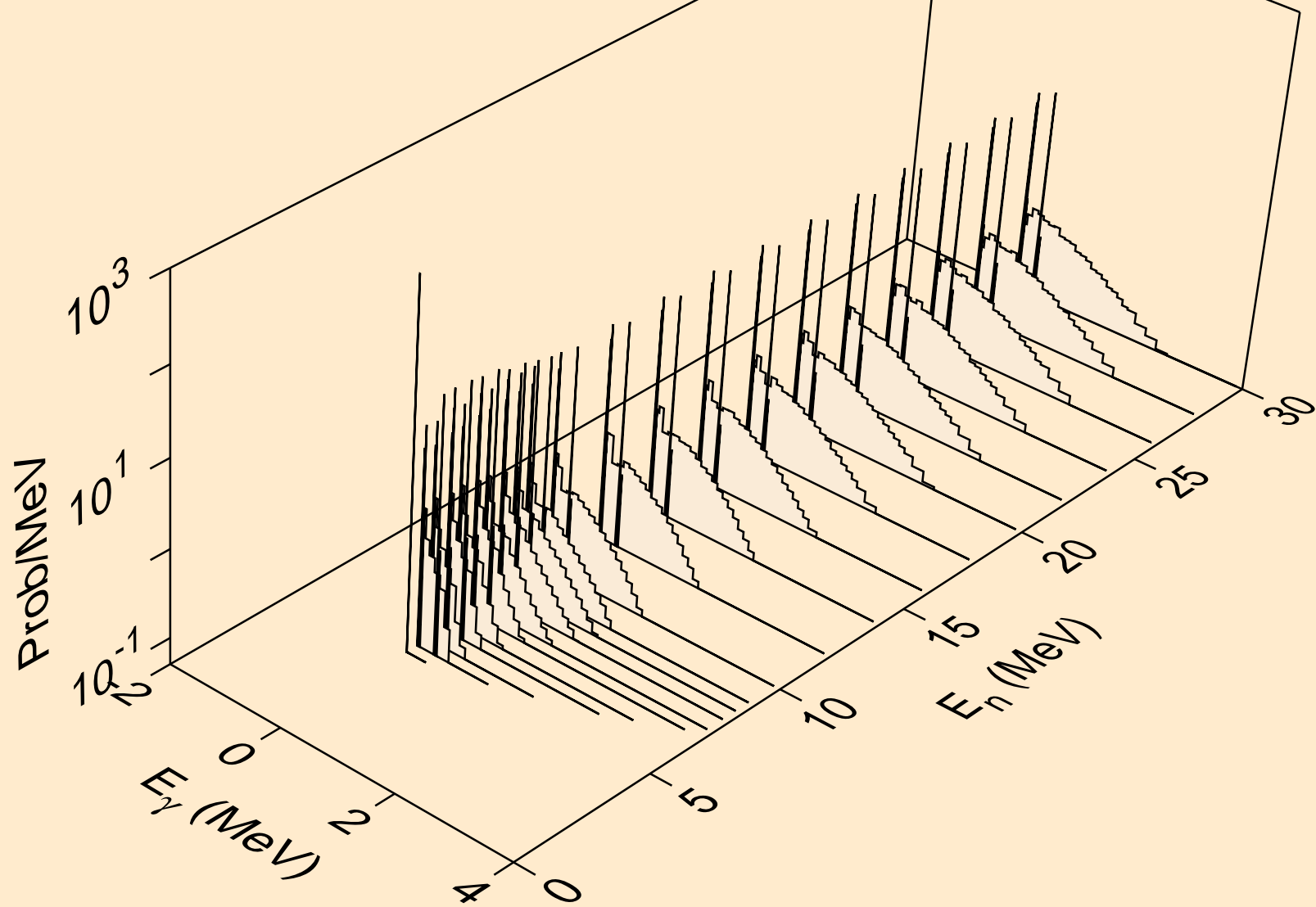

MT280 NEUTRON ACER TENDL-2023 LIBRARY; T=0.K  
Photon emission for (n,he3)

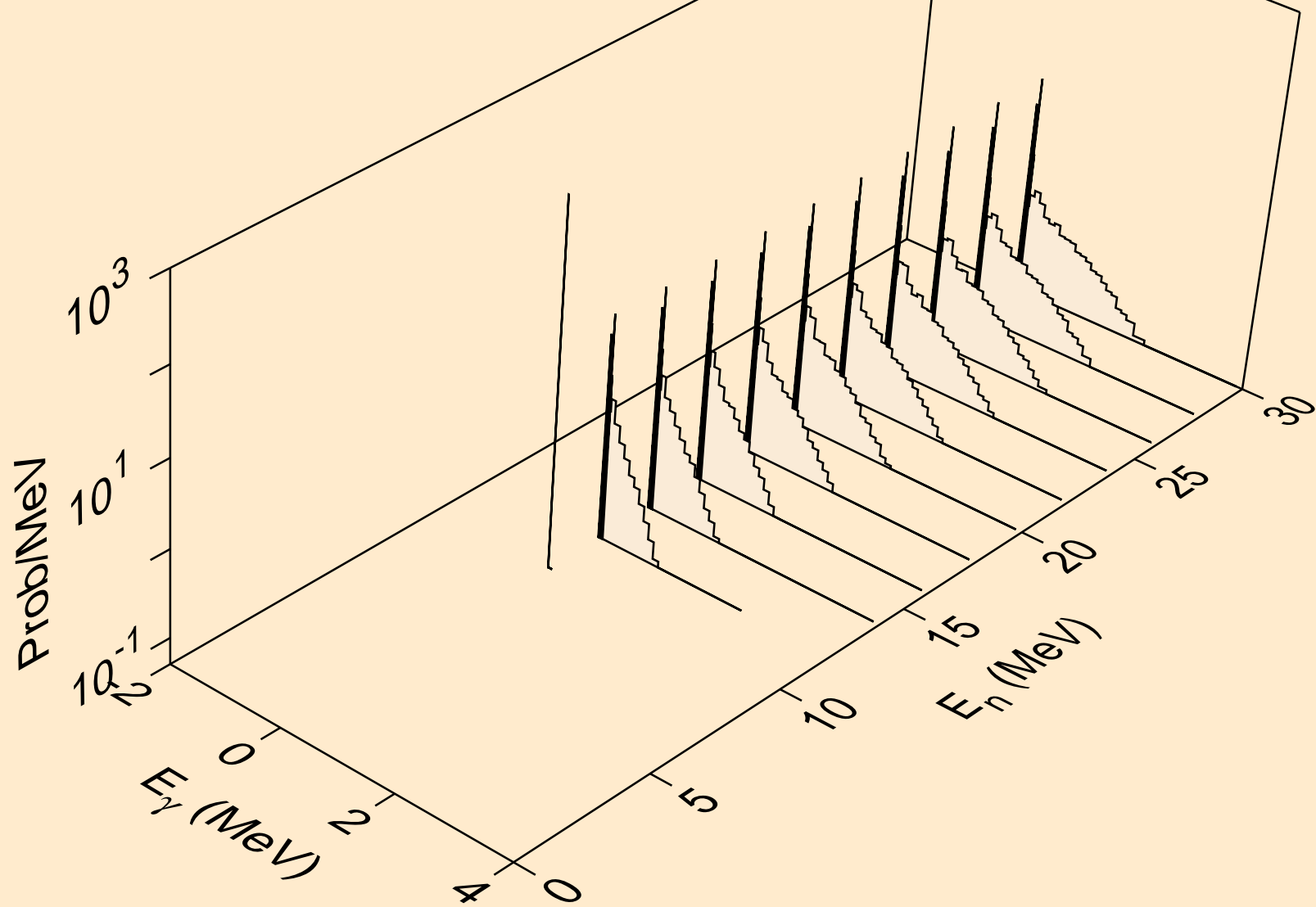

MT280 NEUTRON ACER TENDL-2023 LIBRARY; T=0.K  
Photon emission for (n,a)

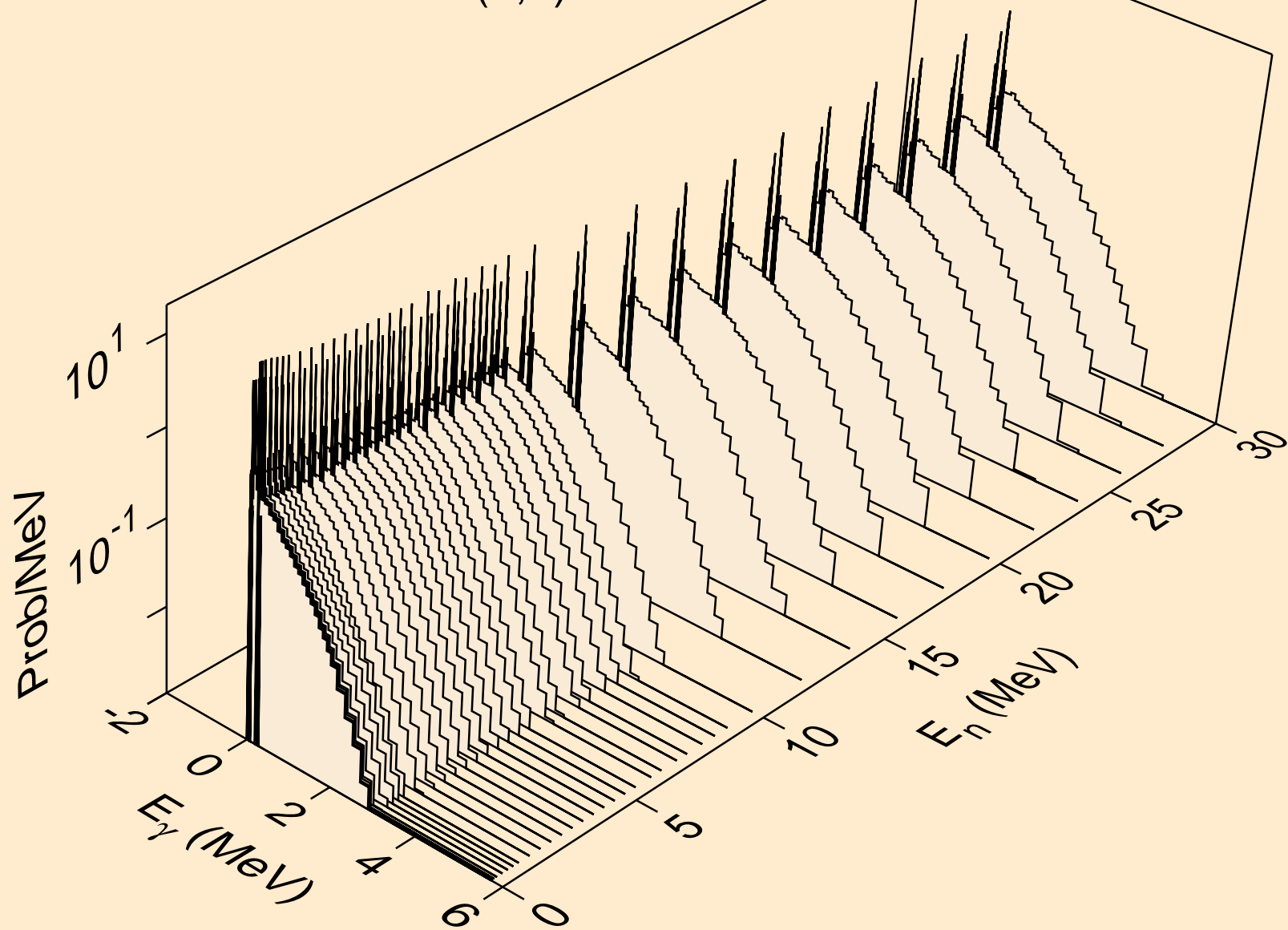



MT280 NEUTRON ACER TENDL-2023 LIBRARY; T=0.K  
Photon emission for (n,2p)

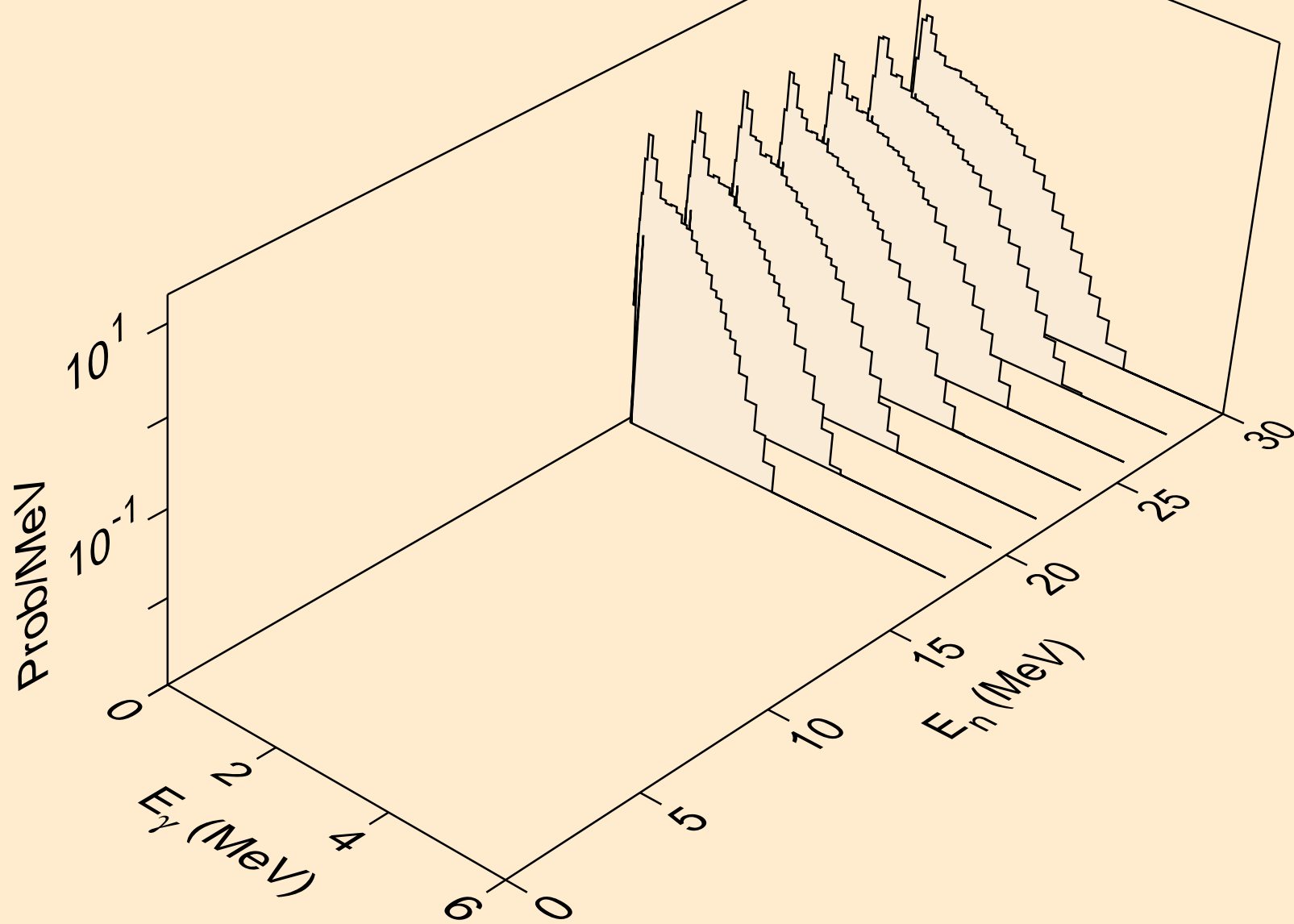

MT280 NEUTRON ACER TENDL-2023 LIBRARY; T=0.K  
Photon emission for (n,p)

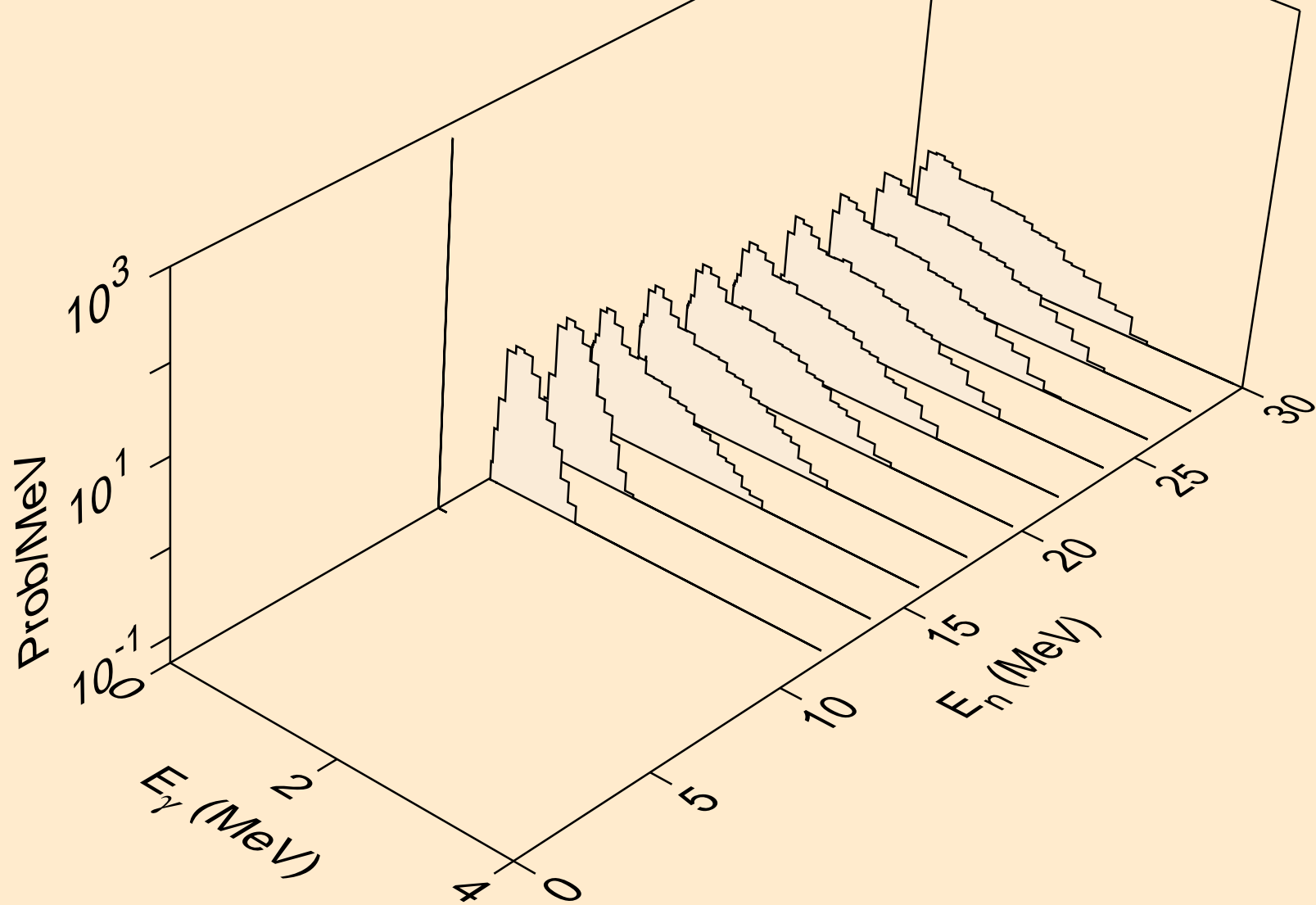

MT280 NEUTRON ACER TENDL-2023 LIBRARY; T=0.K  
thermal capture photon spectrum

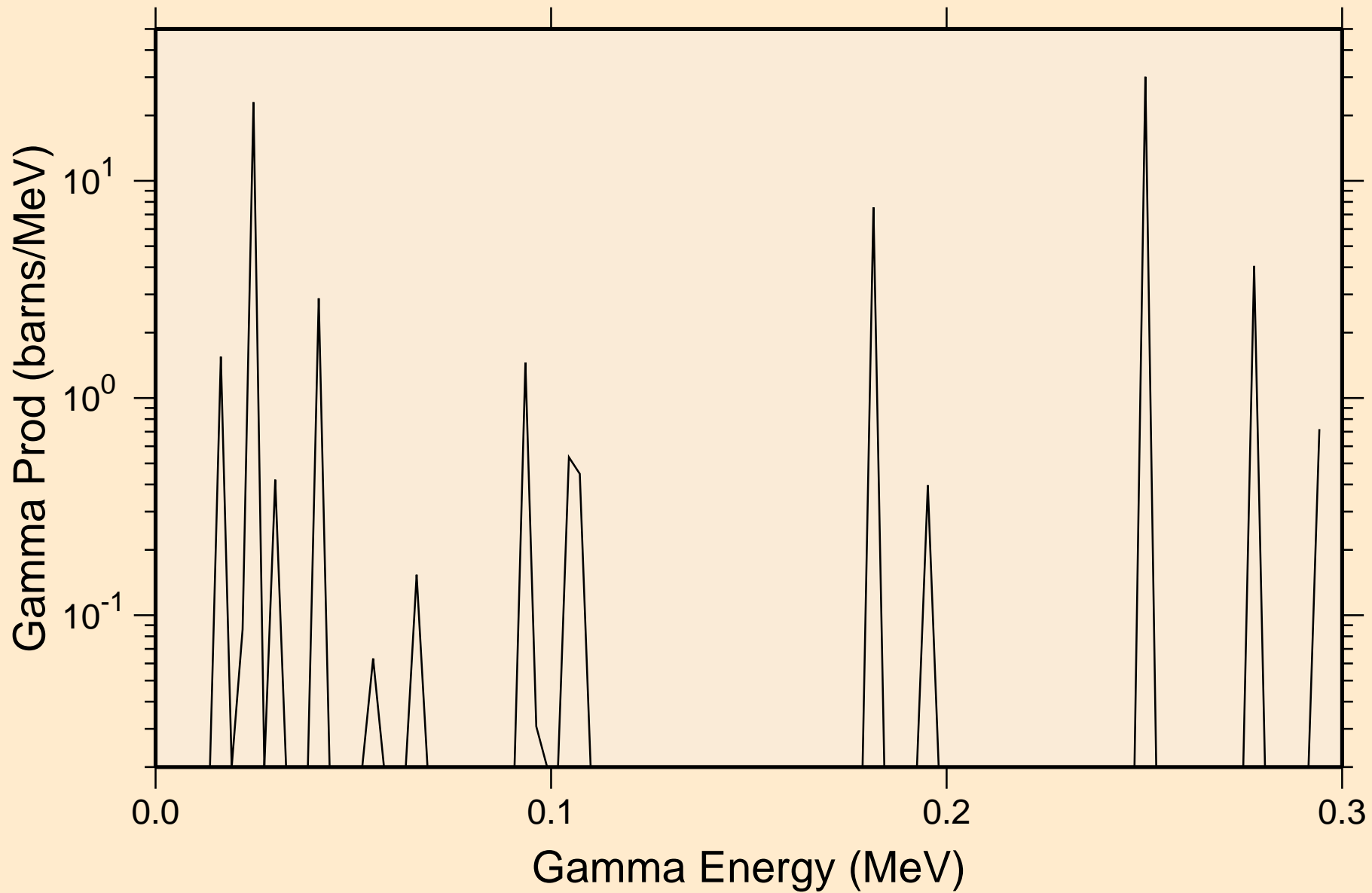

MT280 NEUTRON ACER TENDL-2023 LIBRARY; T=0.K  
14 MeV photon spectrum

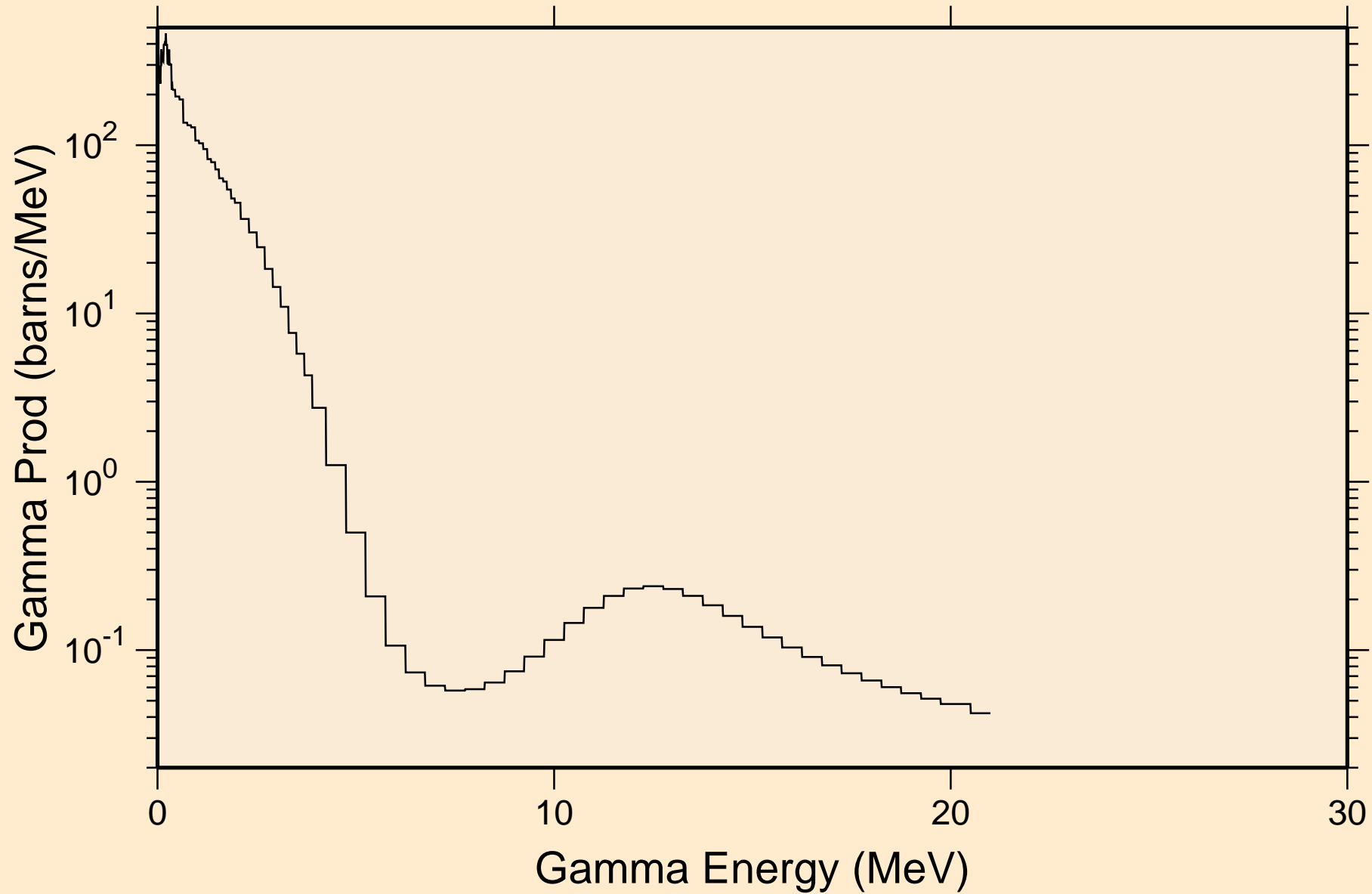

# MT280 NEUTRON ACER TENDL-2023 LIBRARY; T=0.K

## Particle heating contributions

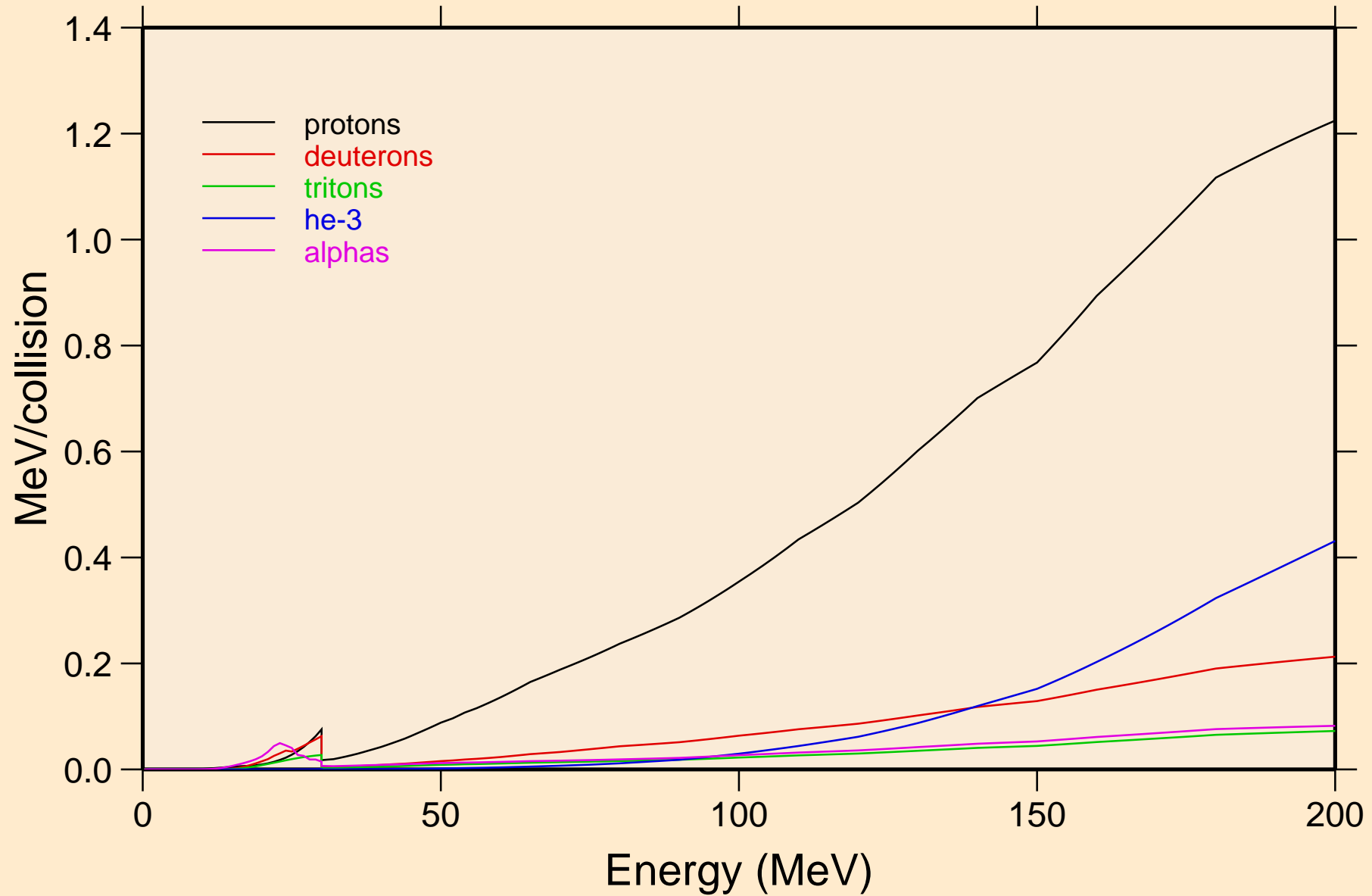

MT280 NEUTRON ACER TENDL-2023 LIBRARY; T=0.K  
Recoil Heating

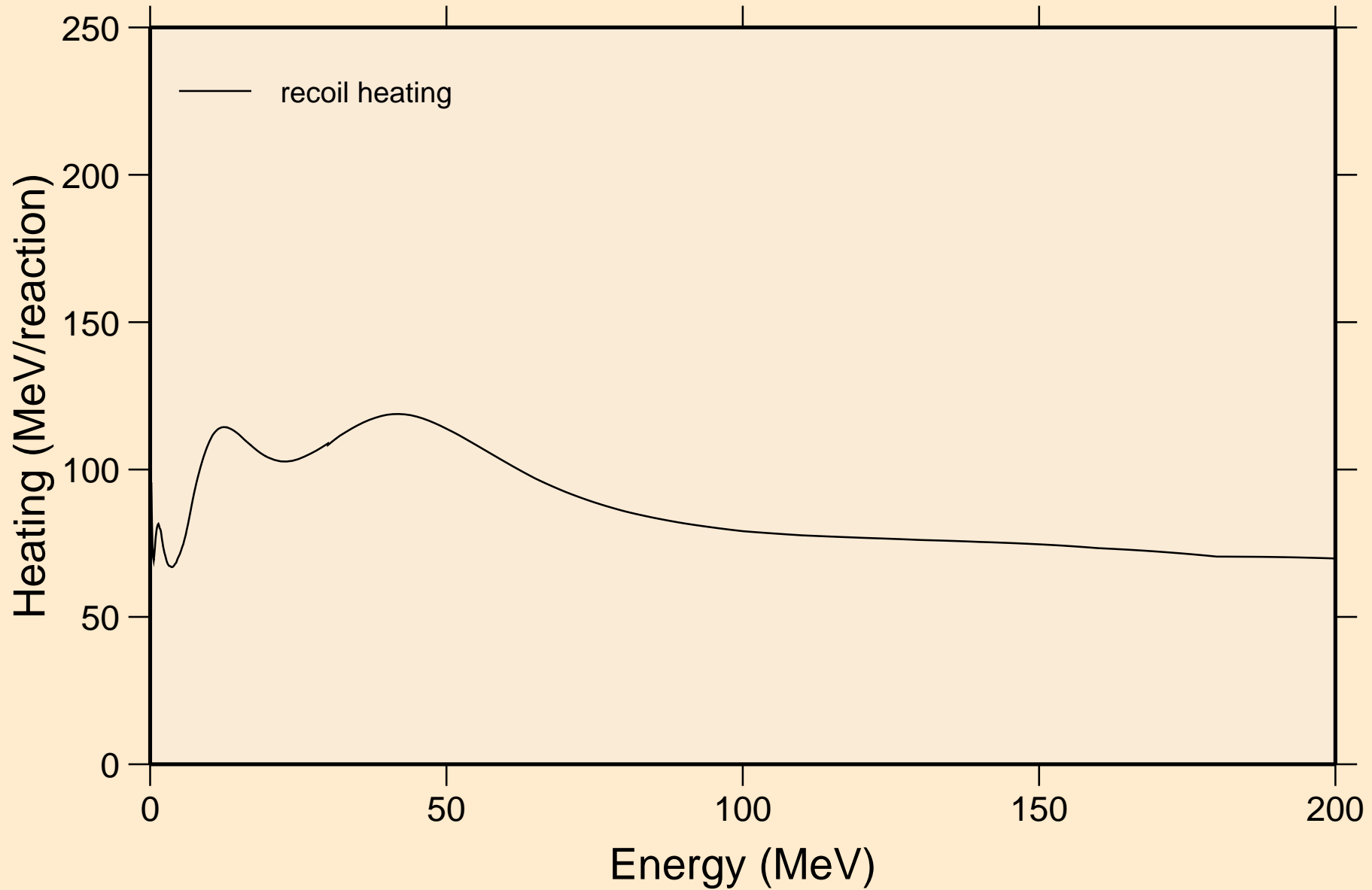

# MT280 NEUTRON ACER TENDL-2023 LIBRARY; T=0.K

## Particle production cross sections

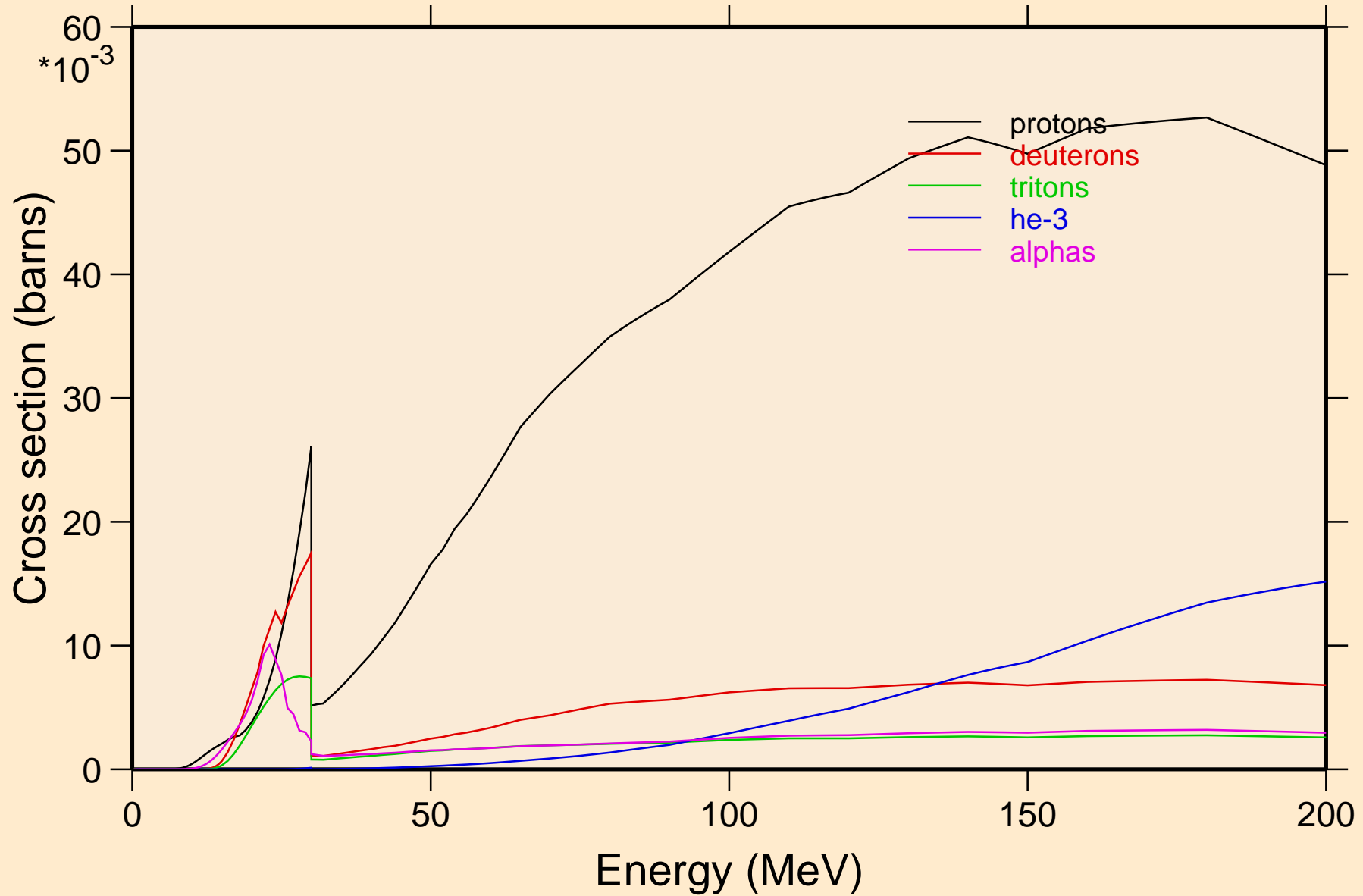

MT280 NEUTRON ACER TENDL-2023 LIBRARY; T=0.K  
protons from (n,x)

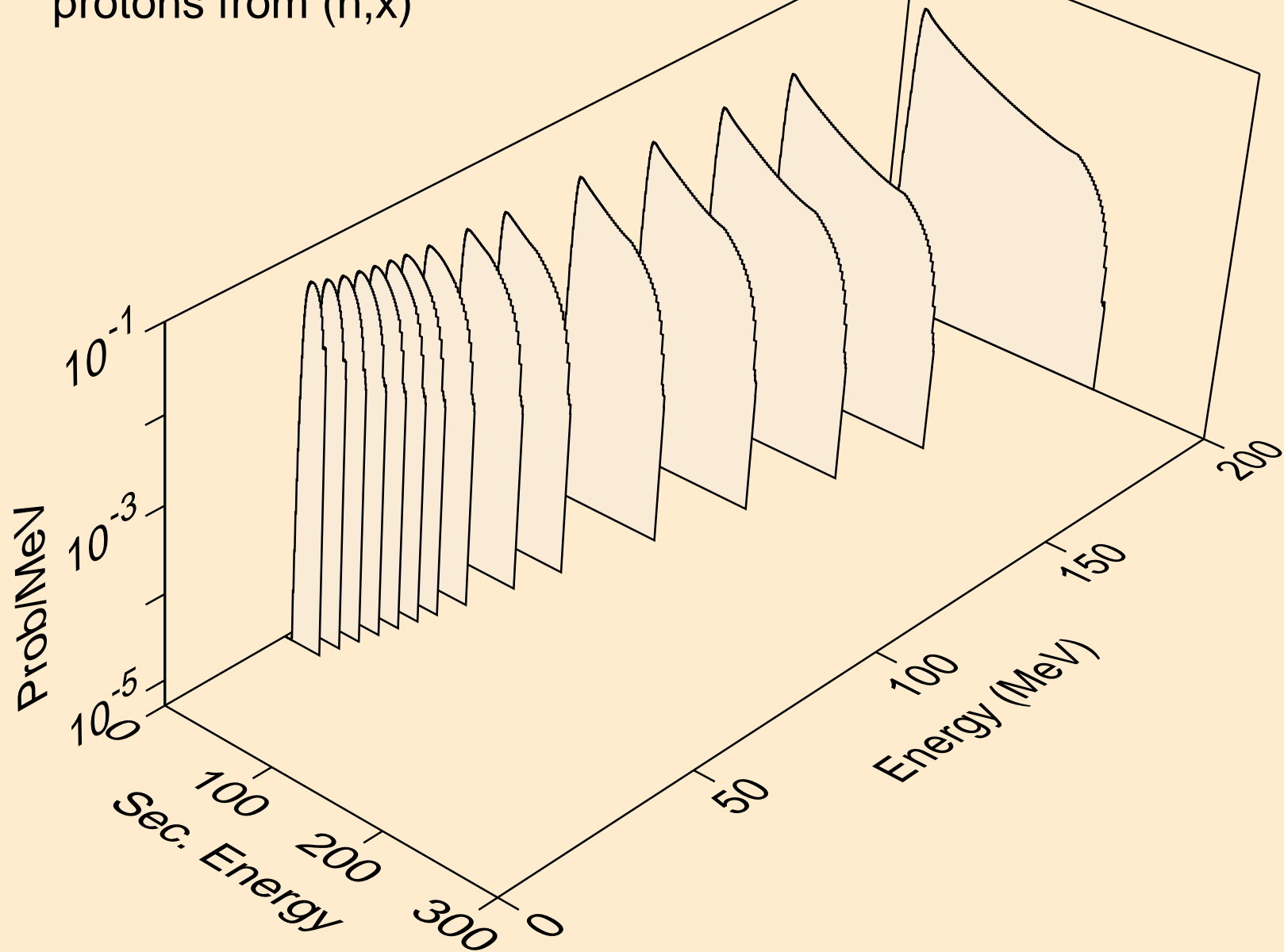



MT280 NEUTRON ACER TENDL-2023 LIBRARY; T=0.K  
protons from (n,n\*)p

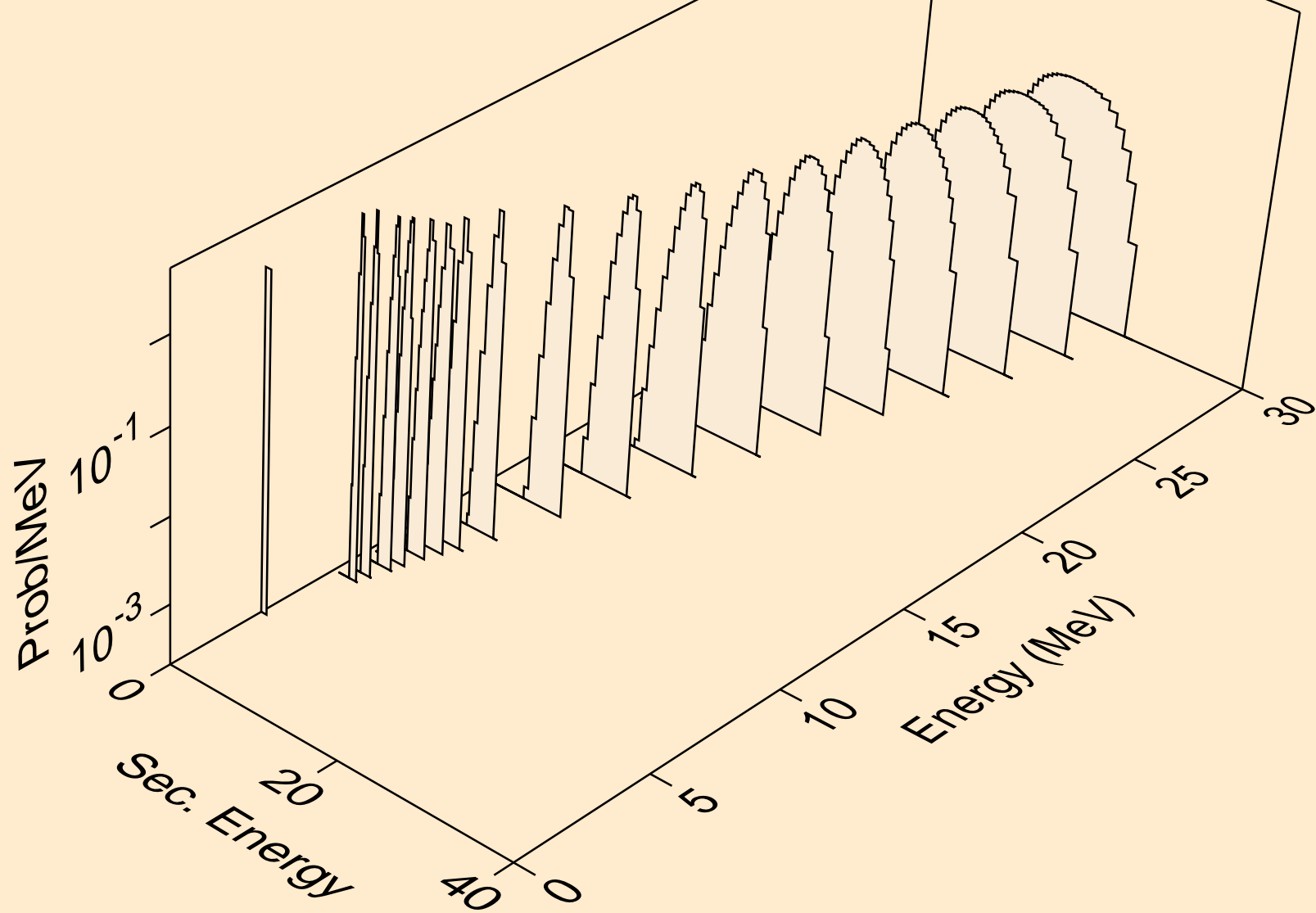

MT280 NEUTRON ACER TENDL-2023 LIBRARY; T=0.K  
protons from (n,2np)

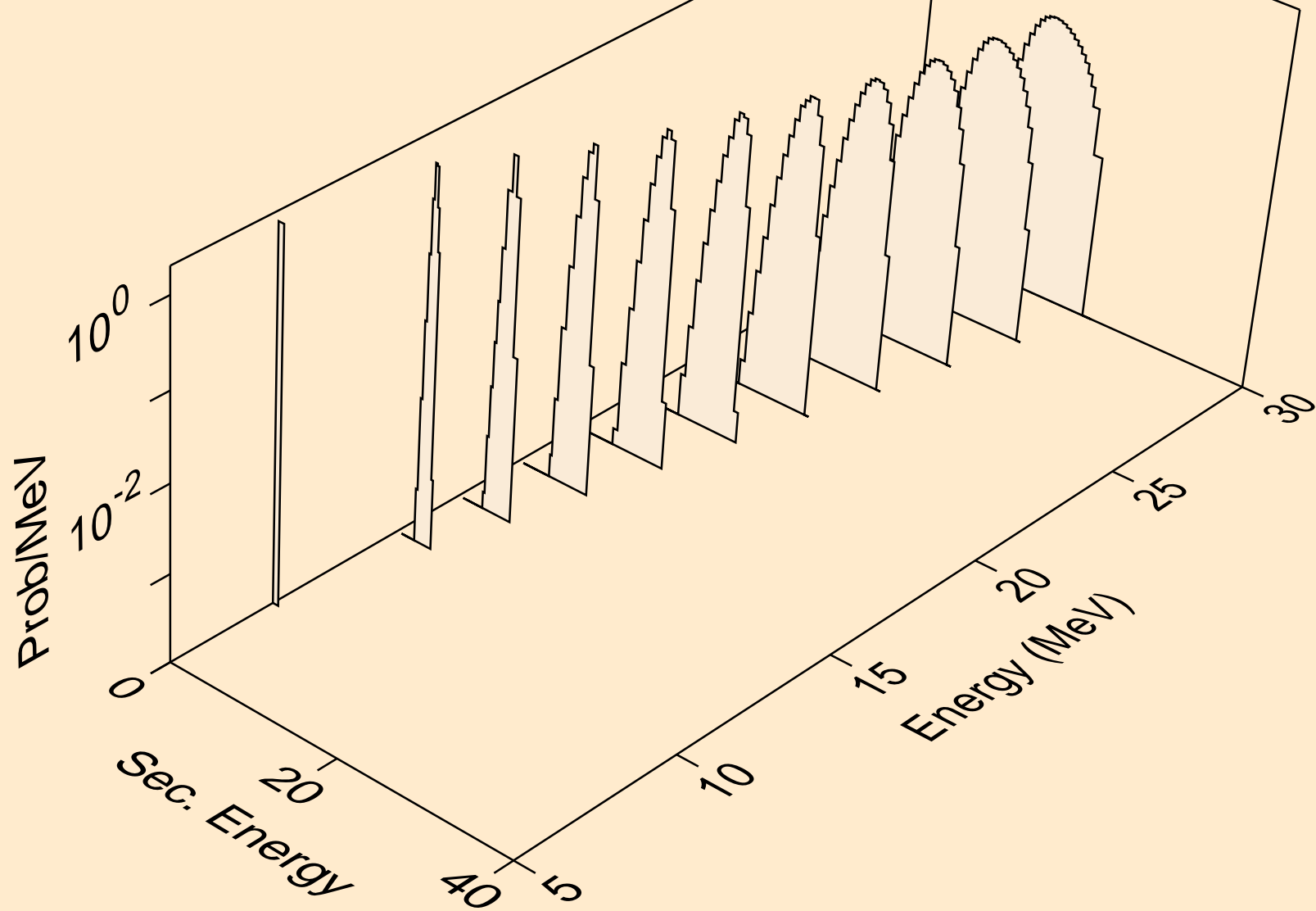

MT280 NEUTRON ACER TENDL-2023 LIBRARY; T=0.K  
protons from (n,3np)

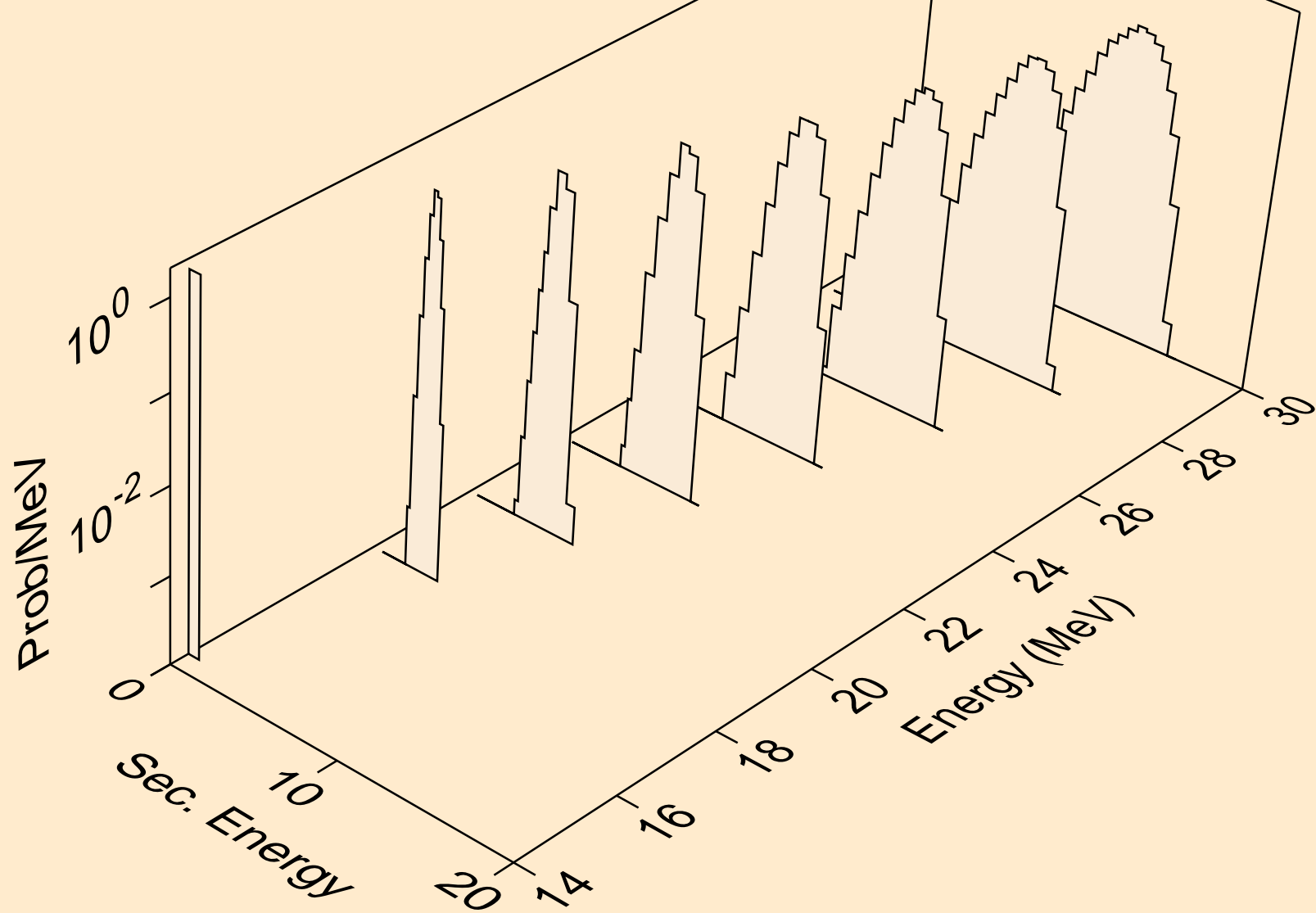

MT280 NEUTRON ACER TENDL-2023 LIBRARY; T=0.K  
protons from (n,n2p)

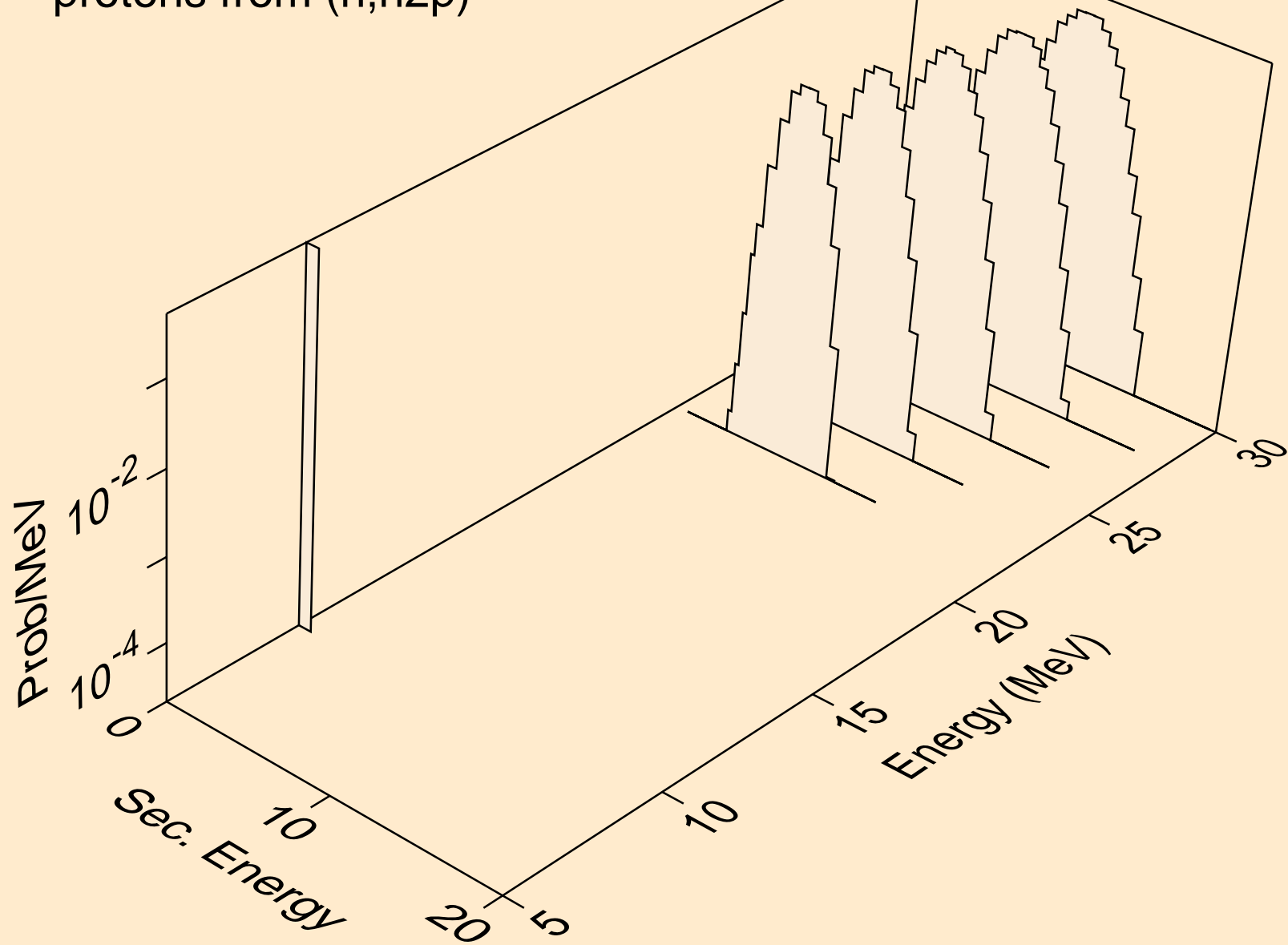

MT280 NEUTRON ACER TENDL-2023 LIBRARY; T=0.K  
protons from (n,npa)

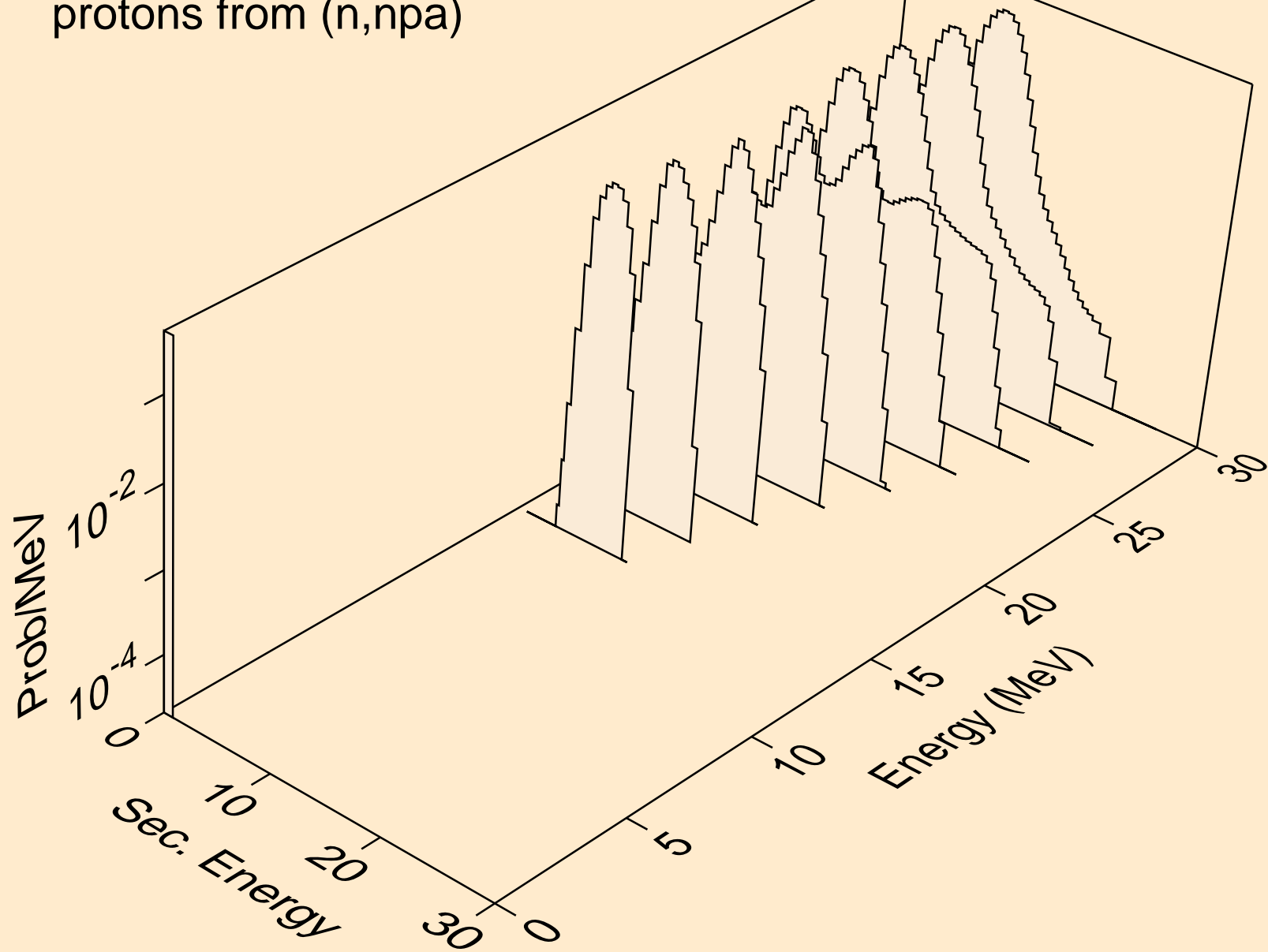

MT280 NEUTRON ACER TENDL-2023 LIBRARY; T=0.K  
protons from (n,p)

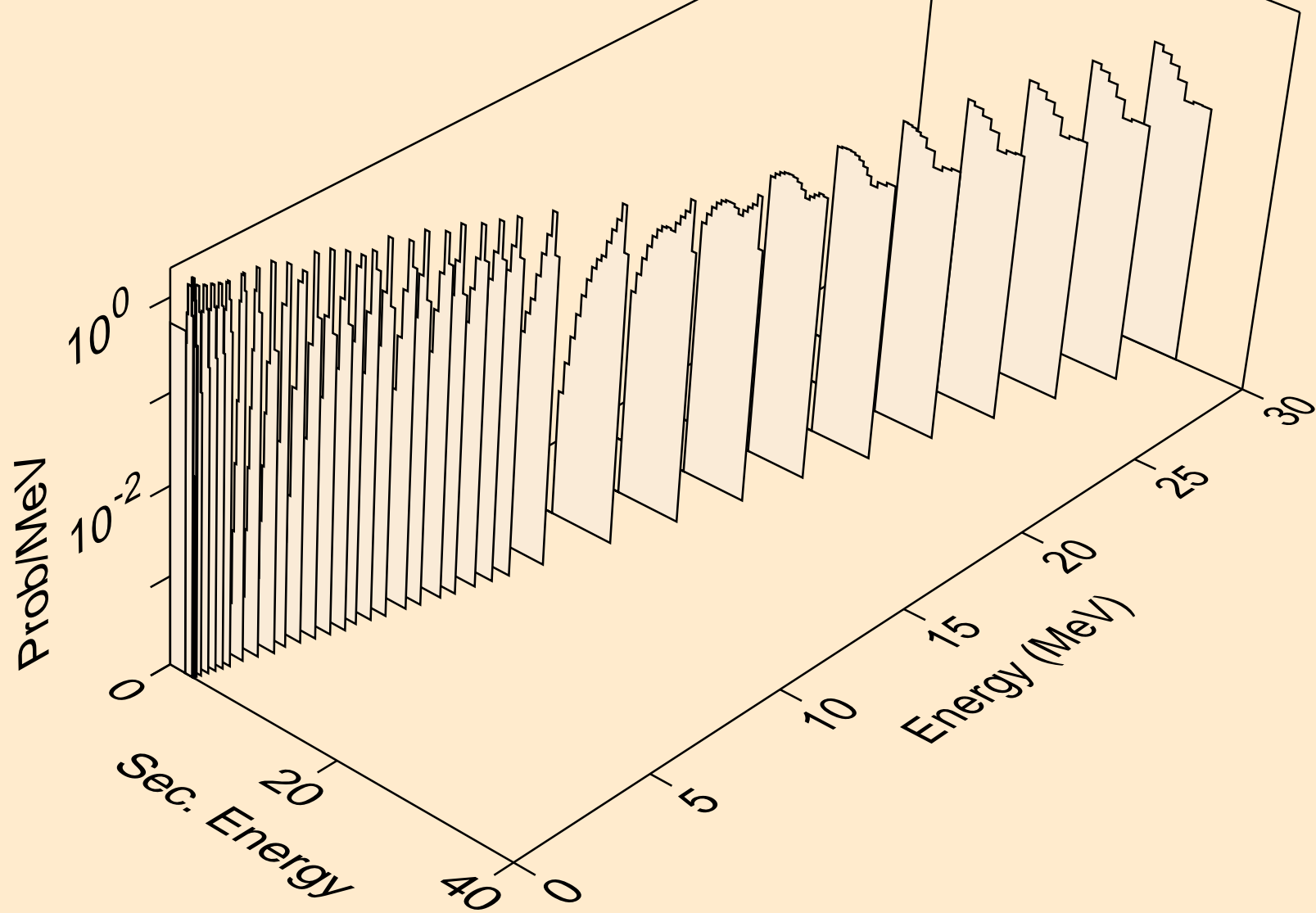

MT280 NEUTRON ACER TENDL-2023 LIBRARY; T=0.K  
protons from (n,2p)

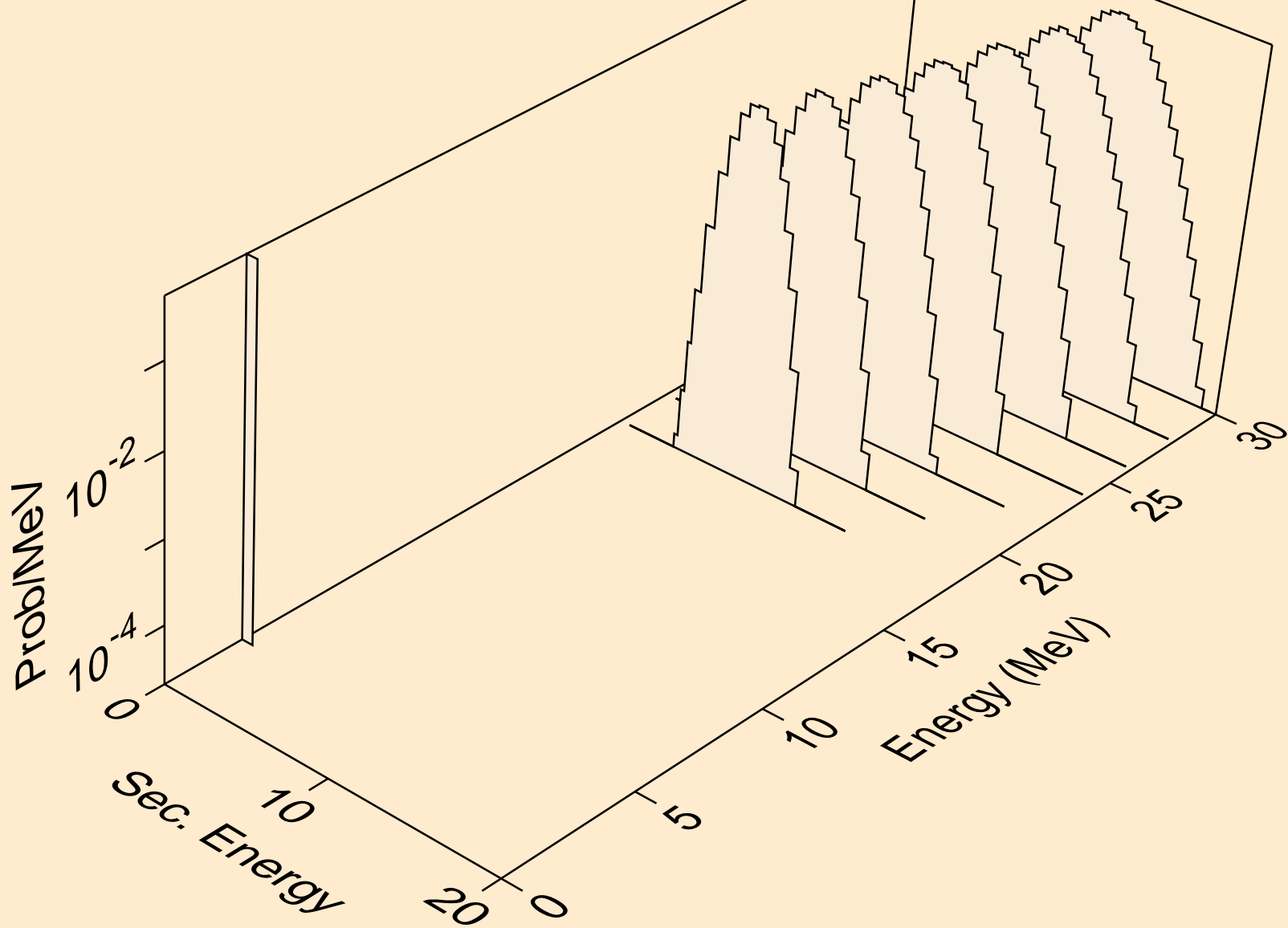

MT280 NEUTRON ACER TENDL-2023 LIBRARY; T=0.K  
protons from (n,p)

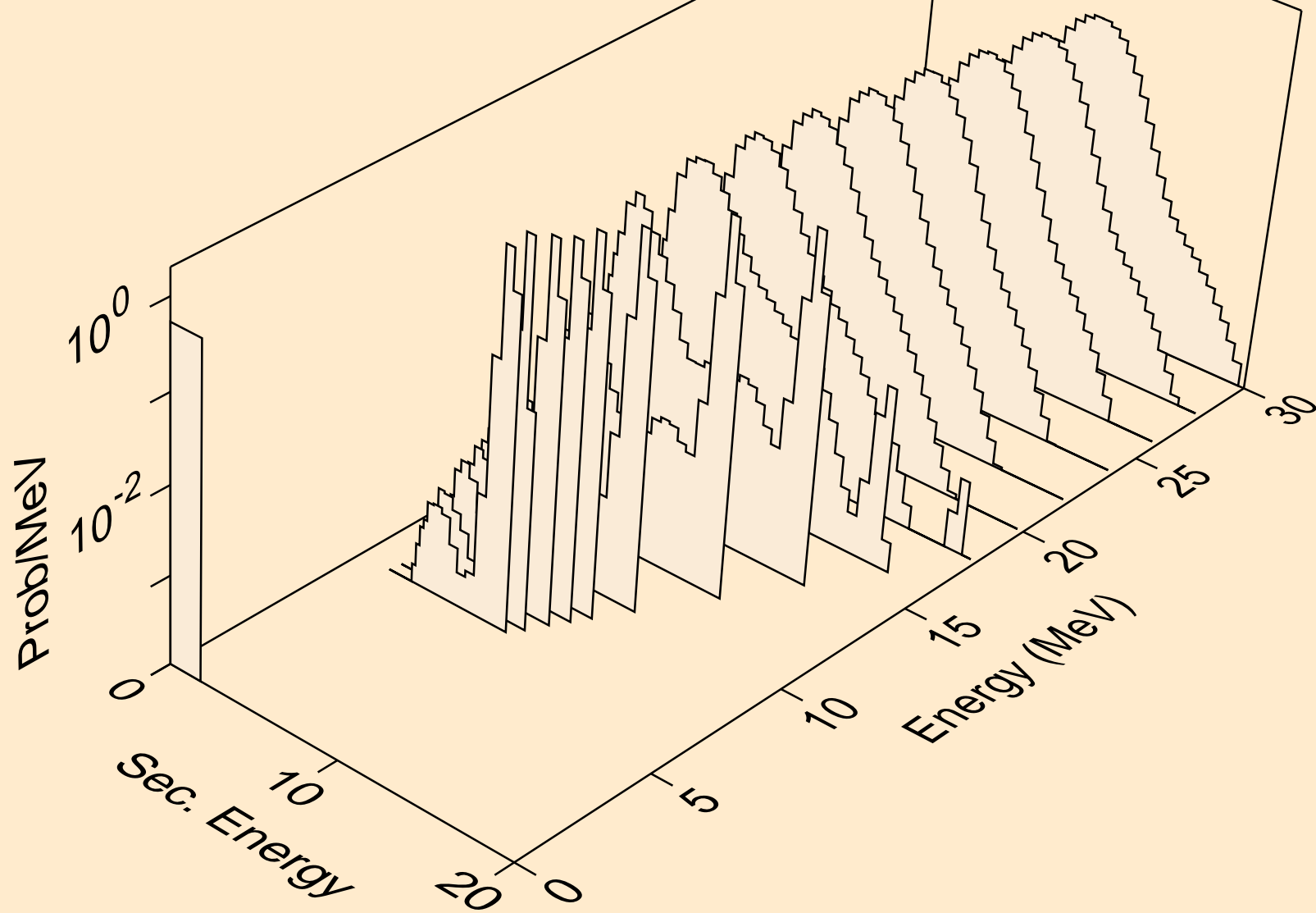



MT280 NEUTRON ACER TENDL-2023 LIBRARY; T=0.K  
deuterons from (n,x)

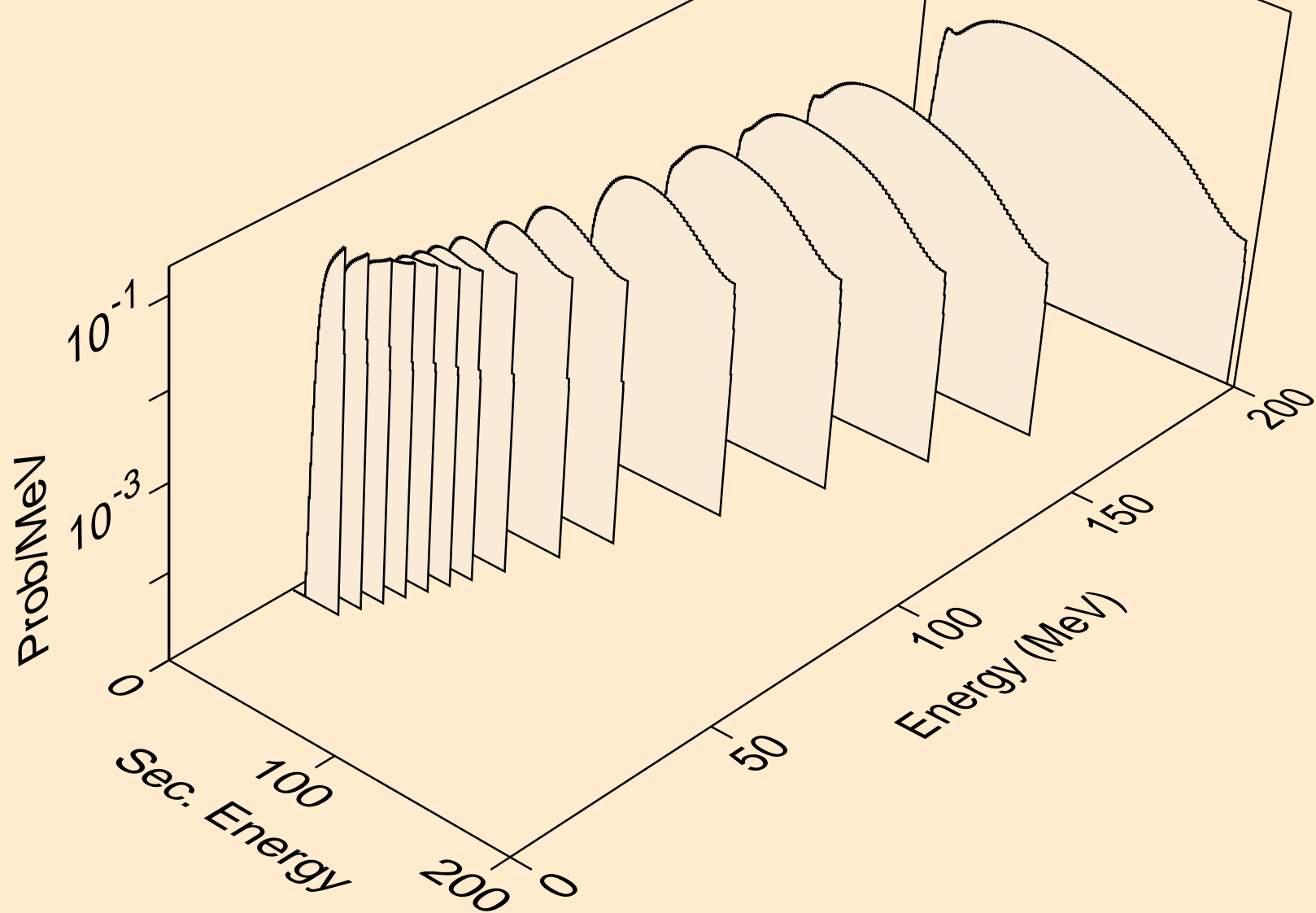

MT280 NEUTRON ACER TENDL-2023 LIBRARY; T=0.K  
deuterons from (n,2nd)

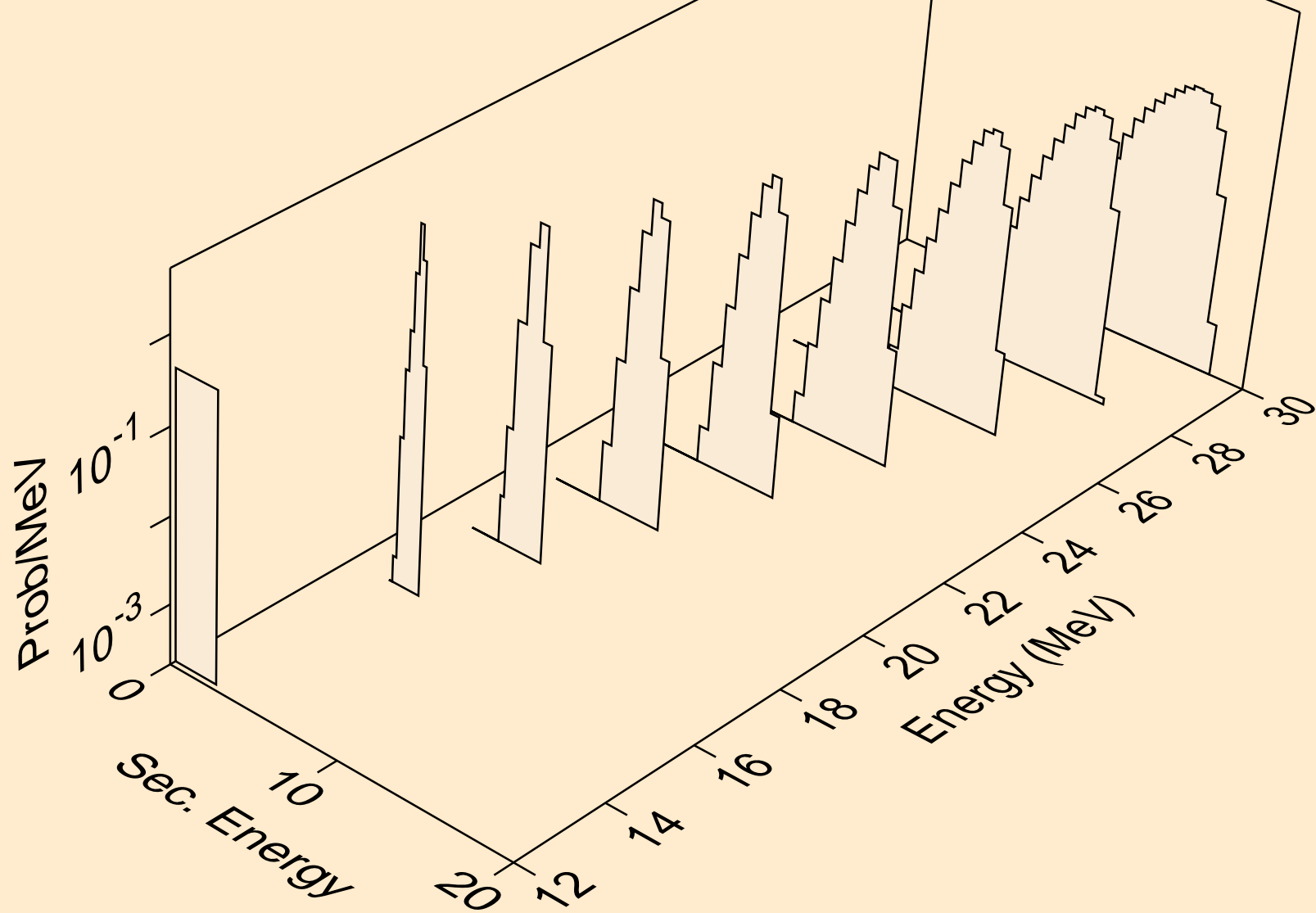

MT280 NEUTRON ACER TENDL-2023 LIBRARY; T=0.K  
deuterons from (n,n\*)d

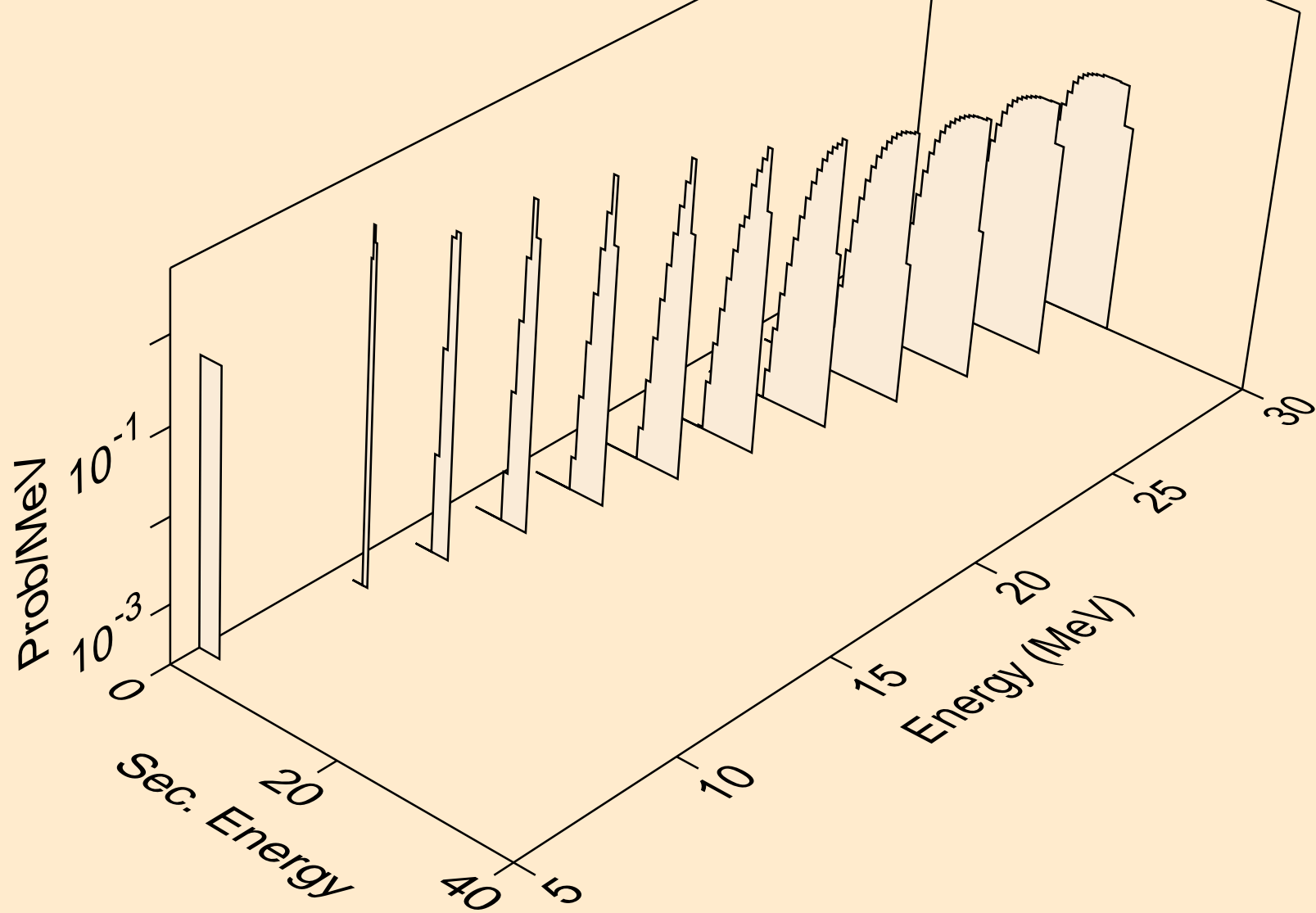

MT280 NEUTRON ACER TENDL-2023 LIBRARY; T=0.K  
deuterons from (n,d)

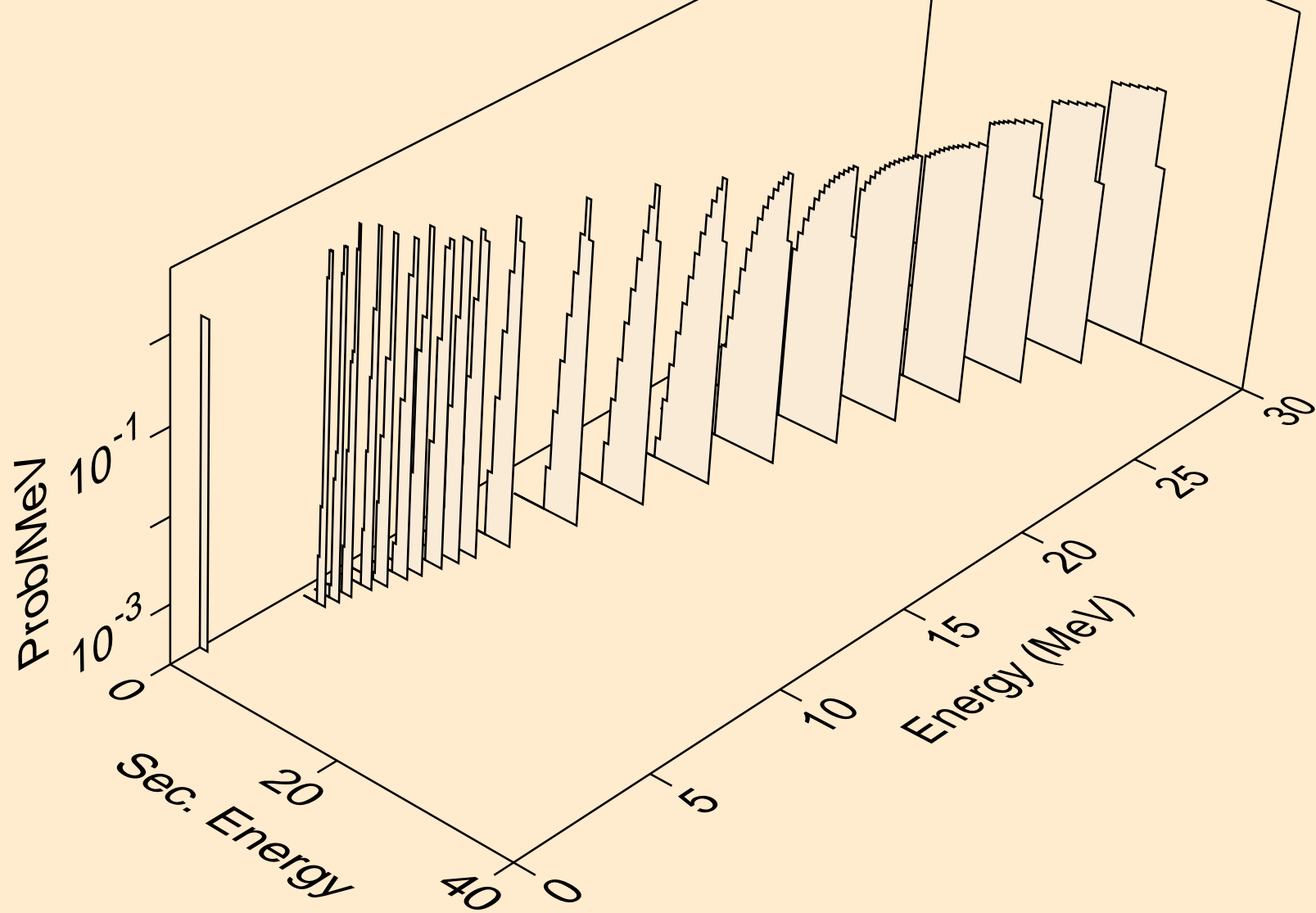

MT280 NEUTRON ACER TENDL-2023 LIBRARY; T=0.K  
tritons from (n,x)

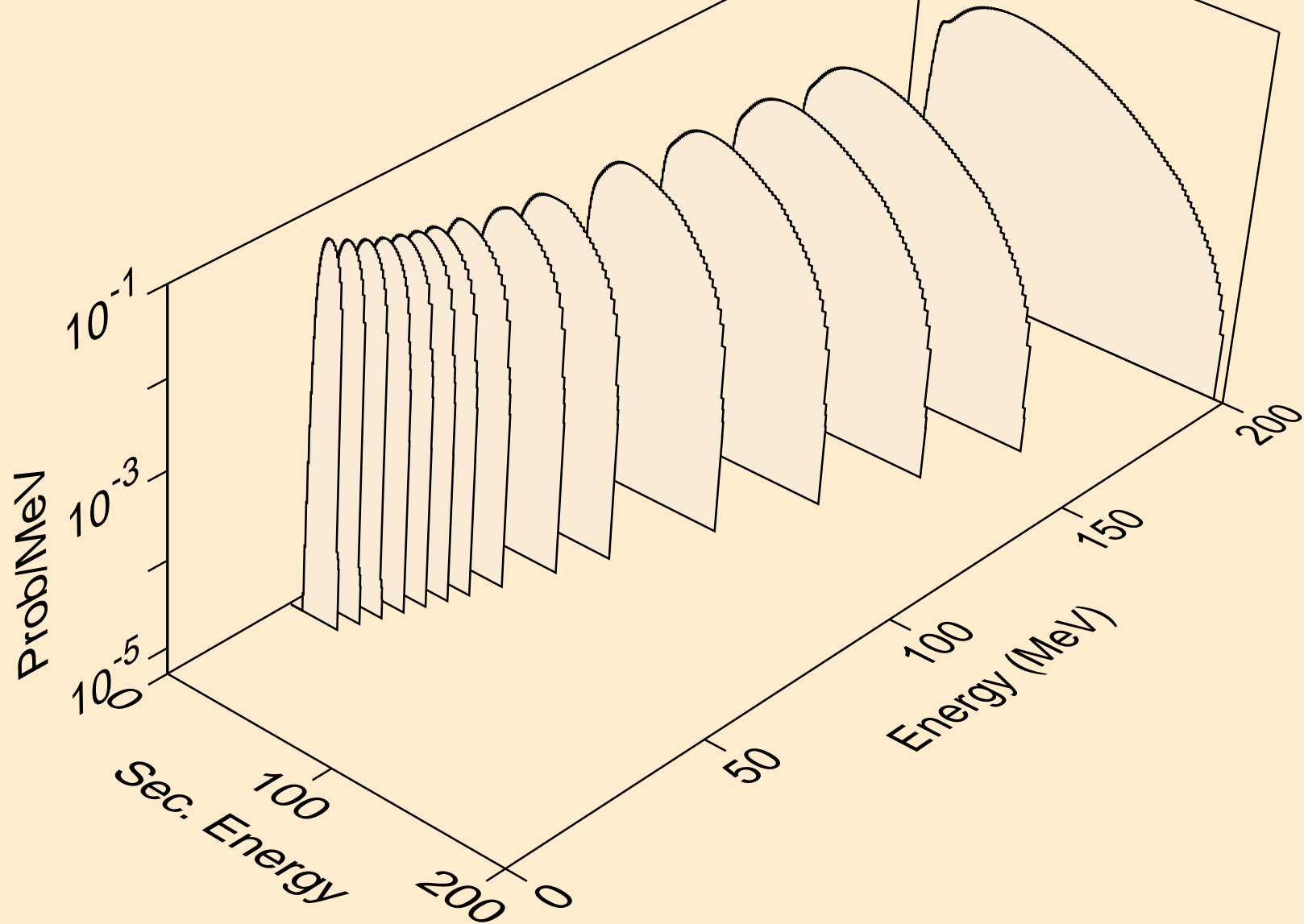

MT280 NEUTRON ACER TENDL-2023 LIBRARY; T=0.K  
tritons from (n,n\*)t

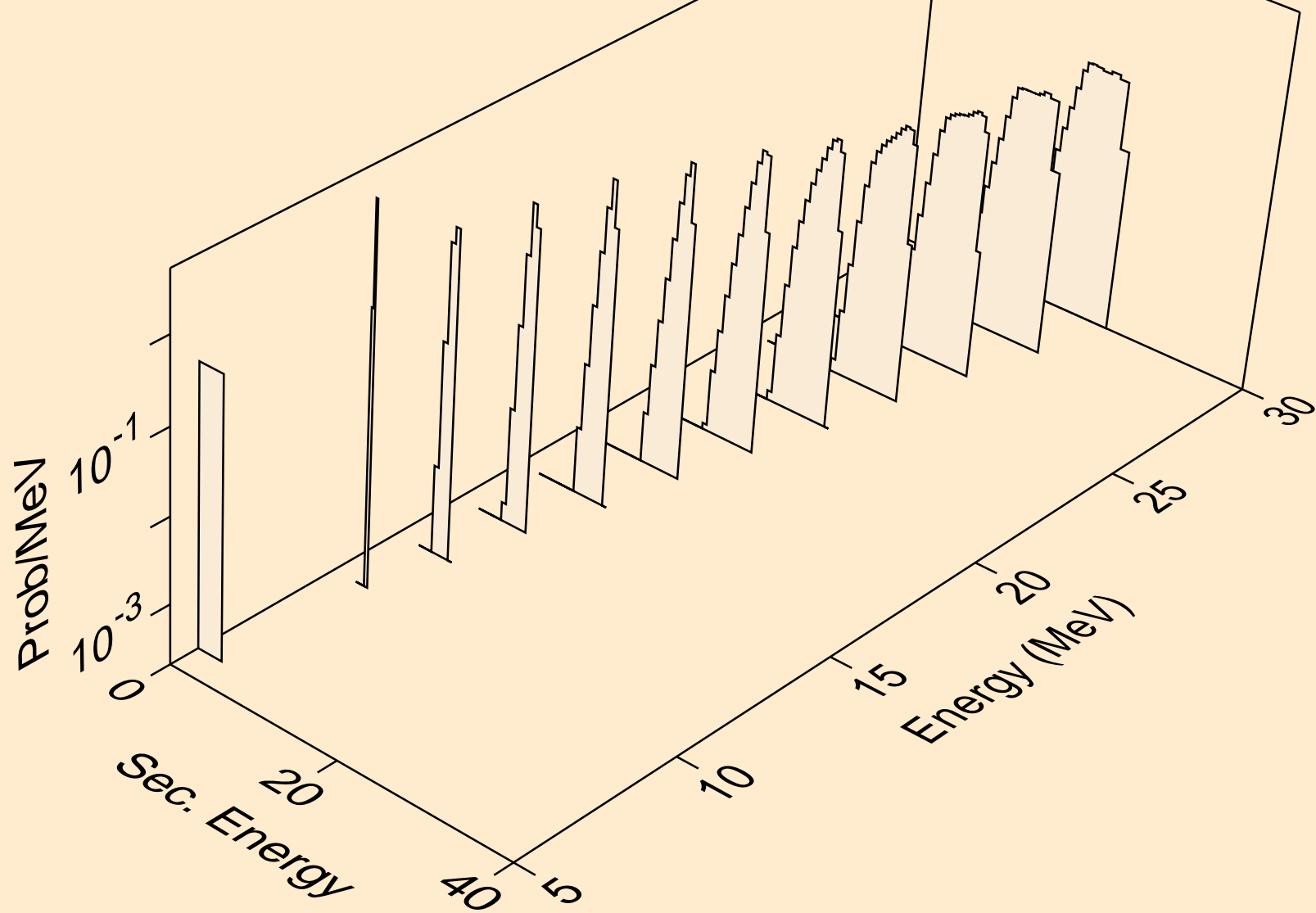

MT280 NEUTRON ACER TENDL-2023 LIBRARY; T=0.K  
tritons from (n,t)

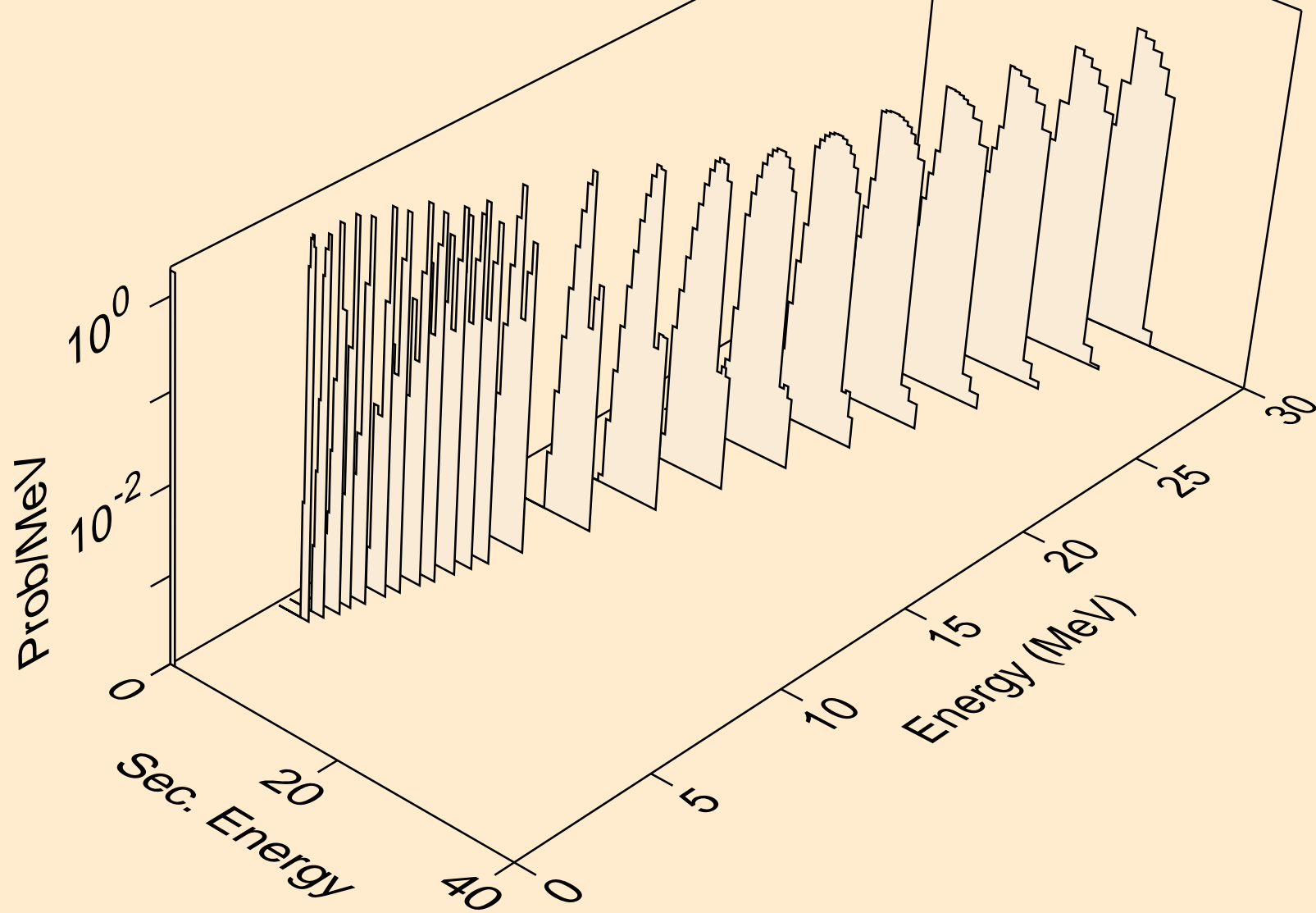

MT280 NEUTRON ACER TENDL-2023 LIBRARY; T=0.K  
he3s from (n,x)

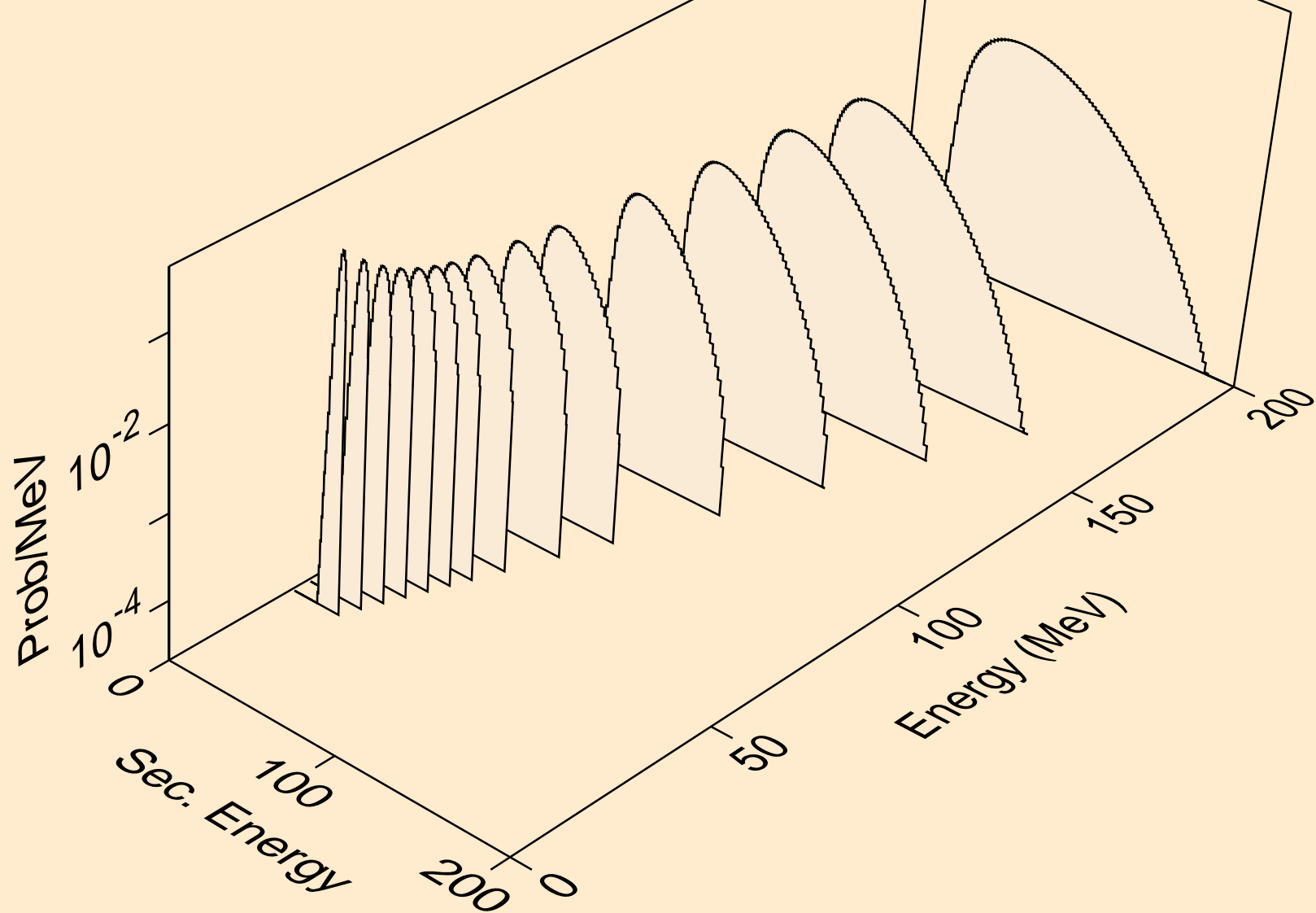



MT280 NEUTRON ACER TENDL-2023 LIBRARY; T=0.K  
he3s from (n,n\*)he3

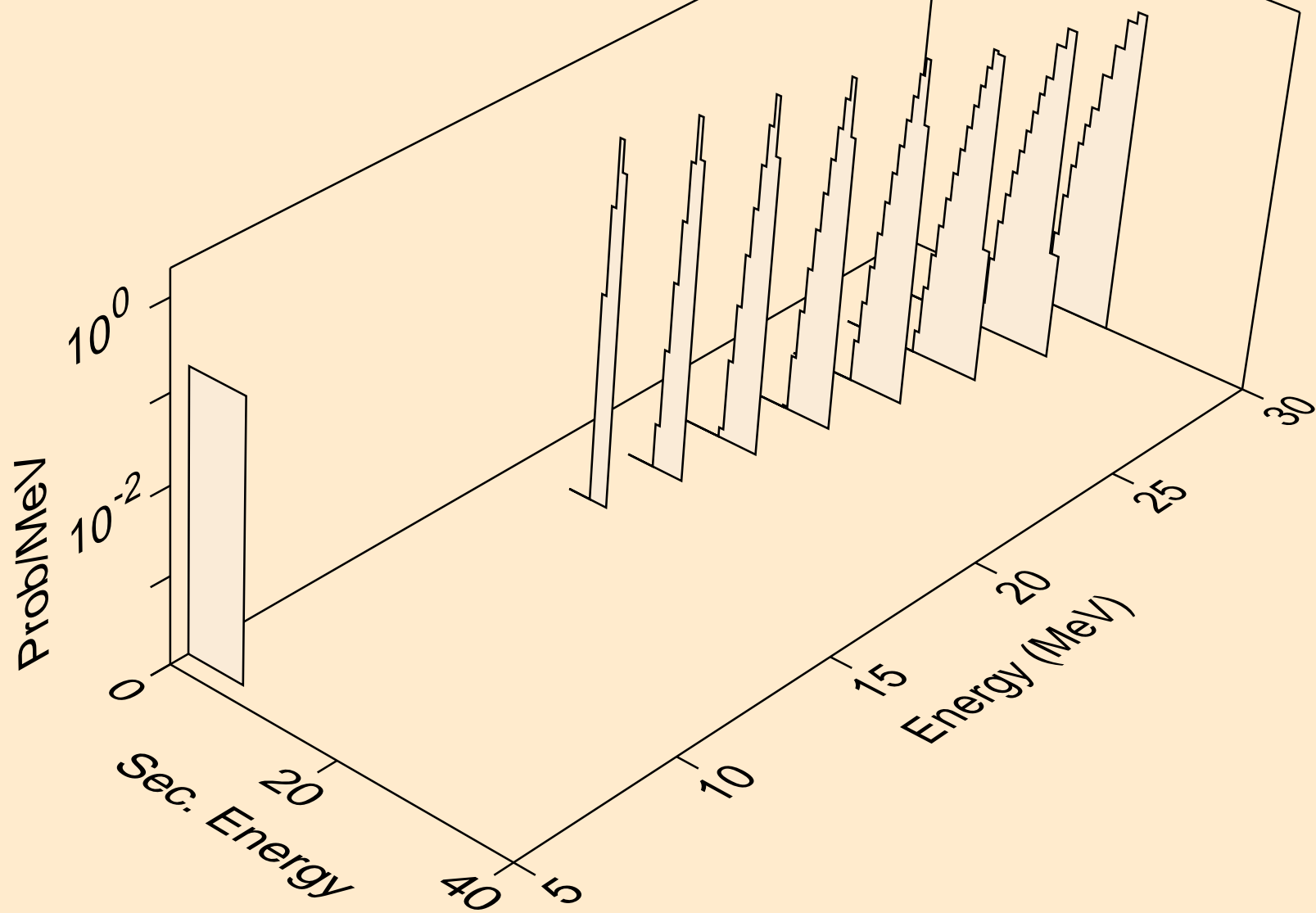

MT280 NEUTRON ACER TENDL-2023 LIBRARY; T=0.K  
he3s from (n,he3)

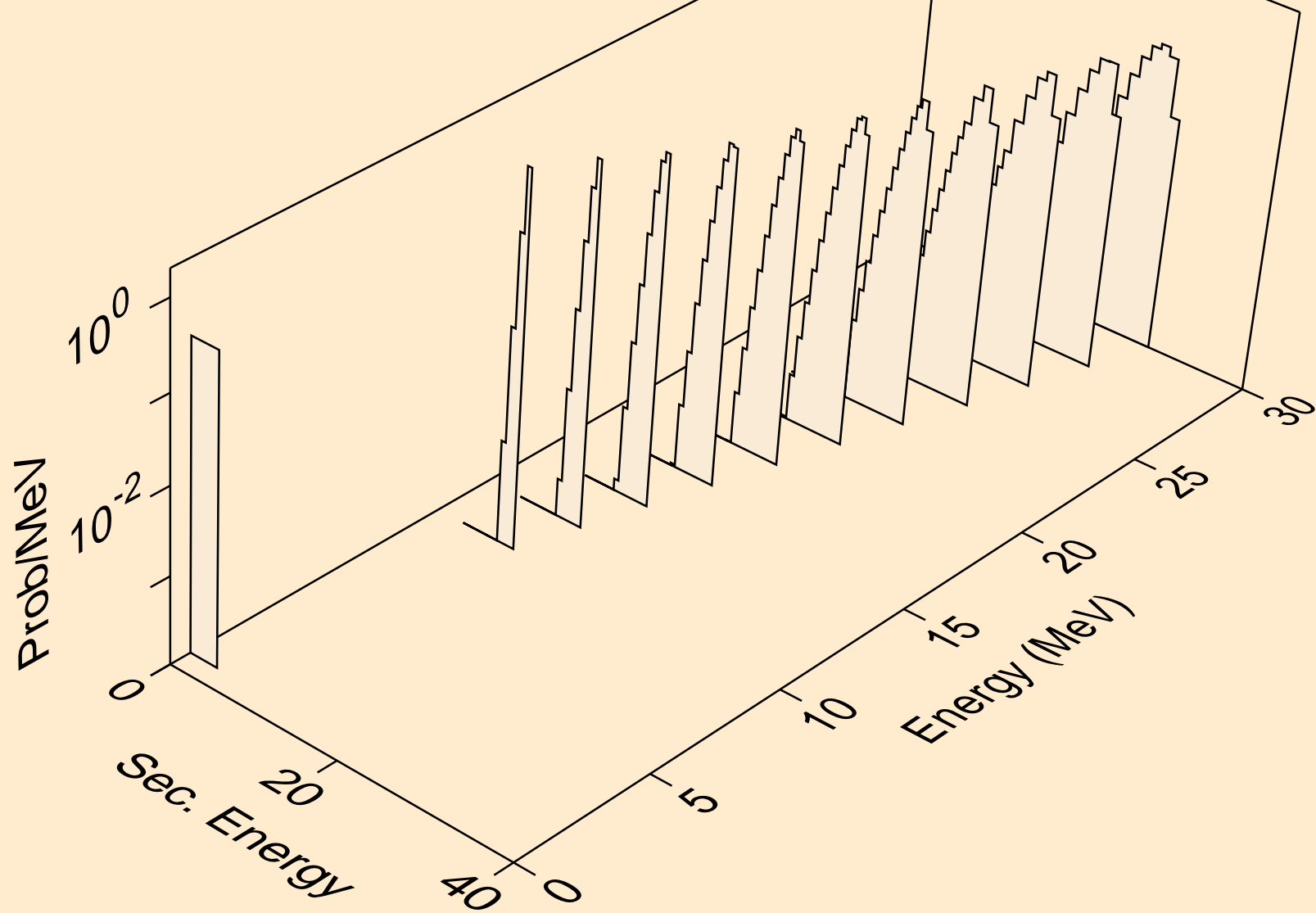

MT280 NEUTRON ACER TENDL-2023 LIBRARY; T=0.K  
alphas from (n,x)

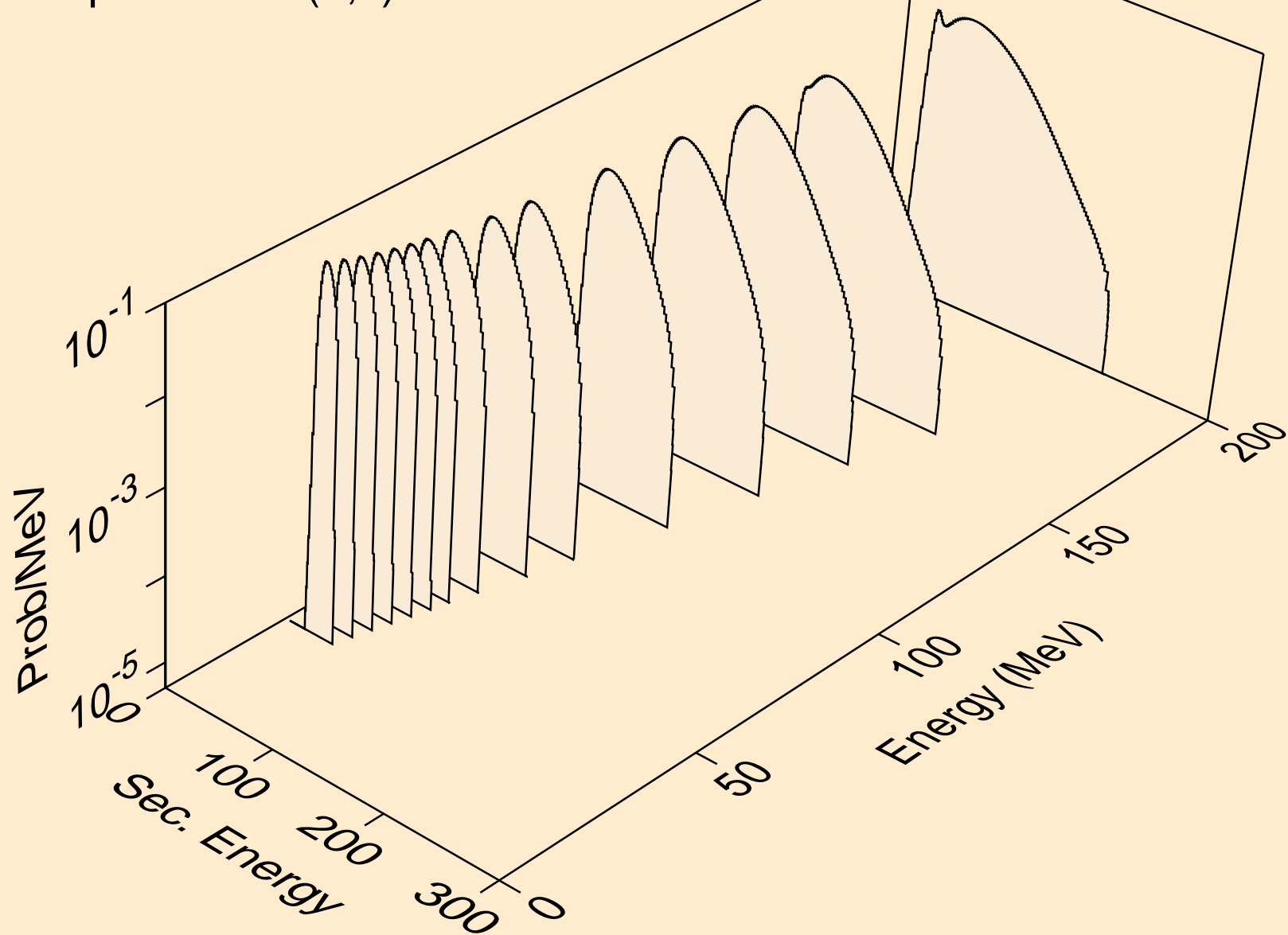

MT280 NEUTRON ACER TENDL-2023 LIBRARY; T=0.K  
alphas from (n,n\*)a

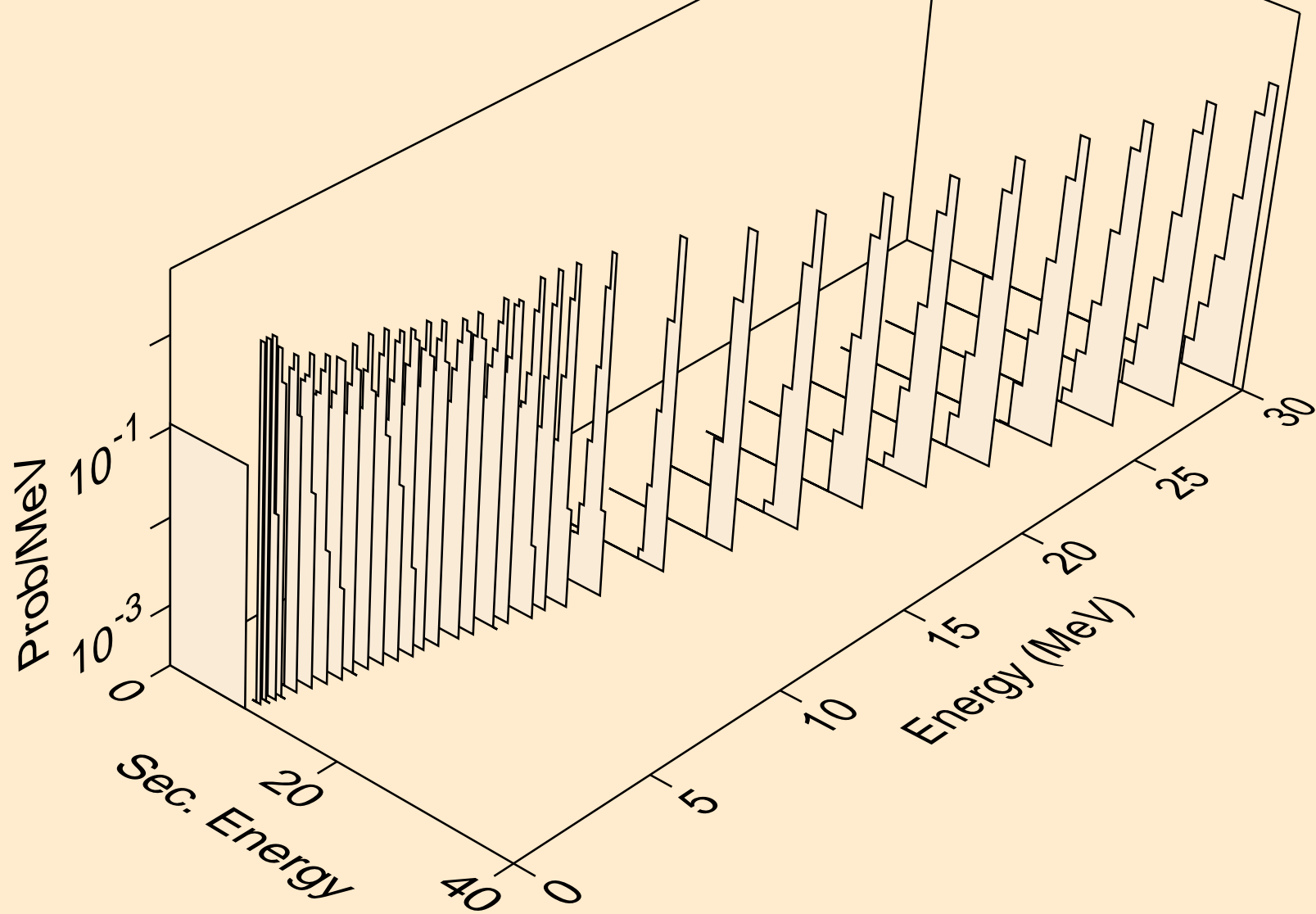

MT280 NEUTRON ACER TENDL-2023 LIBRARY; T=0.K  
alphas from (n,2n)a

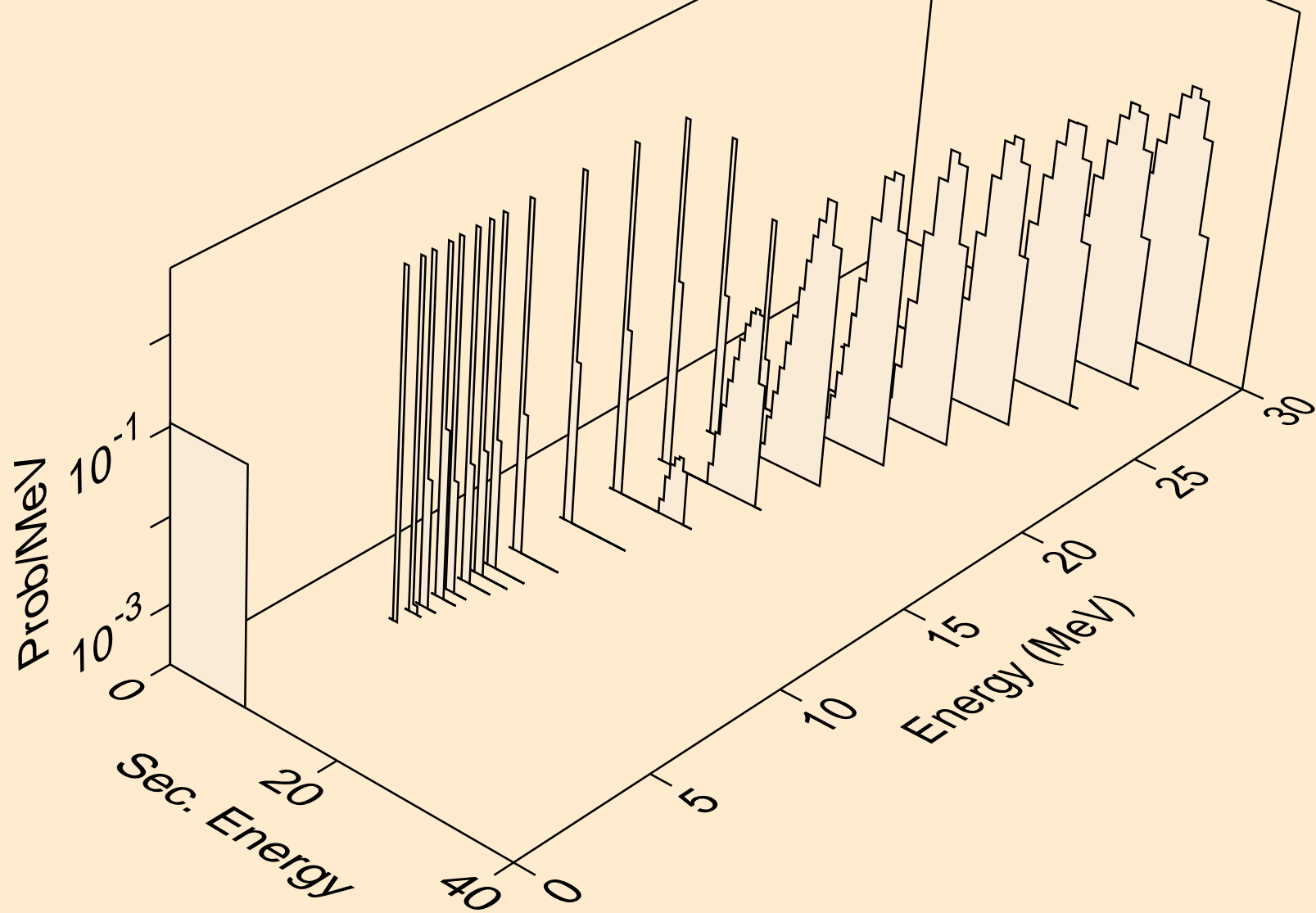

MT280 NEUTRON ACER TENDL-2023 LIBRARY; T=0.K  
alphas from (n,3n)a

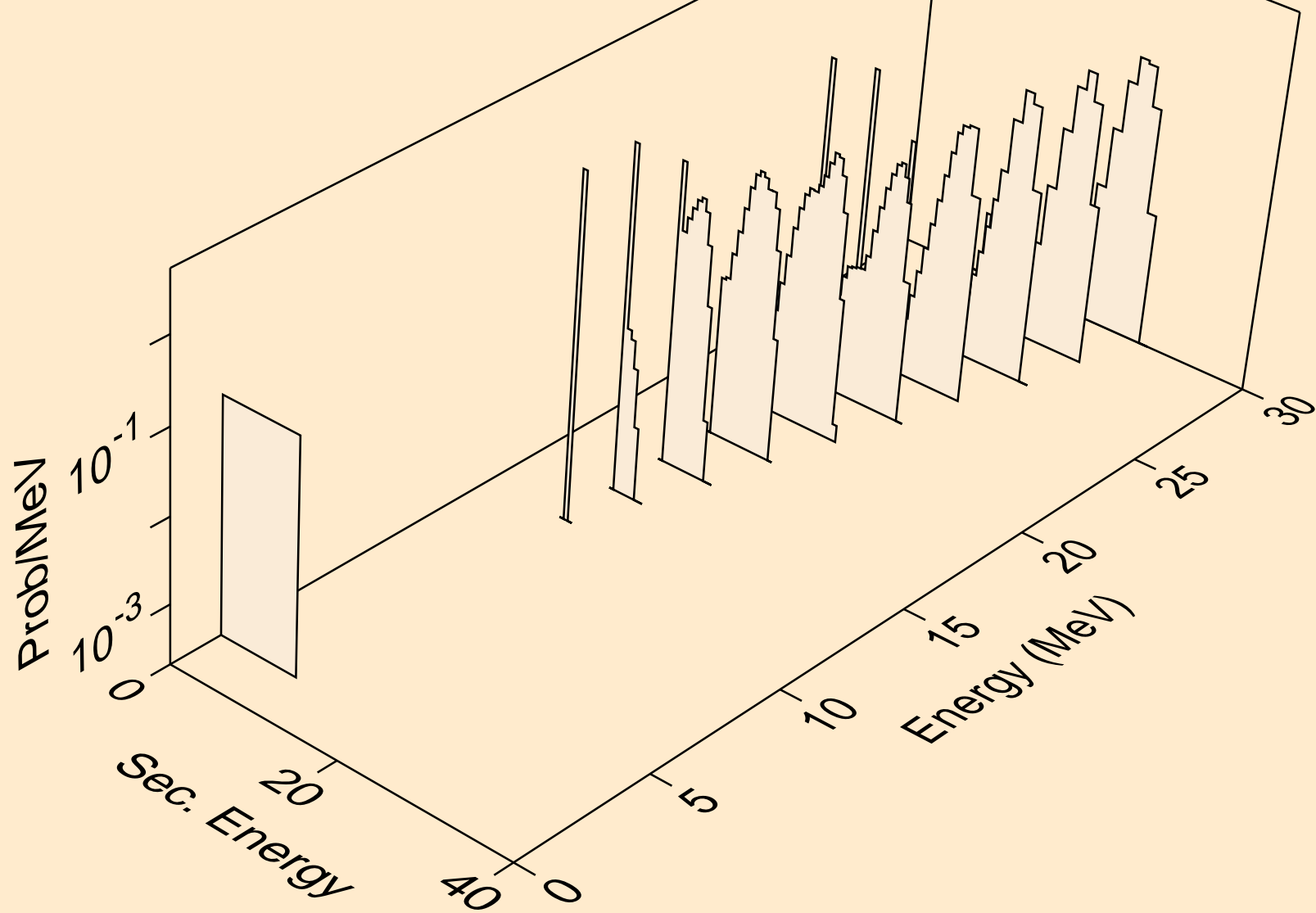

MT280 NEUTRON ACER TENDL-2023 LIBRARY; T=0.K  
alphas from (n,npa)

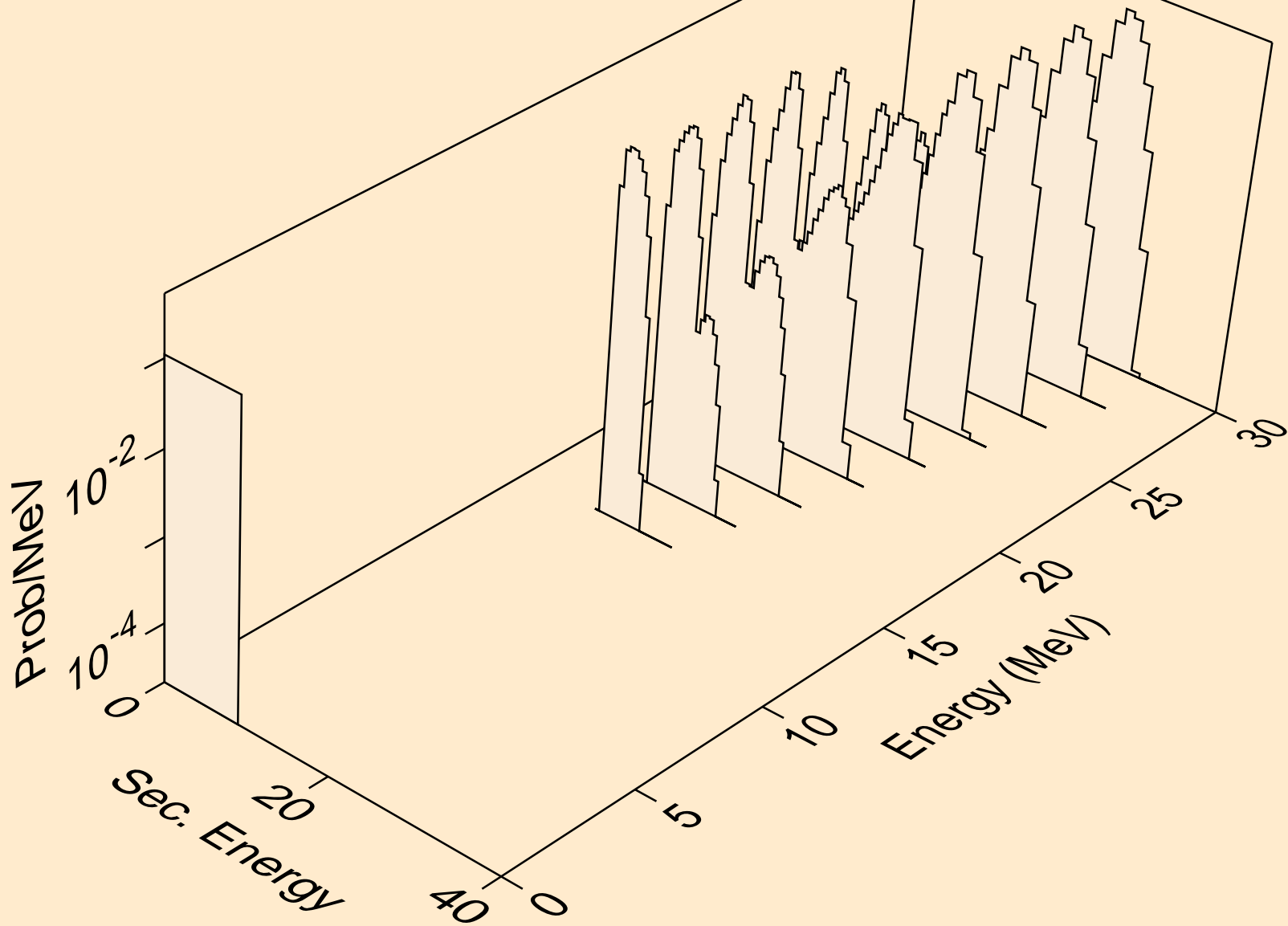

MT280 NEUTRON ACER TENDL-2023 LIBRARY; T=0.K  
alphas from (n,a)

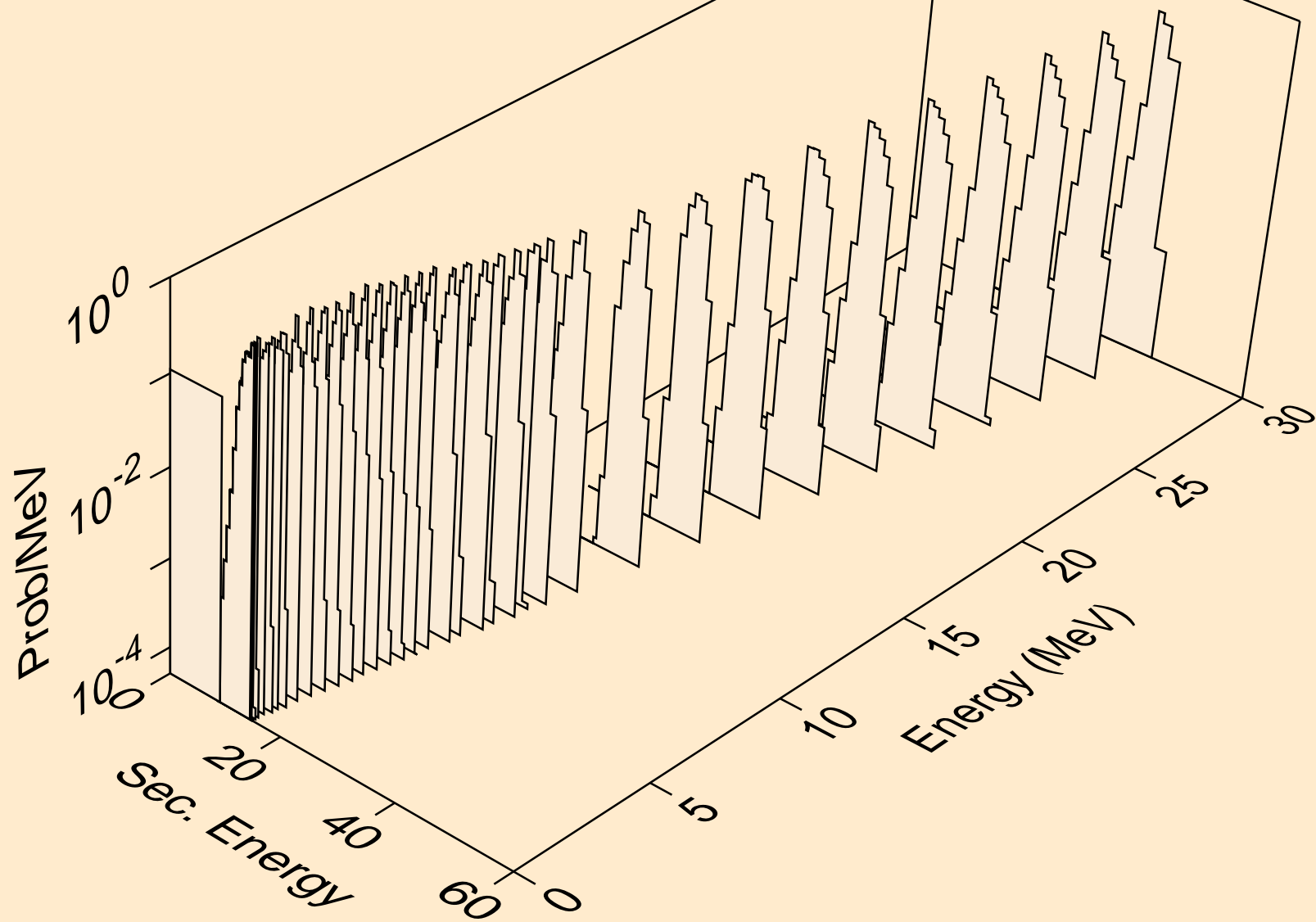



MT280 NEUTRON ACER TENDL-2023 LIBRARY; T=0.K  
alphas from (n,pa)

