

MT281 NEUTRON ACER TENDL-2023 LIBRARY; T=0.K

Principal cross sections

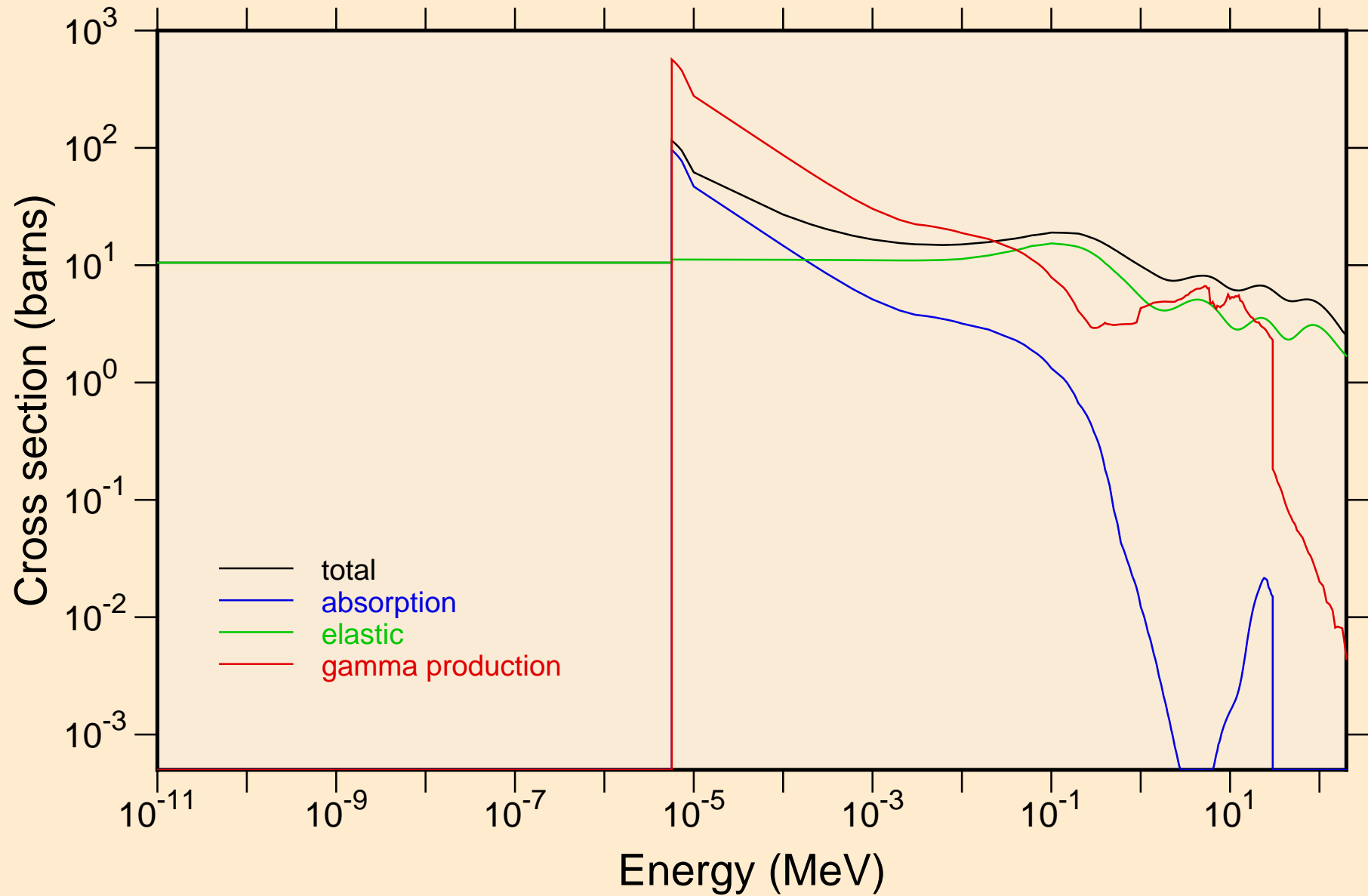

MT281 NEUTRON ACER TENDL-2023 LIBRARY; T=0.K
Heating

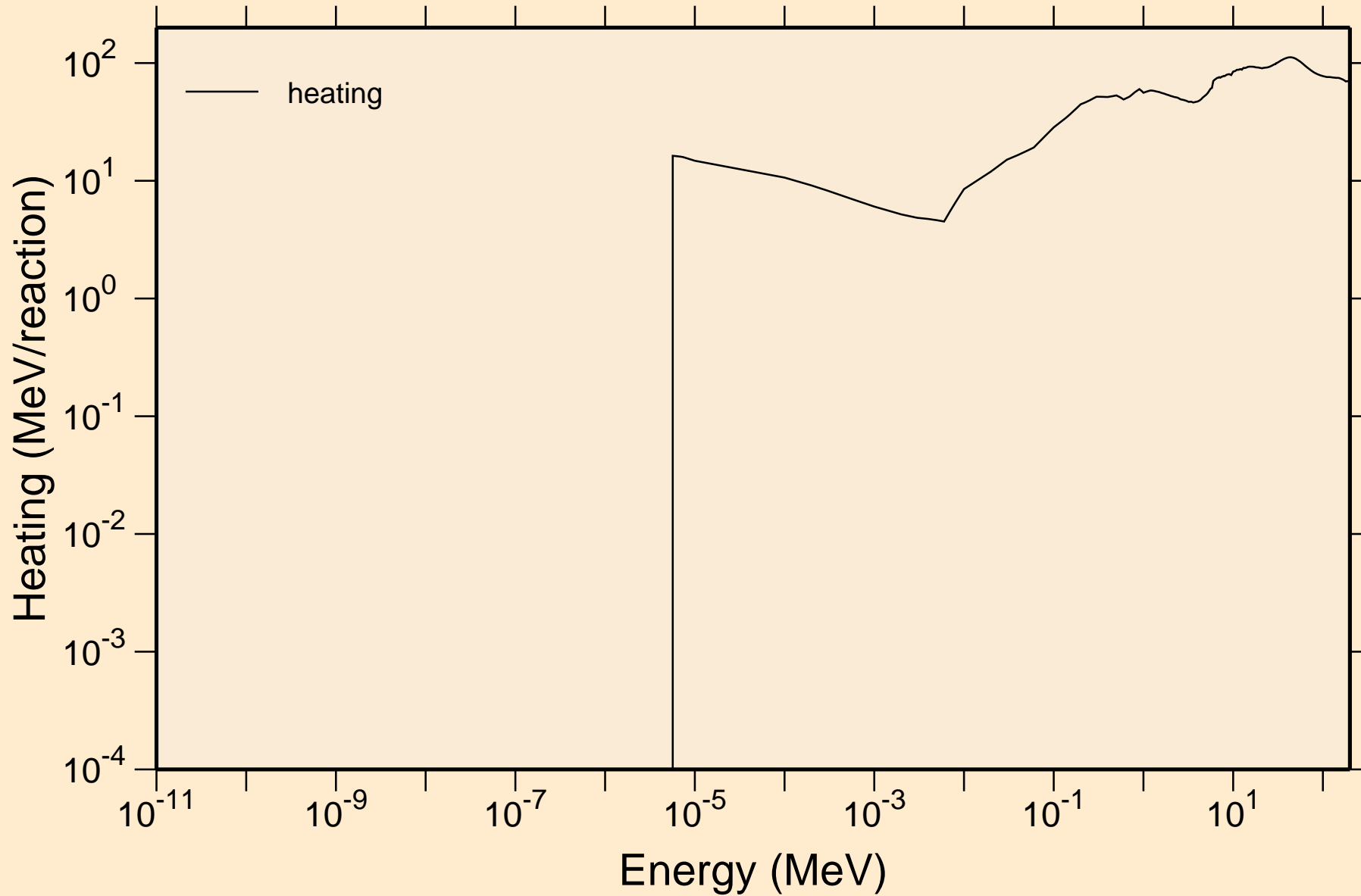

MT281 NEUTRON ACER TENDL-2023 LIBRARY; T=0.K

Damage

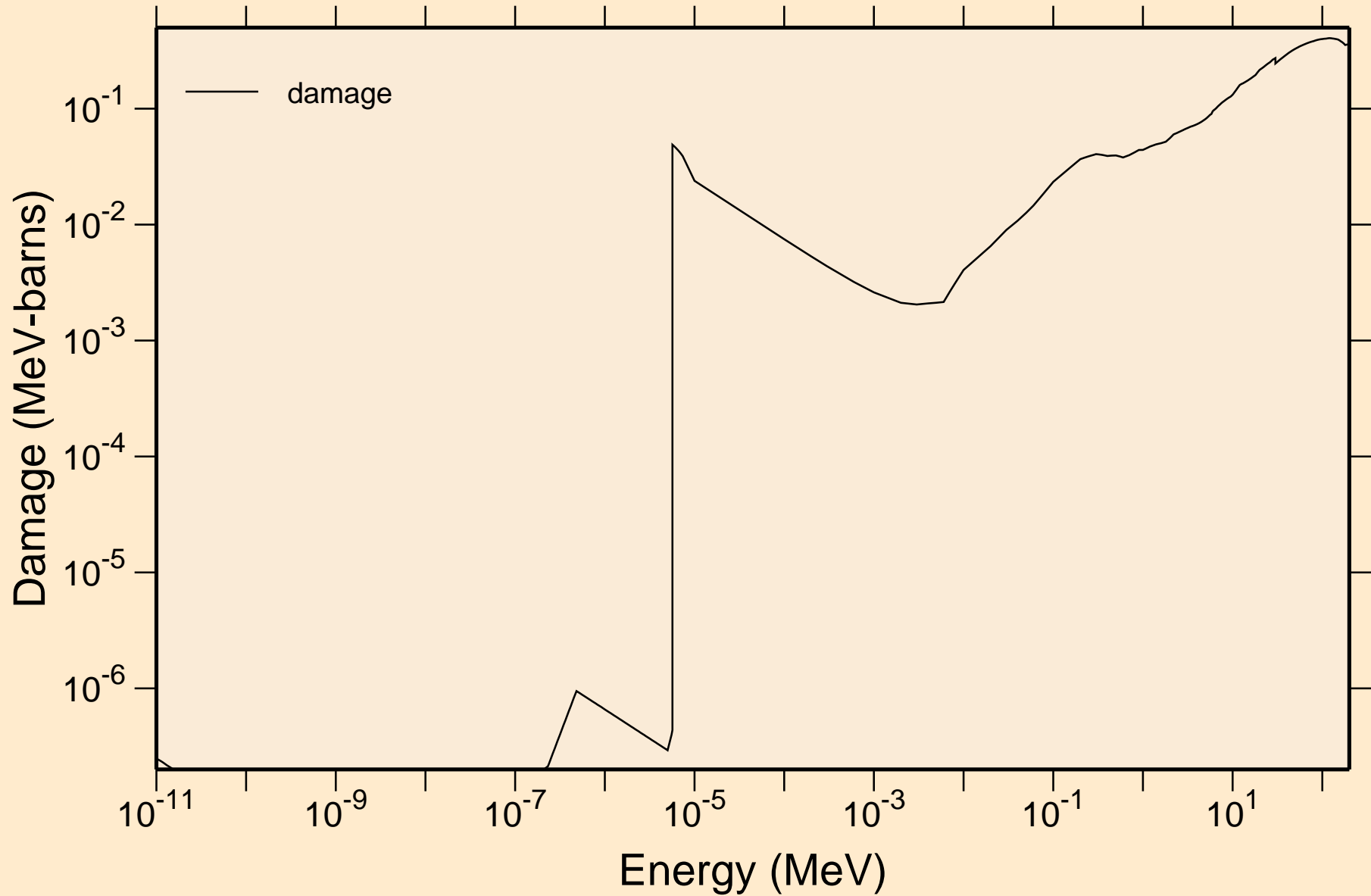

MT281 NEUTRON ACER TENDL-2023 LIBRARY; T=0.K

Non-threshold reactions

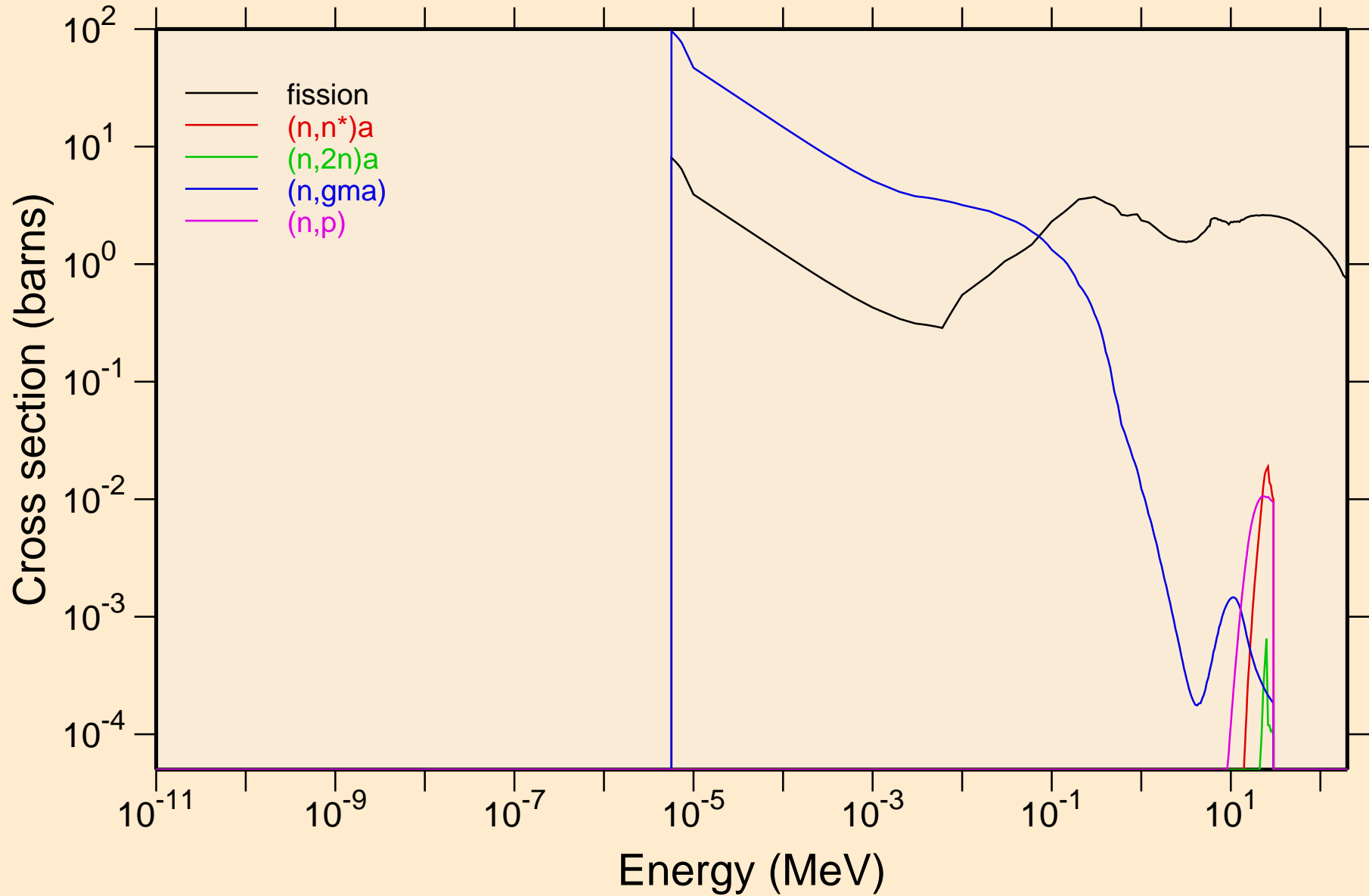

MT281 NEUTRON ACER TENDL-2023 LIBRARY; T=0.K
Non-threshold reactions

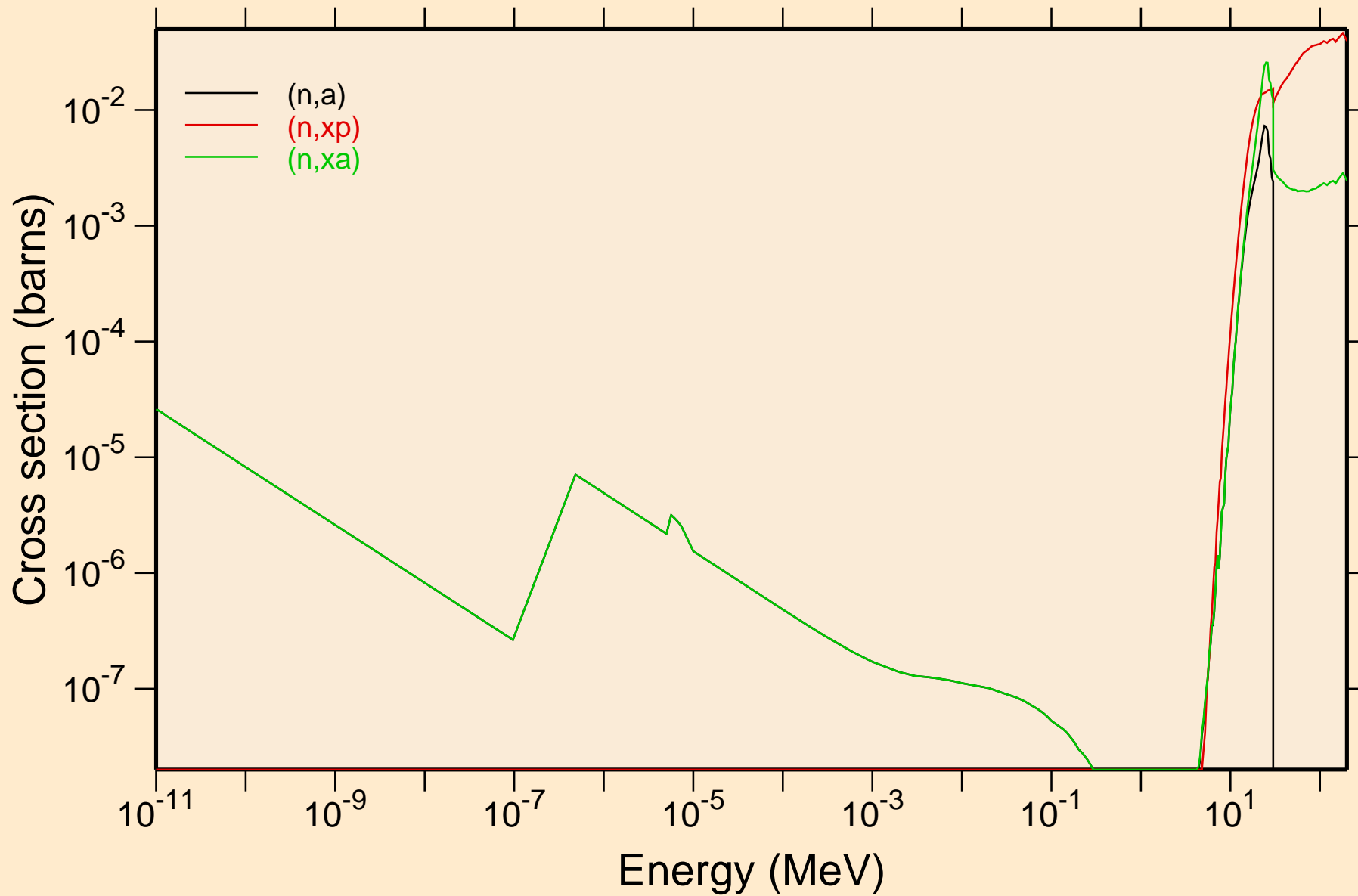

MT281 NEUTRON ACER TENDL-2023 LIBRARY; T=0.K

Principal cross sections

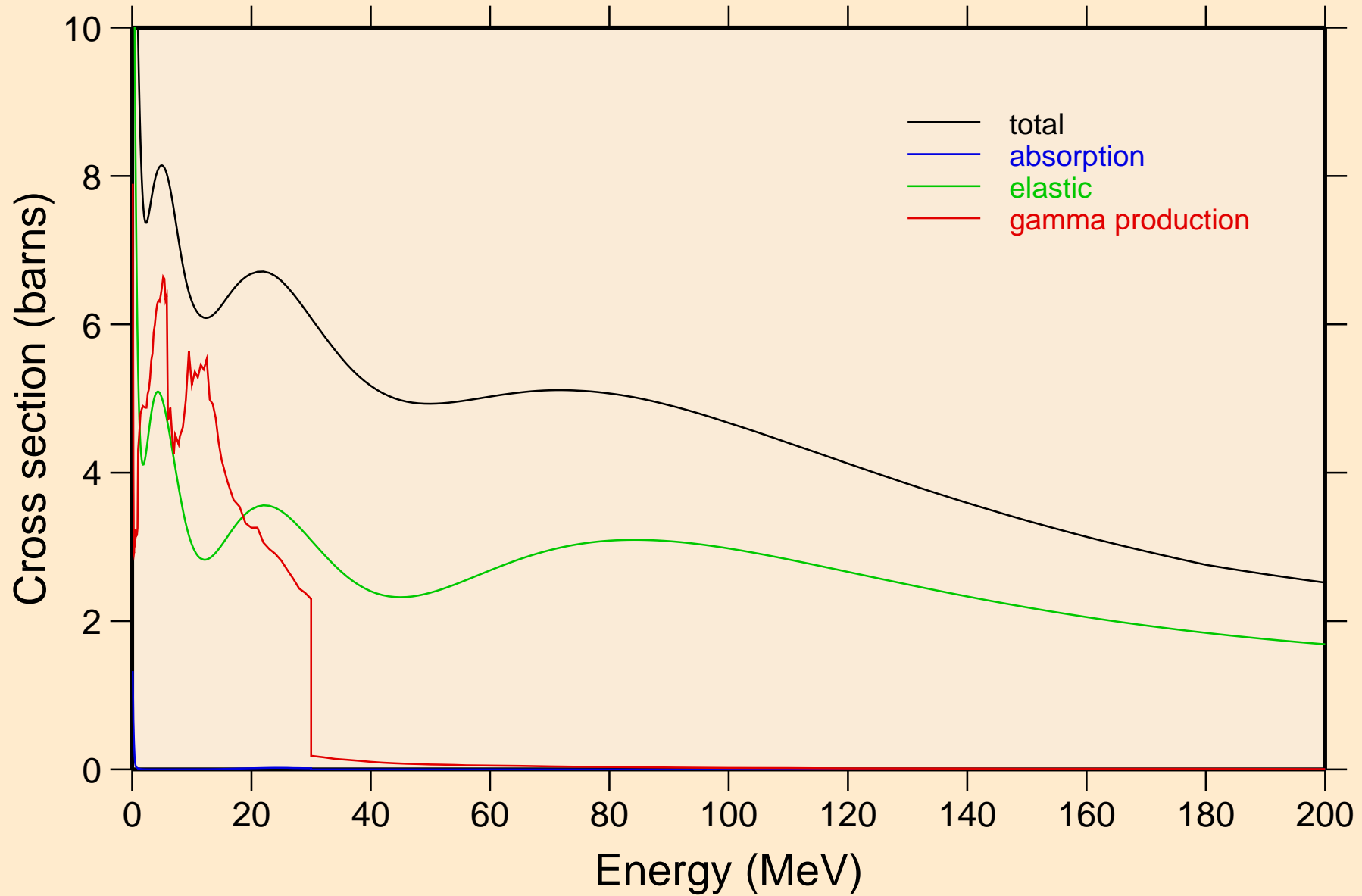

MT281 NEUTRON ACER TENDL-2023 LIBRARY; T=0.K
Heating

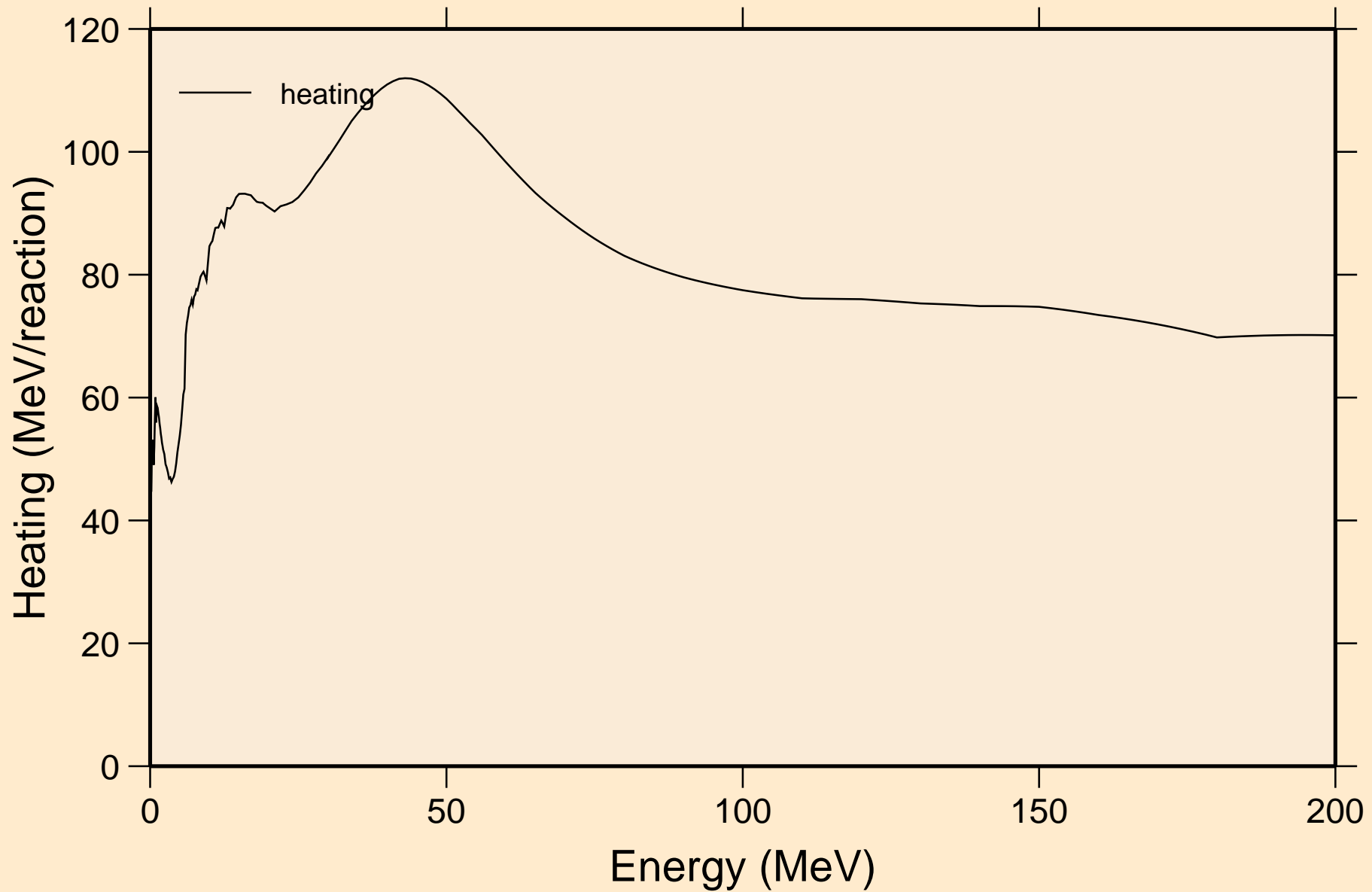

MT281 NEUTRON ACER TENDL-2023 LIBRARY; T=0.K
Damage

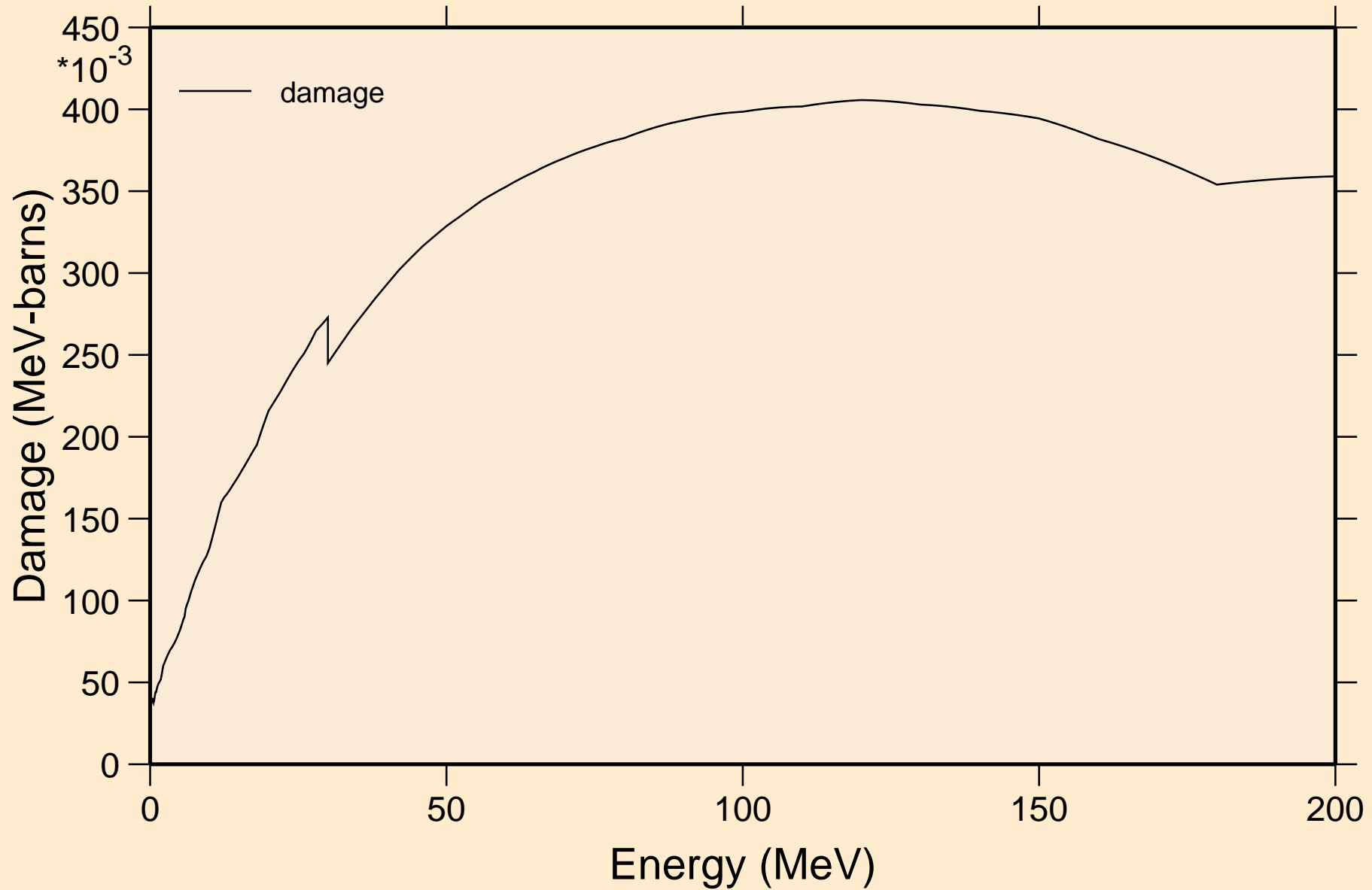

MT281 NEUTRON ACER TENDL-2023 LIBRARY; T=0.K

Non-threshold reactions

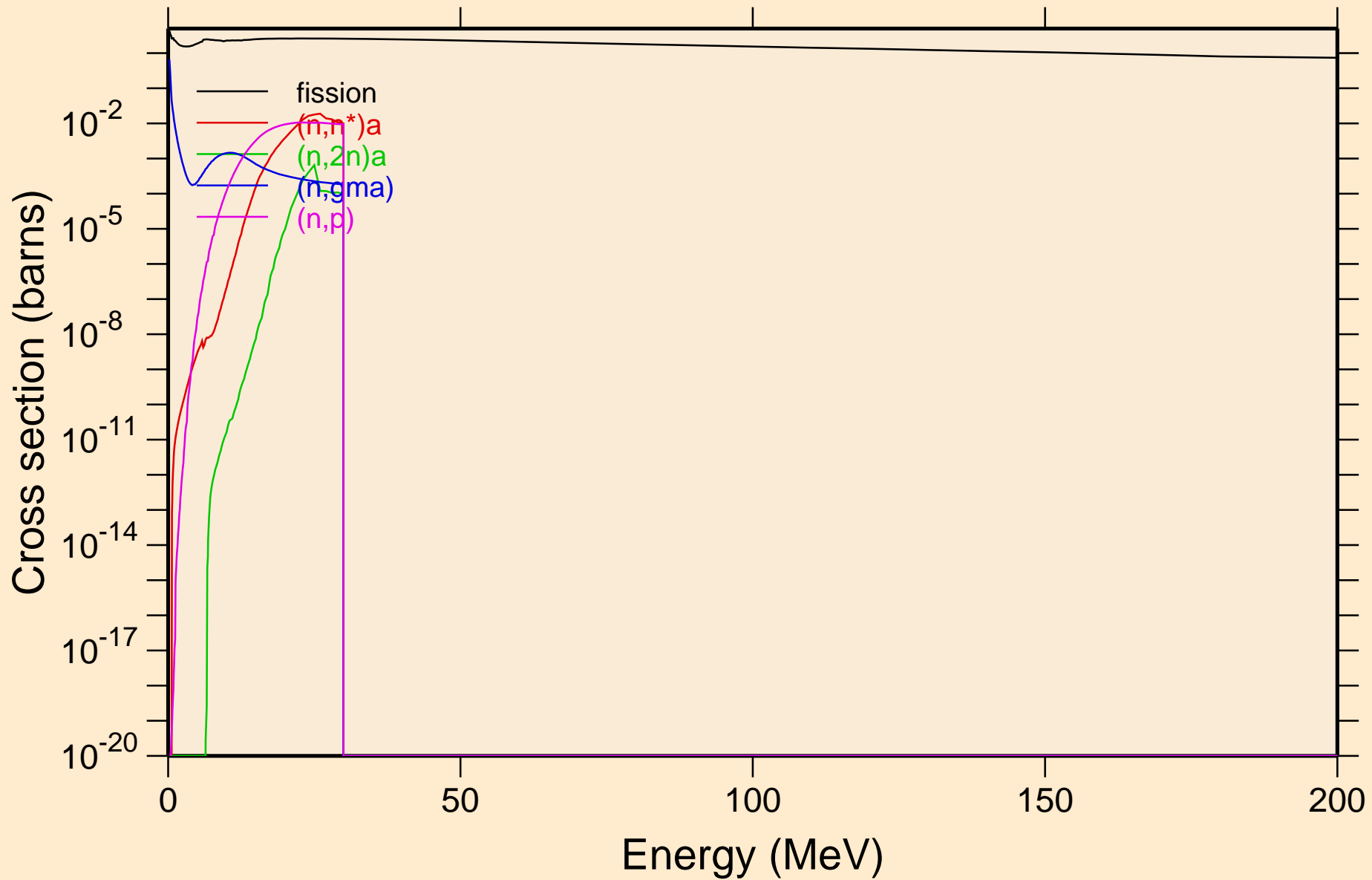

MT281 NEUTRON ACER TENDL-2023 LIBRARY; T=0.K
Non-threshold reactions

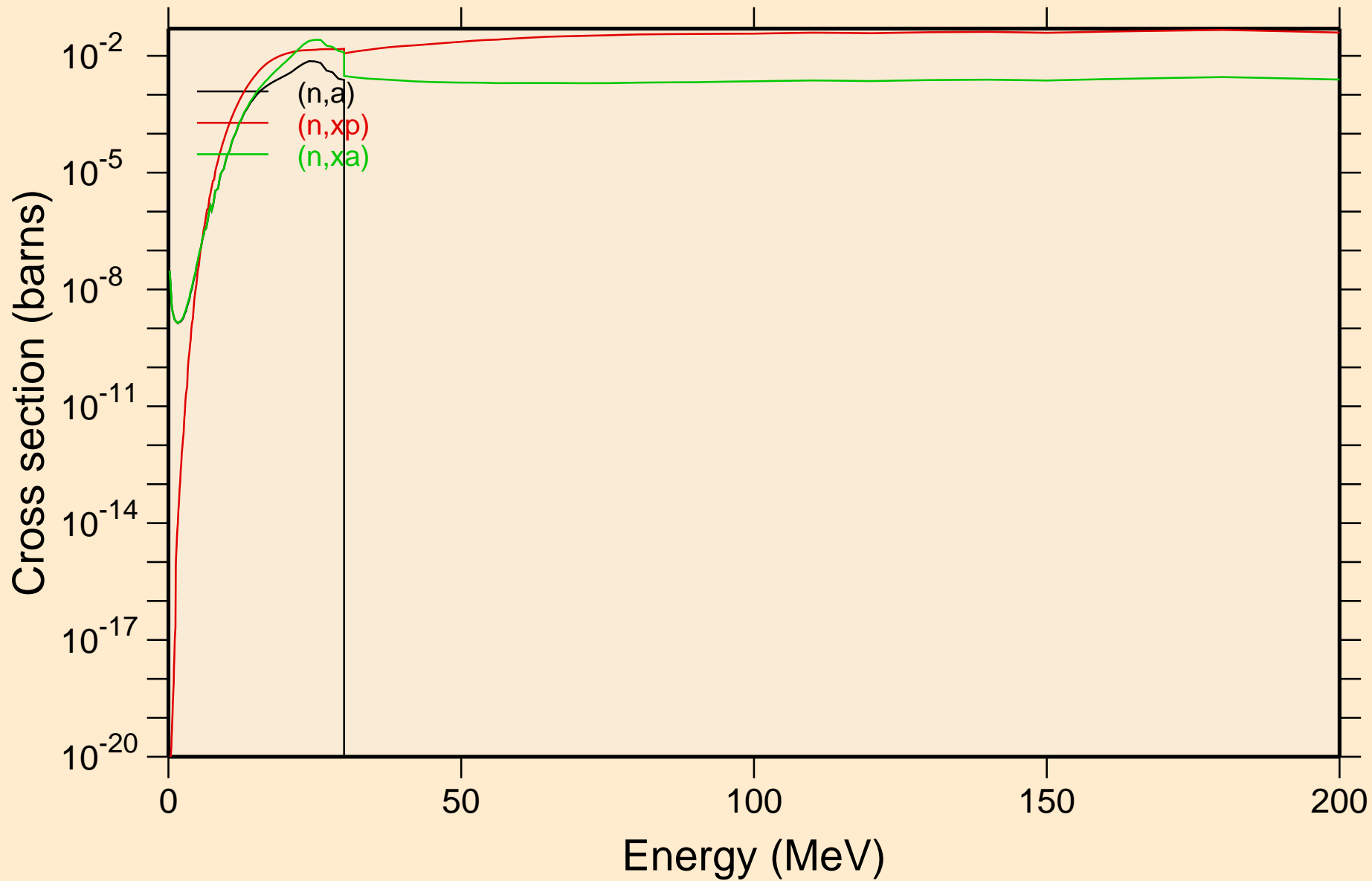

MT281 NEUTRON ACER TENDL-2023 LIBRARY; T=0.K
Inelastic levels

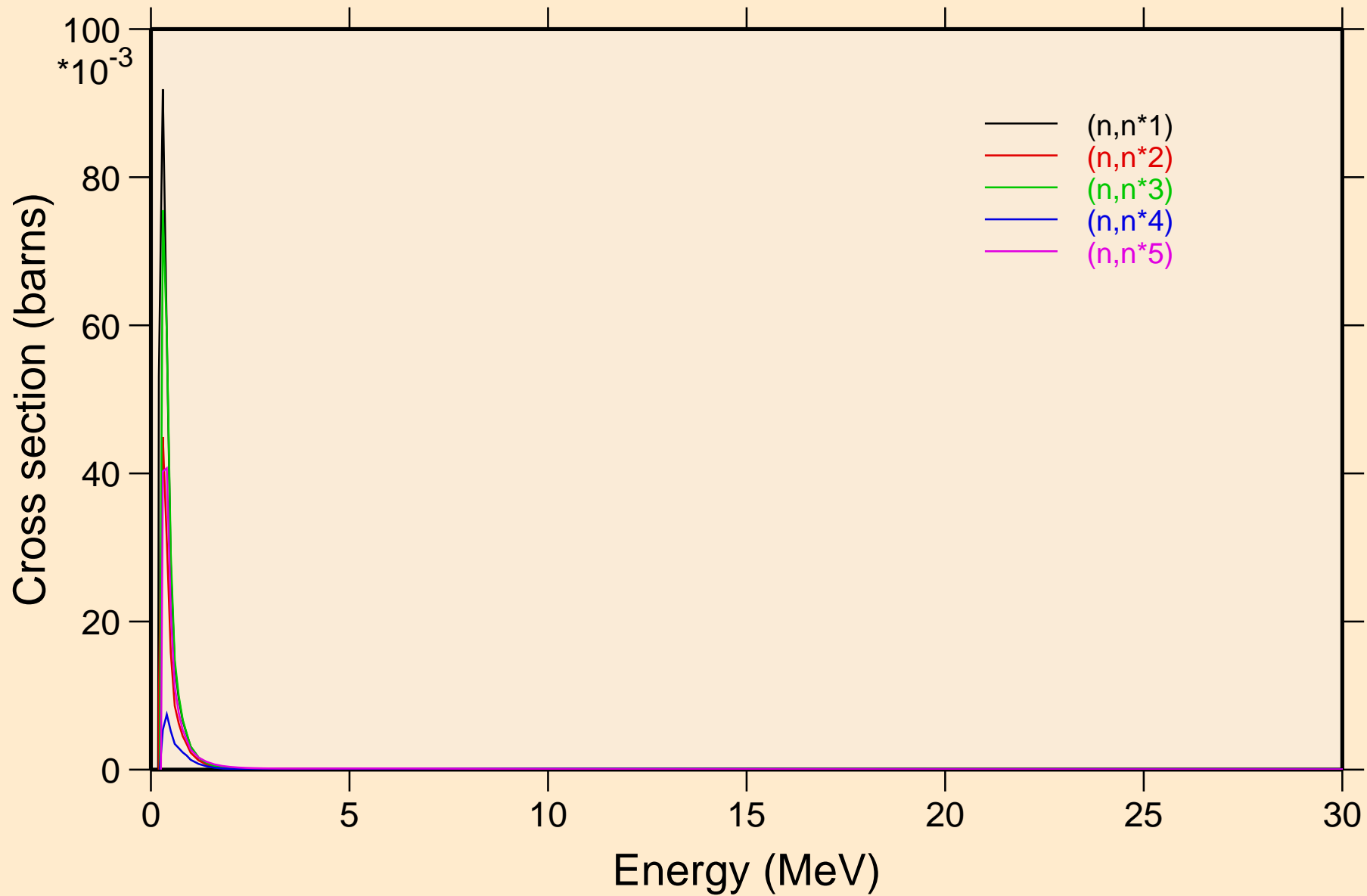

MT281 NEUTRON ACER TENDL-2023 LIBRARY; T=0.K
Inelastic levels

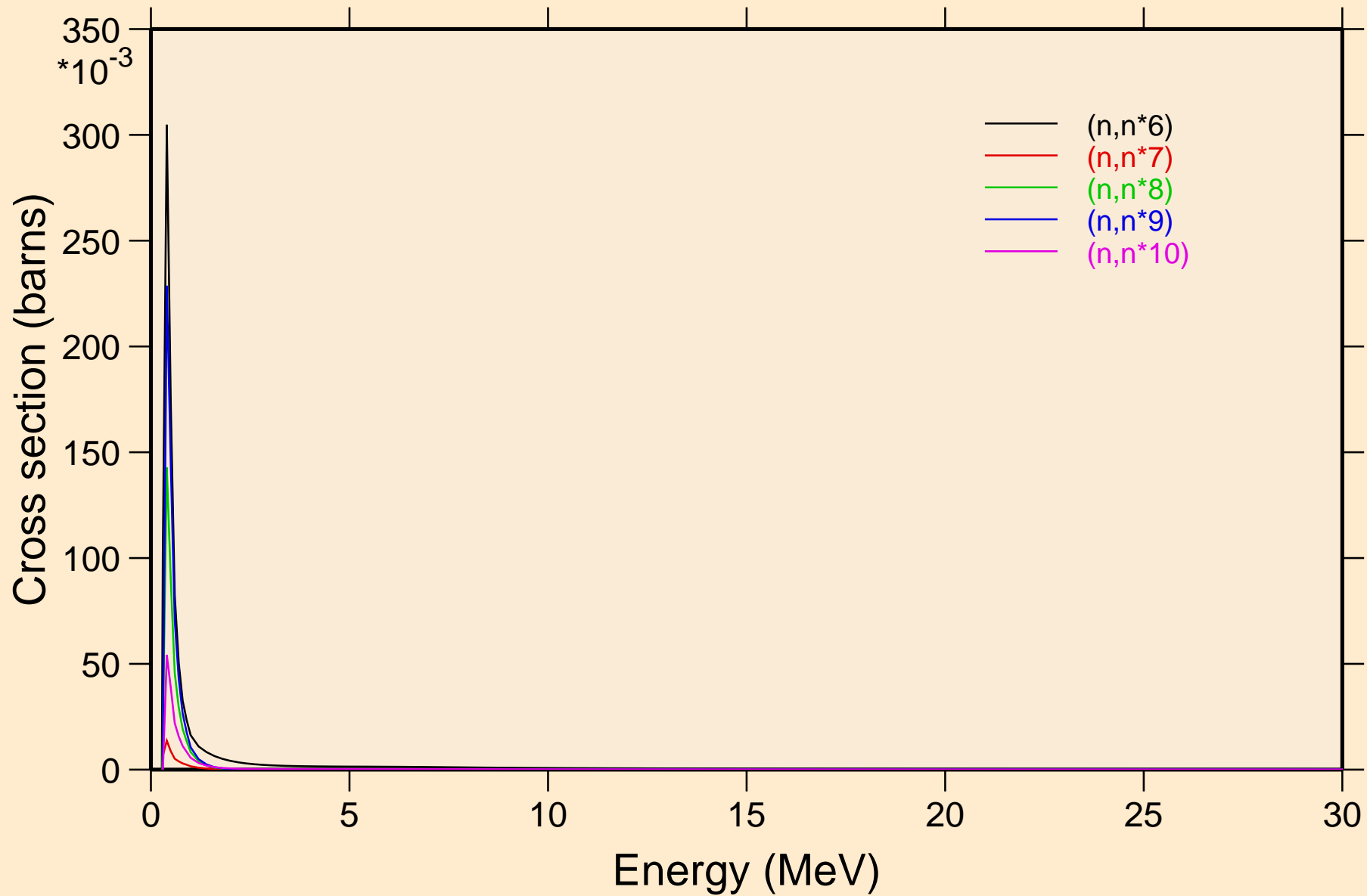

MT281 NEUTRON ACER TENDL-2023 LIBRARY; T=0.K
Inelastic levels

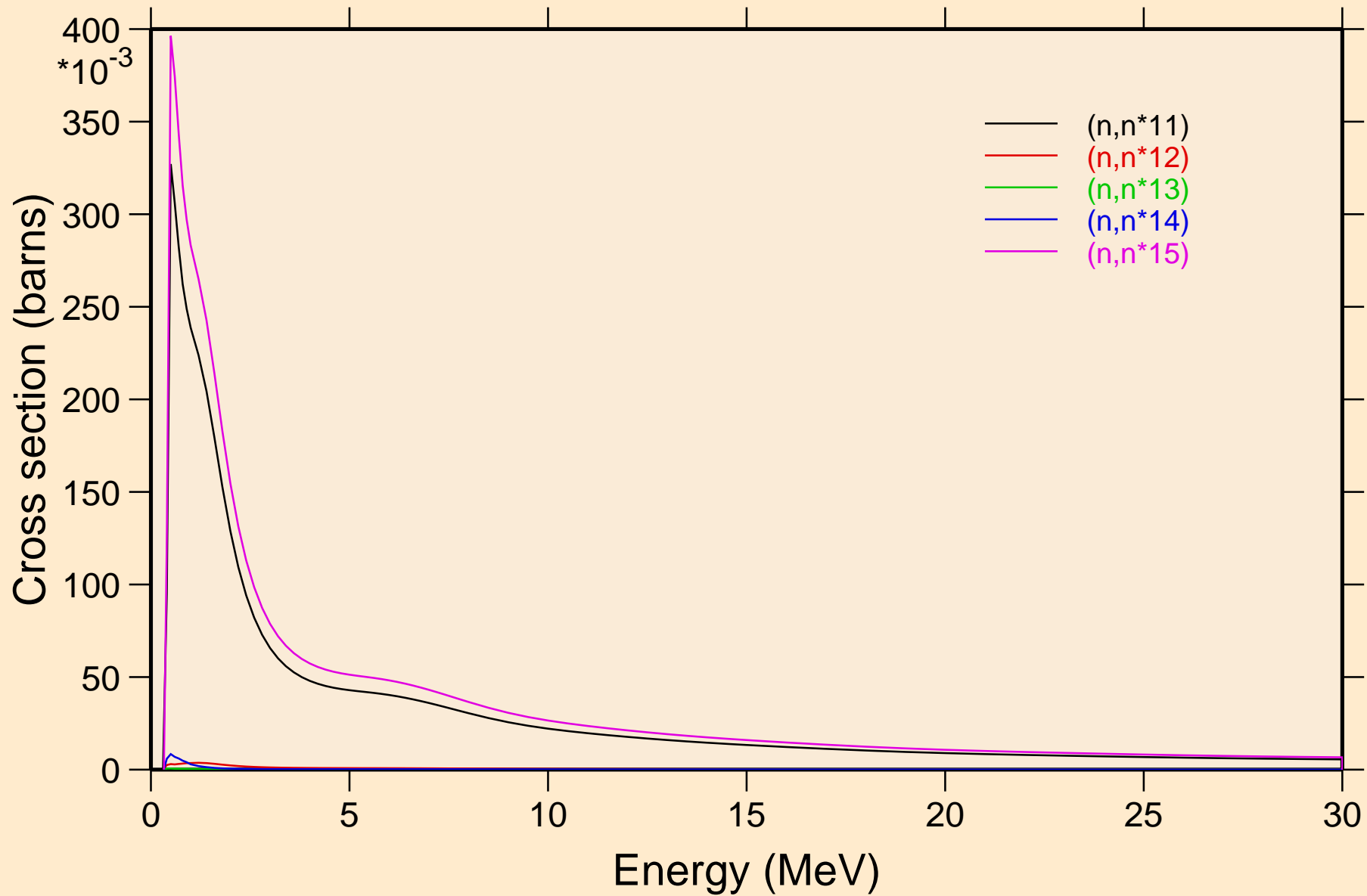

MT281 NEUTRON ACER TENDL-2023 LIBRARY; T=0.K
Inelastic levels

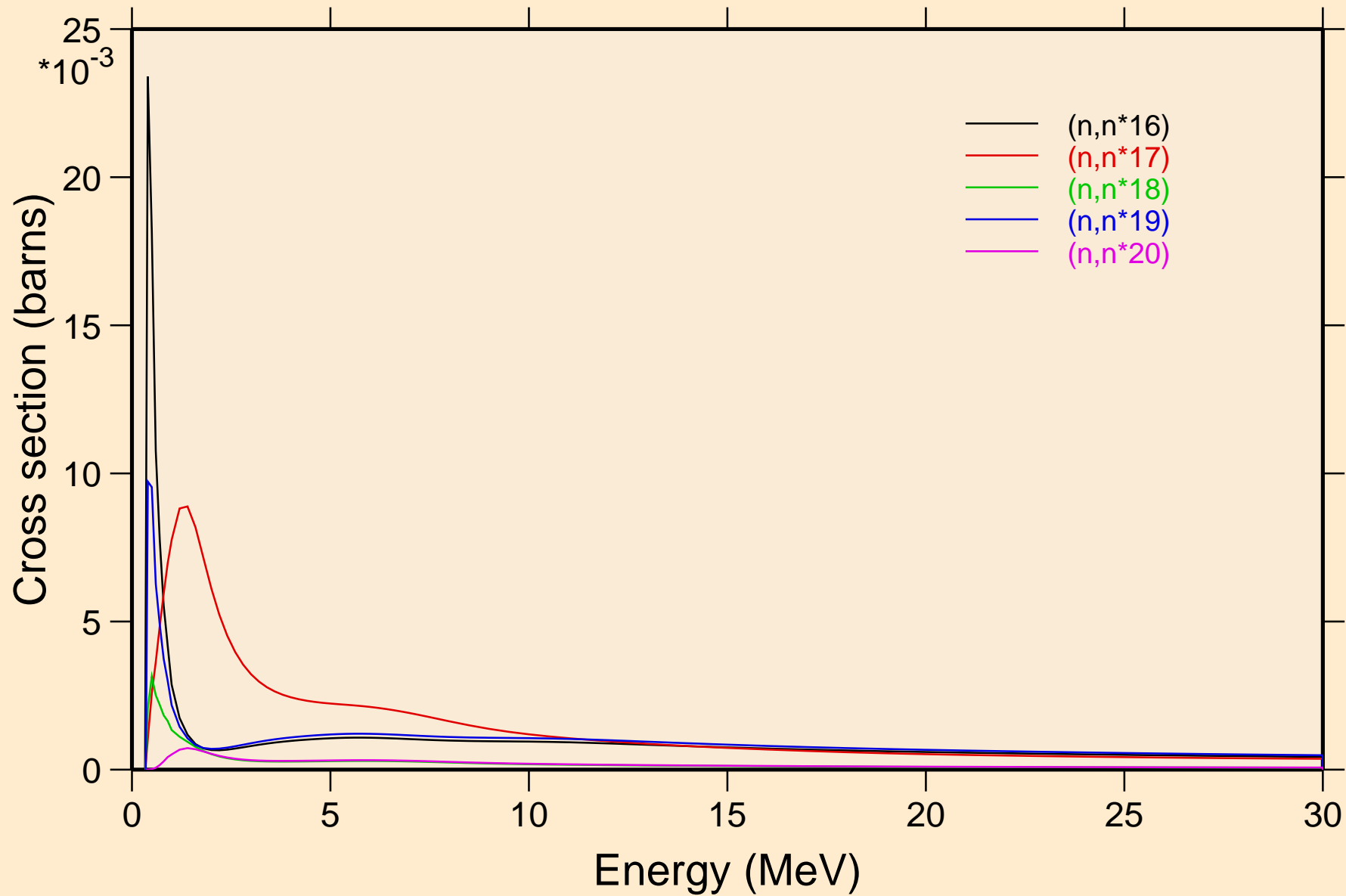

MT281 NEUTRON ACER TENDL-2023 LIBRARY; T=0.K
Inelastic levels

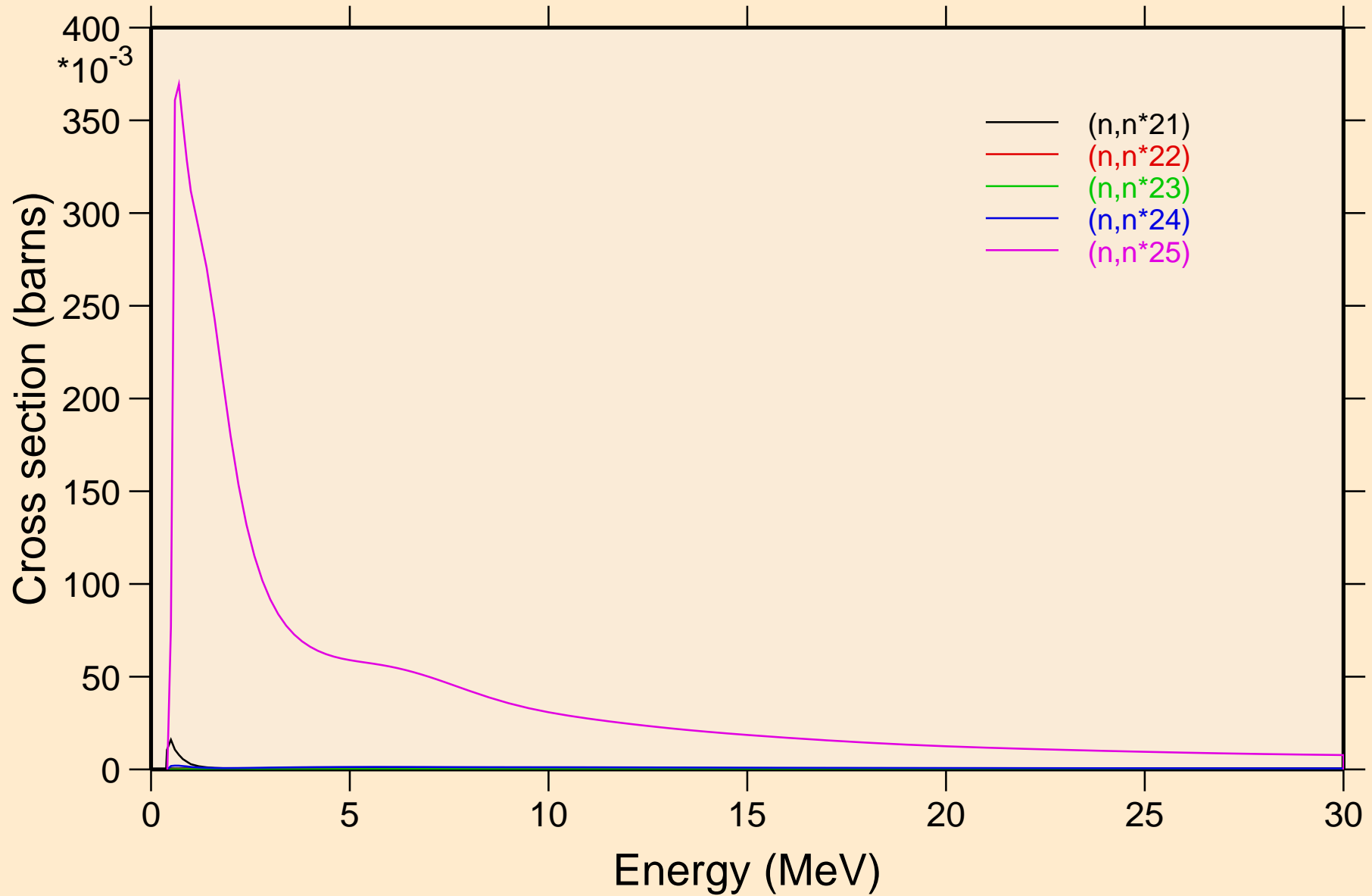

MT281 NEUTRON ACER TENDL-2023 LIBRARY; T=0.K
Inelastic levels

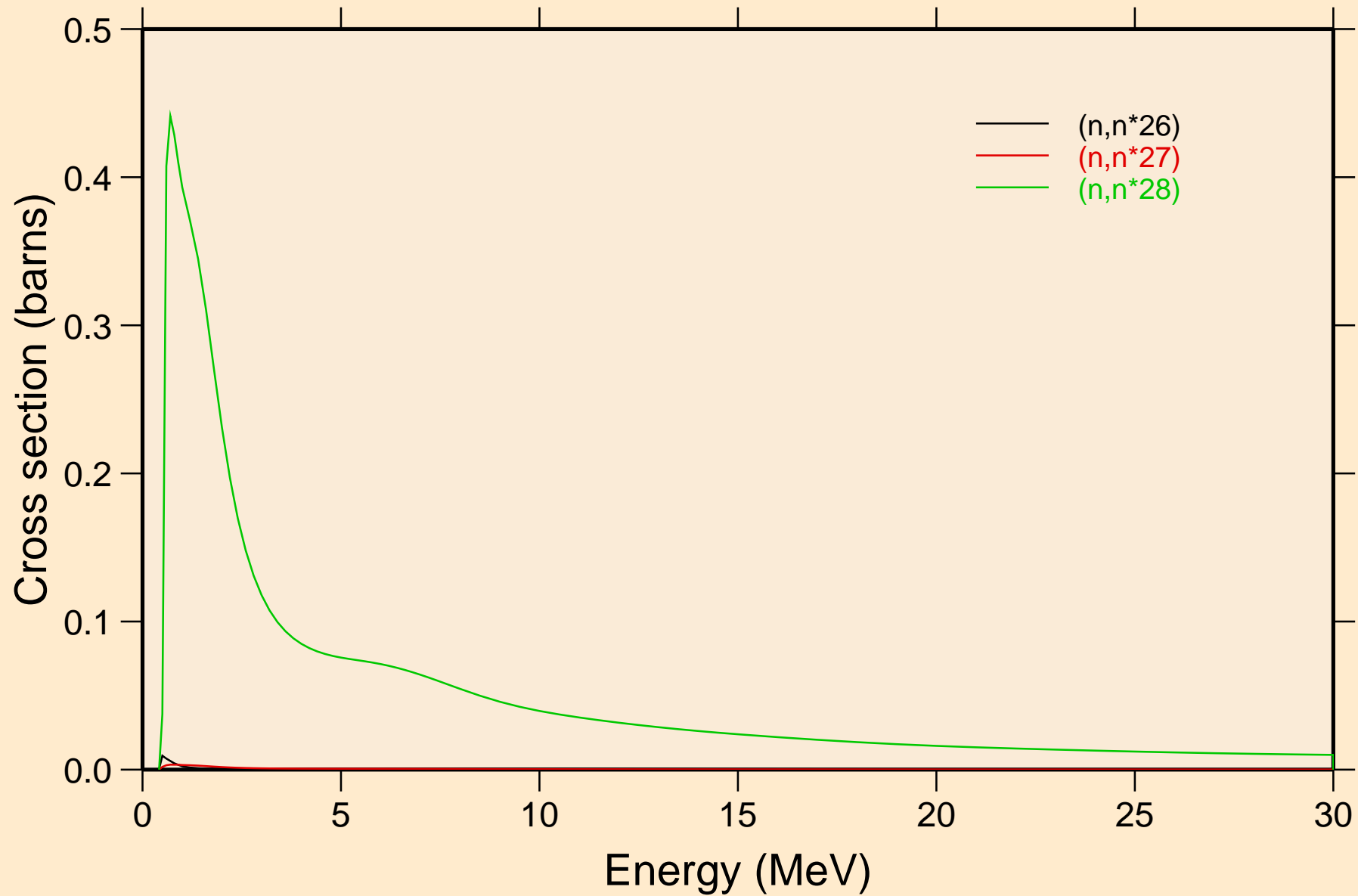

MT281 NEUTRON ACER TENDL-2023 LIBRARY; T=0.K
Threshold reactions

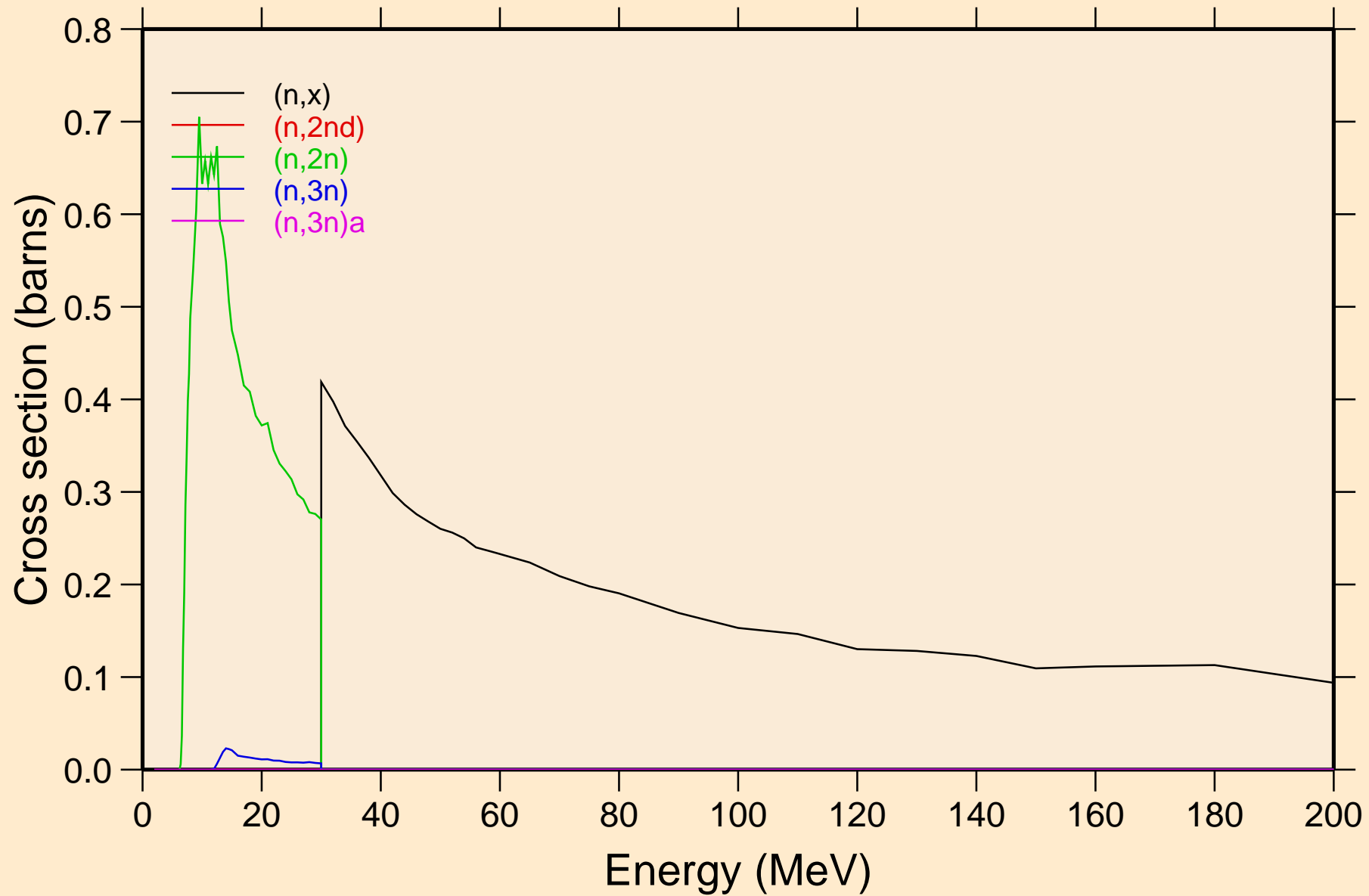

MT281 NEUTRON ACER TENDL-2023 LIBRARY; T=0.K
Threshold reactions

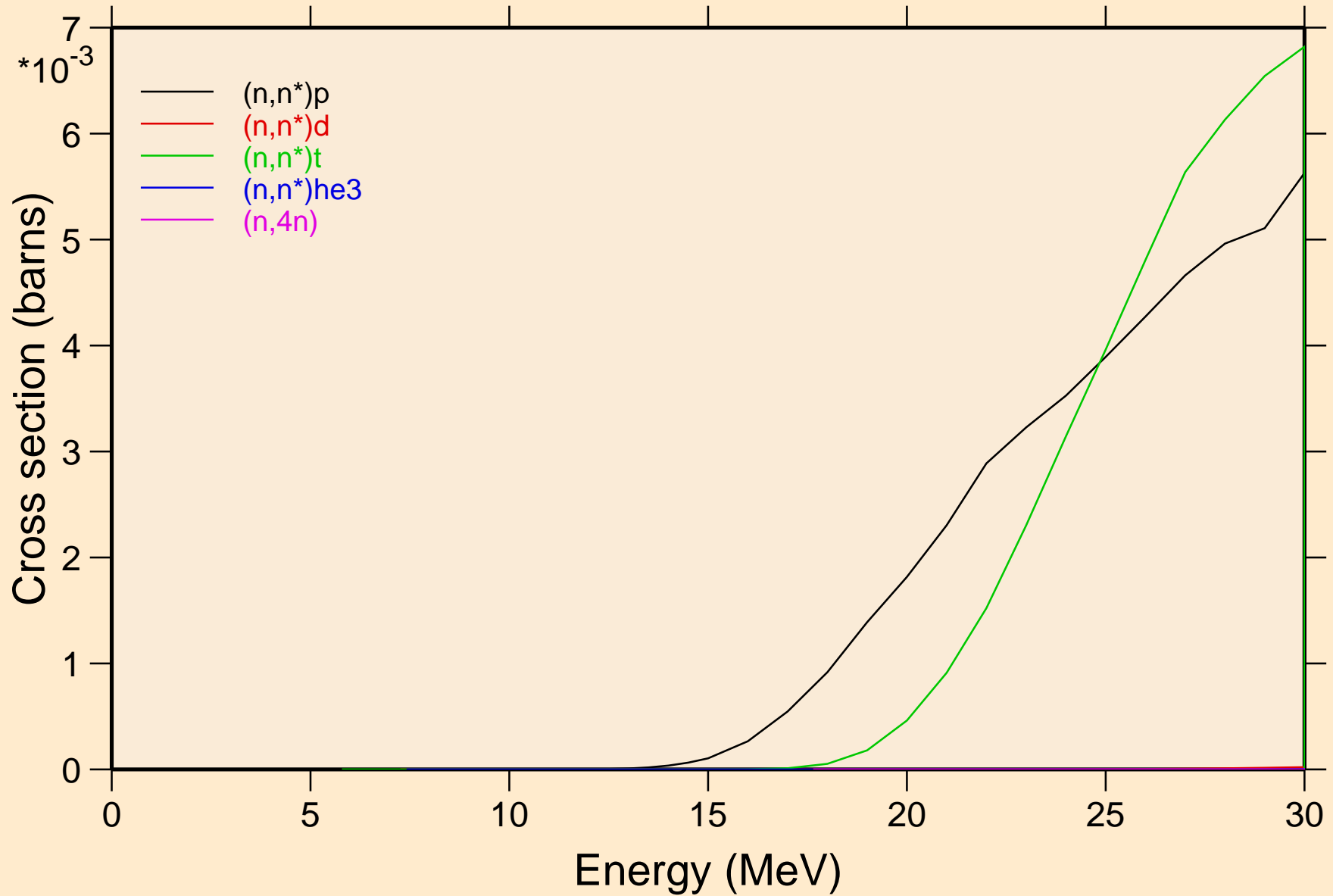

MT281 NEUTRON ACER TENDL-2023 LIBRARY; T=0.K
Threshold reactions

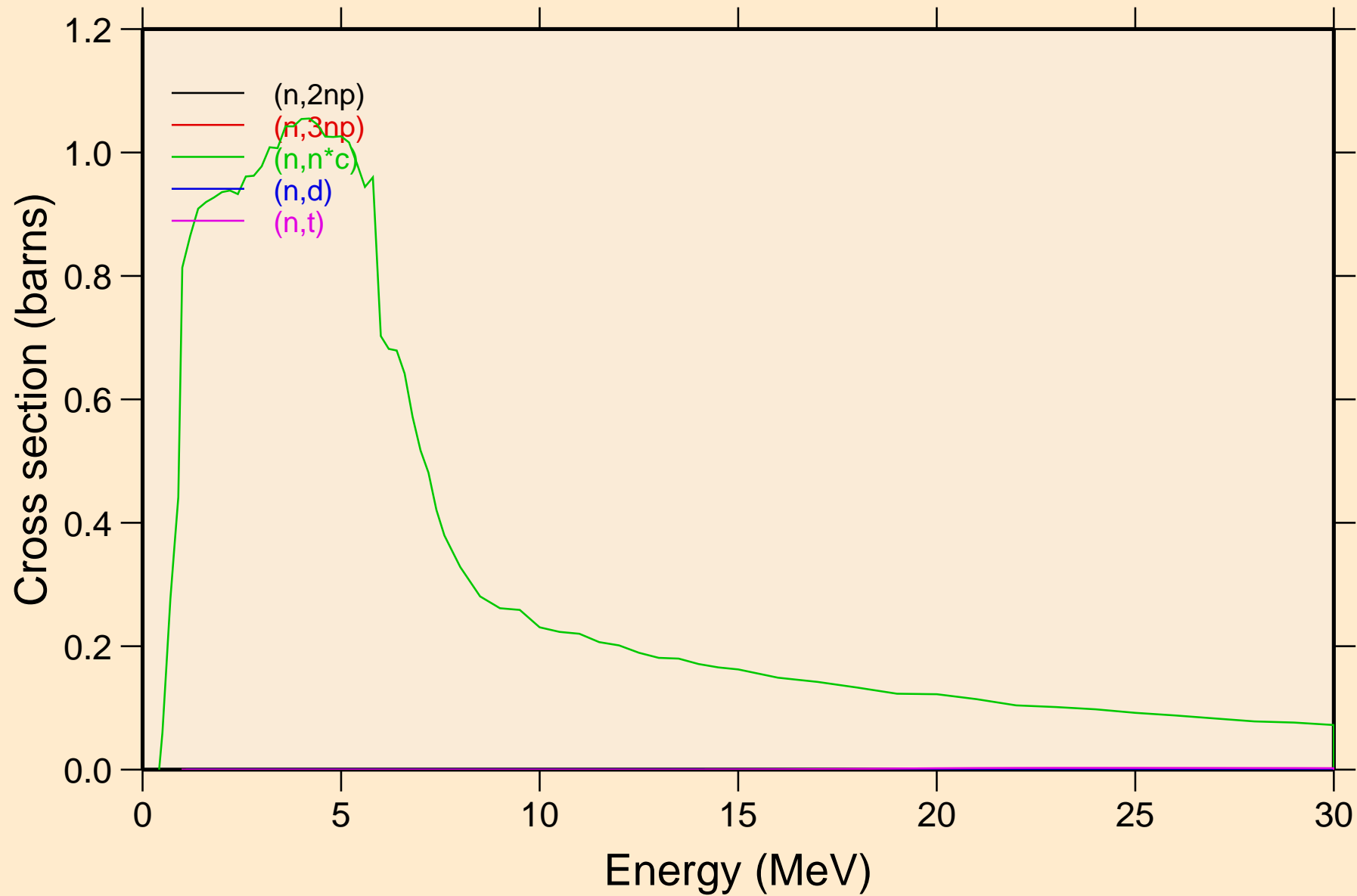

MT281 NEUTRON ACER TENDL-2023 LIBRARY; T=0.K
Threshold reactions

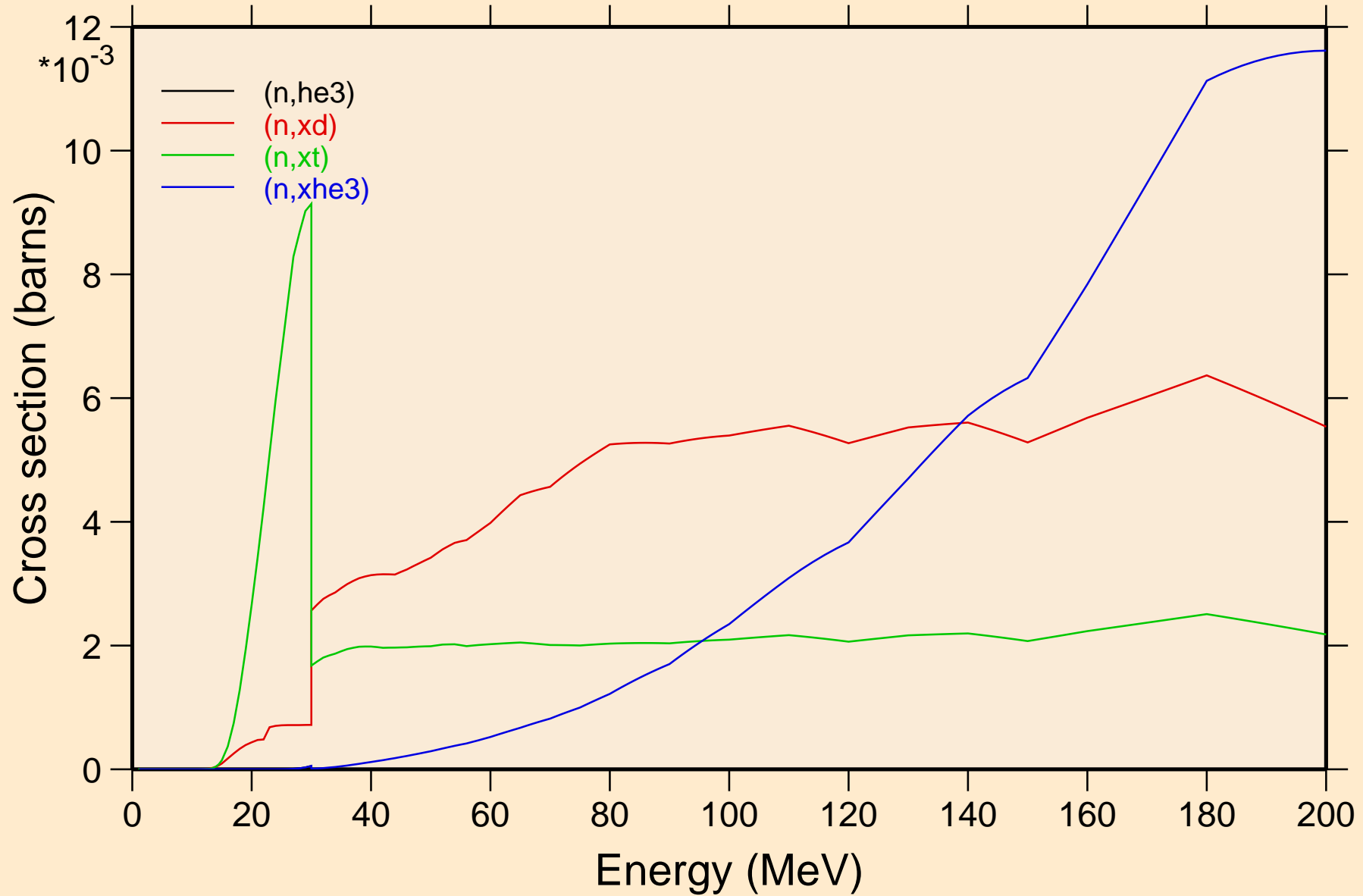

MT281 NEUTRON ACER TENDL-2023 LIBRARY; T=0.K
angular distribution for elastic

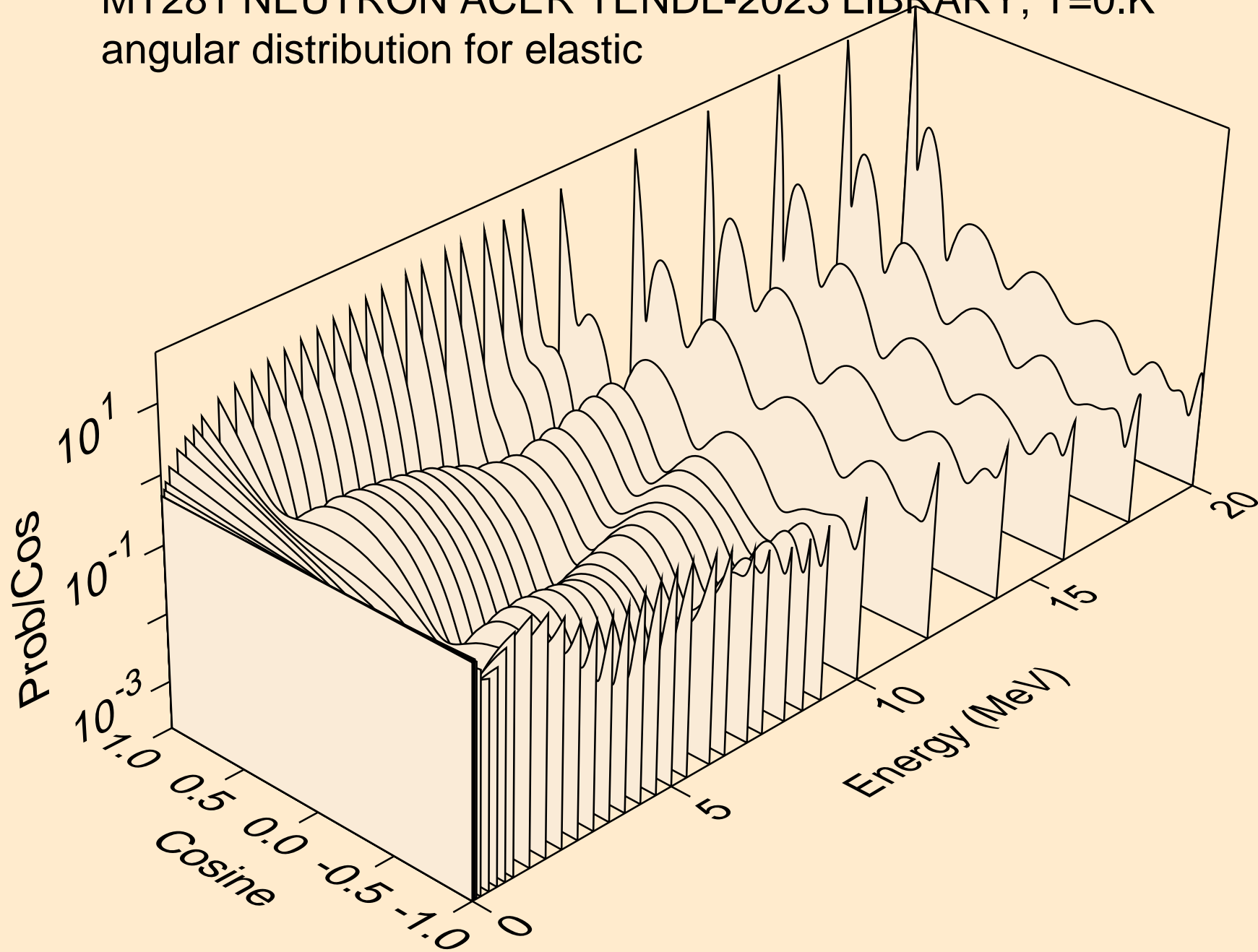

MT281 NEUTRON ACER TENDL-2023 LIBRARY; T=0.K
angular distribution for elastic

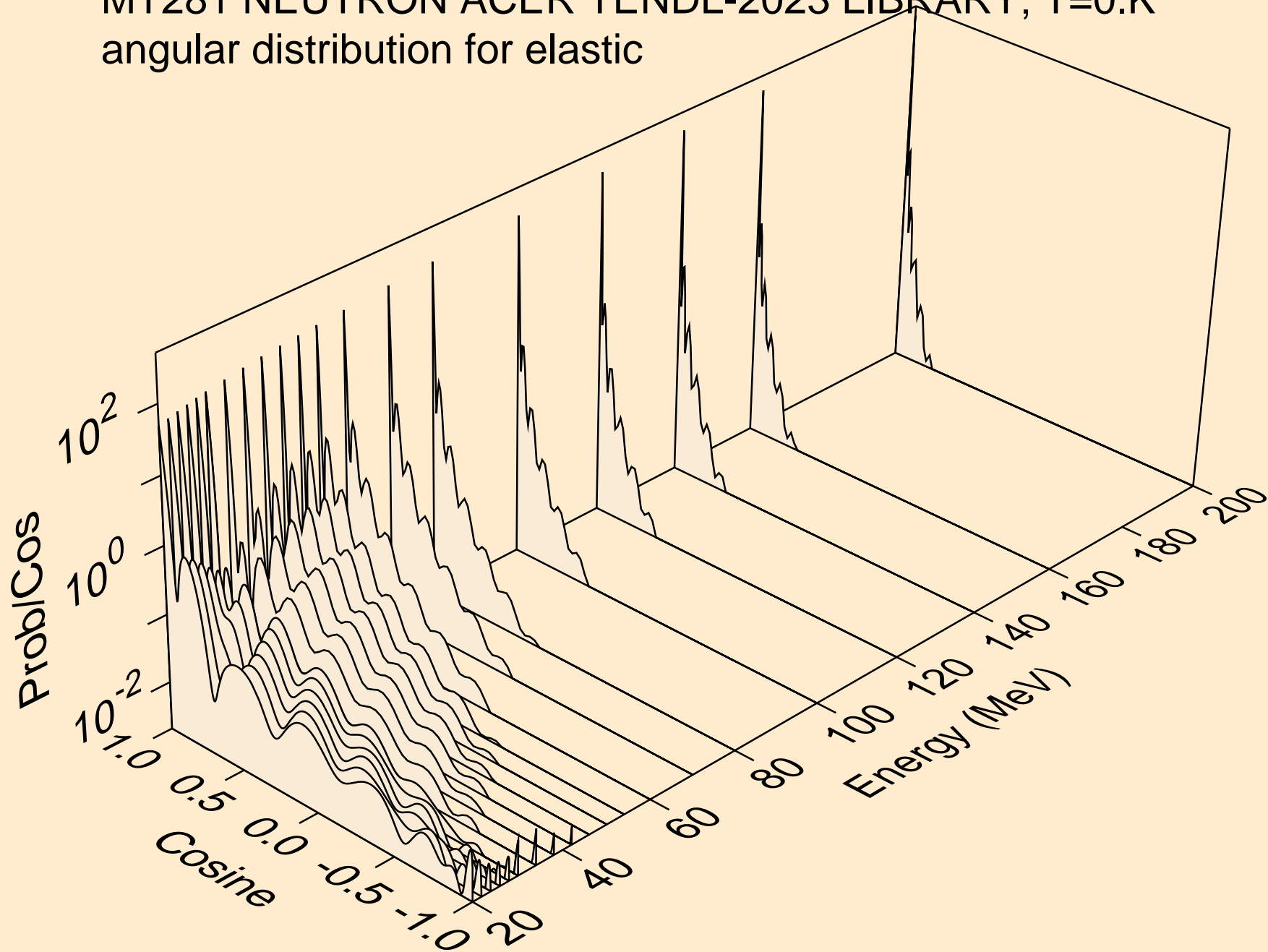

MT281 NEUTRON ACER TENDL-2023 LIBRARY; T=0.K
angular distribution for (n,n*1)

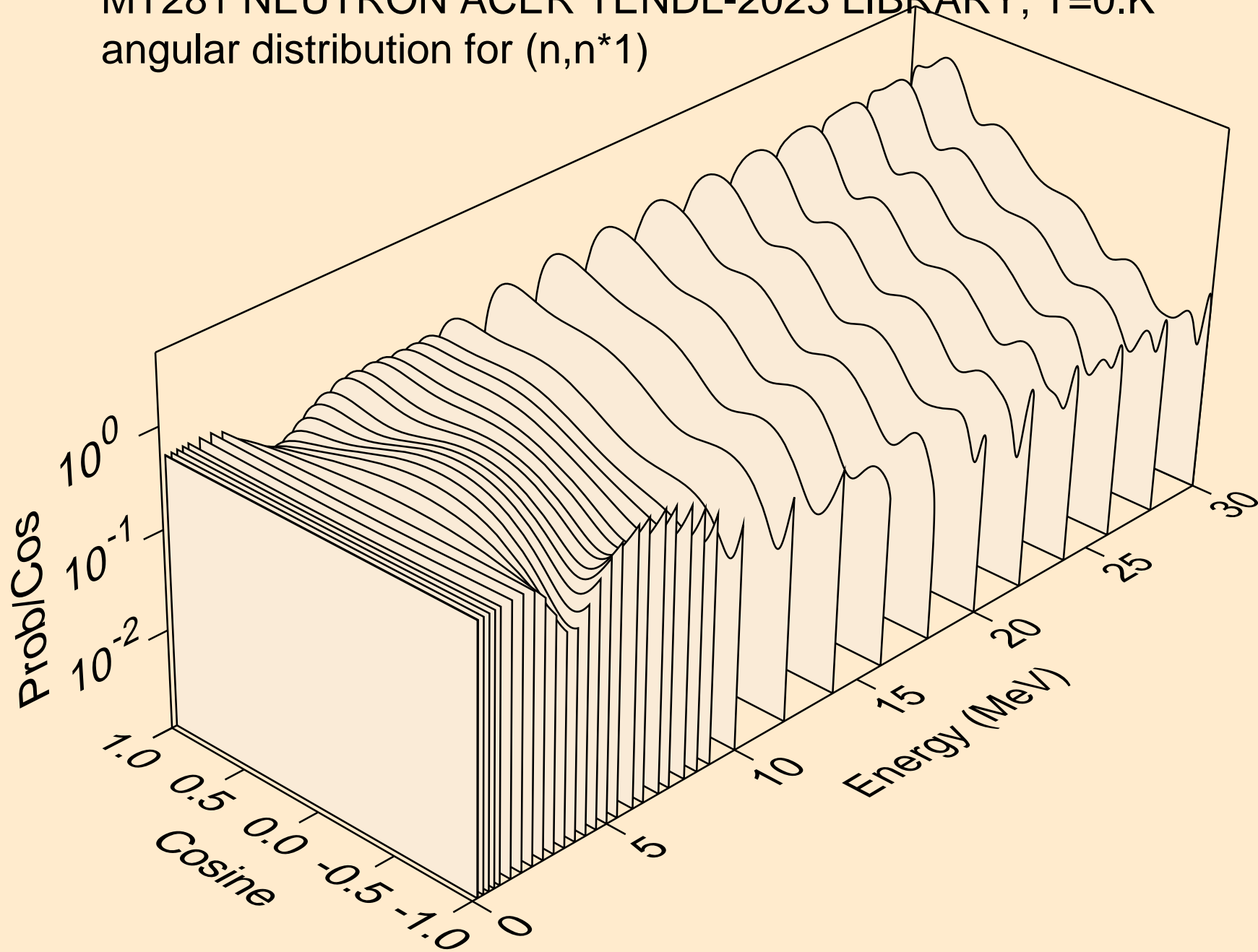

MT281 NEUTRON ACER TENDL-2023 LIBRARY; T=0.K
angular distribution for (n,n*2)

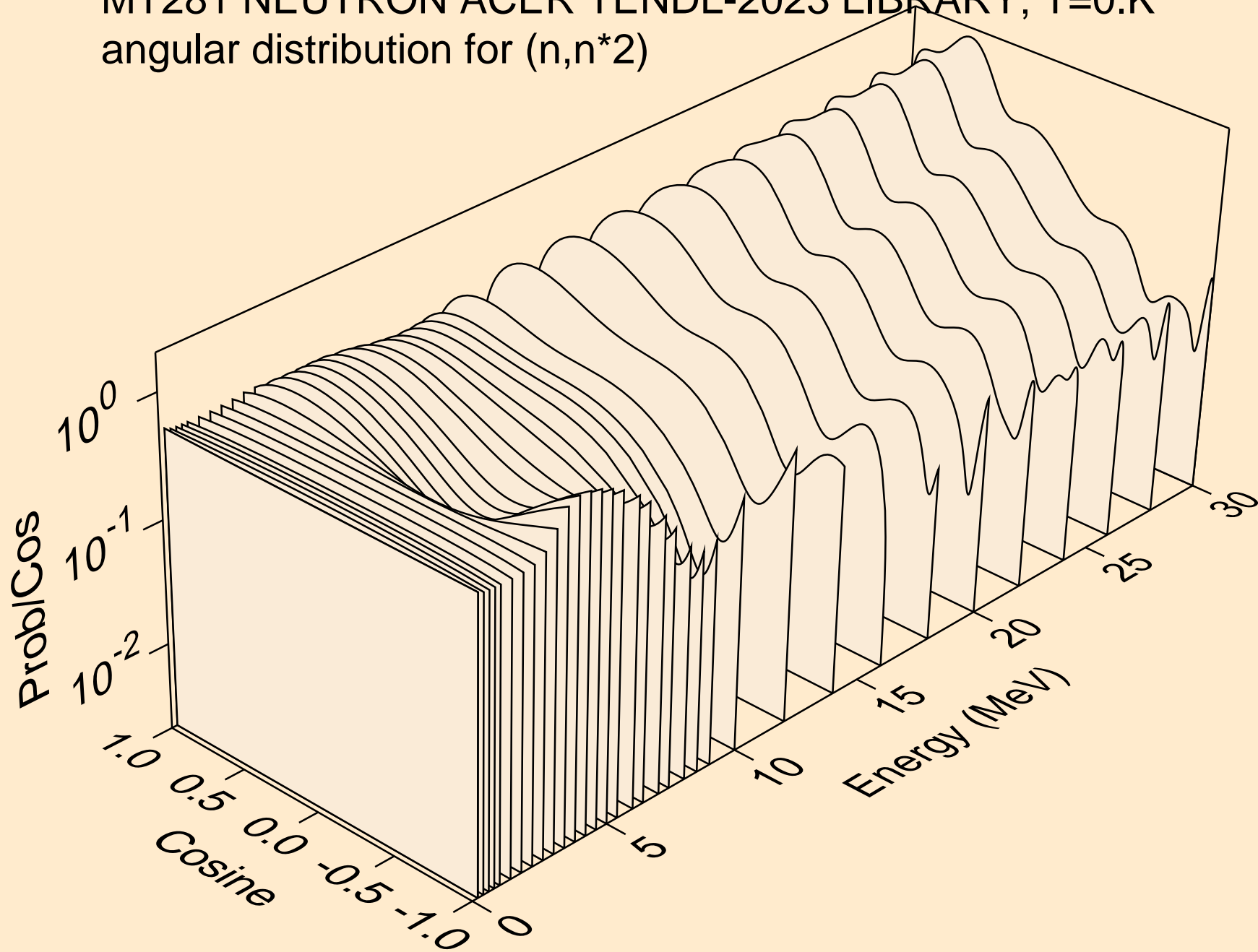

MT281 NEUTRON ACER TENDL-2023 LIBRARY; T=0.K
angular distribution for (n,n*3)

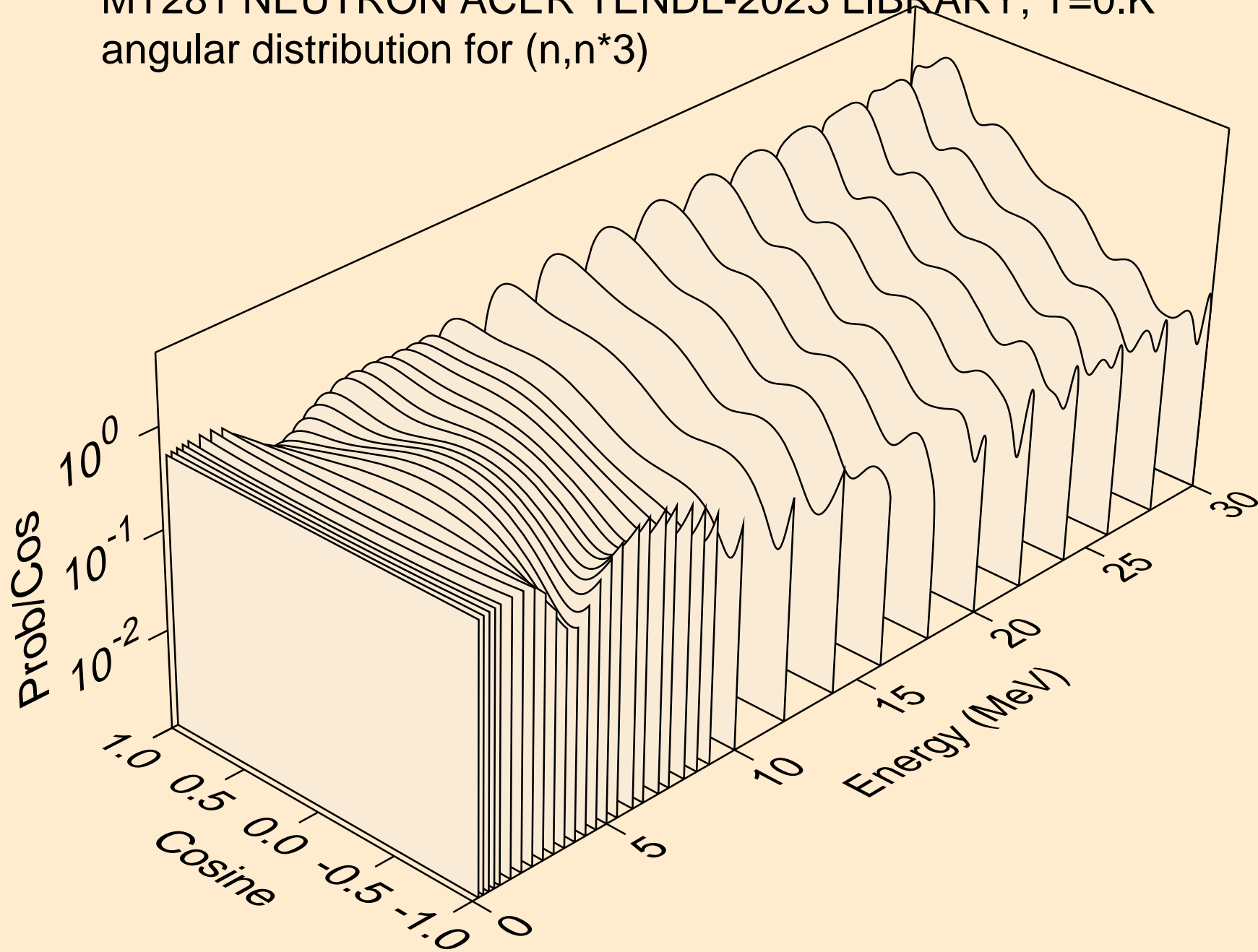

MT281 NEUTRON ACER TENDL-2023 LIBRARY; T=0.K
angular distribution for (n,n*4)

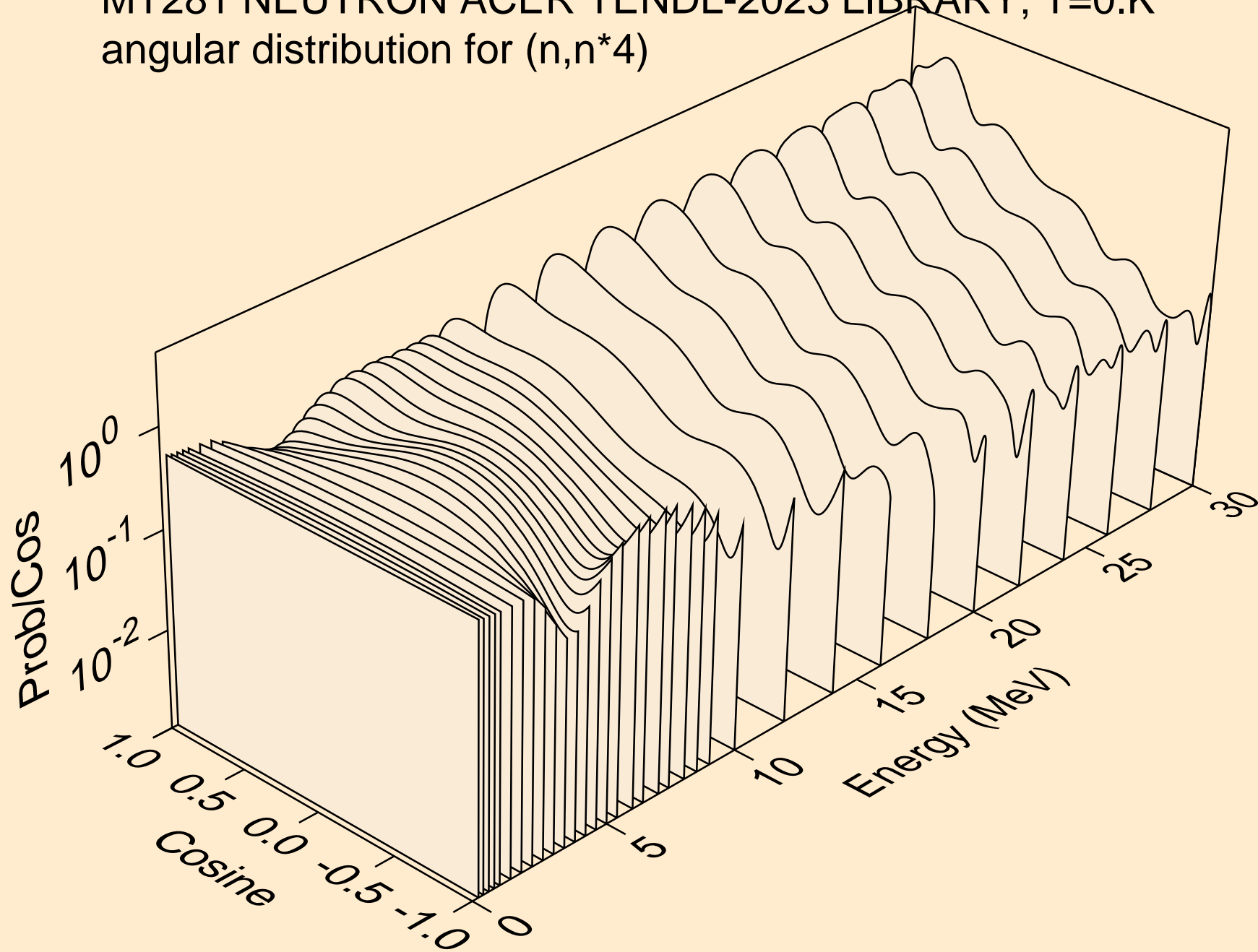

MT281 NEUTRON ACER TENDL-2023 LIBRARY; T=0.K
angular distribution for (n,n*5)

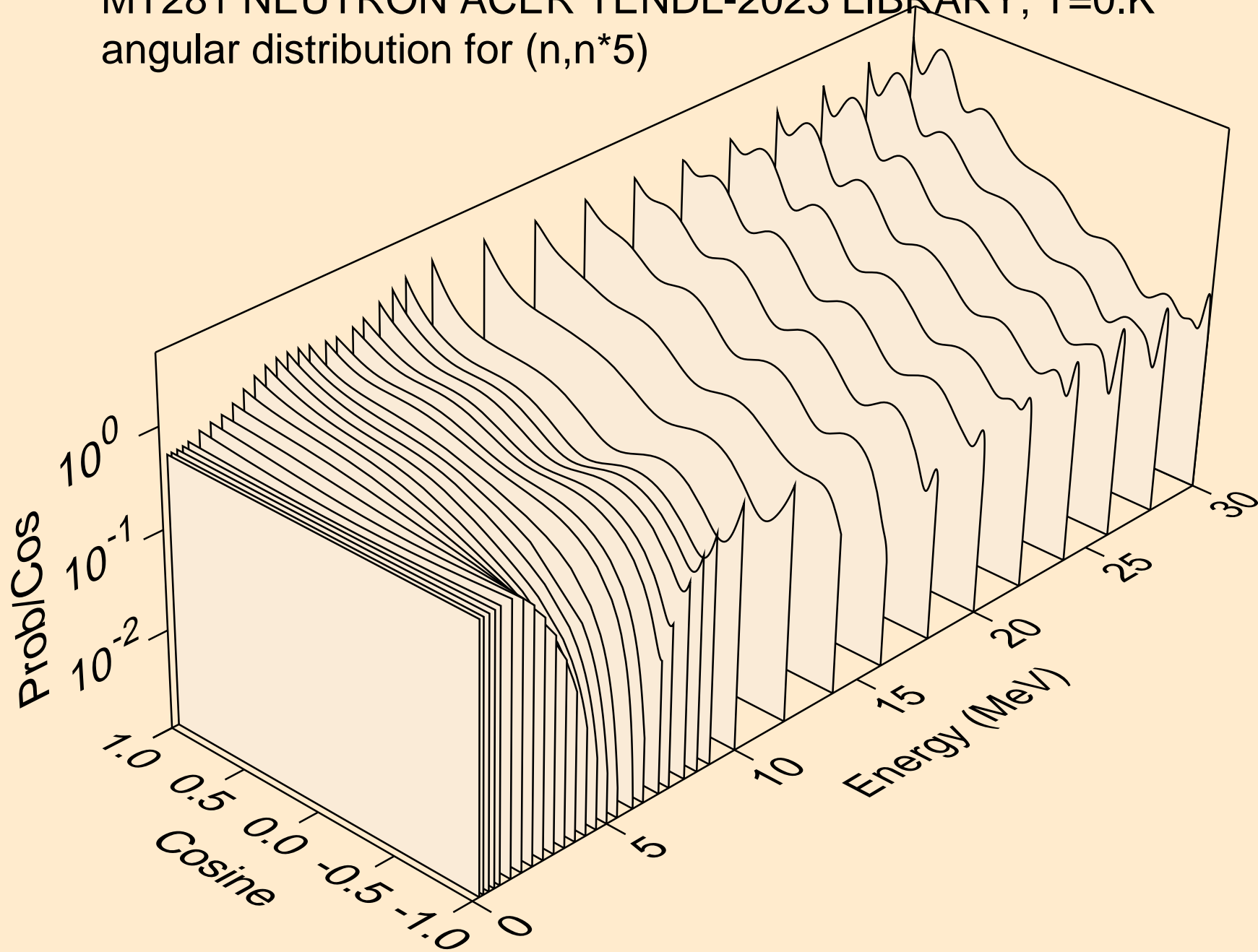

MT281 NEUTRON ACER TENDL-2023 LIBRARY; T=0.K
angular distribution for (n,n*6)

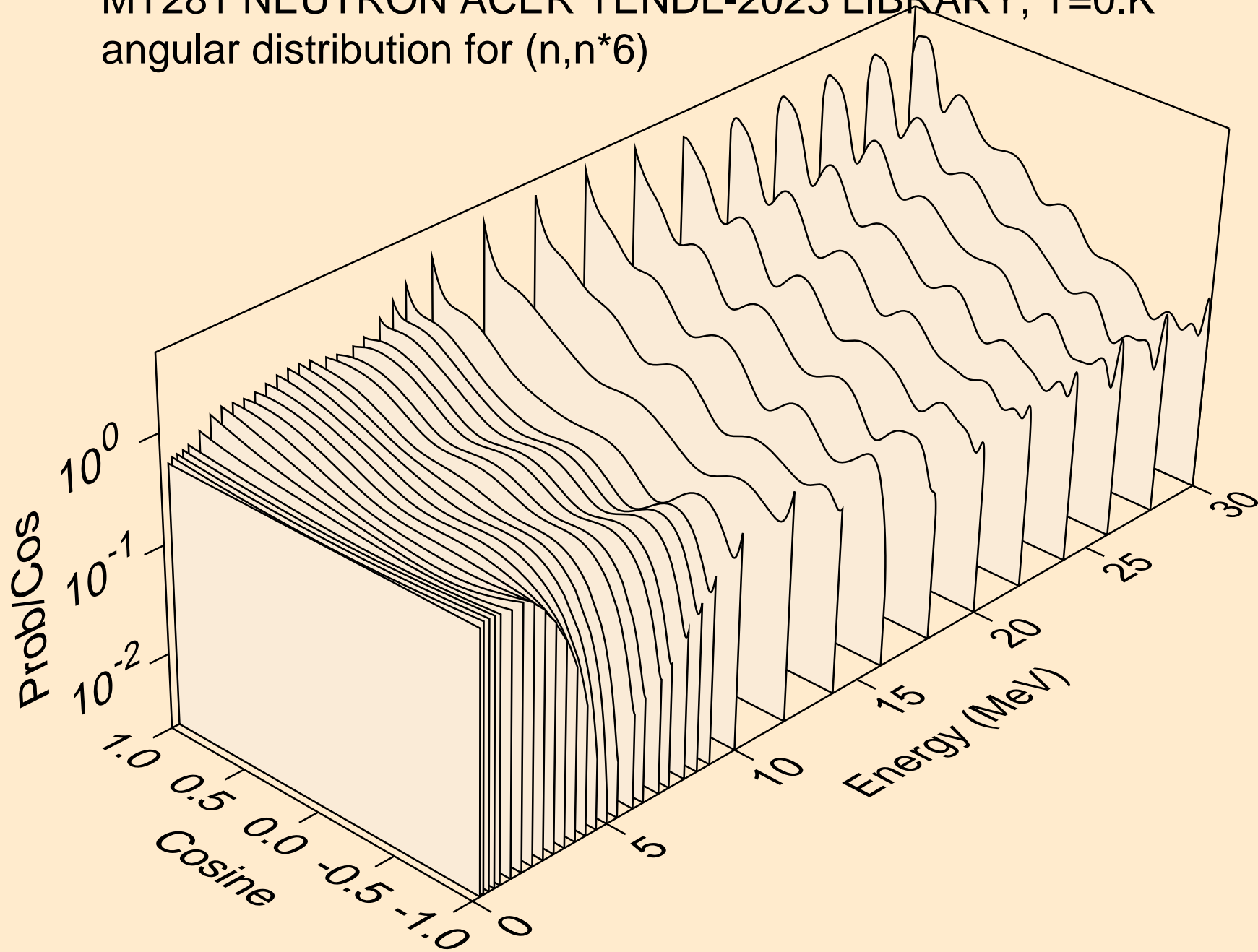

MT281 NEUTRON ACER TENDL-2023 LIBRARY; T=0.K
angular distribution for (n,n*7)

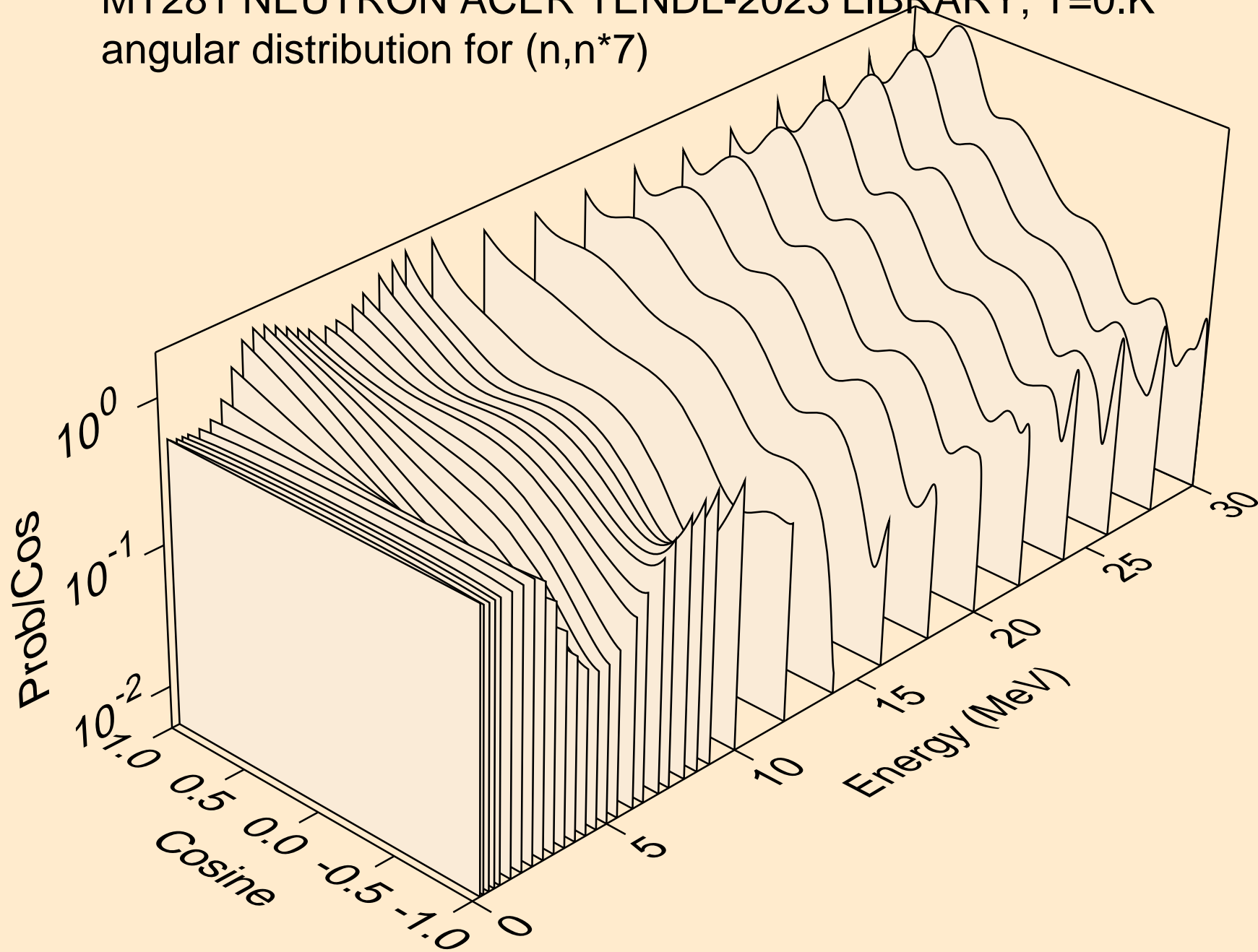

MT281 NEUTRON ACER TENDL-2023 LIBRARY; T=0.K
angular distribution for (n,n*8)

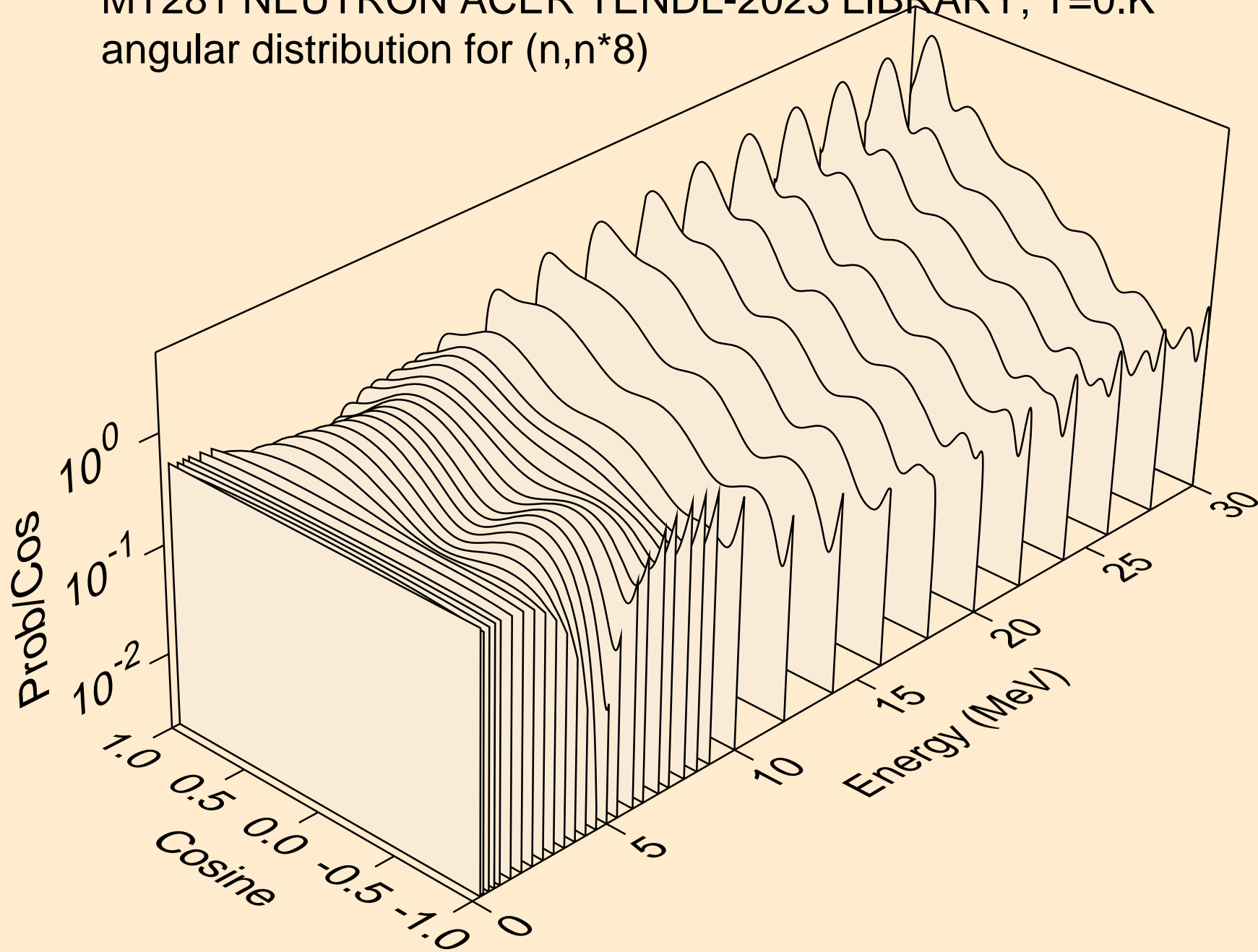

MT281 NEUTRON ACER TENDL-2023 LIBRARY; T=0.K
angular distribution for (n,n*9)

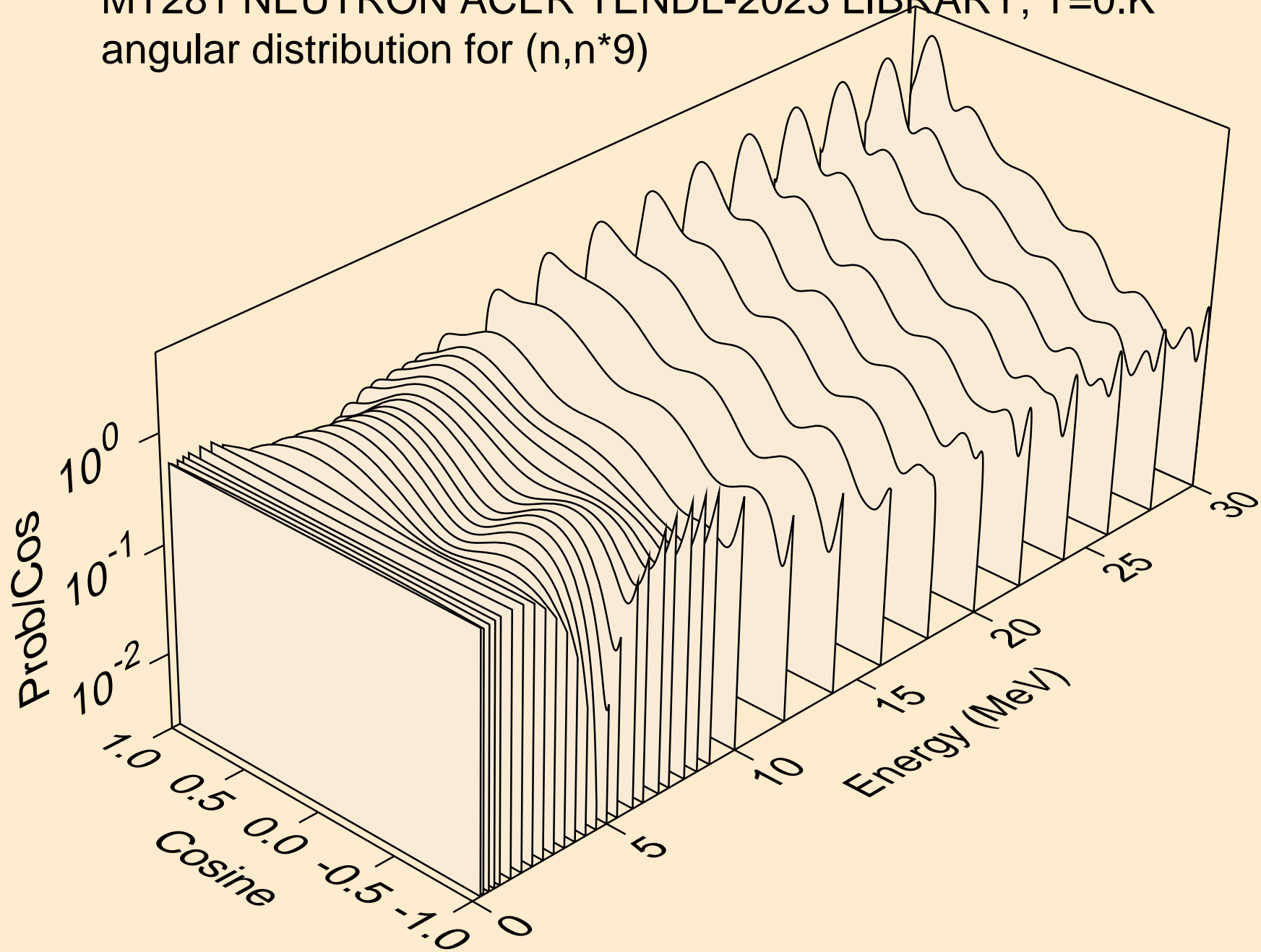

MT281 NEUTRON ACER TENDL-2023 LIBRARY; T=0.K
angular distribution for (n,n*10)

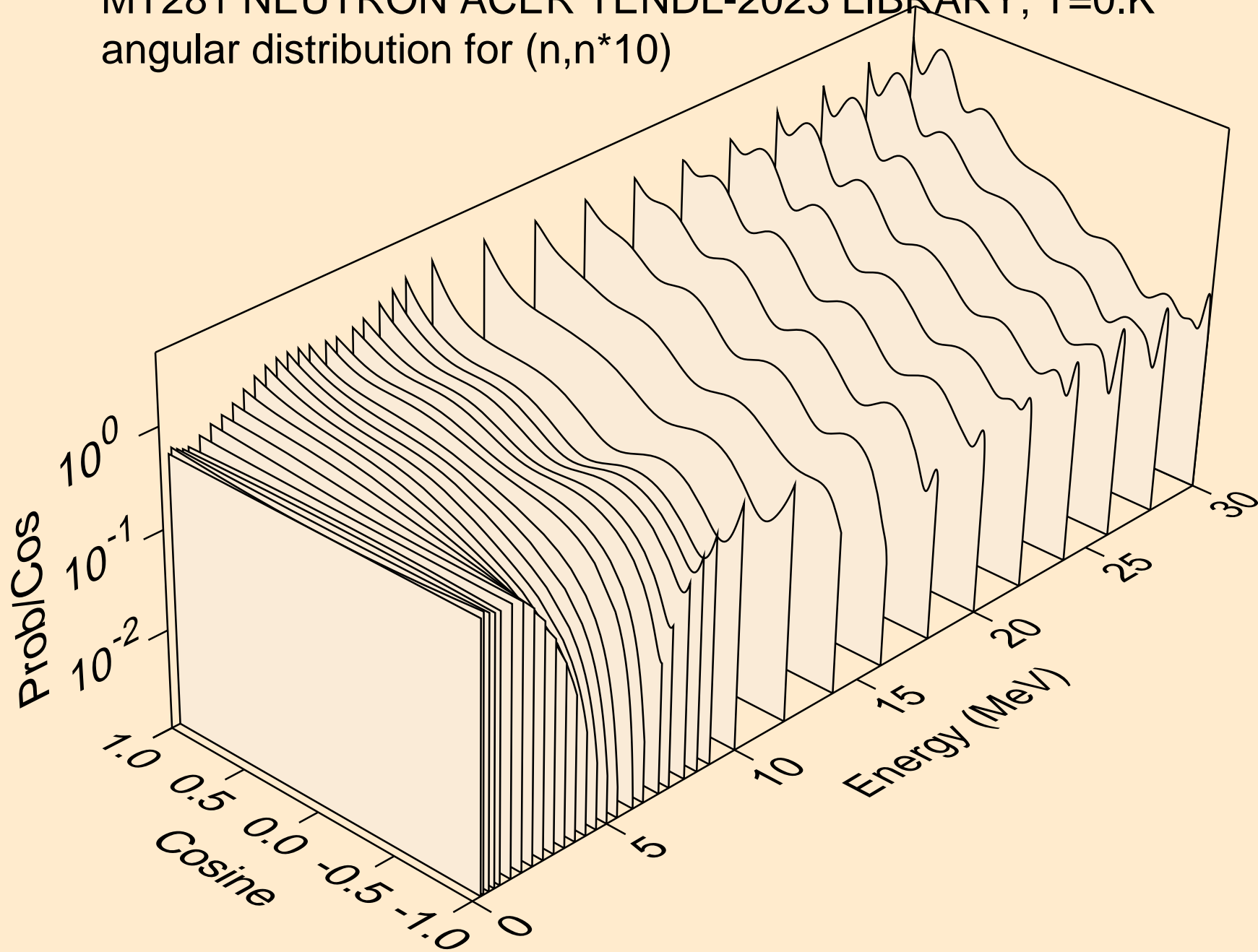

MT281 NEUTRON ACER TENDL-2023 LIBRARY; T=0.K
angular distribution for (n,n*11)

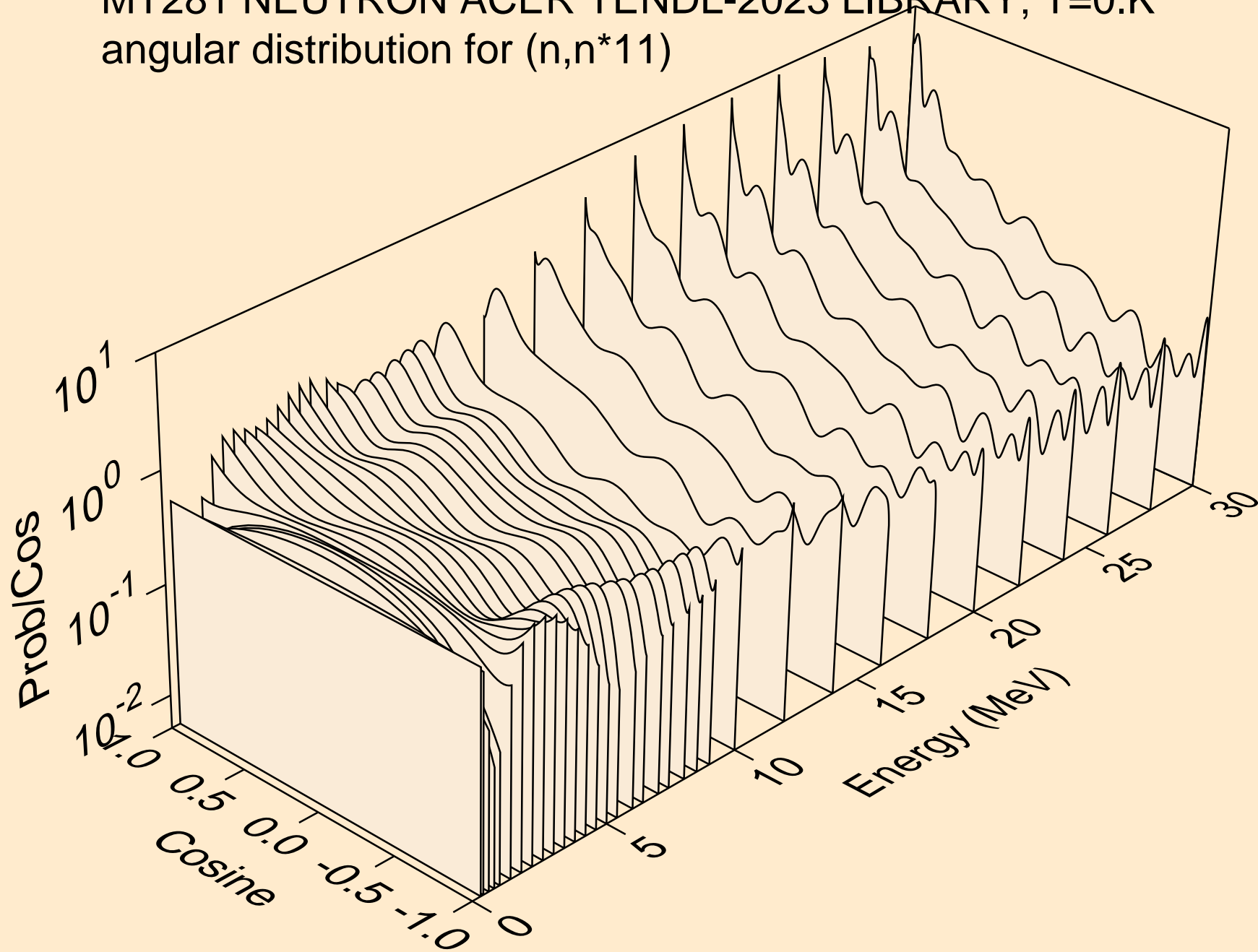

MT281 NEUTRON ACER TENDL-2023 LIBRARY; T=0.K
angular distribution for (n,n*12)

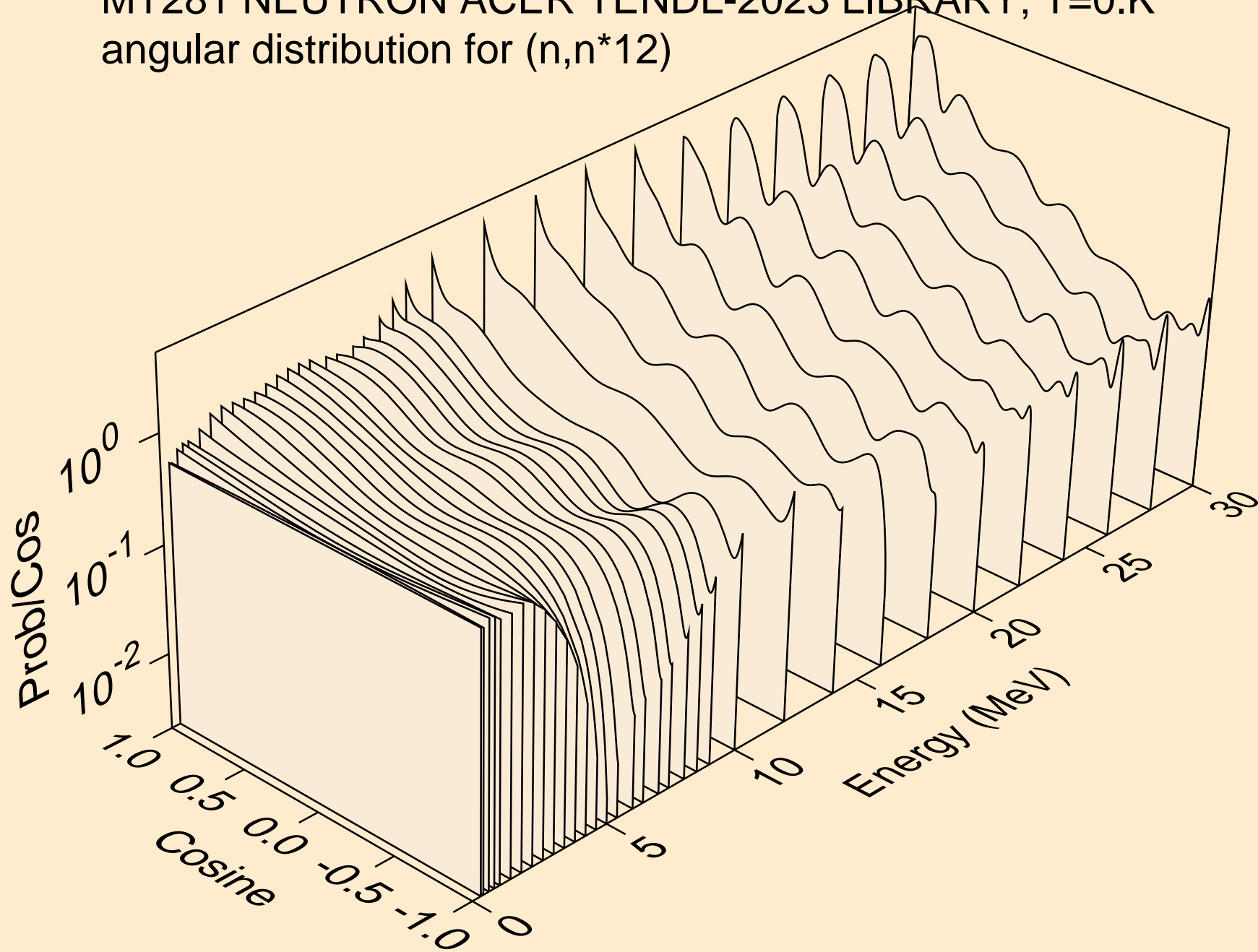

MT281 NEUTRON ACER TENDL-2023 LIBRARY; T=0.K
angular distribution for (n,n*13)

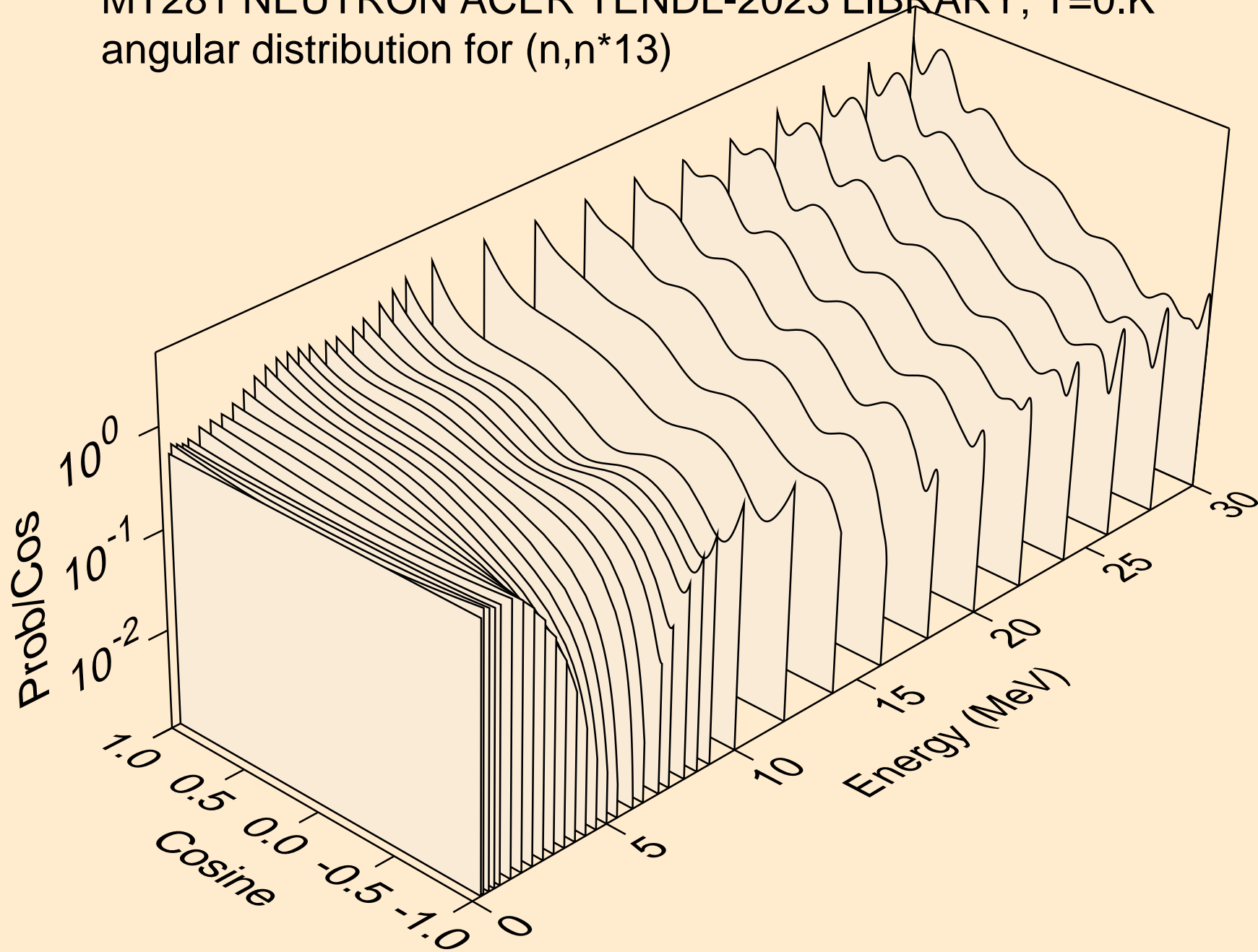

MT281 NEUTRON ACER TENDL-2023 LIBRARY; T=0.K
angular distribution for (n,n*14)

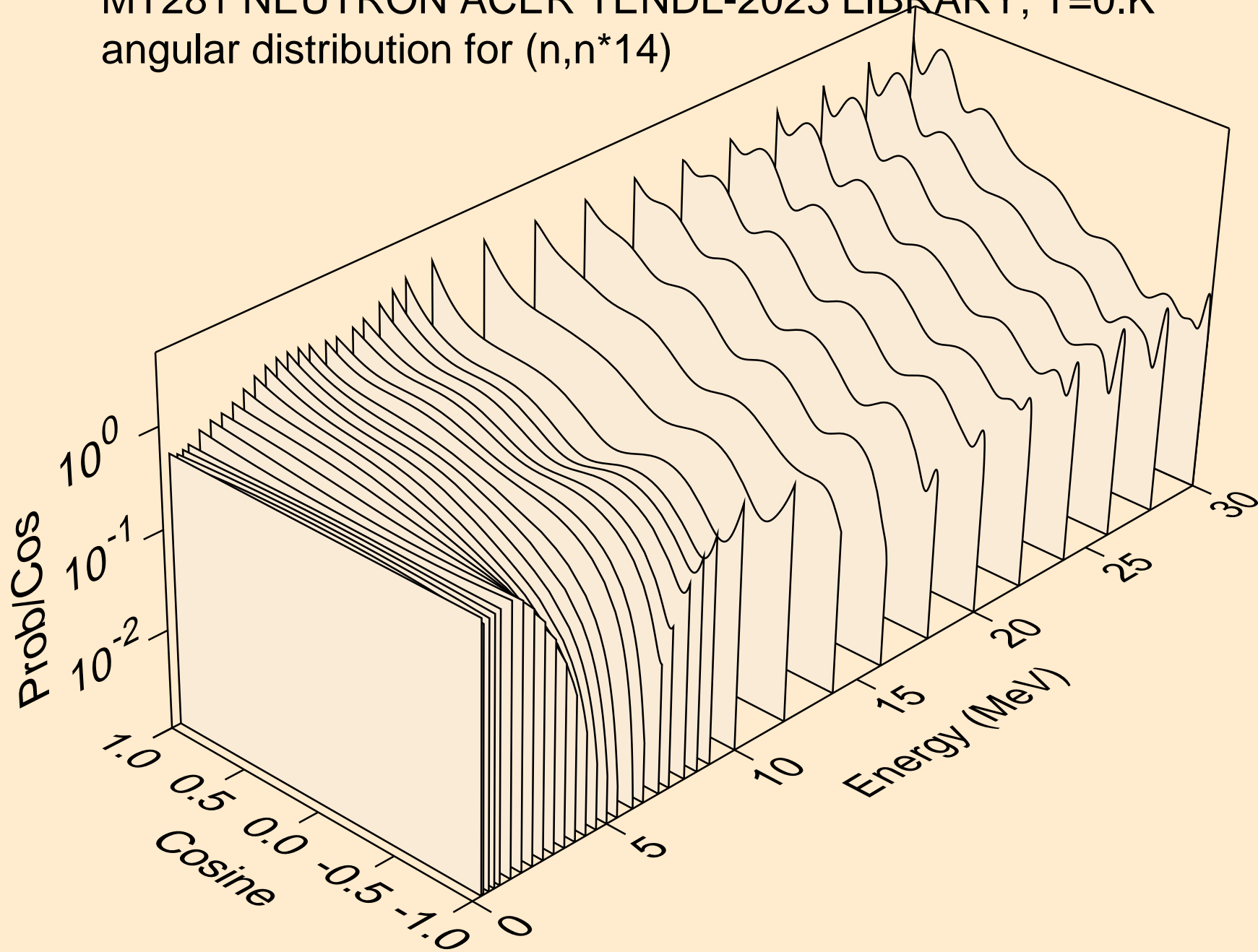

MT281 NEUTRON ACER TENDL-2023 LIBRARY; T=0.K
angular distribution for (n,n*15)

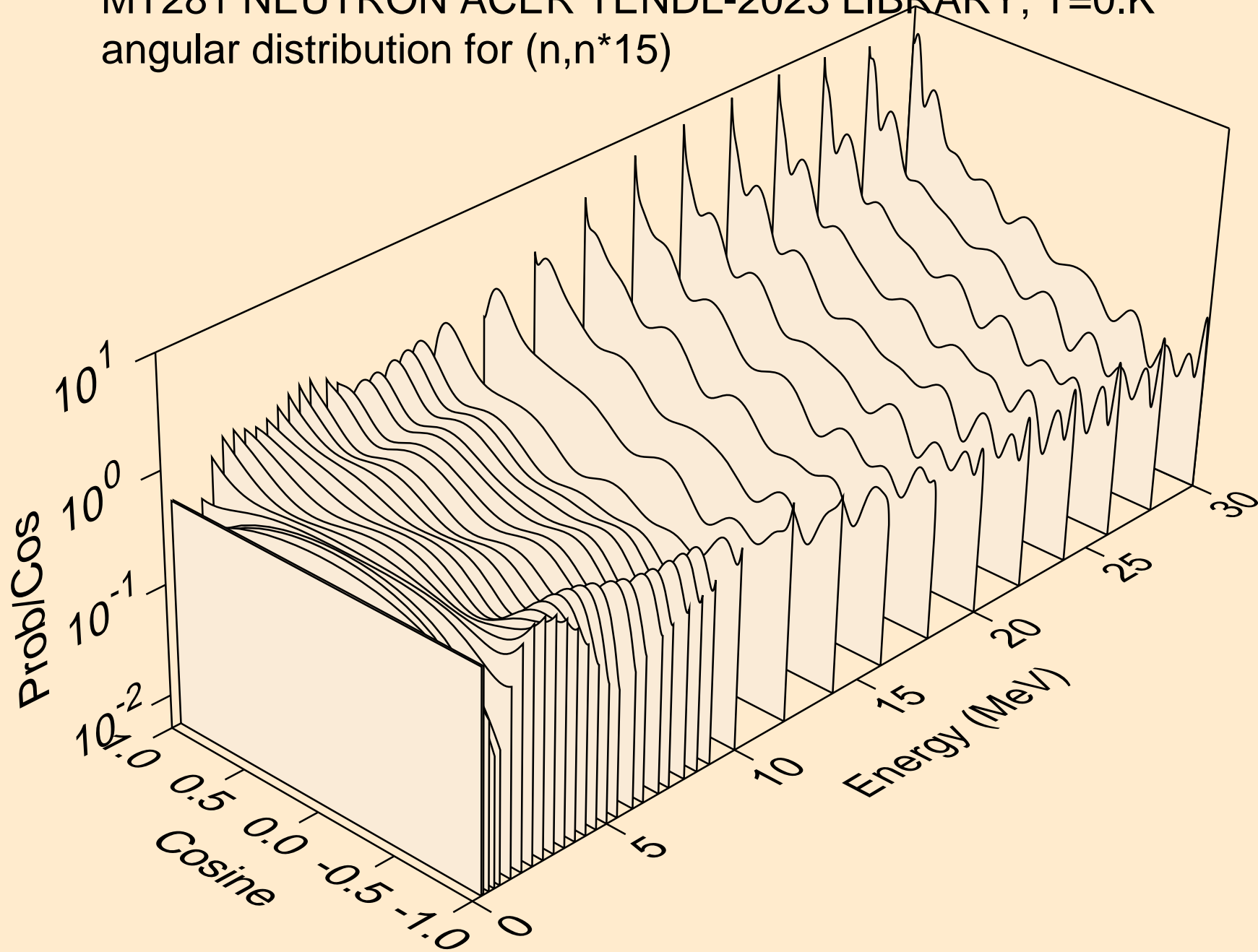

MT281 NEUTRON ACER TENDL-2023 LIBRARY; T=0.K
angular distribution for (n,n*16)

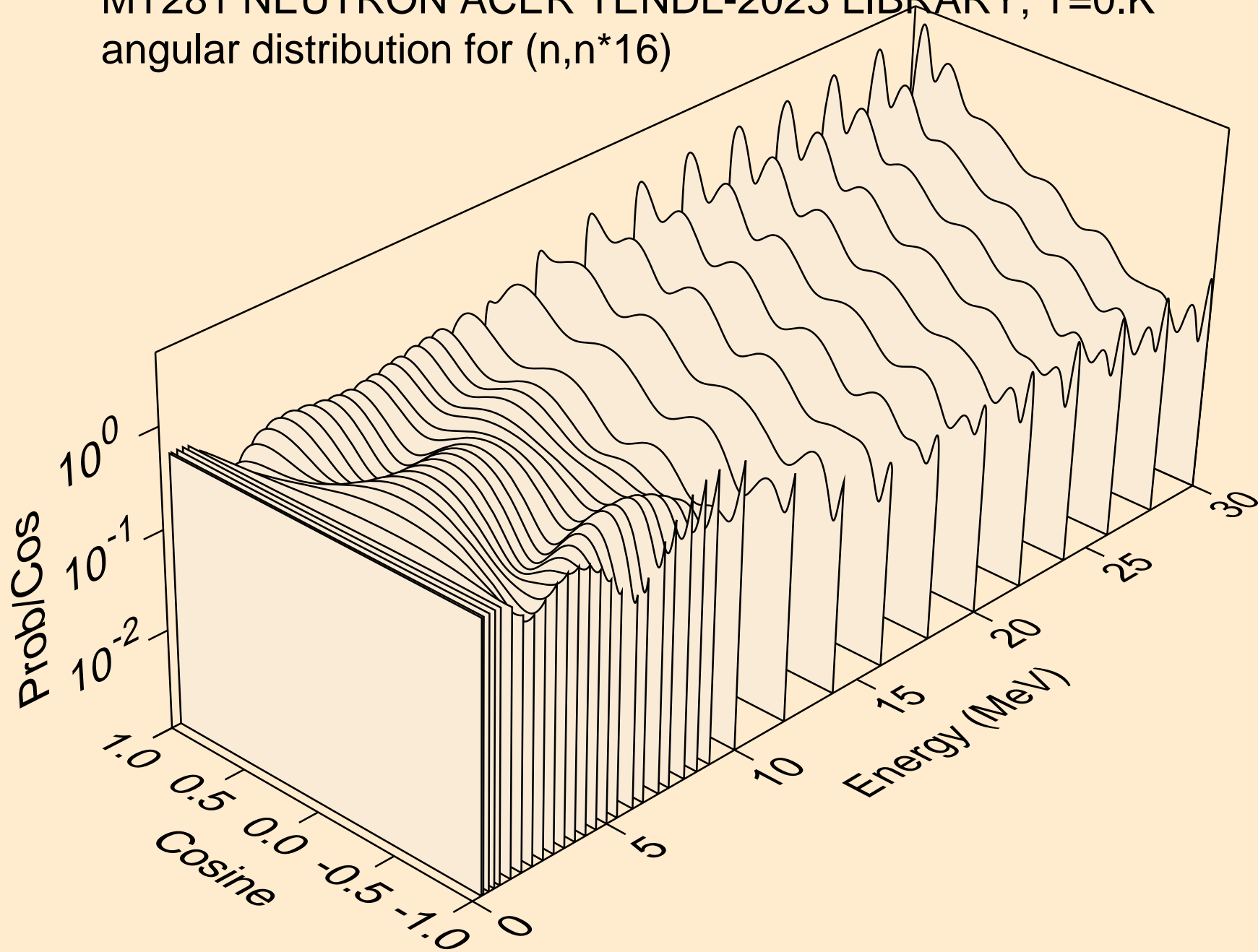

MT281 NEUTRON ACER TENDL-2023 LIBRARY; T=0.K
angular distribution for (n,n*17)

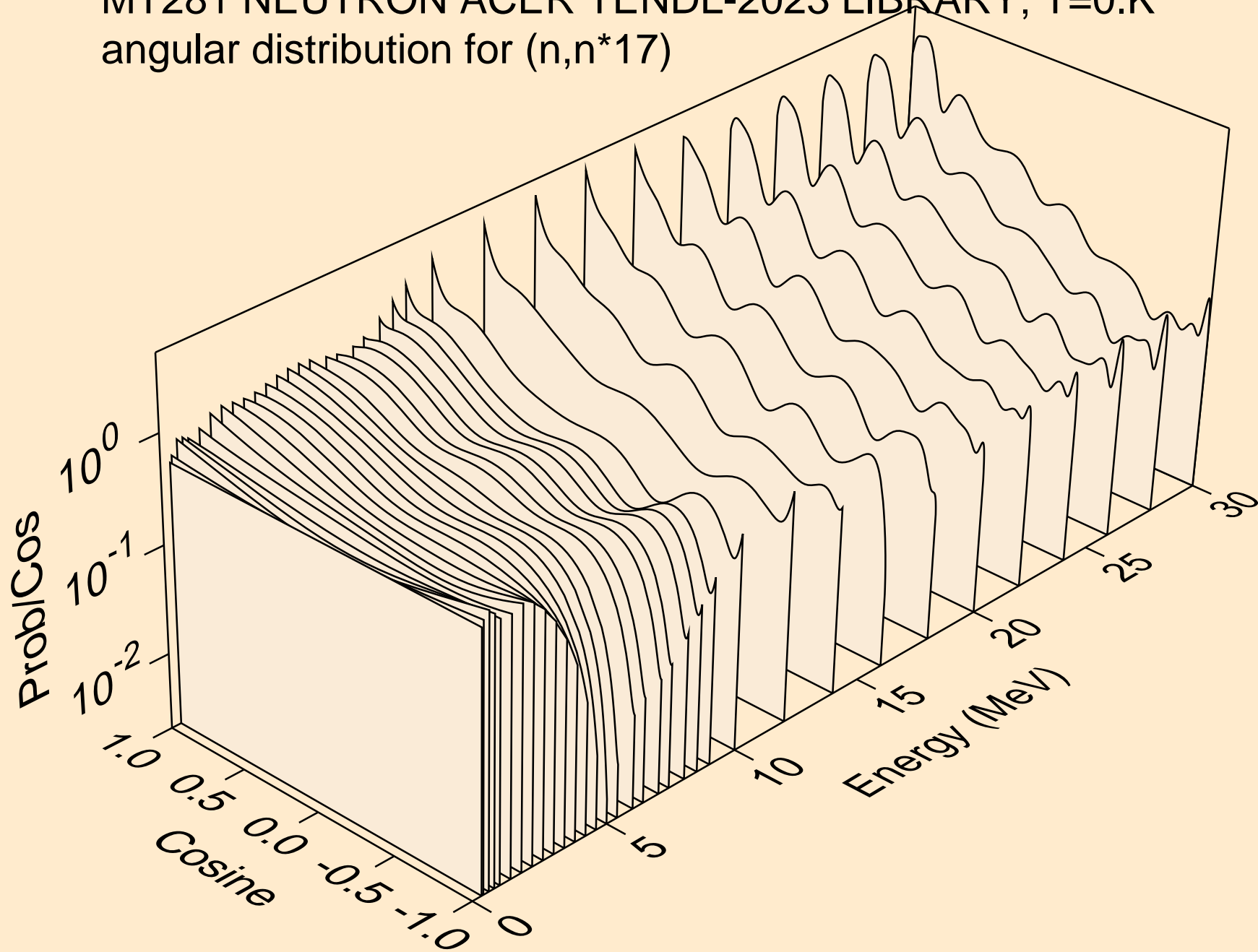

MT281 NEUTRON ACER TENDL-2023 LIBRARY; T=0.K
angular distribution for (n,n*18)

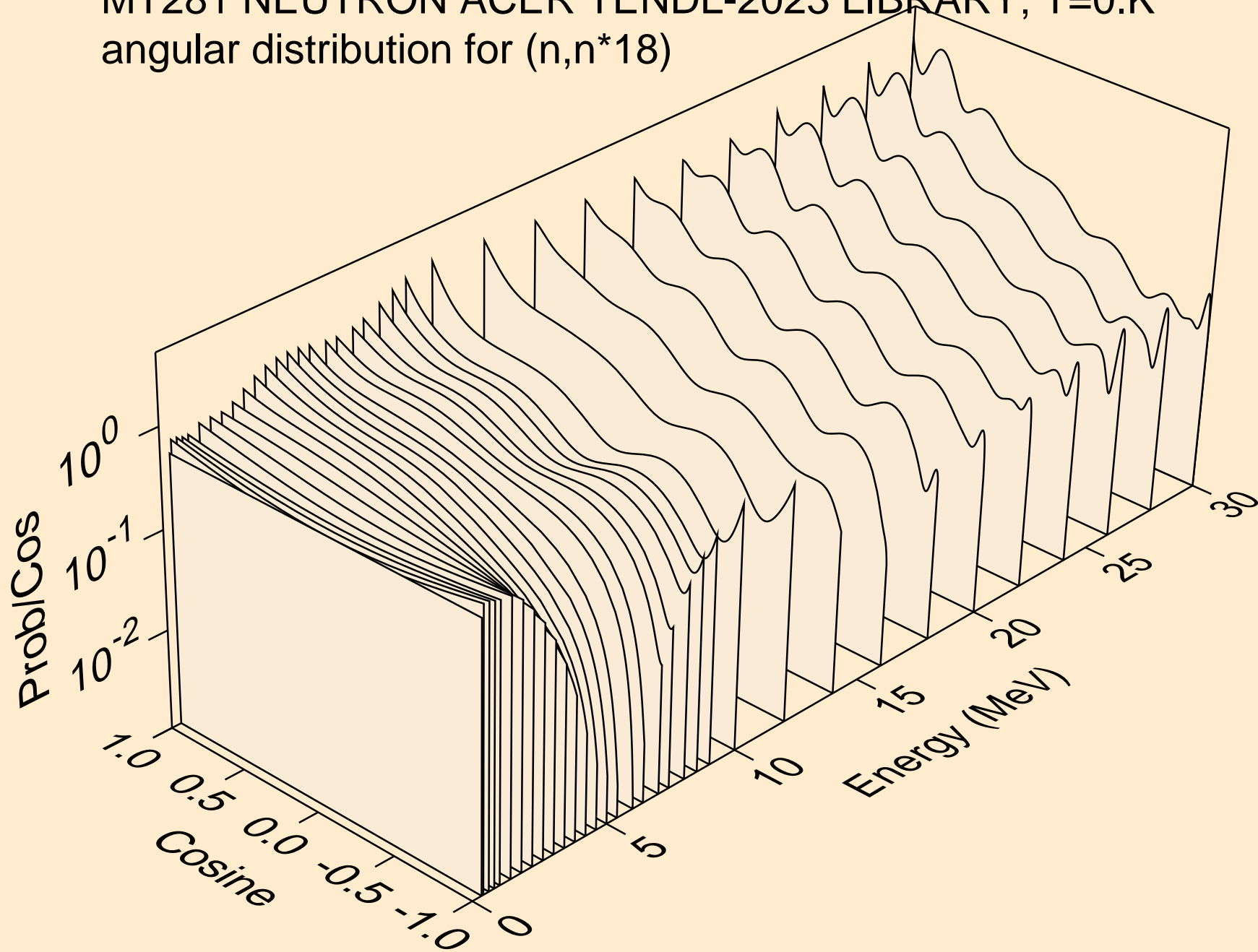

MT281 NEUTRON ACER TENDL-2023 LIBRARY; T=0.K
angular distribution for (n,n*19)

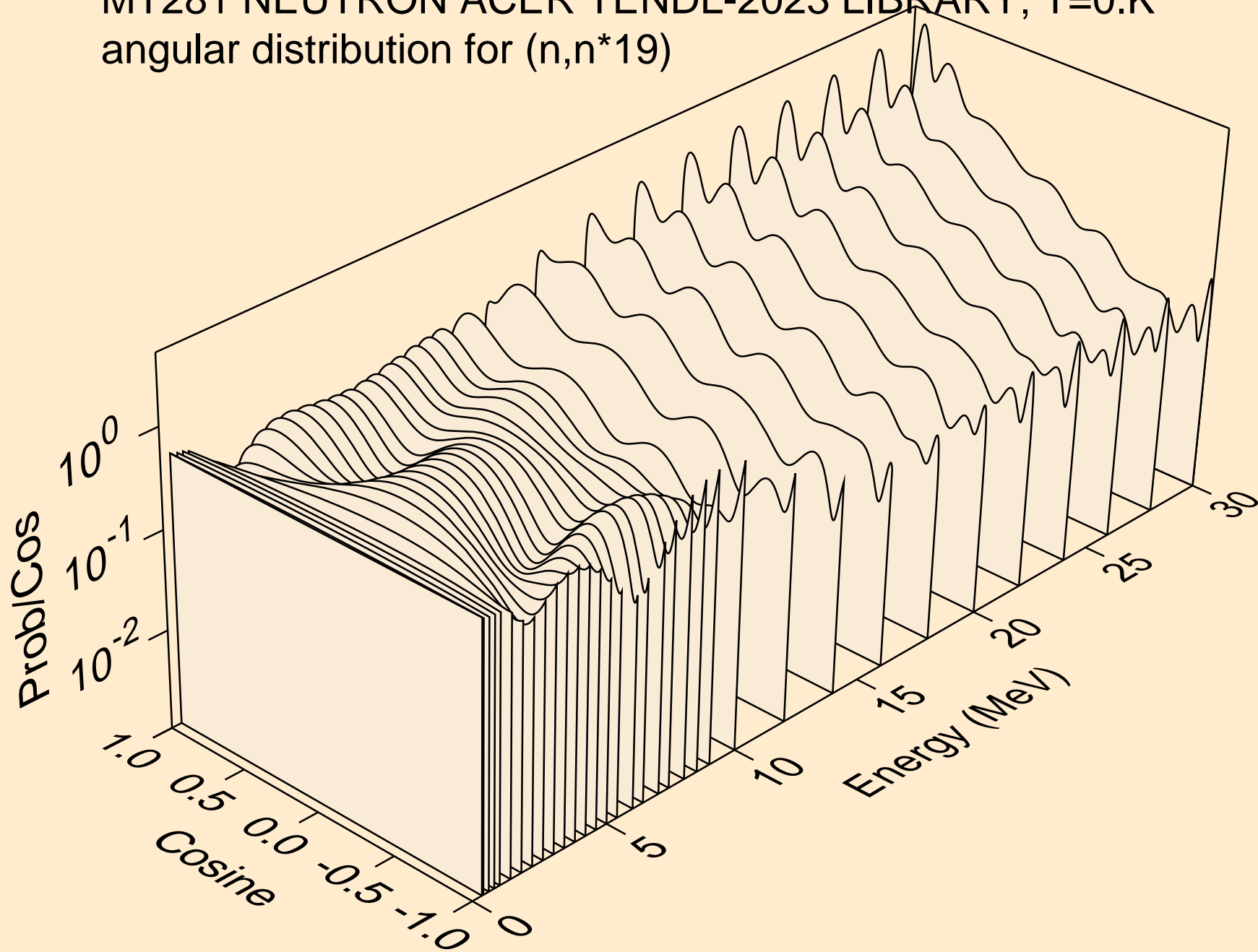

MT281 NEUTRON ACER TENDL-2023 LIBRARY; T=0.K
angular distribution for (n,n*20)

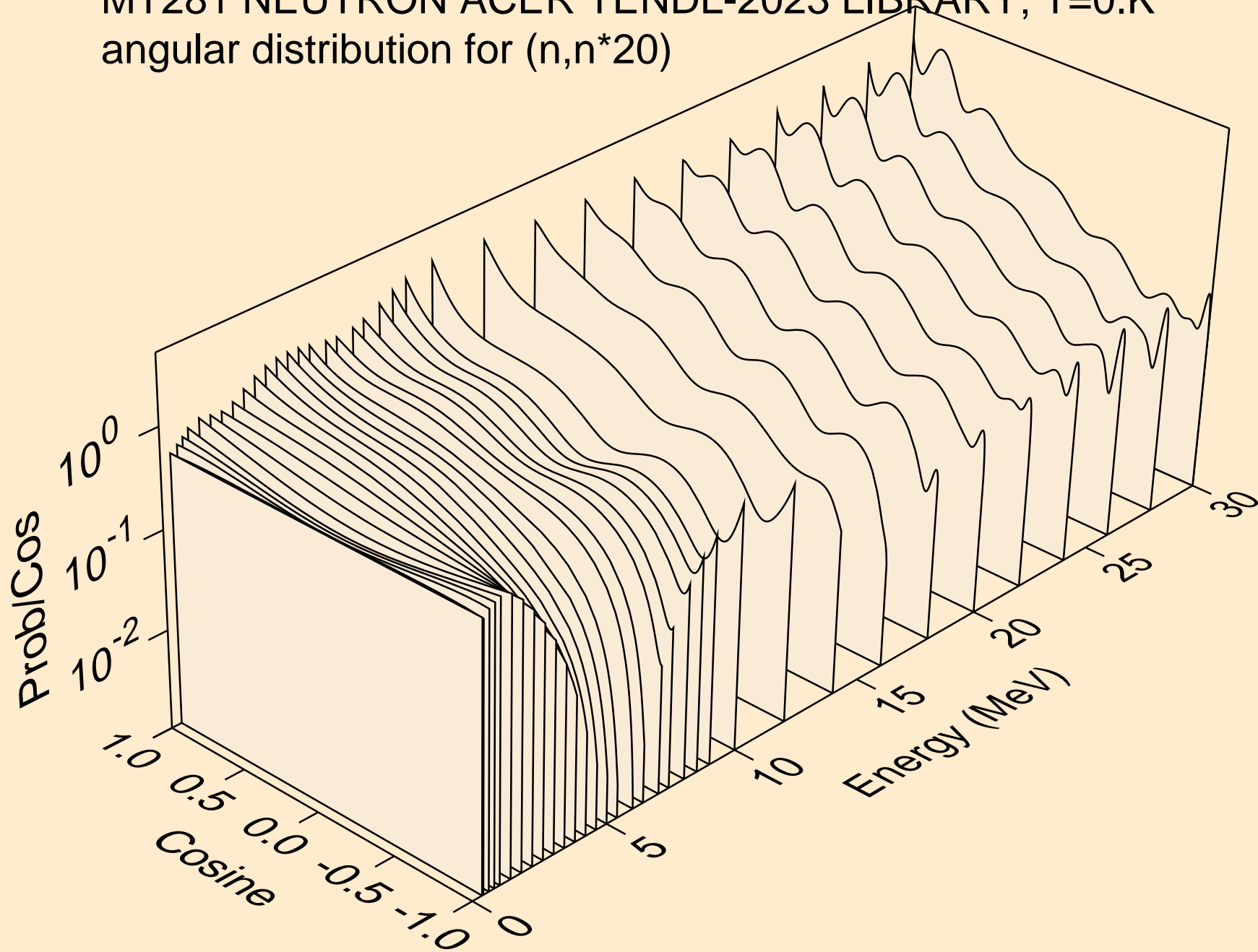

MT281 NEUTRON ACER TENDL-2023 LIBRARY; T=0.K
angular distribution for (n,n*21)

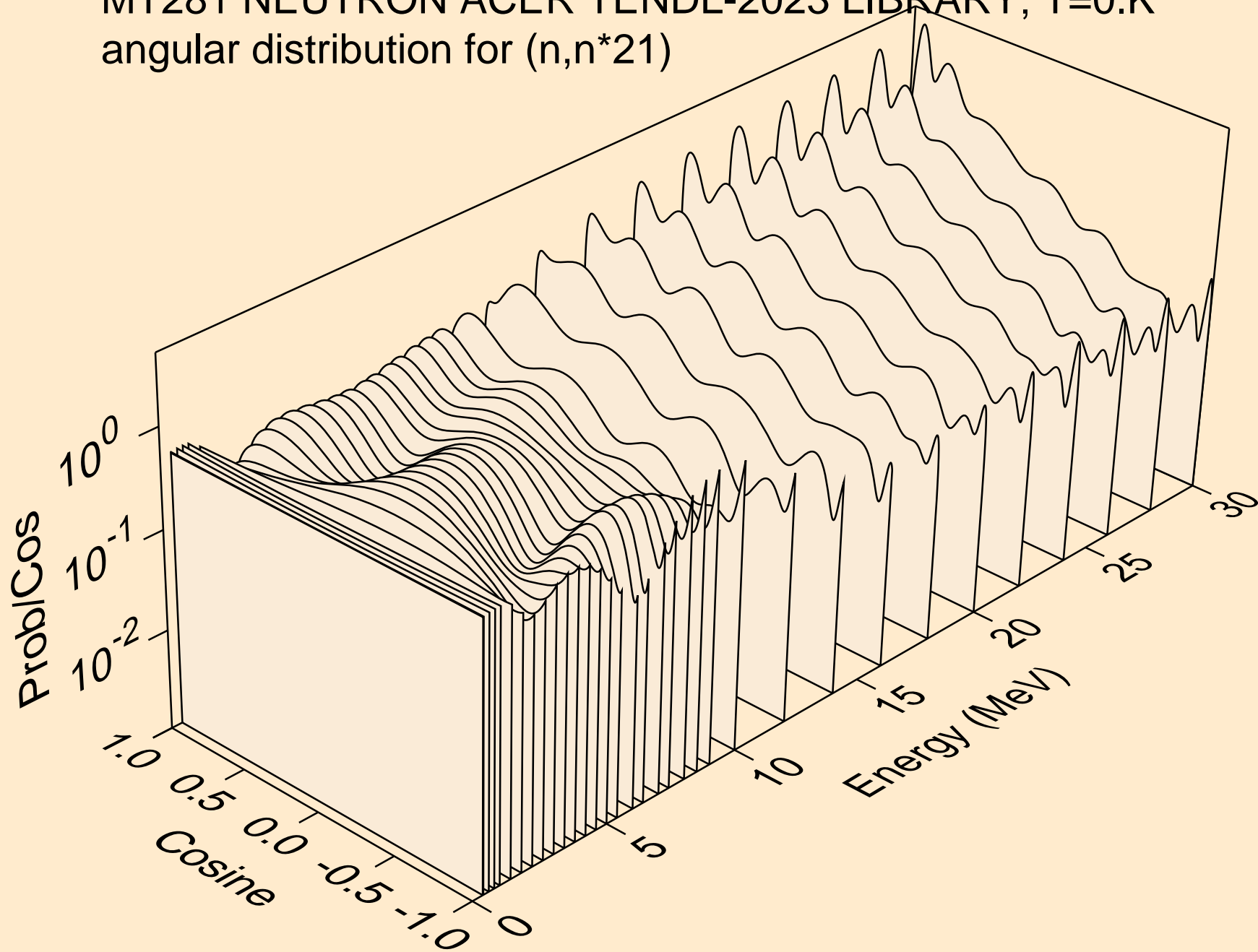

MT281 NEUTRON ACER TENDL-2023 LIBRARY; T=0.K
angular distribution for (n,n*22)

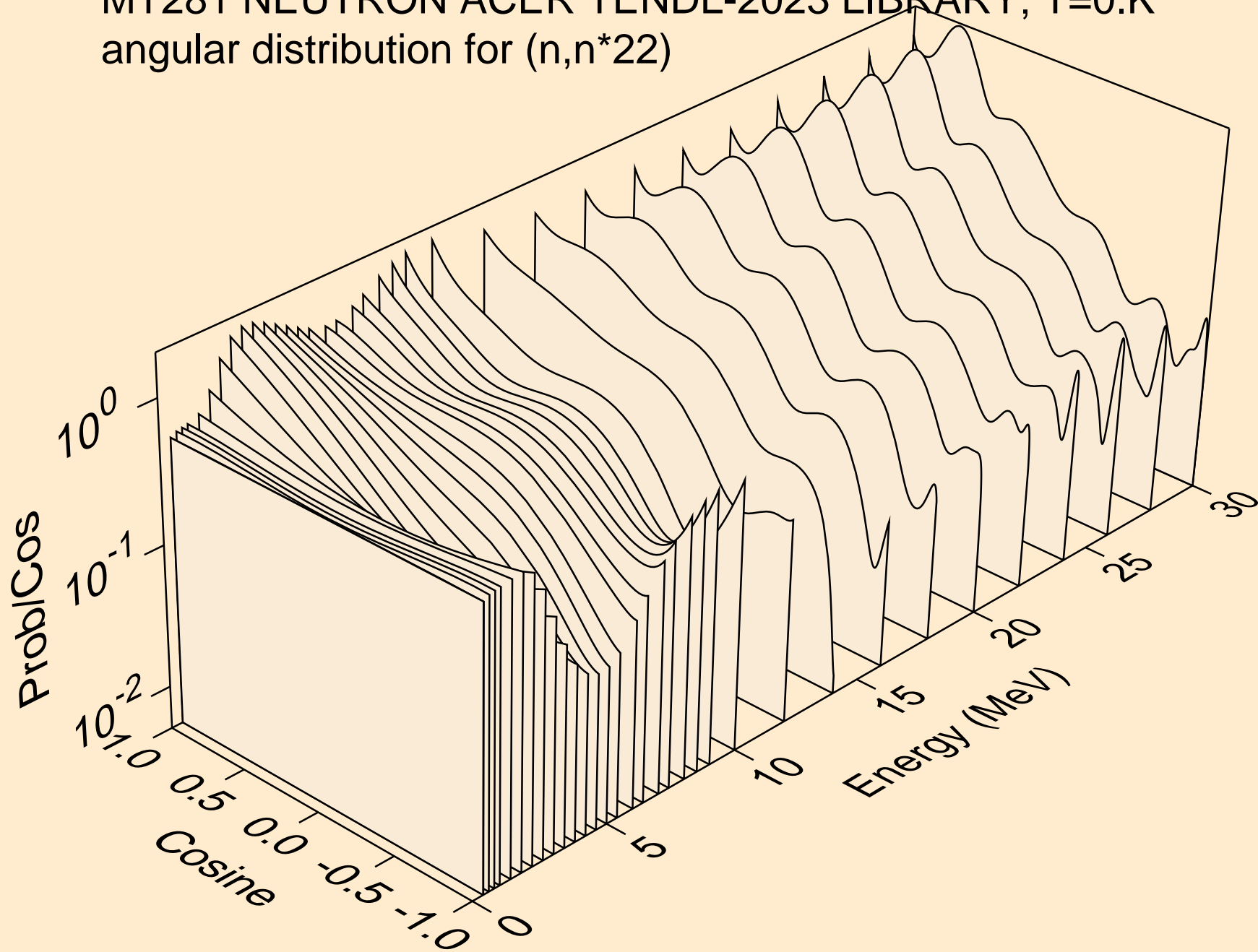

MT281 NEUTRON ACER TENDL-2023 LIBRARY; T=0.K
angular distribution for (n,n*23)

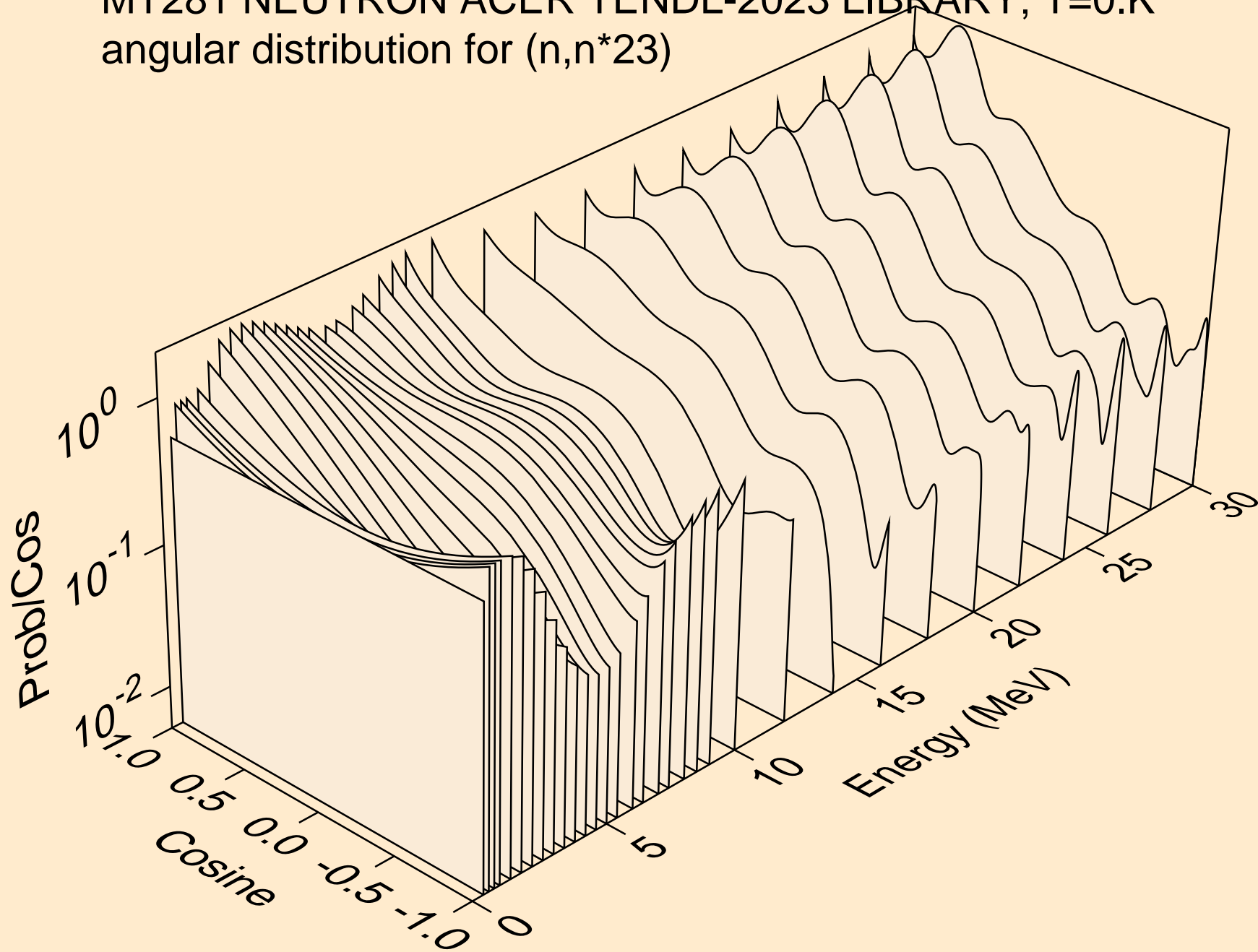

MT281 NEUTRON ACER TENDL-2023 LIBRARY; T=0.K
angular distribution for (n,n*24)

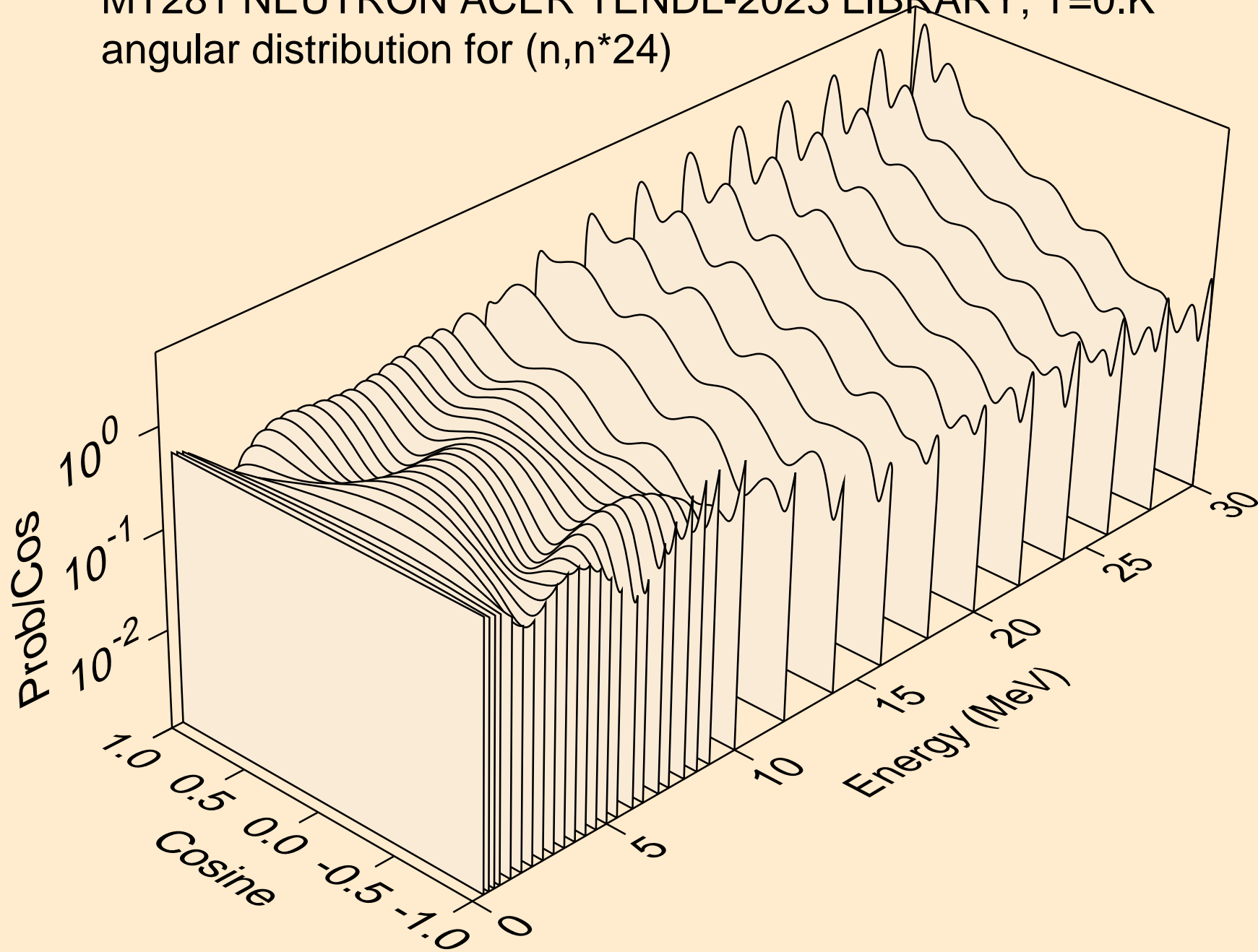

MT281 NEUTRON ACER TENDL-2023 LIBRARY; T=0.K
angular distribution for (n,n*25)

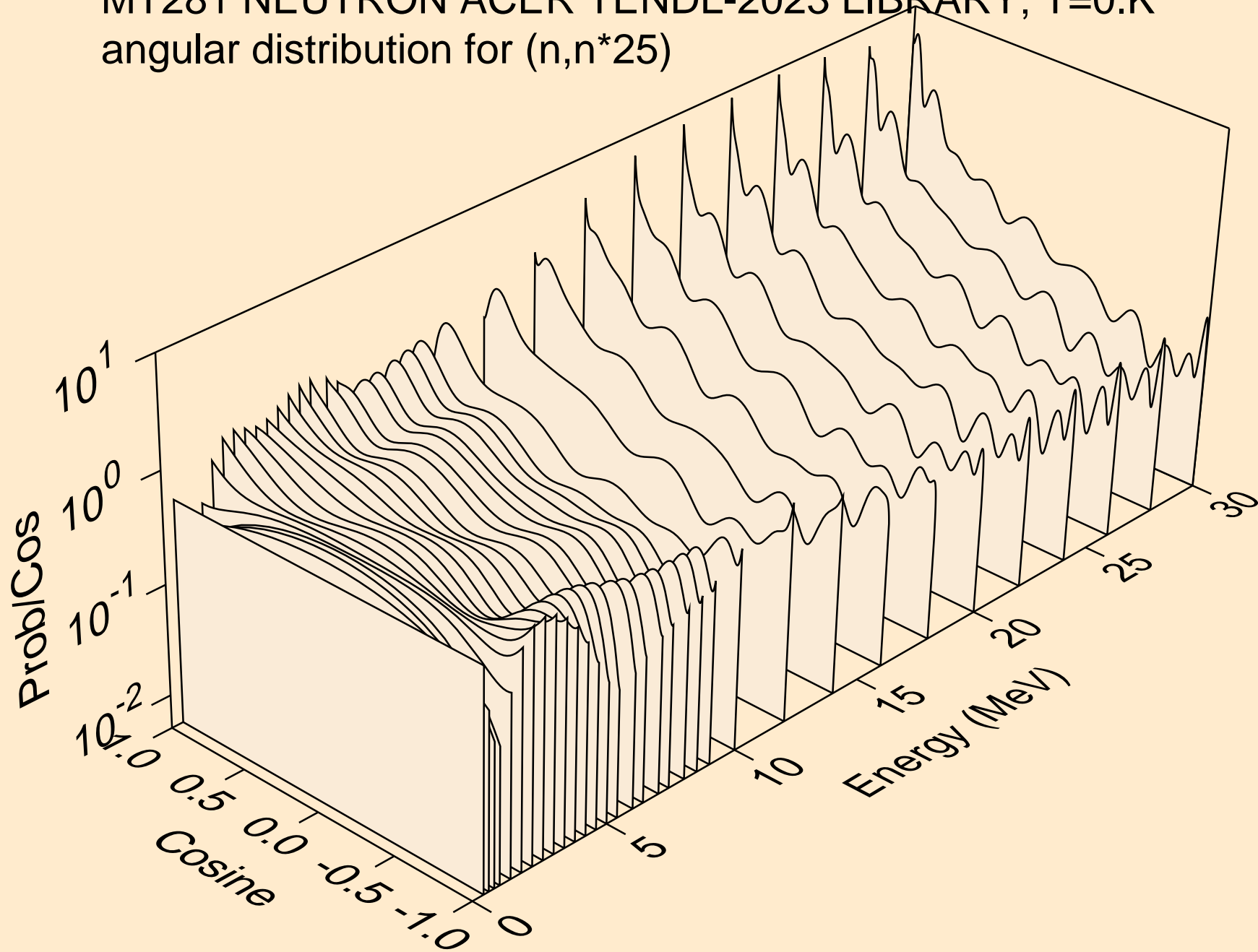

MT281 NEUTRON ACER TENDL-2023 LIBRARY; T=0.K
angular distribution for (n,n*26)

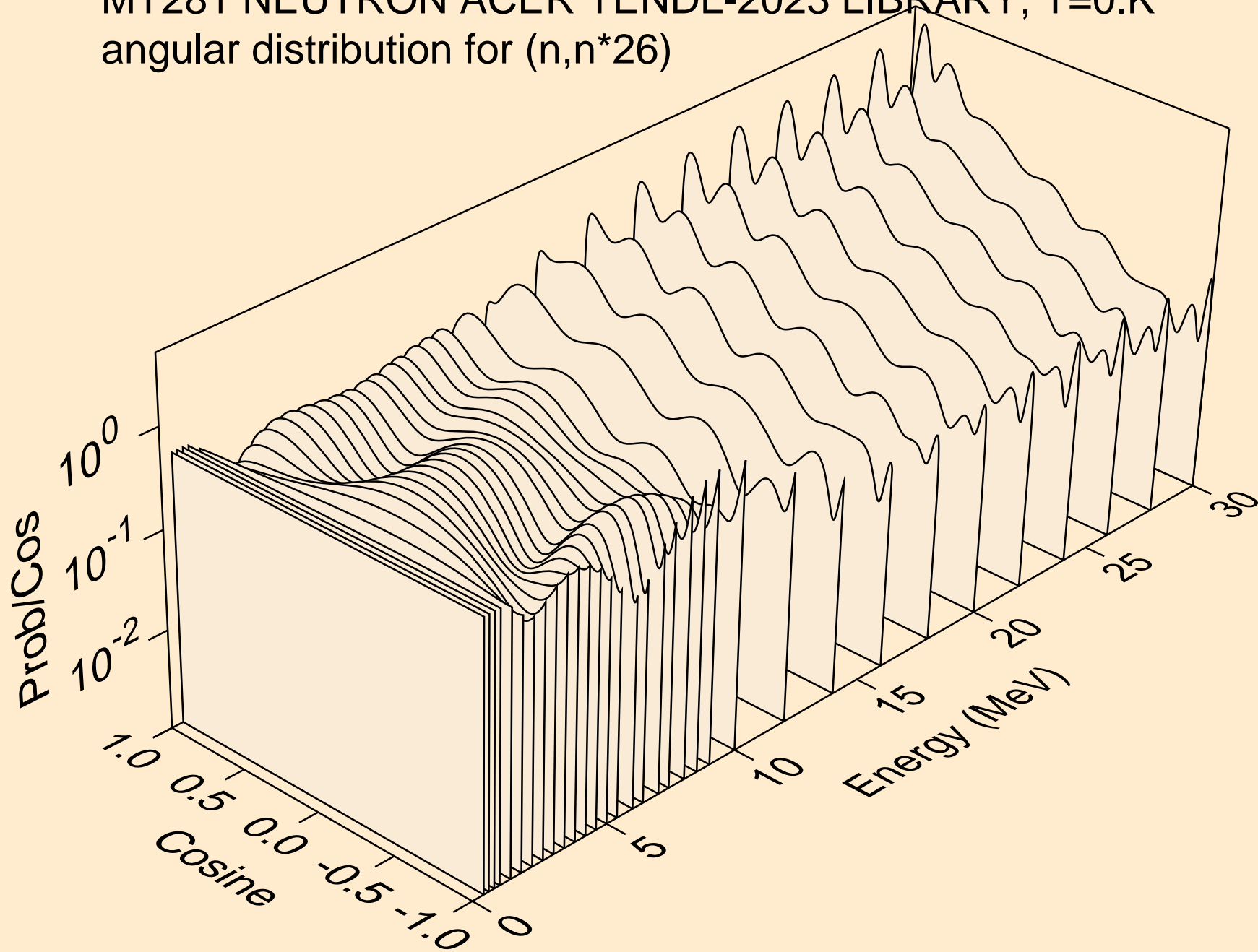

MT281 NEUTRON ACER TENDL-2023 LIBRARY; T=0.K
angular distribution for (n,n*27)

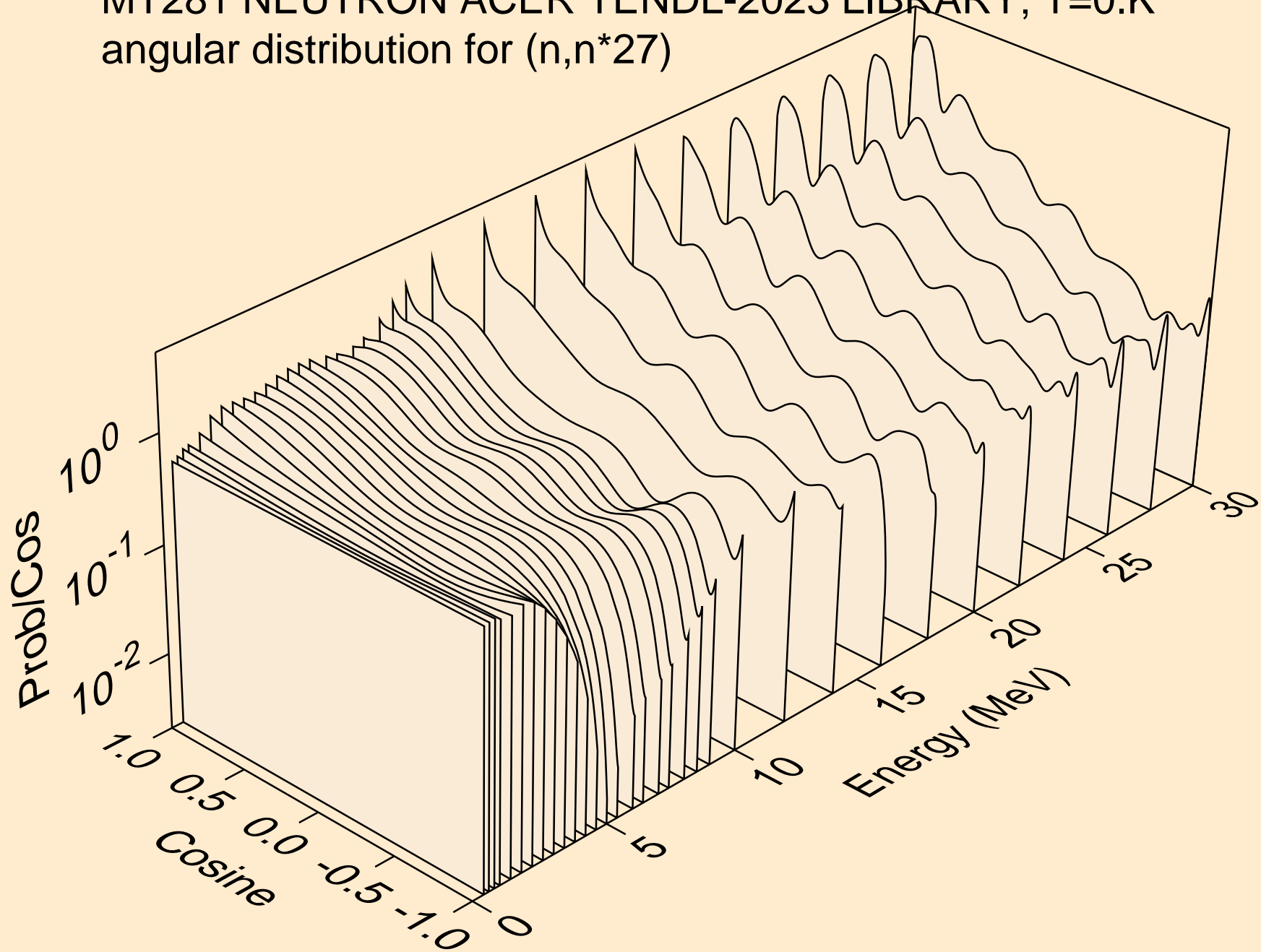

MT281 NEUTRON ACER TENDL-2023 LIBRARY; T=0.K
angular distribution for (n,n*28)

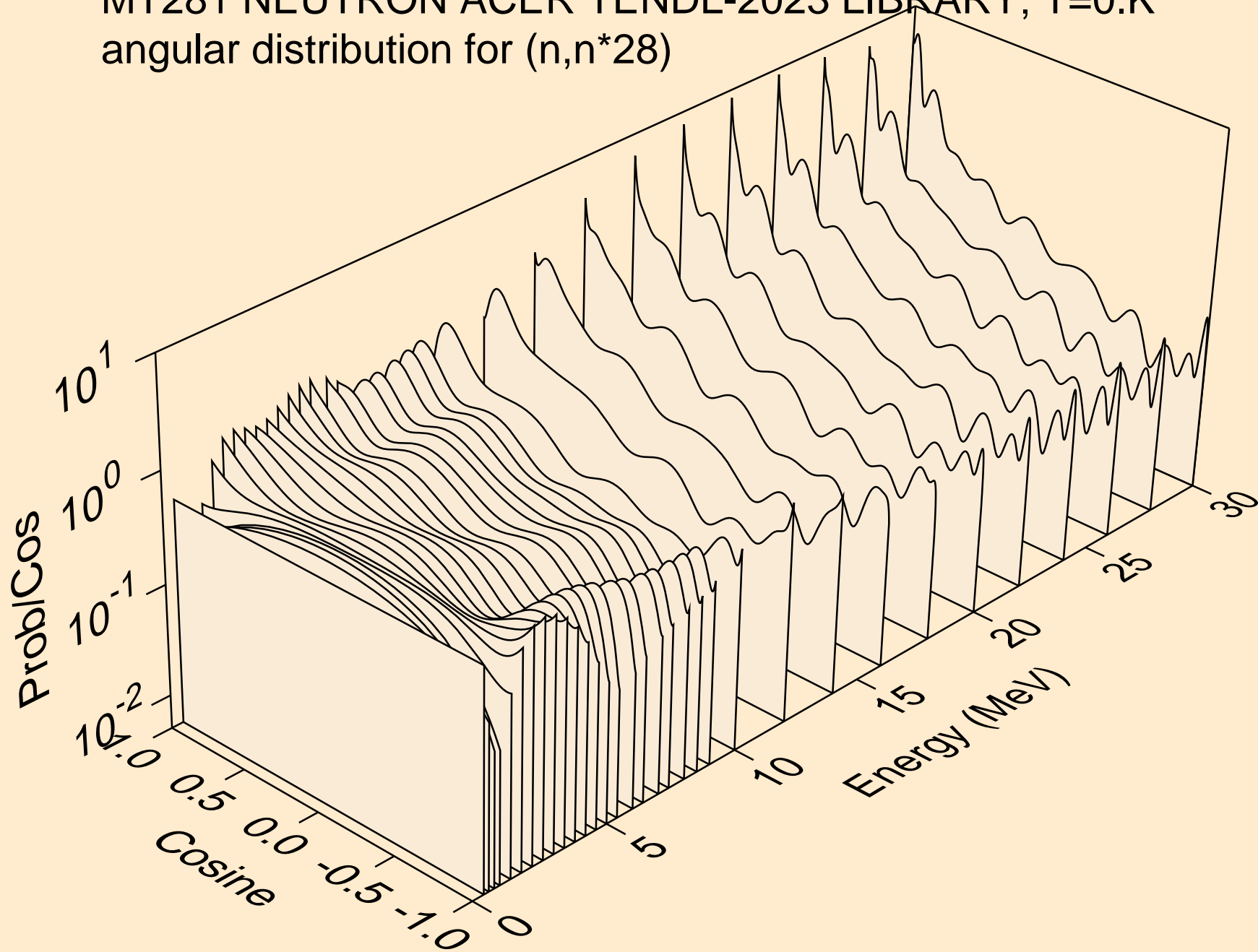

MT281 NEUTRON ACER TENDL-2023 LIBRARY; T=0.K
Total fission nubar

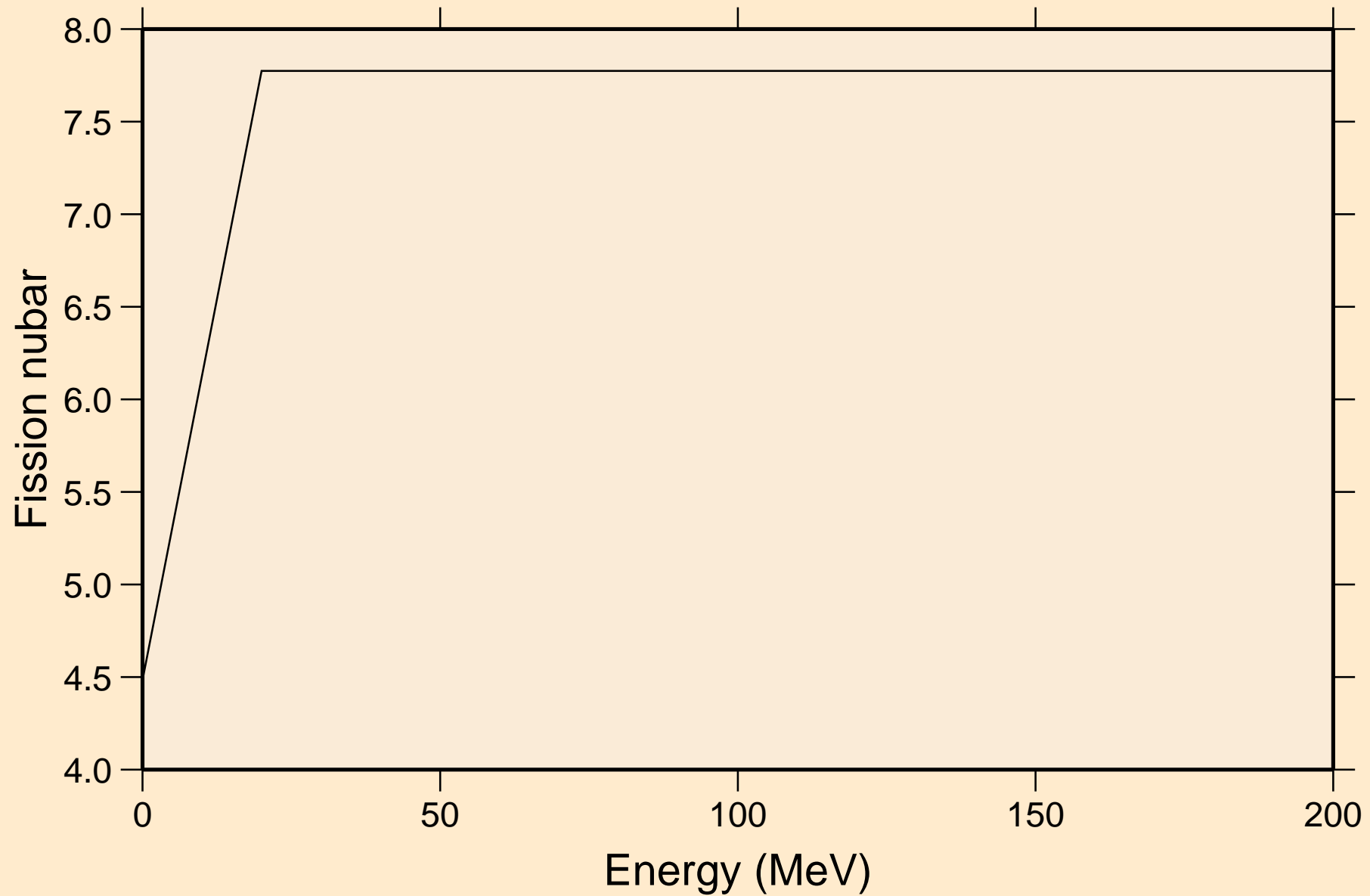

MT281 NEUTRON ACER TENDL-2023 LIBRARY; T=0.K
Neutron emission for (n,x)

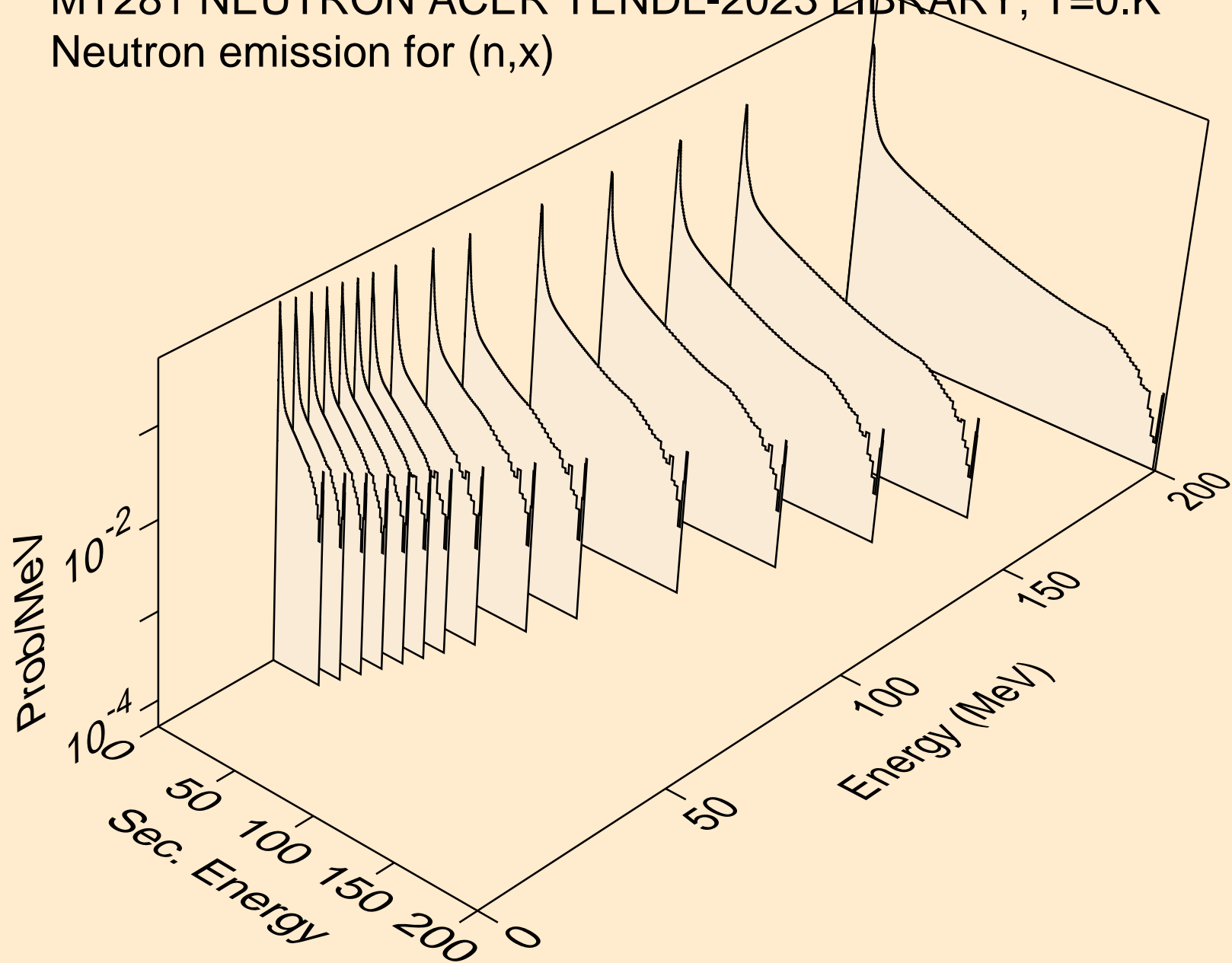

MT281 NEUTRON ACER TENDL-2023 LIBRARY; T=0.K
Neutron emission for (n,2nd)

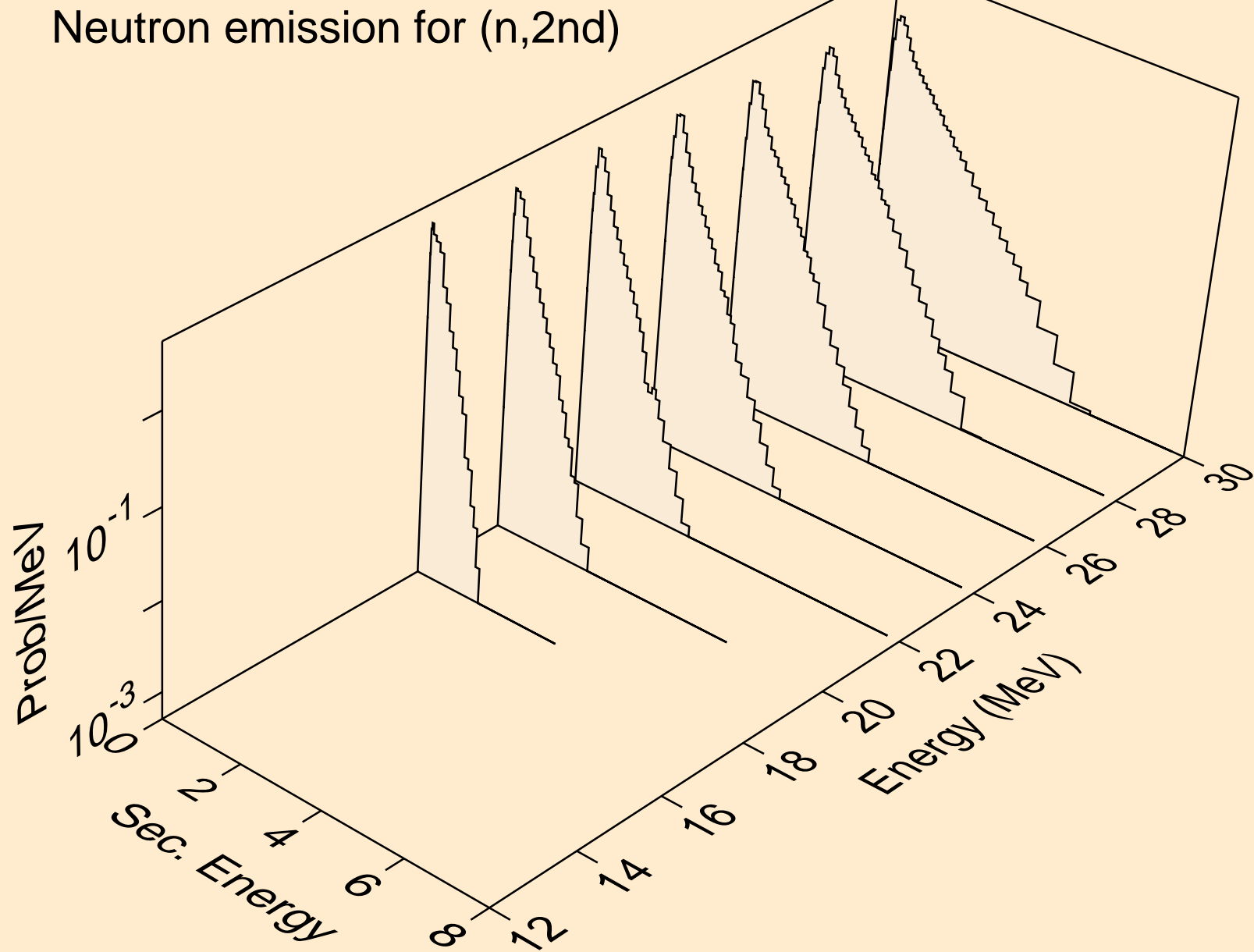

MT281 NEUTRON ACER TENDL-2023 LIBRARY; T=0.K
Neutron emission for (n,2n)

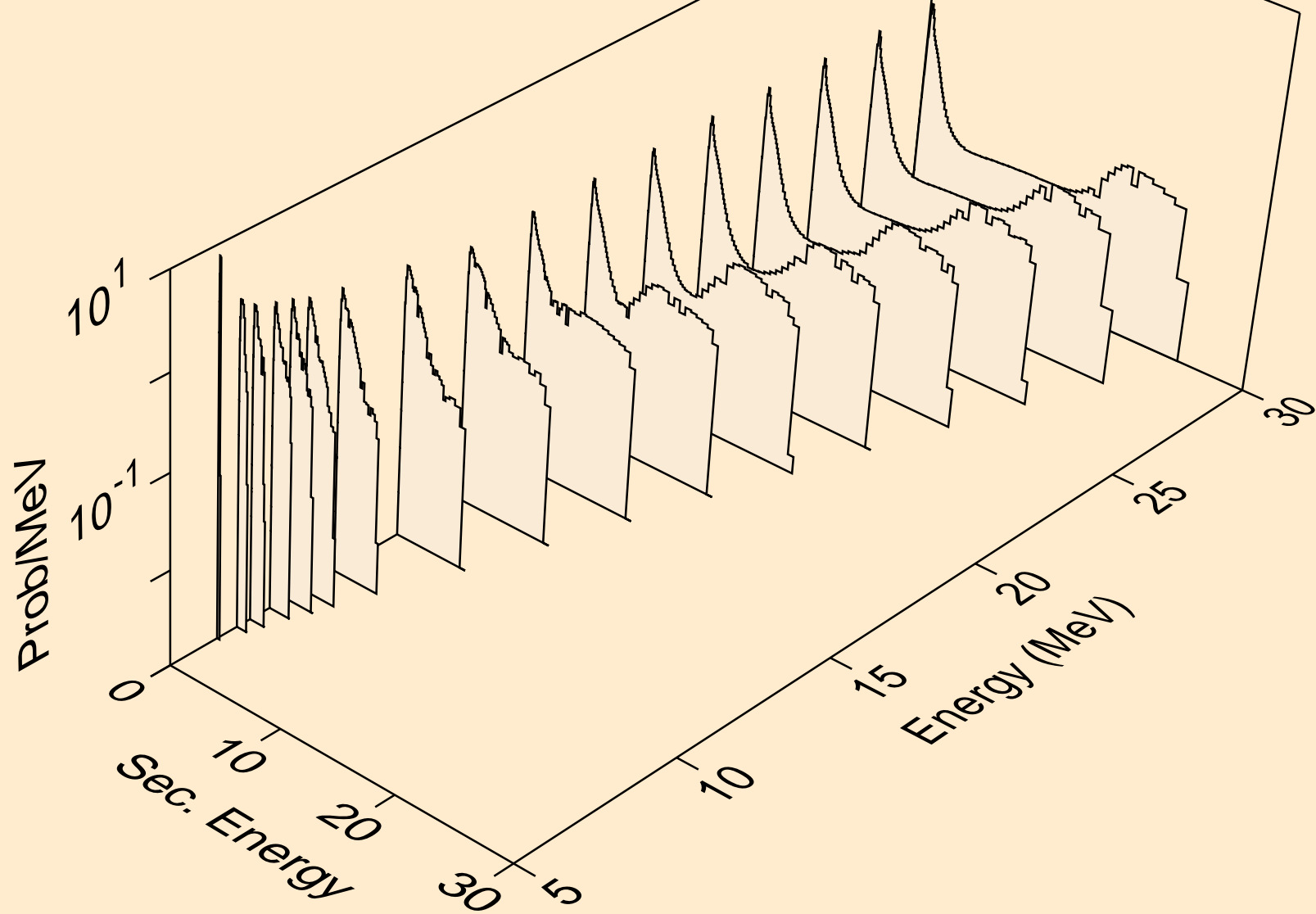

MT281 NEUTRON ACER TENDL-2023 LIBRARY; T=0.K
Neutron emission for (n,3n)

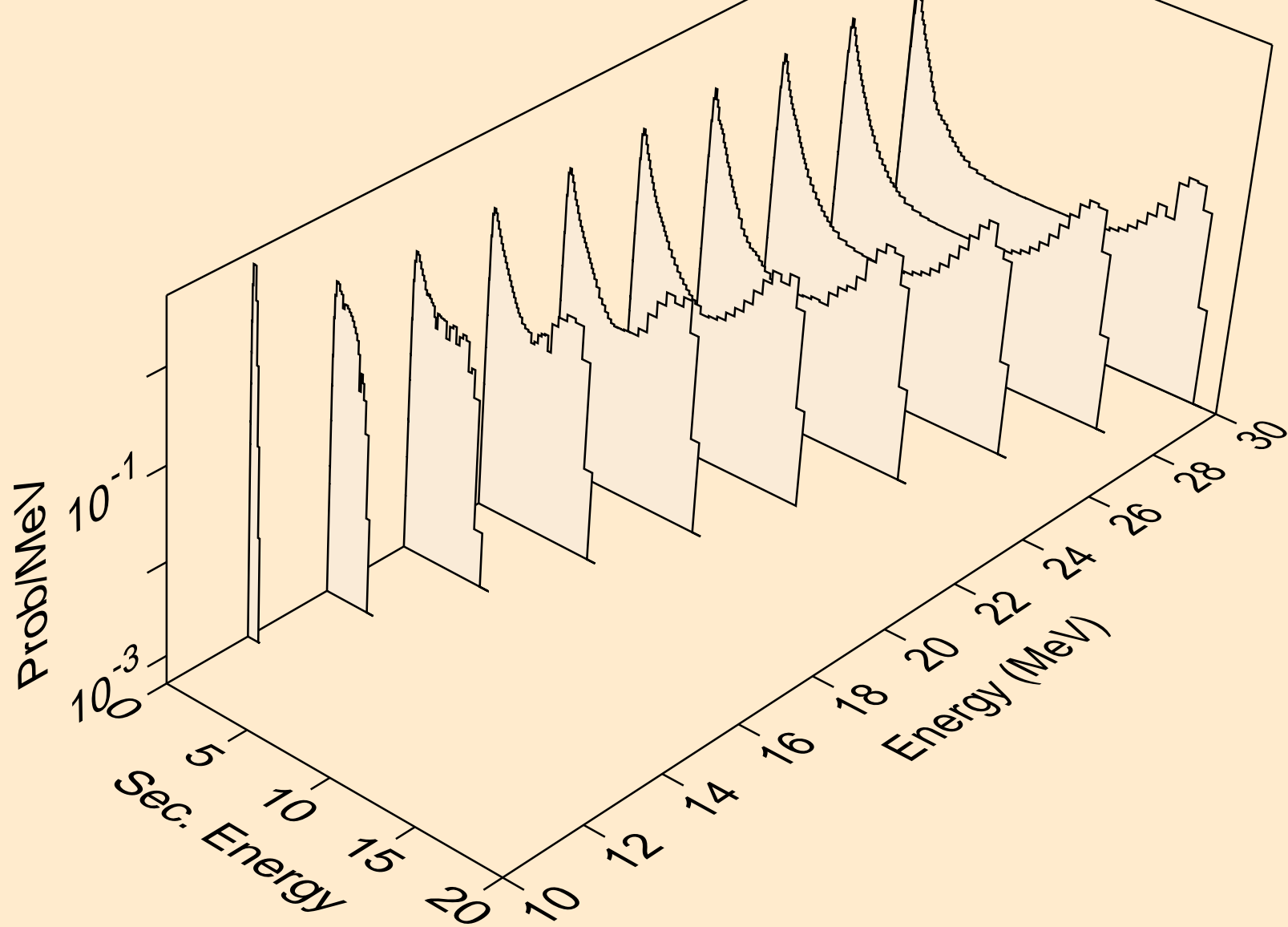

MT281 NEUTRON ACER TENDL-2023 LIBRARY; T=0.K
Neutron emission for fission

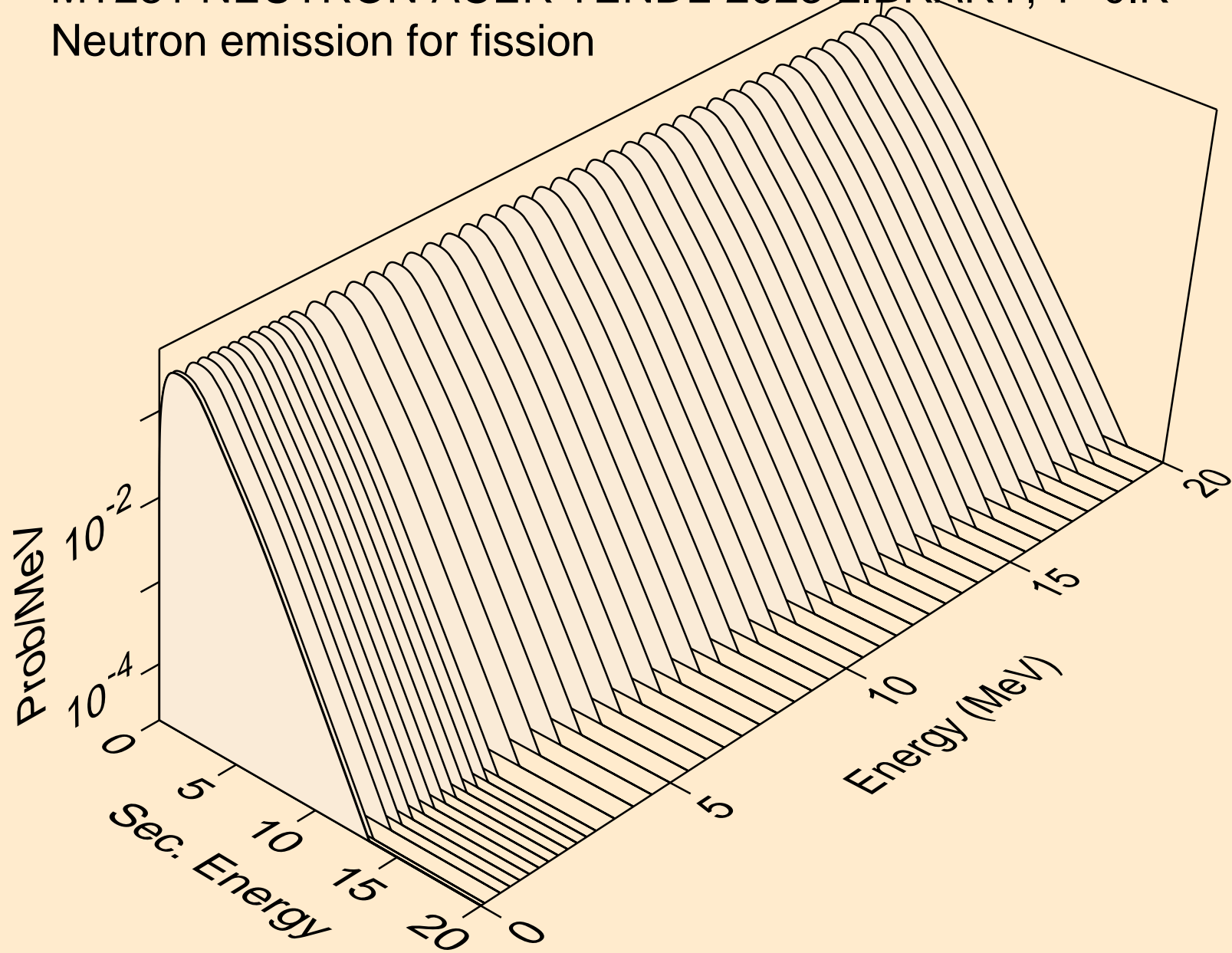

MT281 NEUTRON ACER TENDL-2023 LIBRARY; T=0.K
Neutron emission for (n,n*)a

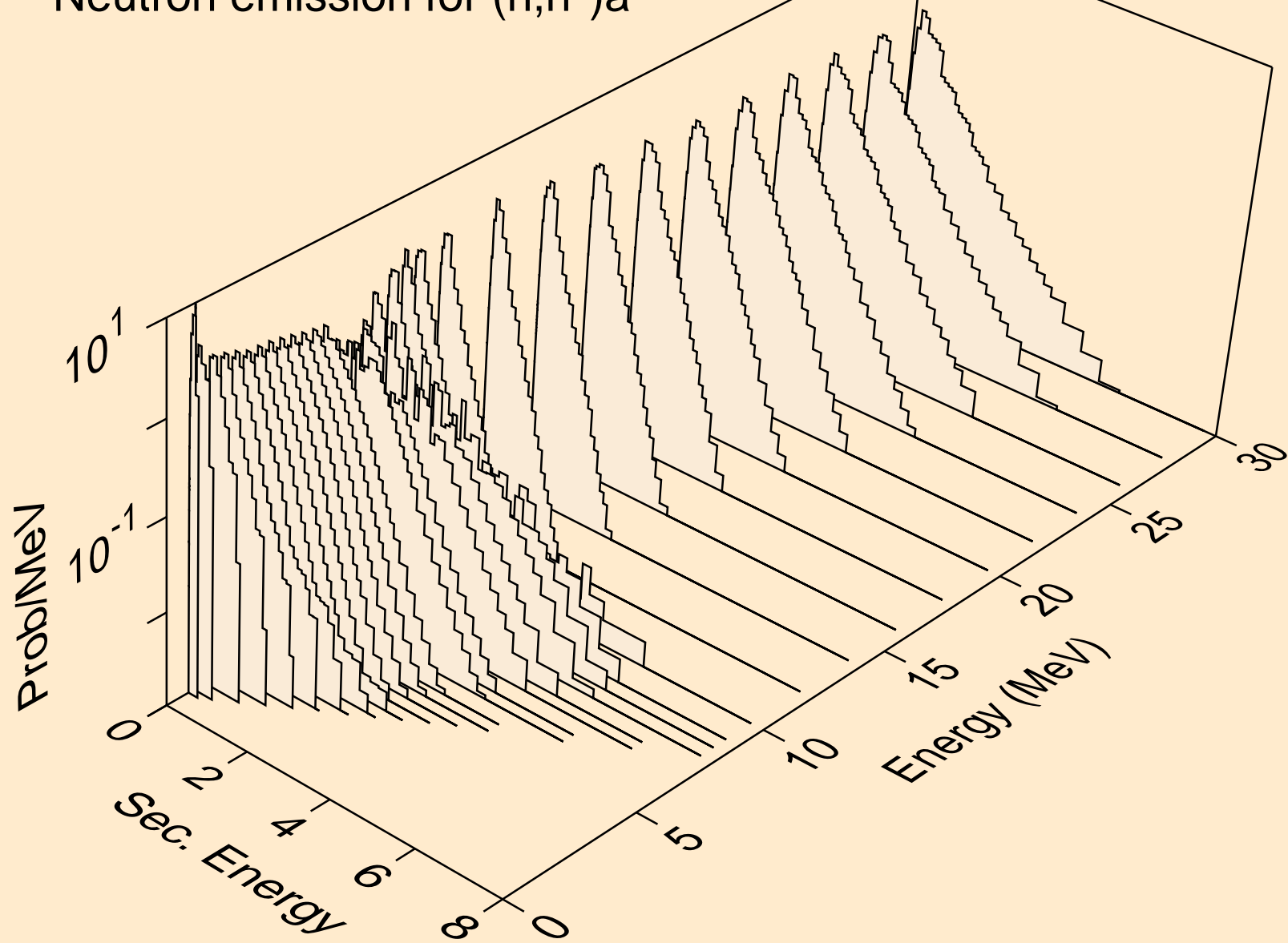

MT281 NEUTRON ACER TENDL-2023 LIBRARY; T=0.K
Neutron emission for (n,2n)a

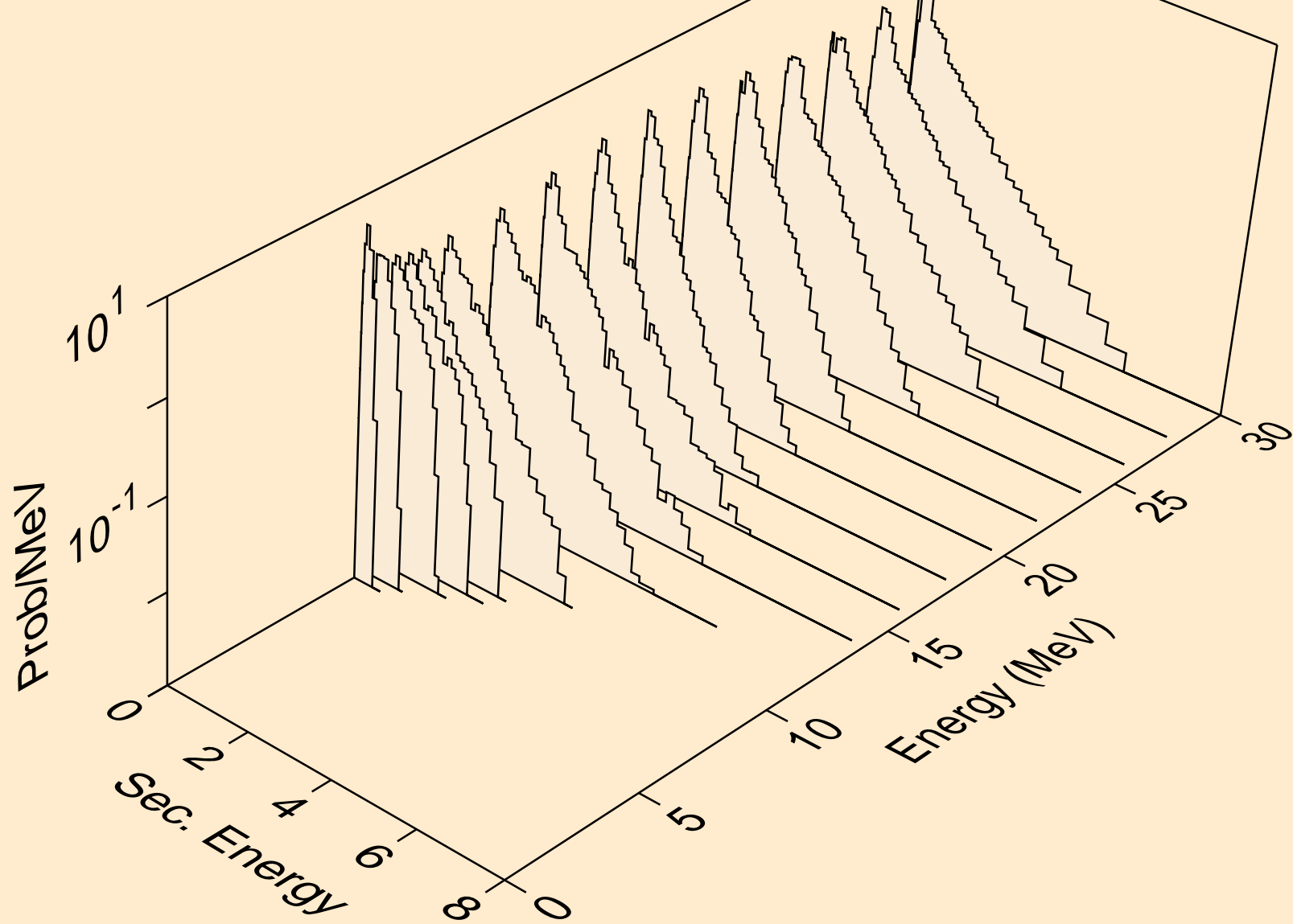

MT281 NEUTRON ACER TENDL-2023 LIBRARY; T=0.K
Neutron emission for (n,3n)a

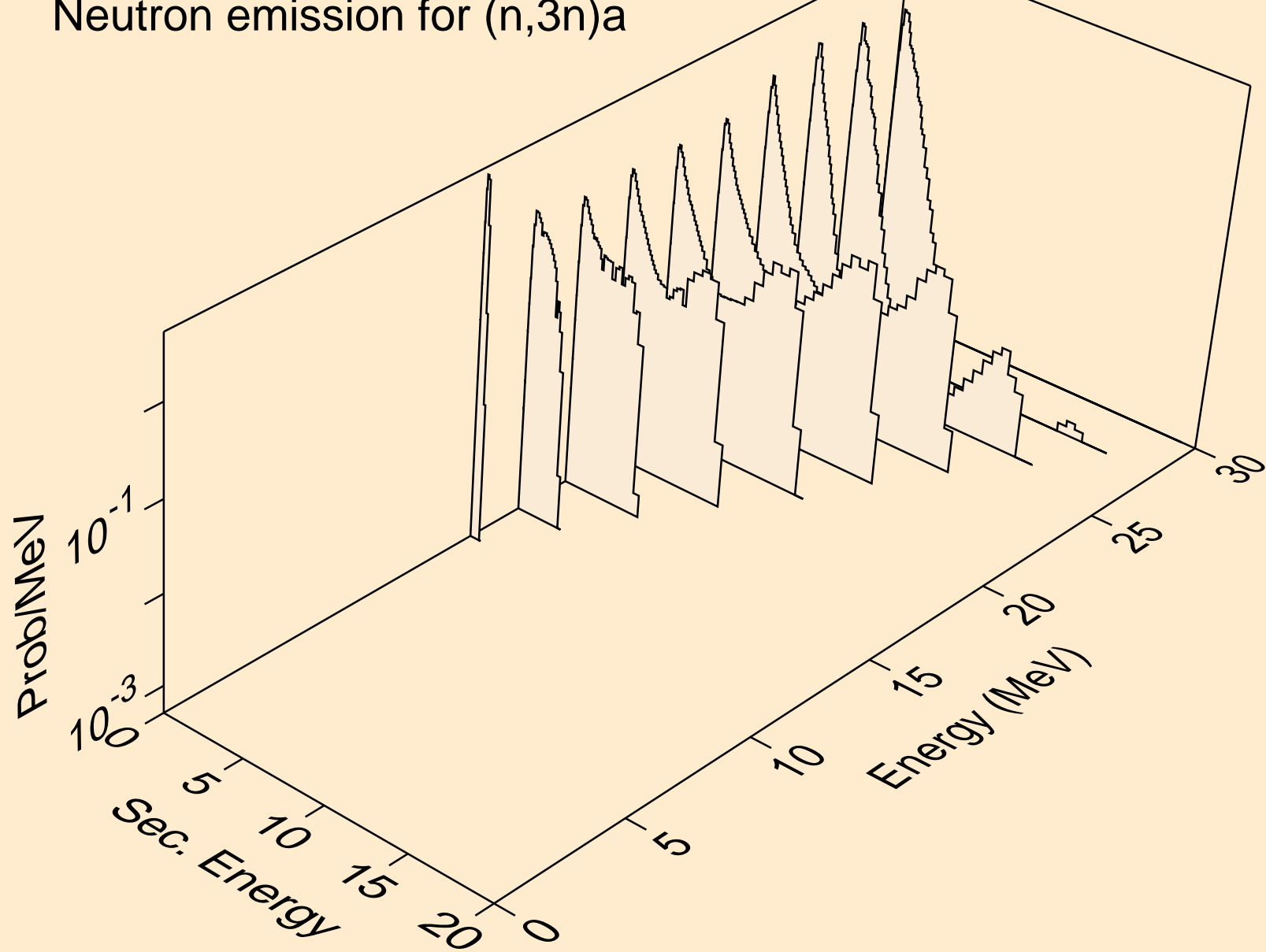

MT281 NEUTRON ACER TENDL-2023 LIBRARY; T=0.K
Neutron emission for (n,n*)p

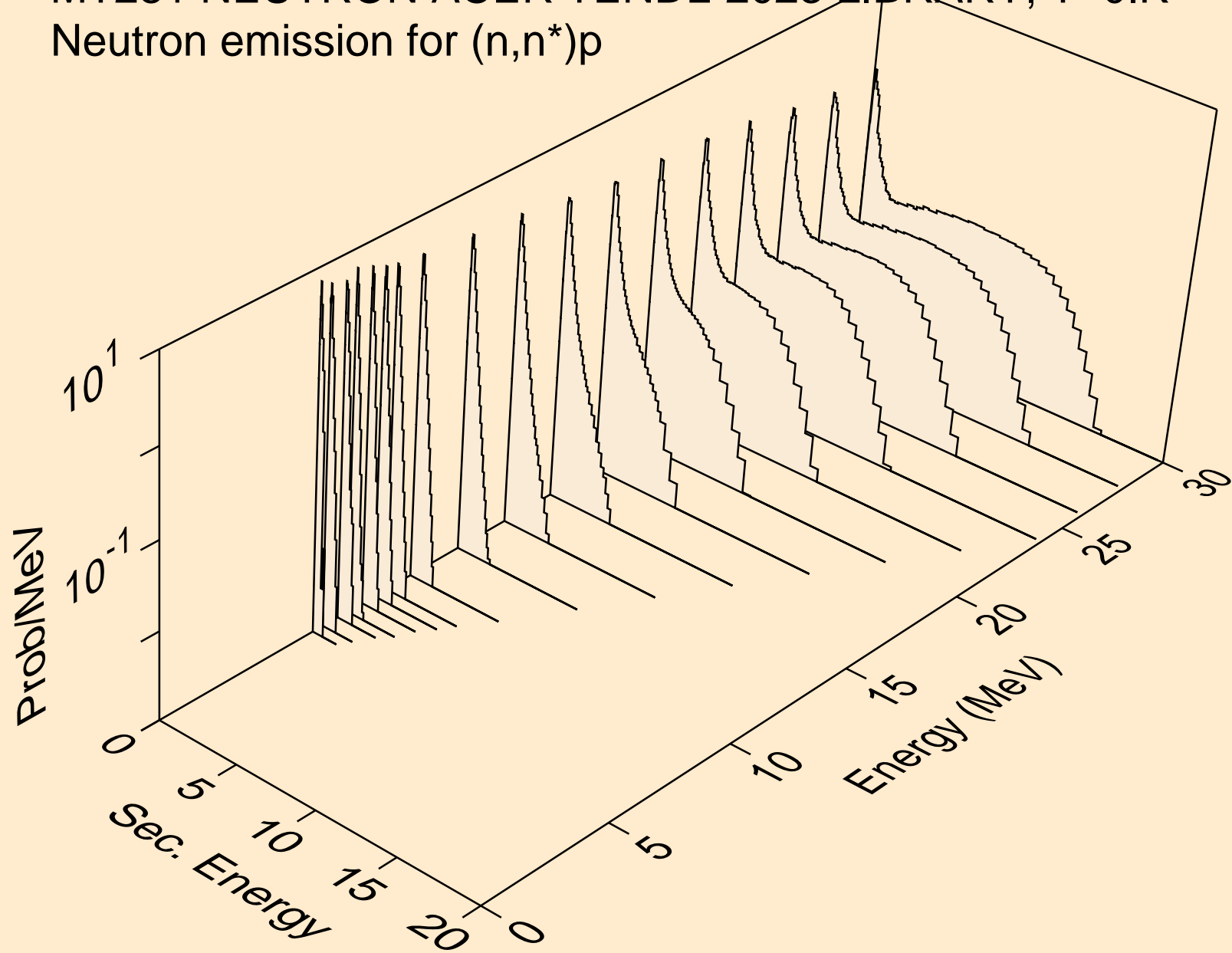

MT281 NEUTRON ACER TENDL-2023 LIBRARY; T=0.K
Neutron emission for (n,n*)d

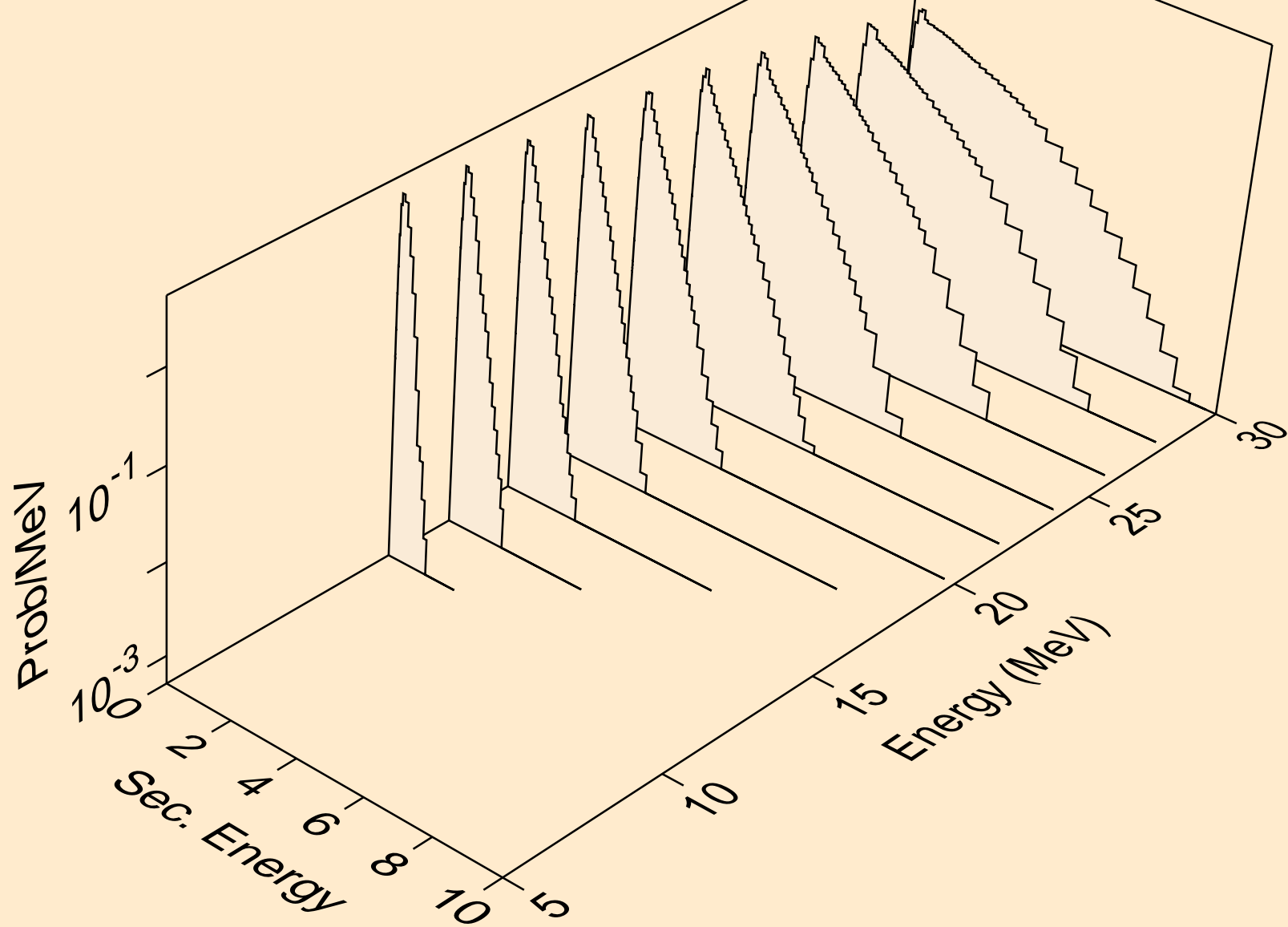

MT281 NEUTRON ACER TENDL-2023 LIBRARY; T=0.K
Neutron emission for (n,n*)t

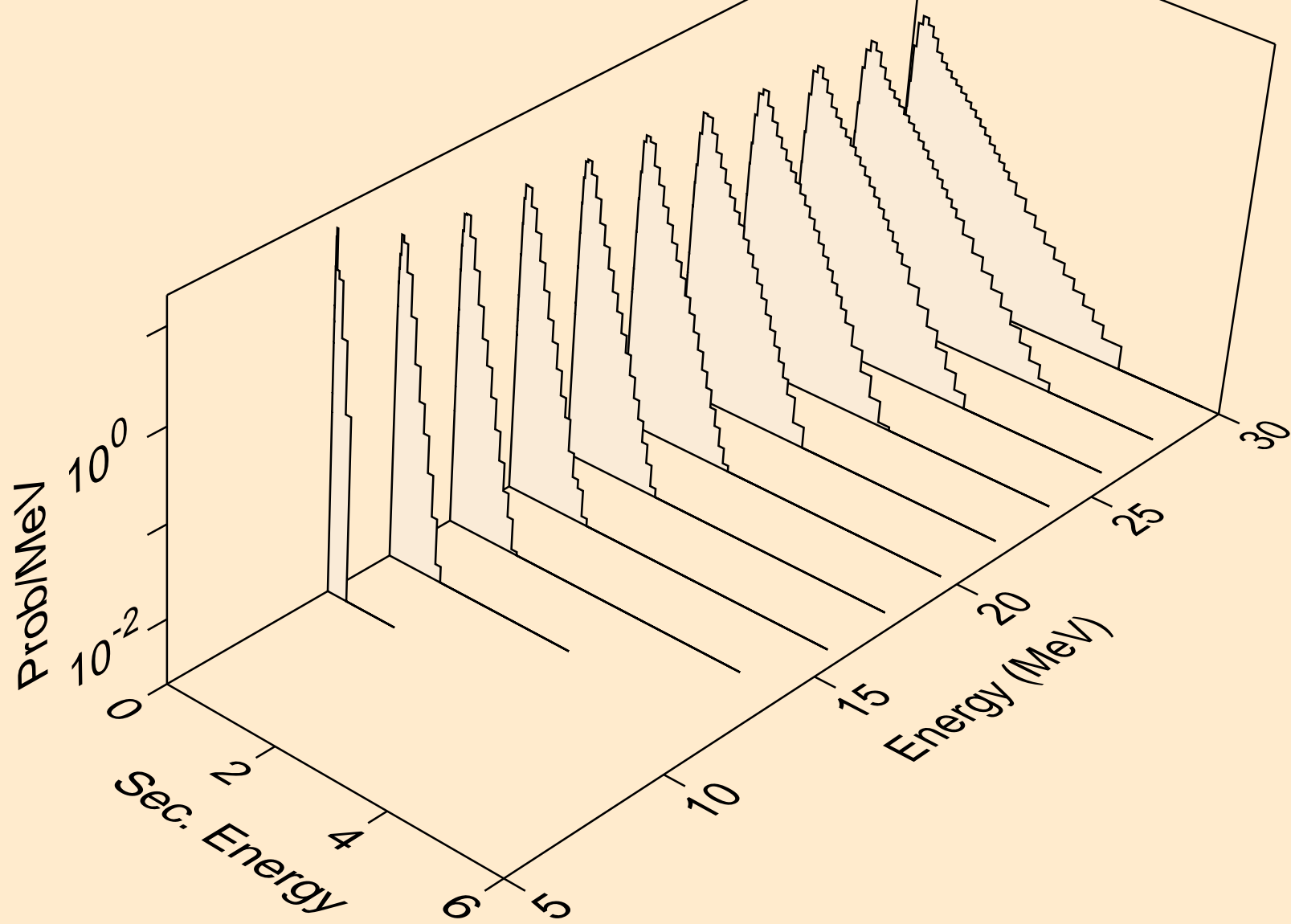

MT281 NEUTRON ACER TENDL-2023 LIBRARY; T=0.K
Neutron emission for (n,n*)he3

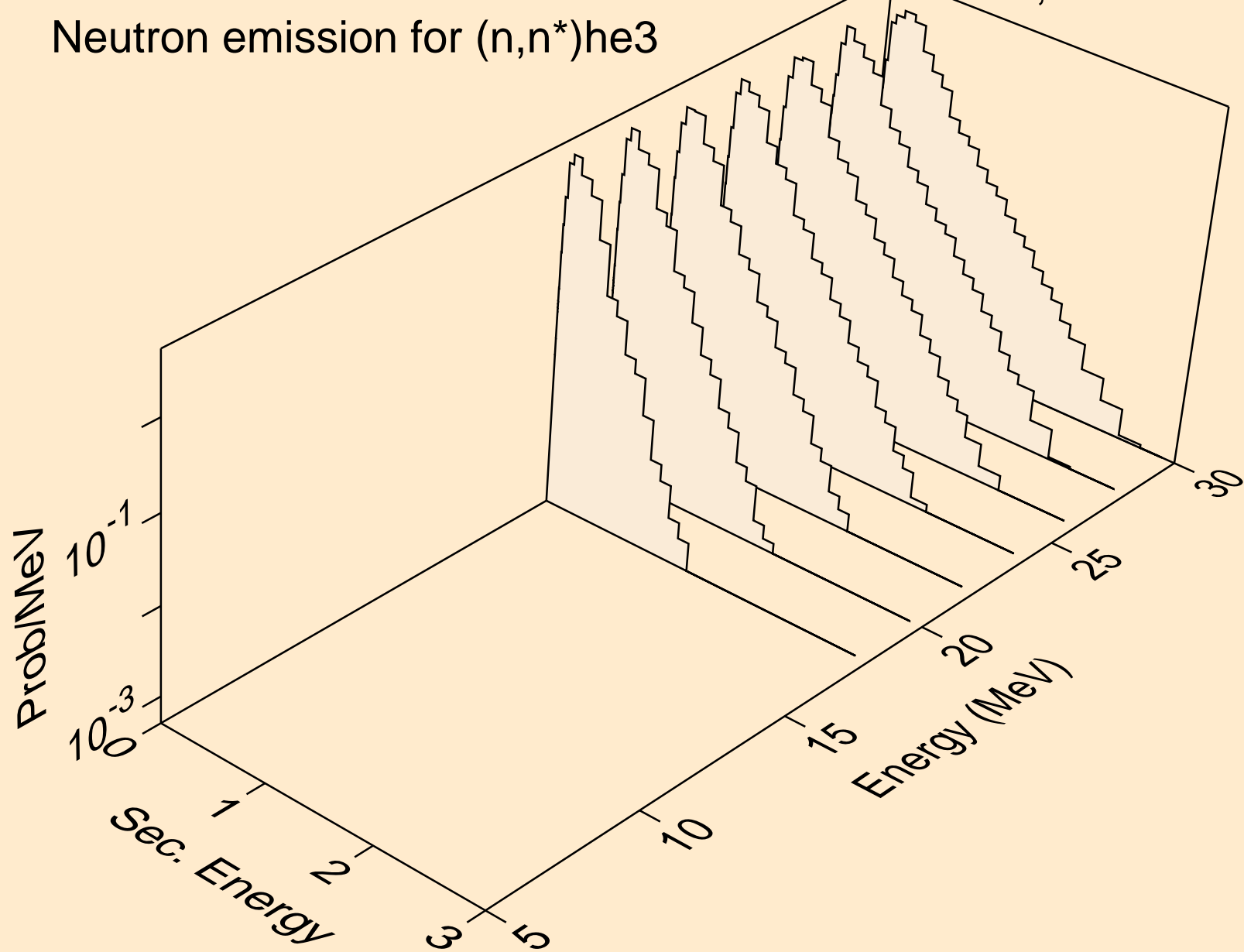

MT281 NEUTRON ACER TENDL-2023 LIBRARY; T=0.K
Neutron emission for (n,4n)

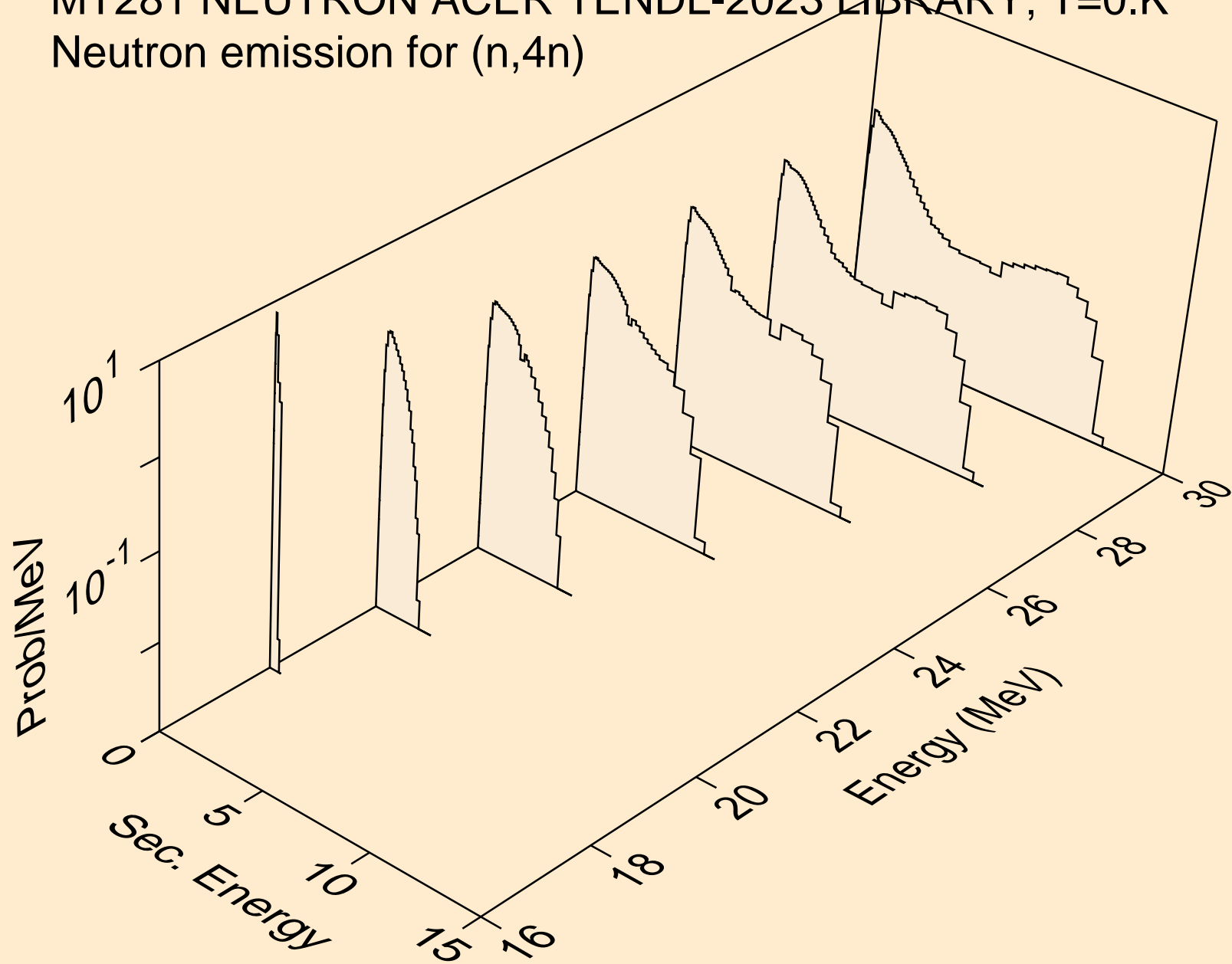

MT281 NEUTRON ACER TENDL-2023 LIBRARY; T=0.K
Neutron emission for (n,2np)

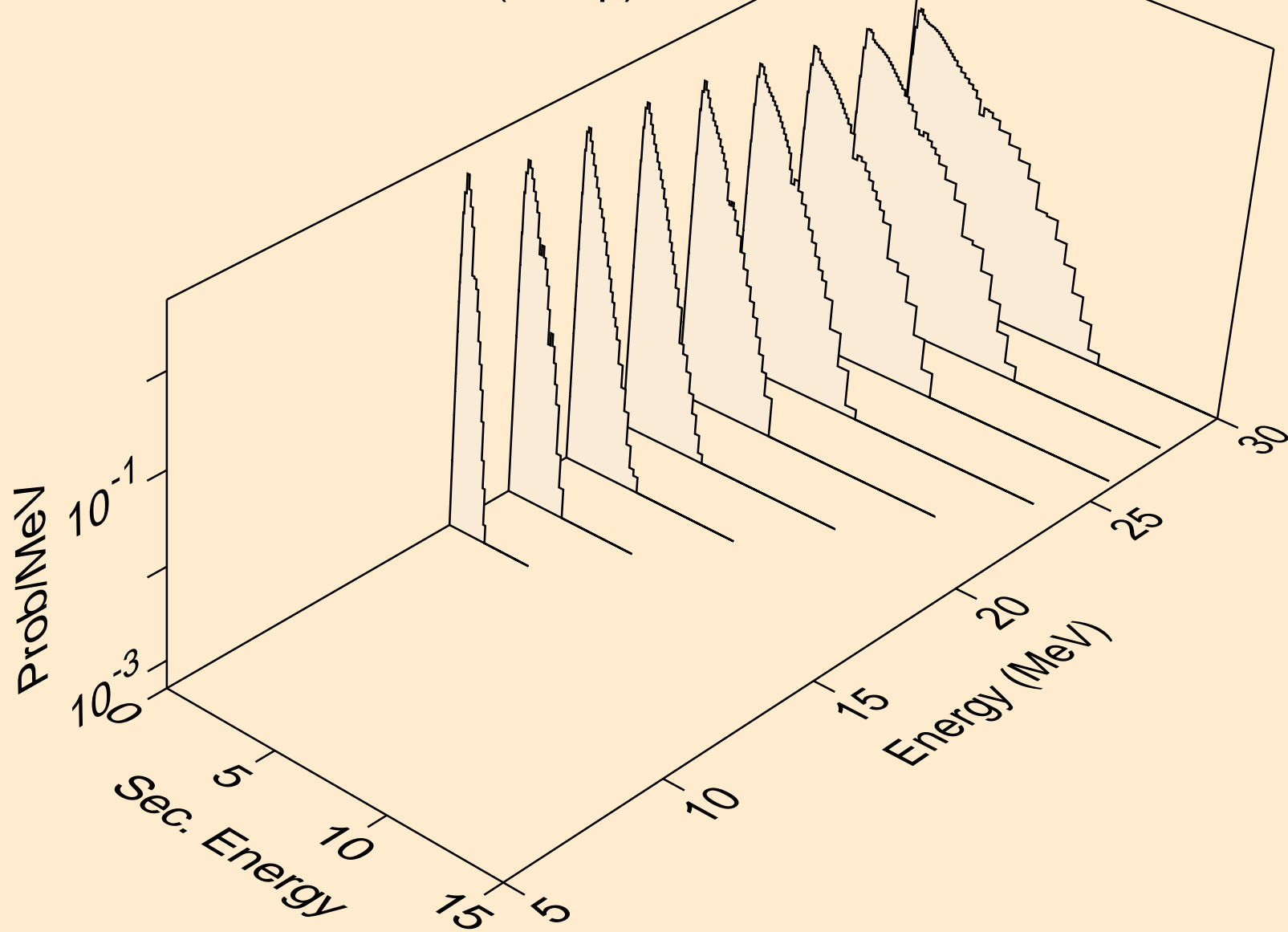

MT281 NEUTRON ACER TENDL-2023 LIBRARY; T=0.K
Neutron emission for (n,3np)

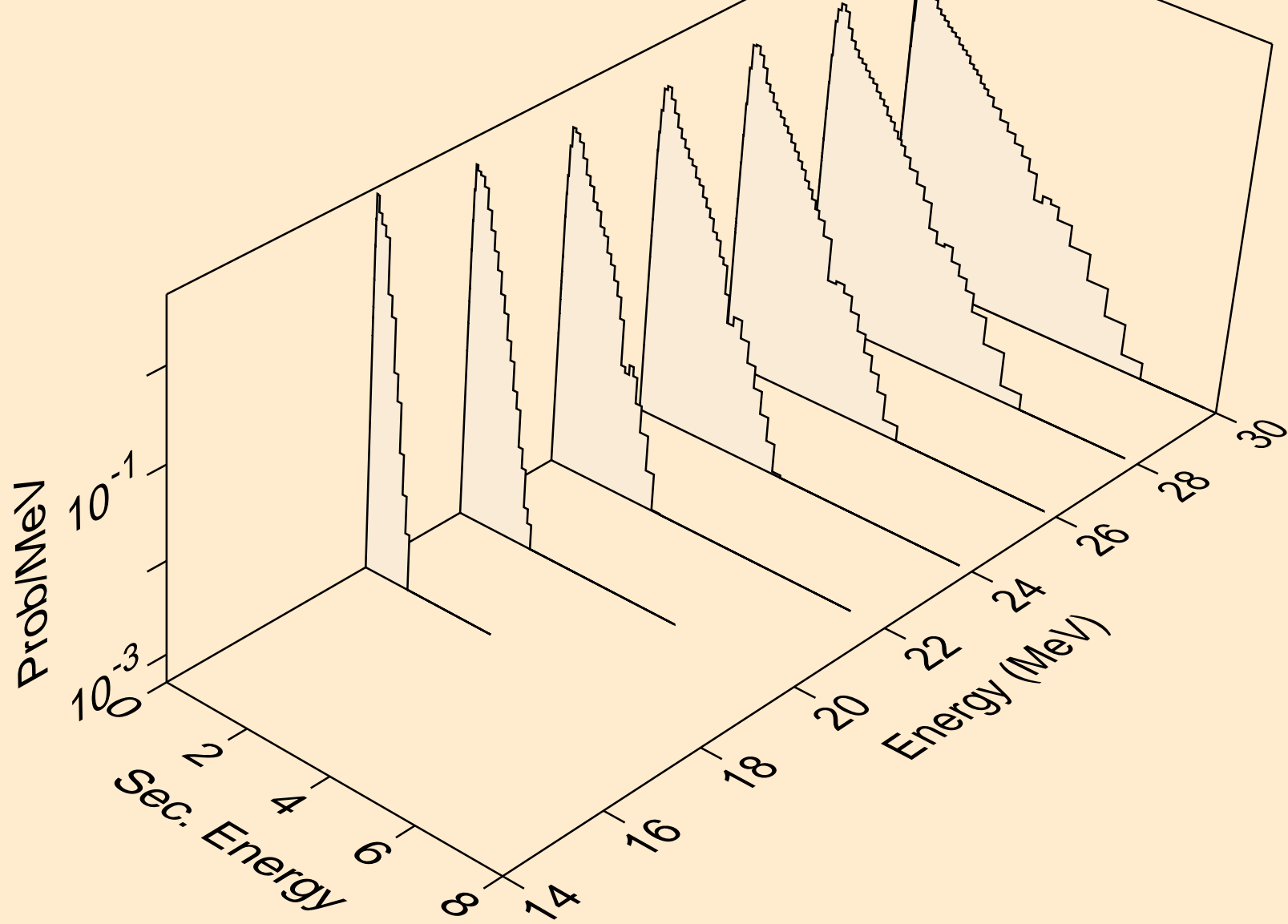

MT281 NEUTRON ACER TENDL-2023 LIBRARY; T=0.K
Neutron emission for (n,n*c)

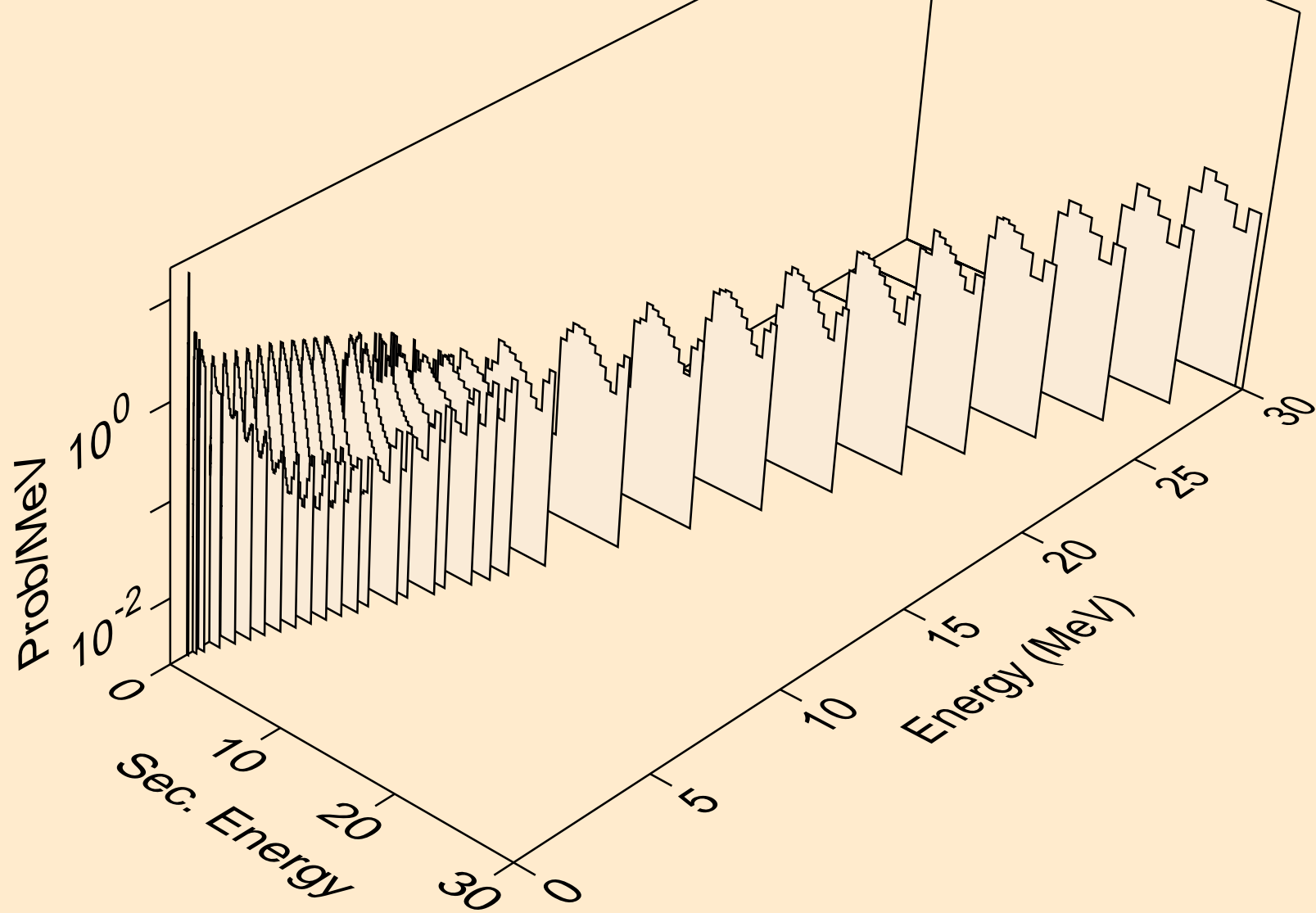

MT281 NEUTRON ACER TENDL-2023 LIBRARY; T=0.K

Delayed nubar

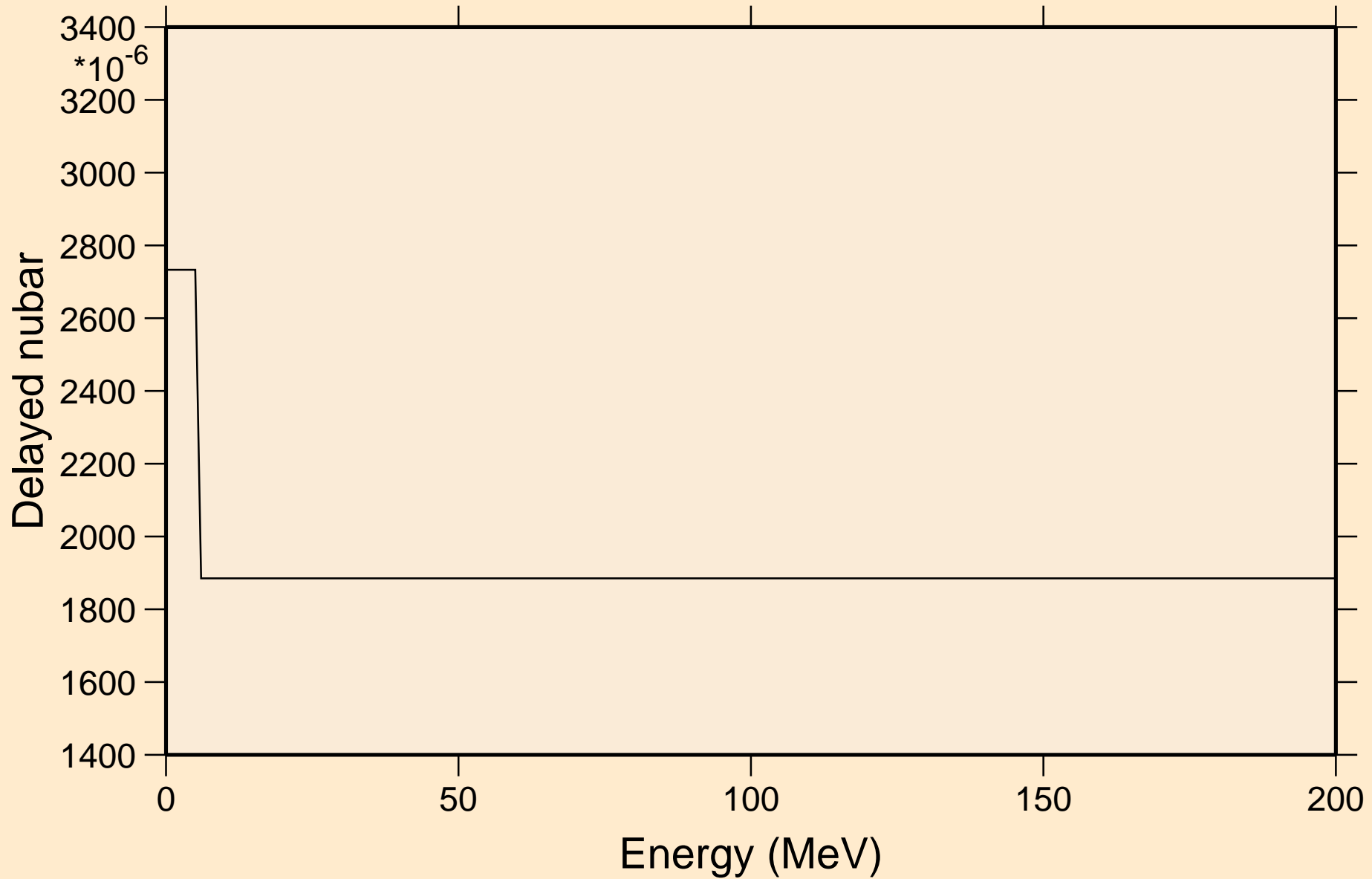

MT281 NEUTRON ACER TENDL-2023 LIBRARY; T=0.K

Delayed neutron spectra

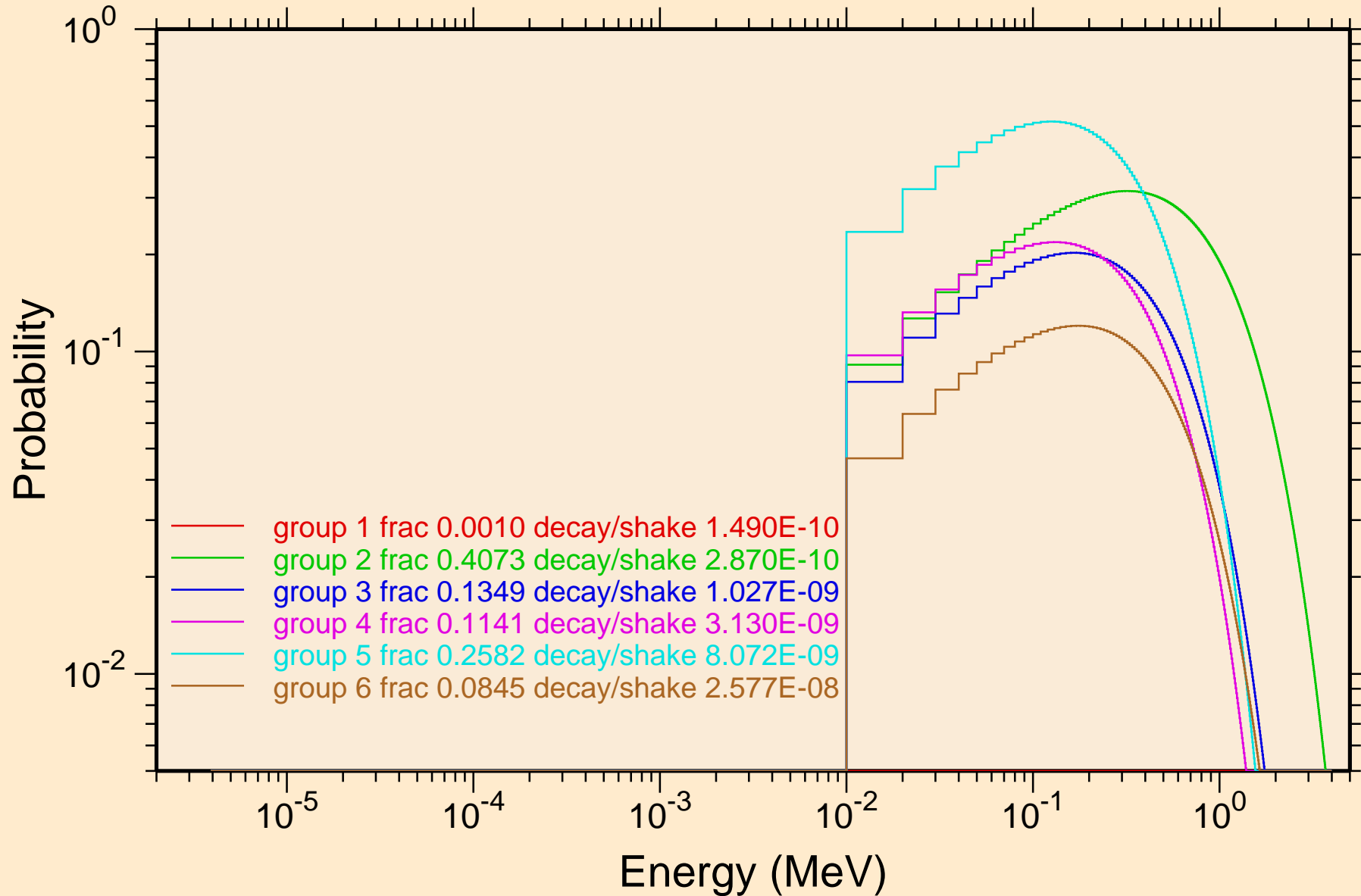

MT281 NEUTRON ACER TENDL-2023 LIBRARY; T=0.K
Photon emission for (n,x)

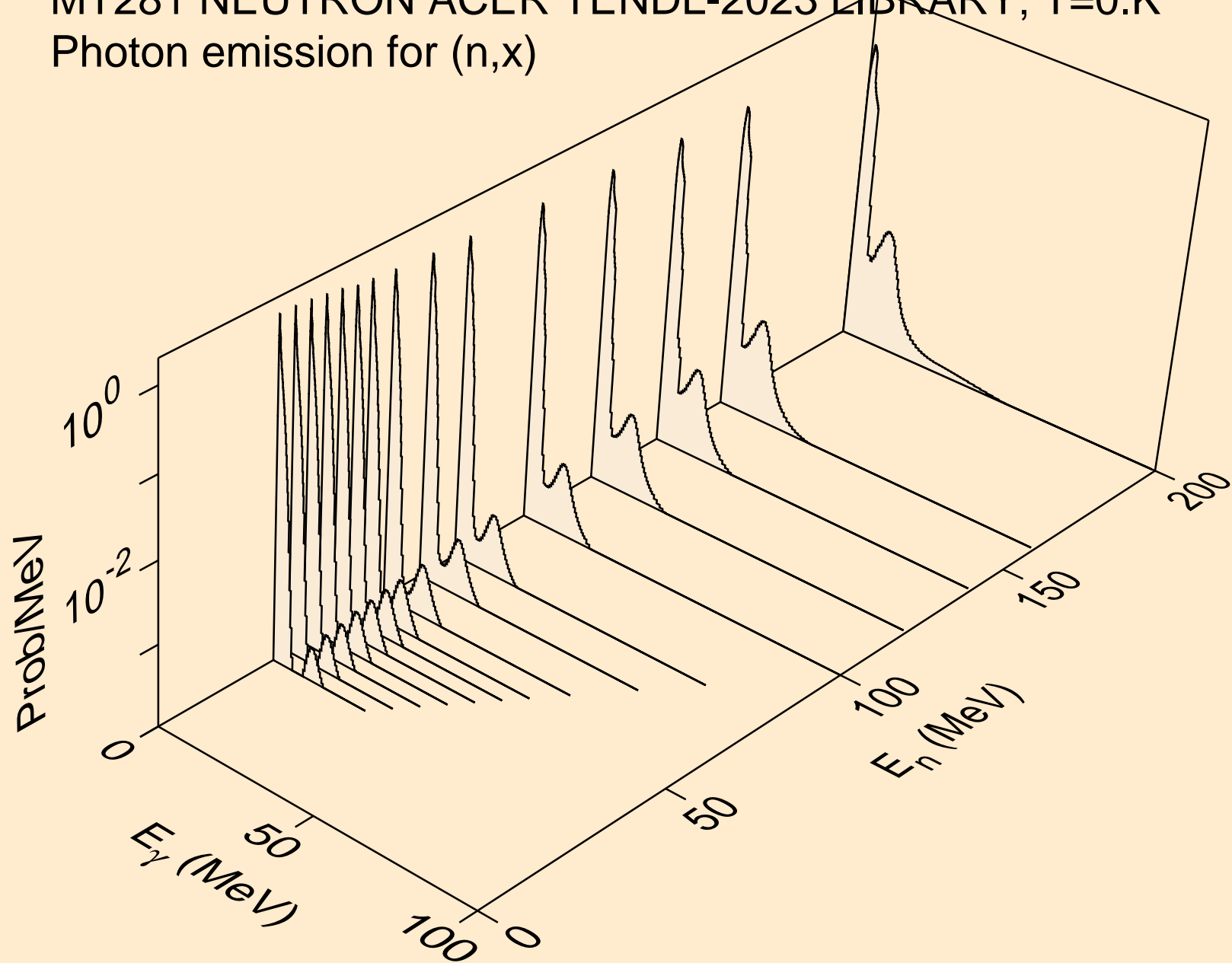

MT281 NEUTRON ACER TENDL-2023 LIBRARY; T=0.K
Photon emission for (n,2nd)

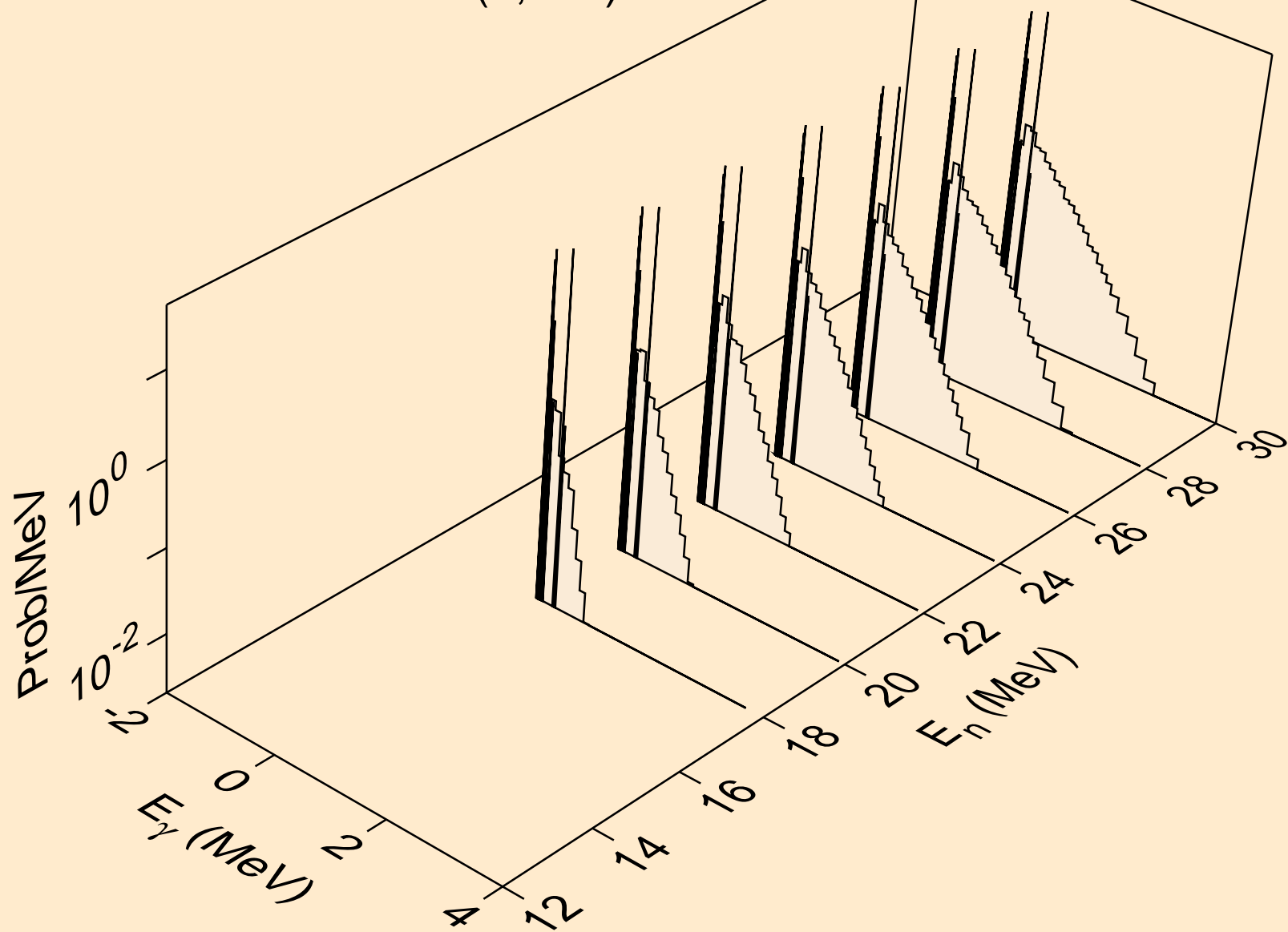

MT281 NEUTRON ACER TENDL-2023 LIBRARY; T=0.K
Photon emission for (n,2n)

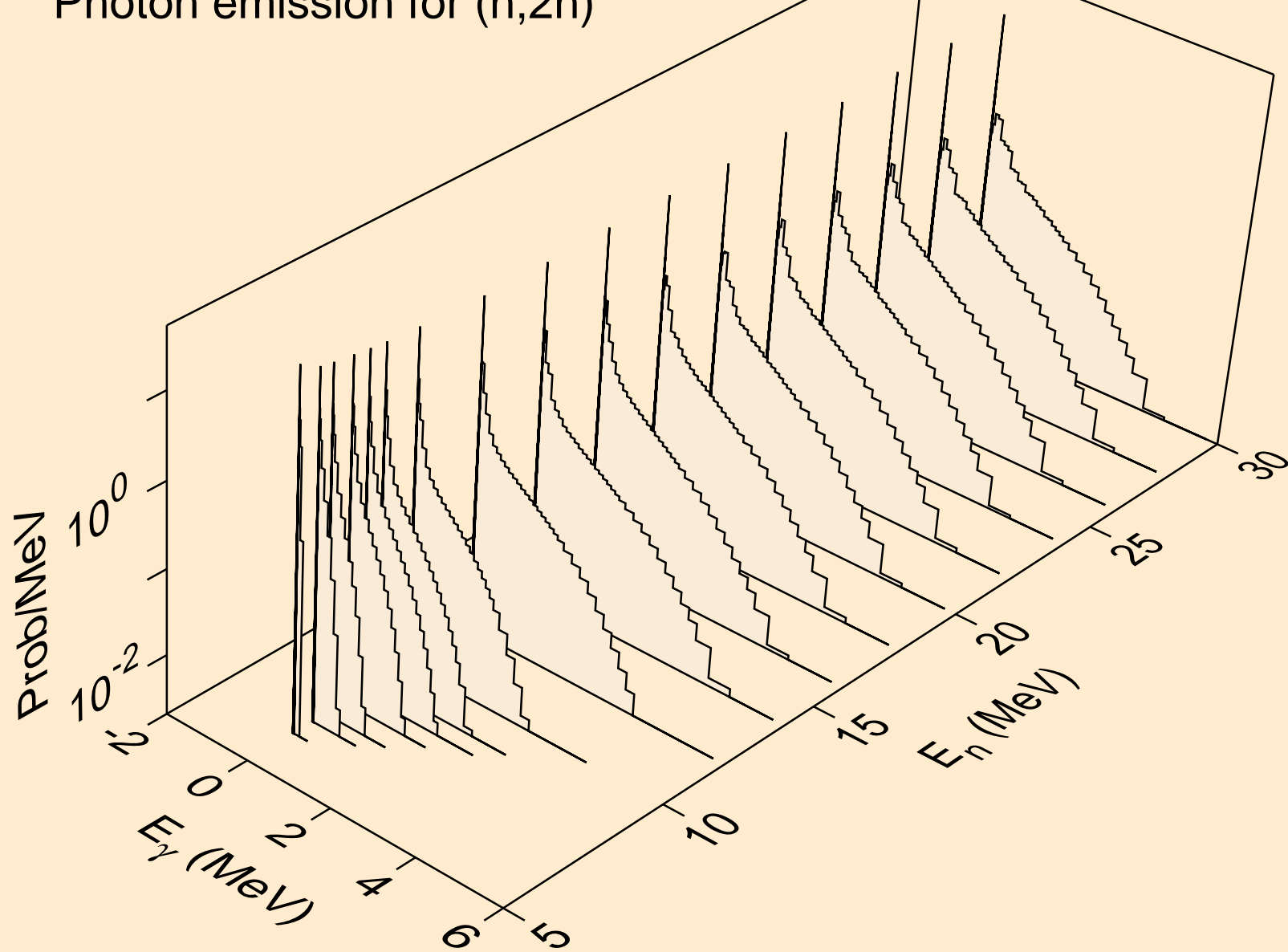

MT281 NEUTRON ACER TENDL-2023 LIBRARY; T=0.K
Photon emission for (n,3n)

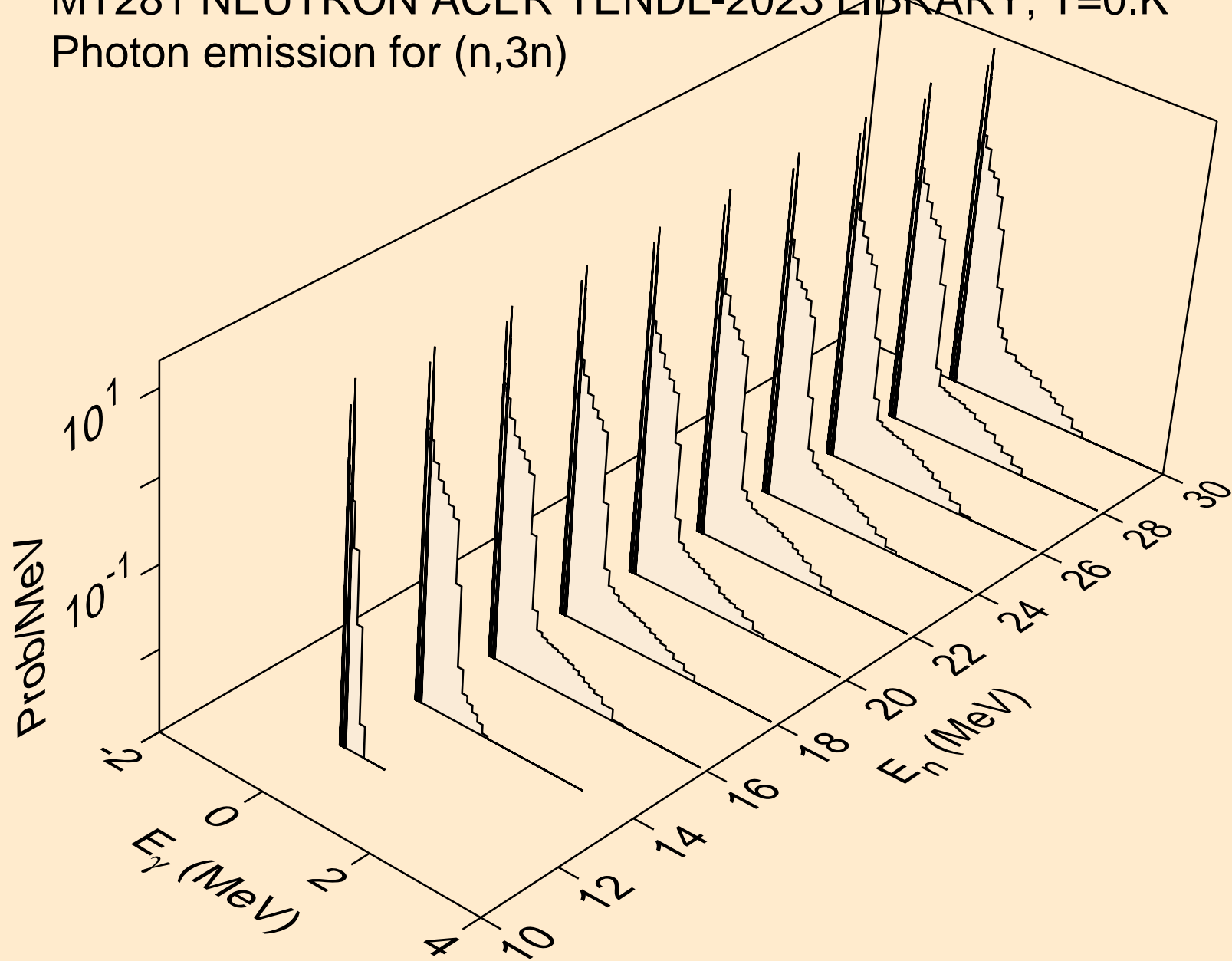

MT281 NEUTRON ACER TENDL-2023 LIBRARY; T=0.K
Photon emission for (n,n*)a

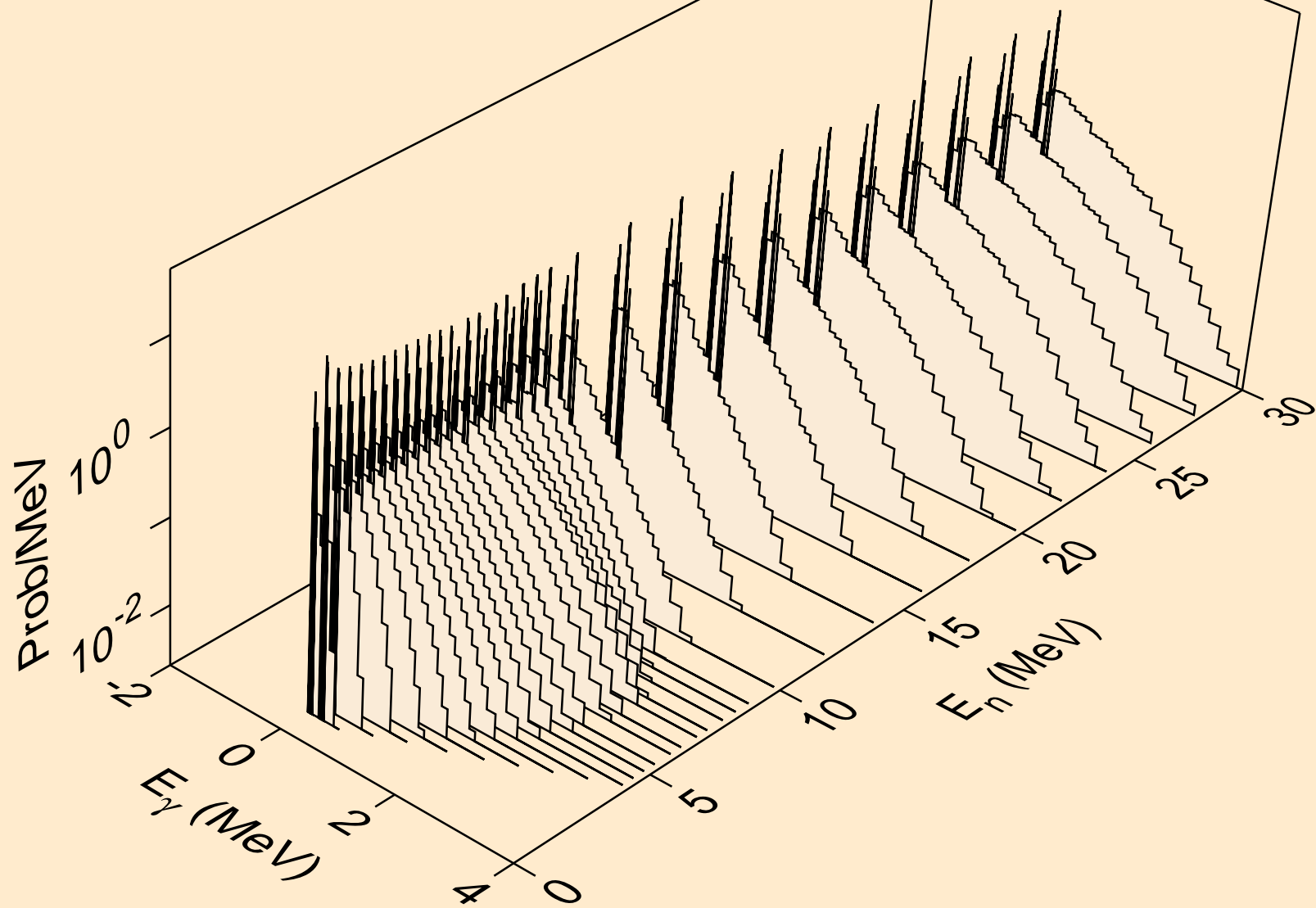

MT281 NEUTRON ACER TENDL-2023 LIBRARY; T=0.K
Photon emission for (n,2n)a

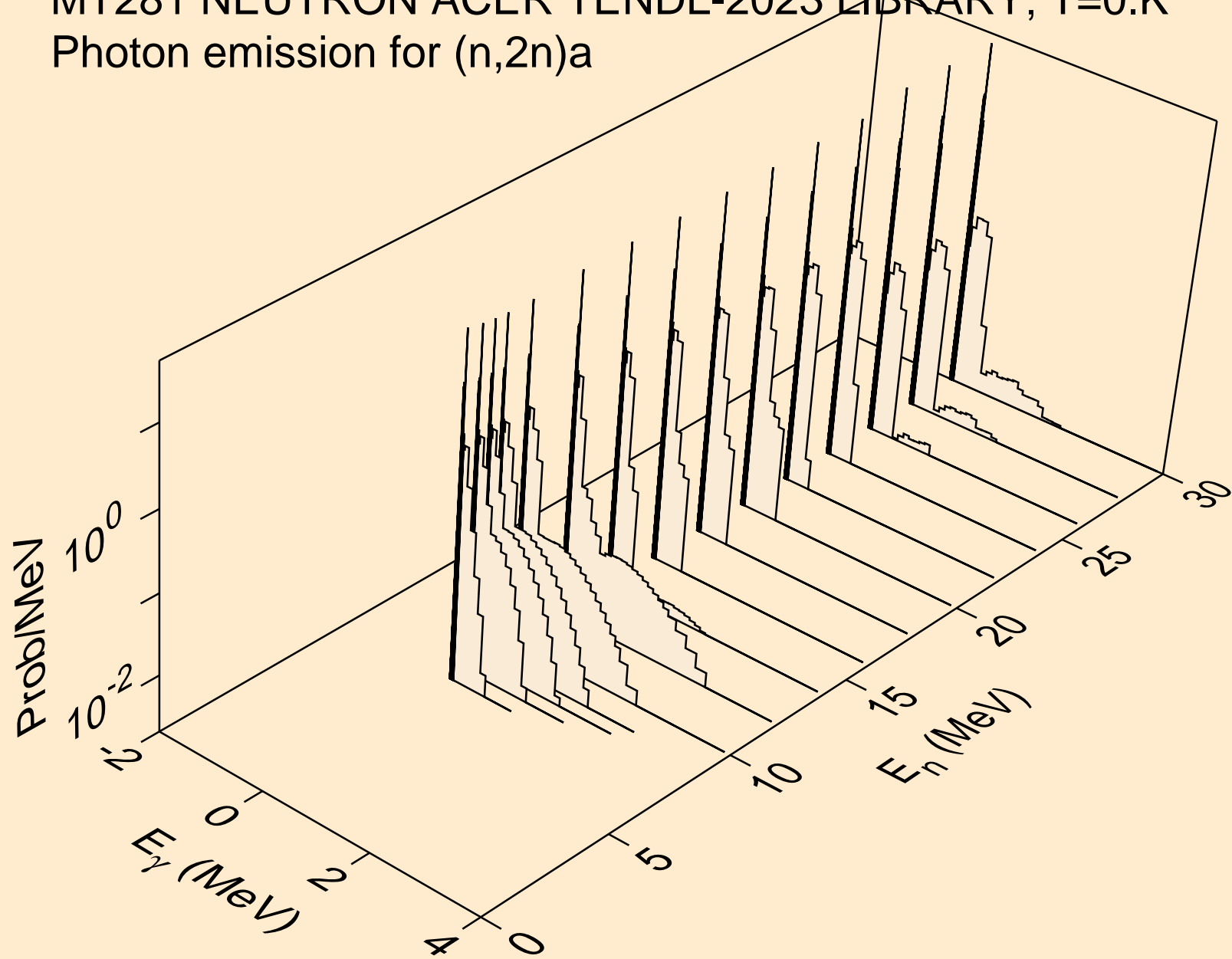

MT281 NEUTRON ACER TENDL-2023 LIBRARY; T=0.K
Photon emission for (n,3n)a

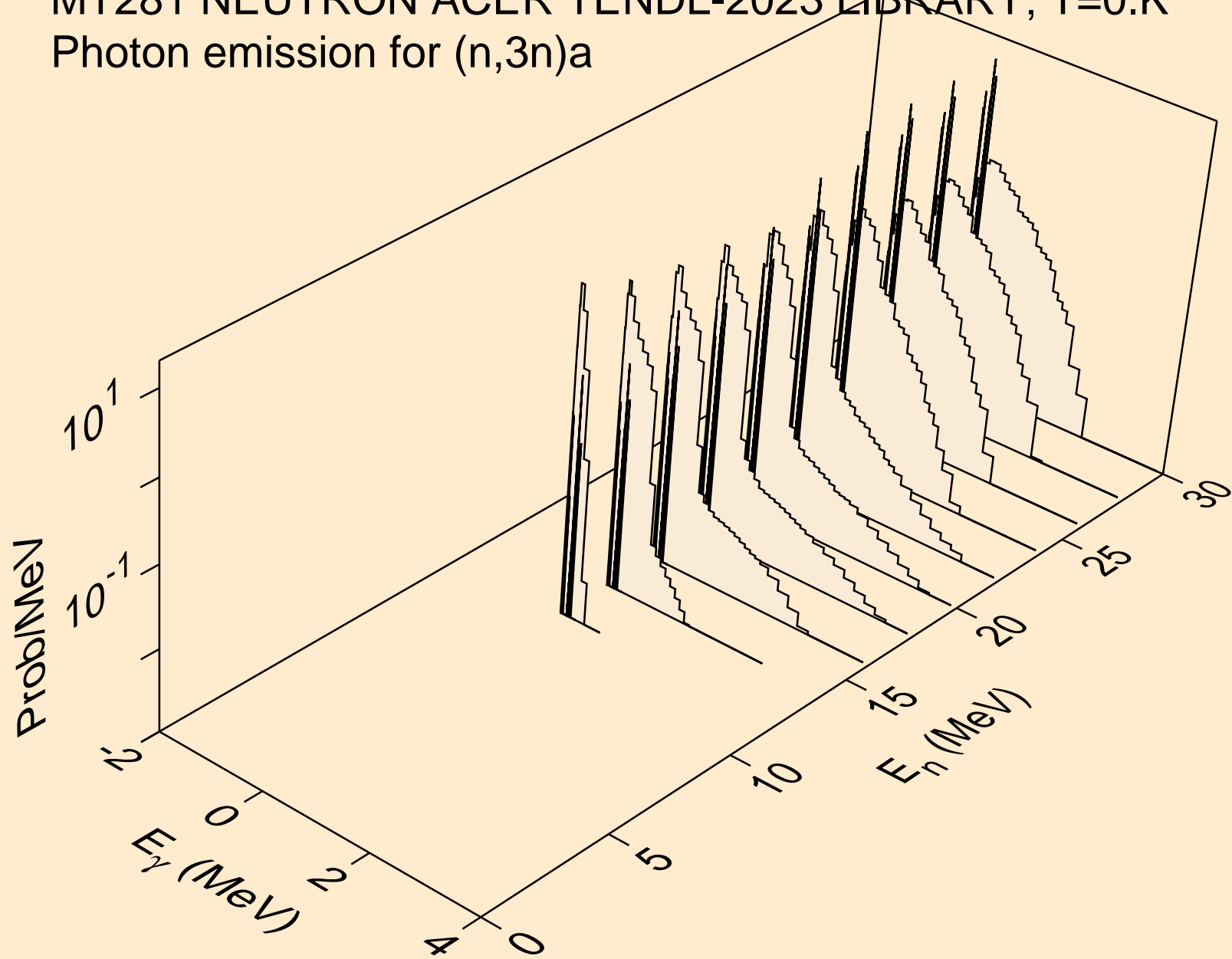

MT281 NEUTRON ACER TENDL-2023 LIBRARY; T=0.K
Photon emission for (n,n*)p

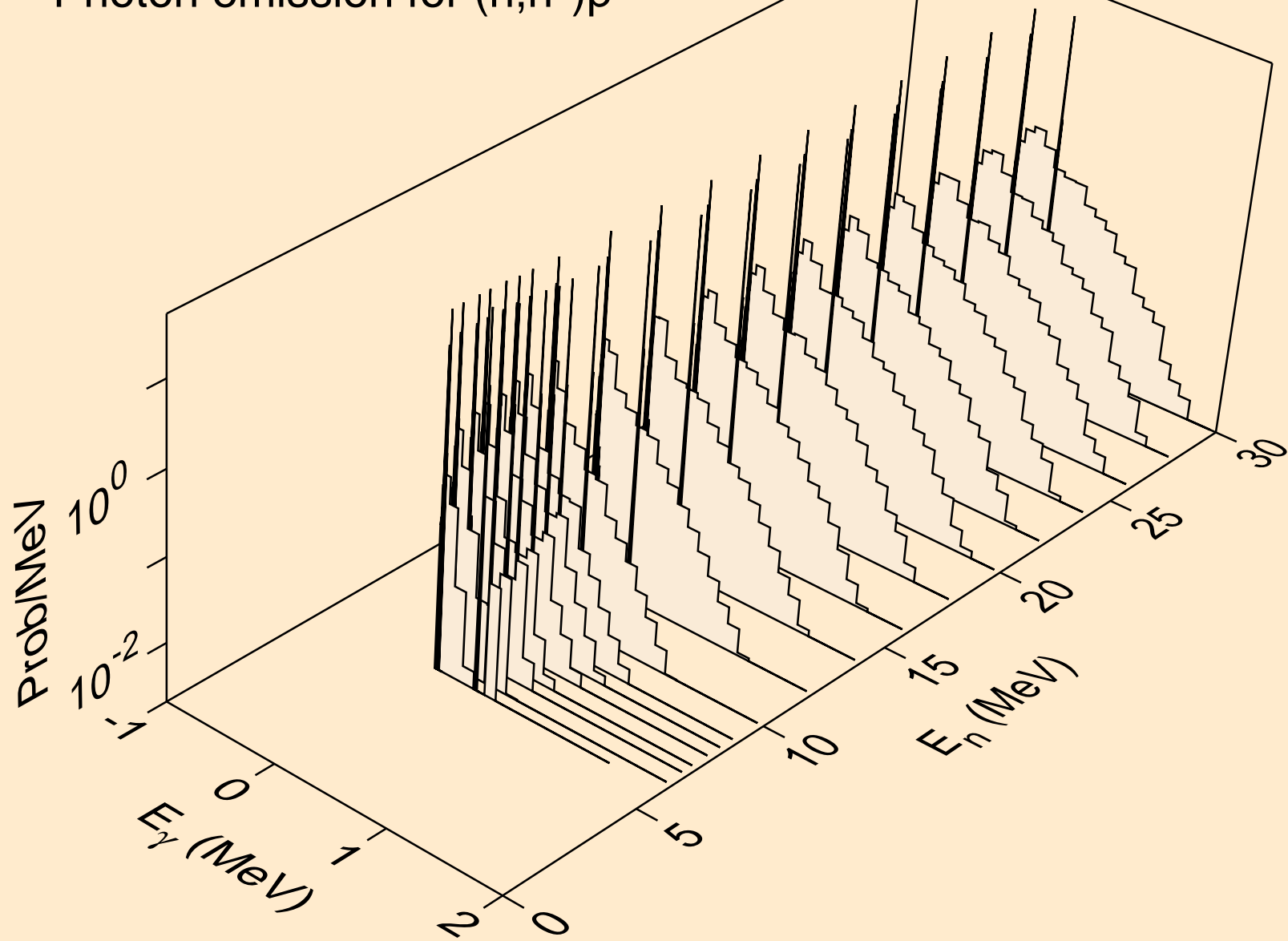

MT281 NEUTRON ACER TENDL-2023 LIBRARY; T=0.K
Photon emission for (n,n*)d

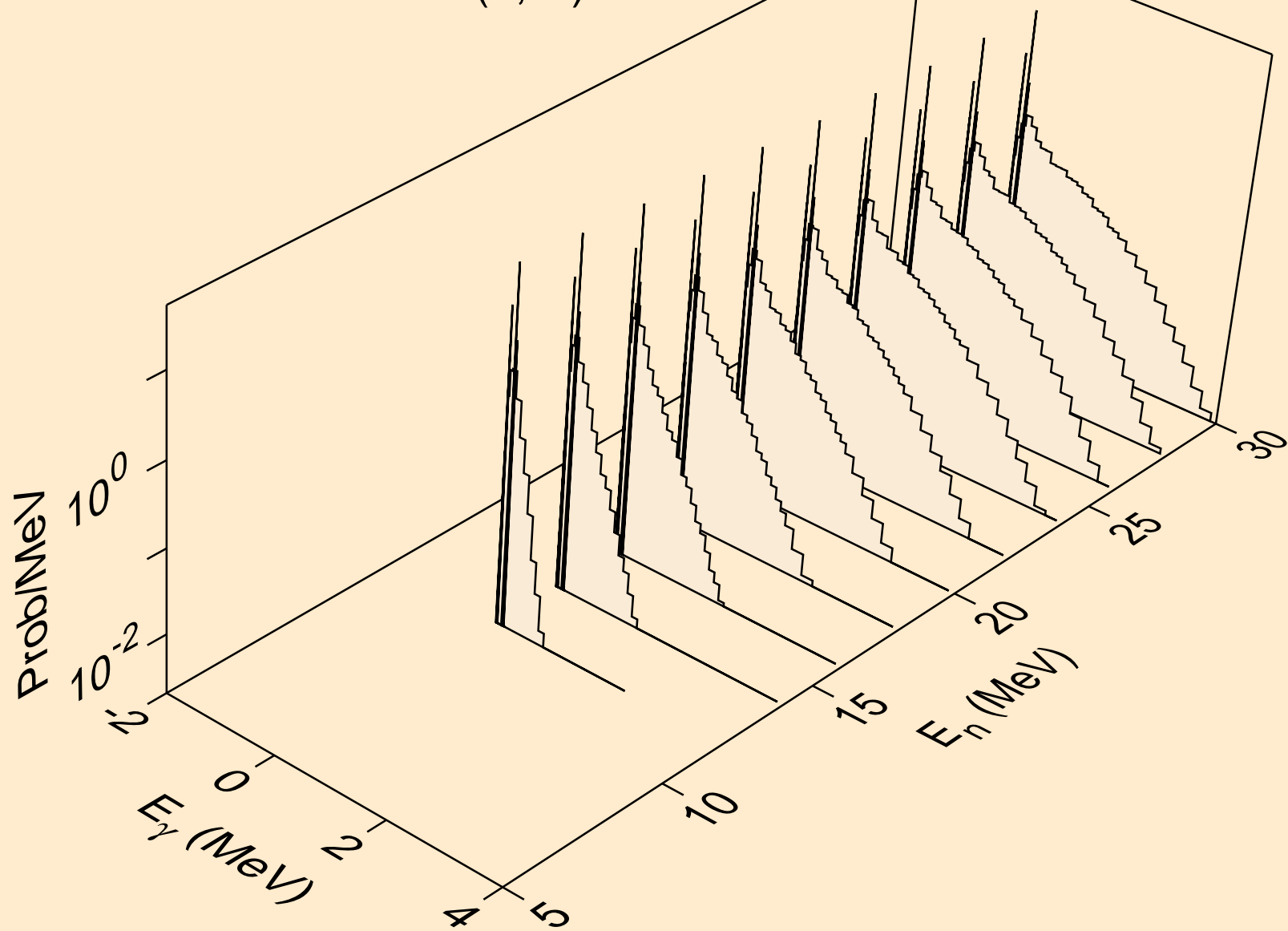

MT281 NEUTRON ACER TENDL-2023 LIBRARY; T=0.K
Photon emission for (n,n*)t

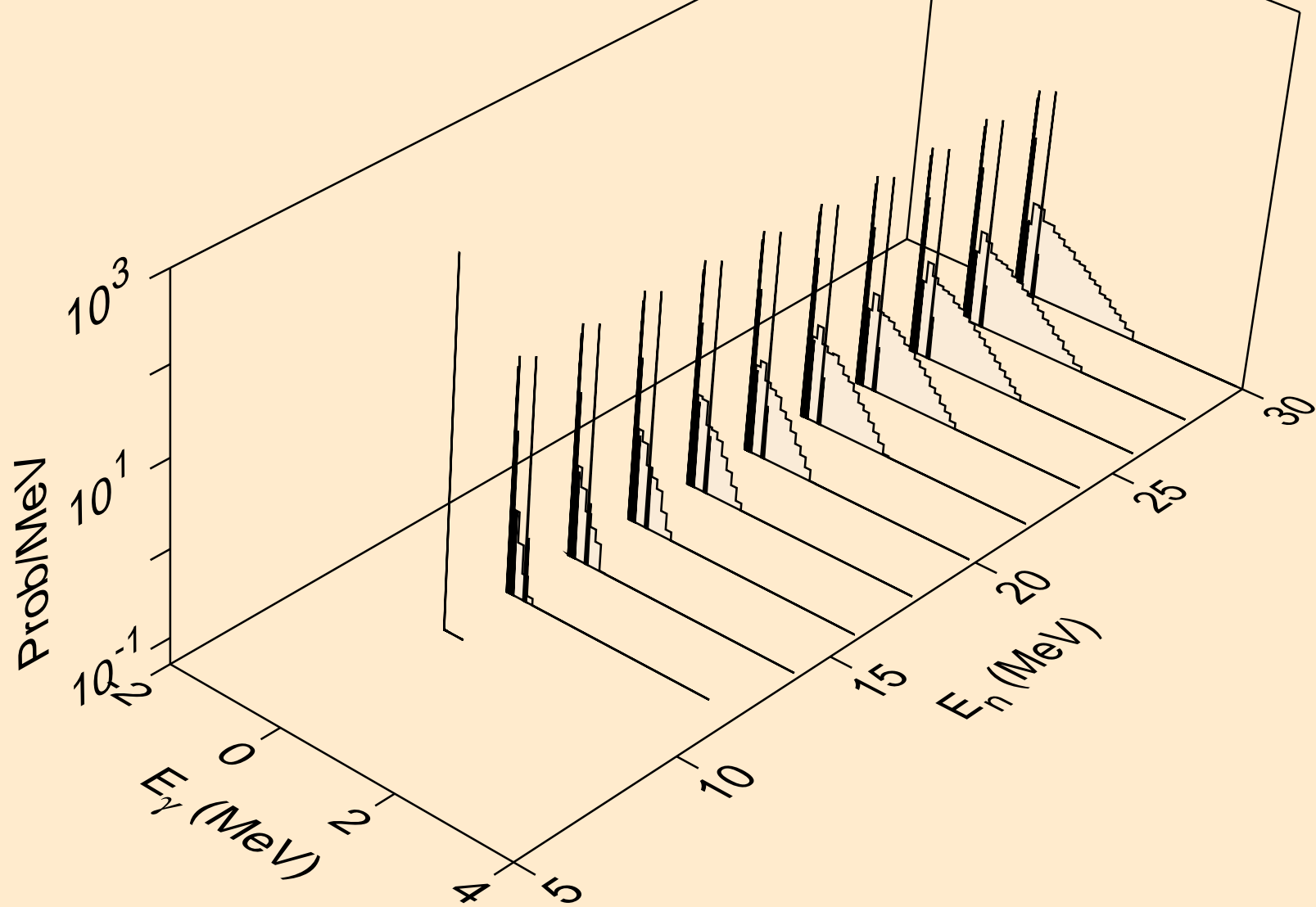

MT281 NEUTRON ACER TENDL-2023 LIBRARY; T=0.K
Photon emission for (n,n*)he3

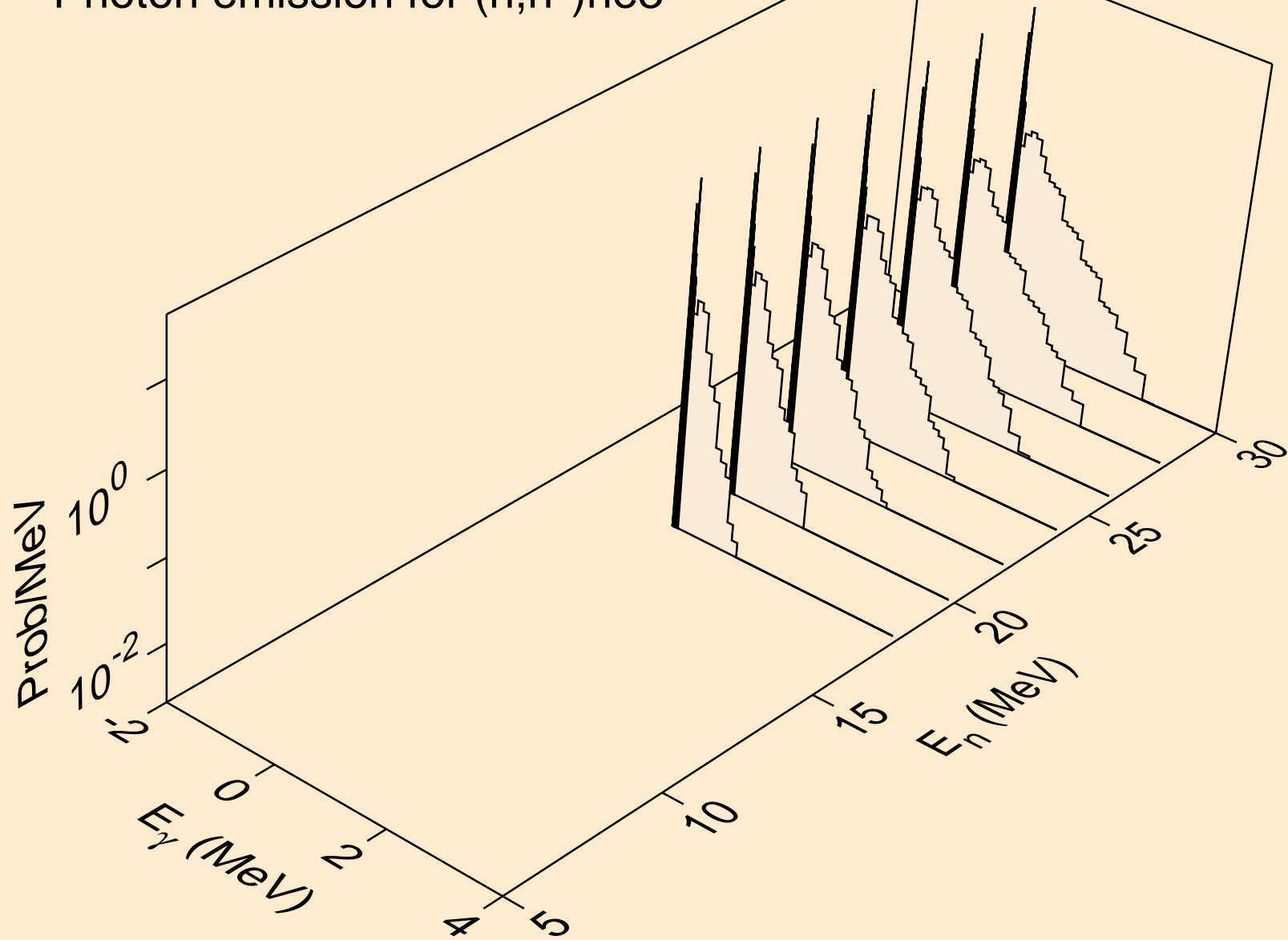

MT281 NEUTRON ACER TENDL-2023 LIBRARY; T=0.K
Photon emission for (n,4n)

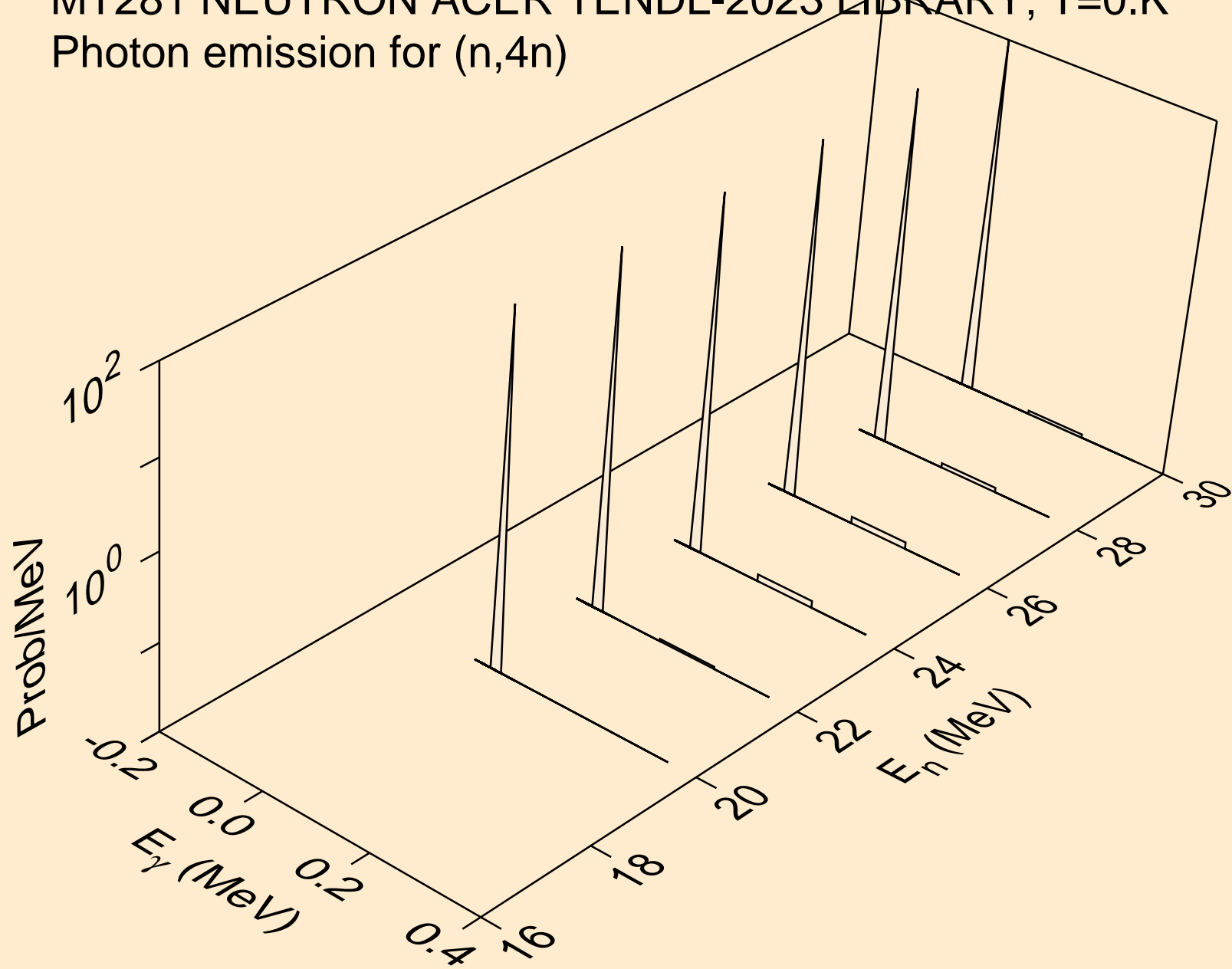

MT281 NEUTRON ACER TENDL-2023 LIBRARY; T=0.K
Photon emission for (n,2np)

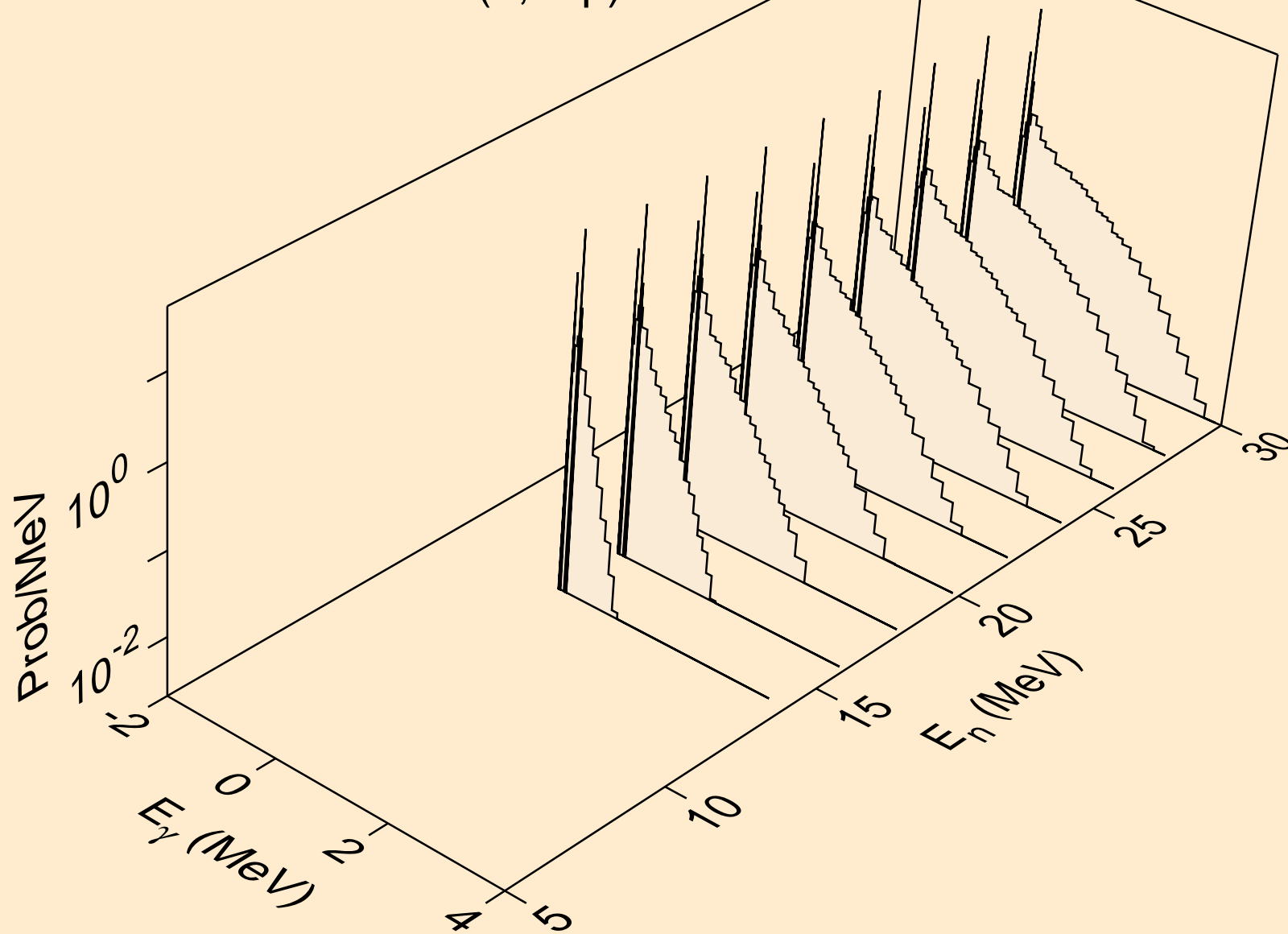

MT281 NEUTRON ACER TENDL-2023 LIBRARY; T=0.K
Photon emission for (n,3np)

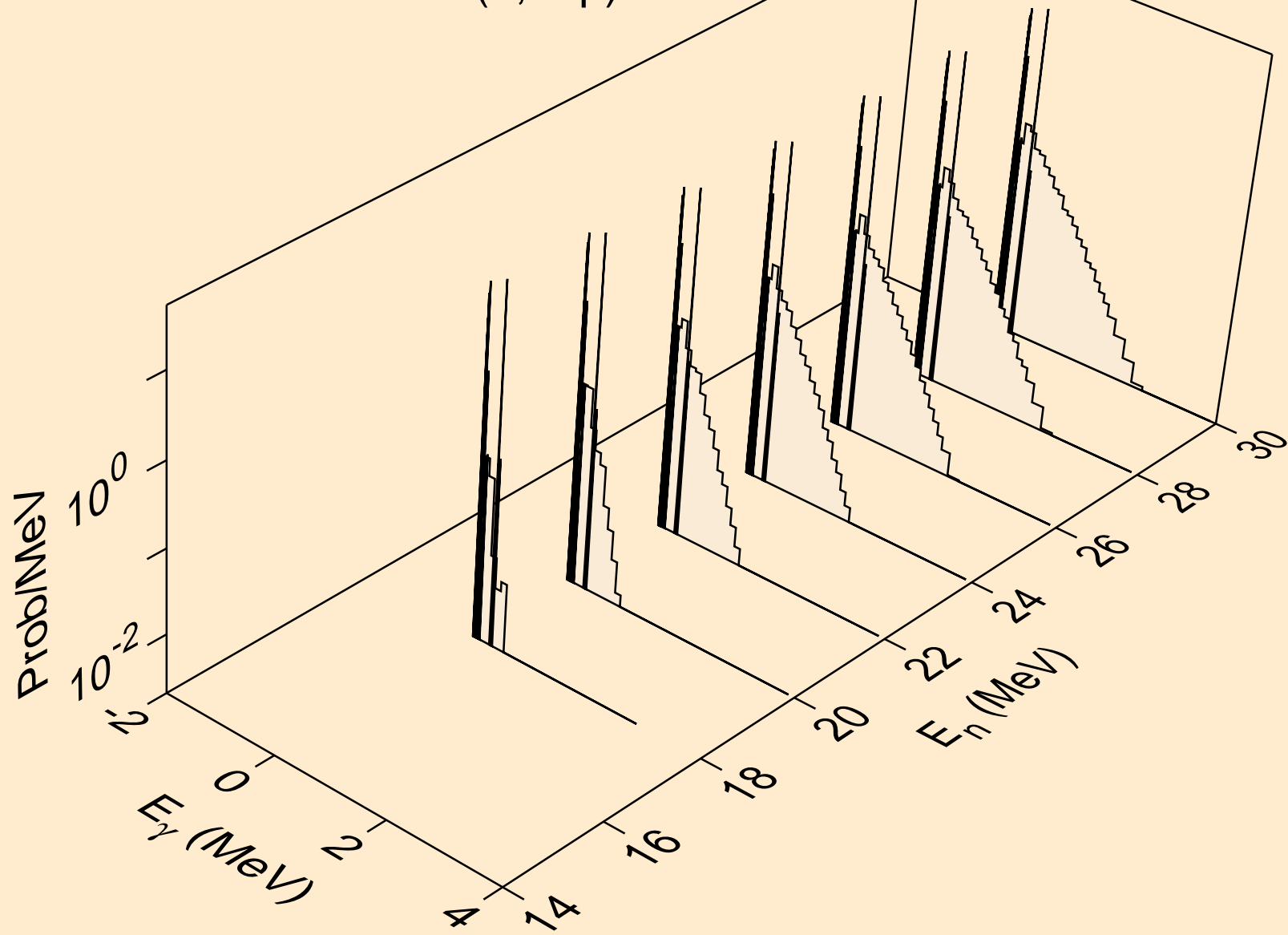

MT281 NEUTRON ACER TENDL-2023 LIBRARY; T=0.K
Photon emission for (n,n*c)

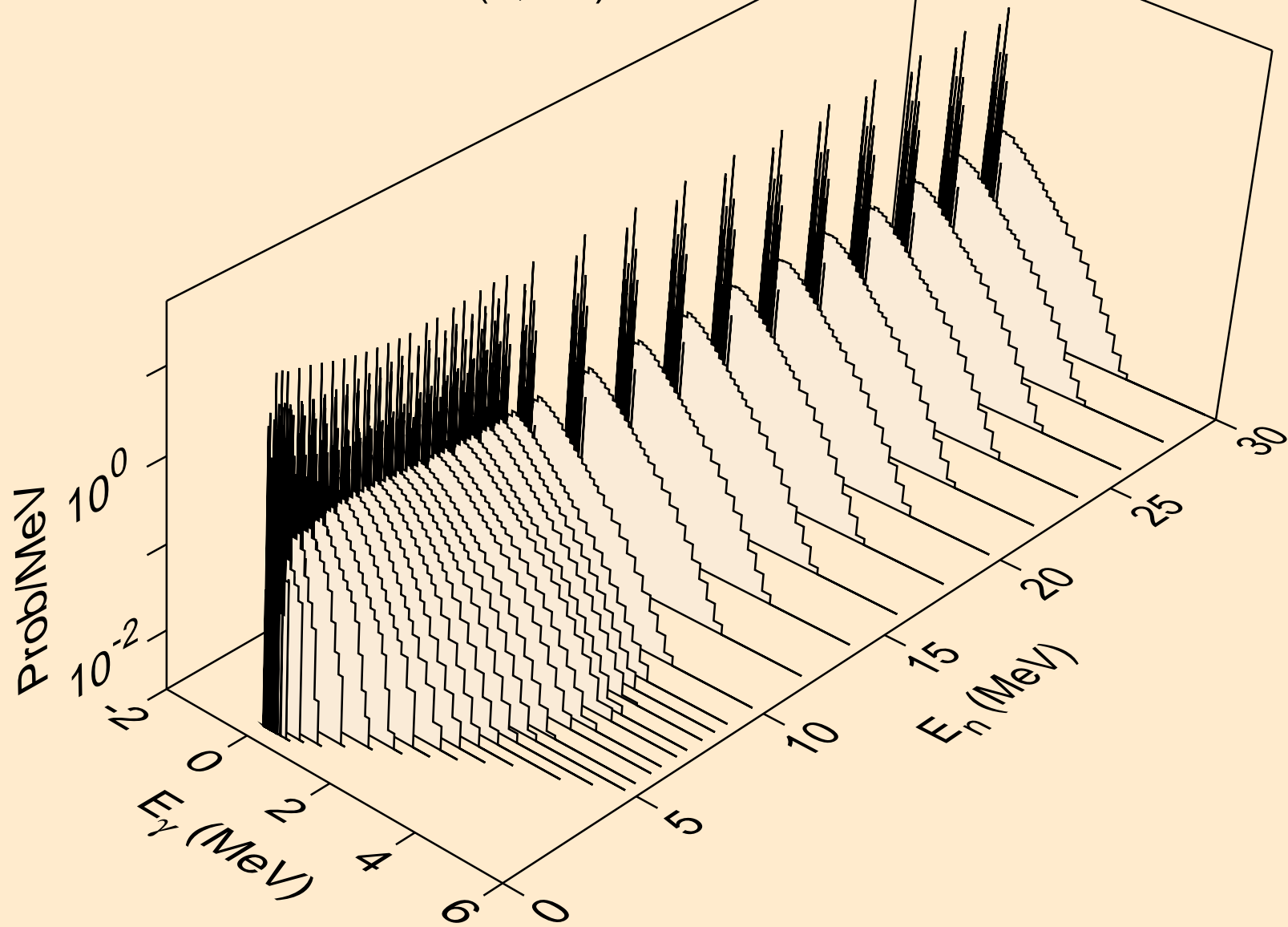

MT281 NEUTRON ACER TENDL-2023 LIBRARY; T=0.K
Photon emission for (n,gma)

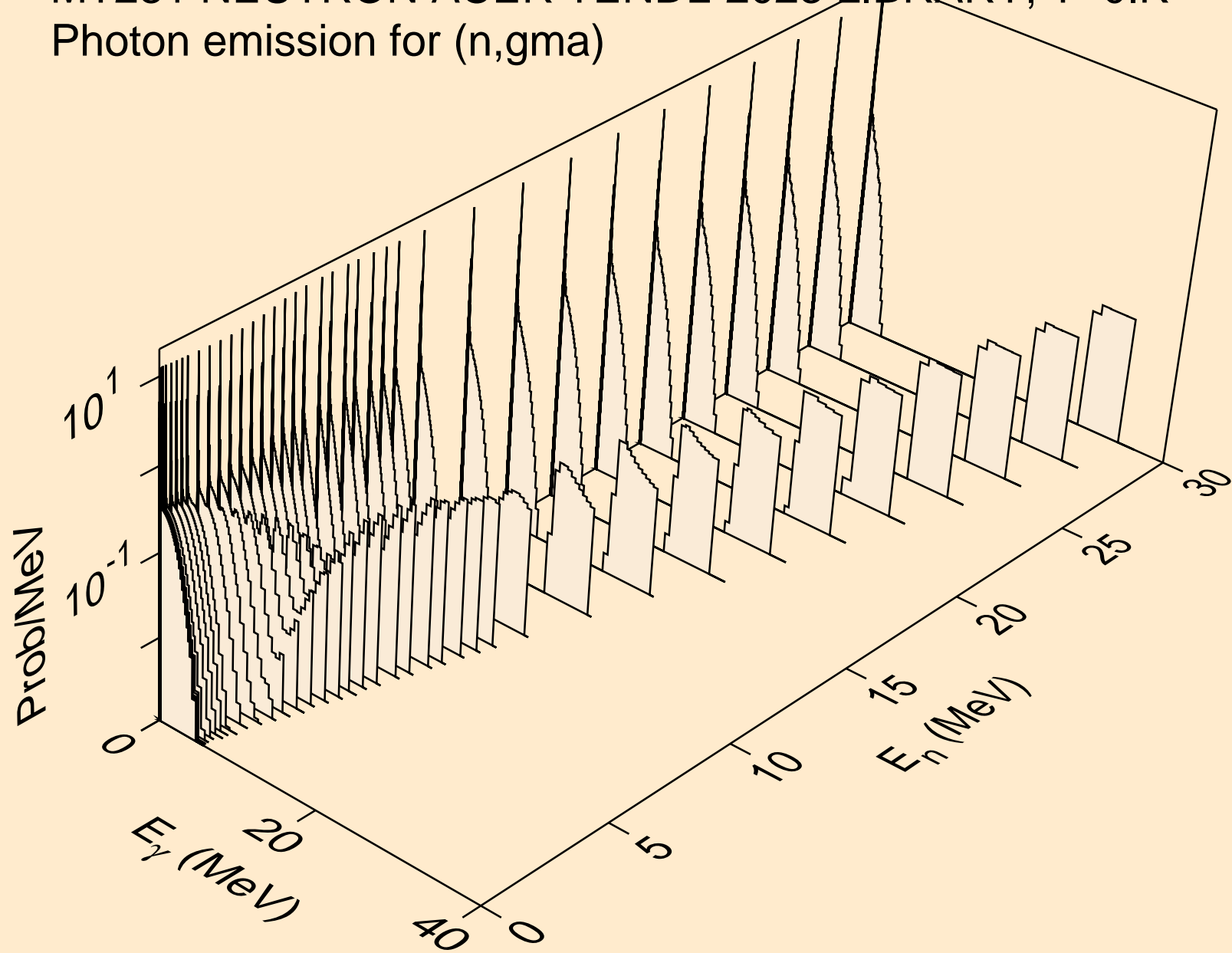

MT281 NEUTRON ACER TENDL-2023 LIBRARY; T=0.K
Photon emission for (n,p)

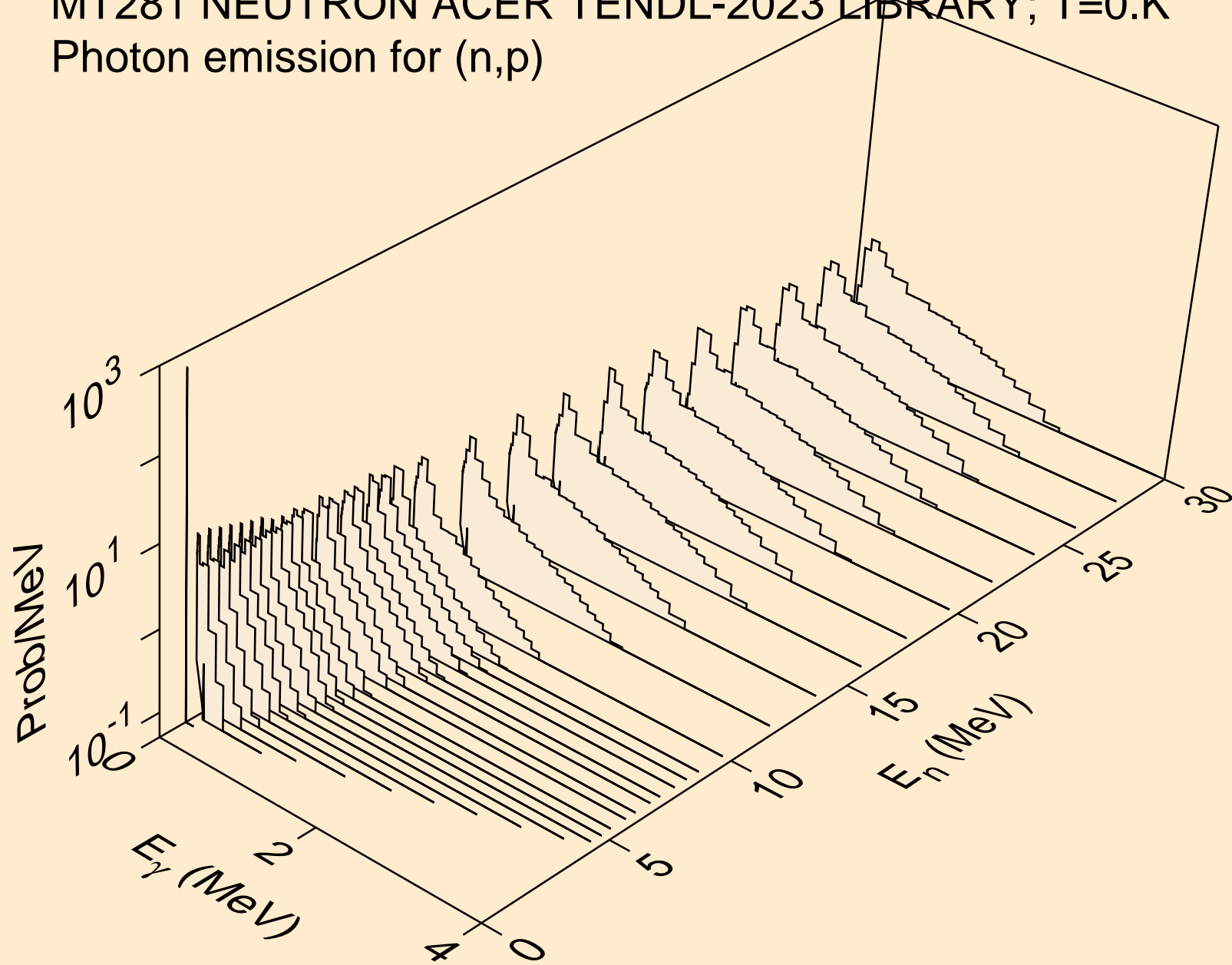

MT281 NEUTRON ACER TENDL-2023 LIBRARY; T=0.K
Photon emission for (n,d)

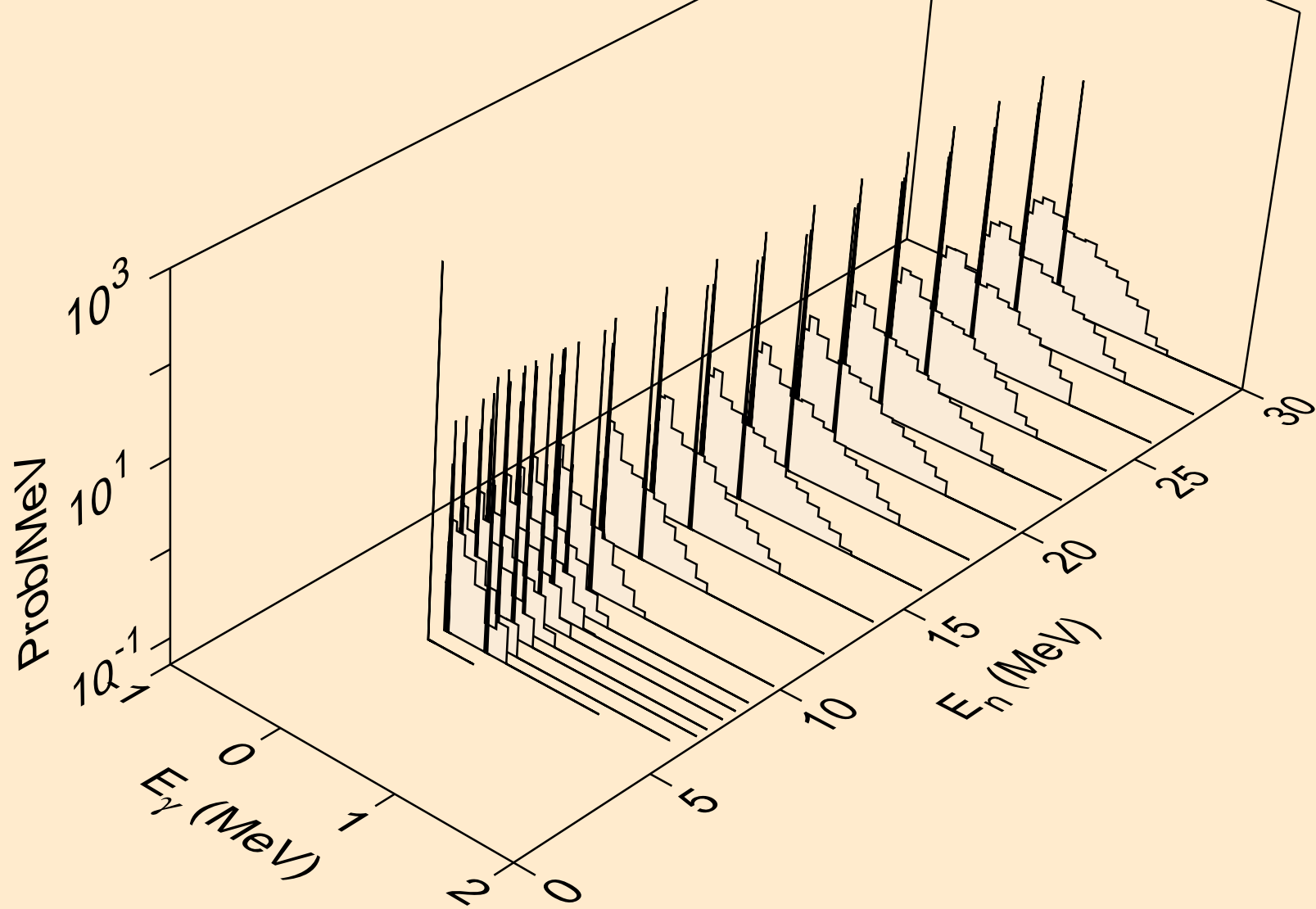

MT281 NEUTRON ACER TENDL-2023 LIBRARY; T=0.K
Photon emission for (n,t)

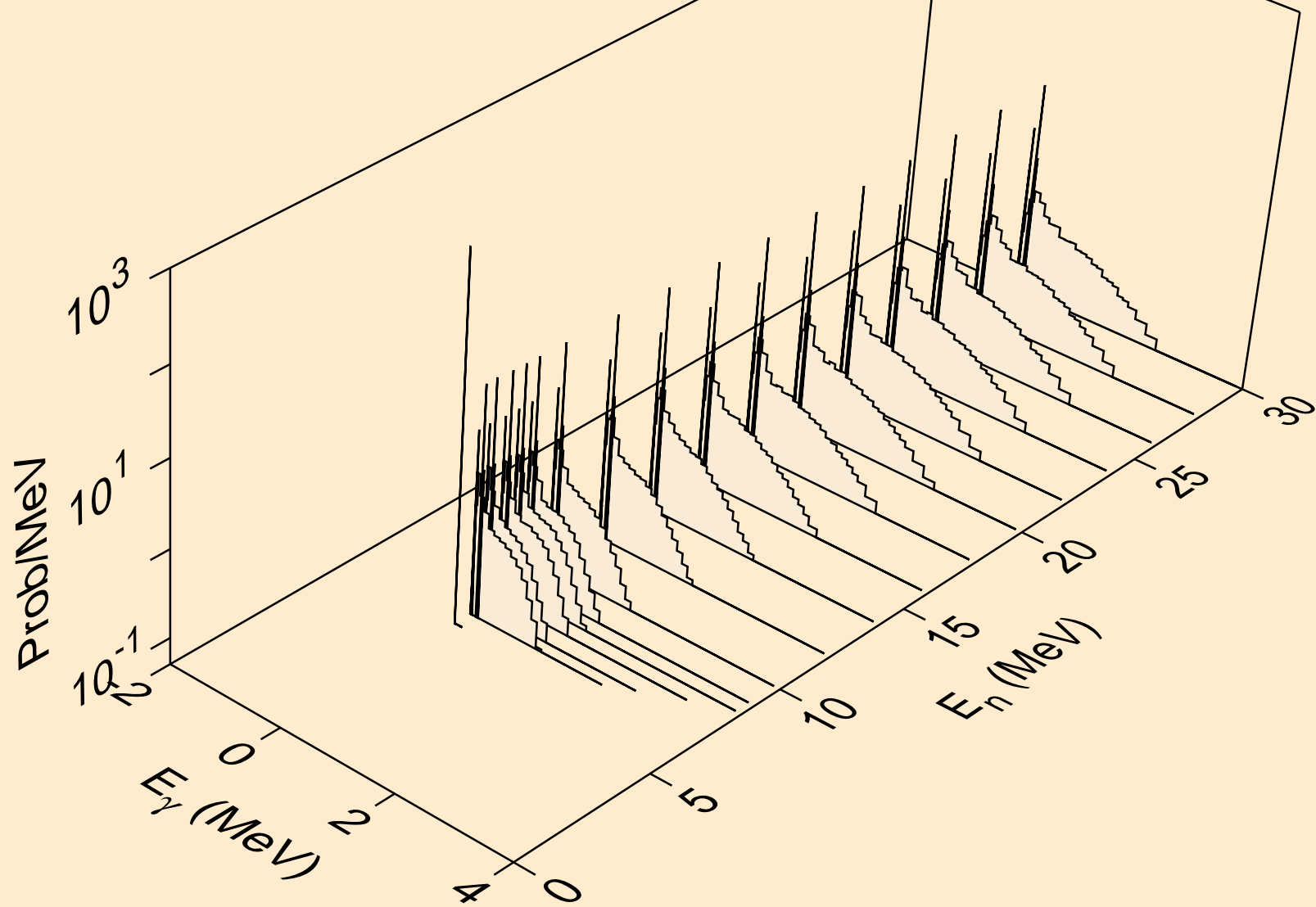

MT281 NEUTRON ACER TENDL-2023 LIBRARY; T=0.K
Photon emission for (n,he3)

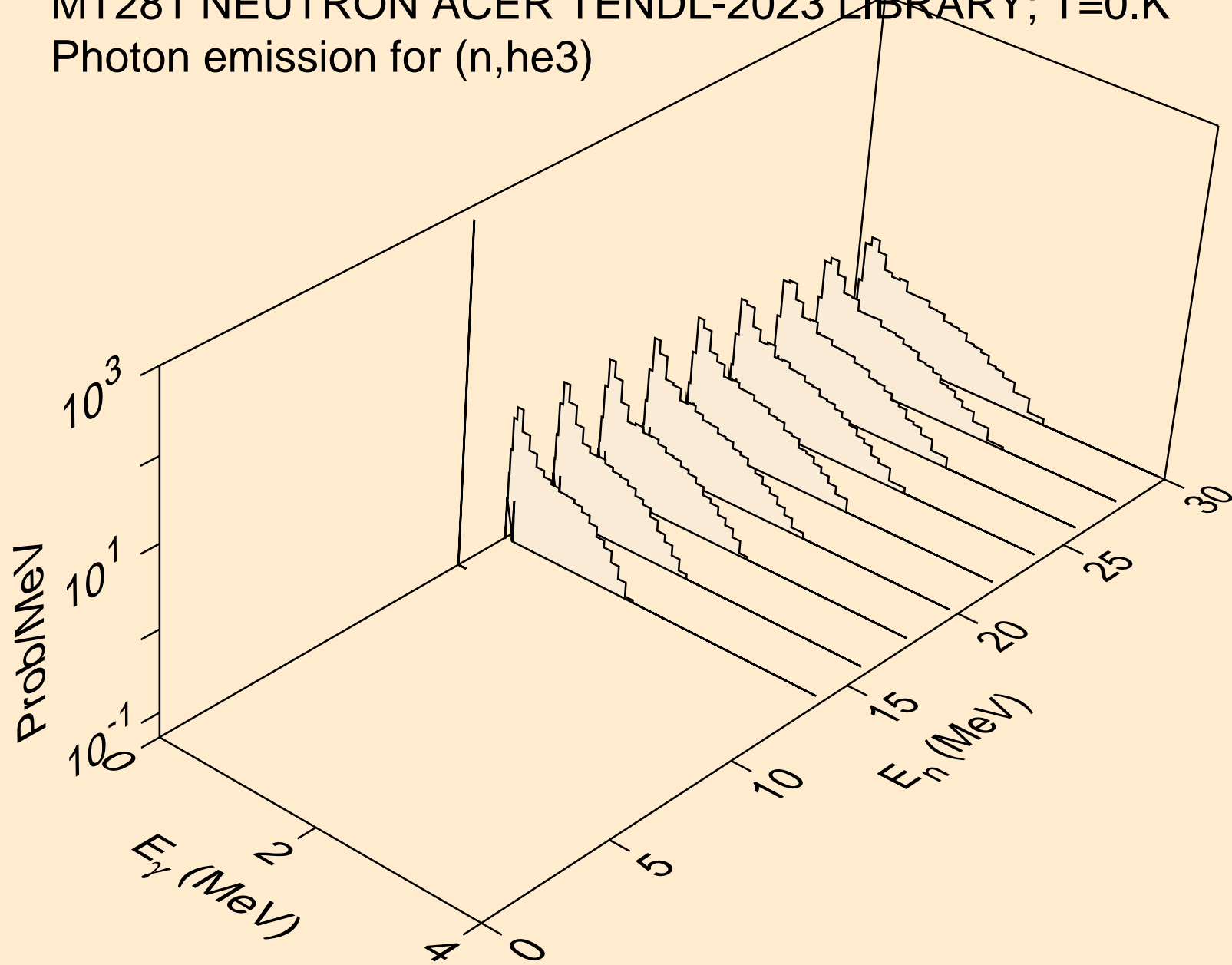

MT281 NEUTRON ACER TENDL-2023 LIBRARY; T=0.K
Photon emission for (n,a)

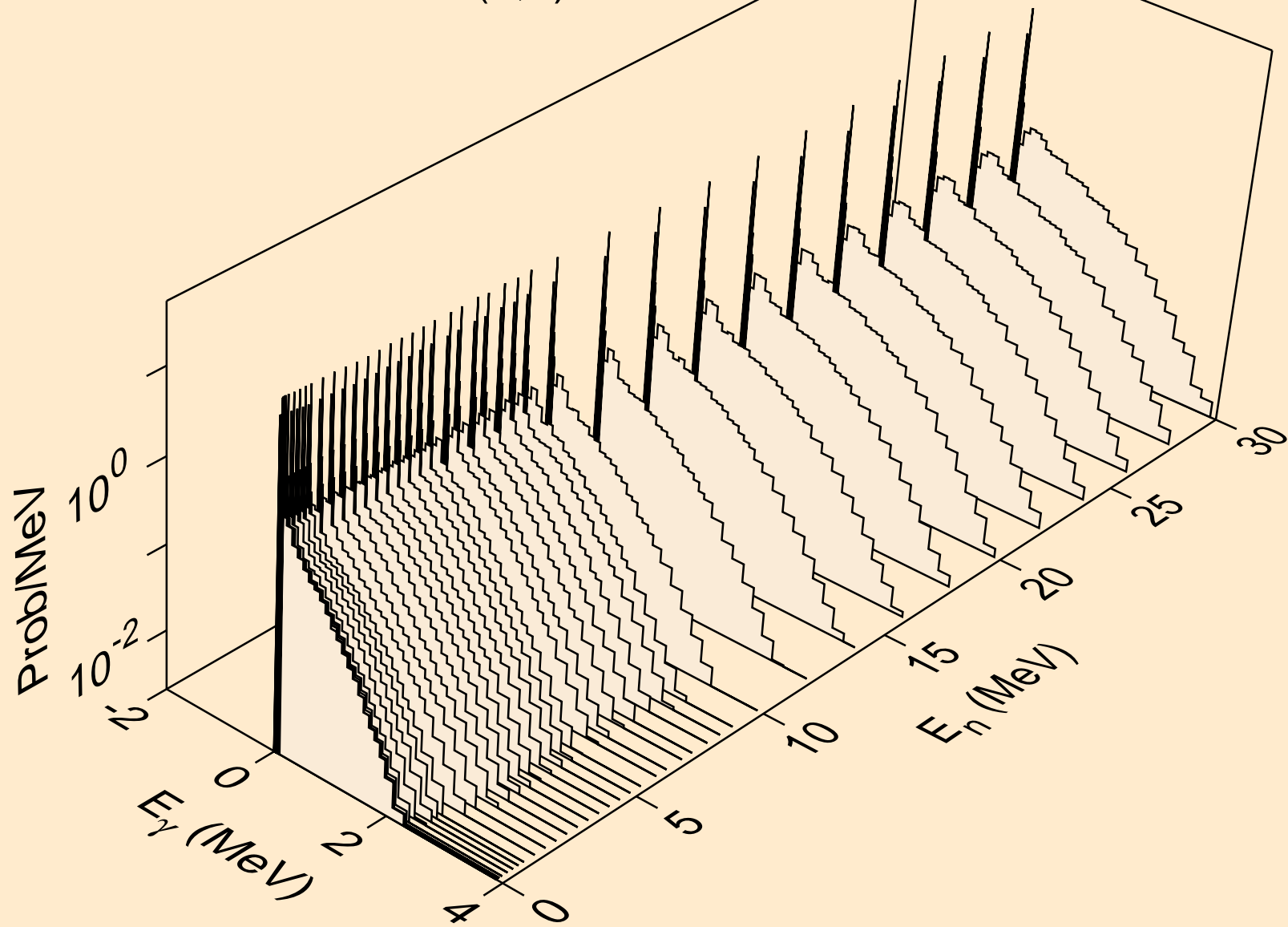

MT281 NEUTRON ACER TENDL-2023 LIBRARY; T=0.K
thermal capture photon spectrum

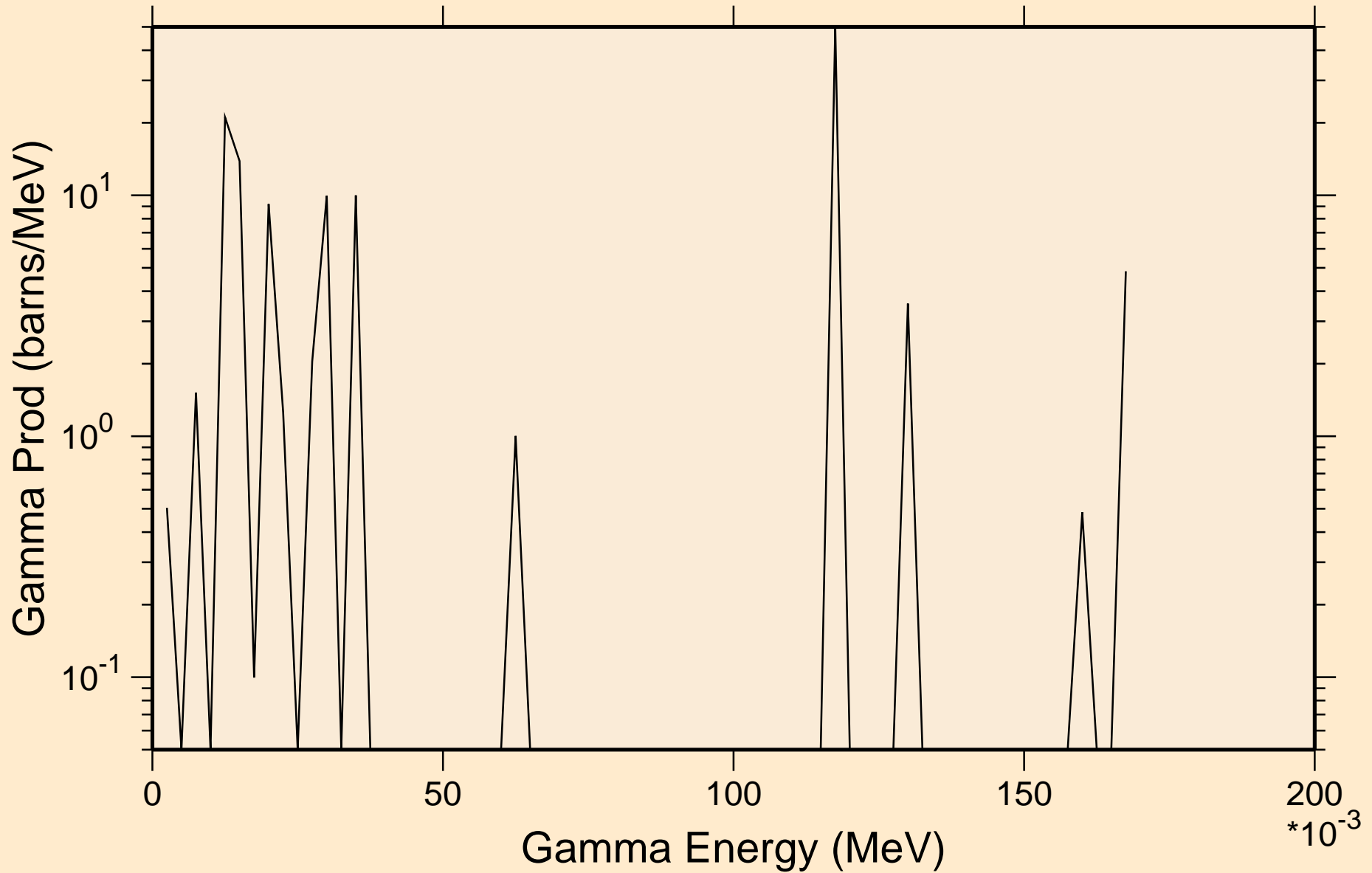

MT281 NEUTRON ACER TENDL-2023 LIBRARY; T=0.K
14 MeV photon spectrum

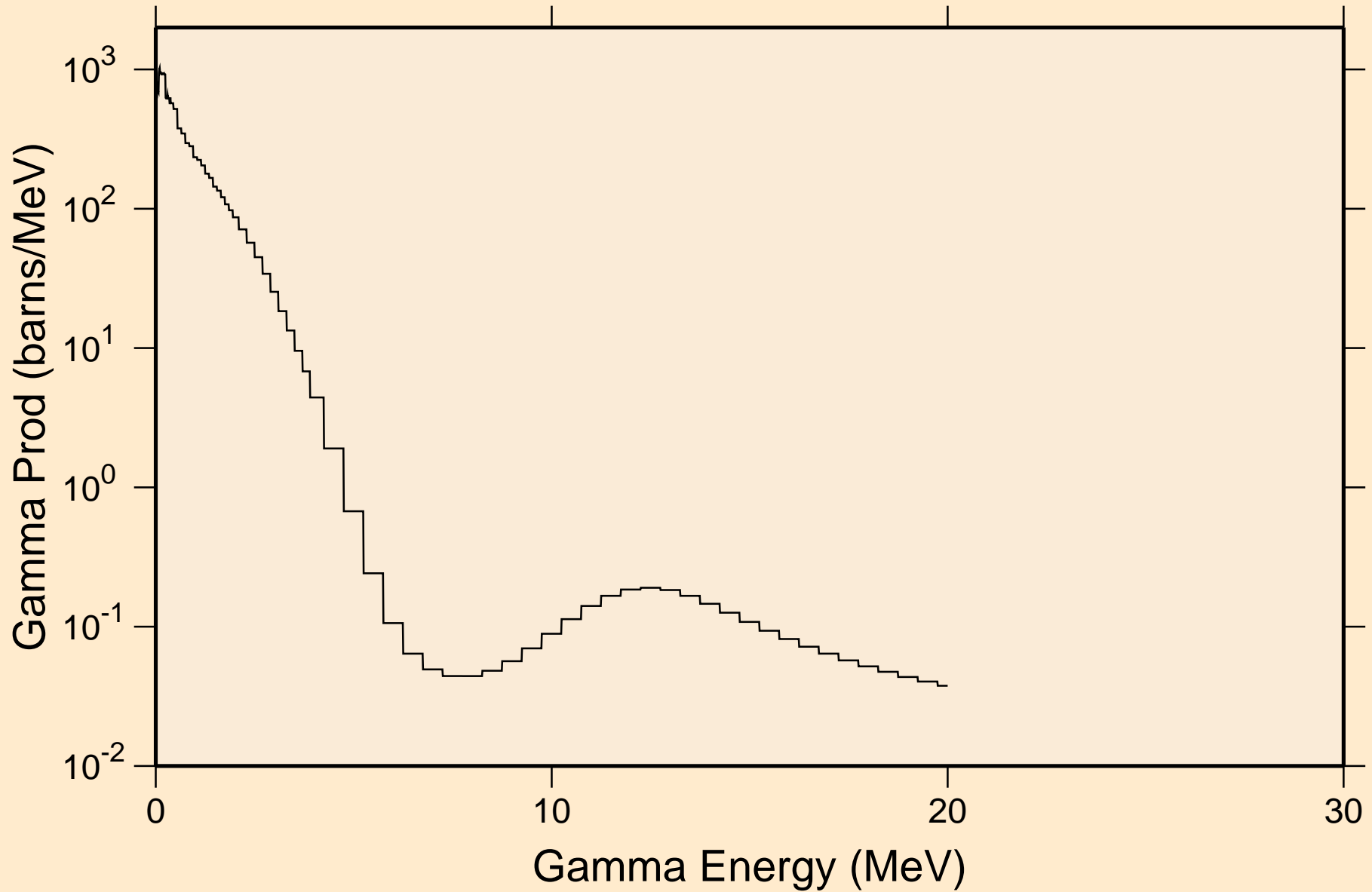

MT281 NEUTRON ACER TENDL-2023 LIBRARY; T=0.K

Particle heating contributions

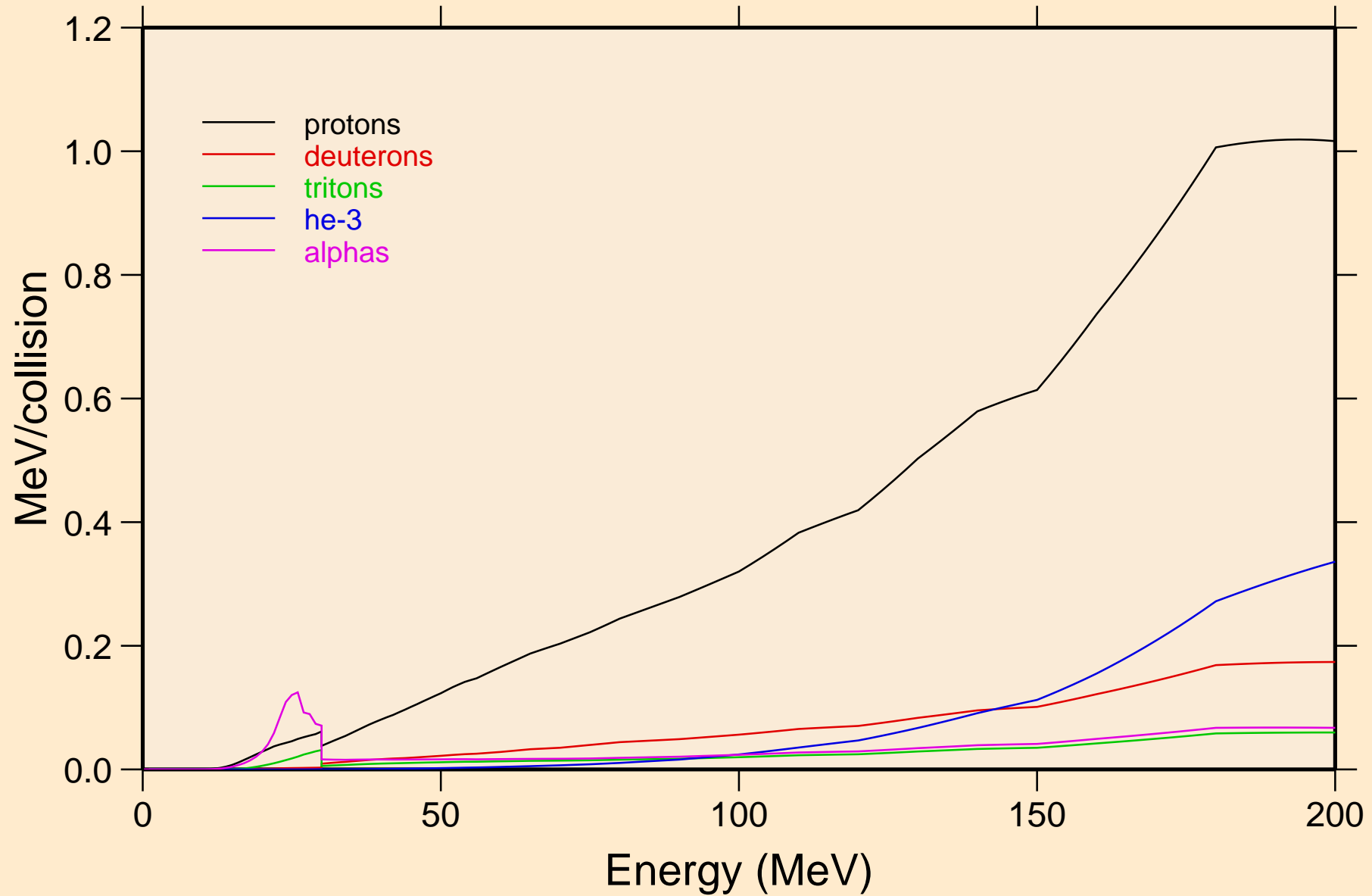

MT281 NEUTRON ACER TENDL-2023 LIBRARY; T=0.K
Recoil Heating

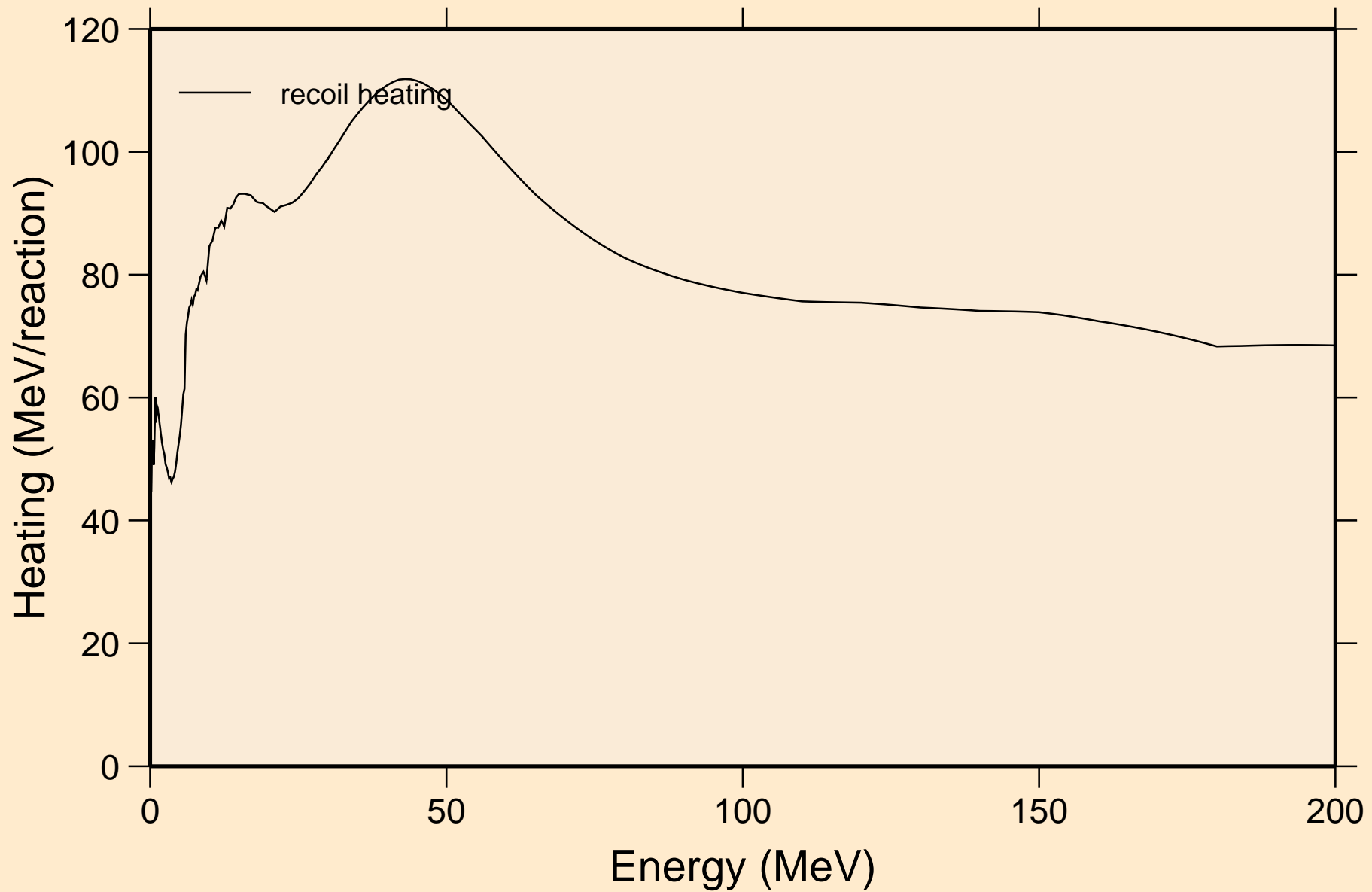

MT281 NEUTRON ACER TENDL-2023 LIBRARY; T=0.K

Particle production cross sections

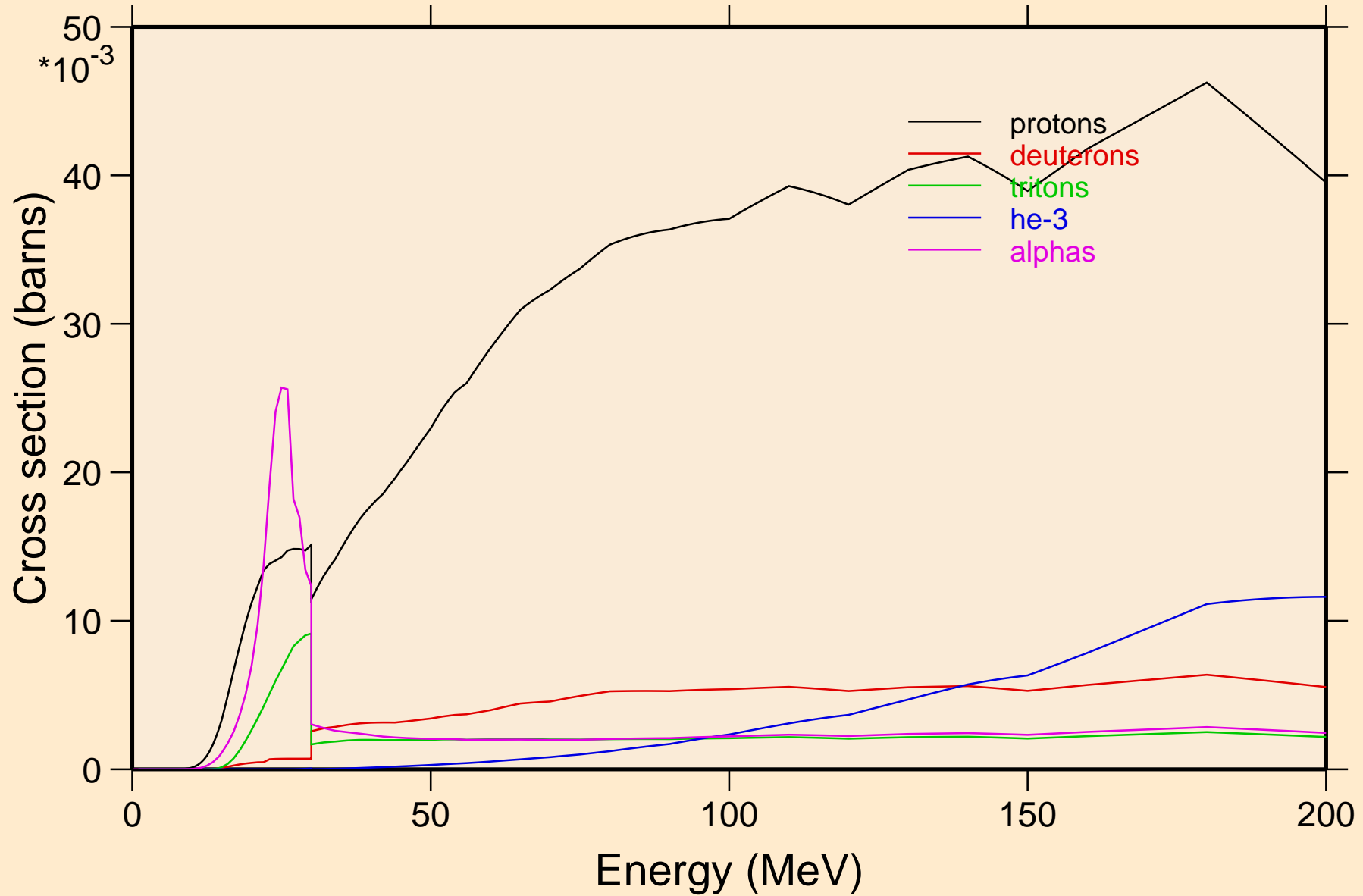

MT281 NEUTRON ACER TENDL-2023 LIBRARY; T=0.K
protons from (n,x)

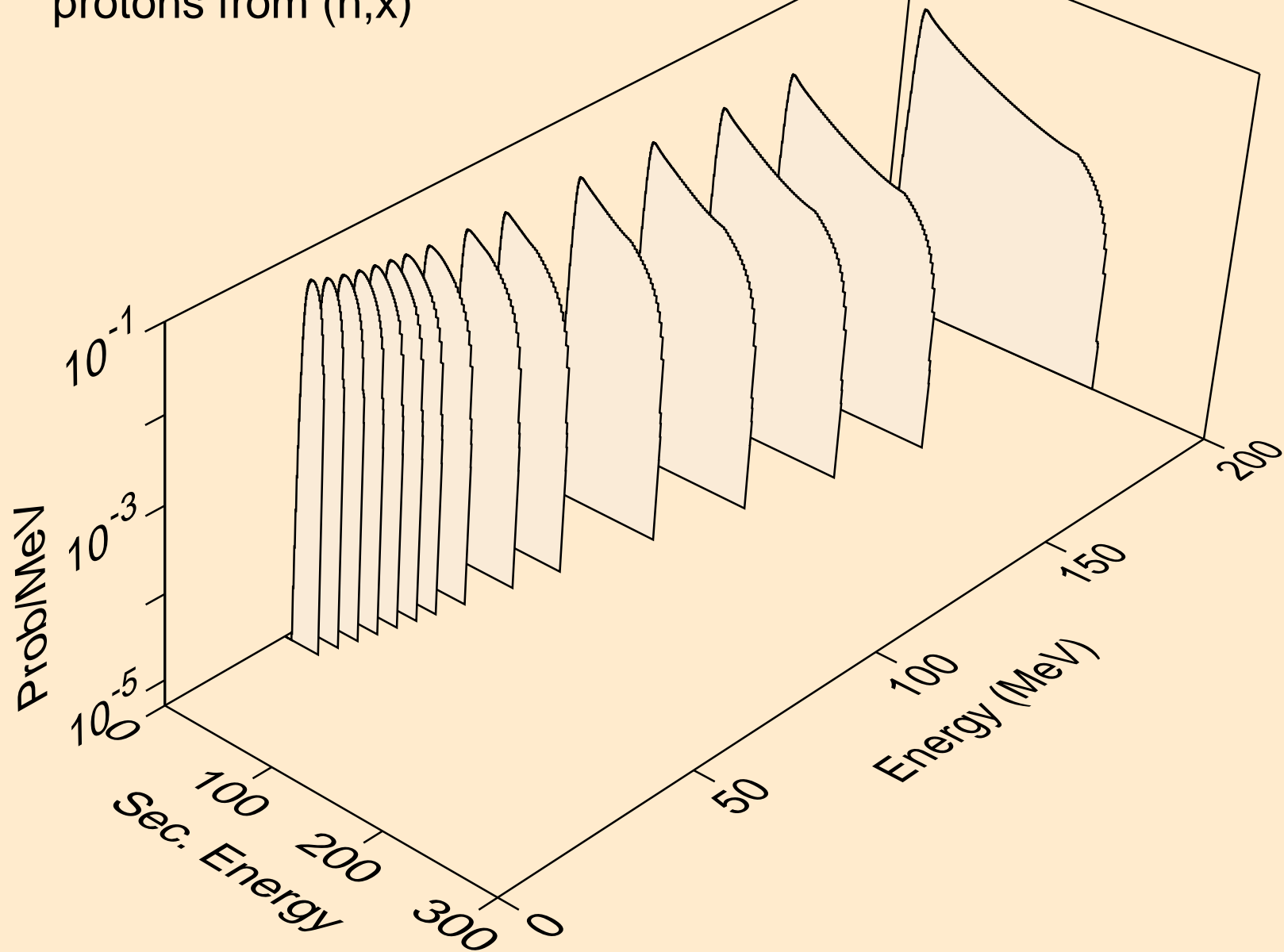

MT281 NEUTRON ACER TENDL-2023 LIBRARY; T=0.K
protons from (n,n*)p

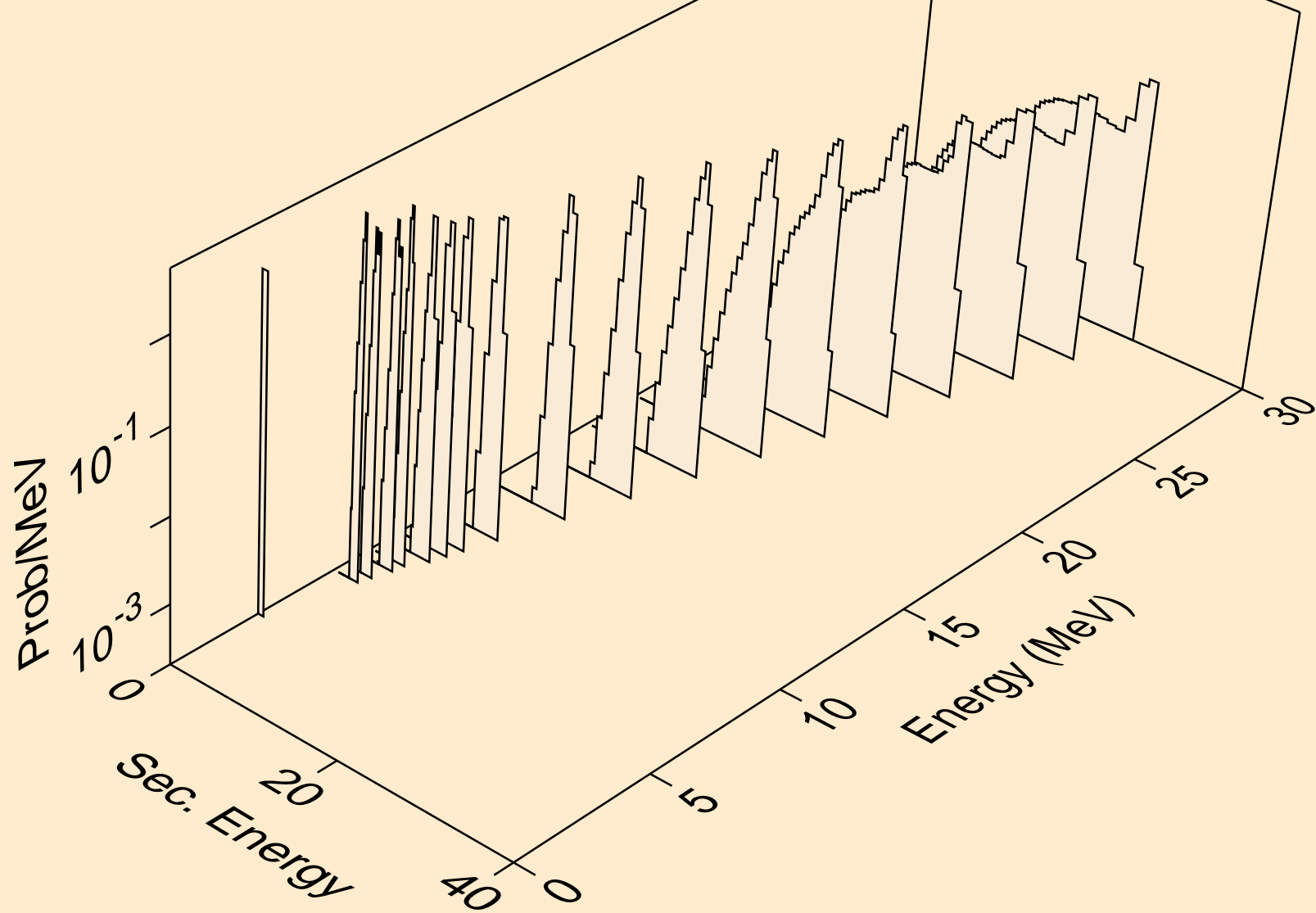

MT281 NEUTRON ACER TENDL-2023 LIBRARY; T=0.K
protons from (n,2np)

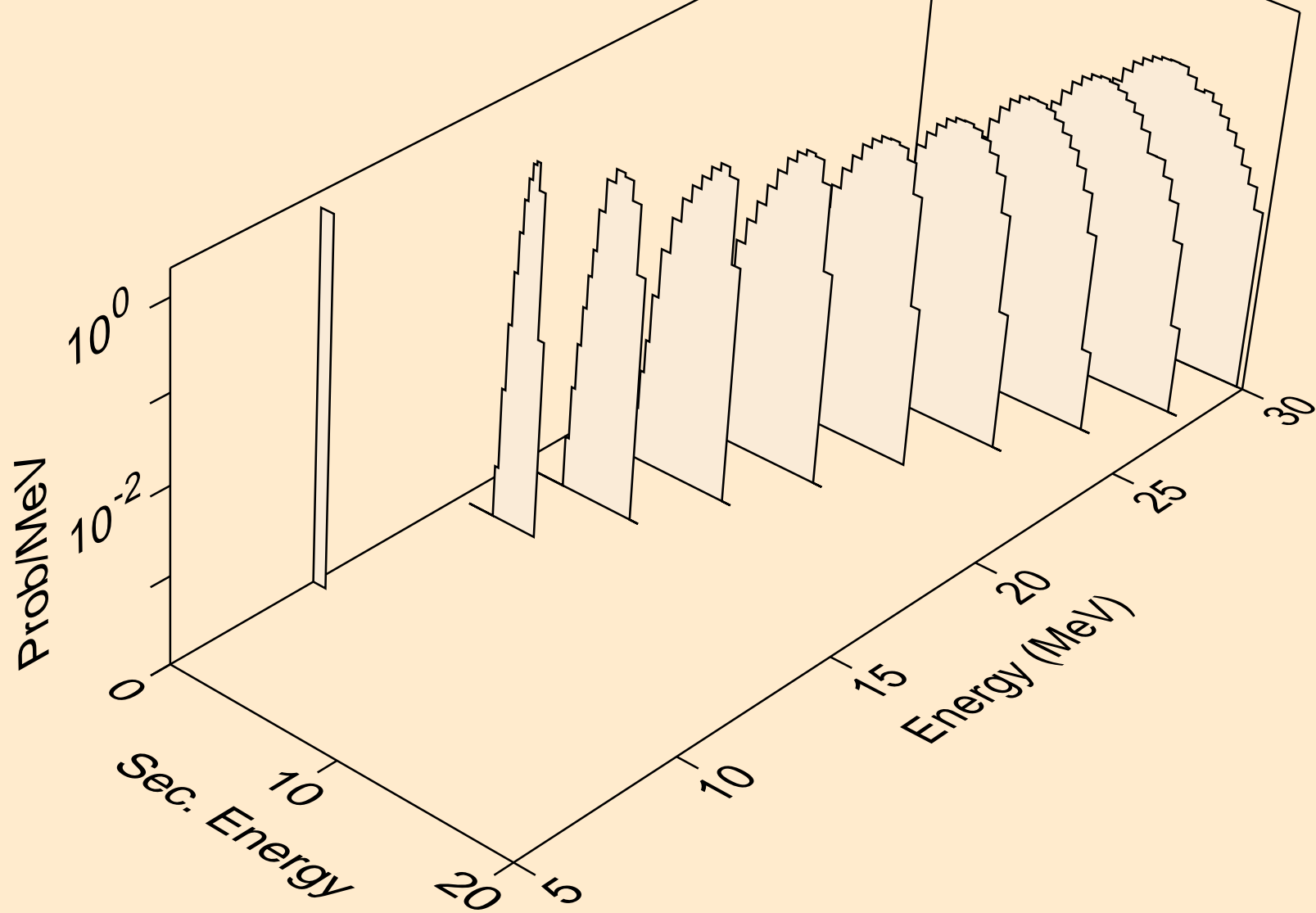

MT281 NEUTRON ACER TENDL-2023 LIBRARY; T=0.K
protons from (n,3np)

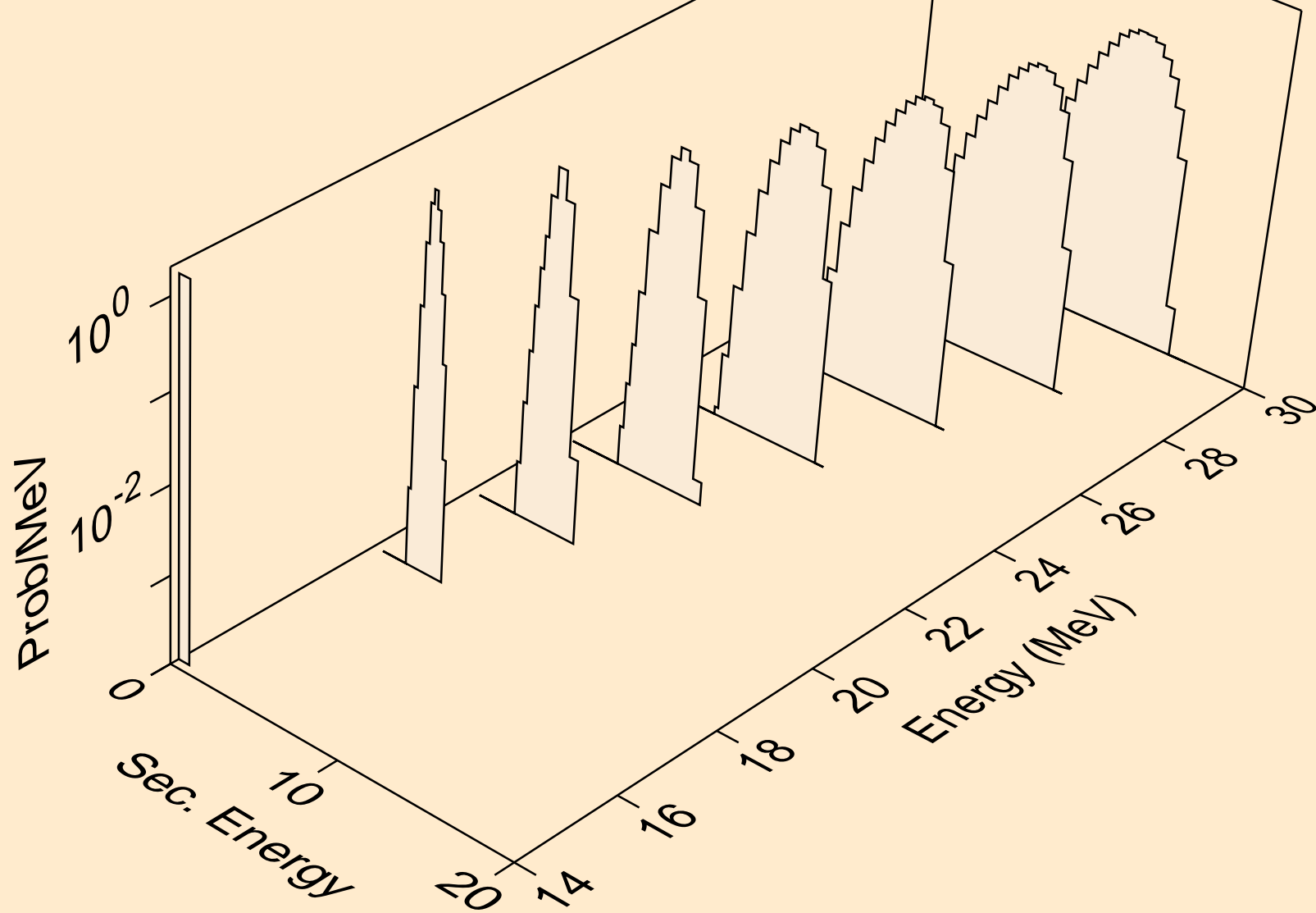

MT281 NEUTRON ACER TENDL-2023 LIBRARY; T=0.K
protons from (n,p)

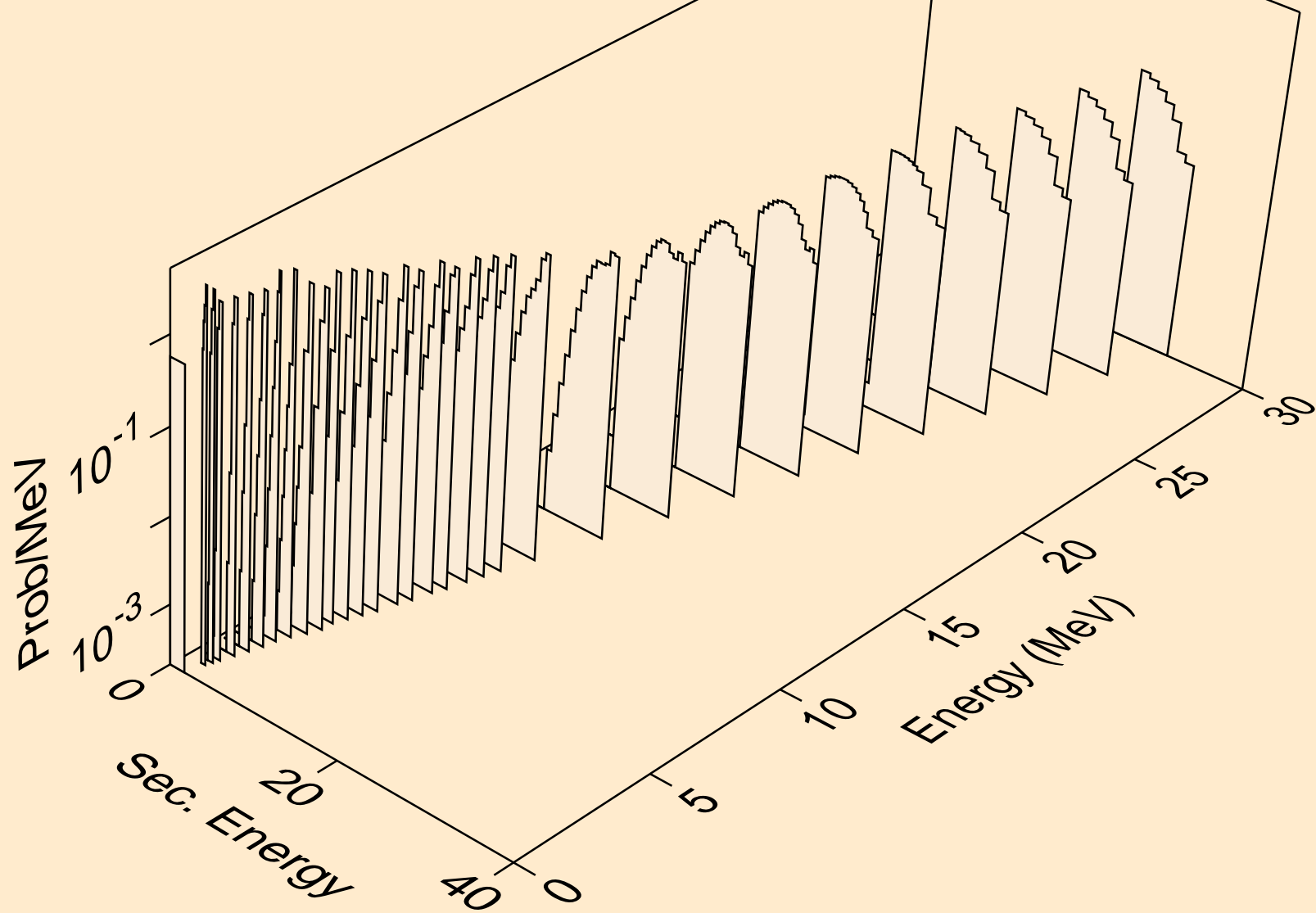

MT281 NEUTRON ACER TENDL-2023 LIBRARY; T=0.K
deuterons from (n,x)

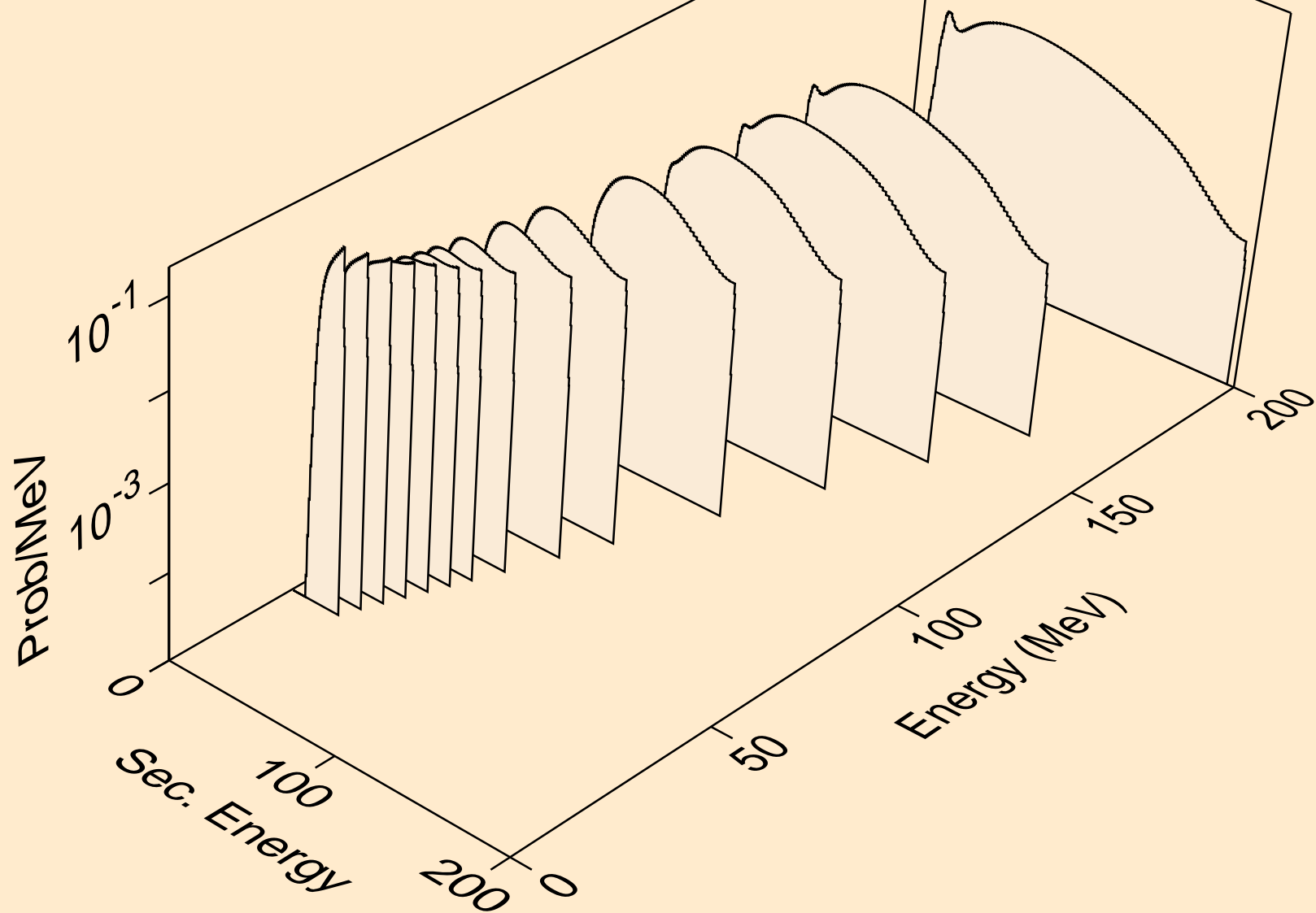

MT281 NEUTRON ACER TENDL-2023 LIBRARY; T=0.K
deuterons from (n,2nd)

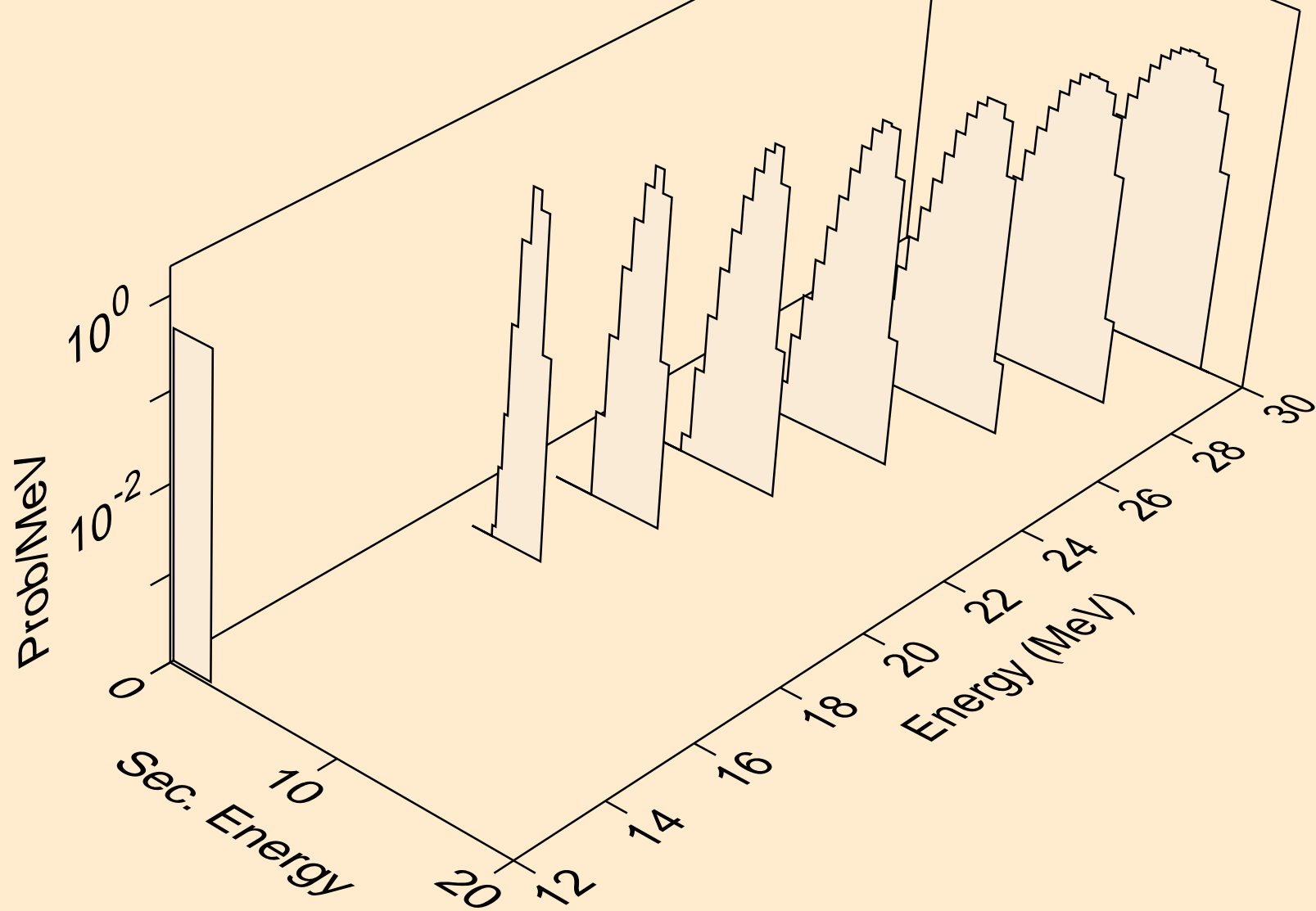

MT281 NEUTRON ACER TENDL-2023 LIBRARY; T=0.K
deuterons from (n,n*)d

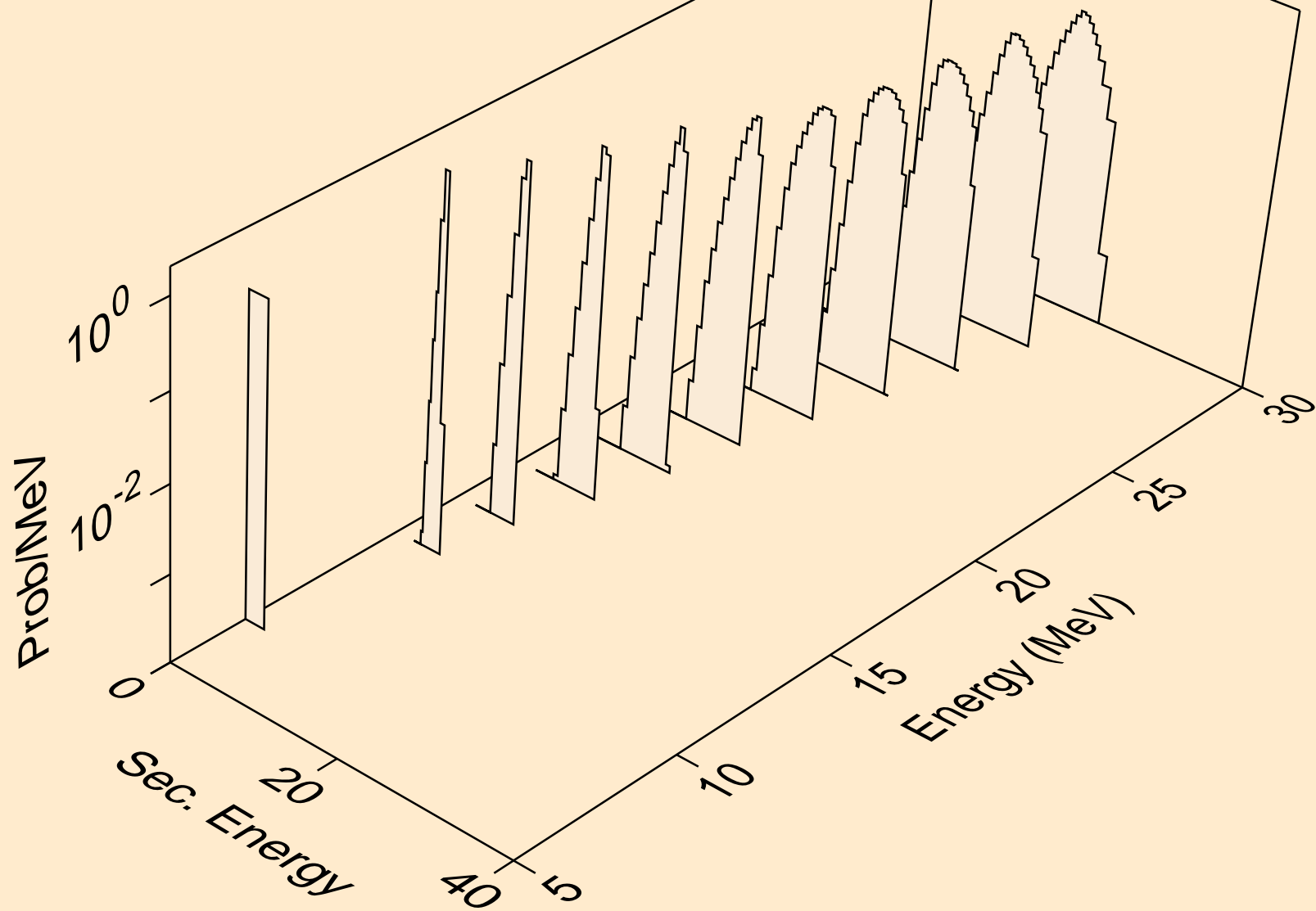

MT281 NEUTRON ACER TENDL-2023 LIBRARY; T=0.K
deuterons from (n,d)

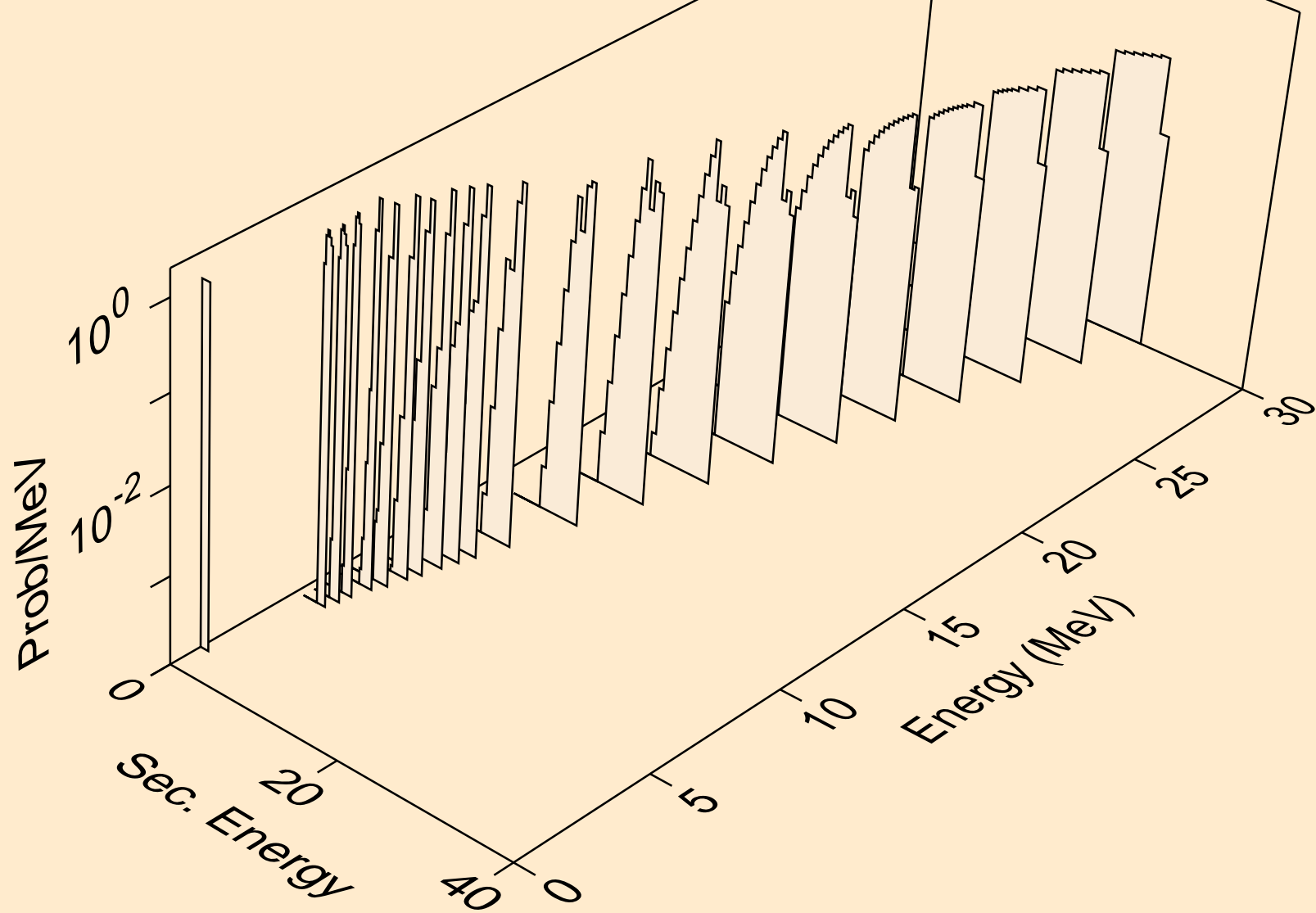

MT281 NEUTRON ACER TENDL-2023 LIBRARY; T=0.K
tritons from (n,x)

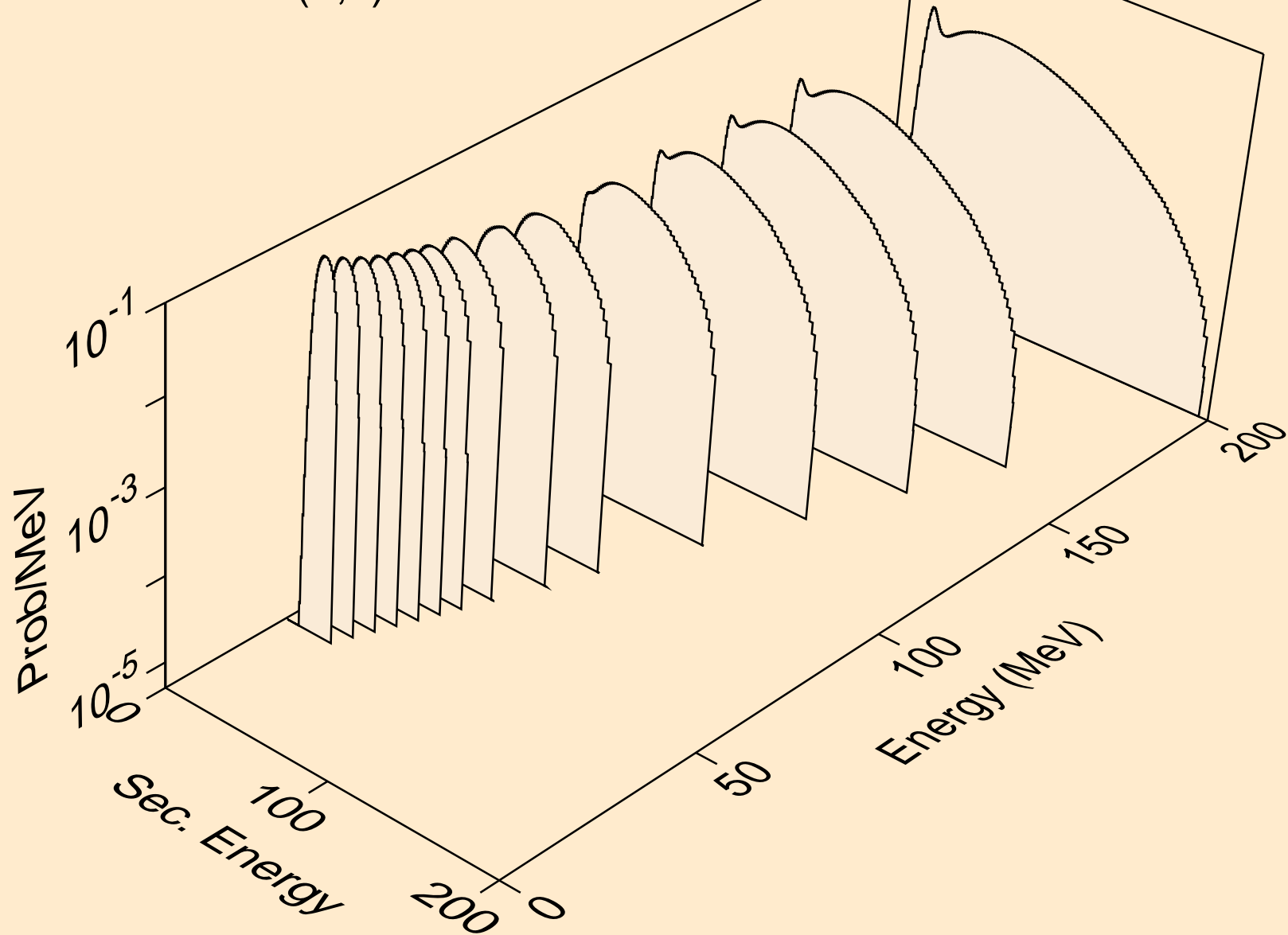

MT281 NEUTRON ACER TENDL-2023 LIBRARY; T=0.K
tritons from (n,n*)t

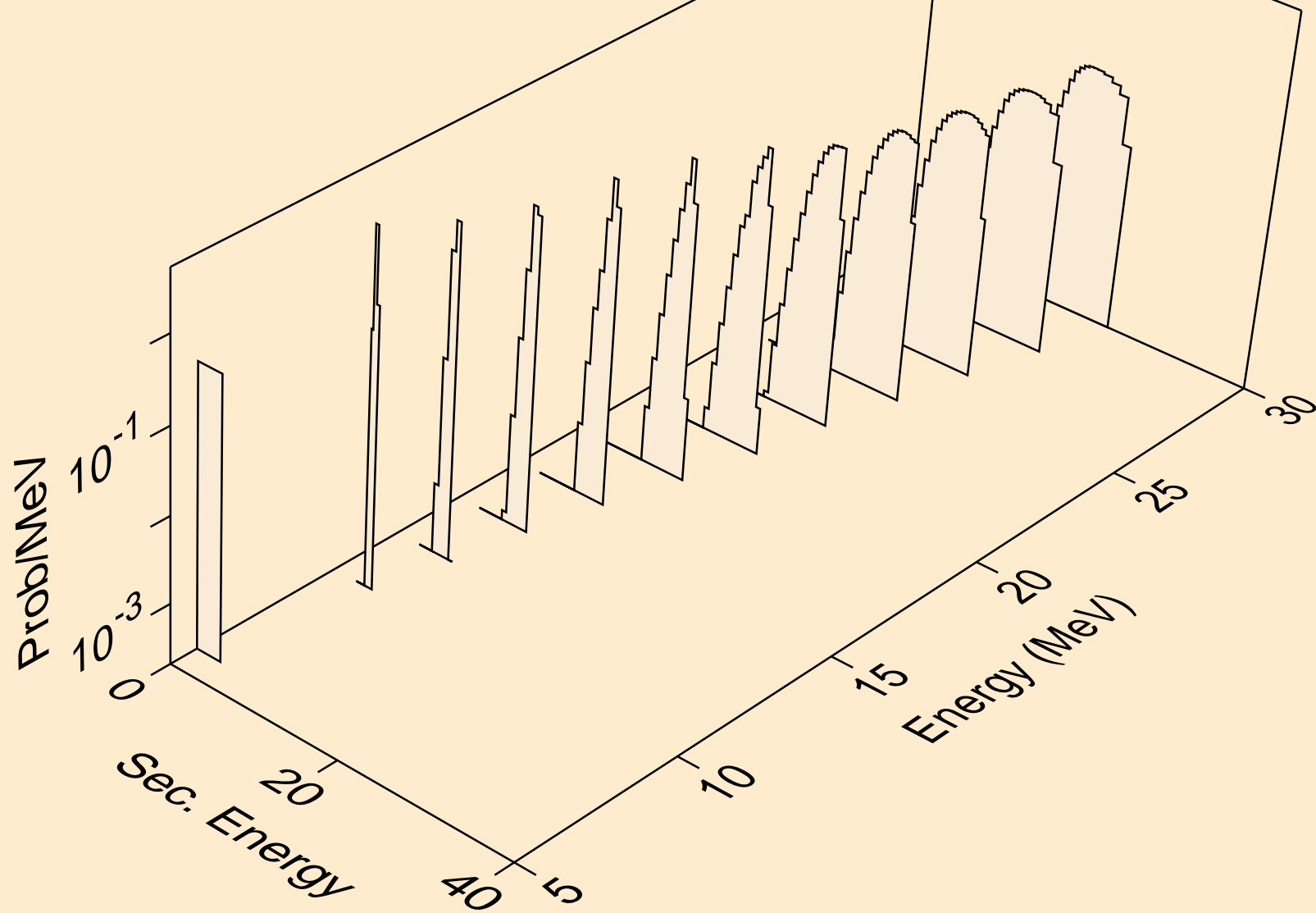

MT281 NEUTRON ACER TENDL-2023 LIBRARY; T=0.K
tritons from (n,t)

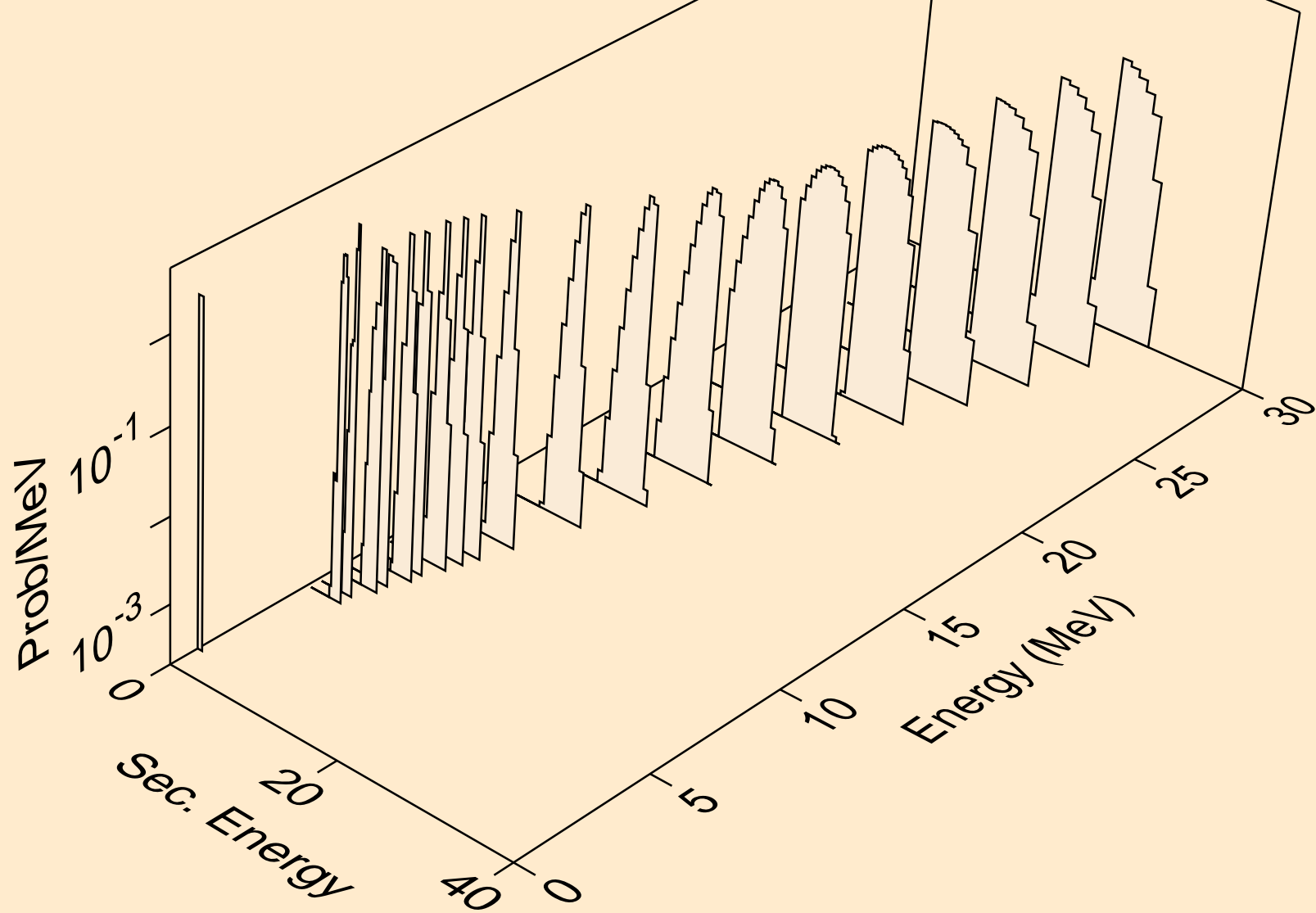

MT281 NEUTRON ACER TENDL-2023 LIBRARY; T=0.K
he3s from (n,x)

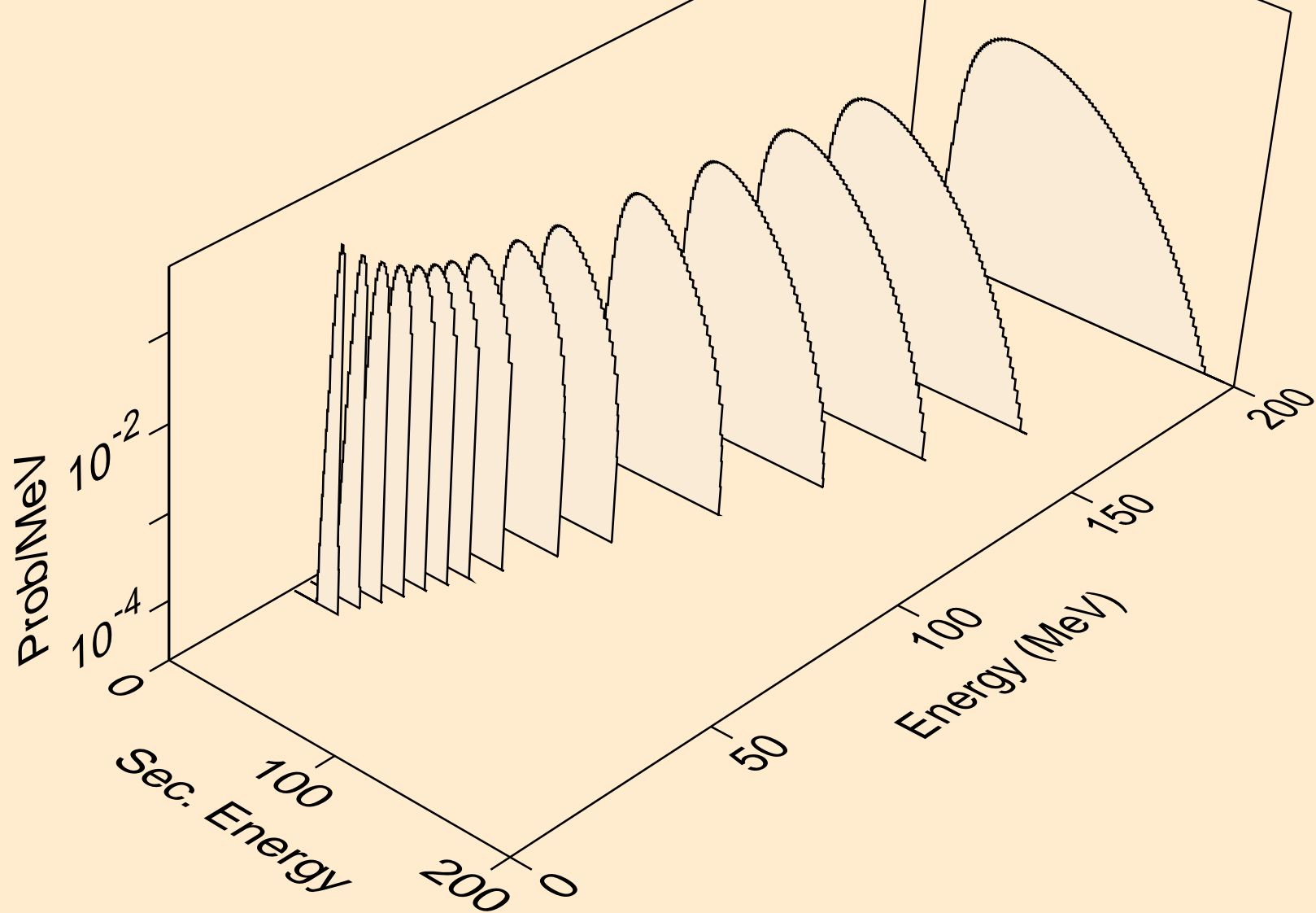

MT281 NEUTRON ACER TENDL-2023 LIBRARY; T=0.K
he3s from (n,n*)he3

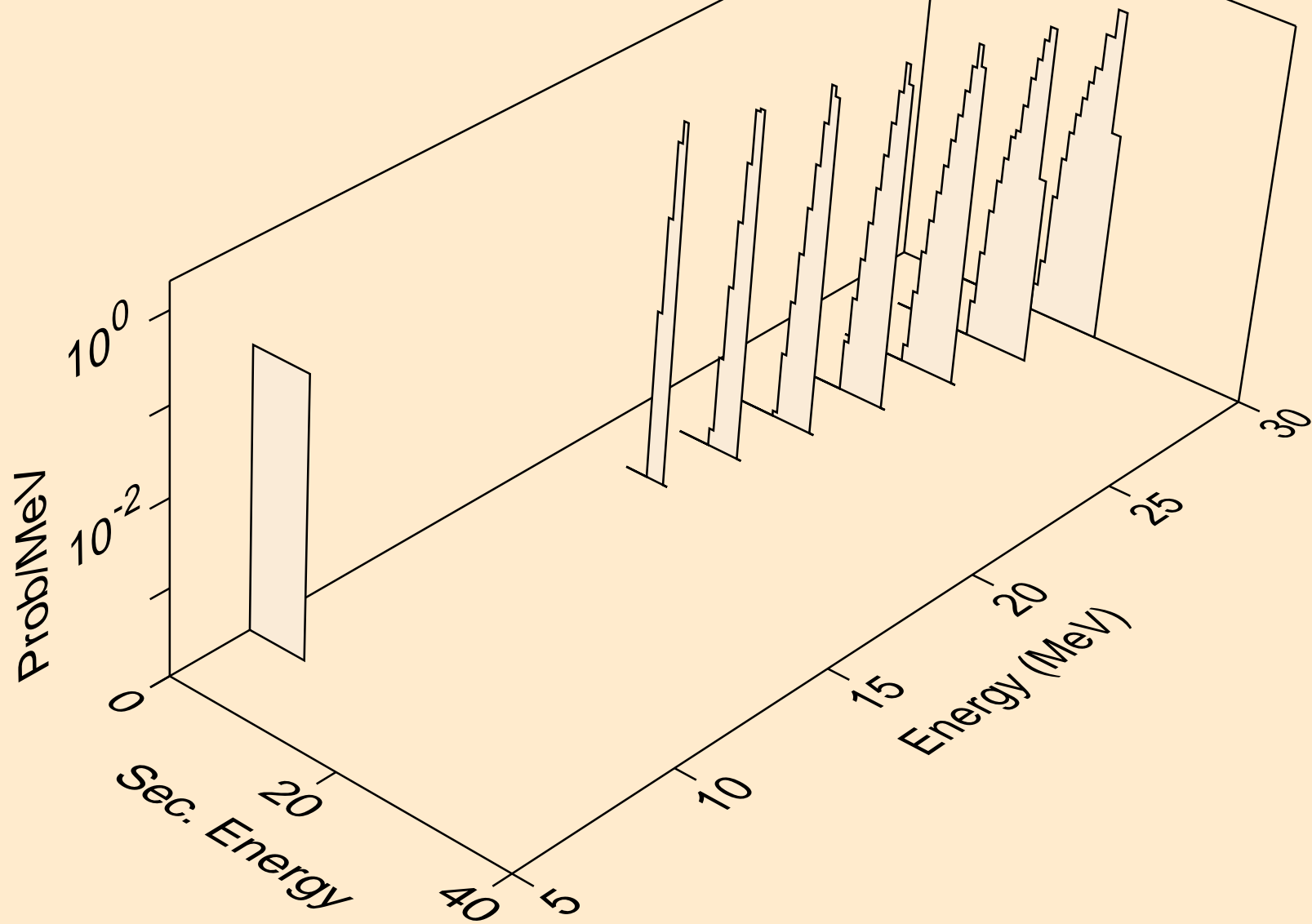

MT281 NEUTRON ACER TENDL-2023 LIBRARY; T=0.K
he3s from (n,he3)

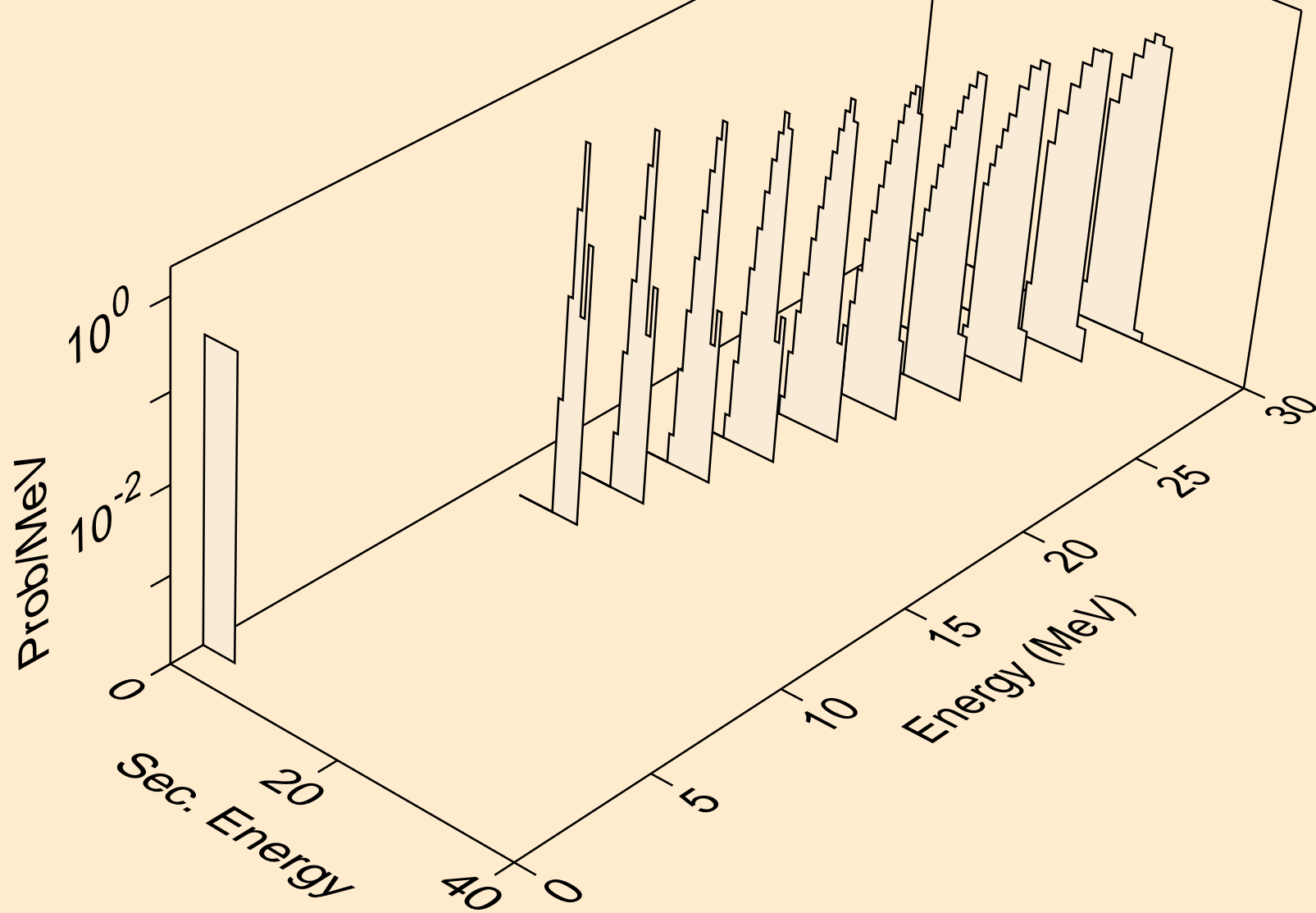

MT281 NEUTRON ACER TENDL-2023 LIBRARY; T=0.K
alphas from (n,x)

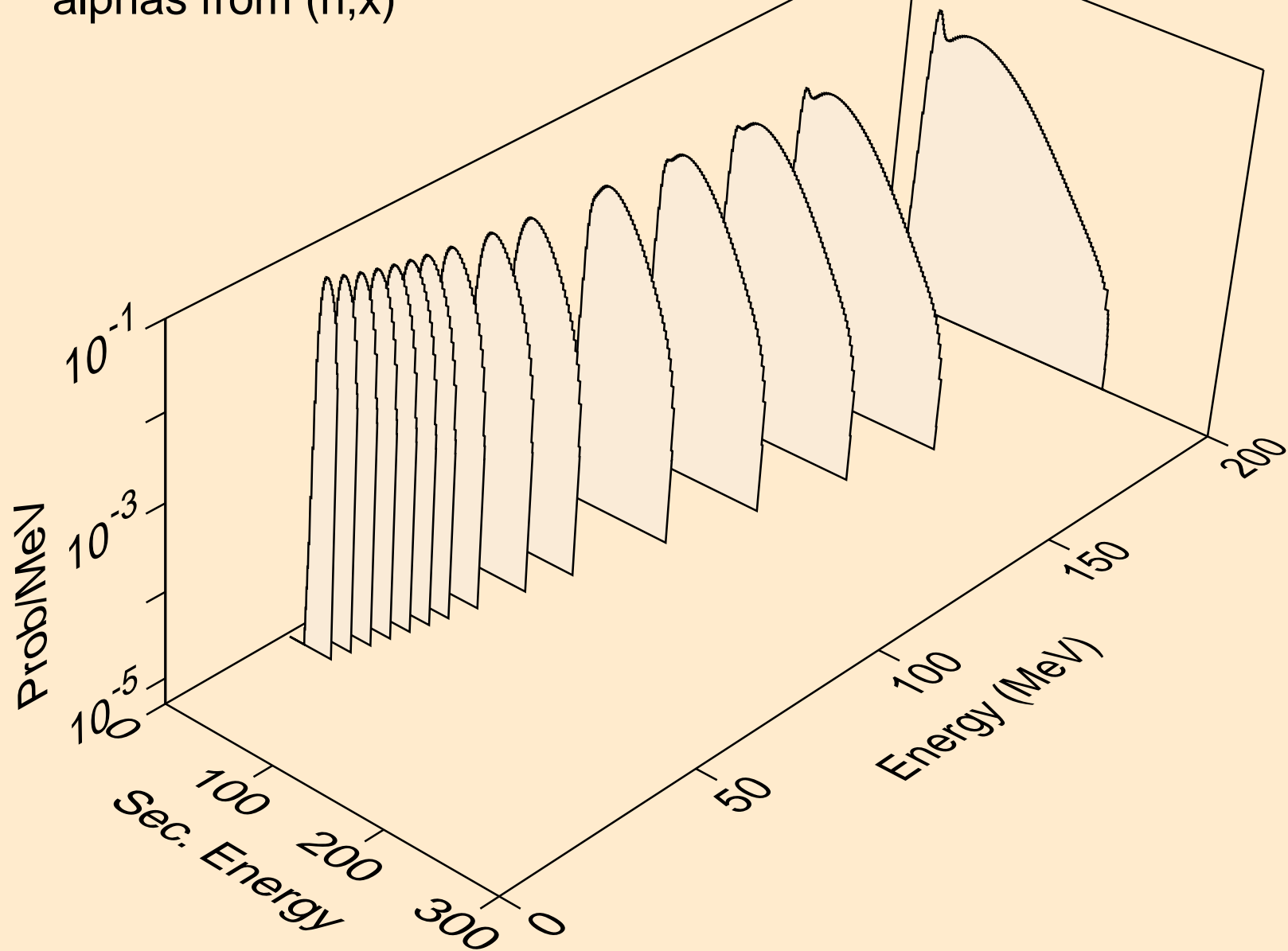

MT281 NEUTRON ACER TENDL-2023 LIBRARY; T=0.K
alphas from (n,n*)a

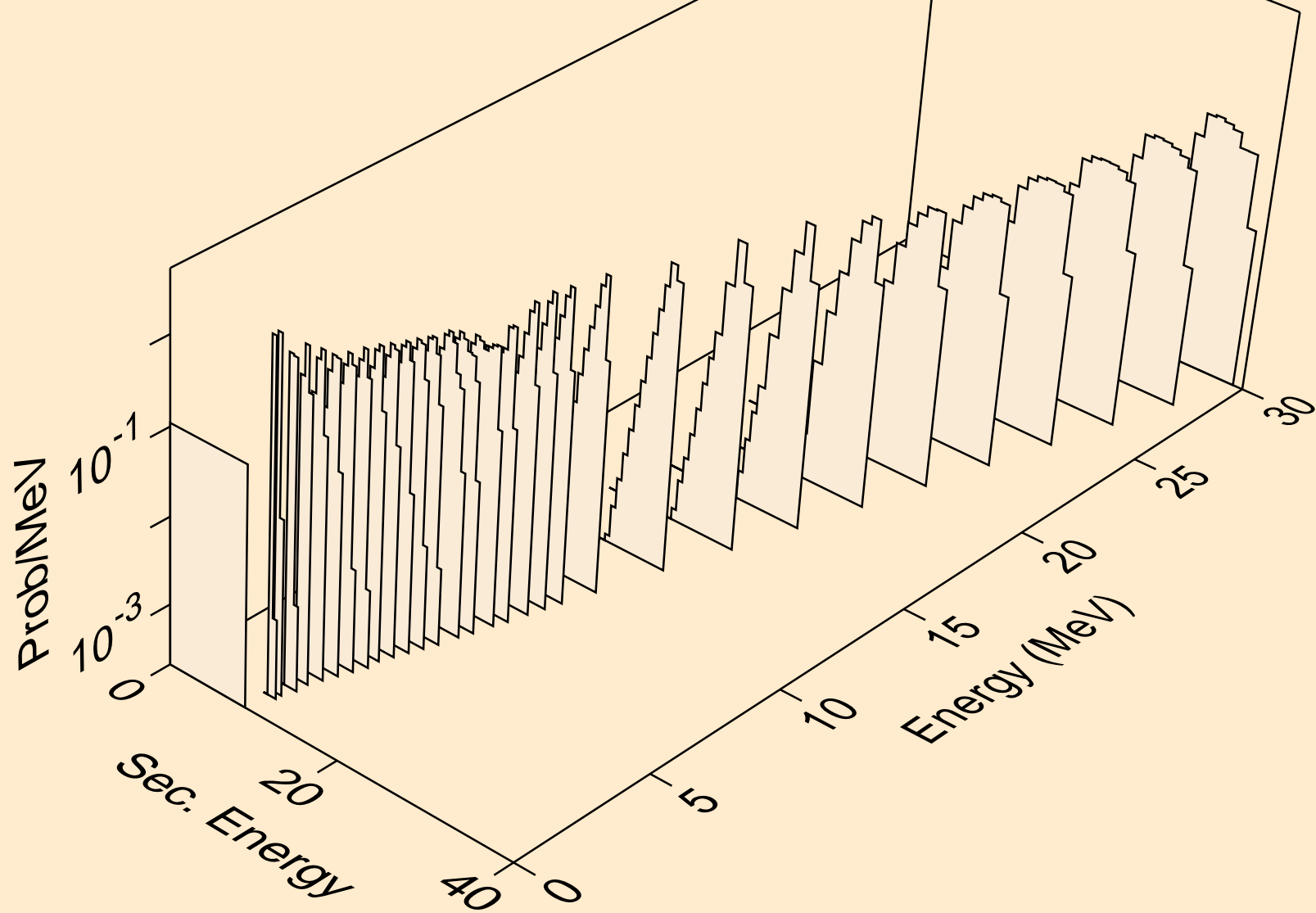

MT281 NEUTRON ACER TENDL-2023 LIBRARY; T=0.K
alphas from (n,2n)a

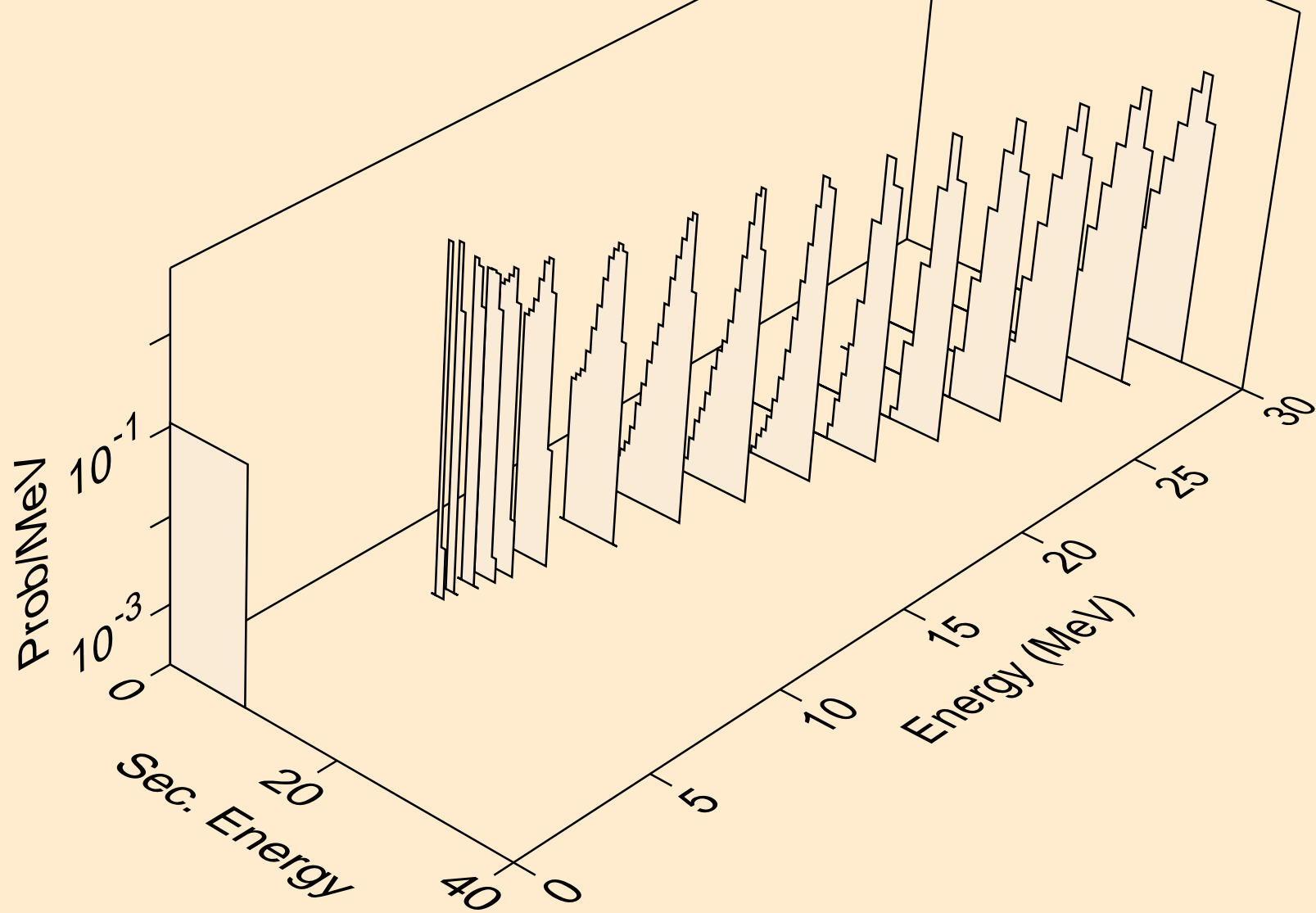

MT281 NEUTRON ACER TENDL-2023 LIBRARY; T=0.K
alphas from (n,3n)a

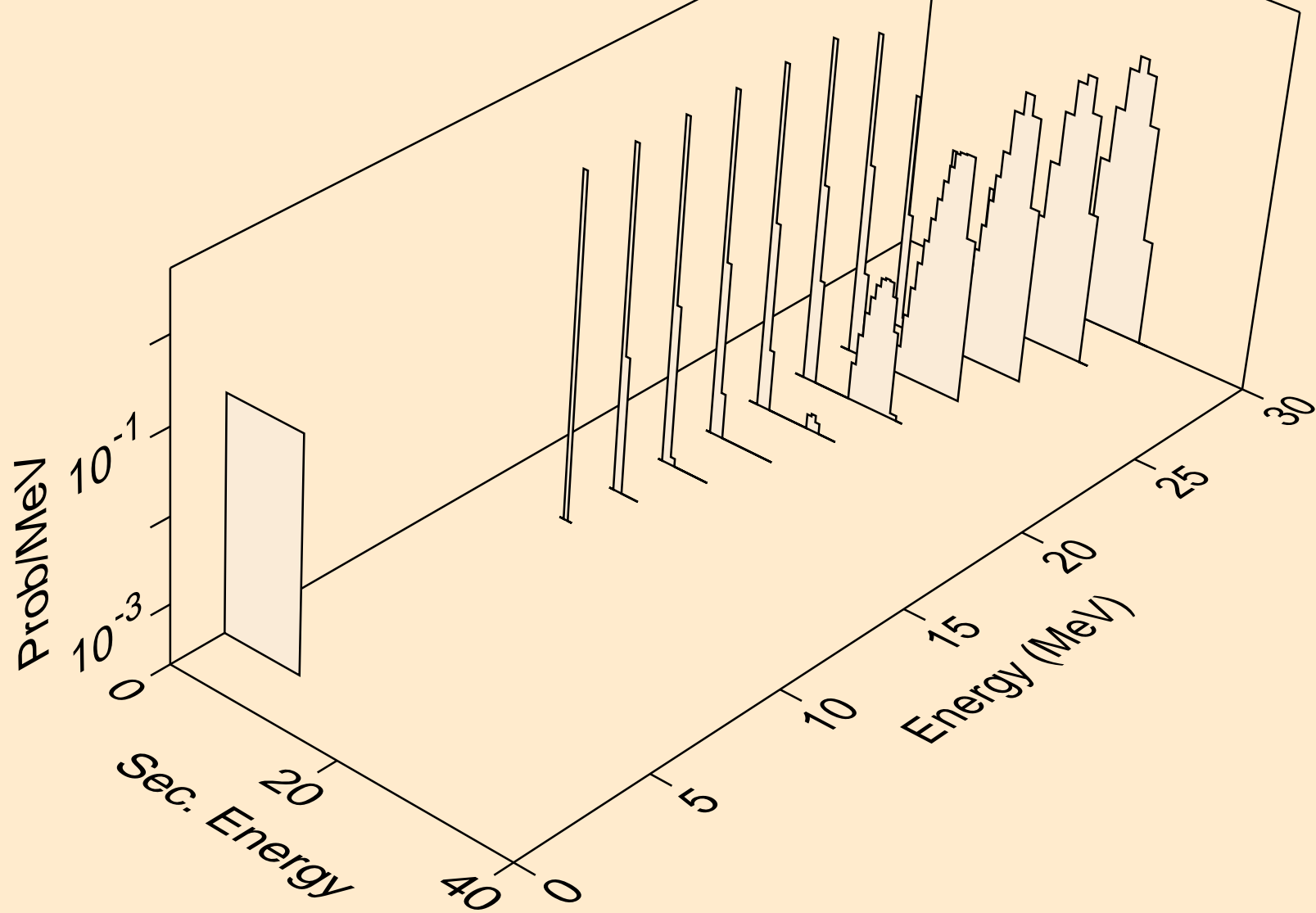

MT281 NEUTRON ACER TENDL-2023 LIBRARY; T=0.K
alphas from (n,a)

