

# NI060 NEUTRON ACER TENDL-2023 LIBRARY; T=0.K

## Principal cross sections

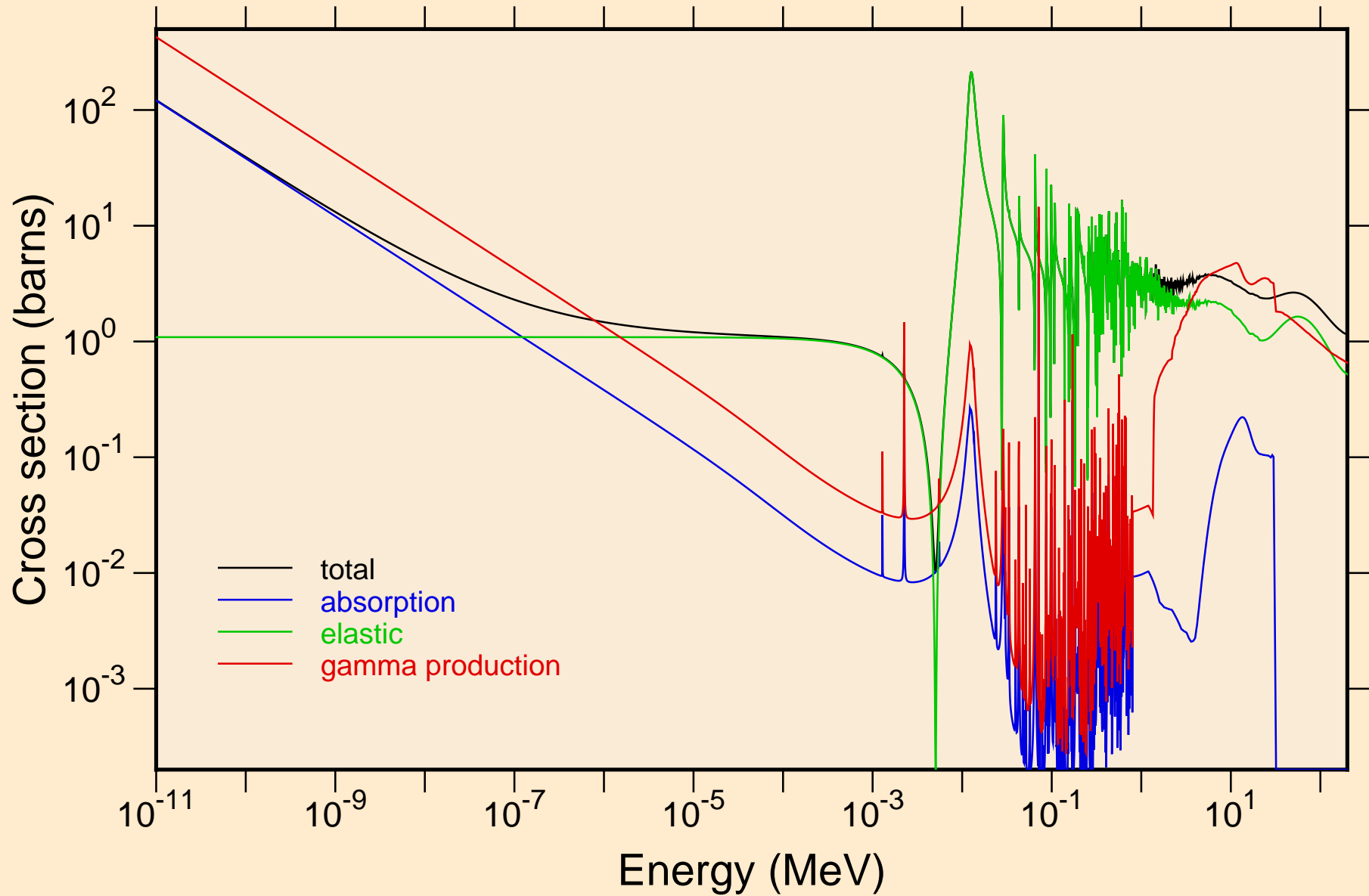

NI060 NEUTRON ACER TENDL-2023 LIBRARY; T=0.K  
resonance total cross section

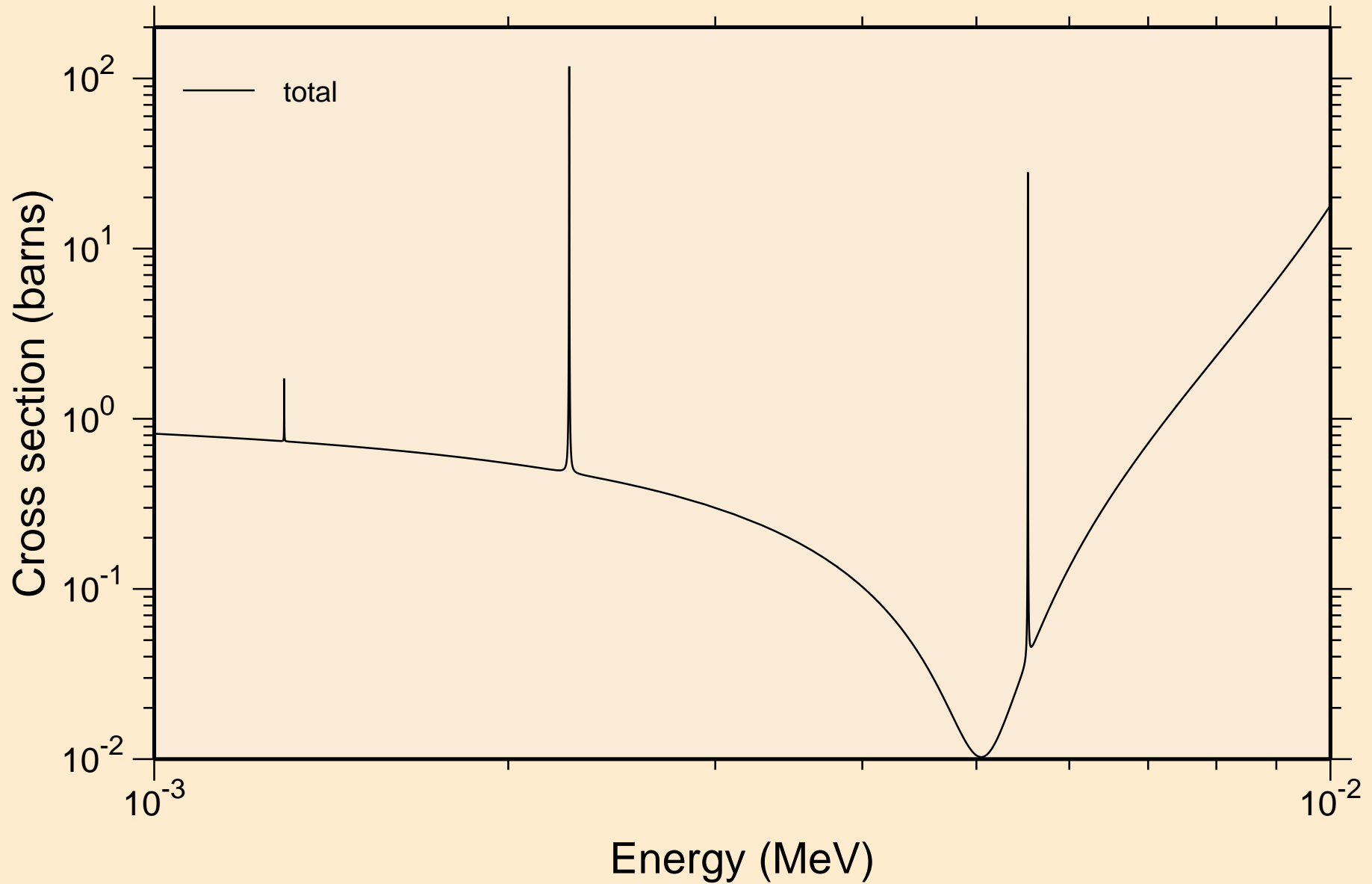

NI060 NEUTRON ACER TENDL-2023 LIBRARY; T=0.K  
resonance total cross section

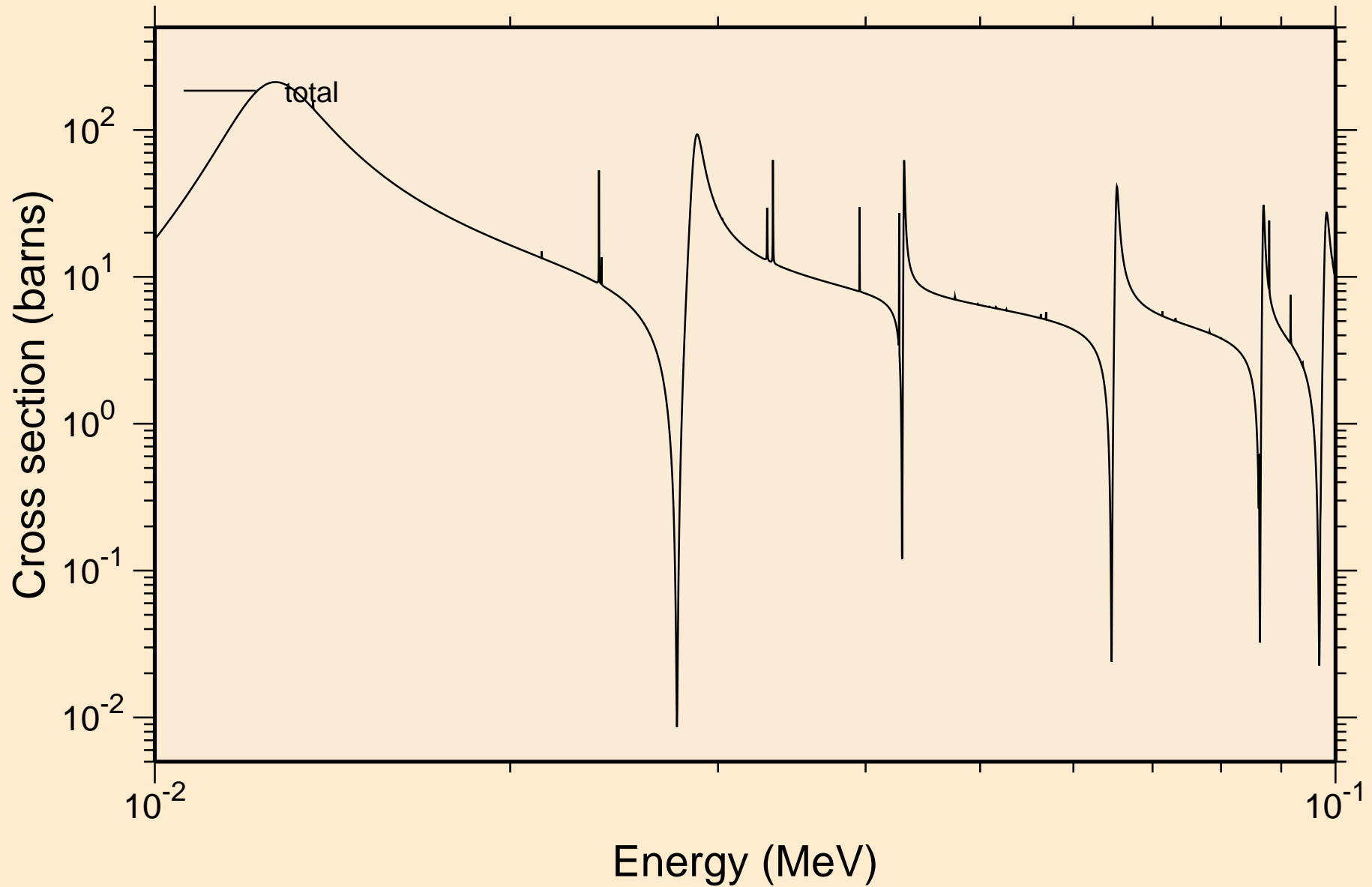

NI060 NEUTRON ACER TENDL-2023 LIBRARY; T=0.K  
resonance total cross section

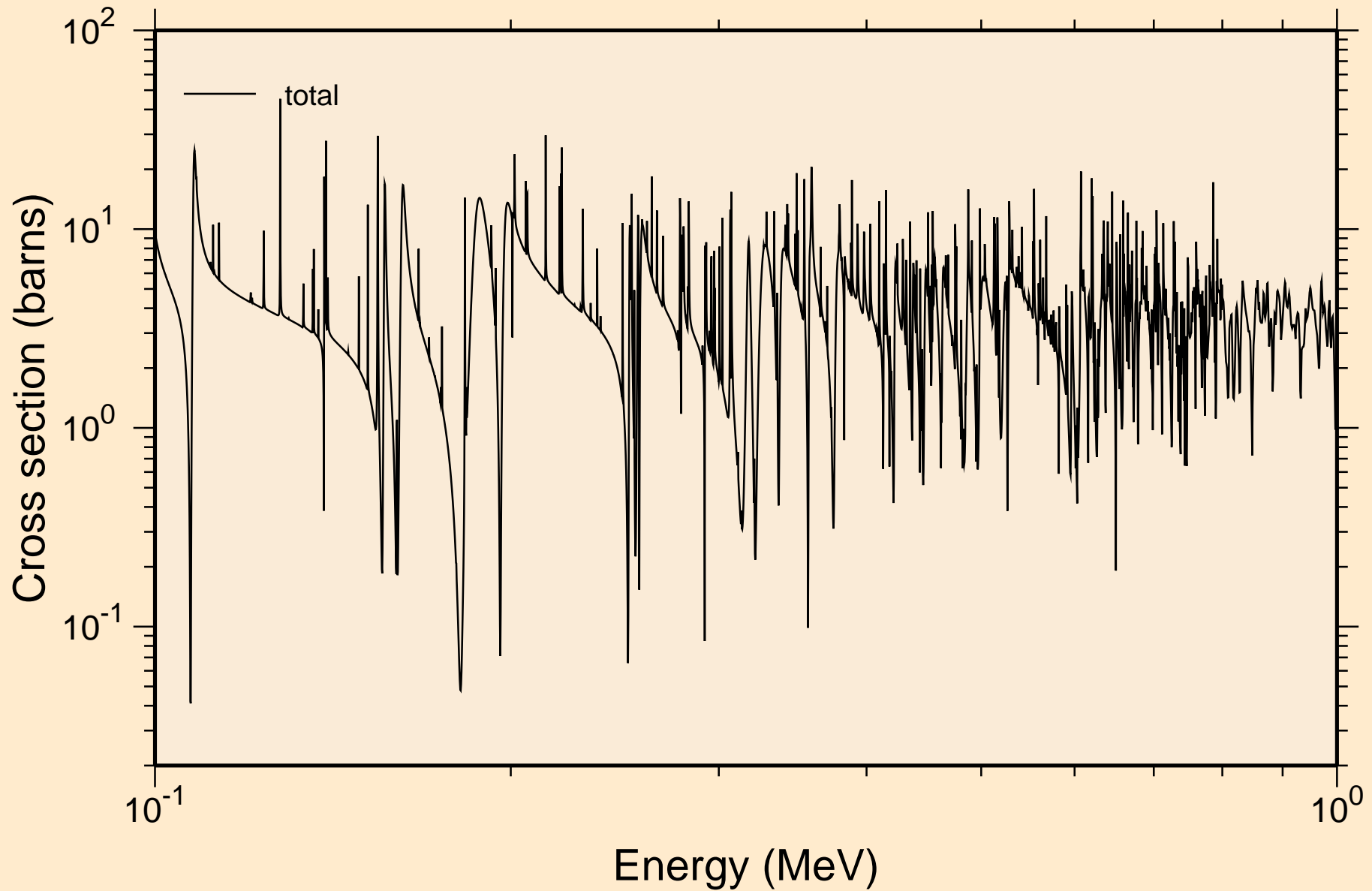

NI060 NEUTRON ACER TENDL-2023 LIBRARY; T=0.K  
resonance total cross section

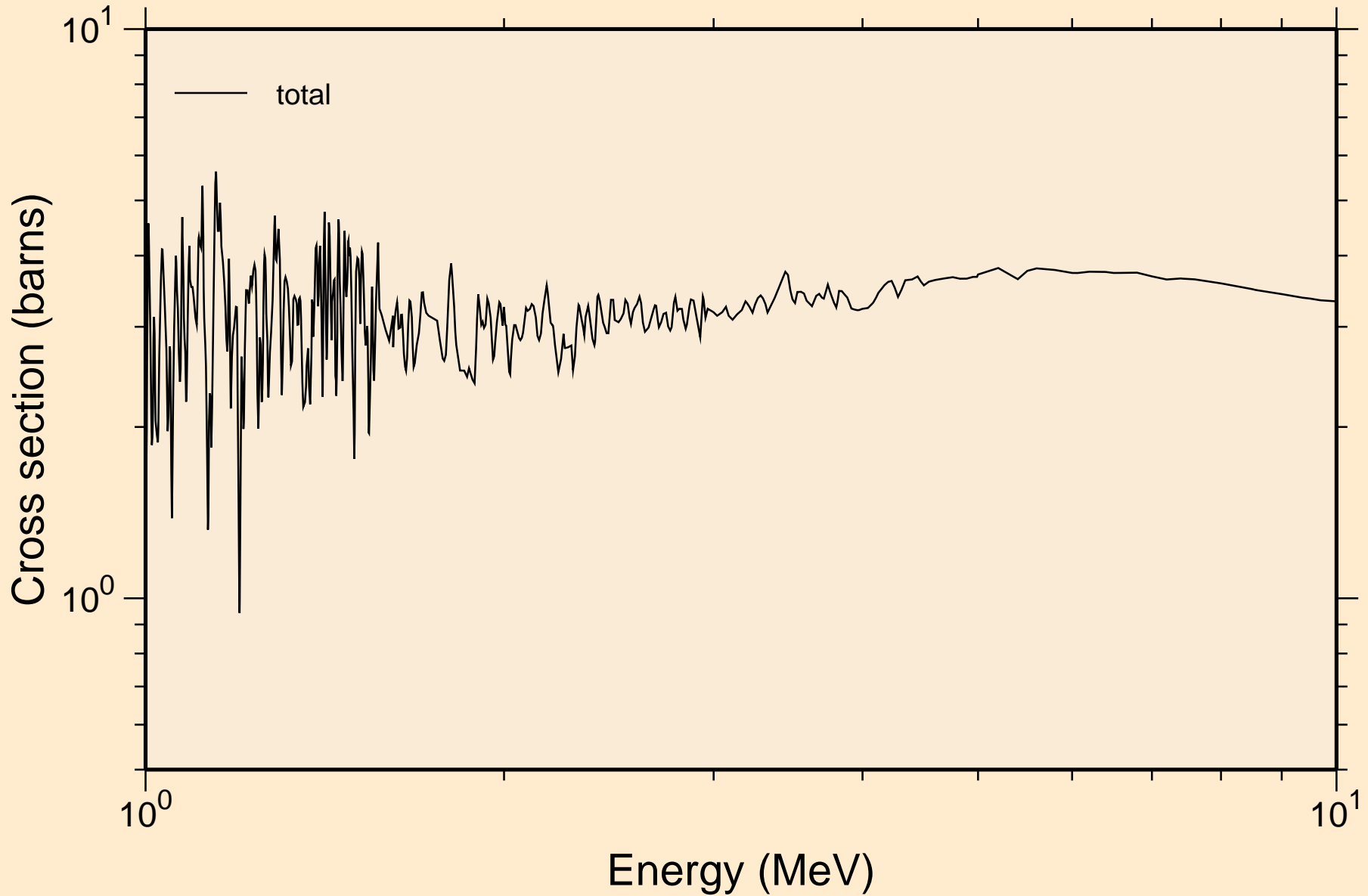

NI060 NEUTRON ACER TENDL-2023 LIBRARY; T=0.K  
resonance absorption cross sections

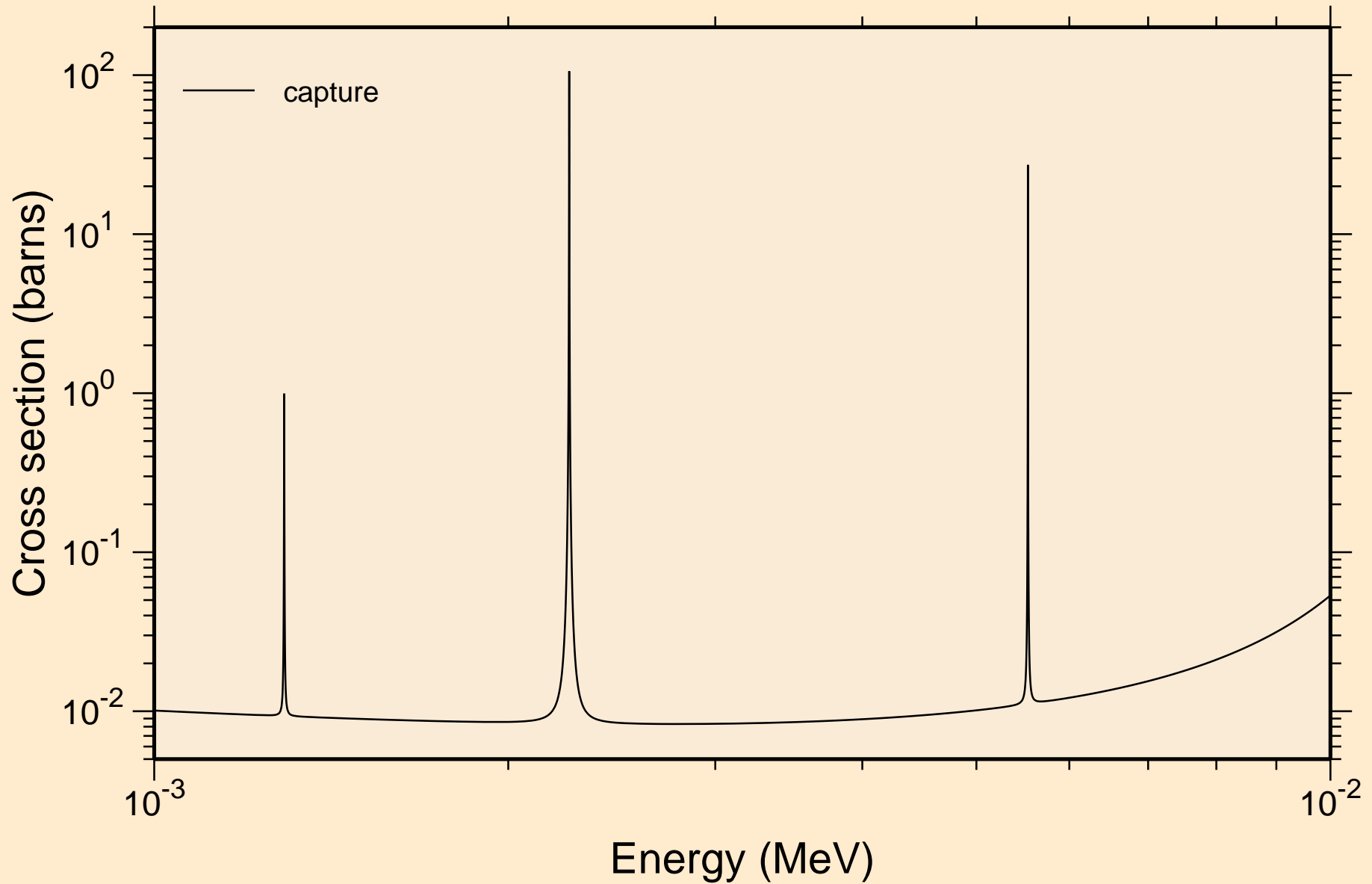

NI060 NEUTRON ACER TENDL-2023 LIBRARY; T=0.K  
resonance absorption cross sections

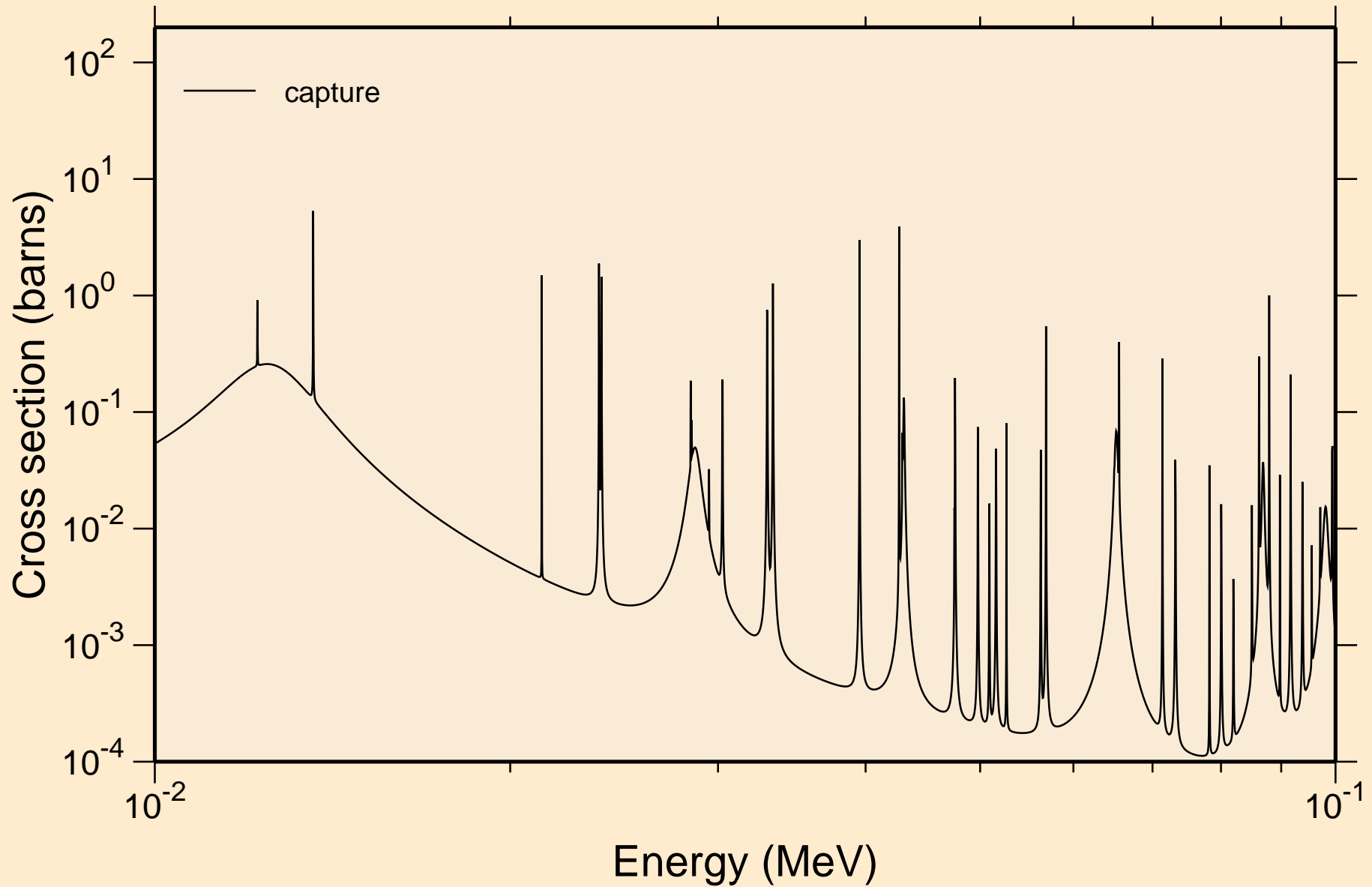

NI060 NEUTRON ACER TENDL-2023 LIBRARY; T=0.K  
resonance absorption cross sections

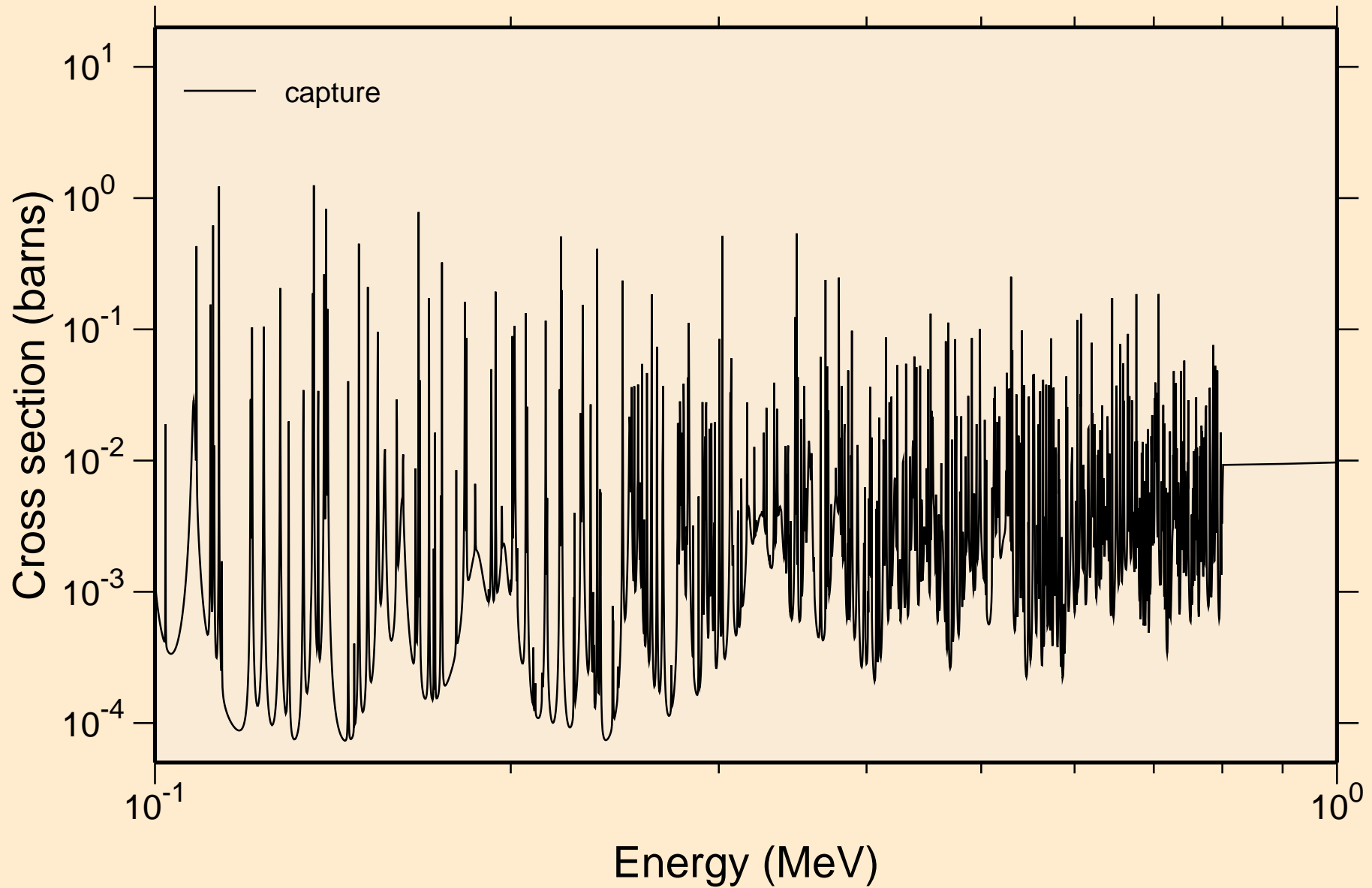



NI060 NEUTRON ACER TENDL-2023 LIBRARY; T=0.K  
resonance absorption cross sections

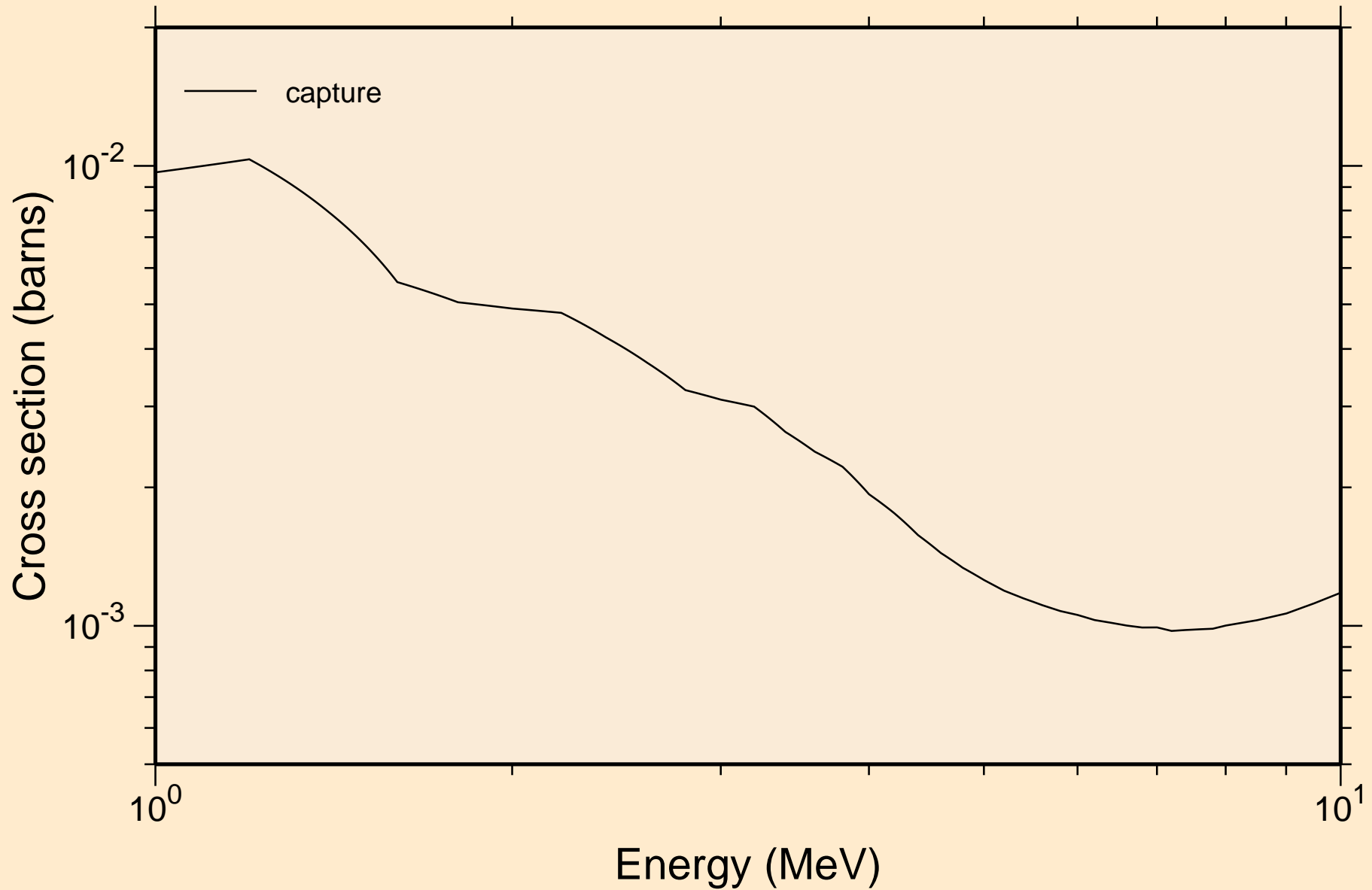

# NI060 NEUTRON ACER TENDL-2023 LIBRARY; T=0.K

## Heating

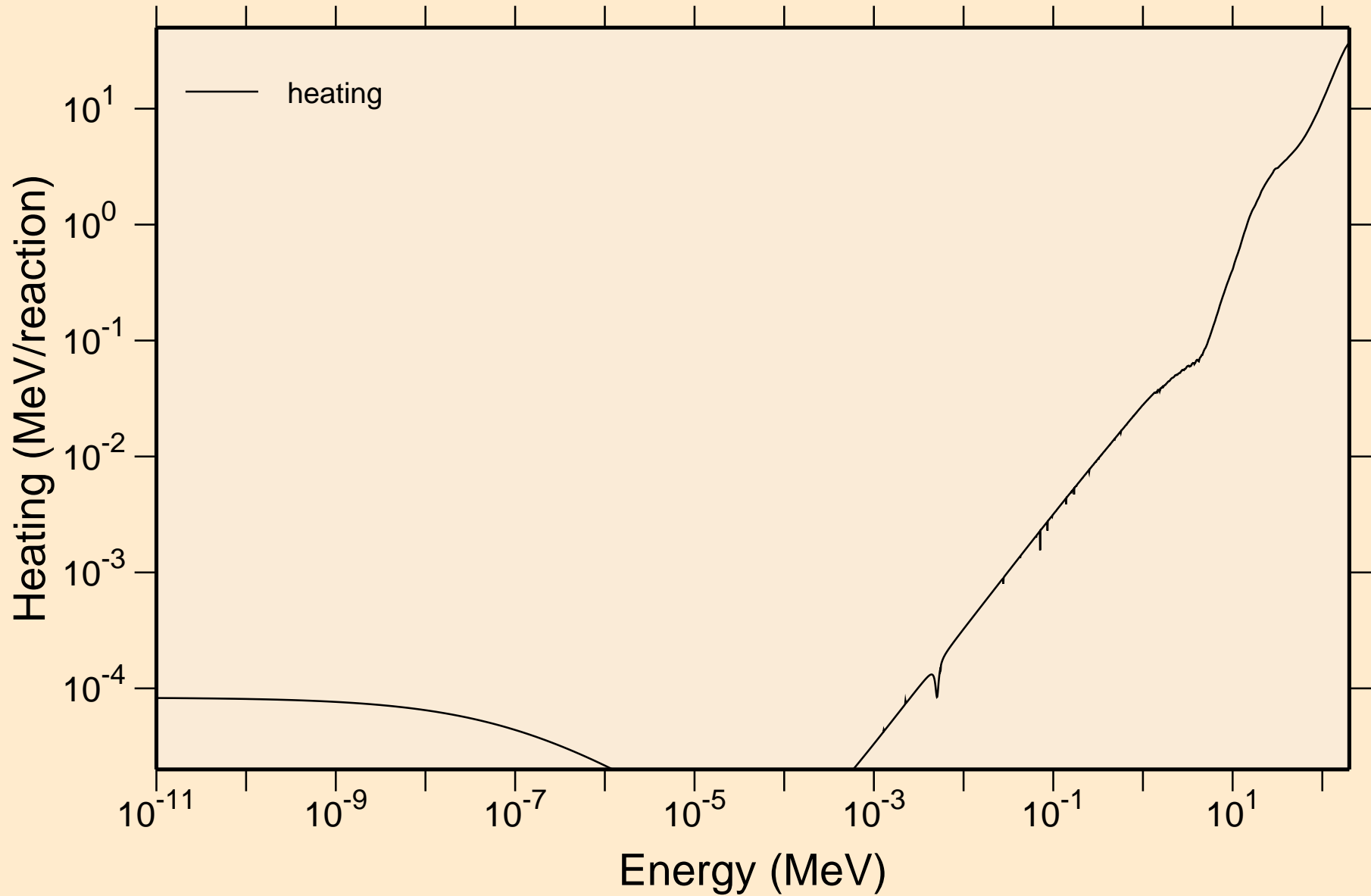

NI060 NEUTRON ACER TENDL-2023 LIBRARY; T=0.K  
Damage

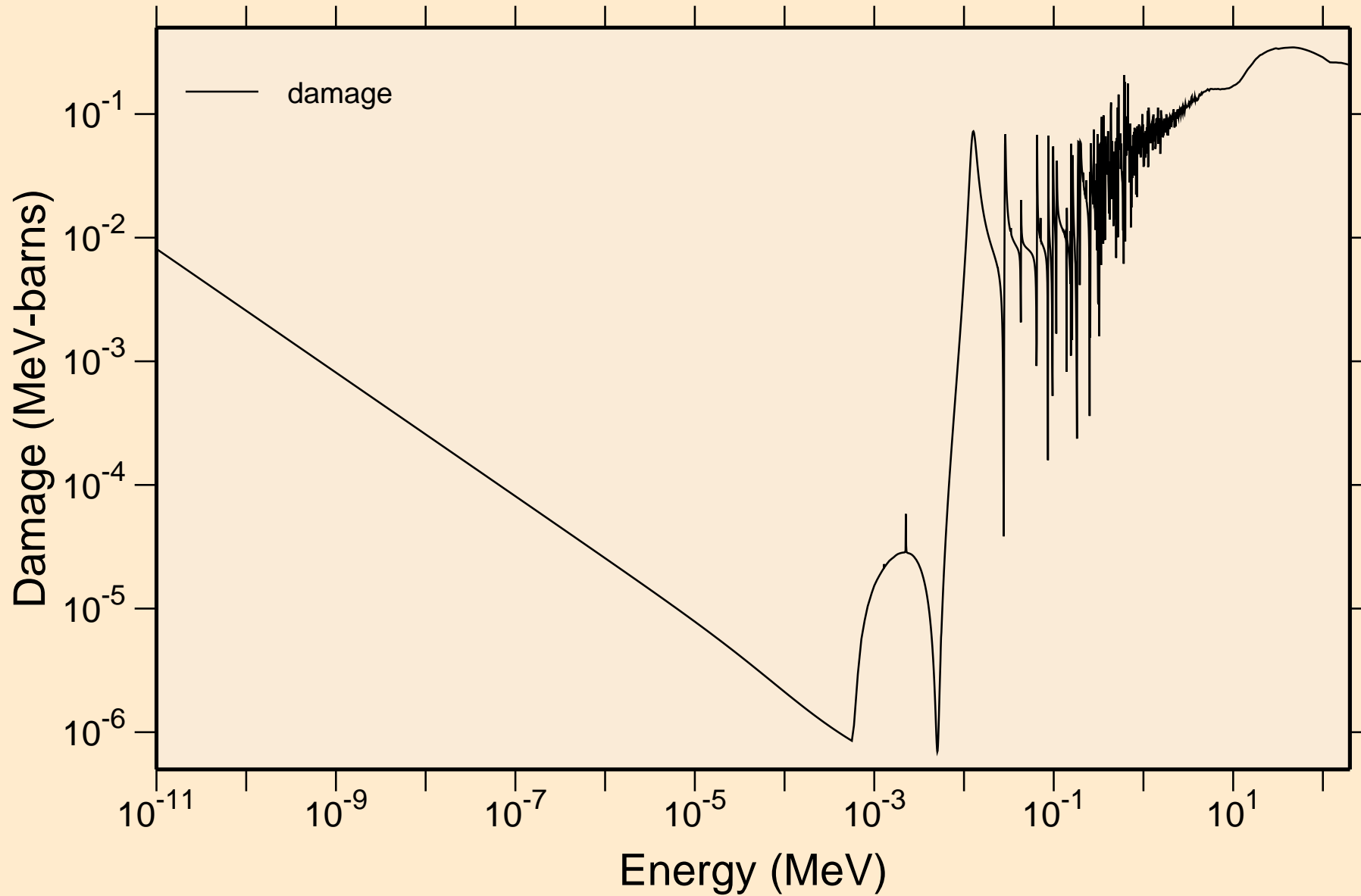

# NI060 NEUTRON ACER TENDL-2023 LIBRARY; T=0.K

## Non-threshold reactions

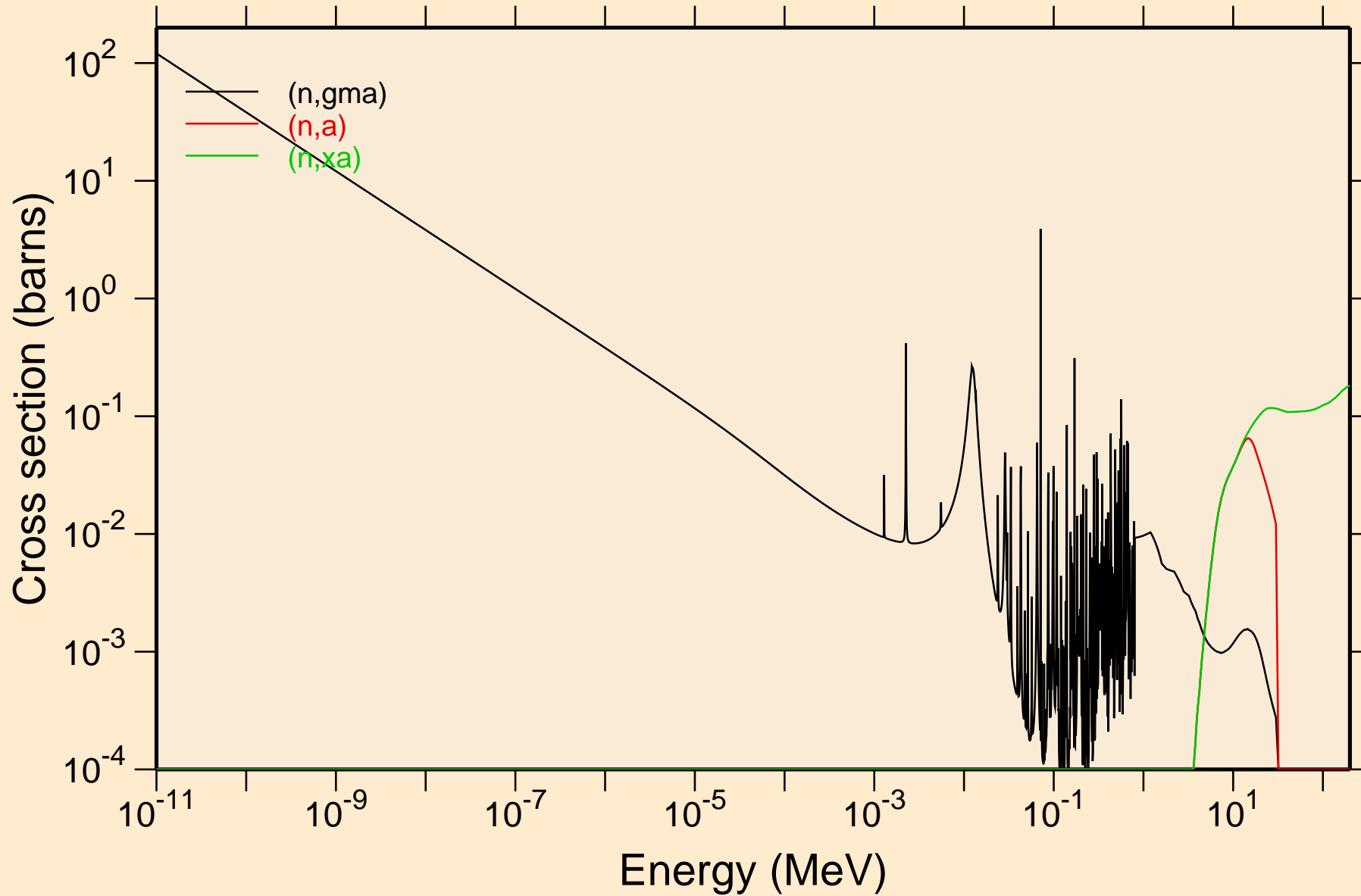

# NI060 NEUTRON ACER TENDL-2023 LIBRARY; T=0.K

## Principal cross sections

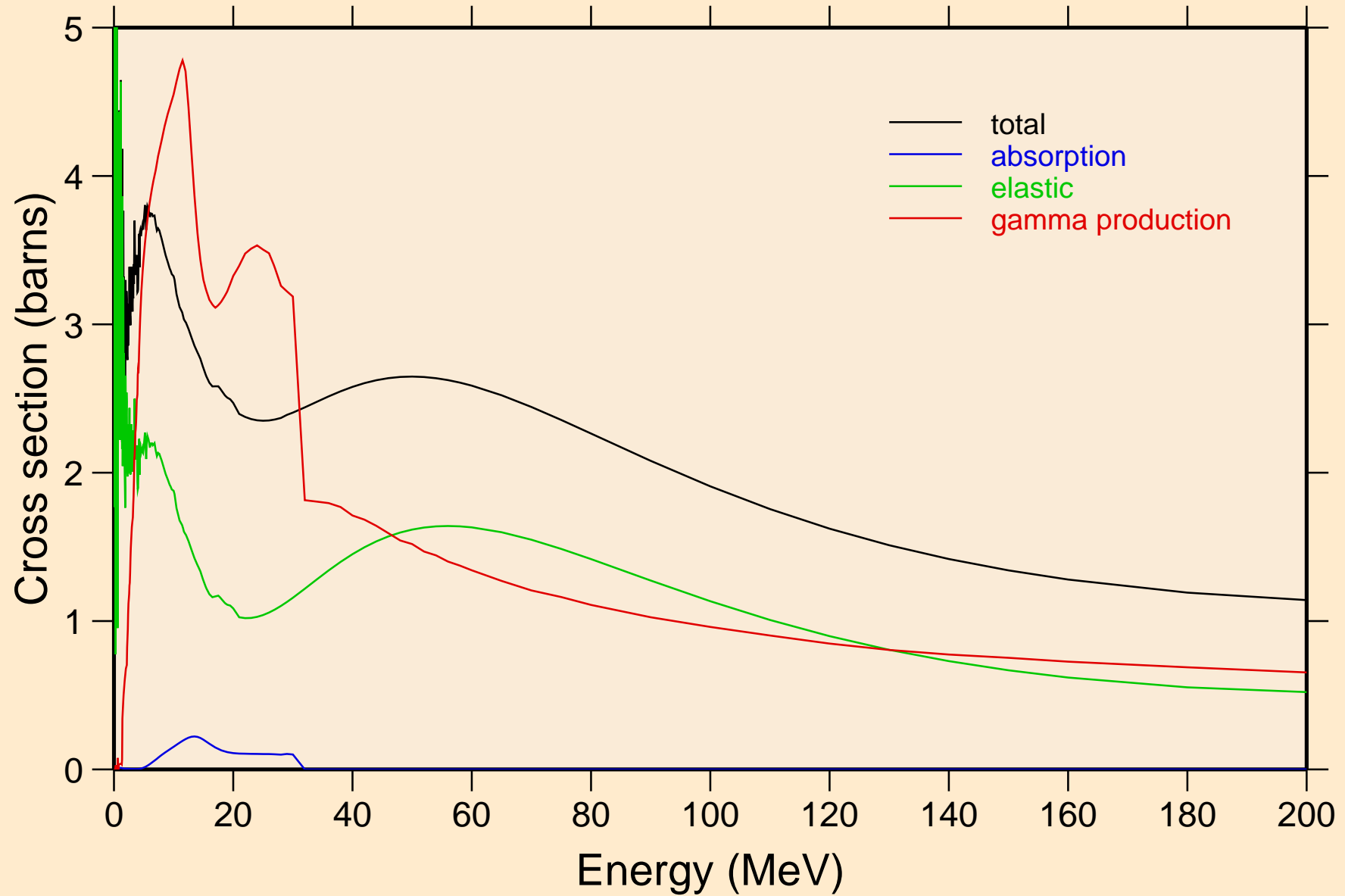

# NI060 NEUTRON ACER TENDL-2023 LIBRARY; T=0.K

## Heating

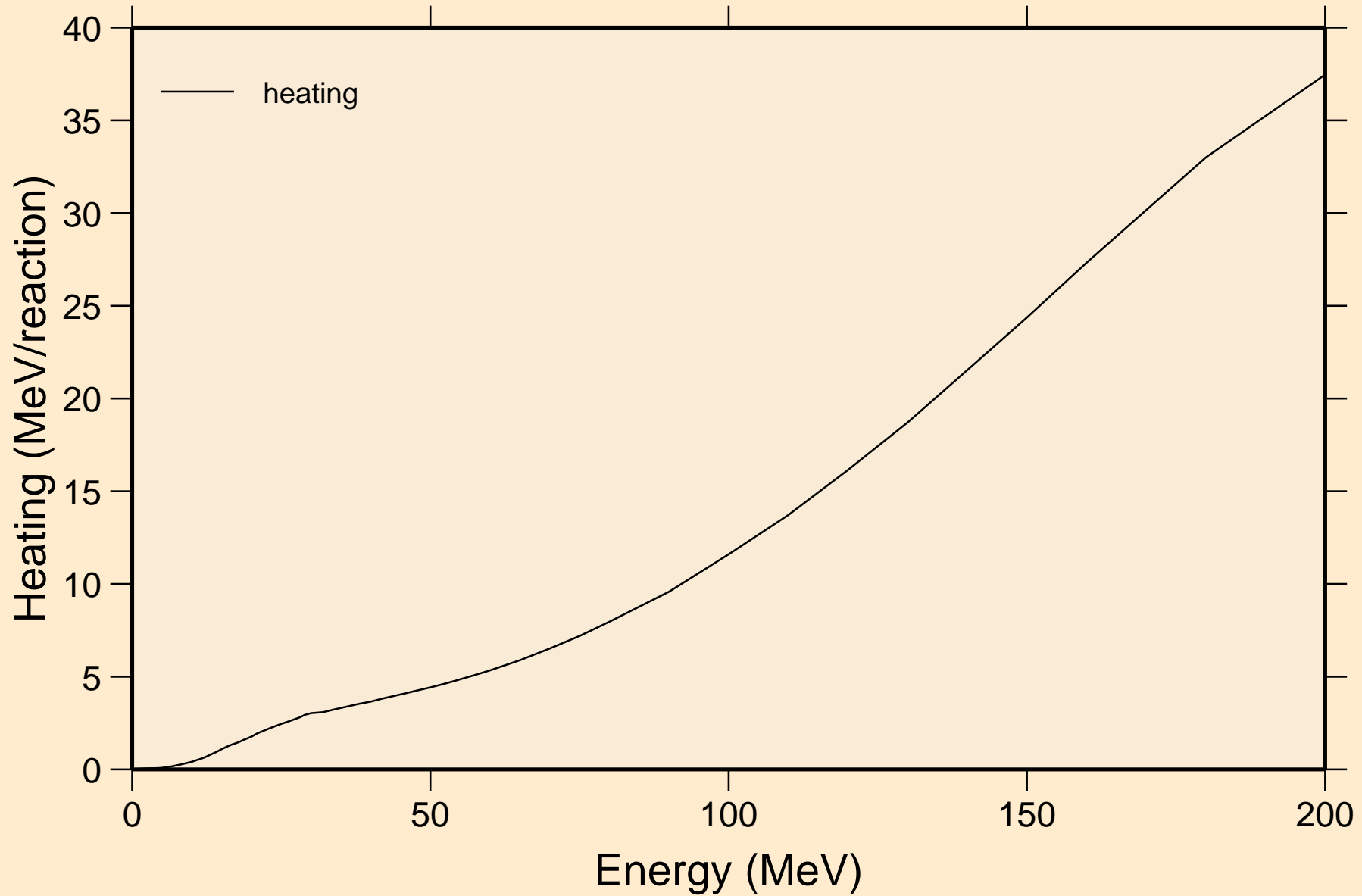

# NI060 NEUTRON ACER TENDL-2023 LIBRARY; T=0.K

## Damage

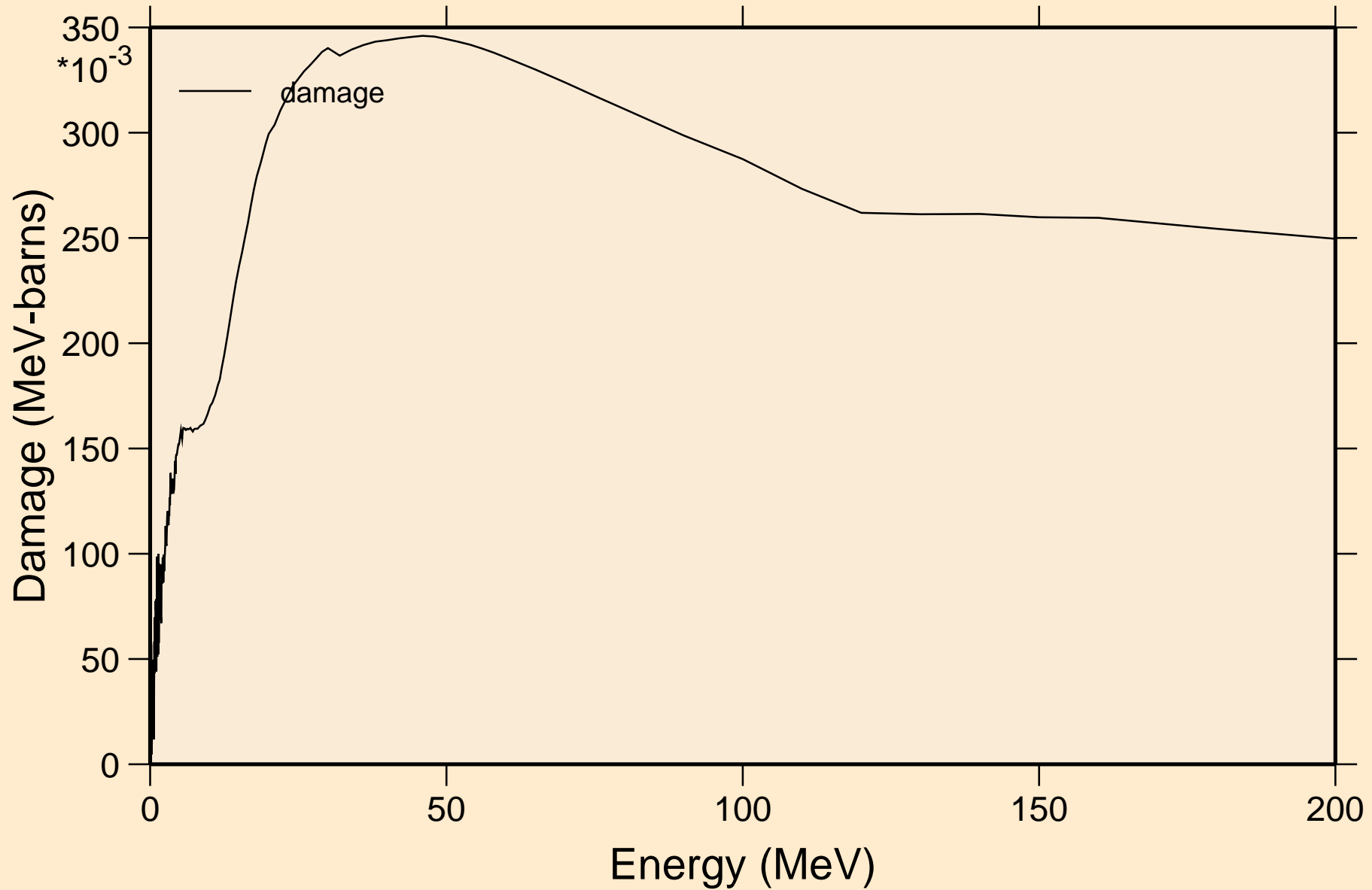

NI060 NEUTRON ACER TENDL-2023 LIBRARY; T=0.K  
Non-threshold reactions

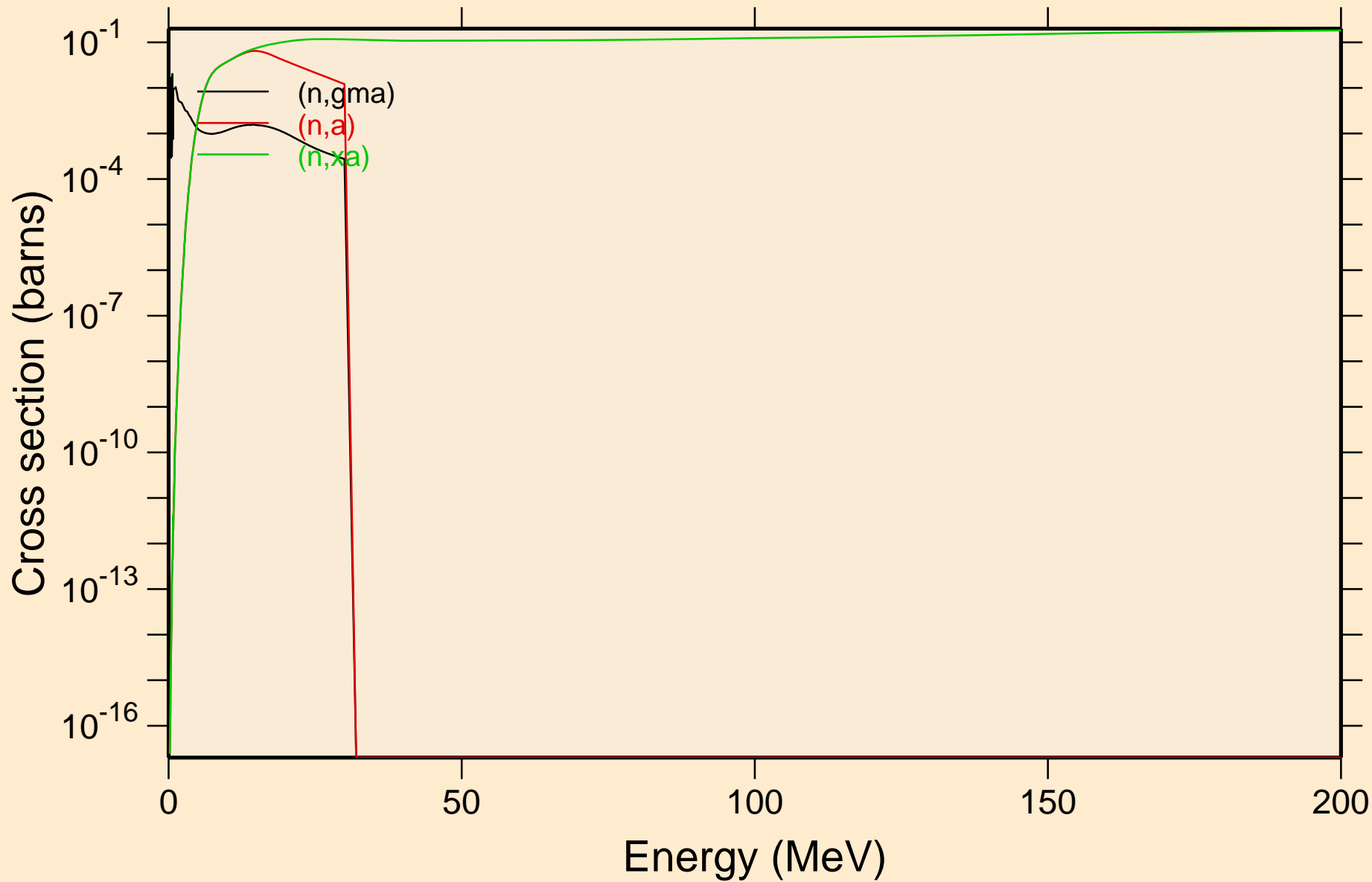



NI060 NEUTRON ACER TENDL-2023 LIBRARY; T=0.K  
Inelastic levels

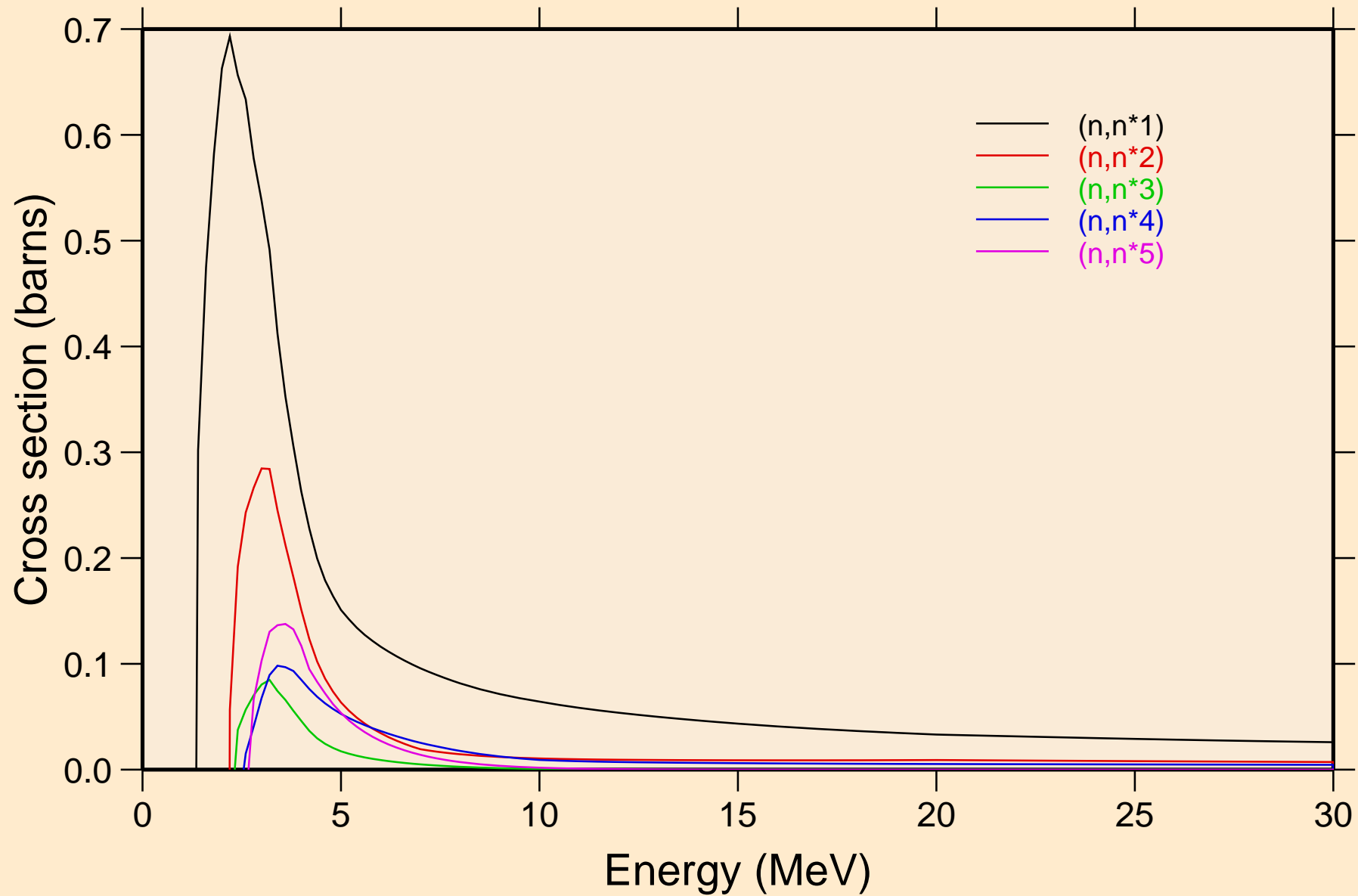

NI060 NEUTRON ACER TENDL-2023 LIBRARY; T=0.K  
Inelastic levels

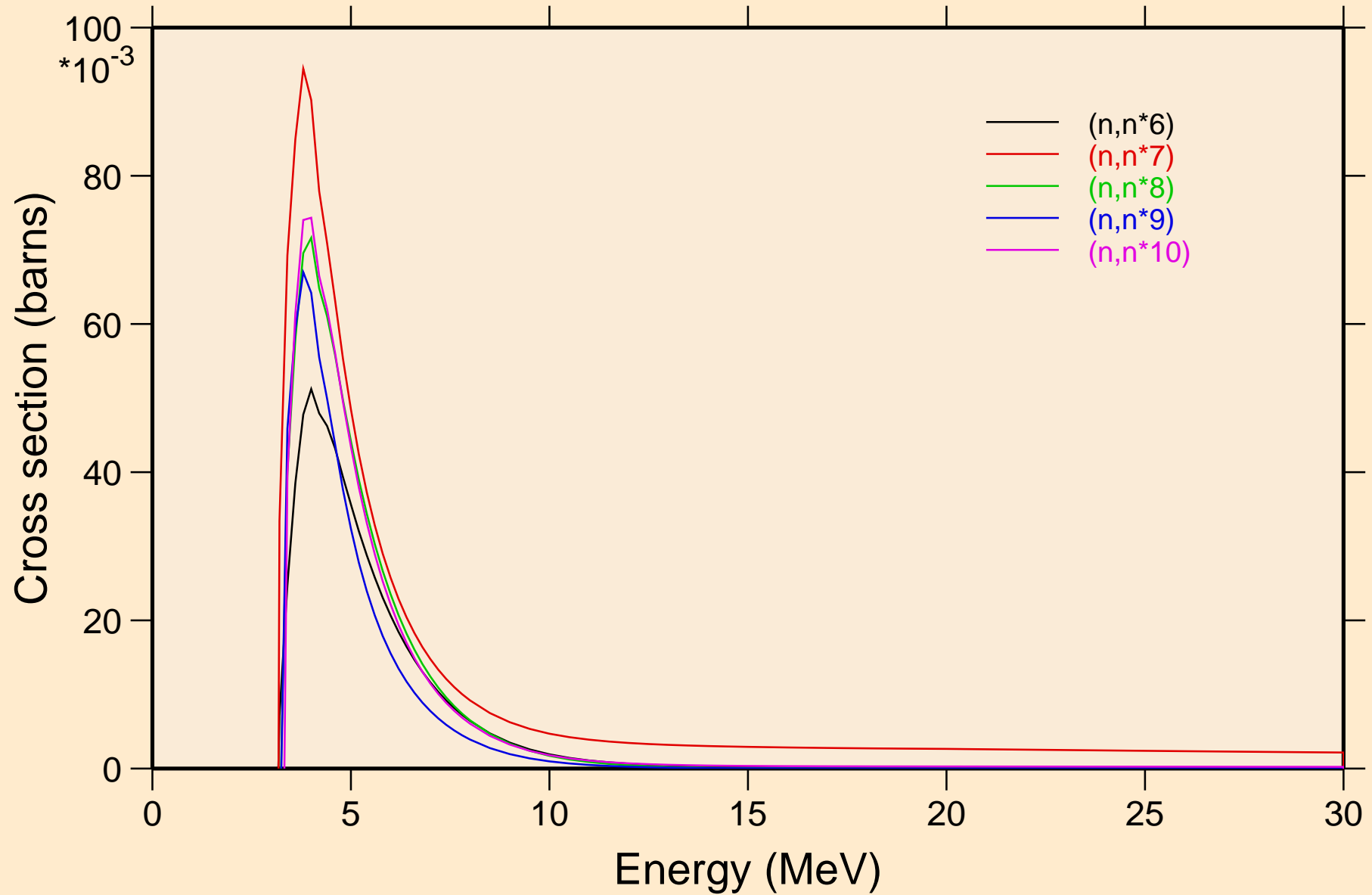

NI060 NEUTRON ACER TENDL-2023 LIBRARY; T=0.K  
Inelastic levels

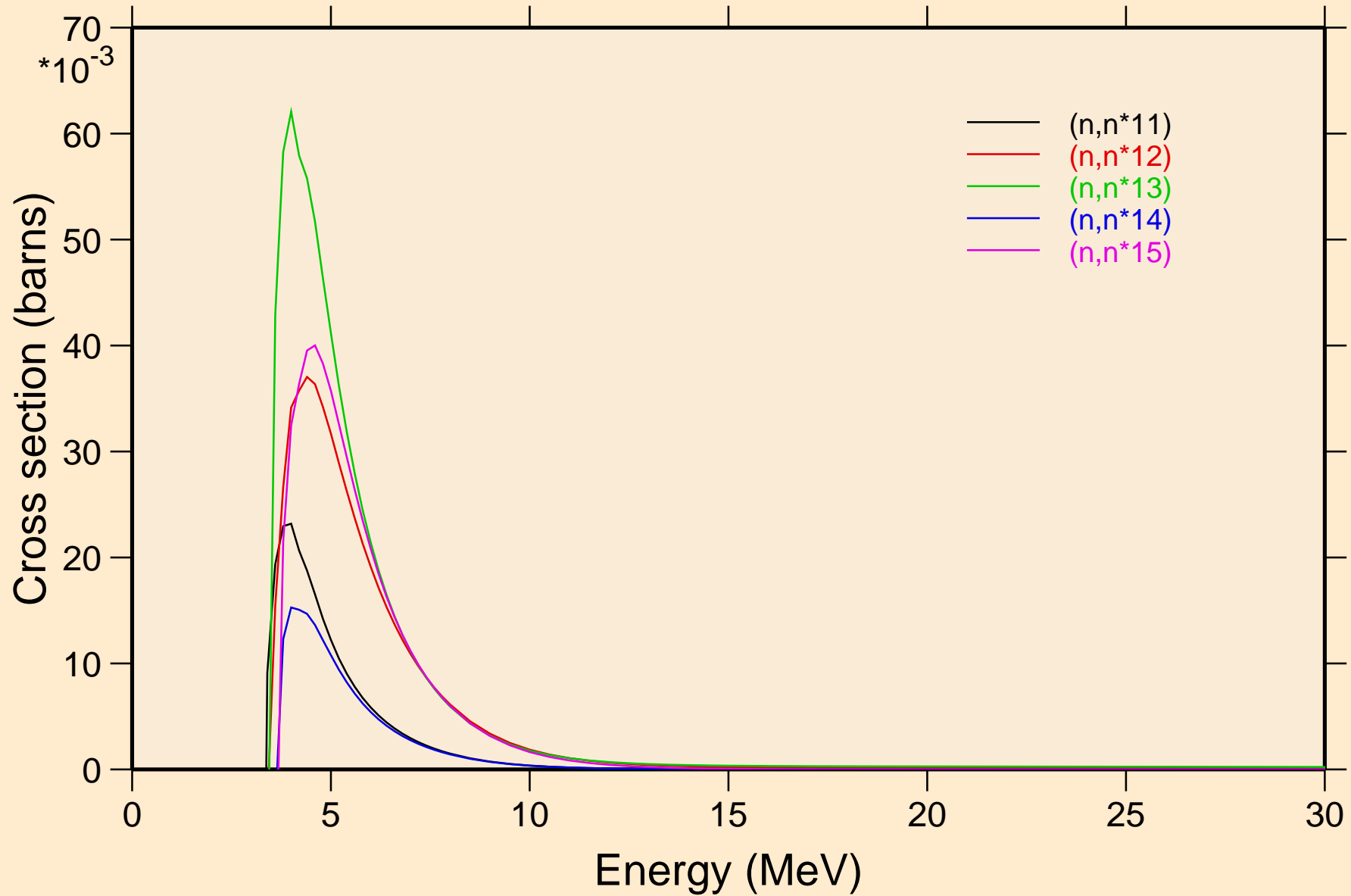

NI060 NEUTRON ACER TENDL-2023 LIBRARY; T=0.K  
Inelastic levels

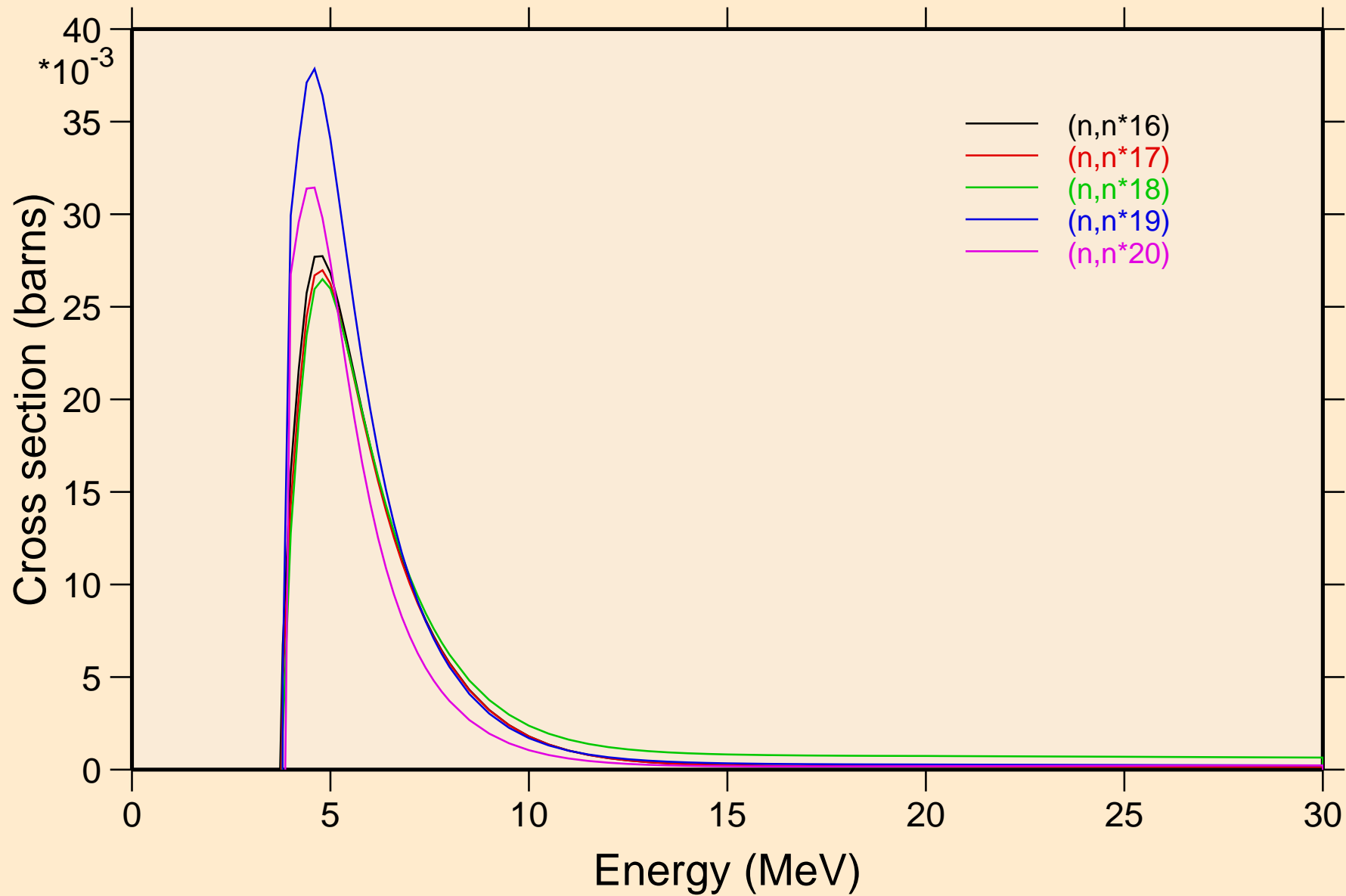

NI060 NEUTRON ACER TENDL-2023 LIBRARY; T=0.K  
Inelastic levels

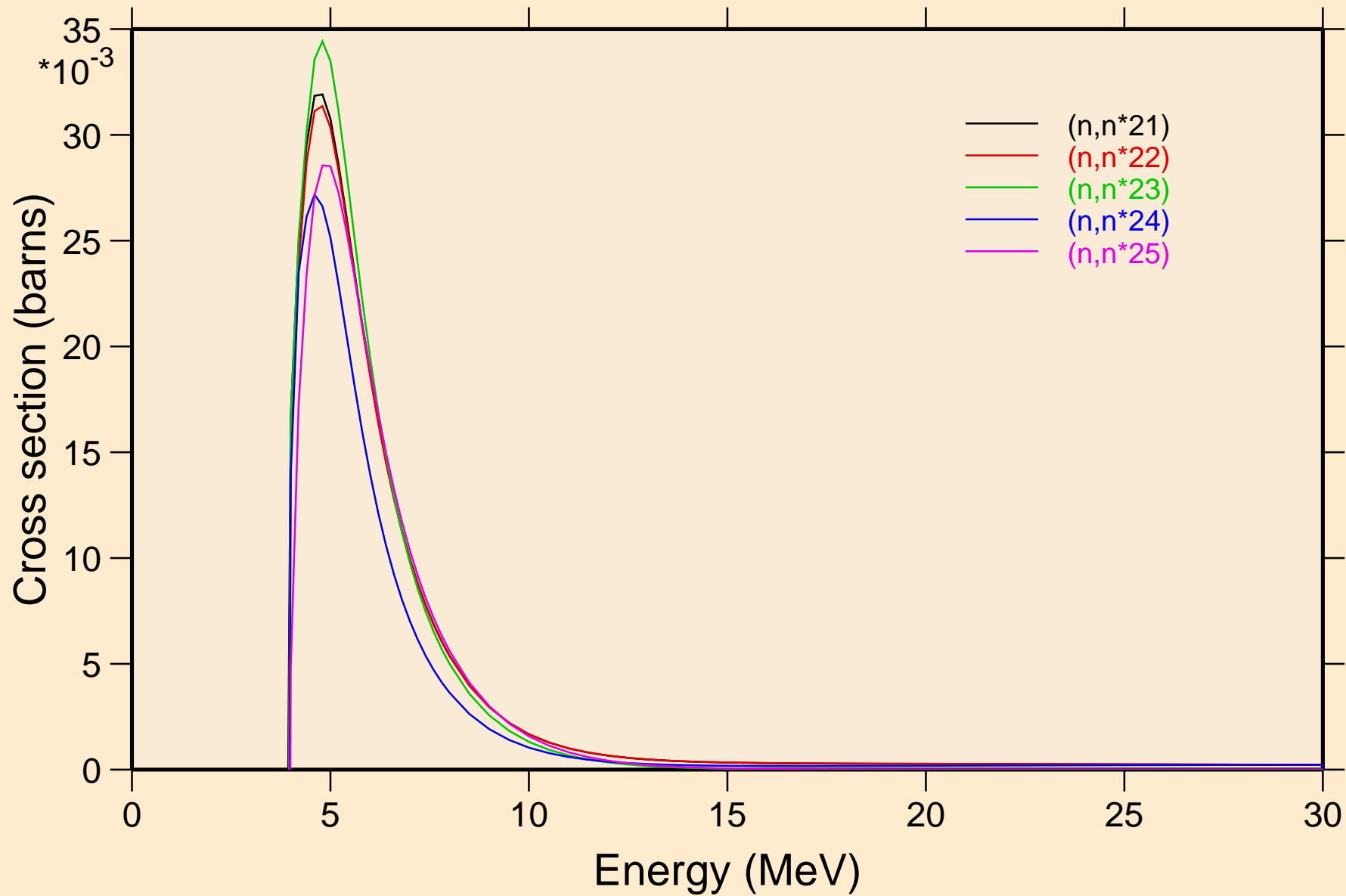

NI060 NEUTRON ACER TENDL-2023 LIBRARY; T=0.K  
Inelastic levels

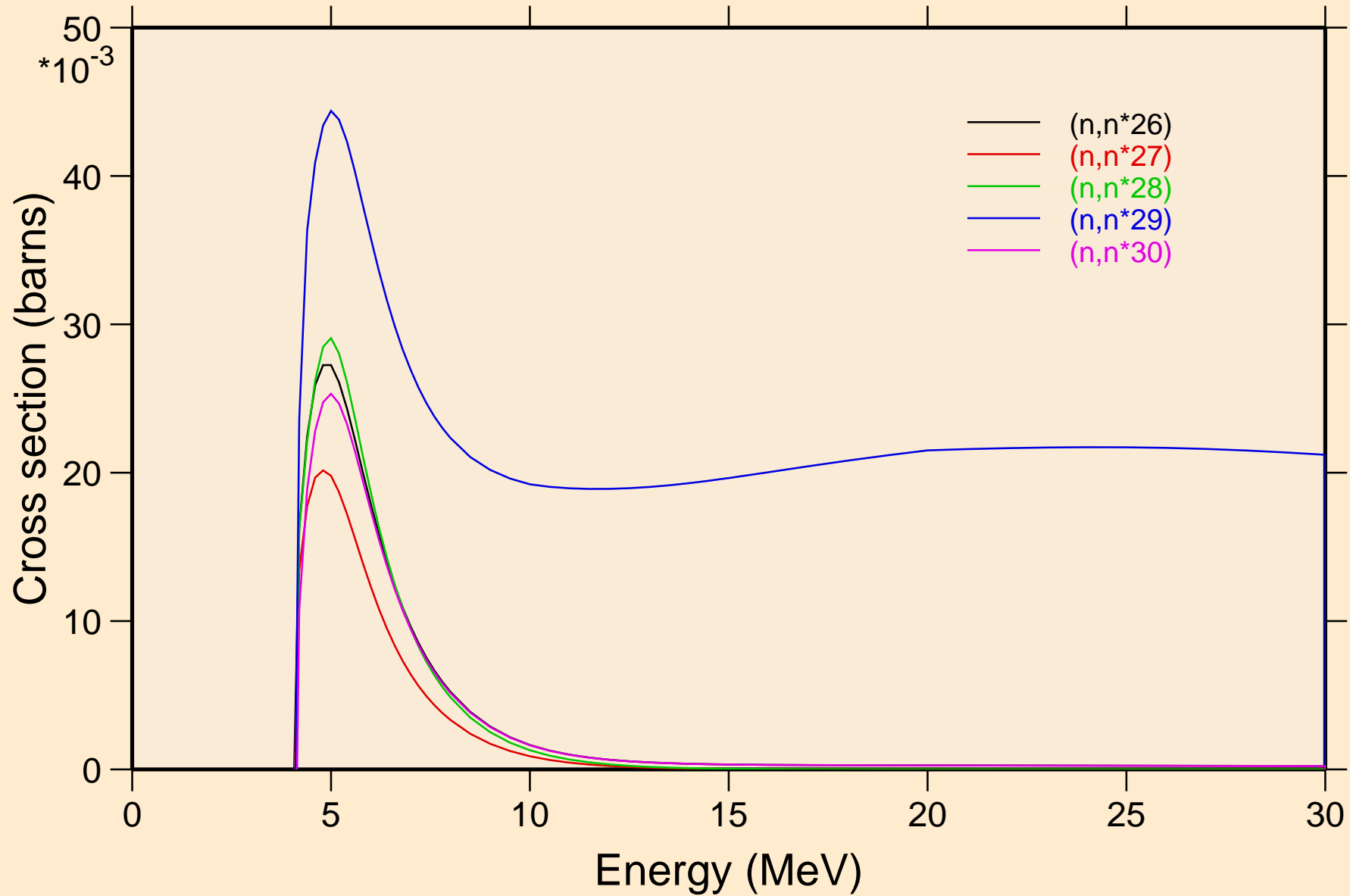

NI060 NEUTRON ACER TENDL-2023 LIBRARY; T=0.K  
Threshold reactions

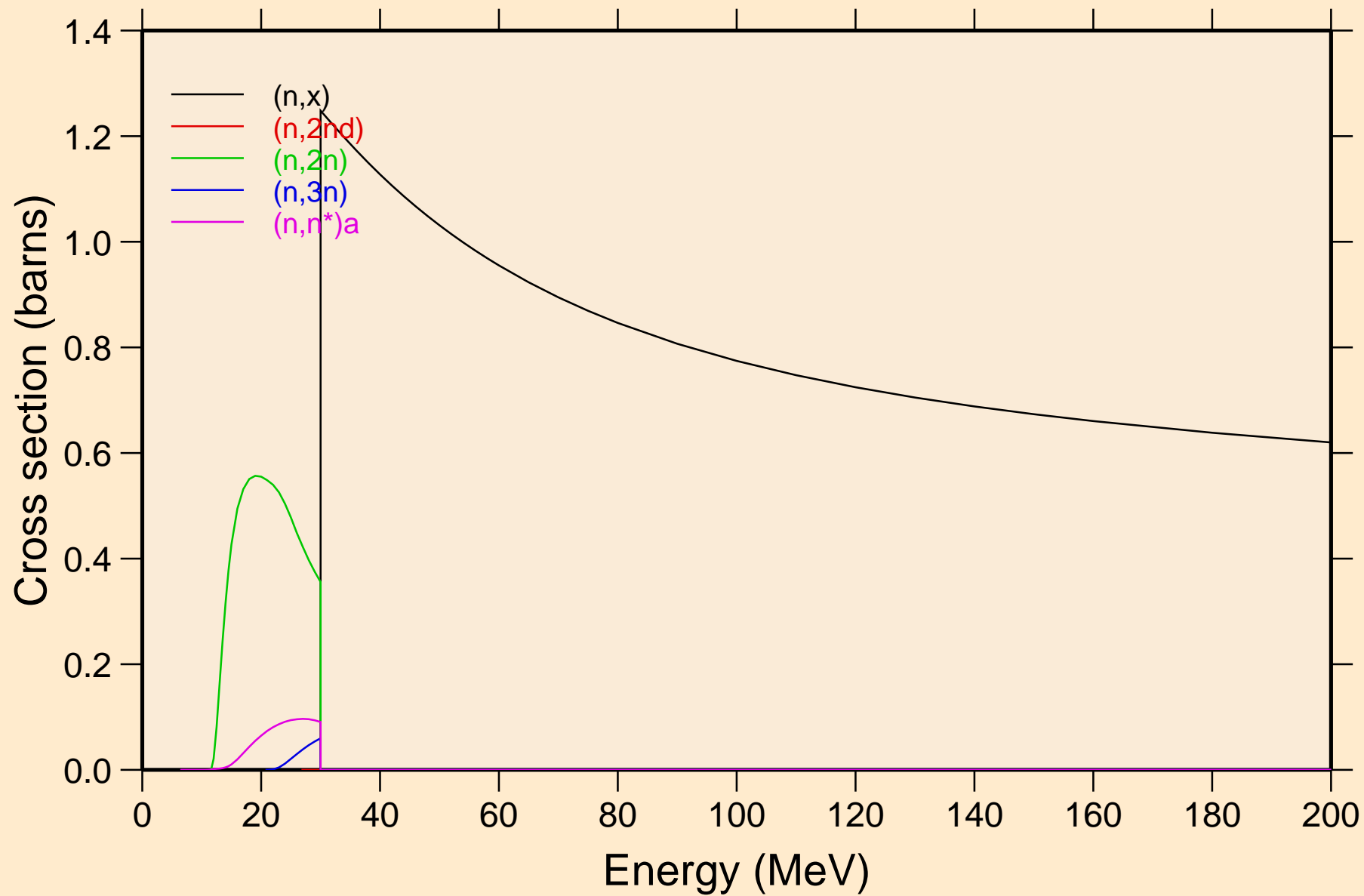

NI060 NEUTRON ACER TENDL-2023 LIBRARY; T=0.K  
Threshold reactions

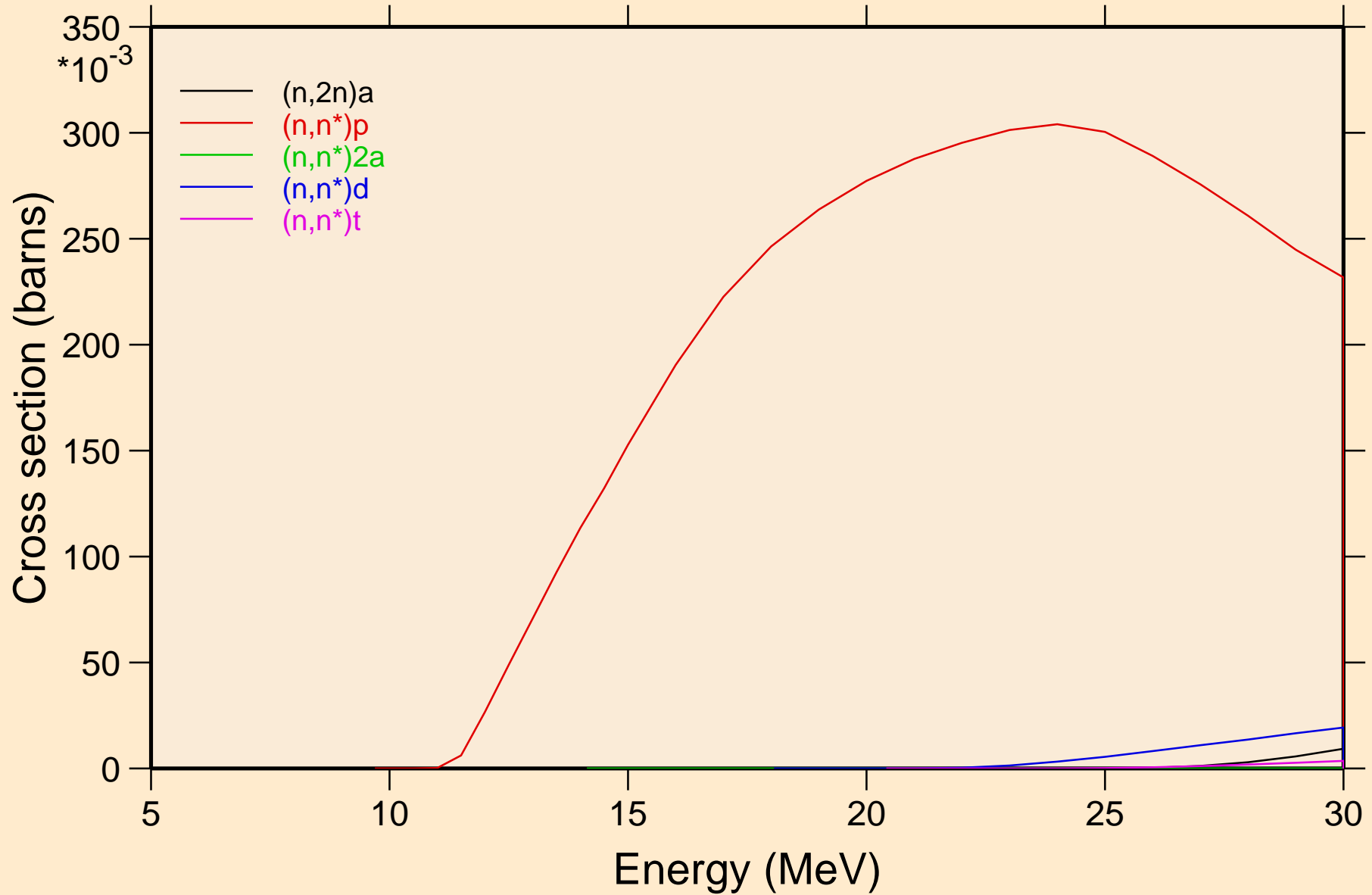



NI060 NEUTRON ACER TENDL-2023 LIBRARY; T=0.K  
Threshold reactions

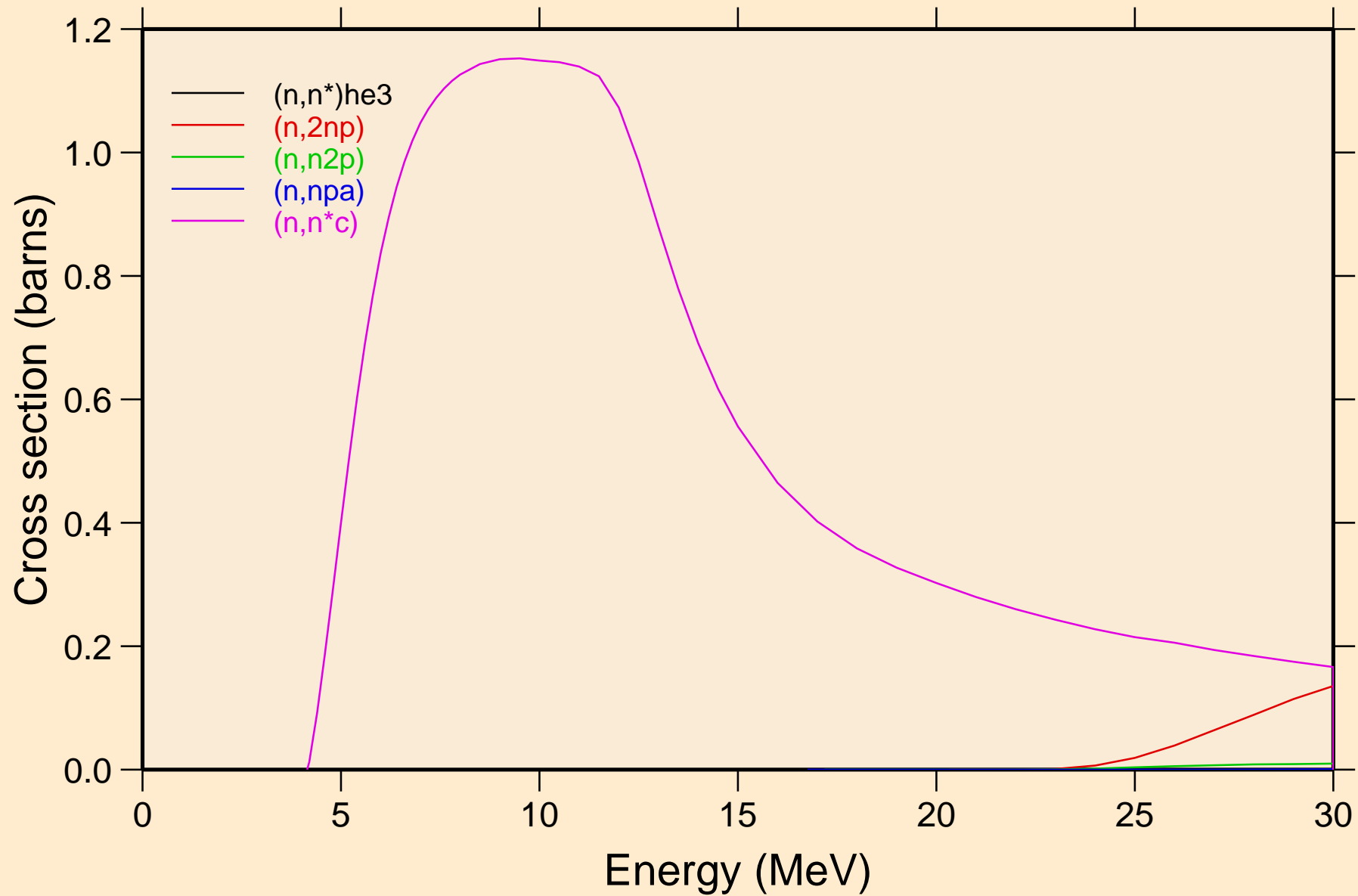

# NI060 NEUTRON ACER TENDL-2023 LIBRARY; T=0.K

## Threshold reactions

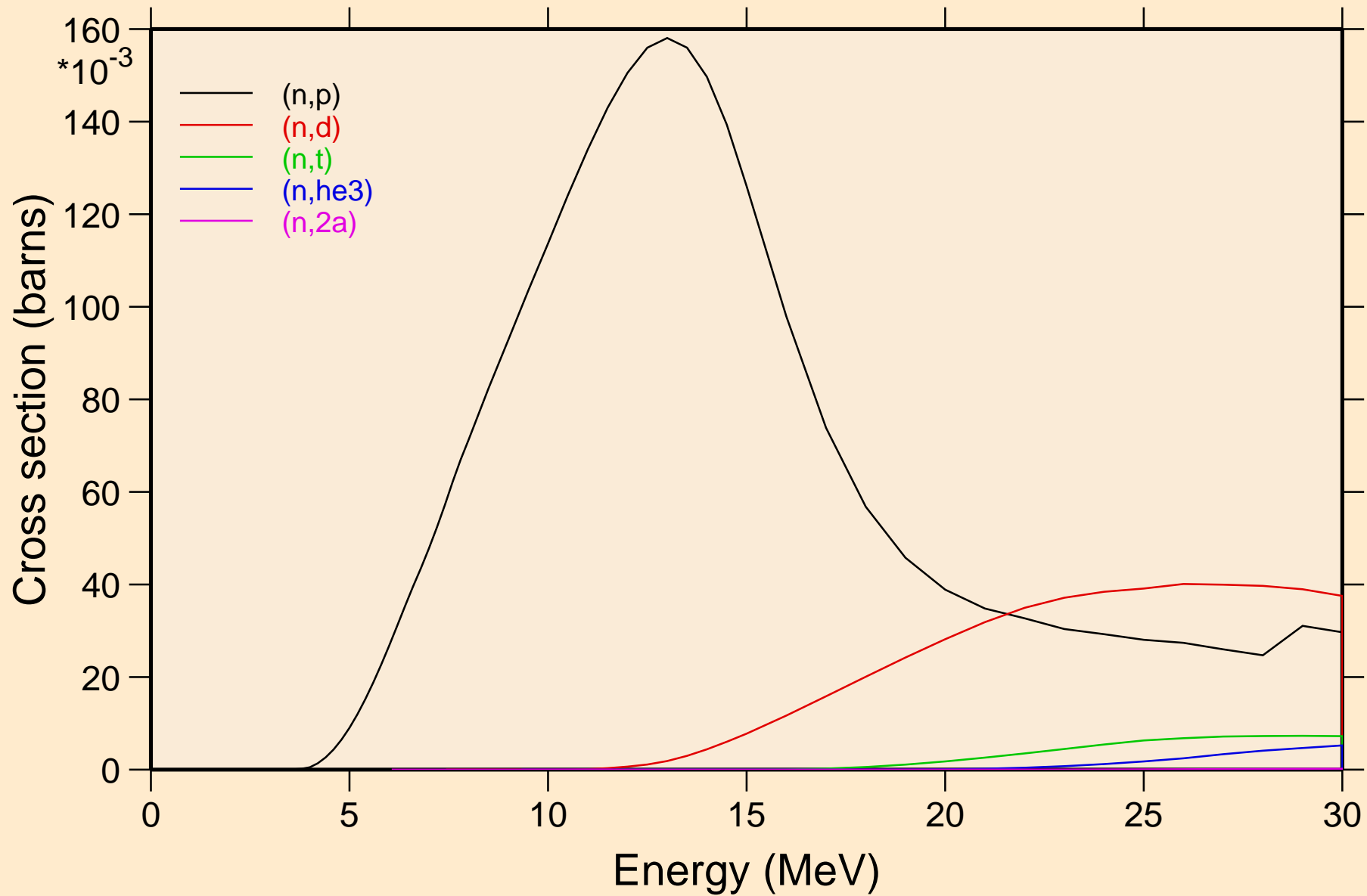

# NI060 NEUTRON ACER TENDL-2023 LIBRARY; T=0.K

## Threshold reactions

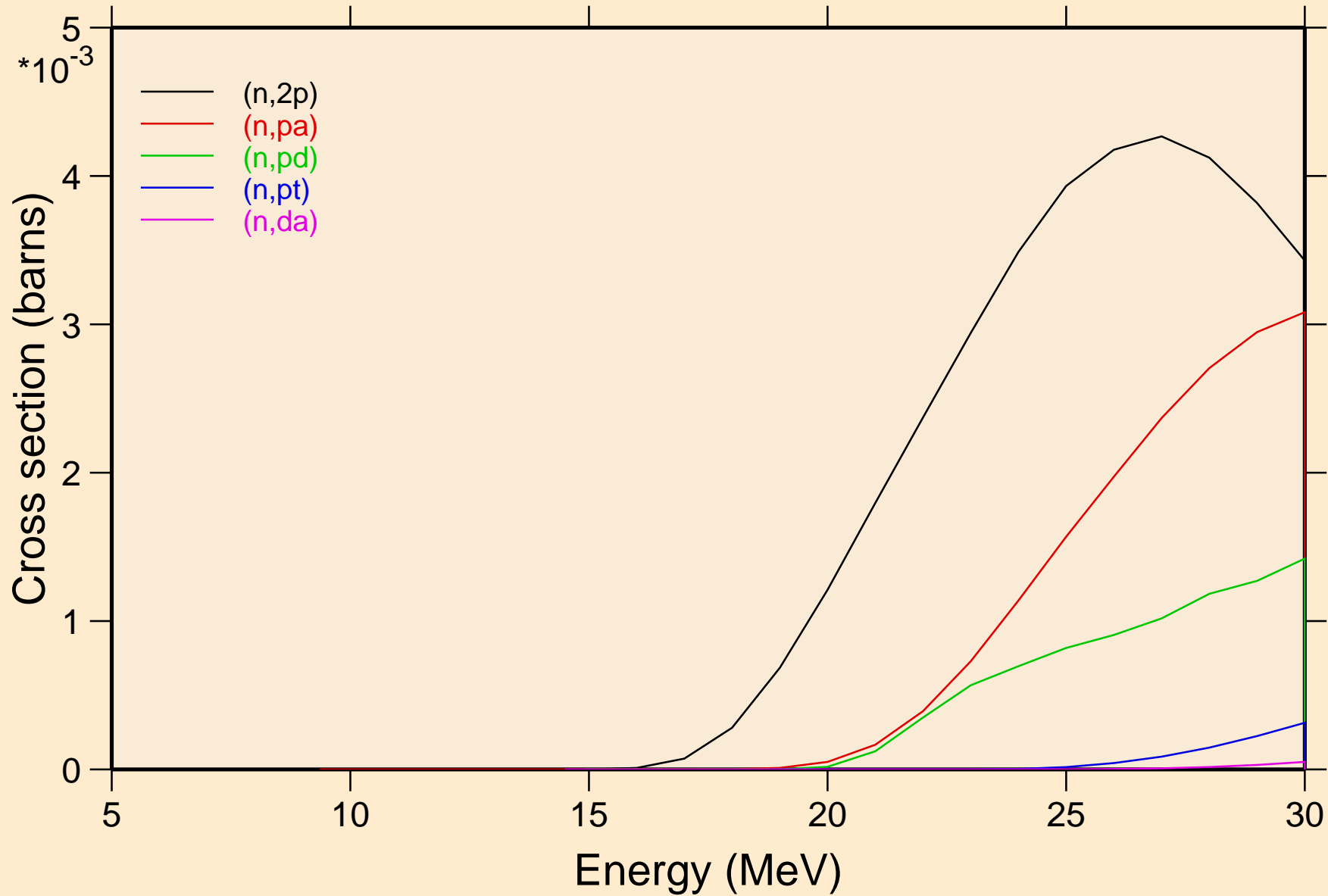

# NI060 NEUTRON ACER TENDL-2023 LIBRARY; T=0.K

## Threshold reactions

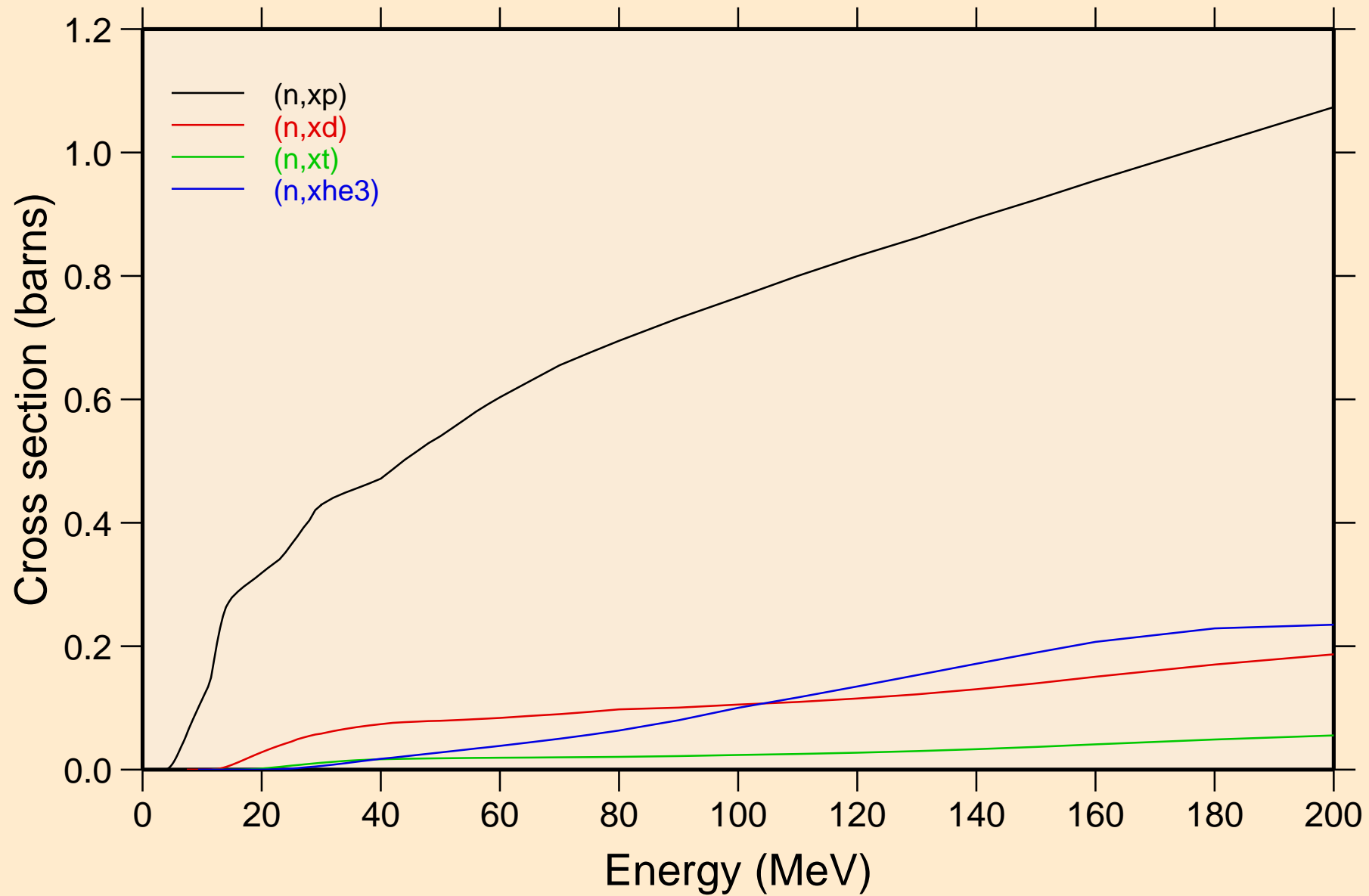

NI060 NEUTRON ACER TENDL-2023 LIBRARY; T=0.K  
angular distribution for elastic

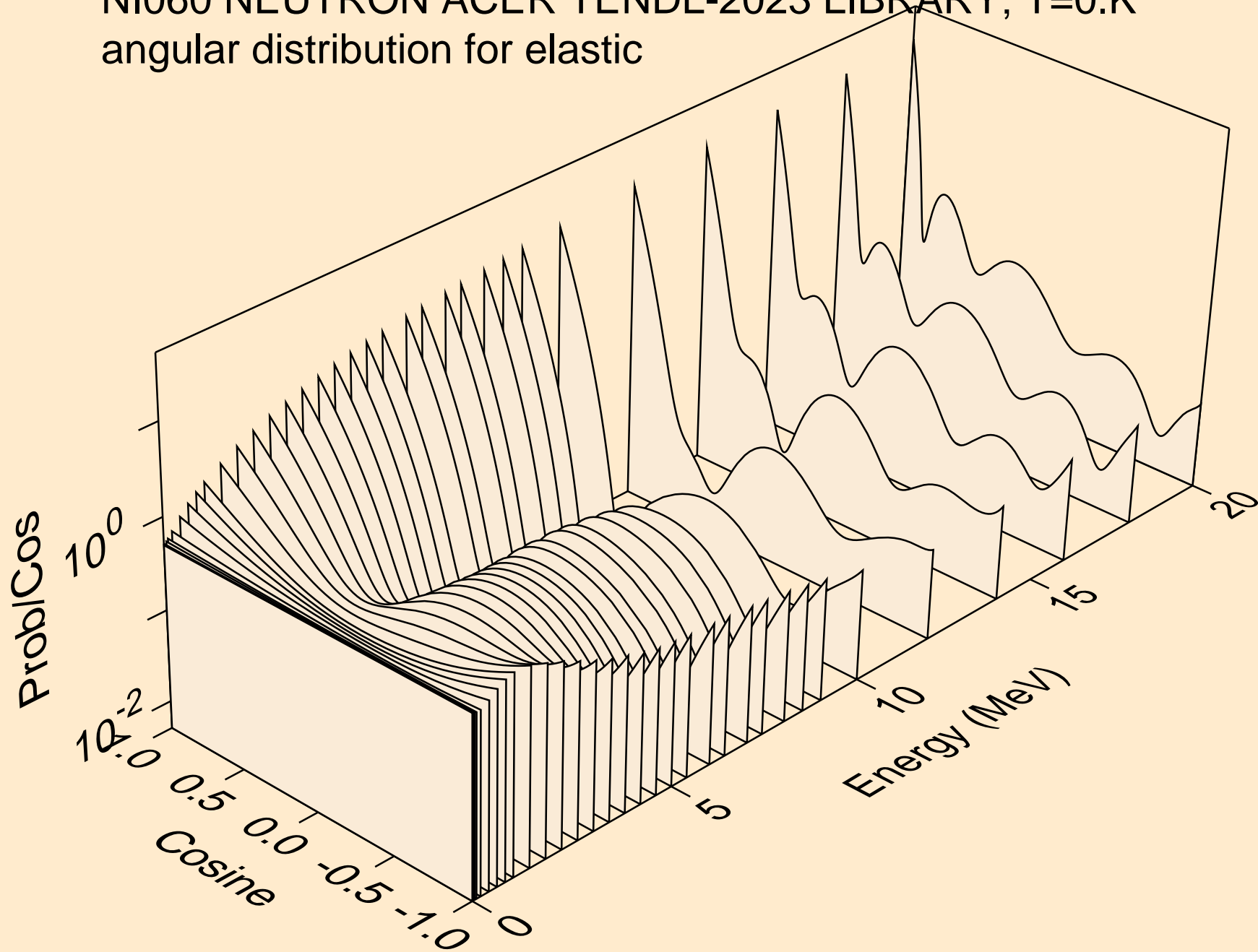

NI060 NEUTRON ACER TENDL-2023 LIBRARY; T=0.K  
angular distribution for elastic

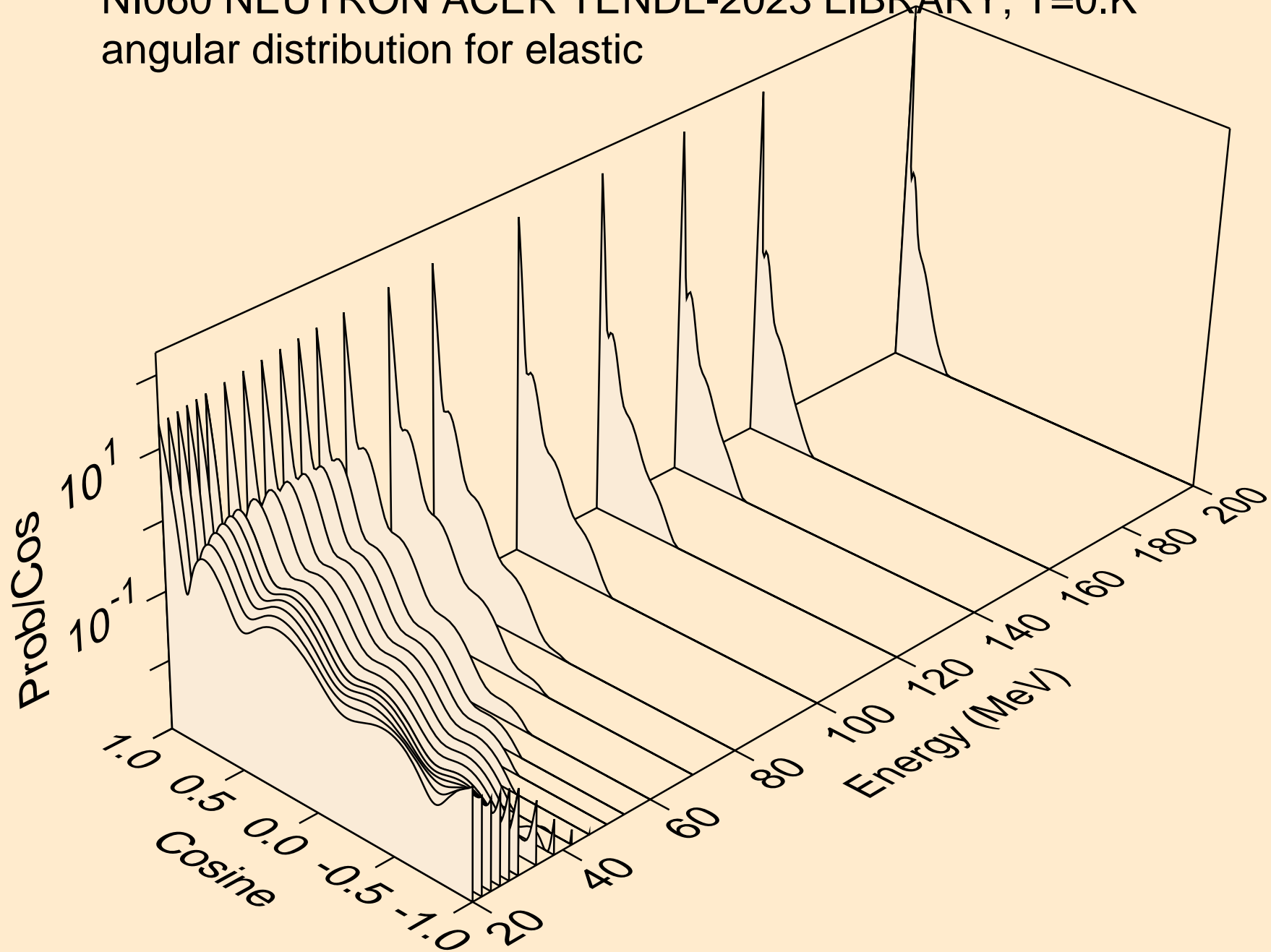

NI060 NEUTRON ACER TENDL-2023 LIBRARY; T=0.K  
angular distribution for (n,n\*1)

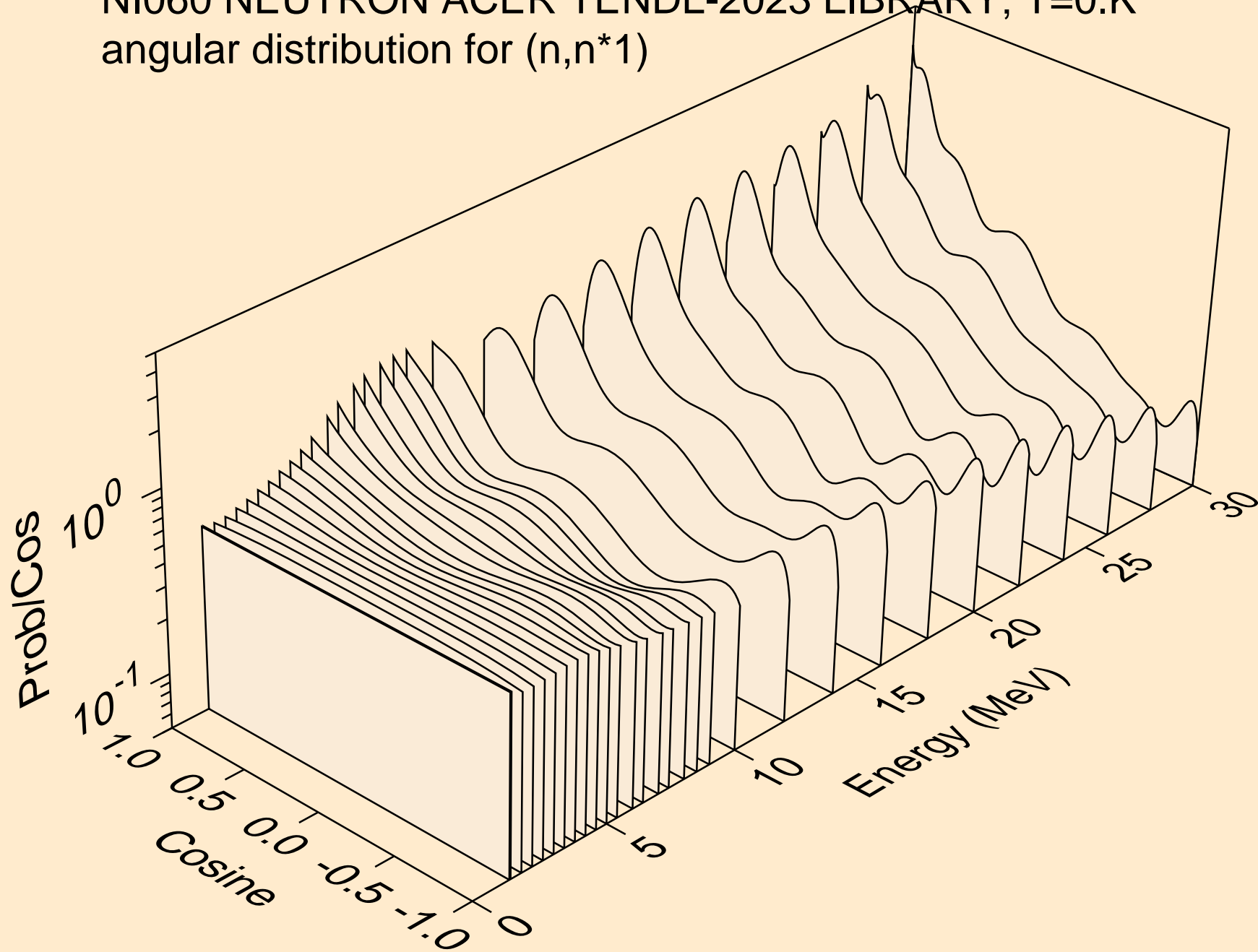

NI060 NEUTRON ACER TENDL-2023 LIBRARY; T=0.K  
angular distribution for (n,n\*2)

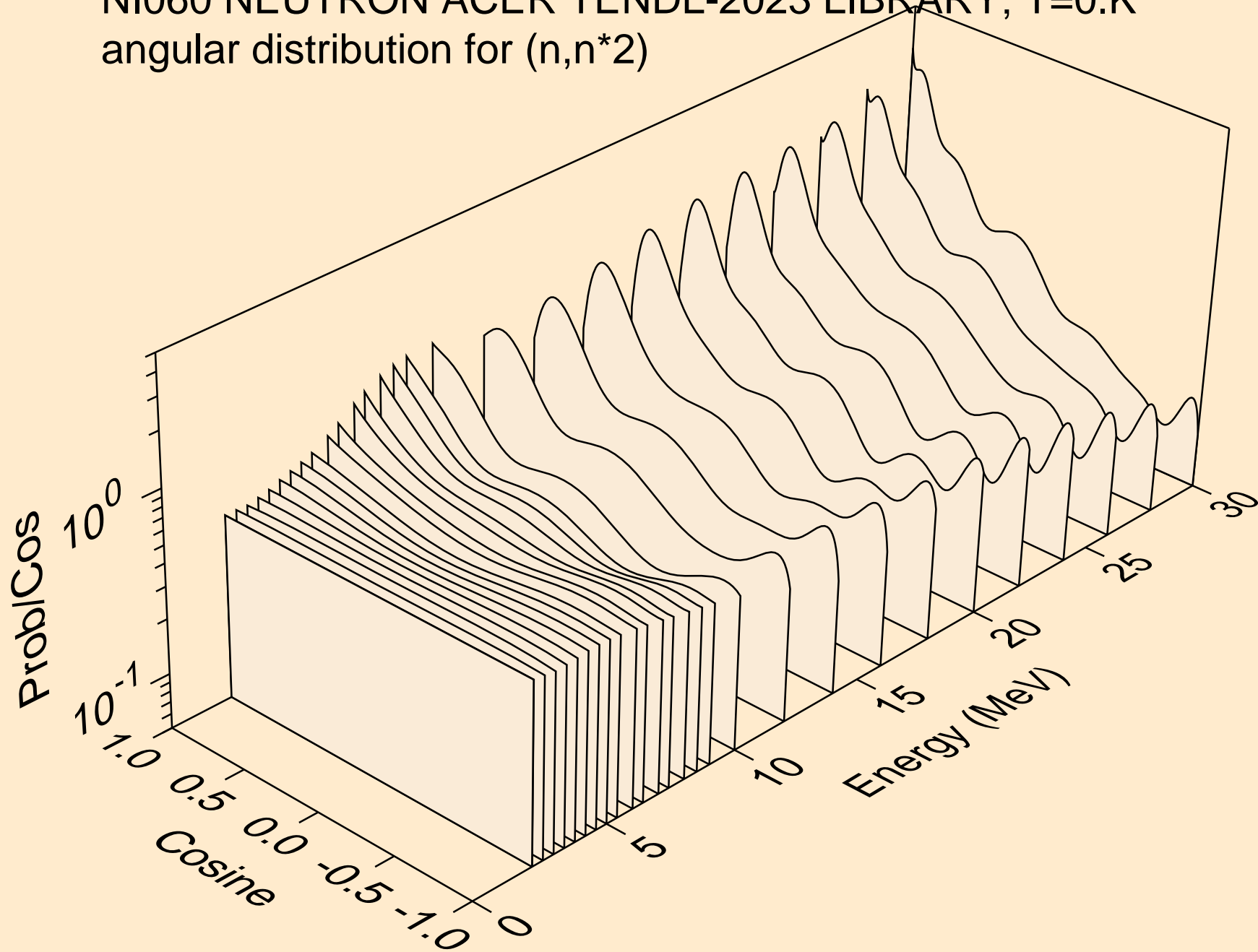



NI060 NEUTRON ACER TENDL-2023 LIBRARY; T=0.K  
angular distribution for (n,n\*3)

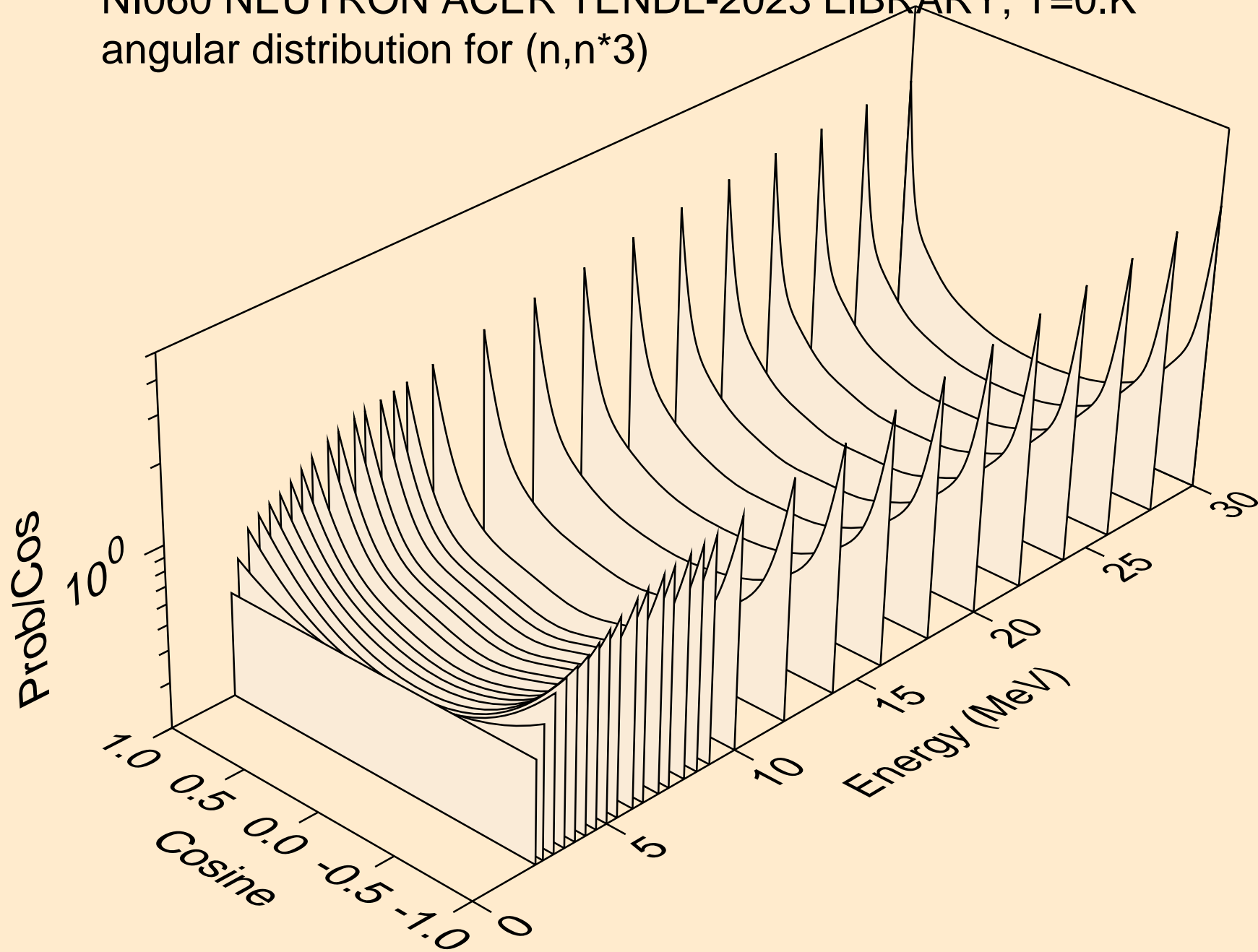

NI060 NEUTRON ACER TENDL-2023 LIBRARY; T=0.K  
angular distribution for (n,n\*4)

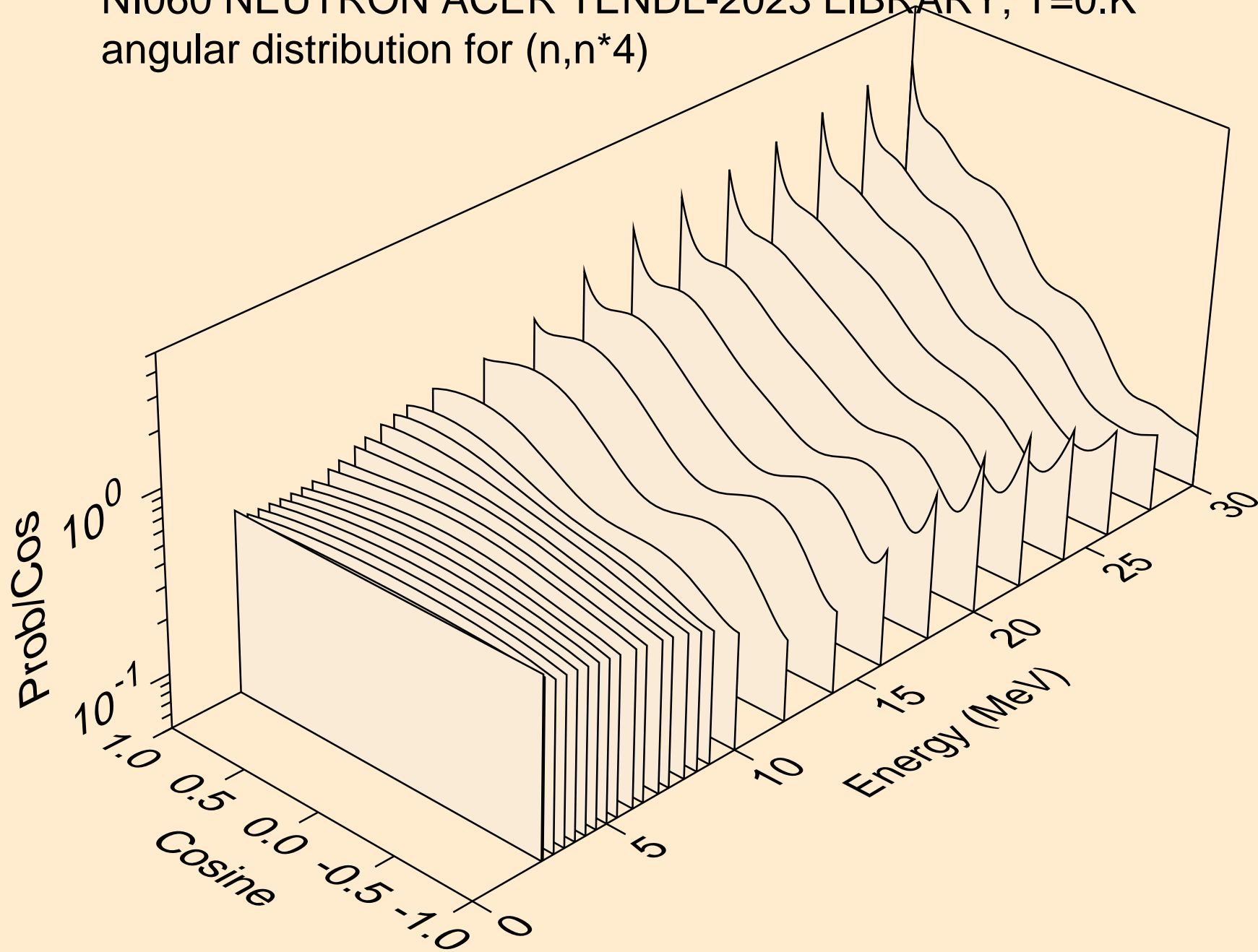

NI060 NEUTRON ACER TENDL-2023 LIBRARY; T=0.K  
angular distribution for (n,n\*5)

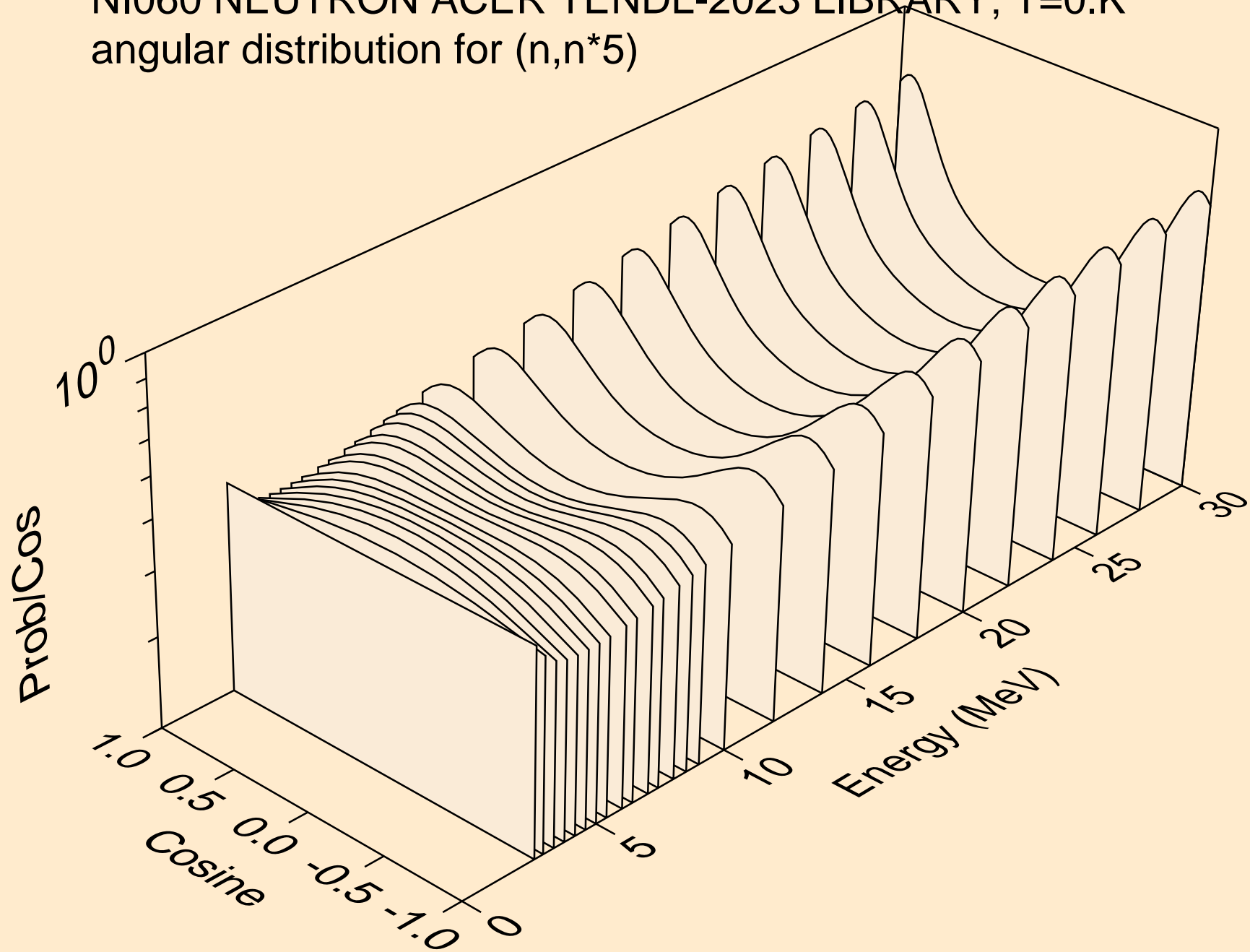

NI060 NEUTRON ACER TENDL-2023 LIBRARY; T=0.K  
angular distribution for (n,n\*6)

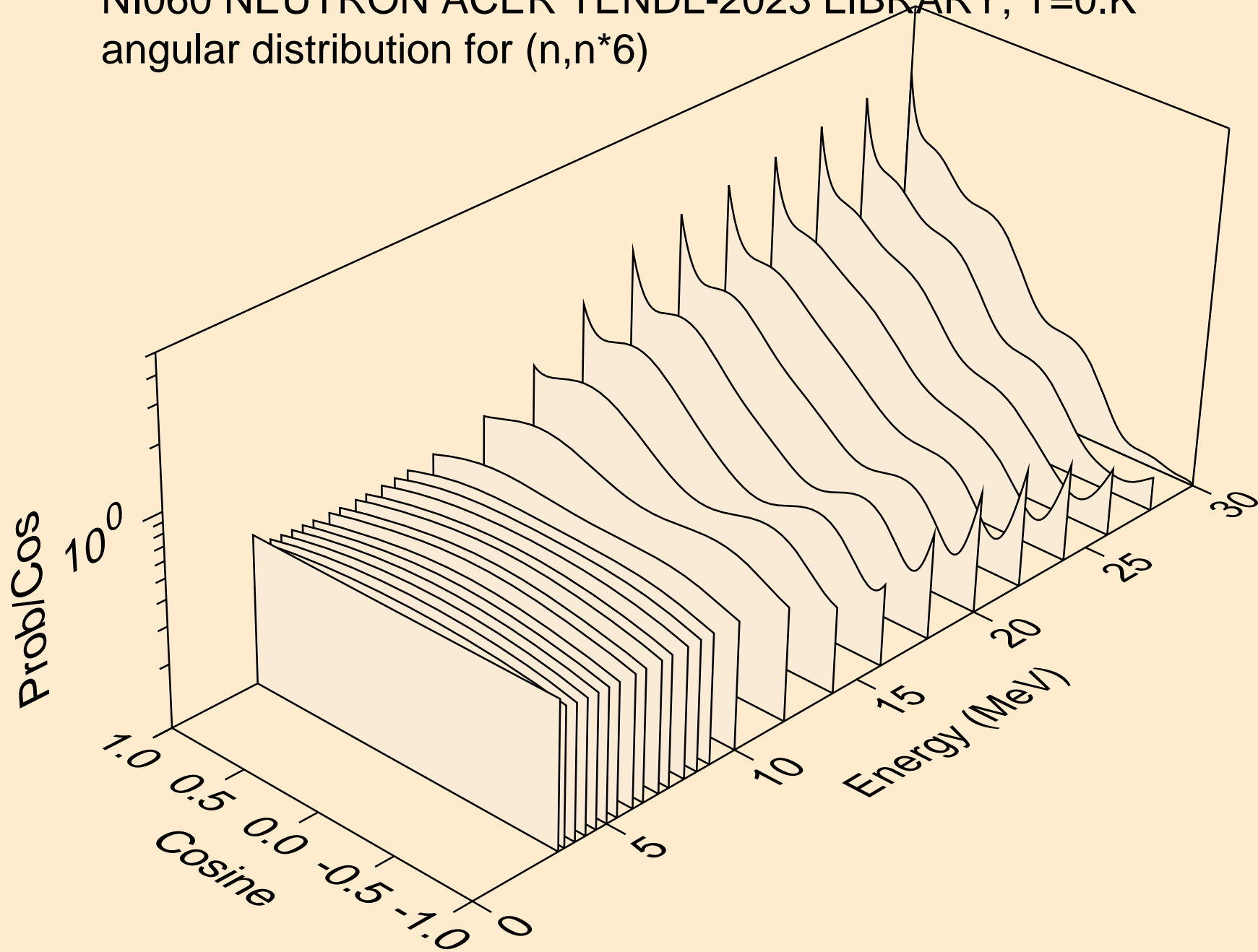

NI060 NEUTRON ACER TENDL-2023 LIBRARY; T=0.K  
angular distribution for (n,n\*7)

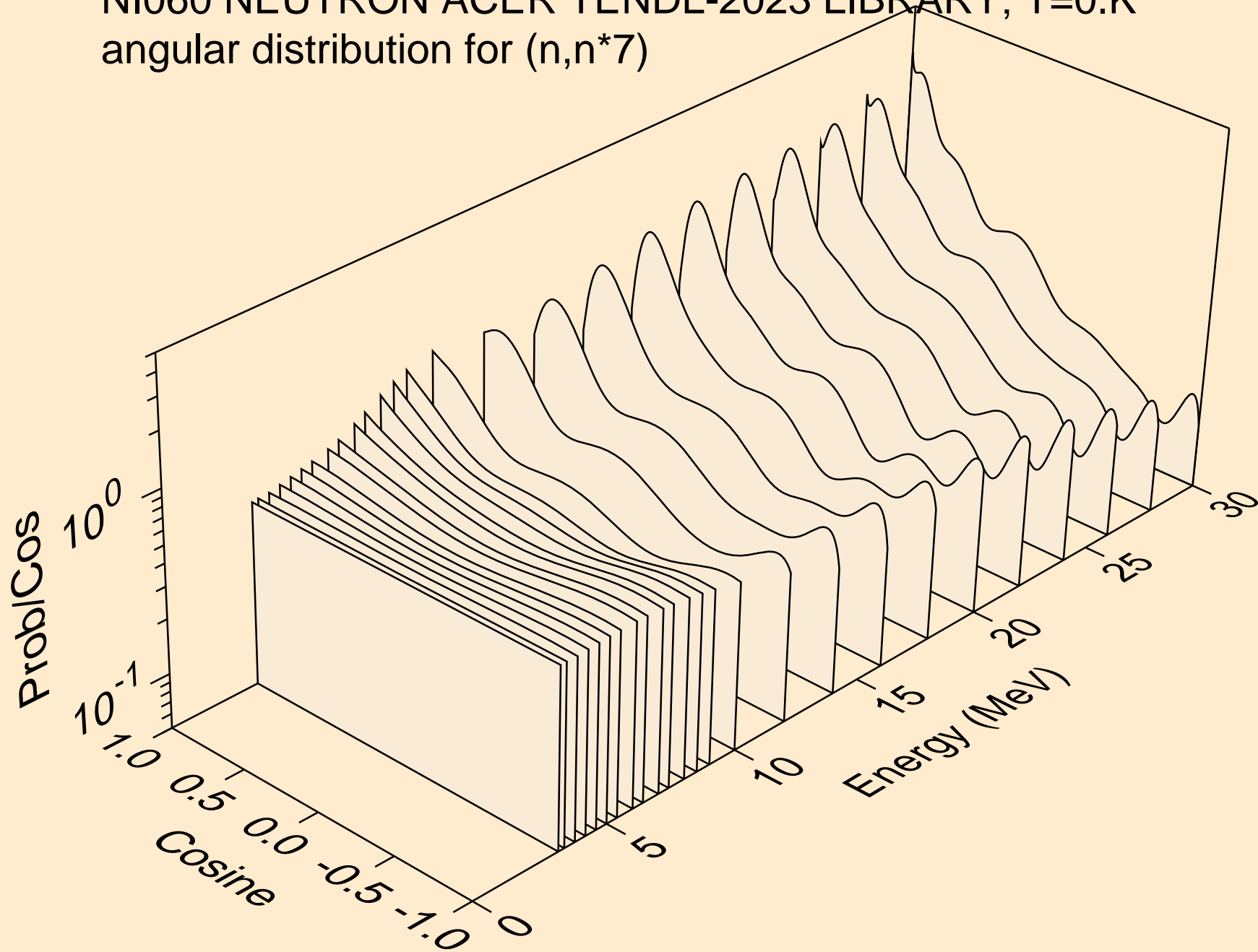

NI060 NEUTRON ACER TENDL-2023 LIBRARY; T=0.K  
angular distribution for (n,n\*8)

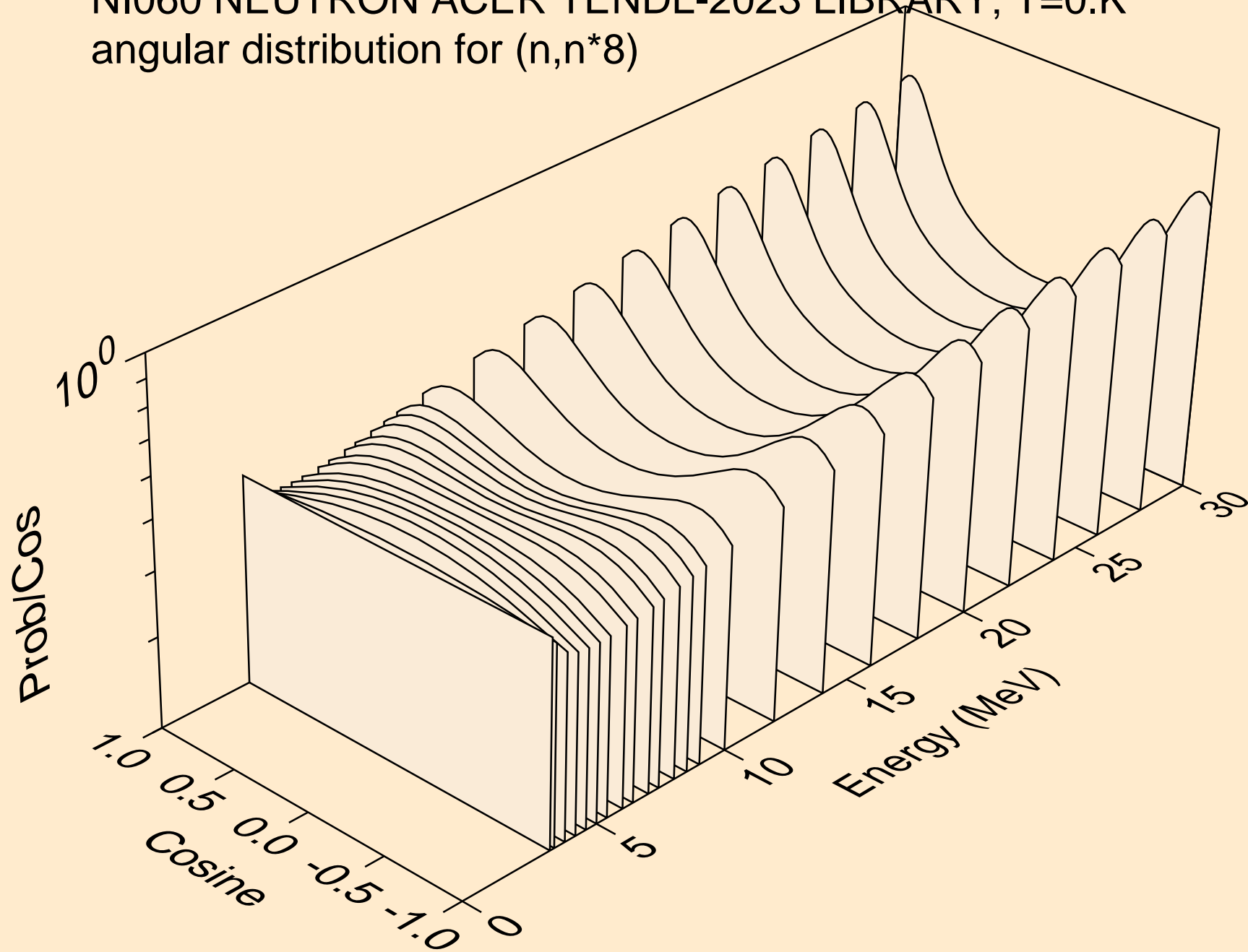

NI060 NEUTRON ACER TENDL-2023 LIBRARY; T=0.K  
angular distribution for (n,n\*9)

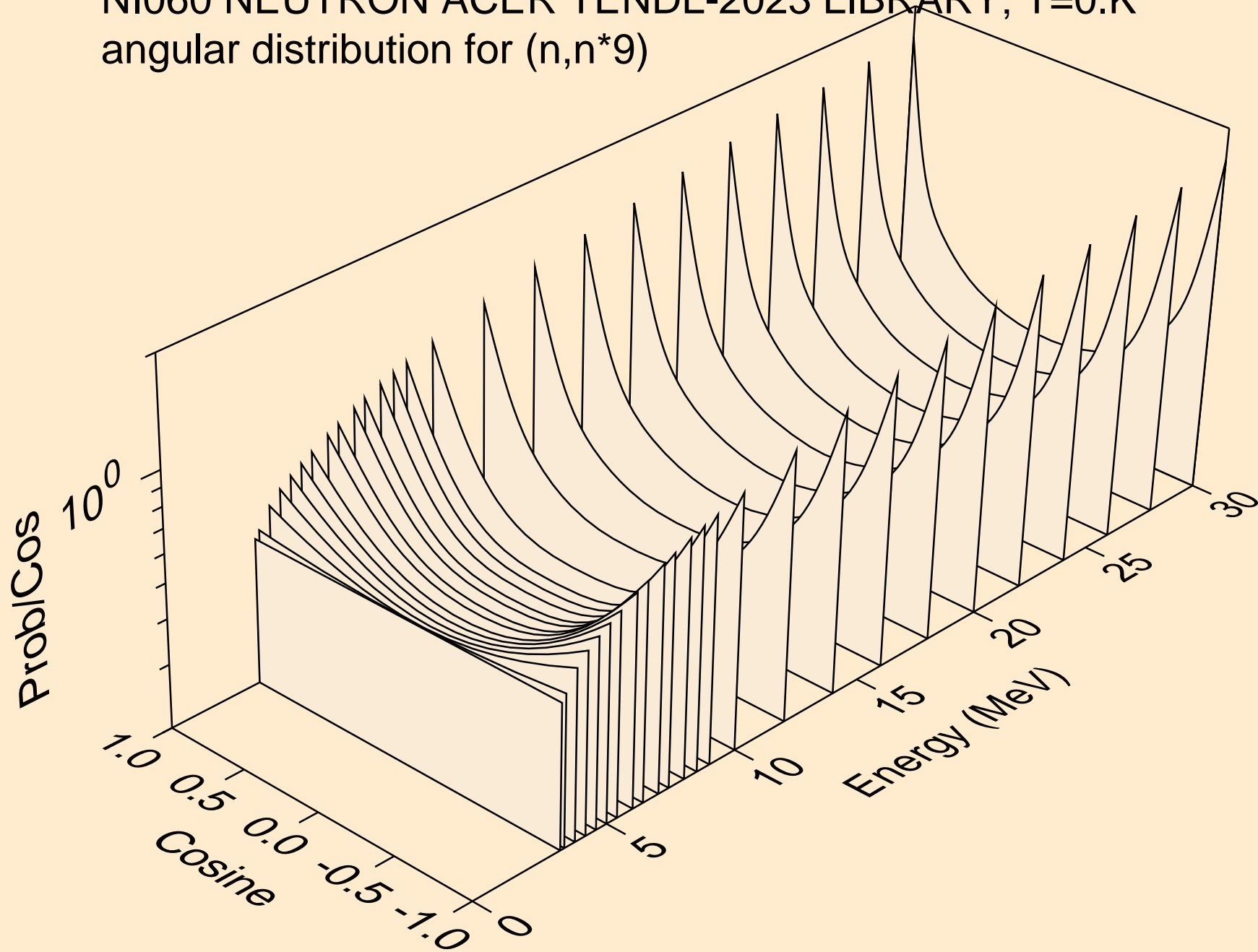

NI060 NEUTRON ACER TENDL-2023 LIBRARY; T=0.K  
angular distribution for (n,n\*10)

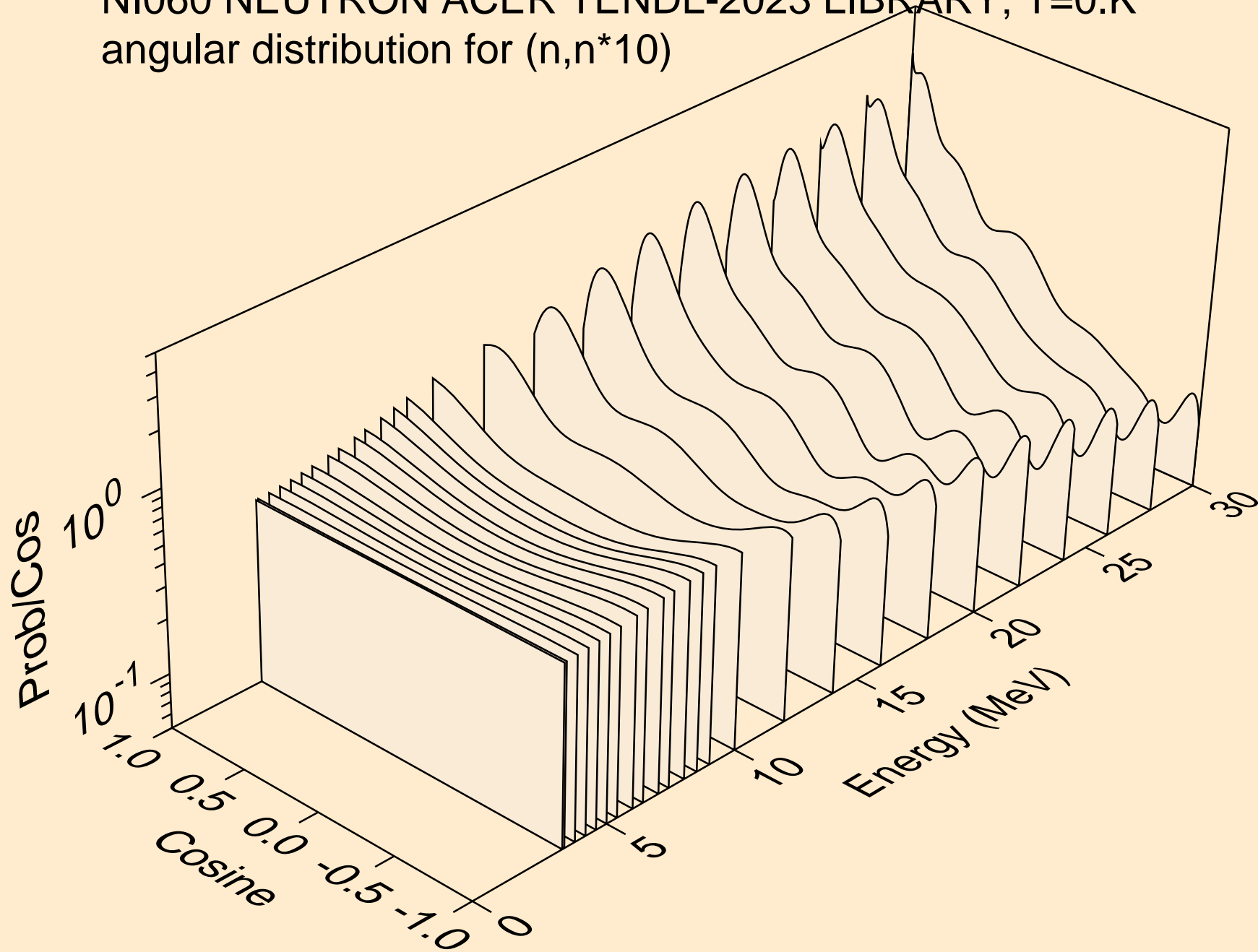



NI060 NEUTRON ACER TENDL-2023 LIBRARY; T=0.K  
angular distribution for (n,n\*11)

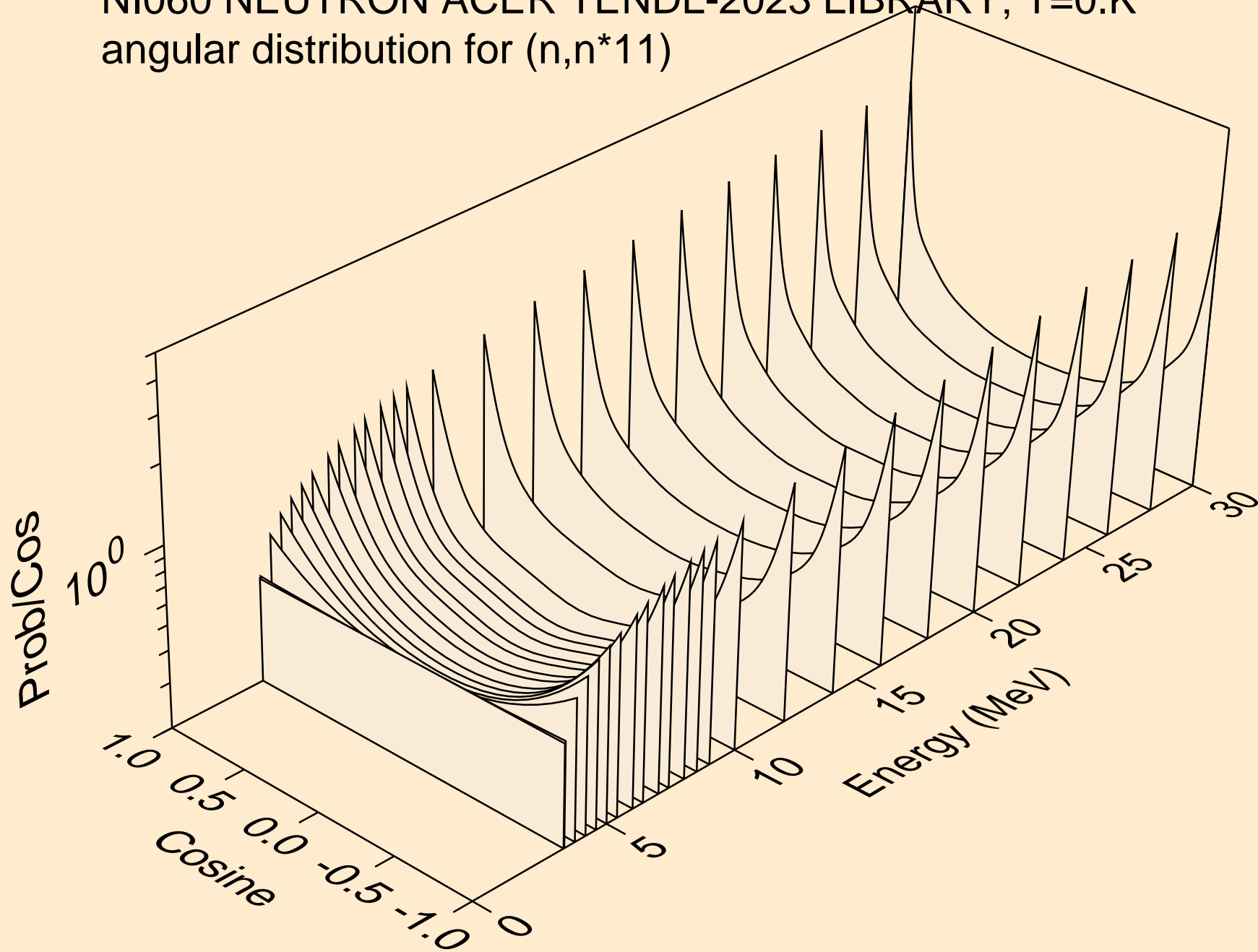

NI060 NEUTRON ACER TENDL-2023 LIBRARY; T=0.K  
angular distribution for (n,n\*12)

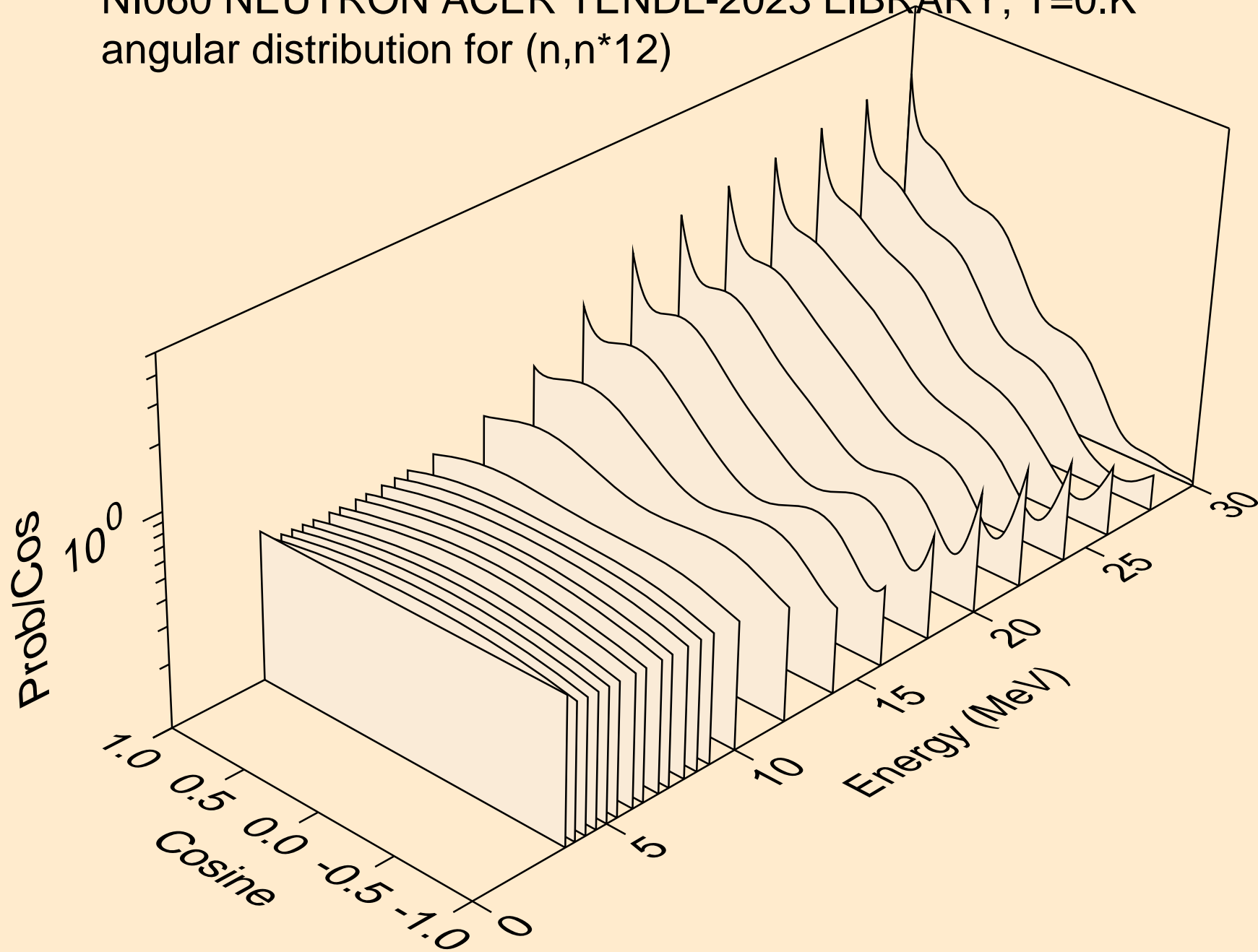

NI060 NEUTRON ACER TENDL-2023 LIBRARY; T=0.K  
angular distribution for (n,n\*13)

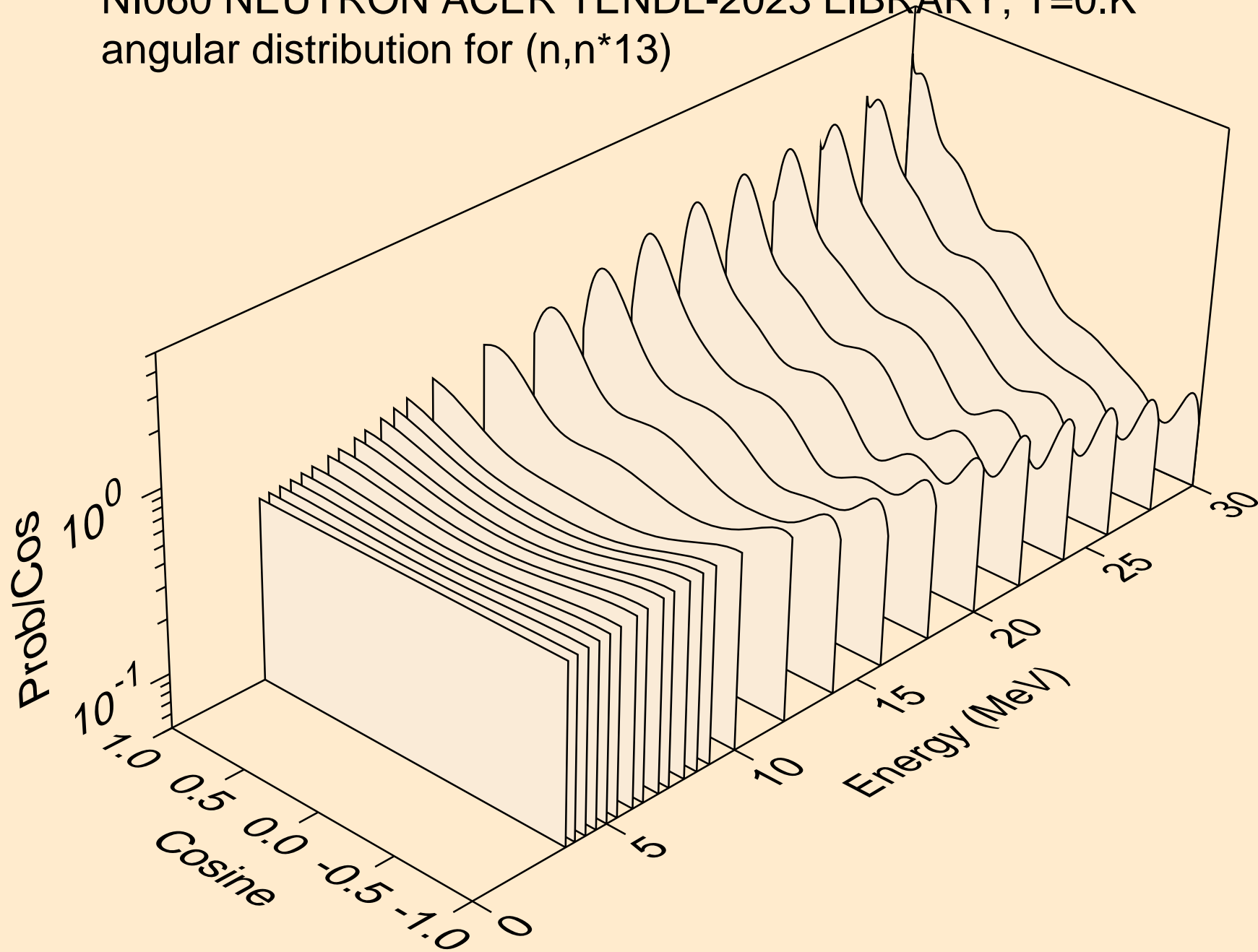

NI060 NEUTRON ACER TENDL-2023 LIBRARY; T=0.K  
angular distribution for (n,n\*14)

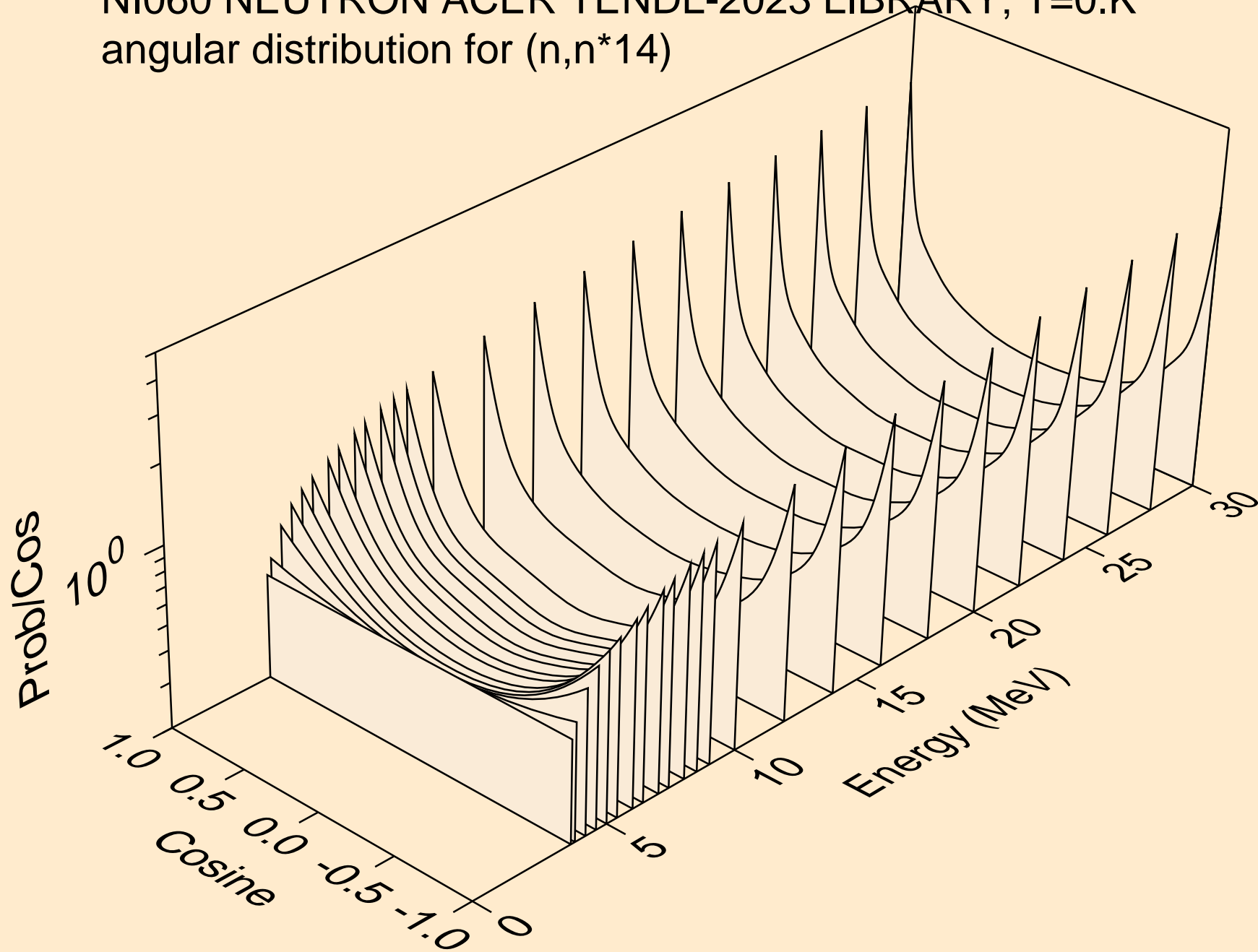

NI060 NEUTRON ACER TENDL-2023 LIBRARY; T=0.K  
angular distribution for (n,n\*15)

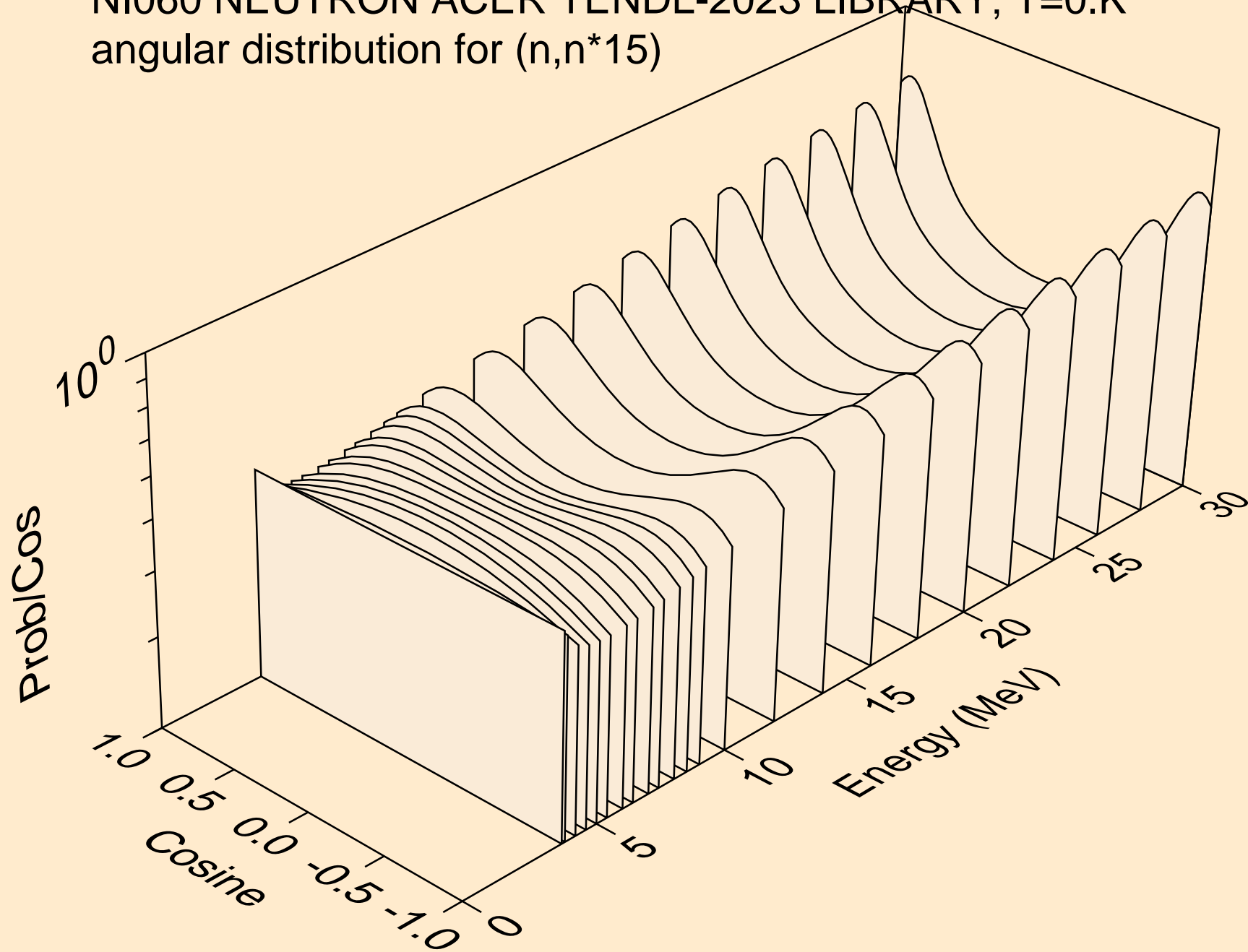

NI060 NEUTRON ACER TENDL-2023 LIBRARY; T=0.K  
angular distribution for (n,n\*16)

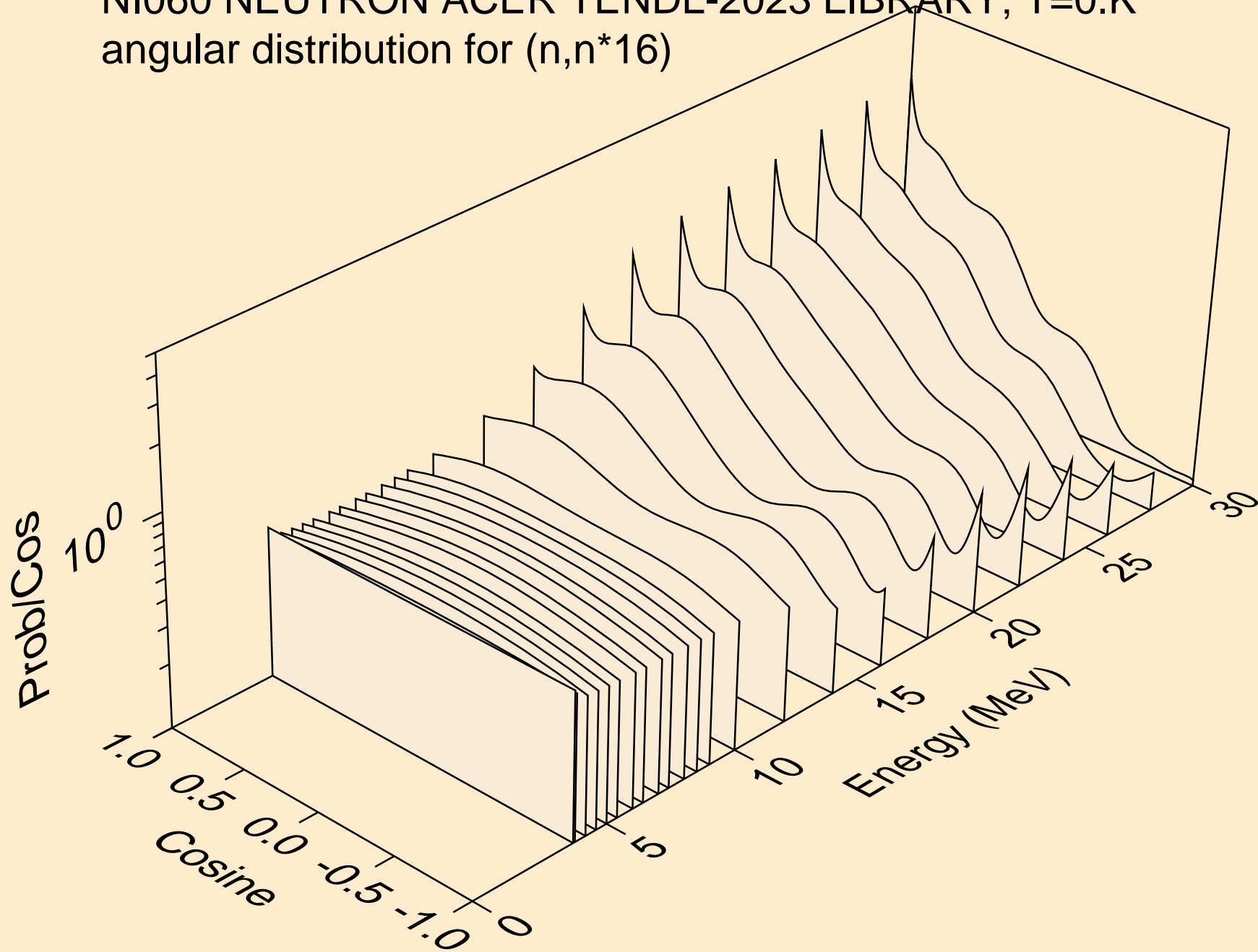

NI060 NEUTRON ACER TENDL-2023 LIBRARY; T=0.K  
angular distribution for (n,n\*17)

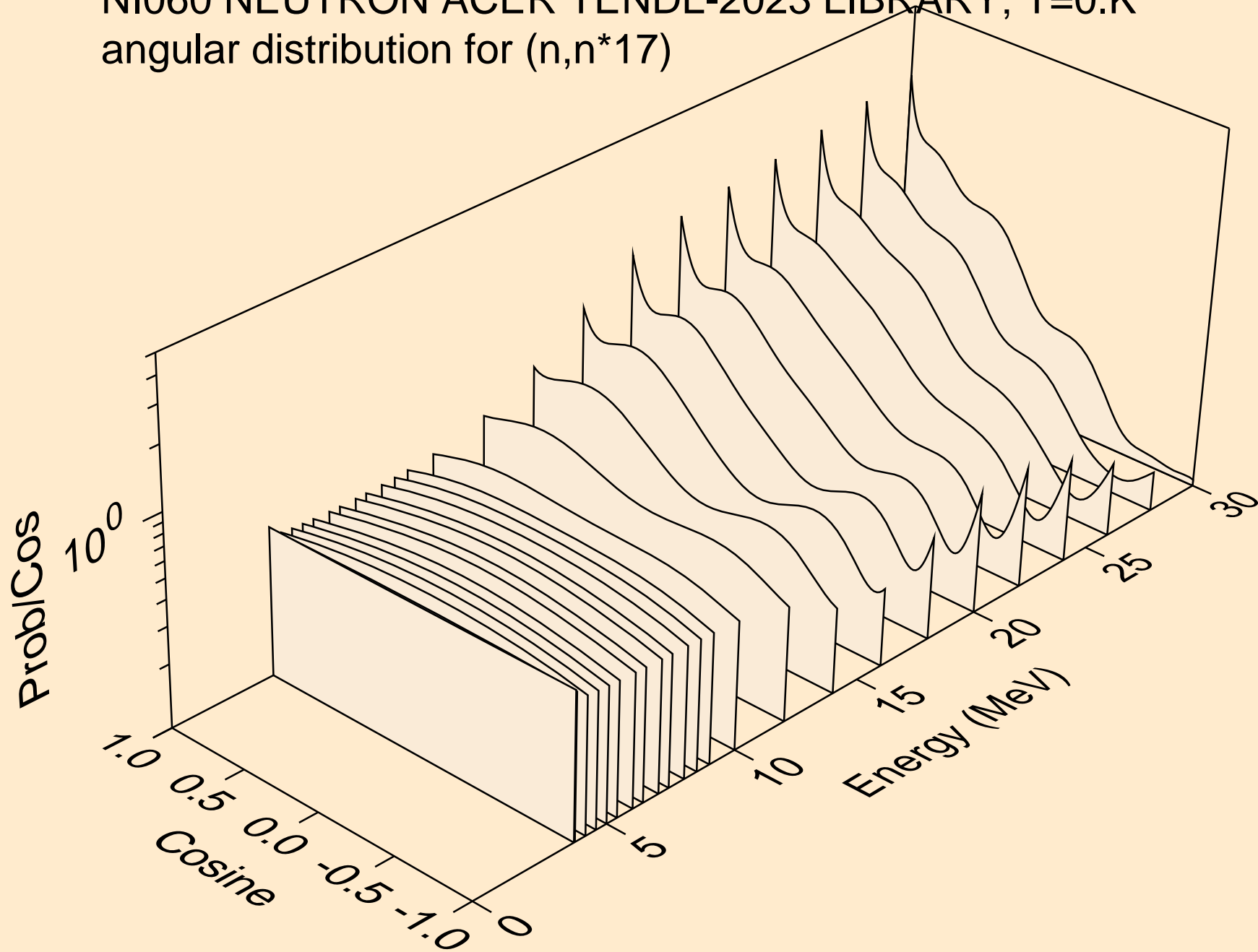

NI060 NEUTRON ACER TENDL-2023 LIBRARY; T=0.K  
angular distribution for (n,n\*18)

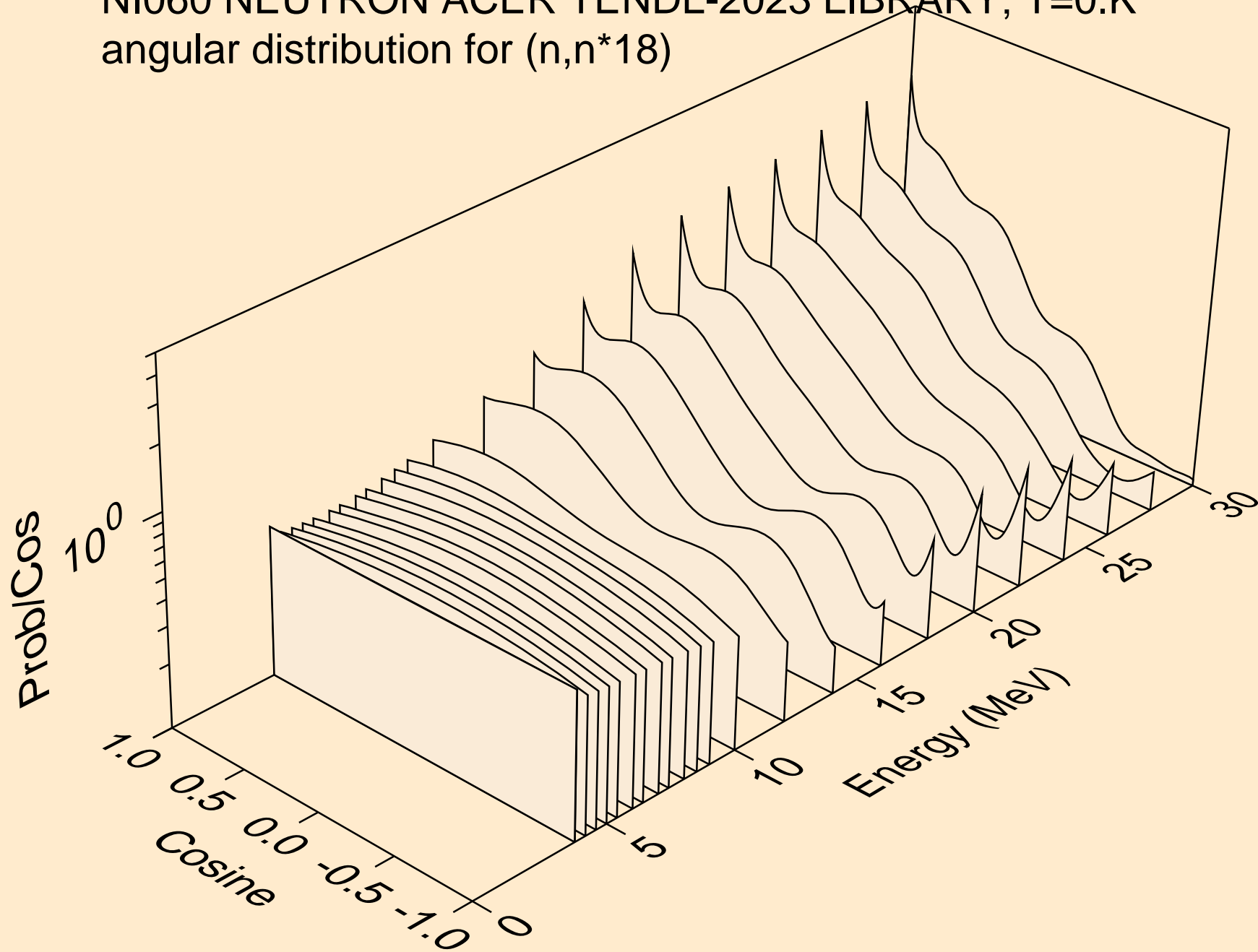



NI060 NEUTRON ACER TENDL-2023 LIBRARY; T=0.K  
angular distribution for (n,n\*19)

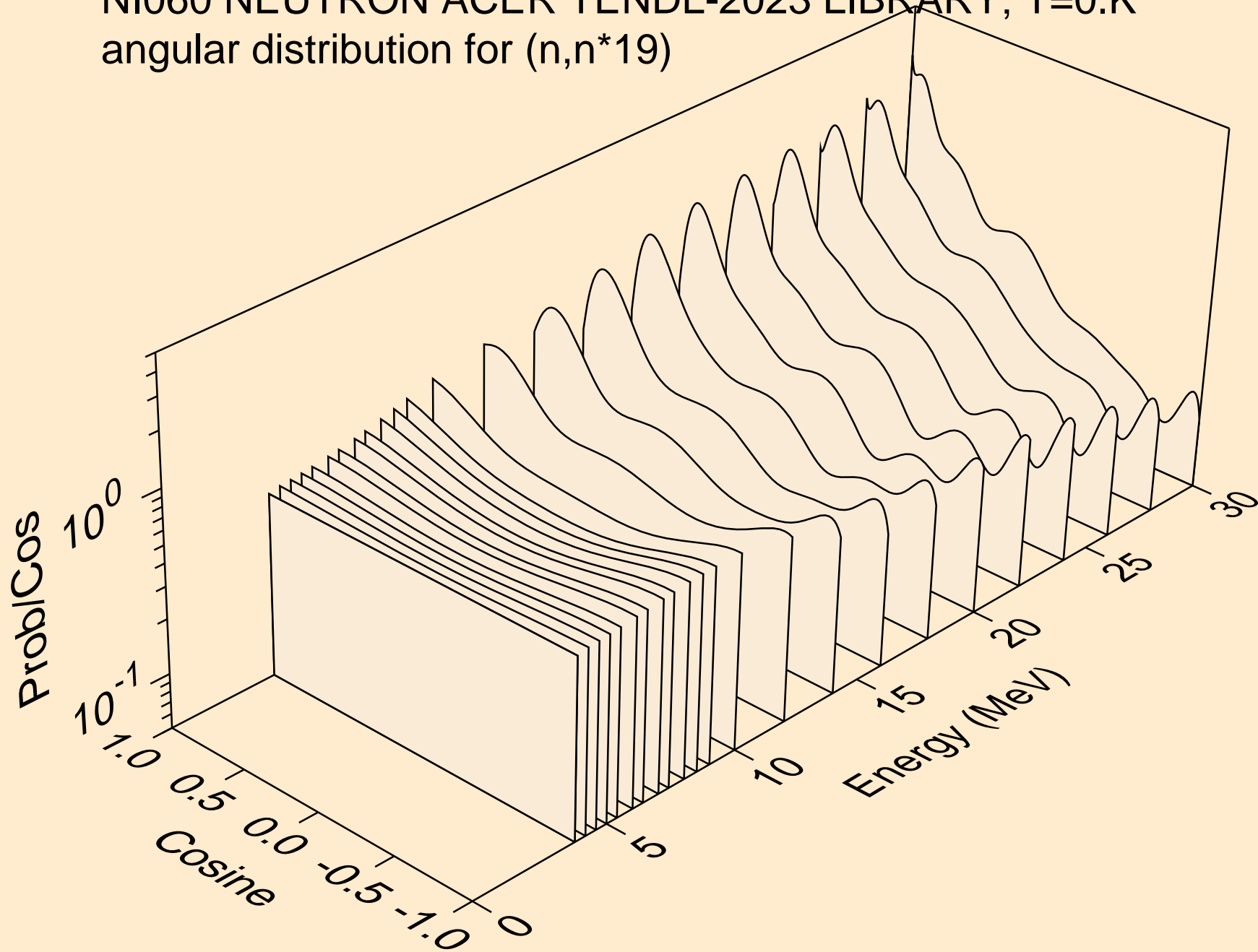

NI060 NEUTRON ACER TENDL-2023 LIBRARY; T=0.K  
angular distribution for (n,n\*20)

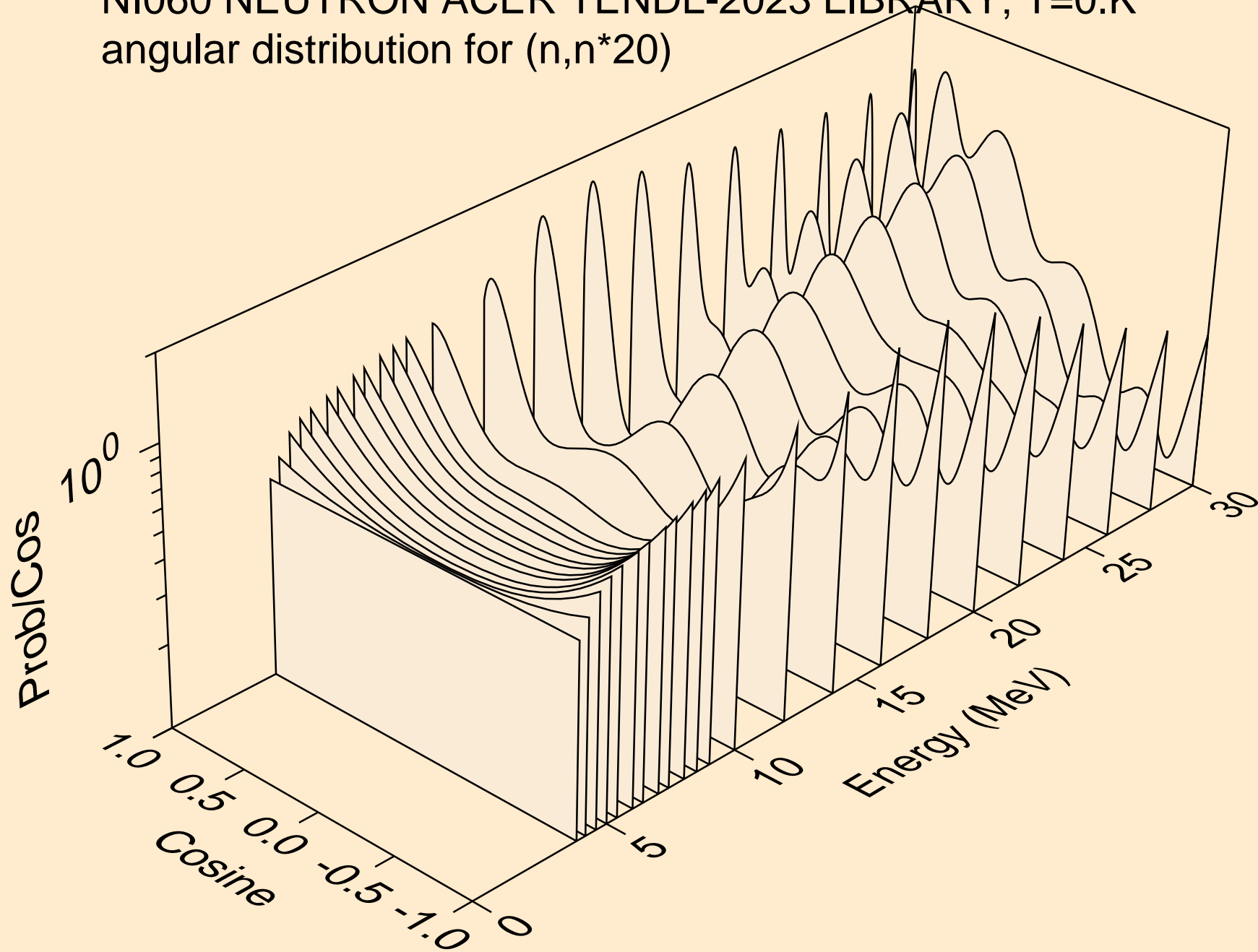

NI060 NEUTRON ACER TENDL-2023 LIBRARY; T=0.K  
angular distribution for (n,n\*21)

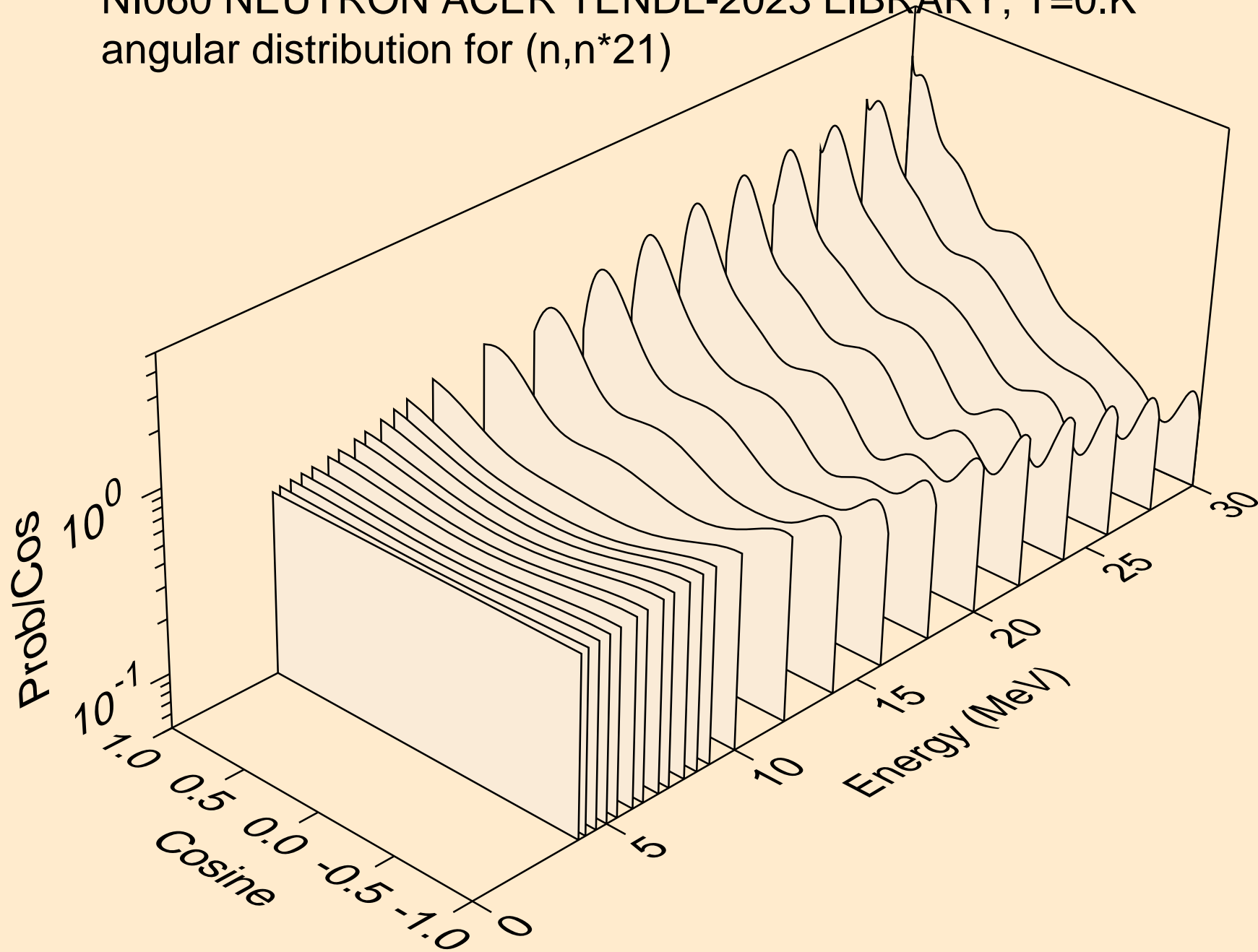

NI060 NEUTRON ACER TENDL-2023 LIBRARY; T=0.K  
angular distribution for (n,n\*22)

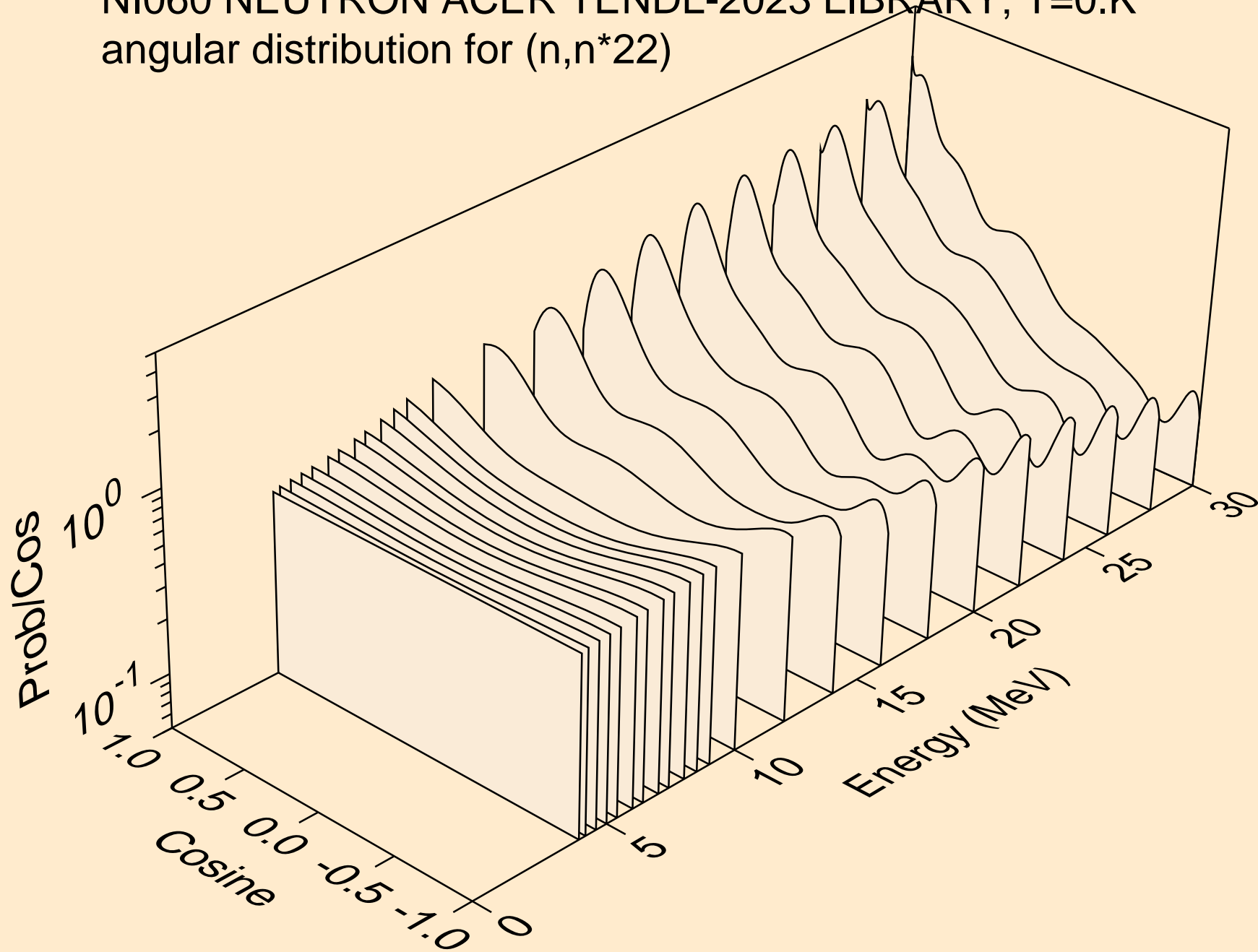

NI060 NEUTRON ACER TENDL-2023 LIBRARY; T=0.K  
angular distribution for (n,n\*23)

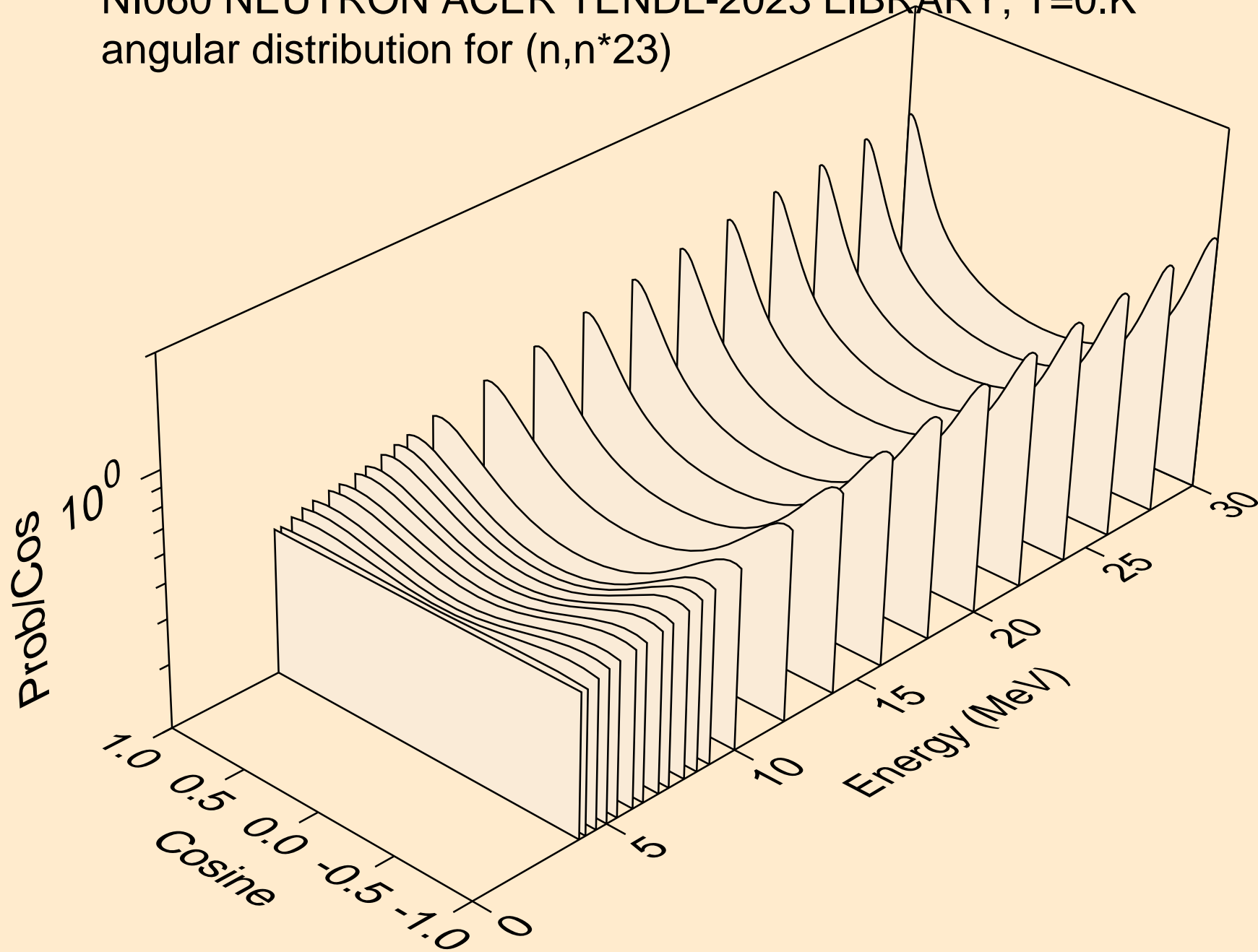

NI060 NEUTRON ACER TENDL-2023 LIBRARY; T=0.K  
angular distribution for (n,n\*24)

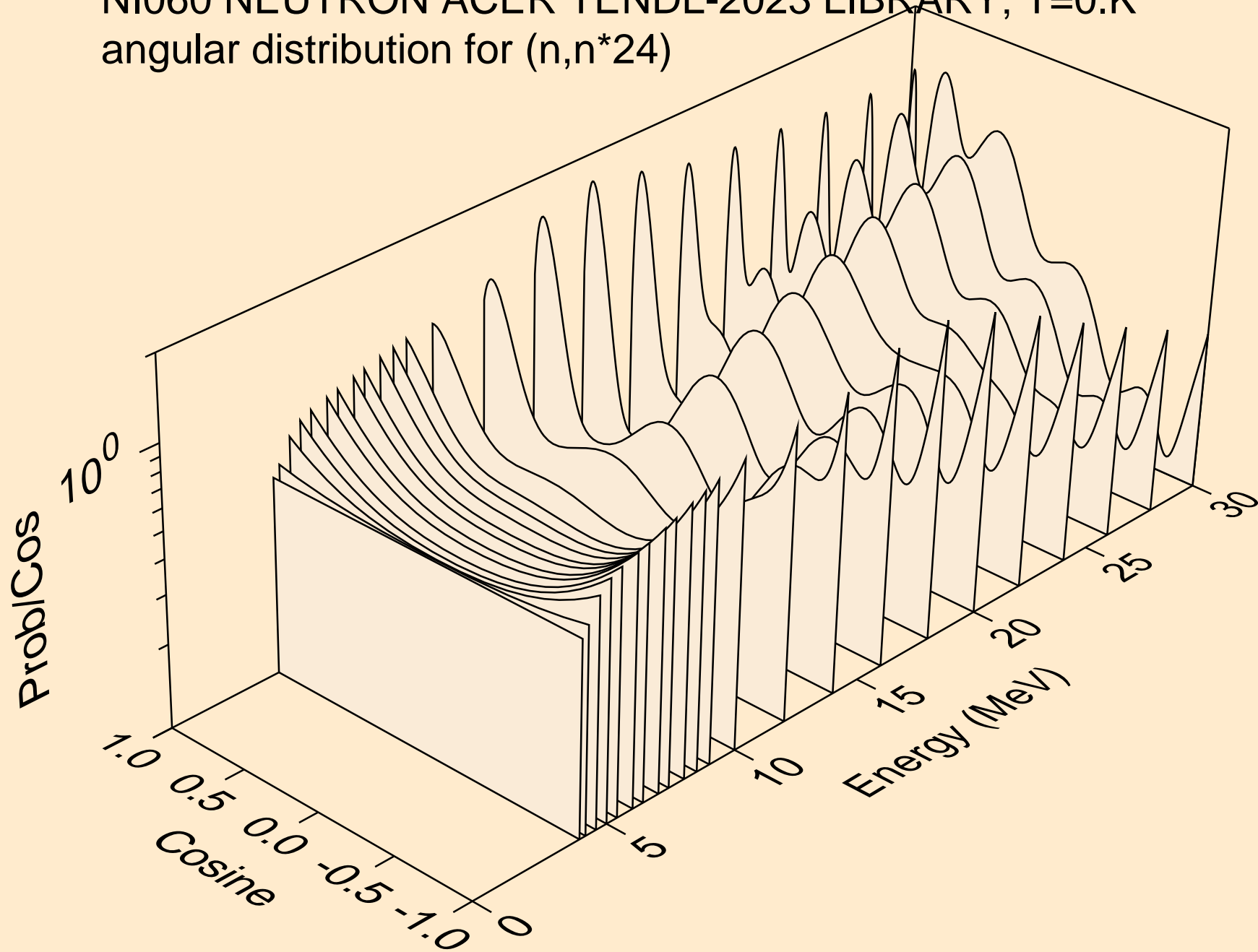

NI060 NEUTRON ACER TENDL-2023 LIBRARY; T=0.K  
angular distribution for (n,n\*25)

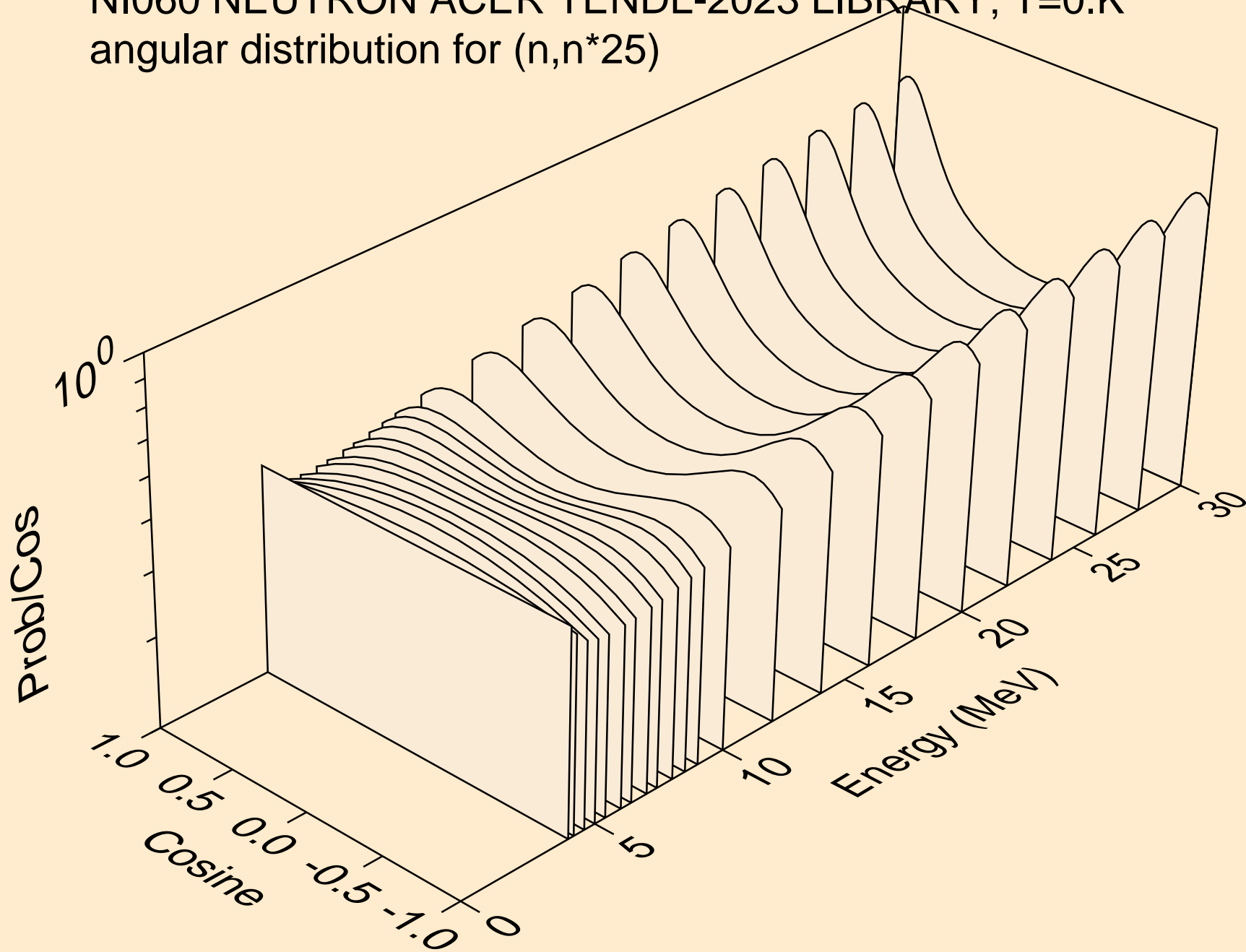

NI060 NEUTRON ACER TENDL-2023 LIBRARY; T=0.K  
angular distribution for (n,n\*26)

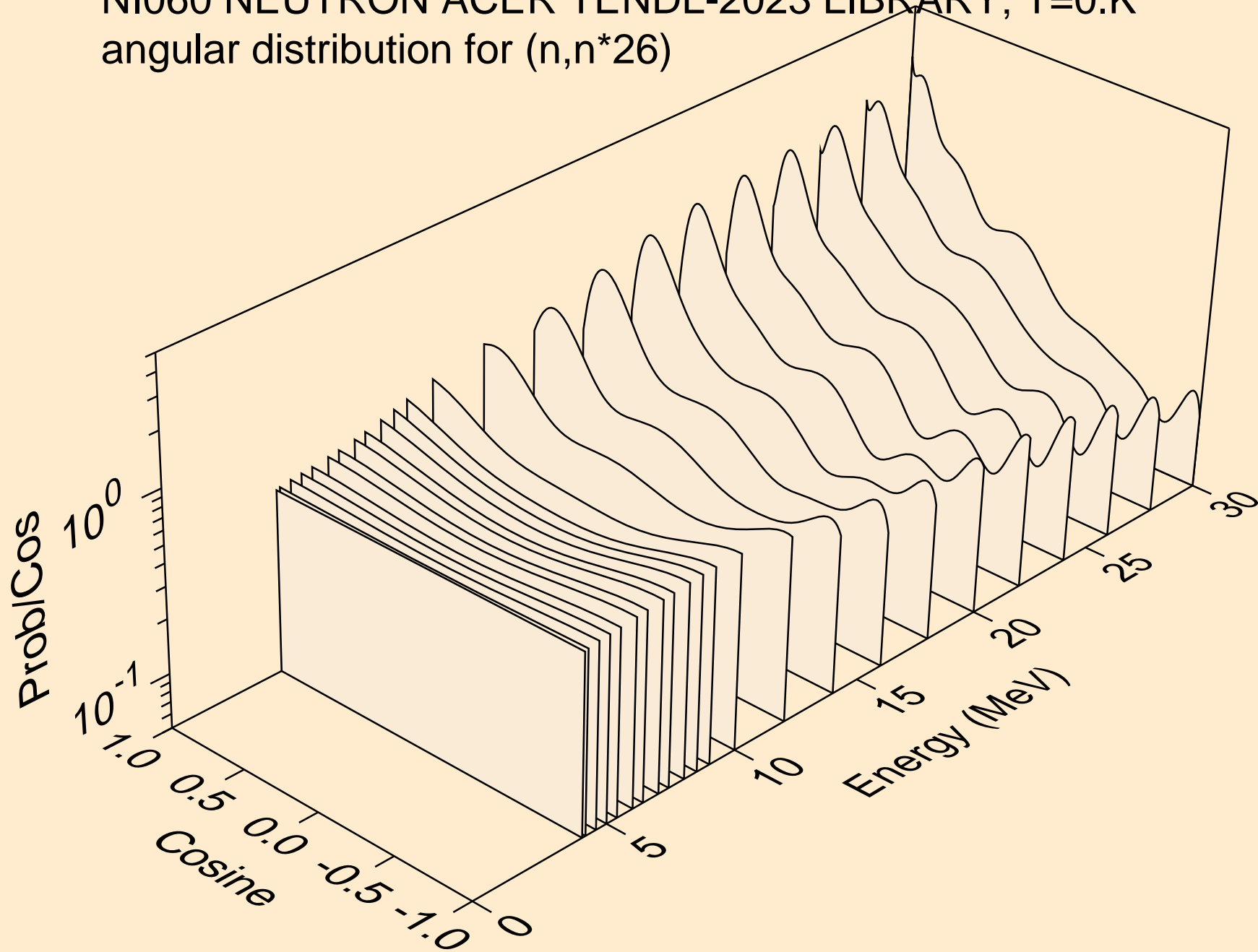



NI060 NEUTRON ACER TENDL-2023 LIBRARY; T=0.K  
angular distribution for (n,n\*27)

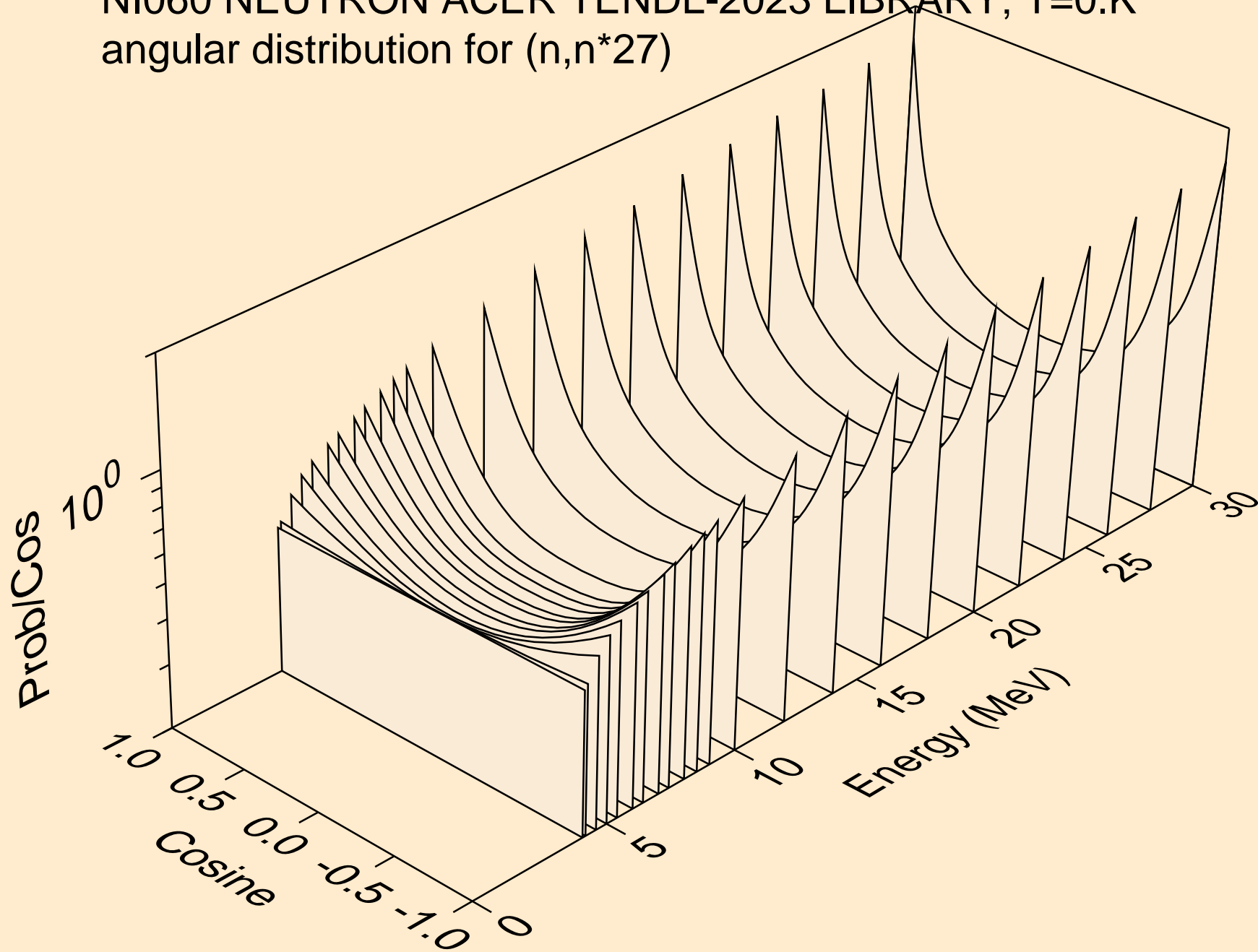

NI060 NEUTRON ACER TENDL-2023 LIBRARY; T=0.K  
angular distribution for (n,n\*28)

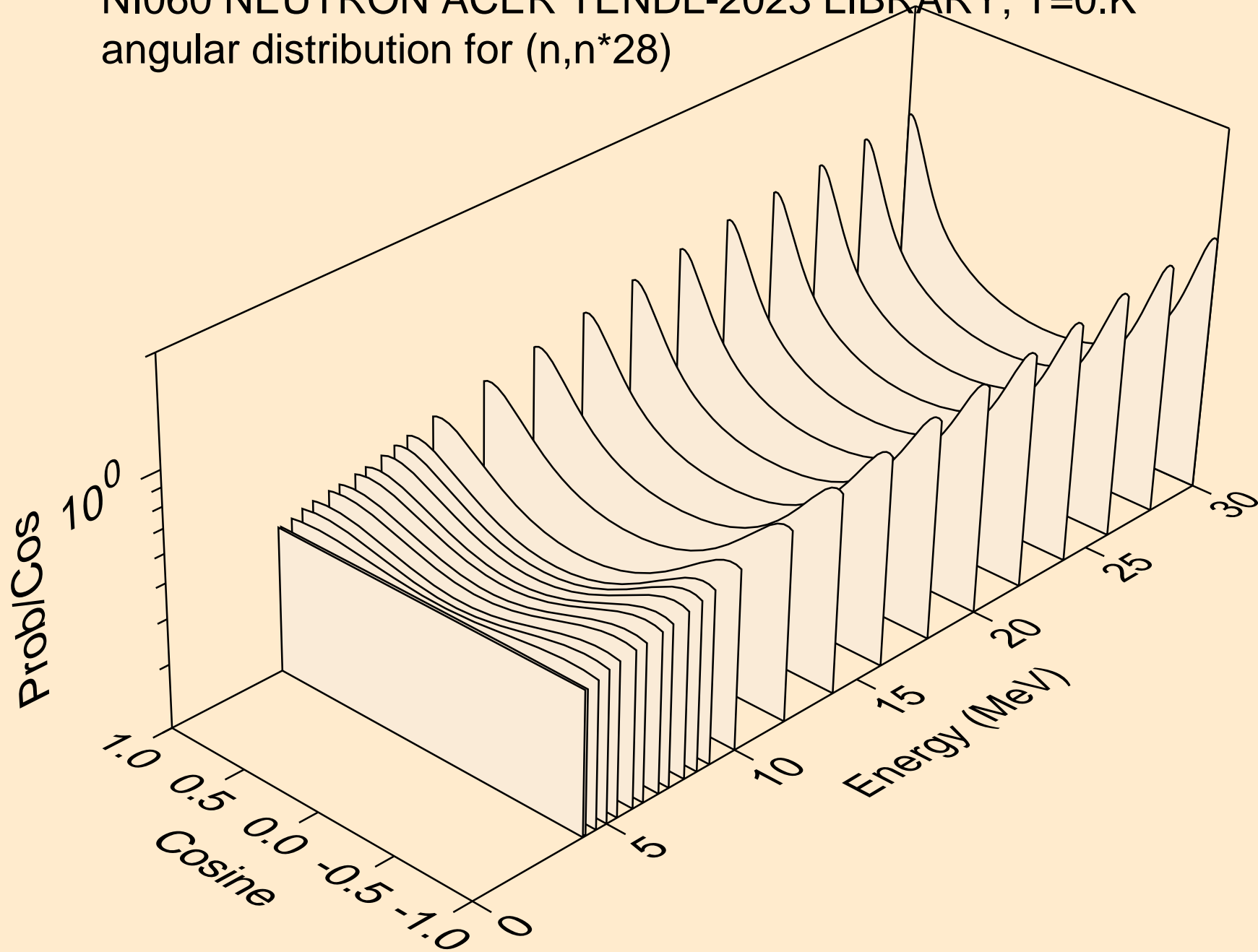

NI060 NEUTRON ACER TENDL-2023 LIBRARY; T=0.K  
angular distribution for (n,n\*29)

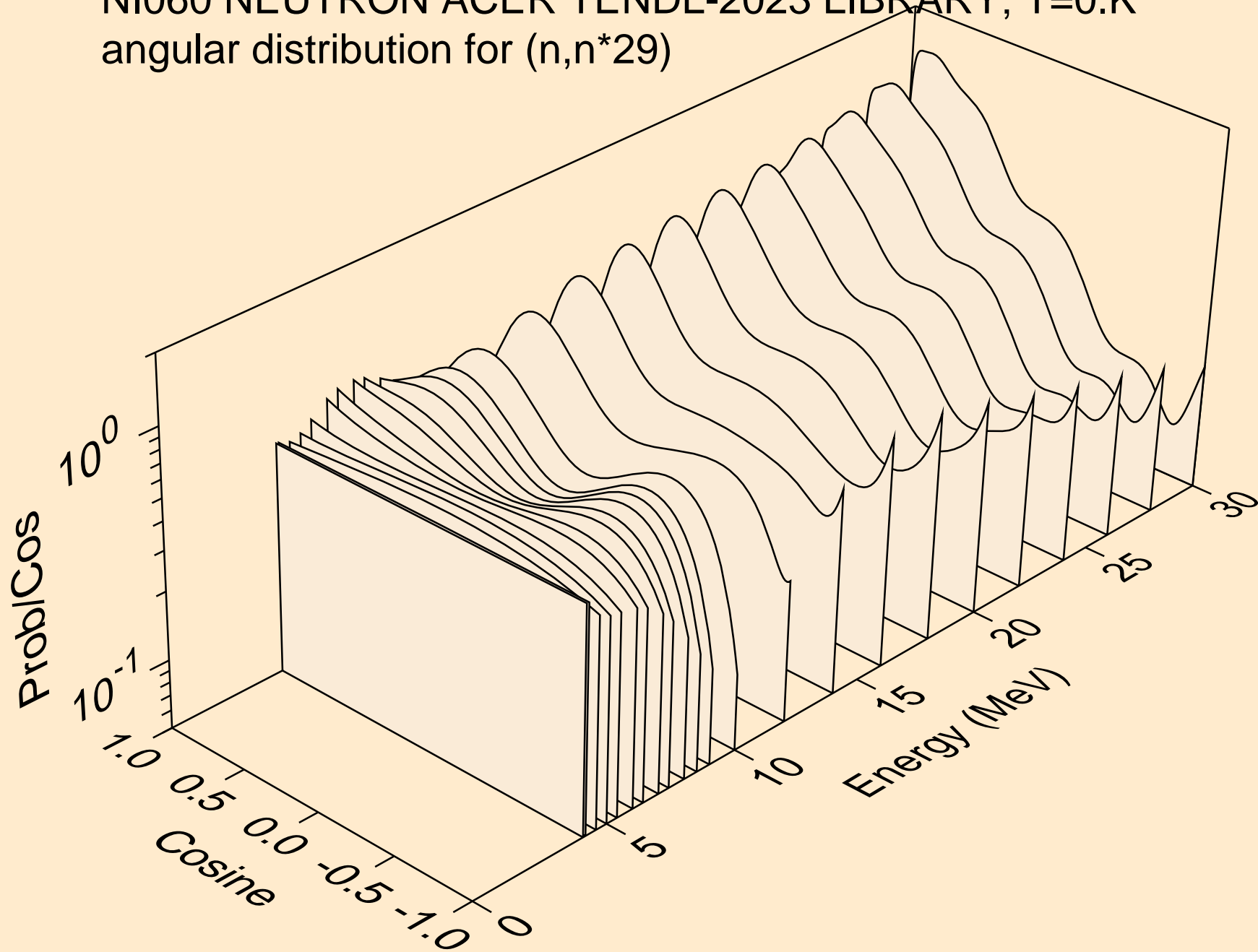

NI060 NEUTRON ACER TENDL-2023 LIBRARY; T=0.K  
angular distribution for (n,n\*30)

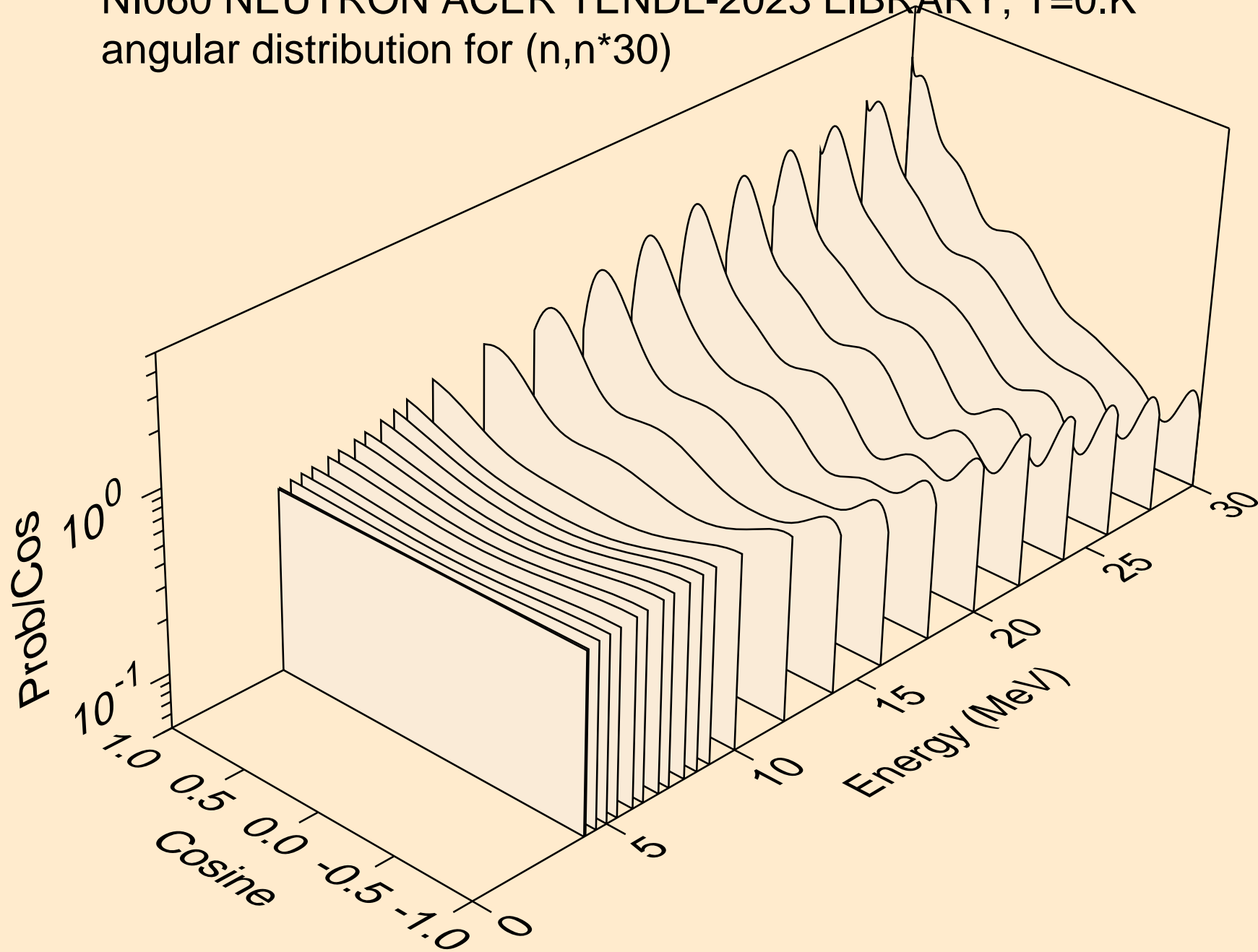

NI060 NEUTRON ACER TENDL-2023 LIBRARY; T=0.K  
Neutron emission for (n,x)

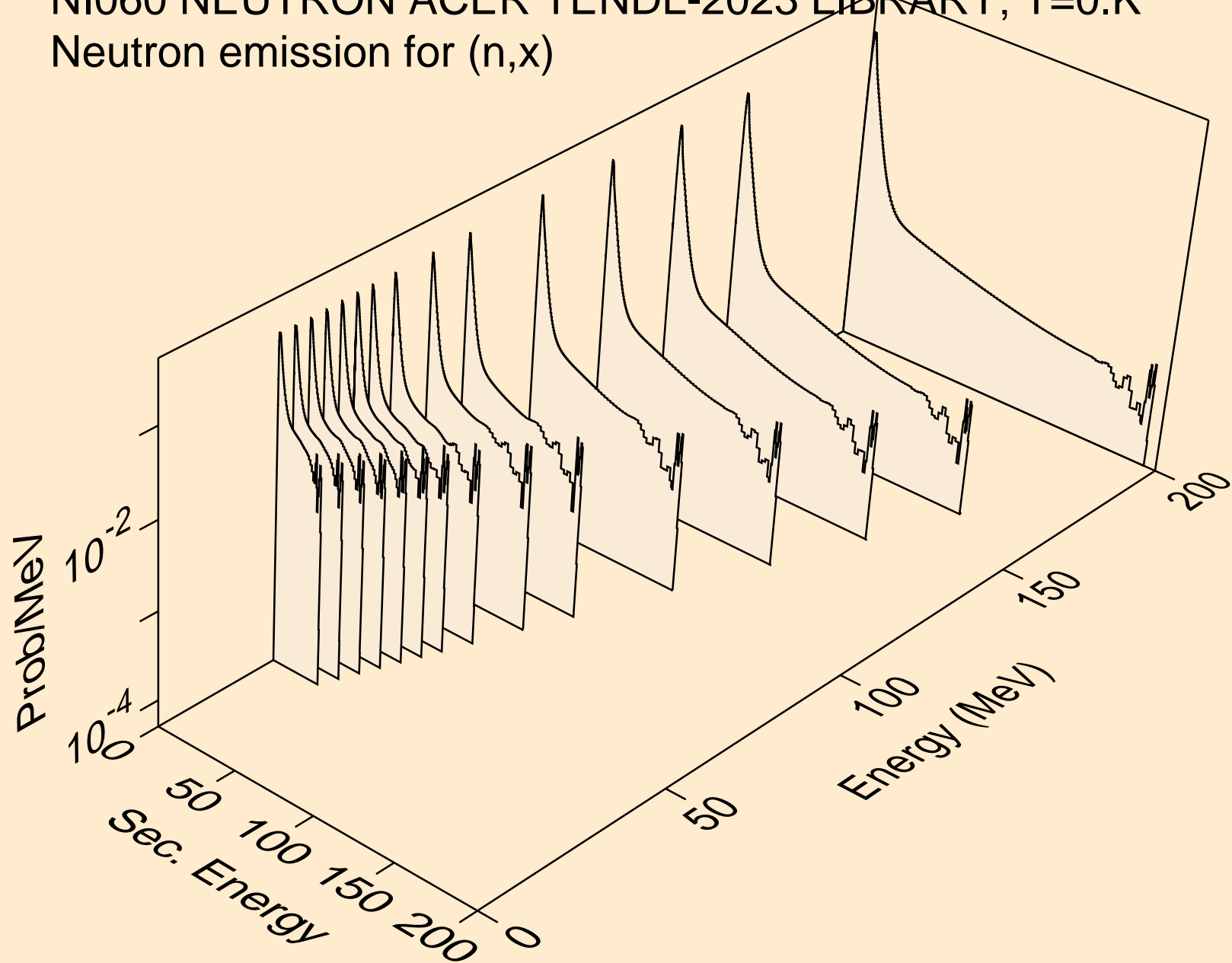

NI060 NEUTRON ACER TENDL-2023 LIBRARY; T=0.K  
Neutron emission for (n,2nd)

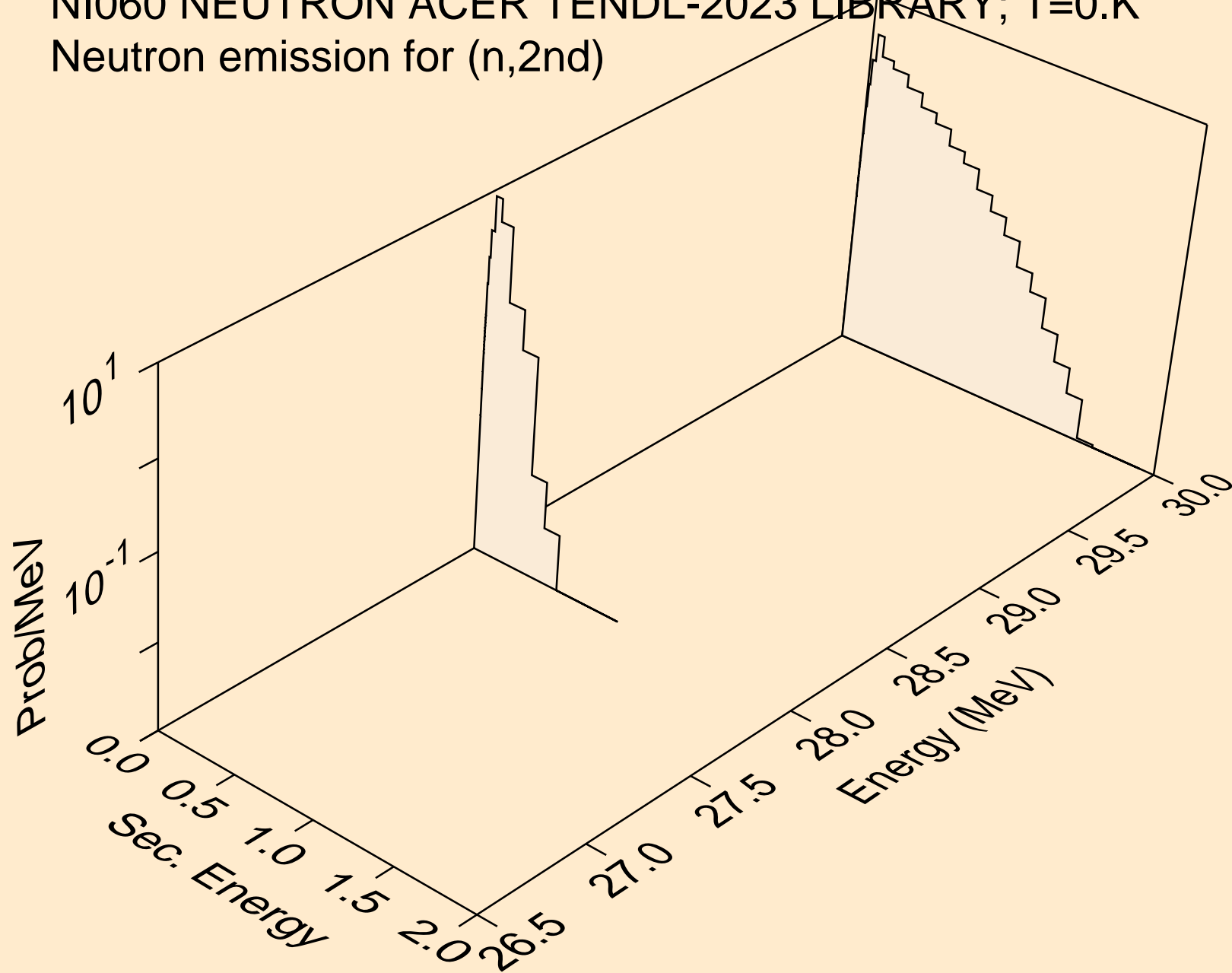

NI060 NEUTRON ACER TENDL-2023 LIBRARY; T=0.K  
Neutron emission for (n,2n)

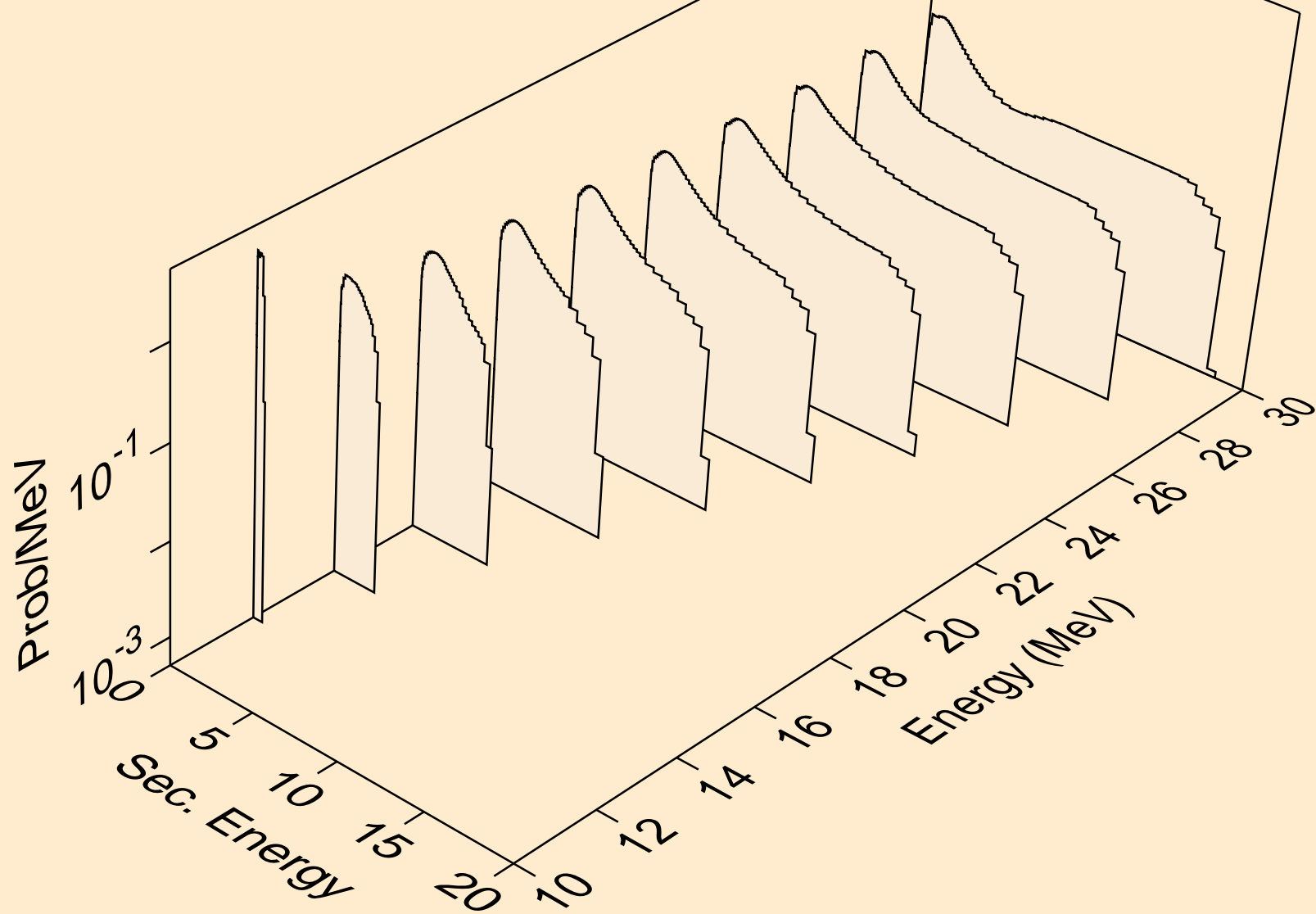

NI060 NEUTRON ACER TENDL-2023 LIBRARY; T=0.K  
Neutron emission for (n,3n)

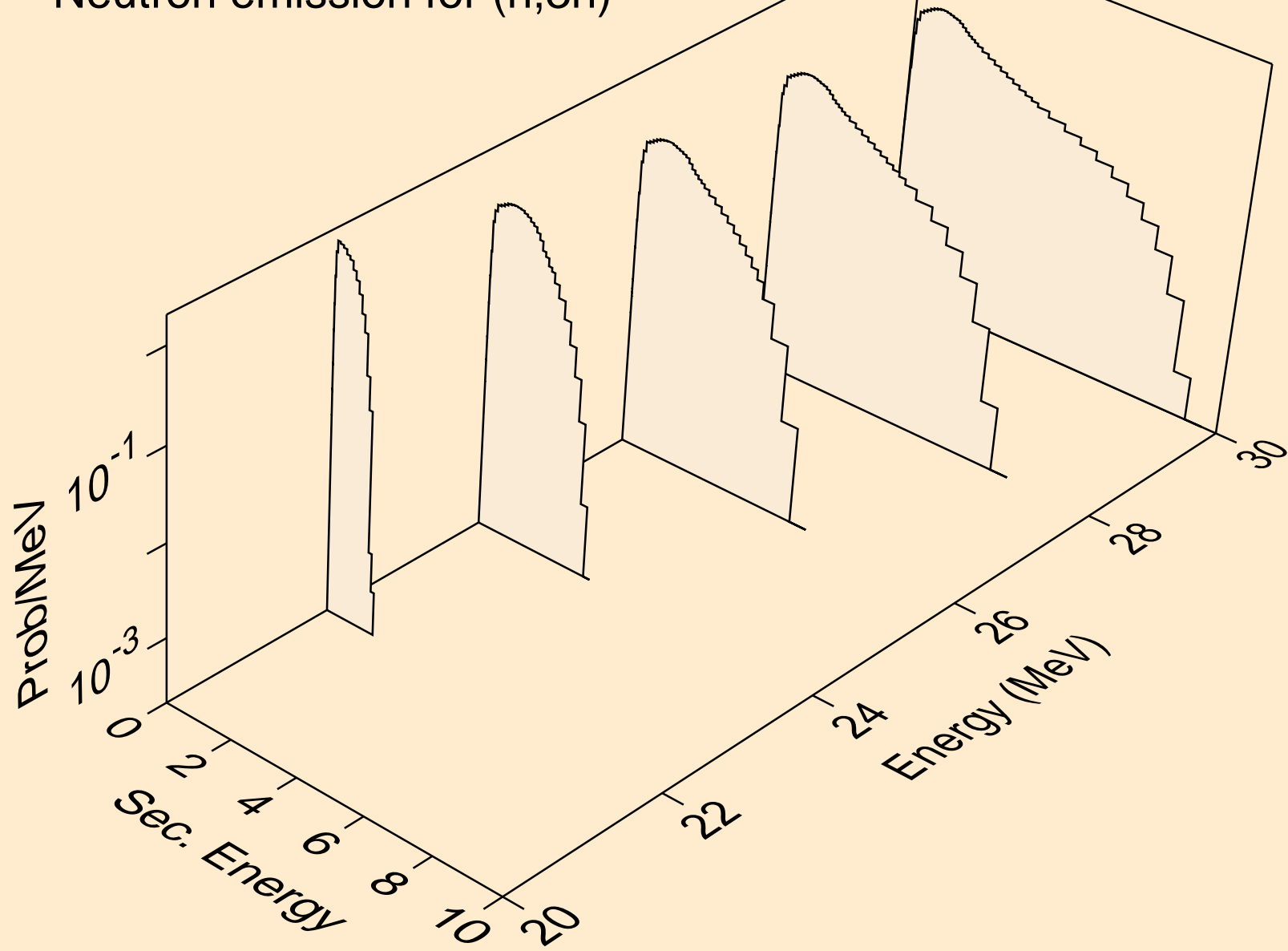



NI060 NEUTRON ACER TENDL-2023 LIBRARY; T=0.K  
Neutron emission for (n,n\*)a

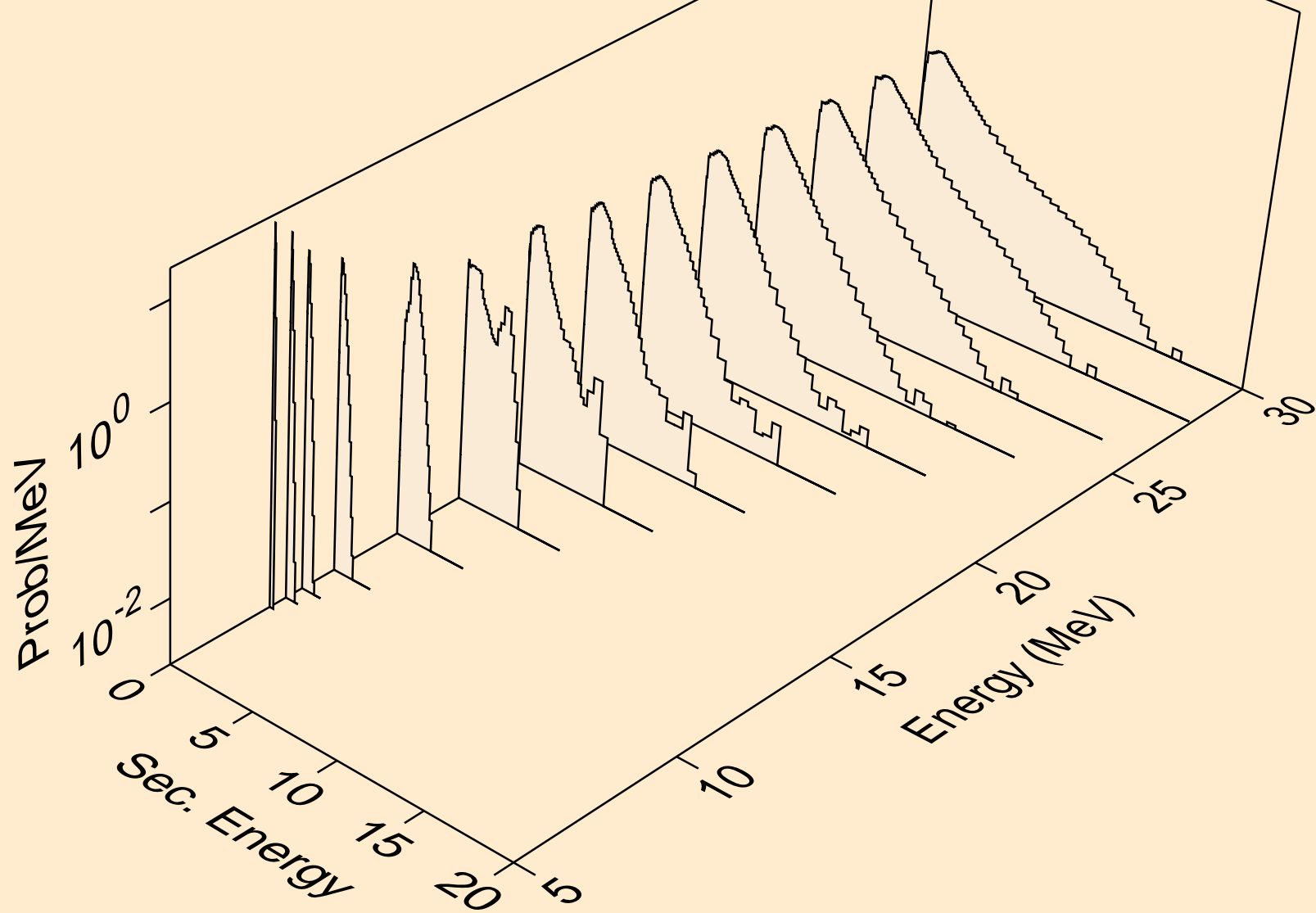

NI060 NEUTRON ACER TENDL-2023 LIBRARY; T=0.K  
Neutron emission for (n,2n)a

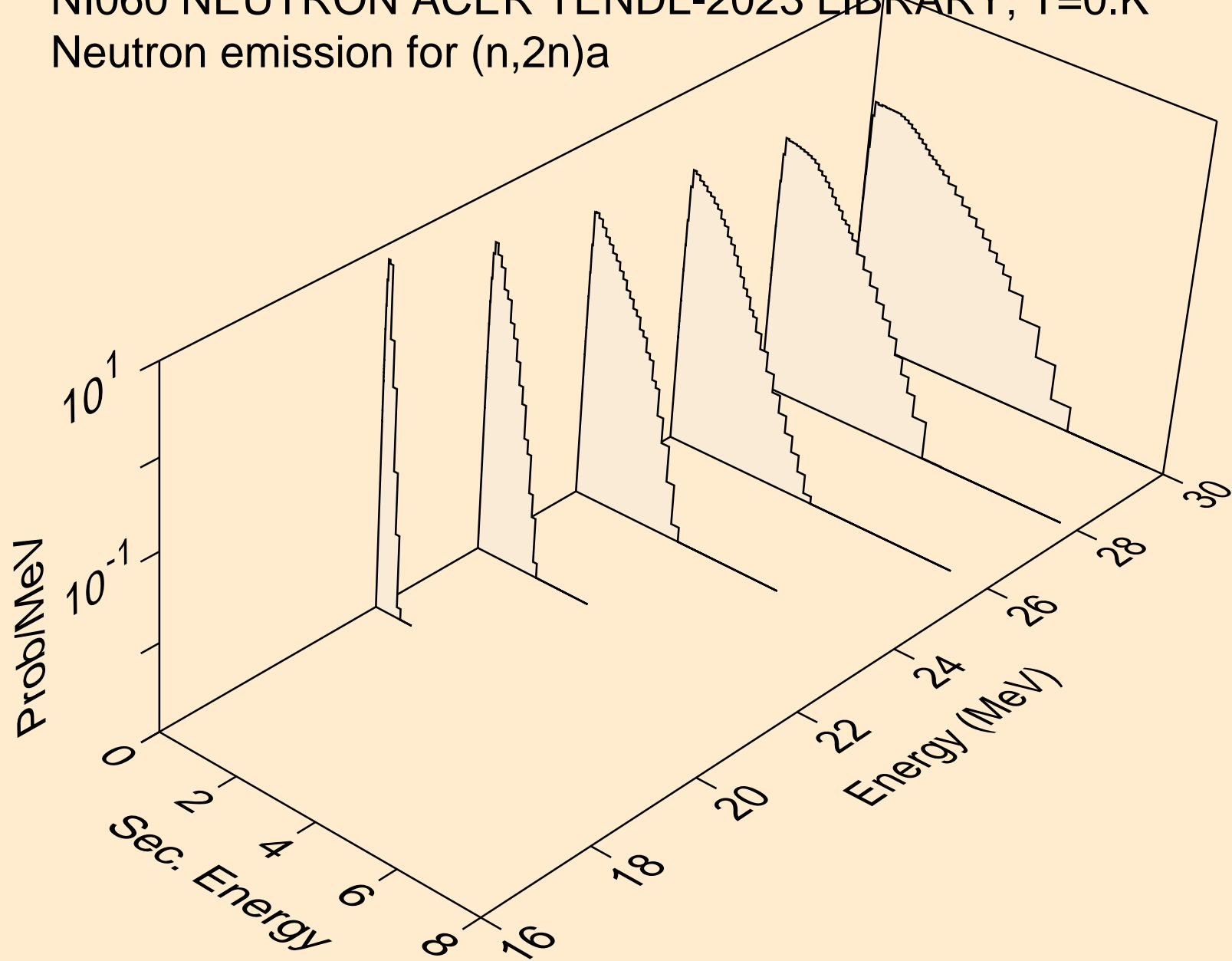

NI060 NEUTRON ACER TENDL-2023 LIBRARY; T=0.K  
Neutron emission for (n,n\*)p

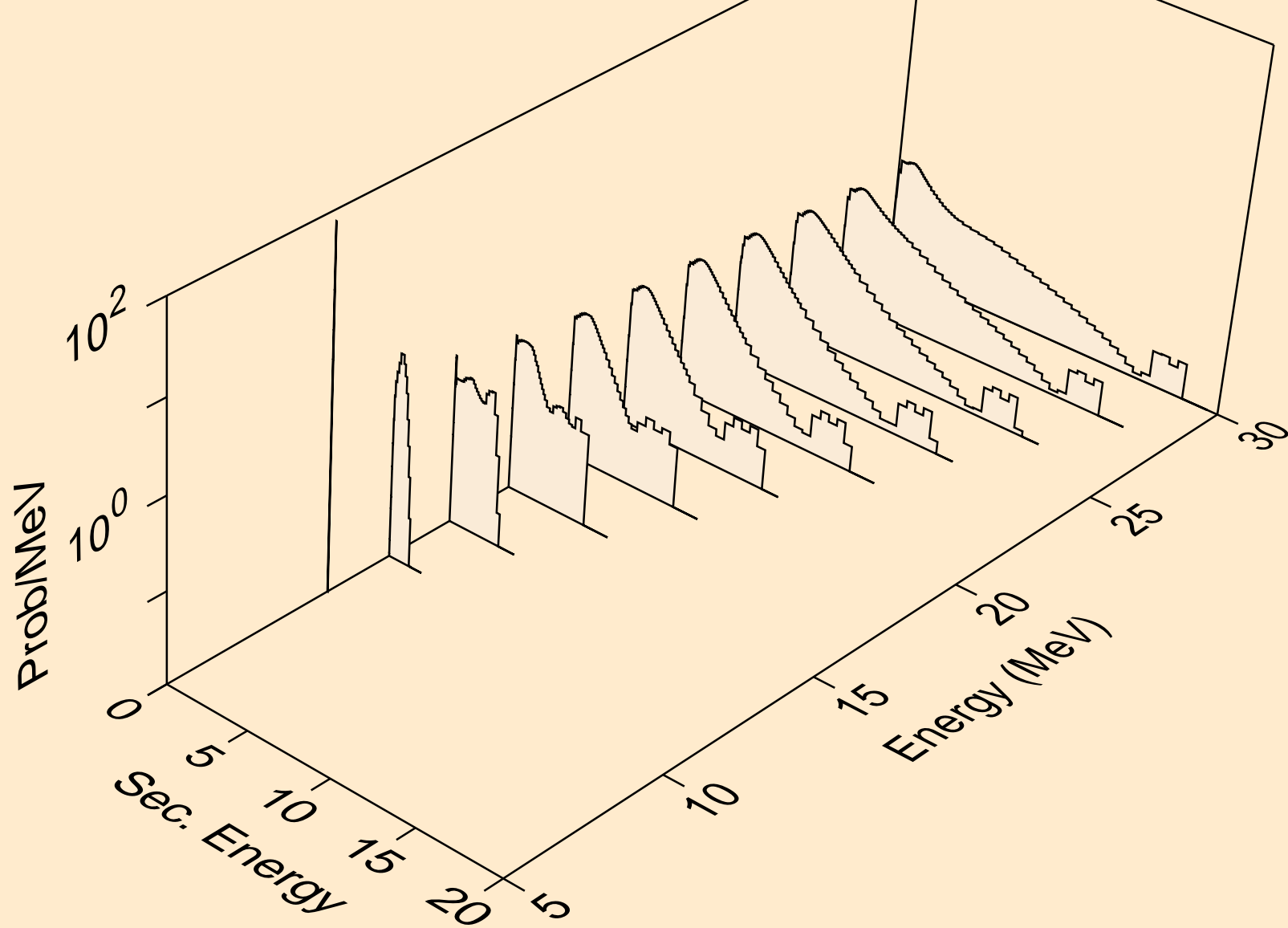

NI060 NEUTRON ACER TENDL-2023 LIBRARY; T=0.K  
Neutron emission for (n,n\*)2a

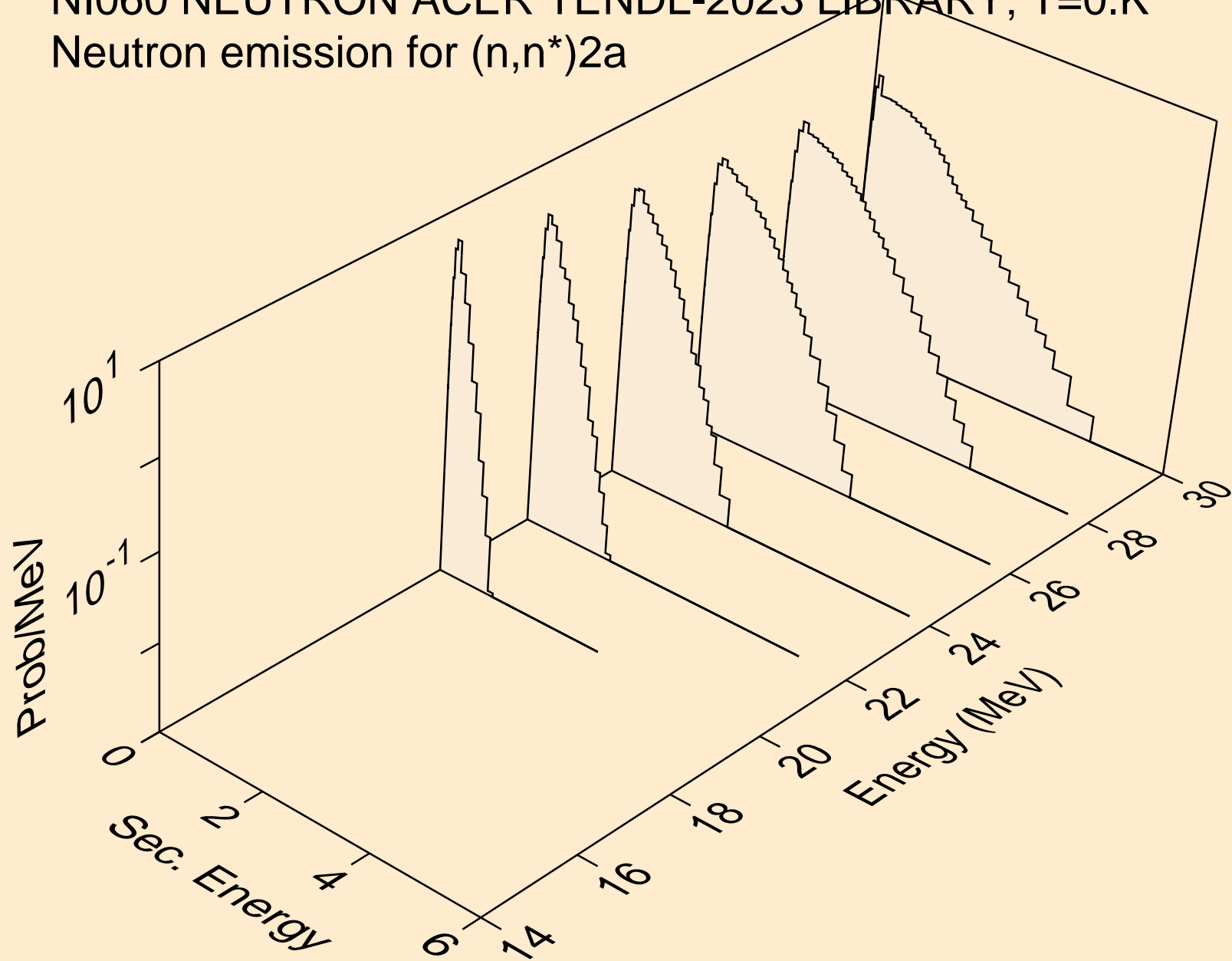

NI060 NEUTRON ACER TENDL-2023 LIBRARY; T=0.K  
Neutron emission for (n,n\*)d

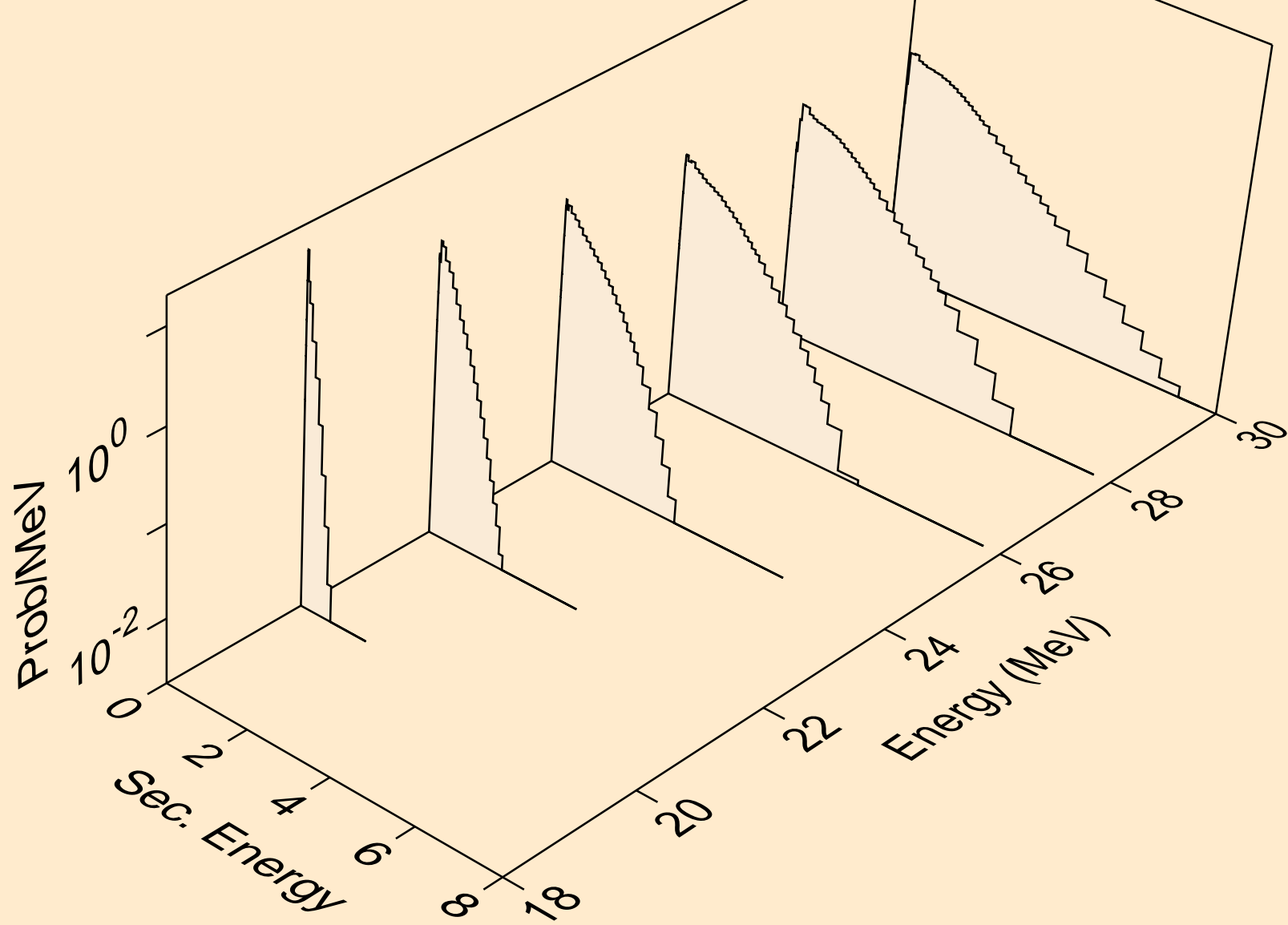

NI060 NEUTRON ACER TENDL-2023 LIBRARY; T=0.K  
Neutron emission for (n,n\*)t

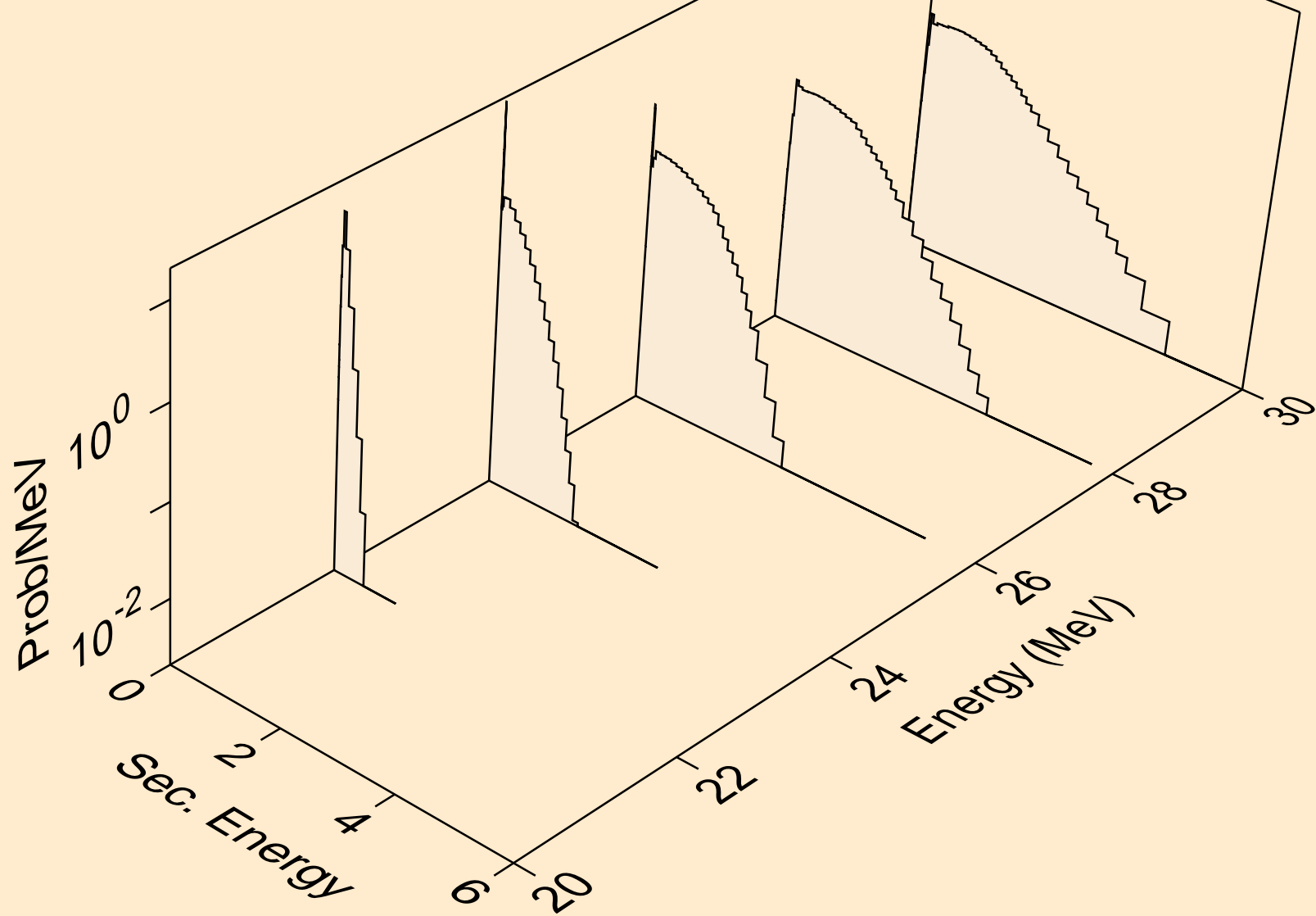

NI060 NEUTRON ACER TENDL-2023 LIBRARY; T=0.K  
Neutron emission for (n,n\*)he3

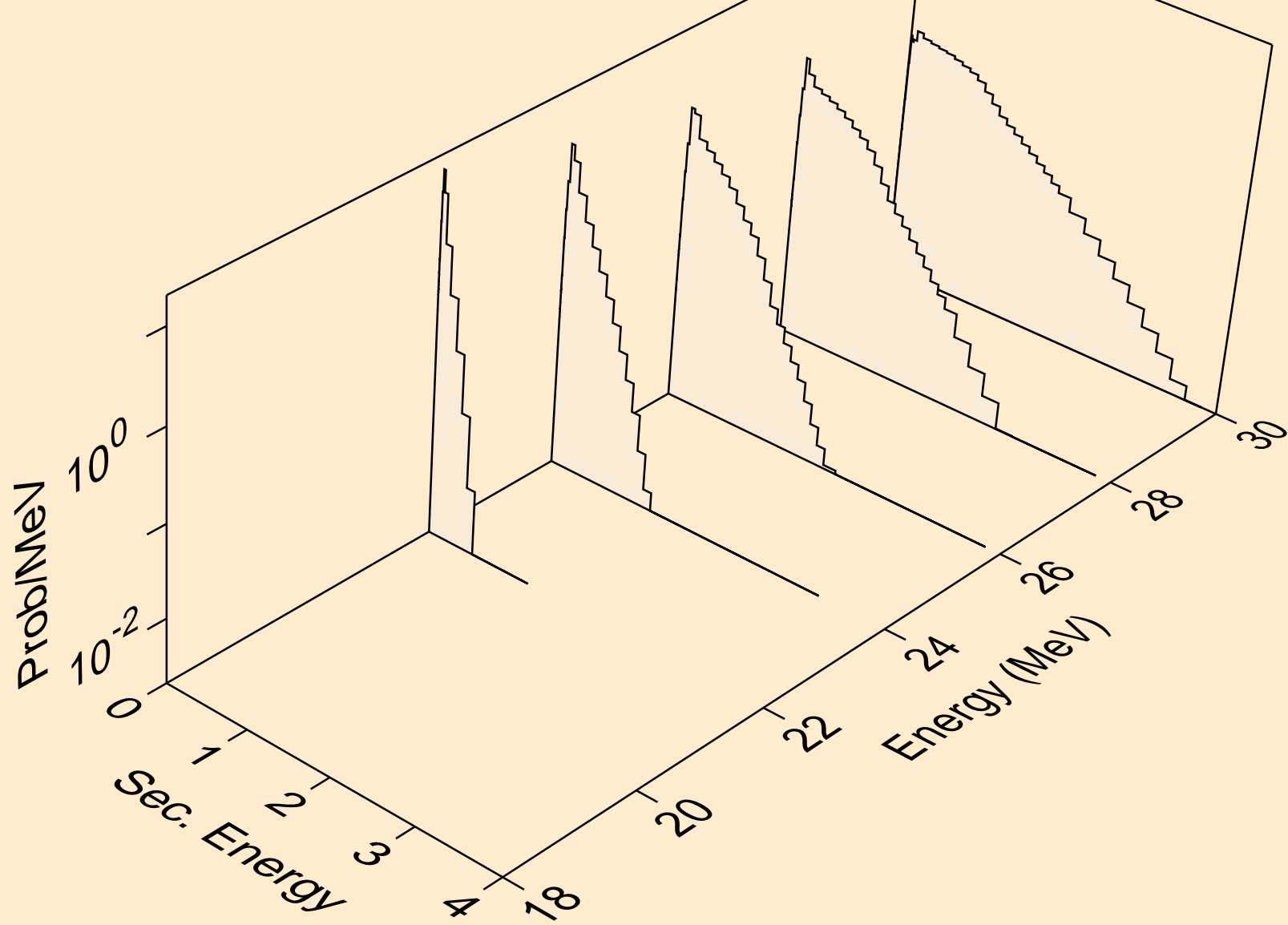

NI060 NEUTRON ACER TENDL-2023 LIBRARY; T=0.K  
Neutron emission for (n,2np)

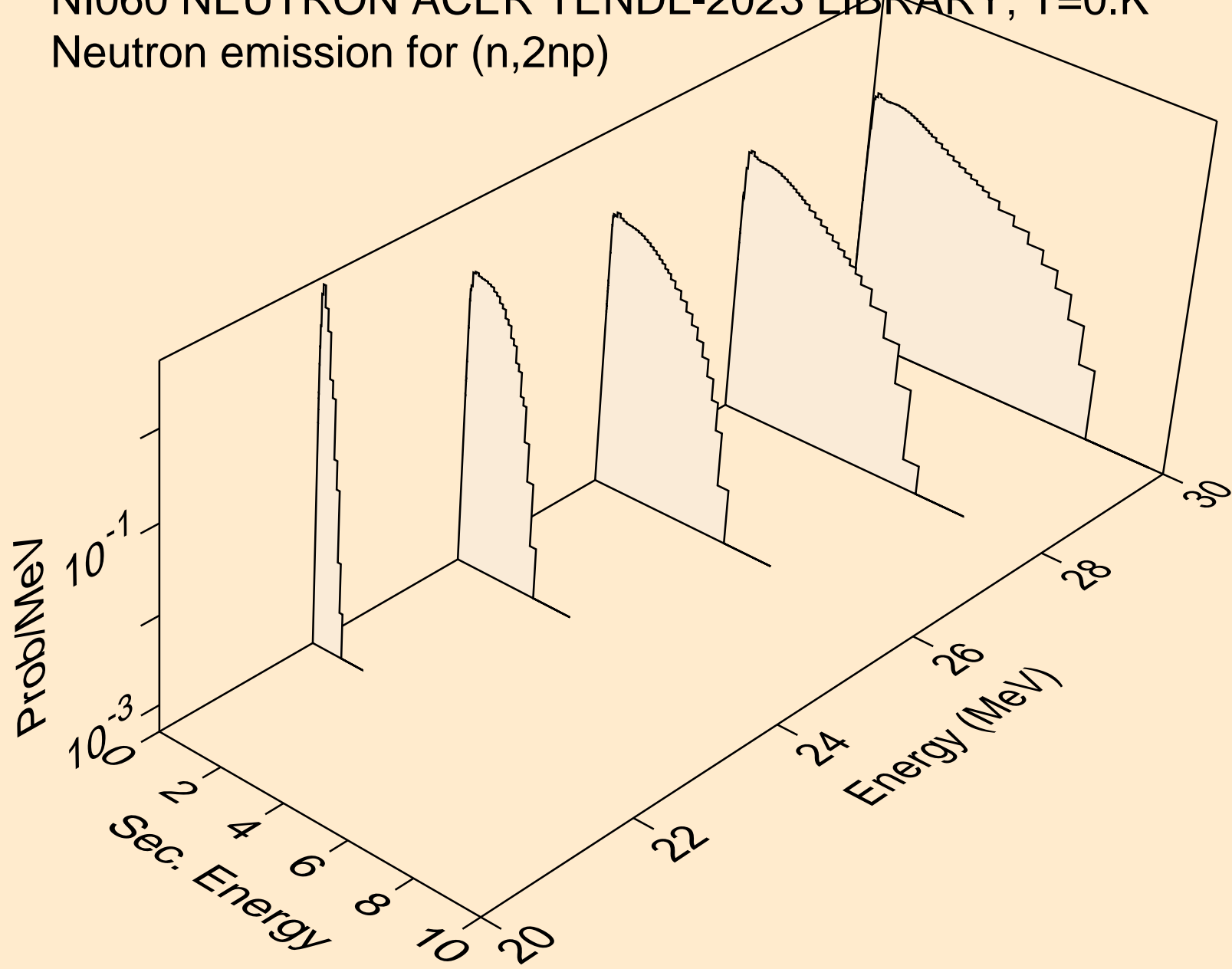



NI060 NEUTRON ACER TENDL-2023 LIBRARY; T=0.K  
Neutron emission for (n,n2p)

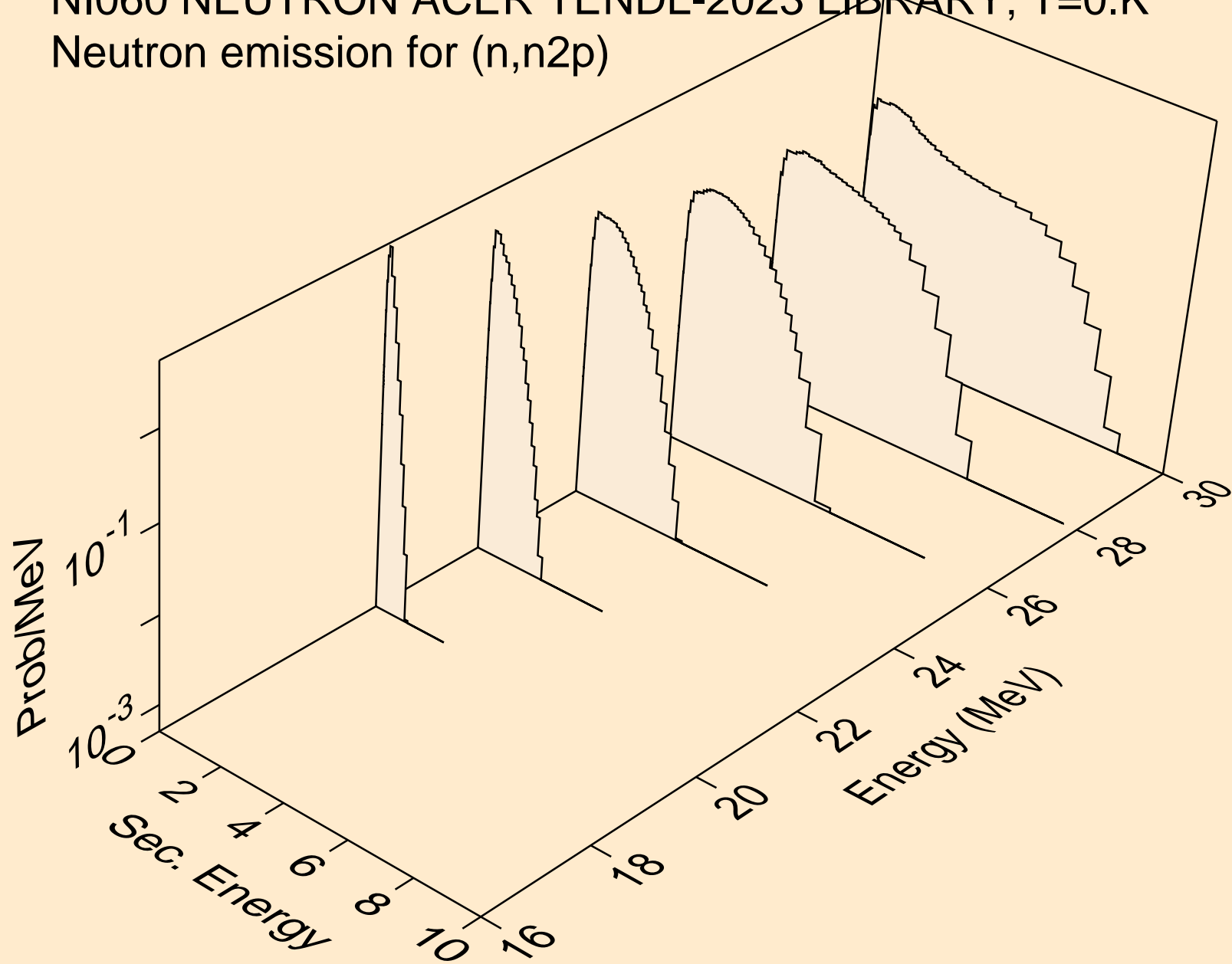

NI060 NEUTRON ACER TENDL-2023 LIBRARY; T=0.K  
Neutron emission for (n,npa)

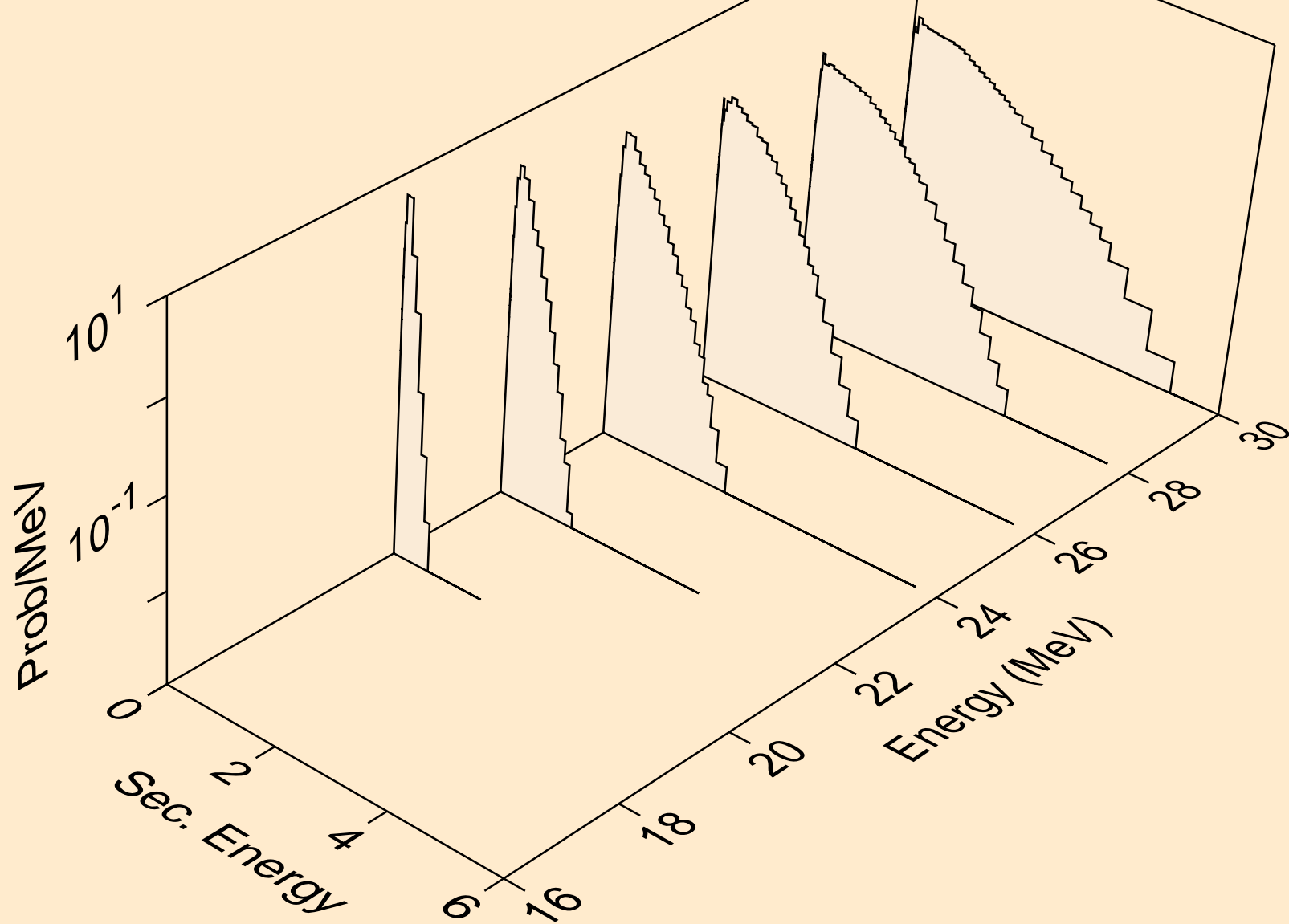

NI060 NEUTRON ACER TENDL-2023 LIBRARY; T=0.K  
Neutron emission for (n,n\*c)

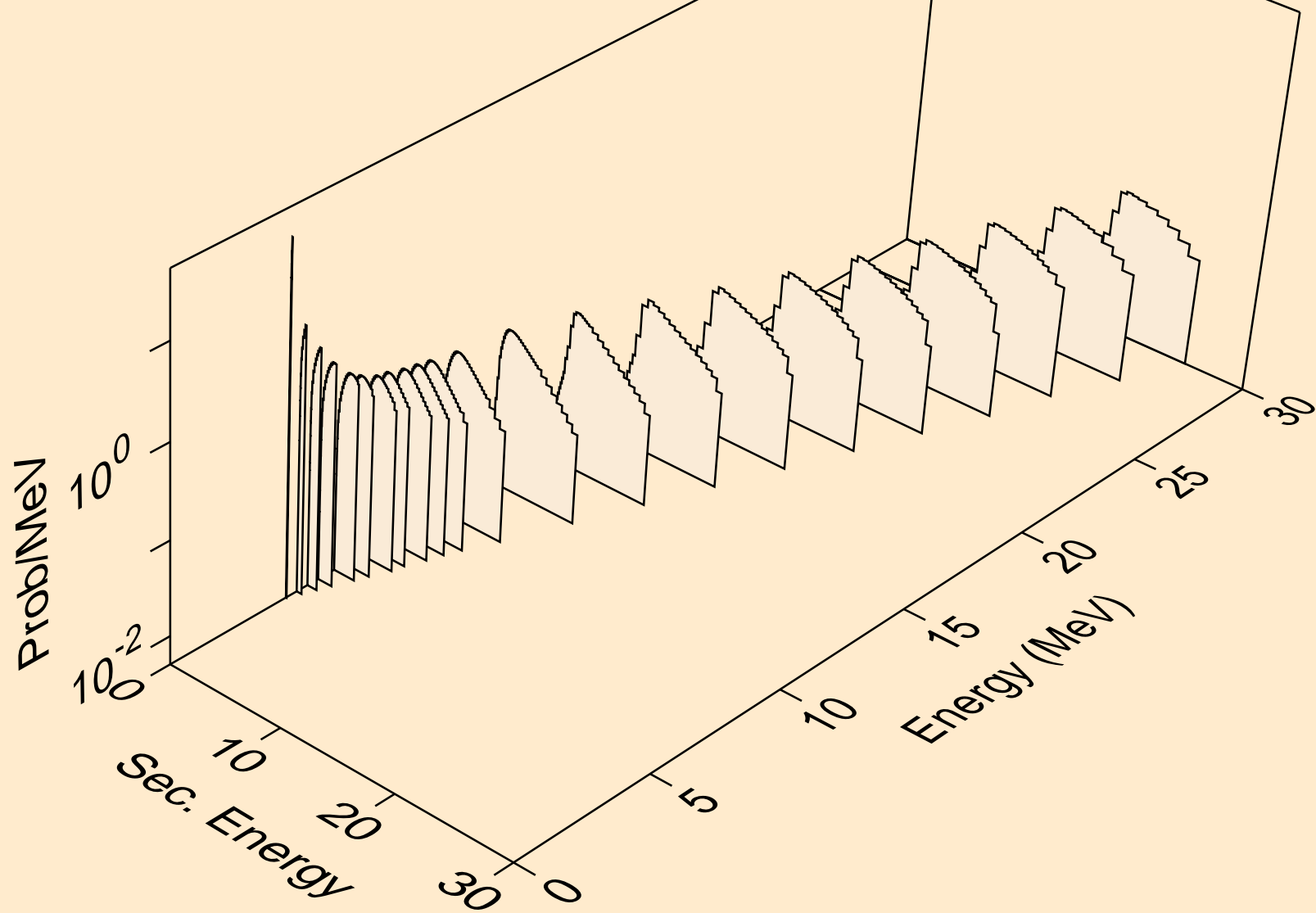

NI060 NEUTRON ACER TENDL-2023 LIBRARY; T=0.K  
Photon emission for (n,x)

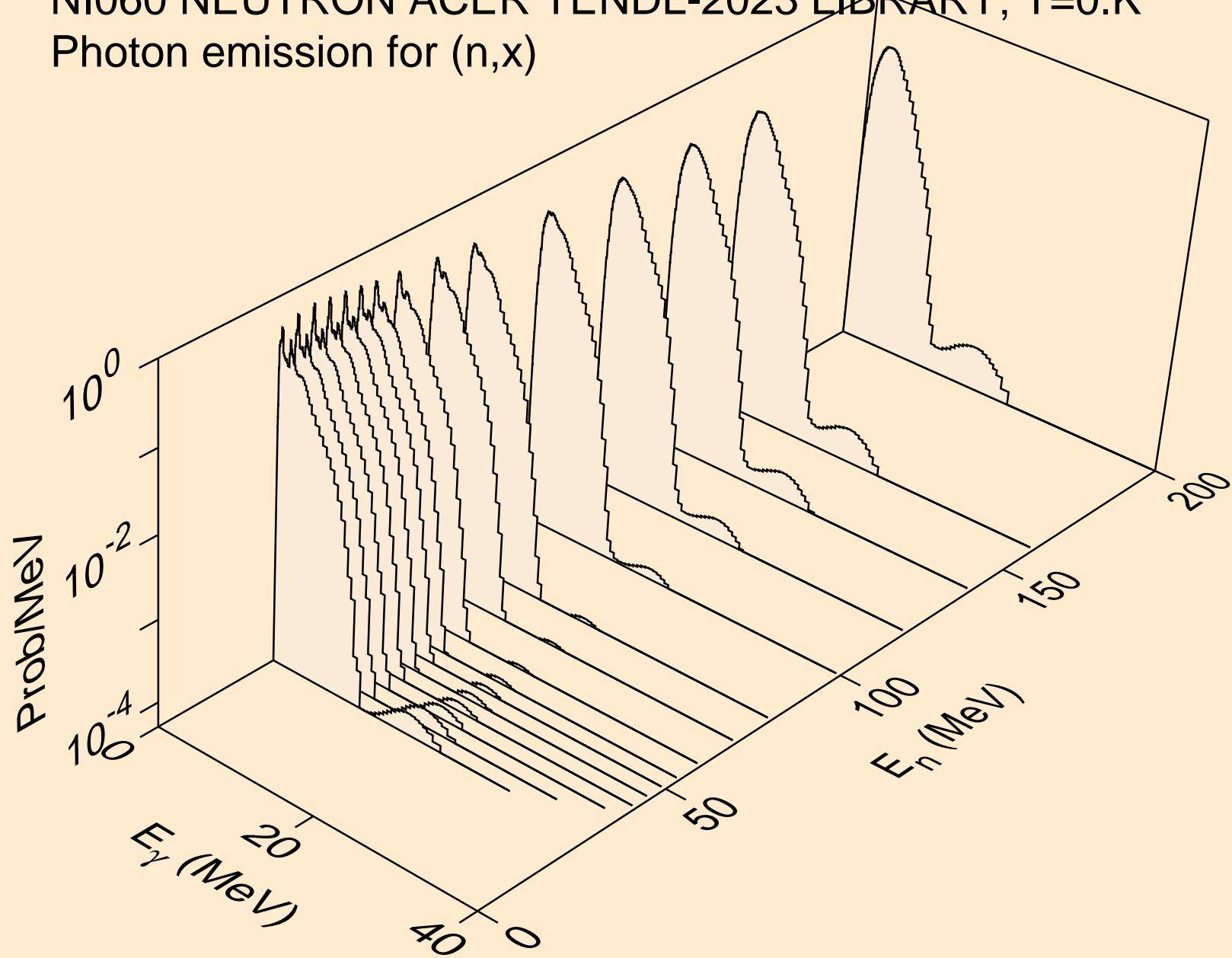

NI060 NEUTRON ACER TENDL-2023 LIBRARY; T=0.K  
Photon emission for (n,2nd)

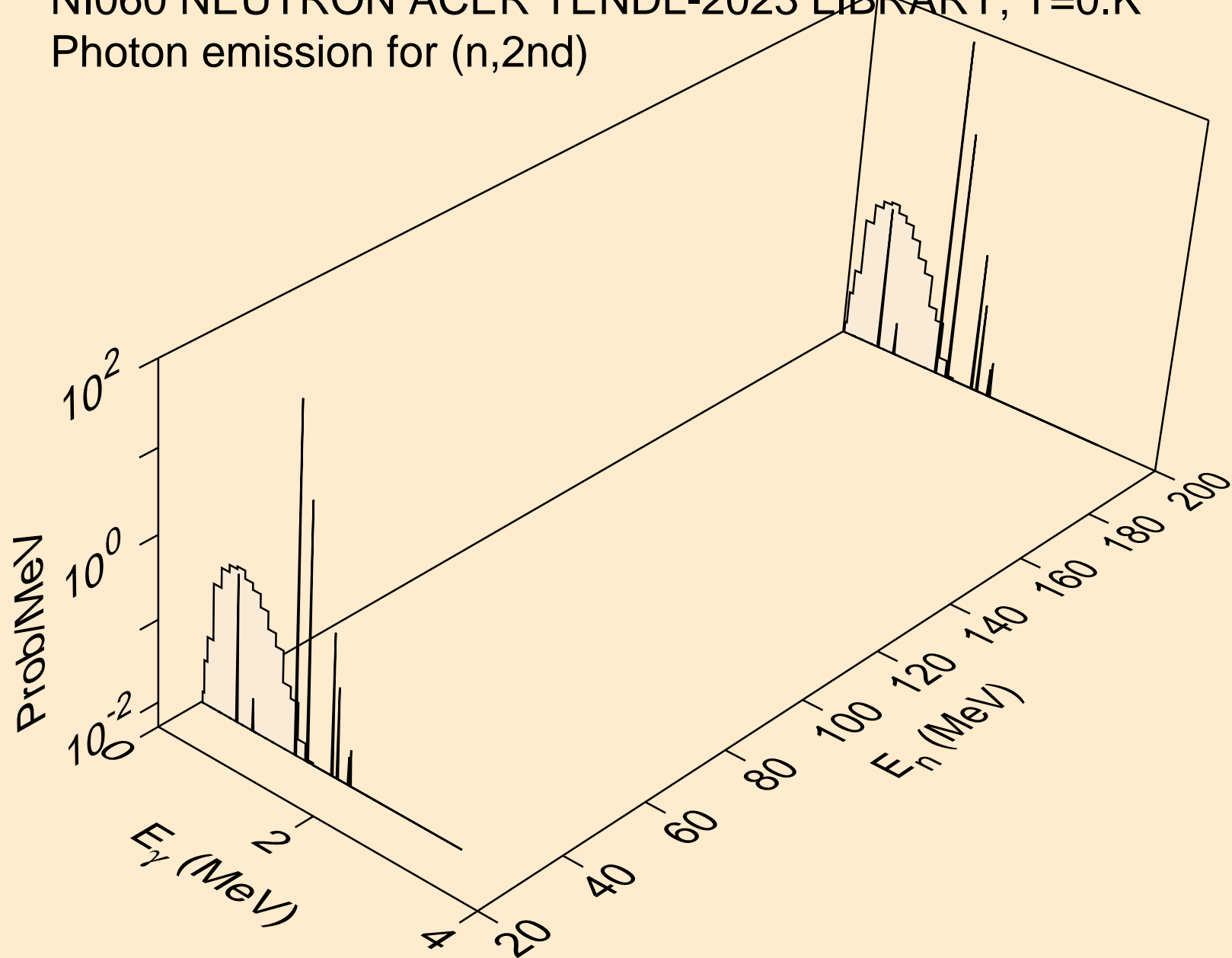

NI060 NEUTRON ACER TENDL-2023 LIBRARY; T=0.K  
Photon emission for (n,2n)

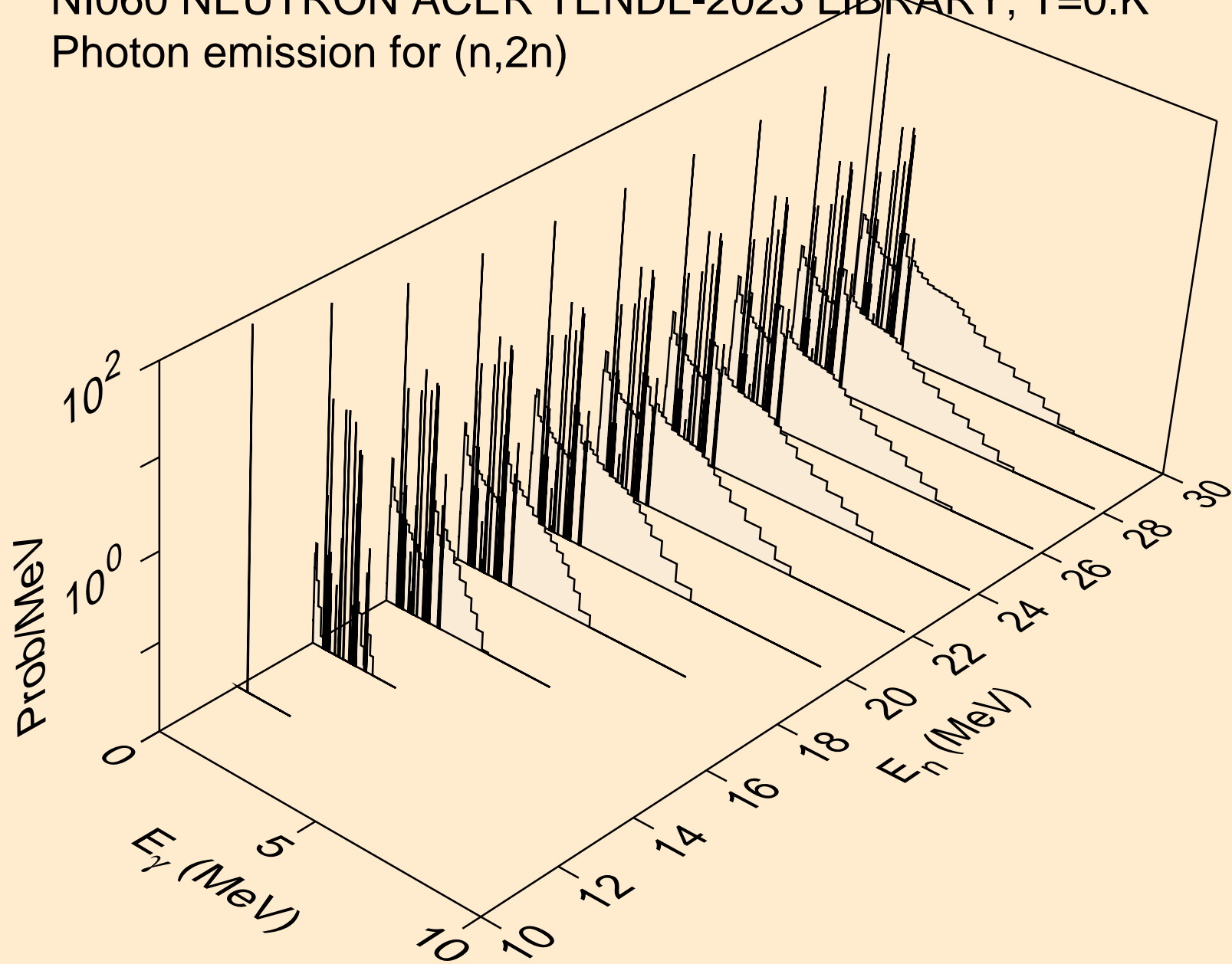

NI060 NEUTRON ACER TENDL-2023 LIBRARY; T=0.K  
Photon emission for (n,3n)

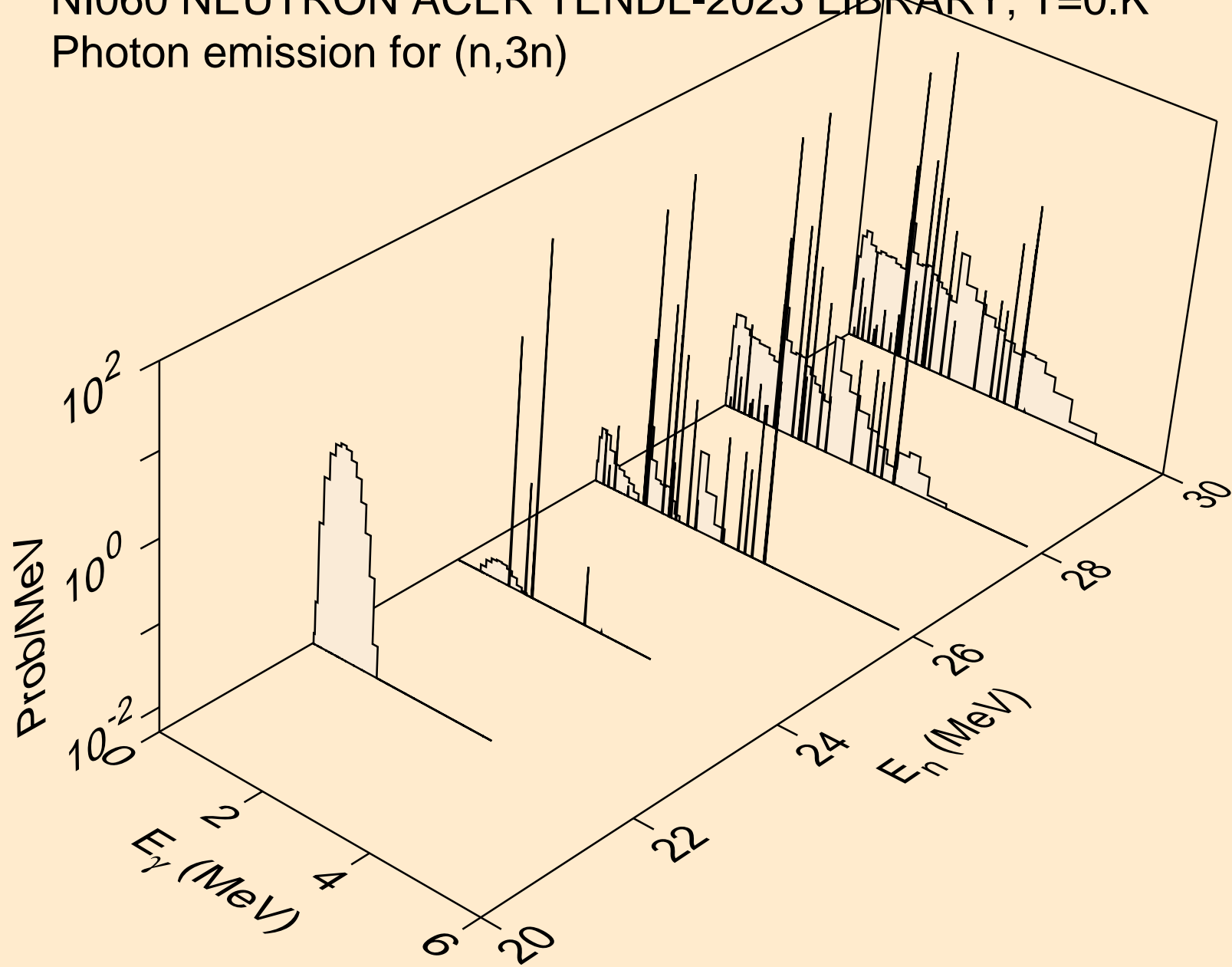

NI060 NEUTRON ACER TENDL-2023 LIBRARY; T=0.K  
Photon emission for (n,n\*)a

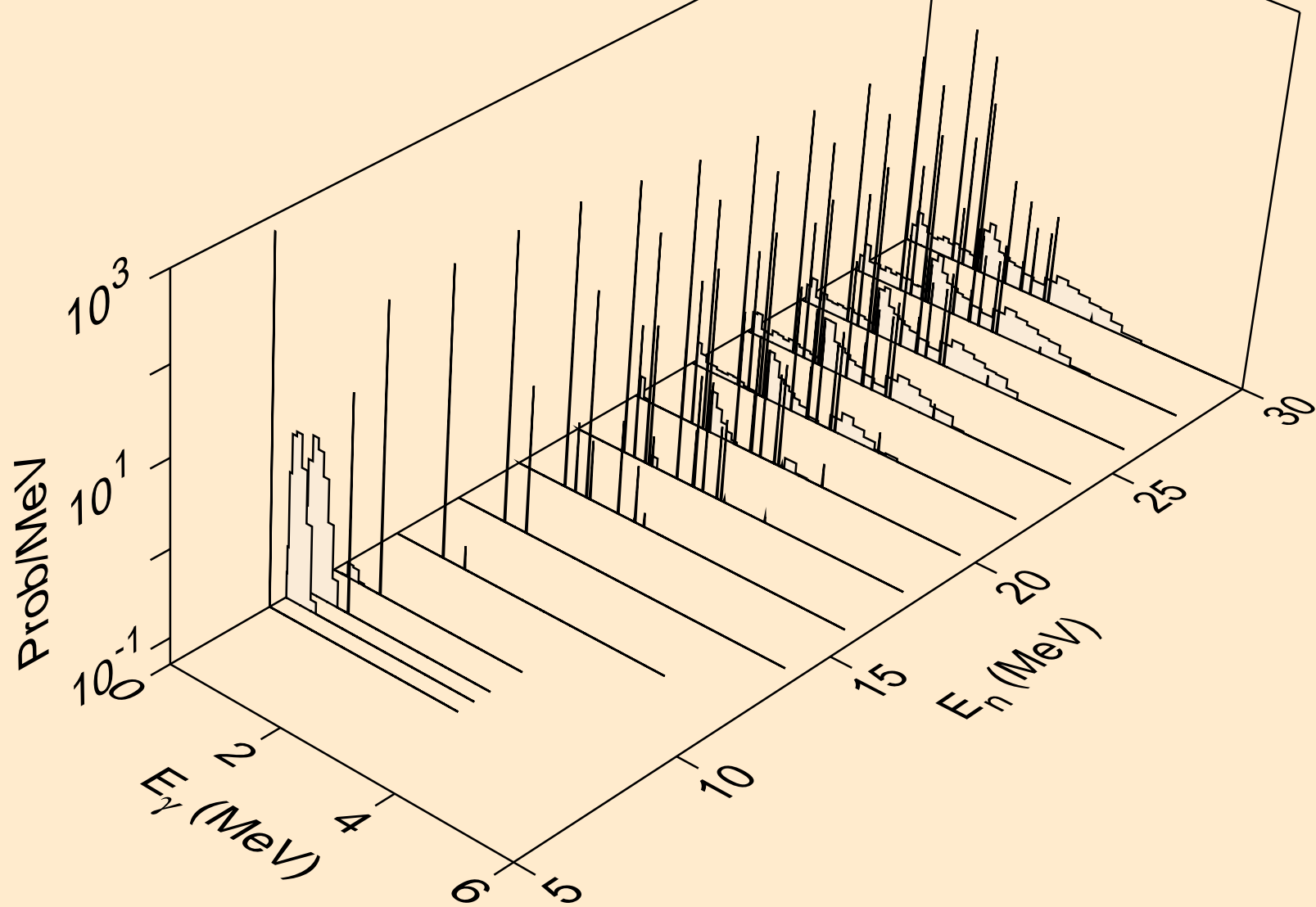



NI060 NEUTRON ACER TENDL-2023 LIBRARY; T=0.K  
Photon emission for (n,2n)a

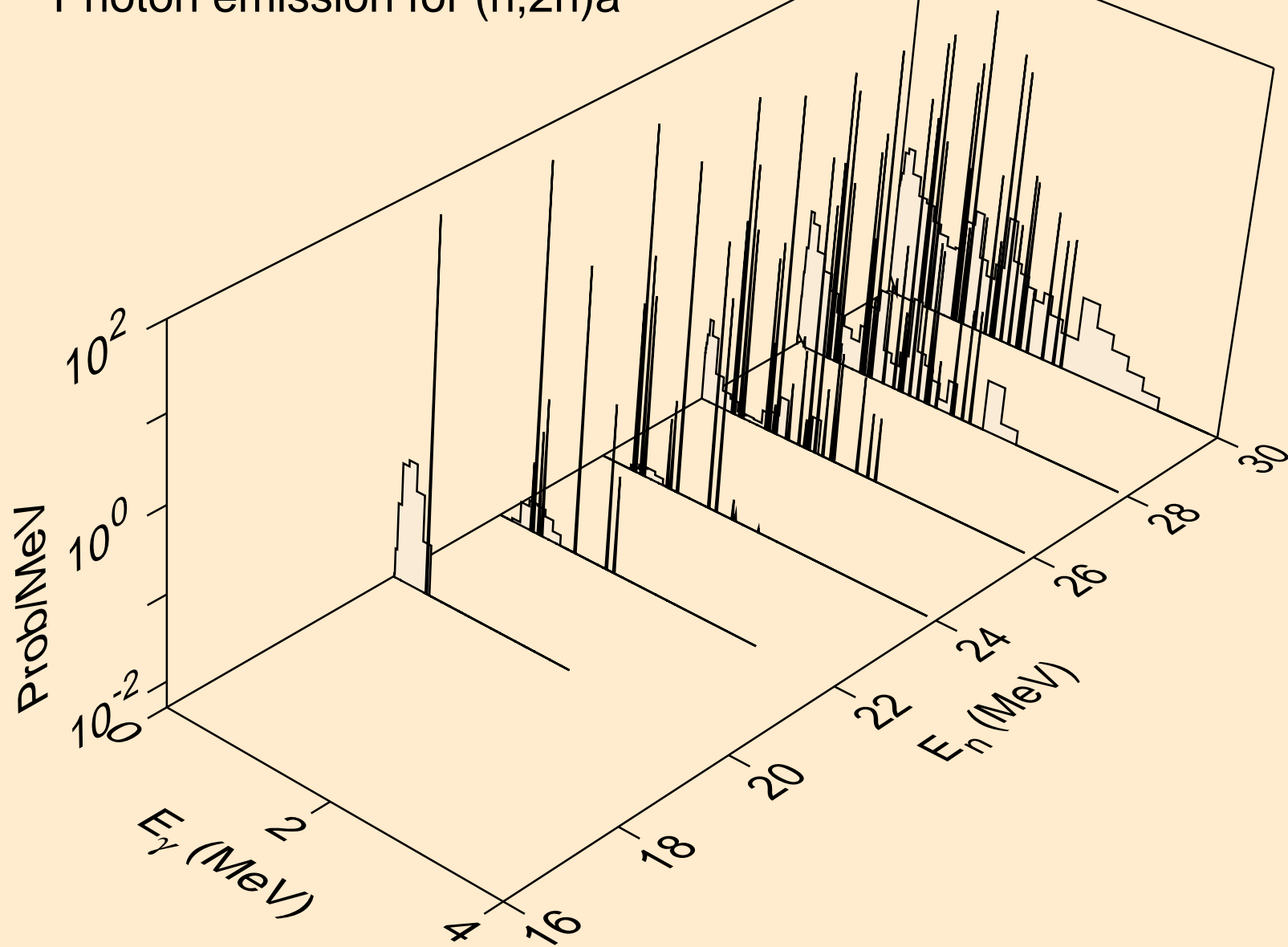

NI060 NEUTRON ACER TENDL-2023 LIBRARY; T=0.K  
Photon emission for (n,n\*)p

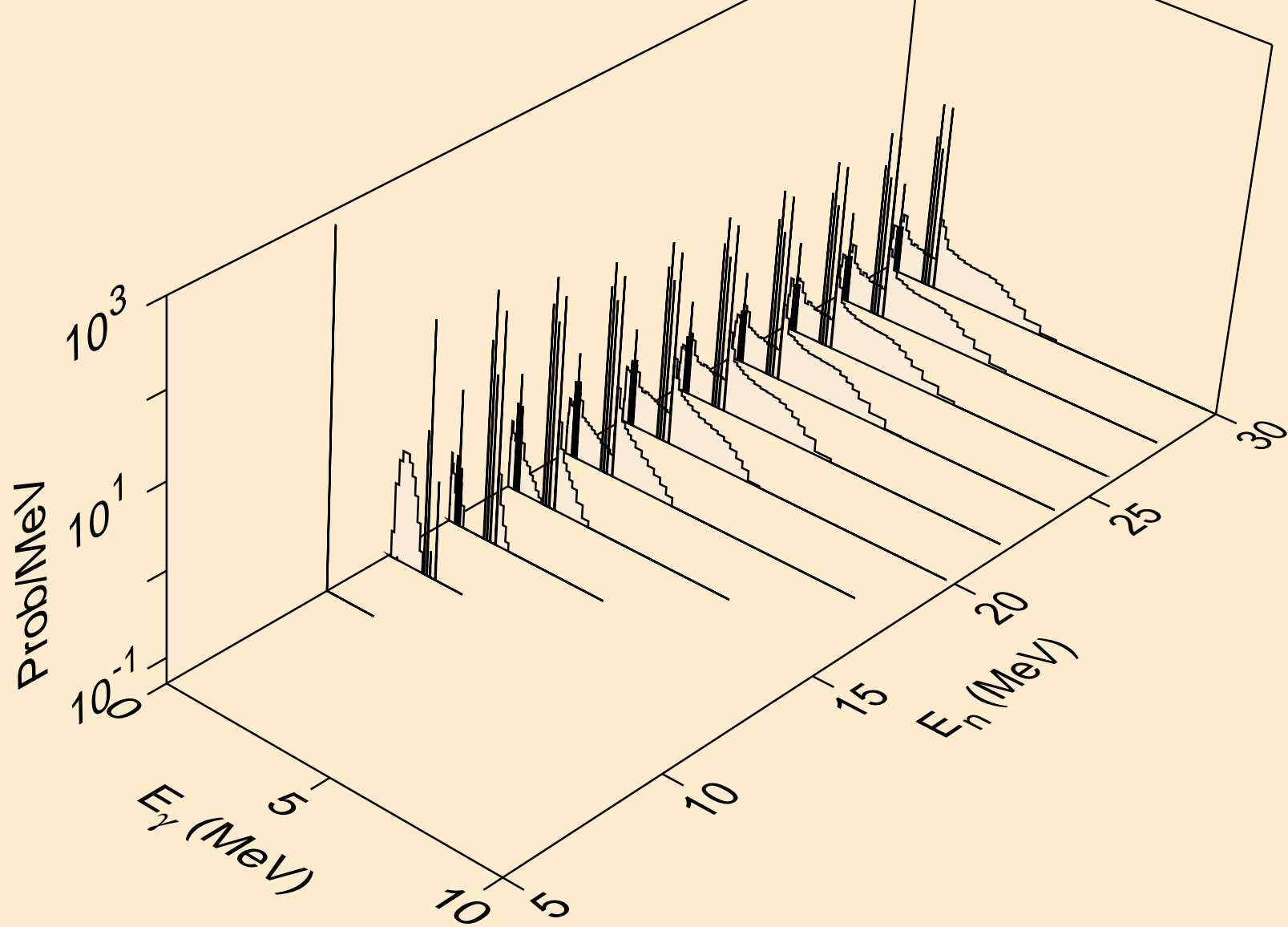

NI060 NEUTRON ACER TENDL-2023 LIBRARY; T=0.K  
Photon emission for (n,n\*)2a

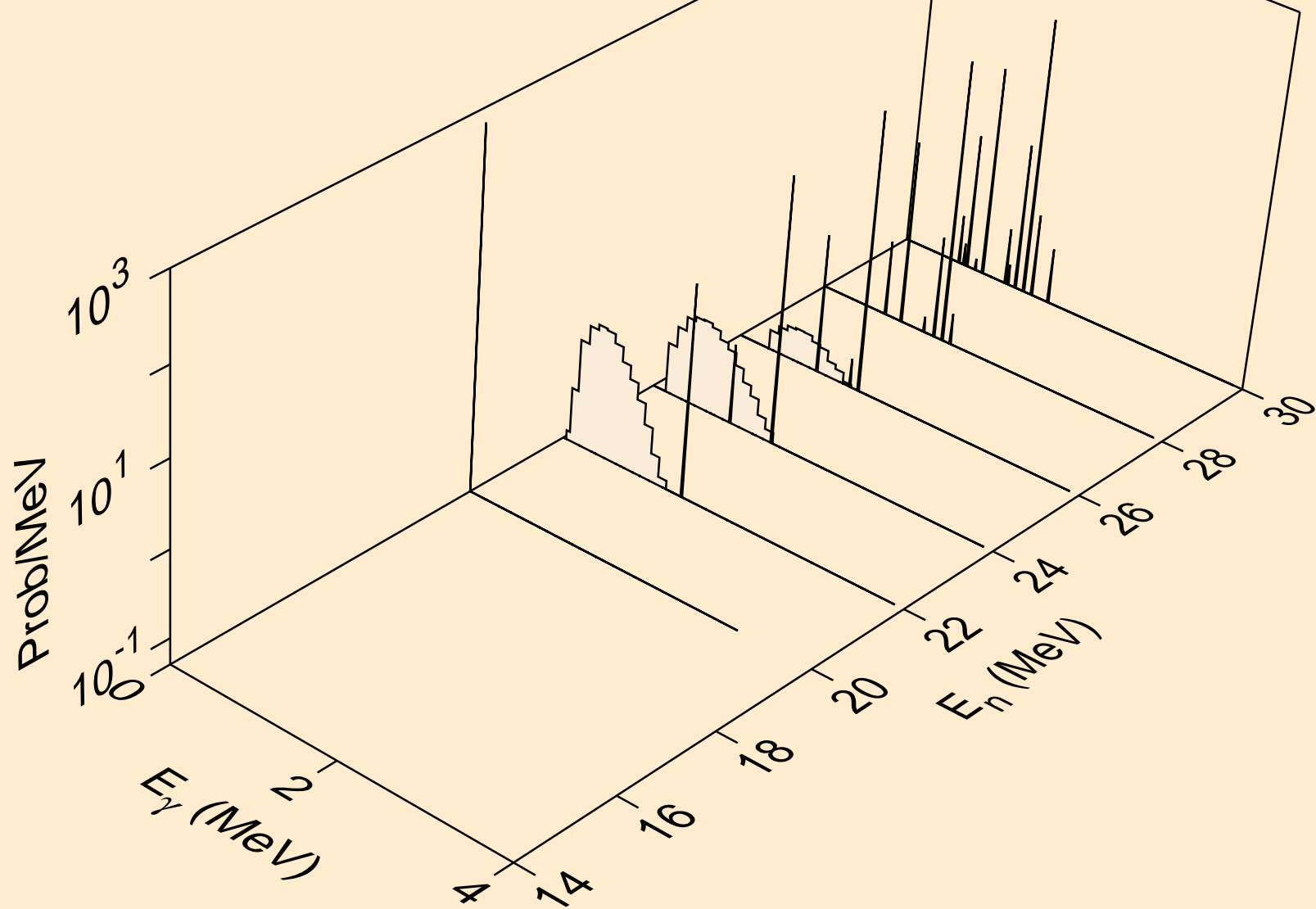

NI060 NEUTRON ACER TENDL-2023 LIBRARY; T=0.K  
Photon emission for (n,n\*)d

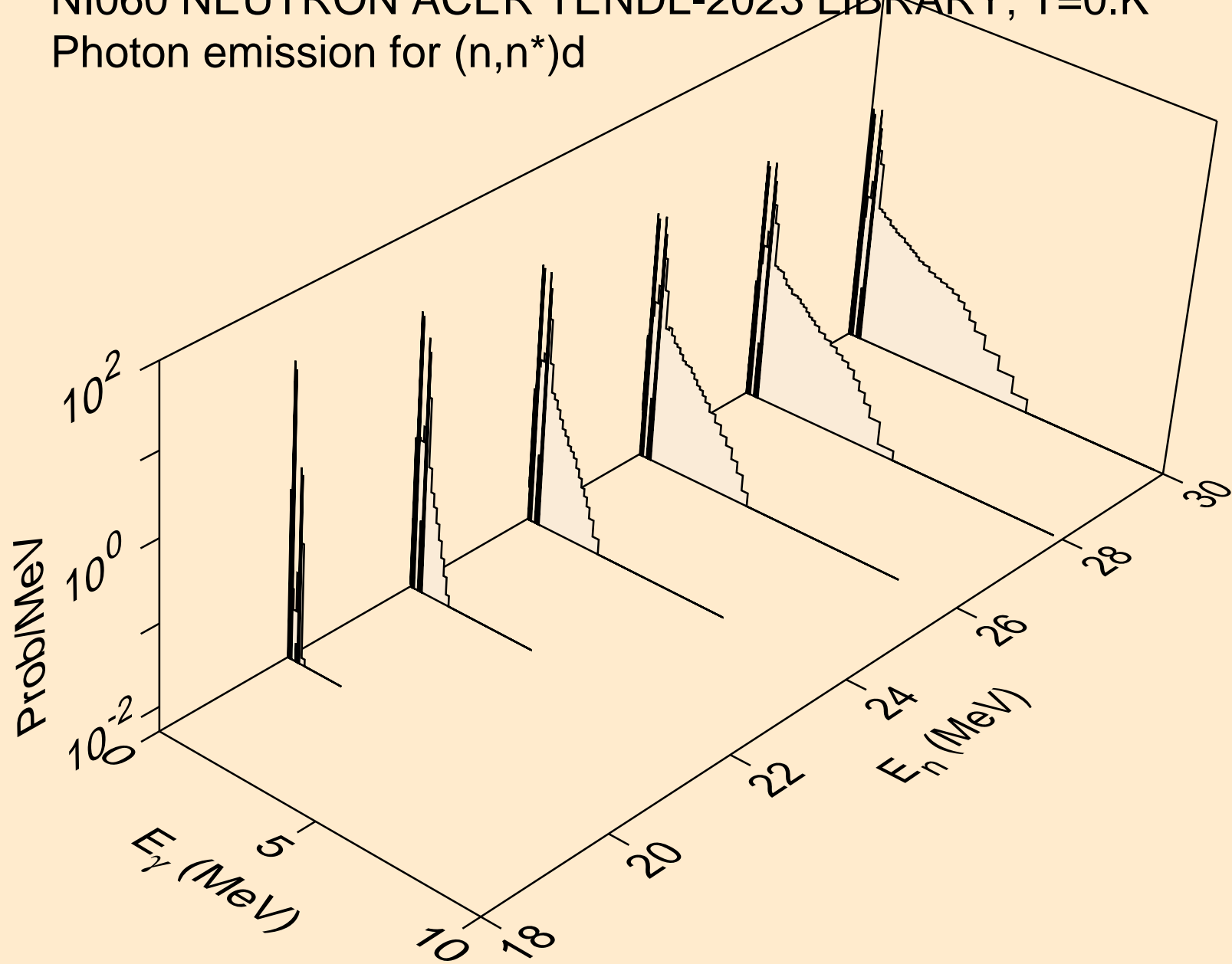

NI060 NEUTRON ACER TENDL-2023 LIBRARY; T=0.K  
Photon emission for (n,n\*)t

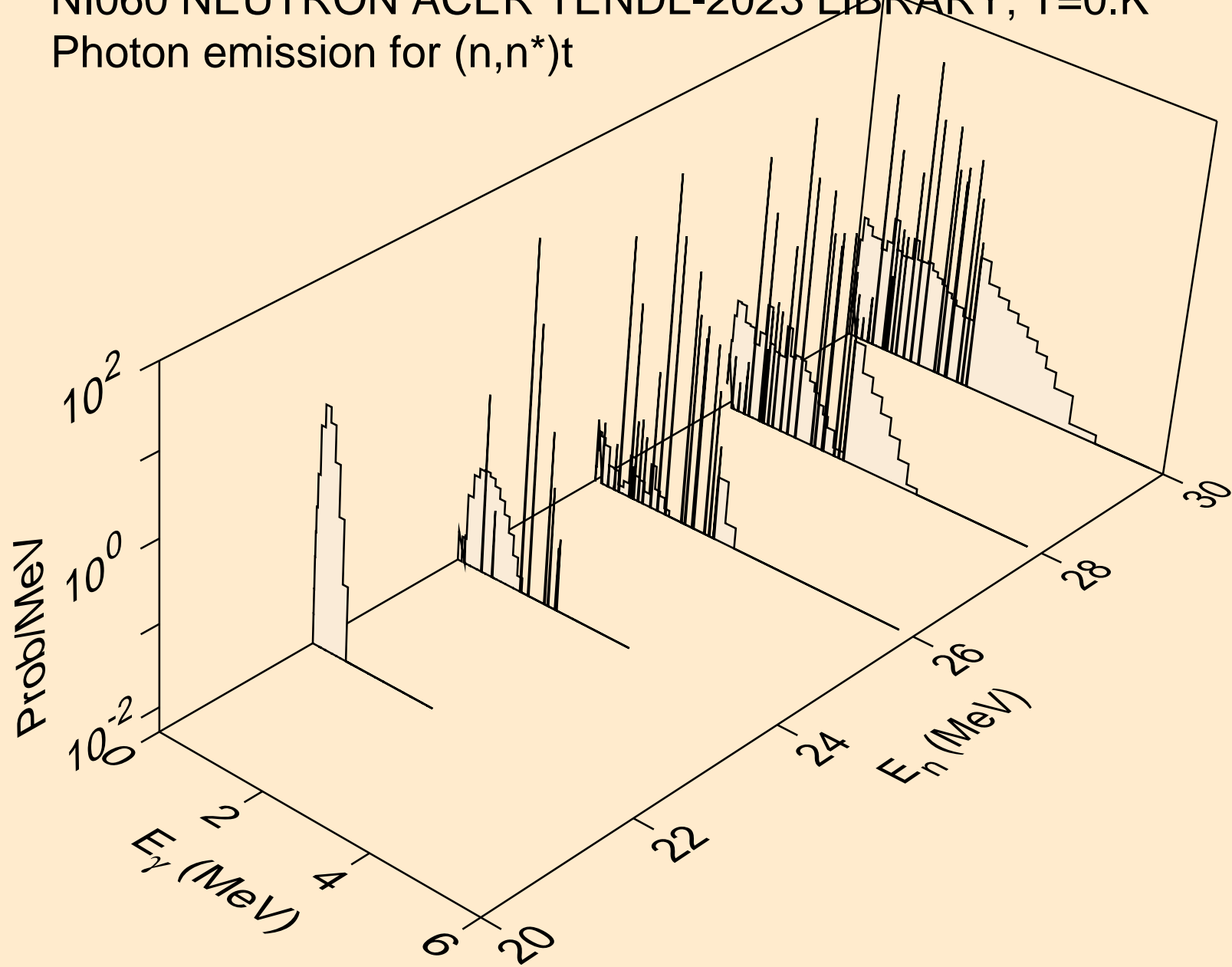

NI060 NEUTRON ACER TENDL-2023 LIBRARY; T=0.K  
Photon emission for (n,n\*)he3

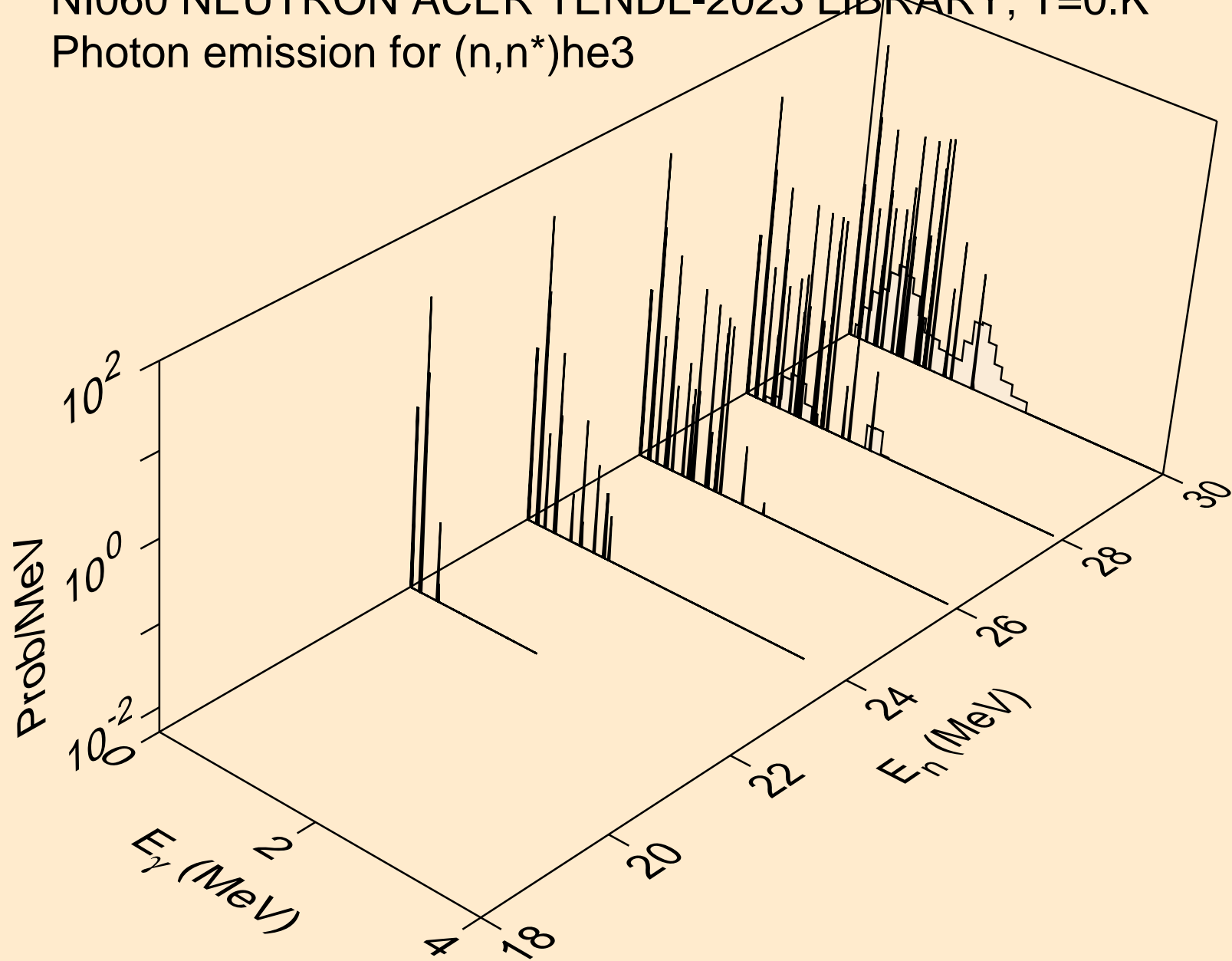

NI060 NEUTRON ACER TENDL-2023 LIBRARY; T=0.K  
Photon emission for (n,2np)

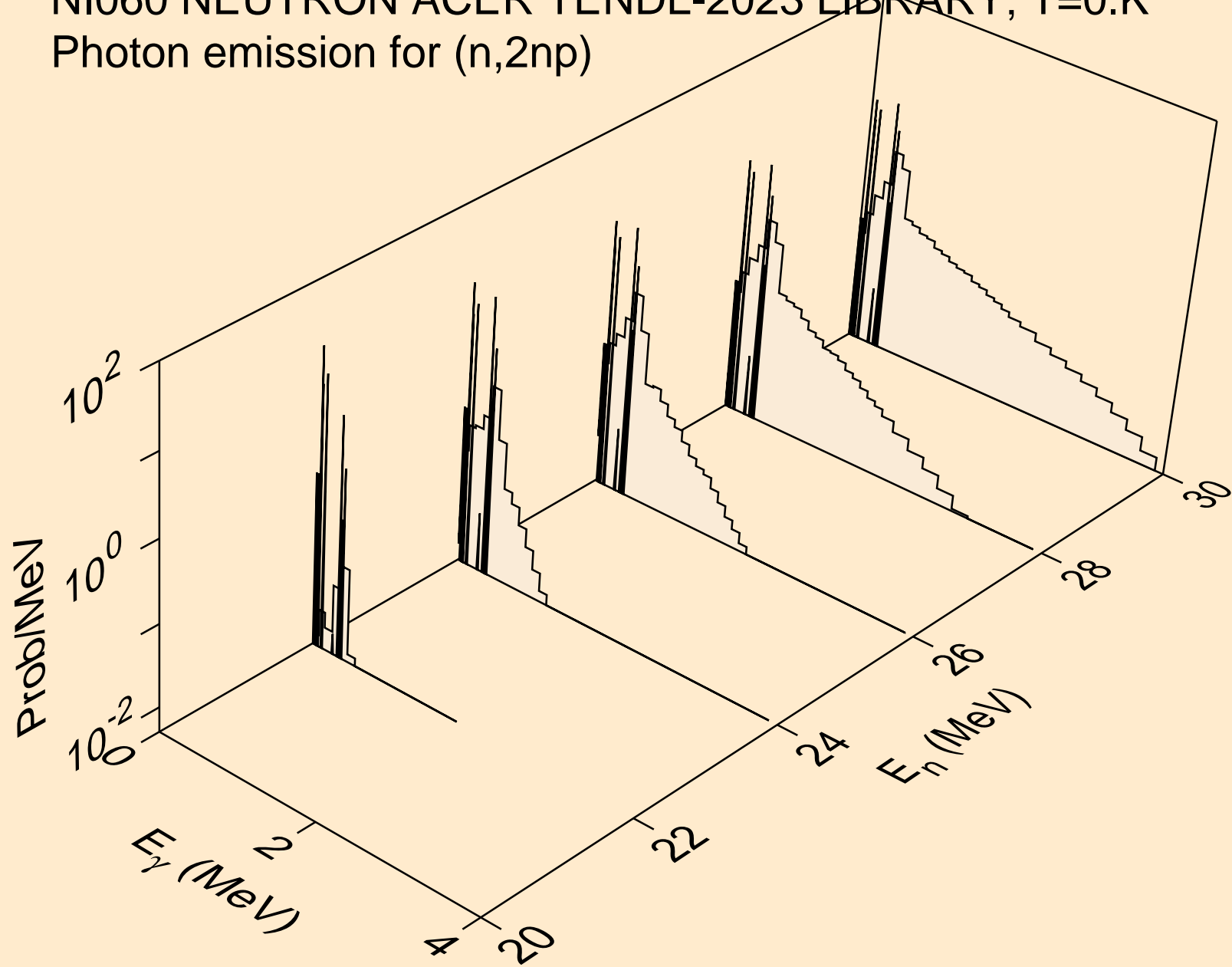

NI060 NEUTRON ACER TENDL-2023 LIBRARY; T=0.K  
Photon emission for (n,n2p)

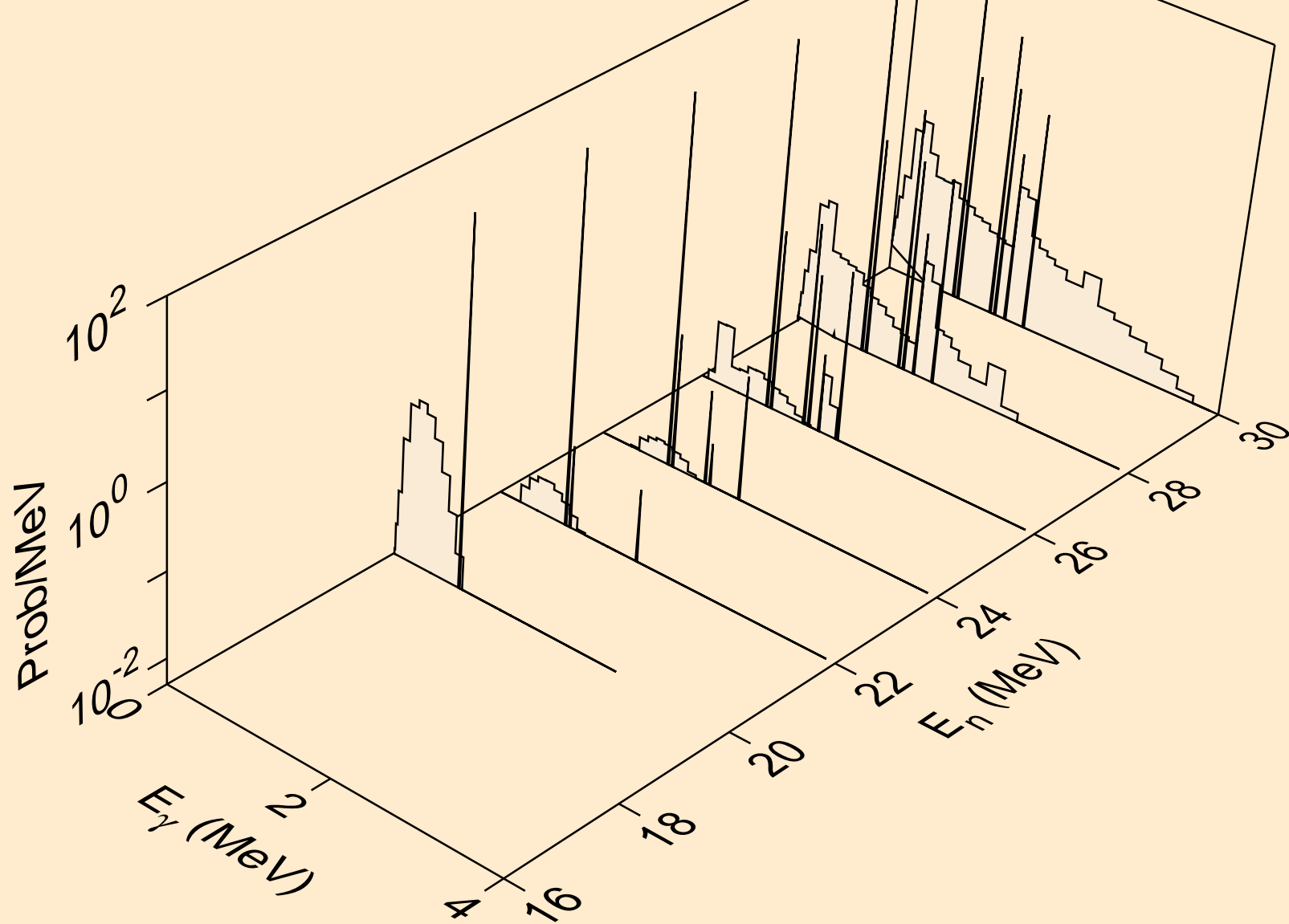



NI060 NEUTRON ACER TENDL-2023 LIBRARY; T=0.K  
Photon emission for (n,npa)

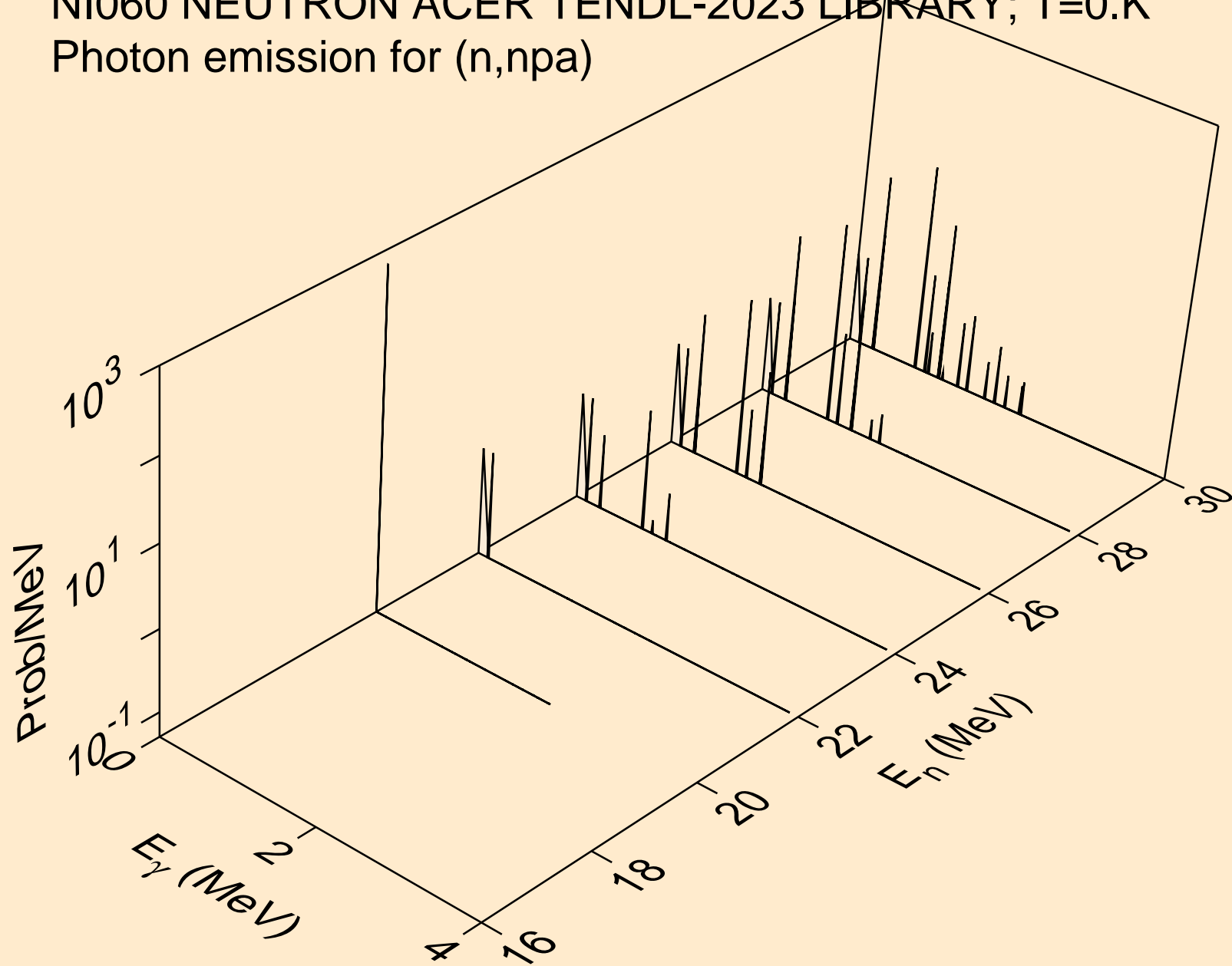

NI060 NEUTRON ACER TENDL-2023 LIBRARY; T=0.K  
Photon emission for (n,n\*c)

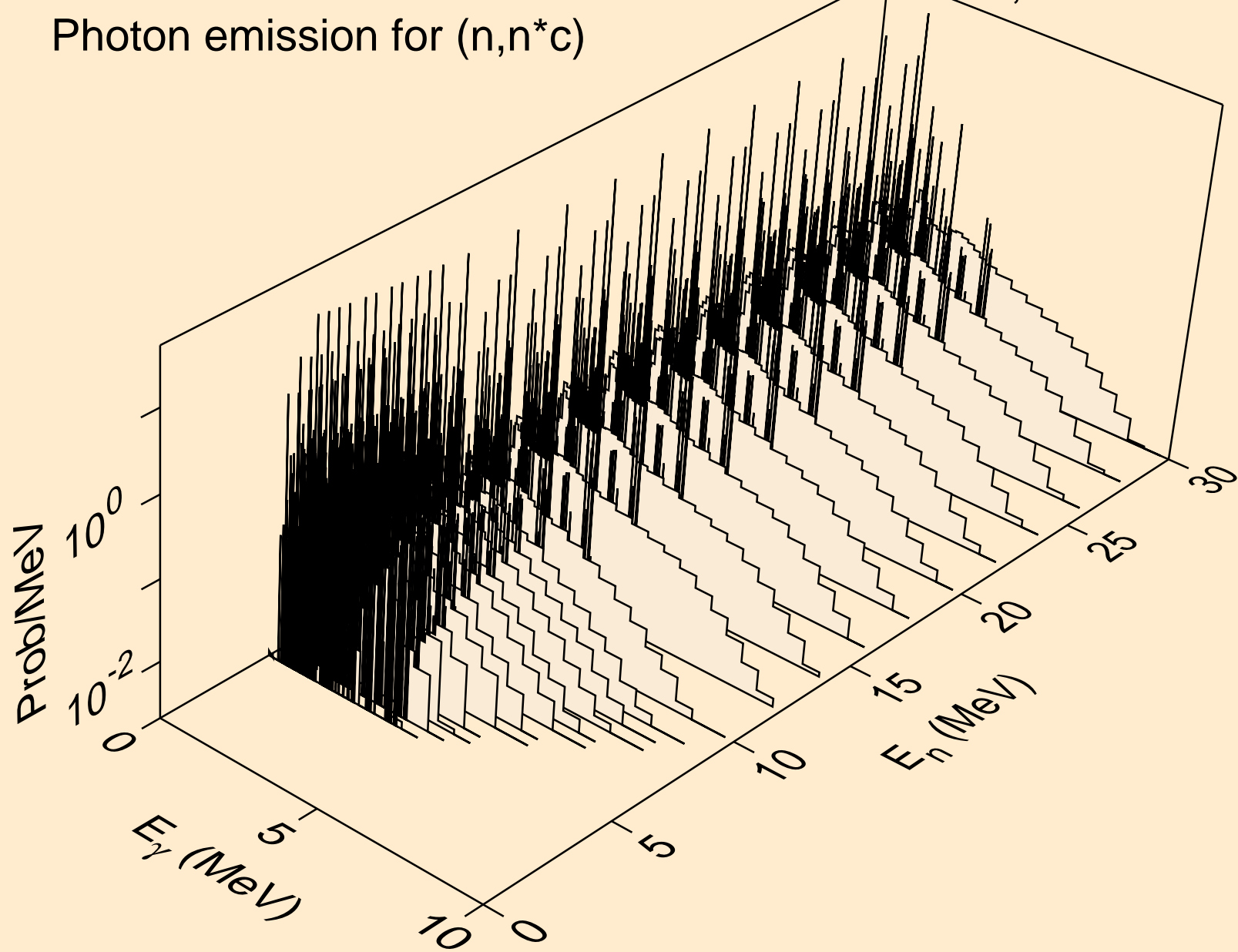

NI060 NEUTRON ACER TENDL-2023 LIBRARY; T=0.K  
Photon emission for (n,gma)

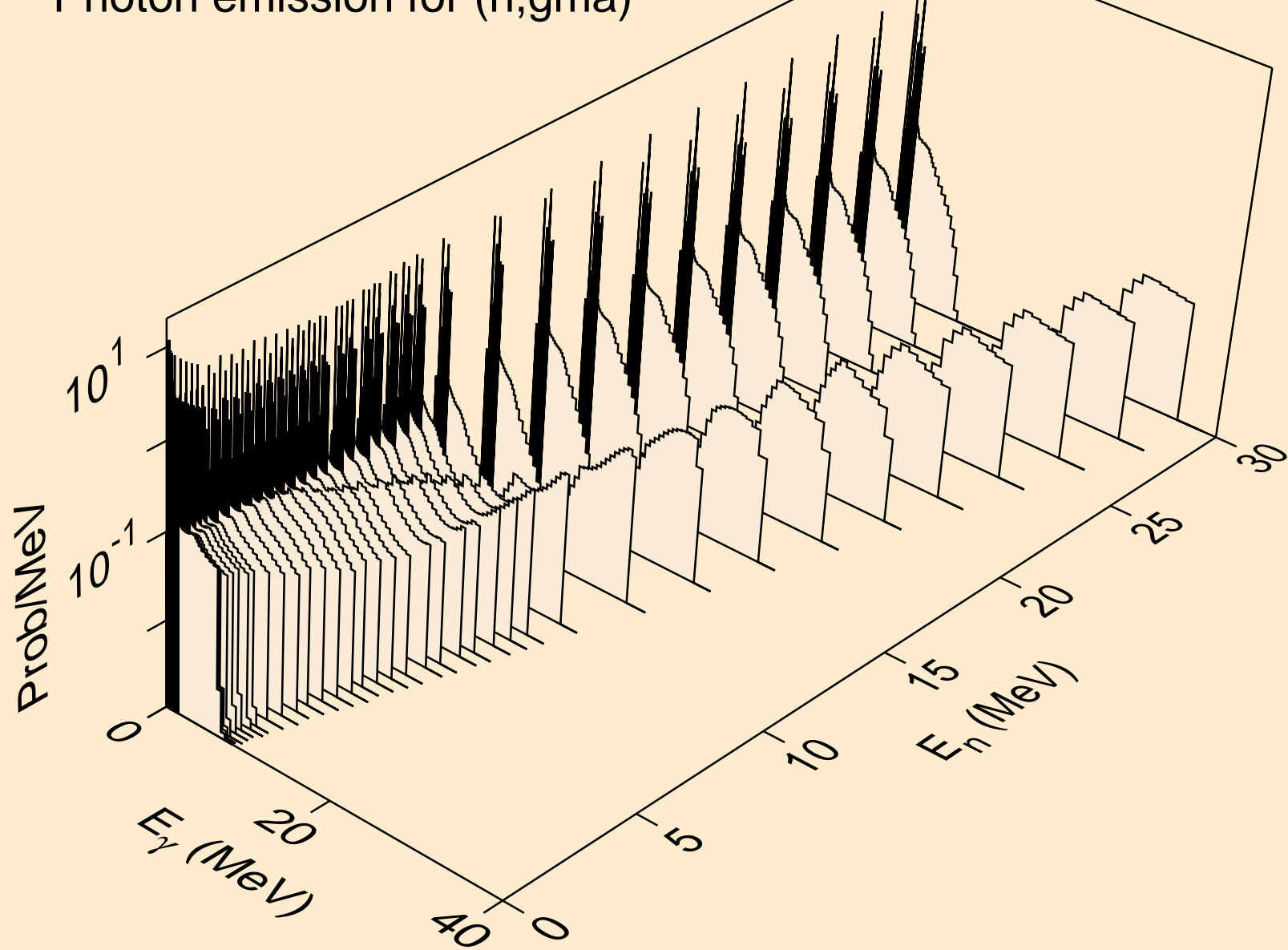

NI060 NEUTRON ACER TENDL-2023 LIBRARY; T=0.K  
Photon emission for (n,p)

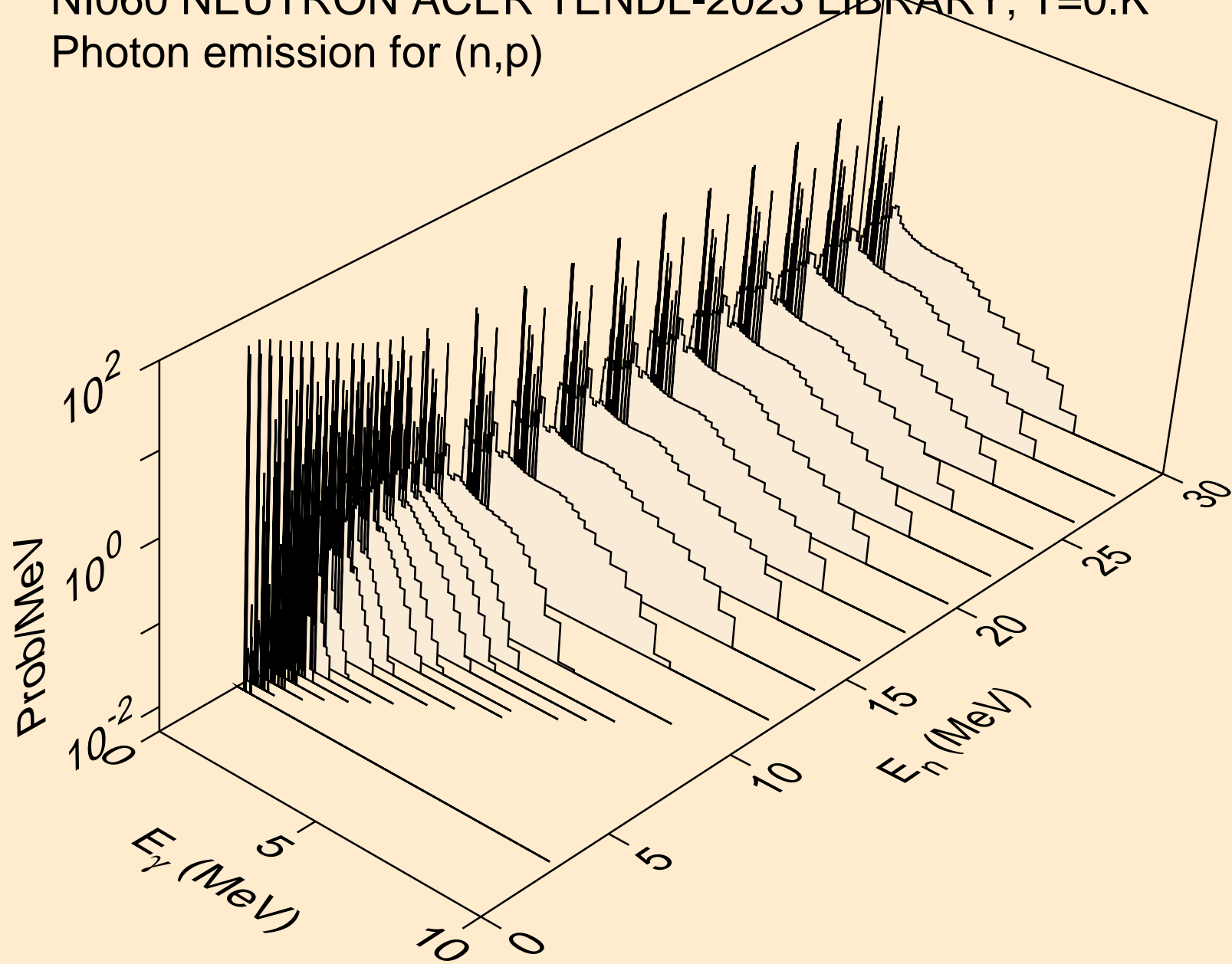

NI060 NEUTRON ACER TENDL-2023 LIBRARY; T=0.K  
Photon emission for (n,d)

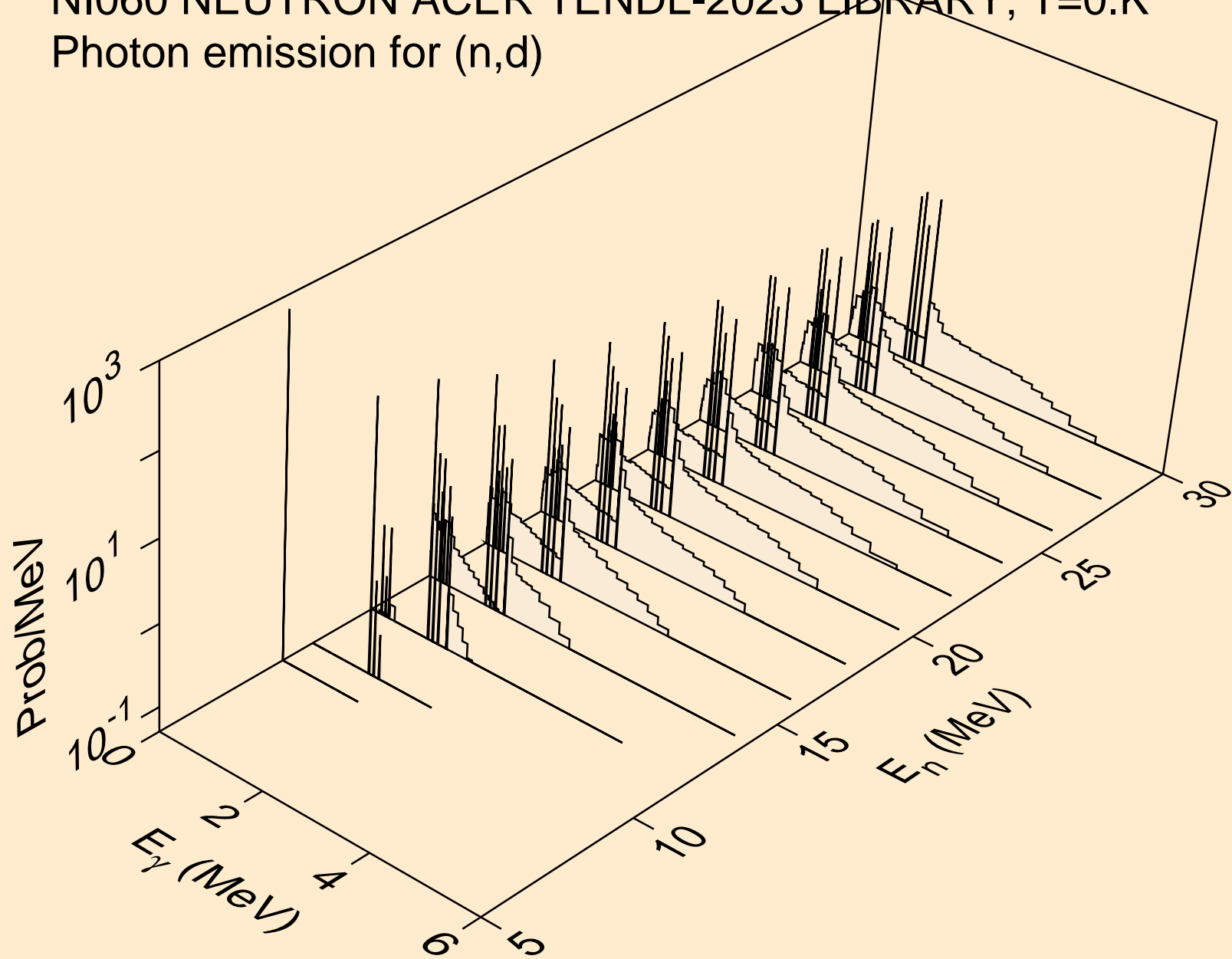

NI060 NEUTRON ACER TENDL-2023 LIBRARY; T=0.K  
Photon emission for (n,t)

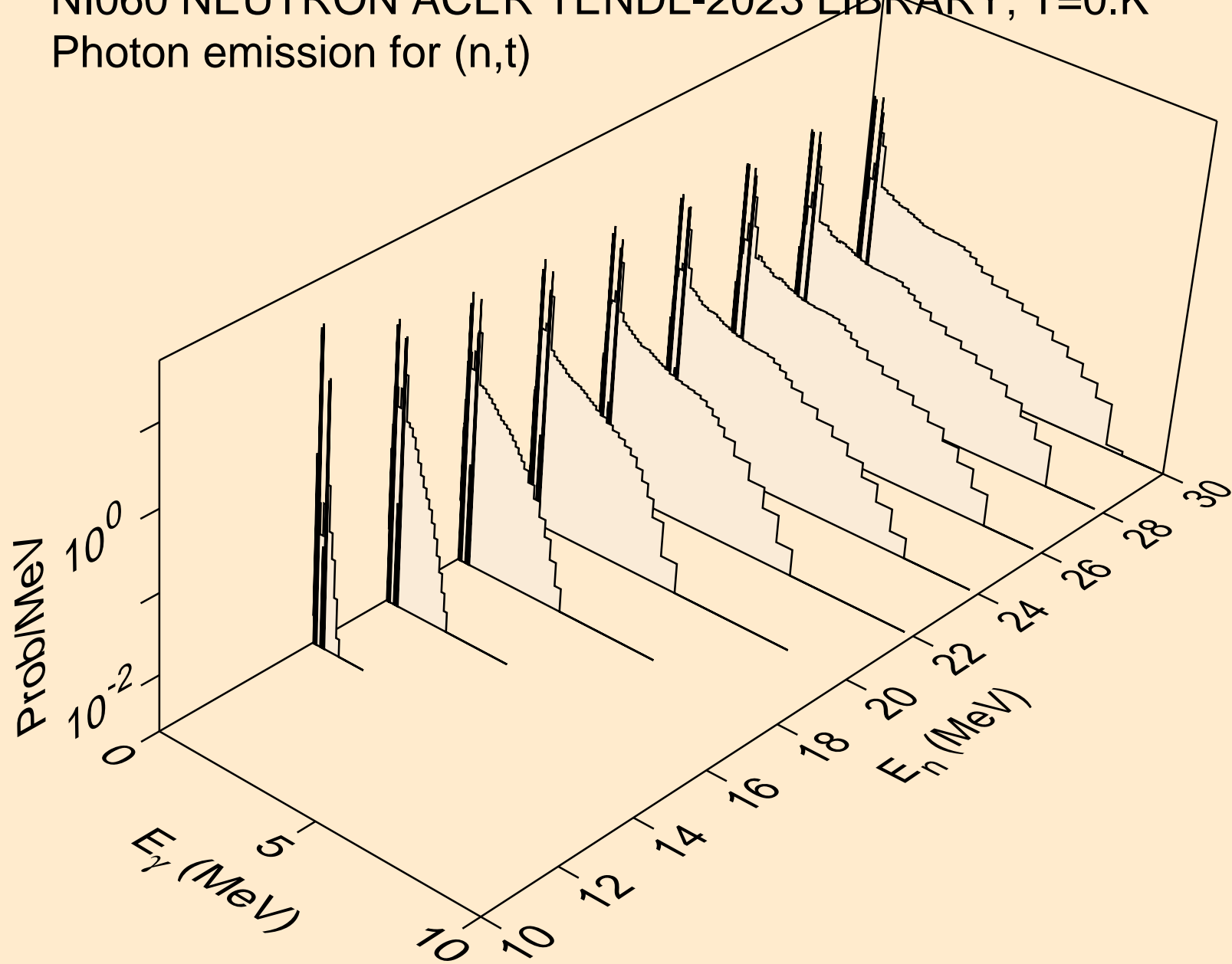

NI060 NEUTRON ACER TENDL-2023 LIBRARY; T=0.K  
Photon emission for (n,he3)

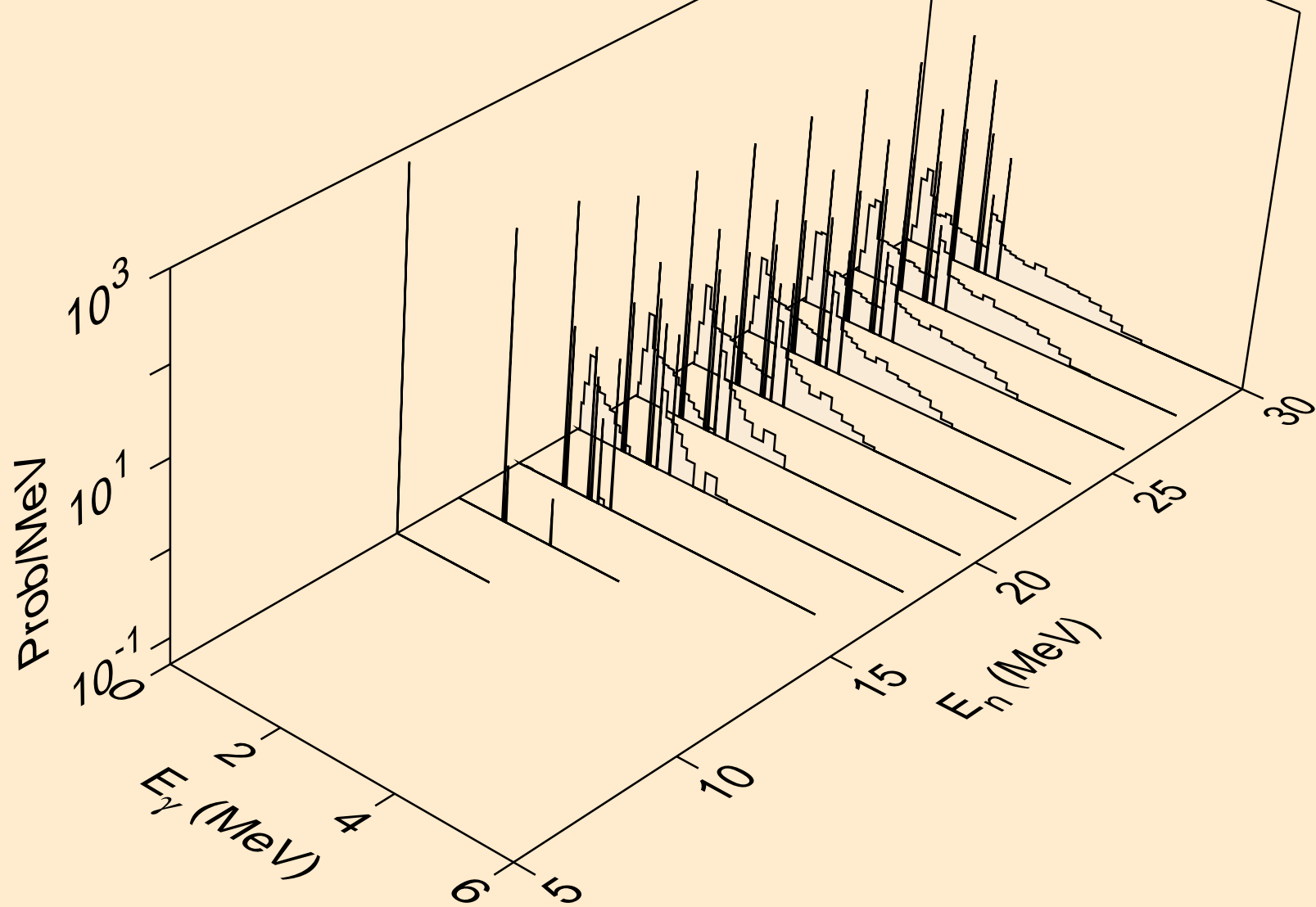

NI060 NEUTRON ACER TENDL-2023 LIBRARY; T=0.K  
Photon emission for (n,a)

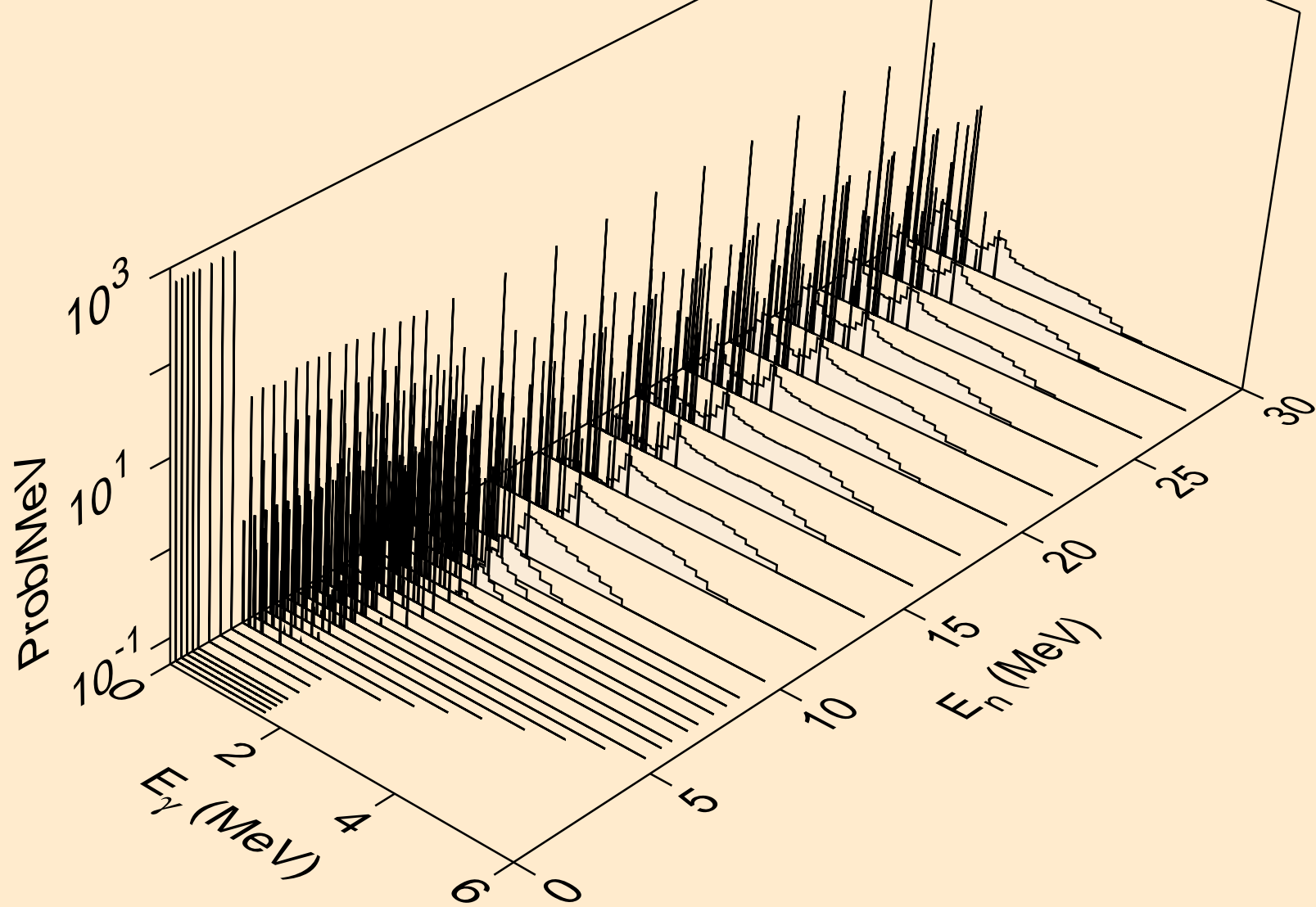



NI060 NEUTRON ACER TENDL-2023 LIBRARY; T=0.K  
Photon emission for (n,2a)

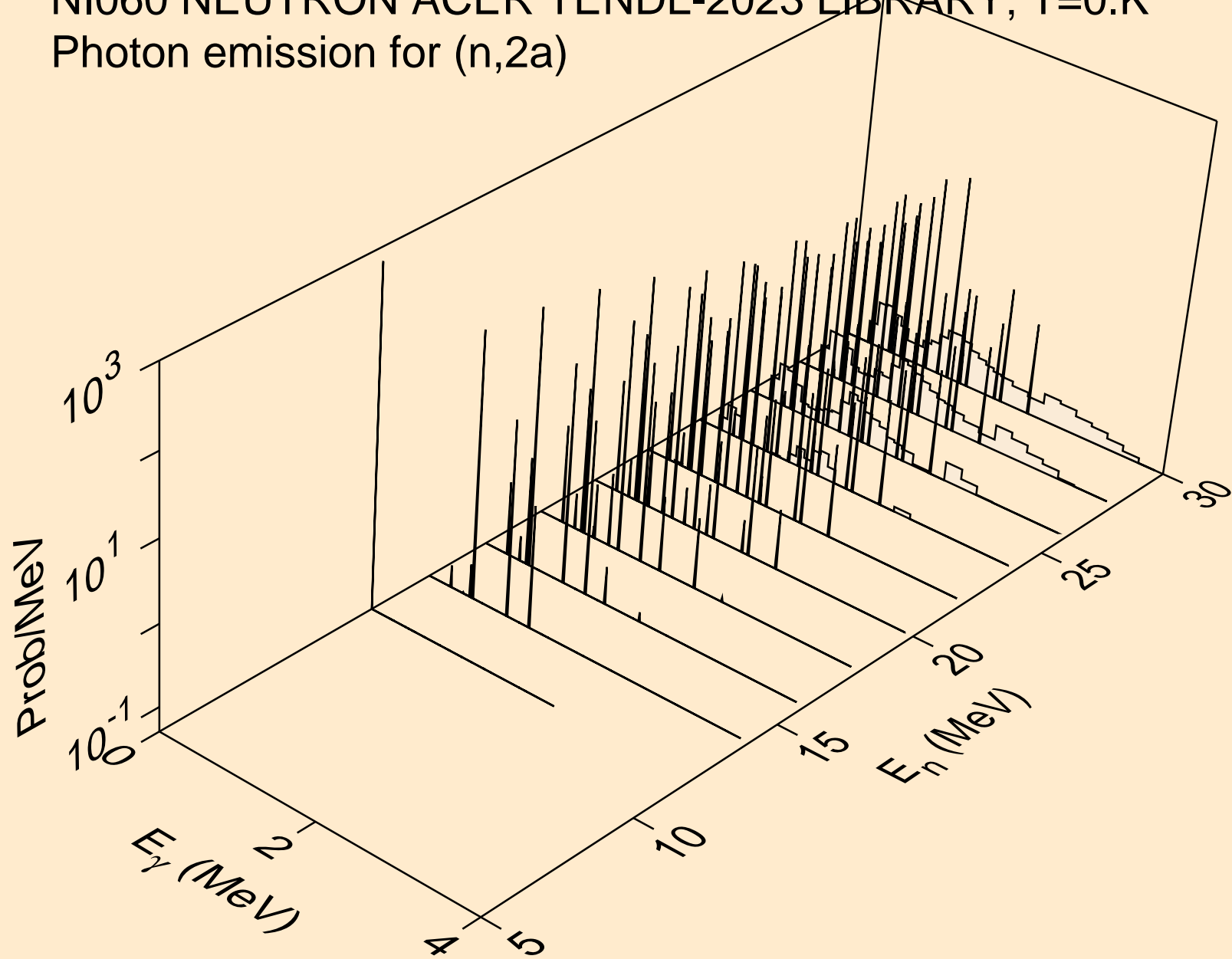

NI060 NEUTRON ACER TENDL-2023 LIBRARY; T=0.K  
Photon emission for (n,2p)

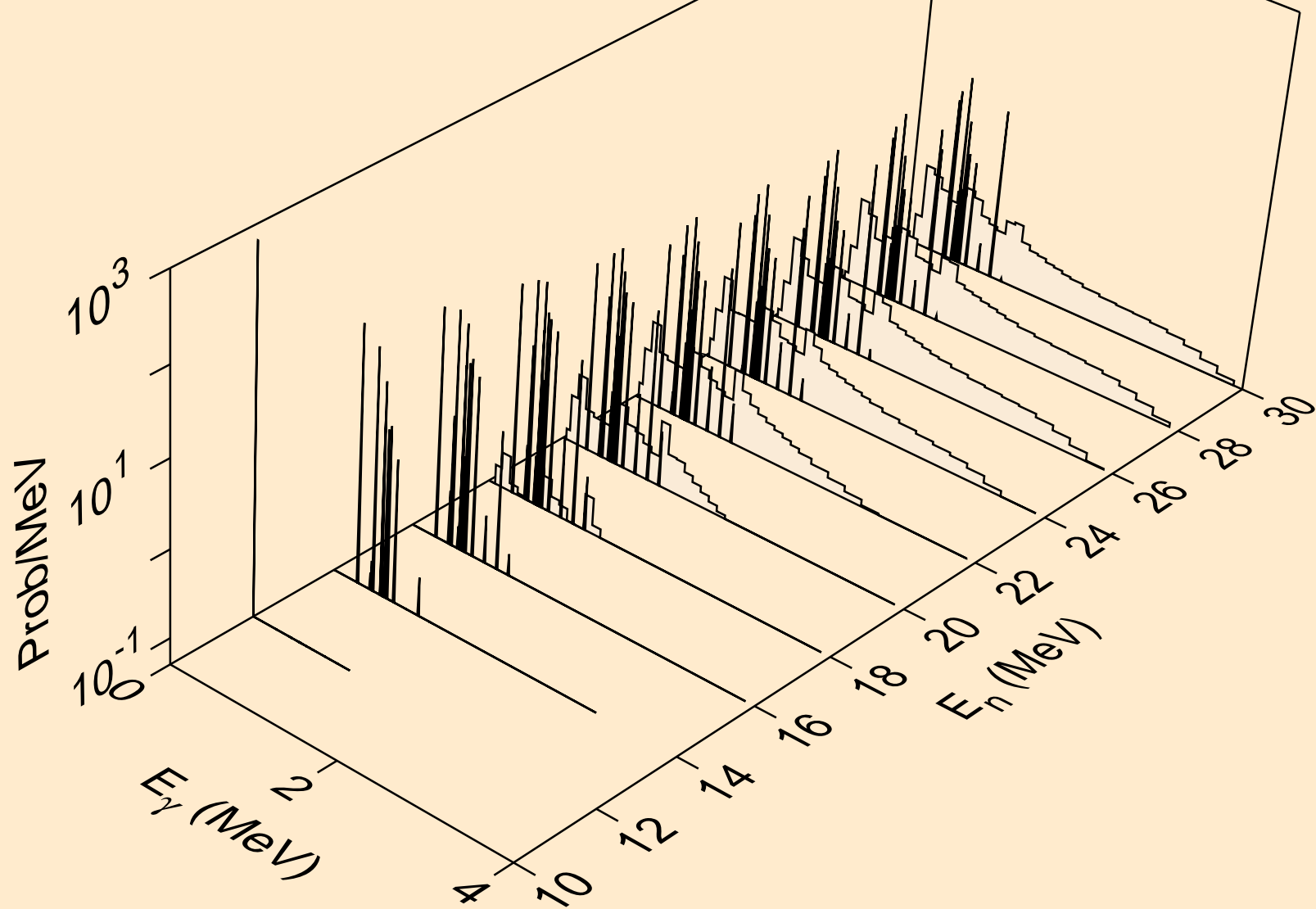

NI060 NEUTRON ACER TENDL-2023 LIBRARY; T=0.K  
Photon emission for (n,p $\alpha$ )

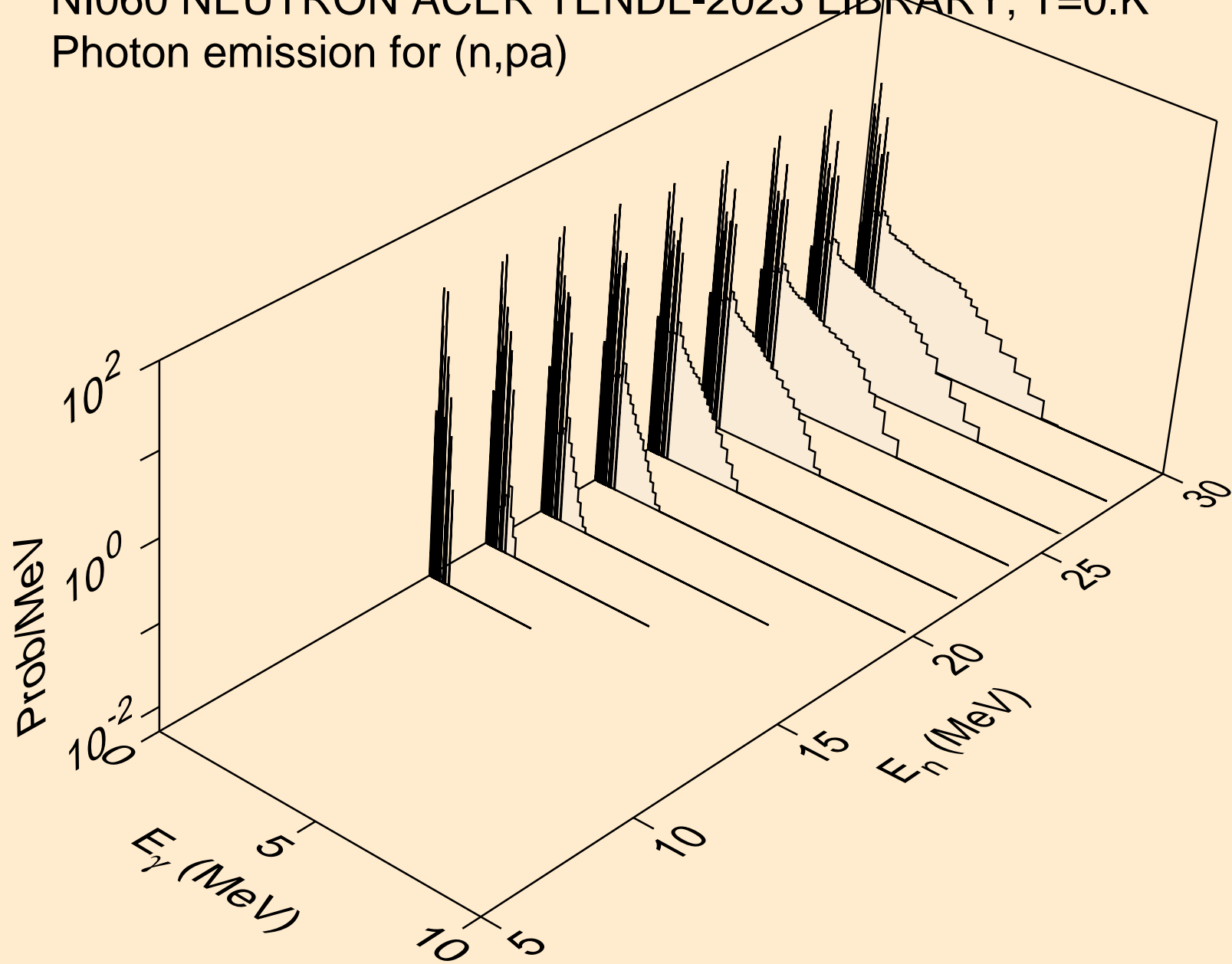

NI060 NEUTRON ACER TENDL-2023 LIBRARY; T=0.K  
Photon emission for (n,pd)

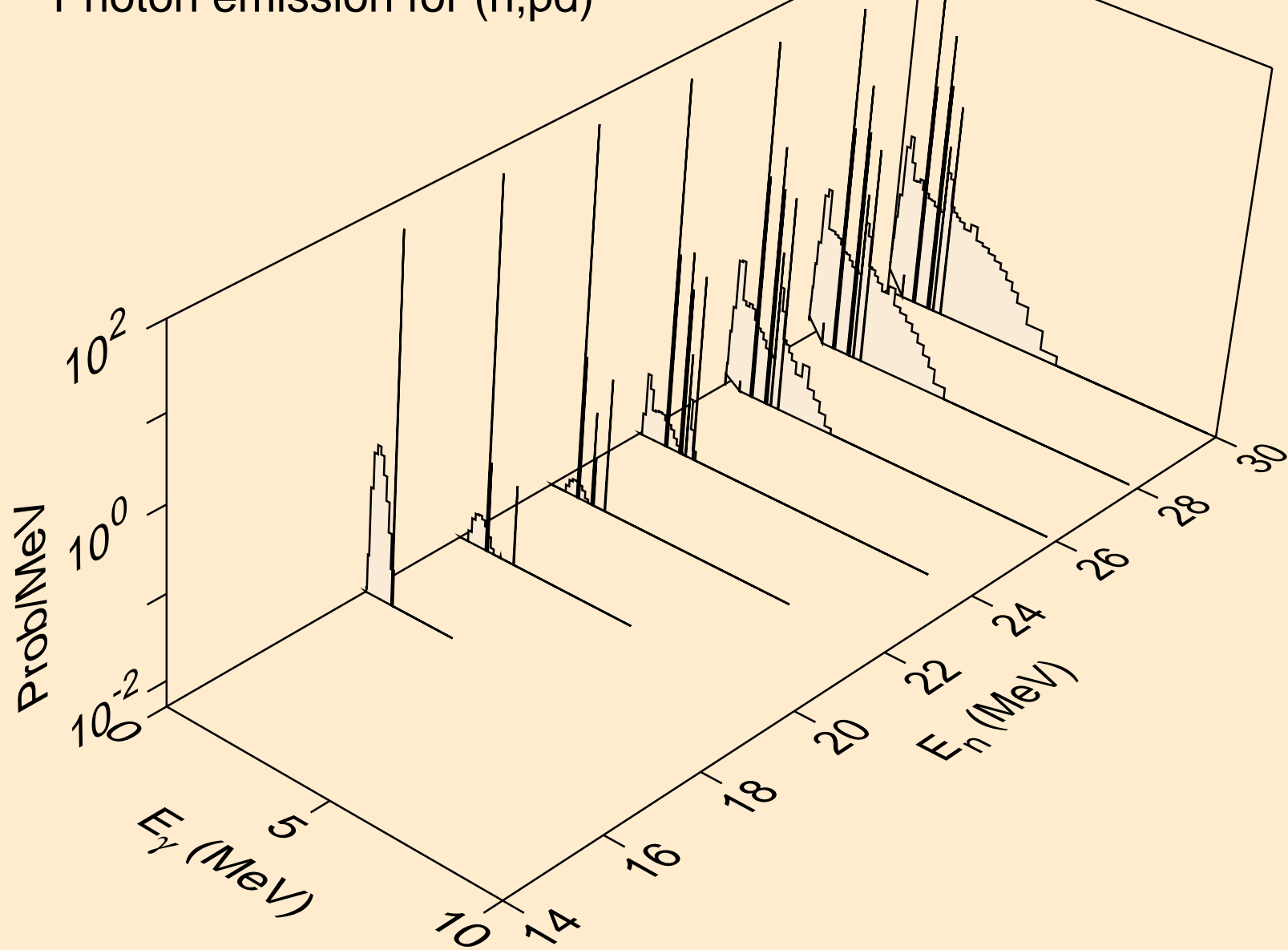

NI060 NEUTRON ACER TENDL-2023 LIBRARY; T=0.K  
Photon emission for (n,pt)

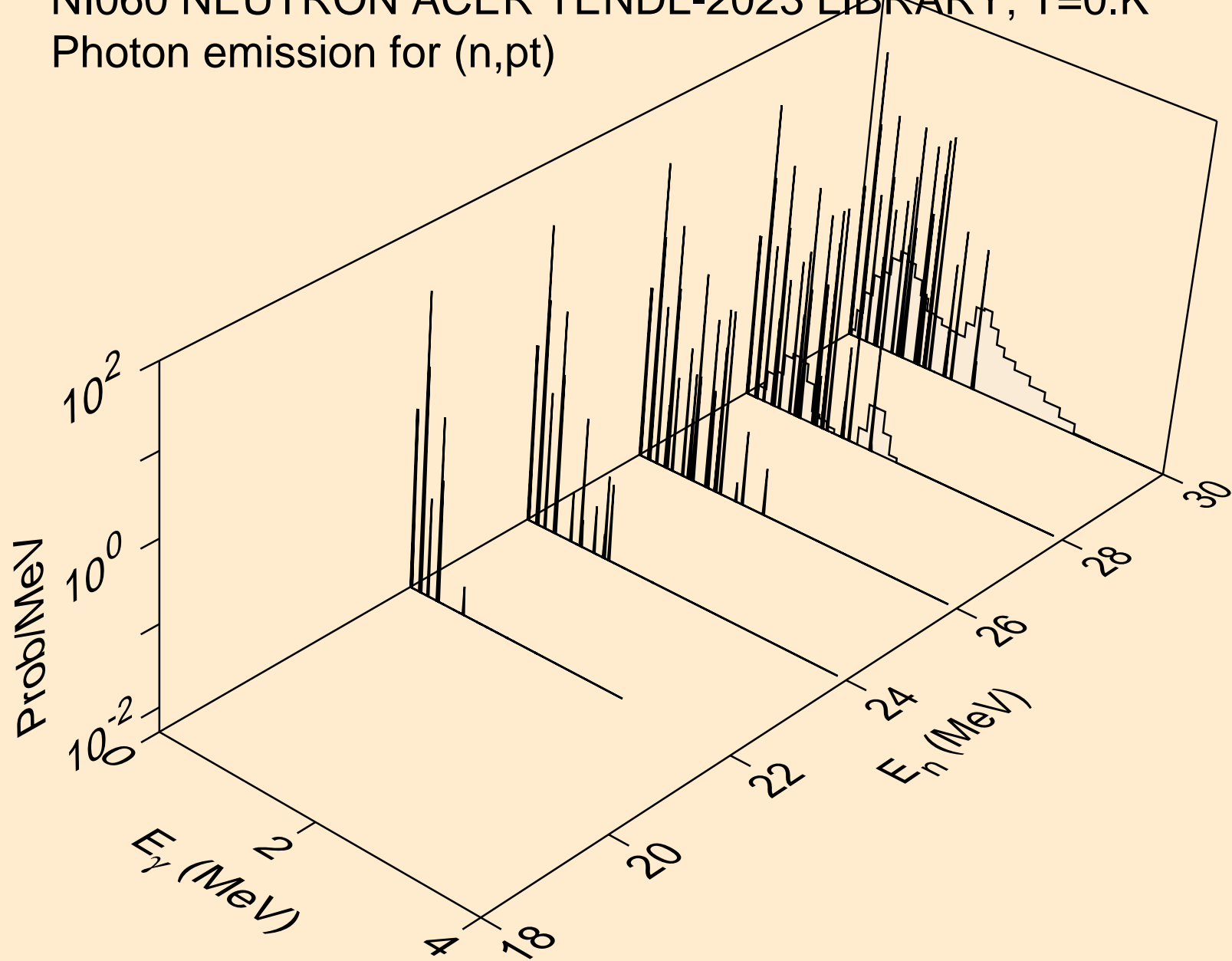

NI060 NEUTRON ACER TENDL-2023 LIBRARY; T=0.K  
Photon emission for (n,da)

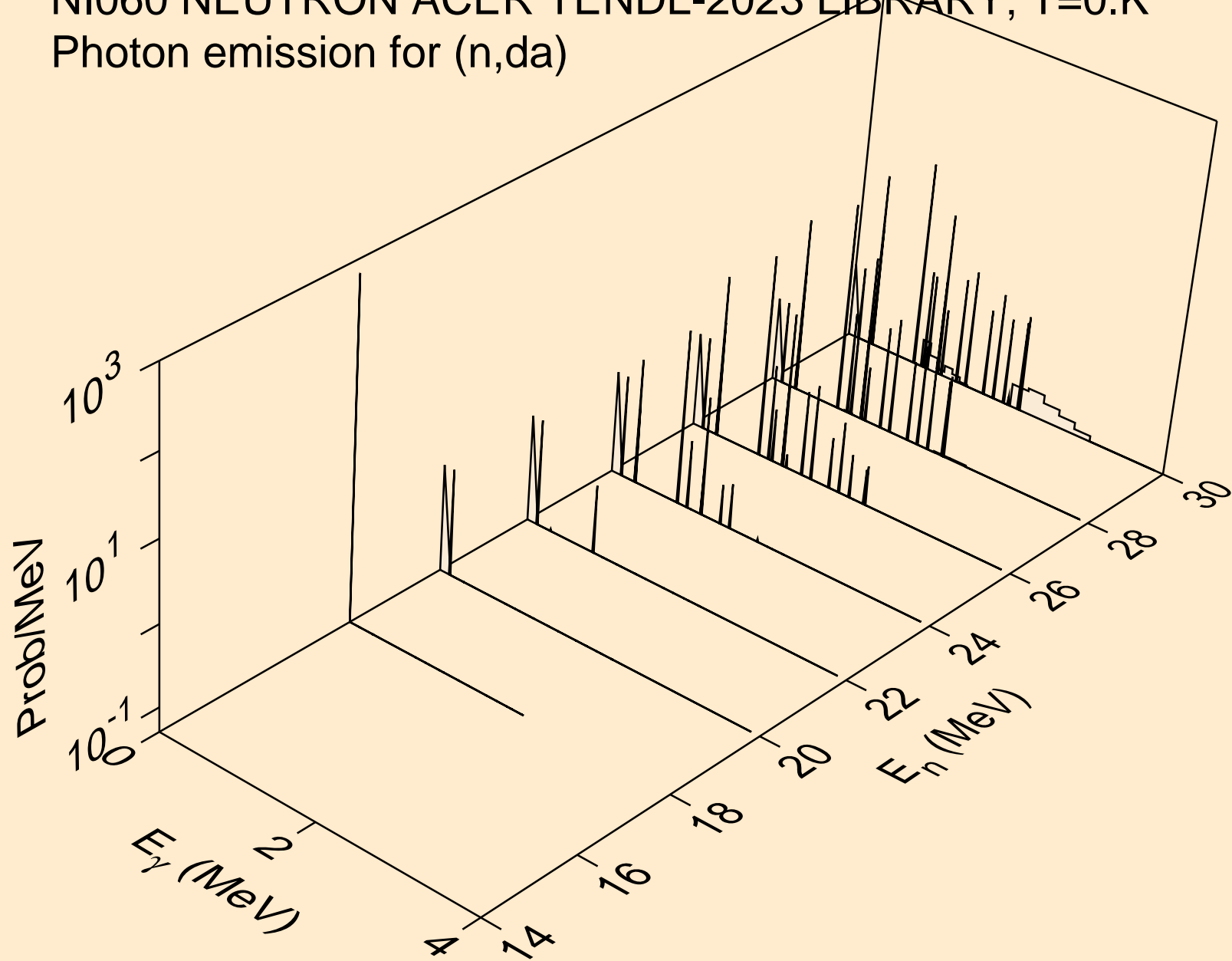

NI060 NEUTRON ACER TENDL-2023 LIBRARY; T=0.K  
thermal capture photon spectrum

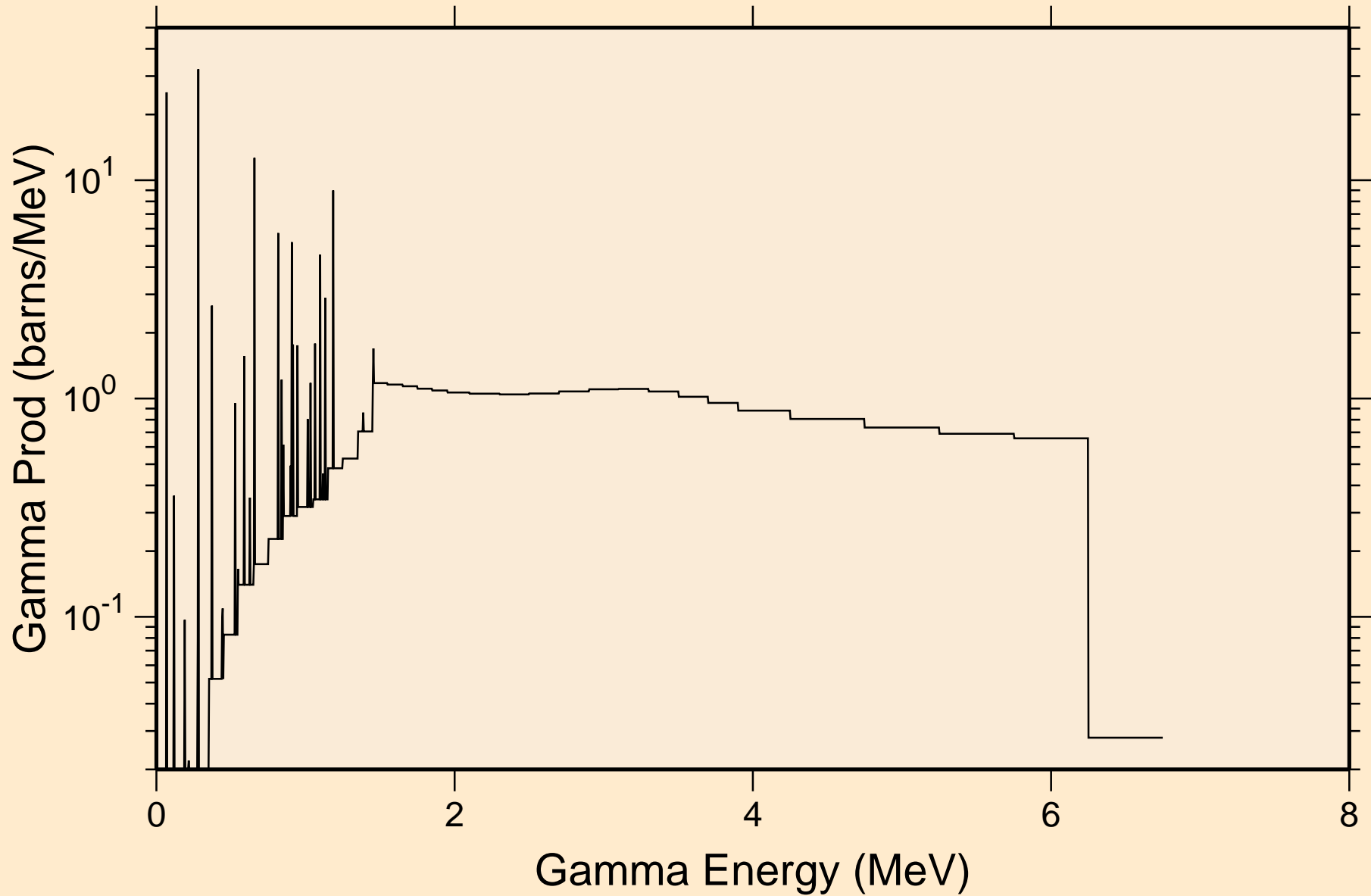

NI060 NEUTRON ACER TENDL-2023 LIBRARY; T=0.K  
14 MeV photon spectrum

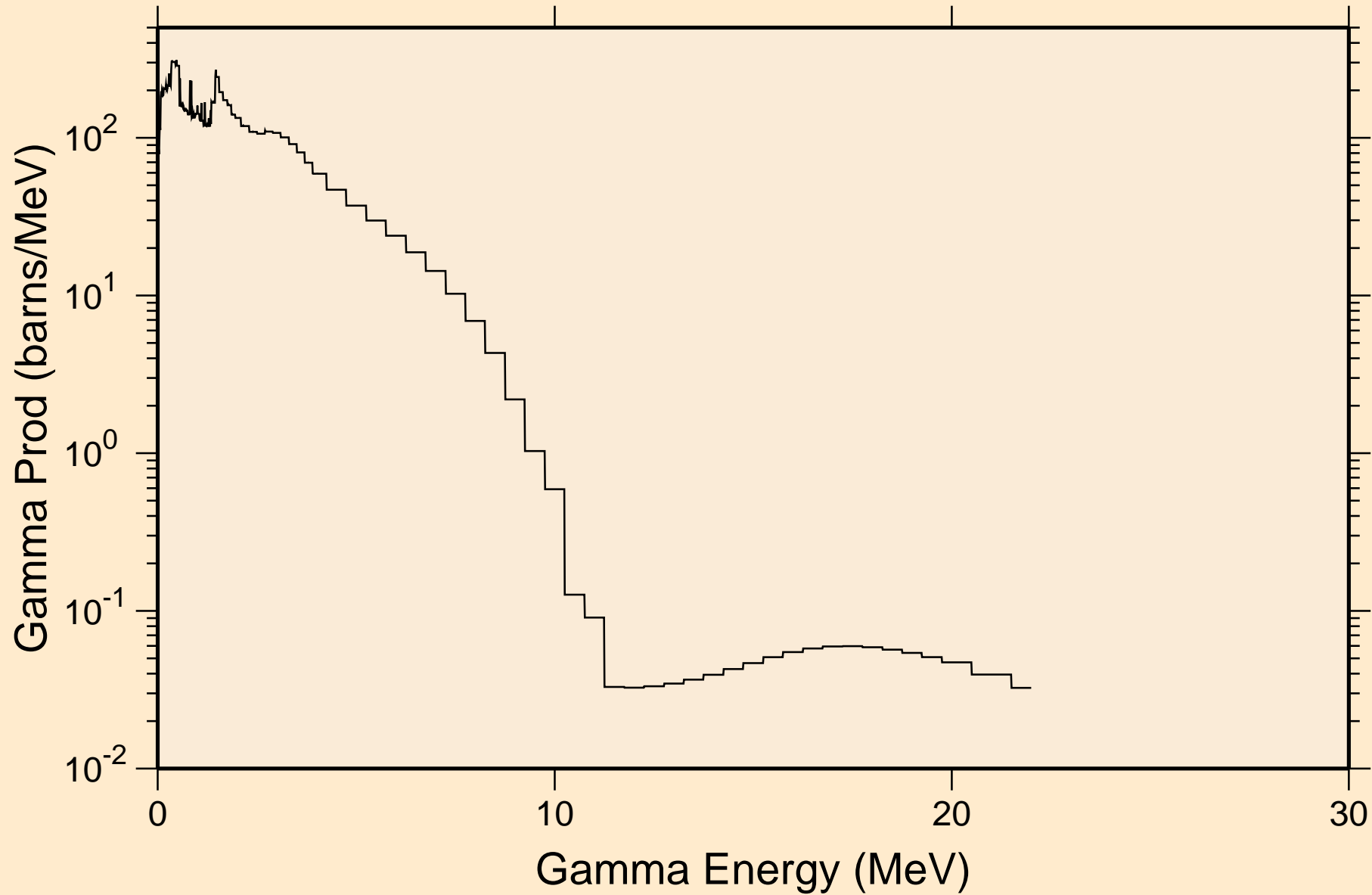



# NI060 NEUTRON ACER TENDL-2023 LIBRARY; T=0.K

## Particle heating contributions

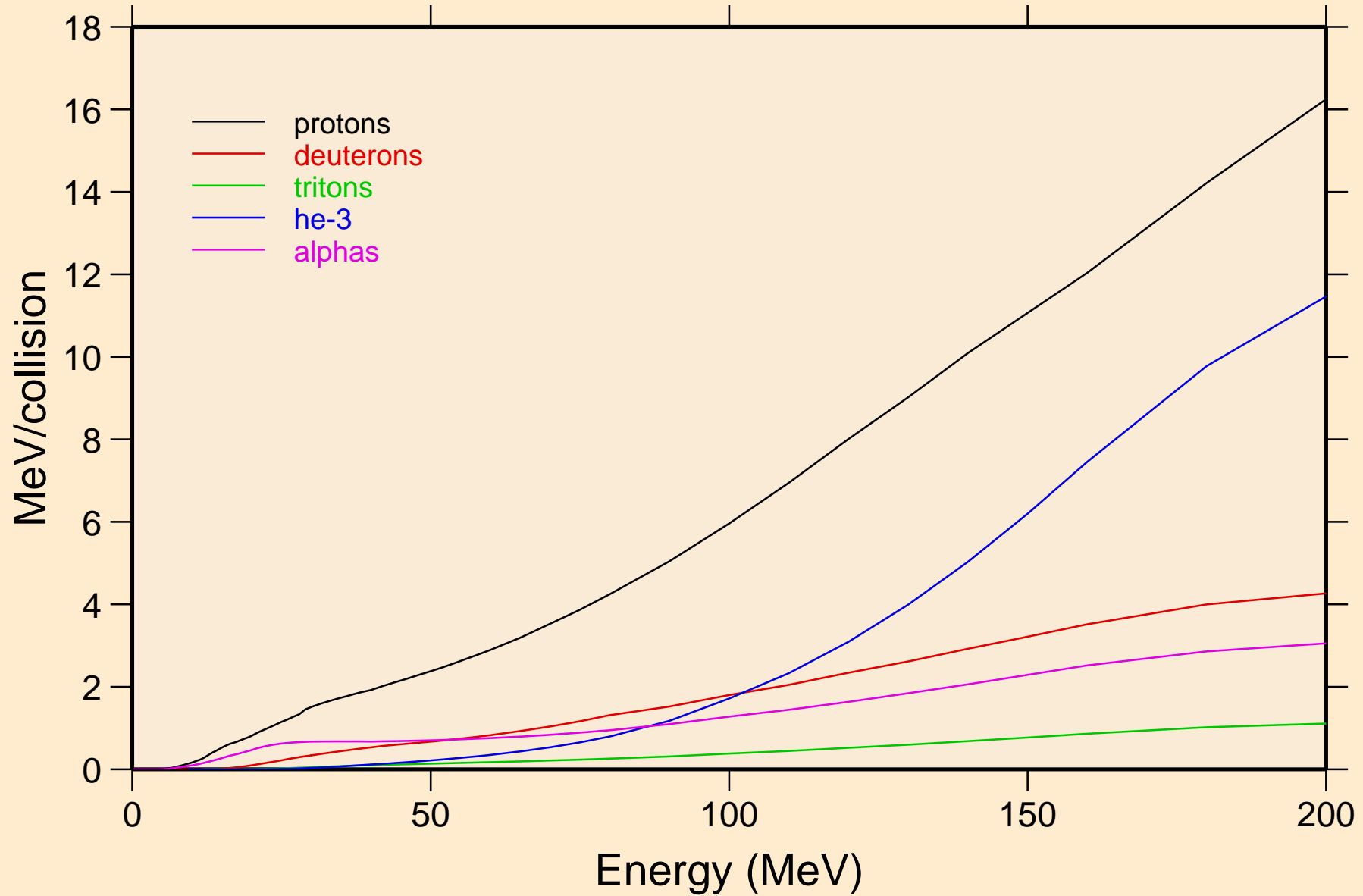

NI060 NEUTRON ACER TENDL-2023 LIBRARY; T=0.K  
Recoil Heating

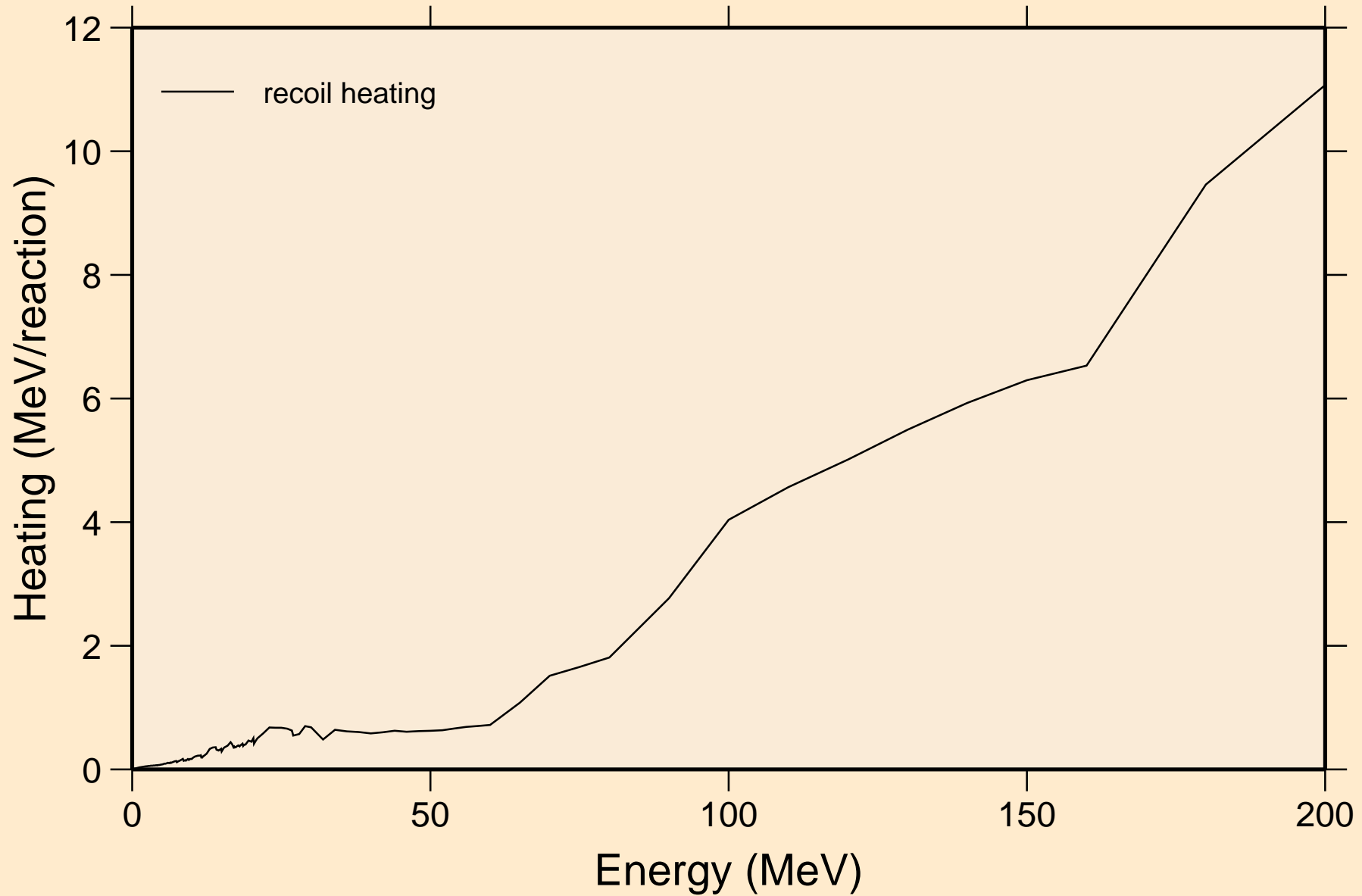

NI060 NEUTRON ACER TENDL-2023 LIBRARY; T=0.K  
Particle production cross sections

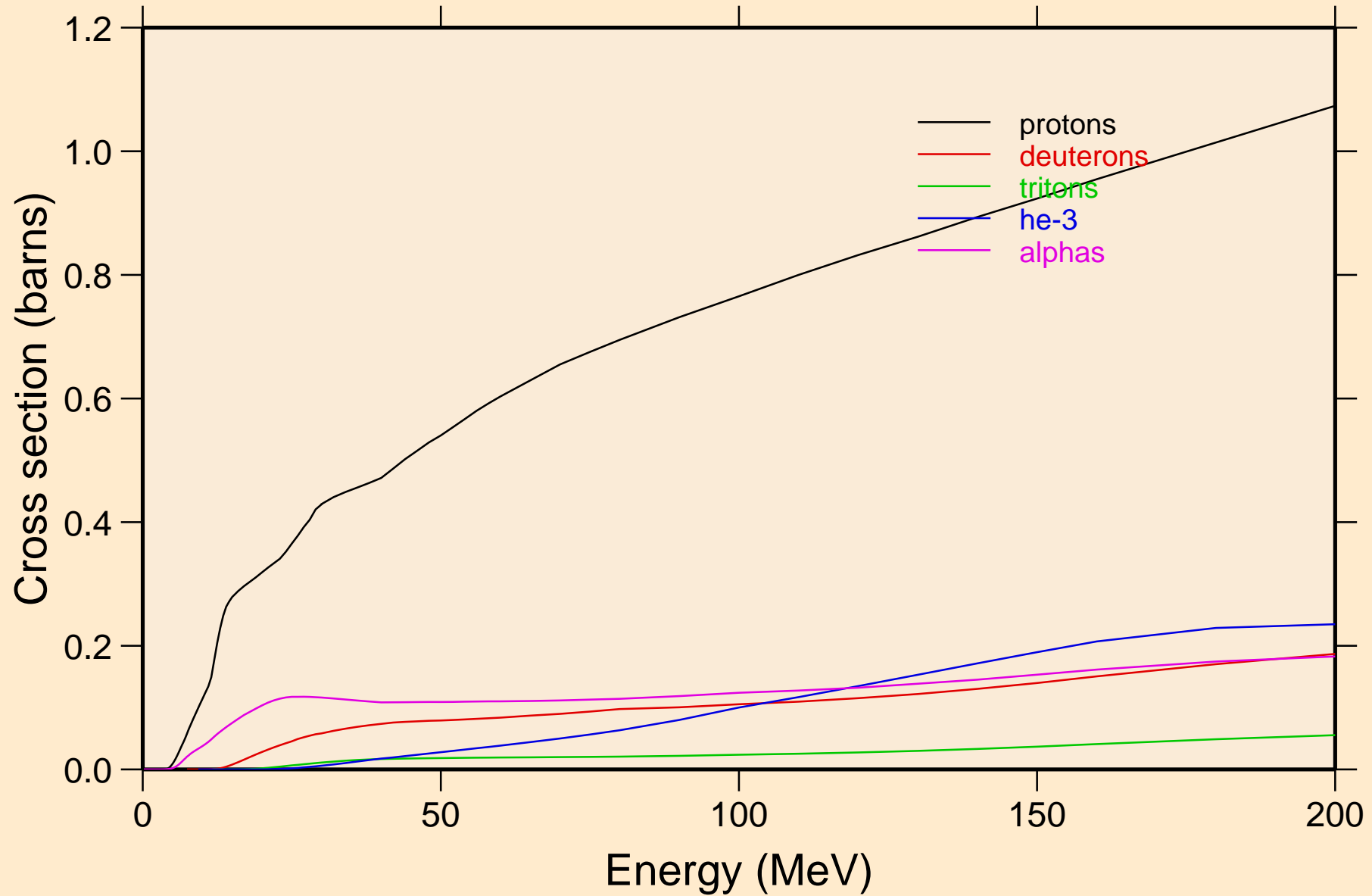

NI060 NEUTRON ACER TENDL-2023 LIBRARY; T=0.K  
protons from (n,x)

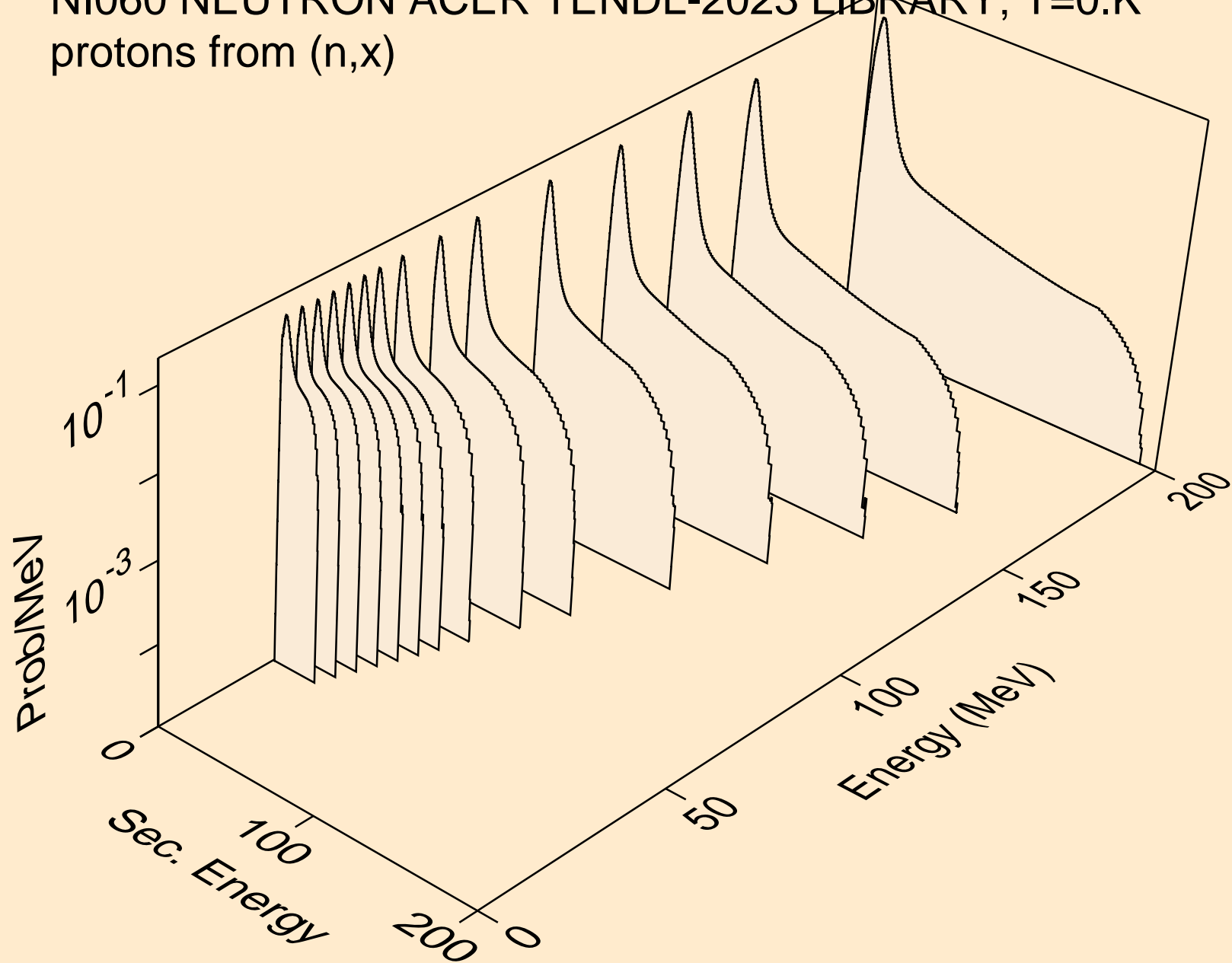

NI060 NEUTRON ACER TENDL-2023 LIBRARY; T=0.K  
protons from (n,n\*)p

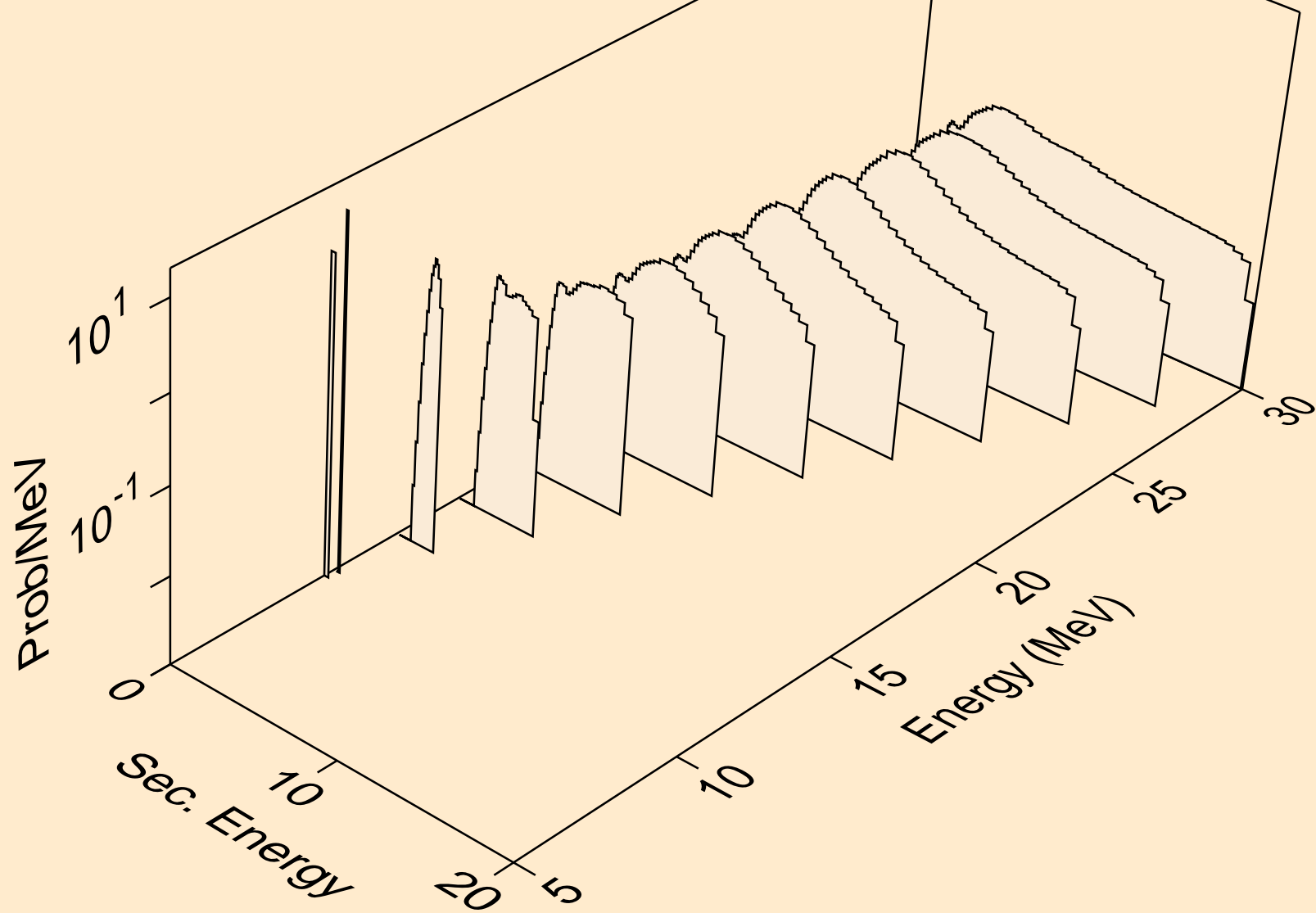

NI060 NEUTRON ACER TENDL-2023 LIBRARY; T=0.K  
protons from (n,2np)

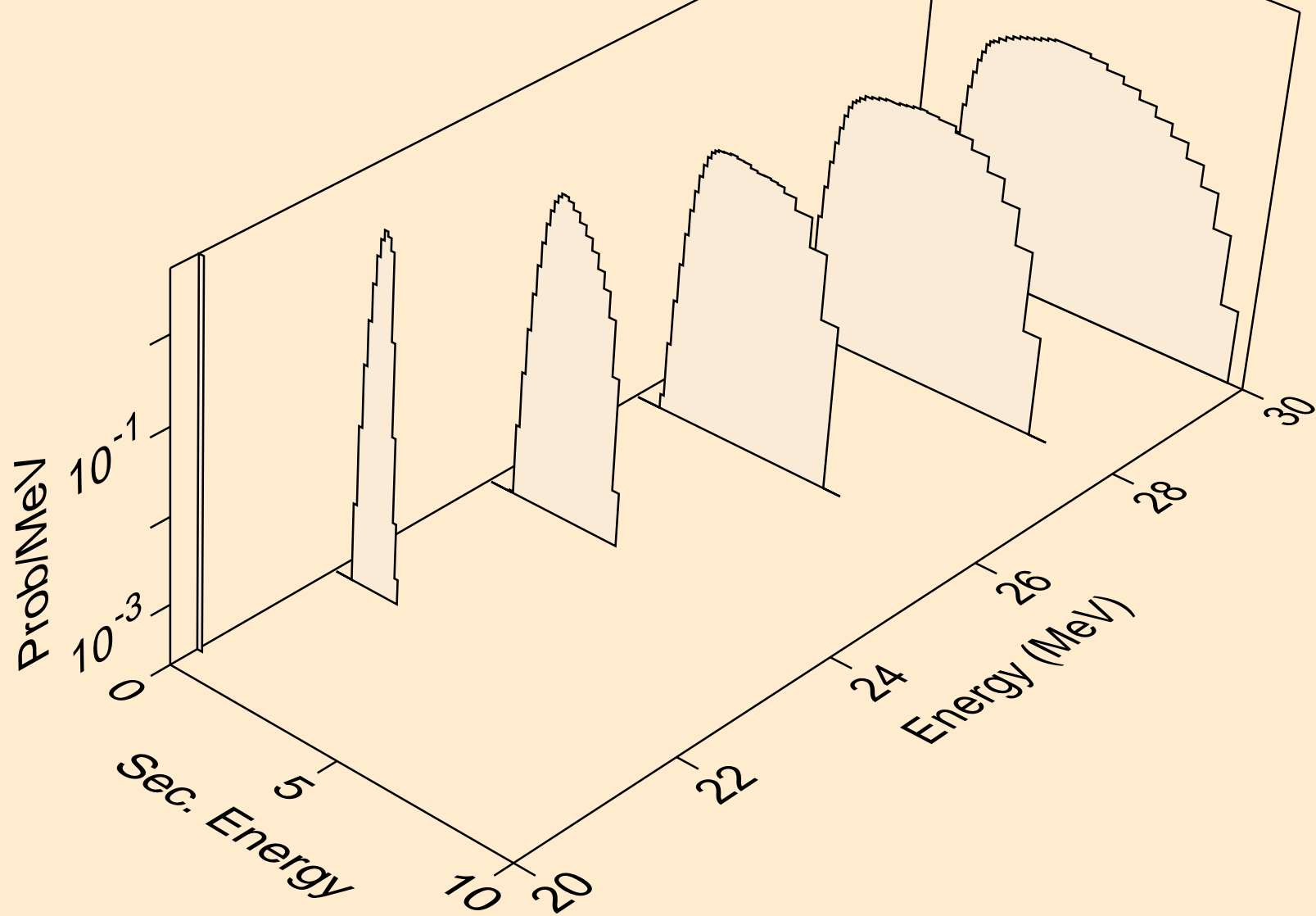

NI060 NEUTRON ACER TENDL-2023 LIBRARY; T=0.K  
protons from (n,n2p)

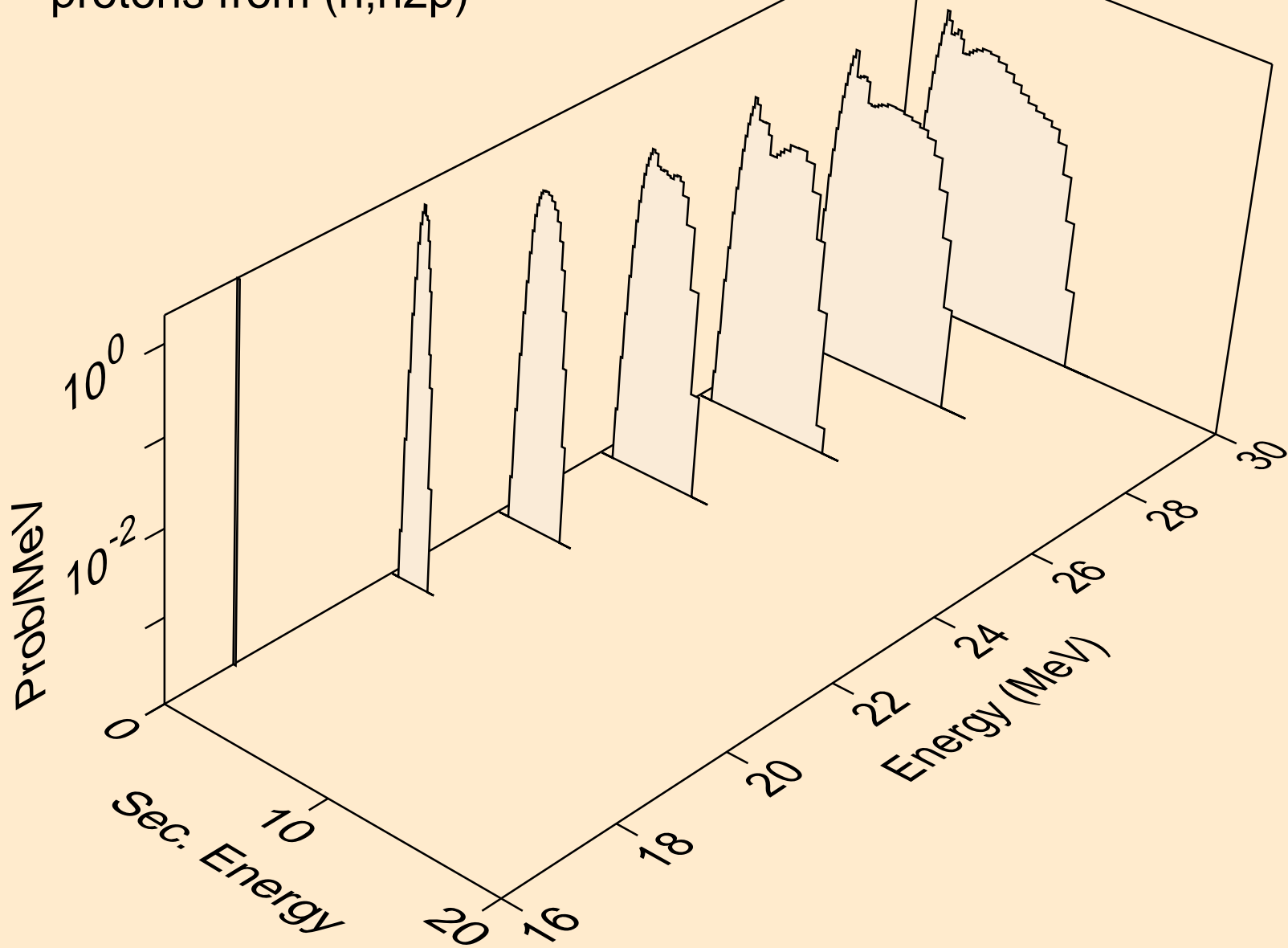

NI060 NEUTRON ACER TENDL-2023 LIBRARY; T=0.K  
protons from (n,npa)

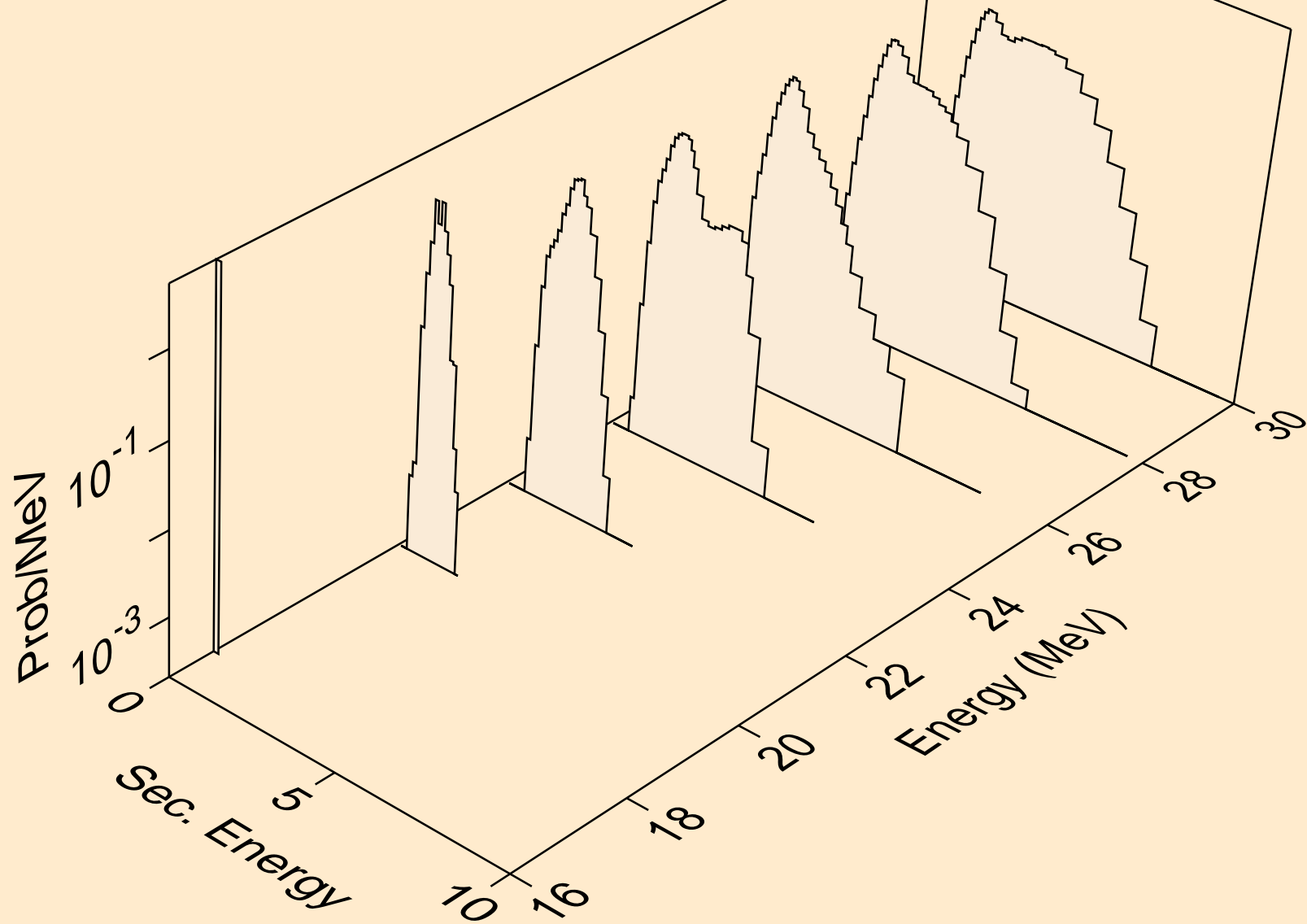



NI060 NEUTRON ACER TENDL-2023 LIBRARY; T=0.K  
protons from (n,p)

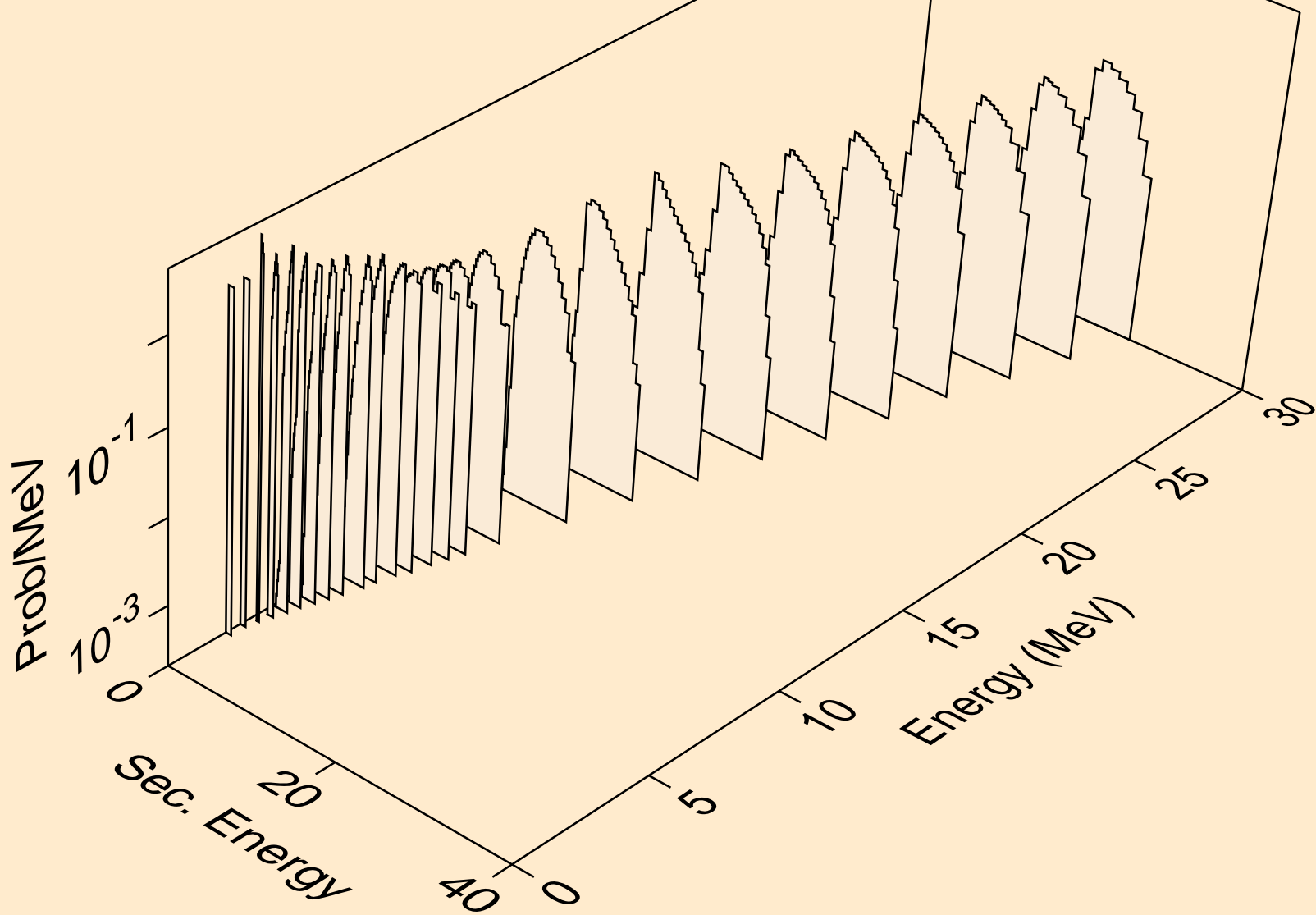

NI060 NEUTRON ACER TENDL-2023 LIBRARY; T=0.K  
protons from (n,2p)

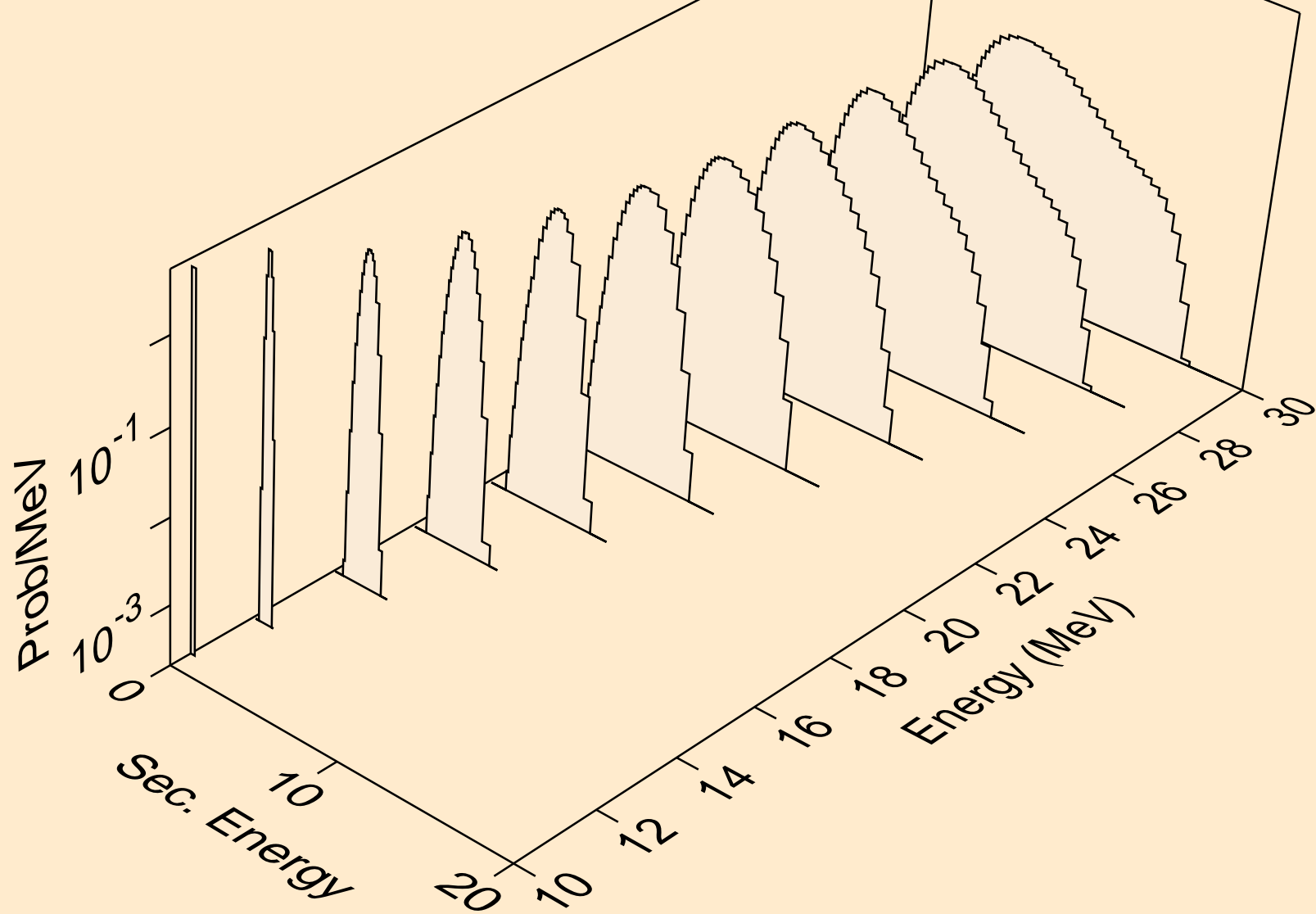

NI060 NEUTRON ACER TENDL-2023 LIBRARY; T=0.K  
protons from (n,p)

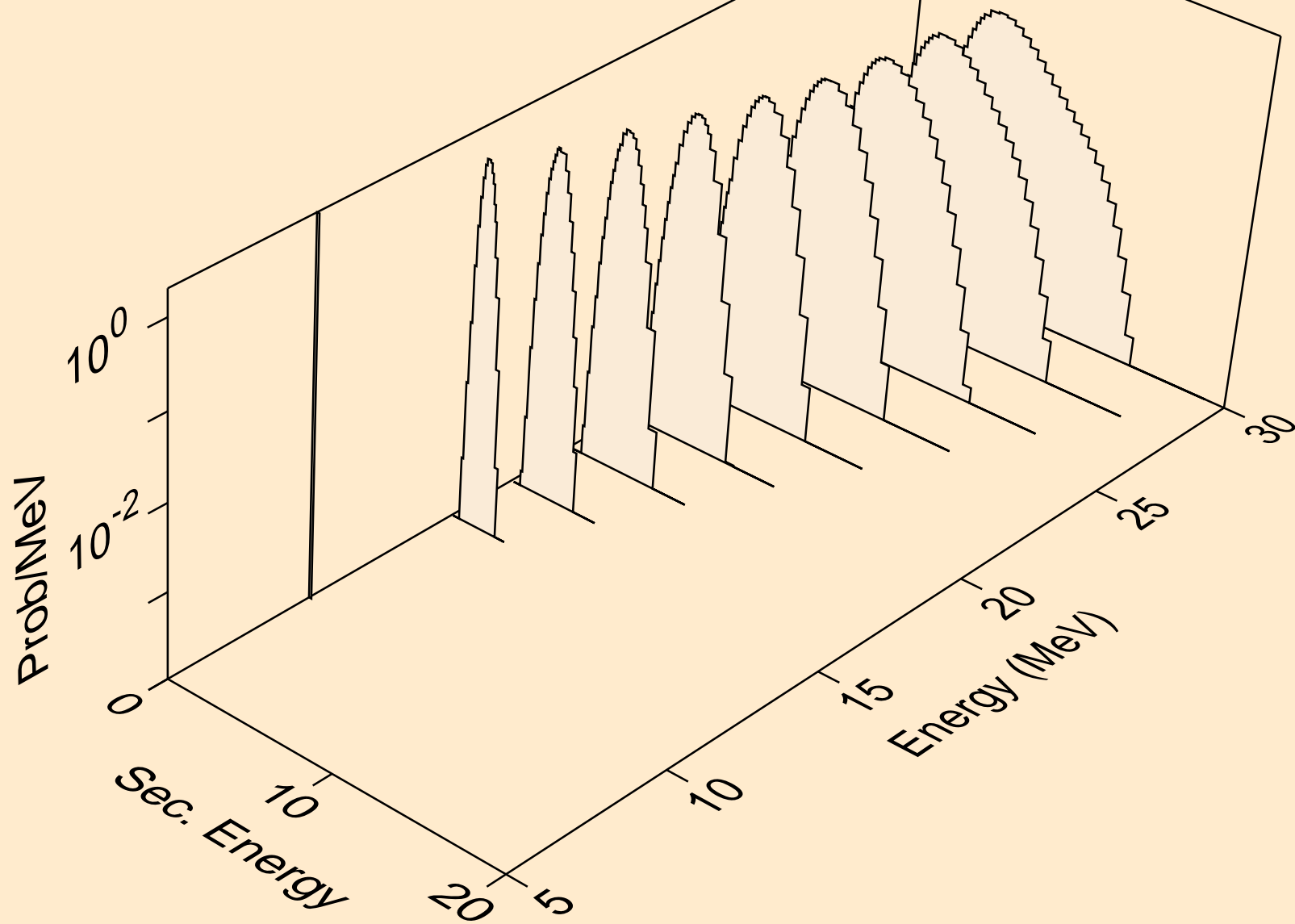

NI060 NEUTRON ACER TENDL-2023 LIBRARY; T=0.K  
protons from (n,pd)

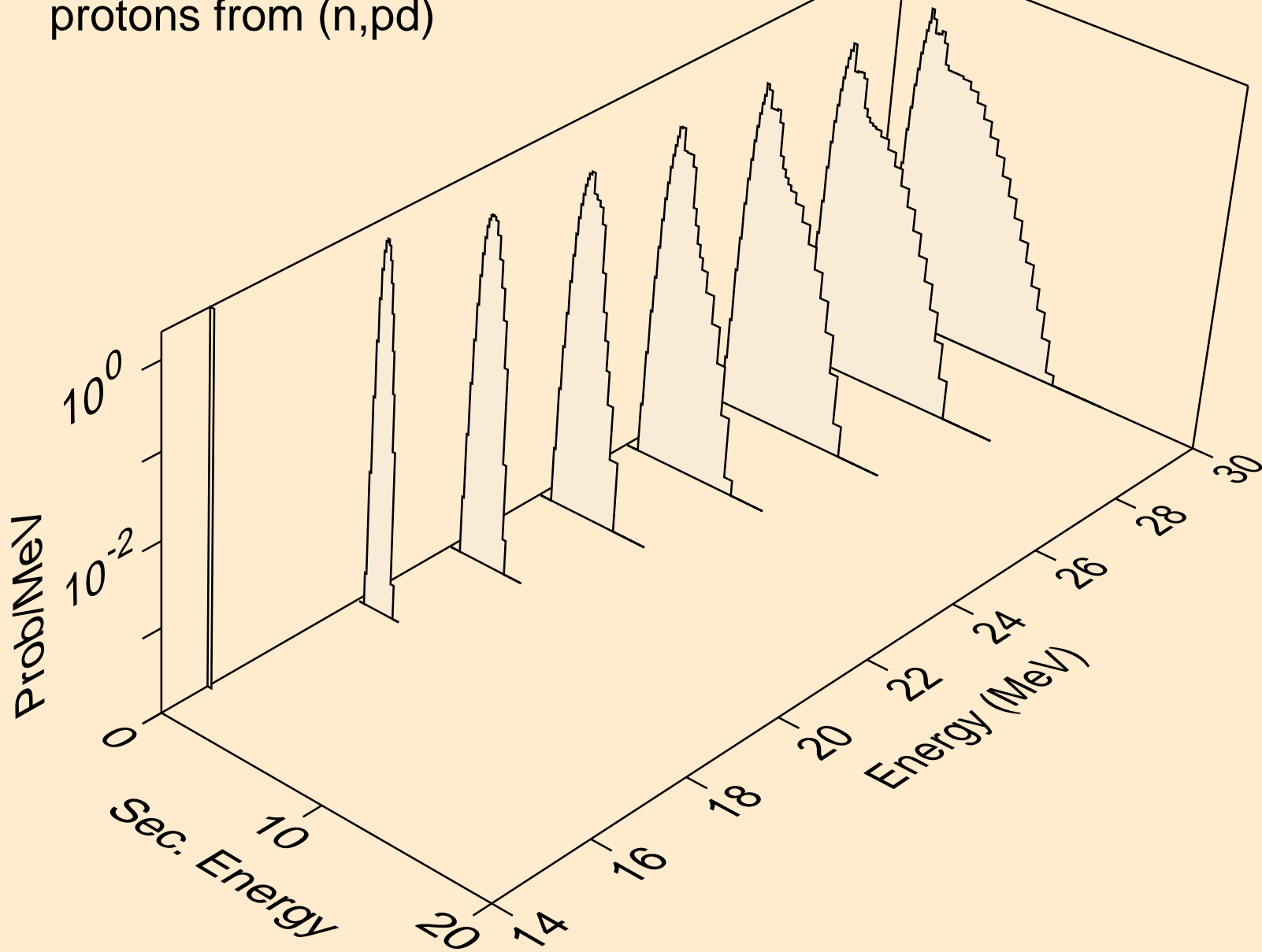

NI060 NEUTRON ACER TENDL-2023 LIBRARY; T=0.K  
protons from (n,pt)

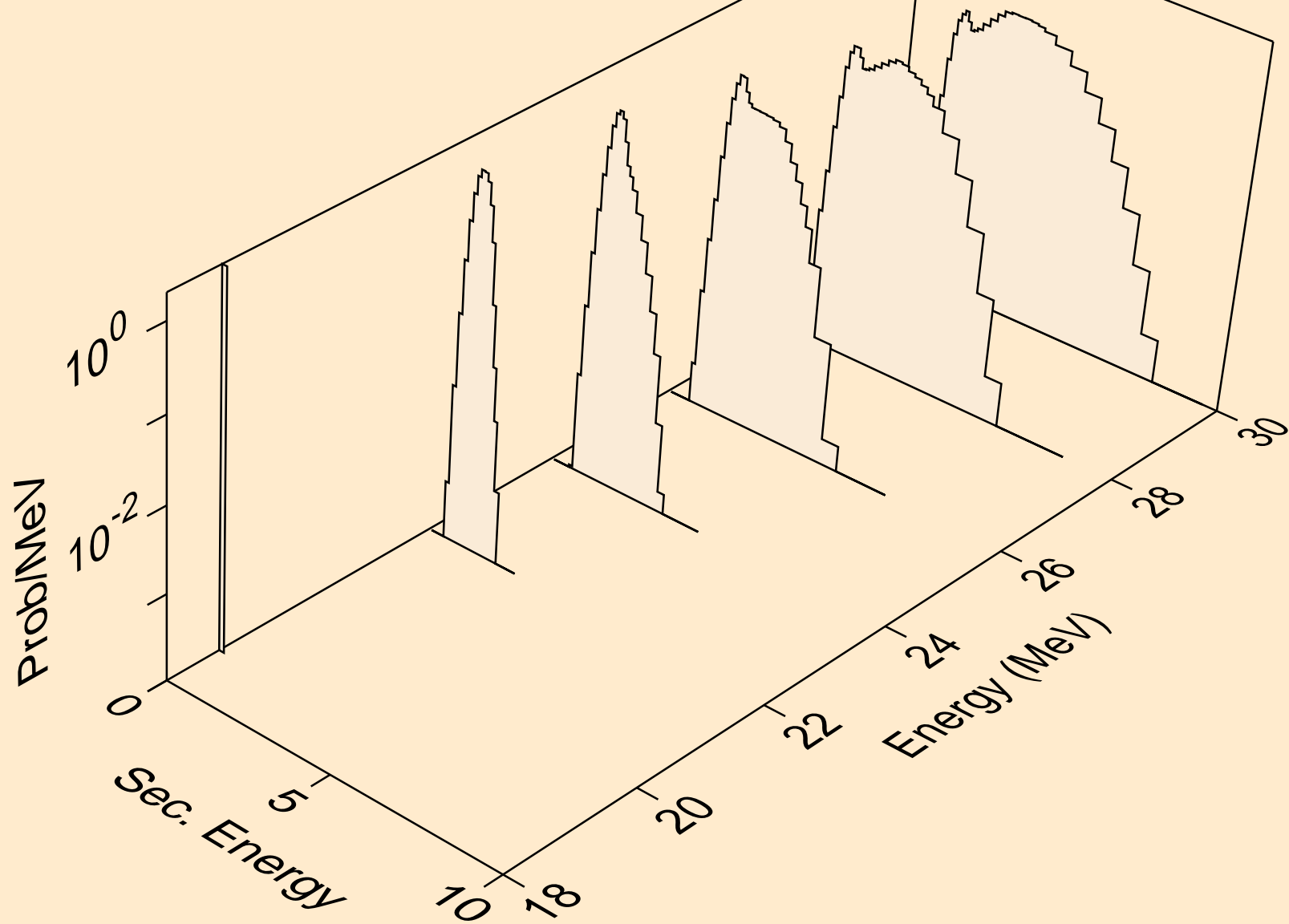

NI060 NEUTRON ACER TENDL-2023 LIBRARY; T=0.K  
deuterons from (n,x)

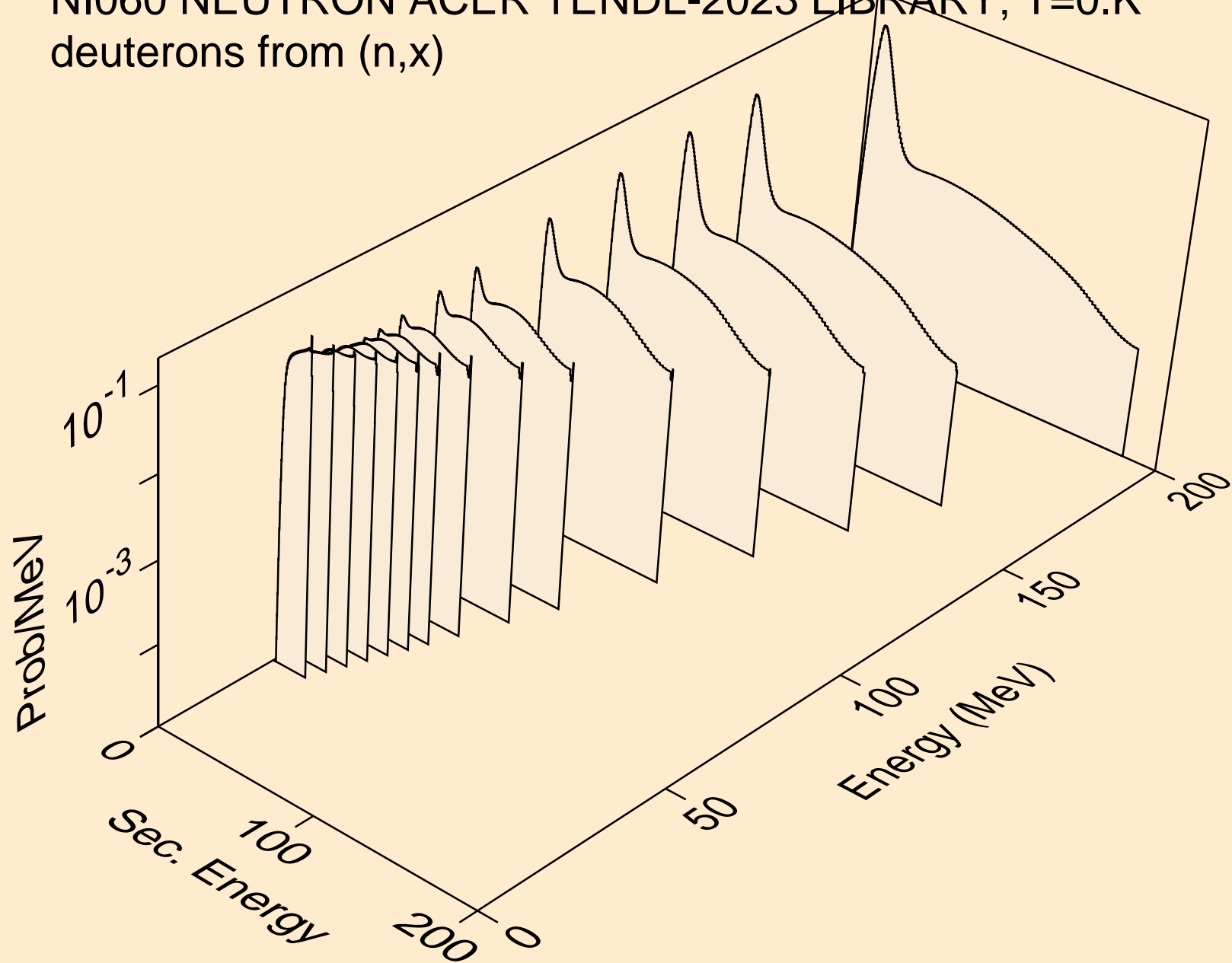

NI060 NEUTRON ACER TENDL-2023 LIBRARY; T=0.K  
deuterons from (n,2nd)

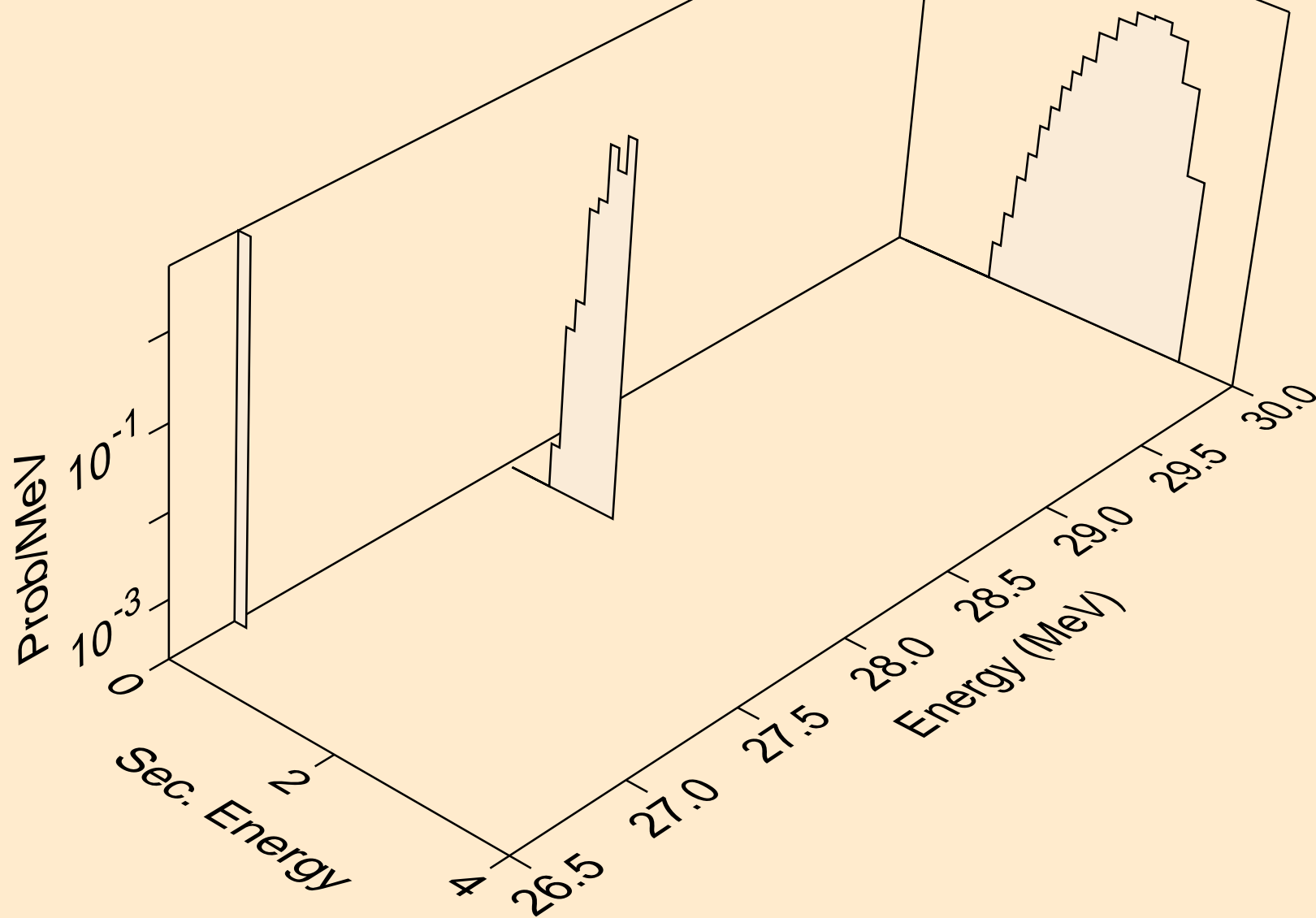

NI060 NEUTRON ACER TENDL-2023 LIBRARY; T=0.K  
deuterons from (n,n\*)d

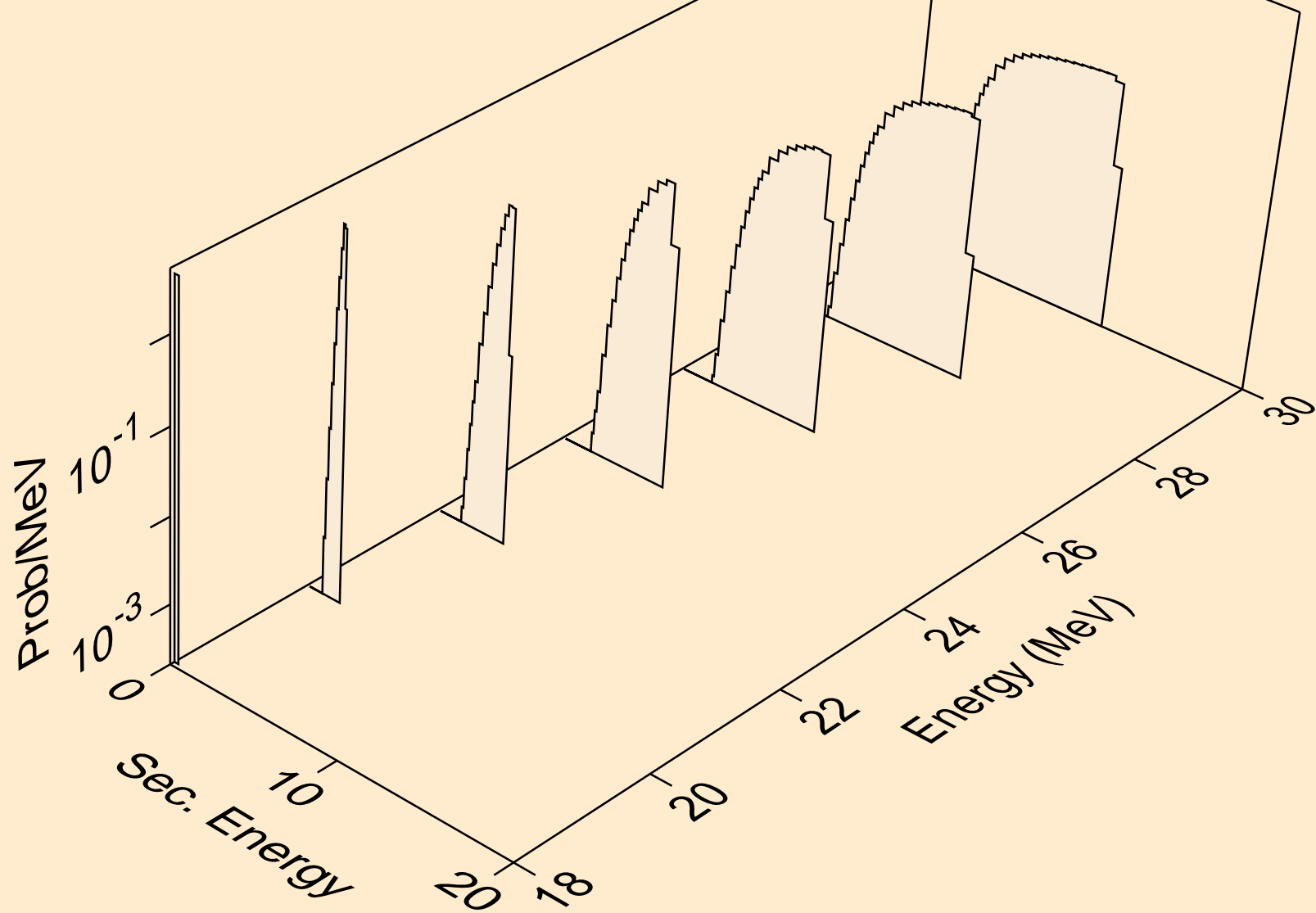



NI060 NEUTRON ACER TENDL-2023 LIBRARY; T=0.K  
deuterons from (n,d)

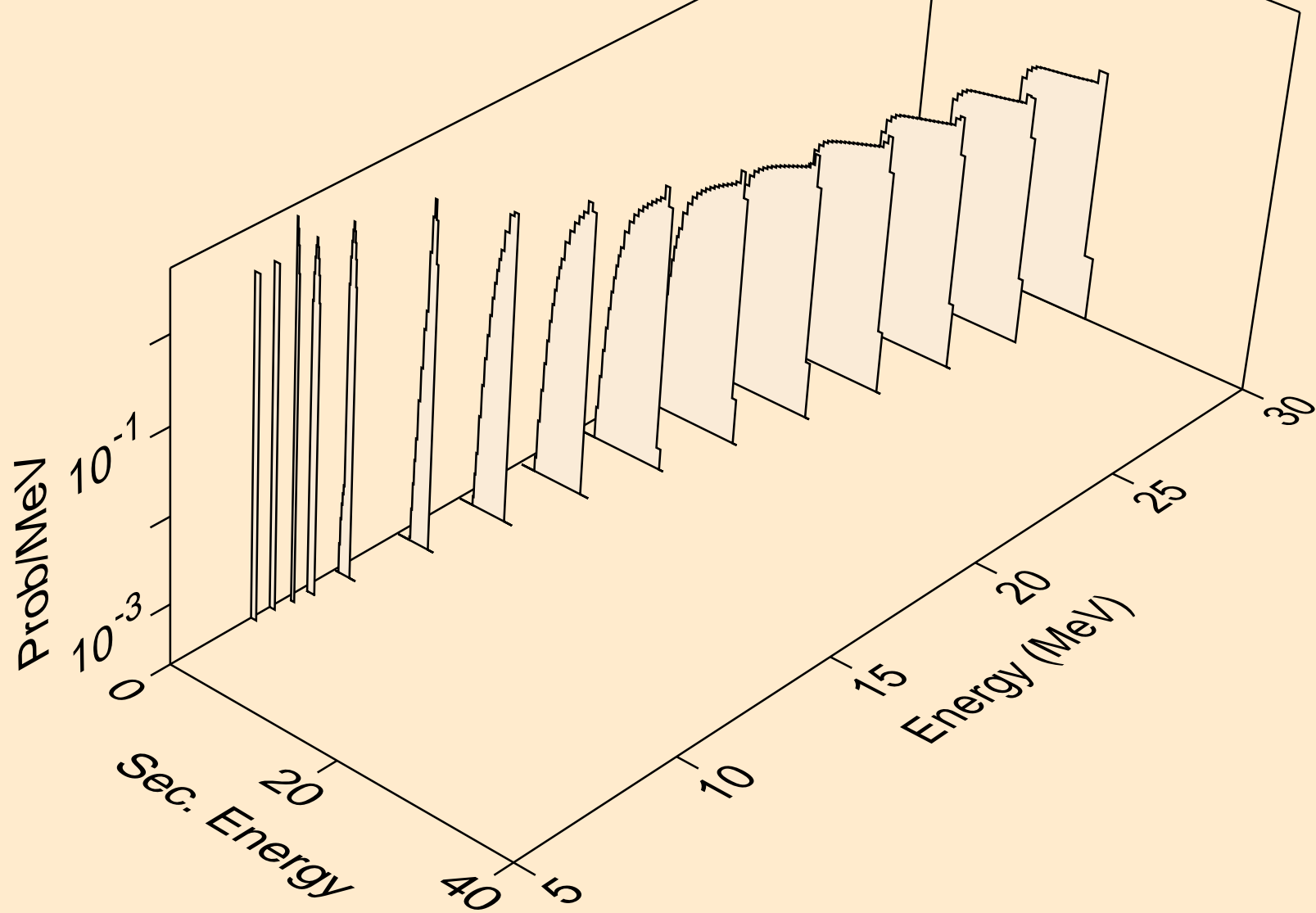

NI060 NEUTRON ACER TENDL-2023 LIBRARY; T=0.K  
deuterons from (n,pd)

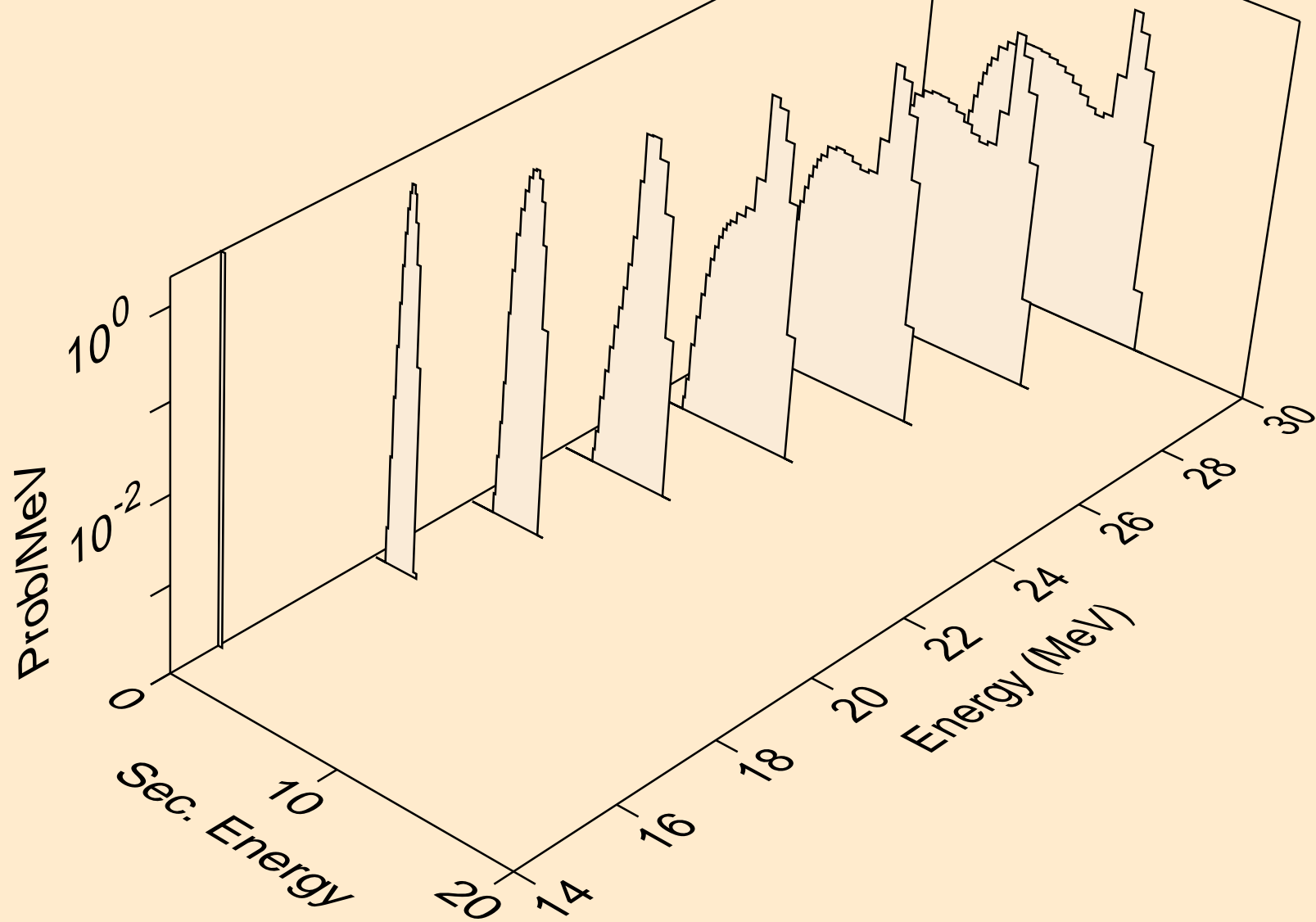

NI060 NEUTRON ACER TENDL-2023 LIBRARY; T=0.K  
deuterons from (n,da)

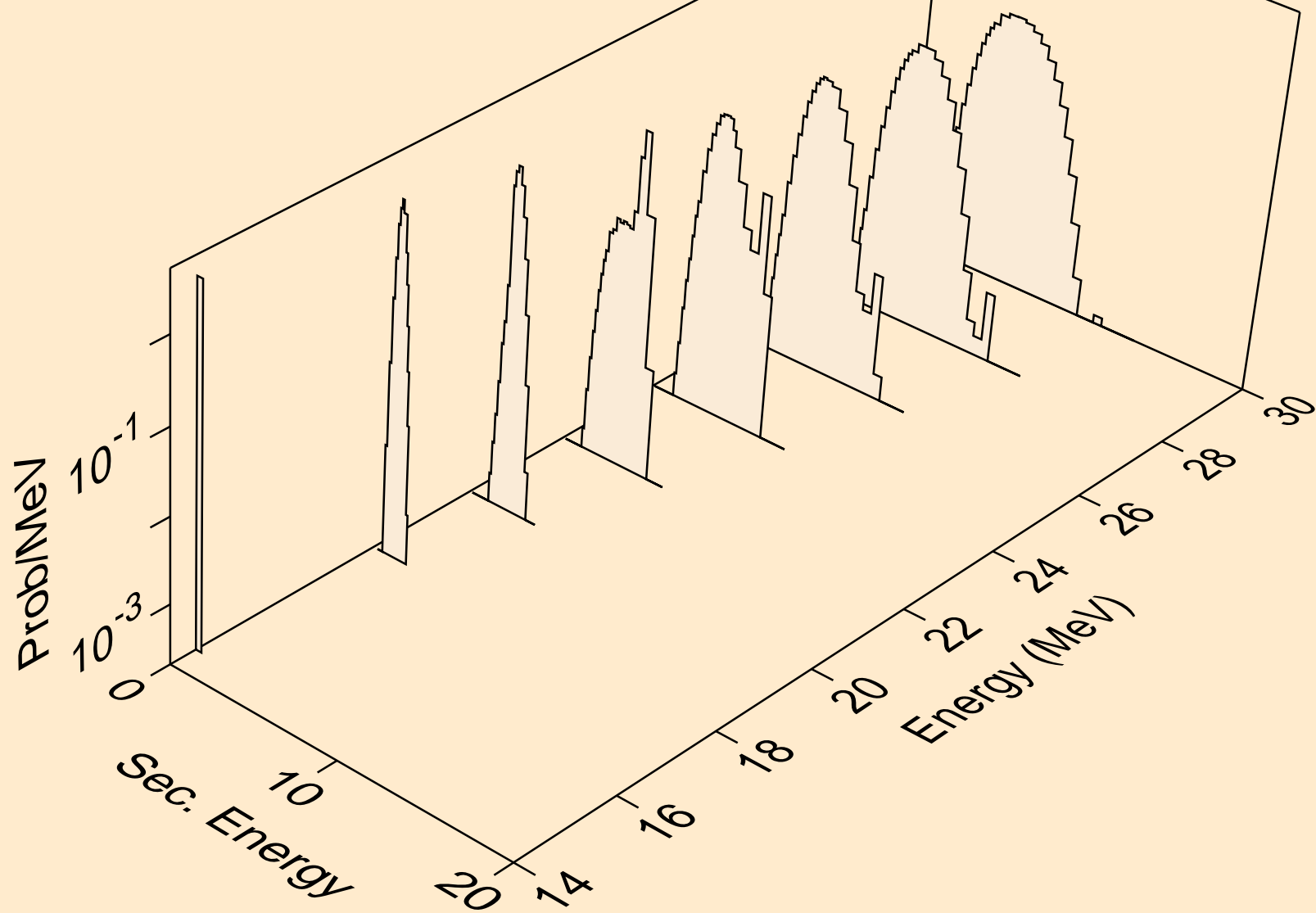

NI060 NEUTRON ACER TENDL-2023 LIBRARY; T=0.K  
tritons from (n,x)

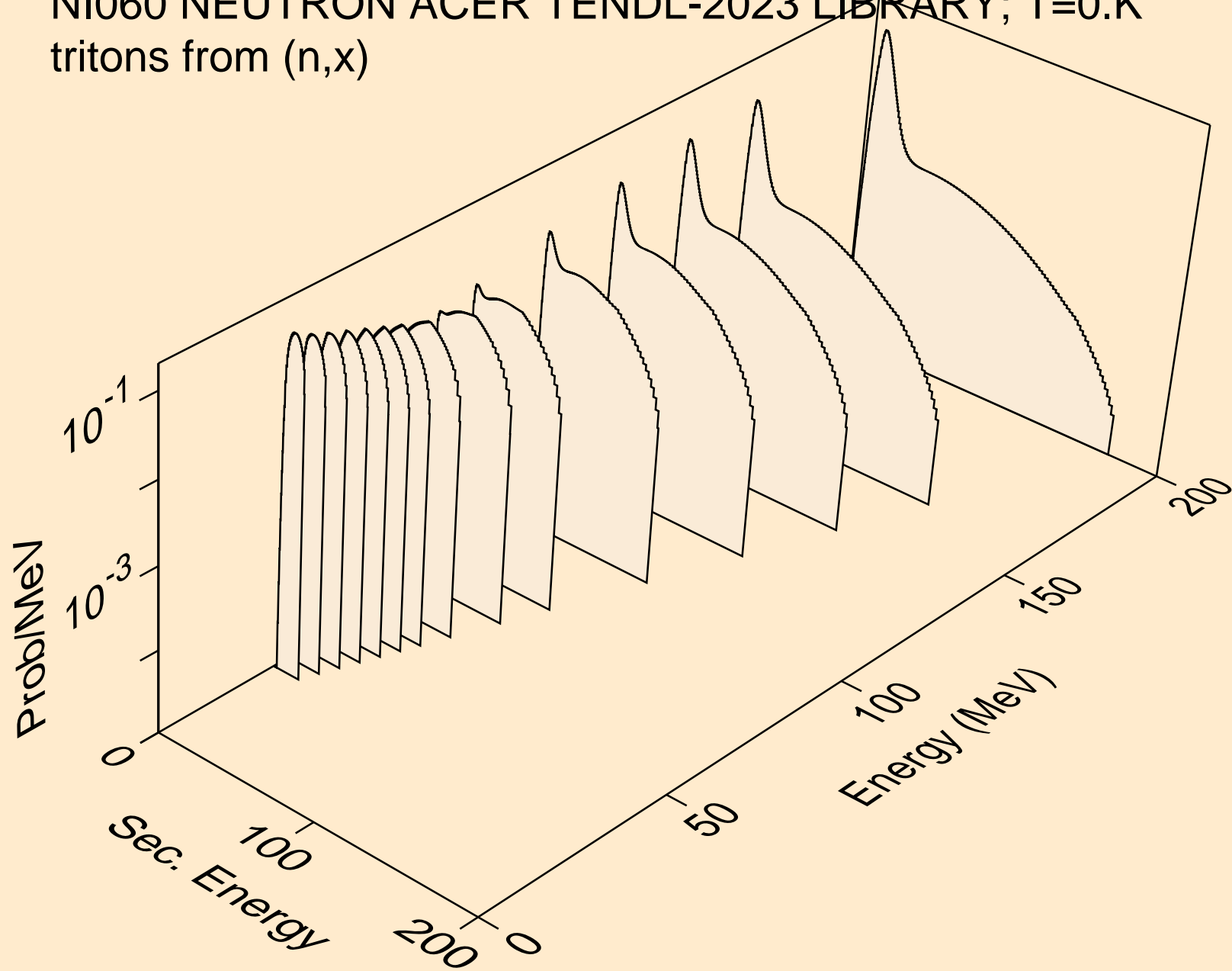

NI060 NEUTRON ACER TENDL-2023 LIBRARY; T=0.K  
tritons from (n,n\*)t

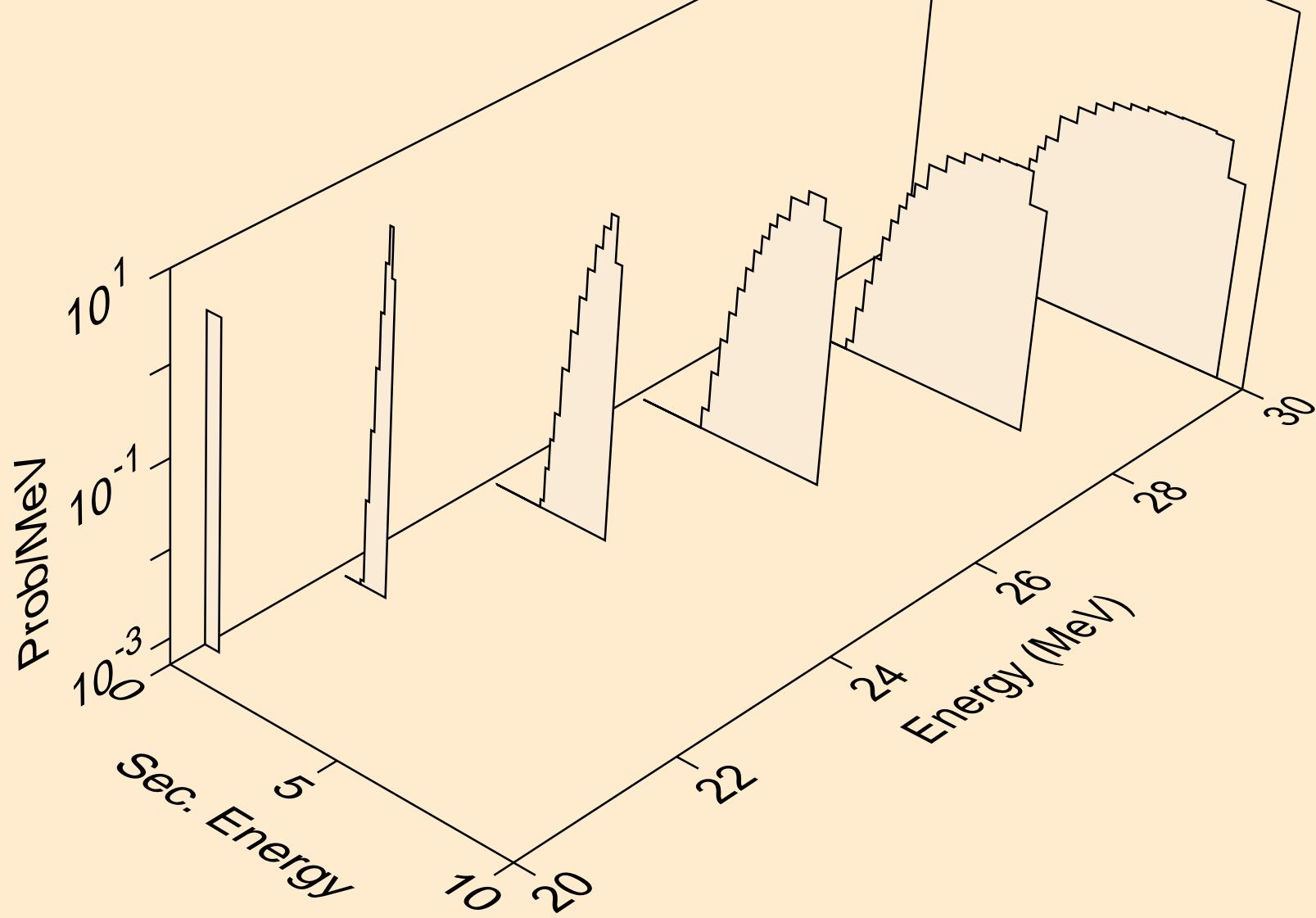

NI060 NEUTRON ACER TENDL-2023 LIBRARY; T=0.K  
tritons from (n,t)

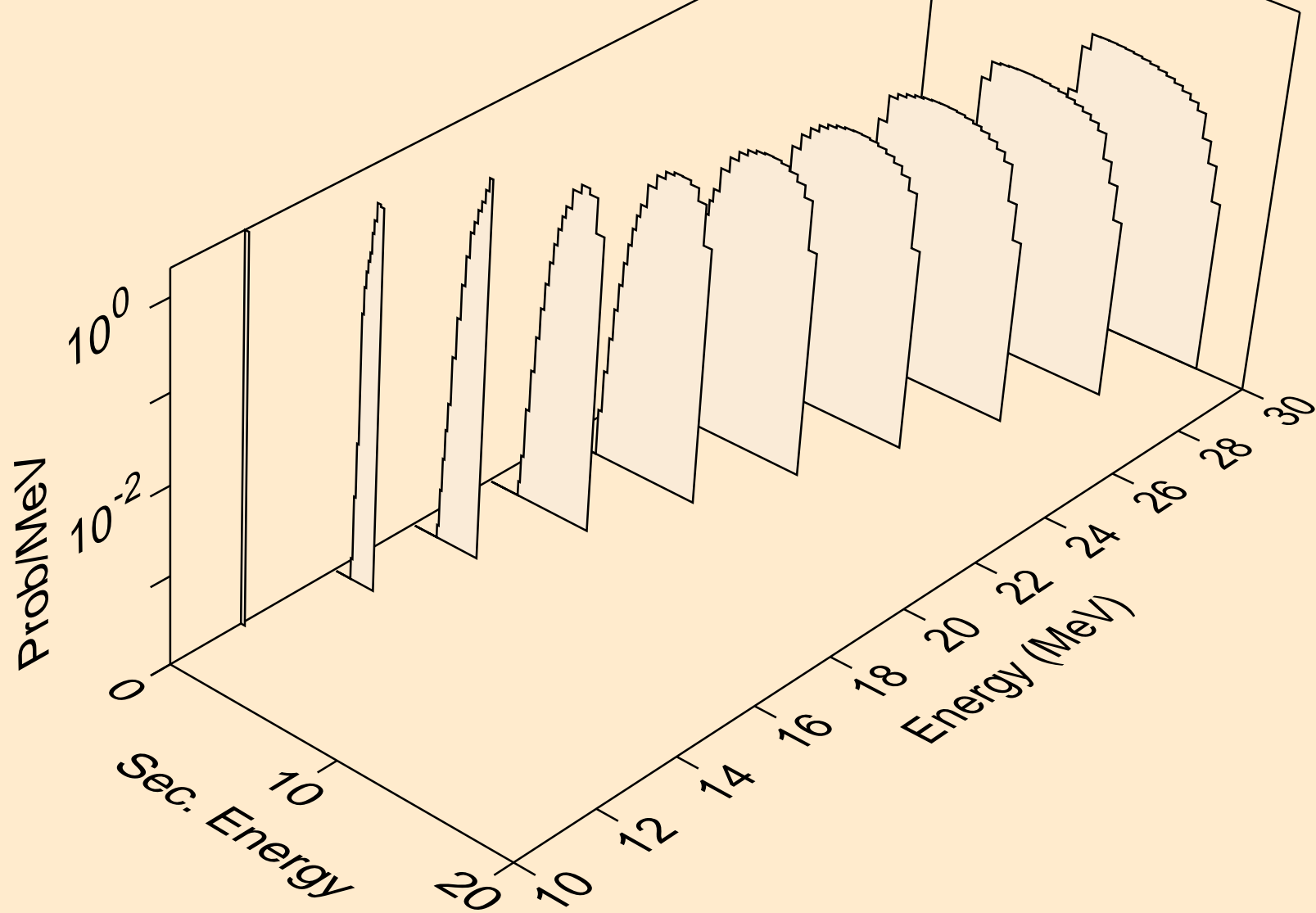

NI060 NEUTRON ACER TENDL-2023 LIBRARY; T=0.K  
tritons from (n,pt)

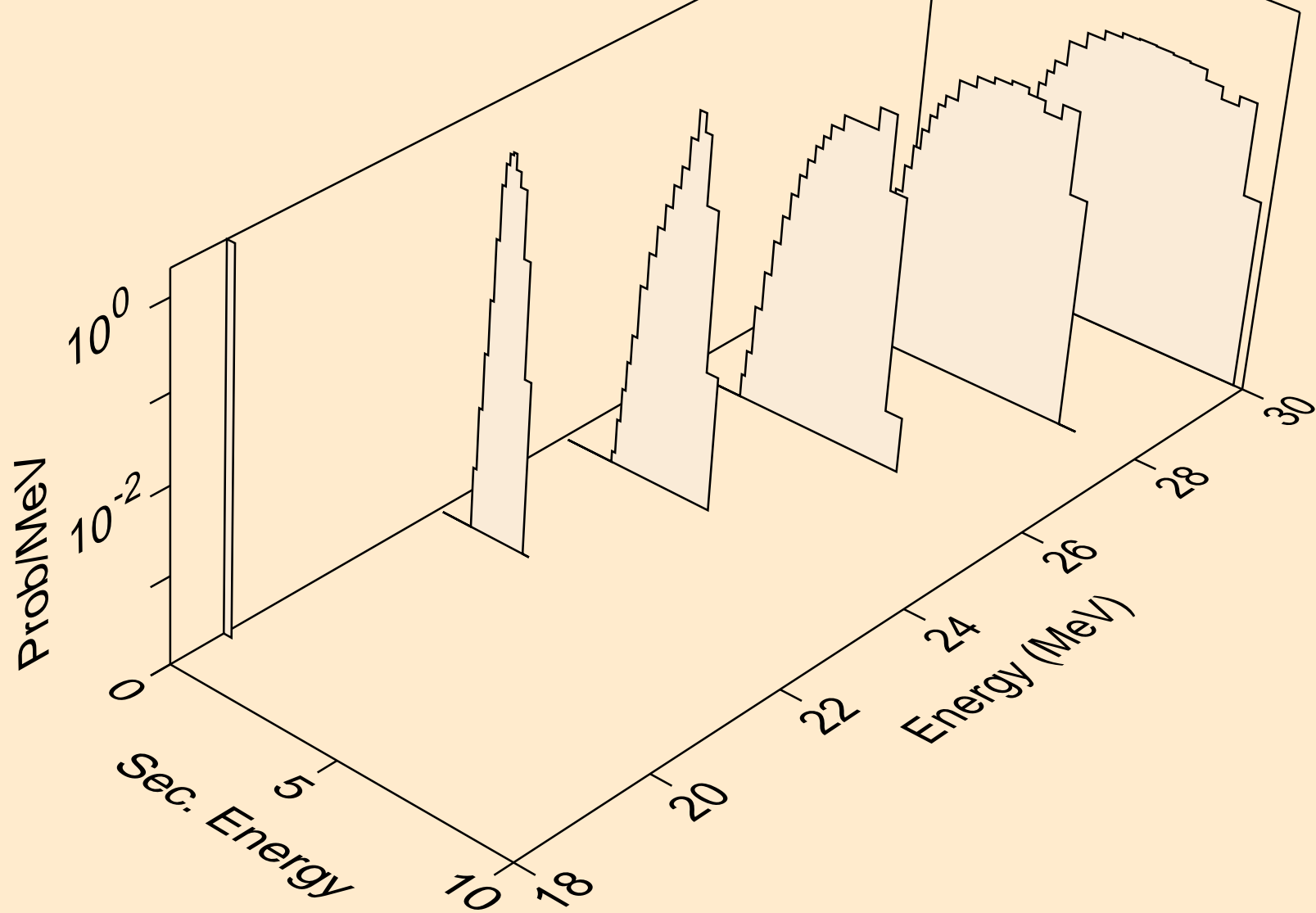

NI060 NEUTRON ACER TENDL-2023 LIBRARY; T=0.K  
he3s from (n,x)

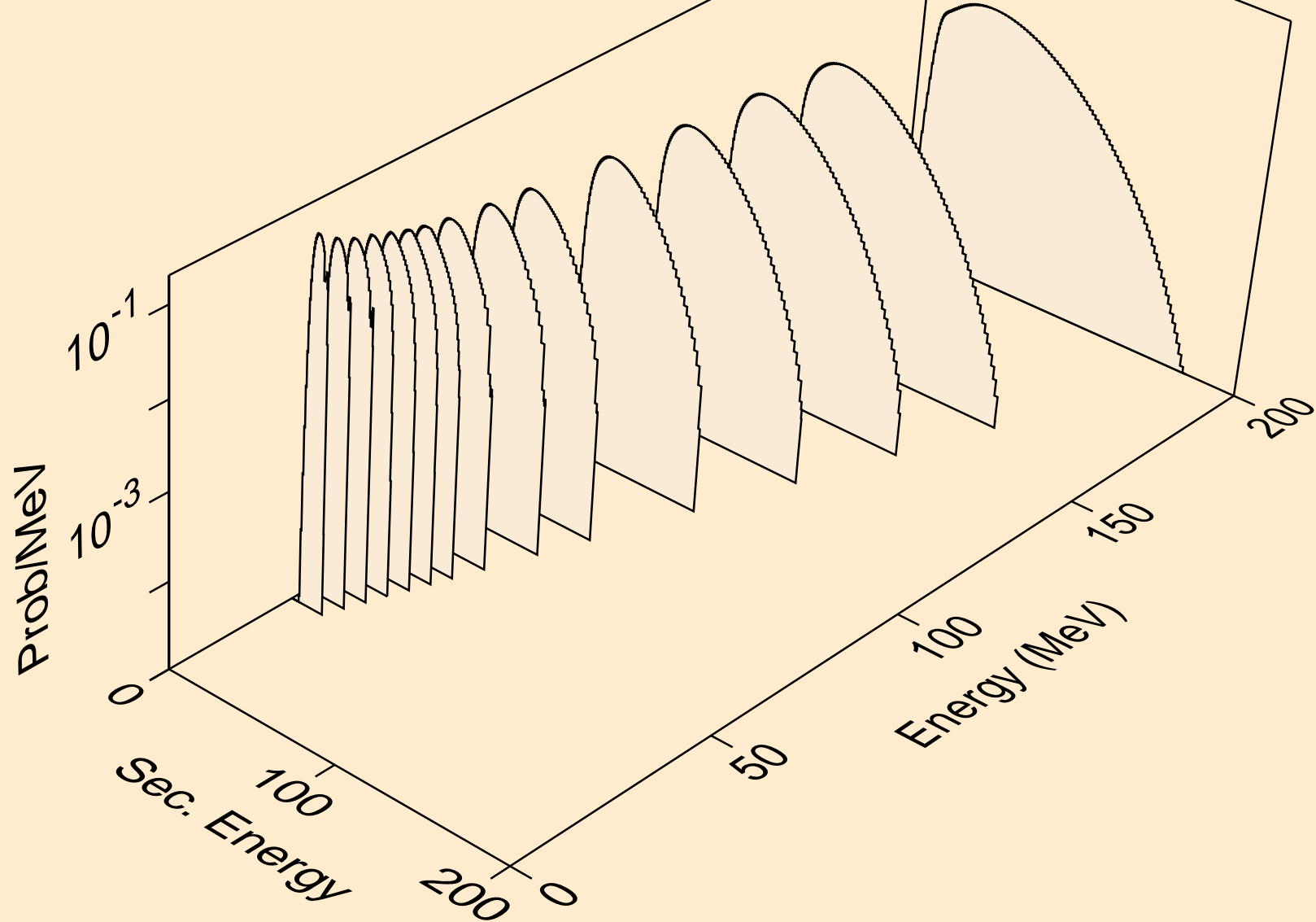



NI060 NEUTRON ACER TENDL-2023 LIBRARY; T=0.K  
he3s from (n,n\*)he3

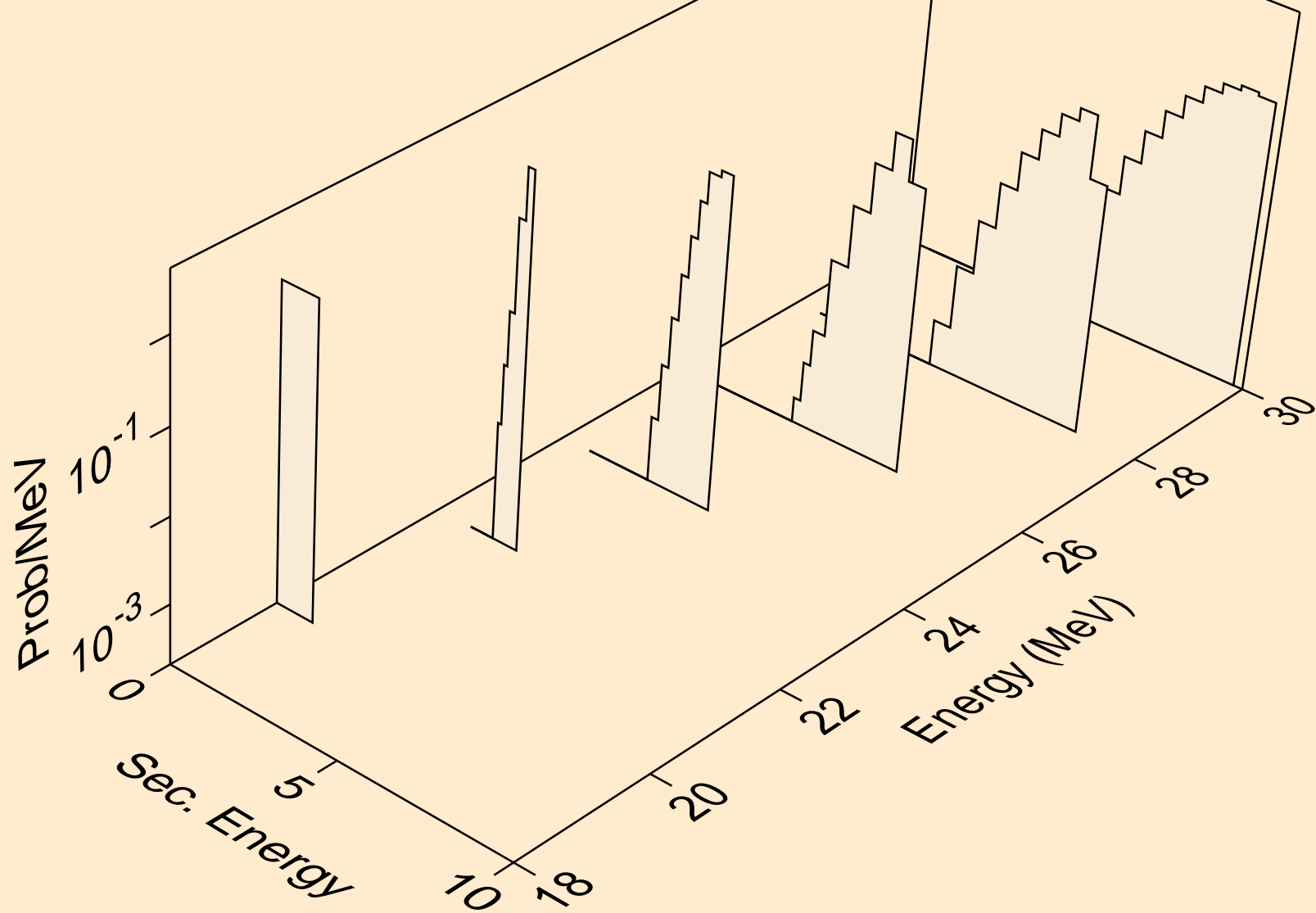

NI060 NEUTRON ACER TENDL-2023 LIBRARY; T=0.K  
he3s from (n,he3)

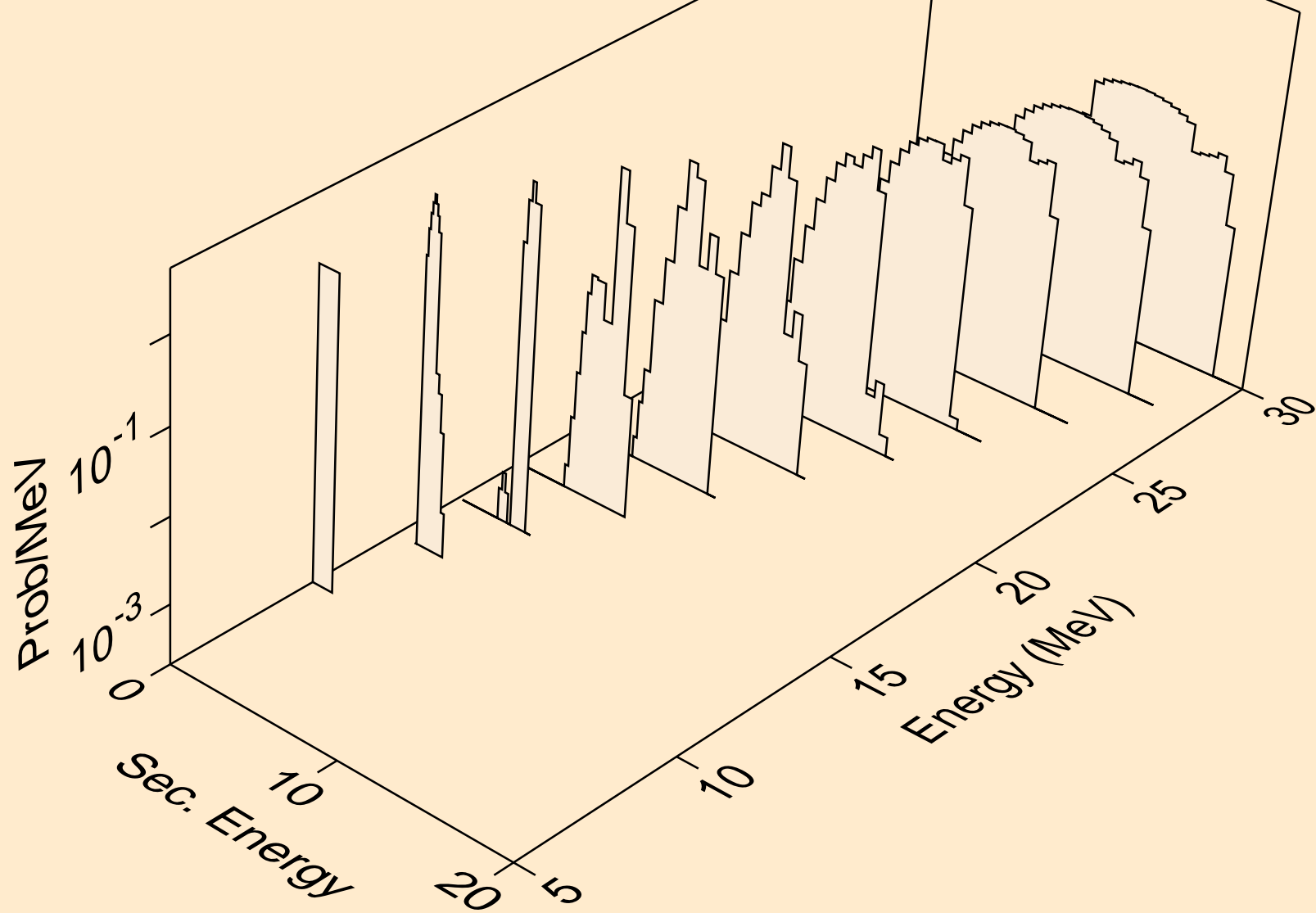

NI060 NEUTRON ACER TENDL-2023 LIBRARY; T=0.K  
alphas from (n,x)

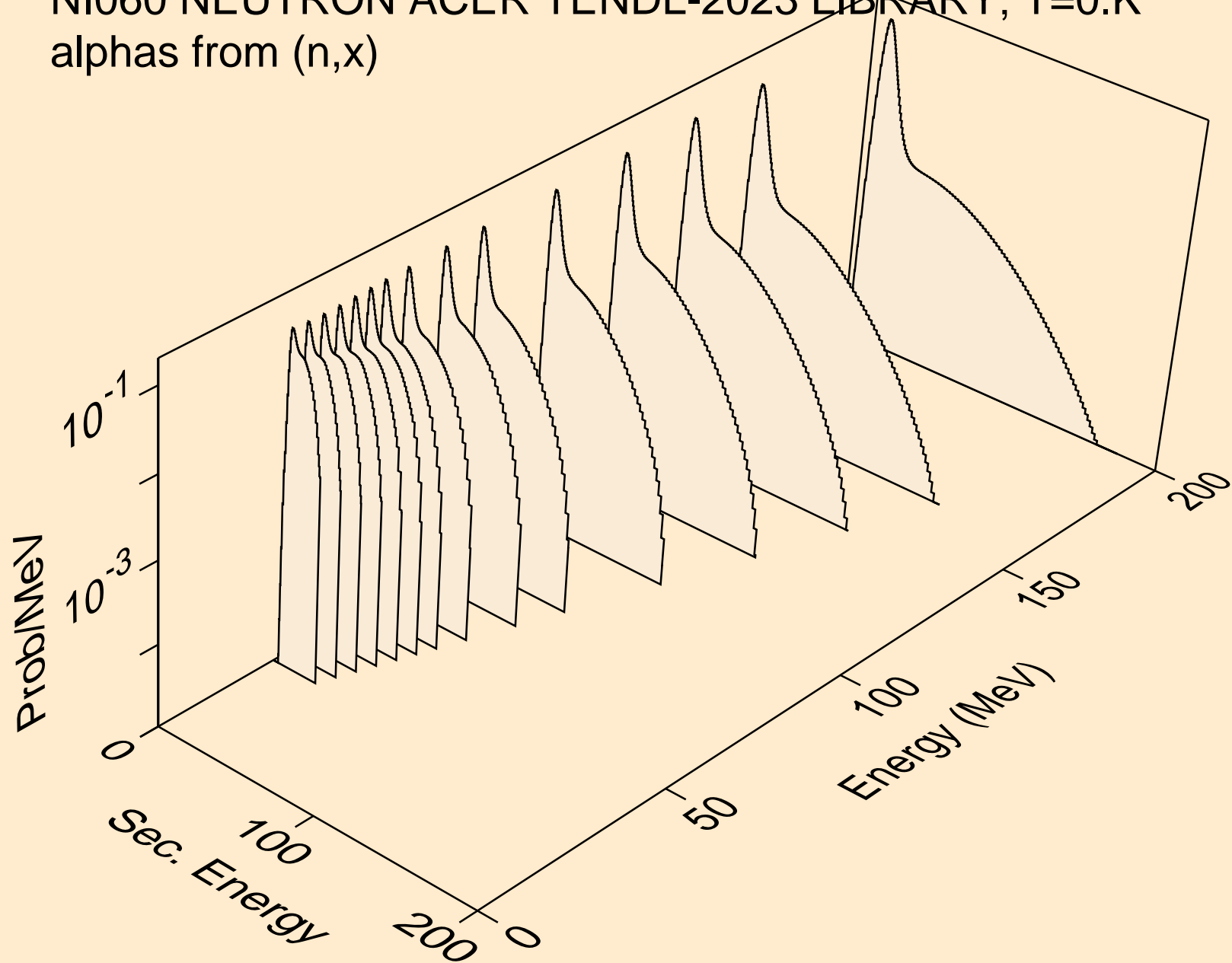

NI060 NEUTRON ACER TENDL-2023 LIBRARY; T=0.K  
alphas from (n,n\*)a

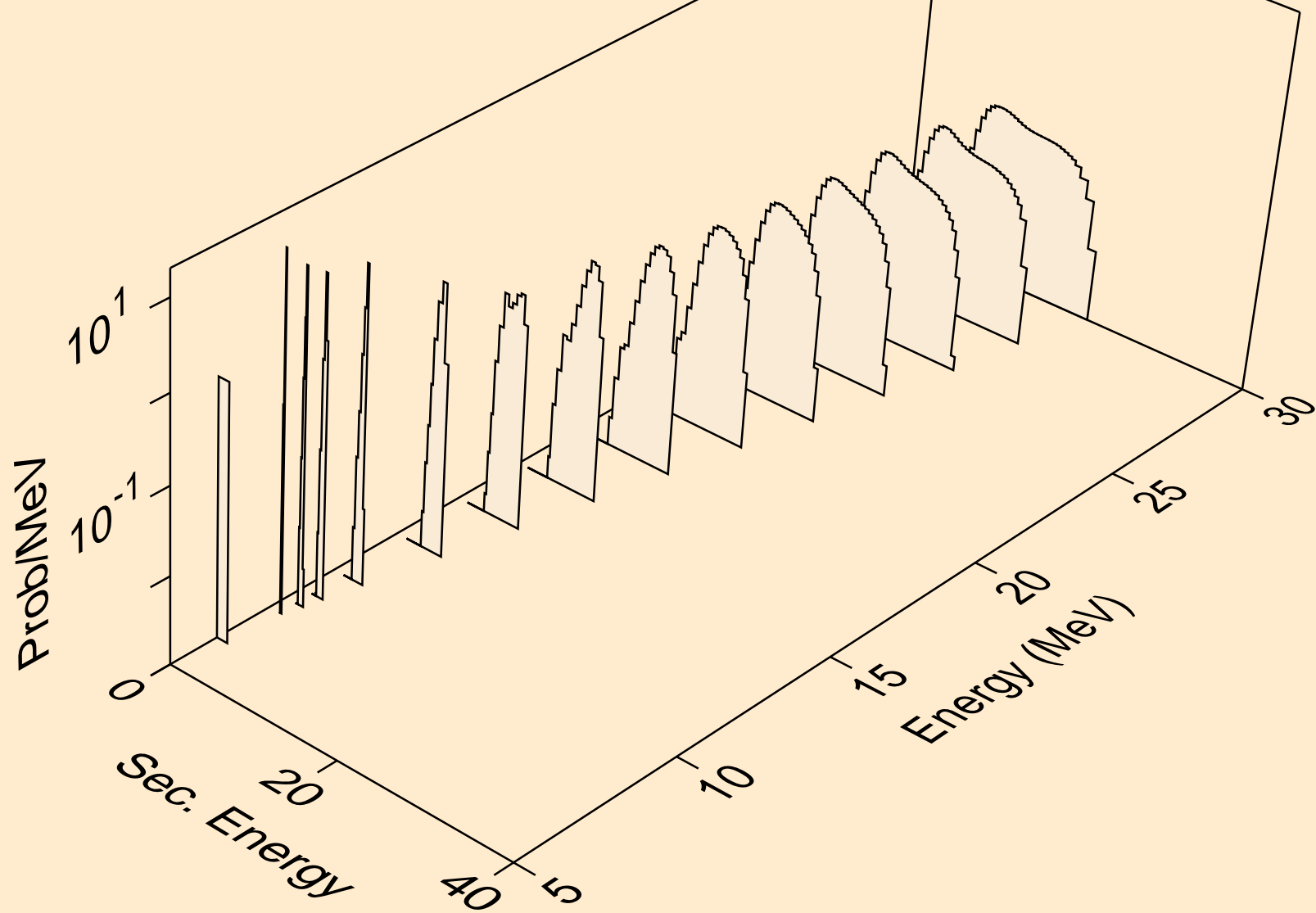

NI060 NEUTRON ACER TENDL-2023 LIBRARY; T=0.K  
alphas from (n,2n)a

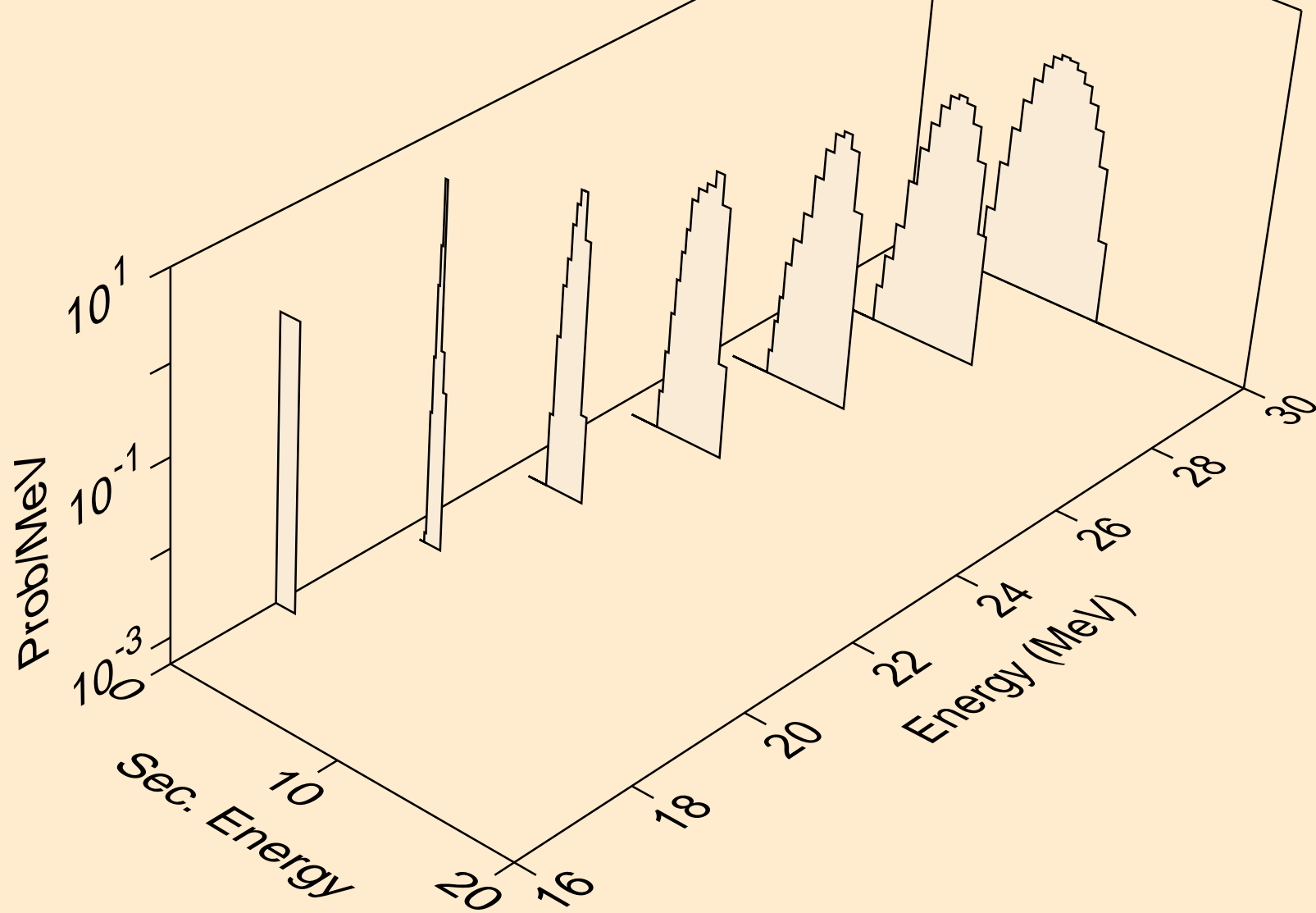

NI060 NEUTRON ACER TENDL-2023 LIBRARY; T=0.K  
alphas from (n,n\*)2a

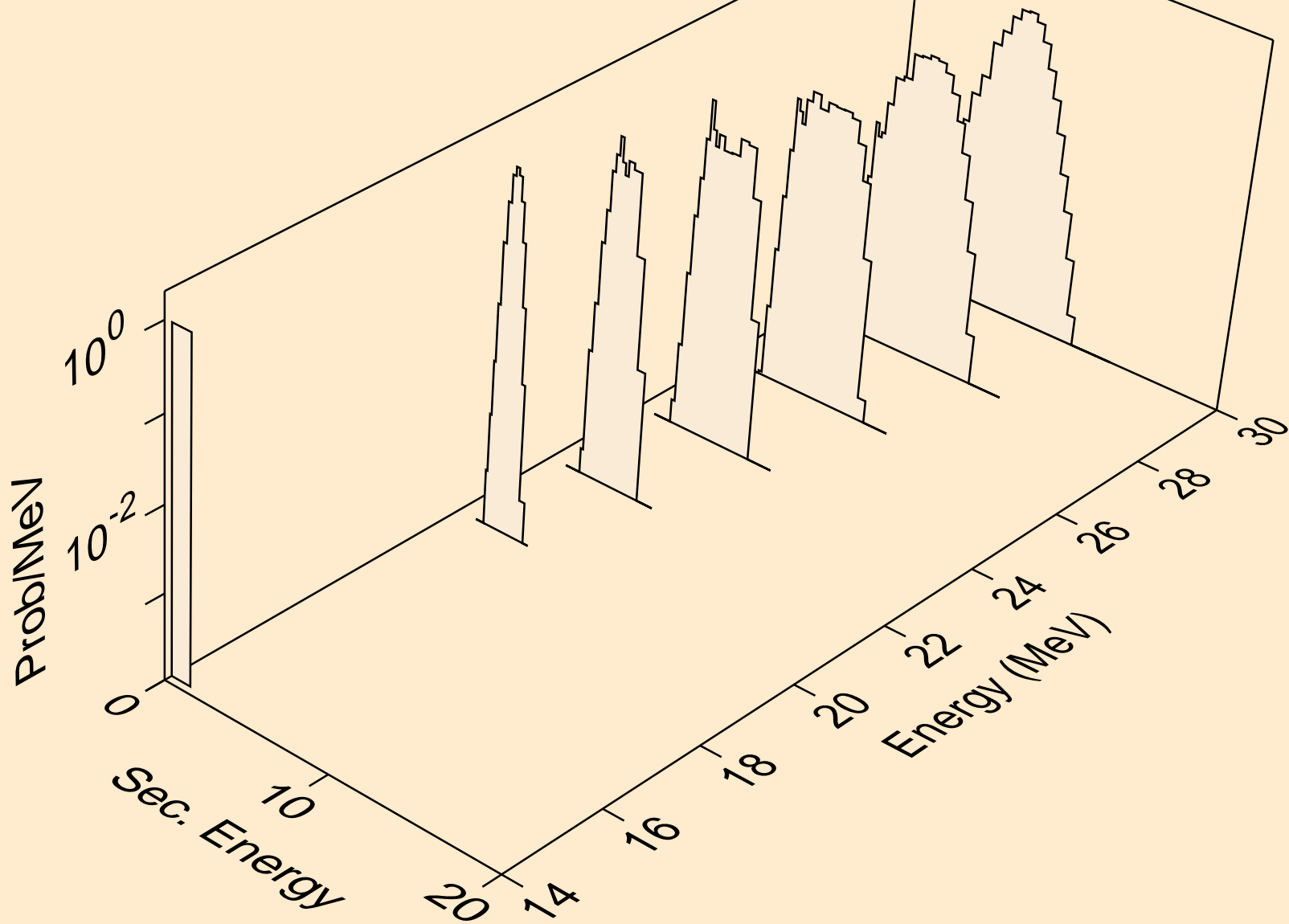

NI060 NEUTRON ACER TENDL-2023 LIBRARY; T=0.K  
alphas from (n,npa)

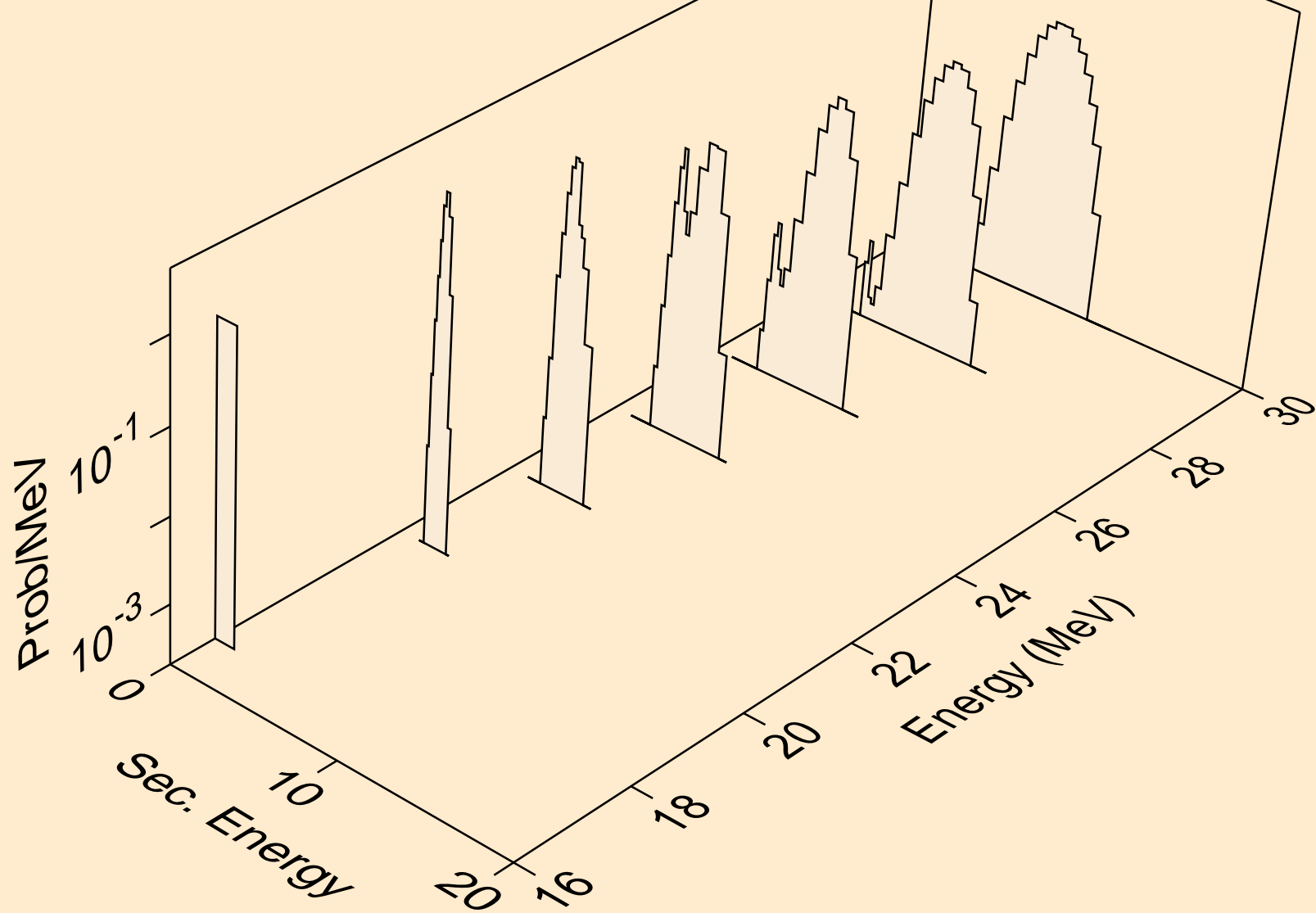

NI060 NEUTRON ACER TENDL-2023 LIBRARY; T=0.K  
alphas from (n,a)

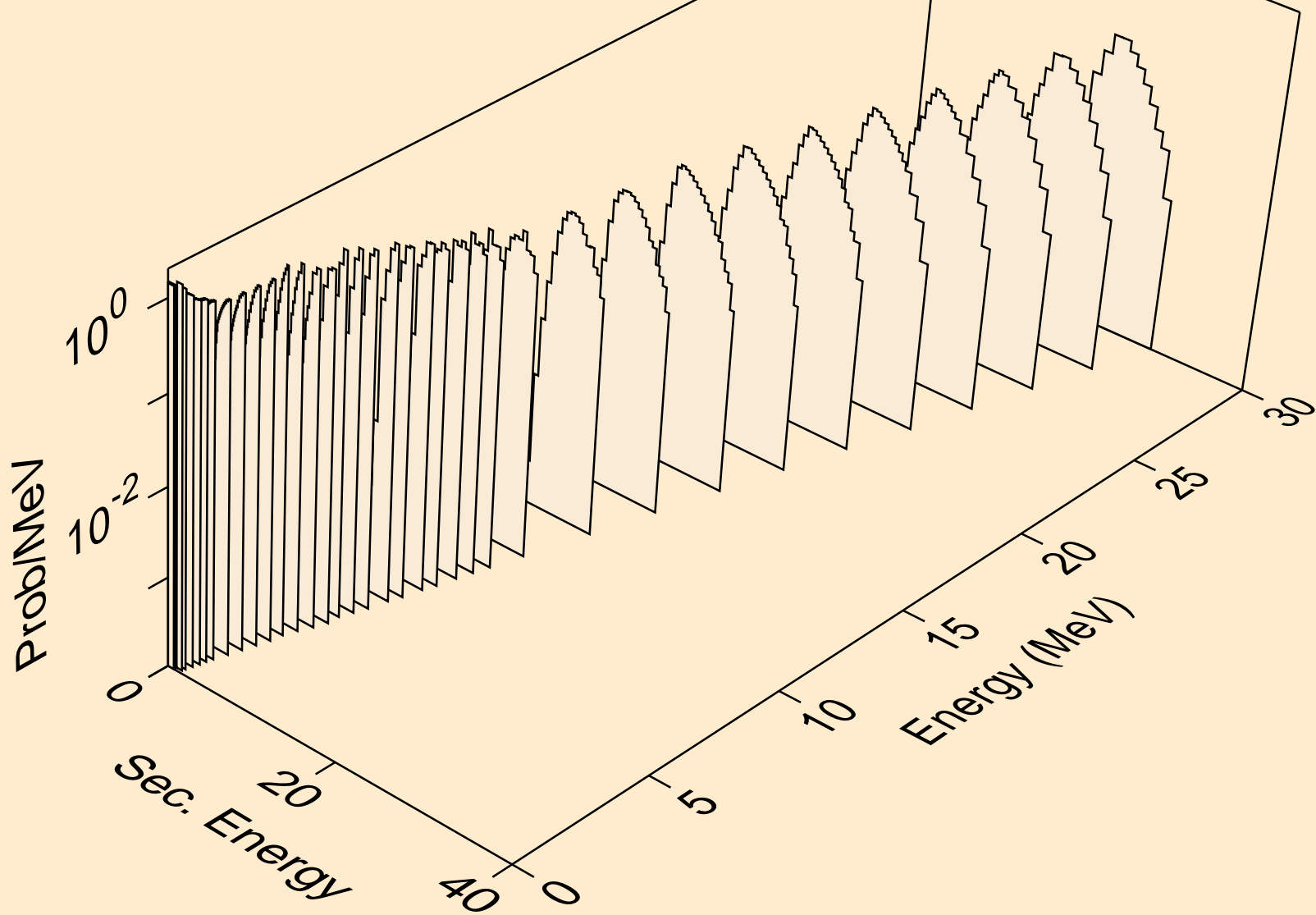



NI060 NEUTRON ACER TENDL-2023 LIBRARY; T=0.K  
alphas from (n,2a)

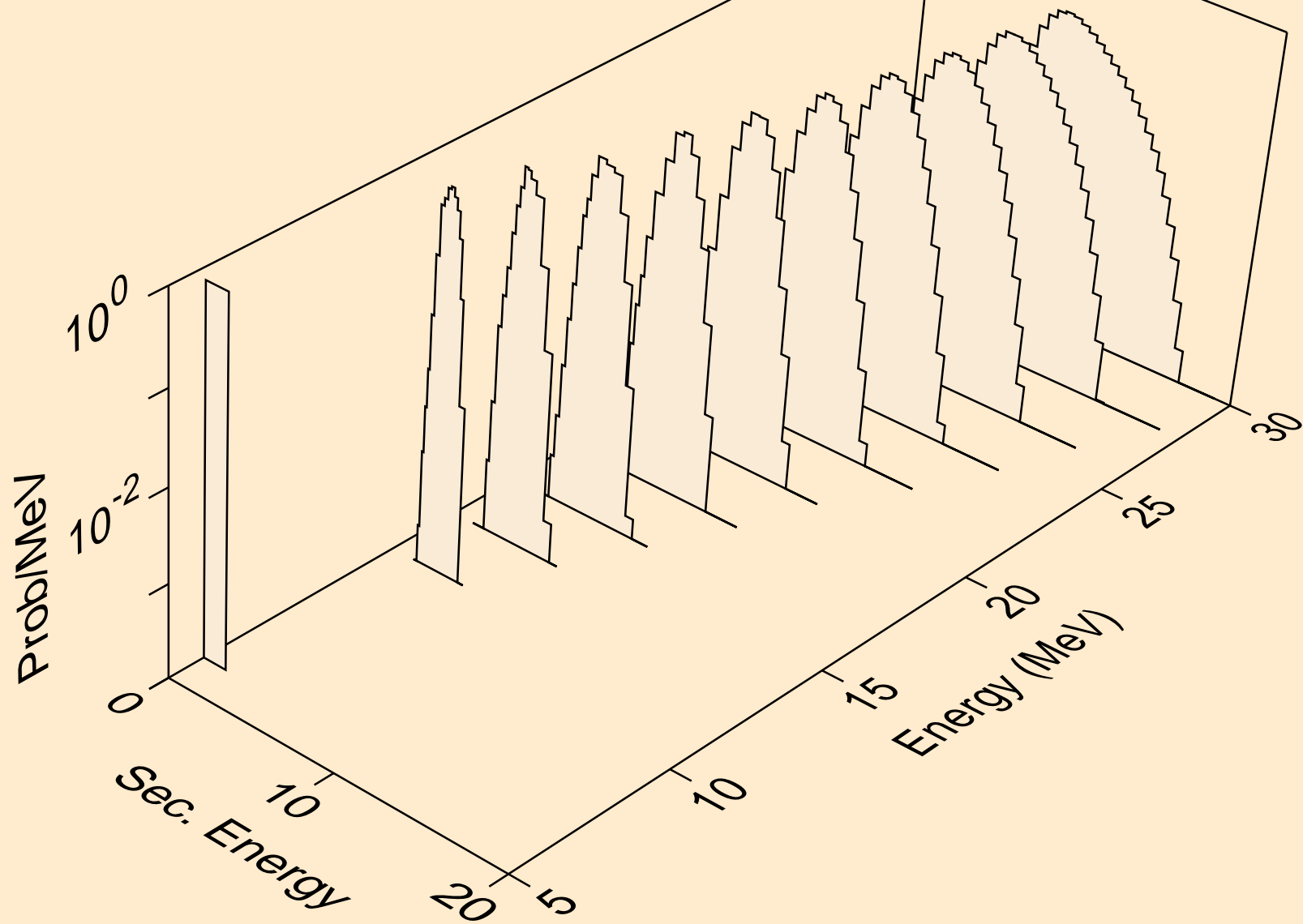

NI060 NEUTRON ACER TENDL-2023 LIBRARY; T=0.K  
alphas from (n,pa)

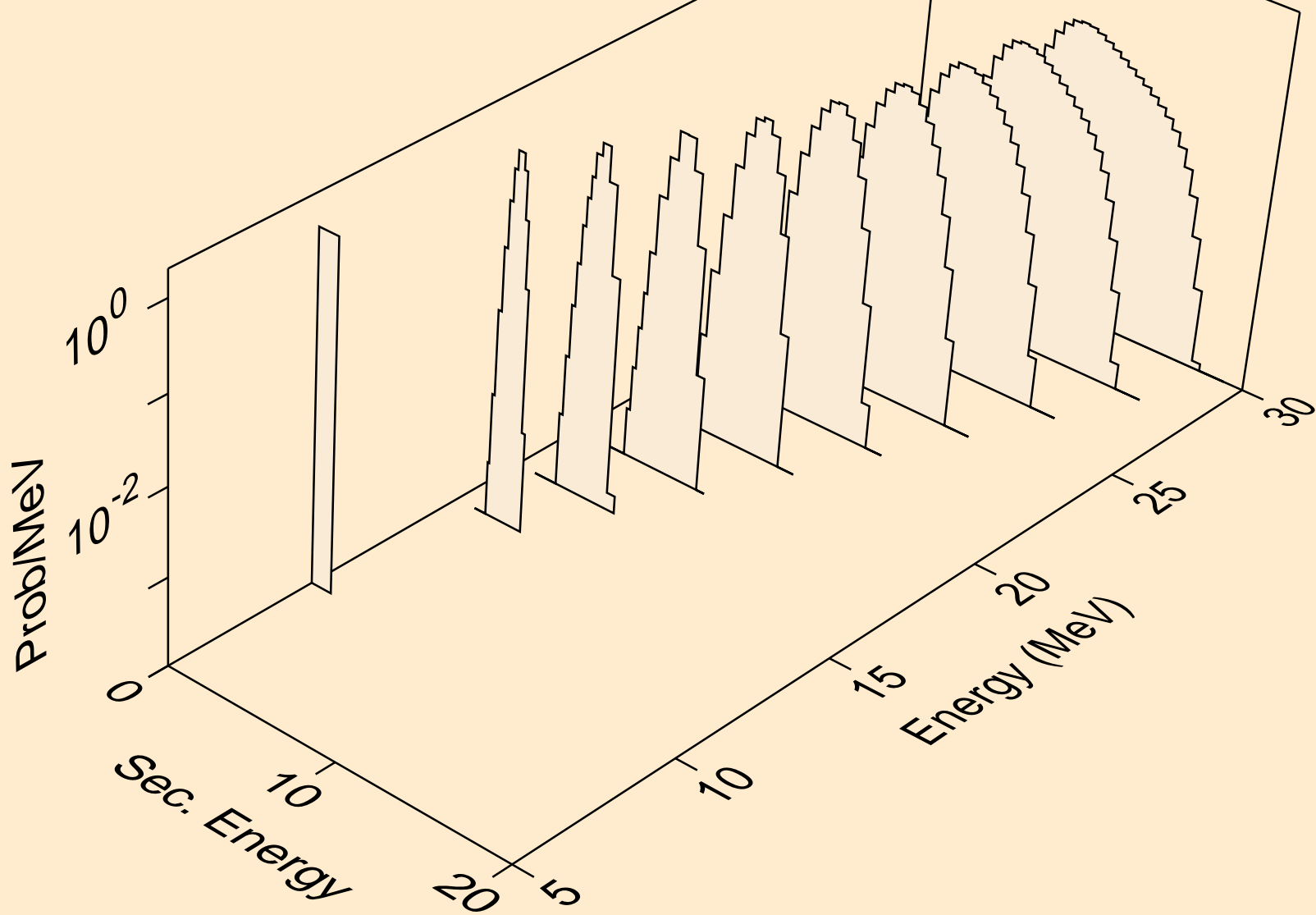

NI060 NEUTRON ACER TENDL-2023 LIBRARY; T=0.K  
alphas from (n,da)

