

NO259 NEUTRON ACER TENDL-2023 LIBRARY; T=0.K

Principal cross sections

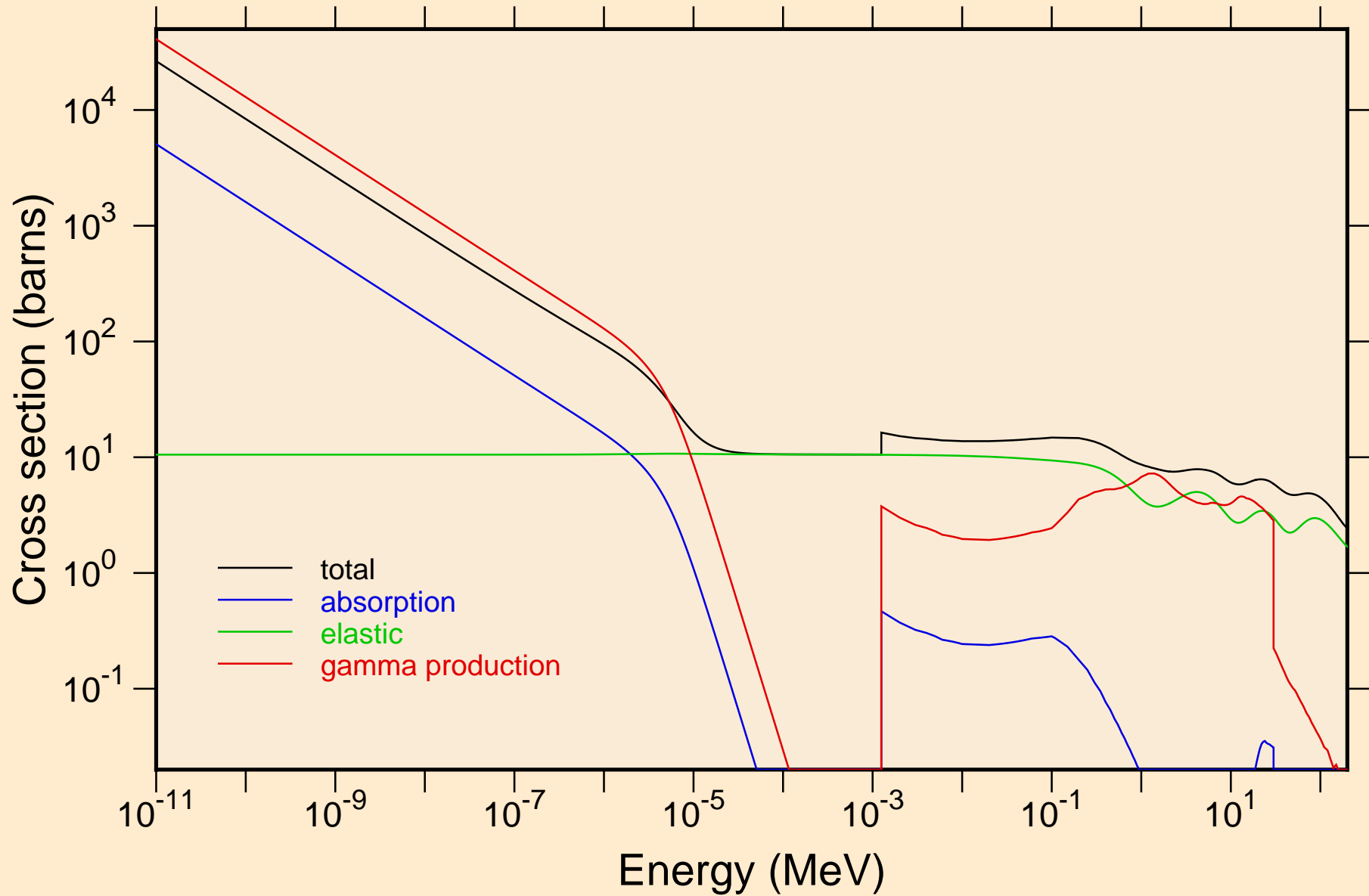

NO259 NEUTRON ACER TENDL-2023 LIBRARY; T=0.K

Heating

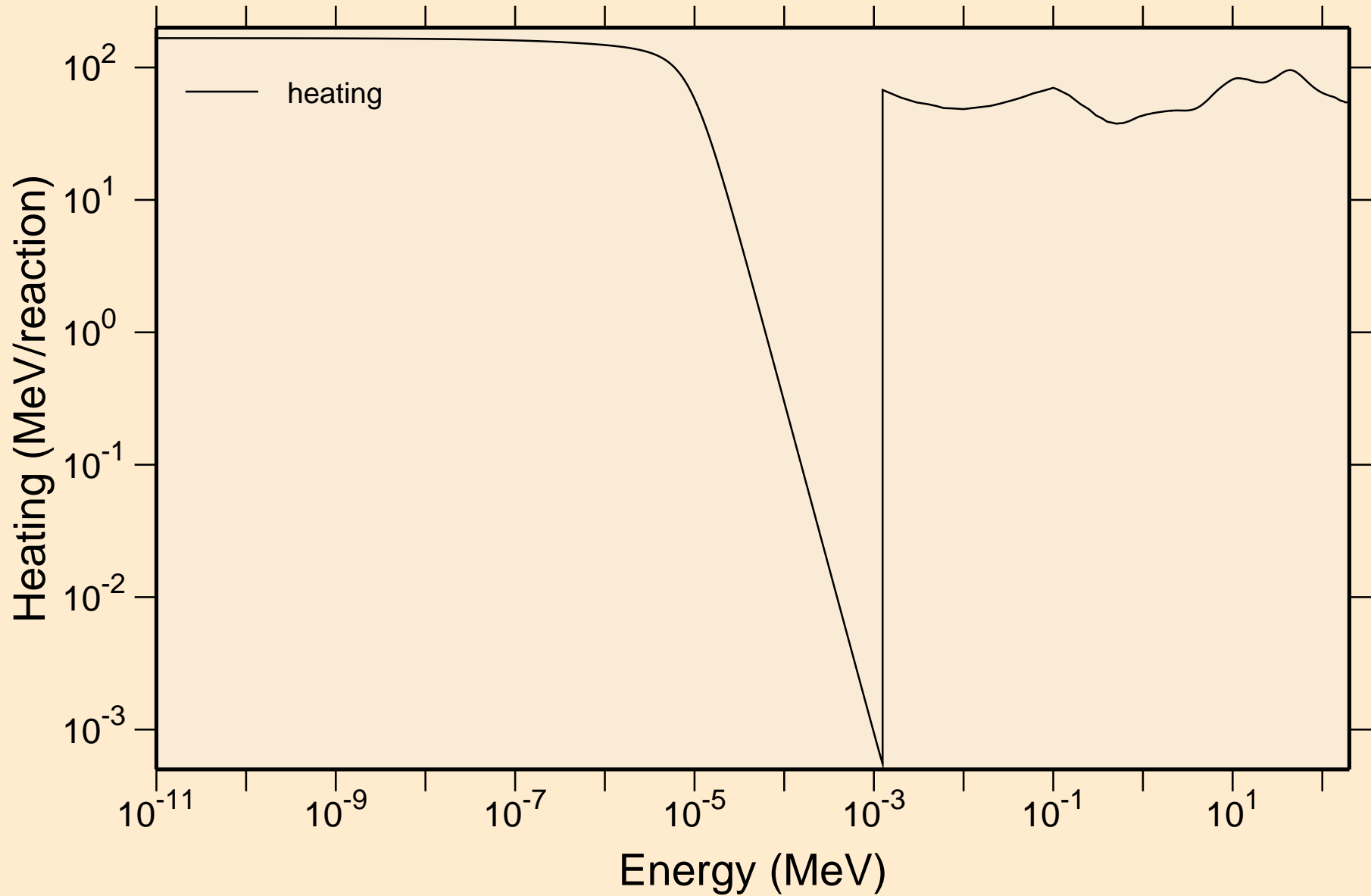

NO259 NEUTRON ACER TENDL-2023 LIBRARY; T=0.K
Damage

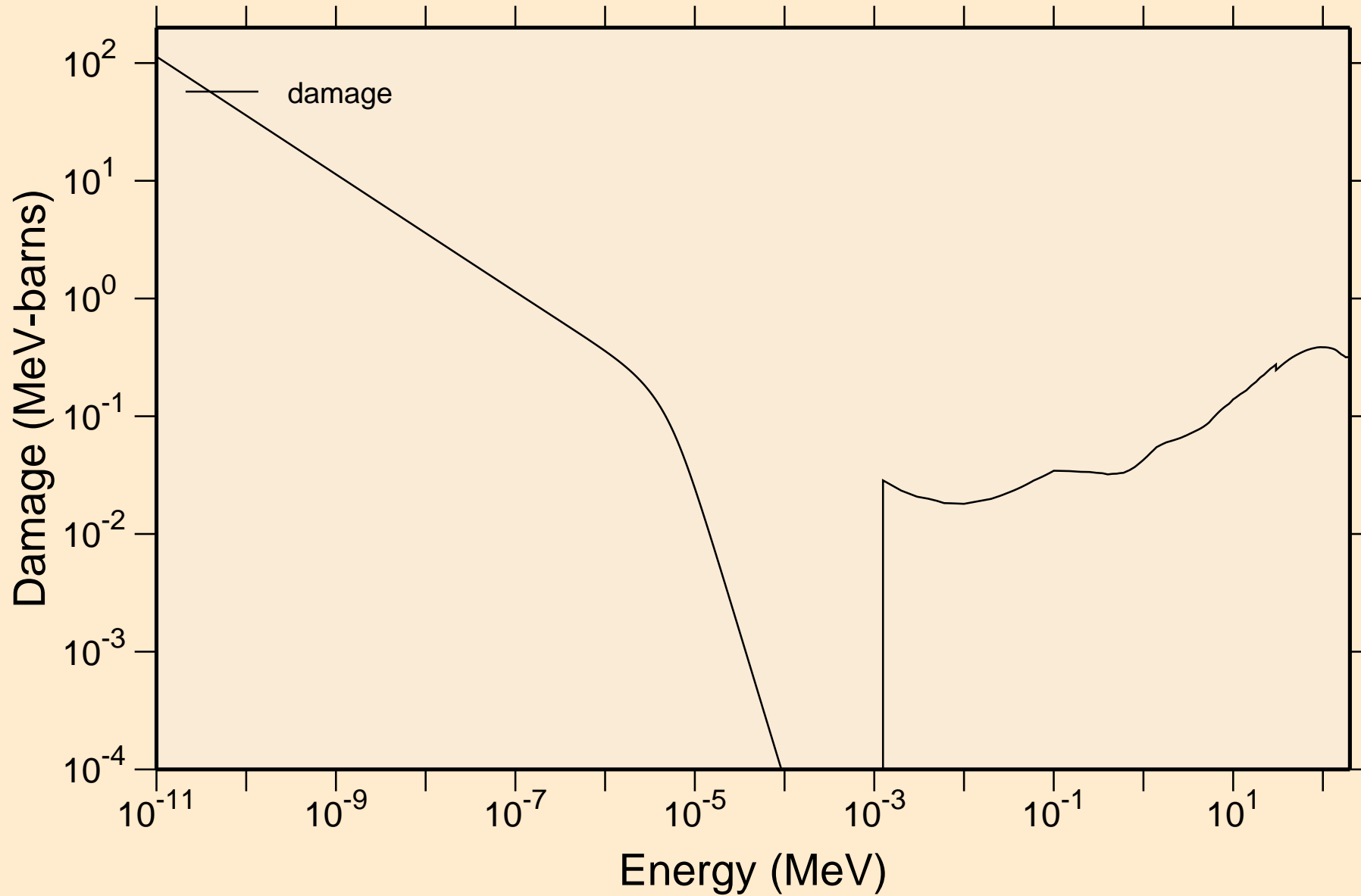

NO259 NEUTRON ACER TENDL-2023 LIBRARY; T=0.K
Non-threshold reactions

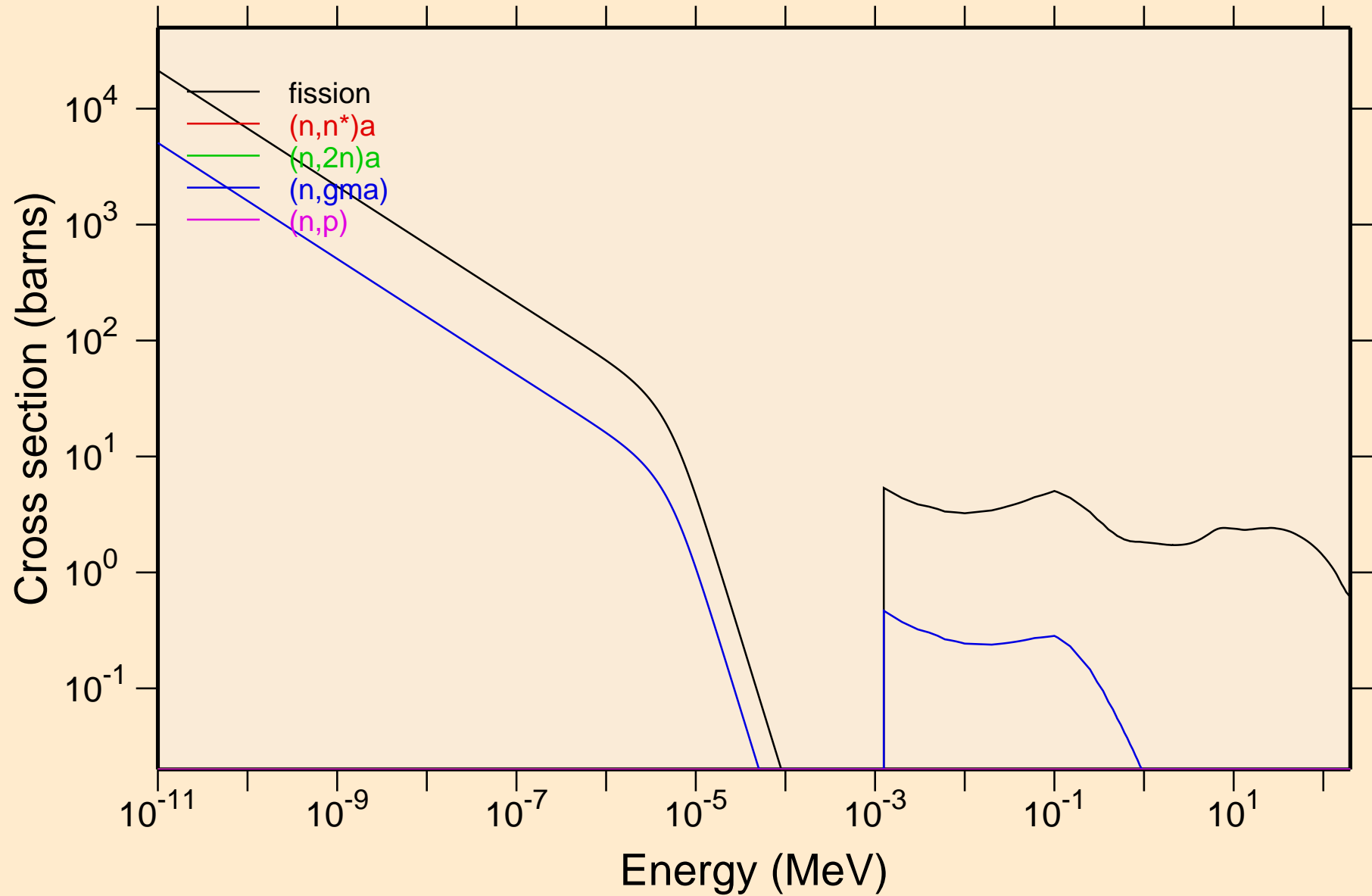

NO259 NEUTRON ACER TENDL-2023 LIBRARY; T=0.K
Non-threshold reactions

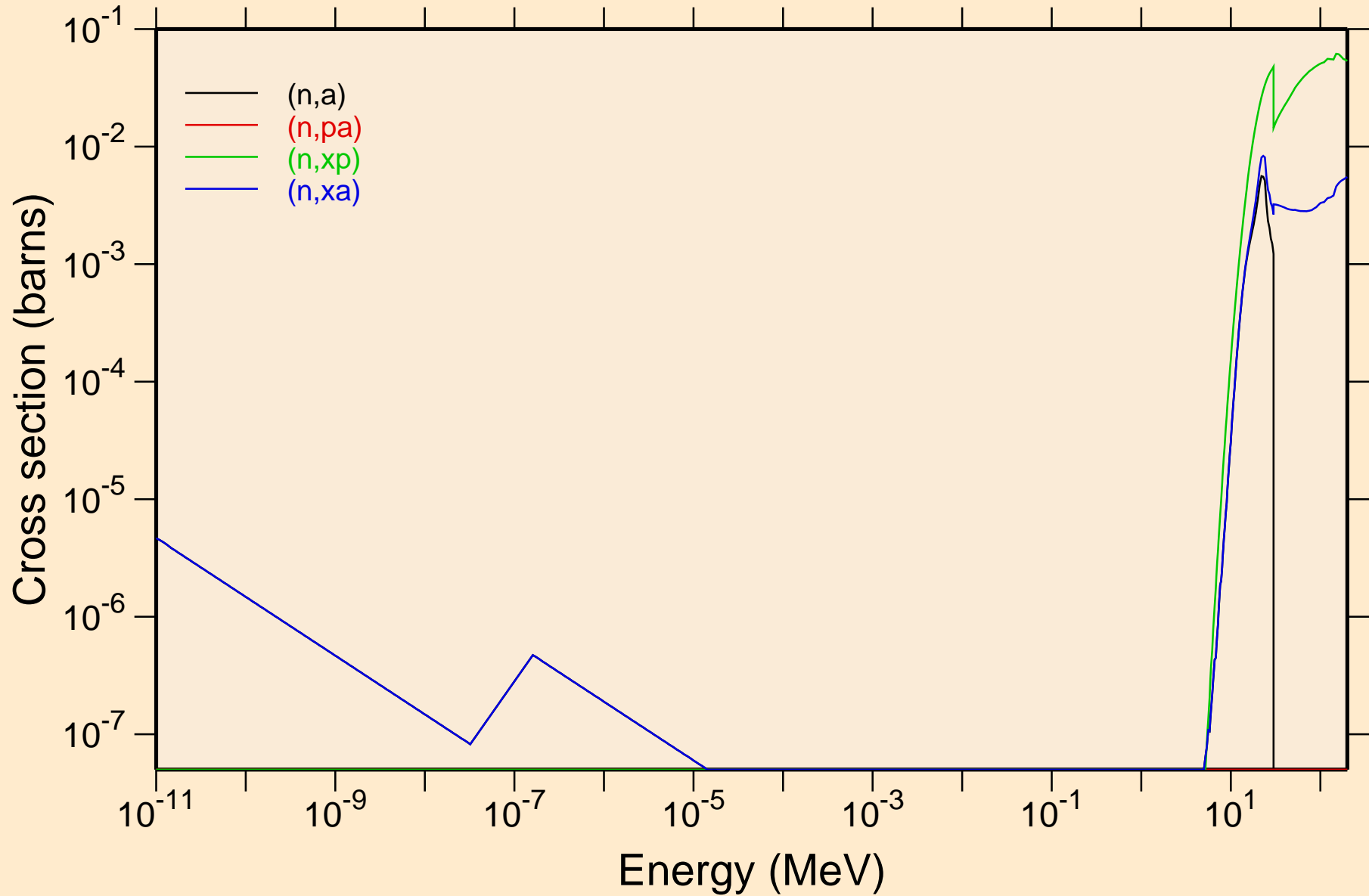

NO259 NEUTRON ACER TENDL-2023 LIBRARY; T=0.K

Principal cross sections

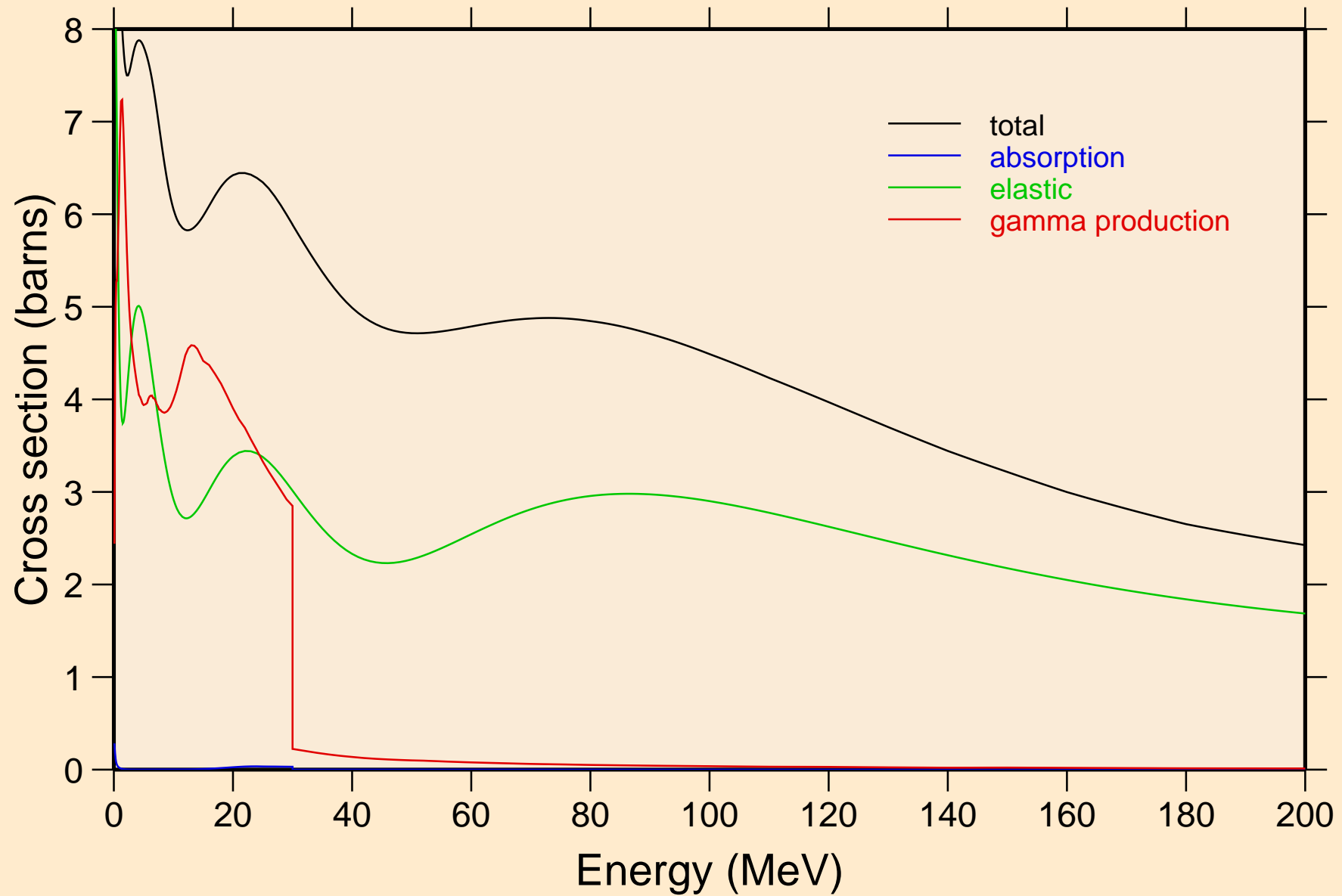

NO259 NEUTRON ACER TENDL-2023 LIBRARY; T=0.K

Heating

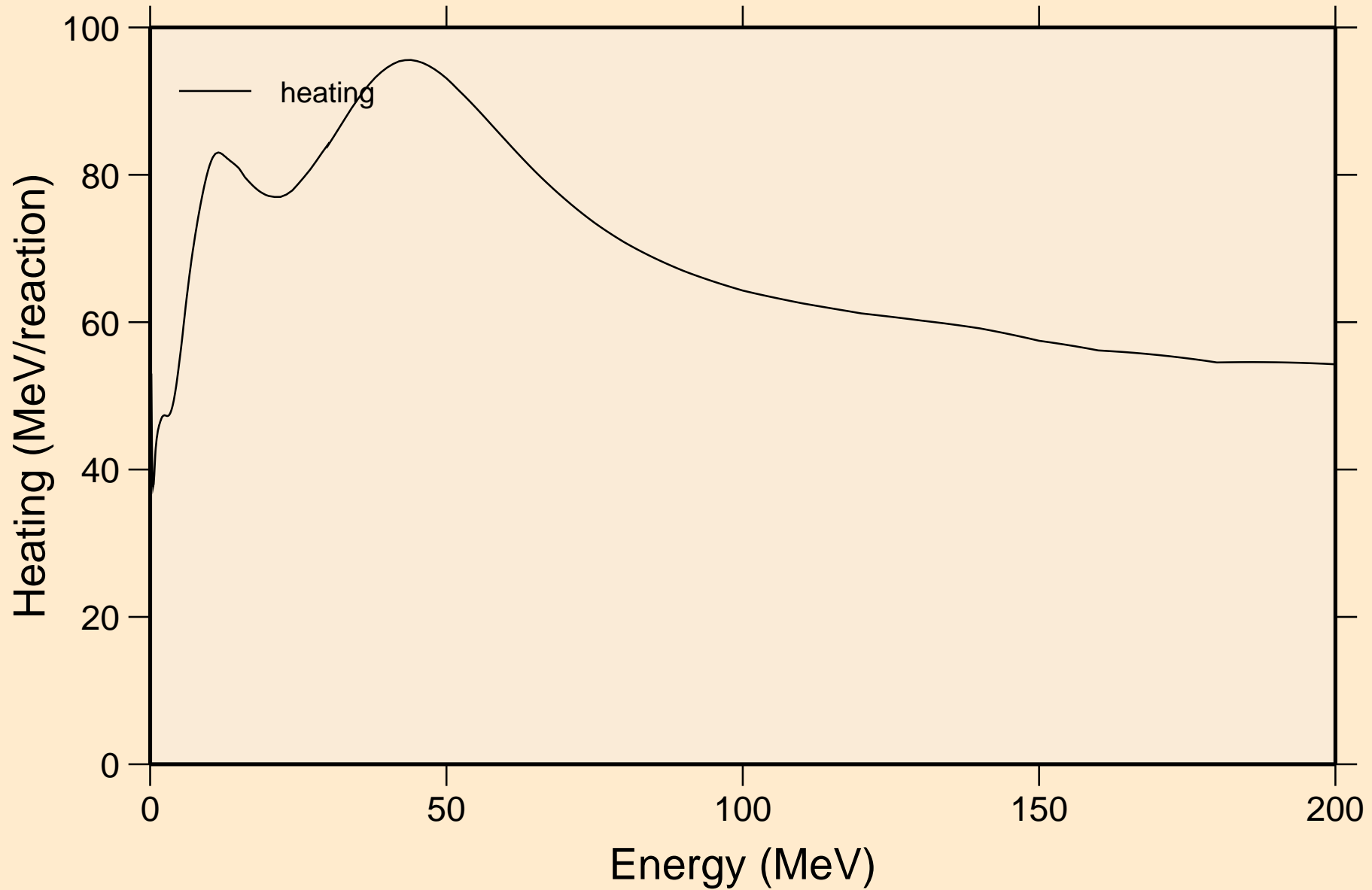

NO259 NEUTRON ACER TENDL-2023 LIBRARY; T=0.K

Damage

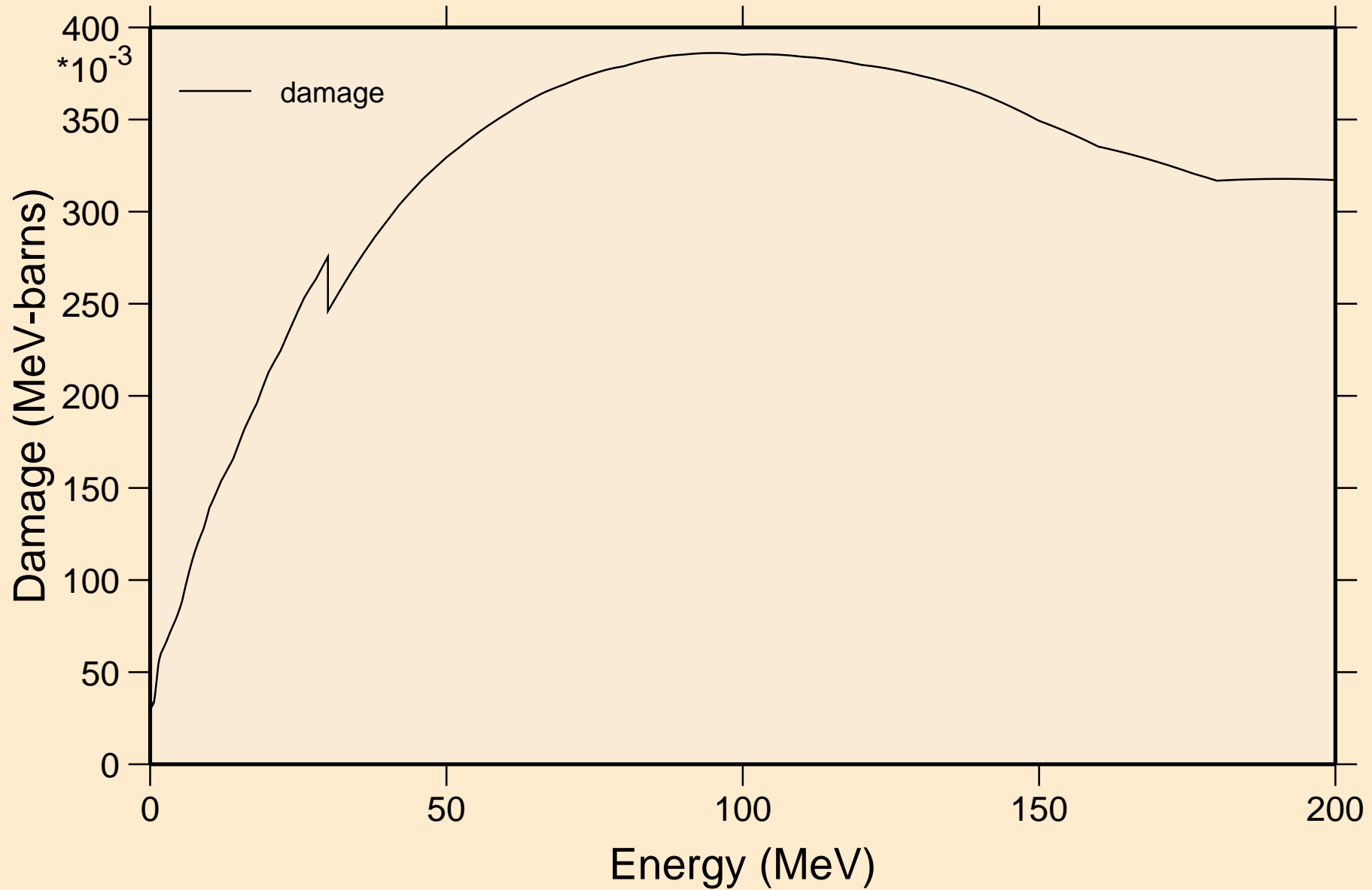

NO259 NEUTRON ACER TENDL-2023 LIBRARY; T=0.K
Non-threshold reactions

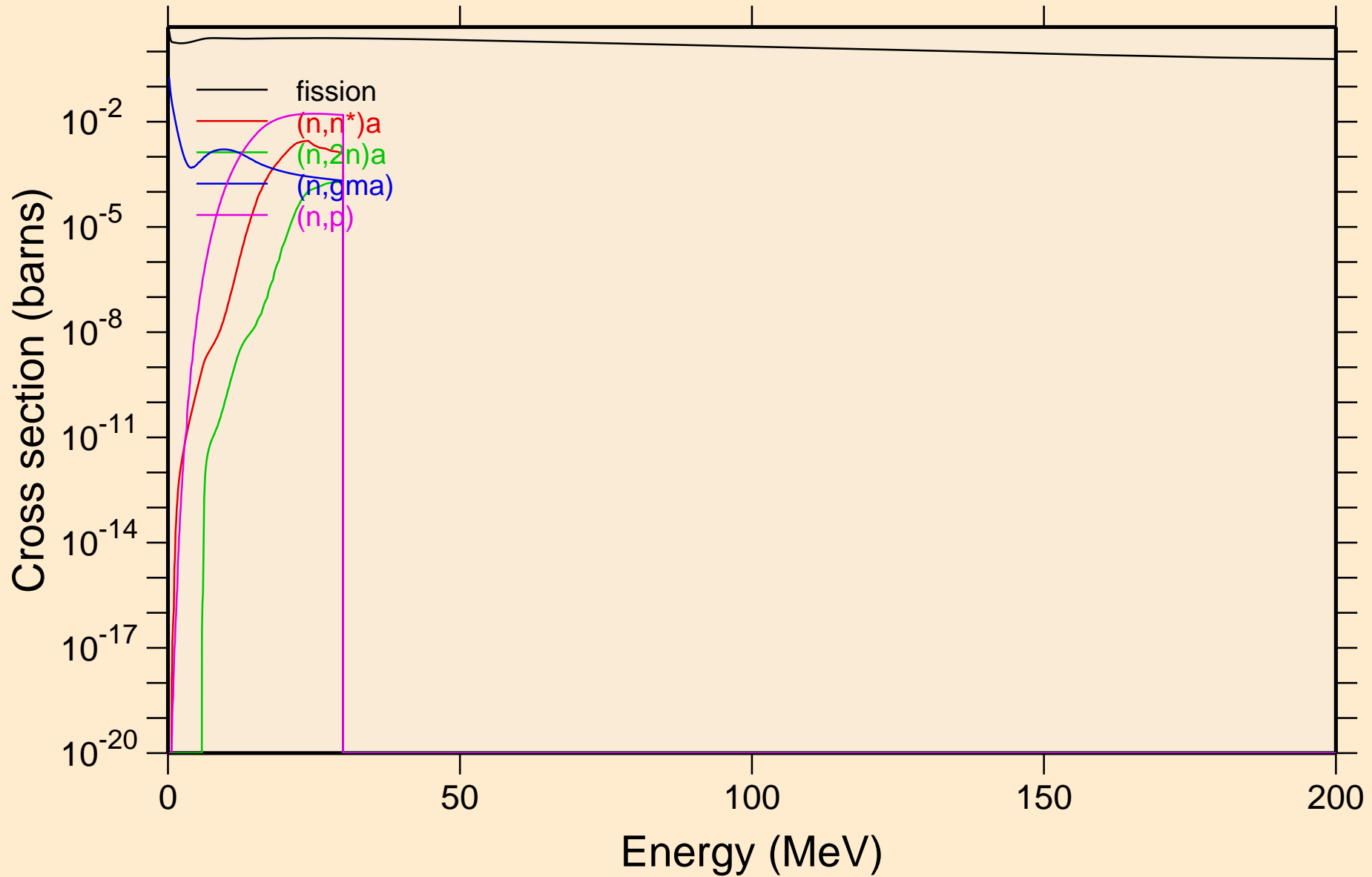

NO259 NEUTRON ACER TENDL-2023 LIBRARY; T=0.K
Non-threshold reactions

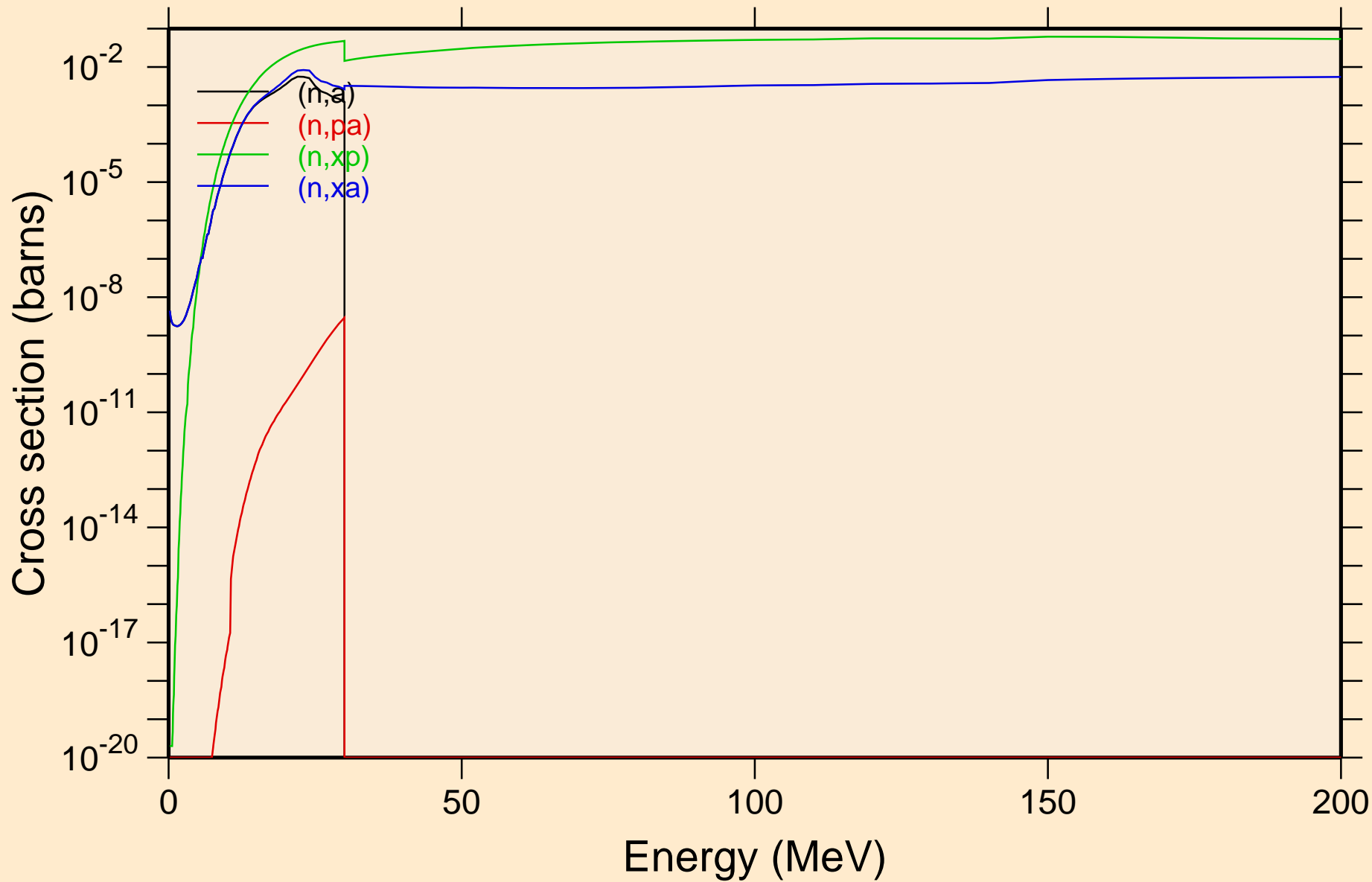

NO259 NEUTRON ACER TENDL-2023 LIBRARY; T=0.K
Inelastic levels

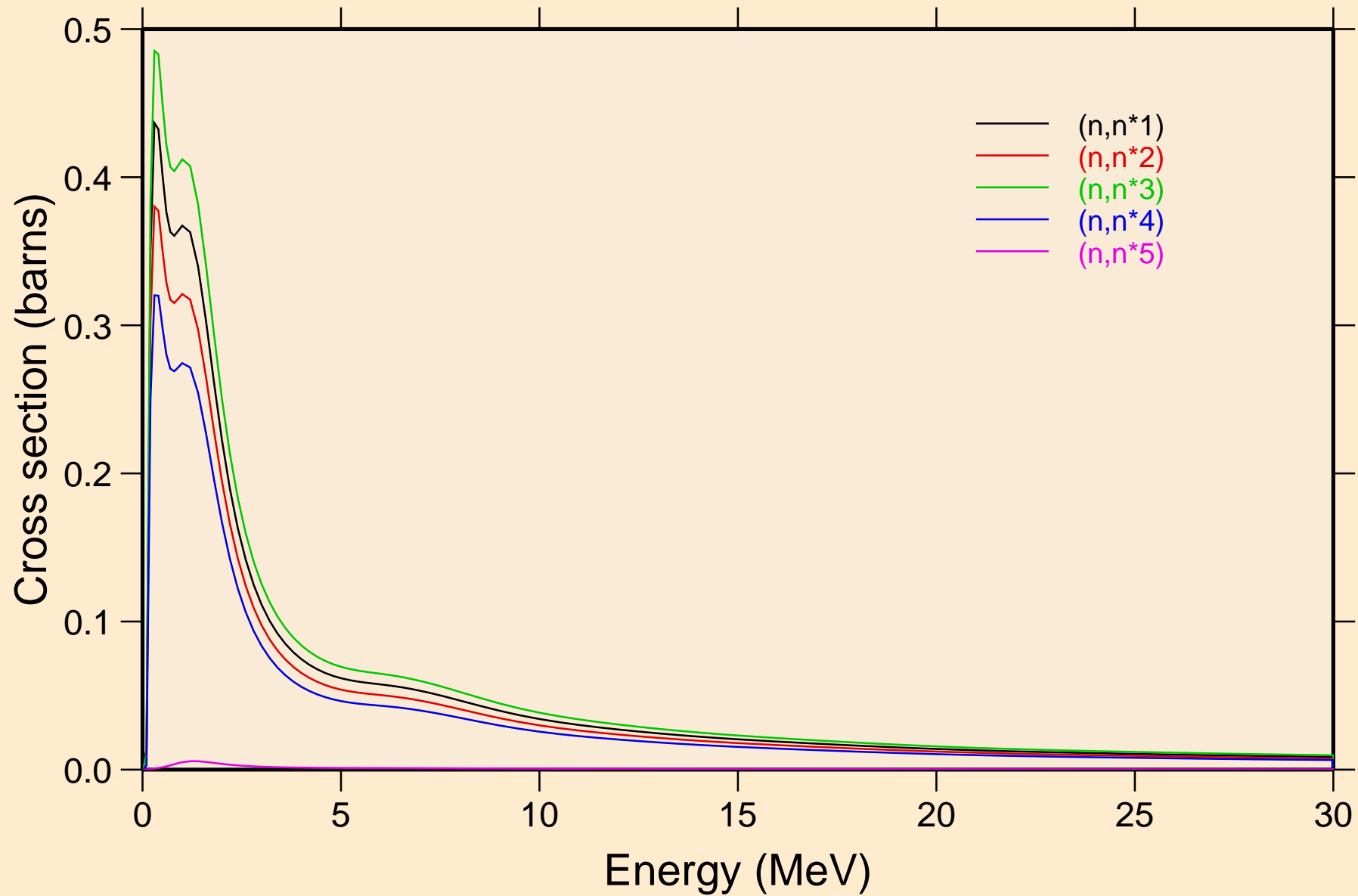

NO259 NEUTRON ACER TENDL-2023 LIBRARY; T=0.K
Inelastic levels

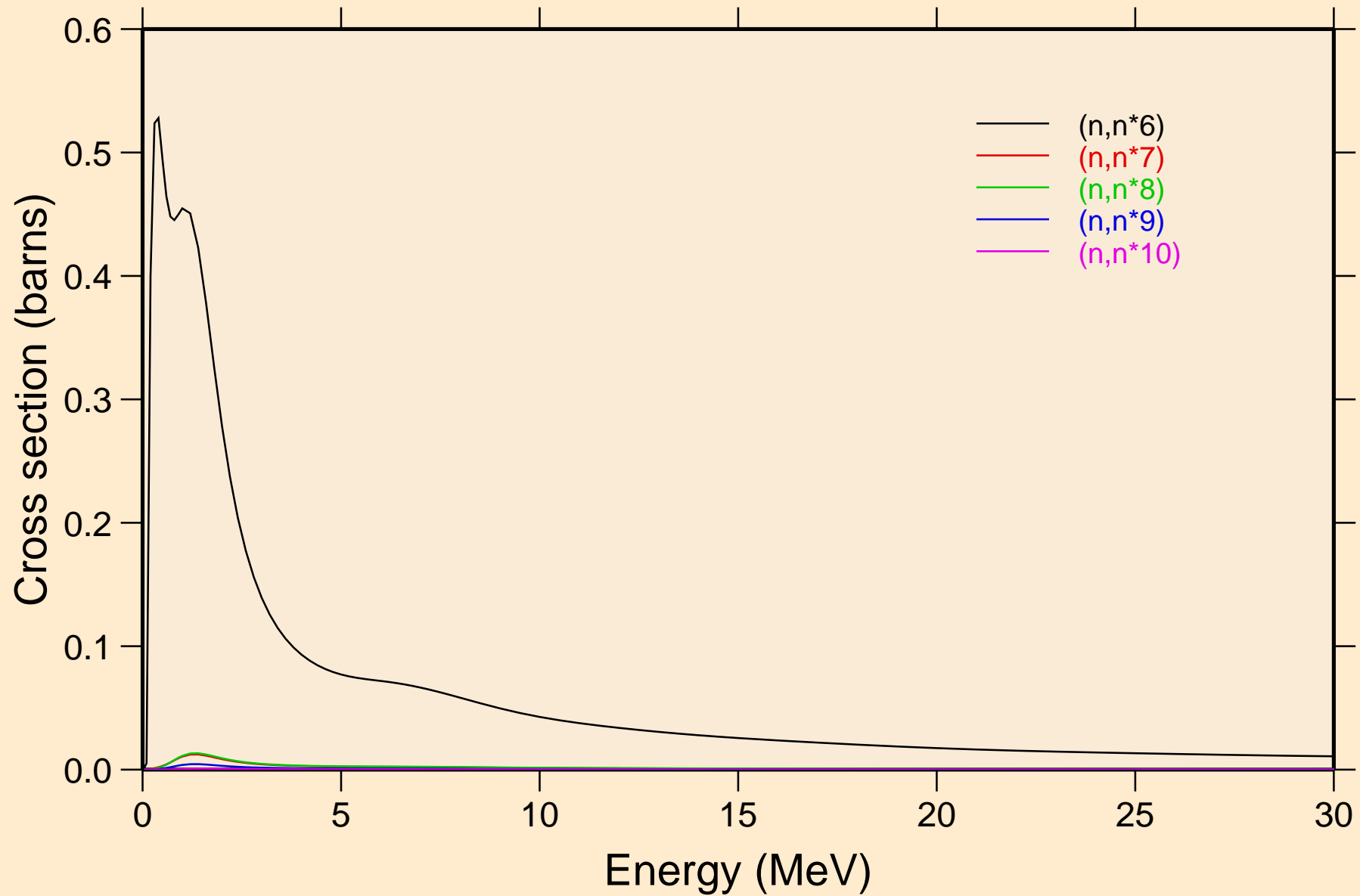

NO259 NEUTRON ACER TENDL-2023 LIBRARY; T=0.K
Inelastic levels

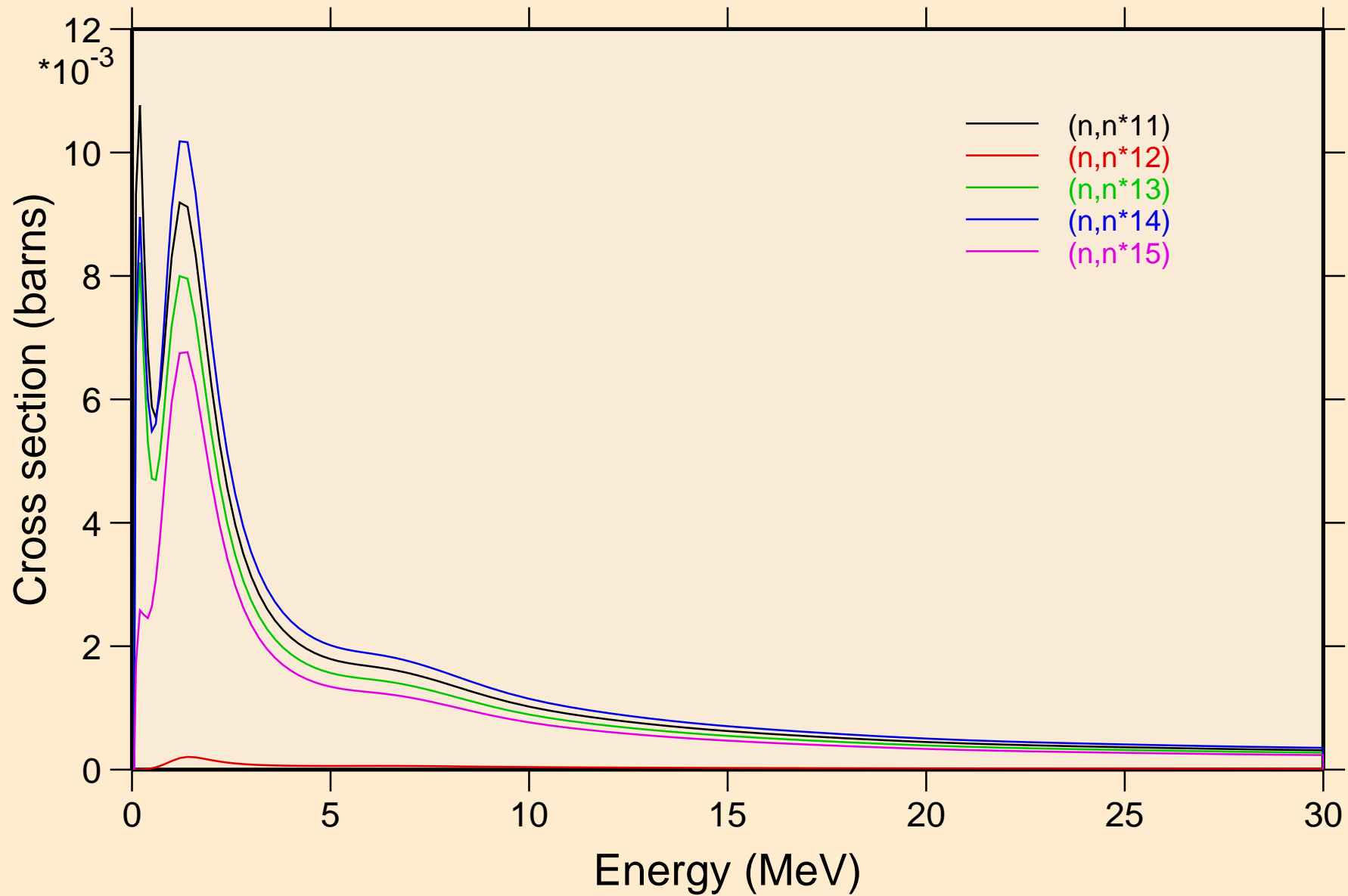

NO259 NEUTRON ACER TENDL-2023 LIBRARY; T=0.K
Inelastic levels

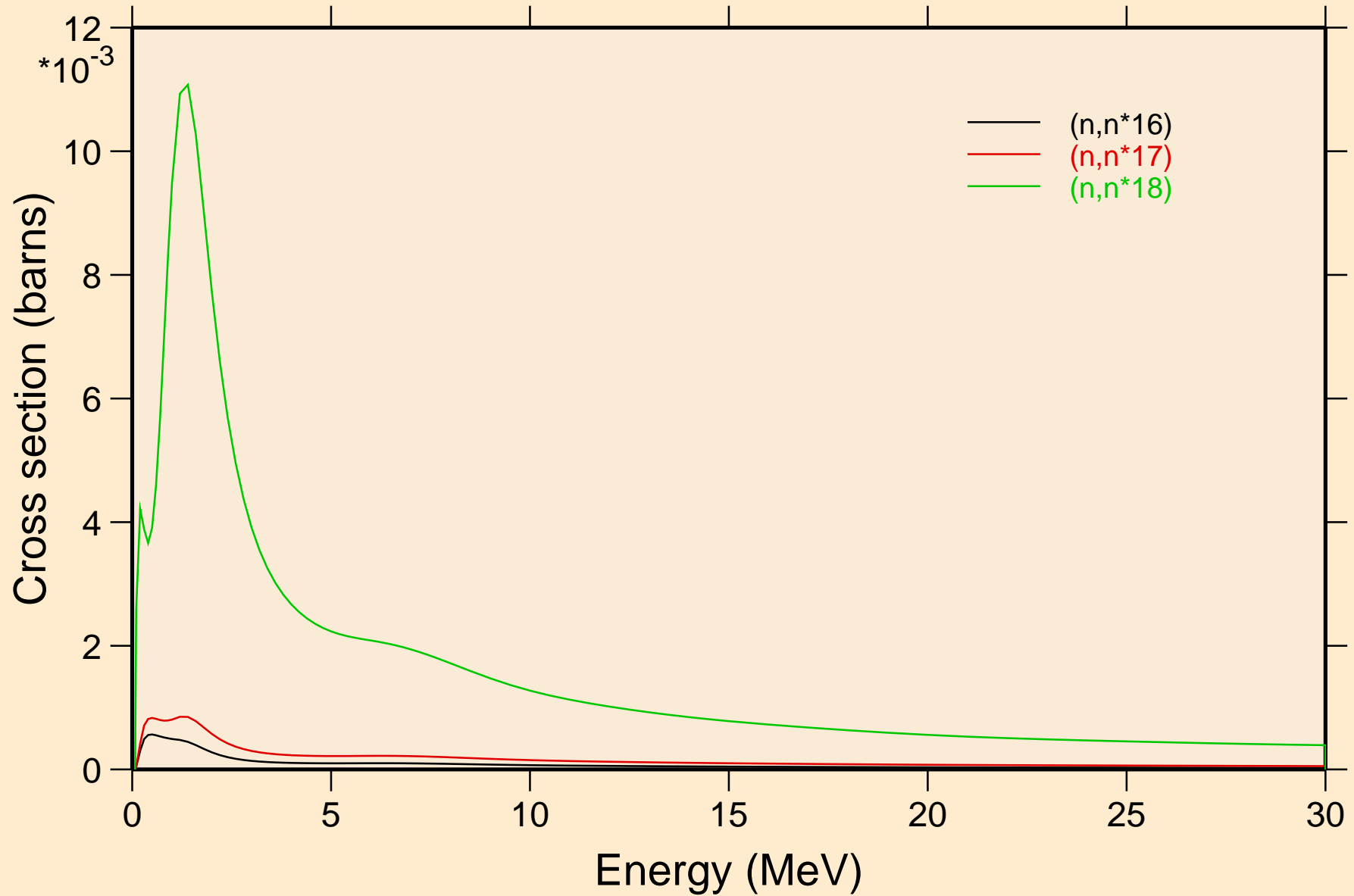

NO259 NEUTRON ACER TENDL-2023 LIBRARY; T=0.K
Threshold reactions

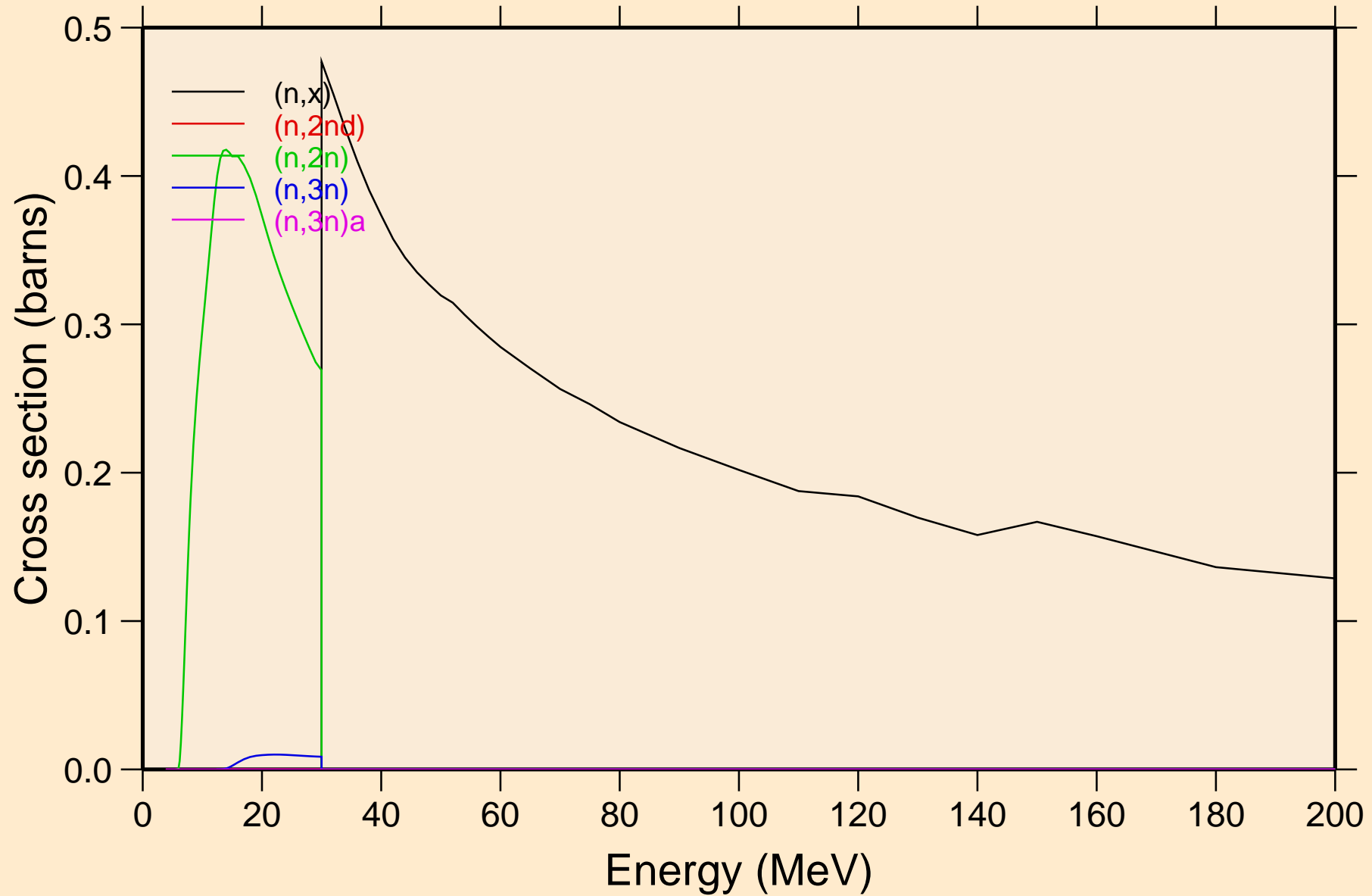

NO259 NEUTRON ACER TENDL-2023 LIBRARY; T=0.K

Threshold reactions

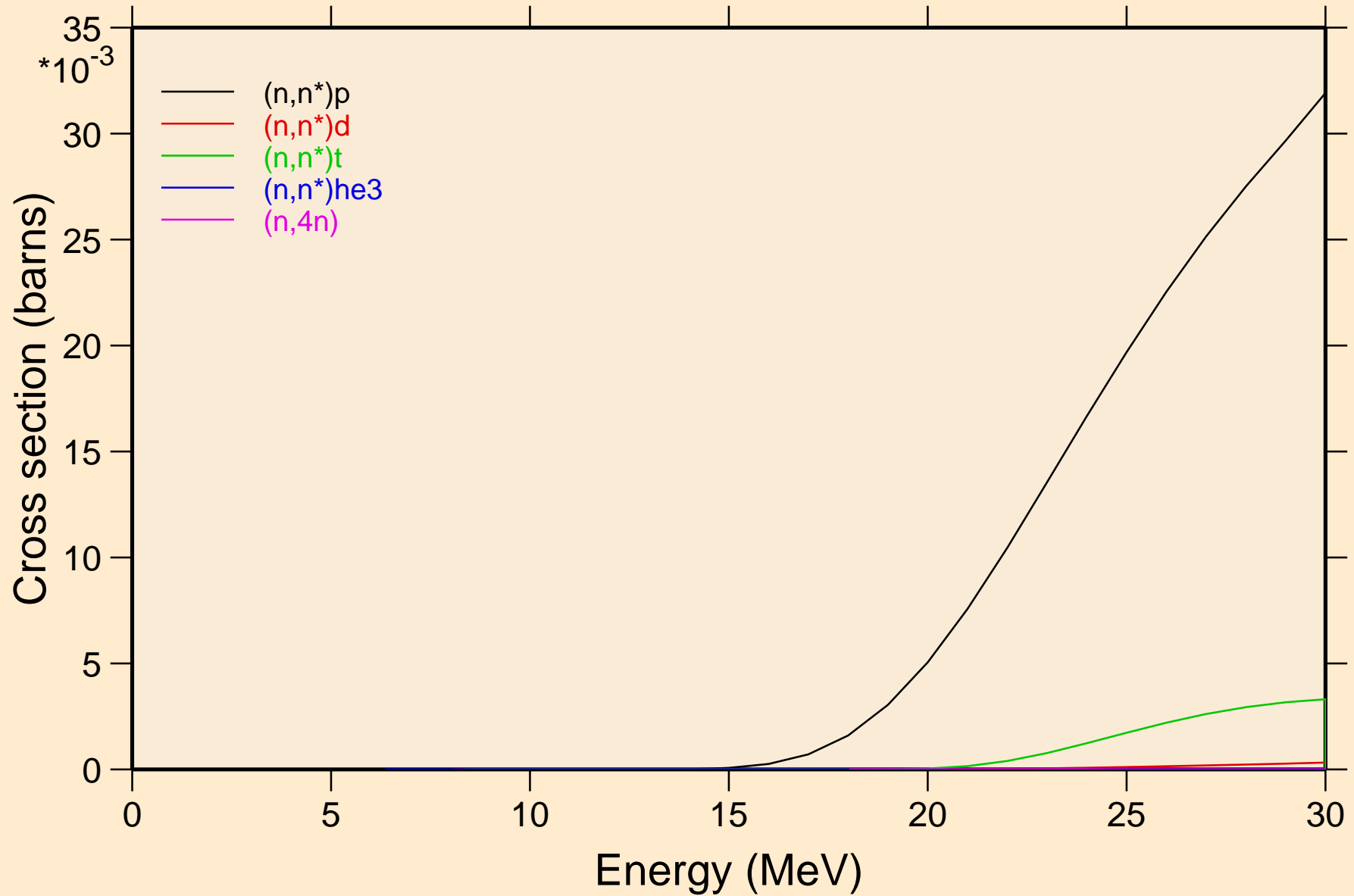

NO259 NEUTRON ACER TENDL-2023 LIBRARY; T=0.K

Threshold reactions

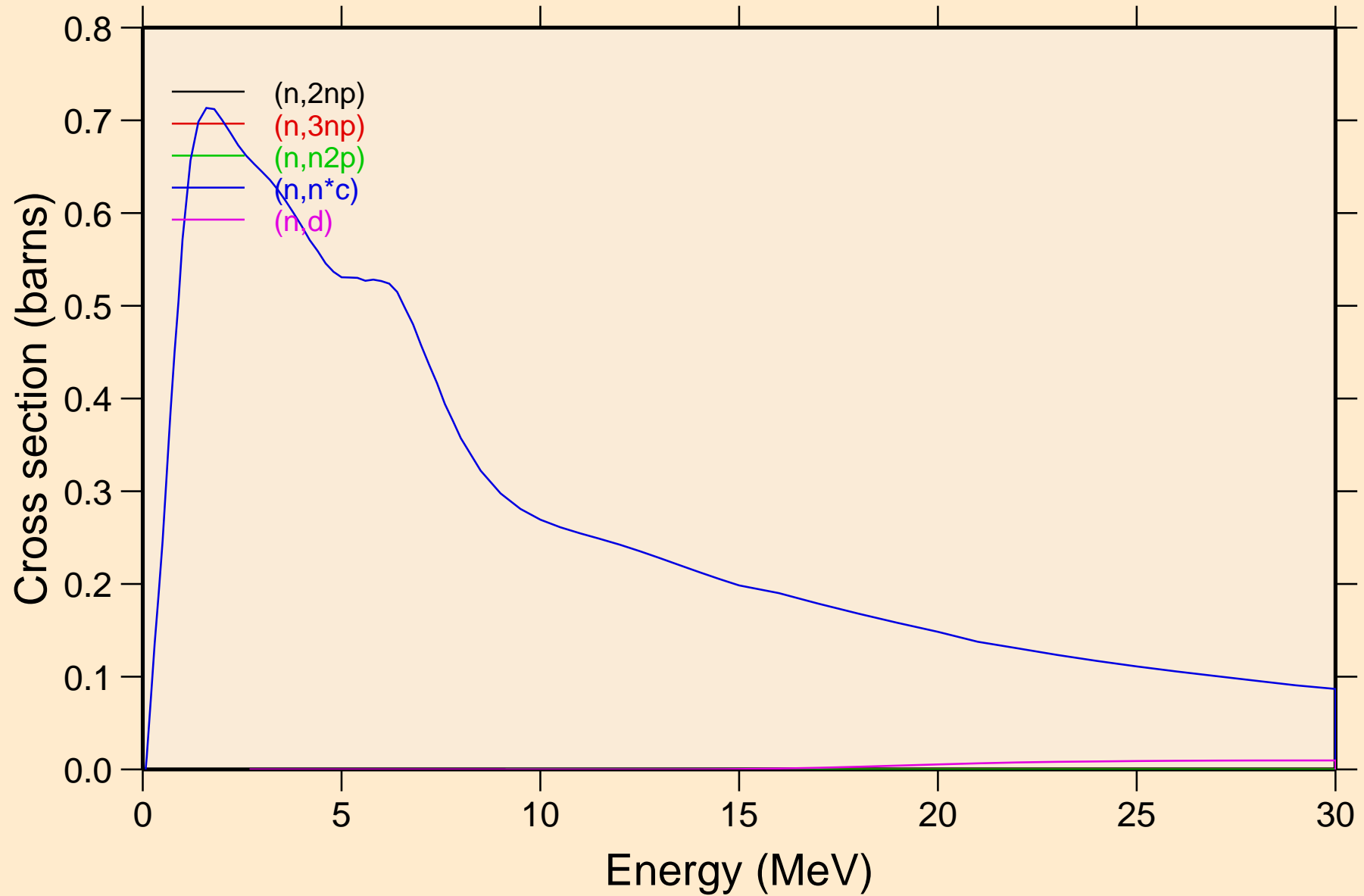

NO259 NEUTRON ACER TENDL-2023 LIBRARY; T=0.K
Threshold reactions

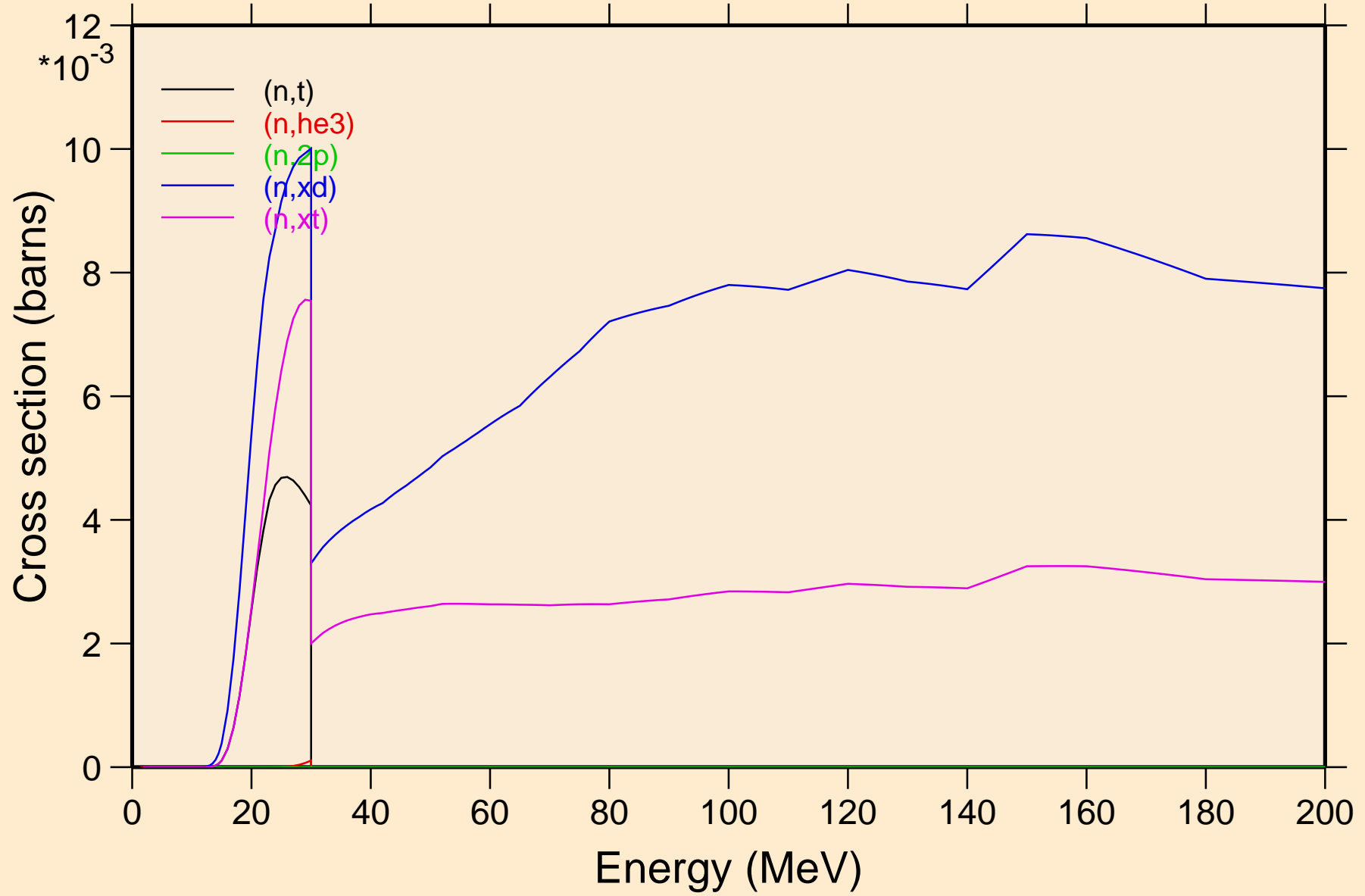

NO259 NEUTRON ACER TENDL-2023 LIBRARY; T=0.K
Threshold reactions

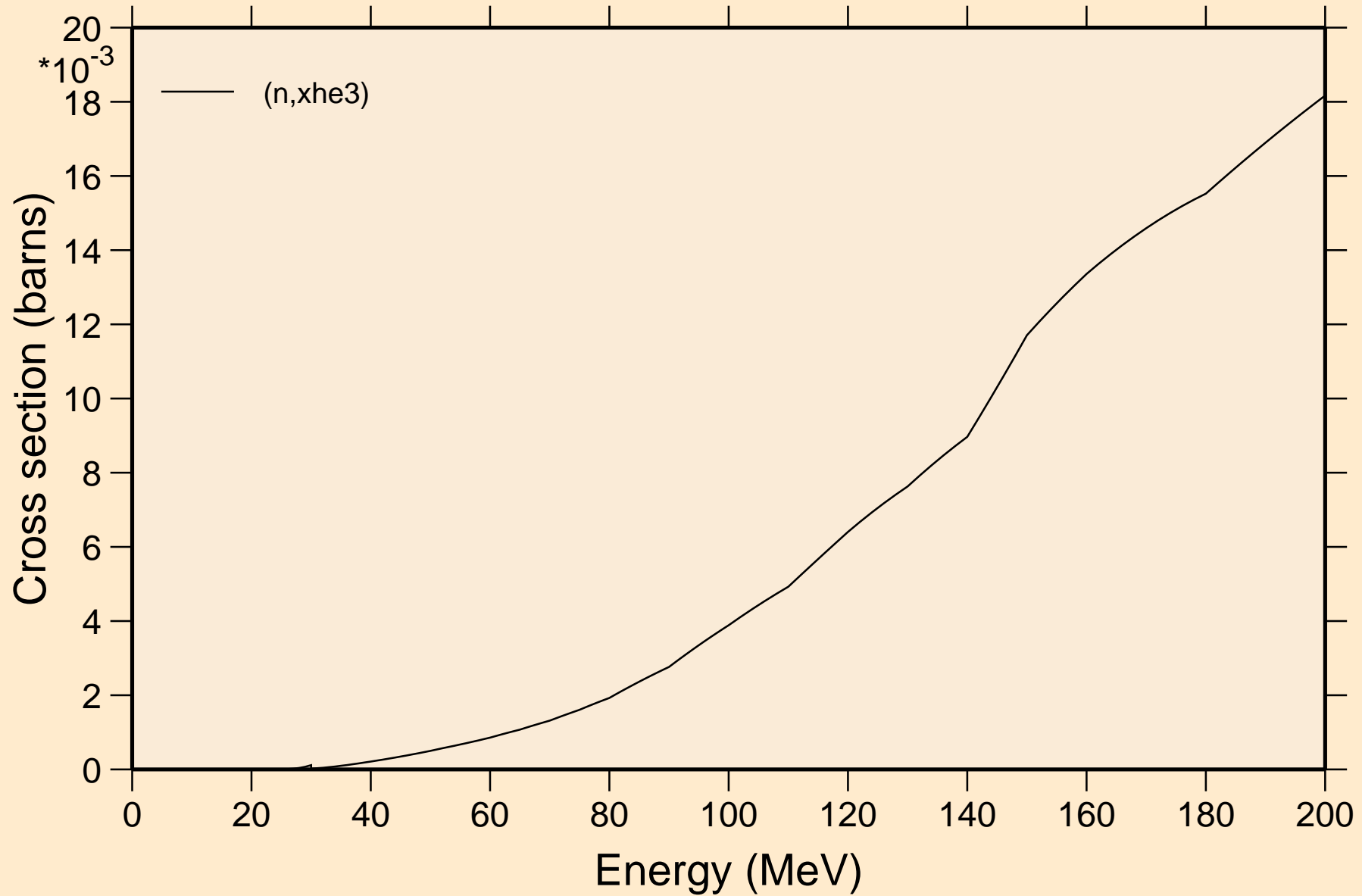

NO259 NEUTRON ACER TENDL-2023 LIBRARY; T=0.K
angular distribution for elastic

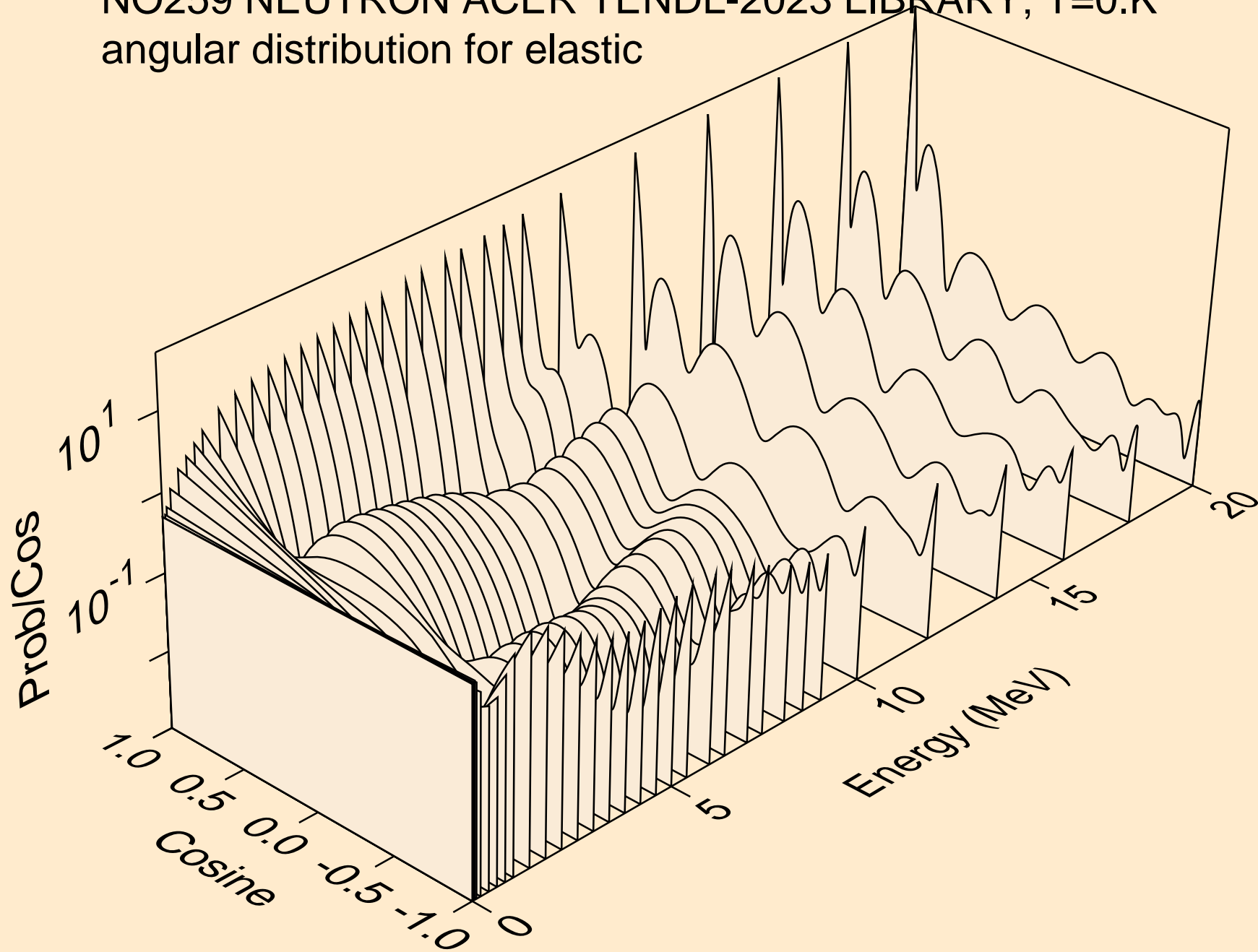

NO259 NEUTRON ACER TENDL-2023 LIBRARY; T=0.K
angular distribution for elastic

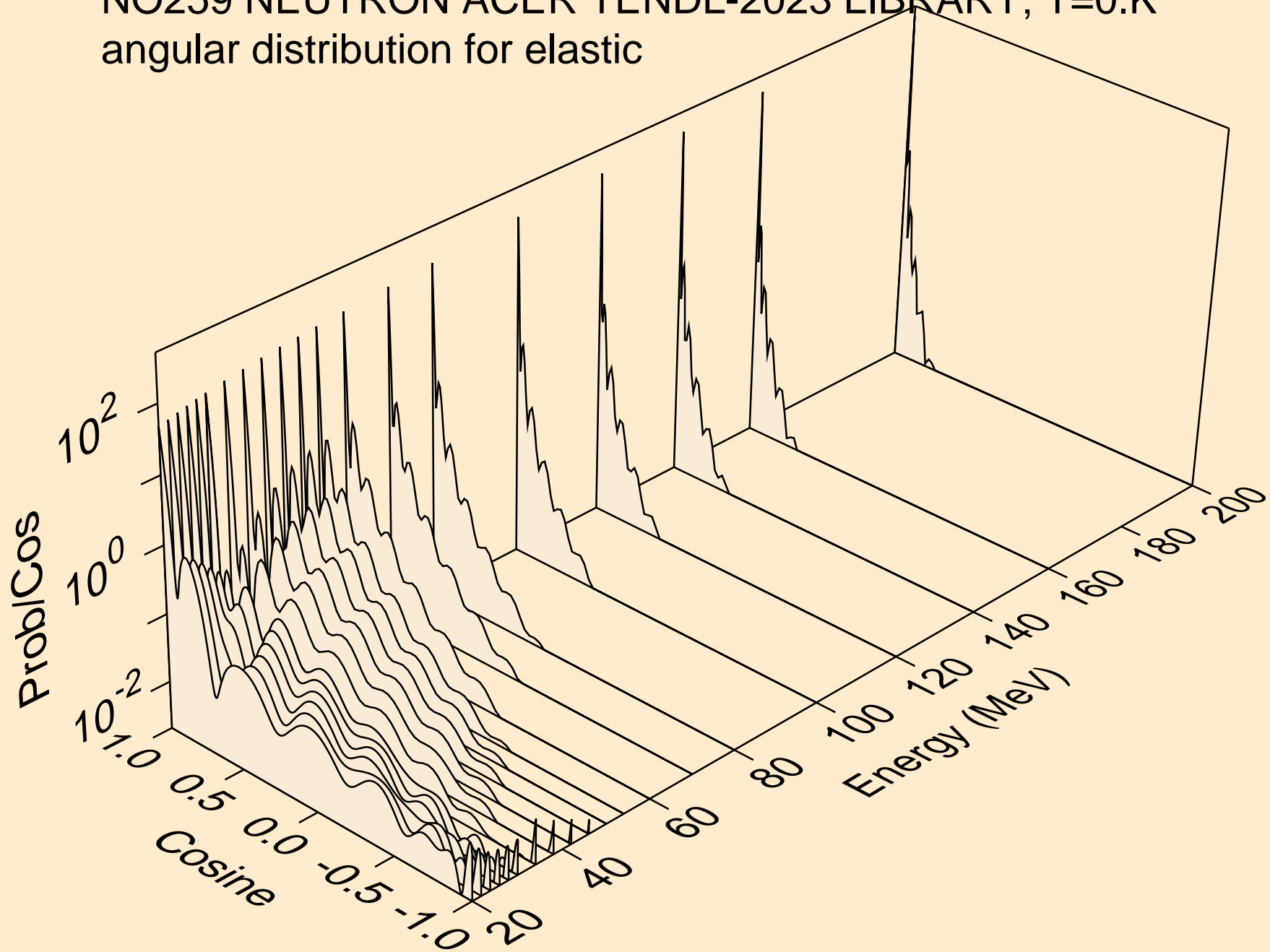

NO259 NEUTRON ACER TENDL-2023 LIBRARY; T=0.K
angular distribution for (n,n*1)

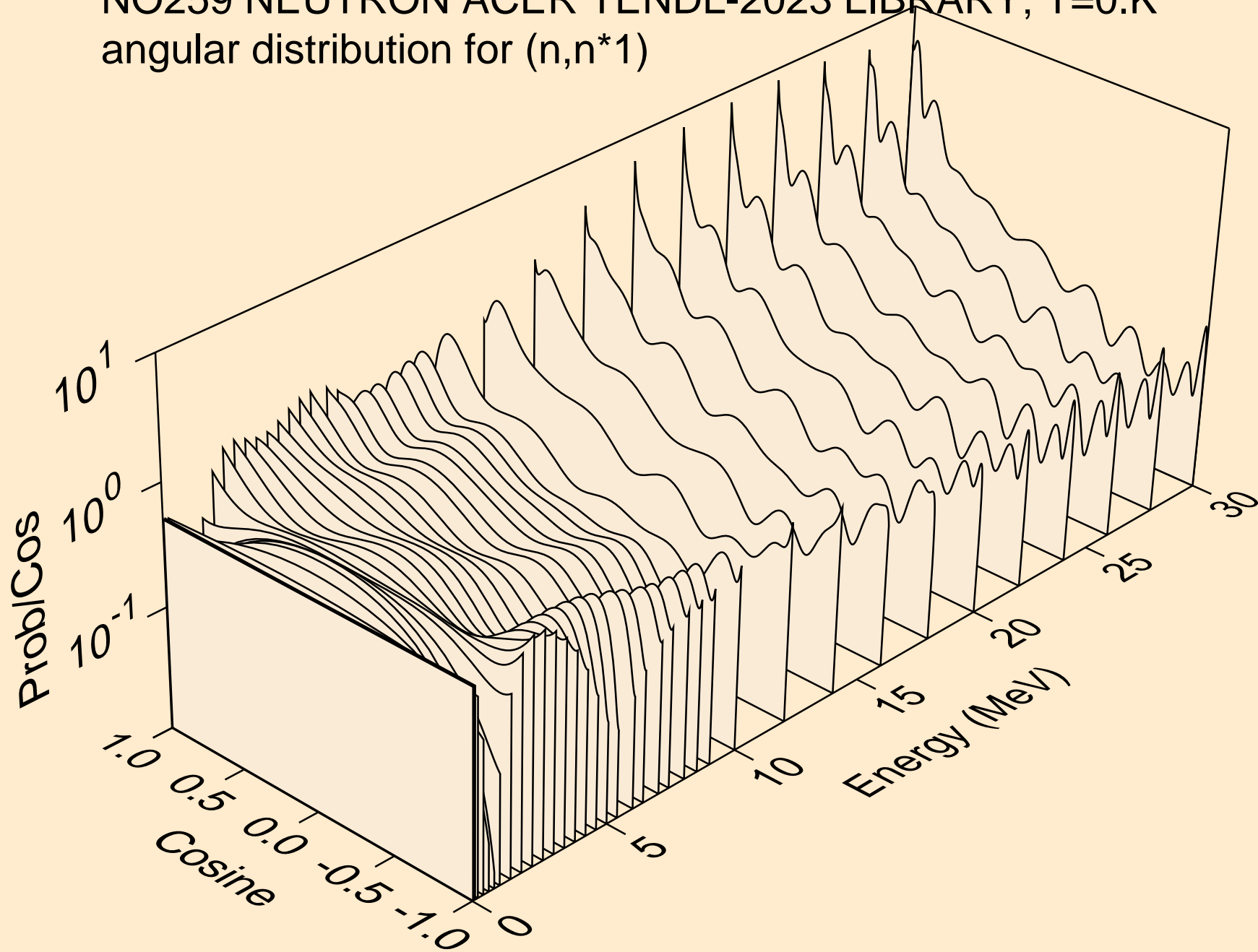

NO259 NEUTRON ACER TENDL-2023 LIBRARY; T=0.K
angular distribution for (n,n*2)

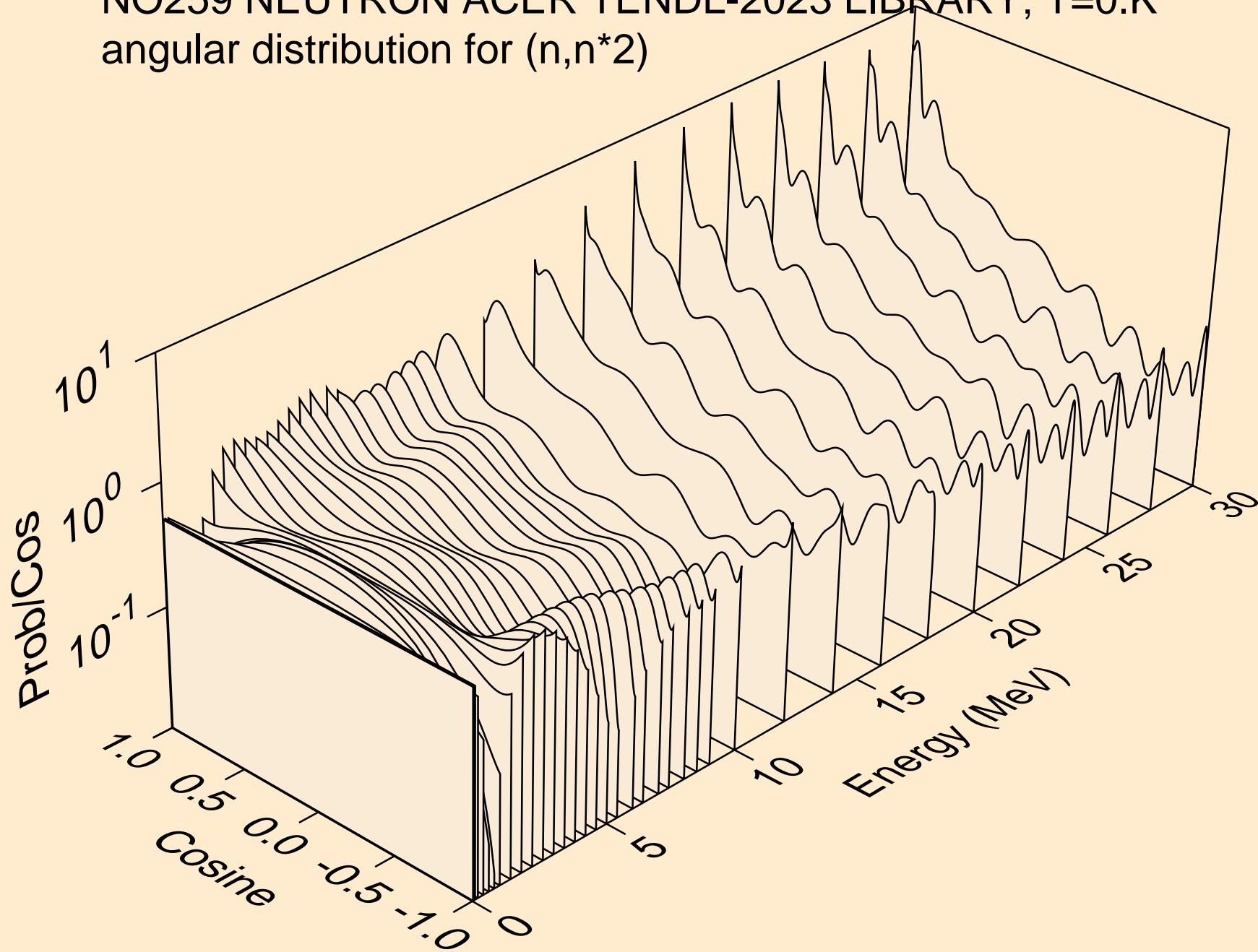

NO259 NEUTRON ACER TENDL-2023 LIBRARY; T=0.K
angular distribution for (n,n*3)

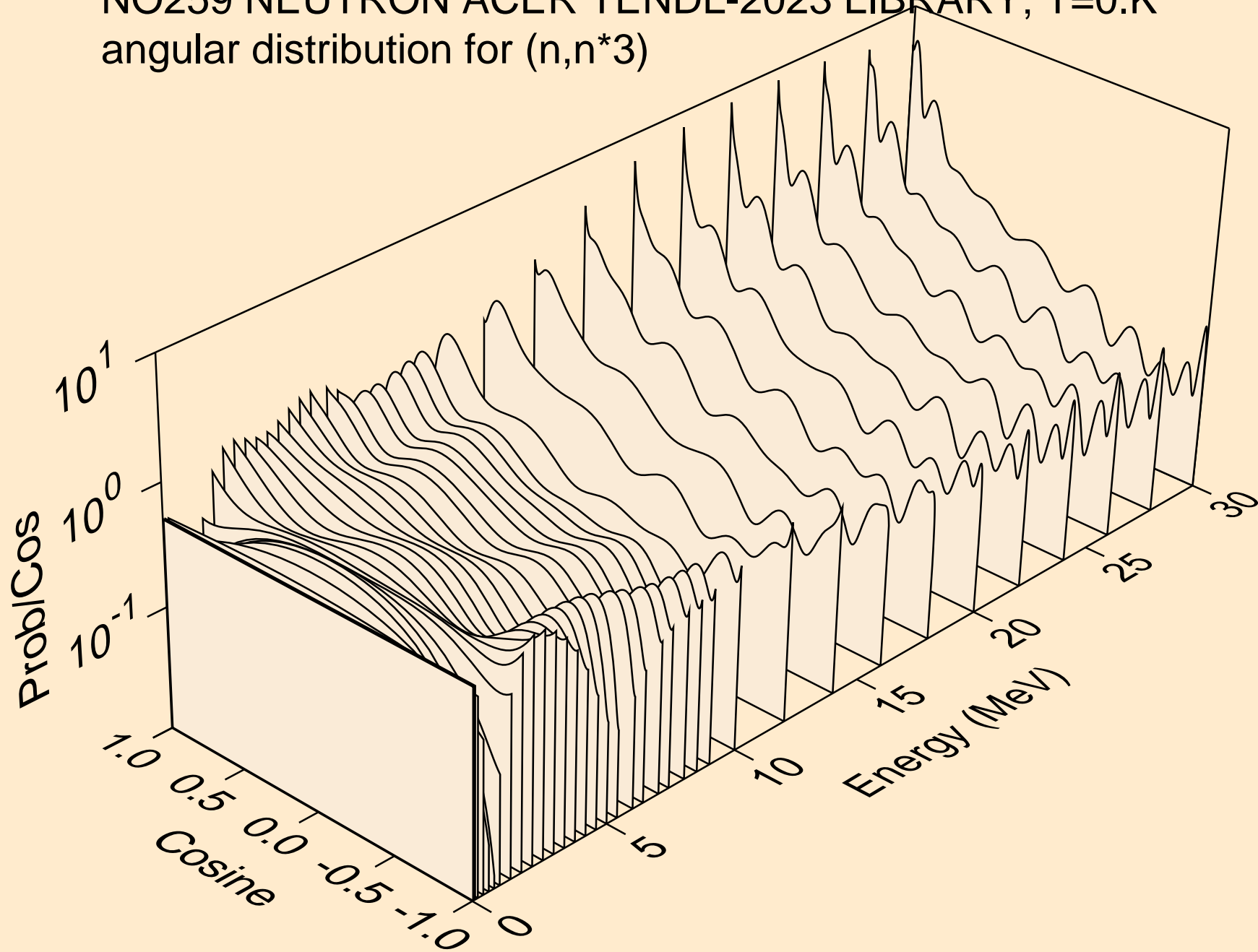

NO259 NEUTRON ACER TENDL-2023 LIBRARY; T=0.K
angular distribution for (n,n*4)

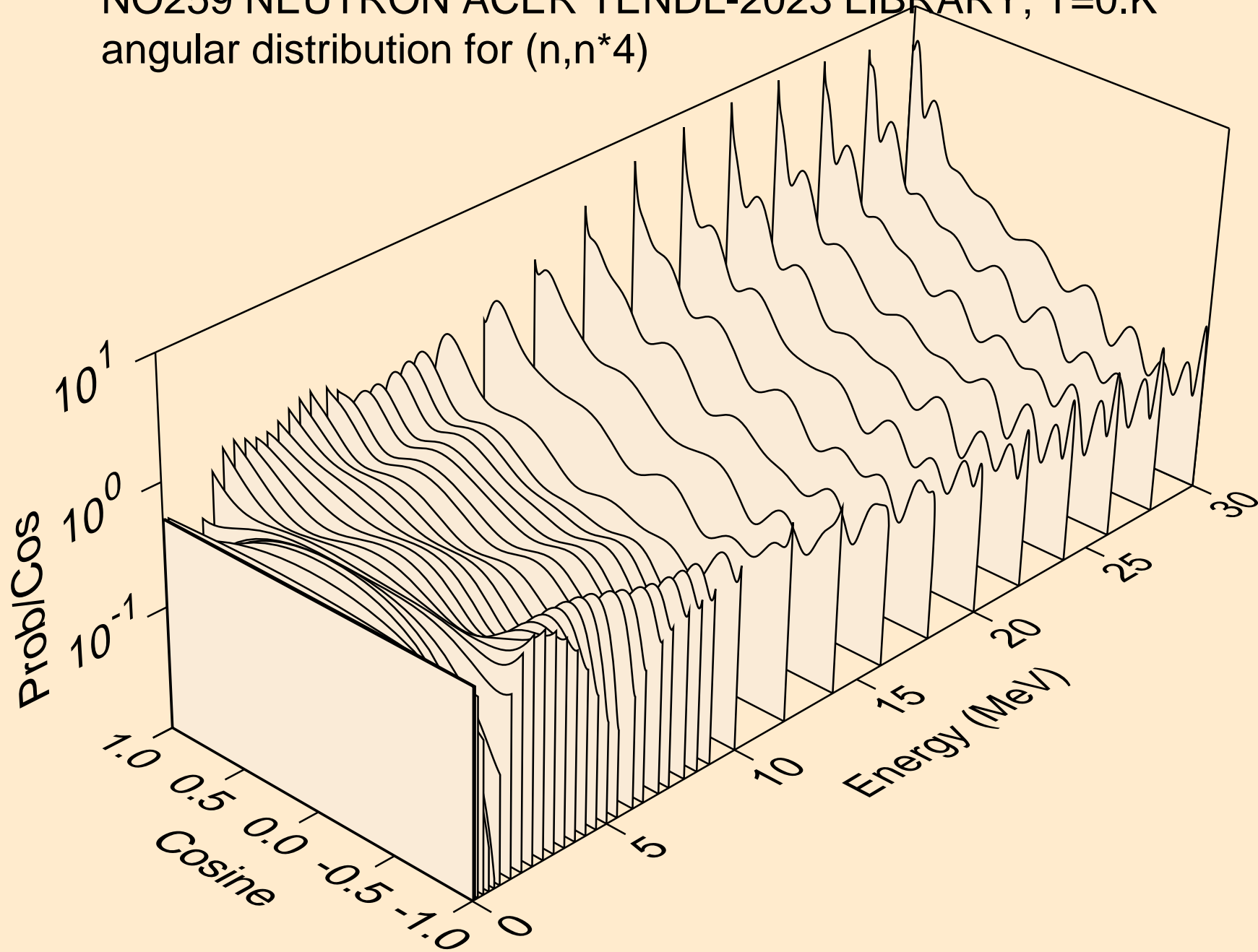

NO259 NEUTRON ACER TENDL-2023 LIBRARY; T=0.K
angular distribution for (n,n*5)

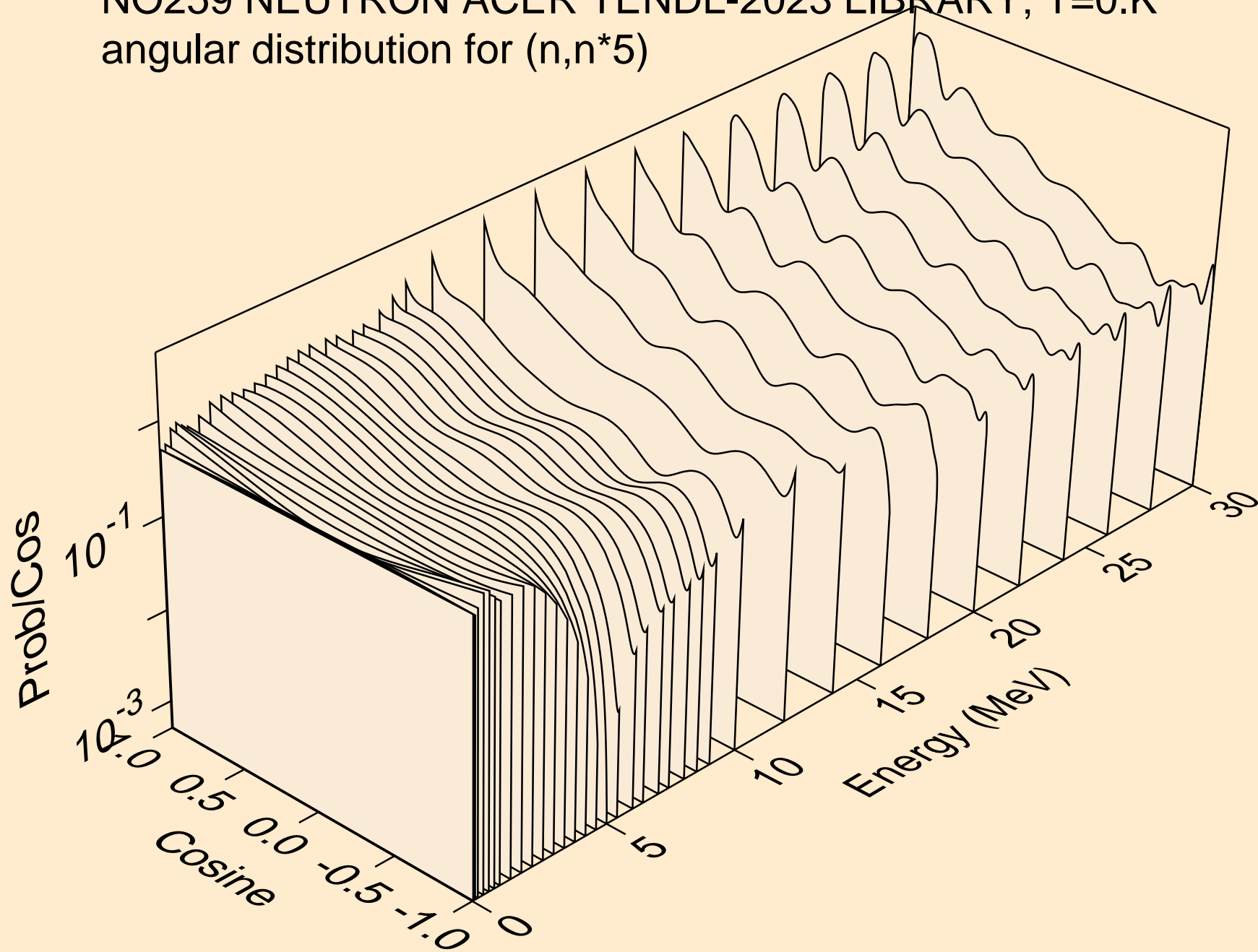

NO259 NEUTRON ACER TENDL-2023 LIBRARY; T=0.K
angular distribution for (n,n*6)

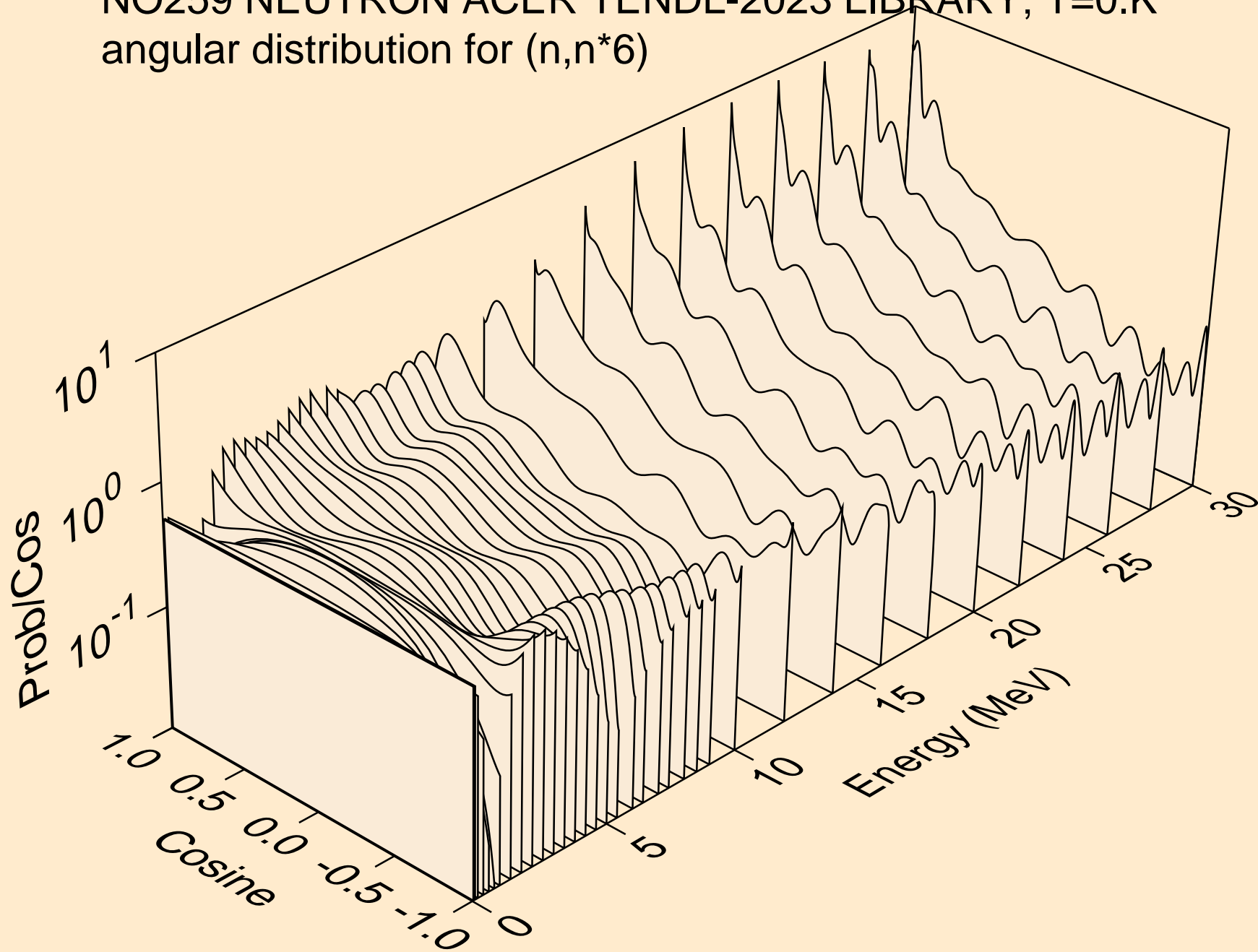

NO259 NEUTRON ACER TENDL-2023 LIBRARY; T=0.K
angular distribution for (n,n*7)

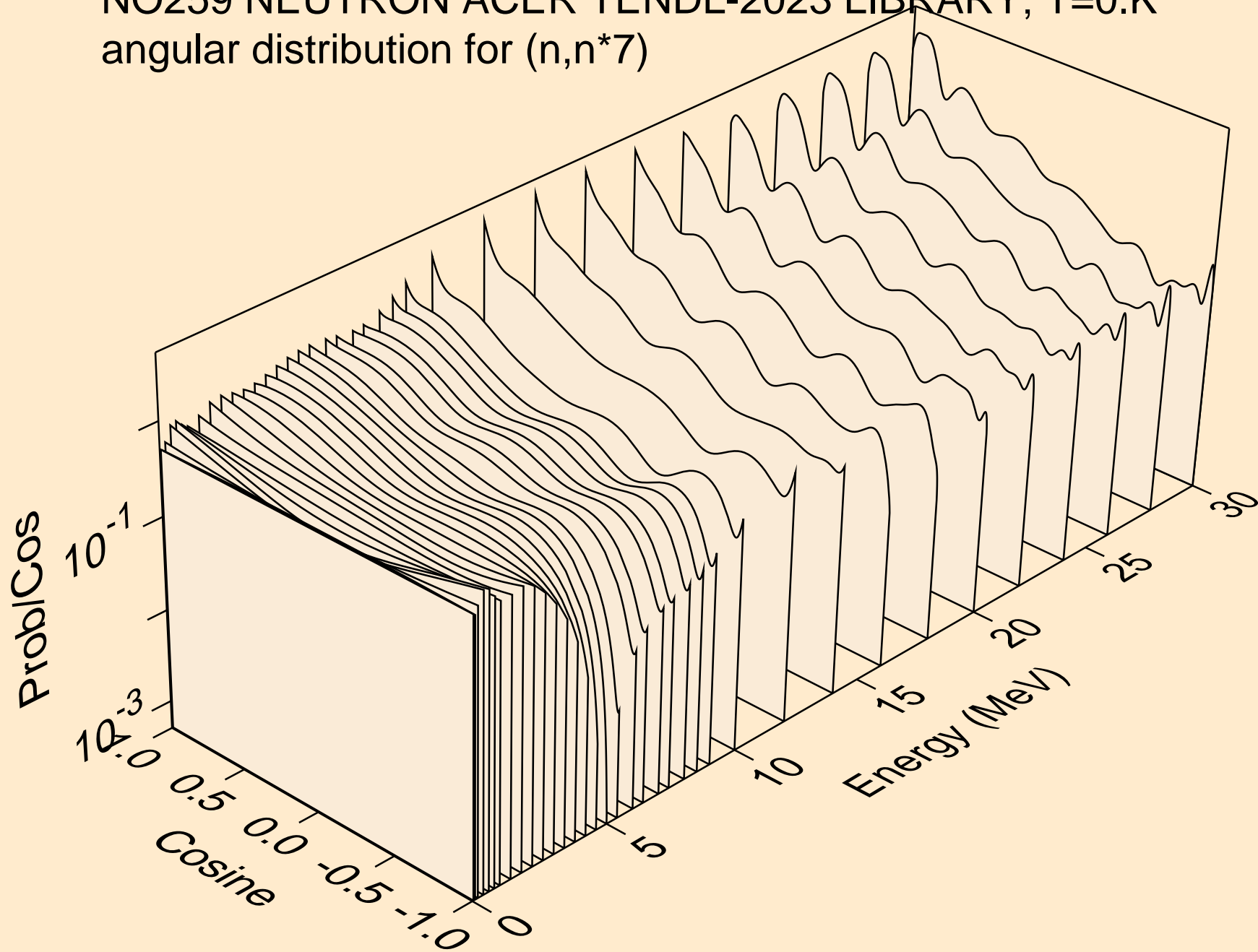

NO259 NEUTRON ACER TENDL-2023 LIBRARY; T=0.K
angular distribution for (n,n*8)

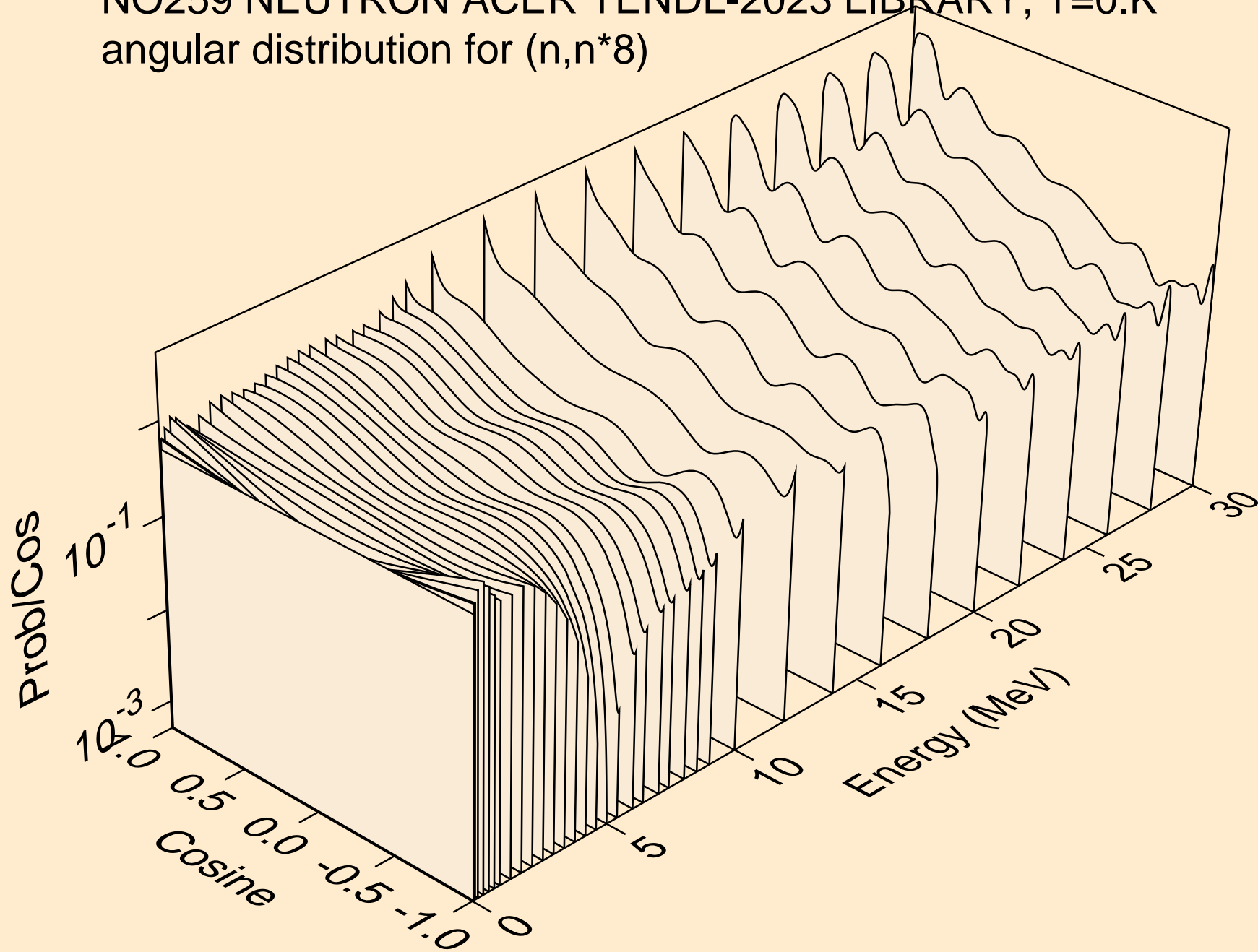

NO259 NEUTRON ACER TENDL-2023 LIBRARY; T=0.K
angular distribution for (n,n*9)

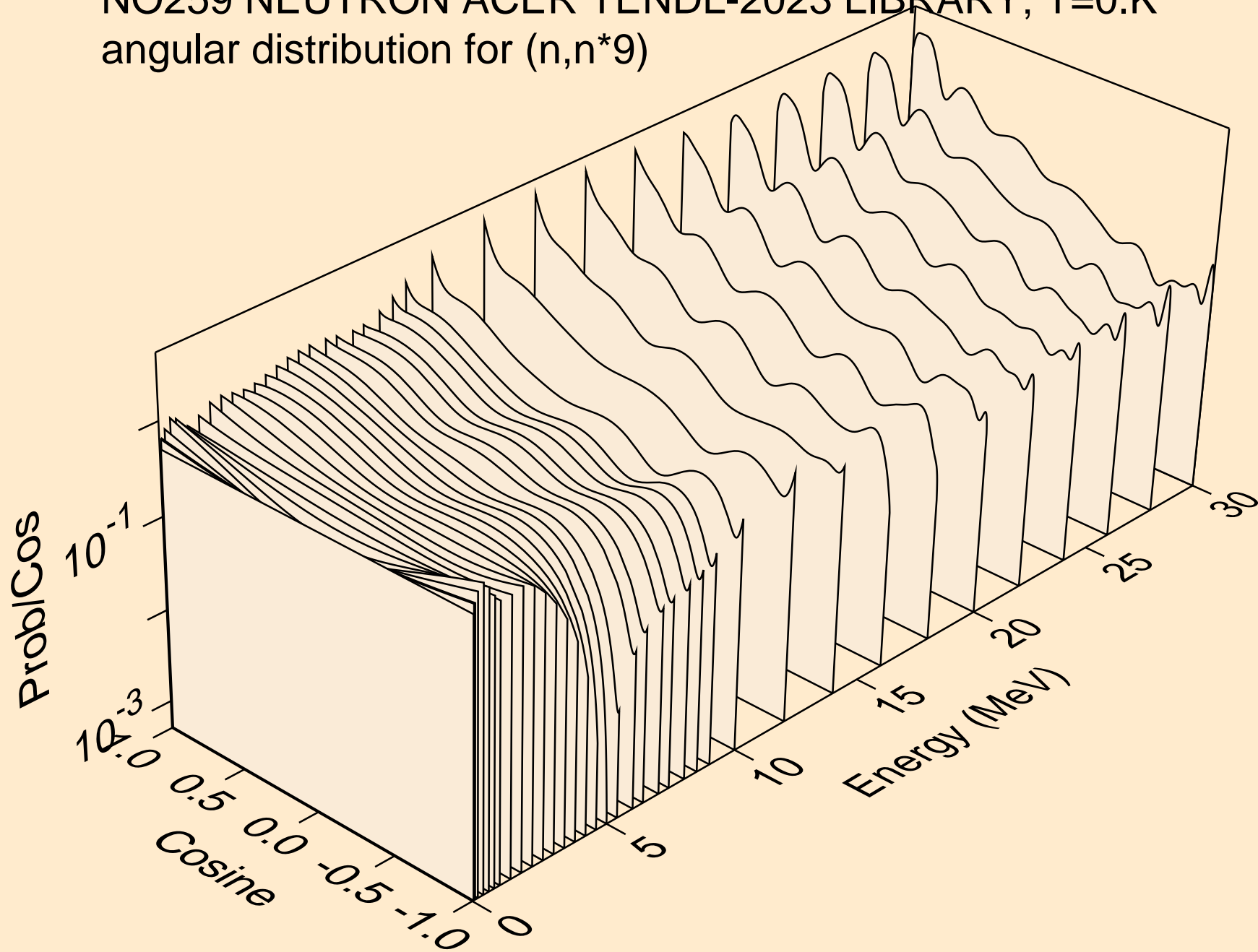

NO259 NEUTRON ACER TENDL-2023 LIBRARY; T=0.K
angular distribution for (n,n*10)

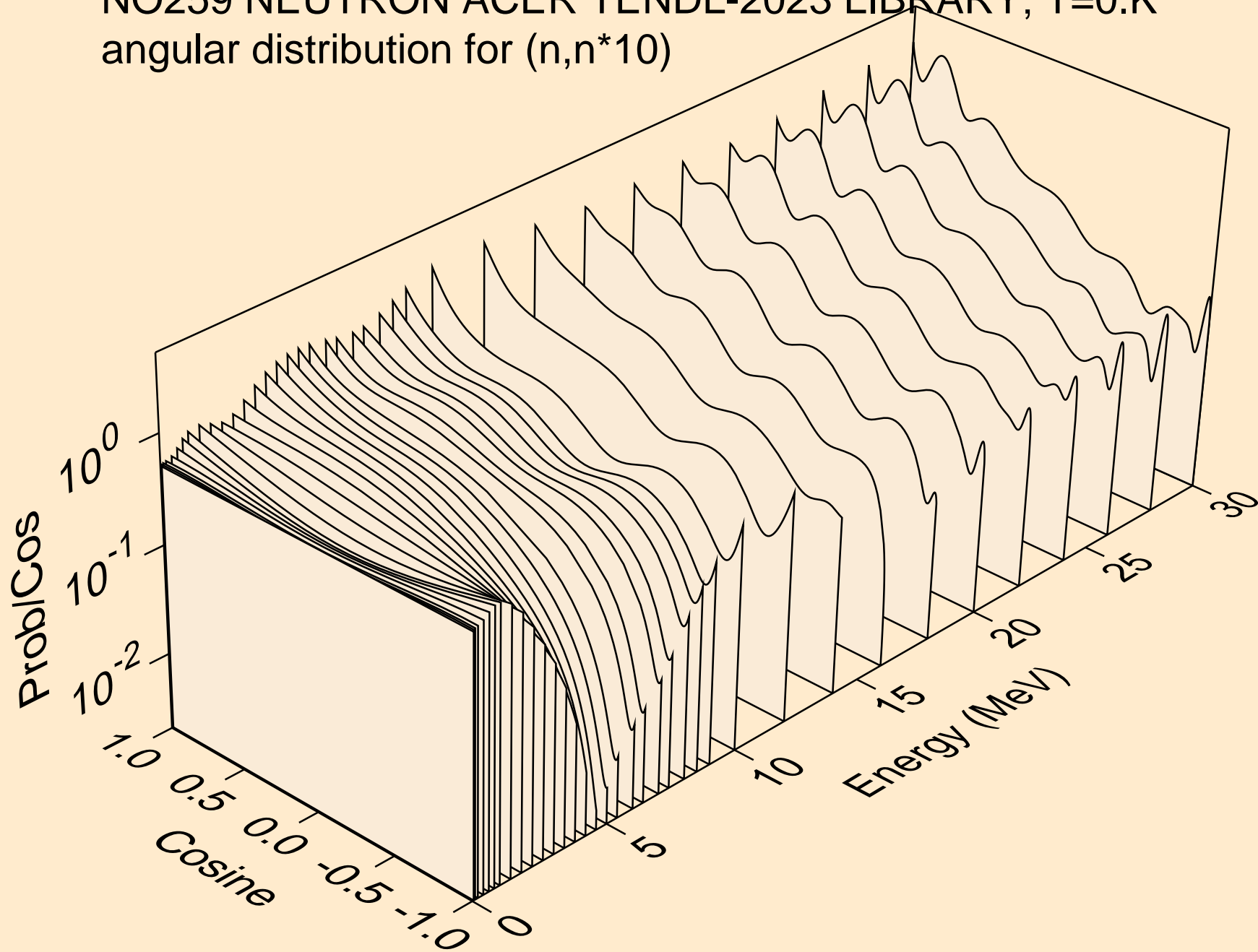

NO259 NEUTRON ACER TENDL-2023 LIBRARY; T=0.K
angular distribution for (n,n*11)

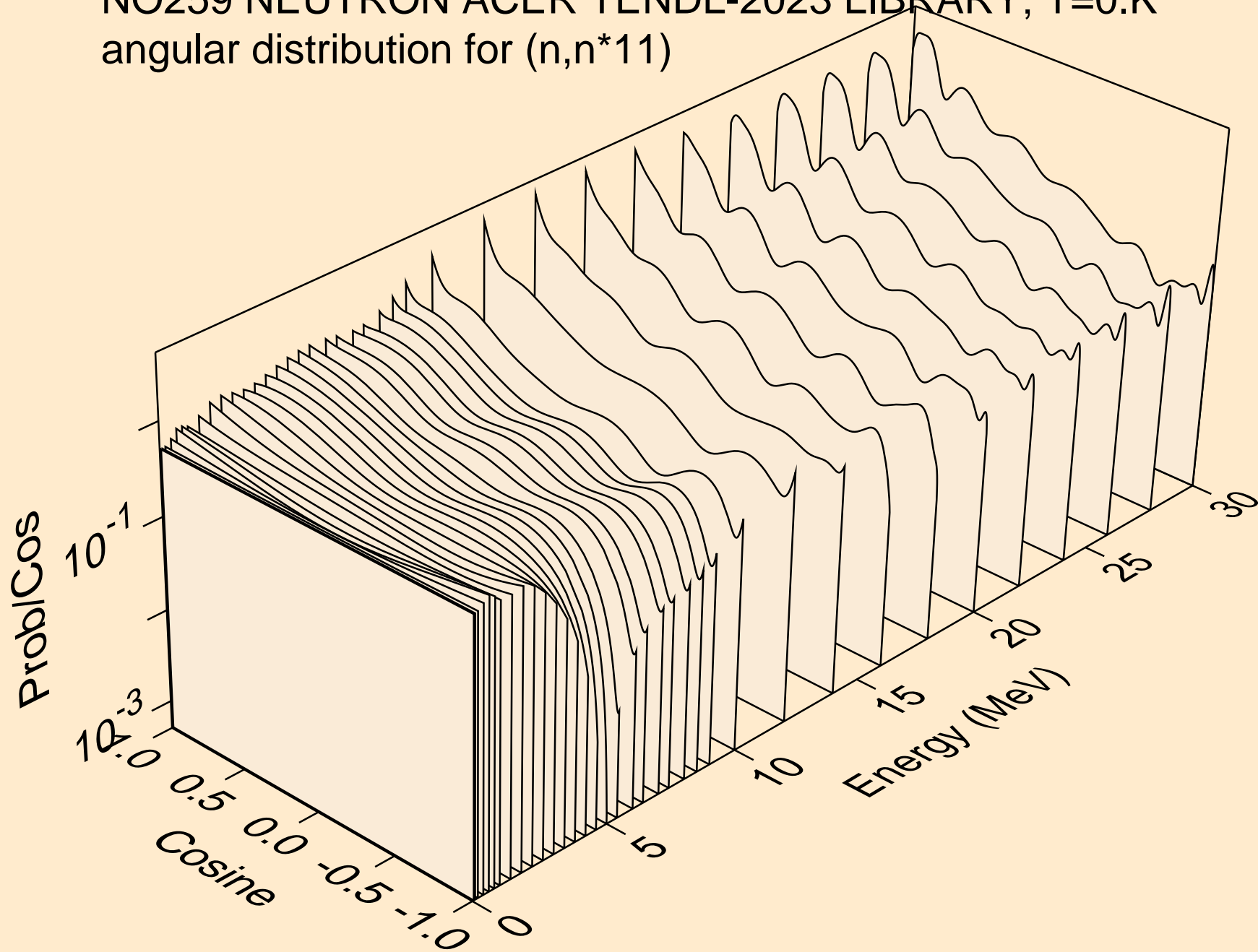

NO259 NEUTRON ACER TENDL-2023 LIBRARY; T=0.K
angular distribution for (n,n*12)

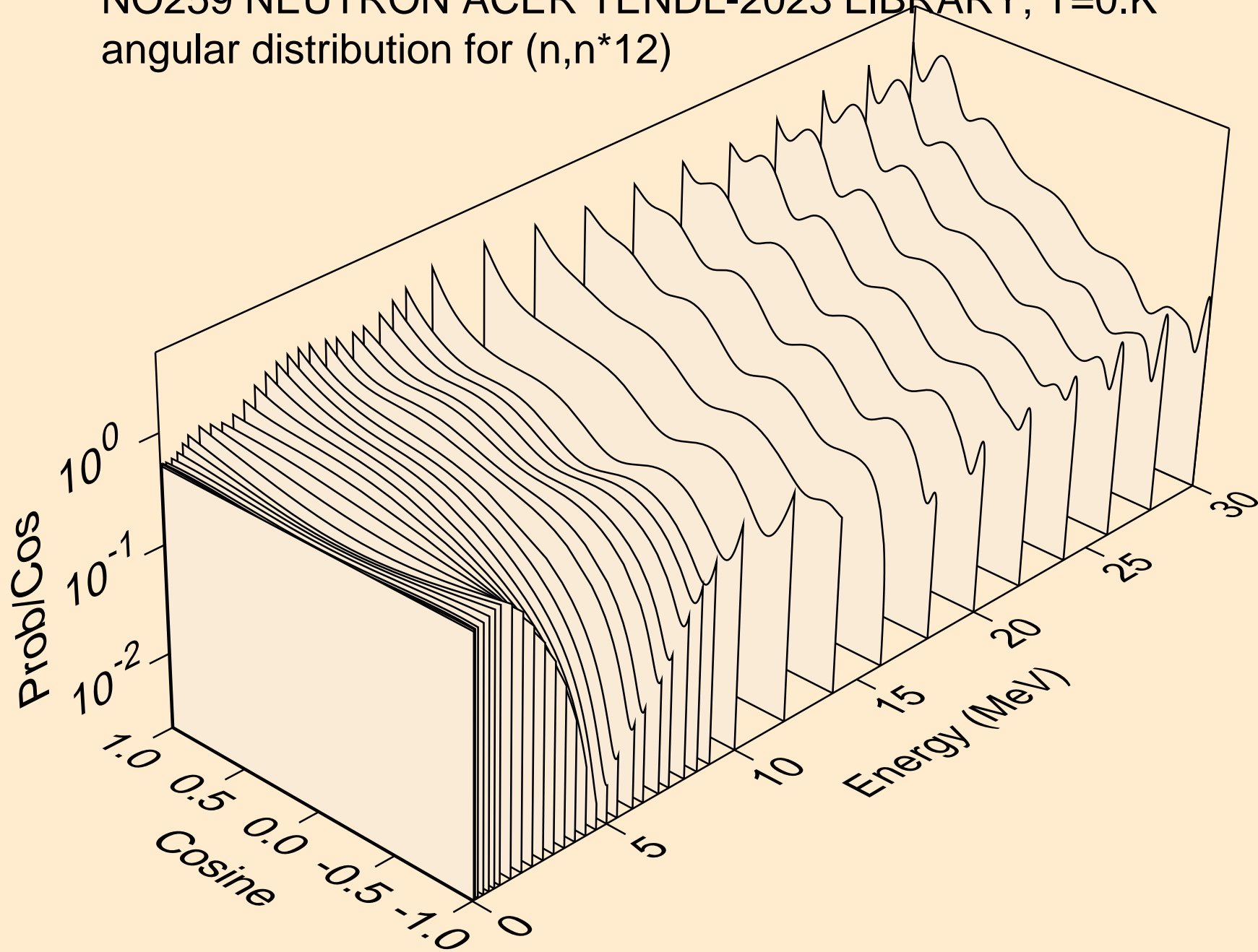

NO259 NEUTRON ACER TENDL-2023 LIBRARY; T=0.K
angular distribution for (n,n*13)

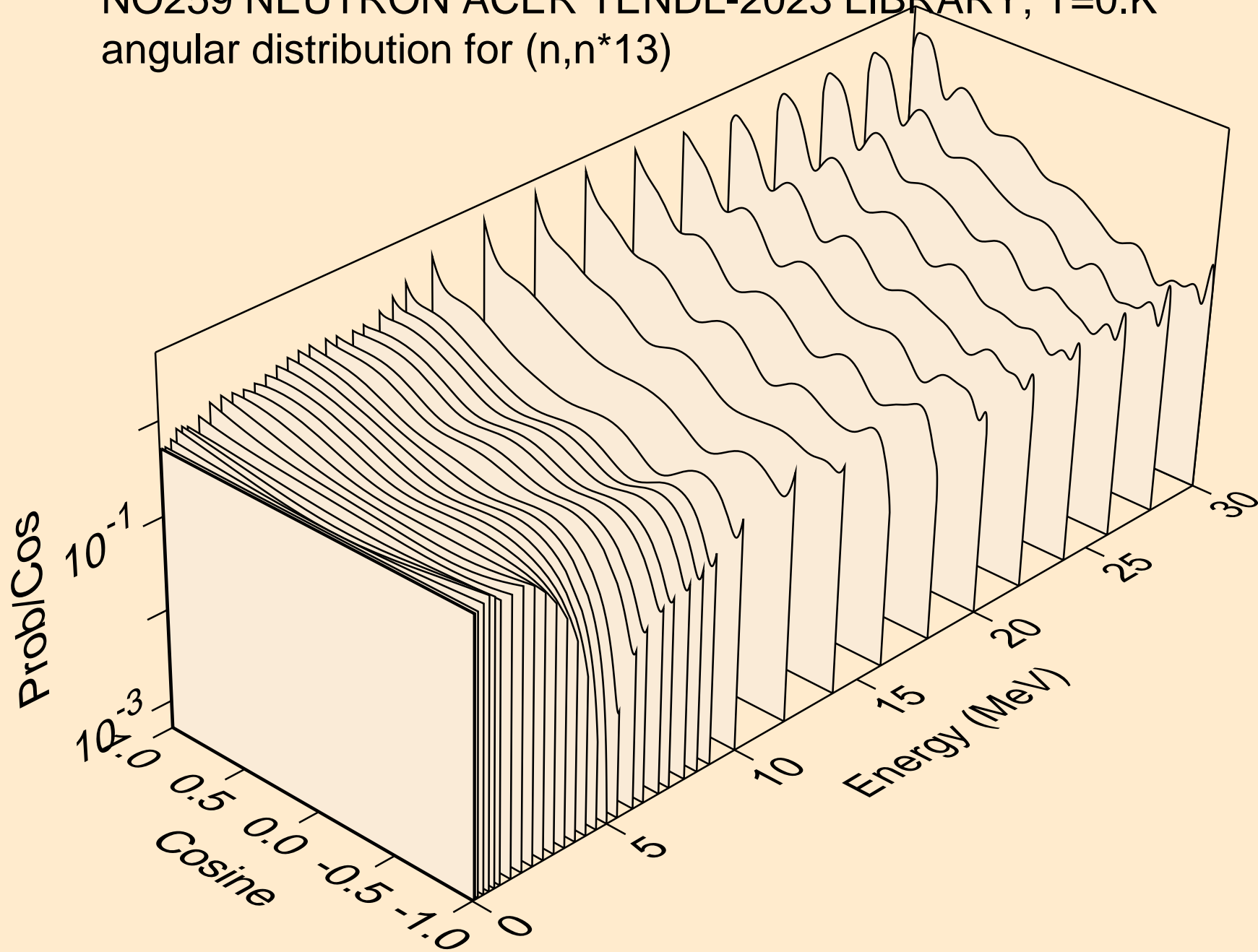

NO259 NEUTRON ACER TENDL-2023 LIBRARY; T=0.K
angular distribution for (n,n*14)

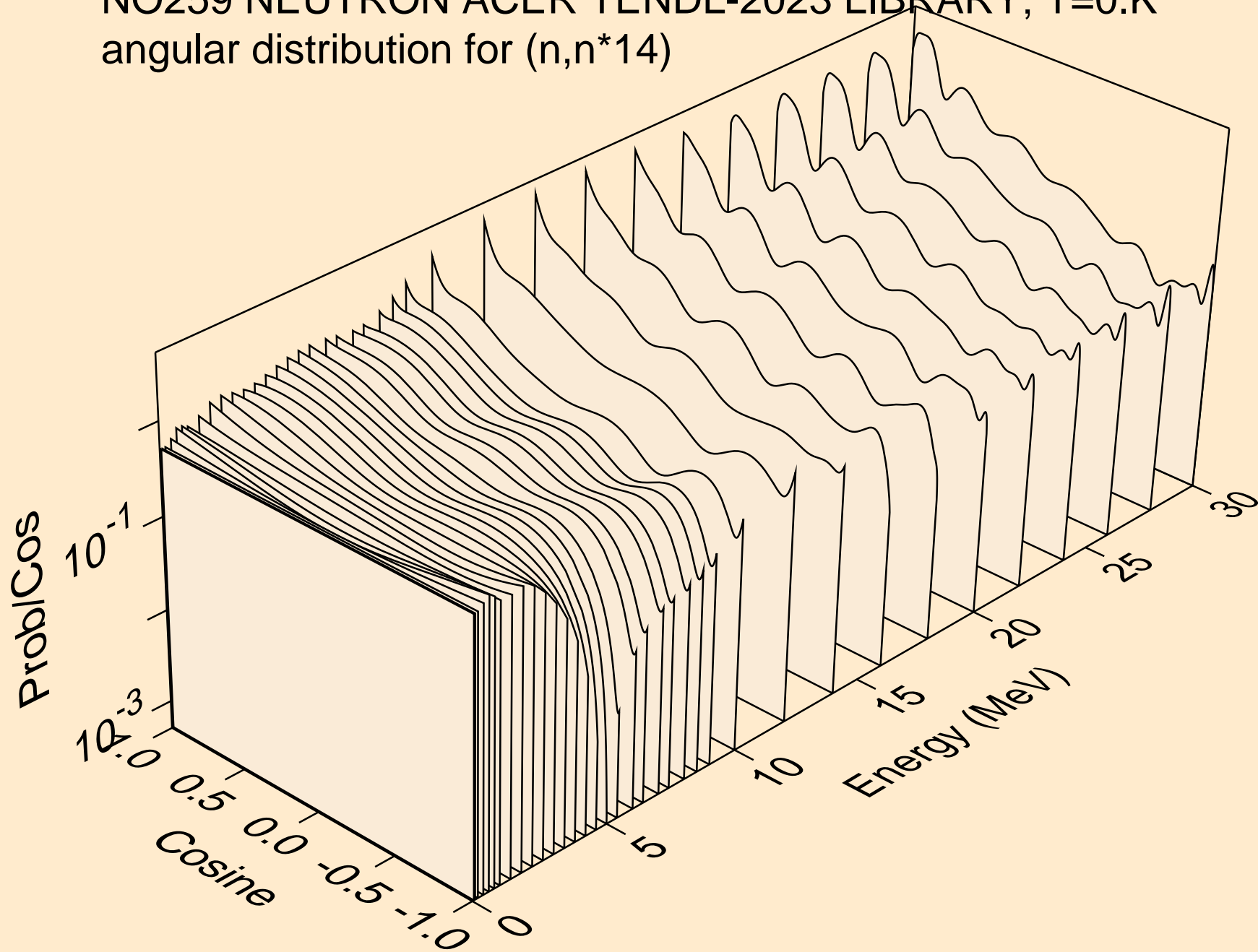

NO259 NEUTRON ACER TENDL-2023 LIBRARY; T=0.K
angular distribution for (n,n*15)

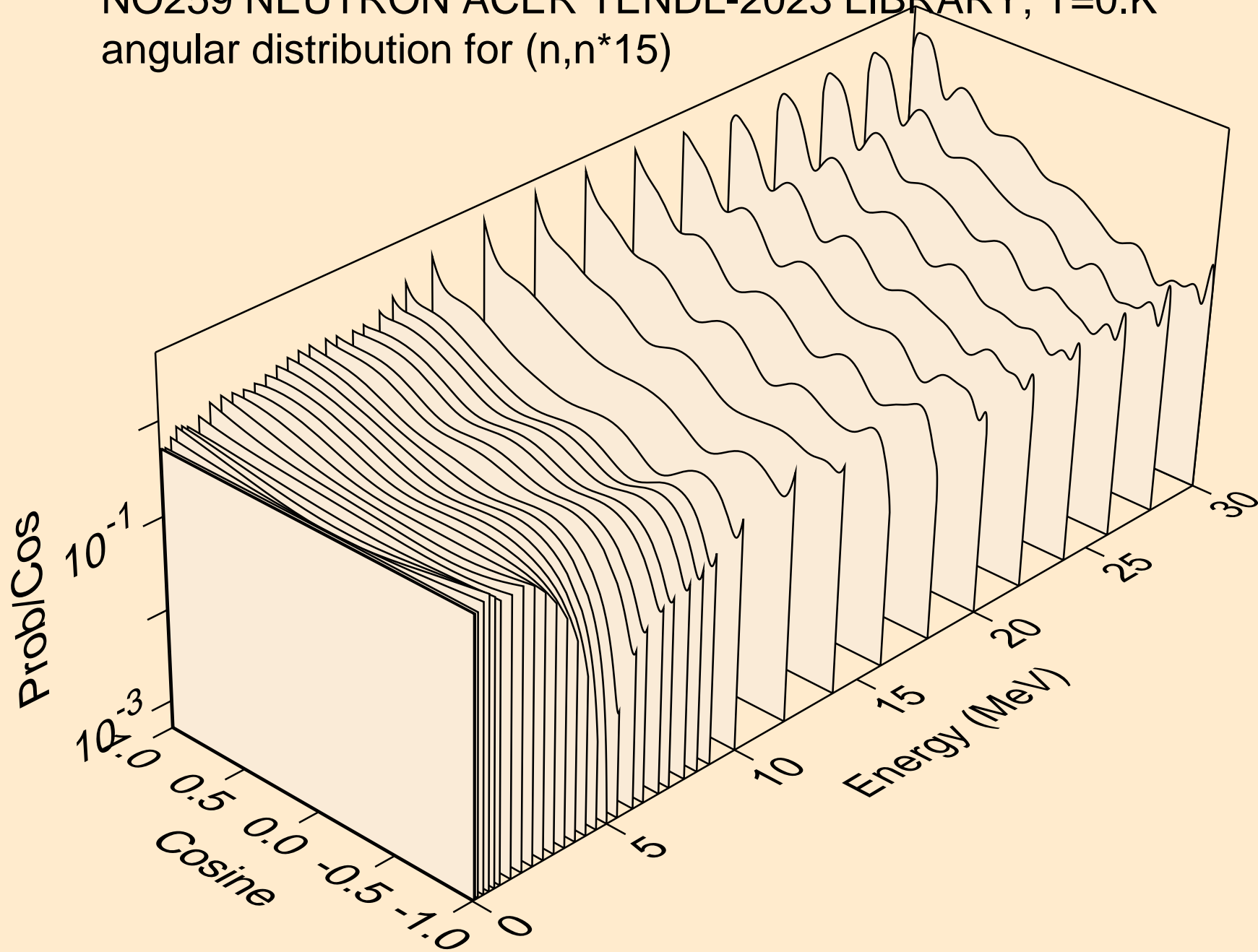

NO259 NEUTRON ACER TENDL-2023 LIBRARY; T=0.K
angular distribution for (n,n*16)

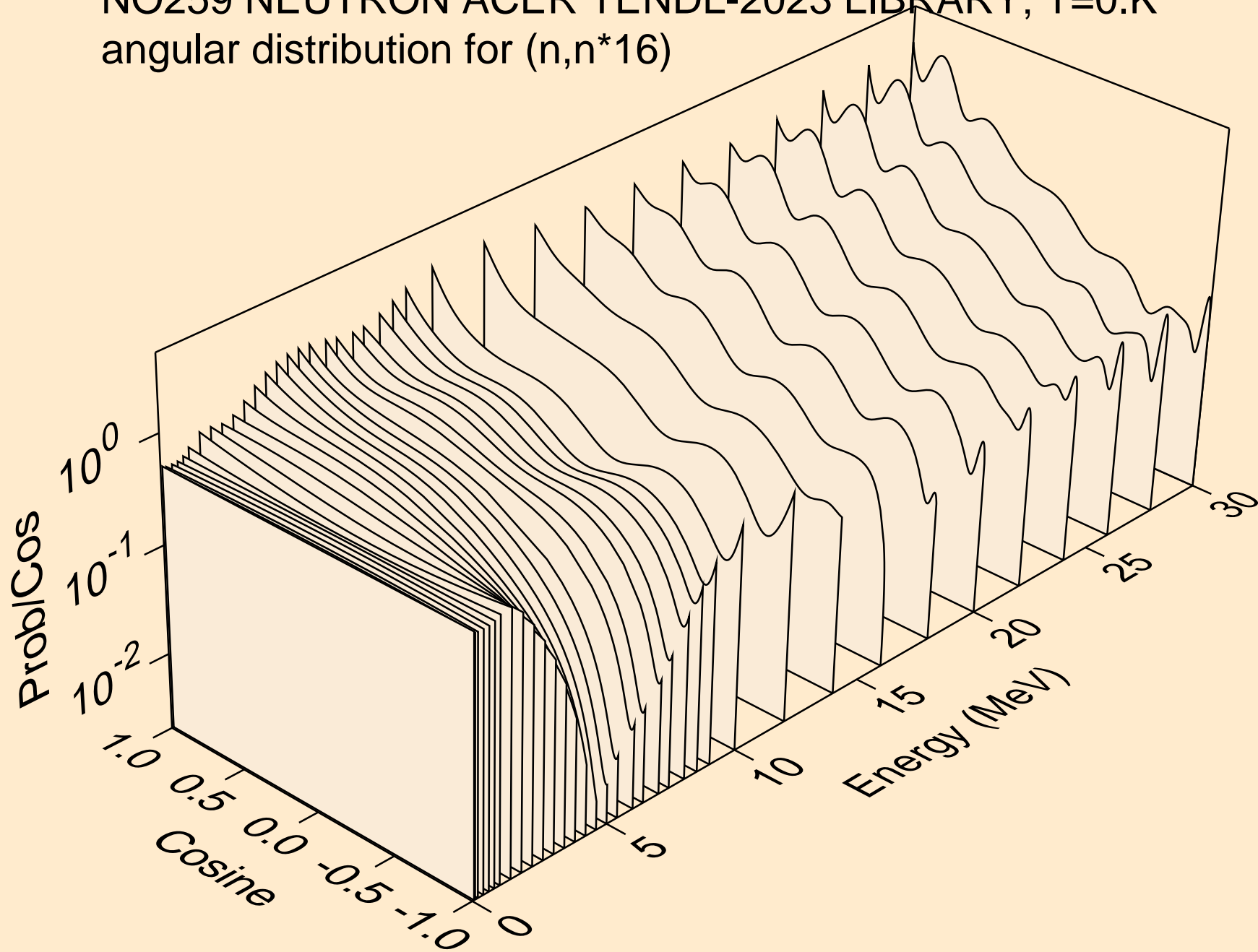

NO259 NEUTRON ACER TENDL-2023 LIBRARY; T=0.K
angular distribution for (n,n*17)

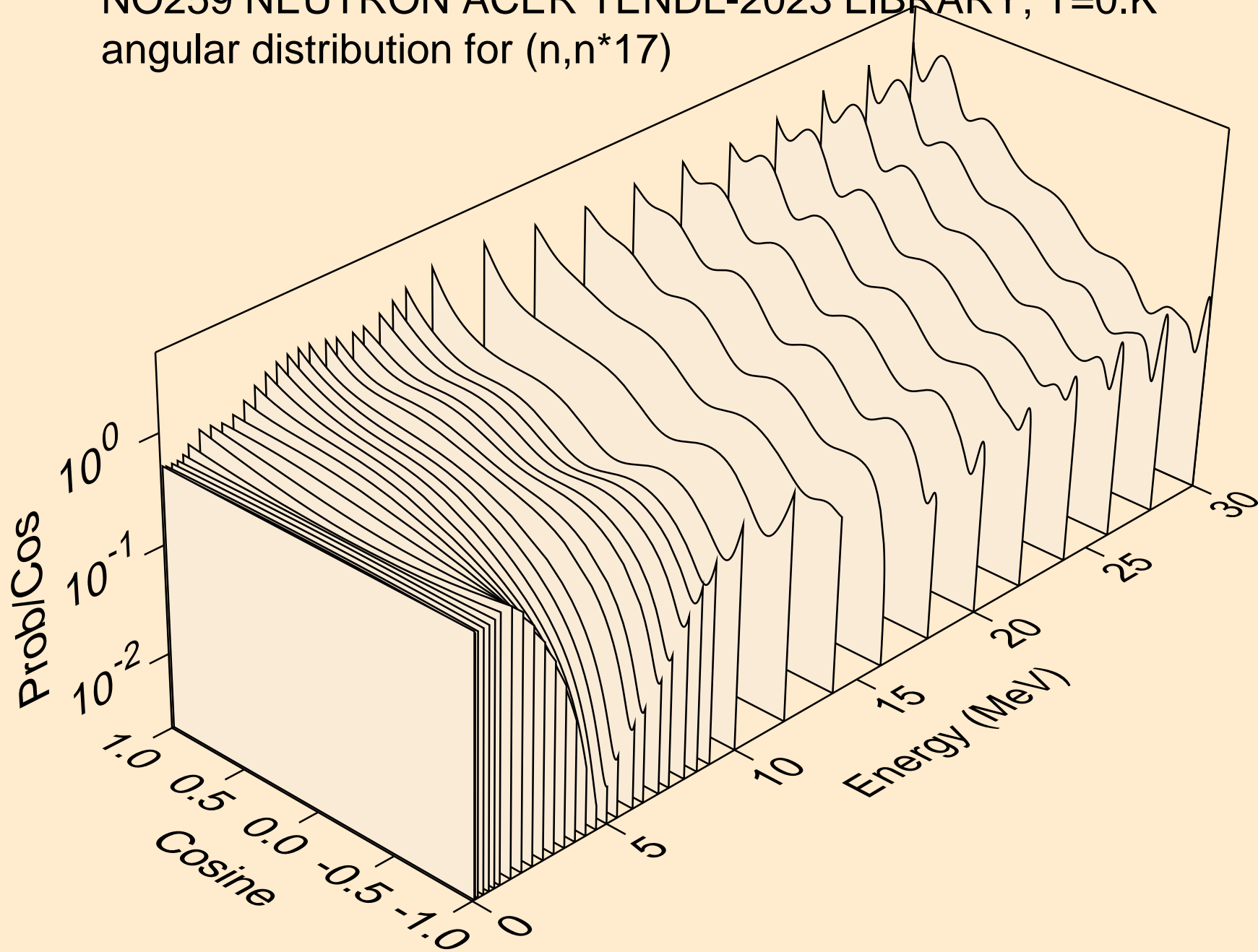

NO259 NEUTRON ACER TENDL-2023 LIBRARY; T=0.K
angular distribution for (n,n*18)

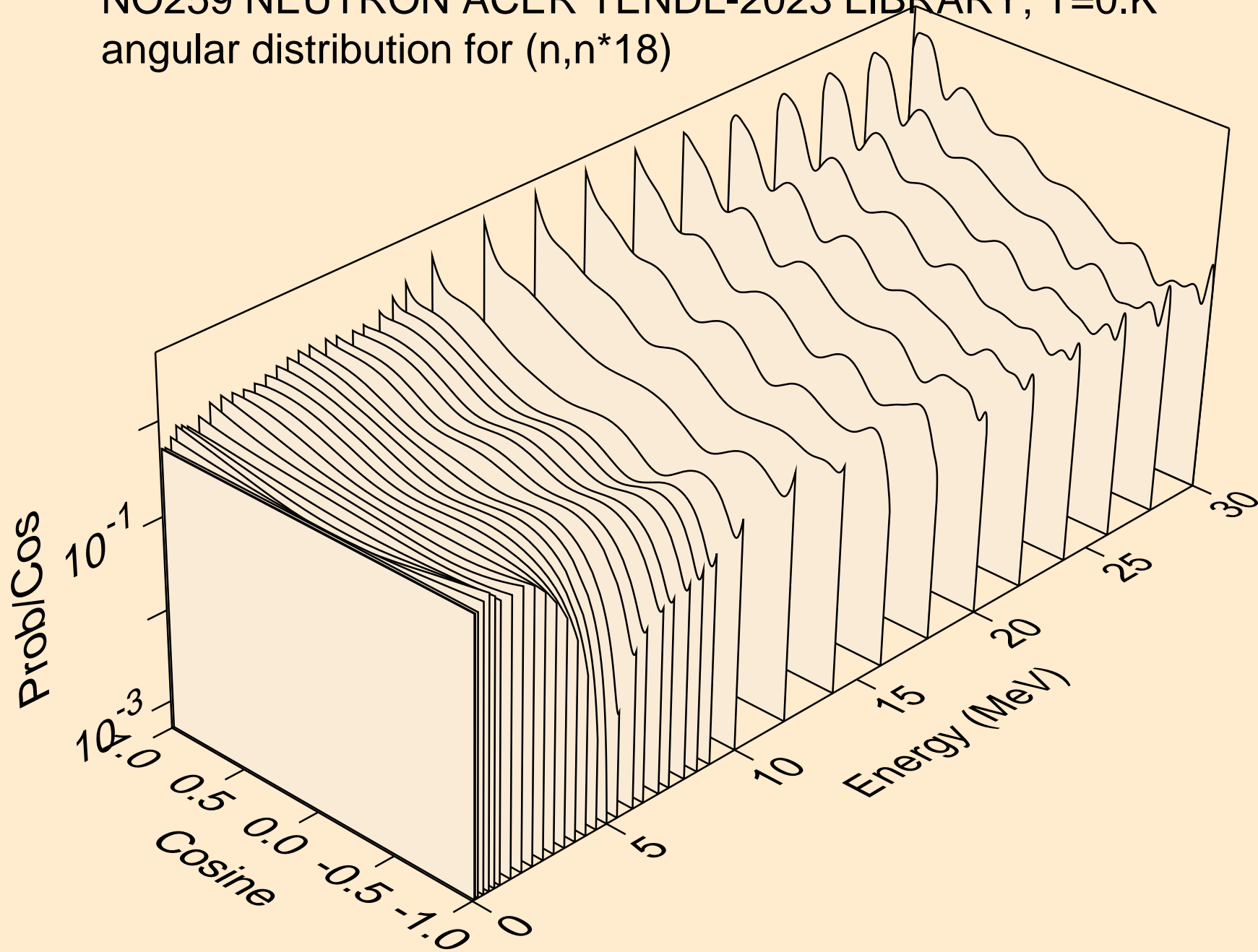

NO259 NEUTRON ACER TENDL-2023 LIBRARY; T=0.K

Total fission nubar

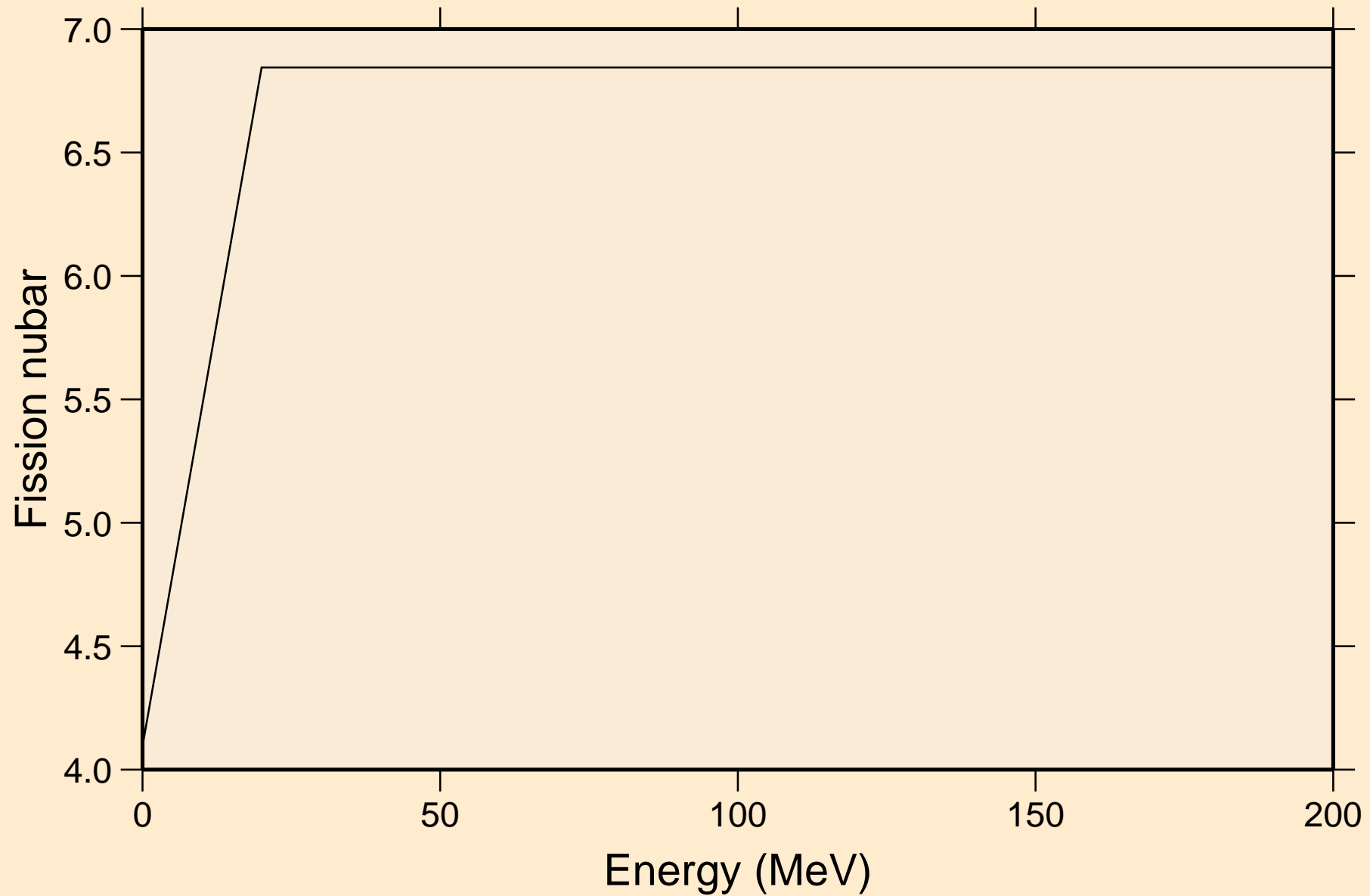

NO259 NEUTRON ACER TENDL-2023 LIBRARY; T=0.K
Neutron emission for (n,x)

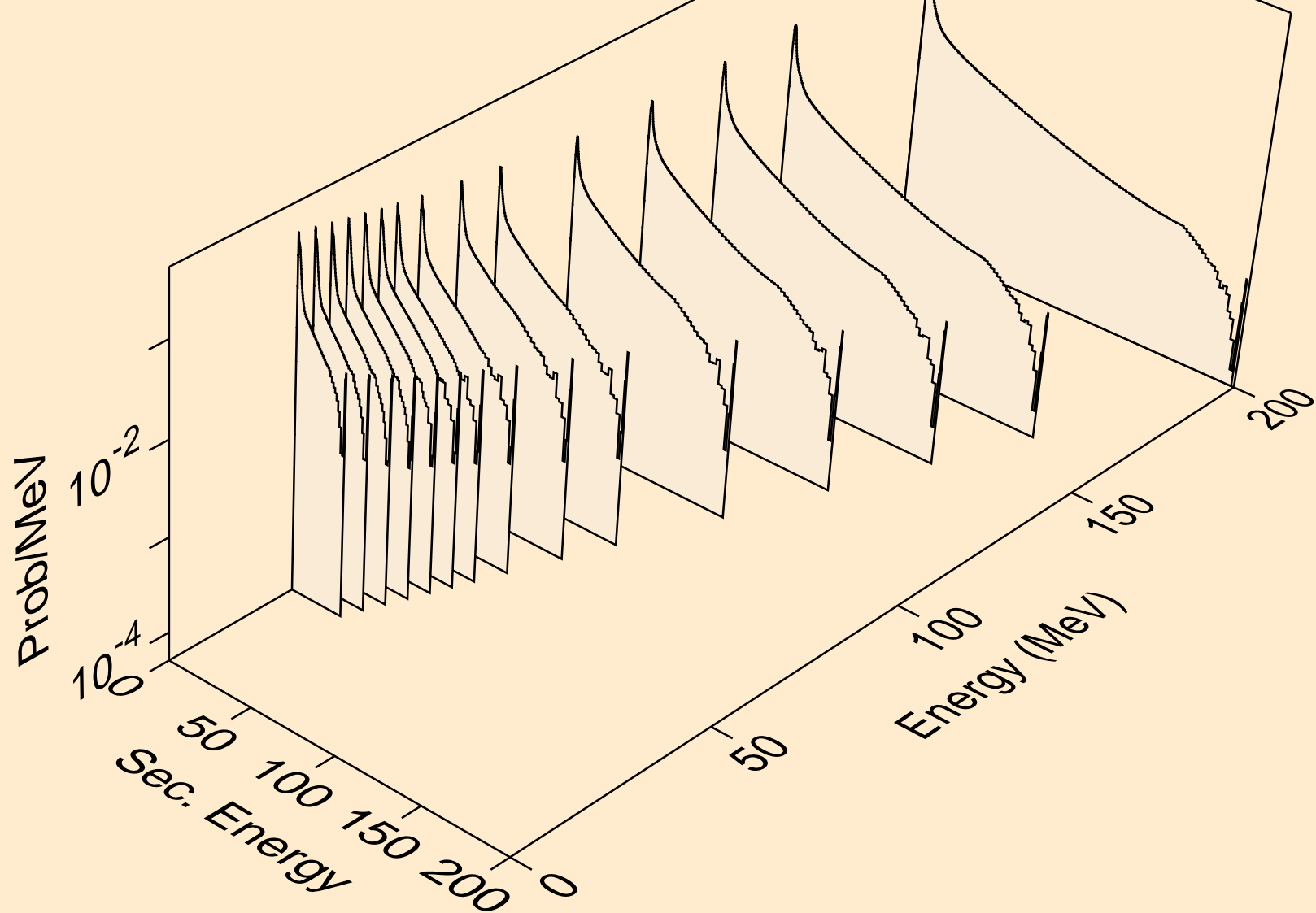

NO259 NEUTRON ACER TENDL-2023 LIBRARY; T=0.K
Neutron emission for (n,2nd)

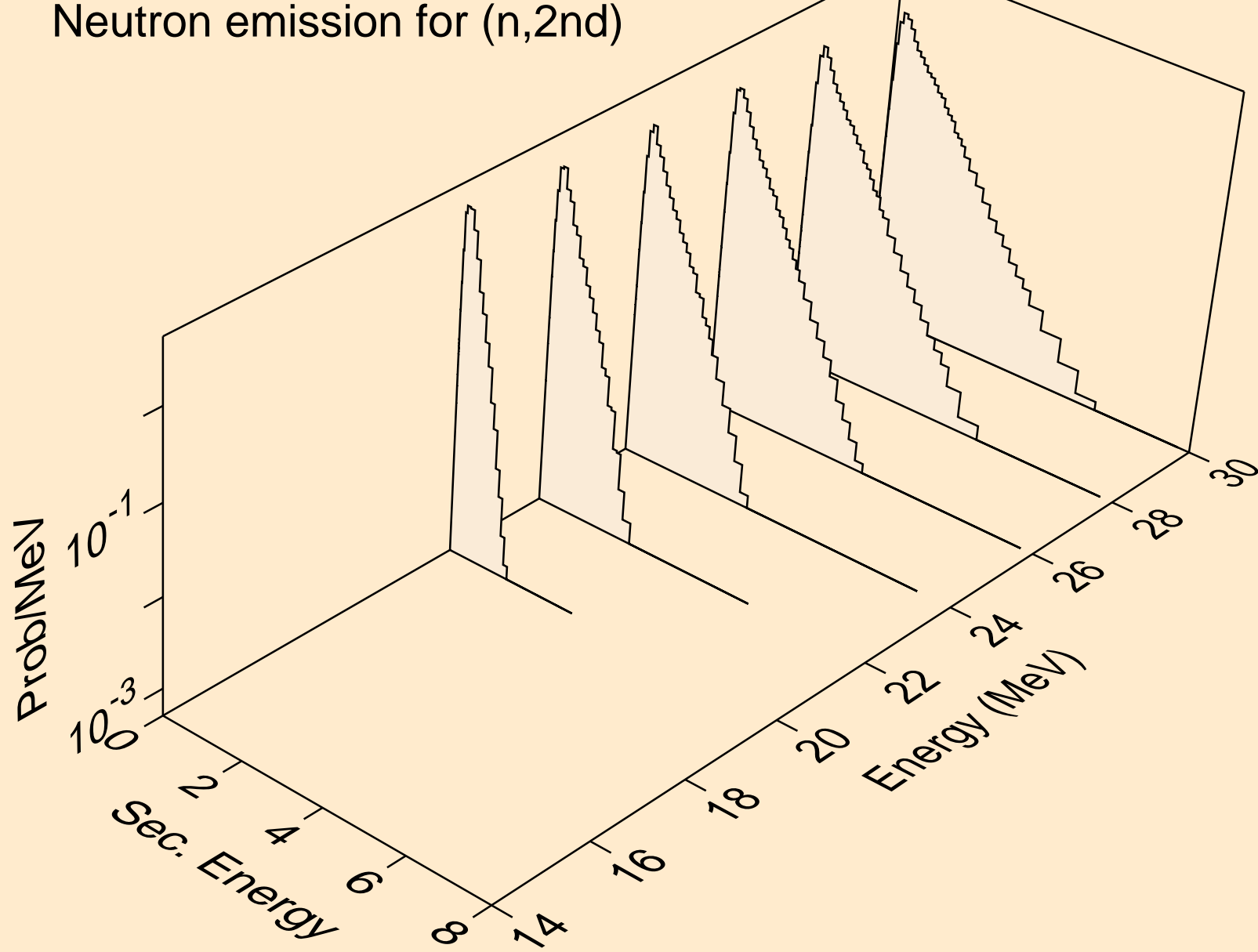

NO259 NEUTRON ACER TENDL-2023 LIBRARY; T=0.K
Neutron emission for (n,2n)

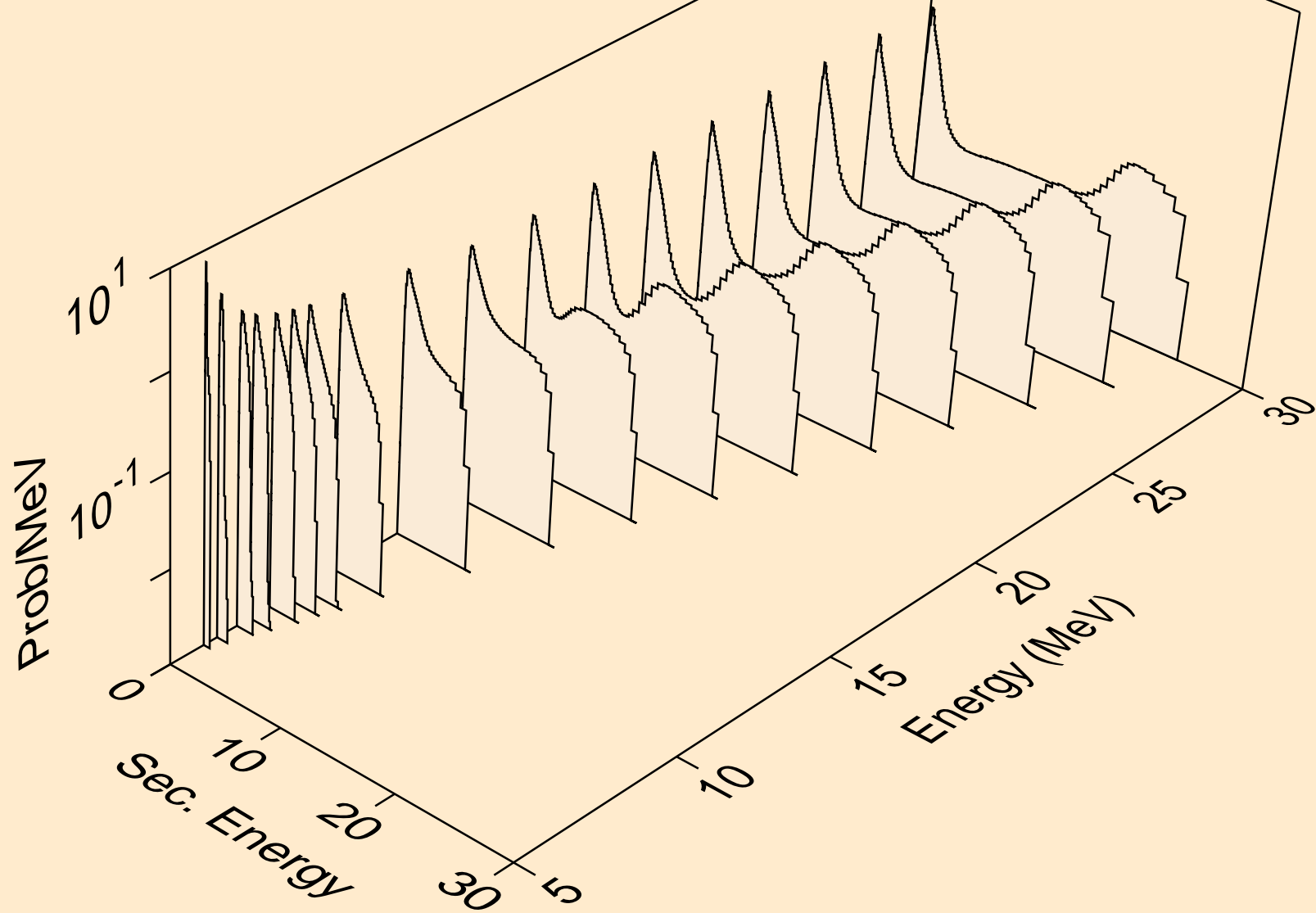

NO259 NEUTRON ACER TENDL-2023 LIBRARY; T=0.K
Neutron emission for (n,3n)

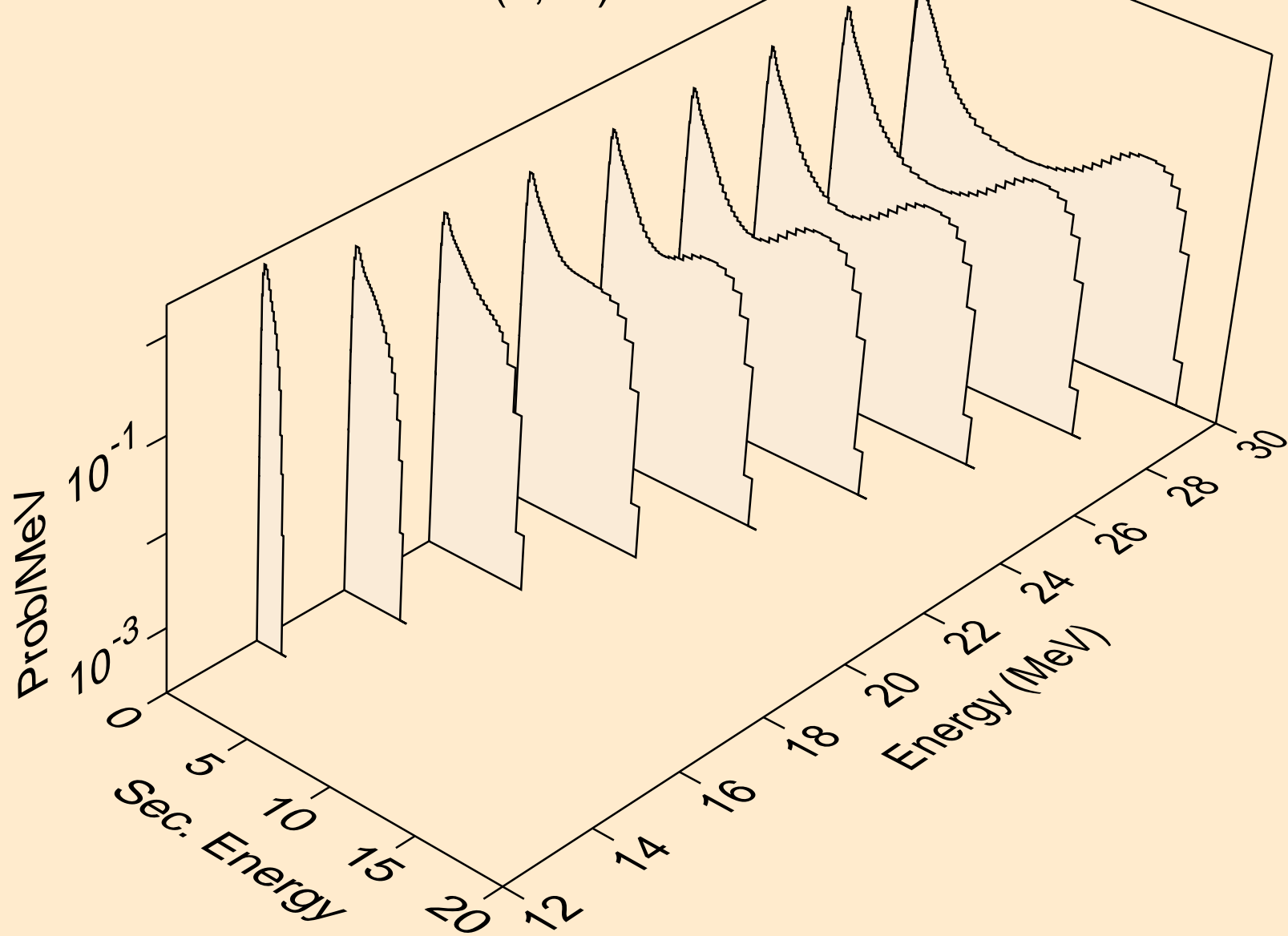

NO259 NEUTRON ACER TENDL-2023 LIBRARY; T=0.K
Neutron emission for fission

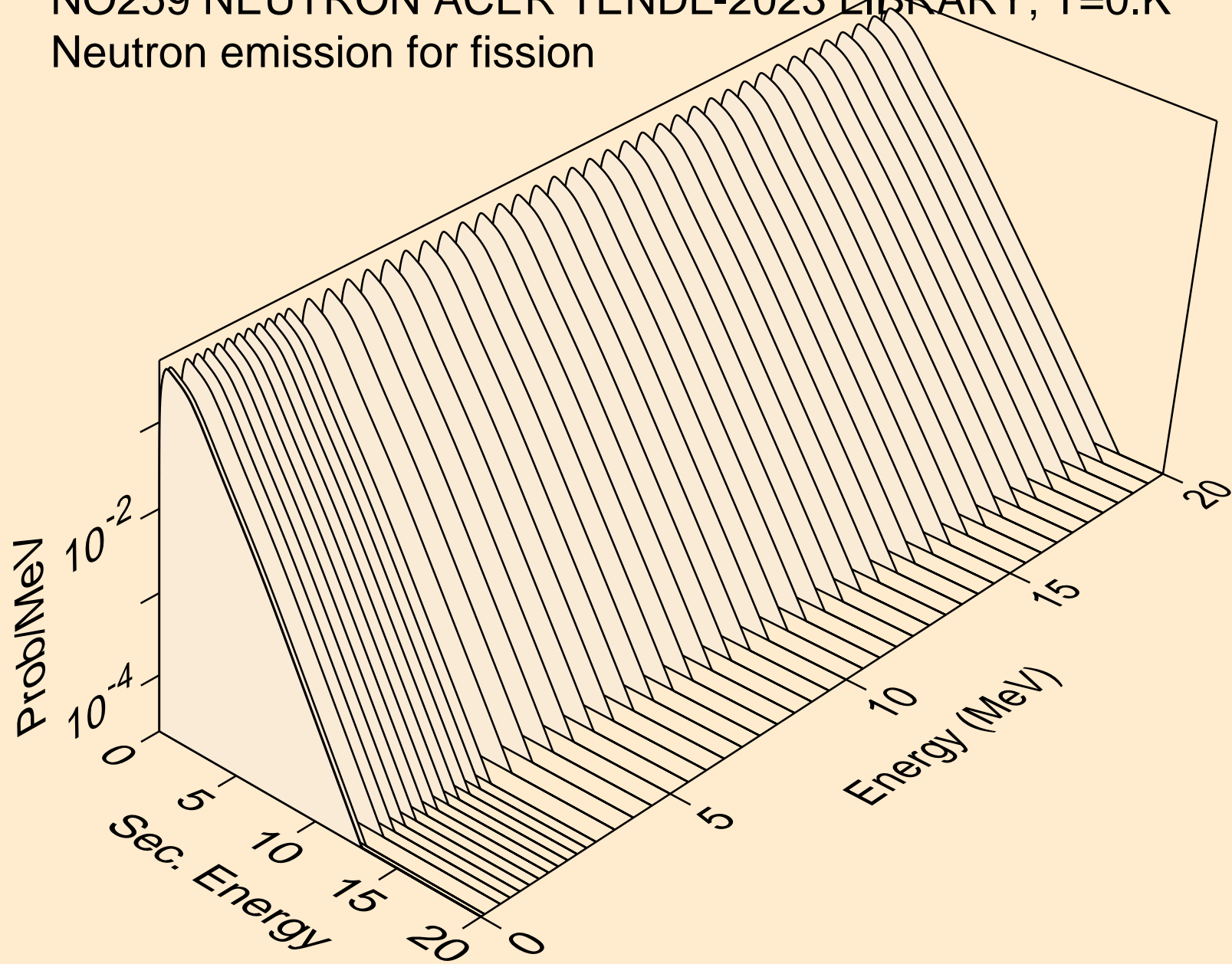

NO259 NEUTRON ACER TENDL-2023 LIBRARY; T=0.K
Neutron emission for (n,n*)a

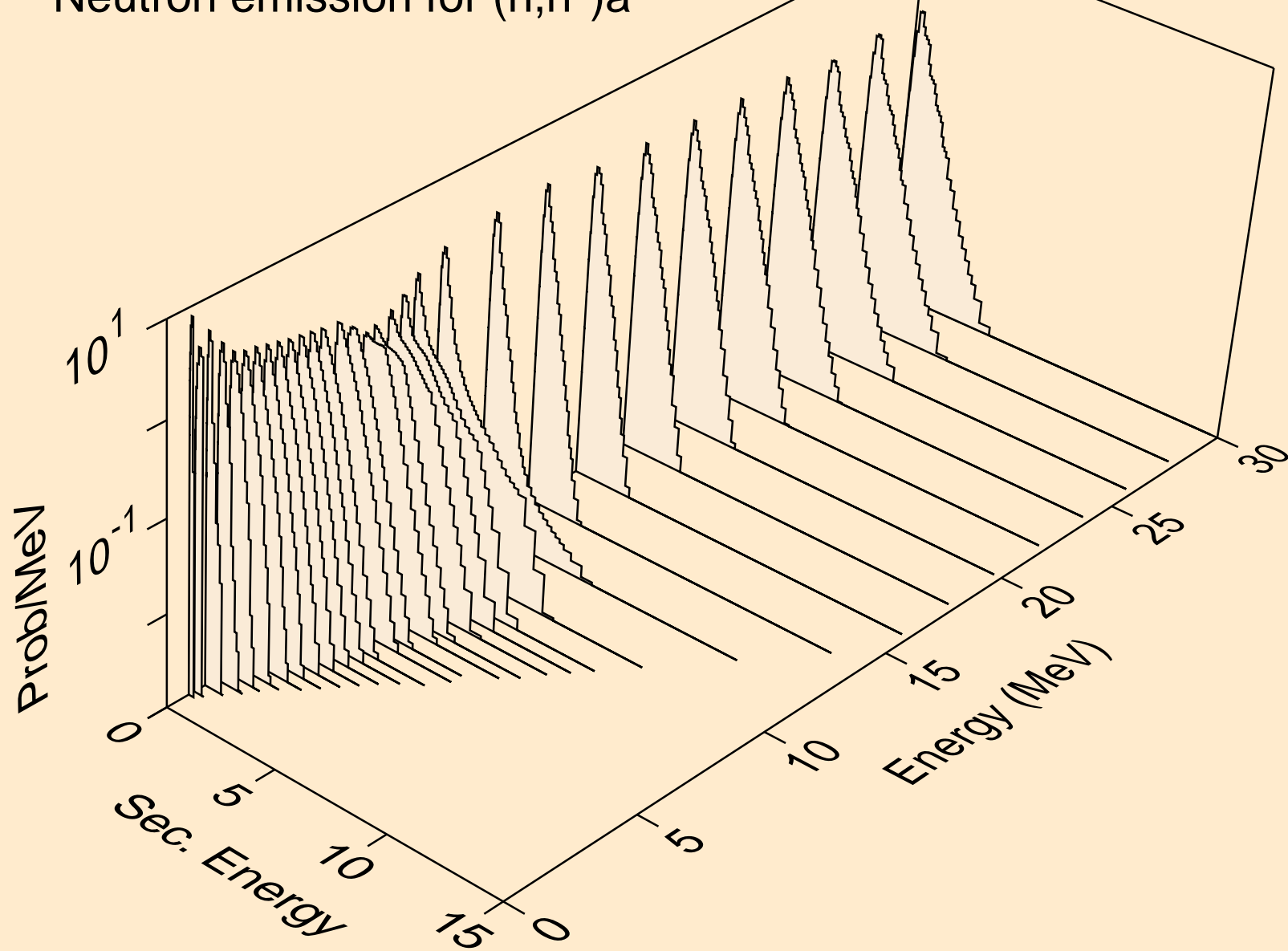

NO259 NEUTRON ACER TENDL-2023 LIBRARY; T=0.K
Neutron emission for (n,2n)a

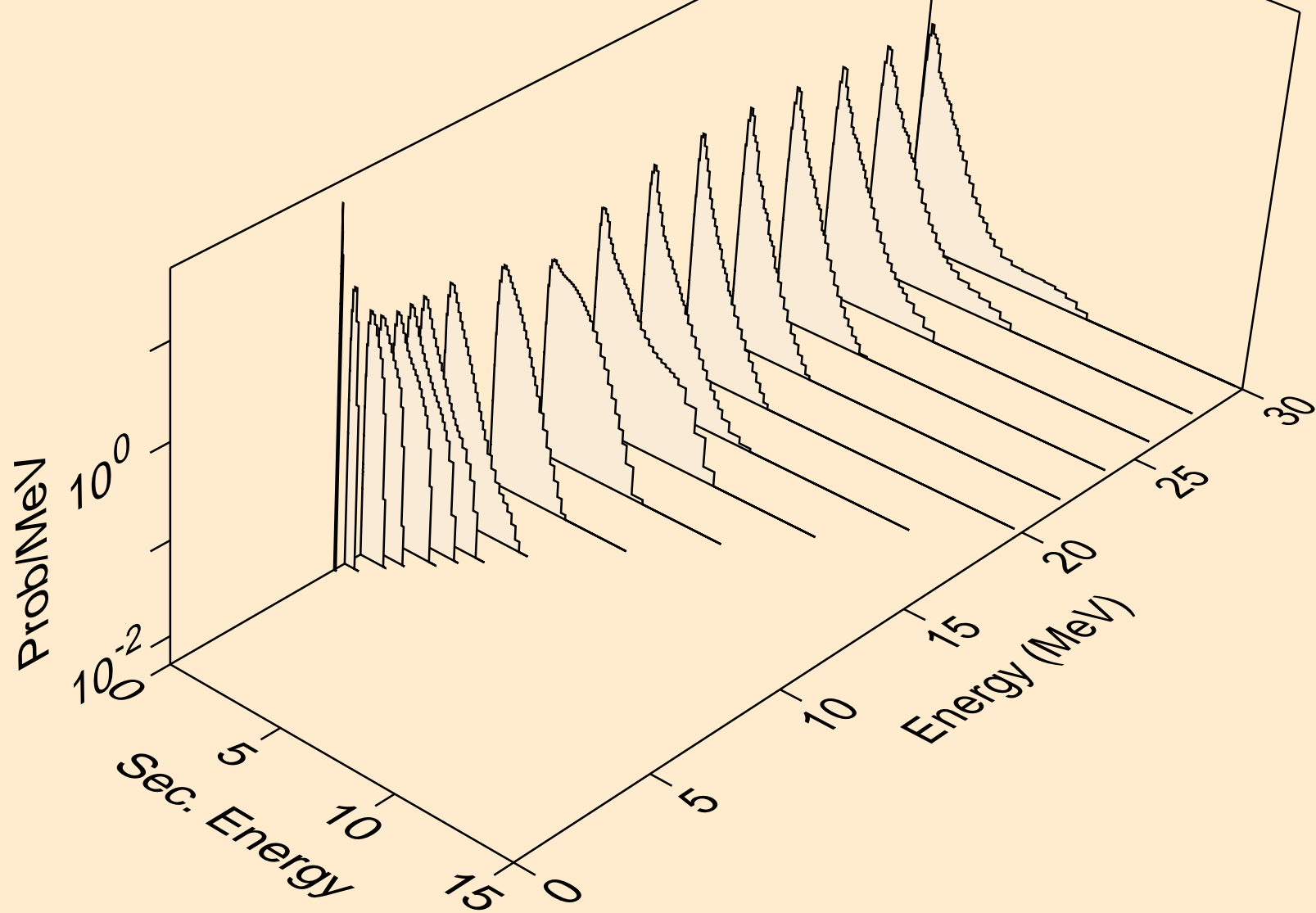

NO259 NEUTRON ACER TENDL-2023 LIBRARY; T=0.K
Neutron emission for (n,3n)a

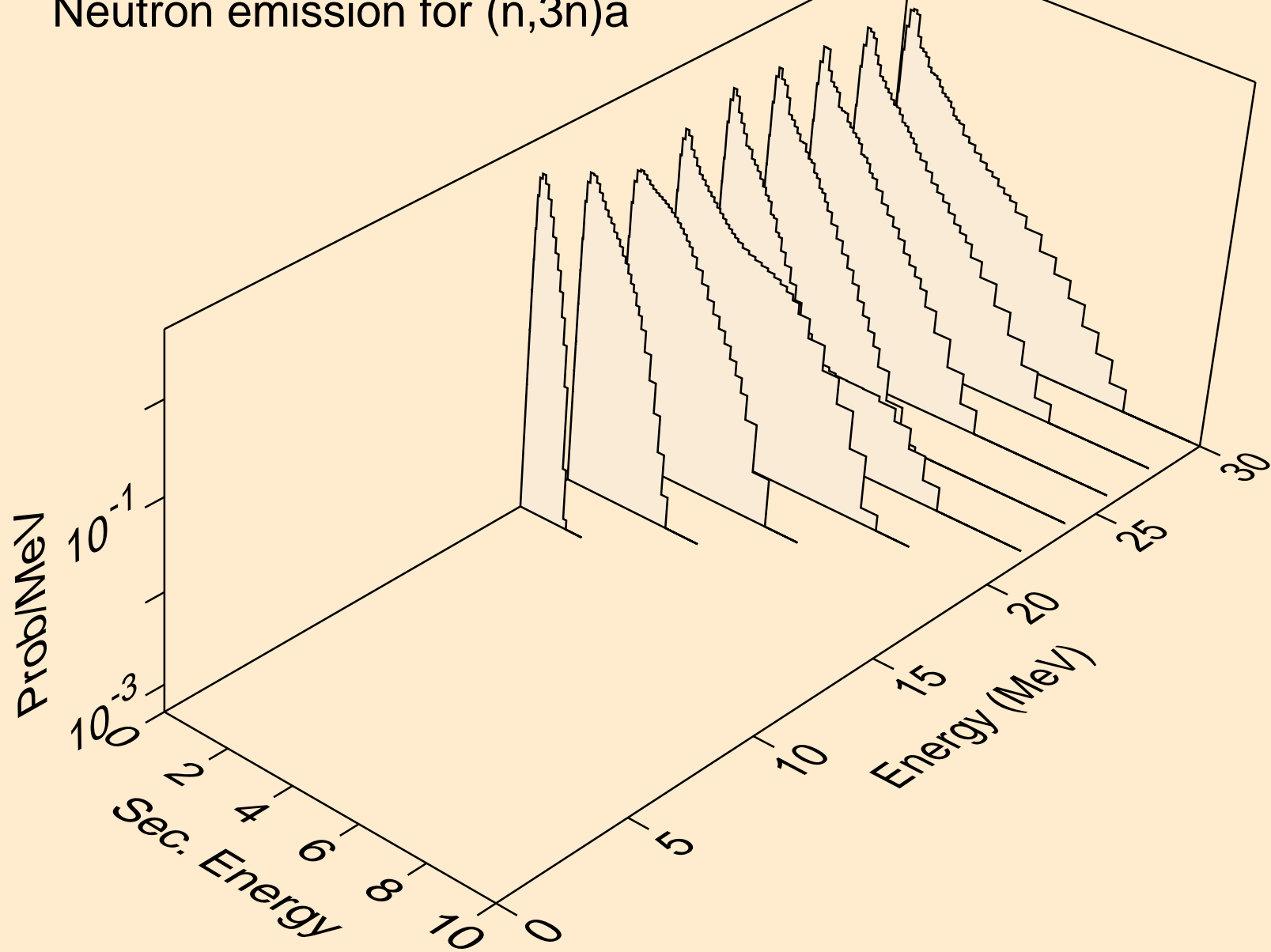

NO259 NEUTRON ACER TENDL-2023 LIBRARY; T=0.K
Neutron emission for (n,n*)p

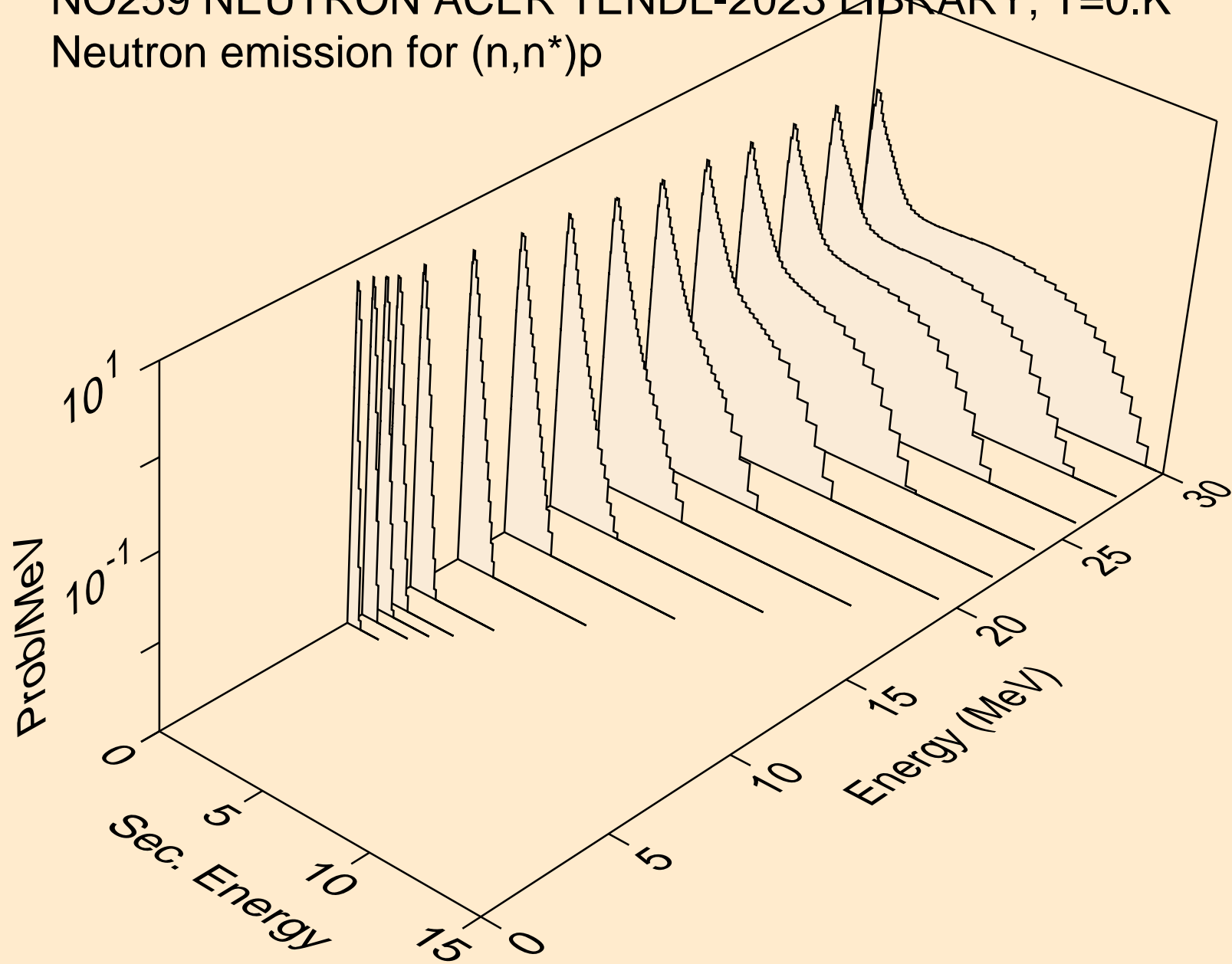

NO259 NEUTRON ACER TENDL-2023 LIBRARY; T=0.K
Neutron emission for (n,n*)d

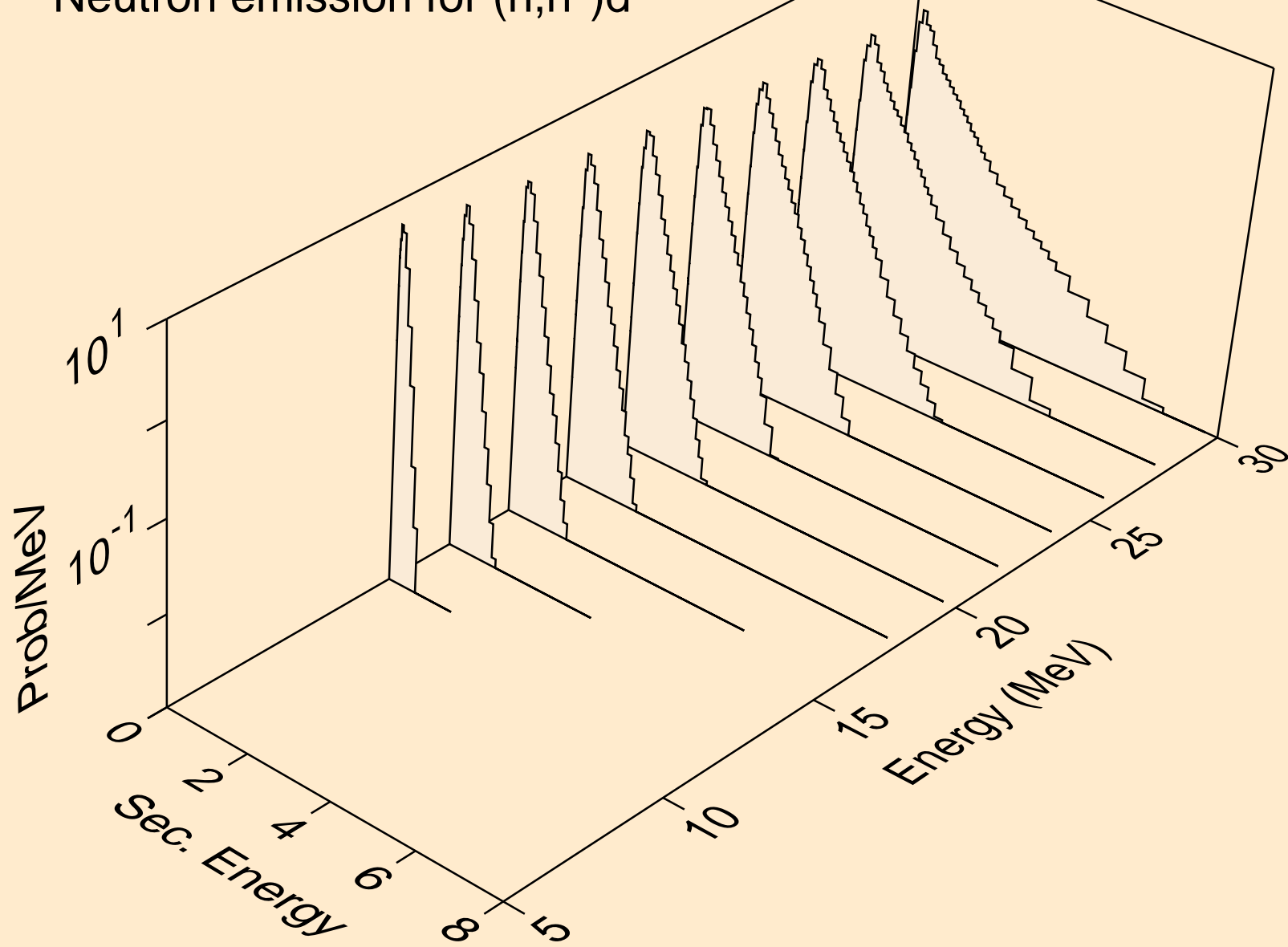

NO259 NEUTRON ACER TENDL-2023 LIBRARY; T=0.K
Neutron emission for (n,n*)t

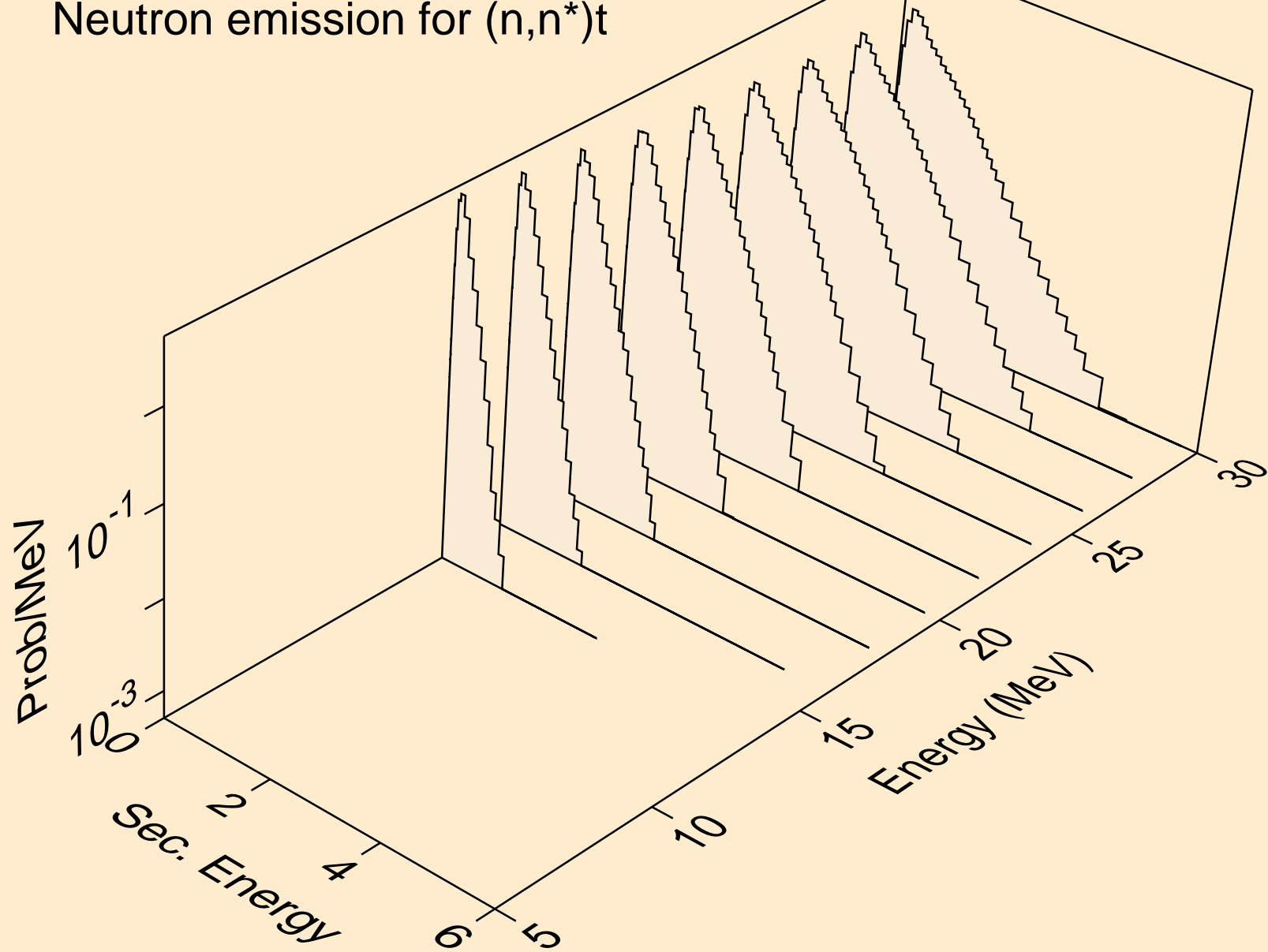

NO259 NEUTRON ACER TENDL-2023 LIBRARY; T=0.K
Neutron emission for (n,n*)he3

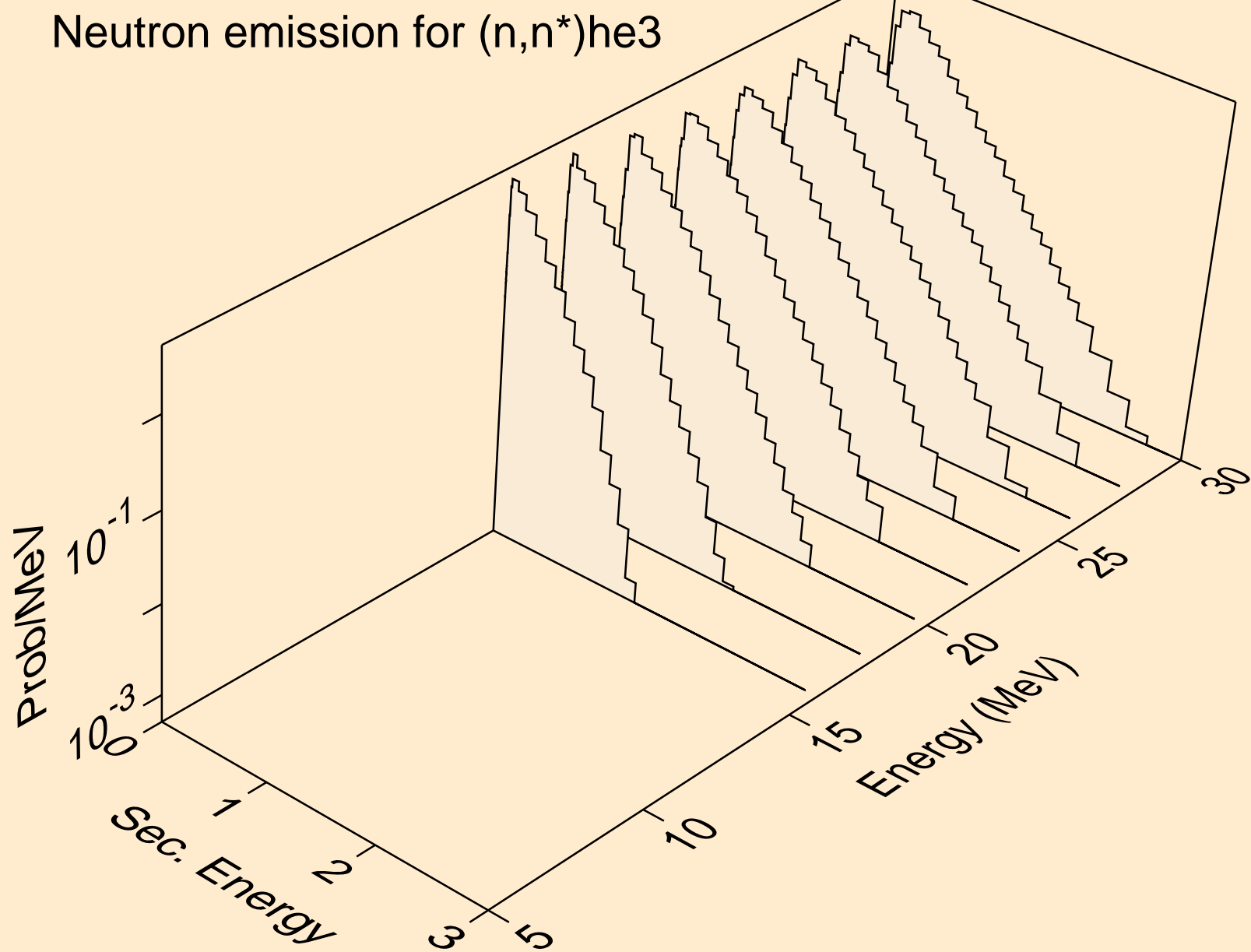

NO259 NEUTRON ACER TENDL-2023 LIBRARY; T=0.K
Neutron emission for (n,4n)

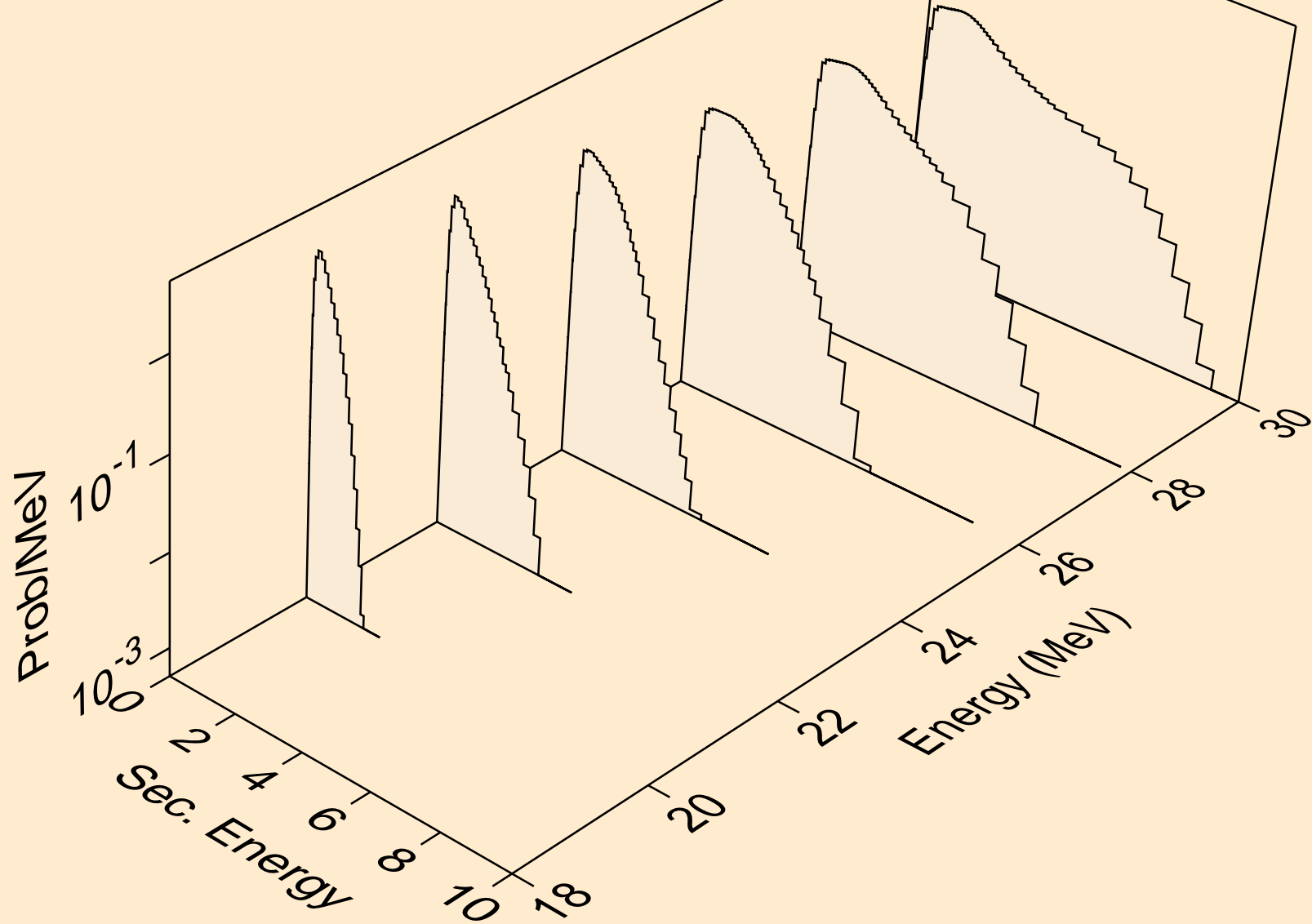

NO259 NEUTRON ACER TENDL-2023 LIBRARY; T=0.K
Neutron emission for (n,2np)

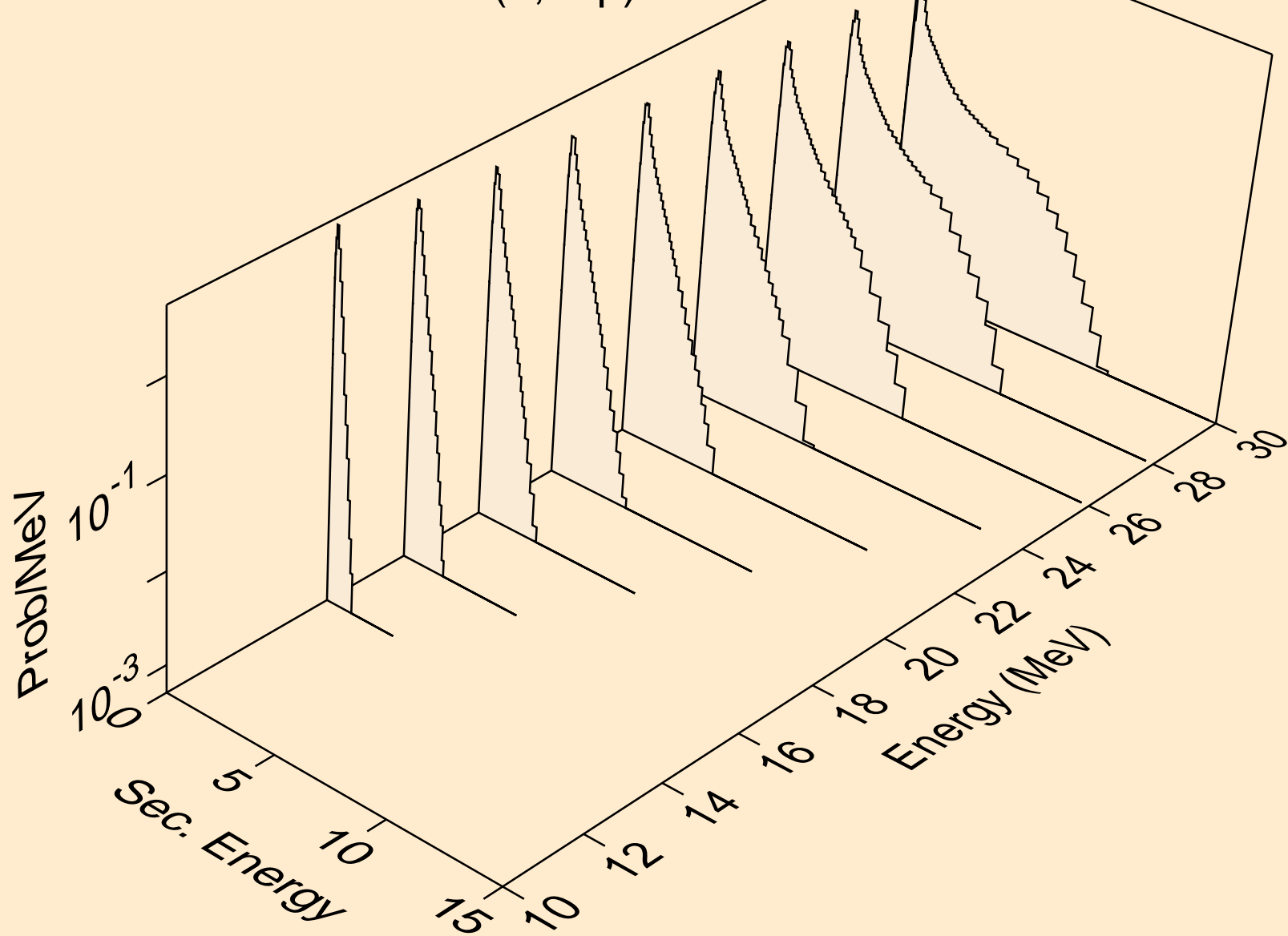

NO259 NEUTRON ACER TENDL-2023 LIBRARY; T=0.K
Neutron emission for (n,3np)

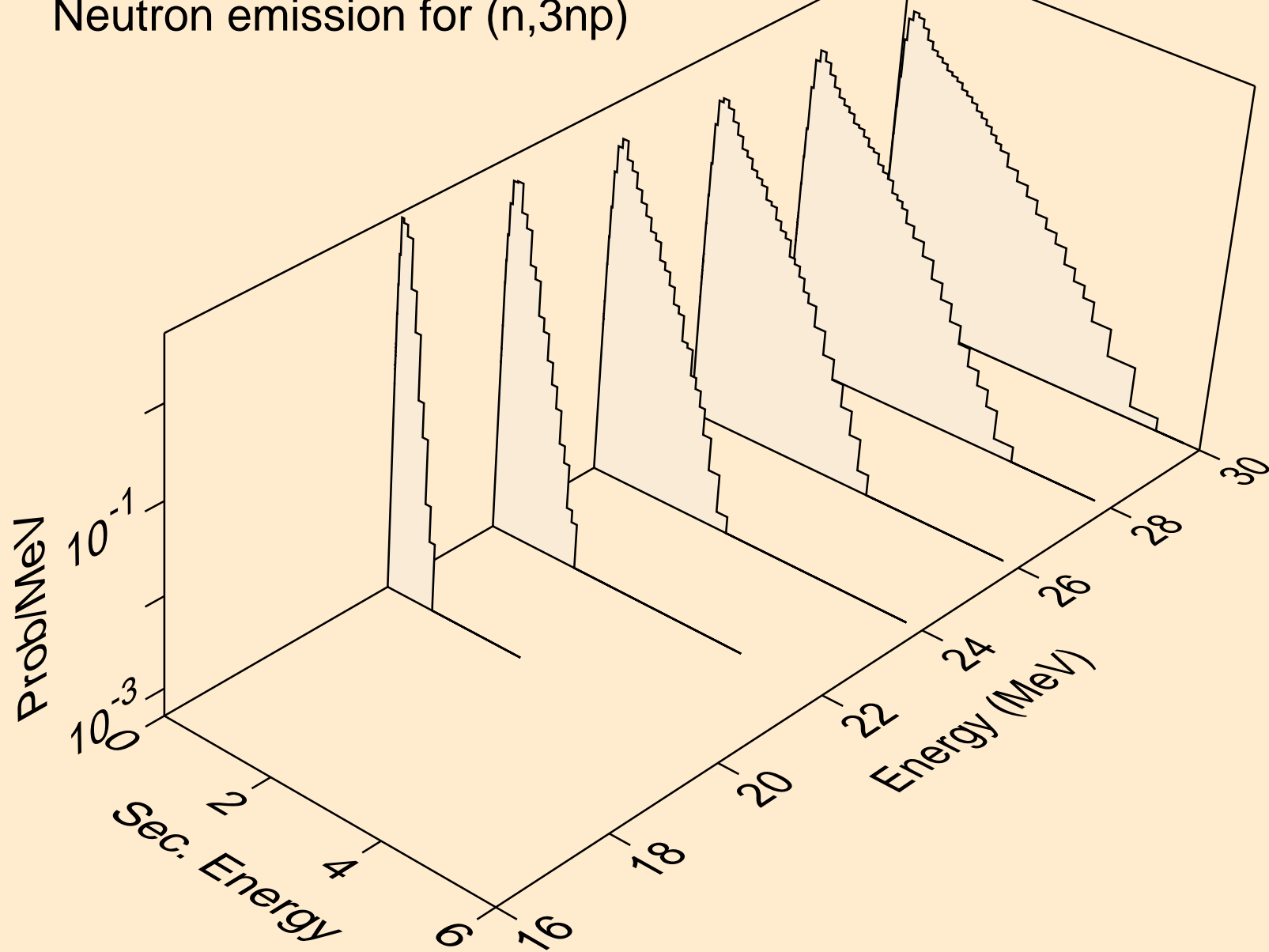

NO259 NEUTRON ACER TENDL-2023 LIBRARY; T=0.K
Neutron emission for (n,n2p)

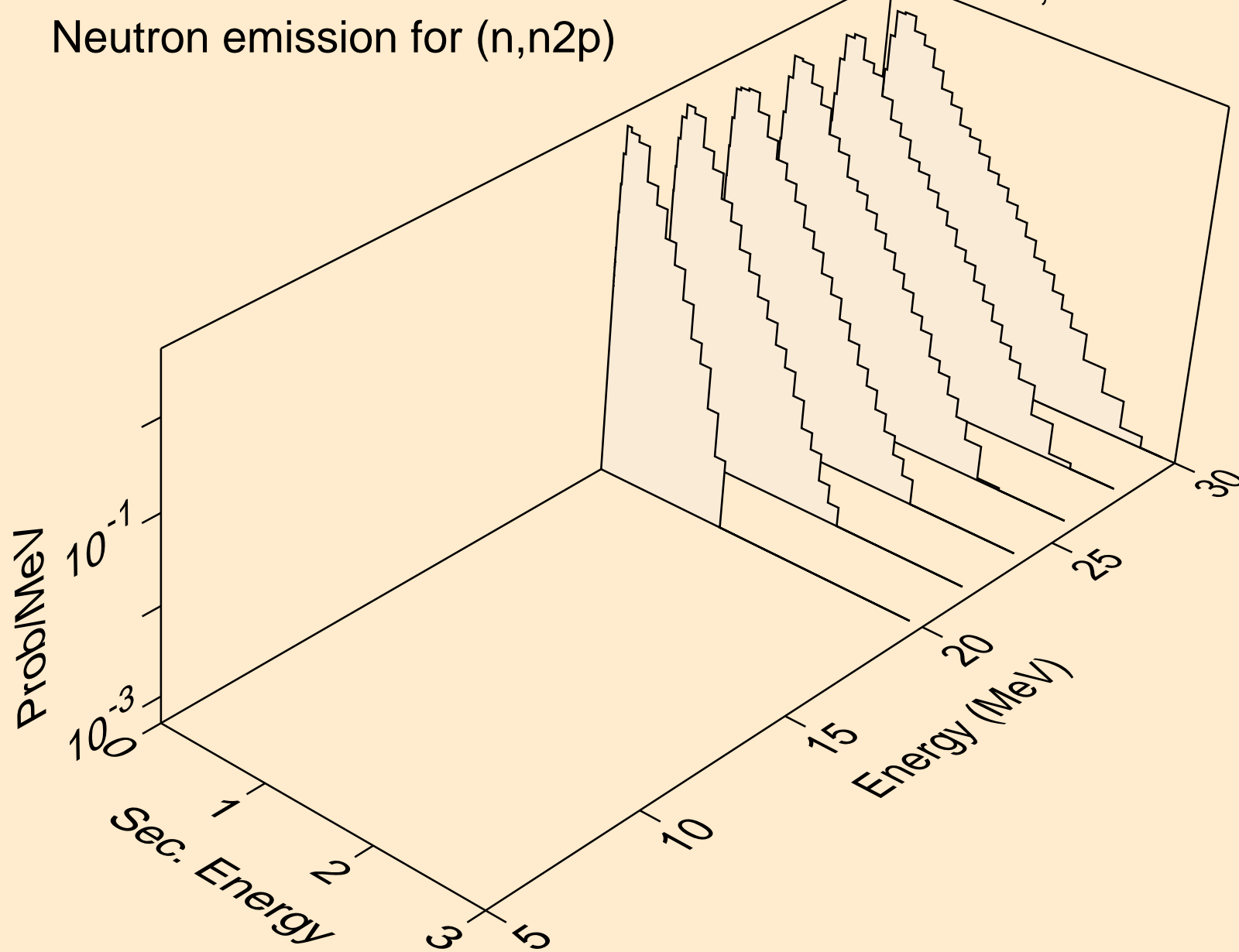

NO259 NEUTRON ACER TENDL-2023 LIBRARY; T=0.K
Neutron emission for (n,n*c)

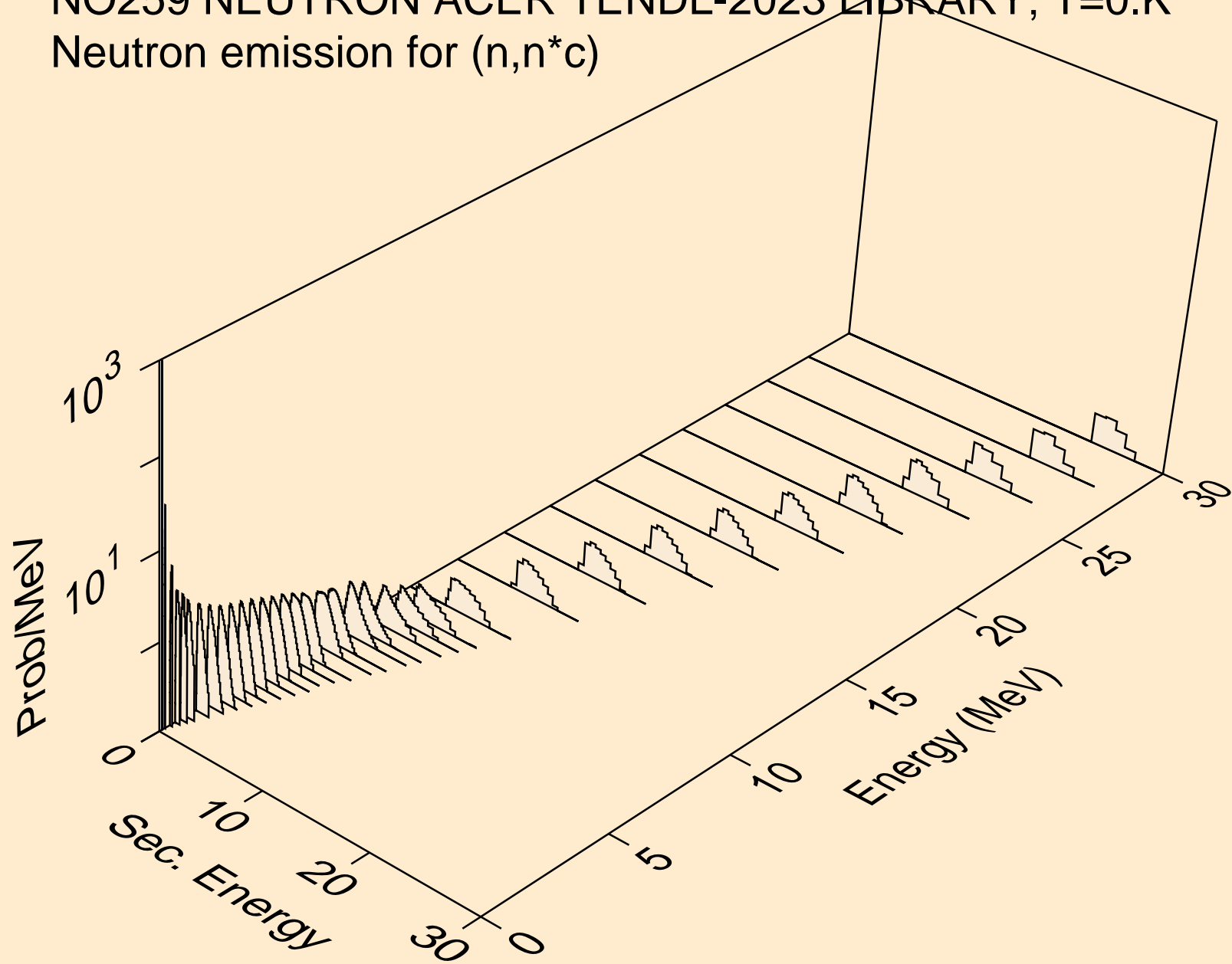

NO259 NEUTRON ACER TENDL-2023 LIBRARY; T=0.K

Delayed nubar

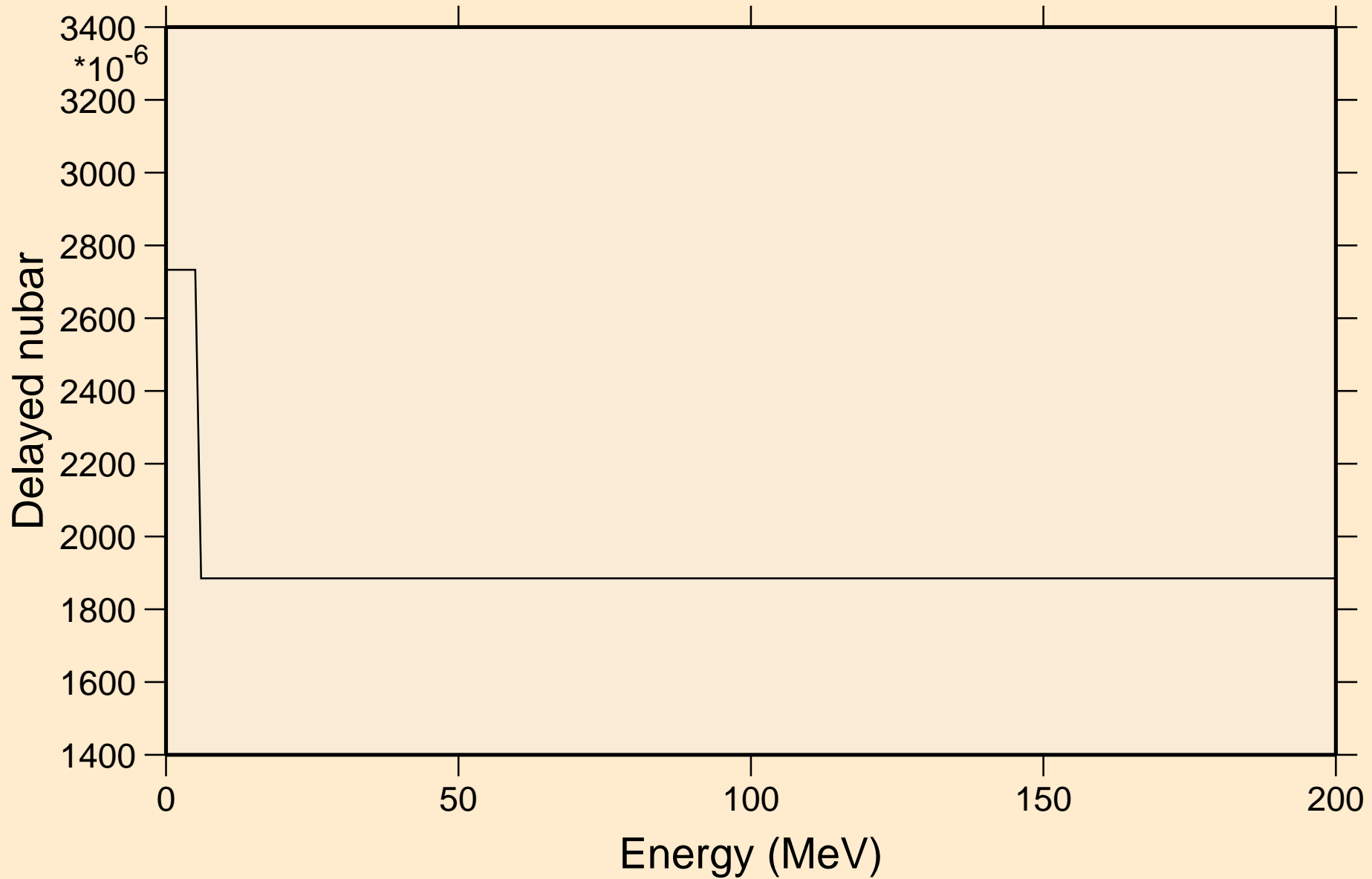

NO259 NEUTRON ACER TENDL-2023 LIBRARY; T=0.K

Delayed neutron spectra

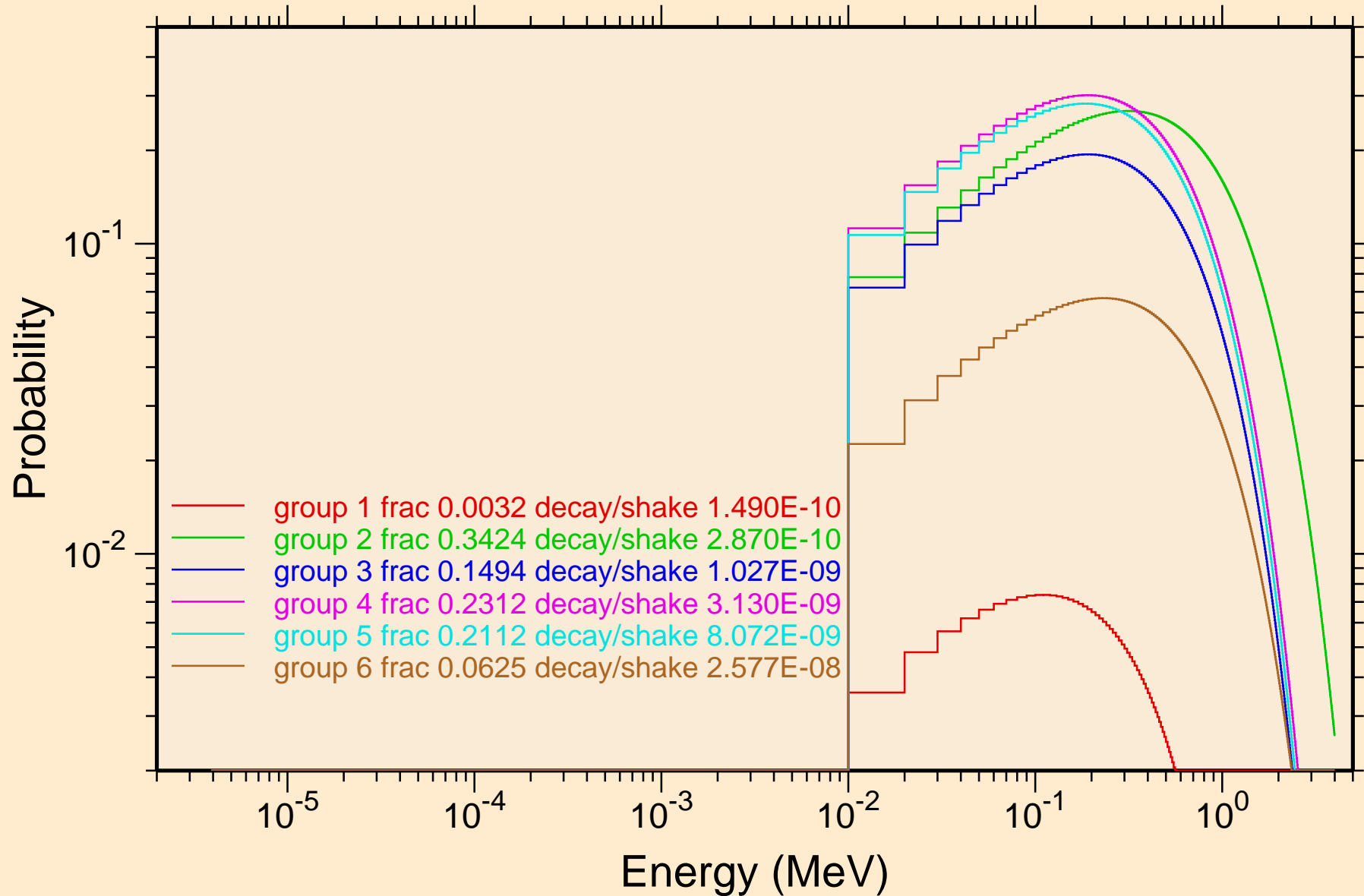

NO259 NEUTRON ACER TENDL-2023 LIBRARY; T=0.K
Photon emission for (n,x)

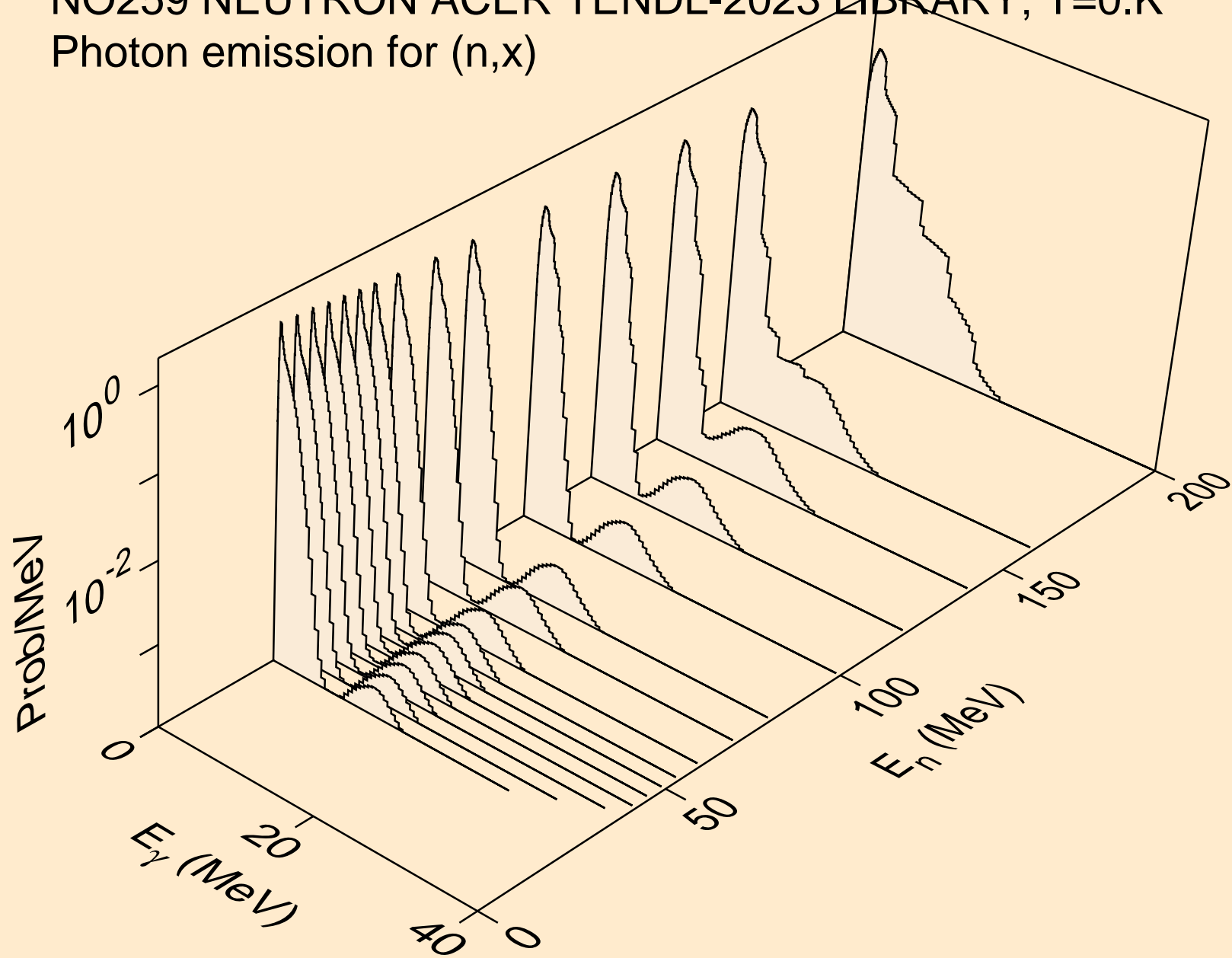

NO259 NEUTRON ACER TENDL-2023 LIBRARY; T=0.K
Photon emission for (n,2nd)

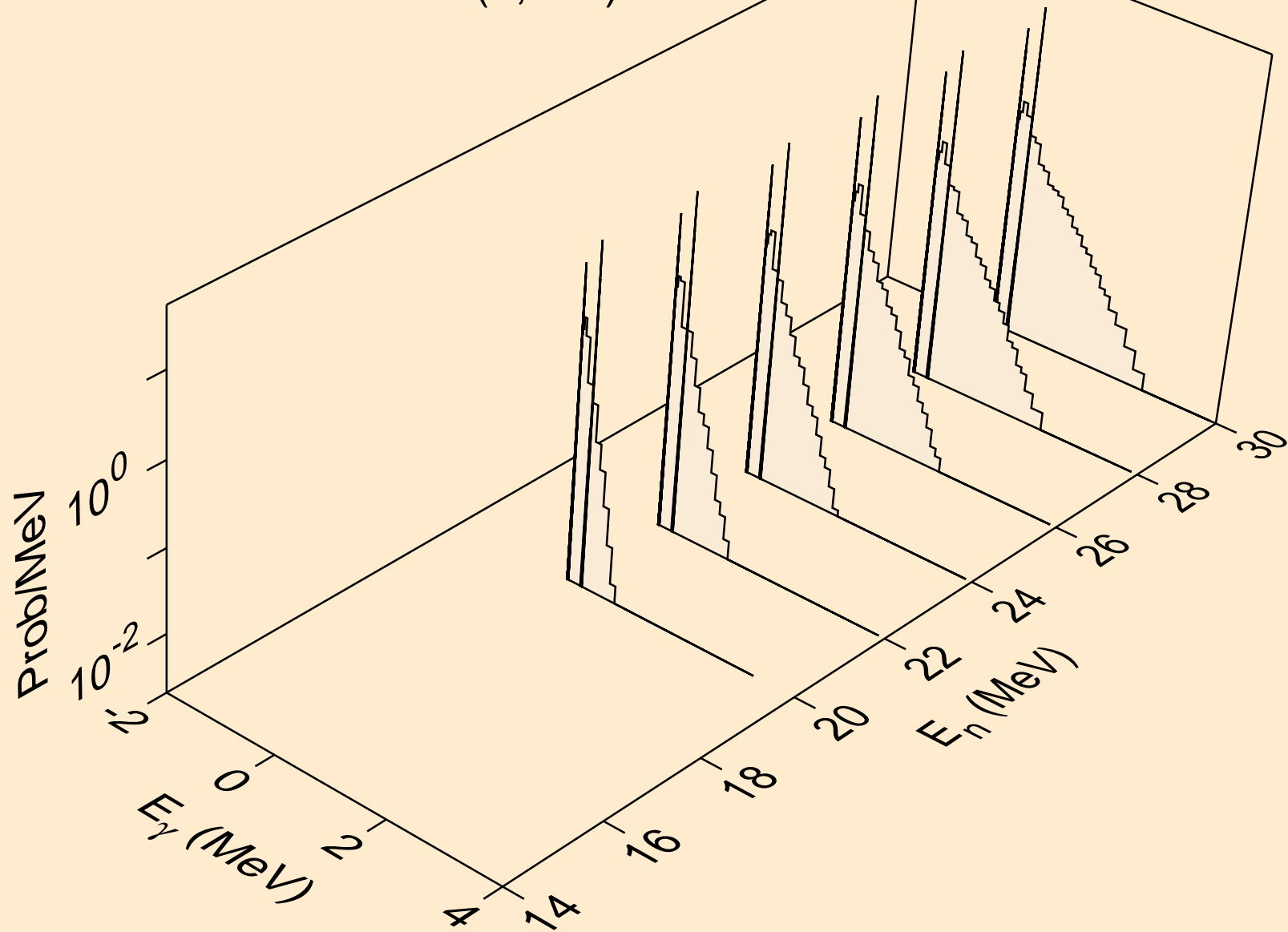

NO259 NEUTRON ACER TENDL-2023 LIBRARY; T=0.K
Photon emission for (n,2n)

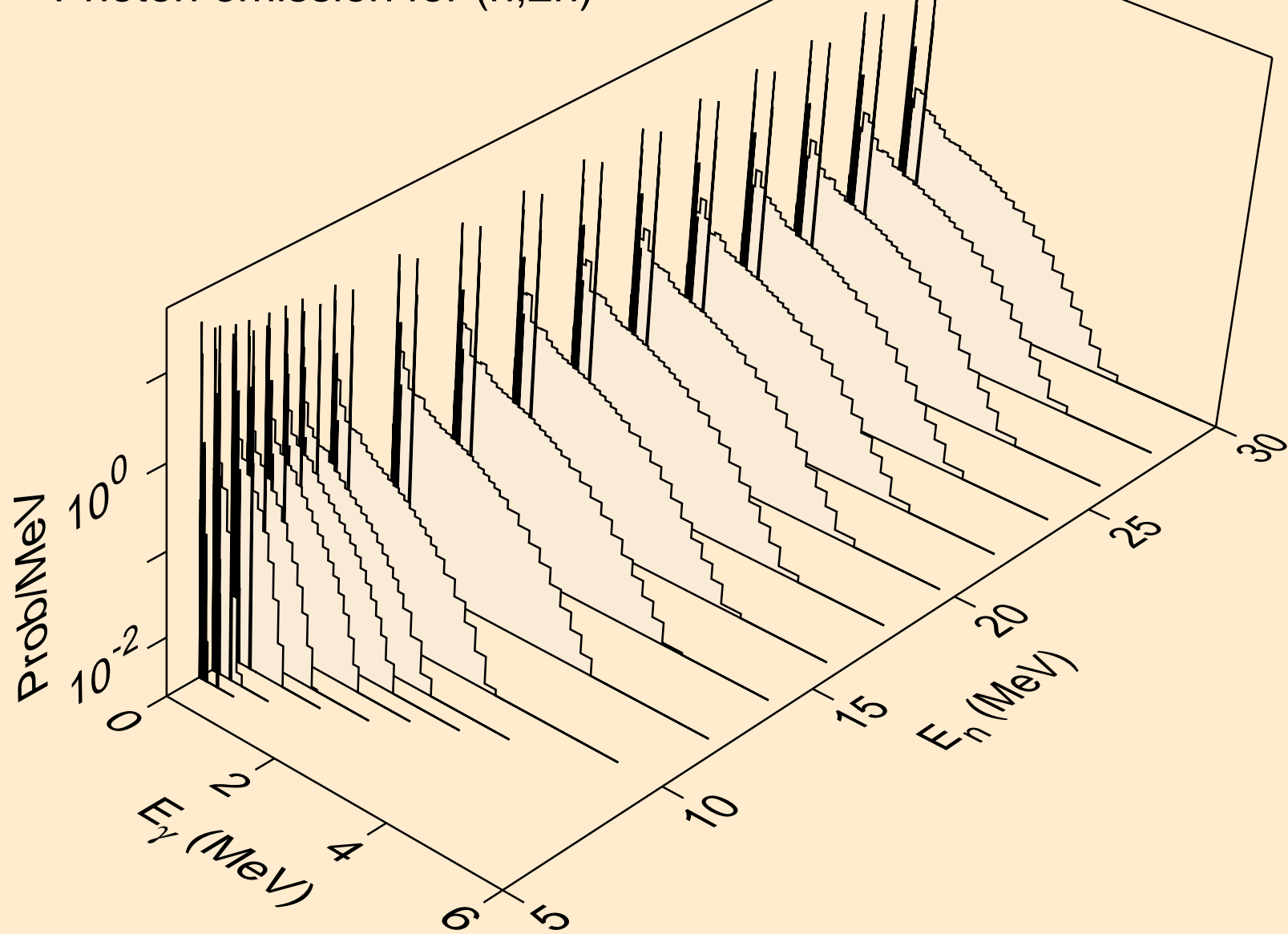

NO259 NEUTRON ACER TENDL-2023 LIBRARY; T=0.K
Photon emission for (n,3n)

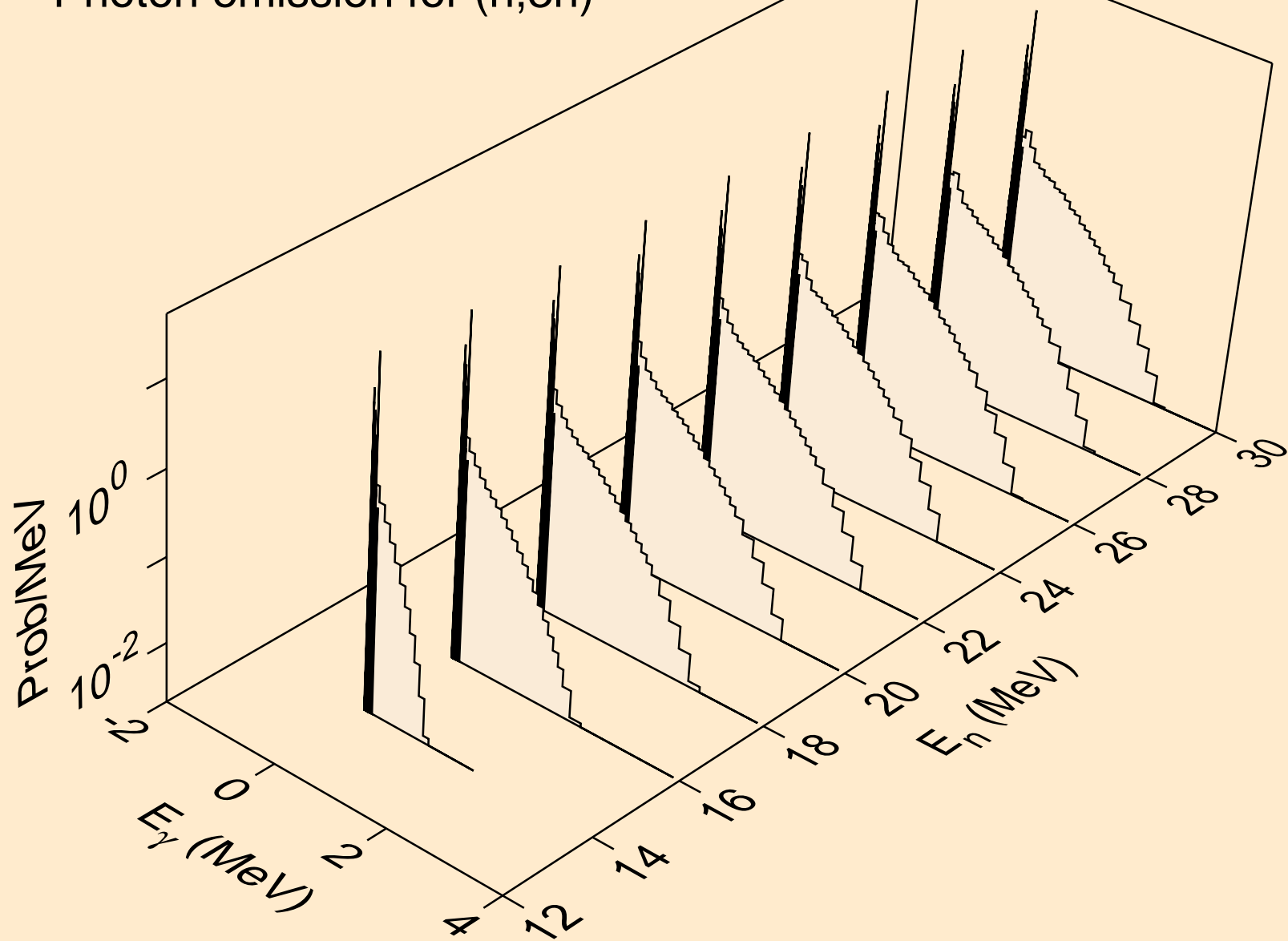

NO259 NEUTRON ACER TENDL-2023 LIBRARY; T=0.K
Photon emission for (n,n*)a

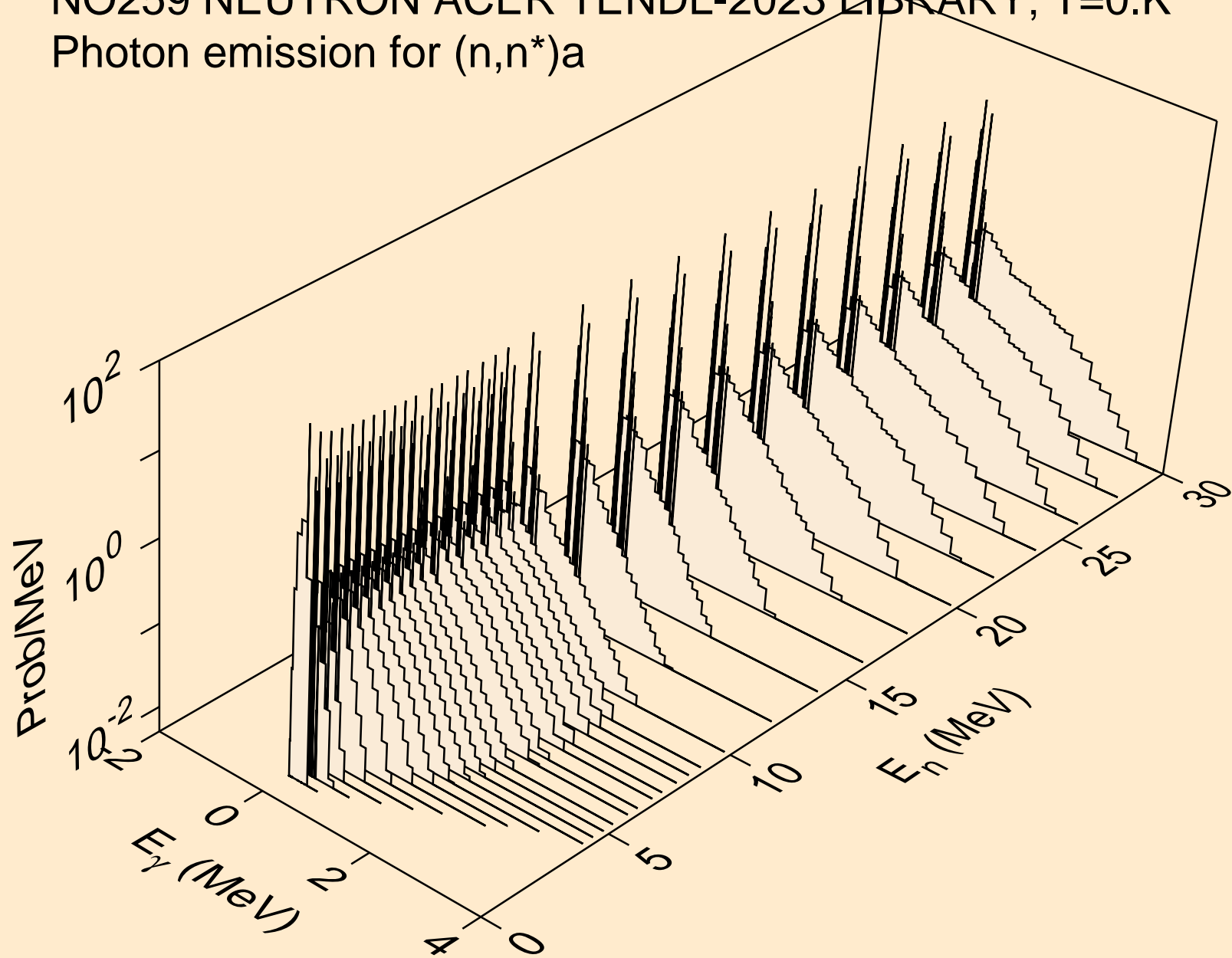

NO259 NEUTRON ACER TENDL-2023 LIBRARY; T=0.K
Photon emission for (n,2n)a

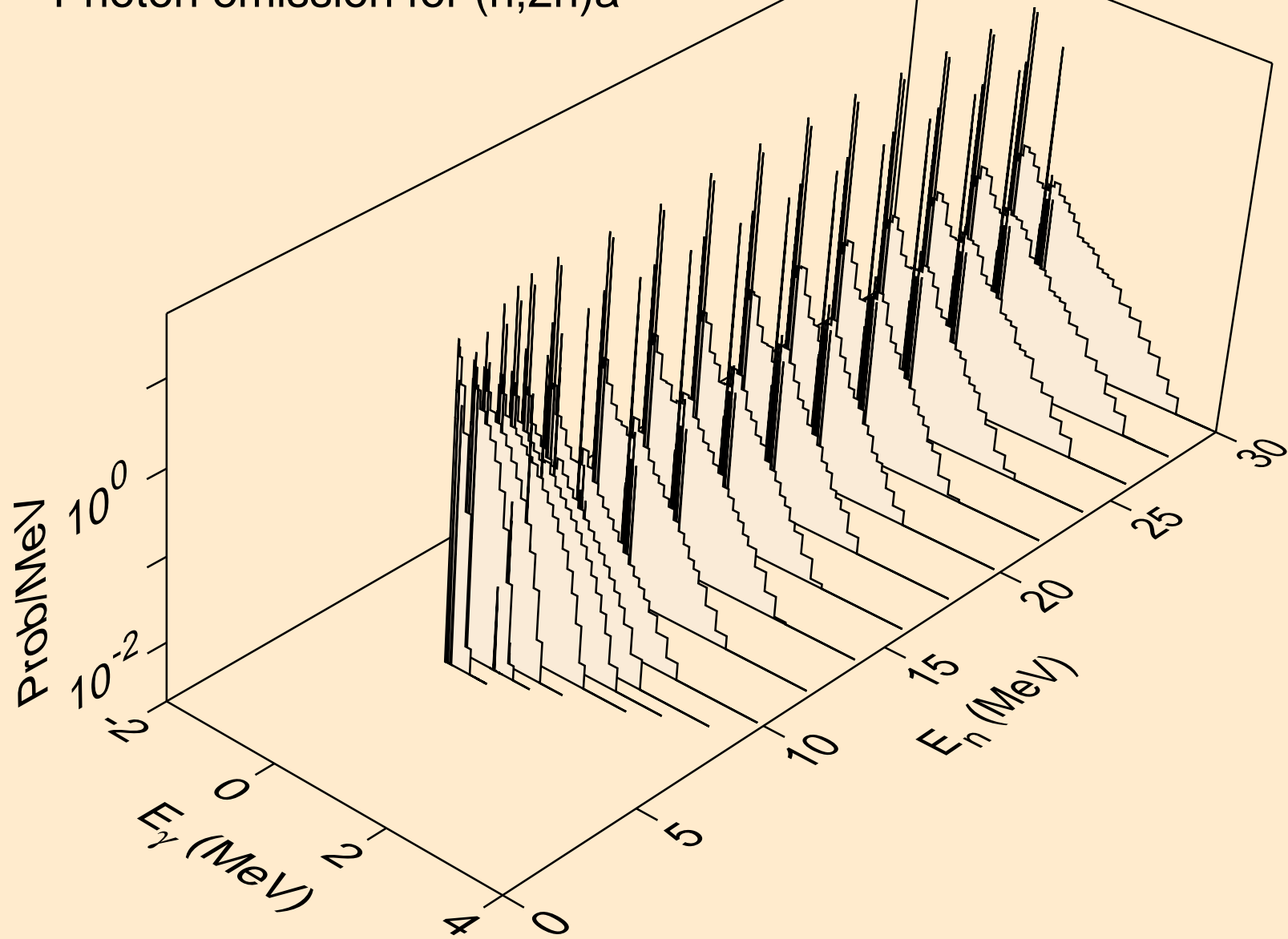

NO259 NEUTRON ACER TENDL-2023 LIBRARY; T=0.K
Photon emission for (n,3n)a

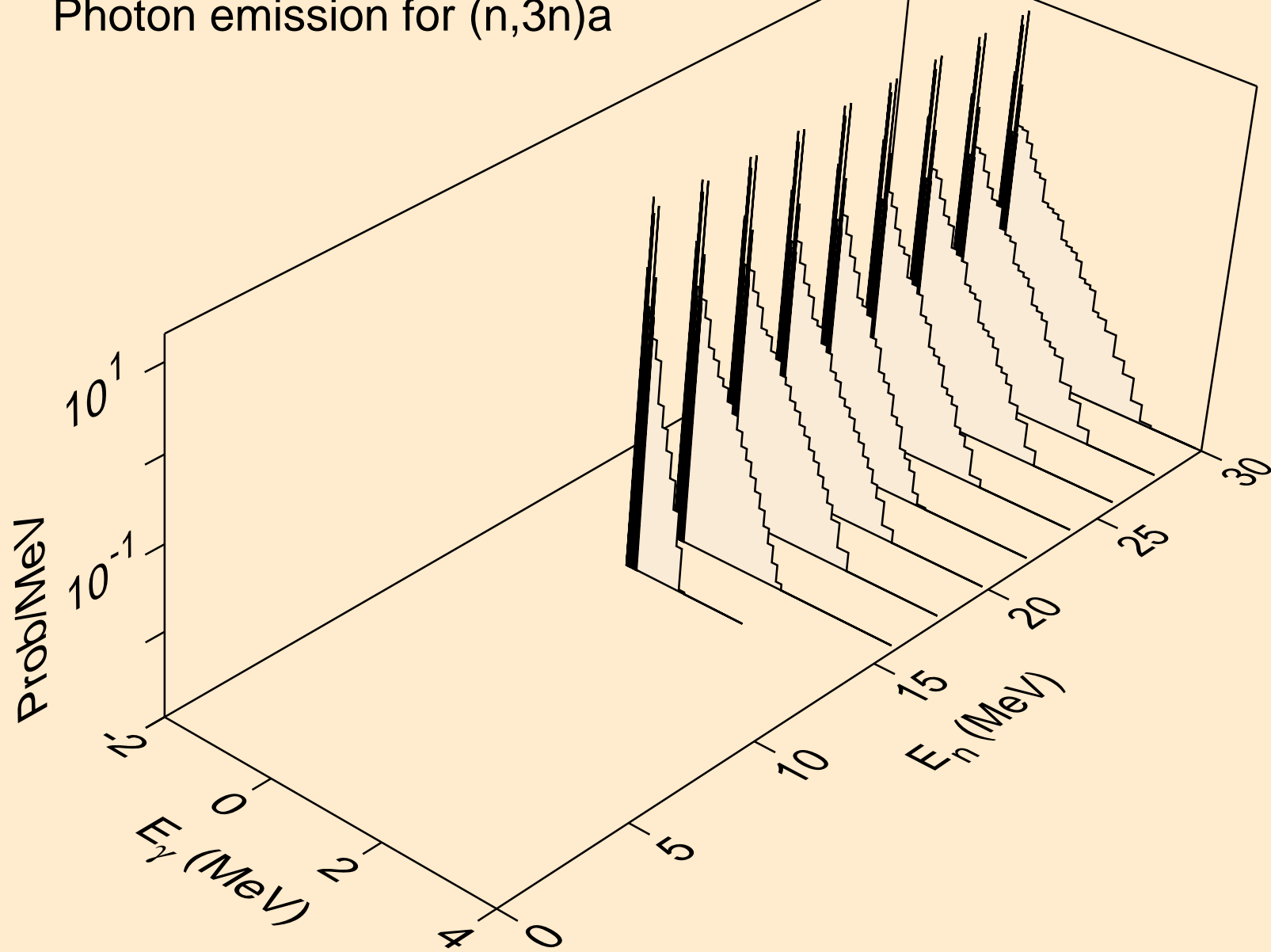

NO259 NEUTRON ACER TENDL-2023 LIBRARY; T=0.K
Photon emission for (n,n*)p

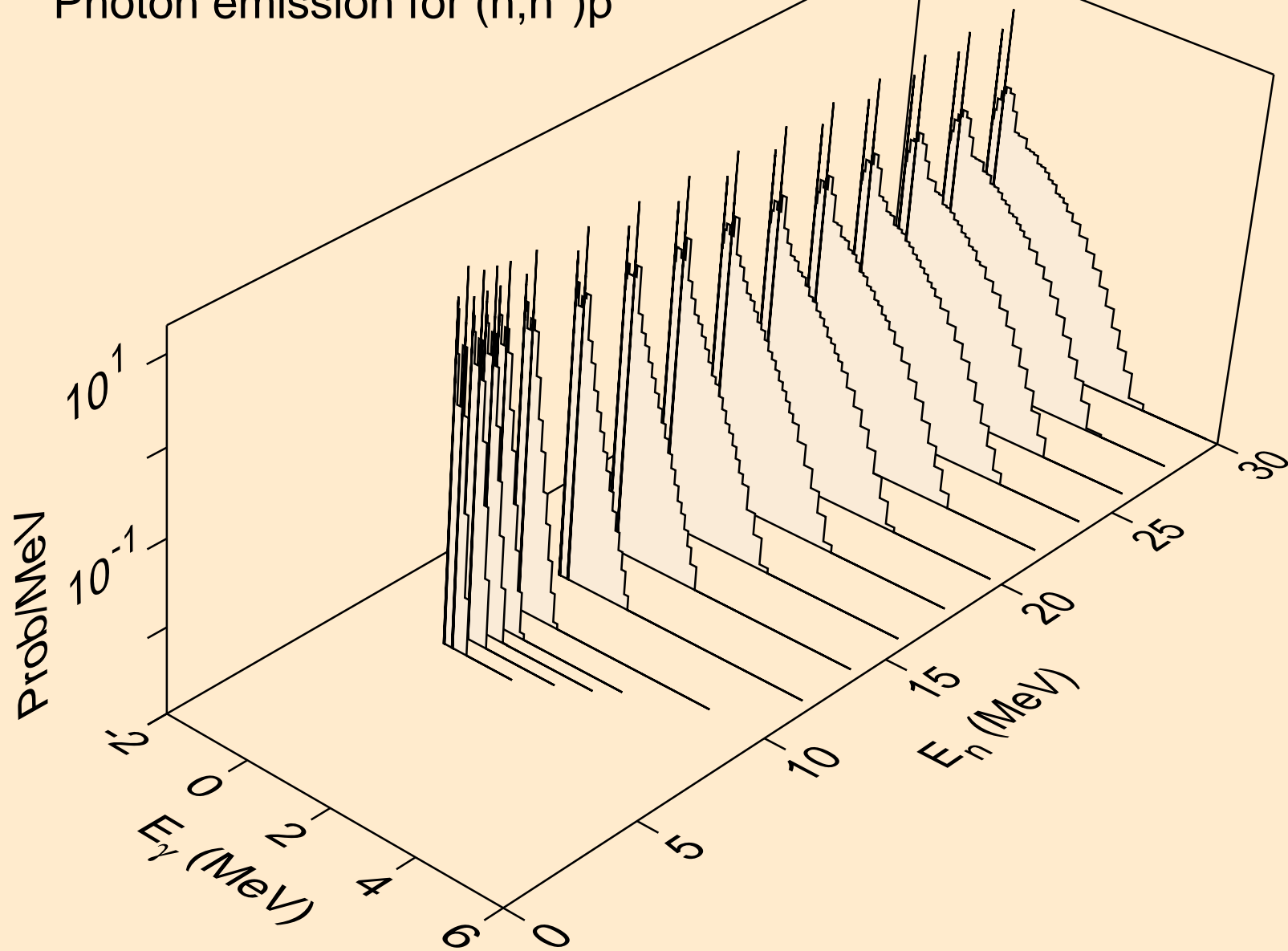

NO259 NEUTRON ACER TENDL-2023 LIBRARY; T=0.K
Photon emission for (n,n*)d

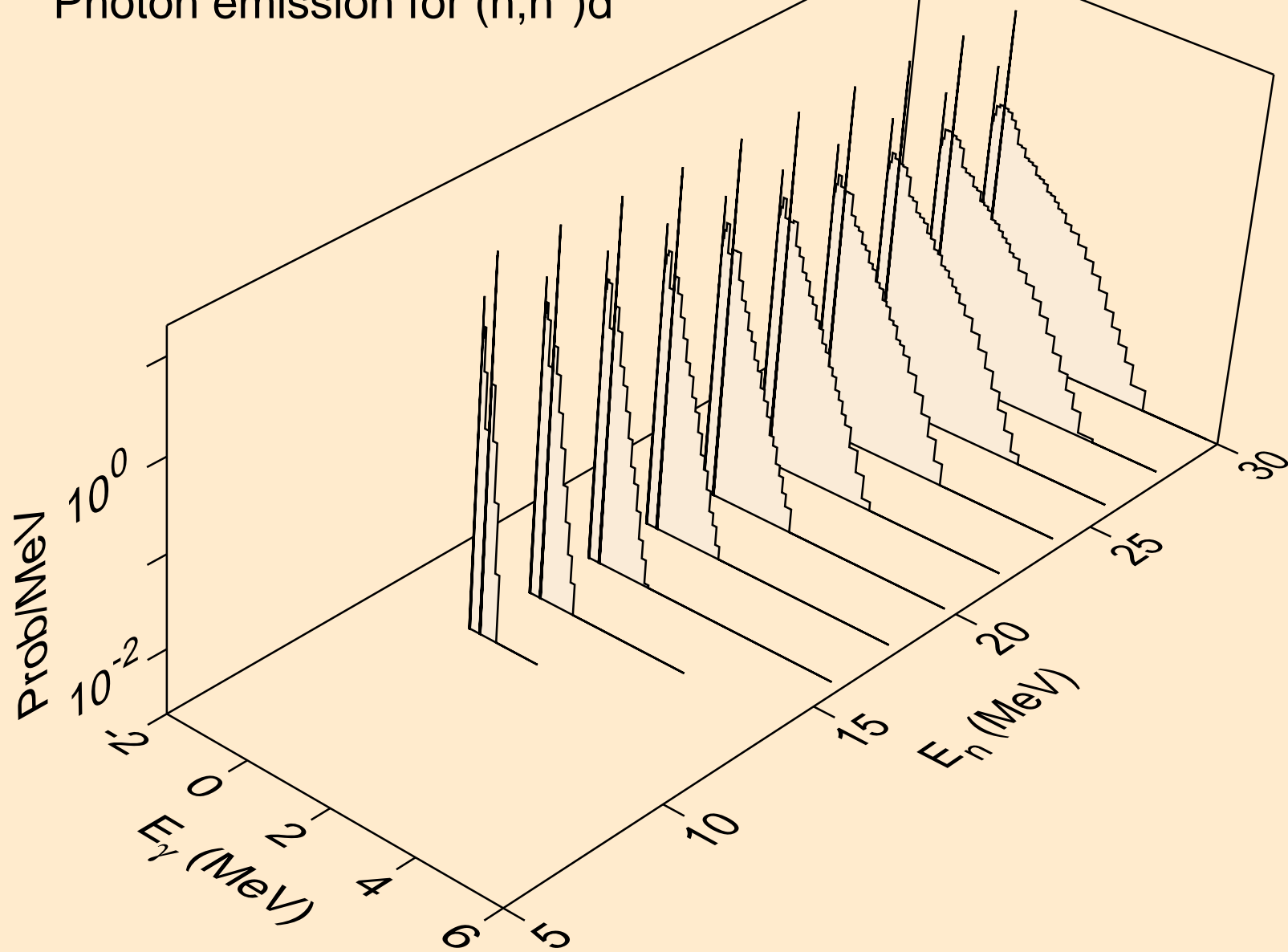

NO259 NEUTRON ACER TENDL-2023 LIBRARY; T=0.K
Photon emission for (n,n*)t

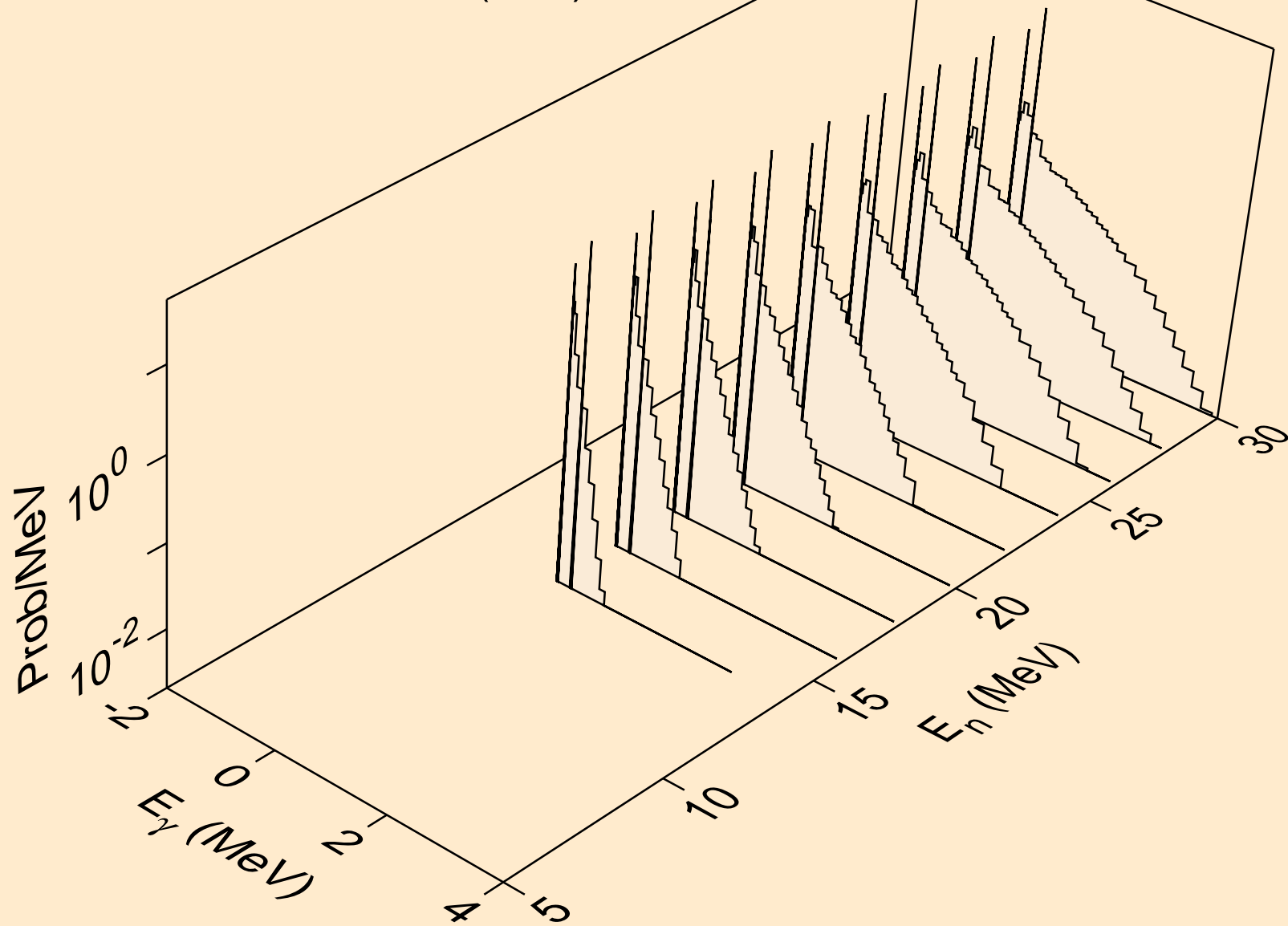

NO259 NEUTRON ACER TENDL-2023 LIBRARY; T=0.K
Photon emission for (n,n*)he3

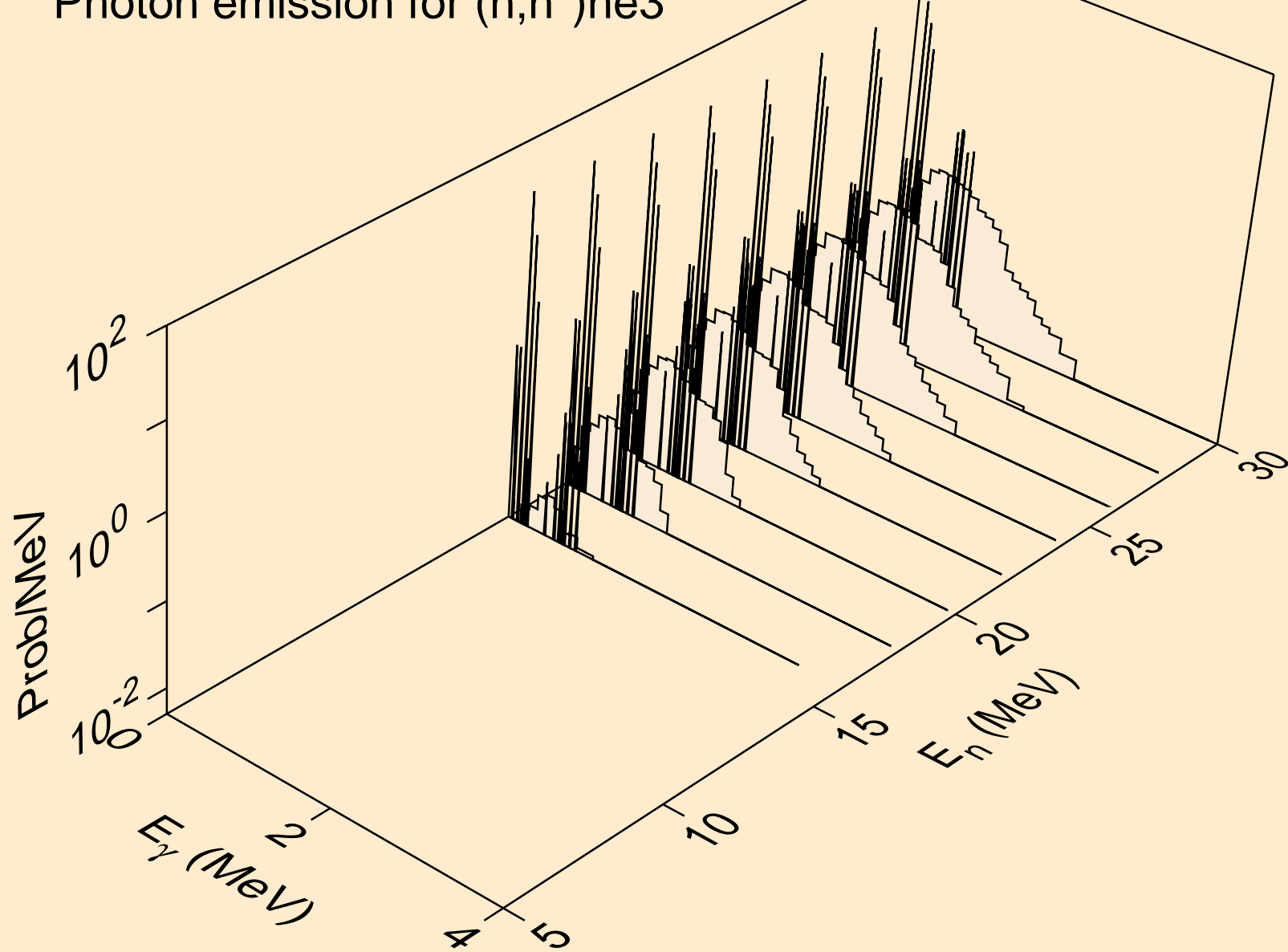

NO259 NEUTRON ACER TENDL-2023 LIBRARY; T=0.K
Photon emission for (n,4n)

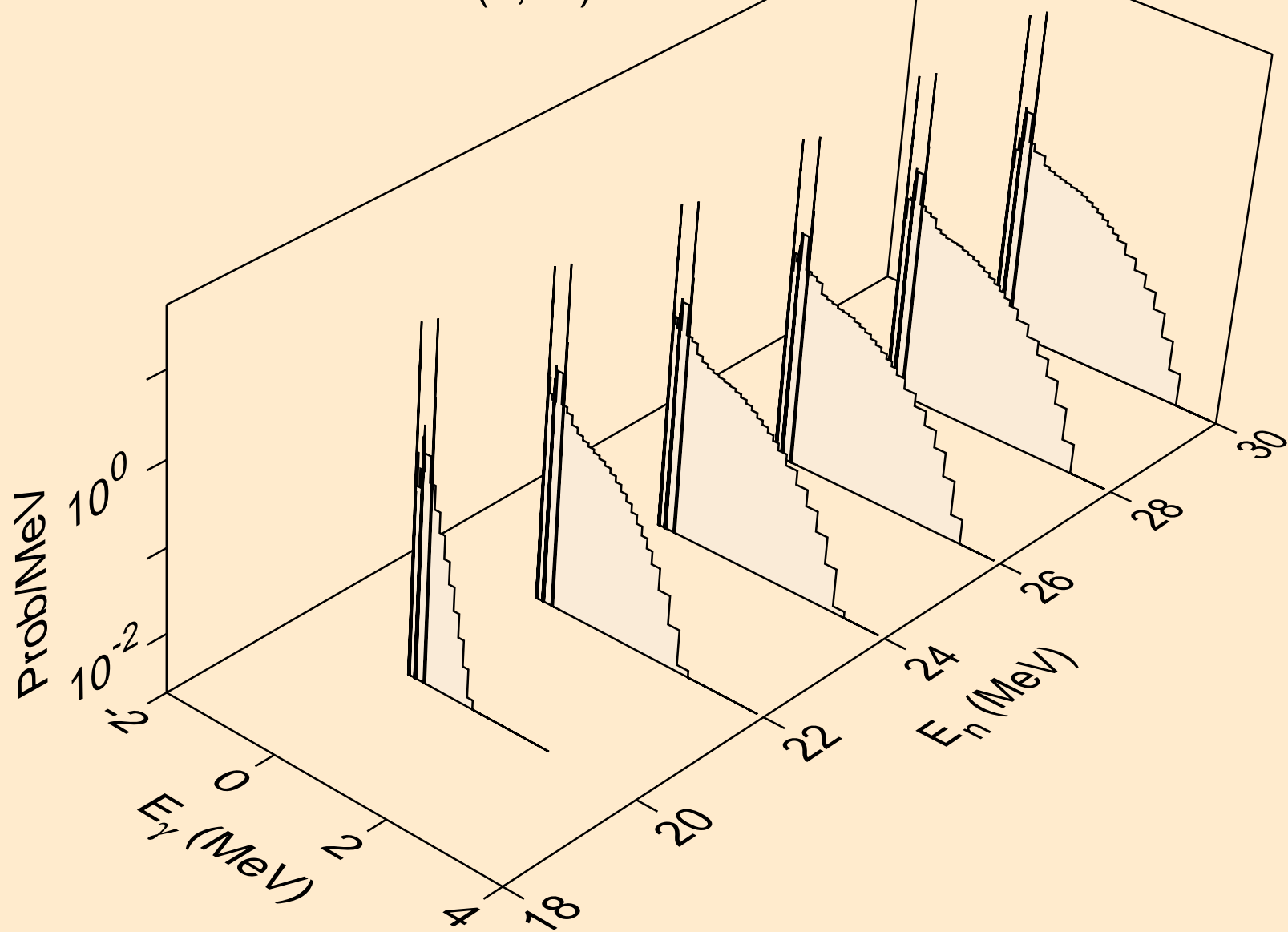

NO259 NEUTRON ACER TENDL-2023 LIBRARY; T=0.K
Photon emission for (n,2np)

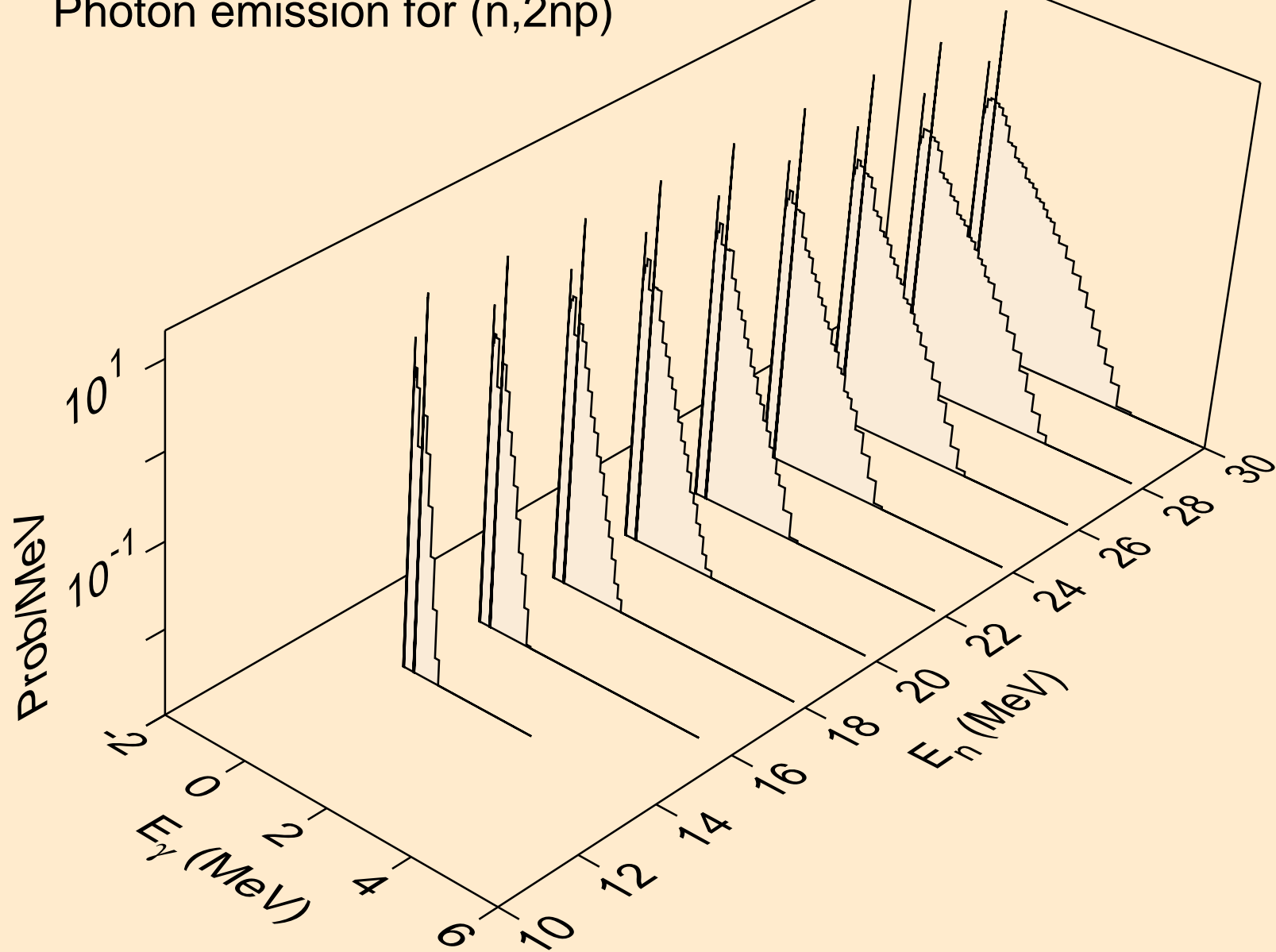

NO259 NEUTRON ACER TENDL-2023 LIBRARY; T=0.K
Photon emission for (n,3np)

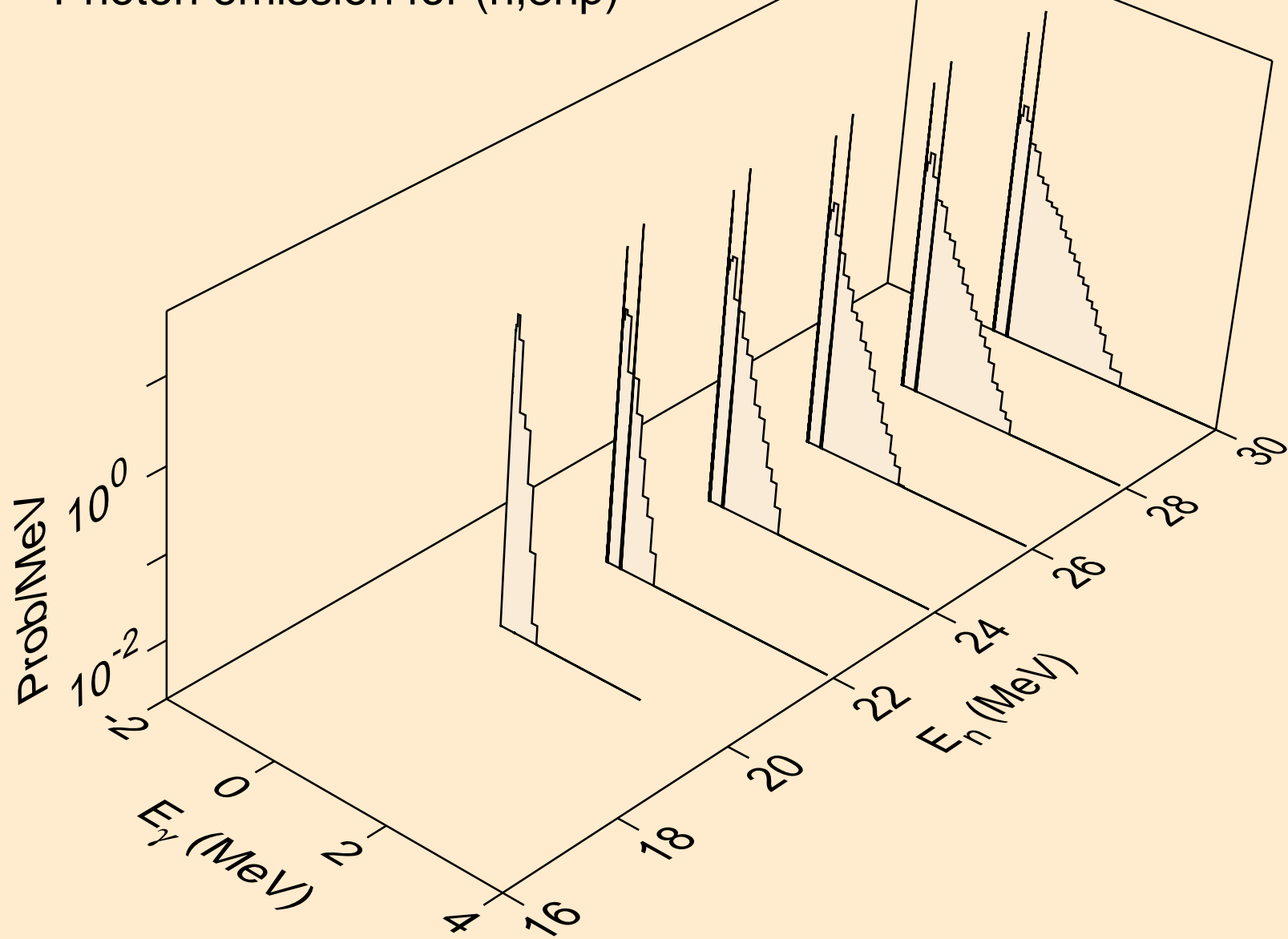

NO259 NEUTRON ACER TENDL-2023 LIBRARY; T=0.K
Photon emission for (n,n2p)

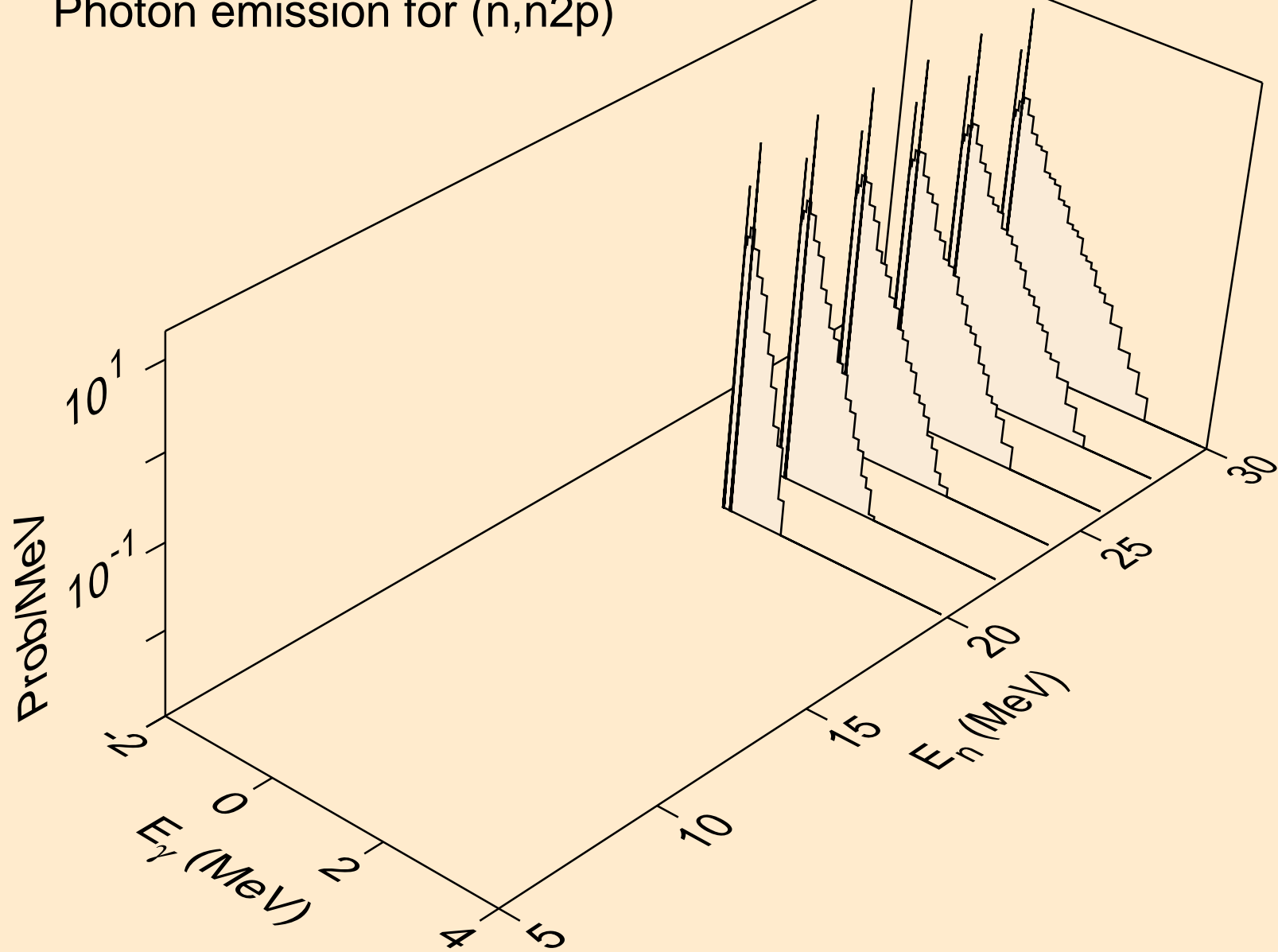

NO259 NEUTRON ACER TENDL-2023 LIBRARY; T=0.K
Photon emission for (n,n*c)

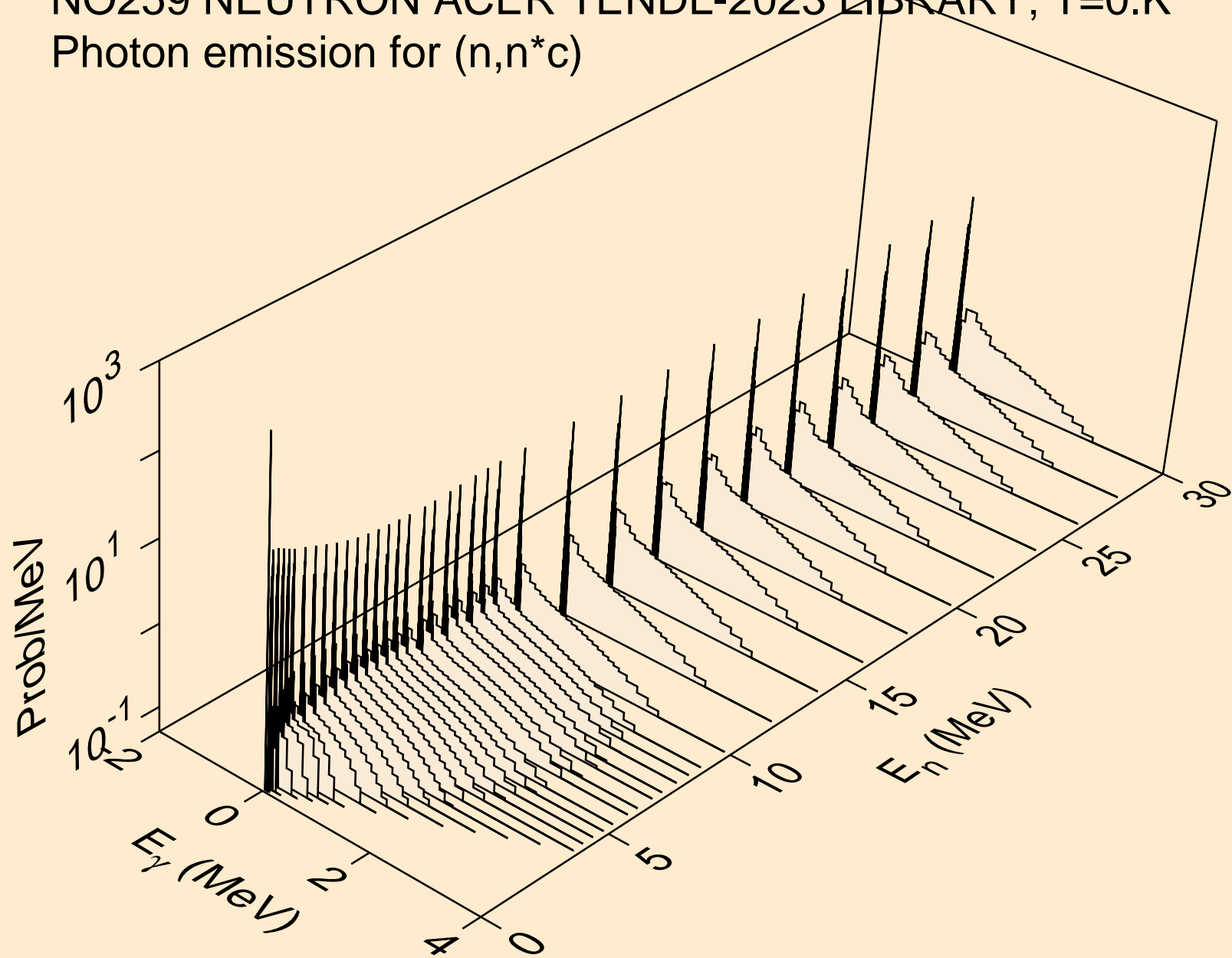

NO259 NEUTRON ACER TENDL-2023 LIBRARY; T=0.K
Photon emission for (n,gma)

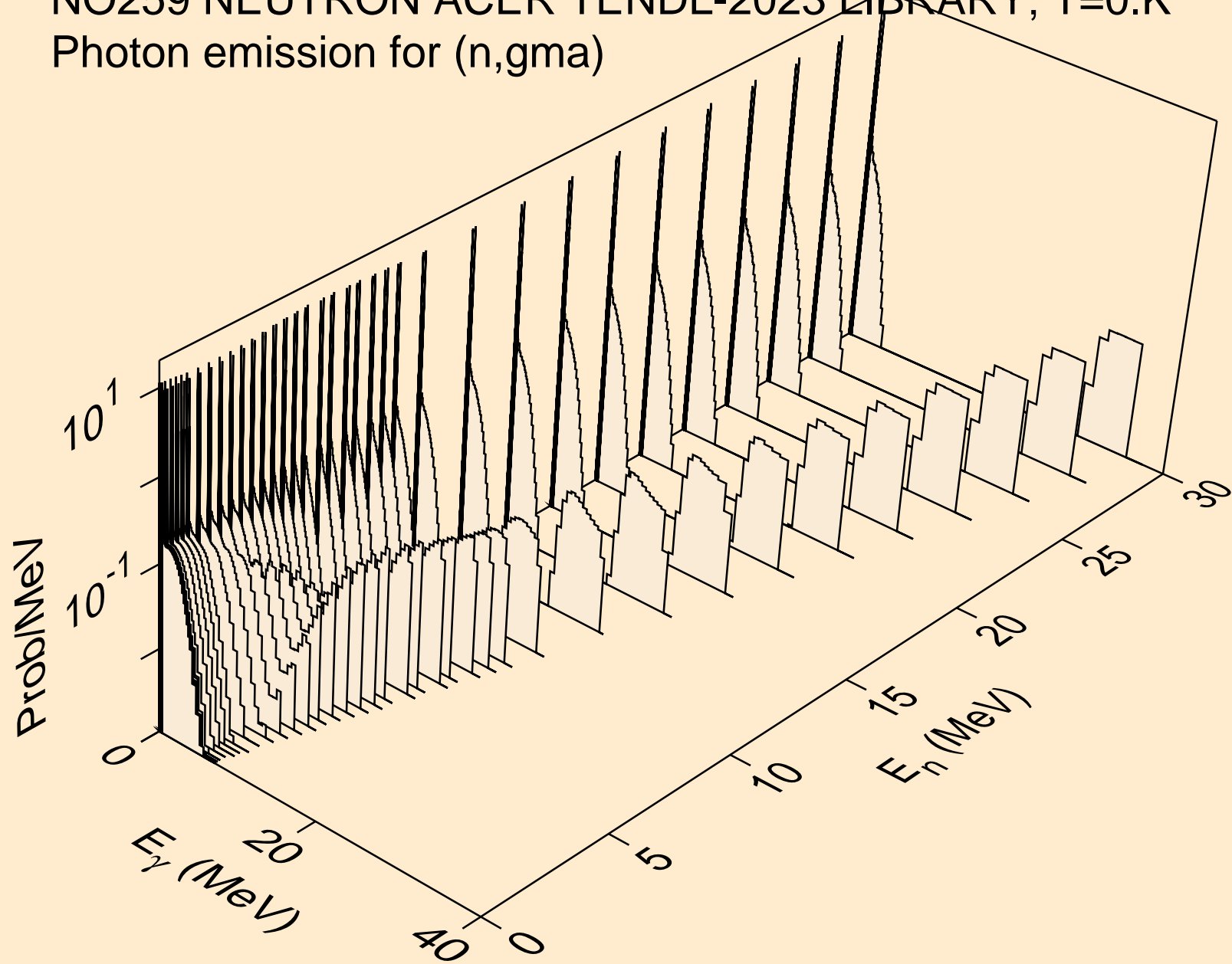

NO259 NEUTRON ACER TENDL-2023 LIBRARY; T=0.K
Photon emission for (n,p)

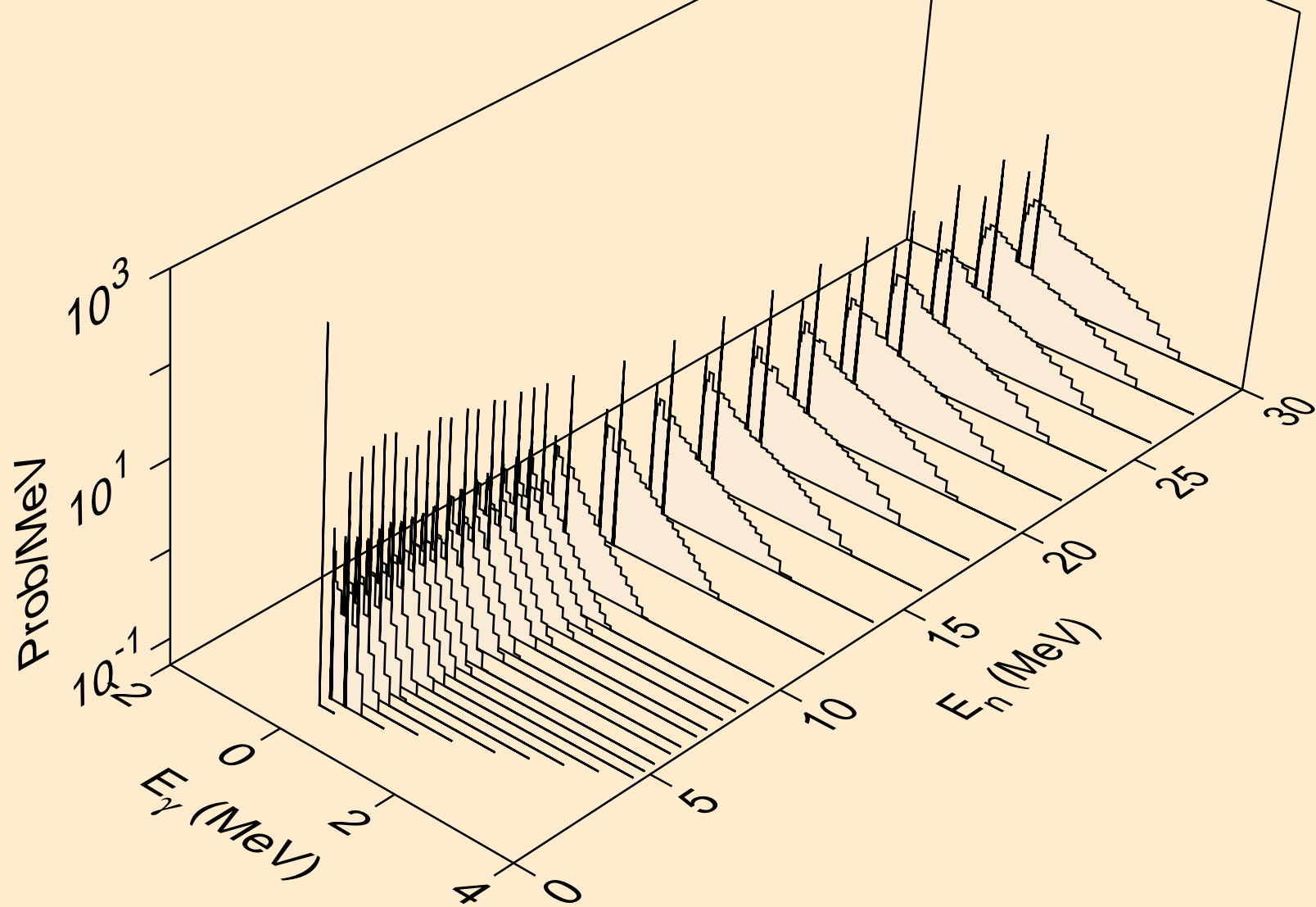

NO259 NEUTRON ACER TENDL-2023 LIBRARY; T=0.K
Photon emission for (n,d)

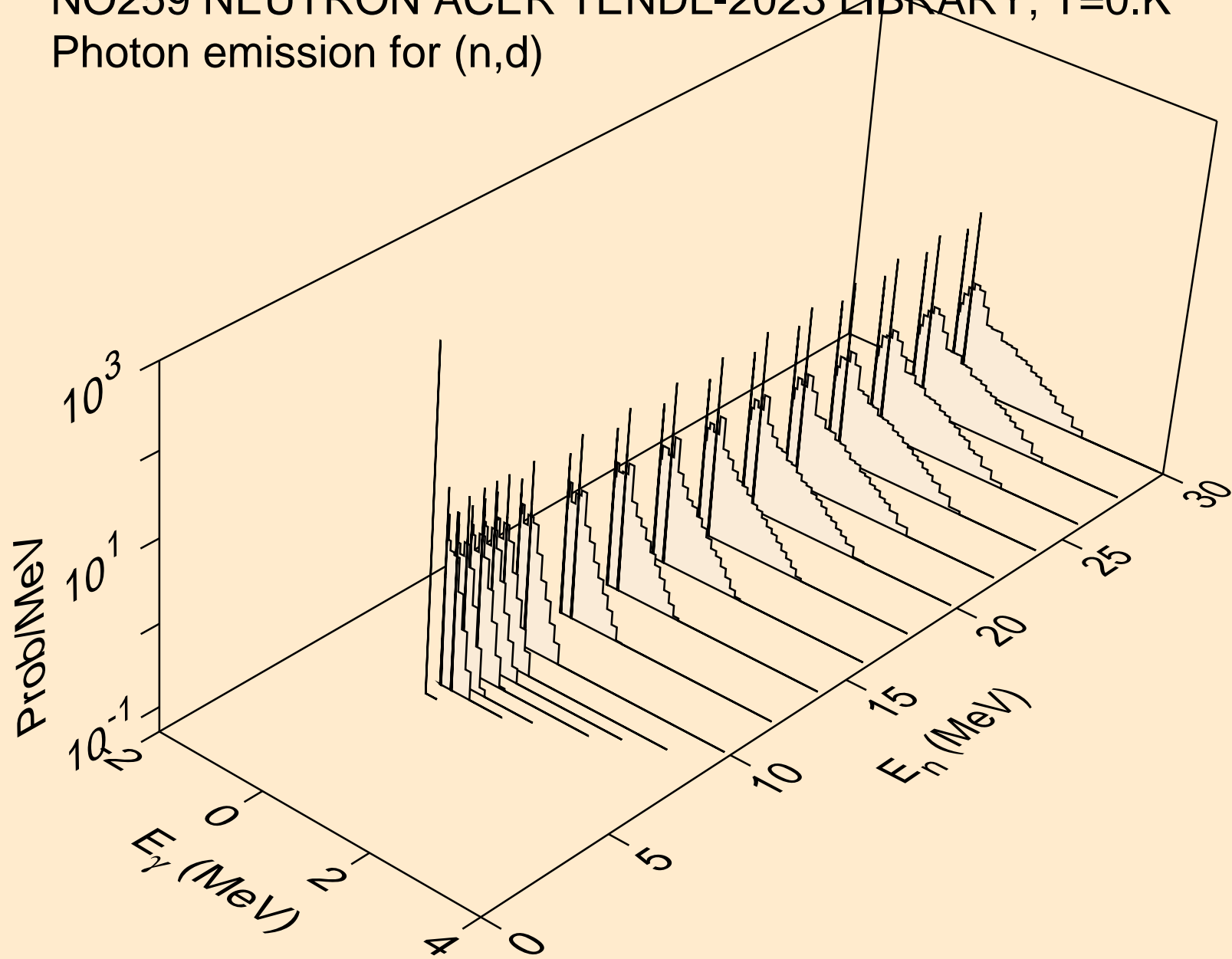

NO259 NEUTRON ACER TENDL-2023 LIBRARY; T=0.K
Photon emission for (n,t)

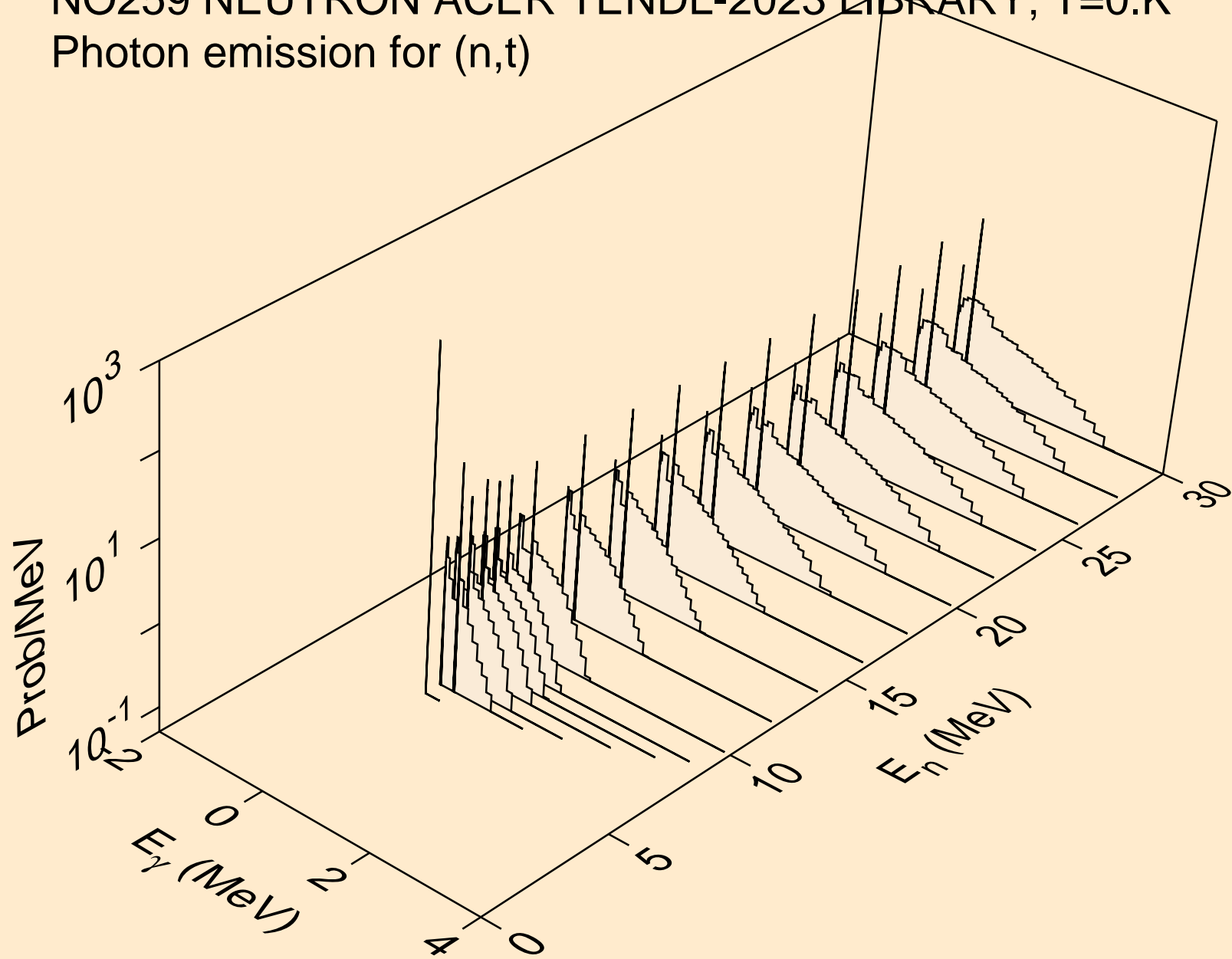

NO259 NEUTRON ACER TENDL-2023 LIBRARY; T=0.K
Photon emission for (n,he3)

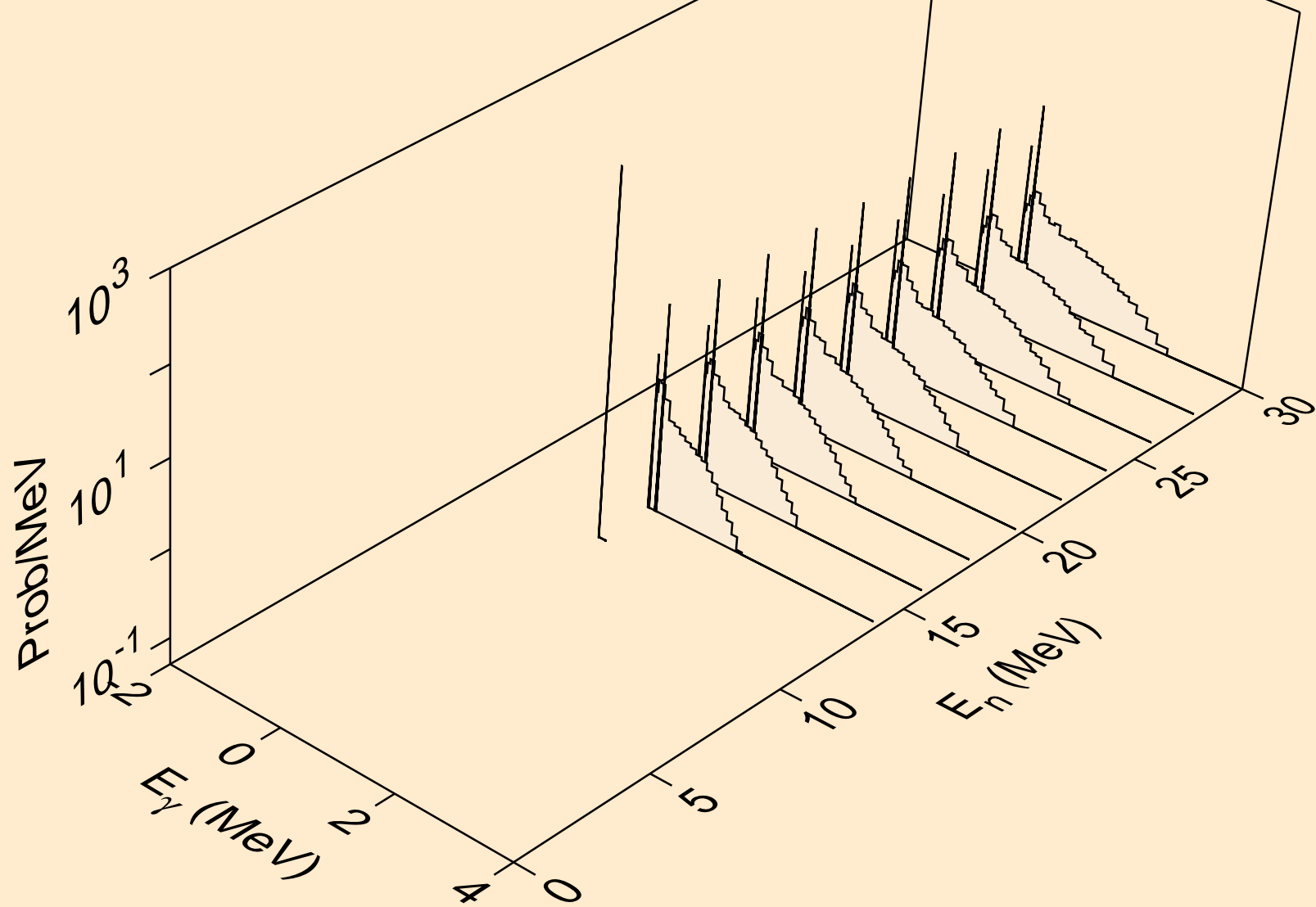

NO259 NEUTRON ACER TENDL-2023 LIBRARY; T=0.K
Photon emission for (n,a)

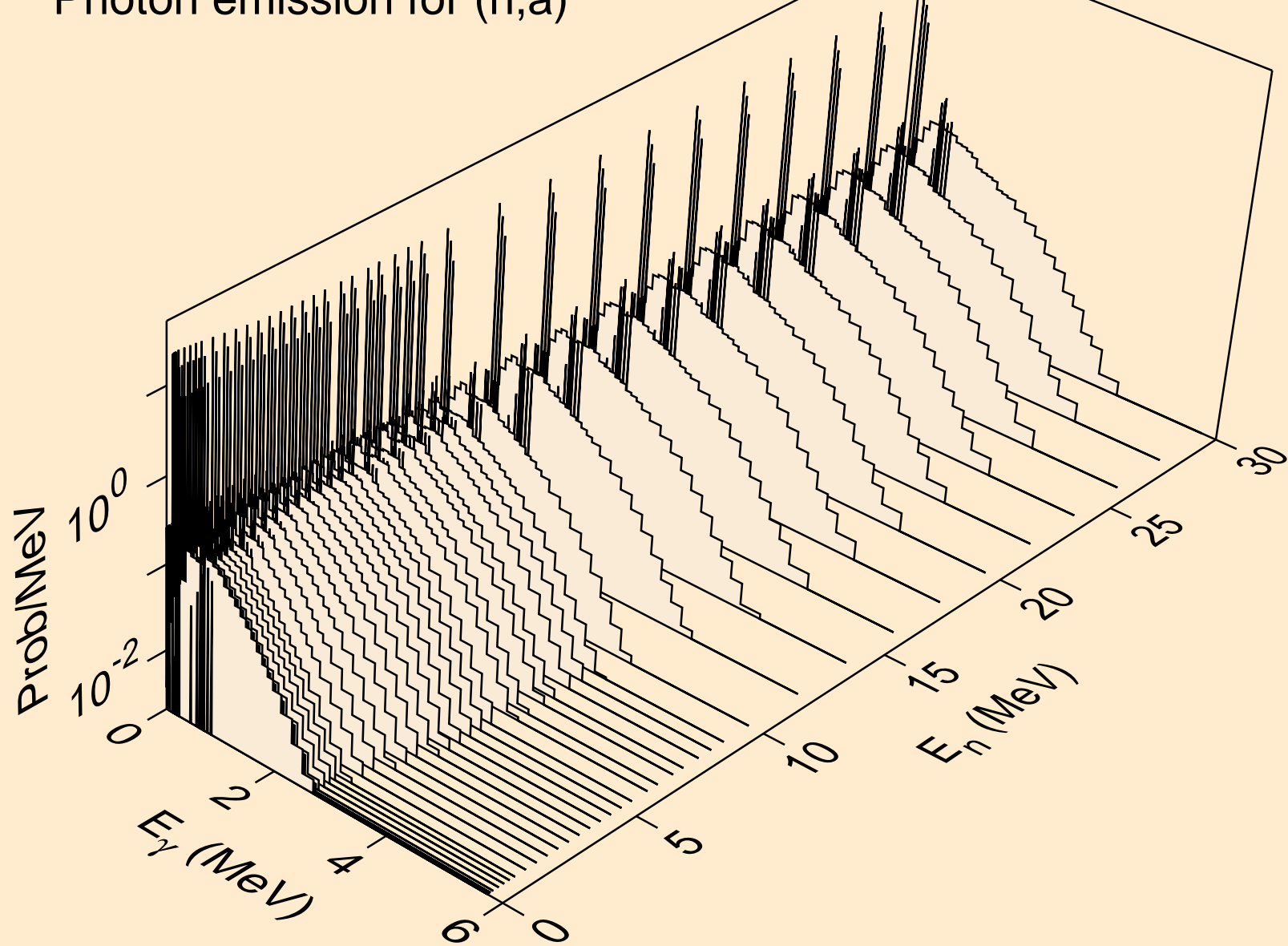

NO259 NEUTRON ACER TENDL-2023 LIBRARY; T=0.K
Photon emission for (n,2p)

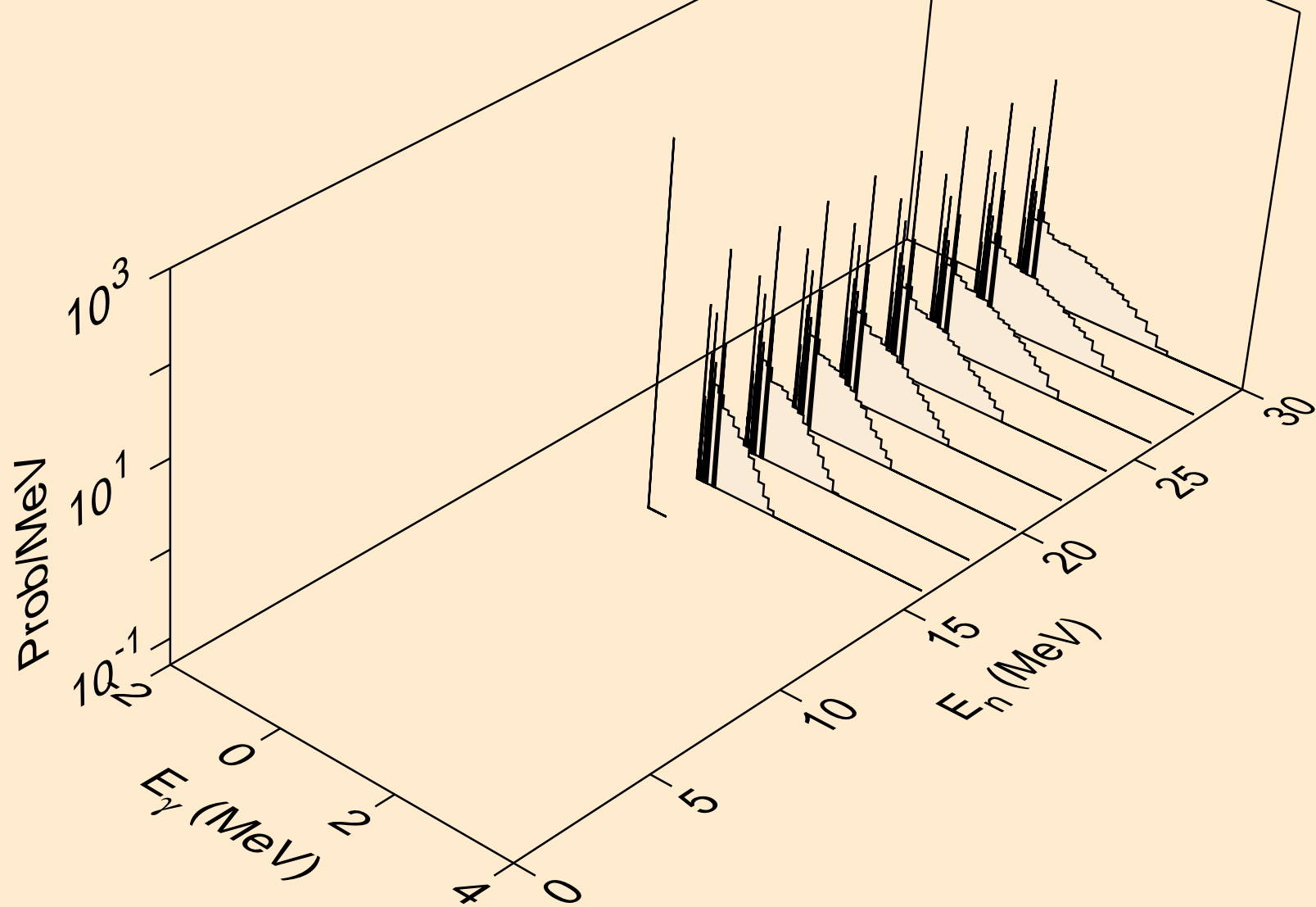

NO259 NEUTRON ACER TENDL-2023 LIBRARY; T=0.K
Photon emission for (n,p)

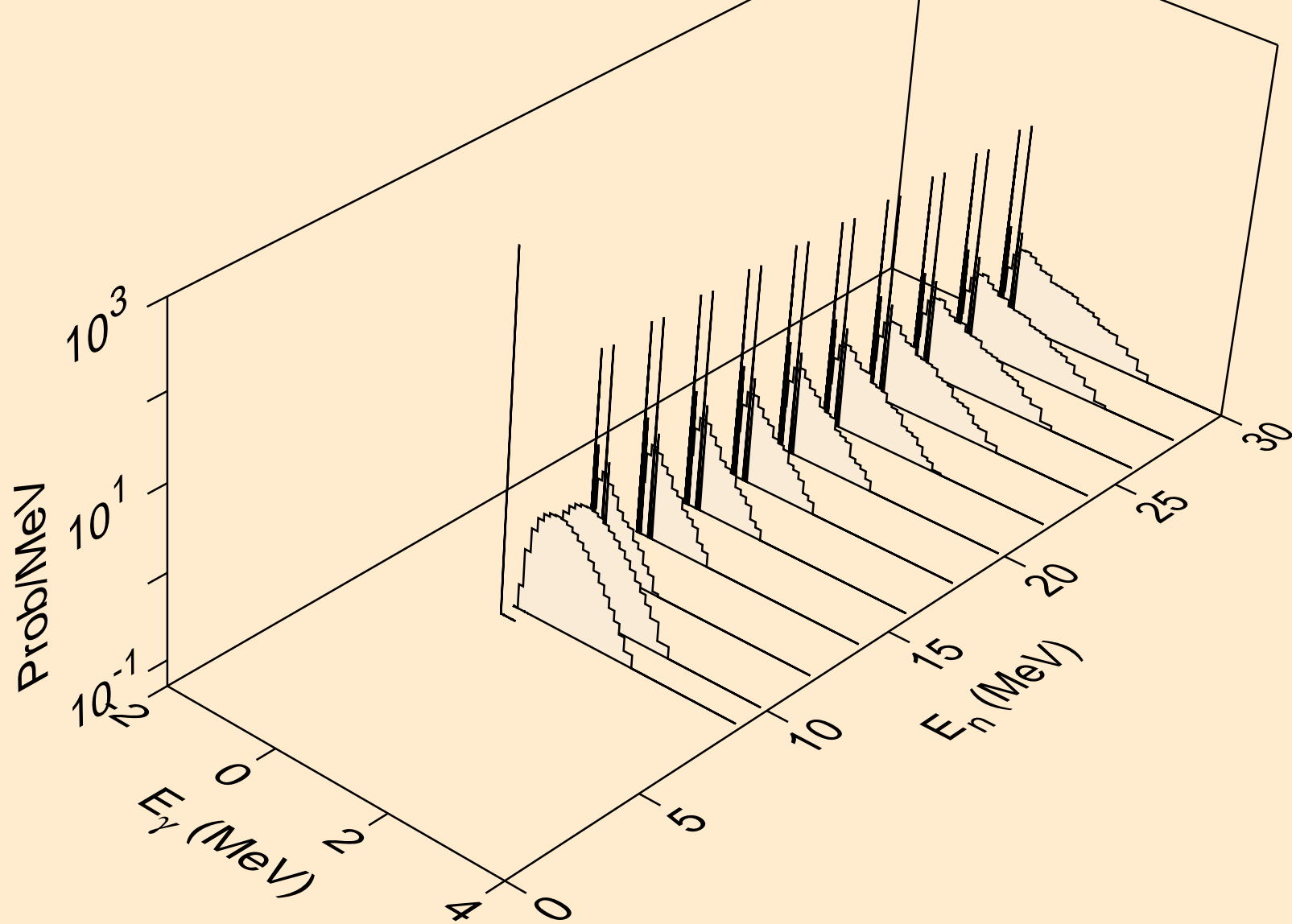

NO259 NEUTRON ACER TENDL-2023 LIBRARY; T=0.K
thermal capture photon spectrum

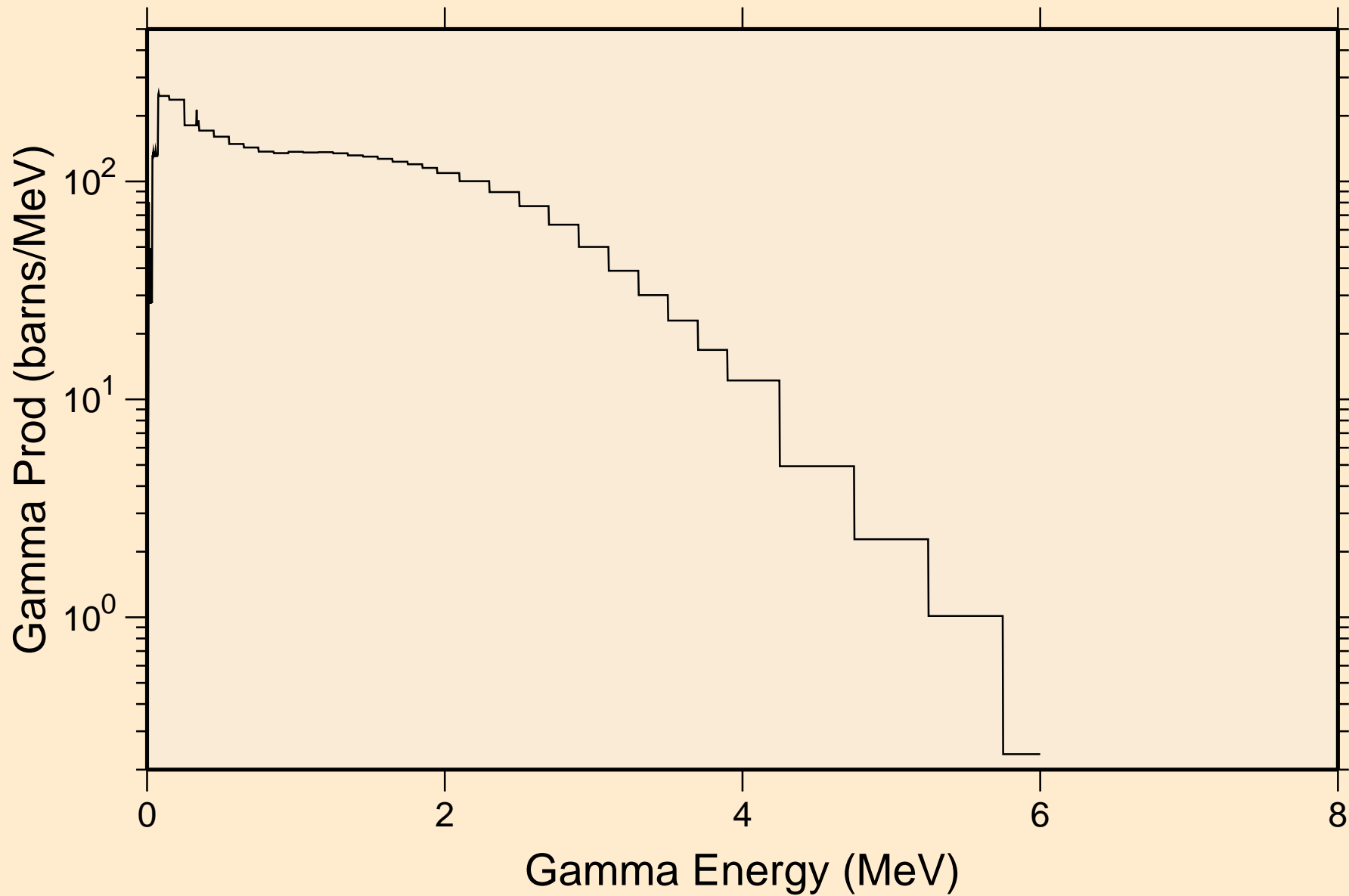

NO259 NEUTRON ACER TENDL-2023 LIBRARY; T=0.K
14 MeV photon spectrum

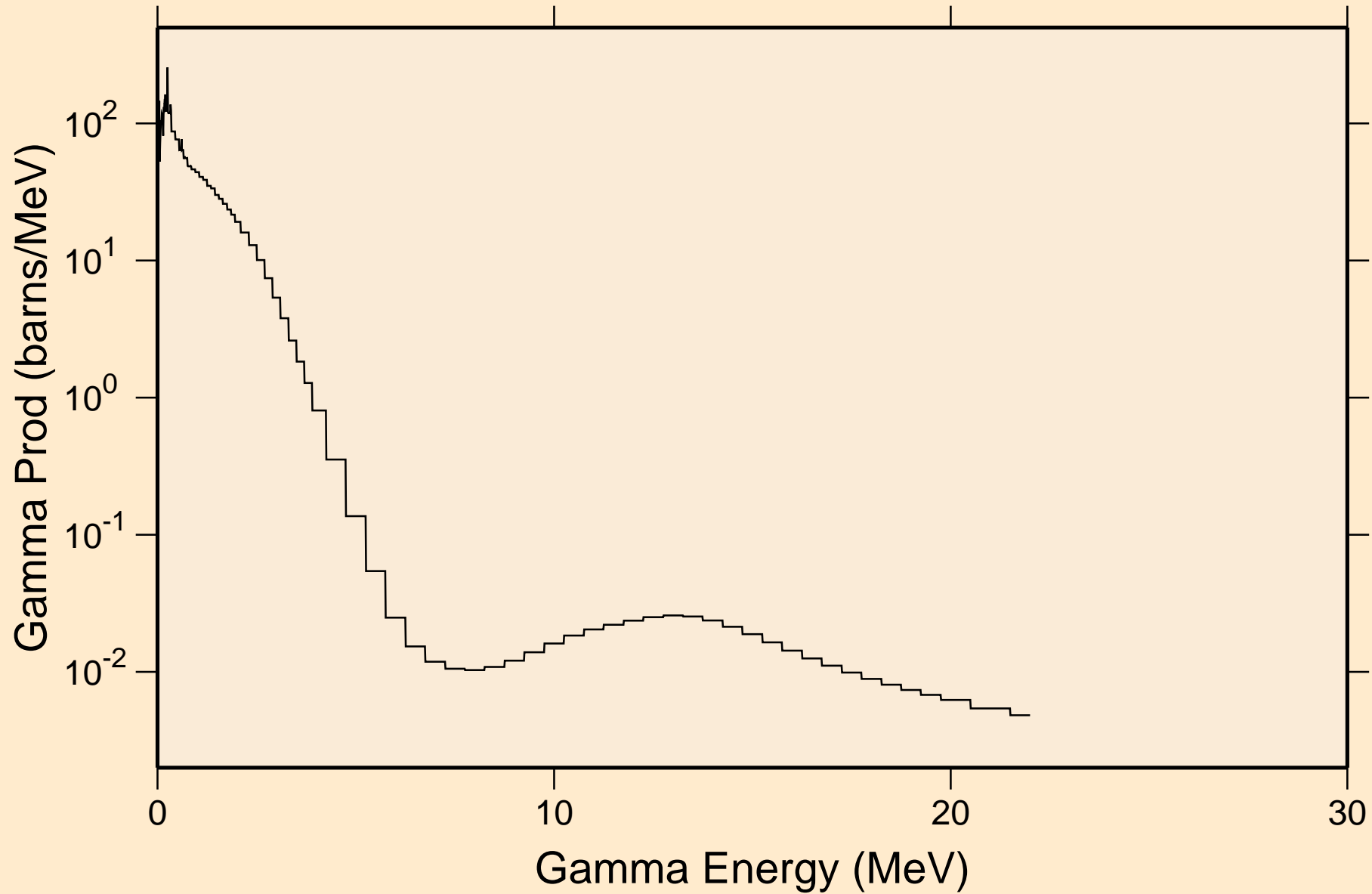

NO259 NEUTRON ACER TENDL-2023 LIBRARY; T=0.K

Particle heating contributions

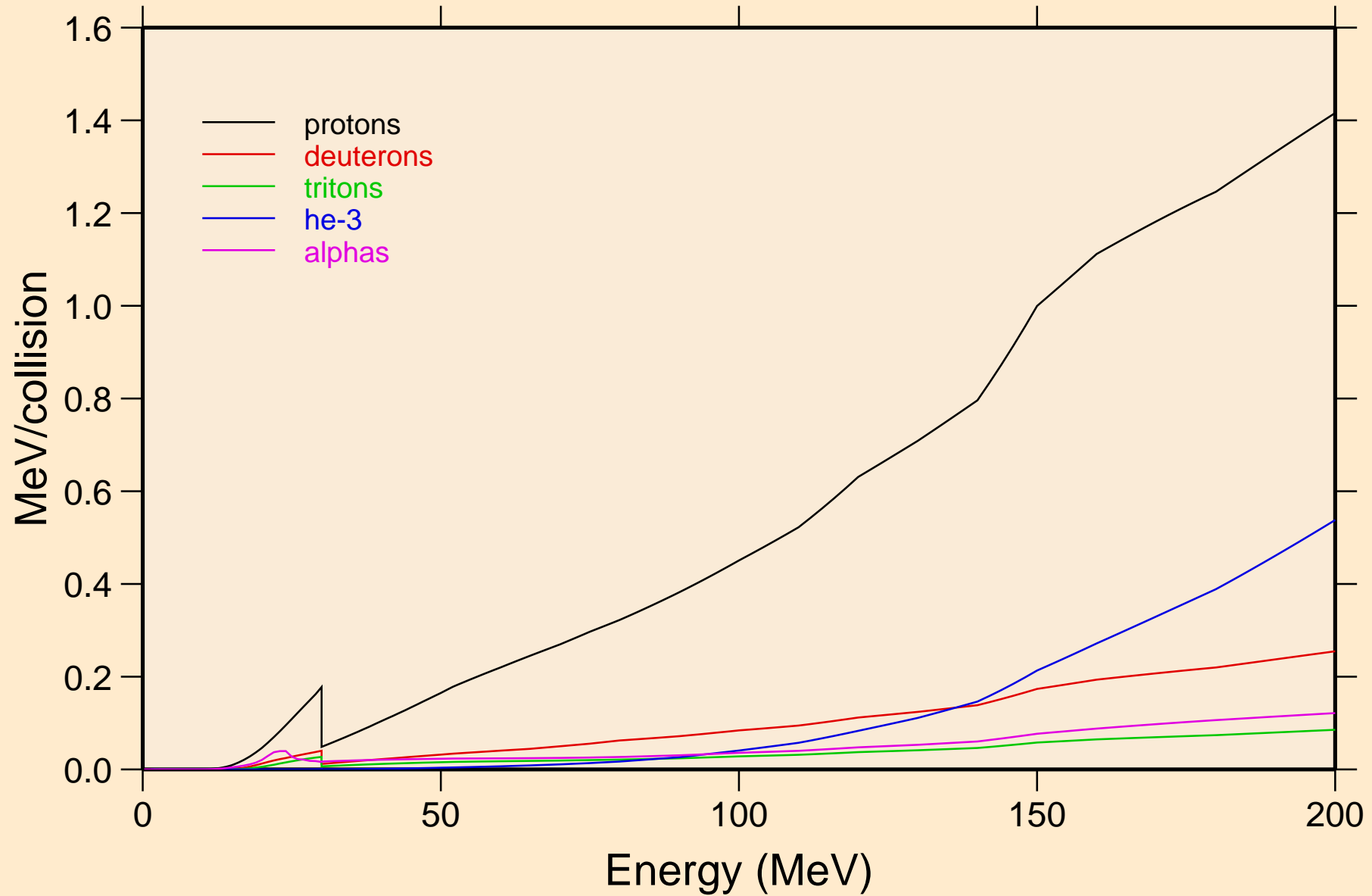

NO259 NEUTRON ACER TENDL-2023 LIBRARY; T=0.K
Recoil Heating

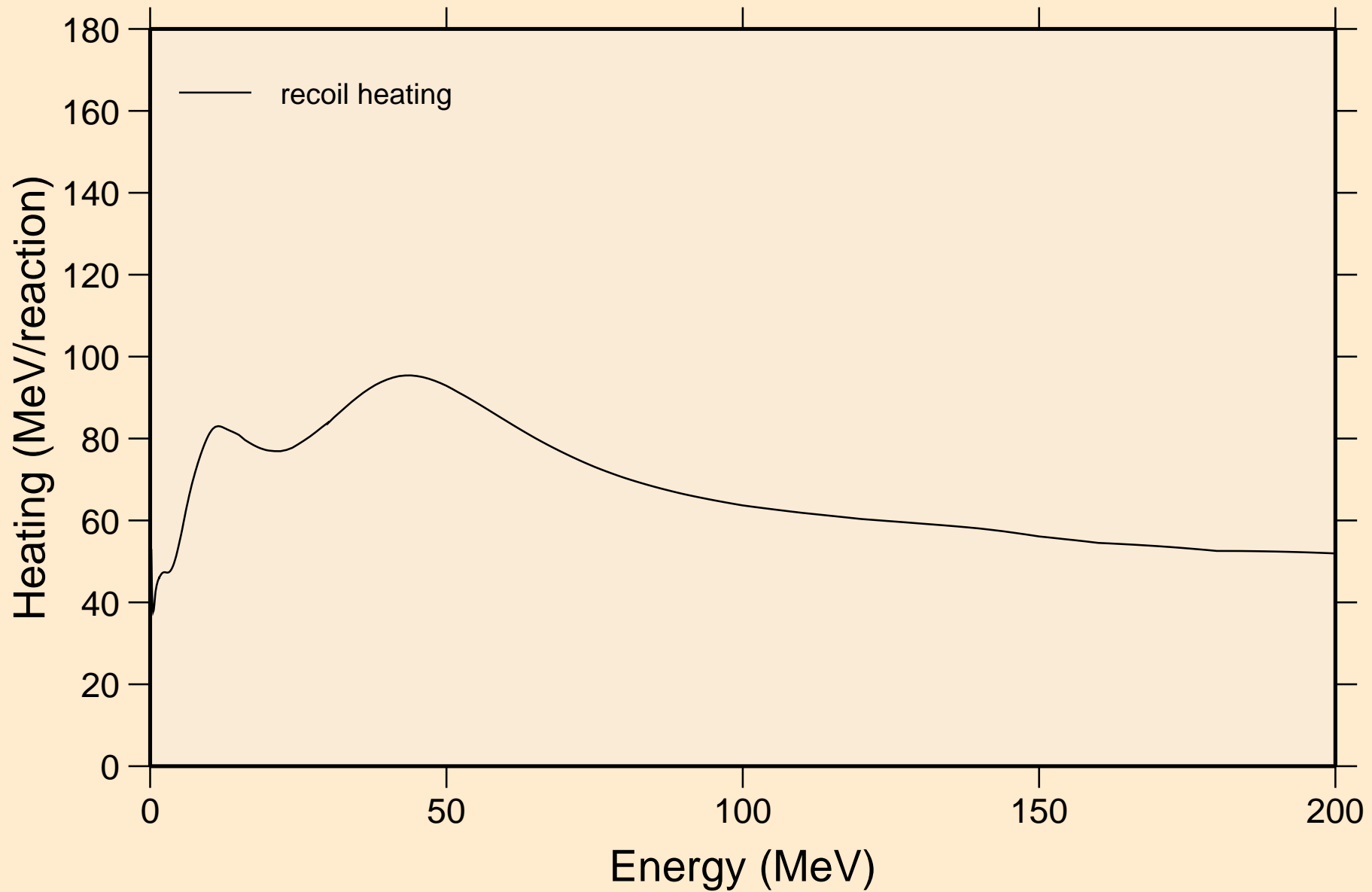

NO259 NEUTRON ACER TENDL-2023 LIBRARY; T=0.K
Particle production cross sections

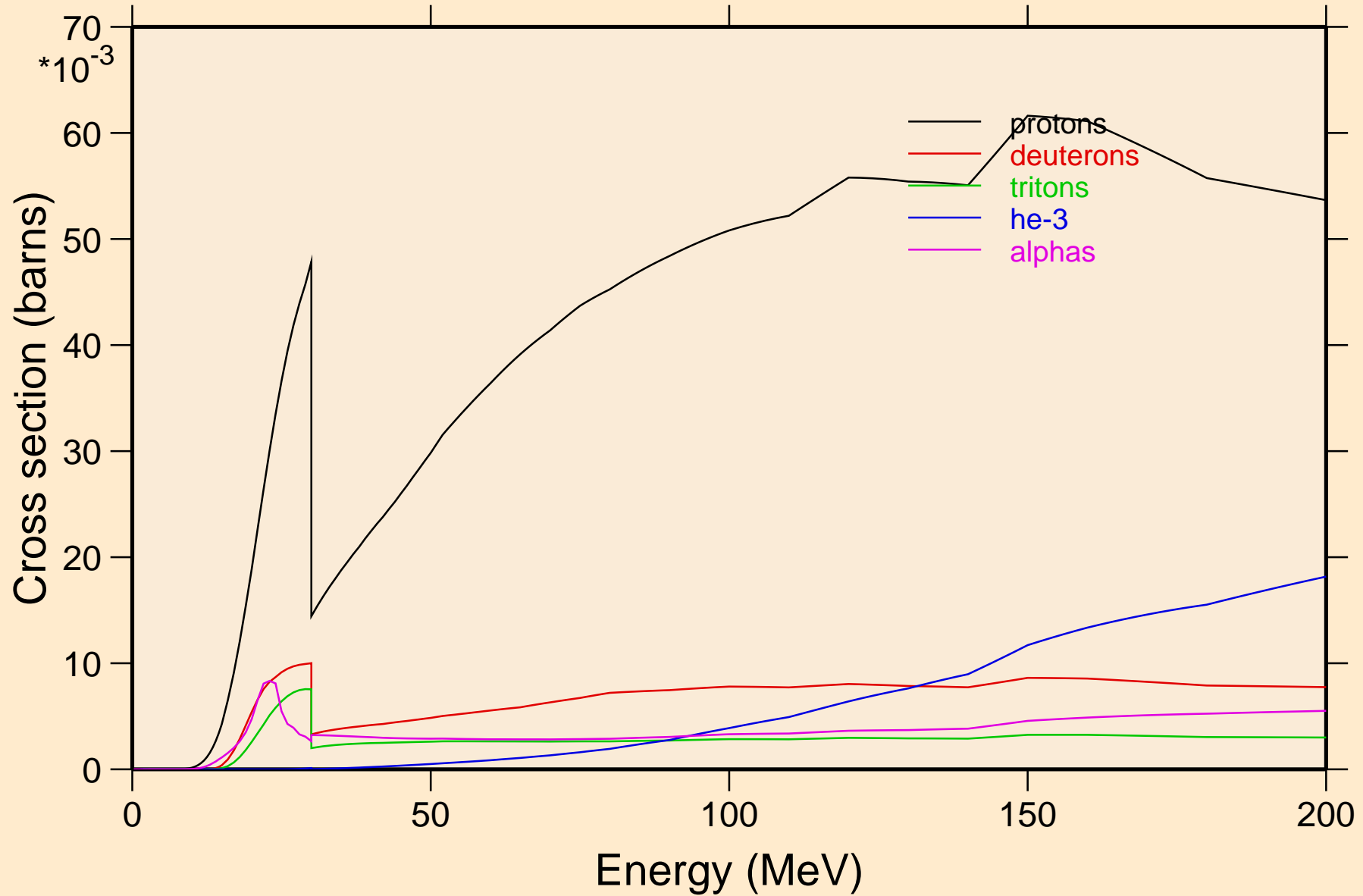

NO259 NEUTRON ACER TENDL-2023 LIBRARY; T=0.K
protons from (n,x)

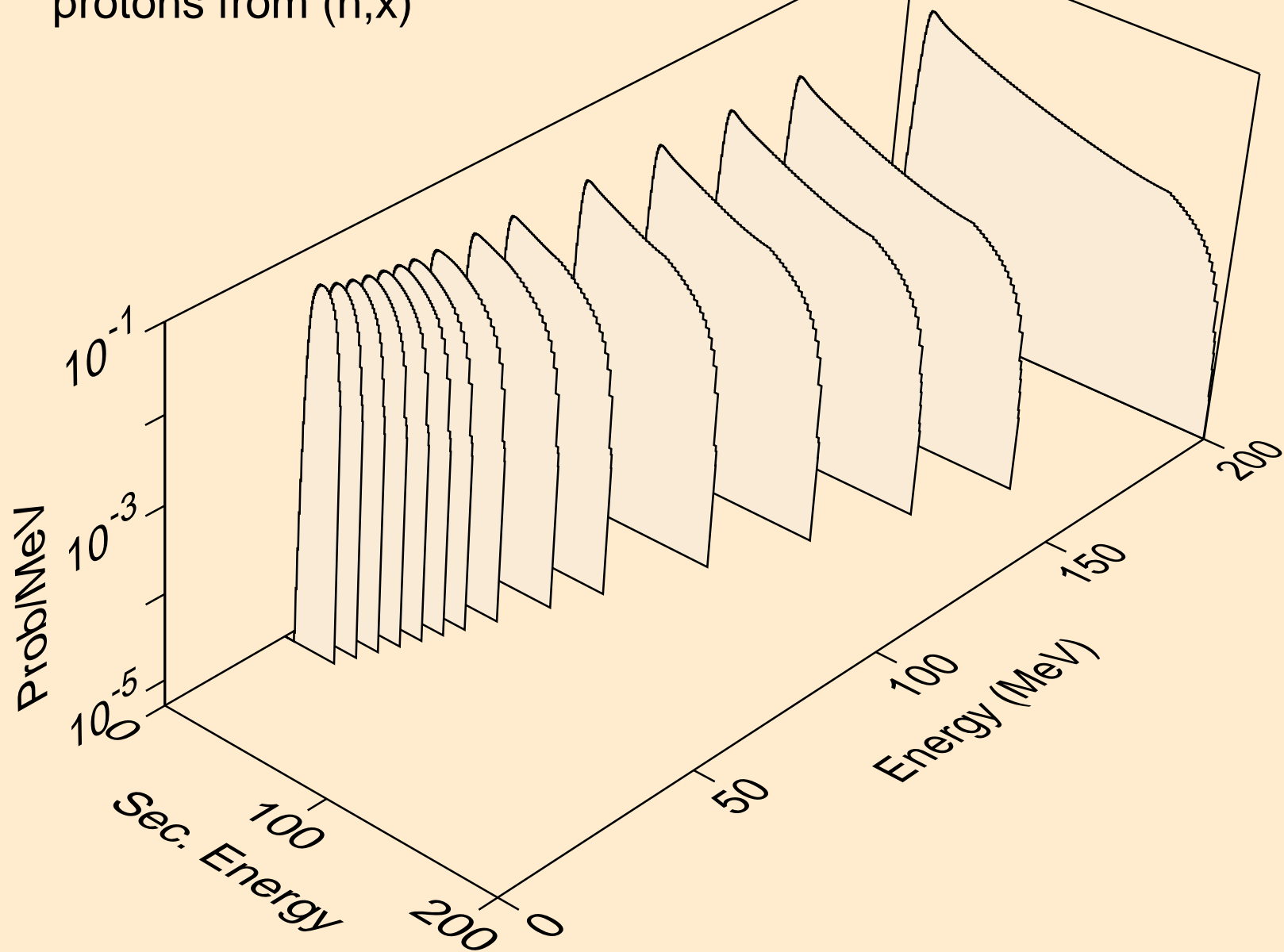

NO259 NEUTRON ACER TENDL-2023 LIBRARY; T=0.K
protons from (n,n*)p

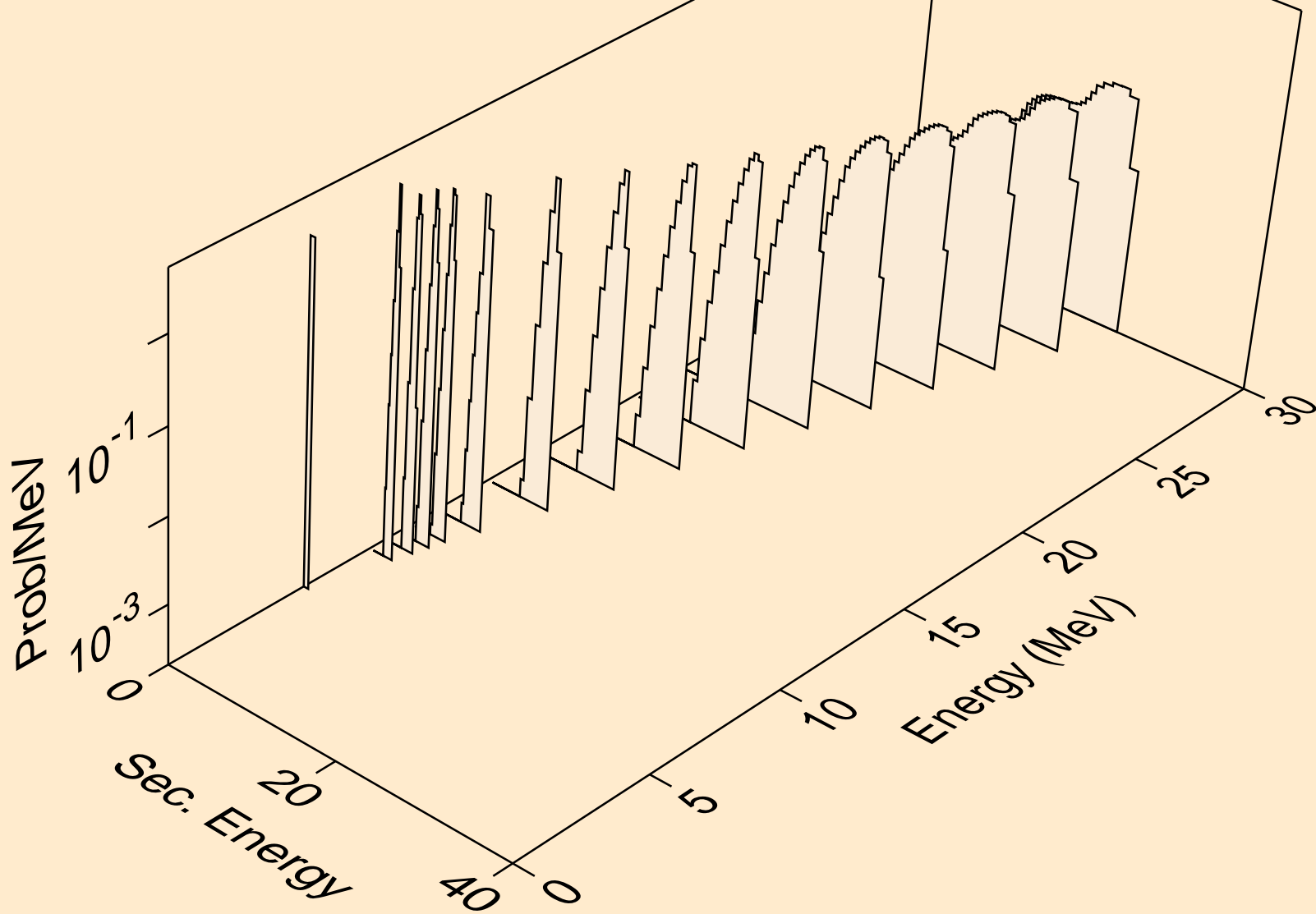

NO259 NEUTRON ACER TENDL-2023 LIBRARY; T=0.K
protons from (n,2np)

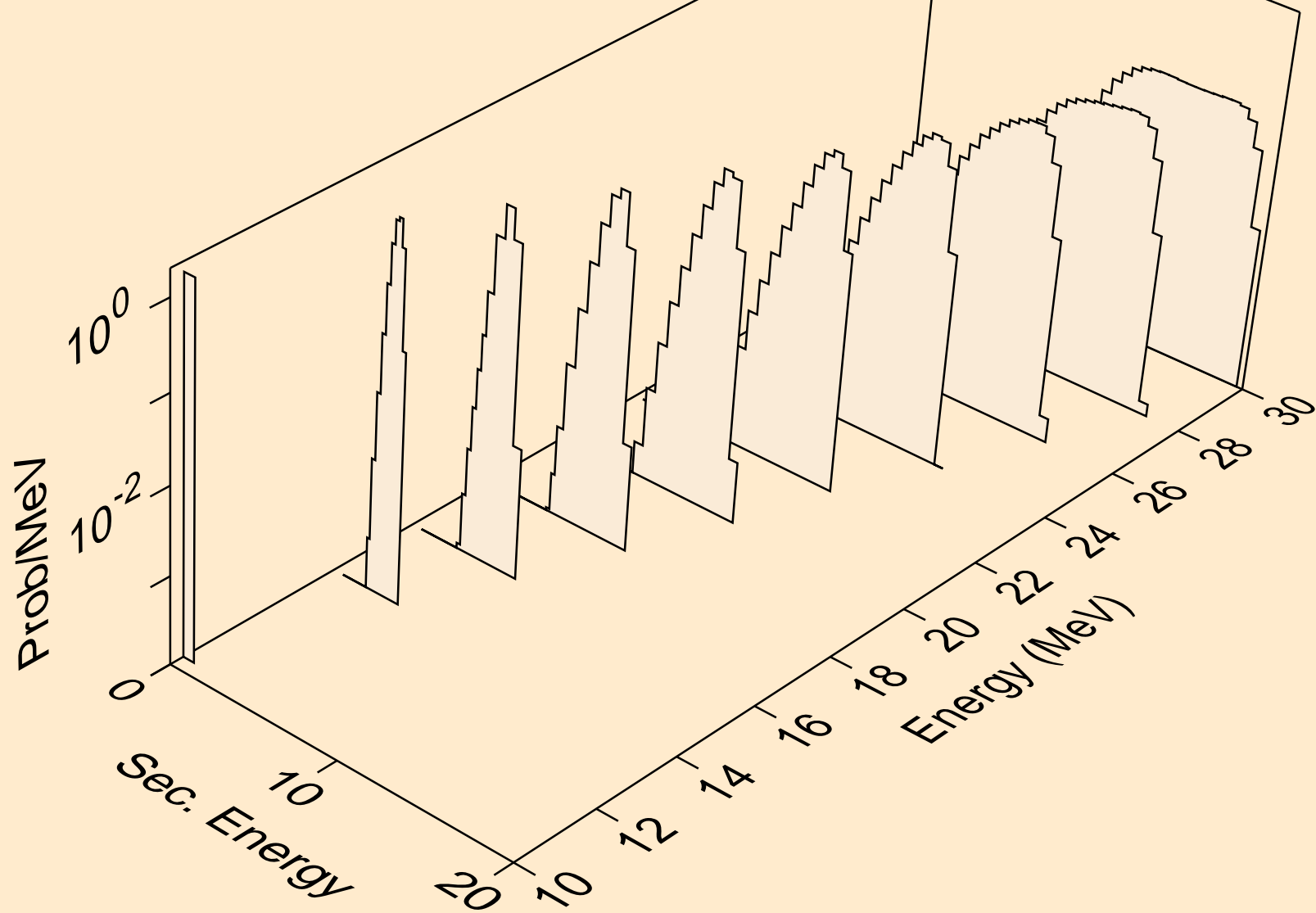

NO259 NEUTRON ACER TENDL-2023 LIBRARY; T=0.K
protons from (n,3np)

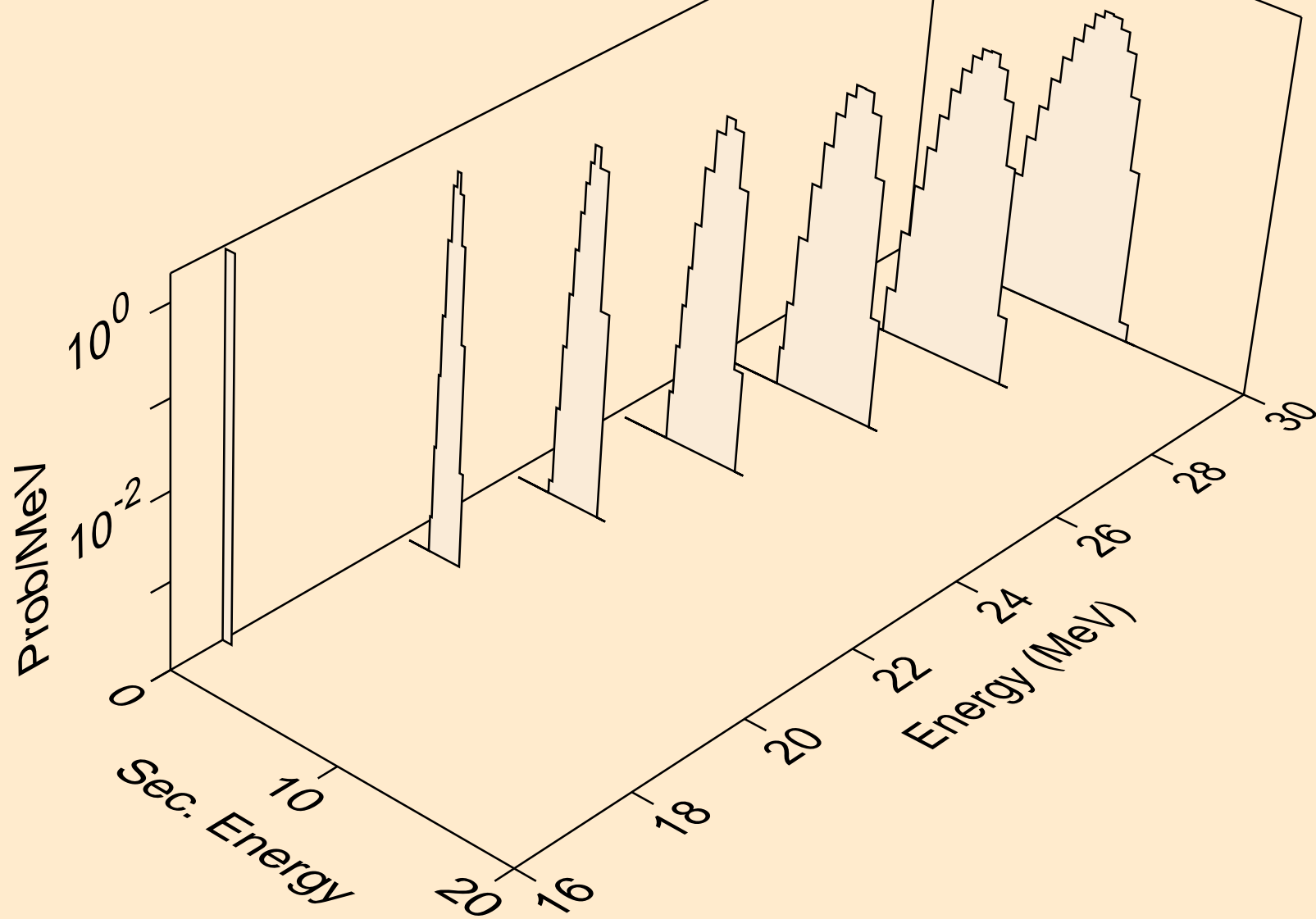

NO259 NEUTRON ACER TENDL-2023 LIBRARY; T=0.K
protons from (n,n2p)

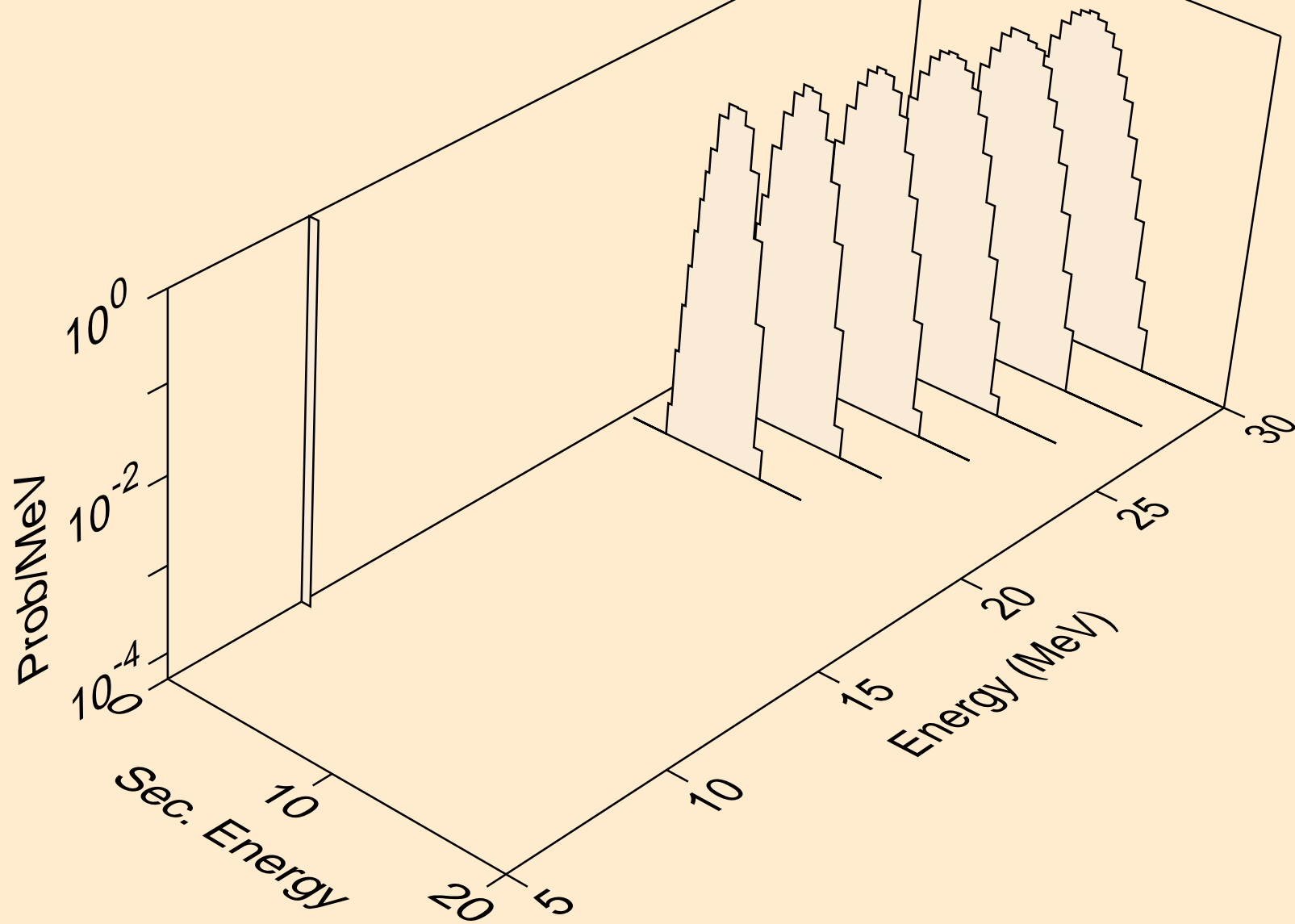

NO259 NEUTRON ACER TENDL-2023 LIBRARY; T=0.K
protons from (n,p)

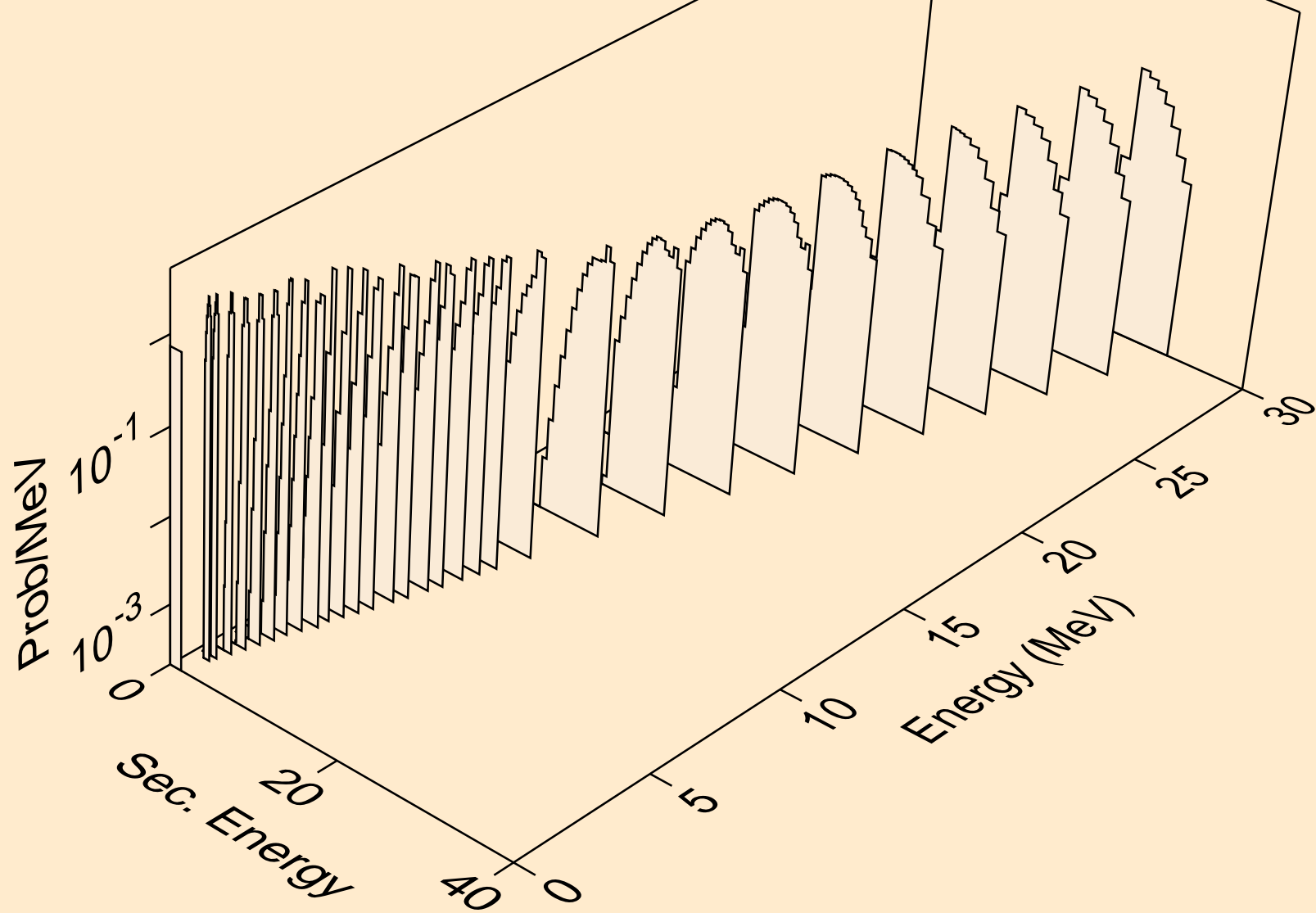

NO259 NEUTRON ACER TENDL-2023 LIBRARY; T=0.K
protons from (n,2p)

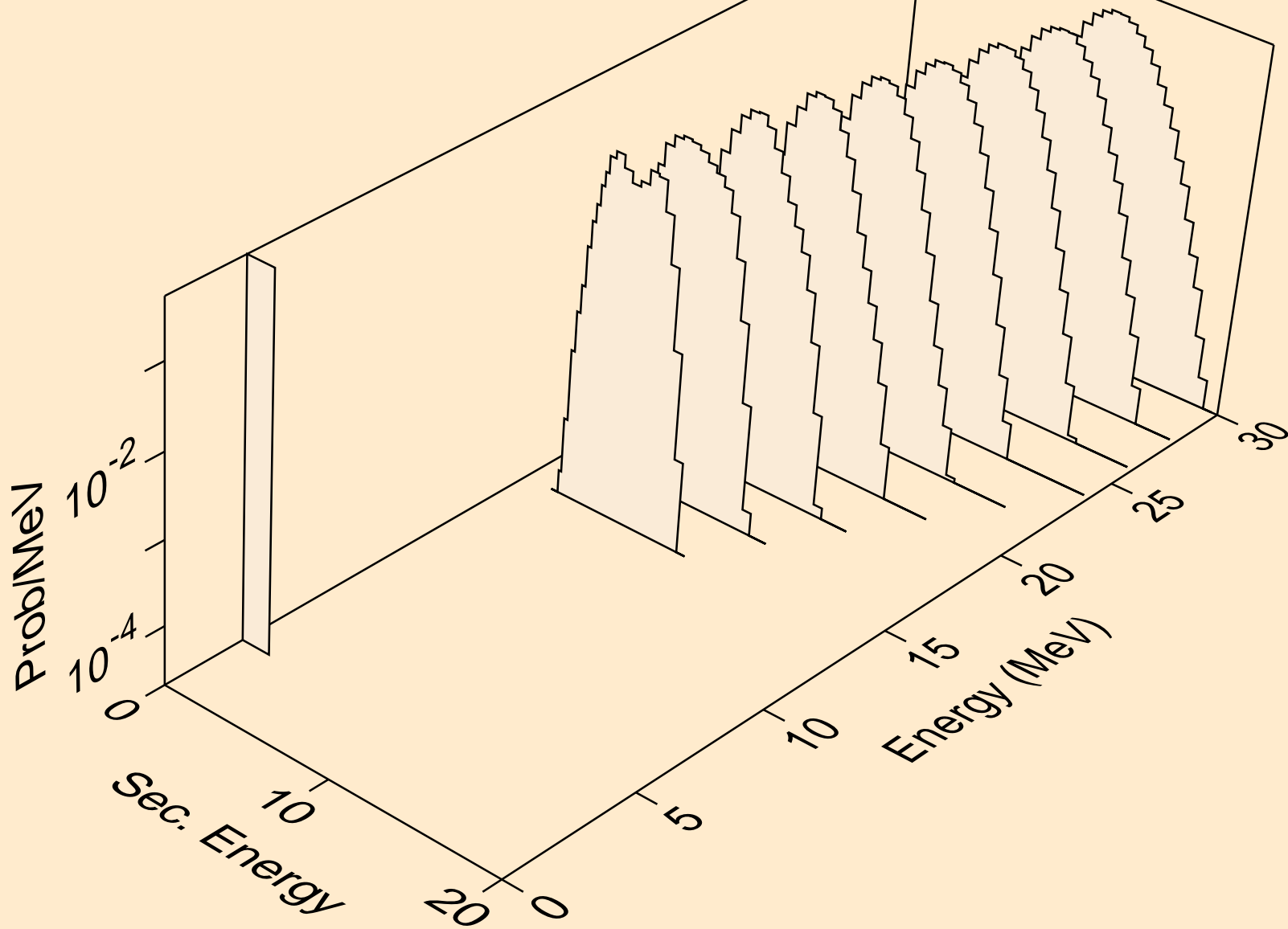

NO259 NEUTRON ACER TENDL-2023 LIBRARY; T=0.K
protons from (n,p)

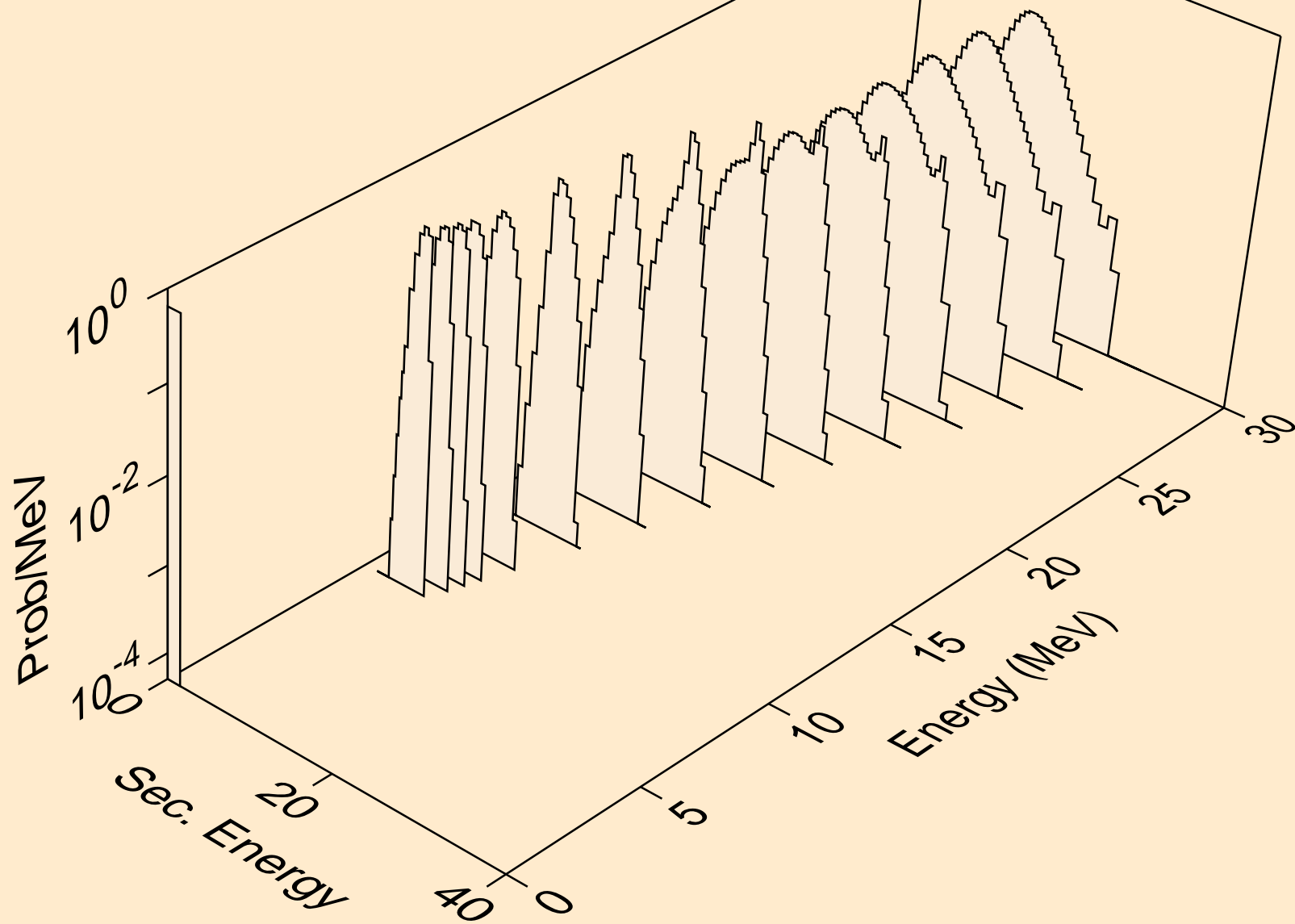

NO259 NEUTRON ACER TENDL-2023 LIBRARY; T=0.K
deuterons from (n,x)

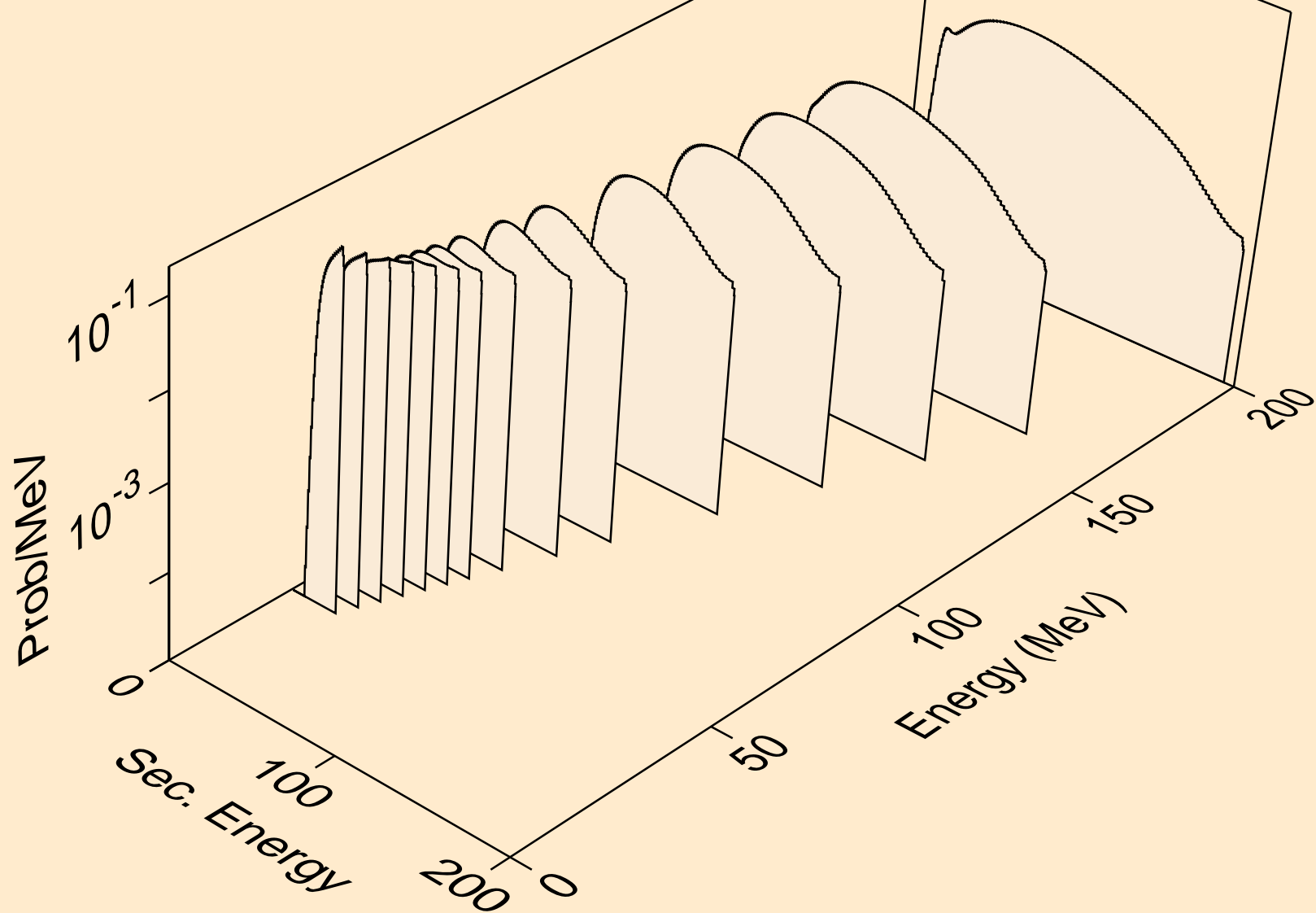

NO259 NEUTRON ACER TENDL-2023 LIBRARY; T=0.K
deuterons from (n,2nd)

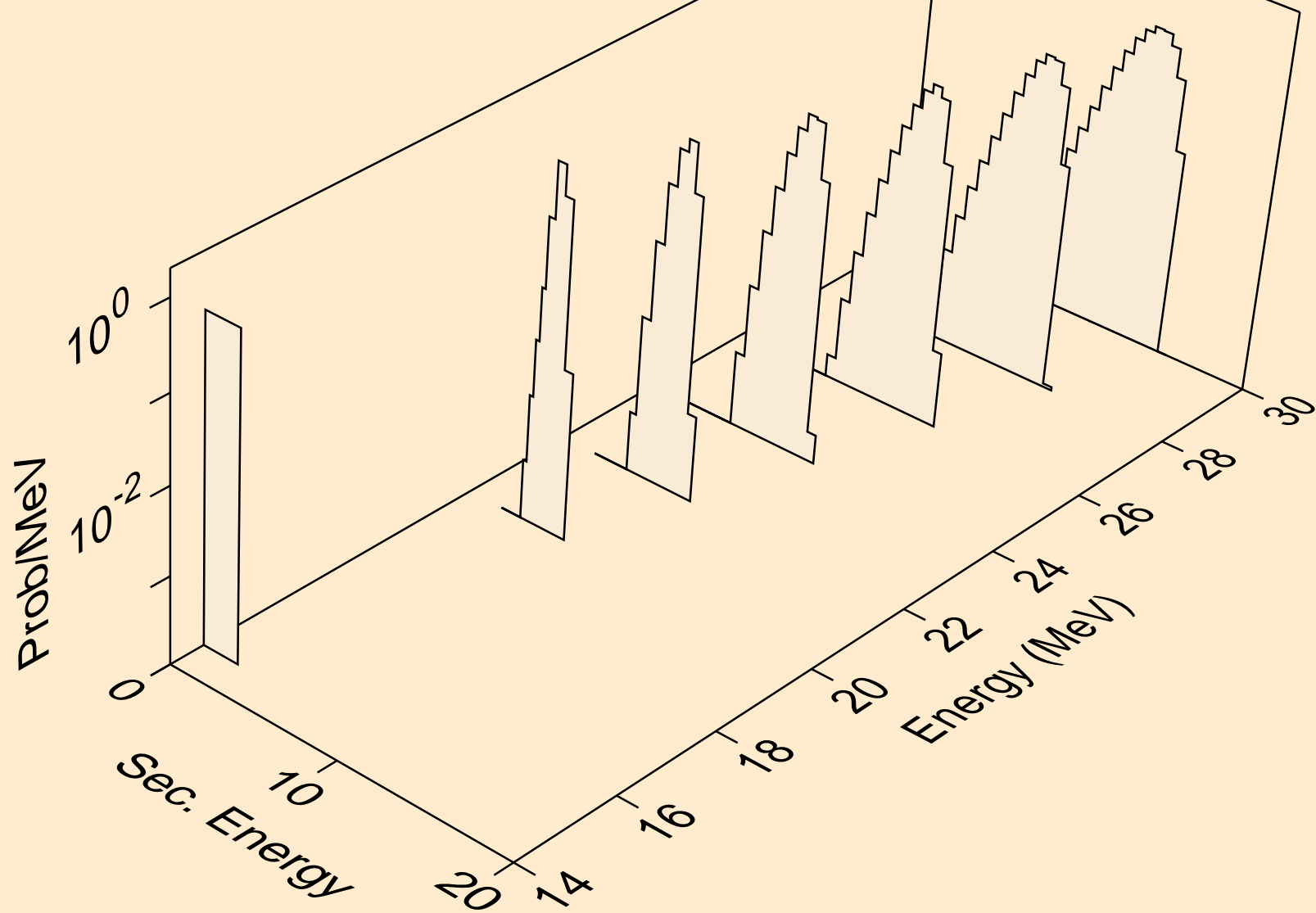

NO259 NEUTRON ACER TENDL-2023 LIBRARY; T=0.K
deuterons from (n,n*)d

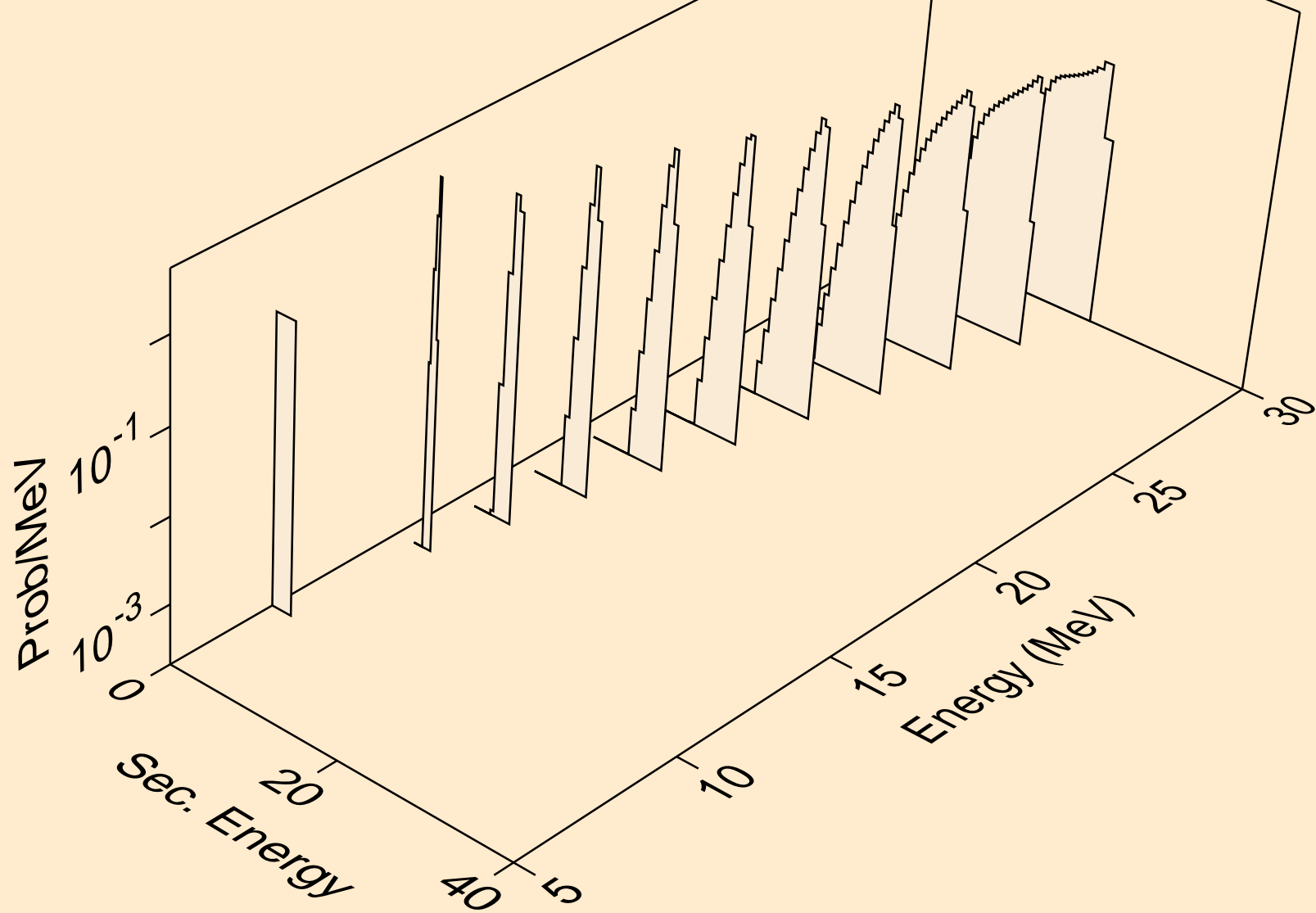

NO259 NEUTRON ACER TENDL-2023 LIBRARY; T=0.K
deuterons from (n,d)

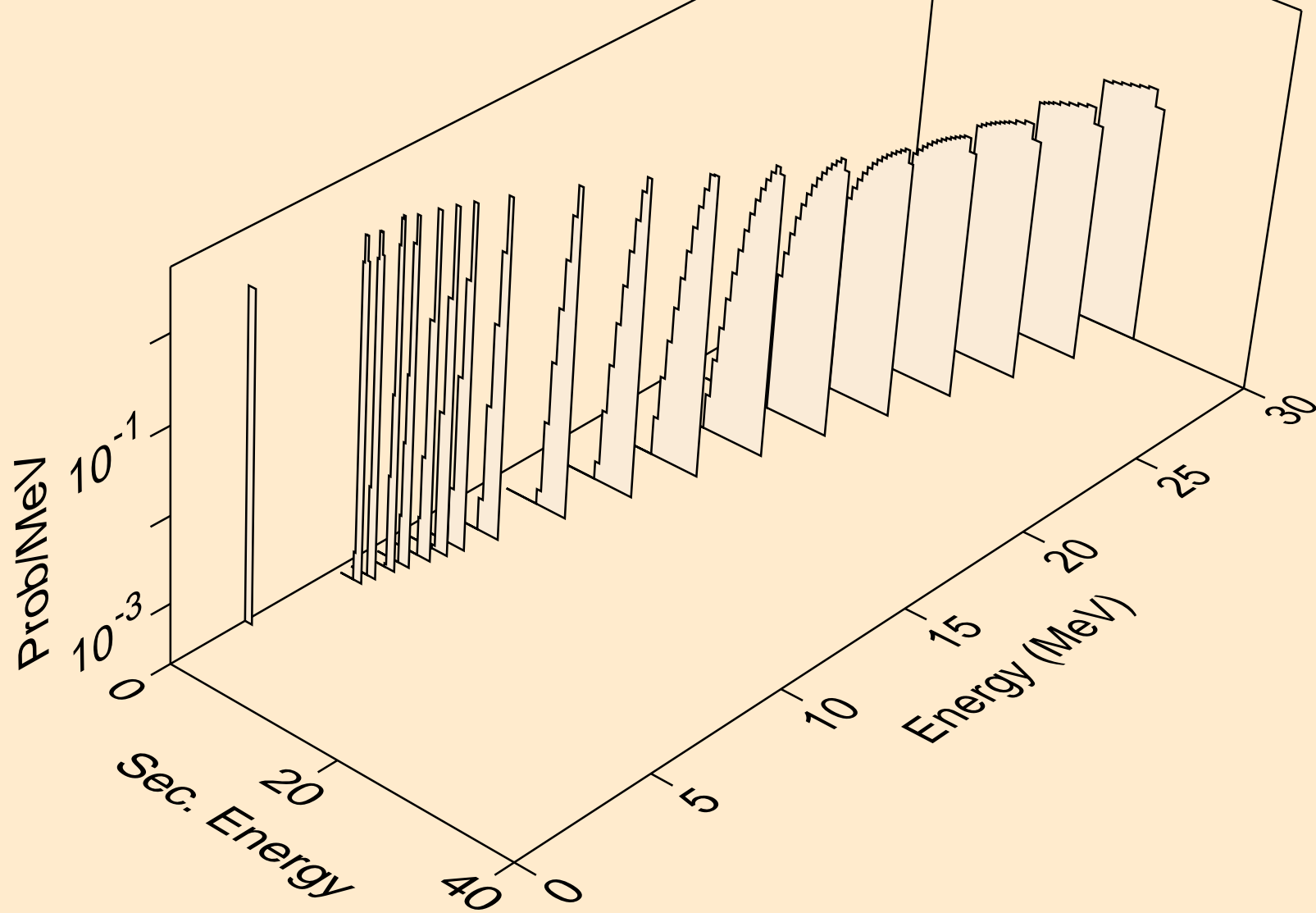

NO259 NEUTRON ACER TENDL-2023 LIBRARY; T=0.K
tritons from (n,x)

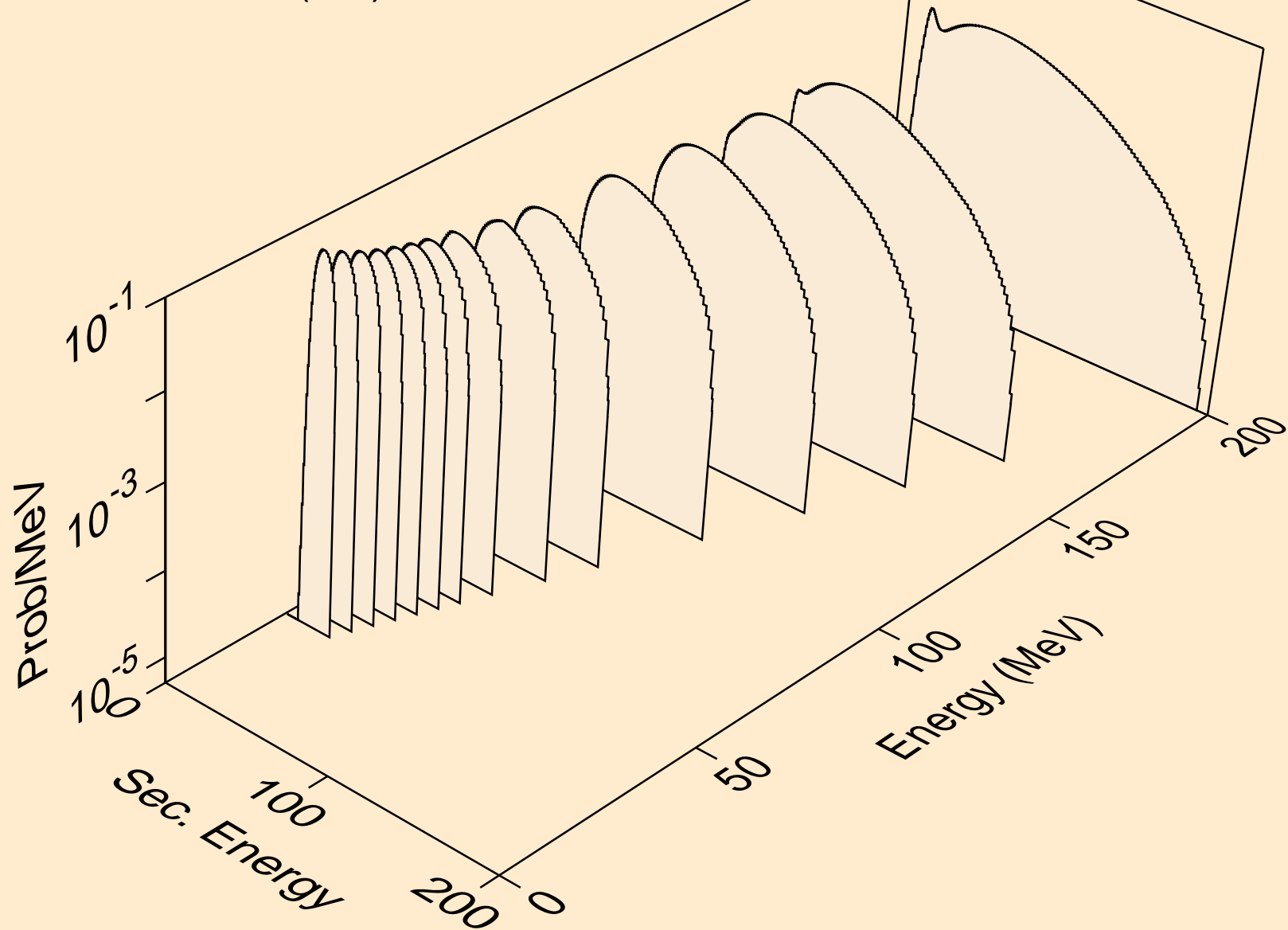

NO259 NEUTRON ACER TENDL-2023 LIBRARY; T=0.K
tritons from (n,n*)t

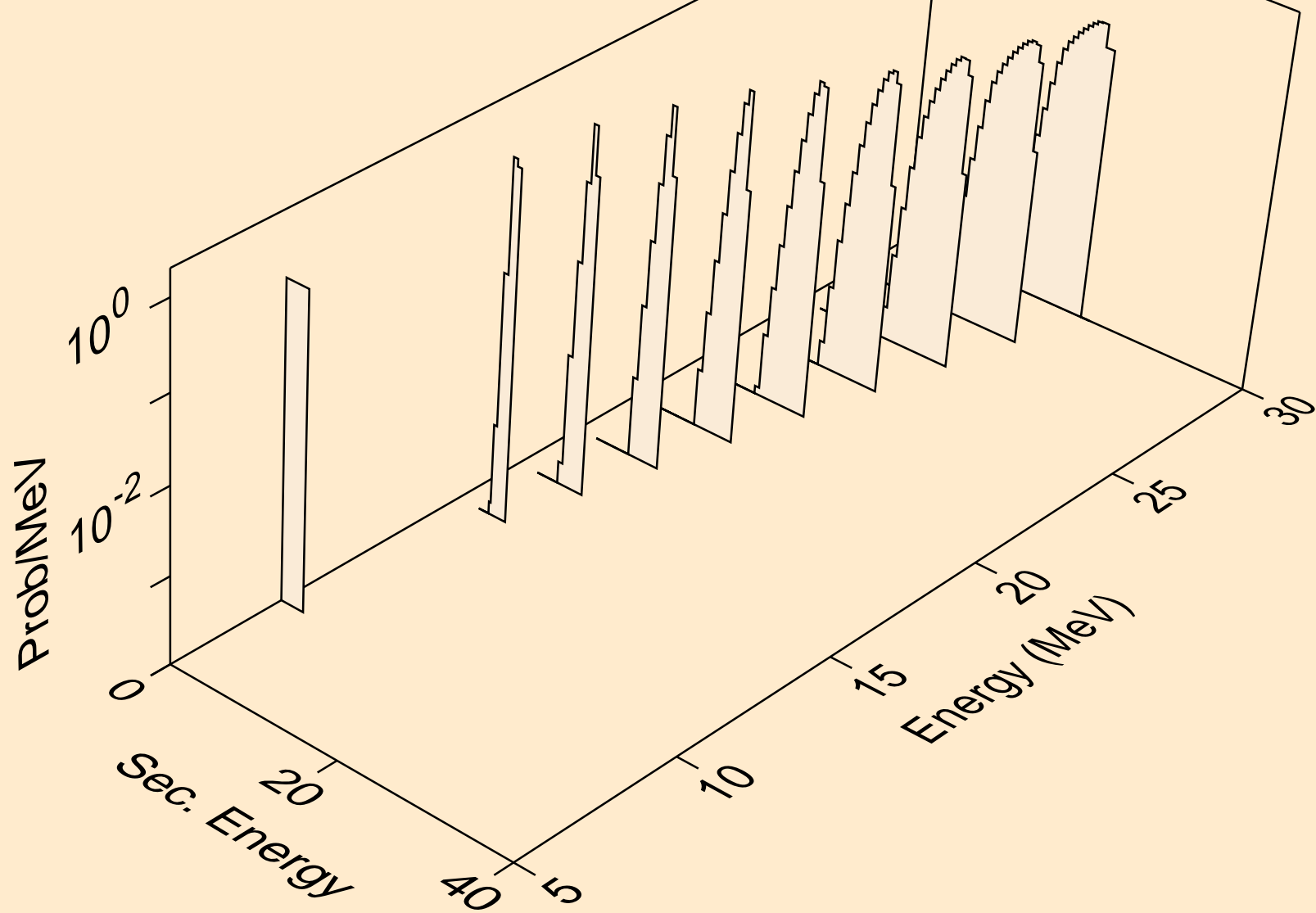

NO259 NEUTRON ACER TENDL-2023 LIBRARY; T=0.K
tritons from (n,t)

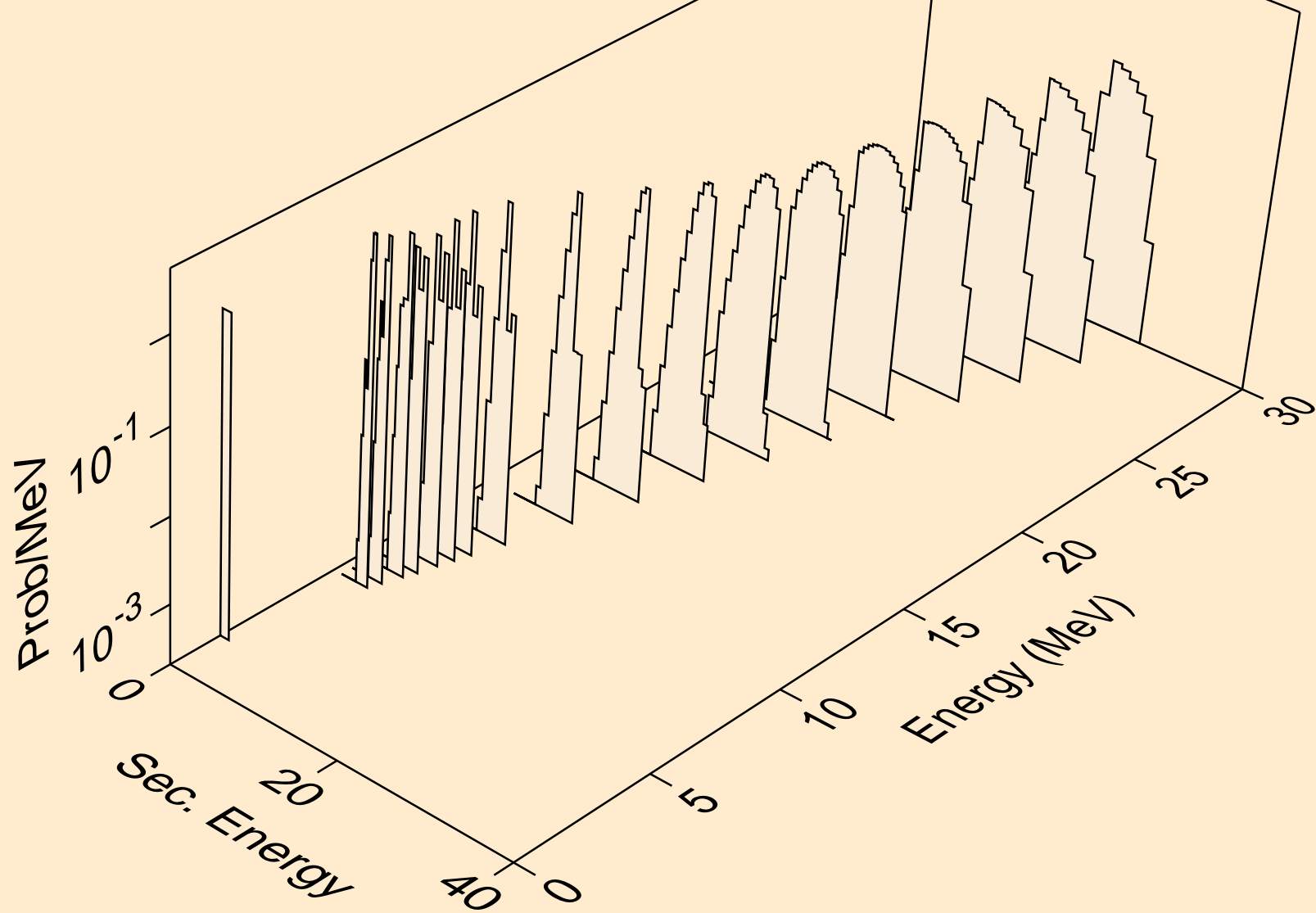

NO259 NEUTRON ACER TENDL-2023 LIBRARY; T=0.K
he3s from (n,x)

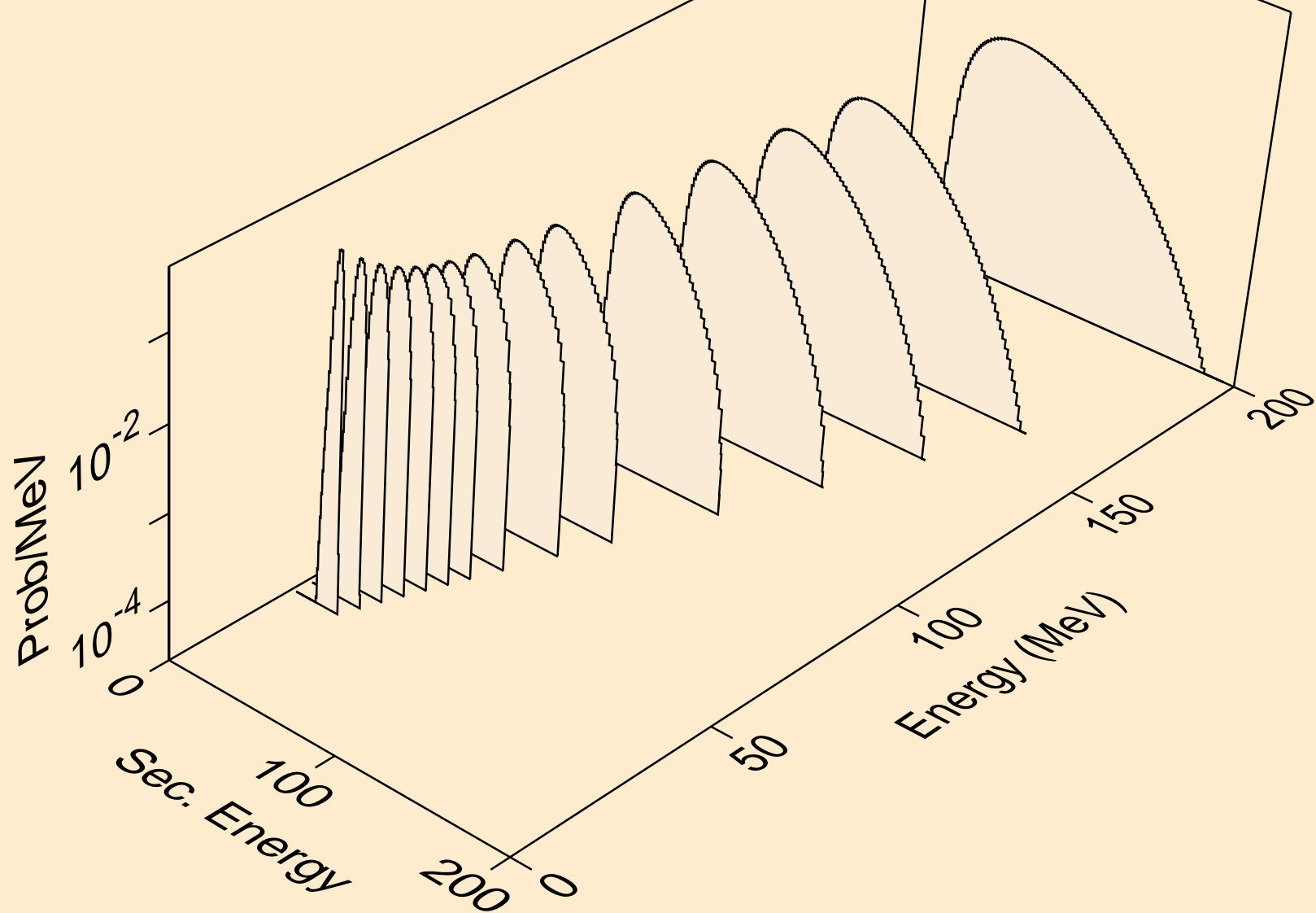

NO259 NEUTRON ACER TENDL-2023 LIBRARY; T=0.K
he3s from (n,n*)he3

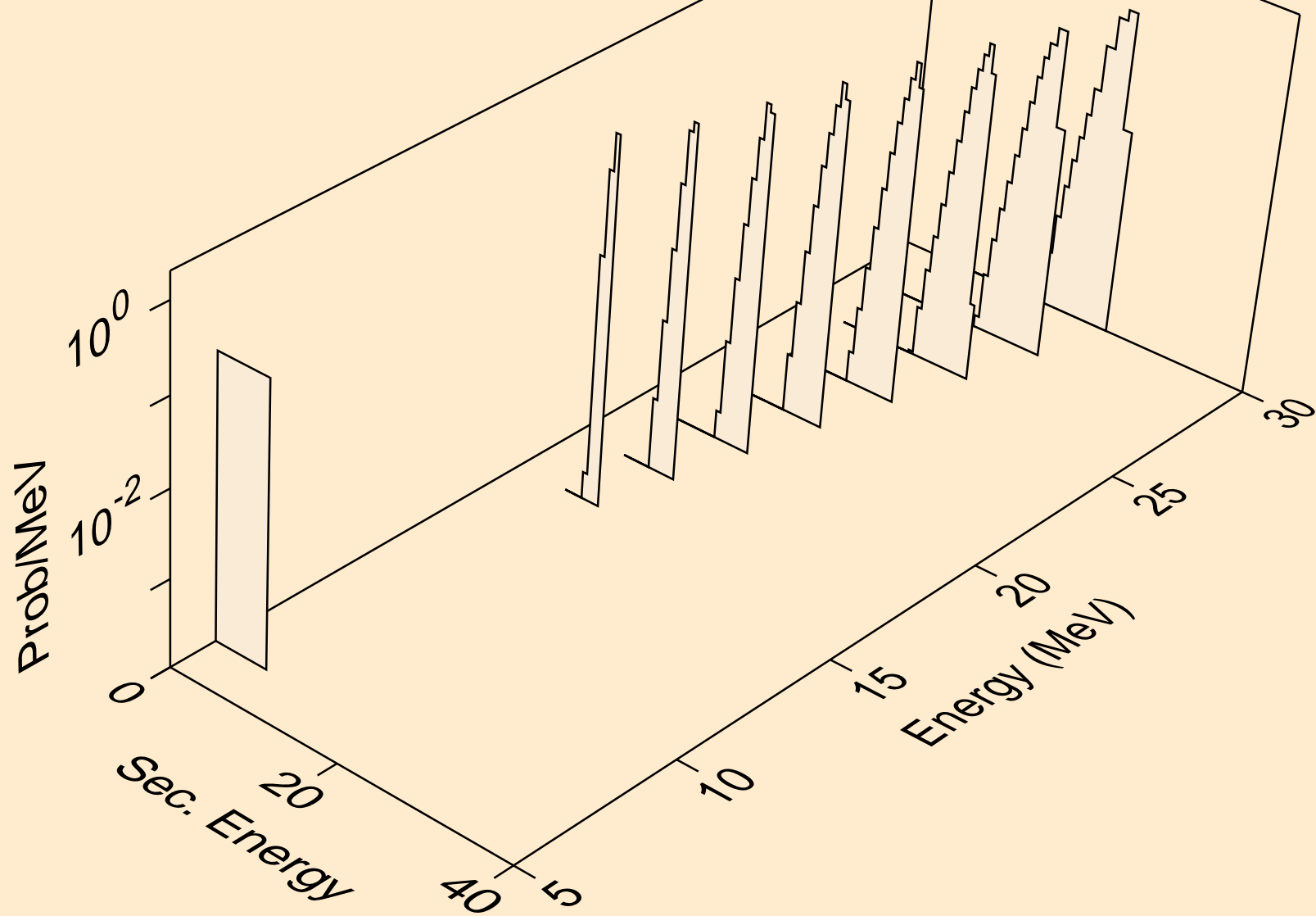

NO259 NEUTRON ACER TENDL-2023 LIBRARY; T=0.K
he3s from (n,he3)

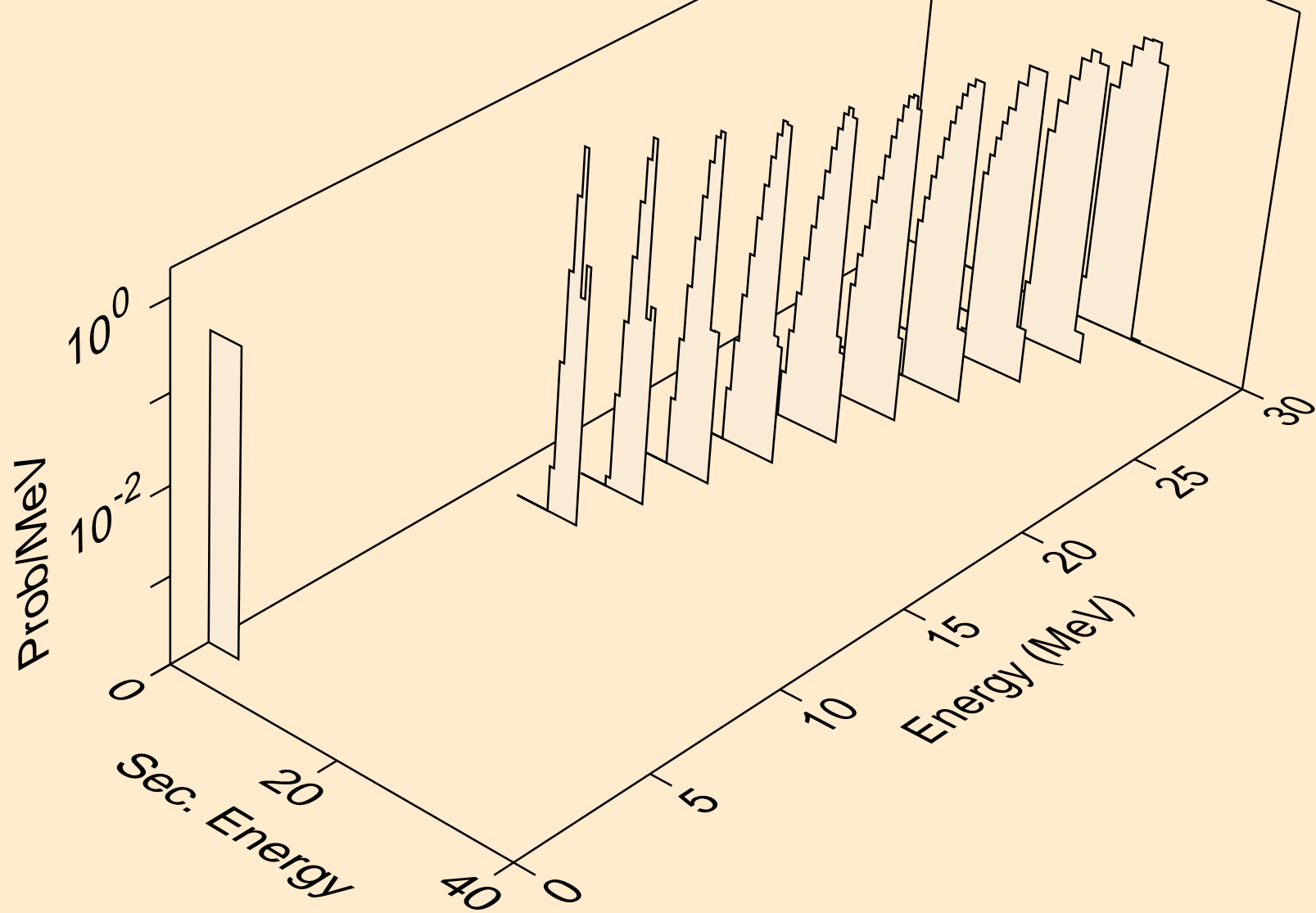

NO259 NEUTRON ACER TENDL-2023 LIBRARY; T=0.K
alphas from (n,x)

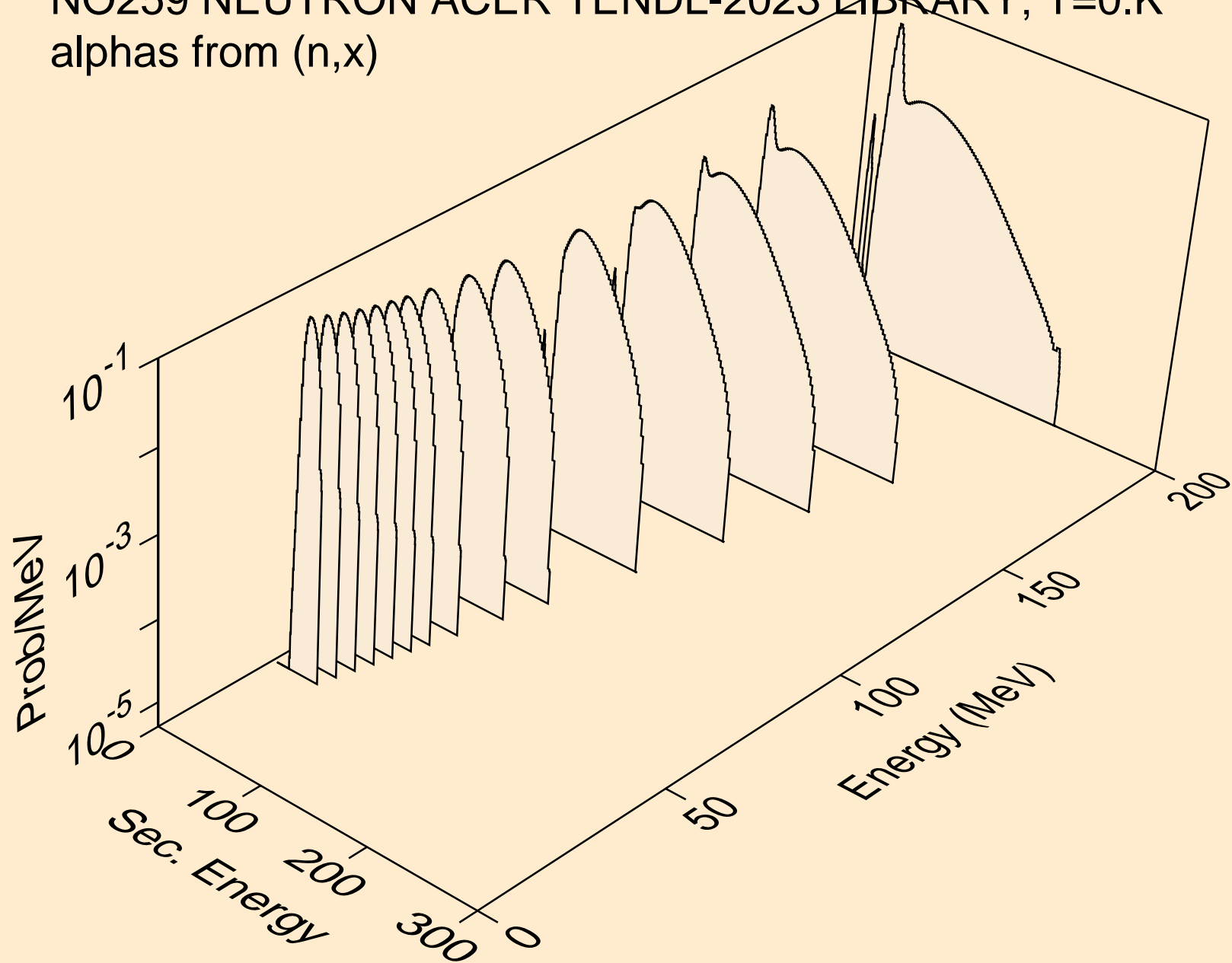

NO259 NEUTRON ACER TENDL-2023 LIBRARY; T=0.K
alphas from (n,n*)a

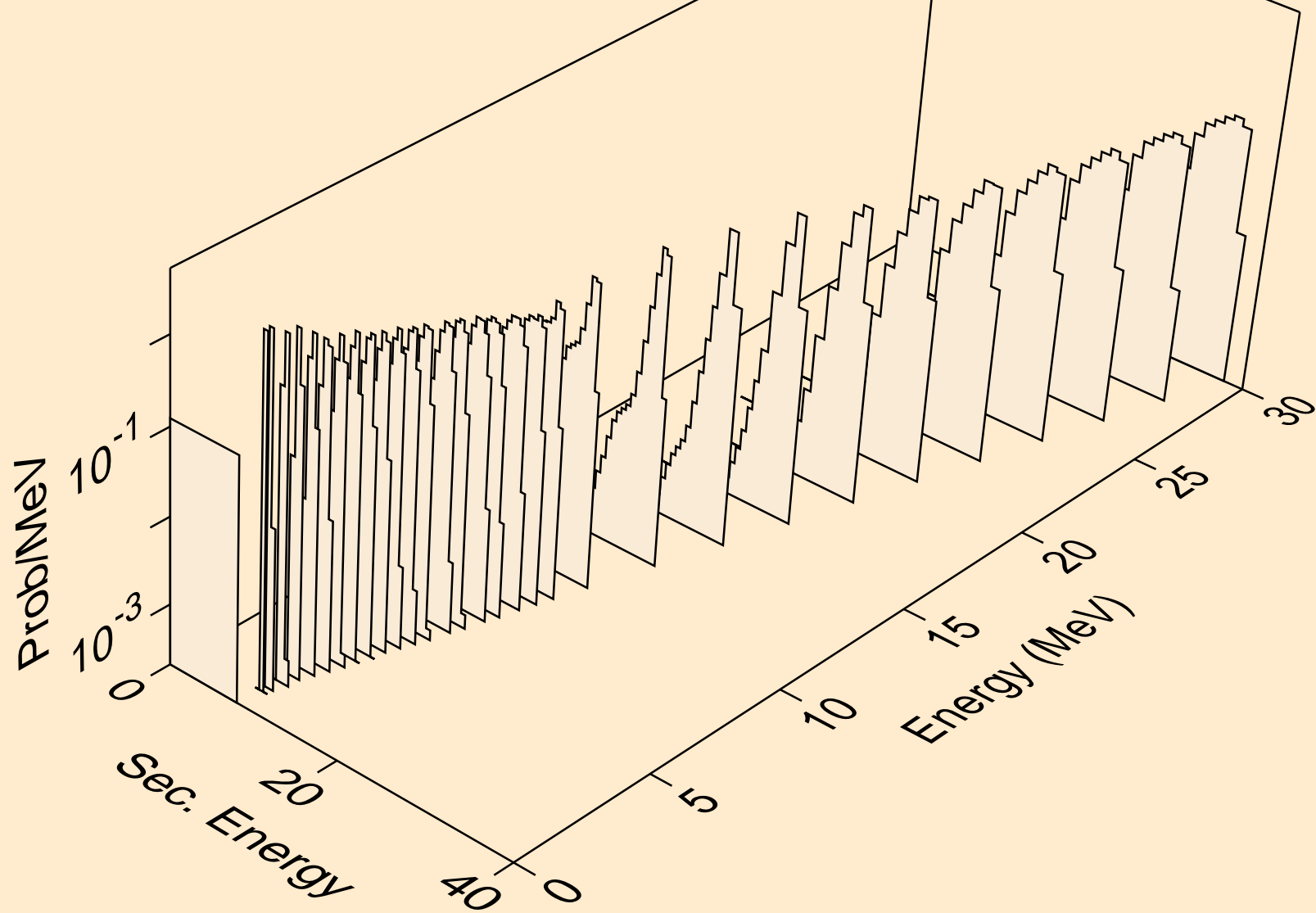

NO259 NEUTRON ACER TENDL-2023 LIBRARY; T=0.K
alphas from (n,2n)a

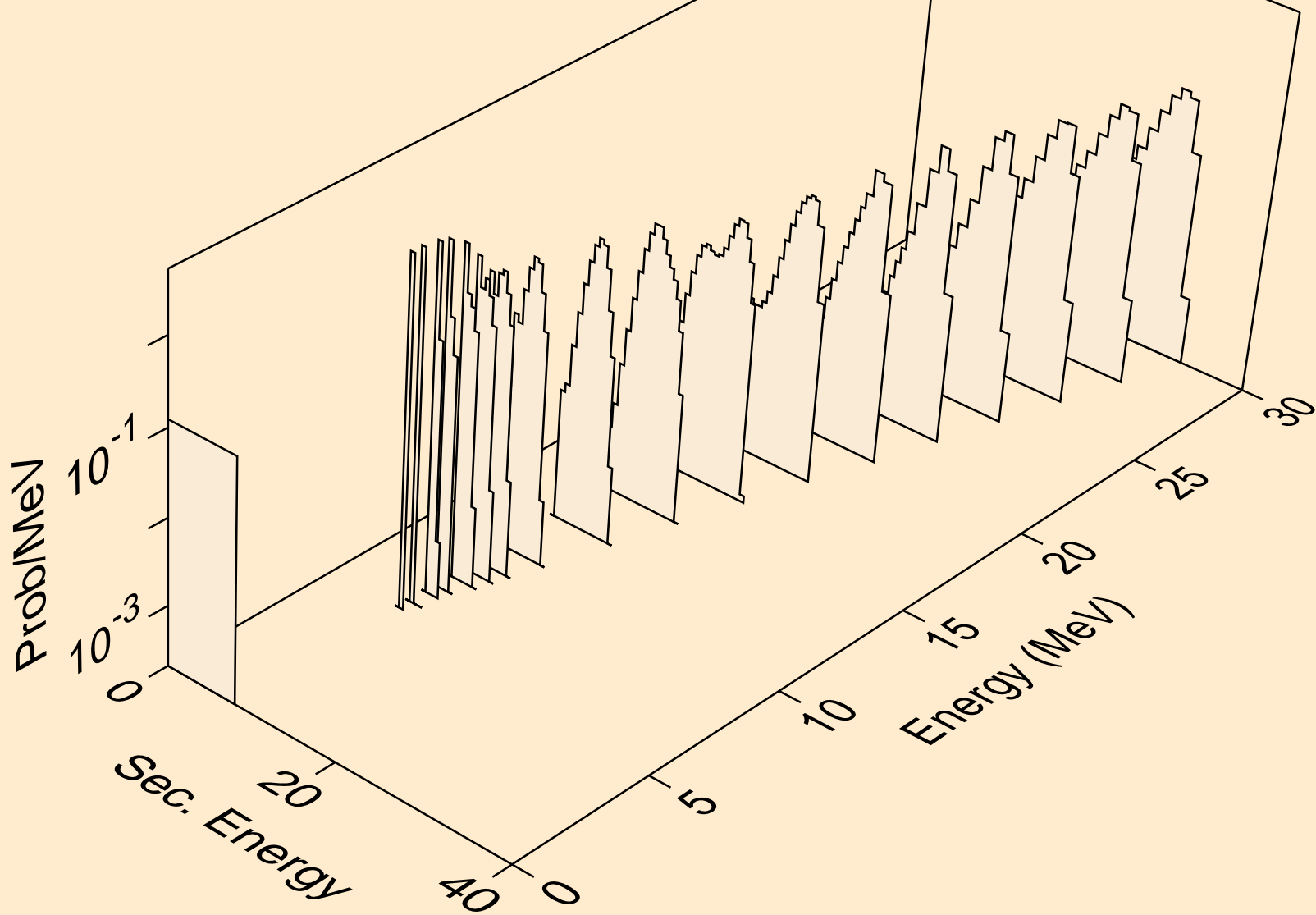

NO259 NEUTRON ACER TENDL-2023 LIBRARY; T=0.K
alphas from (n,3n)a

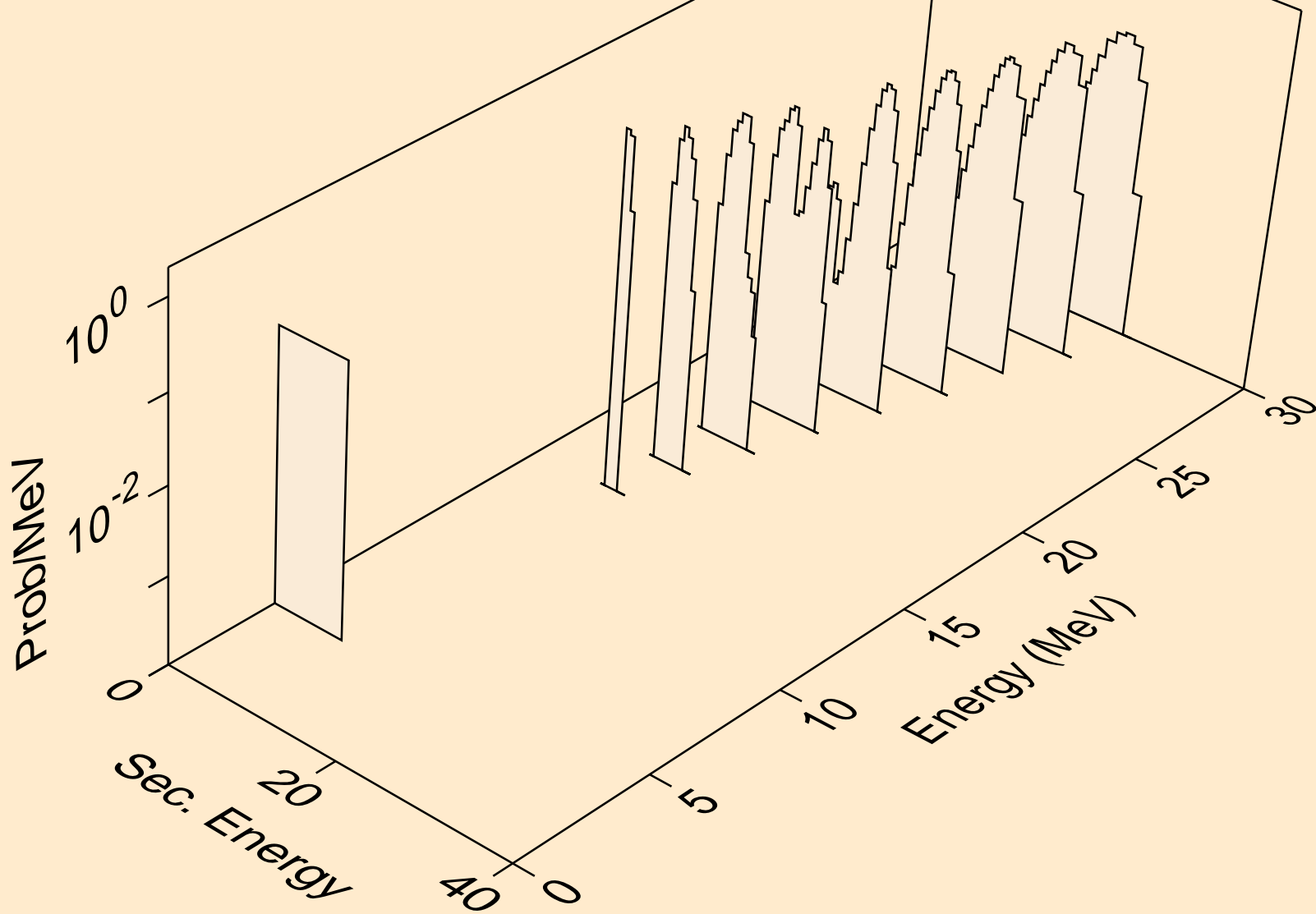

NO259 NEUTRON ACER TENDL-2023 LIBRARY; T=0.K
alphas from (n,a)

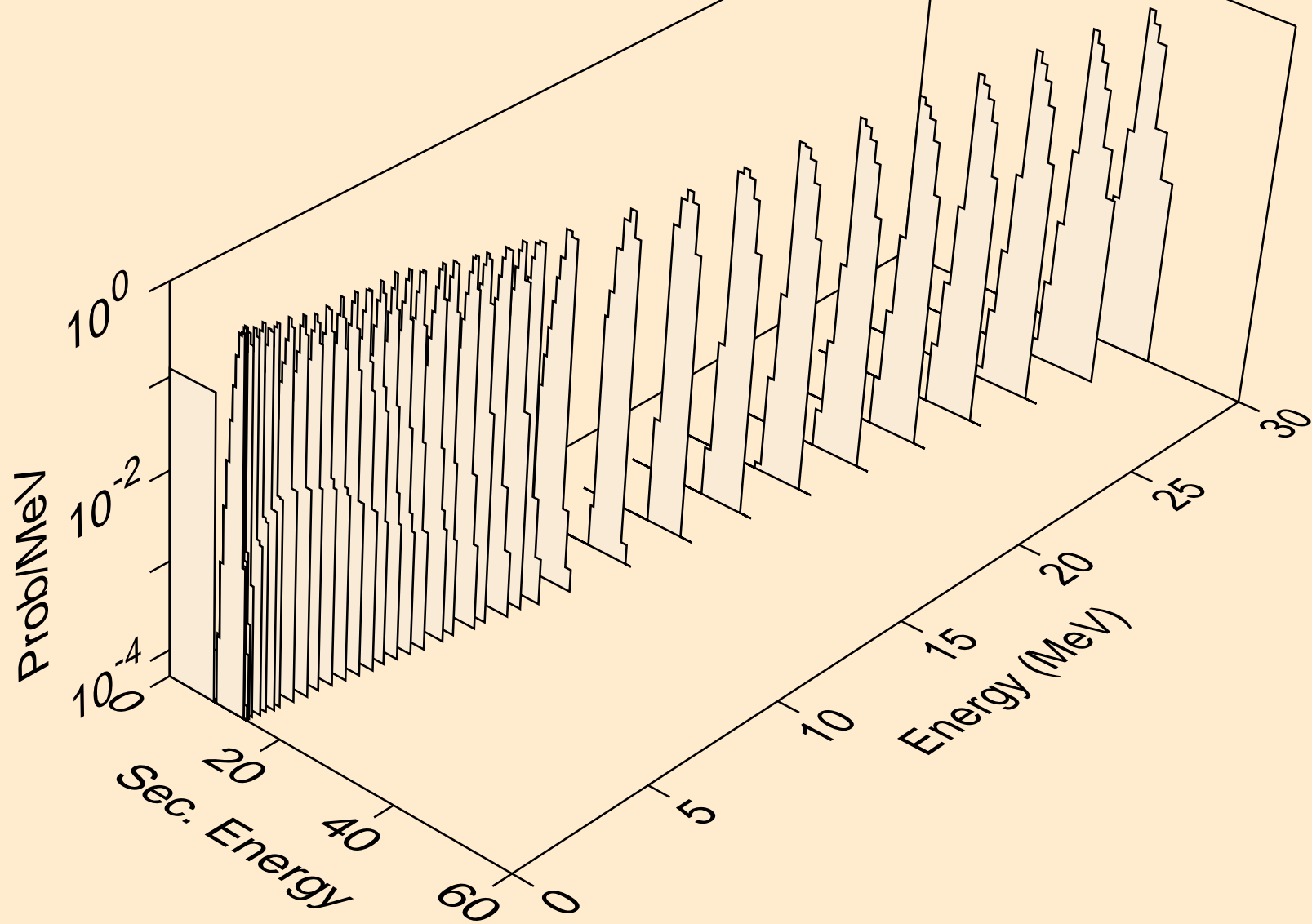

NO259 NEUTRON ACER TENDL-2023 LIBRARY; T=0.K
alphas from (n,pa)

