

# NP236M NEUTRON ACER TENDL-2023 LIBRARY; T=0.K

## Principal cross sections

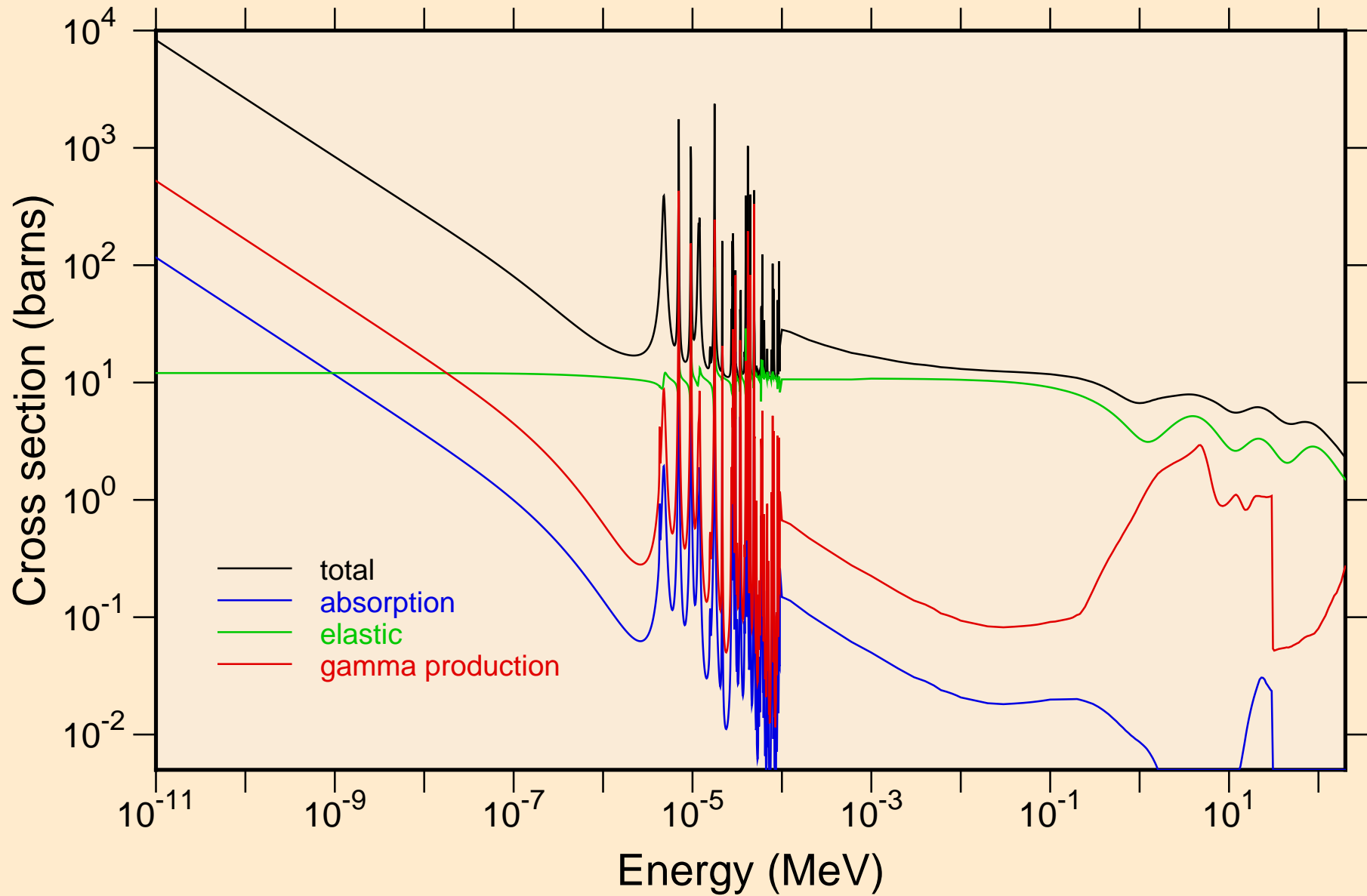

NP236M NEUTRON ACER TENDL-2023 LIBRARY; T=0.K  
resonance total cross section

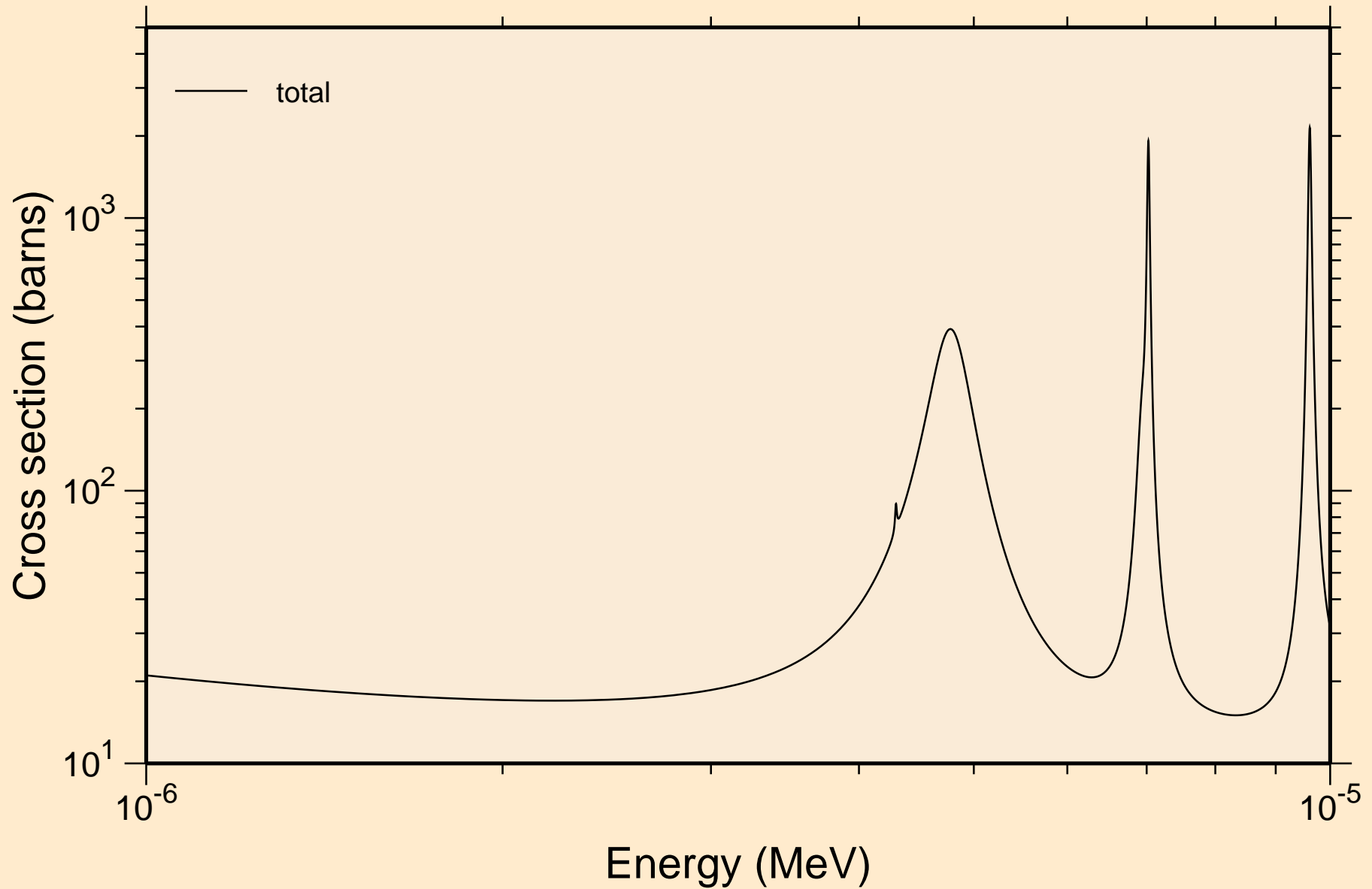

NP236M NEUTRON ACER TENDL-2023 LIBRARY; T=0.K  
resonance total cross section

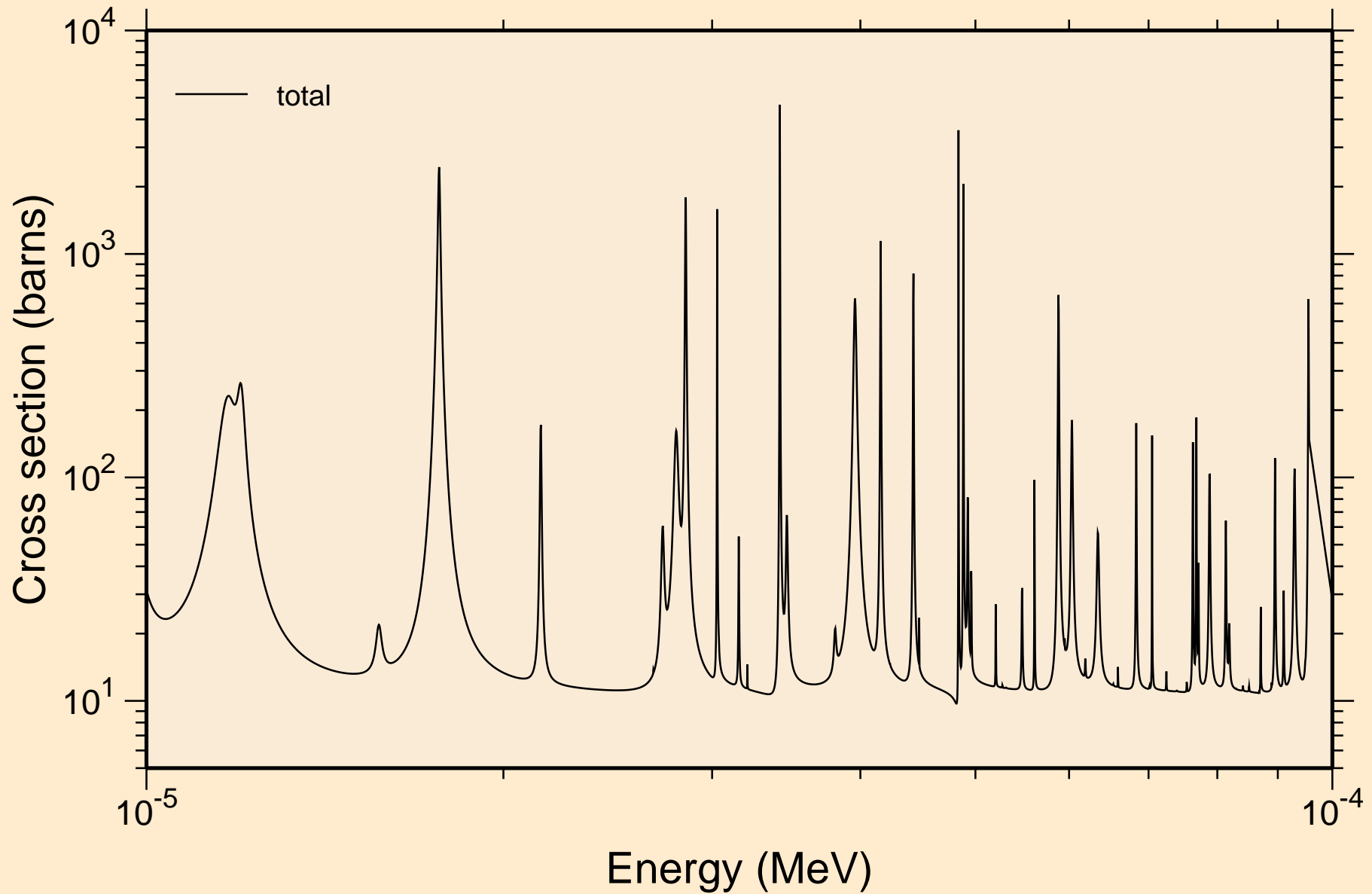

NP236M NEUTRON ACER TENDL-2023 LIBRARY; T=0.K  
resonance total cross section

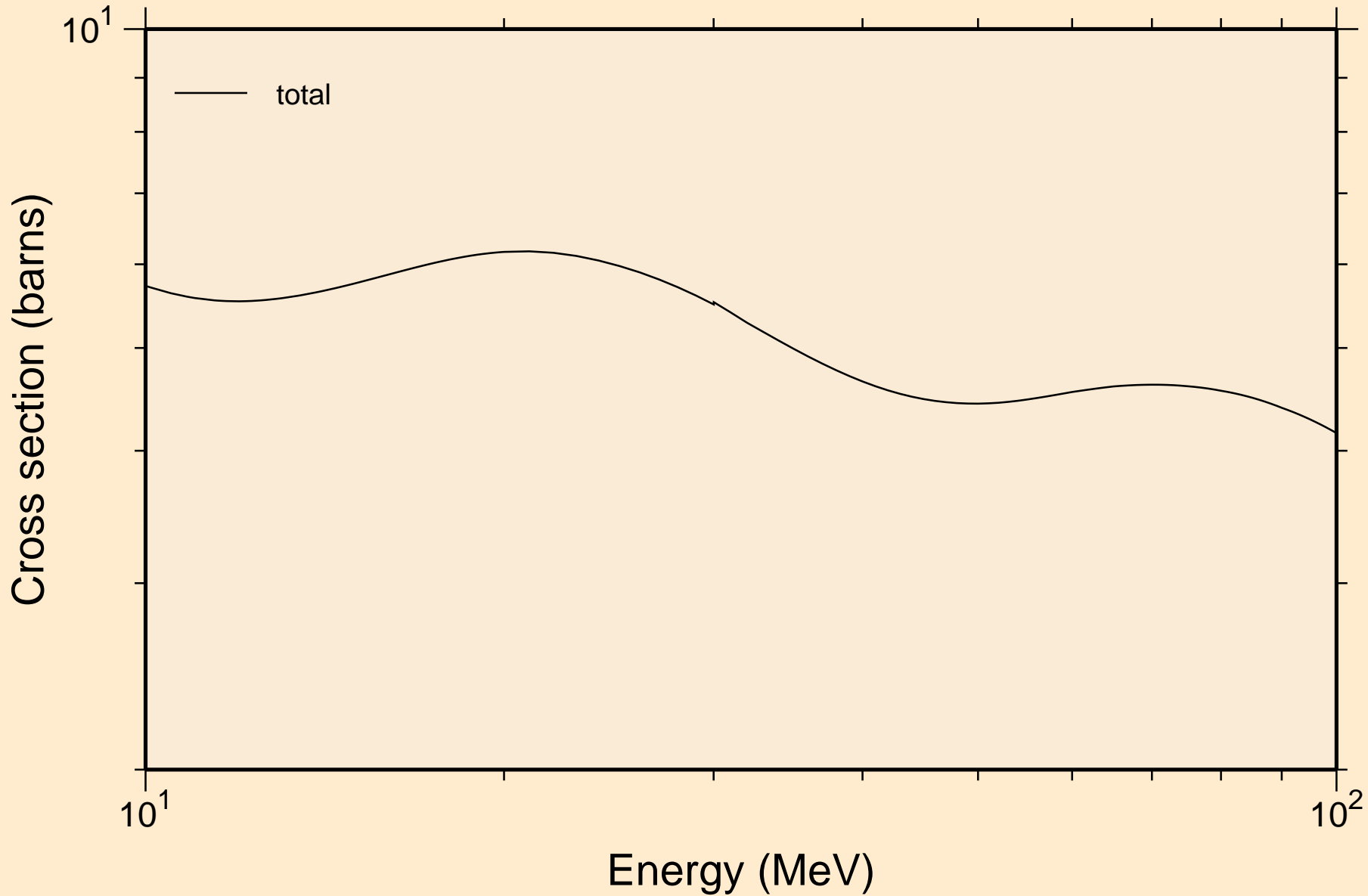

NP236M NEUTRON ACER TENDL-2023 LIBRARY; T=0.K  
resonance absorption cross sections

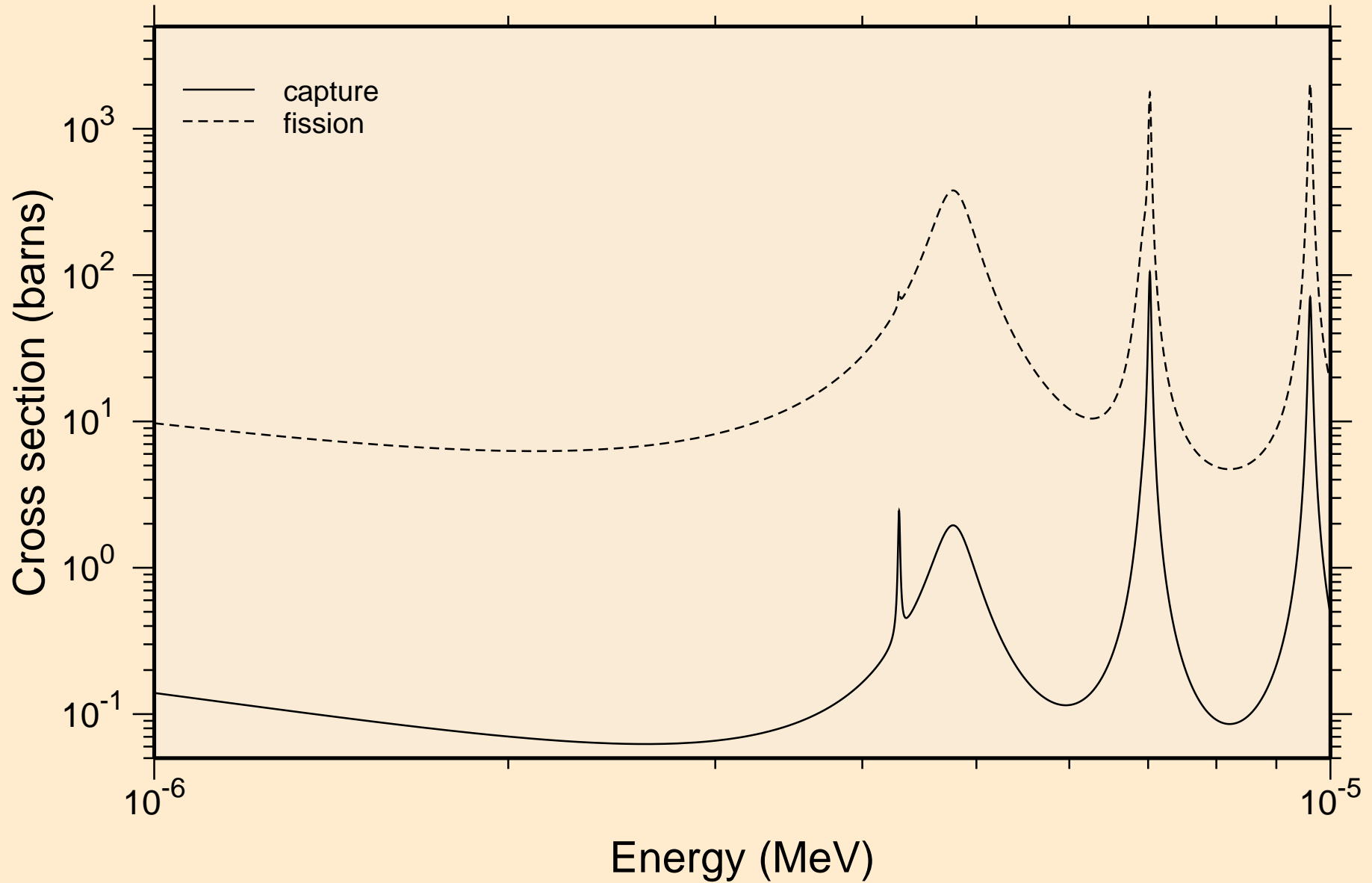

NP236M NEUTRON ACER TENDL-2023 LIBRARY; T=0.K  
resonance absorption cross sections

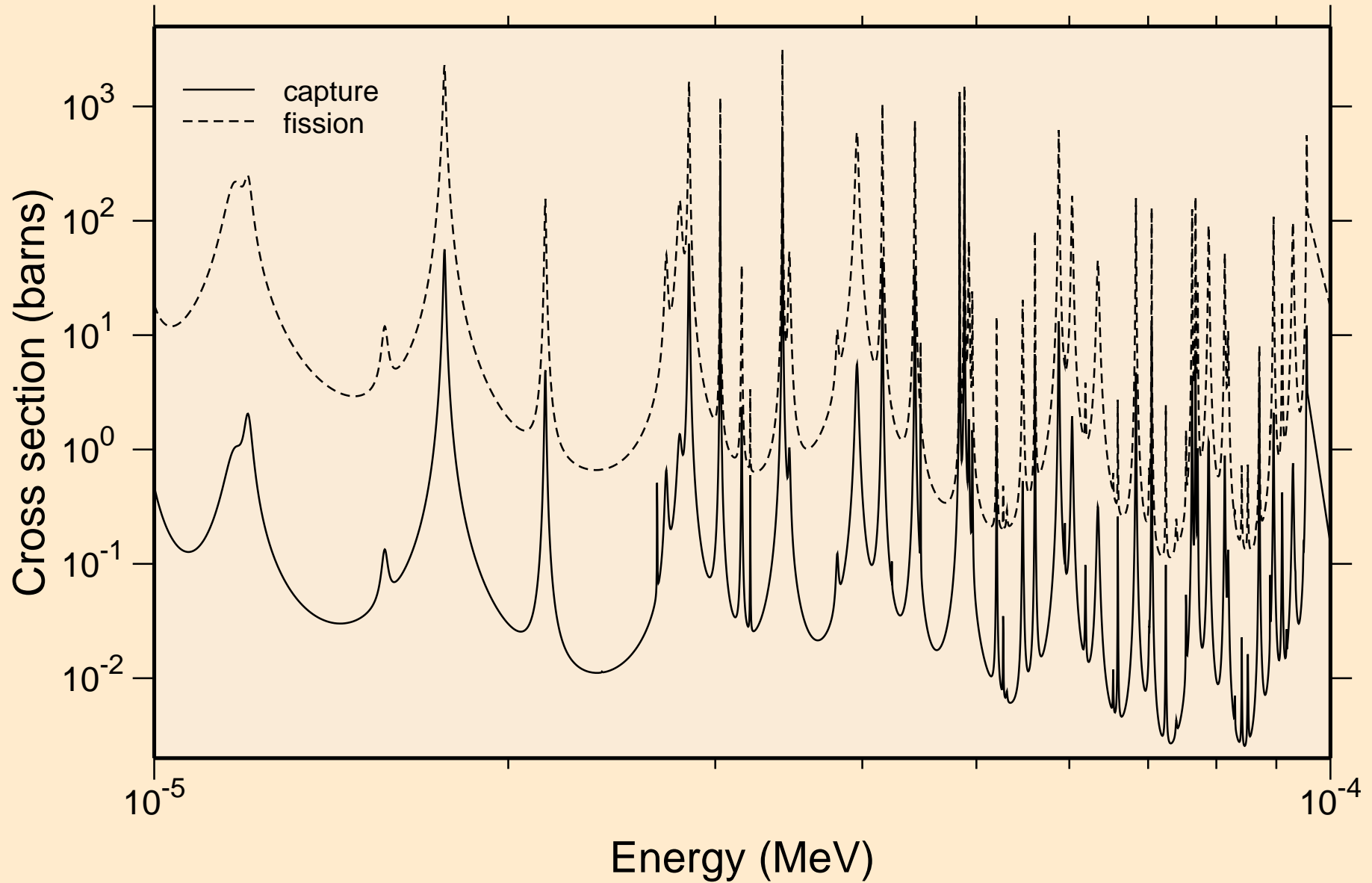

NP236M NEUTRON ACER TENDL-2023 LIBRARY; T=0.K  
resonance absorption cross sections

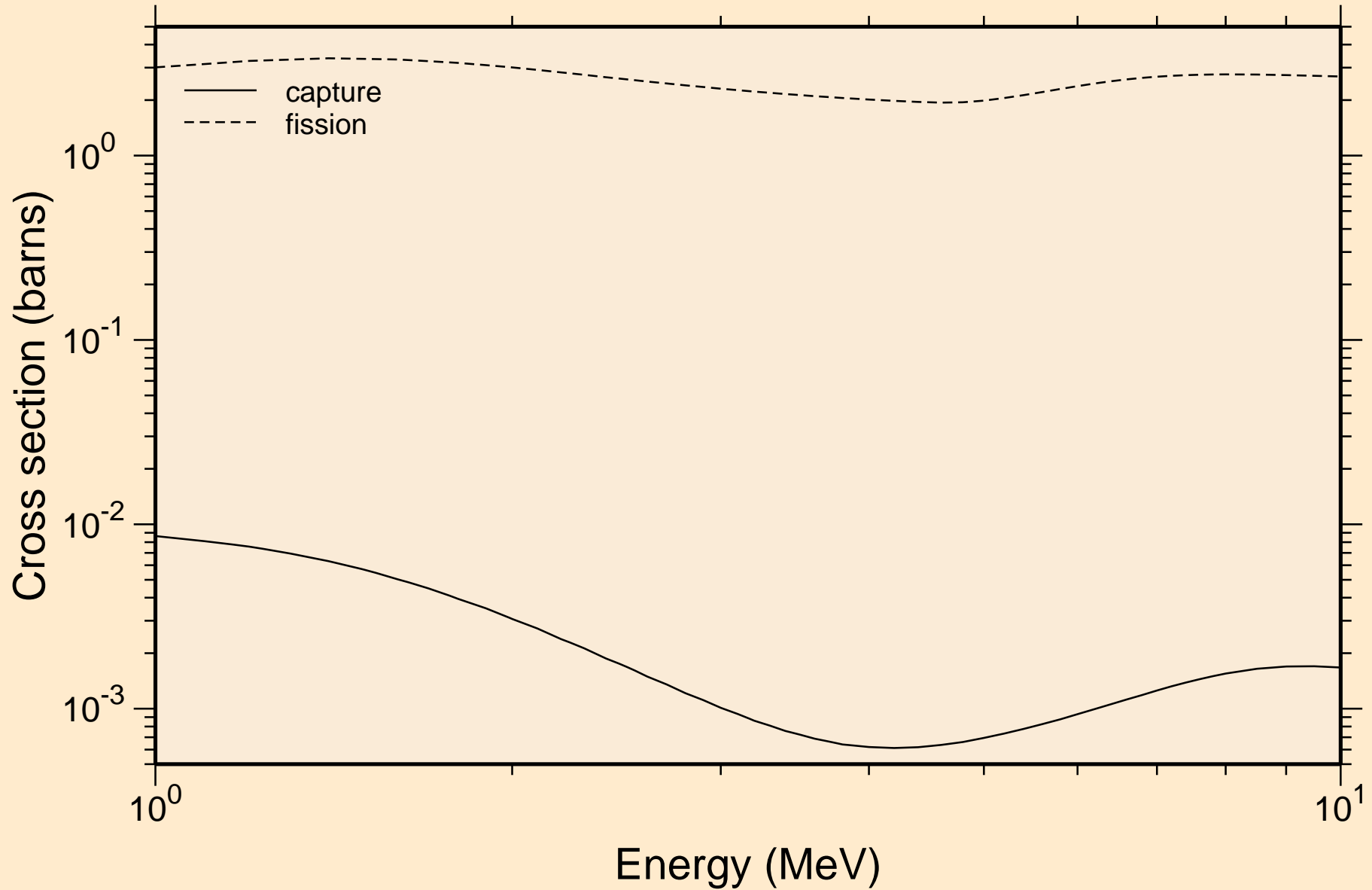

NP236M NEUTRON ACER TENDL-2023 LIBRARY; T=0.K  
Heating

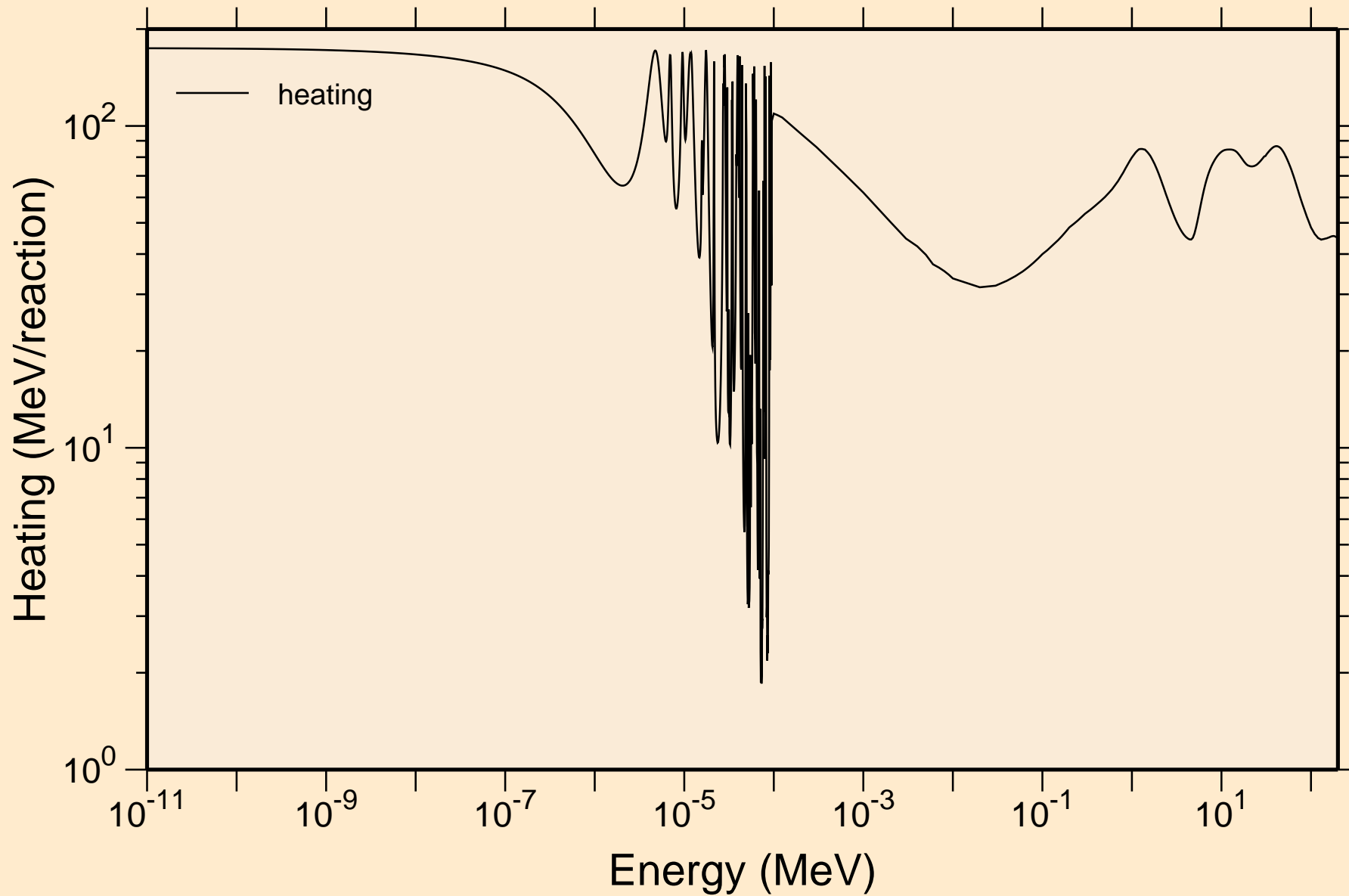



NP236M NEUTRON ACER TENDL-2023 LIBRARY; T=0.K  
Damage

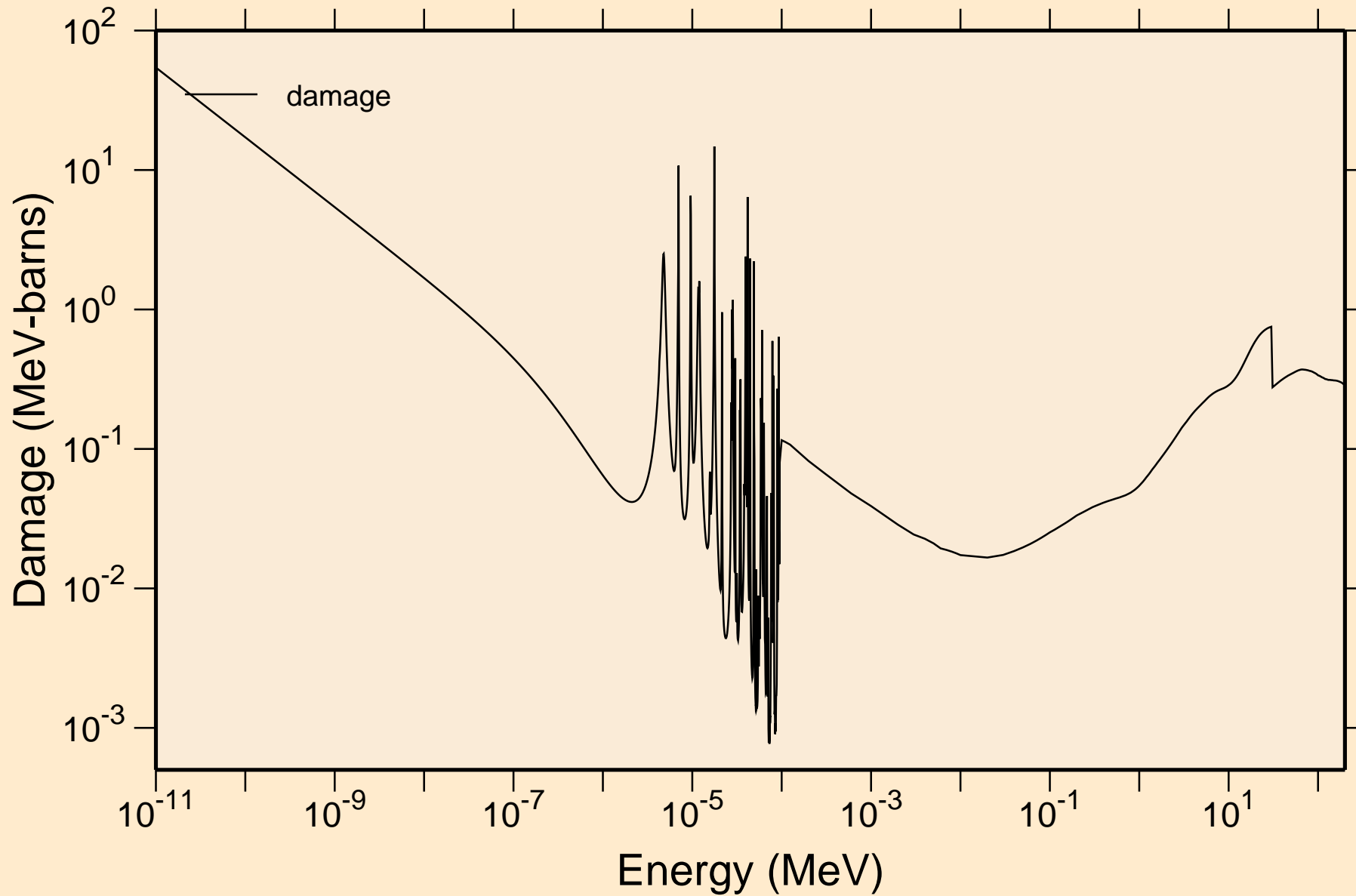

NP236M NEUTRON ACER TENDL-2023 LIBRARY; T=0.K  
Non-threshold reactions

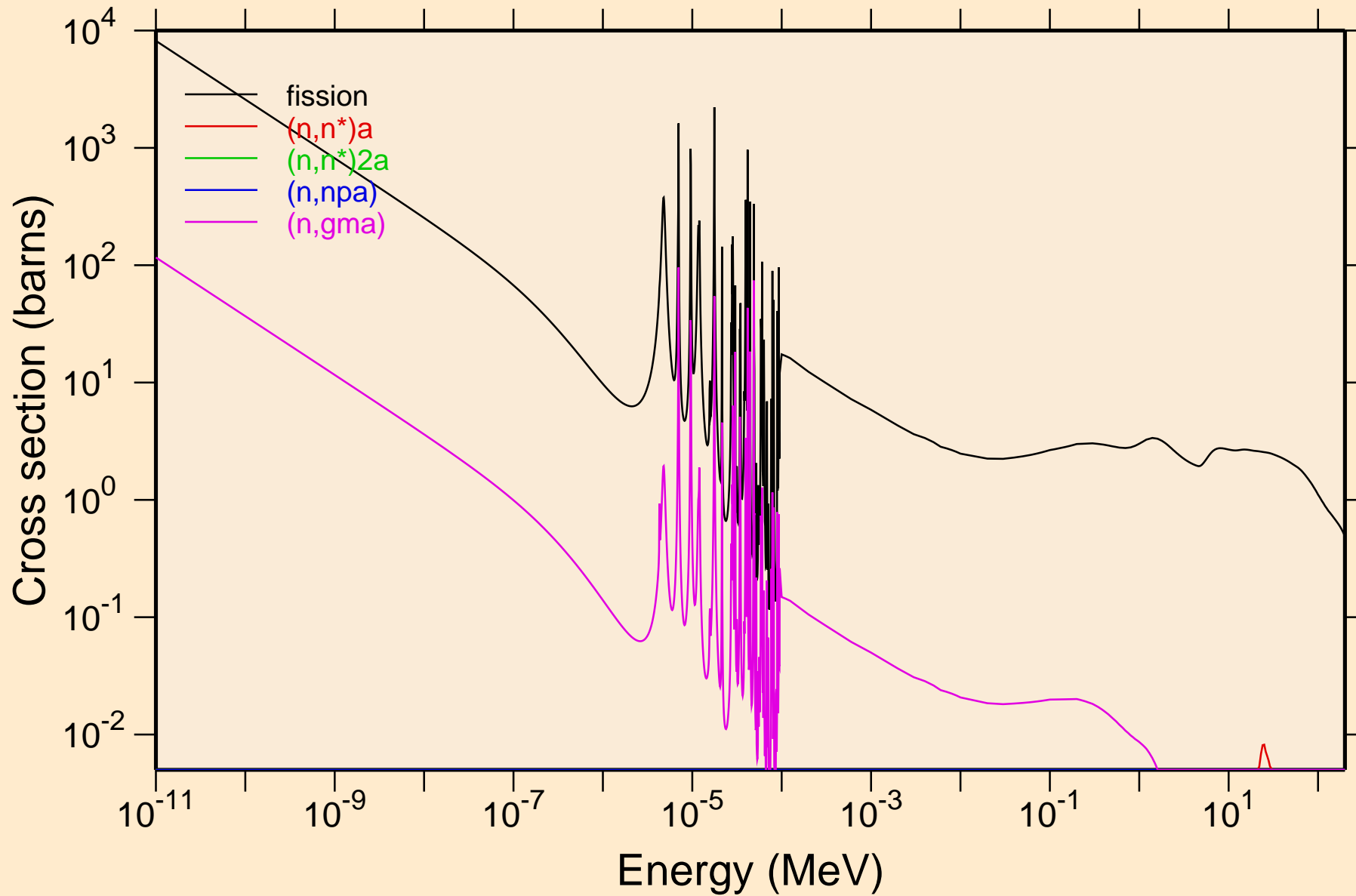

# NP236M NEUTRON ACER TENDL-2023 LIBRARY; T=0.K

## Non-threshold reactions

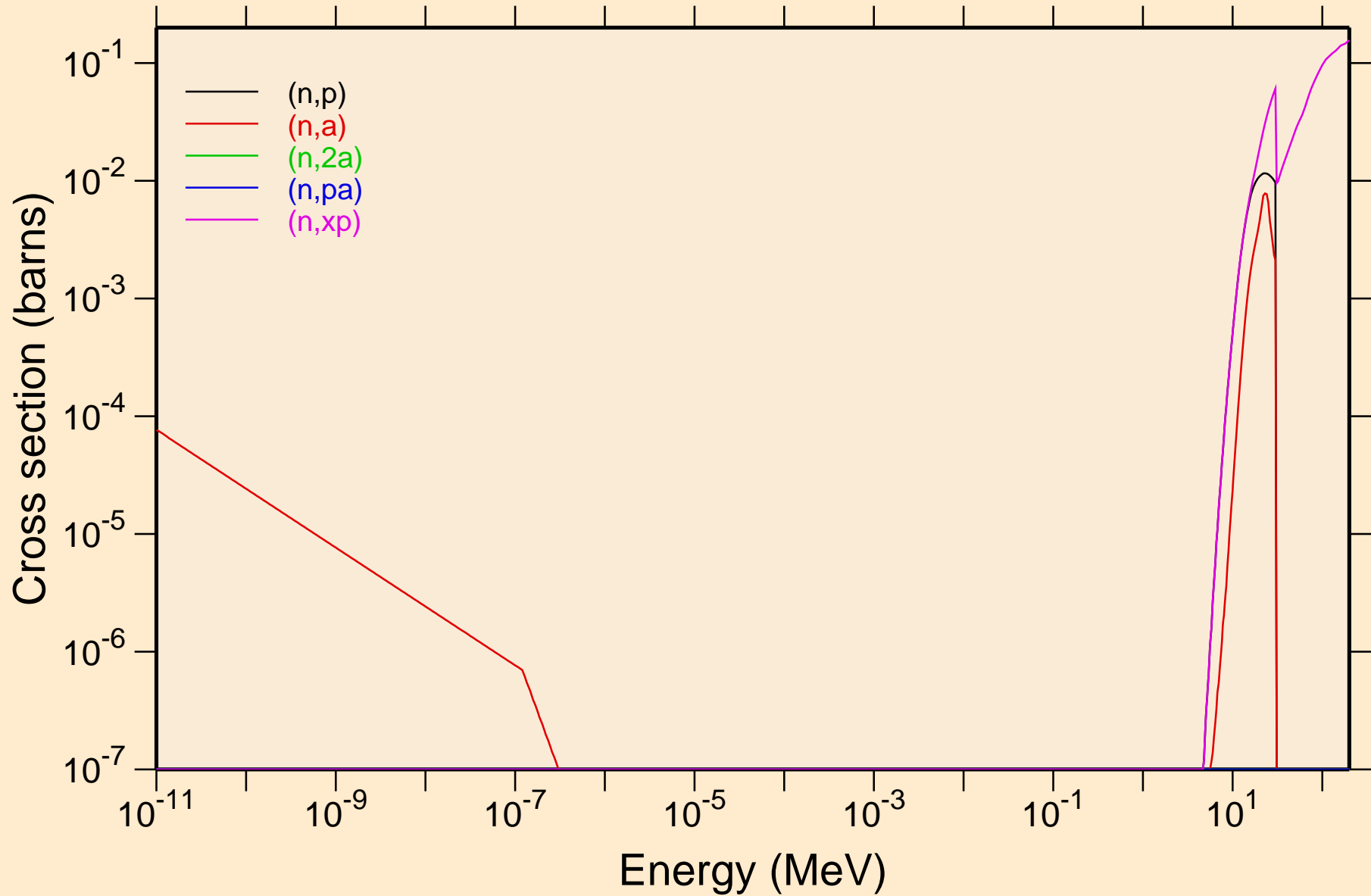

NP236M NEUTRON ACER TENDL-2023 LIBRARY; T=0.K  
Non-threshold reactions

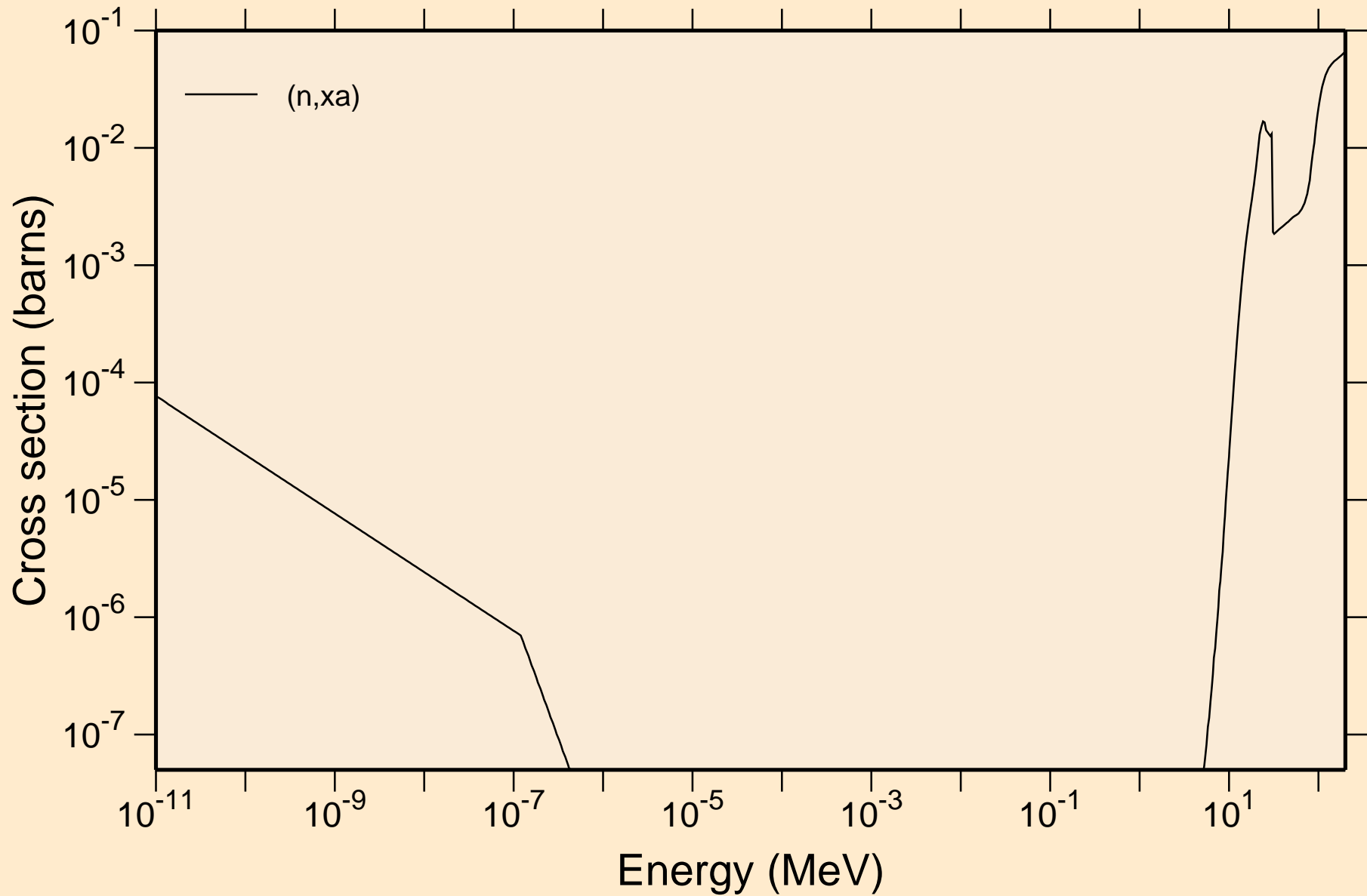

# NP236M NEUTRON ACER TENDL-2023 LIBRARY; T=0.K

## Principal cross sections

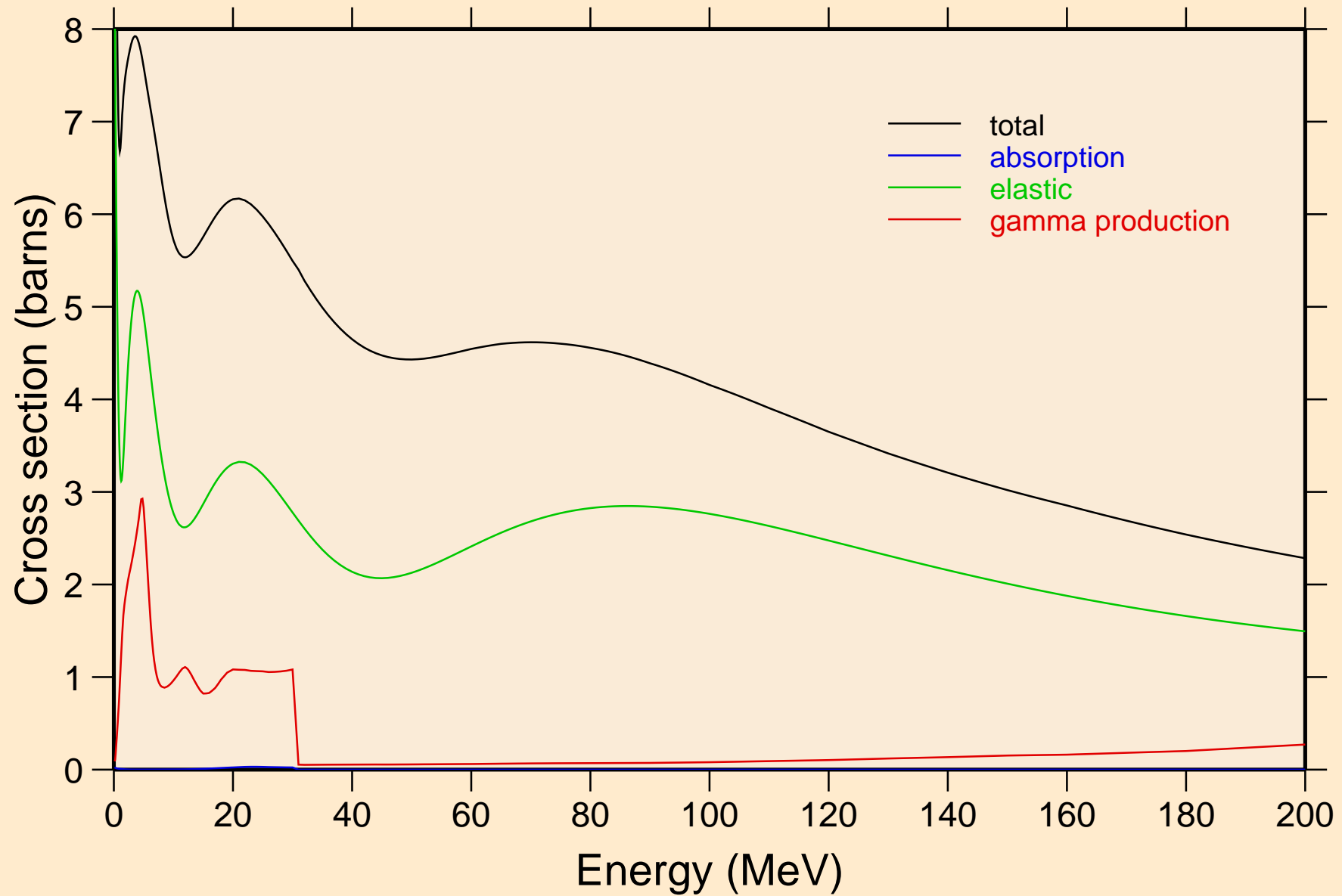

NP236M NEUTRON ACER TENDL-2023 LIBRARY; T=0.K  
Heating

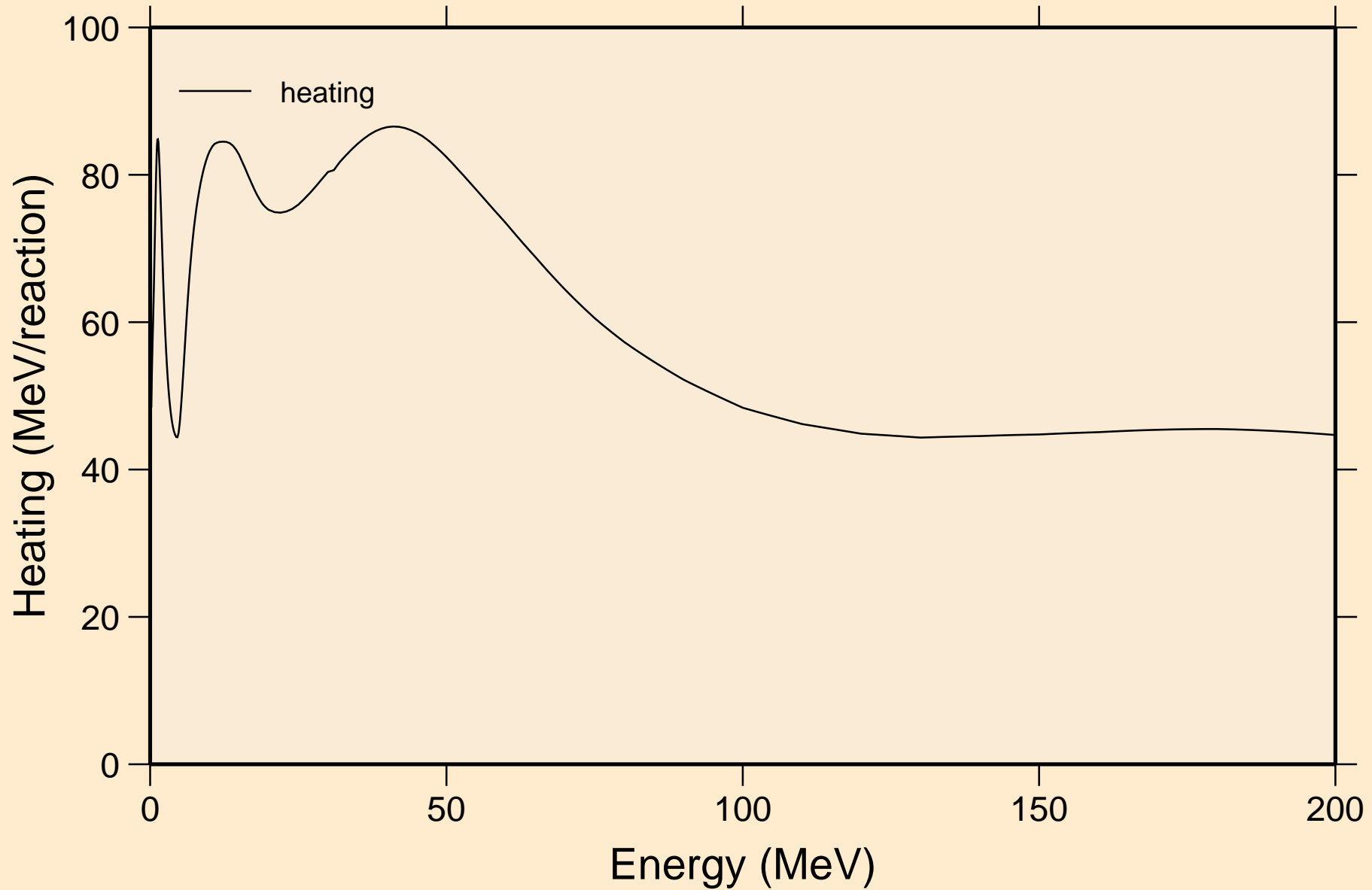

# NP236M NEUTRON ACER TENDL-2023 LIBRARY; T=0.K

## Damage

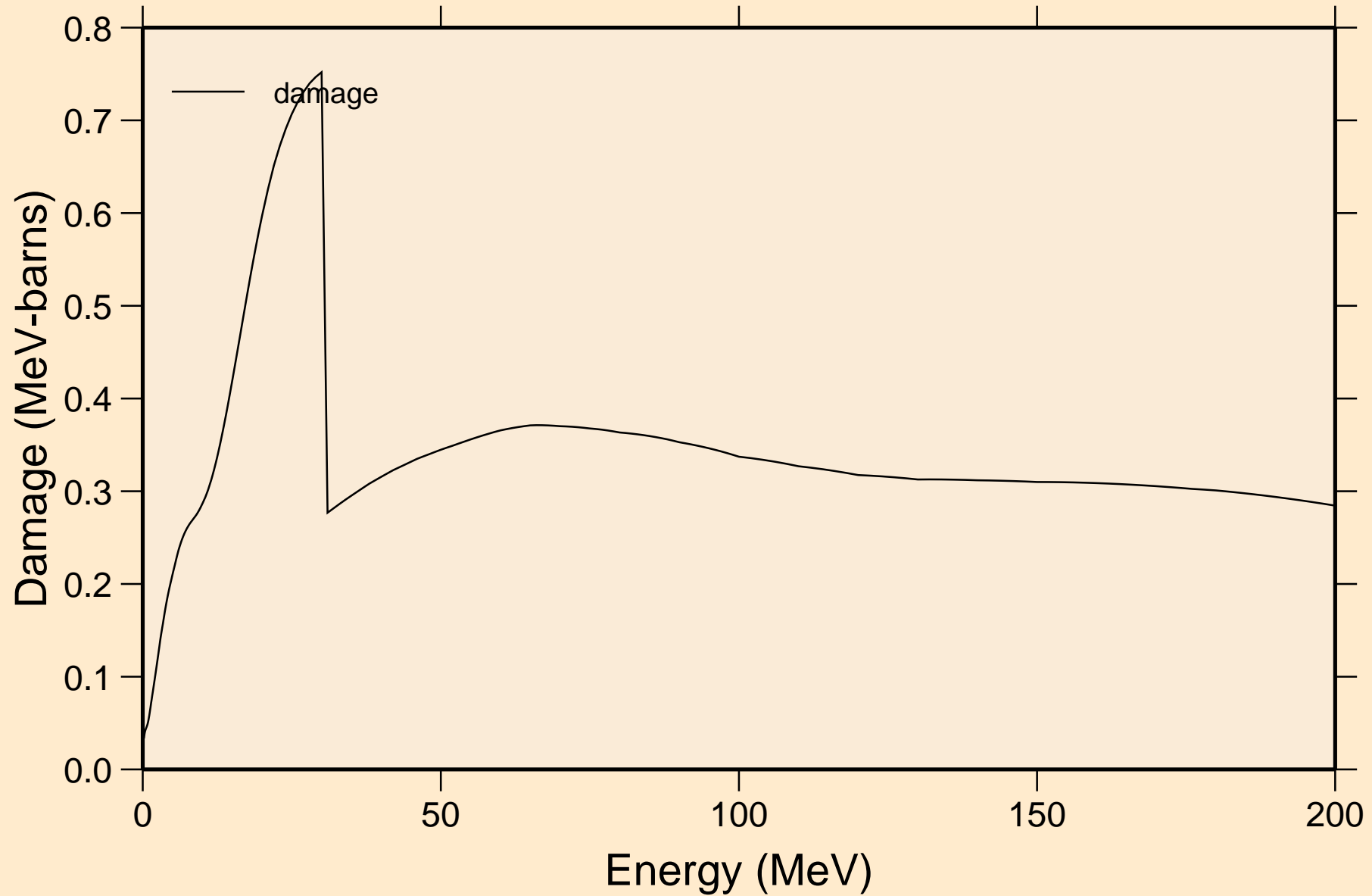

# NP236M NEUTRON ACER TENDL-2023 LIBRARY; T=0.K

## Non-threshold reactions

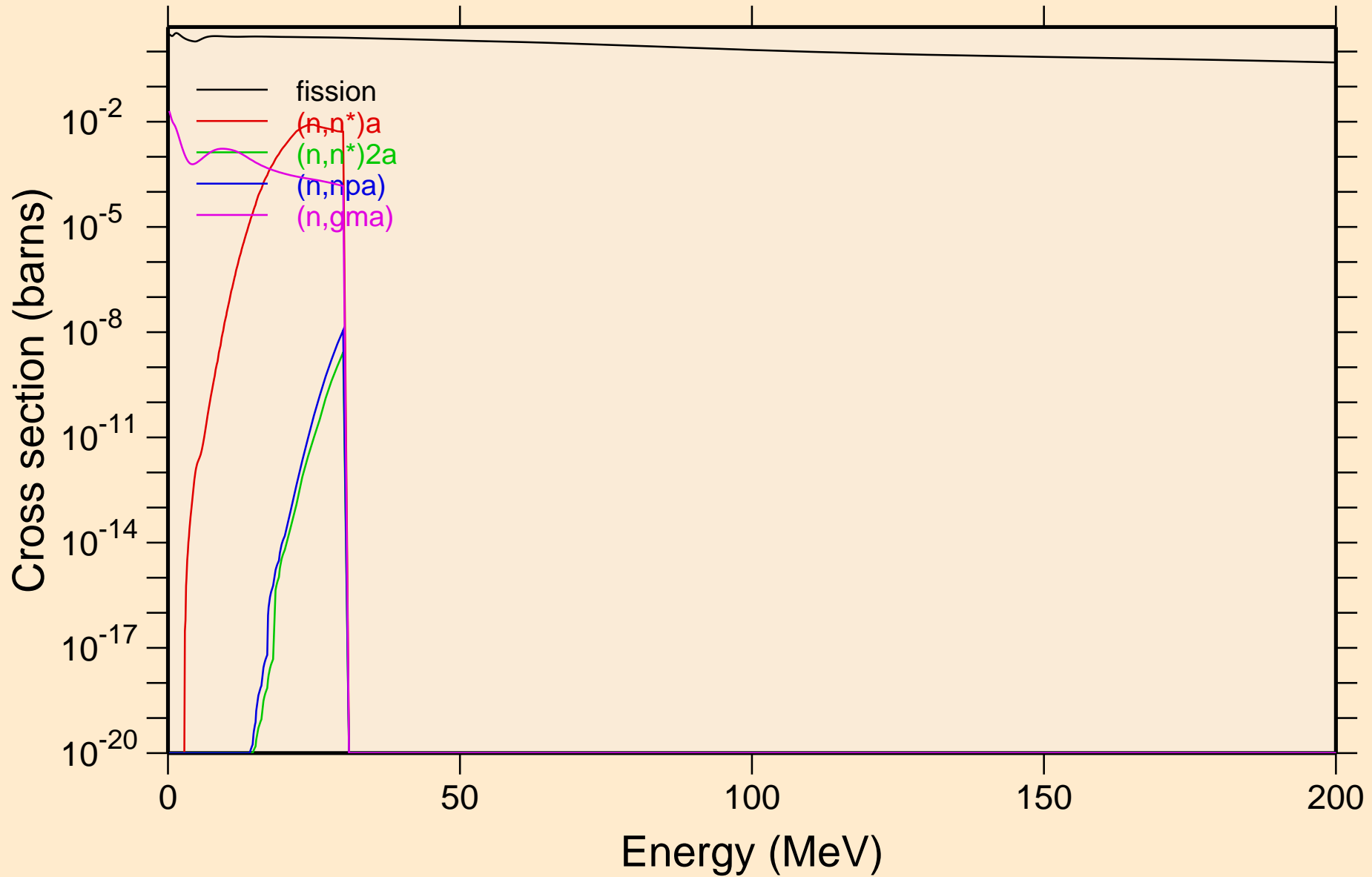



NP236M NEUTRON ACER TENDL-2023 LIBRARY; T=0.K  
Non-threshold reactions

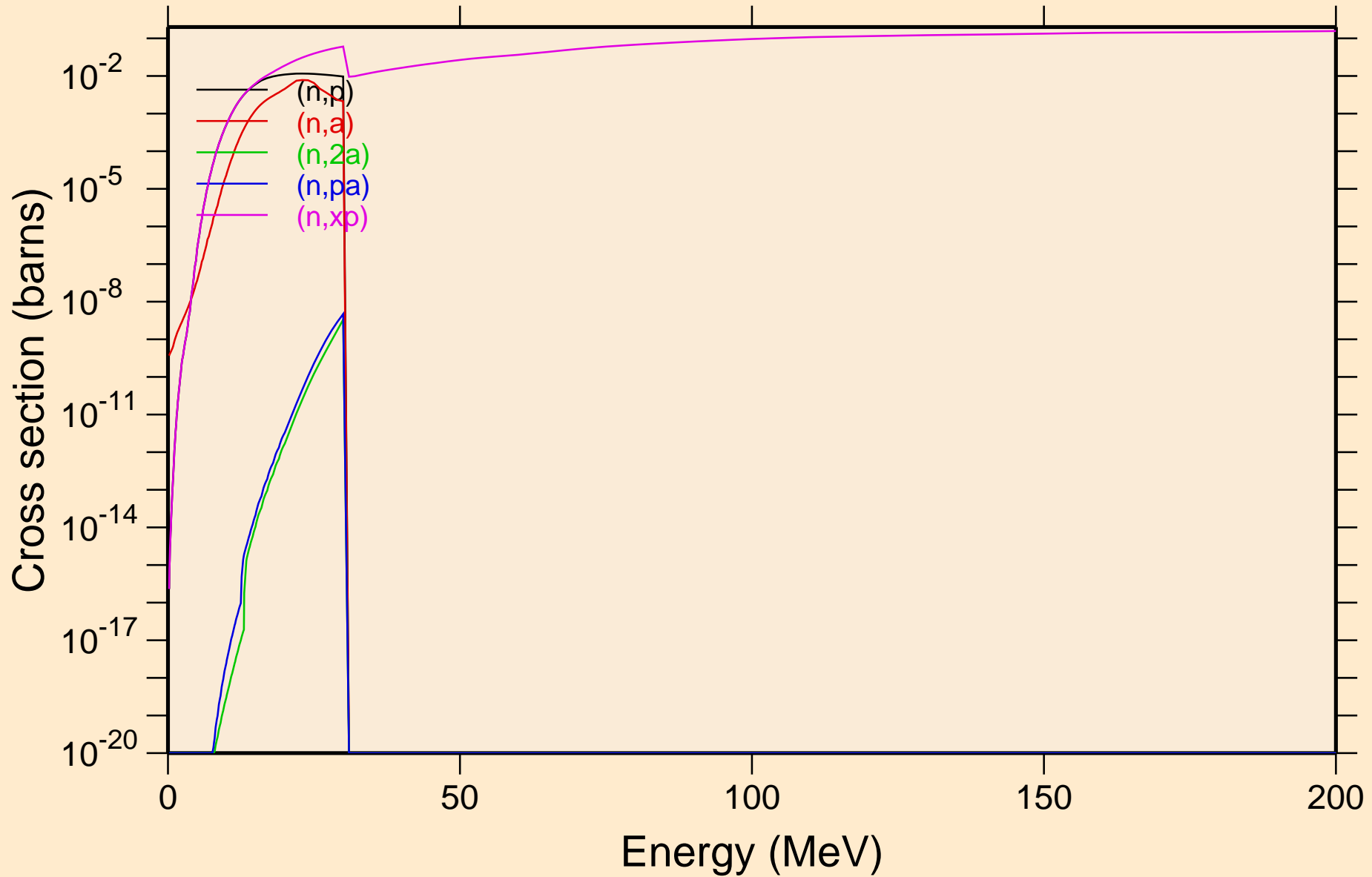

NP236M NEUTRON ACER TENDL-2023 LIBRARY; T=0.K  
Non-threshold reactions

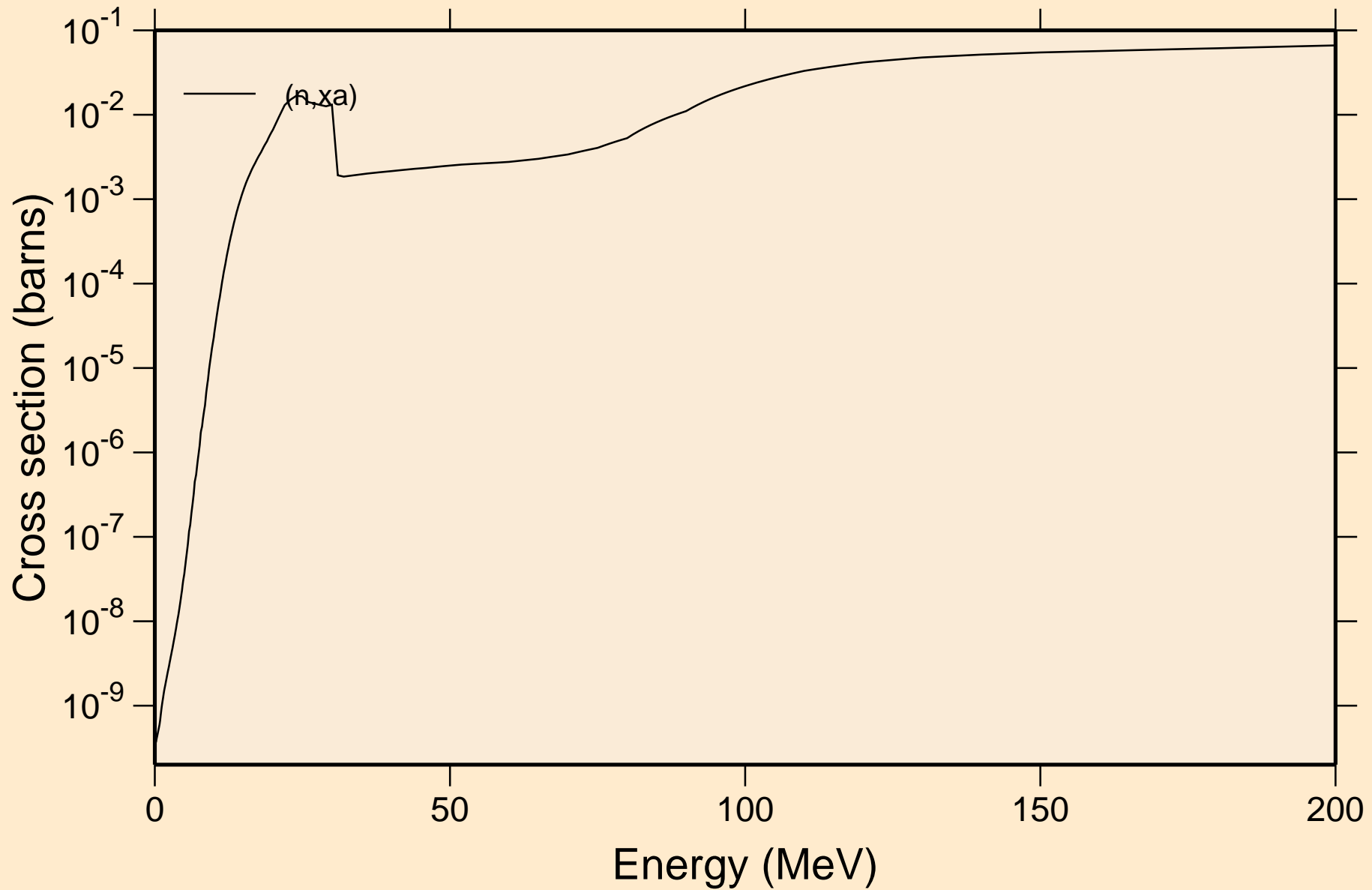

NP236M NEUTRON ACER TENDL-2023 LIBRARY; T=0.K  
Inelastic levels

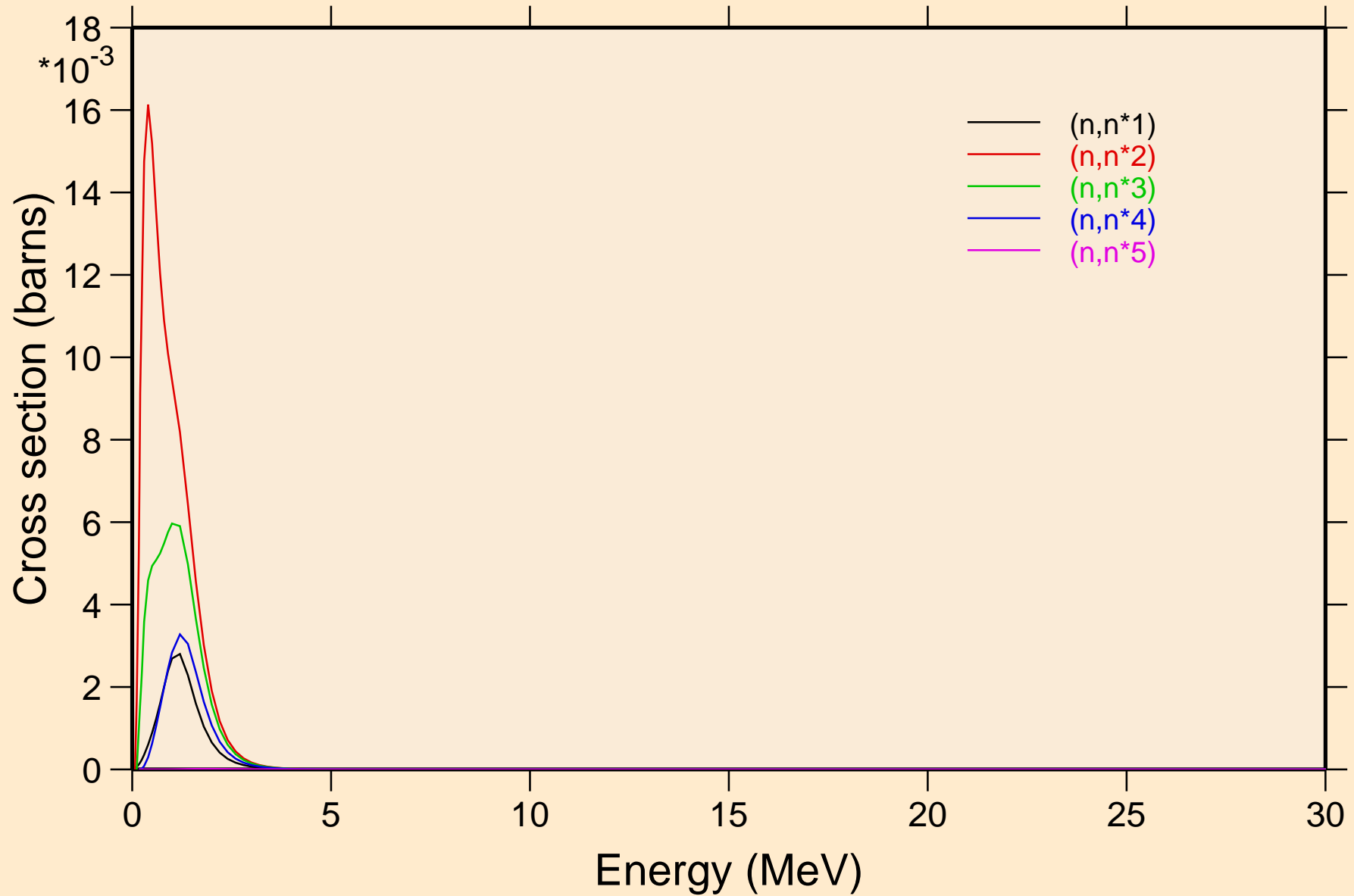

NP236M NEUTRON ACER TENDL-2023 LIBRARY; T=0.K  
Inelastic levels

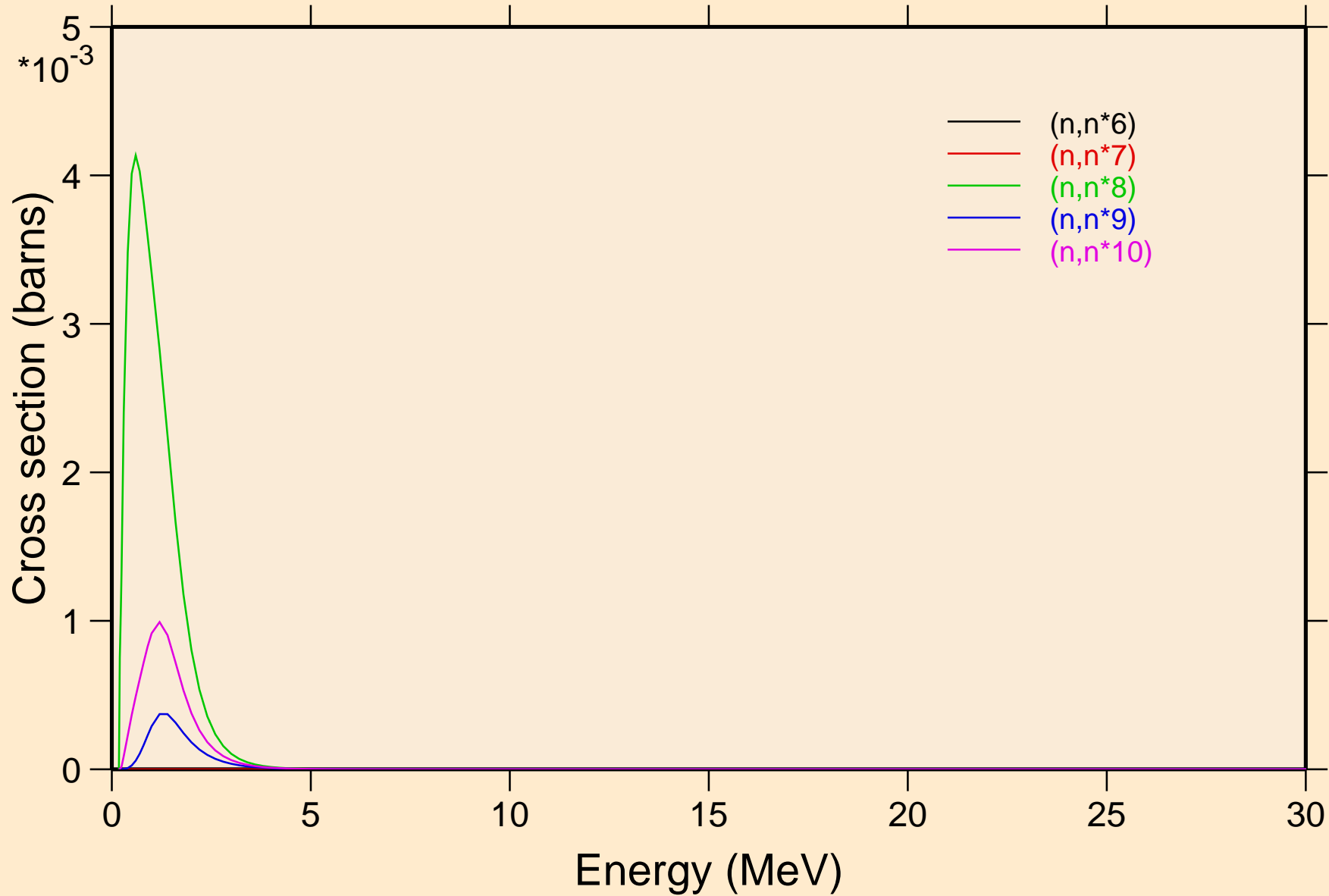

NP236M NEUTRON ACER TENDL-2023 LIBRARY; T=0.K  
Inelastic levels

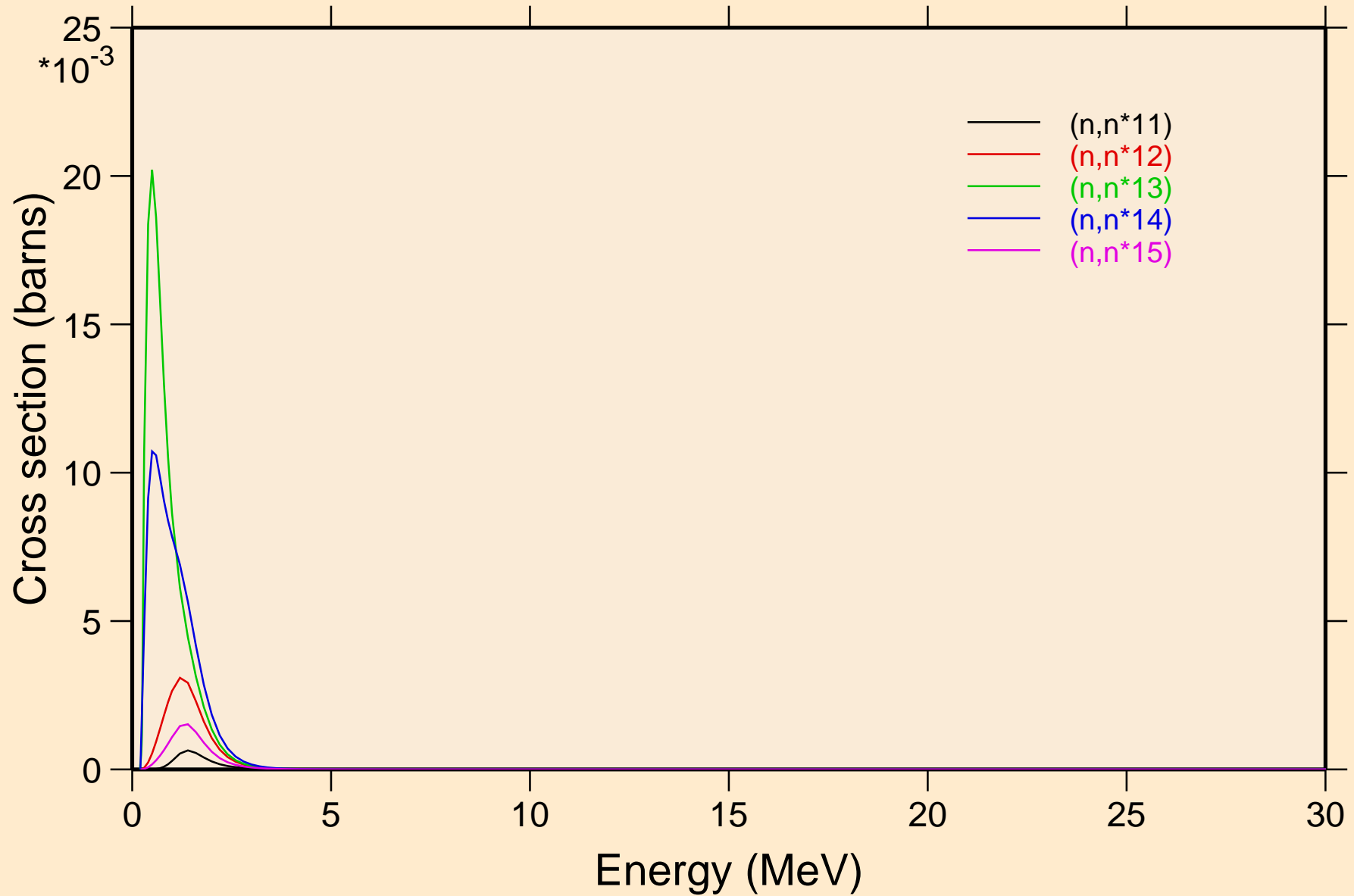

NP236M NEUTRON ACER TENDL-2023 LIBRARY; T=0.K  
Inelastic levels

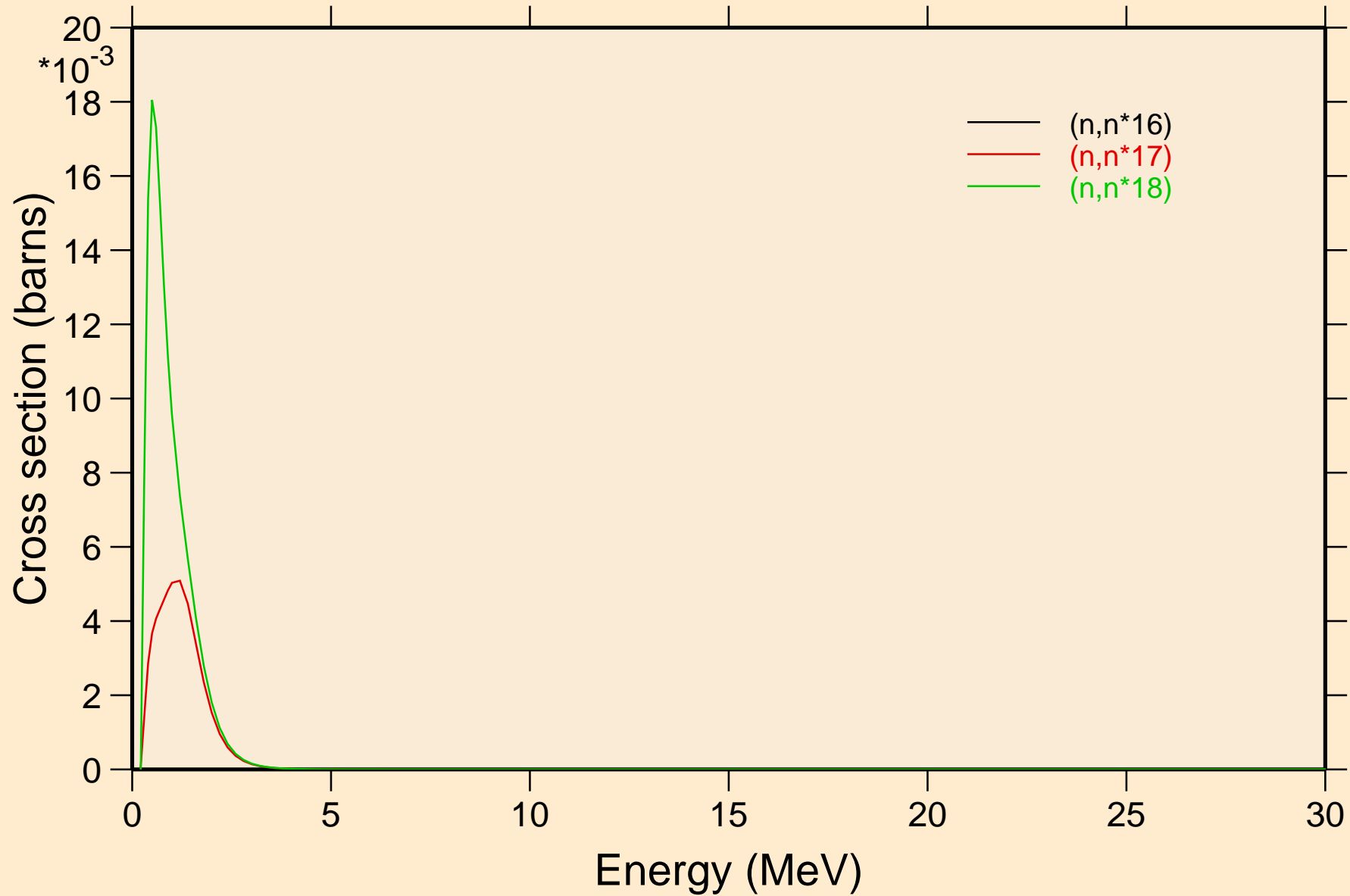

NP236M NEUTRON ACER TENDL-2023 LIBRARY; T=0.K  
Threshold reactions

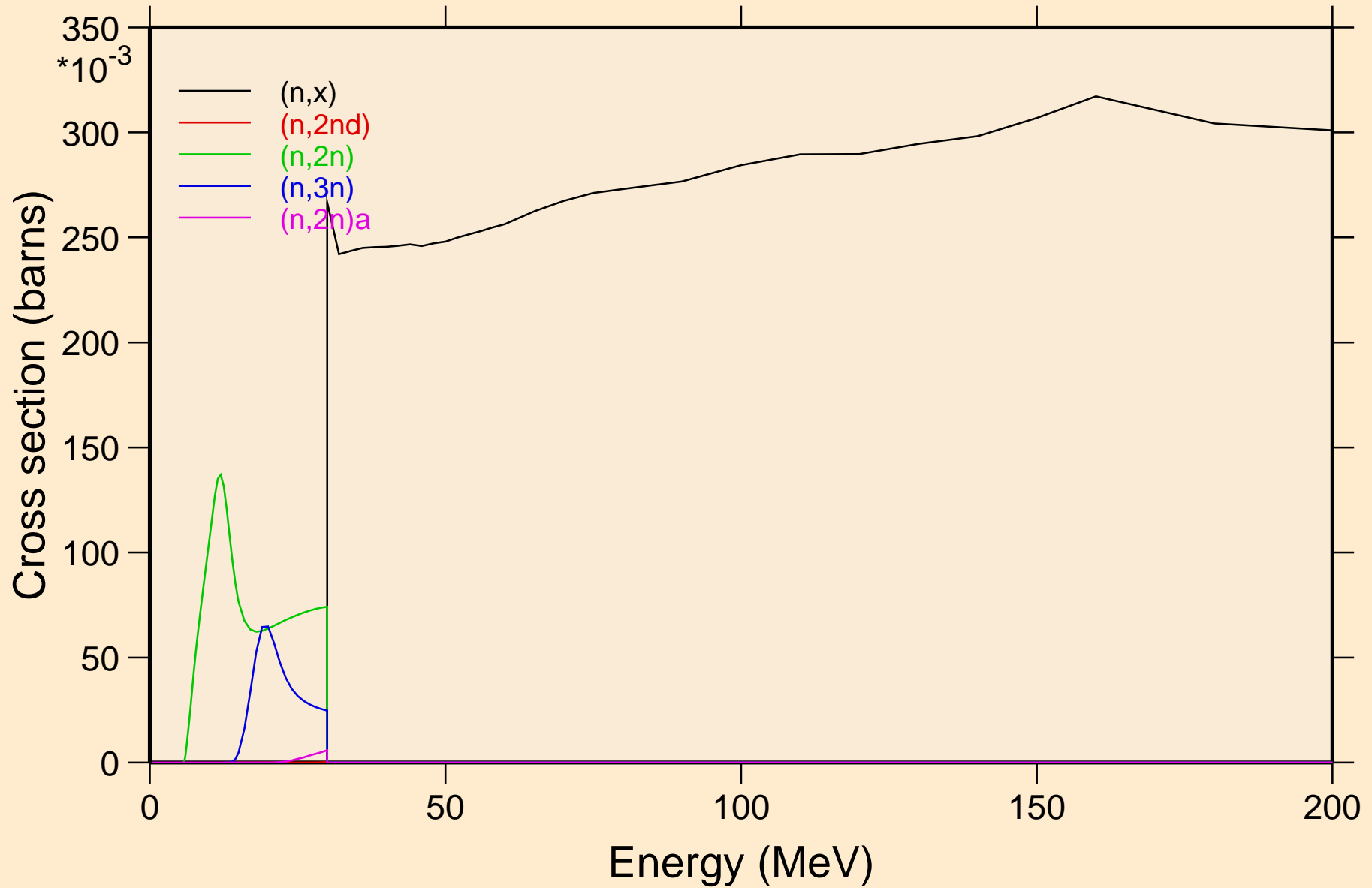

# NP236M NEUTRON ACER TENDL-2023 LIBRARY; T=0.K

## Threshold reactions

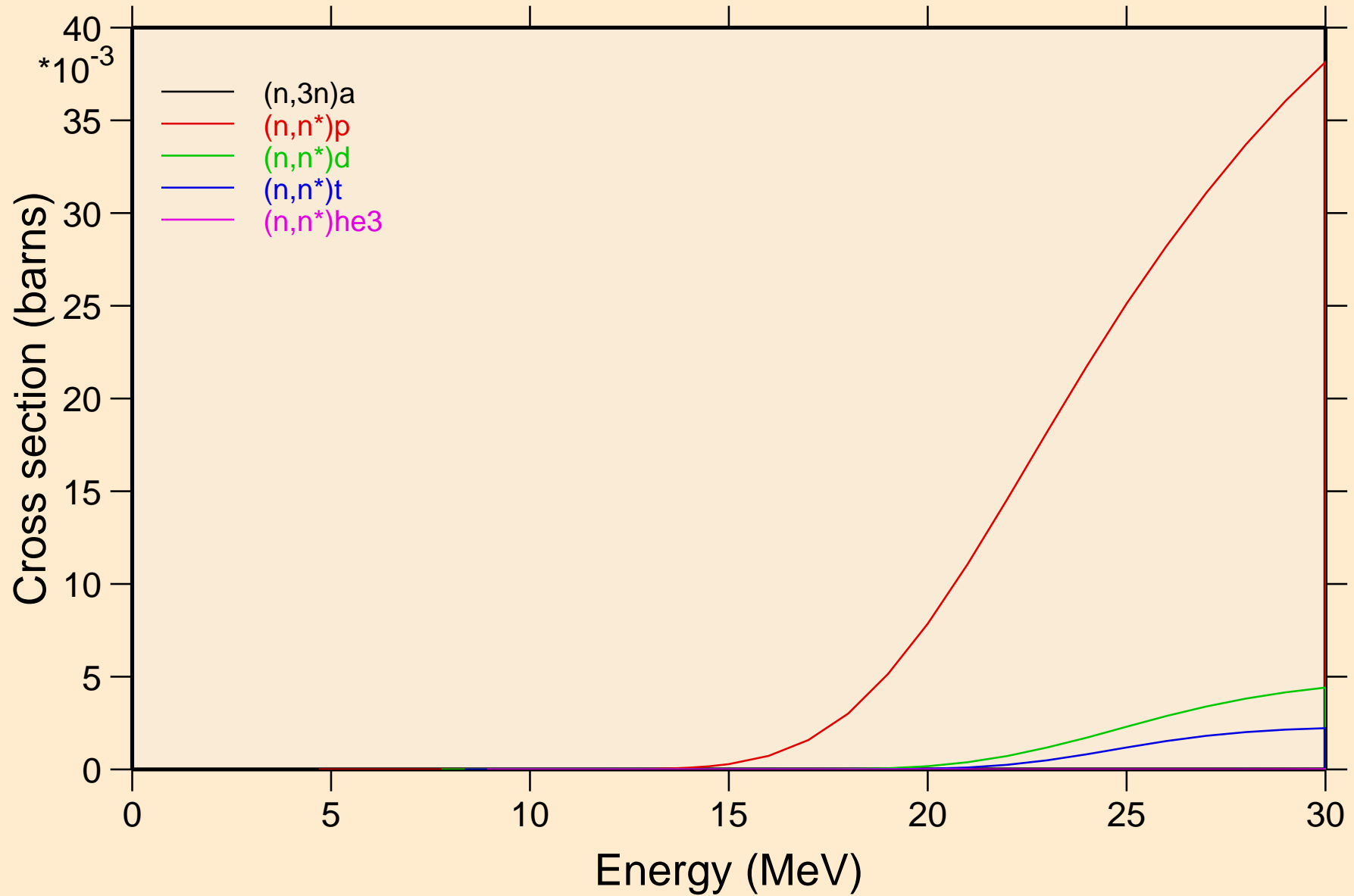



# NP236M NEUTRON ACER TENDL-2023 LIBRARY; T=0.K

## Threshold reactions

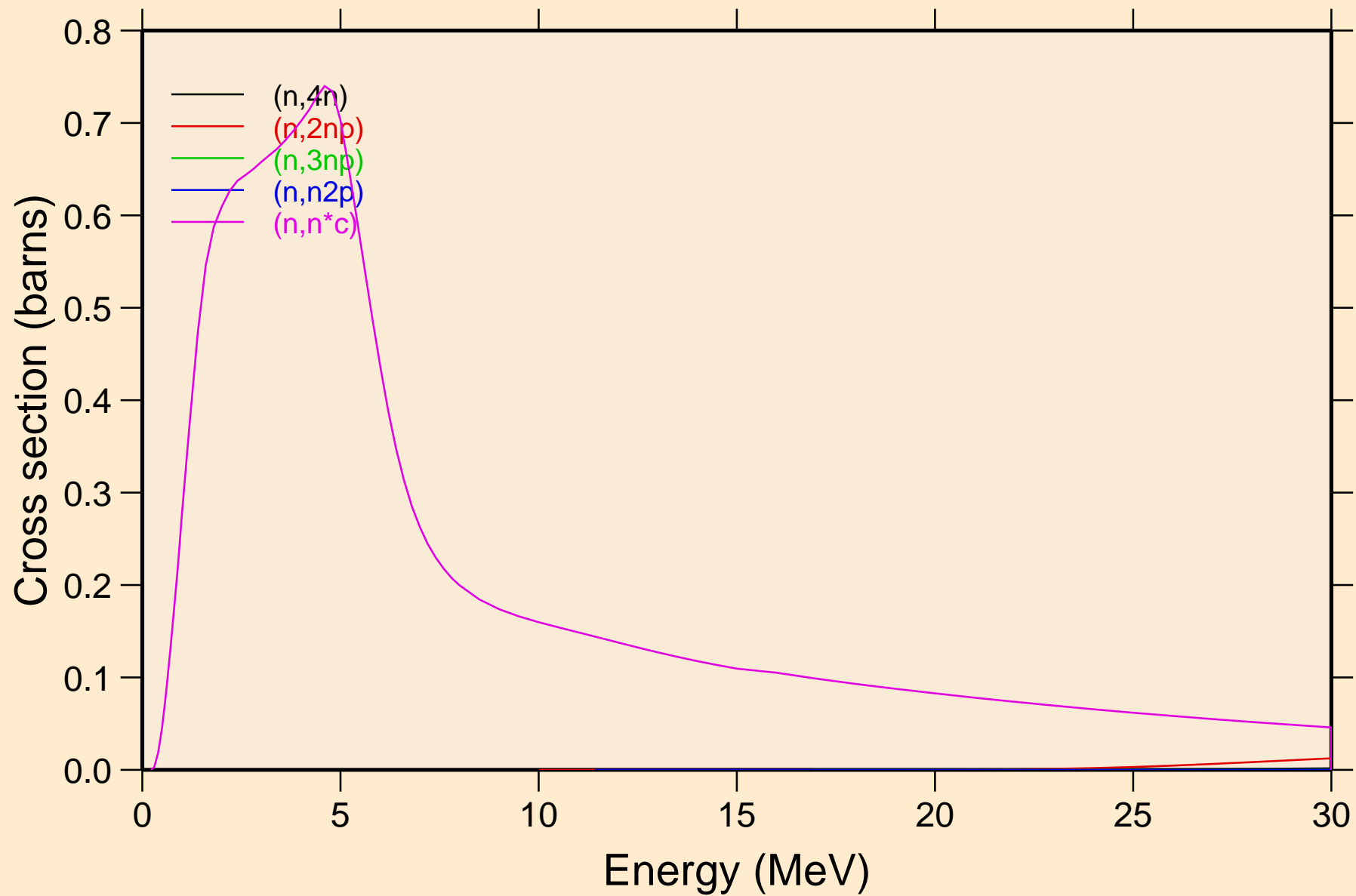

# NP236M NEUTRON ACER TENDL-2023 LIBRARY; T=0.K

## Threshold reactions

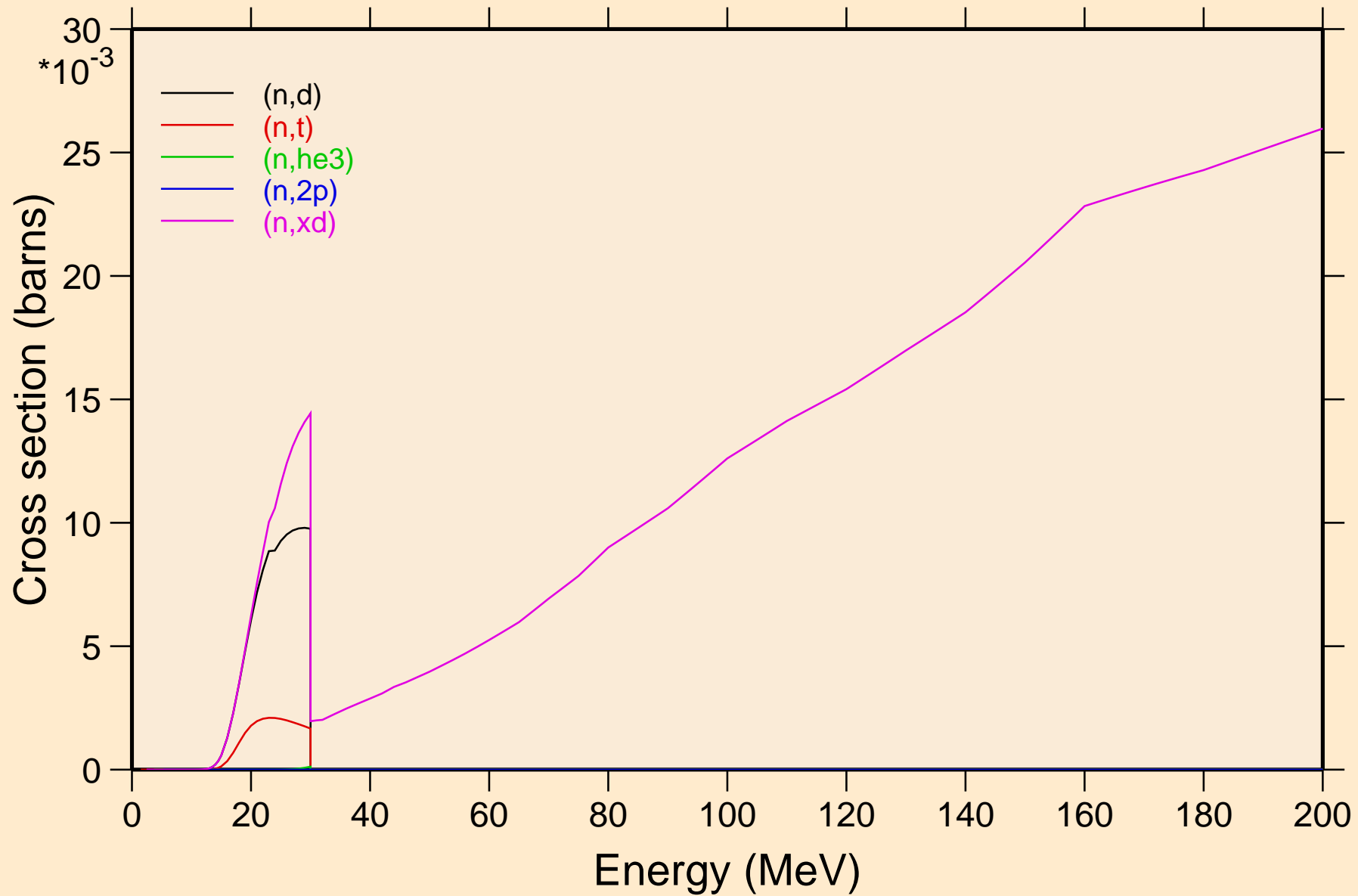

NP236M NEUTRON ACER TENDL-2023 LIBRARY; T=0.K  
Threshold reactions

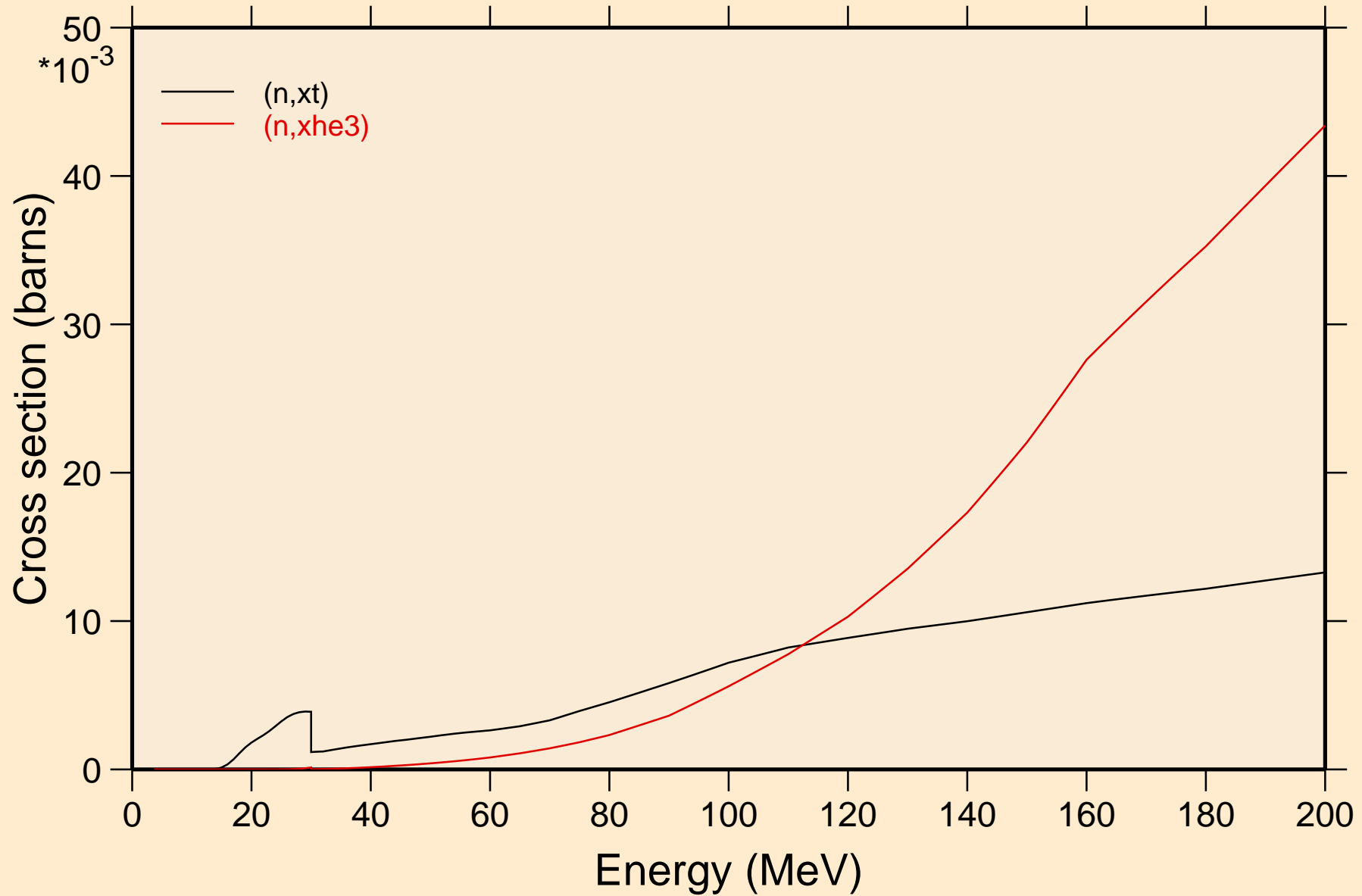

NP236M NEUTRON ACER TENDL-2023 LIBRARY; T=0.K  
angular distribution for elastic

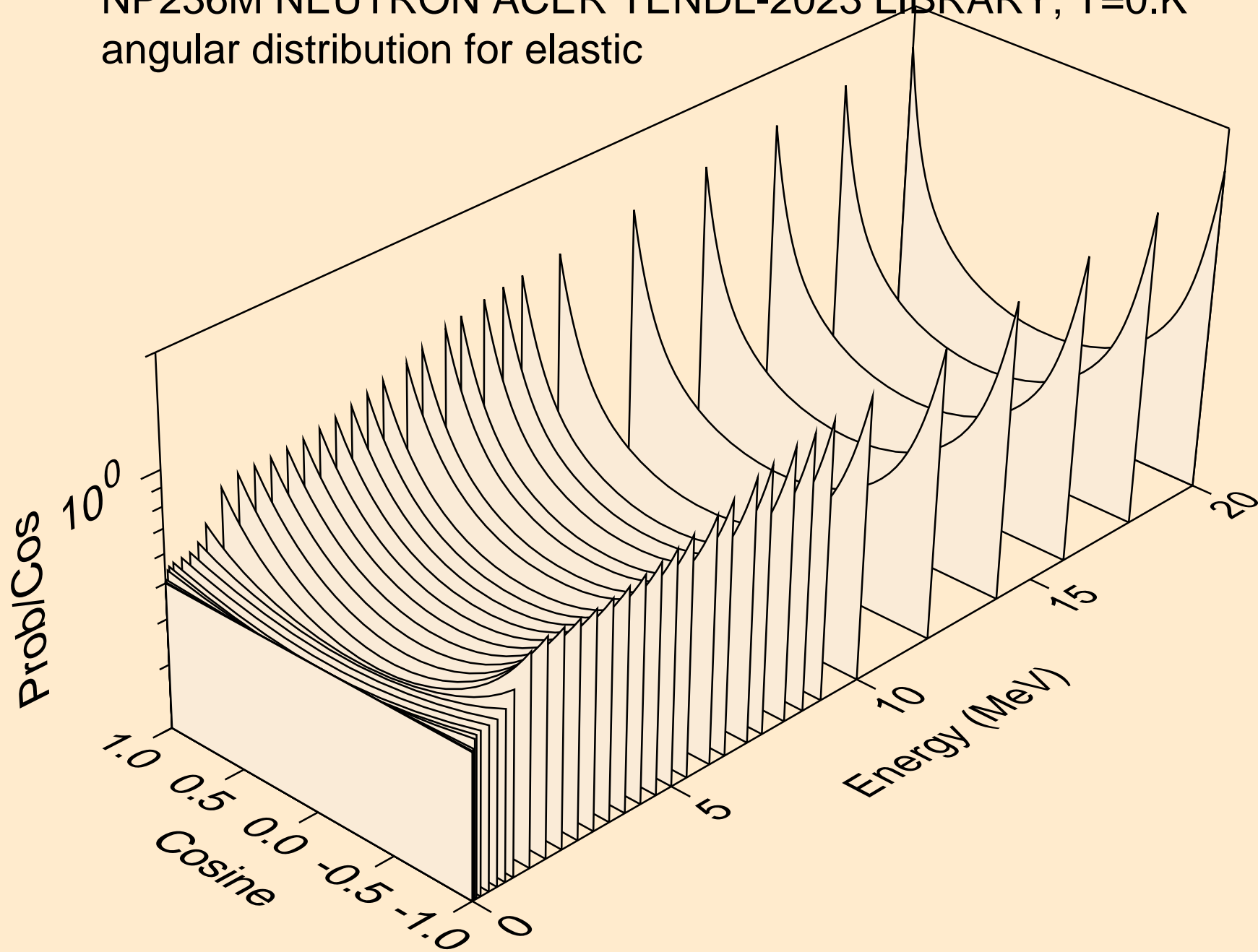

NP236M NEUTRON ACER TENDL-2023 LIBRARY; T=0.K  
angular distribution for elastic

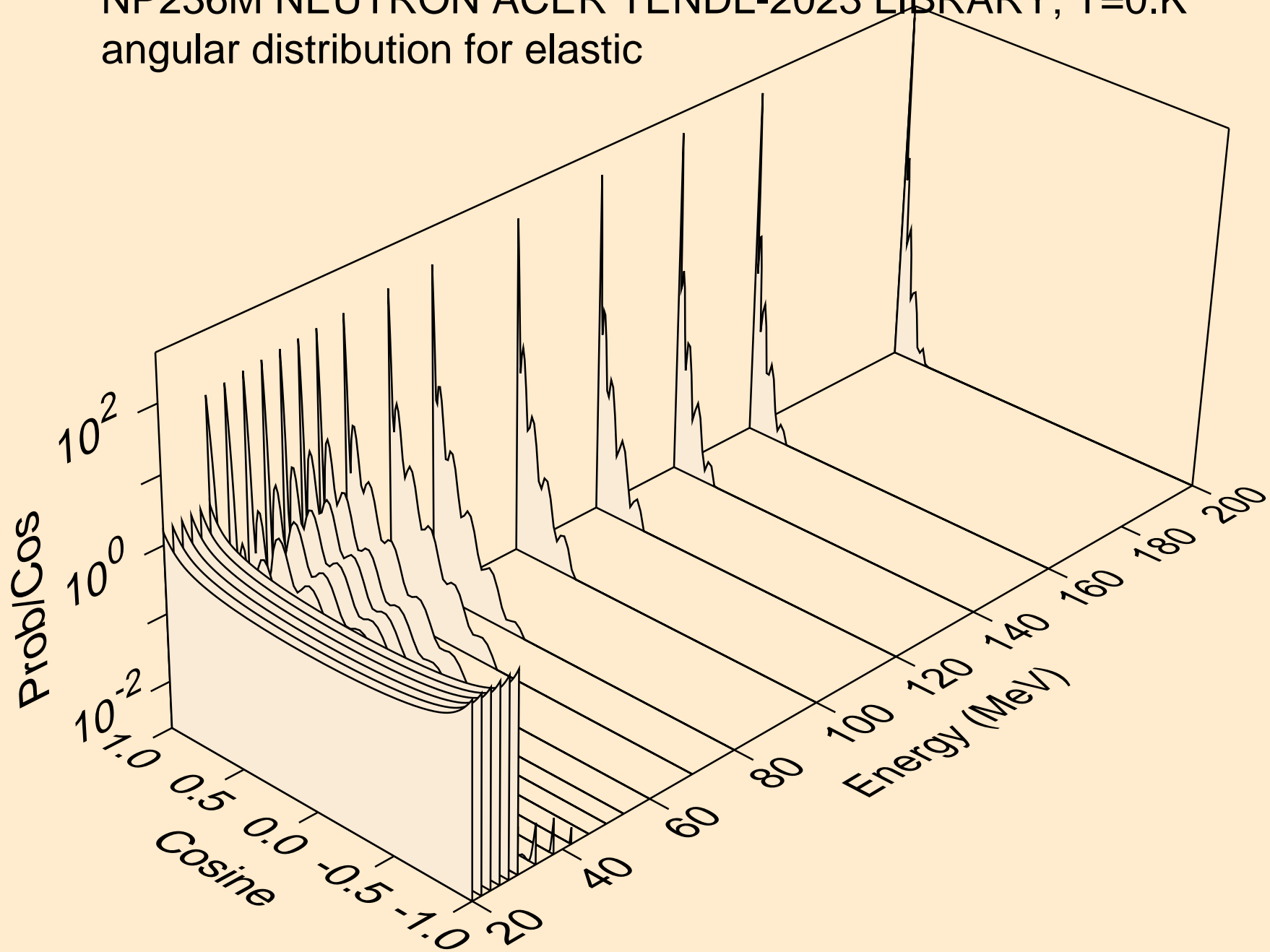

NP236M NEUTRON ACER TENDL-2023 LIBRARY; T=0.K  
angular distribution for (n,n\*1)

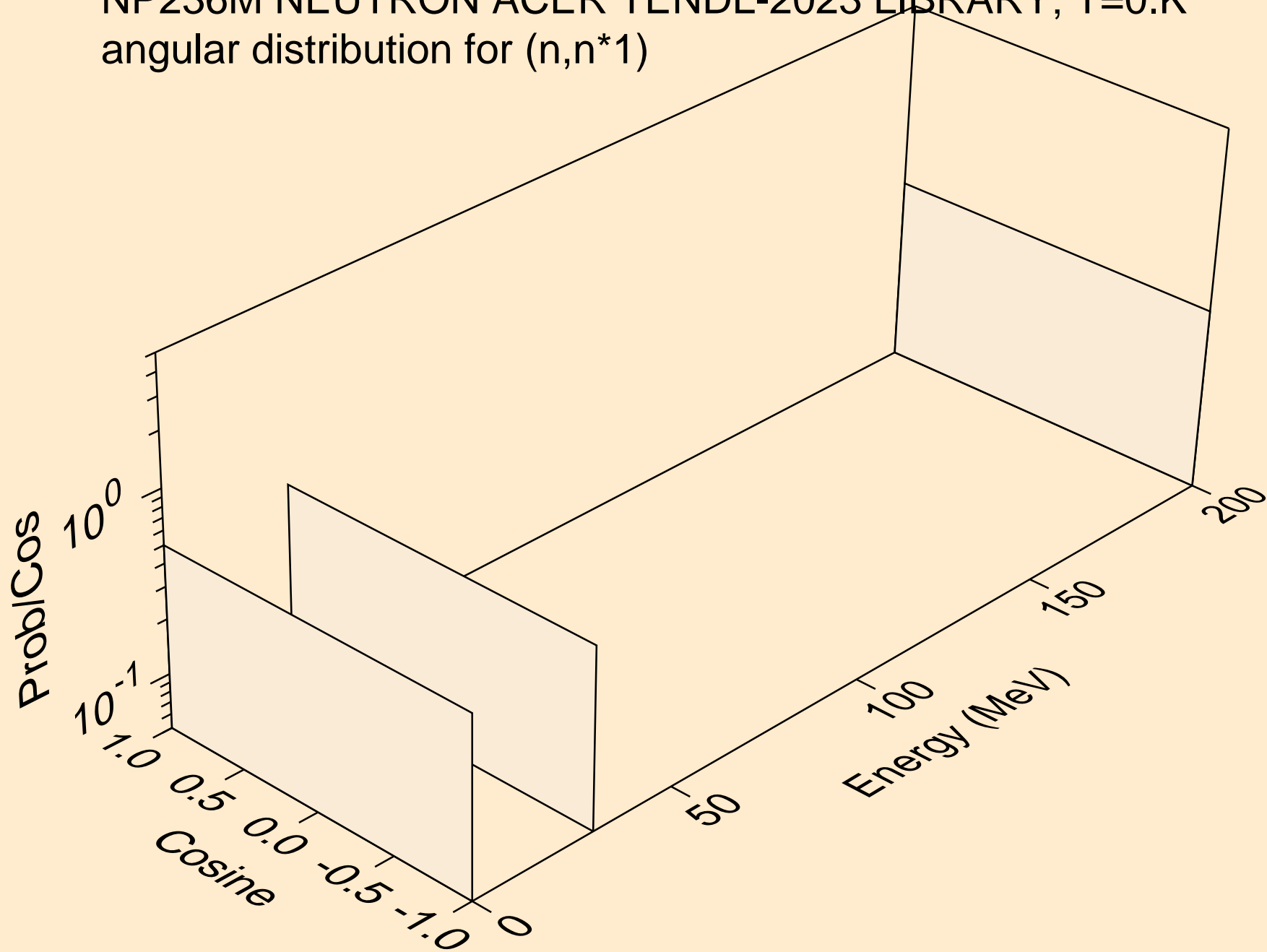

NP236M NEUTRON ACER TENDL-2023 LIBRARY; T=0.K  
angular distribution for (n,n\*2)

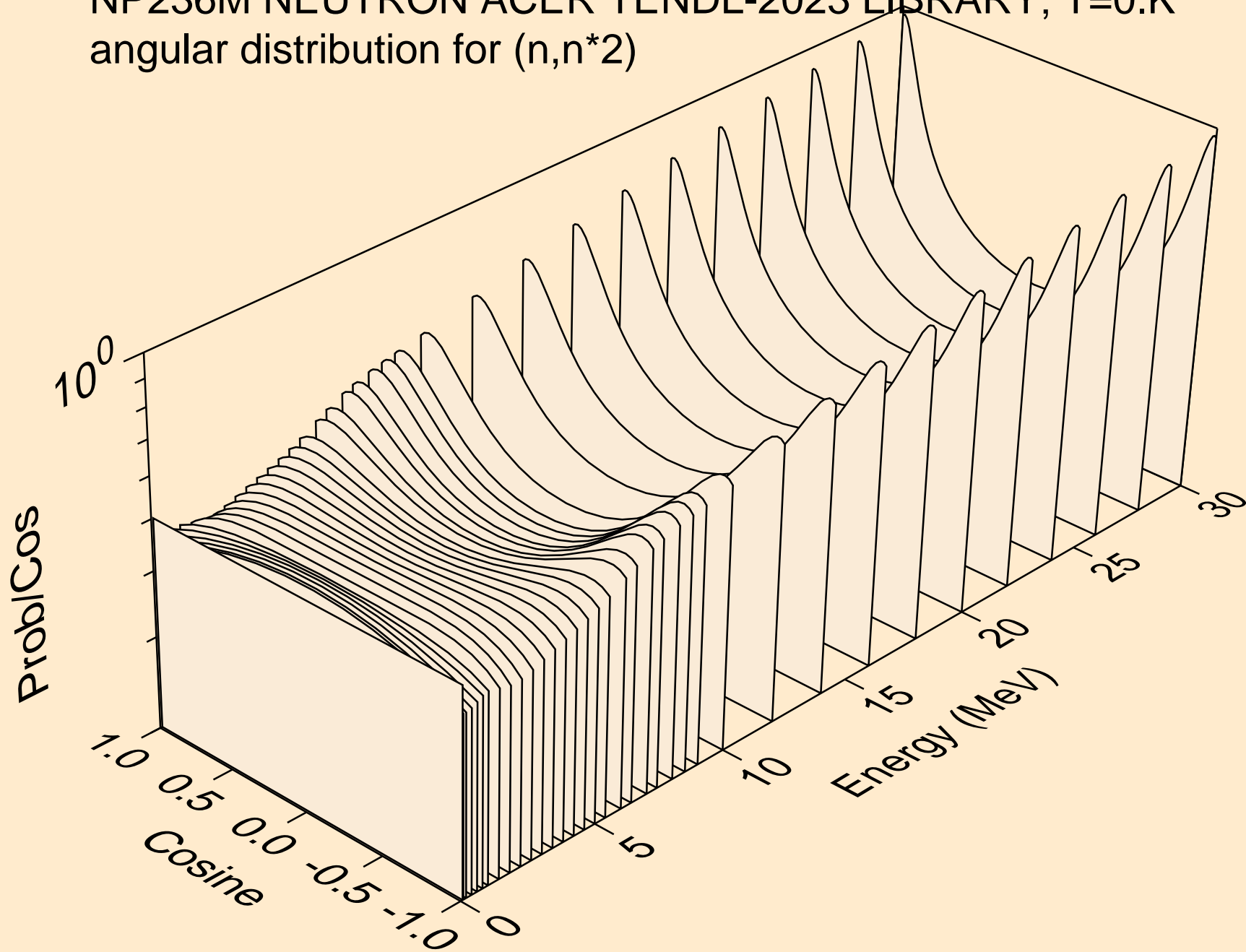

NP236M NEUTRON ACER TENDL-2023 LIBRARY; T=0.K  
angular distribution for (n,n\*3)

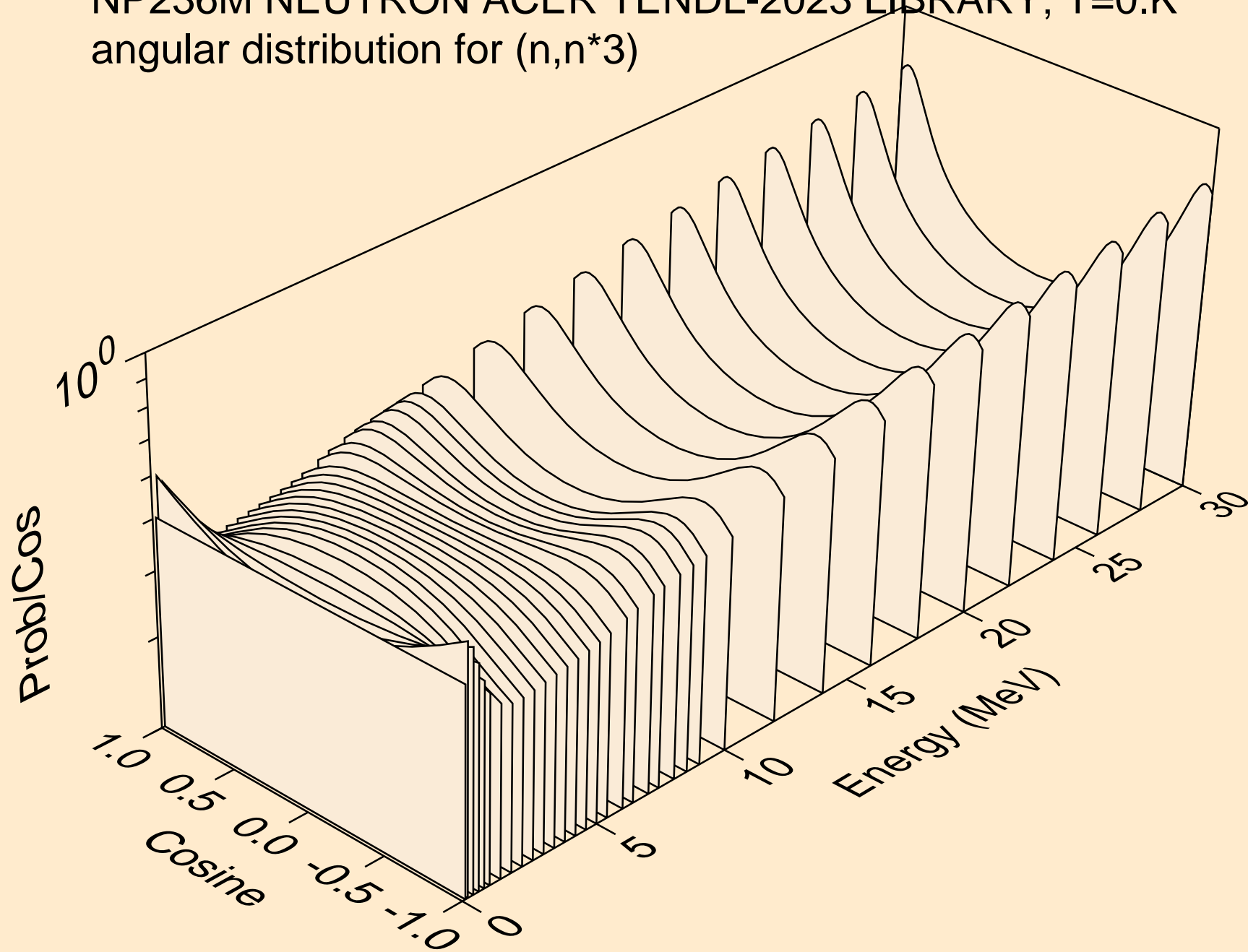



NP236M NEUTRON ACER TENDL-2023 LIBRARY; T=0.K  
angular distribution for (n,n\*4)

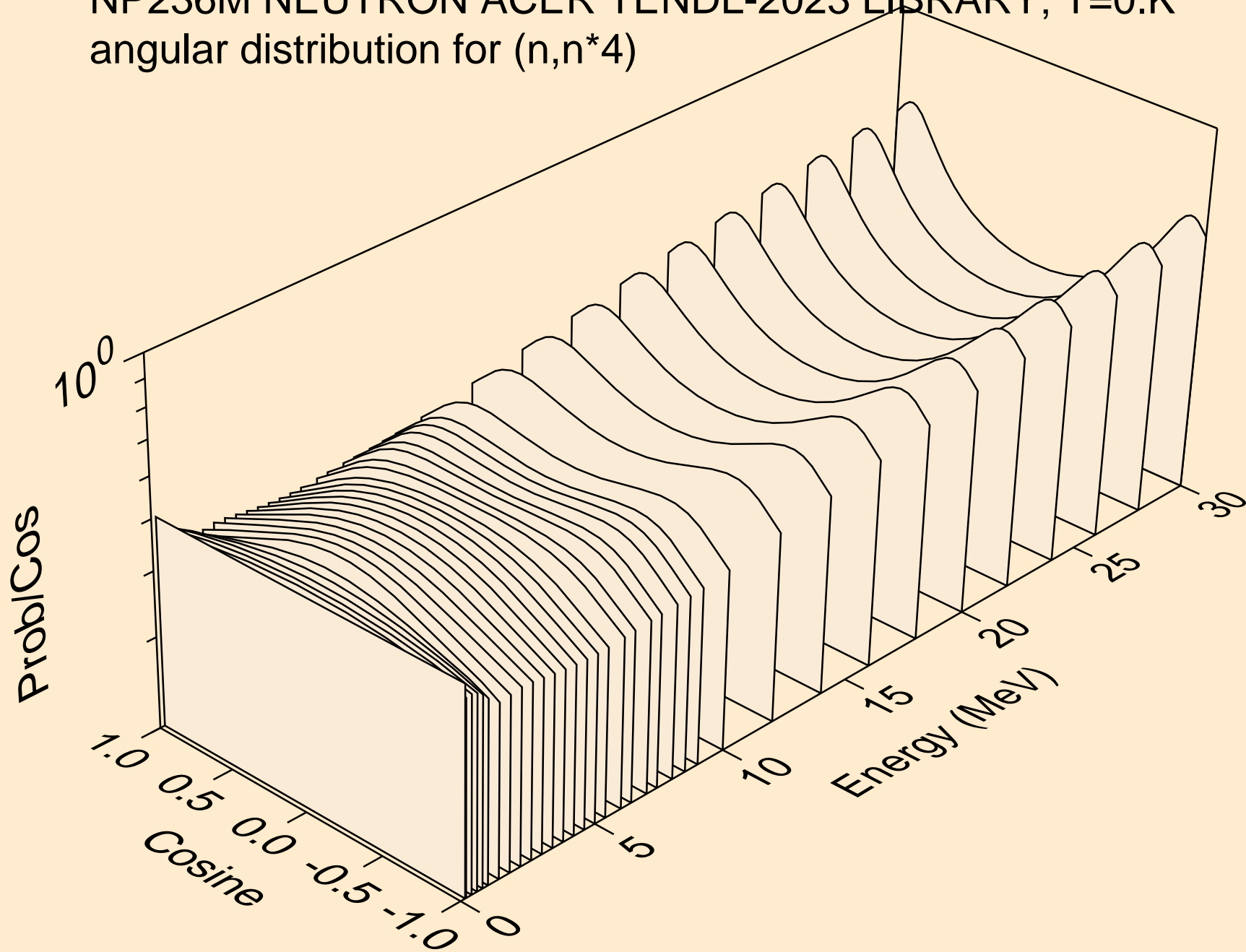

NP236M NEUTRON ACER TENDL-2023 LIBRARY; T=0.K  
angular distribution for (n,n\*5)

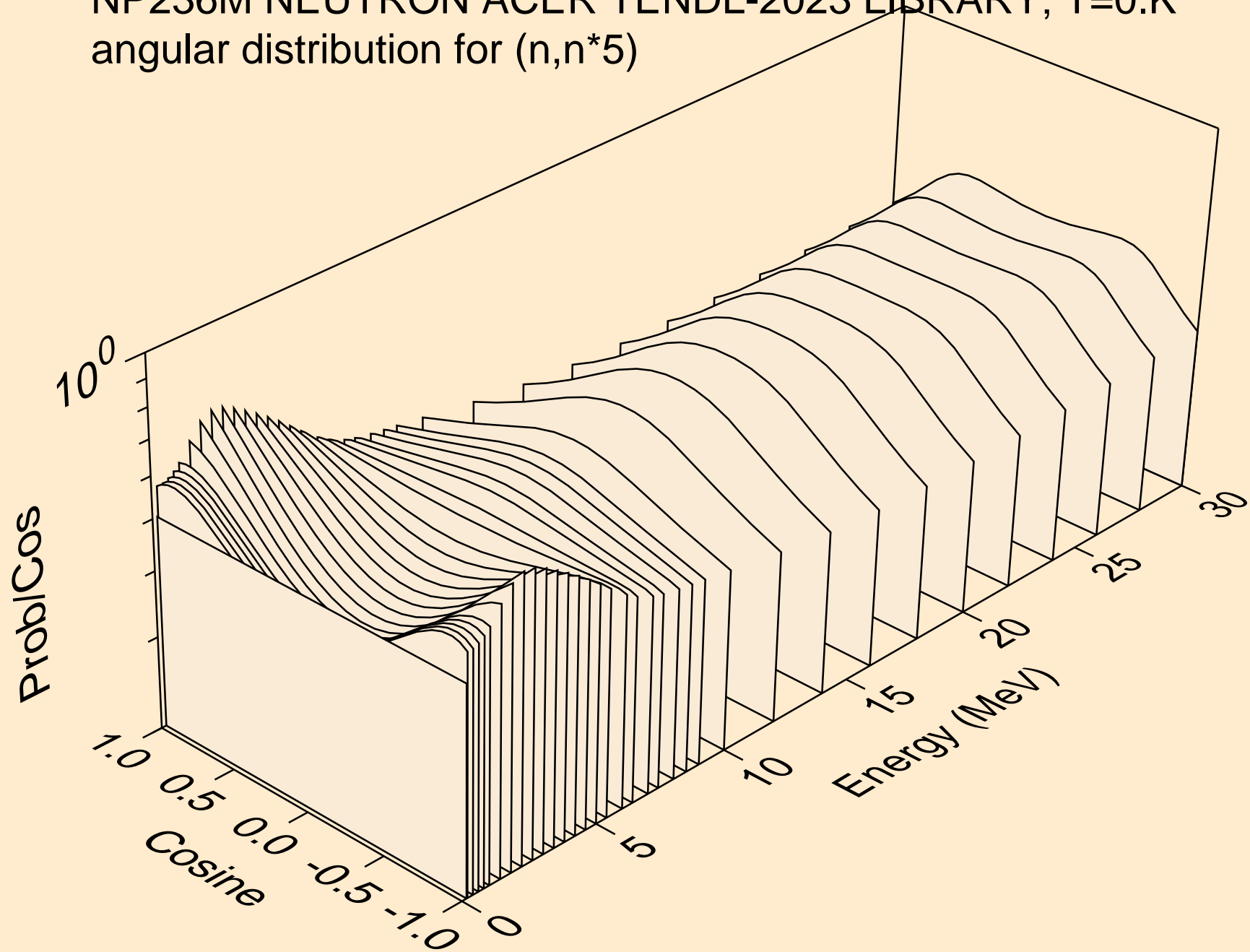

NP236M NEUTRON ACER TENDL-2023 LIBRARY; T=0.K  
angular distribution for (n,n\*6)

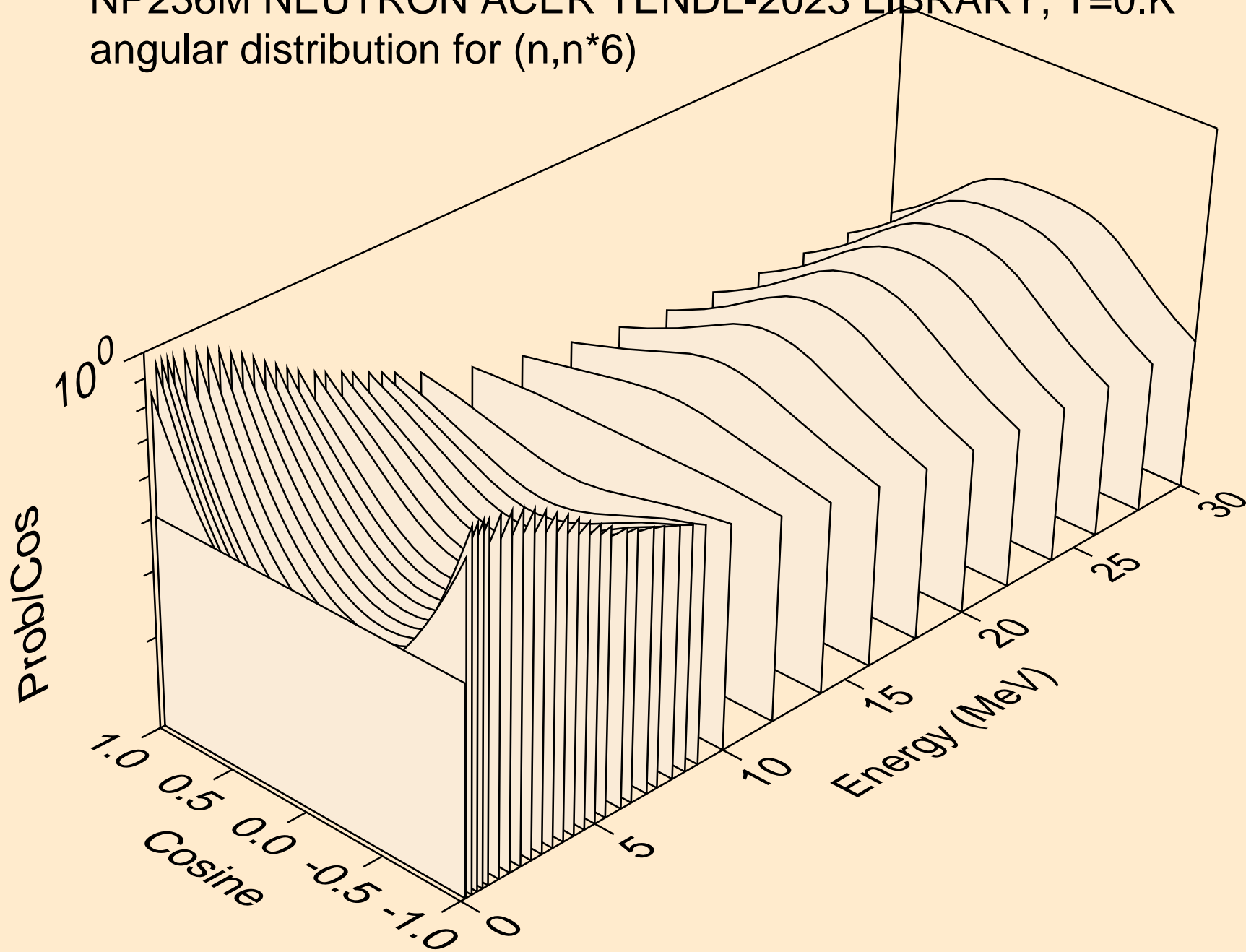

NP236M NEUTRON ACER TENDL-2023 LIBRARY; T=0.K  
angular distribution for (n,n\*7)

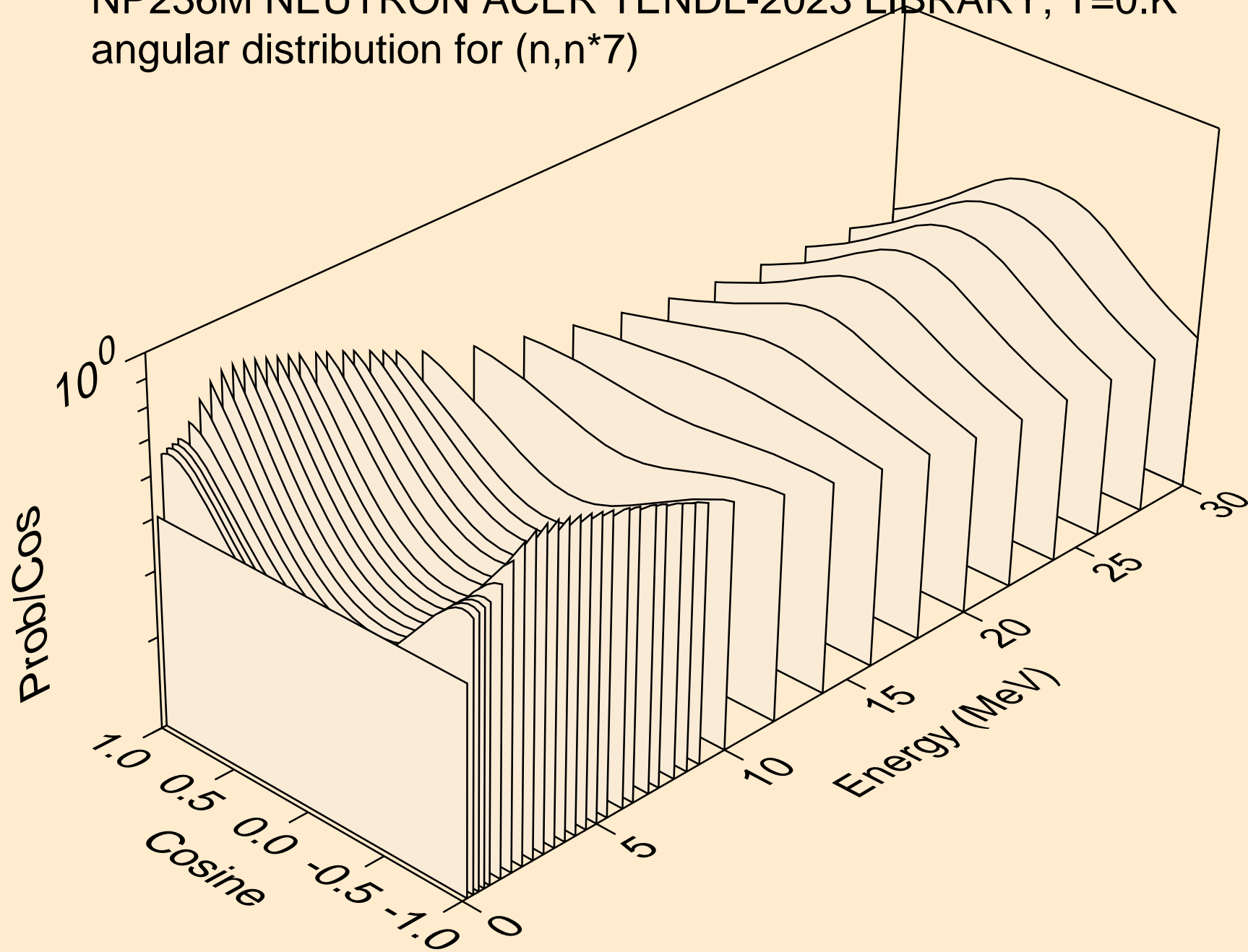

NP236M NEUTRON ACER TENDL-2023 LIBRARY; T=0.K  
angular distribution for (n,n\*8)

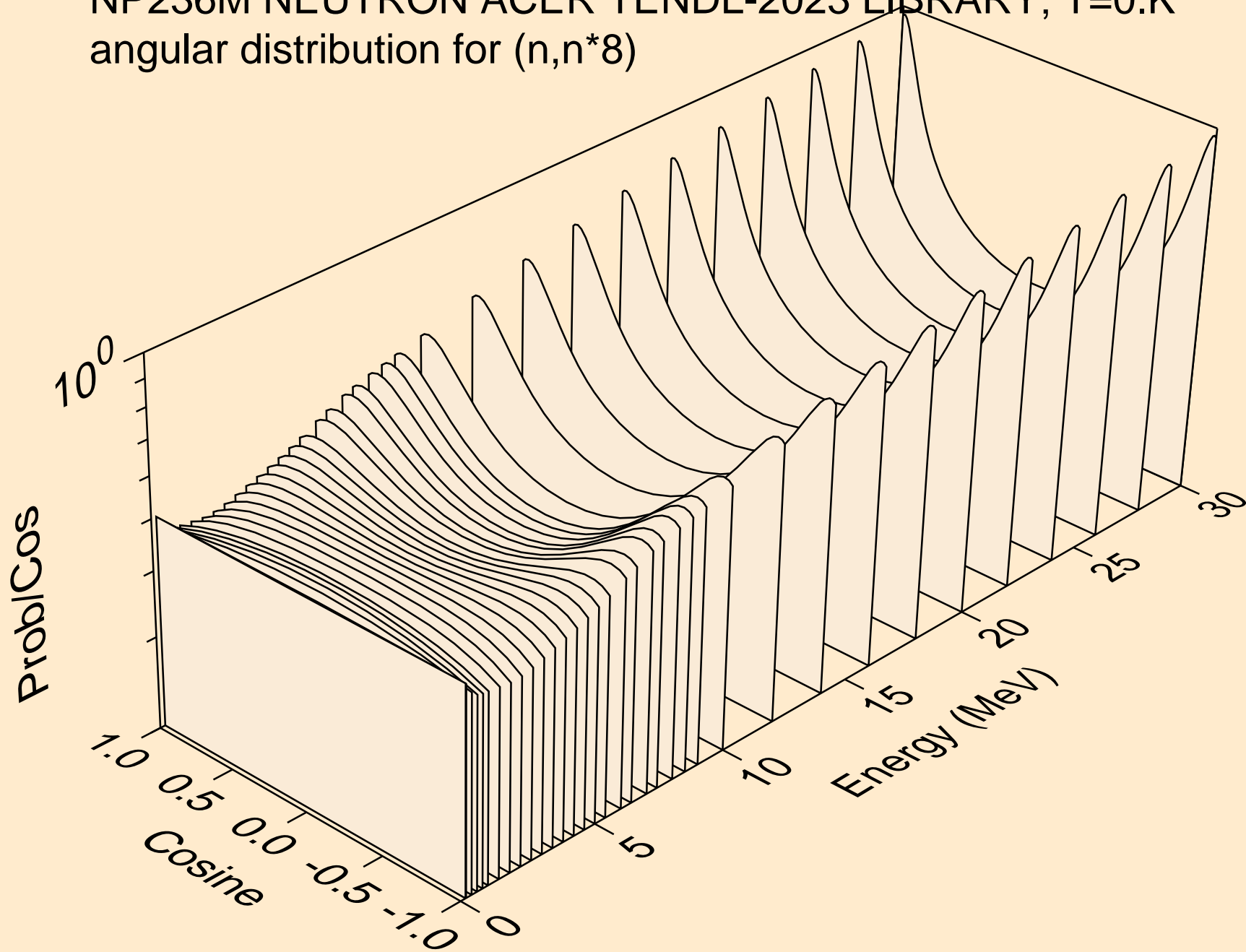

NP236M NEUTRON ACER TENDL-2023 LIBRARY; T=0.K  
angular distribution for (n,n\*9)

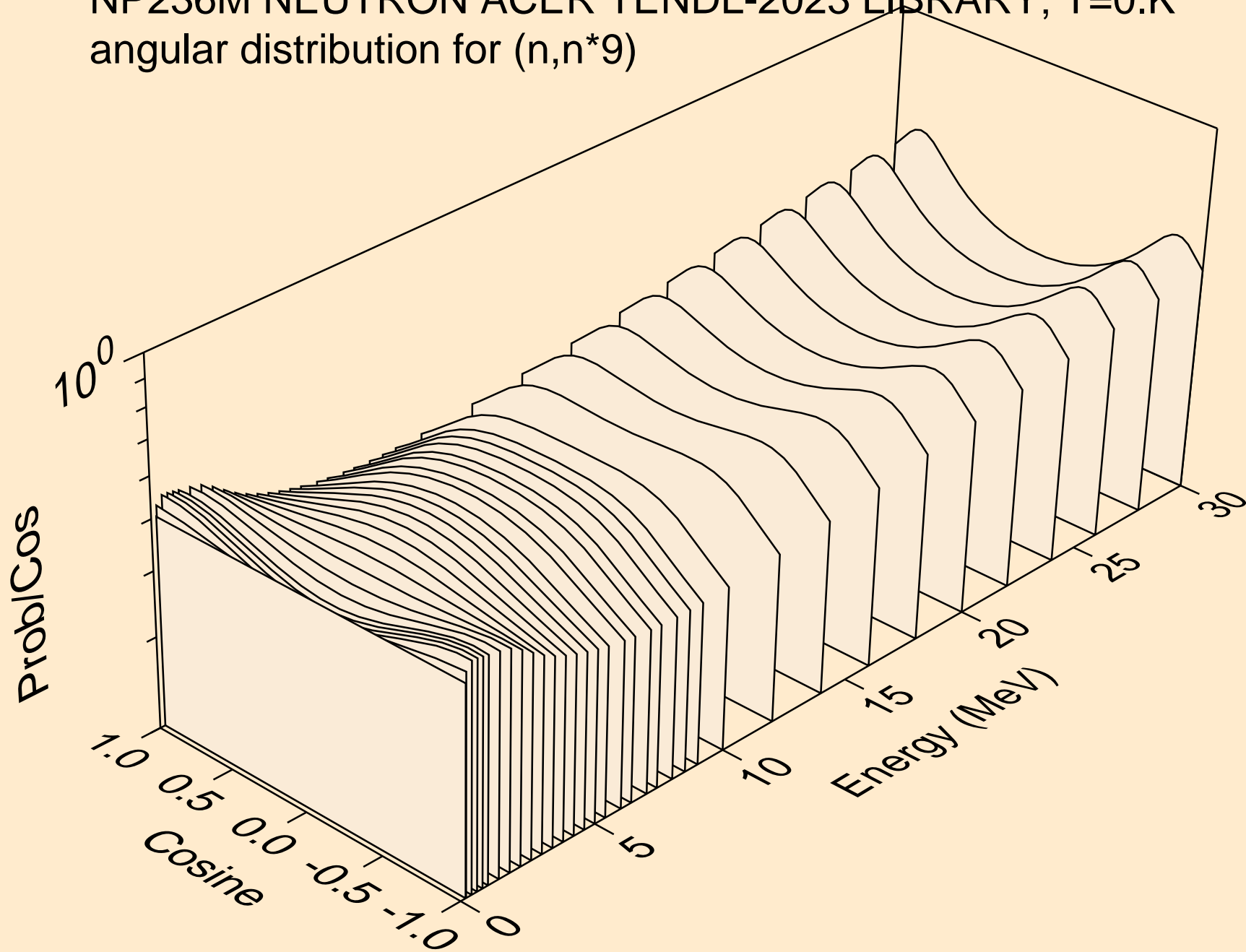

NP236M NEUTRON ACER TENDL-2023 LIBRARY; T=0.K  
angular distribution for (n,n\*10)

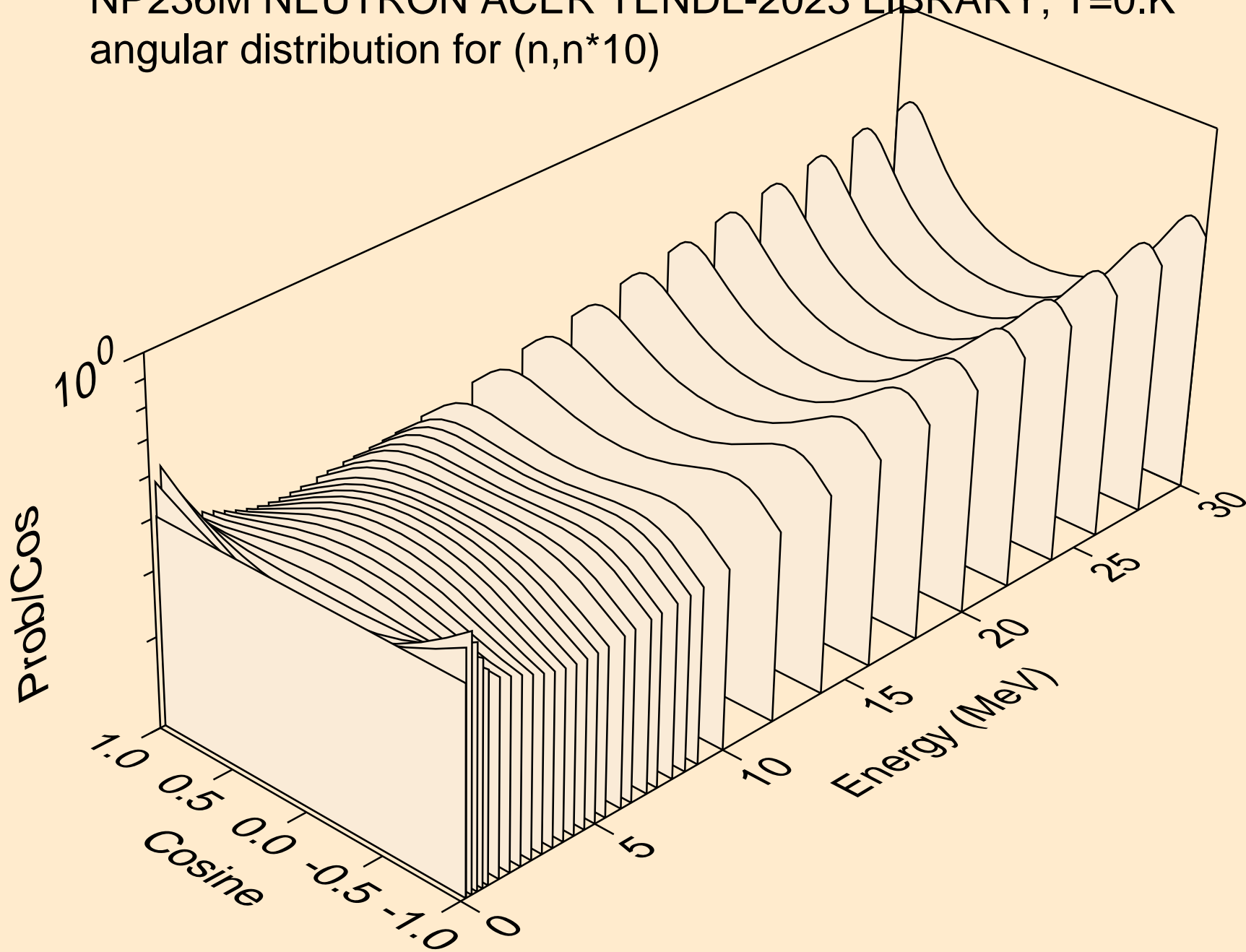

NP236M NEUTRON ACER TENDL-2023 LIBRARY; T=0.K  
angular distribution for (n,n\*11)

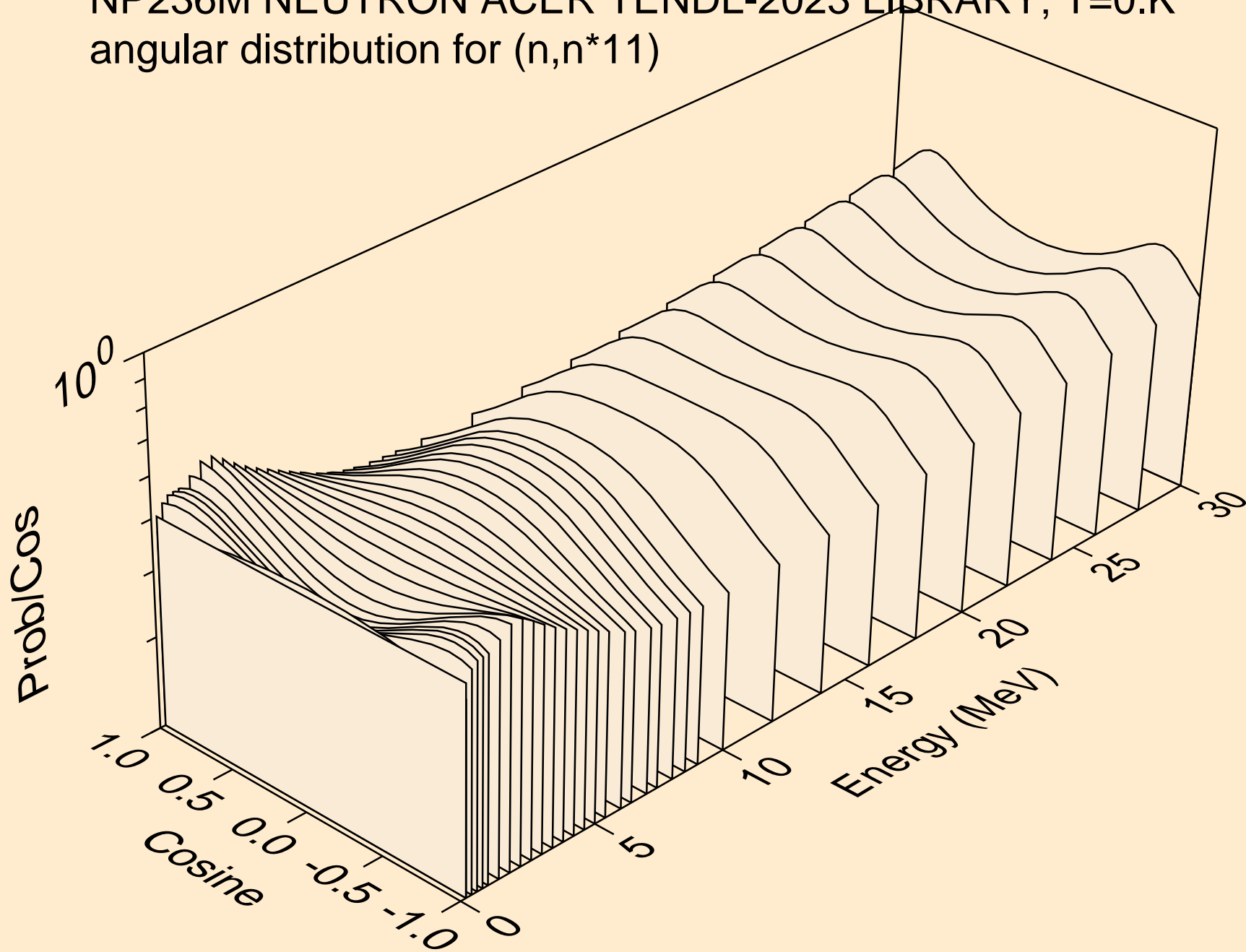



NP236M NEUTRON ACER TENDL-2023 LIBRARY; T=0.K  
angular distribution for (n,n\*12)

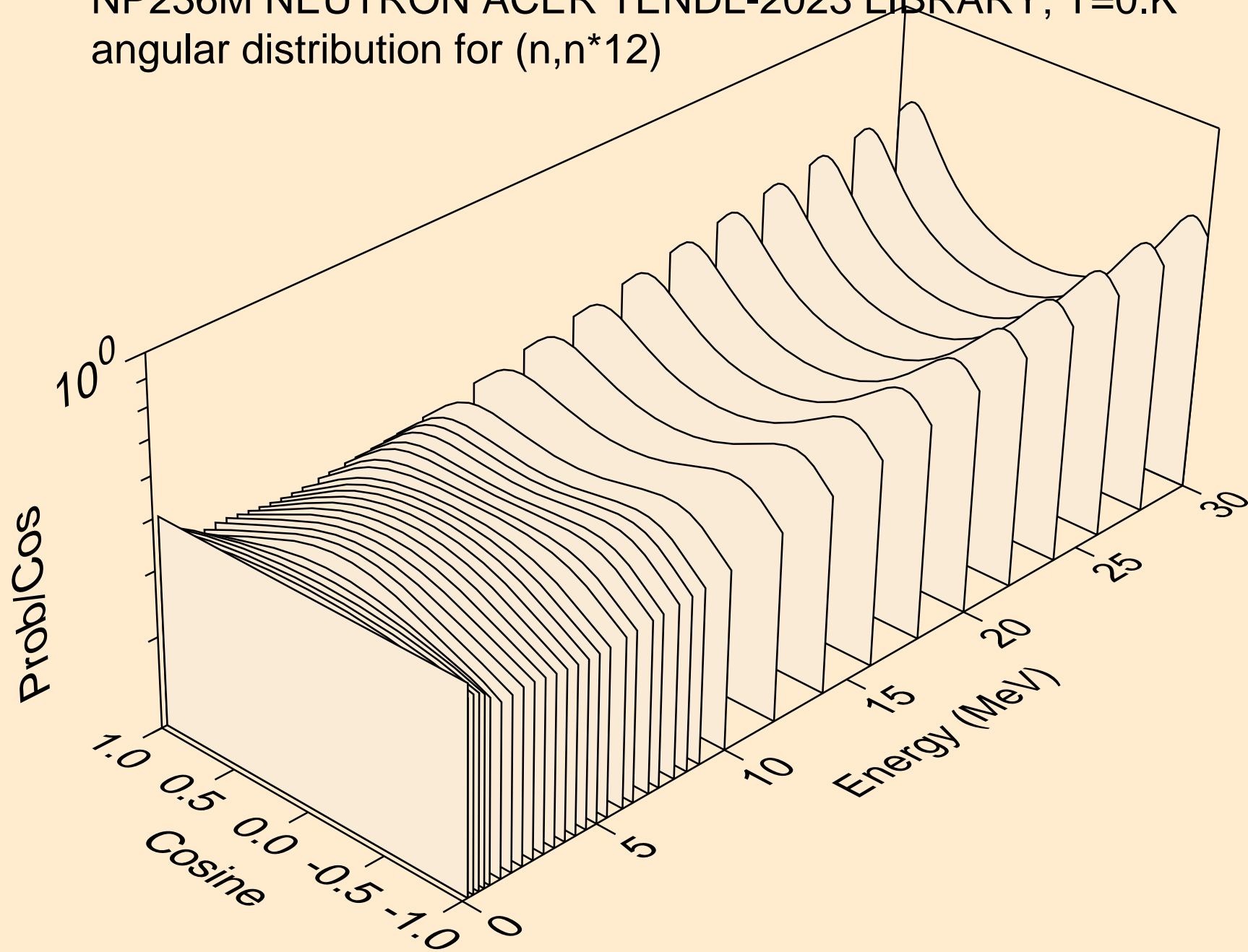

NP236M NEUTRON ACER TENDL-2023 LIBRARY; T=0.K  
angular distribution for (n,n\*13)

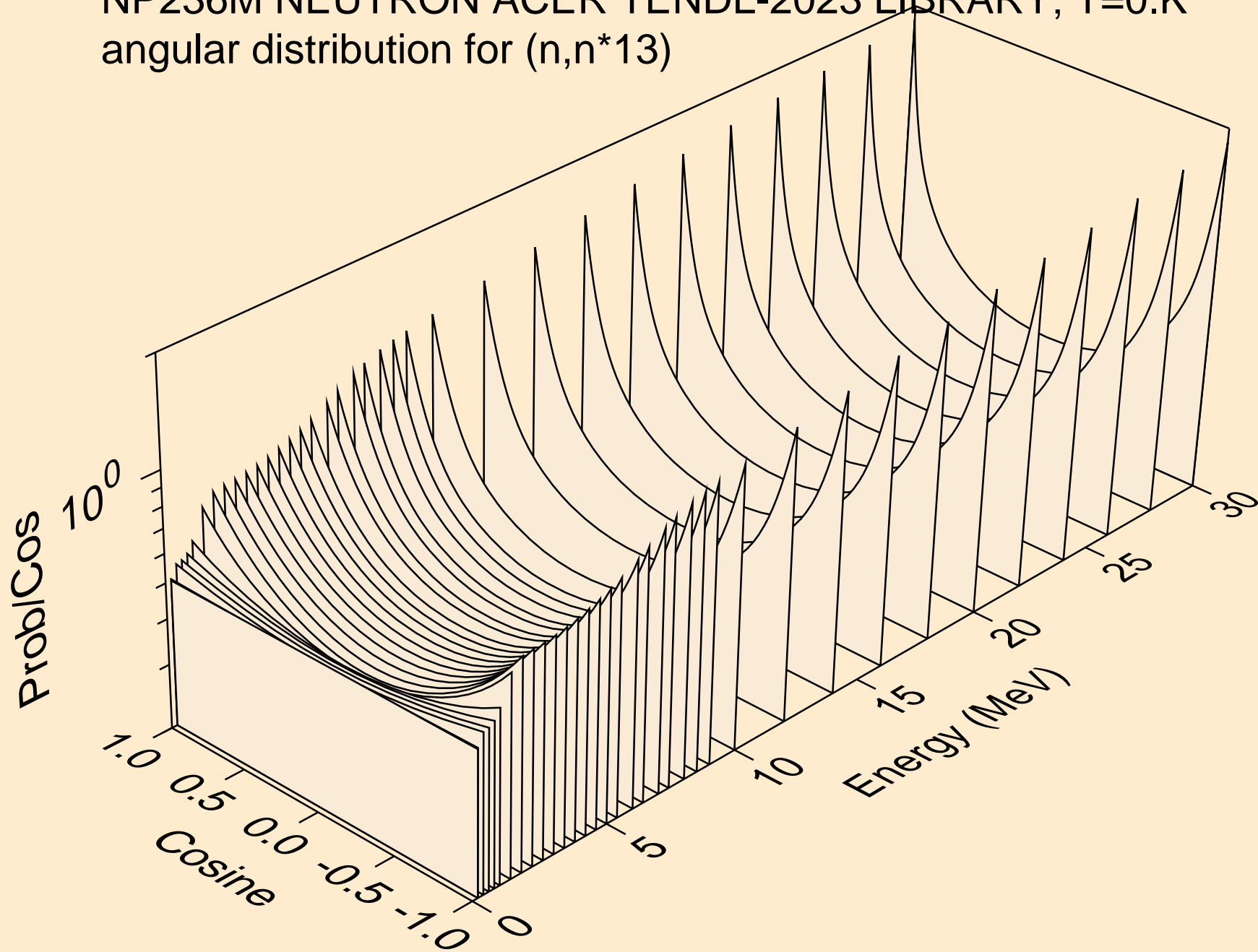

NP236M NEUTRON ACER TENDL-2023 LIBRARY; T=0.K  
angular distribution for (n,n\*14)

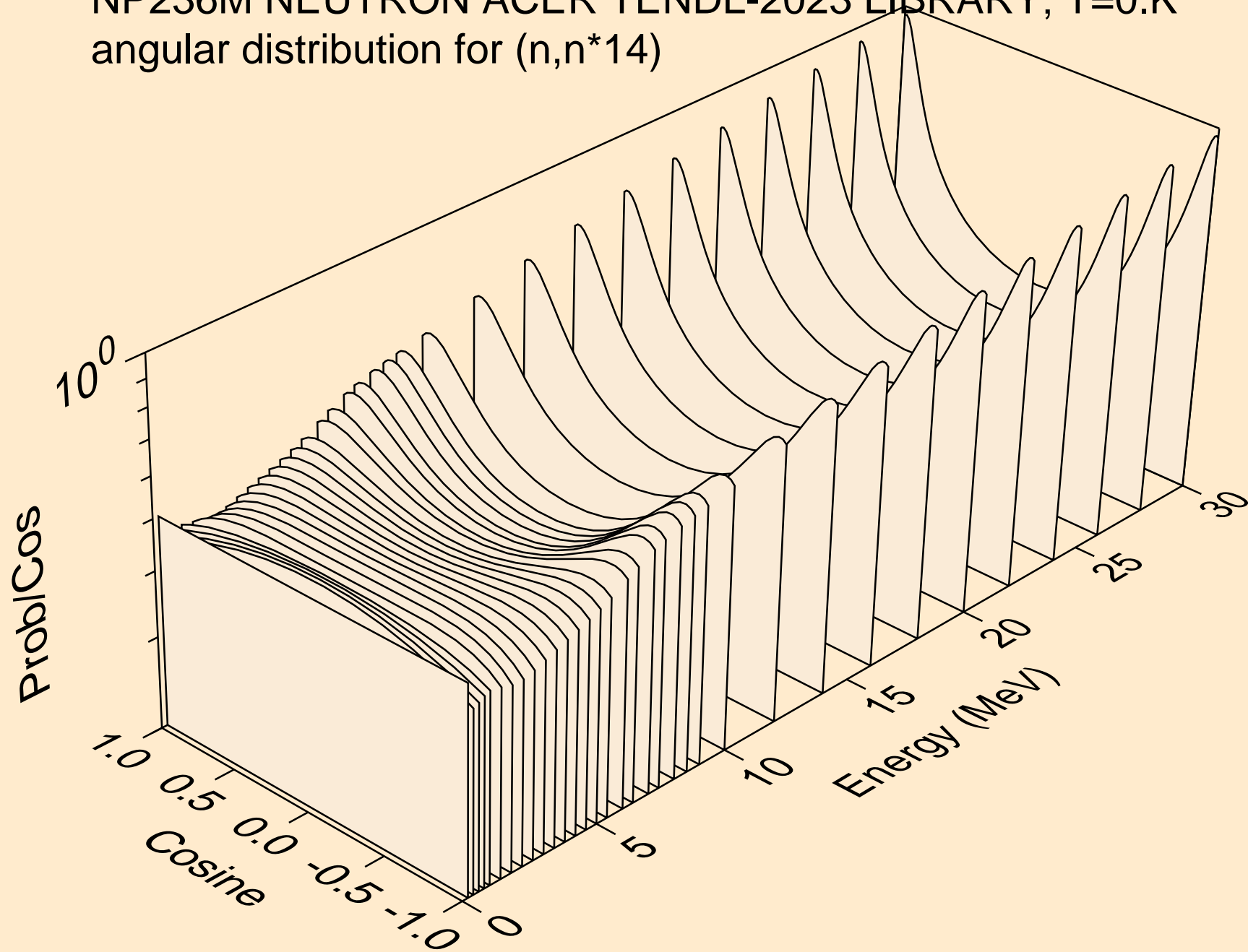

NP236M NEUTRON ACER TENDL-2023 LIBRARY; T=0.K  
angular distribution for (n,n\*15)

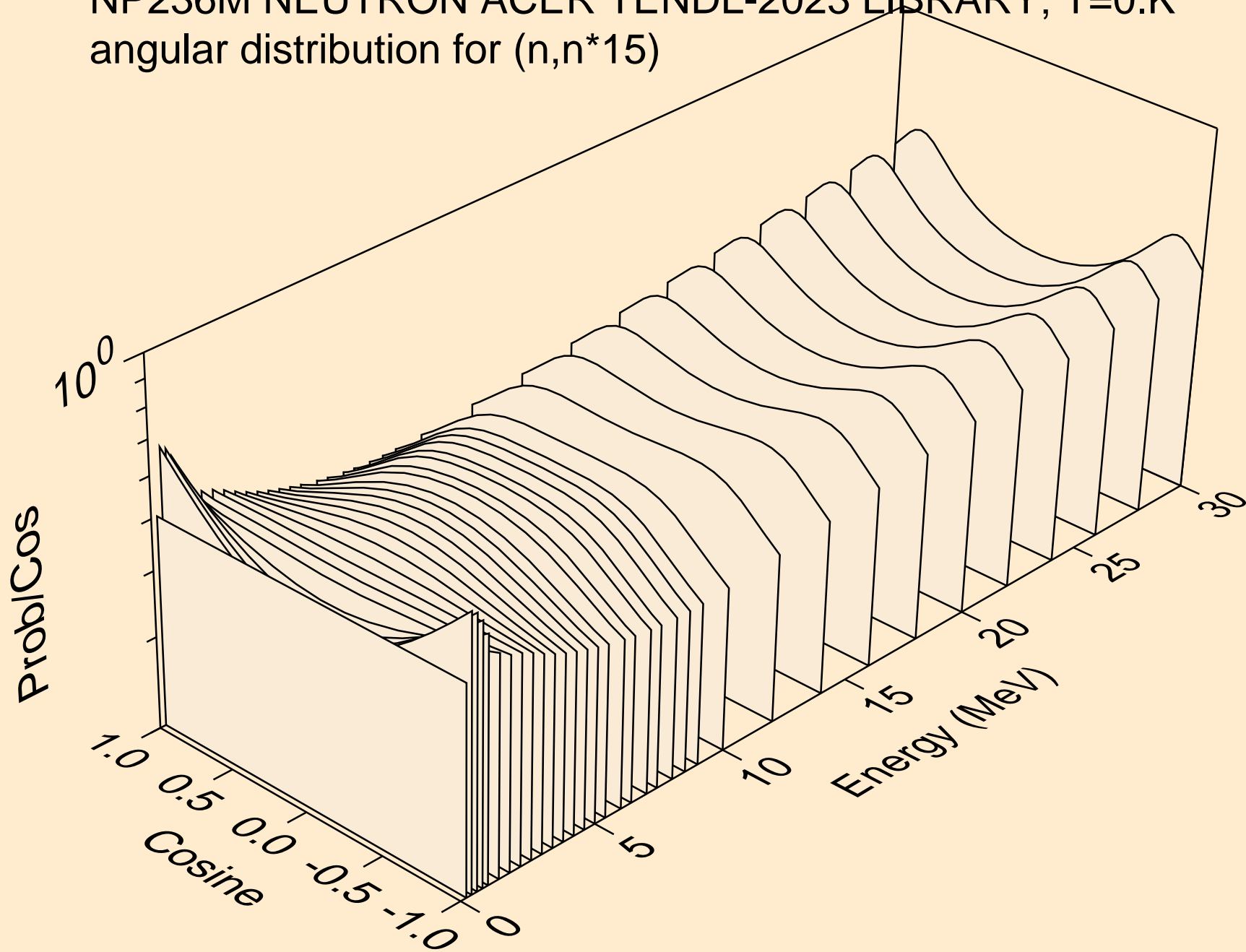

NP236M NEUTRON ACER TENDL-2023 LIBRARY; T=0.K  
angular distribution for (n,n\*16)

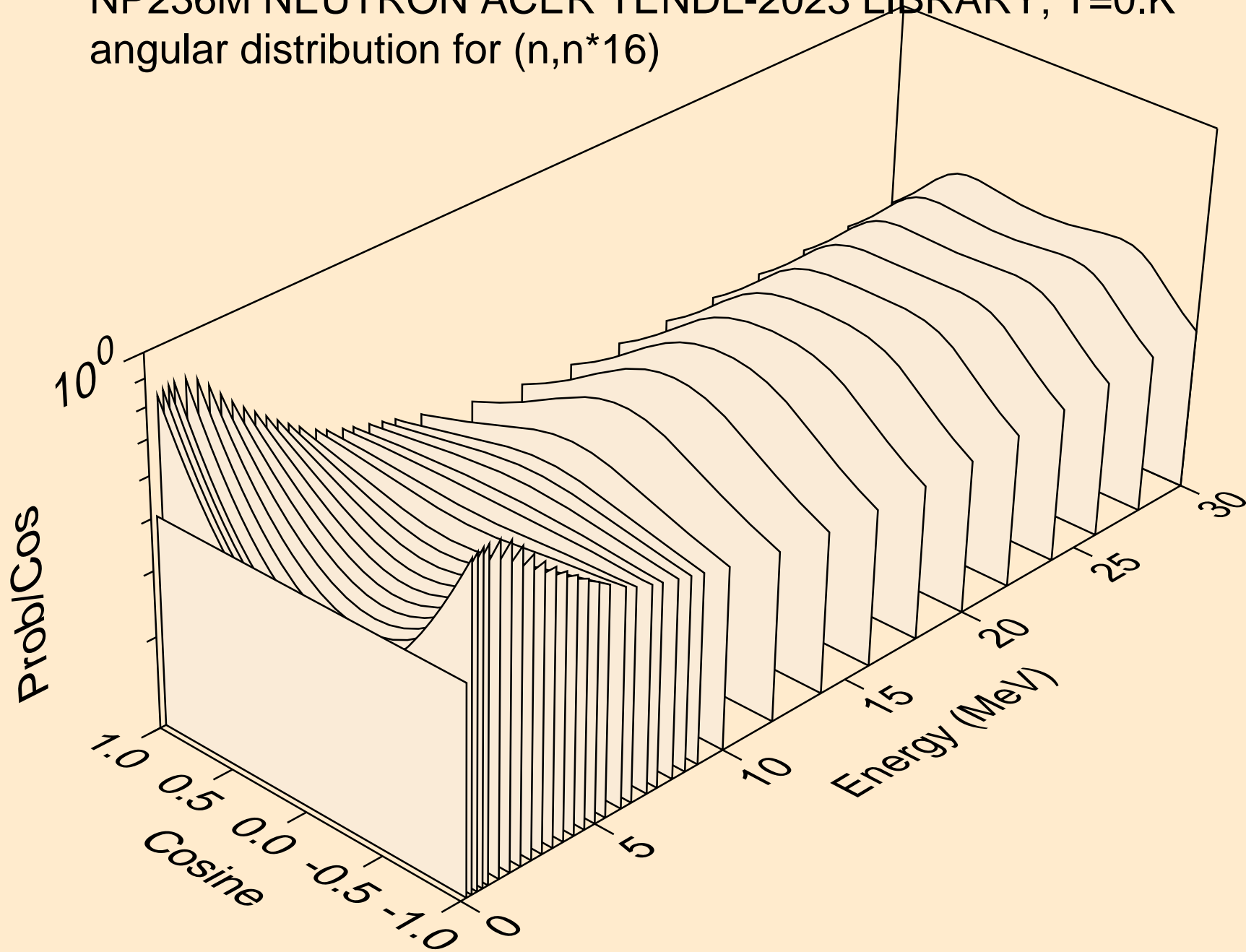

NP236M NEUTRON ACER TENDL-2023 LIBRARY; T=0.K  
angular distribution for (n,n\*17)

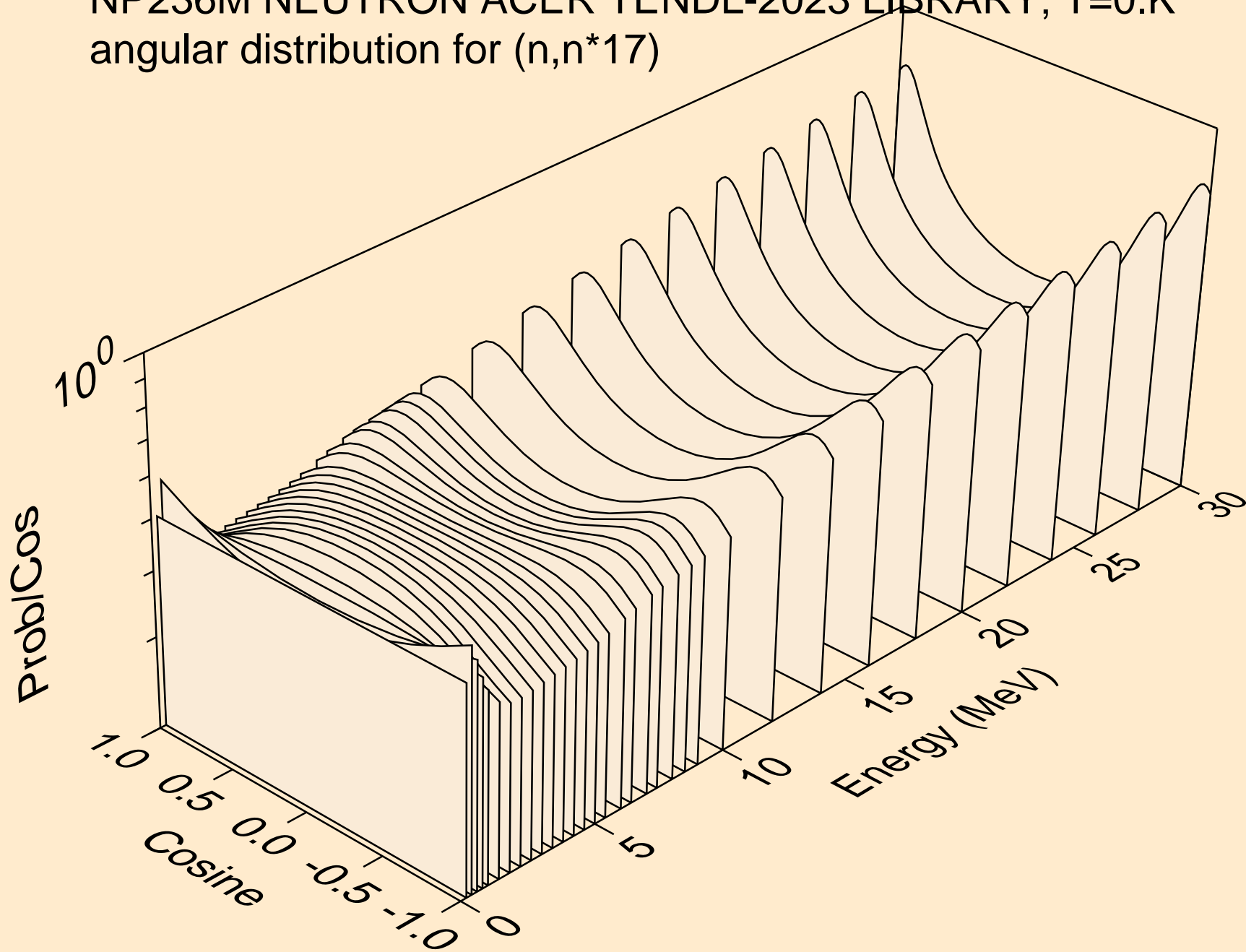

NP236M NEUTRON ACER TENDL-2023 LIBRARY; T=0.K  
angular distribution for (n,n\*18)

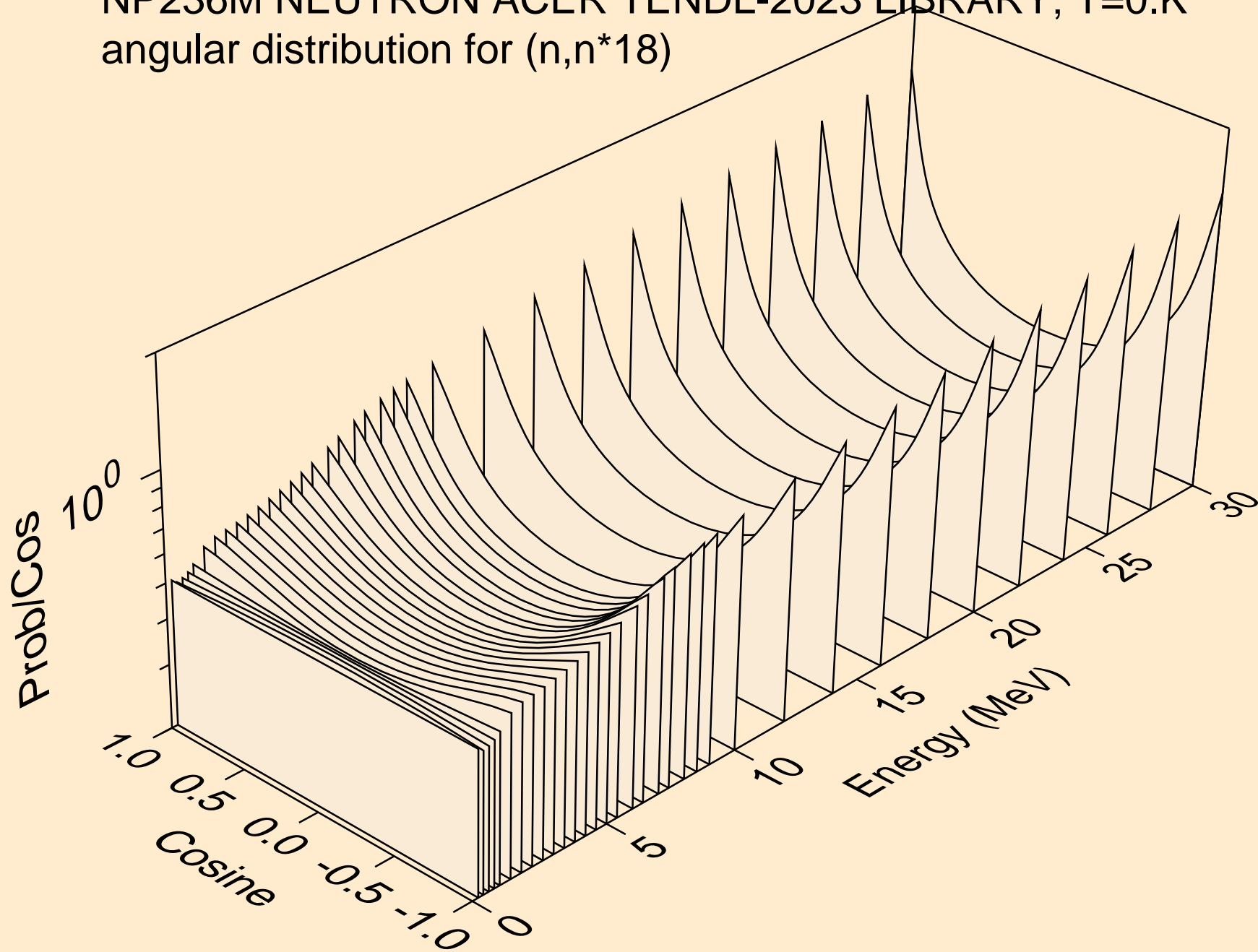

NP236M NEUTRON ACER TENDL-2023 LIBRARY; T=0.K

Total fission nubar

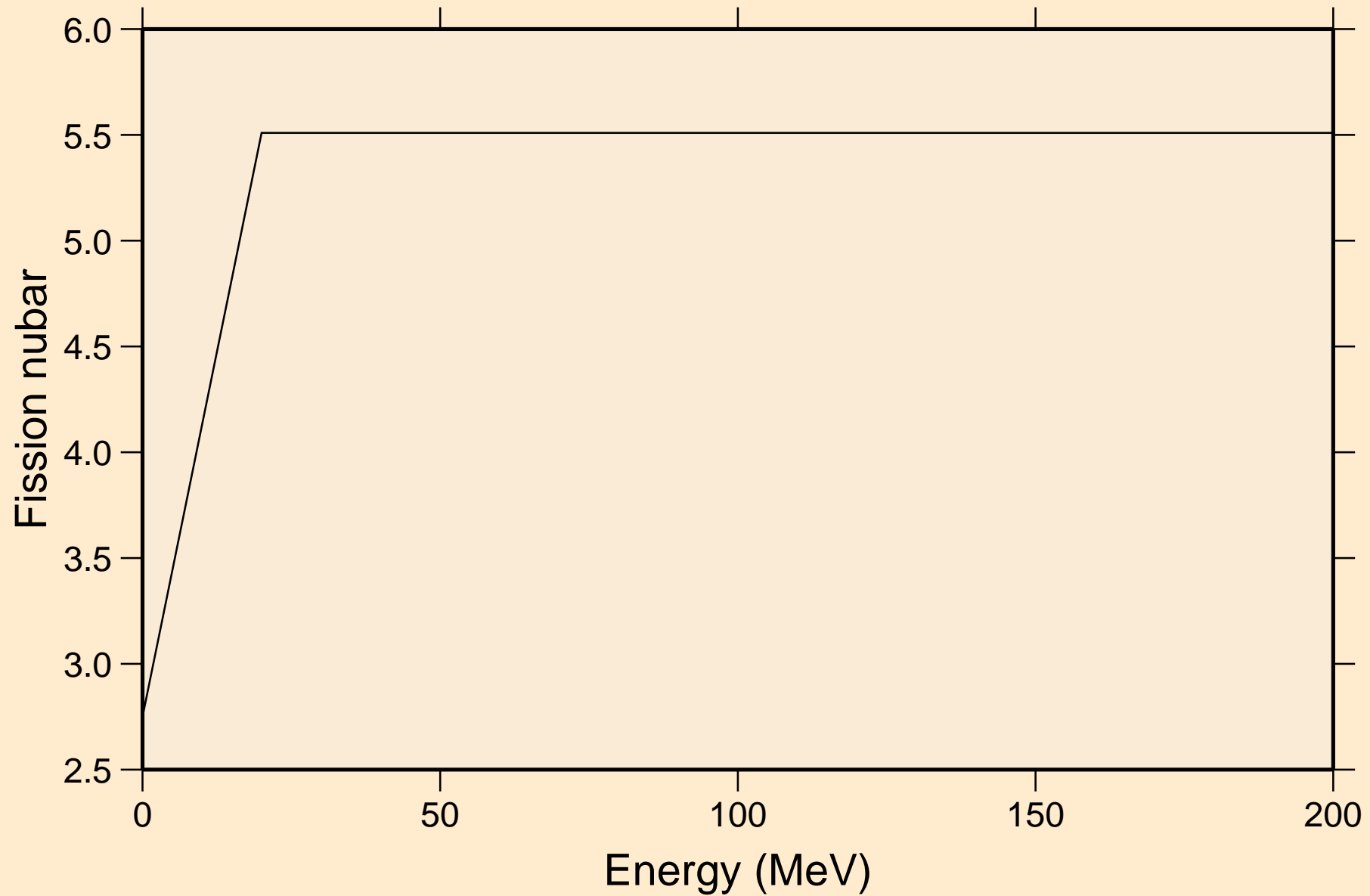



NP236M NEUTRON ACER TENDL-2023 LIBRARY; T=0.K  
Neutron emission for (n,x)

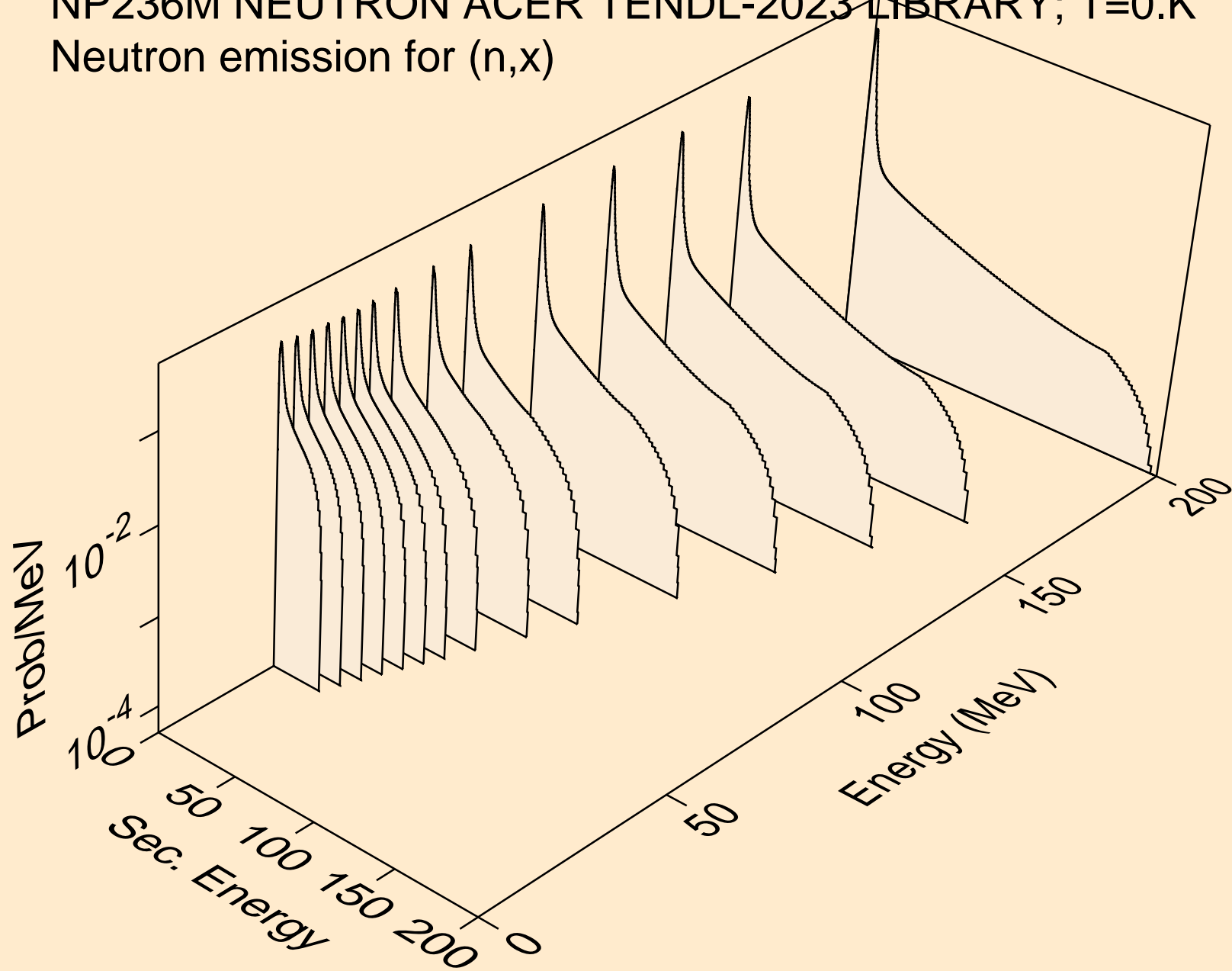

NP236M NEUTRON ACER TENDL-2023 LIBRARY; T=0.K  
Neutron emission for (n,2nd)

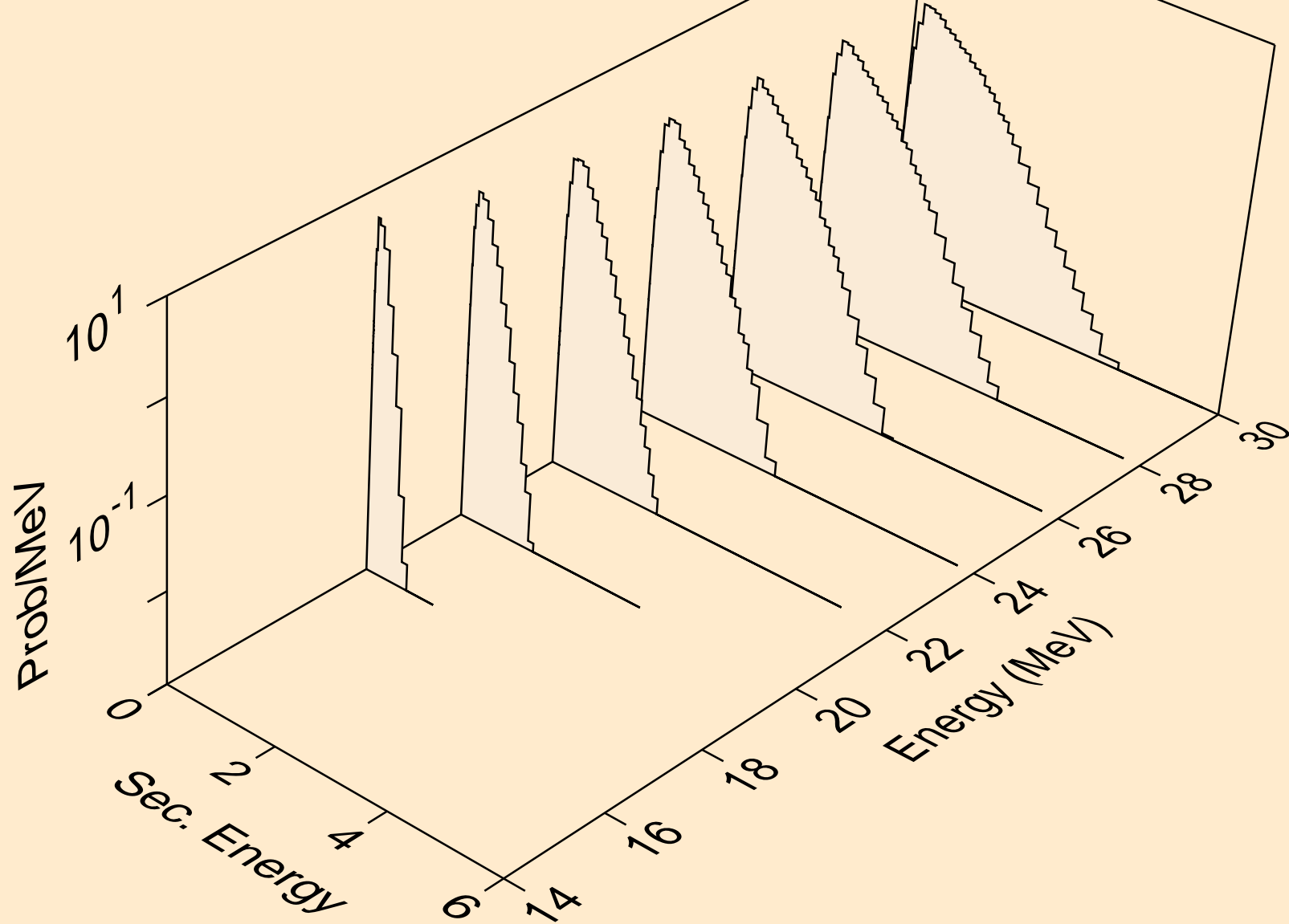

NP236M NEUTRON ACER TENDL-2023 LIBRARY; T=0.K  
Neutron emission for (n,2n)

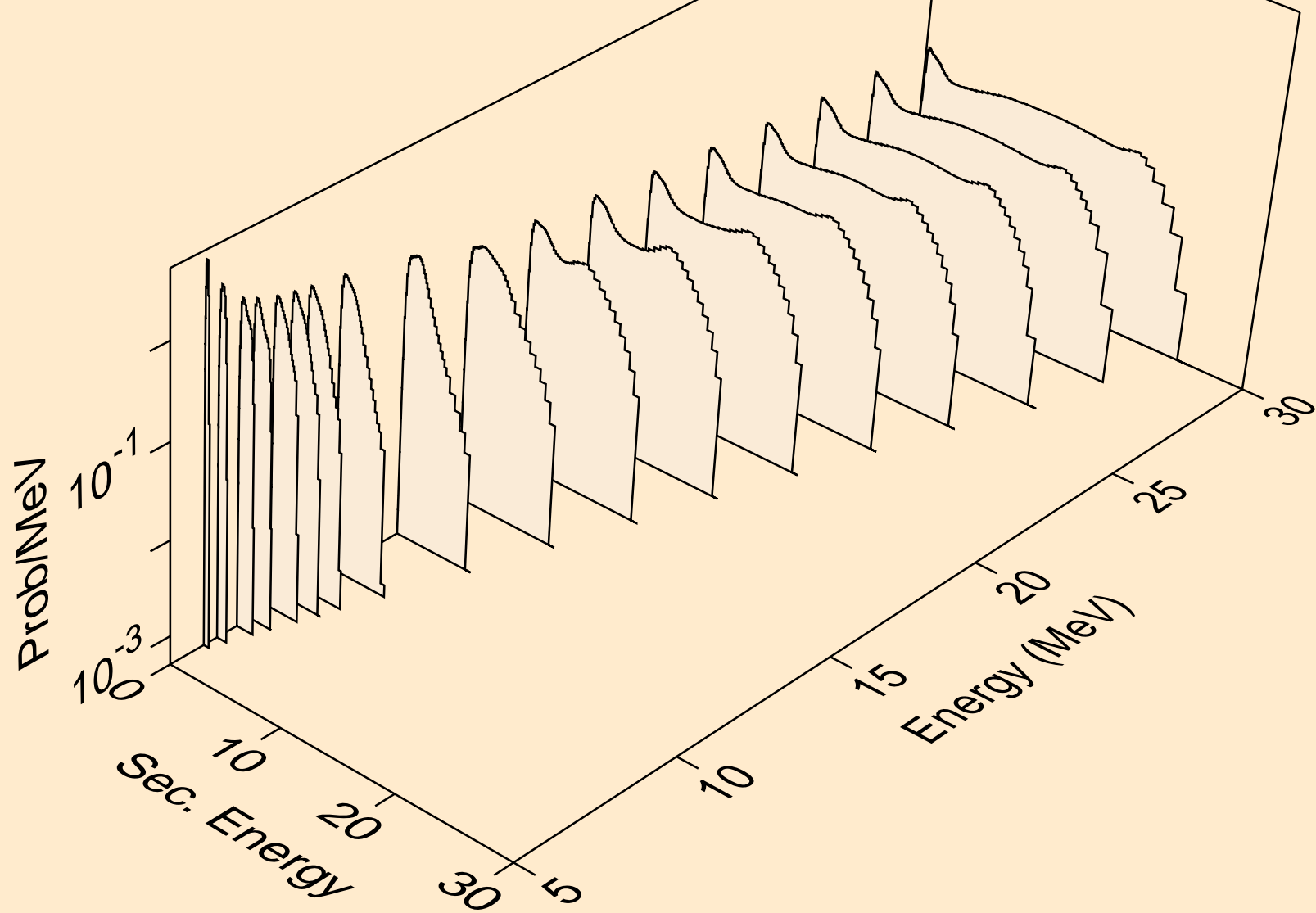

NP236M NEUTRON ACER TENDL-2023 LIBRARY; T=0.K  
Neutron emission for (n,3n)

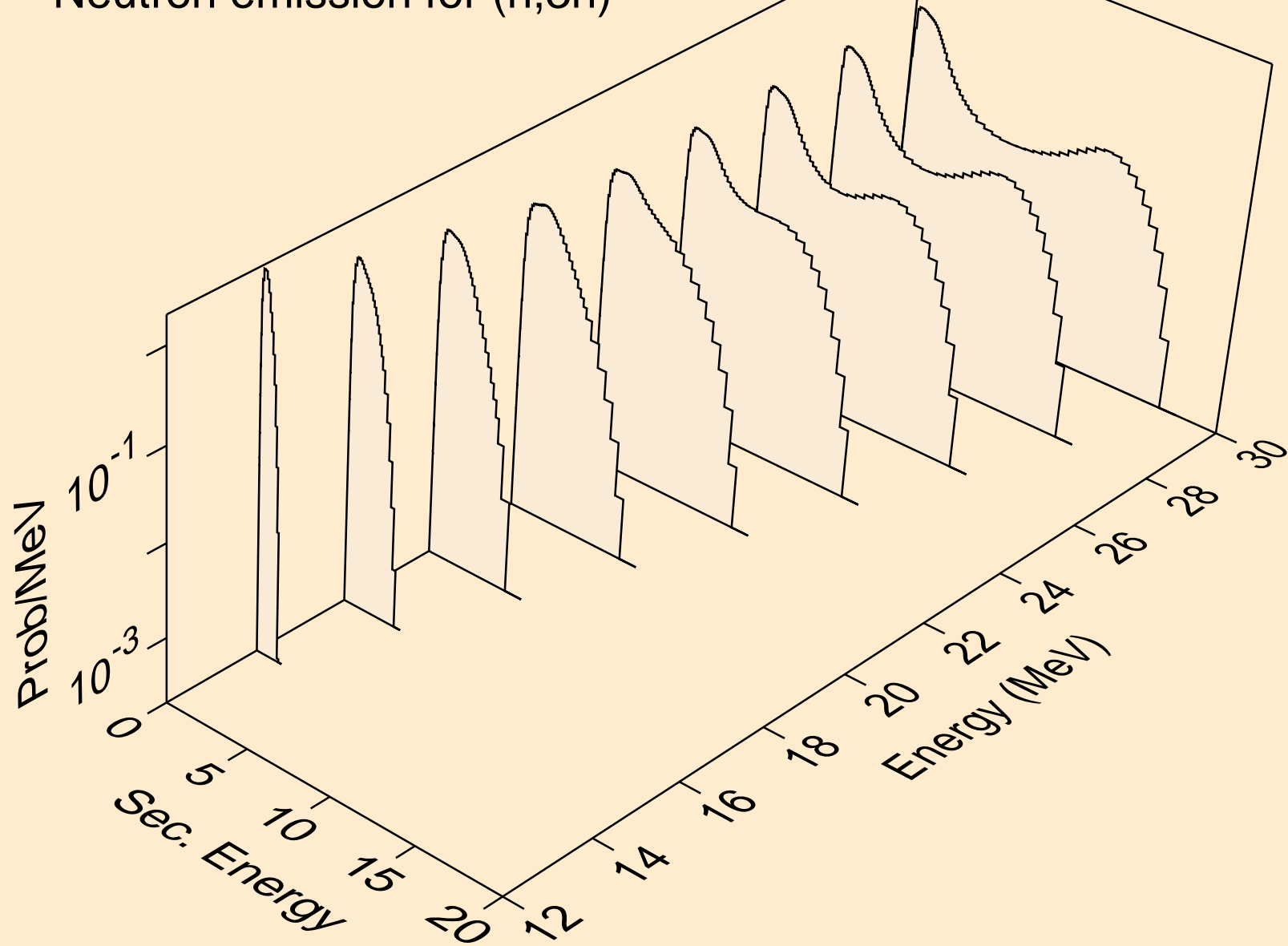

NP236M NEUTRON ACER TENDL-2023 LIBRARY; T=0.K  
Neutron emission for fission

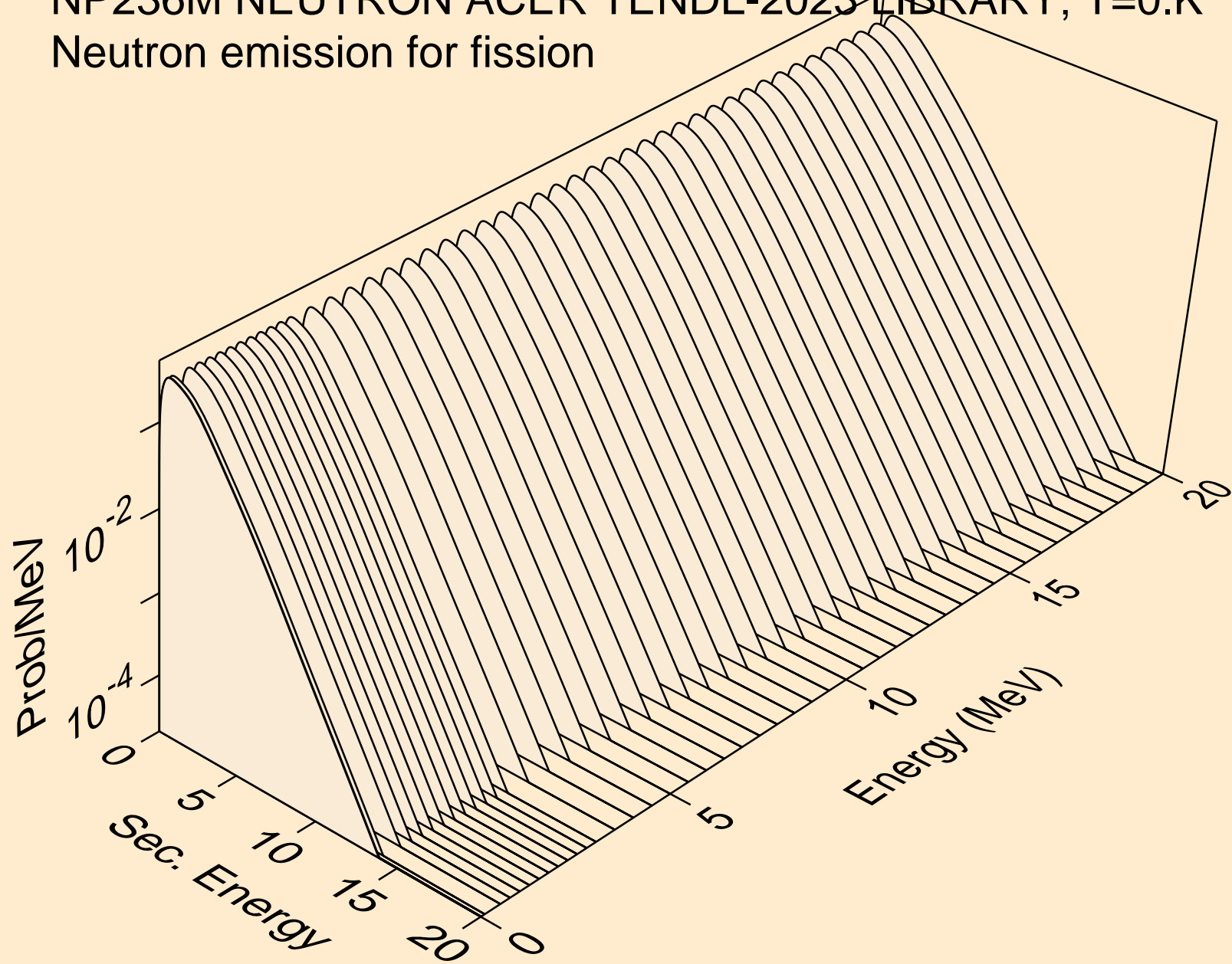

NP236M NEUTRON ACER TENDL-2023 LIBRARY; T=0.K  
Neutron emission for (n,n\*)a

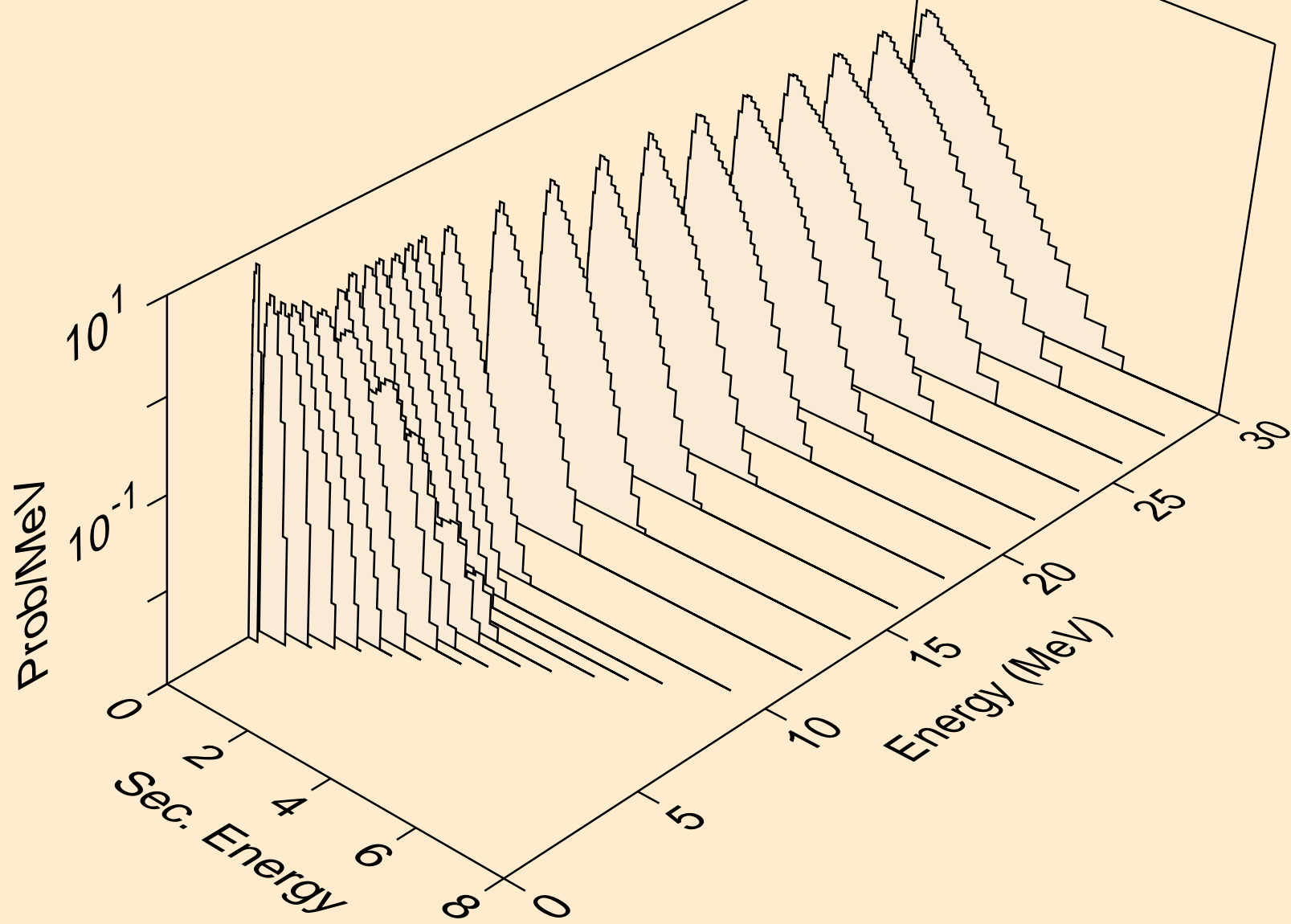

NP236M NEUTRON ACER TENDL-2023 LIBRARY; T=0.K  
Neutron emission for (n,2n)a

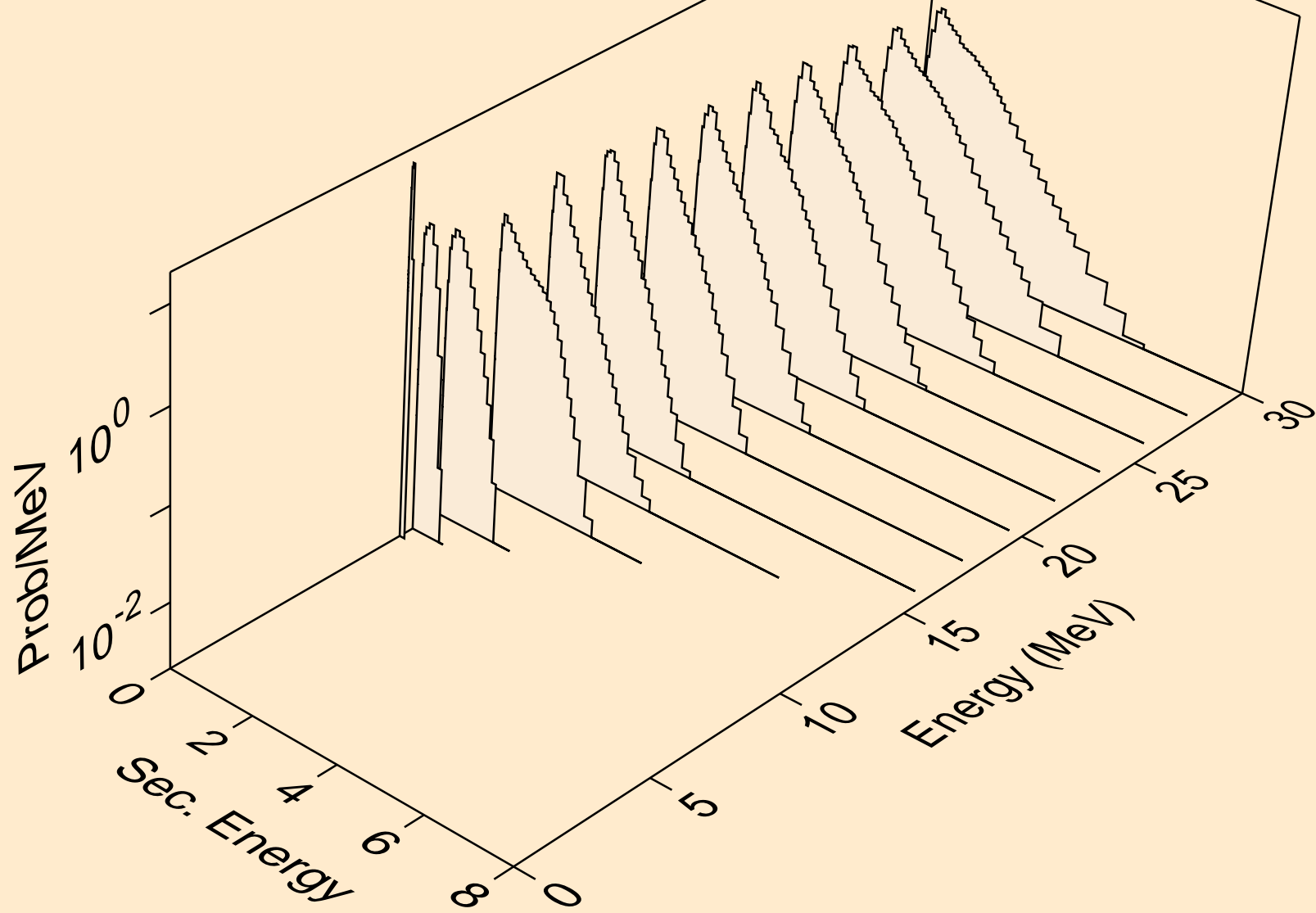

NP236M NEUTRON ACER TENDL-2023 LIBRARY; T=0.K  
Neutron emission for (n,3n)a

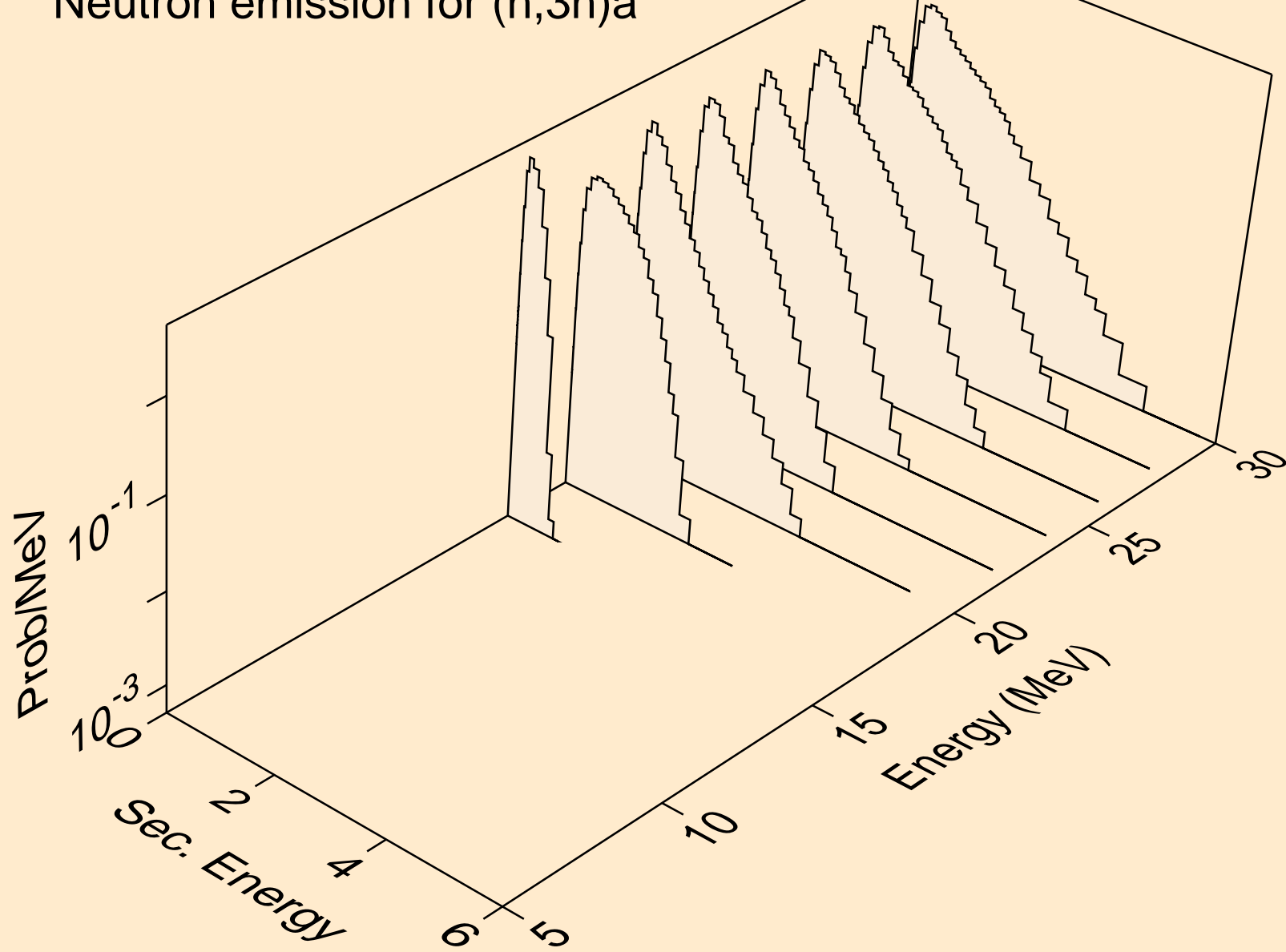



NP236M NEUTRON ACER TENDL-2023 LIBRARY; T=0.K  
Neutron emission for (n,n\*)p

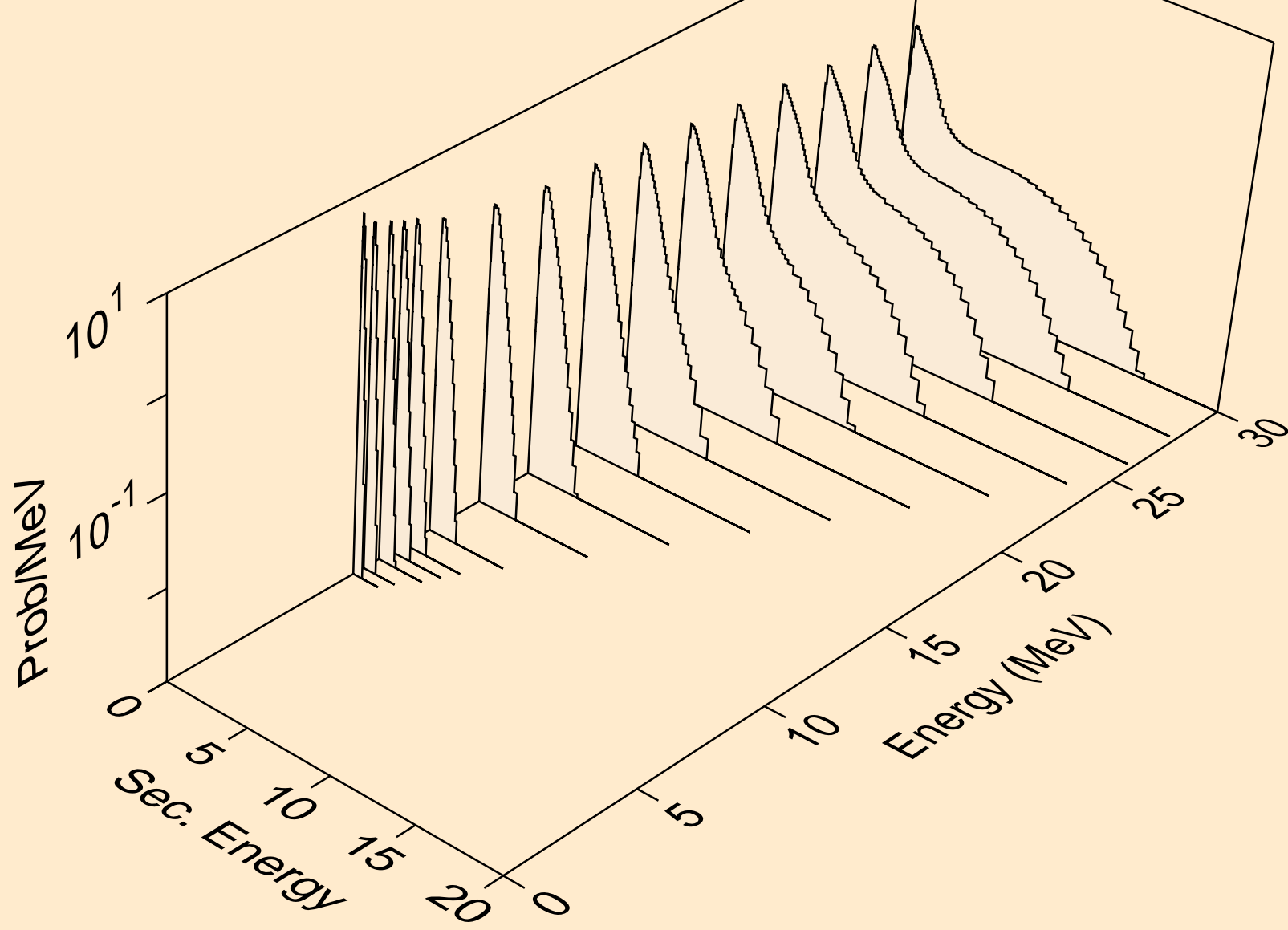

NP236M NEUTRON ACER TENDL-2023 LIBRARY; T=0.K  
Neutron emission for (n,n\*)2a

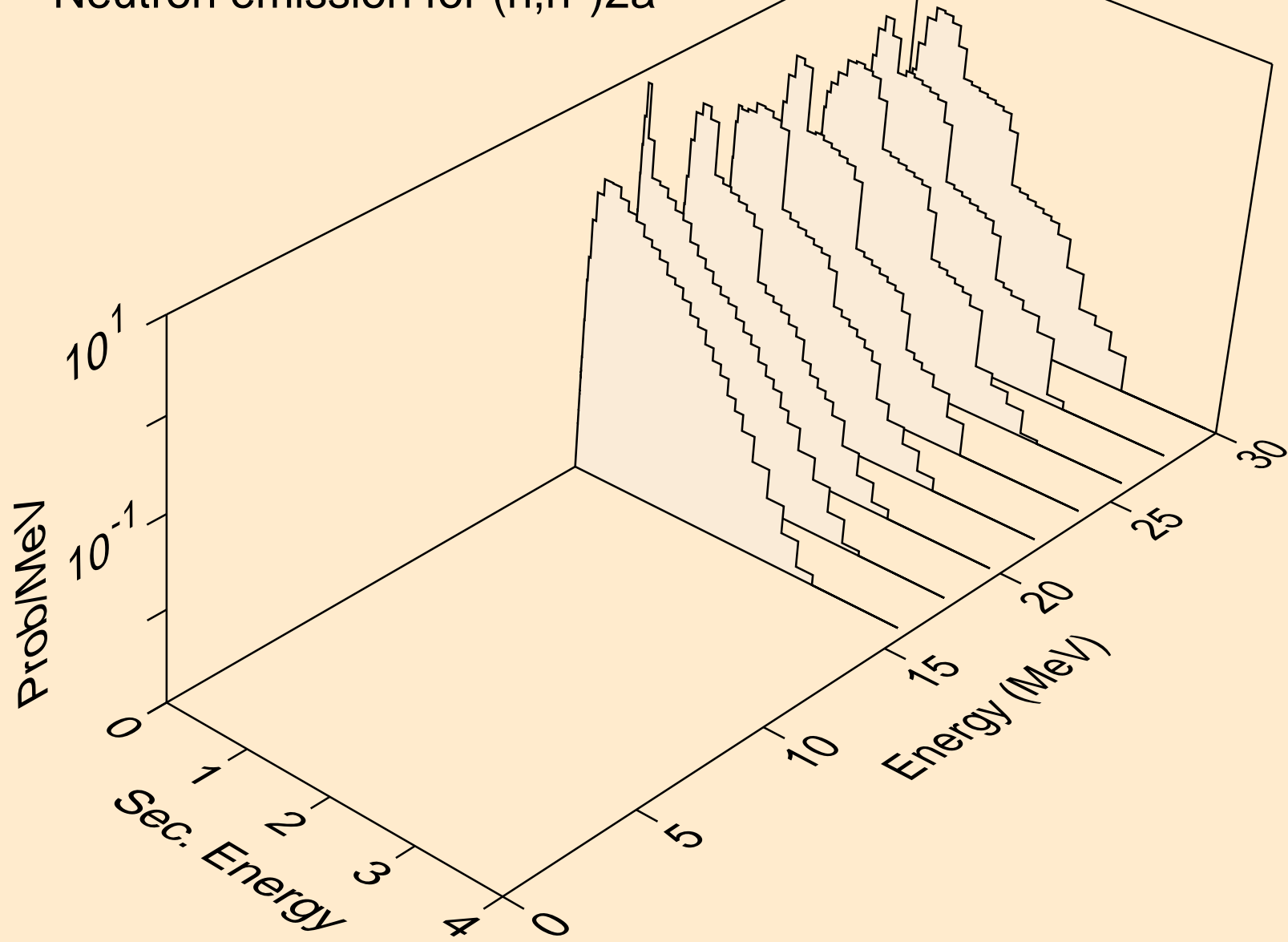

NP236M NEUTRON ACER TENDL-2023 LIBRARY; T=0.K  
Neutron emission for (n,n\*)d

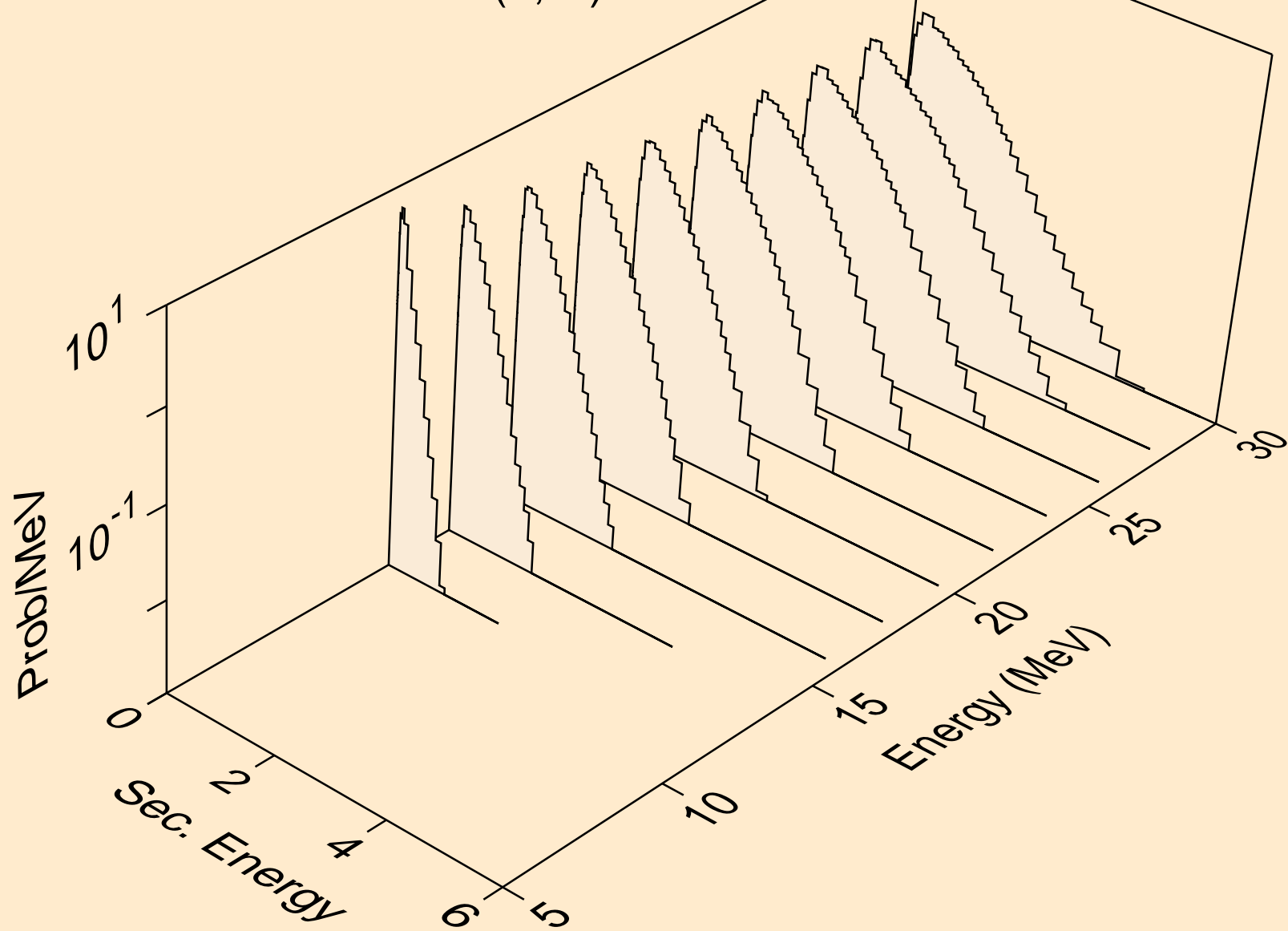

NP236M NEUTRON ACER TENDL-2023 LIBRARY; T=0.K  
Neutron emission for (n,n\*)t

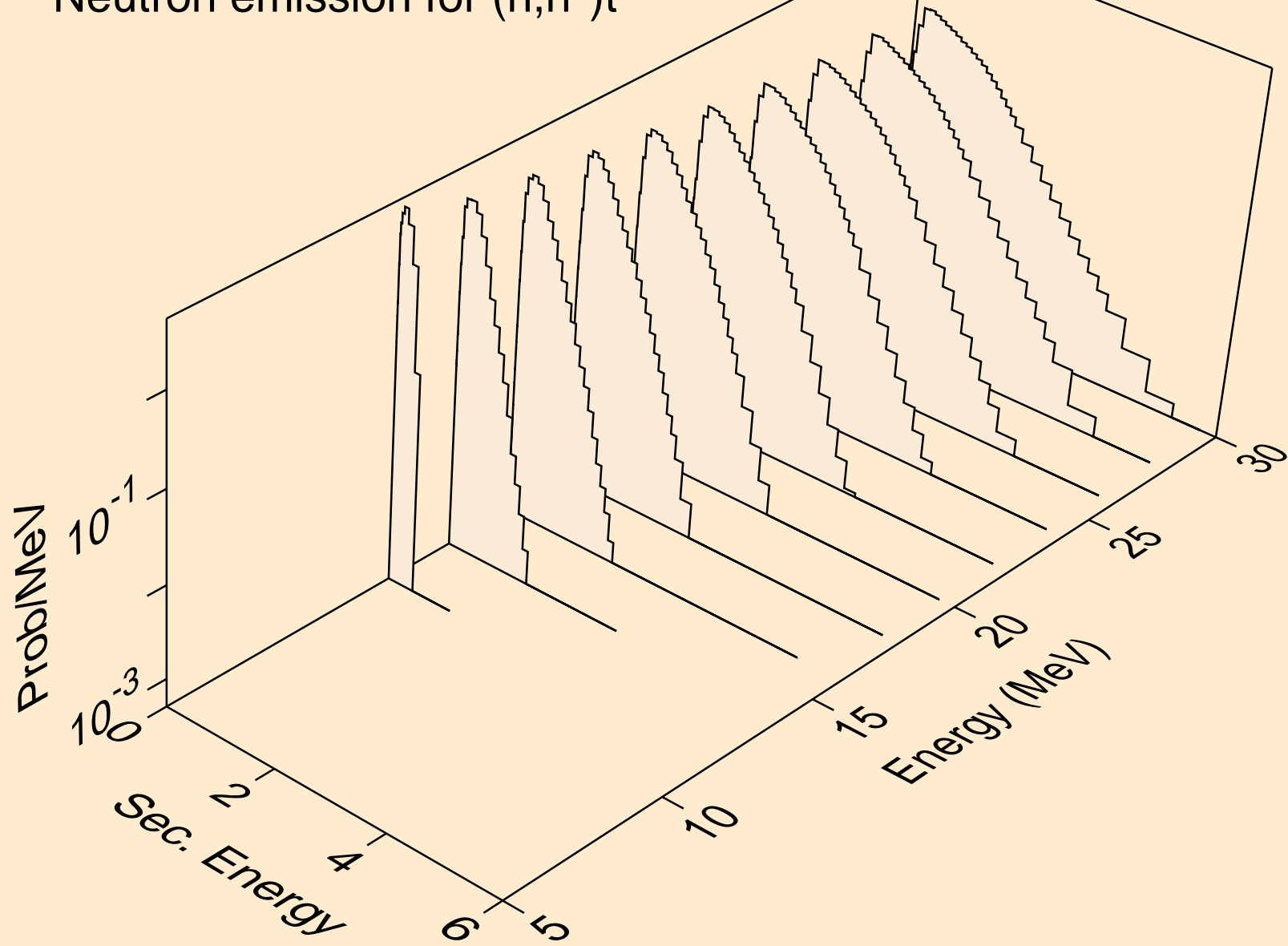

NP236M NEUTRON ACER TENDL-2023 LIBRARY; T=0.K  
Neutron emission for (n,n\*)he3

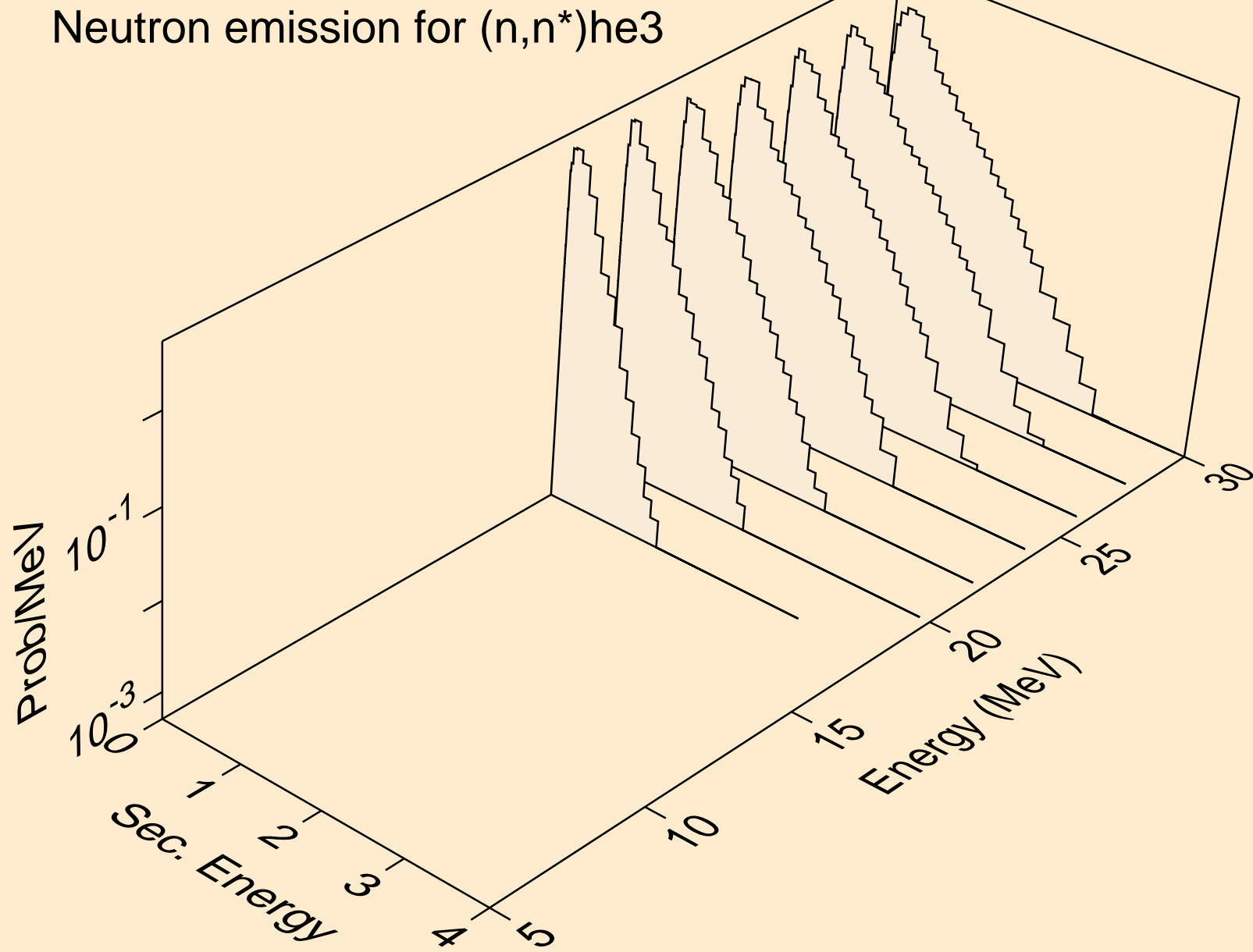

NP236M NEUTRON ACER TENDL-2023 LIBRARY; T=0.K  
Neutron emission for (n,4n)

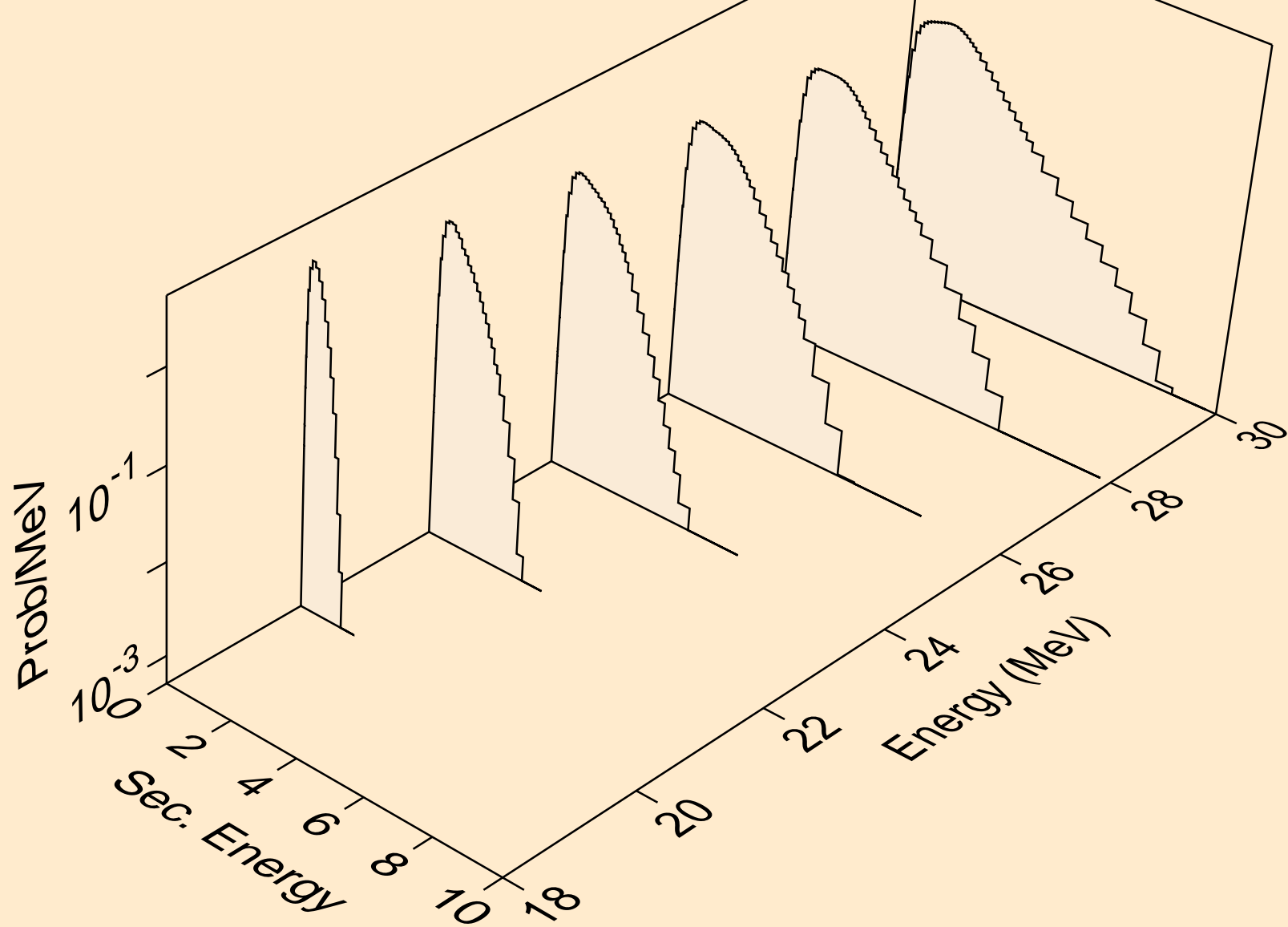

NP236M NEUTRON ACER TENDL-2023 LIBRARY; T=0.K  
Neutron emission for (n,2np)

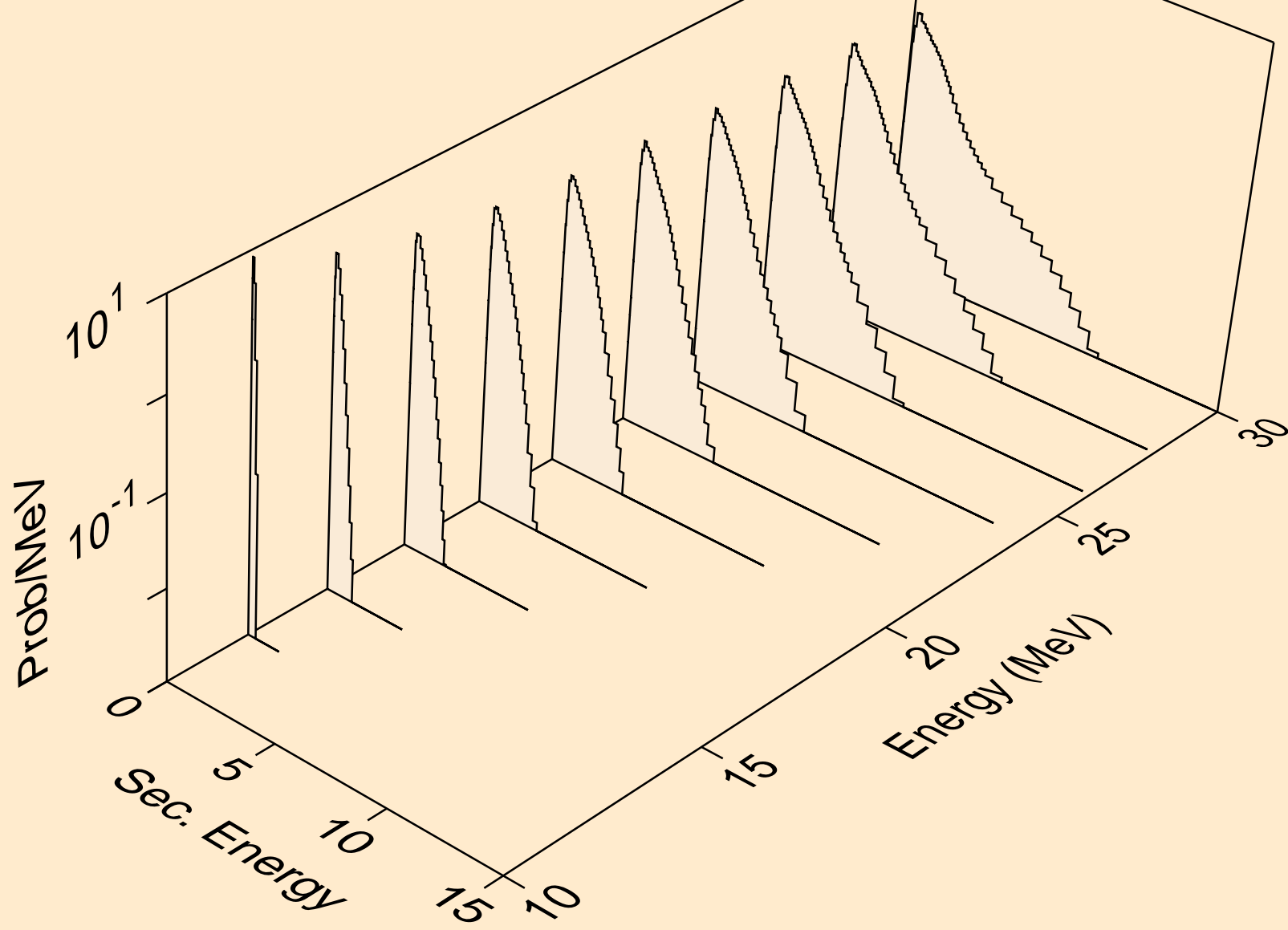

NP236M NEUTRON ACER TENDL-2023 LIBRARY; T=0.K  
Neutron emission for (n,3np)

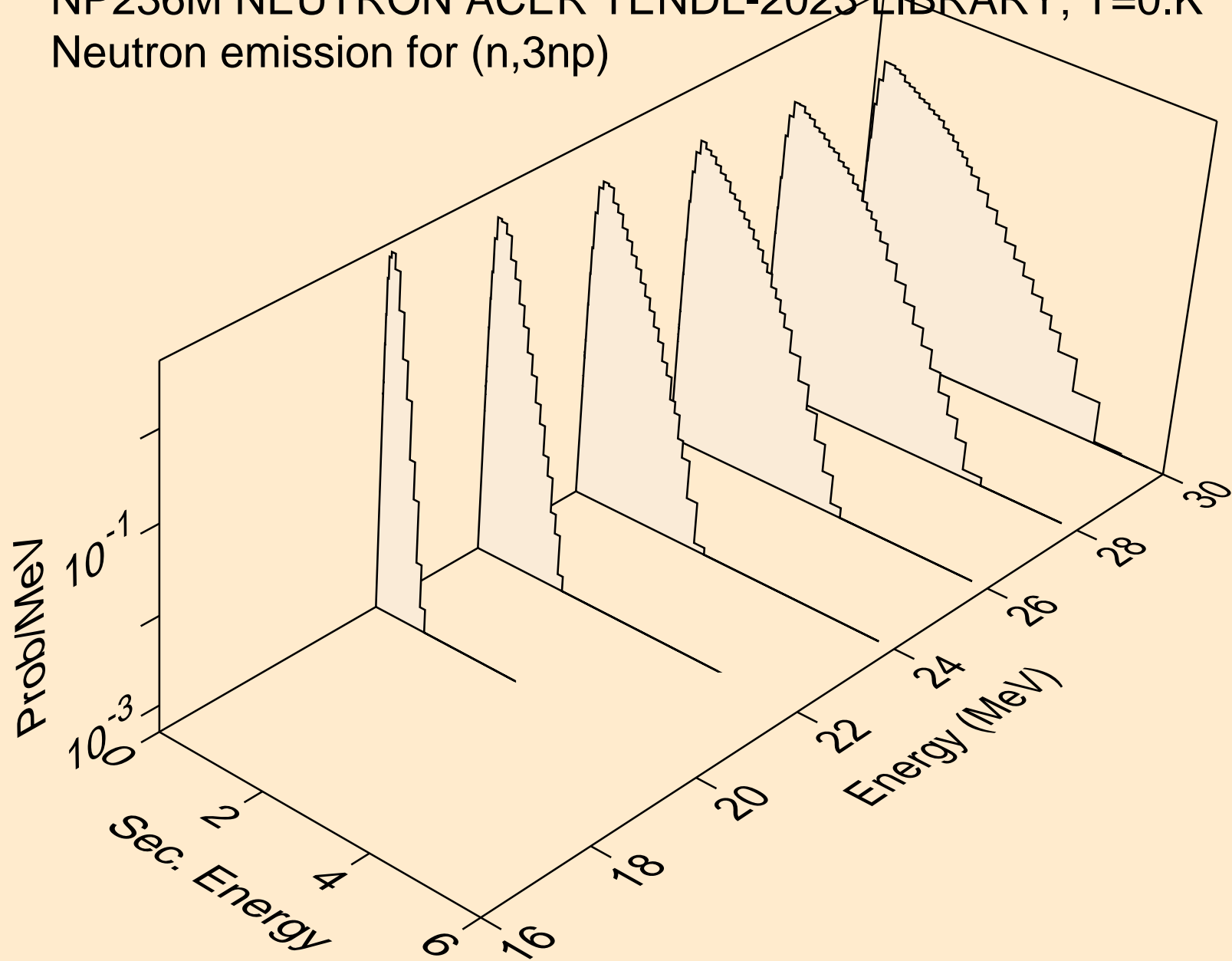



NP236M NEUTRON ACER TENDL-2023 LIBRARY; T=0.K  
Neutron emission for (n,n2p)

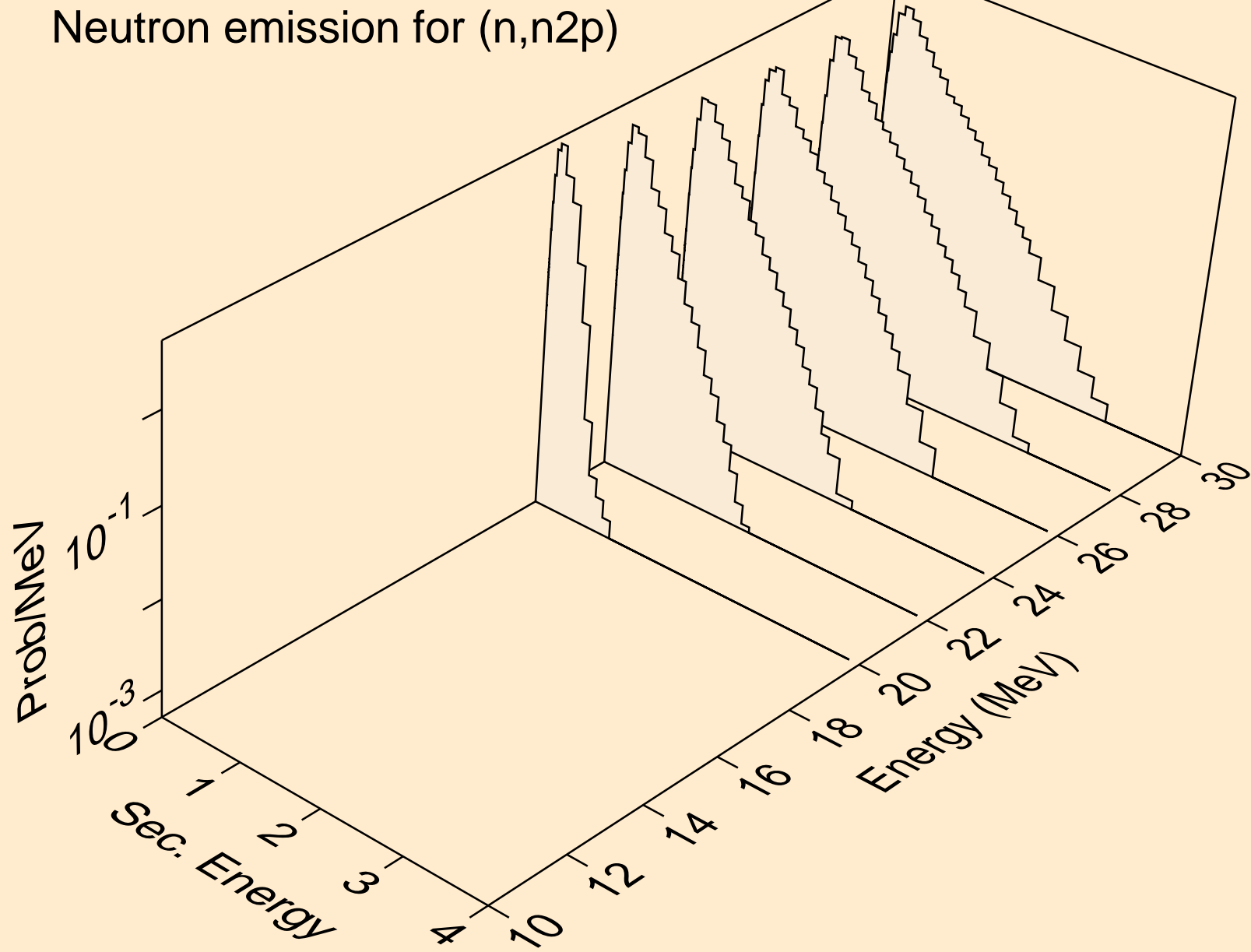

NP236M NEUTRON ACER TENDL-2023 LIBRARY; T=0.K  
Neutron emission for (n,npa)

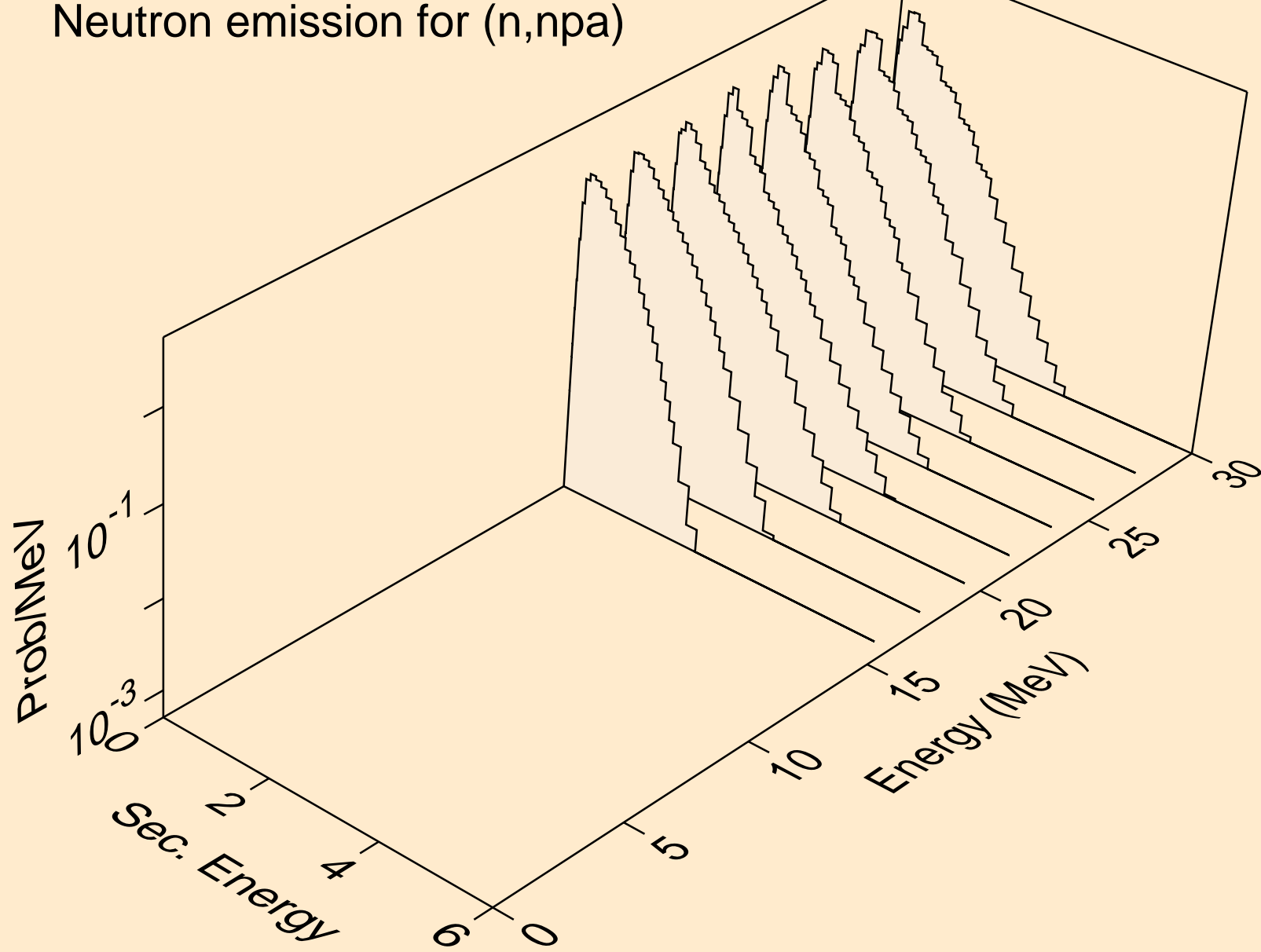

NP236M NEUTRON ACER TENDL-2023 LIBRARY; T=0.K  
Neutron emission for (n,n\*c)

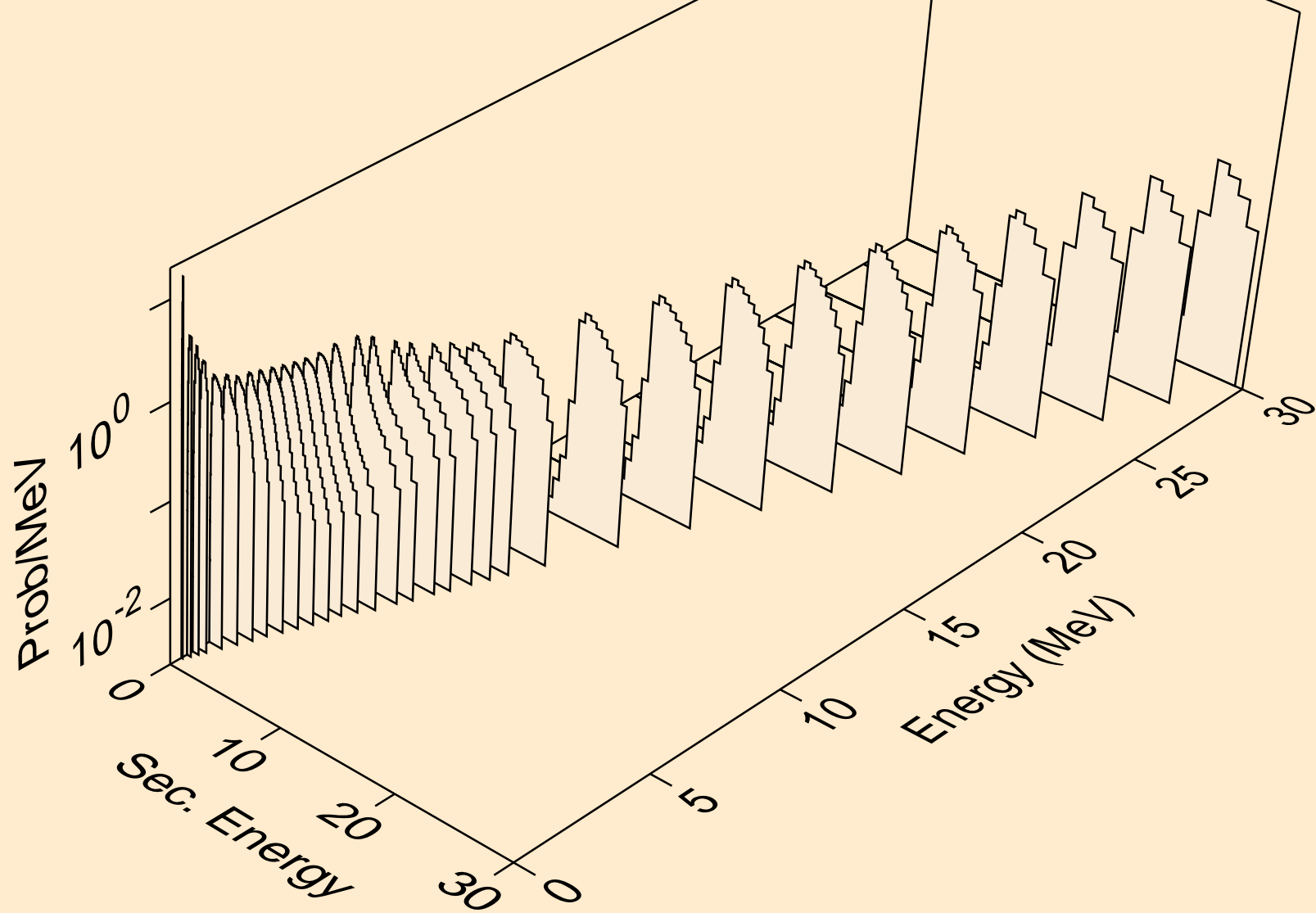

# NP236M NEUTRON ACER TENDL-2023 LIBRARY; T=0.K

Delayed nubar

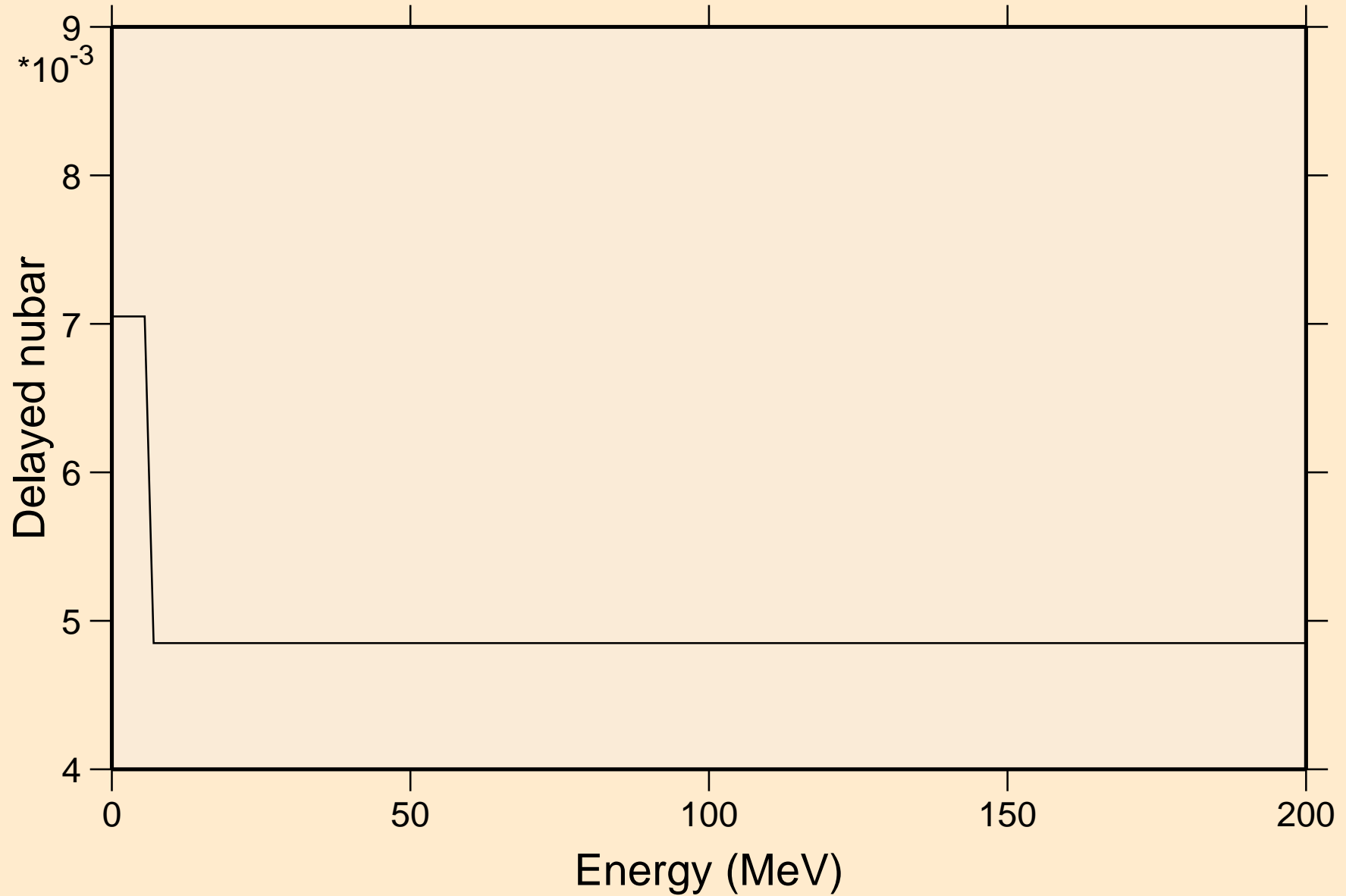

# NP236M NEUTRON ACER TENDL-2023 LIBRARY; T=0.K

## Delayed neutron spectra

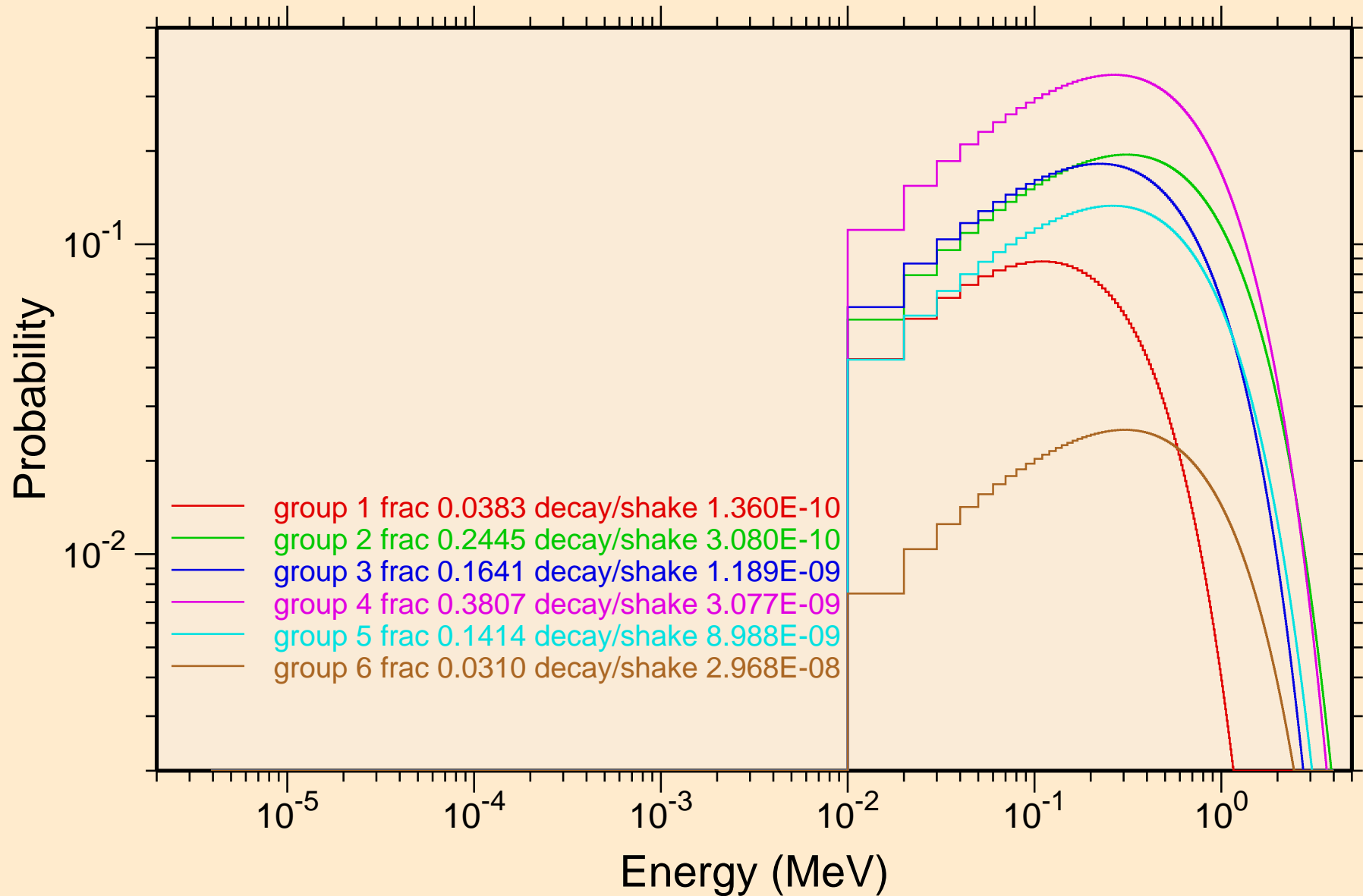

NP236M NEUTRON ACER TENDL-2023 LIBRARY; T=0.K  
Photon emission for (n,x)

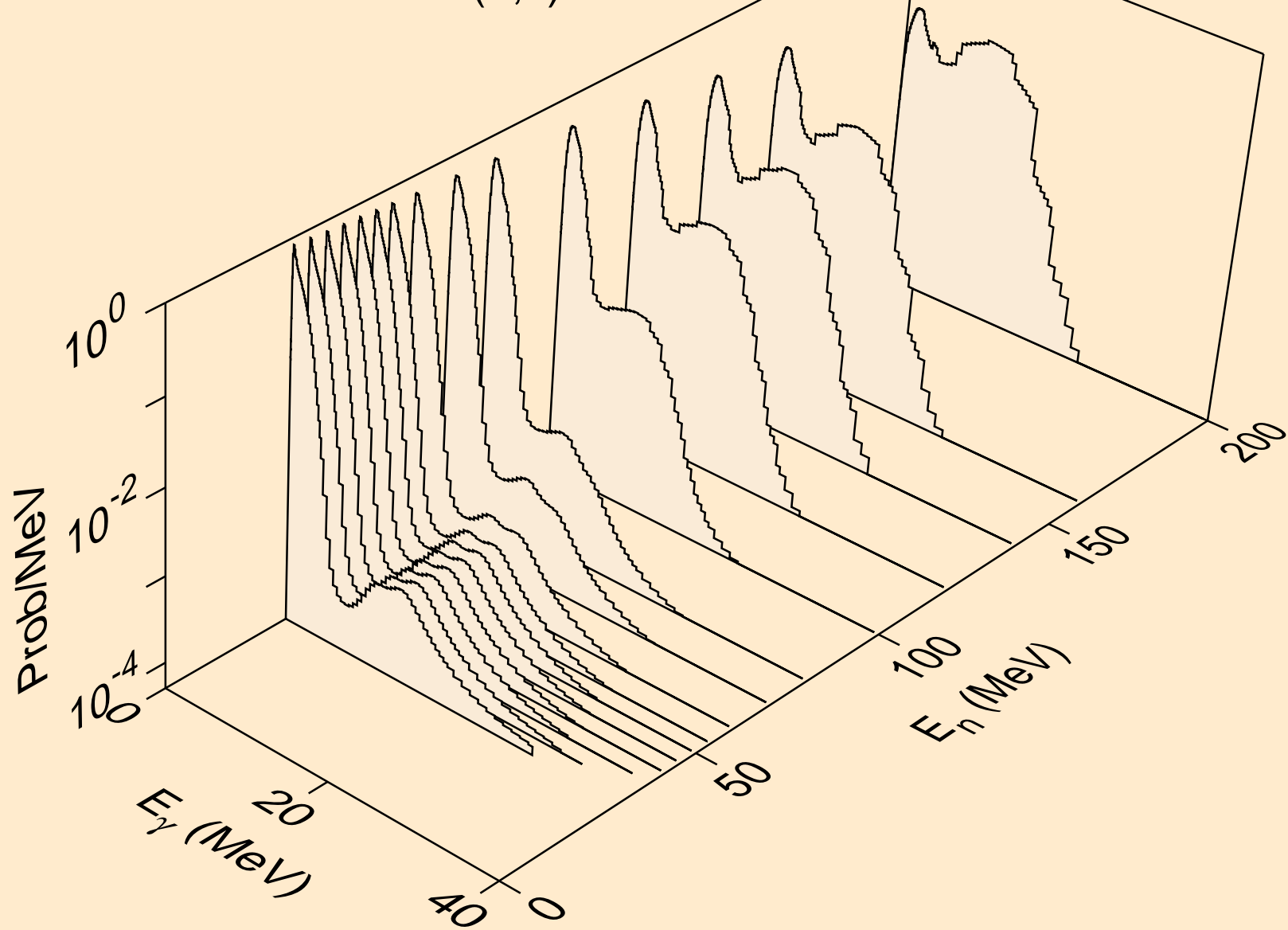

NP236M NEUTRON ACER TENDL-2023 LIBRARY; T=0.K  
Photon emission for (n,2nd)

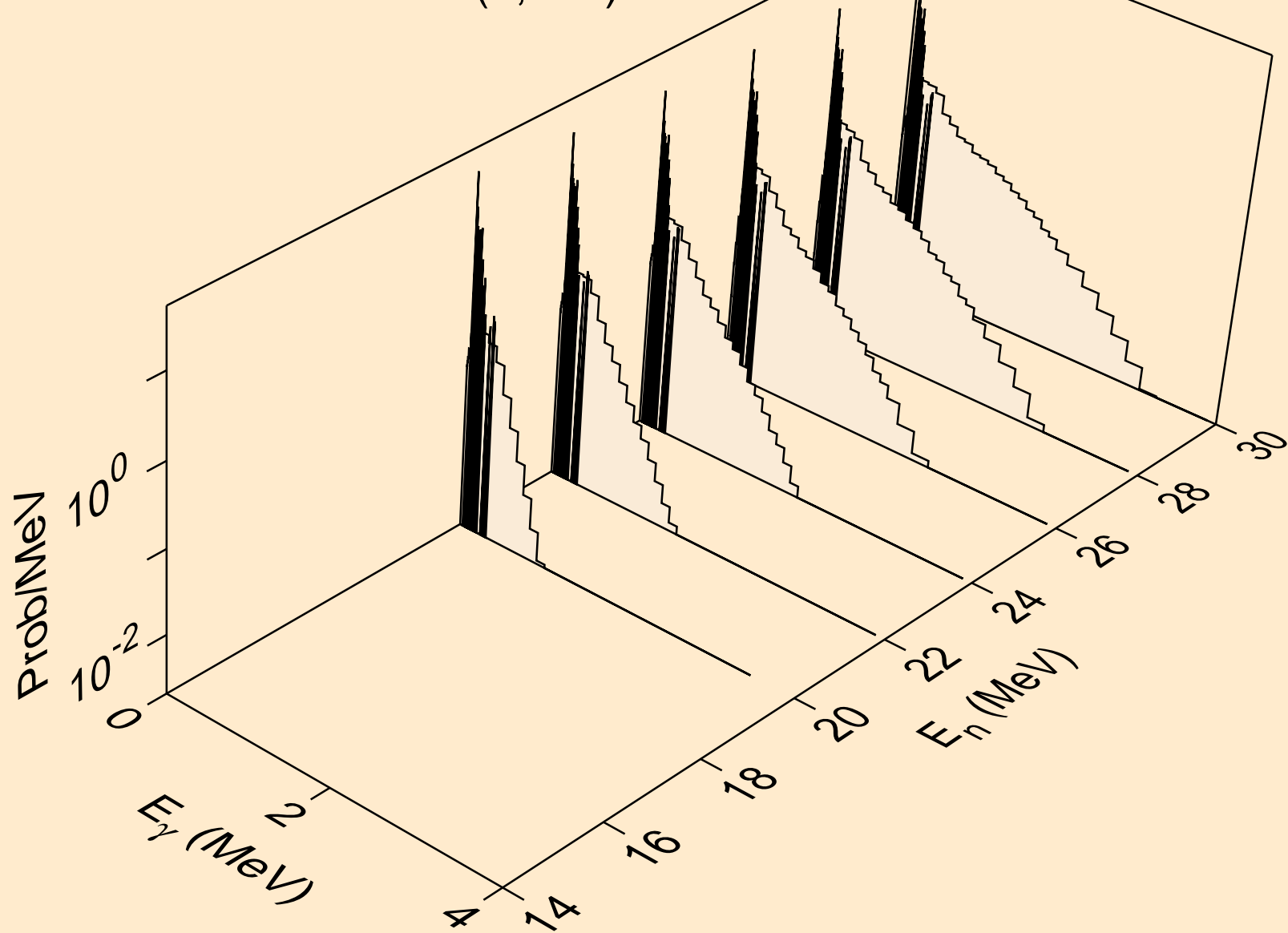

NP236M NEUTRON ACER TENDL-2023 LIBRARY; T=0.K  
Photon emission for (n,2n)

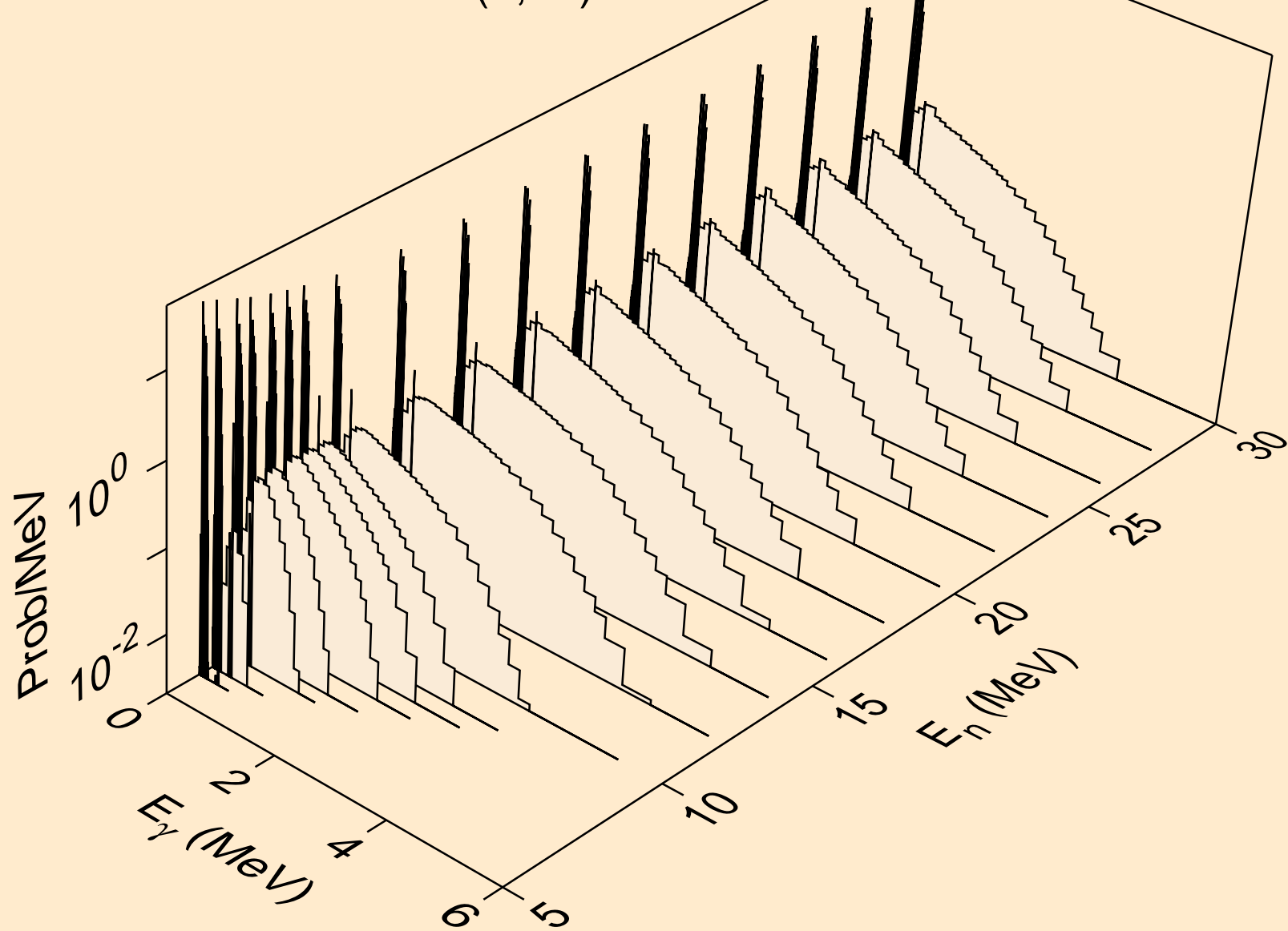



NP236M NEUTRON ACER TENDL-2023 LIBRARY; T=0.K  
Photon emission for (n,3n)

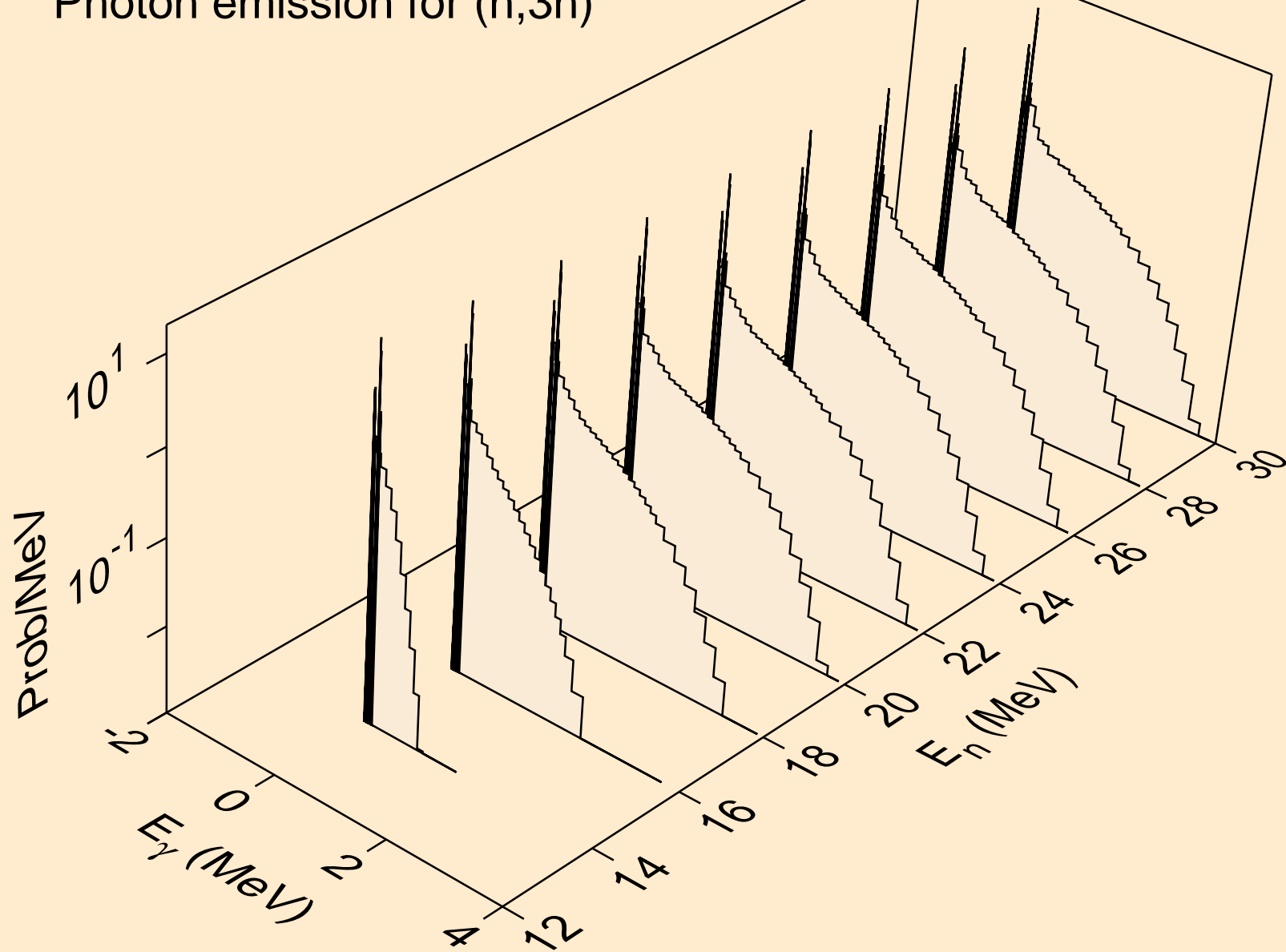

NP236M NEUTRON ACER TENDL-2023 LIBRARY; T=0.K  
Photon emission for (n,n\*)a

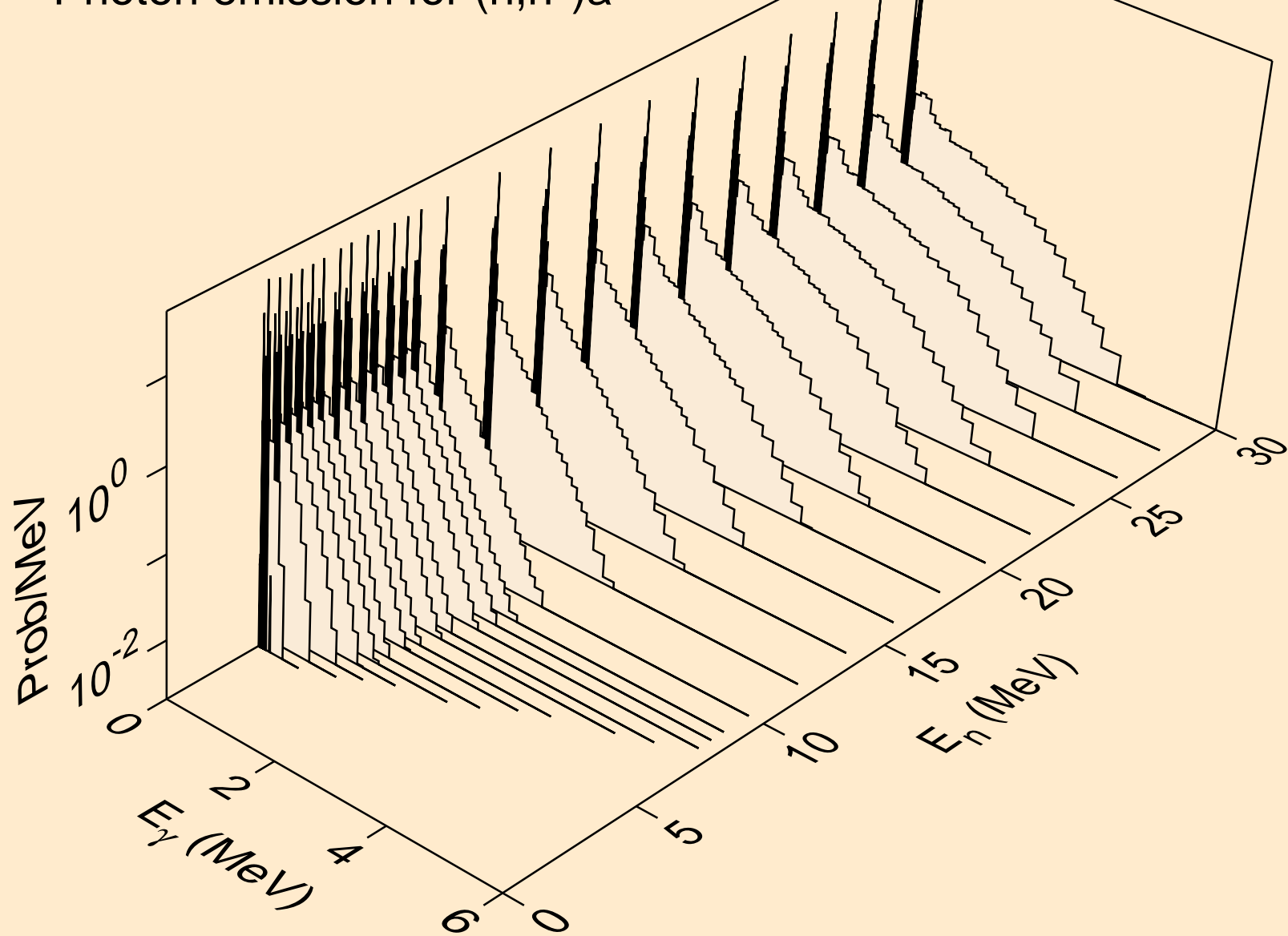

NP236M NEUTRON ACER TENDL-2023 LIBRARY; T=0.K  
Photon emission for (n,2n)a

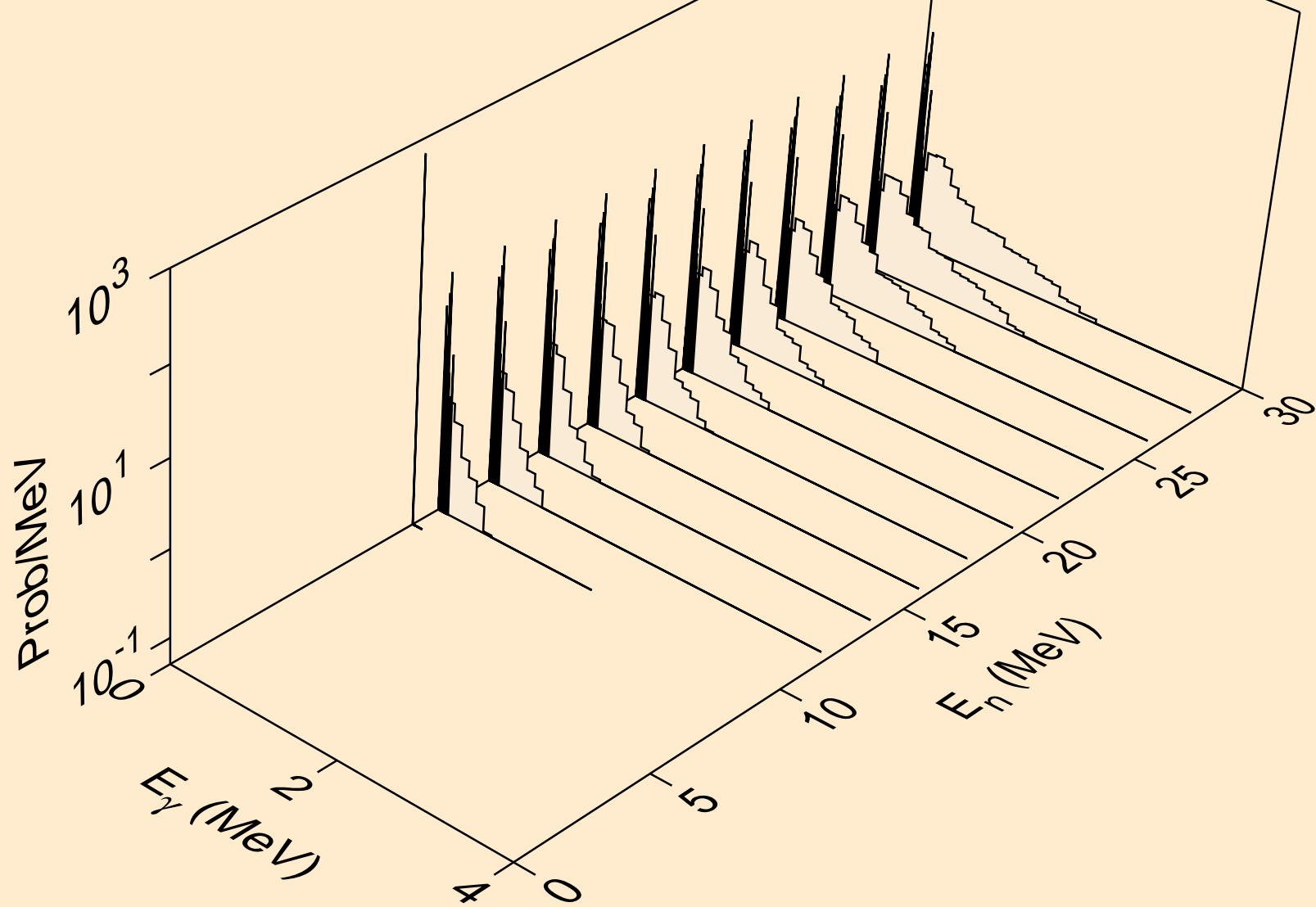

NP236M NEUTRON ACER TENDL-2023 LIBRARY; T=0.K  
Photon emission for (n,3n)a

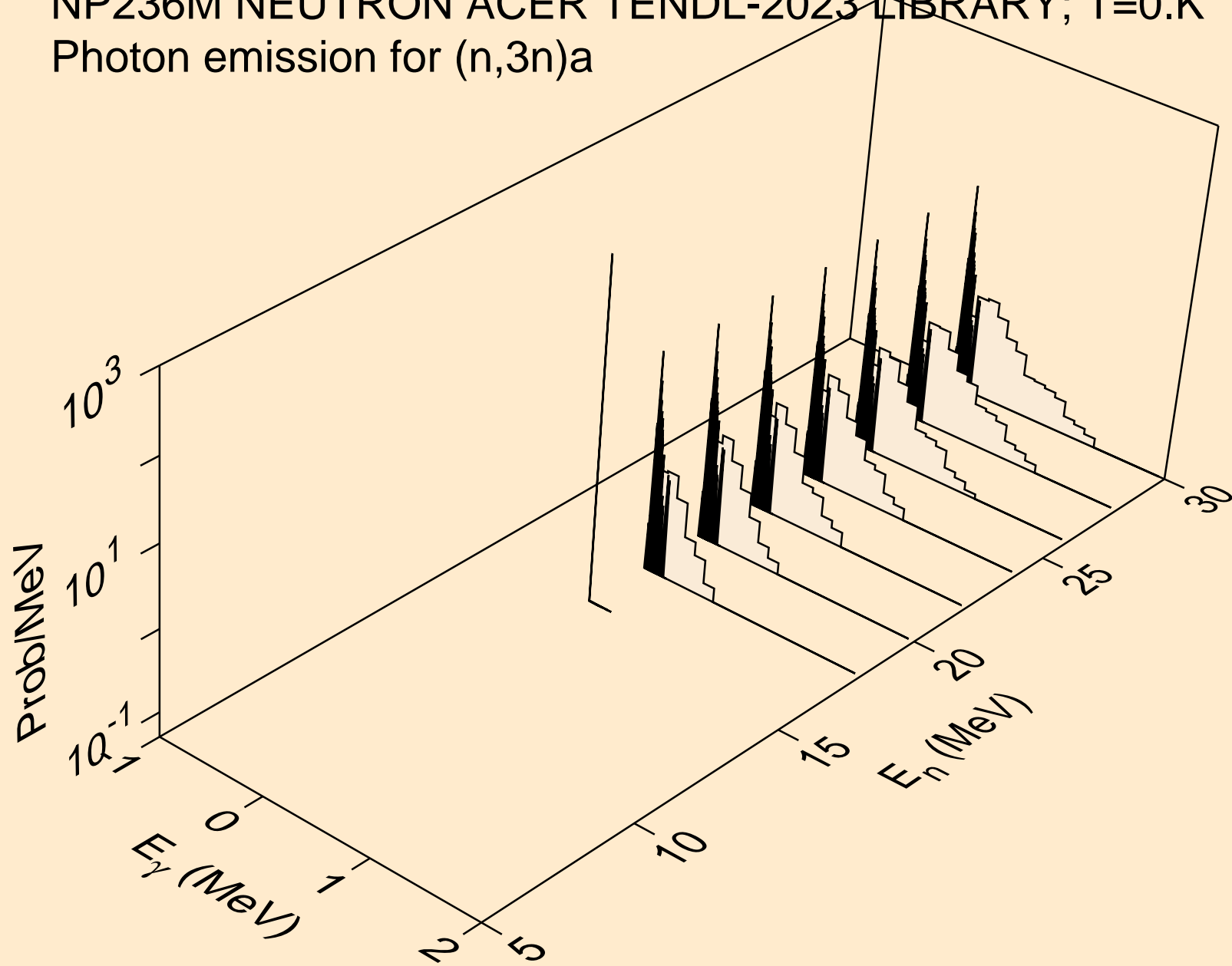

NP236M NEUTRON ACER TENDL-2023 LIBRARY; T=0.K  
Photon emission for (n,n\*)p

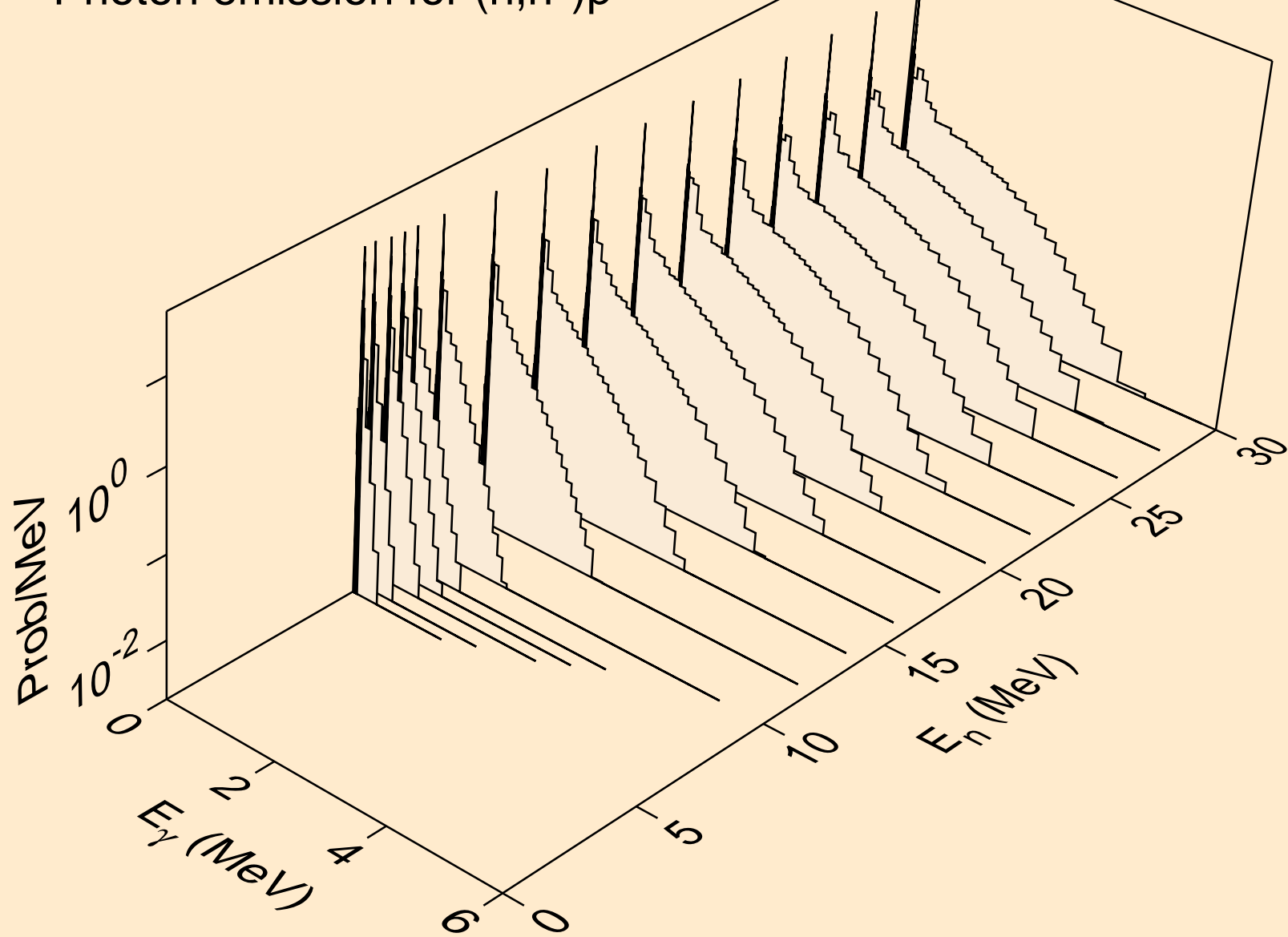

NP236M NEUTRON ACER TENDL-2023 LIBRARY; T=0.K  
Photon emission for (n,n\*)2a

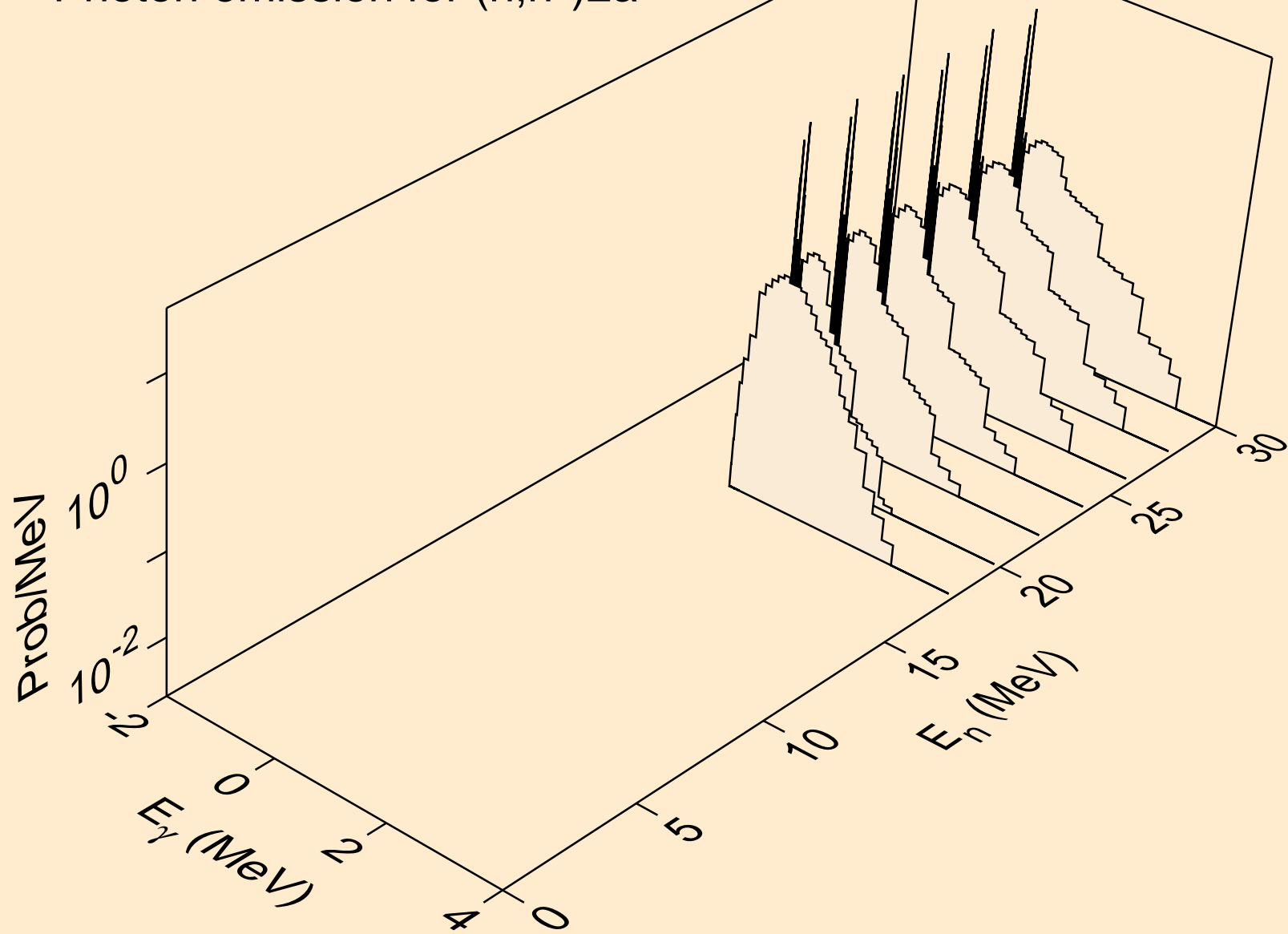

NP236M NEUTRON ACER TENDL-2023 LIBRARY; T=0.K  
Photon emission for (n,n\*)d

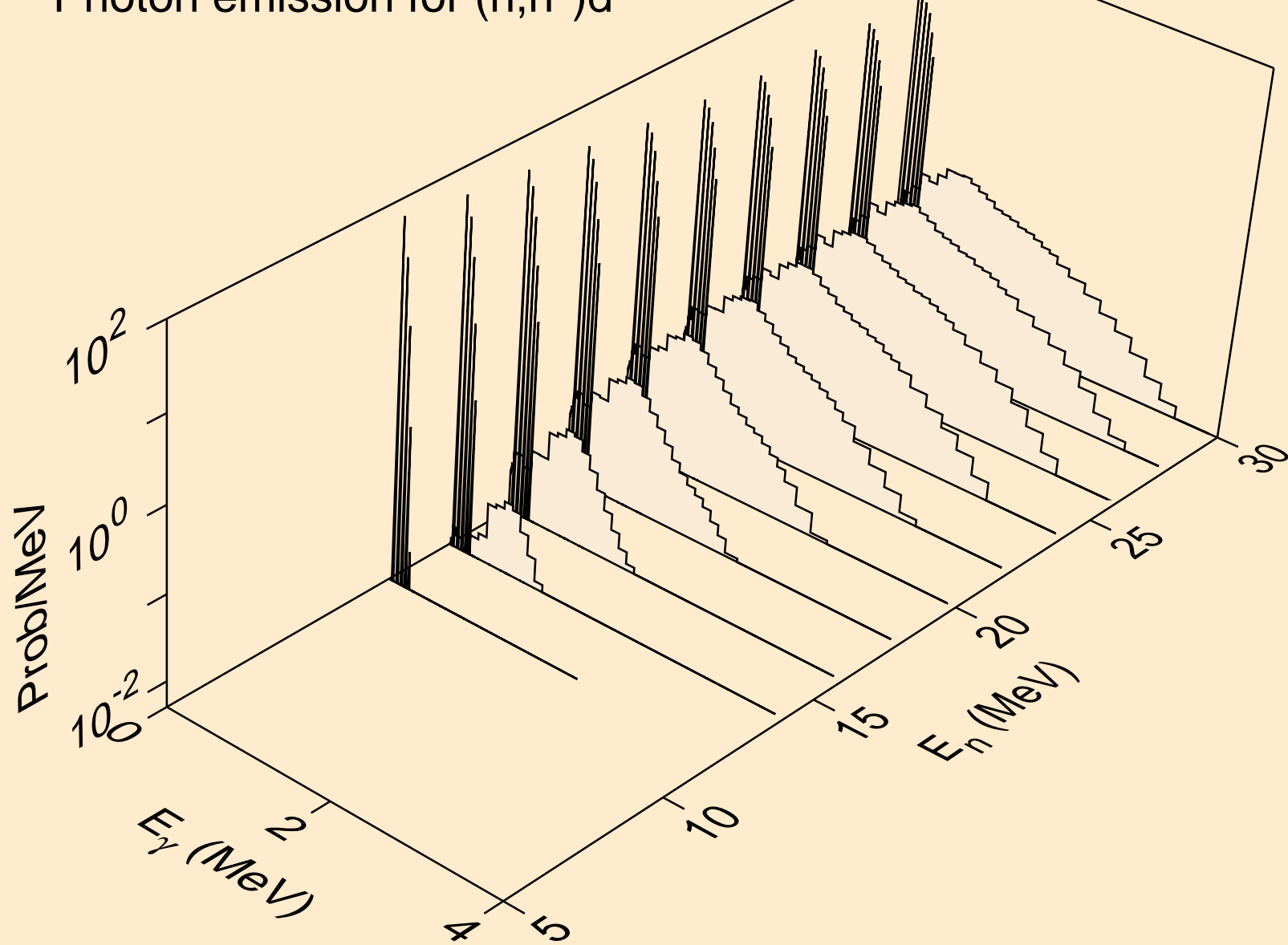

NP236M NEUTRON ACER TENDL-2023 LIBRARY; T=0.K  
Photon emission for (n,n\*)t

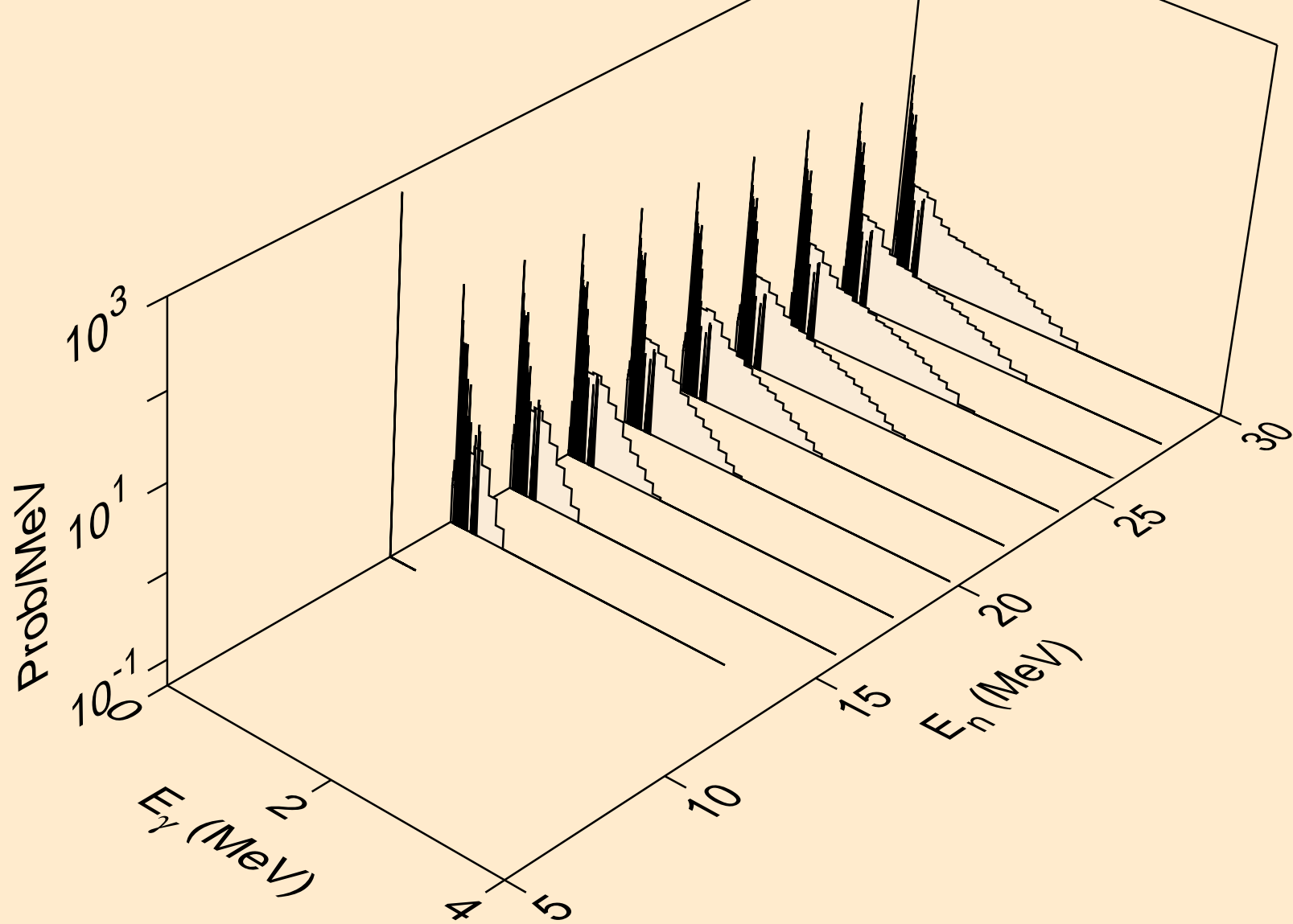



NP236M NEUTRON ACER TENDL-2023 LIBRARY; T=0.K  
Photon emission for (n,n\*)he3

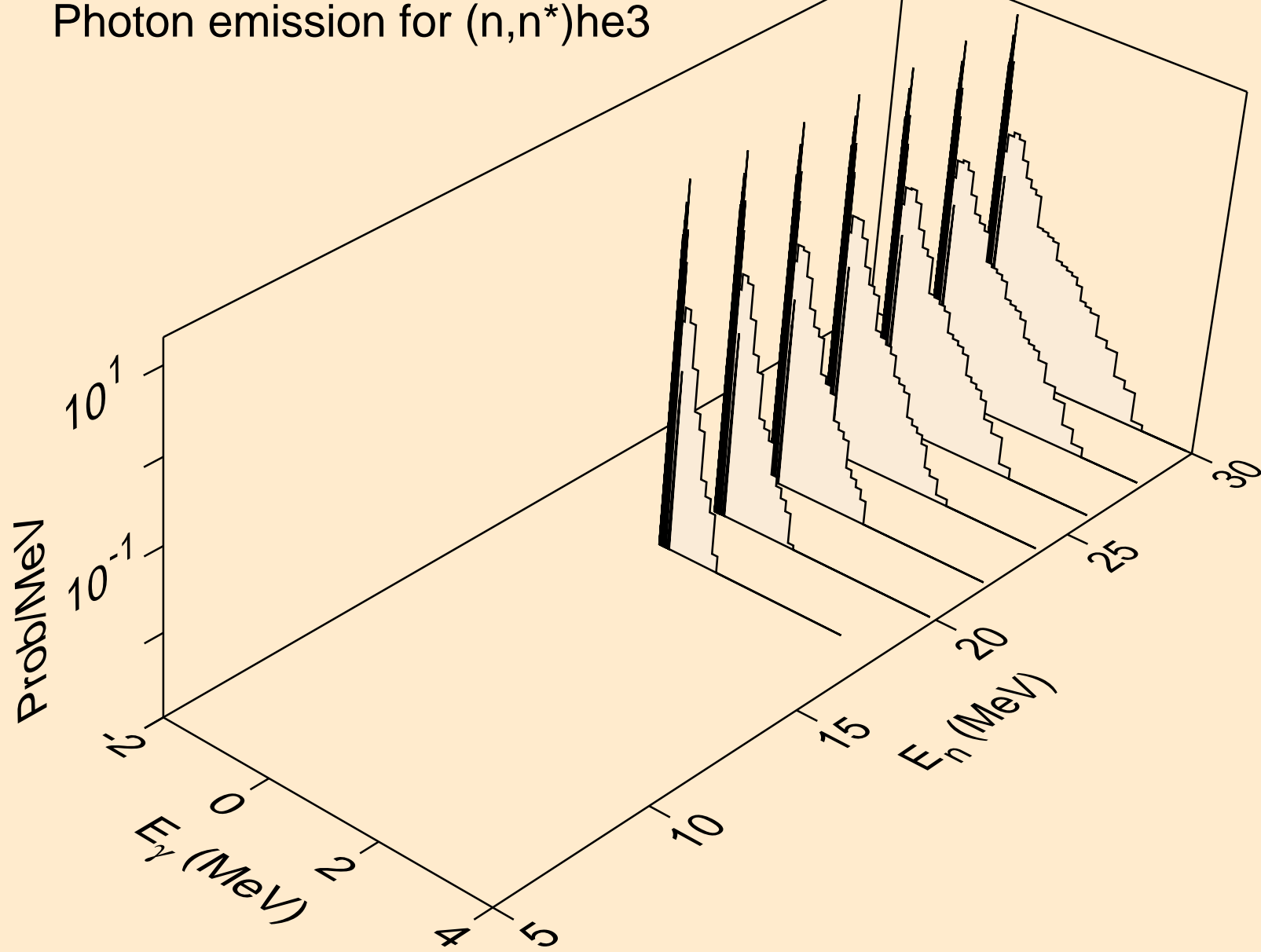

NP236M NEUTRON ACER TENDL-2023 LIBRARY; T=0.K  
Photon emission for (n,4n)

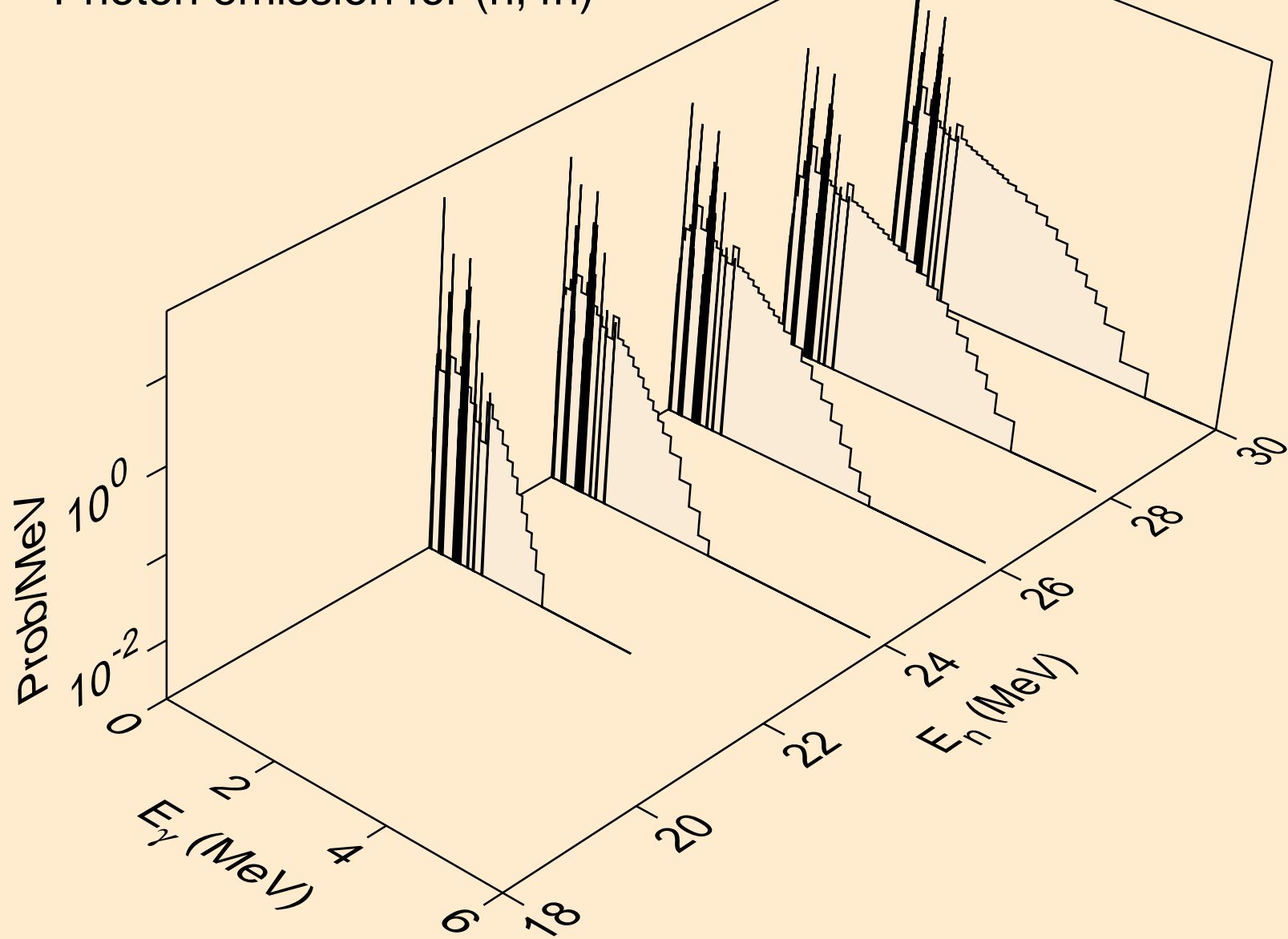

NP236M NEUTRON ACER TENDL-2023 LIBRARY; T=0.K  
Photon emission for (n,2np)

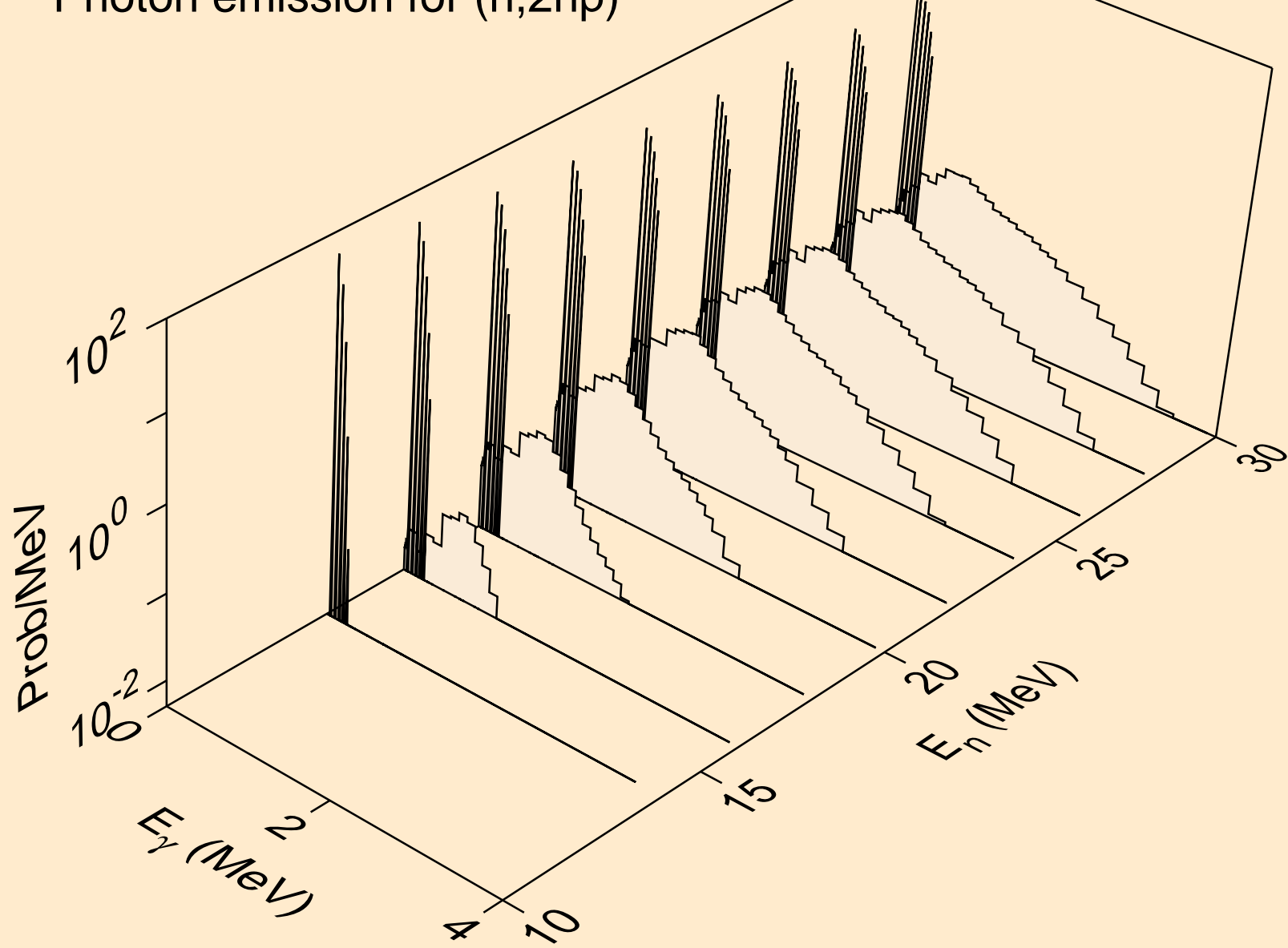

NP236M NEUTRON ACER TENDL-2023 LIBRARY; T=0.K  
Photon emission for (n,3np)

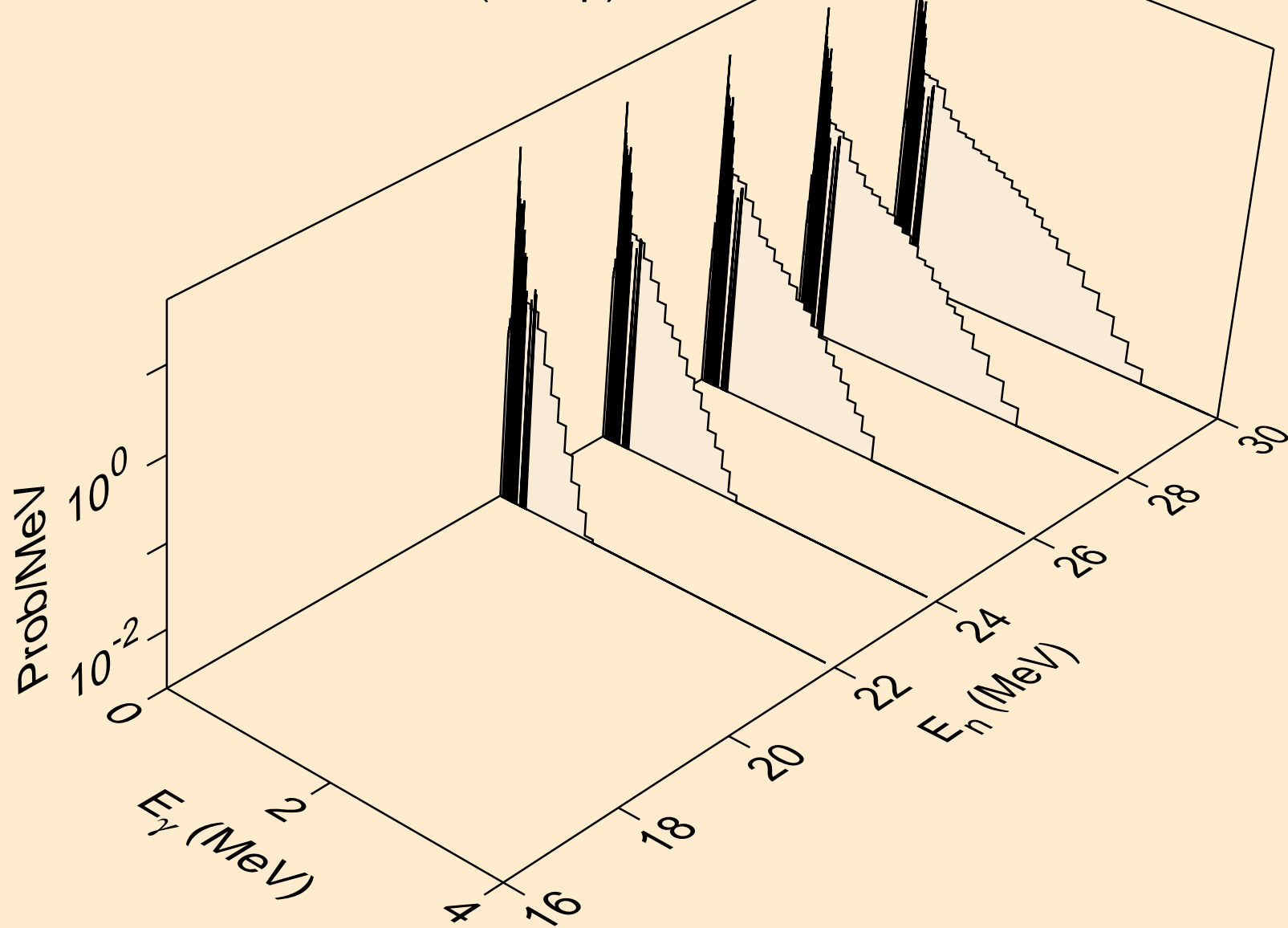

NP236M NEUTRON ACER TENDL-2023 LIBRARY; T=0.K  
Photon emission for (n,n2p)

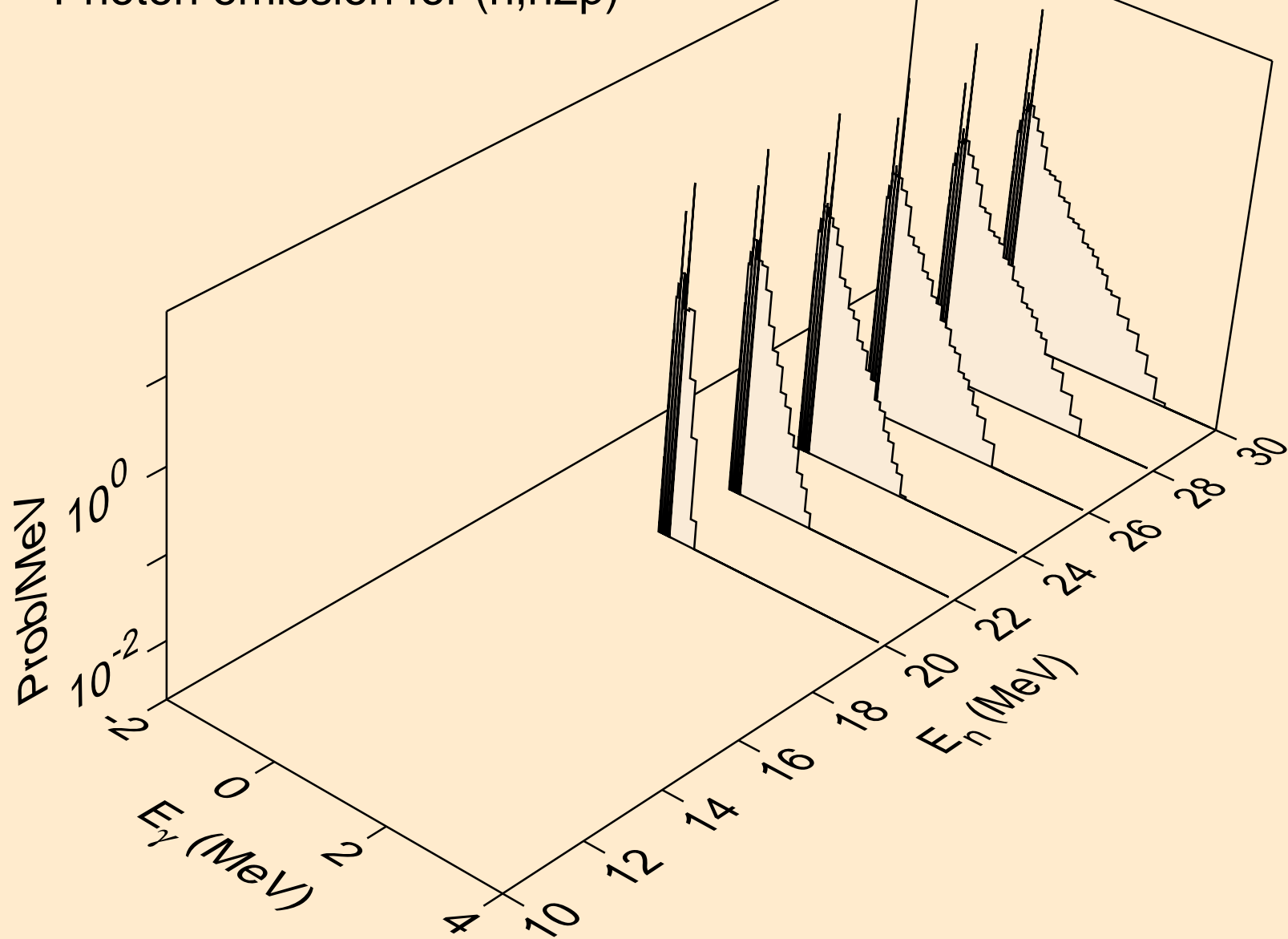

NP236M NEUTRON ACER TENDL-2023 LIBRARY; T=0.K  
Photon emission for (n,npa)

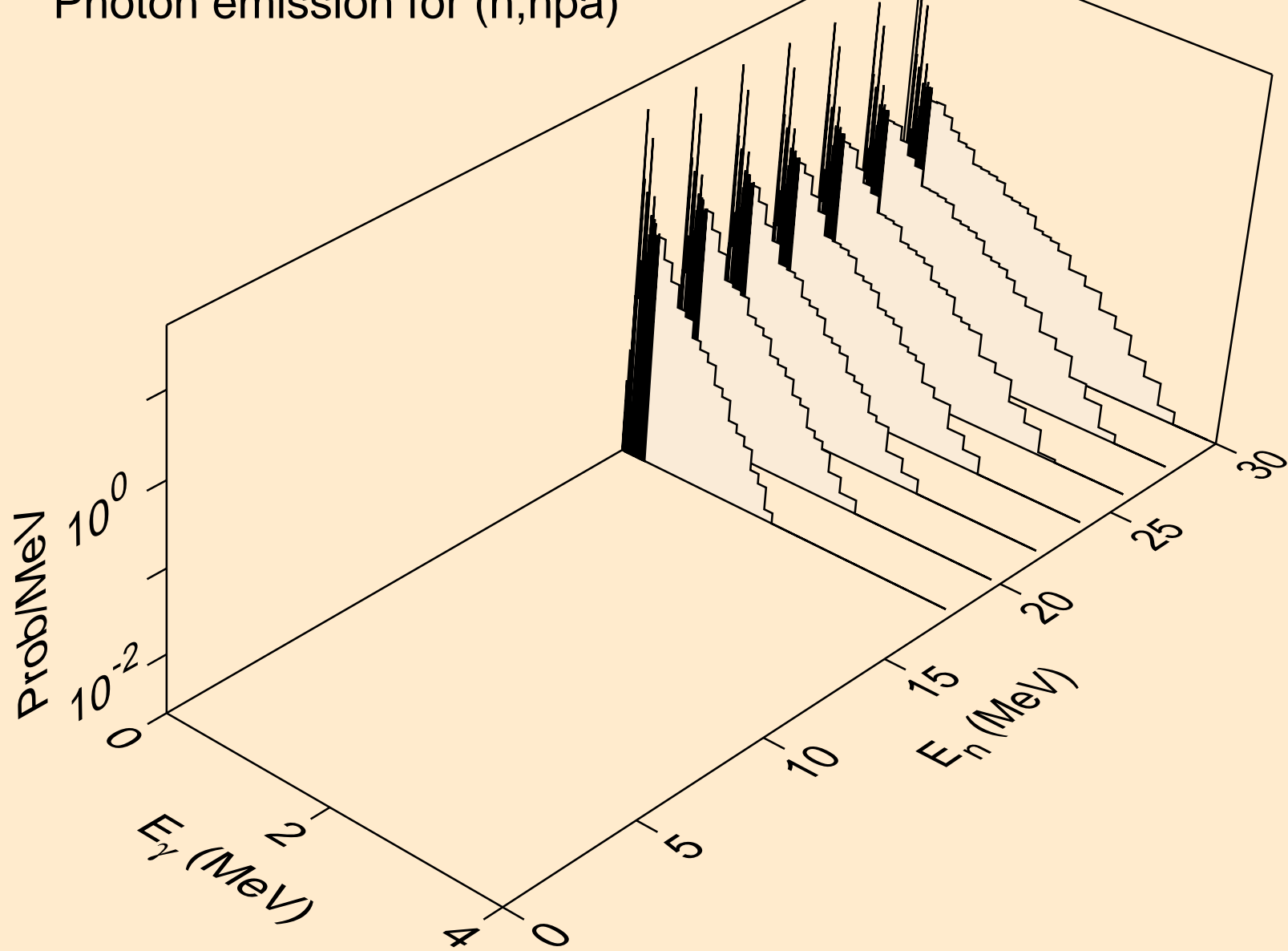

NP236M NEUTRON ACER TENDL-2023 LIBRARY; T=0.K  
Photon emission for (n,n\*2)

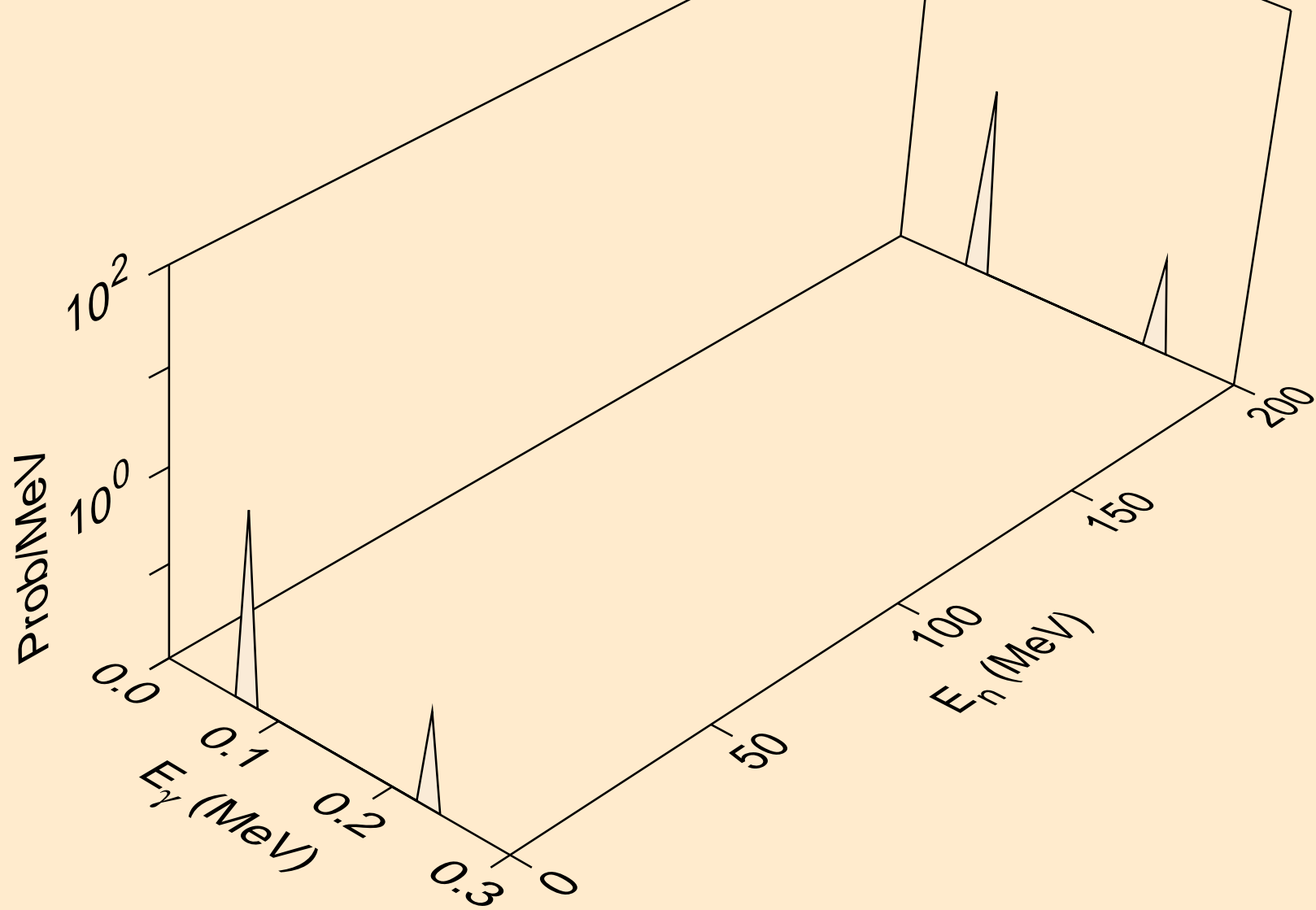

NP236M NEUTRON ACER TENDL-2023 LIBRARY; T=0.K  
Photon emission for (n,n\*3)

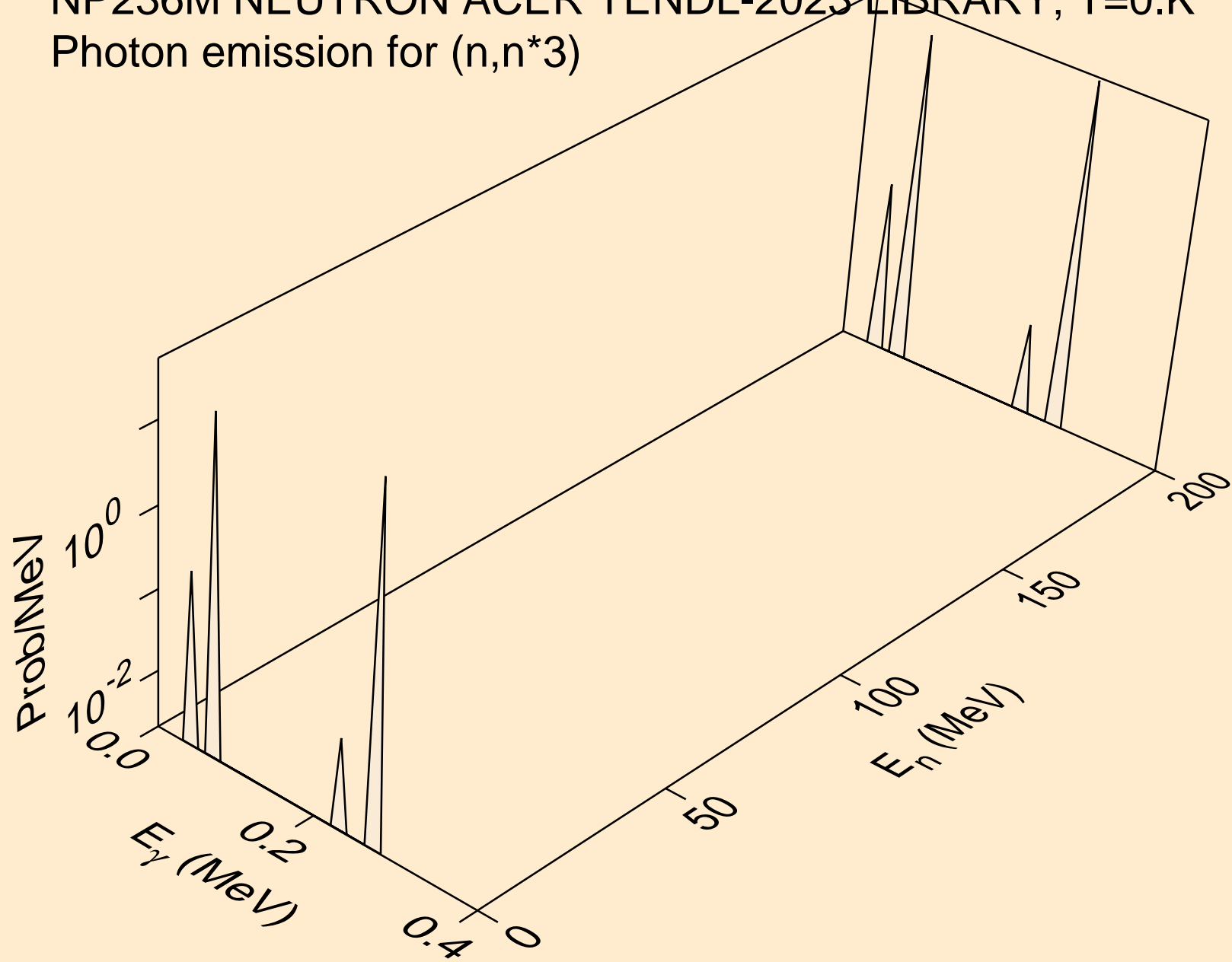



NP236M NEUTRON ACER TENDL-2023 LIBRARY; T=0.K  
Photon emission for (n,n\*4)

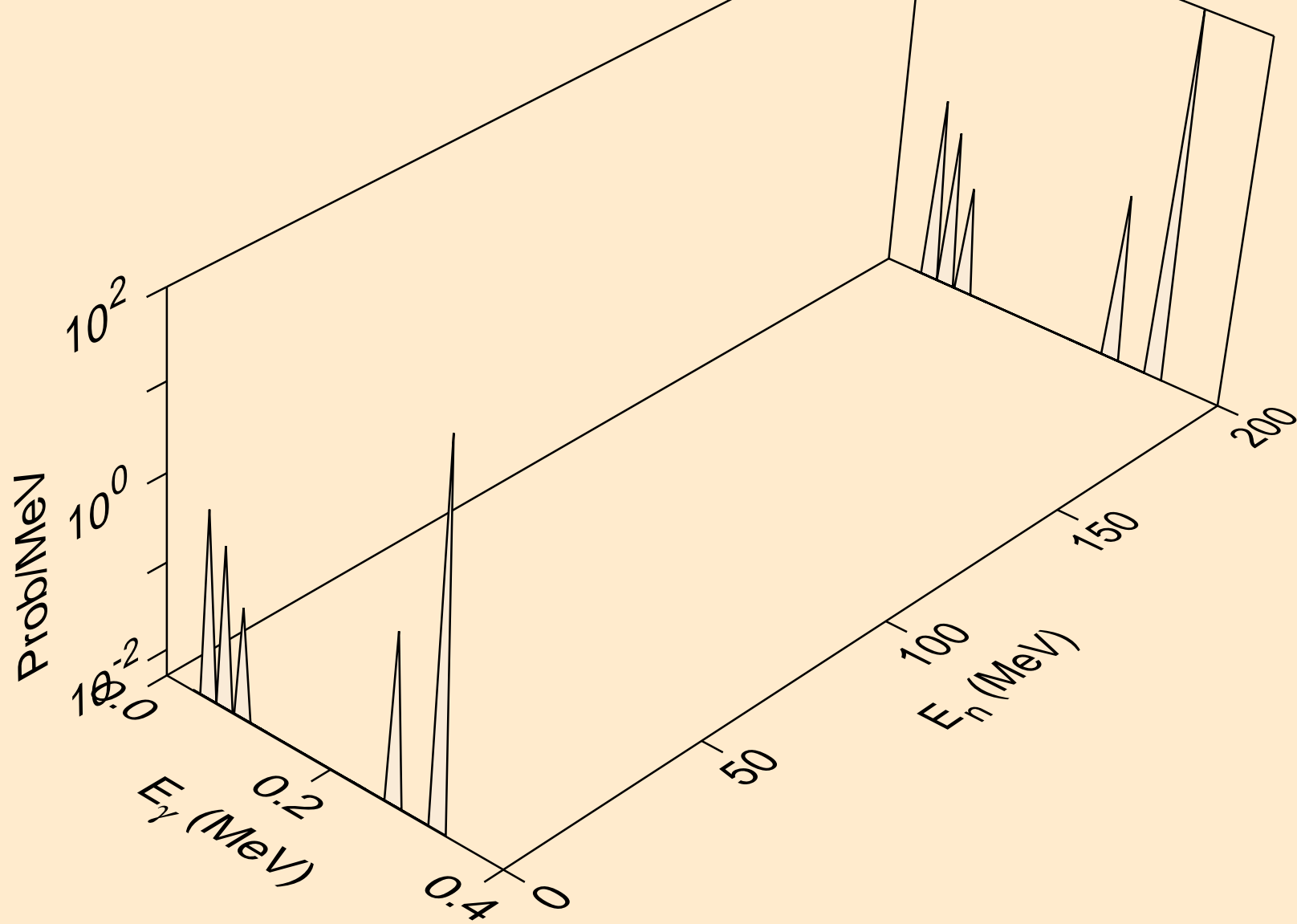

NP236M NEUTRON ACER TENDL-2023 LIBRARY; T=0.K  
Photon emission for (n,n\*5)

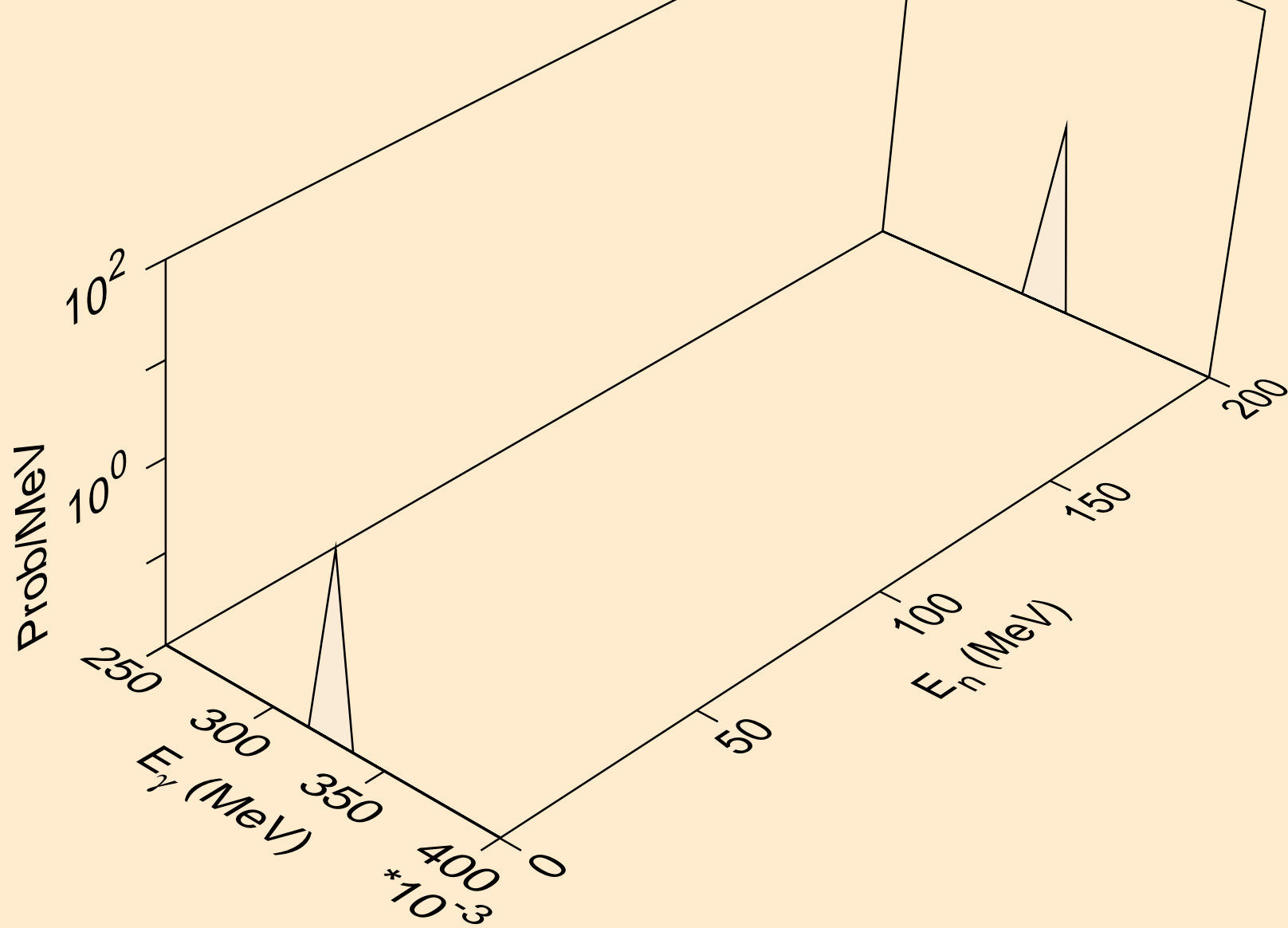

NP236M NEUTRON ACER TENDL-2023 LIBRARY; T=0.K  
Photon emission for (n,n\*6)

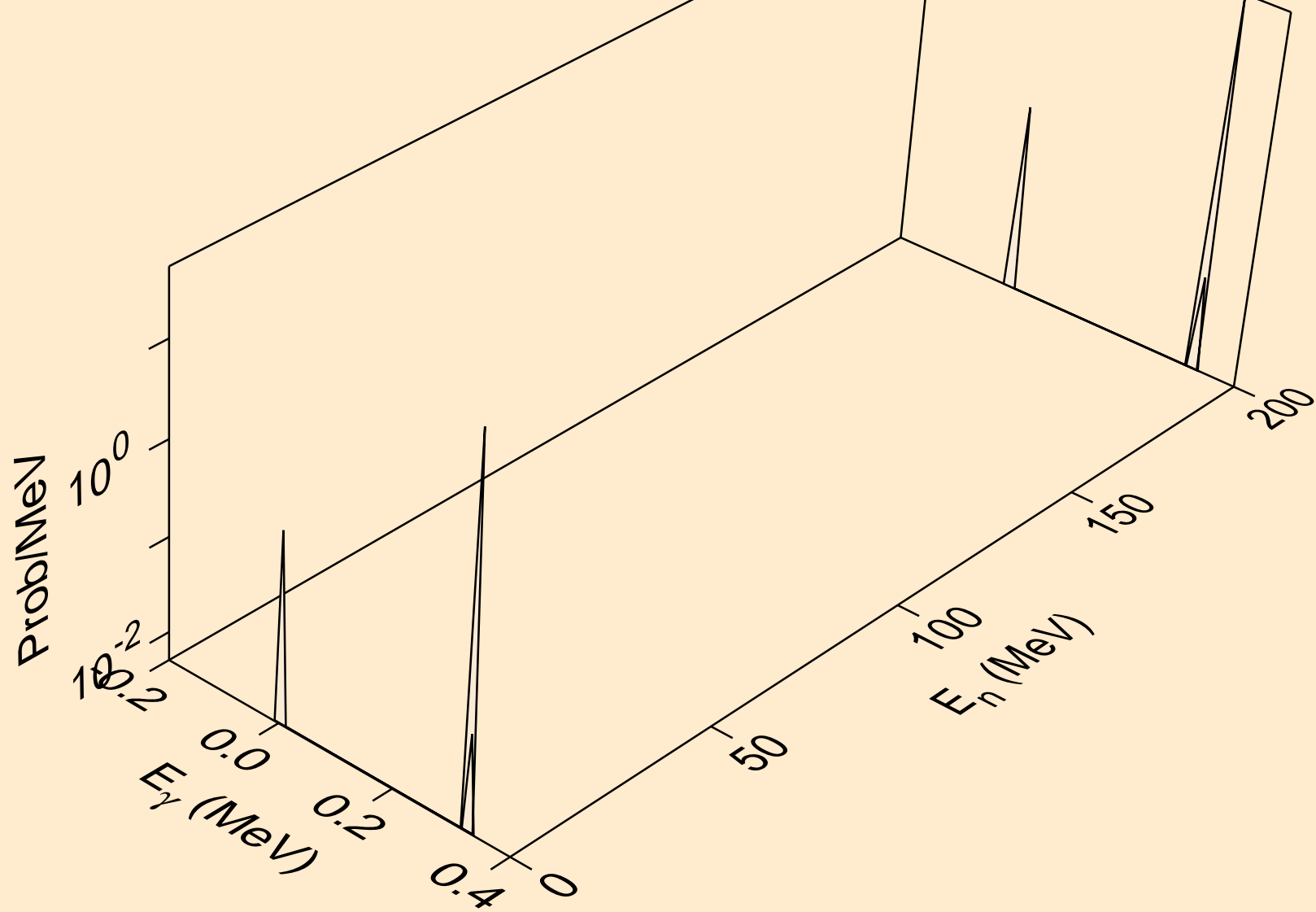

NP236M NEUTRON ACER TENDL-2023 LIBRARY; T=0.K  
Photon emission for (n,n\*7)

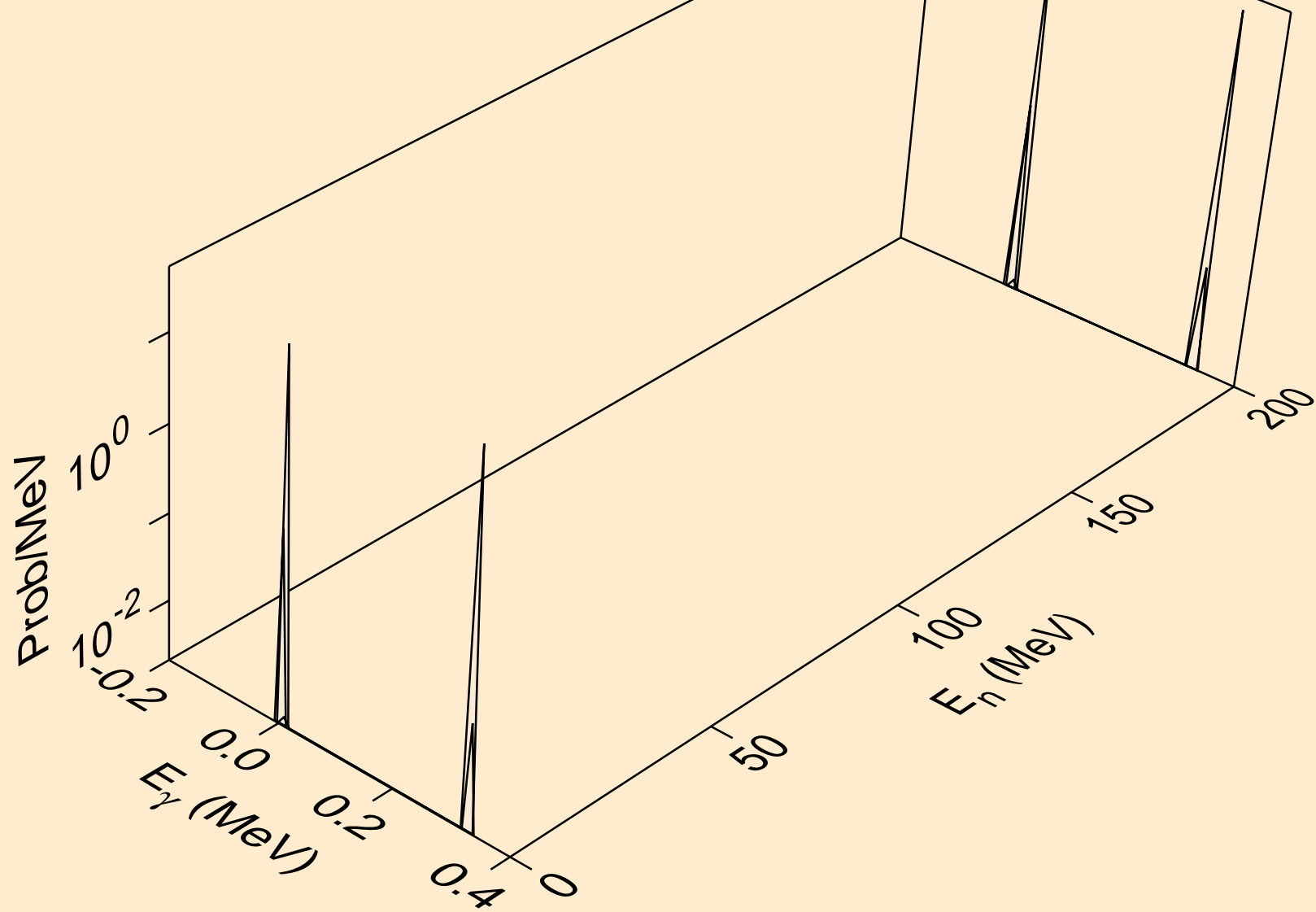

NP236M NEUTRON ACER TENDL-2023 LIBRARY; T=0.K  
Photon emission for (n,n\*8)

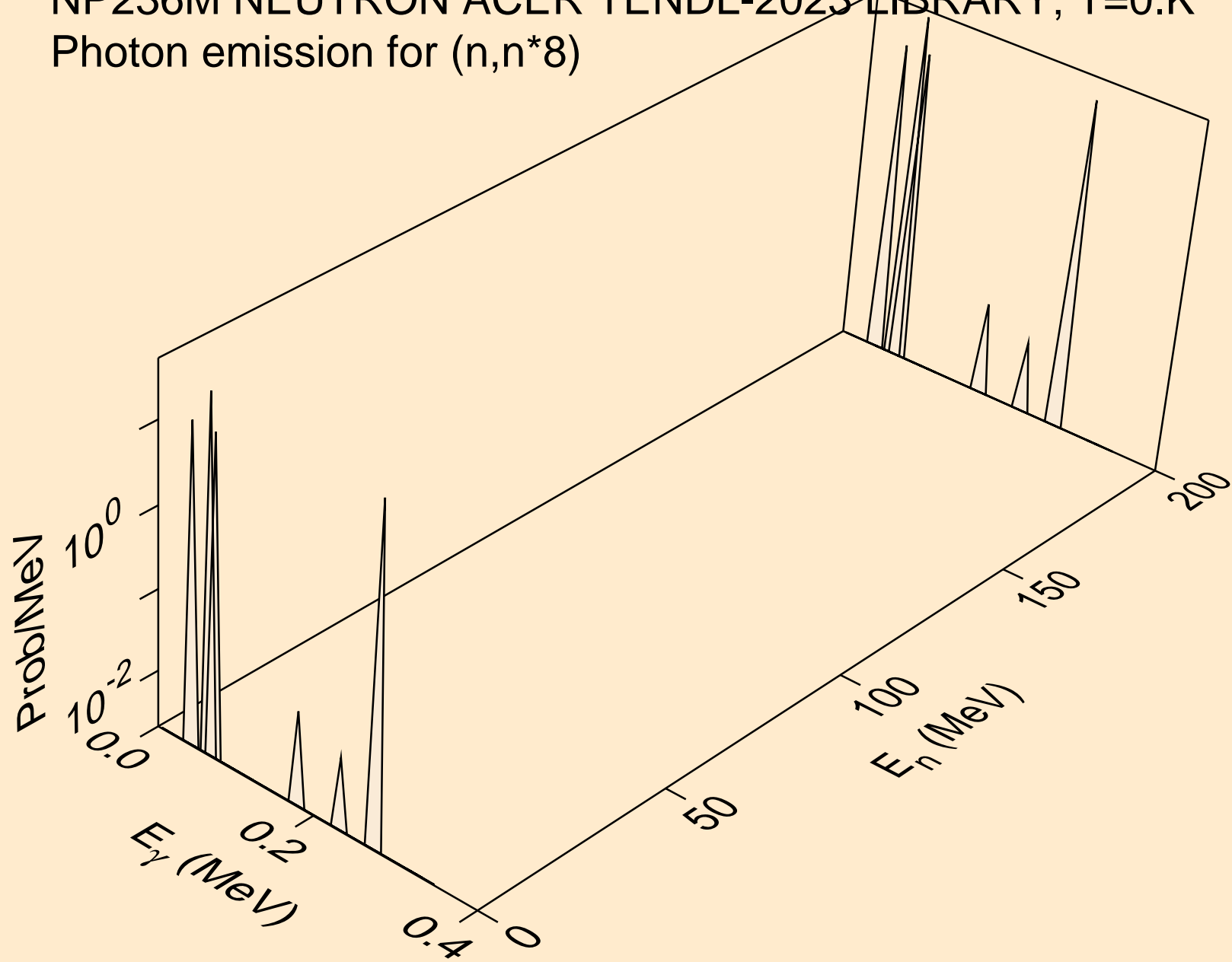

NP236M NEUTRON ACER TENDL-2023 LIBRARY; T=0.K  
Photon emission for (n,n\*9)

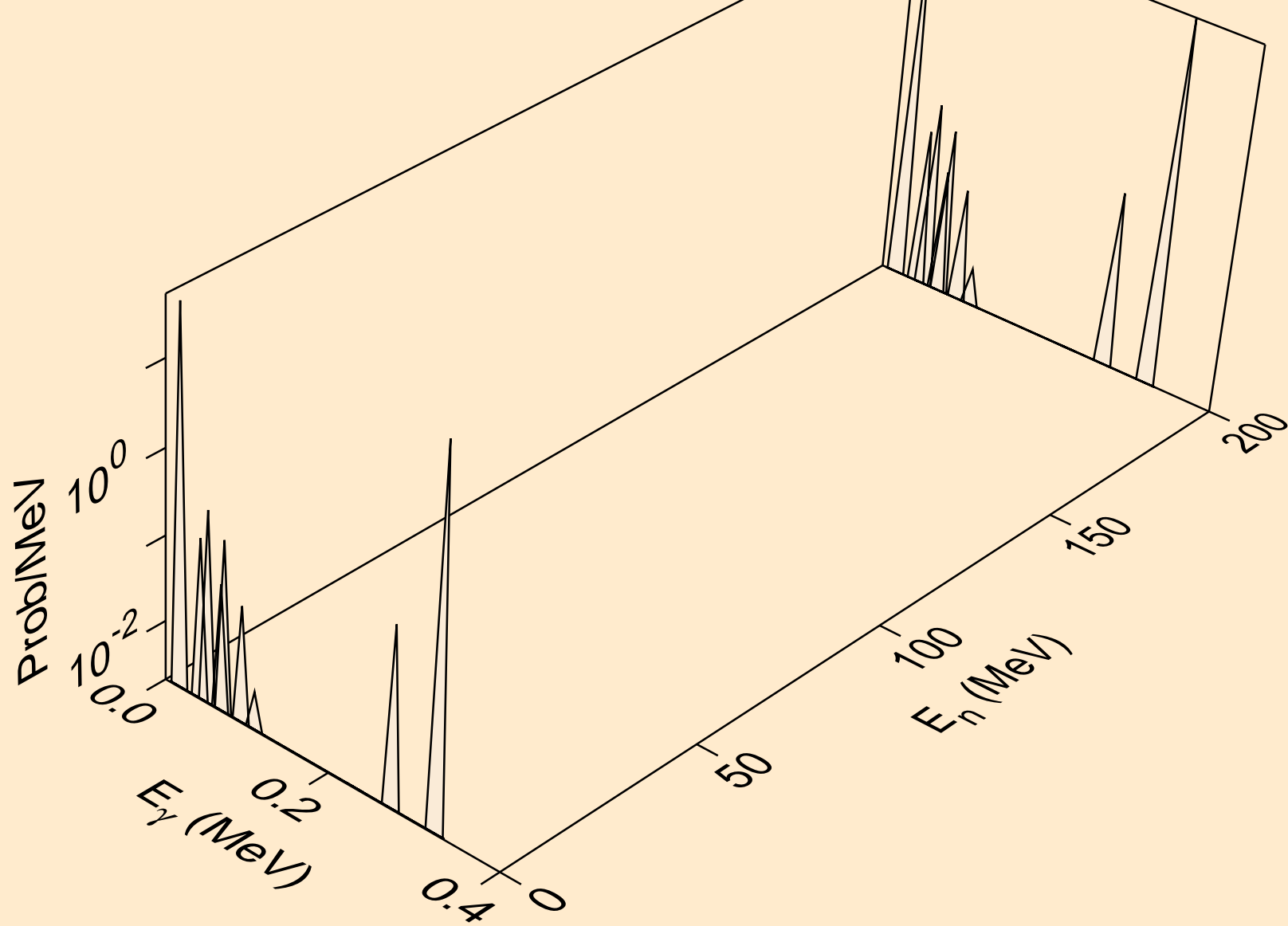

NP236M NEUTRON ACER TENDL-2023 LIBRARY; T=0.K  
Photon emission for (n,n\*10)

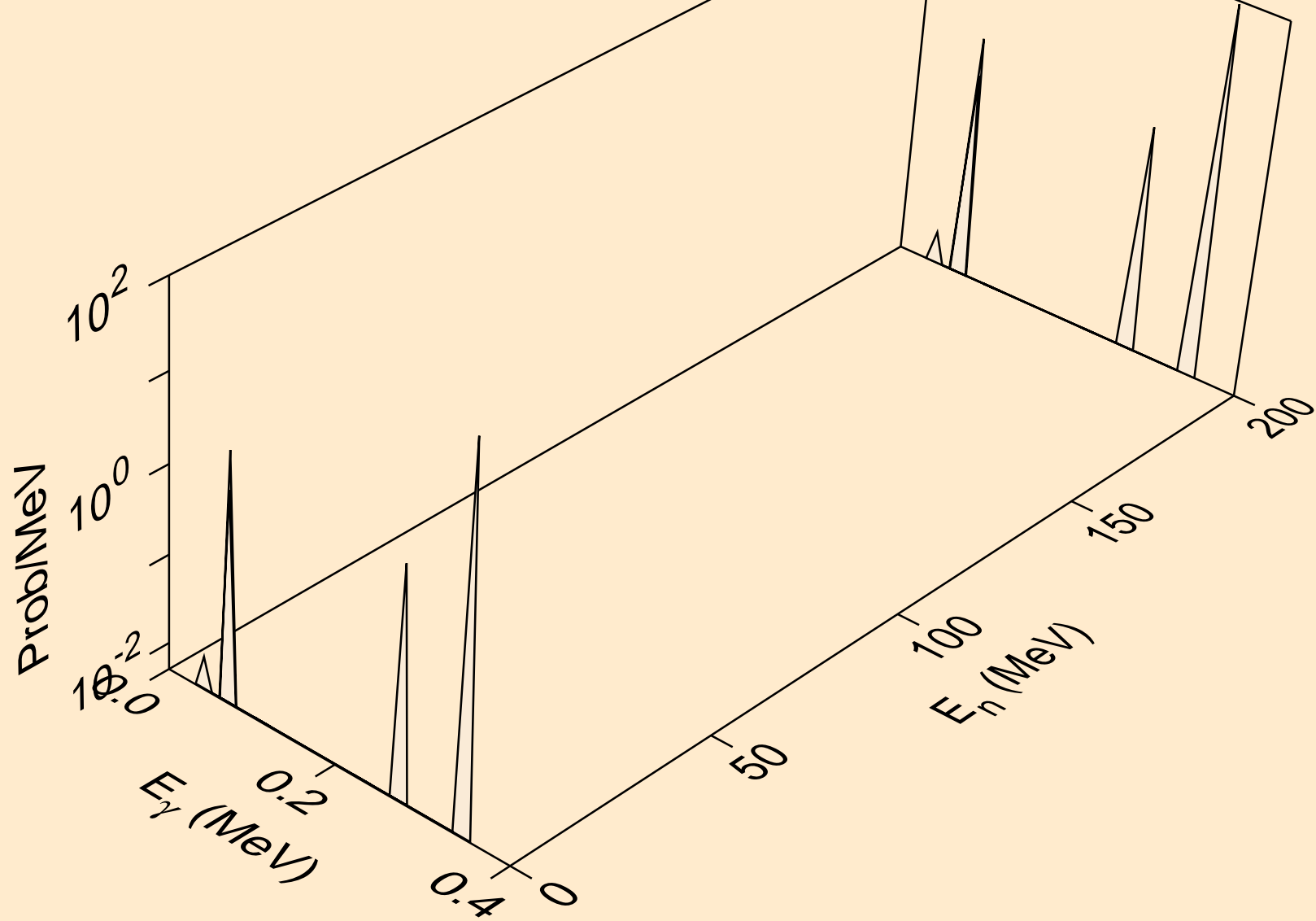

NP236M NEUTRON ACER TENDL-2023 LIBRARY; T=0.K  
Photon emission for (n,n\*11)

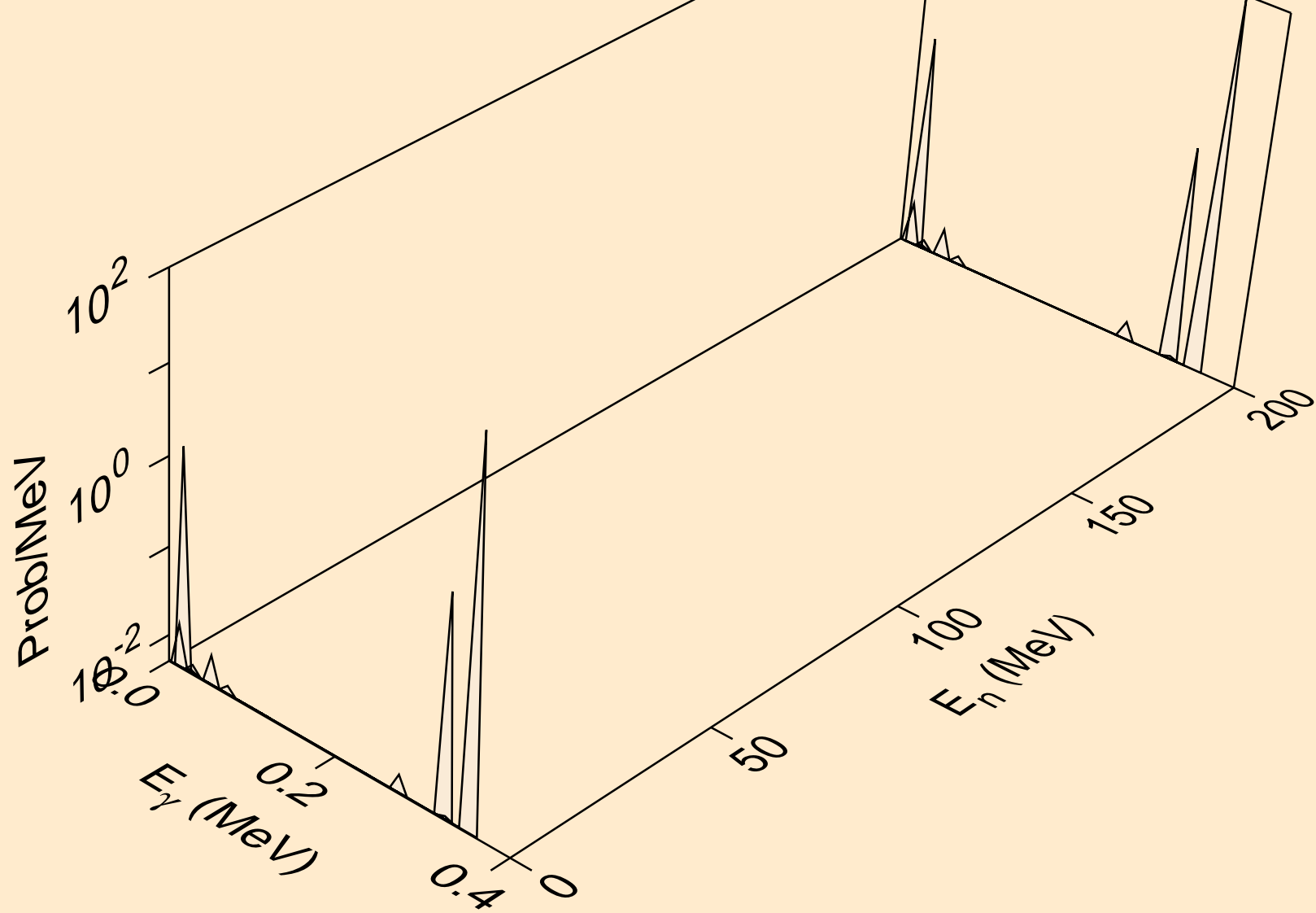



NP236M NEUTRON ACER TENDL-2023 LIBRARY; T=0.K  
Photon emission for (n,n\*12)

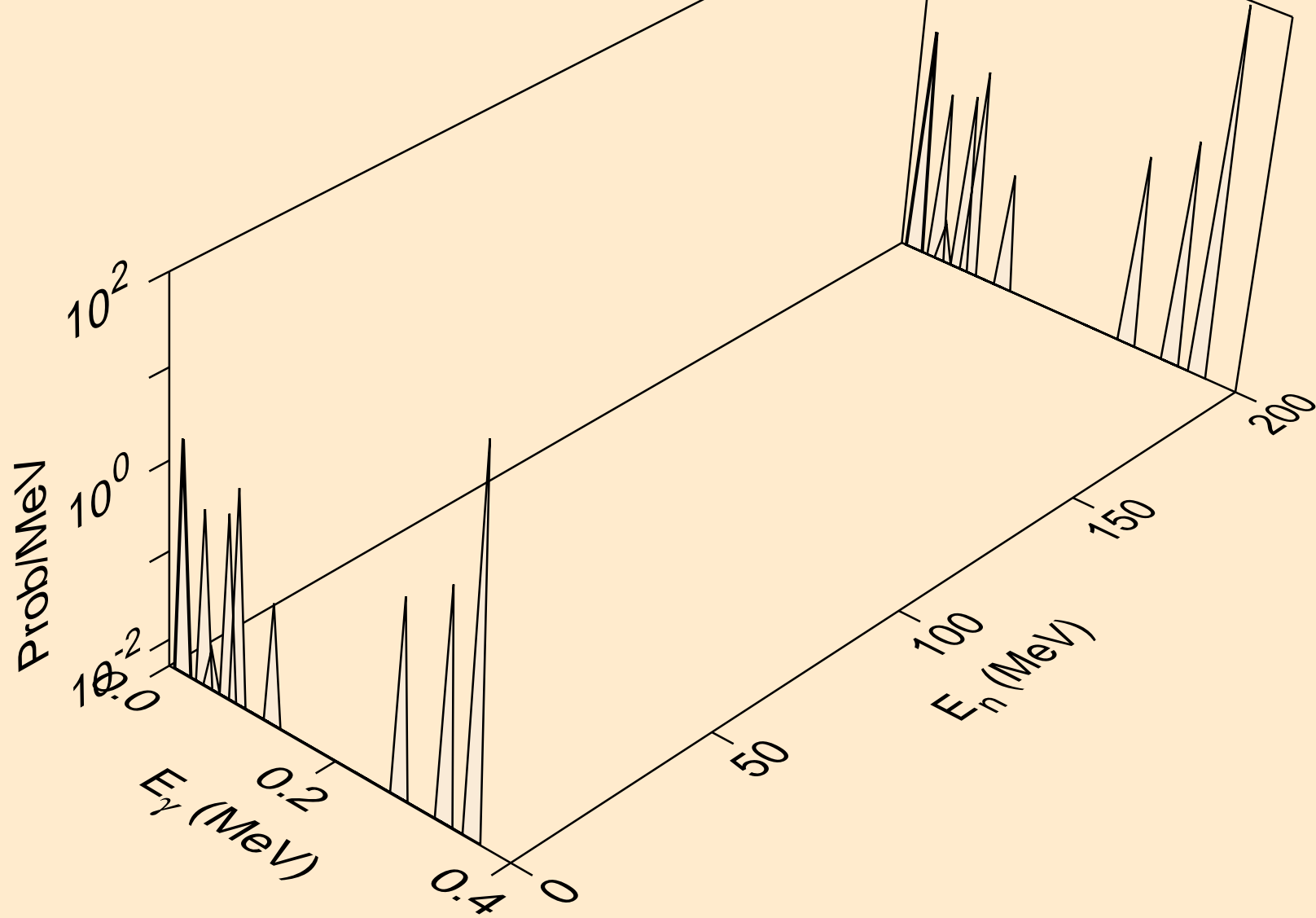

NP236M NEUTRON ACER TENDL-2023 LIBRARY; T=0.K  
Photon emission for (n,n\*13)

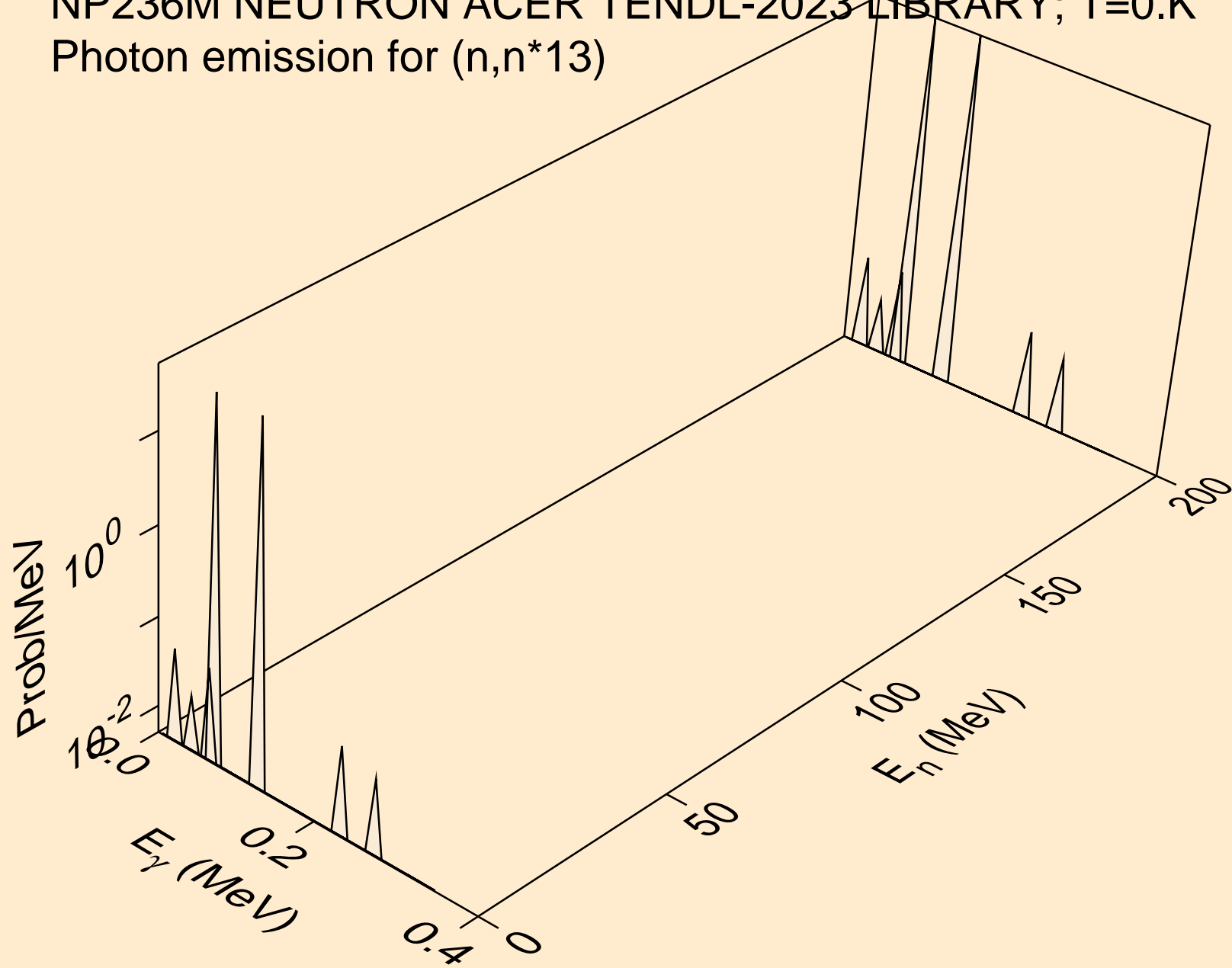

NP236M NEUTRON ACER TENDL-2023 LIBRARY; T=0.K  
Photon emission for (n,n\*14)

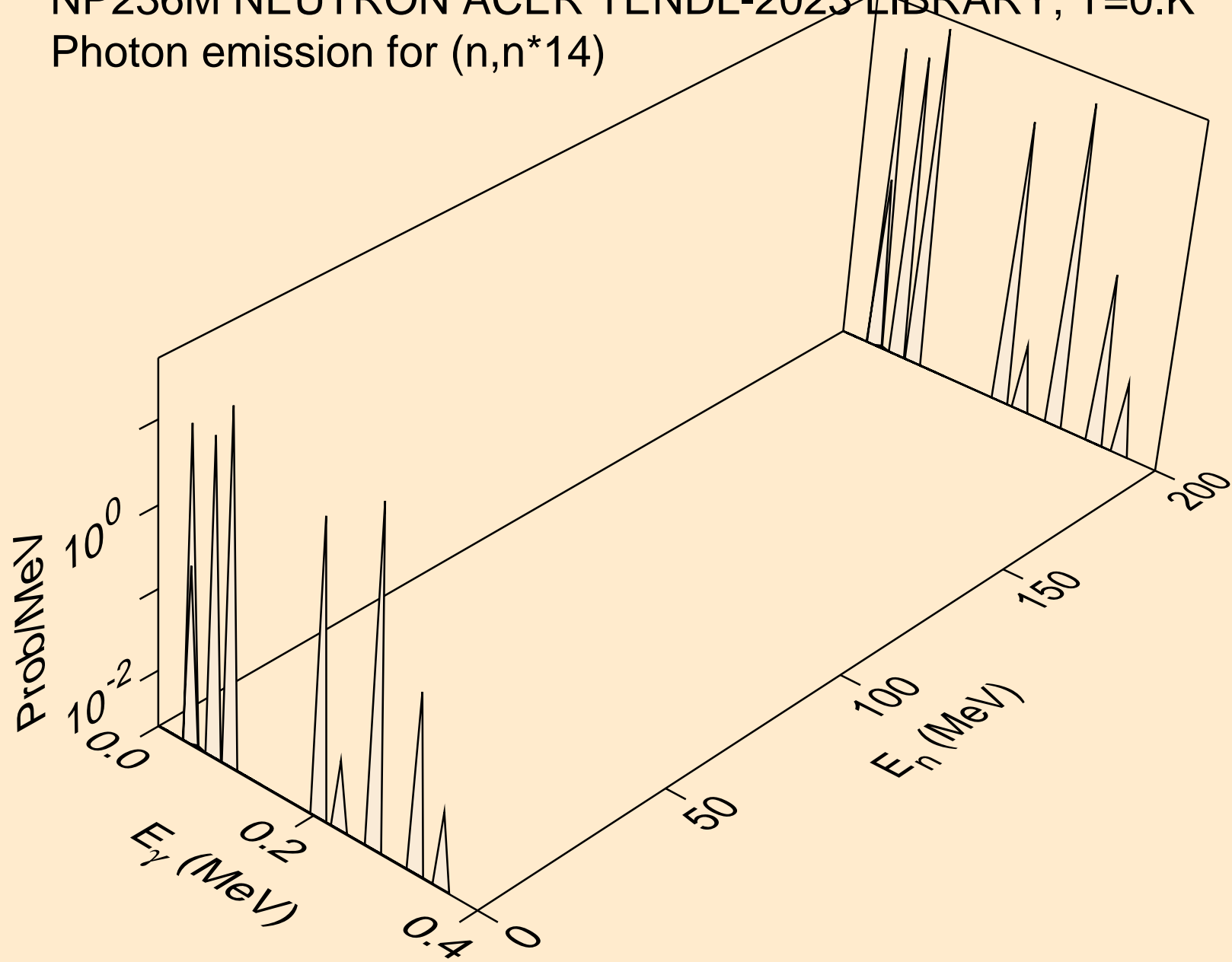

NP236M NEUTRON ACER TENDL-2023 LIBRARY; T=0.K  
Photon emission for (n,n\*15)

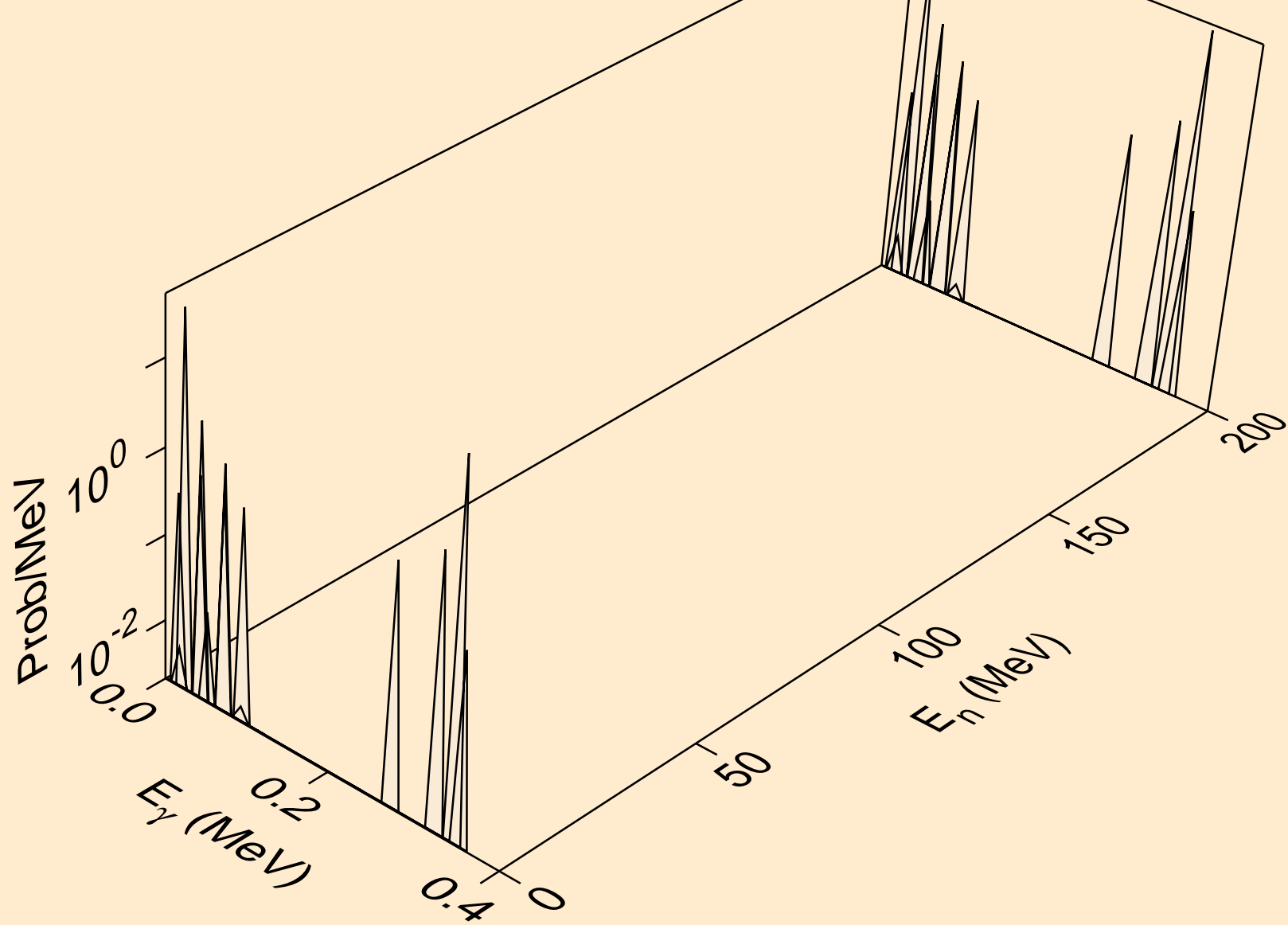

NP236M NEUTRON ACER TENDL-2023 LIBRARY; T=0.K  
Photon emission for (n,n\*16)

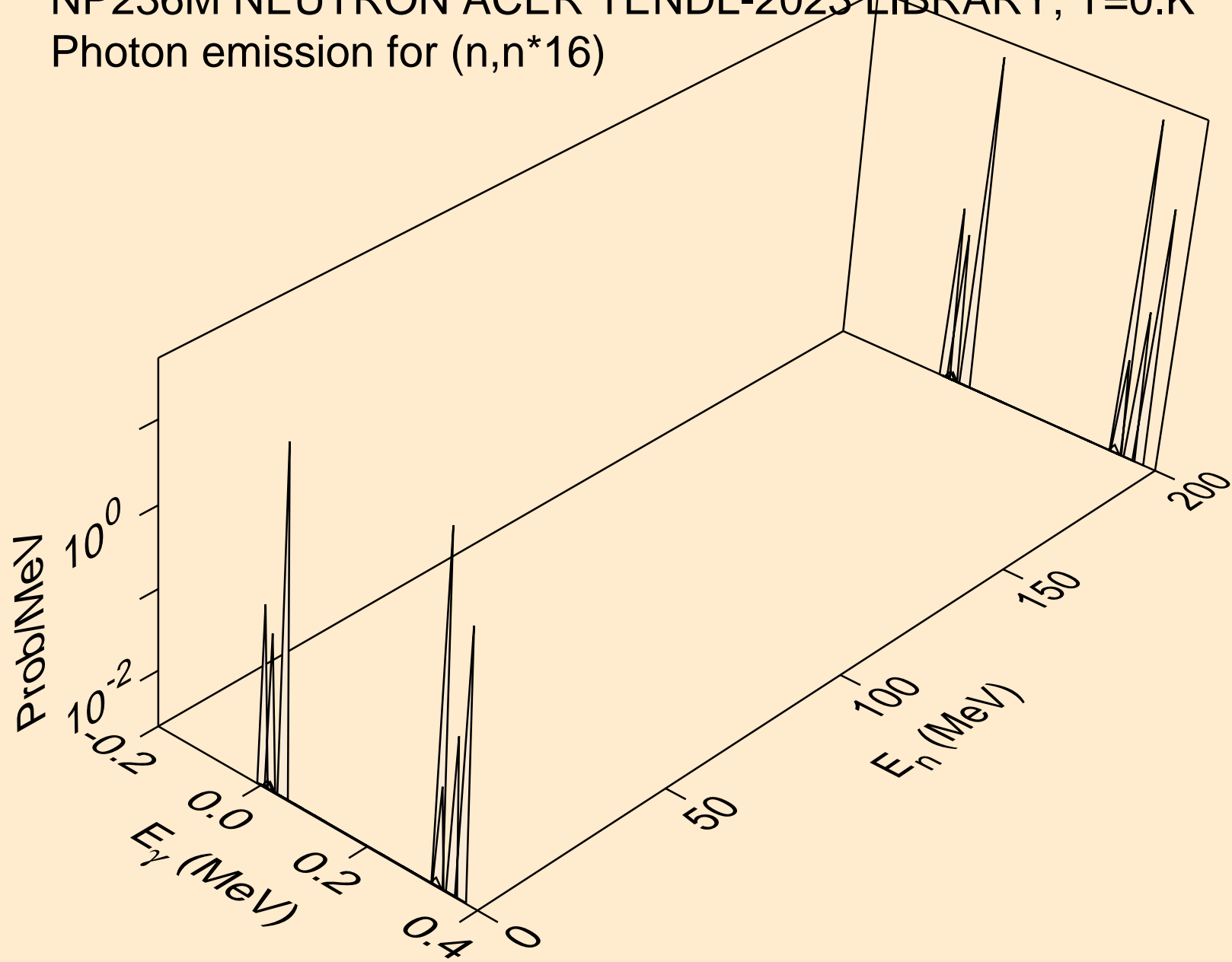

NP236M NEUTRON ACER TENDL-2023 LIBRARY; T=0.K  
Photon emission for (n,n\*17)

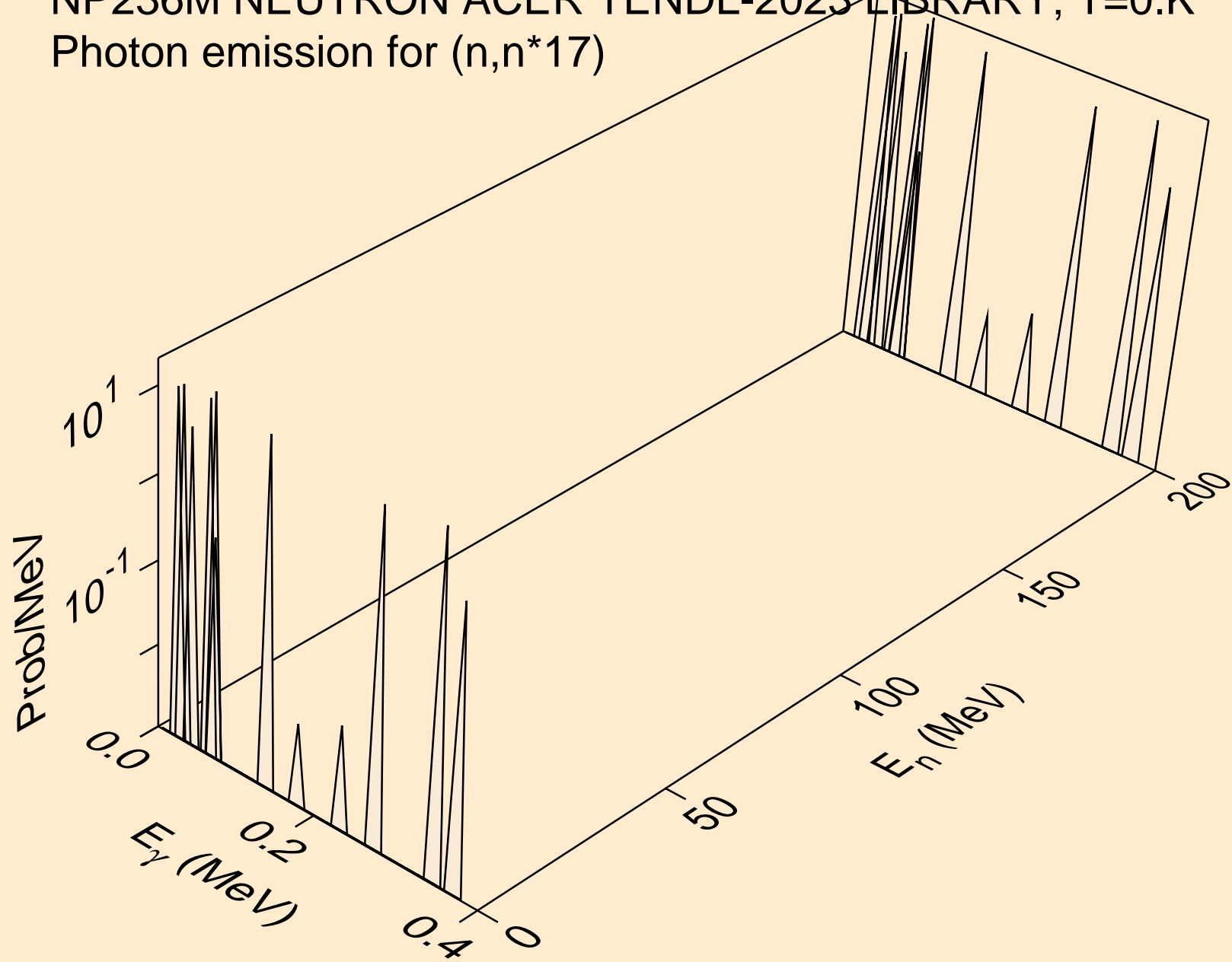

NP236M NEUTRON ACER TENDL-2023 LIBRARY; T=0.K  
Photon emission for (n,n\*18)

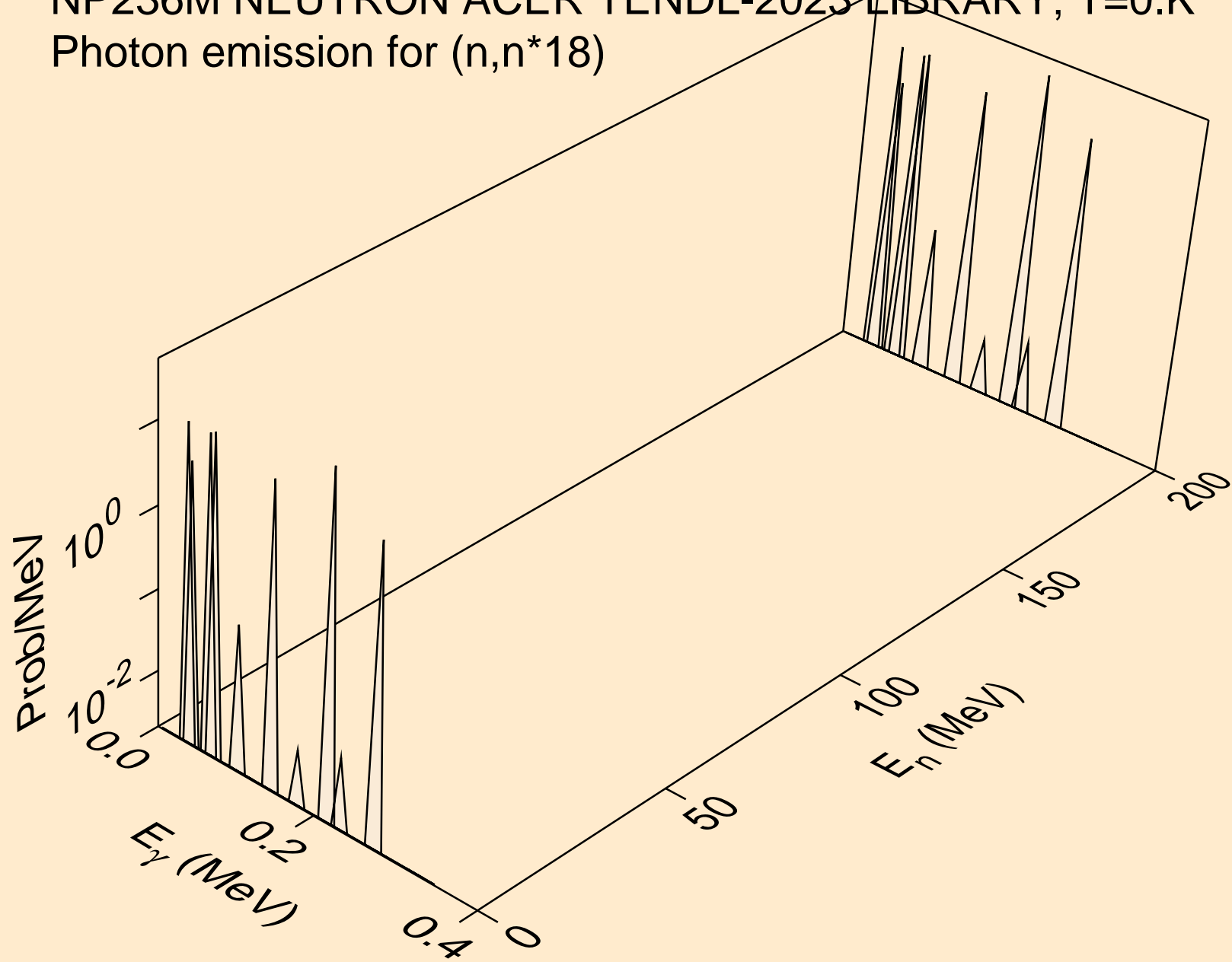

NP236M NEUTRON ACER TENDL-2023 LIBRARY; T=0.K  
Photon emission for (n,n\*c)

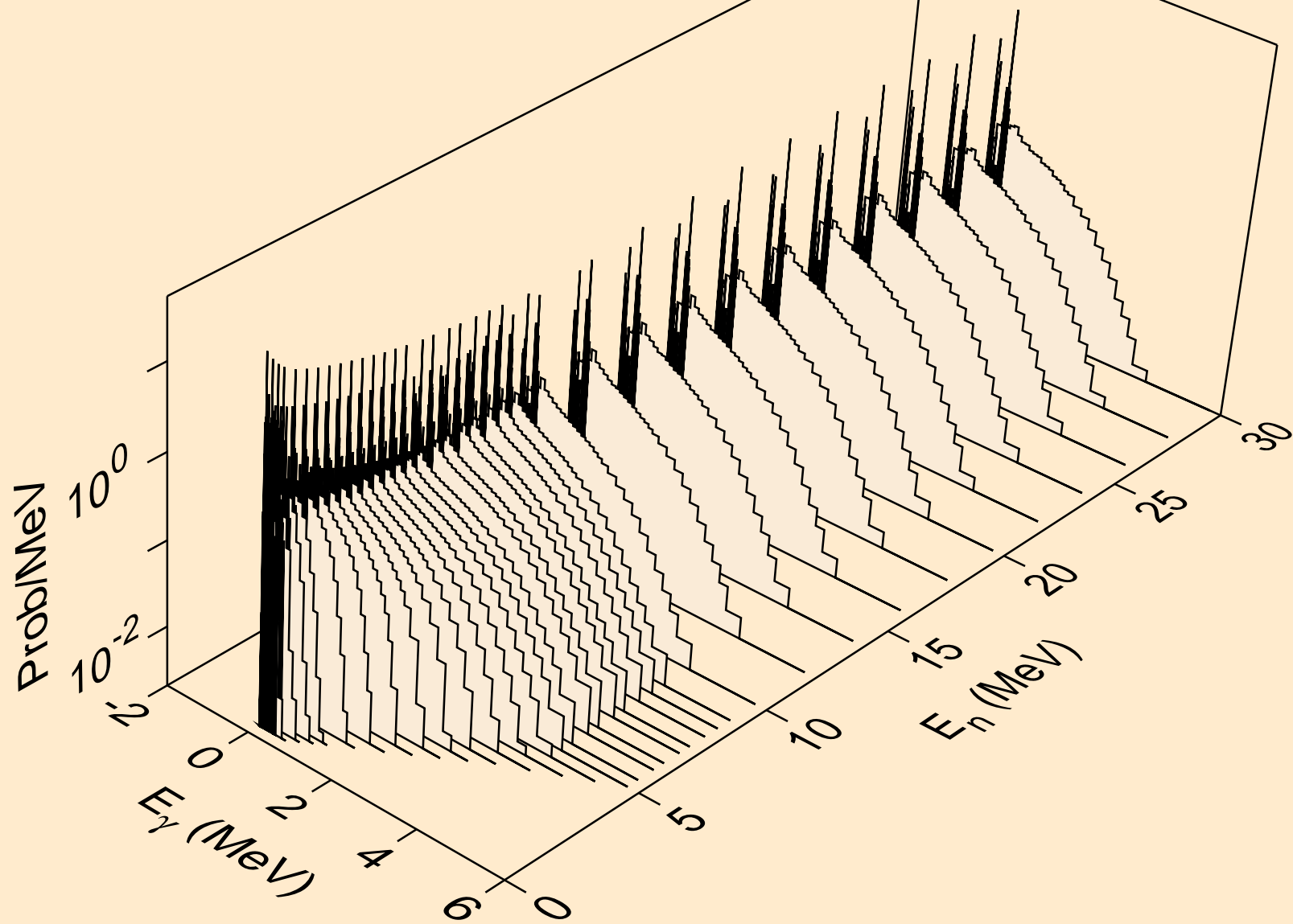



NP236M NEUTRON ACER TENDL-2023 LIBRARY; T=0.K  
Photon emission for (n,gma)

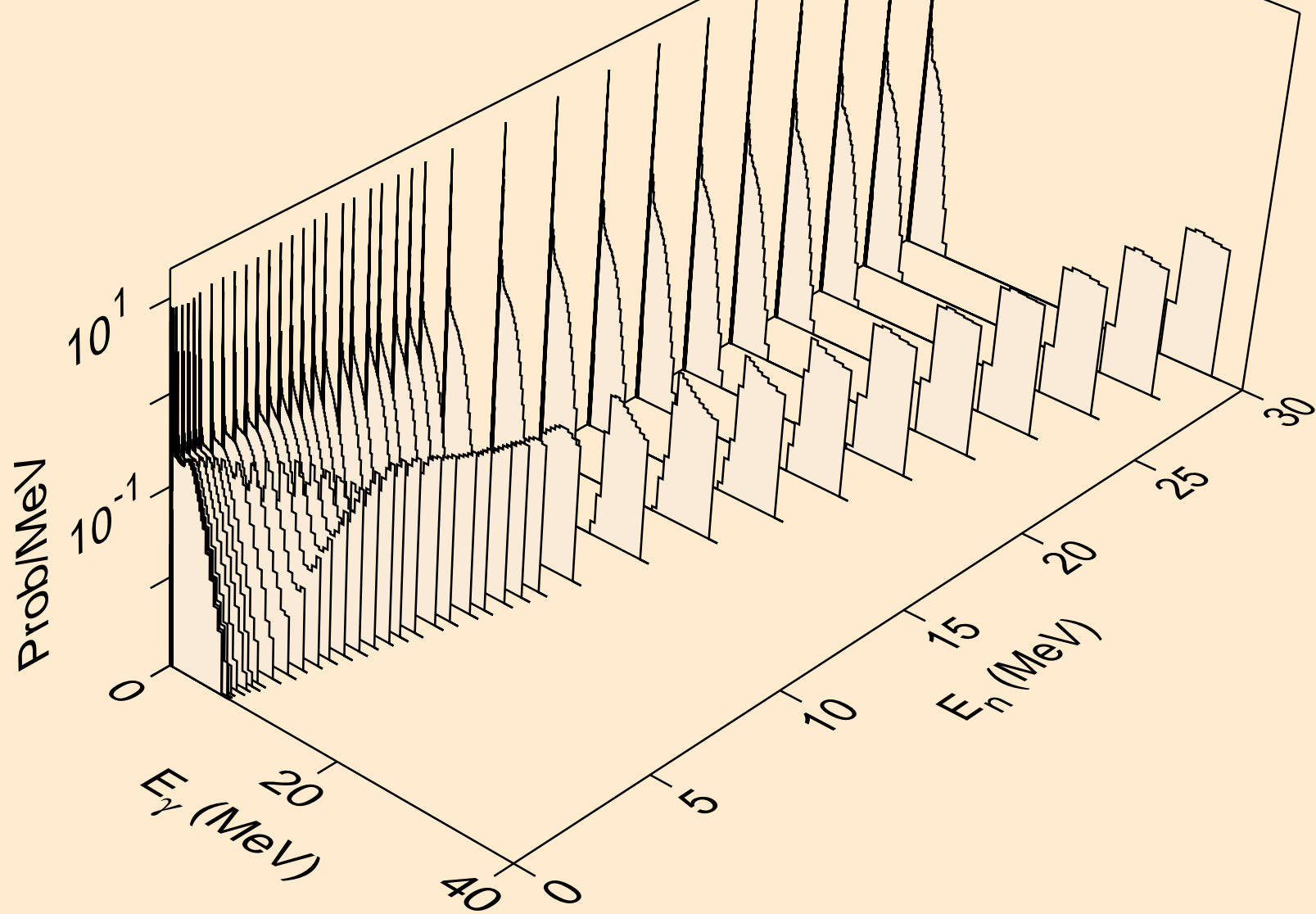

NP236M NEUTRON ACER TENDL-2023 LIBRARY; T=0.K  
Photon emission for (n,p)

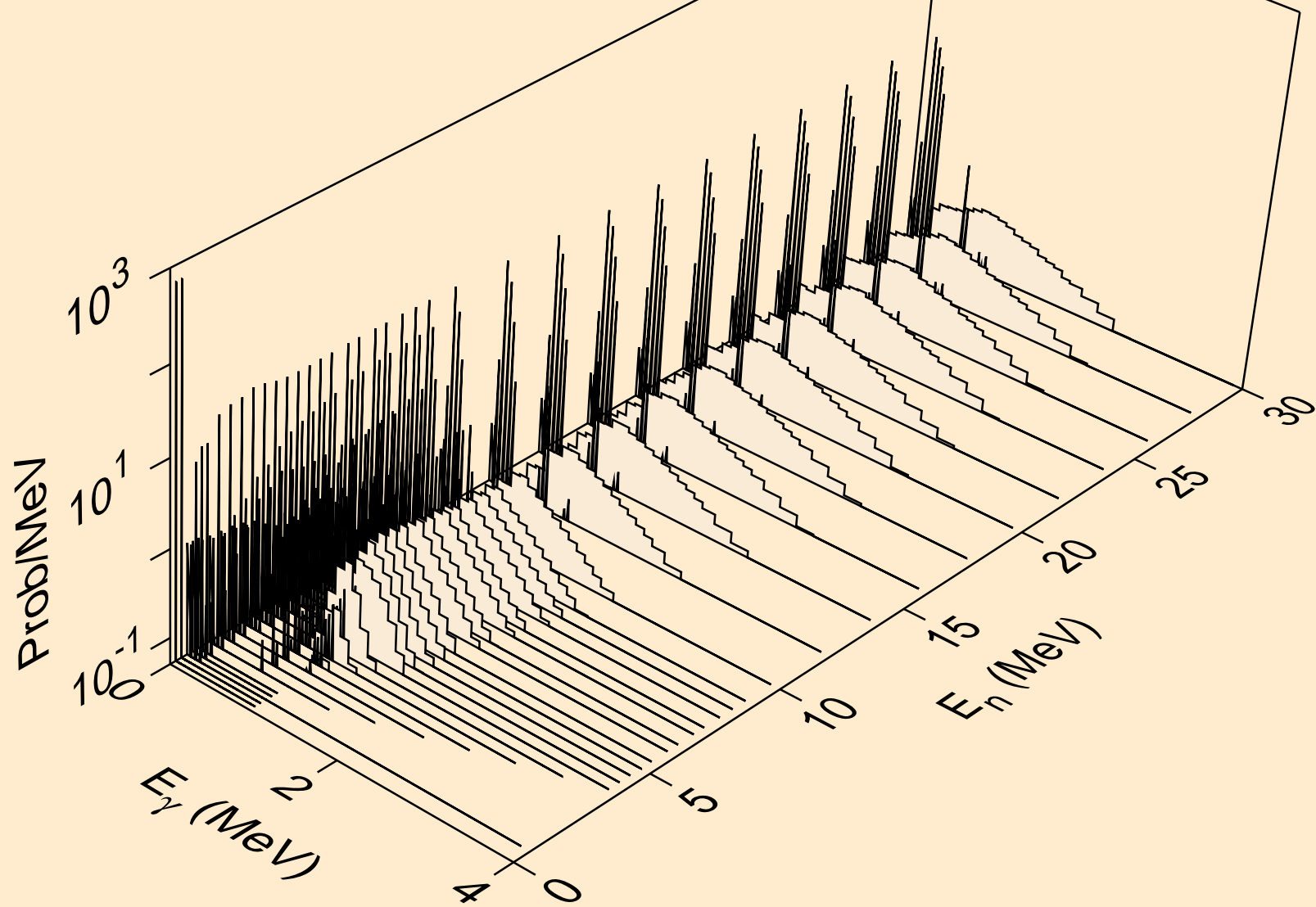

NP236M NEUTRON ACER TENDL-2023 LIBRARY; T=0.K  
Photon emission for (n,d)

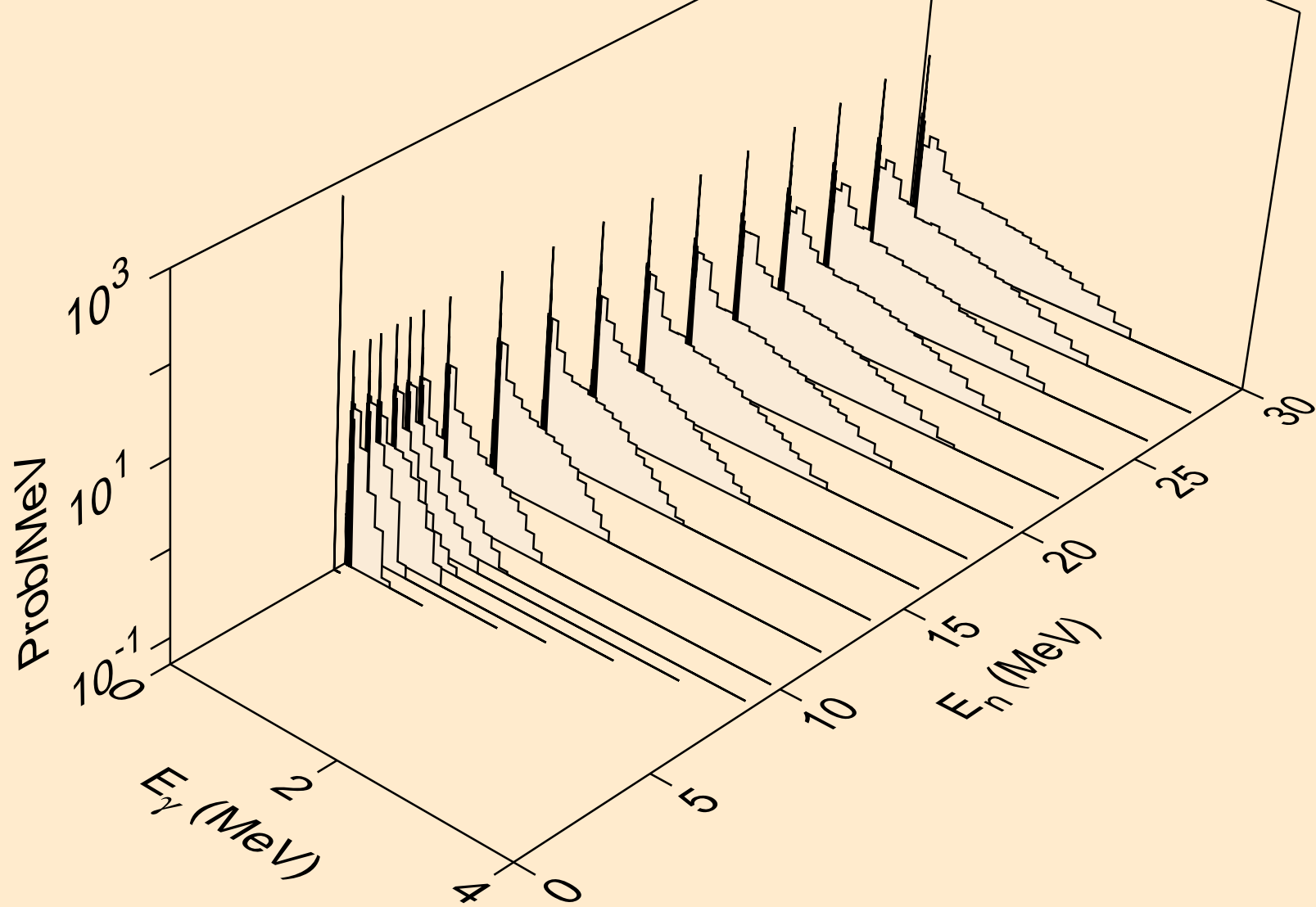

NP236M NEUTRON ACER TENDL-2023 LIBRARY; T=0.K  
Photon emission for (n,t)

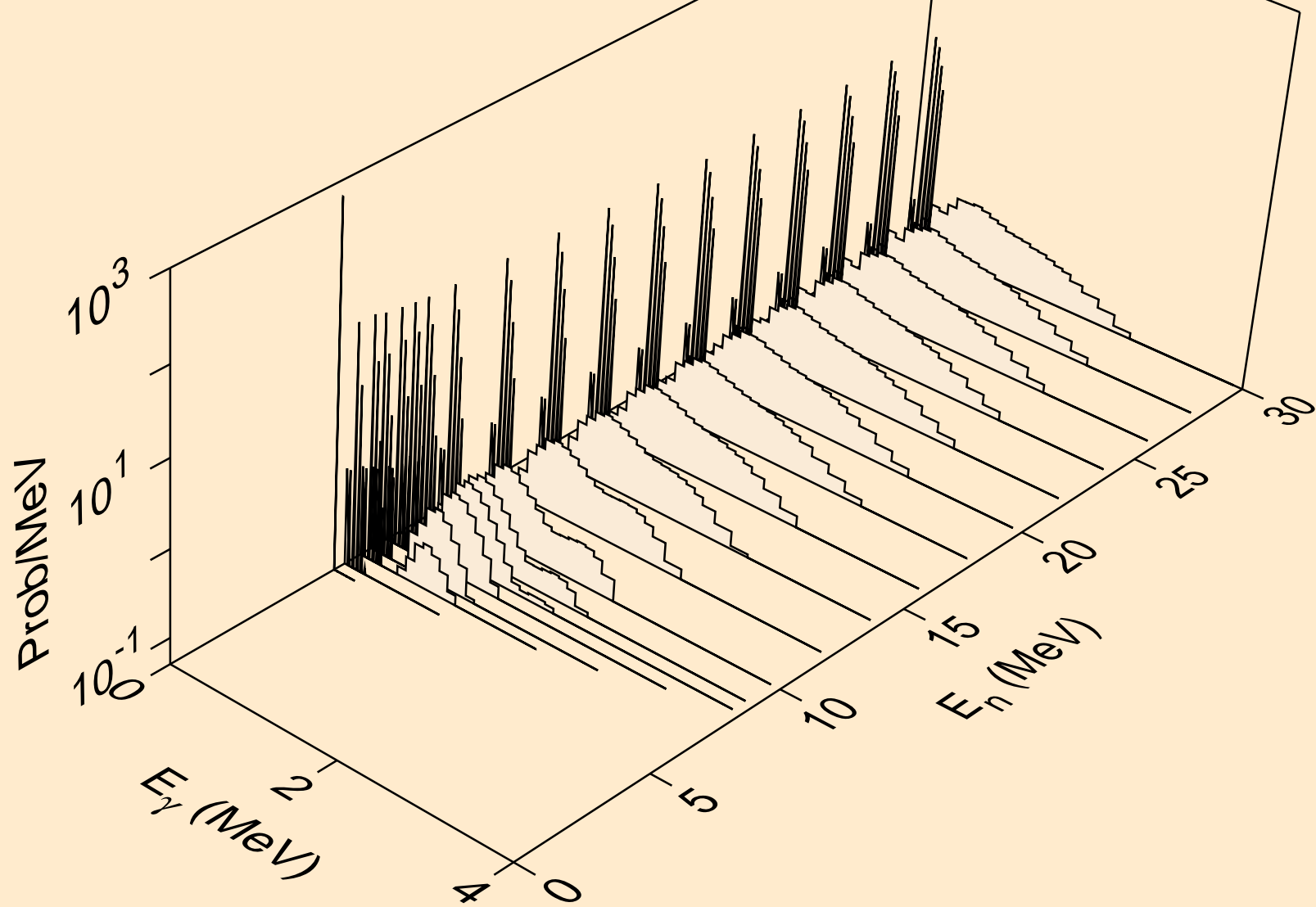

NP236M NEUTRON ACER TENDL-2023 LIBRARY; T=0.K  
Photon emission for (n,he3)

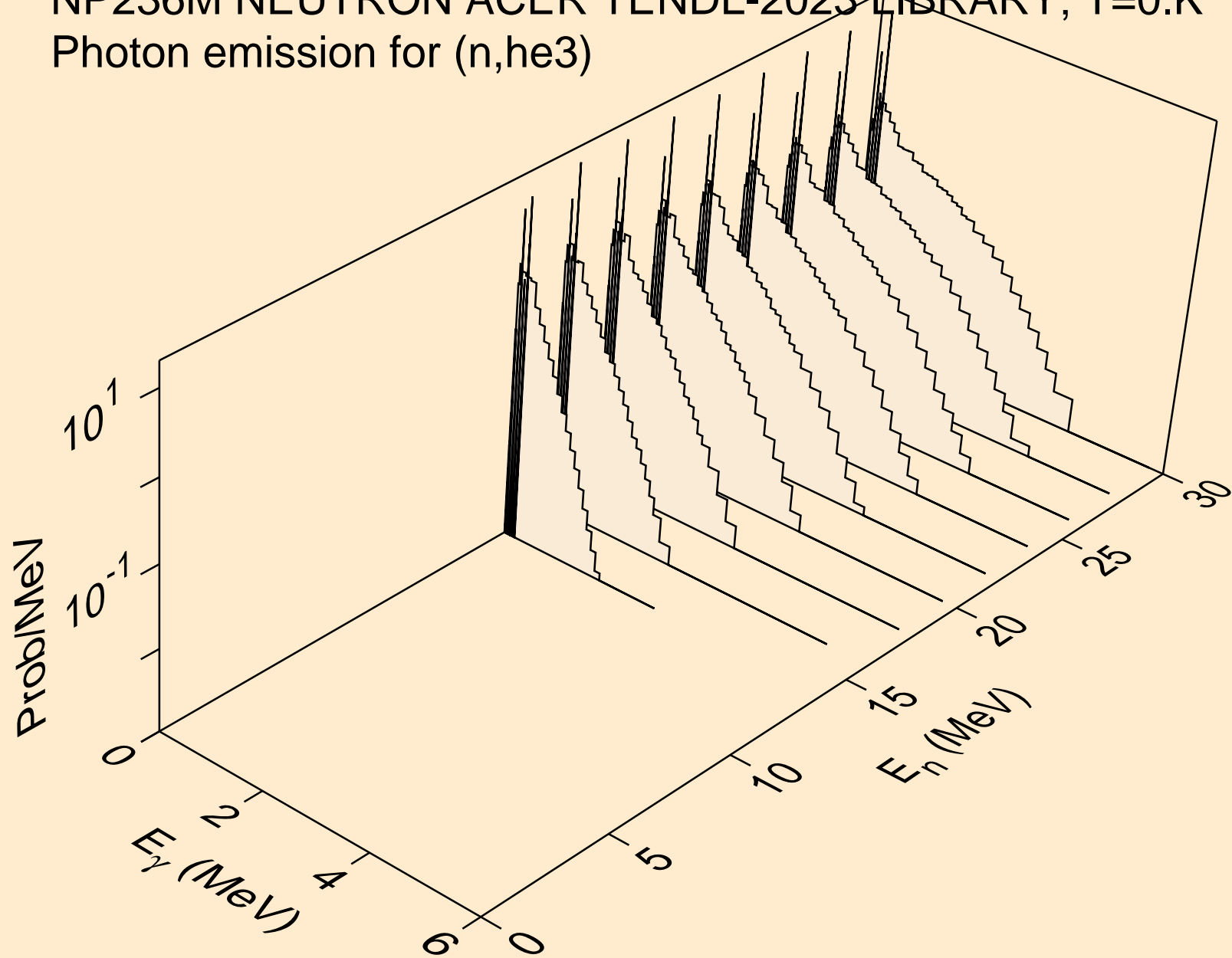

NP236M NEUTRON ACER TENDL-2023 LIBRARY; T=0.K  
Photon emission for (n,a)

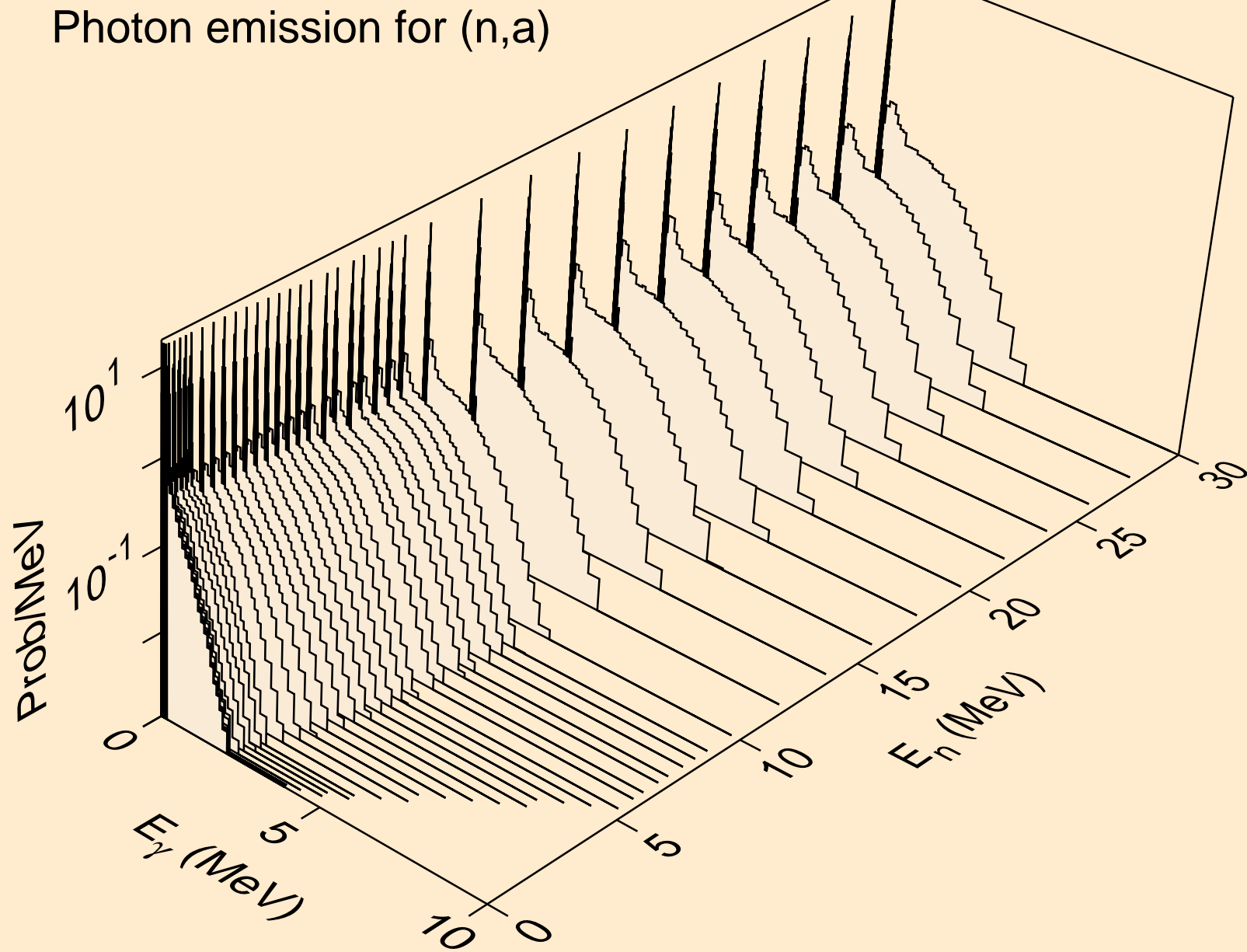

NP236M NEUTRON ACER TENDL-2023 LIBRARY; T=0.K  
Photon emission for (n,2a)

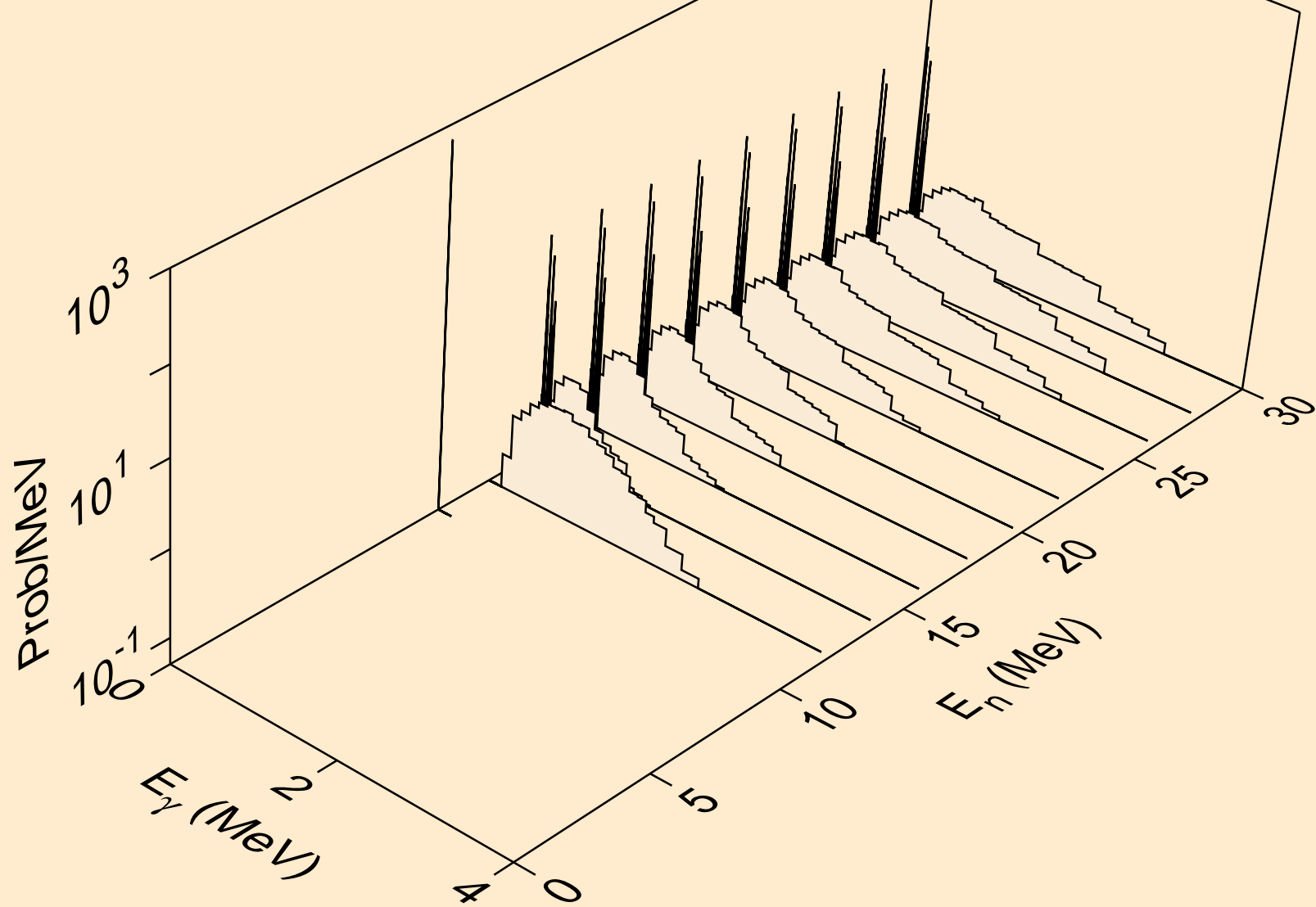

NP236M NEUTRON ACER TENDL-2023 LIBRARY; T=0.K  
Photon emission for (n,2p)

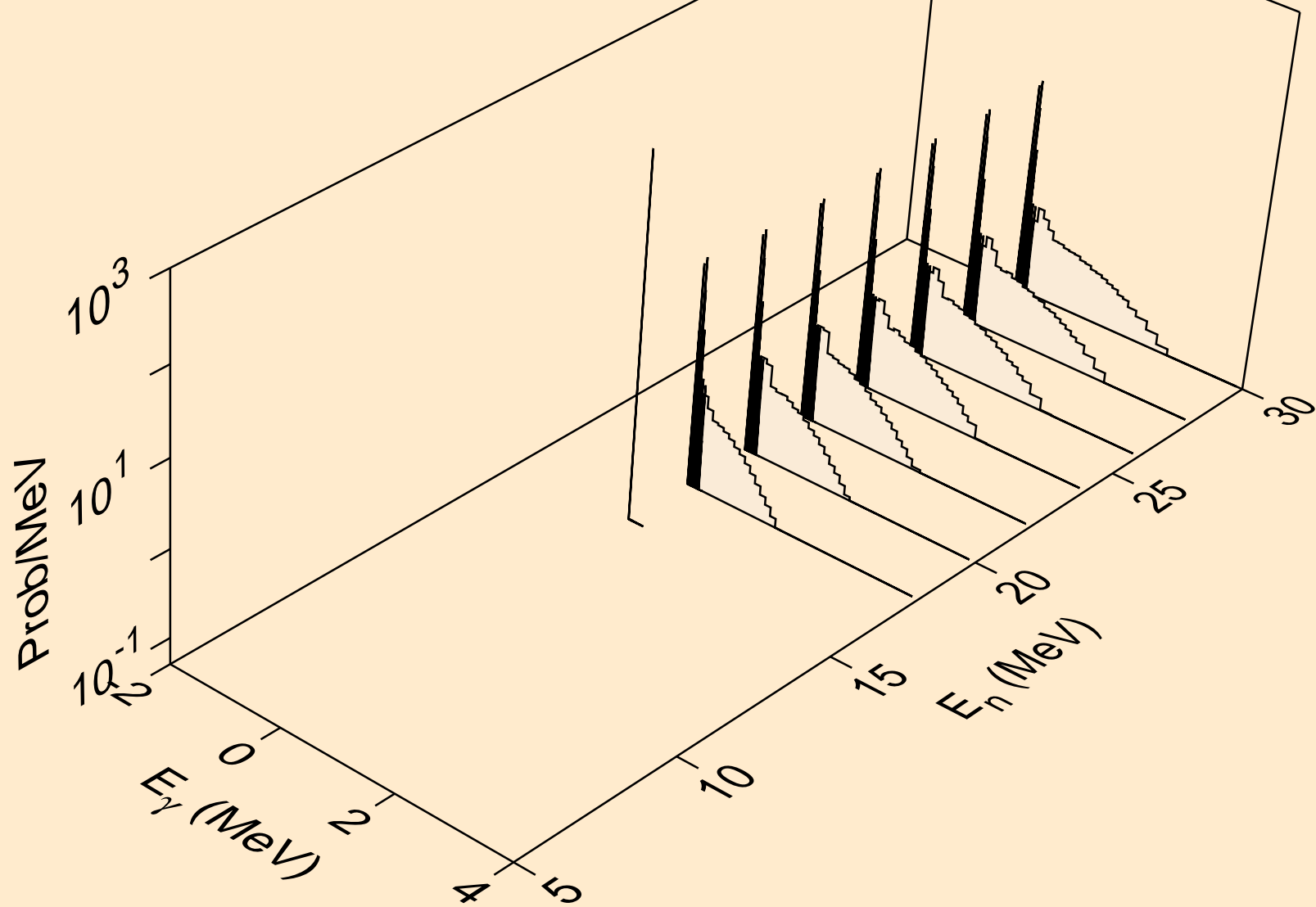



NP236M NEUTRON ACER TENDL-2023 LIBRARY; T=0.K  
Photon emission for (n,pa)

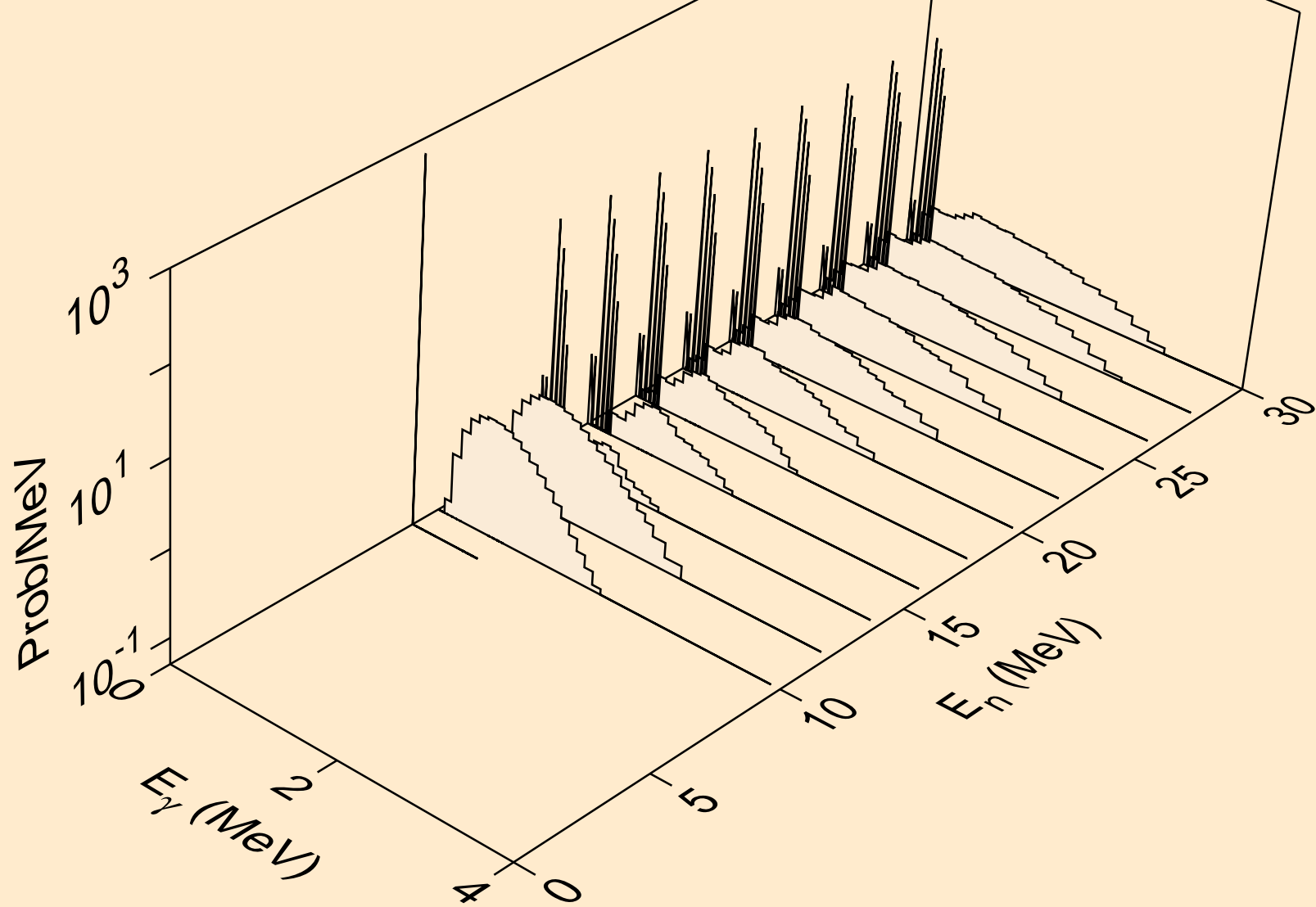

NP236M NEUTRON ACER TENDL-2023 LIBRARY; T=0.K  
thermal capture photon spectrum

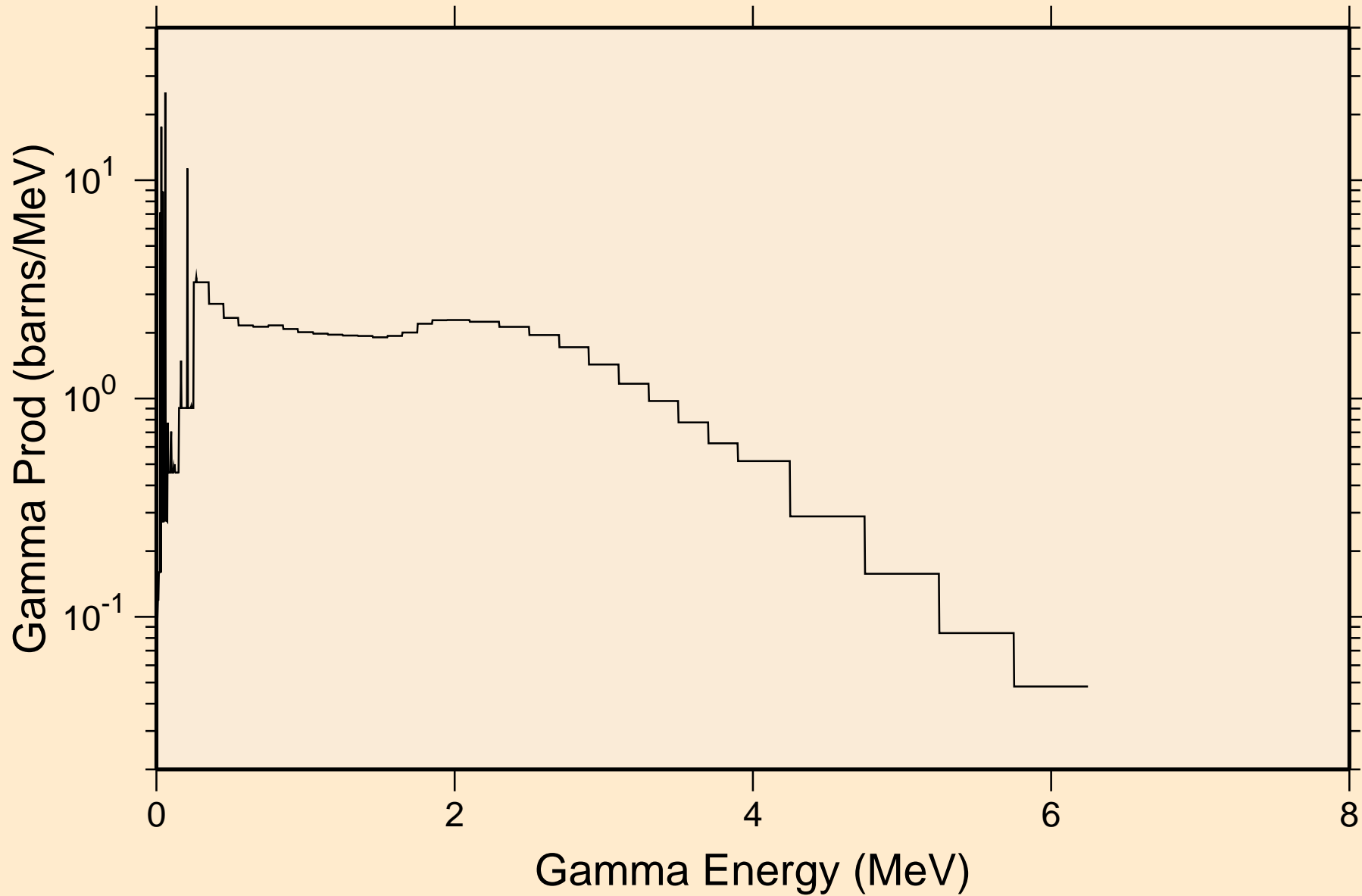

NP236M NEUTRON ACER TENDL-2023 LIBRARY; T=0.K  
14 MeV photon spectrum

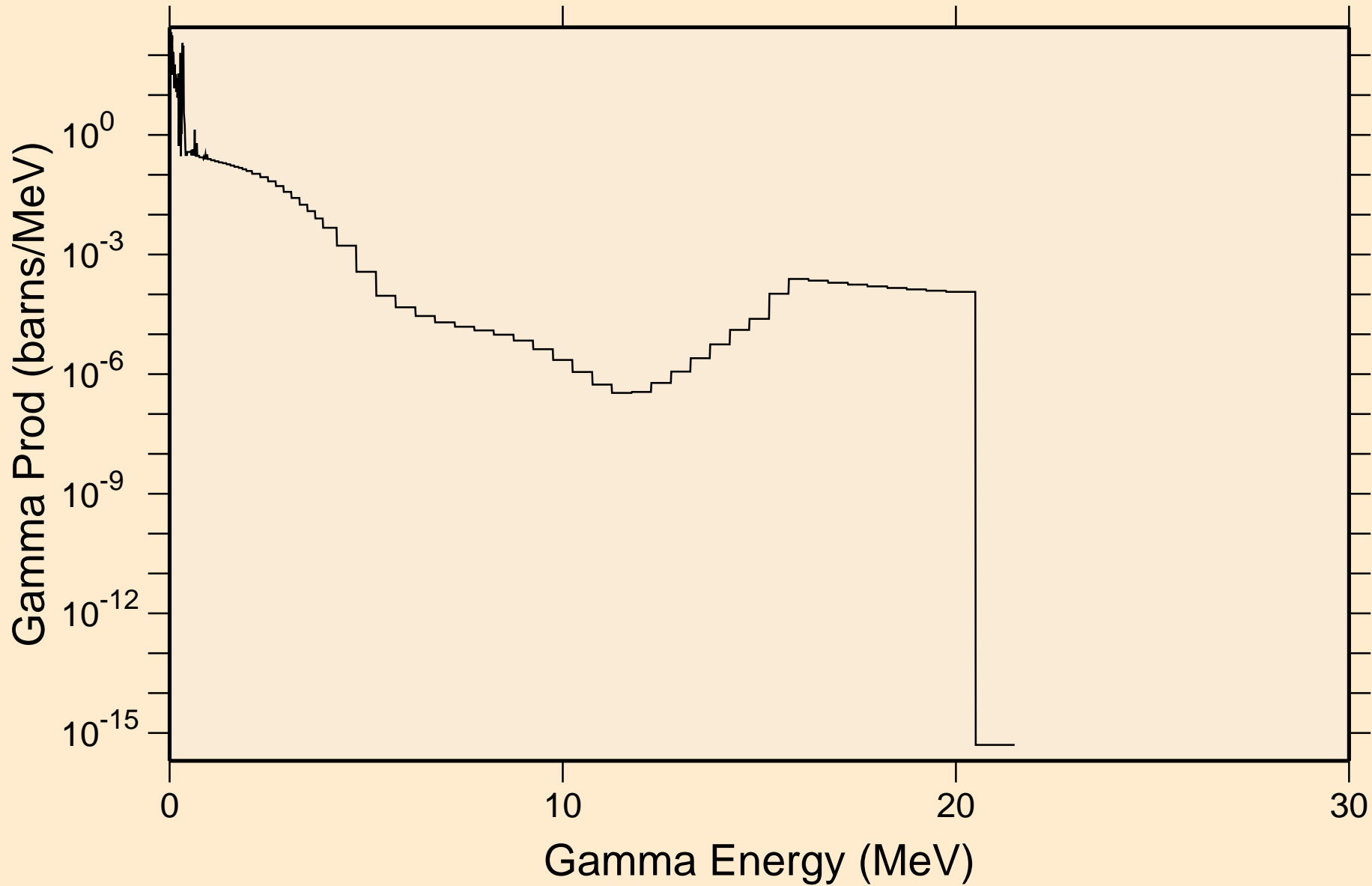

# NP236M NEUTRON ACER TENDL-2023 LIBRARY; T=0.K

## Particle heating contributions

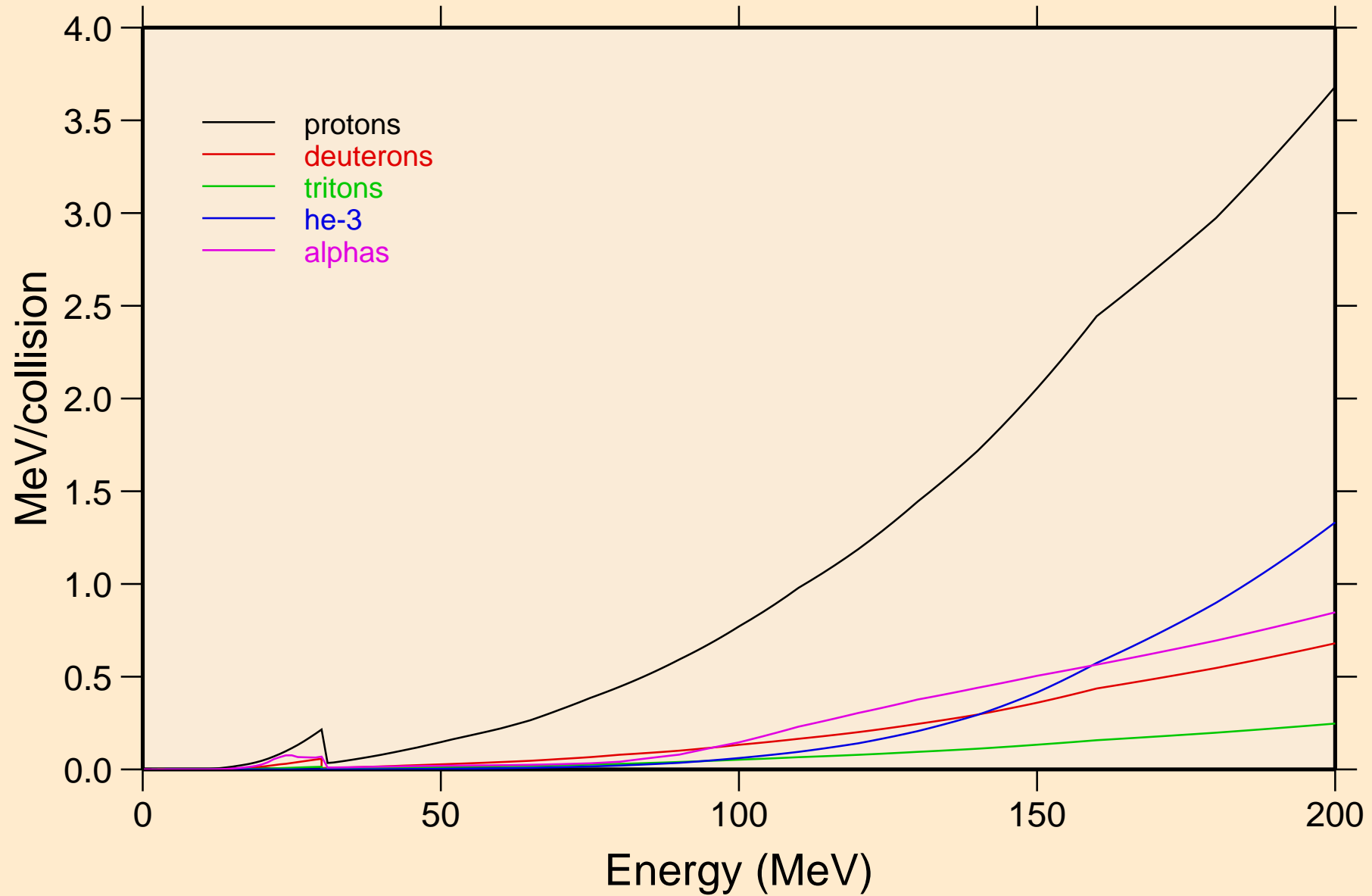

NP236M NEUTRON ACER TENDL-2023 LIBRARY; T=0.K  
Recoil Heating

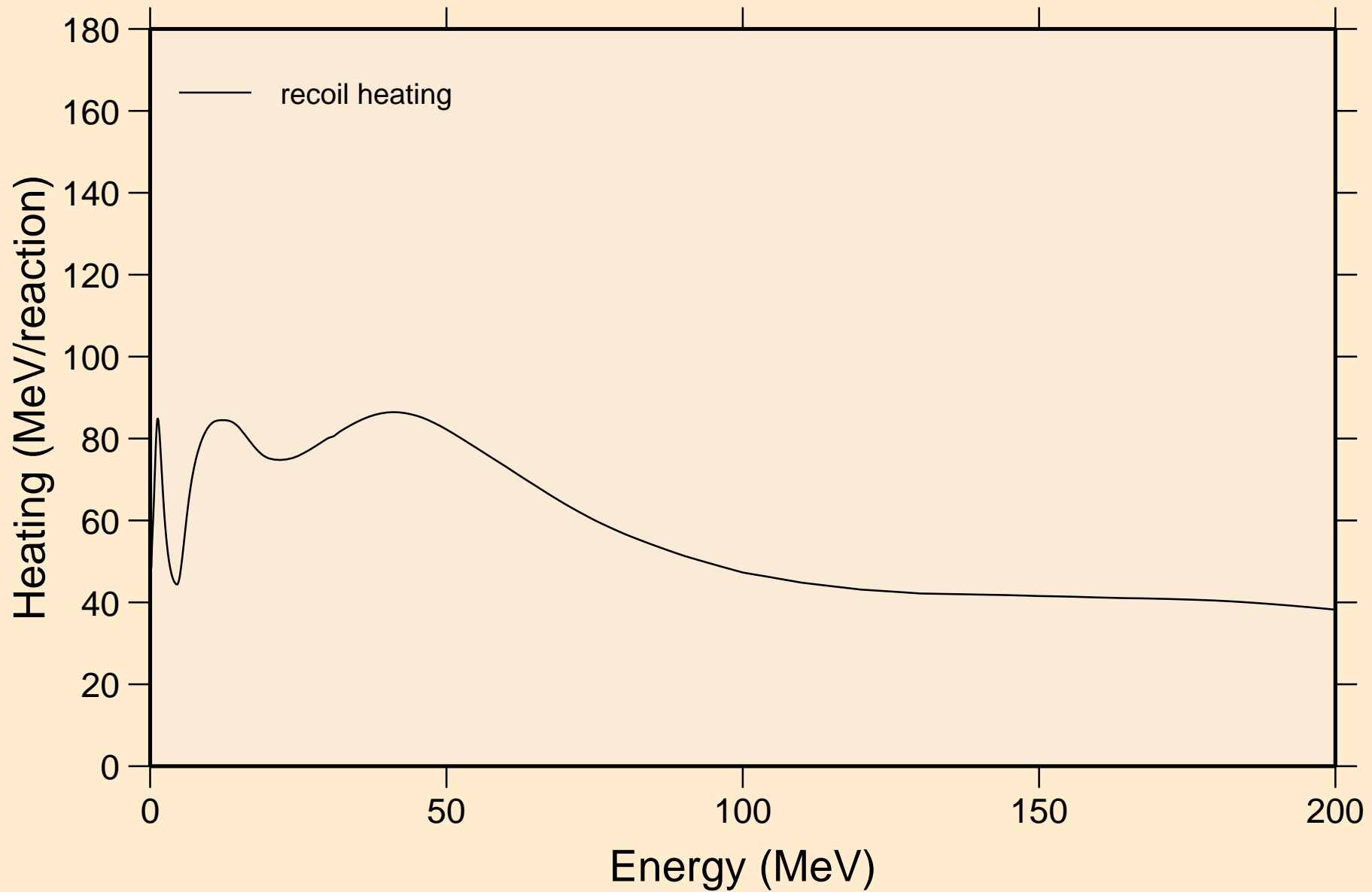

# NP236M NEUTRON ACER TENDL-2023 LIBRARY; T=0.K

## Particle production cross sections

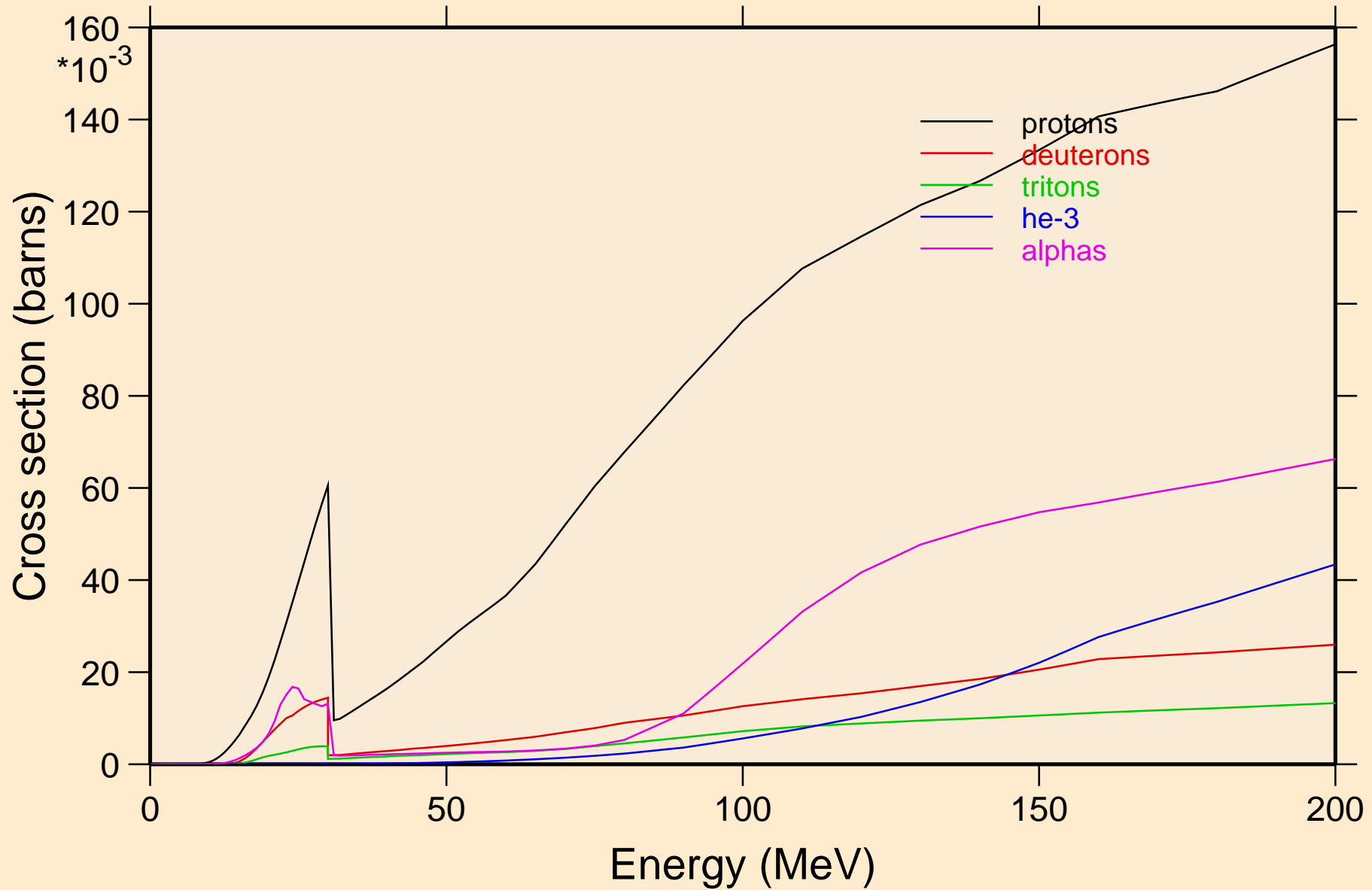

NP236M NEUTRON ACER TENDL-2023 LIBRARY; T=0.K  
protons from (n,x)

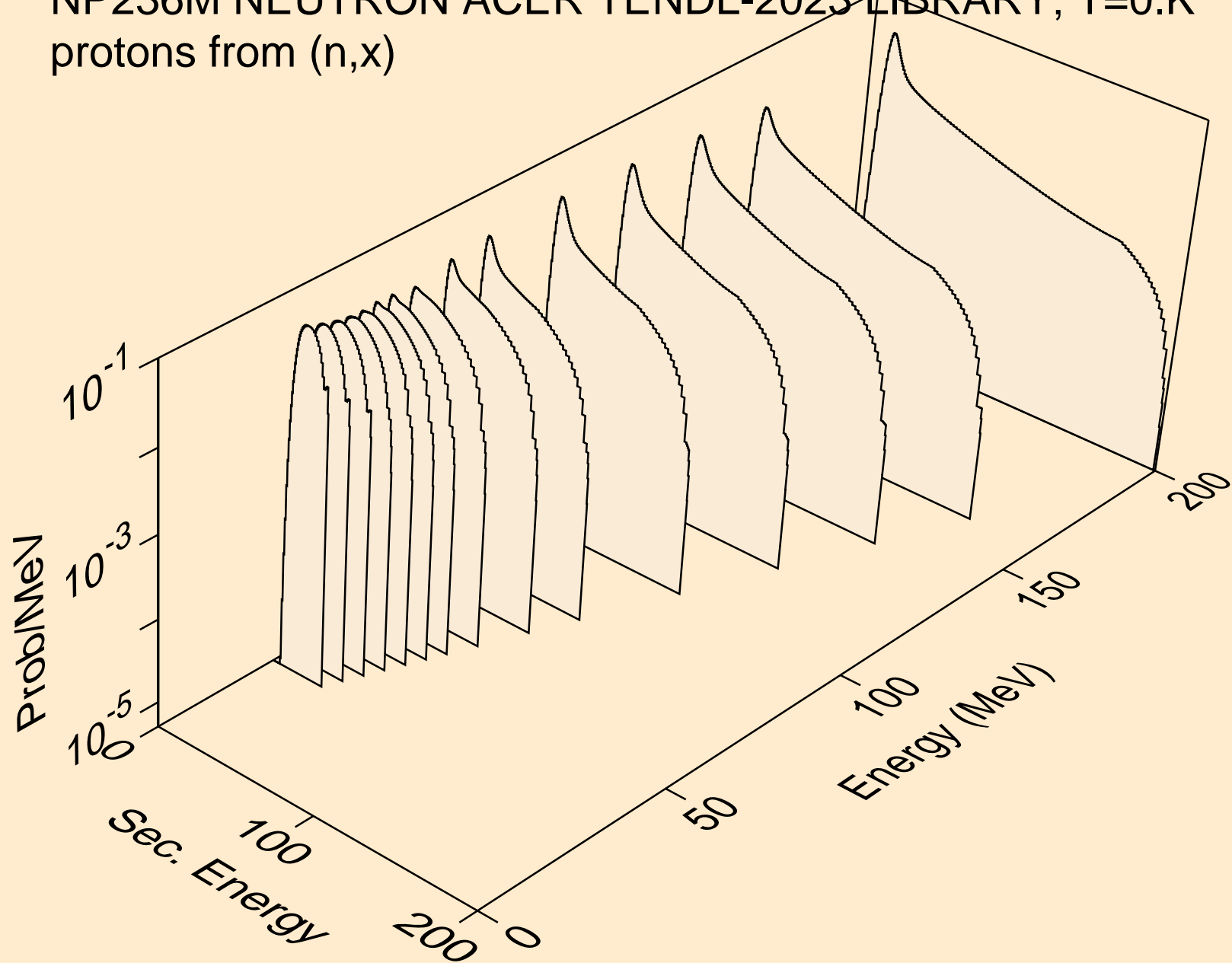

NP236M NEUTRON ACER TENDL-2023 LIBRARY; T=0.K  
protons from (n,n\*)p

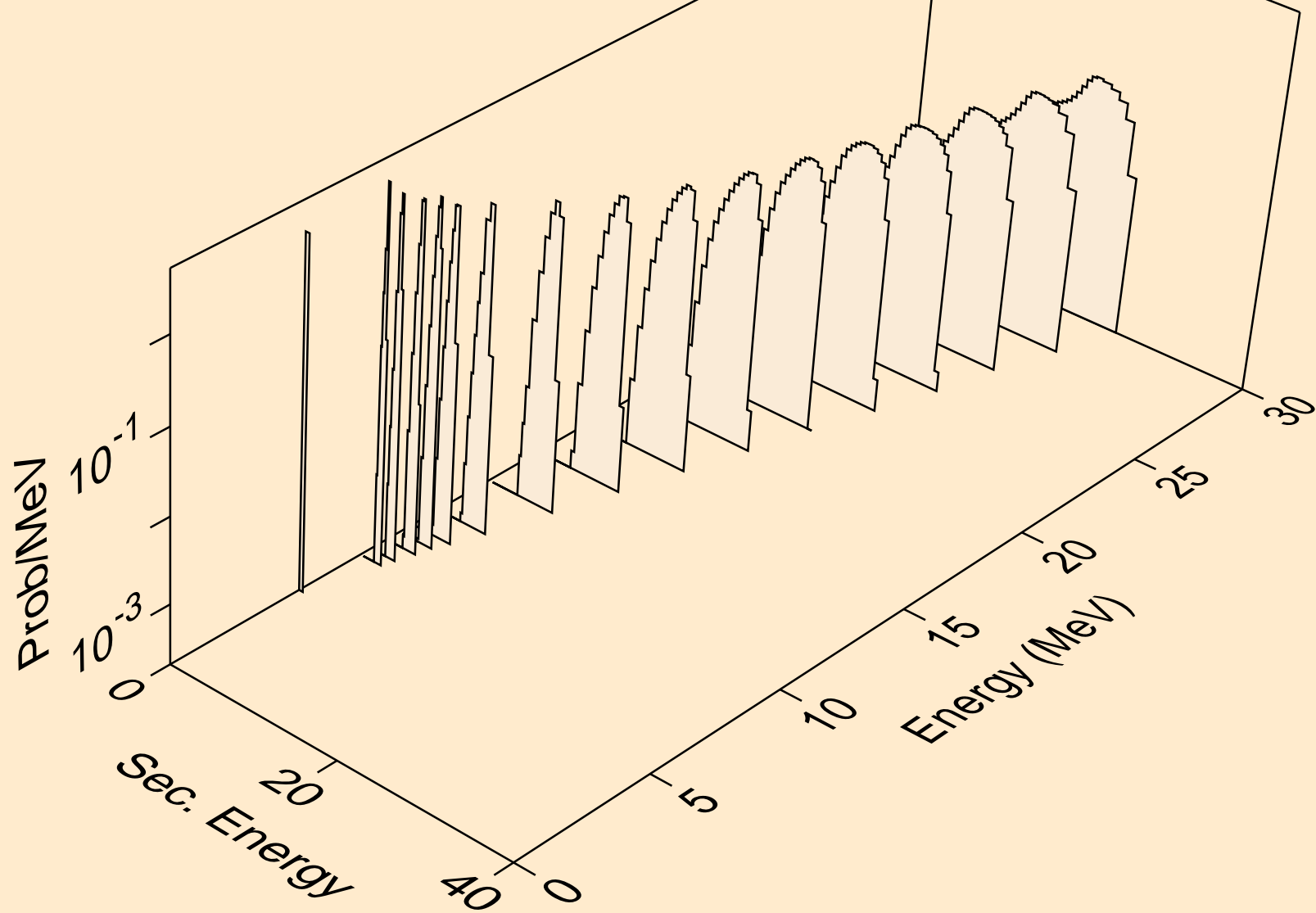



NP236M NEUTRON ACER TENDL-2023 LIBRARY; T=0.K  
protons from (n,2np)

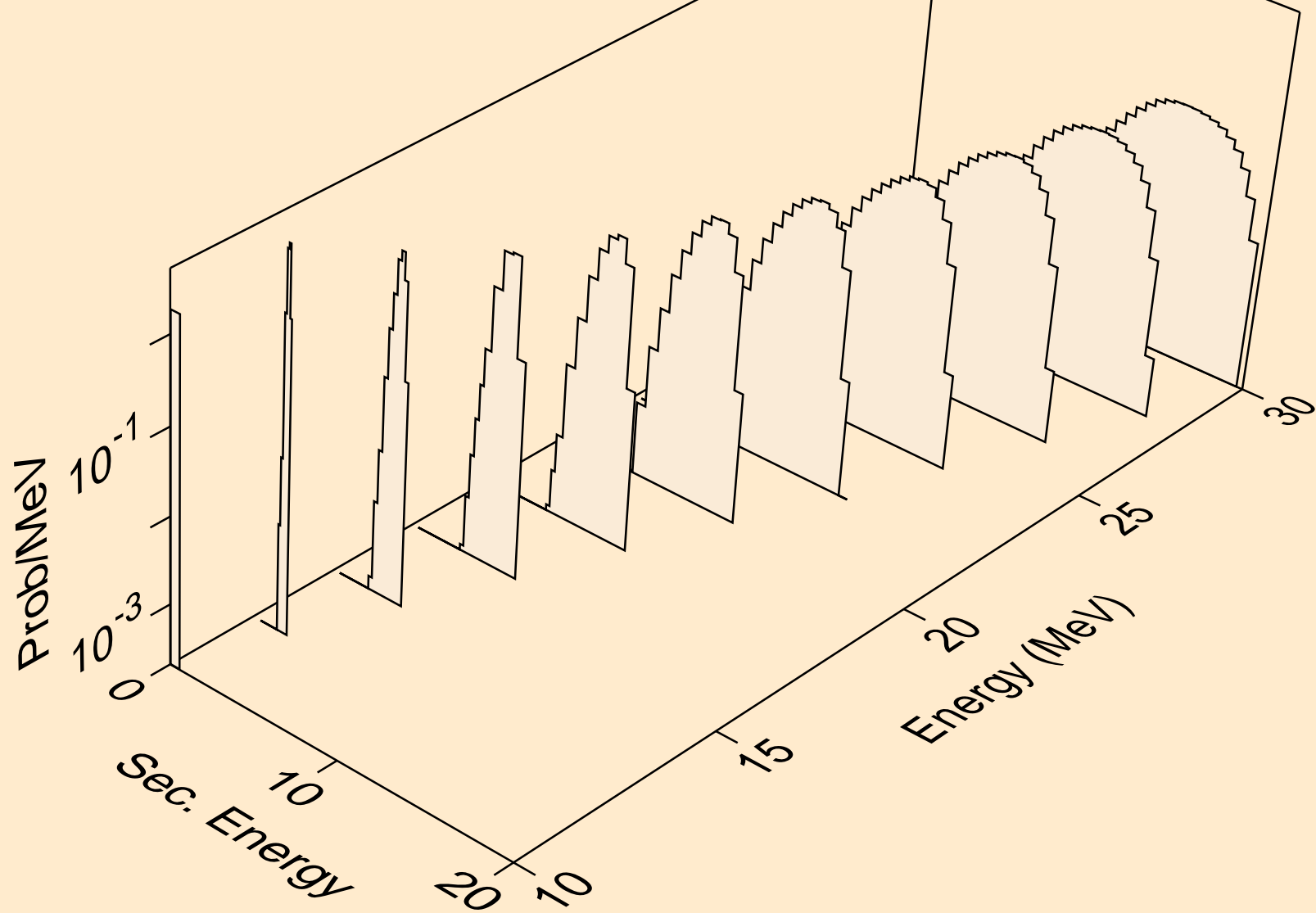

NP236M NEUTRON ACER TENDL-2023 LIBRARY; T=0.K  
protons from (n,3np)

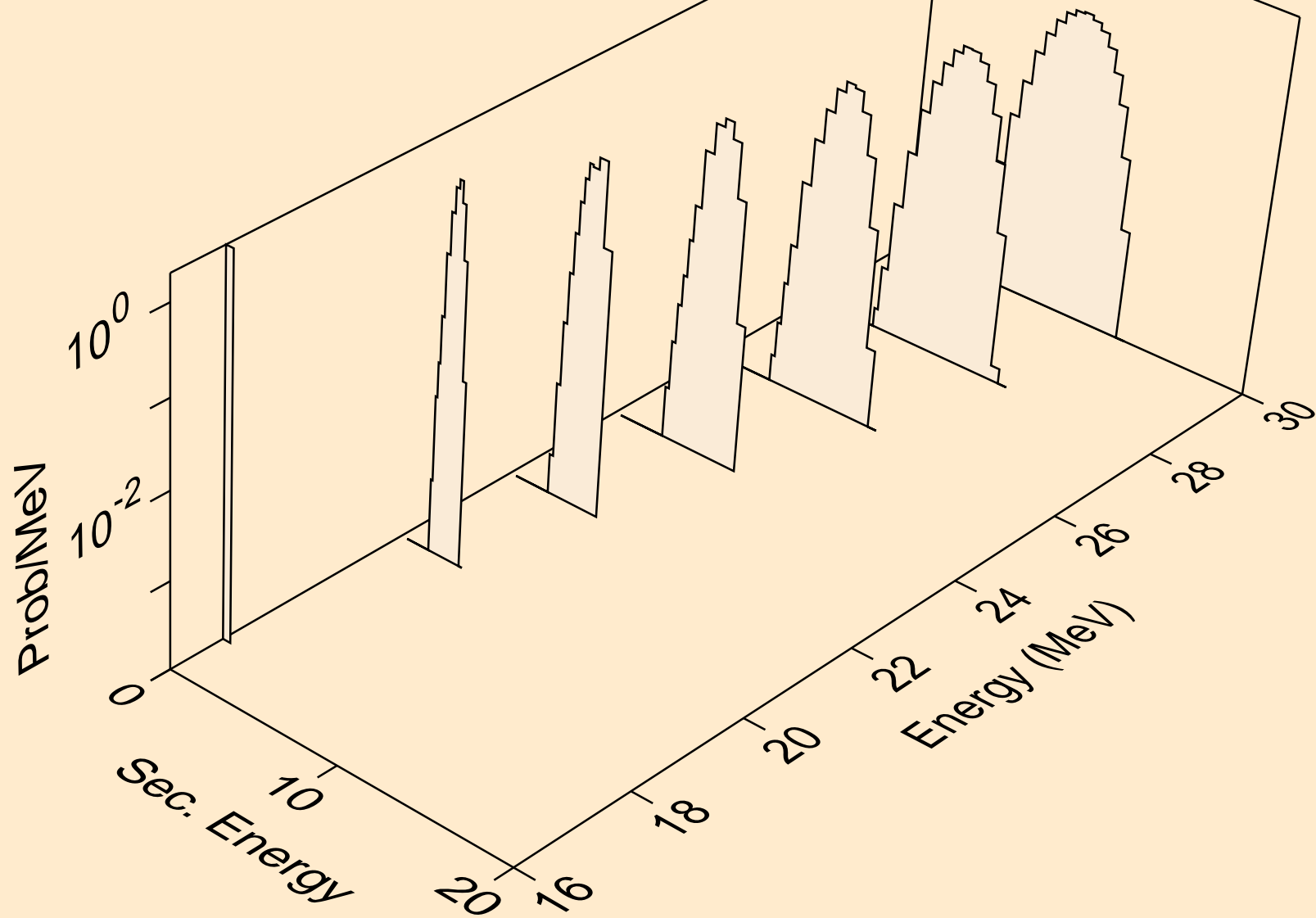

NP236M NEUTRON ACER TENDL-2023 LIBRARY; T=0.K  
protons from (n,n2p)

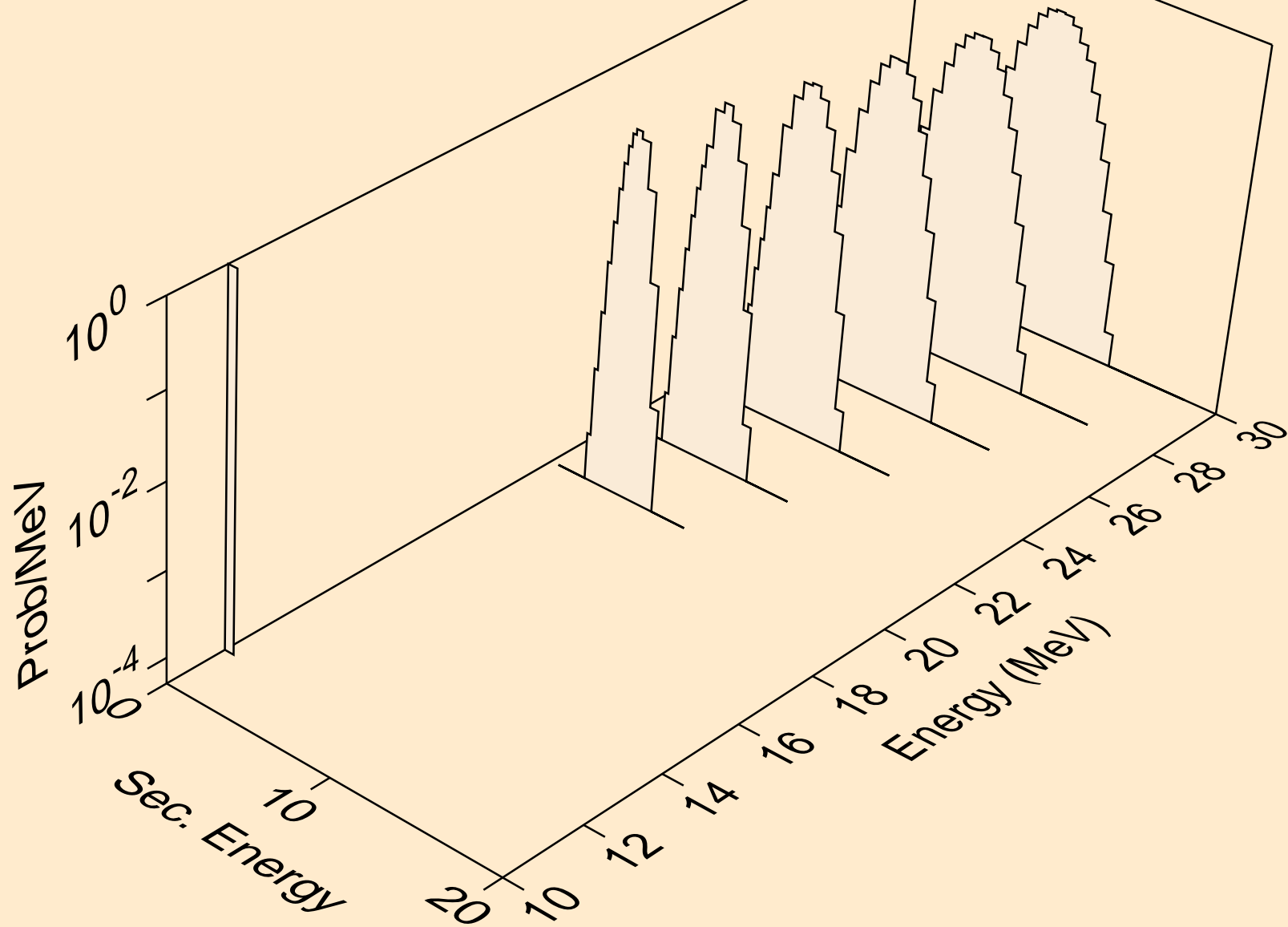

NP236M NEUTRON ACER TENDL-2023 LIBRARY; T=0.K  
protons from (n,npa)

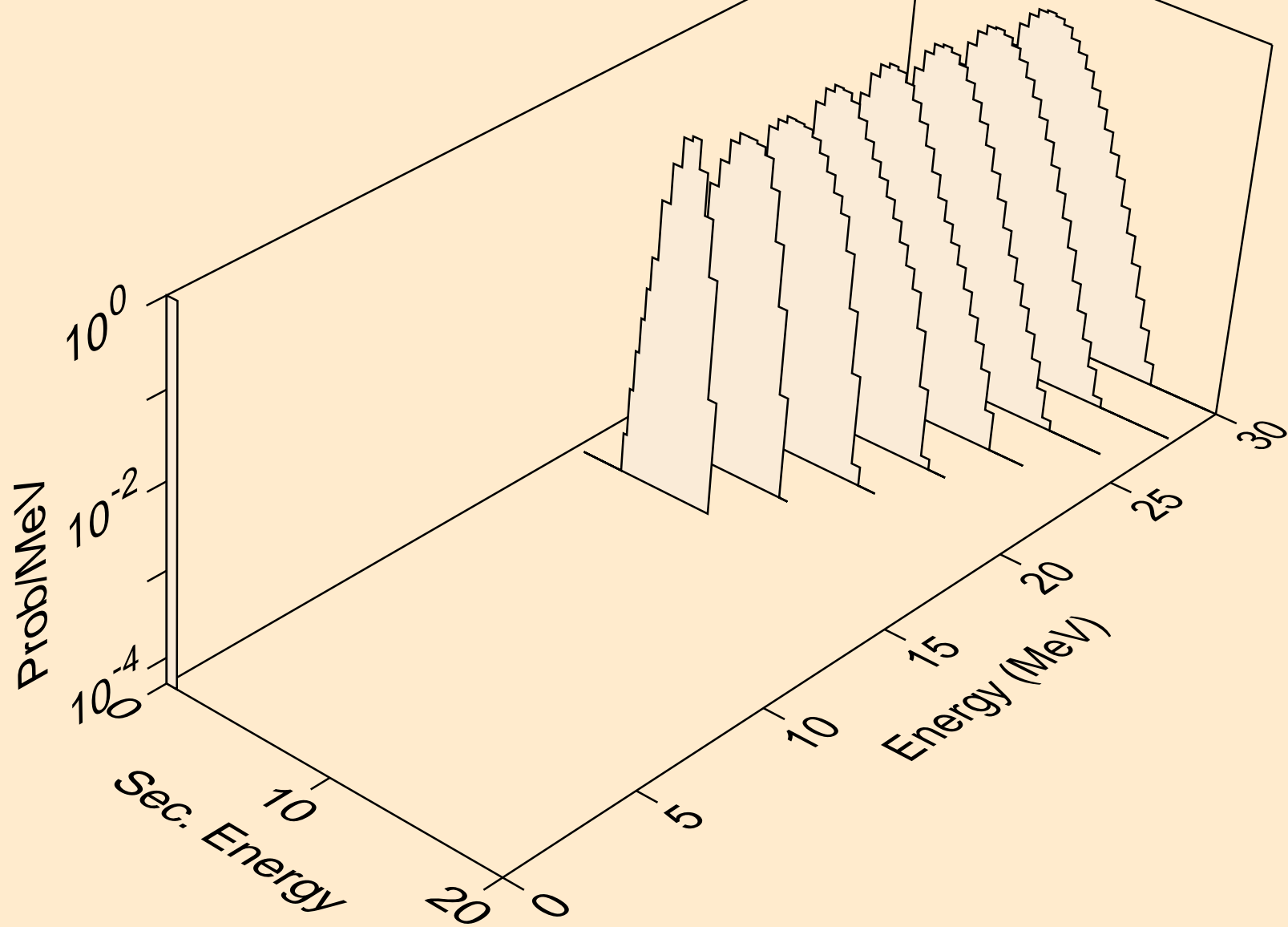

NP236M NEUTRON ACER TENDL-2023 LIBRARY; T=0.K  
protons from (n,p)

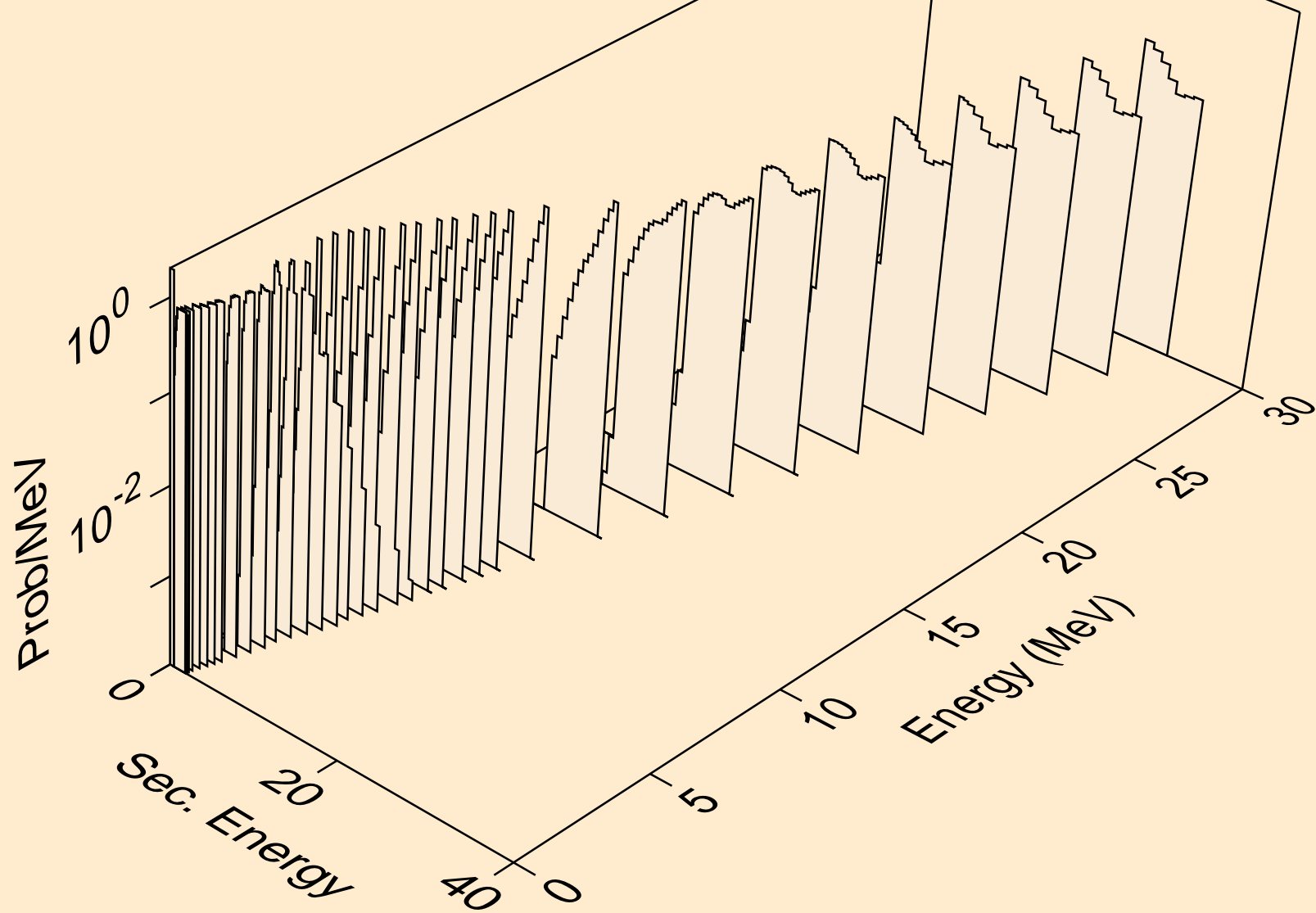

NP236M NEUTRON ACER TENDL-2023 LIBRARY; T=0.K  
protons from (n,2p)

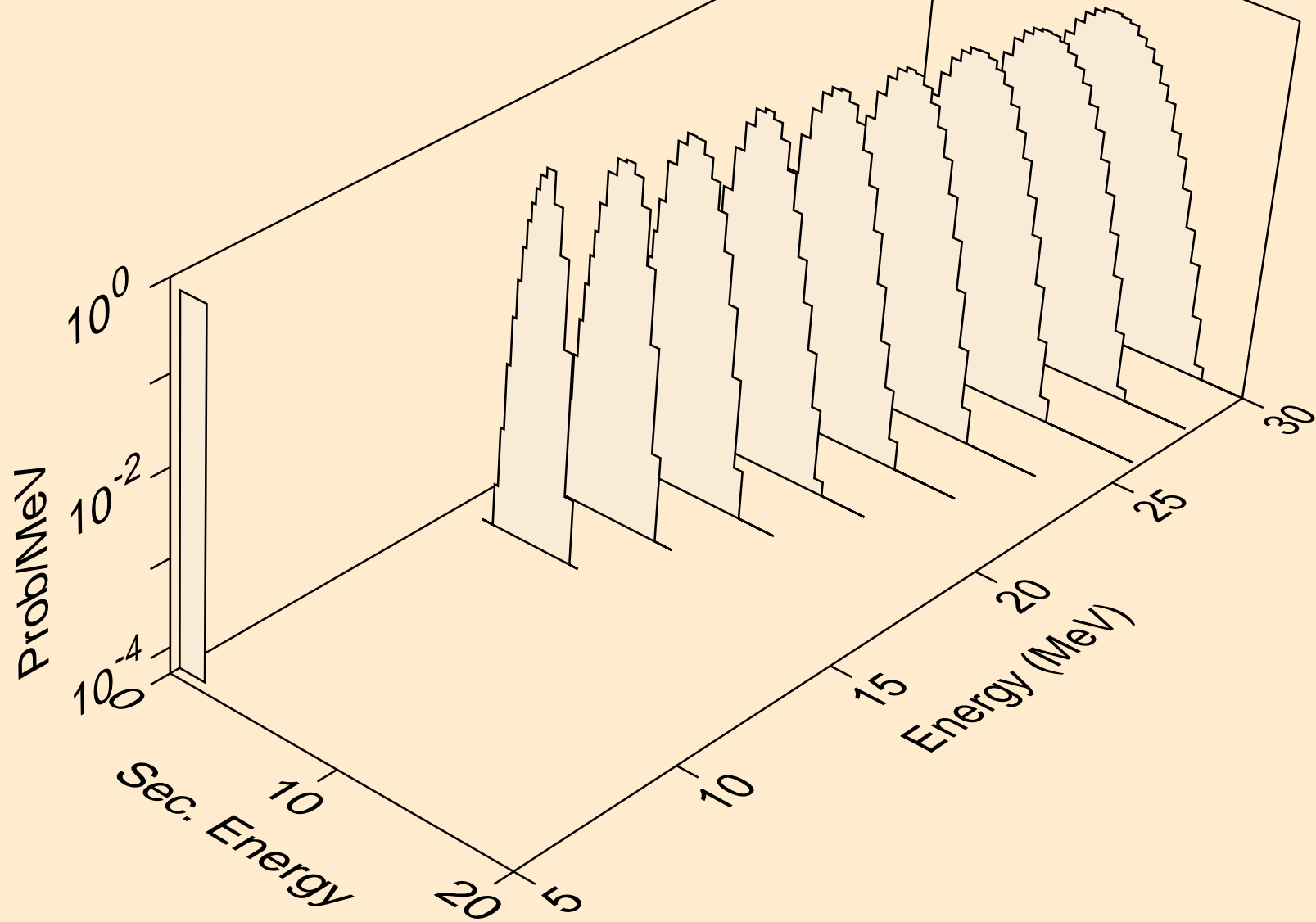

NP236M NEUTRON ACER TENDL-2023 LIBRARY; T=0.K  
protons from (n,p)

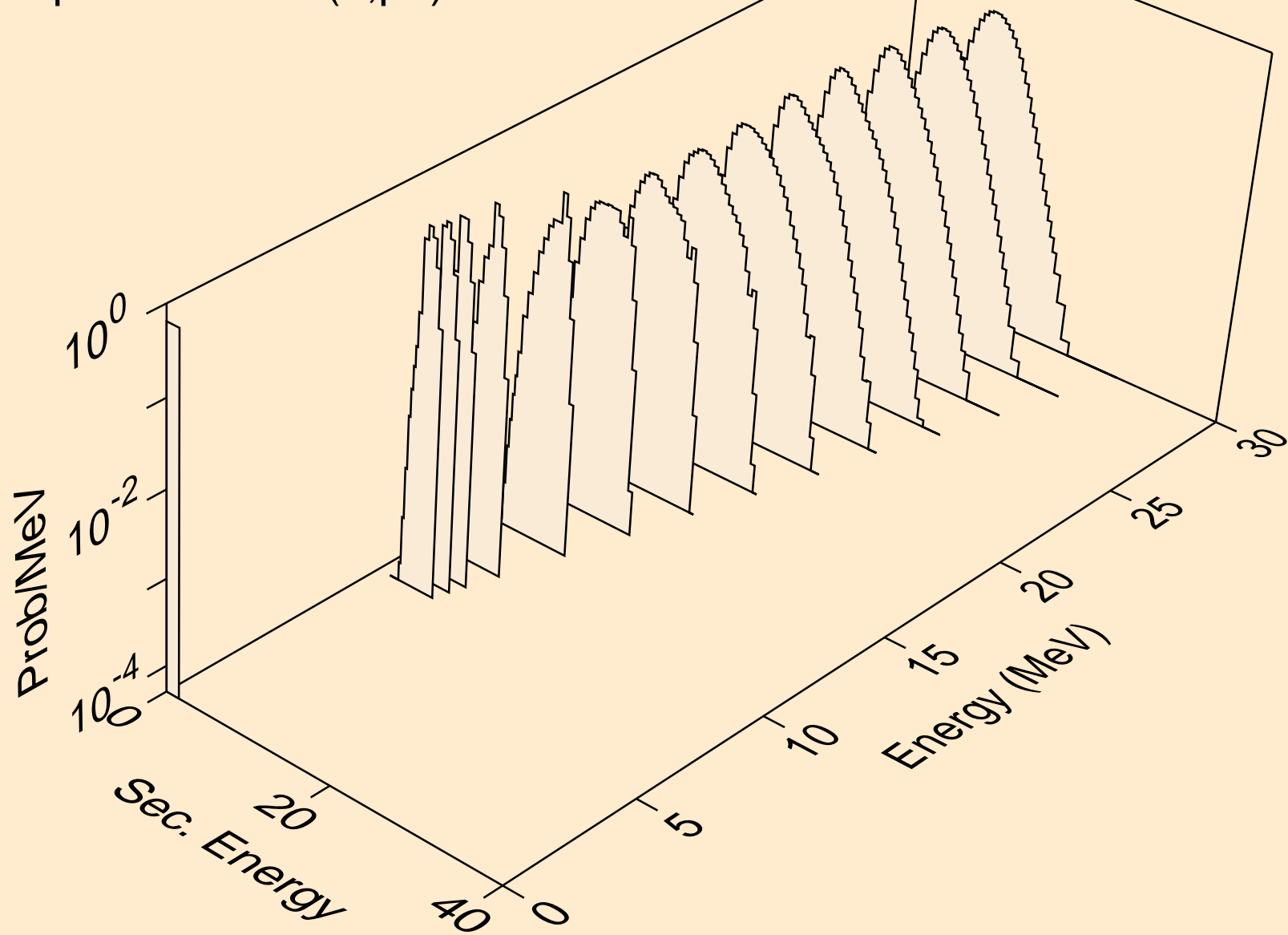

NP236M NEUTRON ACER TENDL-2023 LIBRARY; T=0.K  
deuterons from (n,x)

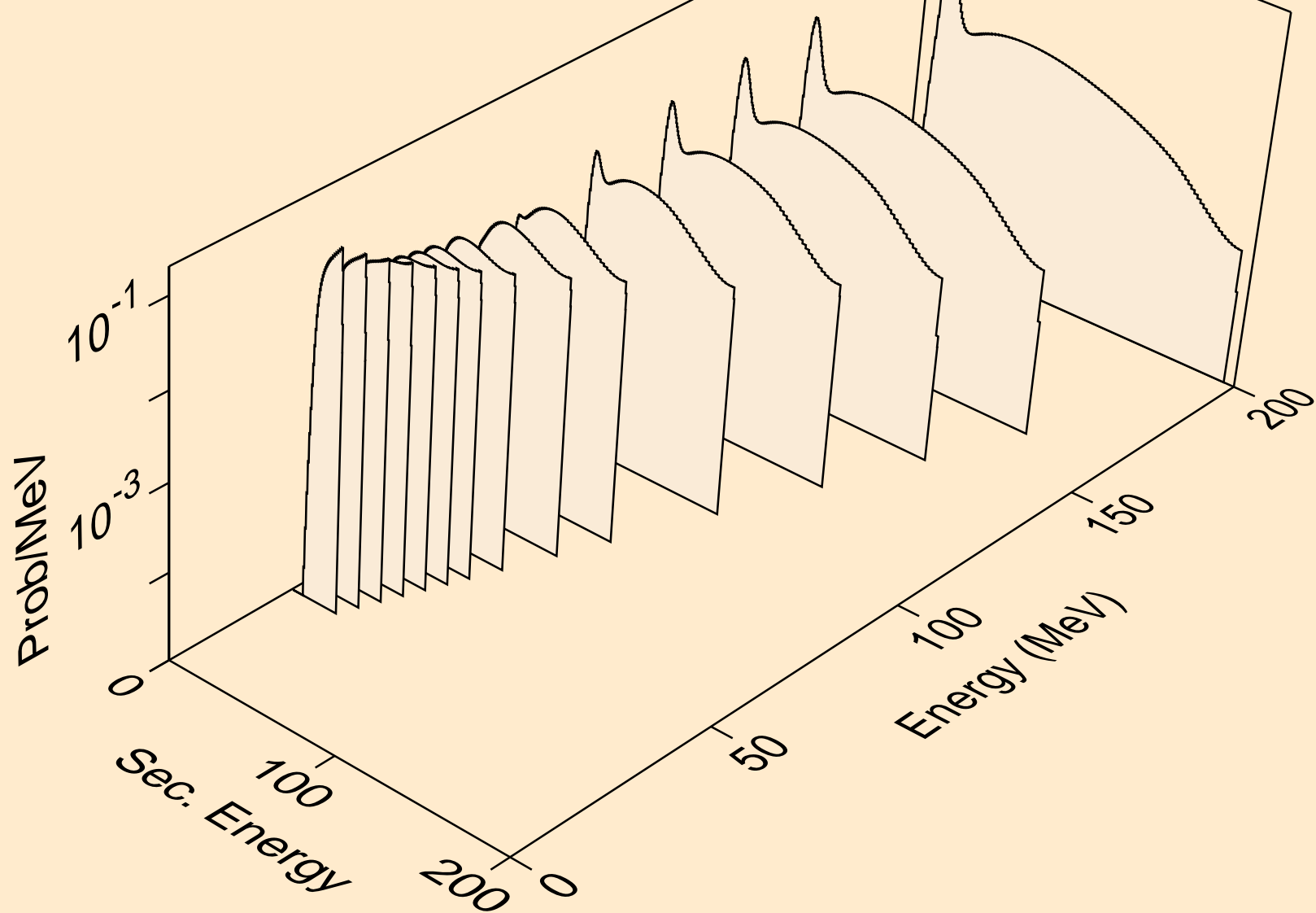



NP236M NEUTRON ACER TENDL-2023 LIBRARY; T=0.K  
deuterons from (n,2nd)

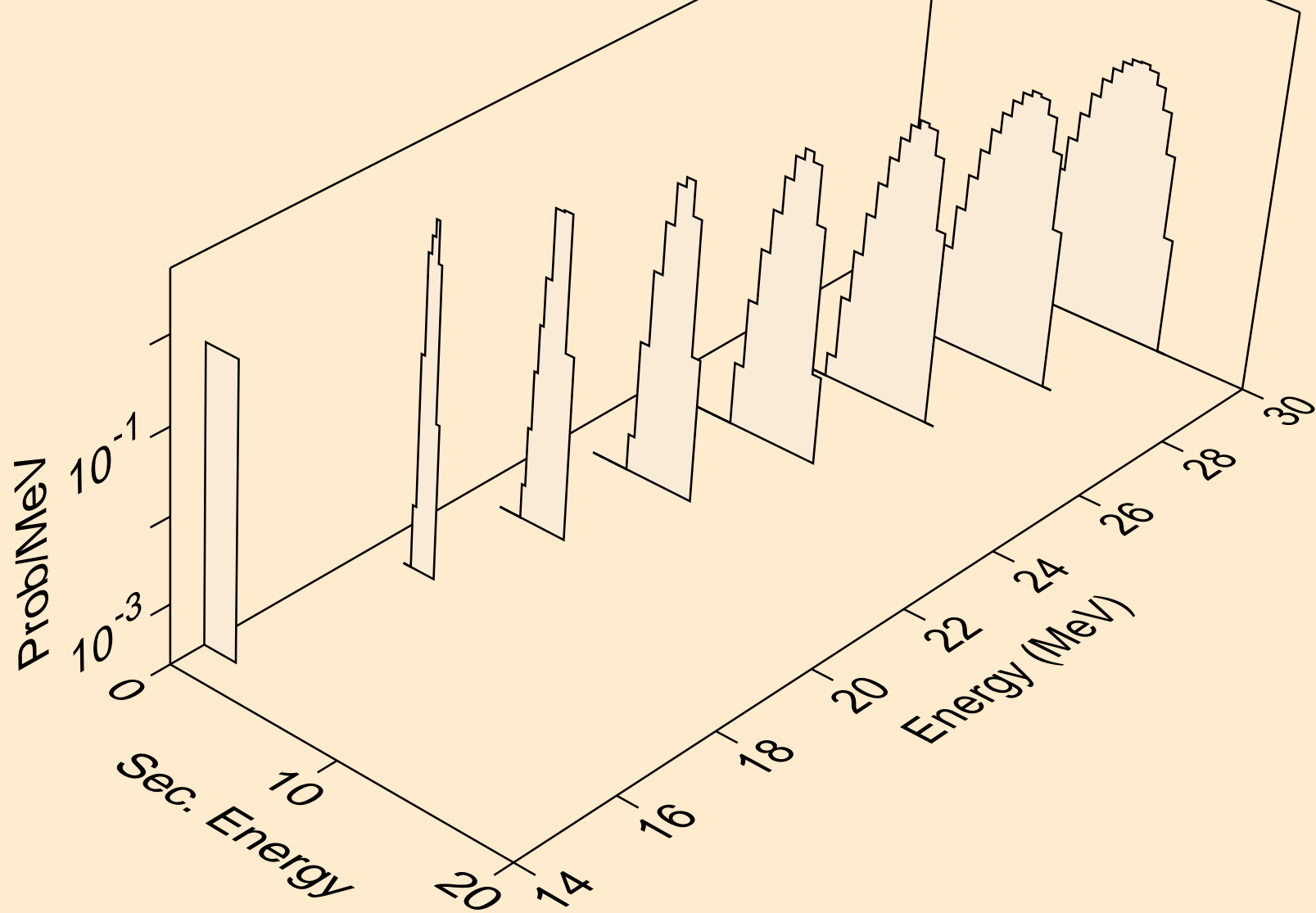

NP236M NEUTRON ACER TENDL-2023 LIBRARY; T=0.K  
deuterons from (n,n\*)d

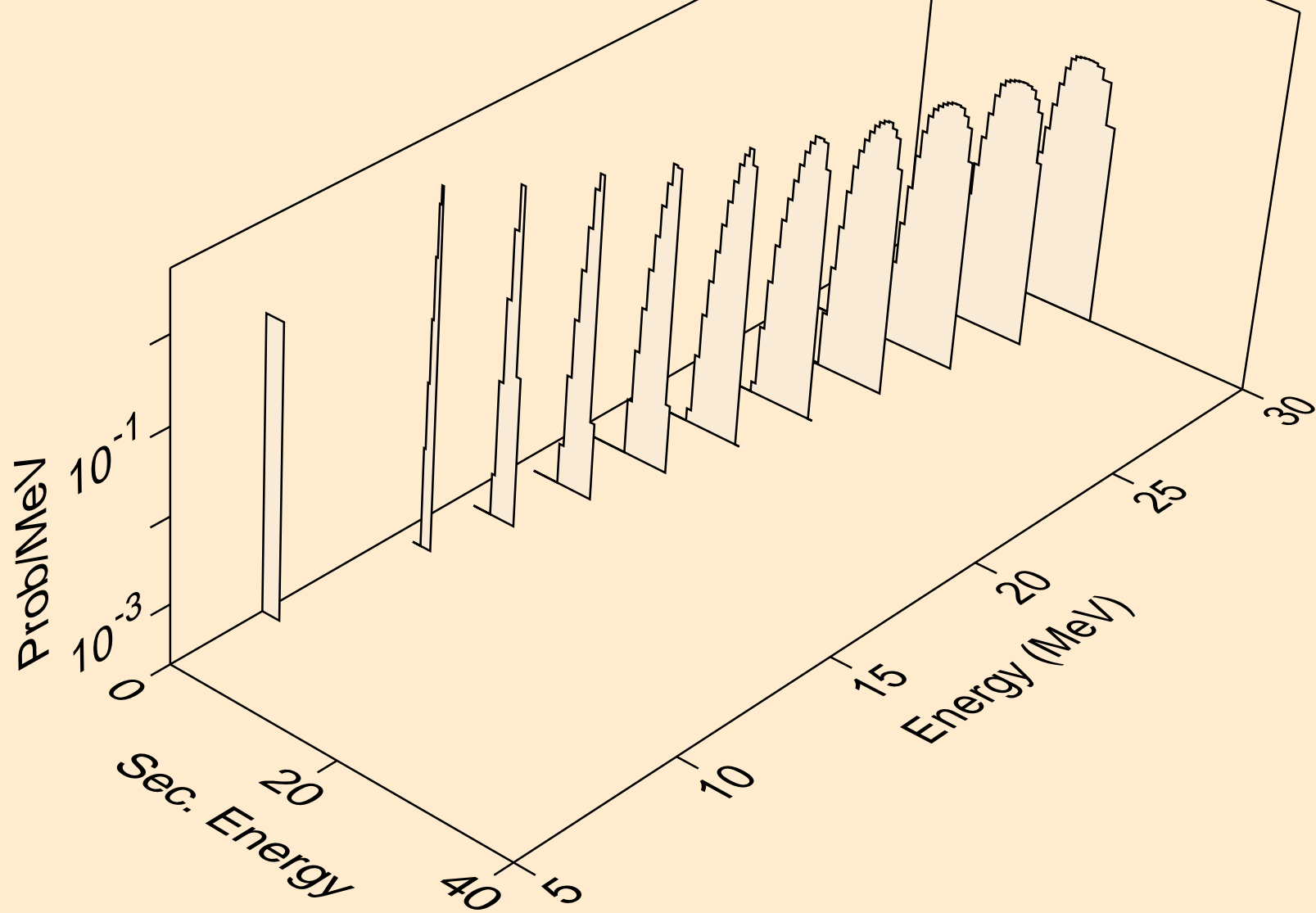

NP236M NEUTRON ACER TENDL-2023 LIBRARY; T=0.K  
deuterons from (n,d)

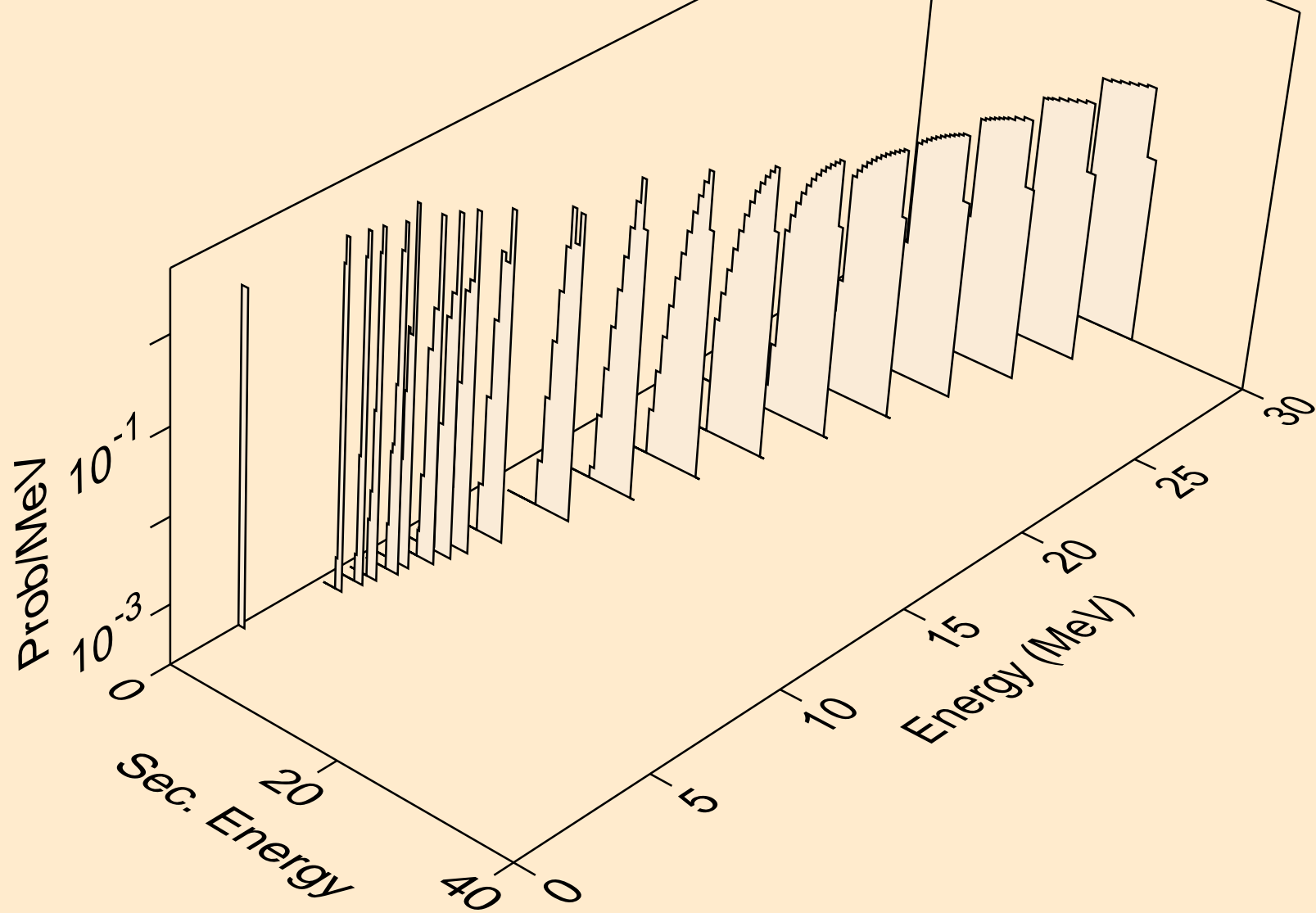

NP236M NEUTRON ACER TENDL-2023 LIBRARY; T=0.K  
tritons from (n,x)

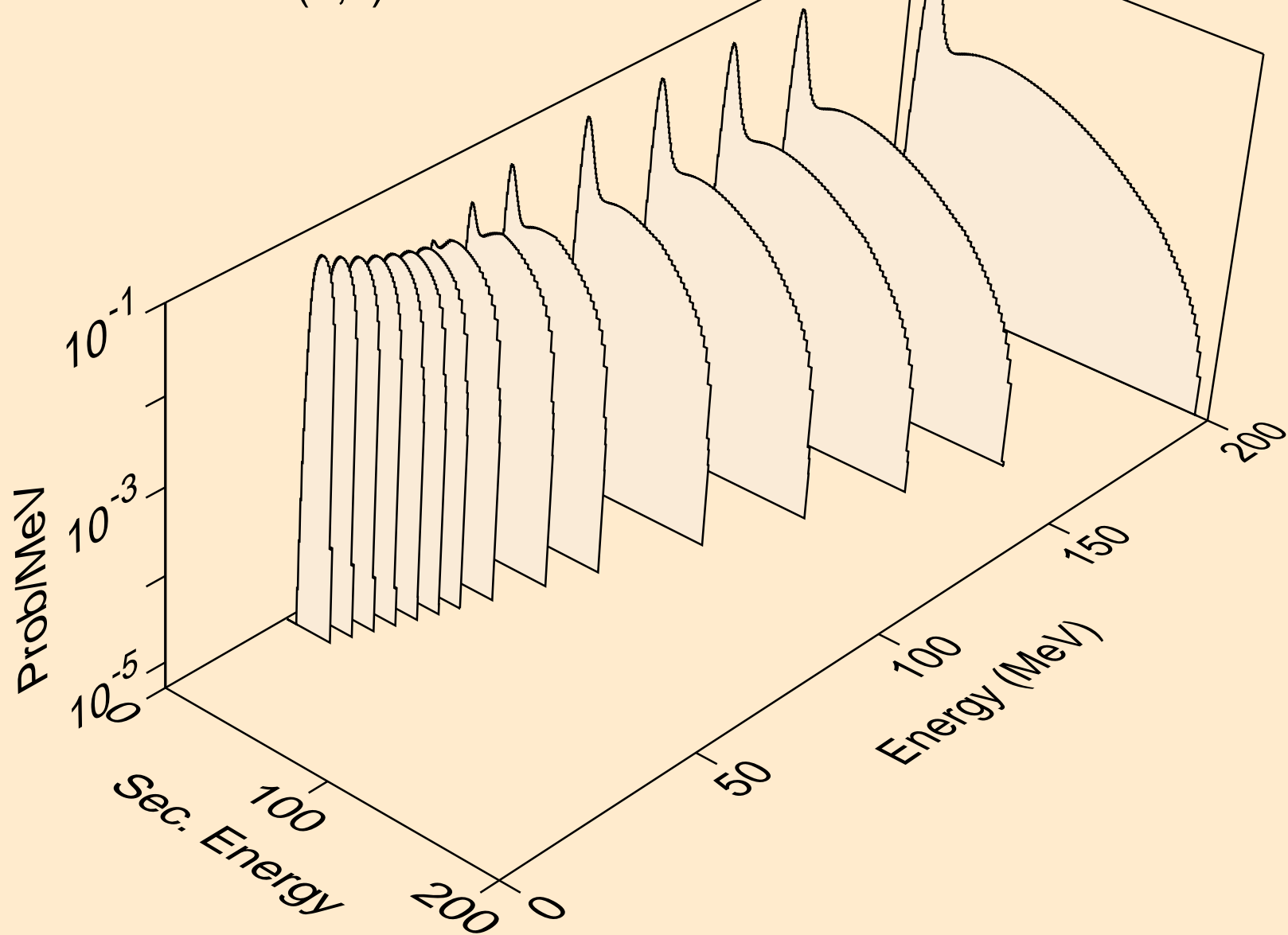

NP236M NEUTRON ACER TENDL-2023 LIBRARY; T=0.K  
tritons from (n,n\*)t

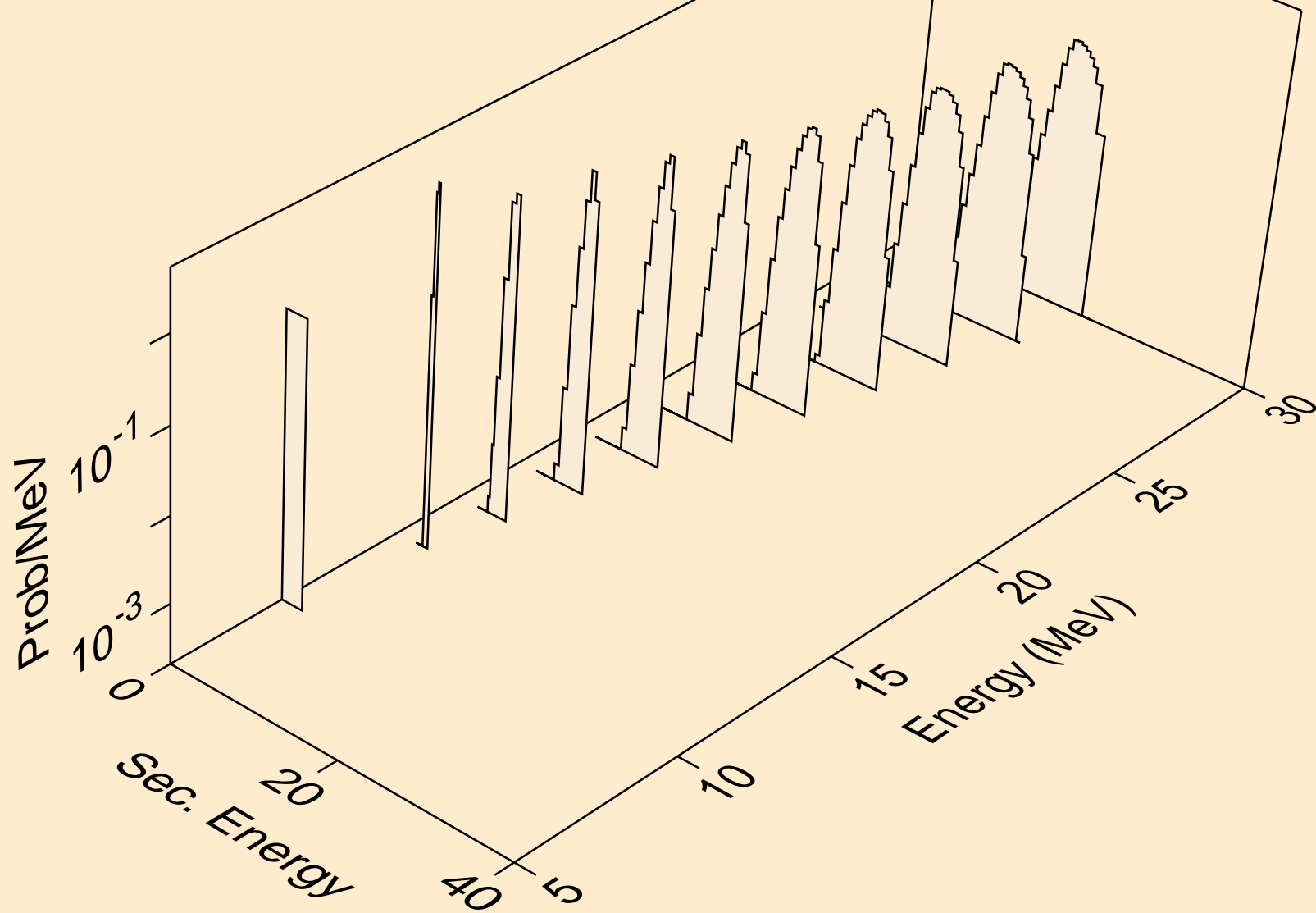

NP236M NEUTRON ACER TENDL-2023 LIBRARY; T=0.K  
tritons from (n,t)

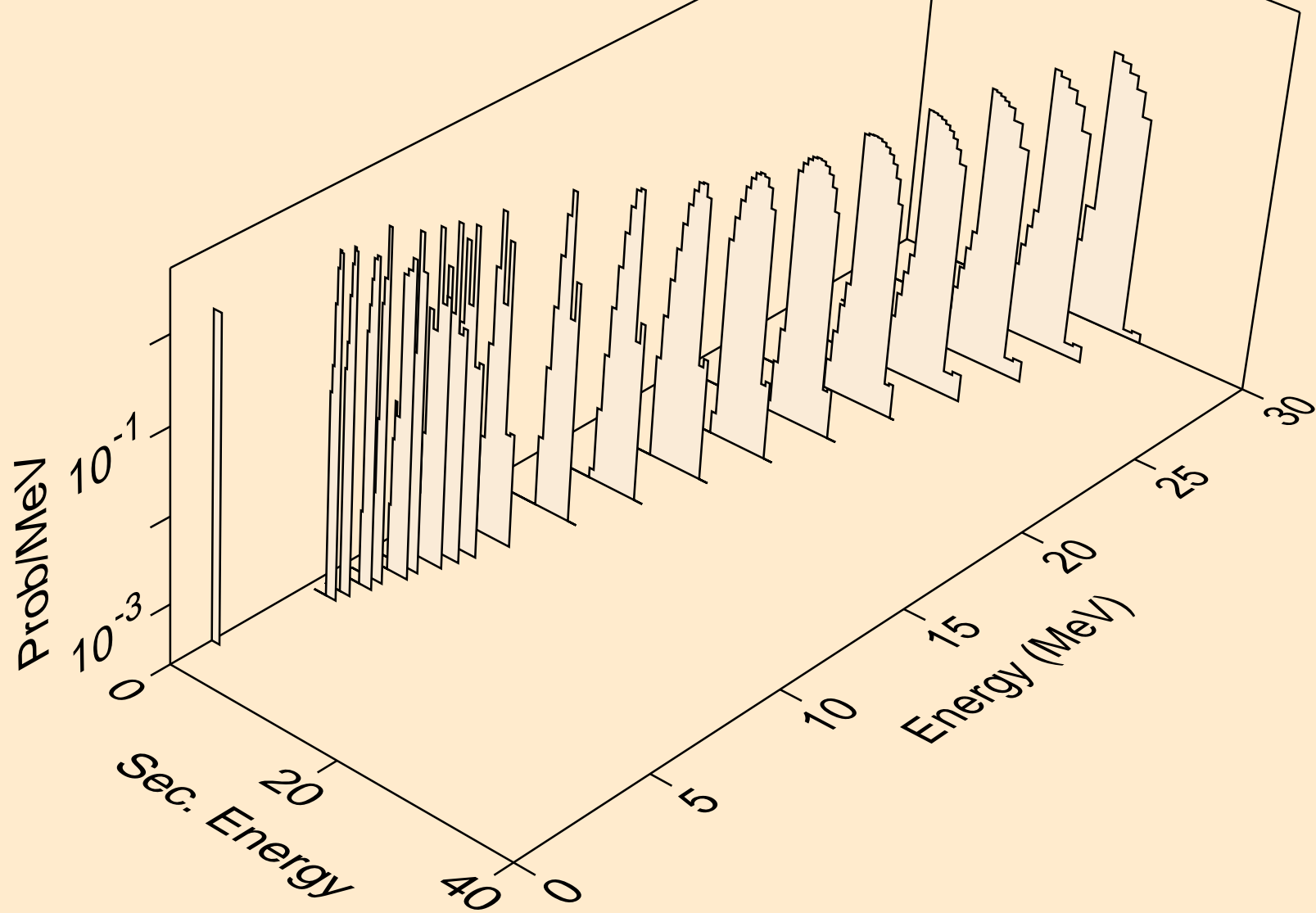

NP236M NEUTRON ACER TENDL-2023 LIBRARY; T=0.K  
he3s from (n,x)

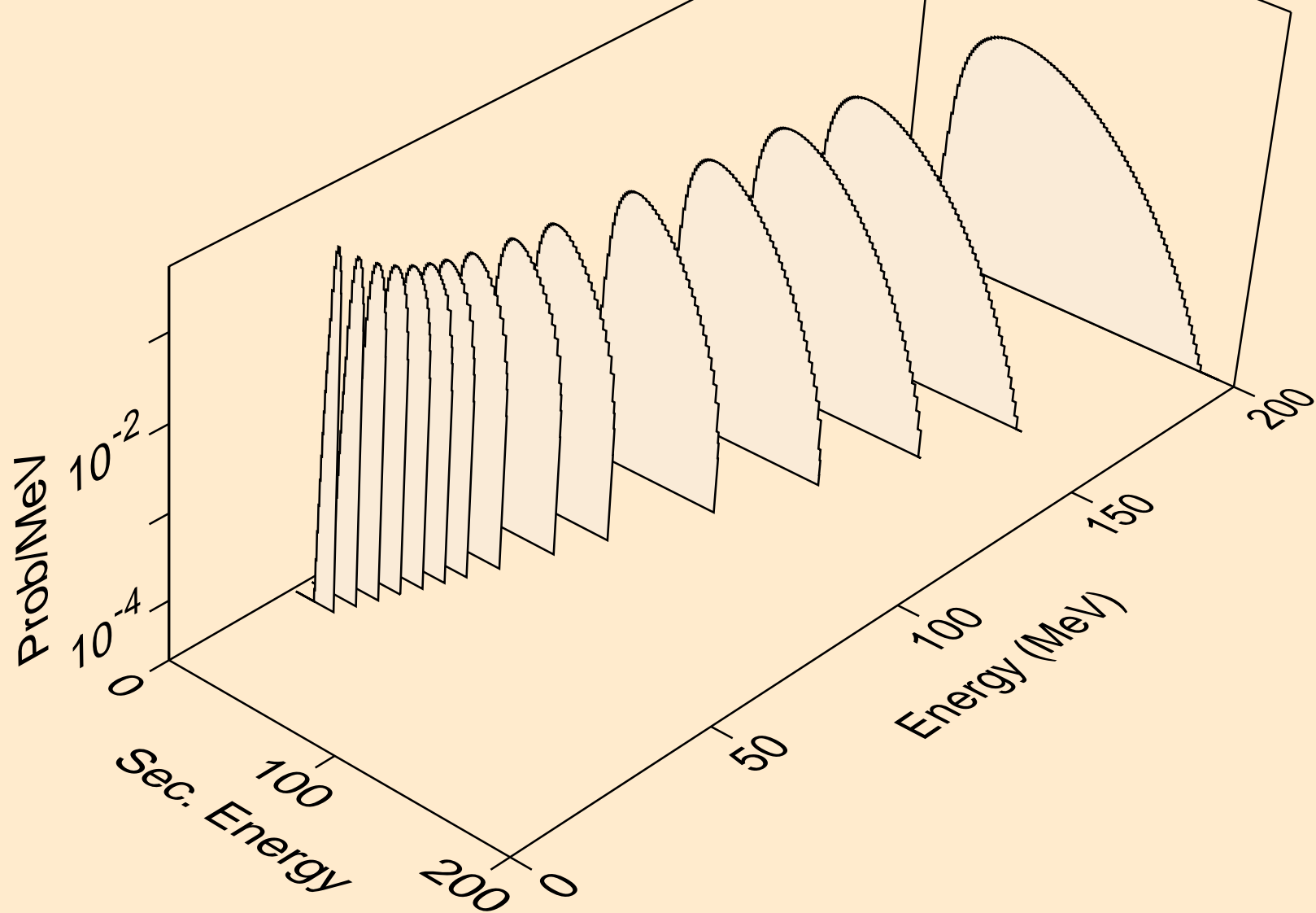

NP236M NEUTRON ACER TENDL-2023 LIBRARY; T=0.K  
he3s from (n,n\*)he3

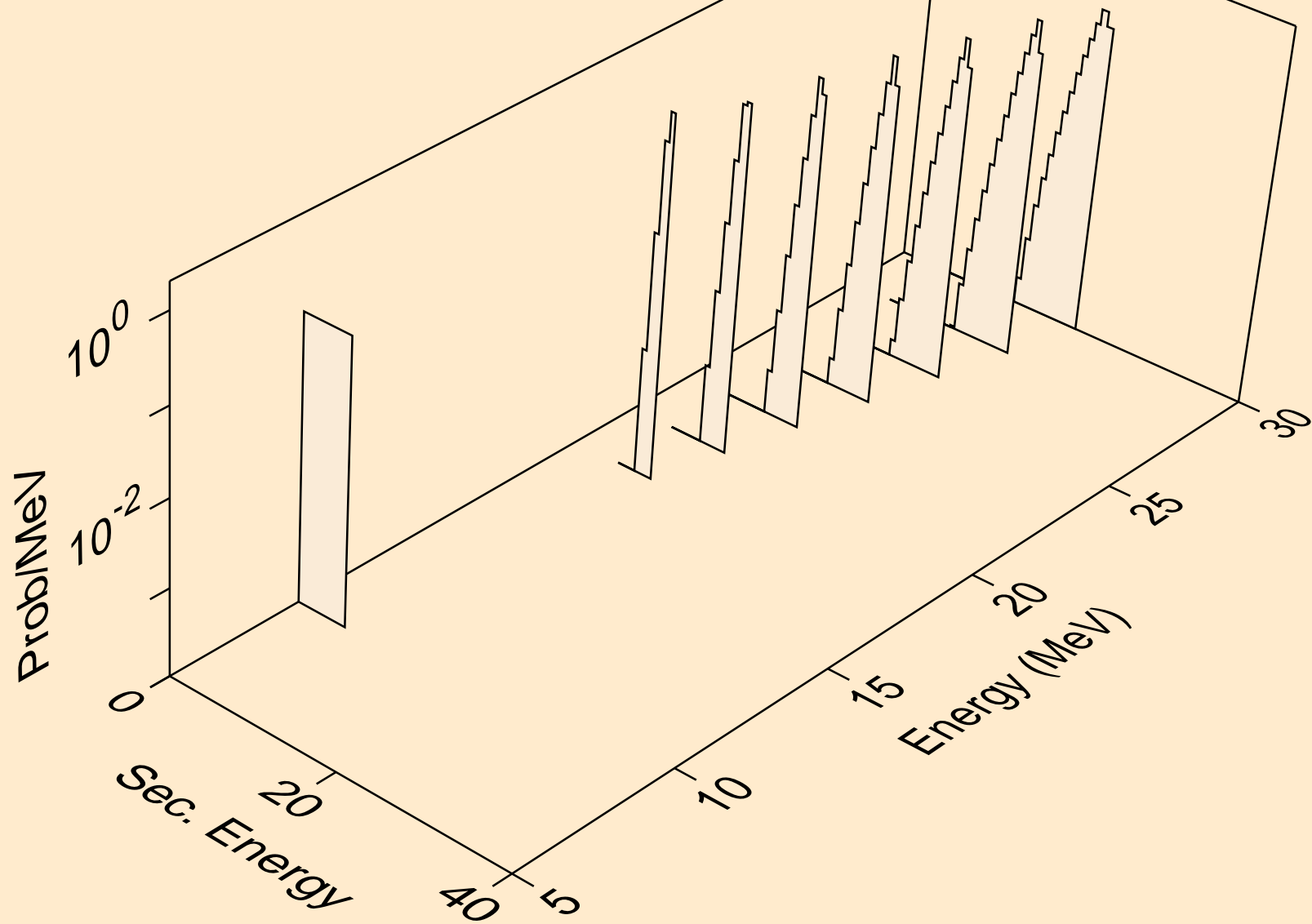



NP236M NEUTRON ACER TENDL-2023 LIBRARY; T=0.K  
he3s from (n,he3)

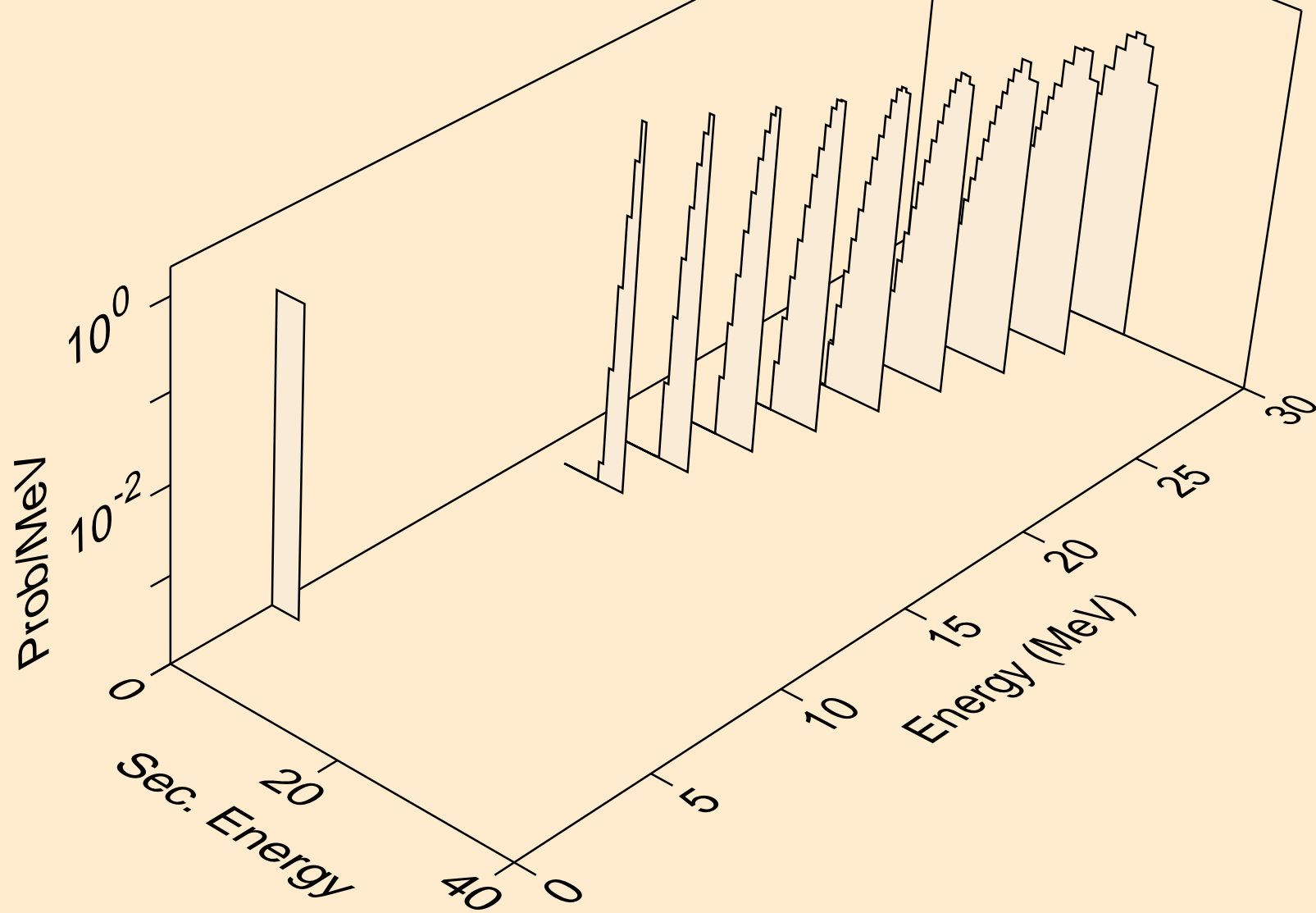

NP236M NEUTRON ACER TENDL-2023 LIBRARY; T=0.K  
alphas from (n,x)

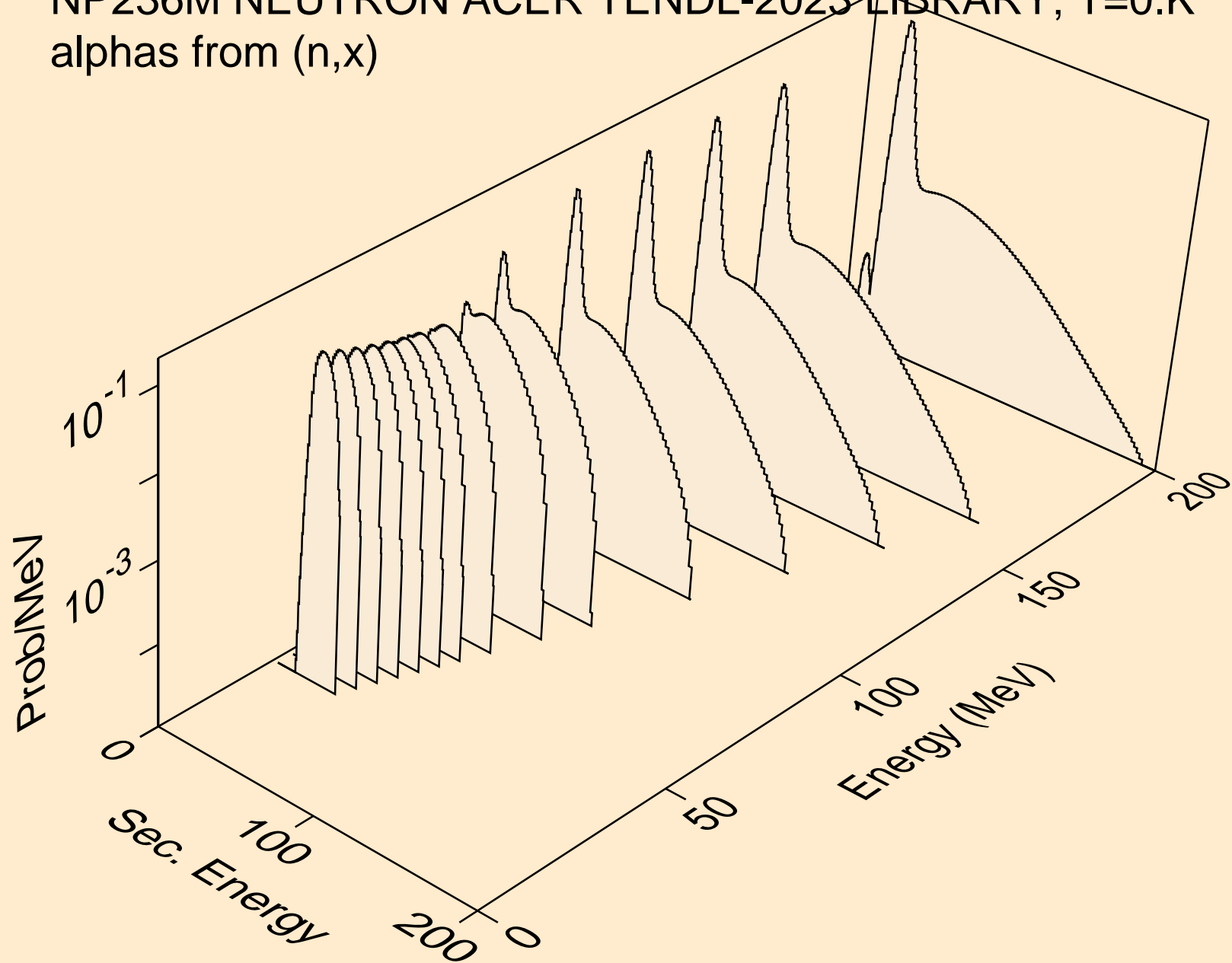

NP236M NEUTRON ACER TENDL-2023 LIBRARY; T=0.K  
alphas from (n,n\*)a

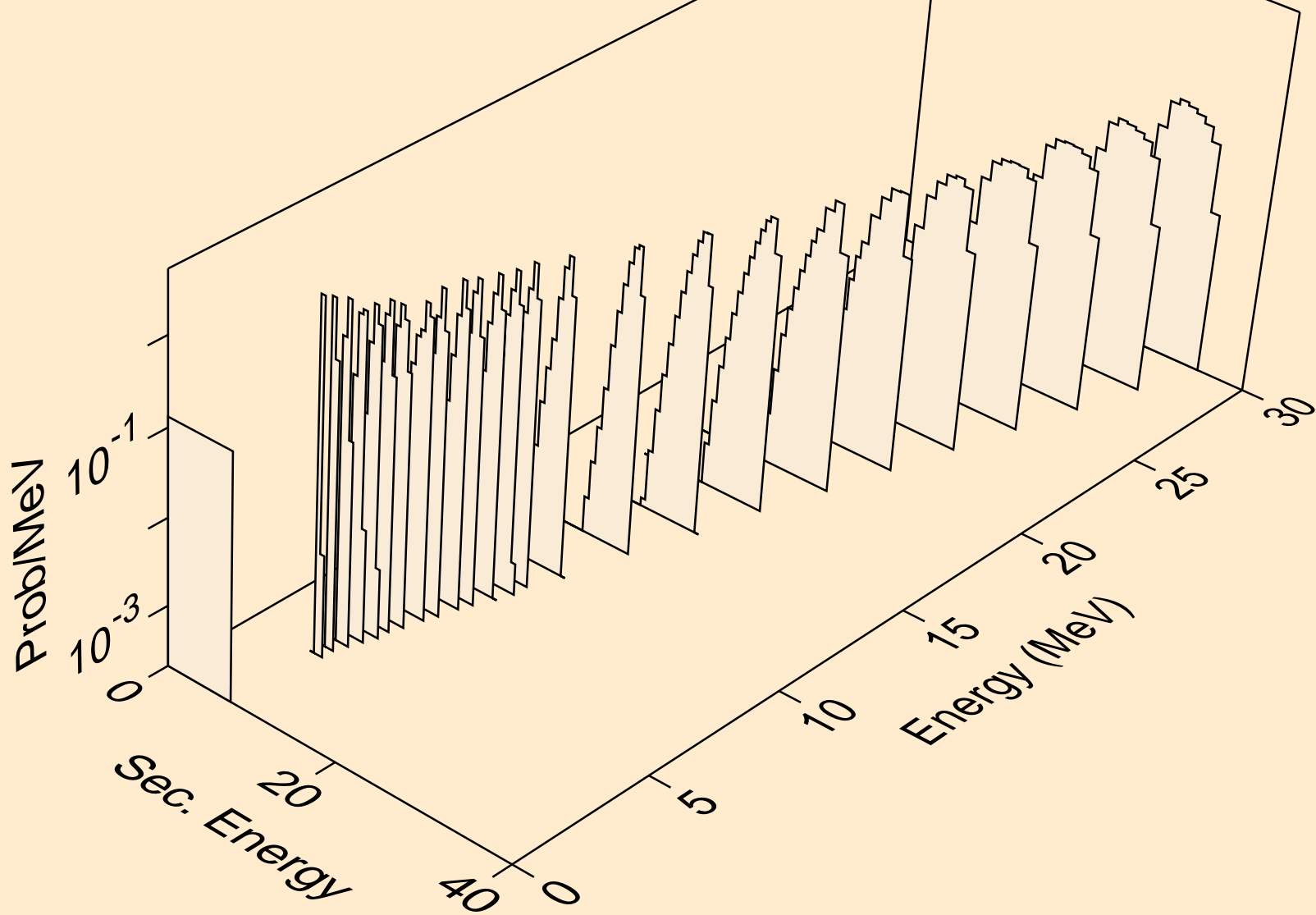

NP236M NEUTRON ACER TENDL-2023 LIBRARY; T=0.K  
alphas from (n,2n)a

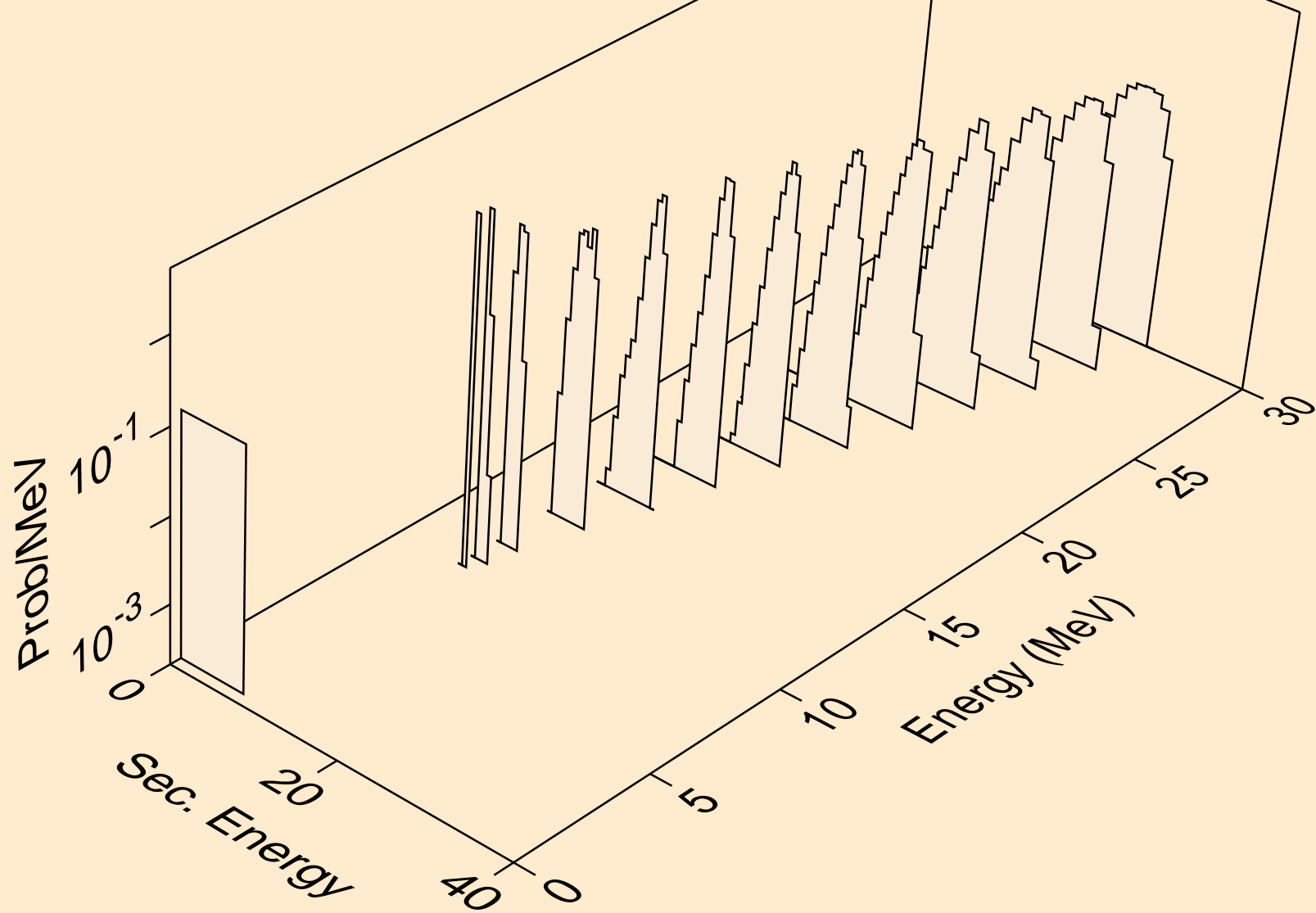

NP236M NEUTRON ACER TENDL-2023 LIBRARY; T=0.K  
alphas from (n,3n)a

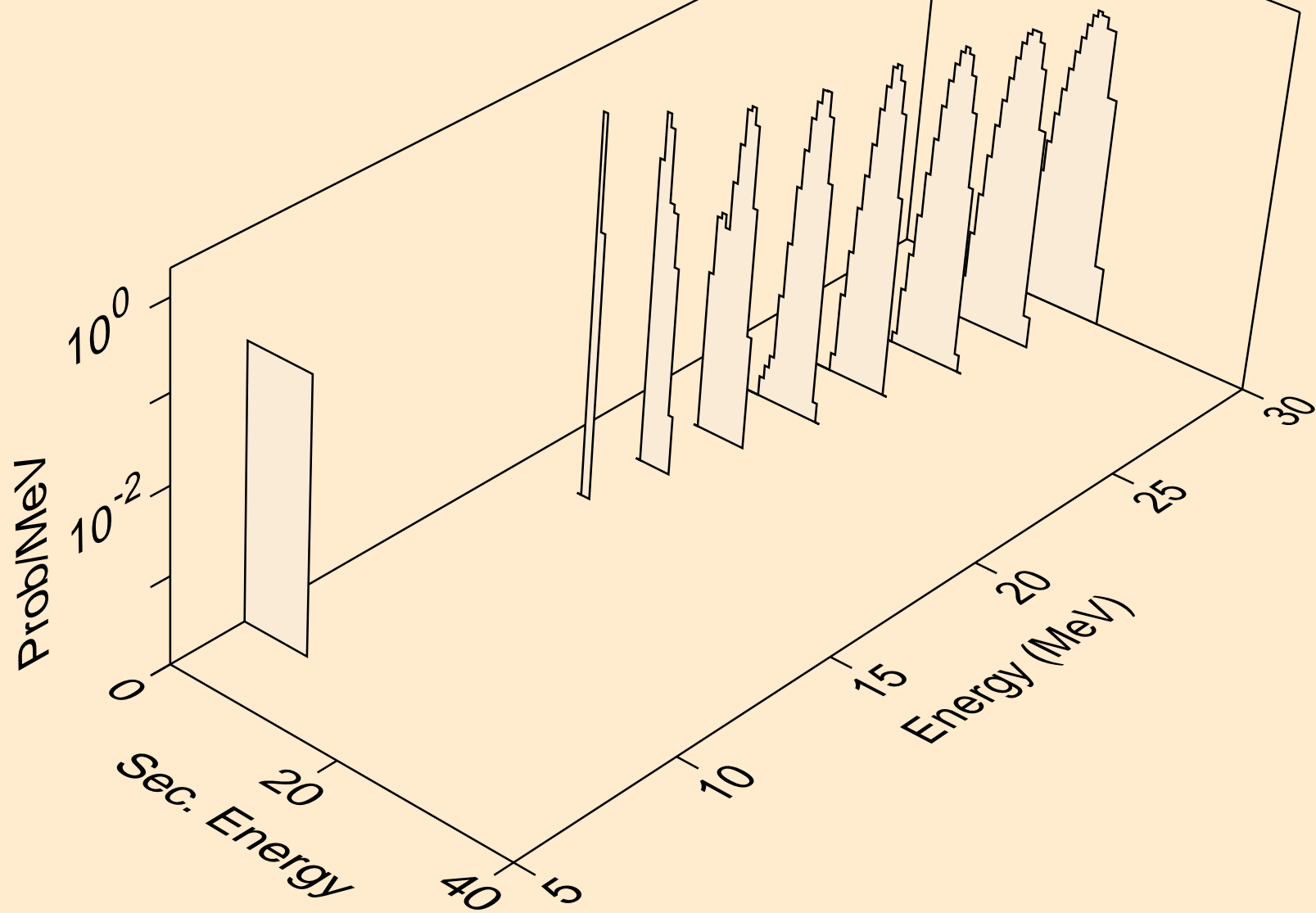

NP236M NEUTRON ACER TENDL-2023 LIBRARY; T=0.K  
alphas from (n,n\*)2a

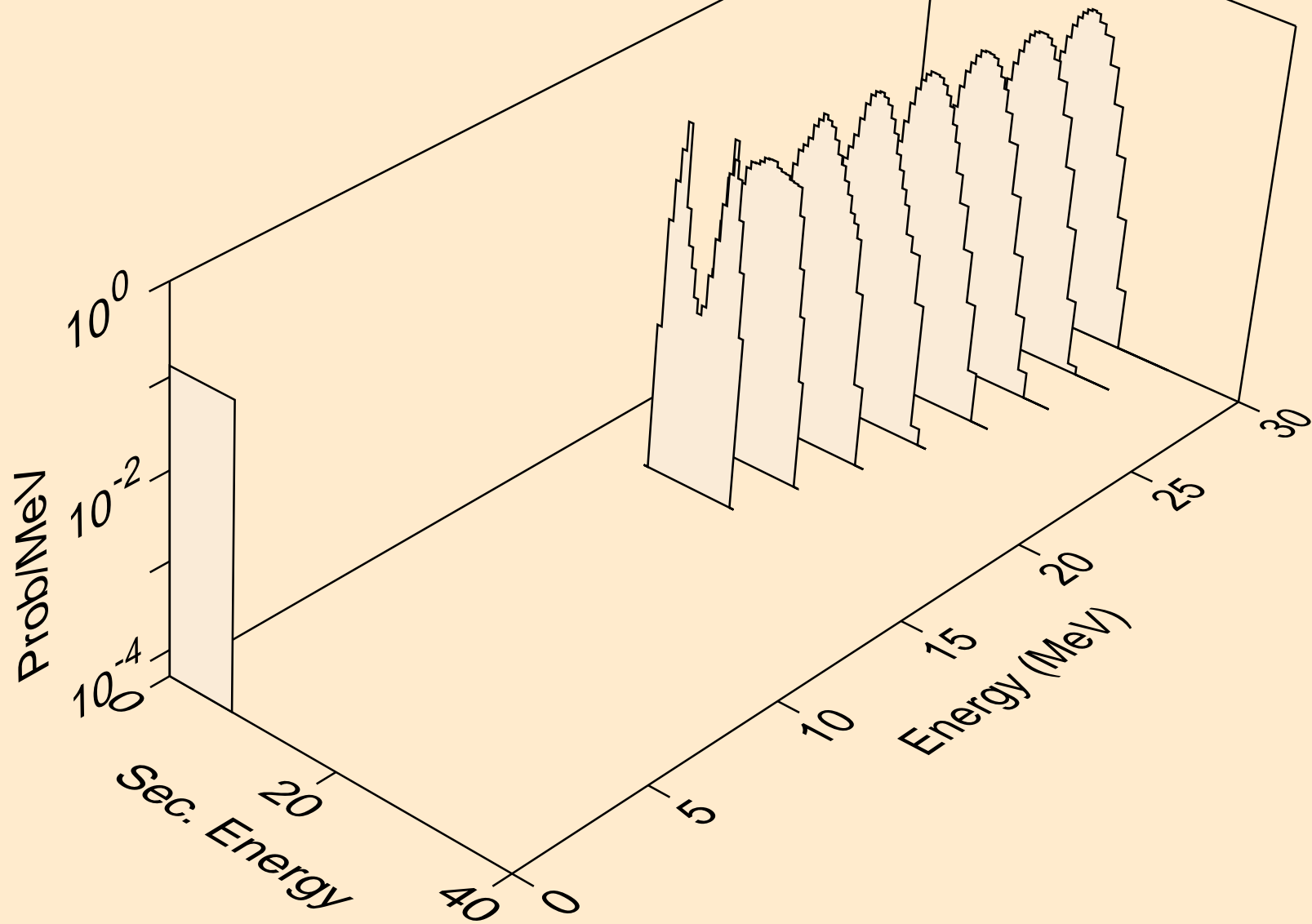

NP236M NEUTRON ACER TENDL-2023 LIBRARY; T=0.K  
alphas from (n,npa)

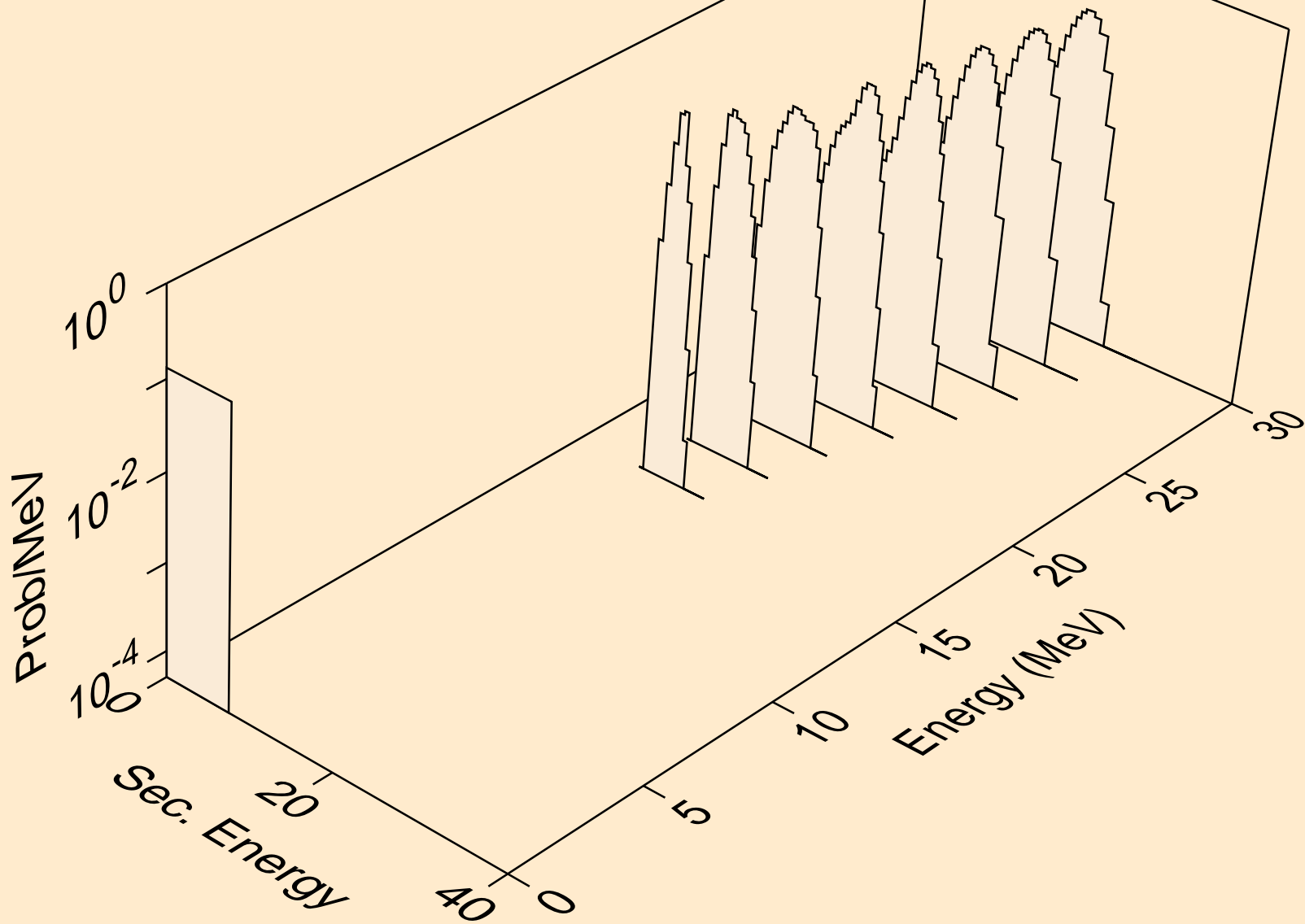

NP236M NEUTRON ACER TENDL-2023 LIBRARY; T=0.K  
alphas from (n,a)

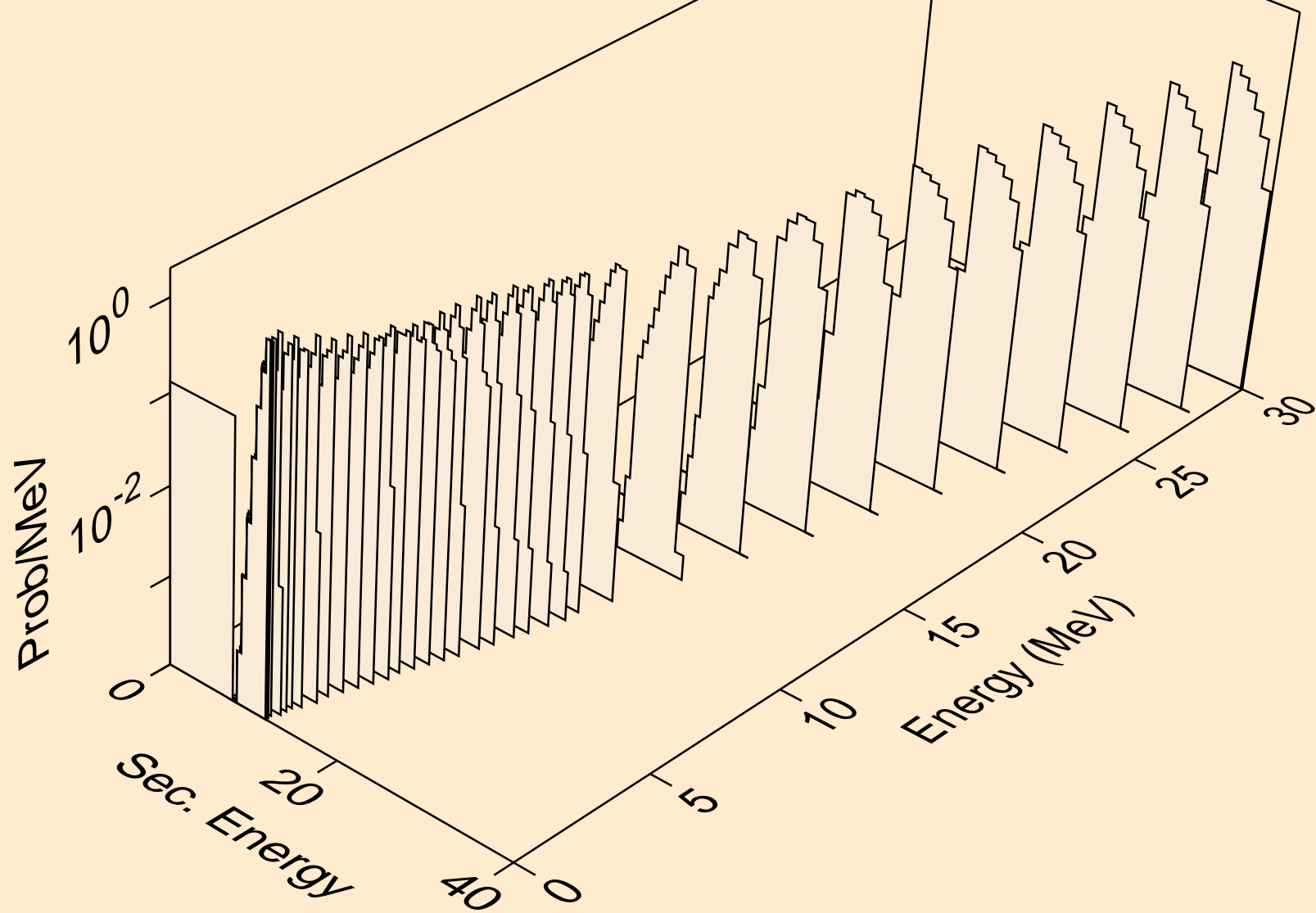



NP236M NEUTRON ACER TENDL-2023 LIBRARY; T=0.K  
alphas from (n,2a)

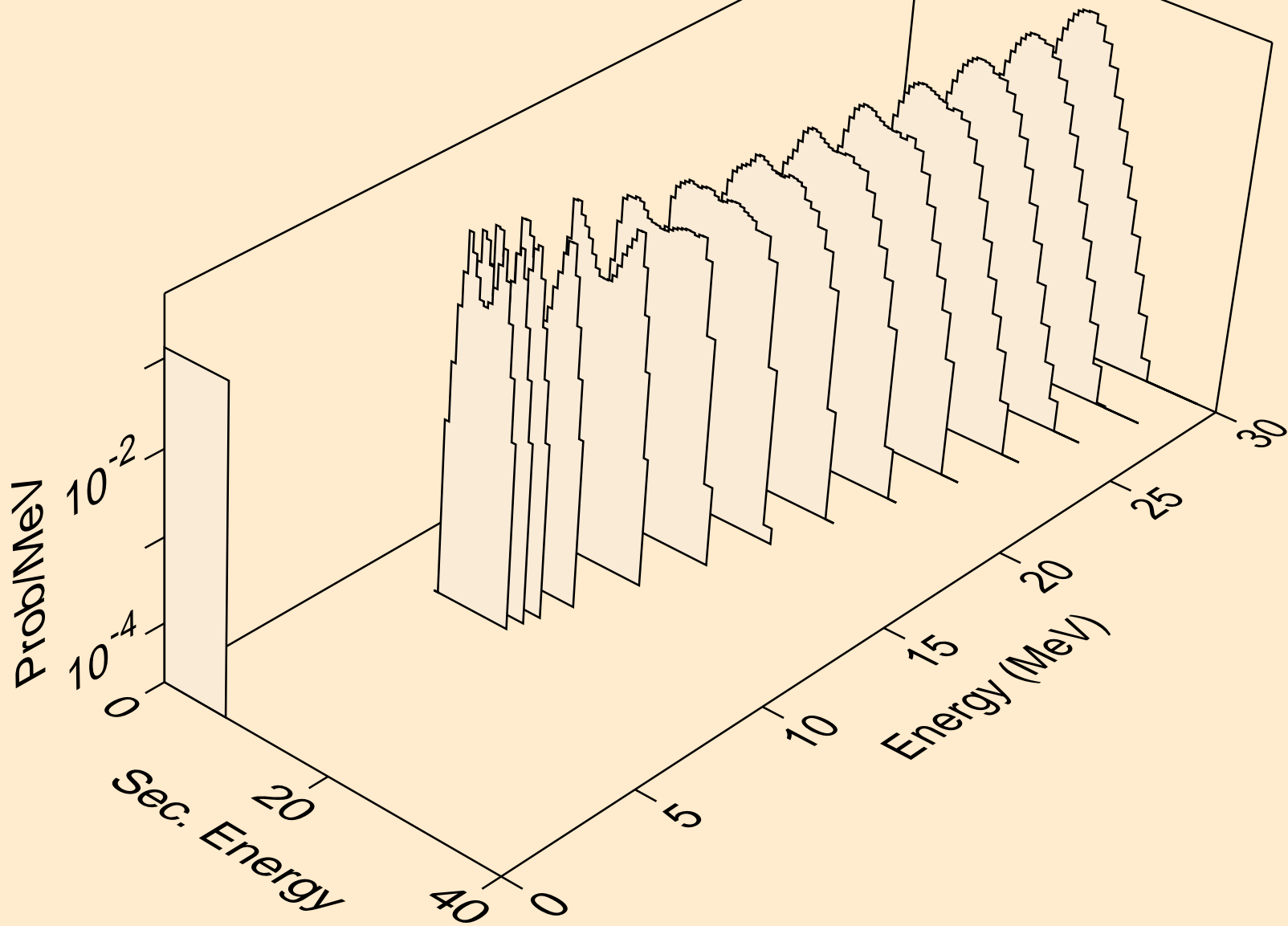

NP236M NEUTRON ACER TENDL-2023 LIBRARY; T=0.K  
alphas from (n,pa)

