

# PA240 NEUTRON ACER TENDL-2023 LIBRARY; T=0.K

## Principal cross sections

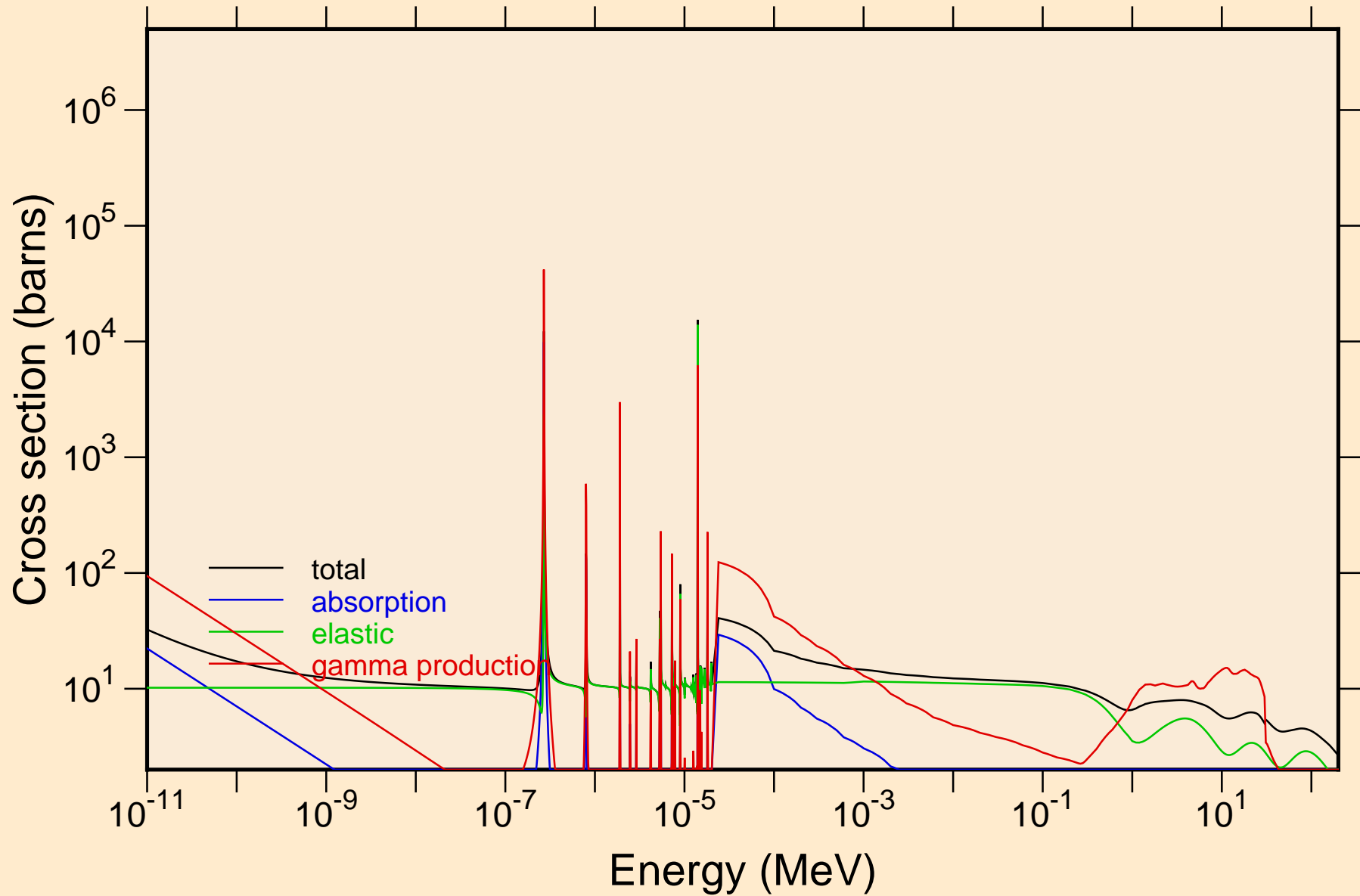

PA240 NEUTRON ACER TENDL-2023 LIBRARY; T=0.K  
resonance total cross section

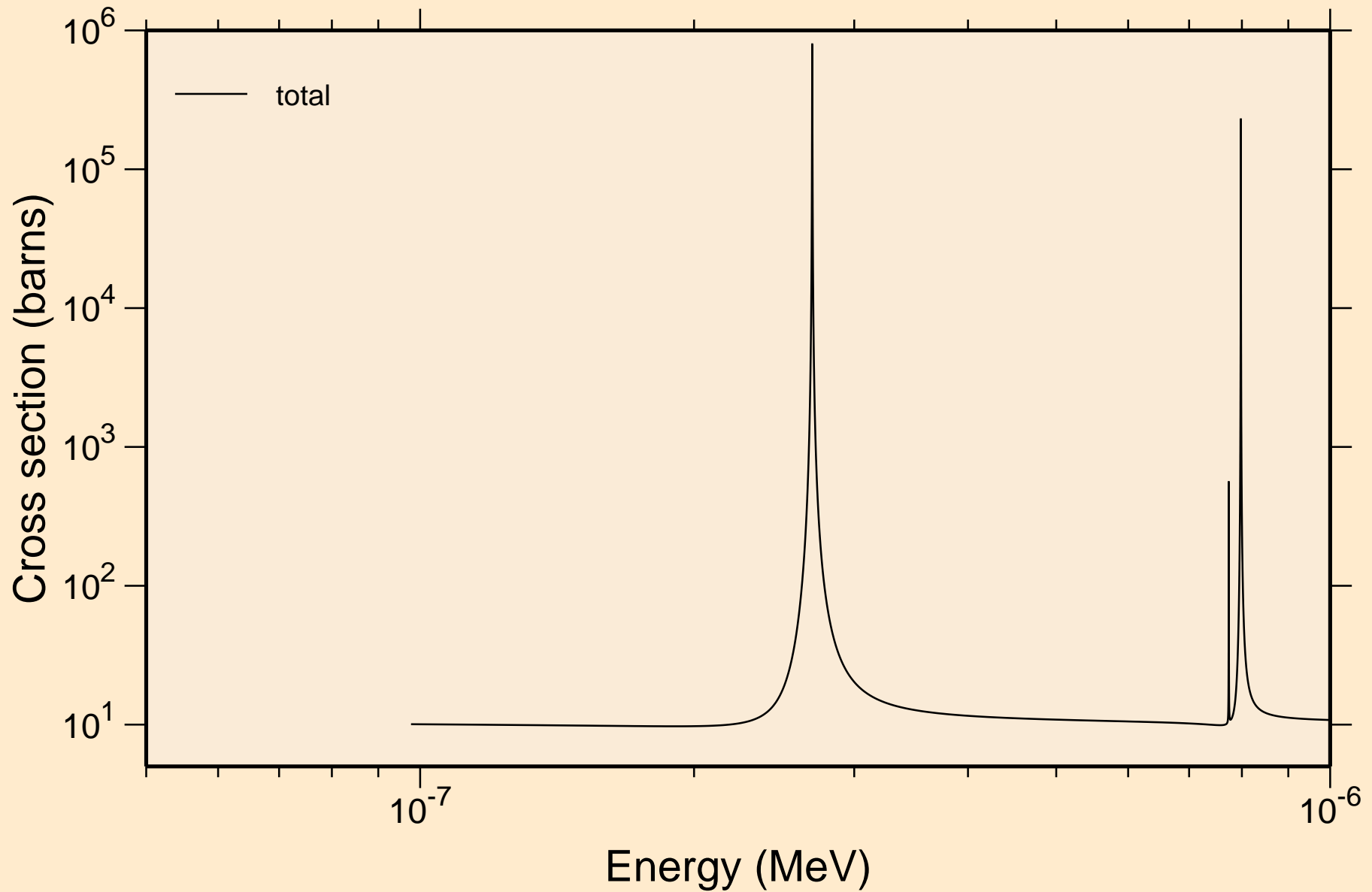

PA240 NEUTRON ACER TENDL-2023 LIBRARY; T=0.K  
resonance total cross section

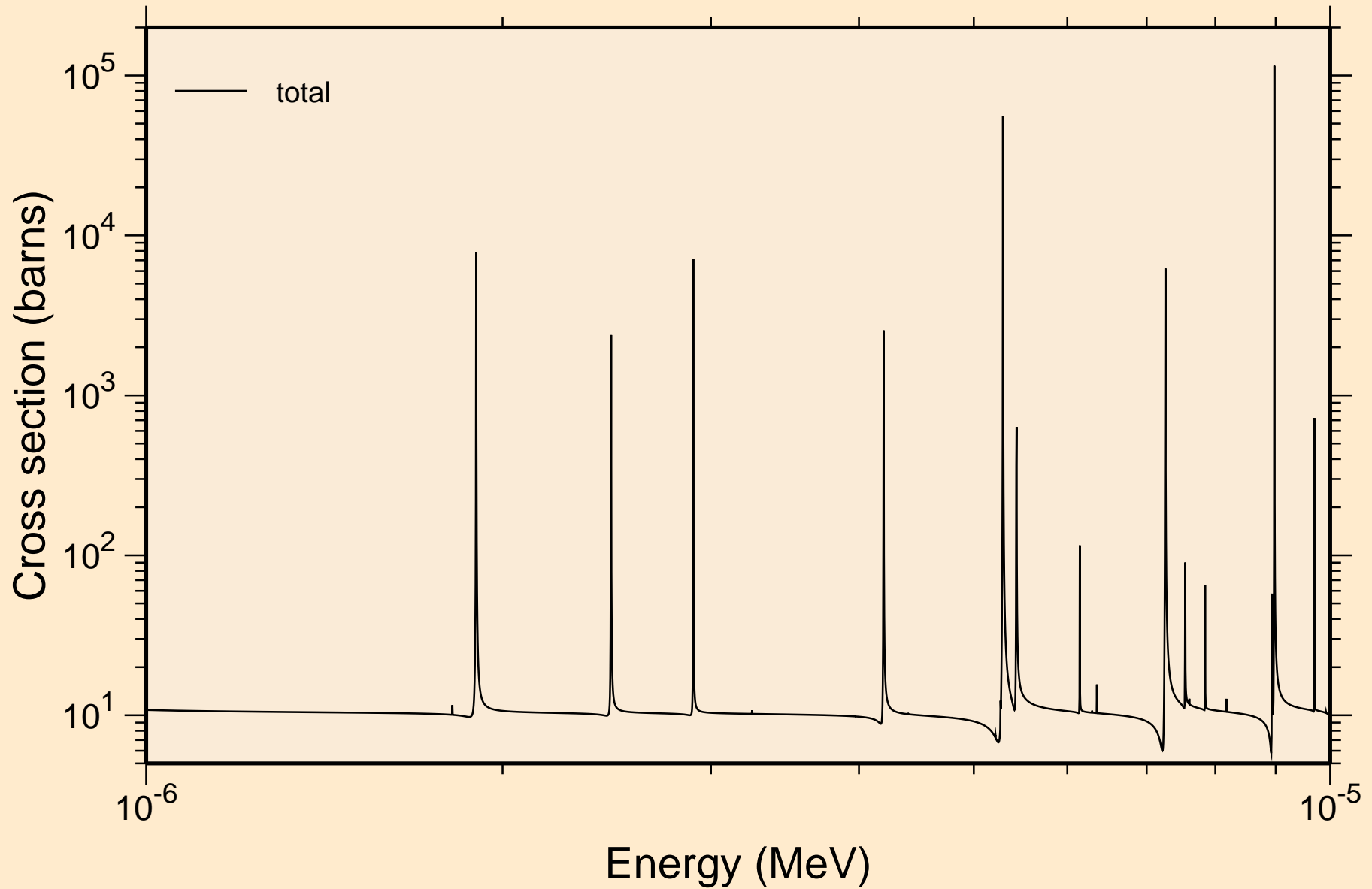

PA240 NEUTRON ACER TENDL-2023 LIBRARY; T=0.K  
resonance total cross section

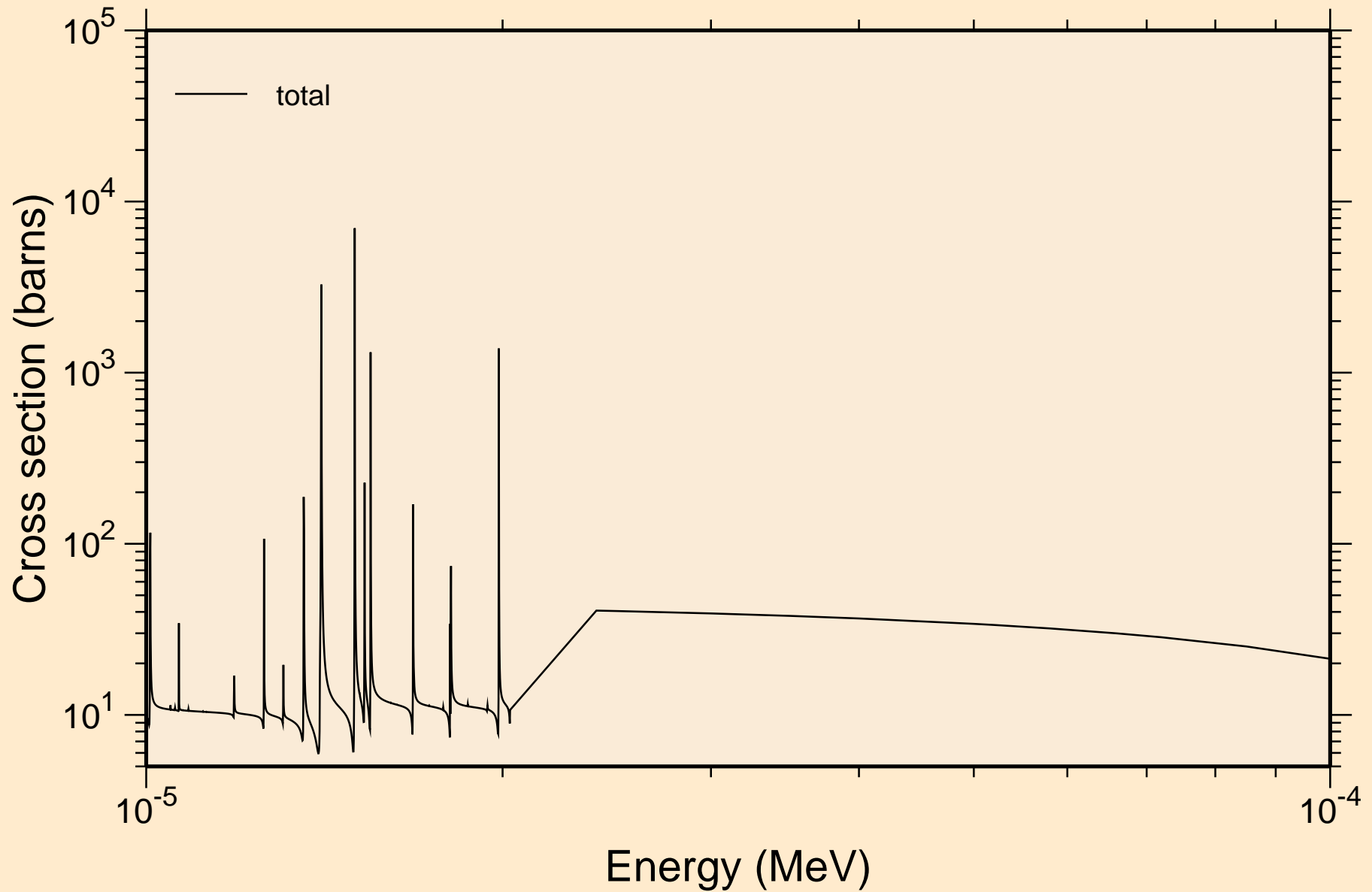

PA240 NEUTRON ACER TENDL-2023 LIBRARY; T=0.K  
resonance total cross section

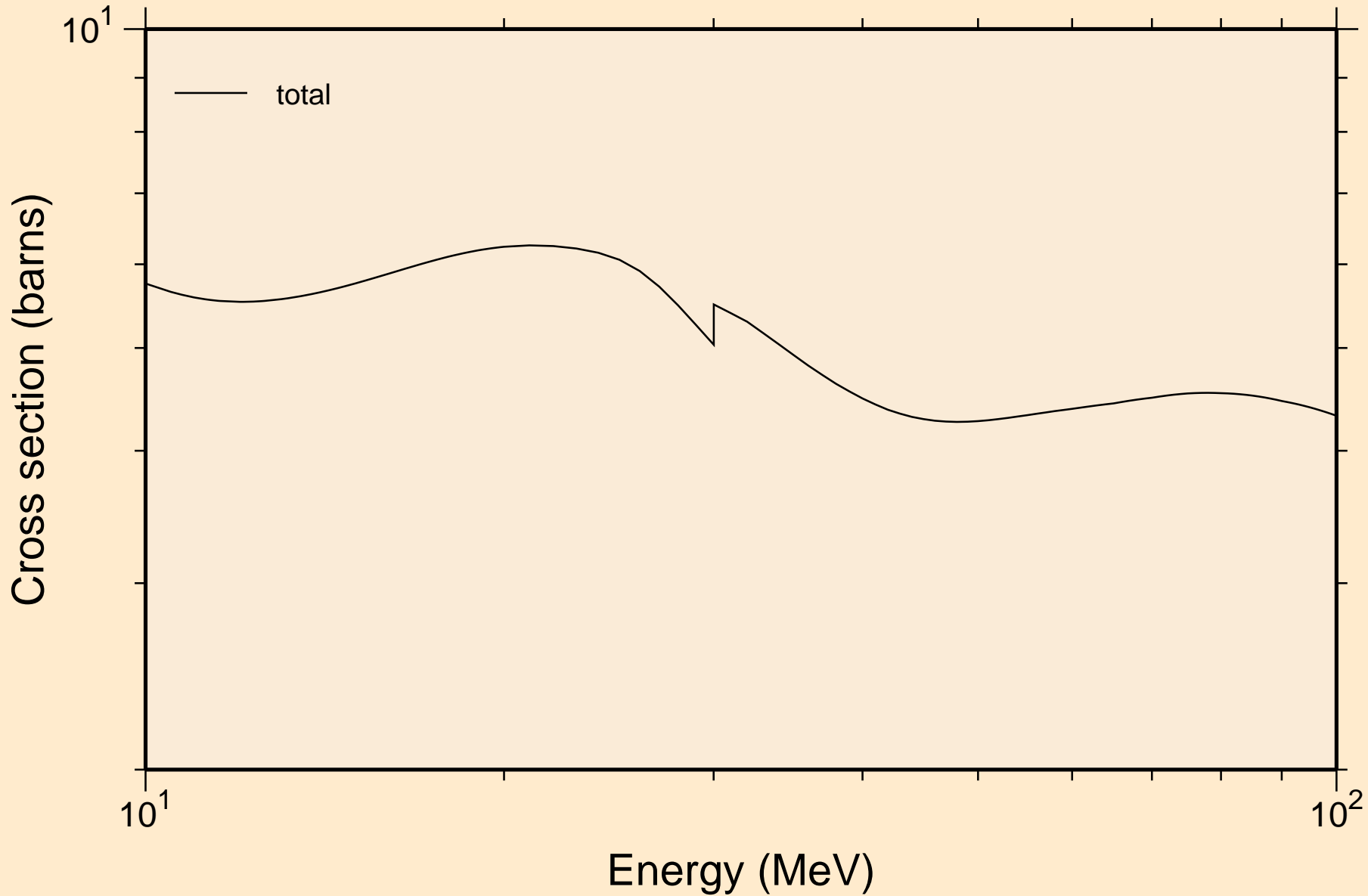

PA240 NEUTRON ACER TENDL-2023 LIBRARY; T=0.K  
resonance absorption cross sections

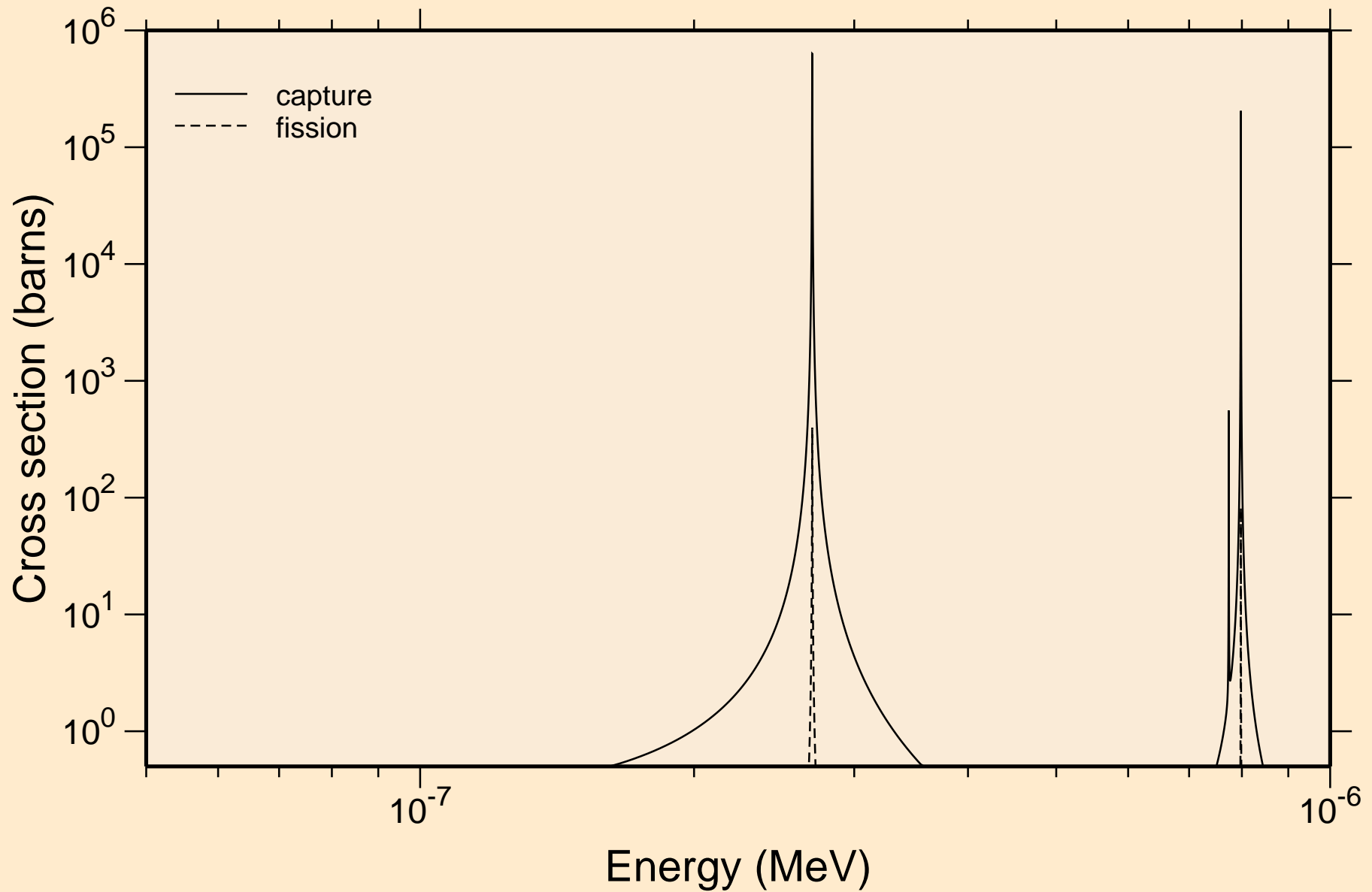

# PA240 NEUTRON ACER TENDL-2023 LIBRARY; T=0.K

## resonance absorption cross sections

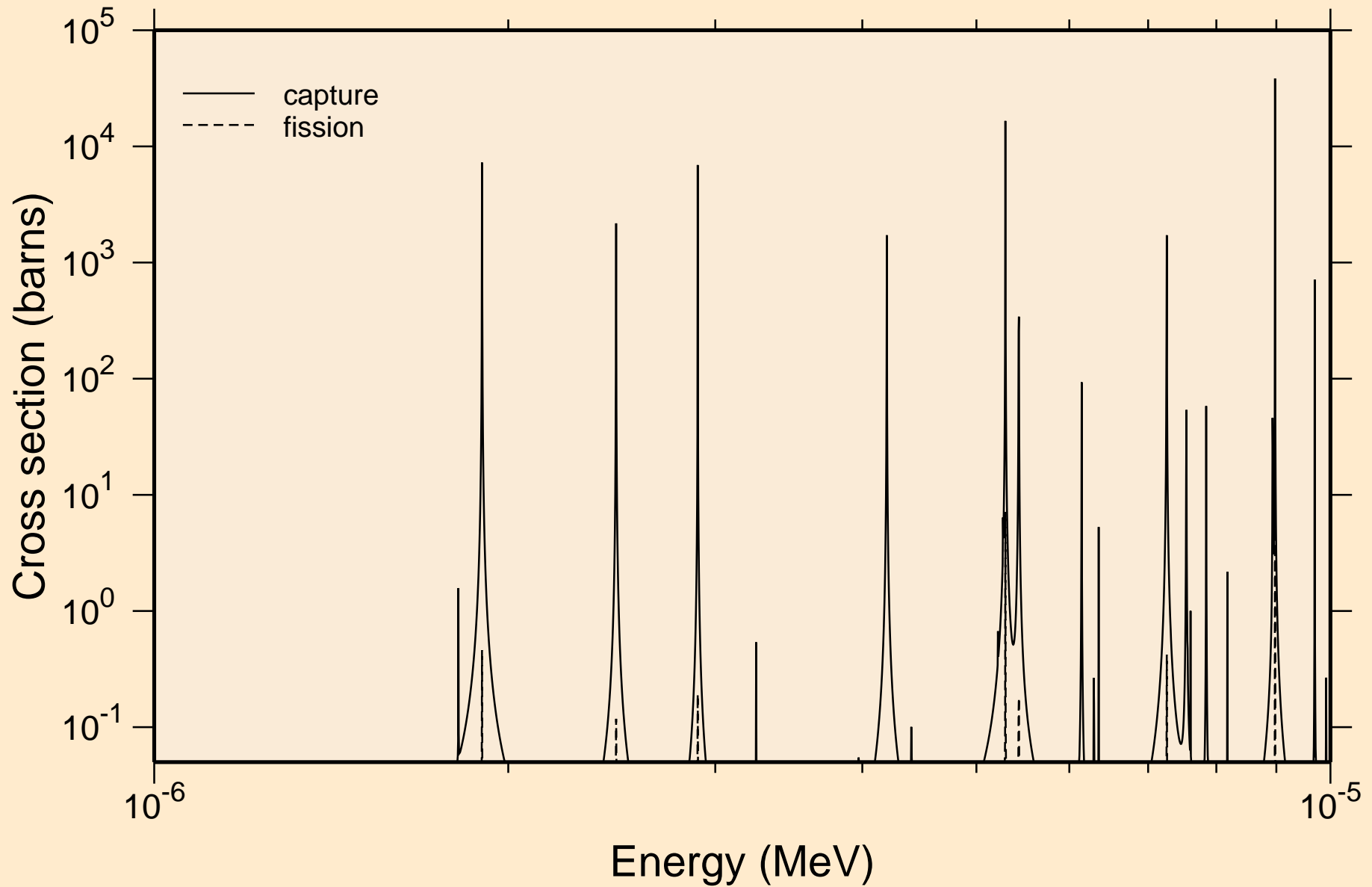

PA240 NEUTRON ACER TENDL-2023 LIBRARY; T=0.K  
resonance absorption cross sections

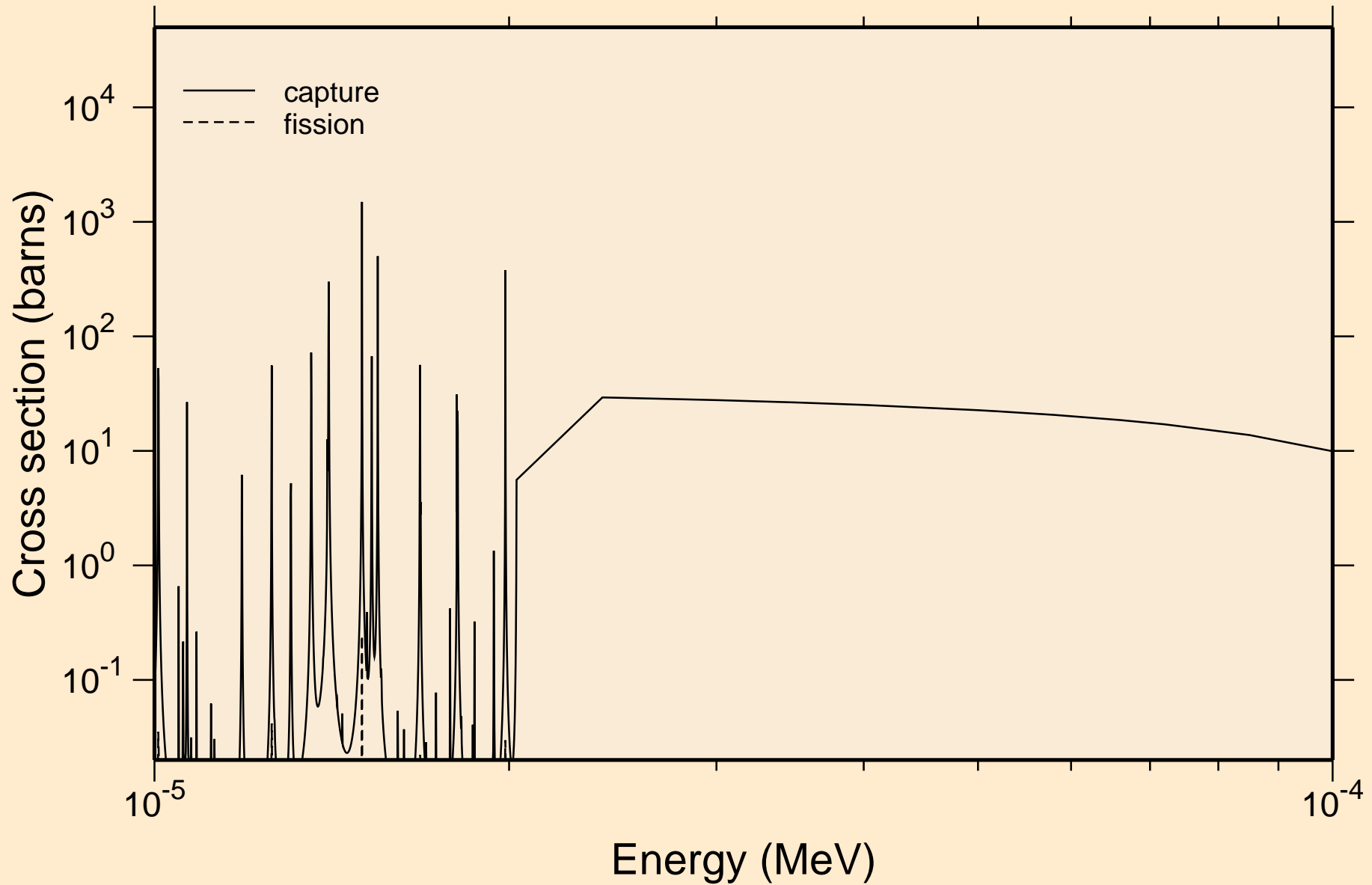



PA240 NEUTRON ACER TENDL-2023 LIBRARY; T=0.K  
resonance absorption cross sections

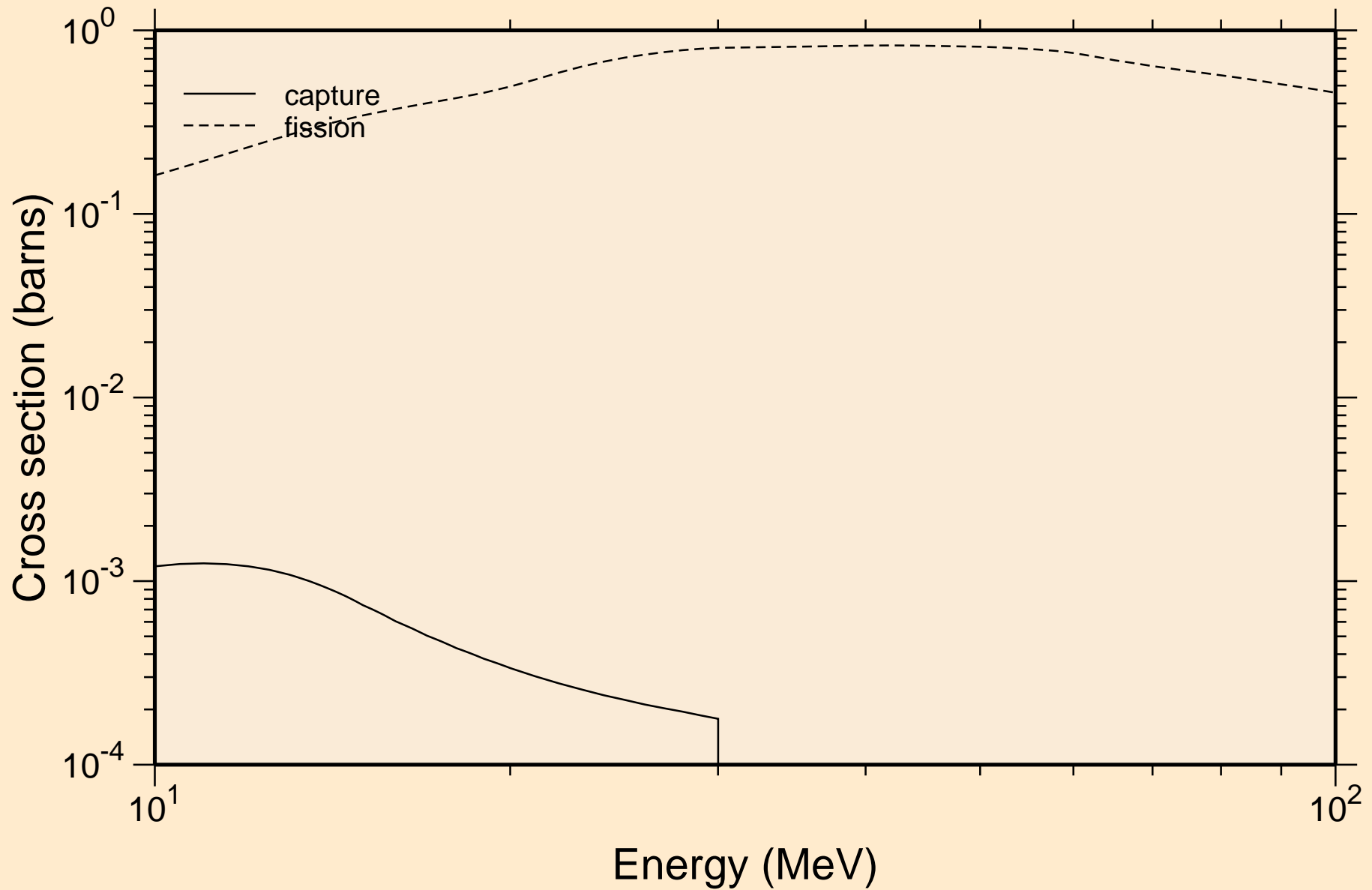

PA240 NEUTRON ACER TENDL-2023 LIBRARY; T=0.K  
Heating

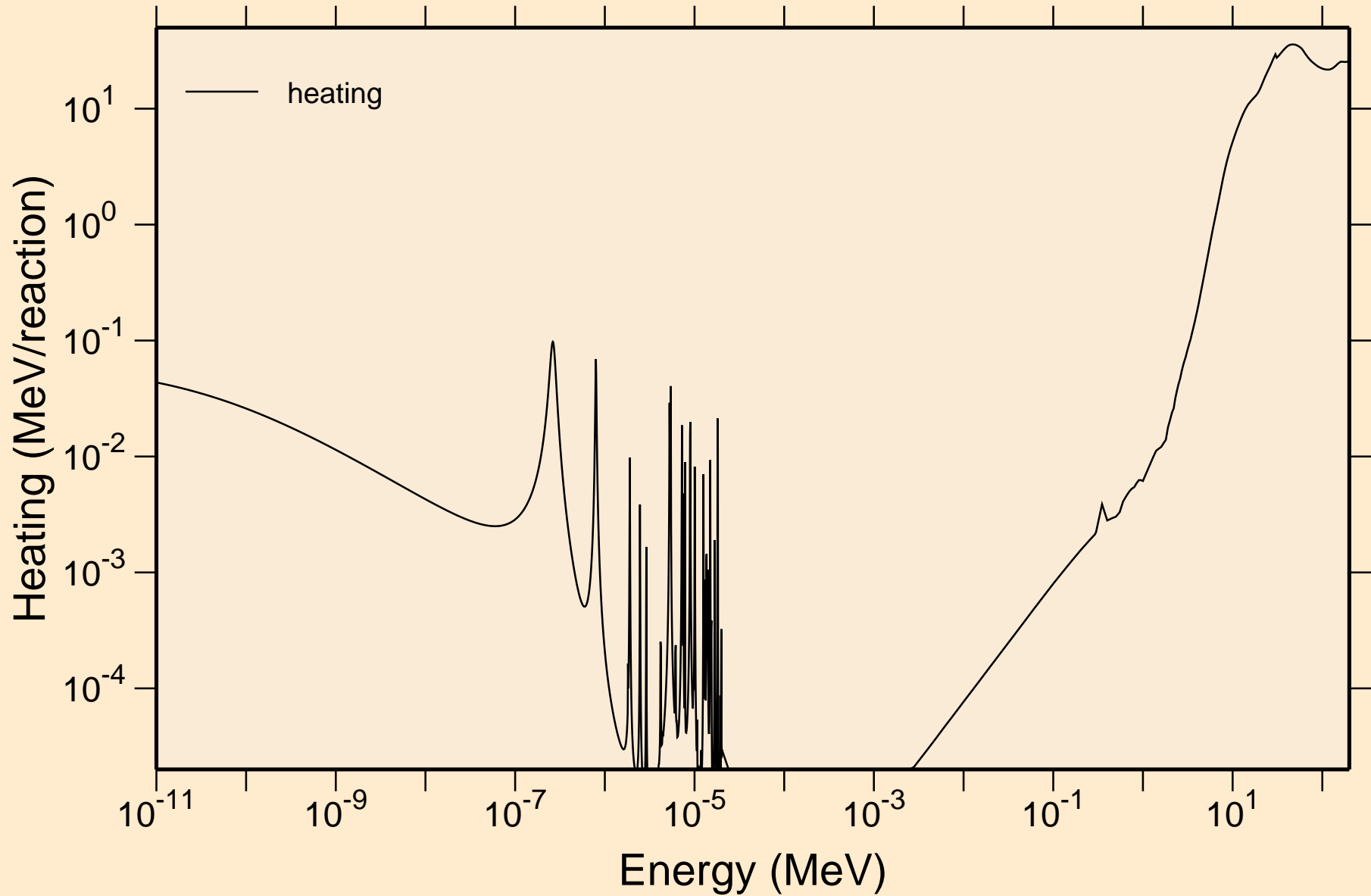

PA240 NEUTRON ACER TENDL-2023 LIBRARY; T=0.K  
Damage

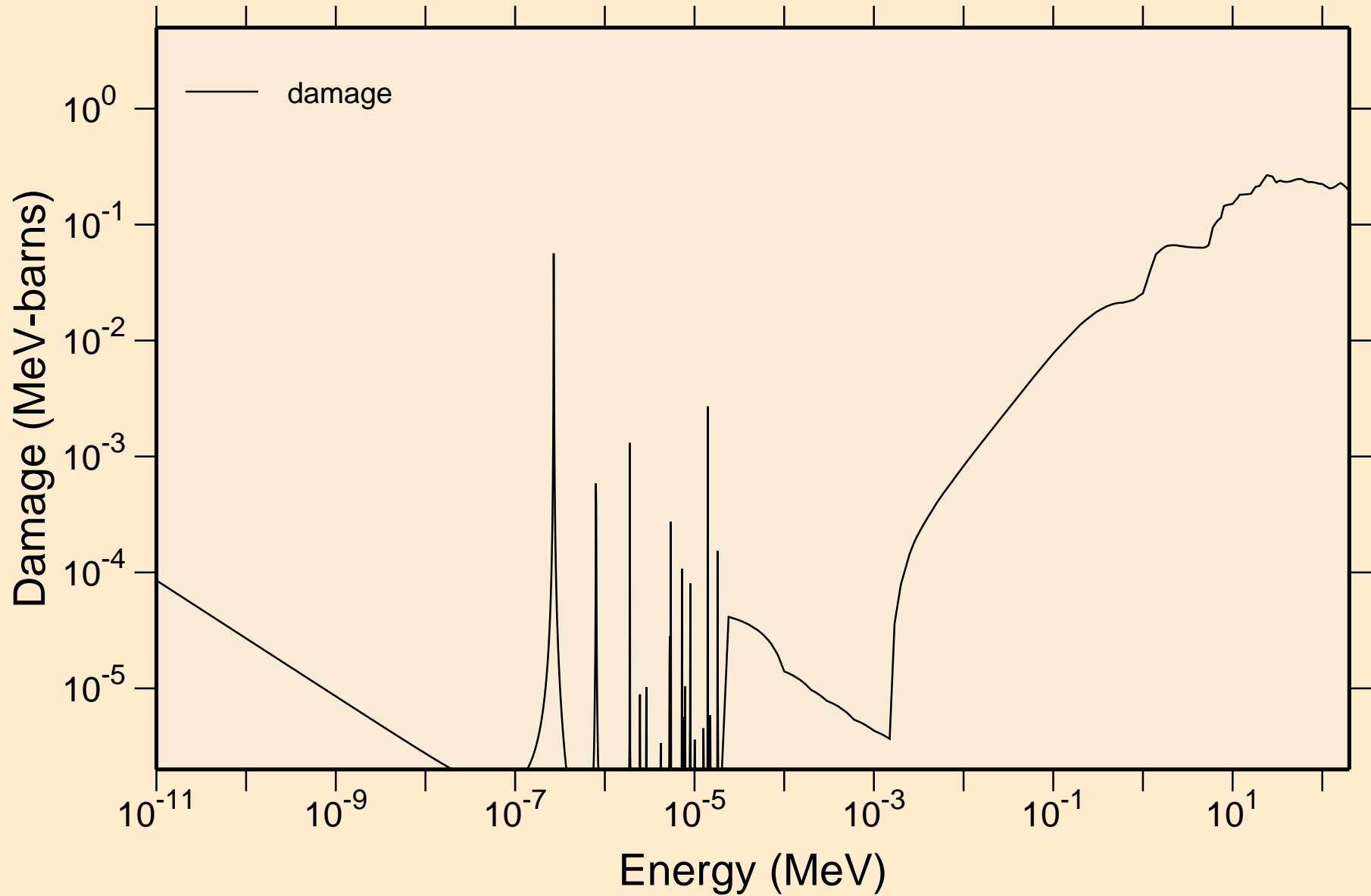

# PA240 NEUTRON ACER TENDL-2023 LIBRARY; T=0.K

## Non-threshold reactions

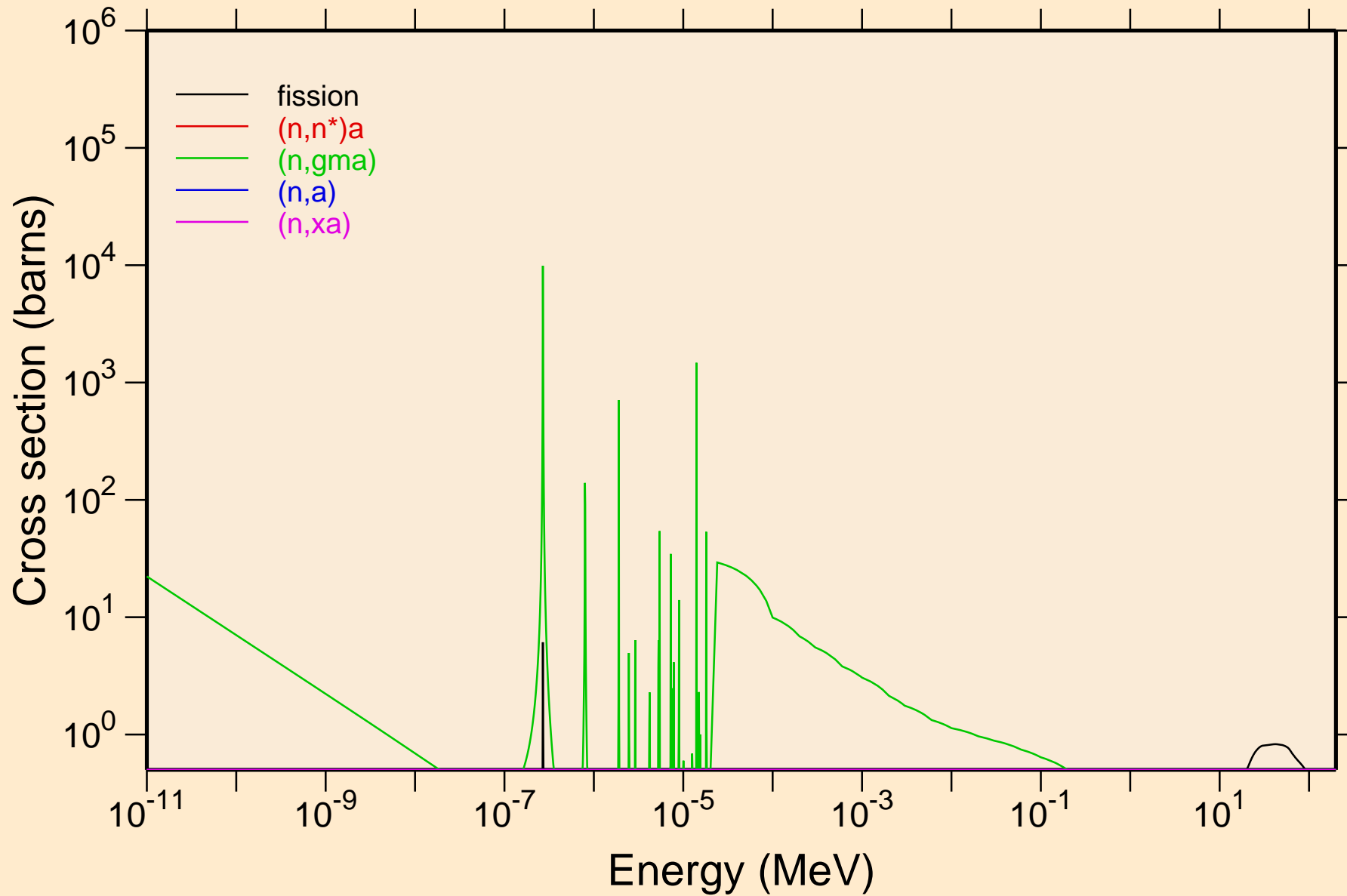

PA240 NEUTRON ACER TENDL-2023 LIBRARY; T=0.K  
Principal cross sections

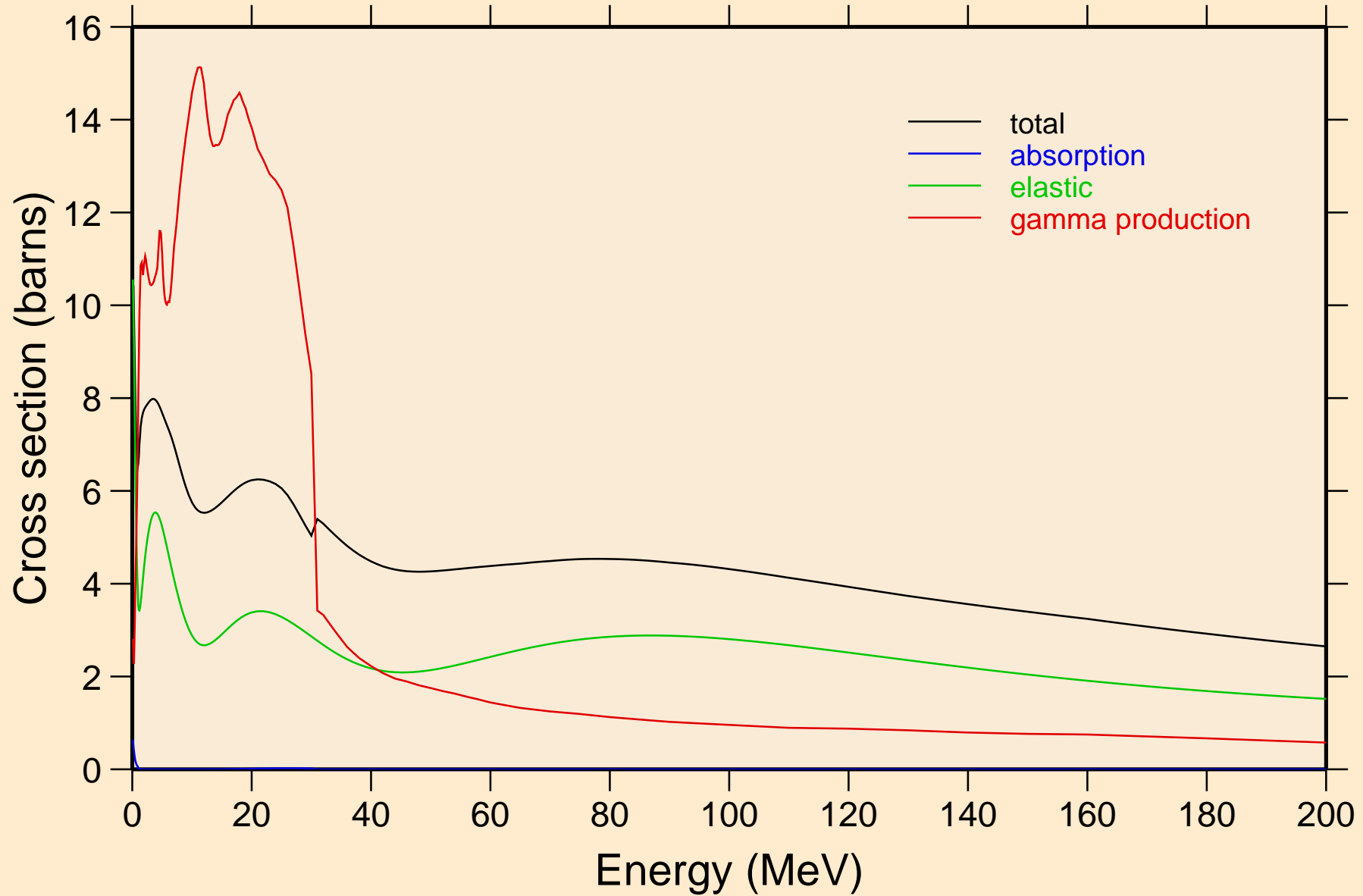

# PA240 NEUTRON ACER TENDL-2023 LIBRARY; T=0.K

## Heating

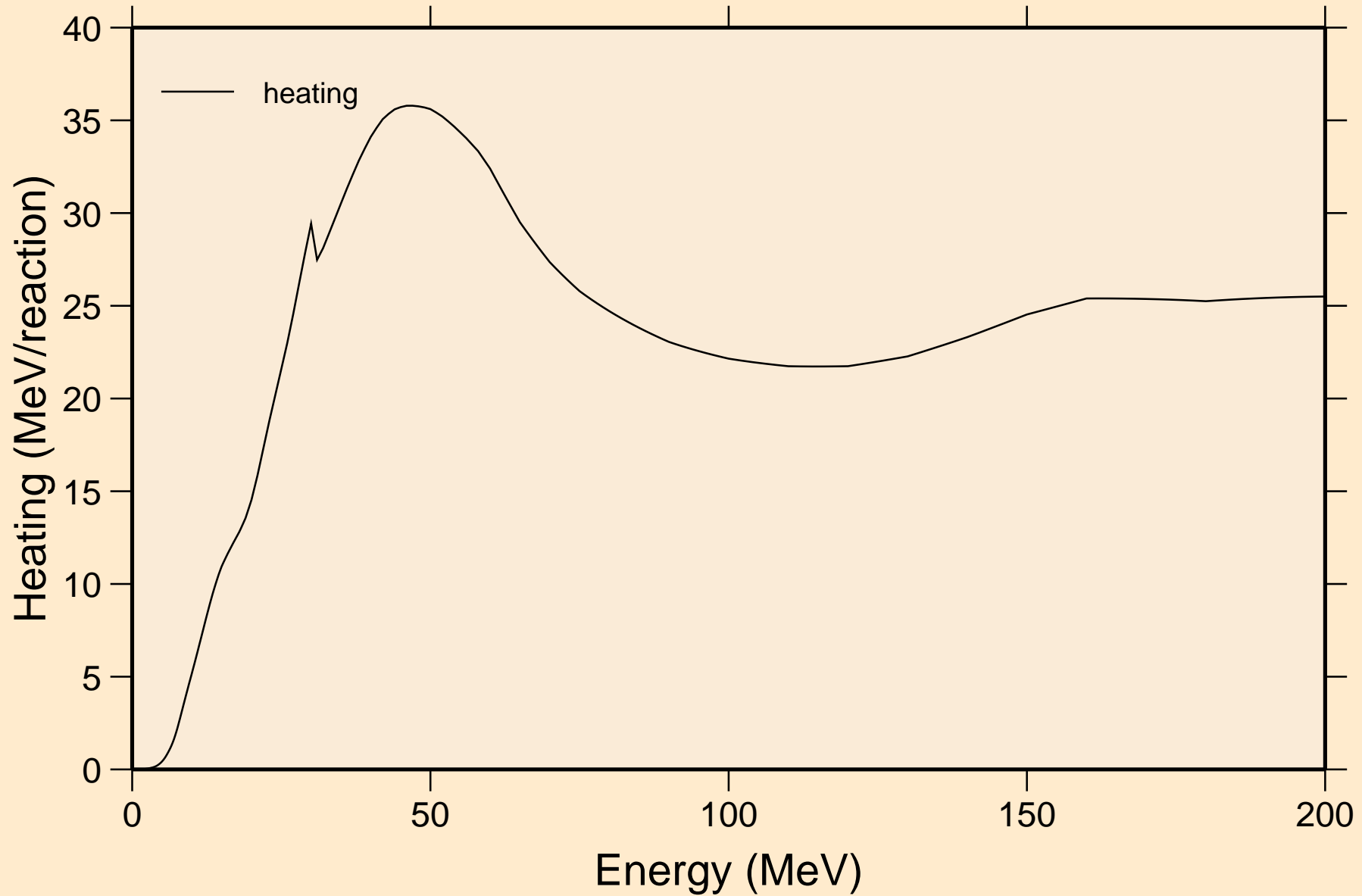

PA240 NEUTRON ACER TENDL-2023 LIBRARY; T=0.K  
Damage

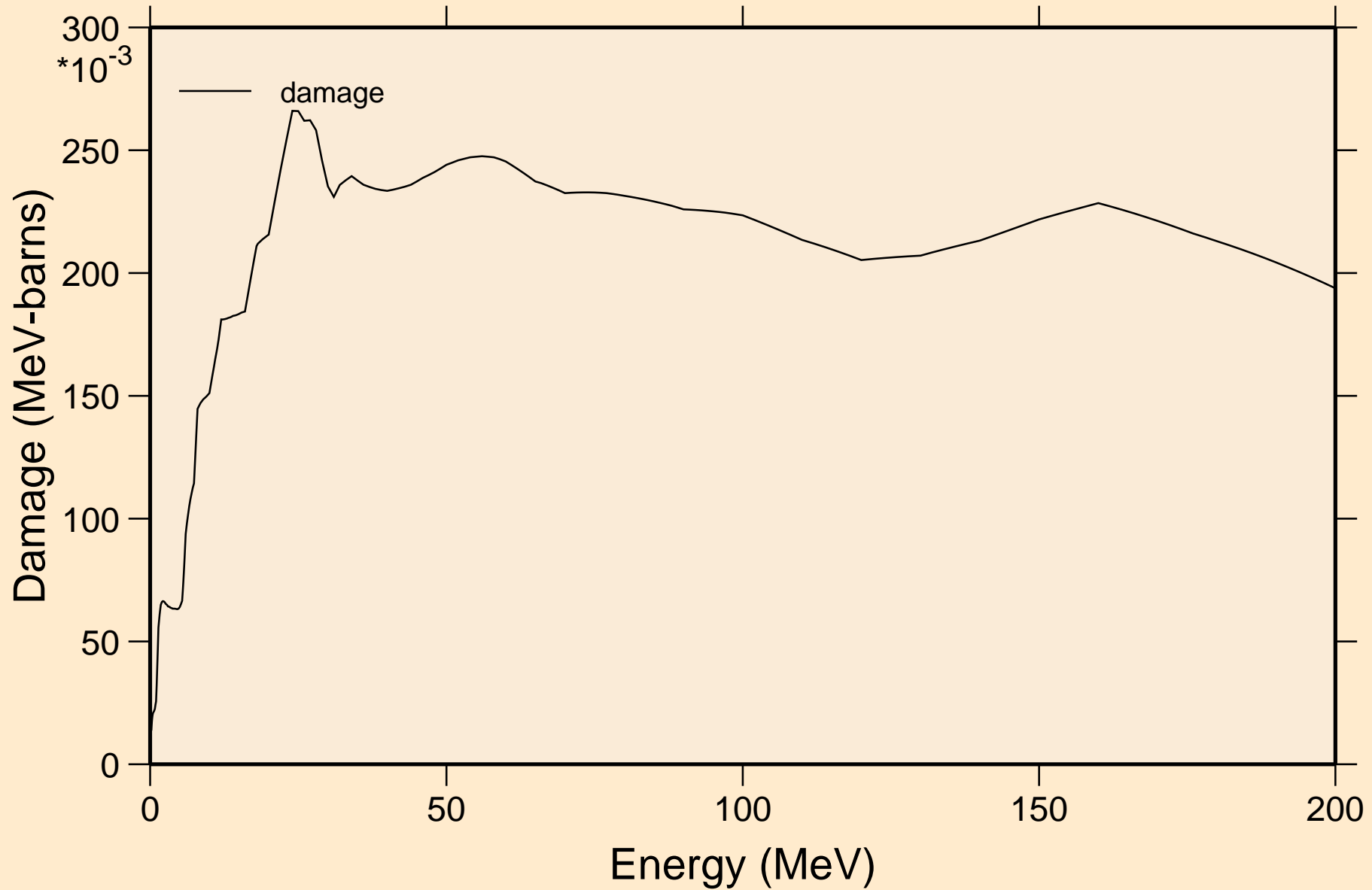

# PA240 NEUTRON ACER TENDL-2023 LIBRARY; T=0.K

## Non-threshold reactions

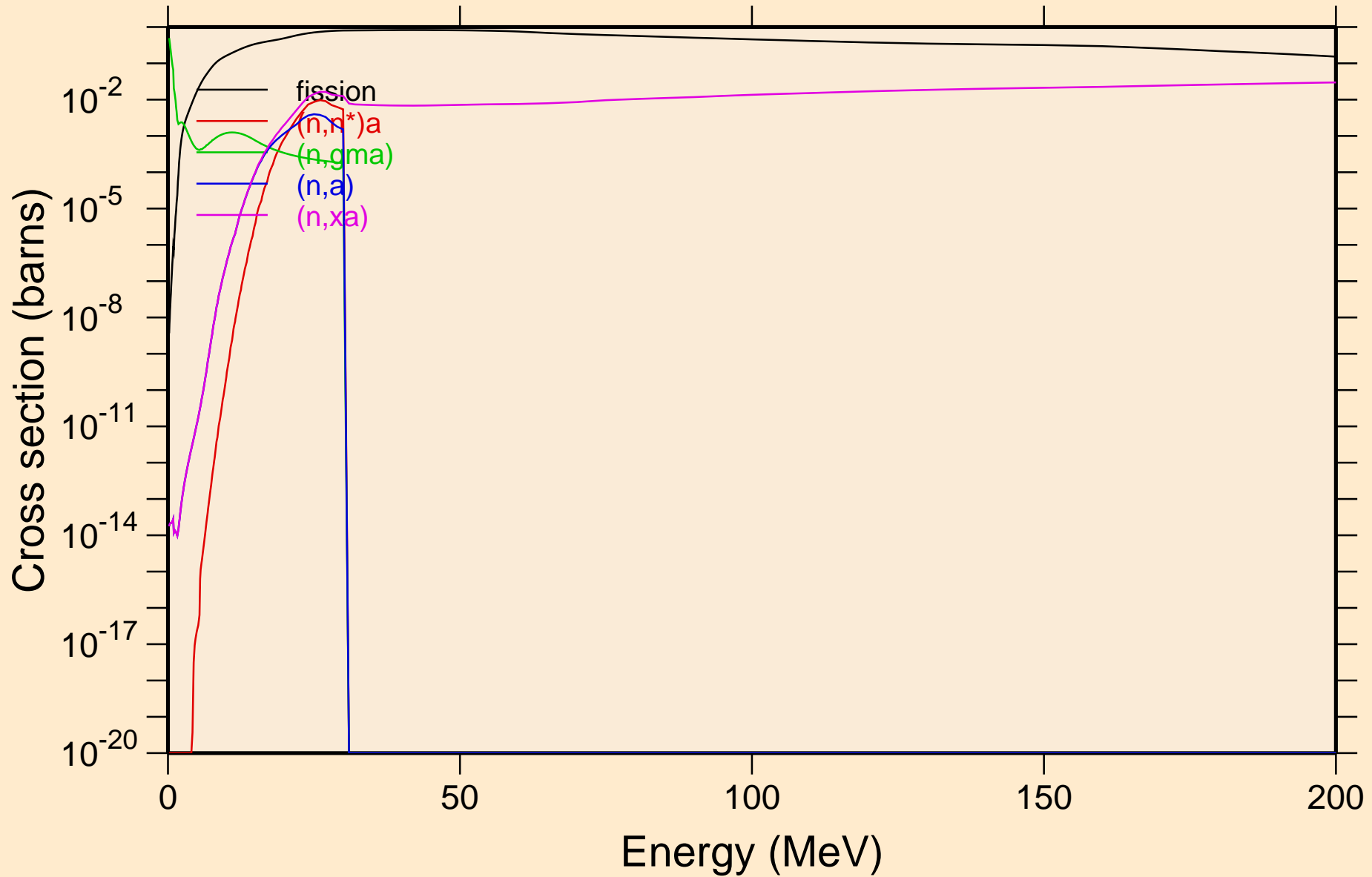



PA240 NEUTRON ACER TENDL-2023 LIBRARY; T=0.K  
Inelastic levels

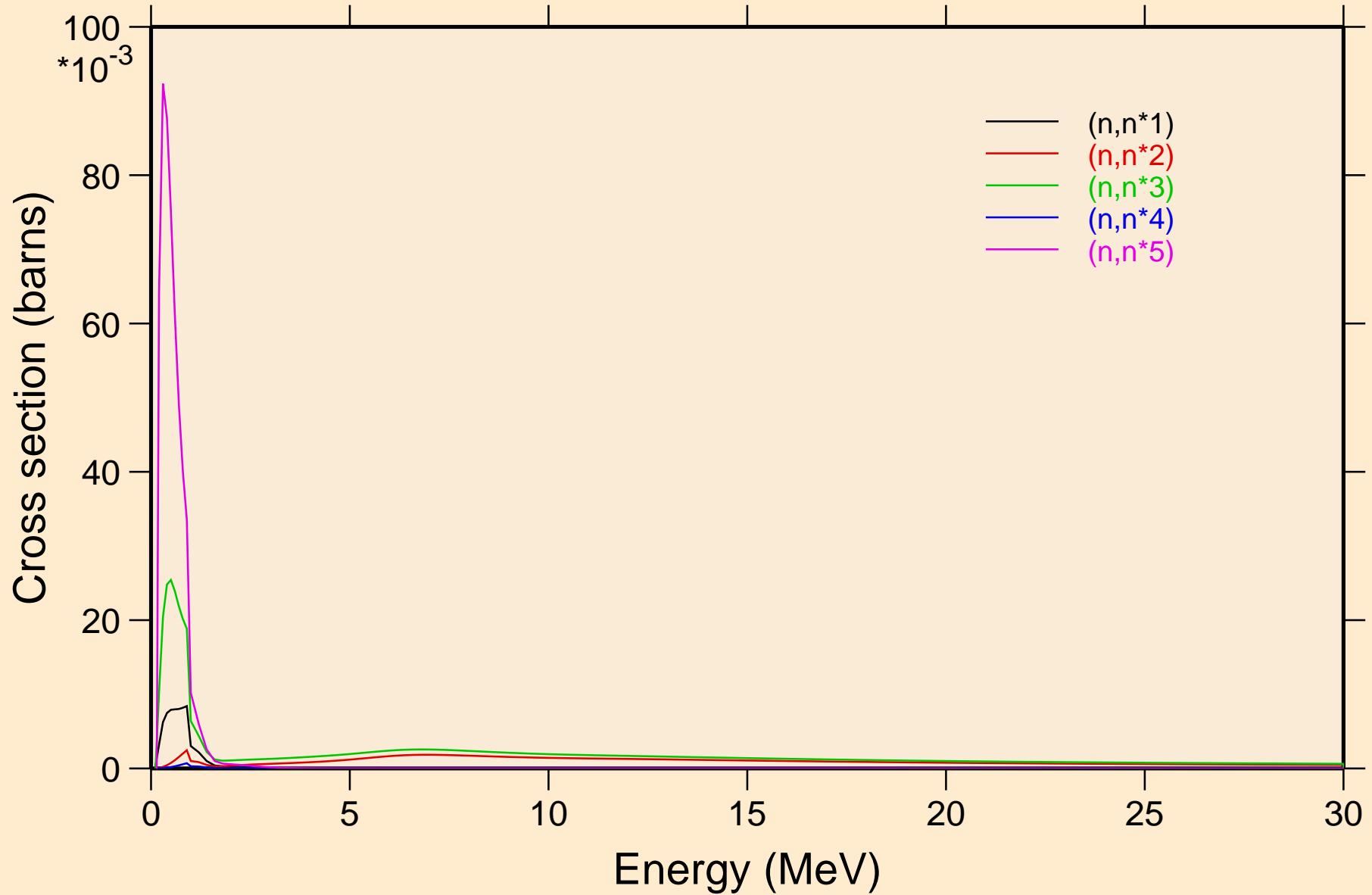

PA240 NEUTRON ACER TENDL-2023 LIBRARY; T=0.K  
Inelastic levels

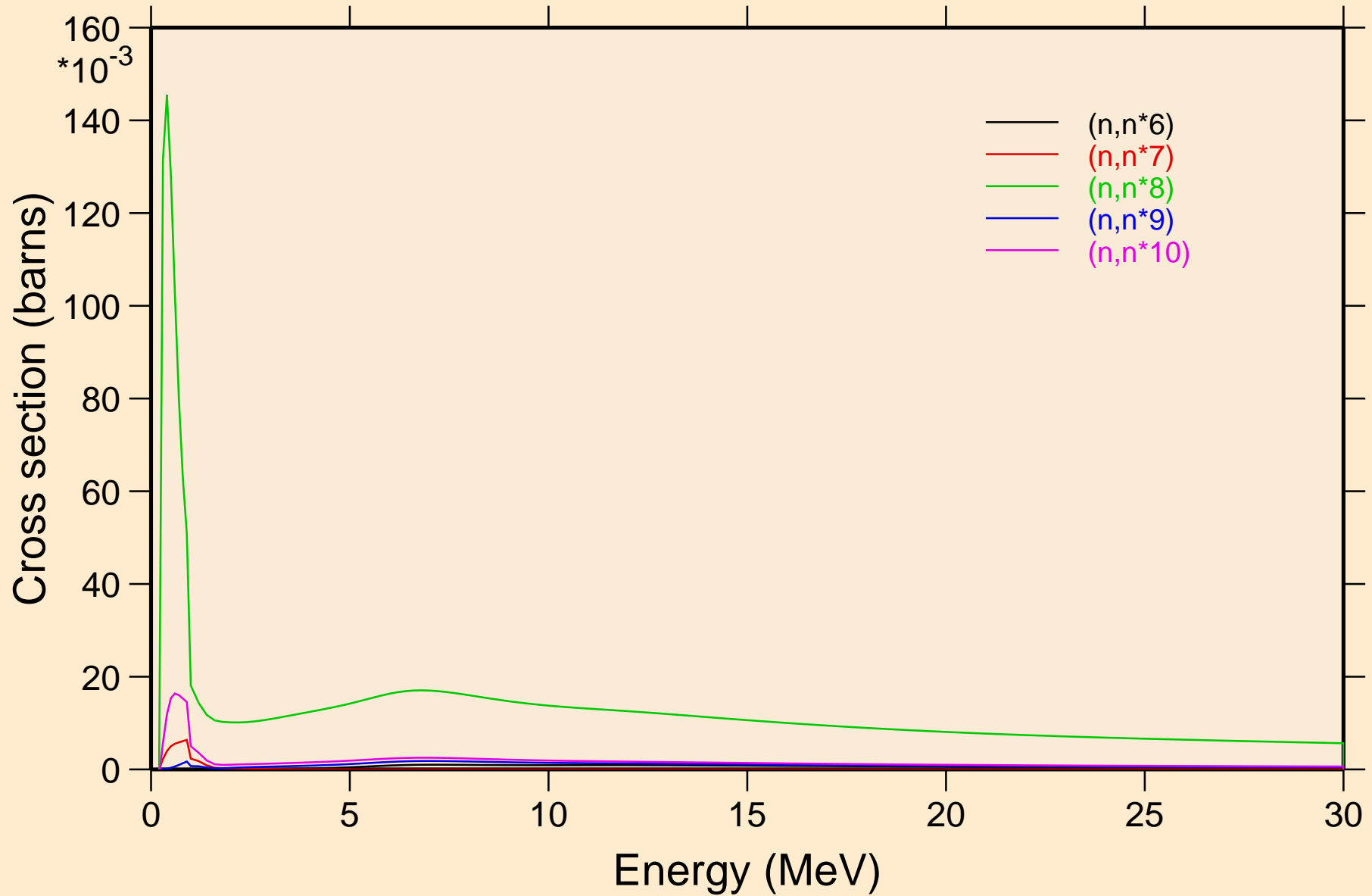

PA240 NEUTRON ACER TENDL-2023 LIBRARY; T=0.K  
Inelastic levels

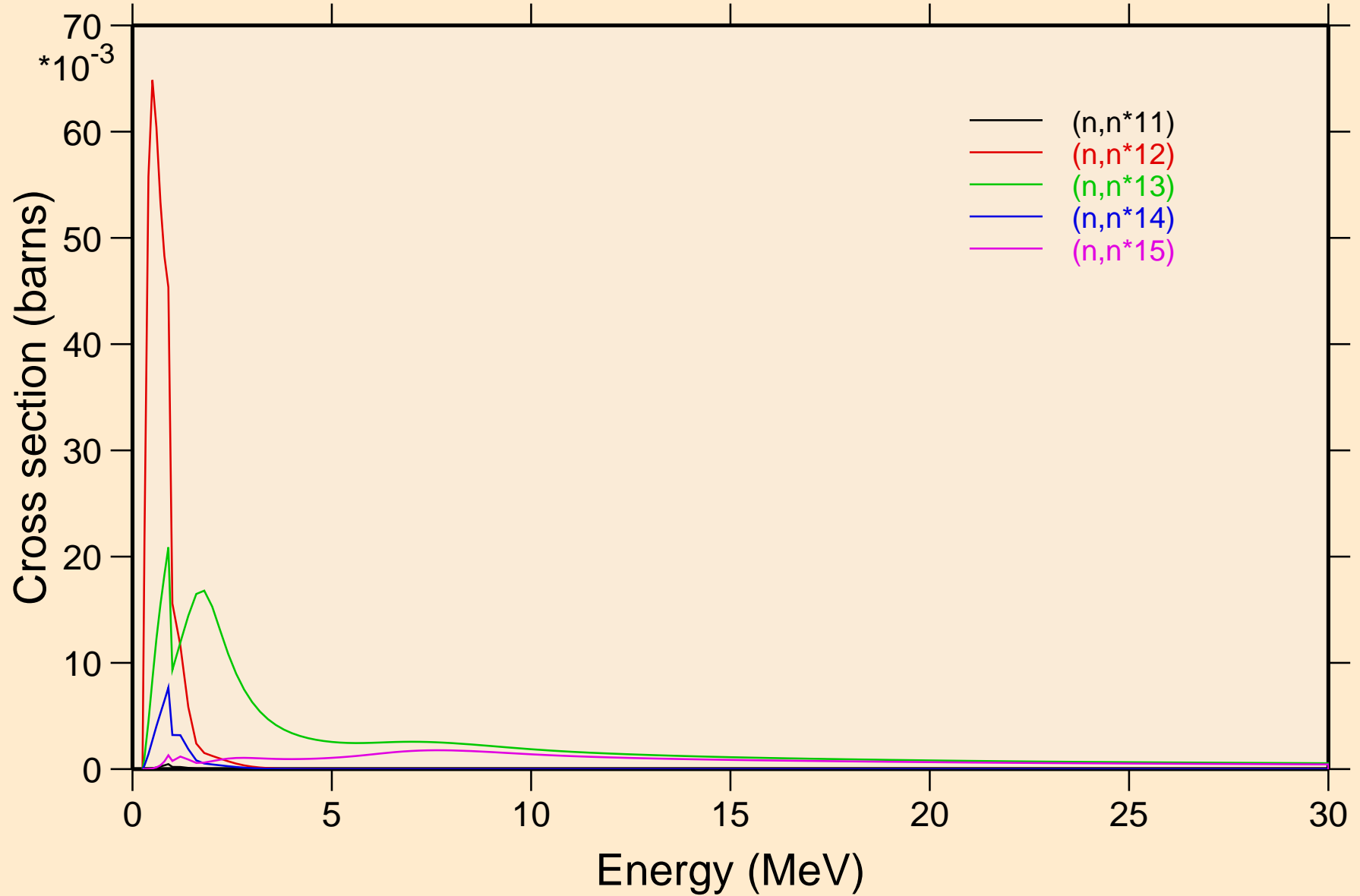

PA240 NEUTRON ACER TENDL-2023 LIBRARY; T=0.K  
Inelastic levels

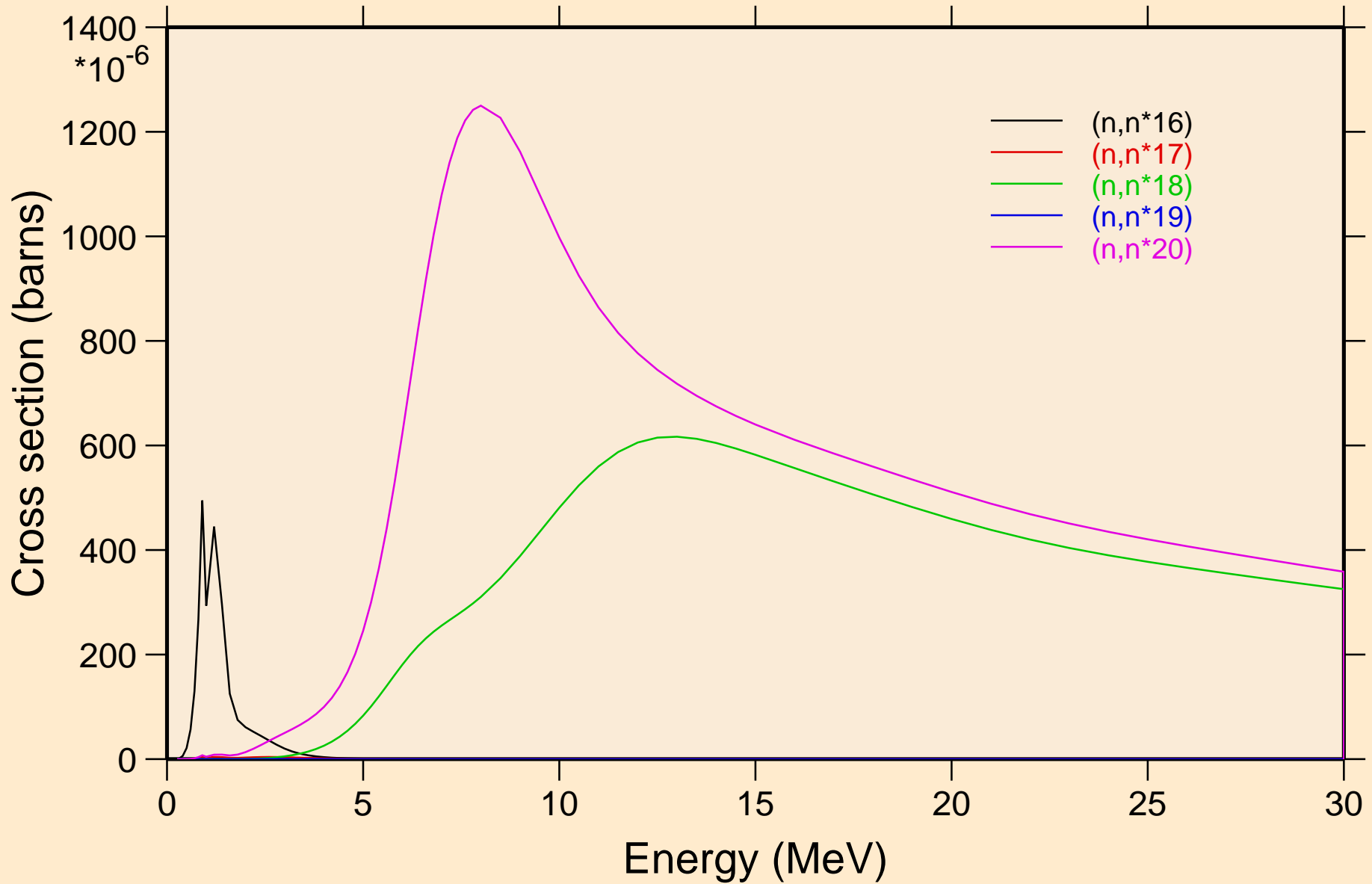

PA240 NEUTRON ACER TENDL-2023 LIBRARY; T=0.K  
Inelastic levels

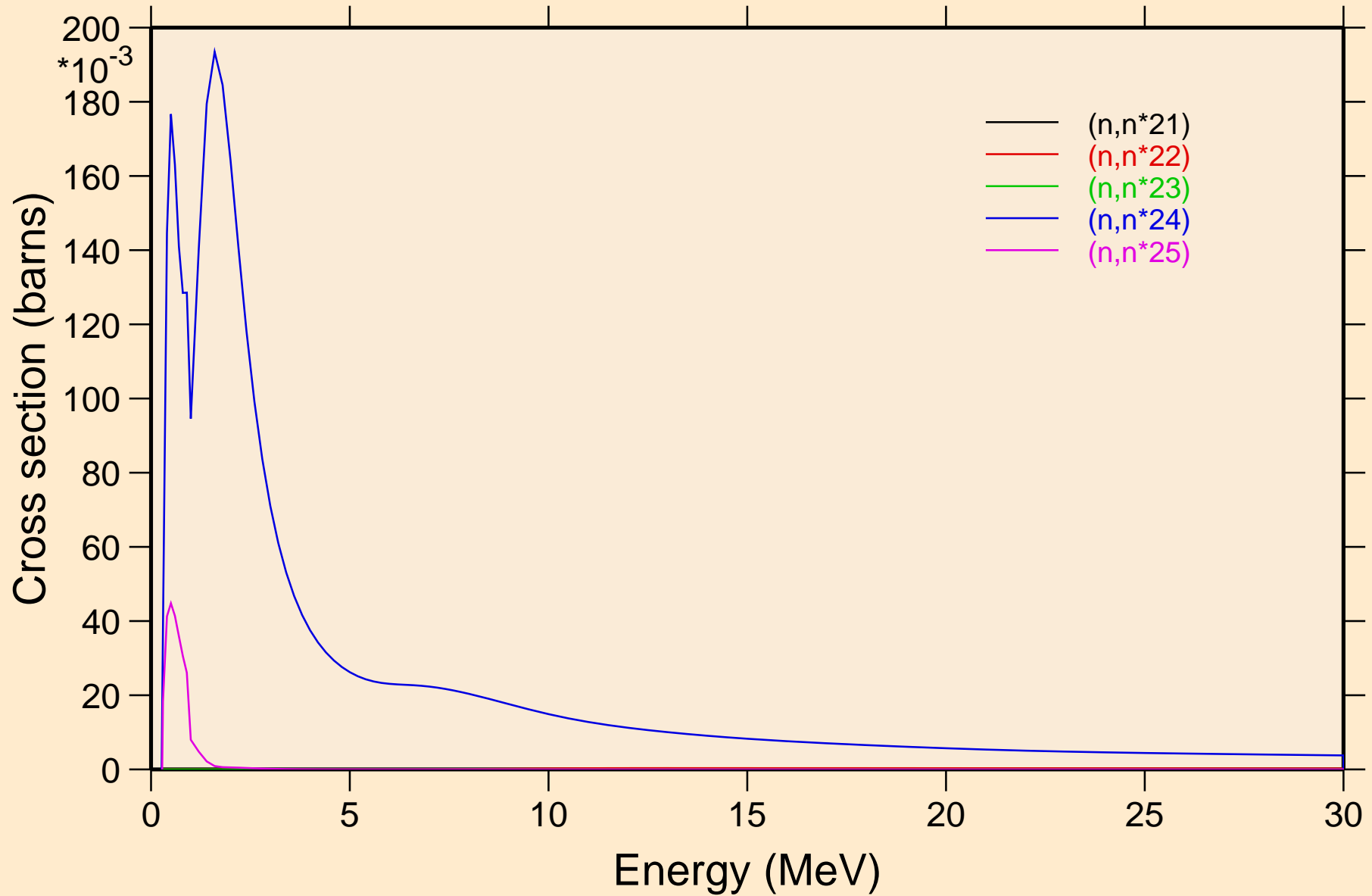

PA240 NEUTRON ACER TENDL-2023 LIBRARY; T=0.K  
Inelastic levels

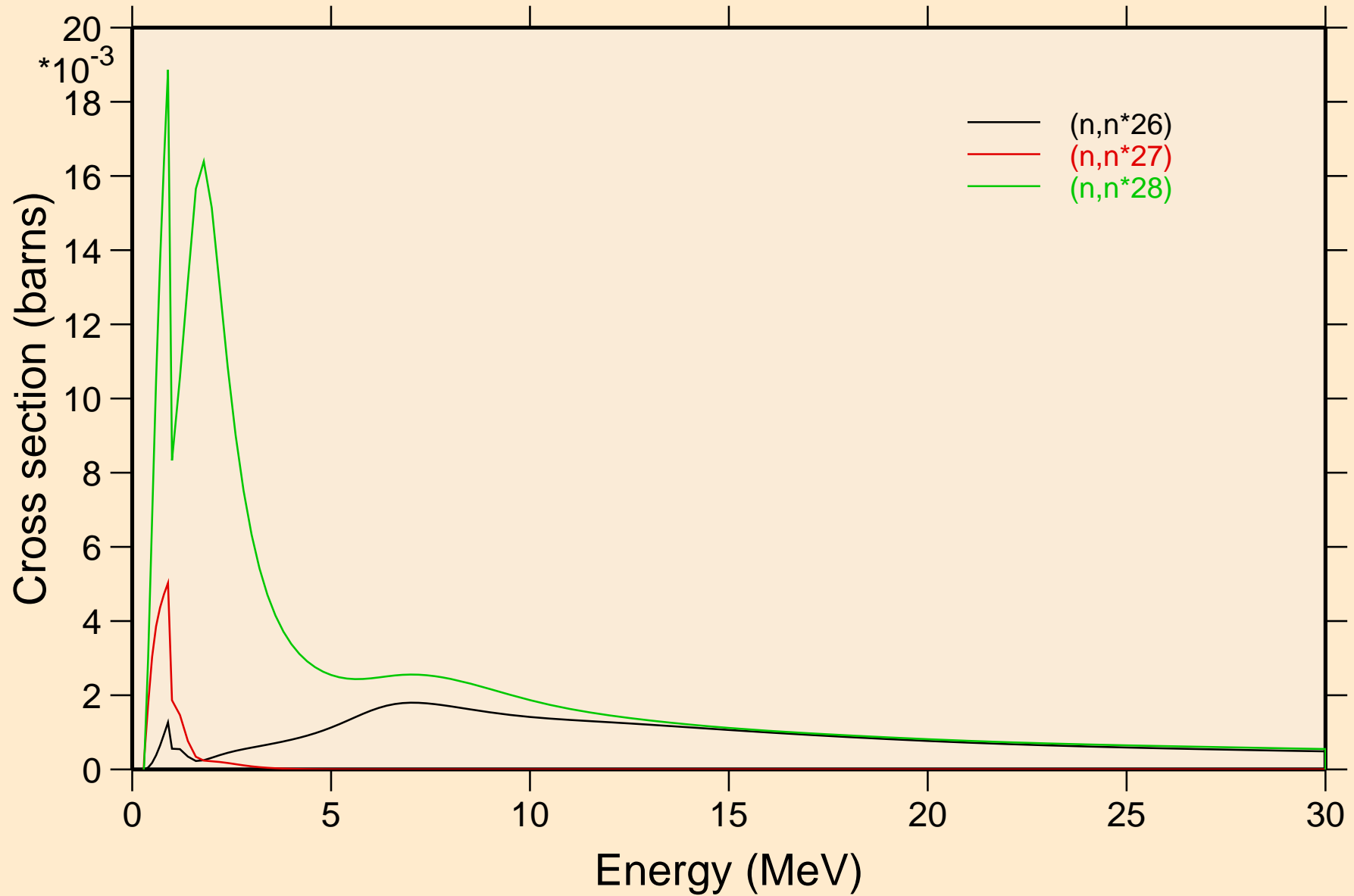

PA240 NEUTRON ACER TENDL-2023 LIBRARY; T=0.K  
Threshold reactions

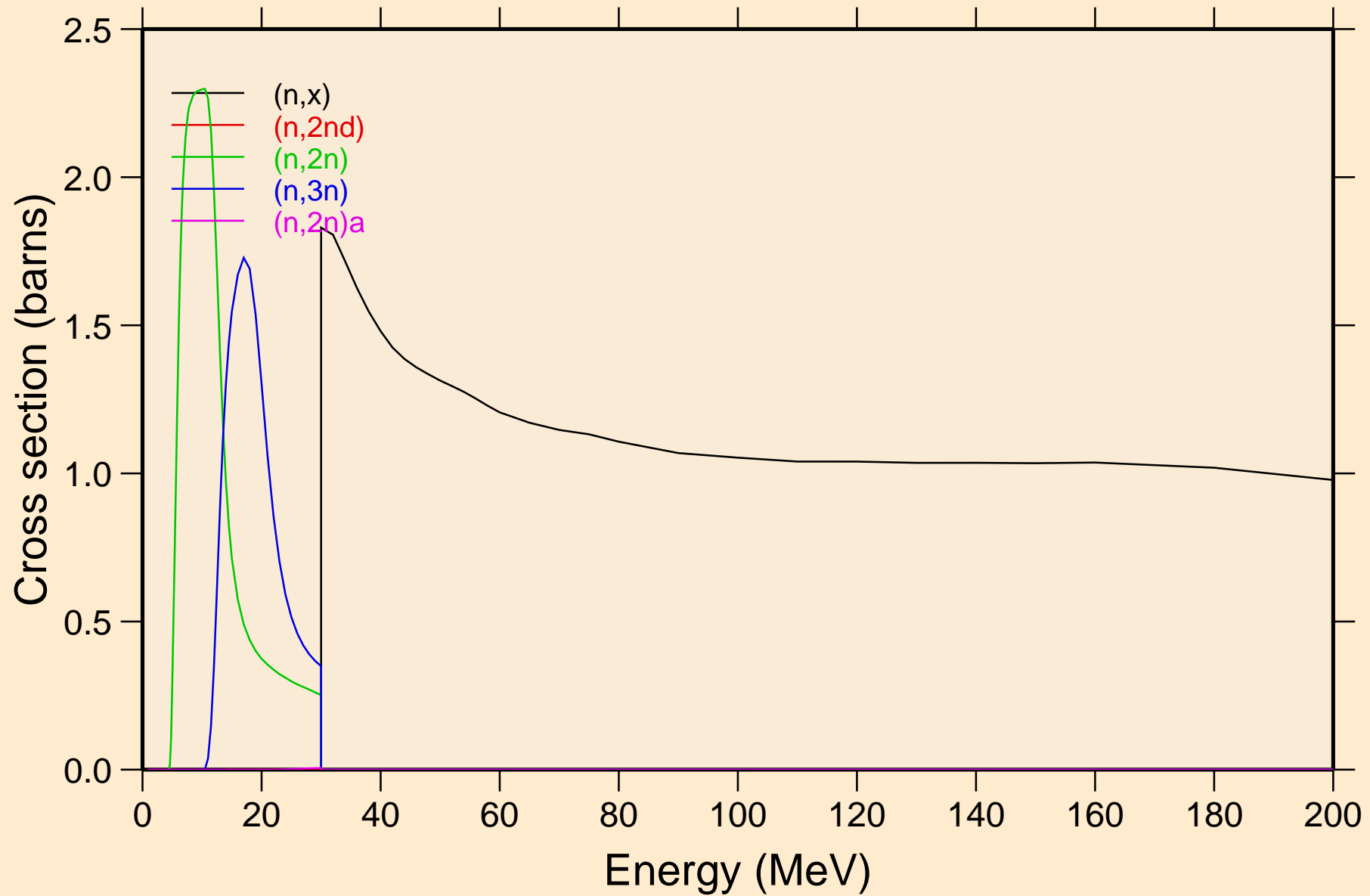

PA240 NEUTRON ACER TENDL-2023 LIBRARY; T=0.K  
Threshold reactions

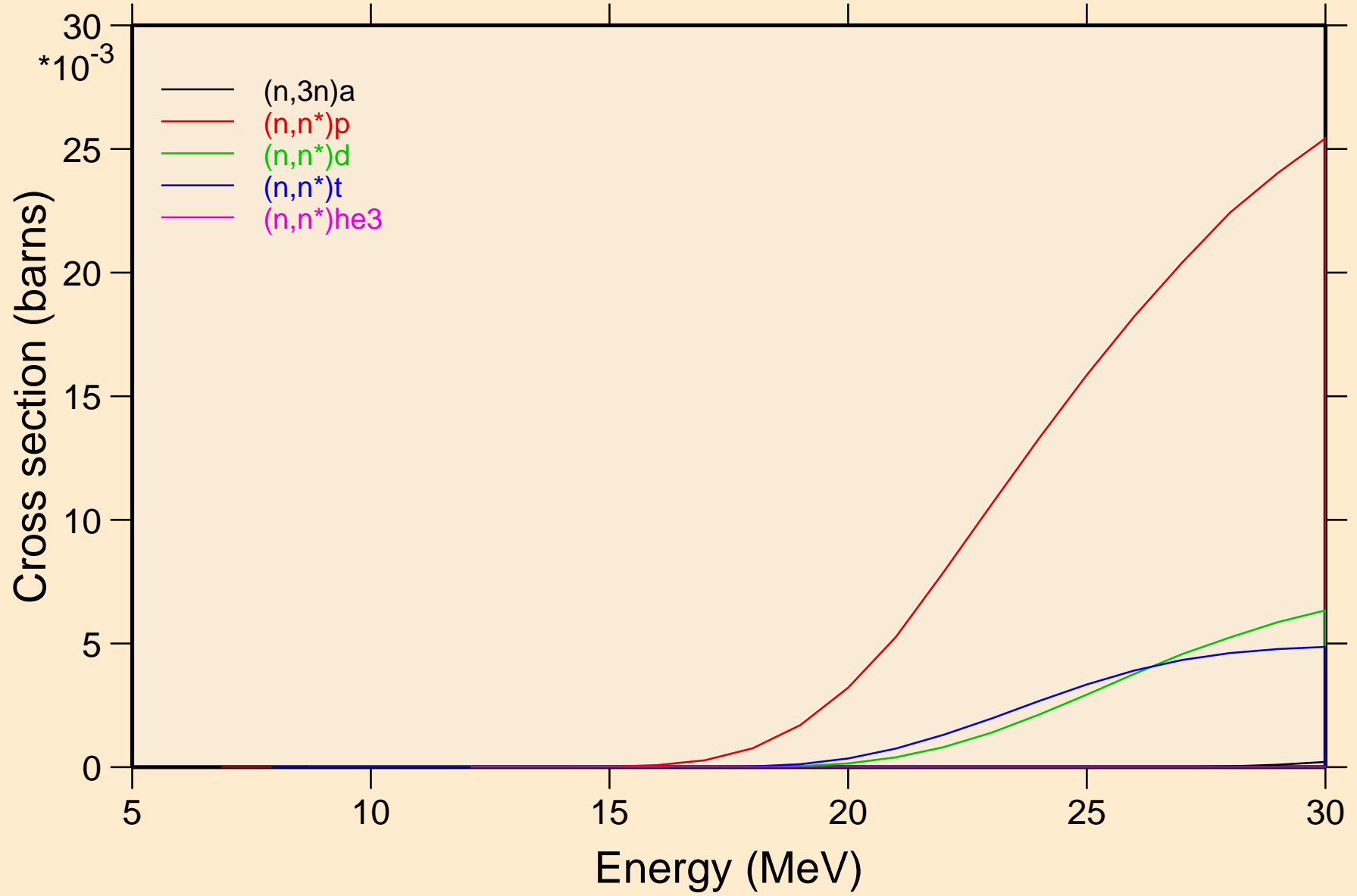



# PA240 NEUTRON ACER TENDL-2023 LIBRARY; T=0.K

## Threshold reactions

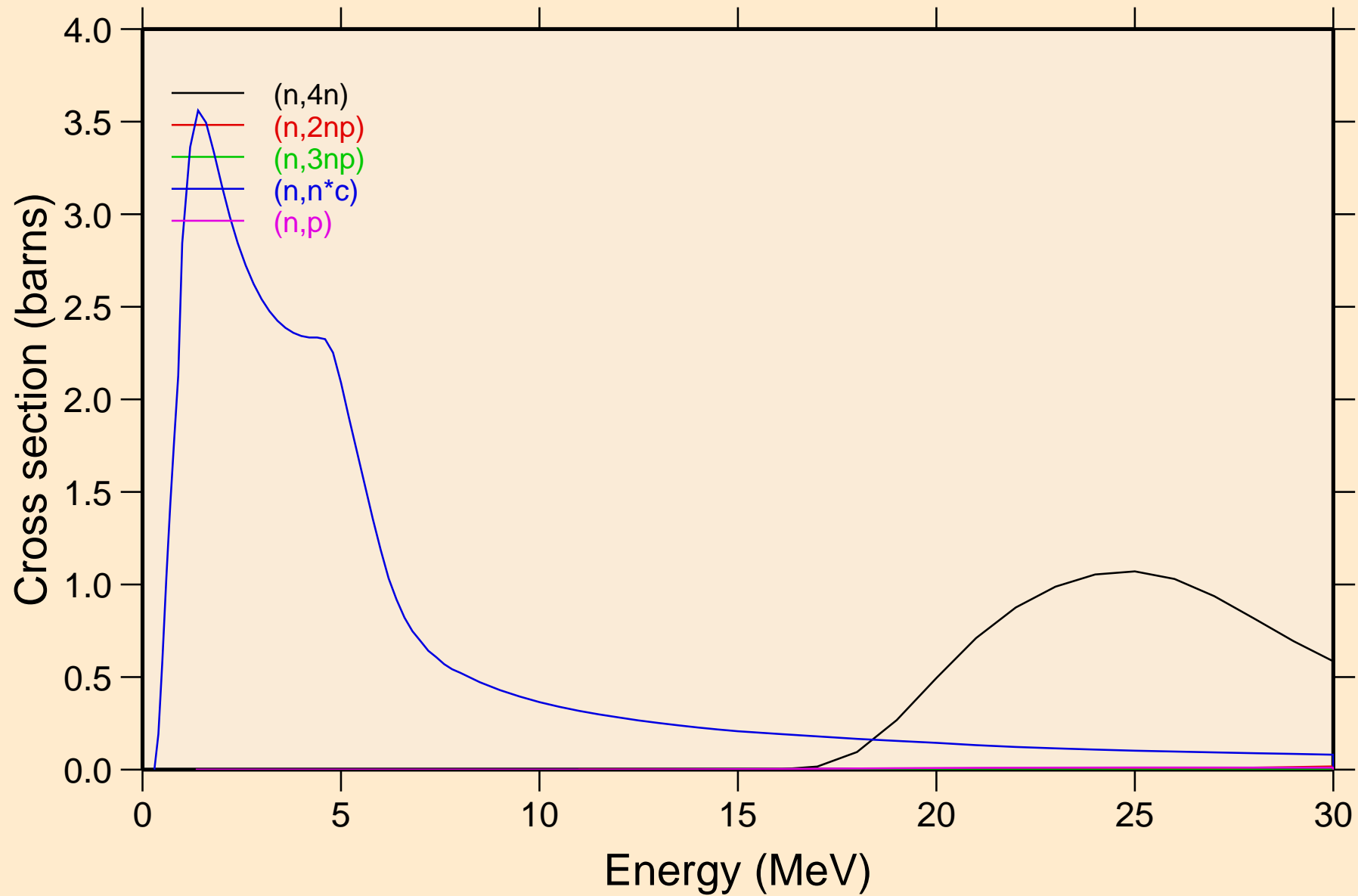

PA240 NEUTRON ACER TENDL-2023 LIBRARY; T=0.K  
Threshold reactions

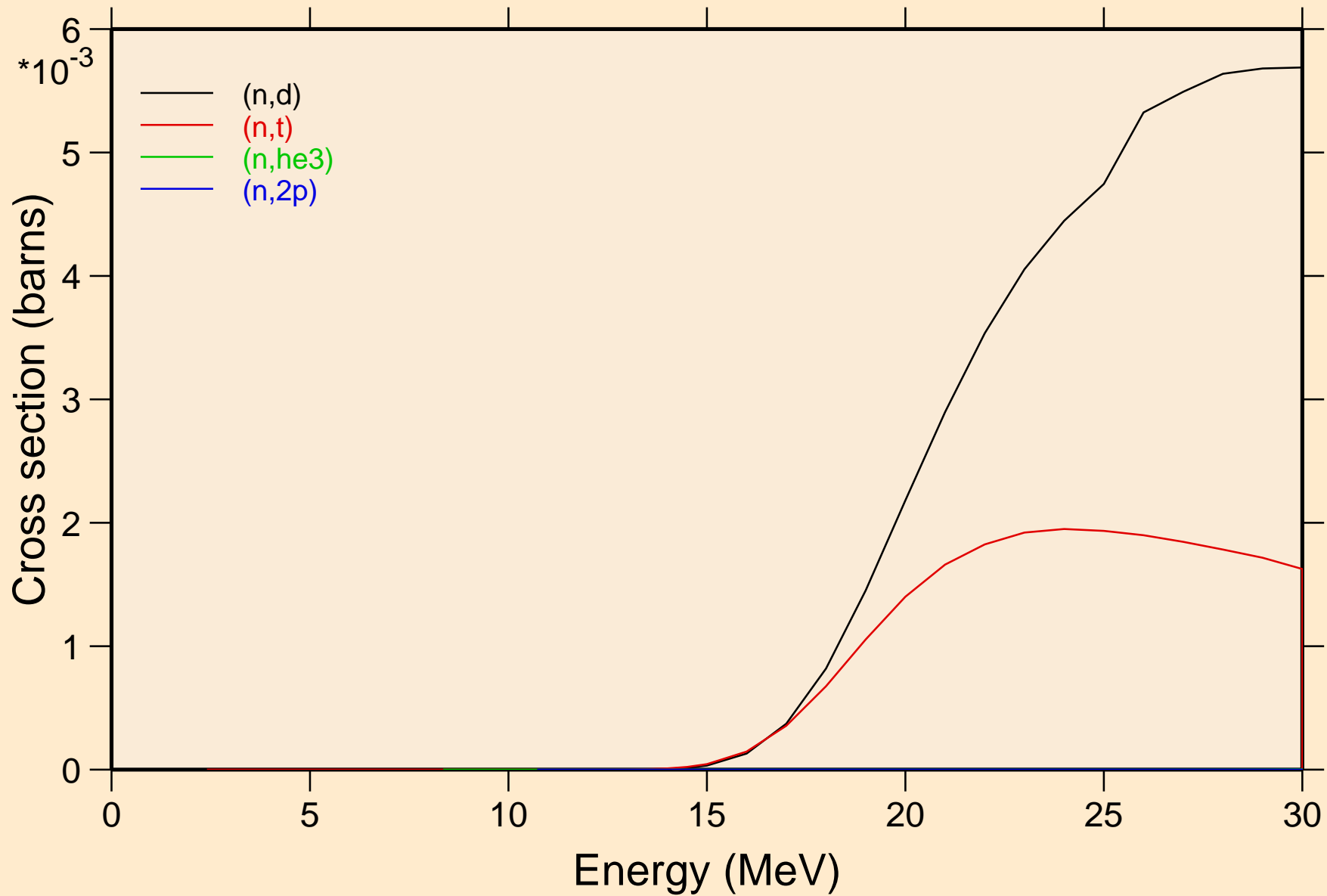

# PA240 NEUTRON ACER TENDL-2023 LIBRARY; T=0.K

## Threshold reactions

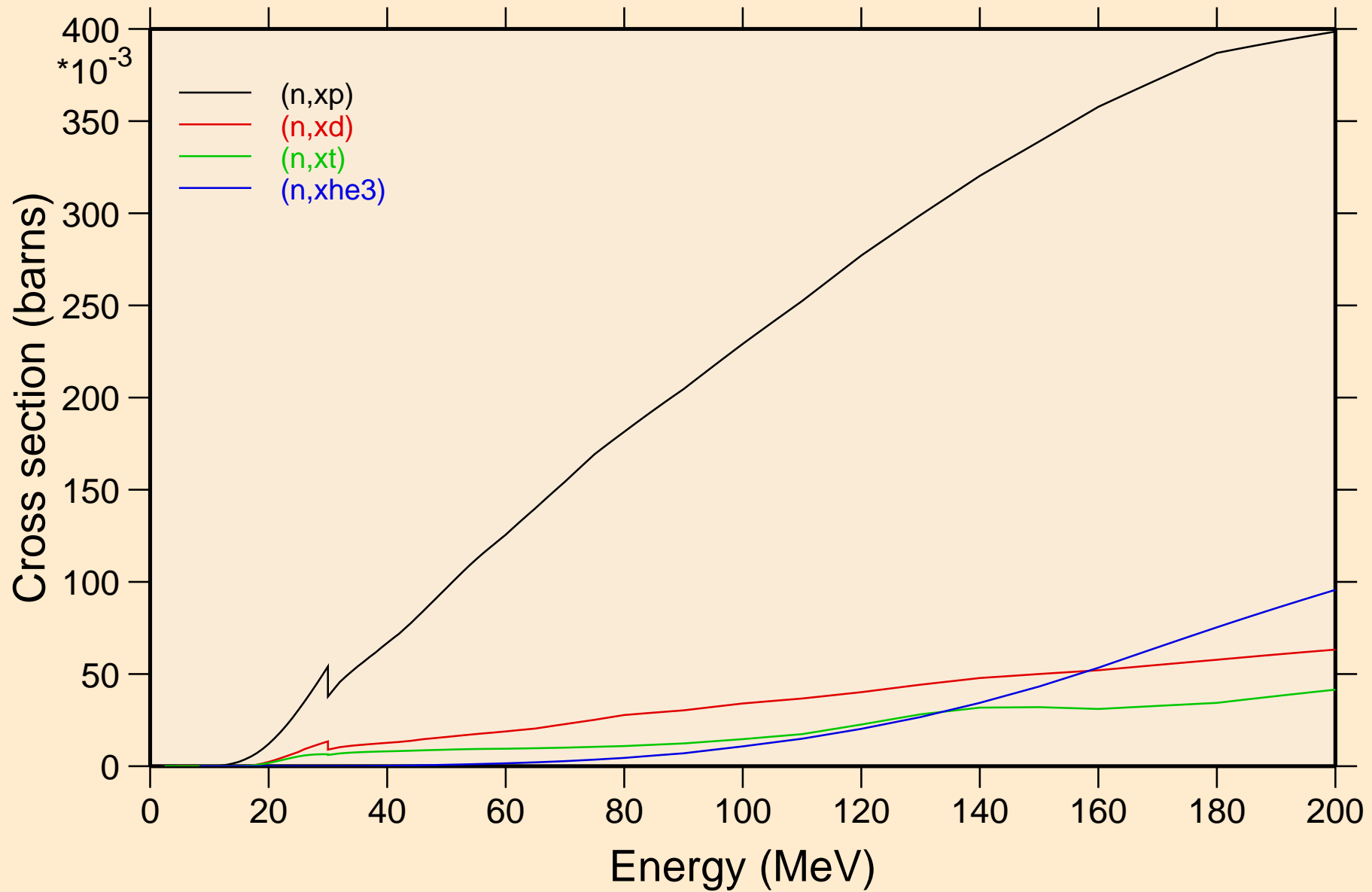

PA240 NEUTRON ACER TENDL-2023 LIBRARY; T=0.K  
angular distribution for elastic

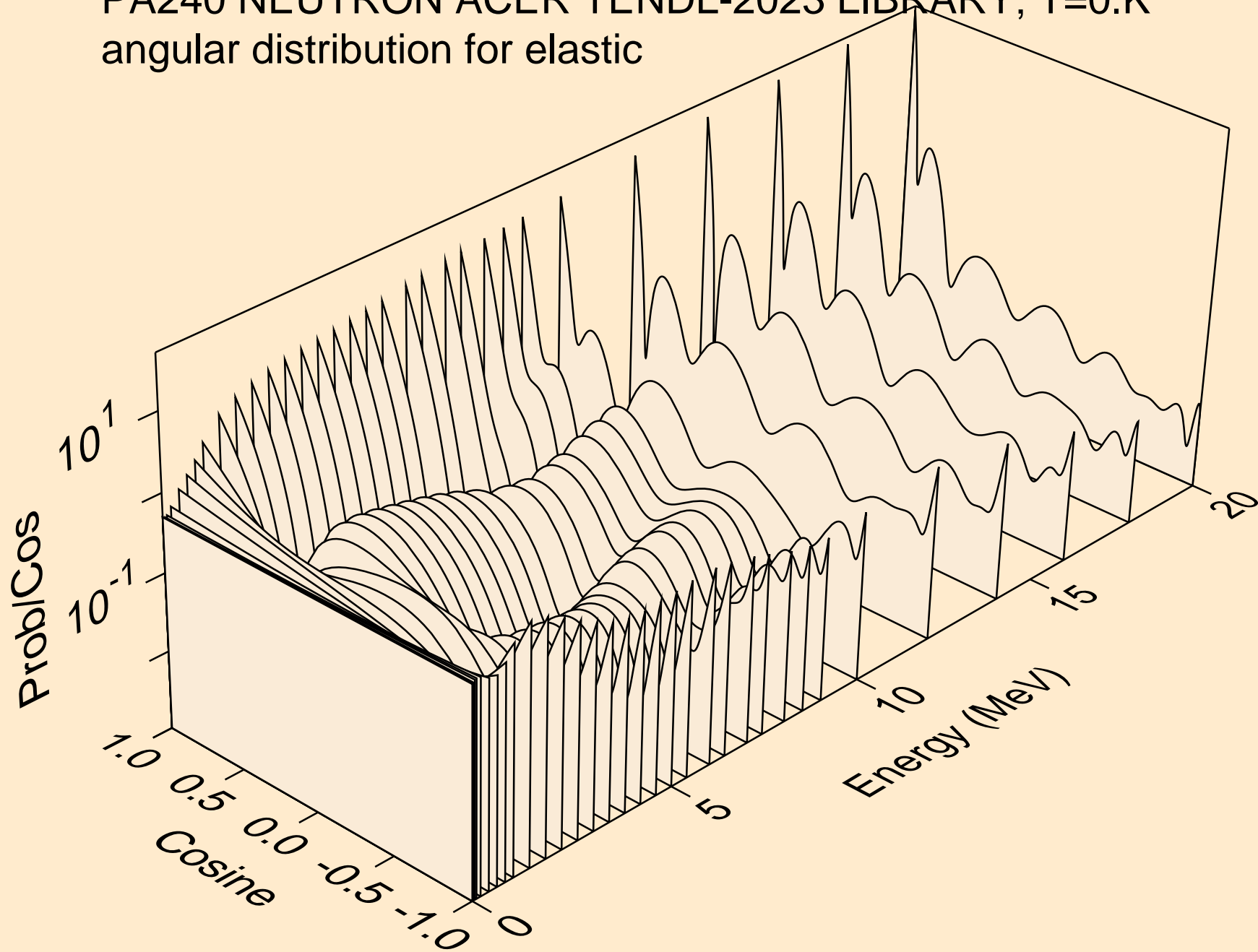

PA240 NEUTRON ACER TENDL-2023 LIBRARY; T=0.K  
angular distribution for elastic

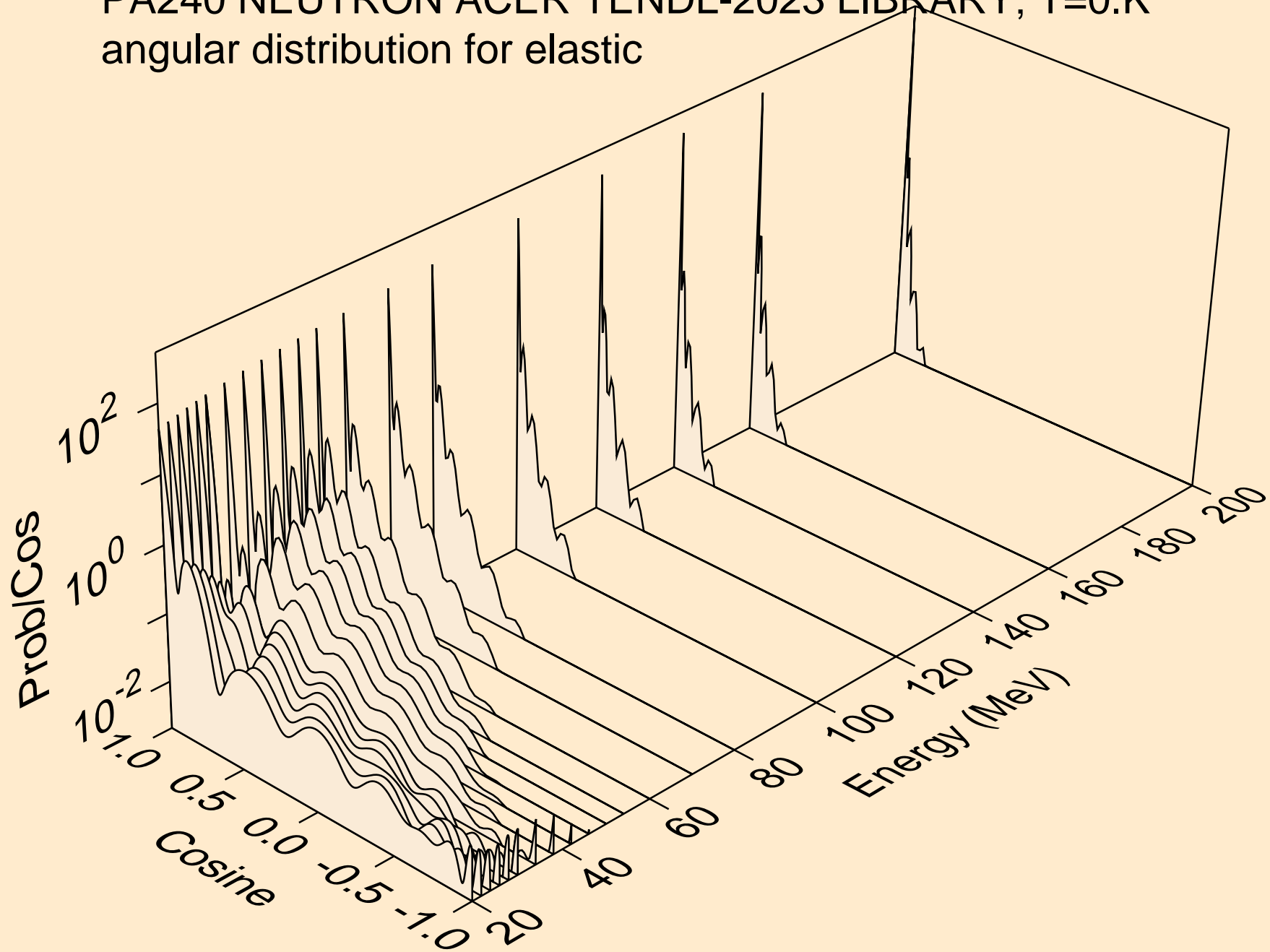

PA240 NEUTRON ACER TENDL-2023 LIBRARY; T=0.K  
angular distribution for (n,n\*1)

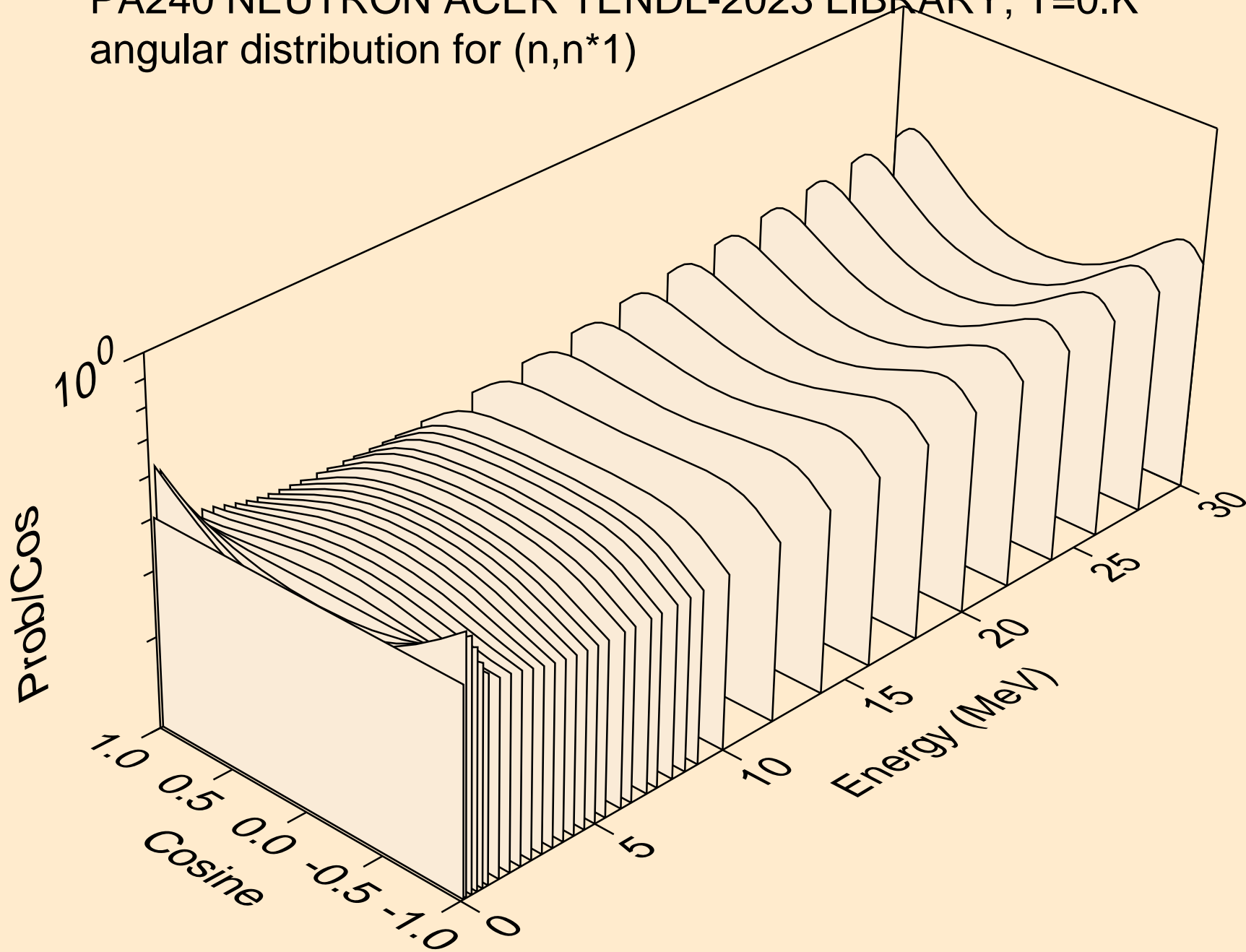

PA240 NEUTRON ACER TENDL-2023 LIBRARY; T=0.K  
angular distribution for (n,n\*2)

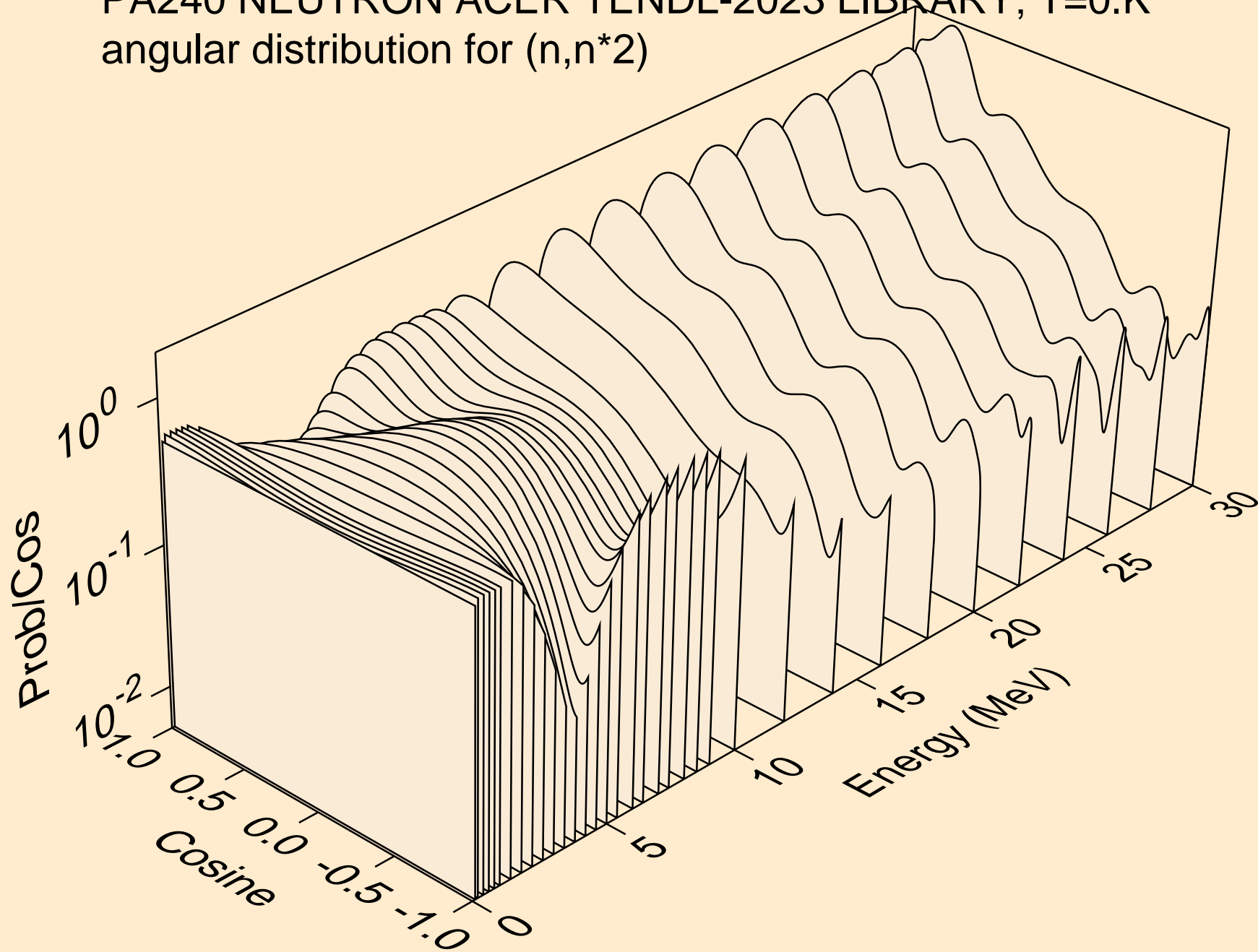

PA240 NEUTRON ACER TENDL-2023 LIBRARY; T=0.K  
angular distribution for (n,n\*3)

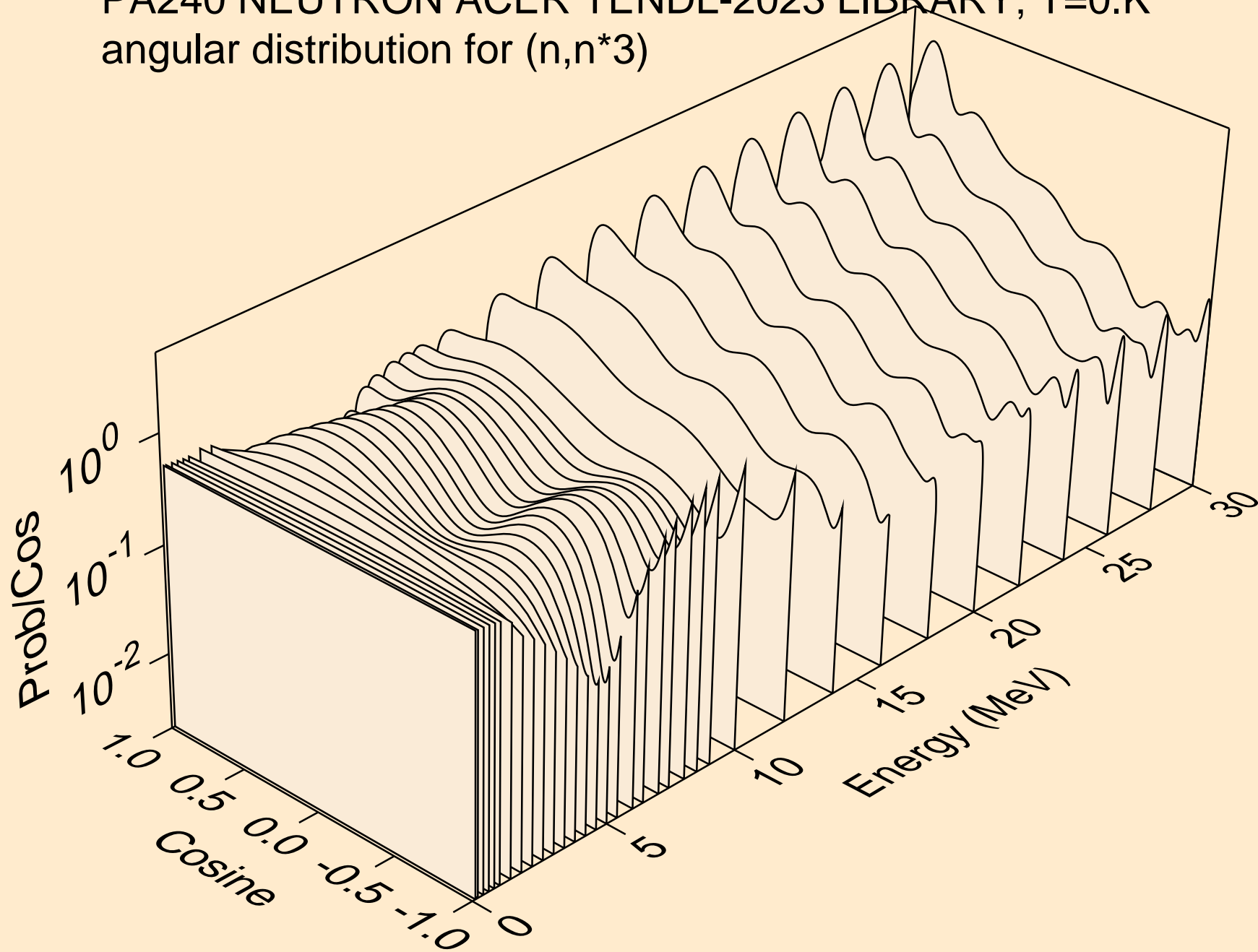



PA240 NEUTRON ACER TENDL-2023 LIBRARY; T=0.K  
angular distribution for (n,n\*4)

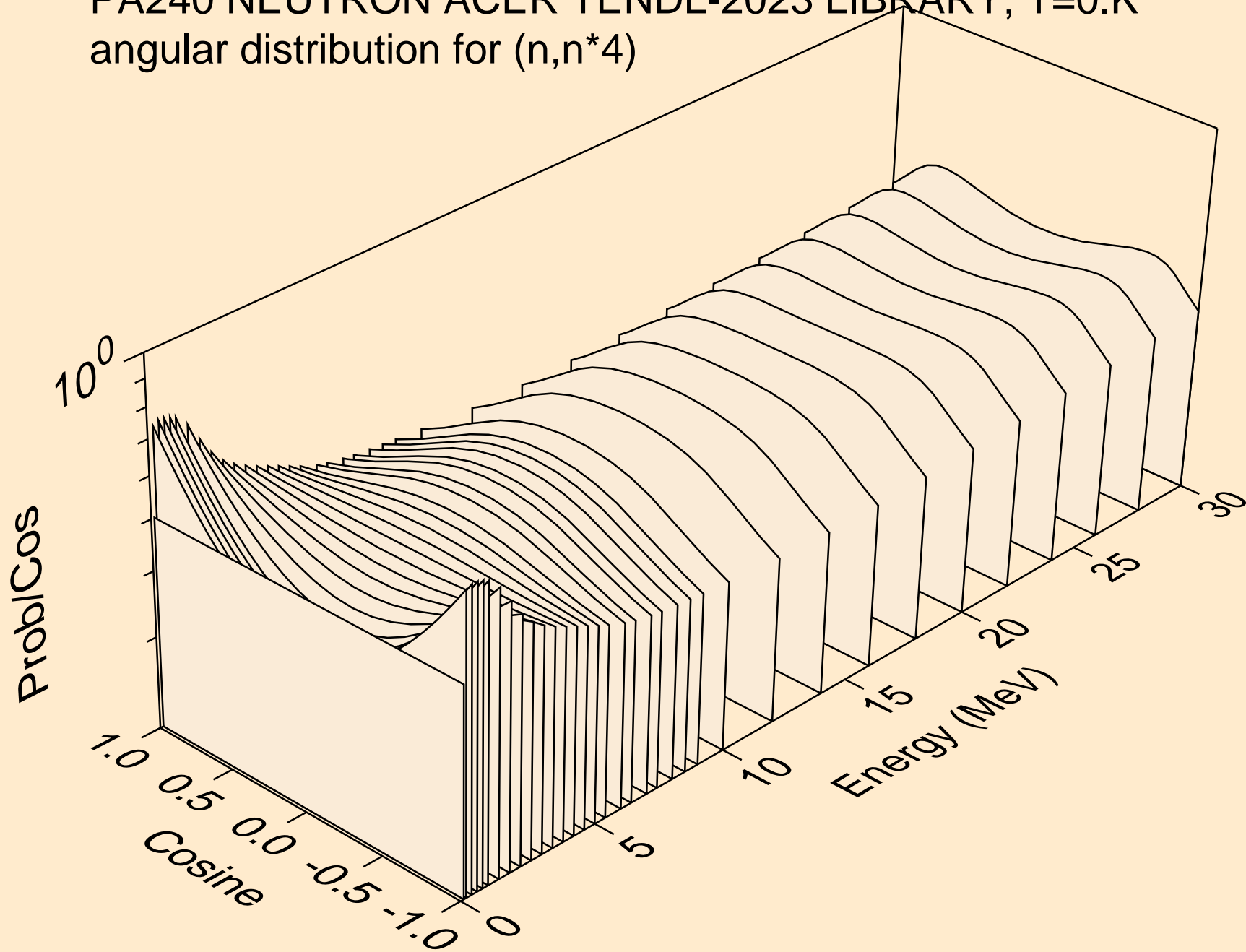

PA240 NEUTRON ACER TENDL-2023 LIBRARY; T=0.K  
angular distribution for (n,n\*5)

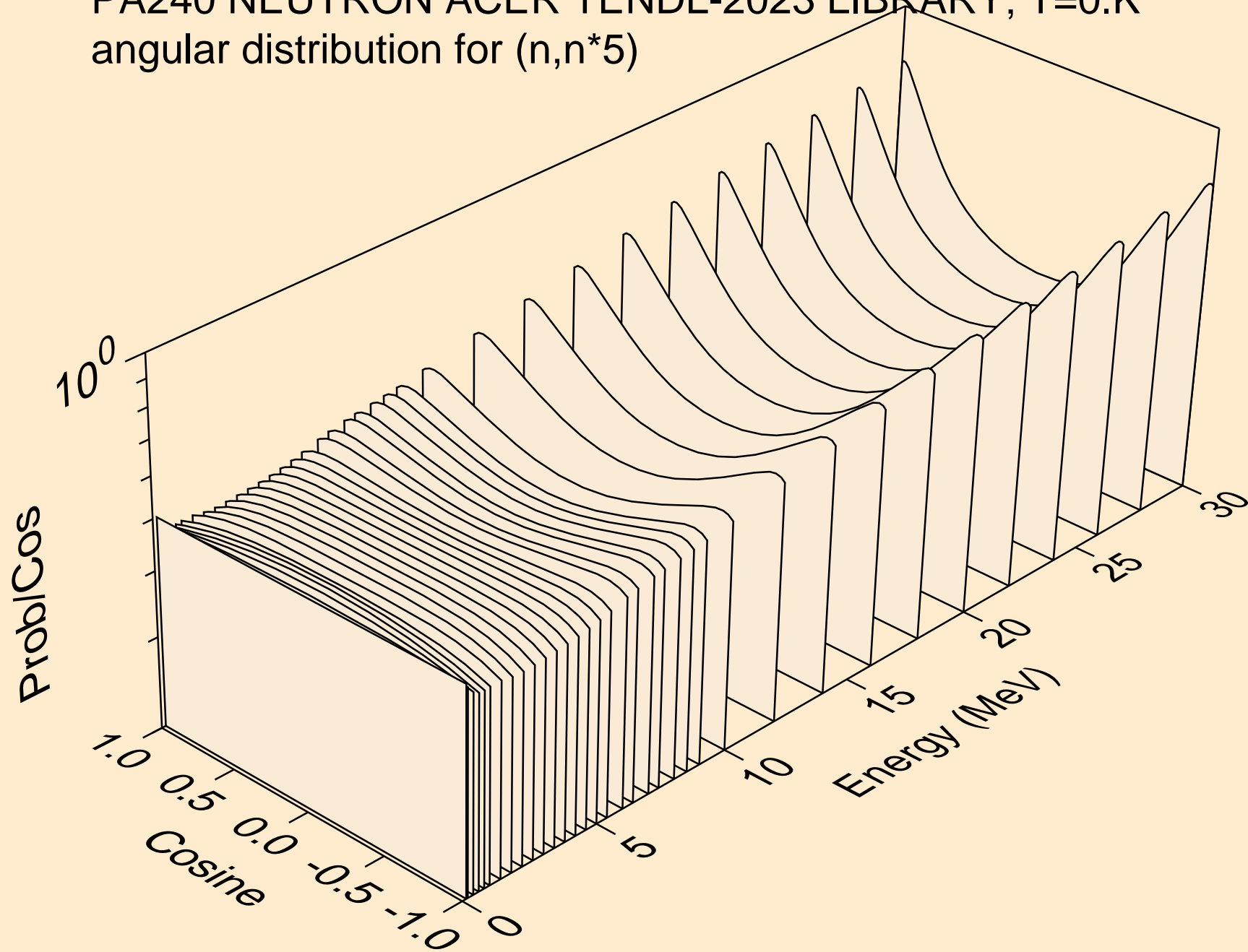

PA240 NEUTRON ACER TENDL-2023 LIBRARY; T=0.K  
angular distribution for (n,n\*6)

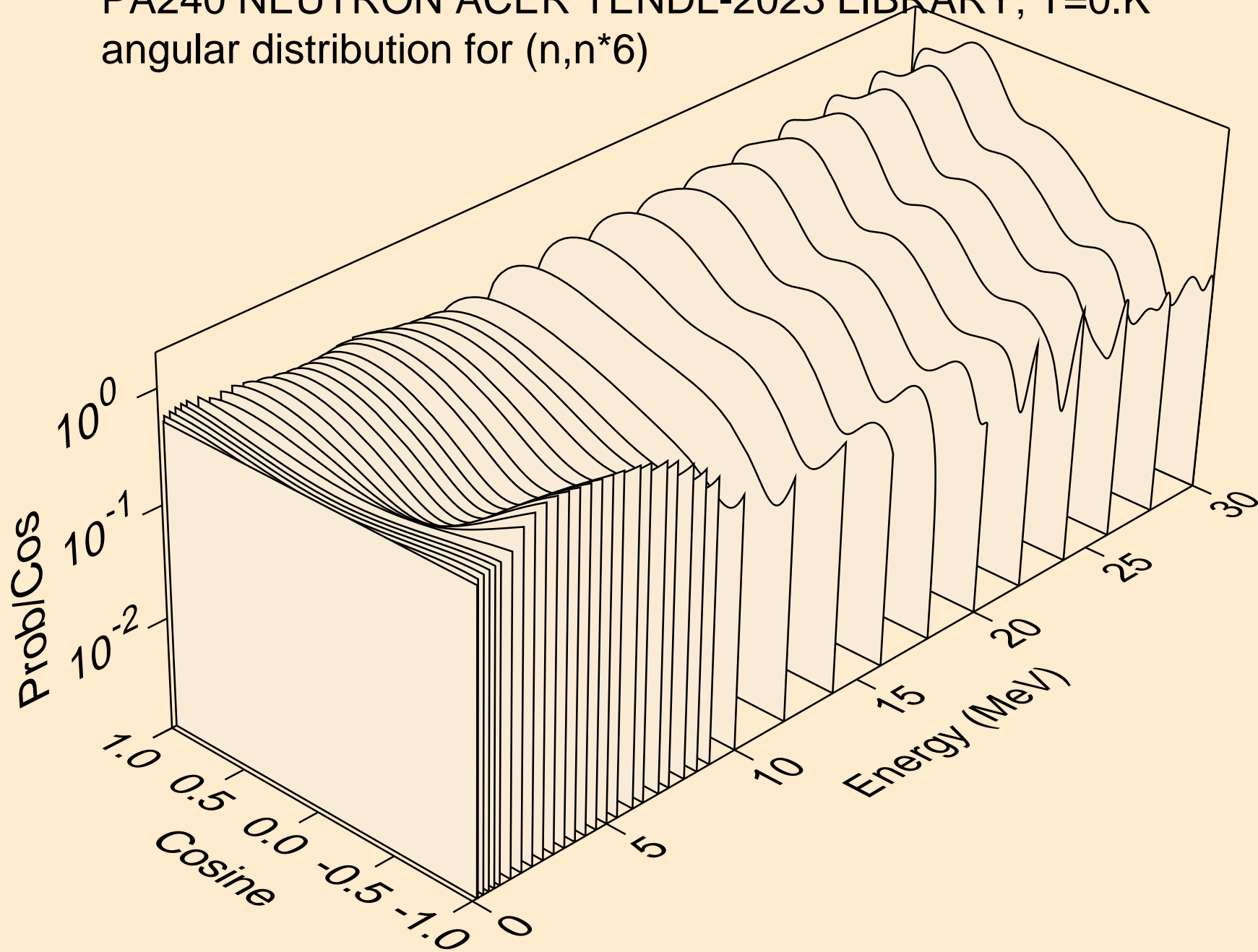

PA240 NEUTRON ACER TENDL-2023 LIBRARY; T=0.K  
angular distribution for (n,n\*7)

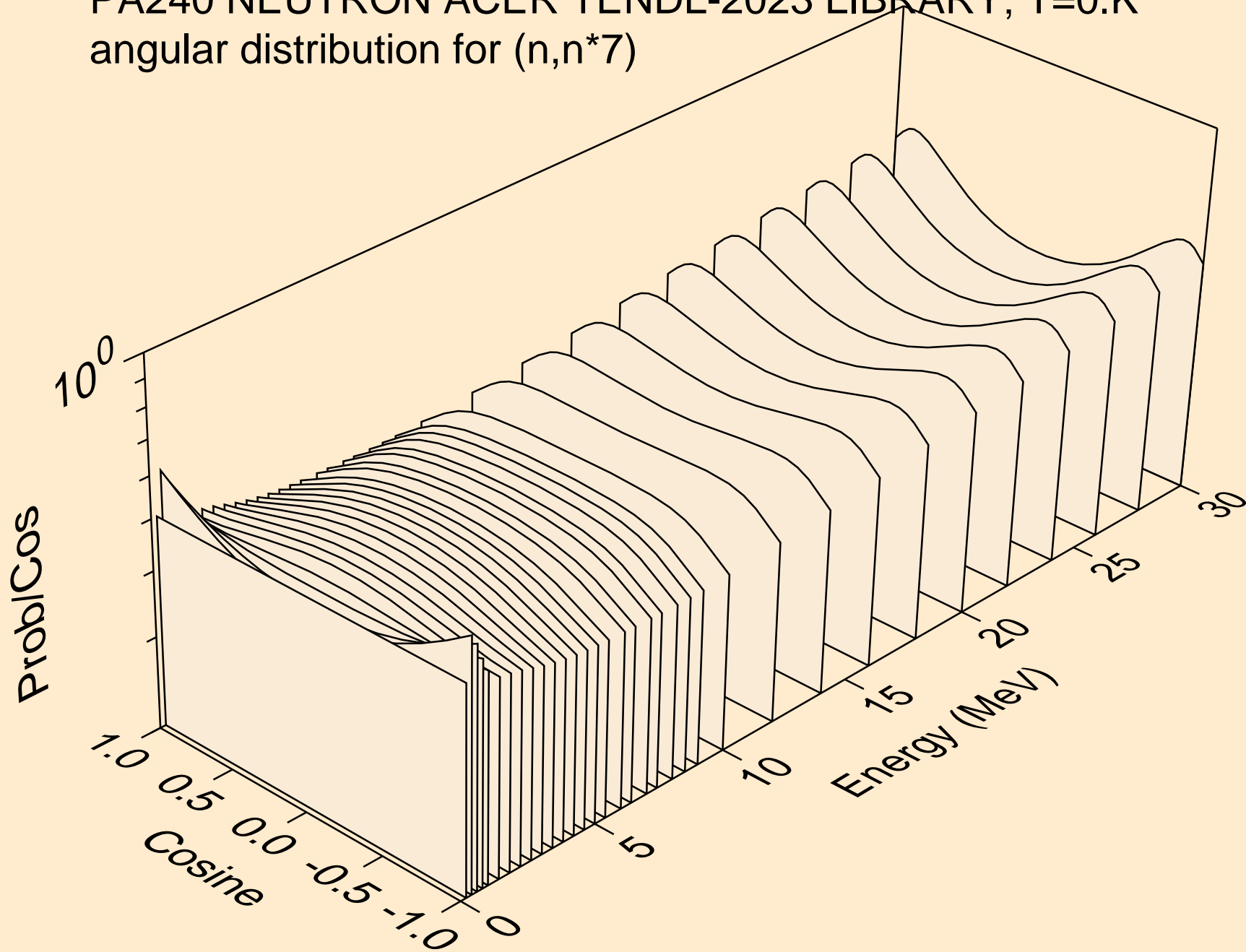

PA240 NEUTRON ACER TENDL-2023 LIBRARY; T=0.K  
angular distribution for (n,n\*8)

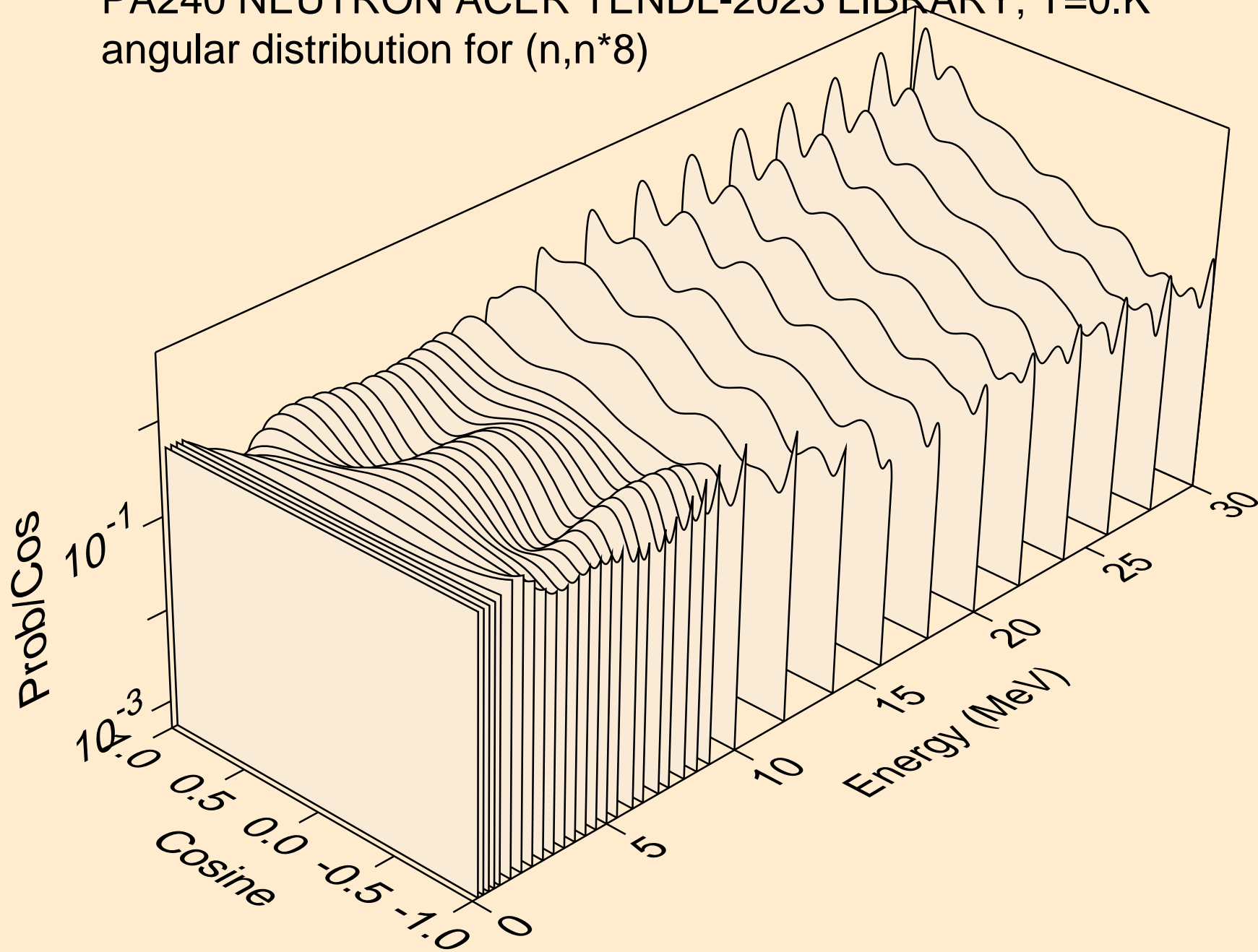

PA240 NEUTRON ACER TENDL-2023 LIBRARY; T=0.K  
angular distribution for (n,n\*9)

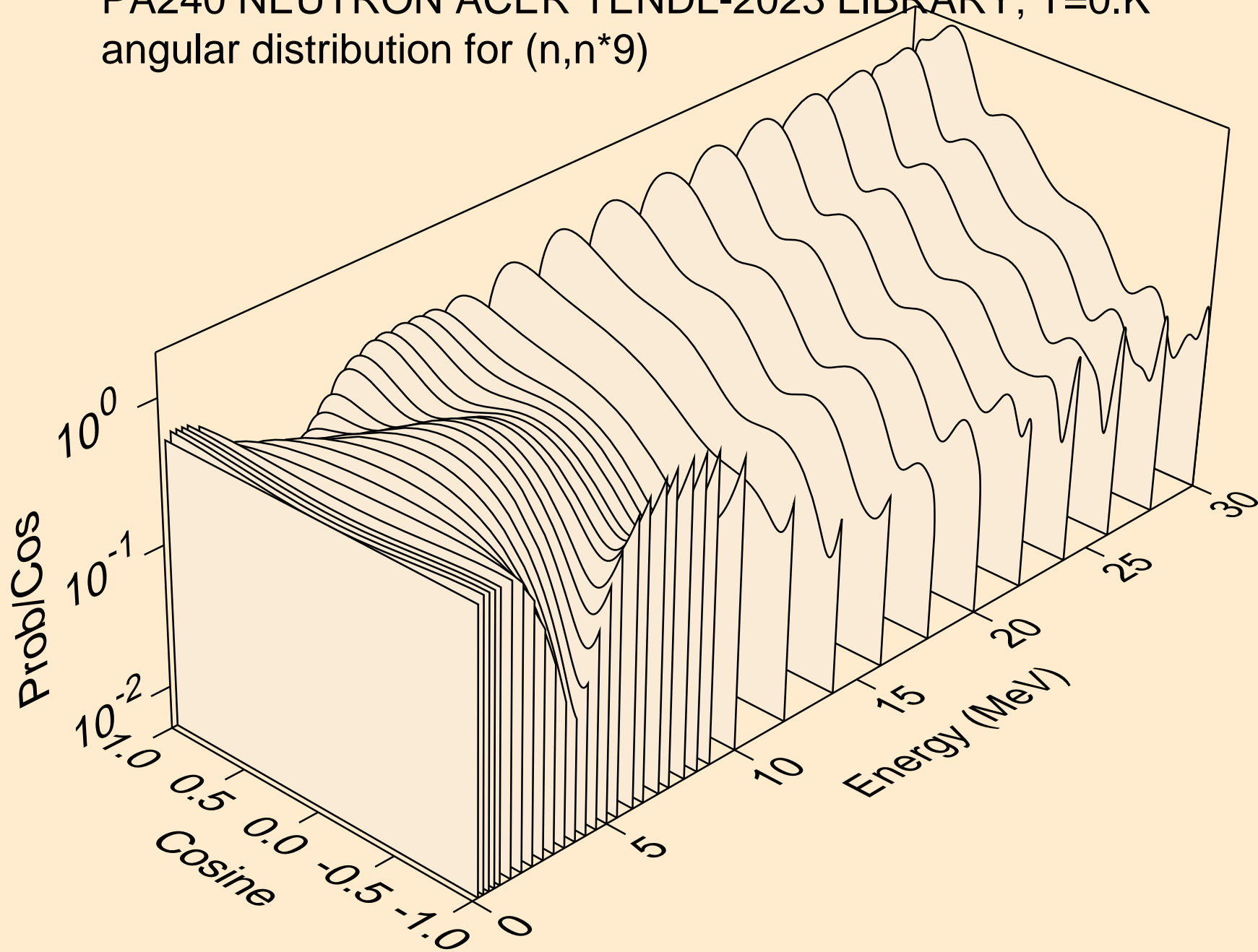

PA240 NEUTRON ACER TENDL-2023 LIBRARY; T=0.K  
angular distribution for (n,n\*10)

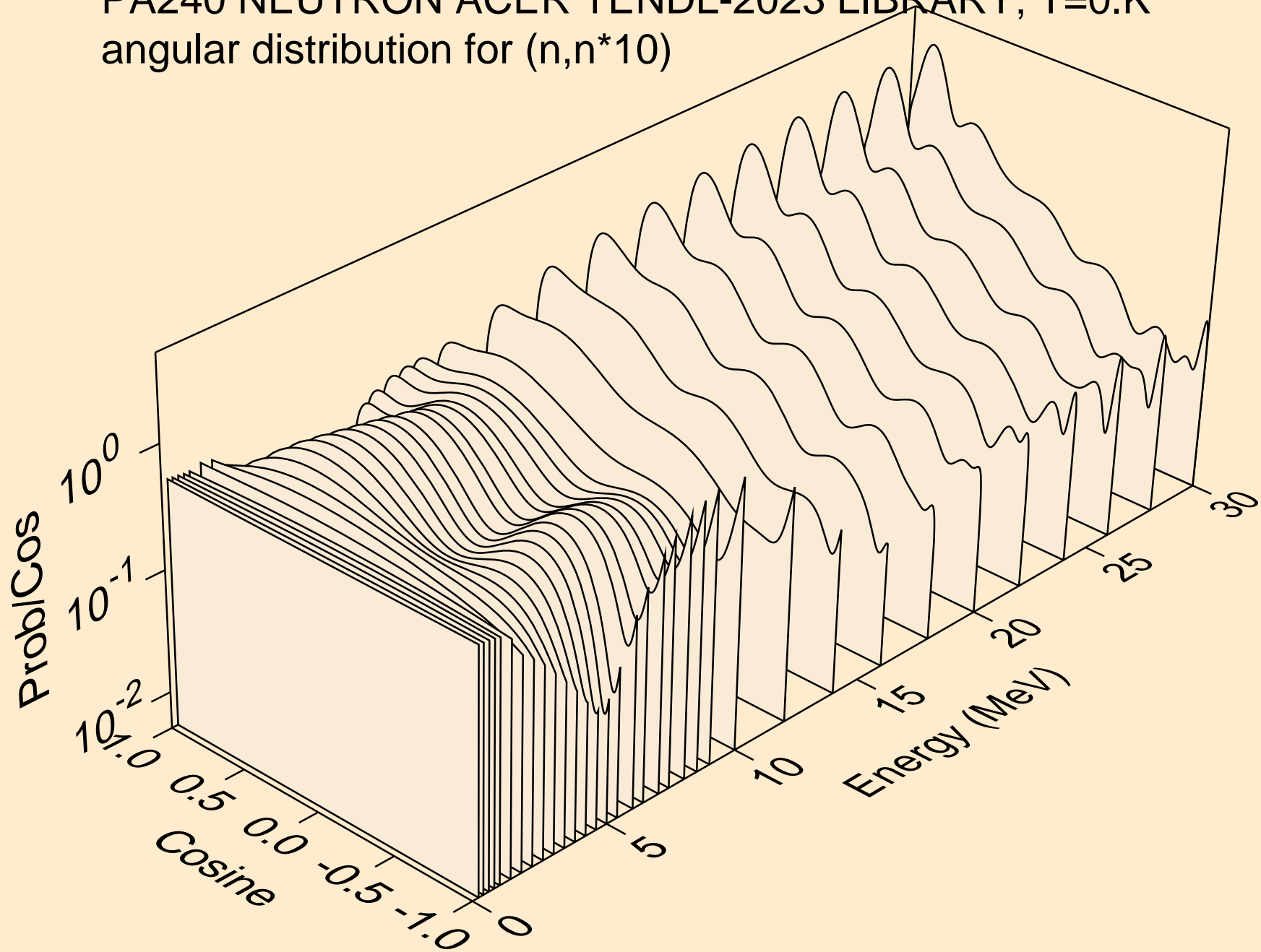

PA240 NEUTRON ACER TENDL-2023 LIBRARY; T=0.K  
angular distribution for (n,n\*11)

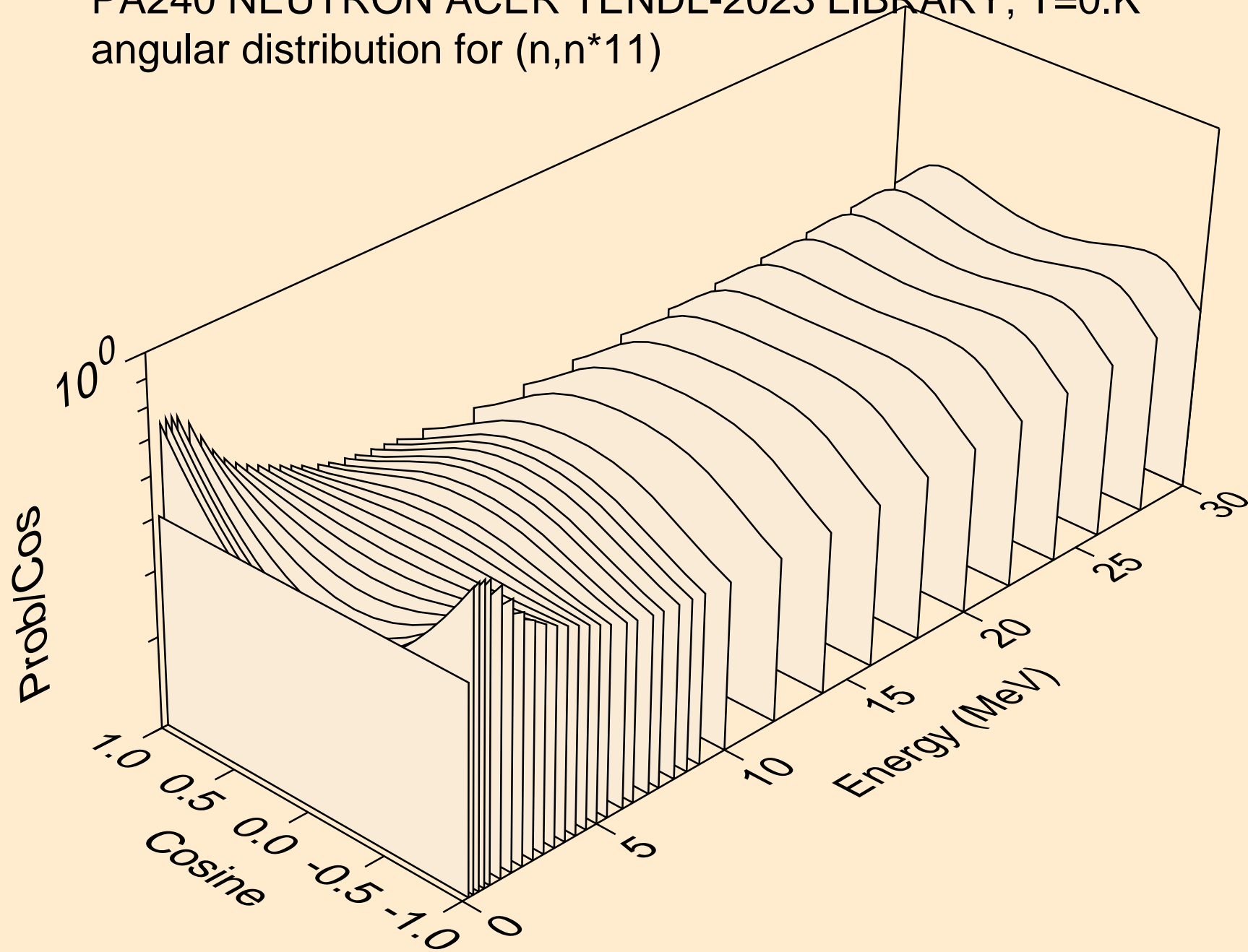



PA240 NEUTRON ACER TENDL-2023 LIBRARY; T=0.K  
angular distribution for (n,n\*12)

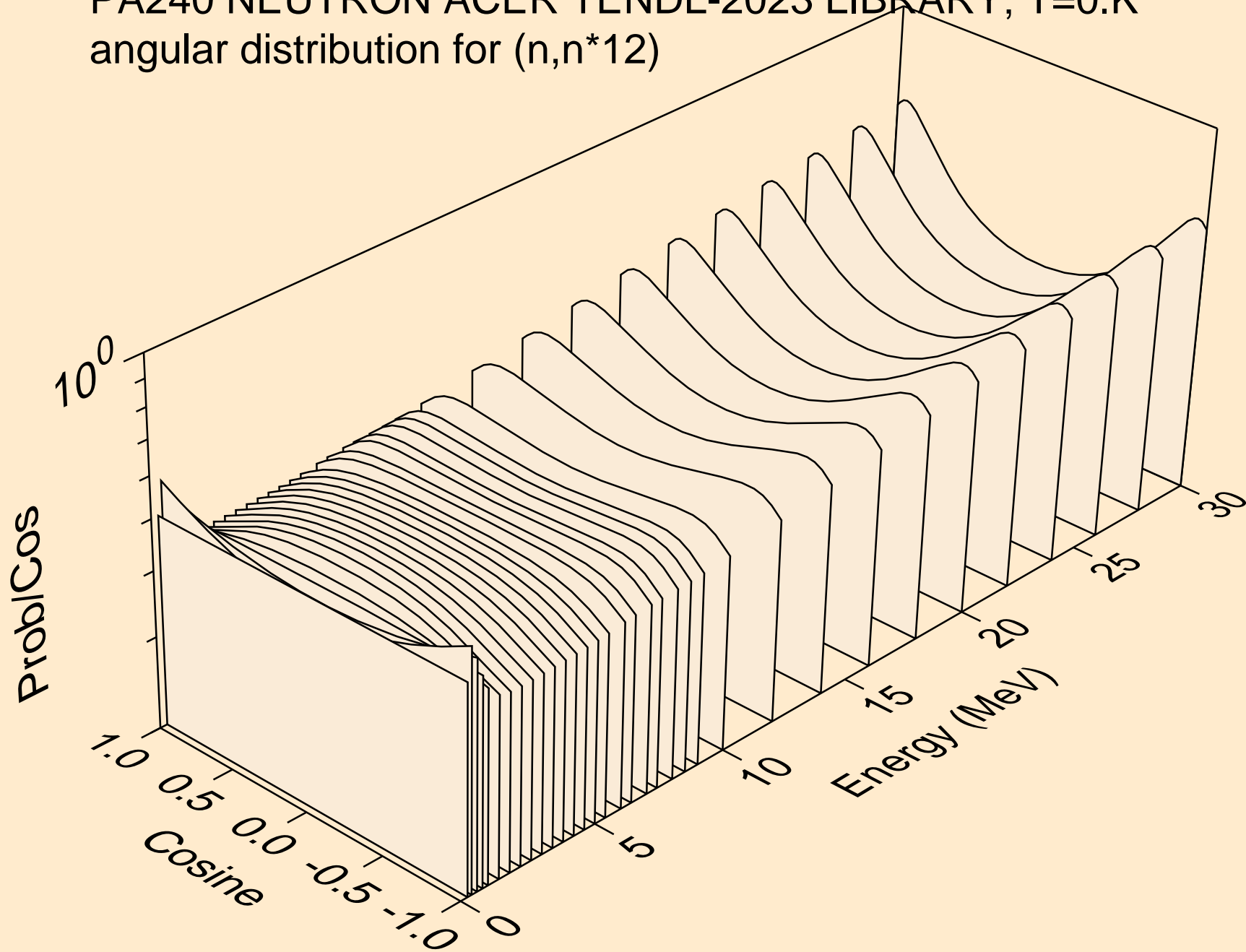

PA240 NEUTRON ACER TENDL-2023 LIBRARY; T=0.K  
angular distribution for (n,n\*13)

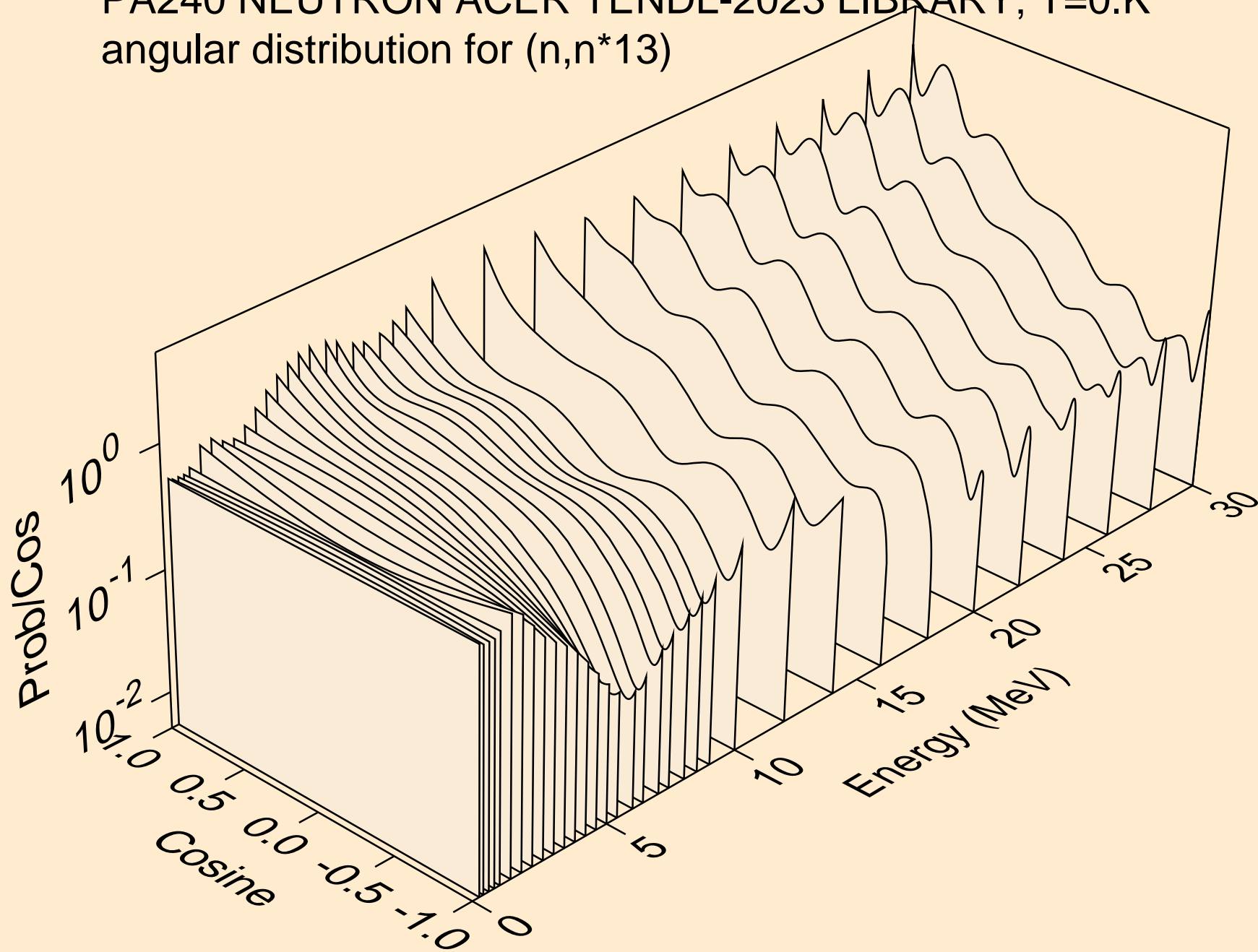

PA240 NEUTRON ACER TENDL-2023 LIBRARY; T=0.K  
angular distribution for (n,n\*14)

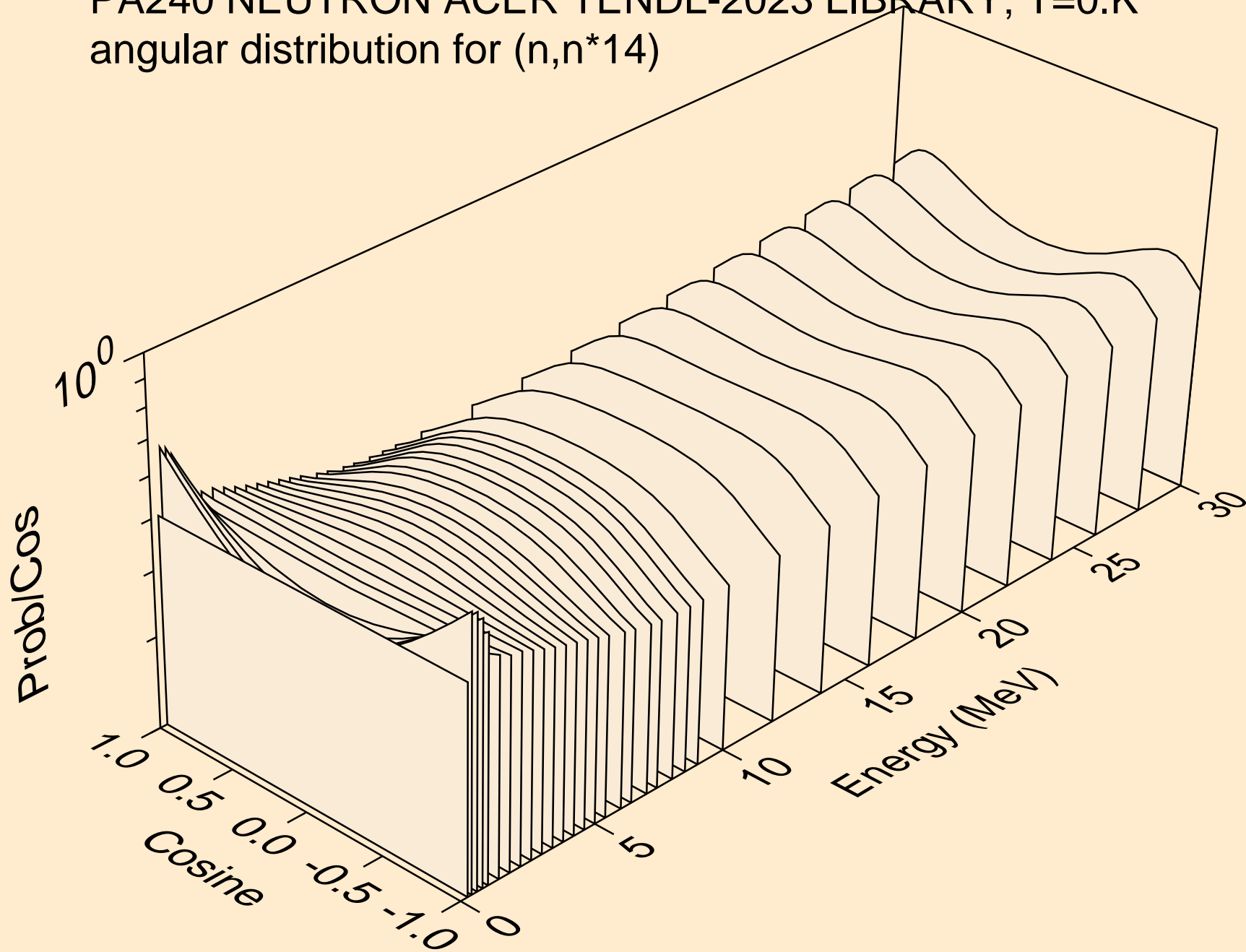

PA240 NEUTRON ACER TENDL-2023 LIBRARY; T=0.K  
angular distribution for (n,n\*15)

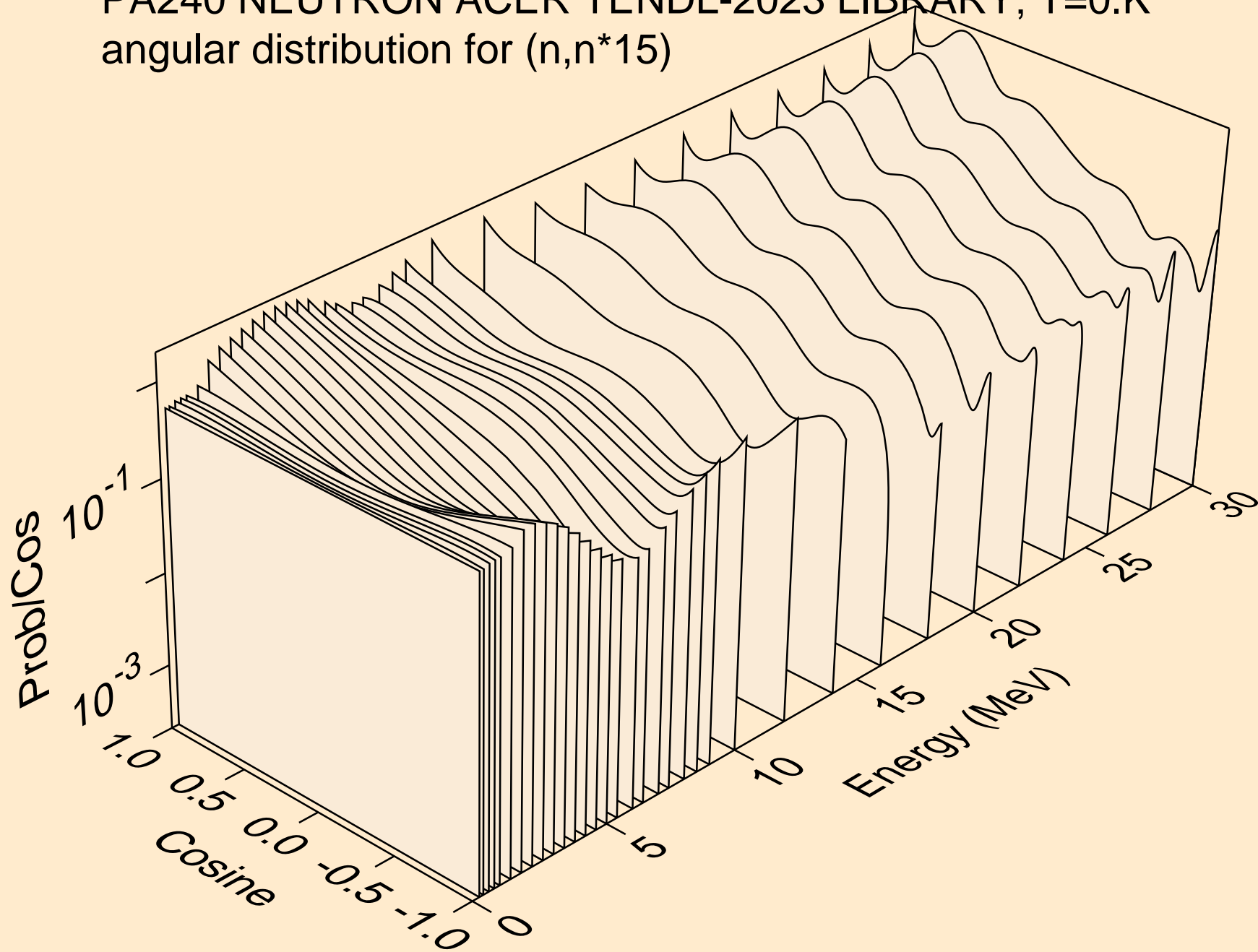

PA240 NEUTRON ACER TENDL-2023 LIBRARY; T=0.K  
angular distribution for (n,n\*16)

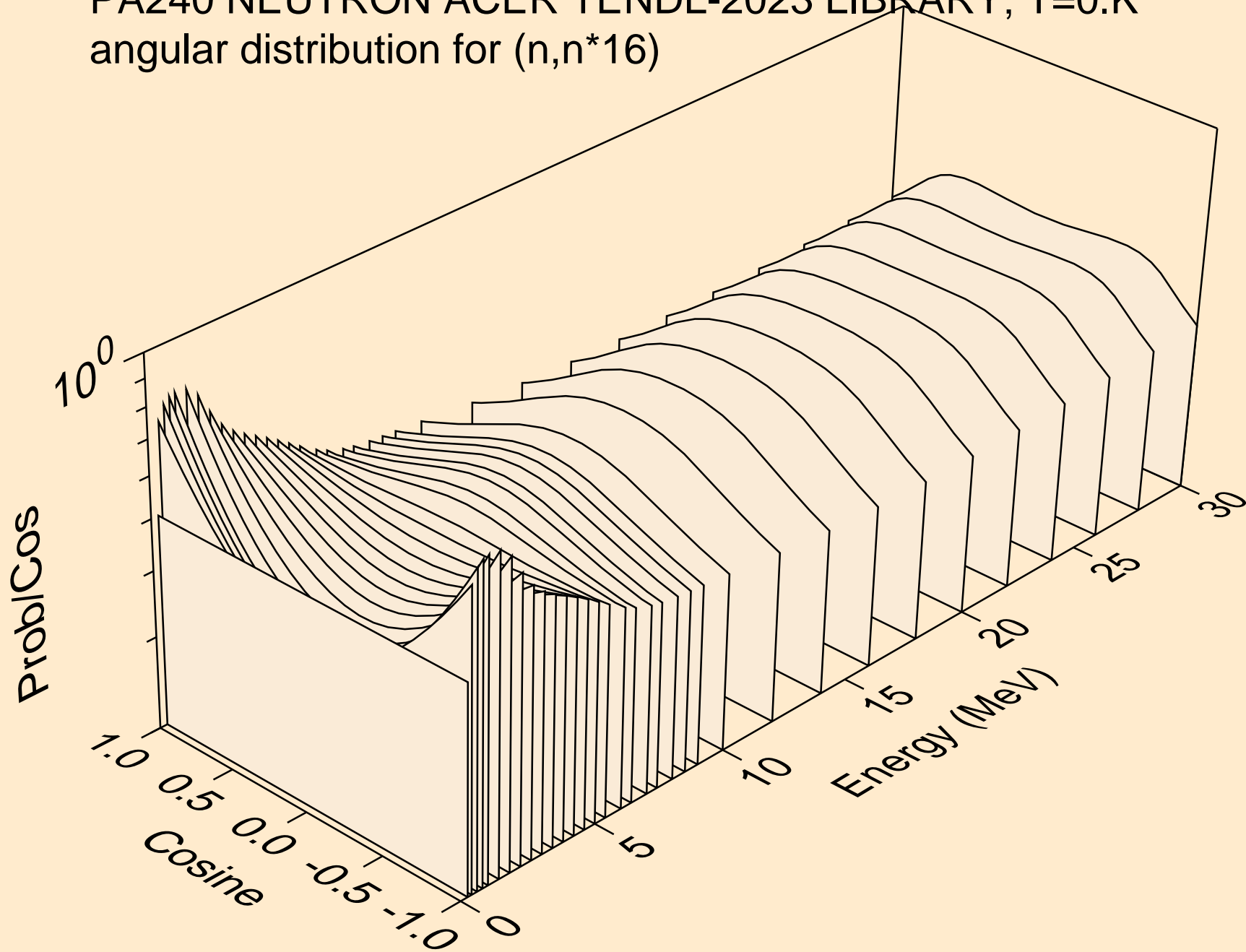

PA240 NEUTRON ACER TENDL-2023 LIBRARY; T=0.K  
angular distribution for (n,n\*17)

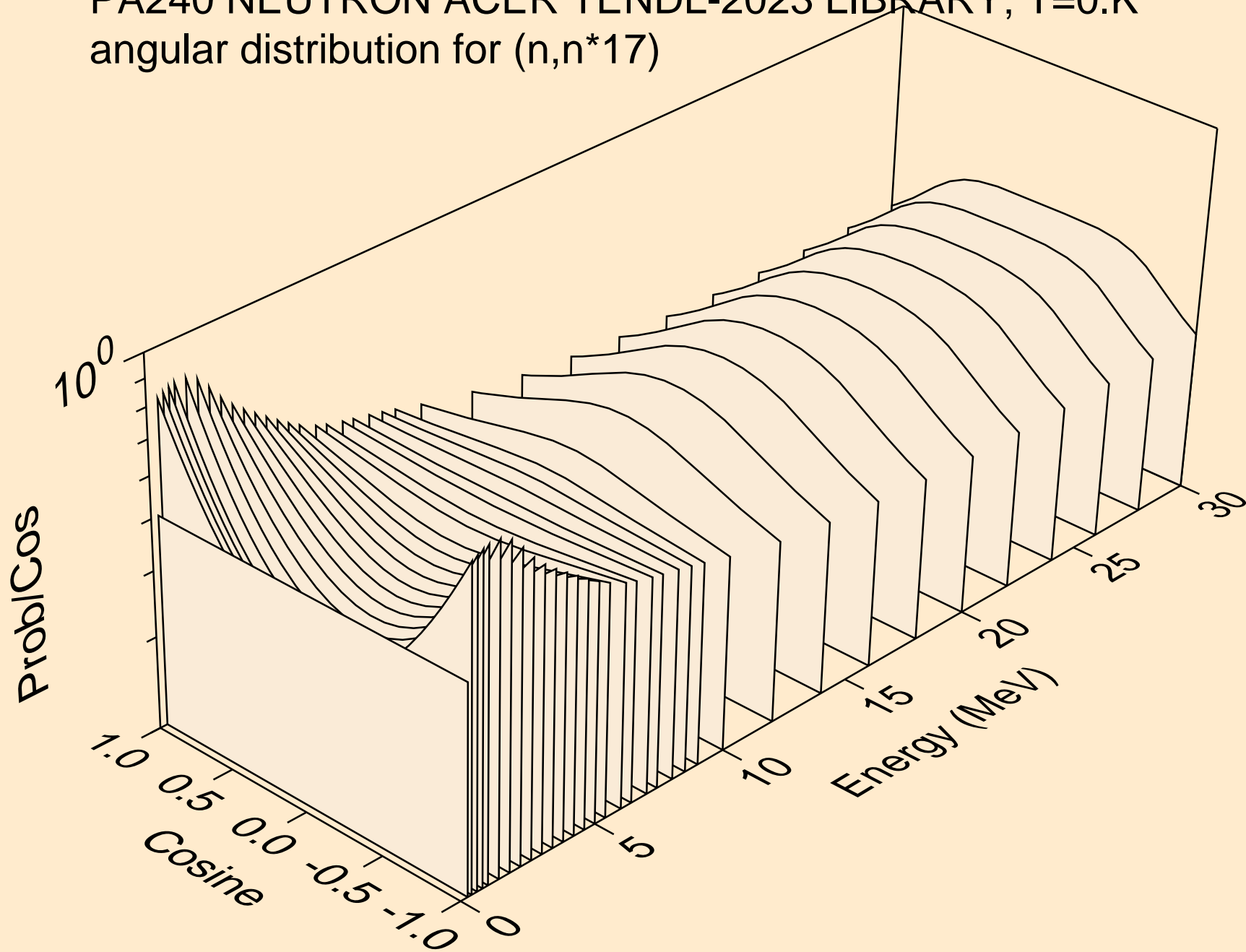

PA240 NEUTRON ACER TENDL-2023 LIBRARY; T=0.K  
angular distribution for (n,n\*18)

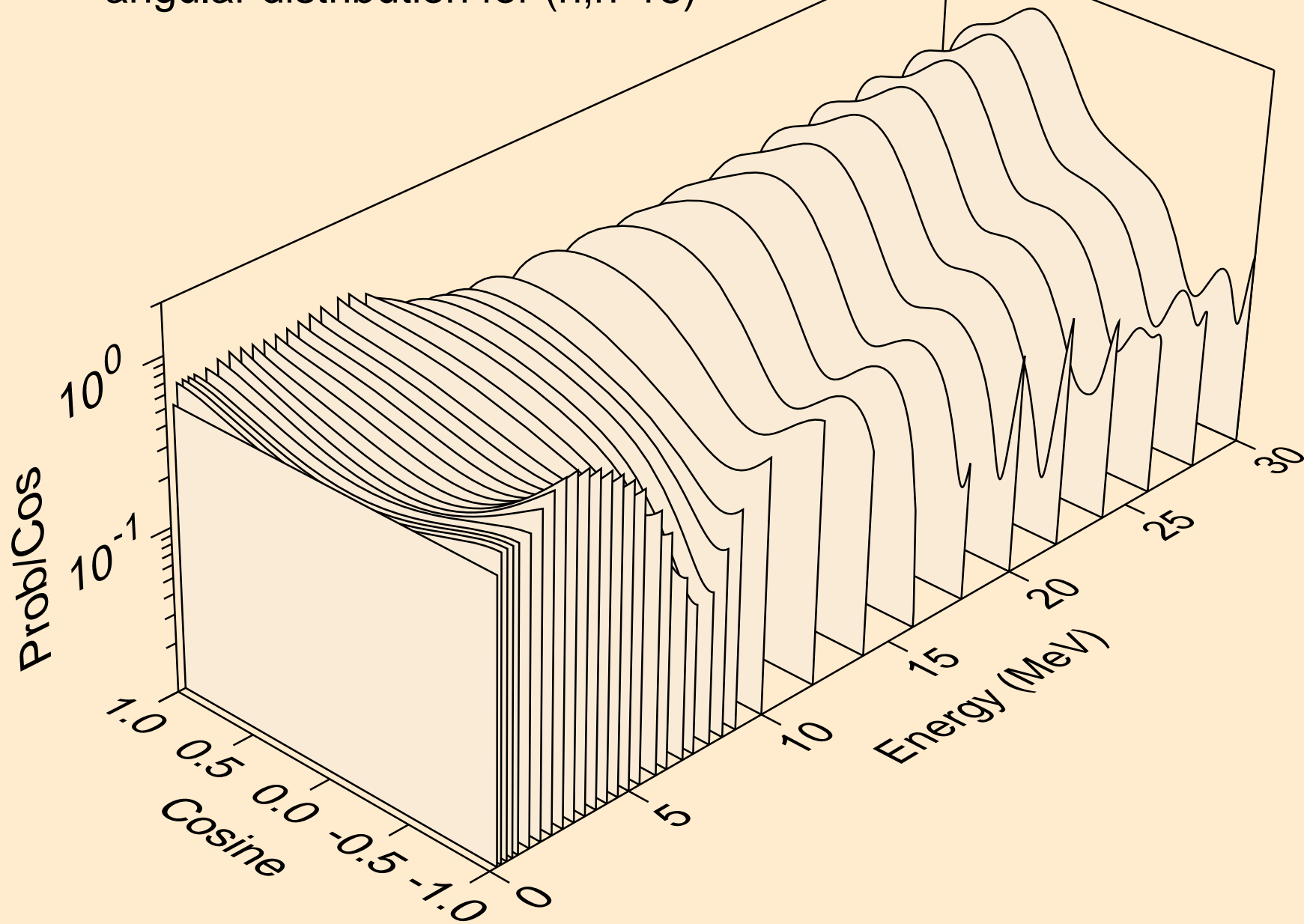

PA240 NEUTRON ACER TENDL-2023 LIBRARY; T=0.K  
angular distribution for (n,n\*19)

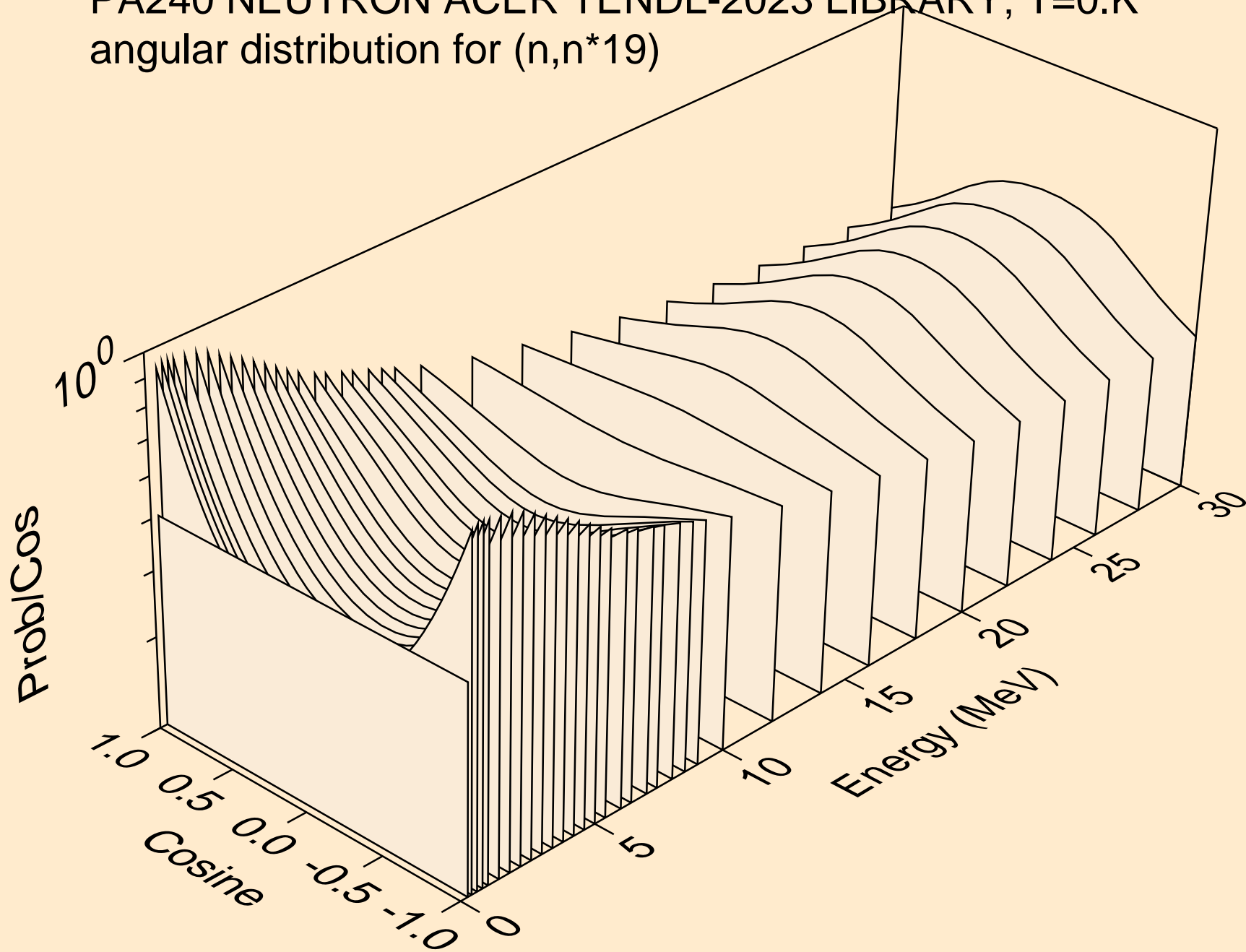



PA240 NEUTRON ACER TENDL-2023 LIBRARY; T=0.K  
angular distribution for (n,n\*20)

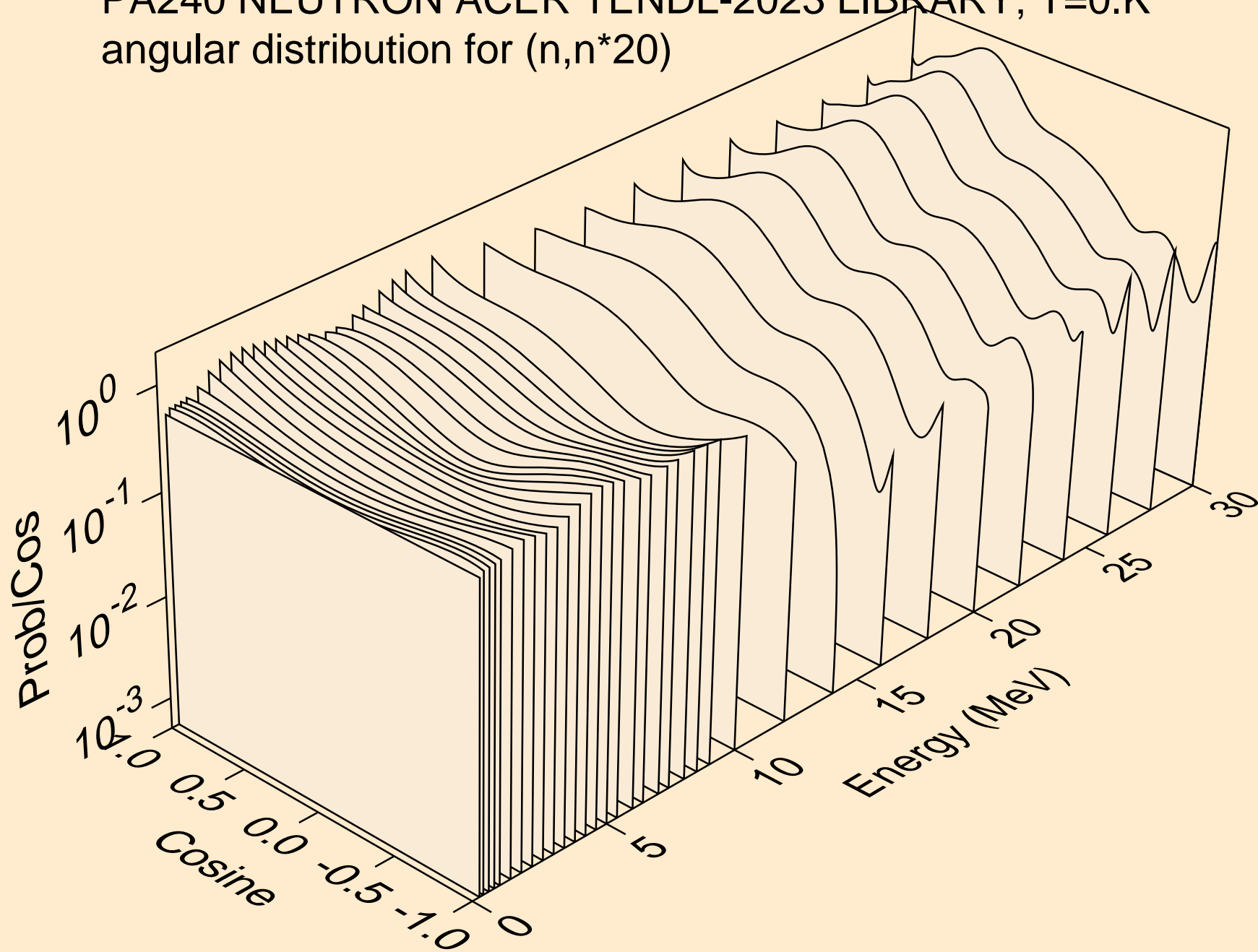

PA240 NEUTRON ACER TENDL-2023 LIBRARY; T=0.K  
angular distribution for (n,n\*21)

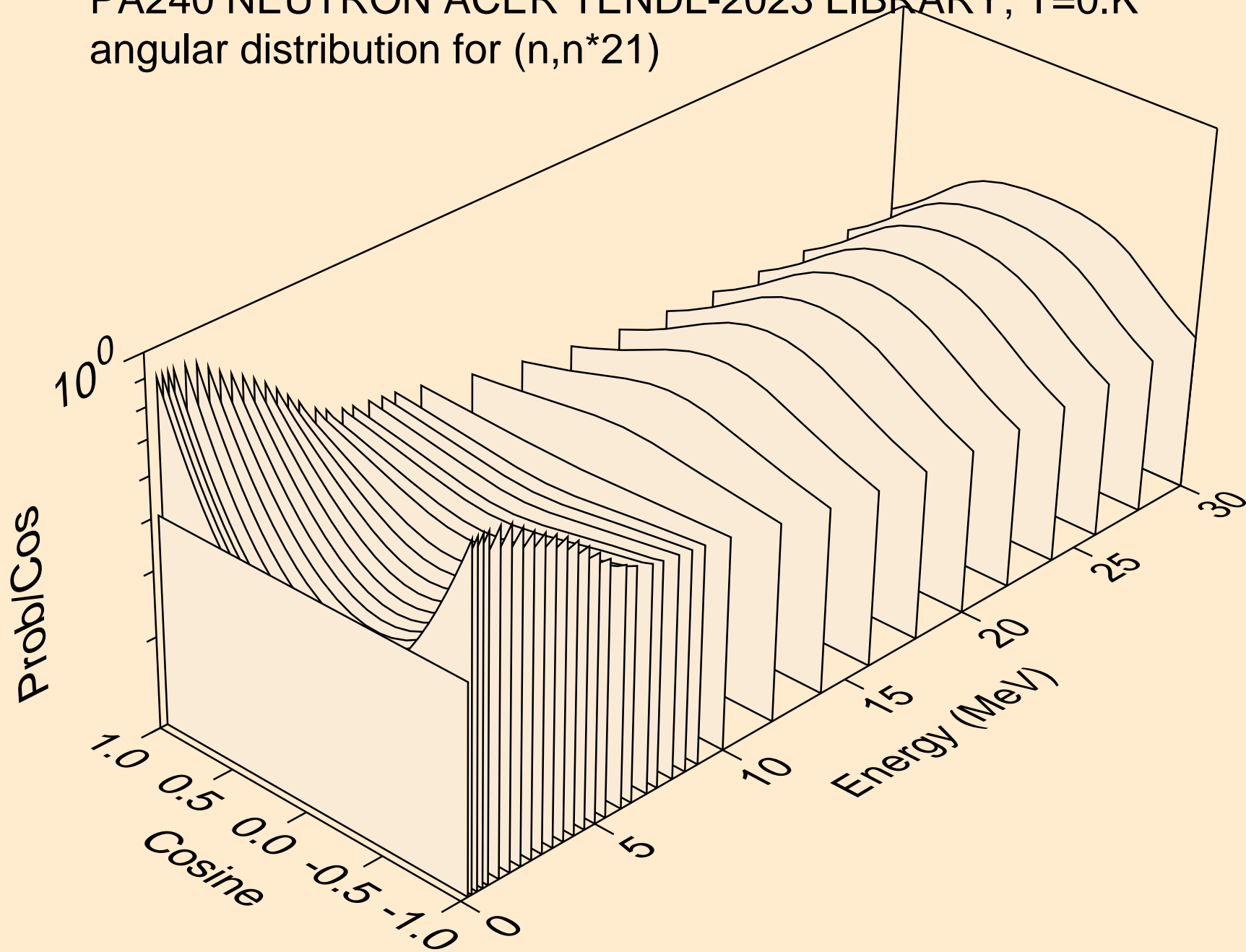

PA240 NEUTRON ACER TENDL-2023 LIBRARY; T=0.K  
angular distribution for (n,n\*22)

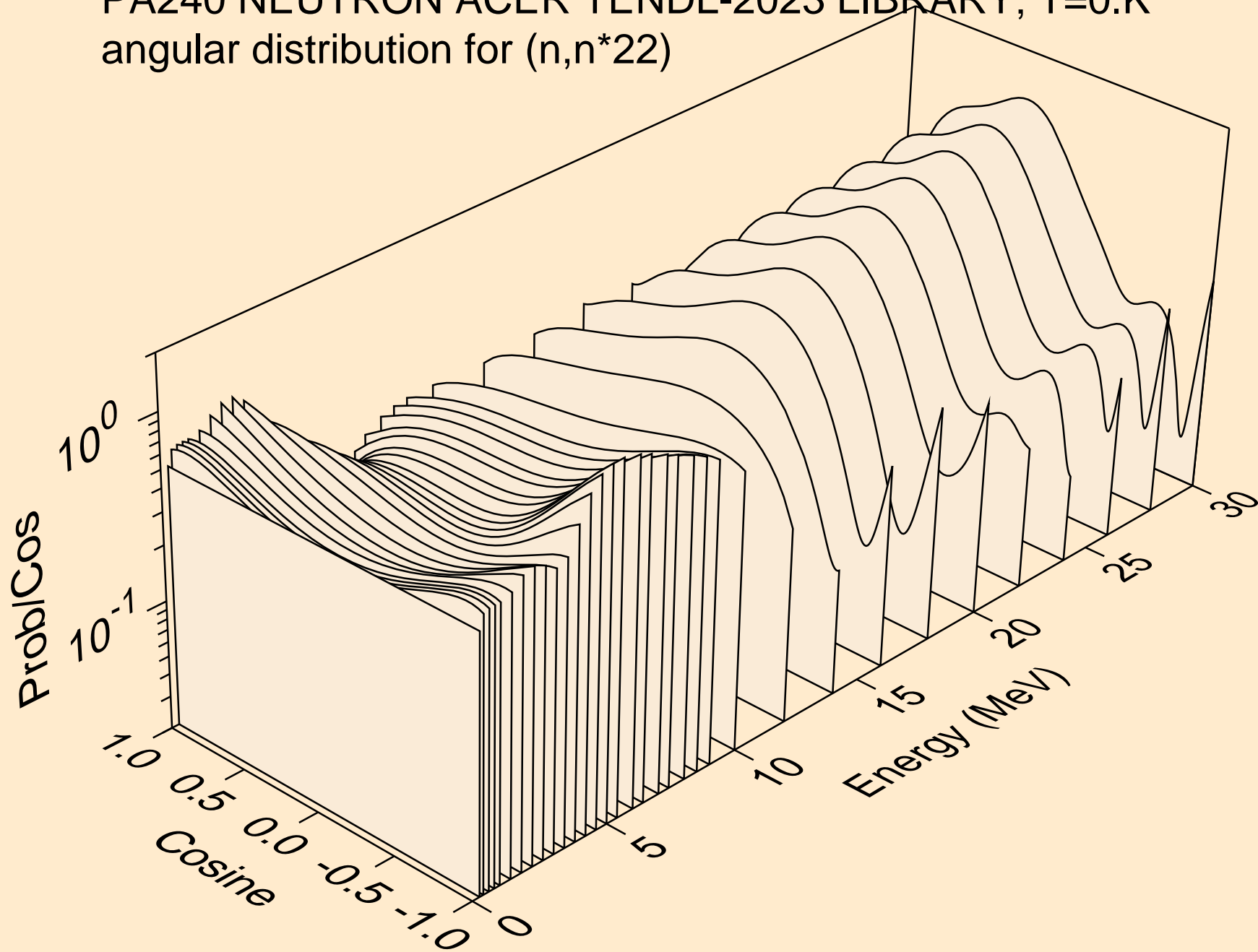

PA240 NEUTRON ACER TENDL-2023 LIBRARY; T=0.K  
angular distribution for (n,n\*23)

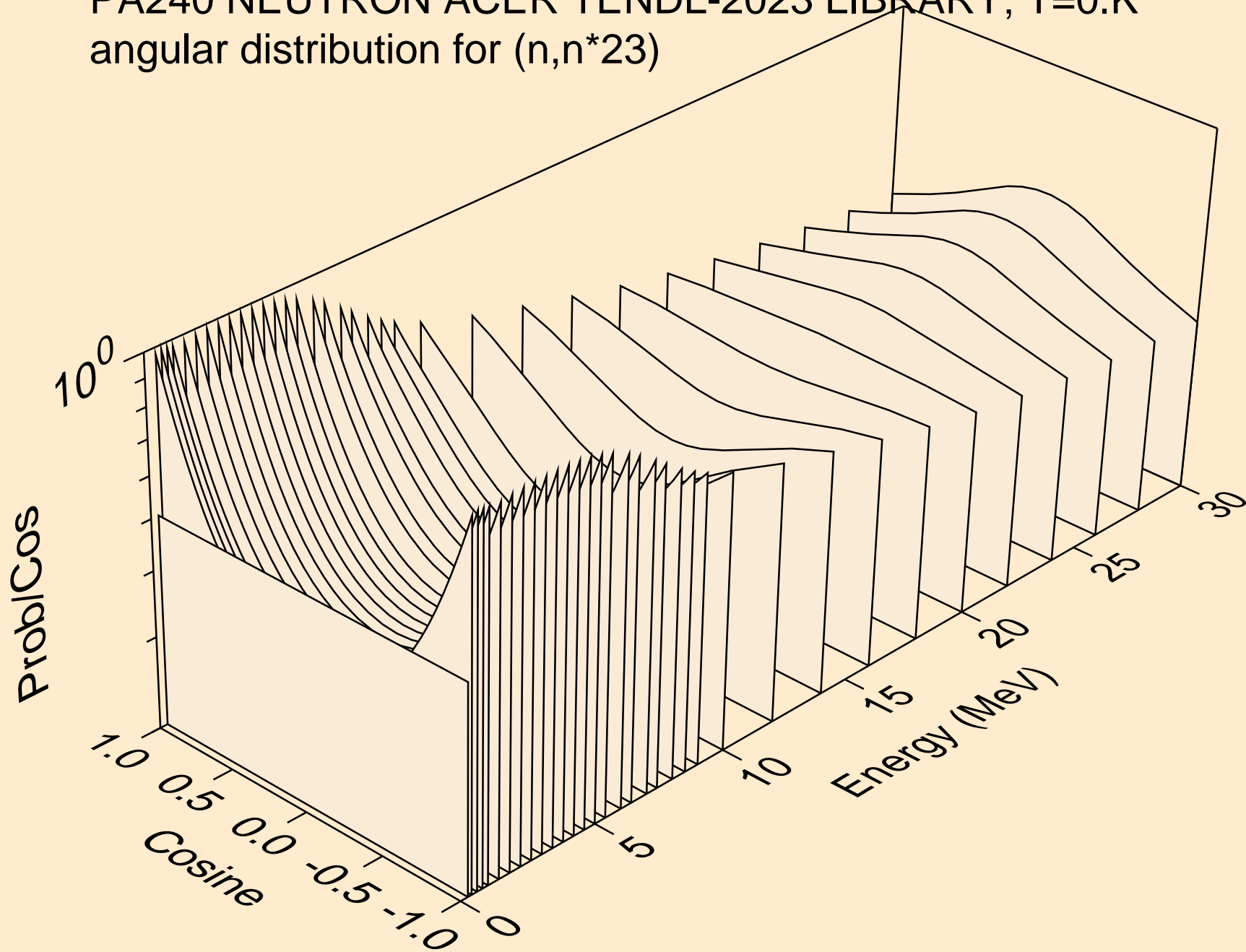

PA240 NEUTRON ACER TENDL-2023 LIBRARY; T=0.K  
angular distribution for (n,n\*24)

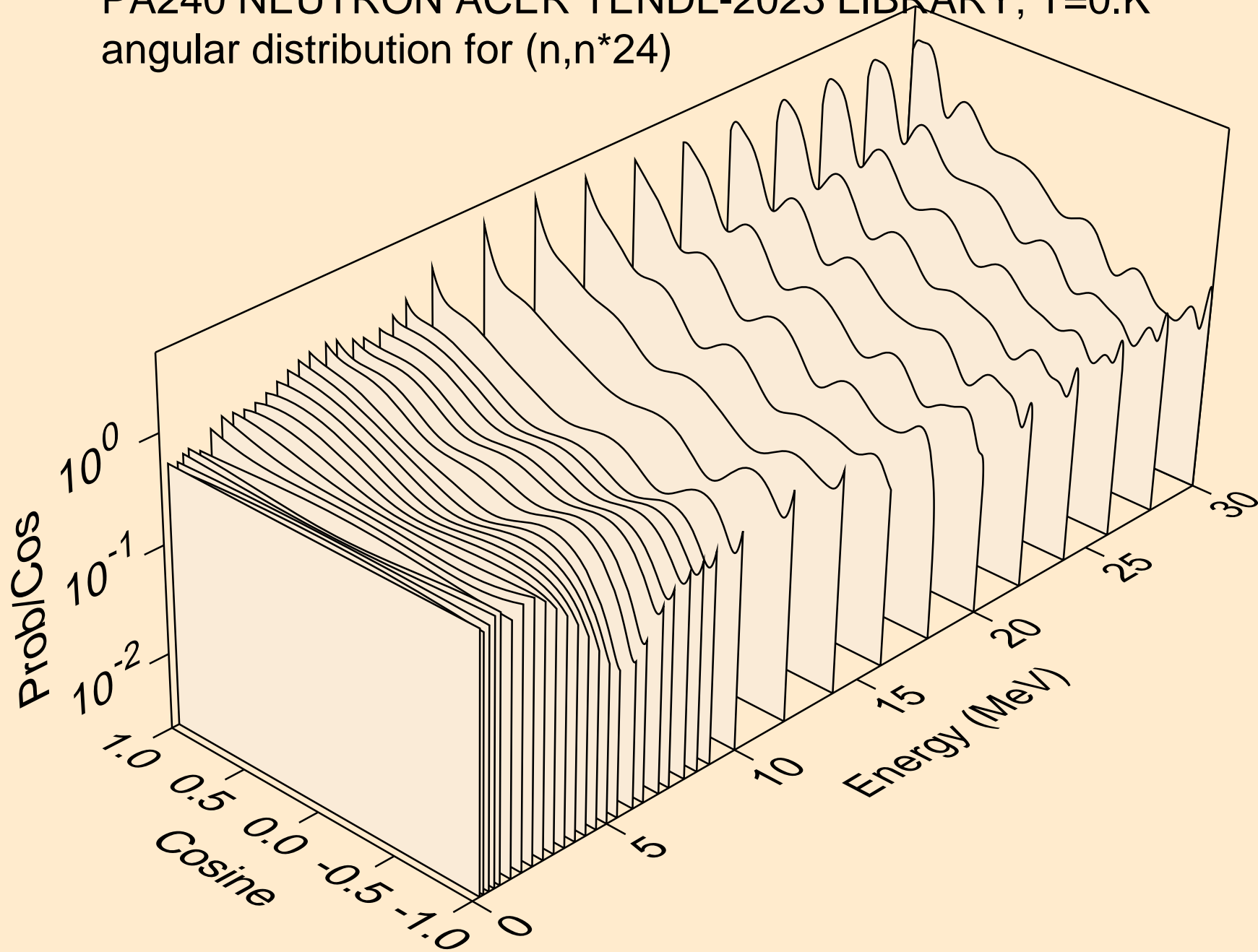

PA240 NEUTRON ACER TENDL-2023 LIBRARY; T=0.K  
angular distribution for (n,n\*25)

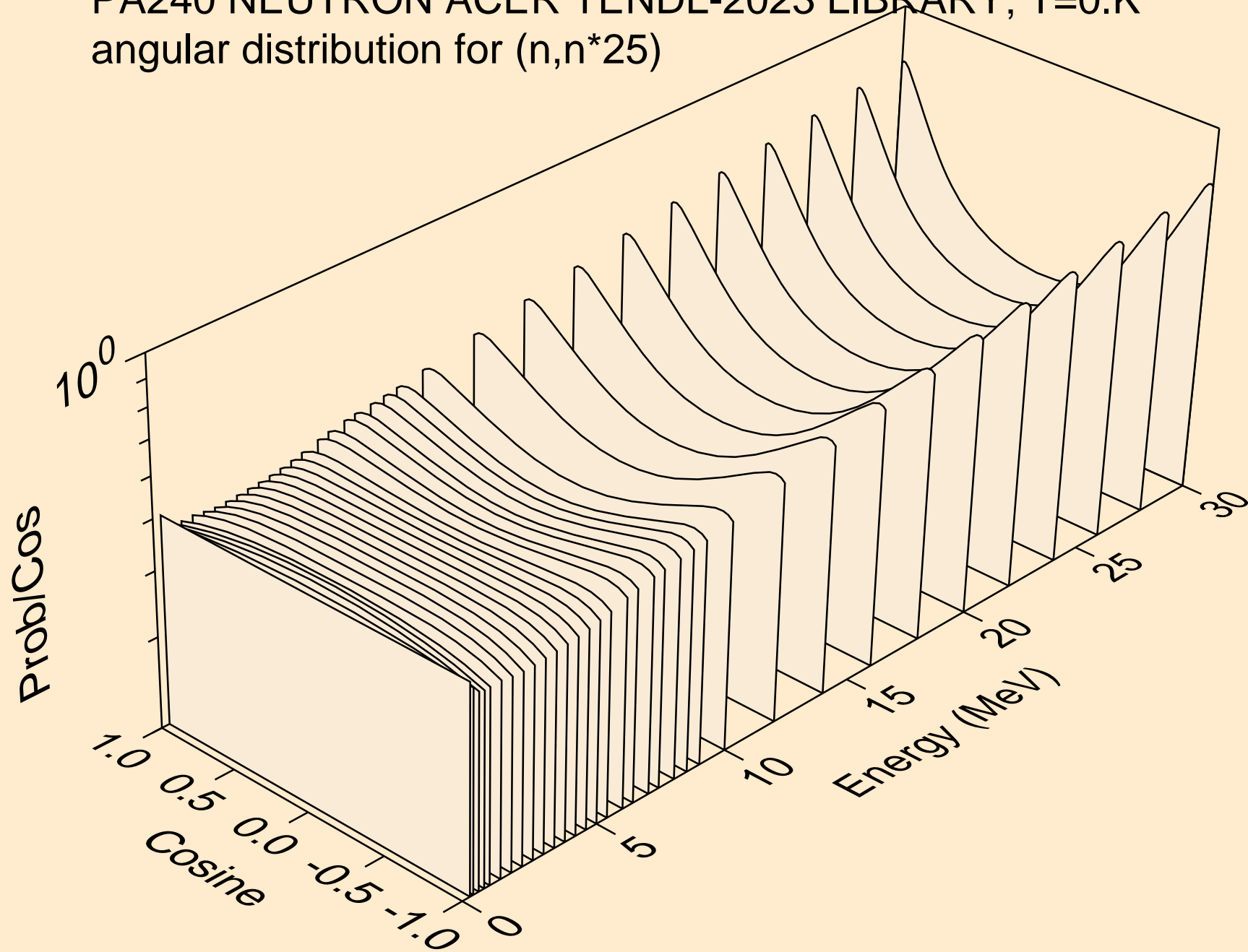

PA240 NEUTRON ACER TENDL-2023 LIBRARY; T=0.K  
angular distribution for (n,n\*26)

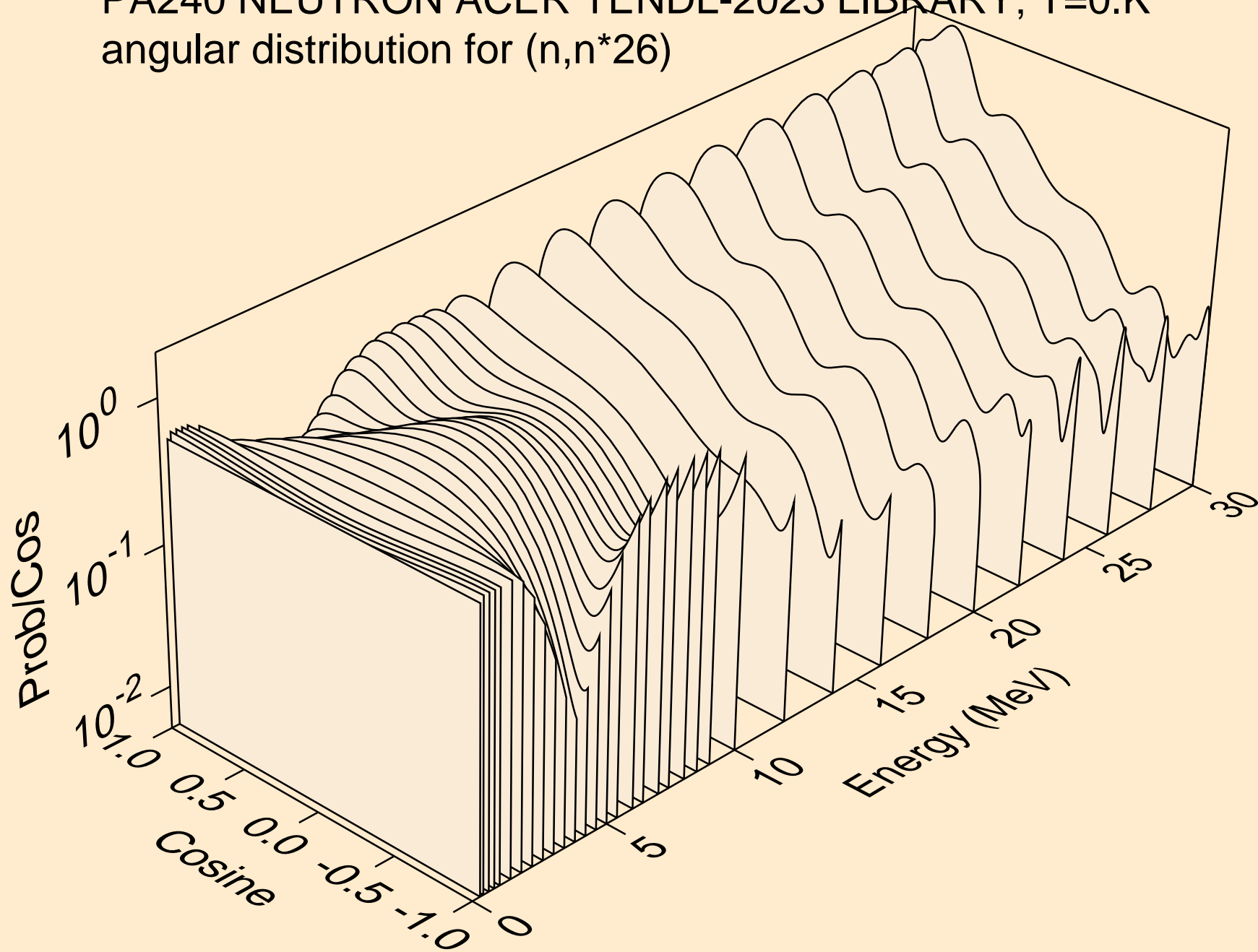

PA240 NEUTRON ACER TENDL-2023 LIBRARY; T=0.K  
angular distribution for (n,n\*27)

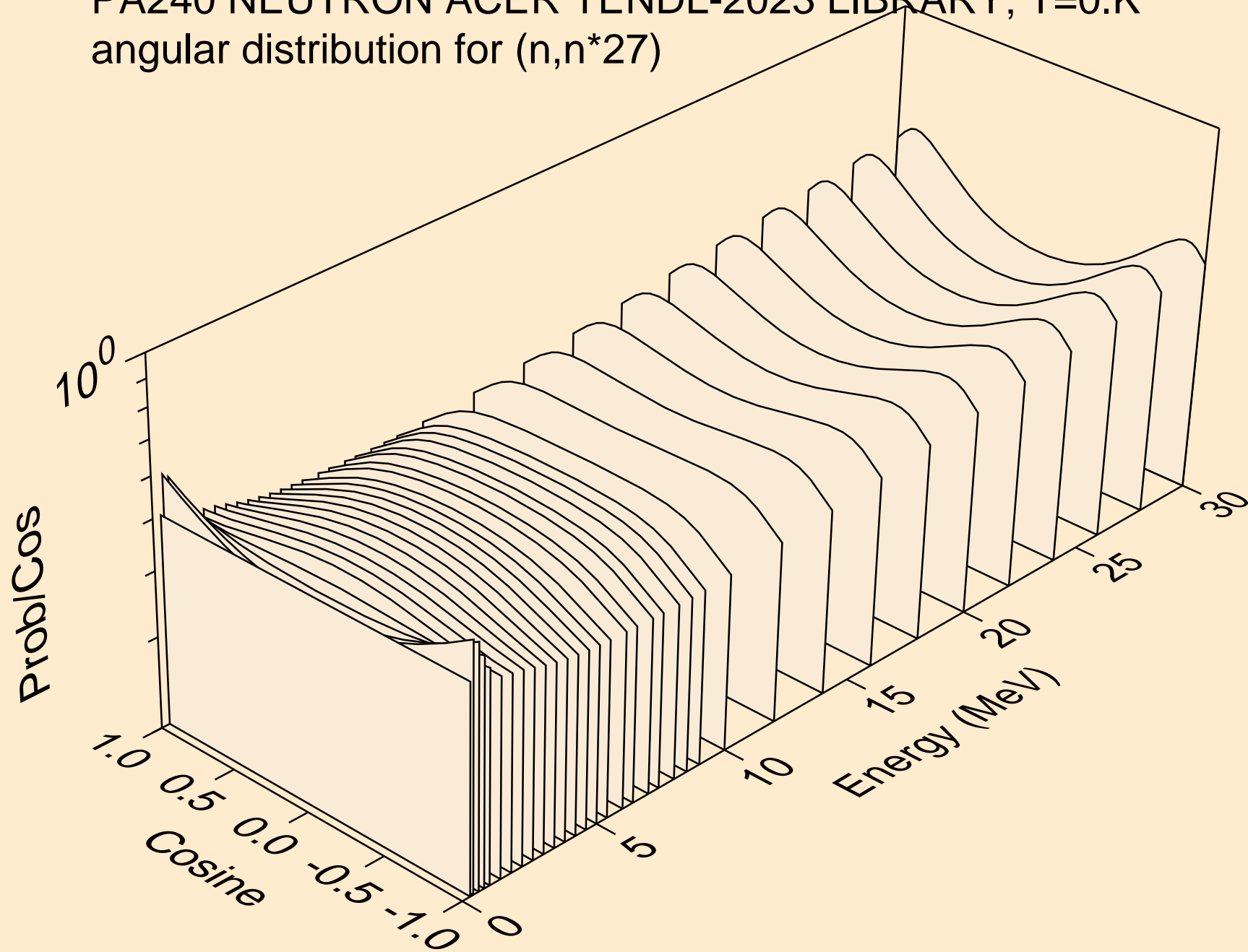



PA240 NEUTRON ACER TENDL-2023 LIBRARY; T=0.K  
angular distribution for (n,n\*28)

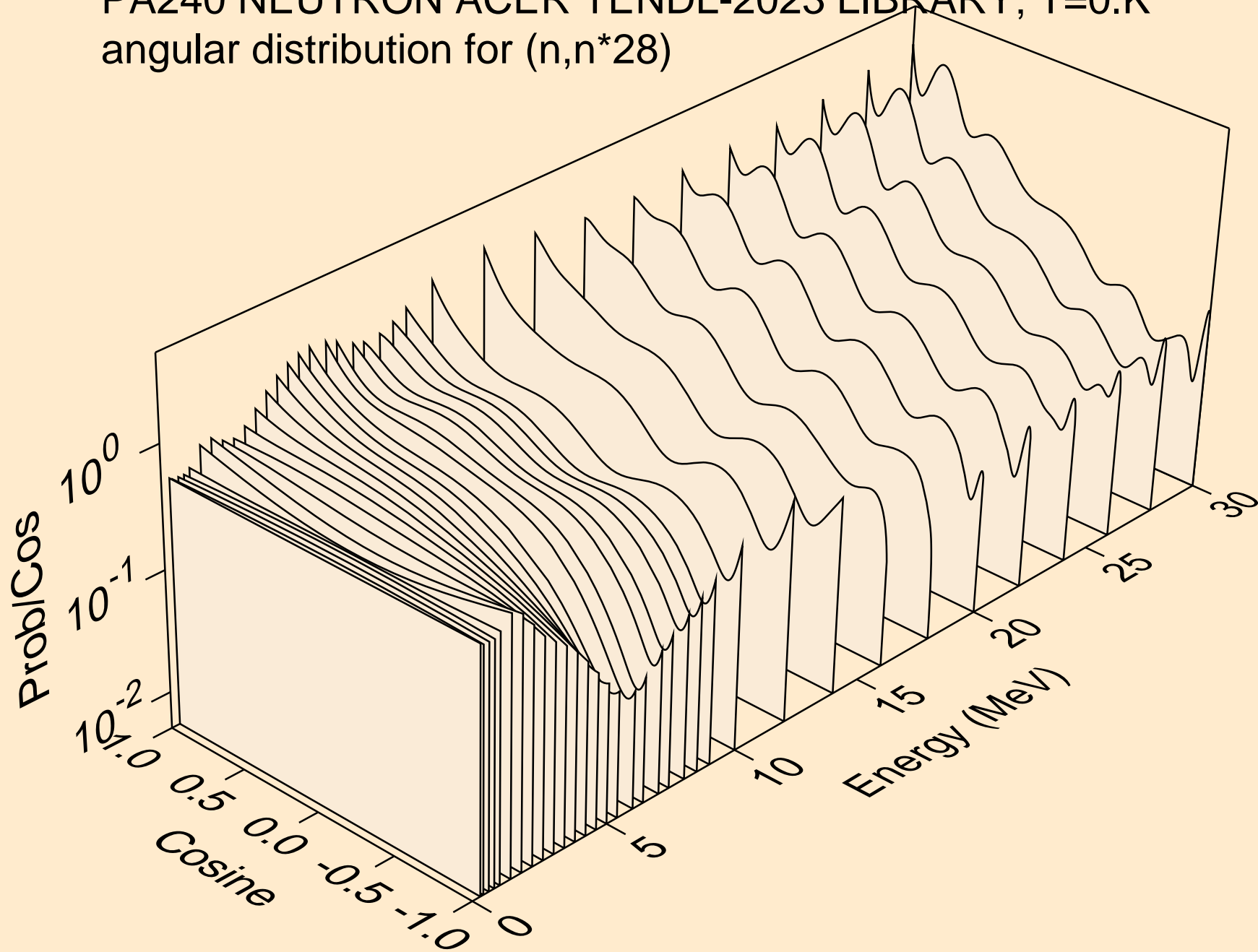

PA240 NEUTRON ACER TENDL-2023 LIBRARY; T=0.K  
Total fission nubar

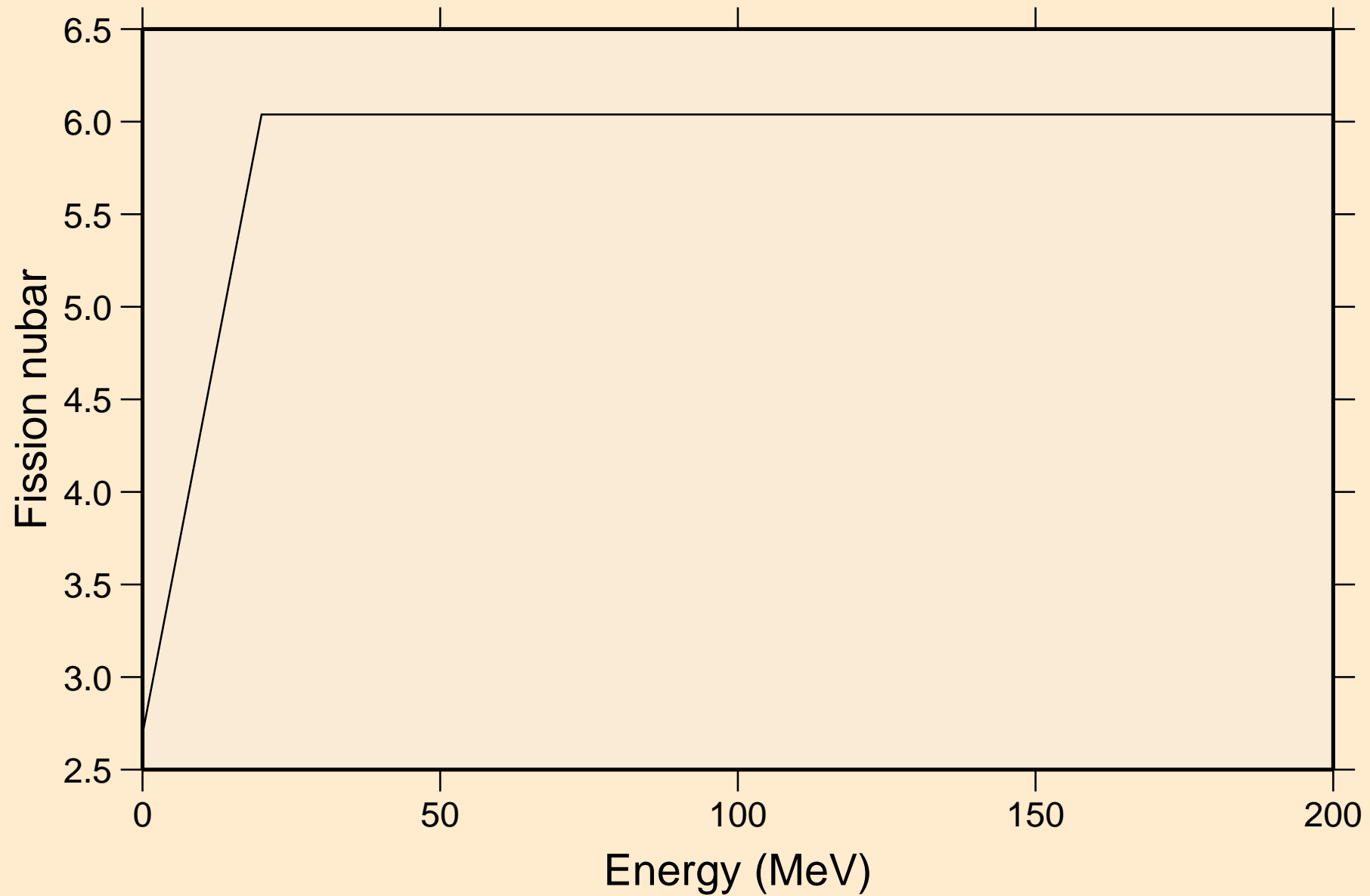

PA240 NEUTRON ACER TENDL-2023 LIBRARY; T=0.K  
Neutron emission for (n,x)

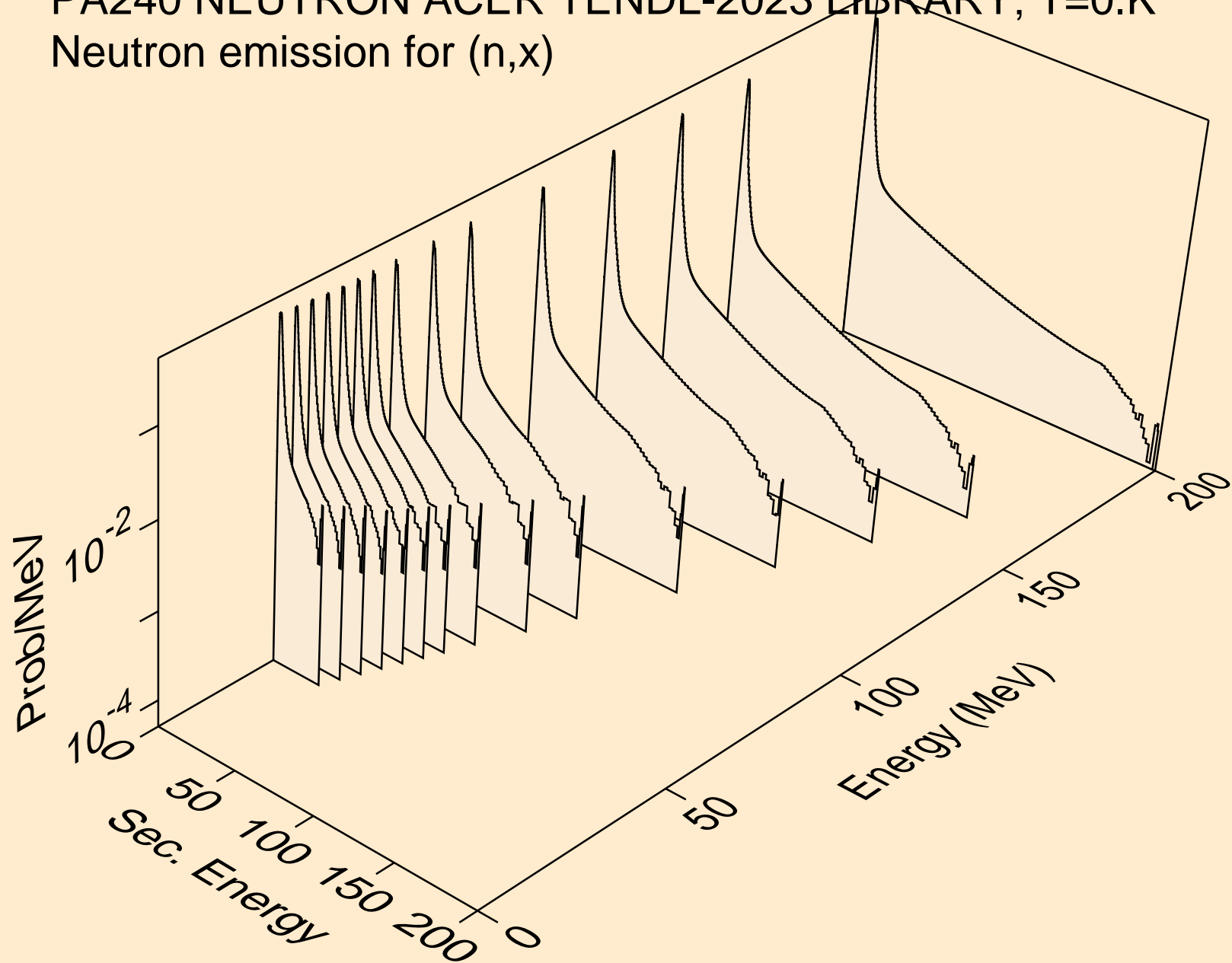

PA240 NEUTRON ACER TENDL-2023 LIBRARY; T=0.K  
Neutron emission for (n,2nd)

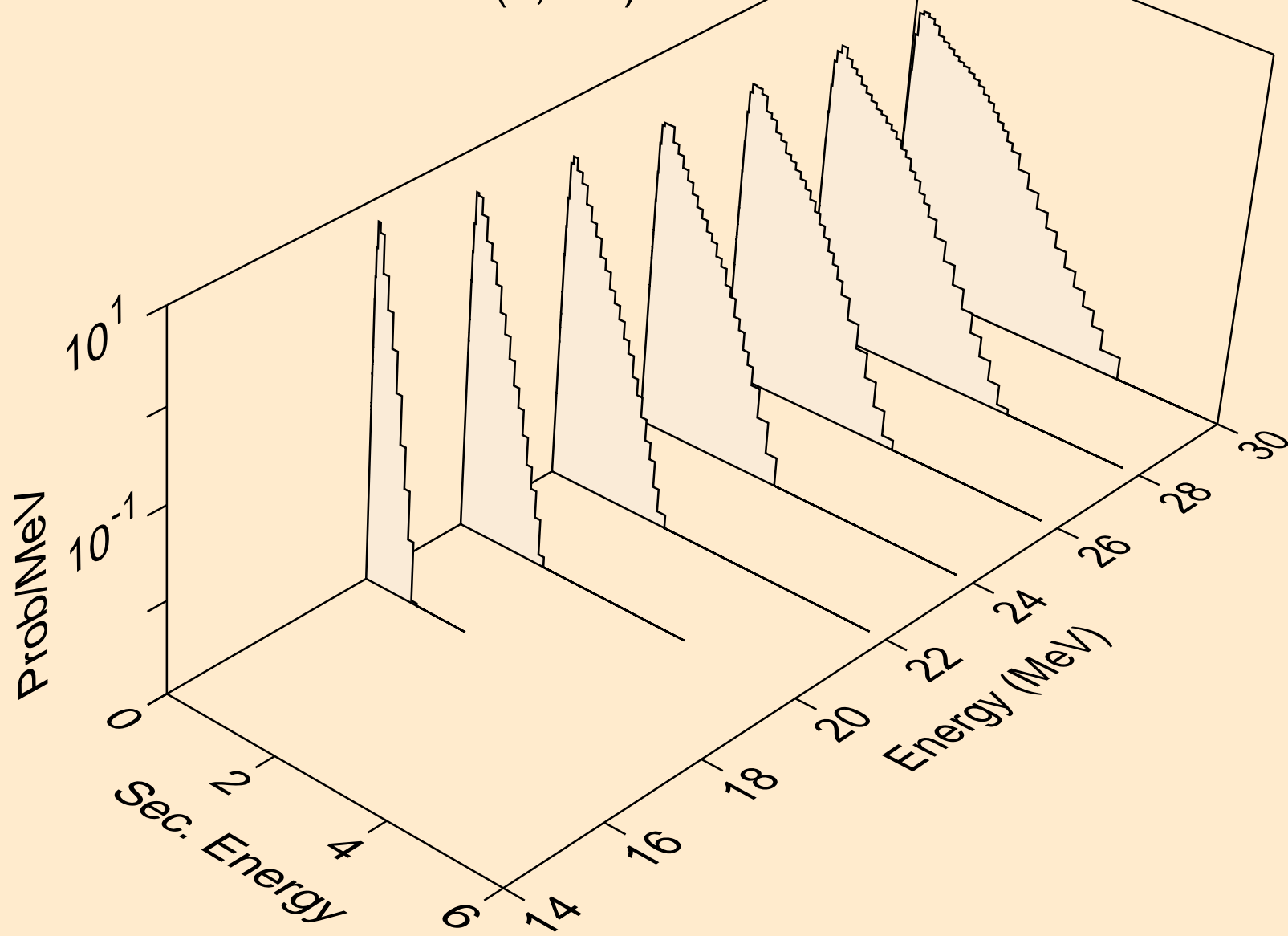

PA240 NEUTRON ACER TENDL-2023 LIBRARY; T=0.K  
Neutron emission for (n,2n)

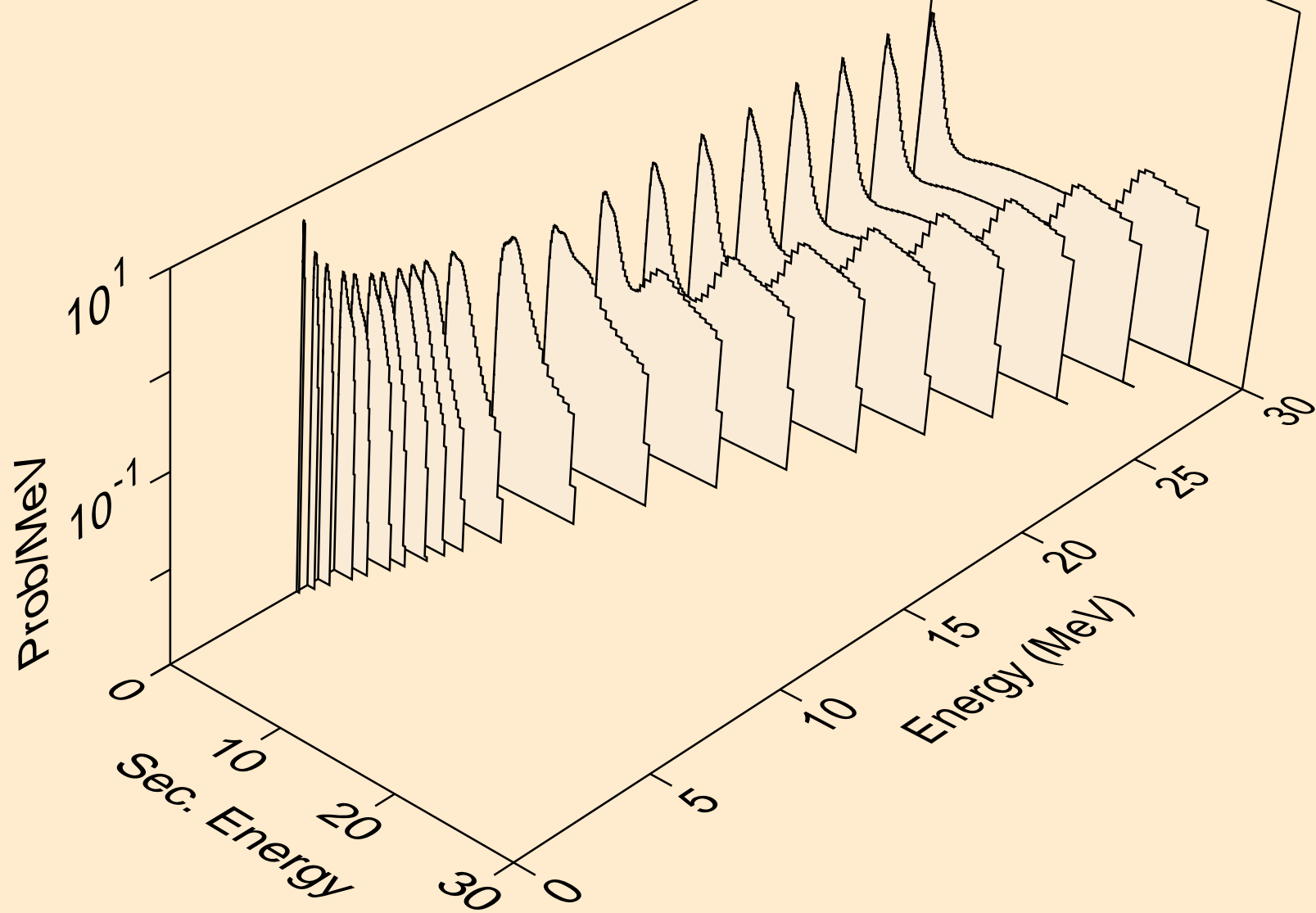

PA240 NEUTRON ACER TENDL-2023 LIBRARY; T=0.K  
Neutron emission for (n,3n)

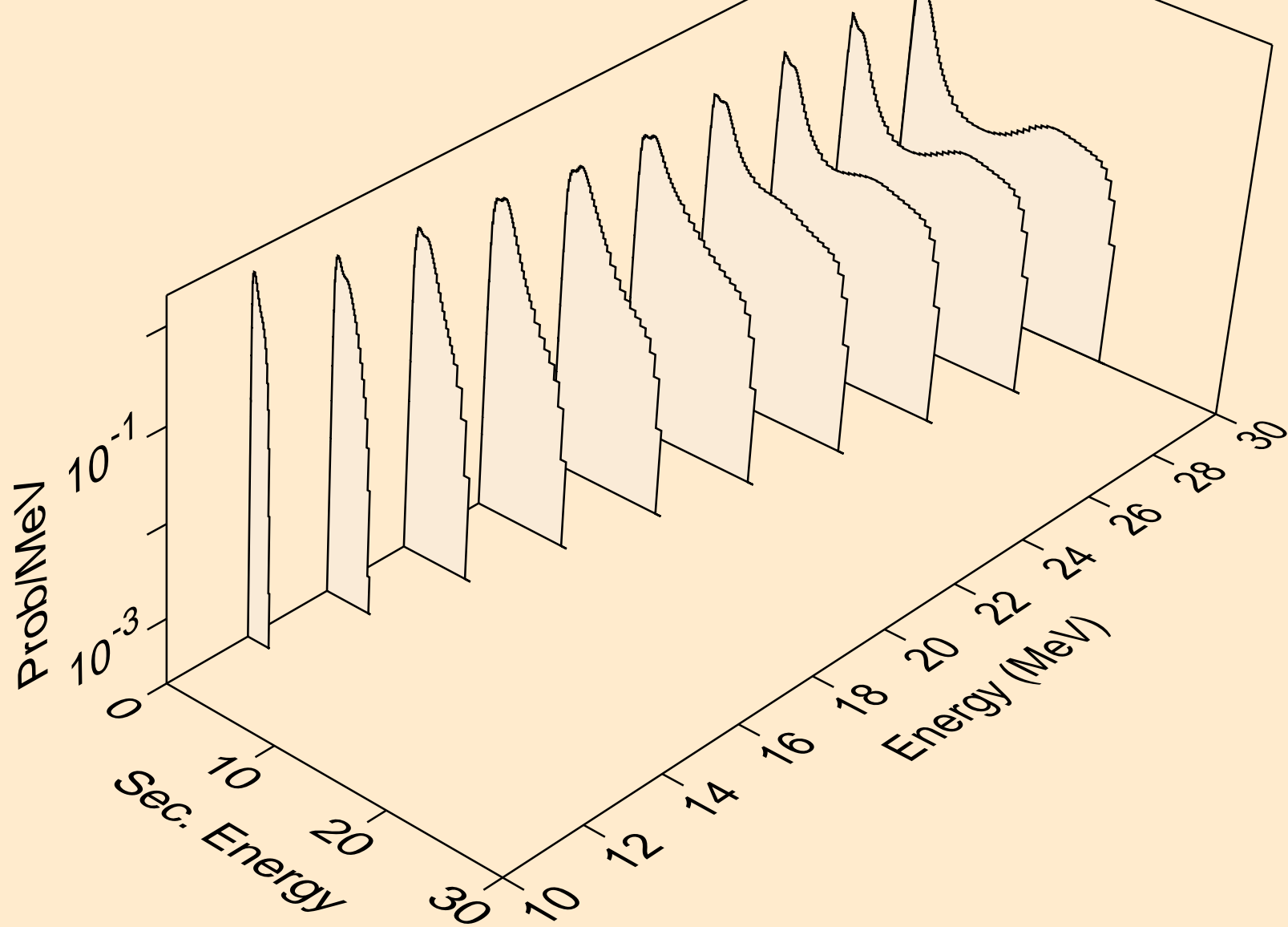

PA240 NEUTRON ACER TENDL-2023 LIBRARY; T=0.K  
Neutron emission for fission

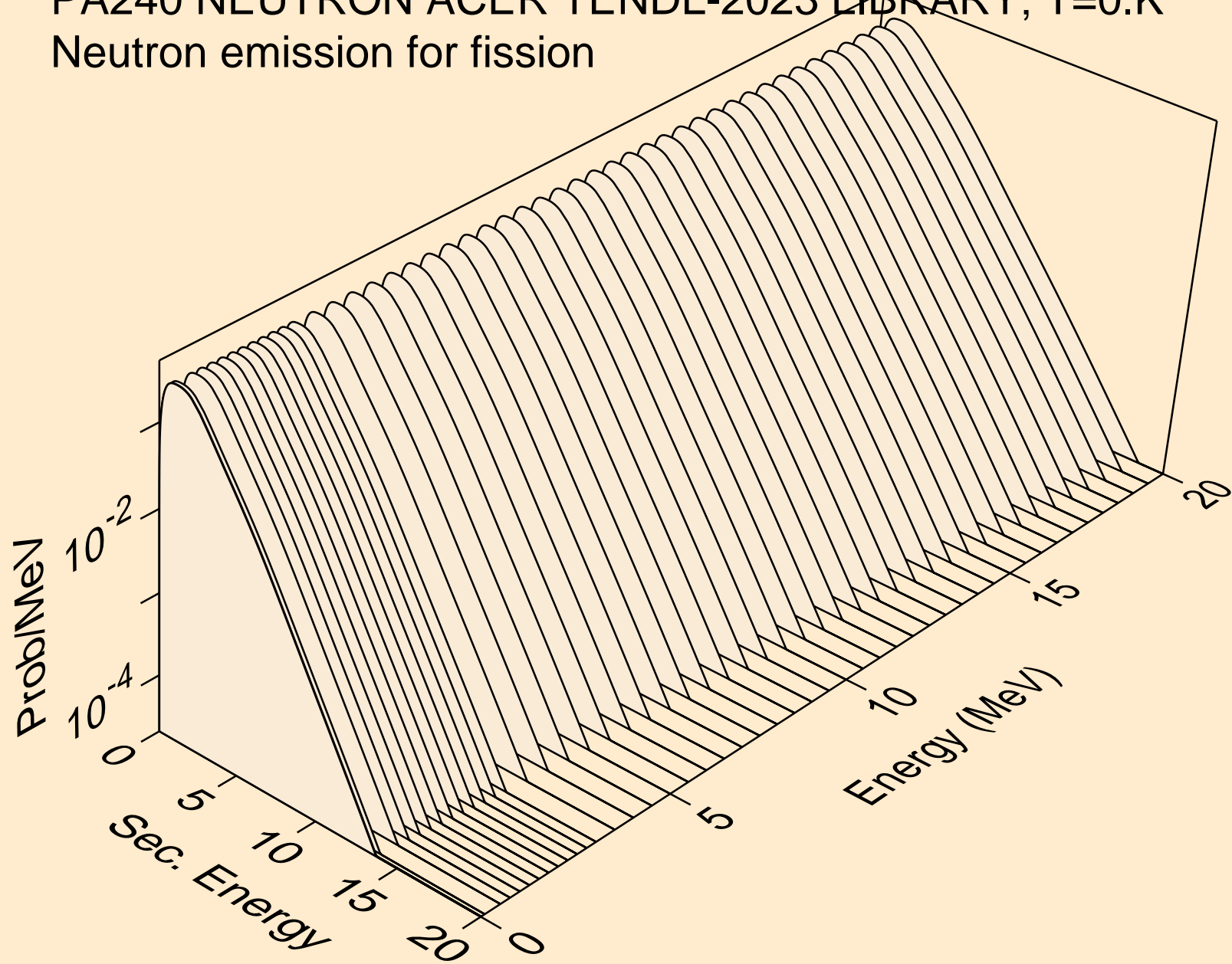

PA240 NEUTRON ACER TENDL-2023 LIBRARY; T=0.K  
Neutron emission for (n,n\*)a

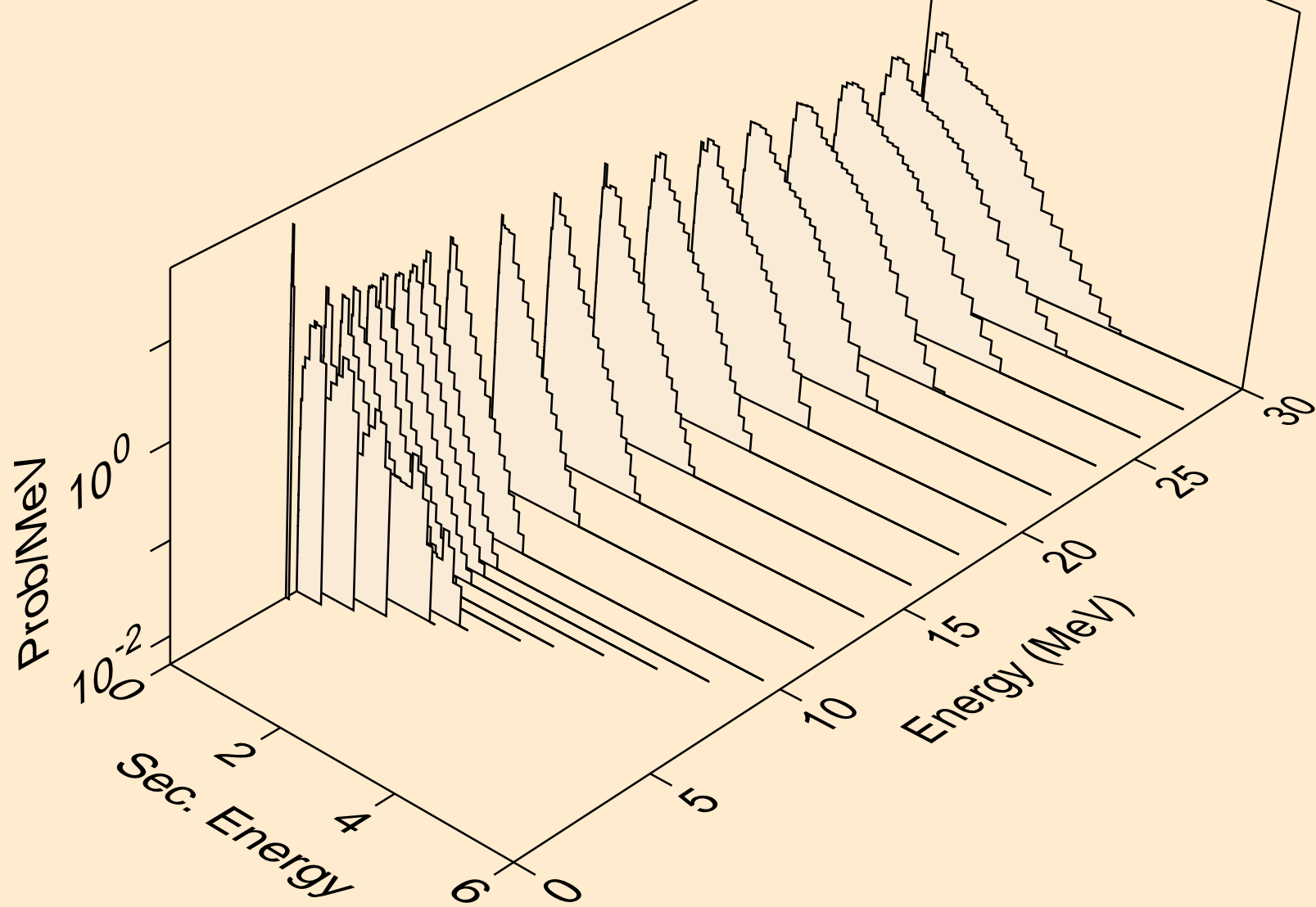



PA240 NEUTRON ACER TENDL-2023 LIBRARY; T=0.K  
Neutron emission for (n,2n)a

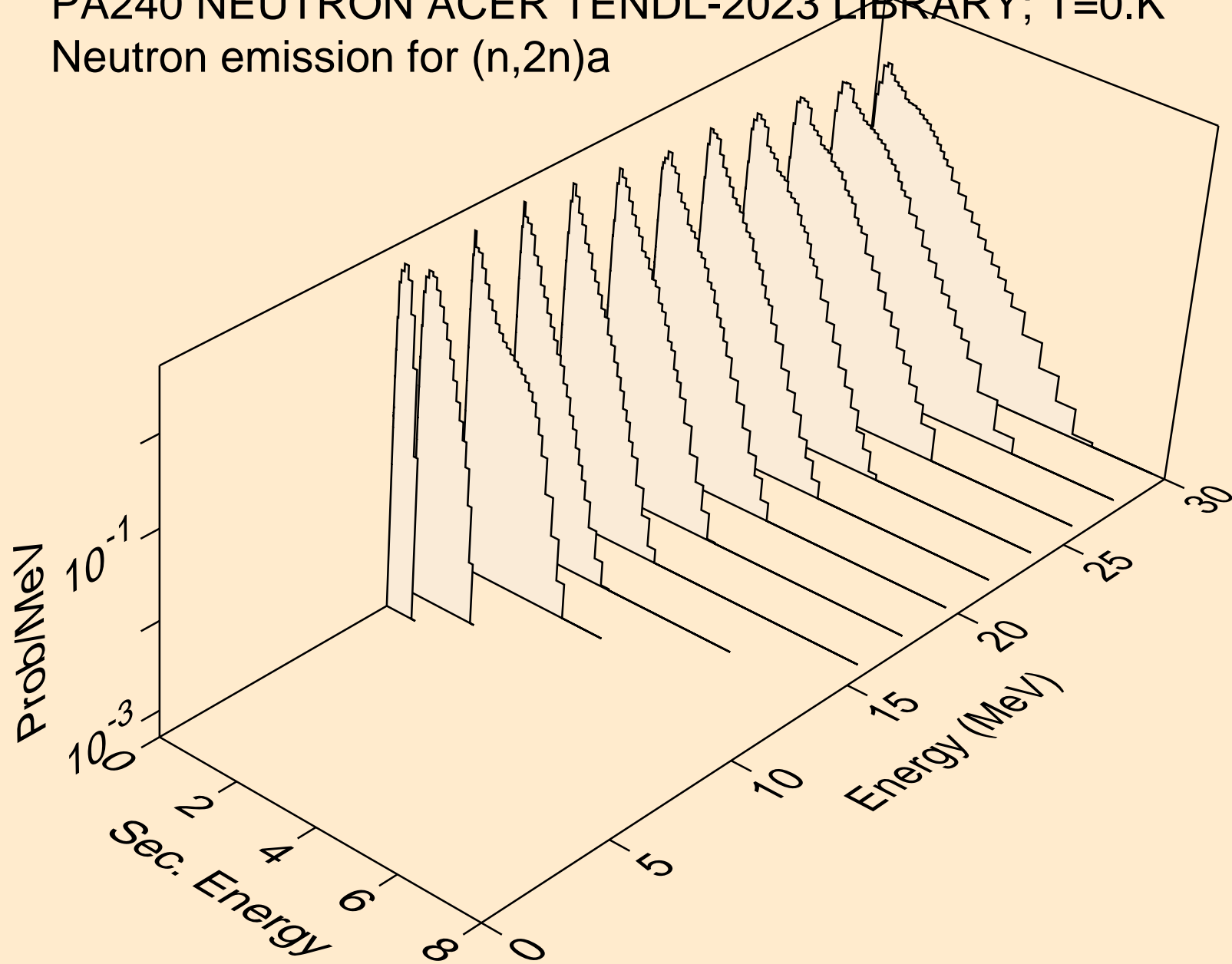

PA240 NEUTRON ACER TENDL-2023 LIBRARY; T=0.K  
Neutron emission for (n,3n)a

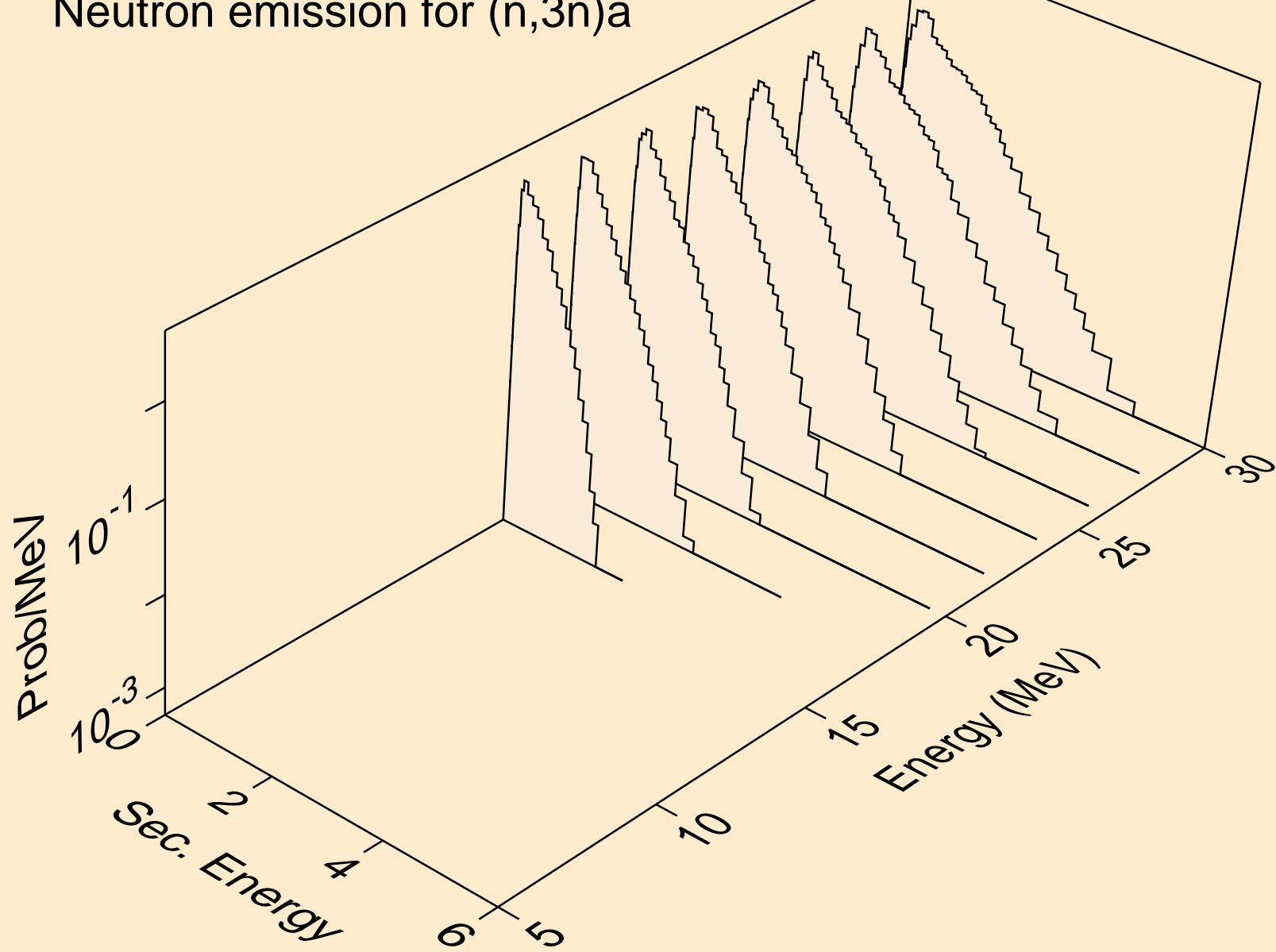

PA240 NEUTRON ACER TENDL-2023 LIBRARY; T=0.K  
Neutron emission for (n,n\*)p

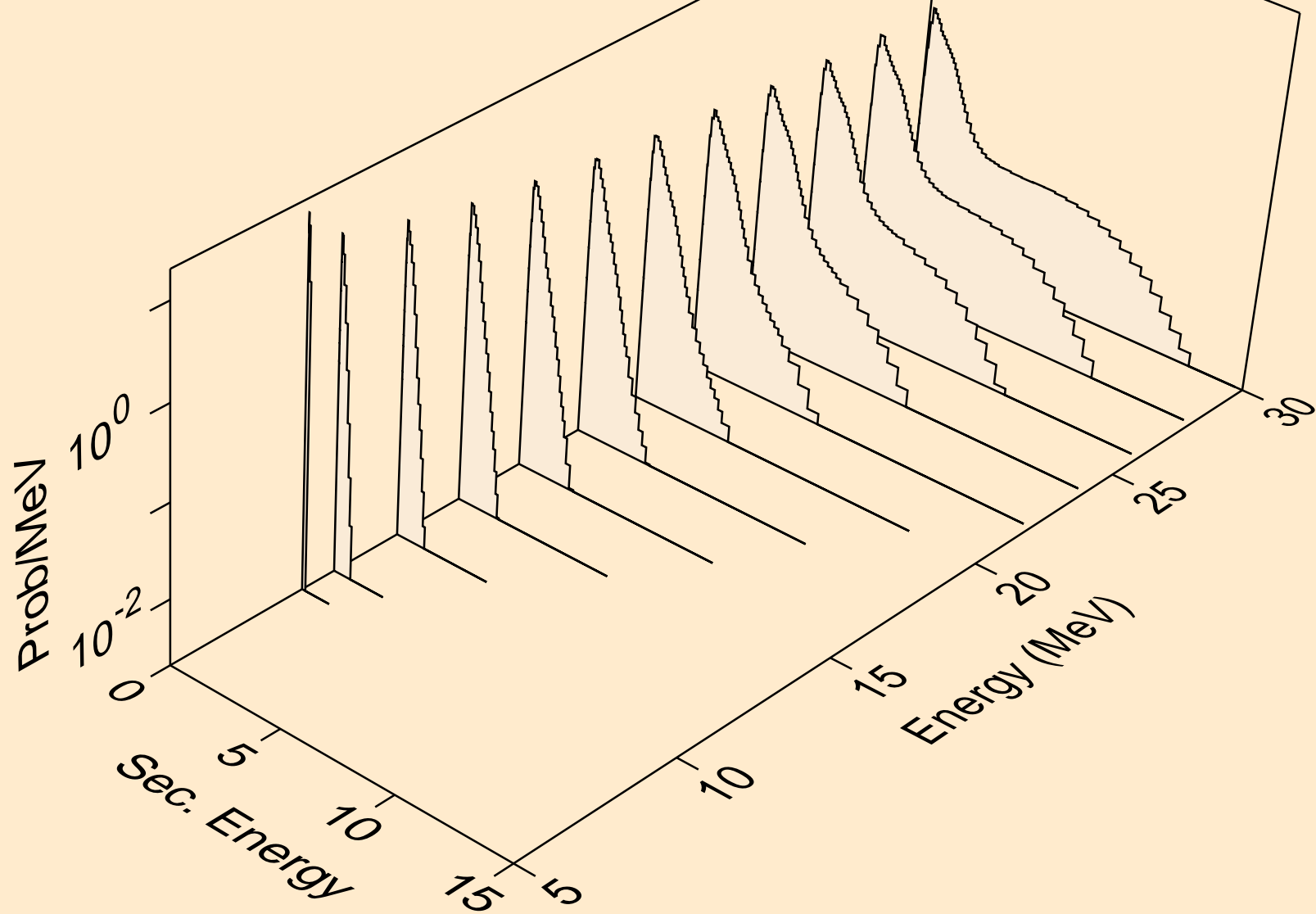

PA240 NEUTRON ACER TENDL-2023 LIBRARY; T=0.K  
Neutron emission for (n,n\*)d

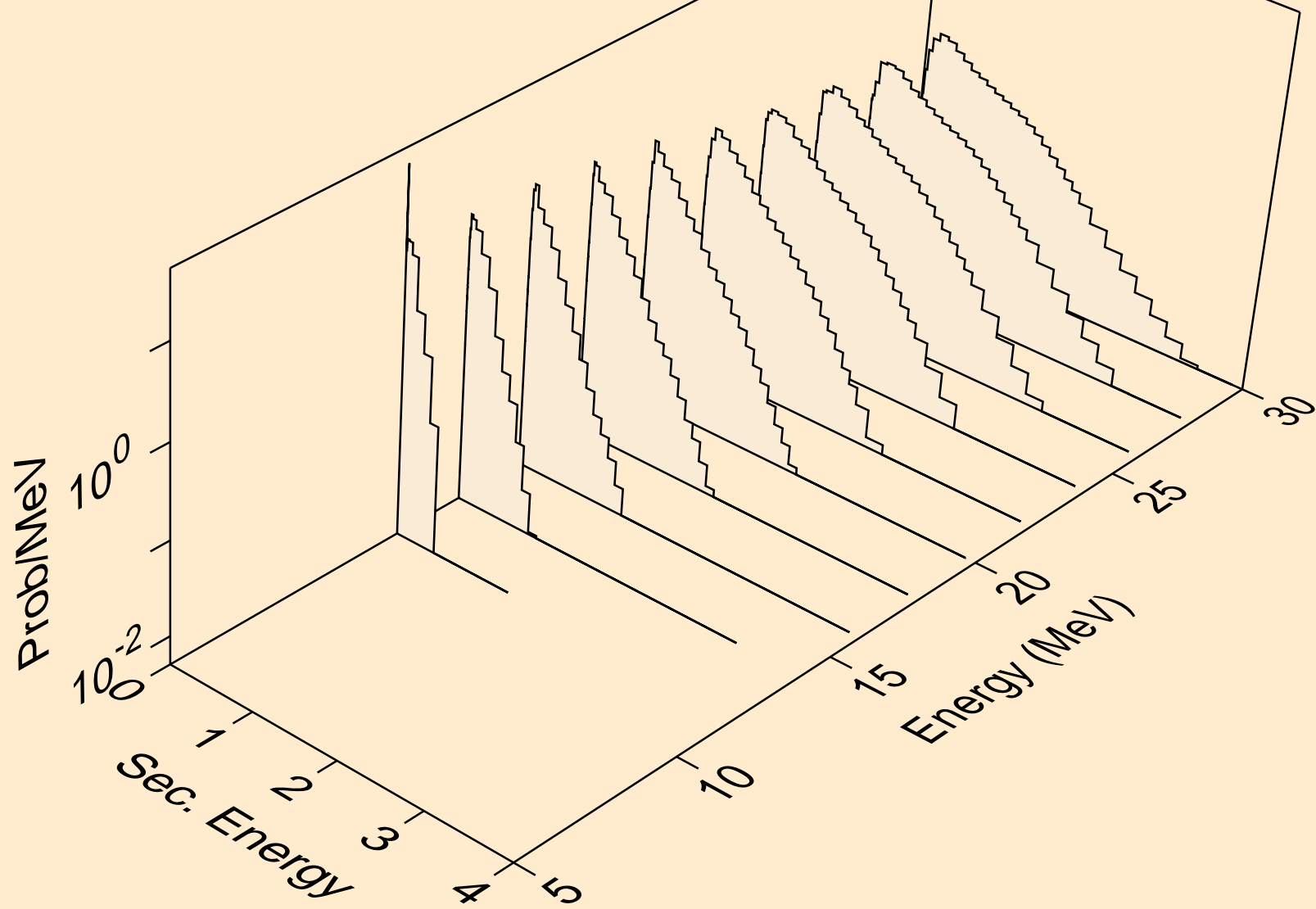

PA240 NEUTRON ACER TENDL-2023 LIBRARY; T=0.K  
Neutron emission for (n,n\*)t

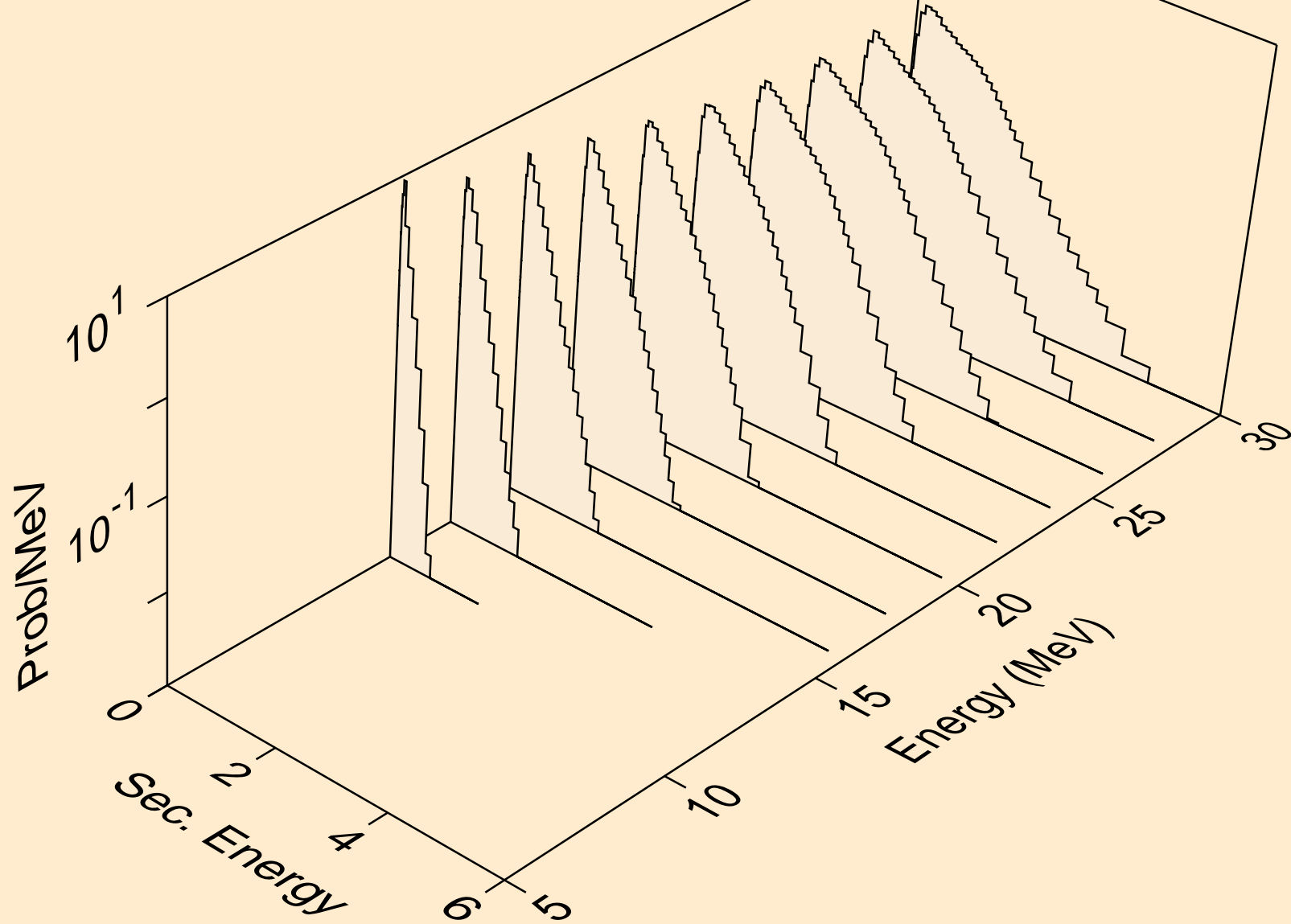

PA240 NEUTRON ACER TENDL-2023 LIBRARY; T=0.K  
Neutron emission for (n,n\*)he3

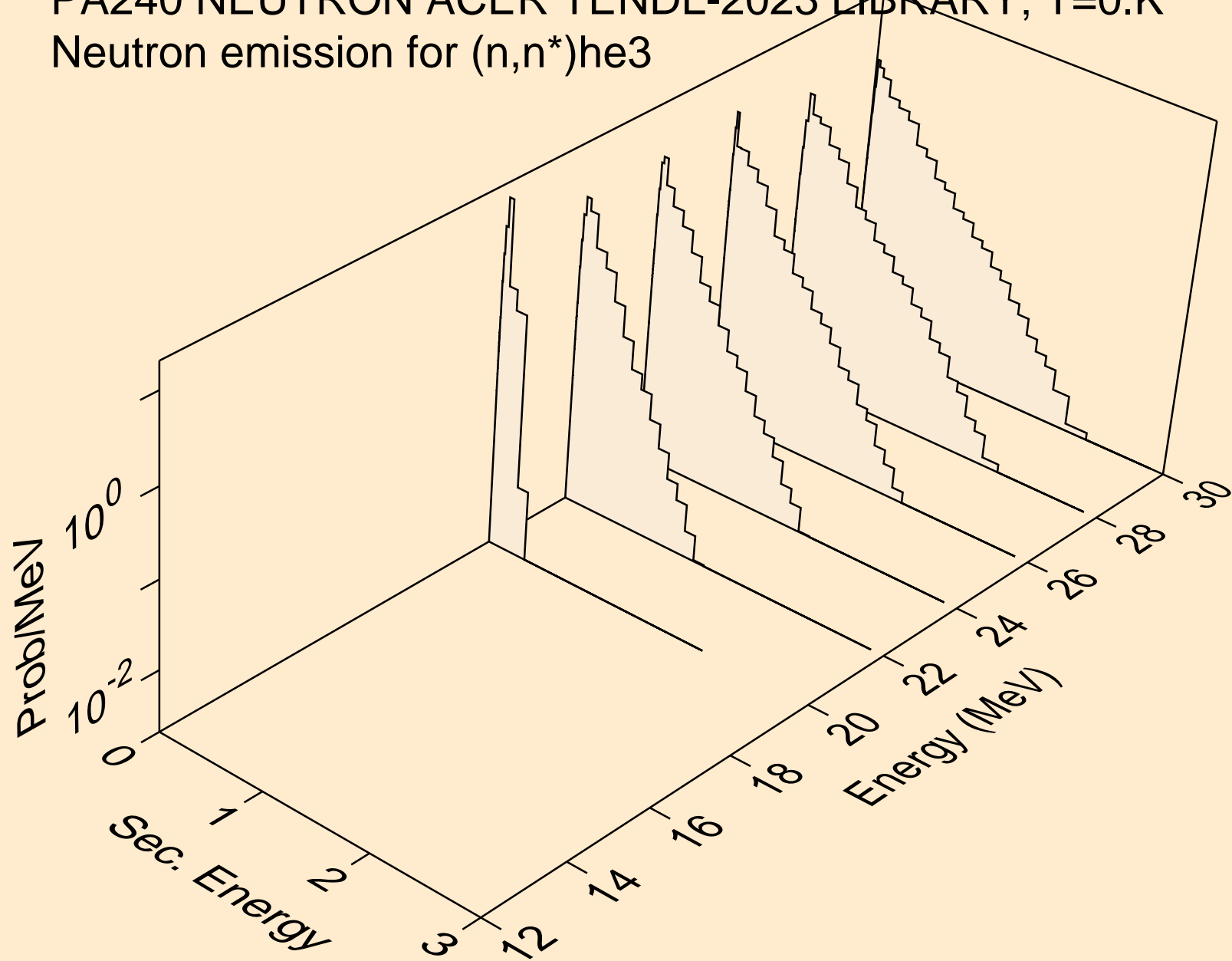

PA240 NEUTRON ACER TENDL-2023 LIBRARY; T=0.K  
Neutron emission for (n,4n)

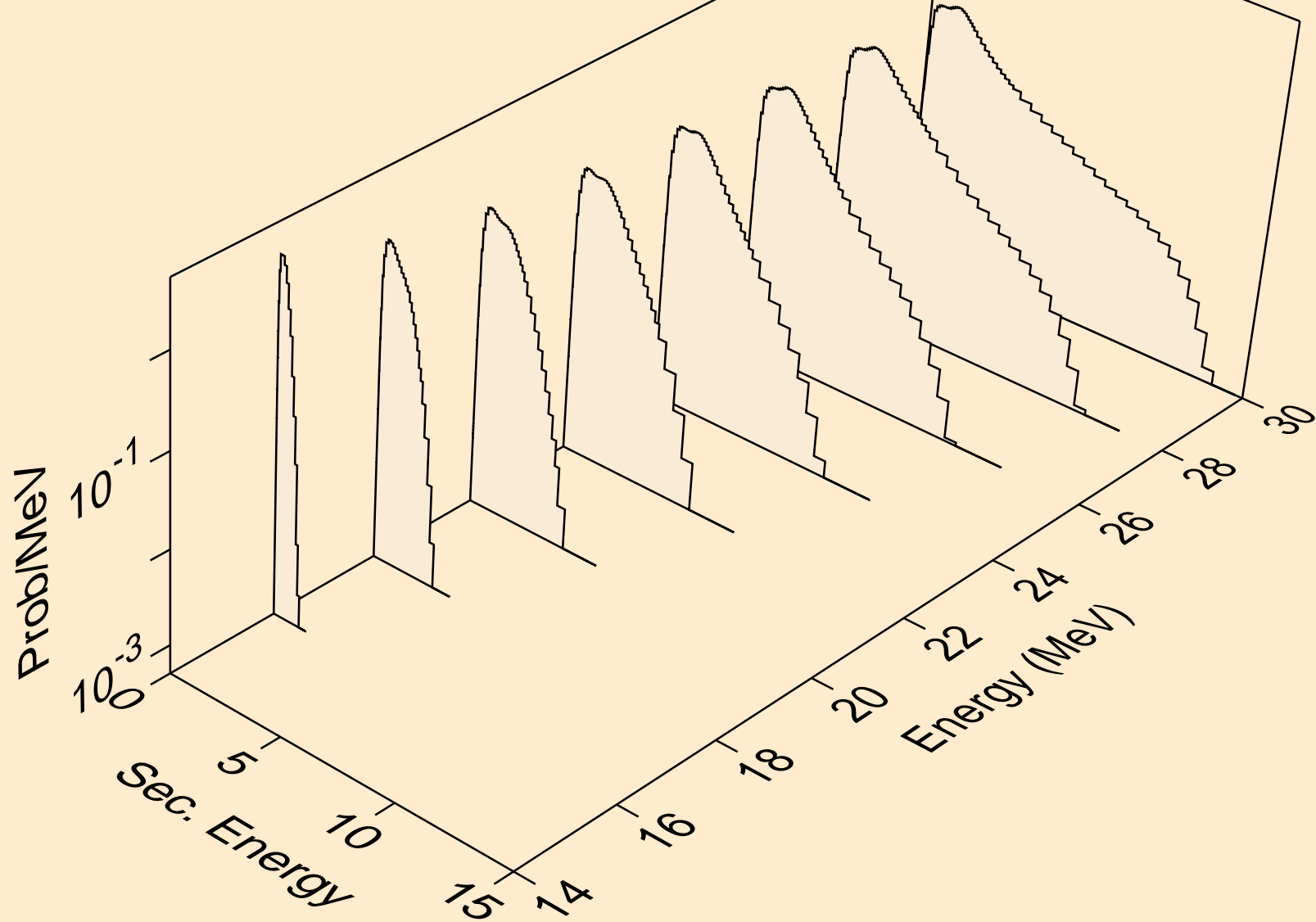

PA240 NEUTRON ACER TENDL-2023 LIBRARY; T=0.K  
Neutron emission for (n,2np)

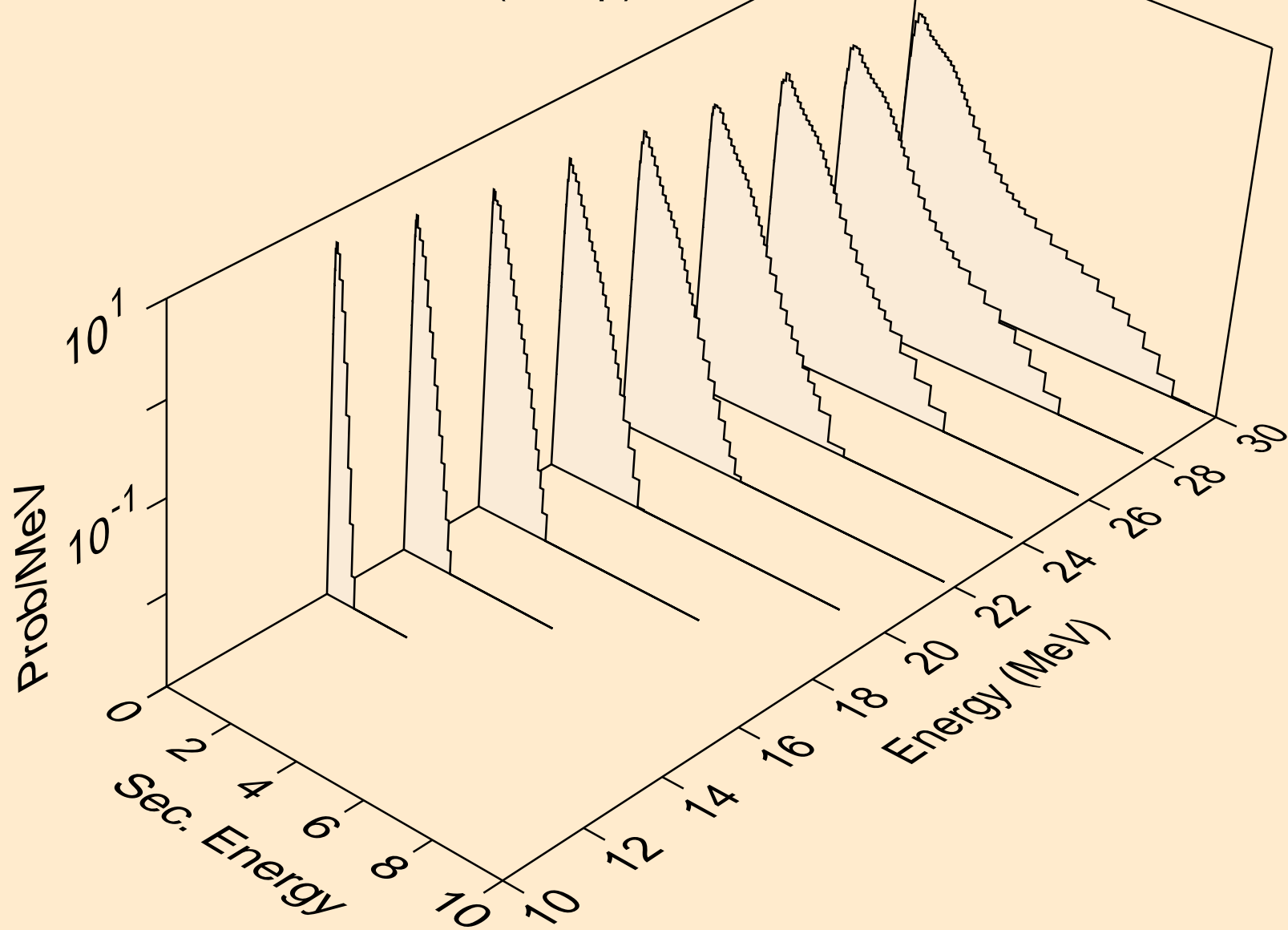



PA240 NEUTRON ACER TENDL-2023 LIBRARY; T=0.K  
Neutron emission for (n,3np)

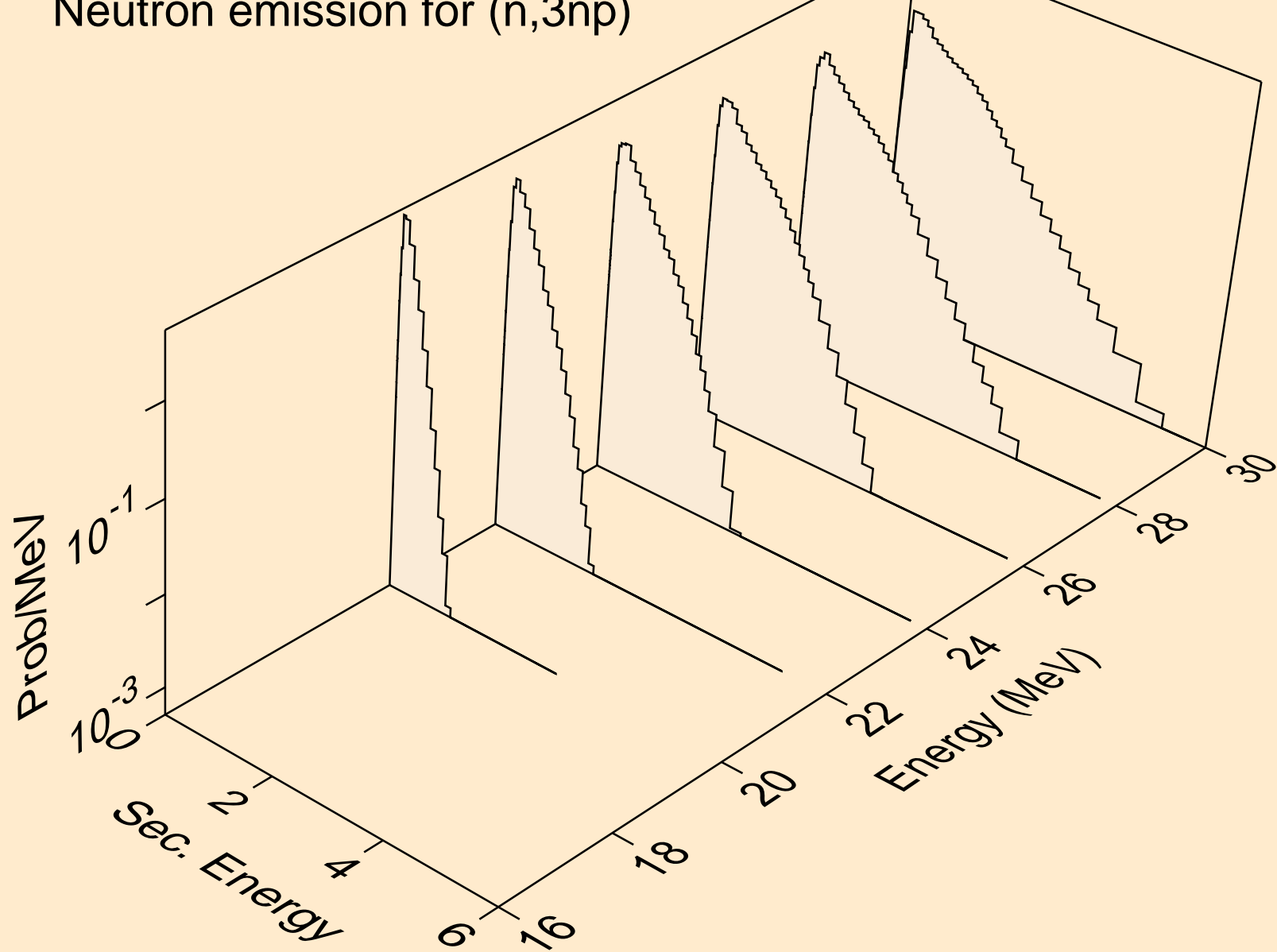

PA240 NEUTRON ACER TENDL-2023 LIBRARY; T=0.K  
Neutron emission for (n,n\*c)

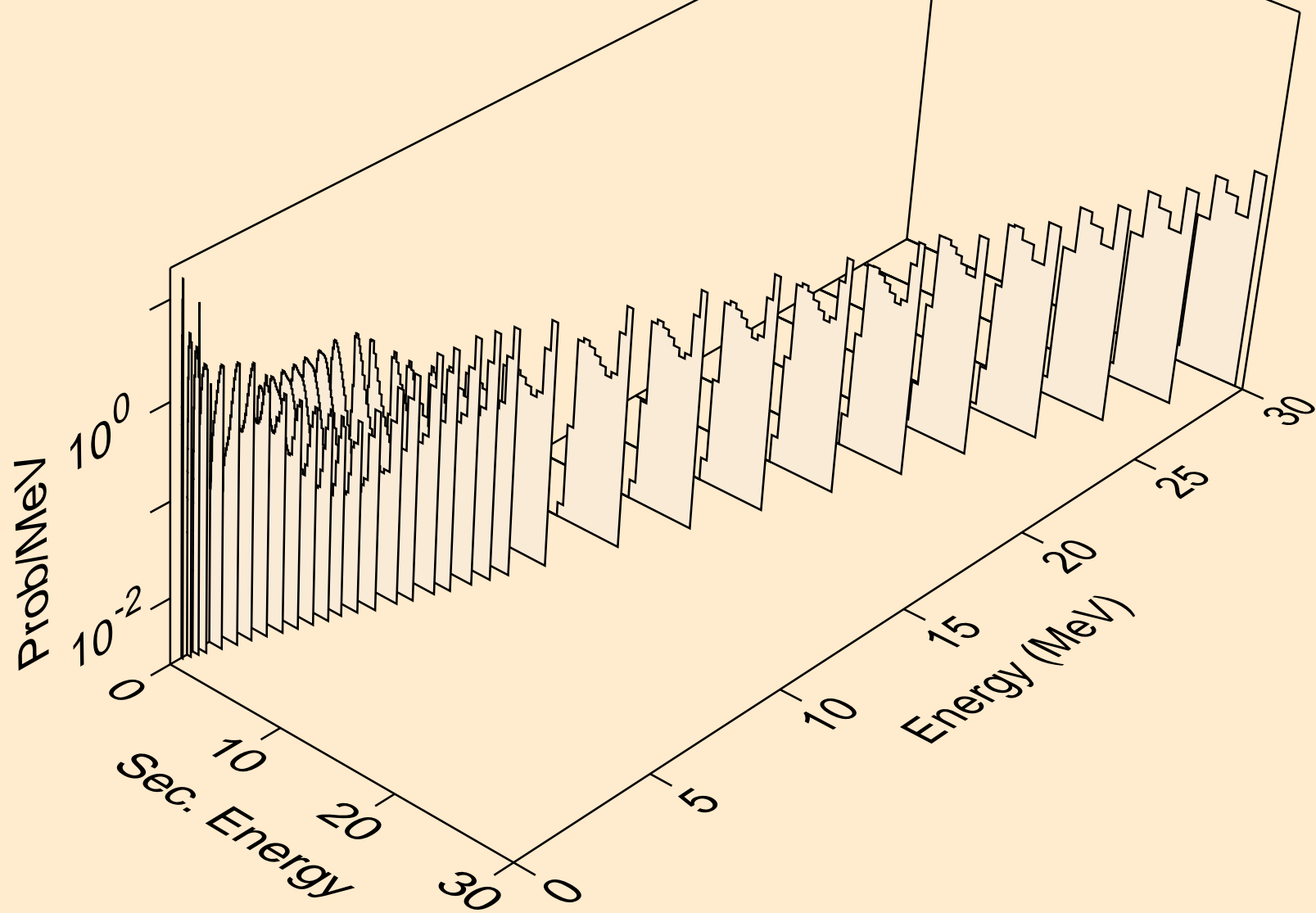

# PA240 NEUTRON ACER TENDL-2023 LIBRARY; T=0.K

## Delayed nubar

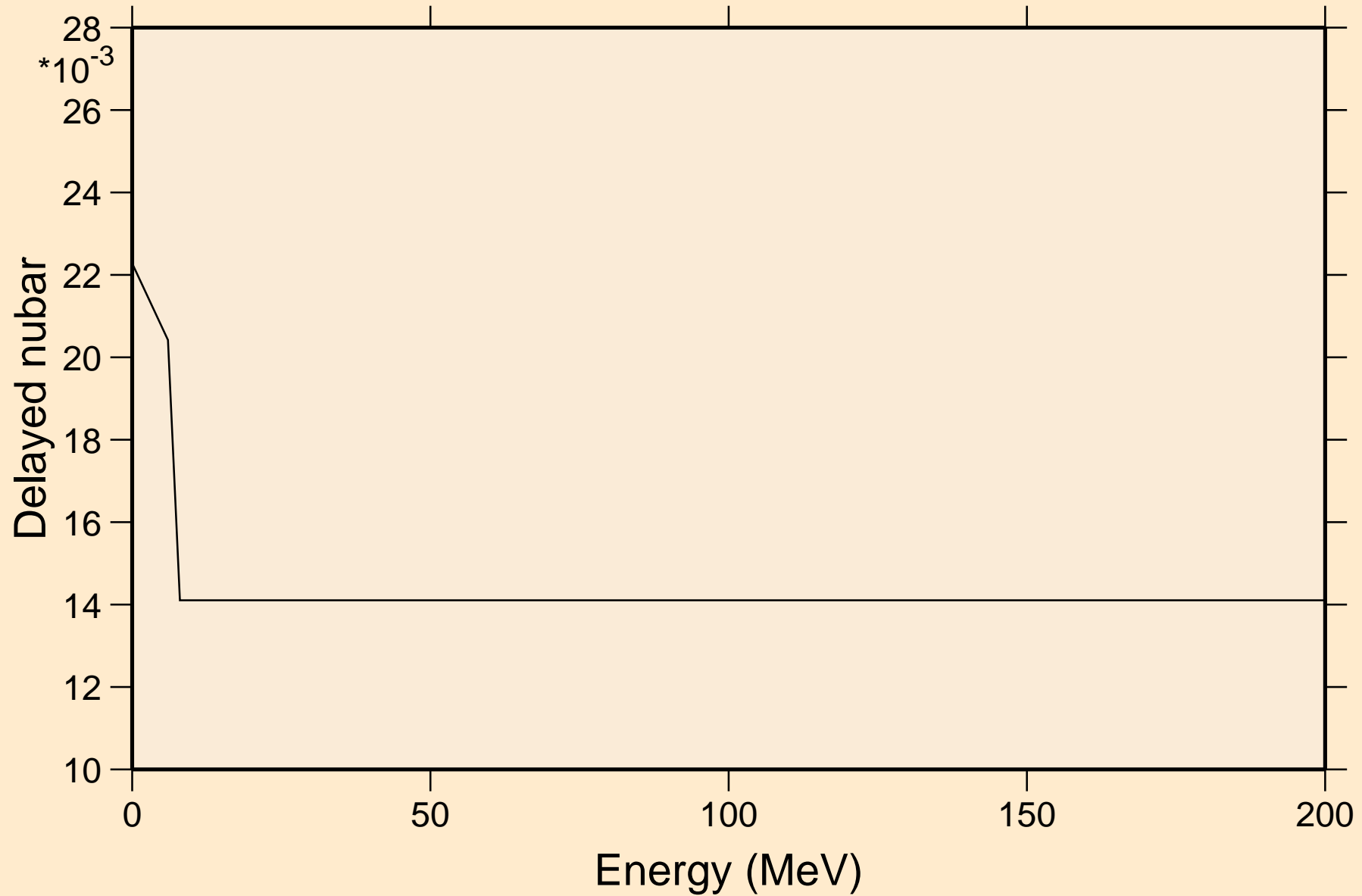

# PA240 NEUTRON ACER TENDL-2023 LIBRARY; T=0.K

## Delayed neutron spectra

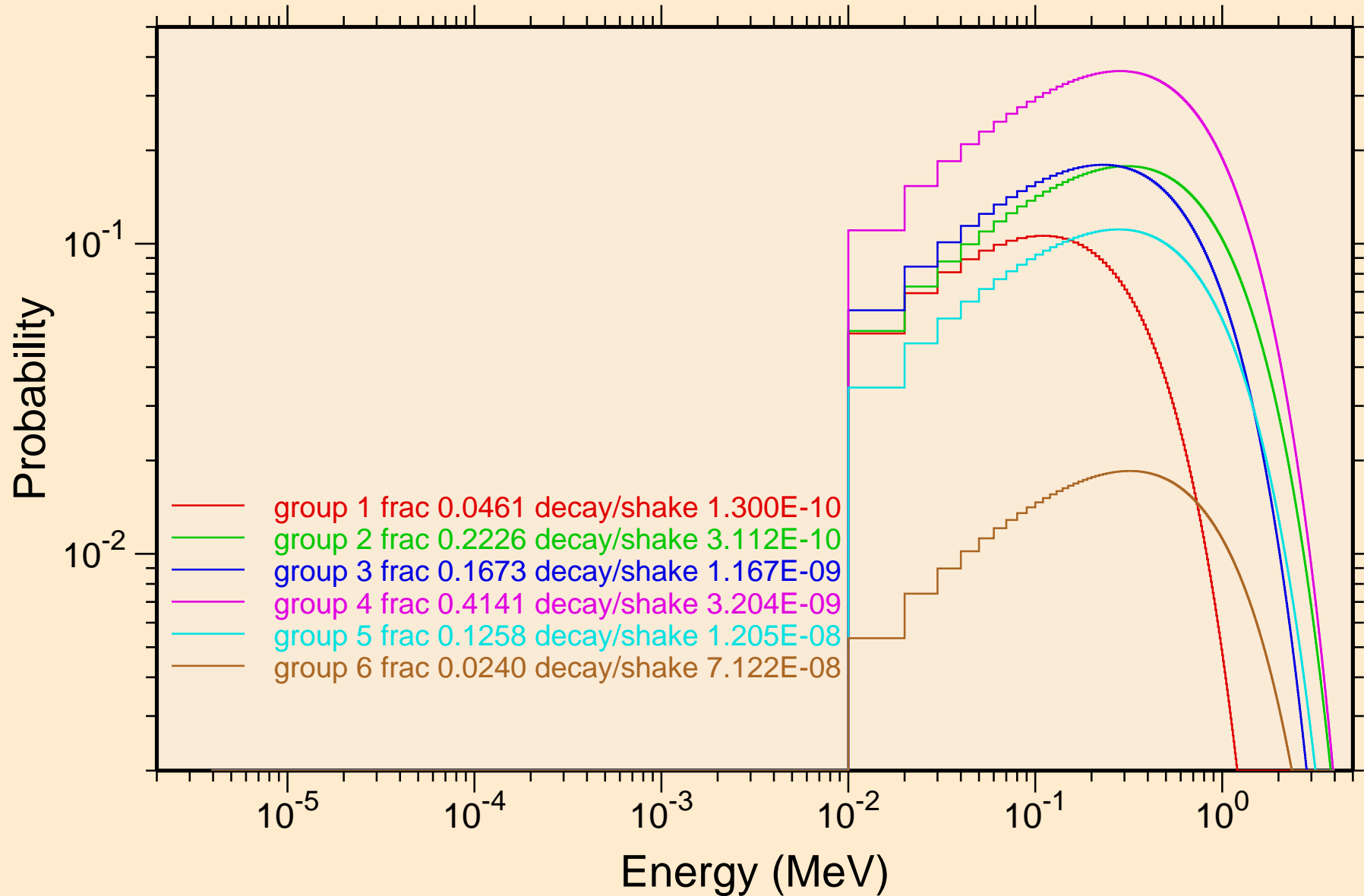

PA240 NEUTRON ACER TENDL-2023 LIBRARY; T=0.K  
Photon emission for (n,x)

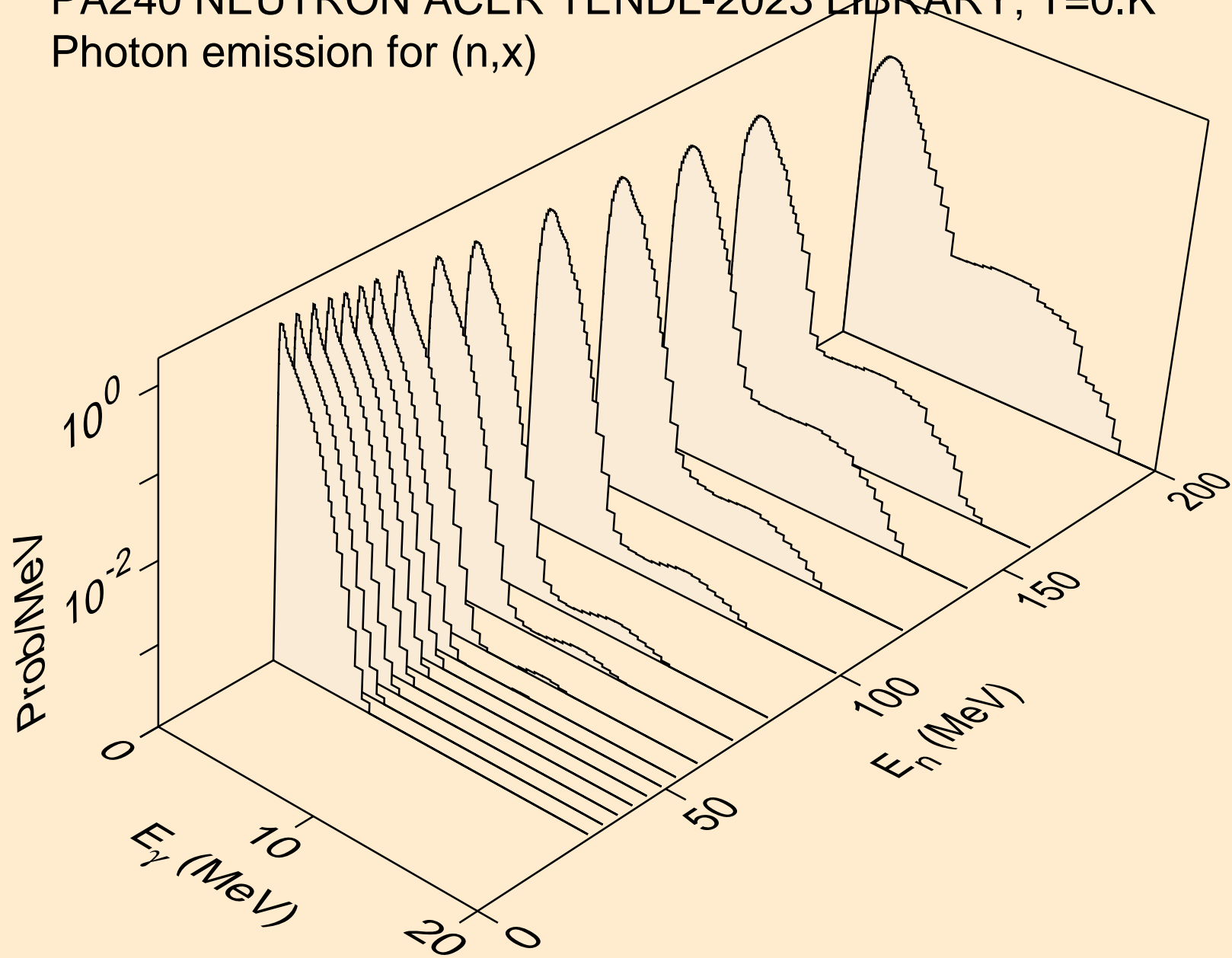

PA240 NEUTRON ACER TENDL-2023 LIBRARY; T=0.K  
Photon emission for (n,2nd)

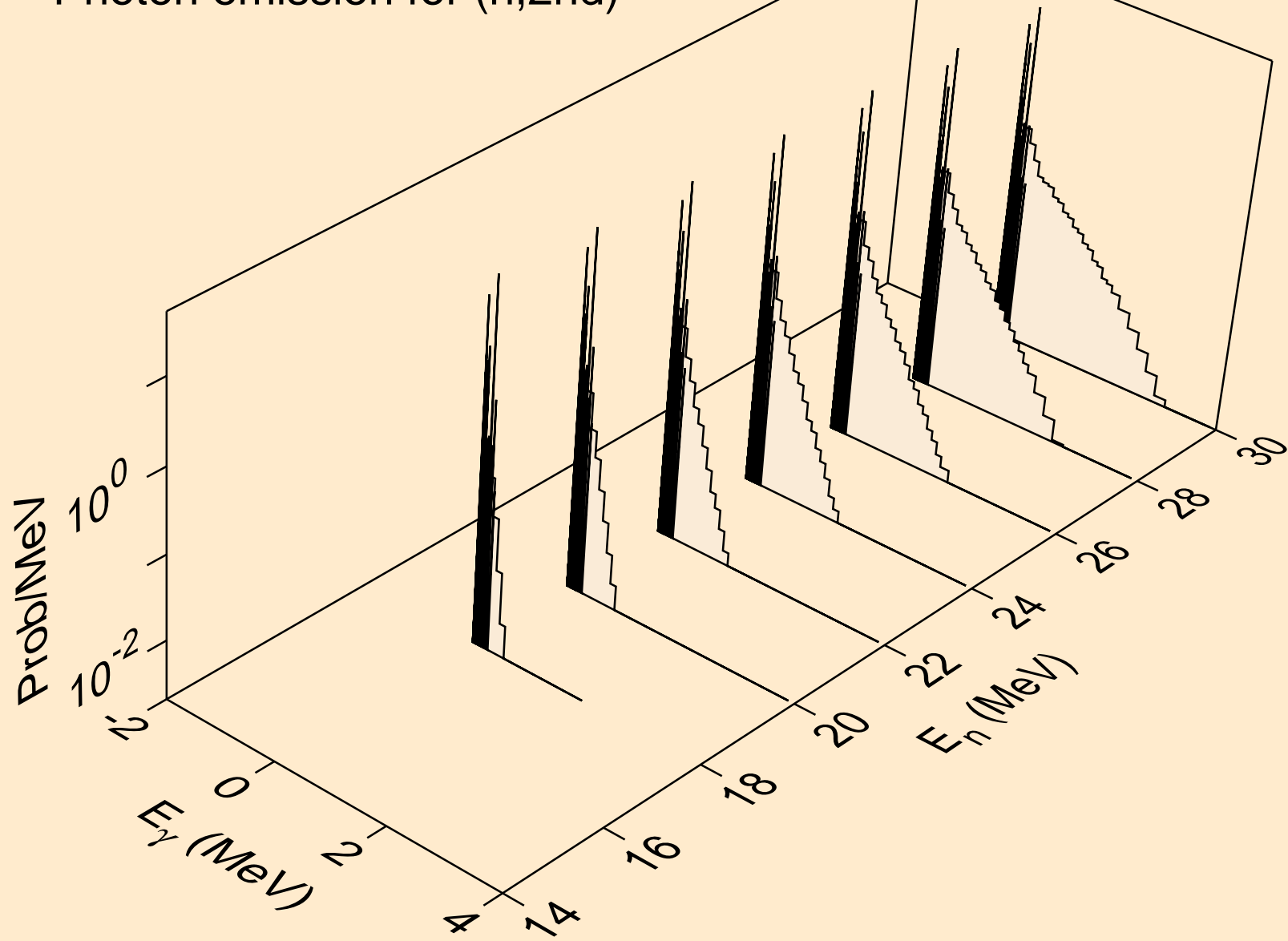

PA240 NEUTRON ACER TENDL-2023 LIBRARY; T=0.K  
Photon emission for (n,2n)

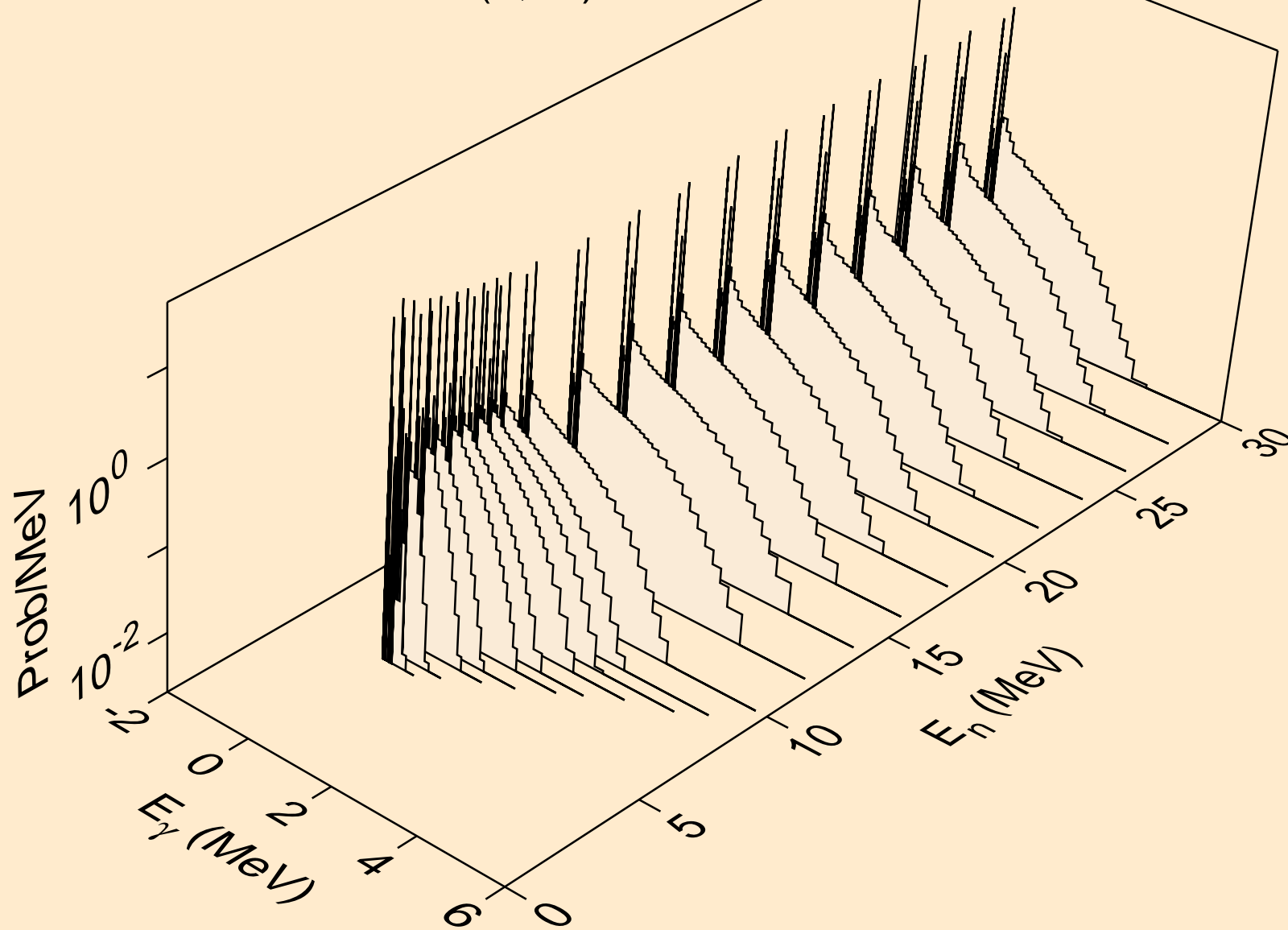

PA240 NEUTRON ACER TENDL-2023 LIBRARY; T=0.K  
Photon emission for (n,3n)

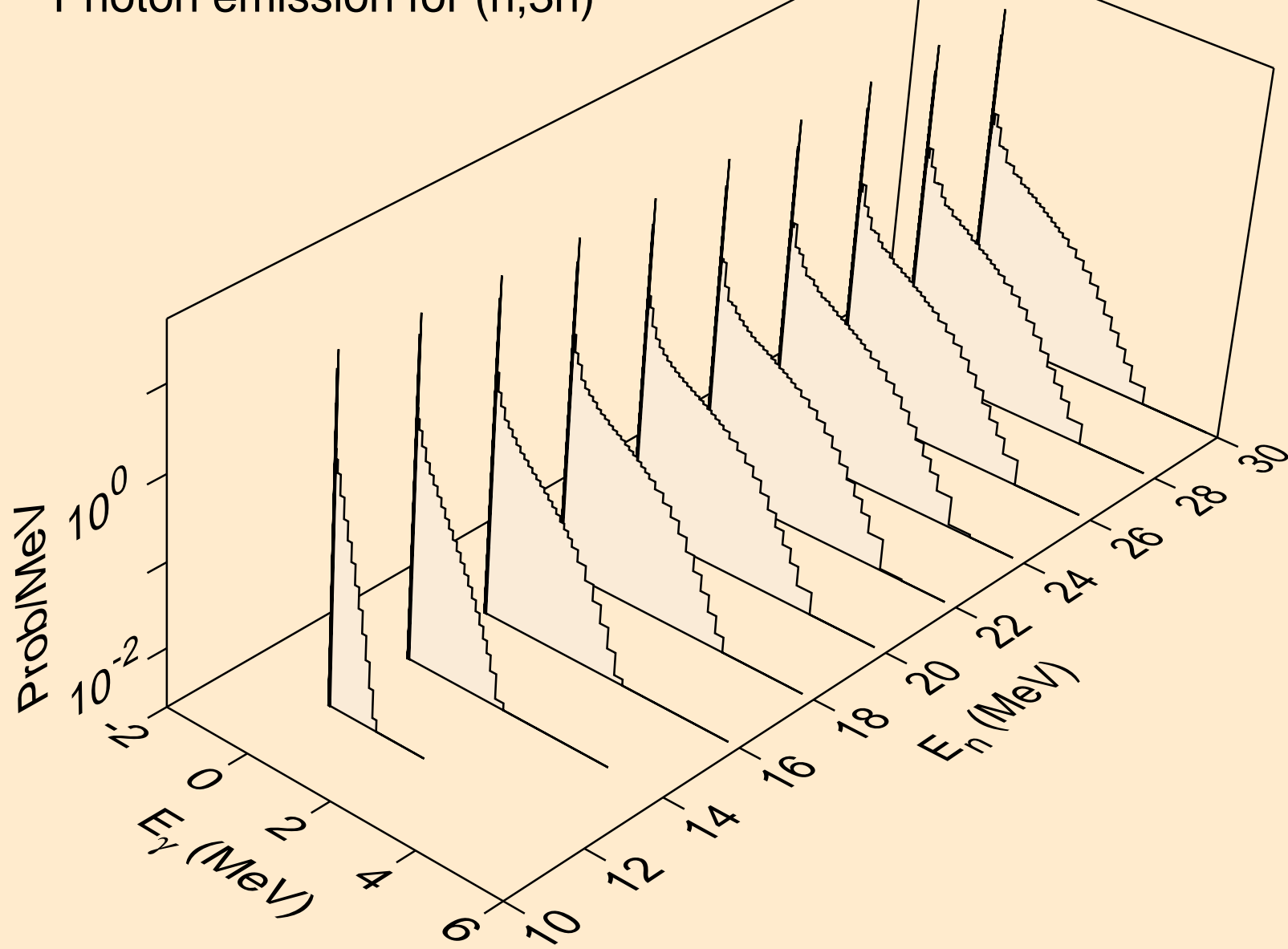



PA240 NEUTRON ACER TENDL-2023 LIBRARY; T=0.K  
Photon emission for (n,n\*)a

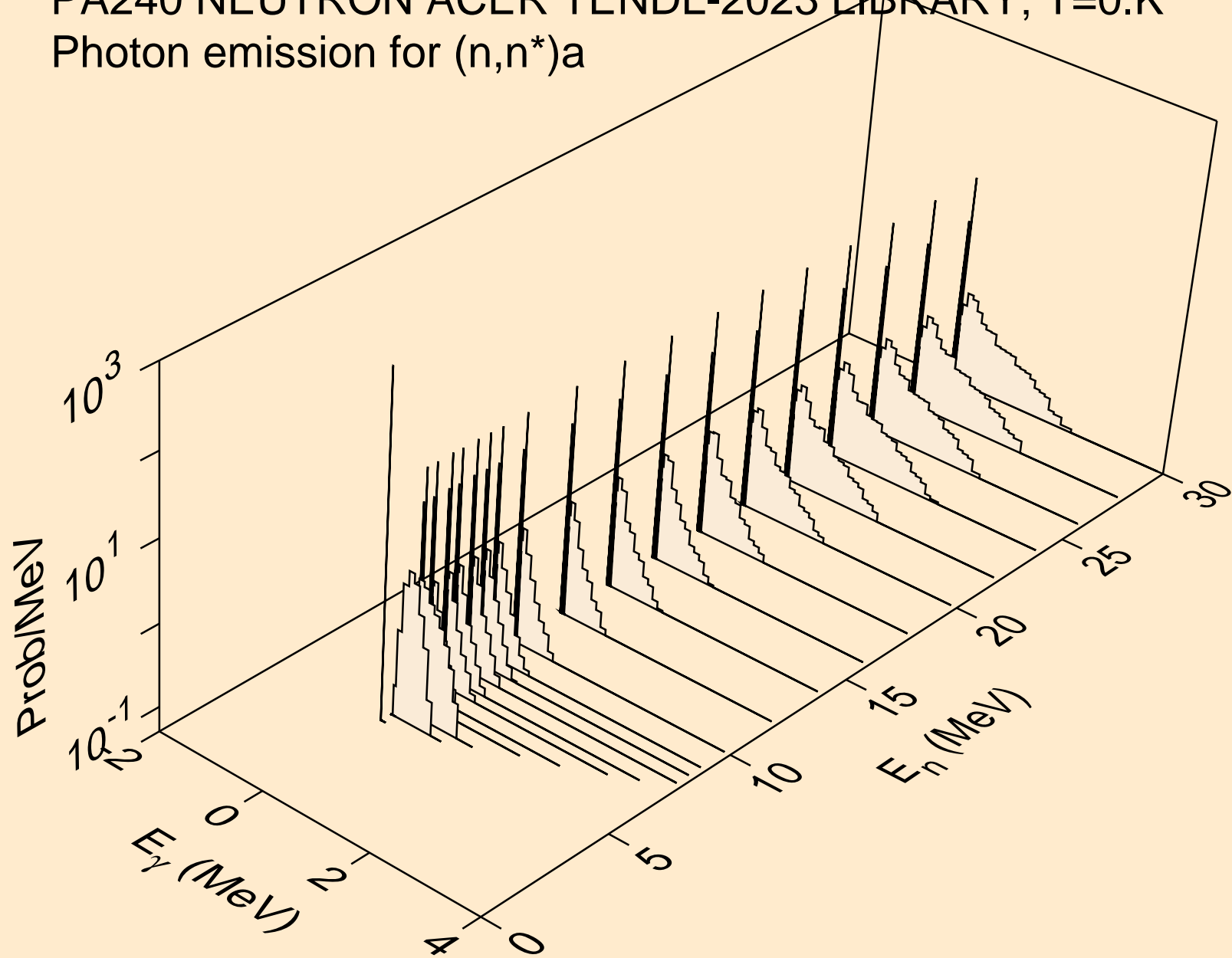

PA240 NEUTRON ACER TENDL-2023 LIBRARY; T=0.K  
Photon emission for (n,2n)a

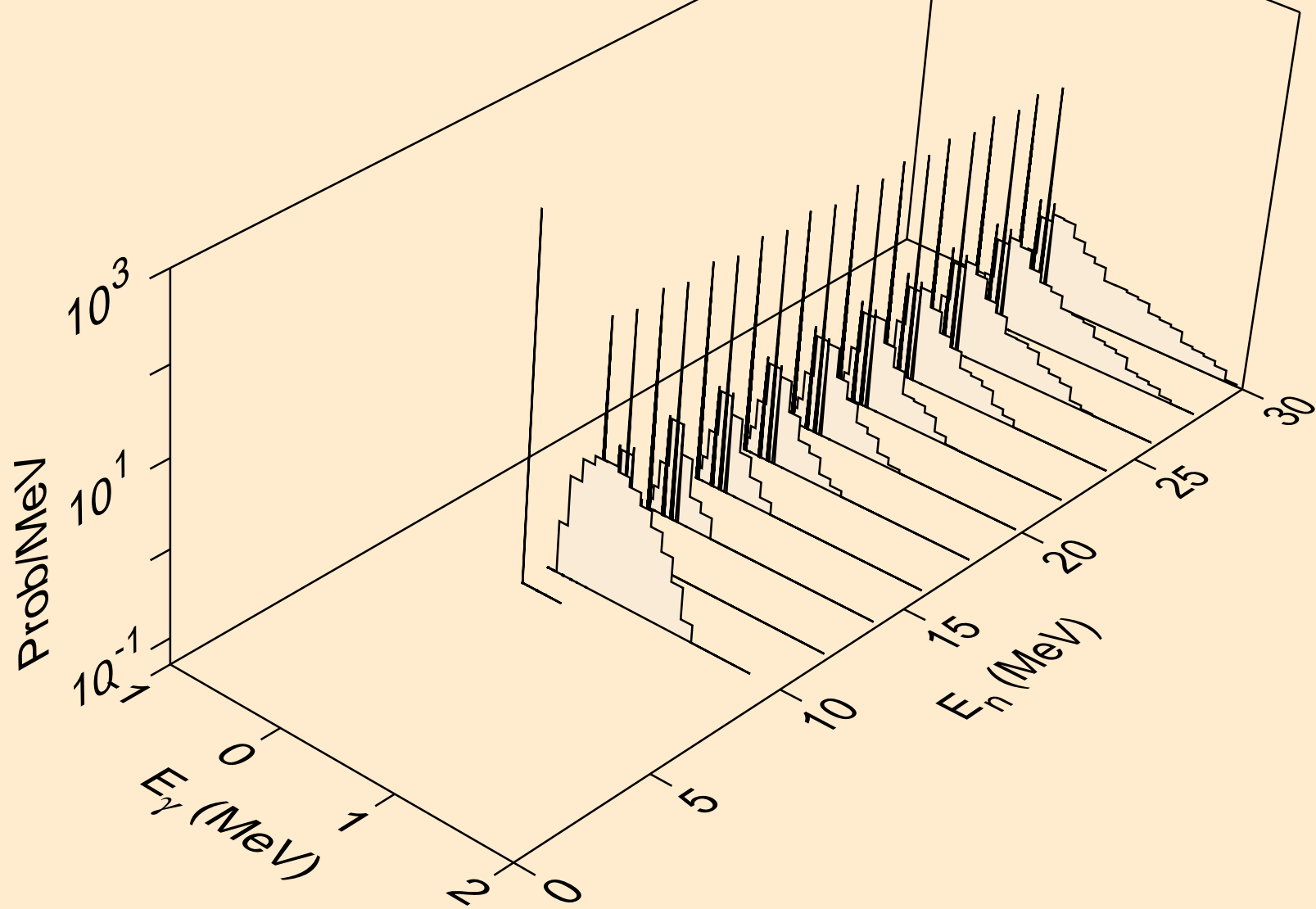

PA240 NEUTRON ACER TENDL-2023 LIBRARY; T=0.K  
Photon emission for (n,3n)a

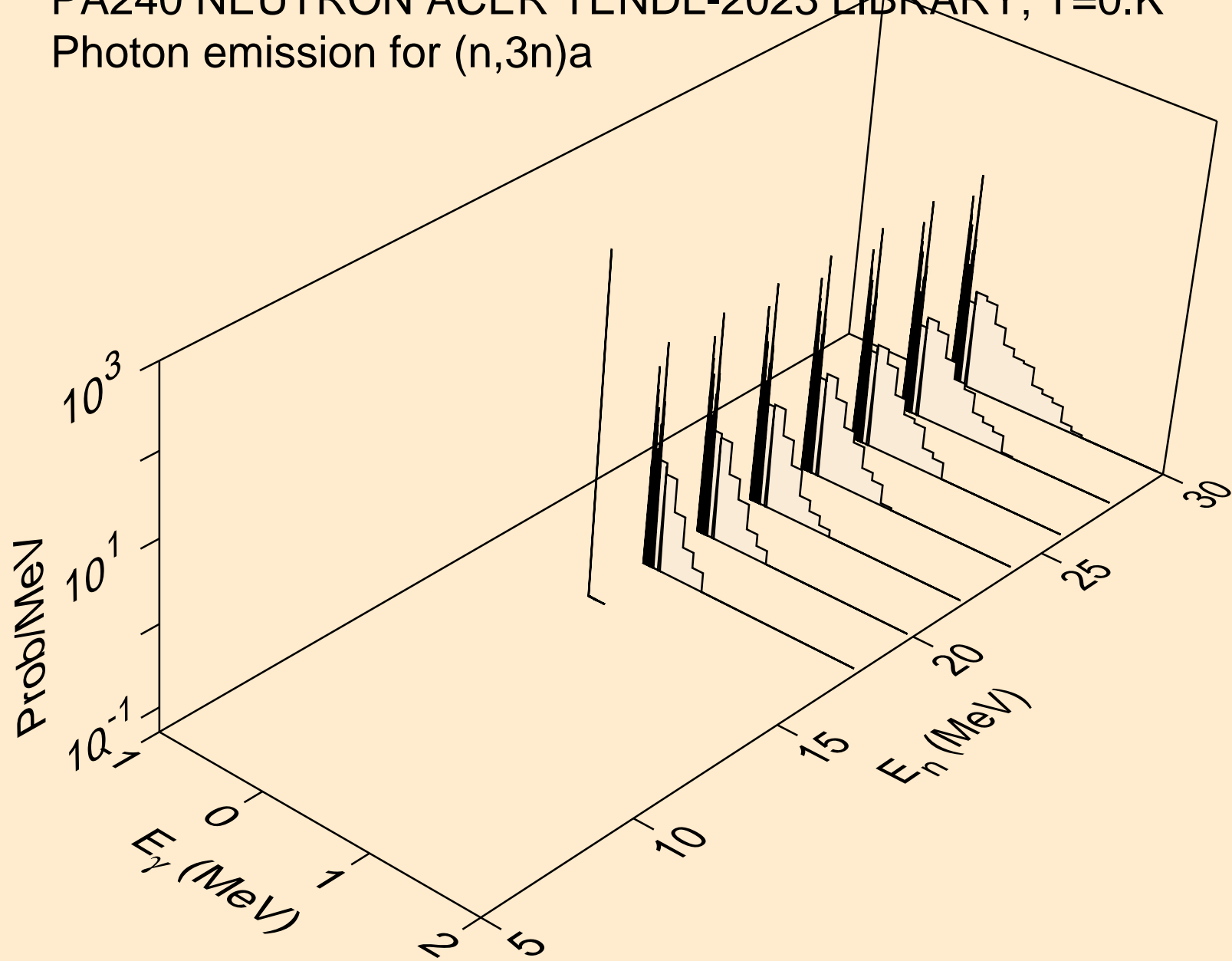

PA240 NEUTRON ACER TENDL-2023 LIBRARY; T=0.K  
Photon emission for (n,n\*)p

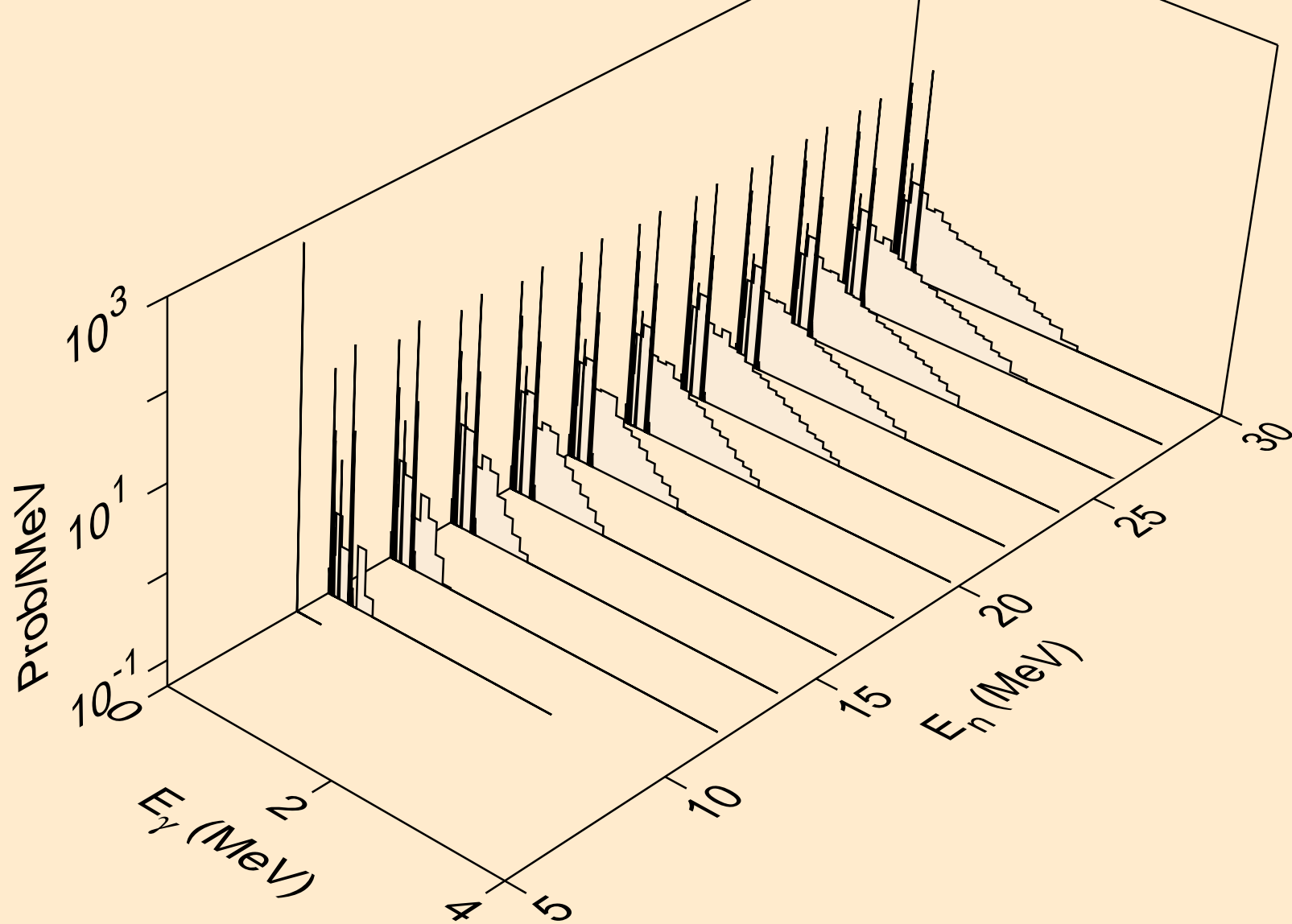

PA240 NEUTRON ACER TENDL-2023 LIBRARY; T=0.K  
Photon emission for (n,n\*)d

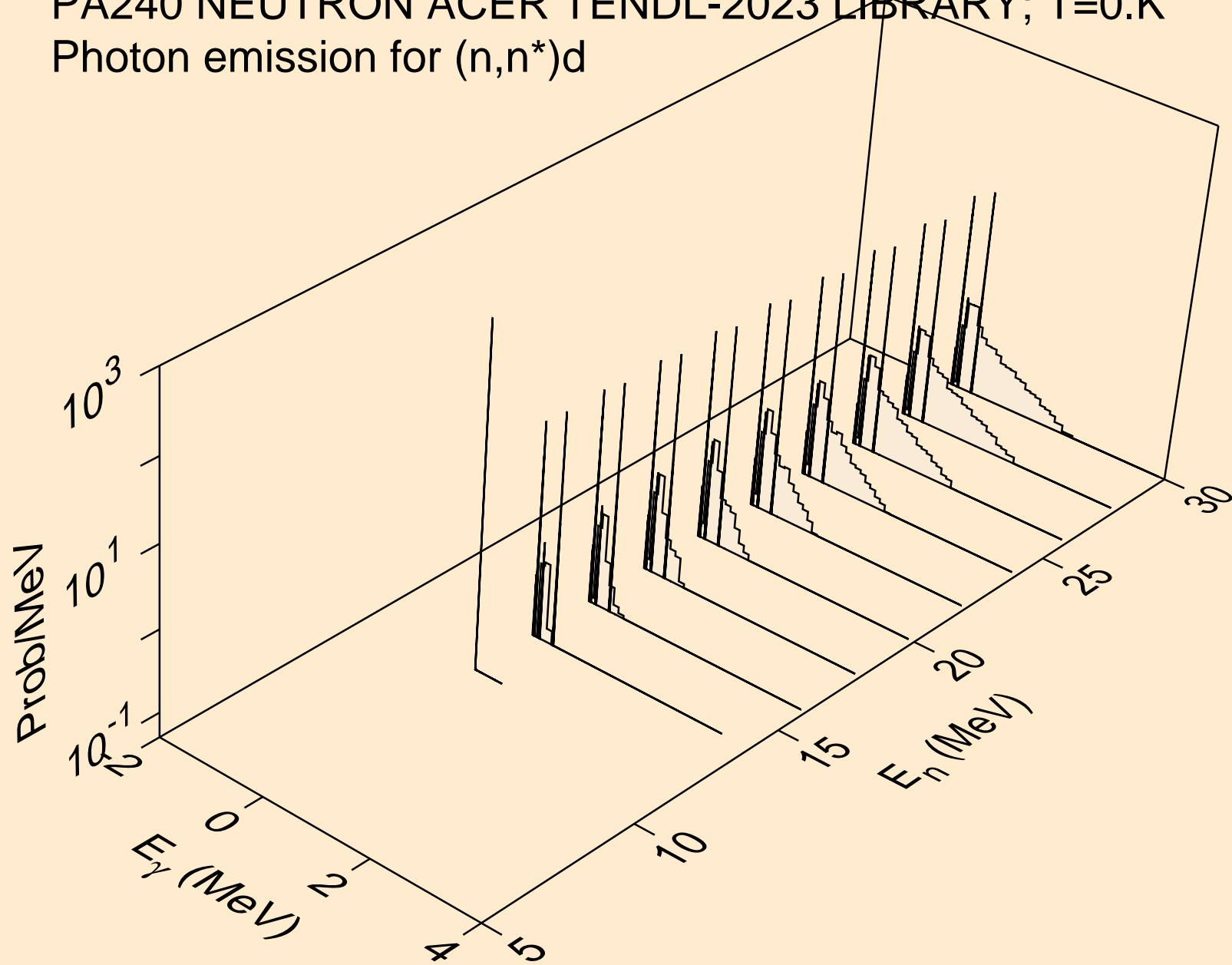

PA240 NEUTRON ACER TENDL-2023 LIBRARY; T=0.K  
Photon emission for (n,n\*)t

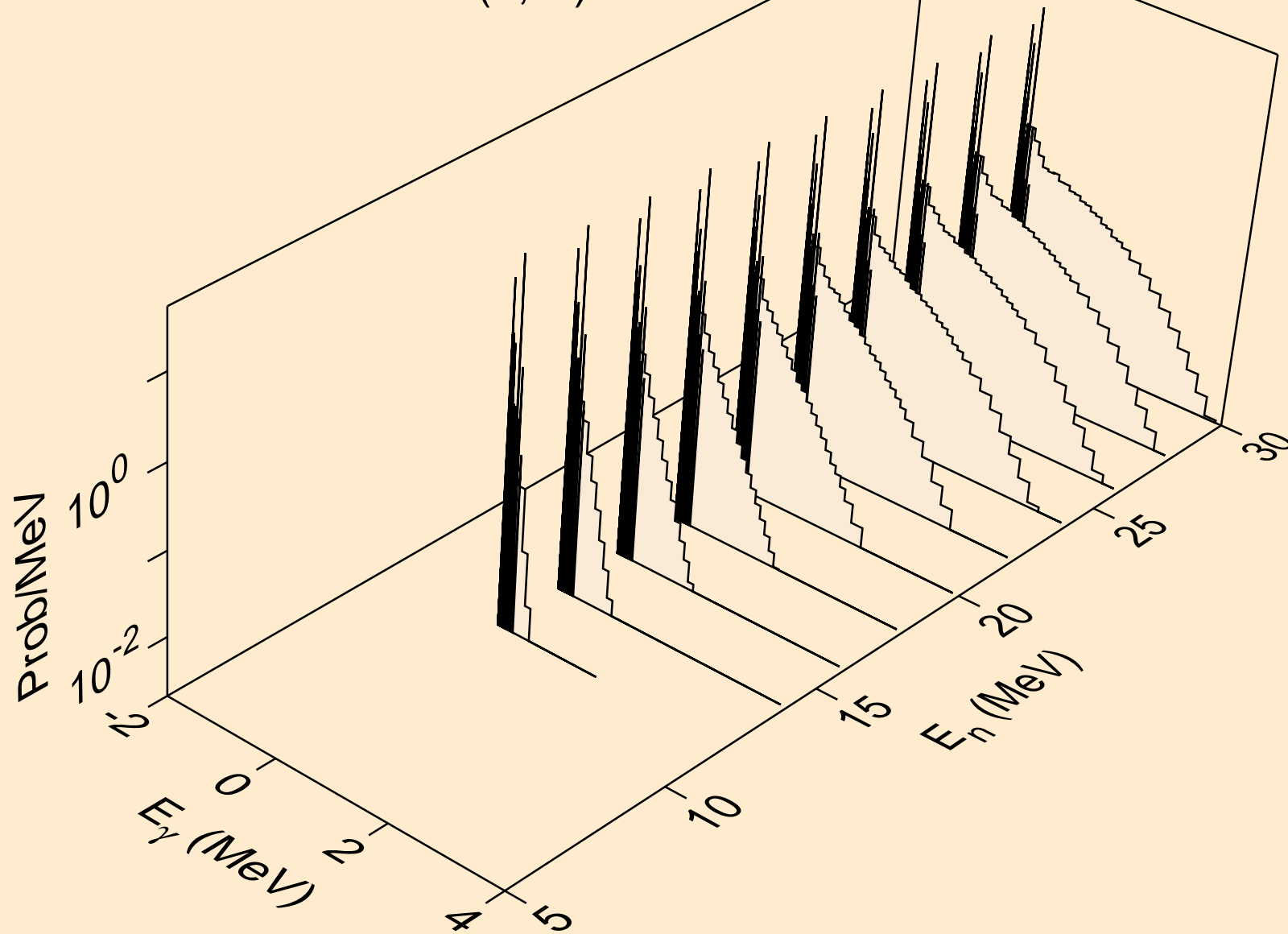

PA240 NEUTRON ACER TENDL-2023 LIBRARY; T=0.K  
Photon emission for (n,n\*)he3

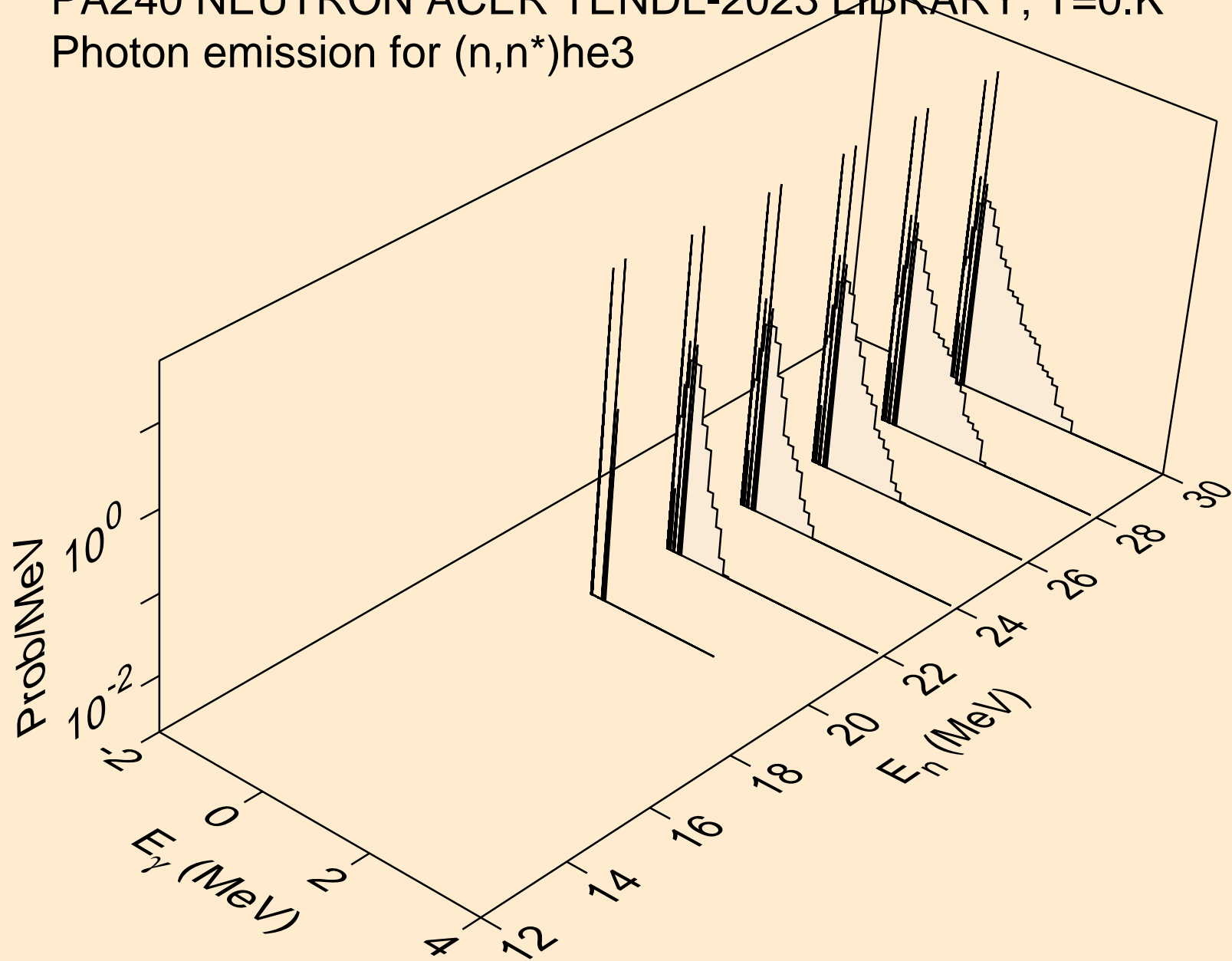

PA240 NEUTRON ACER TENDL-2023 LIBRARY; T=0.K  
Photon emission for (n,4n)

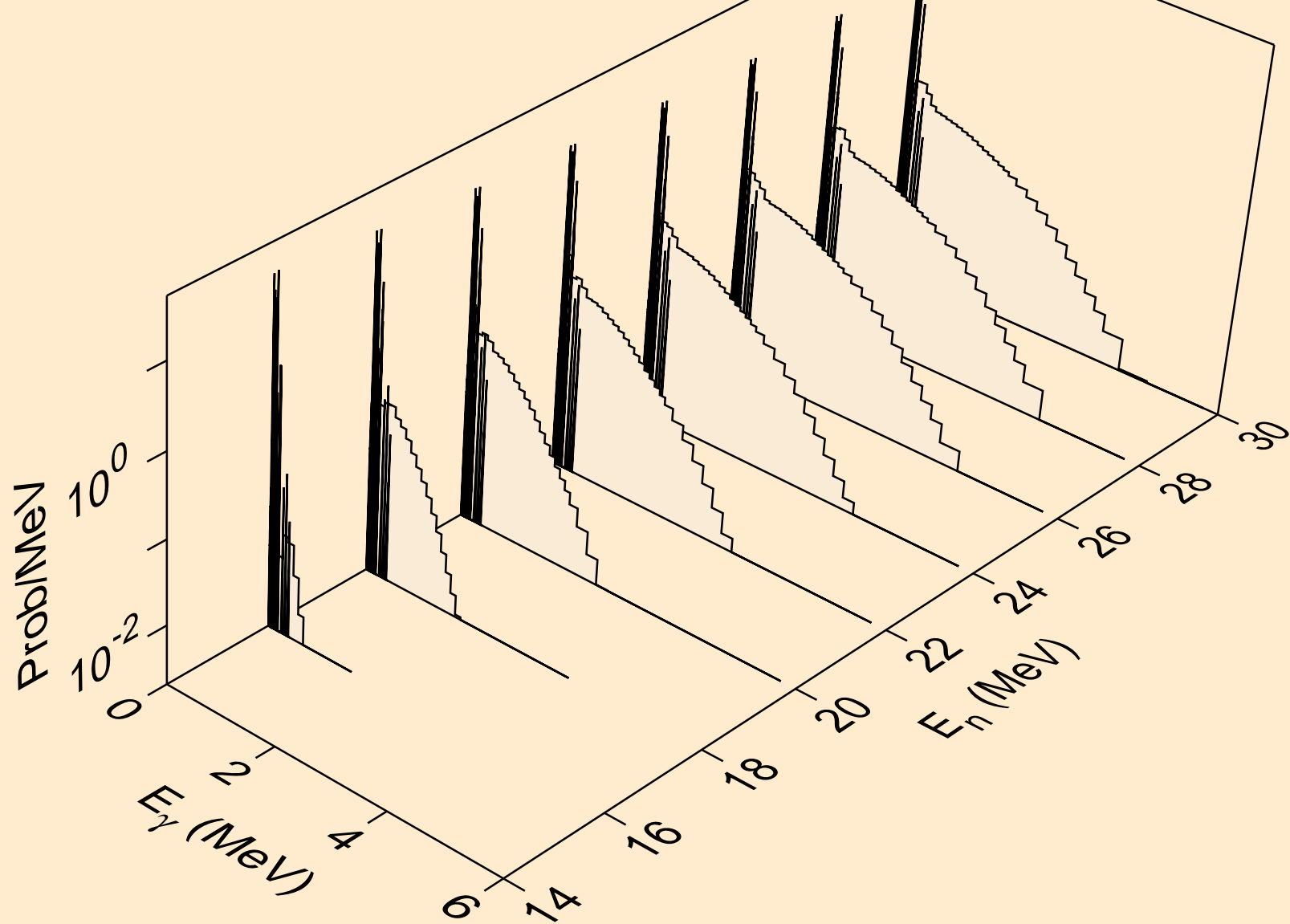



PA240 NEUTRON ACER TENDL-2023 LIBRARY; T=0.K  
Photon emission for (n,2np)

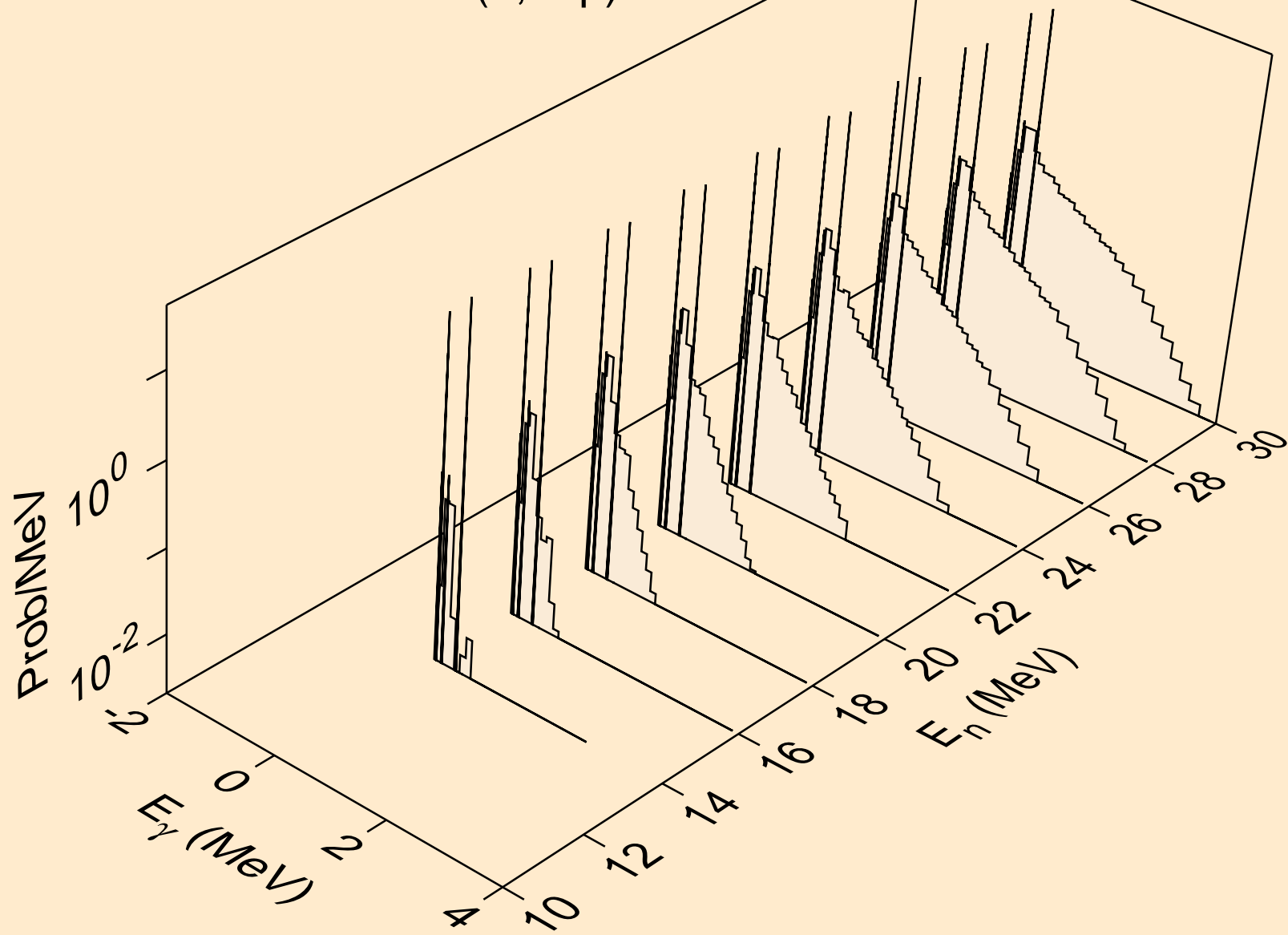

PA240 NEUTRON ACER TENDL-2023 LIBRARY; T=0.K  
Photon emission for (n,3np)

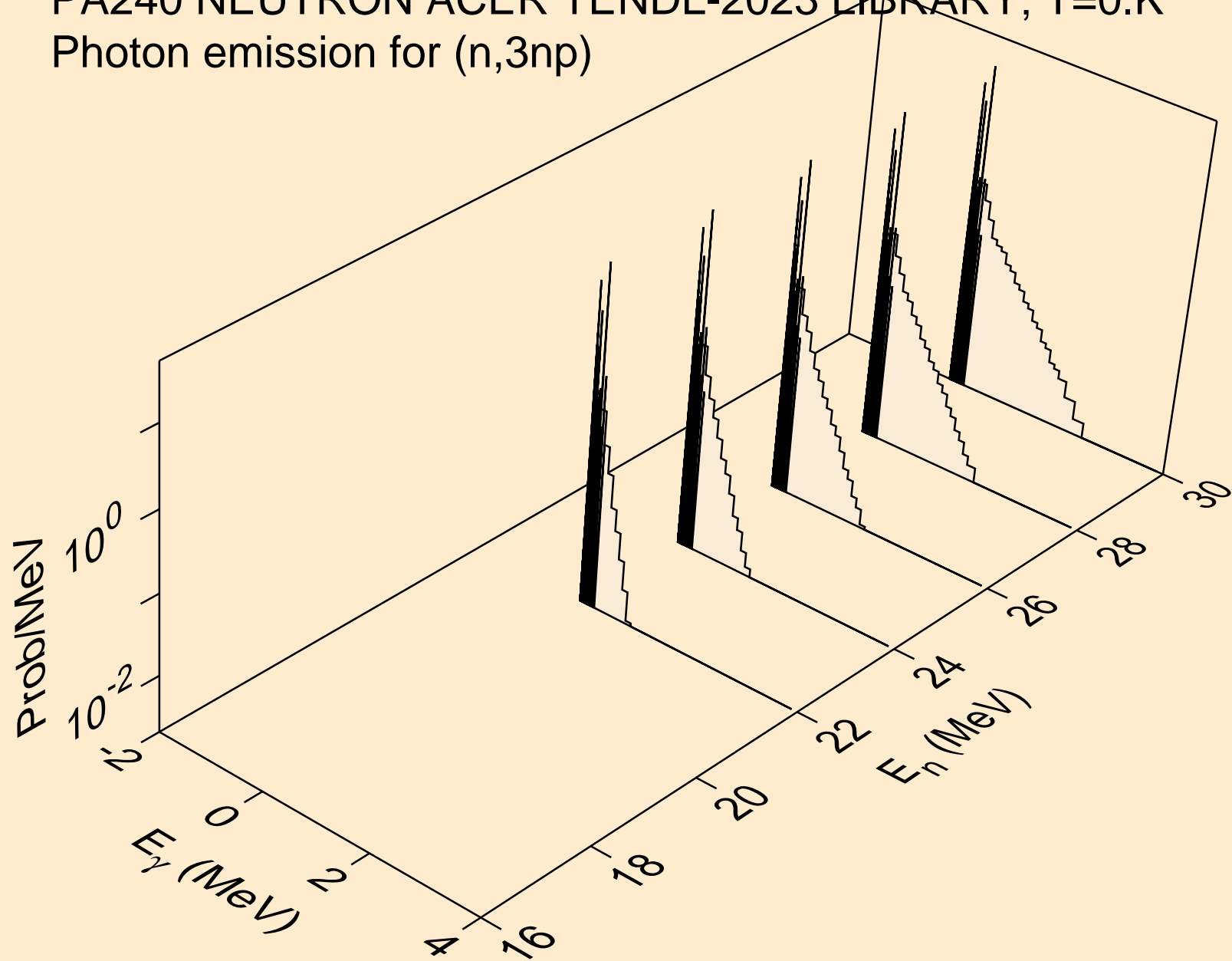

PA240 NEUTRON ACER TENDL-2023 LIBRARY; T=0.K  
Photon emission for (n,n\*c)

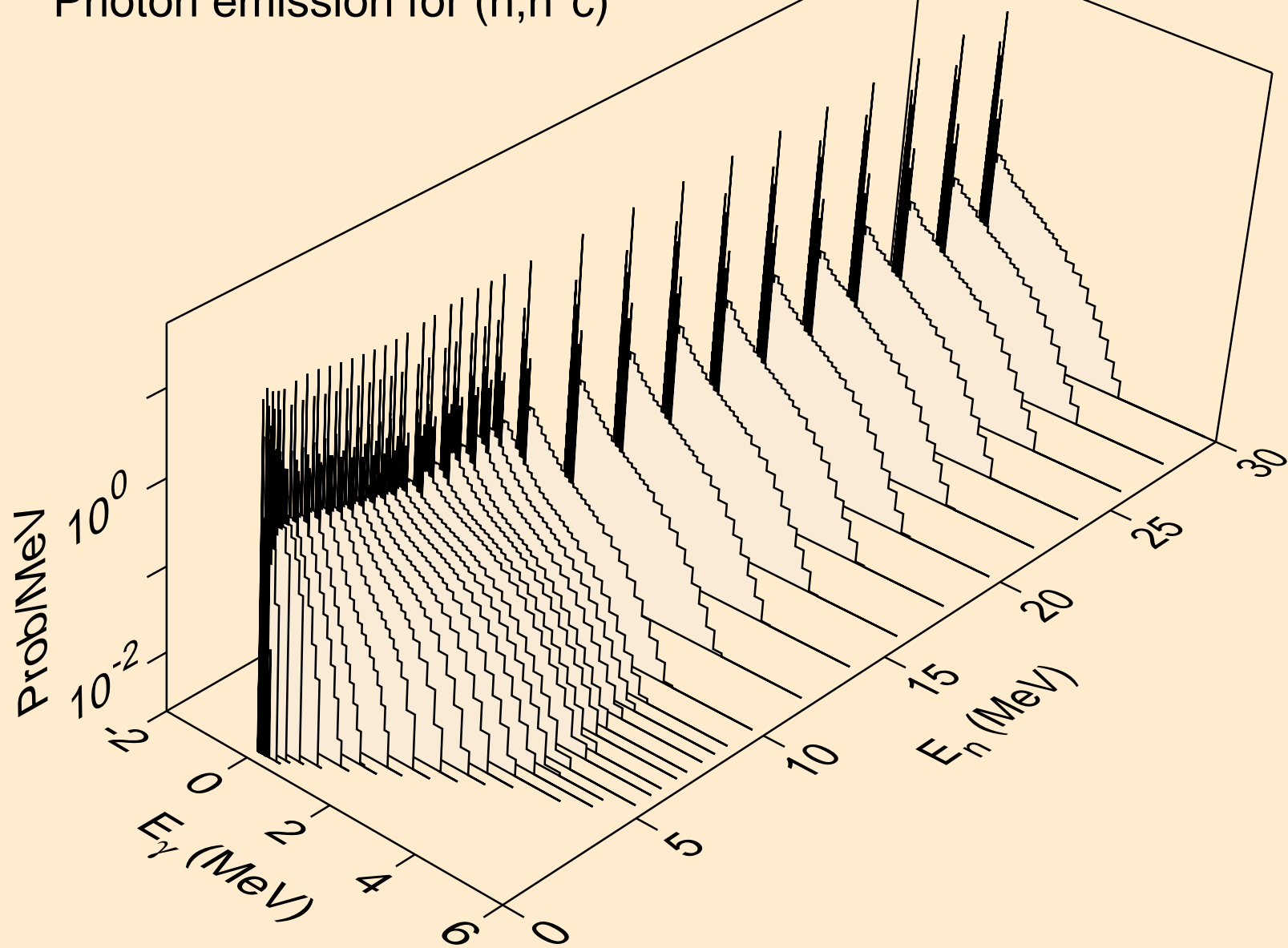

PA240 NEUTRON ACER TENDL-2023 LIBRARY; T=0.K  
Photon emission for (n,gma)

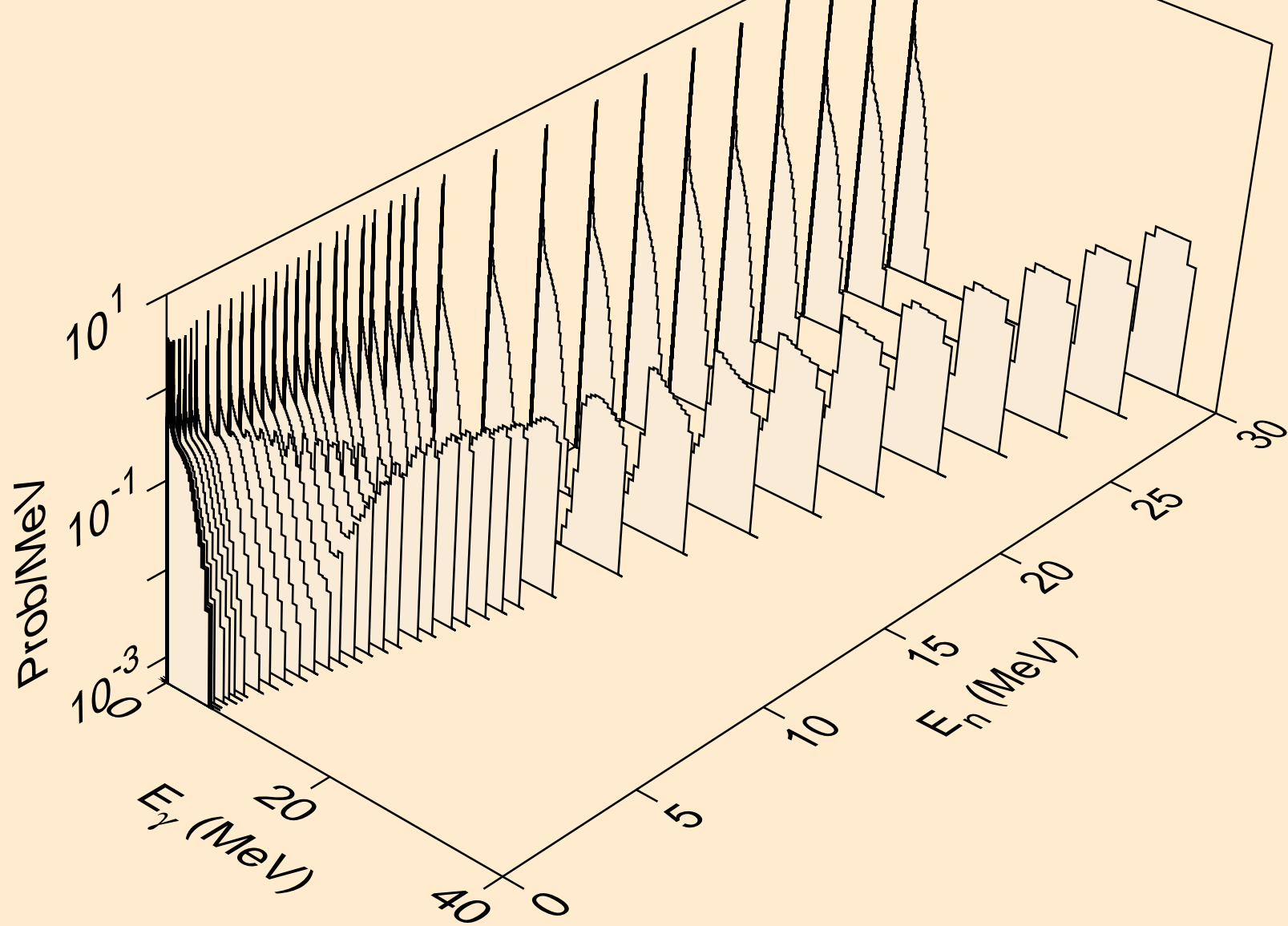

PA240 NEUTRON ACER TENDL-2023 LIBRARY; T=0.K  
Photon emission for (n,p)

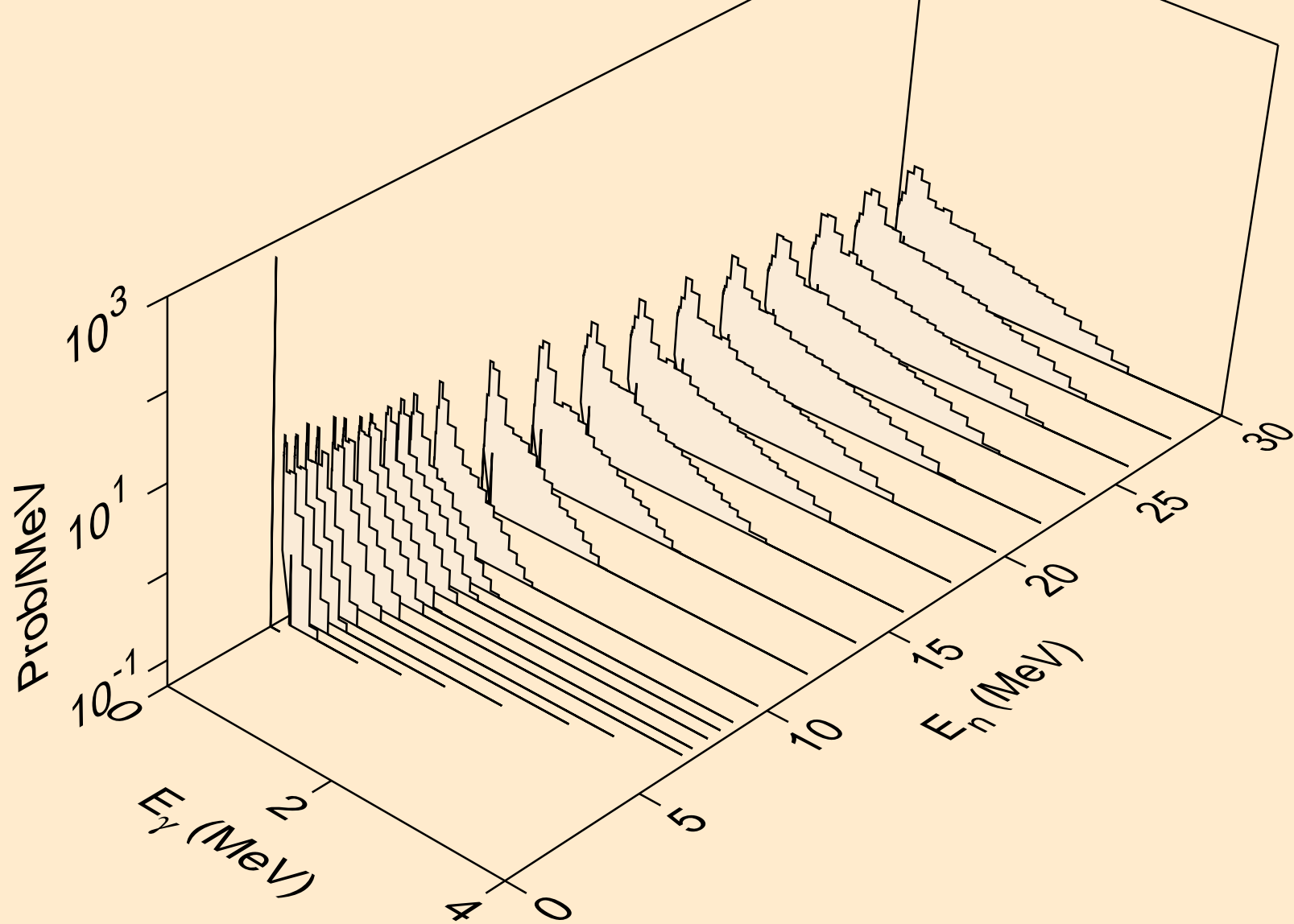

PA240 NEUTRON ACER TENDL-2023 LIBRARY; T=0.K  
Photon emission for (n,d)

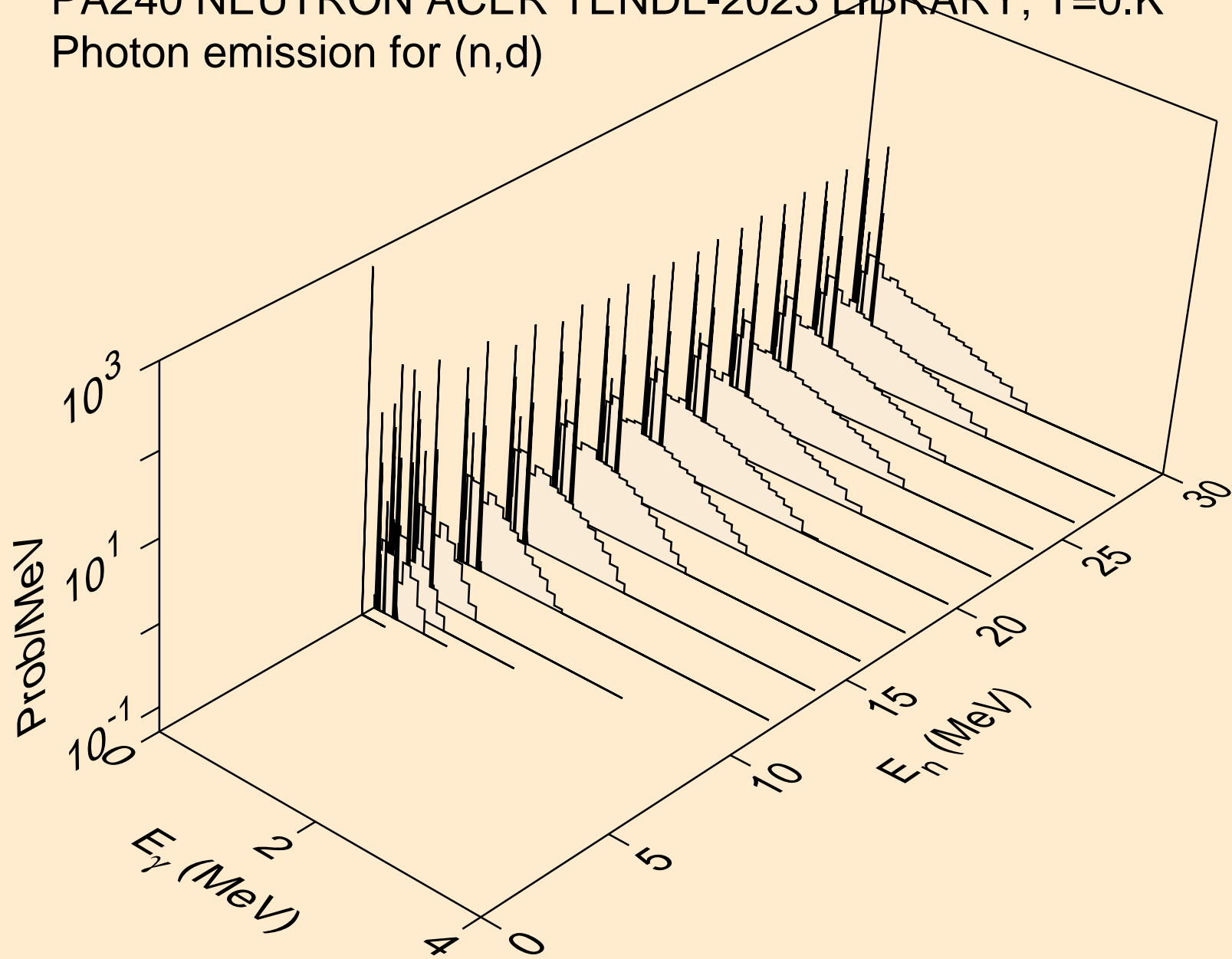

PA240 NEUTRON ACER TENDL-2023 LIBRARY; T=0.K  
Photon emission for (n,t)

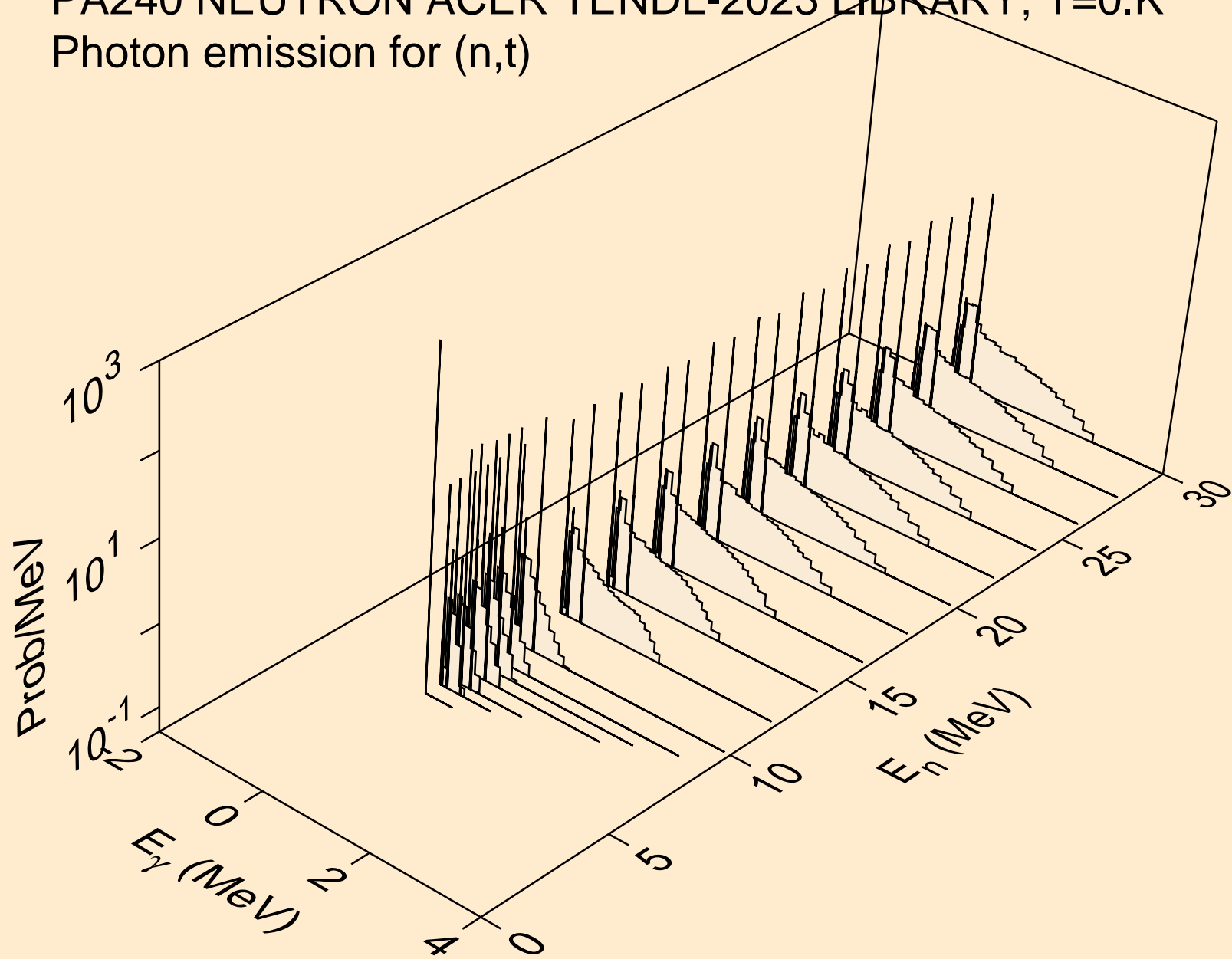

PA240 NEUTRON ACER TENDL-2023 LIBRARY; T=0.K  
Photon emission for (n,he3)

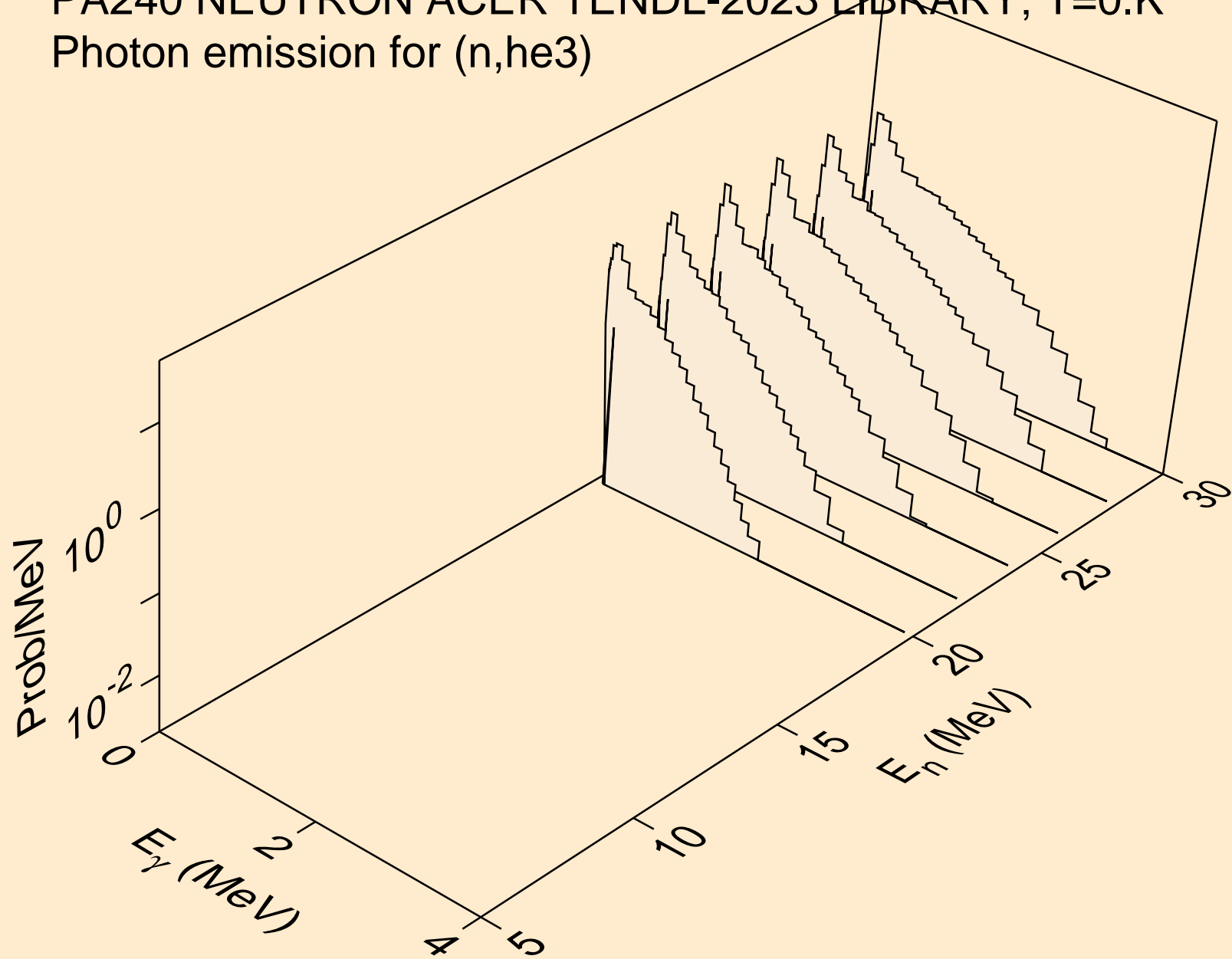



PA240 NEUTRON ACER TENDL-2023 LIBRARY; T=0.K  
Photon emission for (n,a)

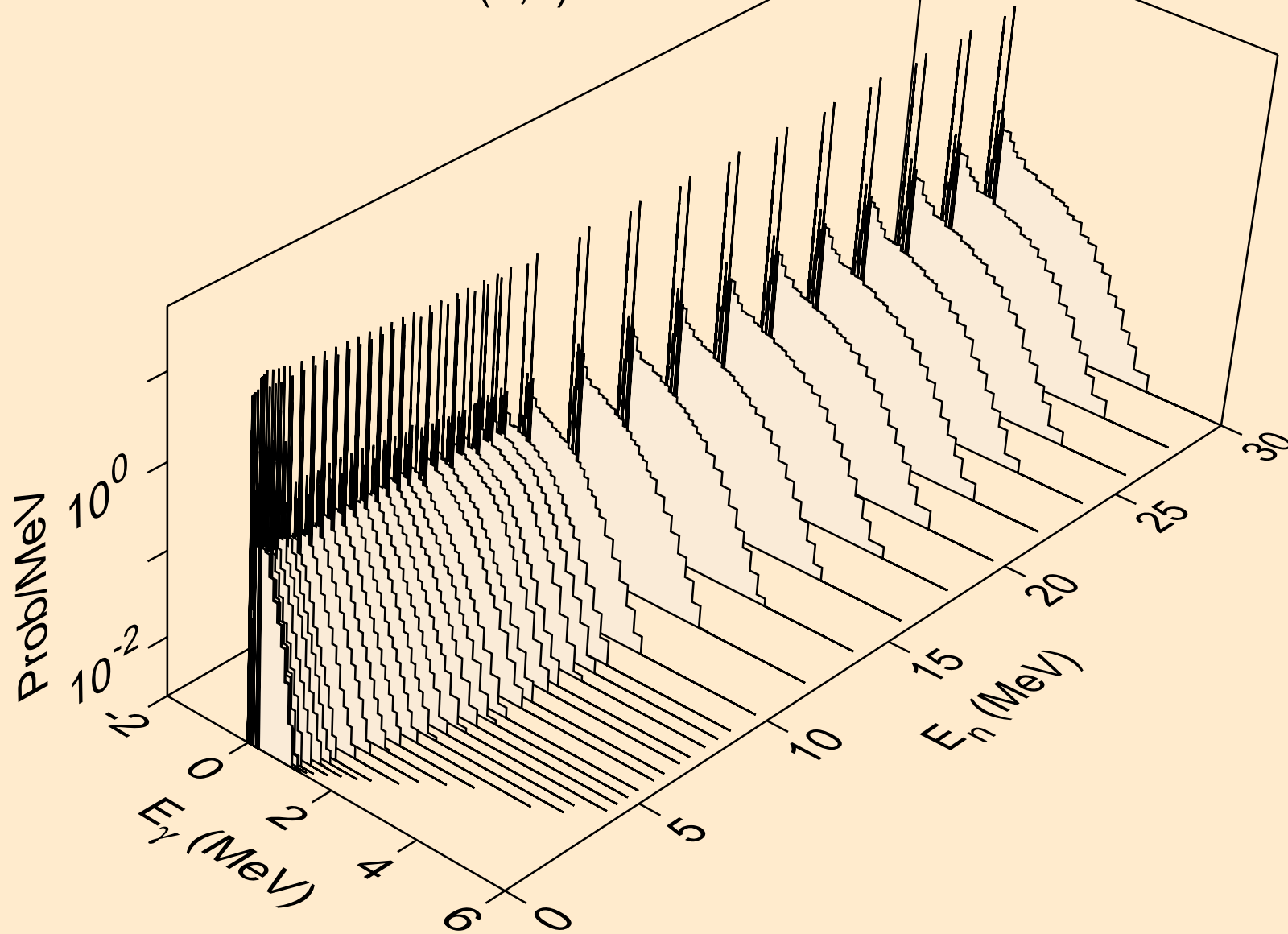

PA240 NEUTRON ACER TENDL-2023 LIBRARY; T=0.K  
Photon emission for (n,2p)

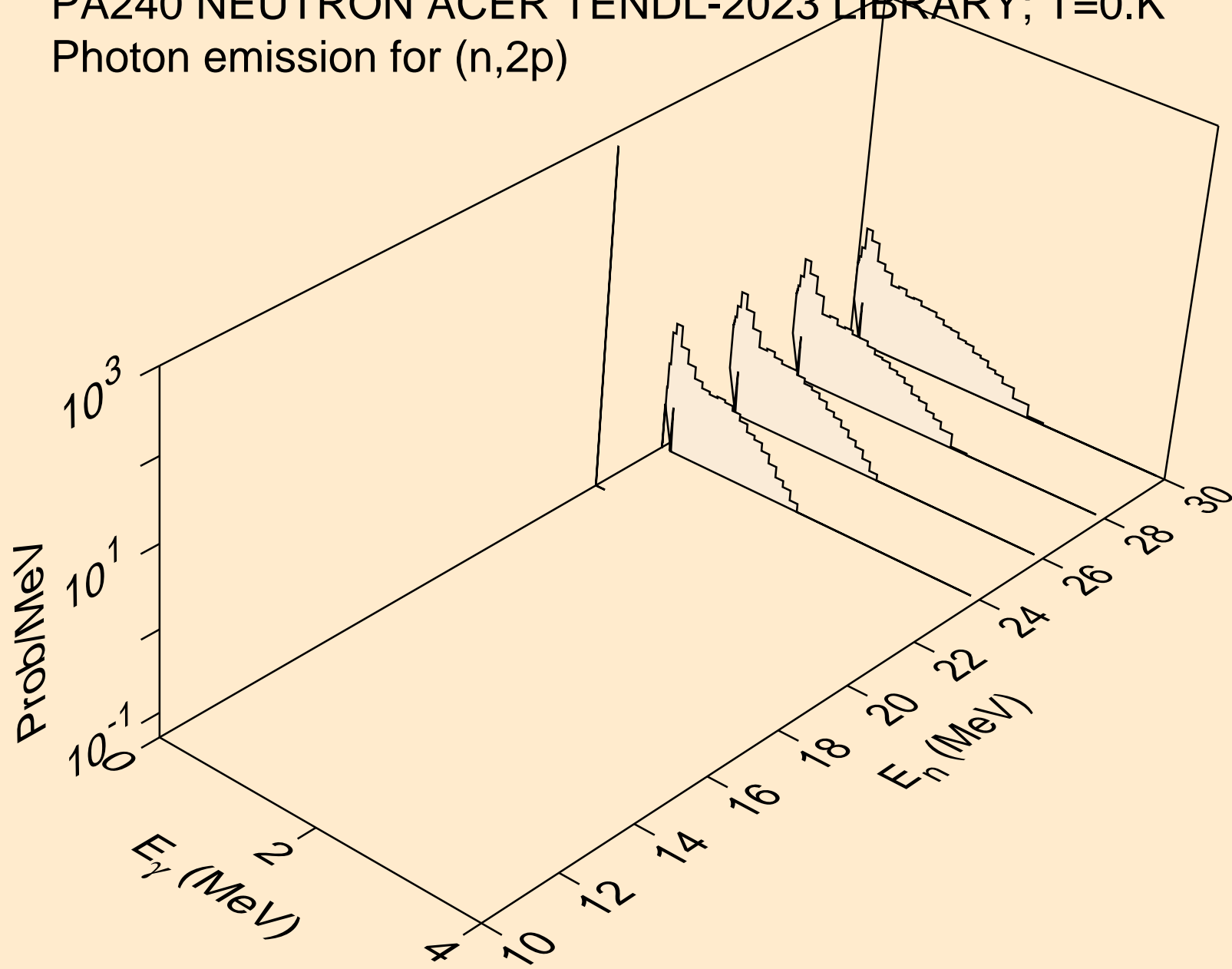

PA240 NEUTRON ACER TENDL-2023 LIBRARY; T=0.K  
thermal capture photon spectrum

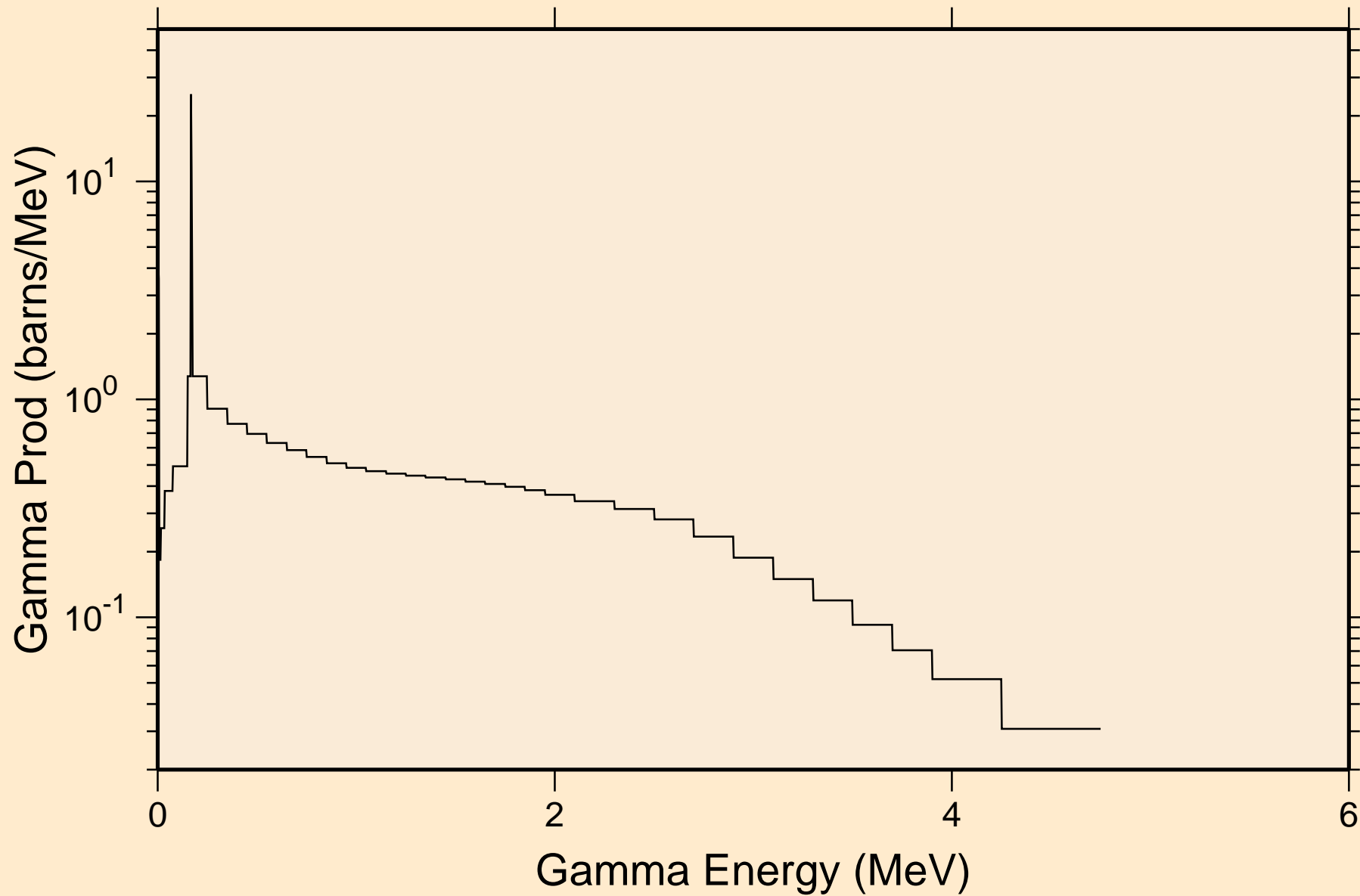

PA240 NEUTRON ACER TENDL-2023 LIBRARY; T=0.K  
14 MeV photon spectrum

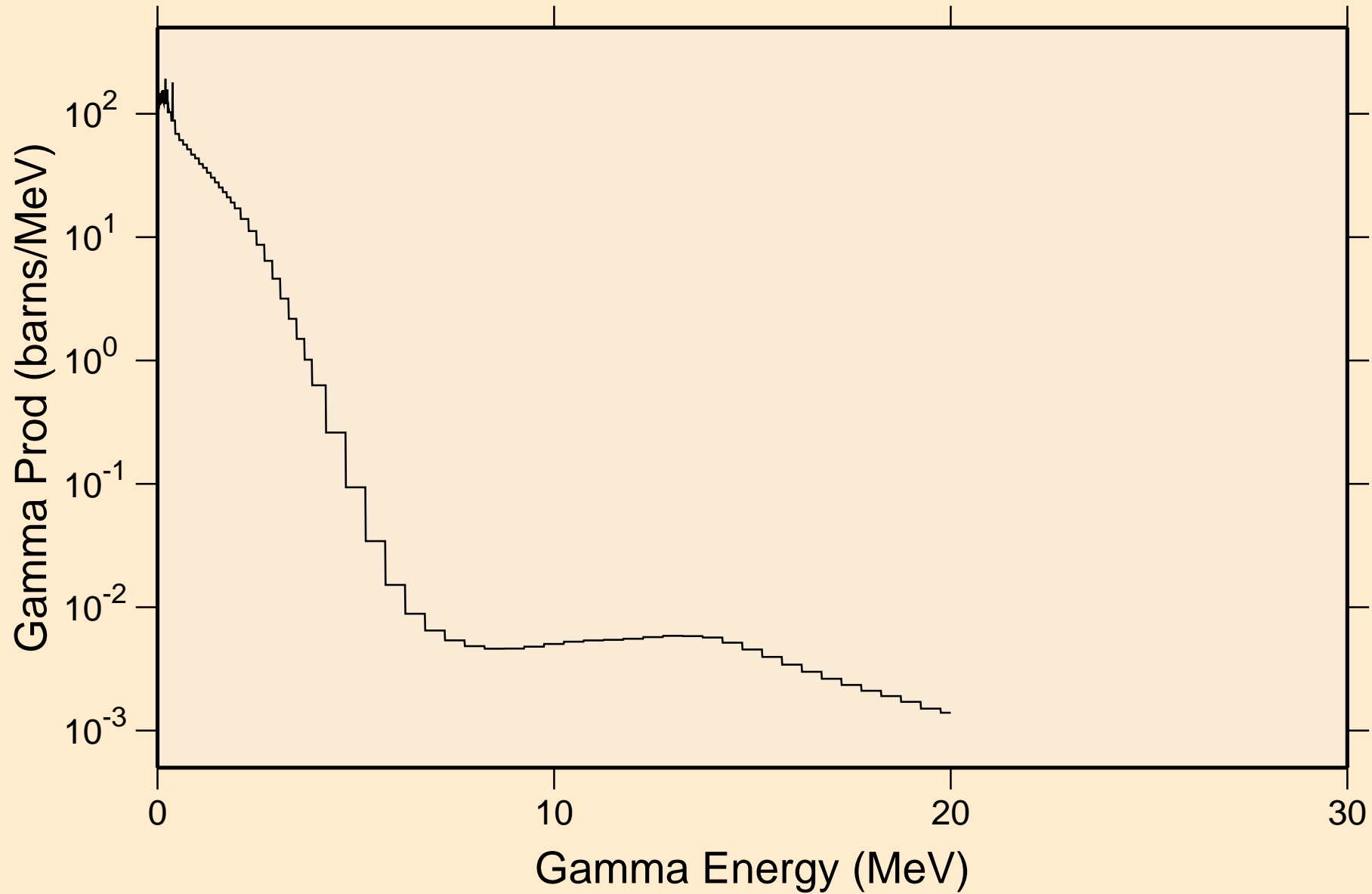

PA240 NEUTRON ACER TENDL-2023 LIBRARY; T=0.K  
Particle heating contributions

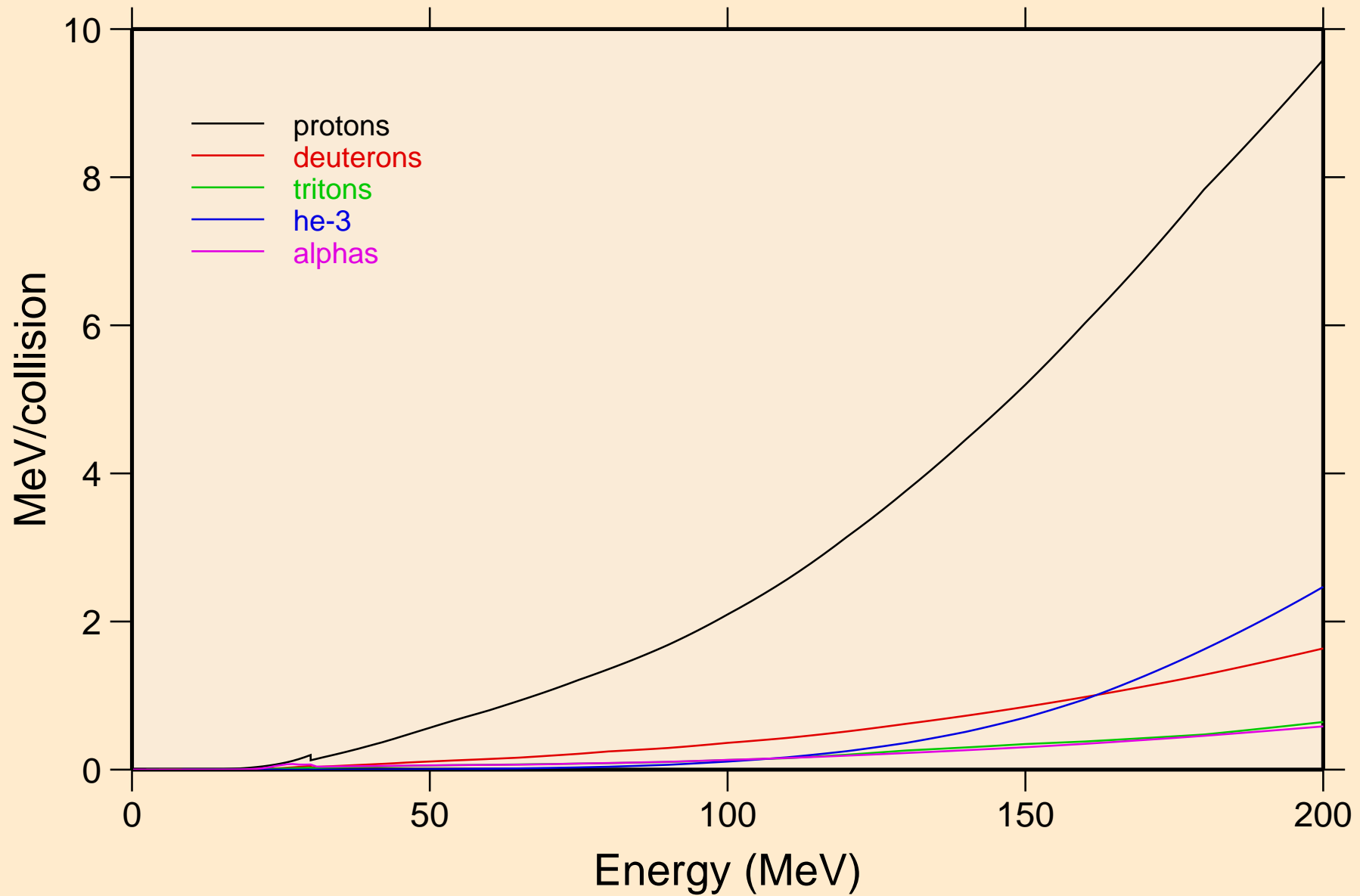

PA240 NEUTRON ACER TENDL-2023 LIBRARY; T=0.K  
Recoil Heating

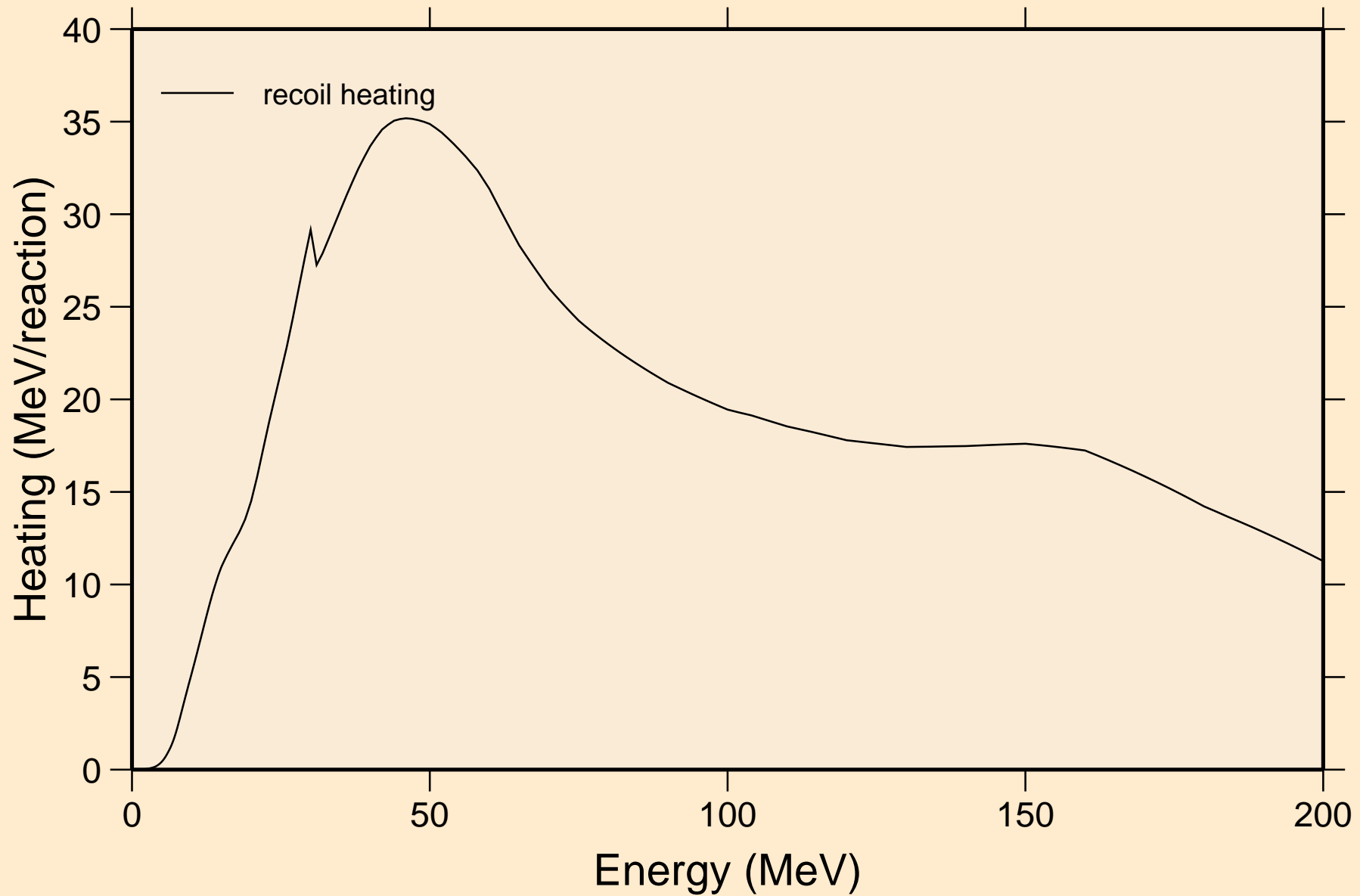

# PA240 NEUTRON ACER TENDL-2023 LIBRARY; T=0.K

## Particle production cross sections

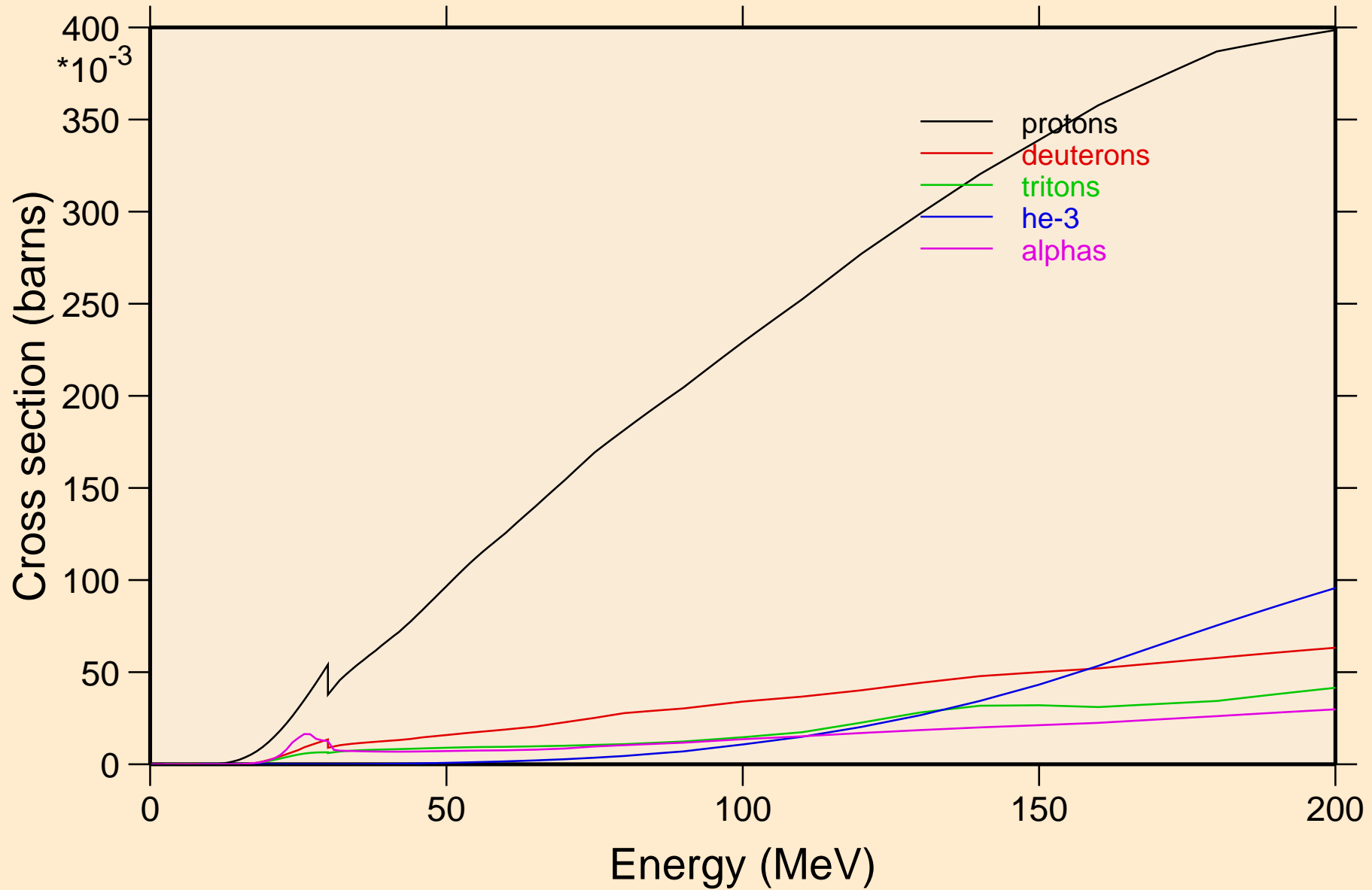

PA240 NEUTRON ACER TENDL-2023 LIBRARY; T=0.K  
protons from (n,x)

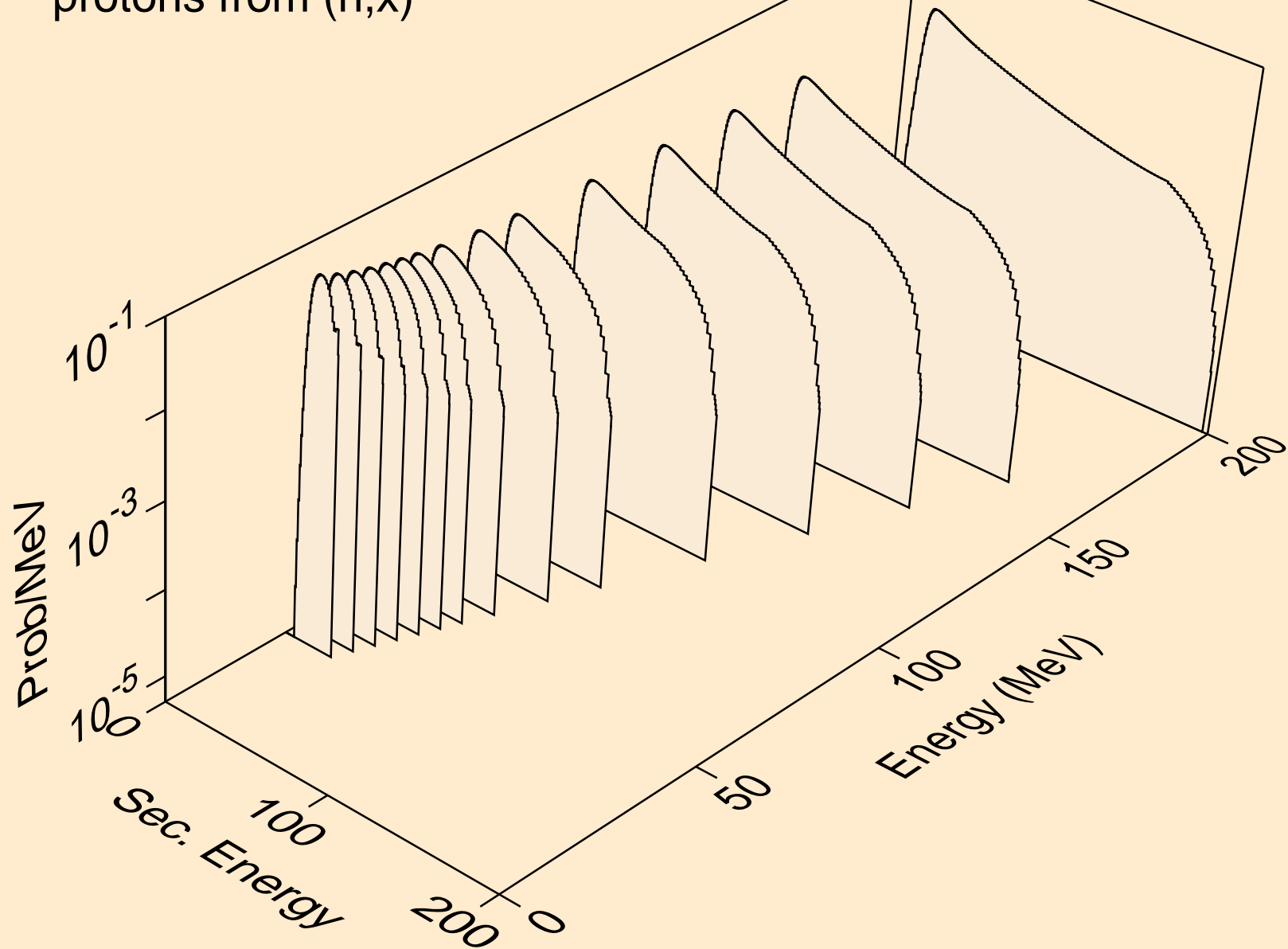



PA240 NEUTRON ACER TENDL-2023 LIBRARY; T=0.K  
protons from (n,n\*)p

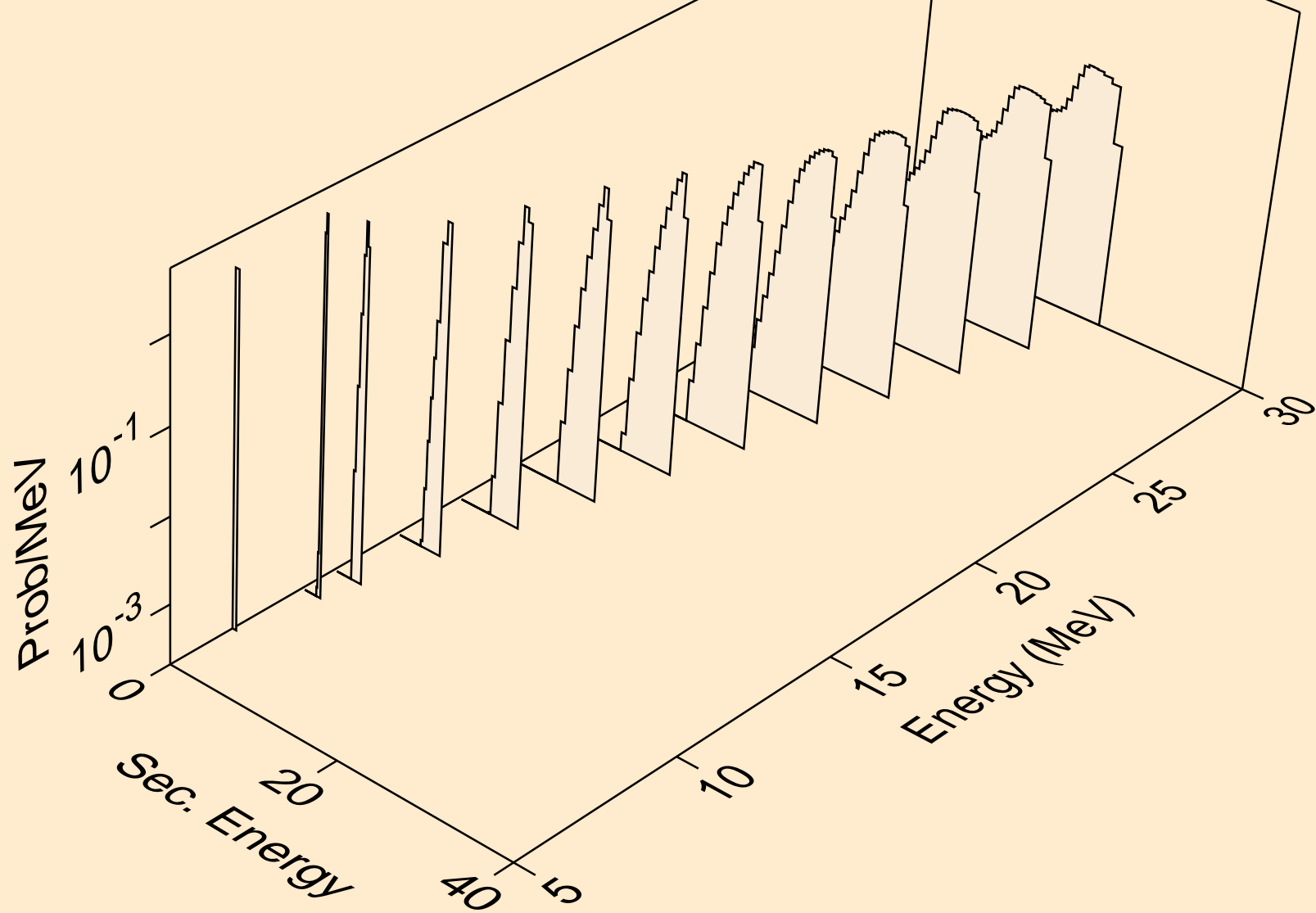

PA240 NEUTRON ACER TENDL-2023 LIBRARY; T=0.K  
protons from (n,2np)

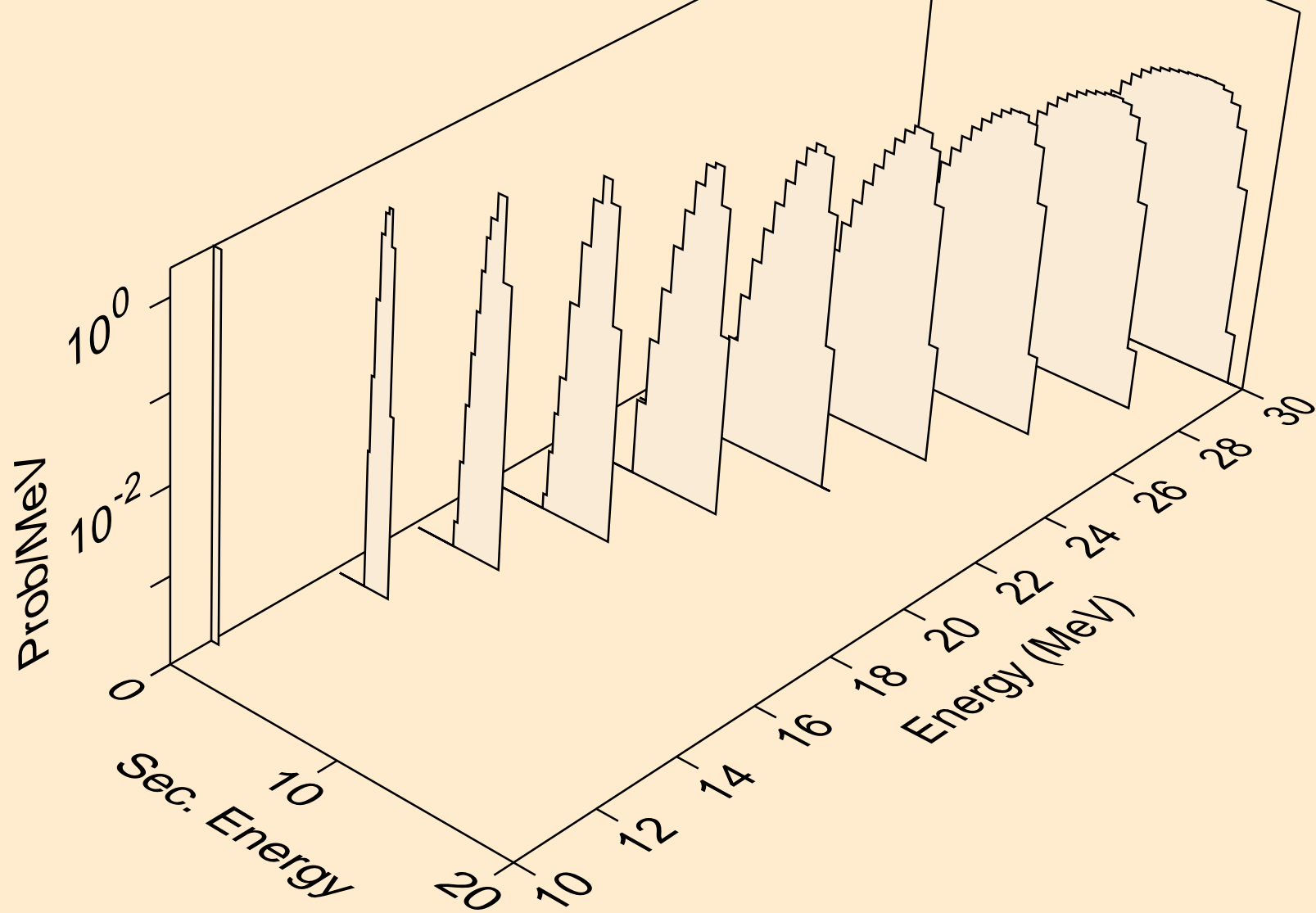

PA240 NEUTRON ACER TENDL-2023 LIBRARY; T=0.K  
protons from (n,3np)

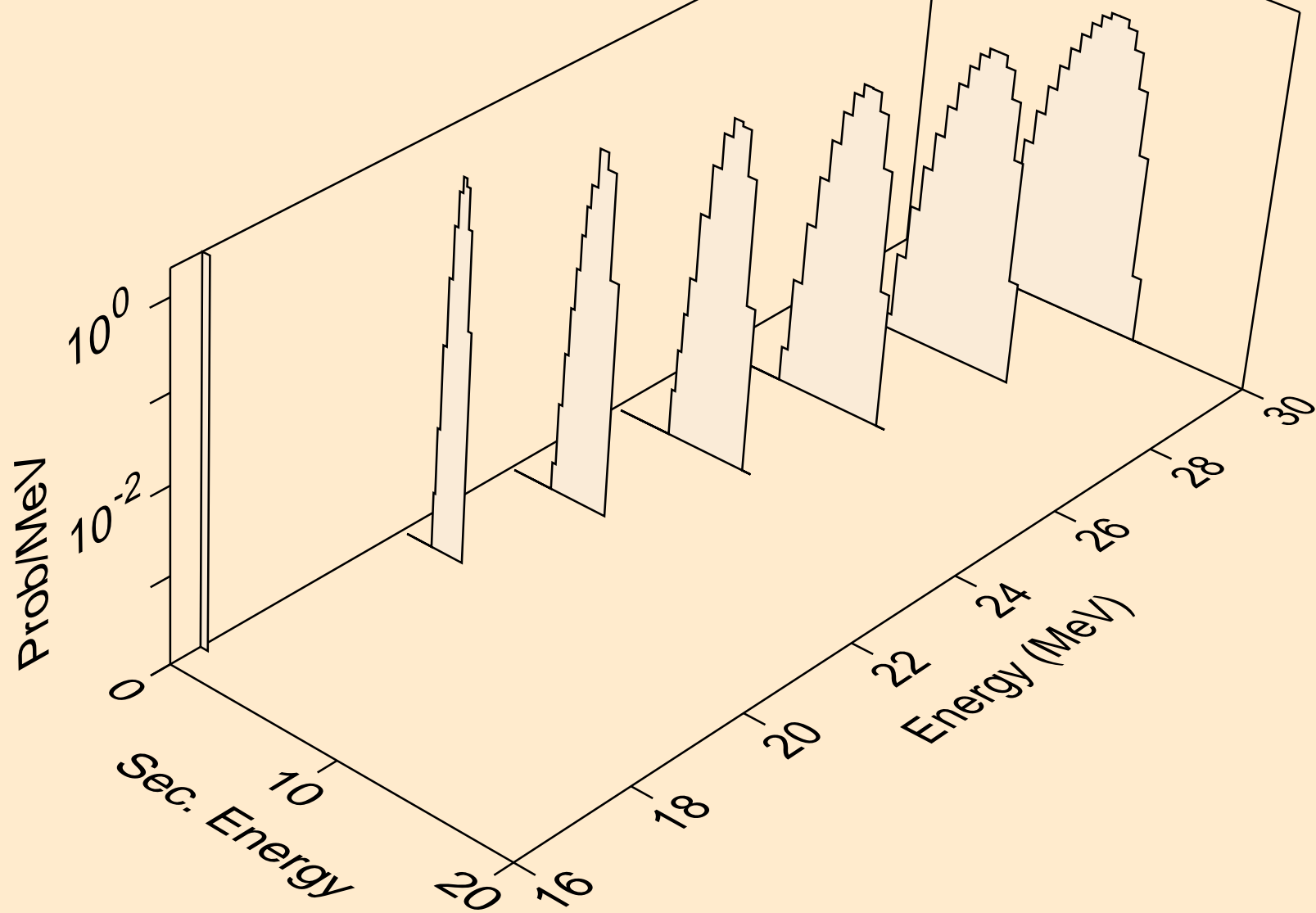

PA240 NEUTRON ACER TENDL-2023 LIBRARY; T=0.K  
protons from (n,p)

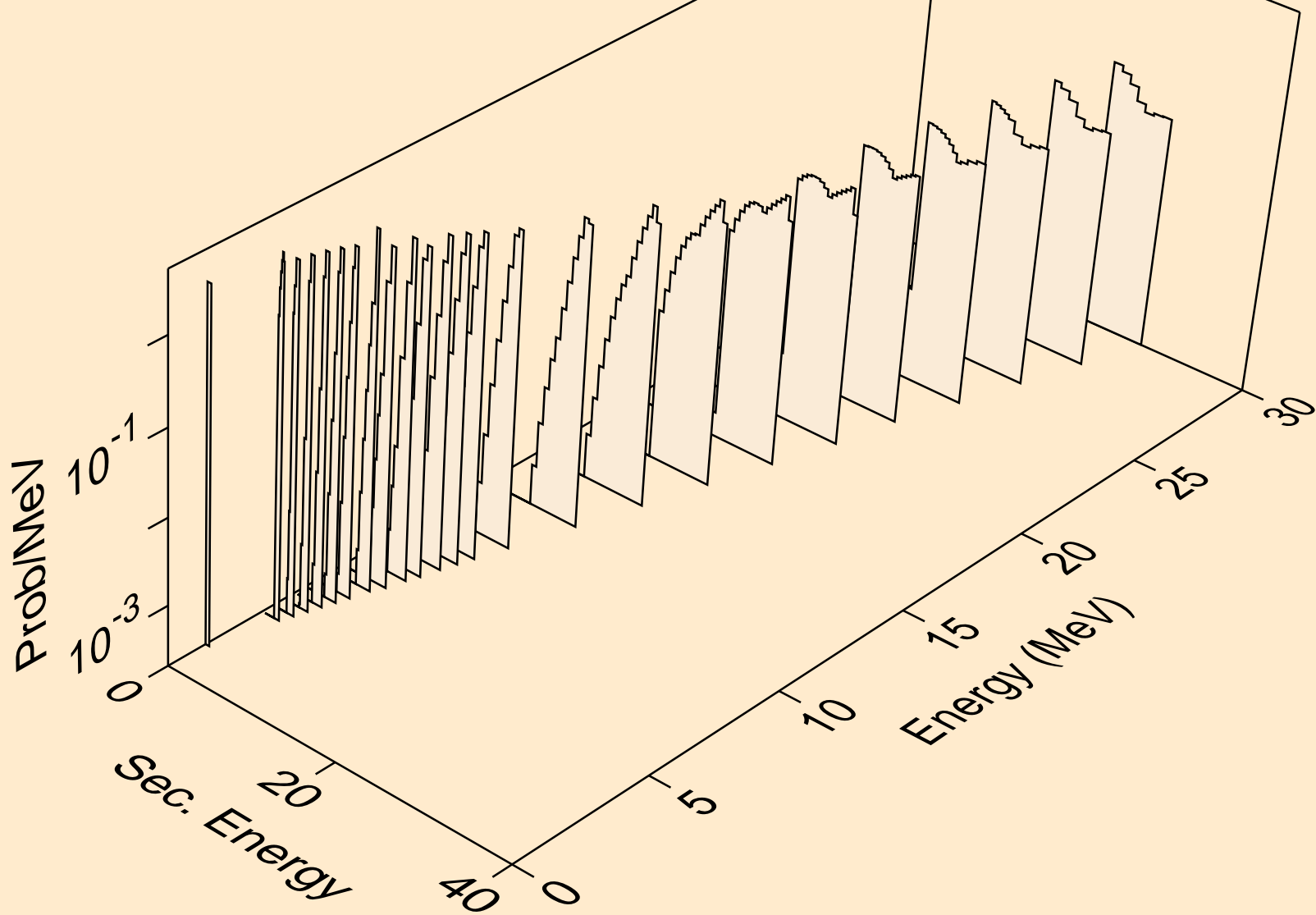

PA240 NEUTRON ACER TENDL-2023 LIBRARY; T=0.K  
protons from (n,2p)

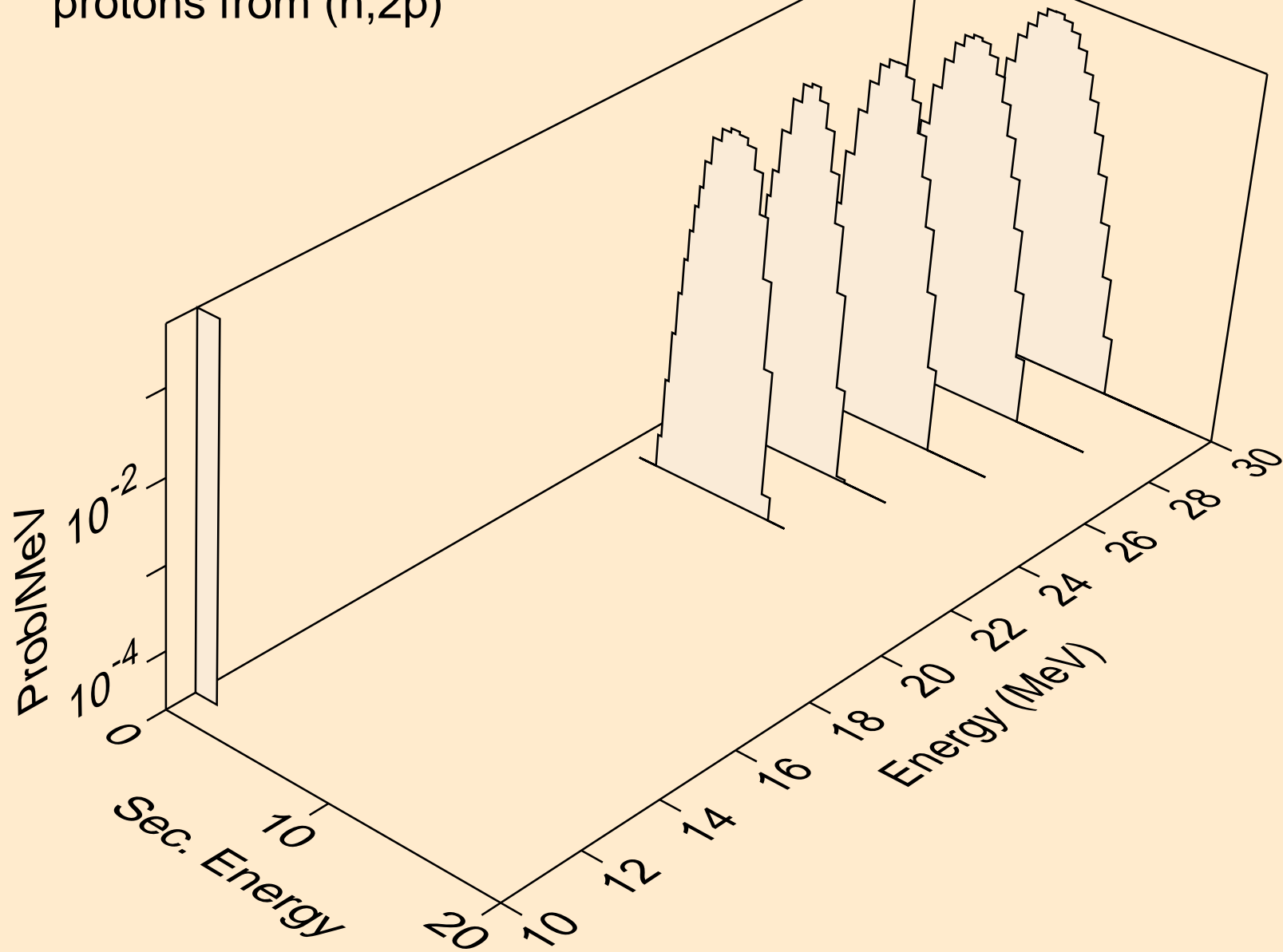

PA240 NEUTRON ACER TENDL-2023 LIBRARY; T=0.K  
deuterons from (n,x)

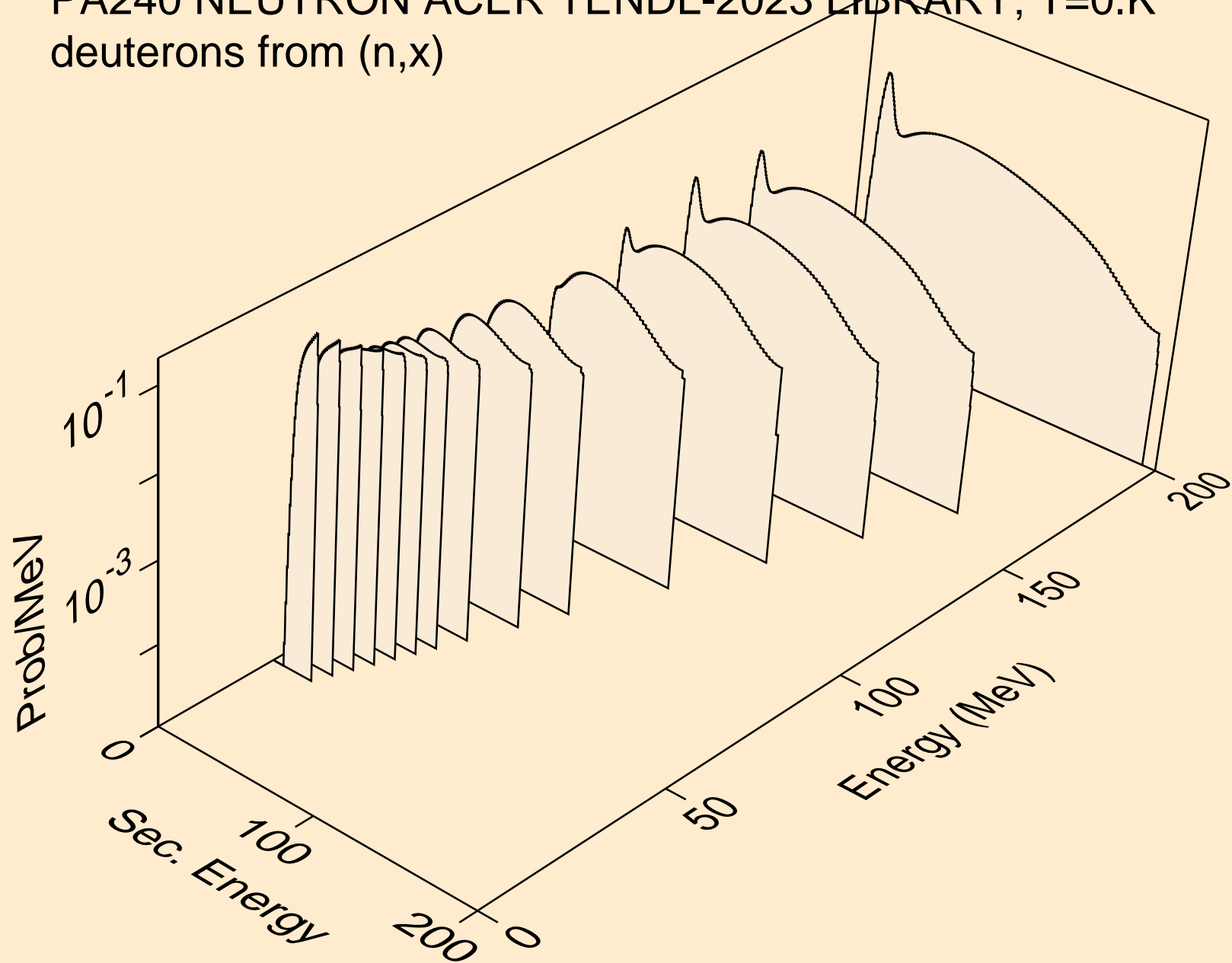

PA240 NEUTRON ACER TENDL-2023 LIBRARY; T=0.K  
deuterons from (n,2nd)

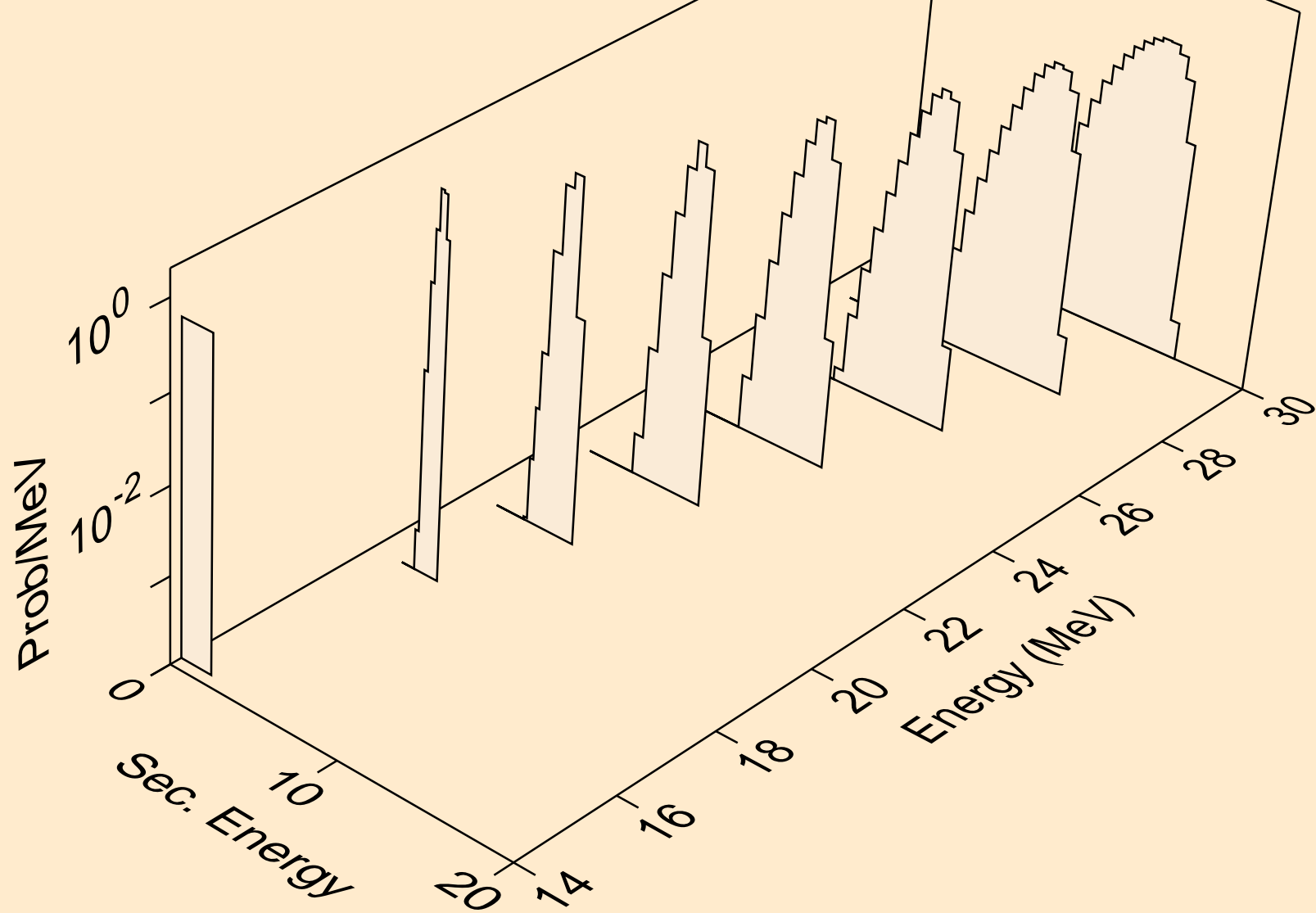

PA240 NEUTRON ACER TENDL-2023 LIBRARY; T=0.K  
deuterons from (n,n\*)d

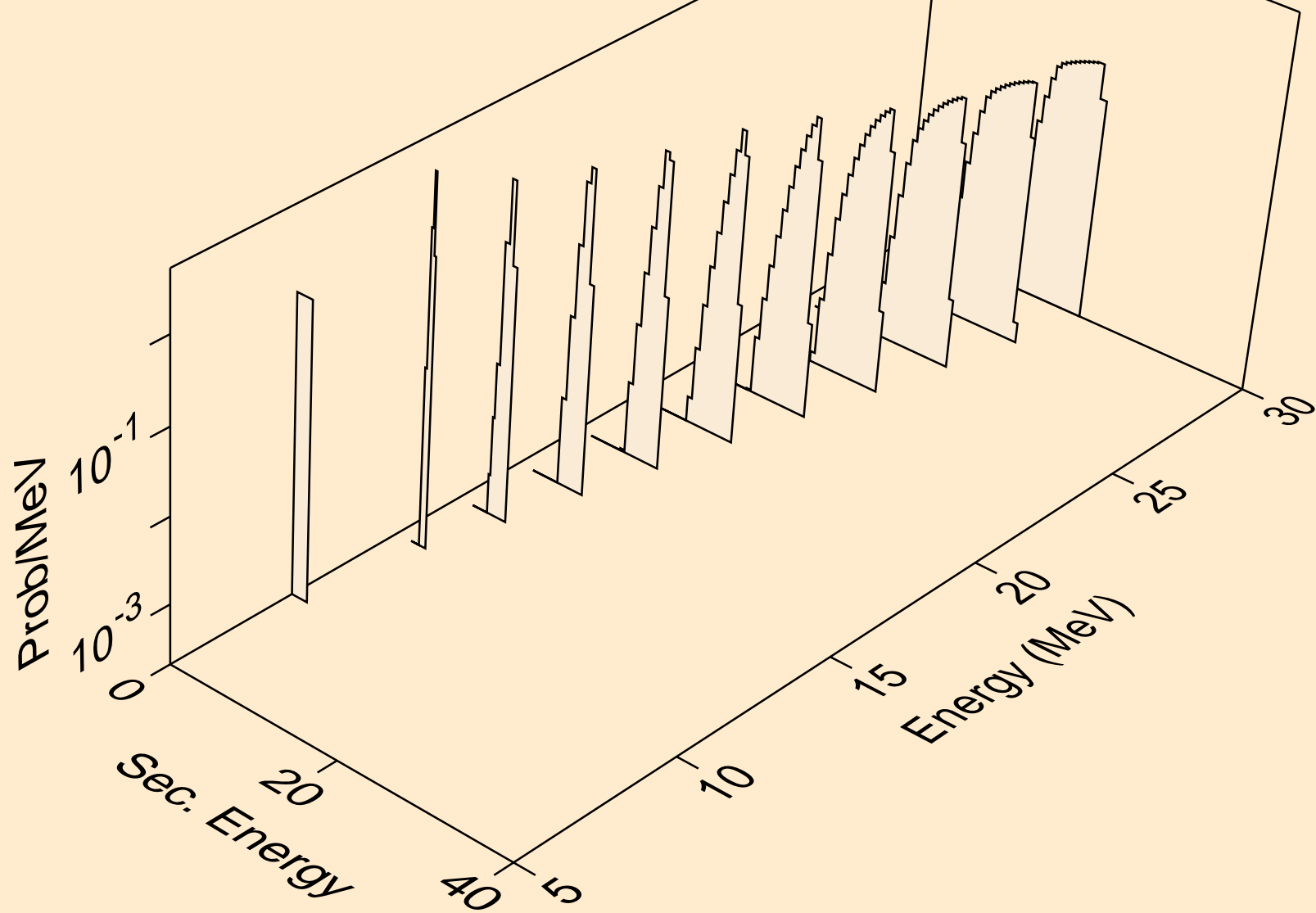



PA240 NEUTRON ACER TENDL-2023 LIBRARY; T=0.K  
deuterons from (n,d)

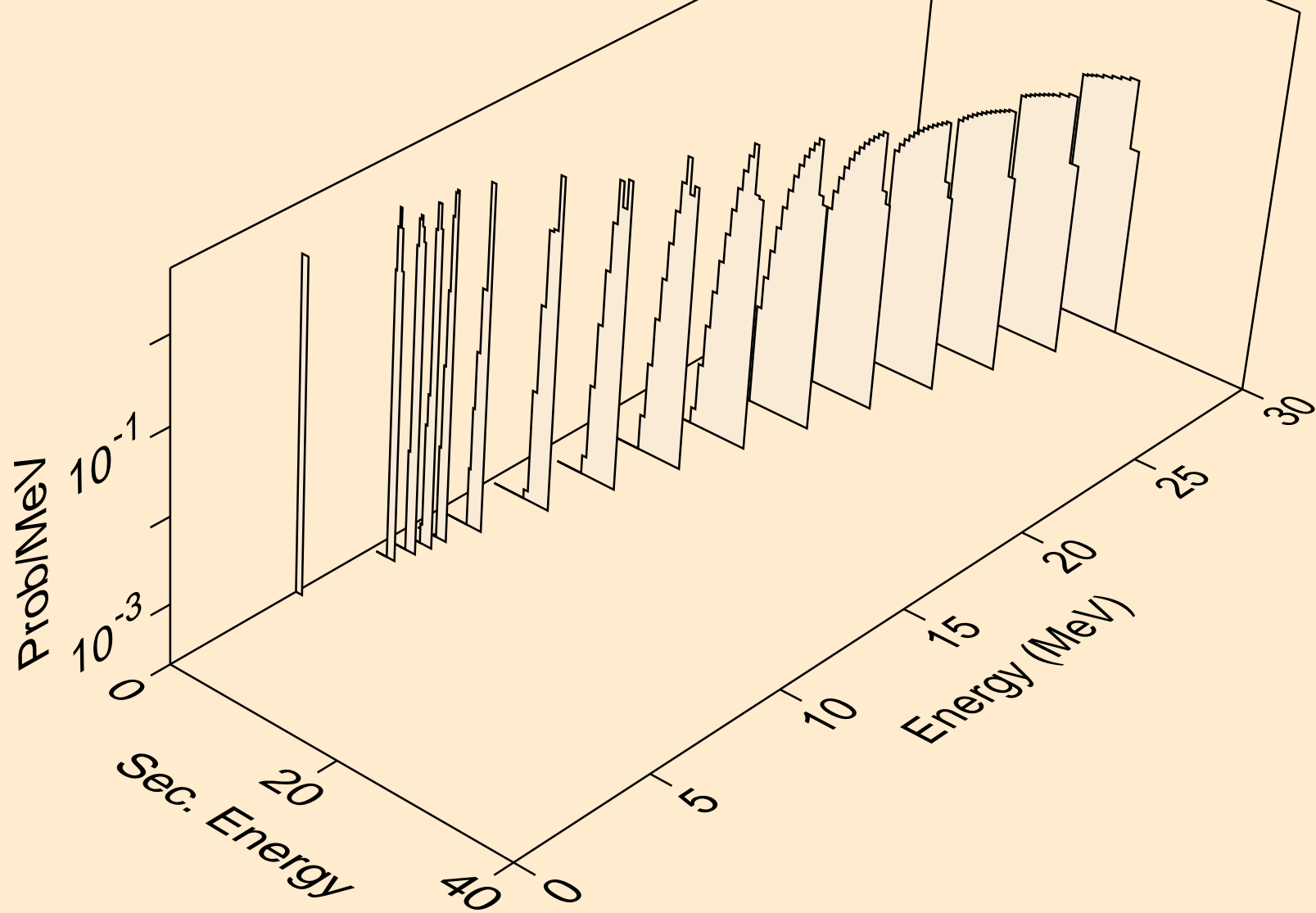

PA240 NEUTRON ACER TENDL-2023 LIBRARY; T=0.K  
tritons from (n,x)

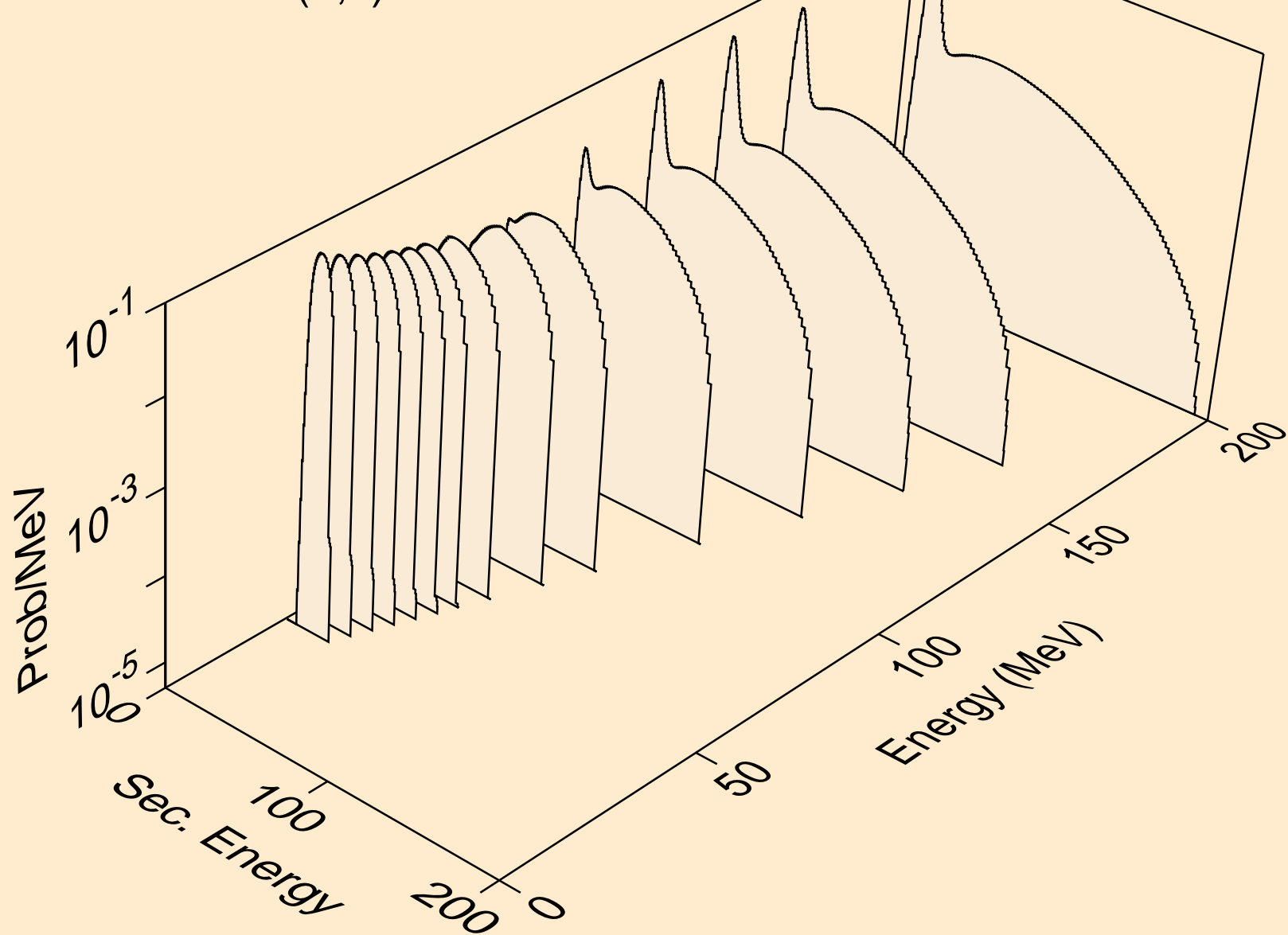

PA240 NEUTRON ACER TENDL-2023 LIBRARY; T=0.K  
tritons from (n,n\*)t

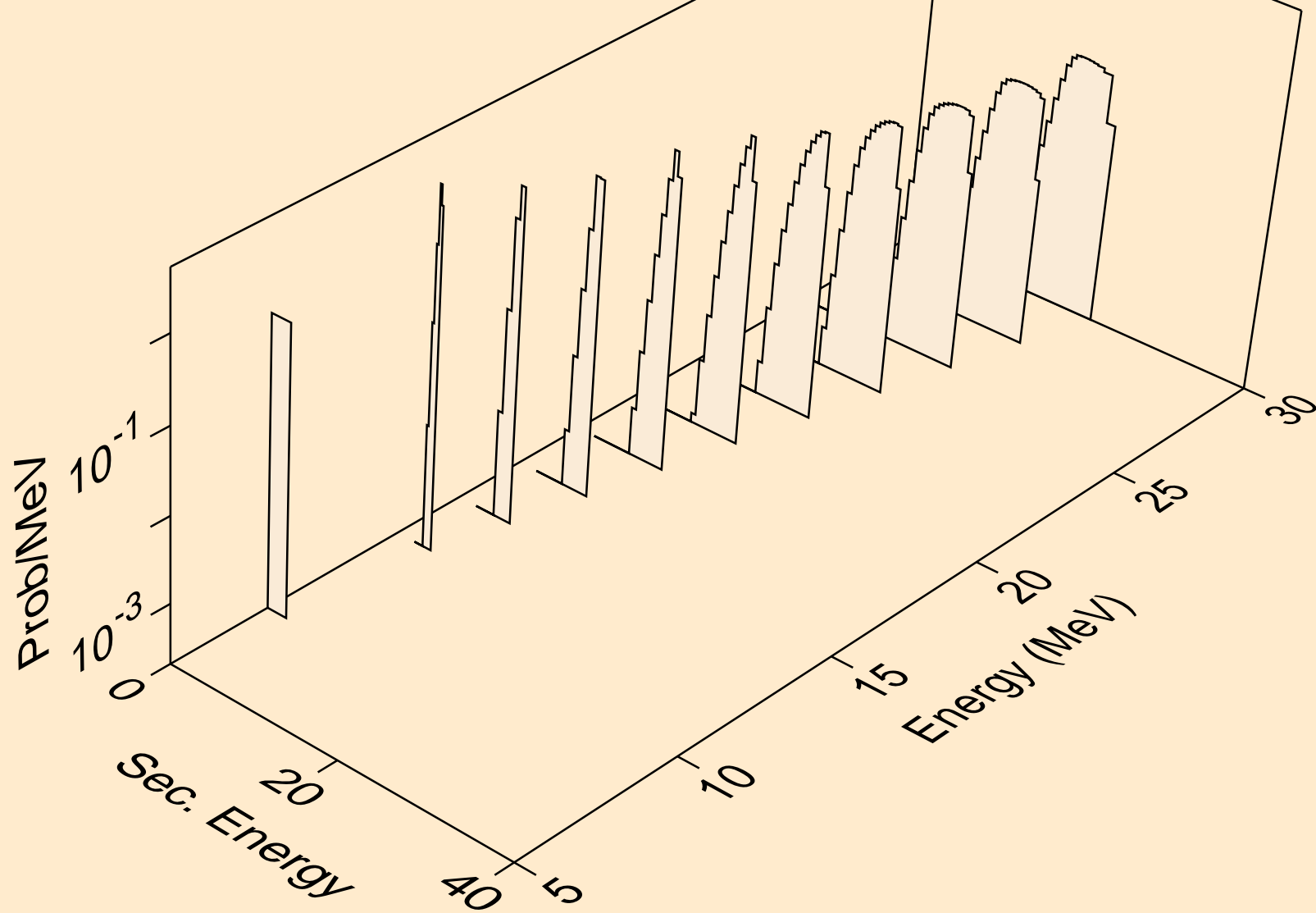

PA240 NEUTRON ACER TENDL-2023 LIBRARY; T=0.K  
tritons from (n,t)

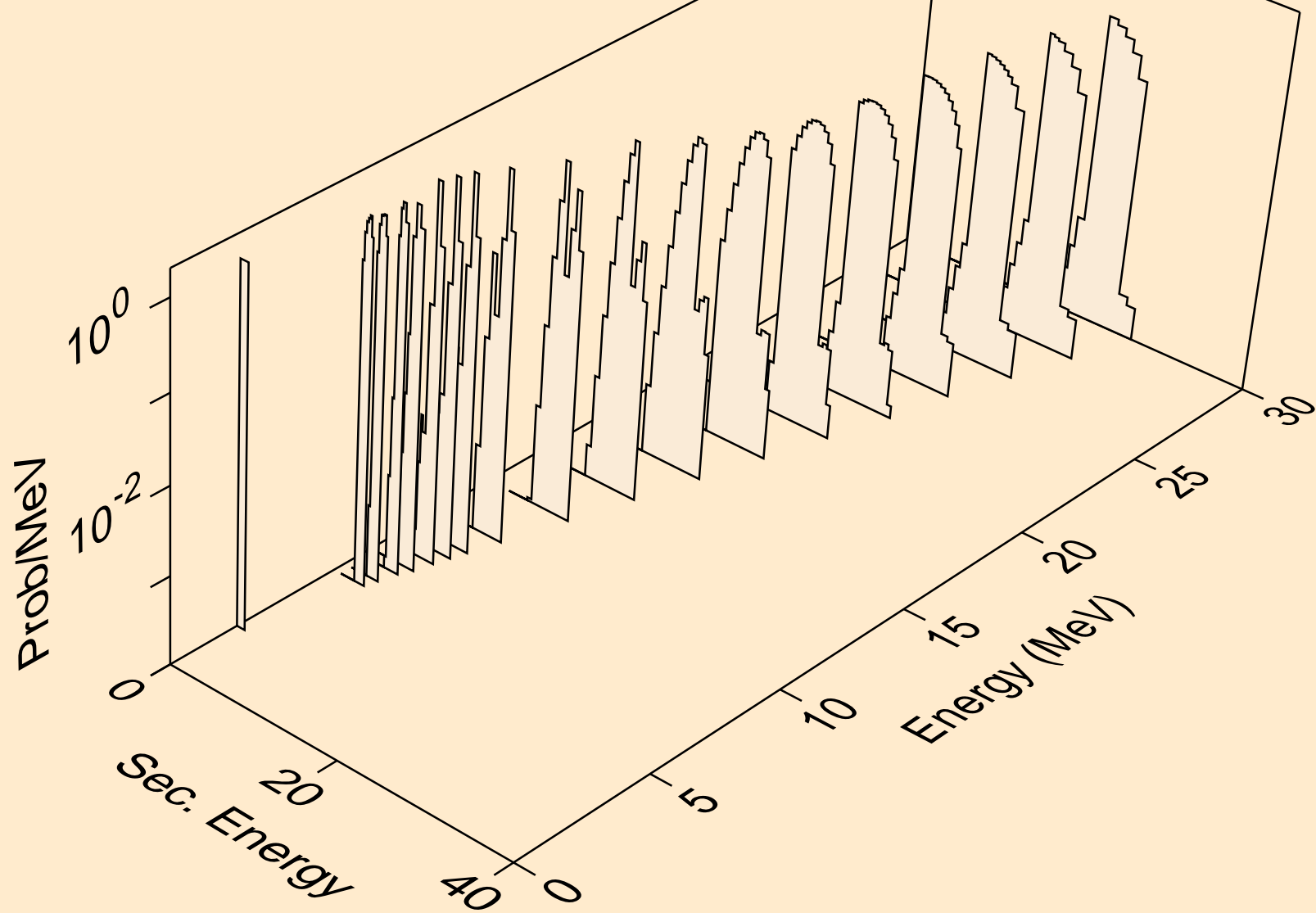

PA240 NEUTRON ACER TENDL-2023 LIBRARY; T=0.K  
he3s from (n,x)

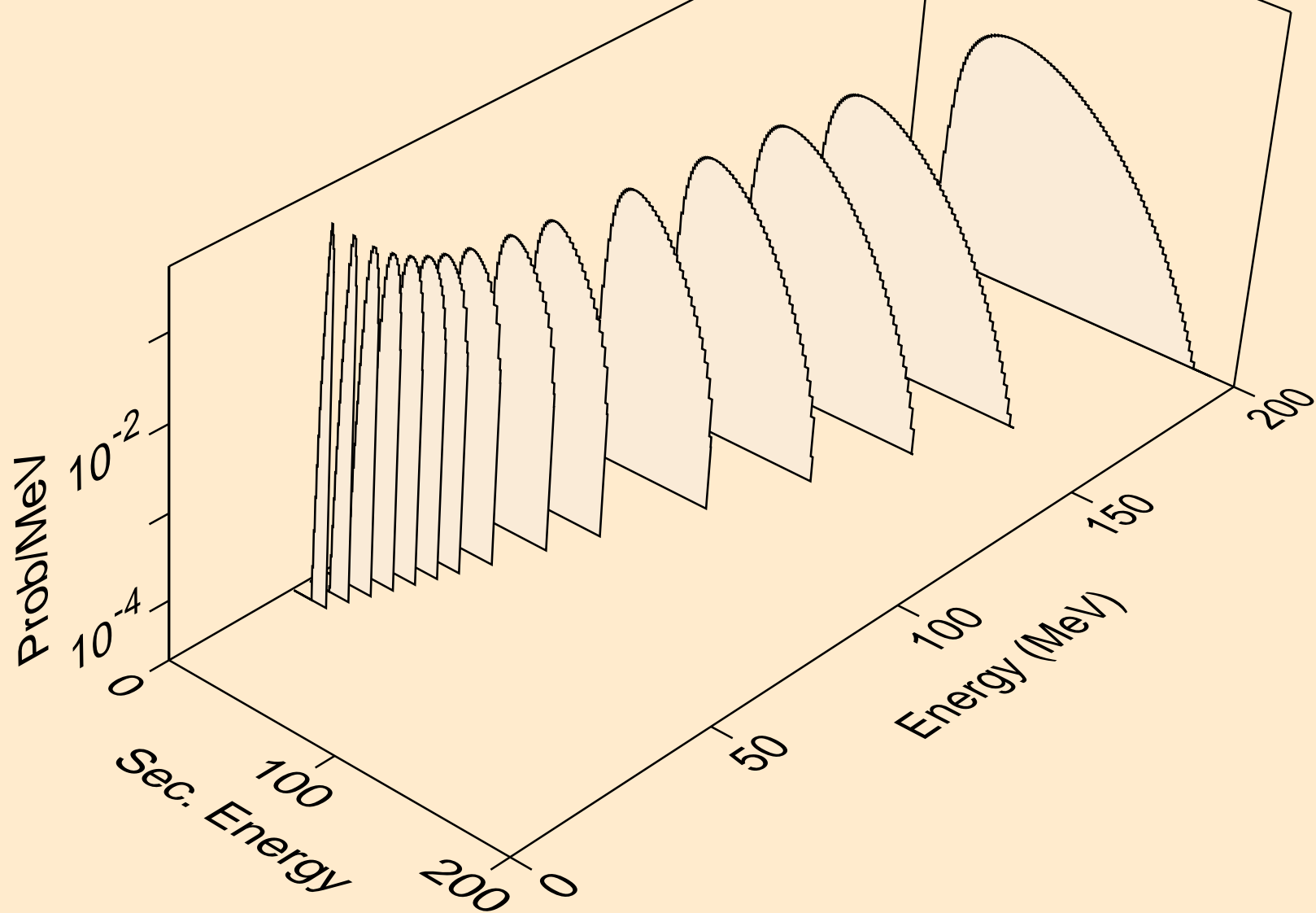

PA240 NEUTRON ACER TENDL-2023 LIBRARY; T=0.K  
he3s from (n,n\*)he3

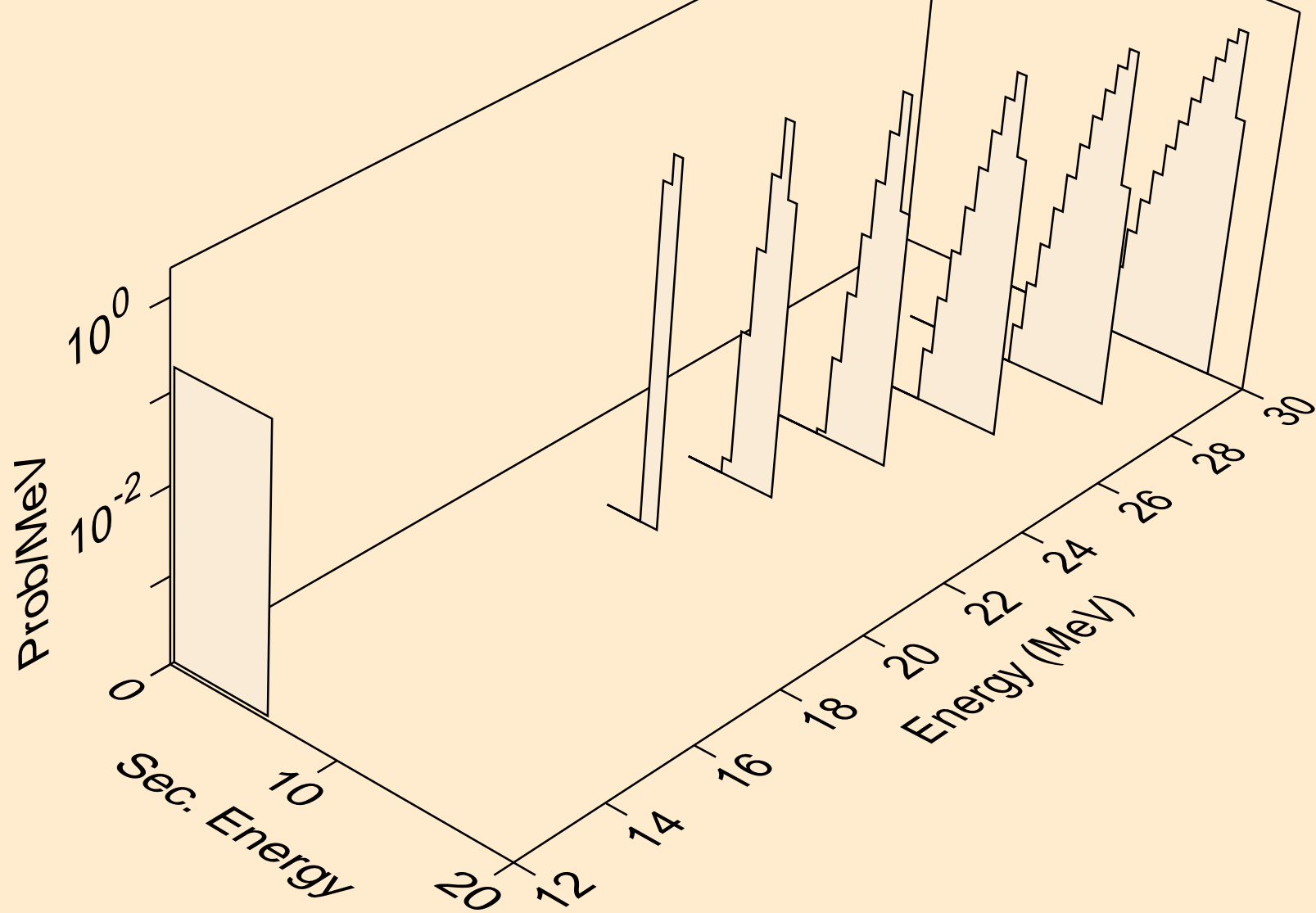

PA240 NEUTRON ACER TENDL-2023 LIBRARY; T=0.K  
he3s from (n,he3)

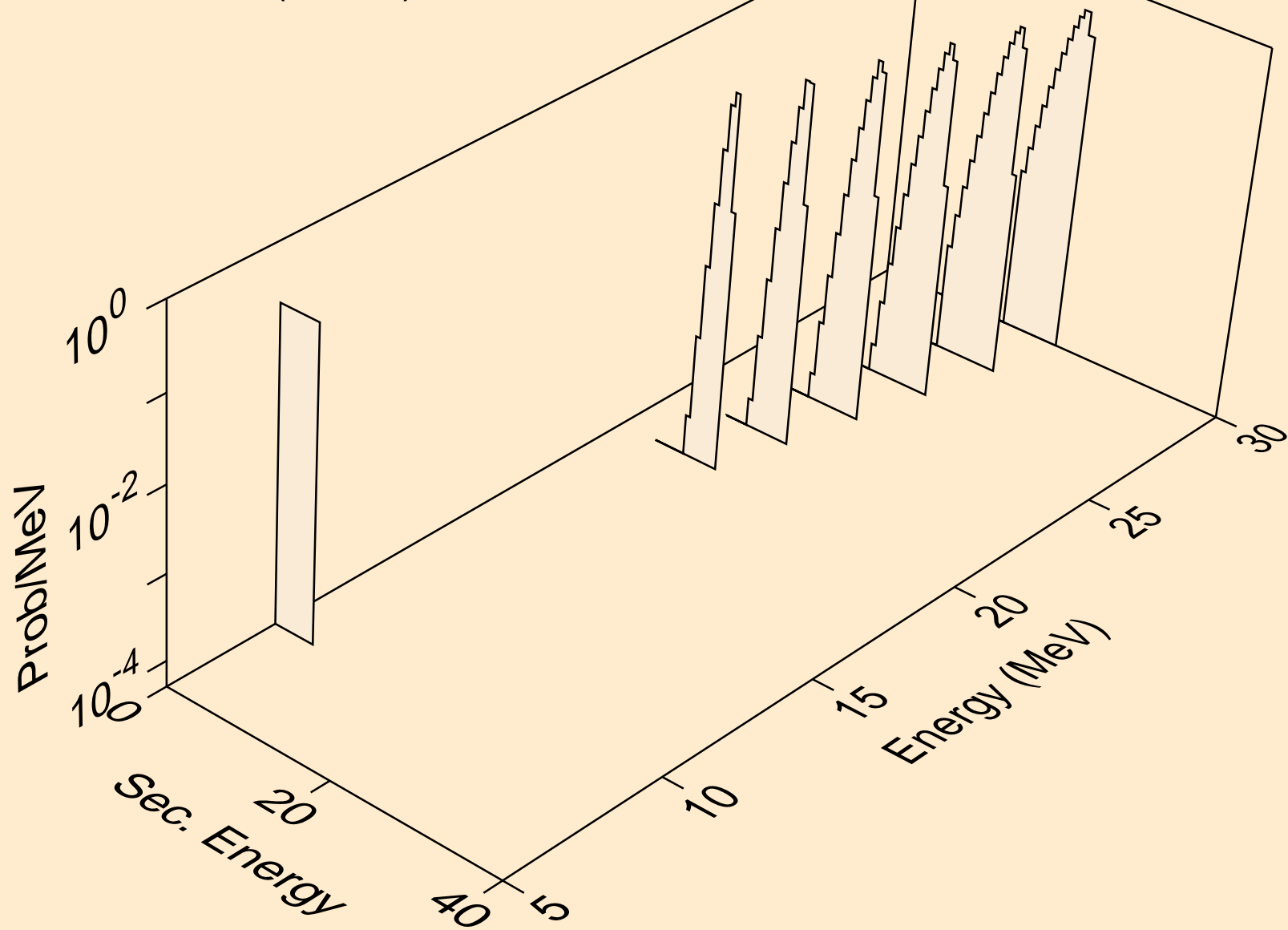

PA240 NEUTRON ACER TENDL-2023 LIBRARY; T=0.K  
alphas from (n,x)

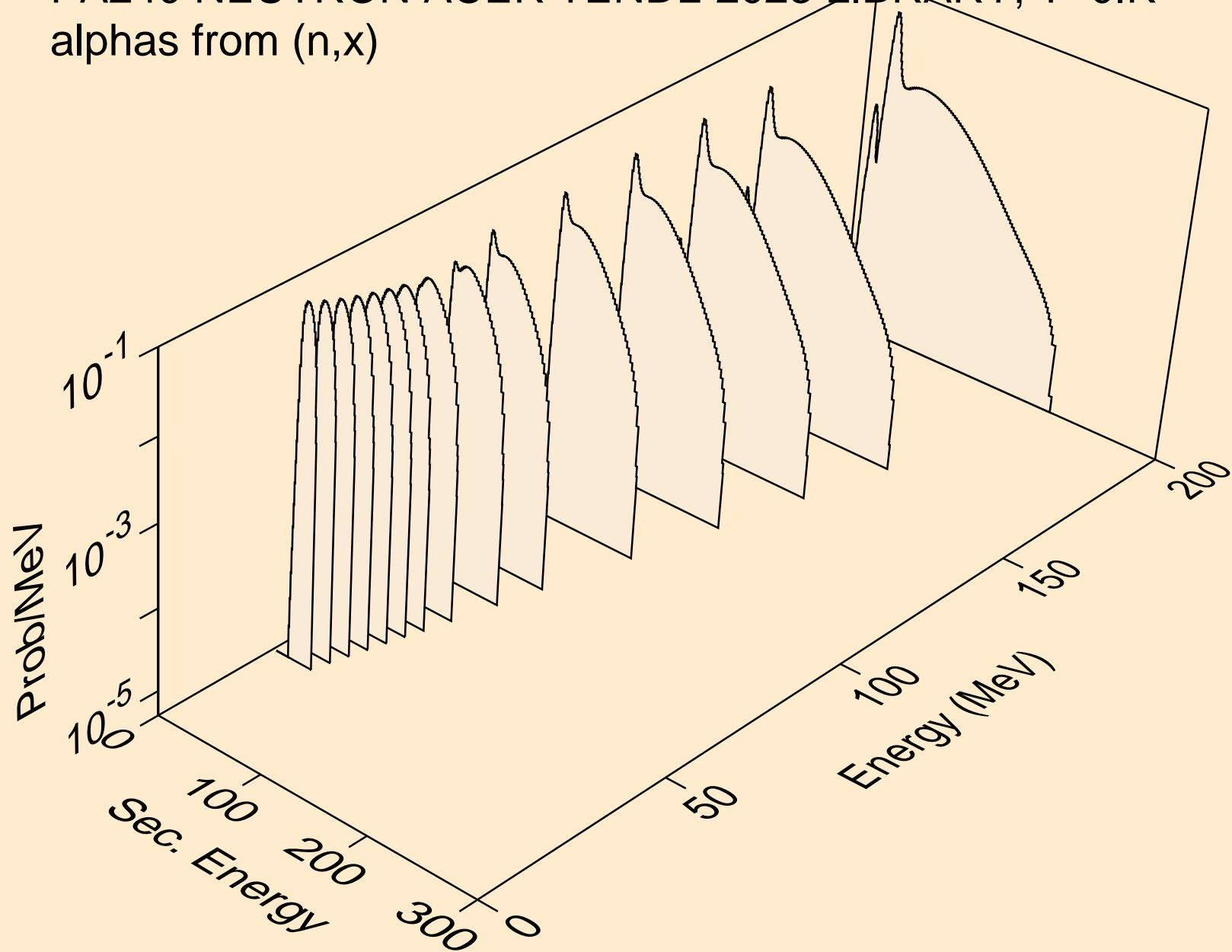



PA240 NEUTRON ACER TENDL-2023 LIBRARY; T=0.K  
alphas from (n,n\*)a

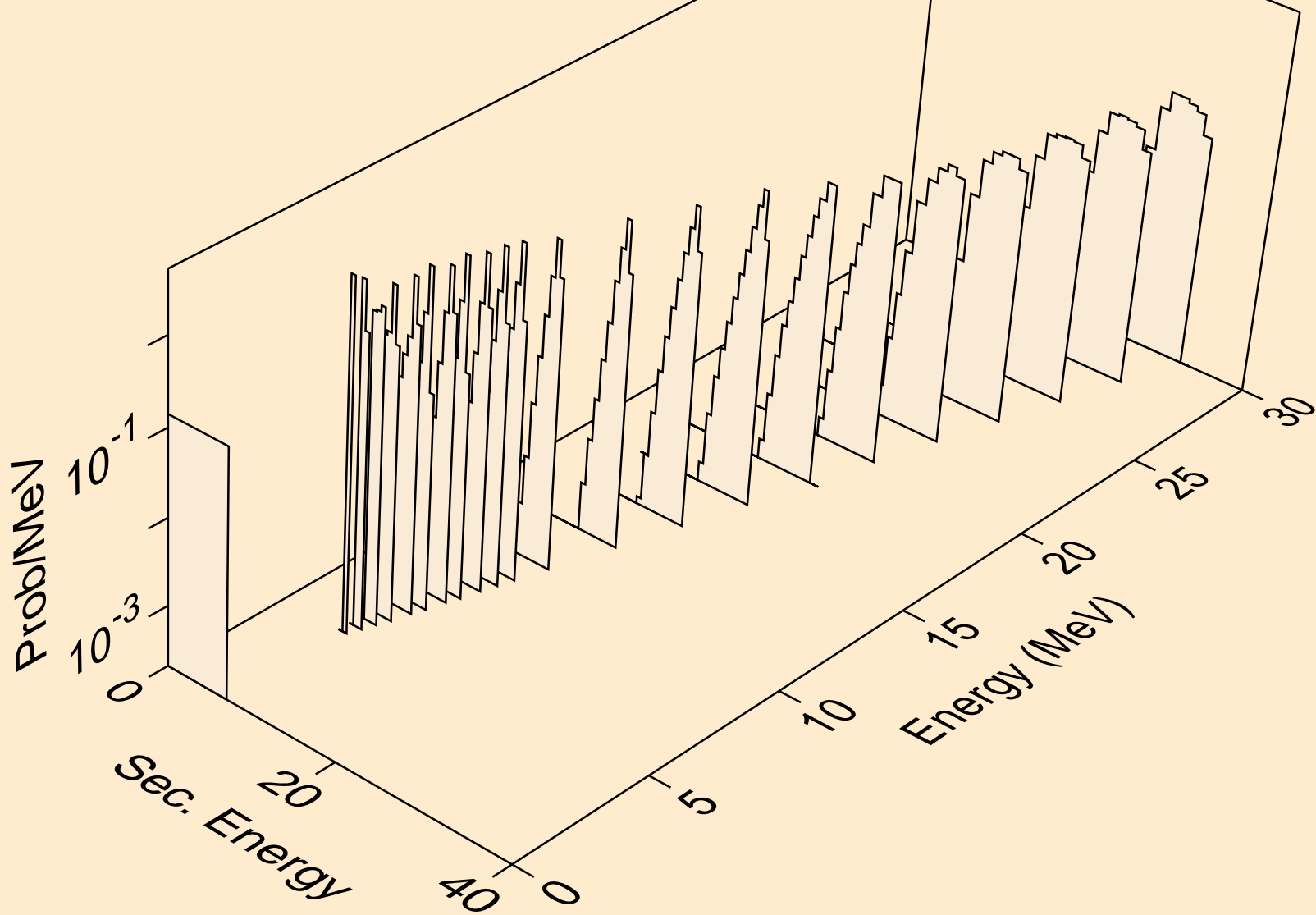

PA240 NEUTRON ACER TENDL-2023 LIBRARY; T=0.K  
alphas from (n,2n)a

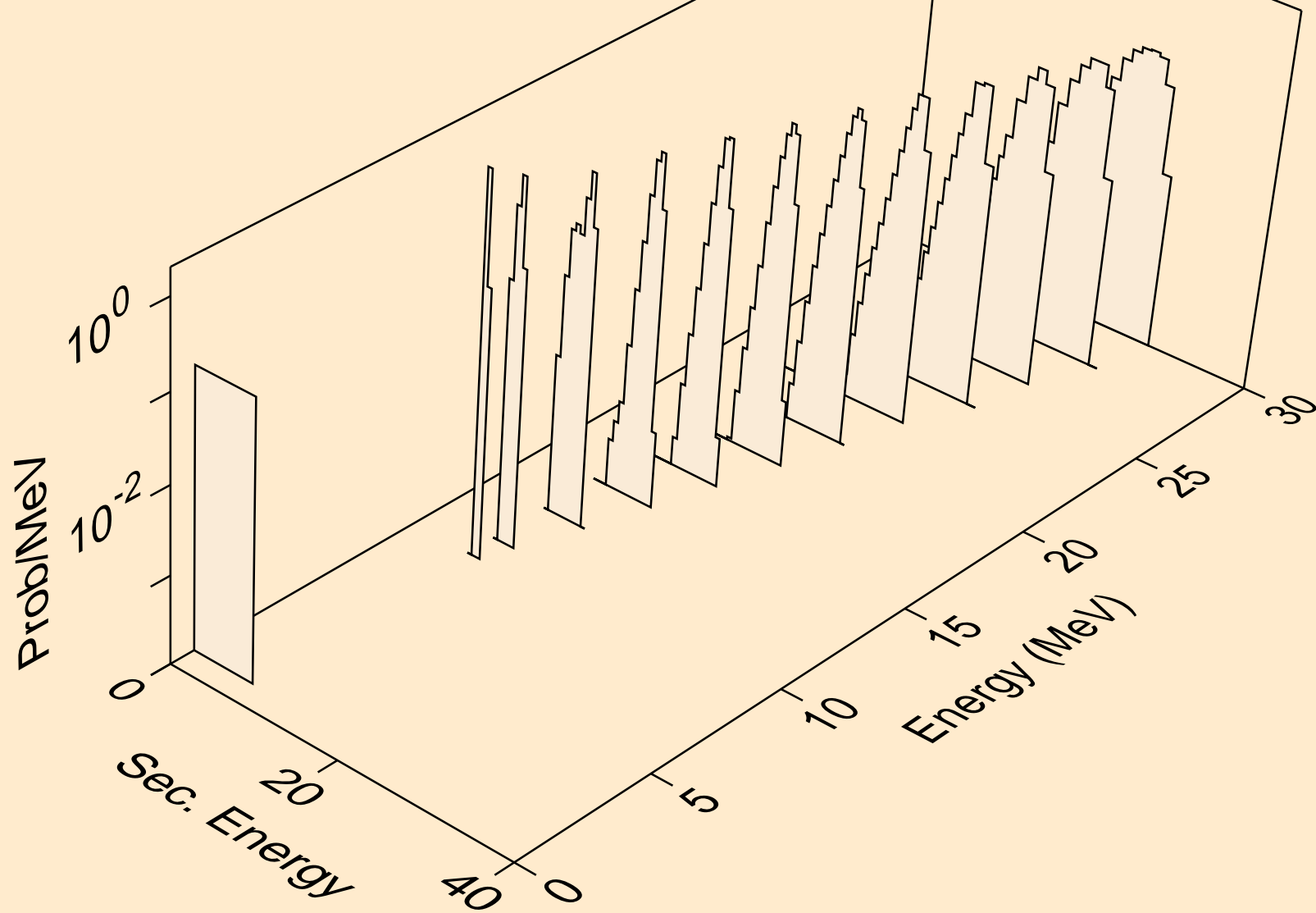

PA240 NEUTRON ACER TENDL-2023 LIBRARY; T=0.K  
alphas from (n,3n)a

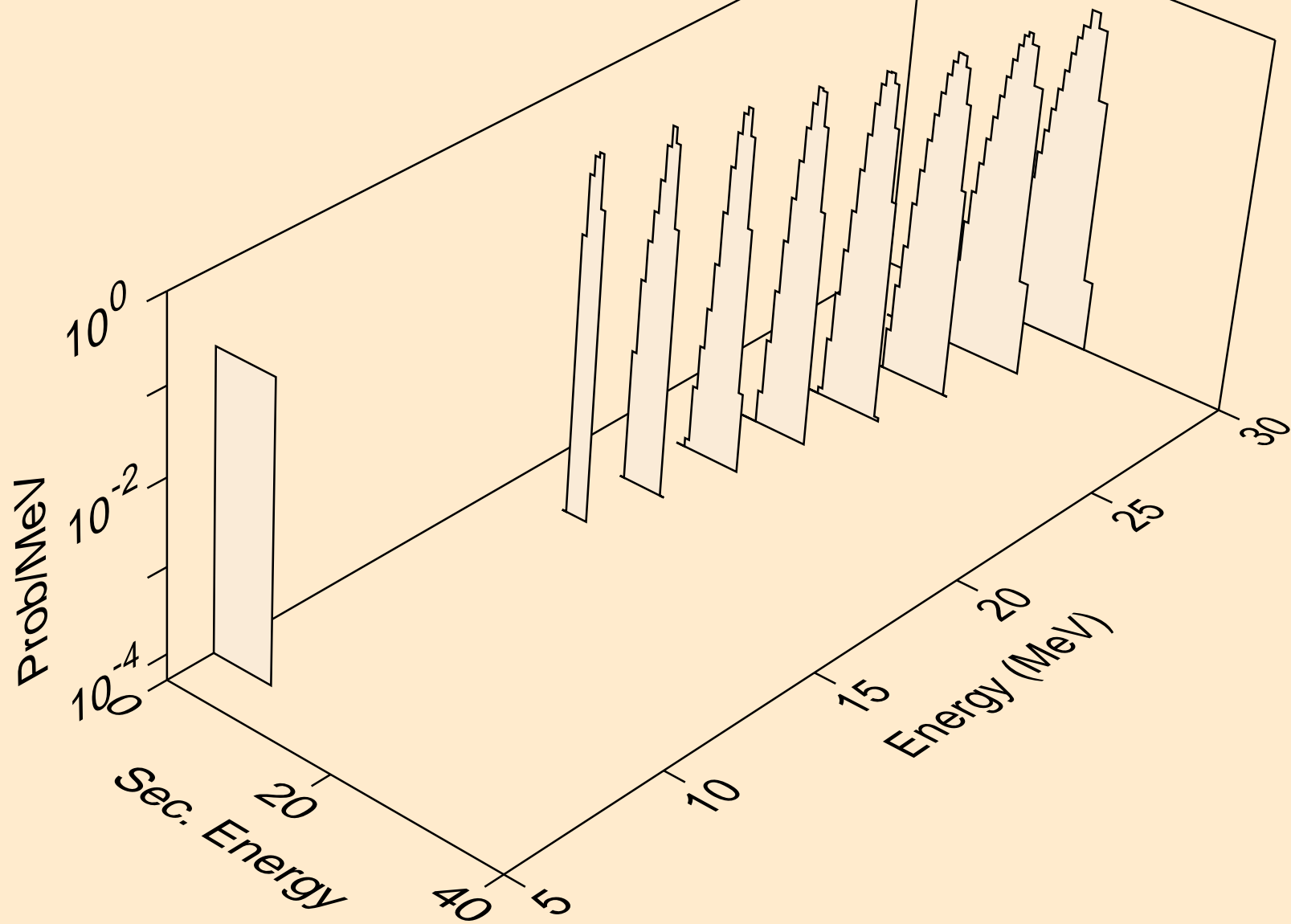

PA240 NEUTRON ACER TENDL-2023 LIBRARY; T=0.K  
alphas from (n,a)

