

PR138M NEUTRON ACER TENDL-2023 LIBRARY; T=0.K  
Principal cross sections

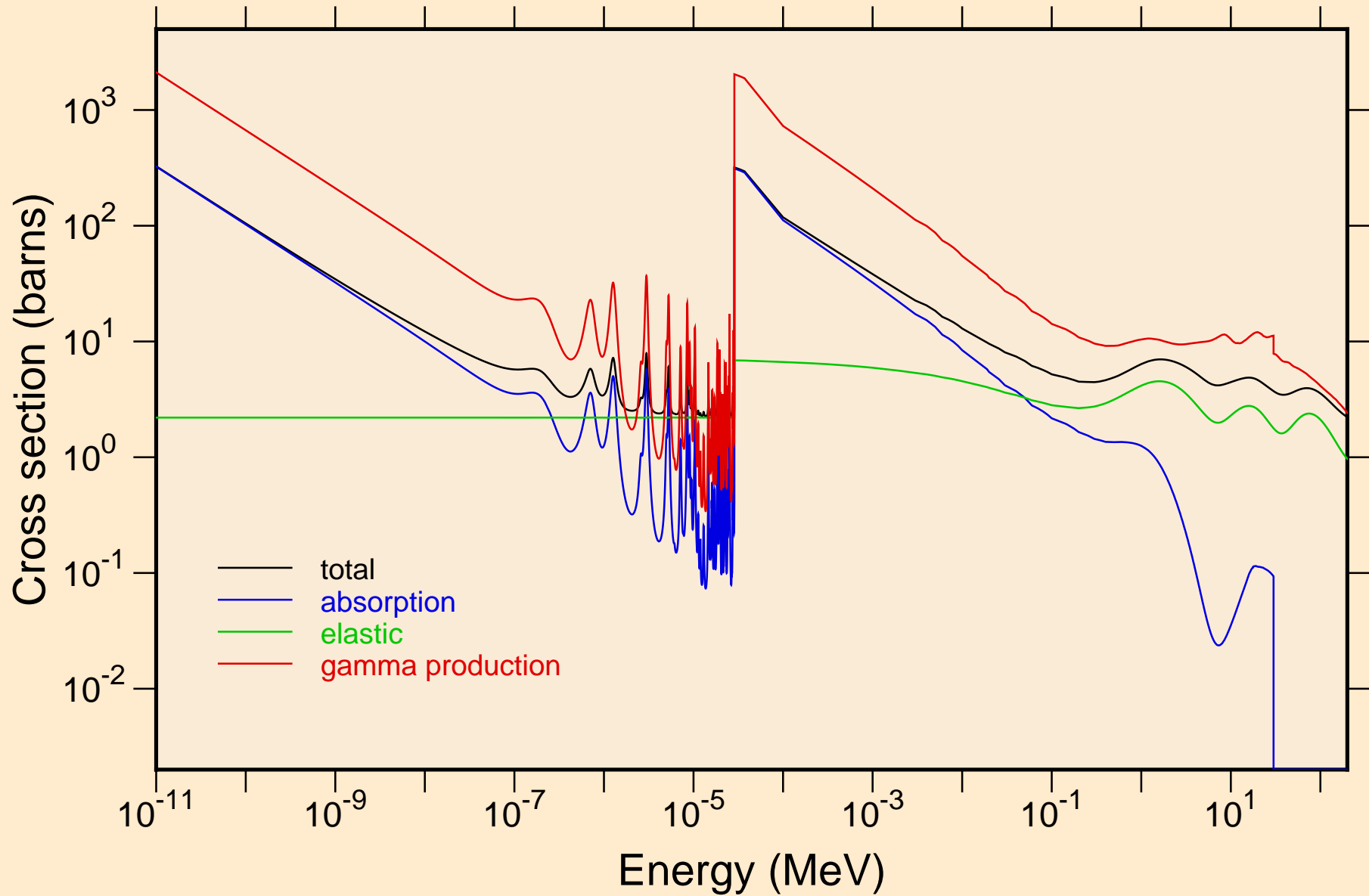

PR138M NEUTRON ACER TENDL-2023 LIBRARY; T=0.K  
resonance total cross section

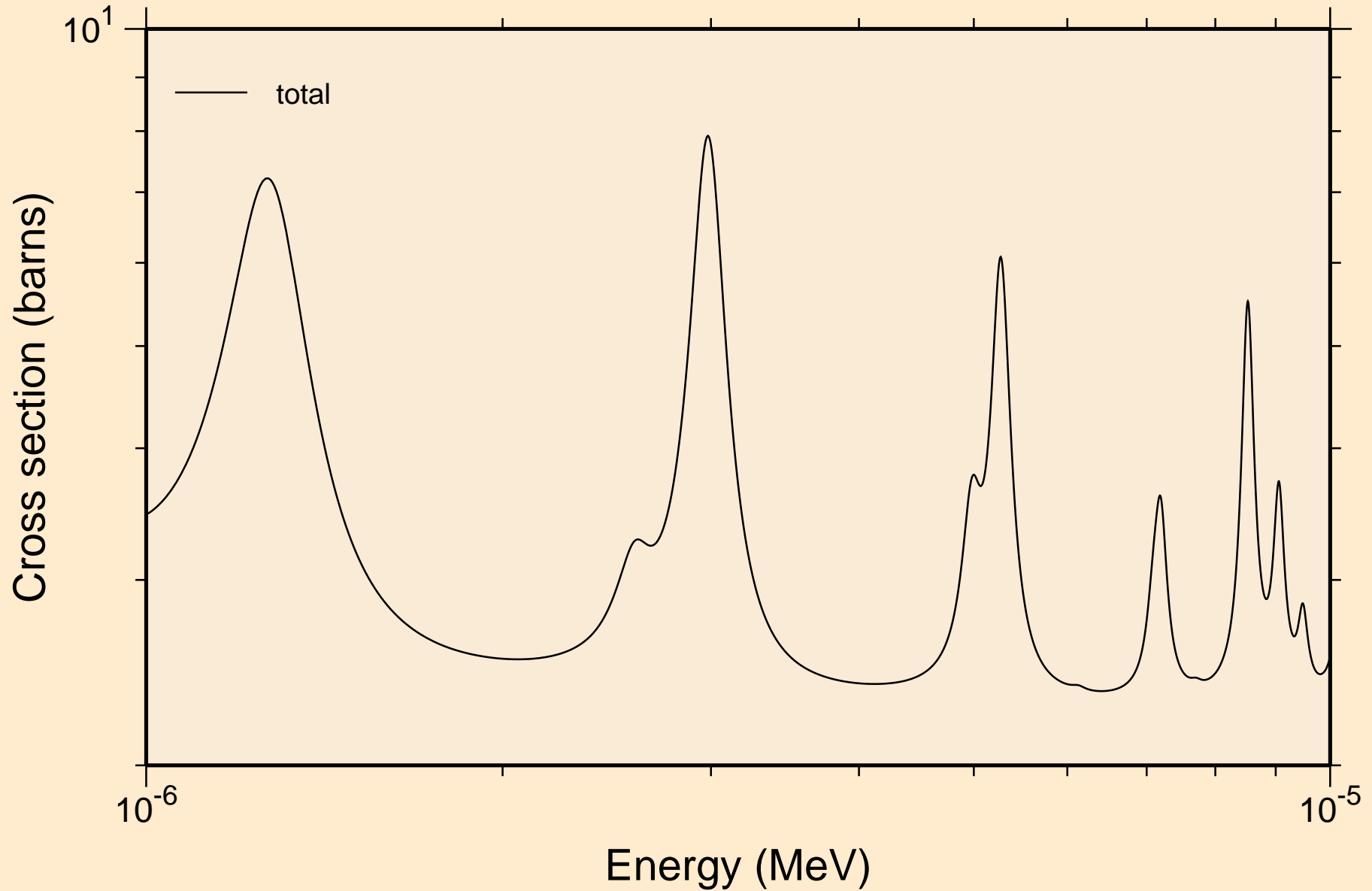

PR138M NEUTRON ACER TENDL-2023 LIBRARY; T=0.K  
resonance total cross section

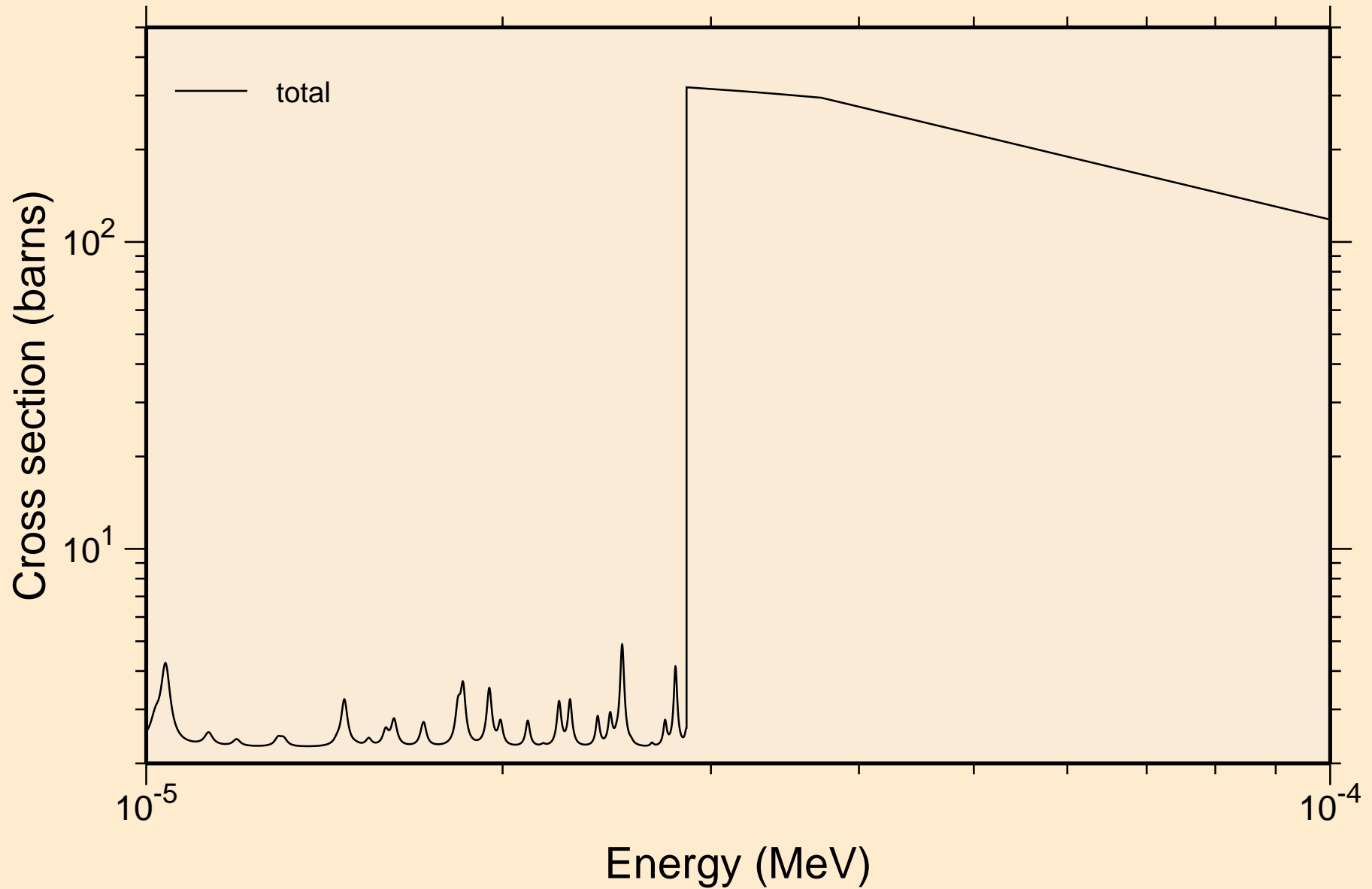

PR138M NEUTRON ACER TENDL-2023 LIBRARY; T=0.K  
resonance total cross section

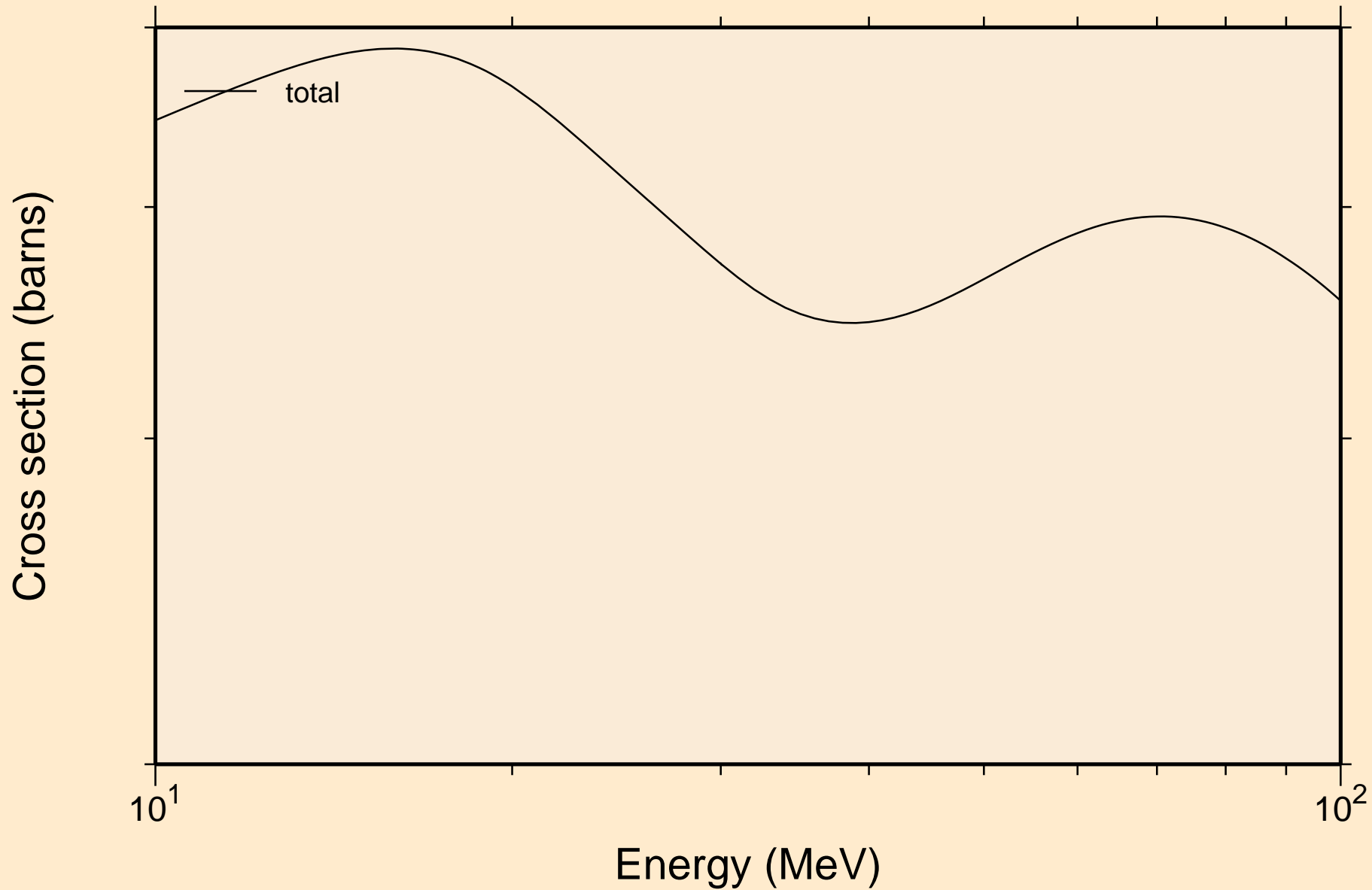

PR138M NEUTRON ACER TENDL-2023 LIBRARY; T=0.K  
resonance absorption cross sections

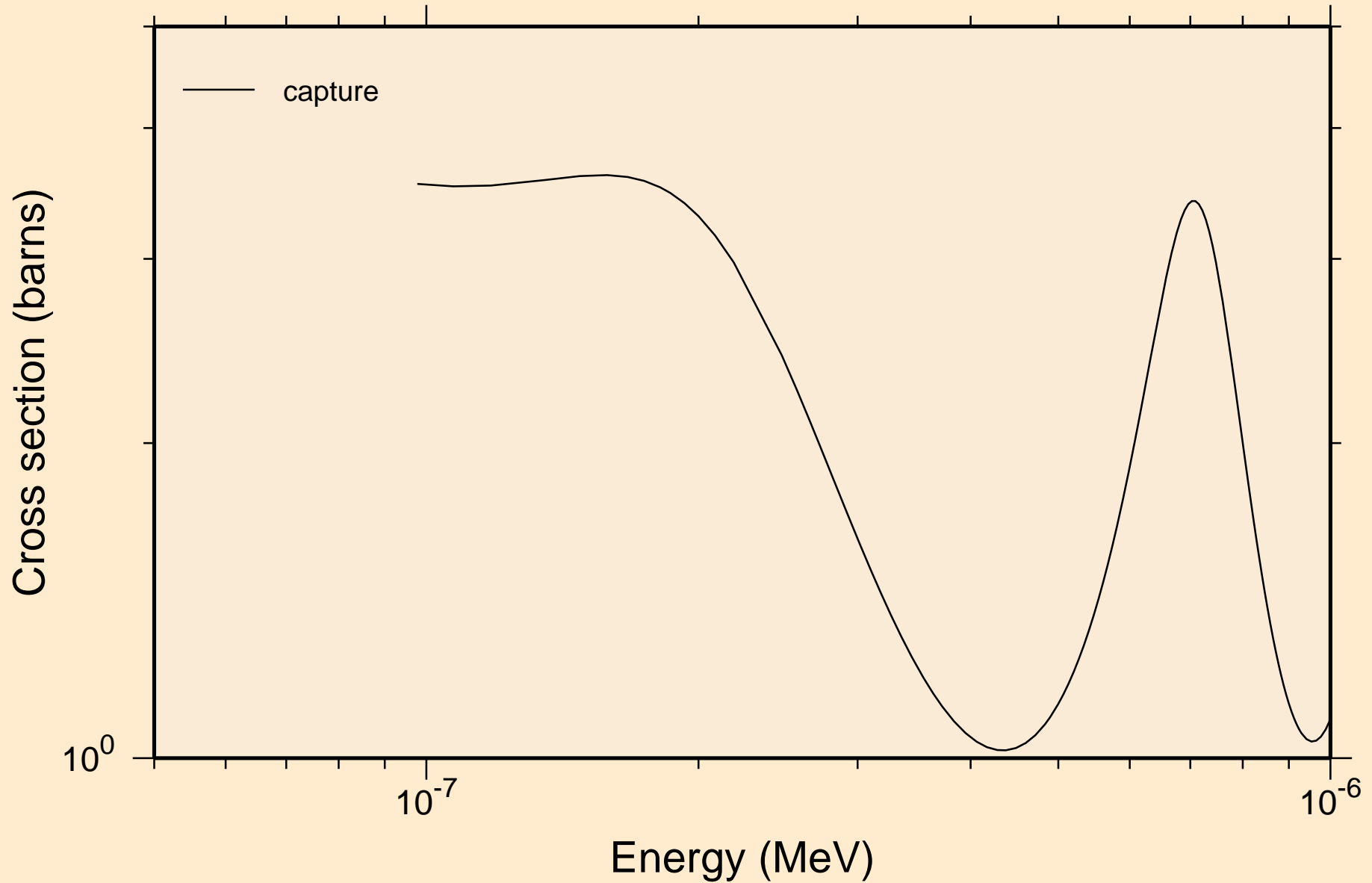

PR138M NEUTRON ACER TENDL-2023 LIBRARY; T=0.K  
resonance absorption cross sections

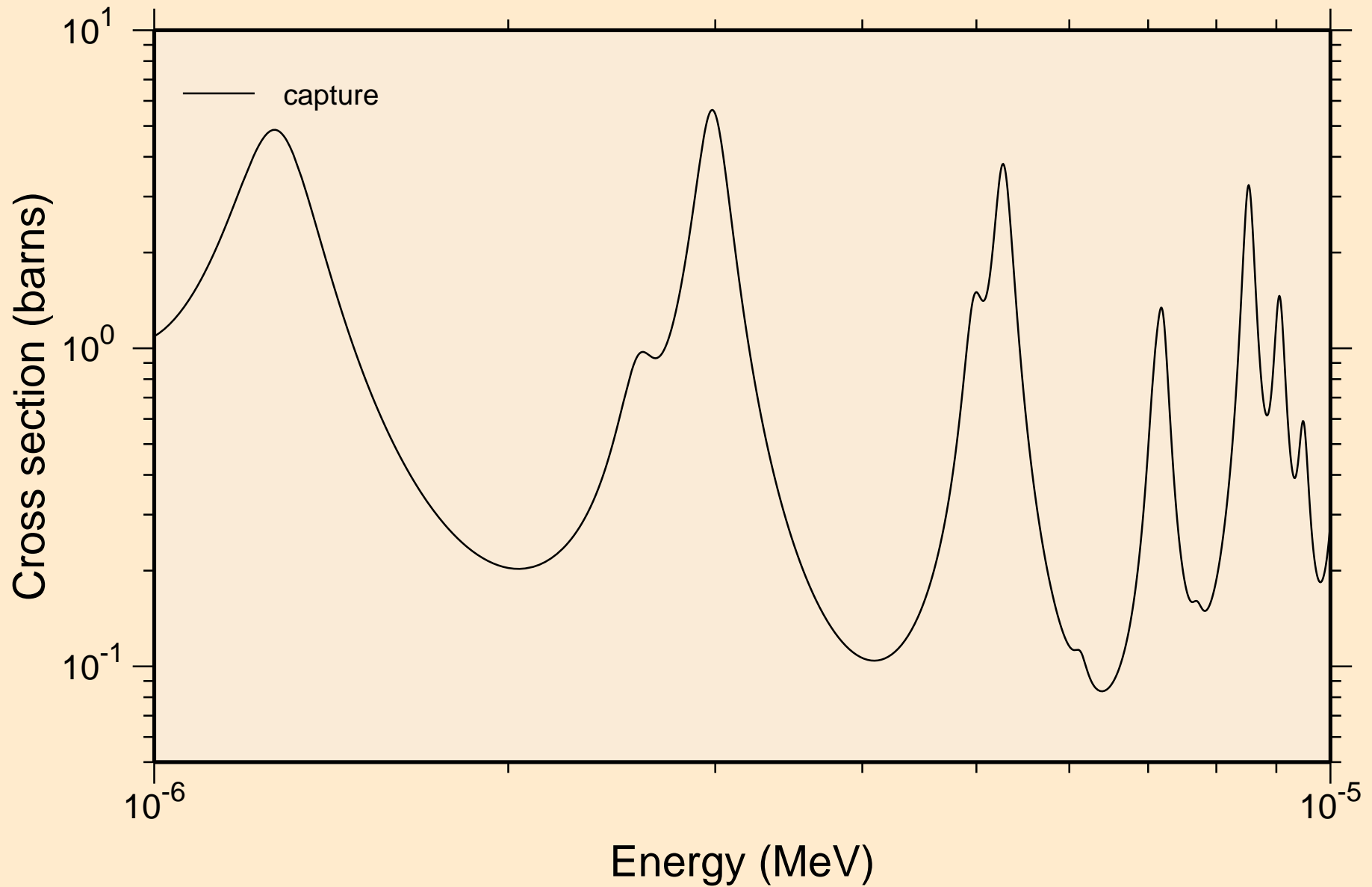

PR138M NEUTRON ACER TENDL-2023 LIBRARY; T=0.K  
resonance absorption cross sections

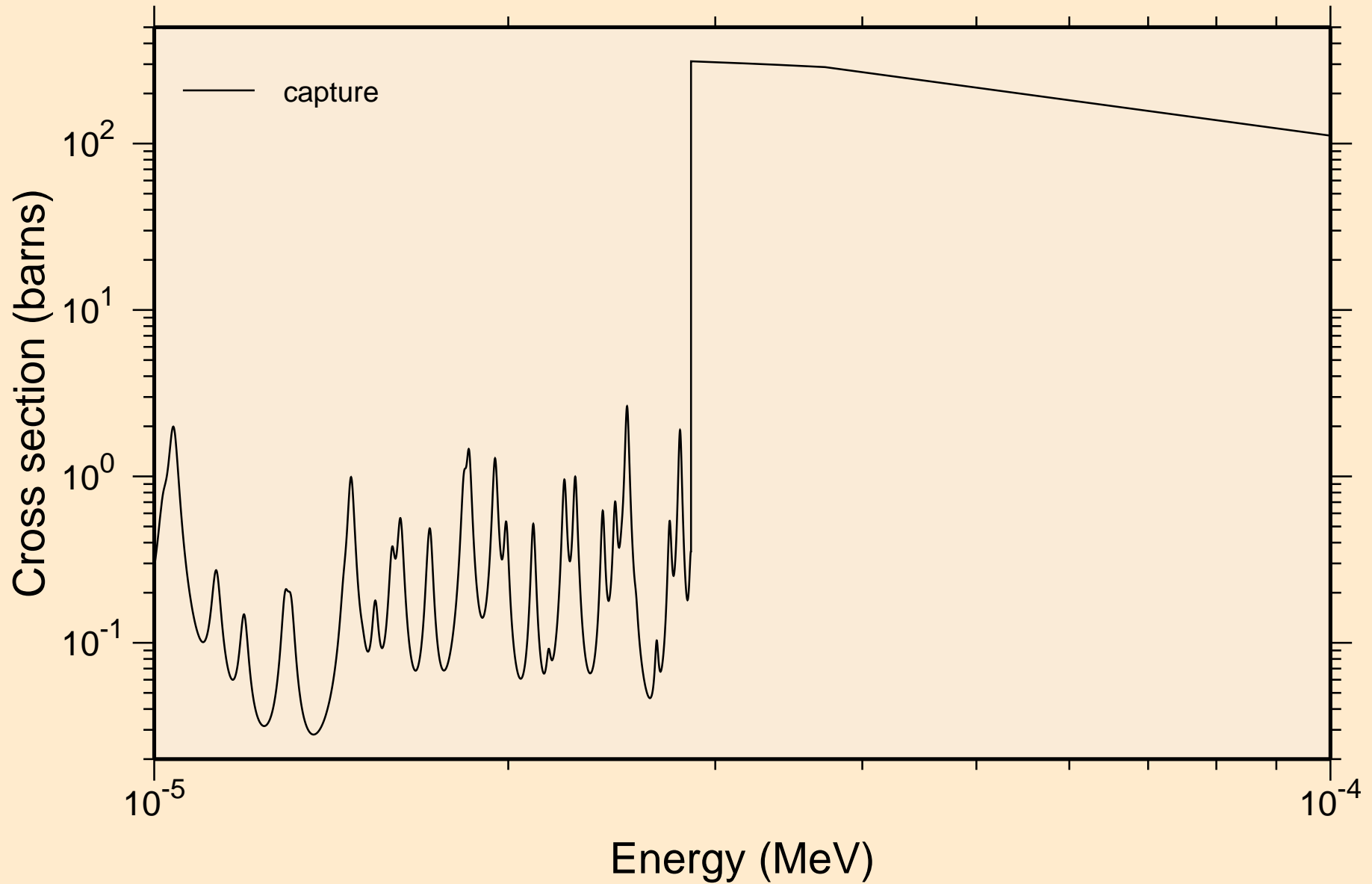

PR138M NEUTRON ACER TENDL-2023 LIBRARY; T=0.K  
resonance absorption cross sections

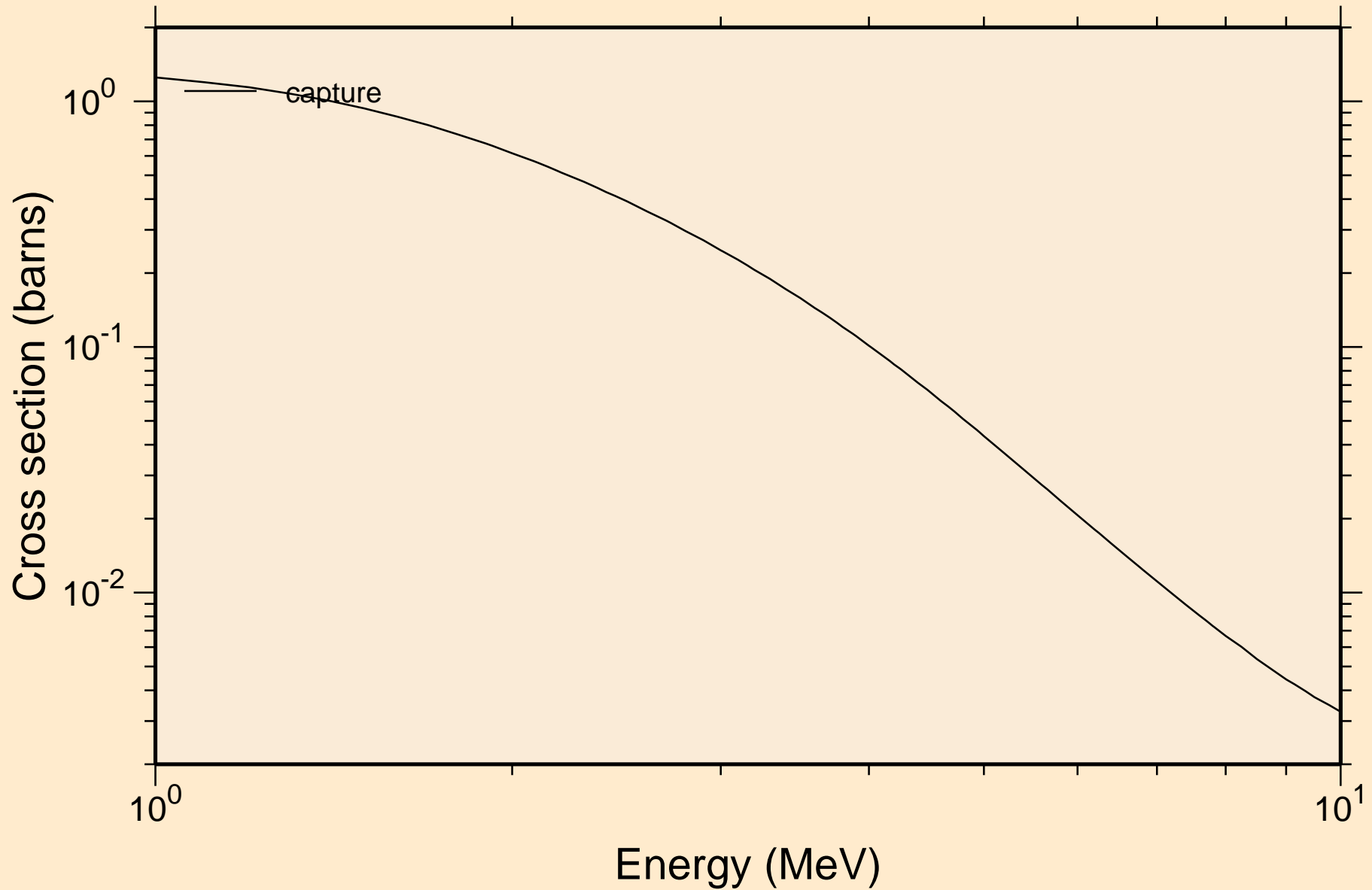



PR138M NEUTRON ACER TENDL-2023 LIBRARY; T=0.K  
Heating

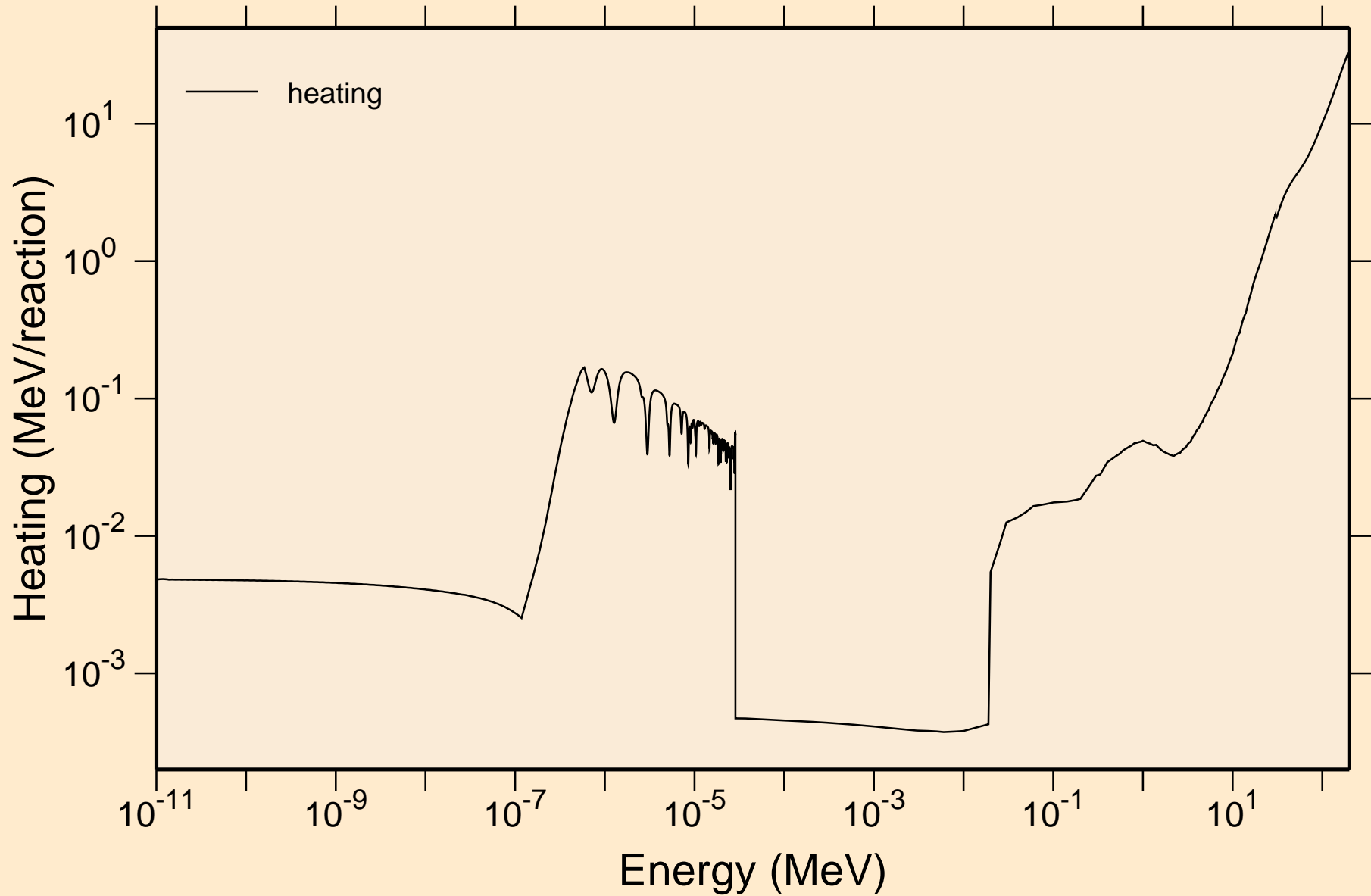

PR138M NEUTRON ACER TENDL-2023 LIBRARY; T=0.K  
Damage

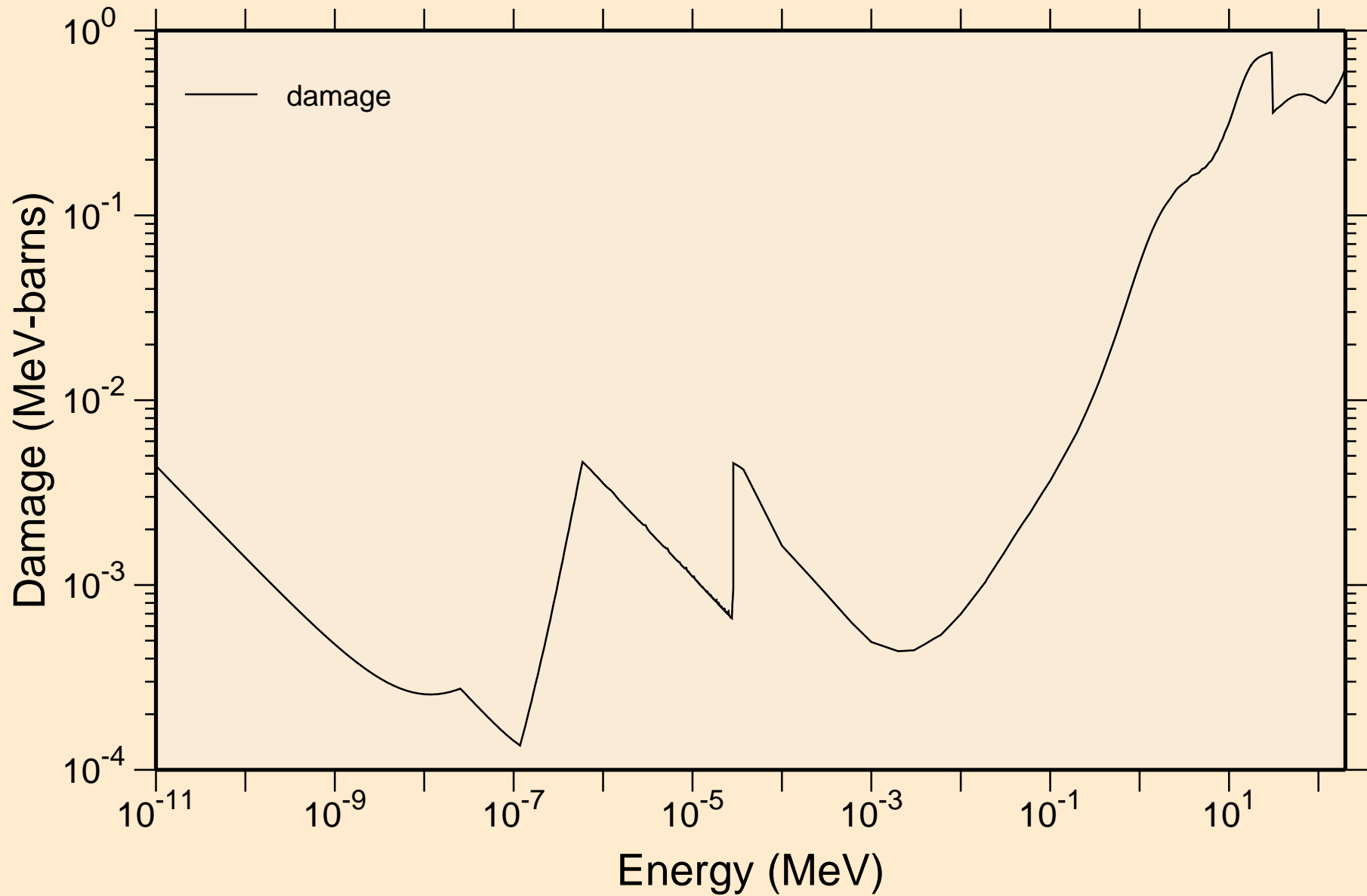

PR138M NEUTRON ACER TENDL-2023 LIBRARY; T=0.K  
Non-threshold reactions

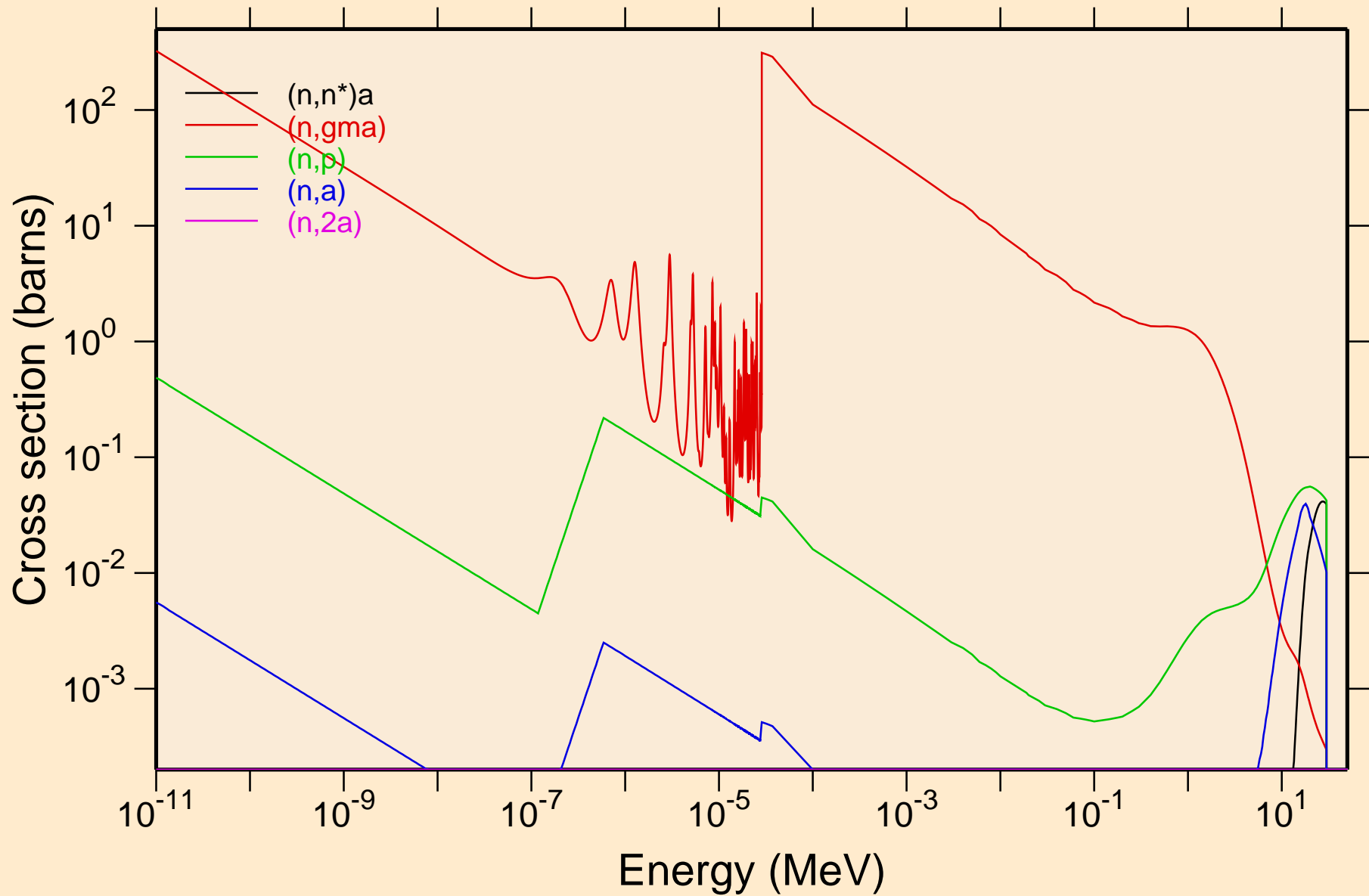

PR138M NEUTRON ACER TENDL-2023 LIBRARY; T=0.K  
Non-threshold reactions

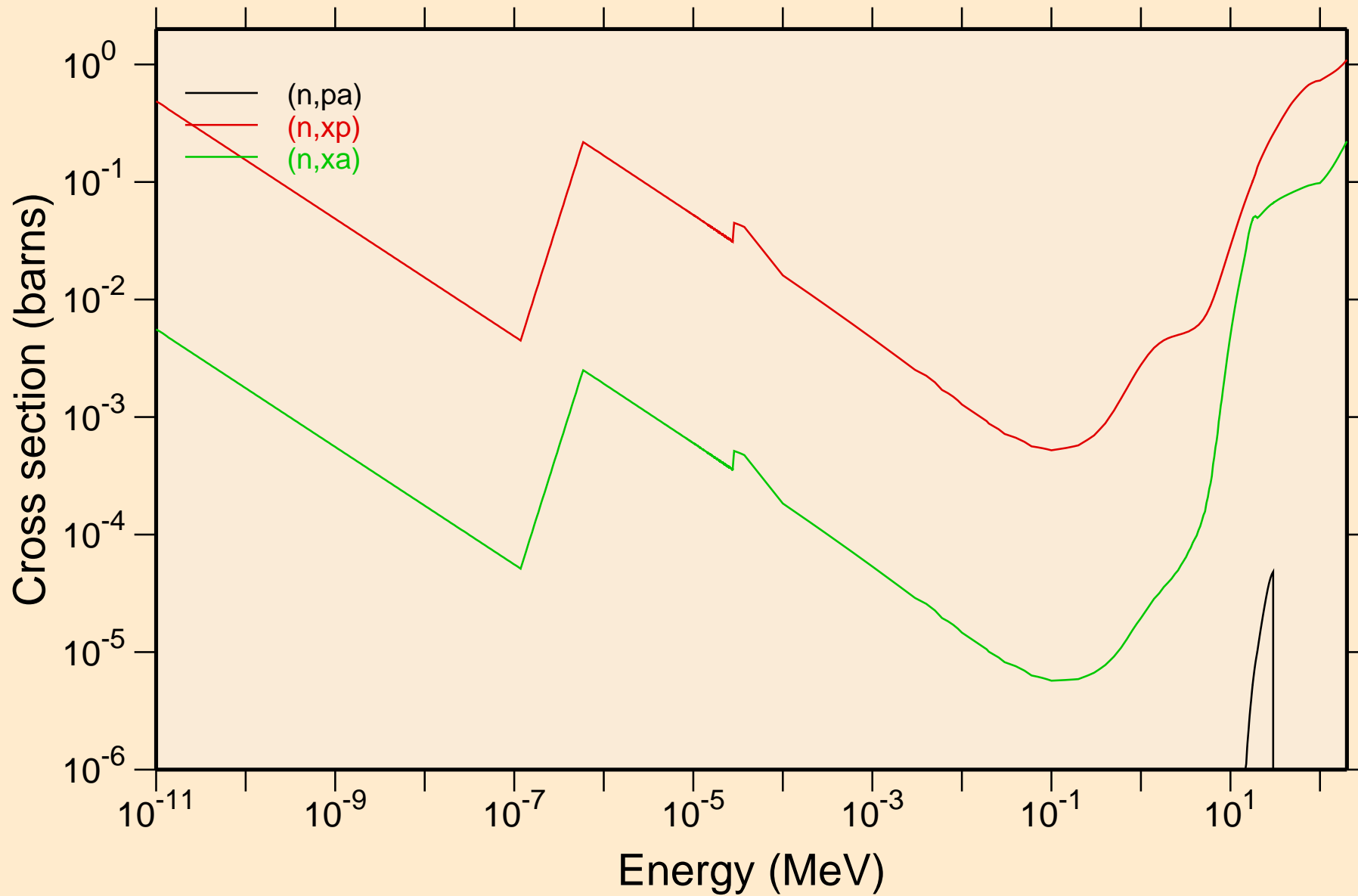

# PR138M NEUTRON ACER TENDL-2023 LIBRARY; T=0.K

## Principal cross sections

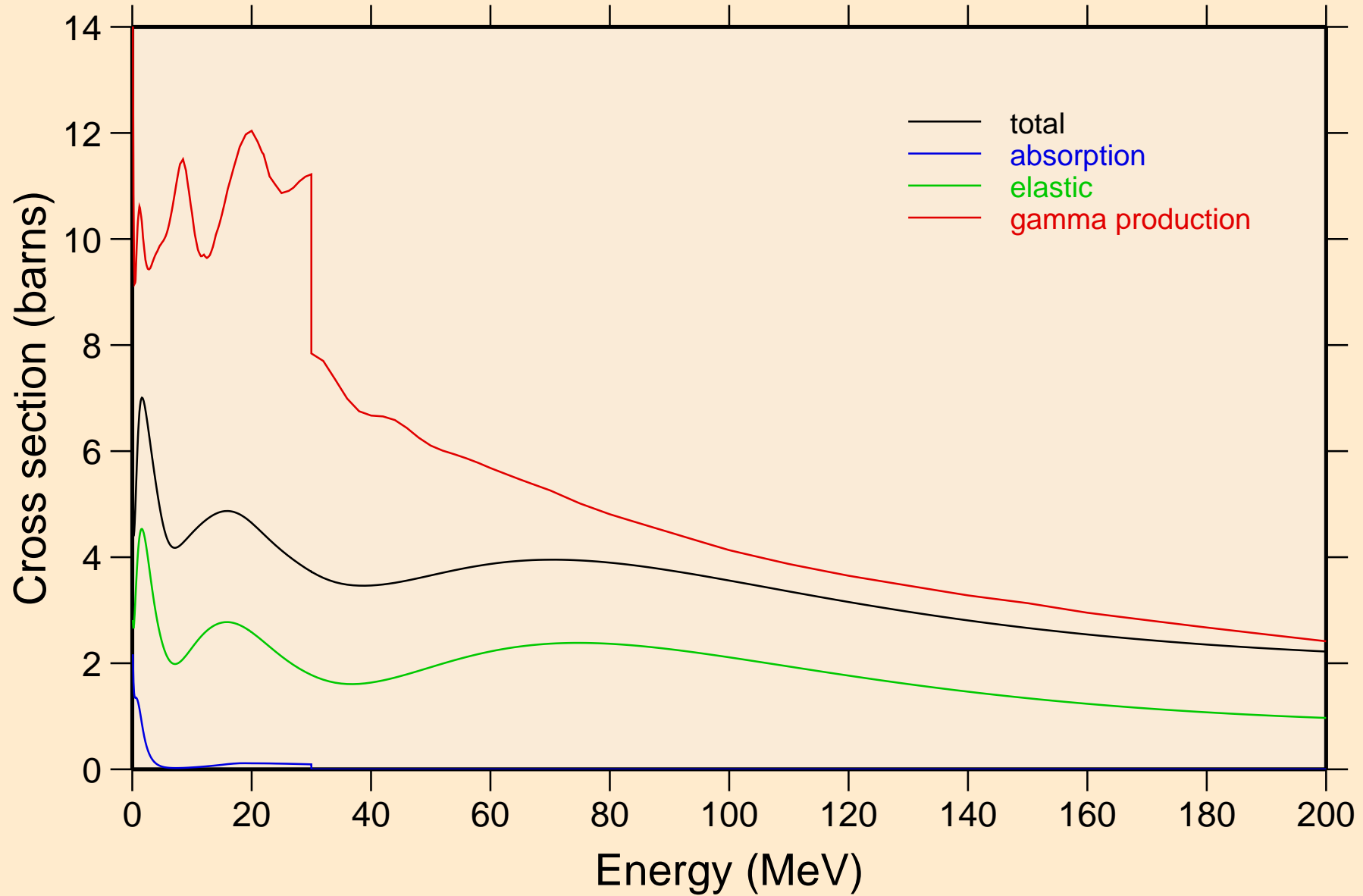

# PR138M NEUTRON ACER TENDL-2023 LIBRARY; T=0.K

## Heating

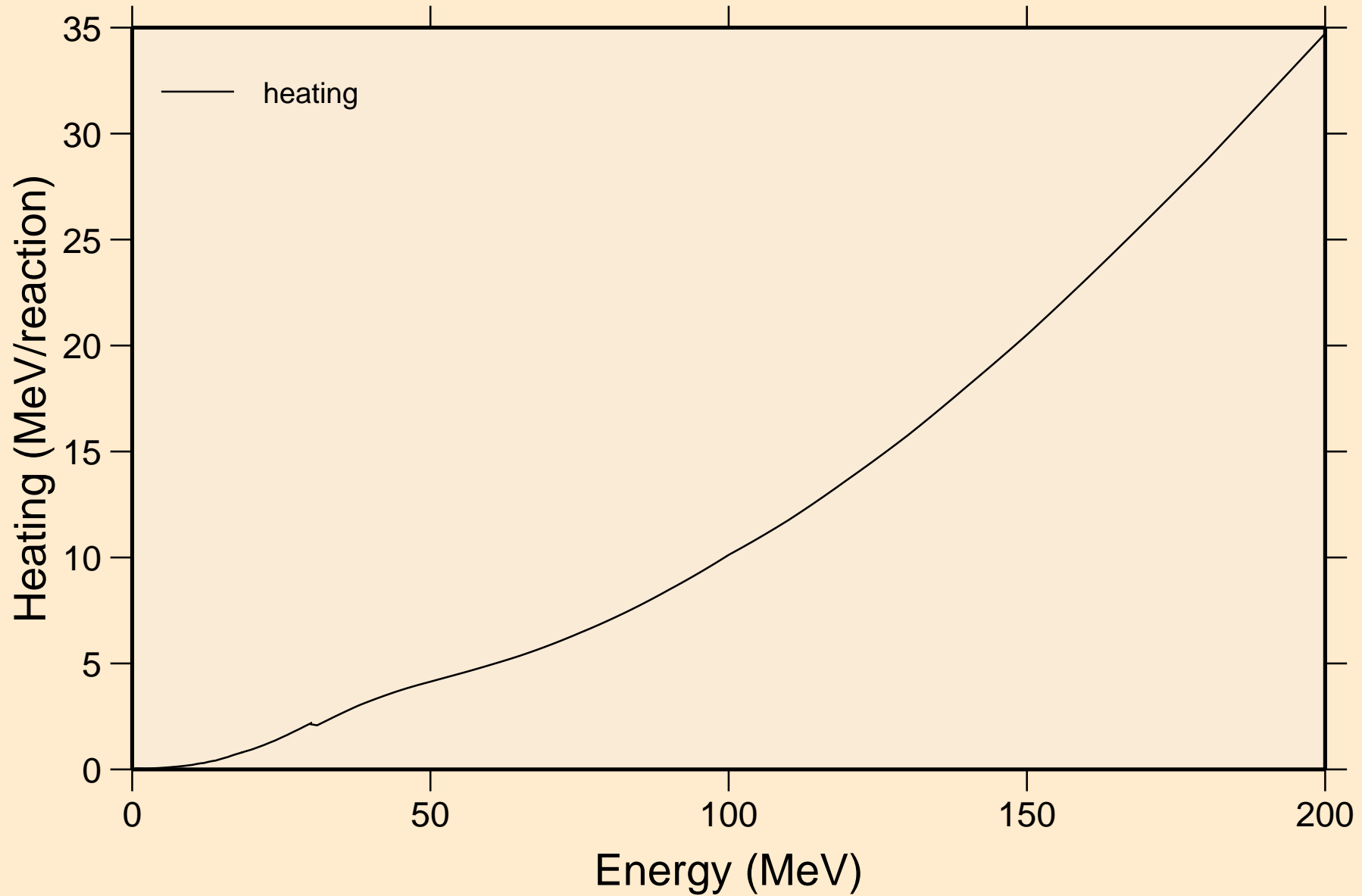

PR138M NEUTRON ACER TENDL-2023 LIBRARY; T=0.K  
Damage

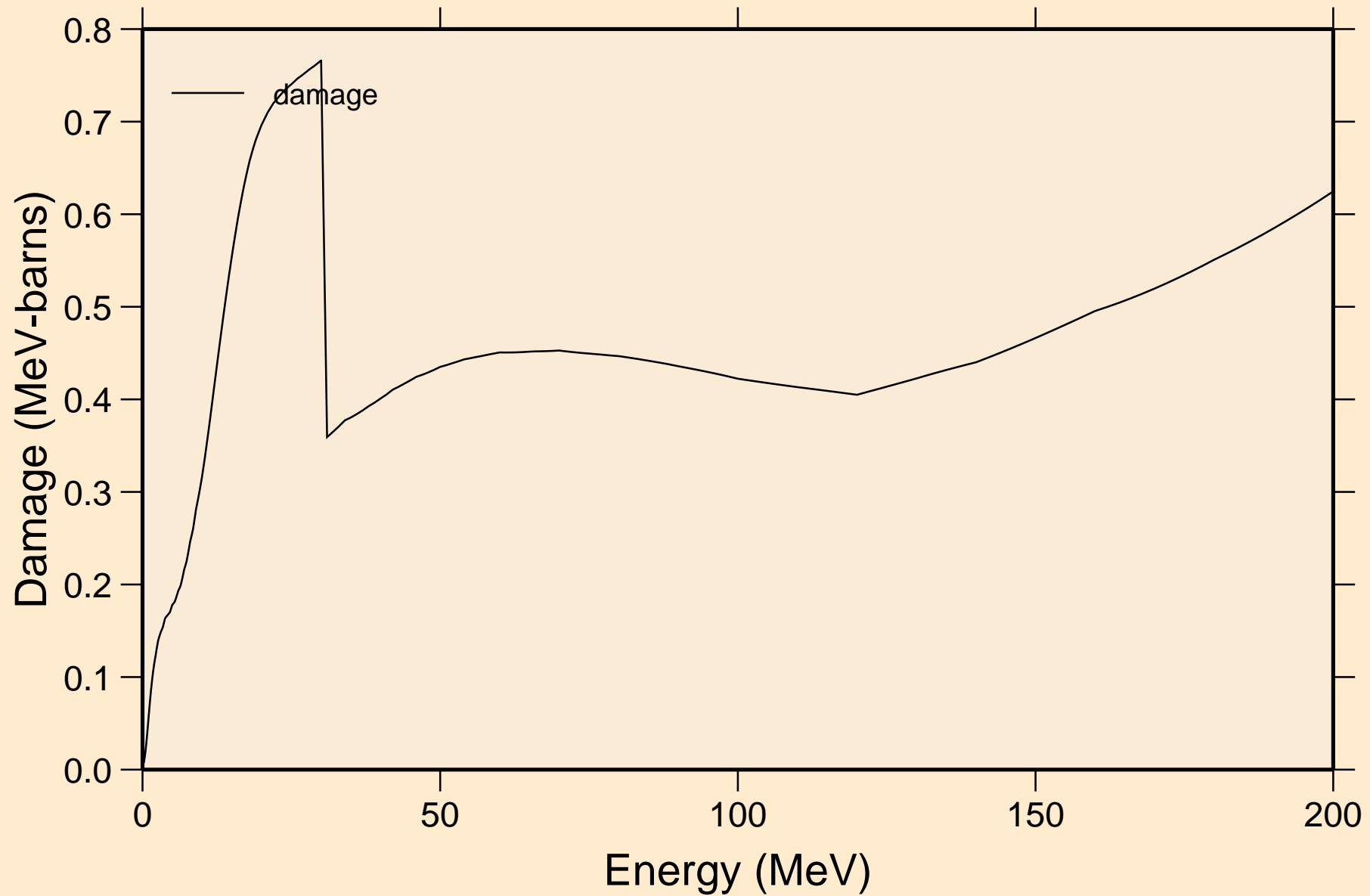

PR138M NEUTRON ACER TENDL-2023 LIBRARY; T=0.K  
Non-threshold reactions

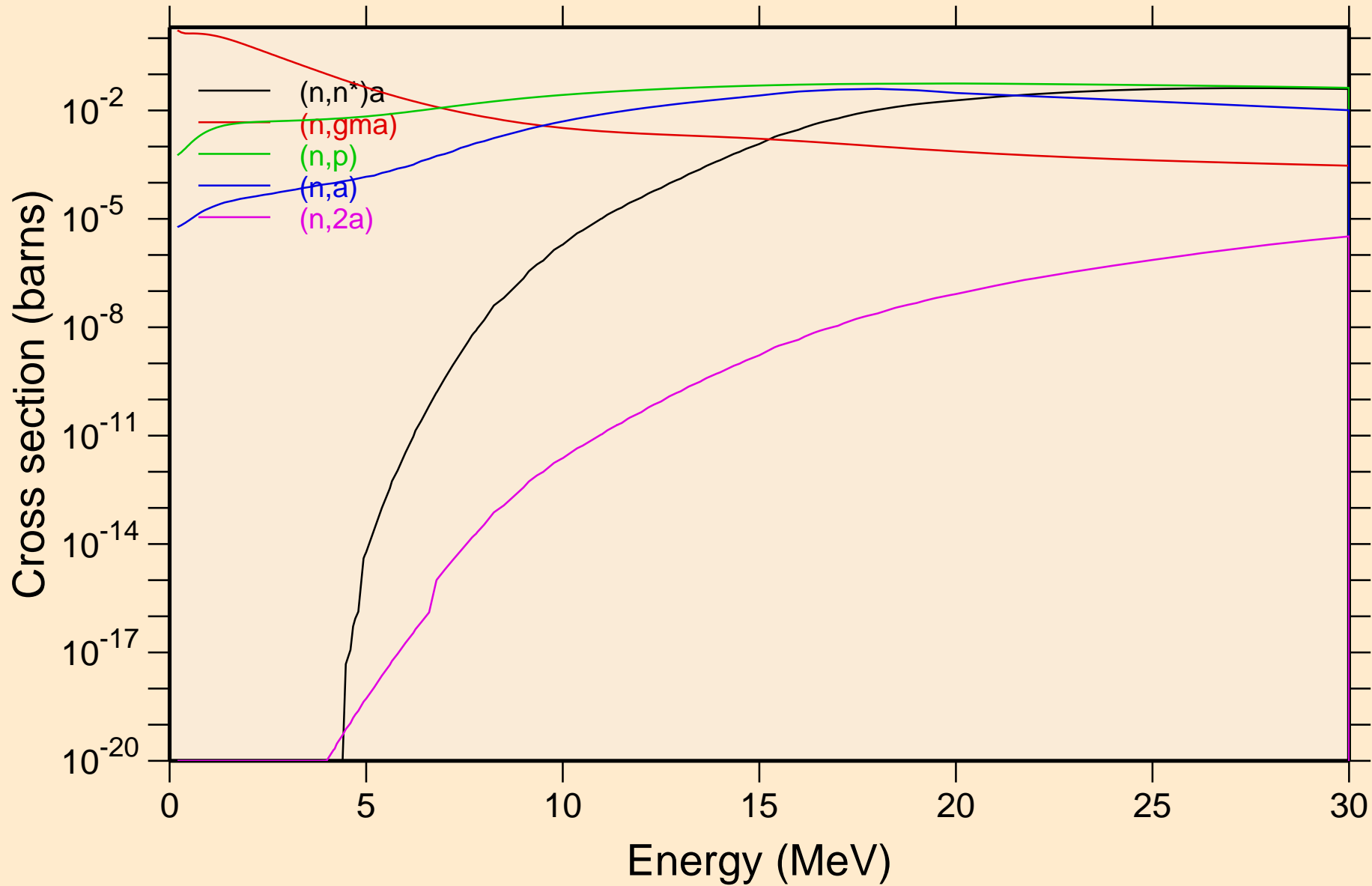



PR138M NEUTRON ACER TENDL-2023 LIBRARY; T=0.K  
Non-threshold reactions

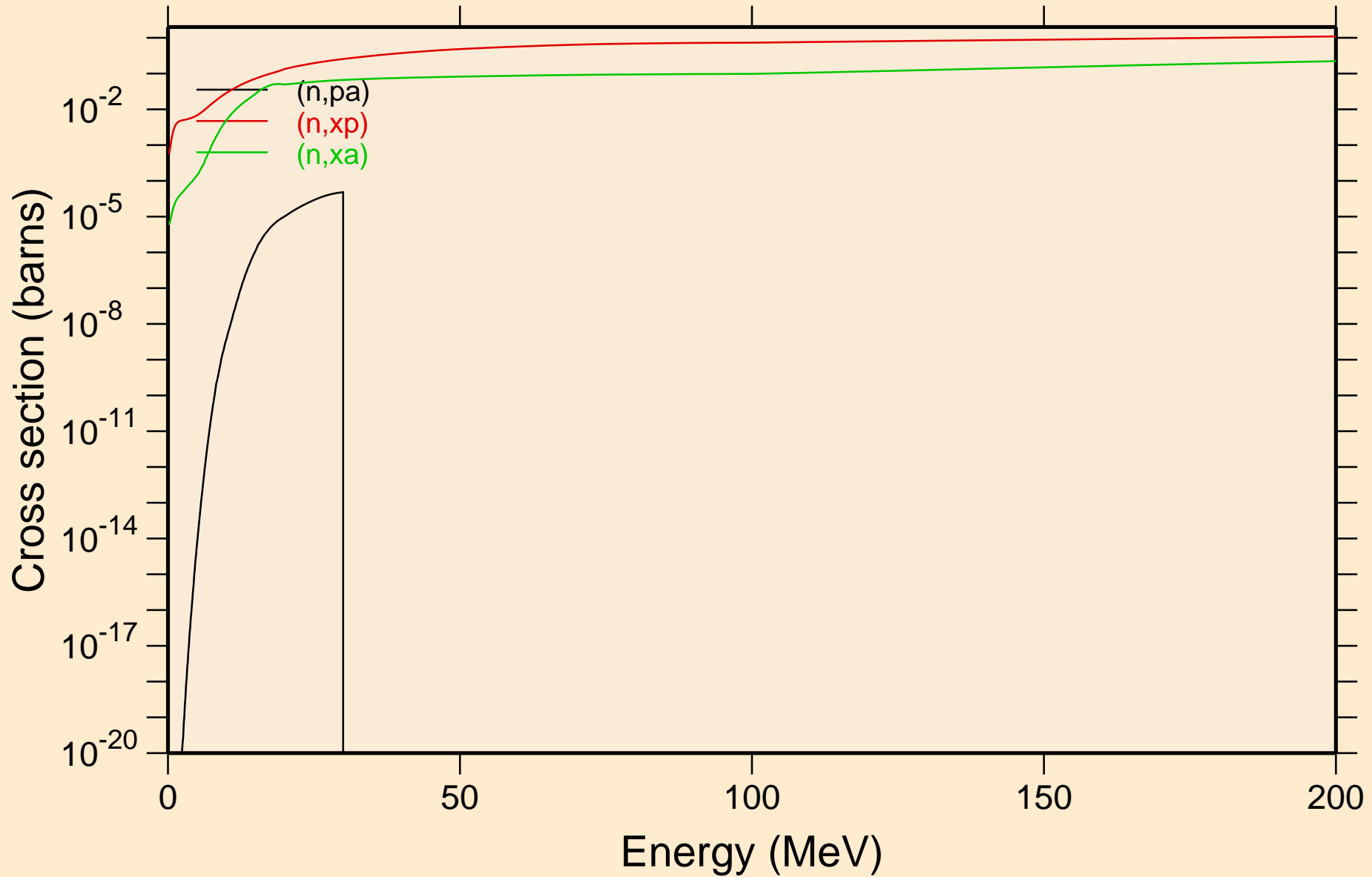

PR138M NEUTRON ACER TENDL-2023 LIBRARY; T=0.K  
Inelastic levels

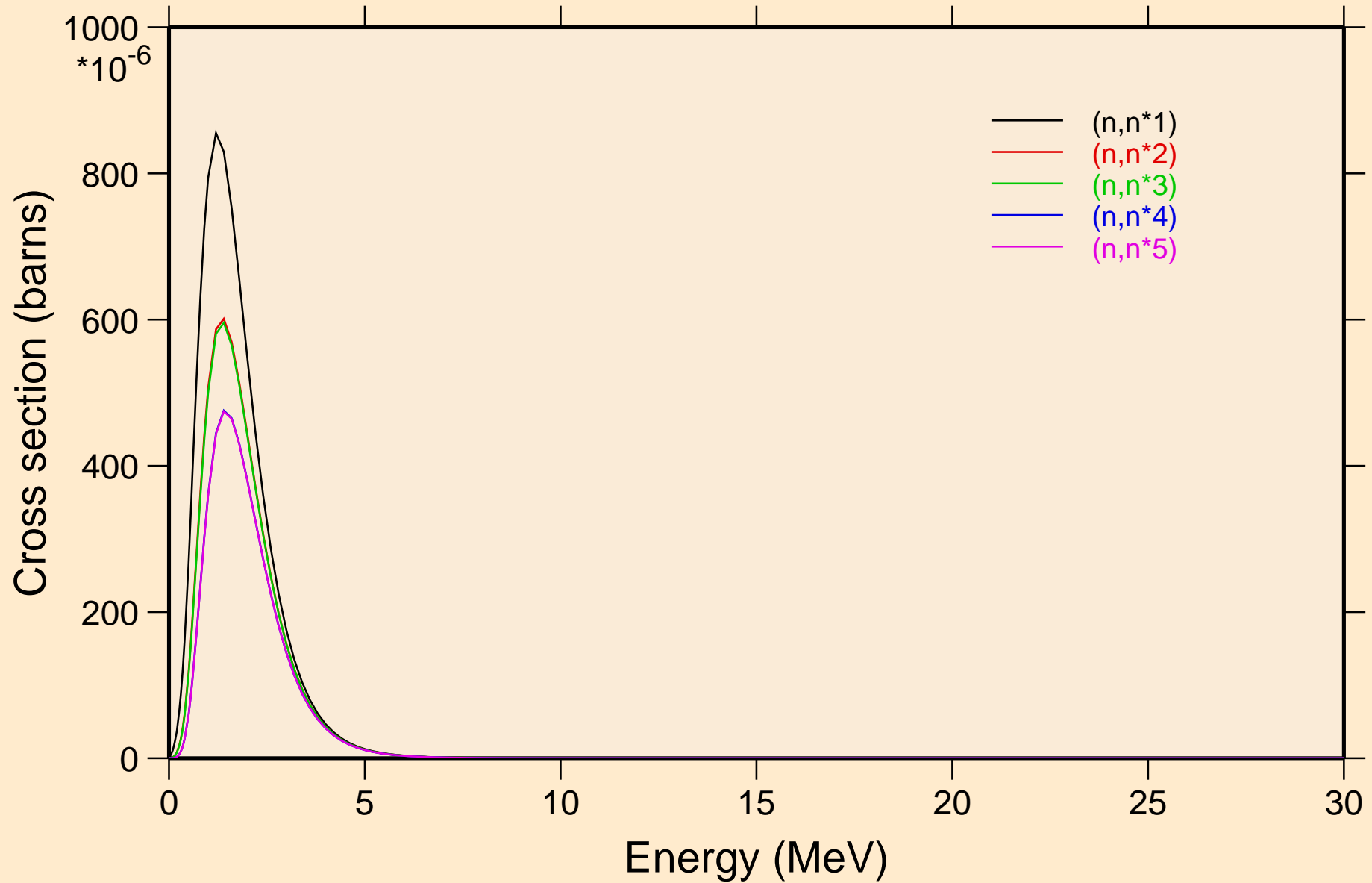

PR138M NEUTRON ACER TENDL-2023 LIBRARY; T=0.K  
Inelastic levels

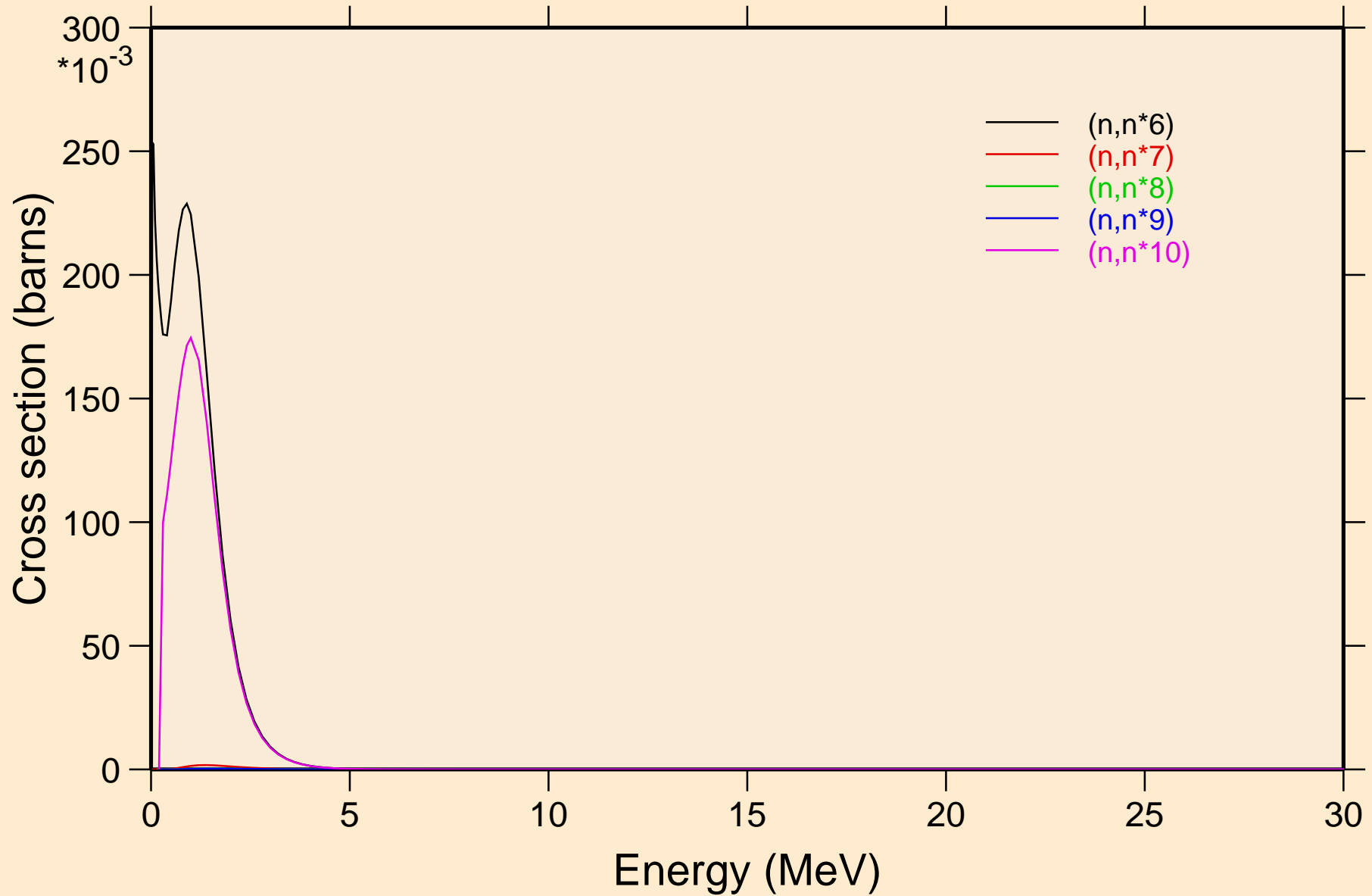

PR138M NEUTRON ACER TENDL-2023 LIBRARY; T=0.K  
Inelastic levels

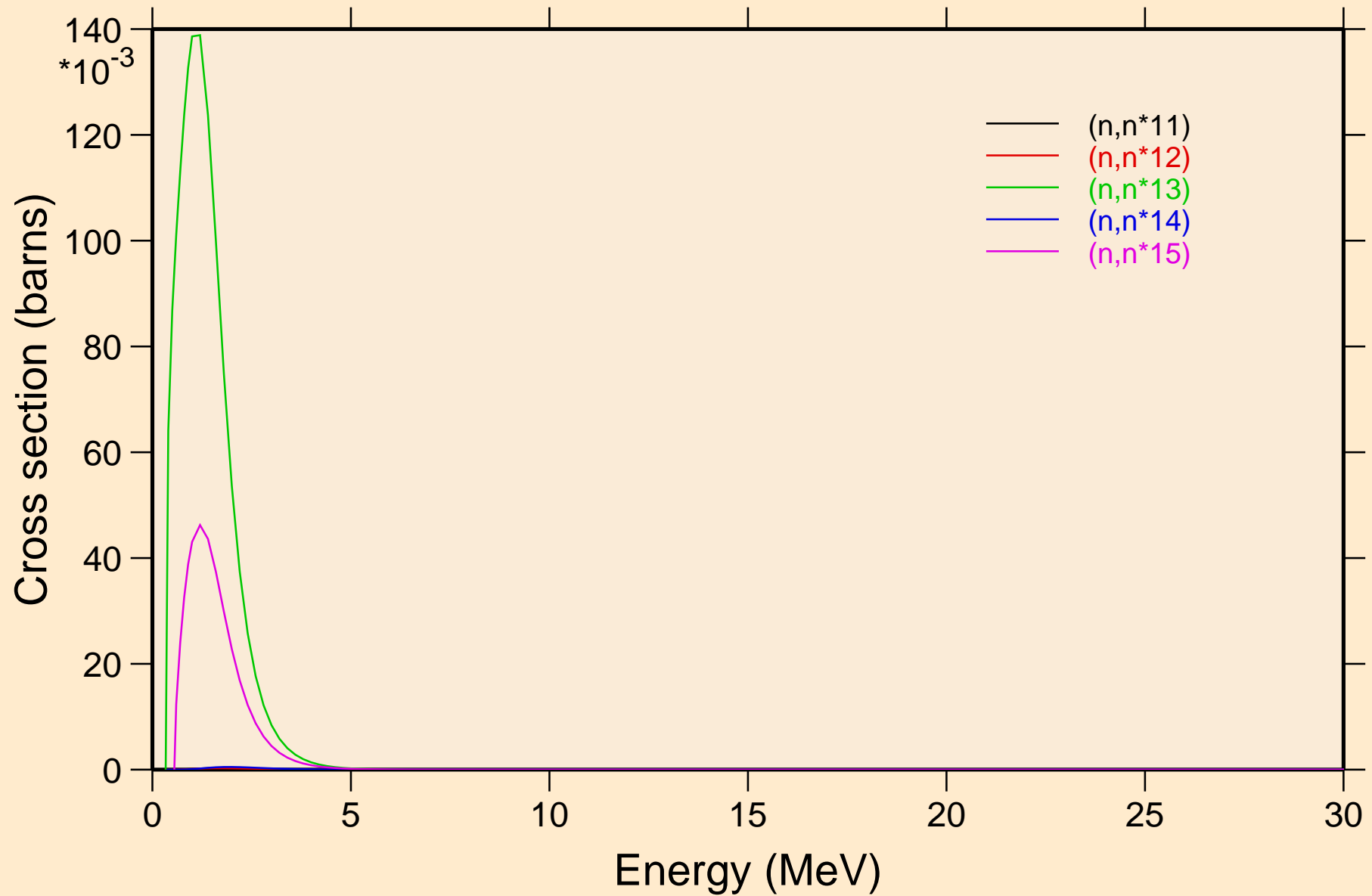

PR138M NEUTRON ACER TENDL-2023 LIBRARY; T=0.K  
Threshold reactions

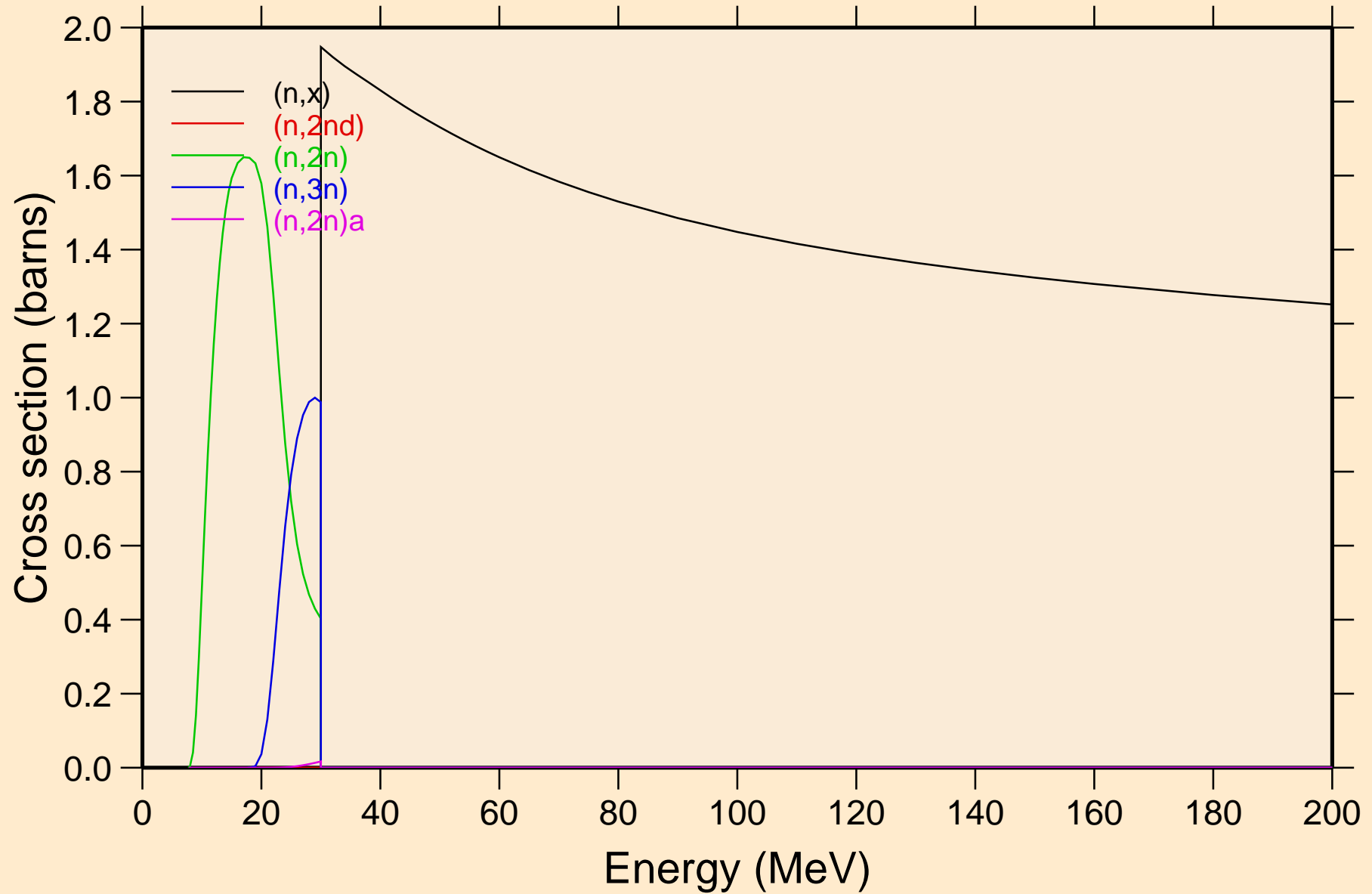

PR138M NEUTRON ACER TENDL-2023 LIBRARY; T=0.K  
Threshold reactions

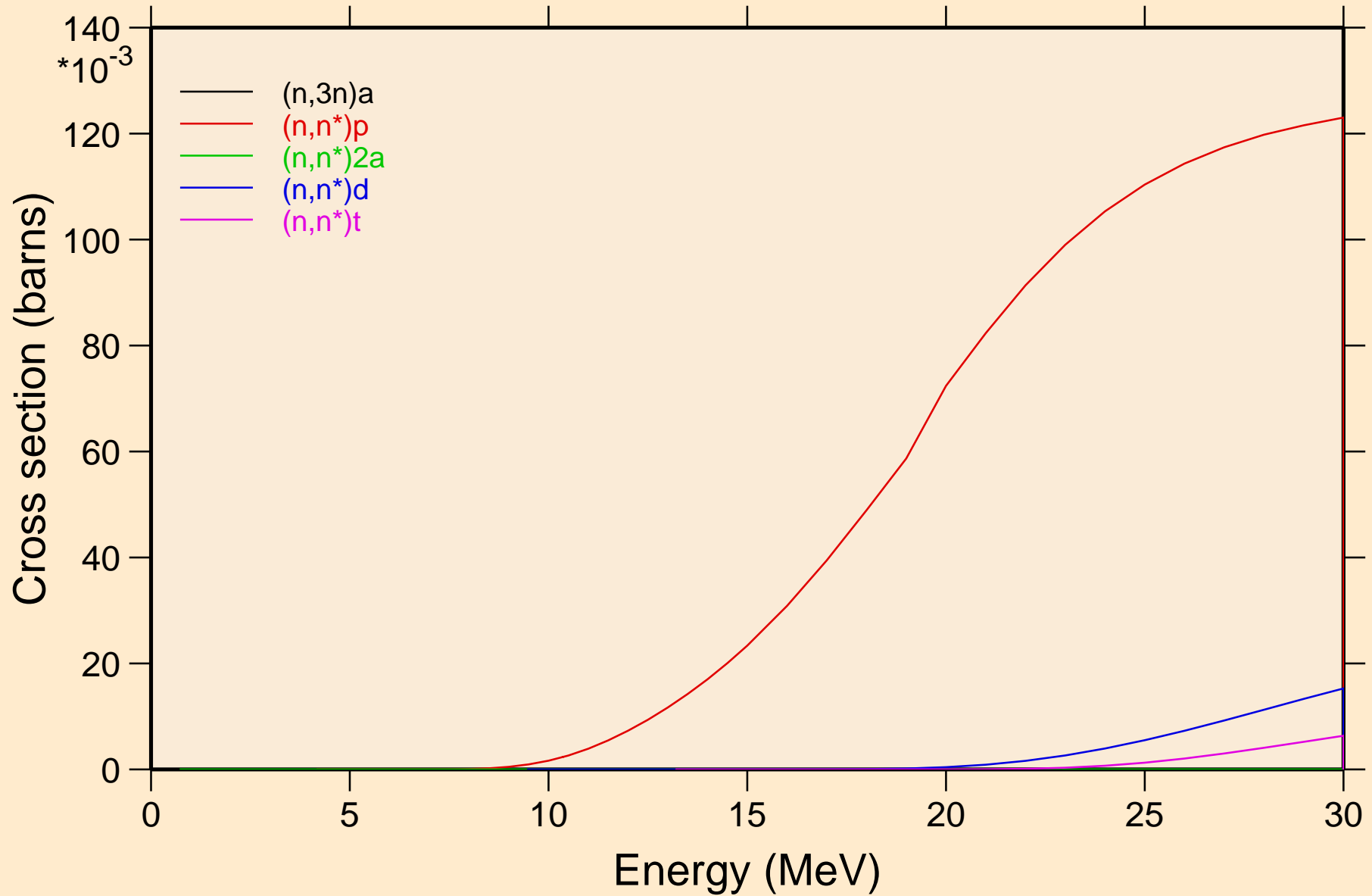

PR138M NEUTRON ACER TENDL-2023 LIBRARY; T=0.K  
Threshold reactions

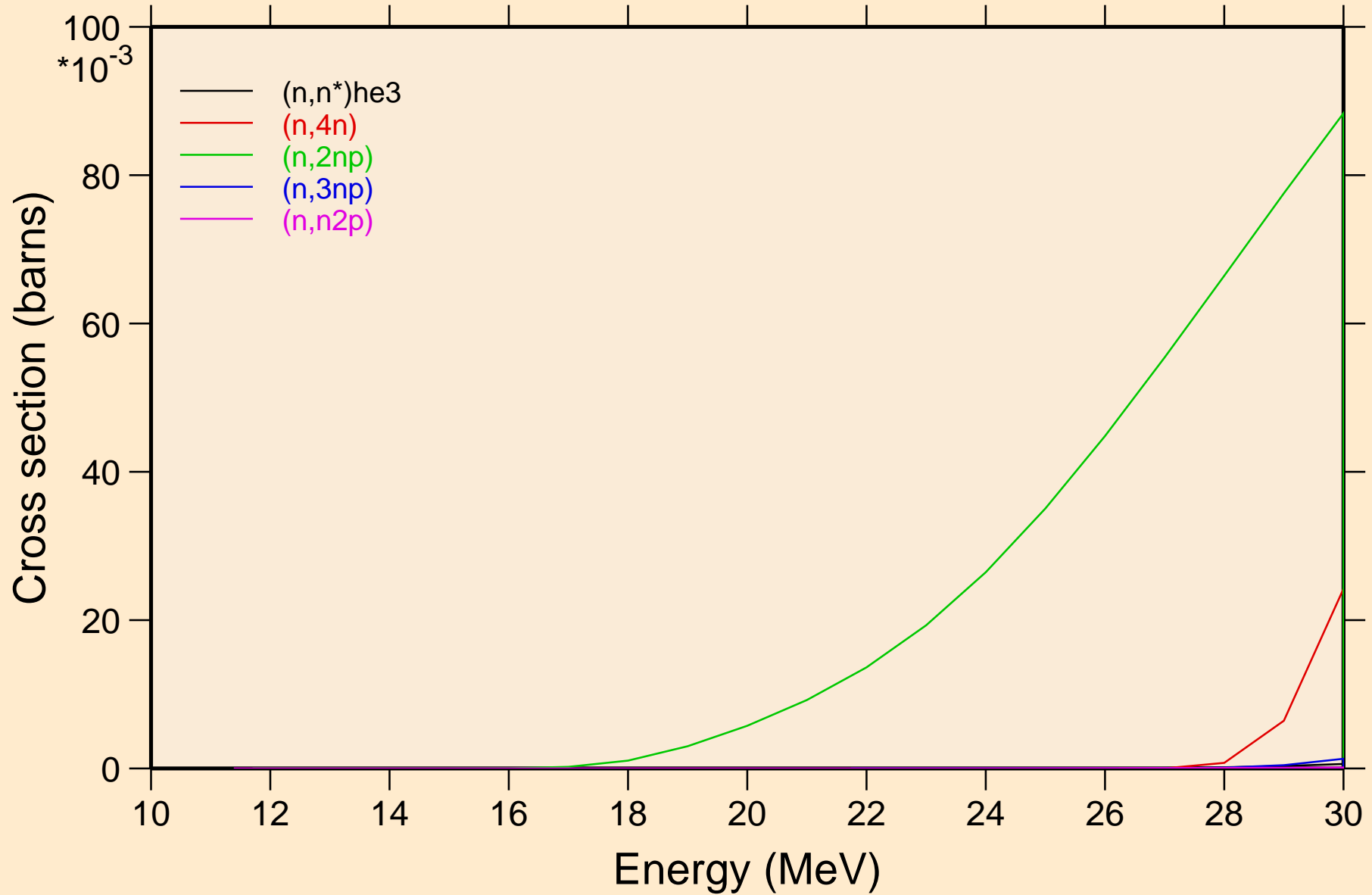

PR138M NEUTRON ACER TENDL-2023 LIBRARY; T=0.K  
Threshold reactions

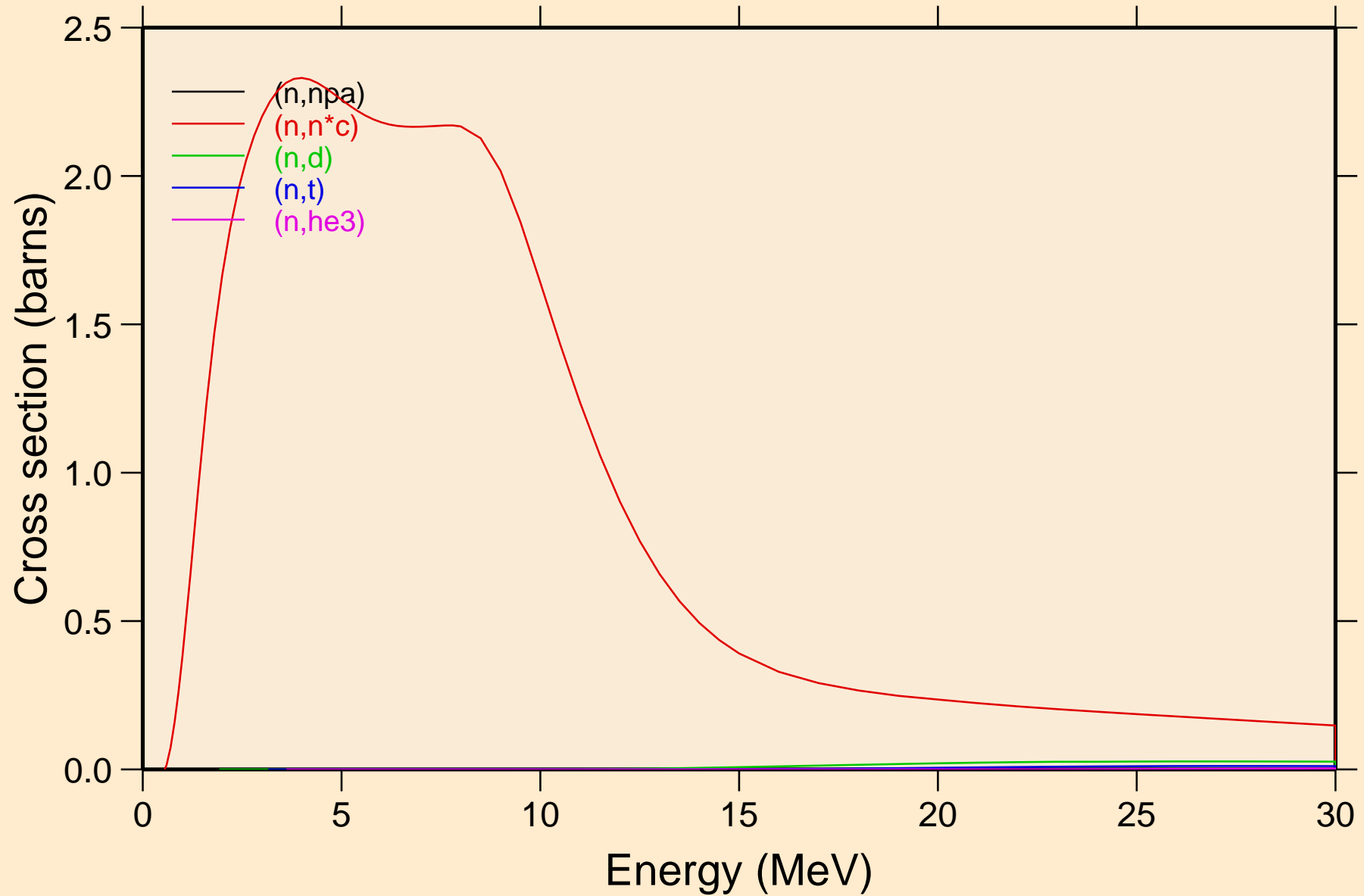



PR138M NEUTRON ACER TENDL-2023 LIBRARY; T=0.K  
Threshold reactions

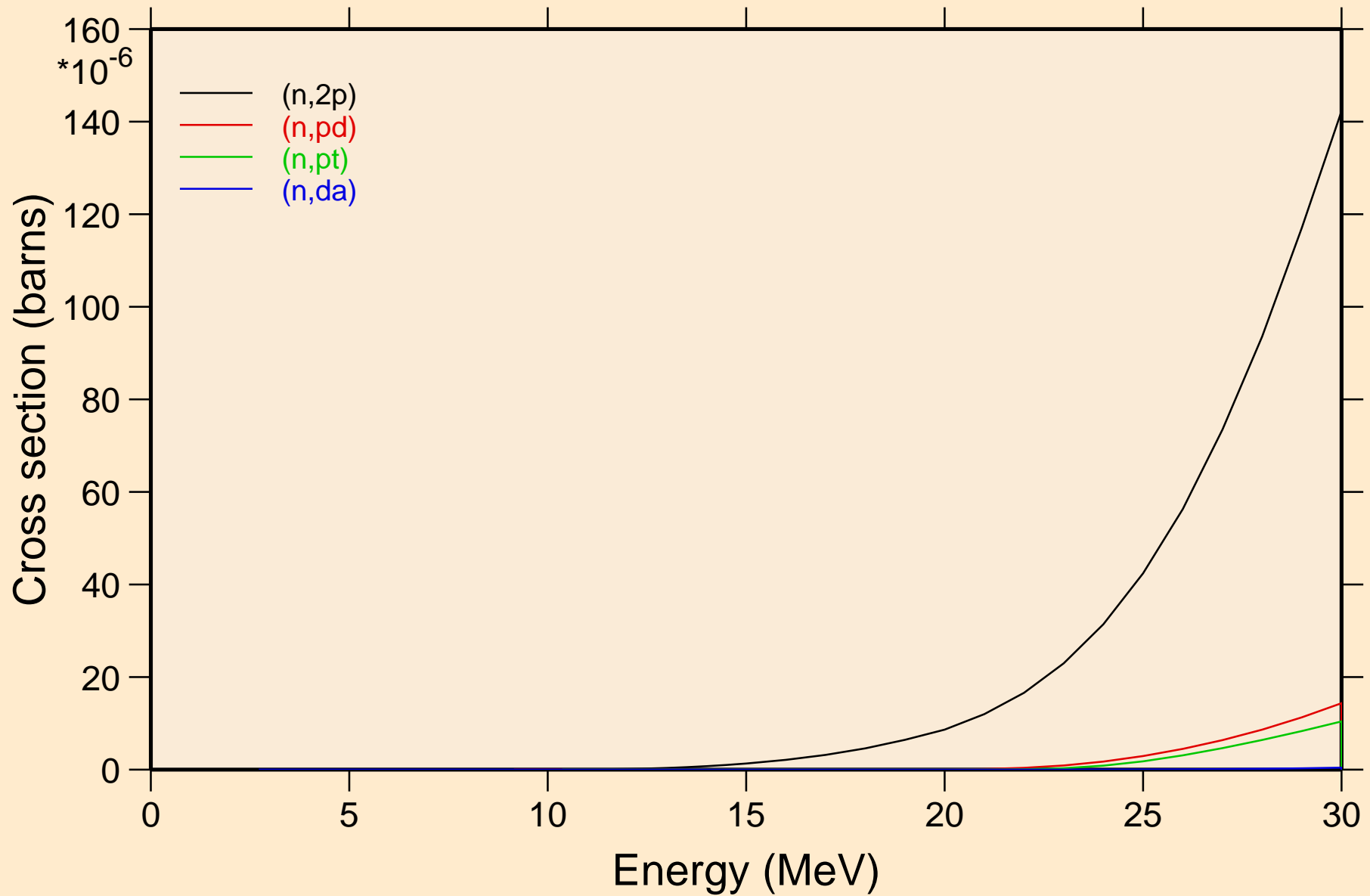

PR138M NEUTRON ACER TENDL-2023 LIBRARY; T=0.K  
Threshold reactions

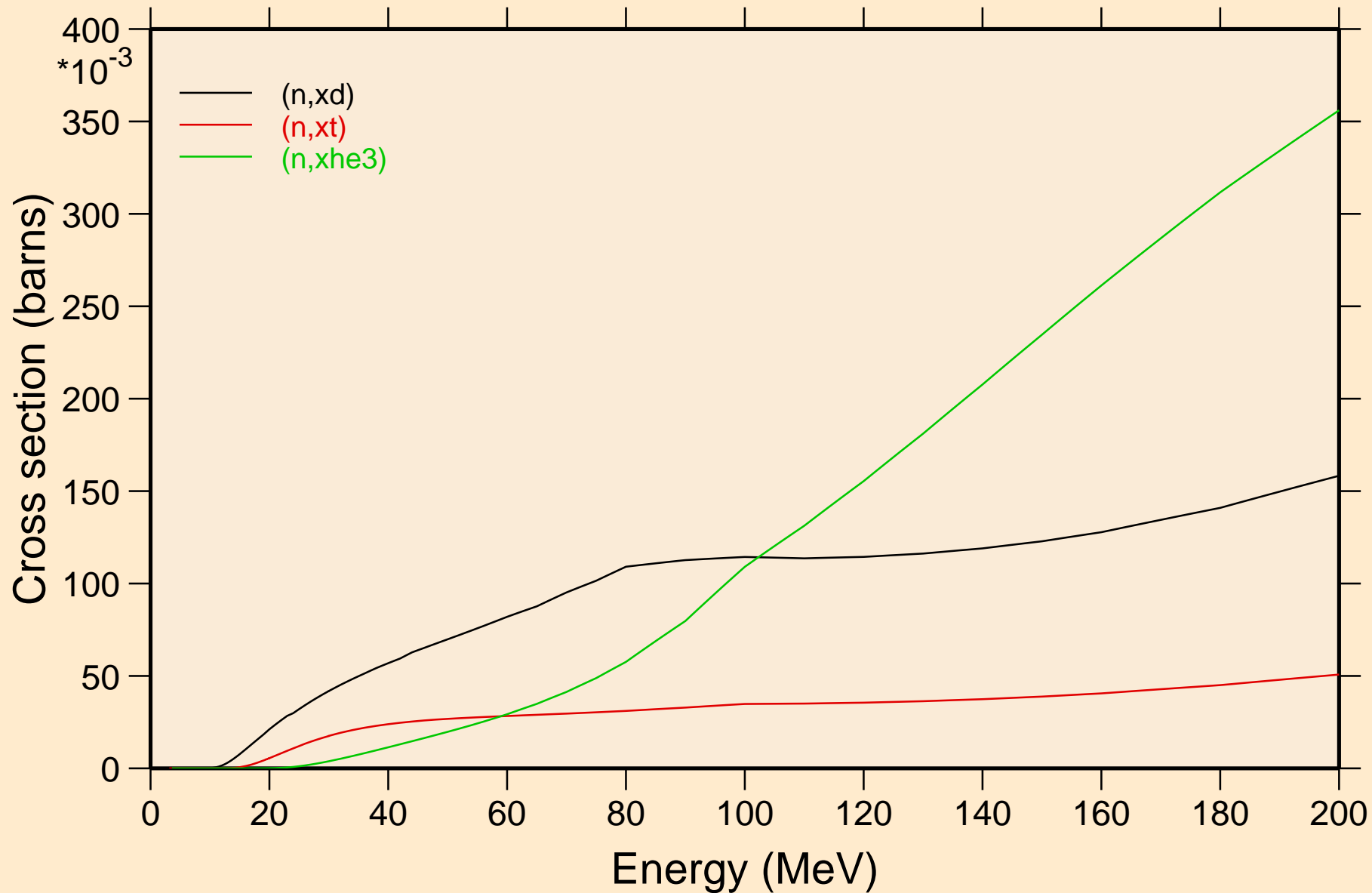

PR138M NEUTRON ACER TENDL-2023 LIBRARY; T=0.K  
angular distribution for elastic

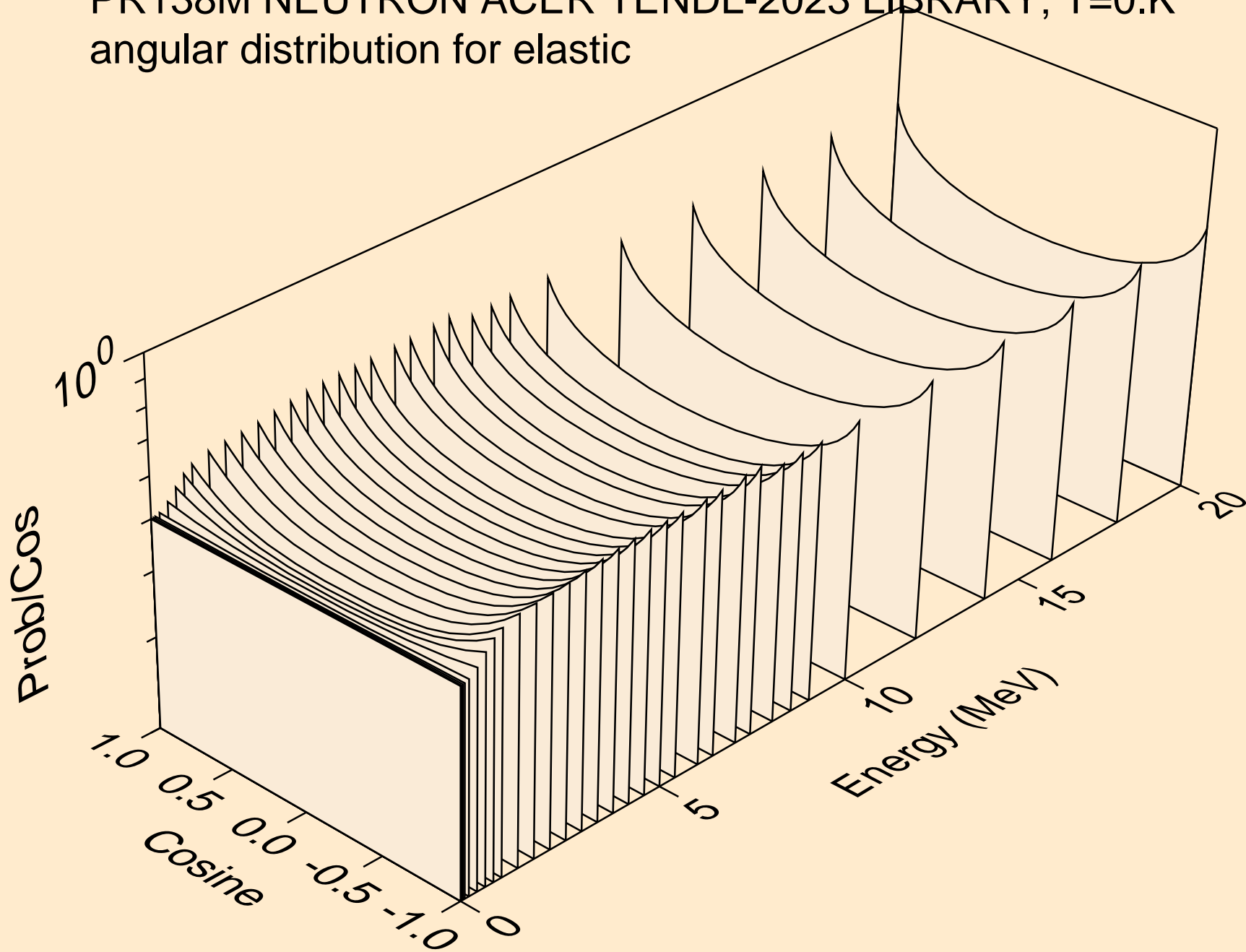

PR138M NEUTRON ACER TENDL-2023 LIBRARY; T=0.K  
angular distribution for elastic

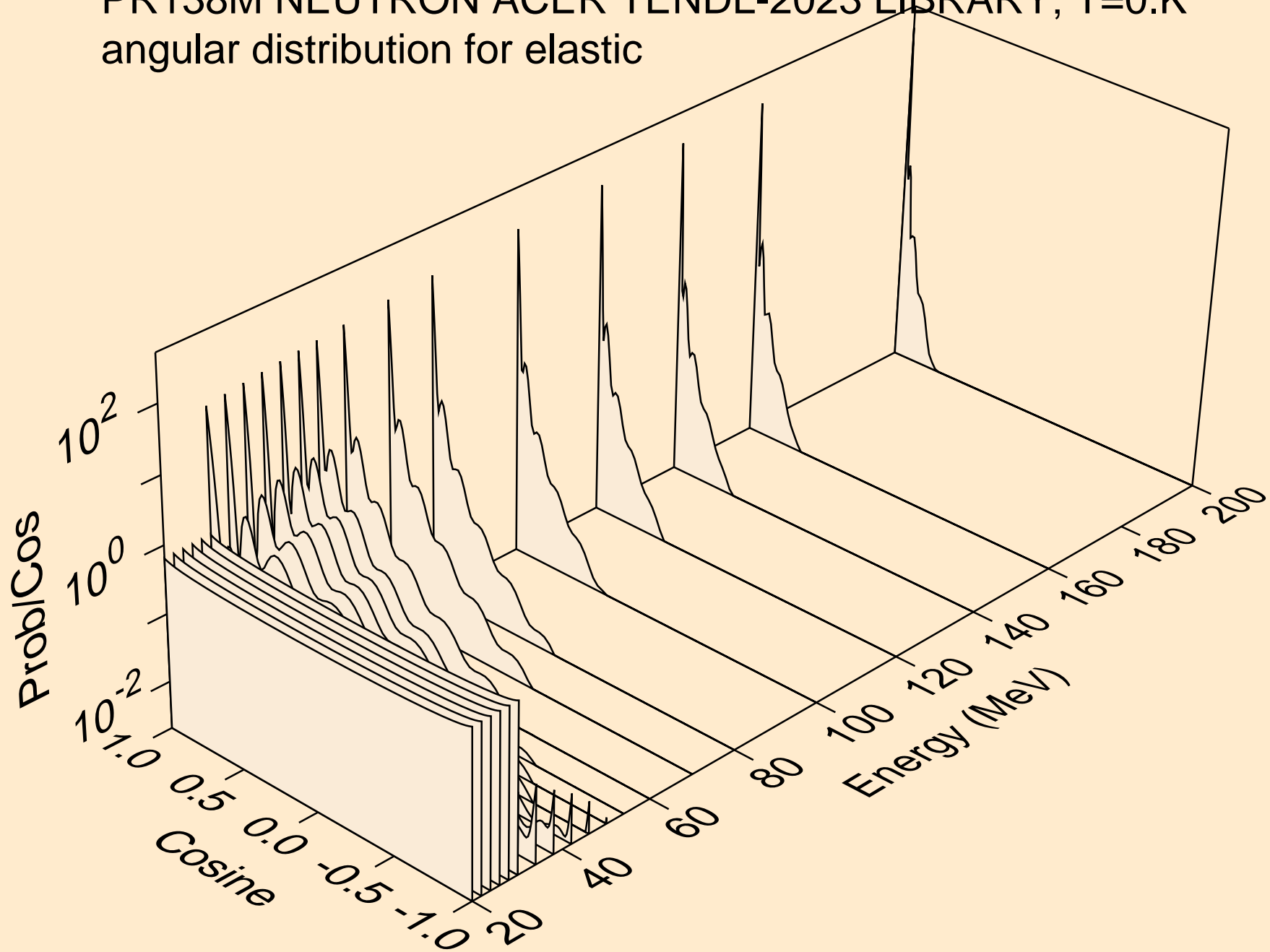

PR138M NEUTRON ACER TENDL-2023 LIBRARY; T=0.K  
angular distribution for (n,n\*1)

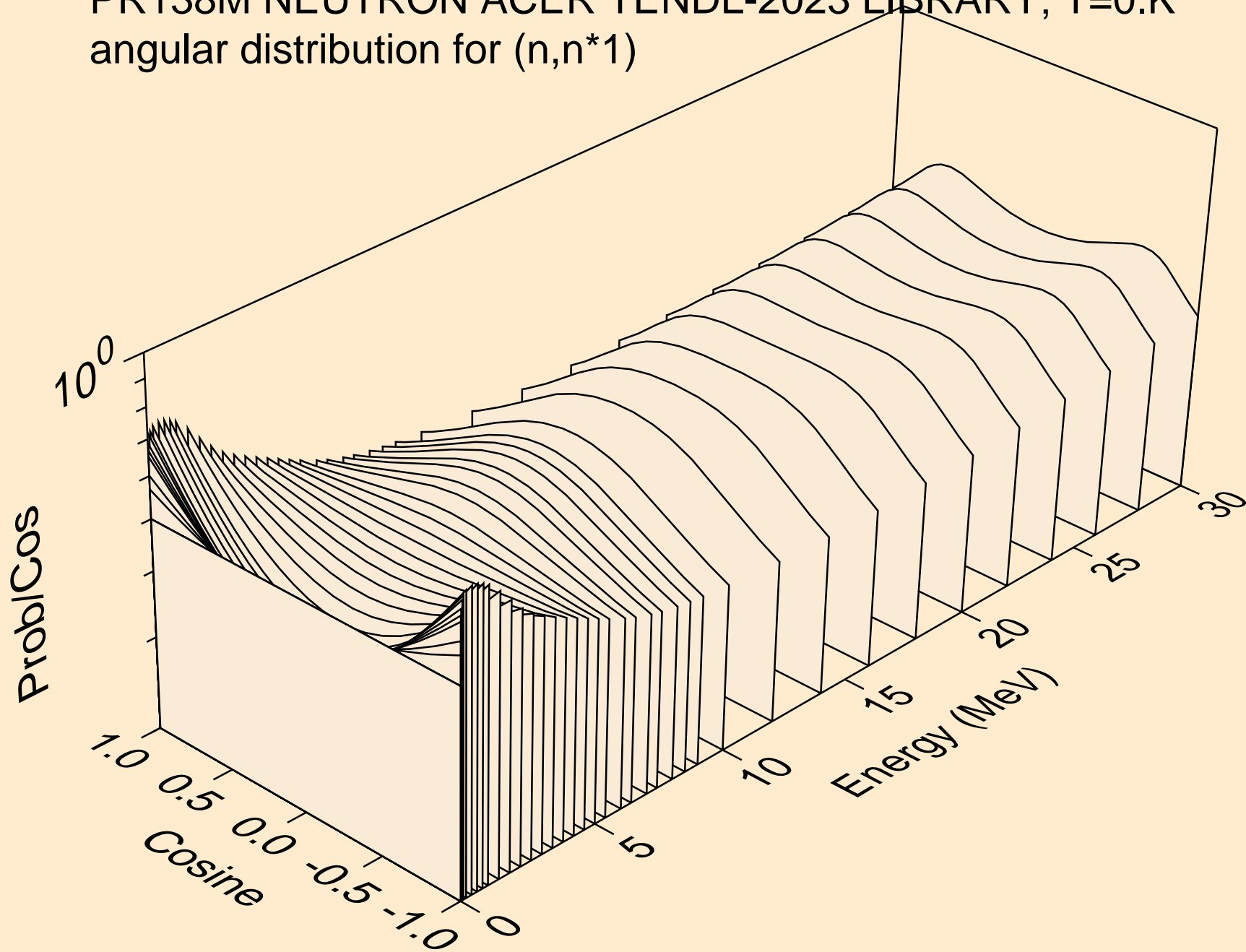

PR138M NEUTRON ACER TENDL-2023 LIBRARY; T=0.K  
angular distribution for (n,n\*2)

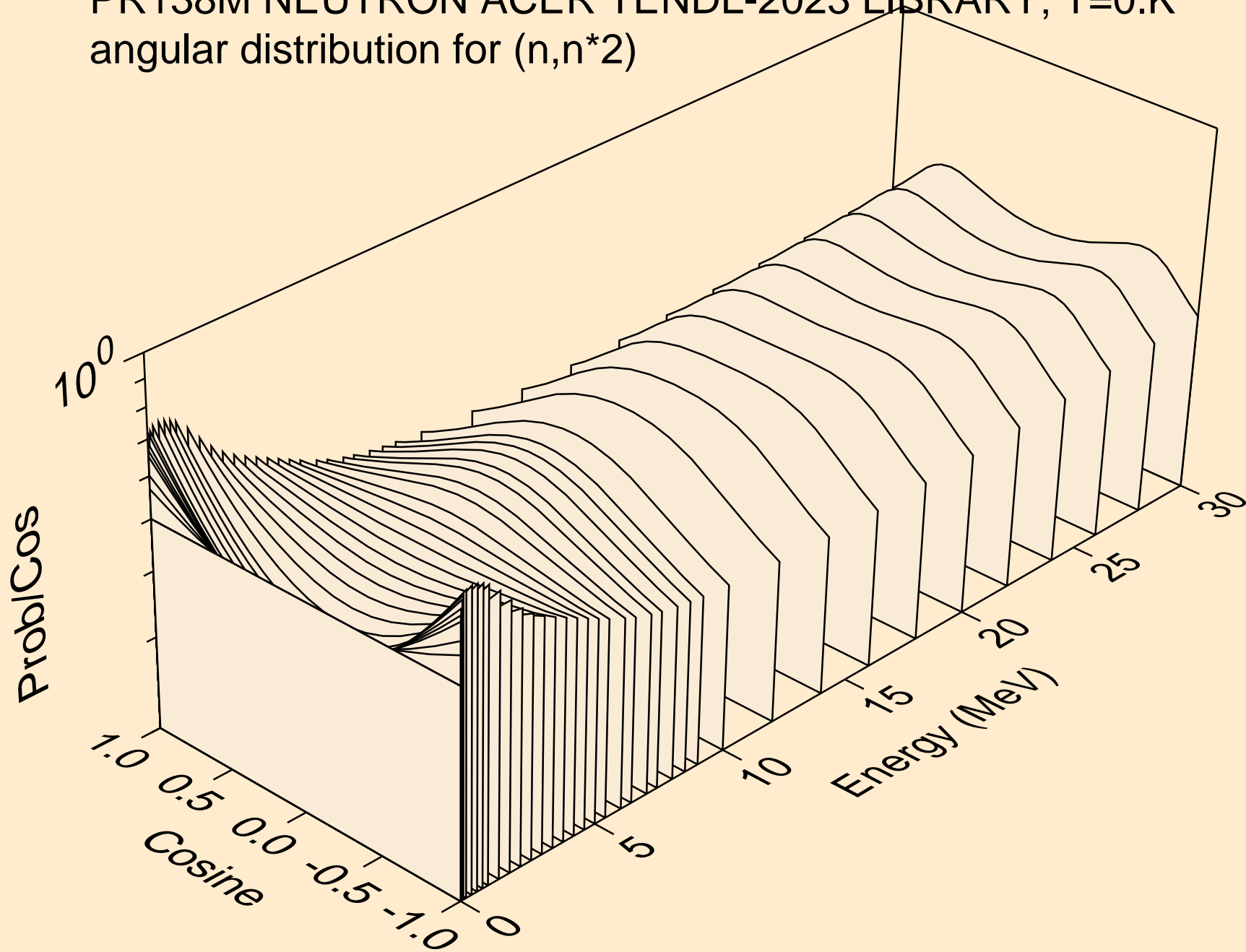

PR138M NEUTRON ACER TENDL-2023 LIBRARY; T=0.K  
angular distribution for (n,n\*3)

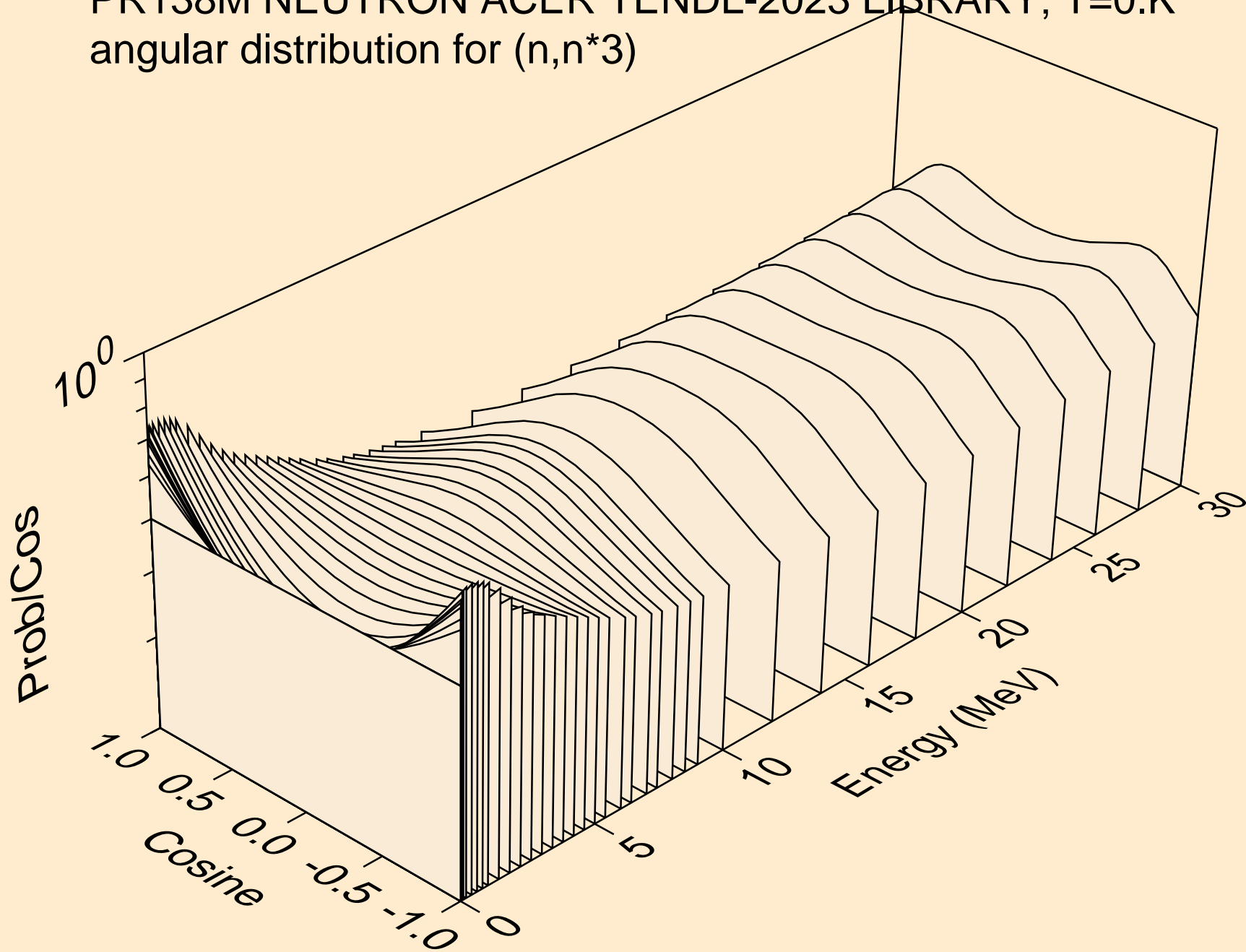

PR138M NEUTRON ACER TENDL-2023 LIBRARY; T=0.K  
angular distribution for (n,n\*4)

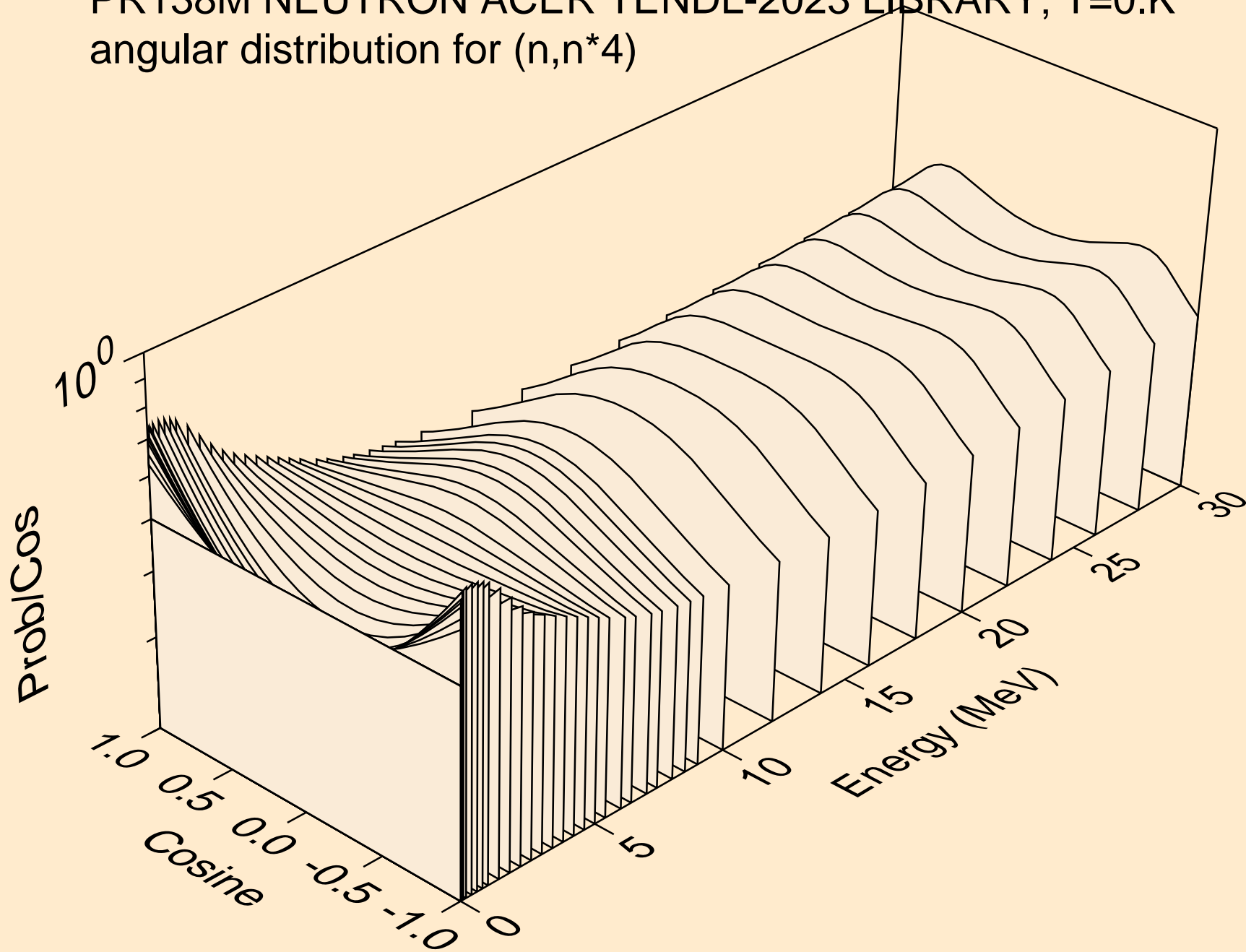



PR138M NEUTRON ACER TENDL-2023 LIBRARY; T=0.K  
angular distribution for (n,n\*5)

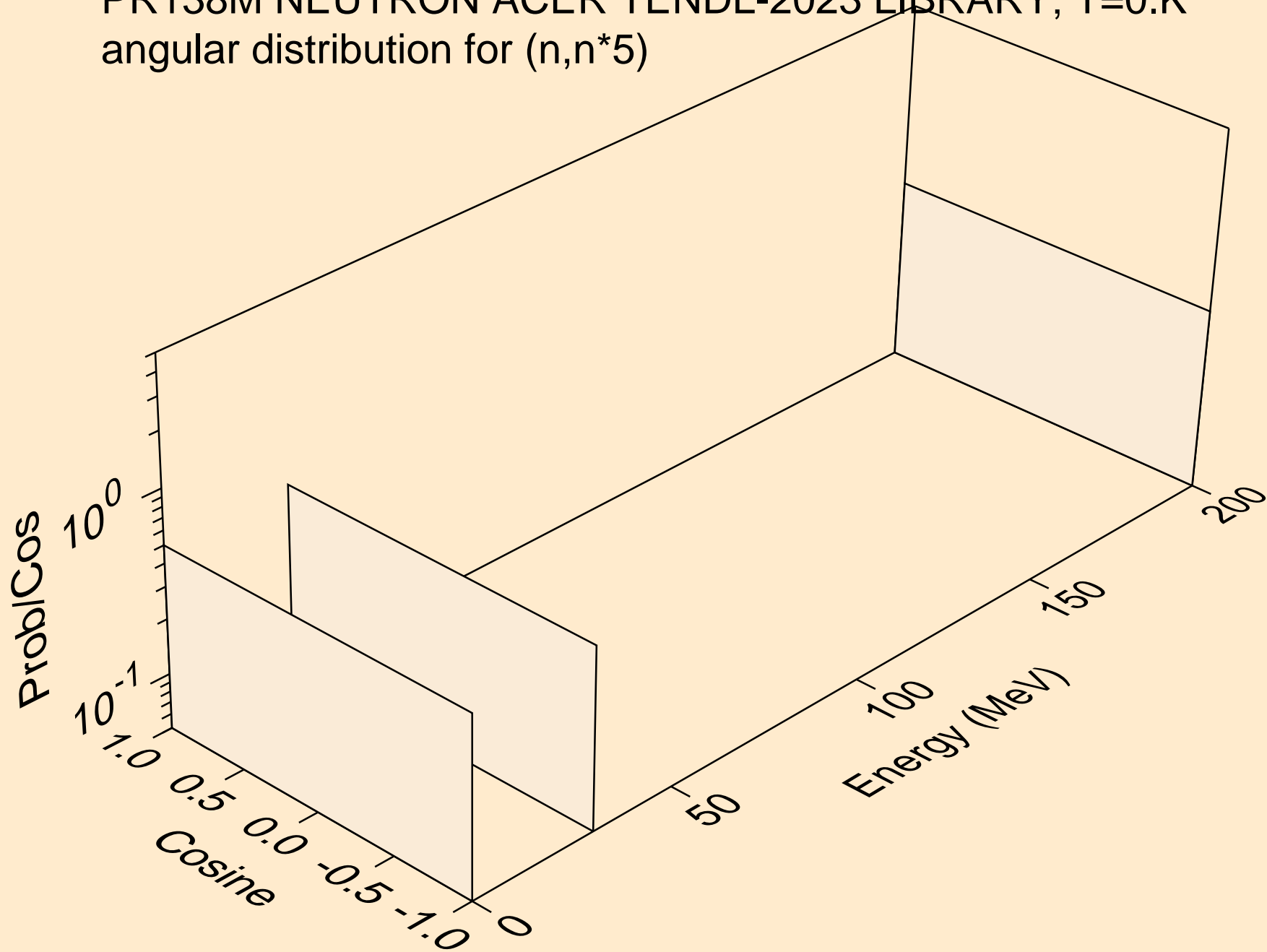

PR138M NEUTRON ACER TENDL-2023 LIBRARY; T=0.K  
angular distribution for (n,n\*6)

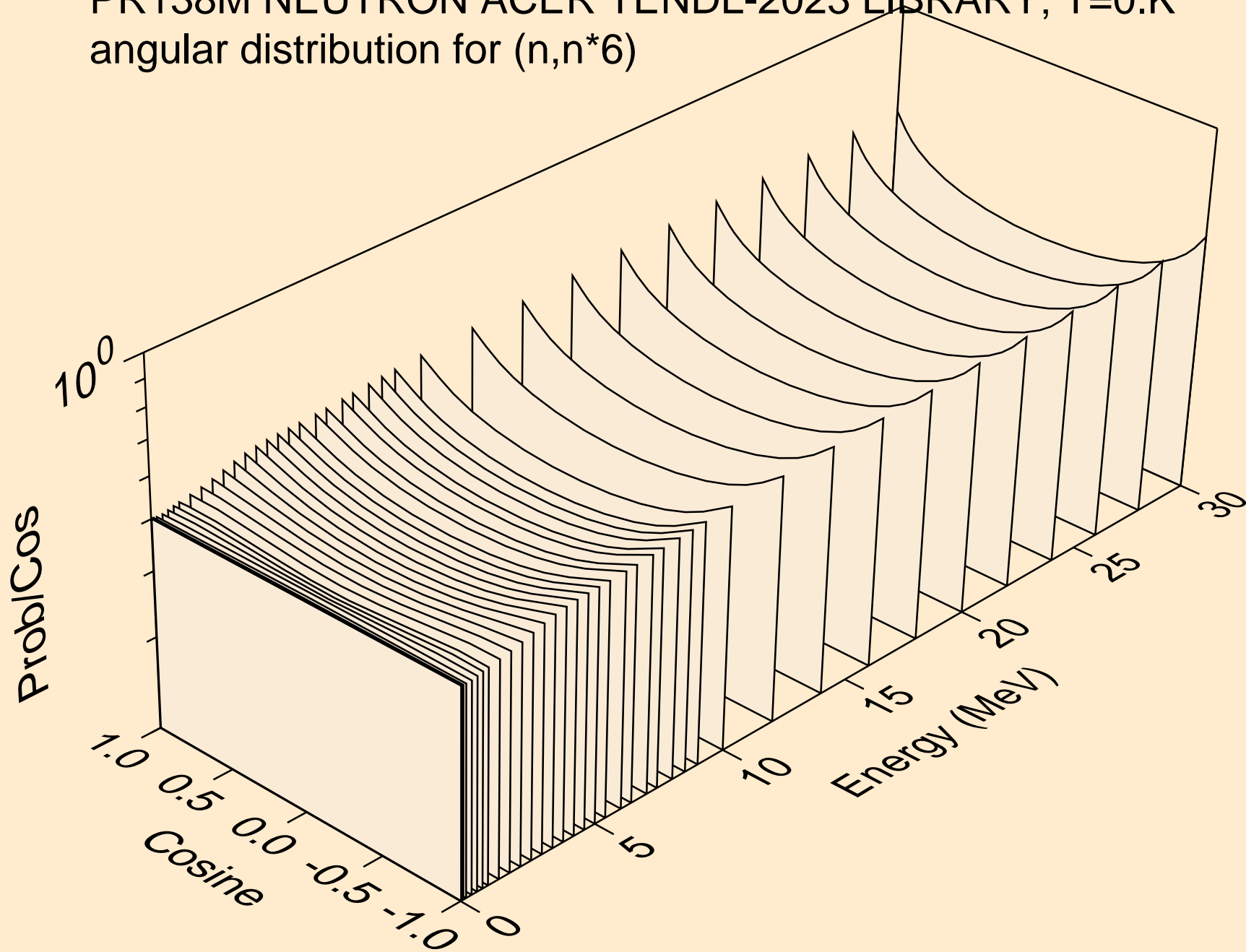

PR138M NEUTRON ACER TENDL-2023 LIBRARY; T=0.K  
angular distribution for (n,n\*7)

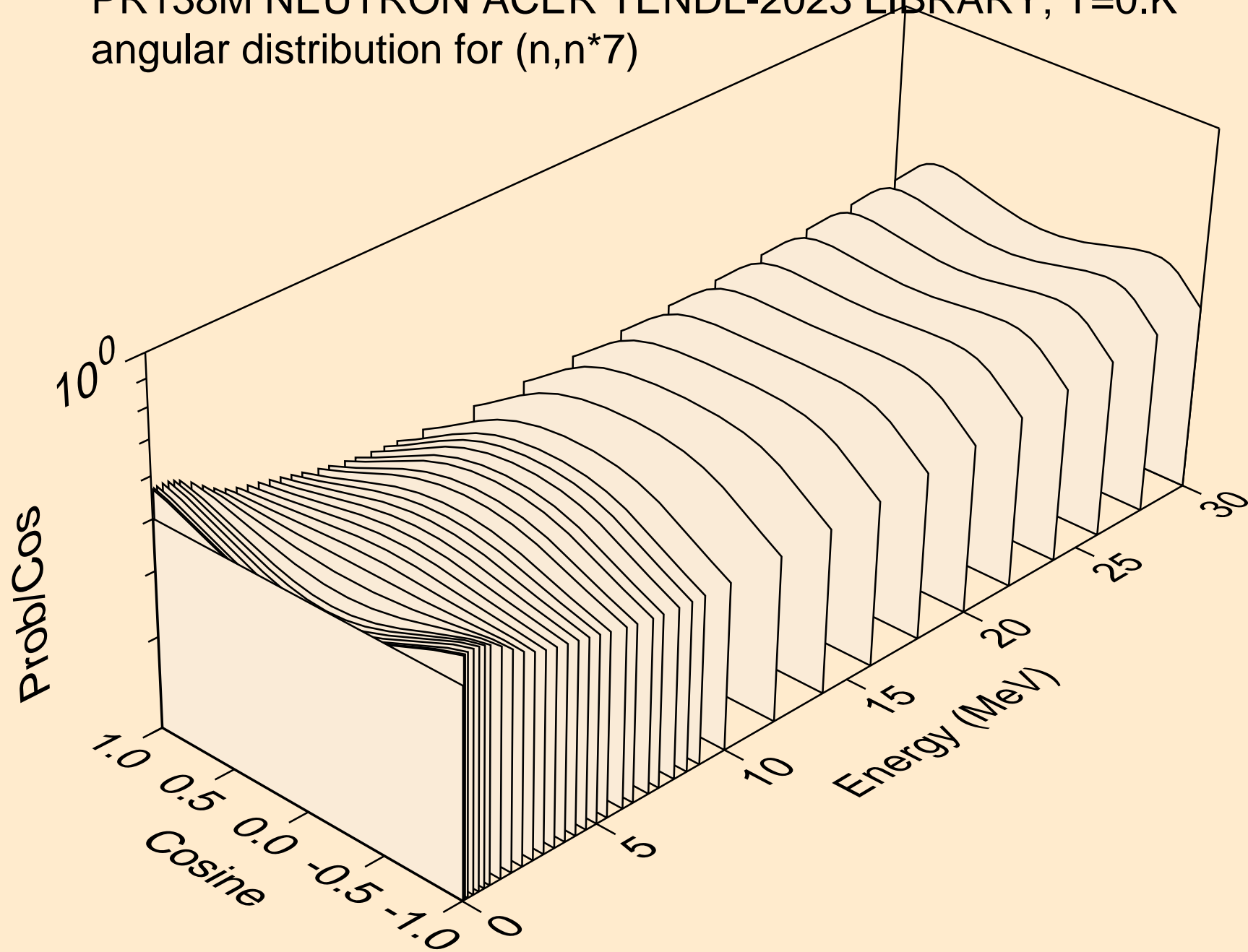

PR138M NEUTRON ACER TENDL-2023 LIBRARY; T=0.K  
angular distribution for (n,n\*8)

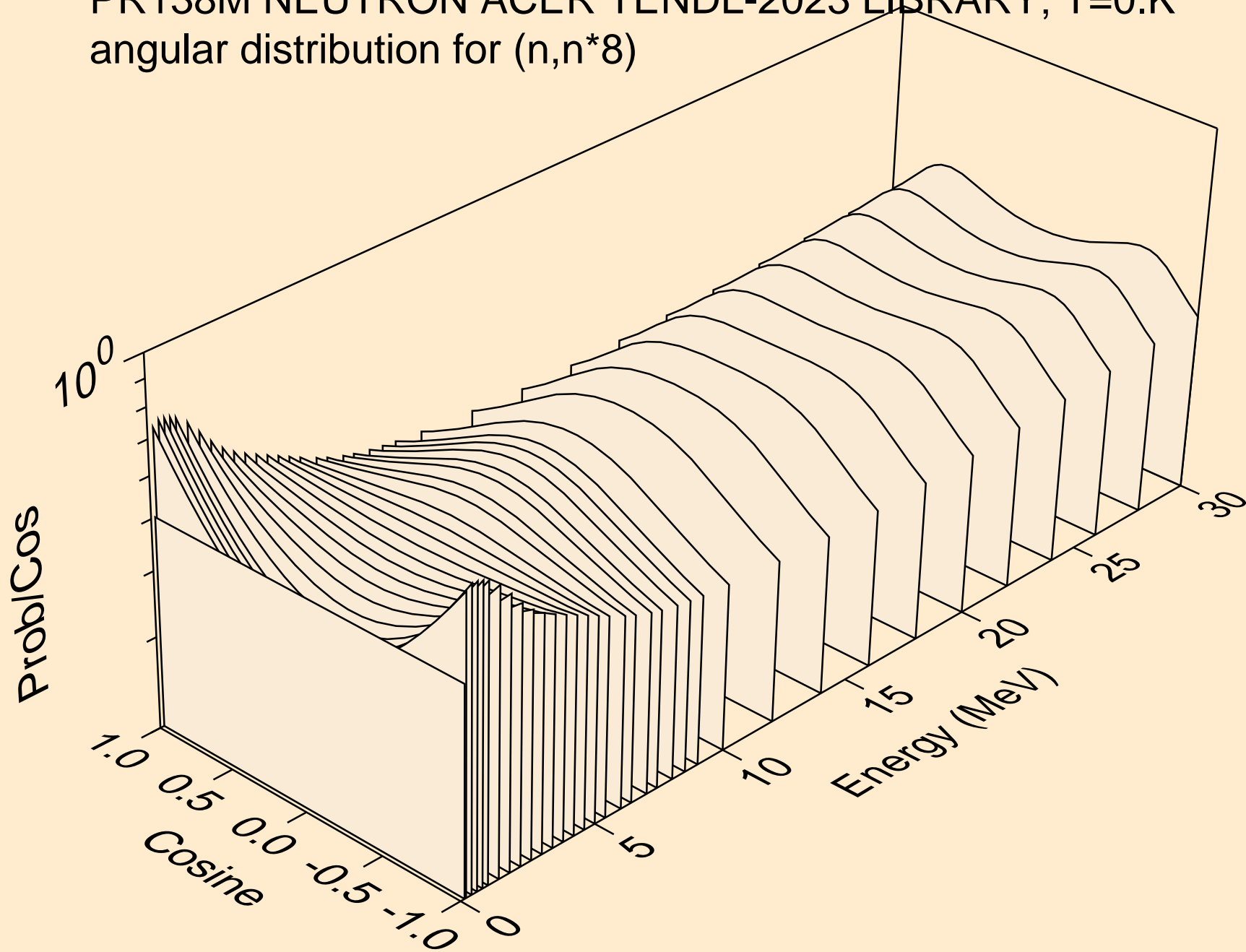

PR138M NEUTRON ACER TENDL-2023 LIBRARY; T=0.K  
angular distribution for (n,n\*9)

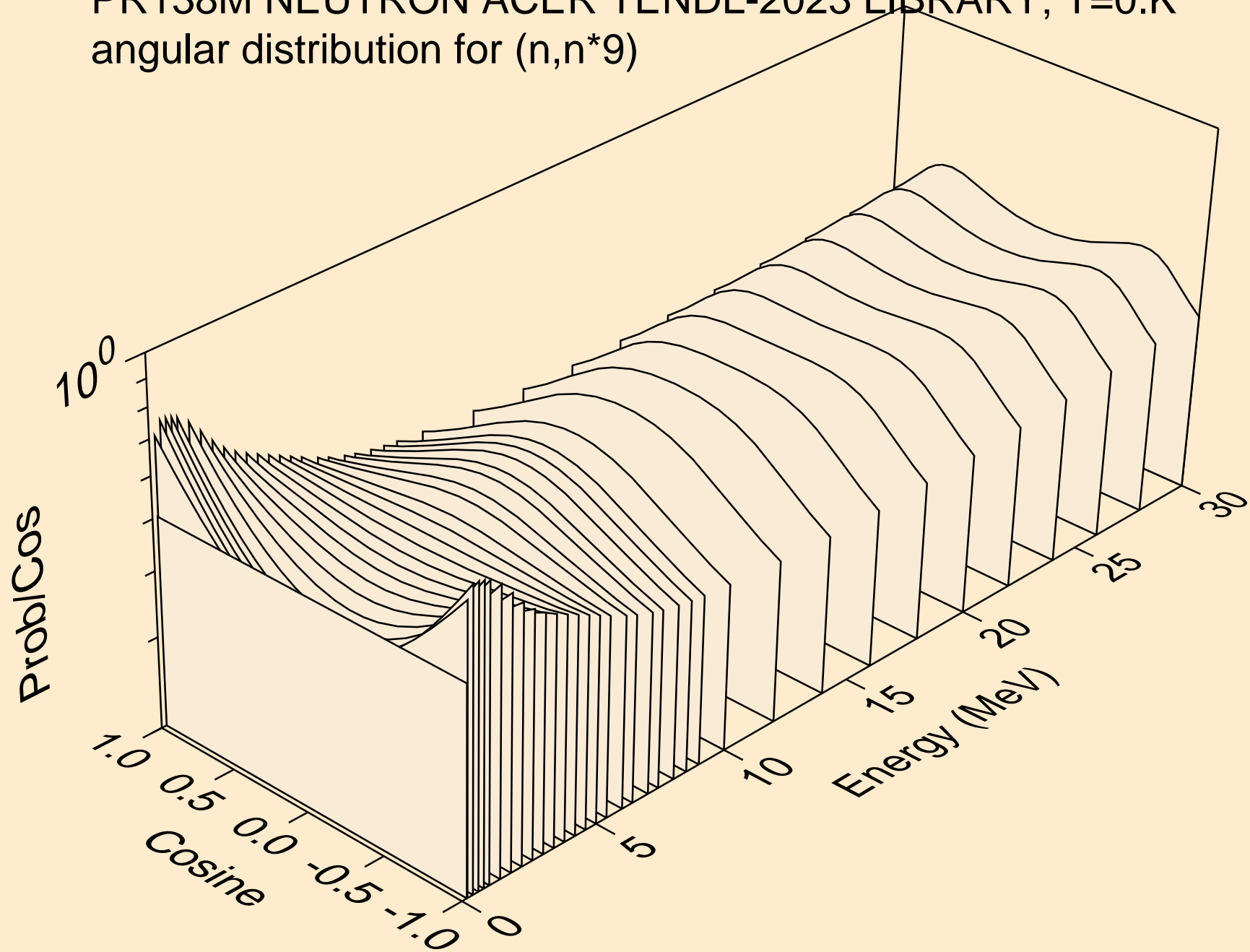

PR138M NEUTRON ACER TENDL-2023 LIBRARY; T=0.K  
angular distribution for (n,n\*10)

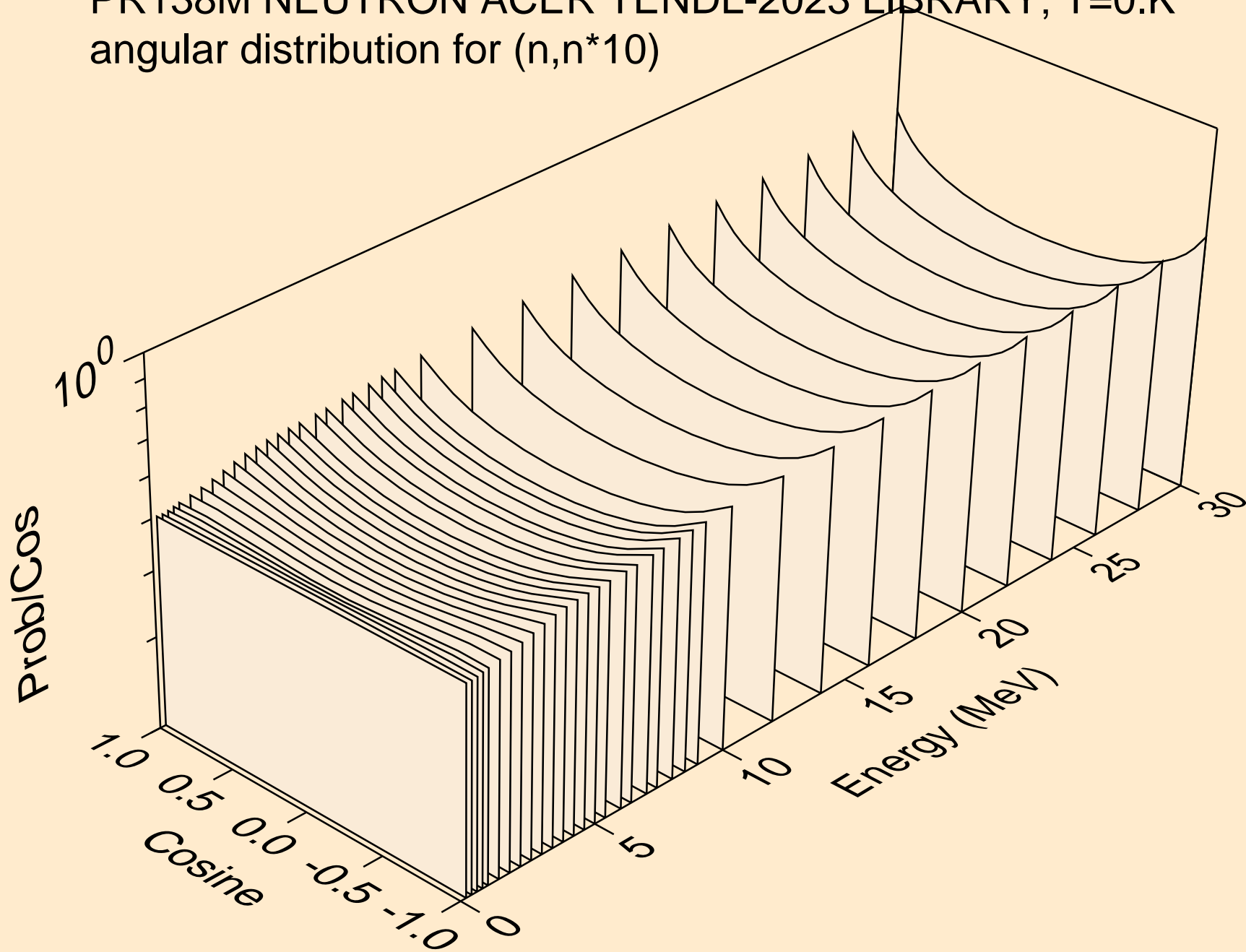

PR138M NEUTRON ACER TENDL-2023 LIBRARY; T=0.K  
angular distribution for (n,n\*11)

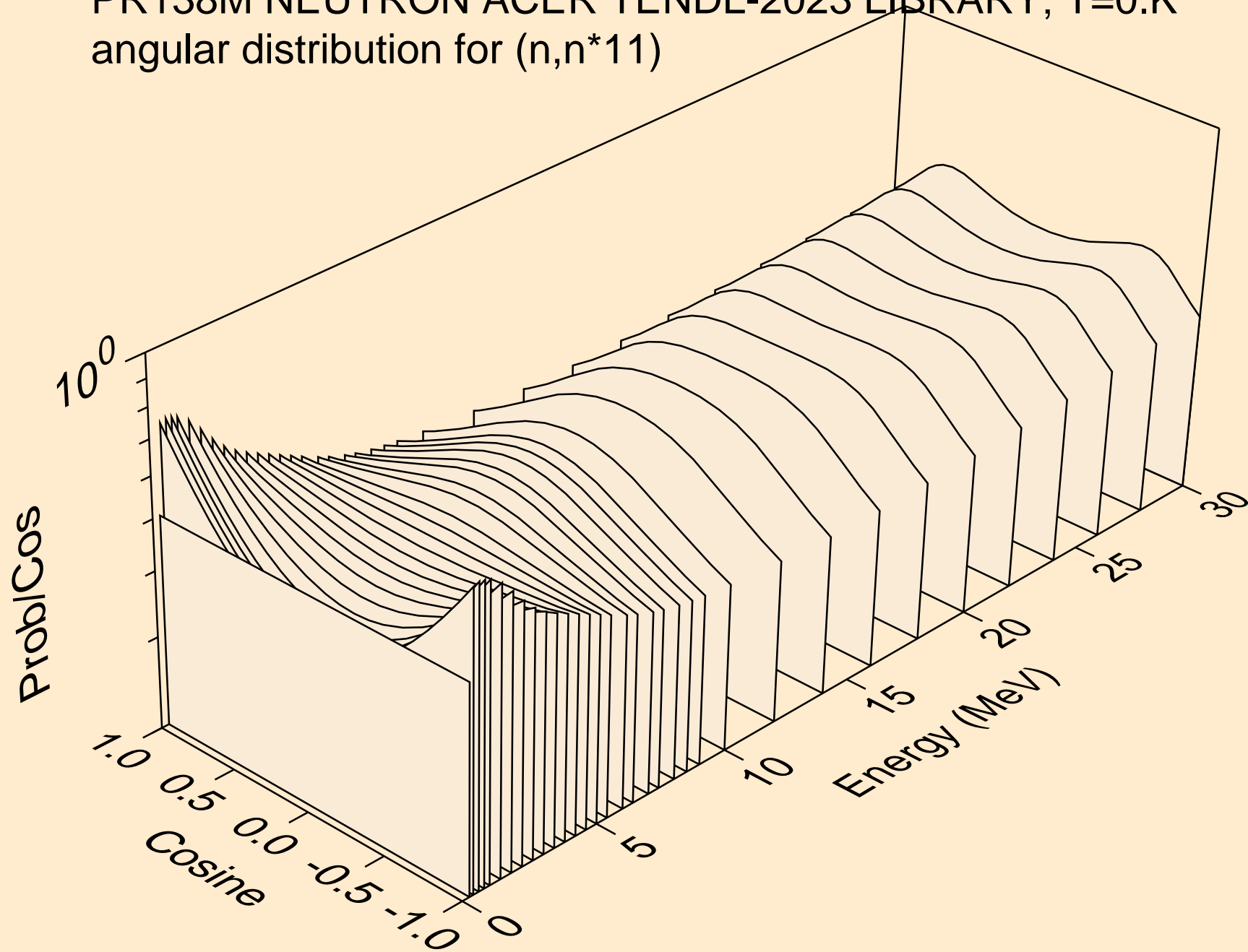

PR138M NEUTRON ACER TENDL-2023 LIBRARY; T=0.K  
angular distribution for (n,n\*12)

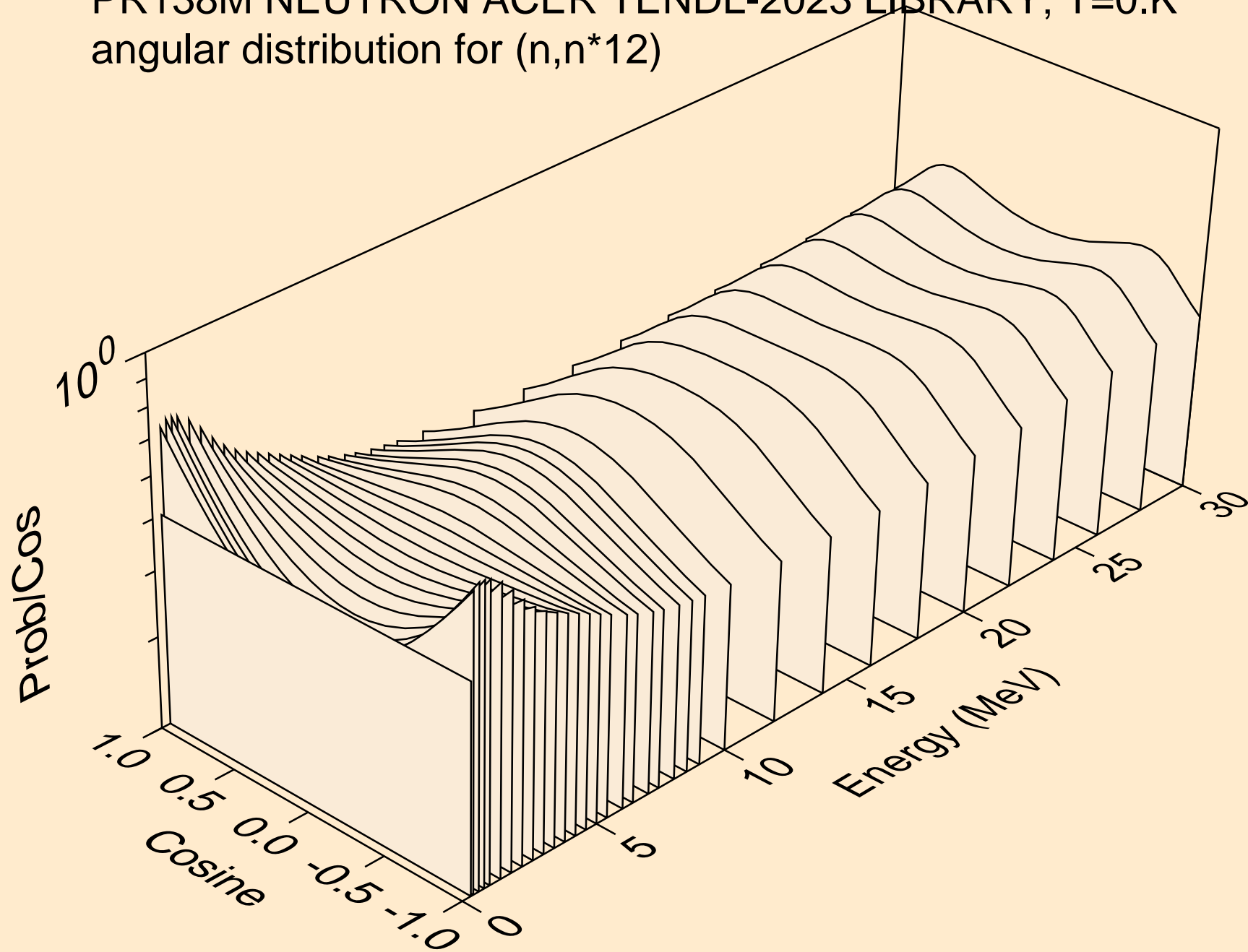



PR138M NEUTRON ACER TENDL-2023 LIBRARY; T=0.K  
angular distribution for (n,n\*13)

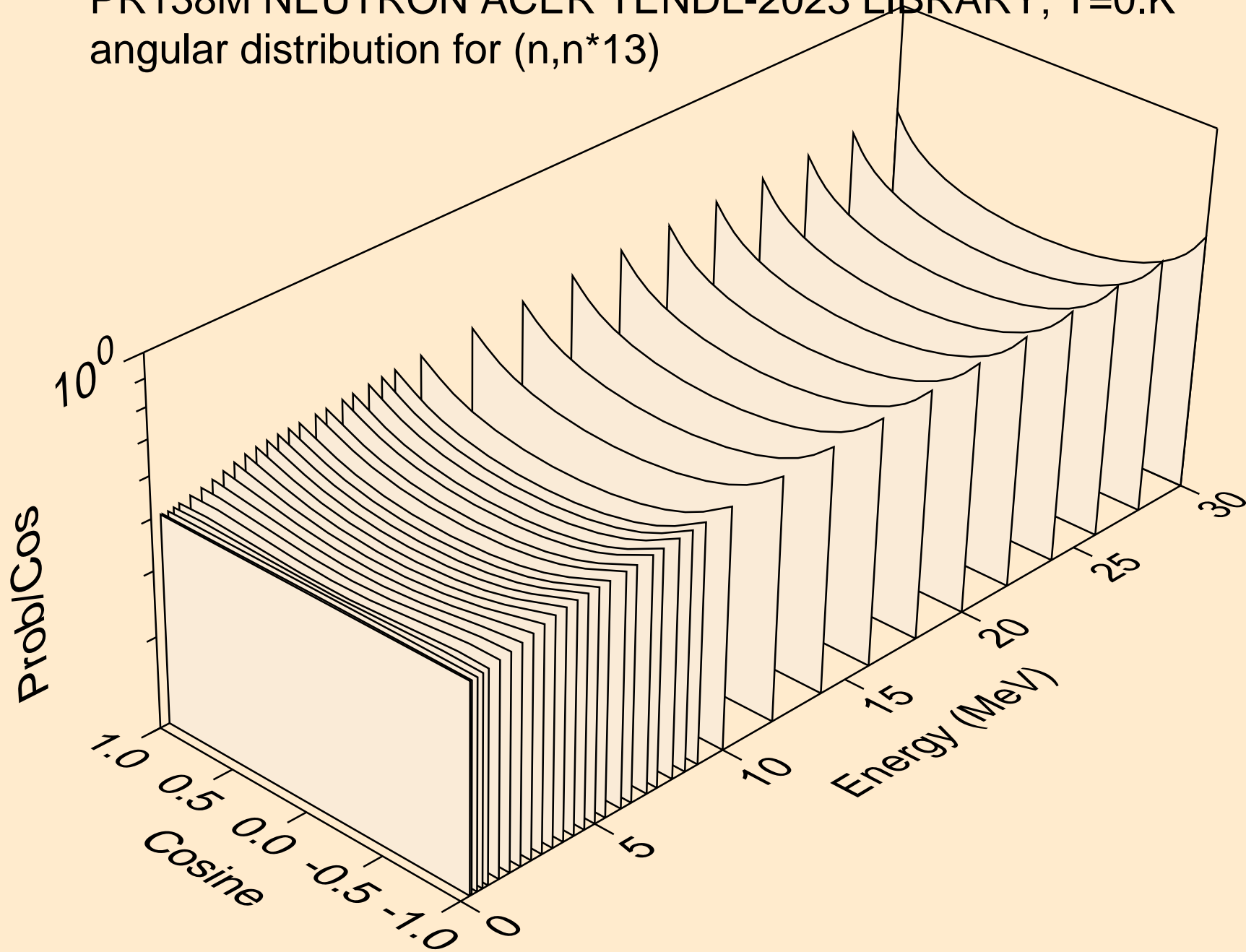

PR138M NEUTRON ACER TENDL-2023 LIBRARY; T=0.K  
angular distribution for (n,n\*14)

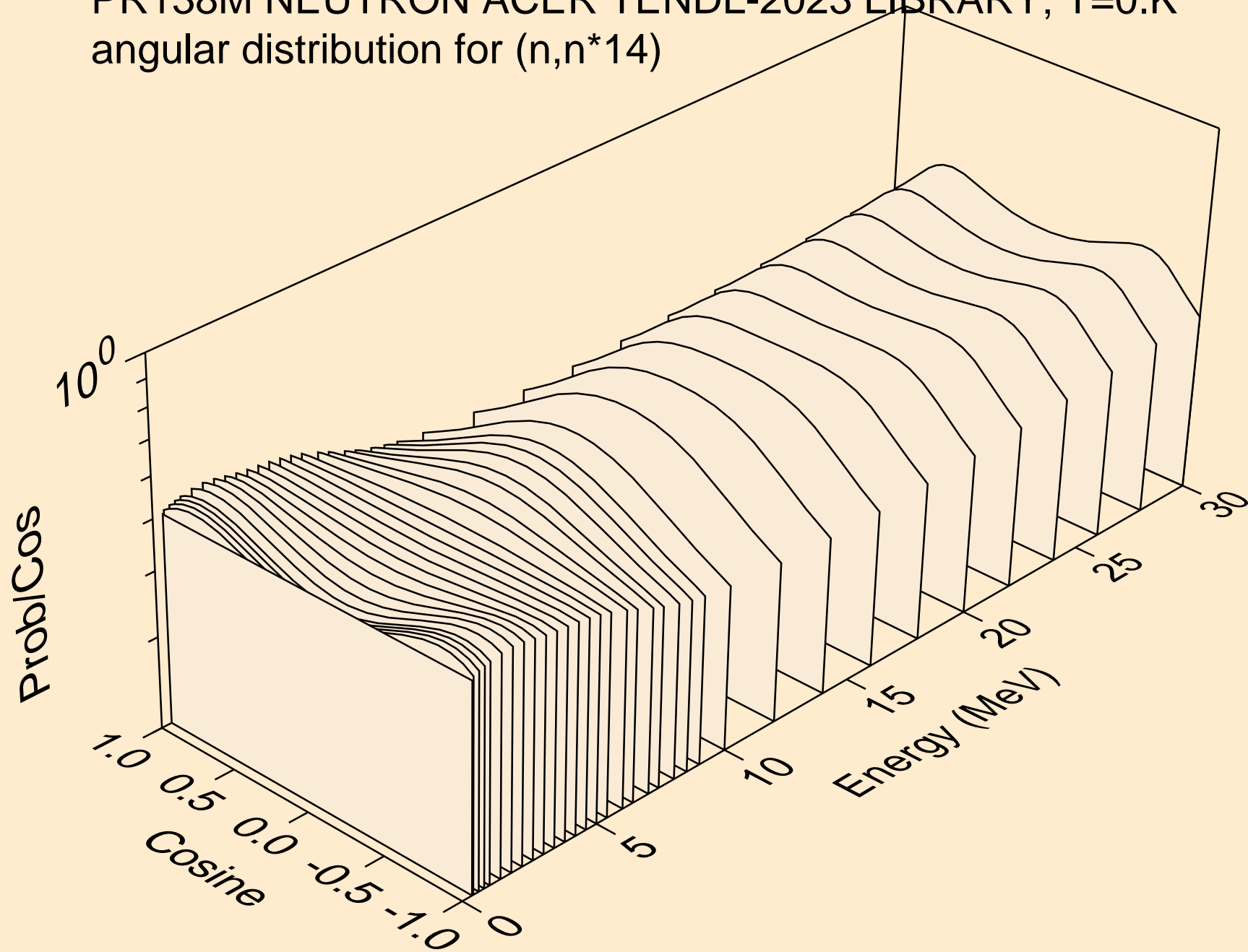

PR138M NEUTRON ACER TENDL-2023 LIBRARY; T=0.K  
angular distribution for (n,n\*15)

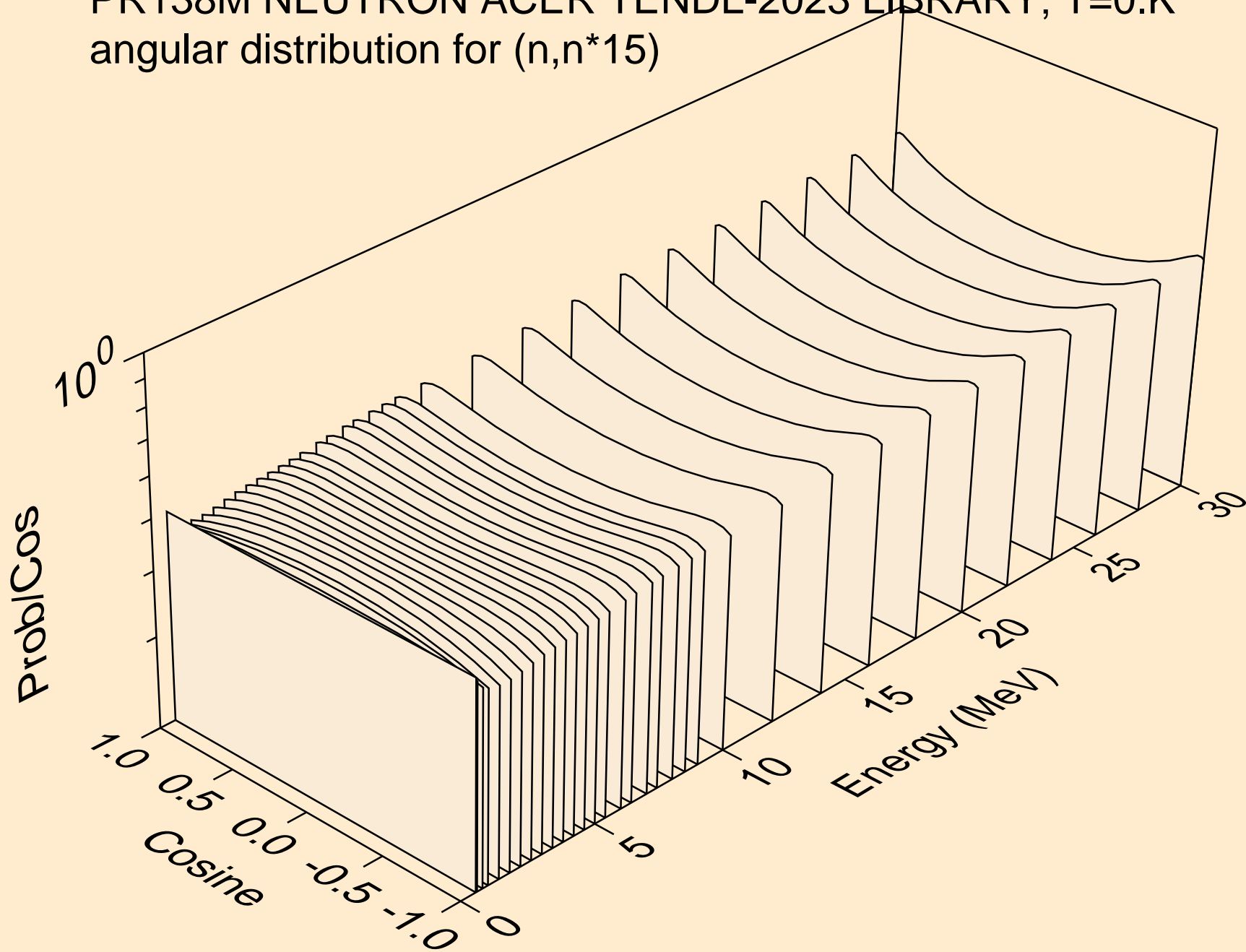

PR138M NEUTRON ACER TENDL-2023 LIBRARY; T=0.K  
Neutron emission for (n,x)

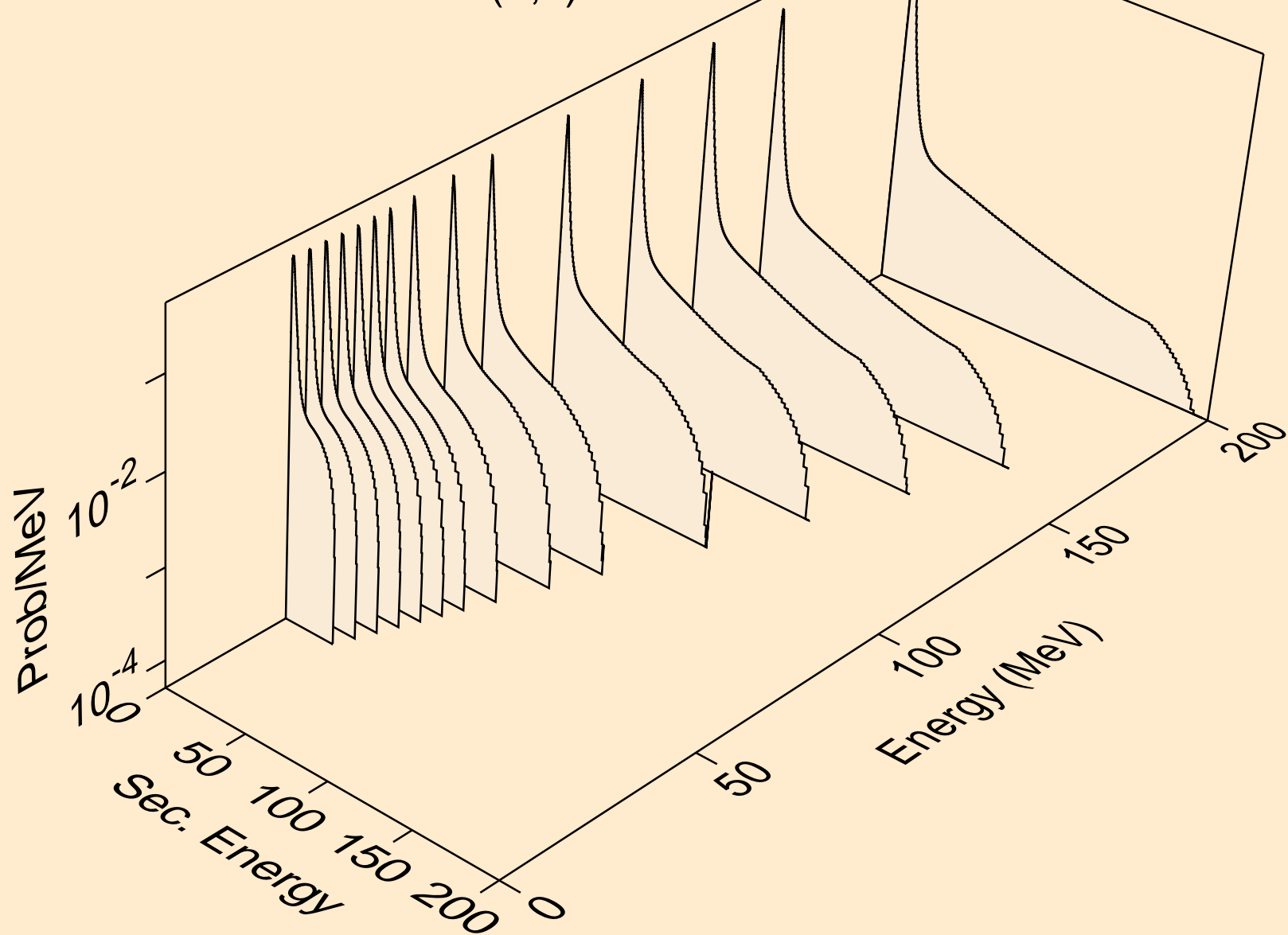

PR138M NEUTRON ACER TENDL-2023 LIBRARY; T=0.K  
Neutron emission for (n,2nd)

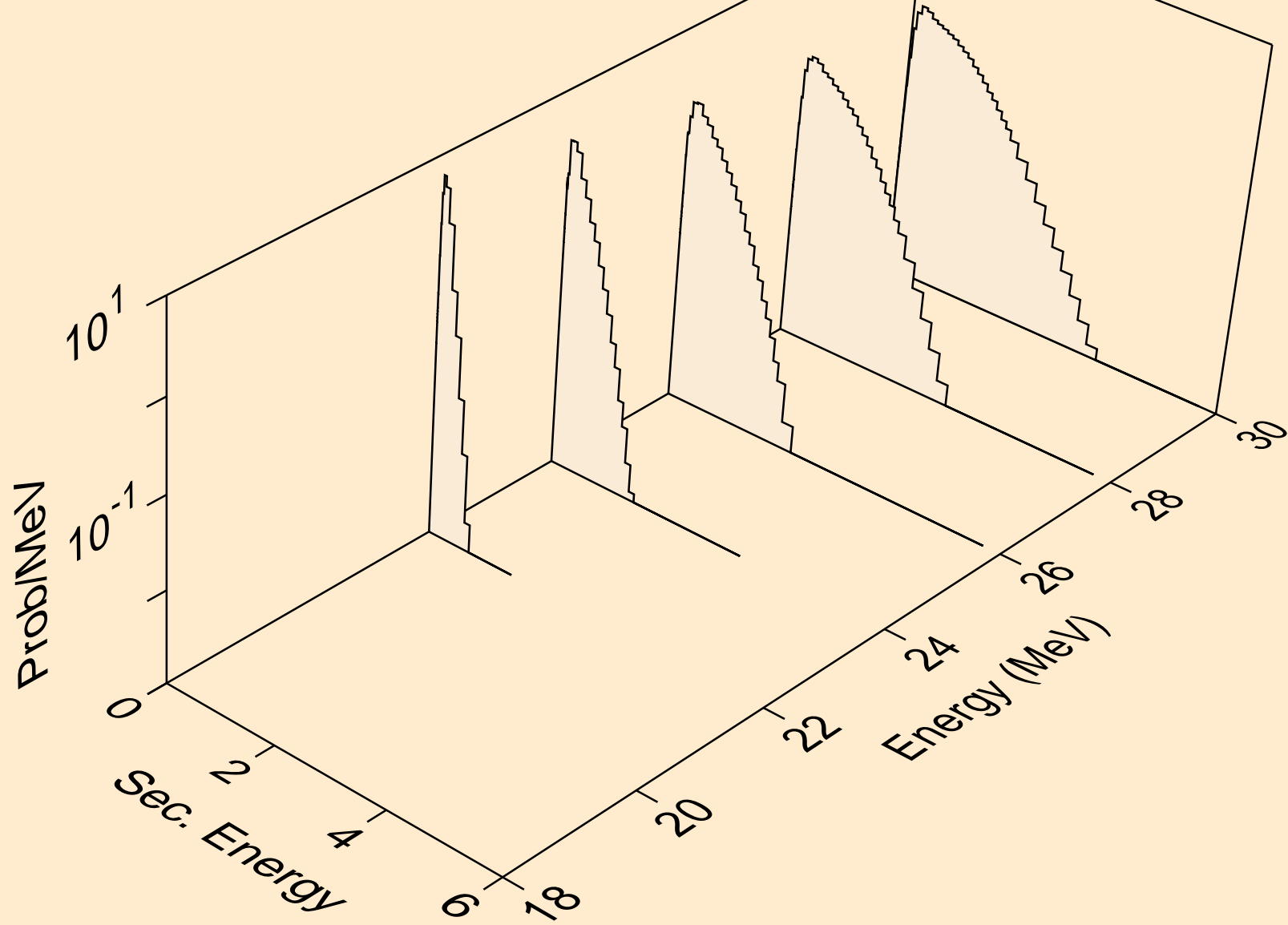

PR138M NEUTRON ACER TENDL-2023 LIBRARY; T=0.K  
Neutron emission for (n,2n)

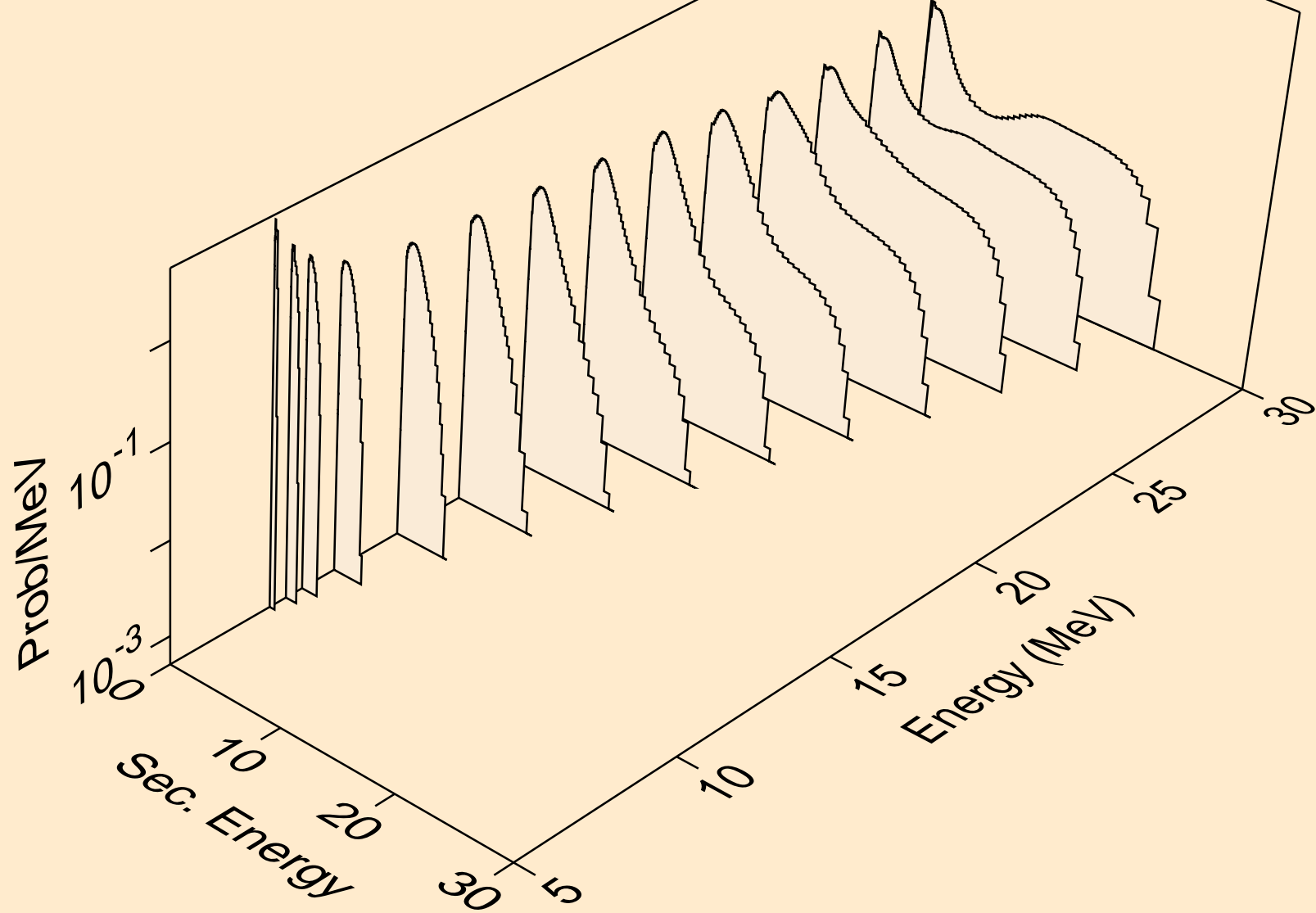

PR138M NEUTRON ACER TENDL-2023 LIBRARY; T=0.K  
Neutron emission for (n,3n)

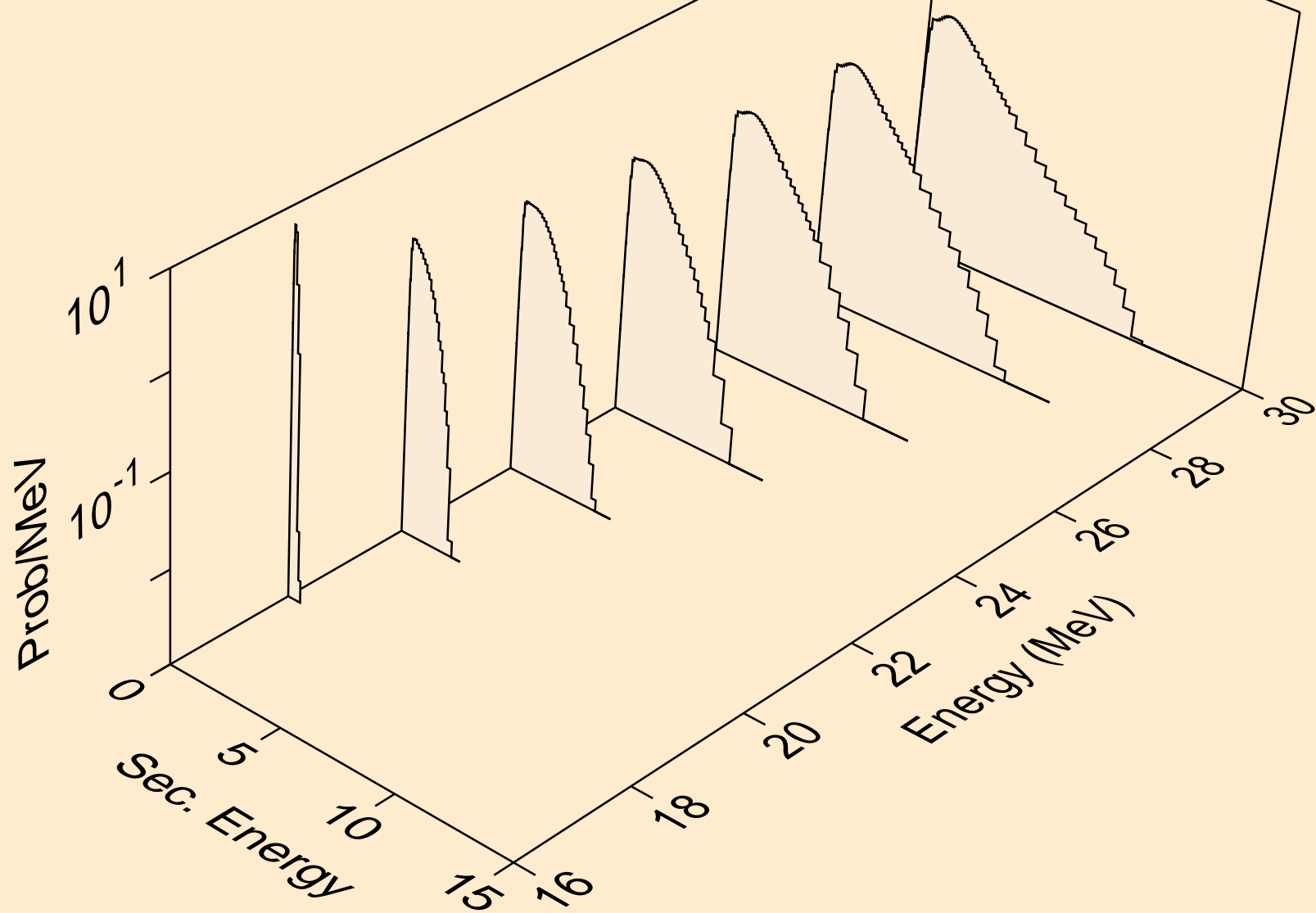

PR138M NEUTRON ACER TENDL-2023 LIBRARY; T=0.K  
Neutron emission for (n,n\*)a

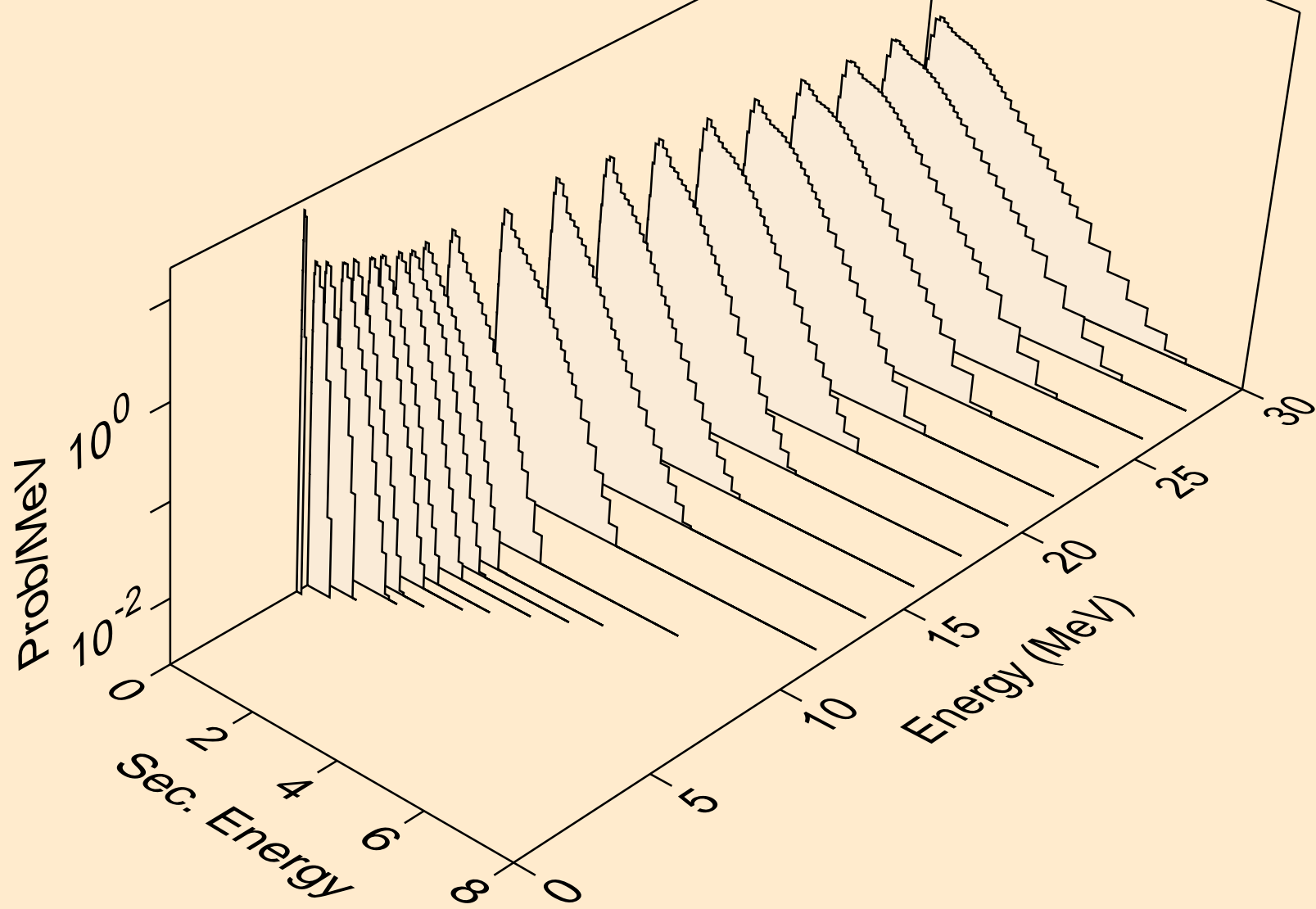



PR138M NEUTRON ACER TENDL-2023 LIBRARY; T=0.K  
Neutron emission for (n,2n)a

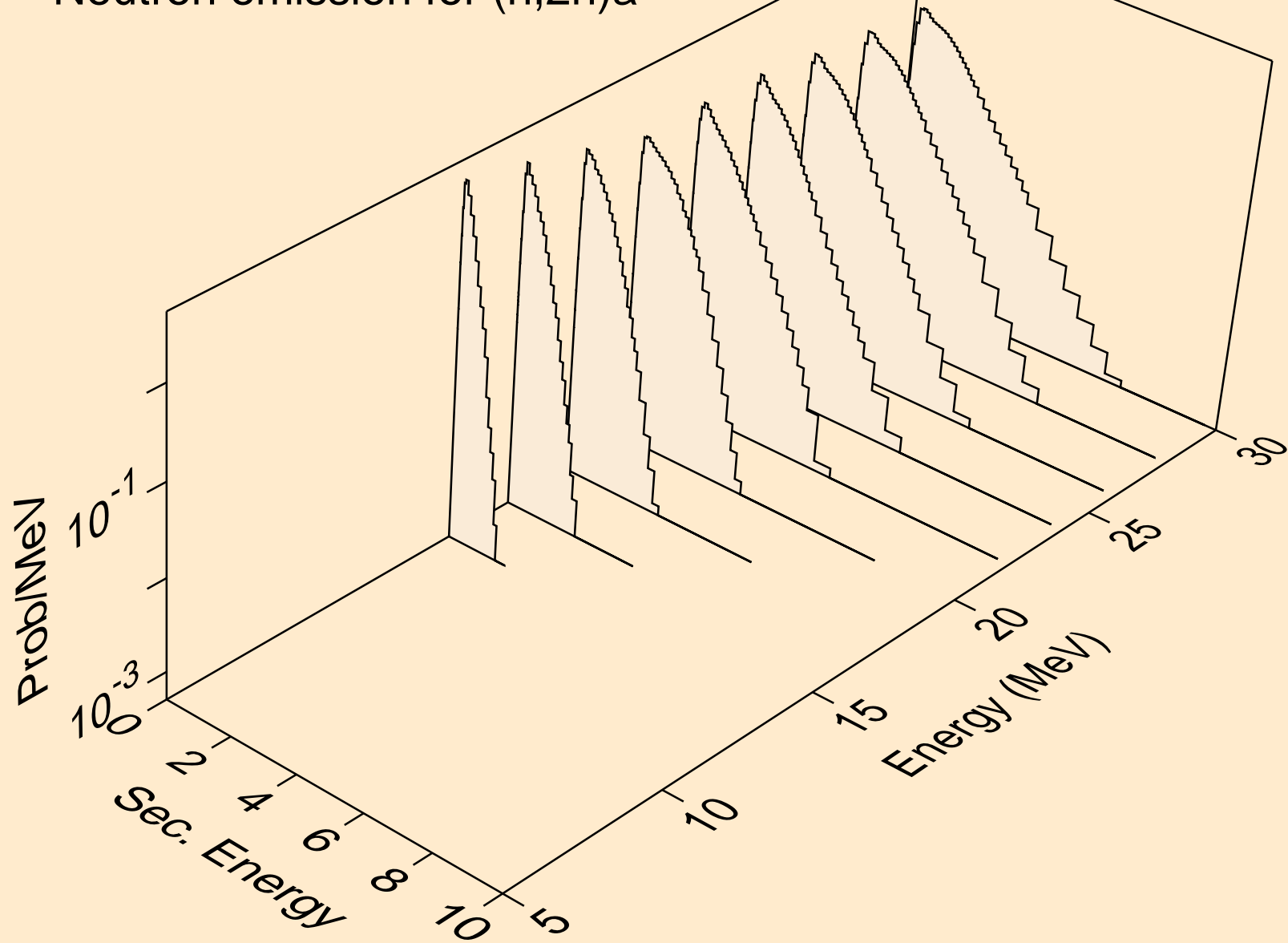

PR138M NEUTRON ACER TENDL-2023 LIBRARY; T=0.K  
Neutron emission for (n,3n)a

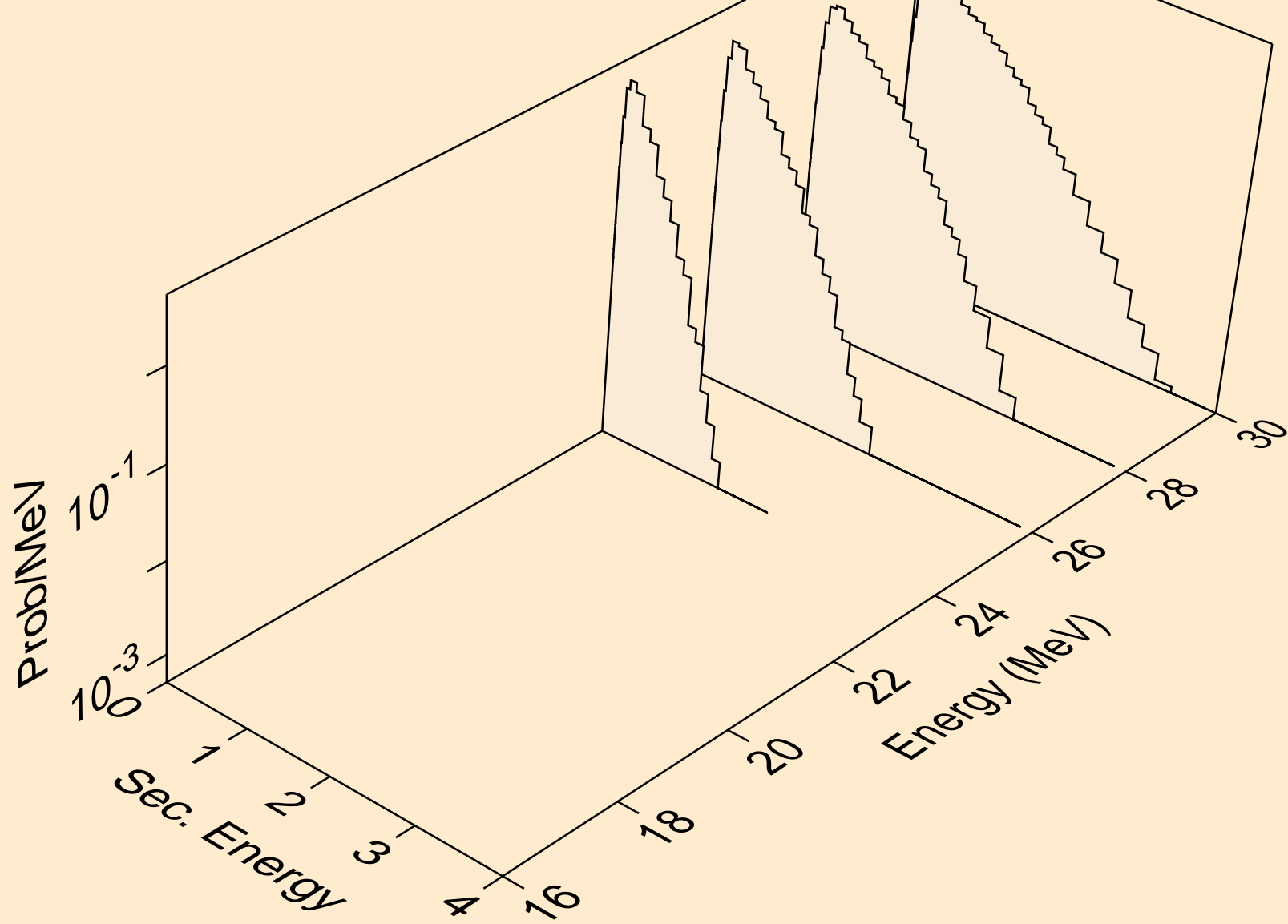

PR138M NEUTRON ACER TENDL-2023 LIBRARY; T=0.K  
Neutron emission for (n,n\*)p

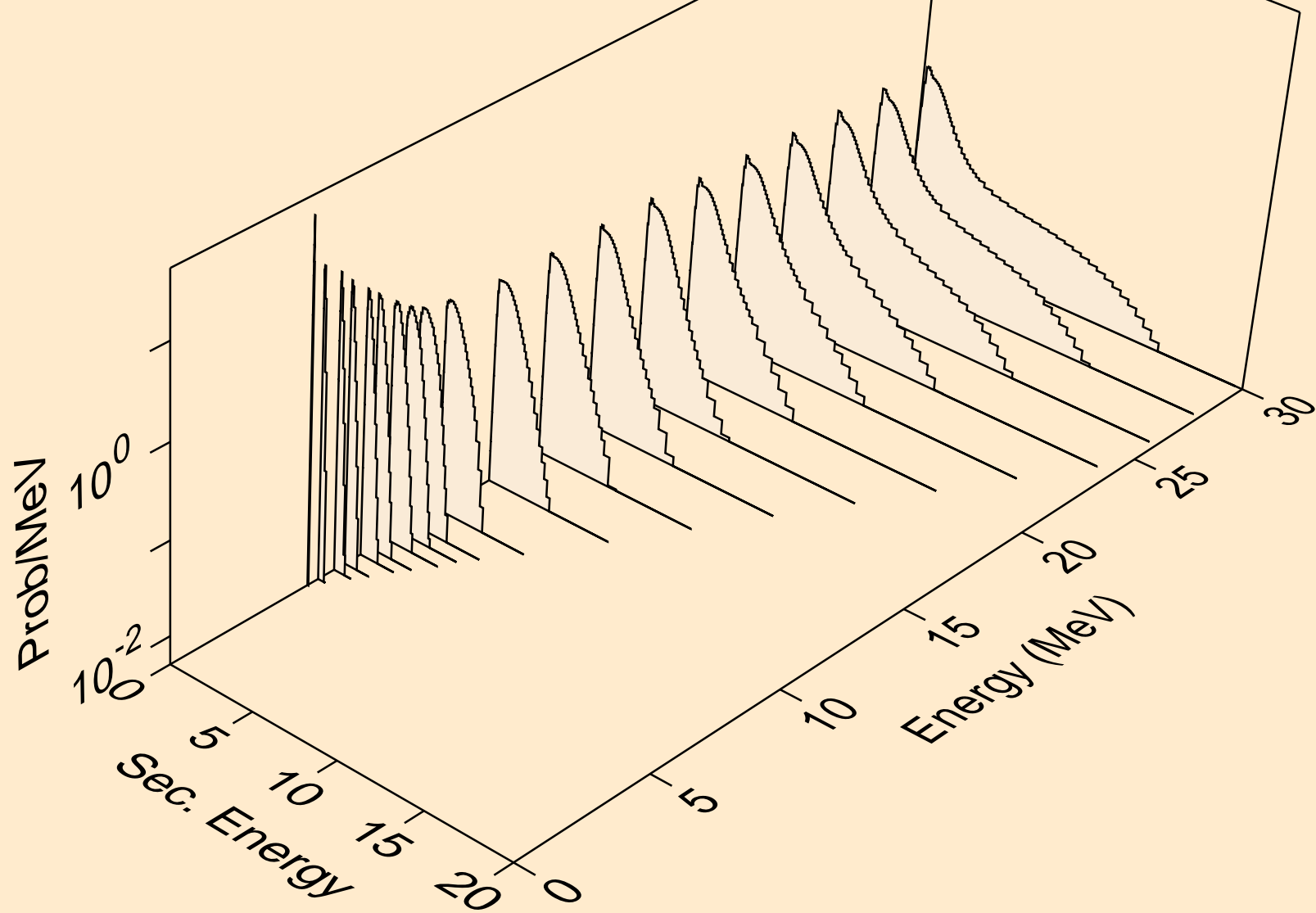

PR138M NEUTRON ACER TENDL-2023 LIBRARY; T=0.K  
Neutron emission for (n,n\*)2a

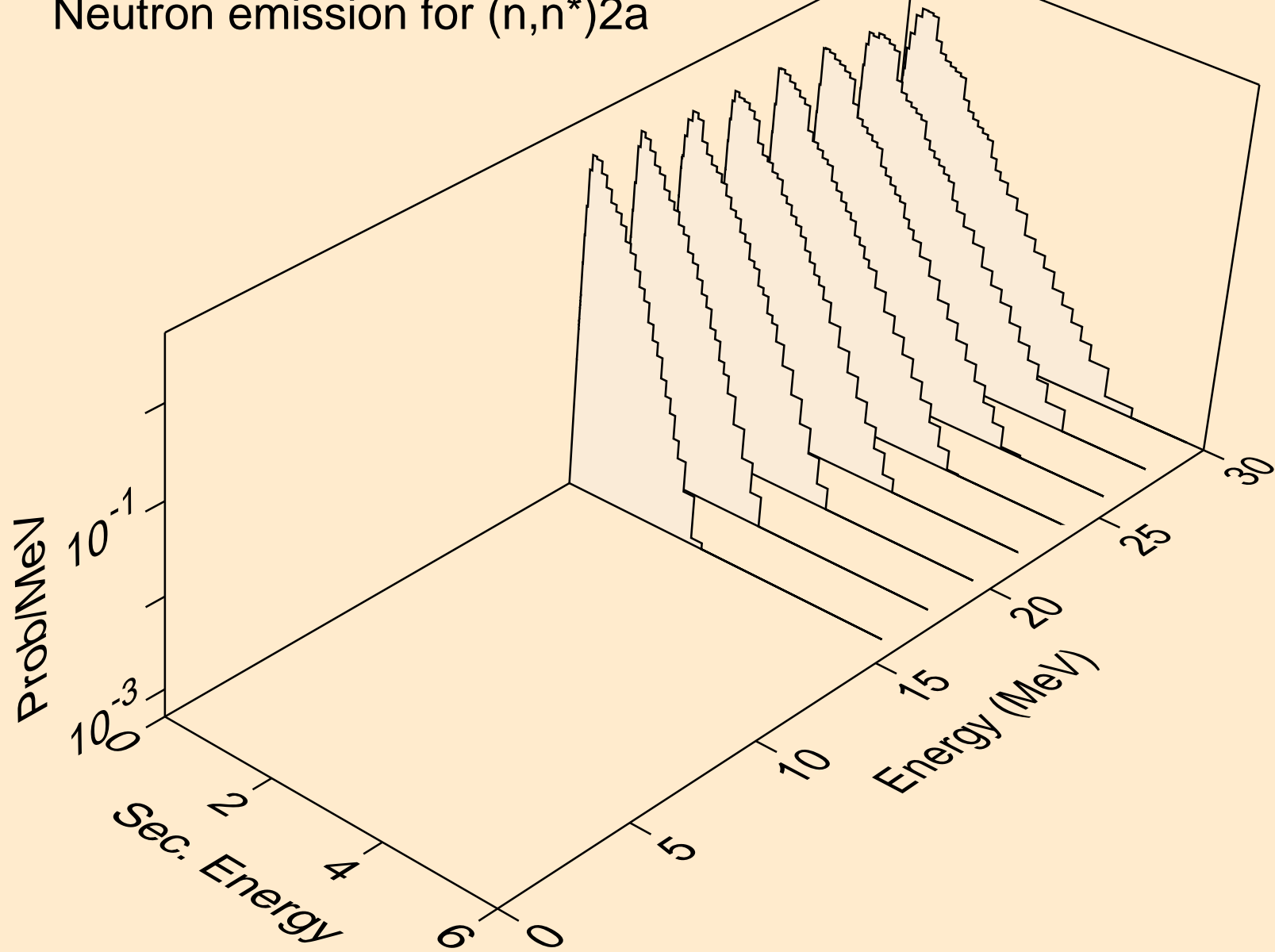

PR138M NEUTRON ACER TENDL-2023 LIBRARY; T=0.K  
Neutron emission for (n,n\*)d

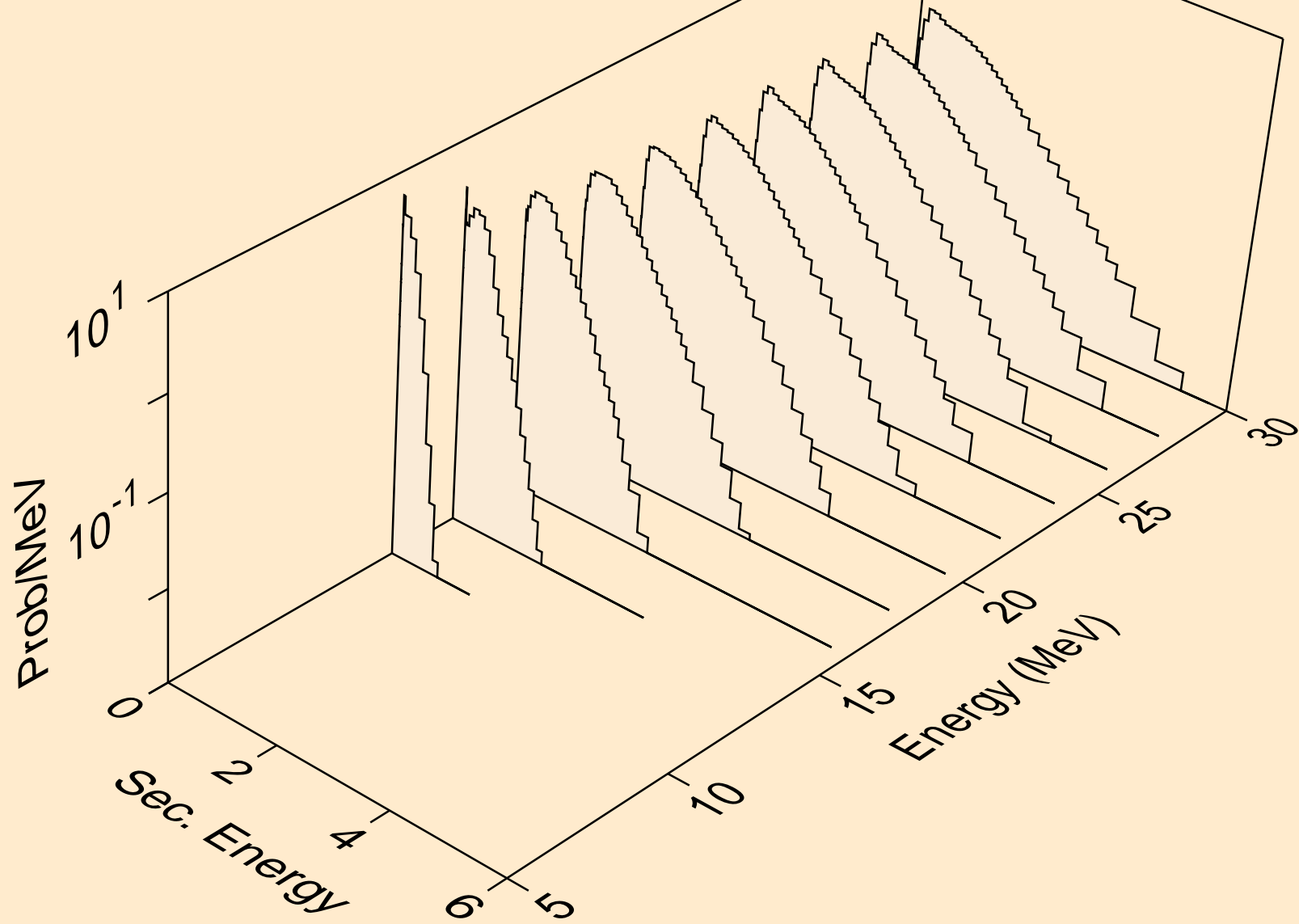

PR138M NEUTRON ACER TENDL-2023 LIBRARY; T=0.K  
Neutron emission for (n,n\*)t

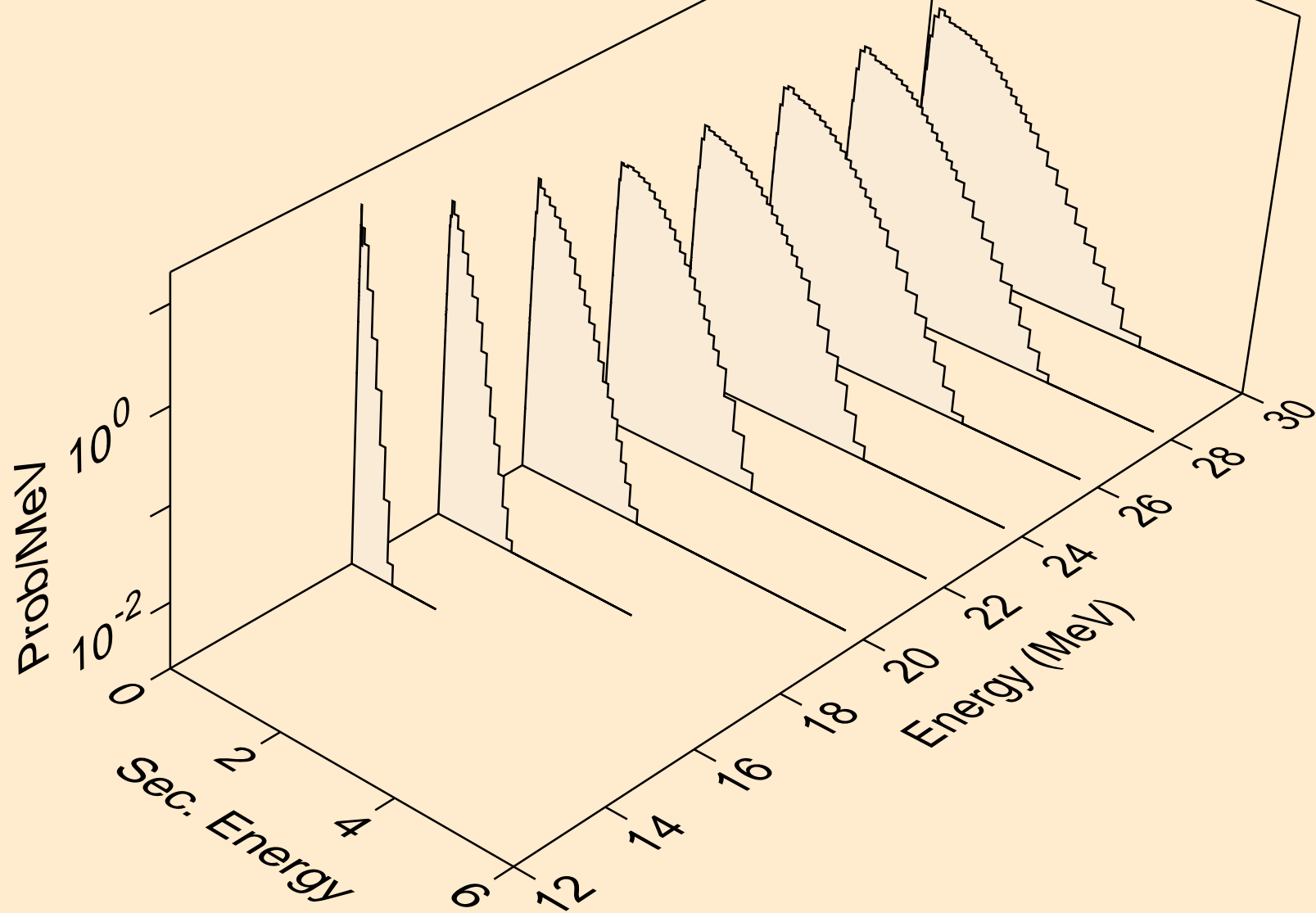

PR138M NEUTRON ACER TENDL-2023 LIBRARY; T=0.K  
Neutron emission for (n,n\*)he3

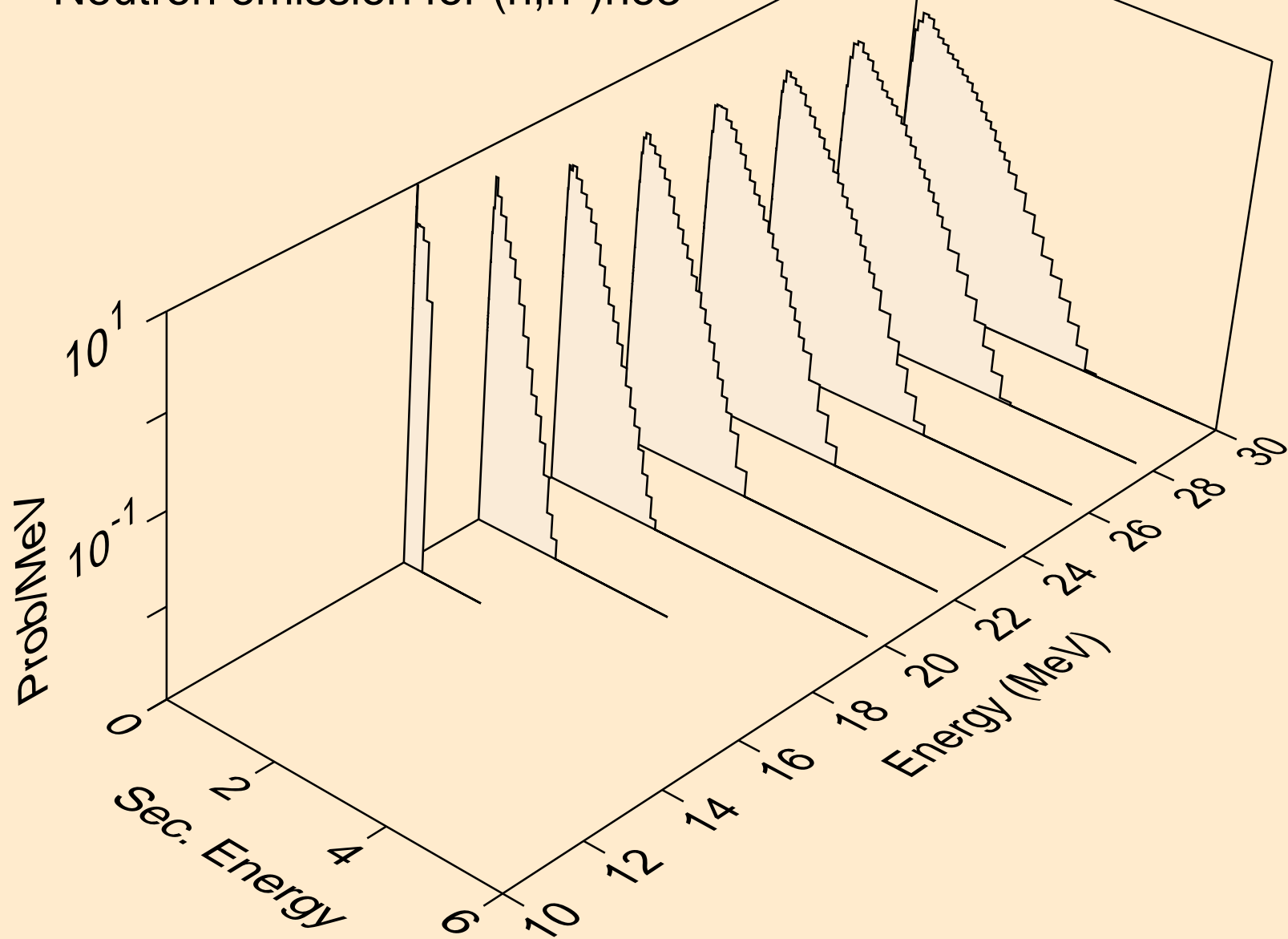

PR138M NEUTRON ACER TENDL-2023 LIBRARY; T=0.K  
Neutron emission for (n,4n)

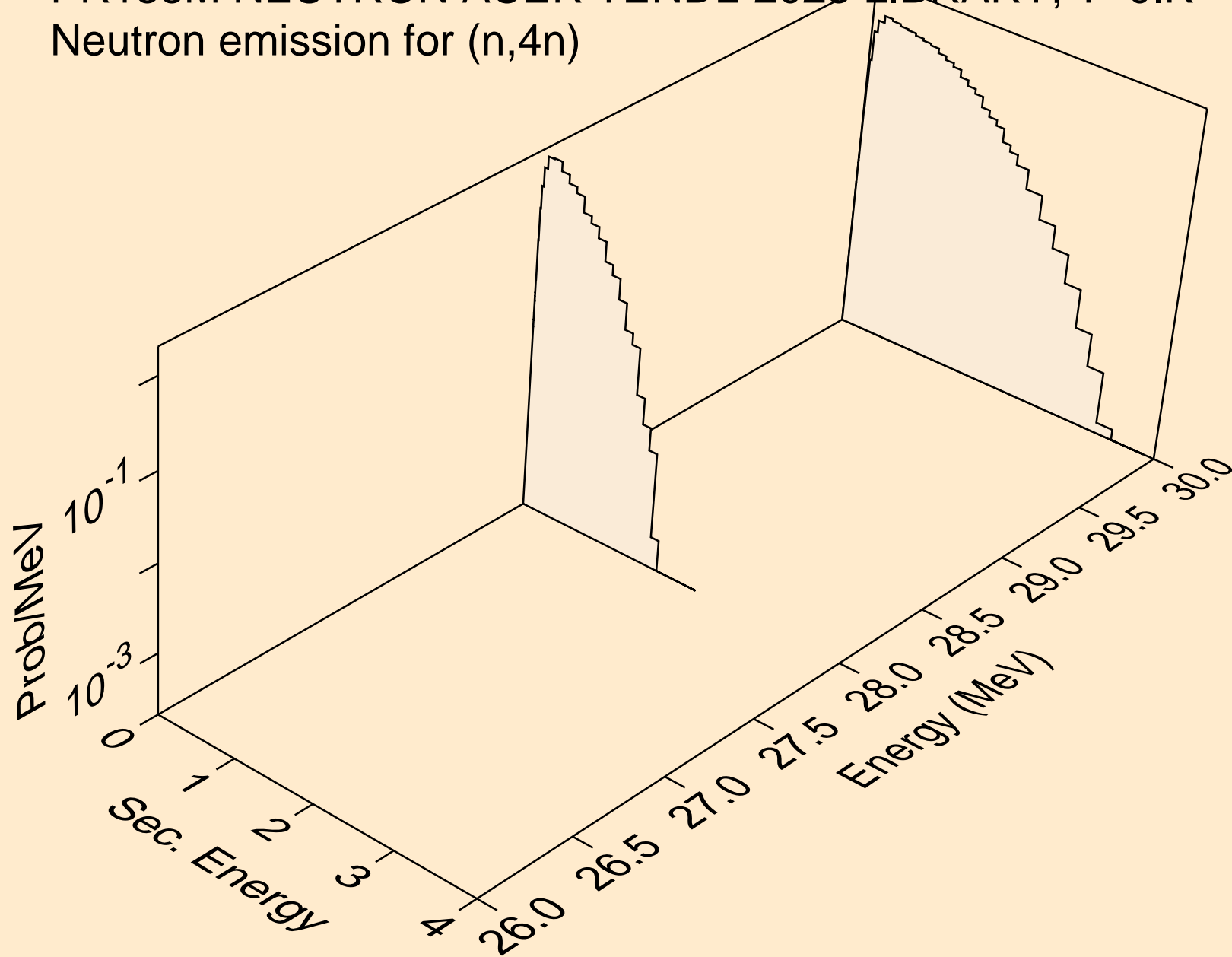



PR138M NEUTRON ACER TENDL-2023 LIBRARY; T=0.K  
Neutron emission for (n,2np)

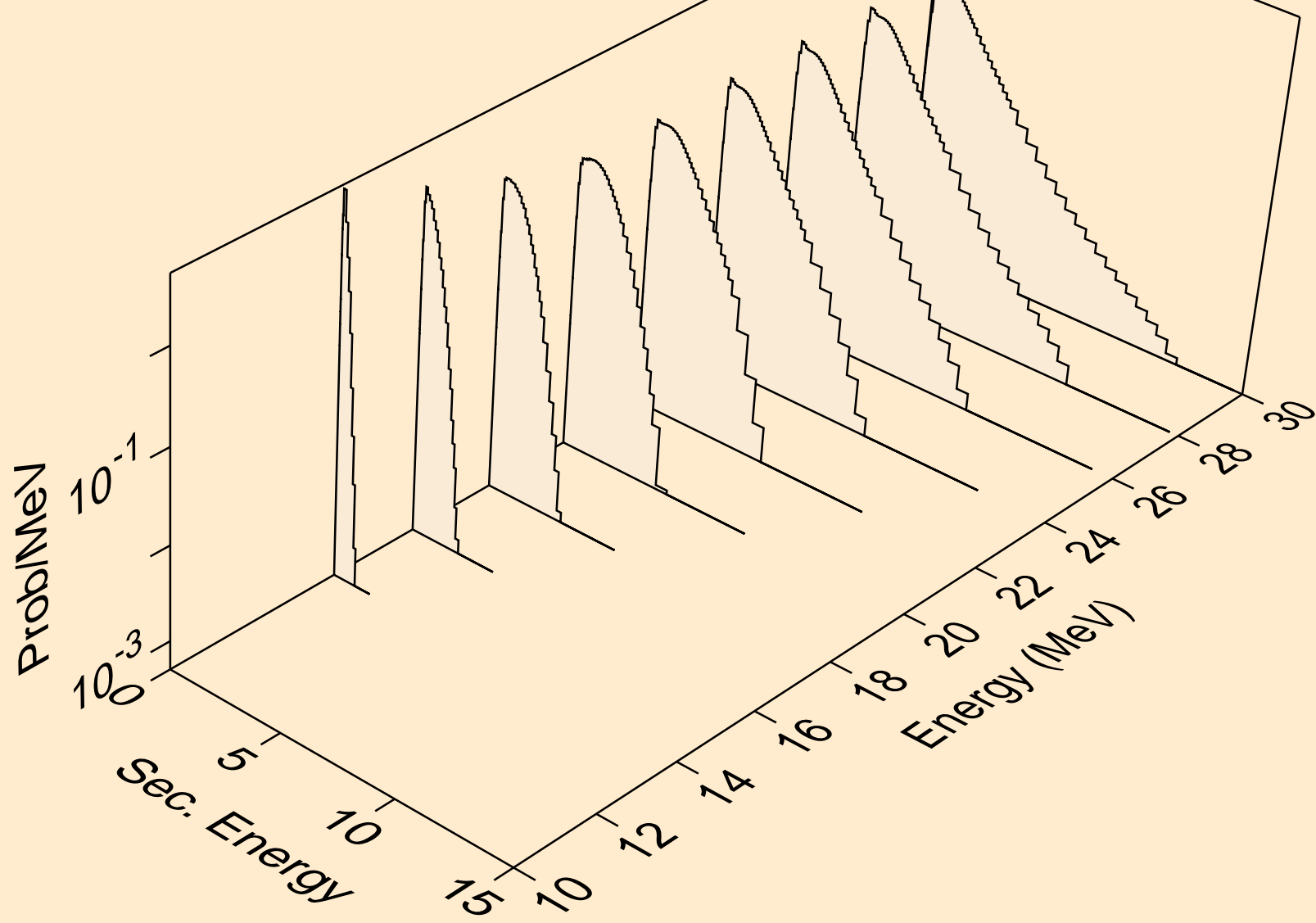

PR138M NEUTRON ACER TENDL-2023 LIBRARY; T=0.K  
Neutron emission for (n,3np)

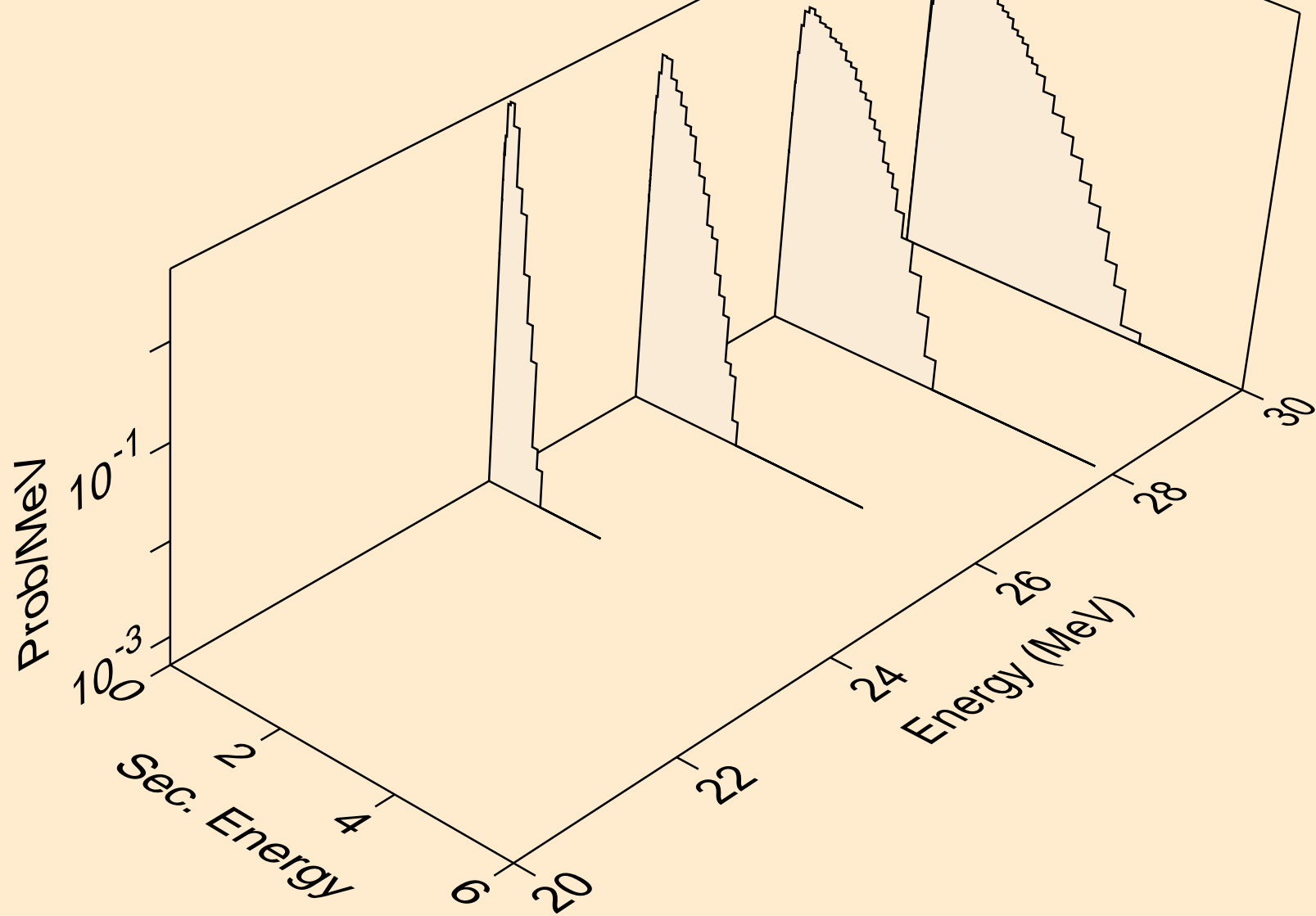

PR138M NEUTRON ACER TENDL-2023 LIBRARY; T=0.K  
Neutron emission for (n,n2p)

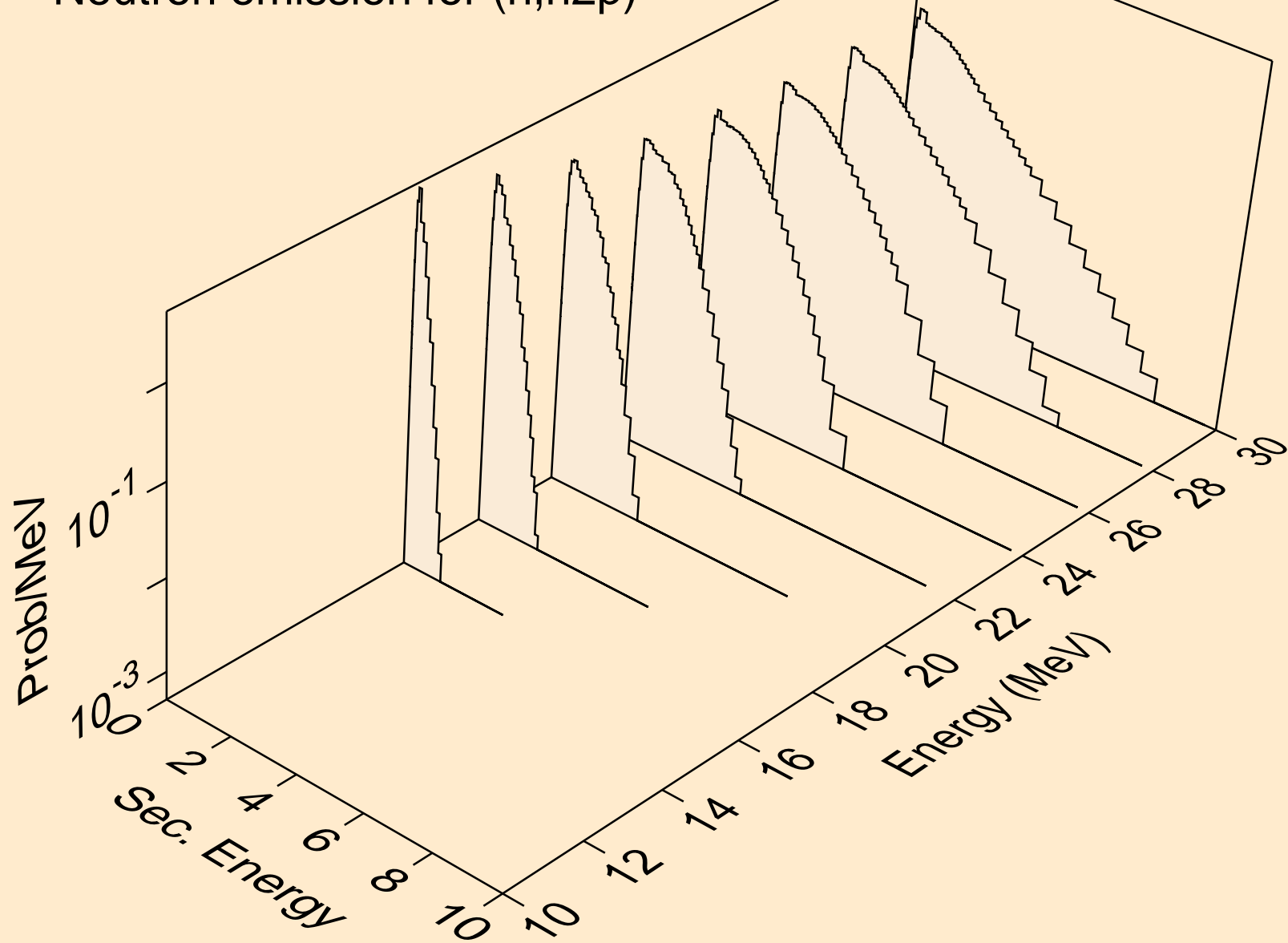

PR138M NEUTRON ACER TENDL-2023 LIBRARY; T=0.K  
Neutron emission for (n,npa)

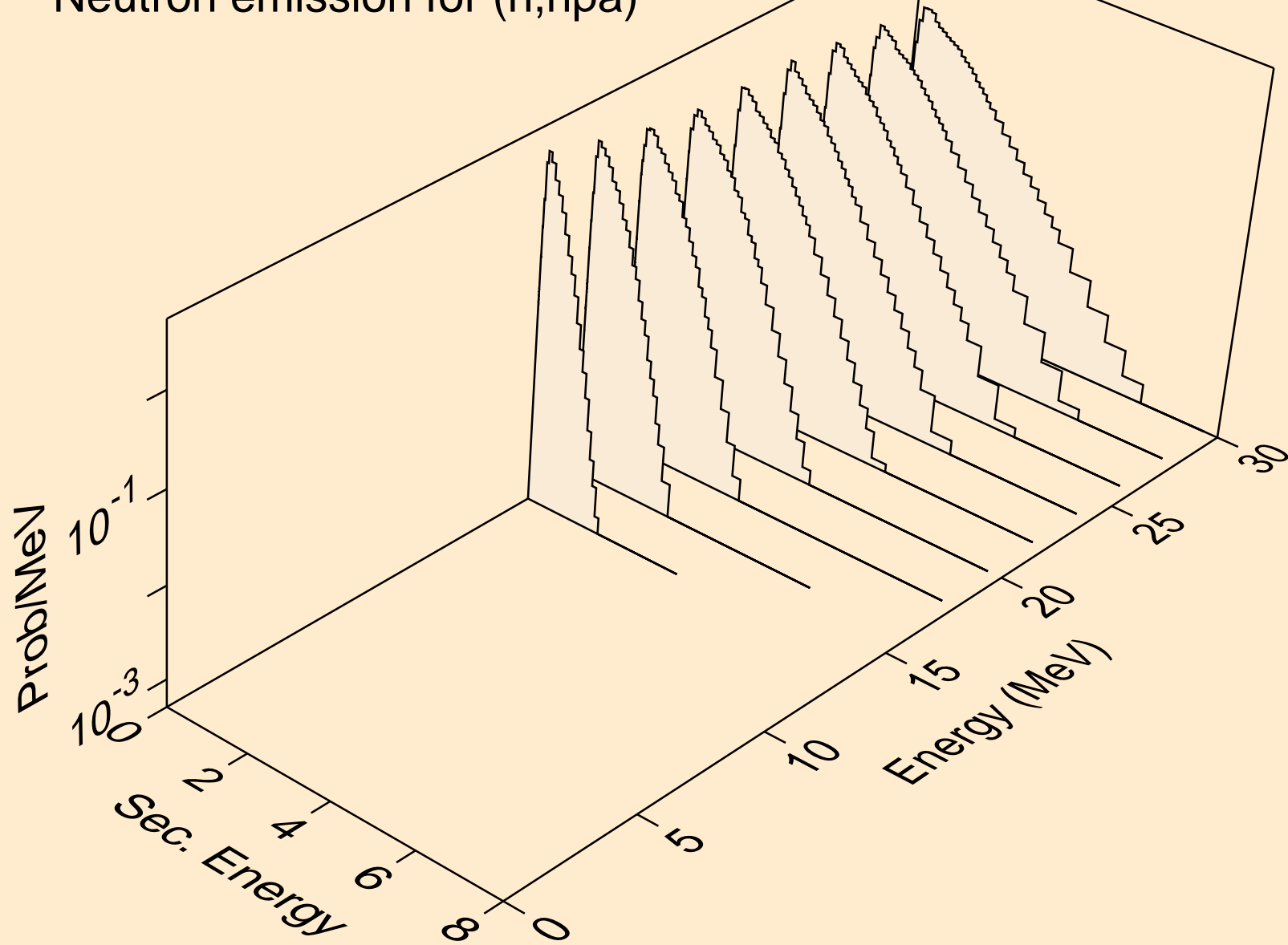

PR138M NEUTRON ACER TENDL-2023 LIBRARY; T=0.K  
Neutron emission for (n,n\*c)

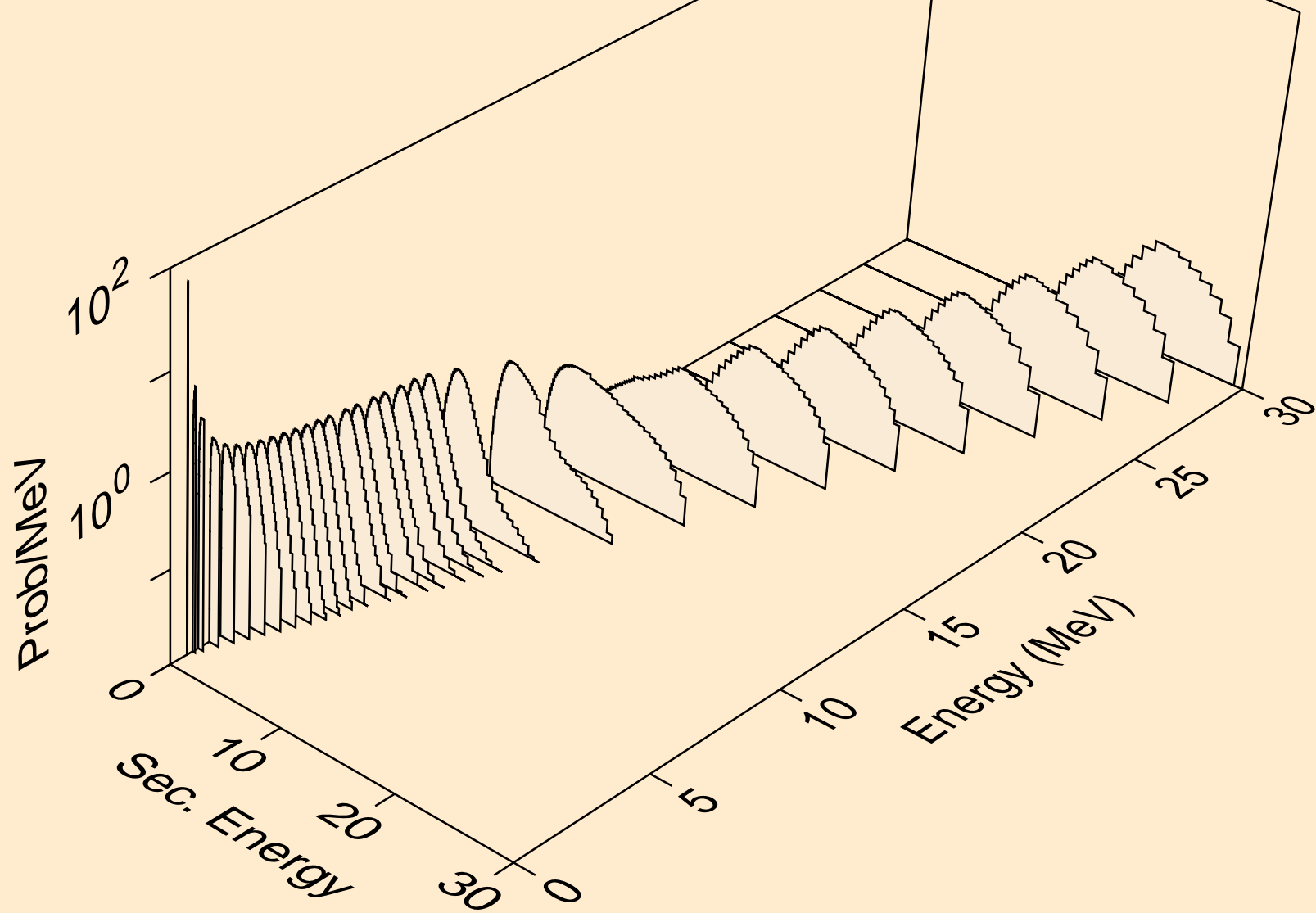

PR138M NEUTRON ACER TENDL-2023 LIBRARY; T=0.K  
Photon emission for (n,x)

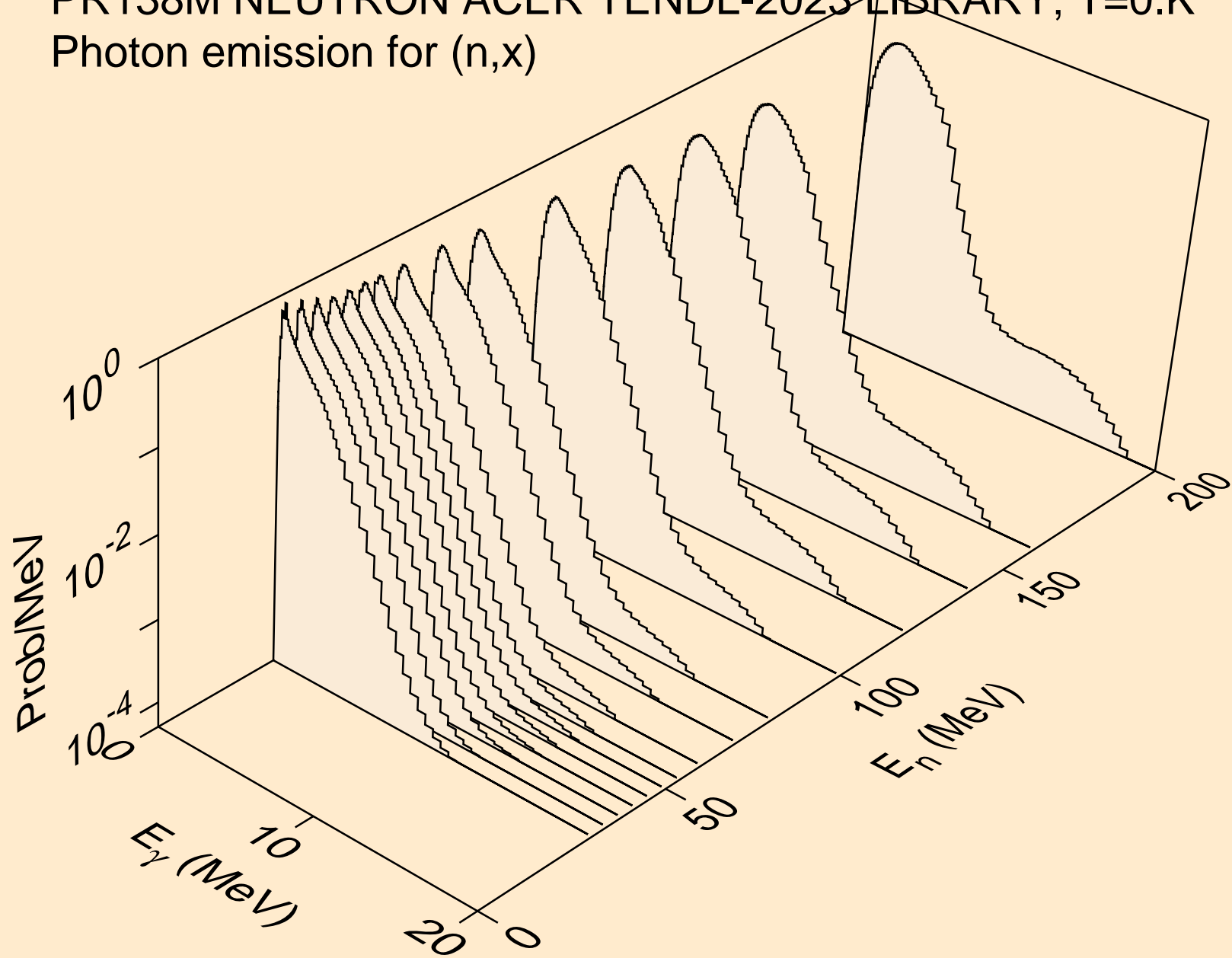

PR138M NEUTRON ACER TENDL-2023 LIBRARY; T=0.K  
Photon emission for (n,2nd)

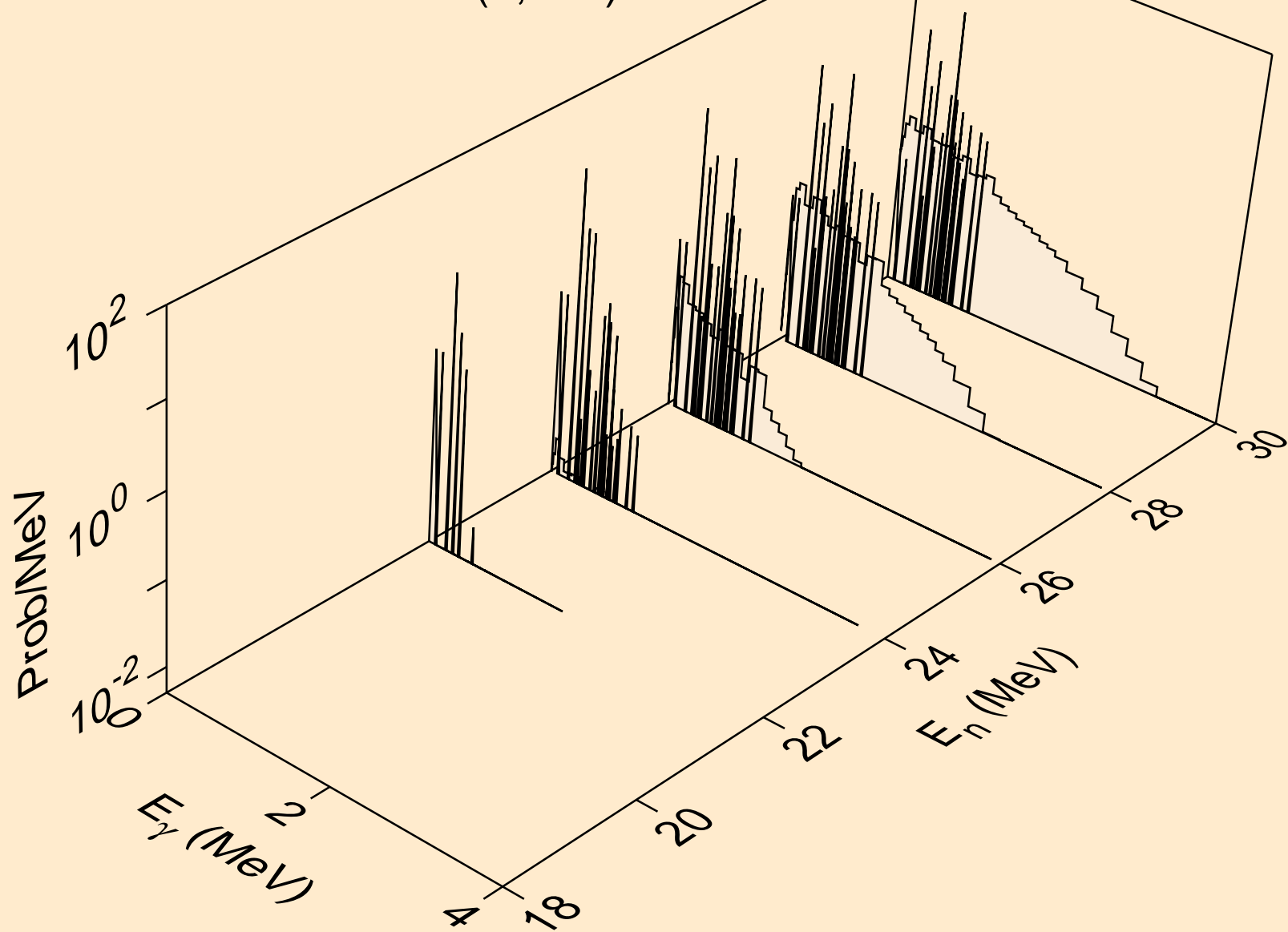

PR138M NEUTRON ACER TENDL-2023 LIBRARY; T=0.K  
Photon emission for (n,2n)

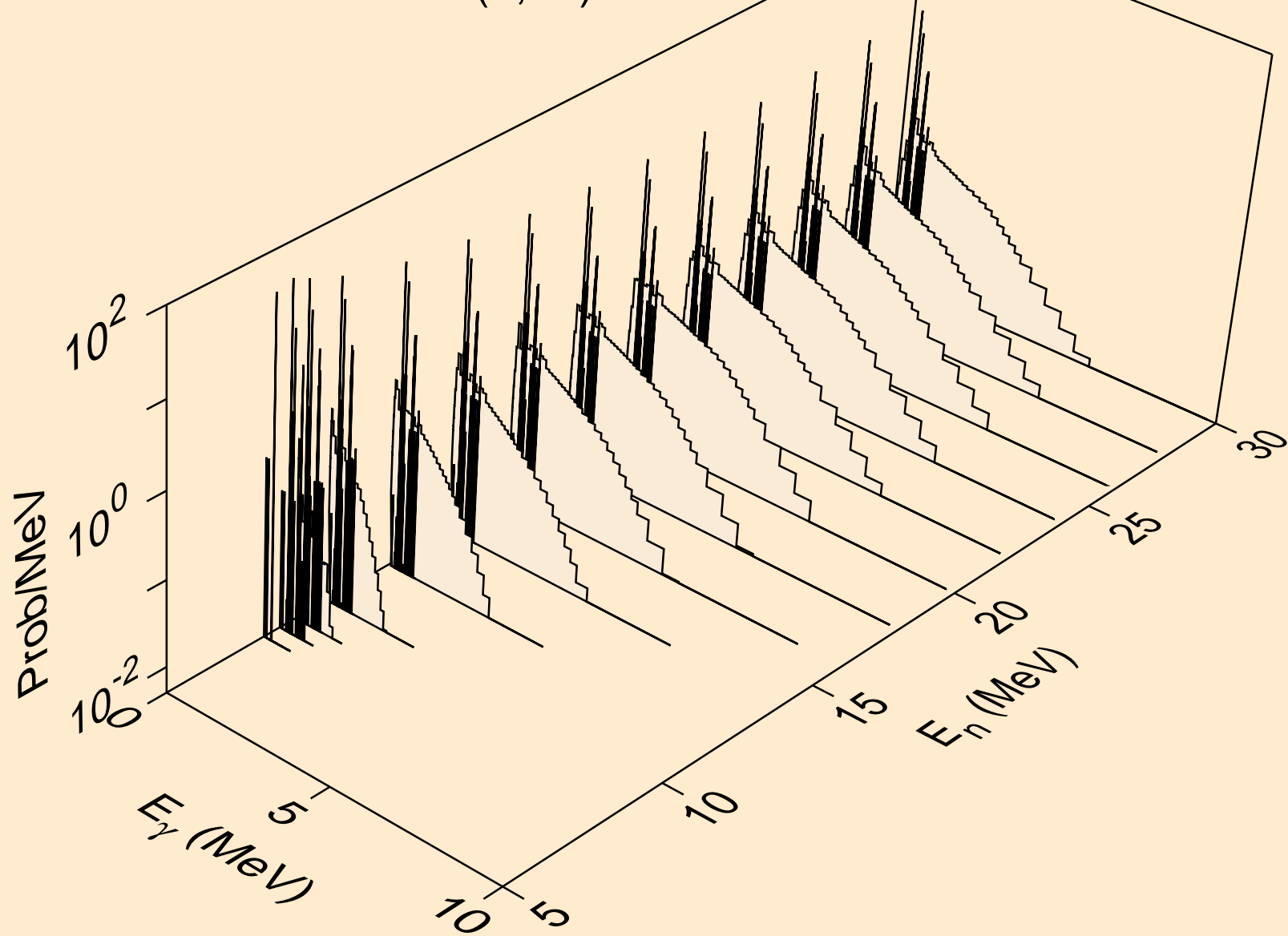



PR138M NEUTRON ACER TENDL-2023 LIBRARY; T=0.K  
Photon emission for (n,3n)

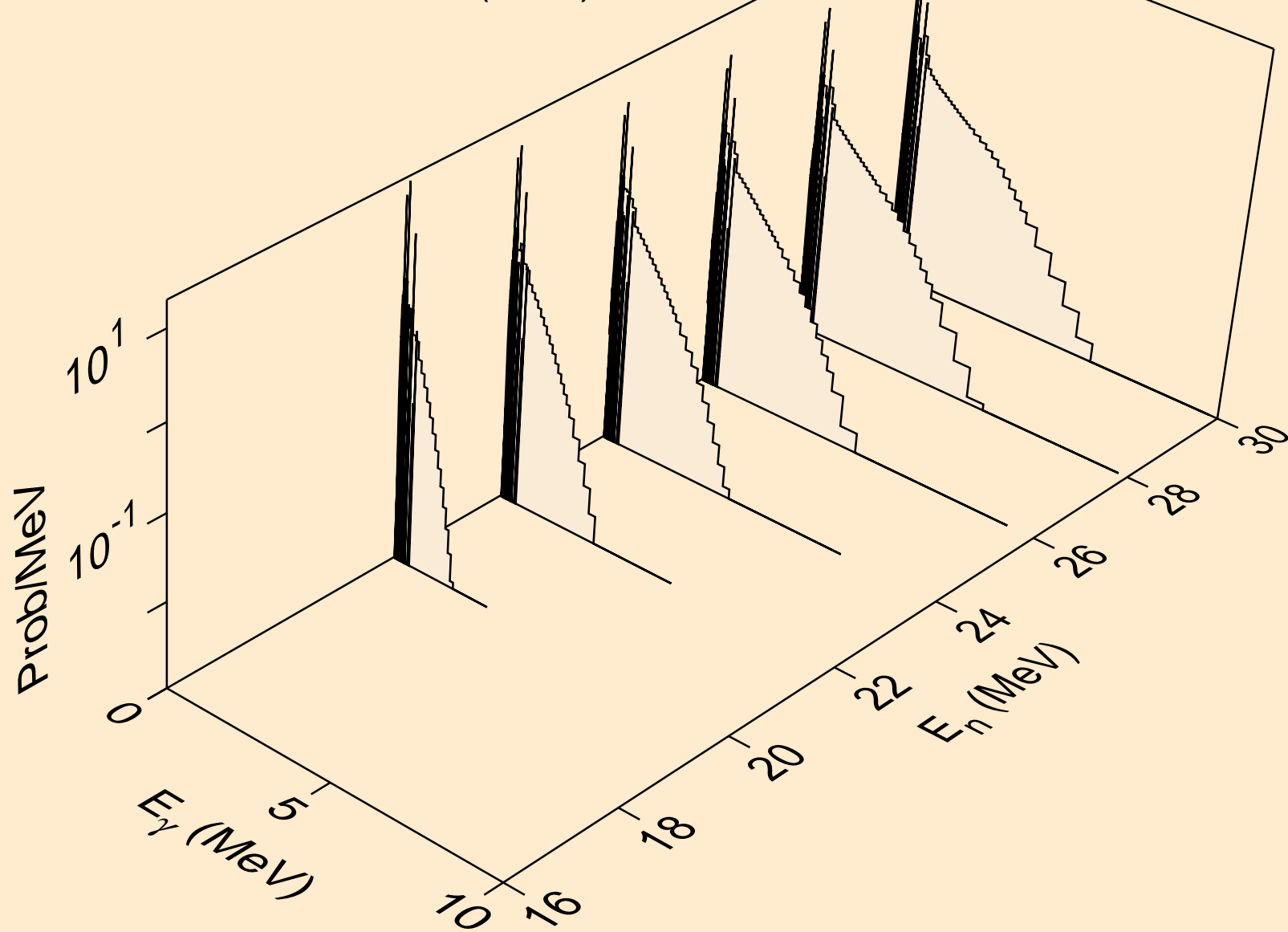

PR138M NEUTRON ACER TENDL-2023 LIBRARY; T=0.K  
Photon emission for (n,n\*)a

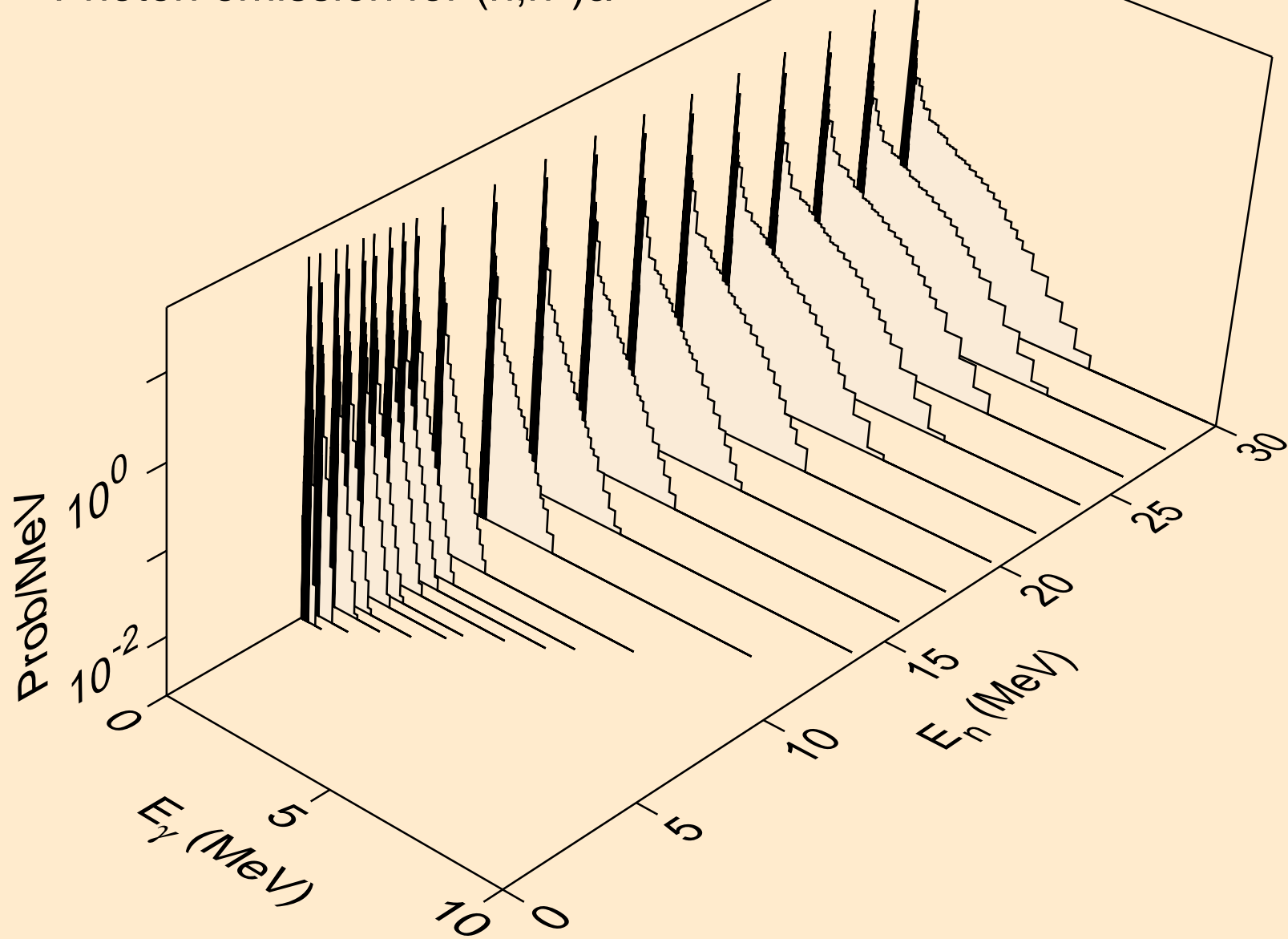

PR138M NEUTRON ACER TENDL-2023 LIBRARY; T=0.K  
Photon emission for (n,2n)a

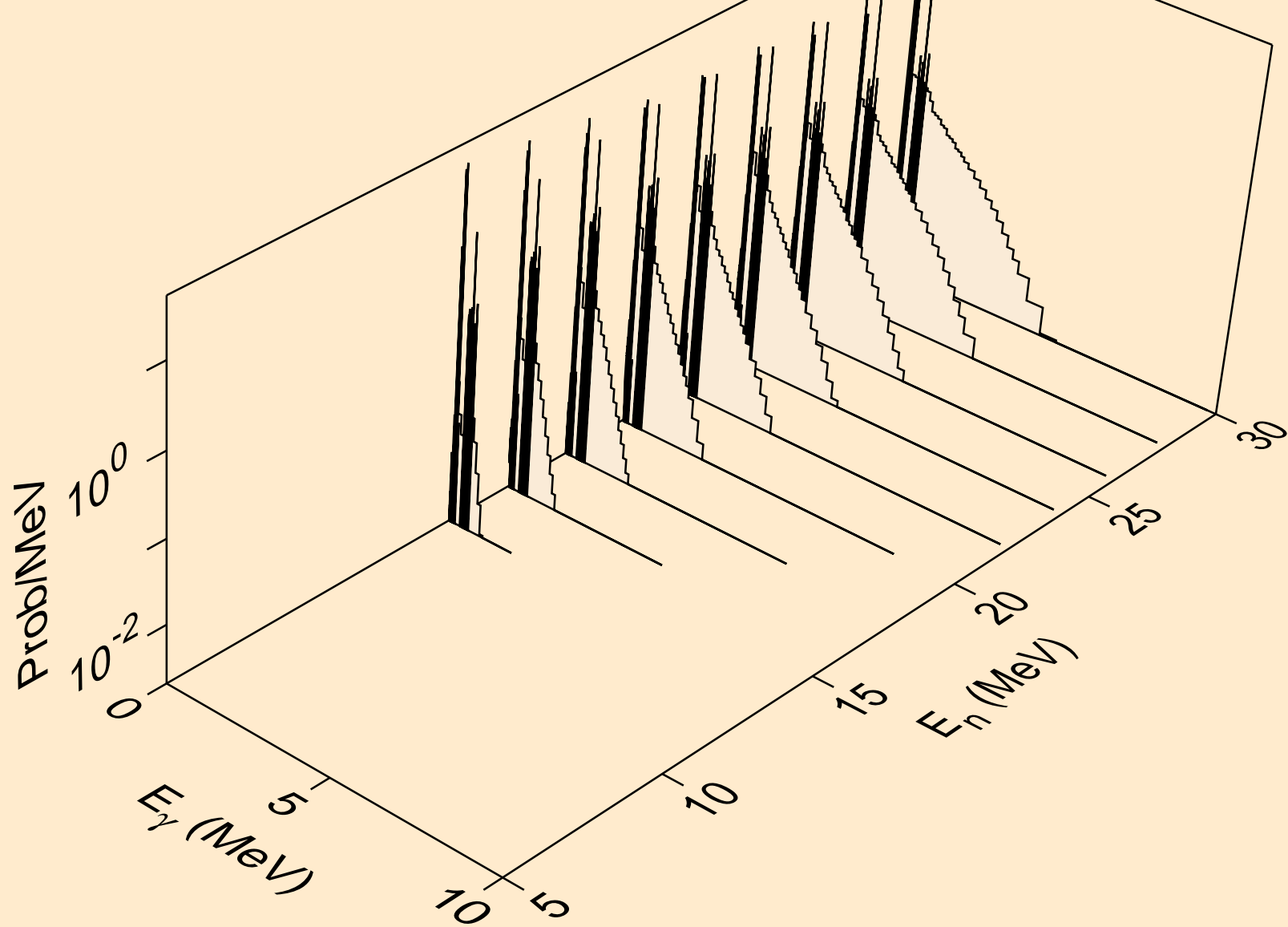

PR138M NEUTRON ACER TENDL-2023 LIBRARY; T=0.K  
Photon emission for (n,3n)a

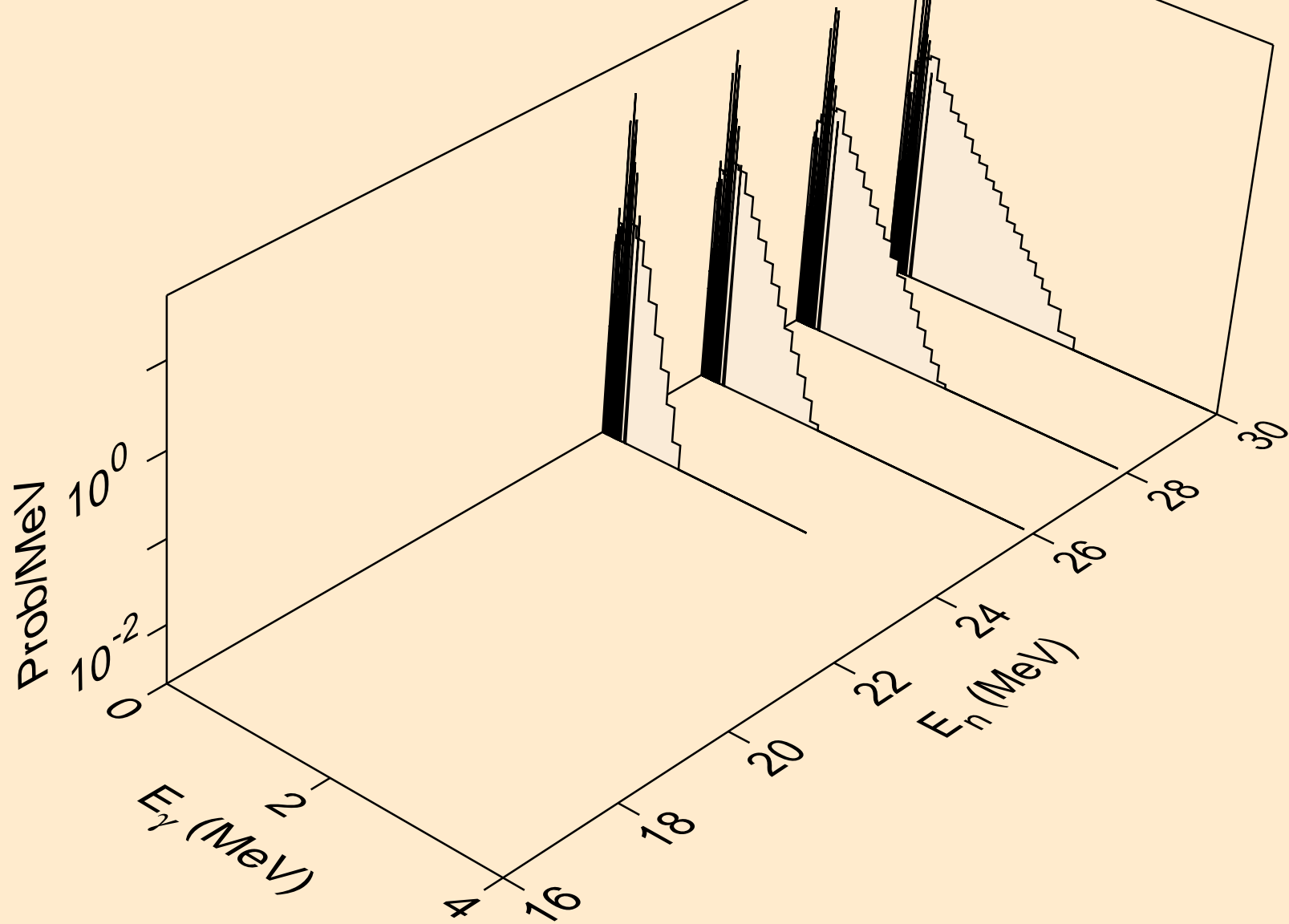

PR138M NEUTRON ACER TENDL-2023 LIBRARY; T=0.K  
Photon emission for (n,n\*)p

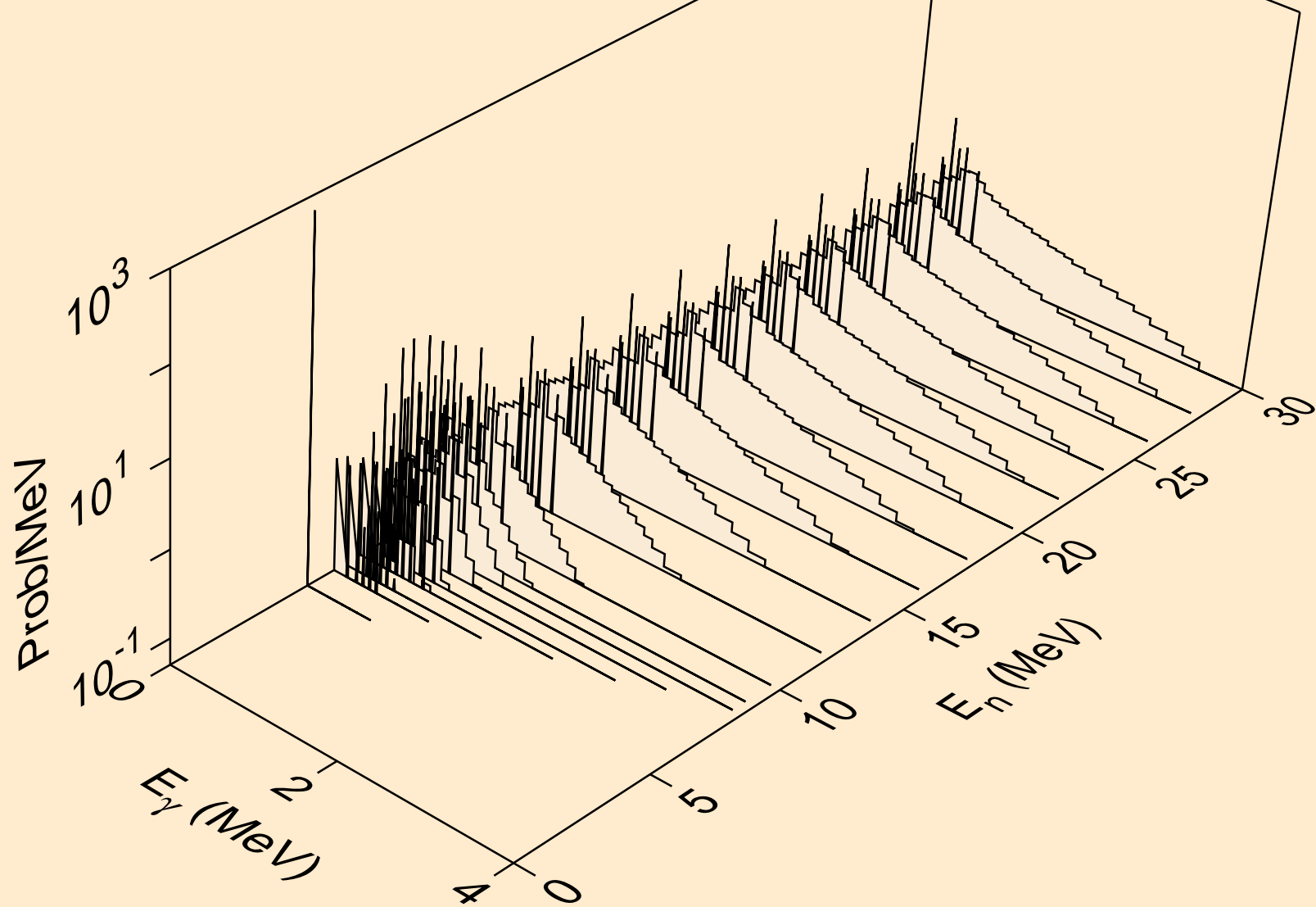

PR138M NEUTRON ACER TENDL-2023 LIBRARY; T=0.K  
Photon emission for (n,n\*)2a

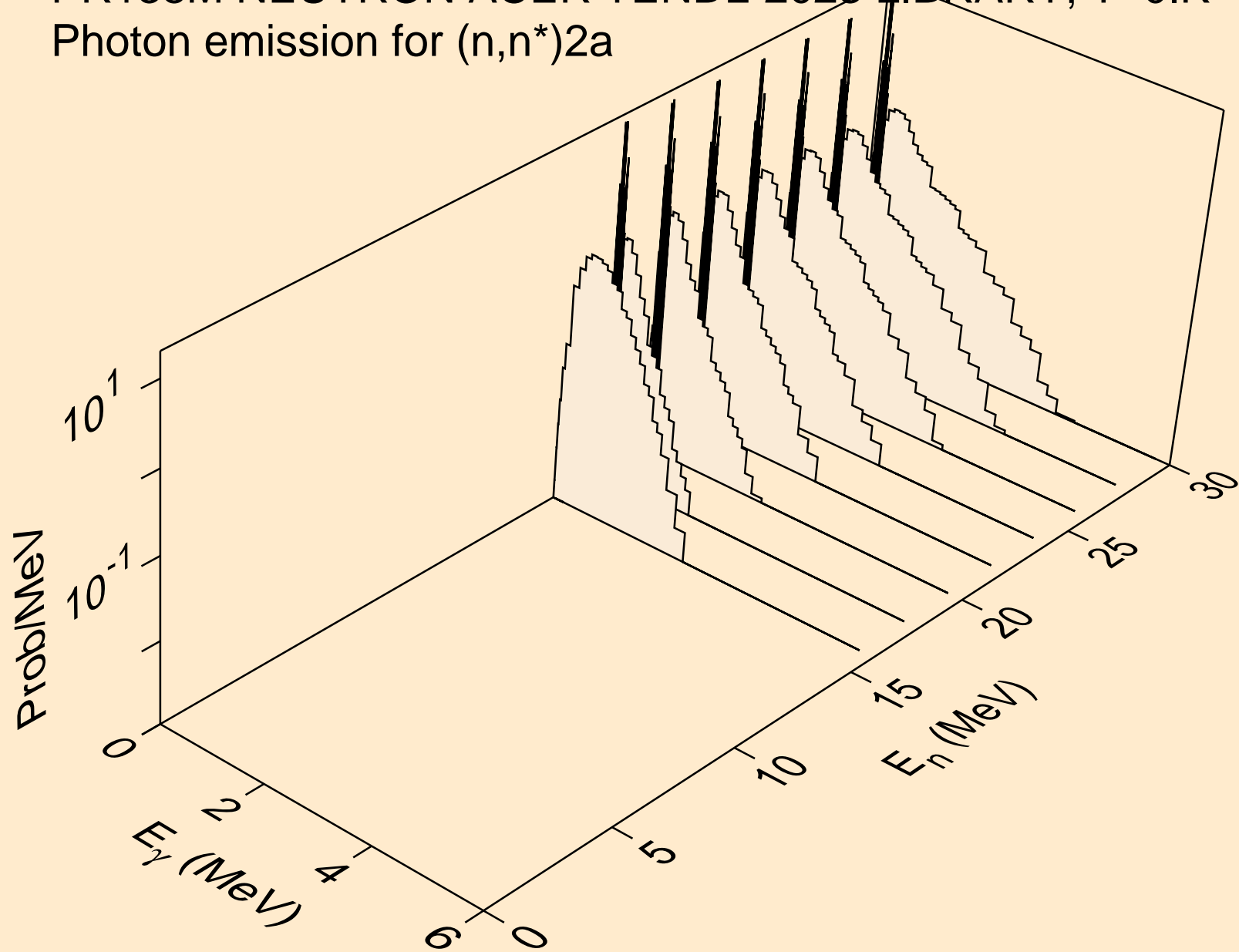

PR138M NEUTRON ACER TENDL-2023 LIBRARY; T=0.K  
Photon emission for (n,n\*)d

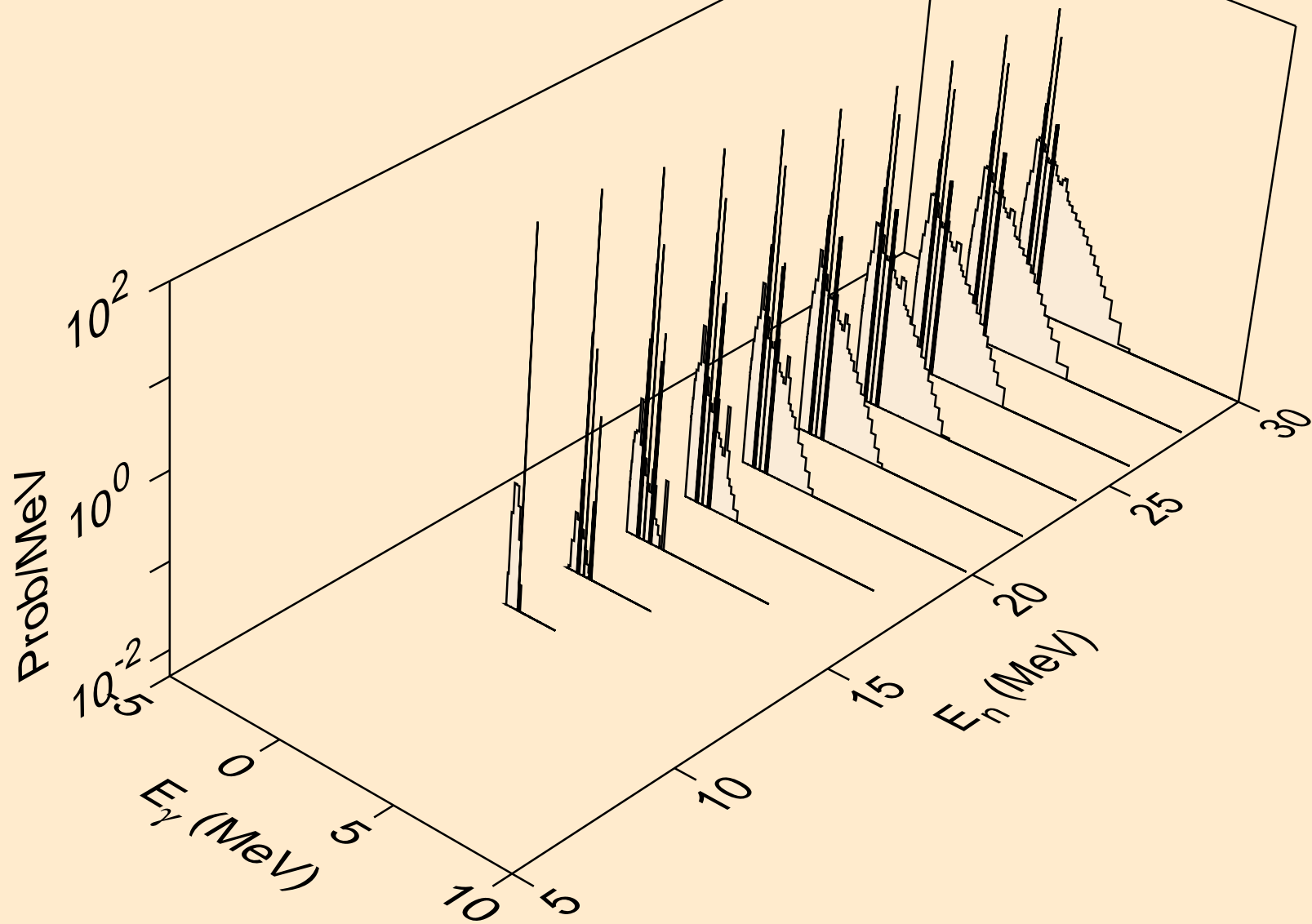

PR138M NEUTRON ACER TENDL-2023 LIBRARY; T=0.K  
Photon emission for (n,n\*)t

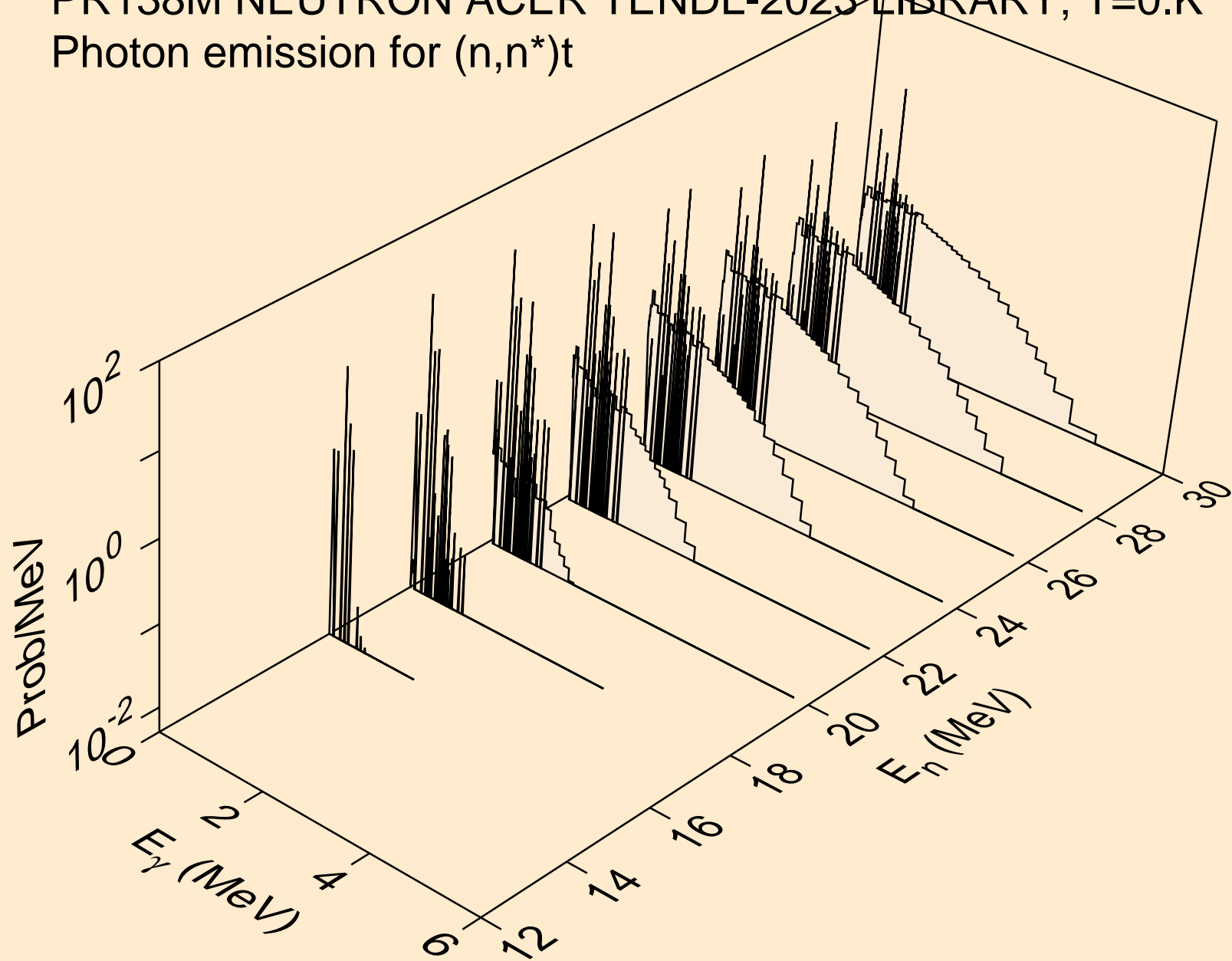



PR138M NEUTRON ACER TENDL-2023 LIBRARY; T=0.K  
Photon emission for (n,n\*)he3

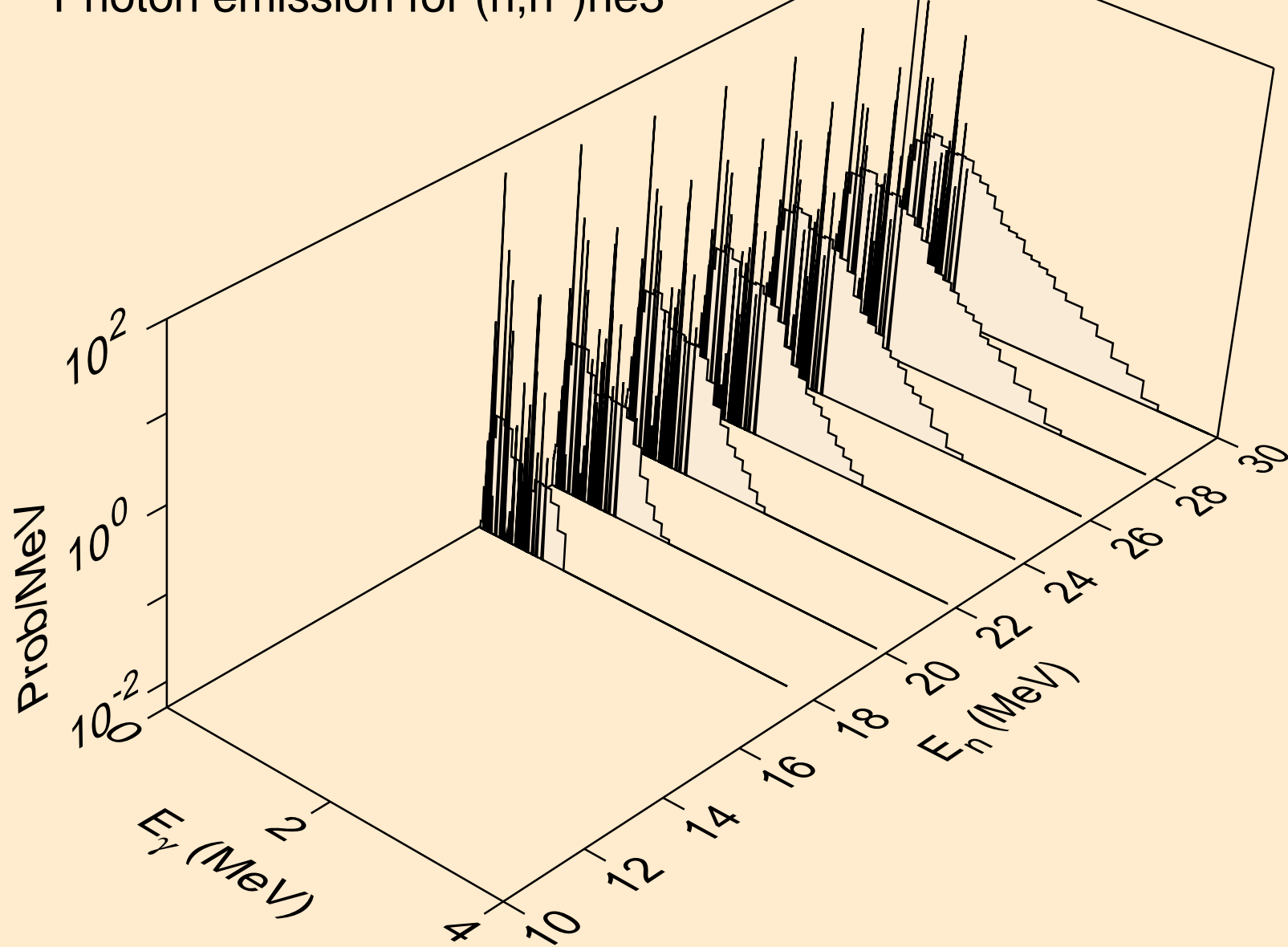

PR138M NEUTRON ACER TENDL-2023 LIBRARY; T=0.K  
Photon emission for (n,4n)

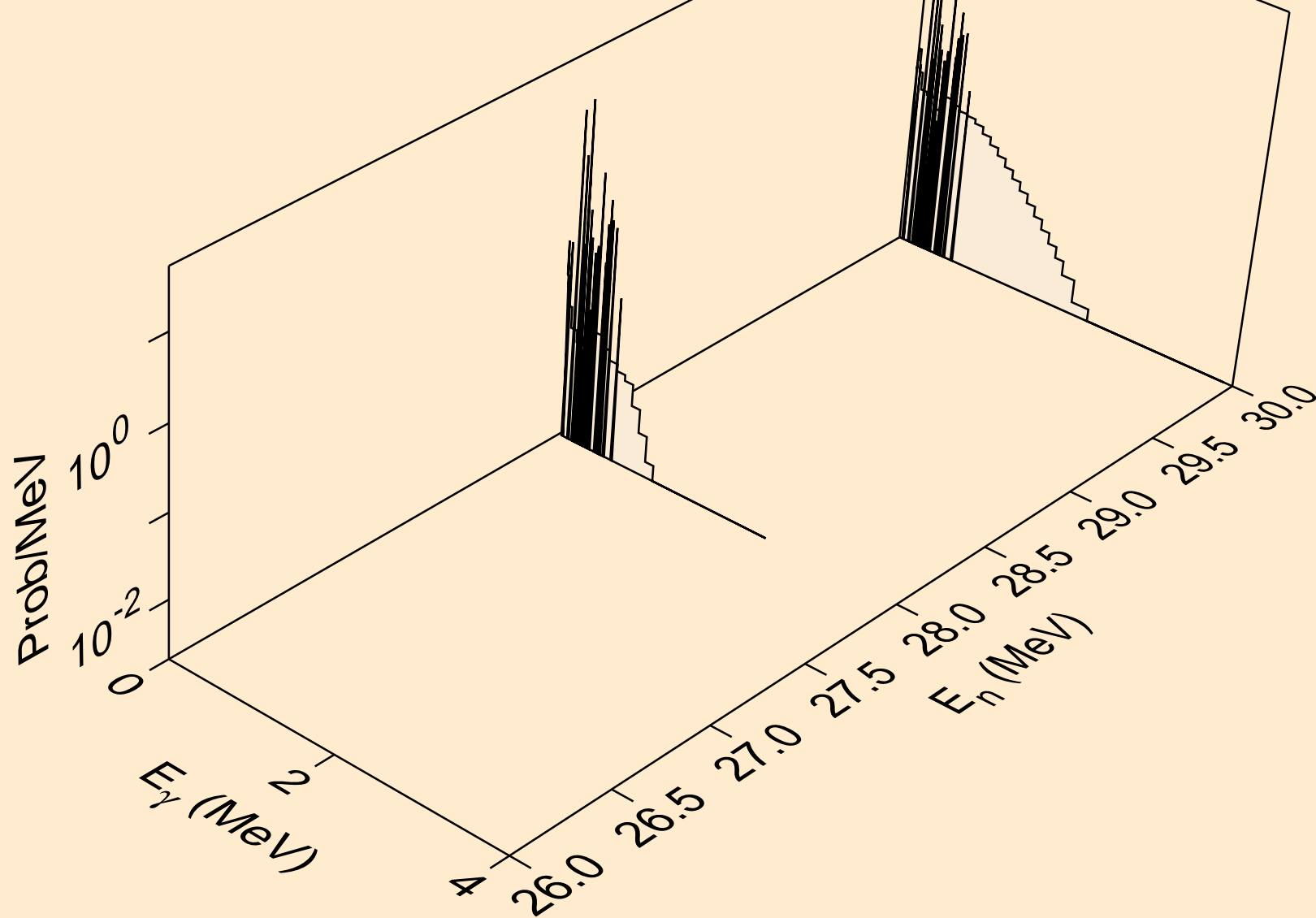

PR138M NEUTRON ACER TENDL-2023 LIBRARY; T=0.K  
Photon emission for (n,2np)

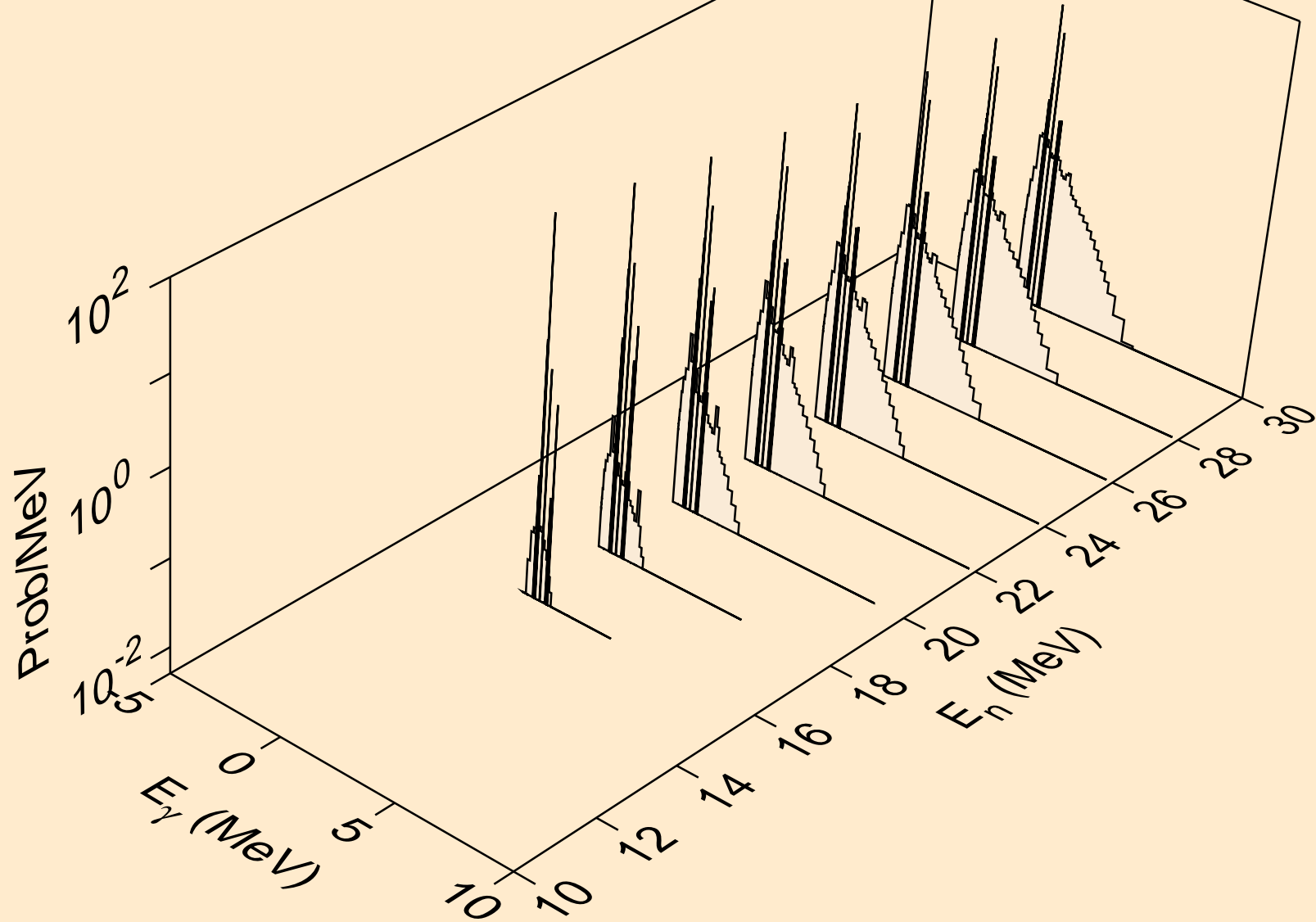

PR138M NEUTRON ACER TENDL-2023 LIBRARY; T=0.K  
Photon emission for (n,3np)

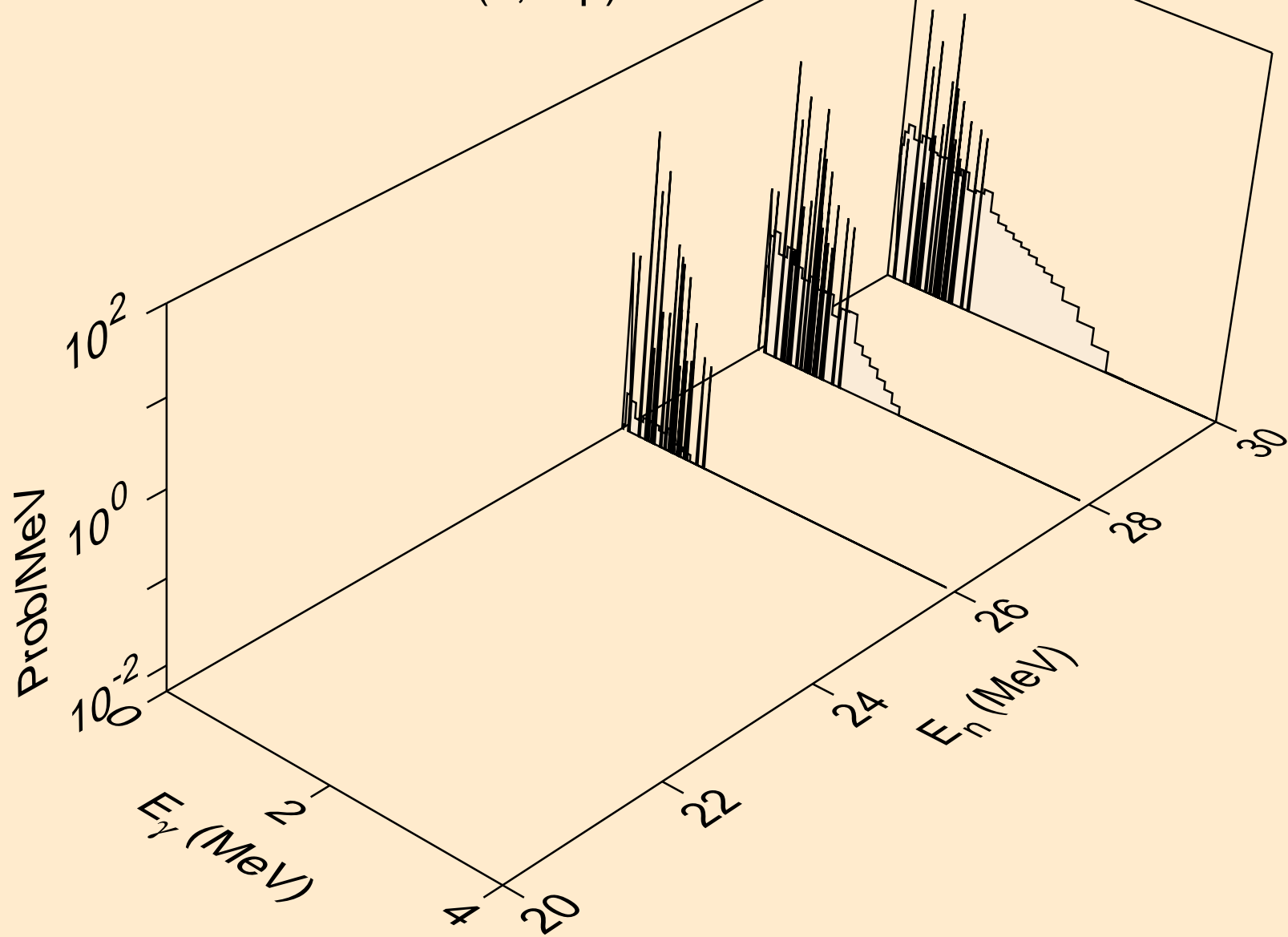

PR138M NEUTRON ACER TENDL-2023 LIBRARY; T=0.K  
Photon emission for (n,n2p)

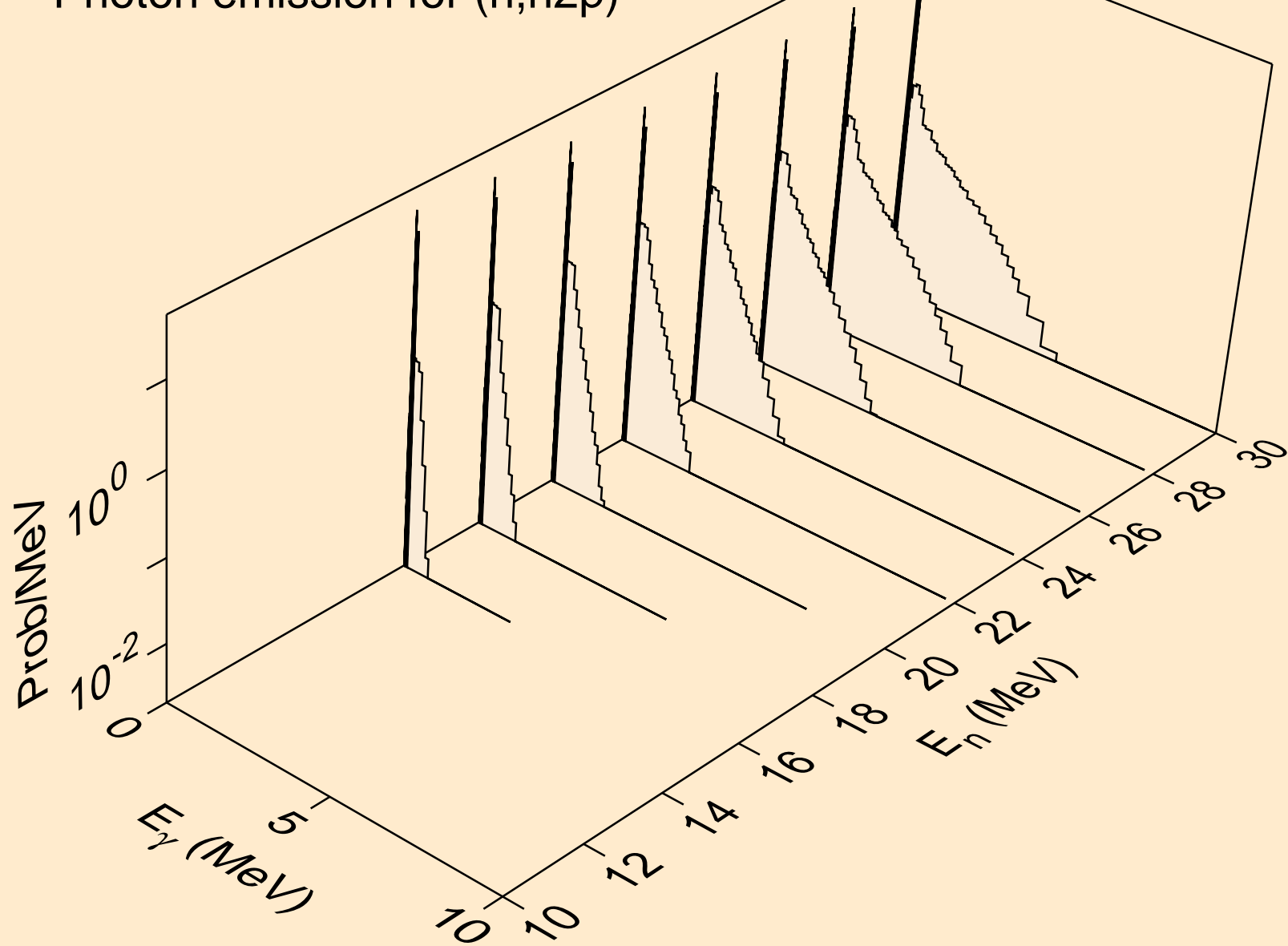

PR138M NEUTRON ACER TENDL-2023 LIBRARY; T=0.K  
Photon emission for (n,npa)

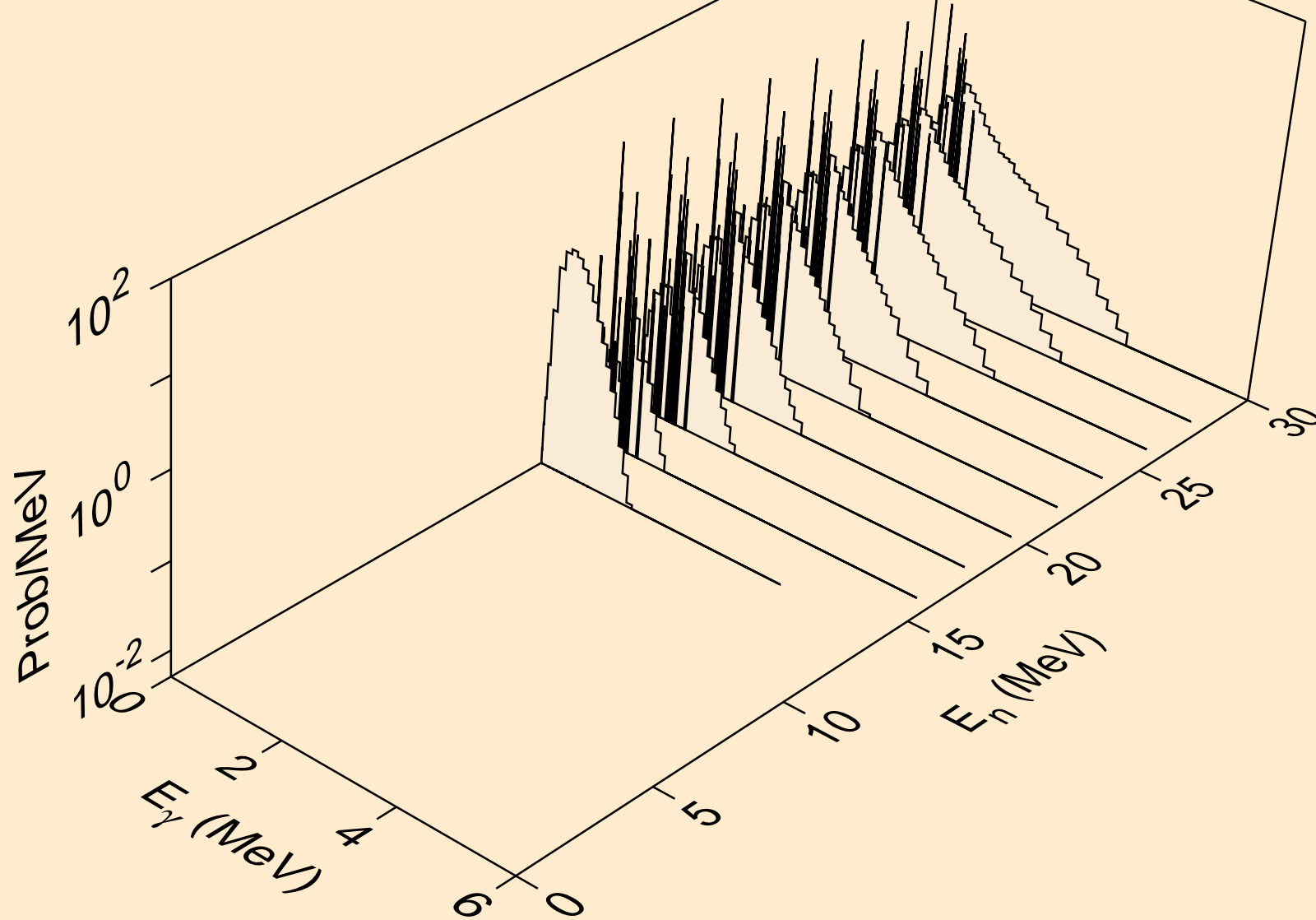

PR138M NEUTRON ACER TENDL-2023 LIBRARY; T=0.K  
Photon emission for (n,n\*1)

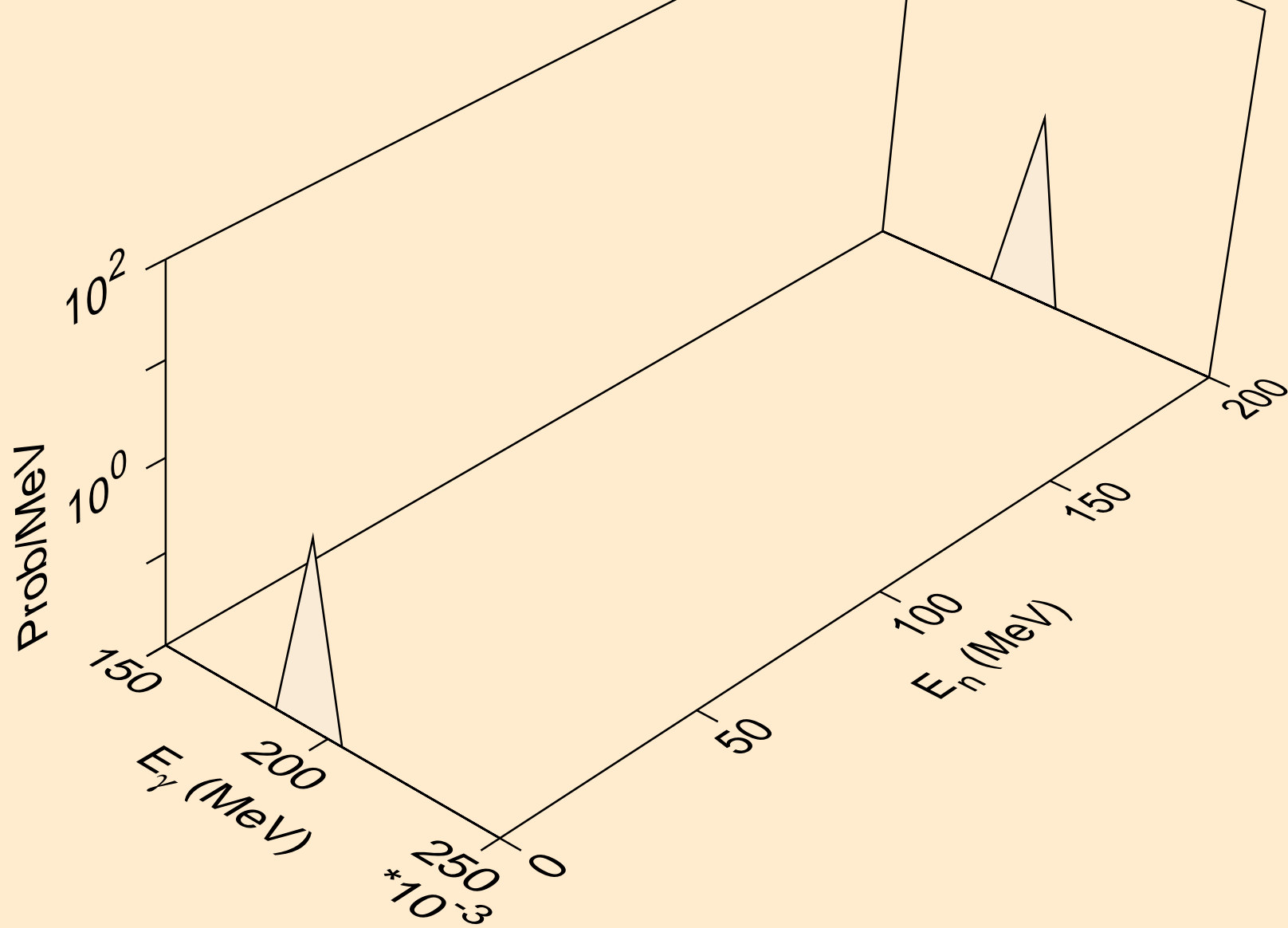

PR138M NEUTRON ACER TENDL-2023 LIBRARY; T=0.K  
Photon emission for (n,n\*2)

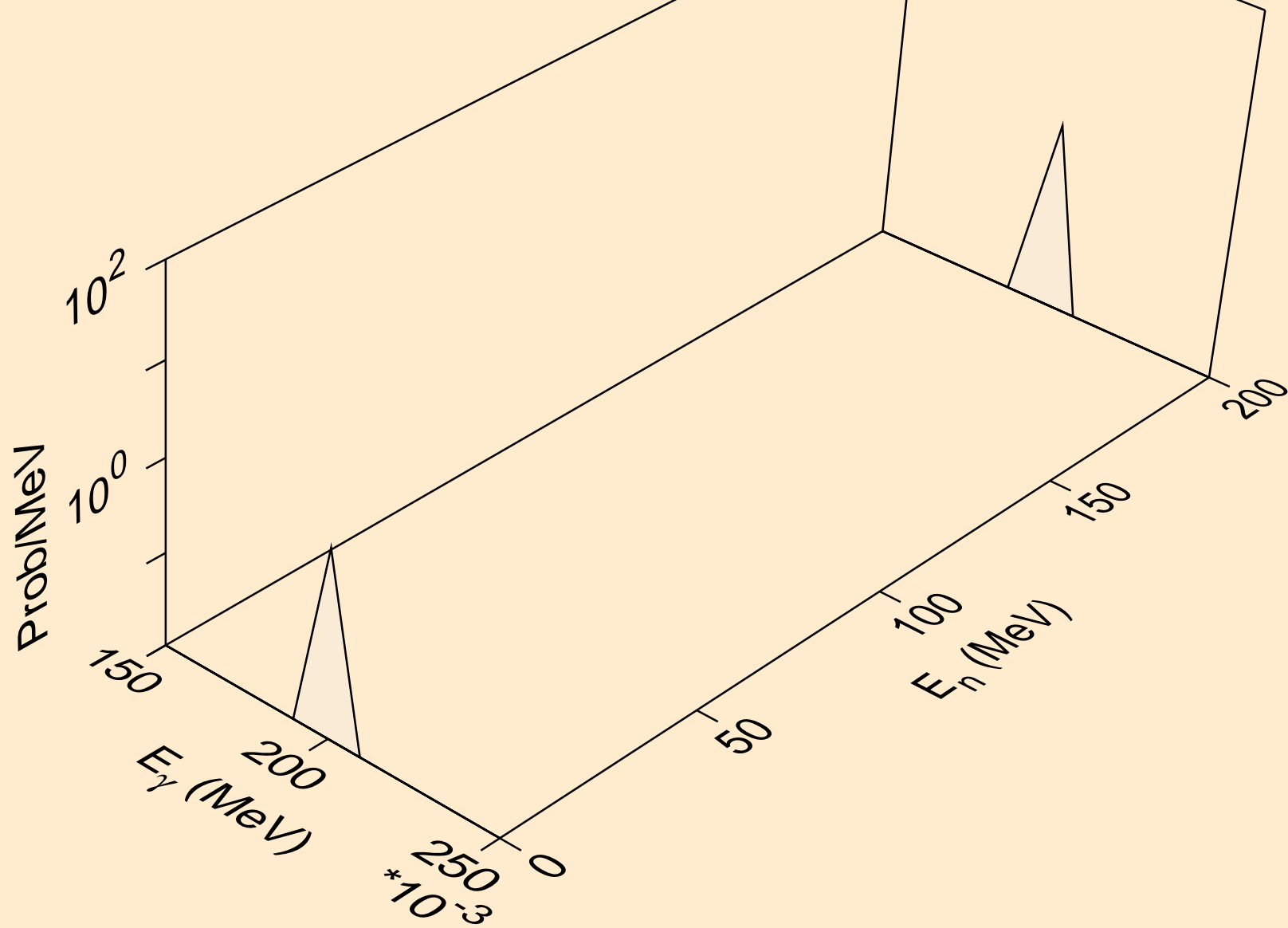



PR138M NEUTRON ACER TENDL-2023 LIBRARY; T=0.K  
Photon emission for (n,n\*3)

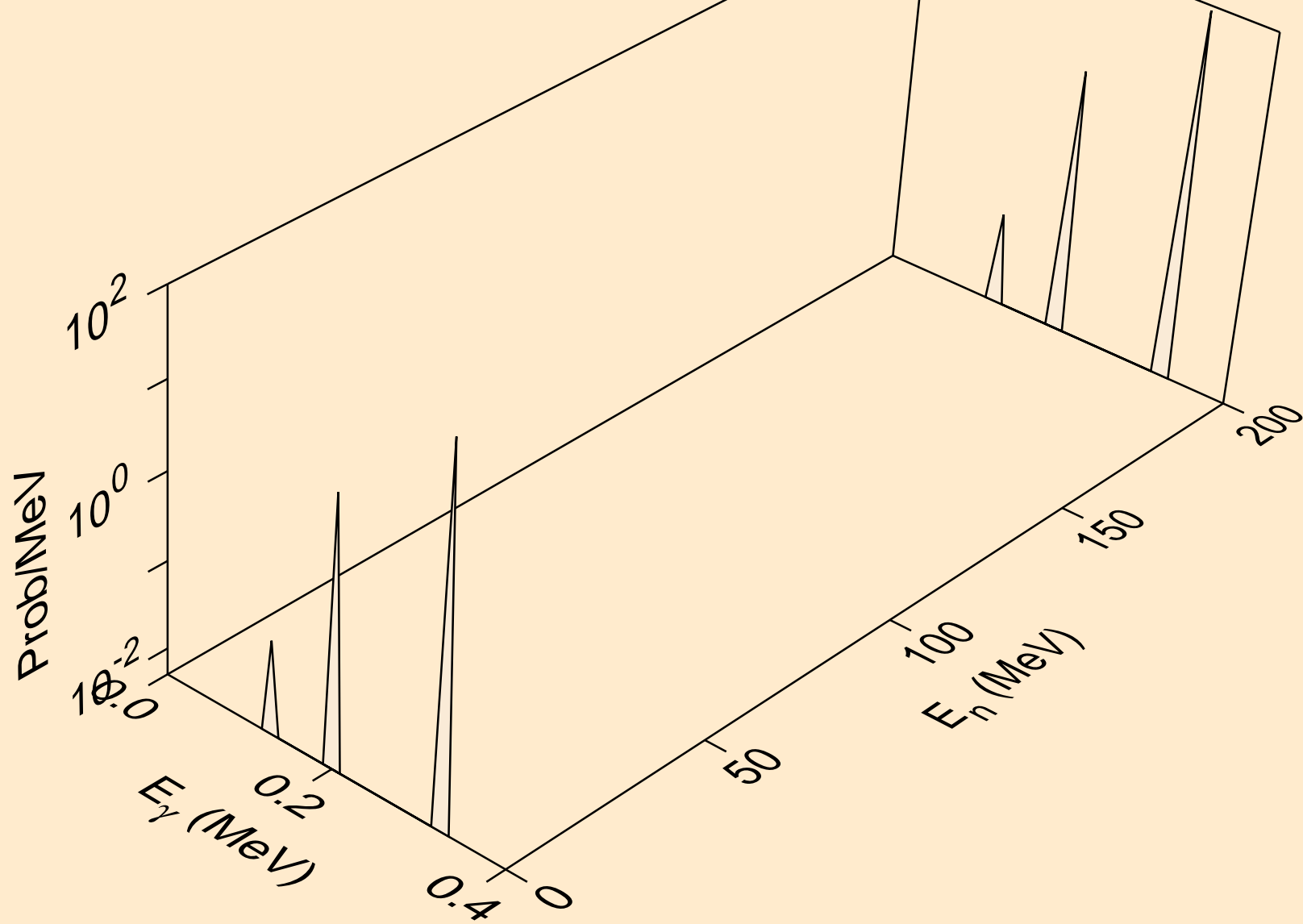

PR138M NEUTRON ACER TENDL-2023 LIBRARY; T=0.K  
Photon emission for (n,n\*4)

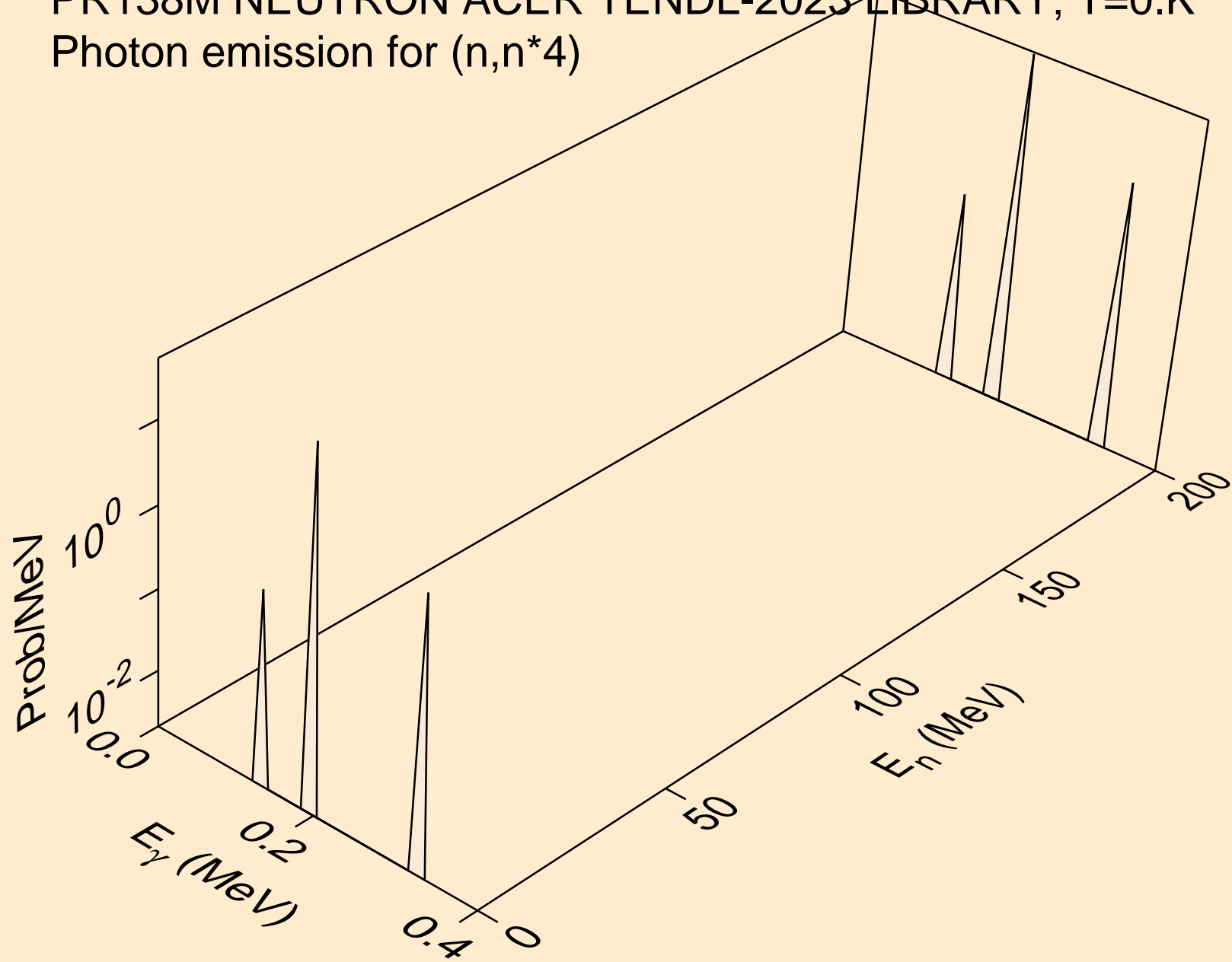

PR138M NEUTRON ACER TENDL-2023 LIBRARY; T=0.K  
Photon emission for (n,n\*6)

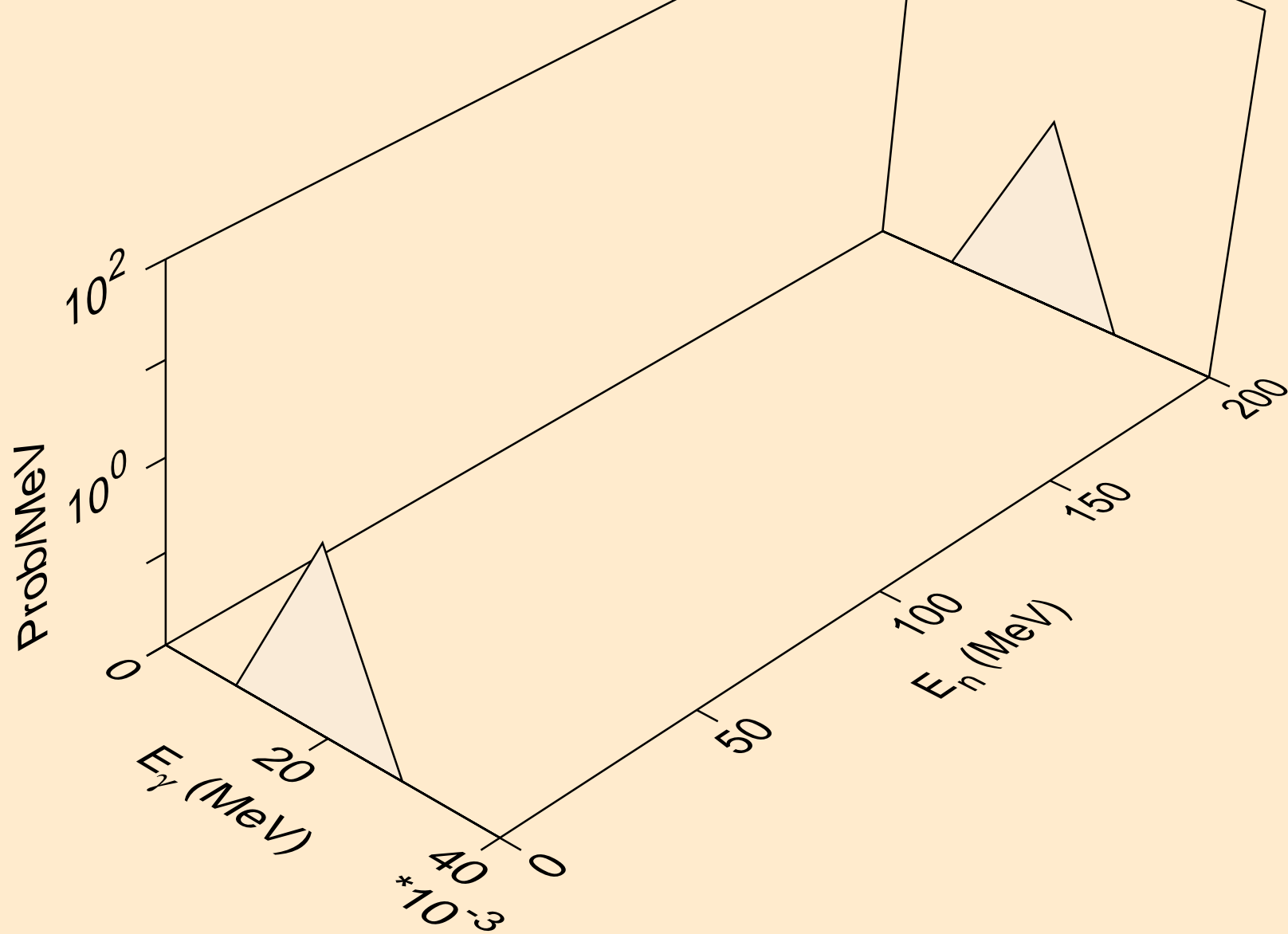

PR138M NEUTRON ACER TENDL-2023 LIBRARY; T=0.K  
Photon emission for (n,n\*7)

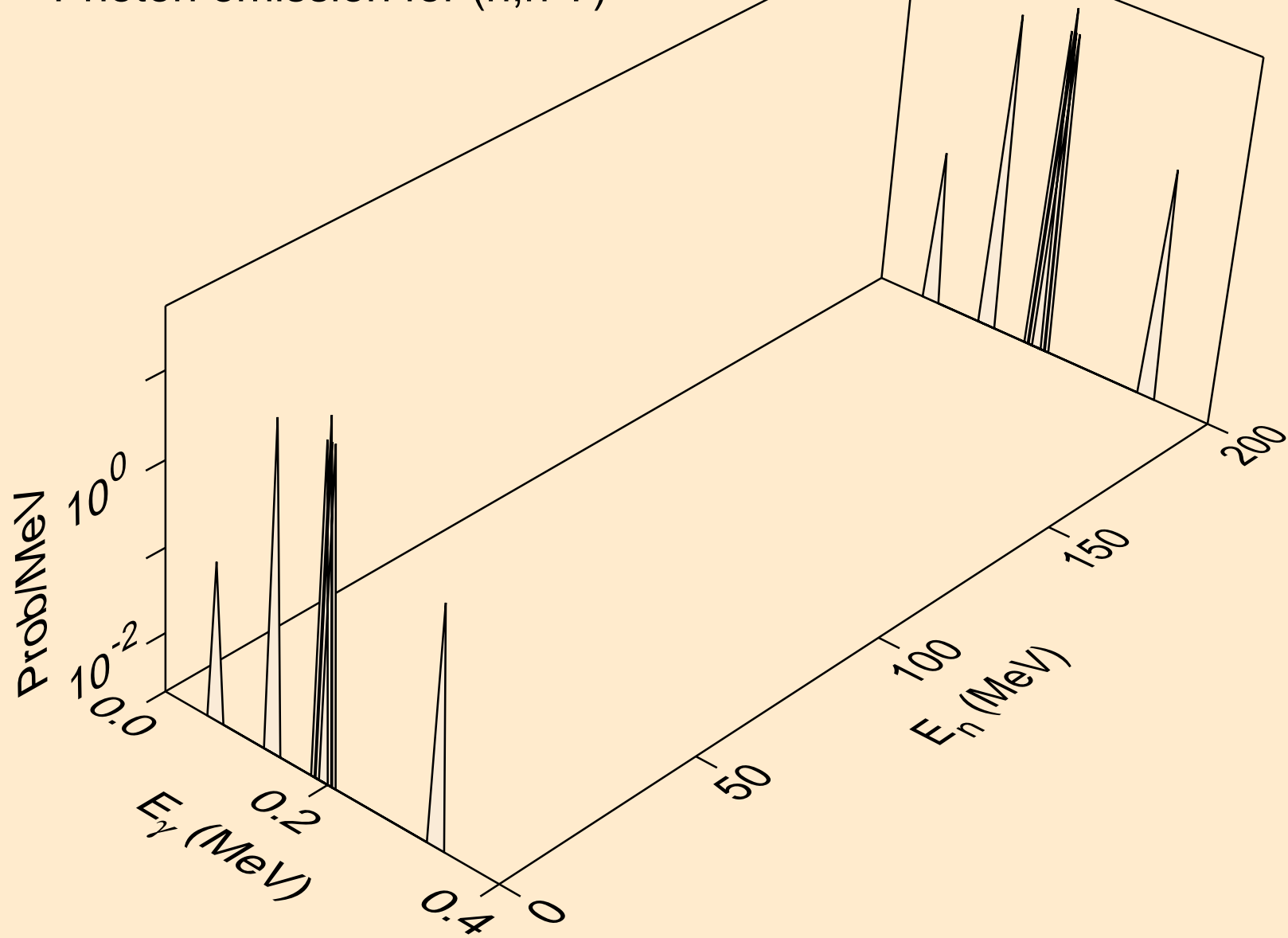

PR138M NEUTRON ACER TENDL-2023 LIBRARY; T=0.K  
Photon emission for (n,n\*8)

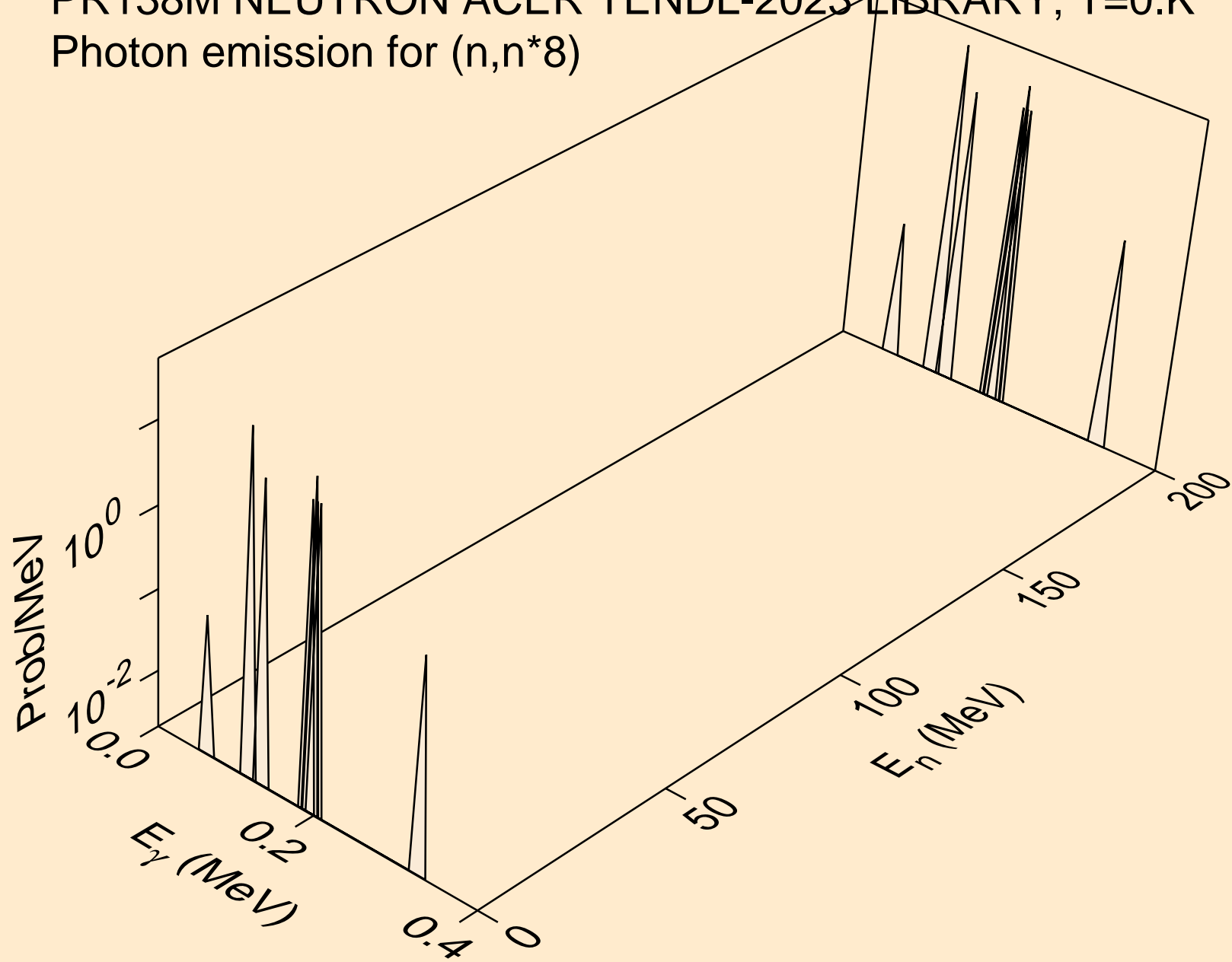

PR138M NEUTRON ACER TENDL-2023 LIBRARY; T=0.K  
Photon emission for (n,n\*9)

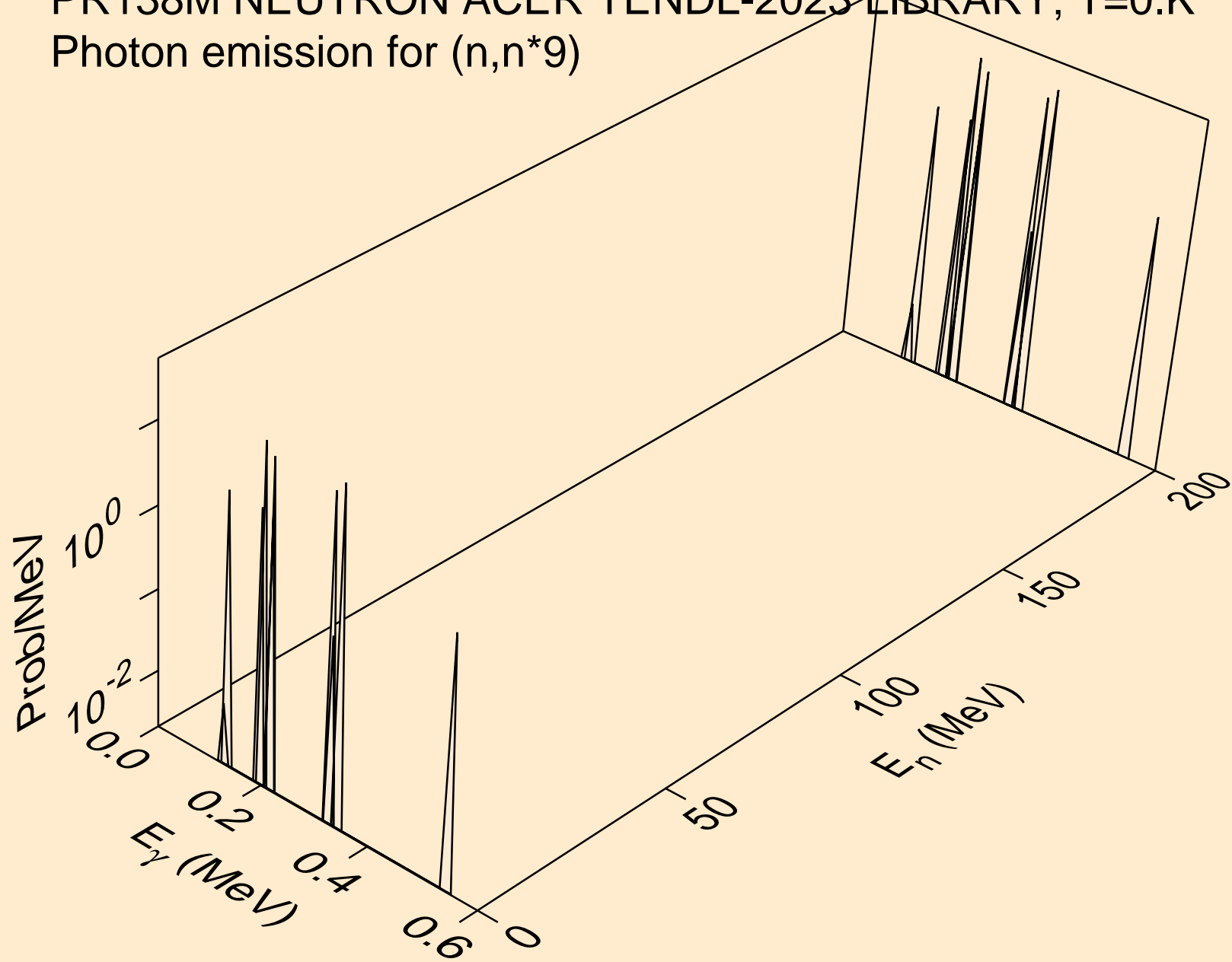

PR138M NEUTRON ACER TENDL-2023 LIBRARY; T=0.K  
Photon emission for (n,n\*10)

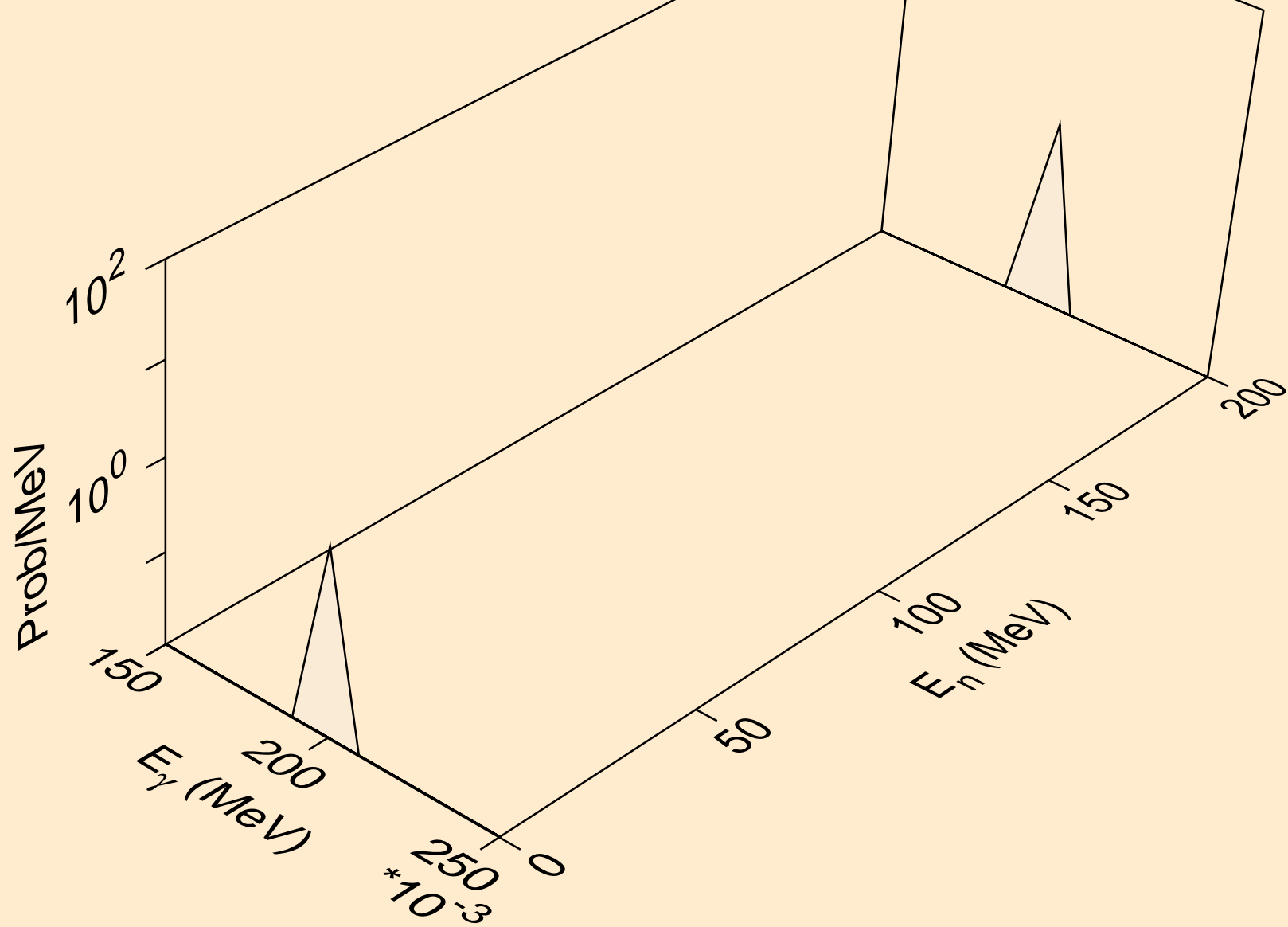

PR138M NEUTRON ACER TENDL-2023 LIBRARY; T=0.K  
Photon emission for (n,n\*11)

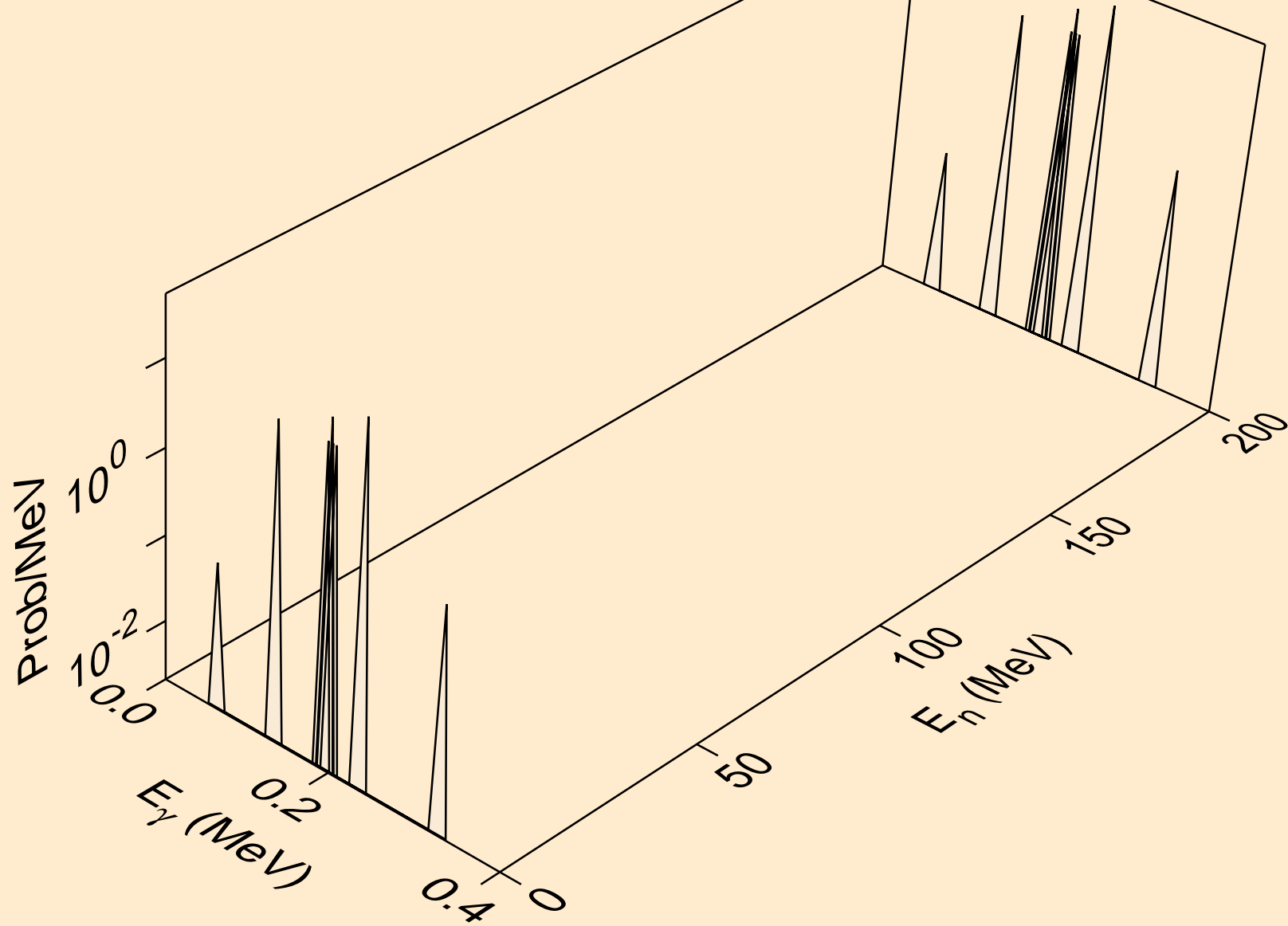



PR138M NEUTRON ACER TENDL-2023 LIBRARY; T=0.K  
Photon emission for (n,n\*12)

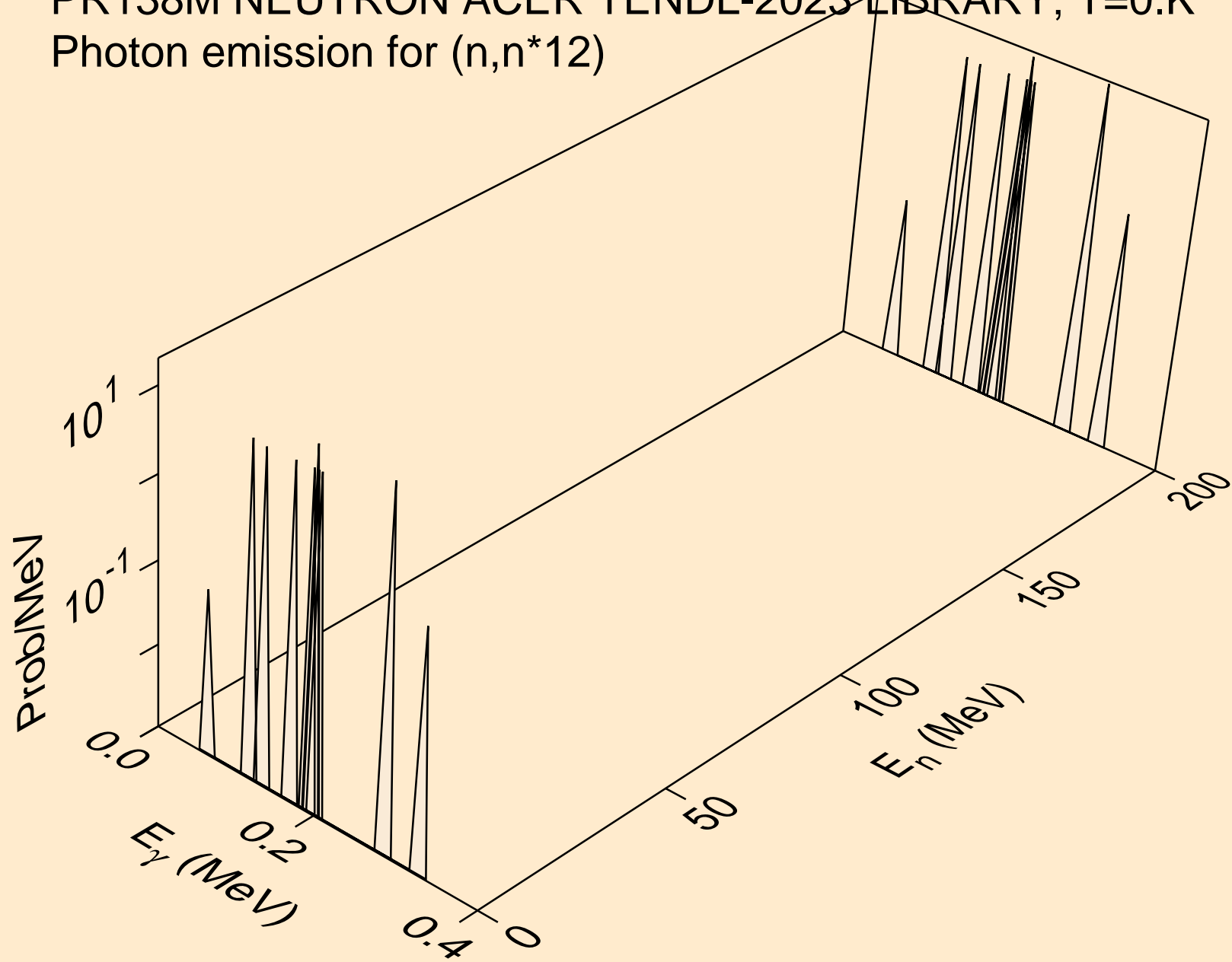

PR138M NEUTRON ACER TENDL-2023 LIBRARY; T=0.K  
Photon emission for (n,n\*13)

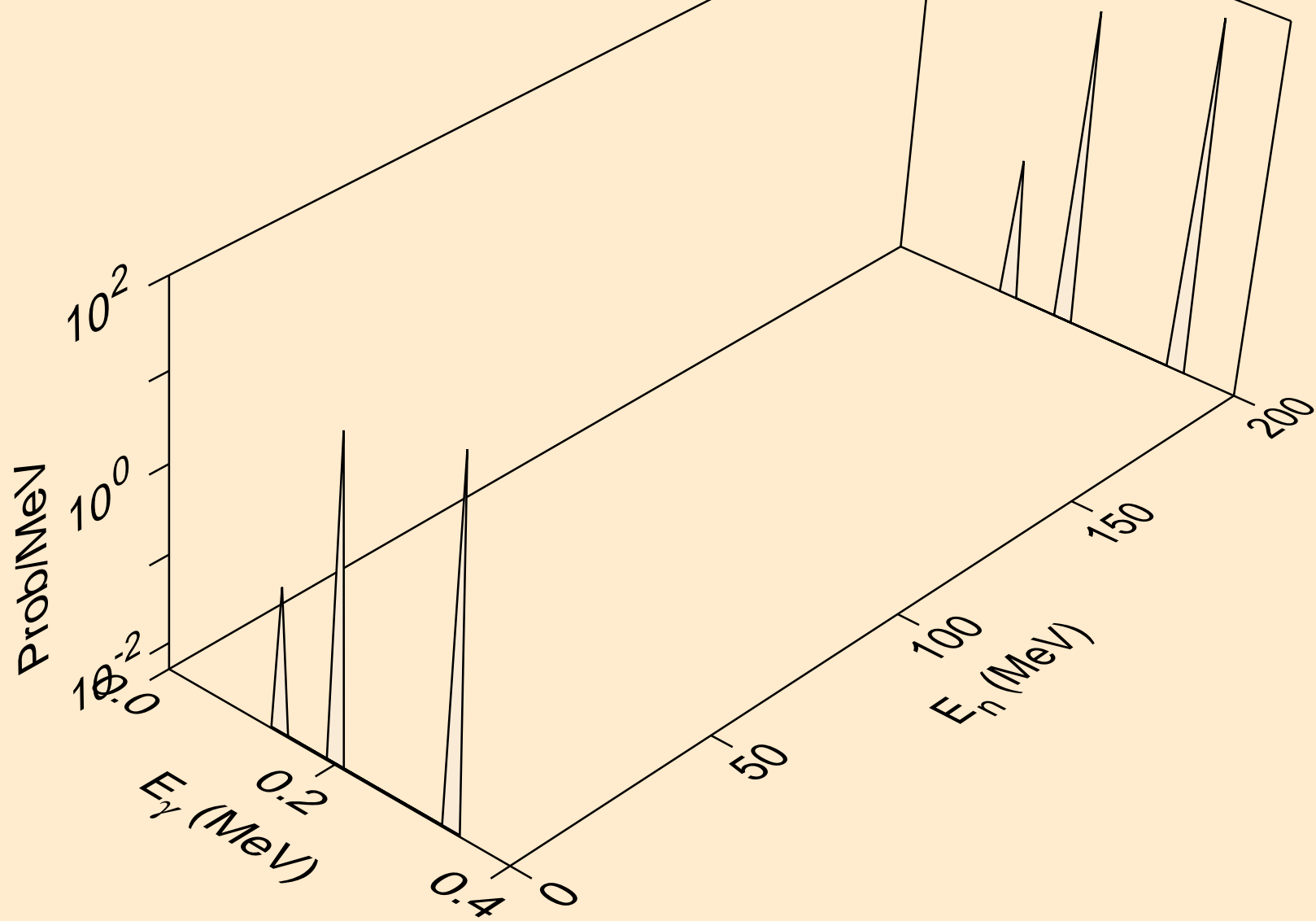

PR138M NEUTRON ACER TENDL-2023 LIBRARY; T=0.K  
Photon emission for (n,n\*14)

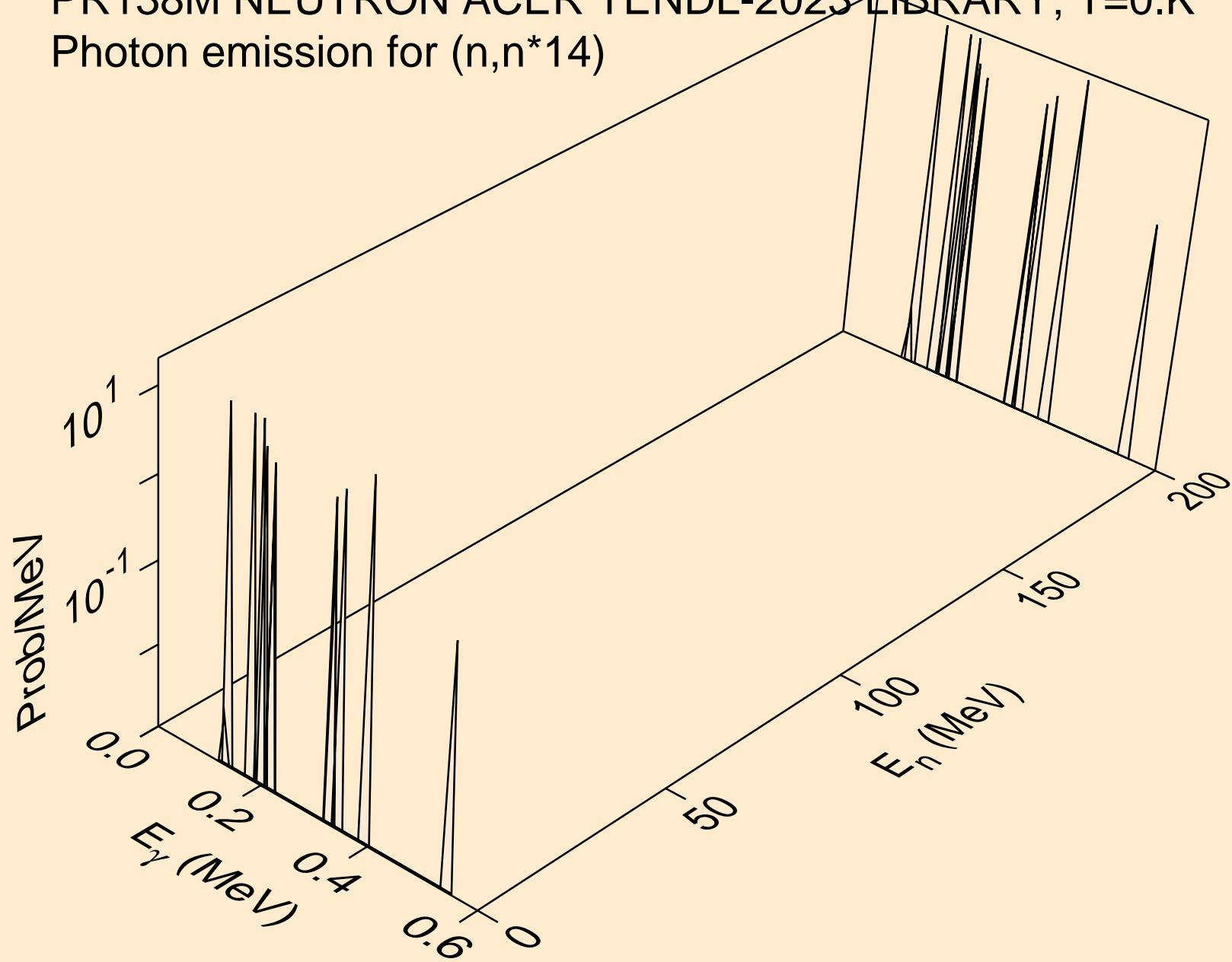

PR138M NEUTRON ACER TENDL-2023 LIBRARY; T=0.K  
Photon emission for (n,n\*15)

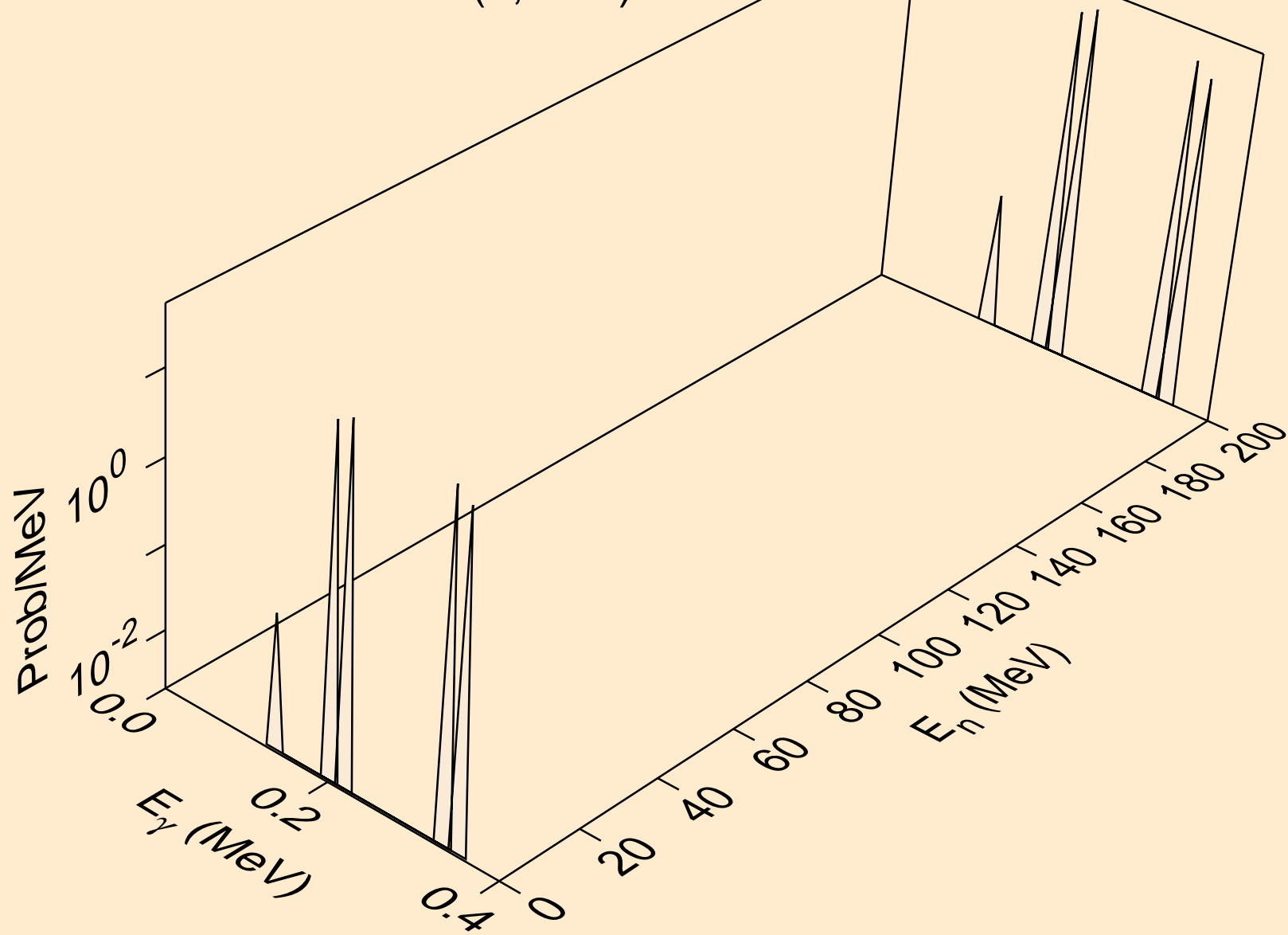

PR138M NEUTRON ACER TENDL-2023 LIBRARY; T=0.K  
Photon emission for (n,n\*c)

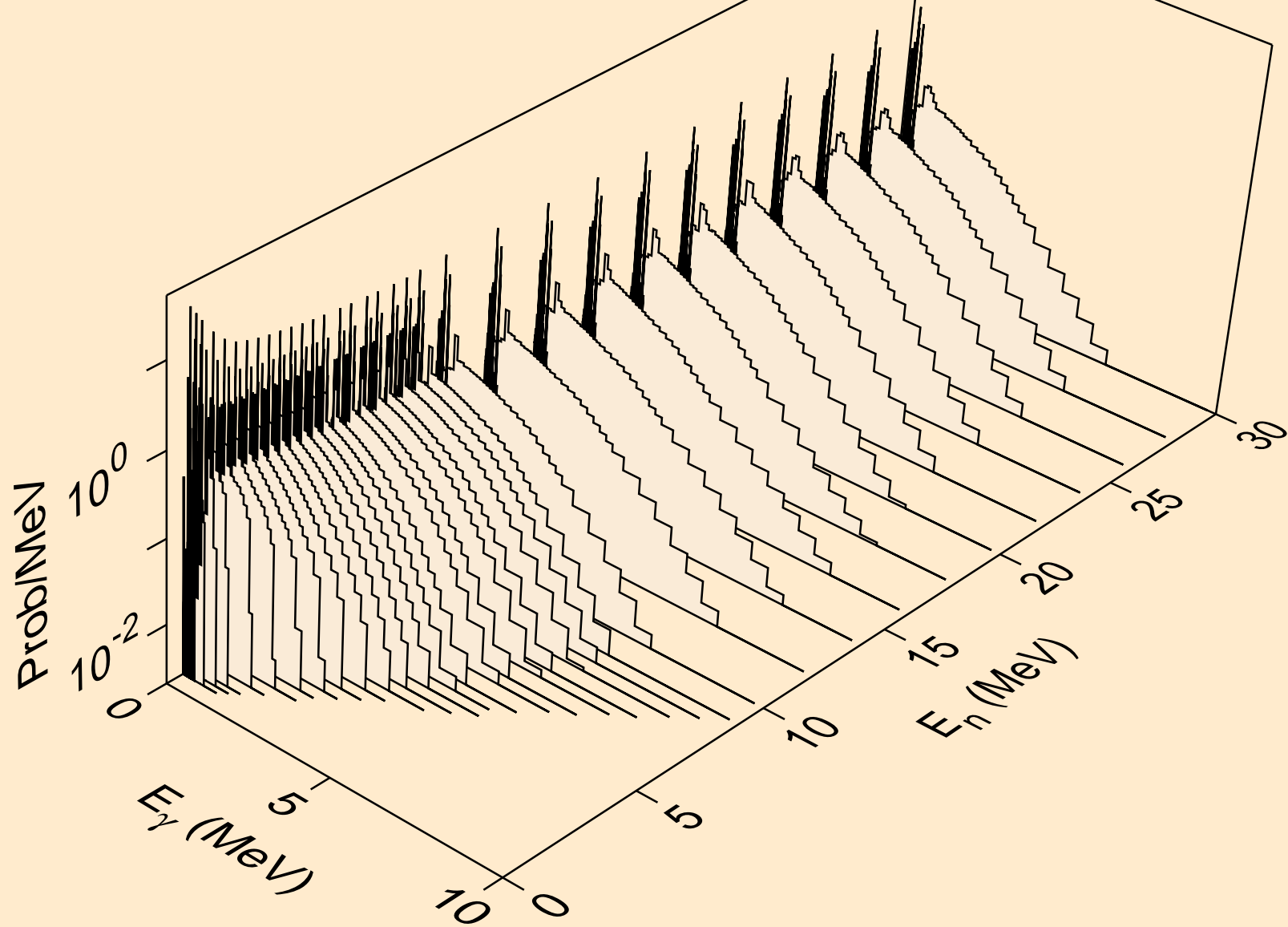

PR138M NEUTRON ACER TENDL-2023 LIBRARY; T=0.K  
Photon emission for (n,gma)

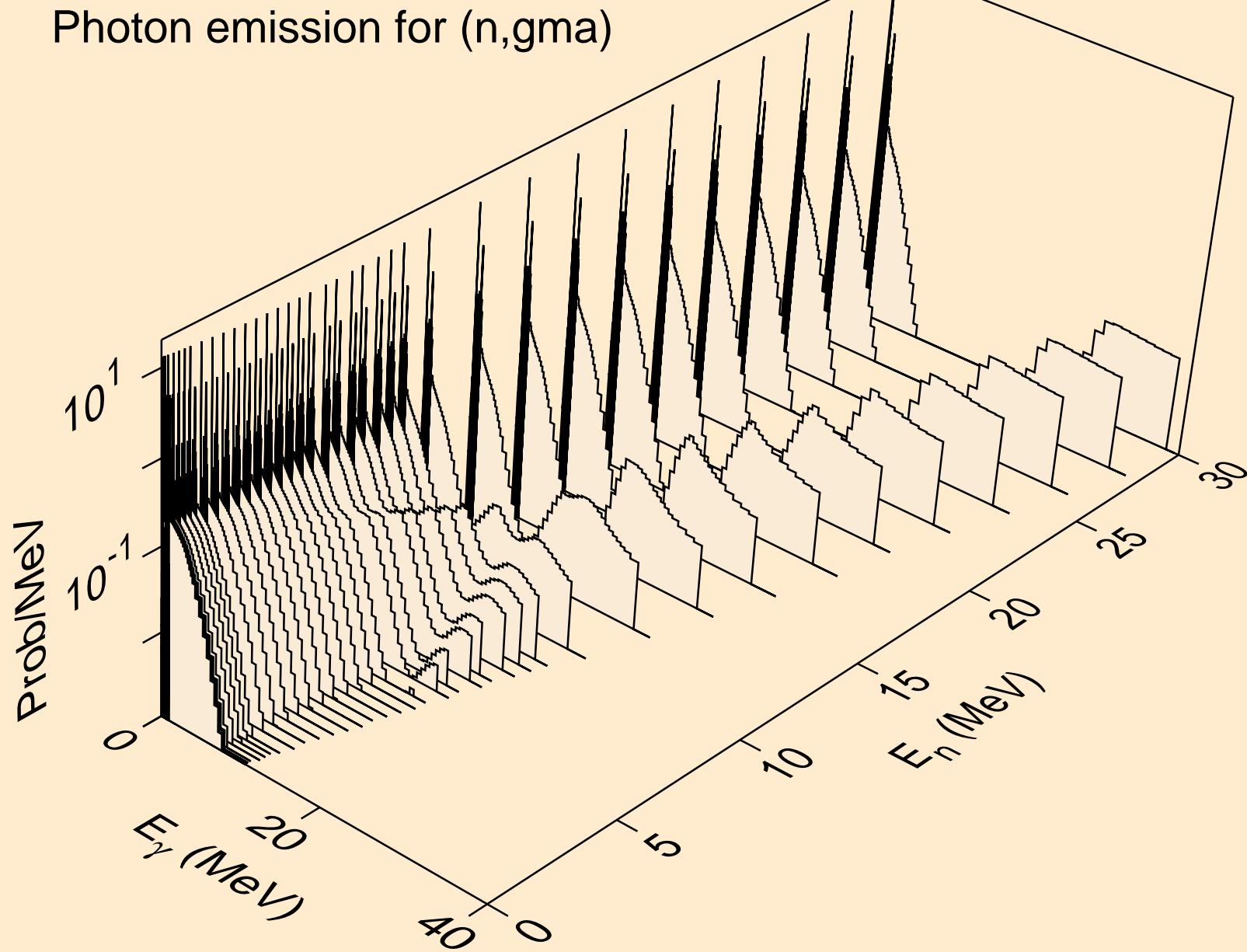

PR138M NEUTRON ACER TENDL-2023 LIBRARY; T=0.K  
Photon emission for (n,p)

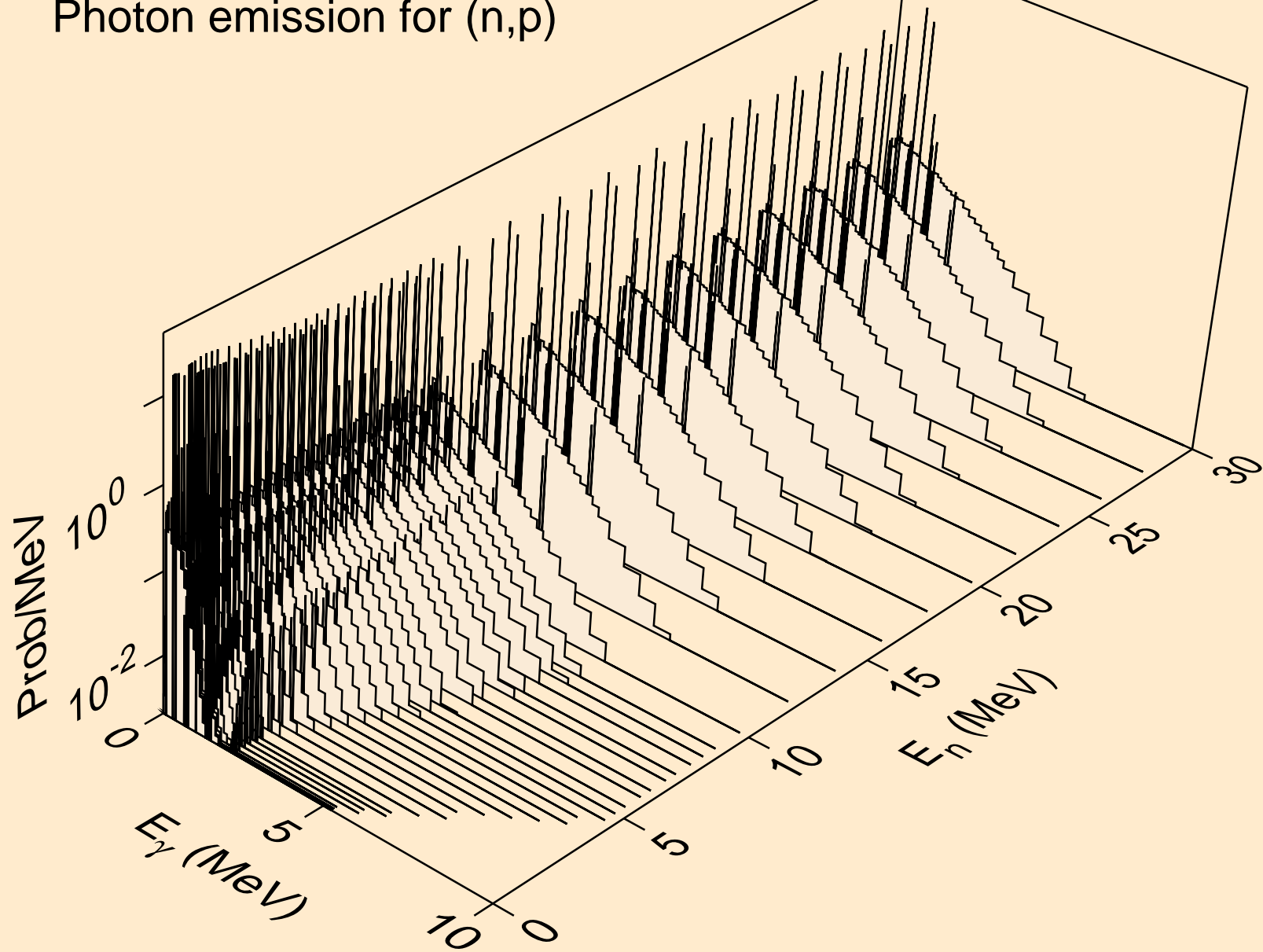

PR138M NEUTRON ACER TENDL-2023 LIBRARY; T=0.K  
Photon emission for (n,d)

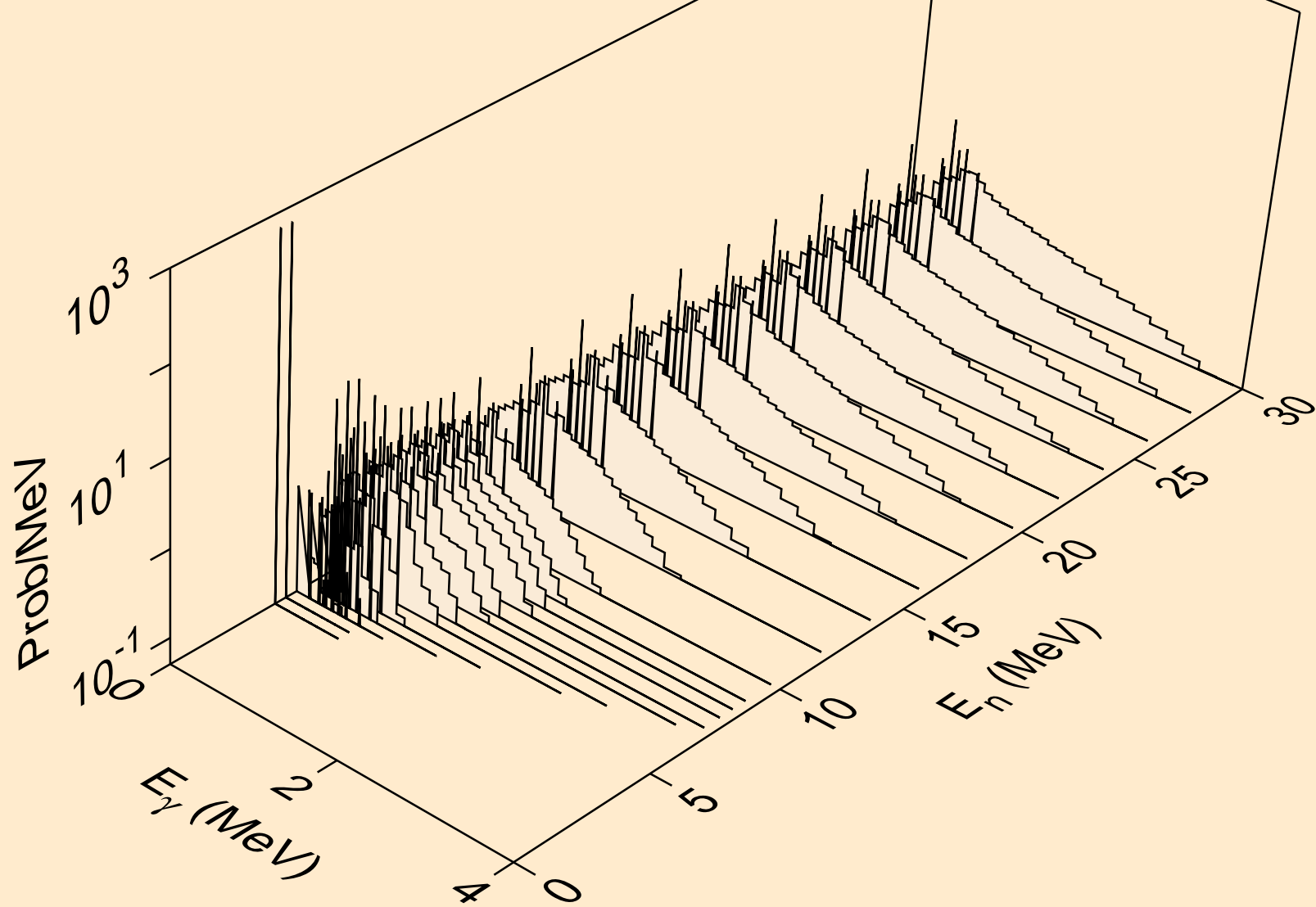



PR138M NEUTRON ACER TENDL-2023 LIBRARY; T=0.K  
Photon emission for (n,t)

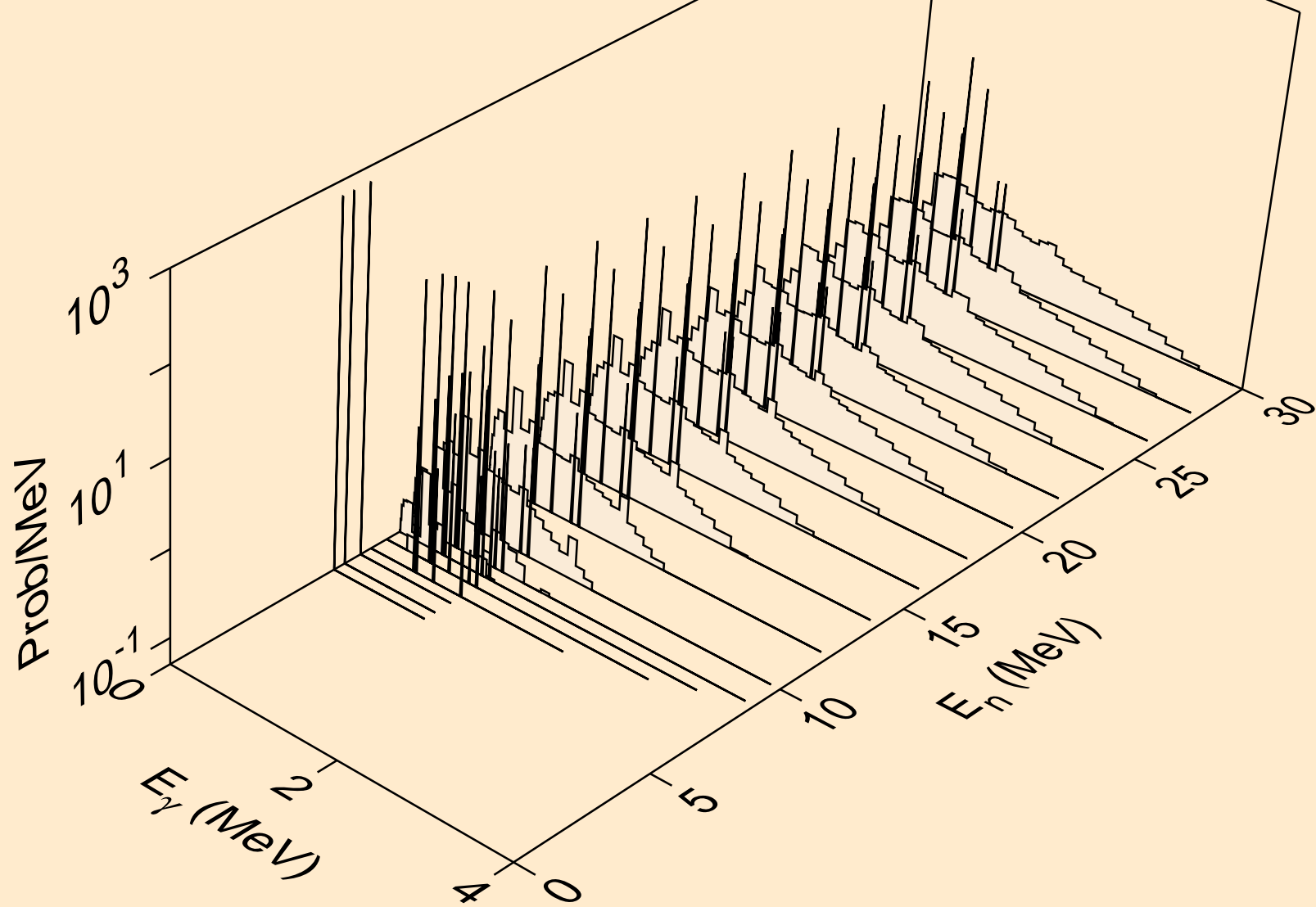

PR138M NEUTRON ACER TENDL-2023 LIBRARY; T=0.K  
Photon emission for (n,he3)

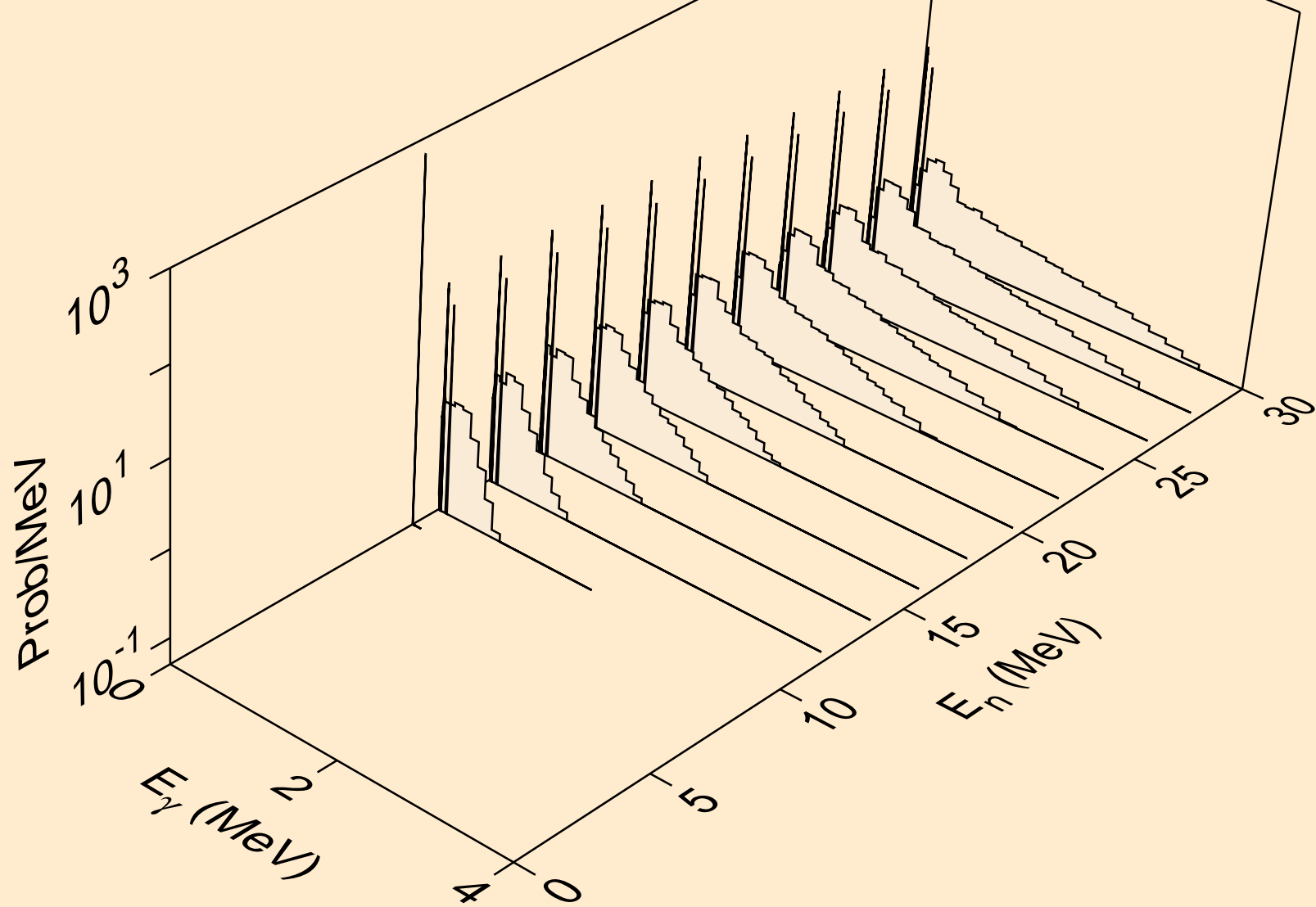

PR138M NEUTRON ACER TENDL-2023 LIBRARY; T=0.K  
Photon emission for (n,a)

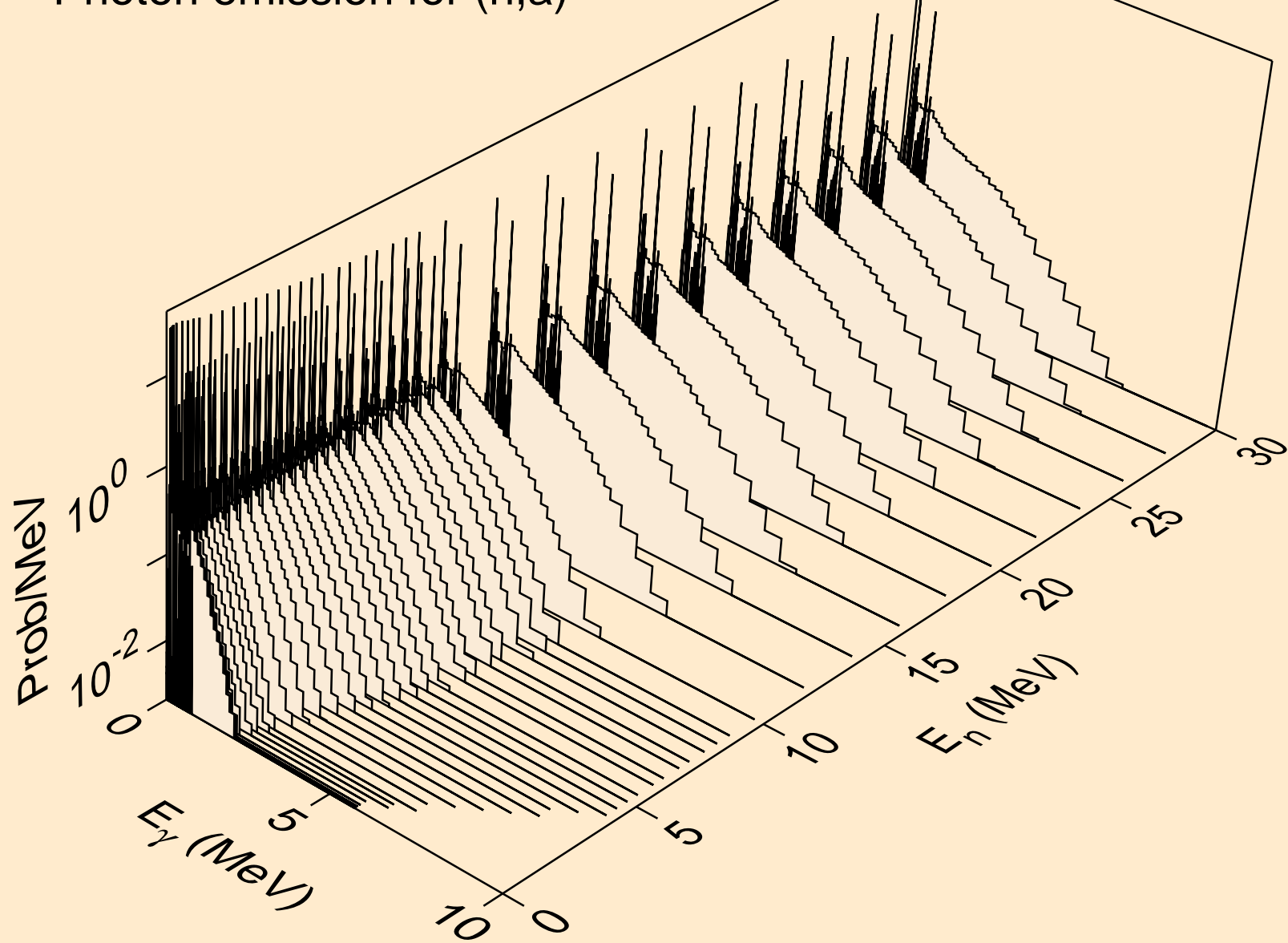

PR138M NEUTRON ACER TENDL-2023 LIBRARY; T=0.K  
Photon emission for (n,2a)

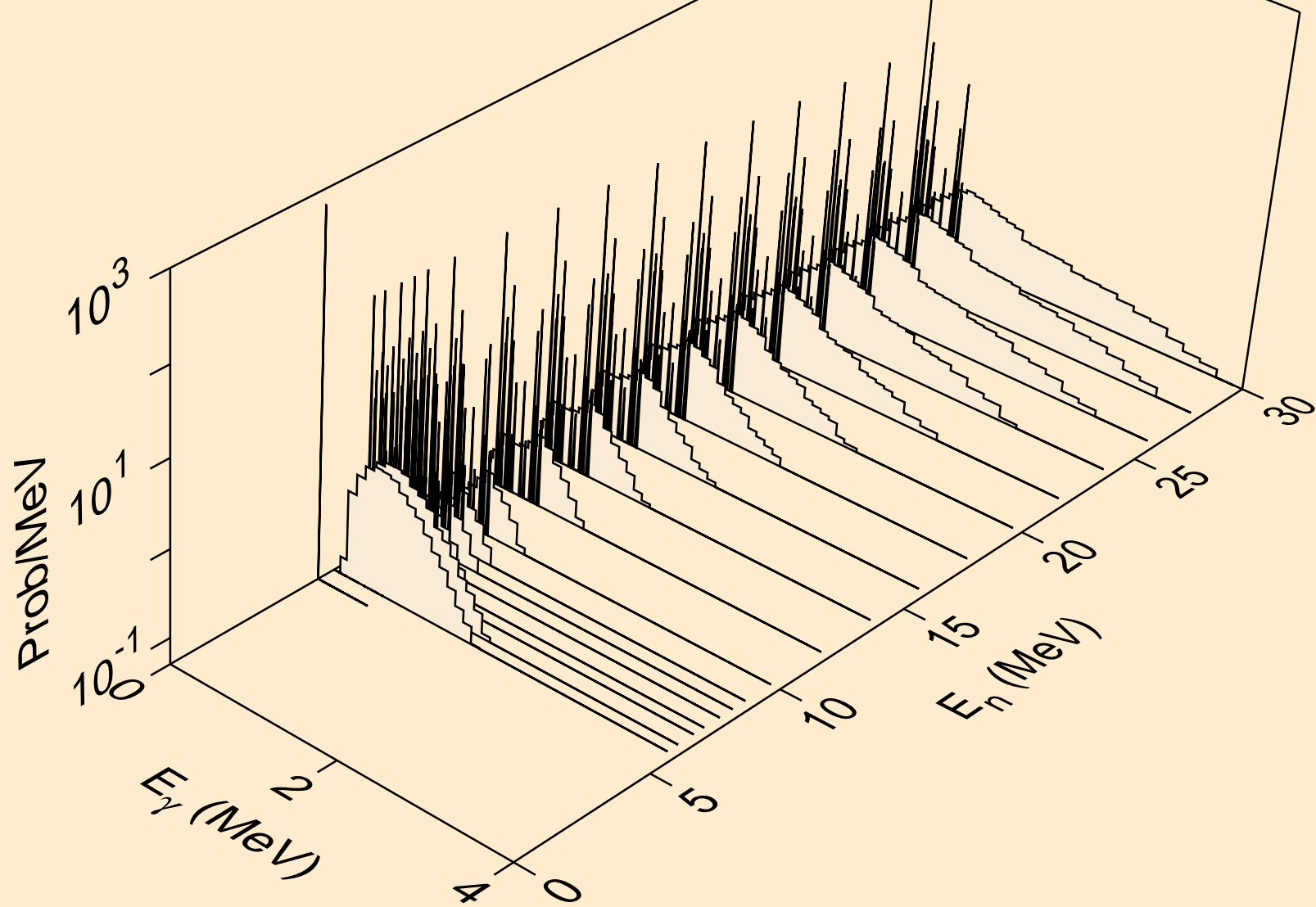

PR138M NEUTRON ACER TENDL-2023 LIBRARY; T=0.K  
Photon emission for (n,2p)

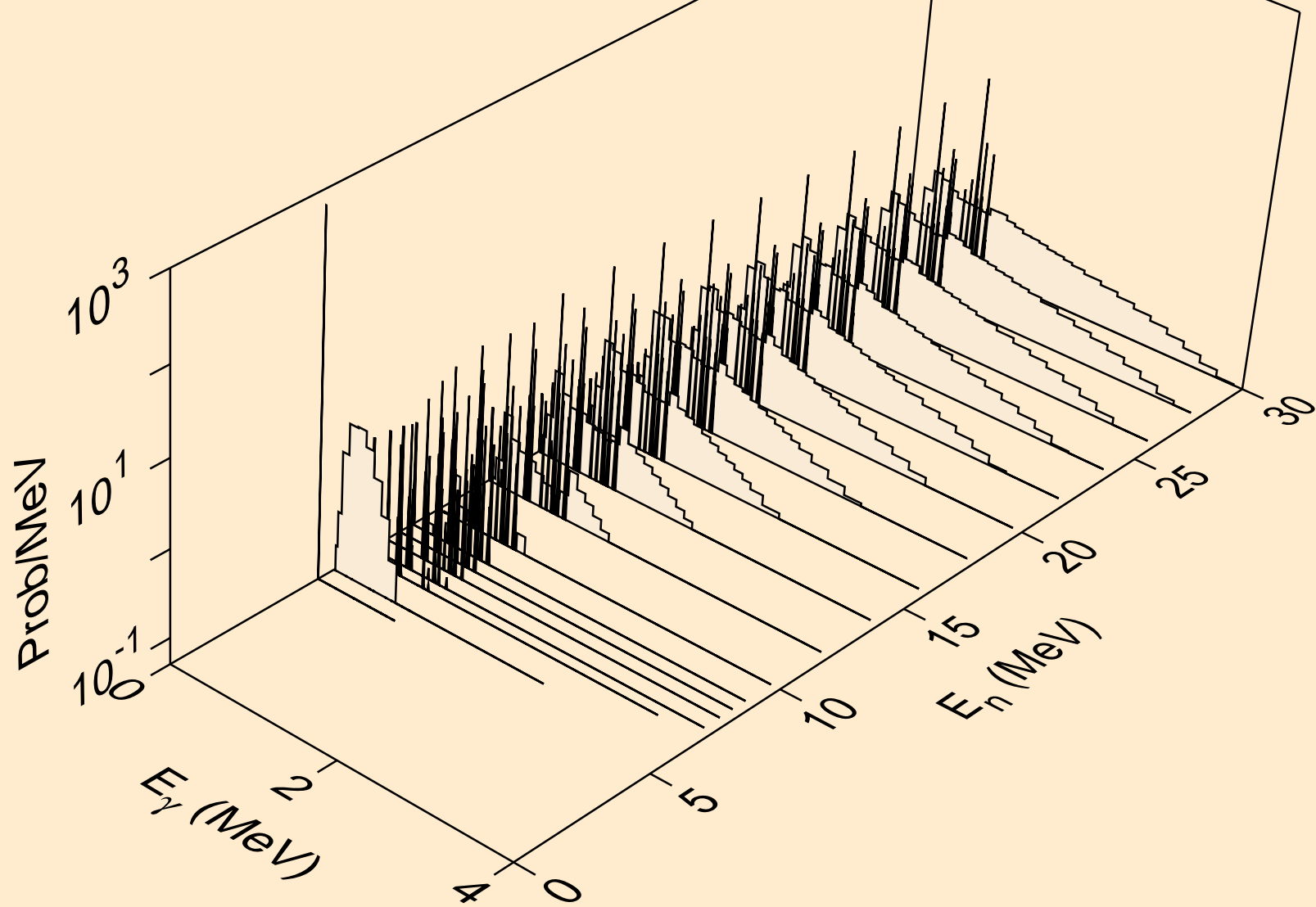

PR138M NEUTRON ACER TENDL-2023 LIBRARY; T=0.K  
Photon emission for (n,p)

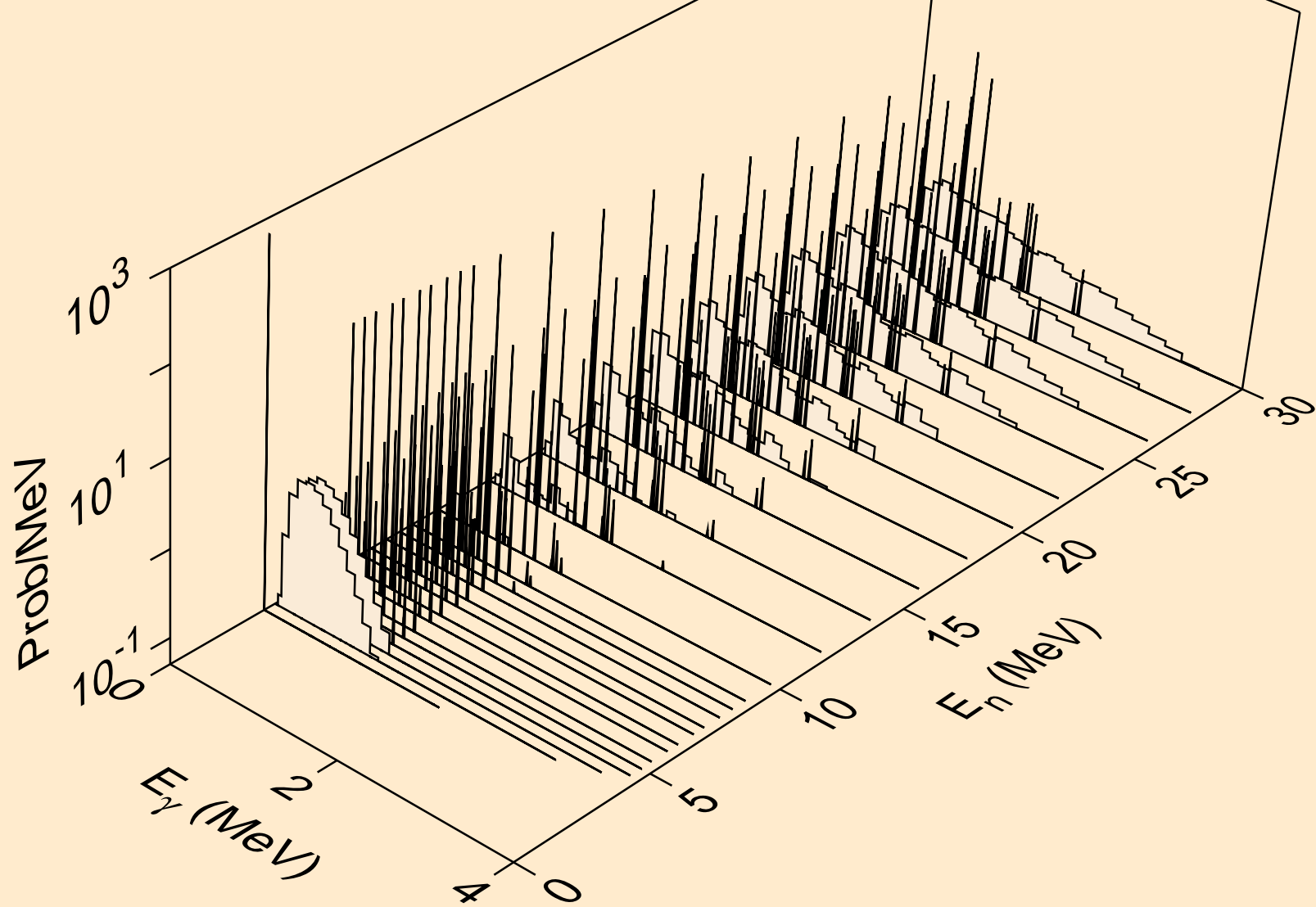

PR138M NEUTRON ACER TENDL-2023 LIBRARY; T=0.K  
Photon emission for (n,pd)

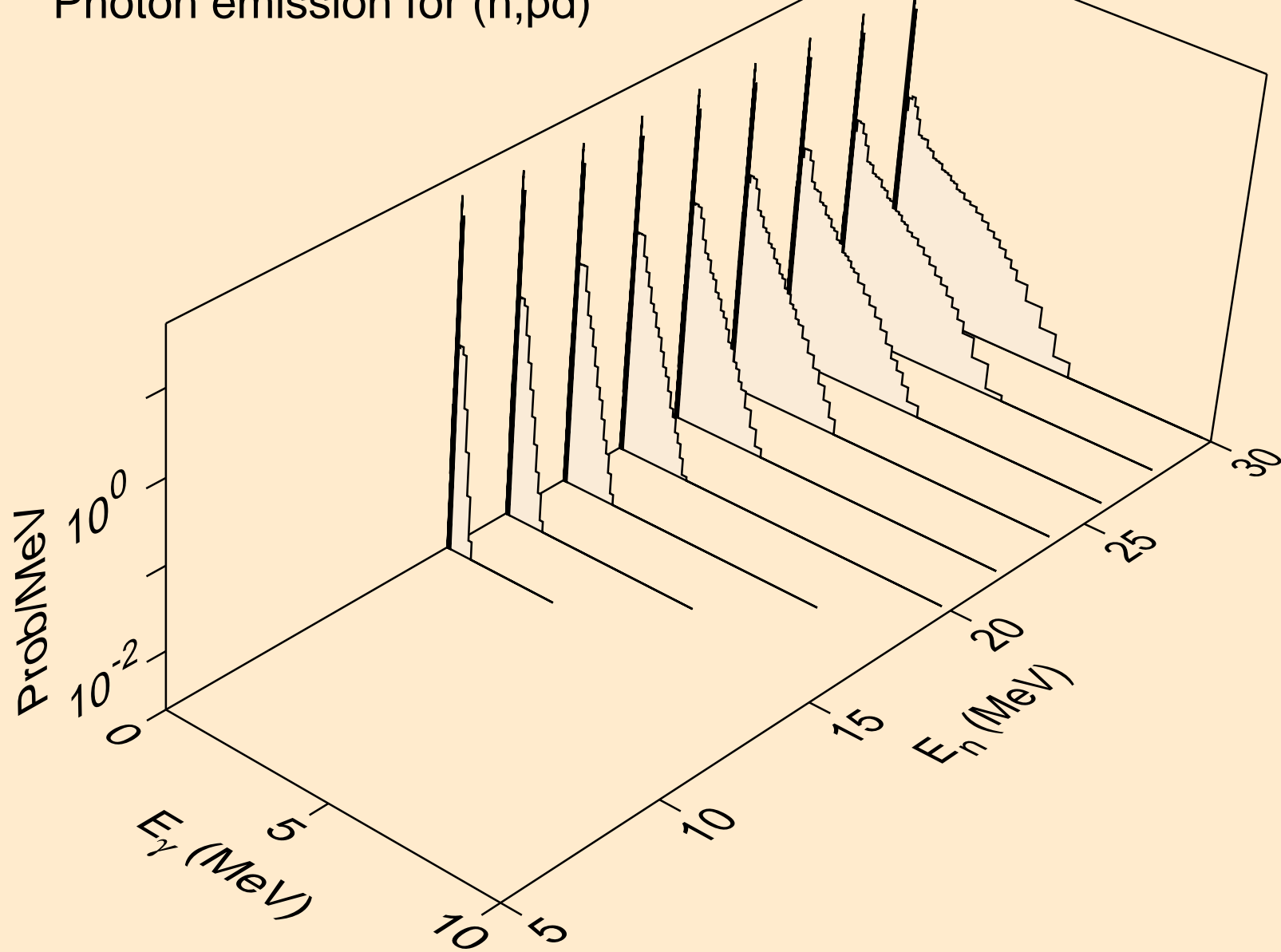

PR138M NEUTRON ACER TENDL-2023 LIBRARY; T=0.K  
Photon emission for (n,pt)

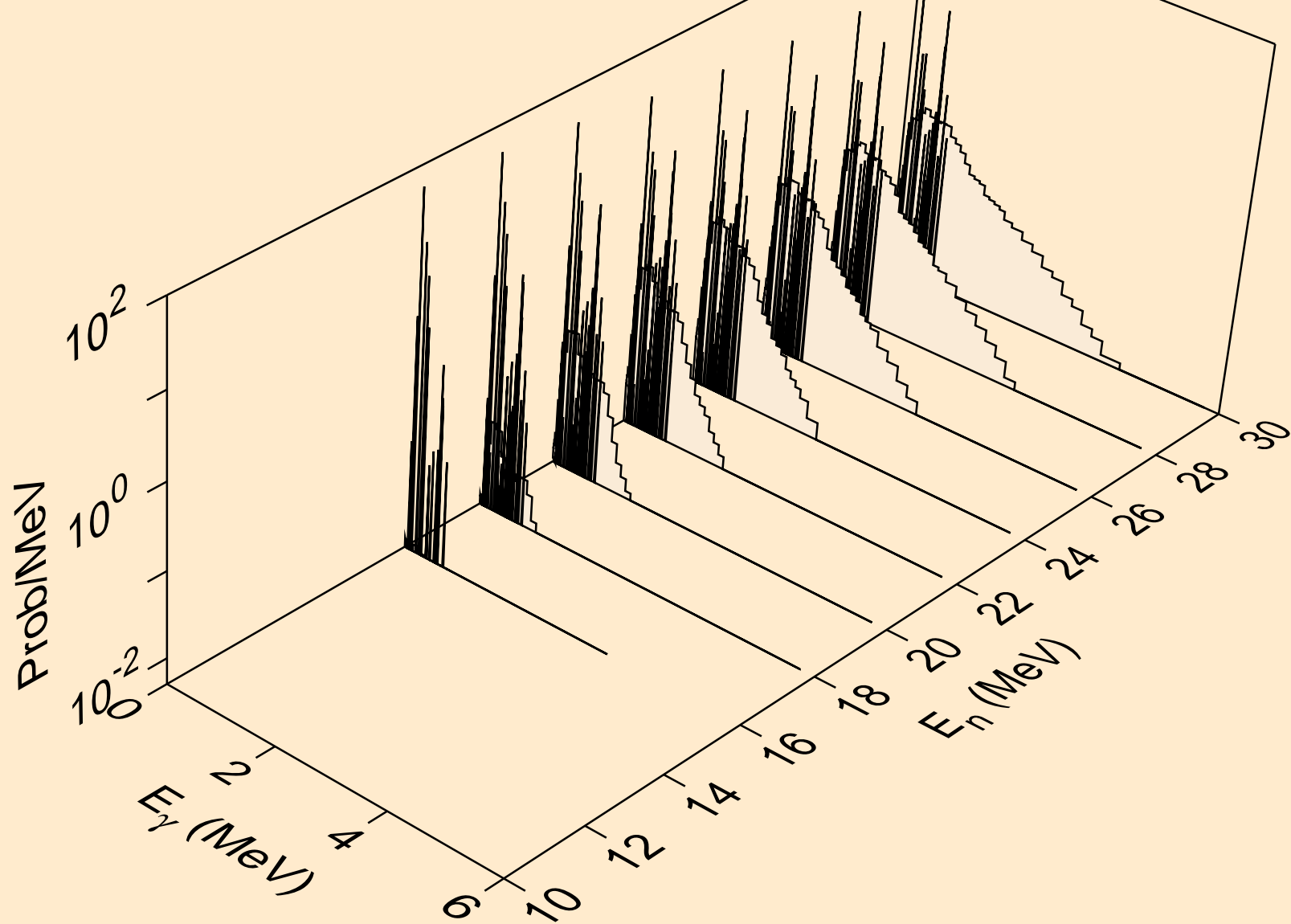



PR138M NEUTRON ACER TENDL-2023 LIBRARY; T=0.K  
Photon emission for (n,da)

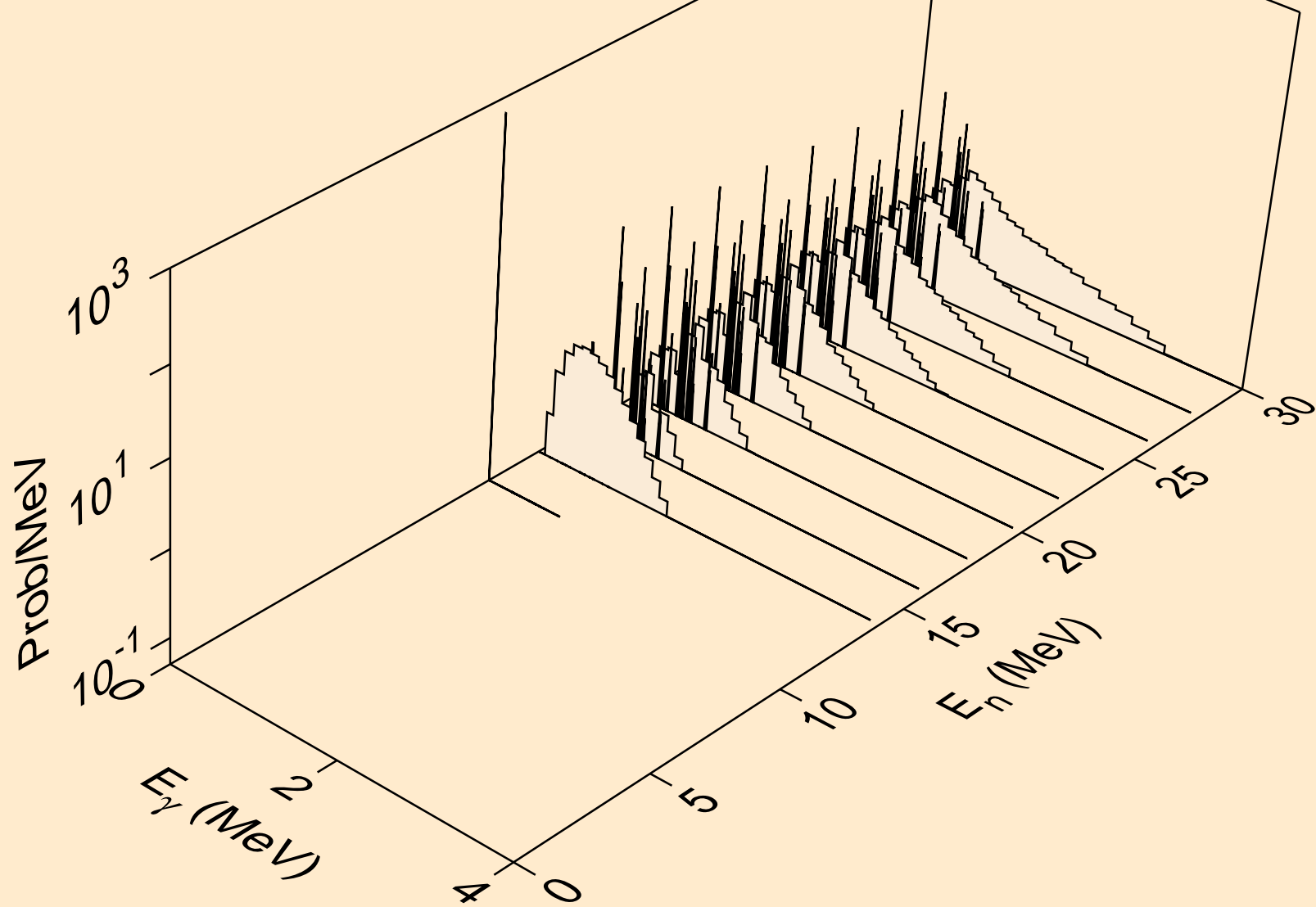

PR138M NEUTRON ACER TENDL-2023 LIBRARY; T=0.K  
thermal capture photon spectrum

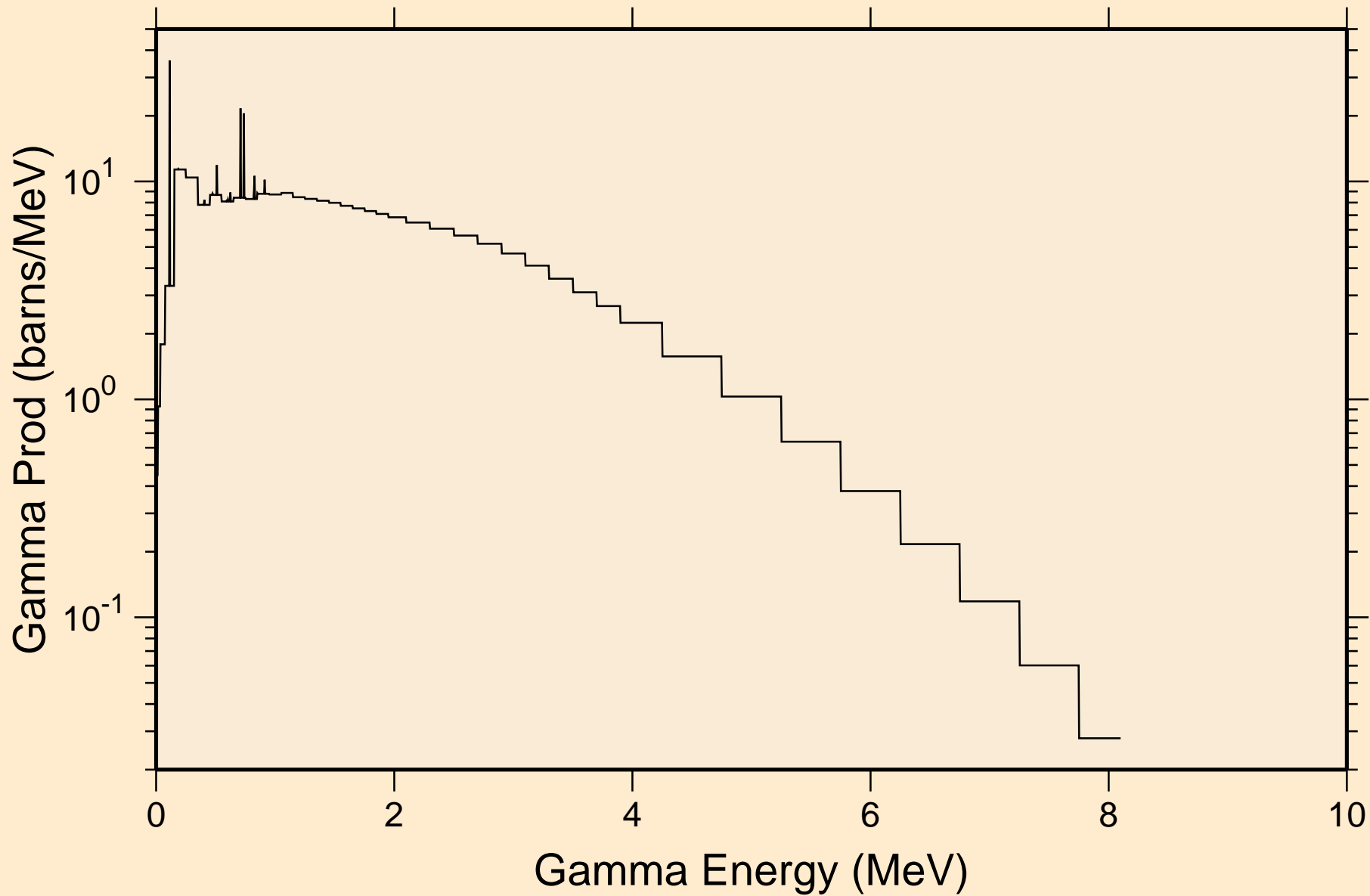

PR138M NEUTRON ACER TENDL-2023 LIBRARY; T=0.K  
14 MeV photon spectrum

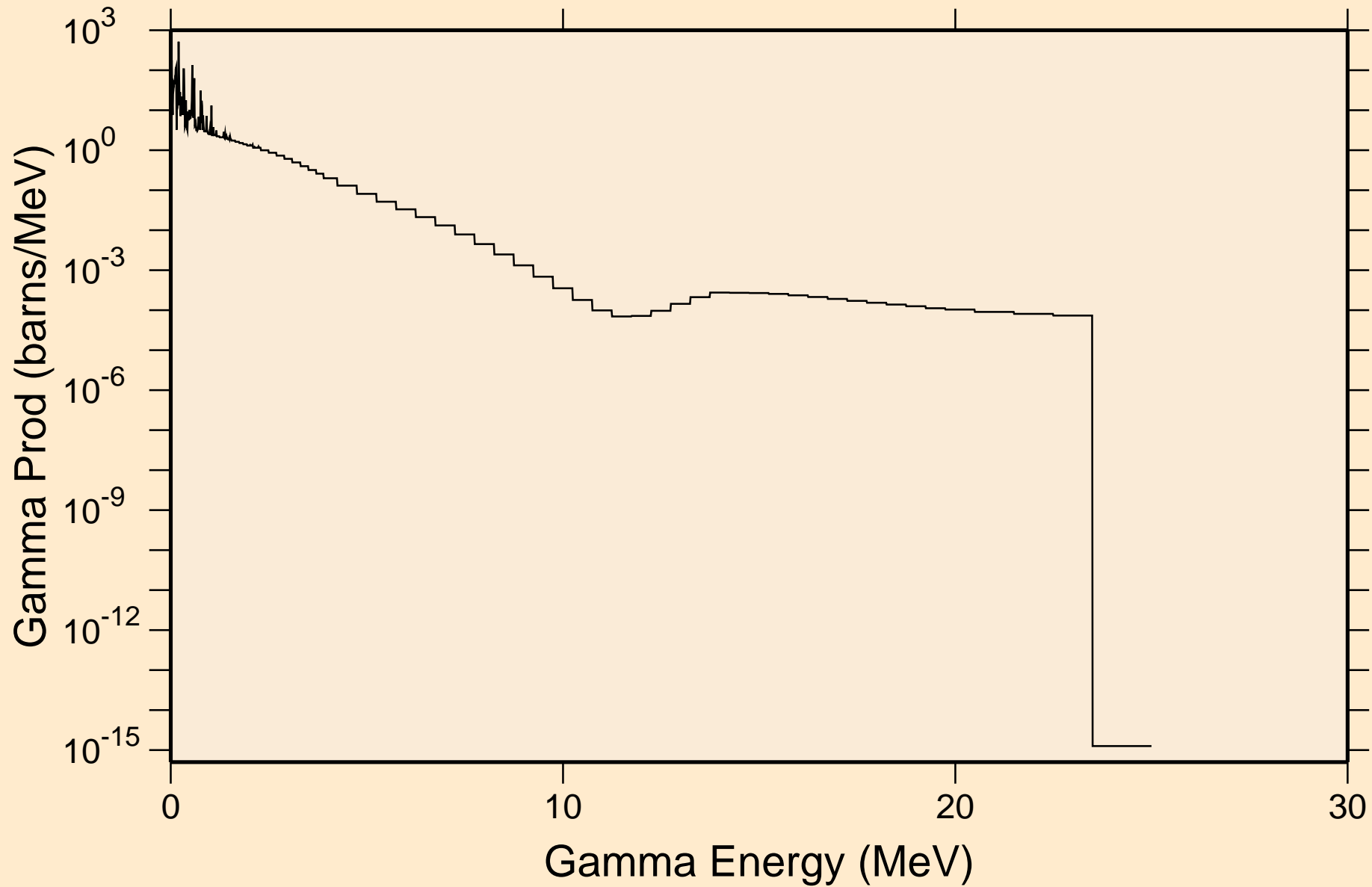

PR138M NEUTRON ACER TENDL-2023 LIBRARY; T=0.K  
Particle heating contributions

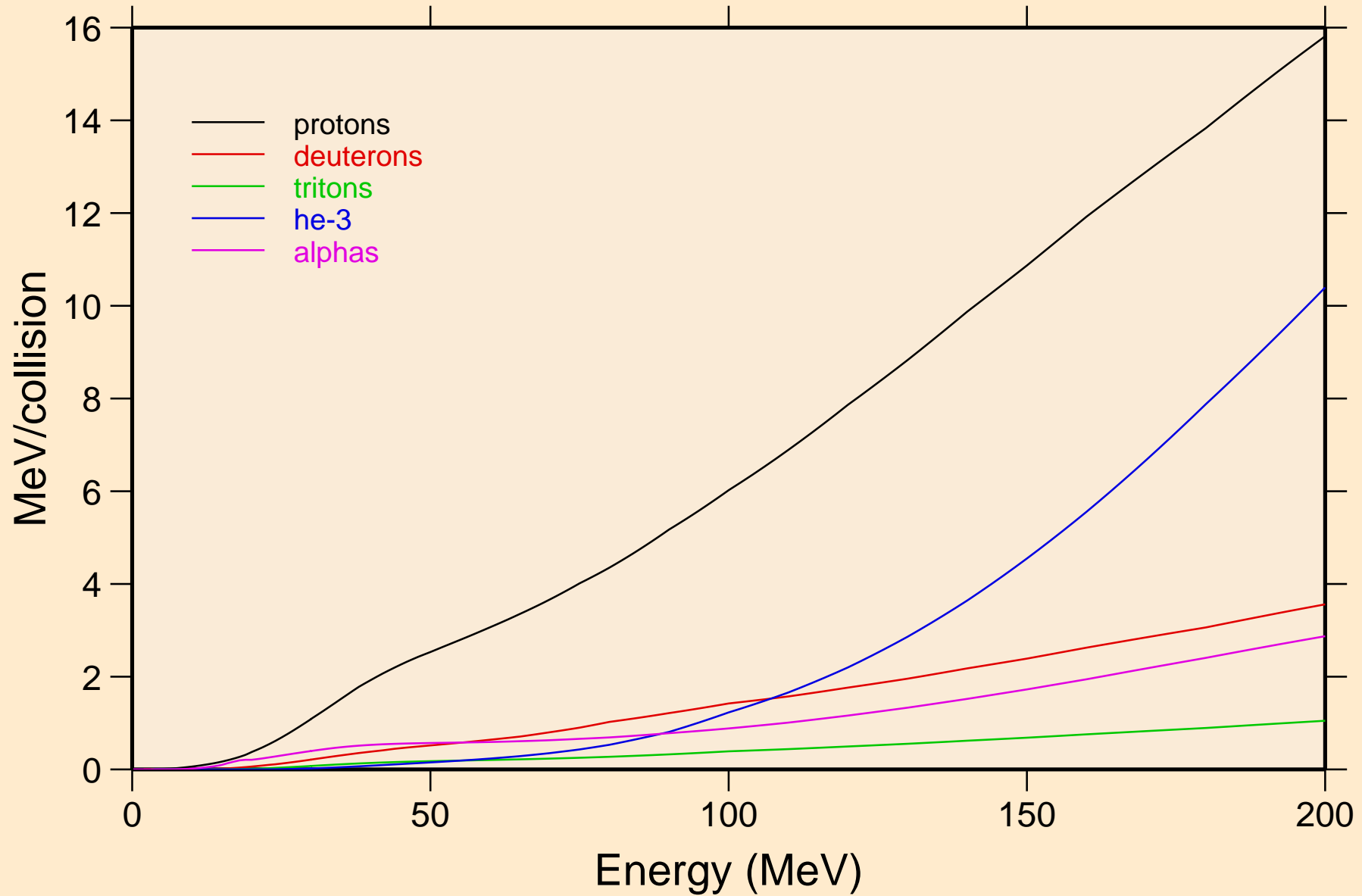

PR138M NEUTRON ACER TENDL-2023 LIBRARY; T=0.K  
Recoil Heating

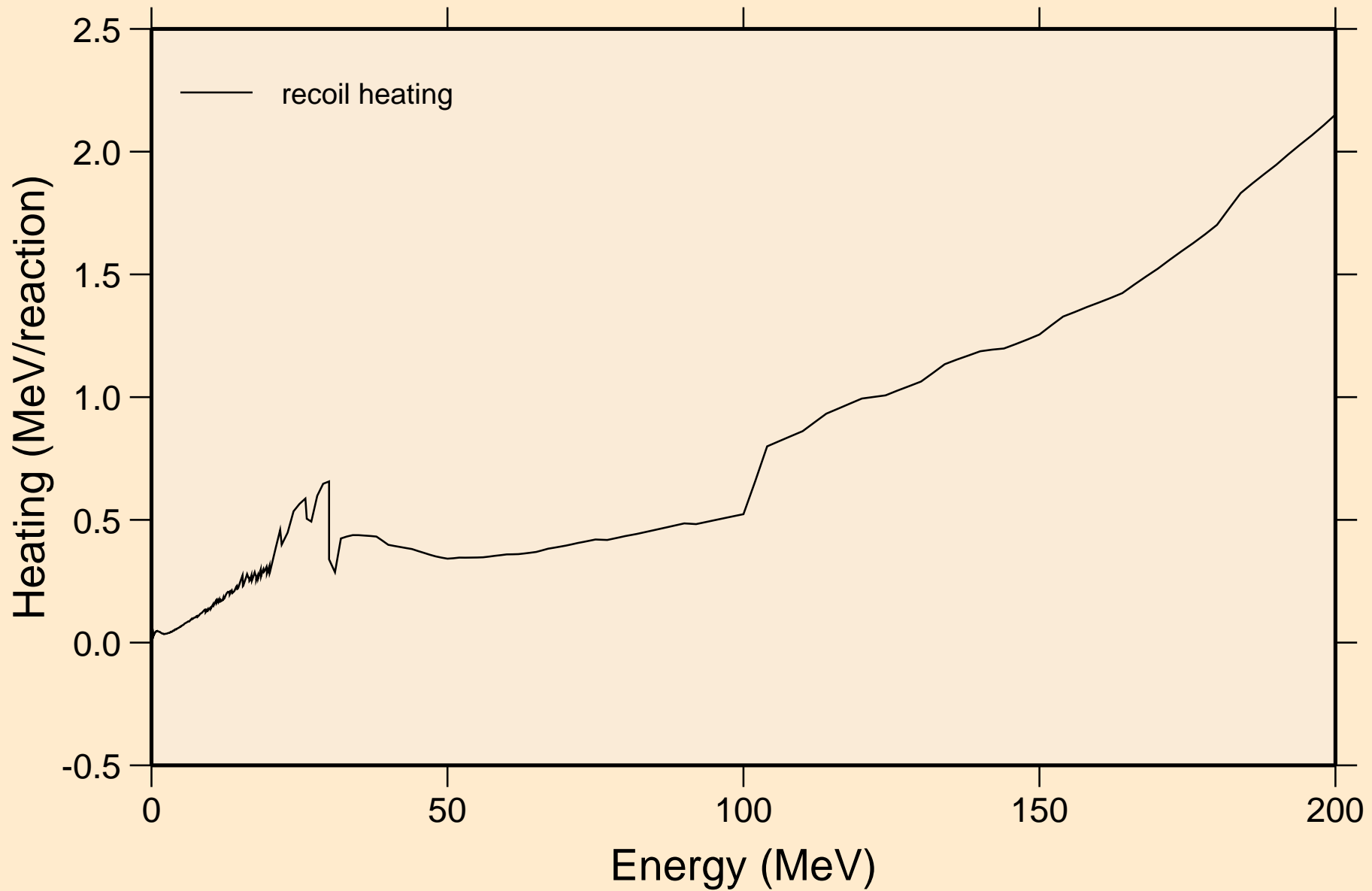

PR138M NEUTRON ACER TENDL-2023 LIBRARY; T=0.K  
Particle production cross sections

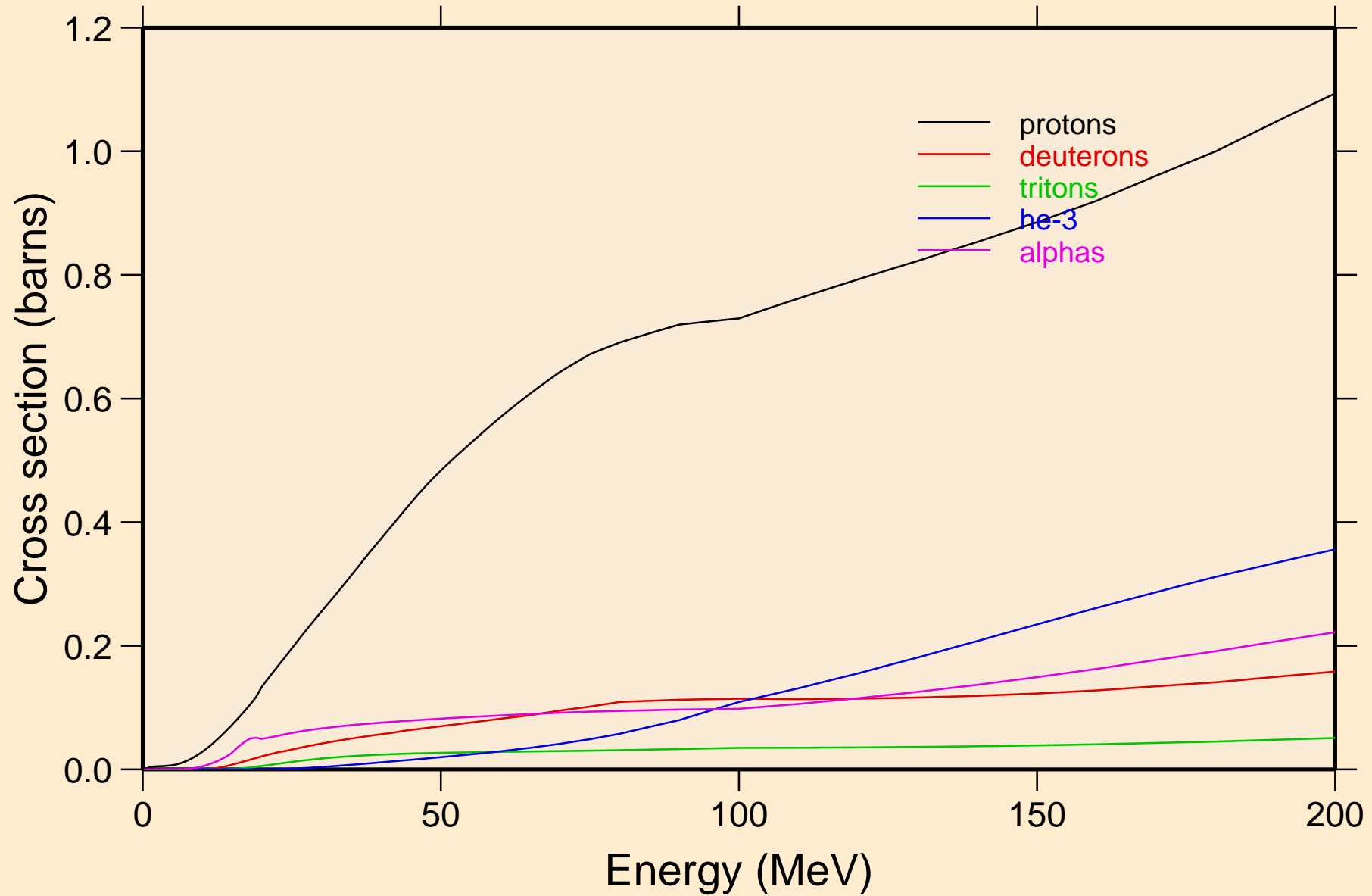

PR138M NEUTRON ACER TENDL-2023 LIBRARY; T=0.K  
protons from (n,x)

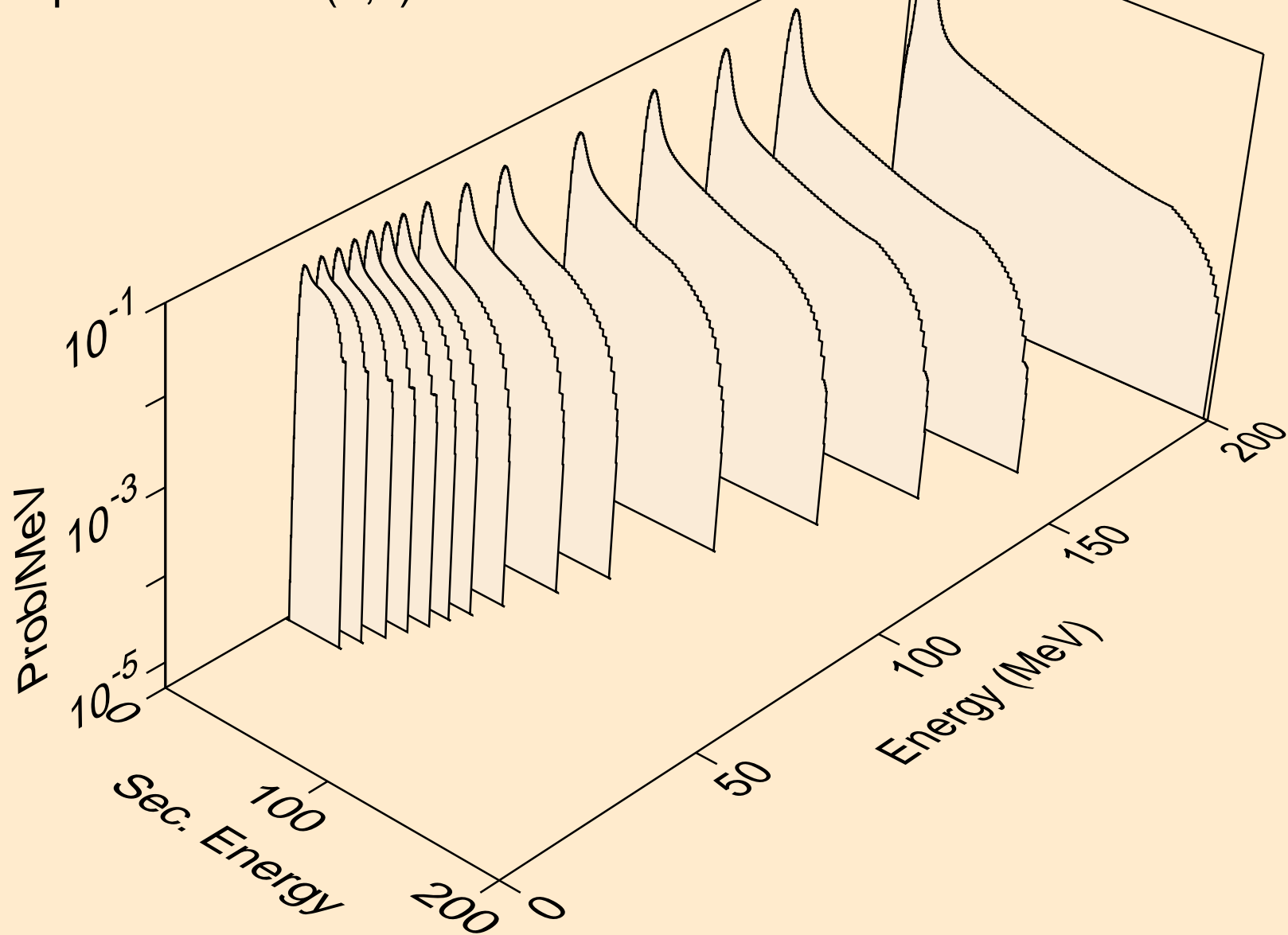

PR138M NEUTRON ACER TENDL-2023 LIBRARY; T=0.K  
protons from (n,n\*)p

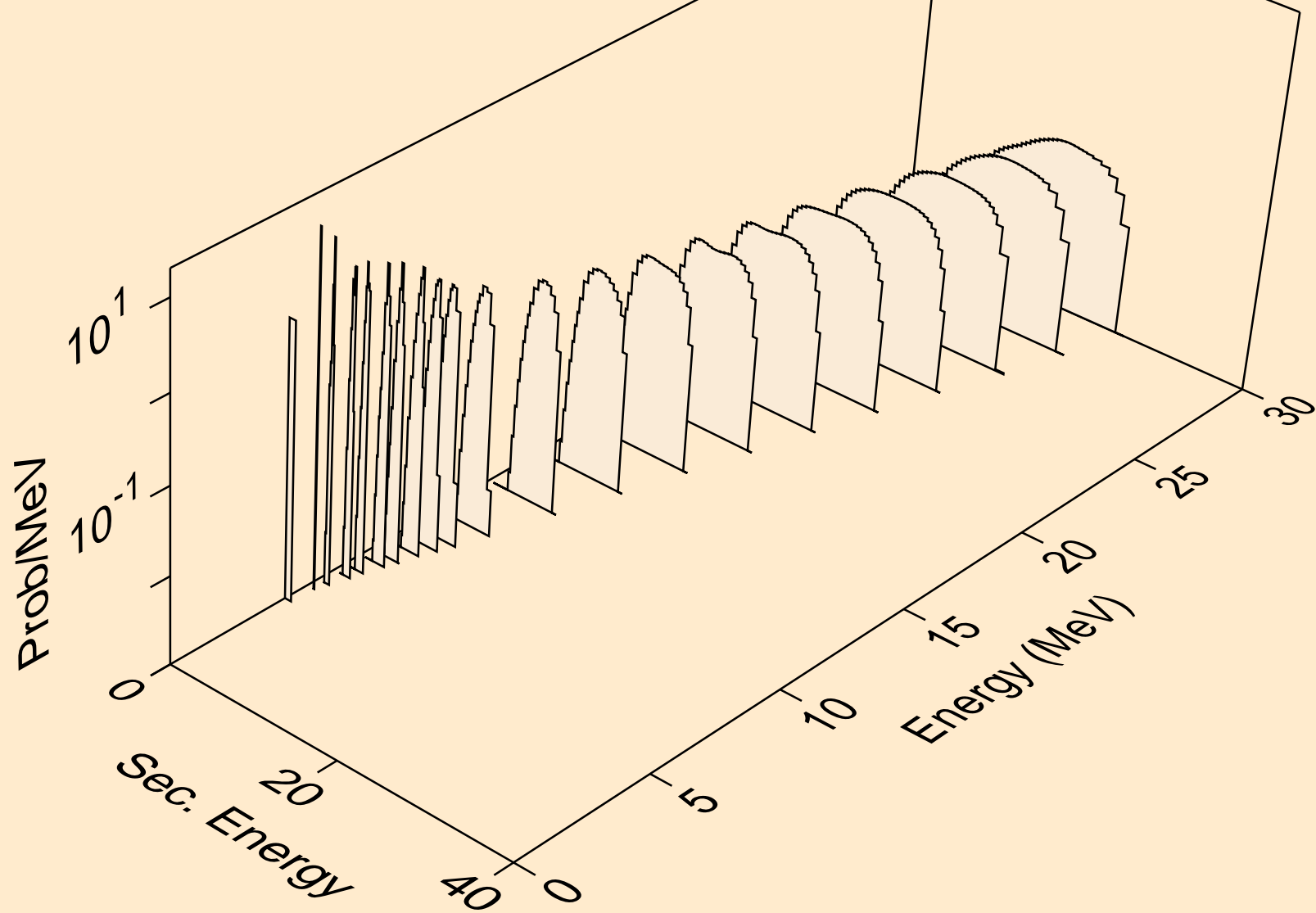



PR138M NEUTRON ACER TENDL-2023 LIBRARY; T=0.K  
protons from (n,2np)

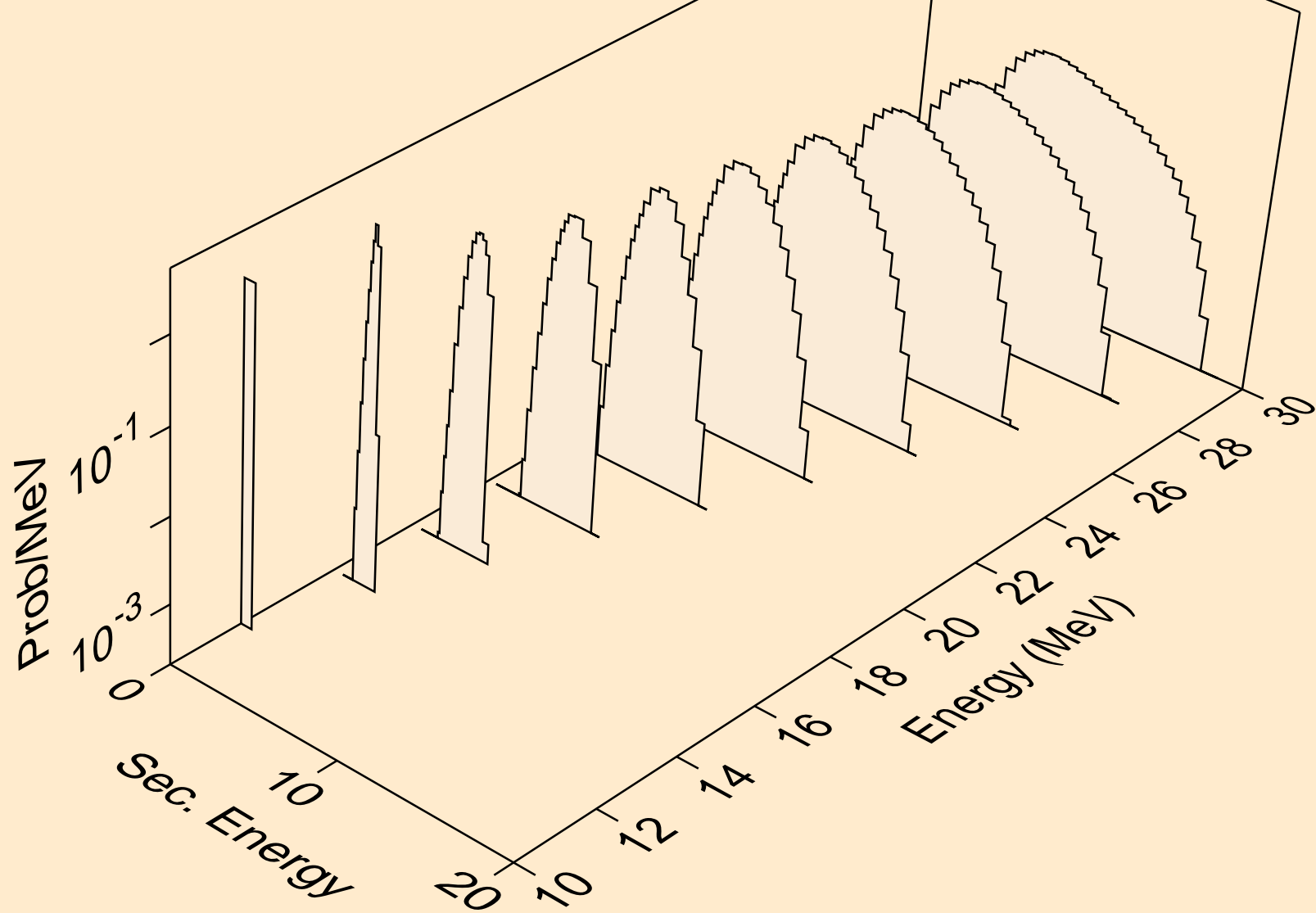

PR138M NEUTRON ACER TENDL-2023 LIBRARY; T=0.K  
protons from (n,3np)

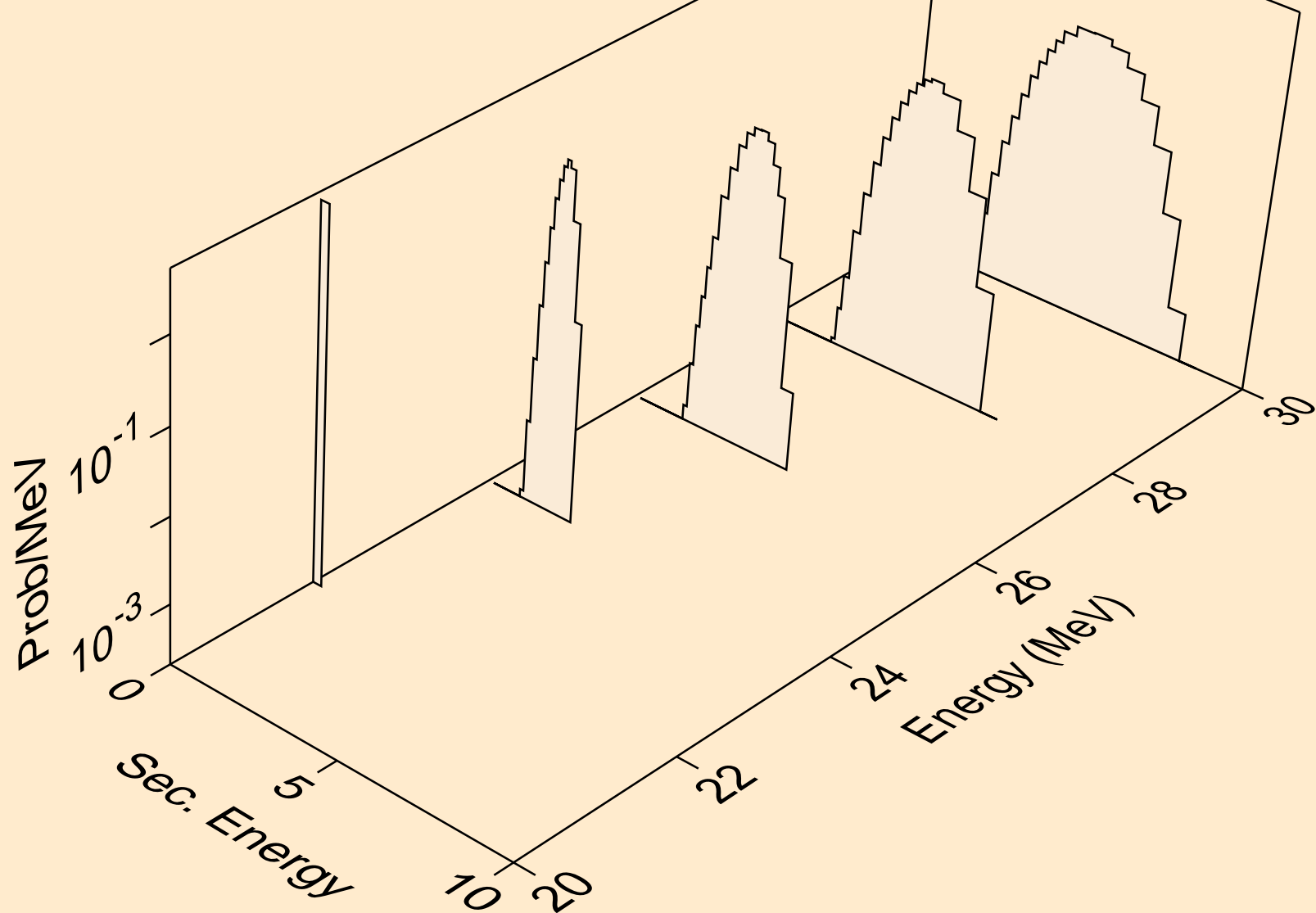

PR138M NEUTRON ACER TENDL-2023 LIBRARY; T=0.K  
protons from (n,n2p)

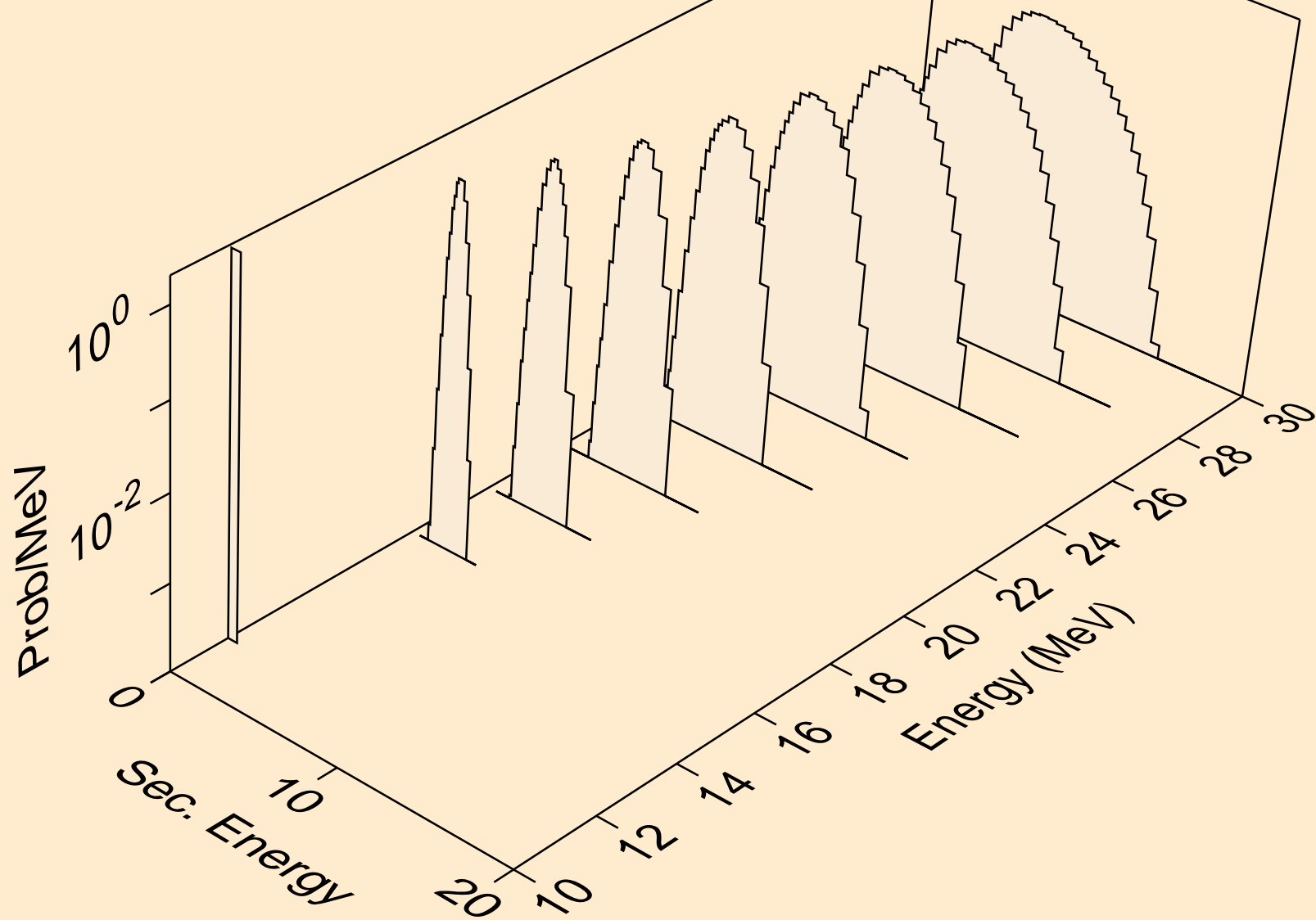

PR138M NEUTRON ACER TENDL-2023 LIBRARY; T=0.K  
protons from (n,npa)

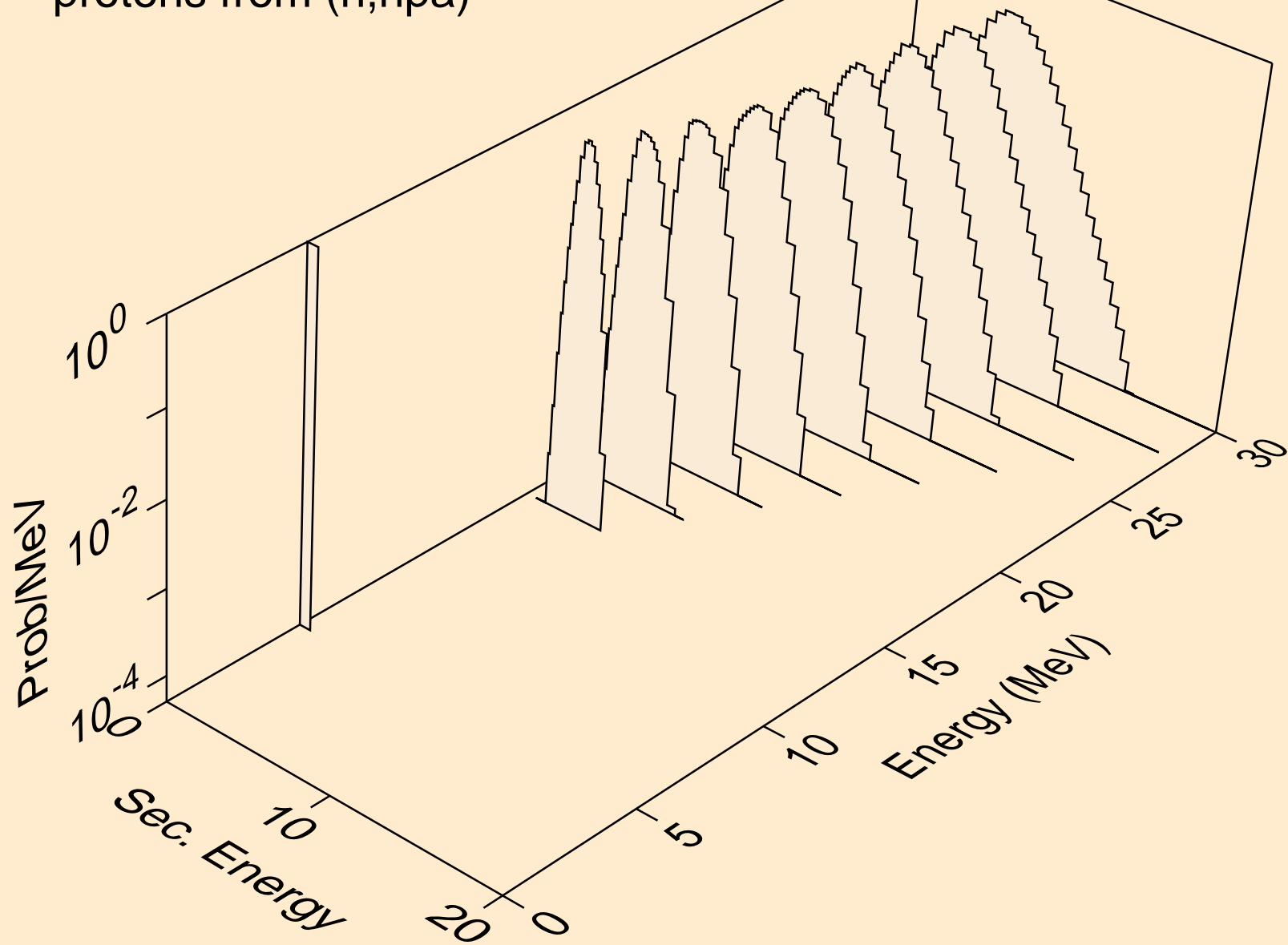

PR138M NEUTRON ACER TENDL-2023 LIBRARY; T=0.K  
protons from (n,p)

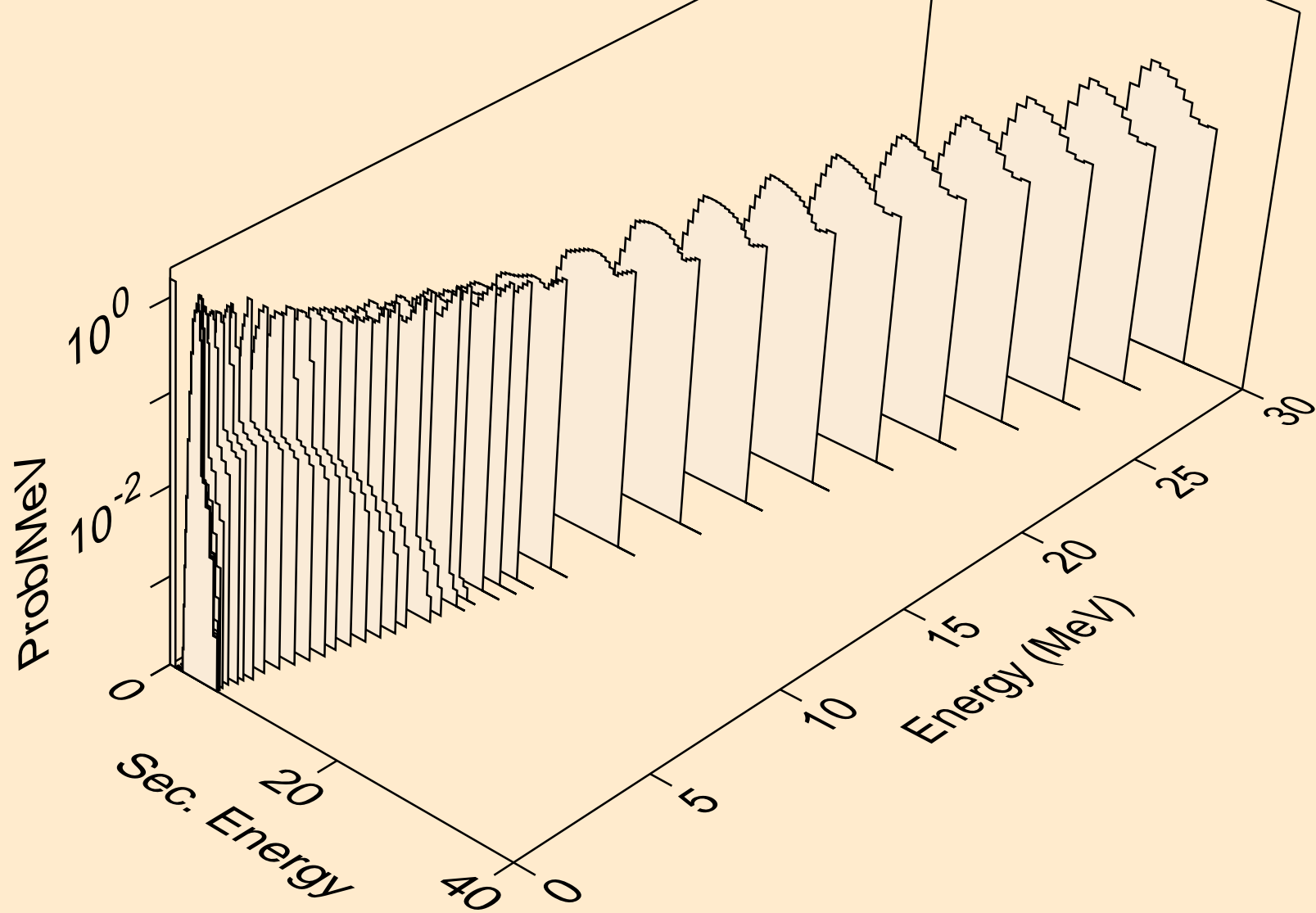

PR138M NEUTRON ACER TENDL-2023 LIBRARY; T=0.K  
protons from (n,2p)

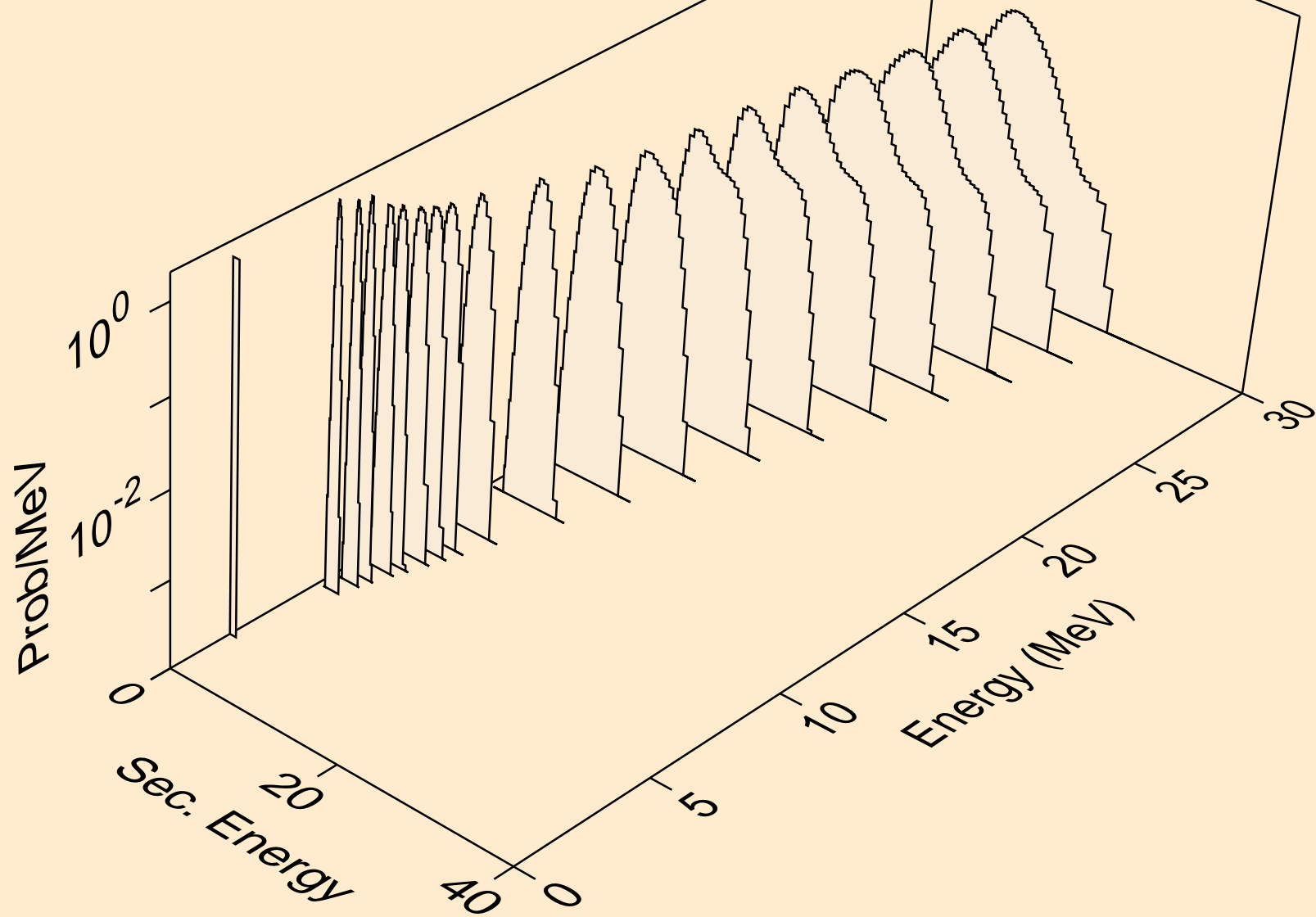

PR138M NEUTRON ACER TENDL-2023 LIBRARY; T=0.K  
protons from (n,p)

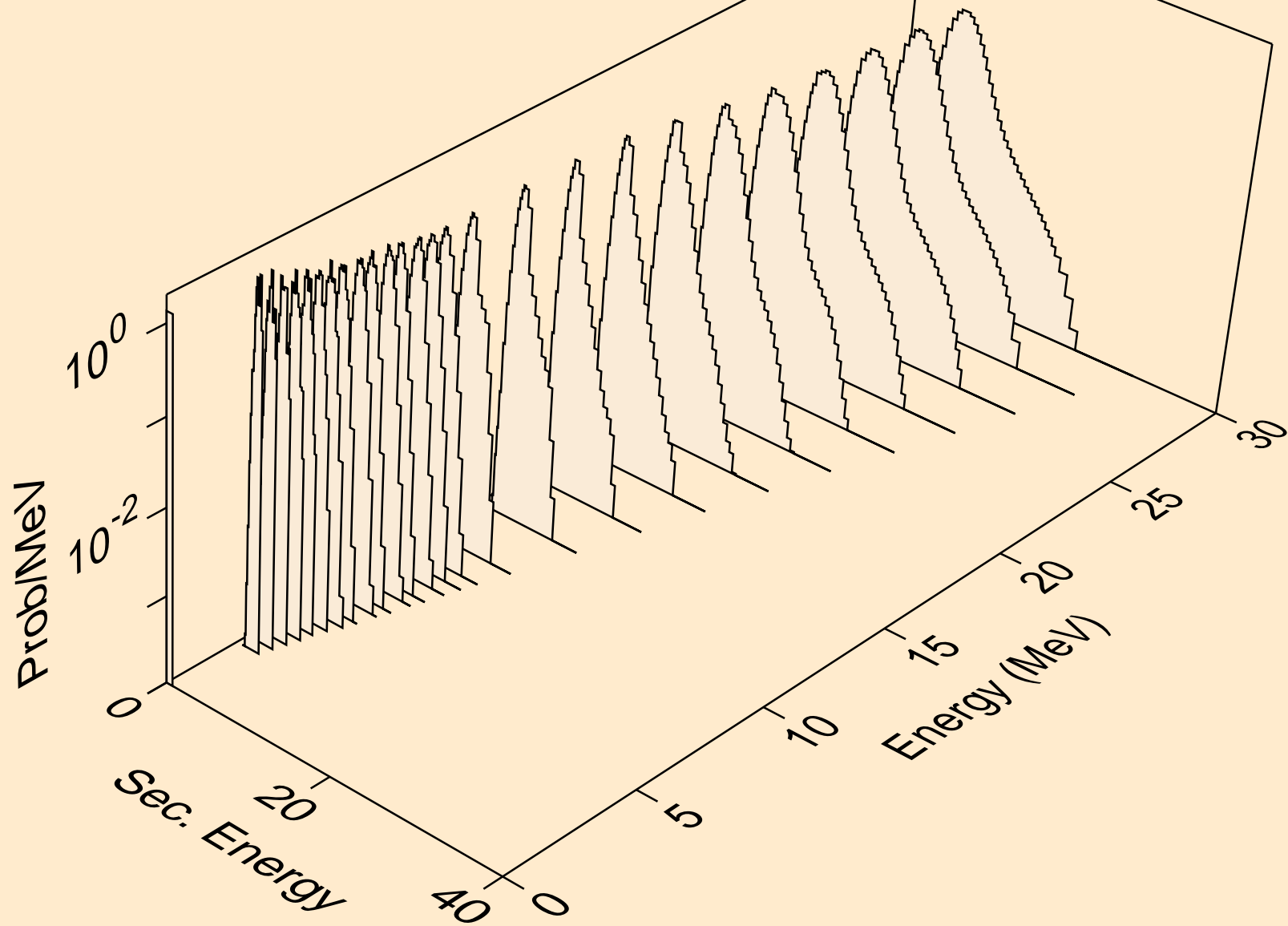

PR138M NEUTRON ACER TENDL-2023 LIBRARY; T=0.K  
protons from (n,pd)

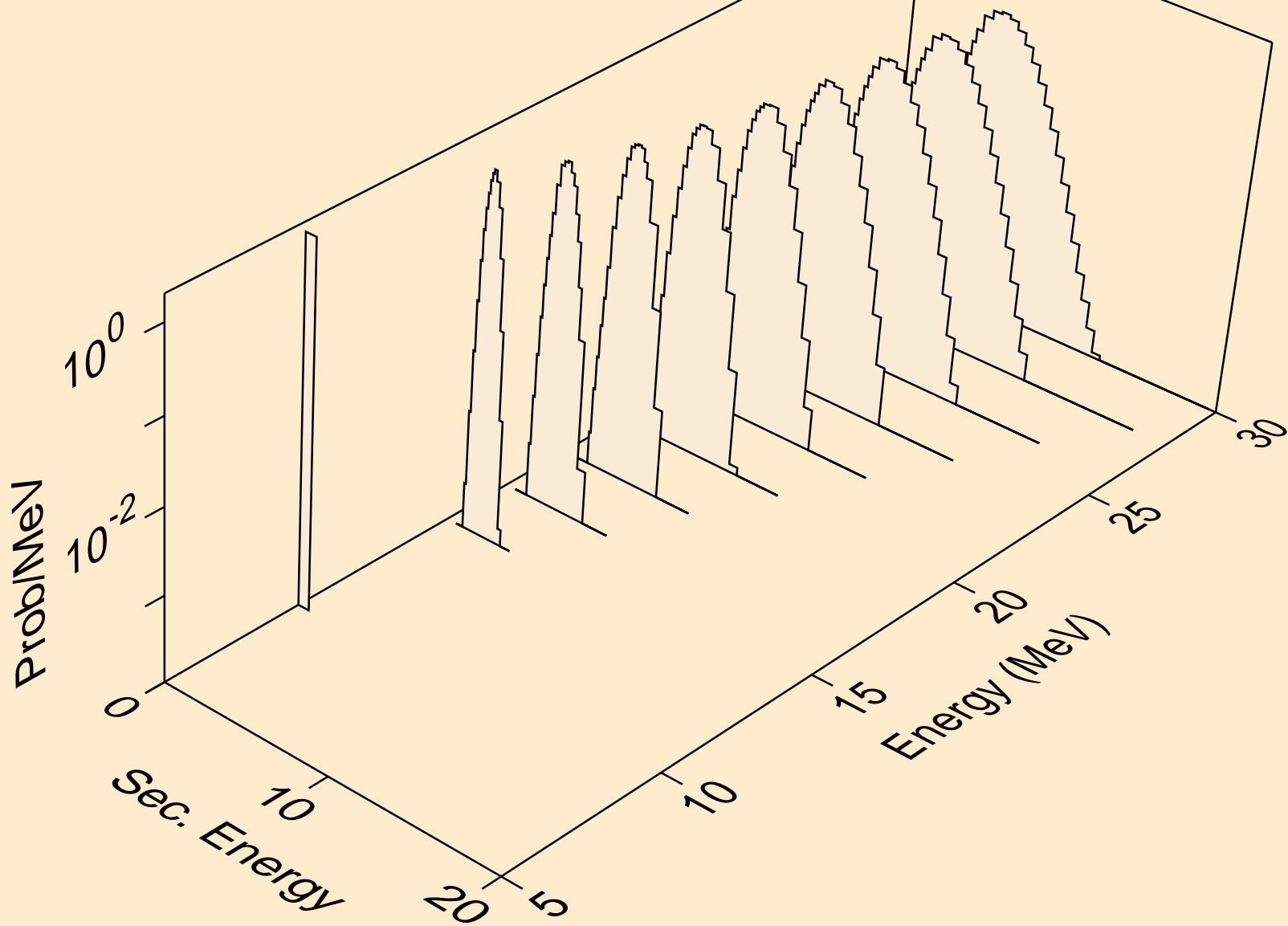



PR138M NEUTRON ACER TENDL-2023 LIBRARY; T=0.K  
protons from (n,pt)

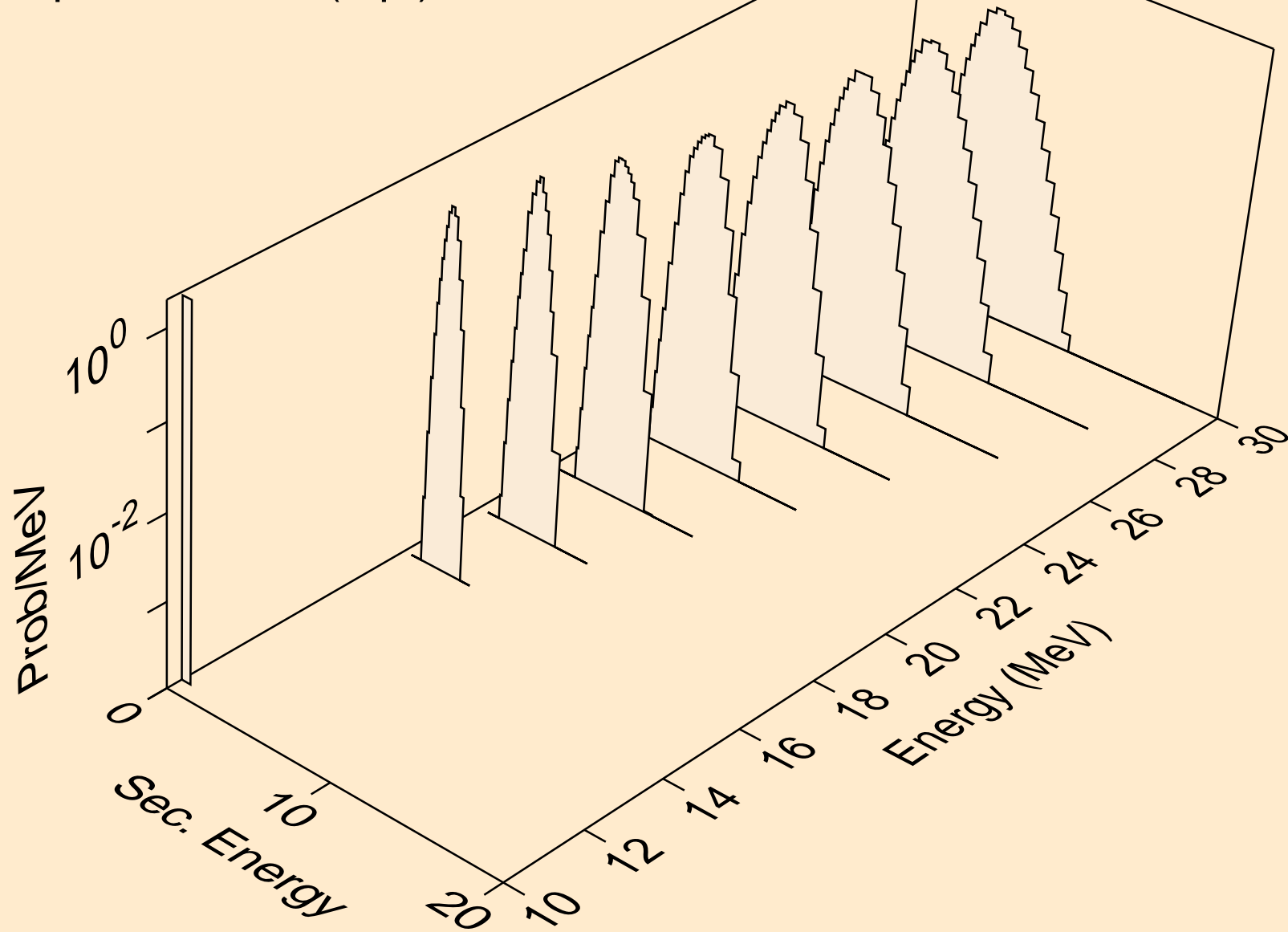

PR138M NEUTRON ACER TENDL-2023 LIBRARY; T=0.K  
deuterons from (n,x)

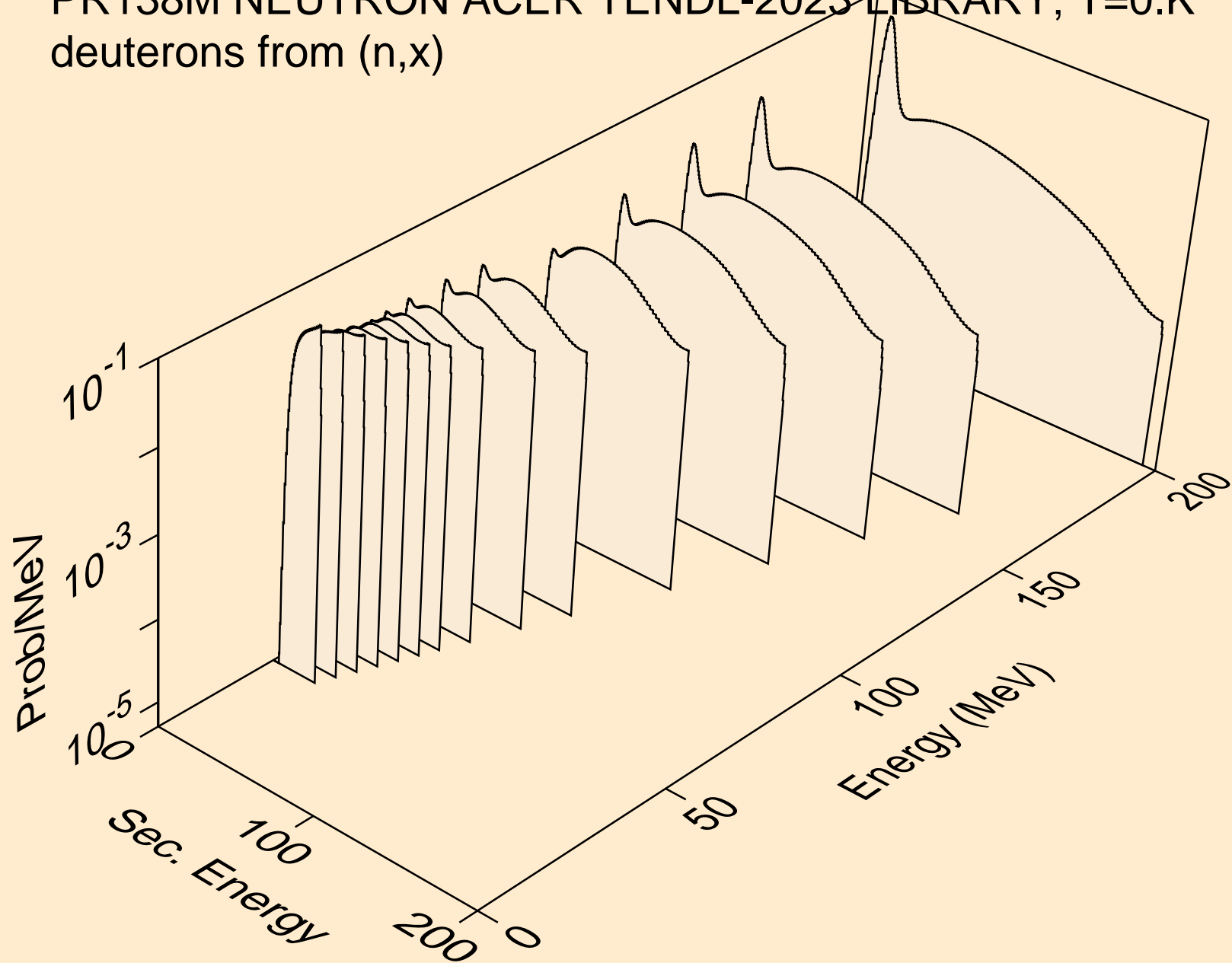

PR138M NEUTRON ACER TENDL-2023 LIBRARY; T=0.K  
deuterons from (n,2nd)

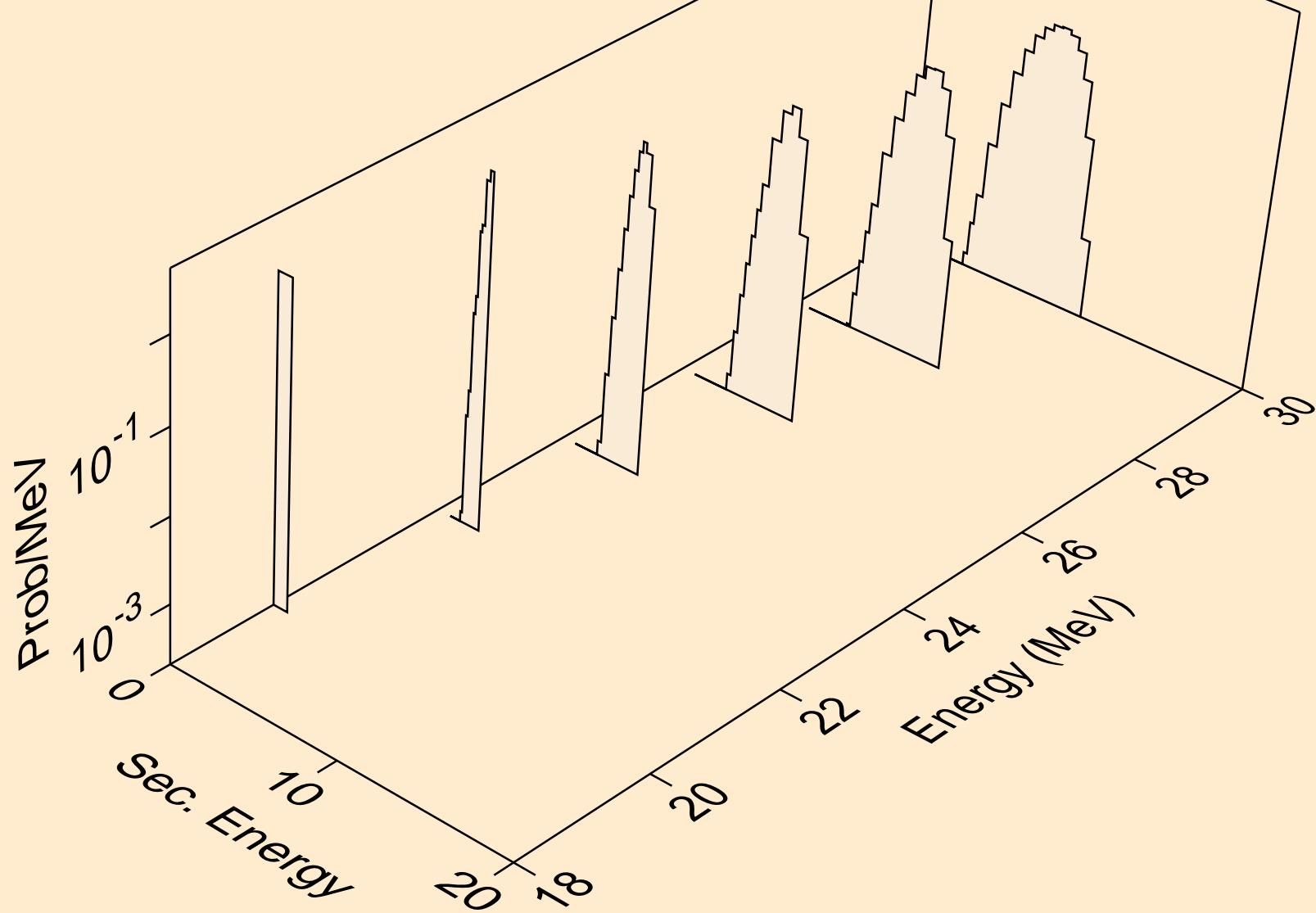

PR138M NEUTRON ACER TENDL-2023 LIBRARY; T=0.K  
deuterons from (n,n\*)d

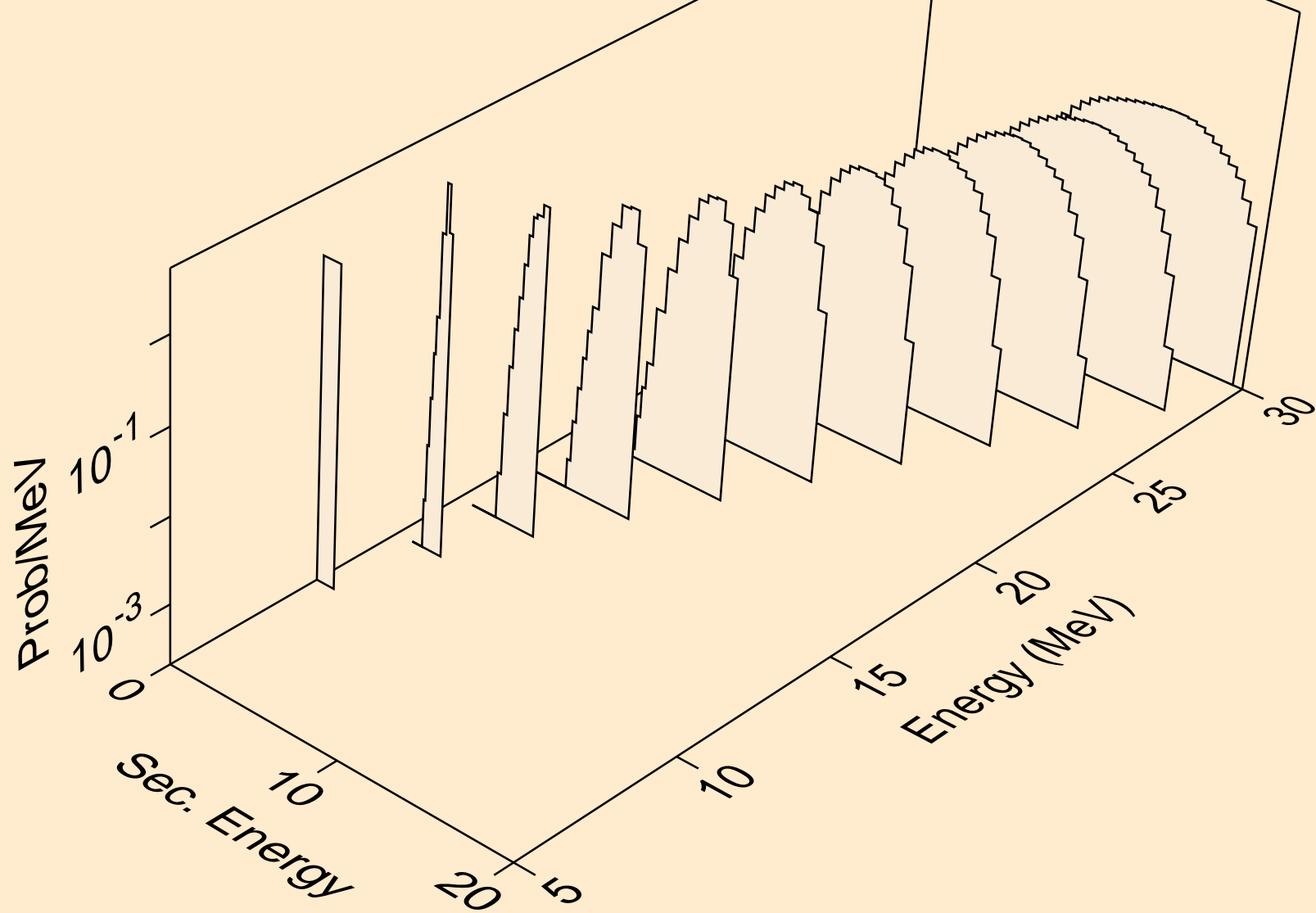

PR138M NEUTRON ACER TENDL-2023 LIBRARY; T=0.K  
deuterons from (n,d)

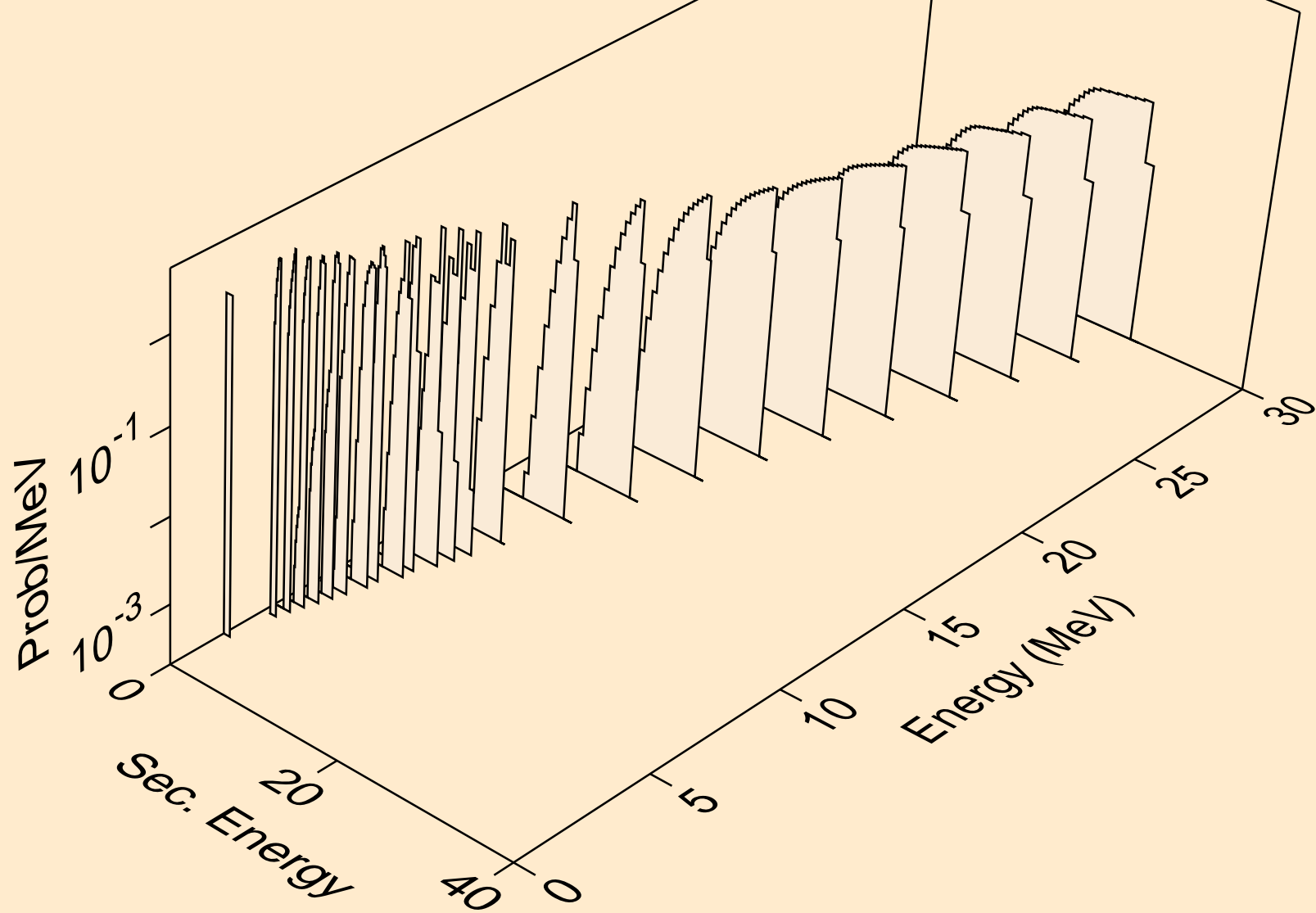

PR138M NEUTRON ACER TENDL-2023 LIBRARY; T=0.K  
deuterons from (n,pd)

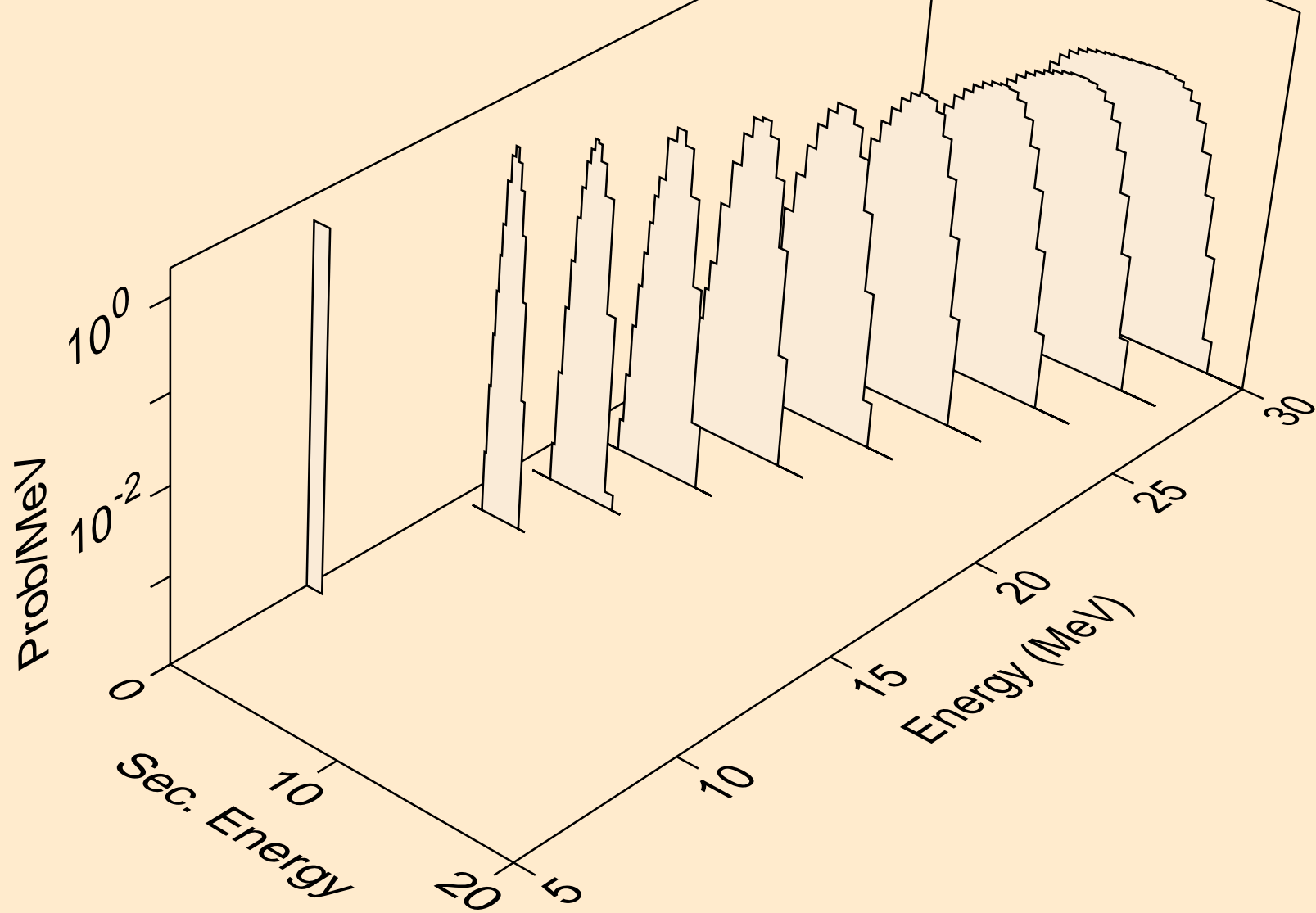

PR138M NEUTRON ACER TENDL-2023 LIBRARY; T=0.K  
deuterons from (n,da)

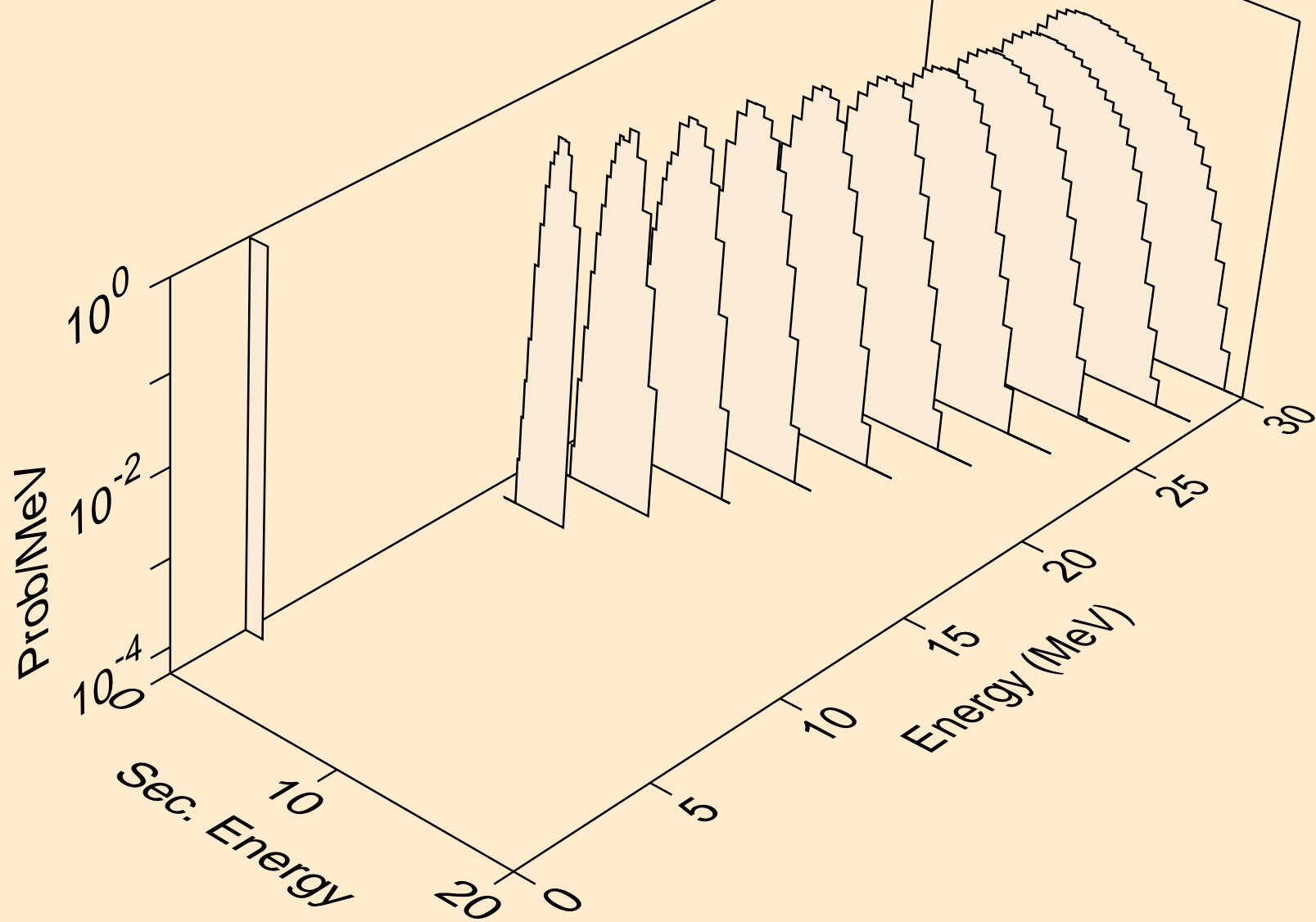

PR138M NEUTRON ACER TENDL-2023 LIBRARY; T=0.K  
tritons from (n,x)

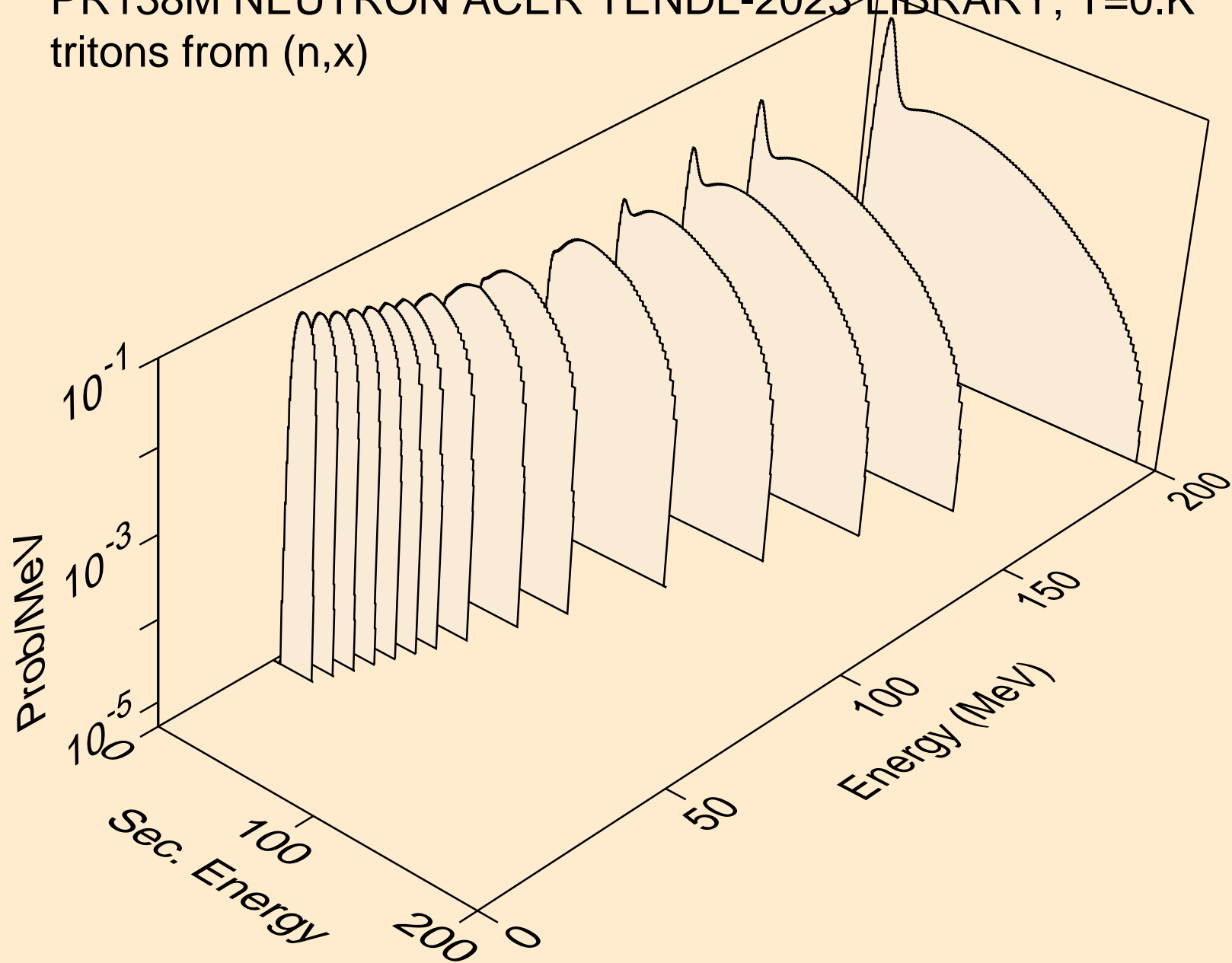



PR138M NEUTRON ACER TENDL-2023 LIBRARY; T=0.K  
tritons from (n,n\*)t

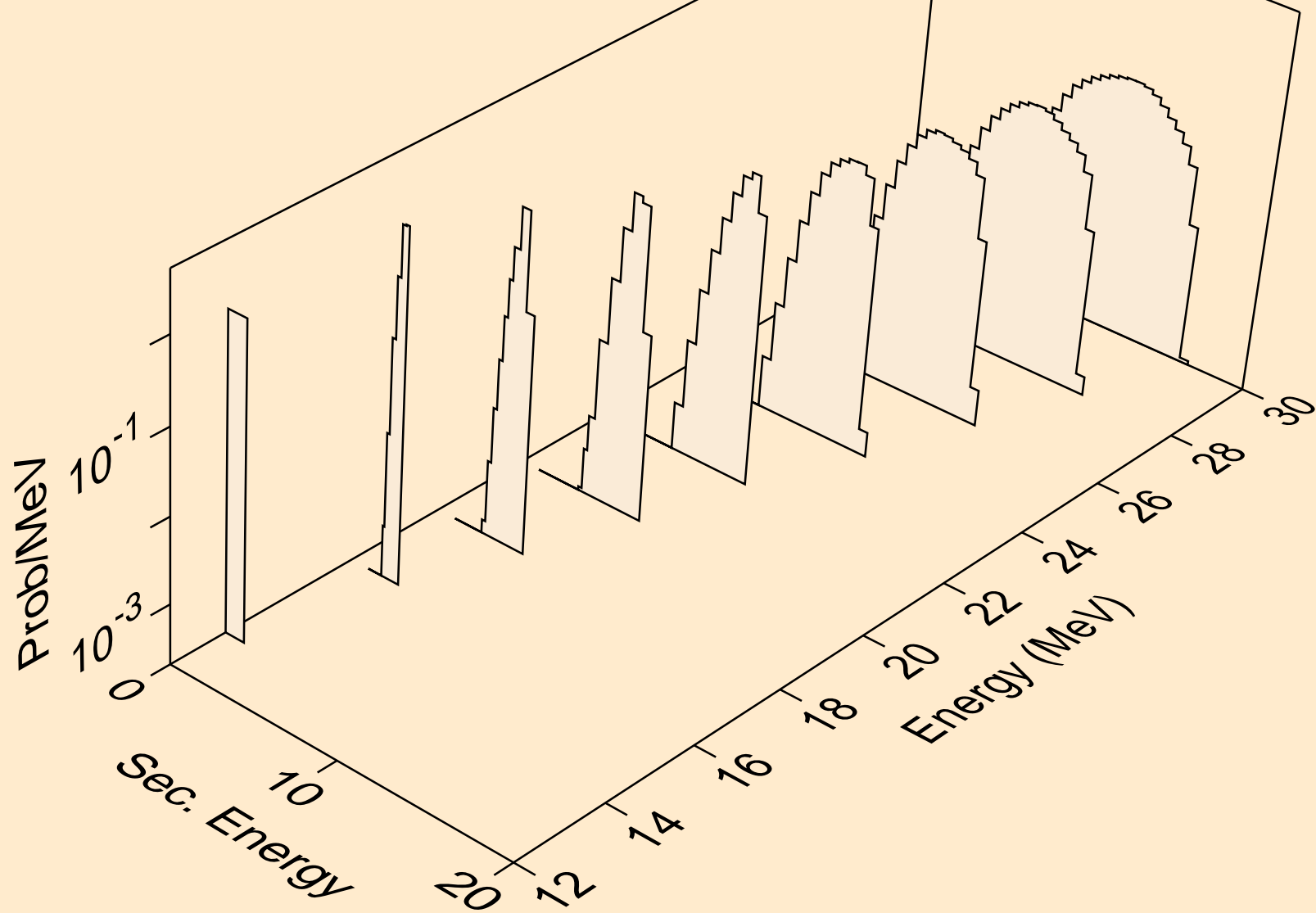

PR138M NEUTRON ACER TENDL-2023 LIBRARY; T=0.K  
tritons from (n,t)

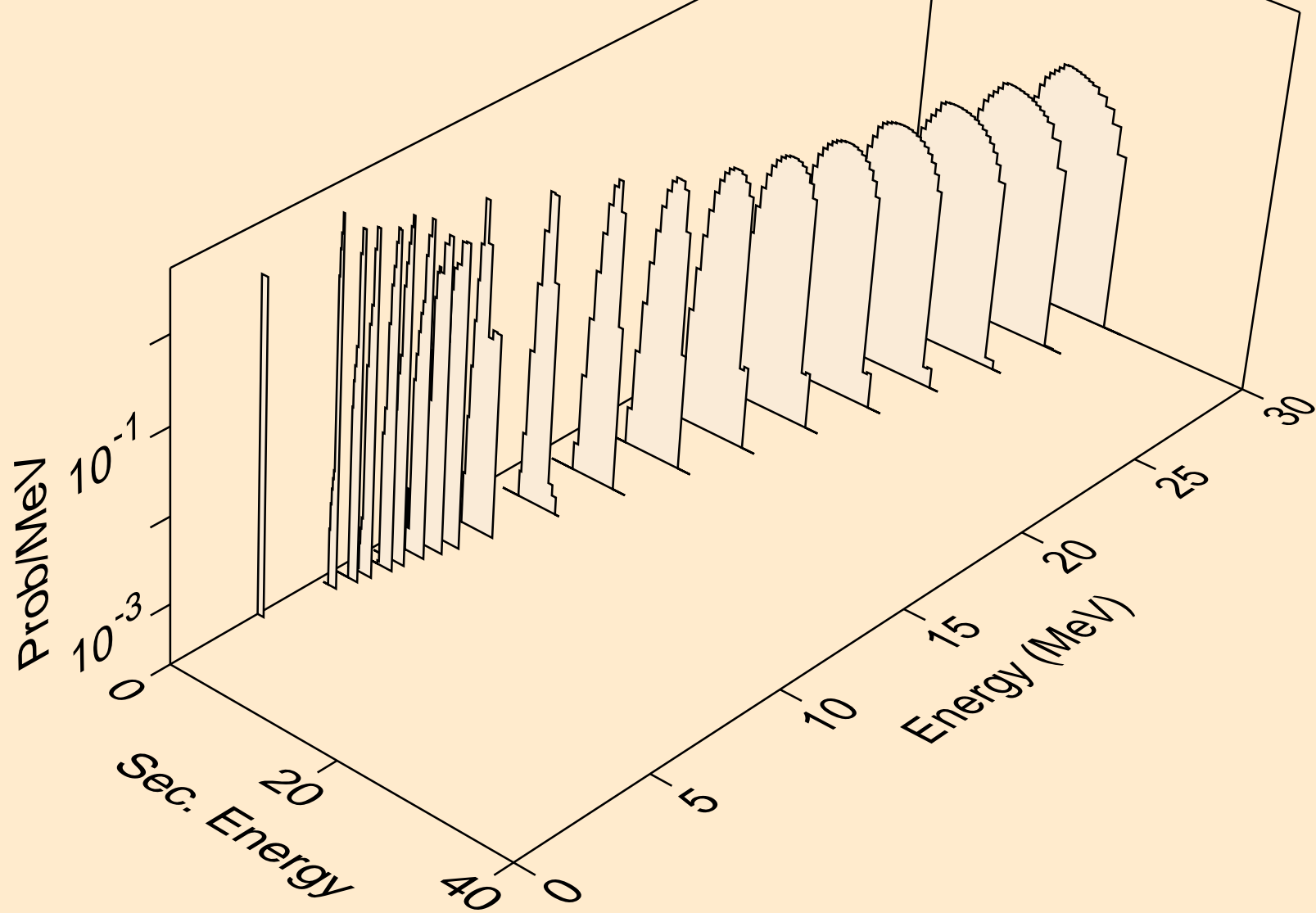

PR138M NEUTRON ACER TENDL-2023 LIBRARY; T=0.K  
tritons from (n,pt)

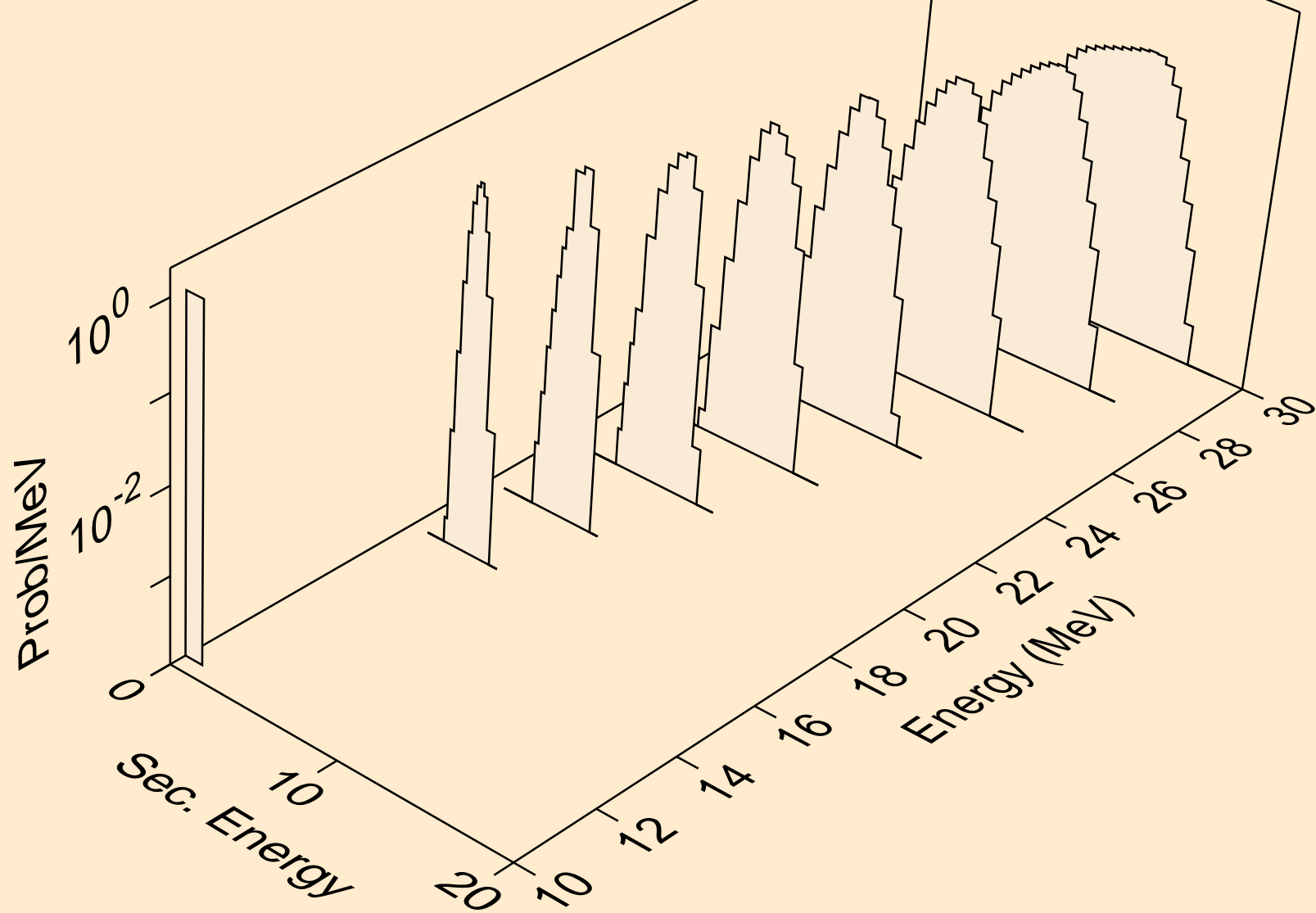

PR138M NEUTRON ACER TENDL-2023 LIBRARY; T=0.K  
he3s from (n,x)

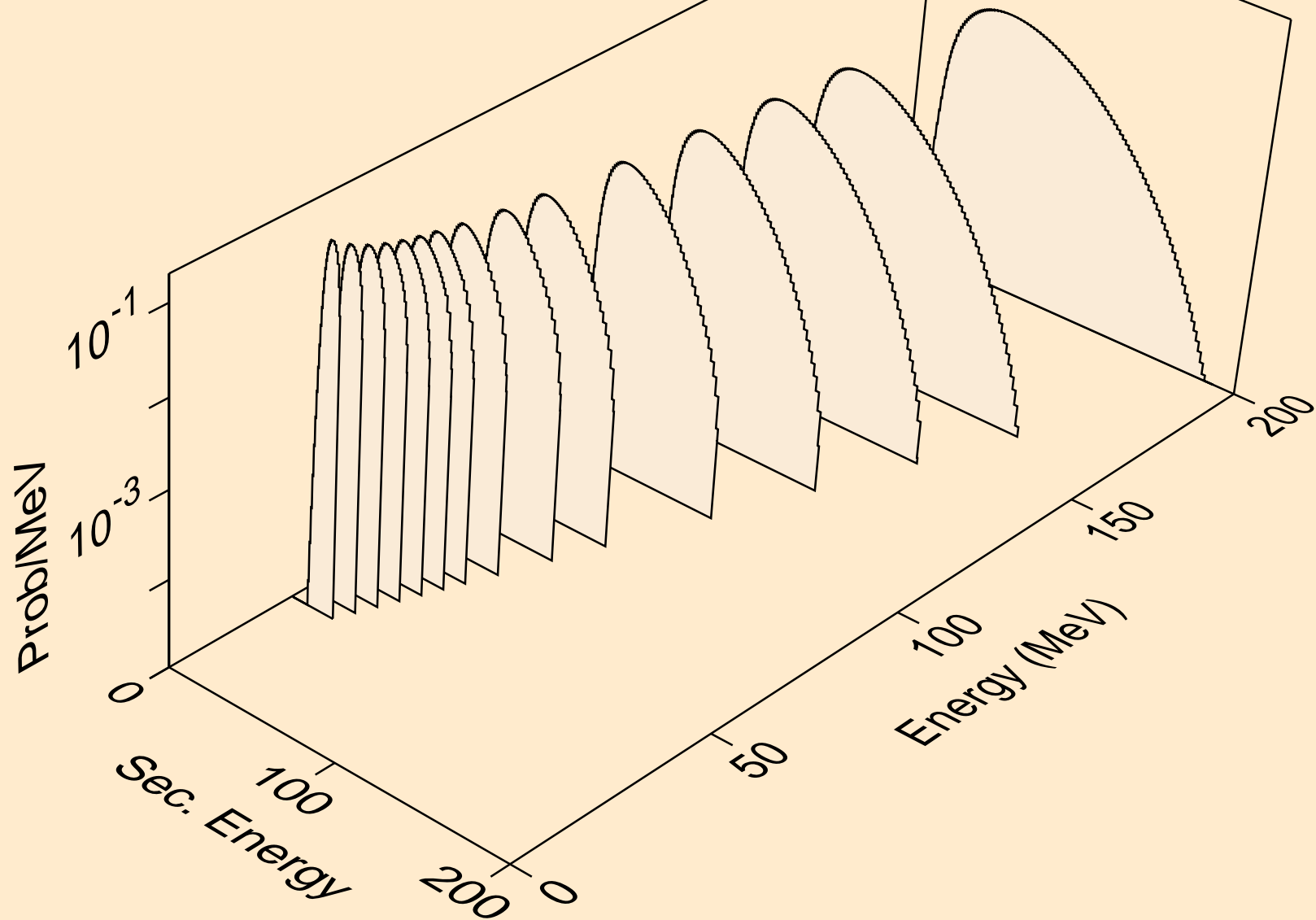

PR138M NEUTRON ACER TENDL-2023 LIBRARY; T=0.K  
he3s from (n,n\*)he3

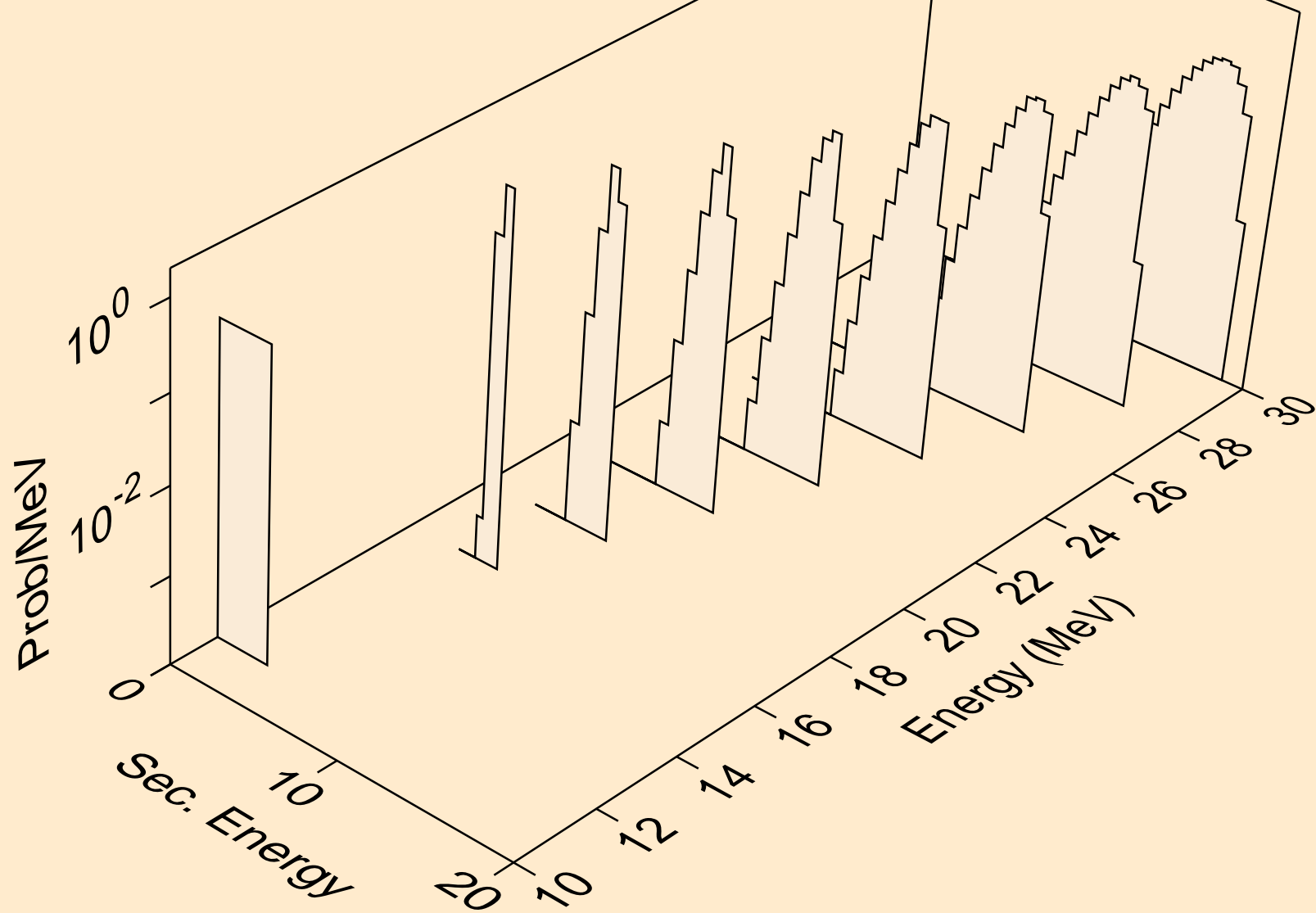

PR138M NEUTRON ACER TENDL-2023 LIBRARY; T=0.K  
he3s from (n,he3)

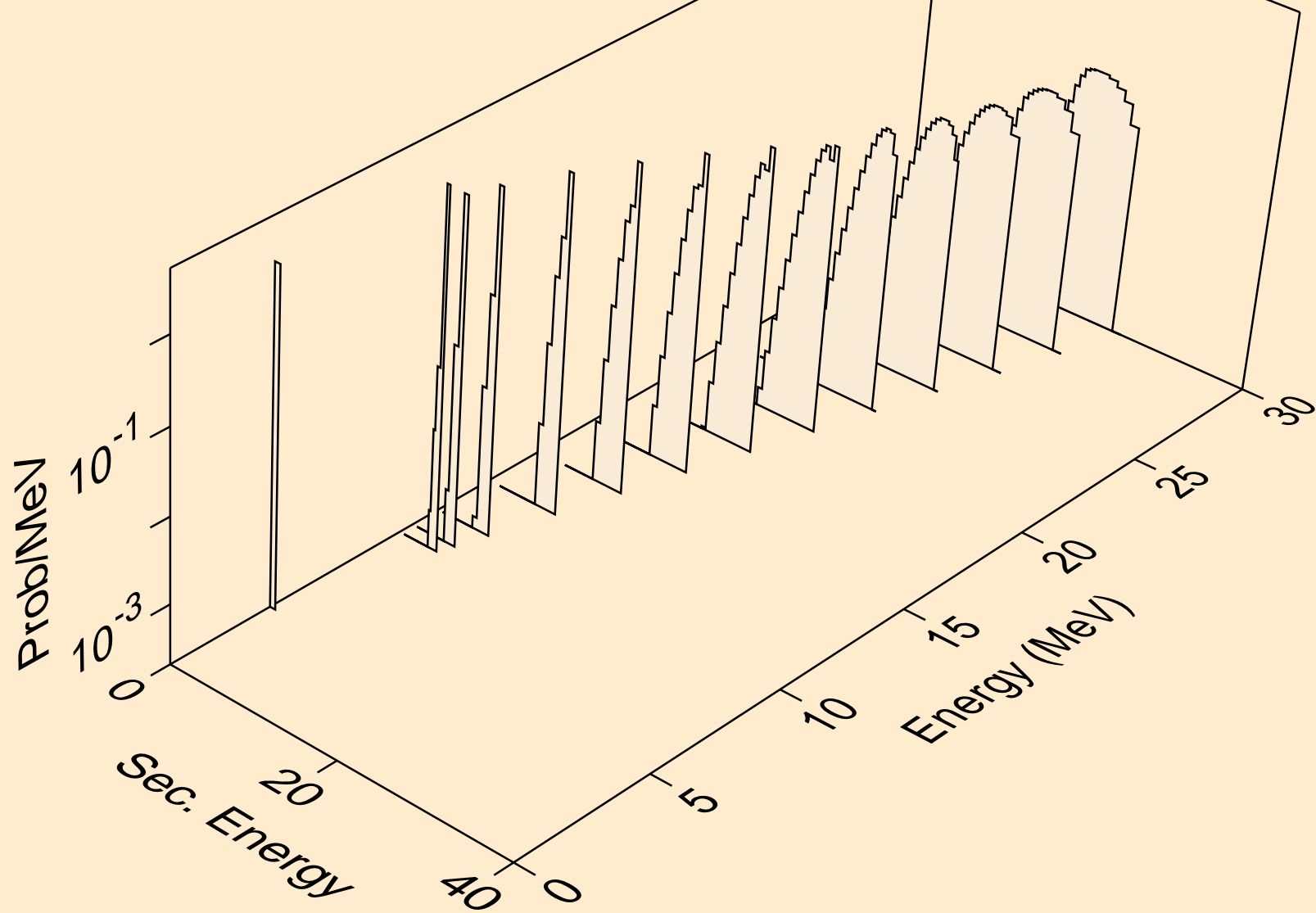

PR138M NEUTRON ACER TENDL-2023 LIBRARY; T=0.K  
alphas from (n,x)

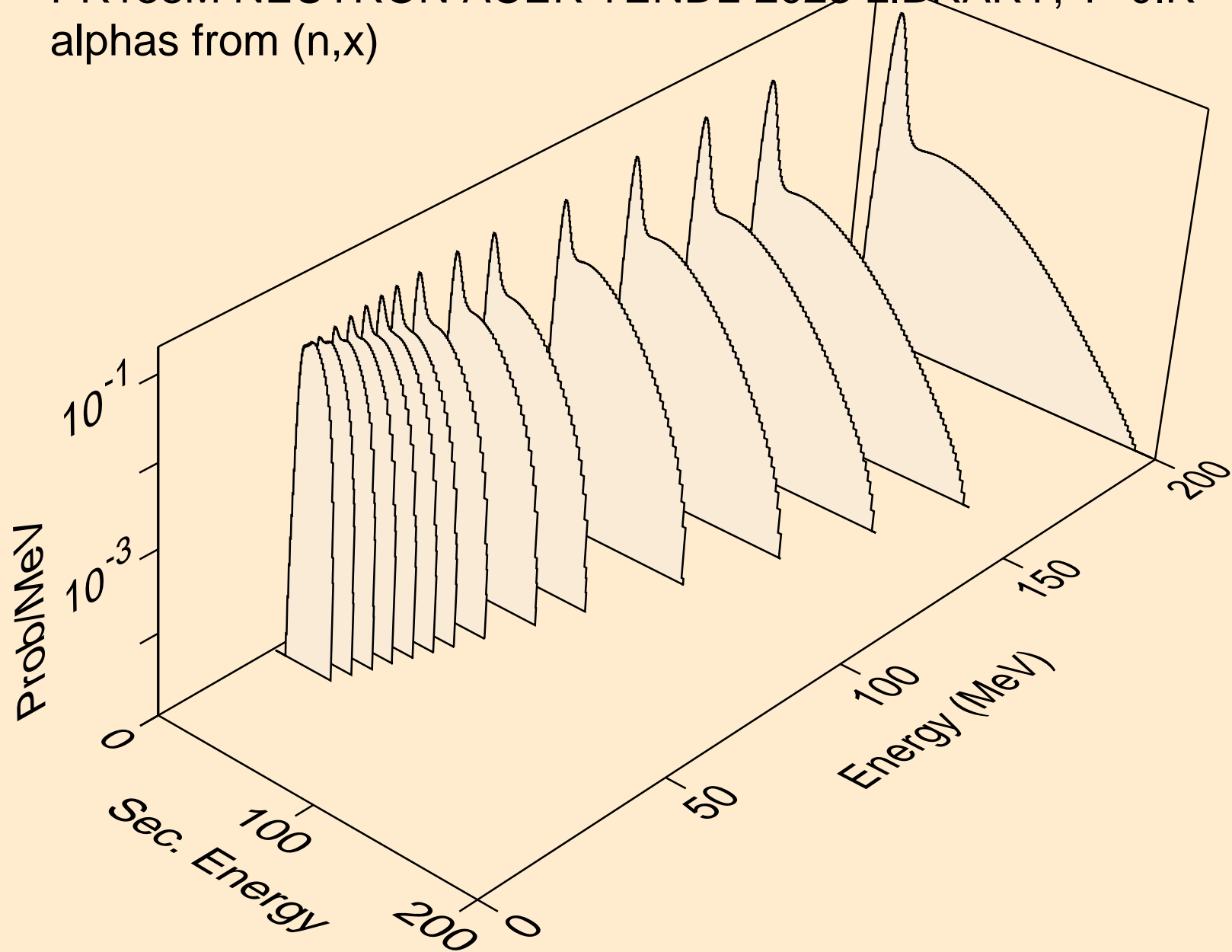

PR138M NEUTRON ACER TENDL-2023 LIBRARY; T=0.K  
alphas from (n,n\*)a

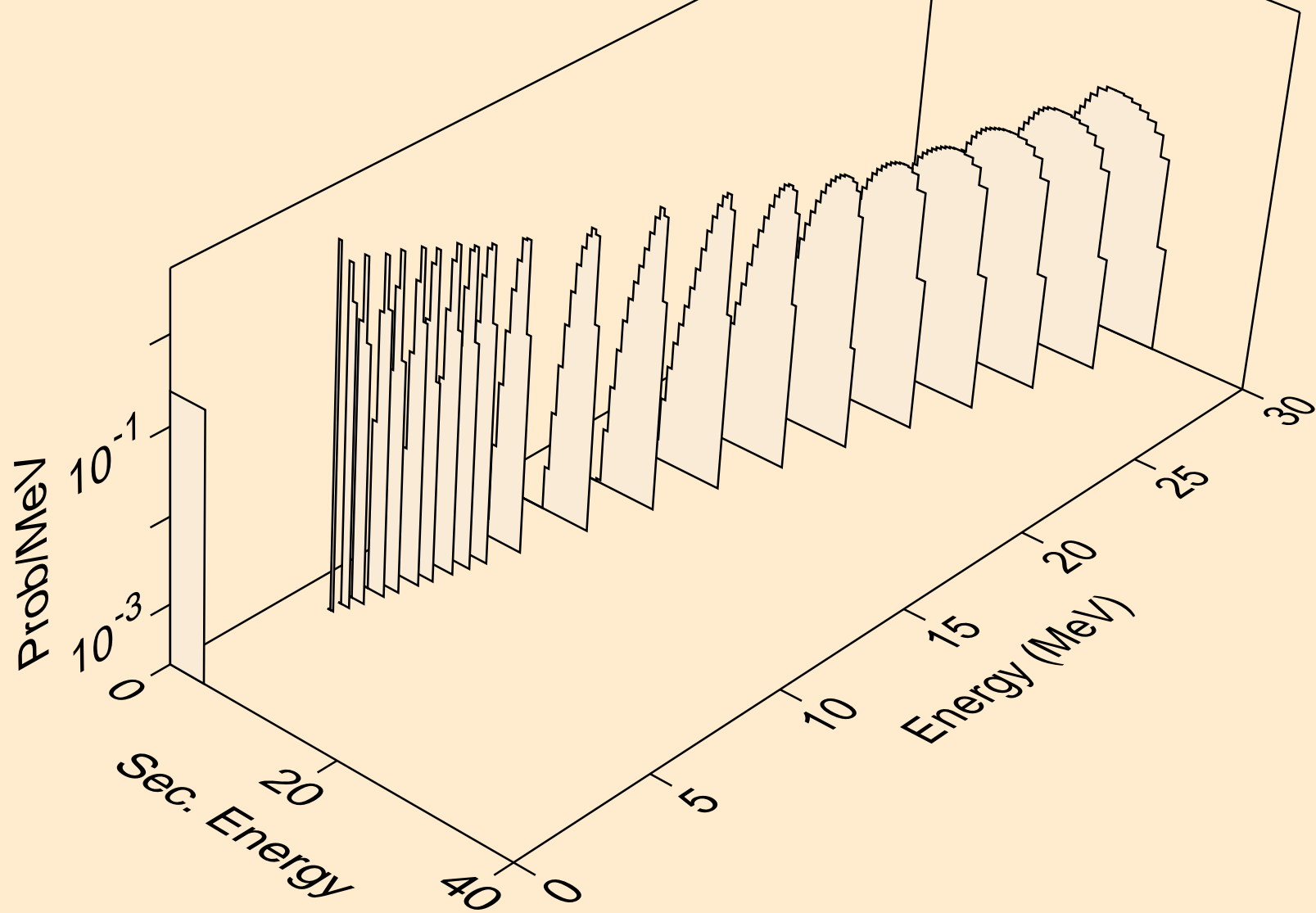



PR138M NEUTRON ACER TENDL-2023 LIBRARY; T=0.K  
alphas from (n,2n)a

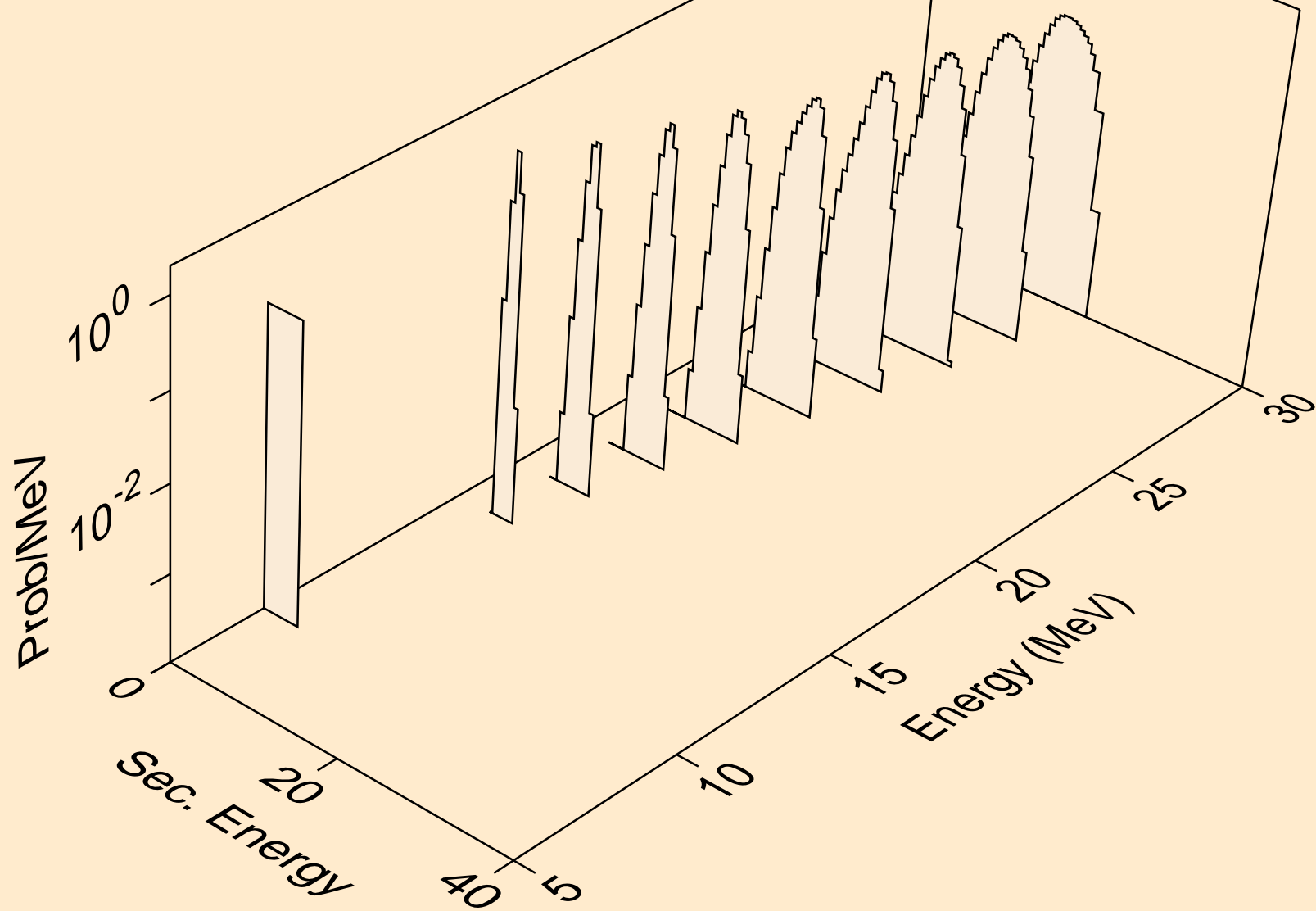

PR138M NEUTRON ACER TENDL-2023 LIBRARY; T=0.K  
alphas from (n,3n)a

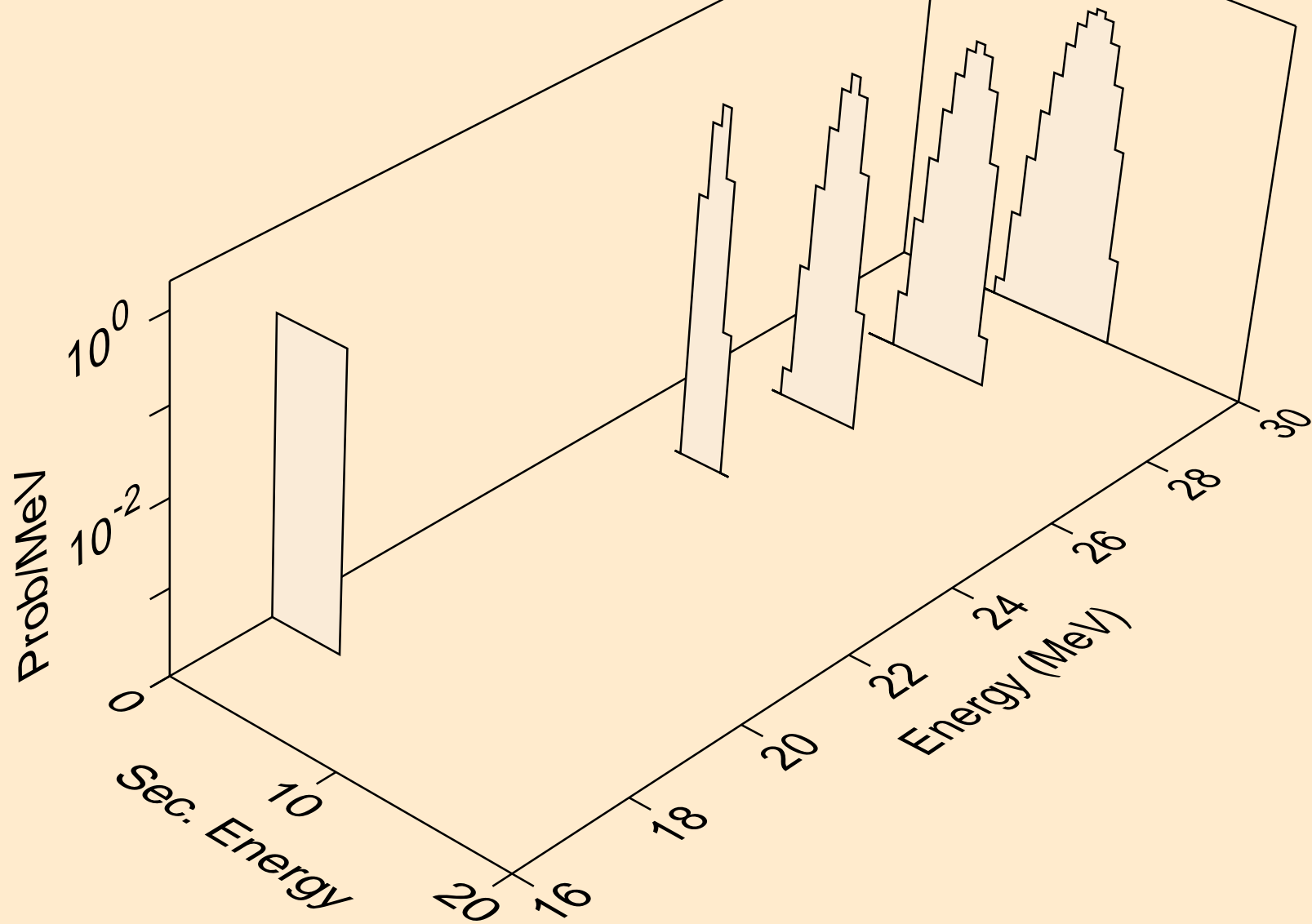

PR138M NEUTRON ACER TENDL-2023 LIBRARY; T=0.K  
alphas from (n,n\*)2a

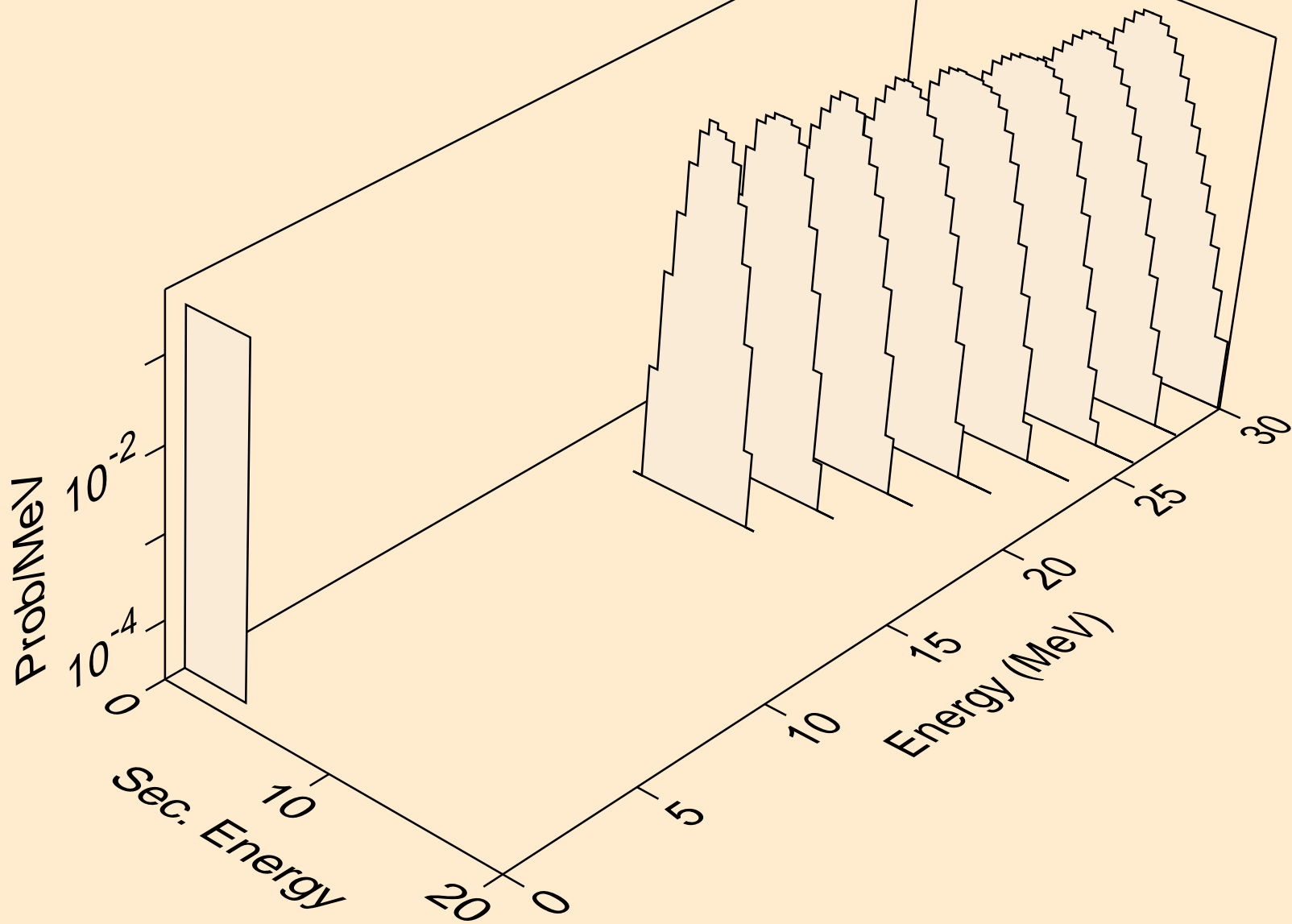

PR138M NEUTRON ACER TENDL-2023 LIBRARY; T=0.K  
alphas from (n,npa)

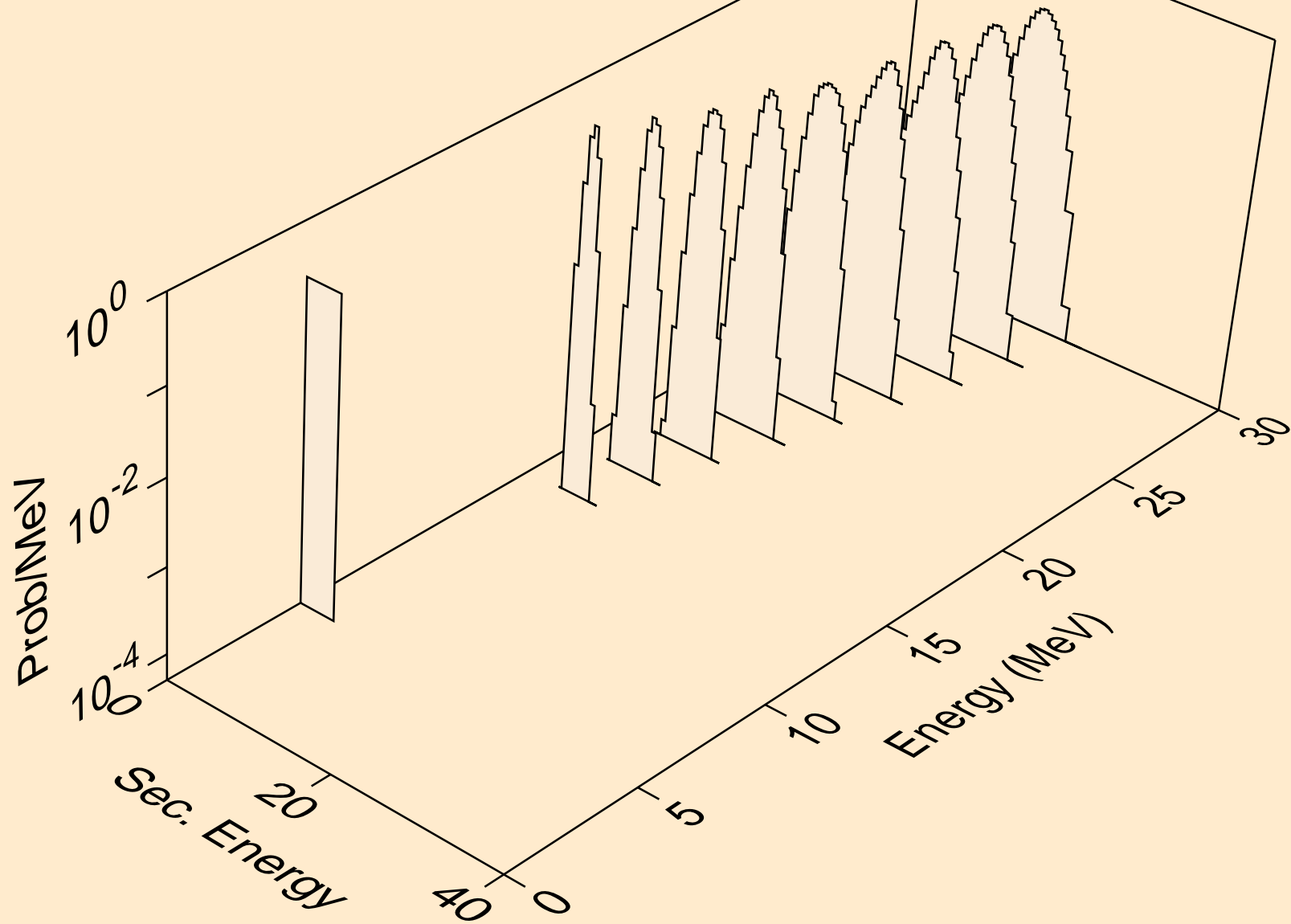

PR138M NEUTRON ACER TENDL-2023 LIBRARY; T=0.K  
alphas from (n,a)

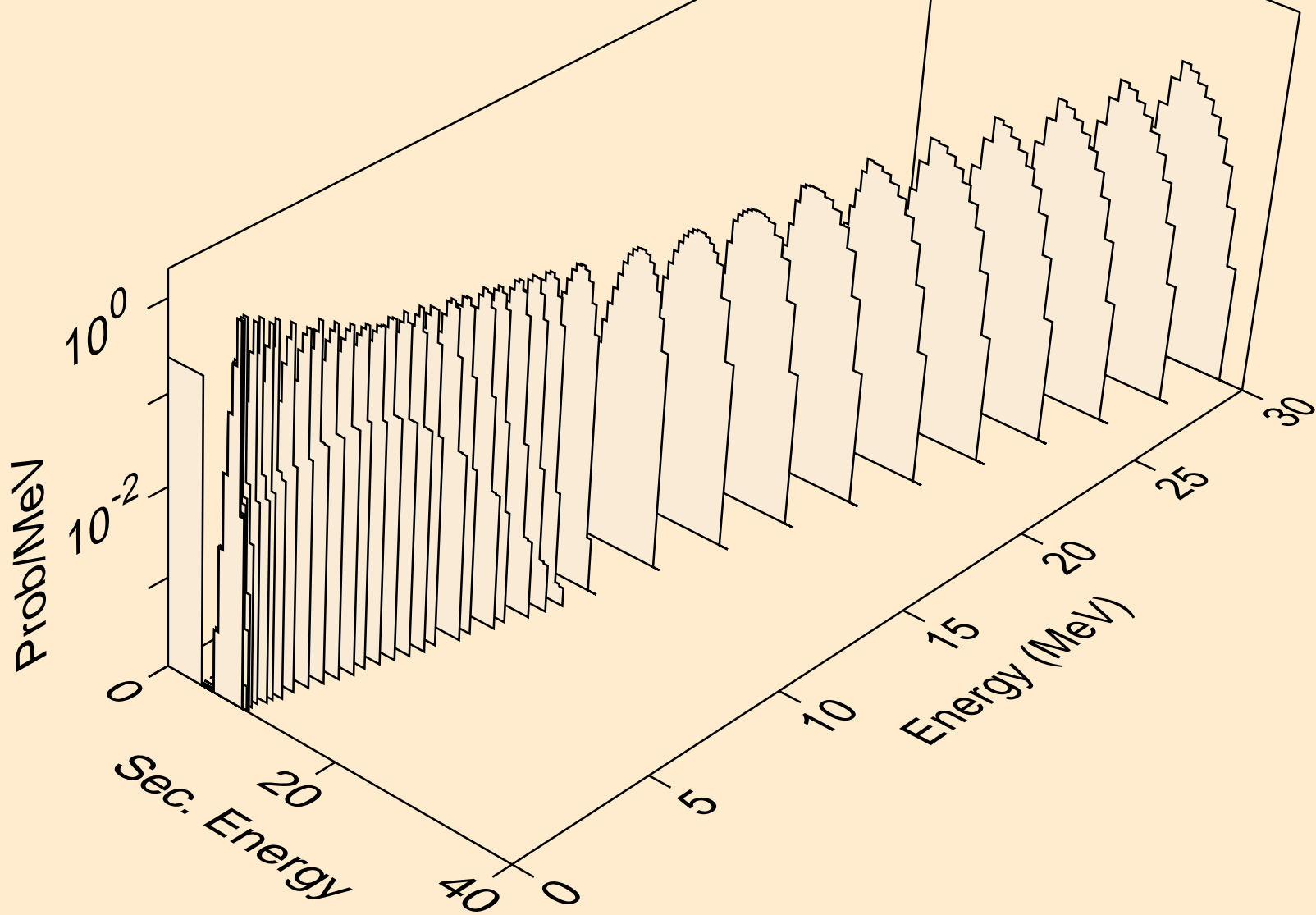

PR138M NEUTRON ACER TENDL-2023 LIBRARY; T=0.K  
alphas from (n,2a)

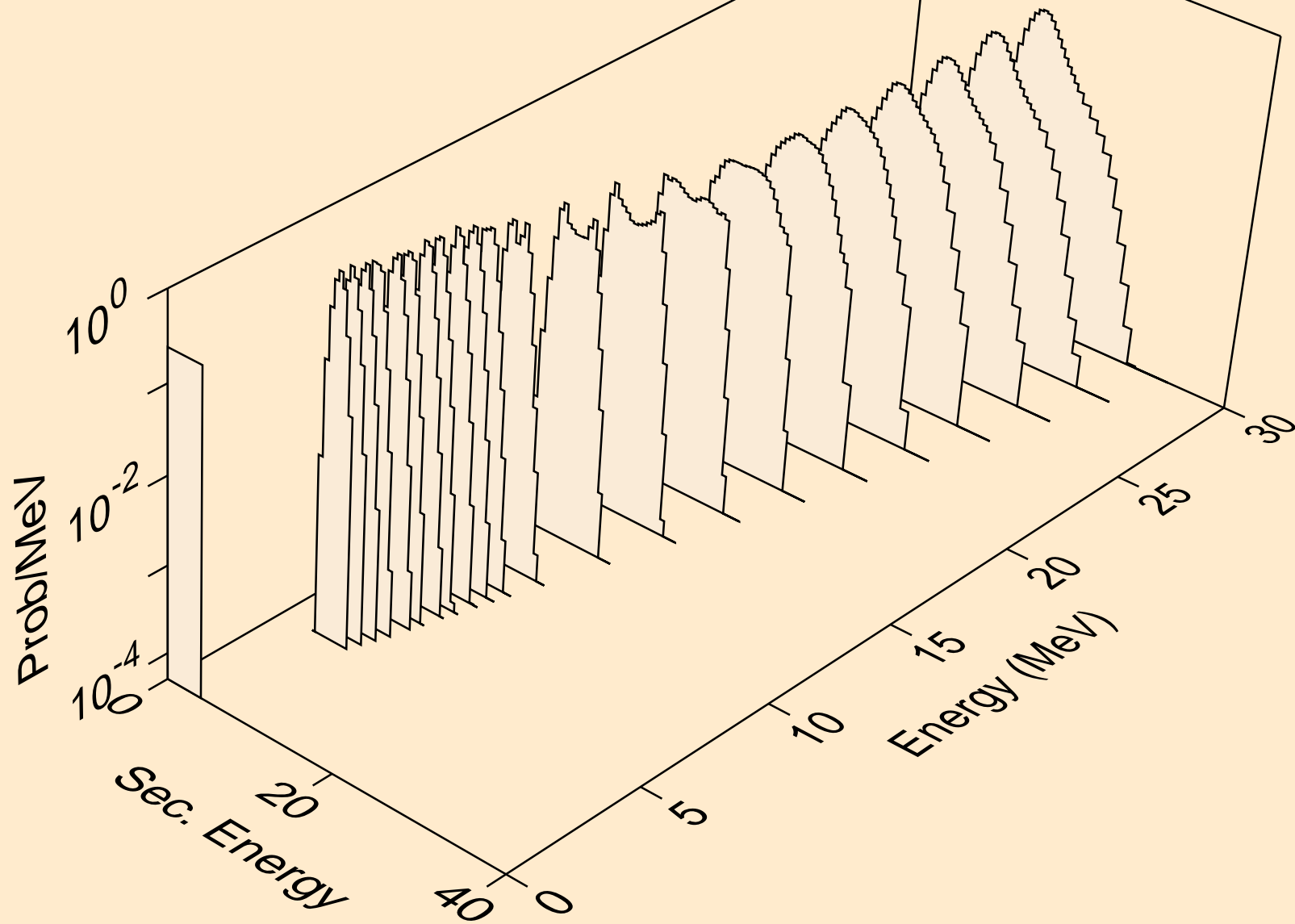

PR138M NEUTRON ACER TENDL-2023 LIBRARY; T=0.K  
alphas from (n,p)

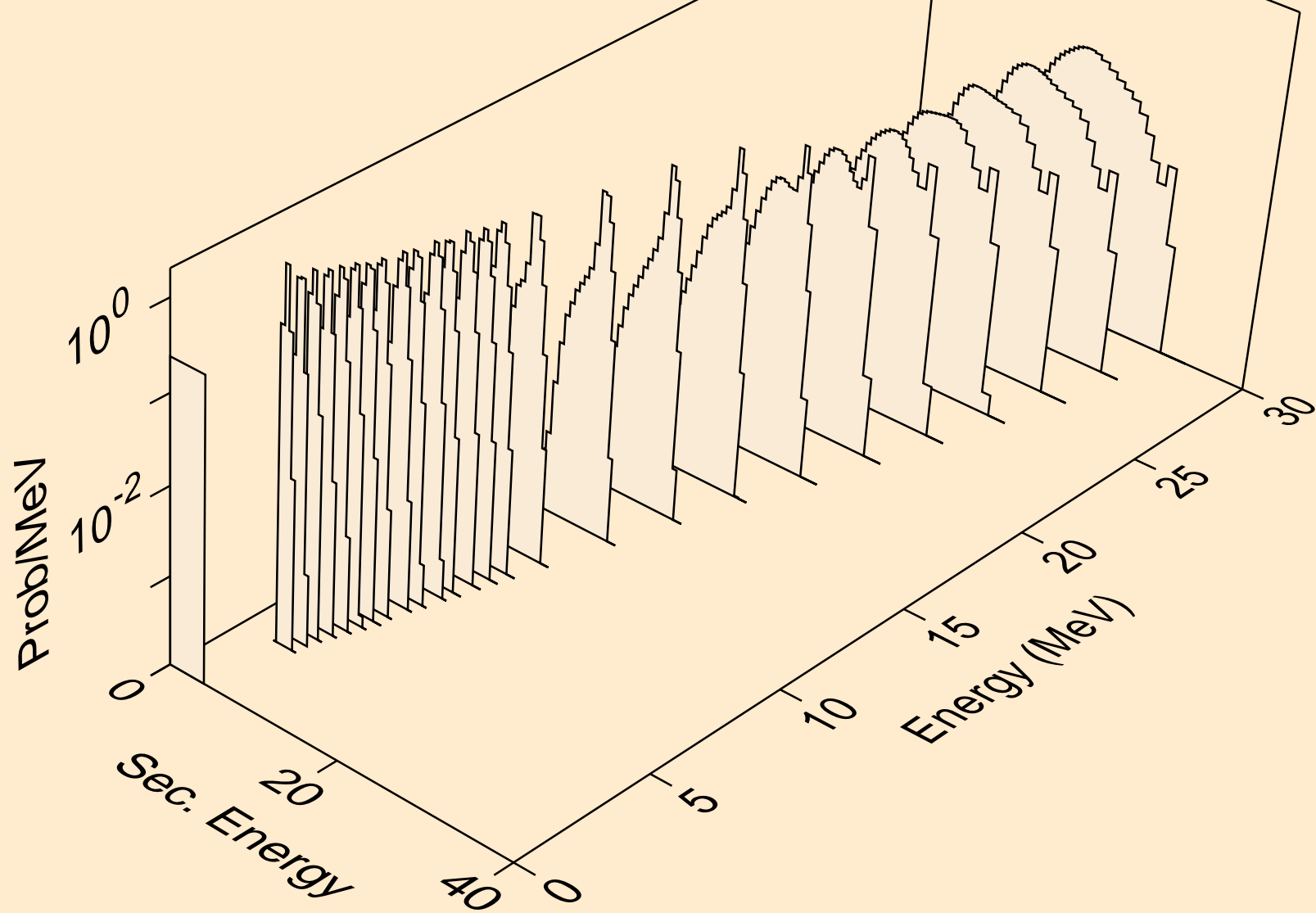

PR138M NEUTRON ACER TENDL-2023 LIBRARY; T=0.K  
alphas from (n,da)

