

# PT203M NEUTRON ACER TENDL-2023 LIBRARY; T=0.K

## Principal cross sections

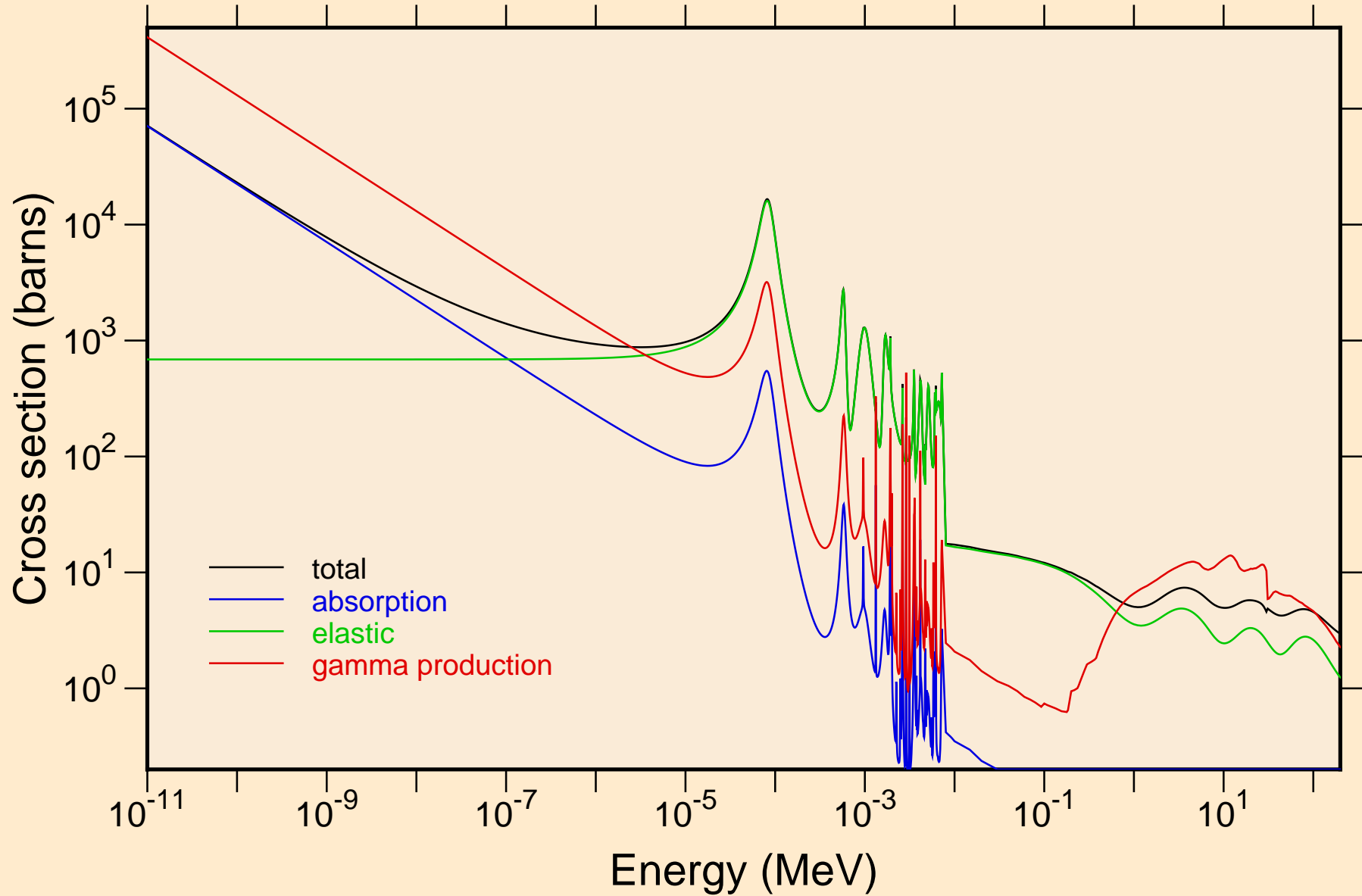

PT203M NEUTRON ACER TENDL-2023 LIBRARY; T=0.K  
resonance total cross section

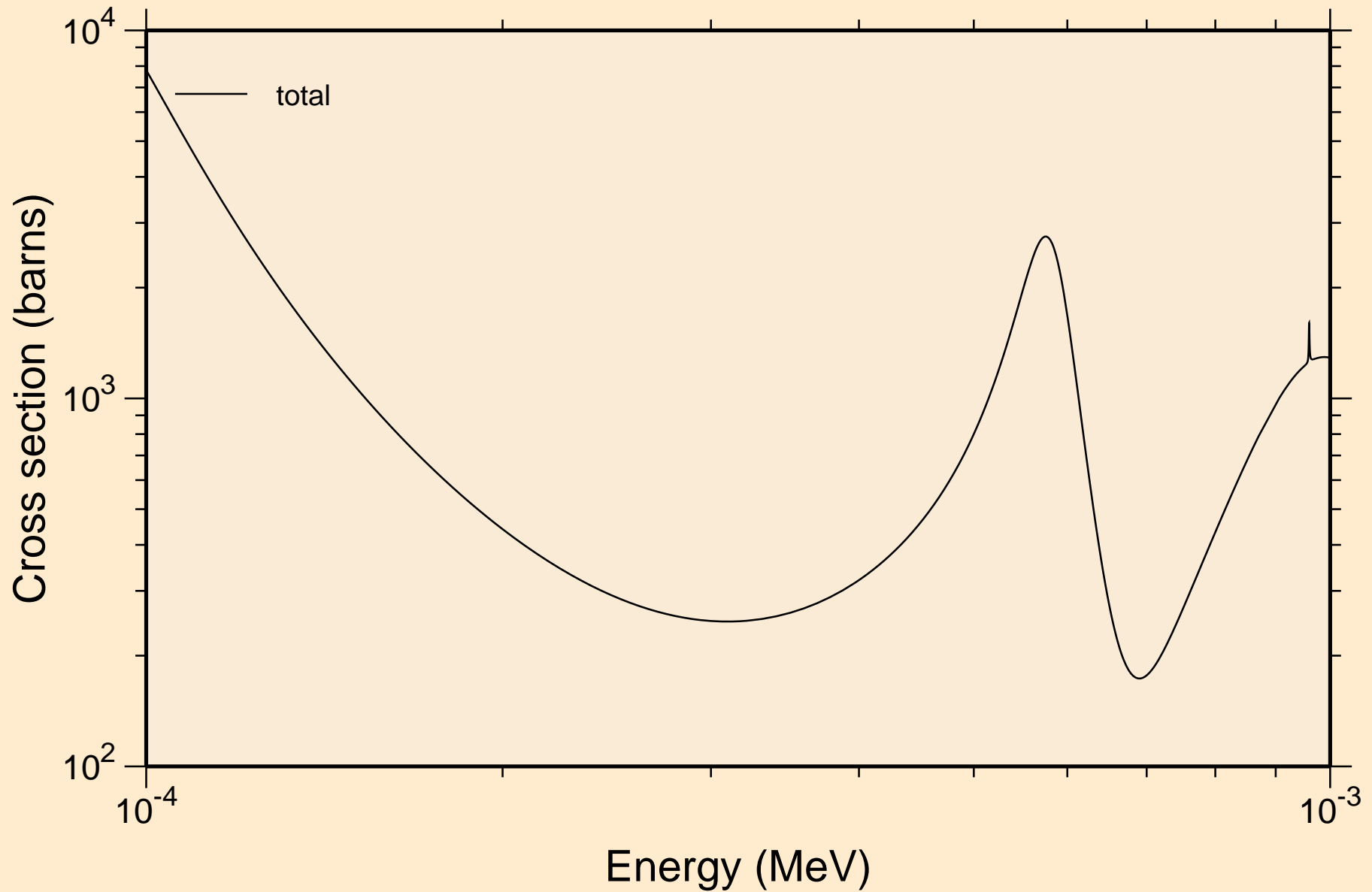

PT203M NEUTRON ACER TENDL-2023 LIBRARY; T=0.K  
resonance total cross section

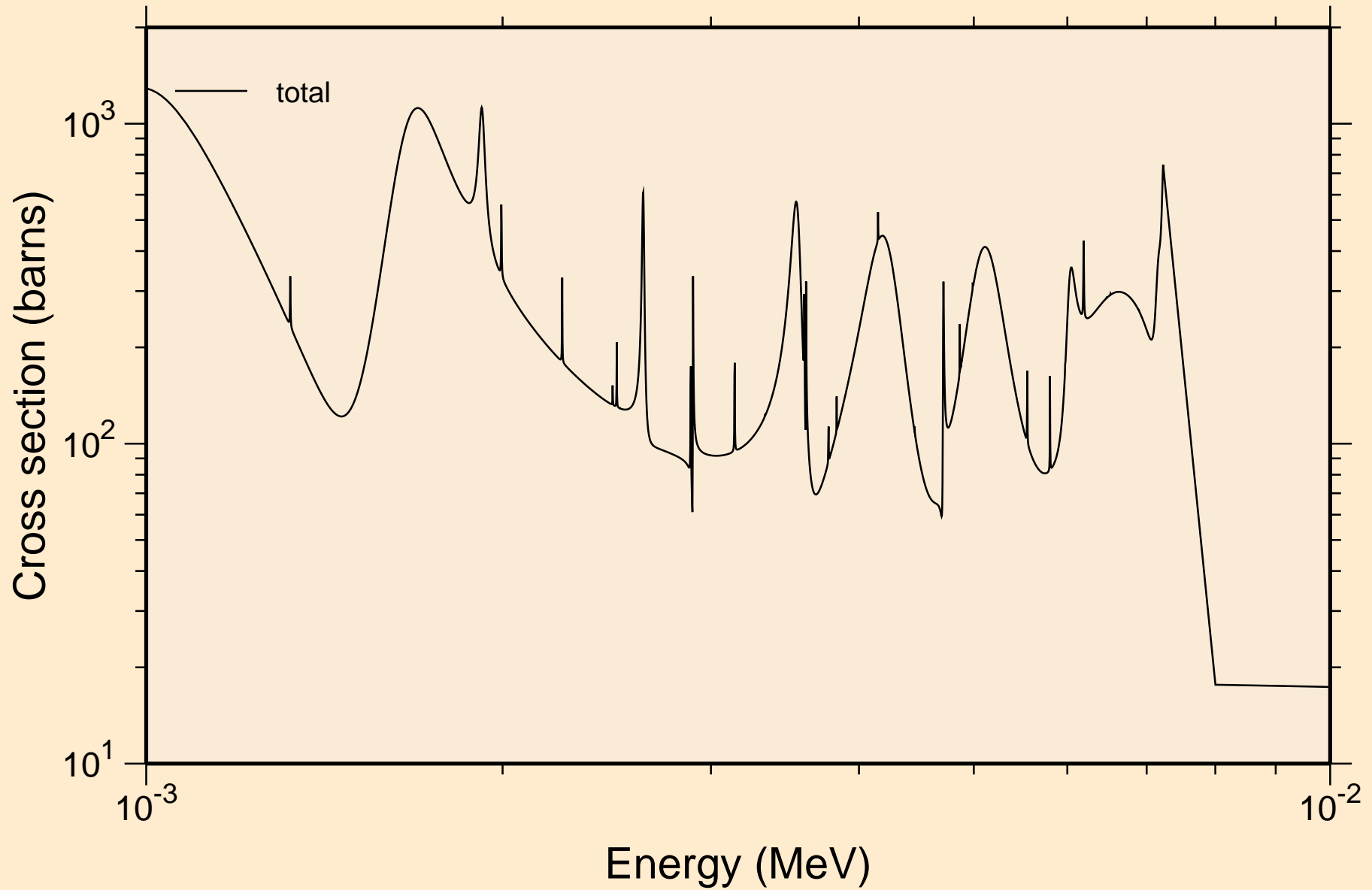

PT203M NEUTRON ACER TENDL-2023 LIBRARY; T=0.K  
resonance total cross section

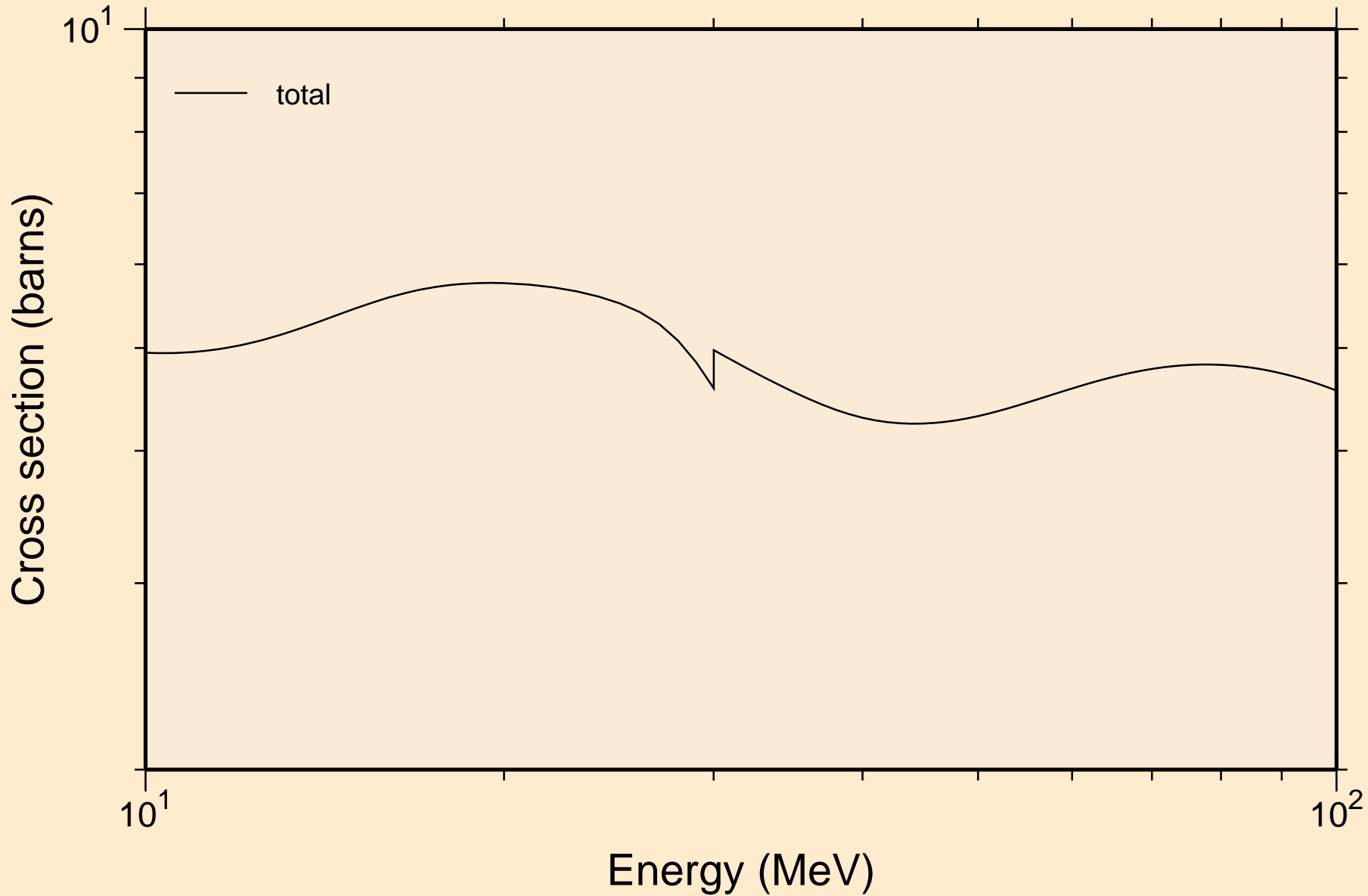

PT203M NEUTRON ACER TENDL-2023 LIBRARY; T=0.K  
resonance absorption cross sections

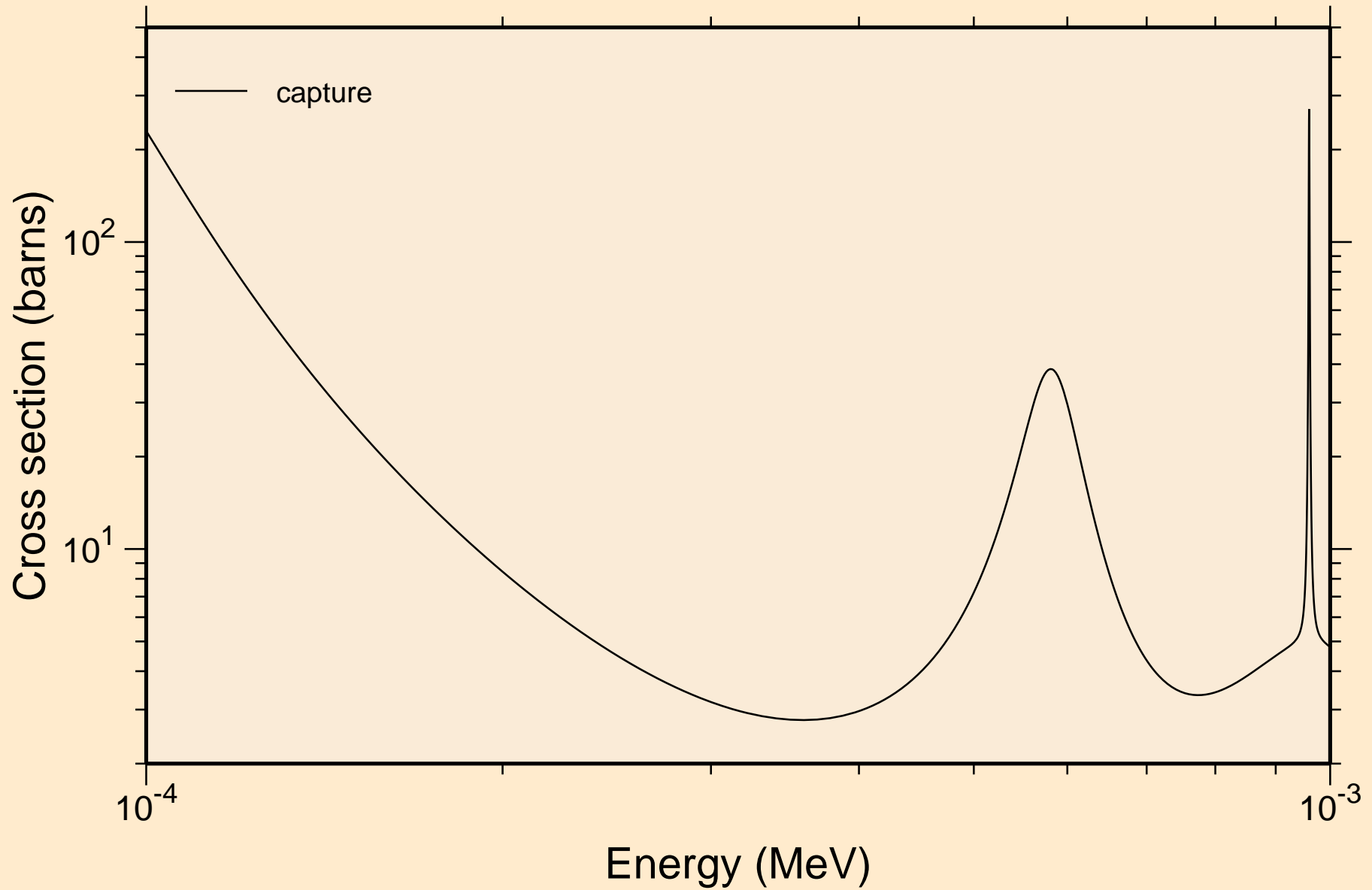

PT203M NEUTRON ACER TENDL-2023 LIBRARY; T=0.K  
resonance absorption cross sections

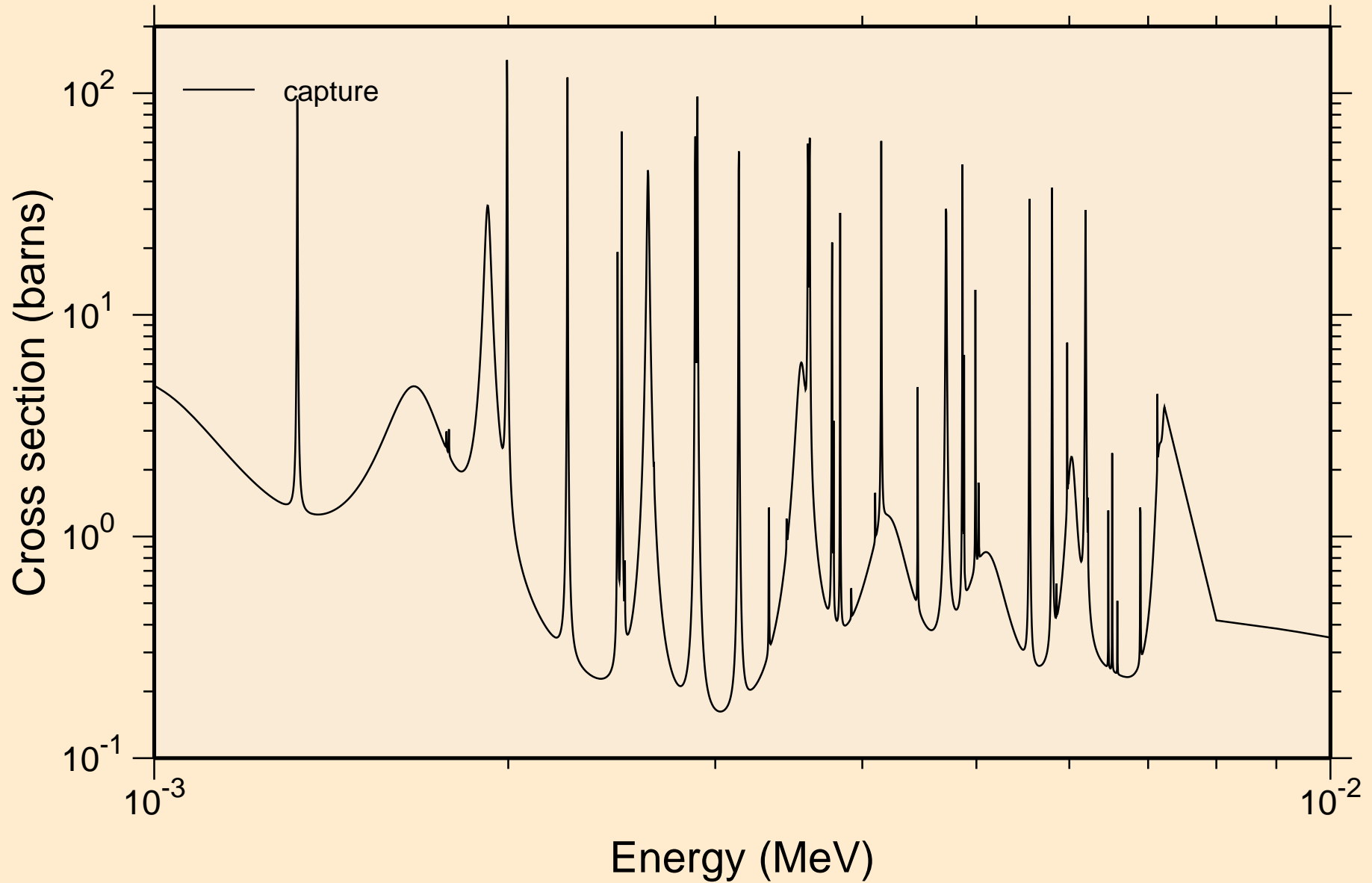

PT203M NEUTRON ACER TENDL-2023 LIBRARY; T=0.K  
resonance absorption cross sections

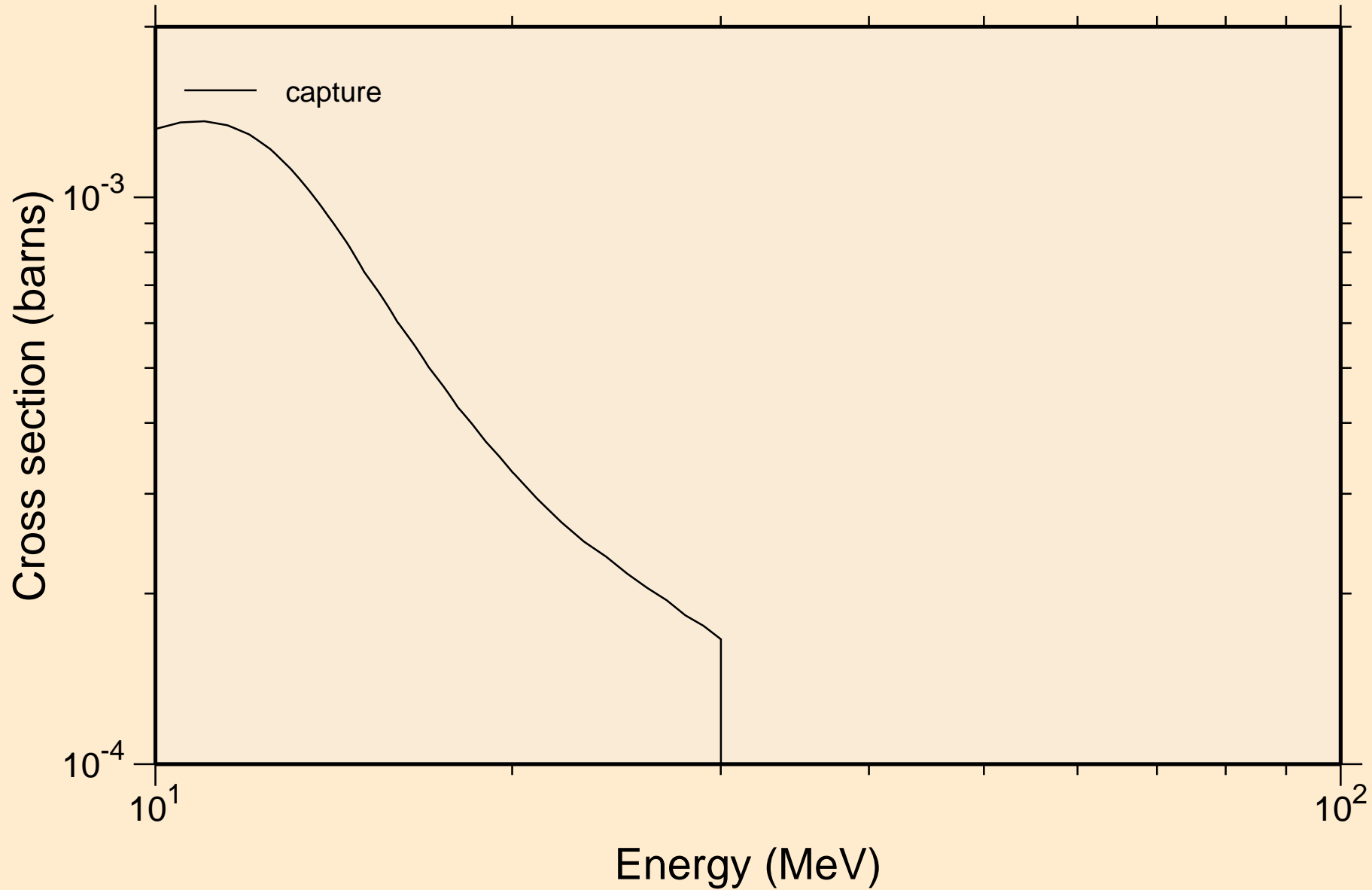

PT203M NEUTRON ACER TENDL-2023 LIBRARY; T=0.K  
Heating

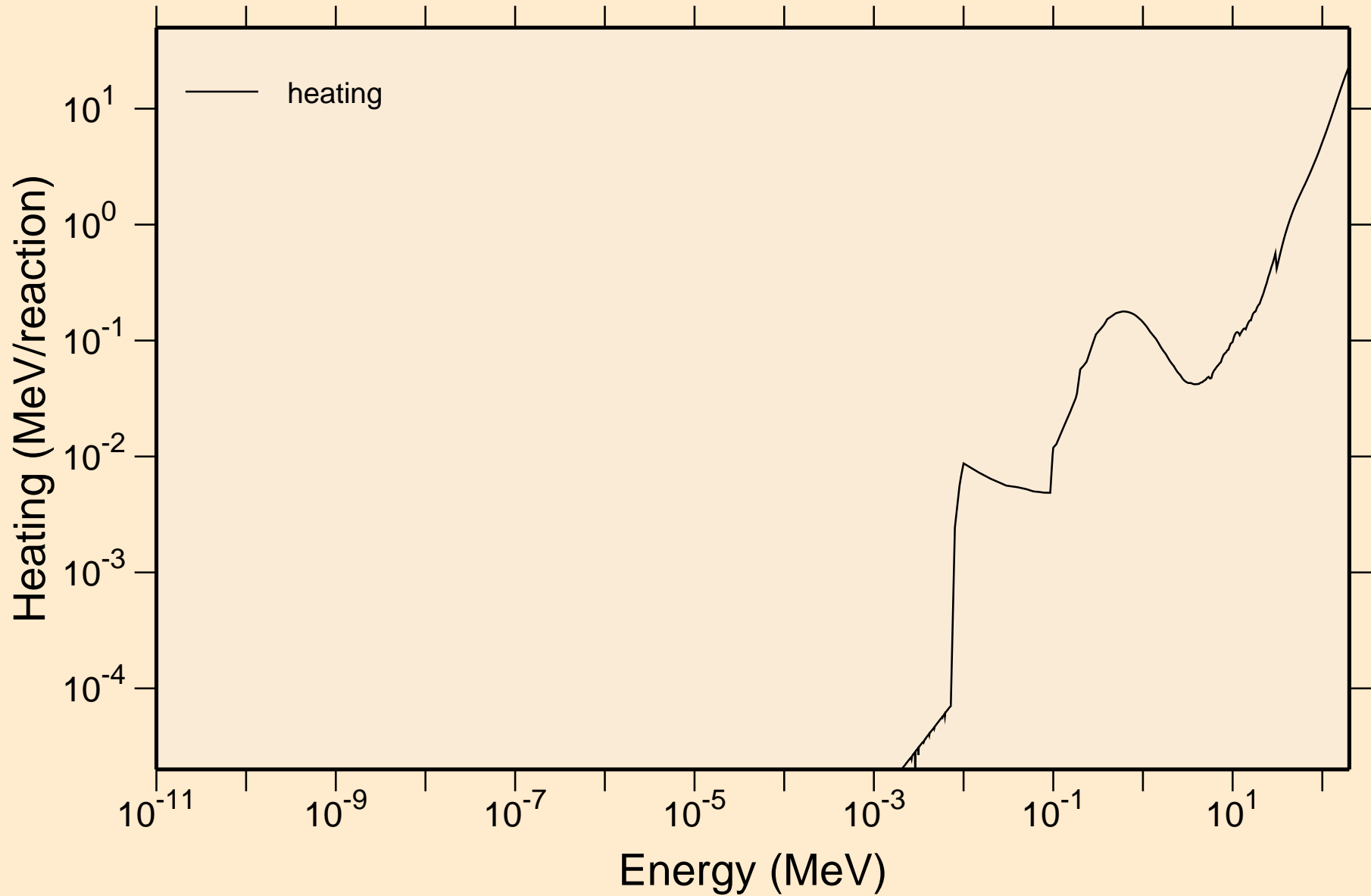



PT203M NEUTRON ACER TENDL-2023 LIBRARY; T=0.K  
Damage

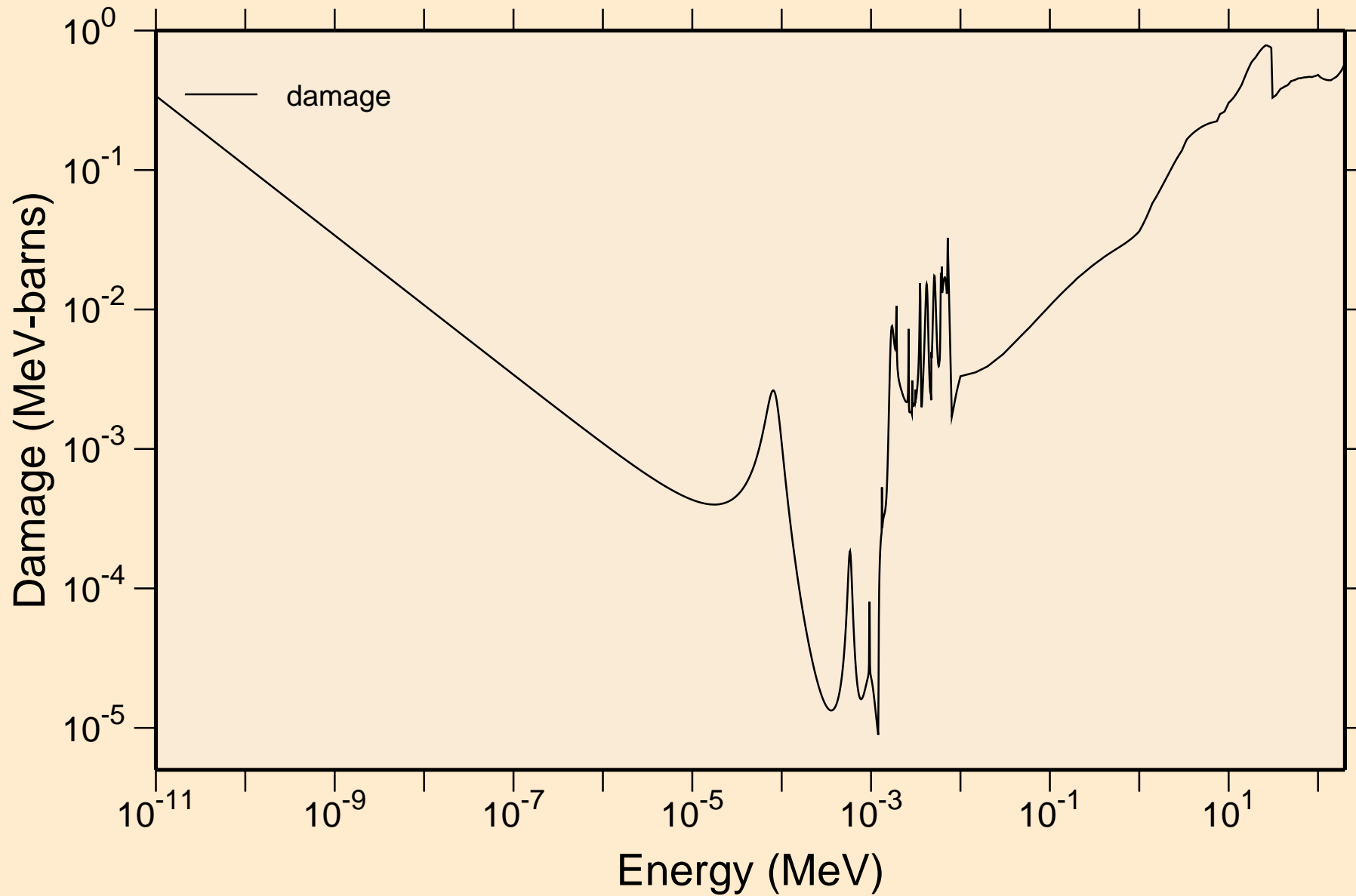

PT203M NEUTRON ACER TENDL-2023 LIBRARY; T=0.K  
Non-threshold reactions

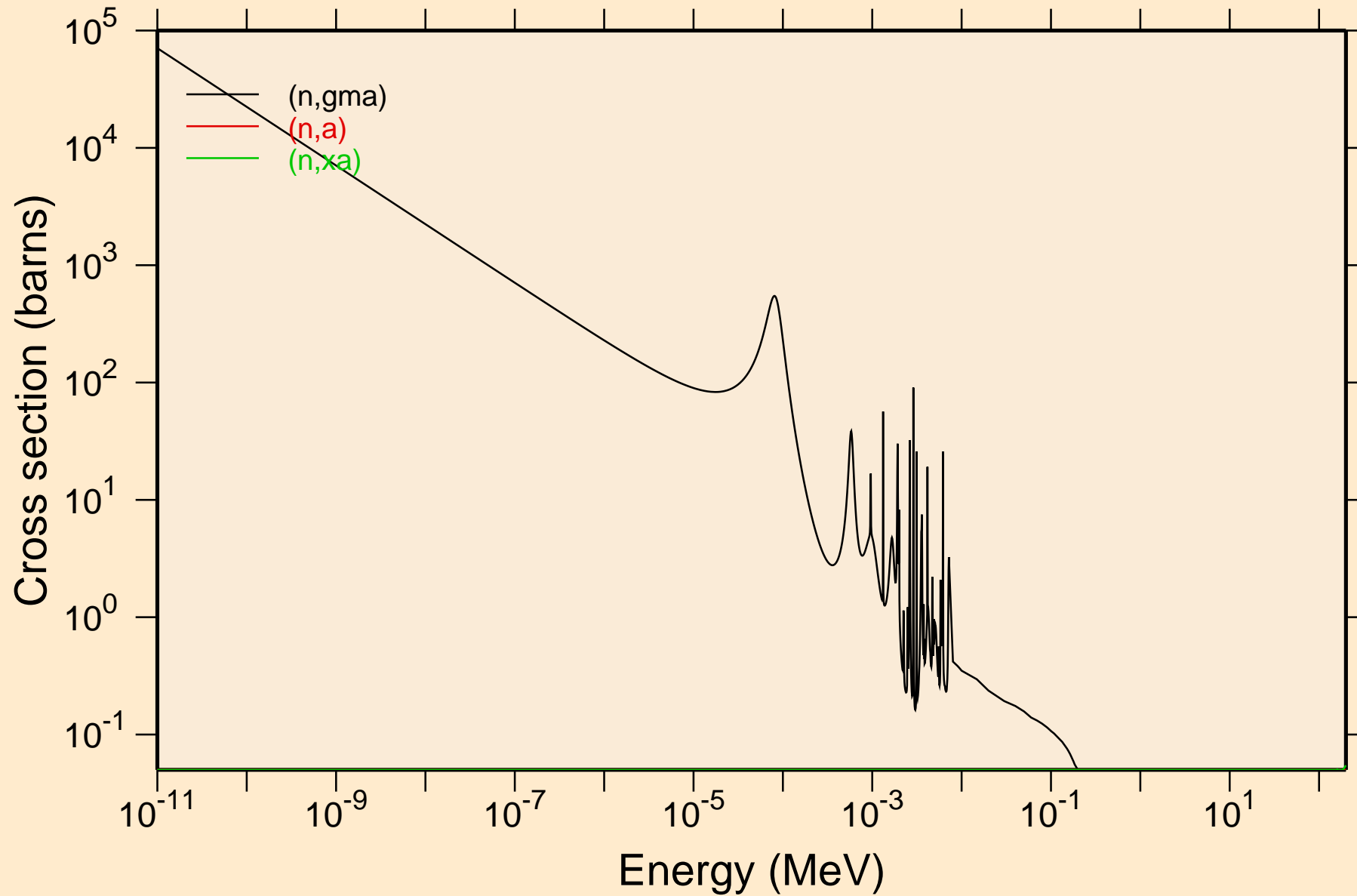

PT203M NEUTRON ACER TENDL-2023 LIBRARY; T=0.K  
Principal cross sections

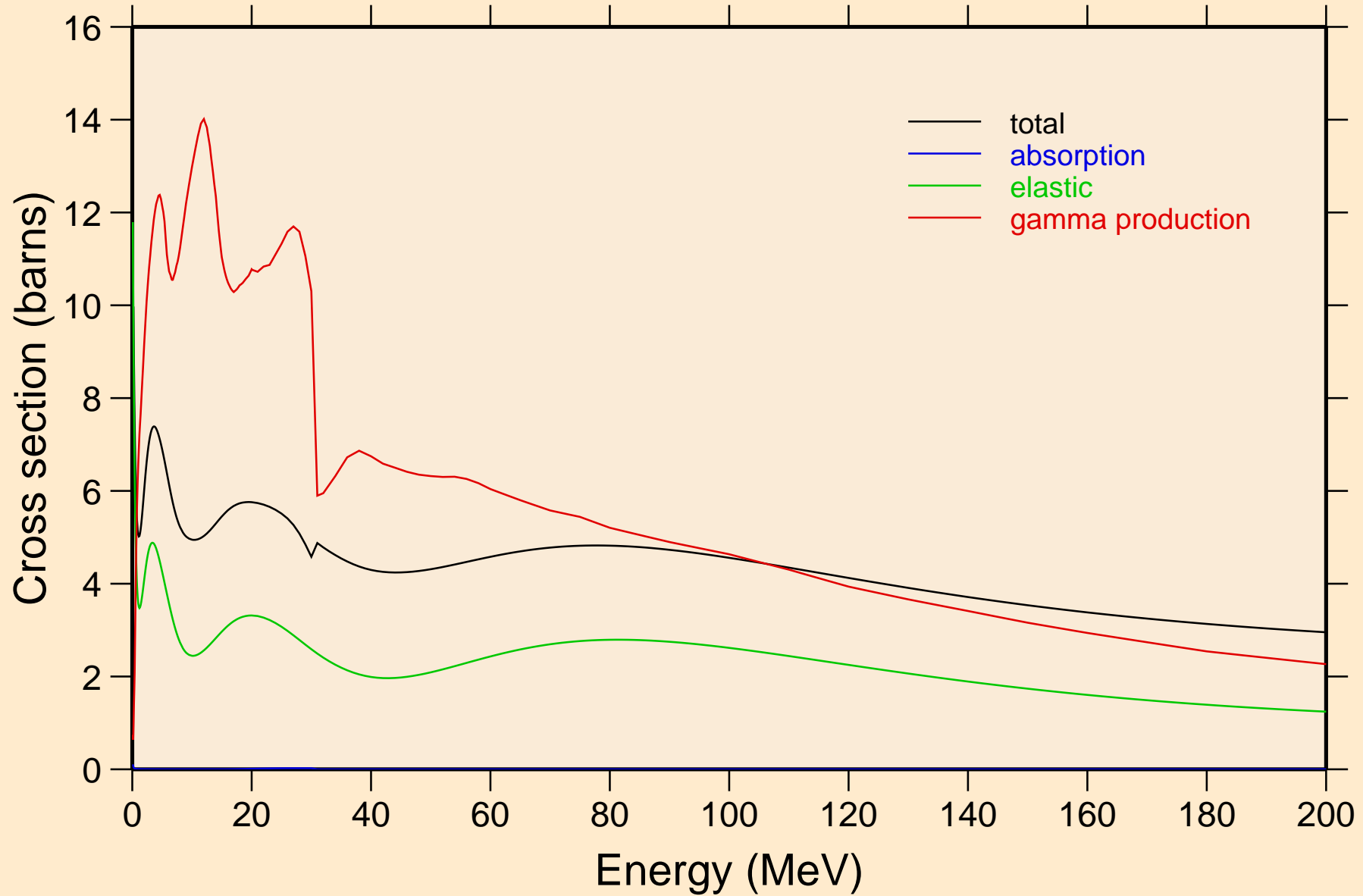

PT203M NEUTRON ACER TENDL-2023 LIBRARY; T=0.K

Heating

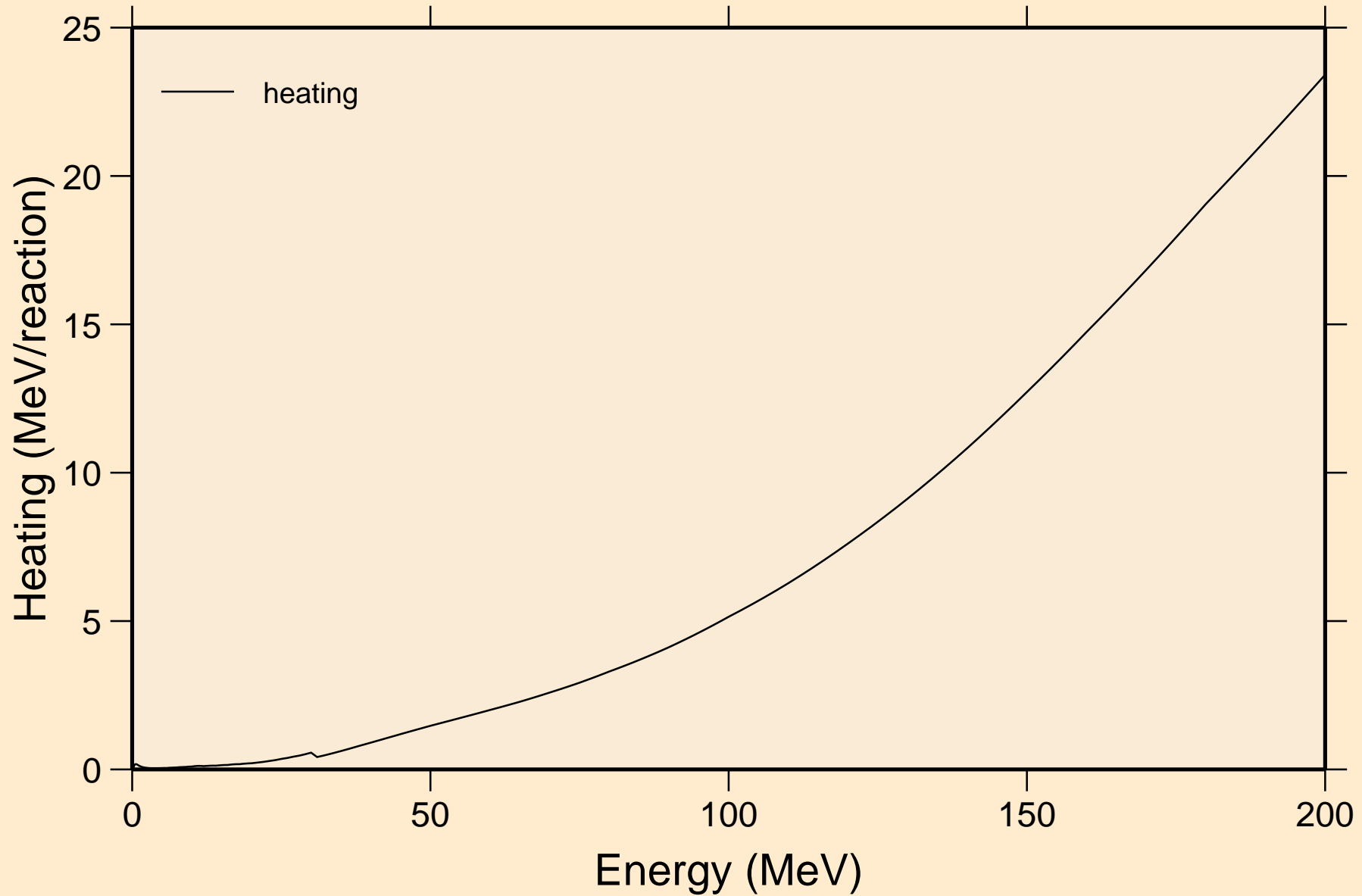

PT203M NEUTRON ACER TENDL-2023 LIBRARY; T=0.K  
Damage

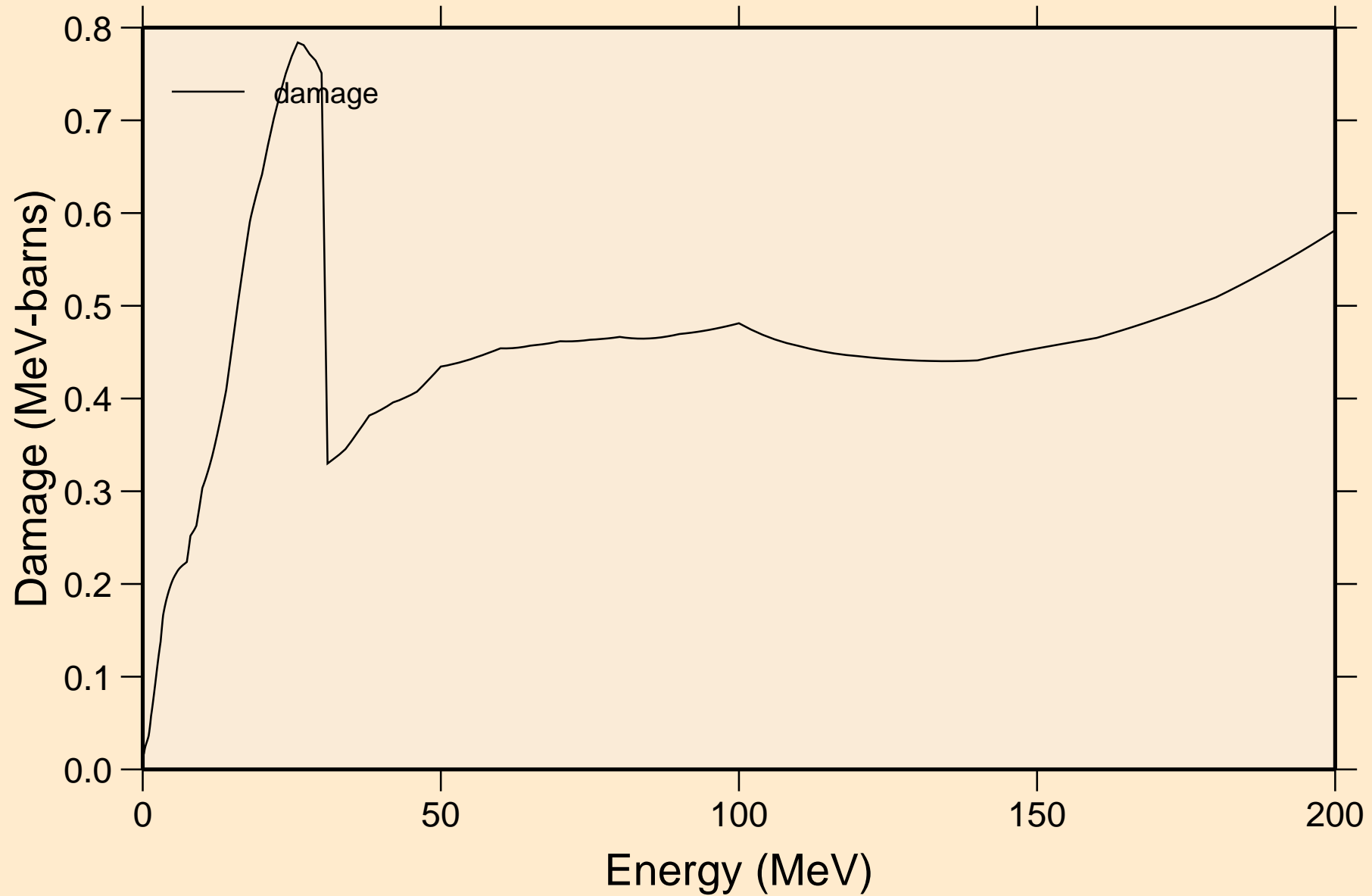

PT203M NEUTRON ACER TENDL-2023 LIBRARY; T=0.K  
Non-threshold reactions

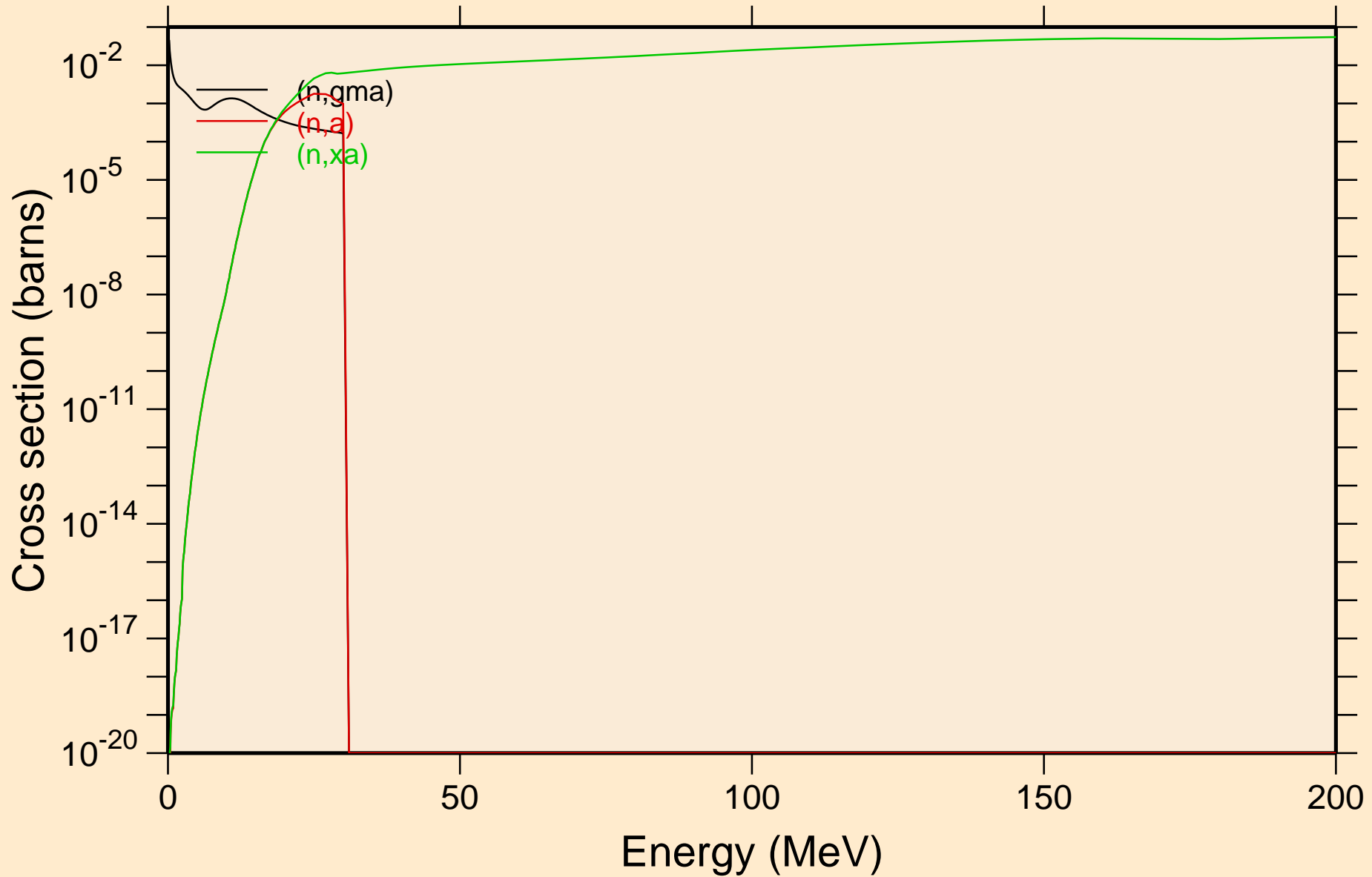

PT203M NEUTRON ACER TENDL-2023 LIBRARY; T=0.K  
Inelastic levels

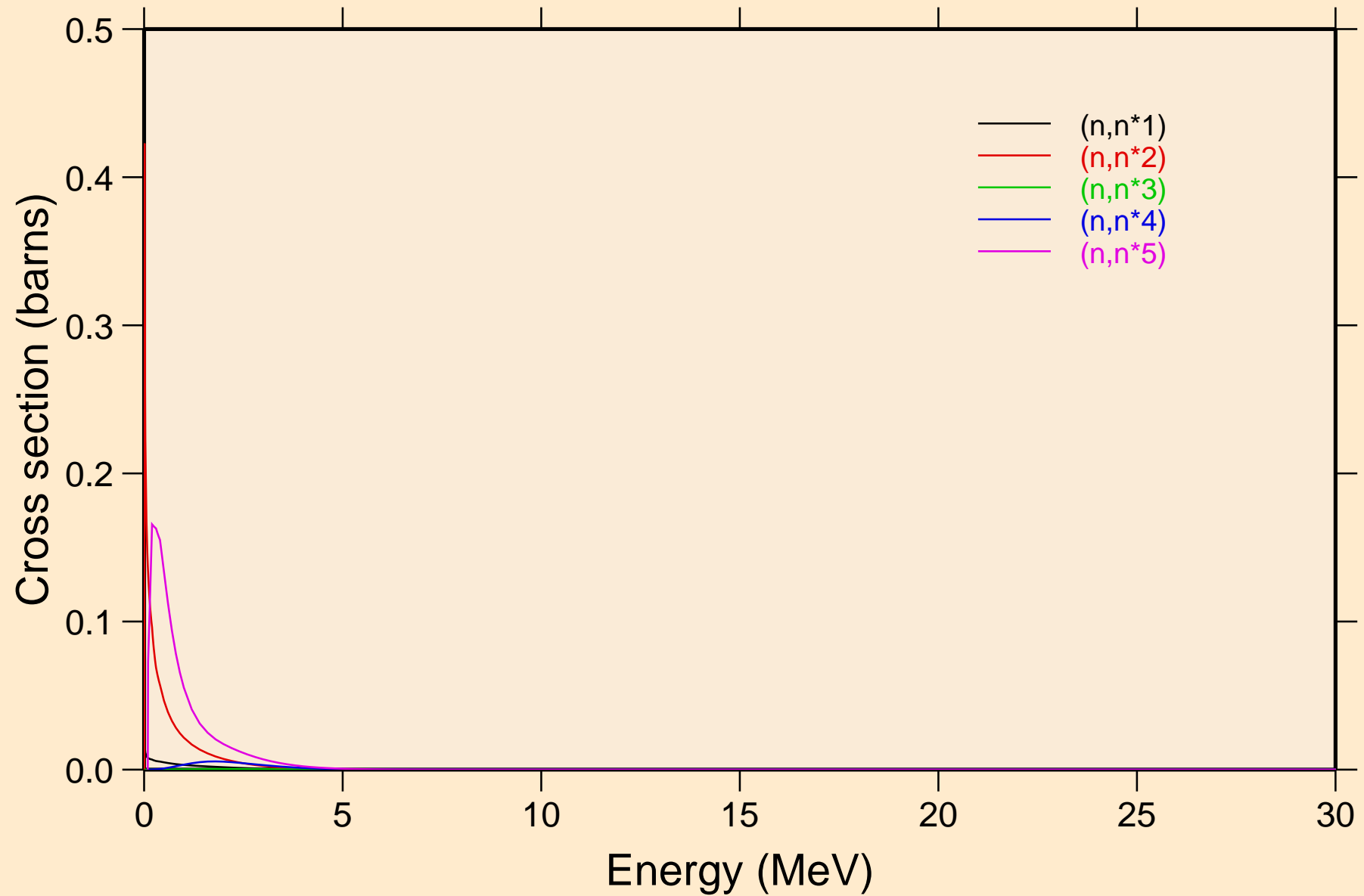

PT203M NEUTRON ACER TENDL-2023 LIBRARY; T=0.K  
Inelastic levels

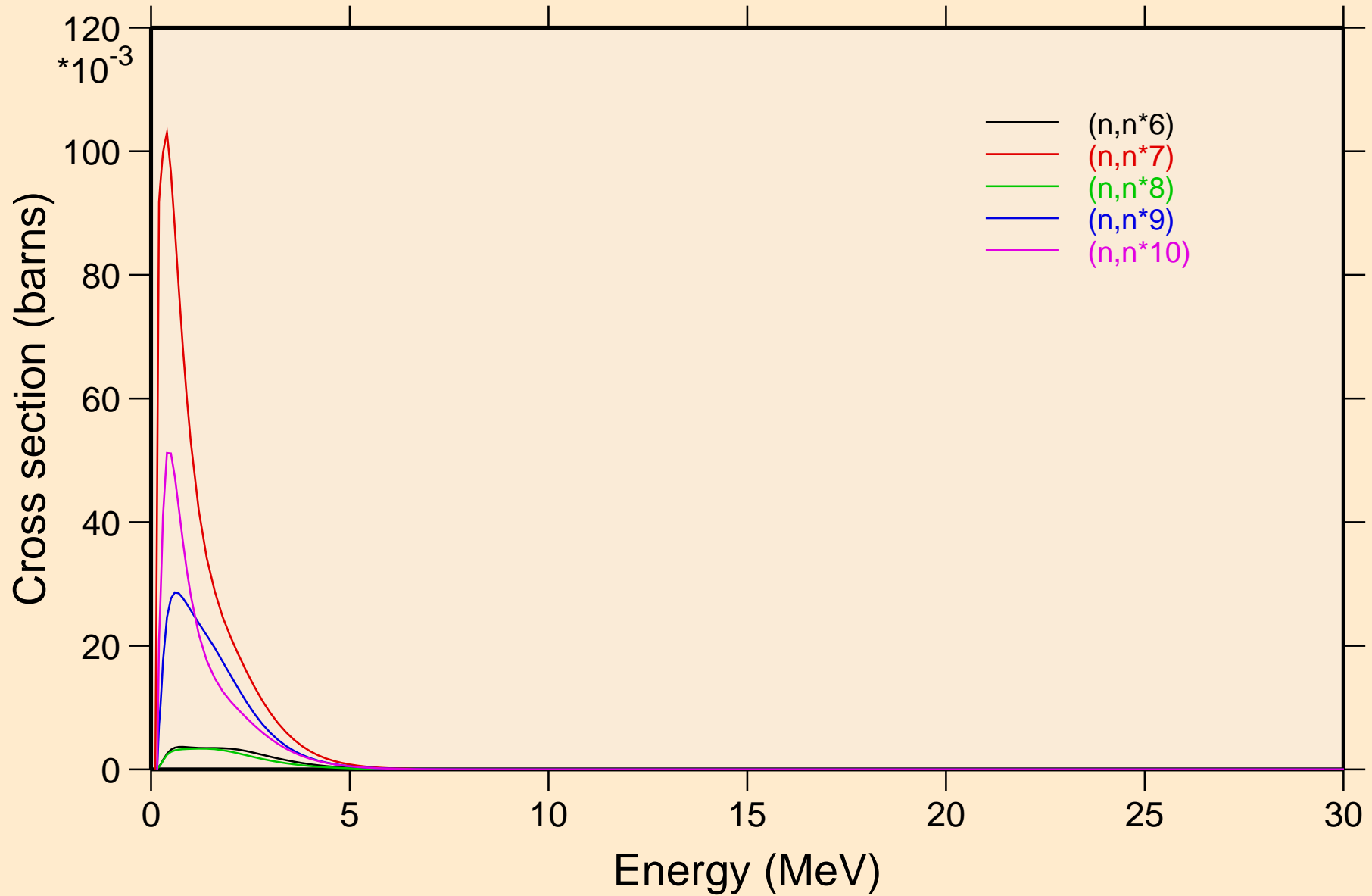



PT203M NEUTRON ACER TENDL-2023 LIBRARY; T=0.K  
Inelastic levels

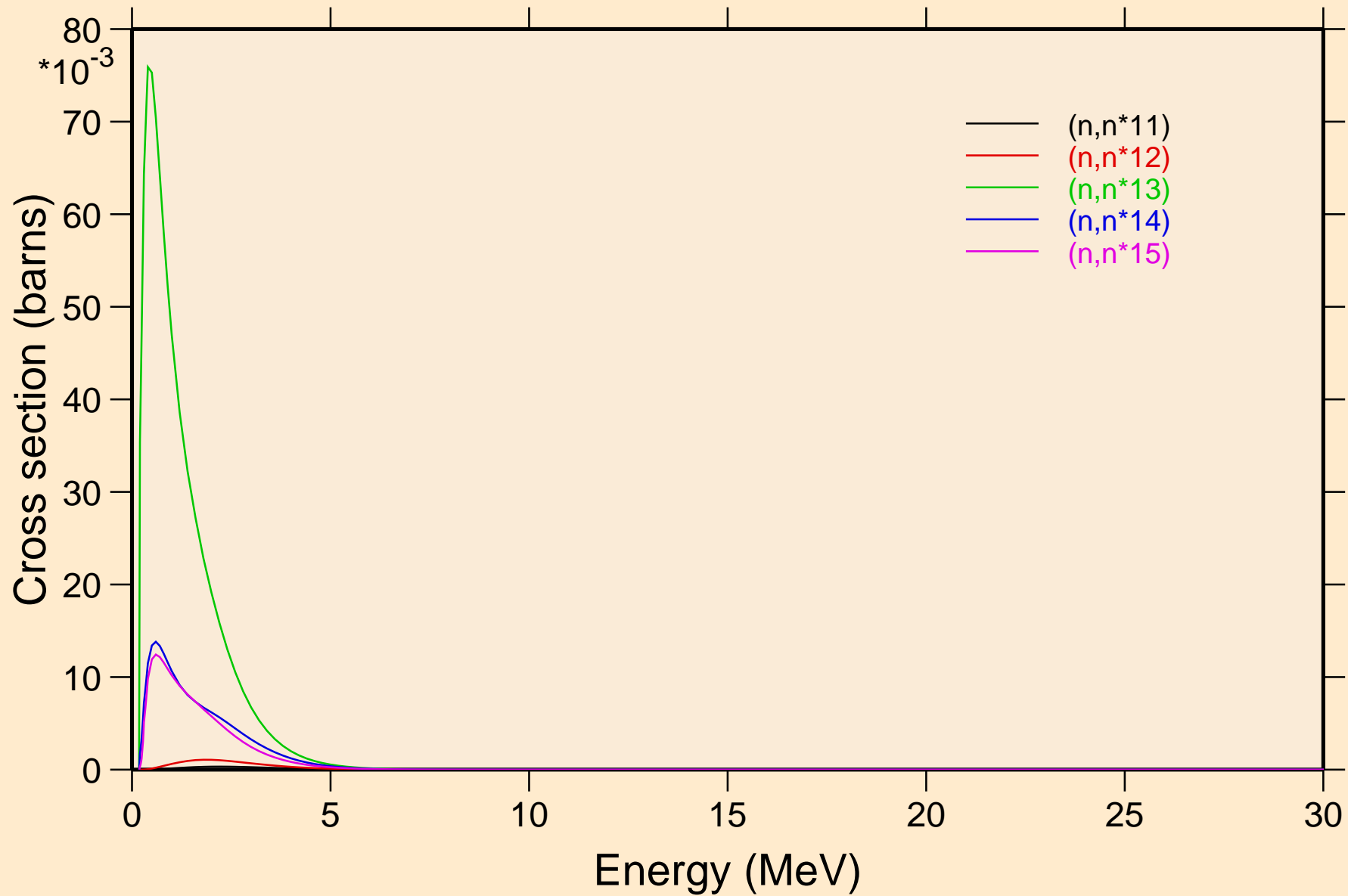

PT203M NEUTRON ACER TENDL-2023 LIBRARY; T=0.K  
Inelastic levels

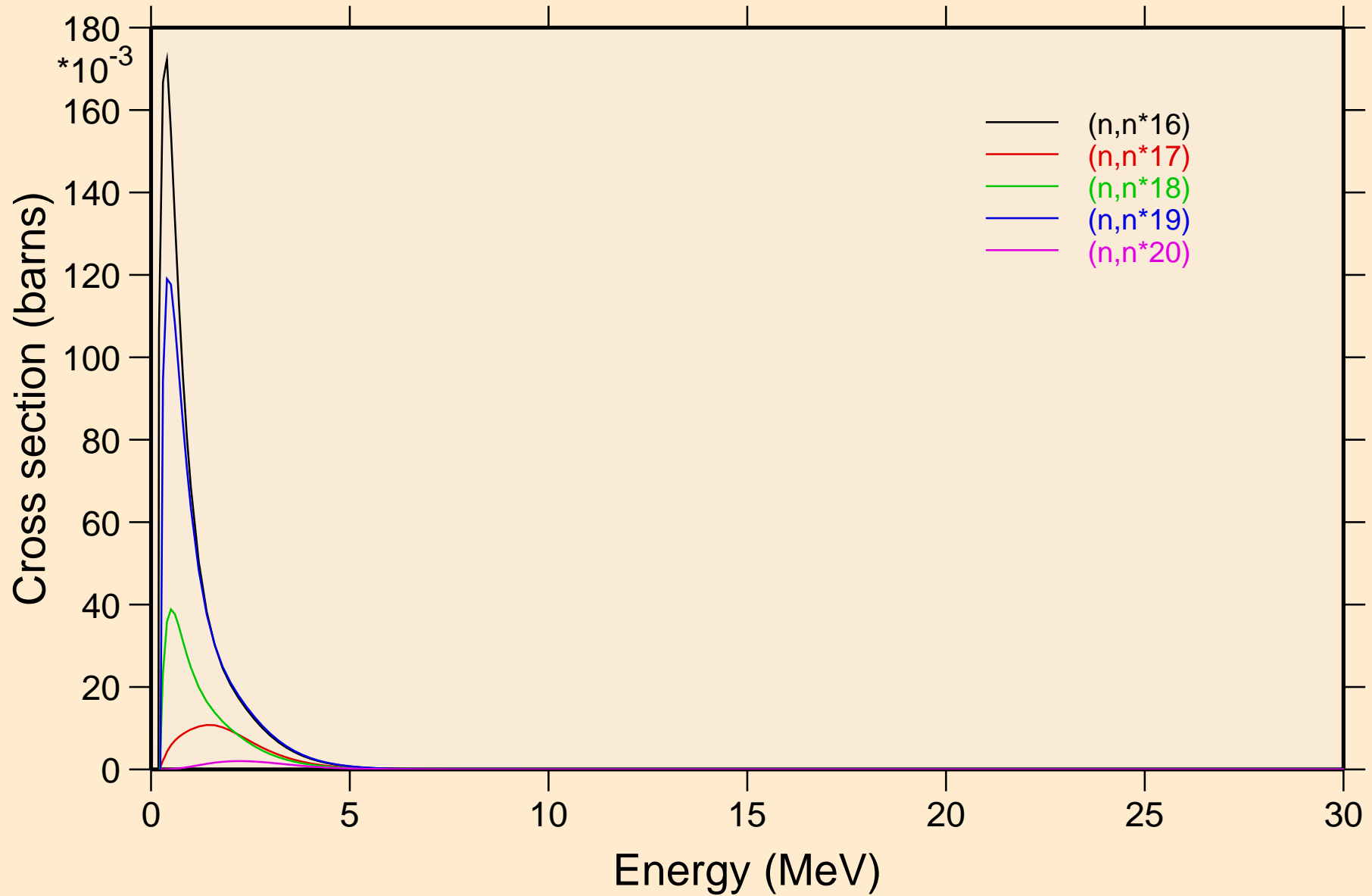

PT203M NEUTRON ACER TENDL-2023 LIBRARY; T=0.K  
Inelastic levels

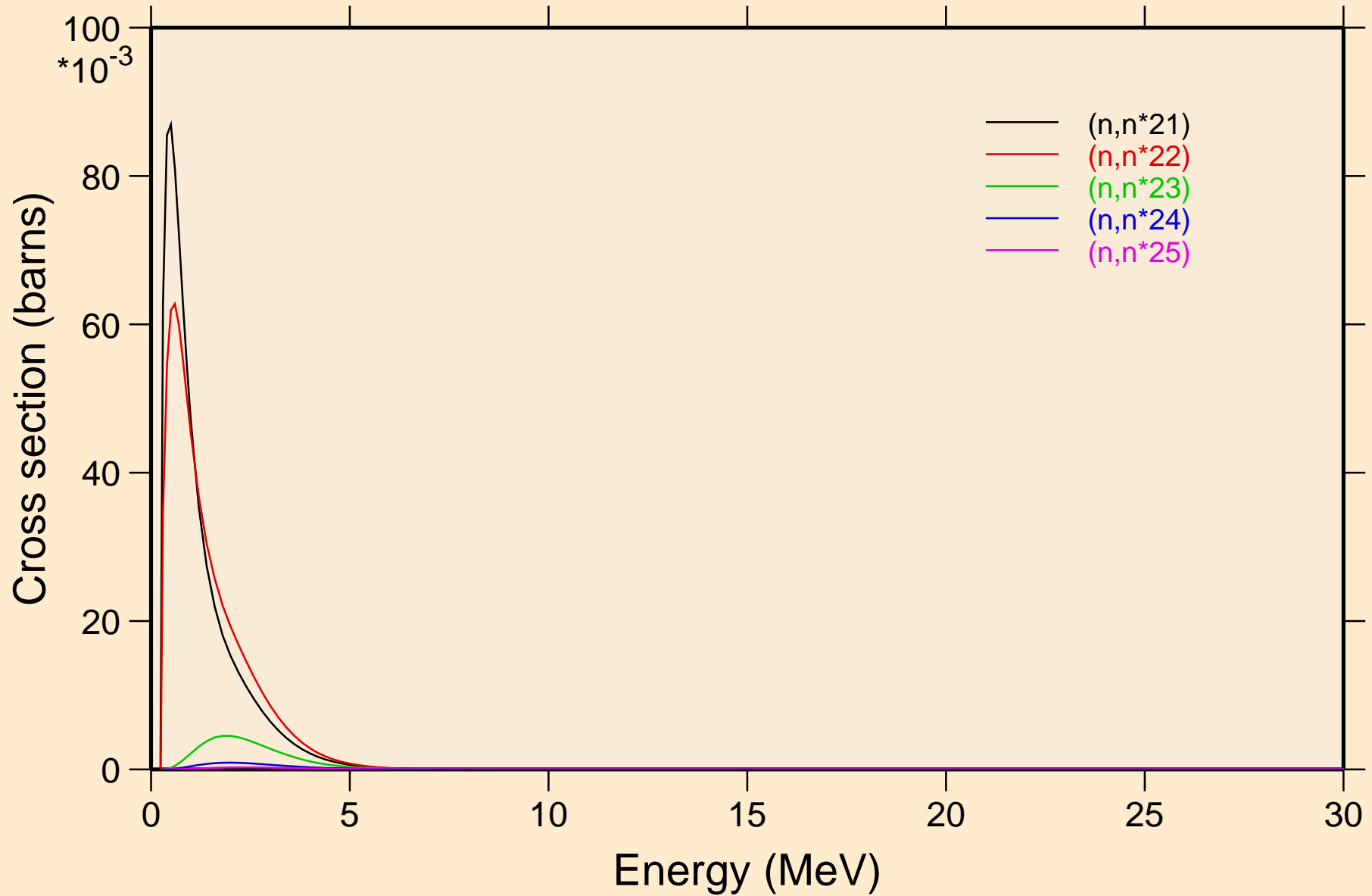

PT203M NEUTRON ACER TENDL-2023 LIBRARY; T=0.K  
Inelastic levels

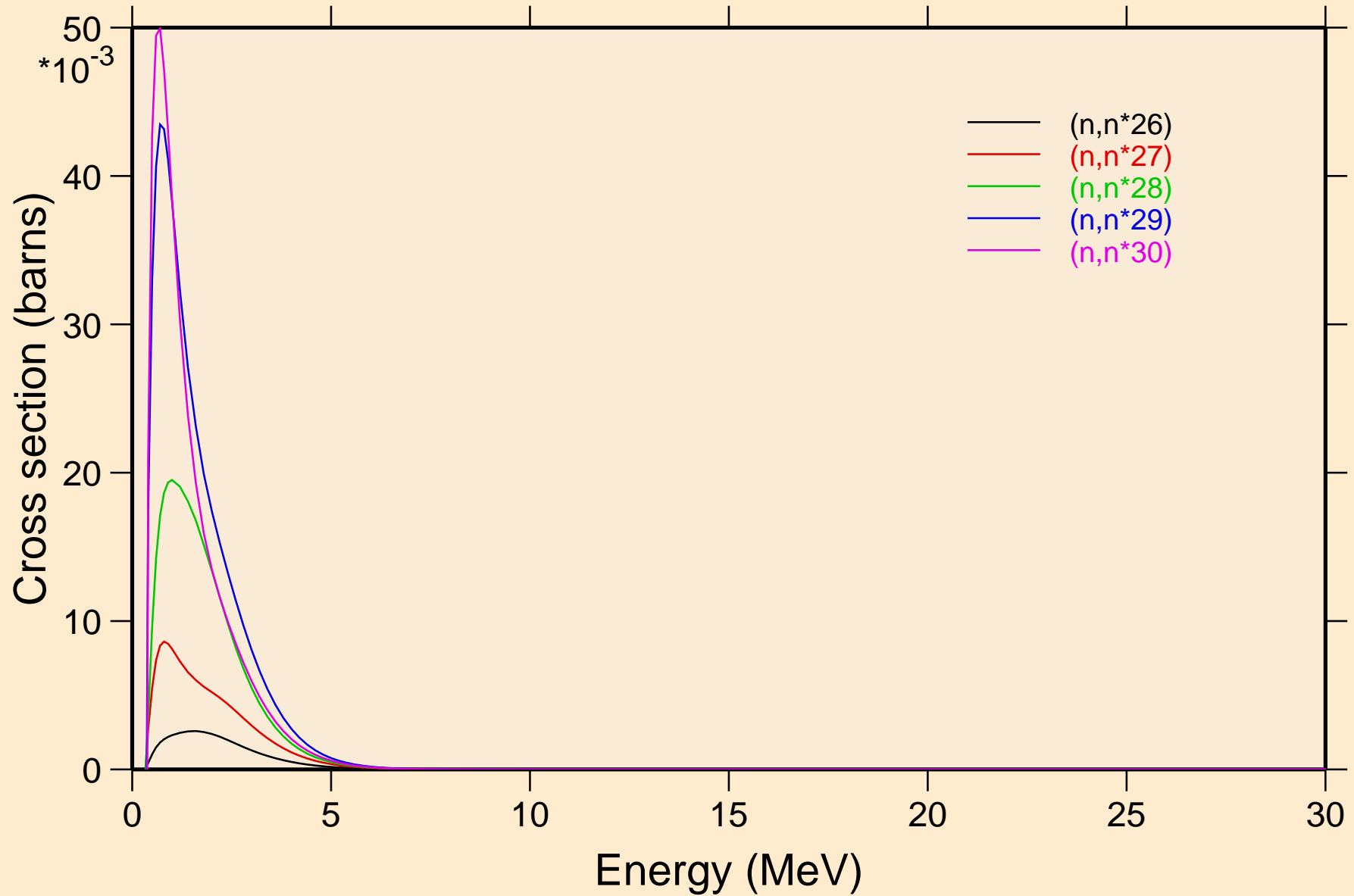

PT203M NEUTRON ACER TENDL-2023 LIBRARY; T=0.K  
Threshold reactions

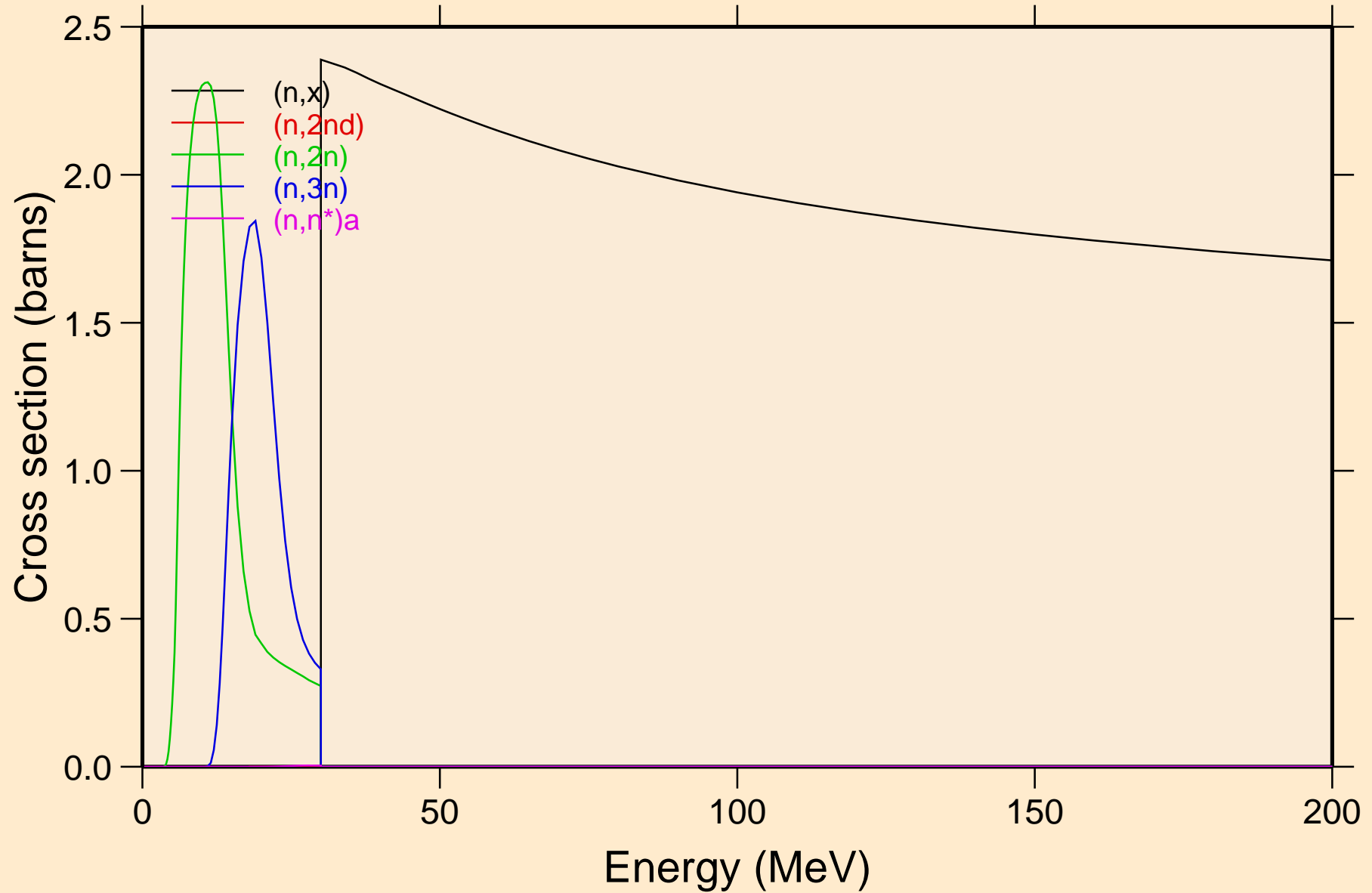

PT203M NEUTRON ACER TENDL-2023 LIBRARY; T=0.K  
Threshold reactions

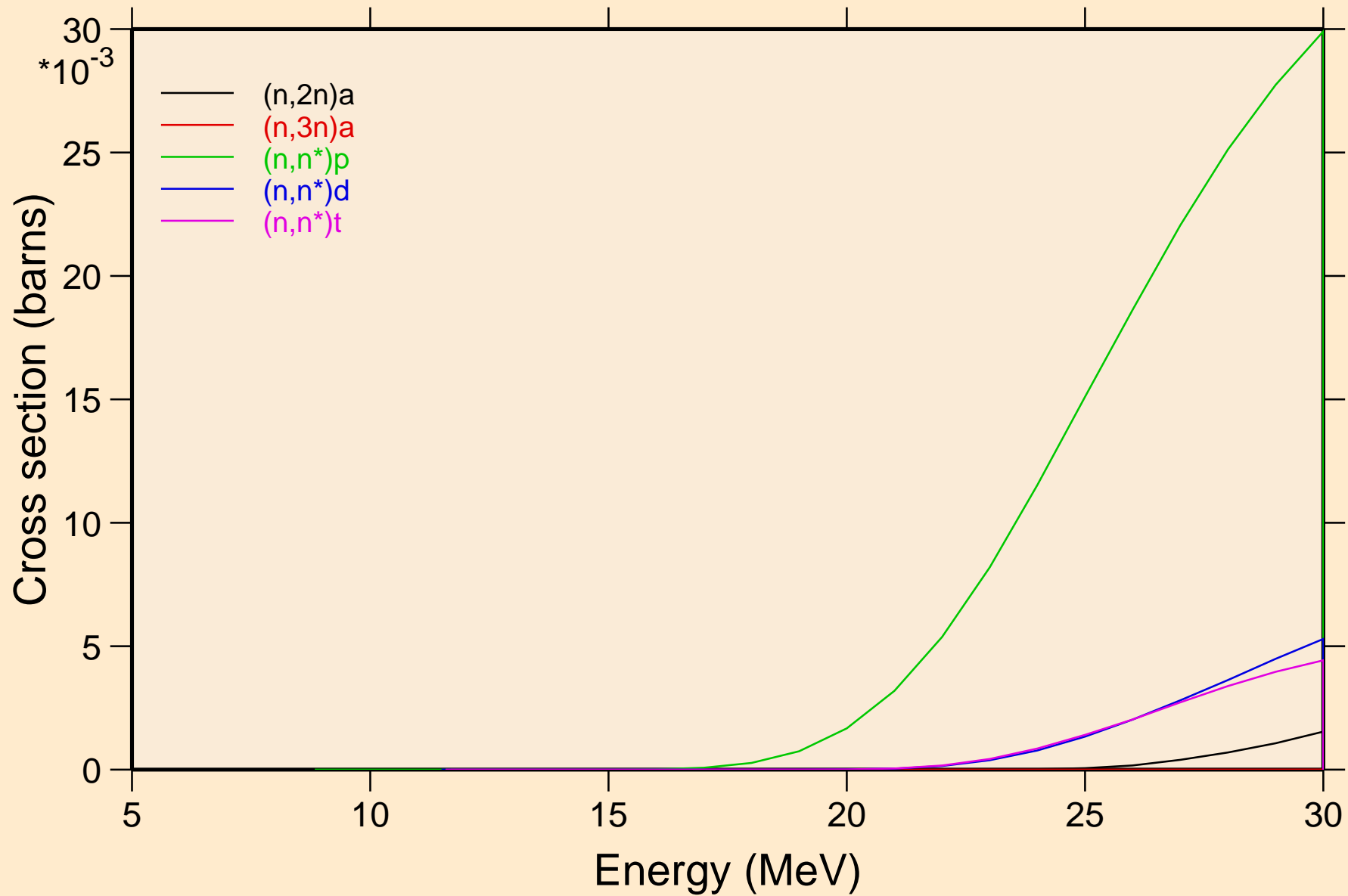

PT203M NEUTRON ACER TENDL-2023 LIBRARY; T=0.K  
Threshold reactions

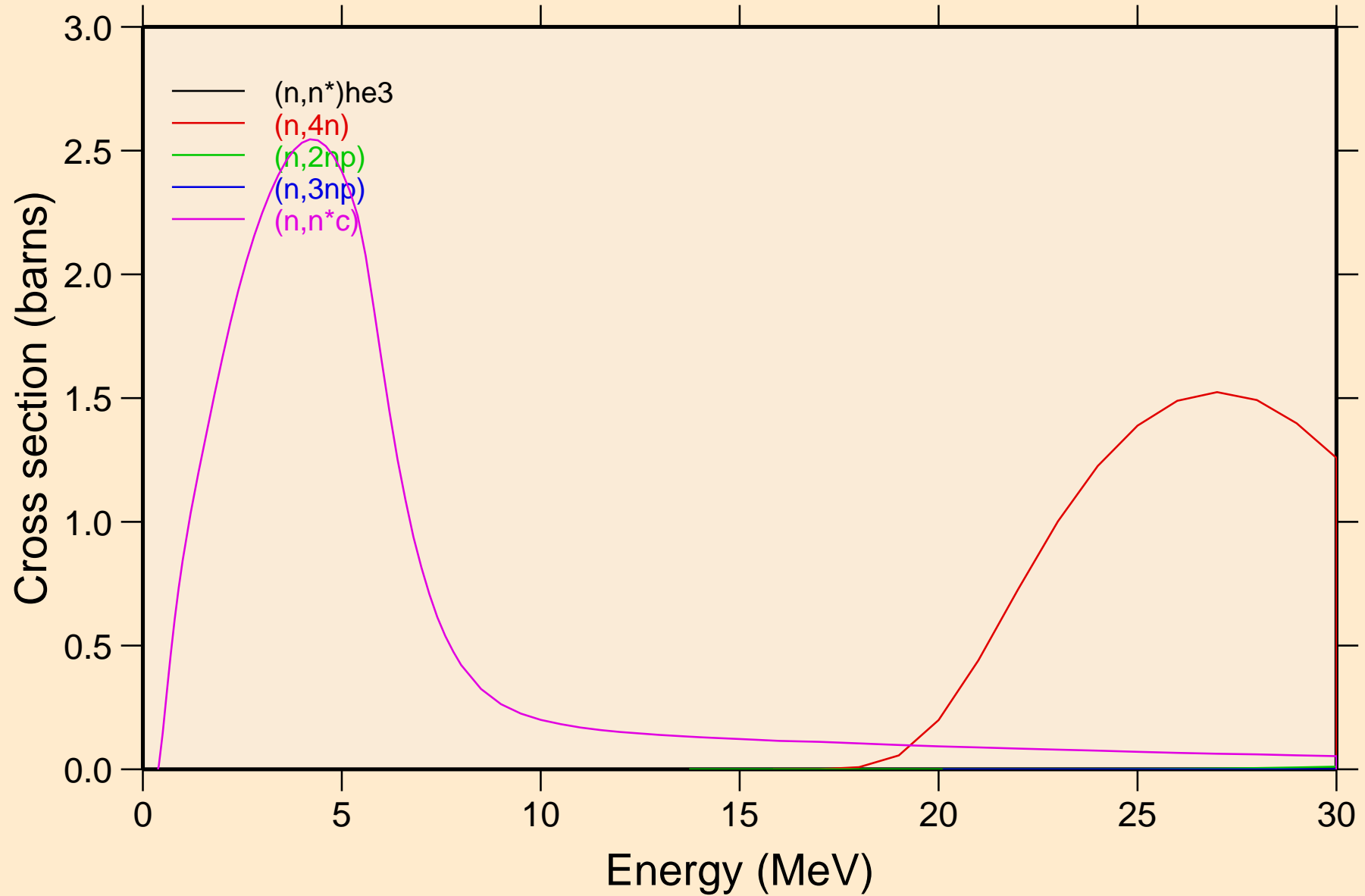

PT203M NEUTRON ACER TENDL-2023 LIBRARY; T=0.K  
Threshold reactions

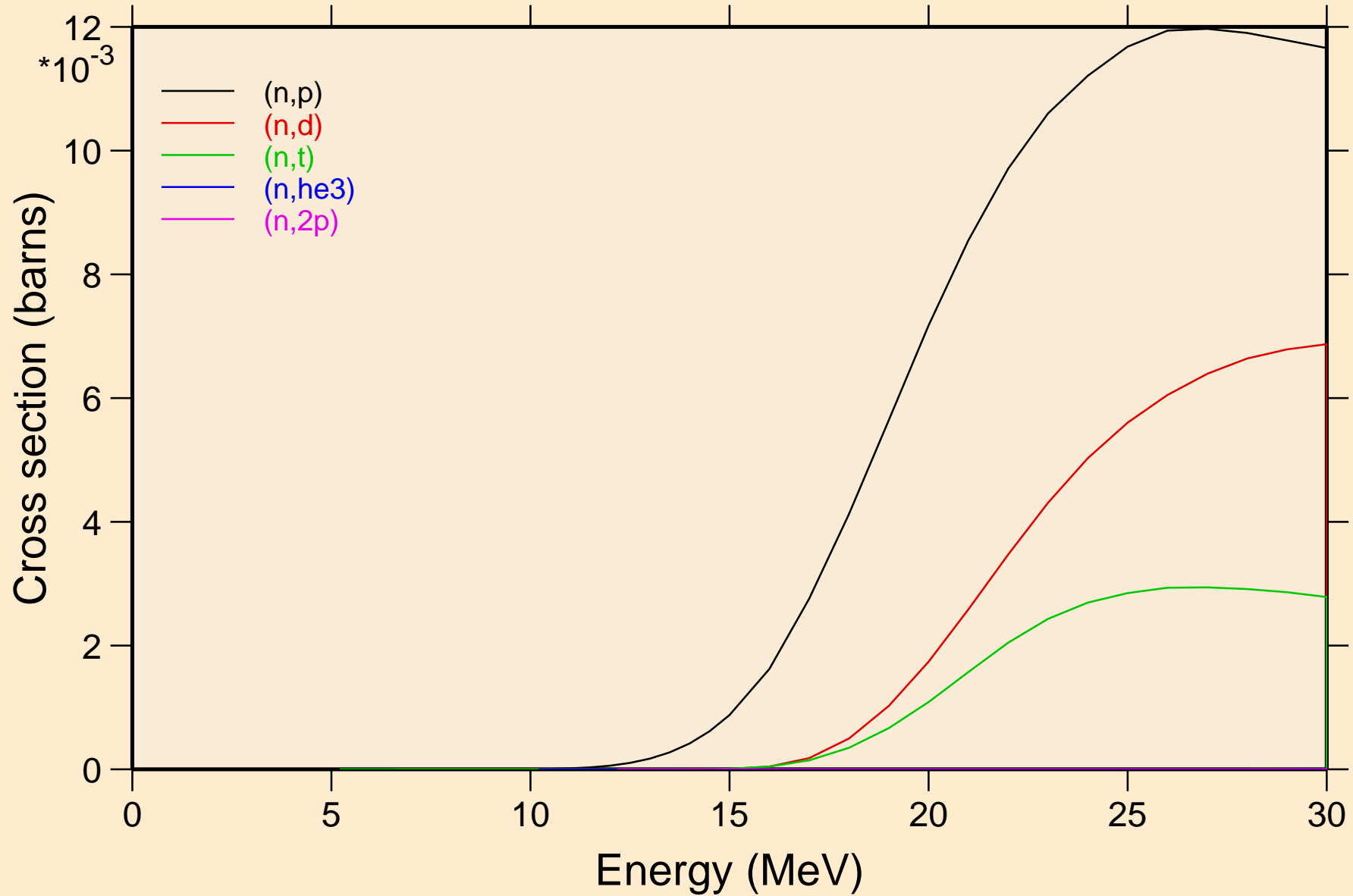



PT203M NEUTRON ACER TENDL-2023 LIBRARY; T=0.K  
Threshold reactions

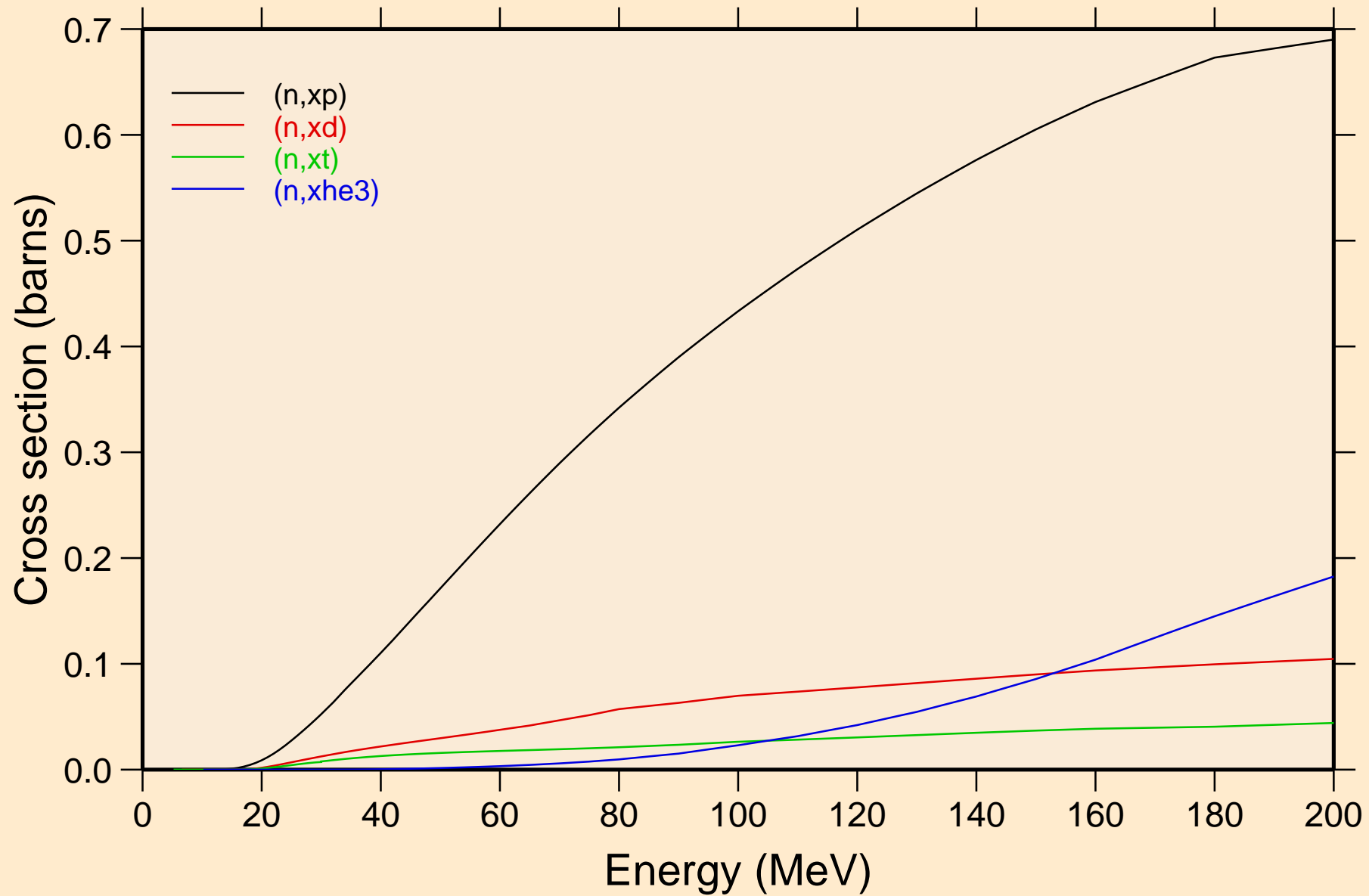

PT203M NEUTRON ACER TENDL-2023 LIBRARY; T=0.K  
angular distribution for elastic

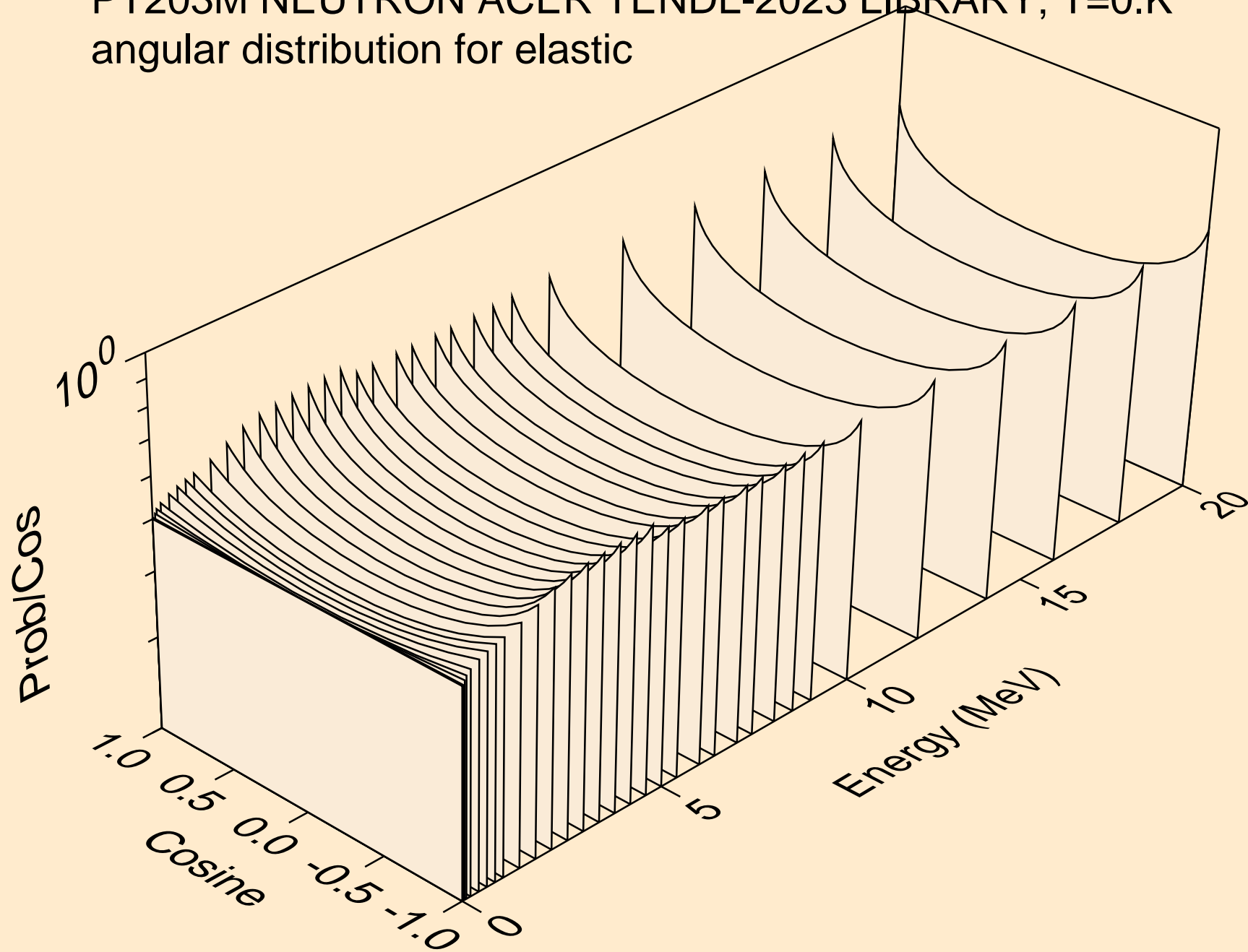

PT203M NEUTRON ACER TENDL-2023 LIBRARY; T=0.K  
angular distribution for elastic

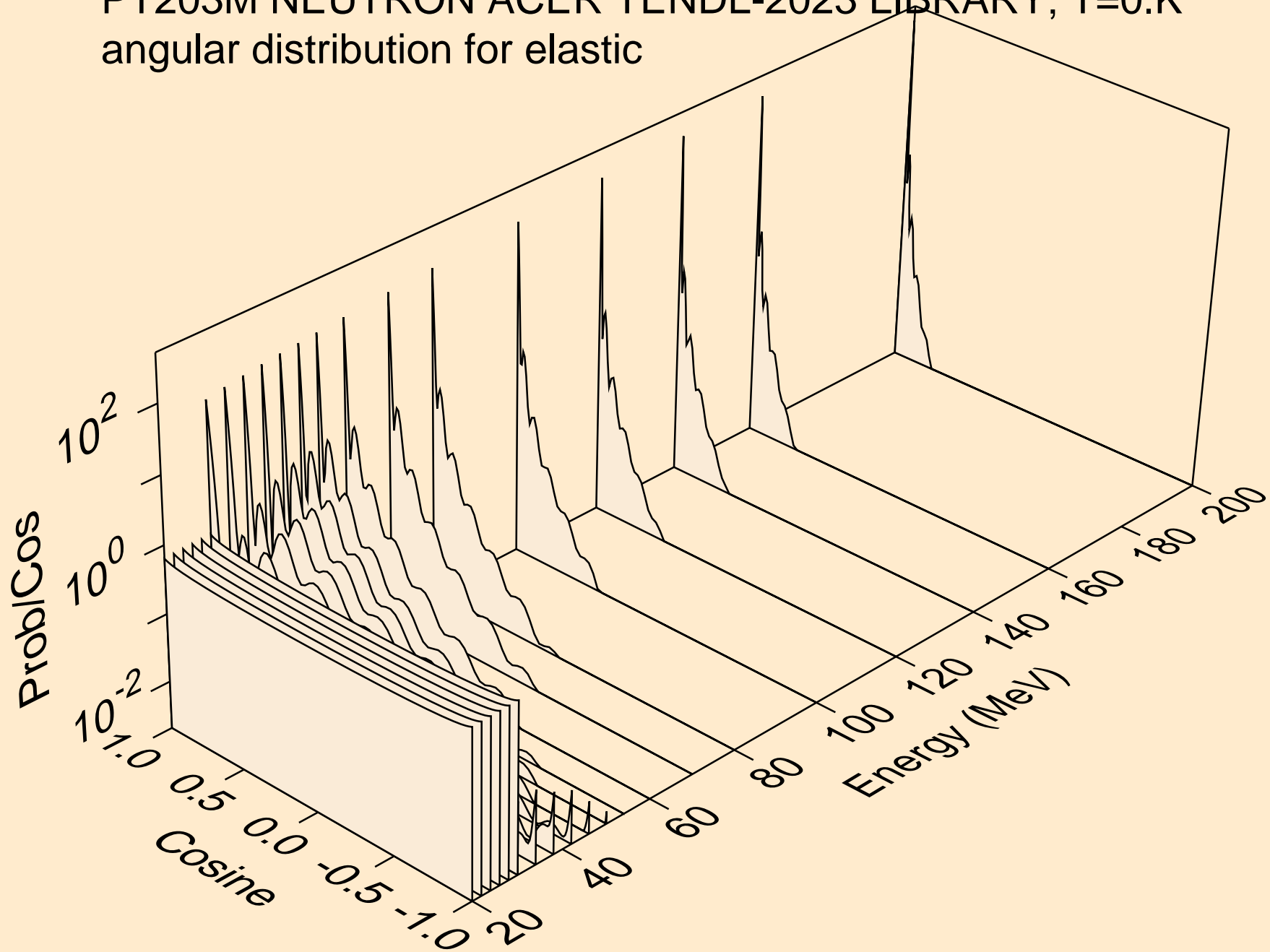

PT203M NEUTRON ACER TENDL-2023 LIBRARY; T=0.K  
angular distribution for (n,n\*1)

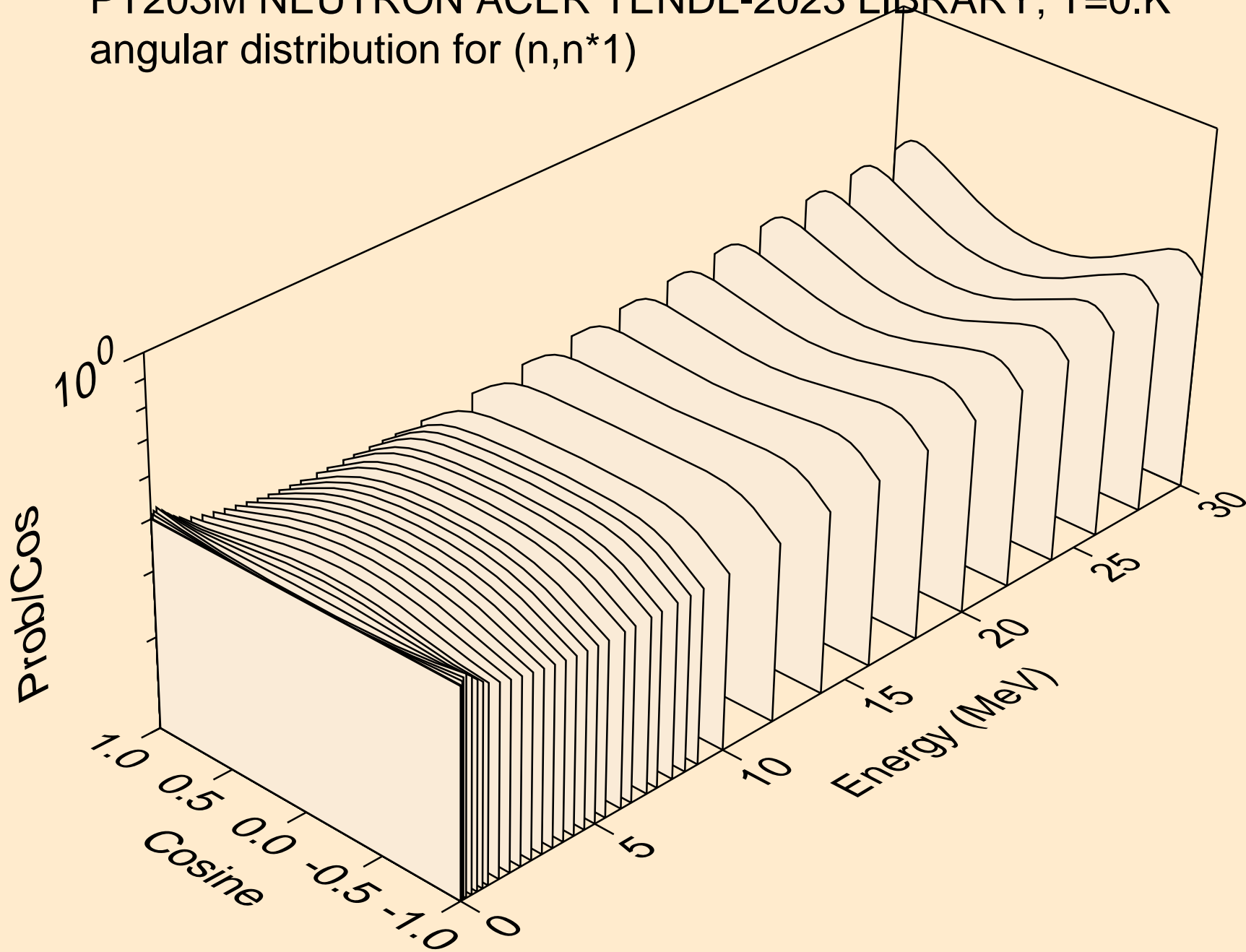

PT203M NEUTRON ACER TENDL-2023 LIBRARY; T=0.K  
angular distribution for (n,n\*2)

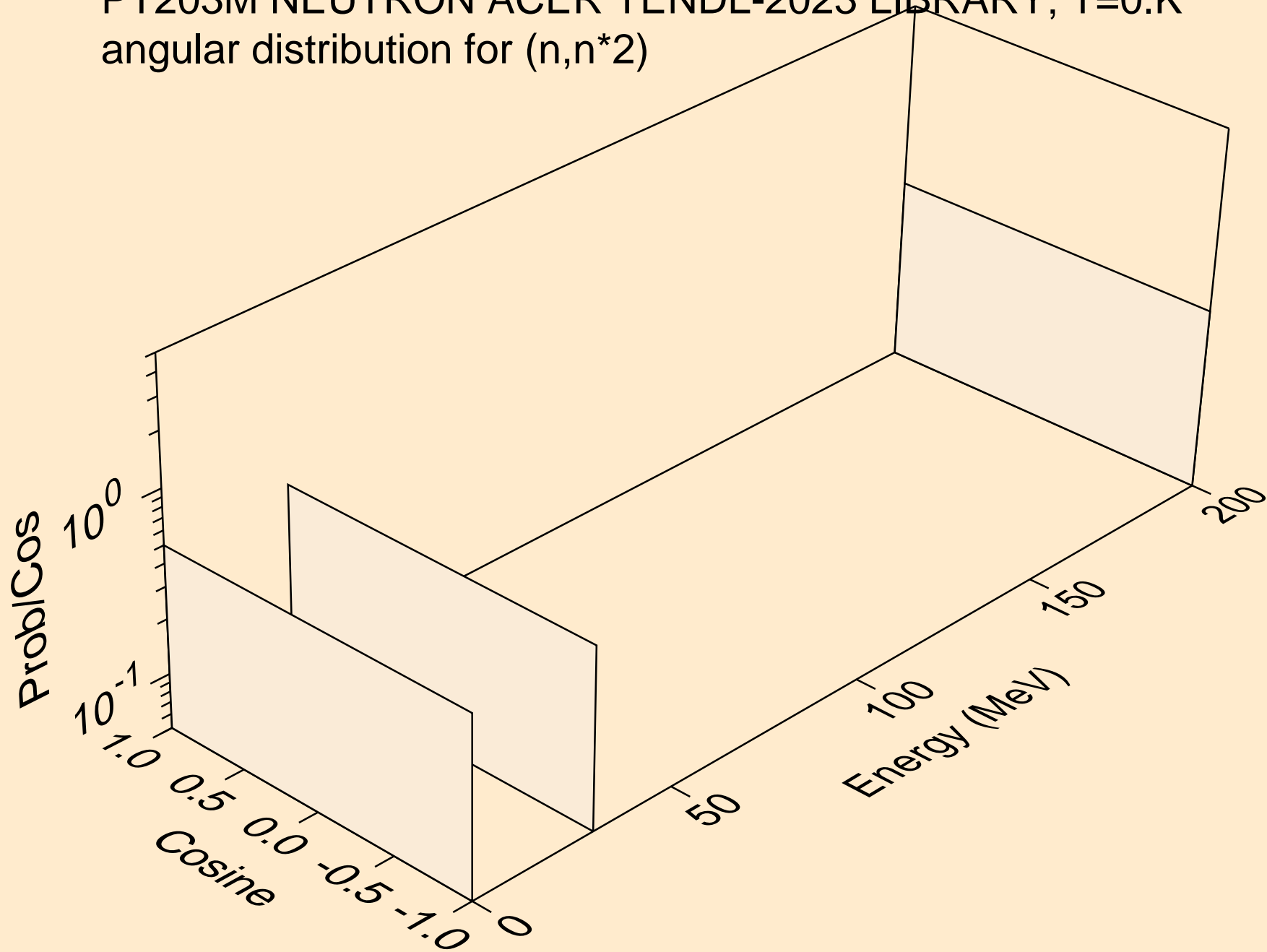

PT203M NEUTRON ACER TENDL-2023 LIBRARY; T=0.K  
angular distribution for (n,n\*3)

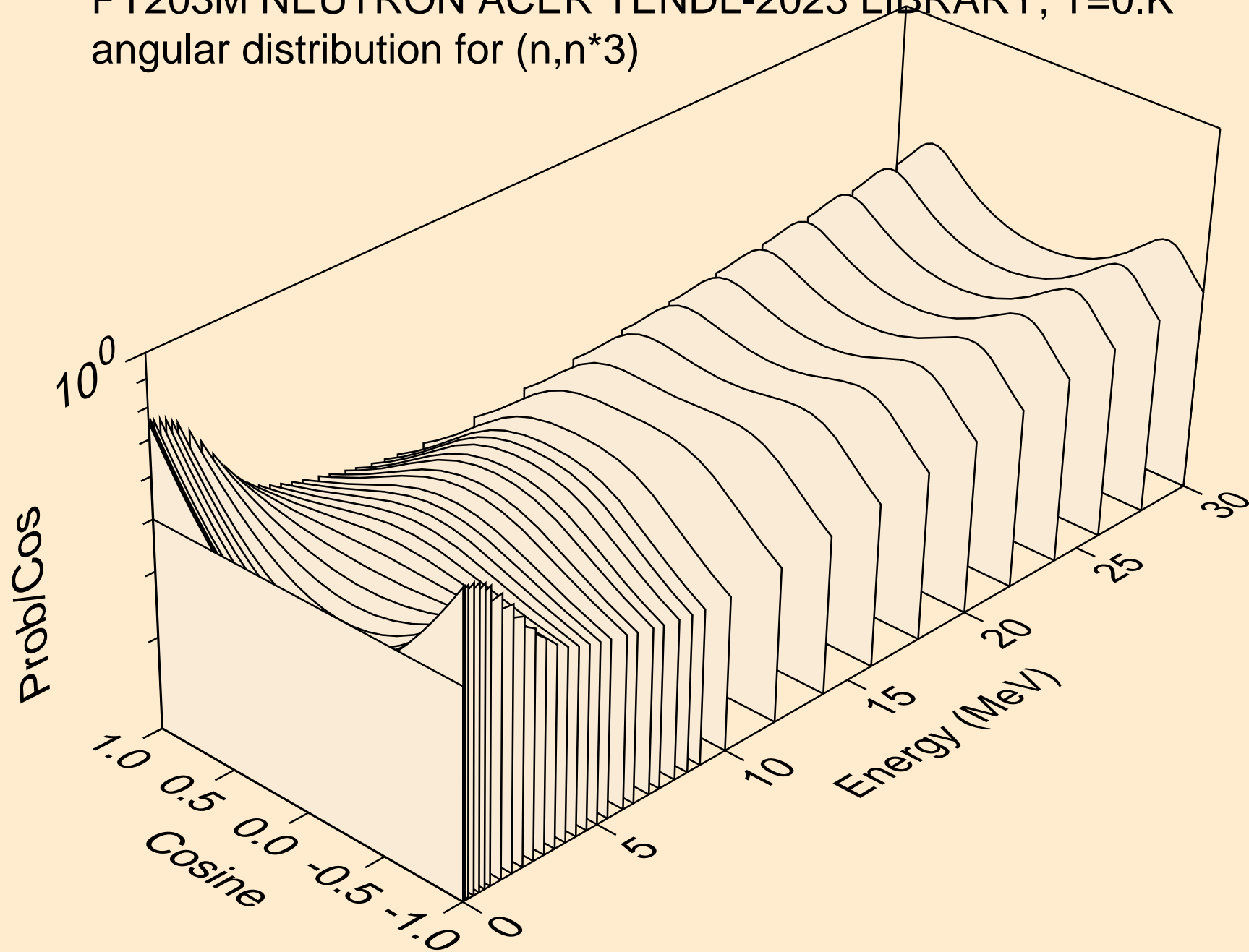

PT203M NEUTRON ACER TENDL-2023 LIBRARY; T=0.K  
angular distribution for (n,n\*4)

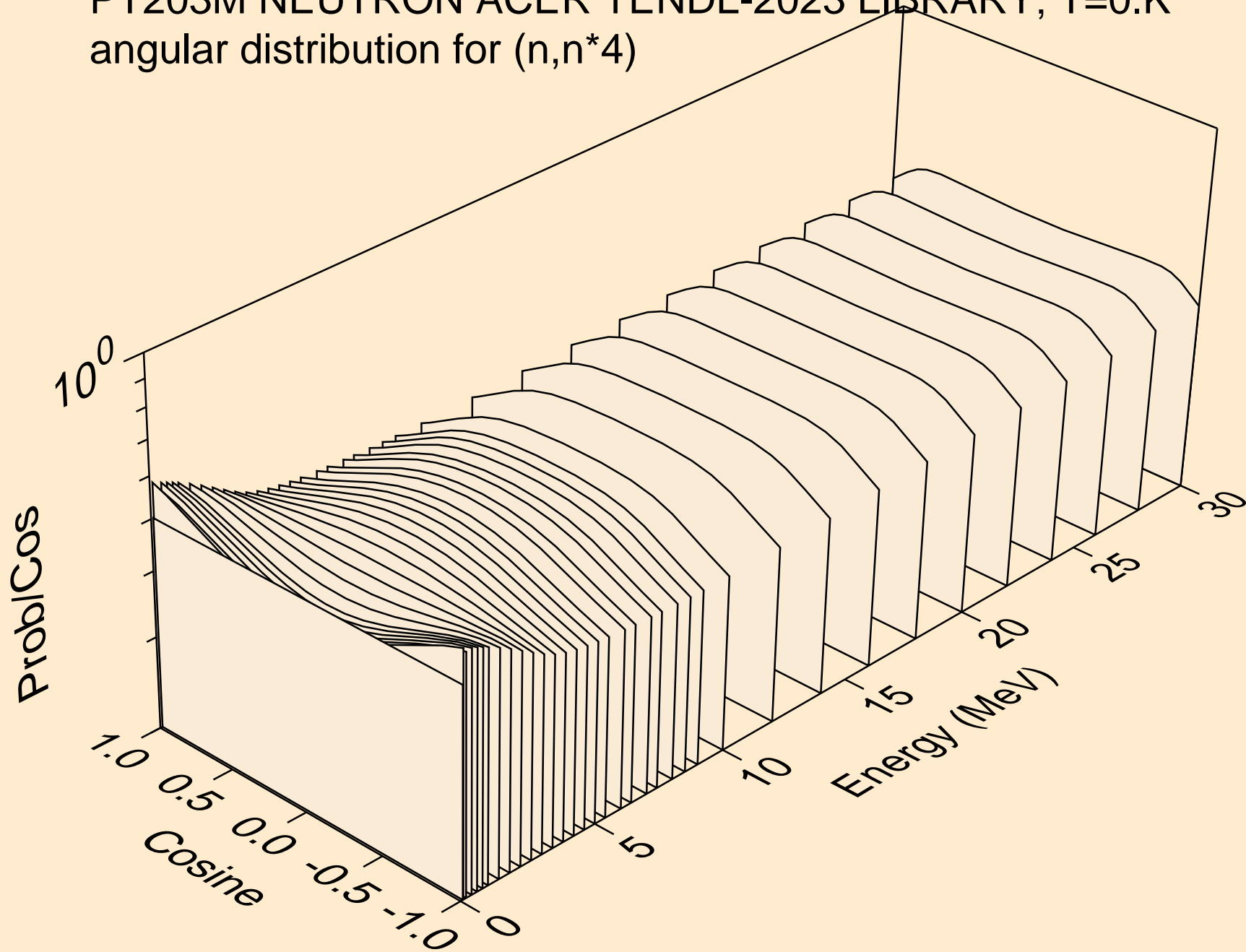

PT203M NEUTRON ACER TENDL-2023 LIBRARY; T=0.K  
angular distribution for (n,n\*5)

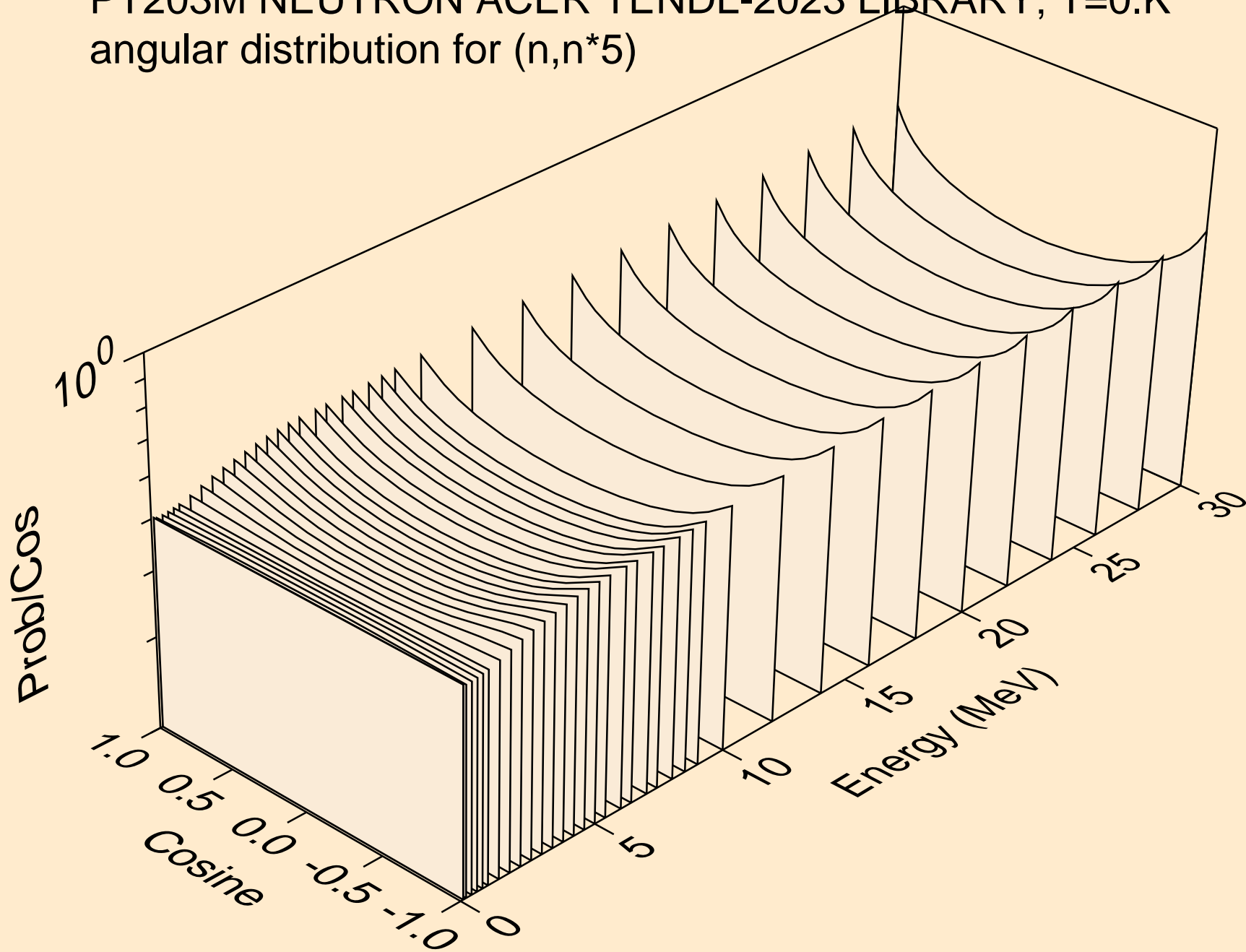



PT203M NEUTRON ACER TENDL-2023 LIBRARY; T=0.K  
angular distribution for (n,n\*6)

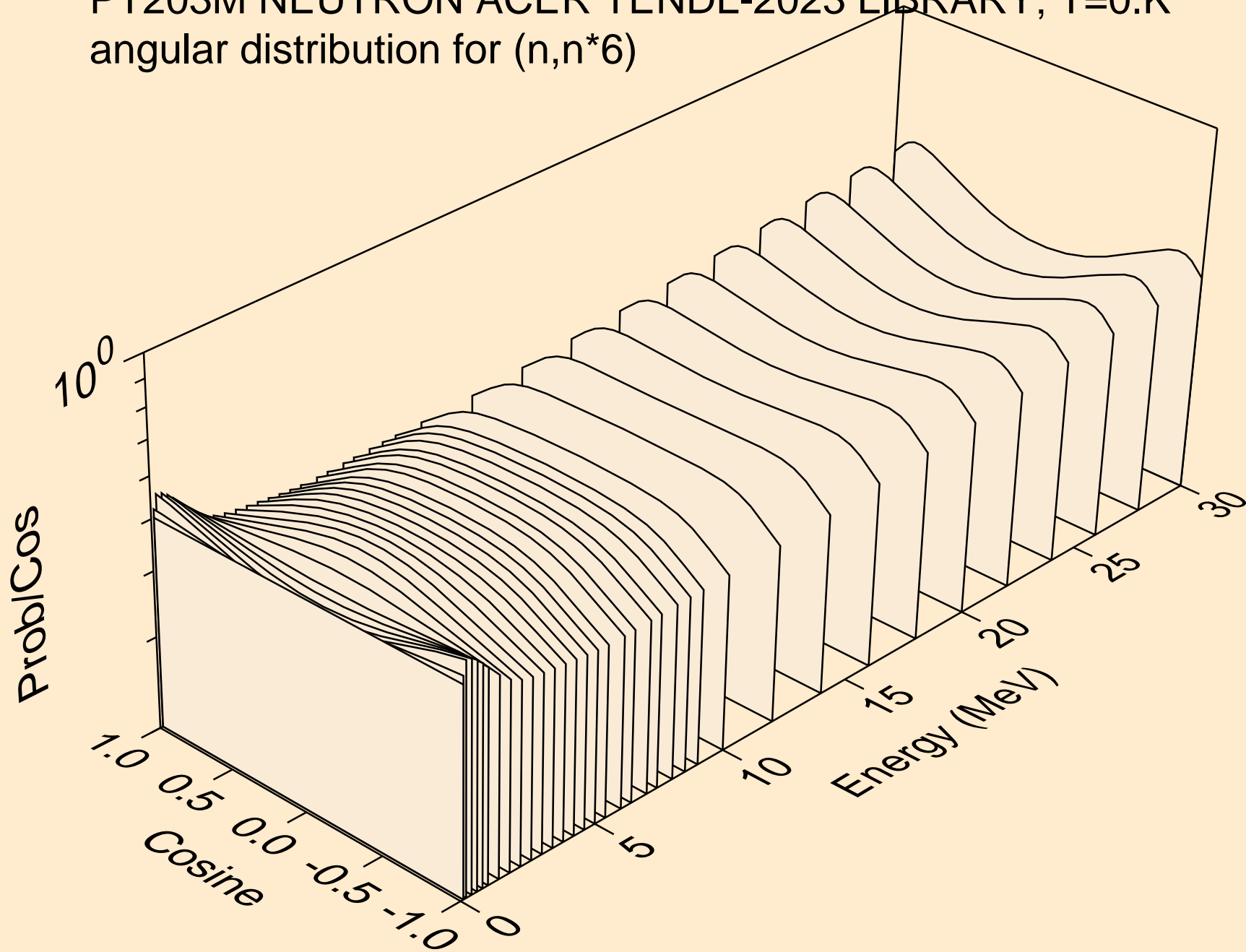

PT203M NEUTRON ACER TENDL-2023 LIBRARY; T=0.K  
angular distribution for (n,n\*7)

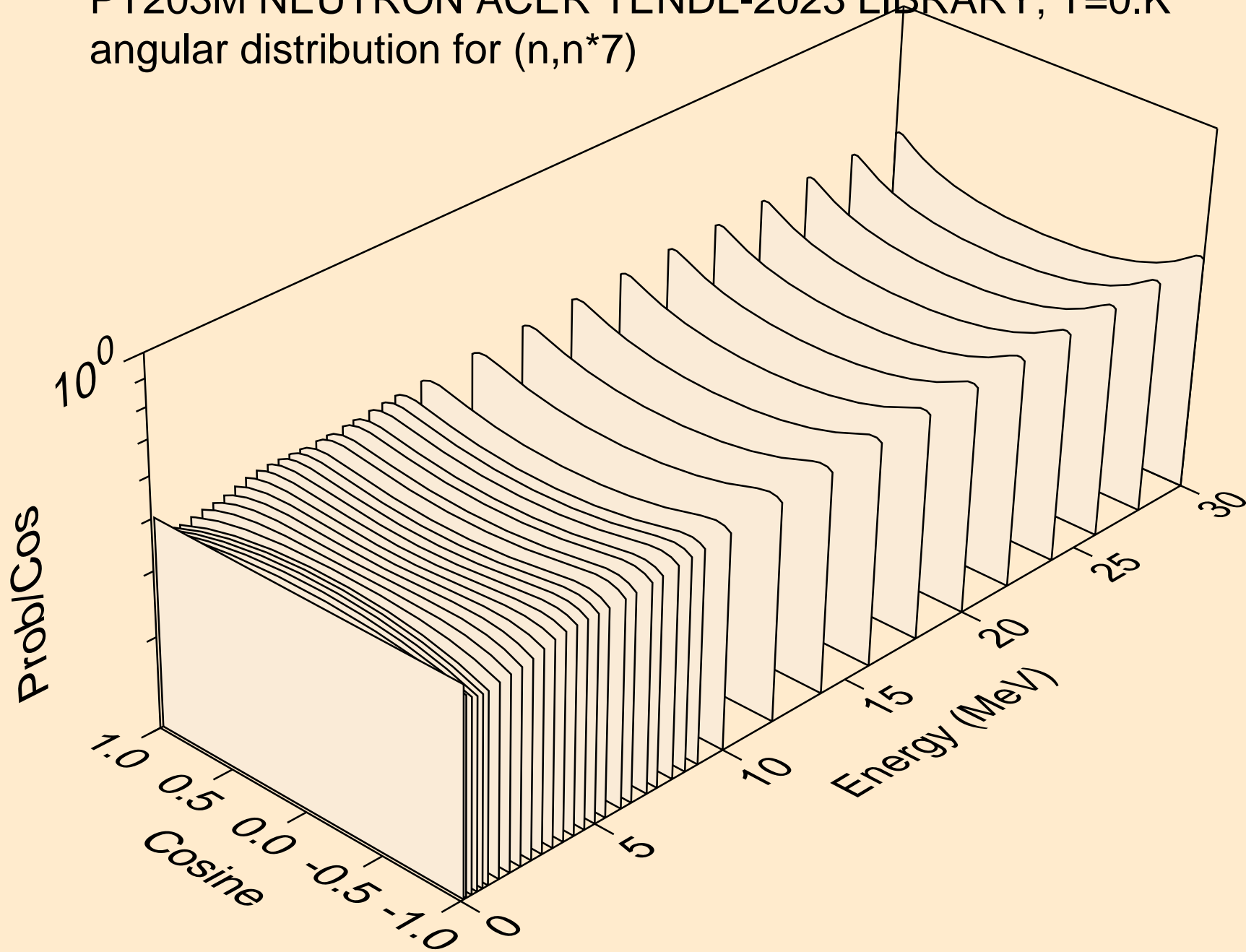

PT203M NEUTRON ACER TENDL-2023 LIBRARY; T=0.K  
angular distribution for (n,n\*8)

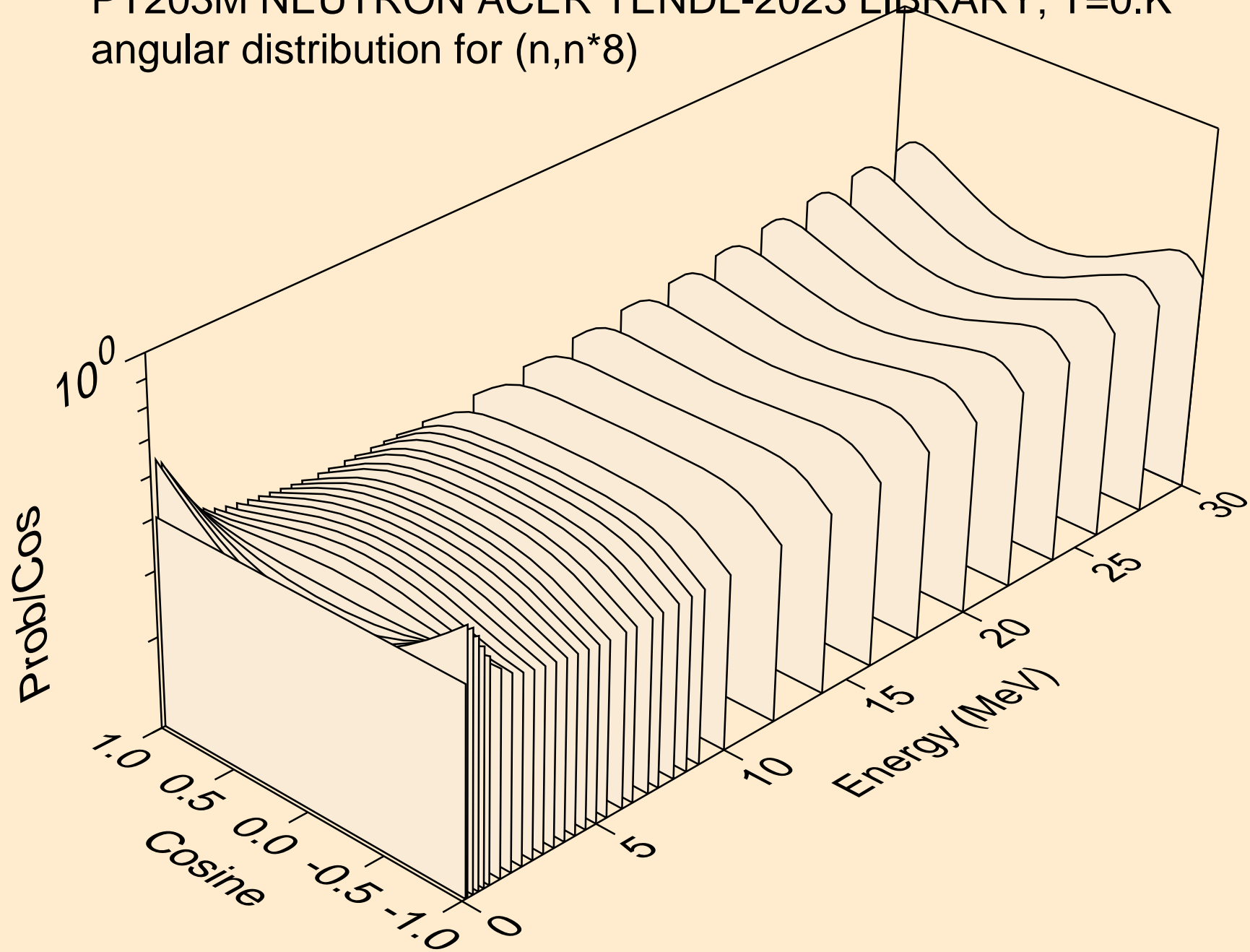

PT203M NEUTRON ACER TENDL-2023 LIBRARY; T=0.K  
angular distribution for (n,n\*9)

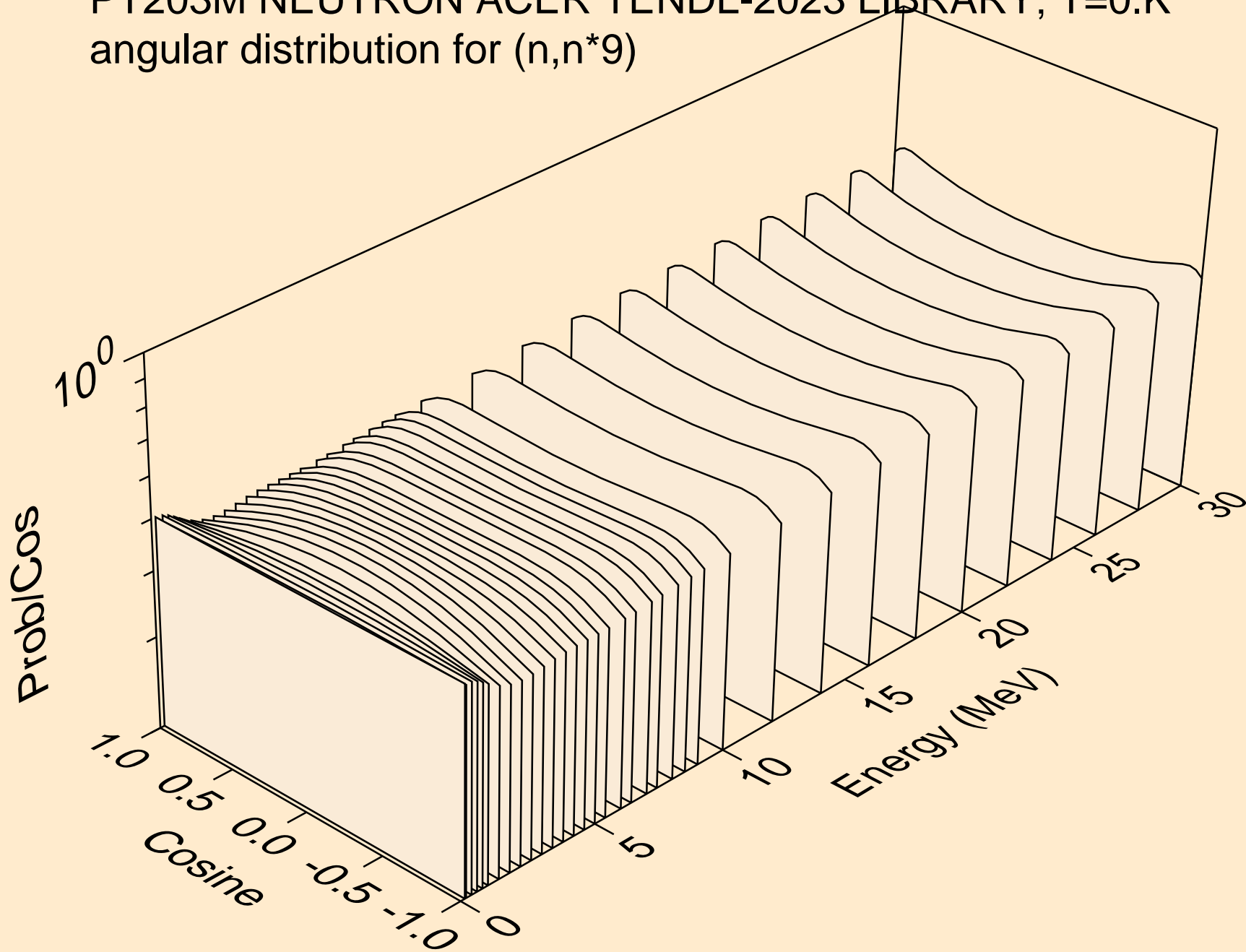

PT203M NEUTRON ACER TENDL-2023 LIBRARY; T=0.K  
angular distribution for (n,n\*10)

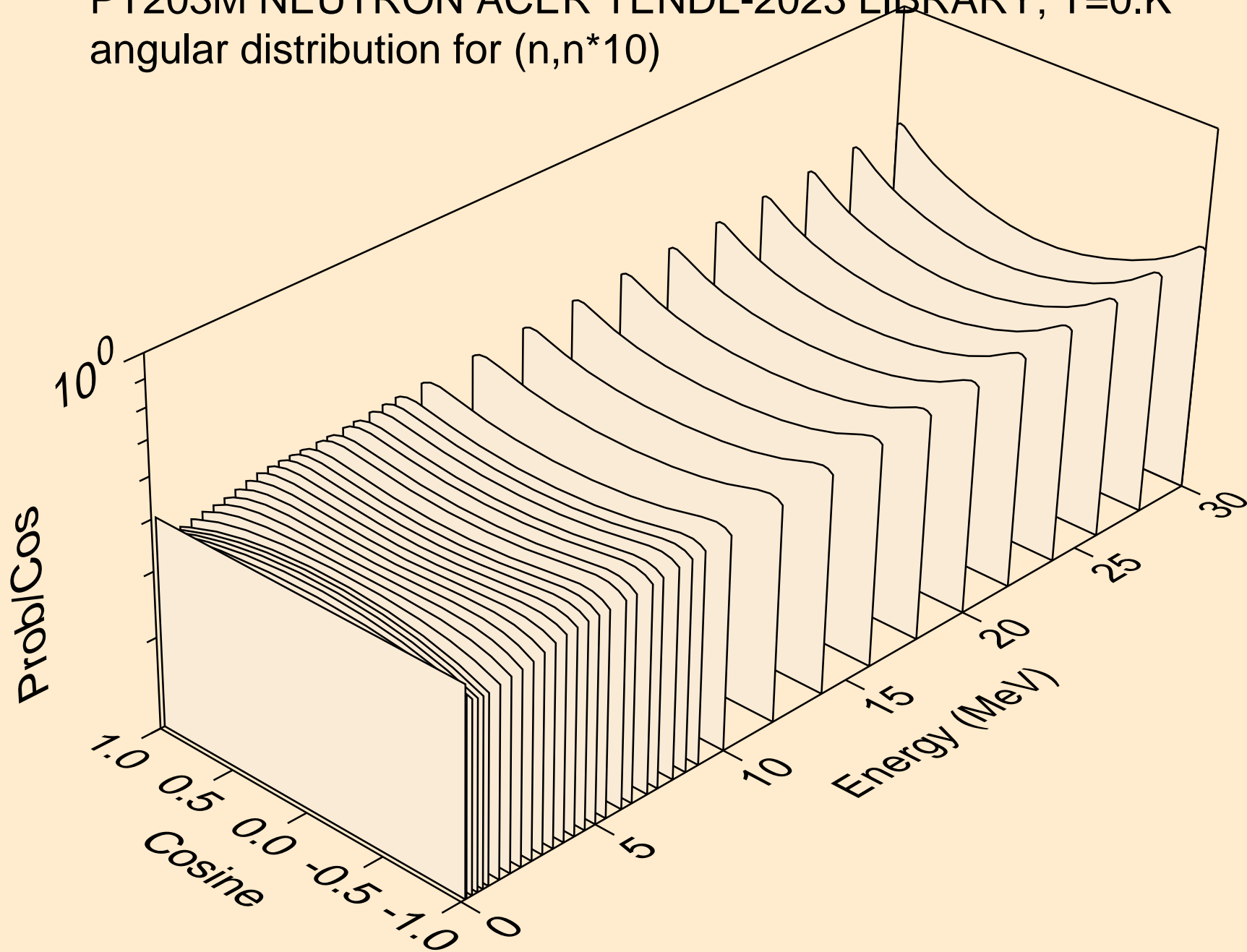

PT203M NEUTRON ACER TENDL-2023 LIBRARY; T=0.K  
angular distribution for (n,n\*11)

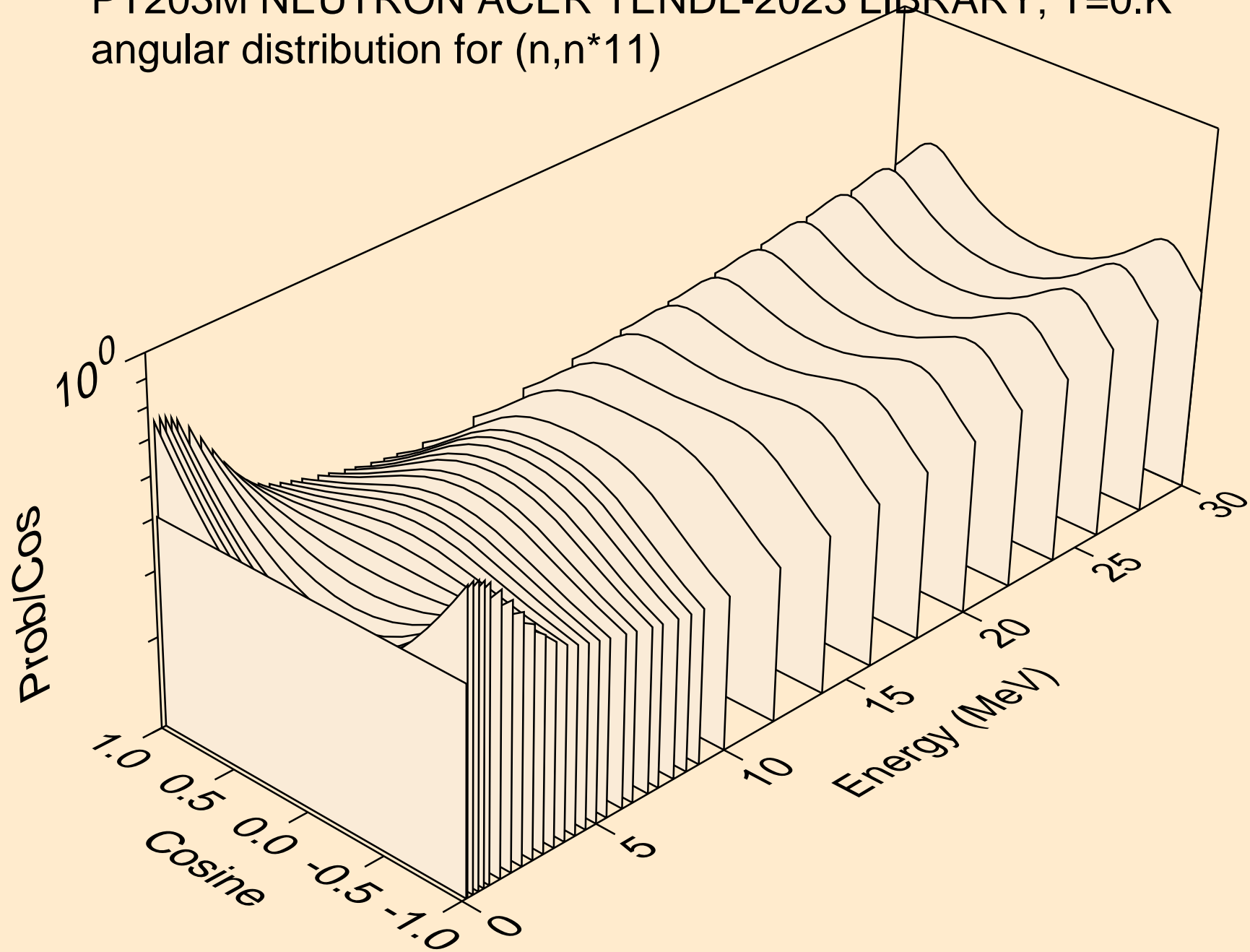

PT203M NEUTRON ACER TENDL-2023 LIBRARY; T=0.K  
angular distribution for (n,n\*12)

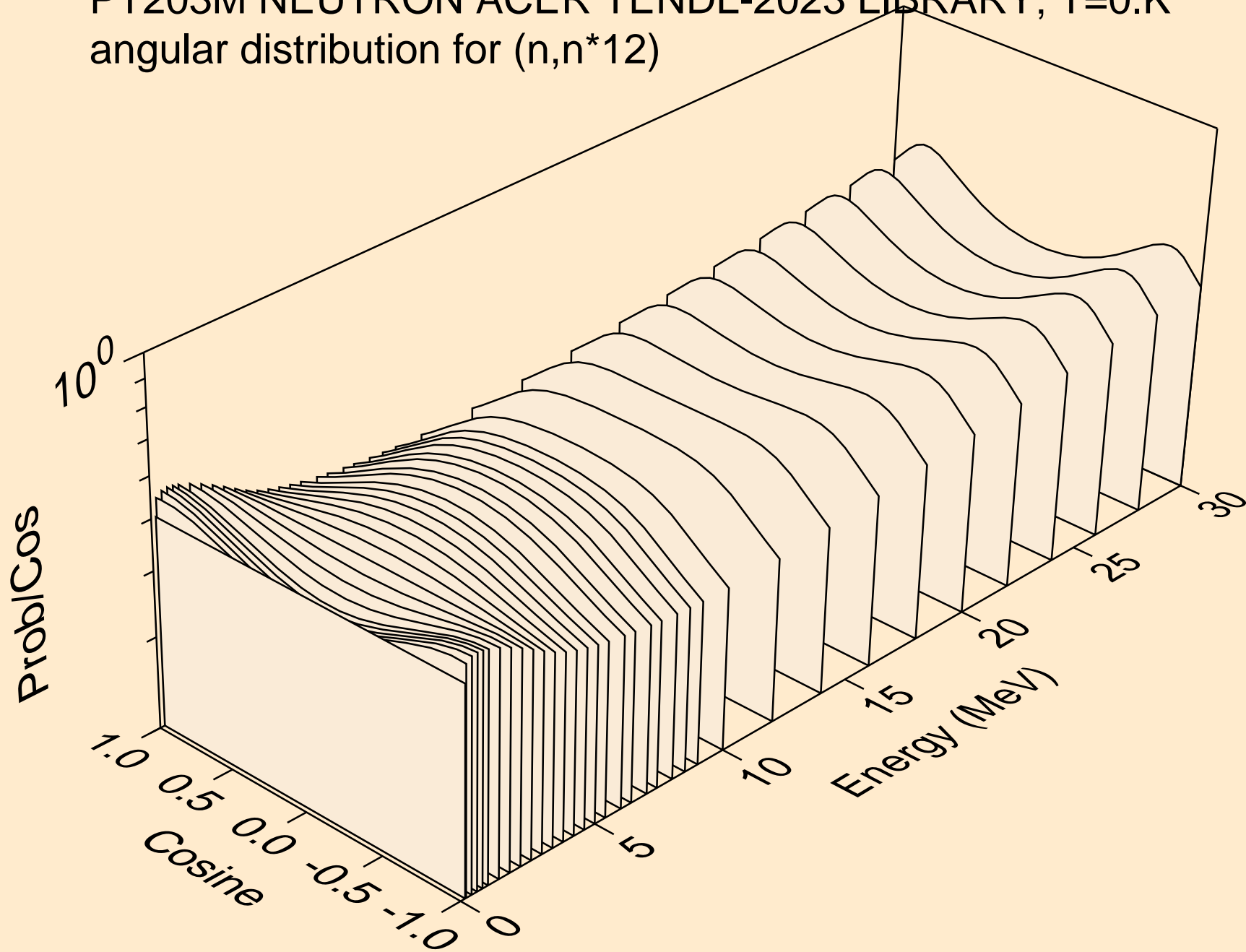

PT203M NEUTRON ACER TENDL-2023 LIBRARY; T=0.K  
angular distribution for (n,n\*13)

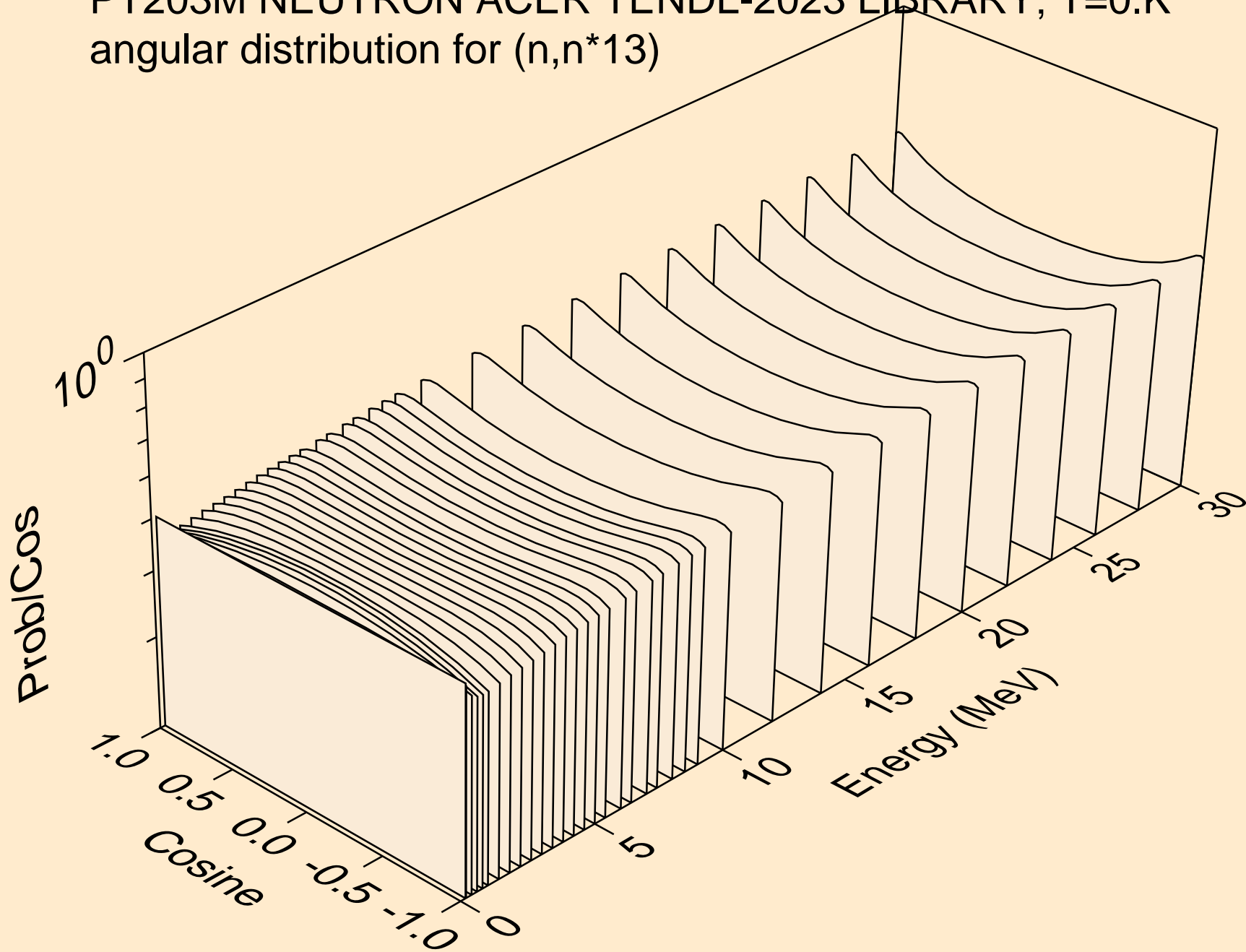



PT203M NEUTRON ACER TENDL-2023 LIBRARY; T=0.K  
angular distribution for (n,n\*14)

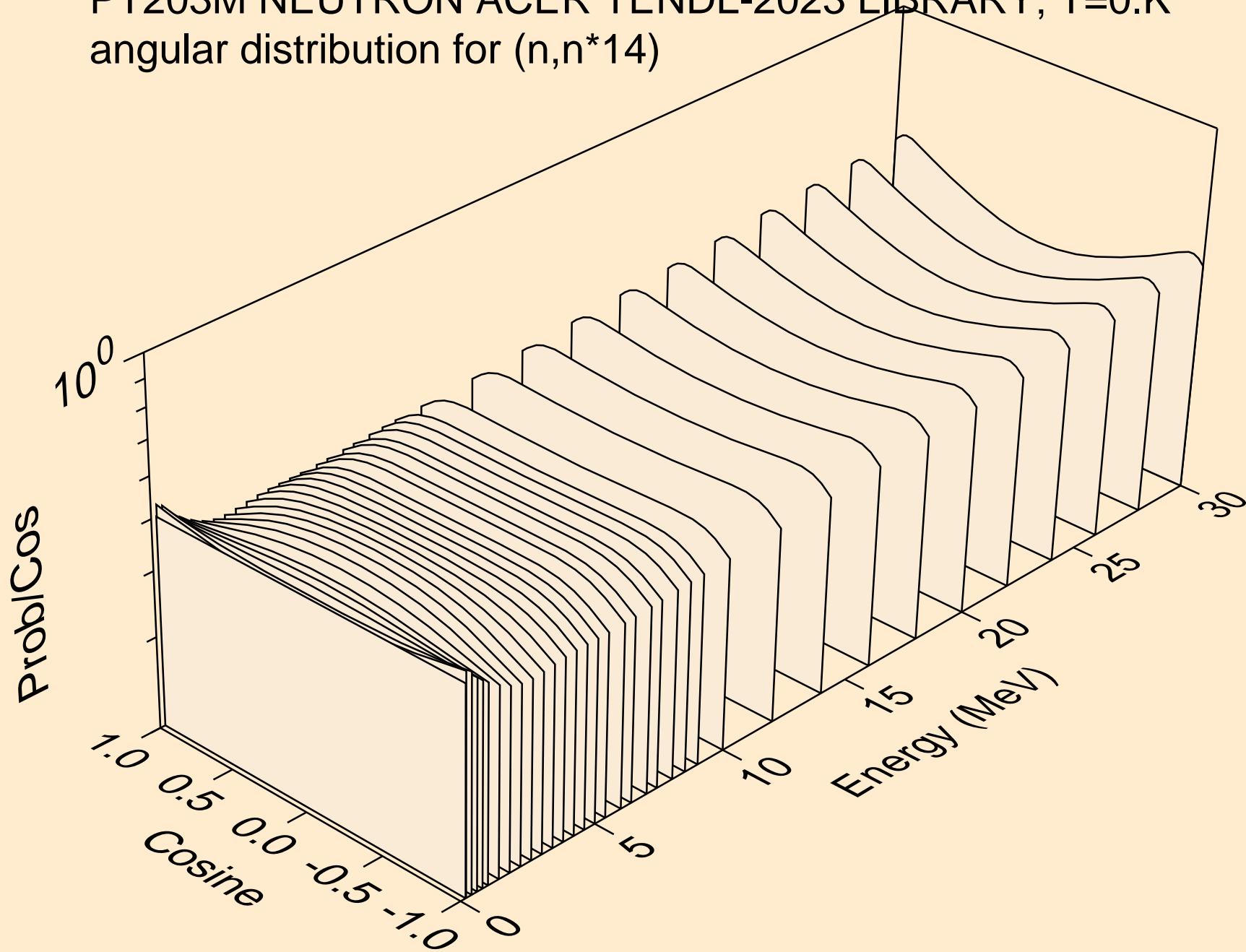

PT203M NEUTRON ACER TENDL-2023 LIBRARY; T=0.K  
angular distribution for (n,n\*15)

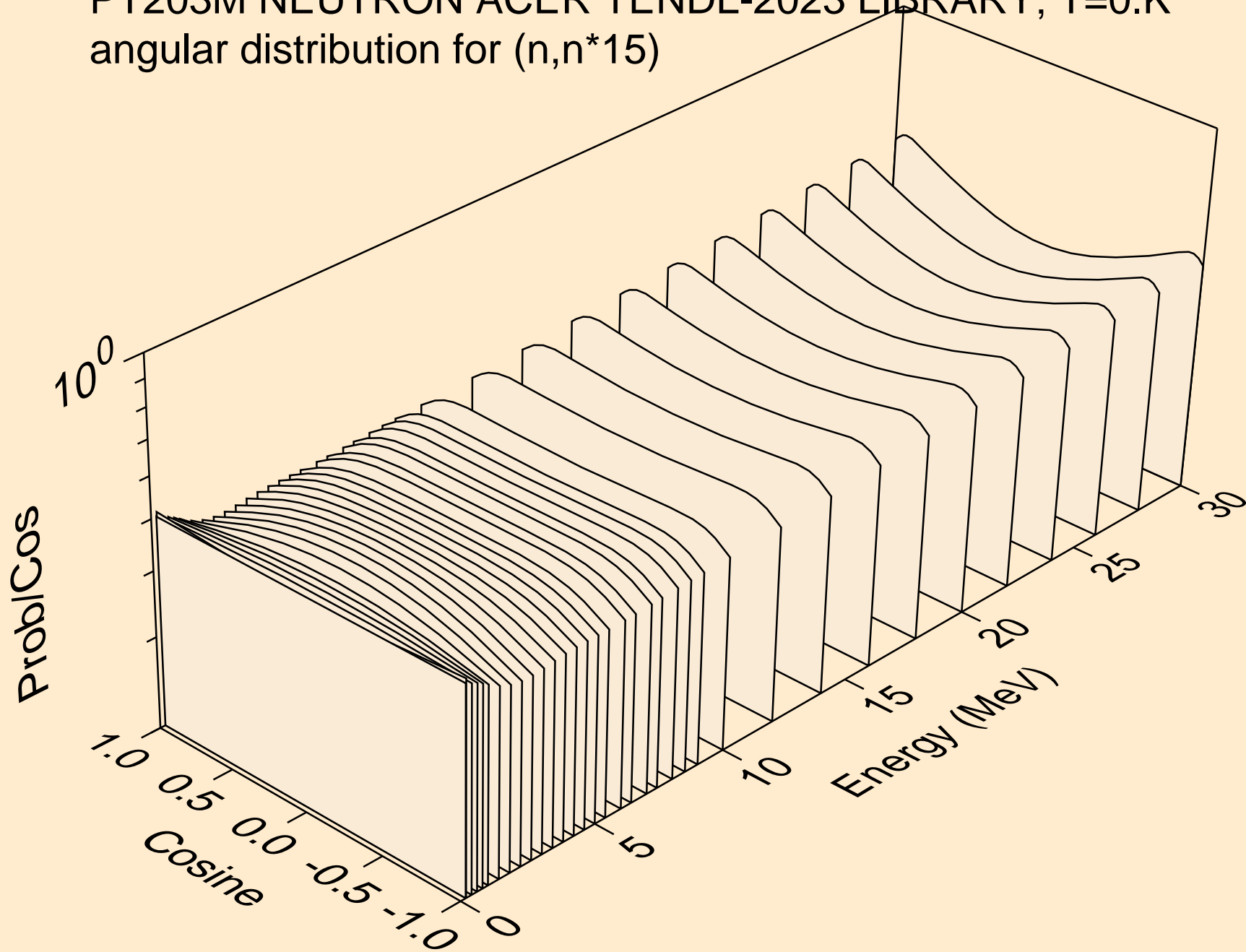

PT203M NEUTRON ACER TENDL-2023 LIBRARY; T=0.K  
angular distribution for (n,n\*16)

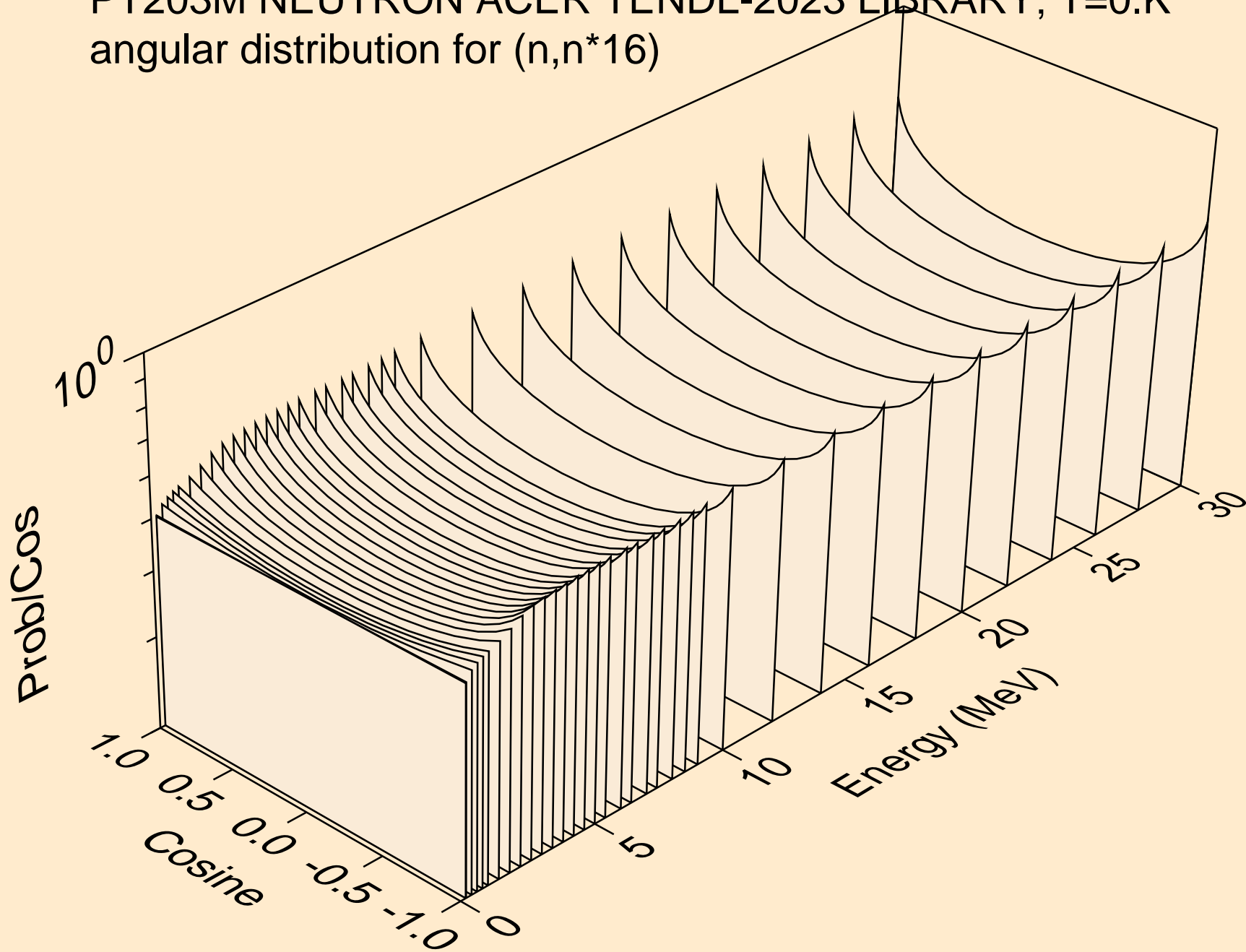

PT203M NEUTRON ACER TENDL-2023 LIBRARY; T=0.K  
angular distribution for (n,n\*17)

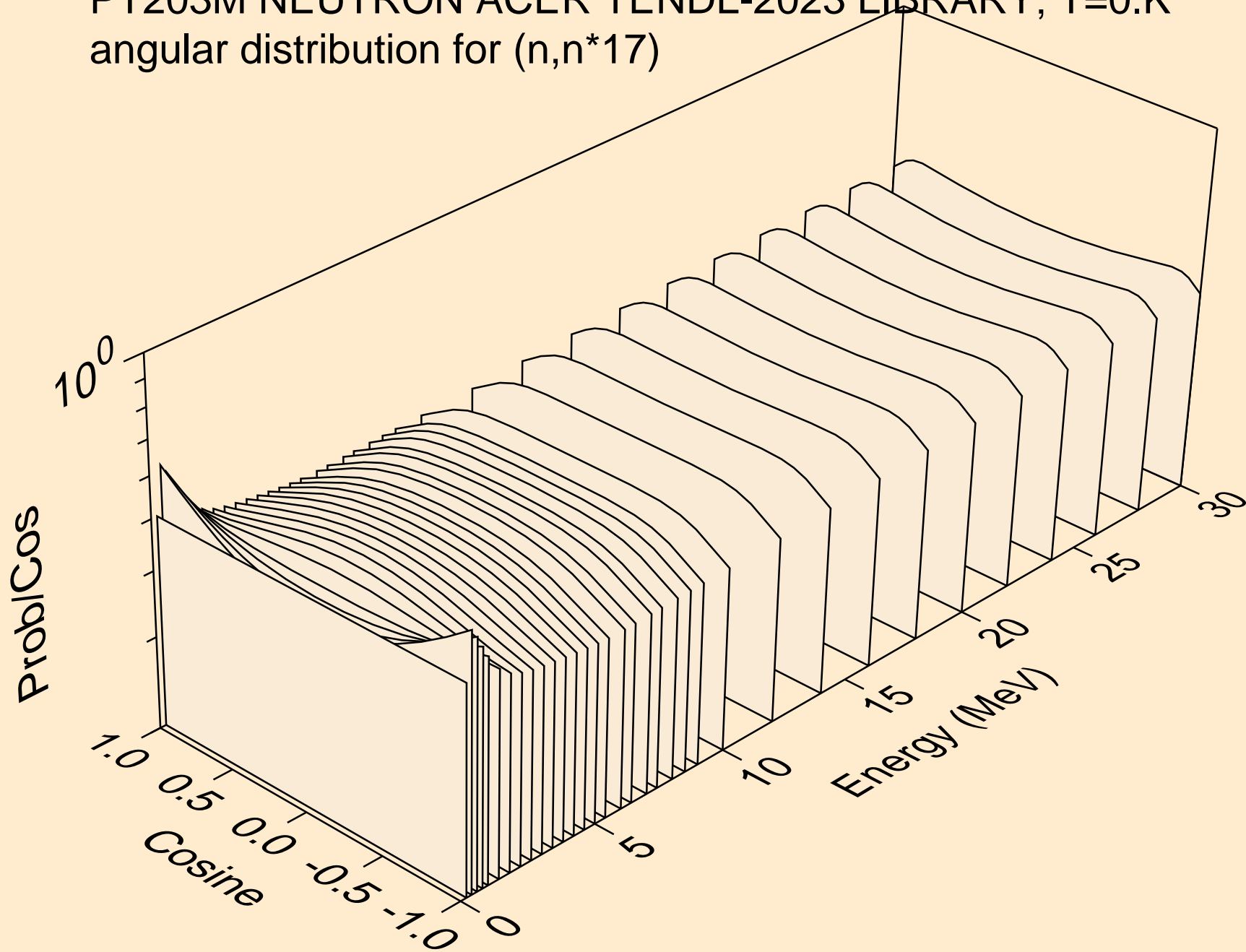

PT203M NEUTRON ACER TENDL-2023 LIBRARY; T=0.K  
angular distribution for (n,n\*18)

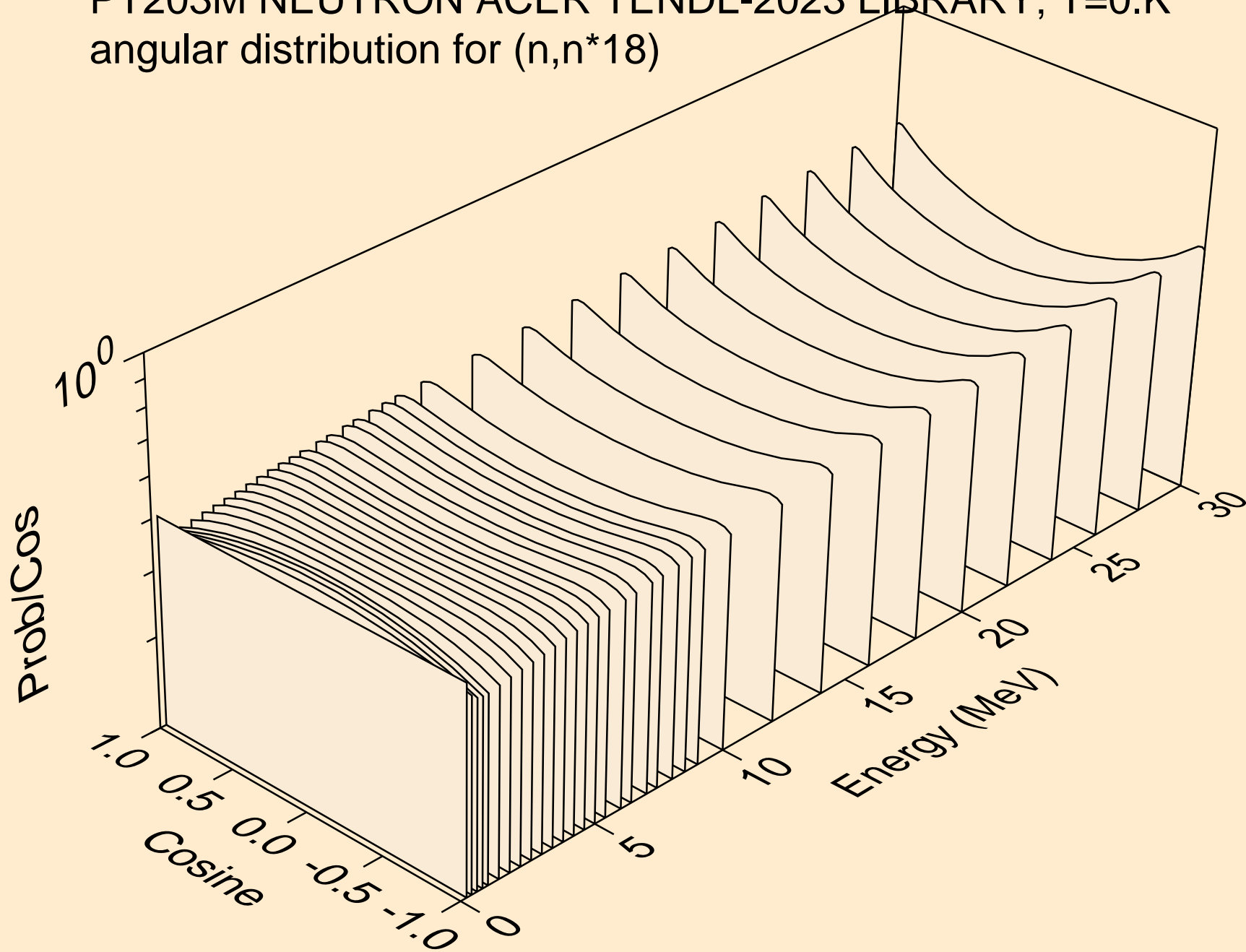

PT203M NEUTRON ACER TENDL-2023 LIBRARY; T=0.K  
angular distribution for (n,n\*19)

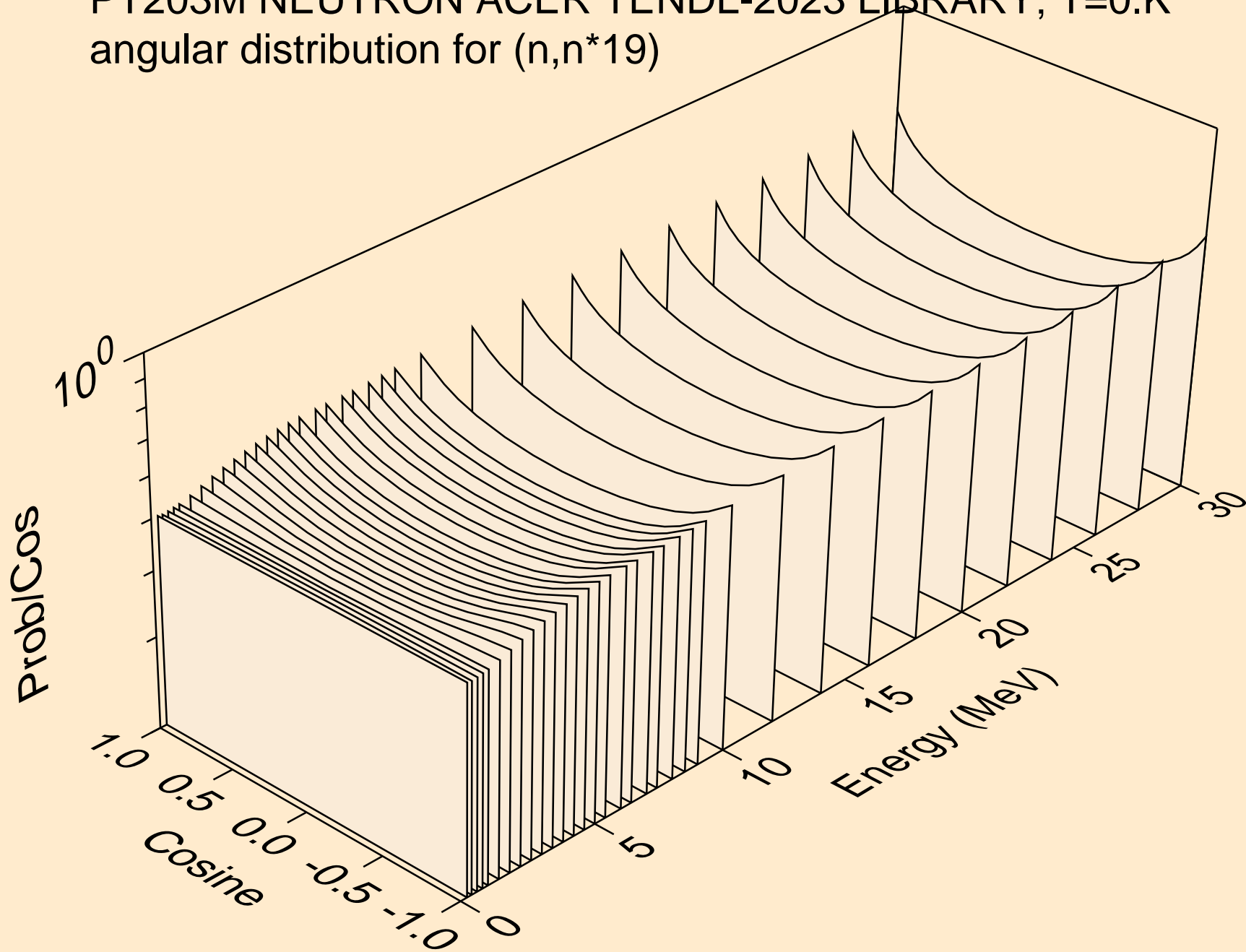

PT203M NEUTRON ACER TENDL-2023 LIBRARY; T=0.K  
angular distribution for (n,n\*20)

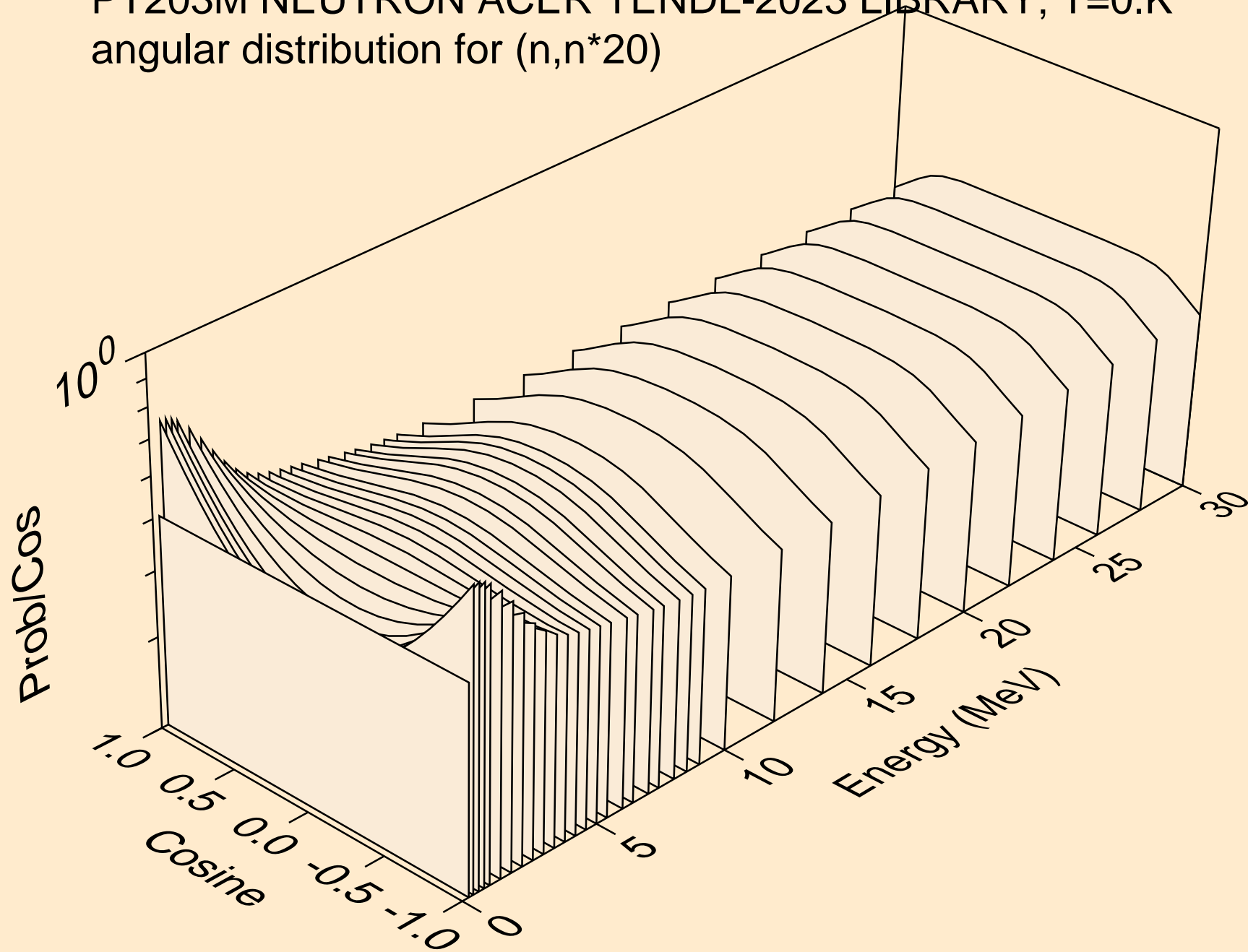

PT203M NEUTRON ACER TENDL-2023 LIBRARY; T=0.K  
angular distribution for (n,n\*21)

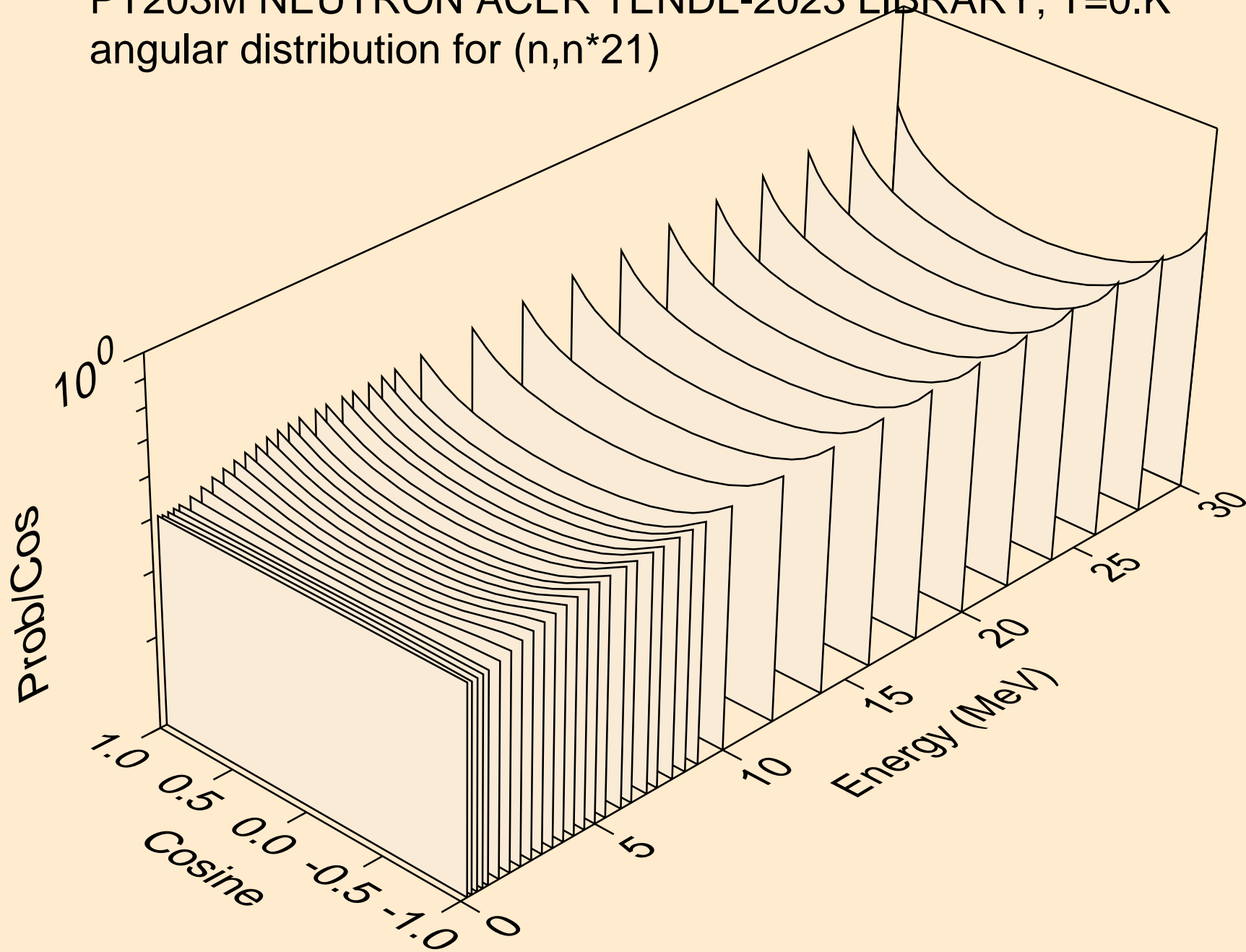



PT203M NEUTRON ACER TENDL-2023 LIBRARY; T=0.K  
angular distribution for (n,n\*22)

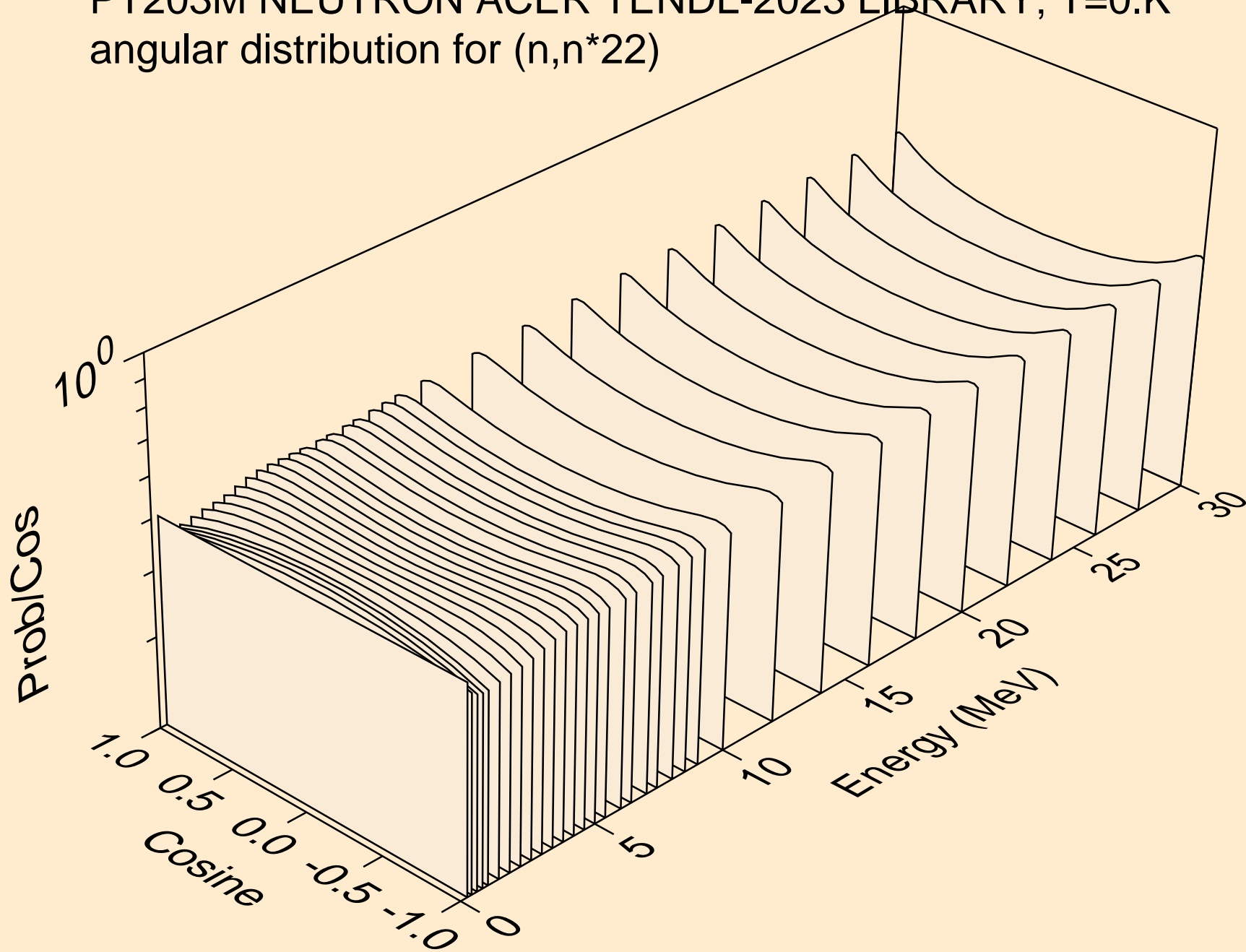

PT203M NEUTRON ACER TENDL-2023 LIBRARY; T=0.K  
angular distribution for (n,n\*23)

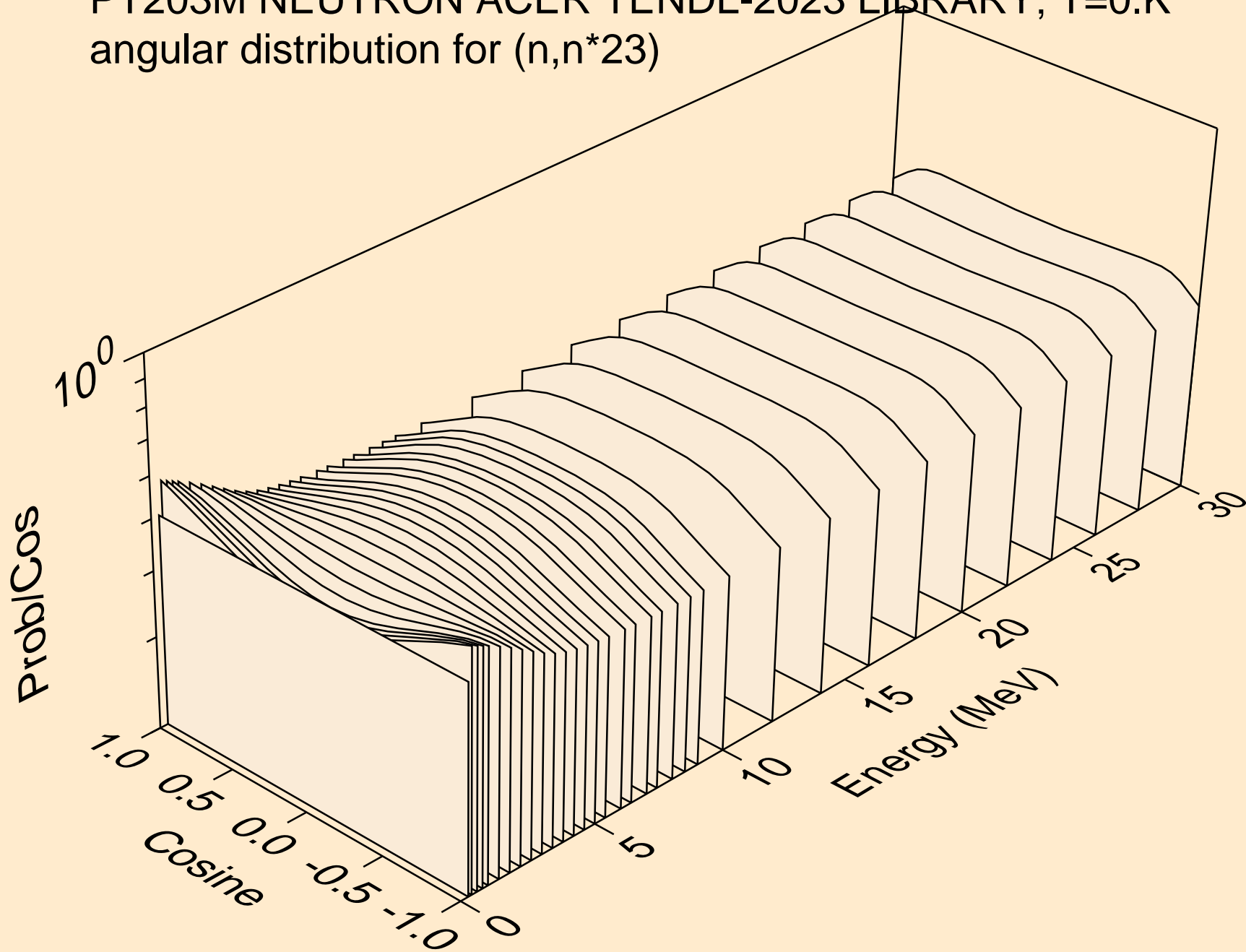

PT203M NEUTRON ACER TENDL-2023 LIBRARY; T=0.K  
angular distribution for (n,n\*24)

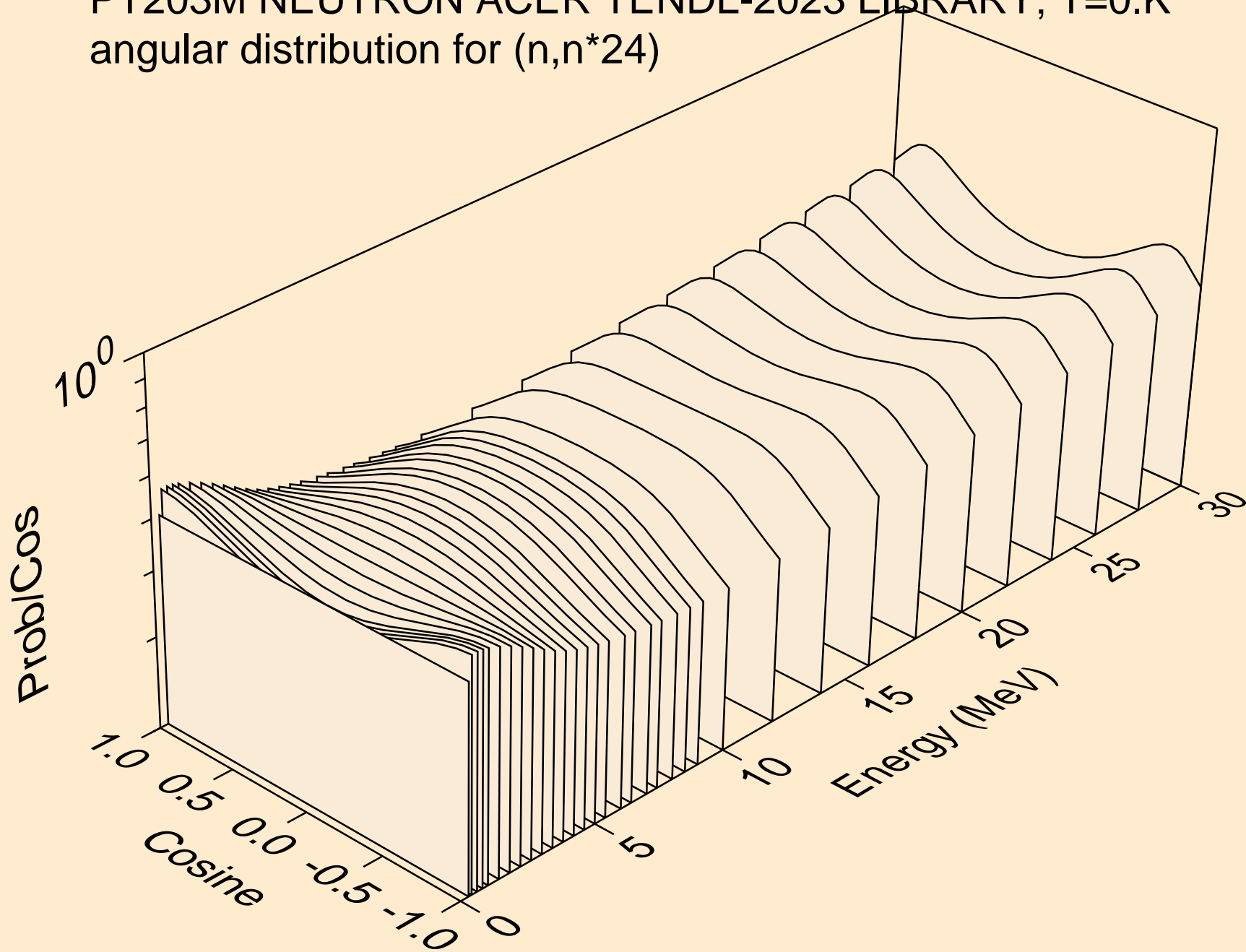

PT203M NEUTRON ACER TENDL-2023 LIBRARY; T=0.K  
angular distribution for (n,n\*25)

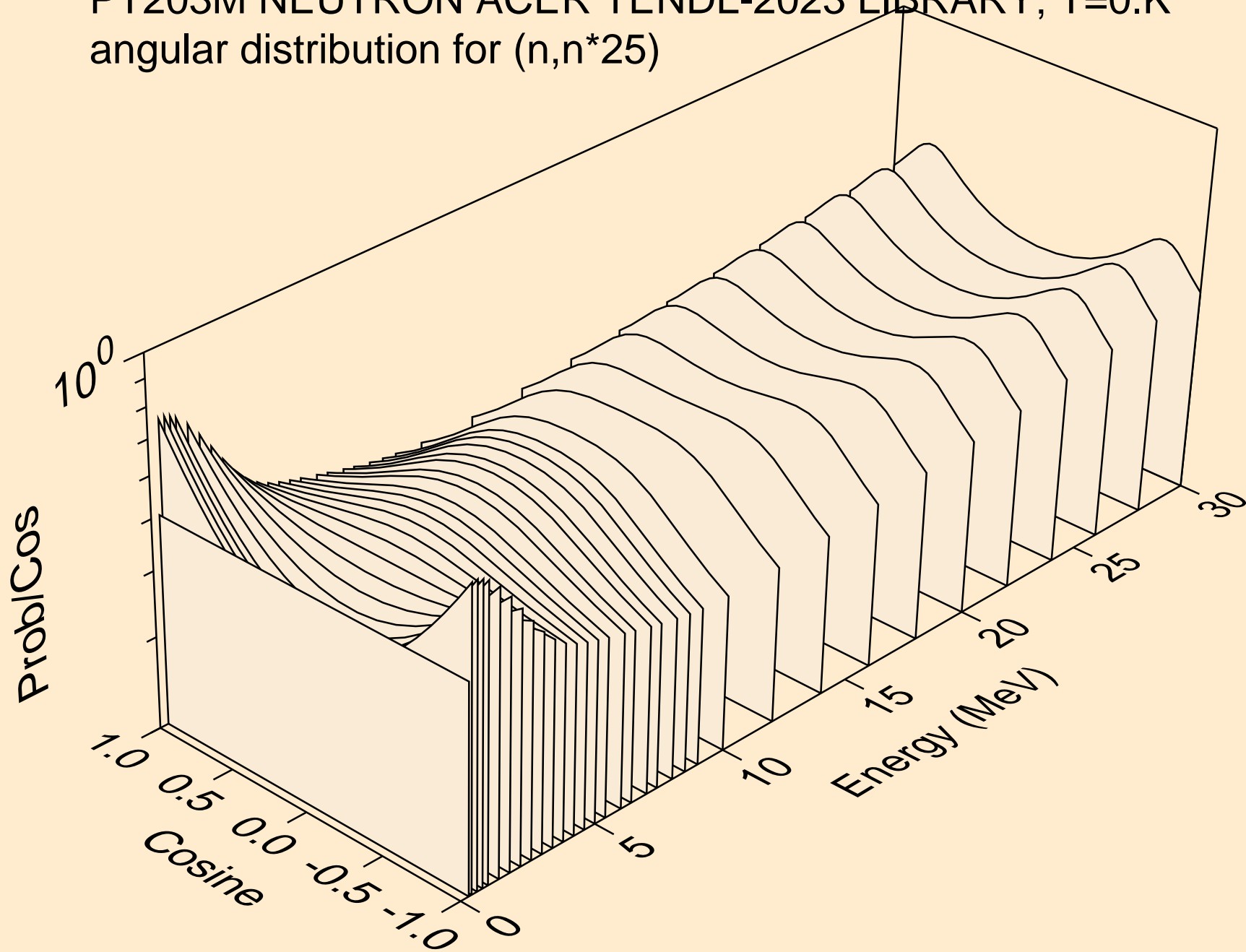

PT203M NEUTRON ACER TENDL-2023 LIBRARY; T=0.K  
angular distribution for (n,n\*26)

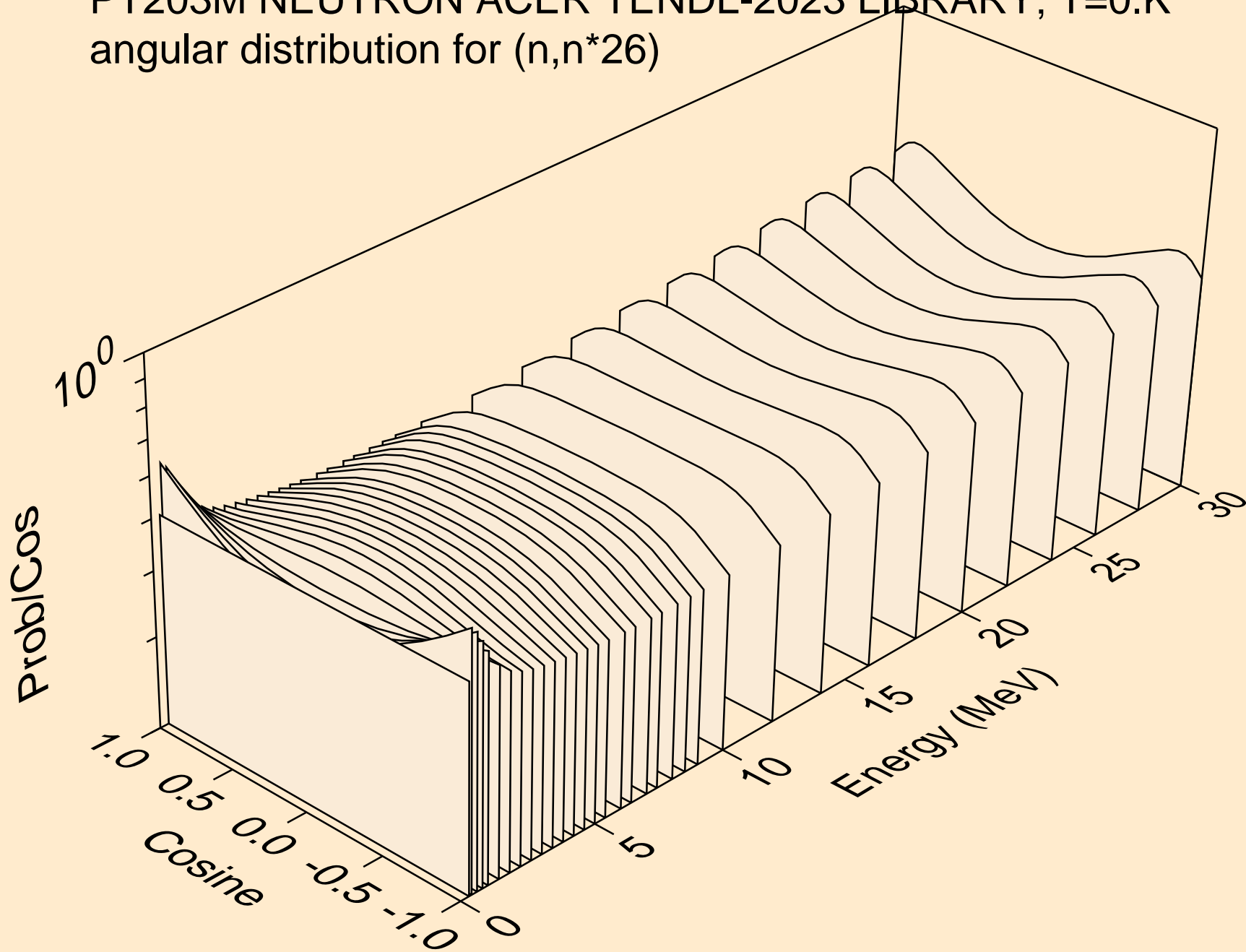

PT203M NEUTRON ACER TENDL-2023 LIBRARY; T=0.K  
angular distribution for (n,n\*27)

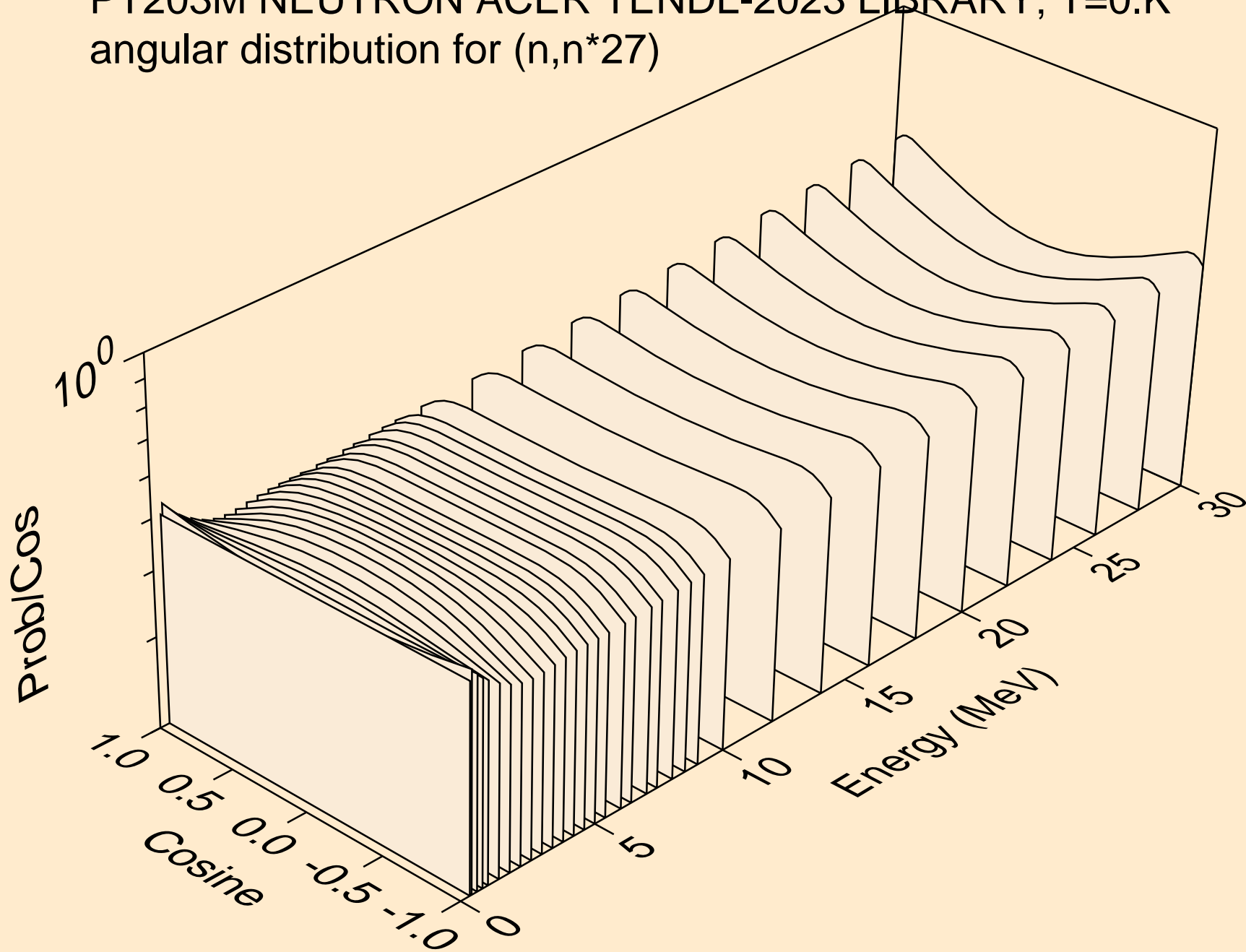

PT203M NEUTRON ACER TENDL-2023 LIBRARY; T=0.K  
angular distribution for (n,n\*28)

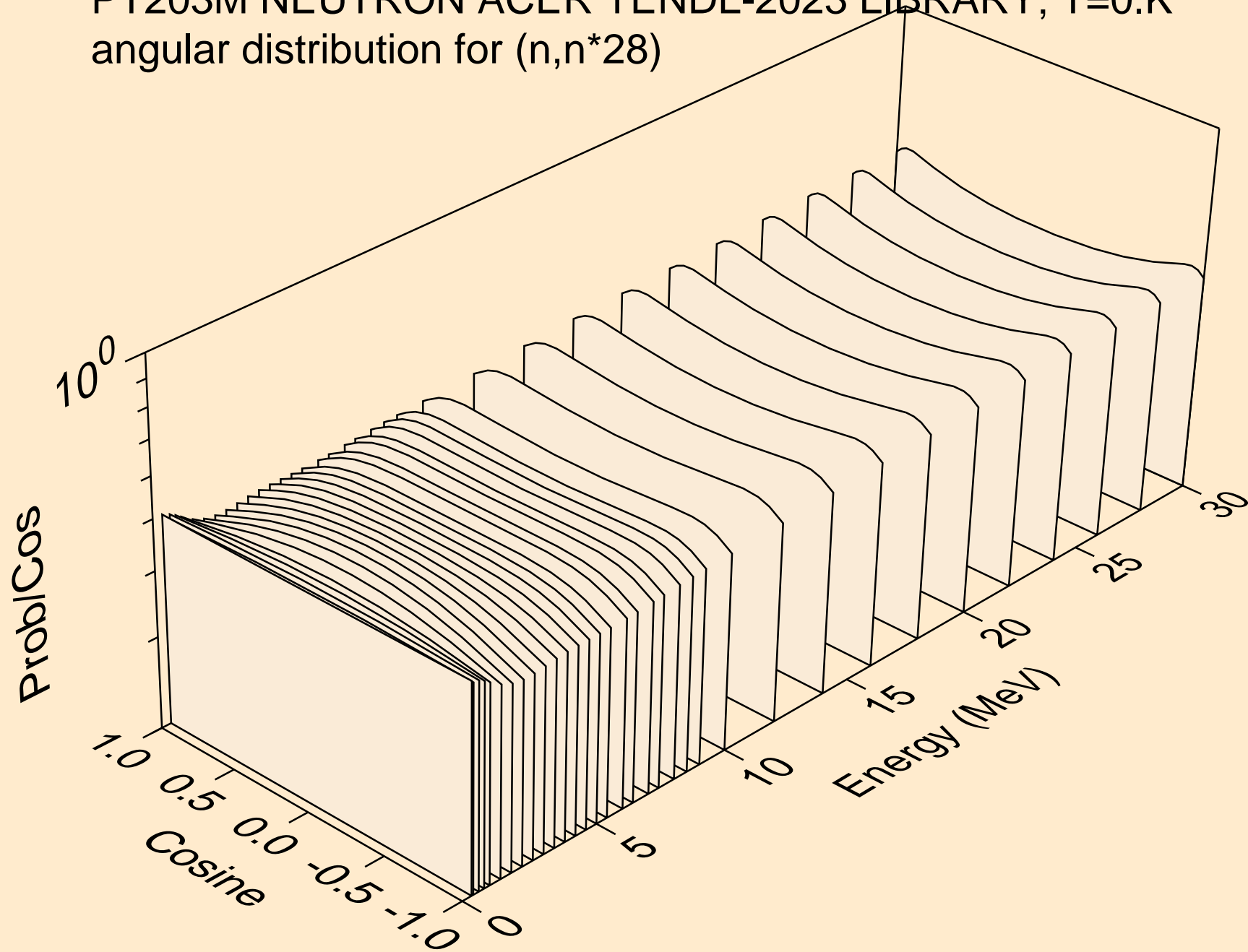

PT203M NEUTRON ACER TENDL-2023 LIBRARY; T=0.K  
angular distribution for (n,n\*29)

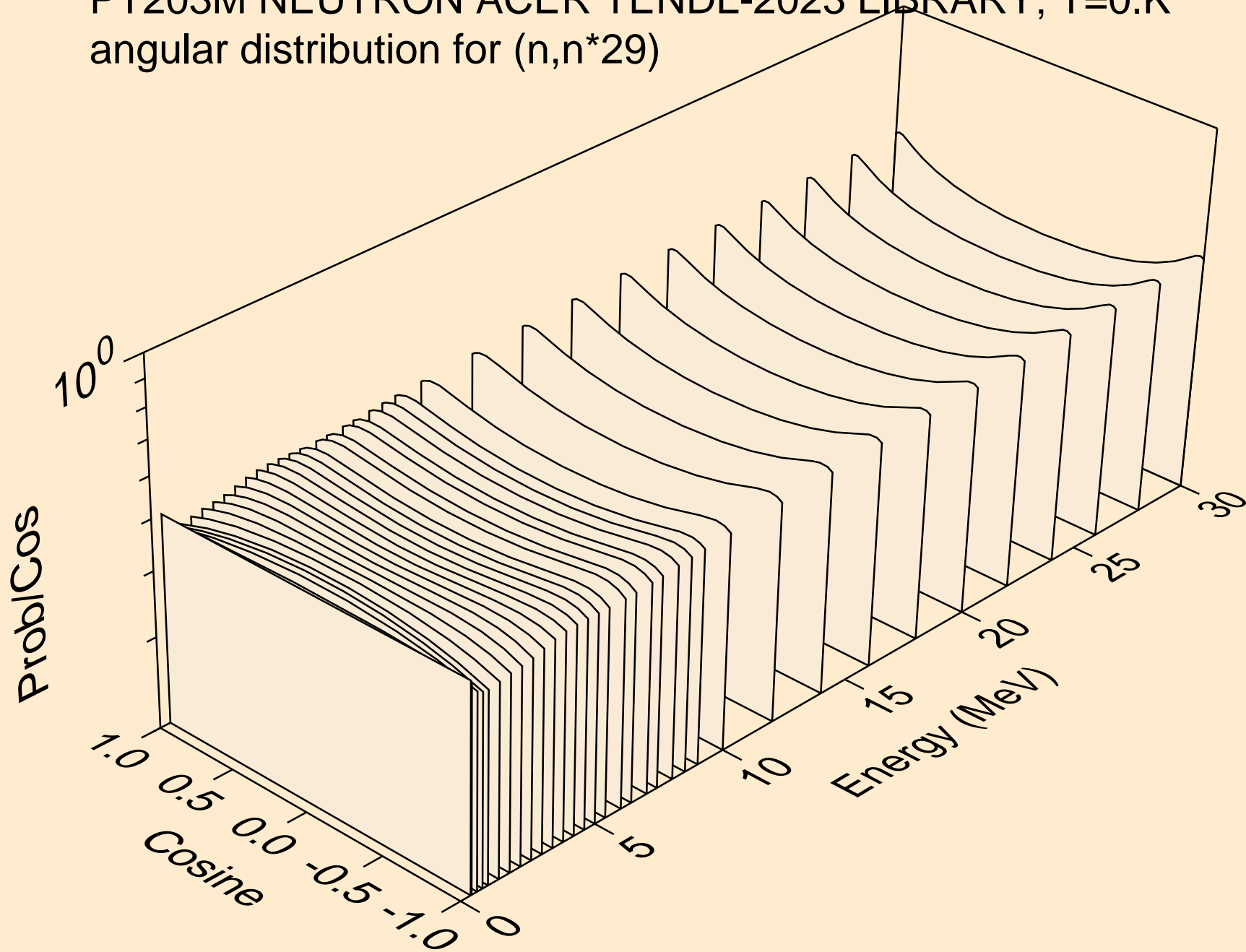



PT203M NEUTRON ACER TENDL-2023 LIBRARY; T=0.K  
angular distribution for (n,n\*30)

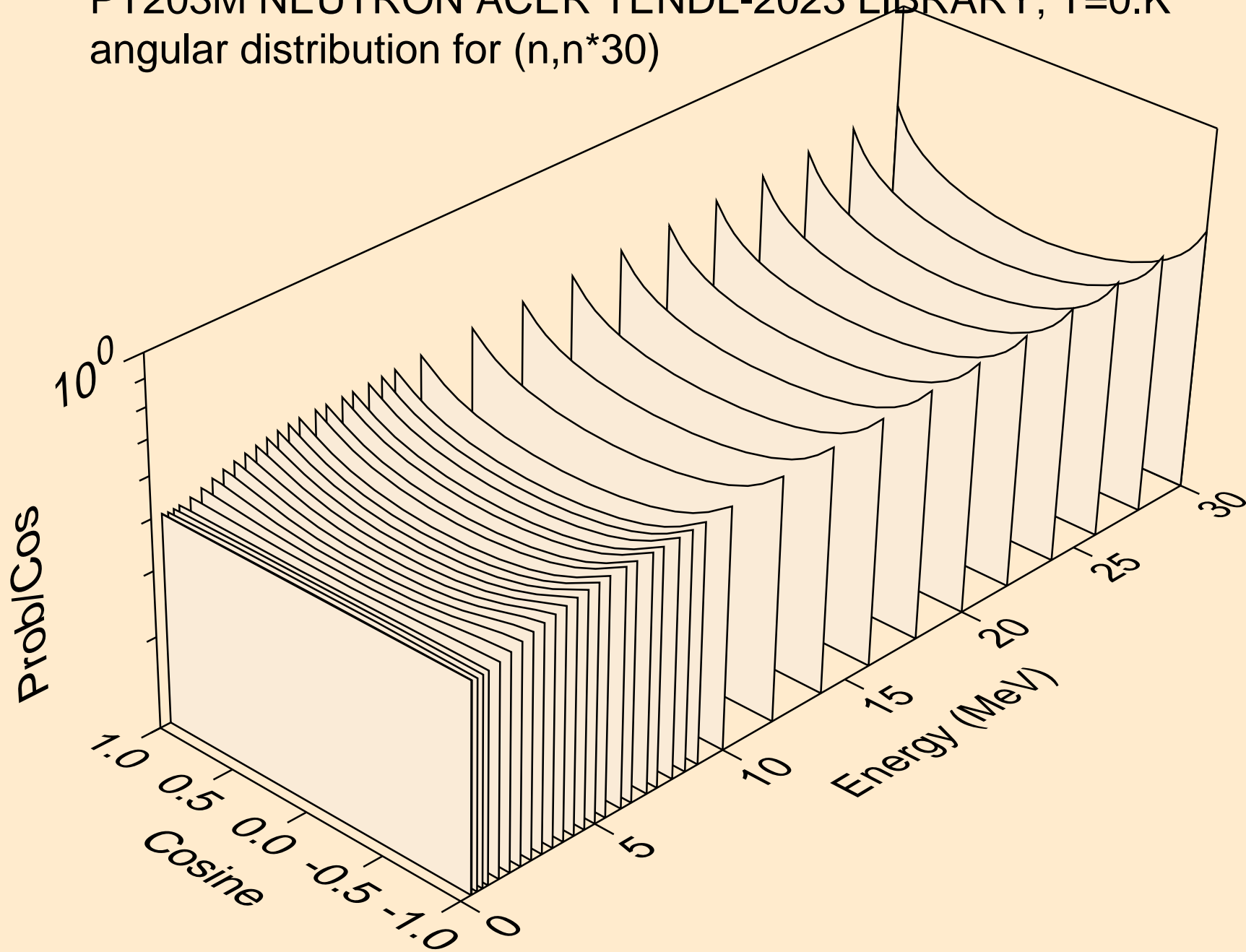

PT203M NEUTRON ACER TENDL-2023 LIBRARY; T=0.K  
Neutron emission for (n,x)

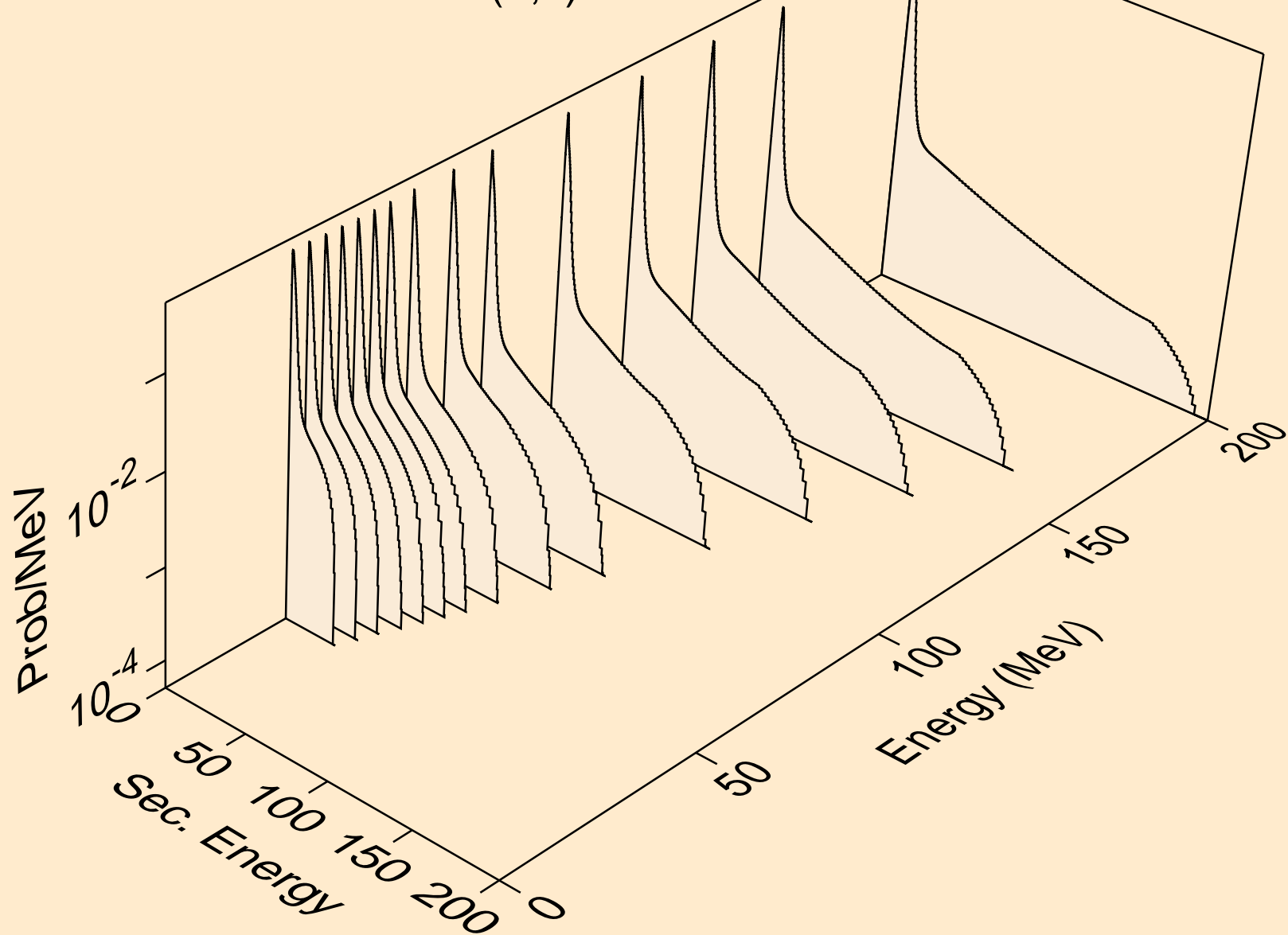

PT203M NEUTRON ACER TENDL-2023 LIBRARY; T=0.K  
Neutron emission for (n,2nd)

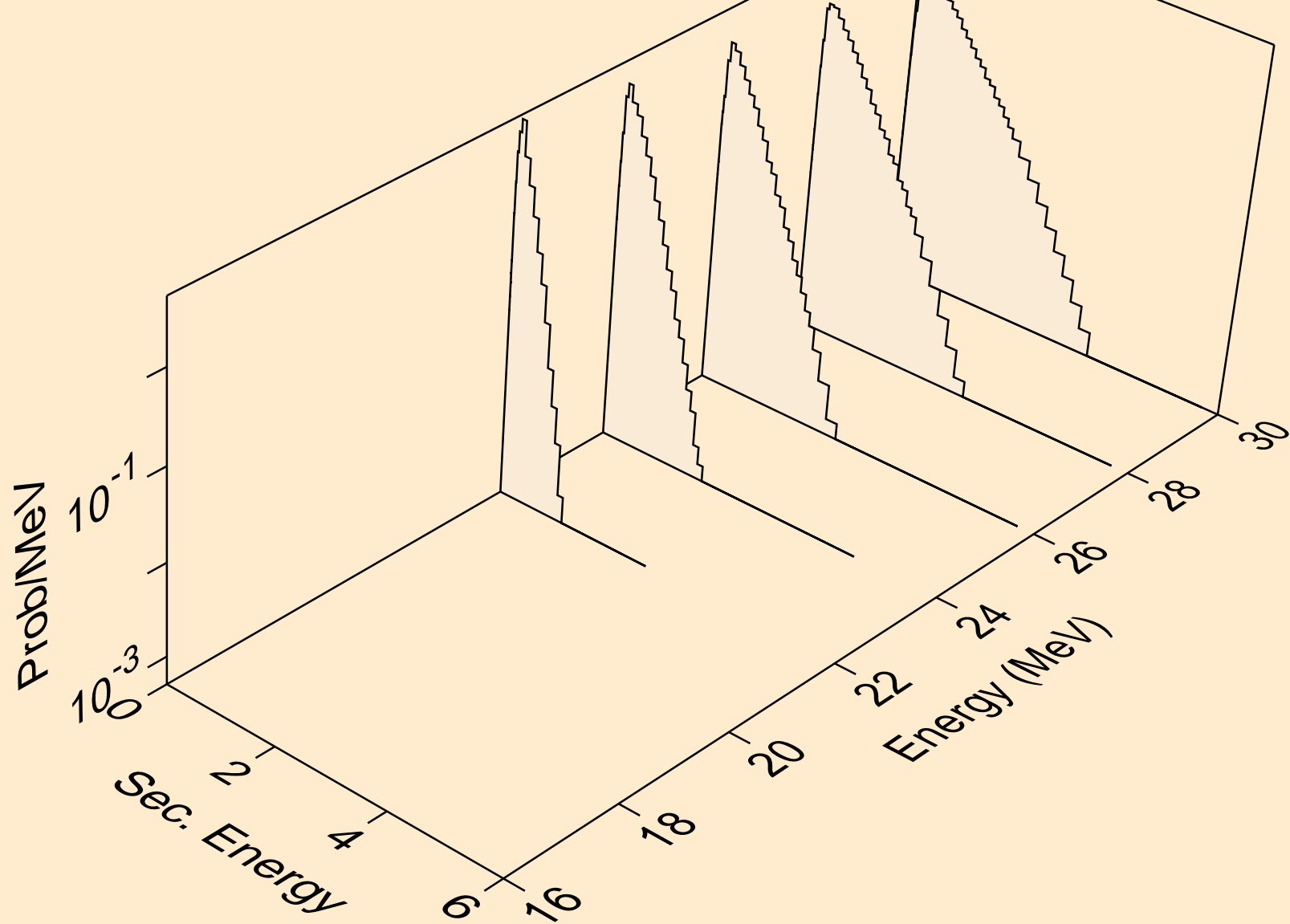

PT203M NEUTRON ACER TENDL-2023 LIBRARY; T=0.K  
Neutron emission for (n,2n)

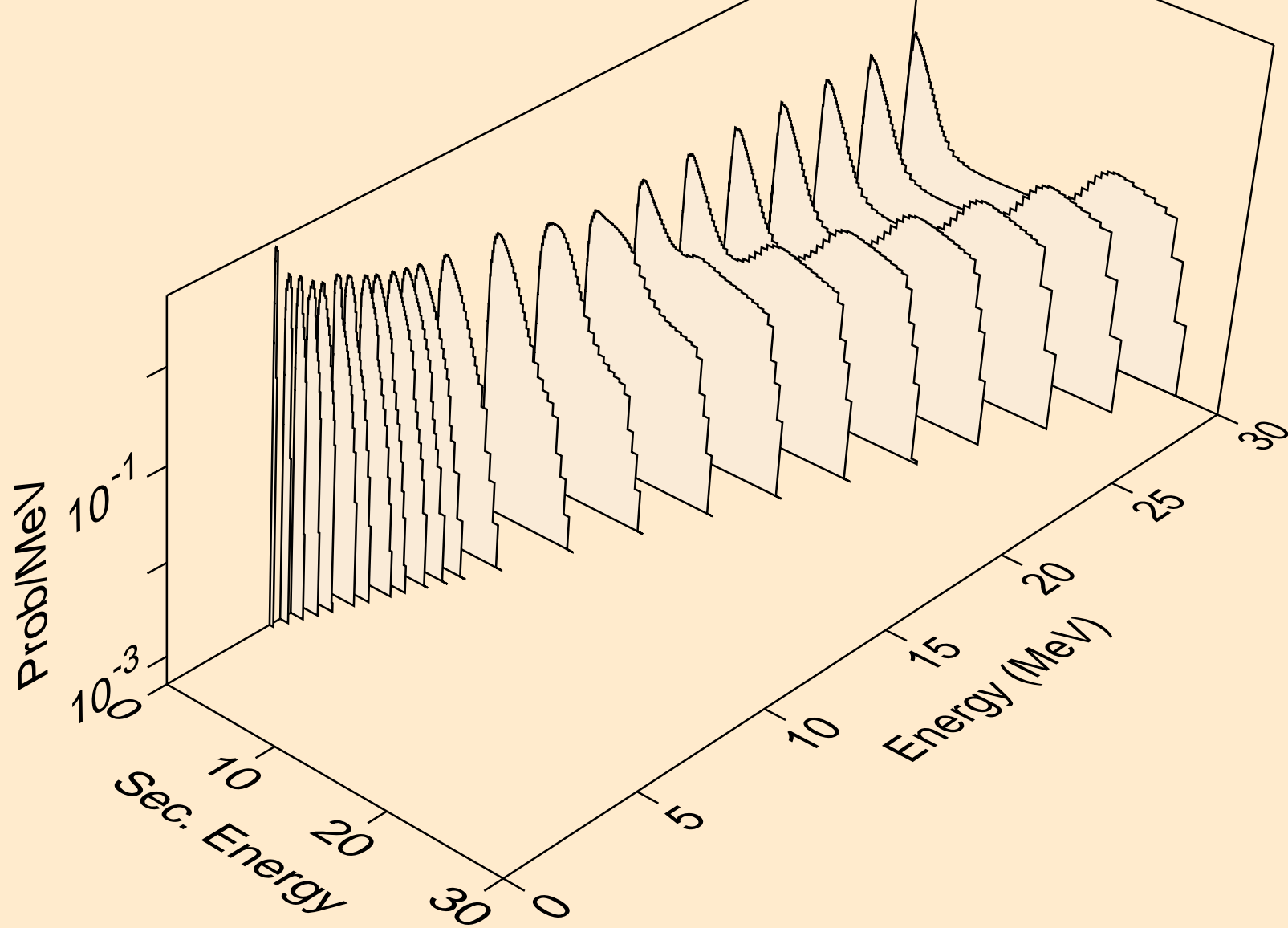

PT203M NEUTRON ACER TENDL-2023 LIBRARY; T=0.K  
Neutron emission for (n,3n)

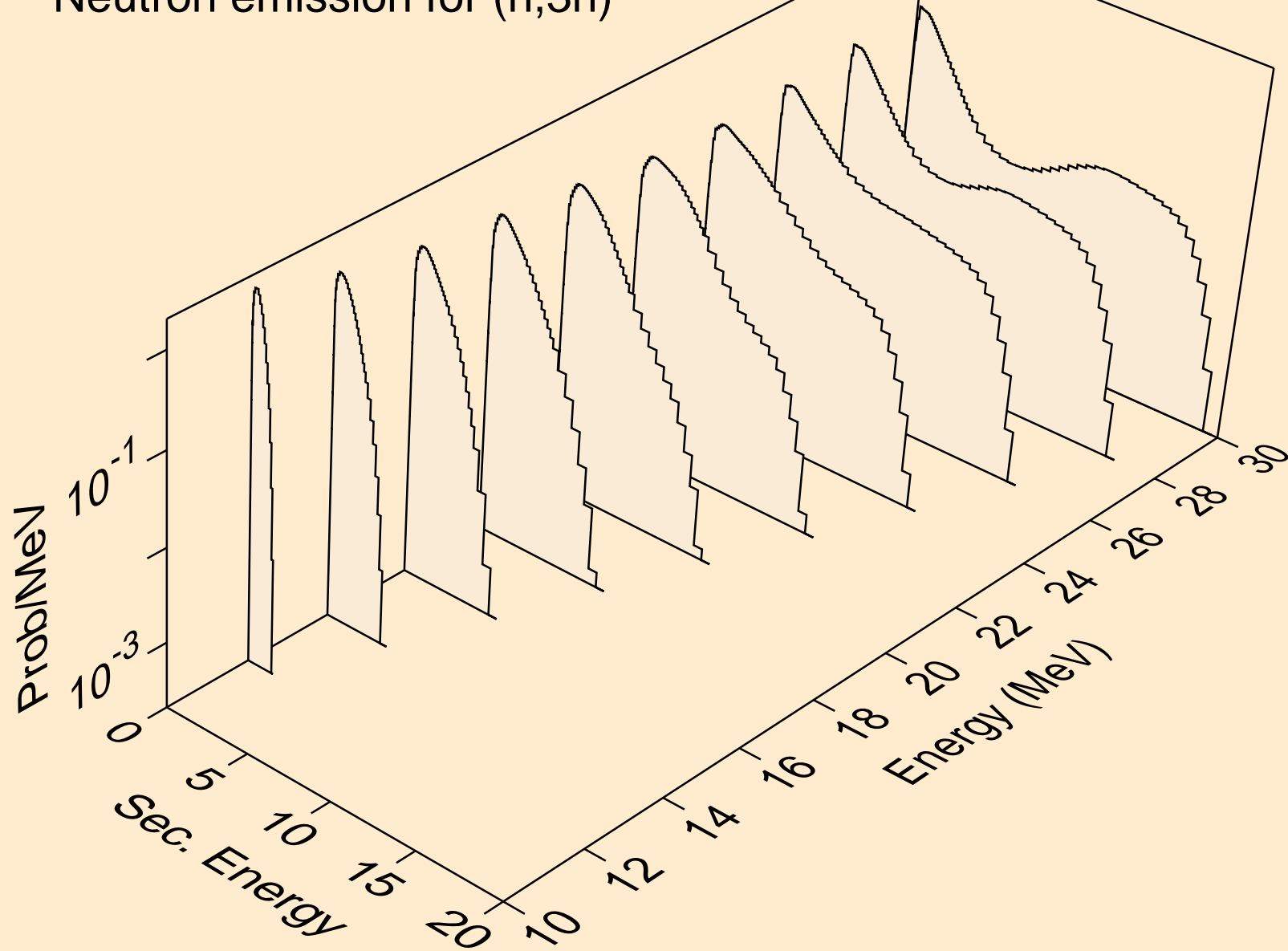

PT203M NEUTRON ACER TENDL-2023 LIBRARY; T=0.K  
Neutron emission for (n,n\*)a

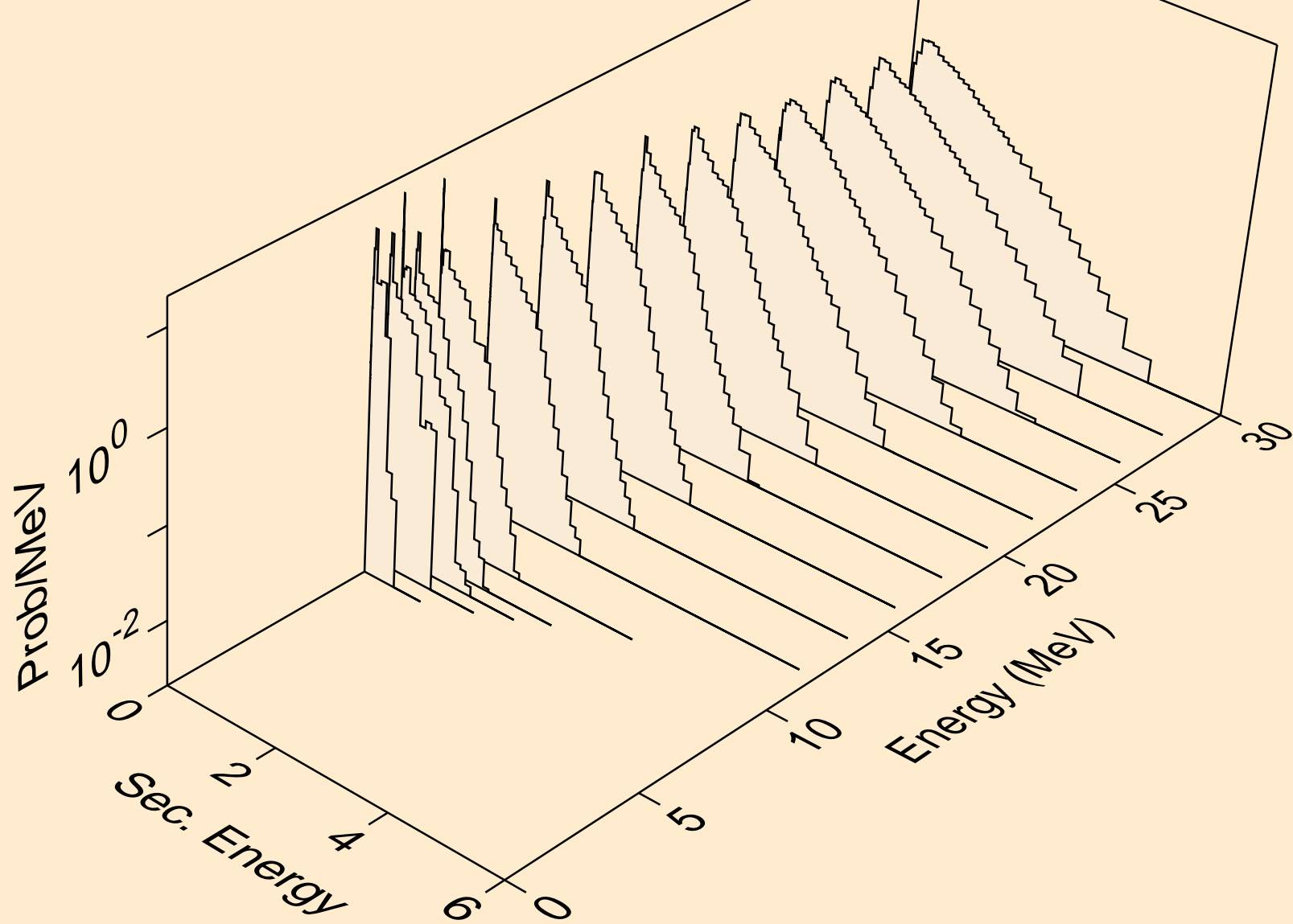

PT203M NEUTRON ACER TENDL-2023 LIBRARY; T=0.K  
Neutron emission for (n,2n)a

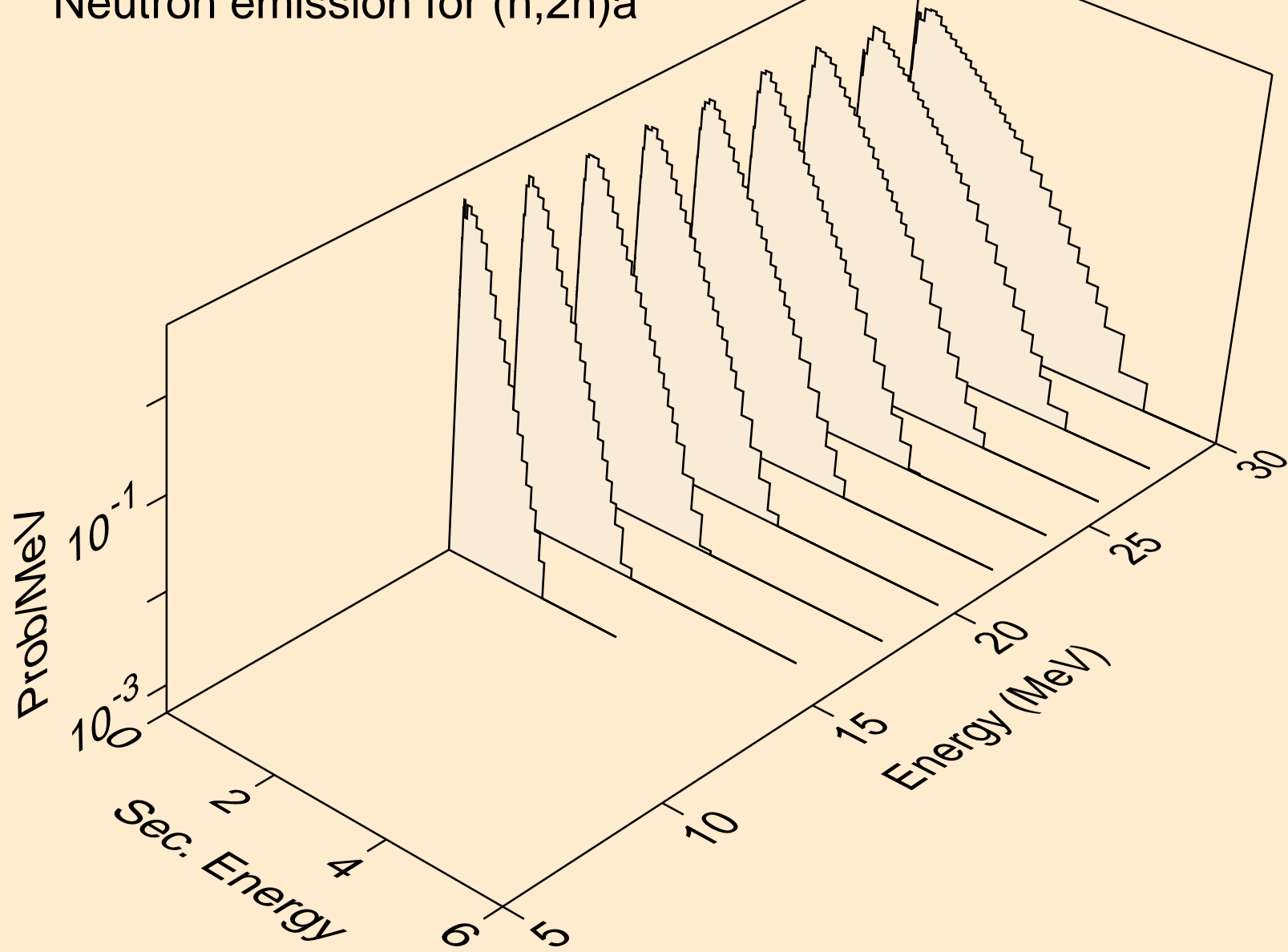

PT203M NEUTRON ACER TENDL-2023 LIBRARY; T=0.K  
Neutron emission for (n,3n)a

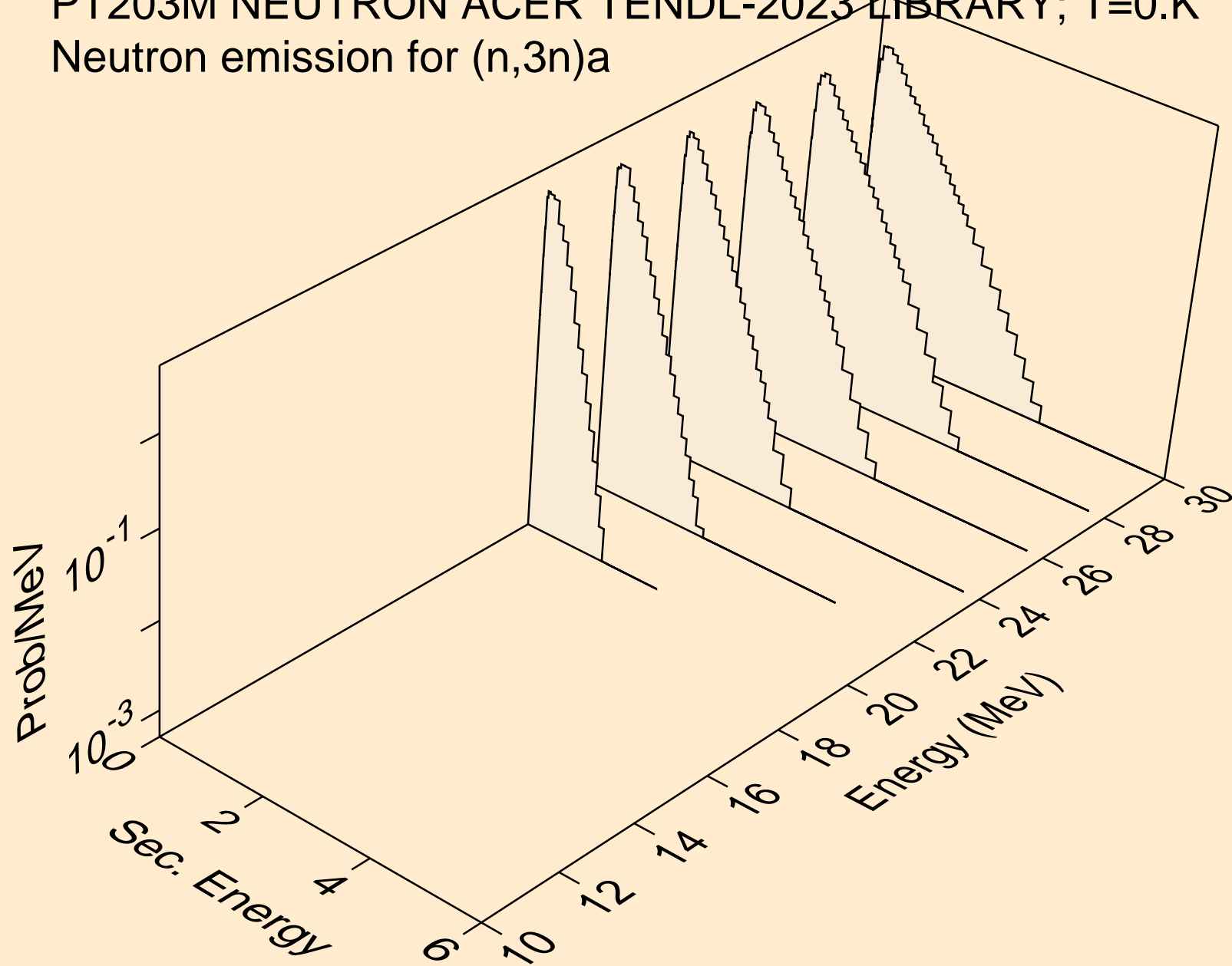



PT203M NEUTRON ACER TENDL-2023 LIBRARY; T=0.K  
Neutron emission for (n,n\*)p

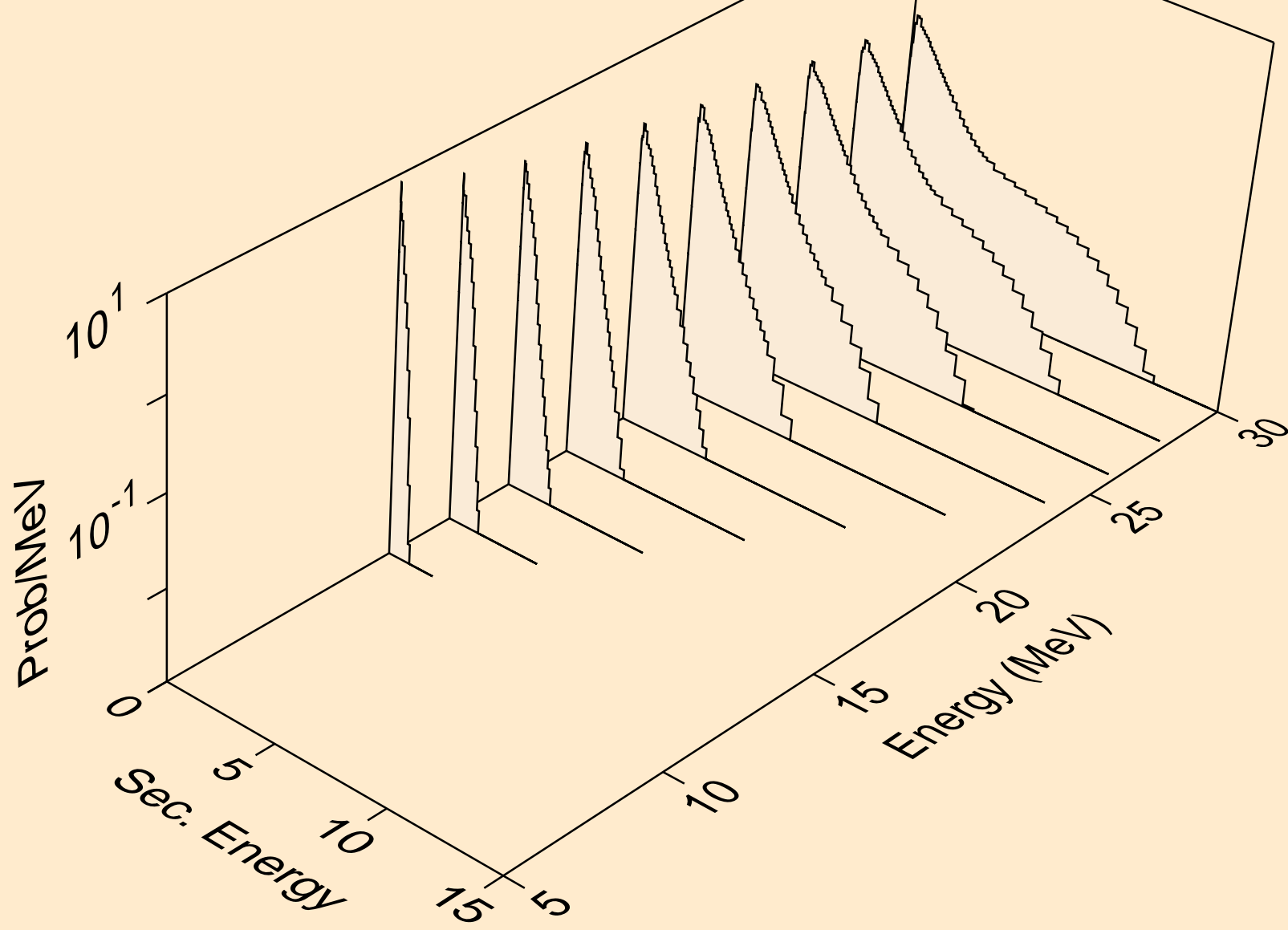

PT203M NEUTRON ACER TENDL-2023 LIBRARY; T=0.K  
Neutron emission for (n,n\*)d

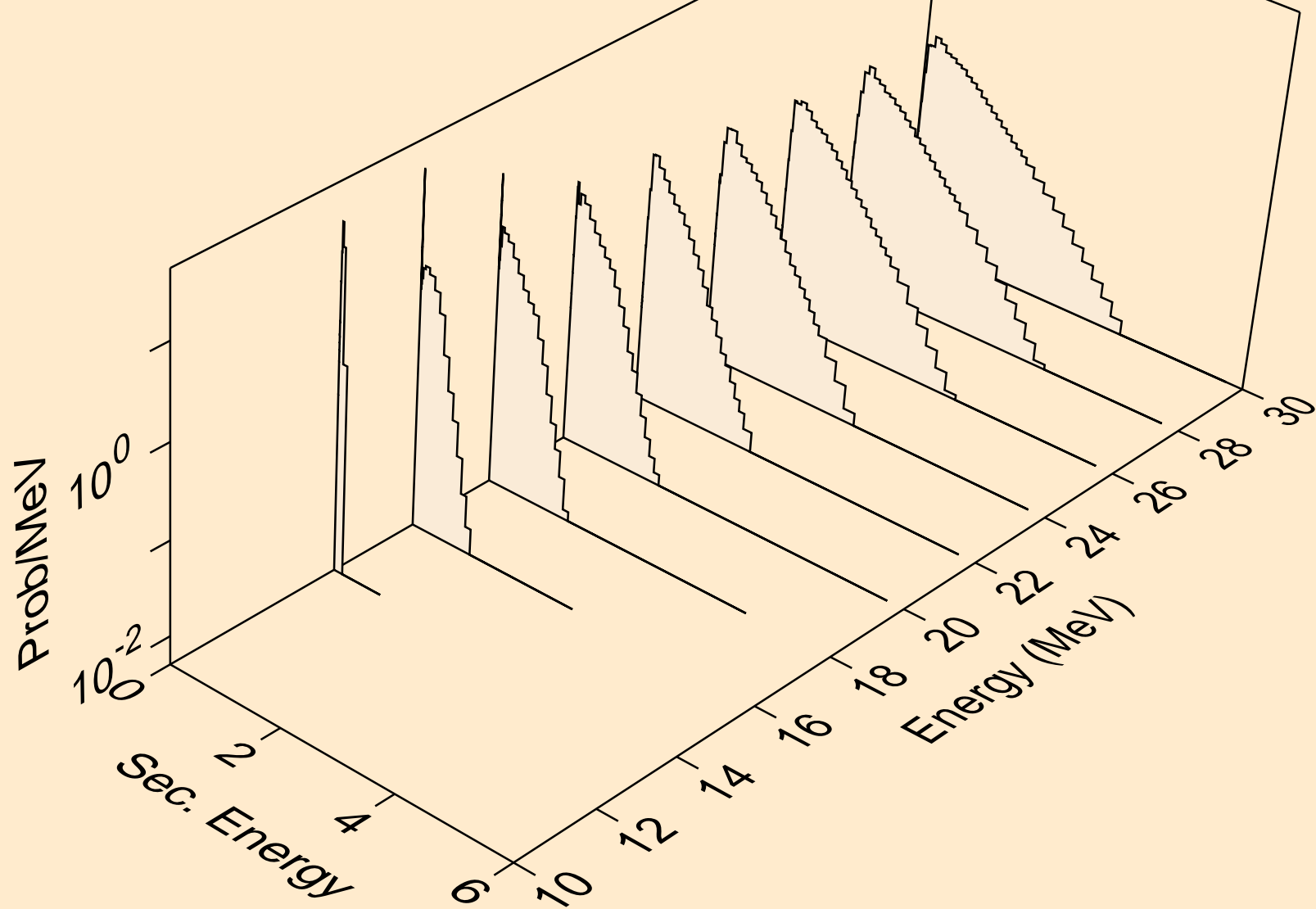

PT203M NEUTRON ACER TENDL-2023 LIBRARY; T=0.K  
Neutron emission for (n,n\*)t

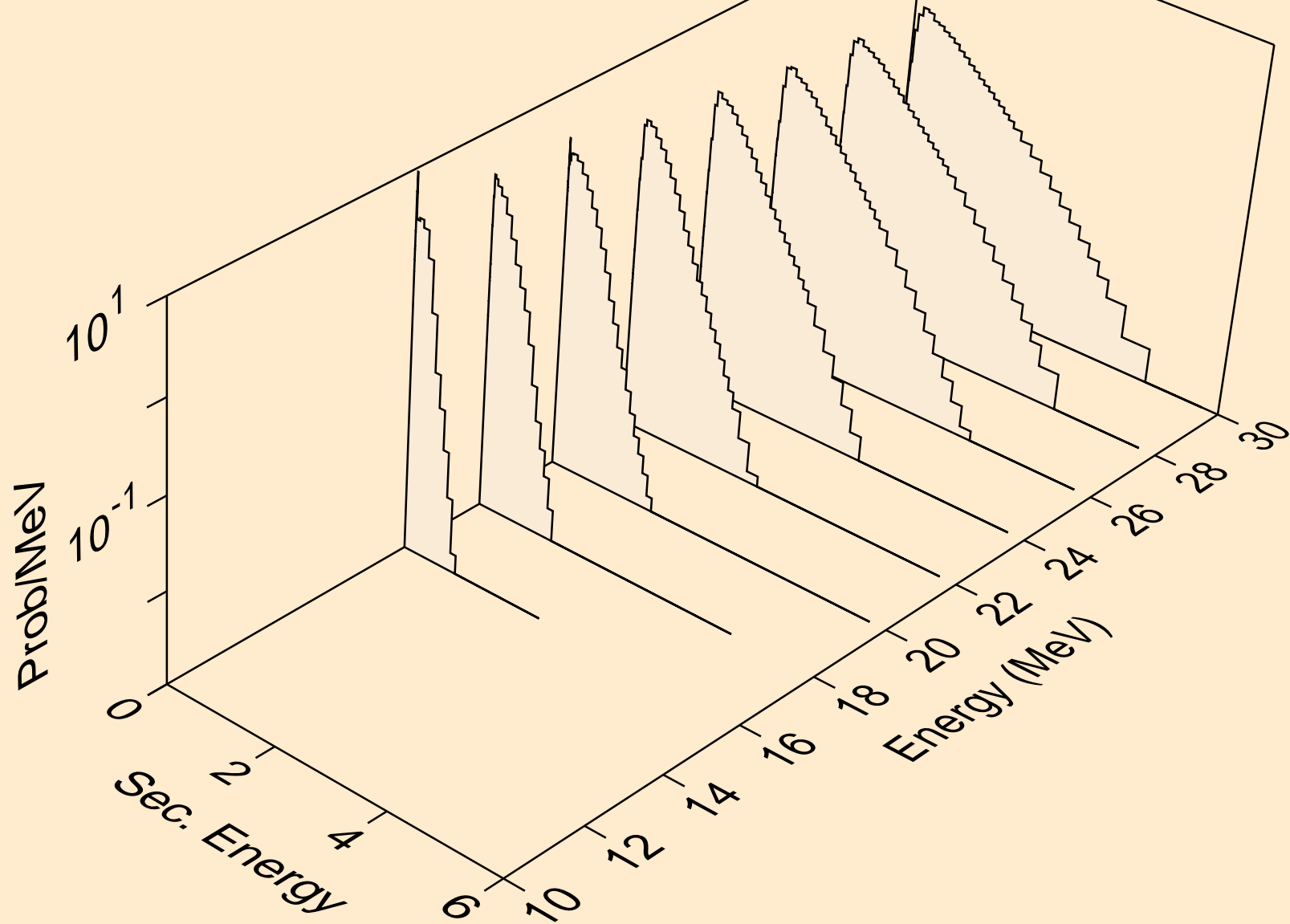

PT203M NEUTRON ACER TENDL-2023 LIBRARY; T=0.K  
Neutron emission for (n,n\*)he3

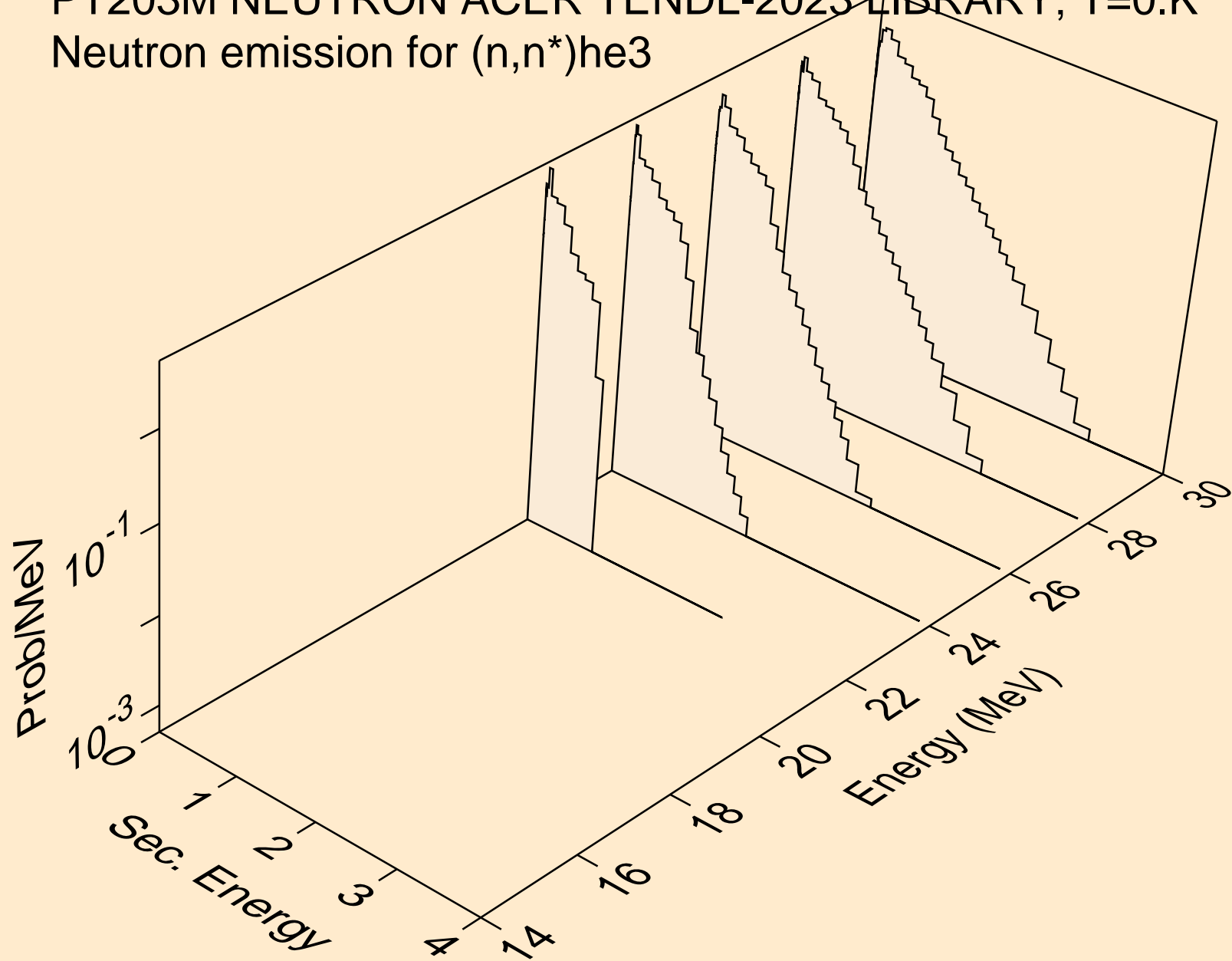

PT203M NEUTRON ACER TENDL-2023 LIBRARY; T=0.K  
Neutron emission for (n,4n)

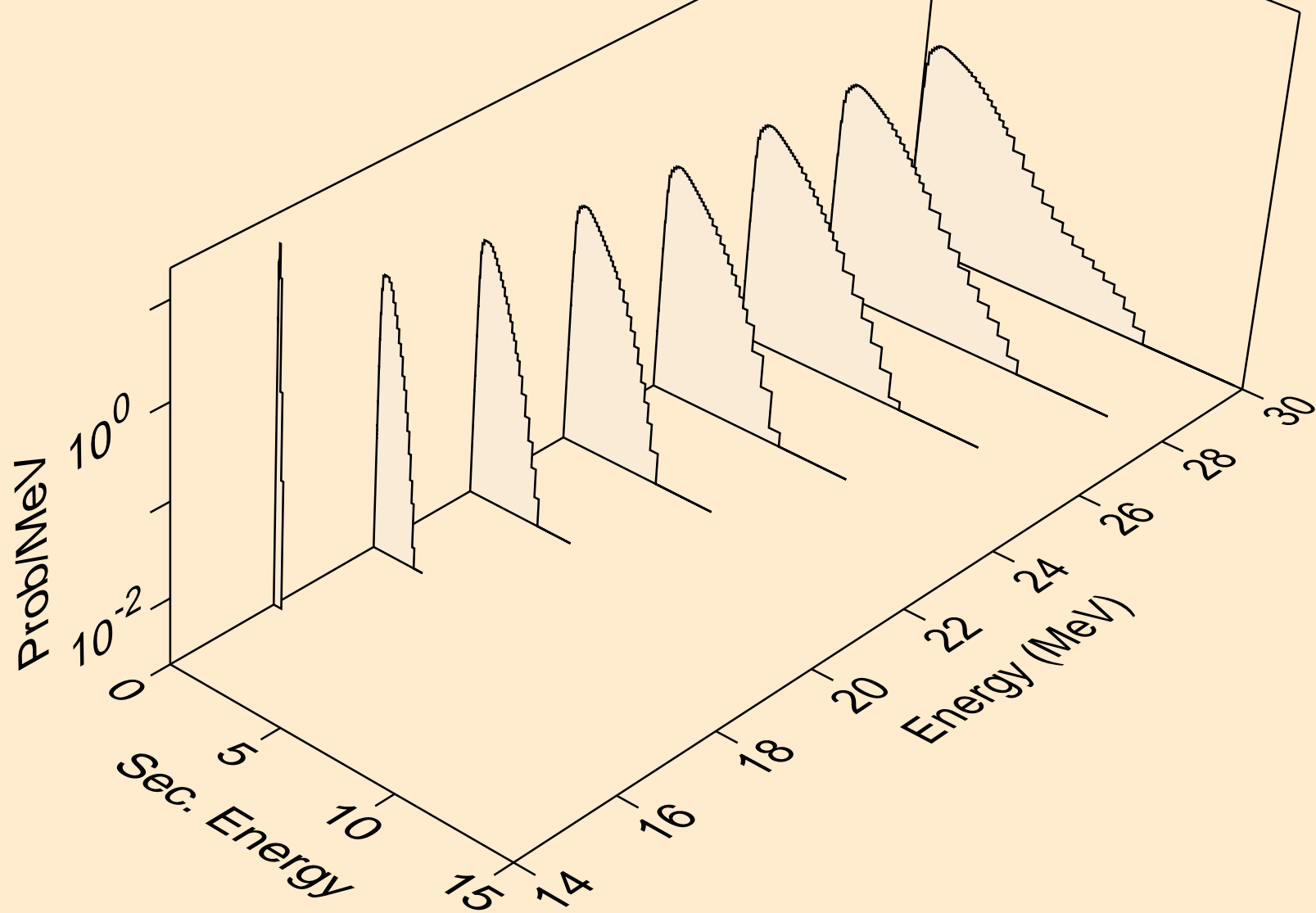

PT203M NEUTRON ACER TENDL-2023 LIBRARY; T=0.K  
Neutron emission for (n,2np)

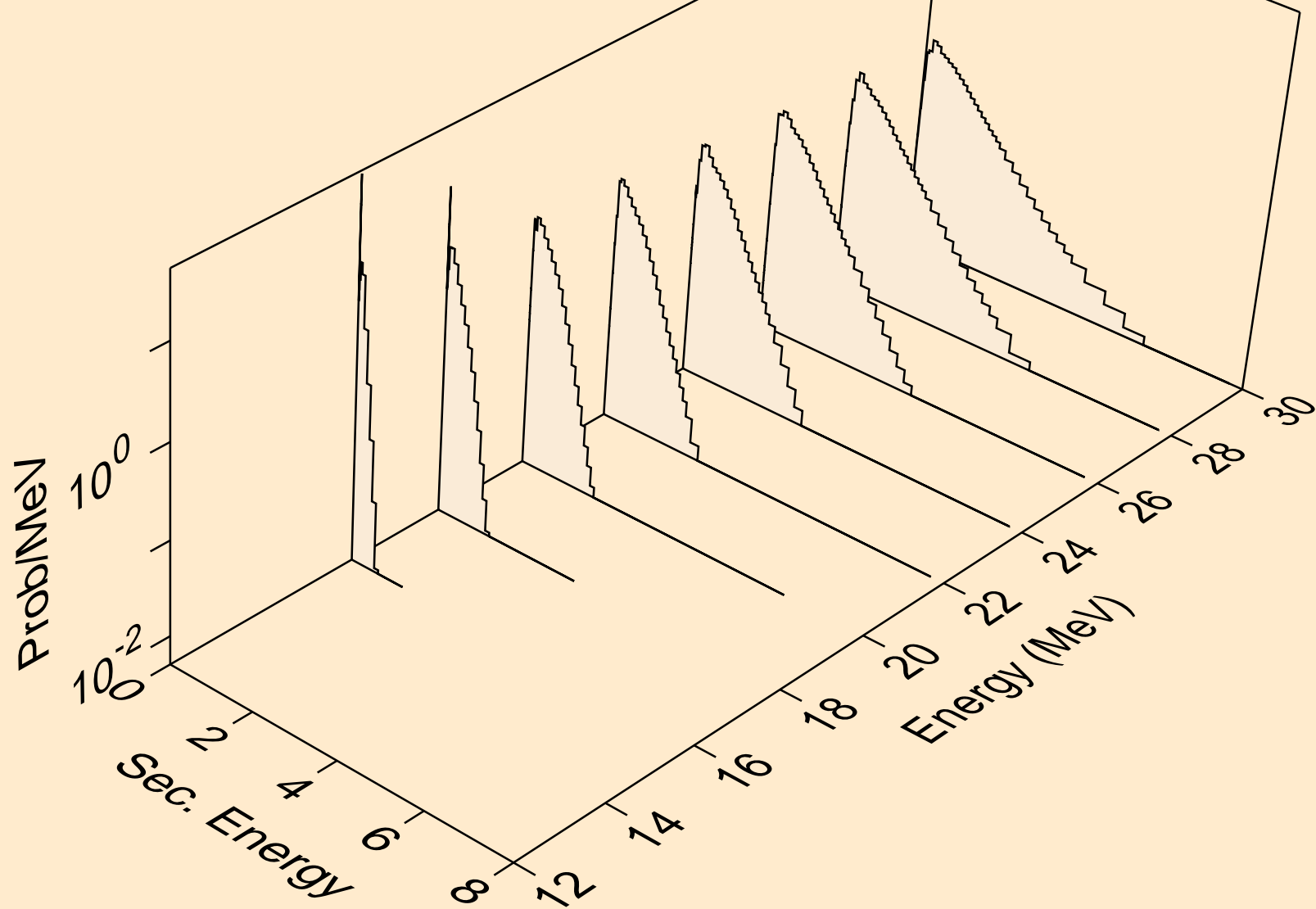

PT203M NEUTRON ACER TENDL-2023 LIBRARY; T=0.K  
Neutron emission for (n,3np)

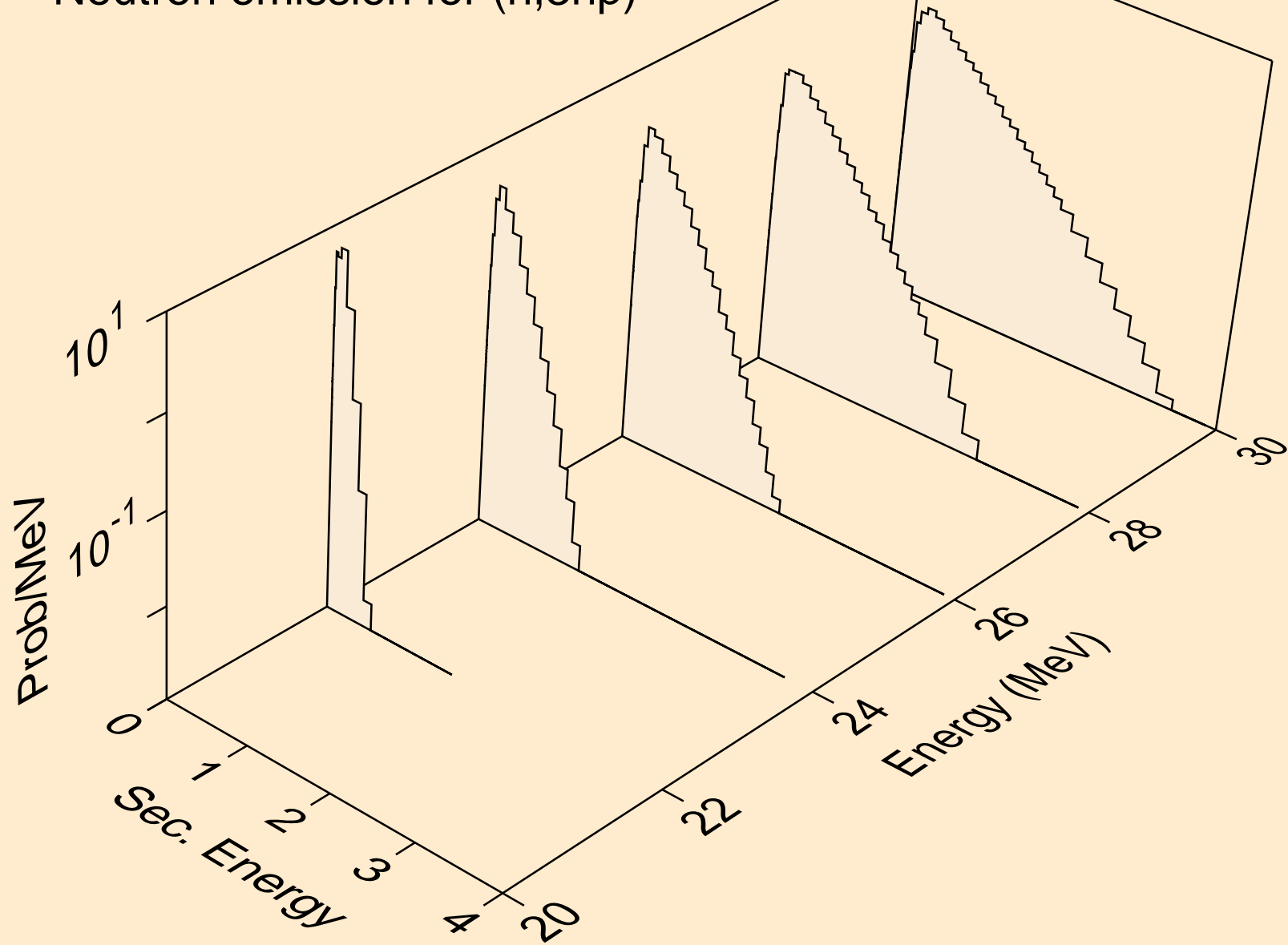

PT203M NEUTRON ACER TENDL-2023 LIBRARY; T=0.K  
Neutron emission for (n,n\*c)

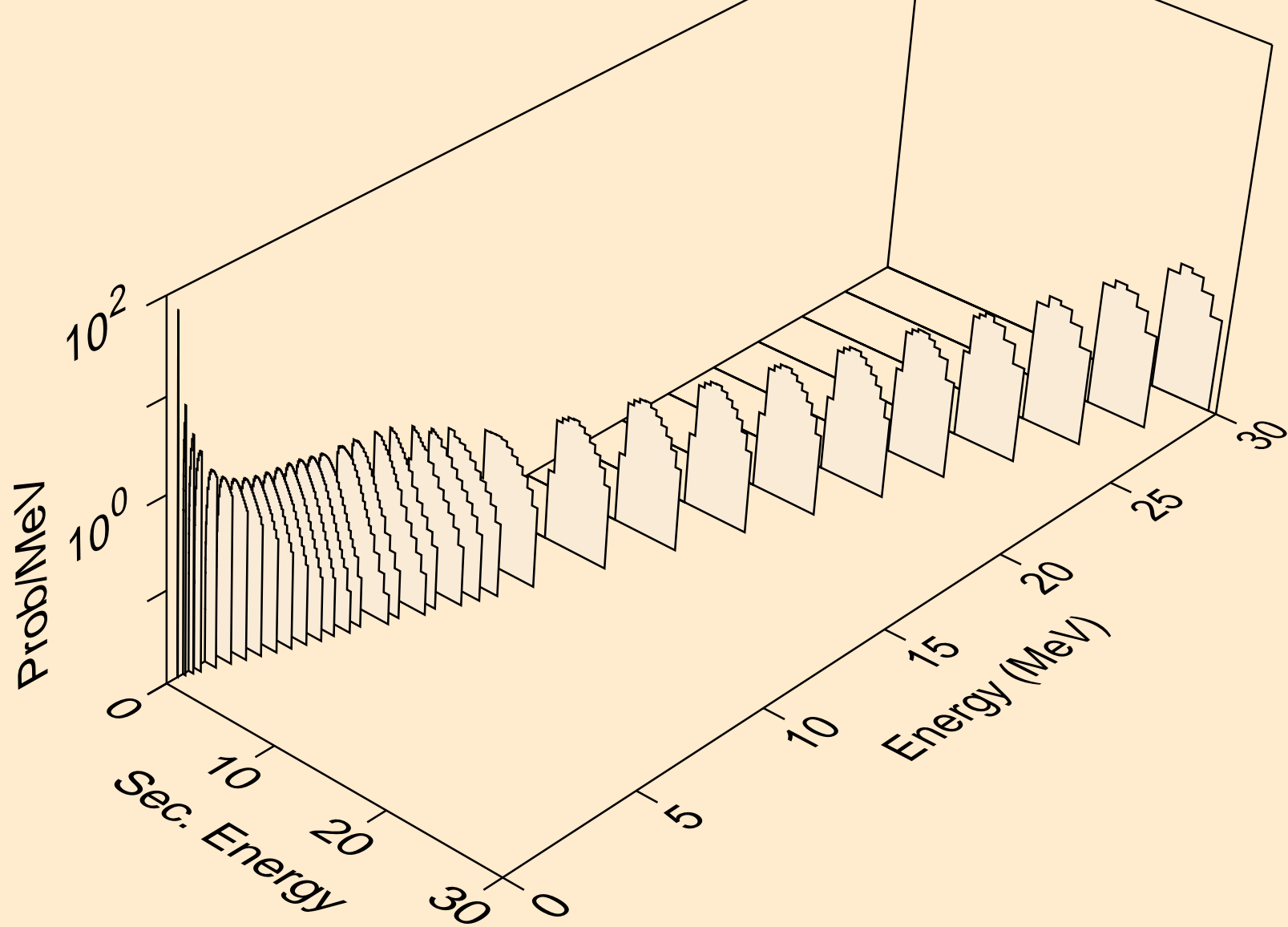



PT203M NEUTRON ACER TENDL-2023 LIBRARY; T=0.K  
Photon emission for (n,x)

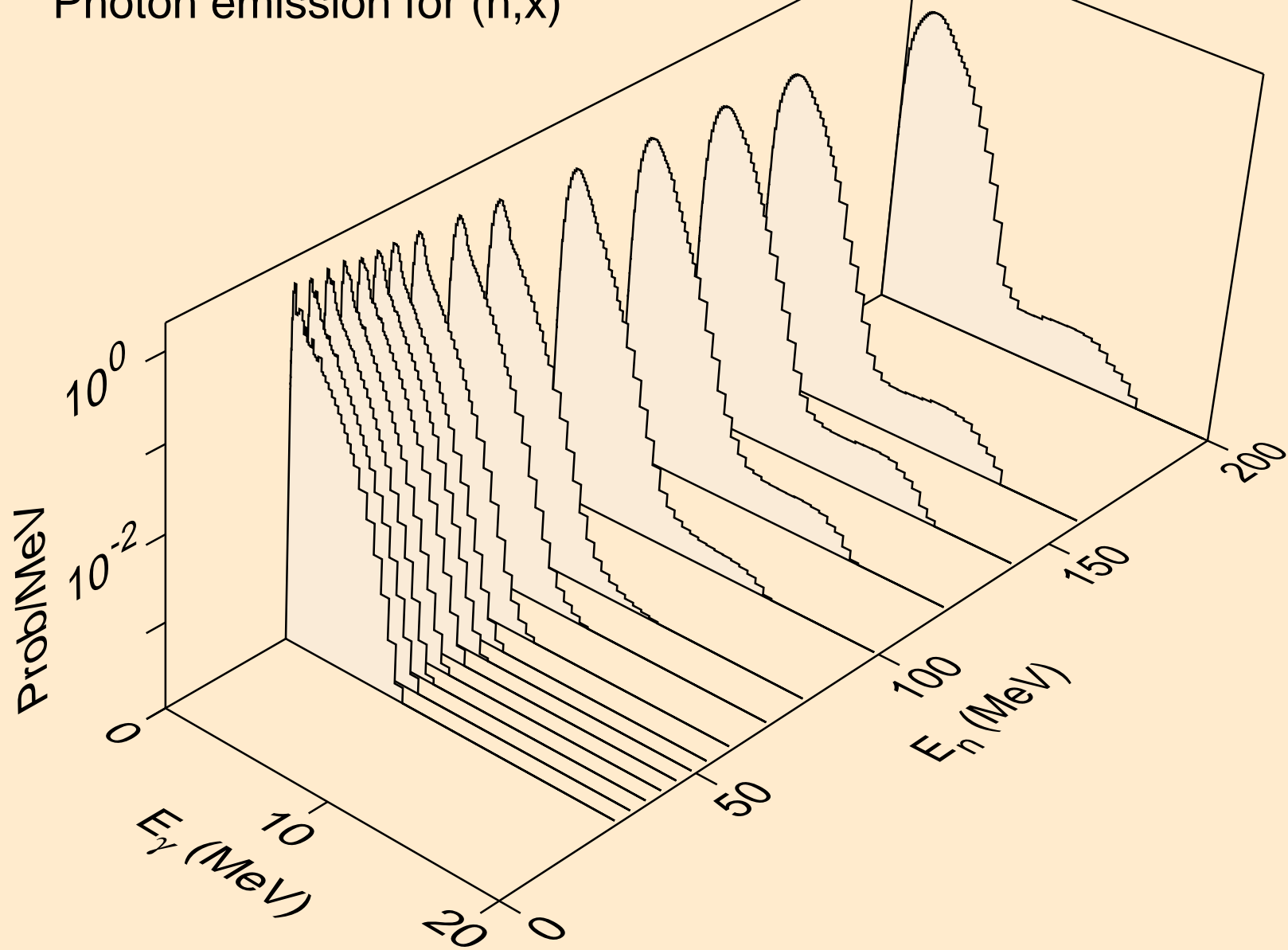

PT203M NEUTRON ACER TENDL-2023 LIBRARY; T=0.K  
Photon emission for (n,2nd)

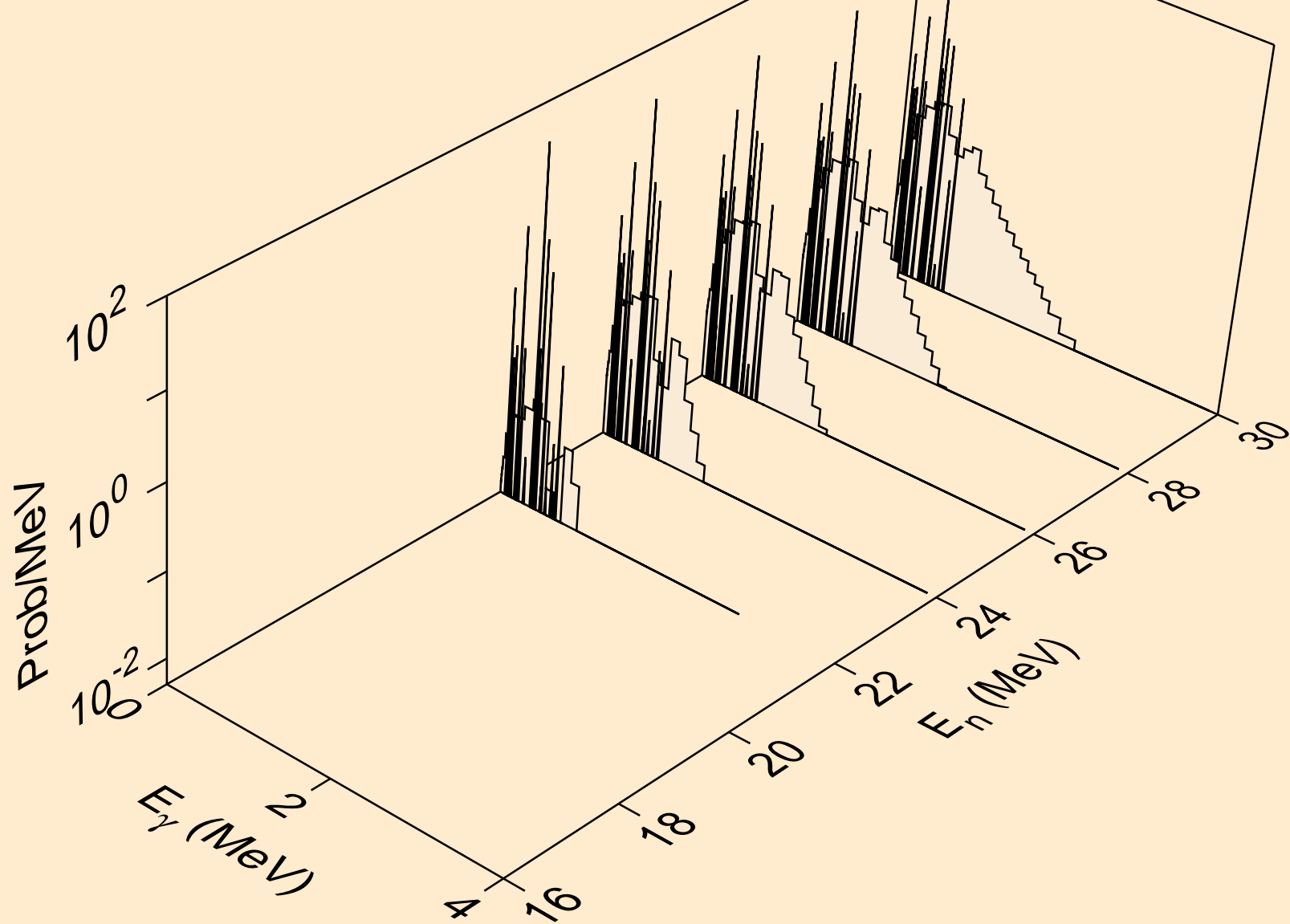

PT203M NEUTRON ACER TENDL-2023 LIBRARY; T=0.K  
Photon emission for (n,2n)

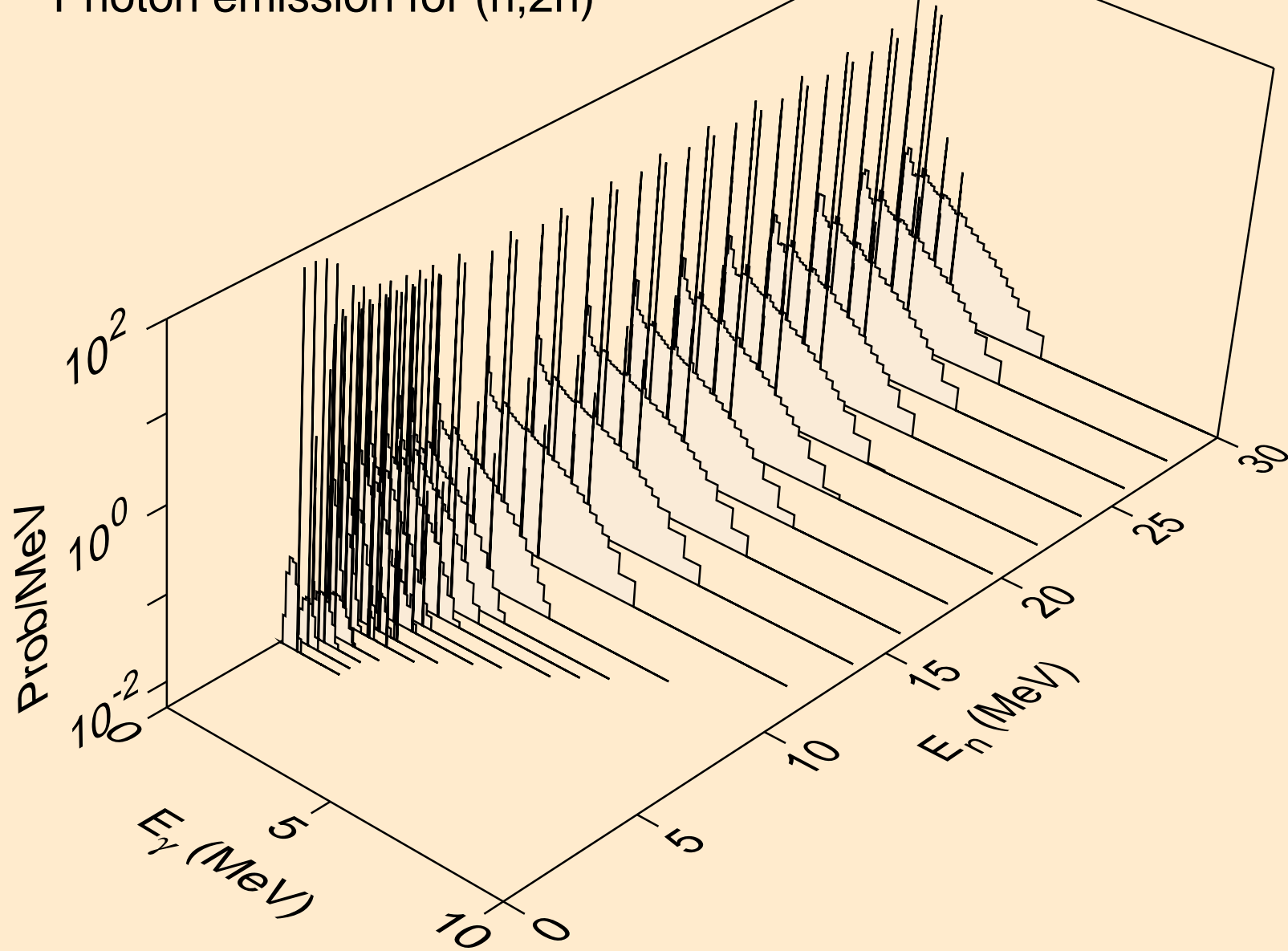

PT203M NEUTRON ACER TENDL-2023 LIBRARY; T=0.K  
Photon emission for (n,3n)

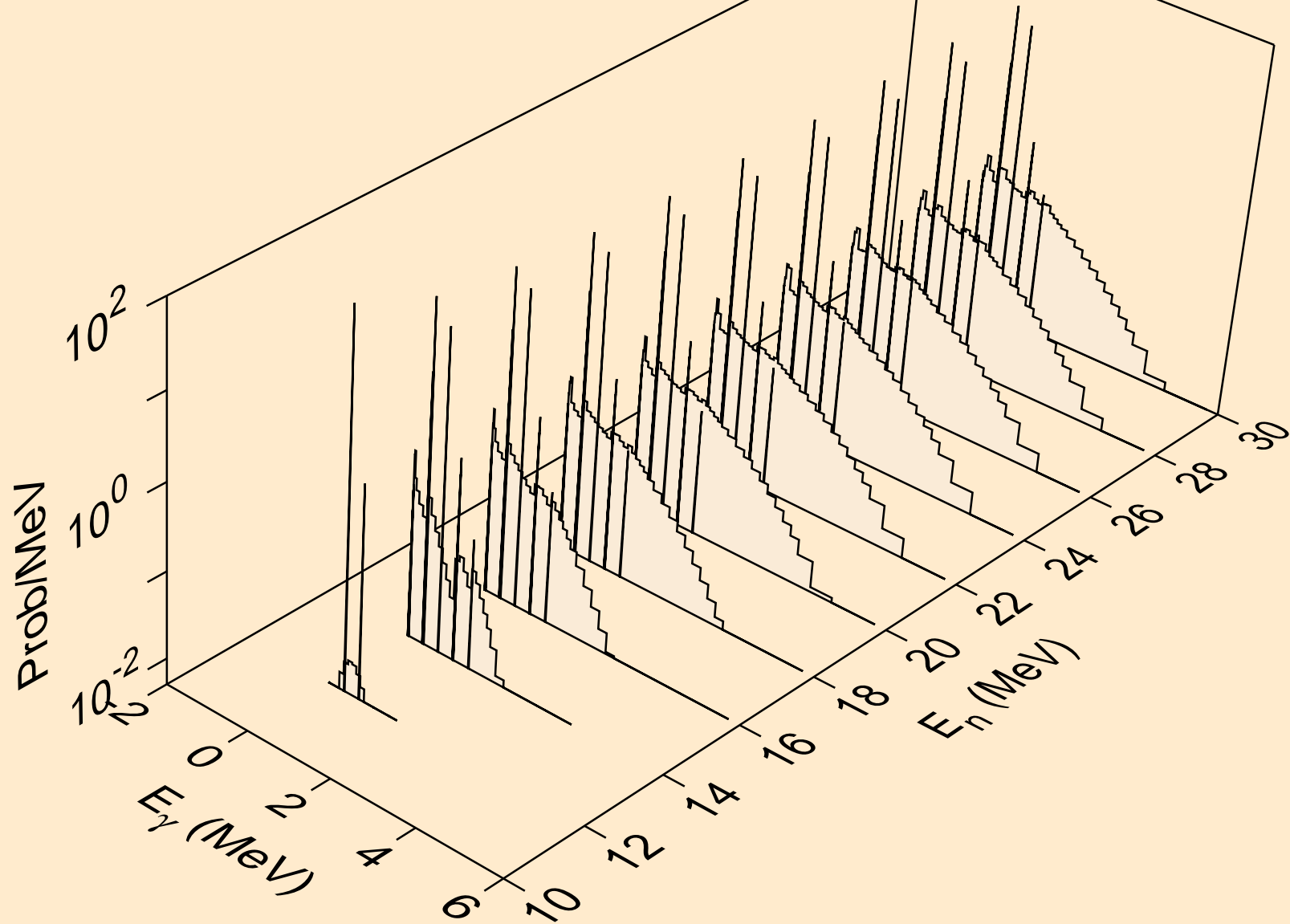

PT203M NEUTRON ACER TENDL-2023 LIBRARY; T=0.K  
Photon emission for (n,n\*)a

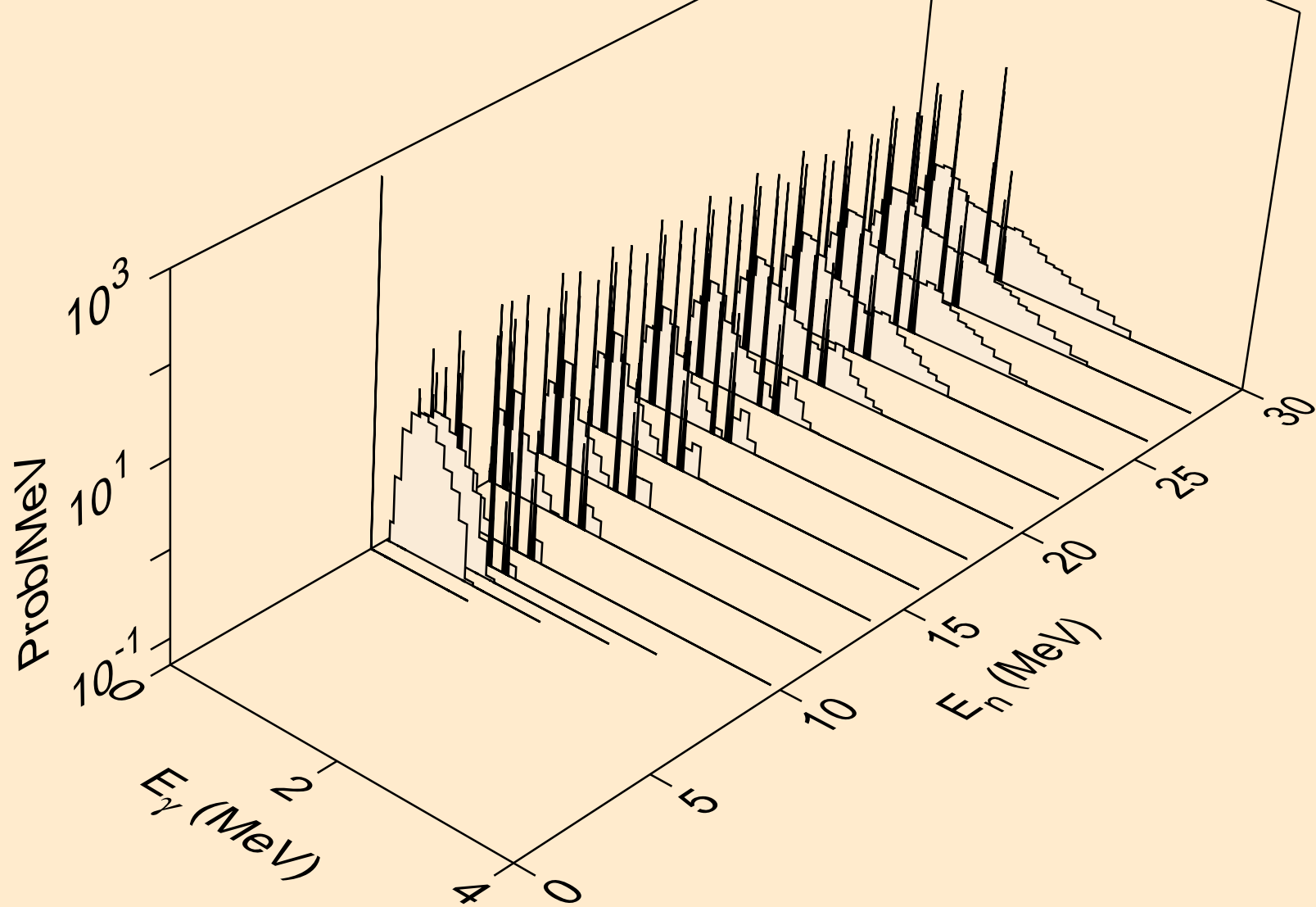

PT203M NEUTRON ACER TENDL-2023 LIBRARY; T=0.K  
Photon emission for (n,2n)a

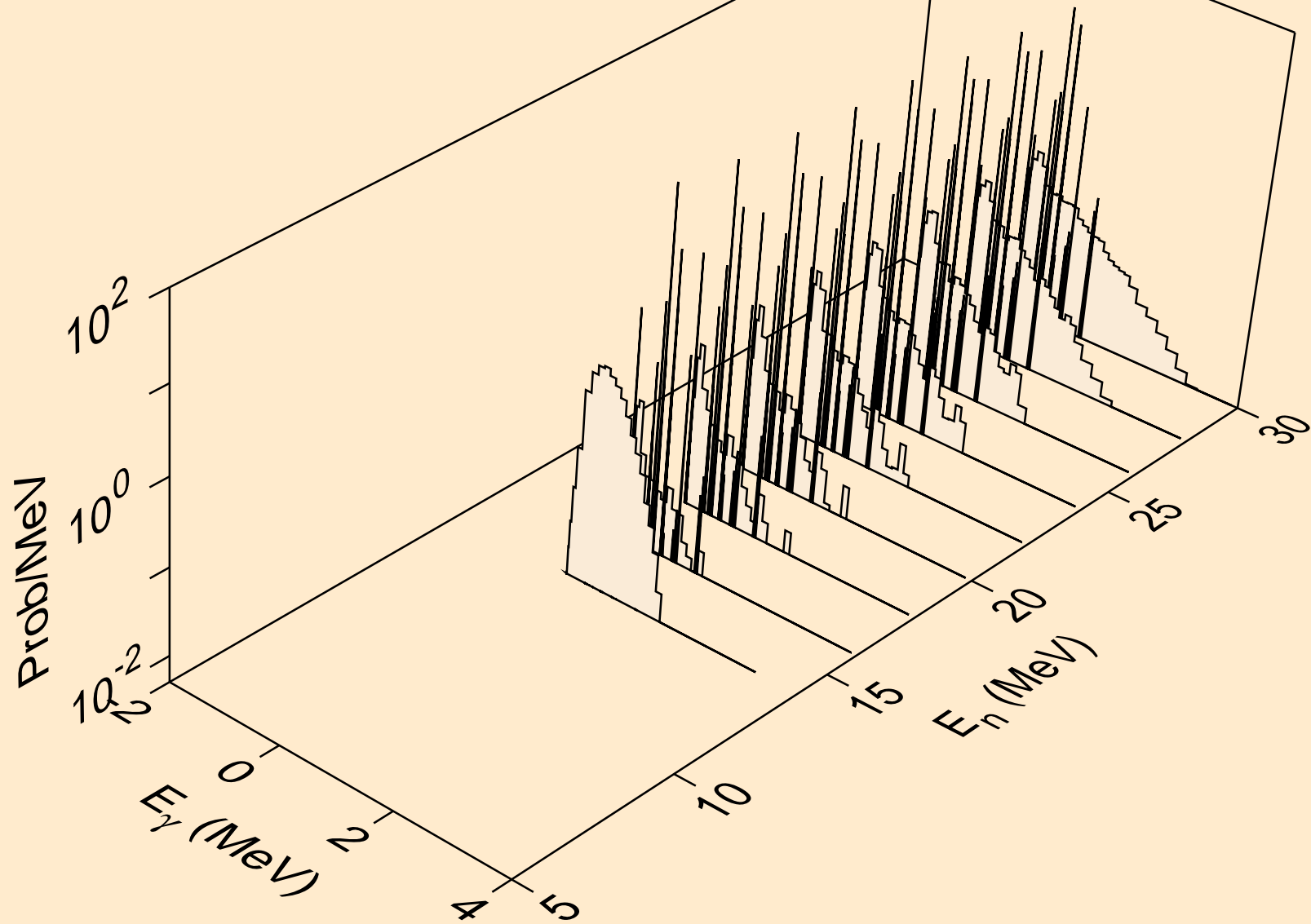

PT203M NEUTRON ACER TENDL-2023 LIBRARY; T=0.K  
Photon emission for (n,3n)a

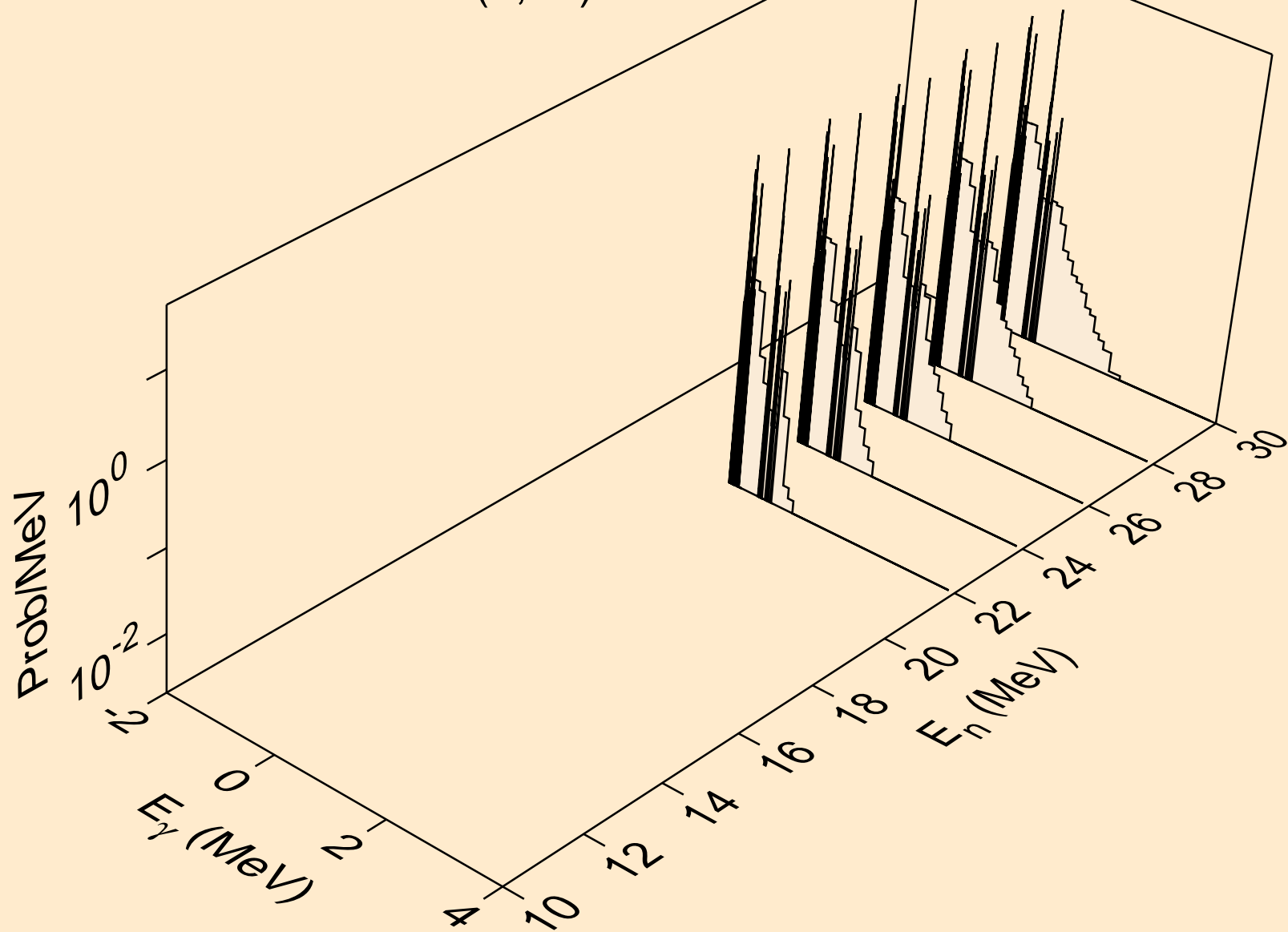

PT203M NEUTRON ACER TENDL-2023 LIBRARY; T=0.K  
Photon emission for (n,n\*)p

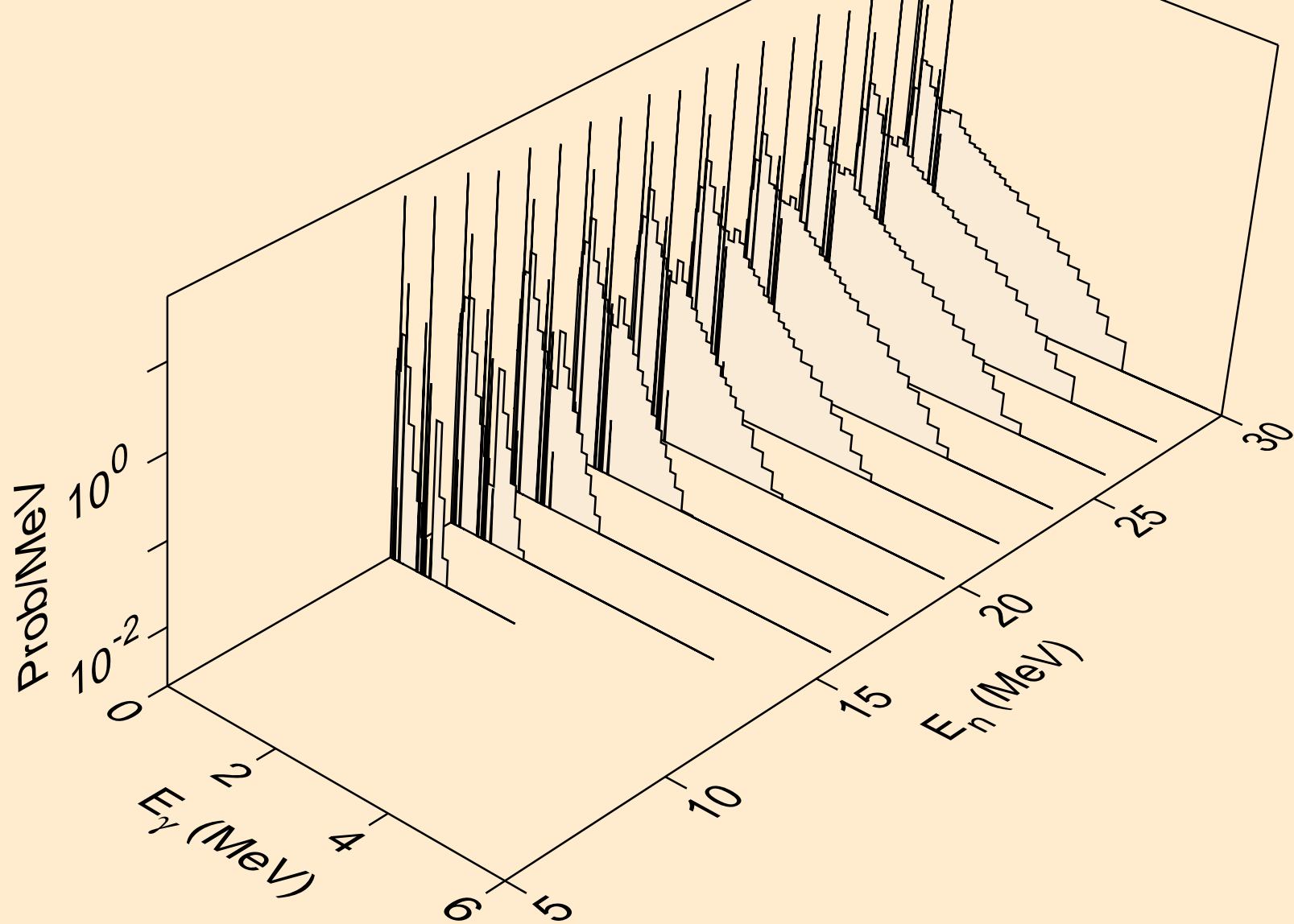



PT203M NEUTRON ACER TENDL-2023 LIBRARY; T=0.K  
Photon emission for (n,n\*)d

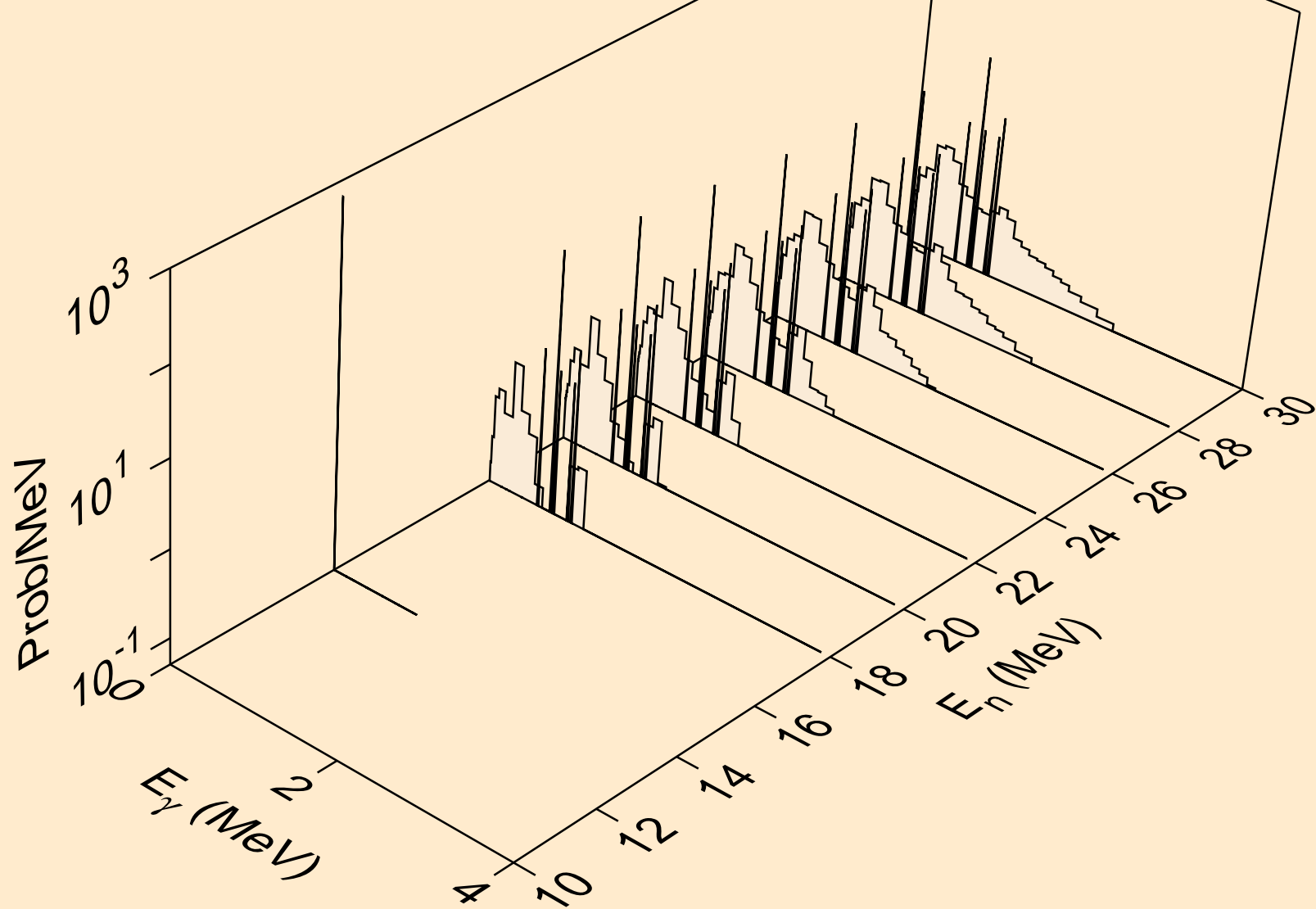

PT203M NEUTRON ACER TENDL-2023 LIBRARY; T=0.K  
Photon emission for (n,n\*)t

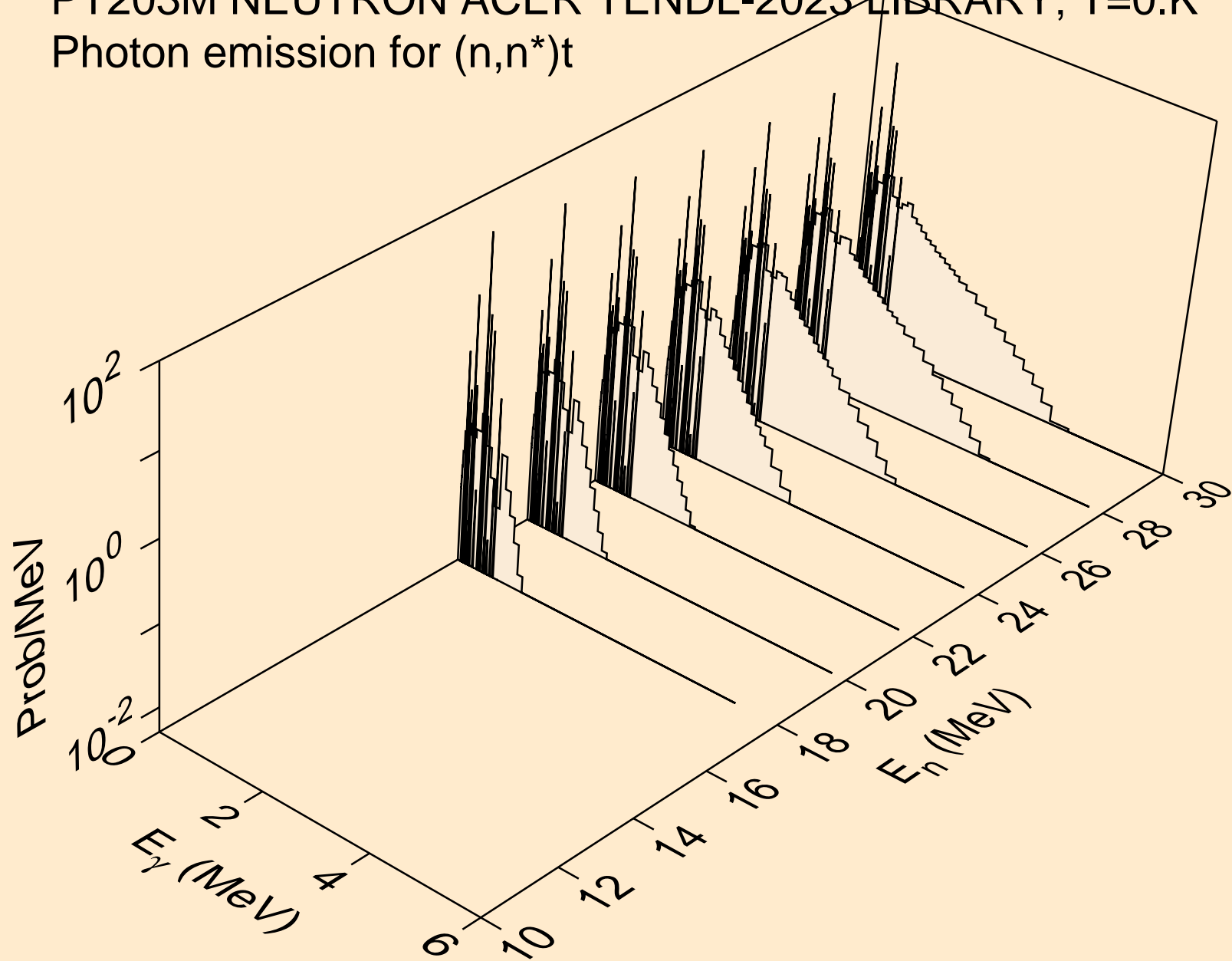

PT203M NEUTRON ACER TENDL-2023 LIBRARY; T=0.K  
Photon emission for (n,n\*)he3

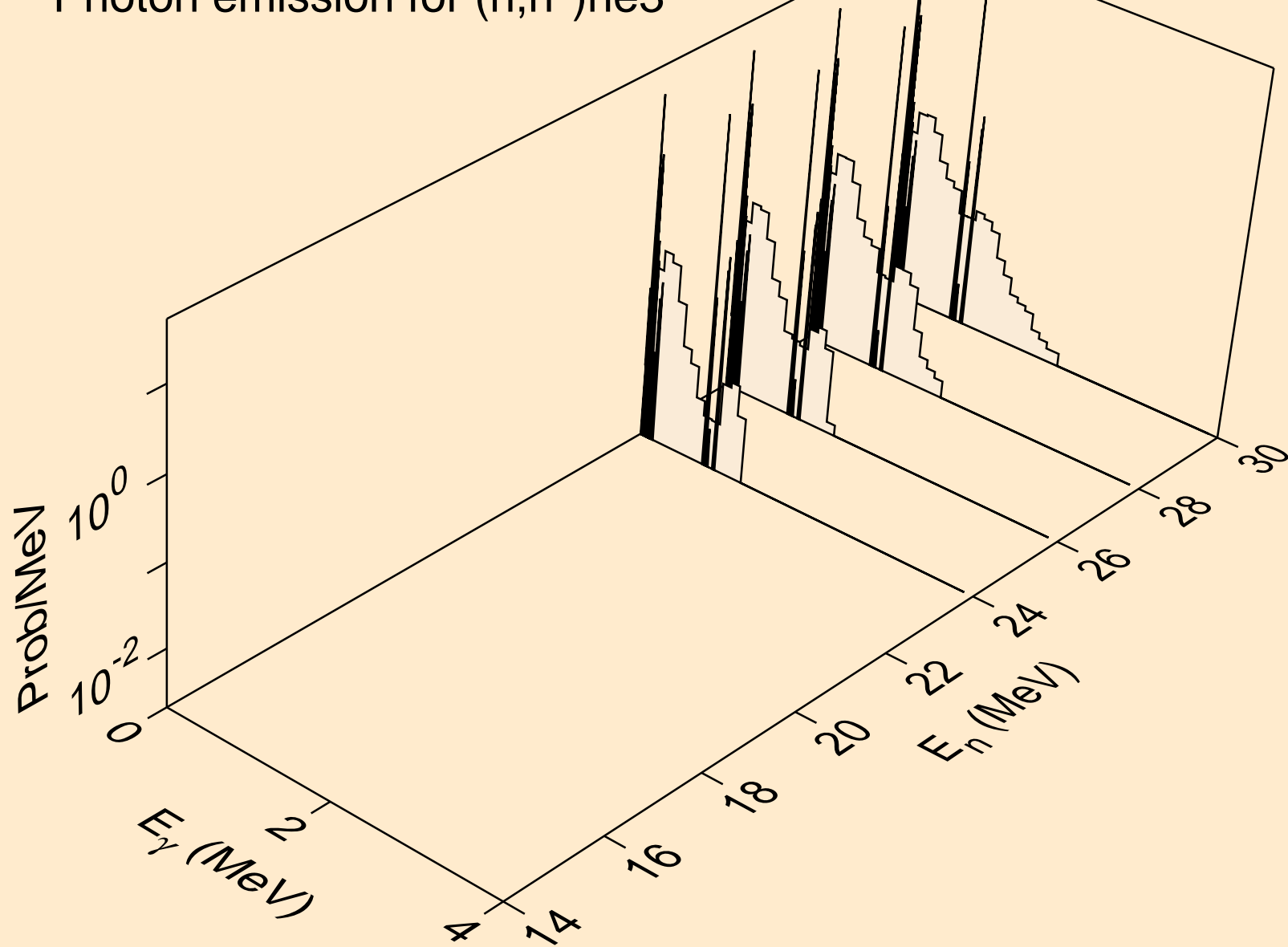

PT203M NEUTRON ACER TENDL-2023 LIBRARY; T=0.K  
Photon emission for (n,4n)

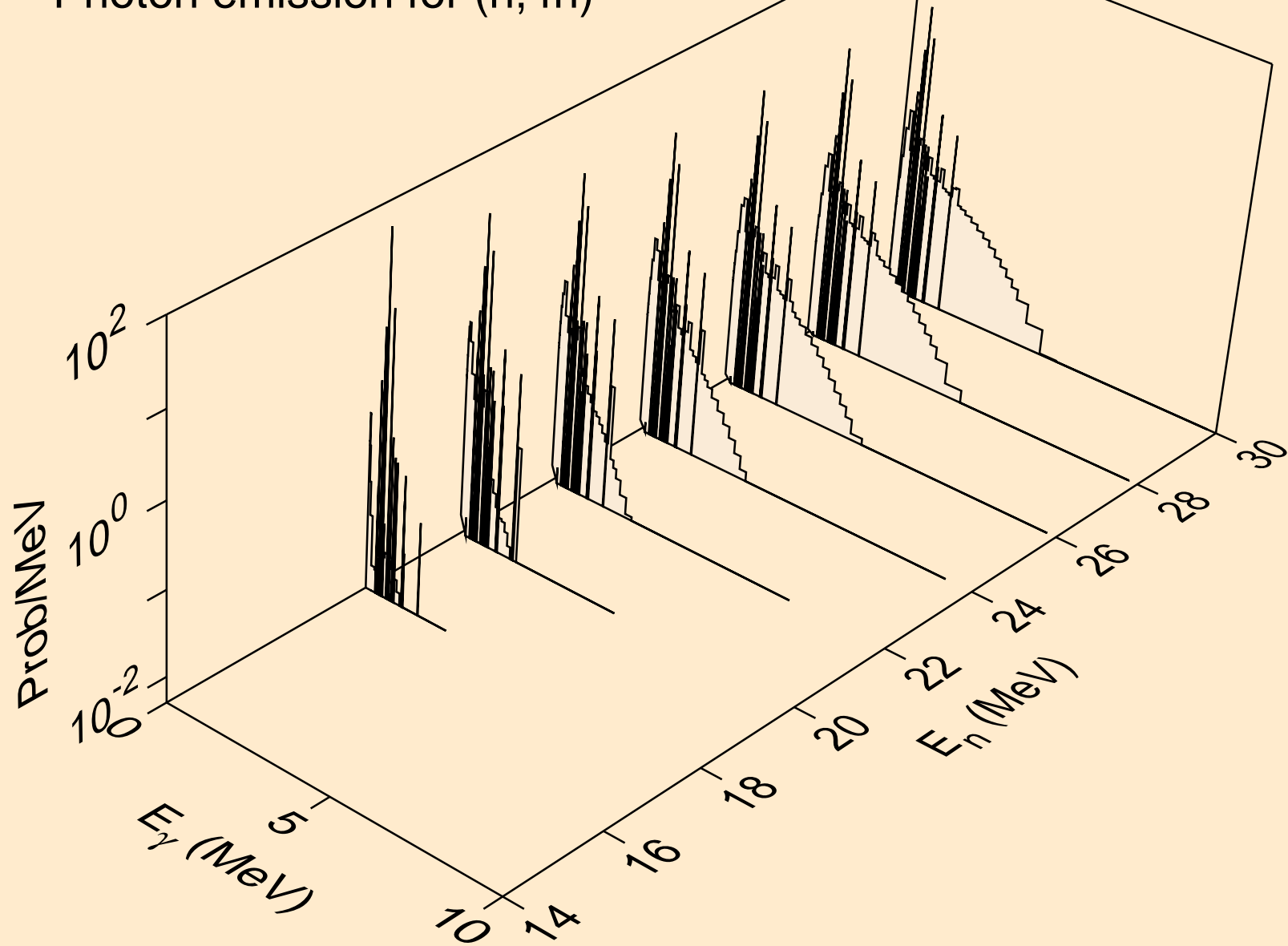

PT203M NEUTRON ACER TENDL-2023 LIBRARY; T=0.K  
Photon emission for (n,2np)

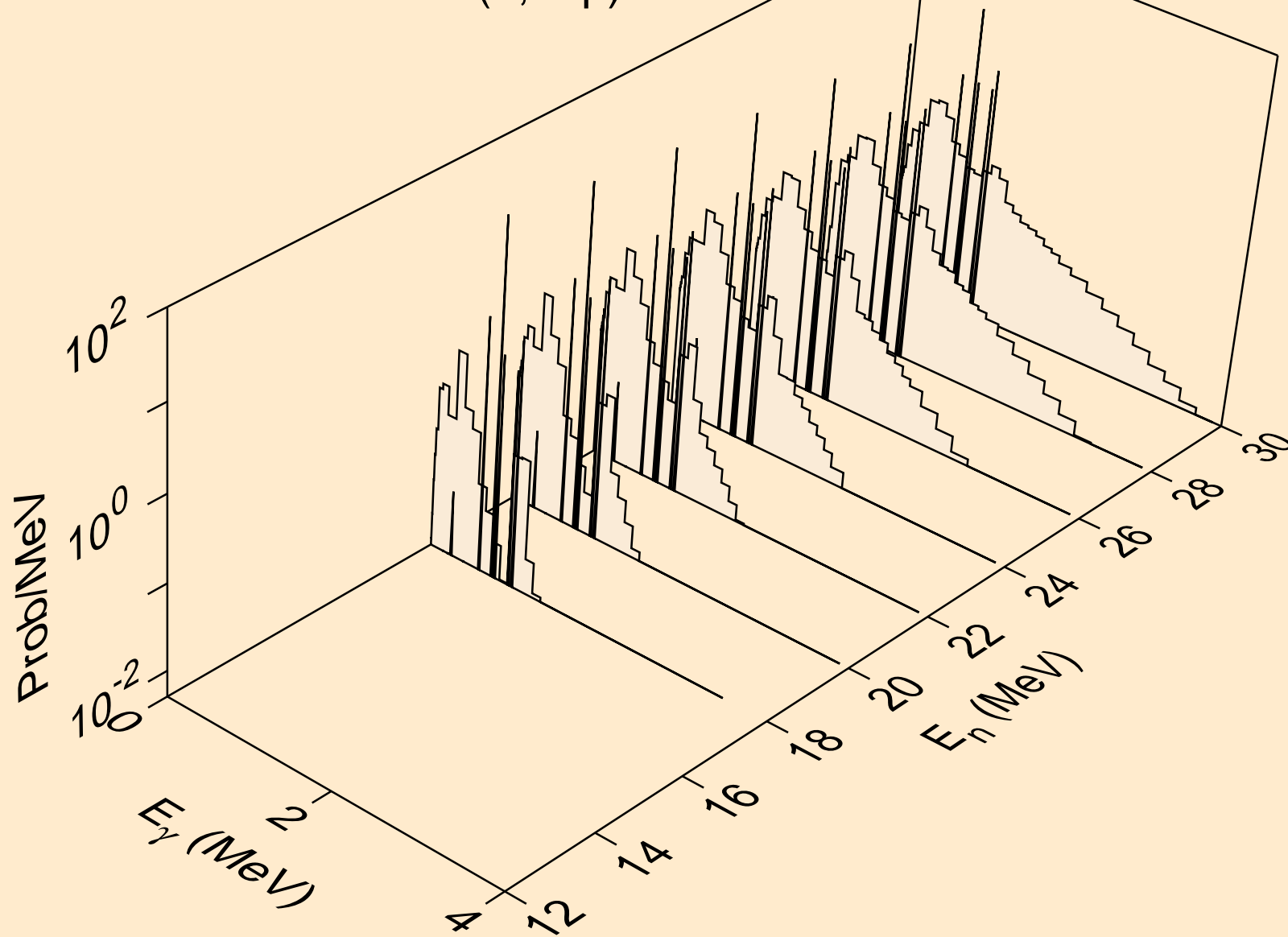

PT203M NEUTRON ACER TENDL-2023 LIBRARY; T=0.K  
Photon emission for (n,3np)

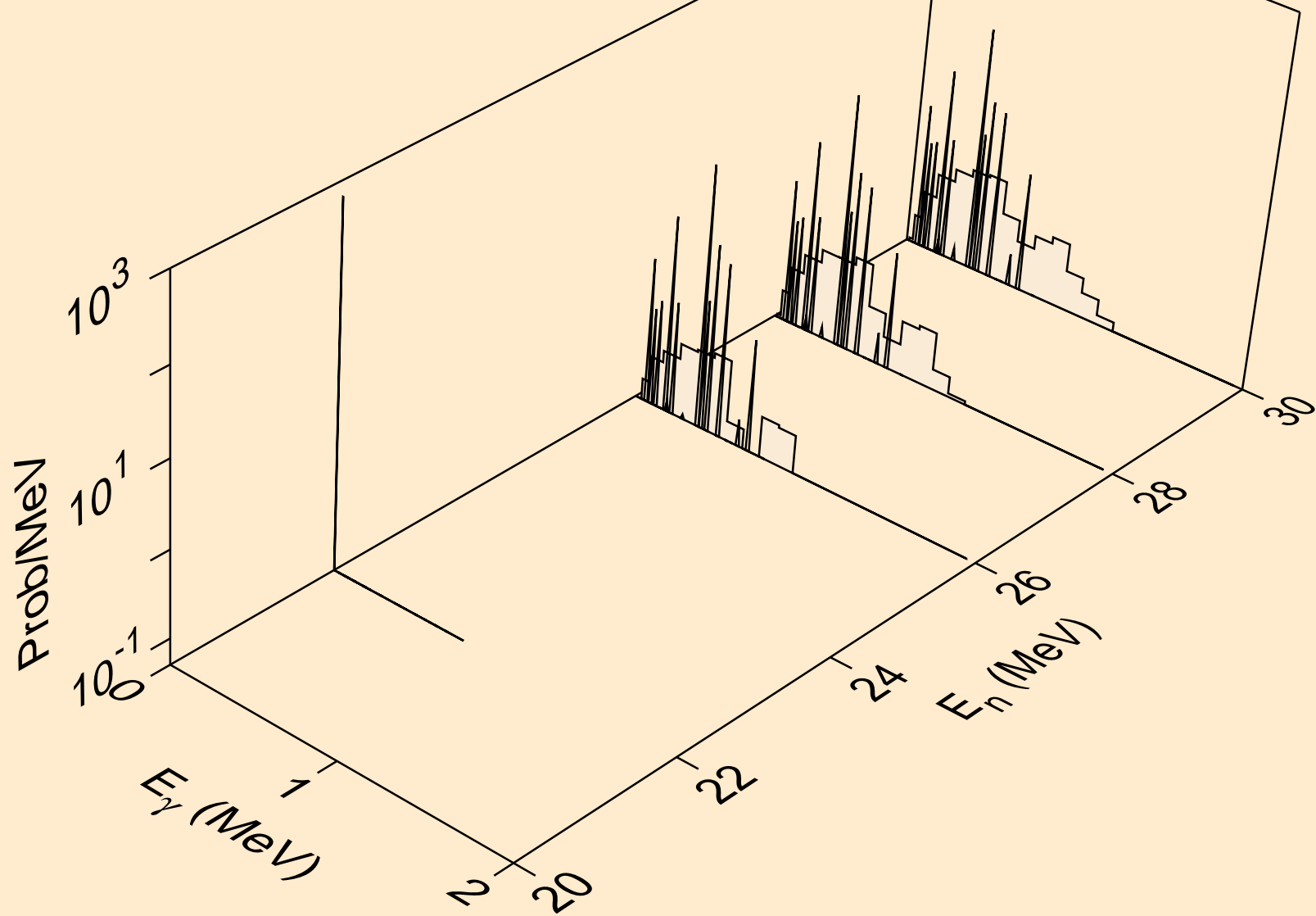

PT203M NEUTRON ACER TENDL-2023 LIBRARY; T=0.K  
Photon emission for (n,n\*1)

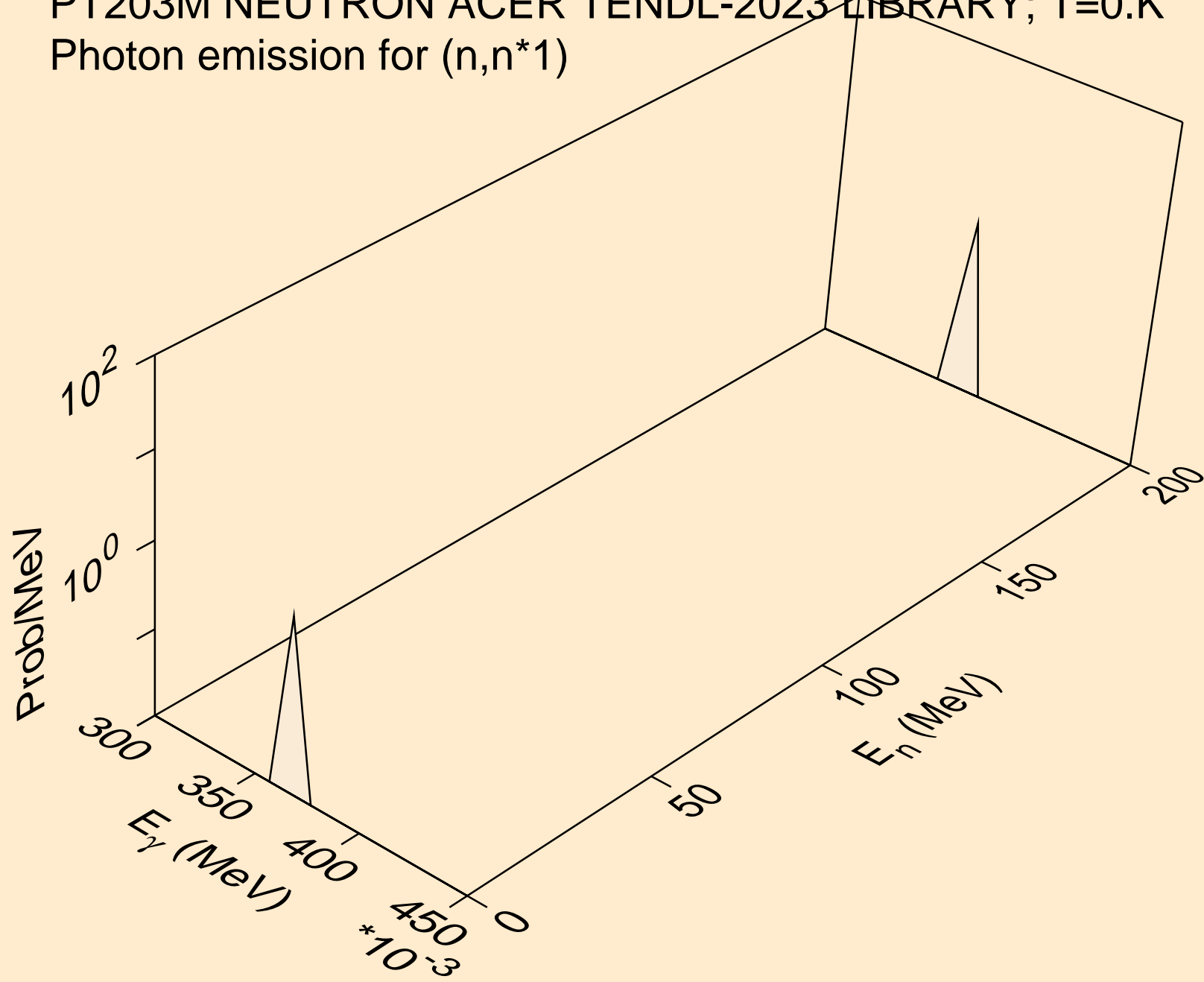

PT203M NEUTRON ACER TENDL-2023 LIBRARY; T=0.K  
Photon emission for (n,n\*3)

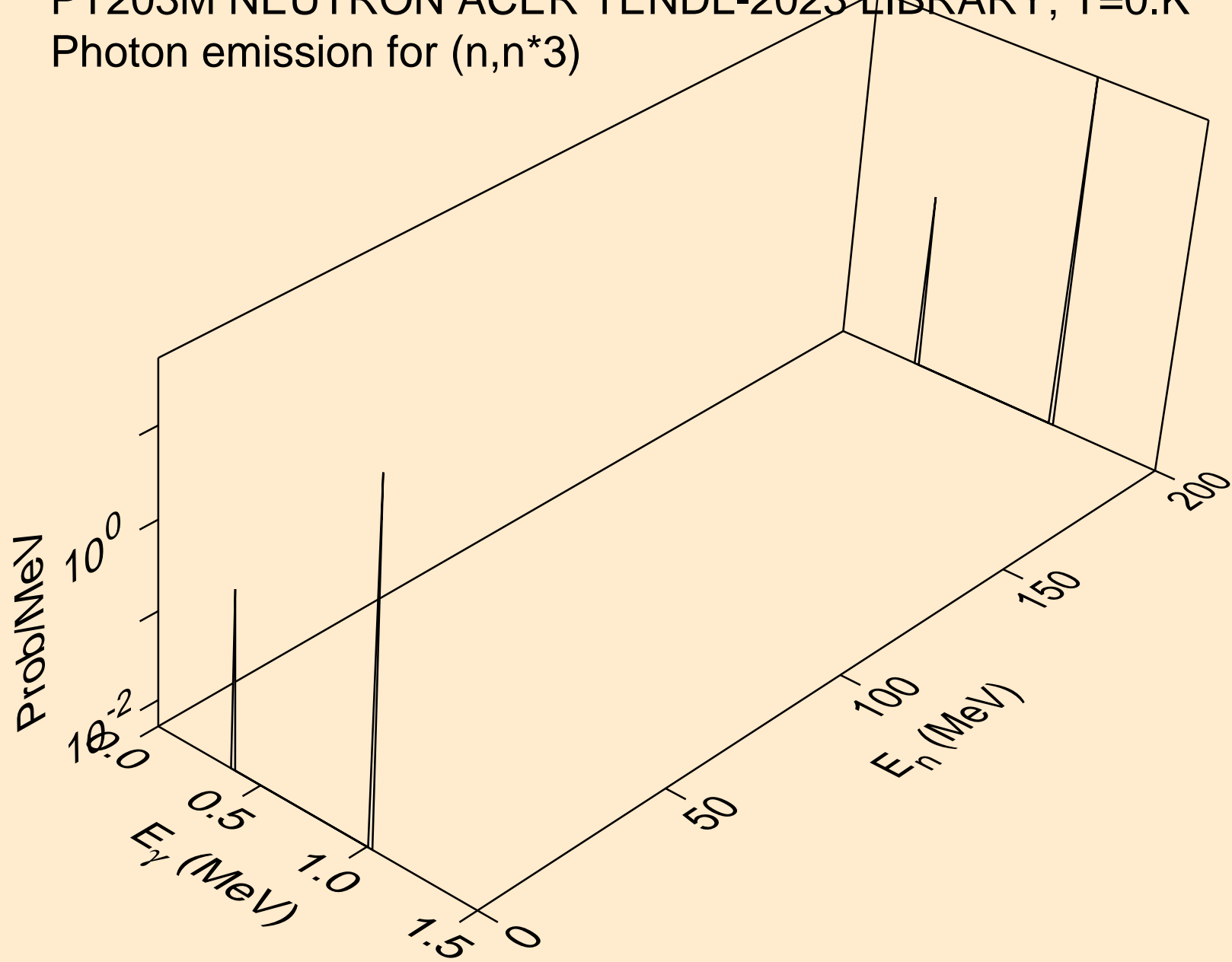



PT203M NEUTRON ACER TENDL-2023 LIBRARY; T=0.K  
Photon emission for (n,n\*4)

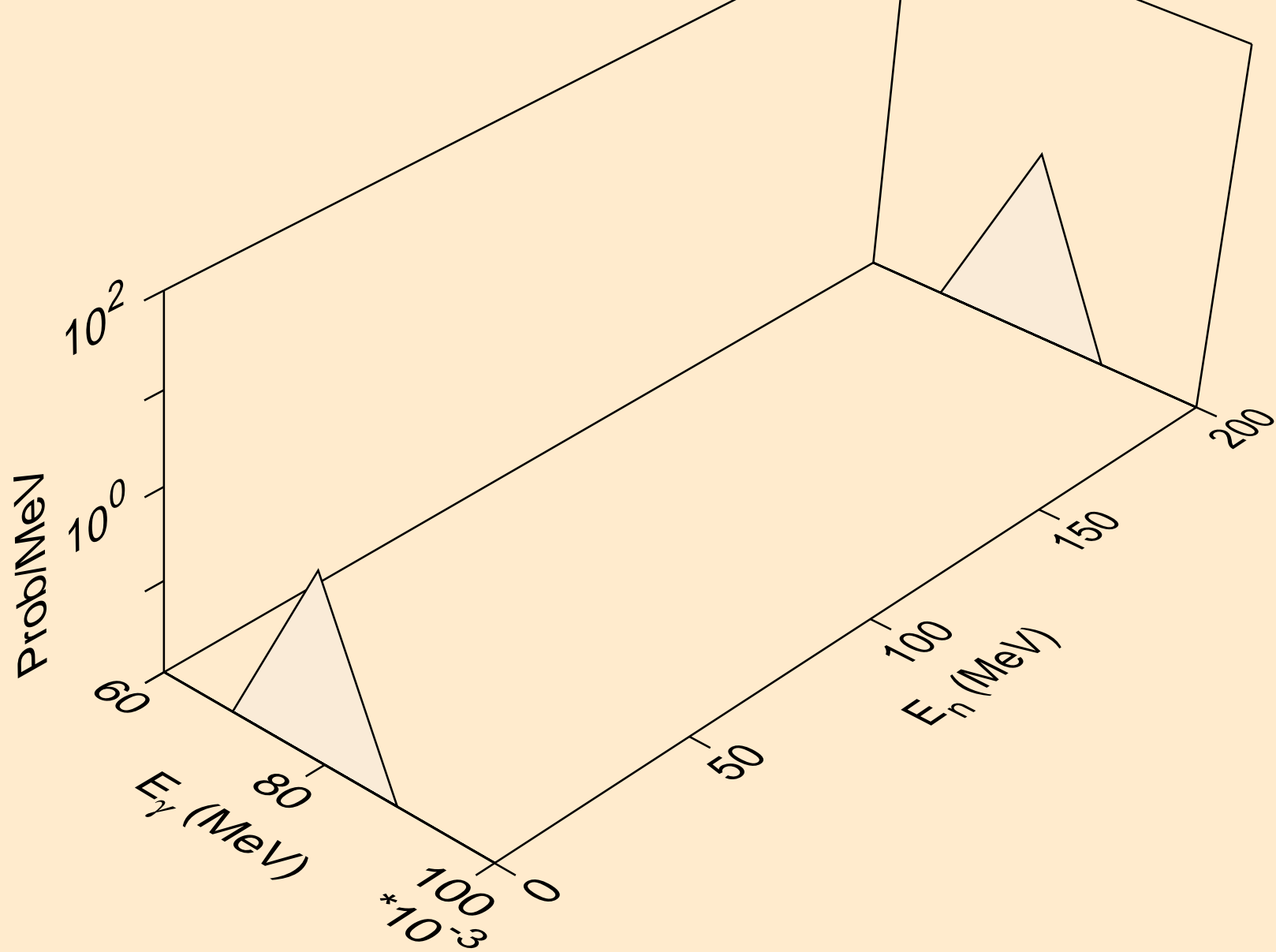

PT203M NEUTRON ACER TENDL-2023 LIBRARY; T=0.K  
Photon emission for (n,n\*5)

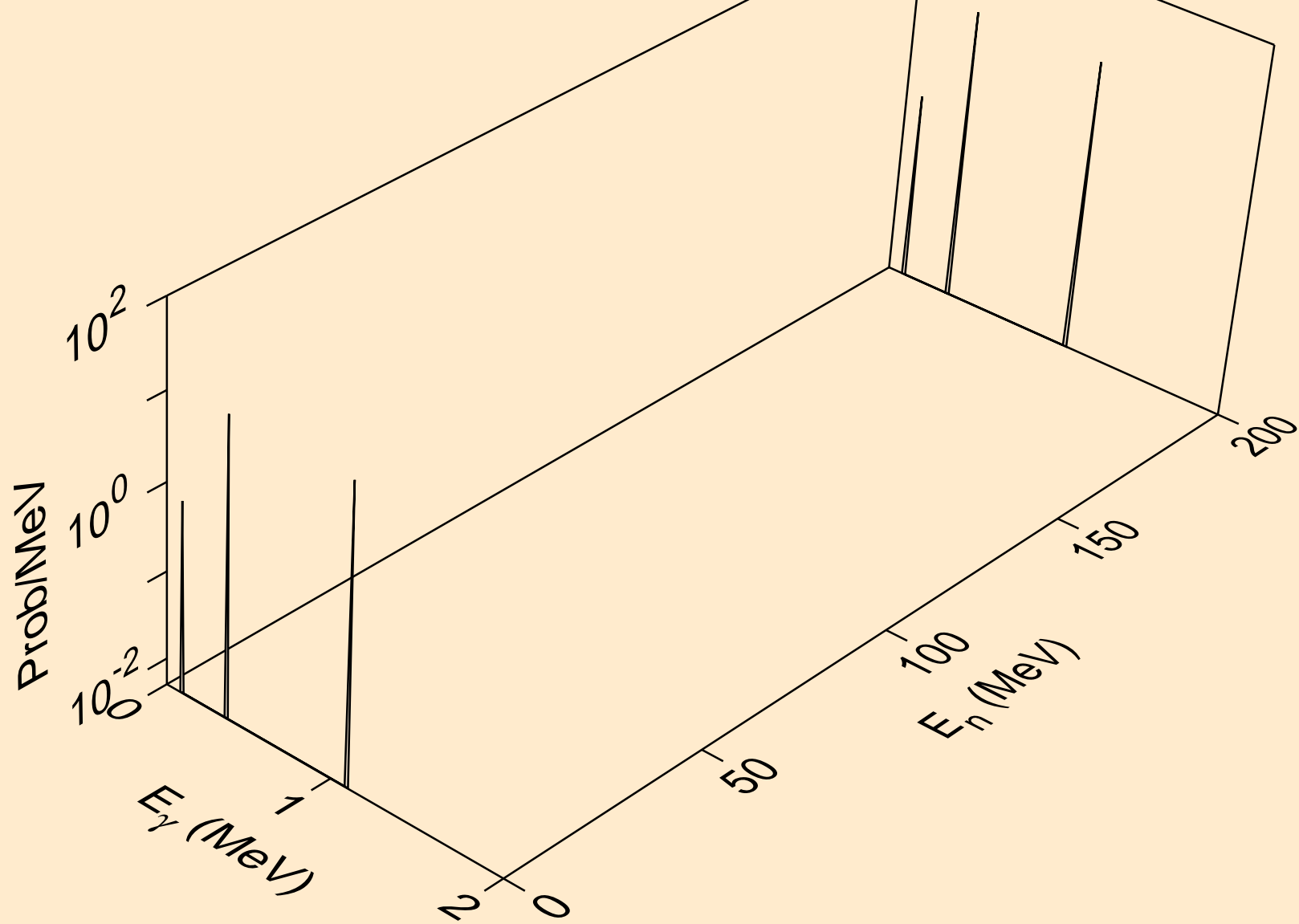

PT203M NEUTRON ACER TENDL-2023 LIBRARY; T=0.K  
Photon emission for (n,n\*6)

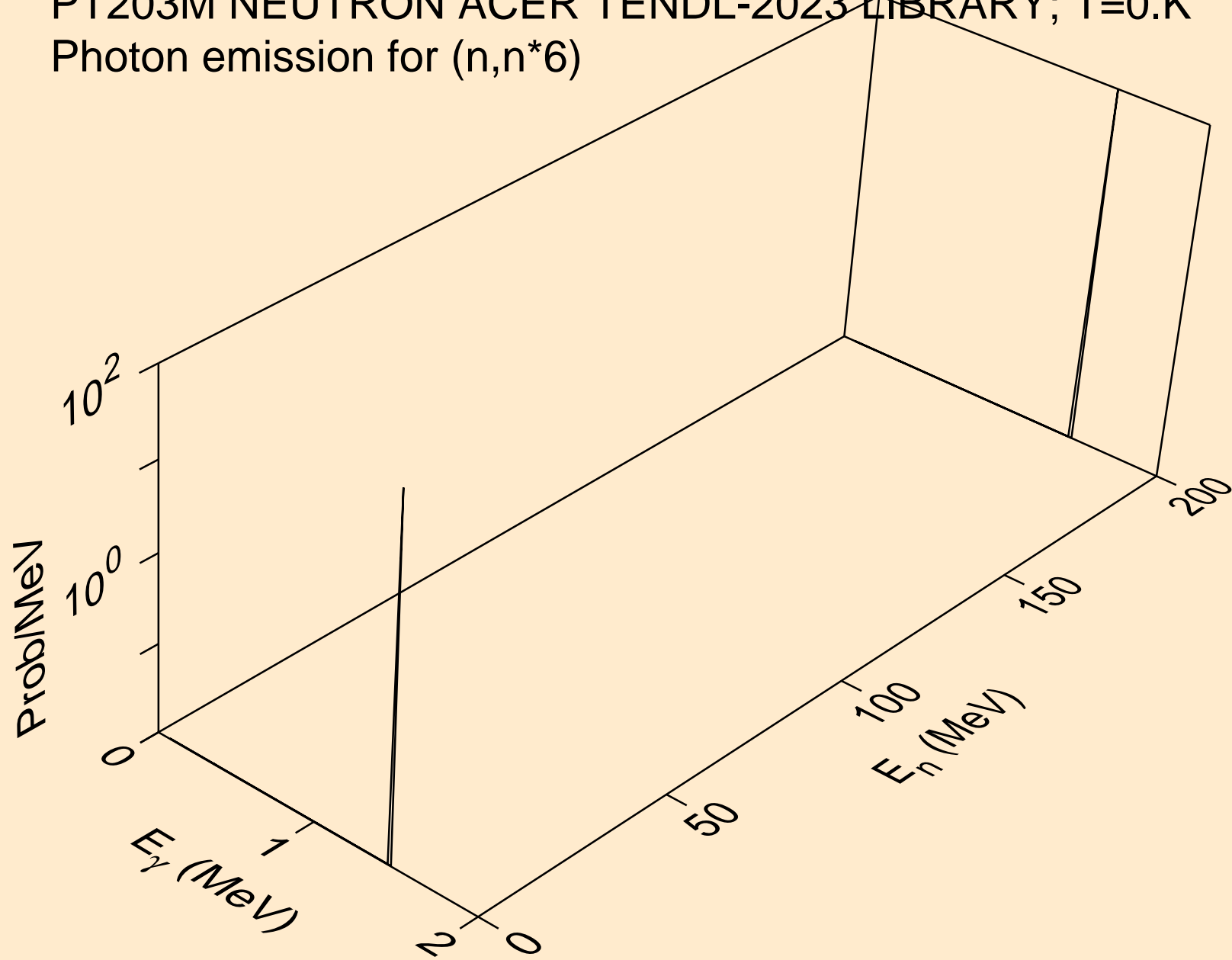

PT203M NEUTRON ACER TENDL-2023 LIBRARY; T=0.K  
Photon emission for (n,n\*7)

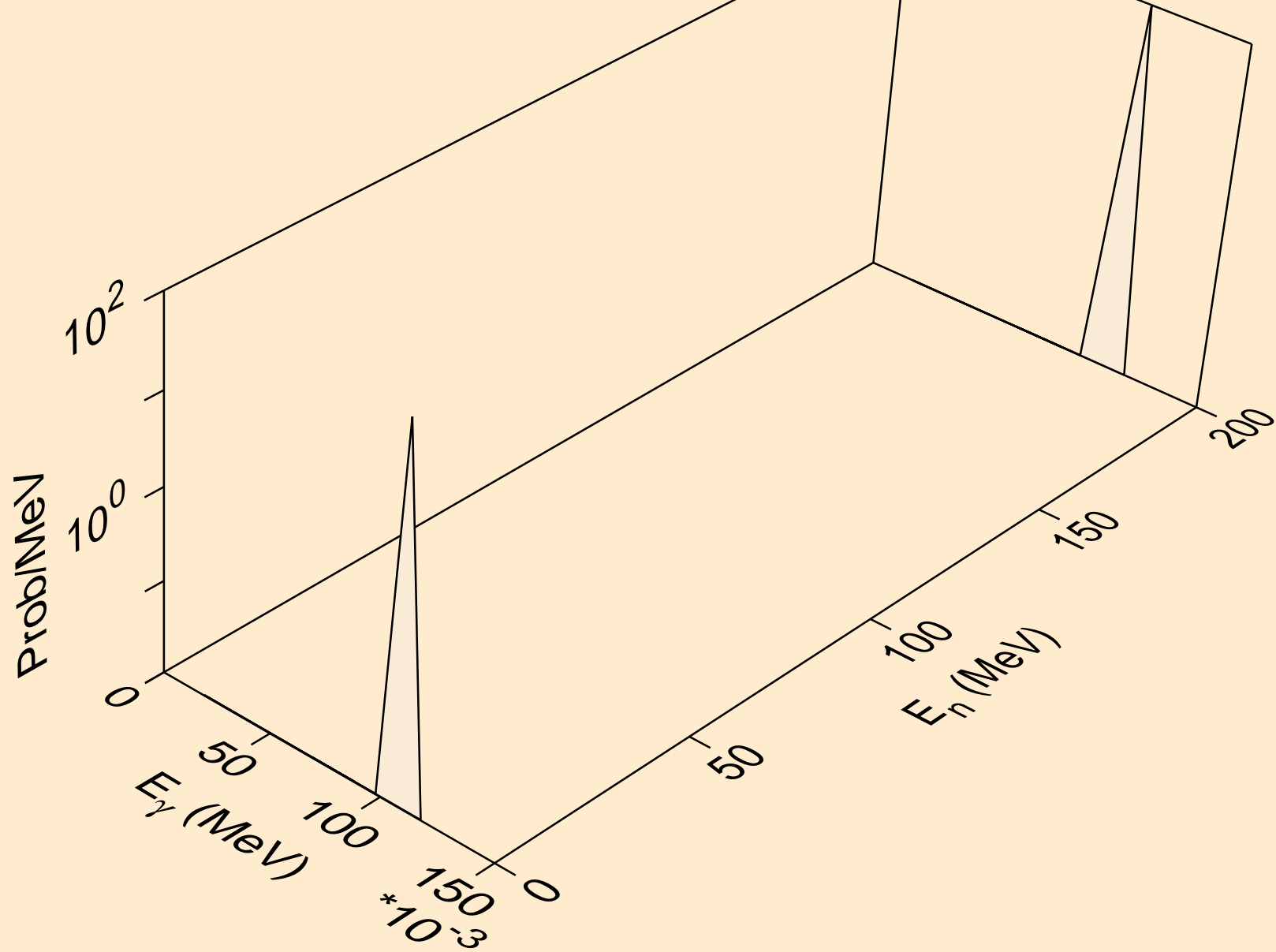

PT203M NEUTRON ACER TENDL-2023 LIBRARY; T=0.K  
Photon emission for (n,n\*8)

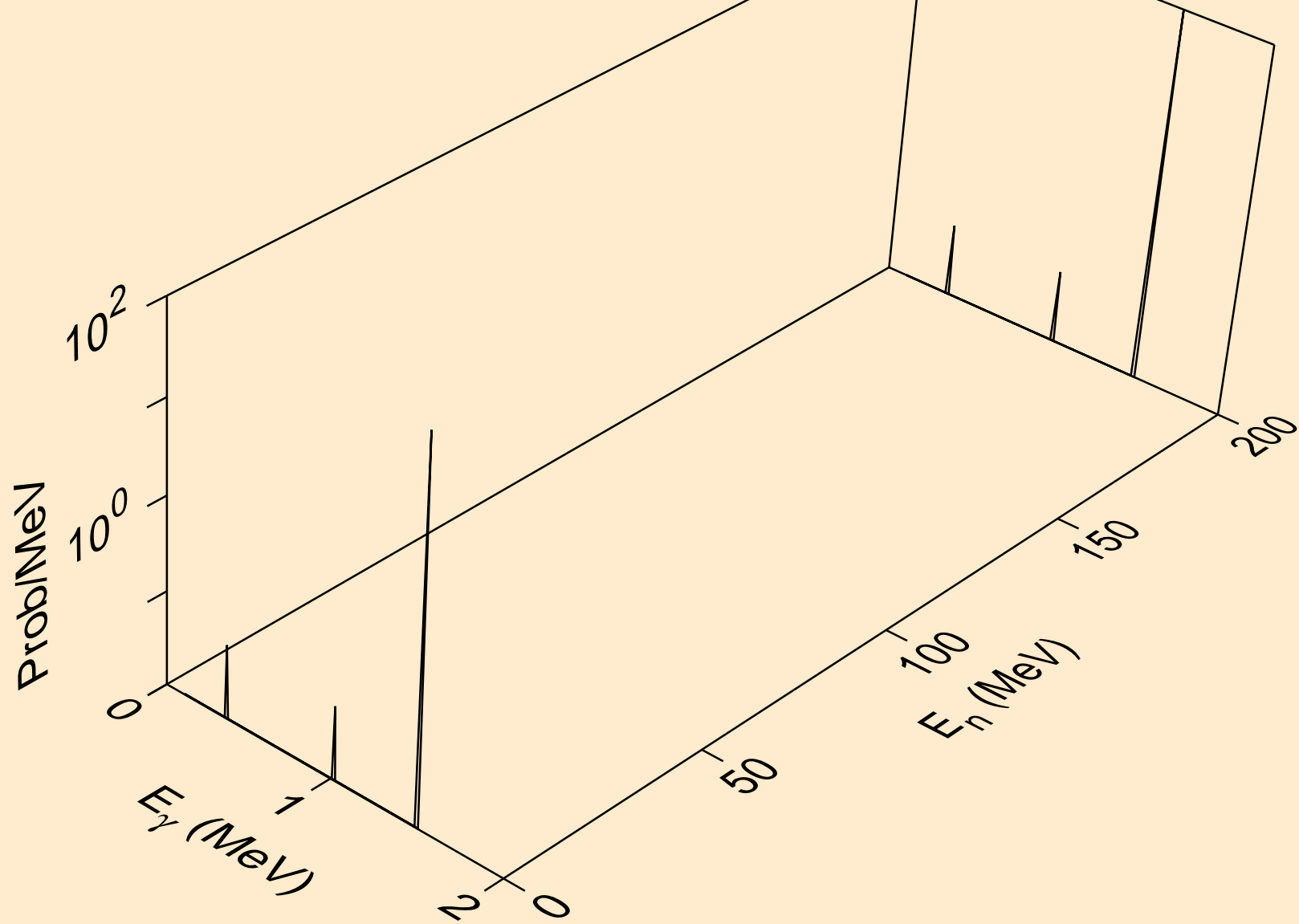

PT203M NEUTRON ACER TENDL-2023 LIBRARY; T=0.K  
Photon emission for (n,n\*9)

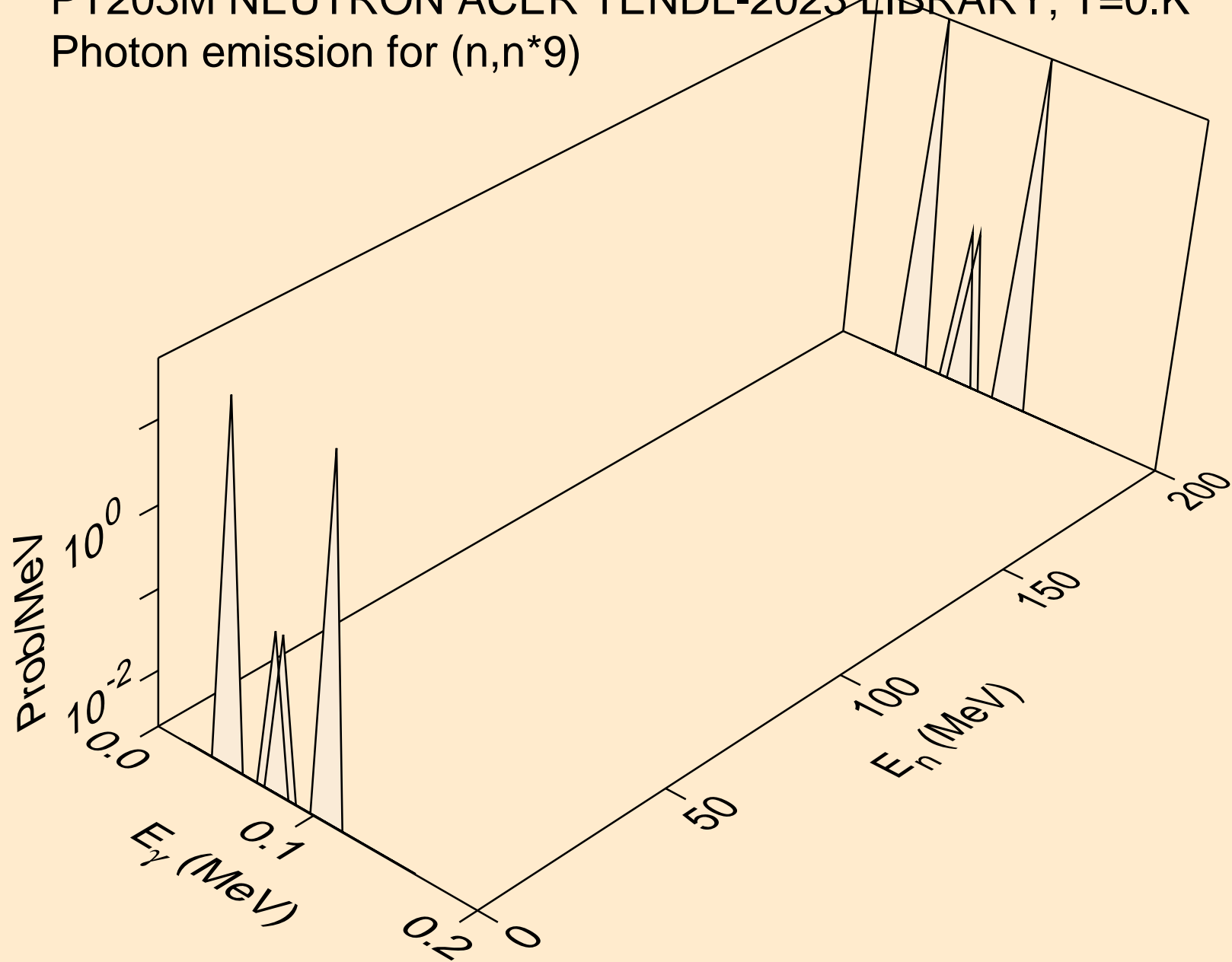

PT203M NEUTRON ACER TENDL-2023 LIBRARY; T=0.K  
Photon emission for (n,n\*10)

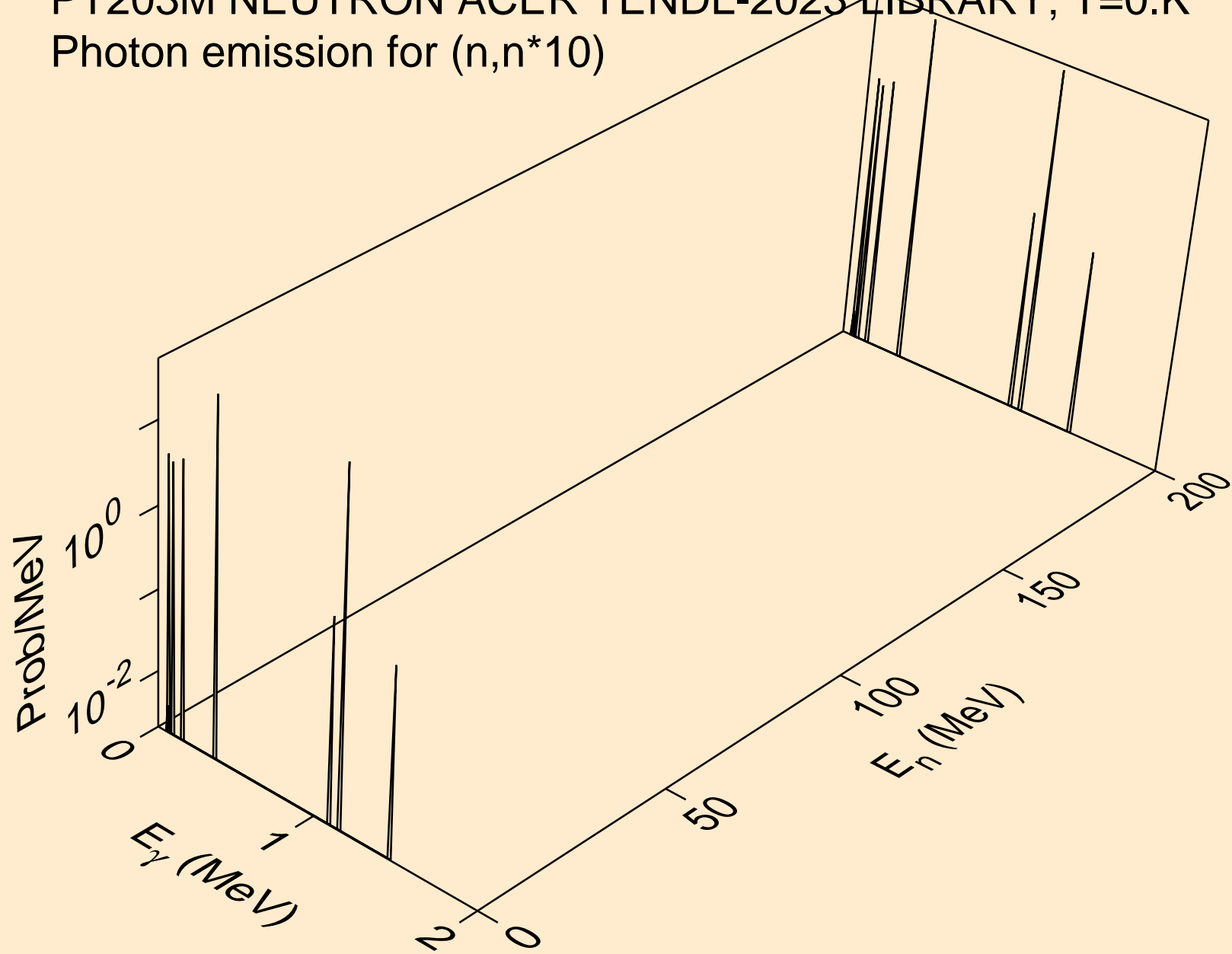

PT203M NEUTRON ACER TENDL-2023 LIBRARY; T=0.K  
Photon emission for (n,n\*11)

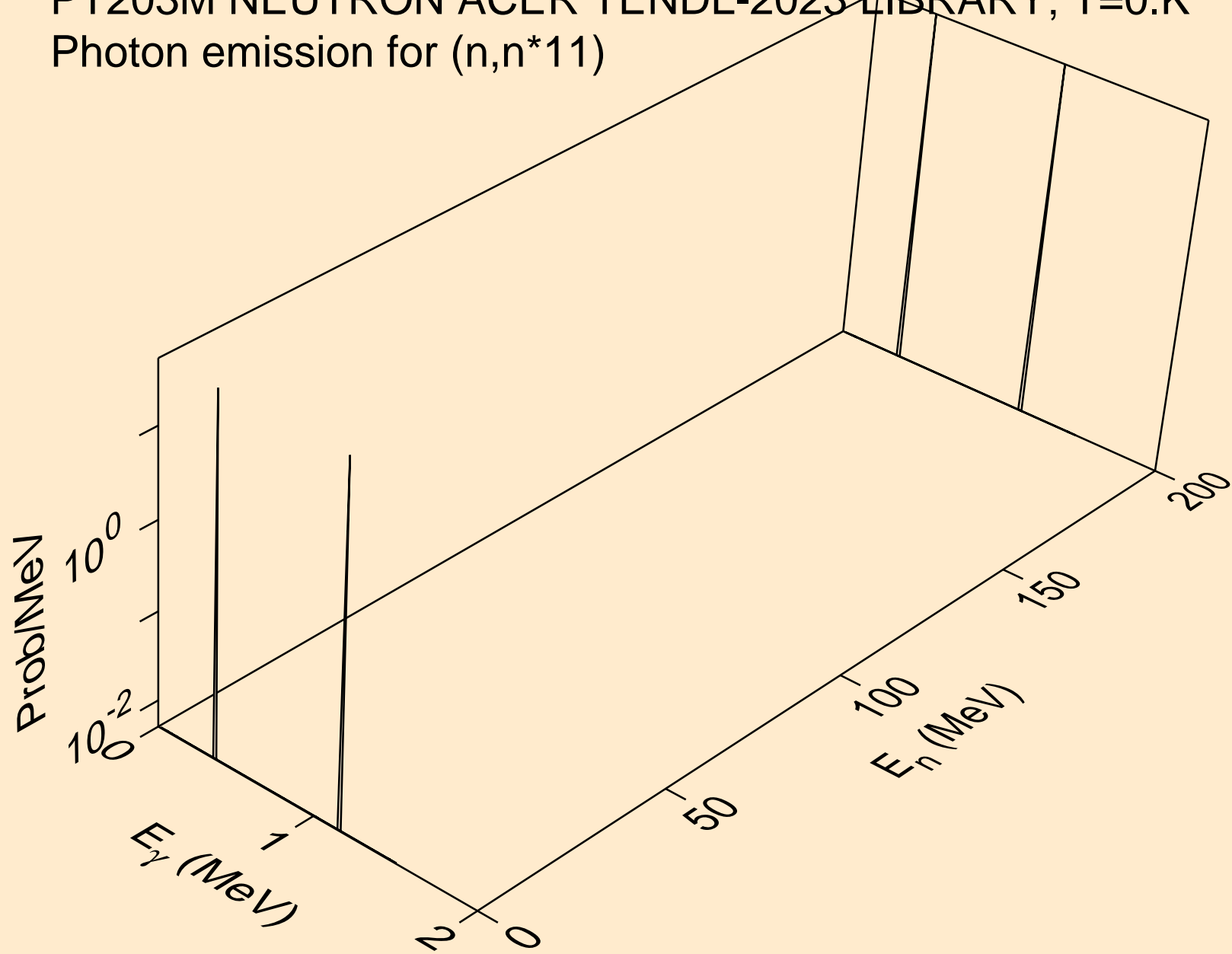



PT203M NEUTRON ACER TENDL-2023 LIBRARY; T=0.K  
Photon emission for (n,n\*12)

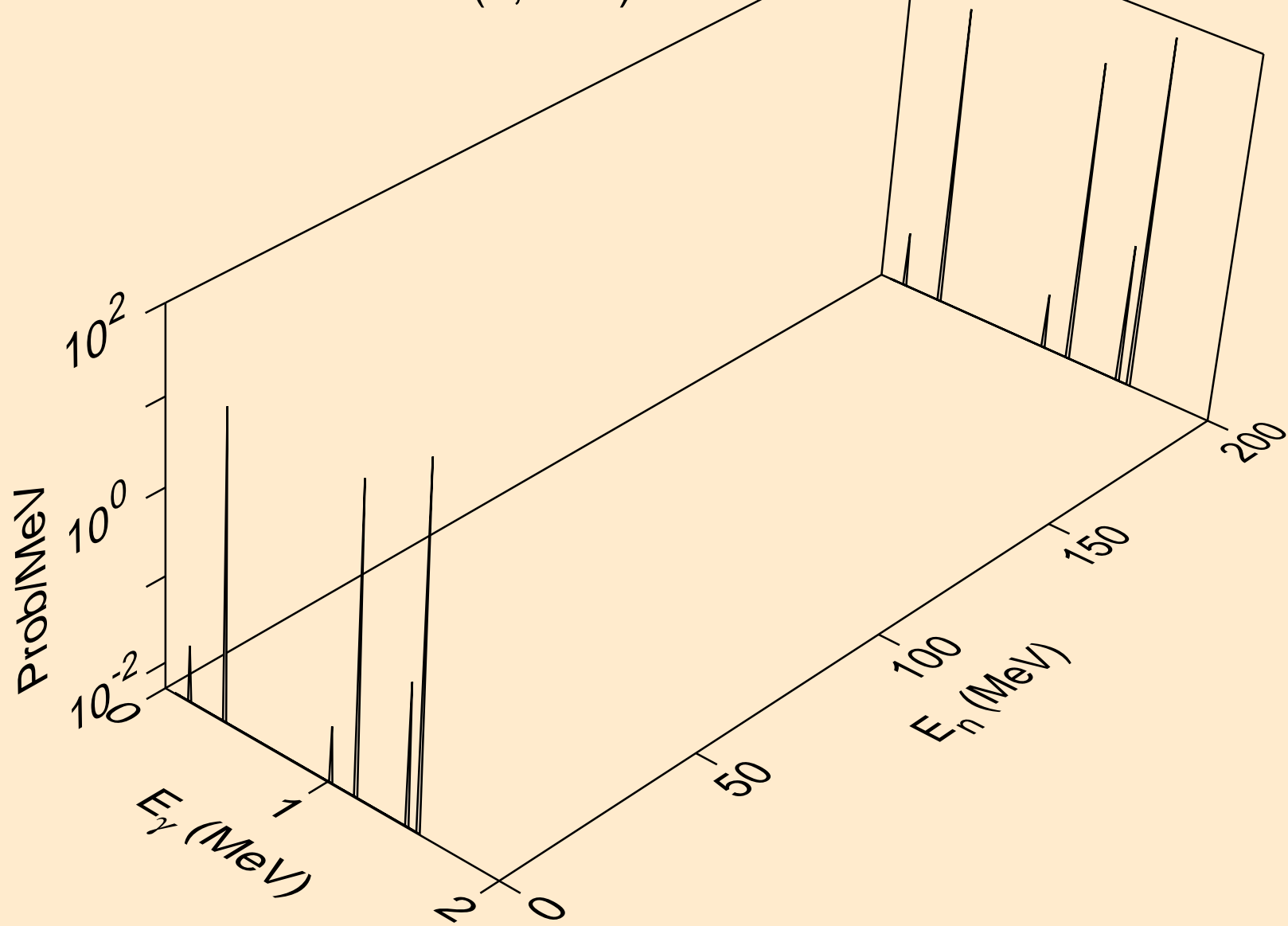

PT203M NEUTRON ACER TENDL-2023 LIBRARY; T=0.K  
Photon emission for (n,n\*13)

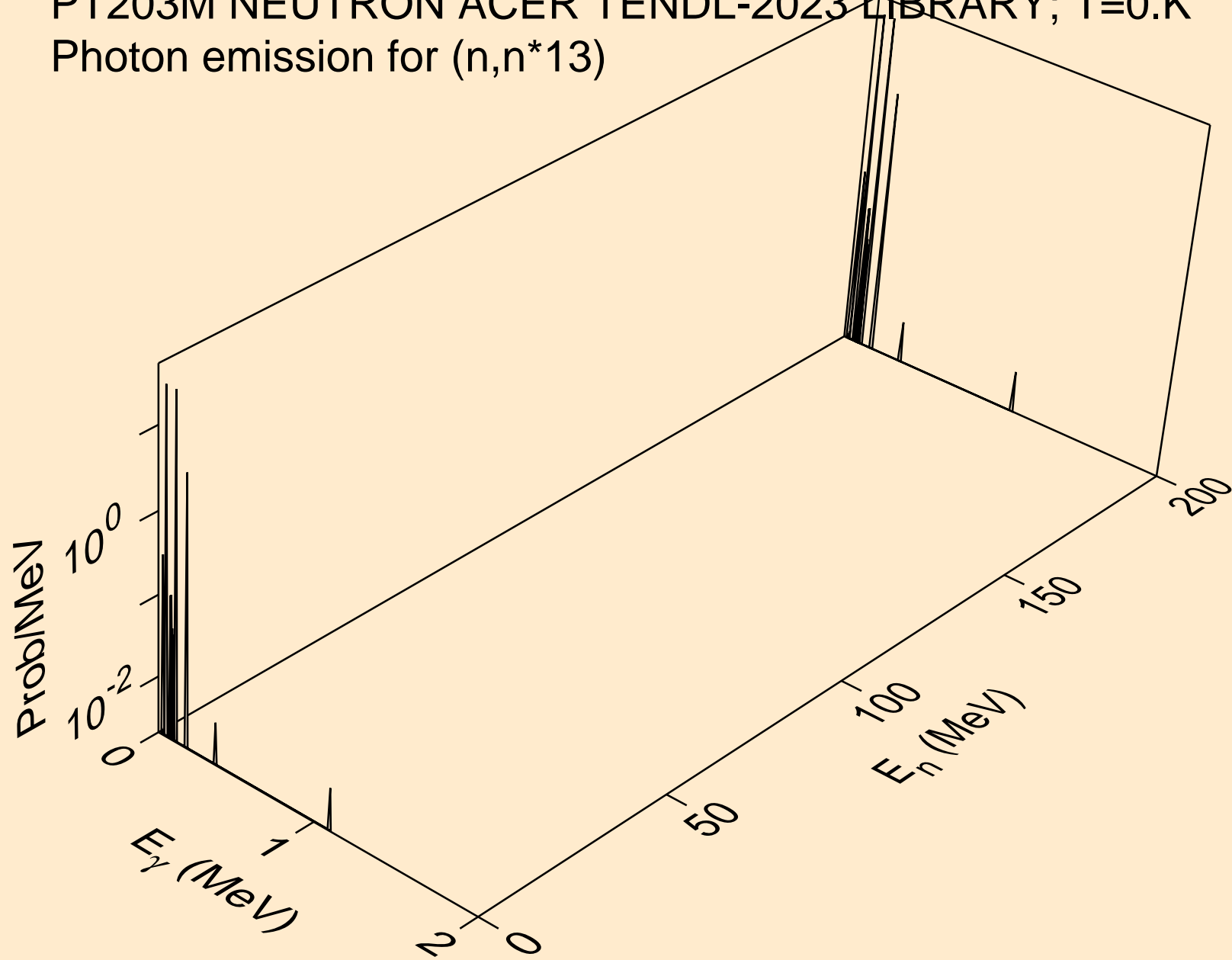

PT203M NEUTRON ACER TENDL-2023 LIBRARY; T=0.K  
Photon emission for (n,n\*14)

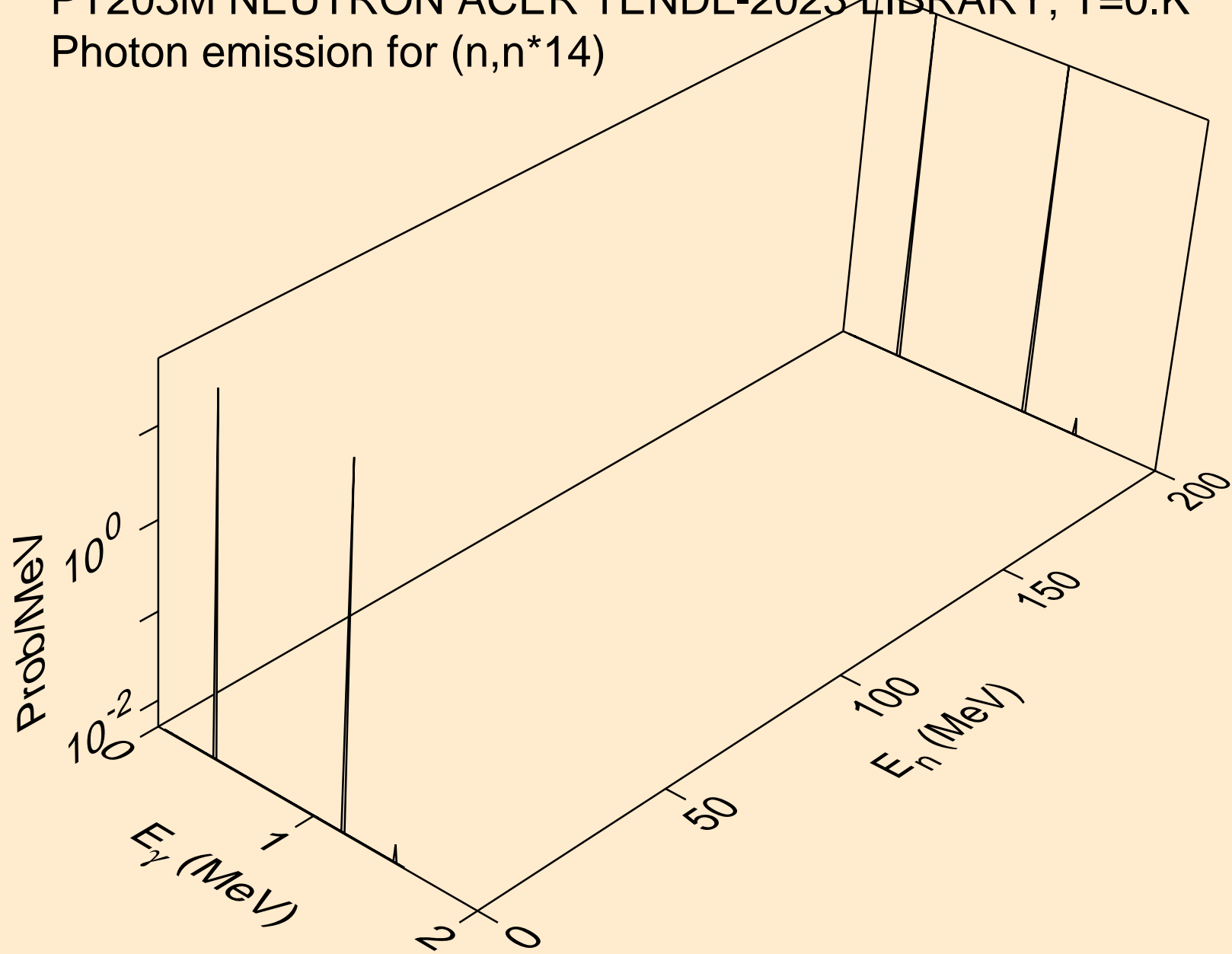

PT203M NEUTRON ACER TENDL-2023 LIBRARY; T=0.K  
Photon emission for (n,n\*15)

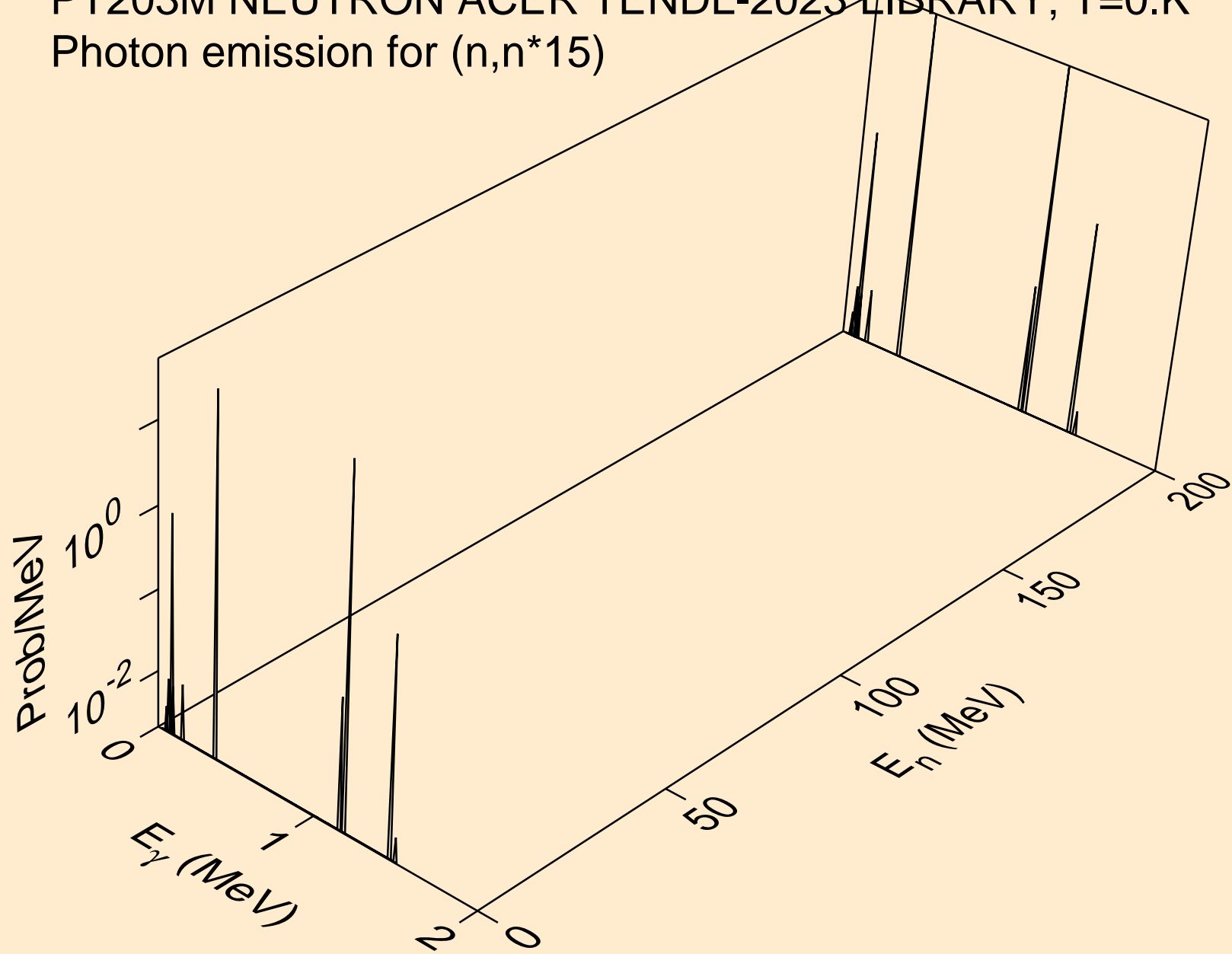

PT203M NEUTRON ACER TENDL-2023 LIBRARY; T=0.K  
Photon emission for (n,n\*16)

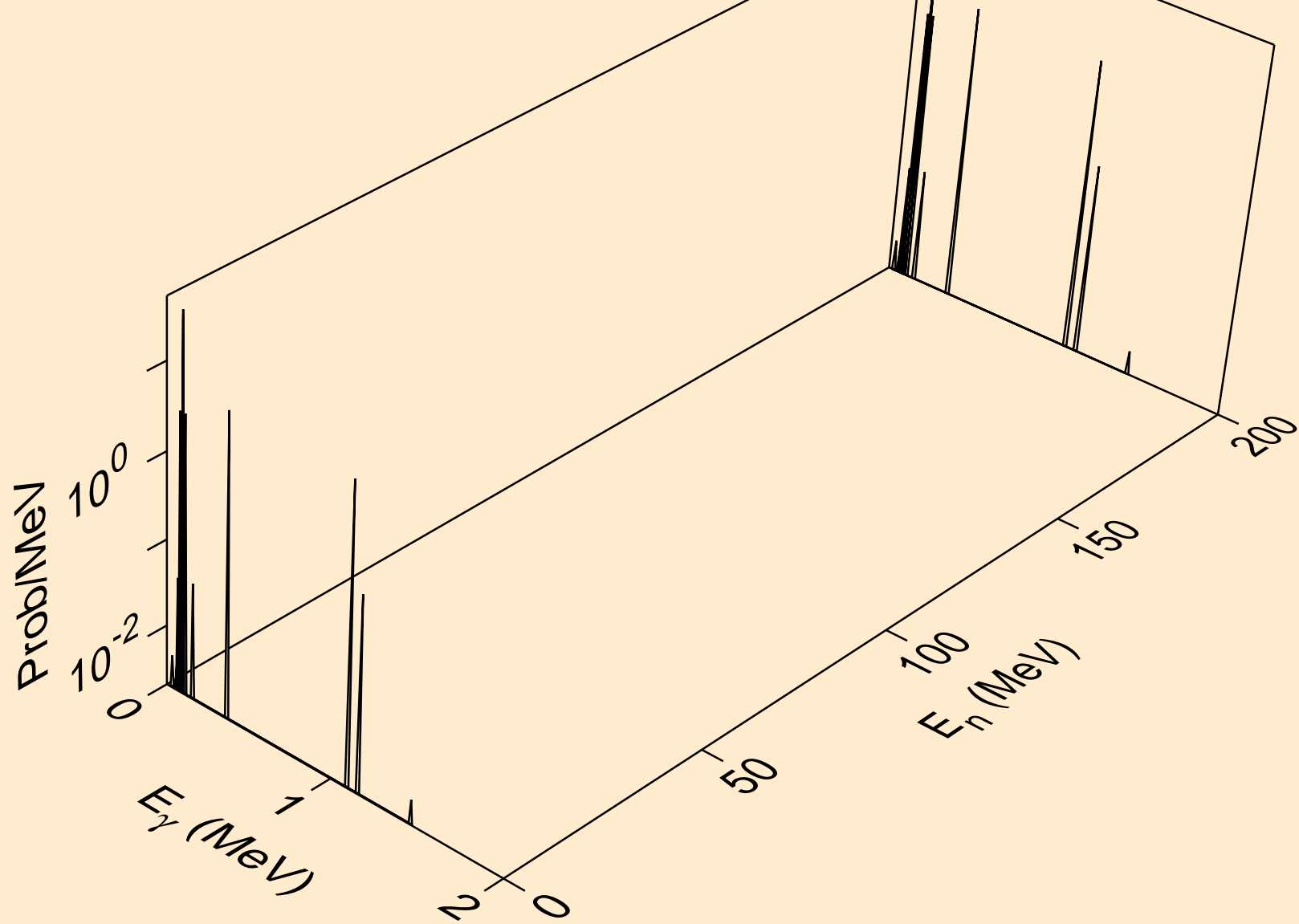

PT203M NEUTRON ACER TENDL-2023 LIBRARY; T=0.K  
Photon emission for (n,n\*17)

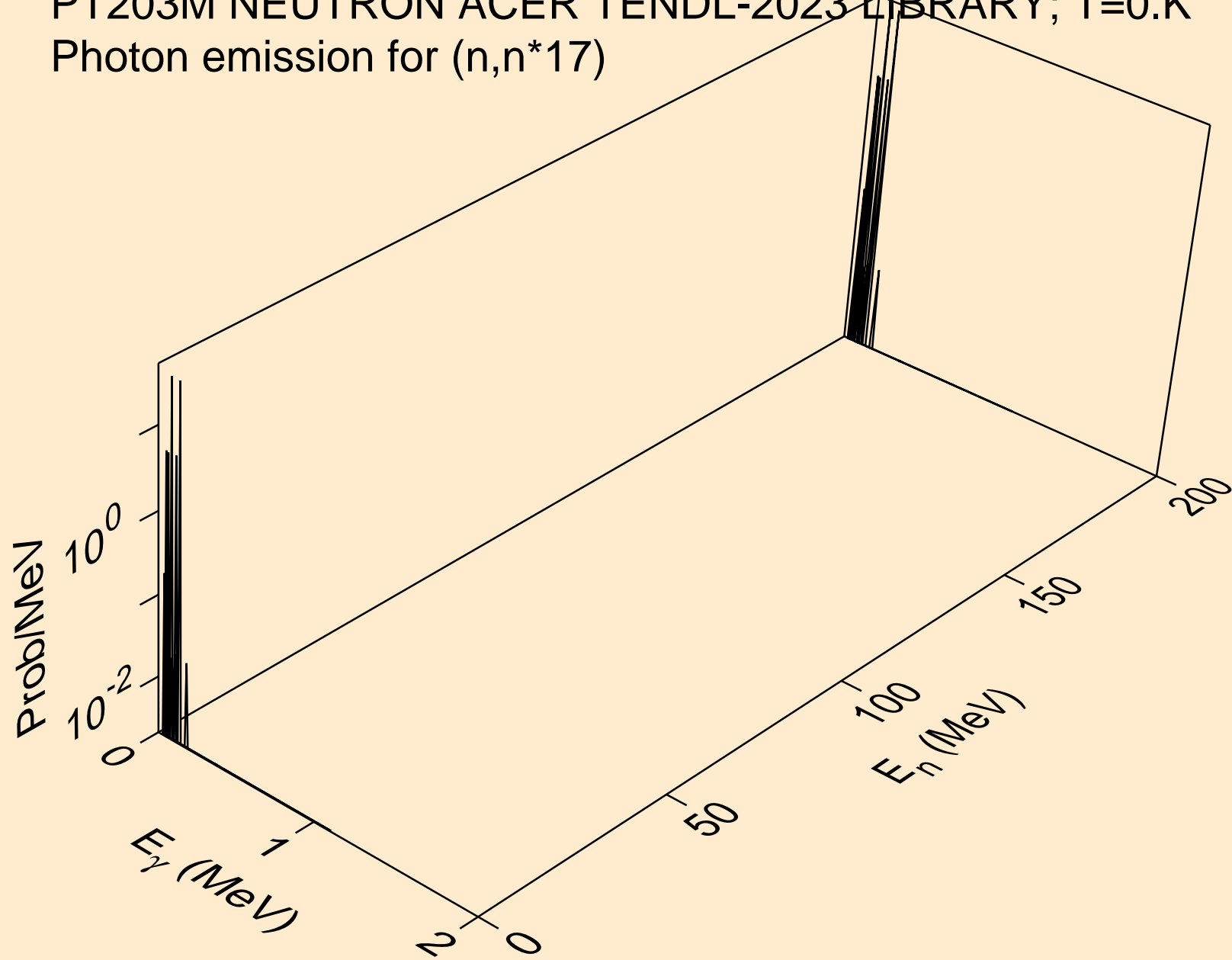

PT203M NEUTRON ACER TENDL-2023 LIBRARY; T=0.K  
Photon emission for (n,n\*18)

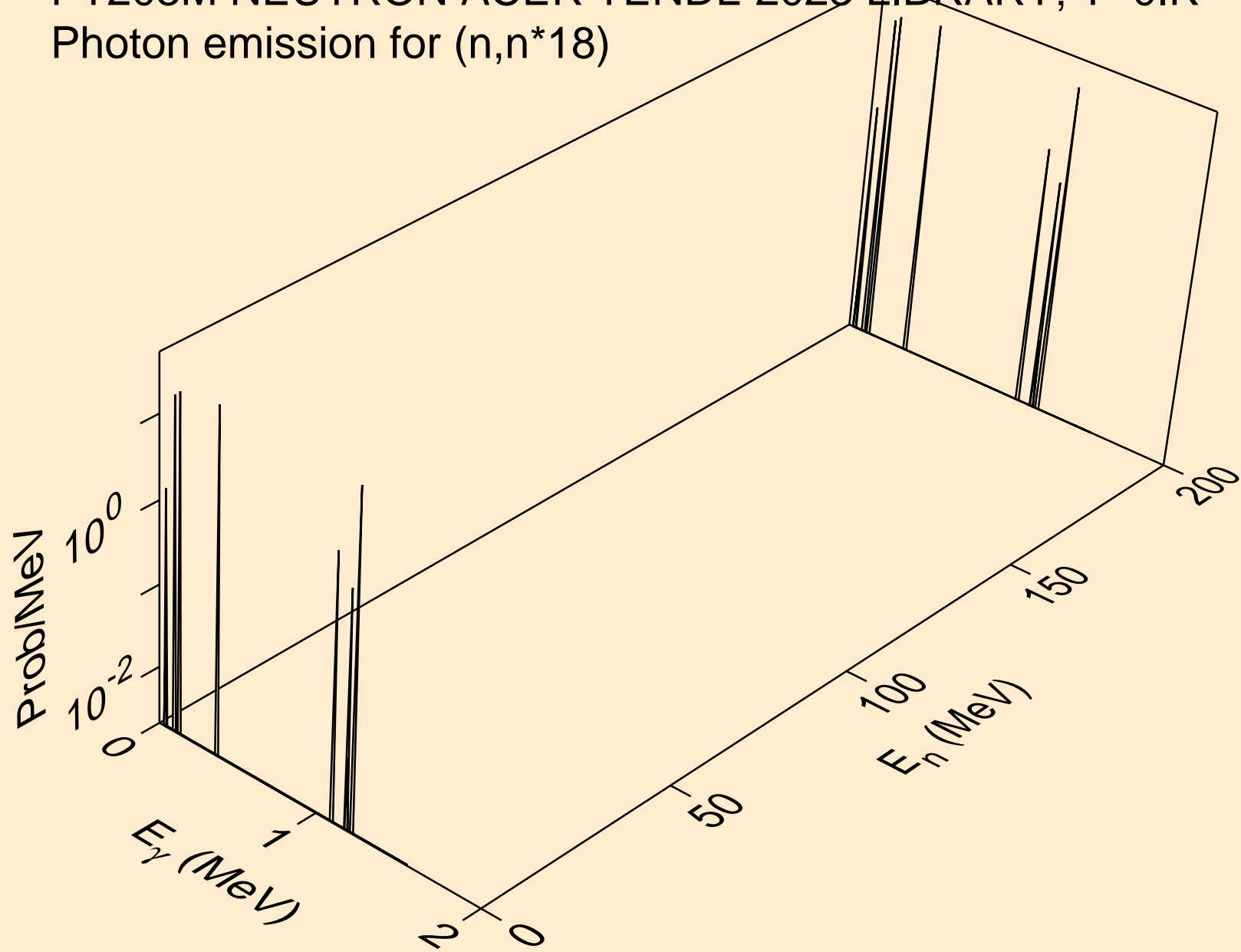

PT203M NEUTRON ACER TENDL-2023 LIBRARY; T=0.K  
Photon emission for (n,n\*19)

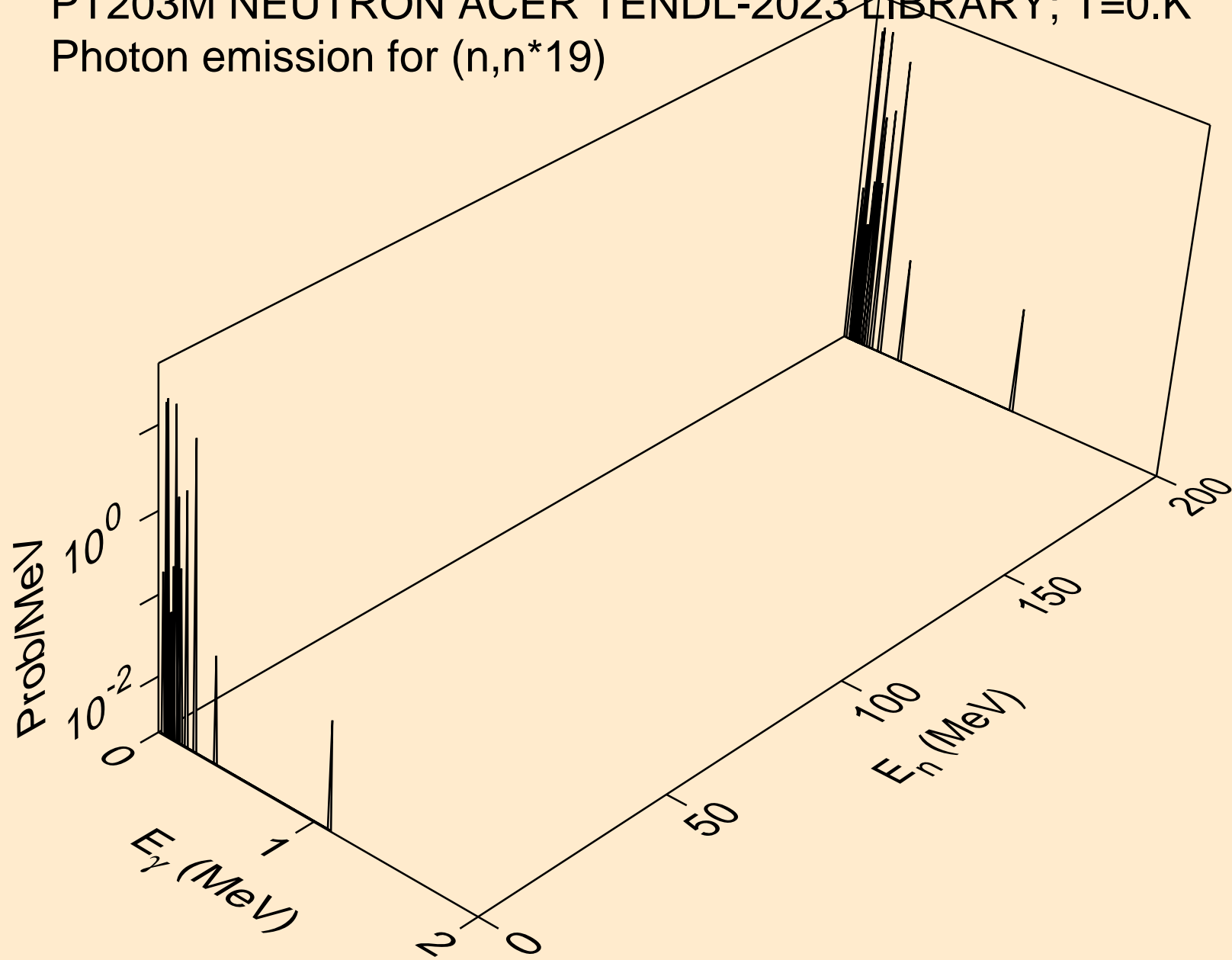



PT203M NEUTRON ACER TENDL-2023 LIBRARY; T=0.K  
Photon emission for (n,n\*20)

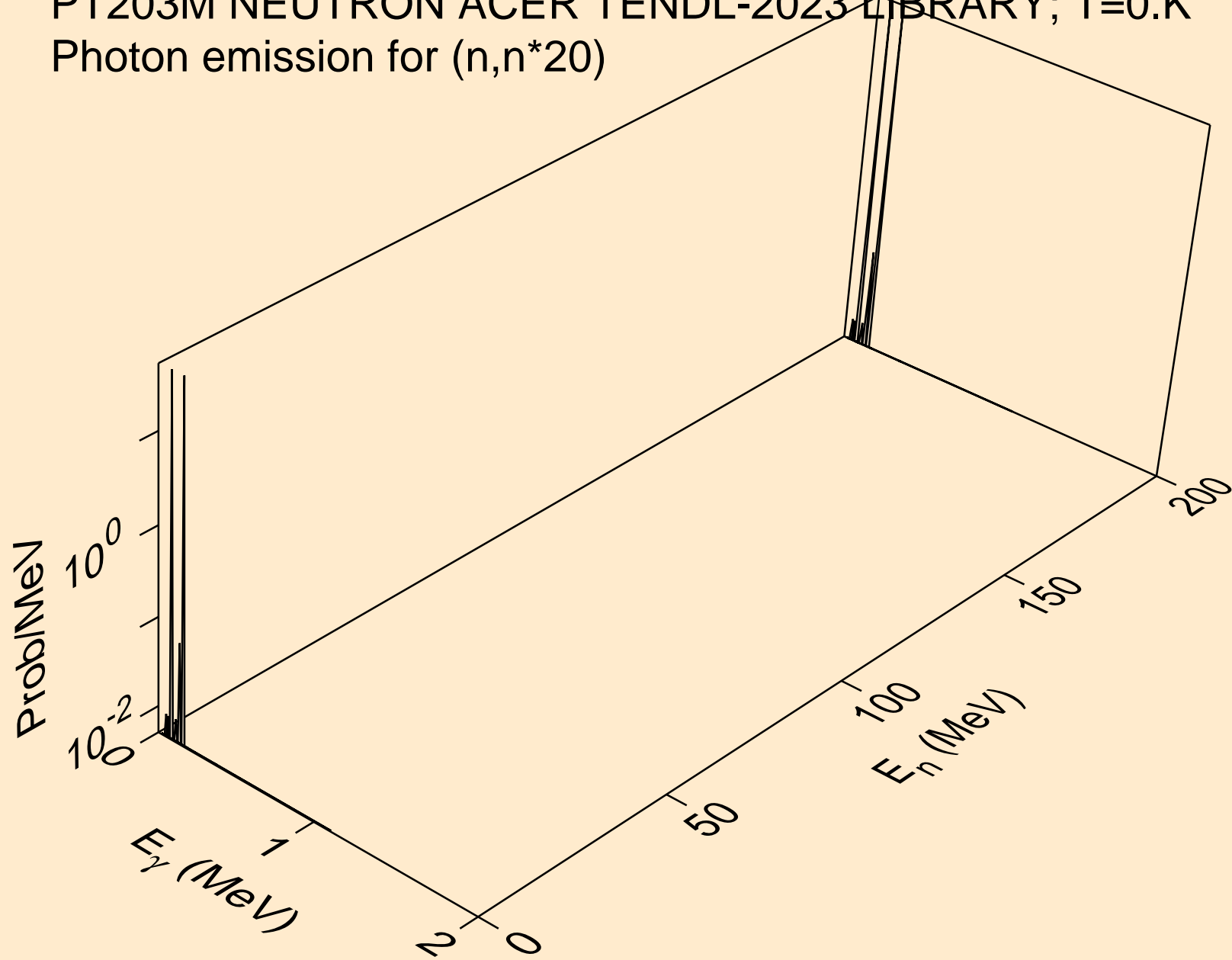

PT203M NEUTRON ACER TENDL-2023 LIBRARY; T=0.K  
Photon emission for (n,n\*21)

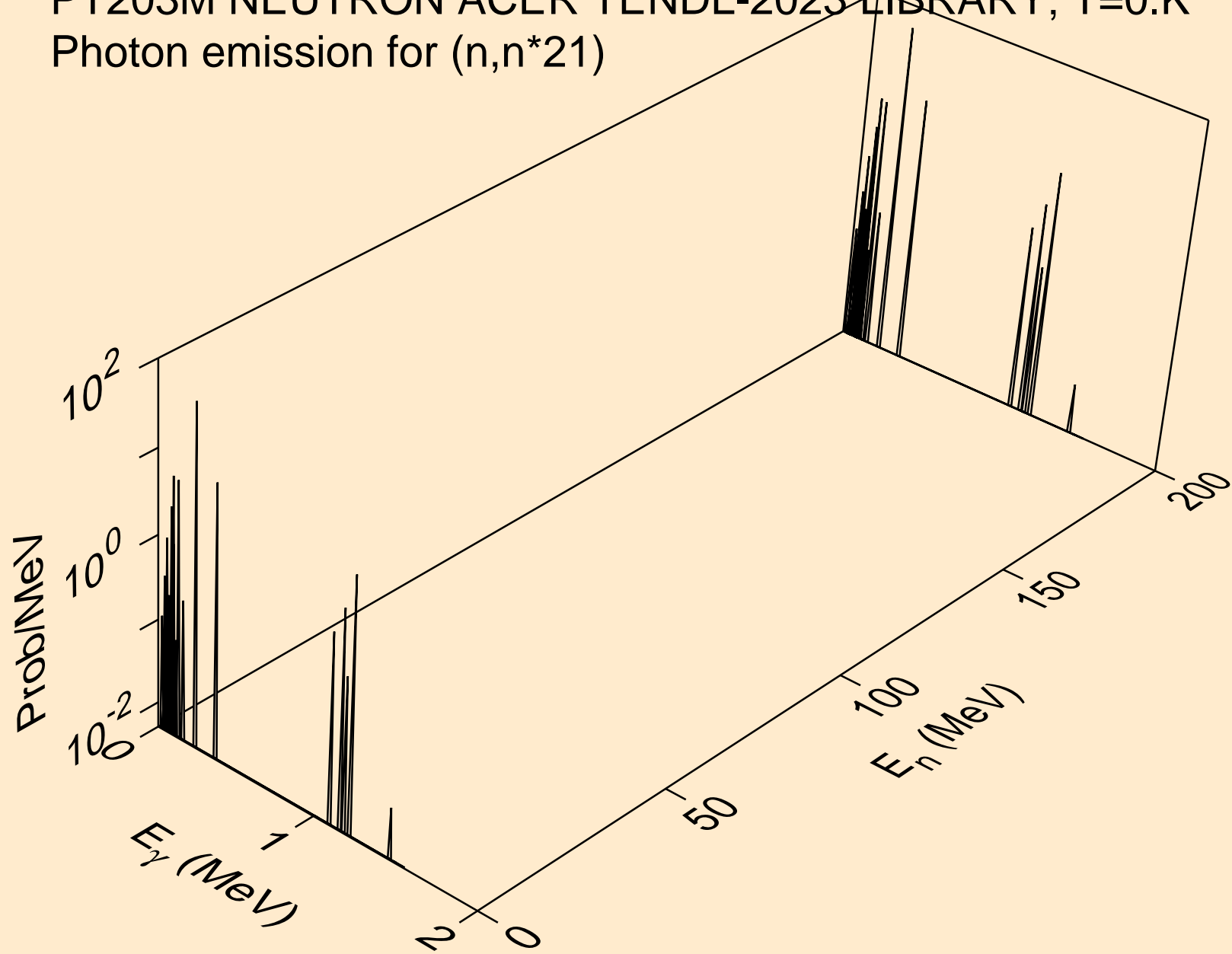

PT203M NEUTRON ACER TENDL-2023 LIBRARY; T=0.K  
Photon emission for (n,n\*22)

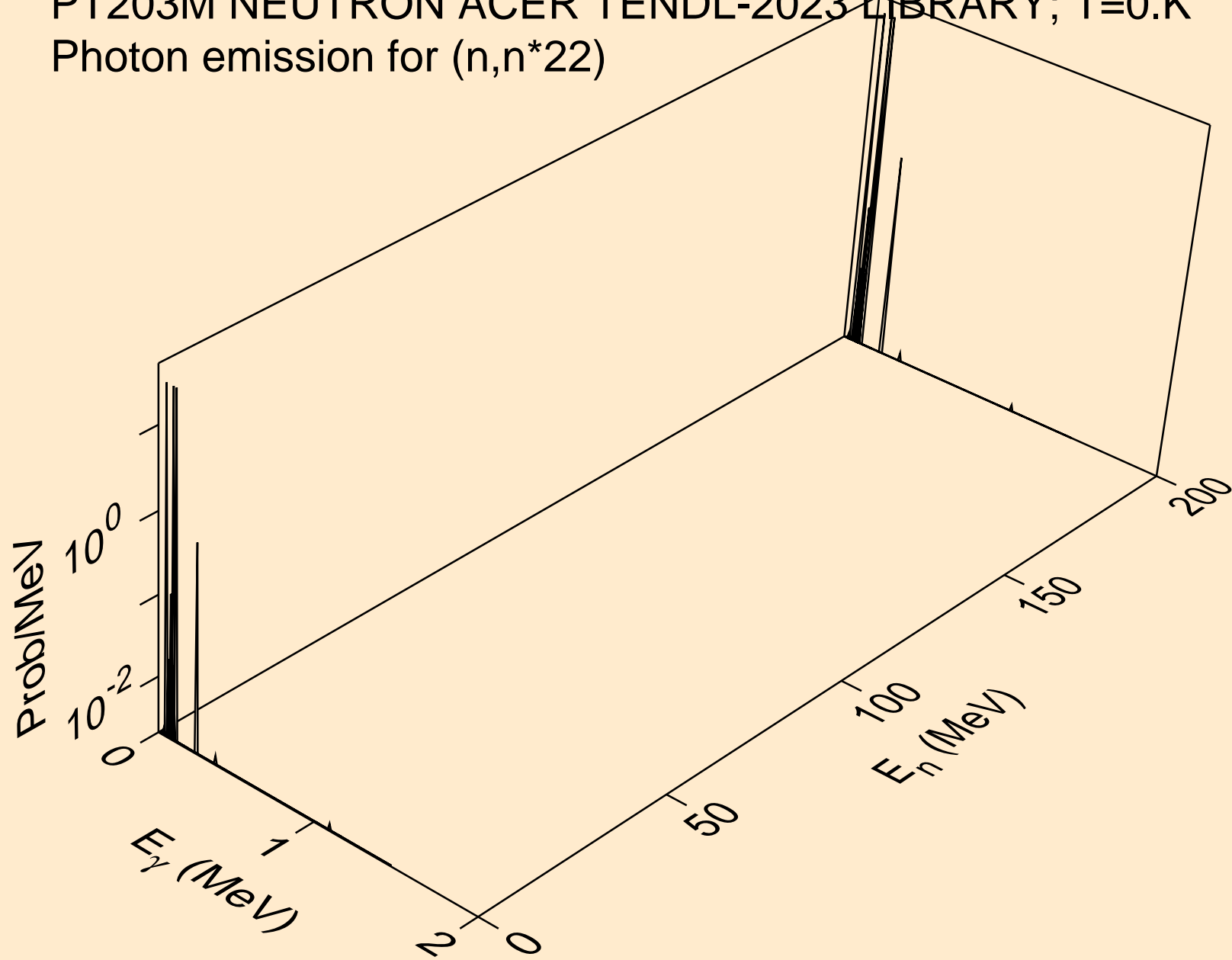

PT203M NEUTRON ACER TENDL-2023 LIBRARY; T=0.K  
Photon emission for (n,n\*23)

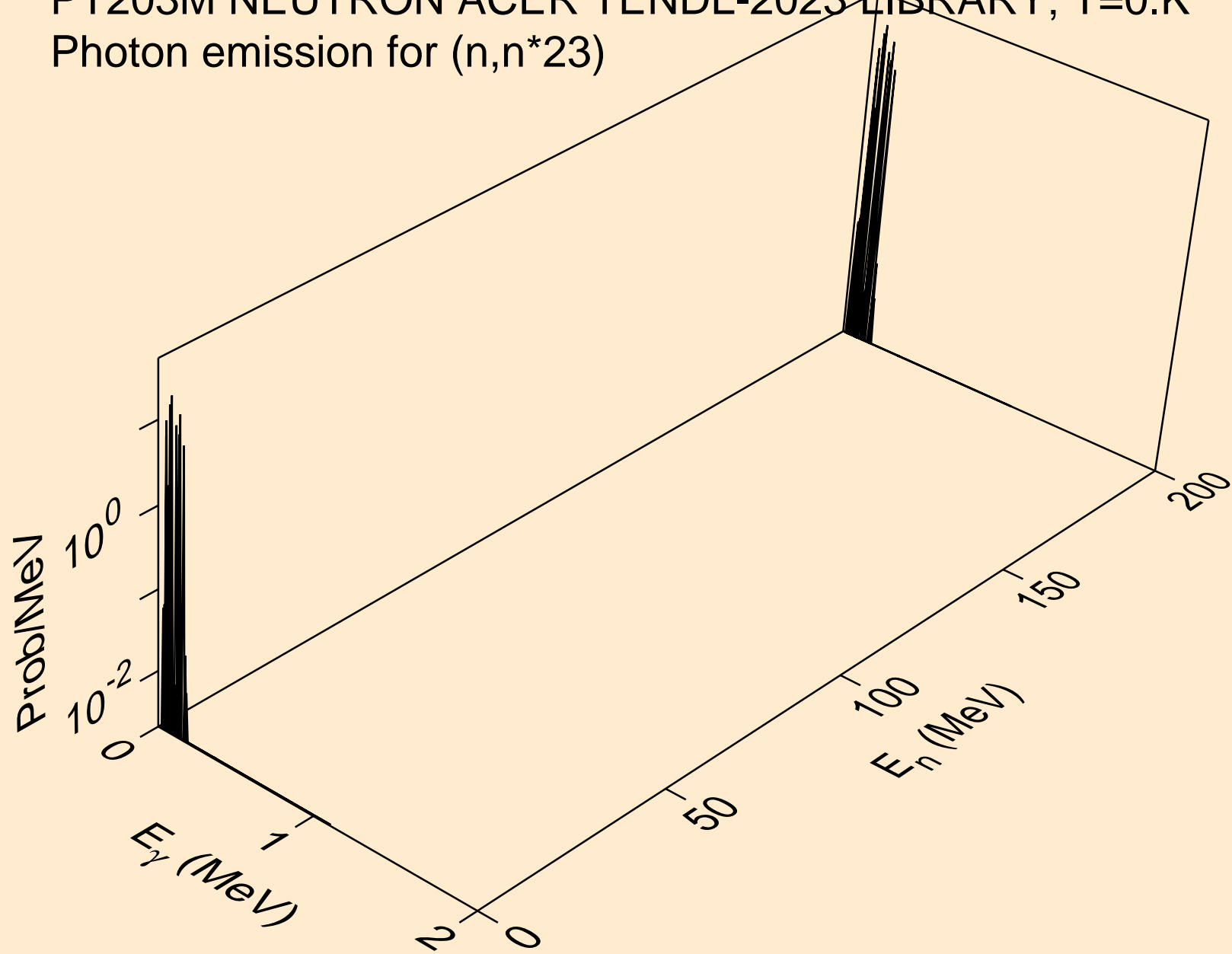

PT203M NEUTRON ACER TENDL-2023 LIBRARY; T=0.K  
Photon emission for (n,n\*24)

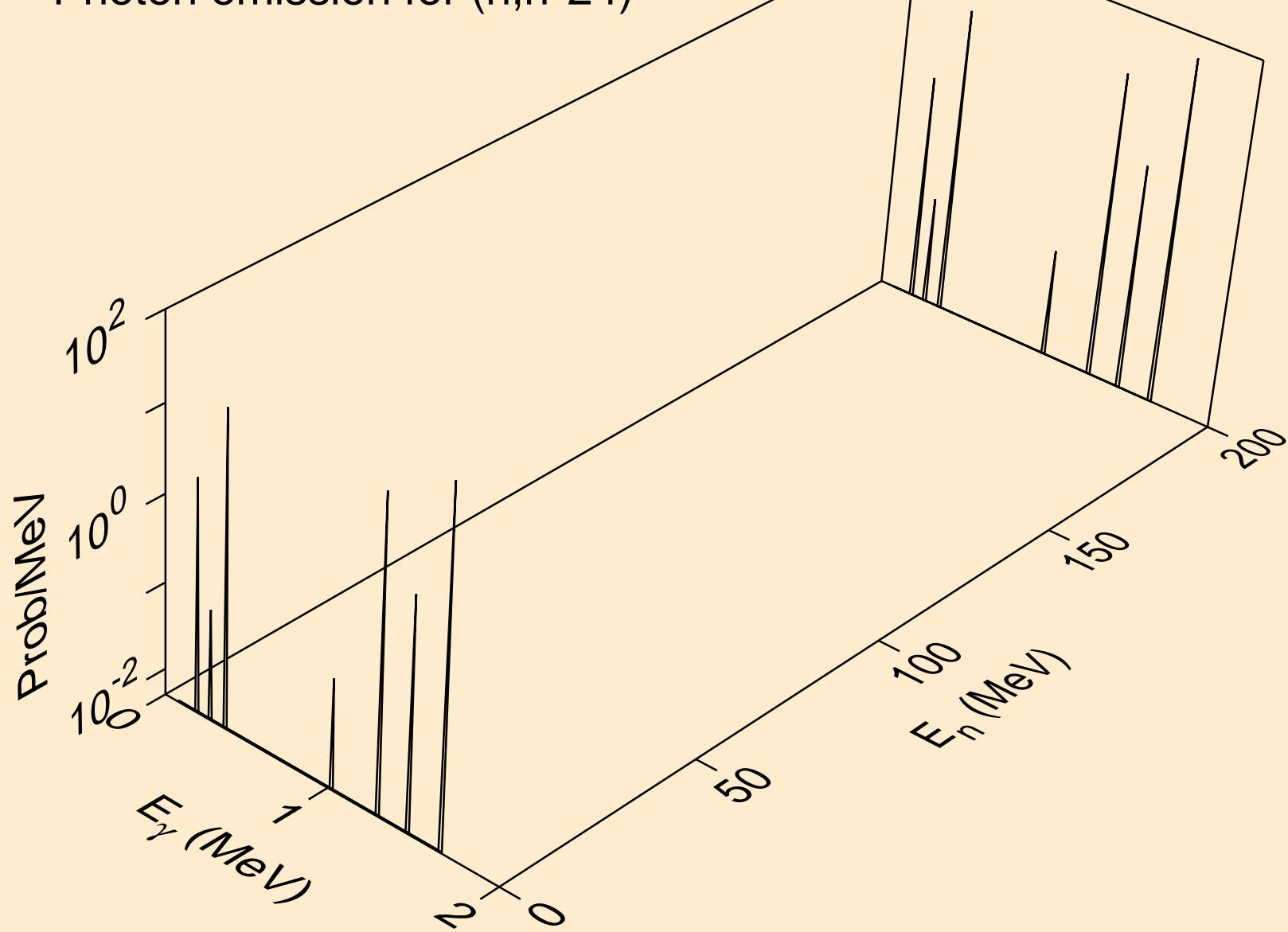

PT203M NEUTRON ACER TENDL-2023 LIBRARY; T=0.K  
Photon emission for (n,n\*25)

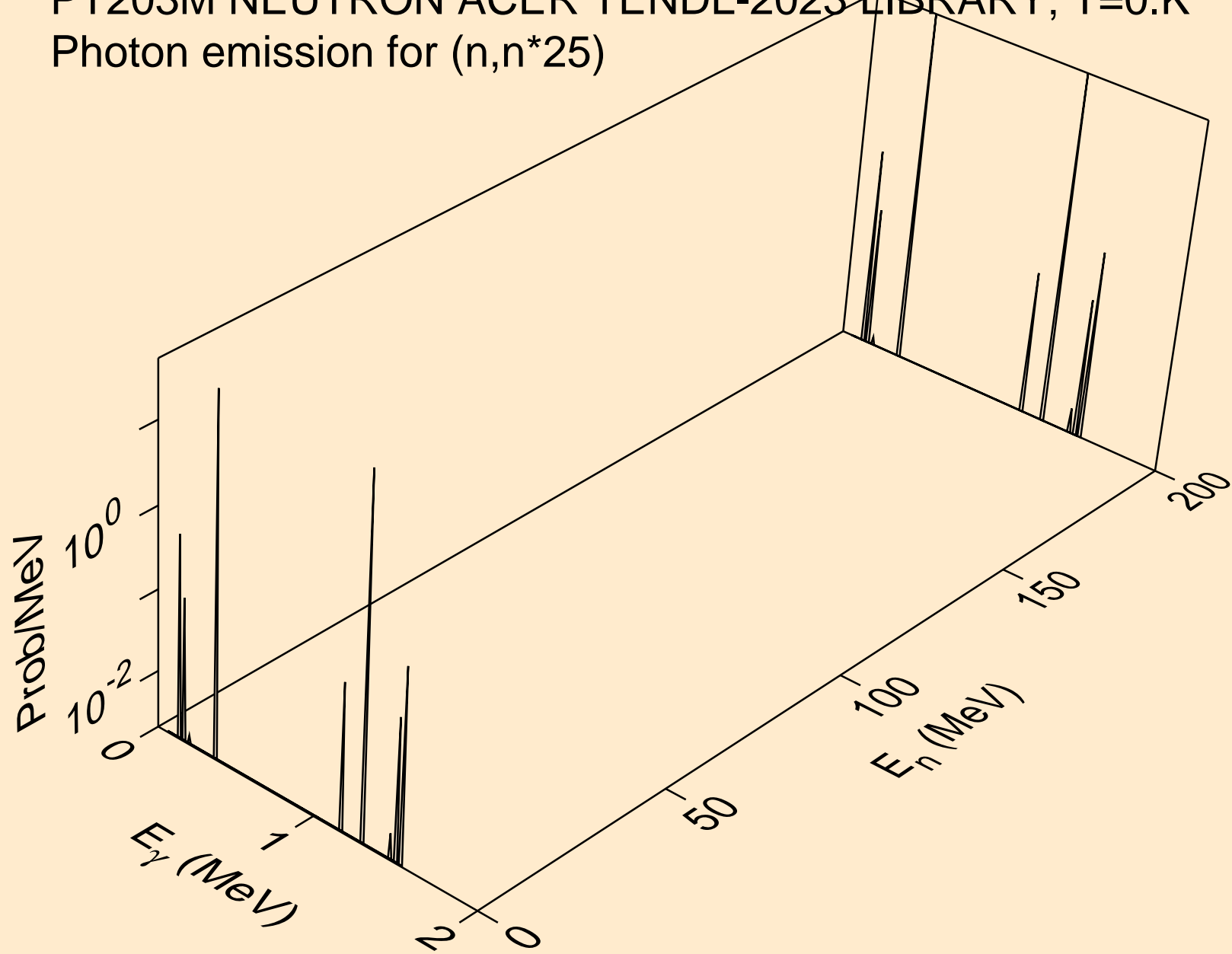

PT203M NEUTRON ACER TENDL-2023 LIBRARY; T=0.K  
Photon emission for (n,n\*26)

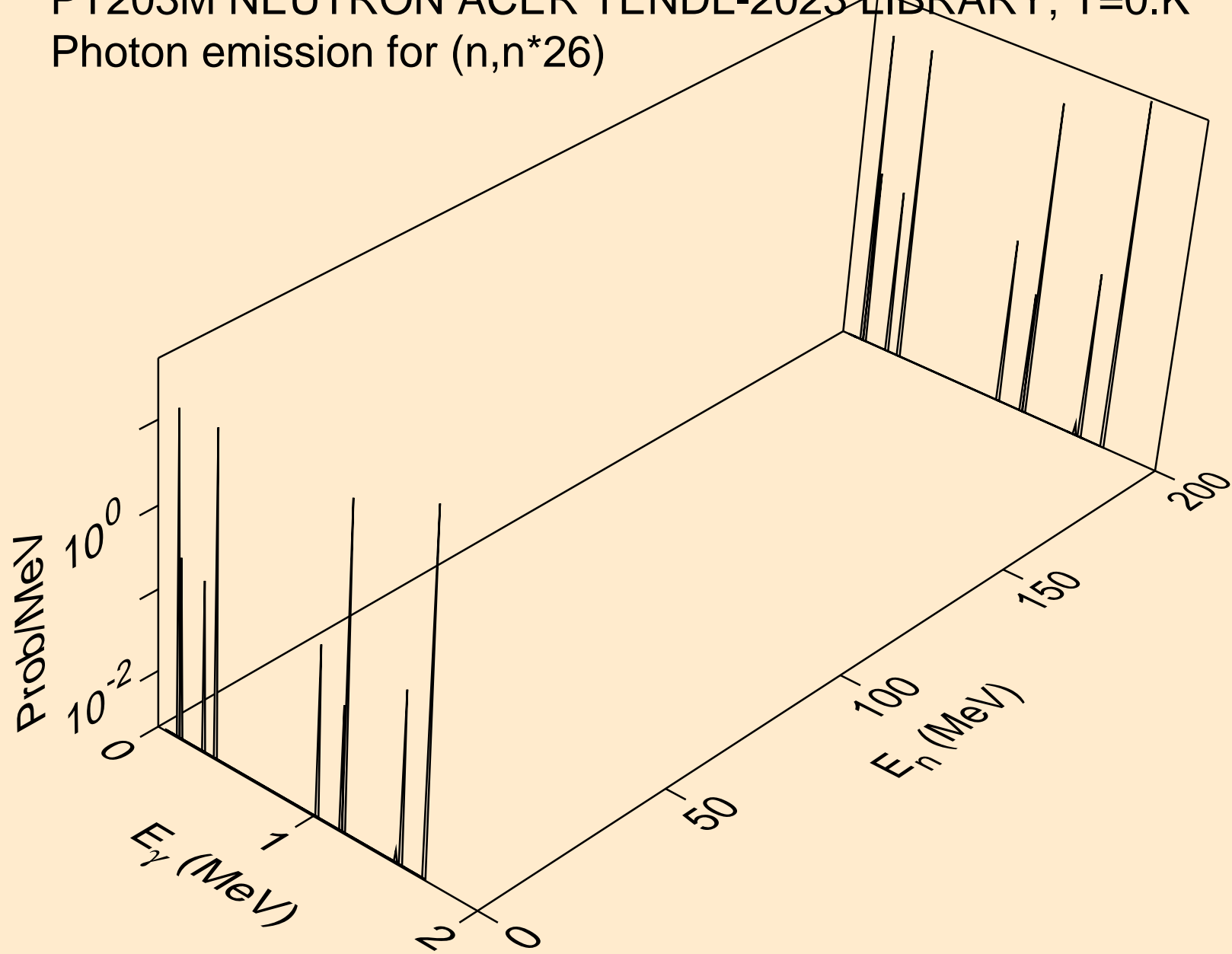

PT203M NEUTRON ACER TENDL-2023 LIBRARY; T=0.K  
Photon emission for (n,n\*27)

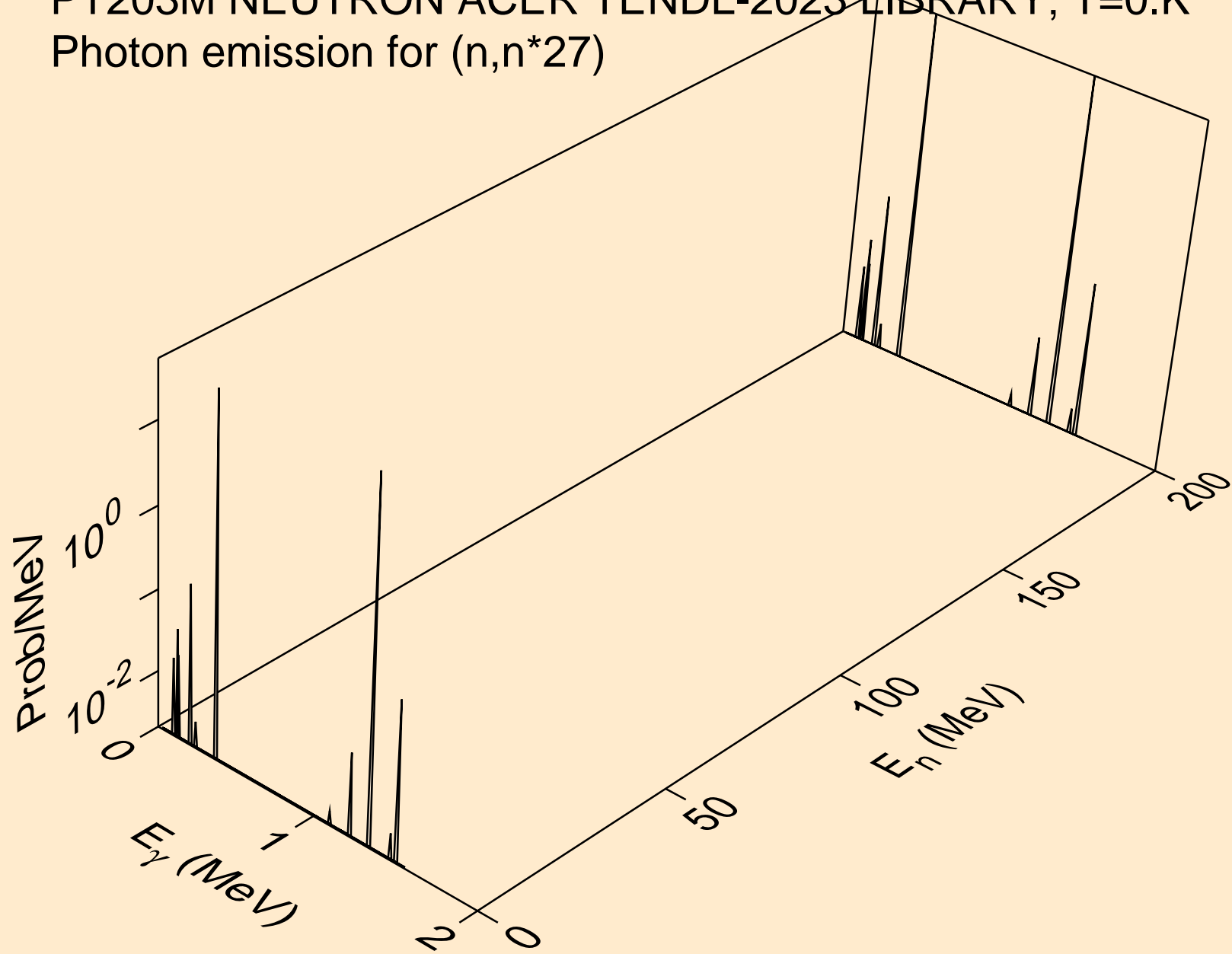



PT203M NEUTRON ACER TENDL-2023 LIBRARY; T=0.K  
Photon emission for (n,n\*28)

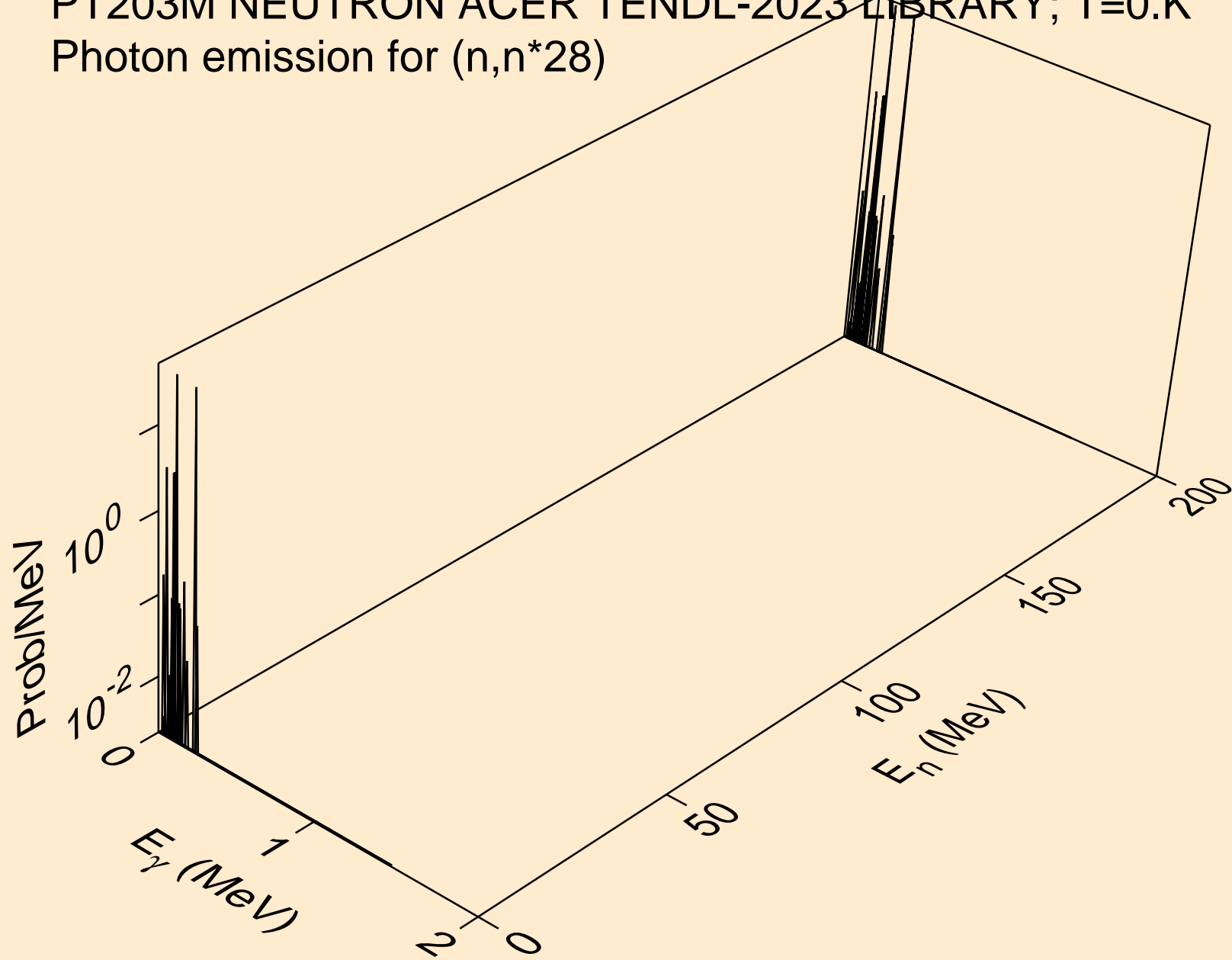

PT203M NEUTRON ACER TENDL-2023 LIBRARY; T=0.K  
Photon emission for (n,n\*29)

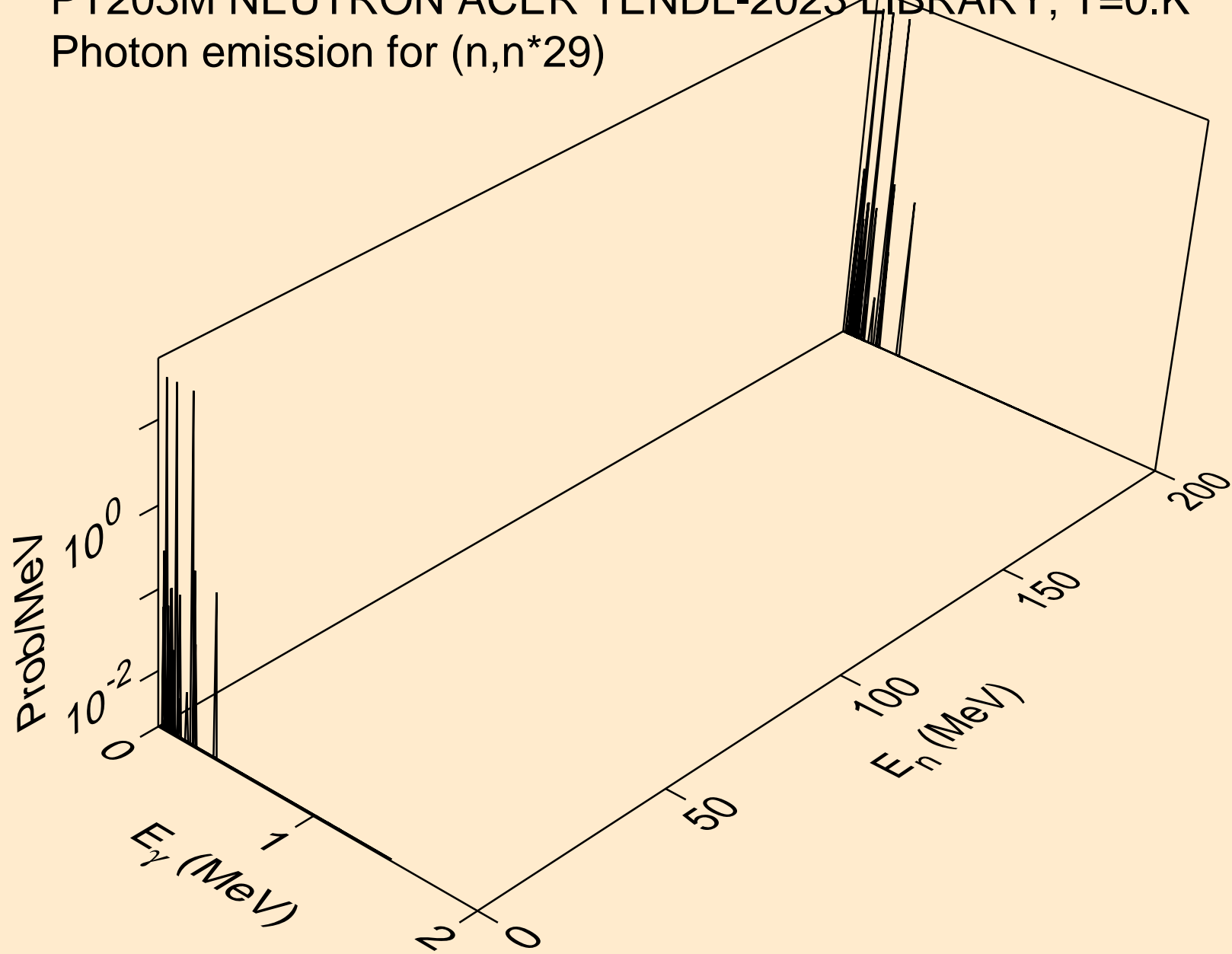

PT203M NEUTRON ACER TENDL-2023 LIBRARY; T=0.K  
Photon emission for (n,n\*30)

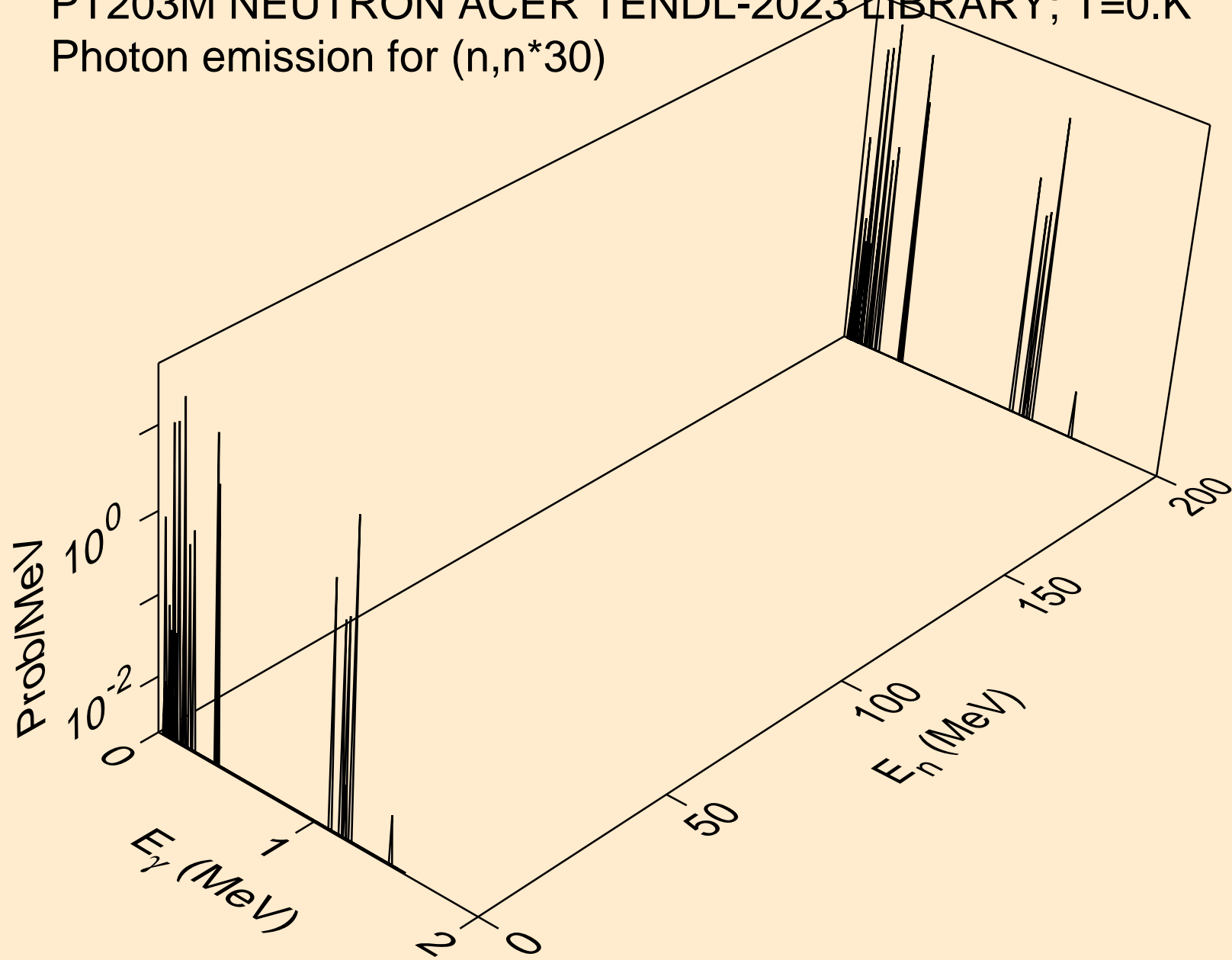

PT203M NEUTRON ACER TENDL-2023 LIBRARY; T=0.K  
Photon emission for (n,n\*c)

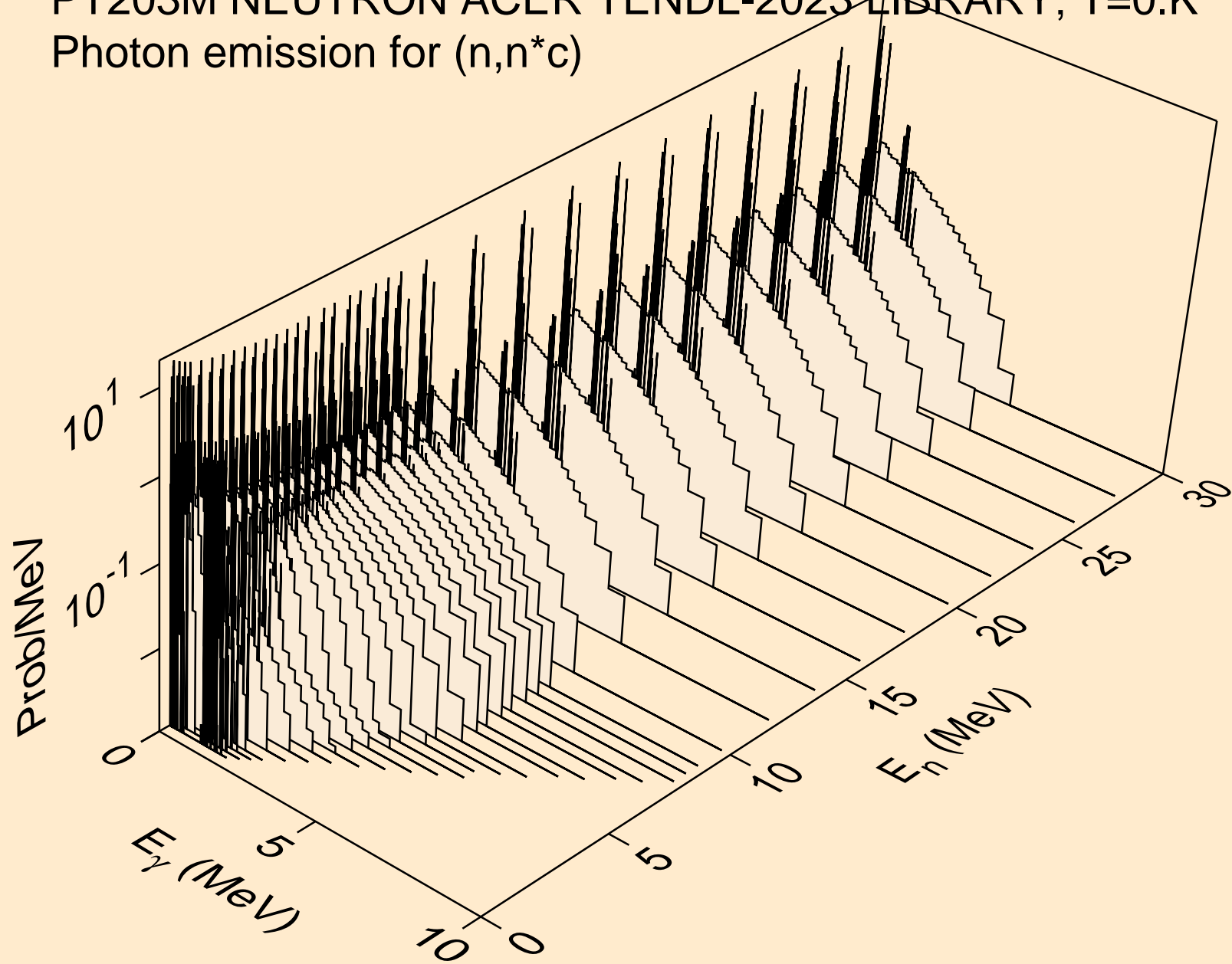

PT203M NEUTRON ACER TENDL-2023 LIBRARY; T=0.K  
Photon emission for (n,gma)

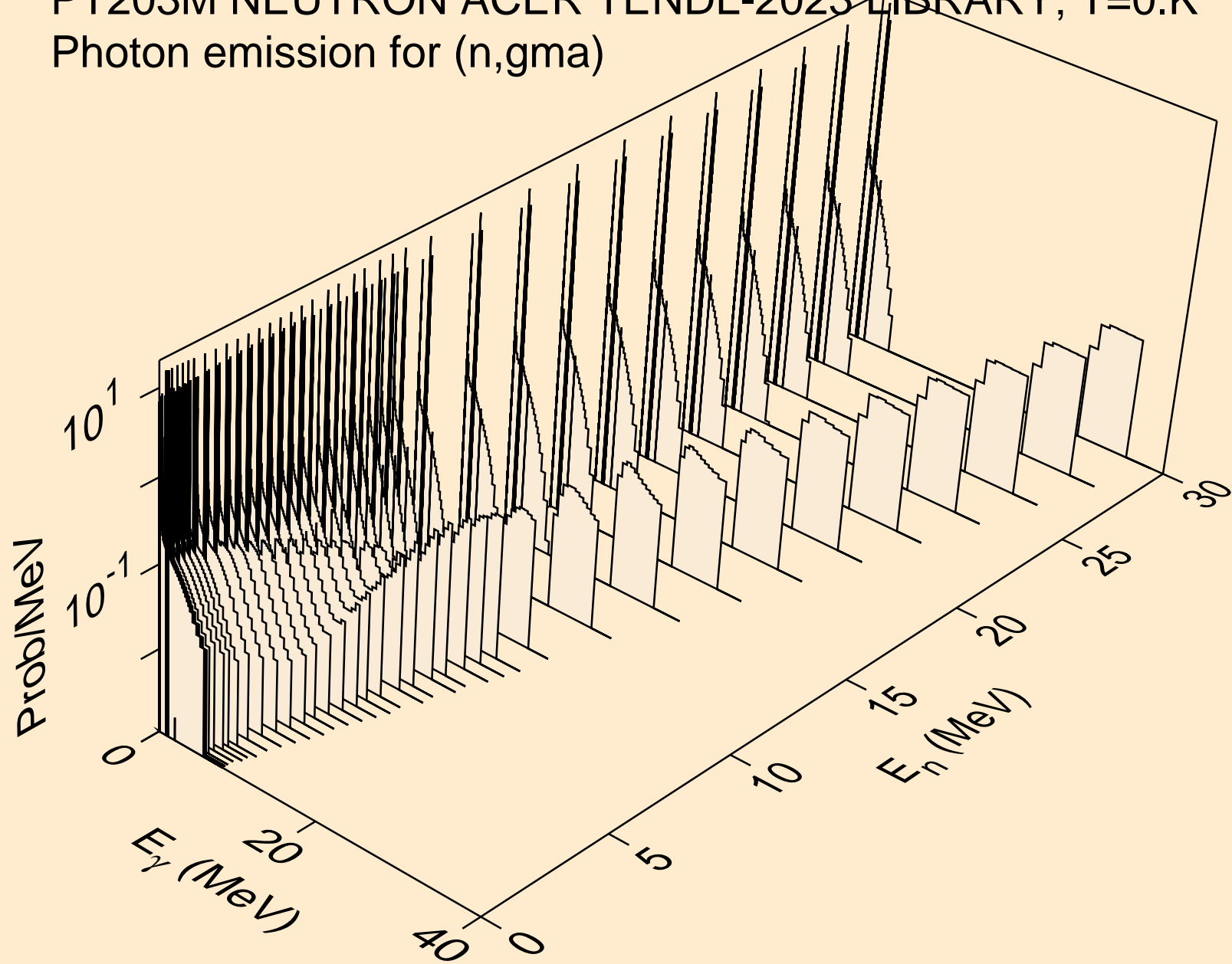

PT203M NEUTRON ACER TENDL-2023 LIBRARY; T=0.K  
Photon emission for (n,p)

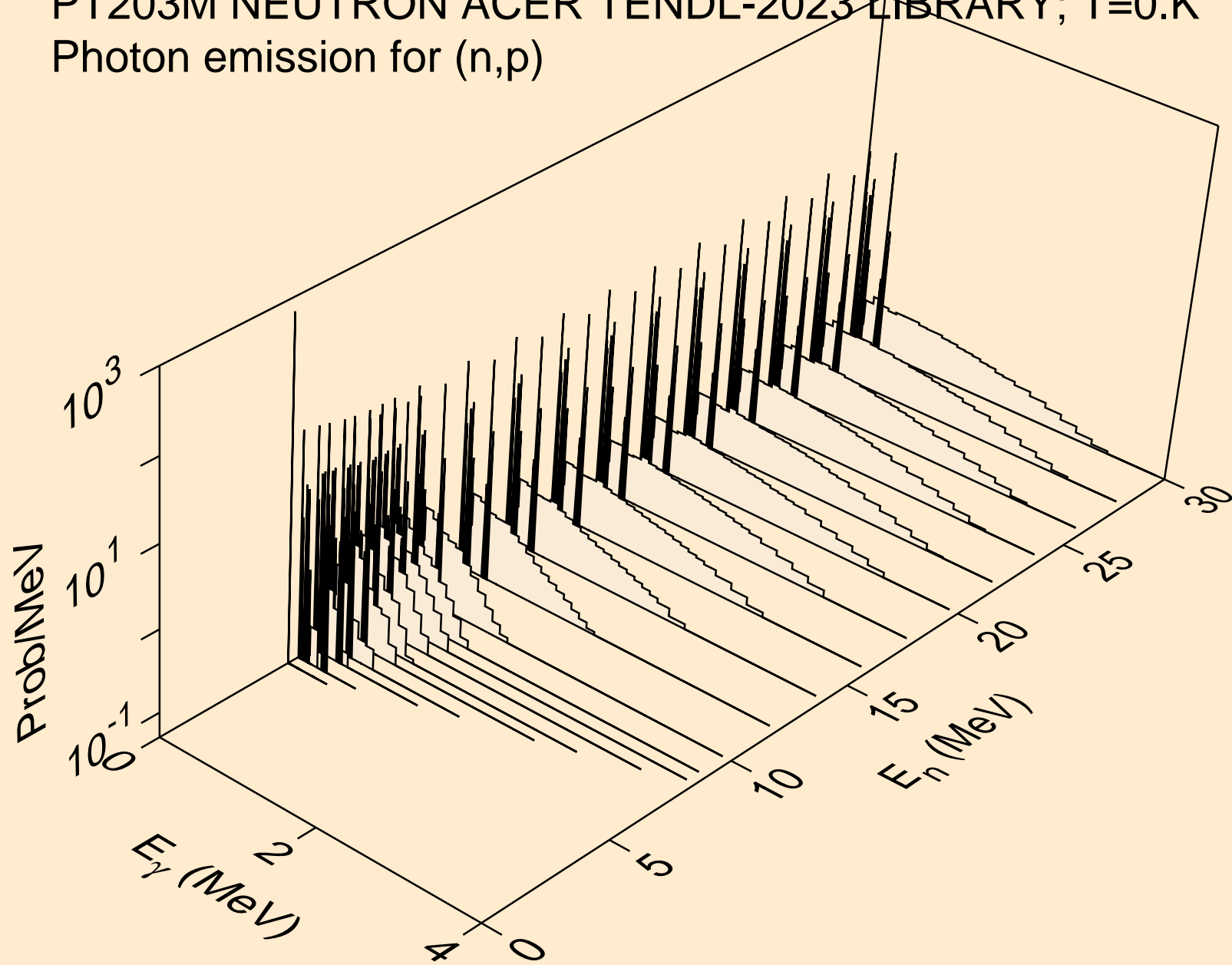

PT203M NEUTRON ACER TENDL-2023 LIBRARY; T=0.K  
Photon emission for (n,d)

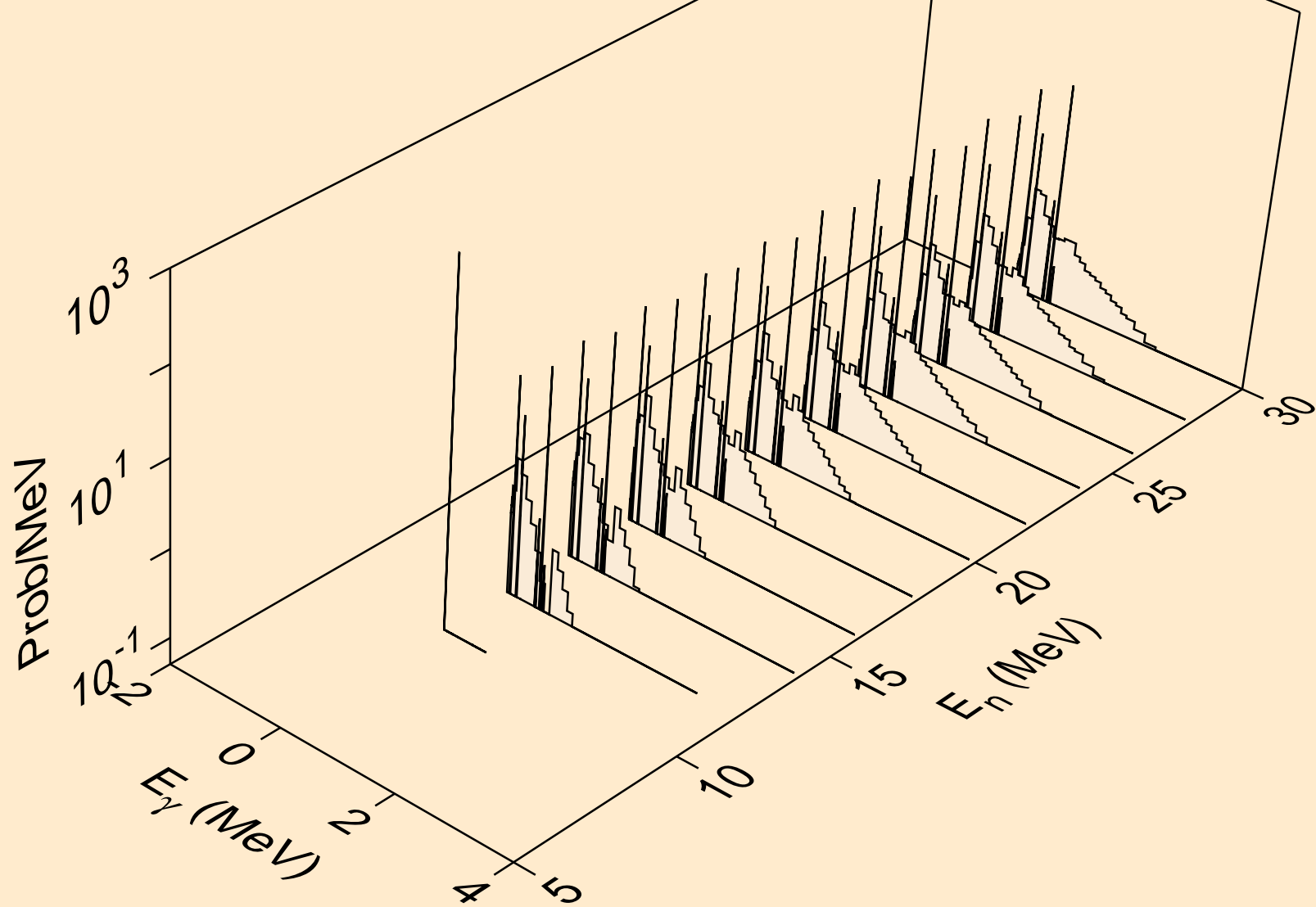

PT203M NEUTRON ACER TENDL-2023 LIBRARY; T=0.K  
Photon emission for (n,t)

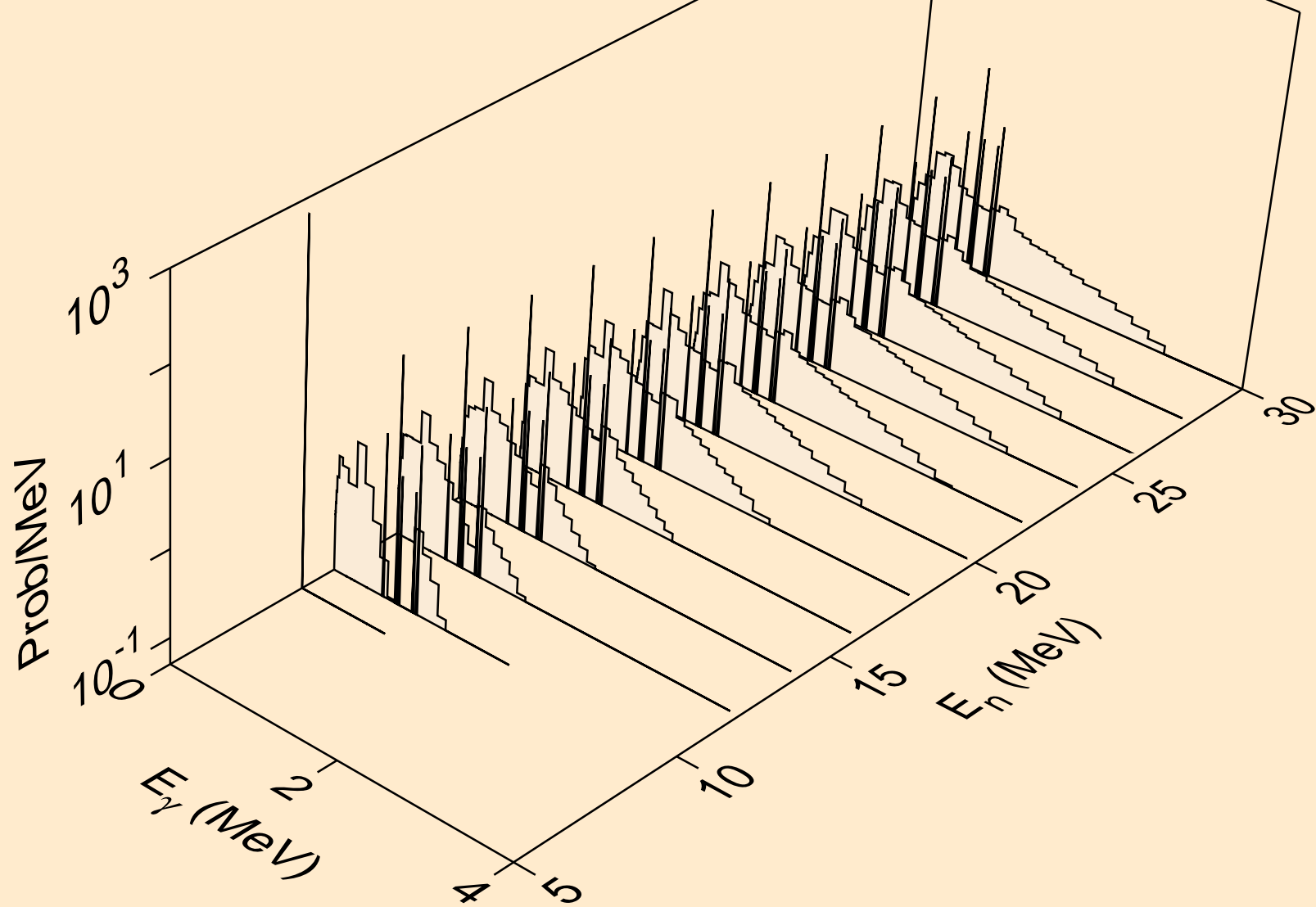



PT203M NEUTRON ACER TENDL-2023 LIBRARY; T=0.K  
Photon emission for (n,he3)

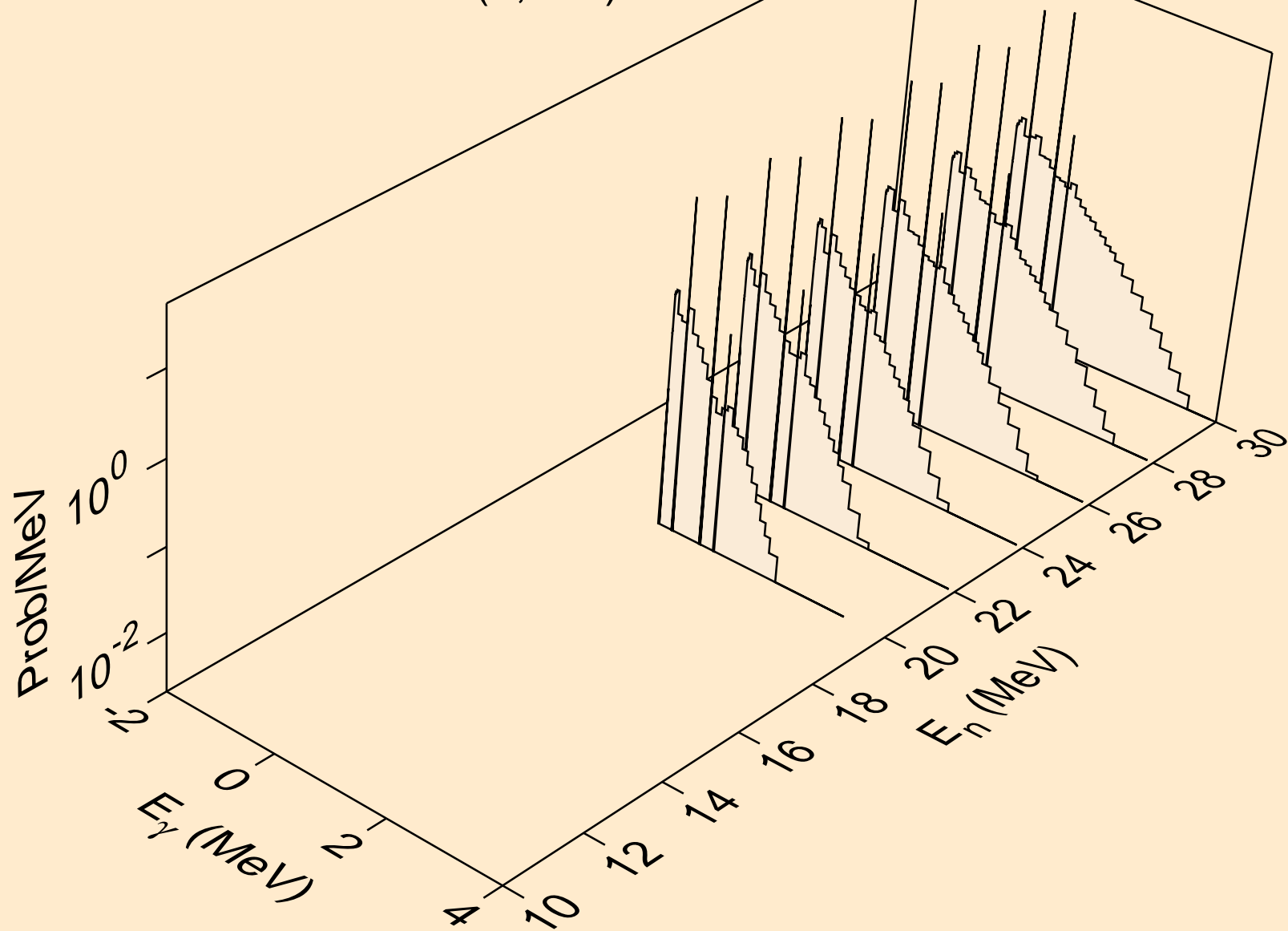

PT203M NEUTRON ACER TENDL-2023 LIBRARY; T=0.K  
Photon emission for (n,a)

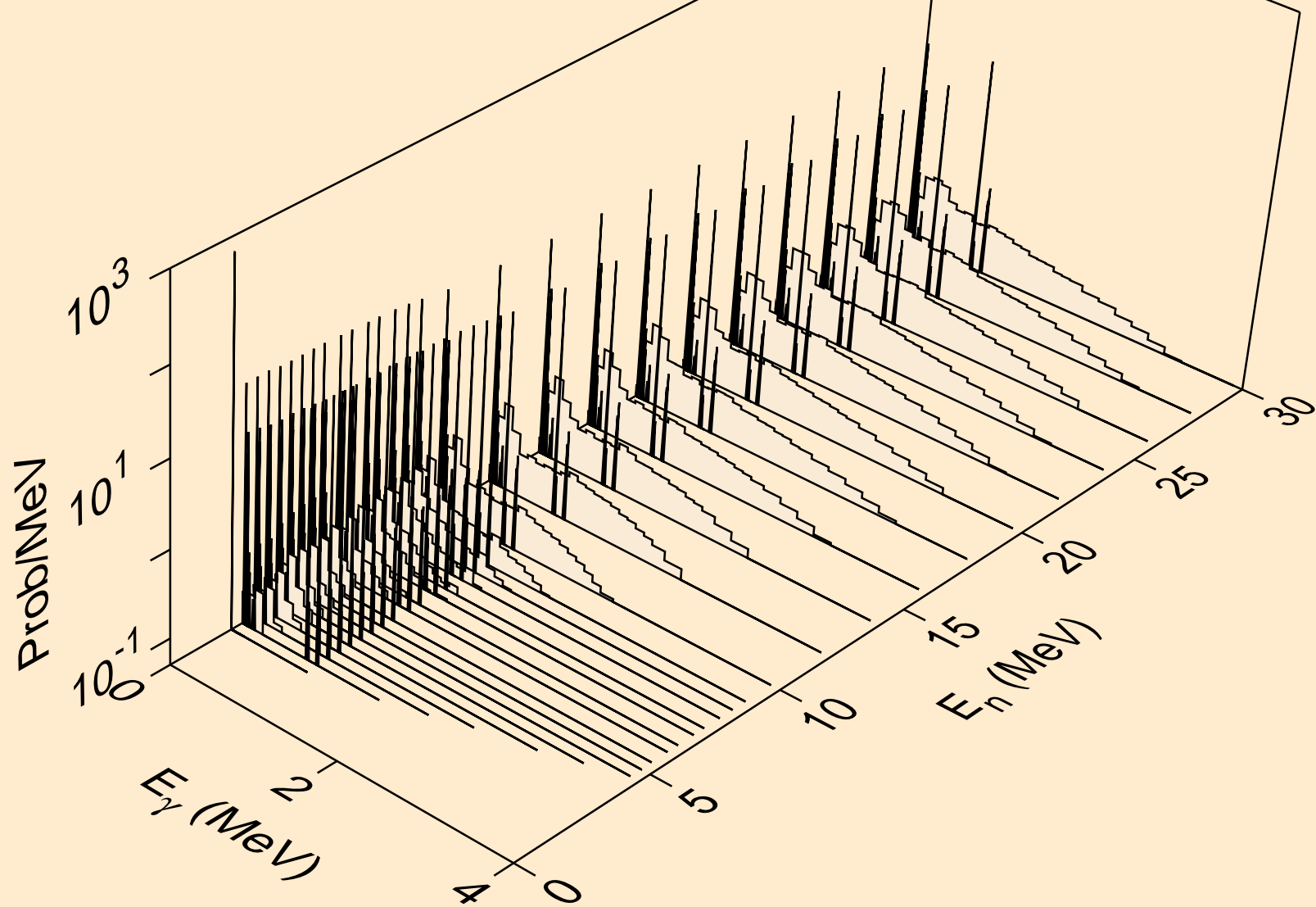

PT203M NEUTRON ACER TENDL-2023 LIBRARY; T=0.K  
Photon emission for (n,2p)

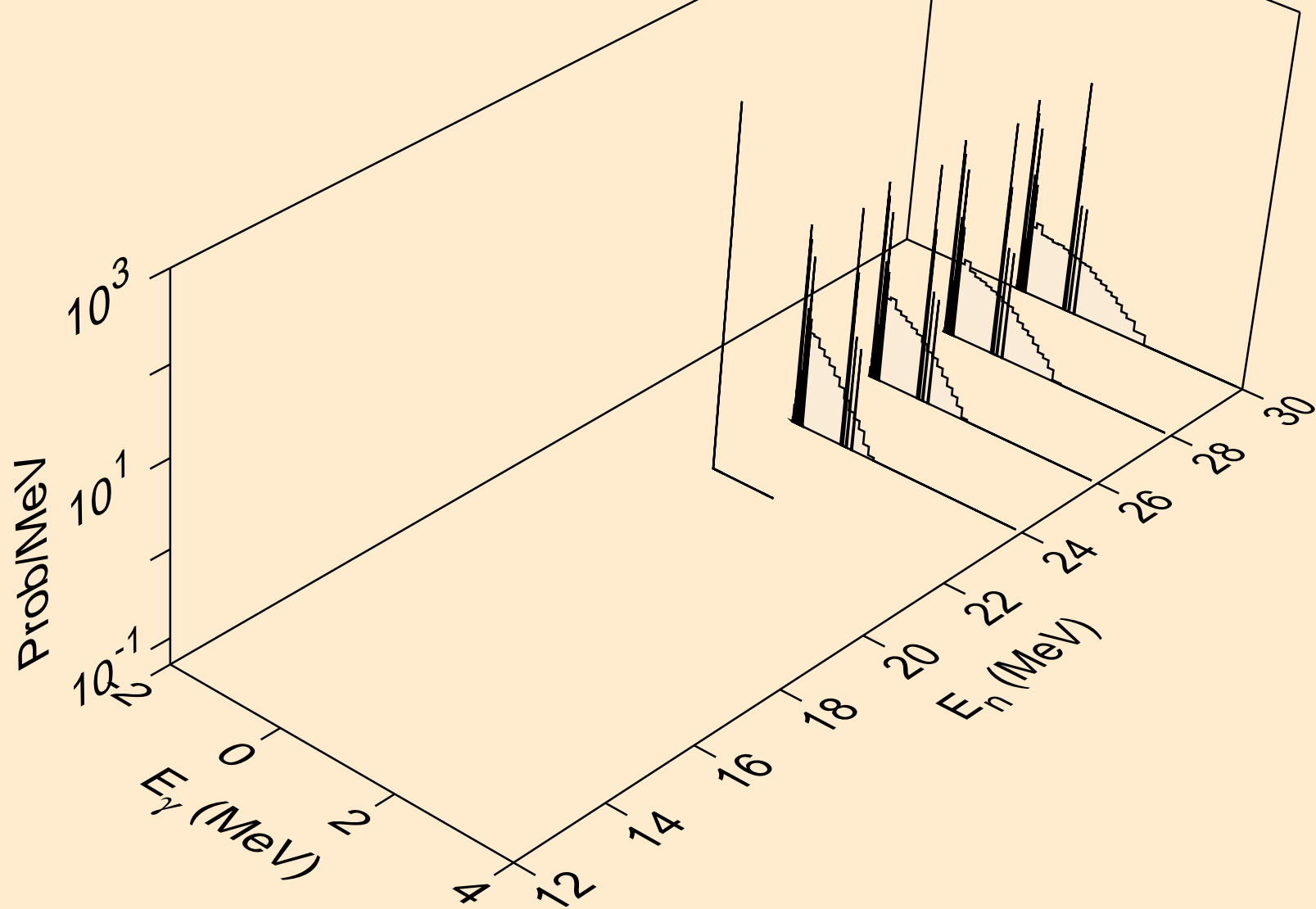

PT203M NEUTRON ACER TENDL-2023 LIBRARY; T=0.K  
thermal capture photon spectrum

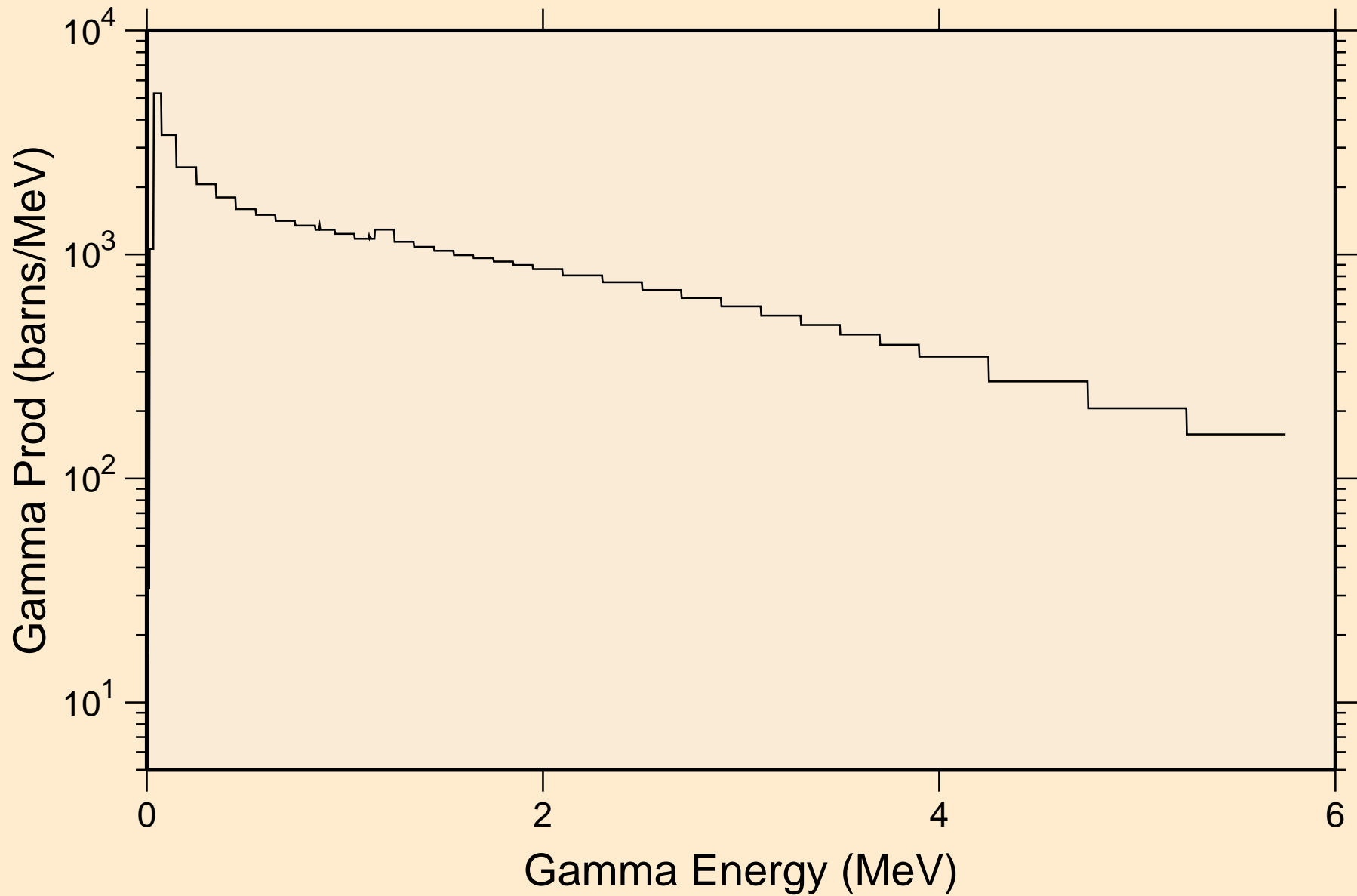

PT203M NEUTRON ACER TENDL-2023 LIBRARY; T=0.K  
14 MeV photon spectrum

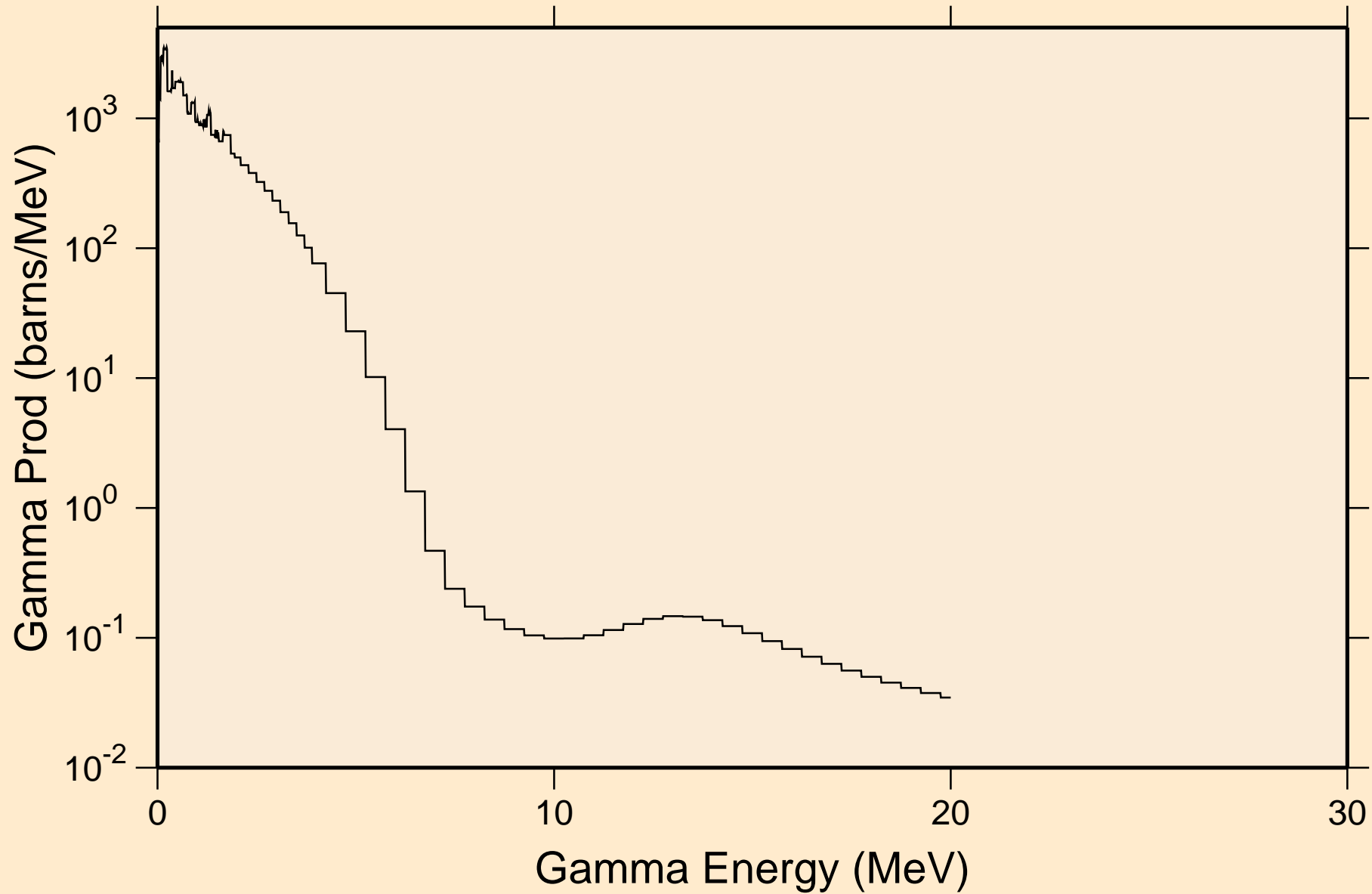

PT203M NEUTRON ACER TENDL-2023 LIBRARY; T=0.K  
Particle heating contributions

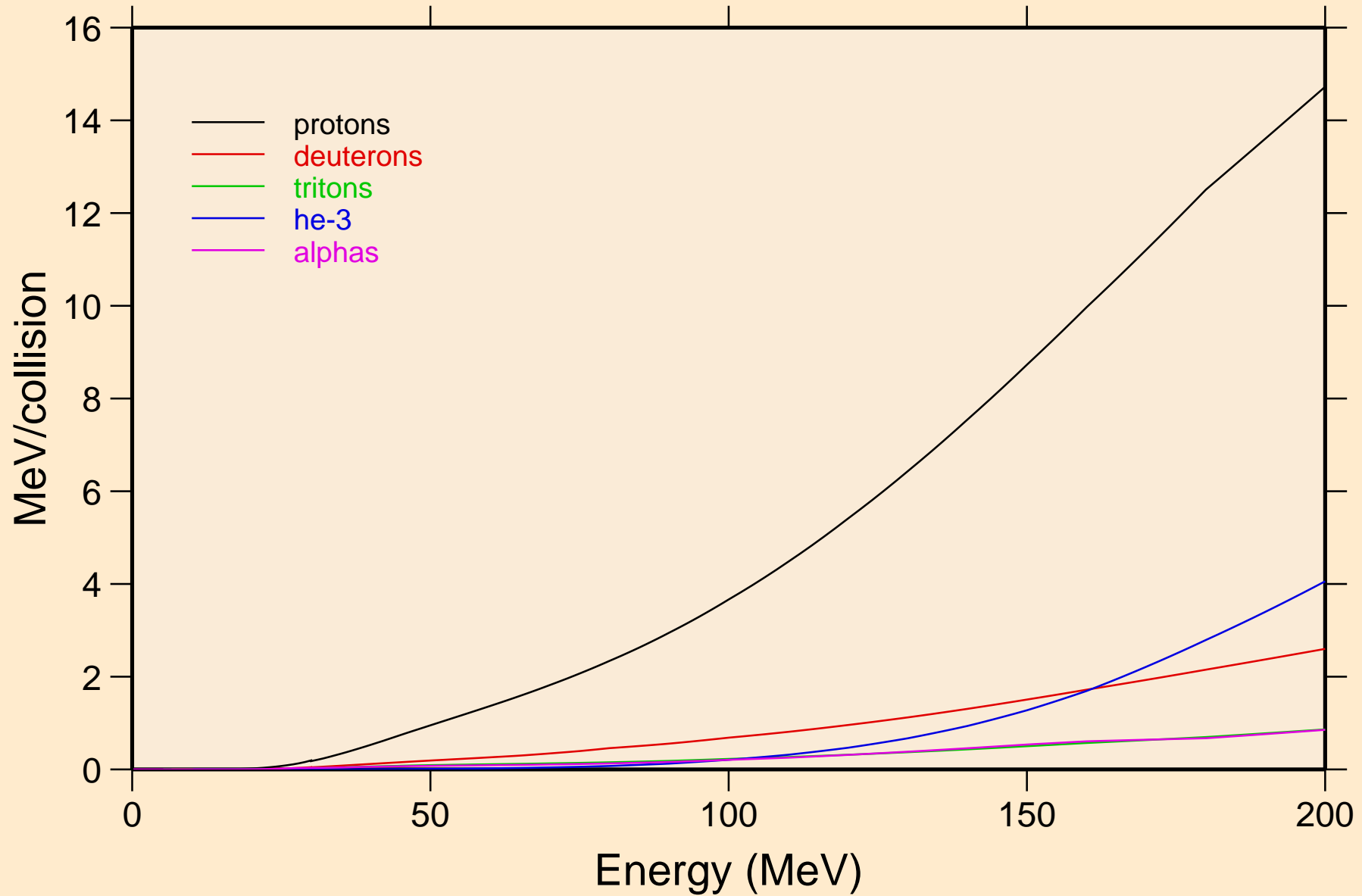

PT203M NEUTRON ACER TENDL-2023 LIBRARY; T=0.K  
Recoil Heating

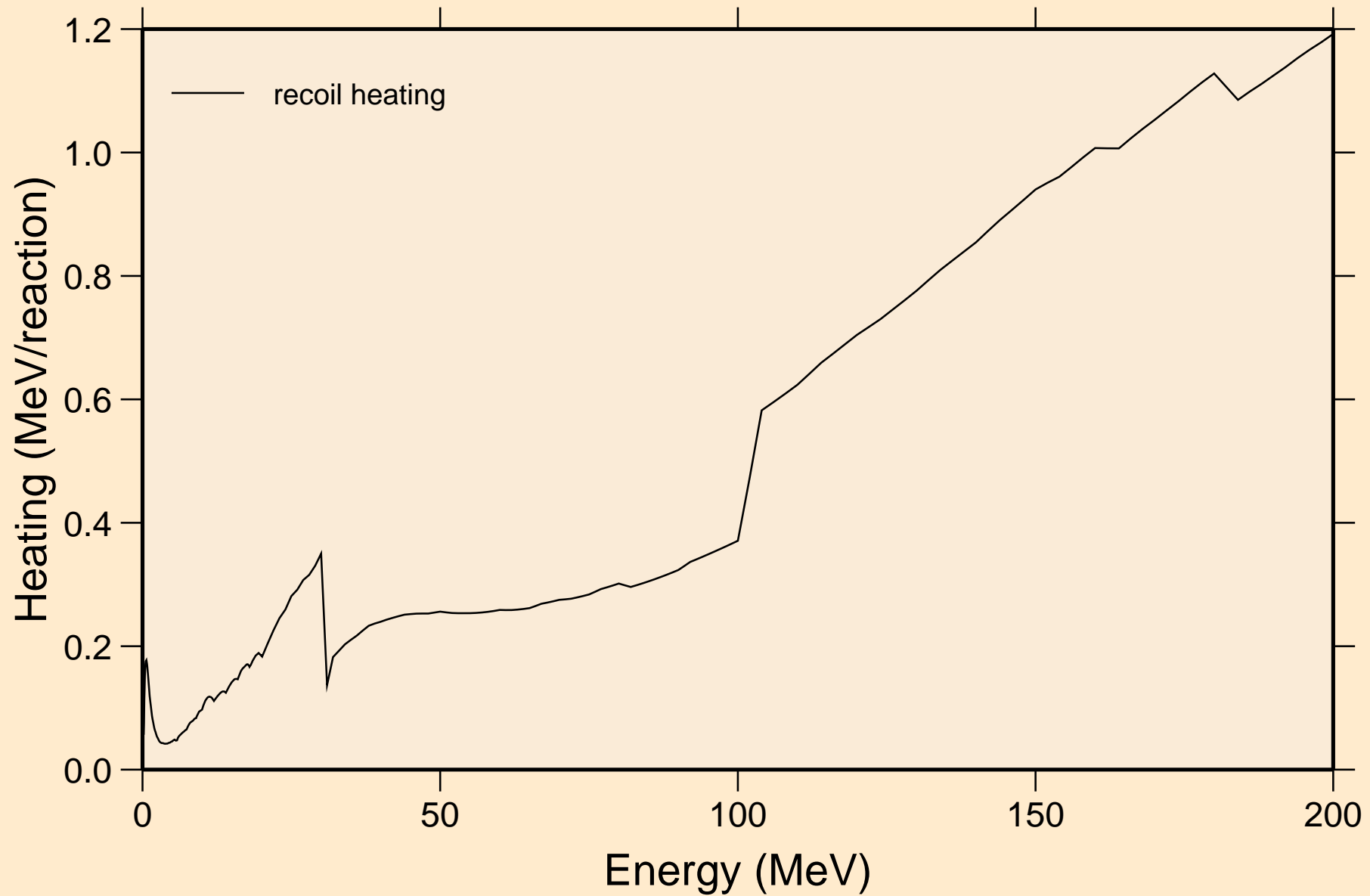

PT203M NEUTRON ACER TENDL-2023 LIBRARY; T=0.K  
Particle production cross sections

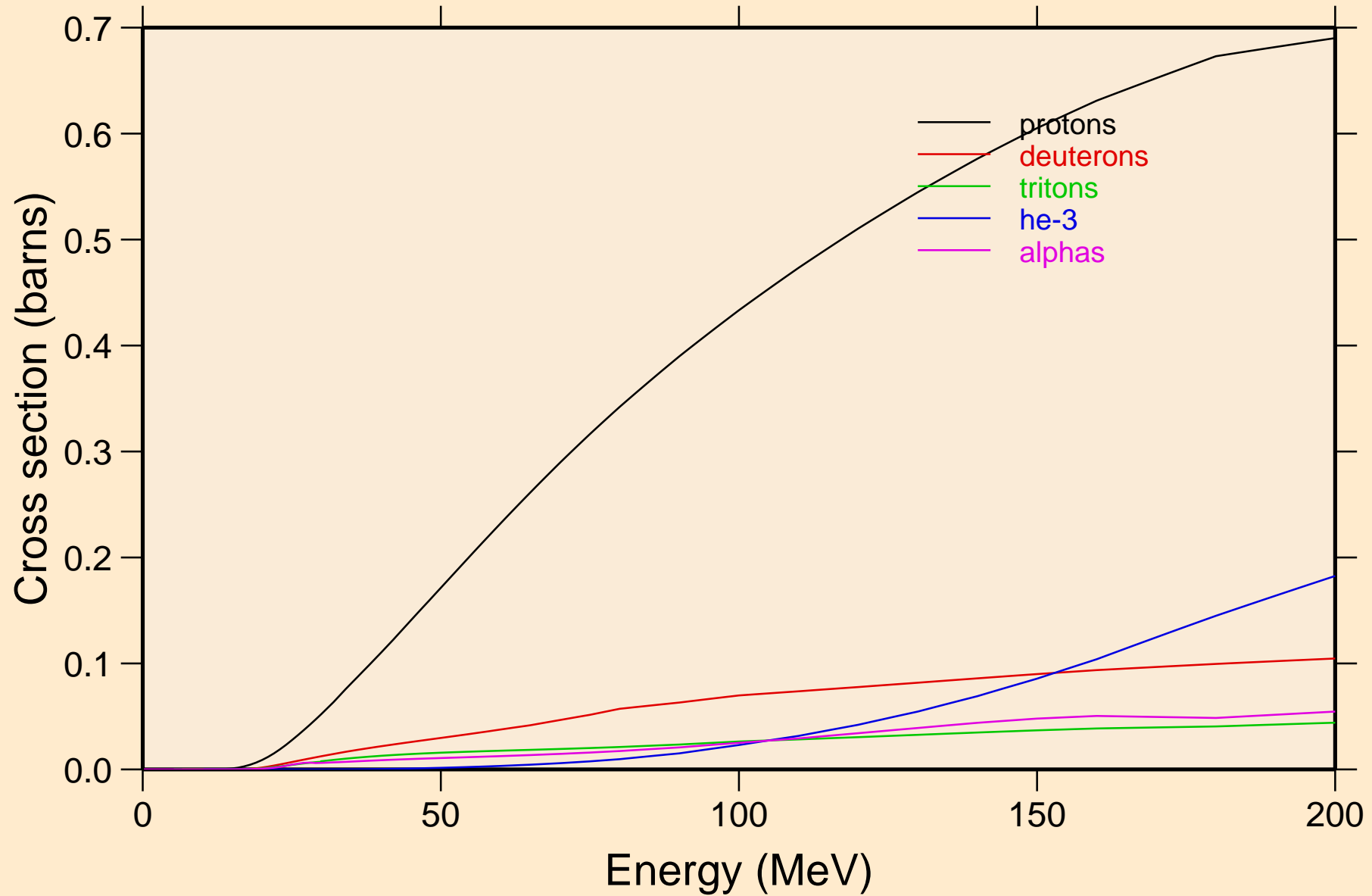



PT203M NEUTRON ACER TENDL-2023 LIBRARY; T=0.K  
protons from (n,x)

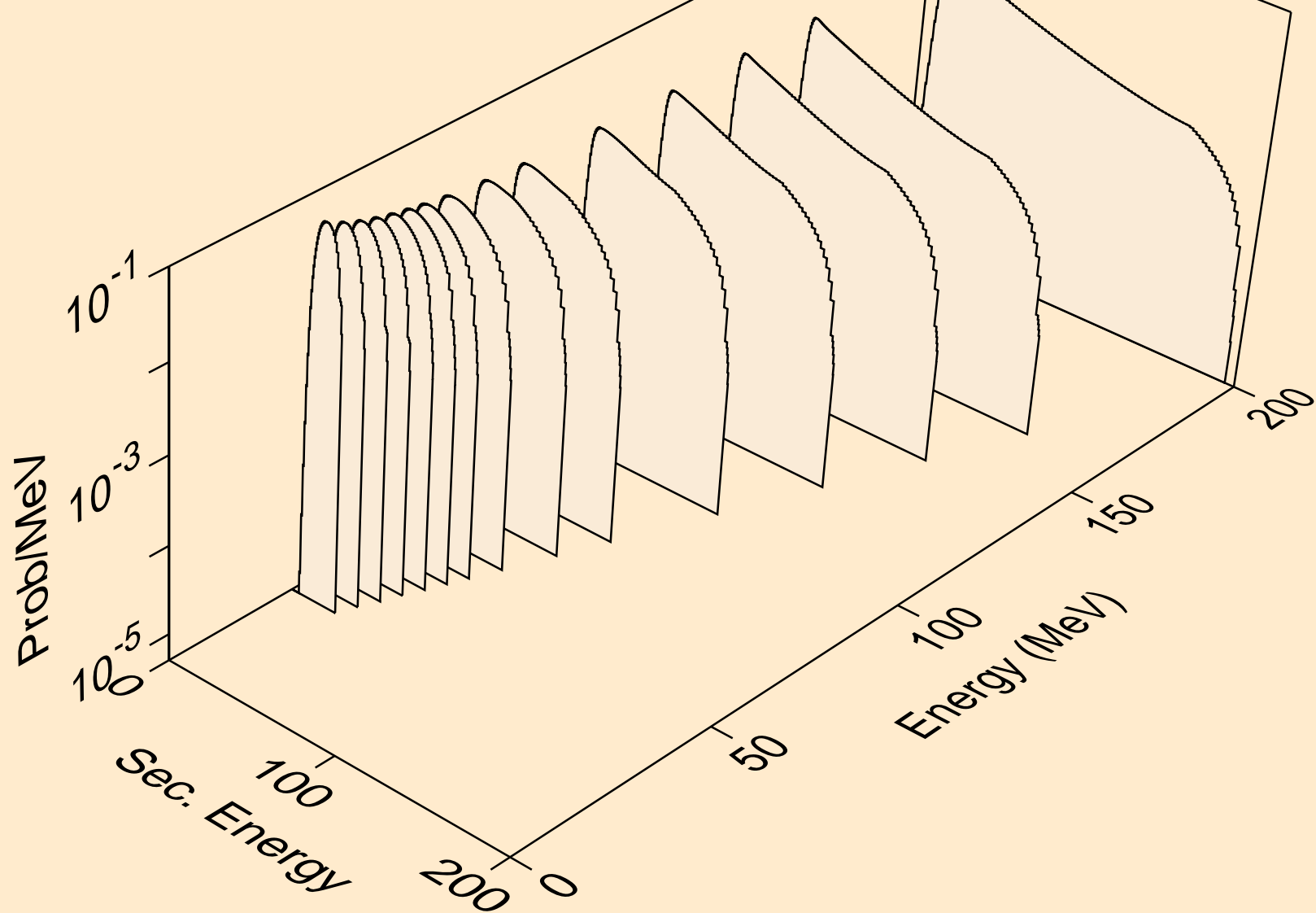

PT203M NEUTRON ACER TENDL-2023 LIBRARY; T=0.K  
protons from (n,n\*)p

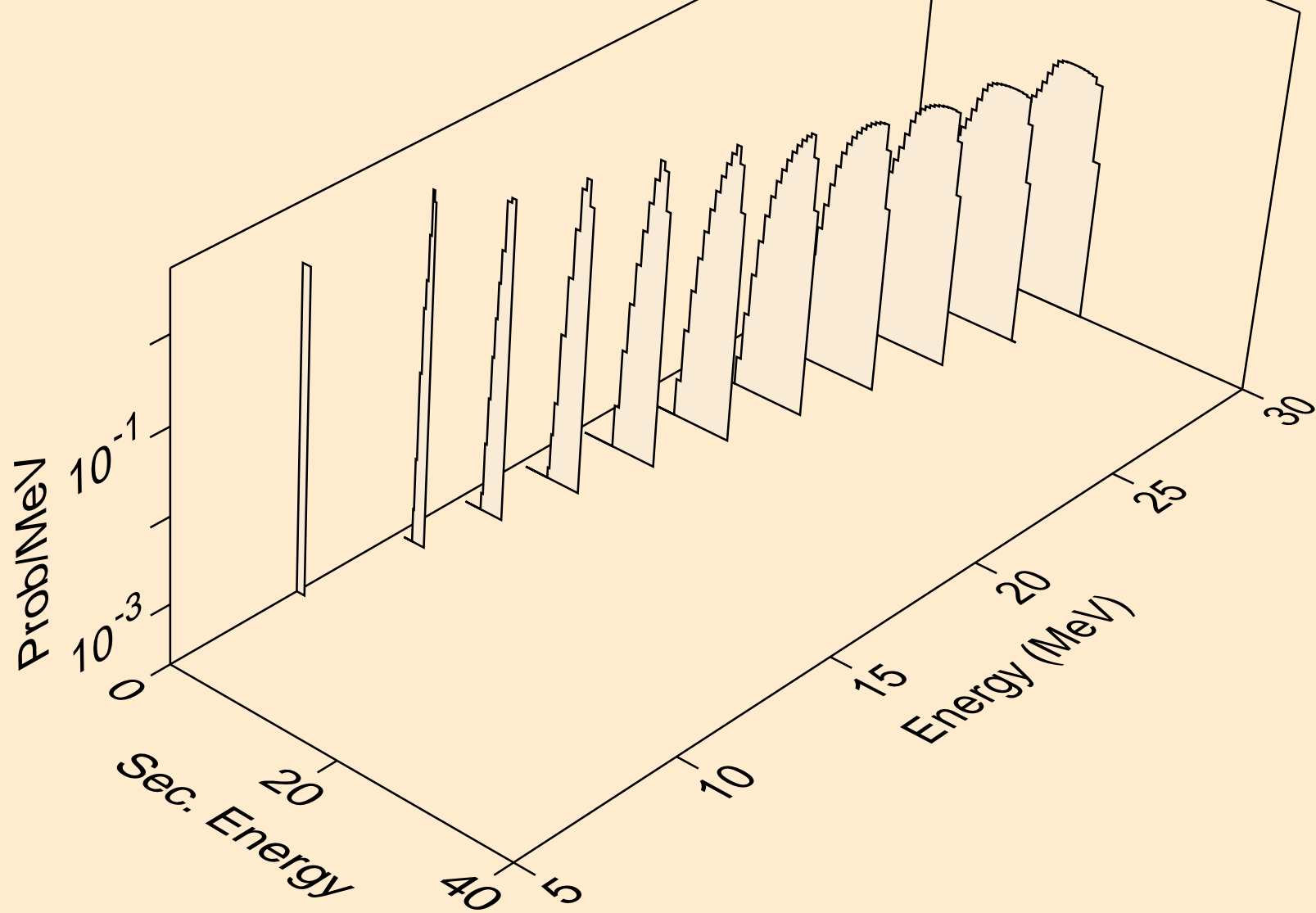

PT203M NEUTRON ACER TENDL-2023 LIBRARY; T=0.K  
protons from (n,2np)

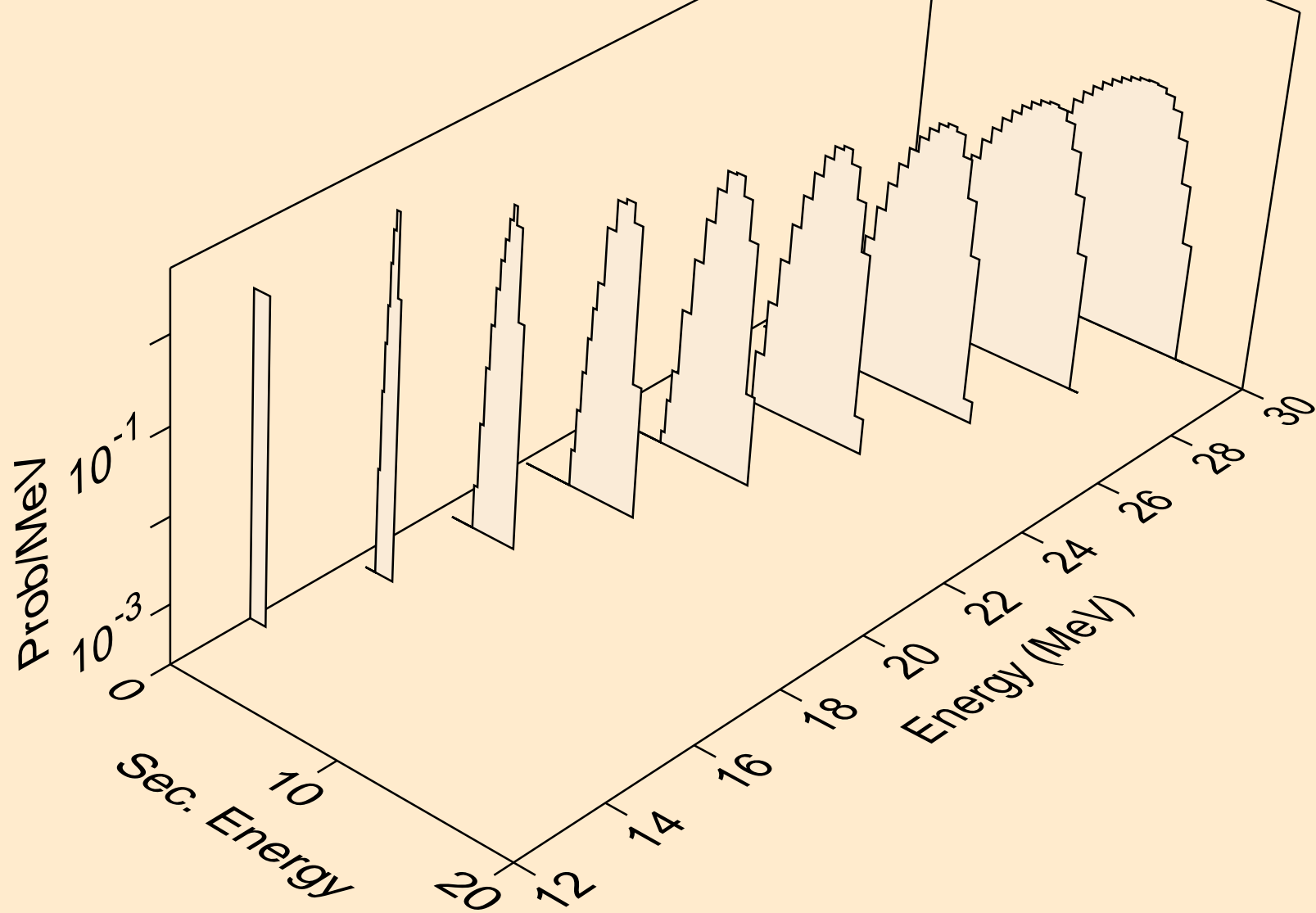

PT203M NEUTRON ACER TENDL-2023 LIBRARY; T=0.K  
protons from (n,3np)

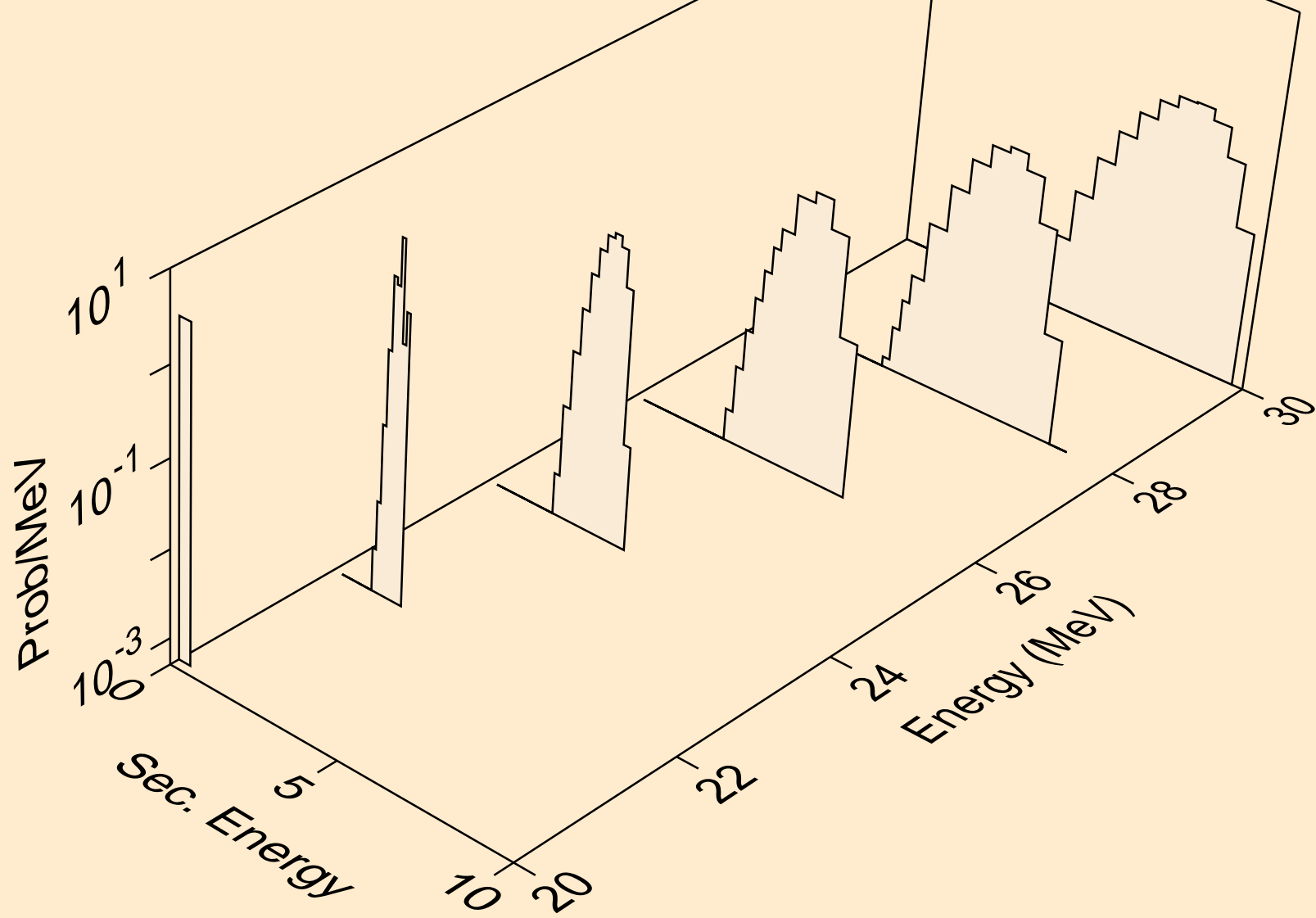

PT203M NEUTRON ACER TENDL-2023 LIBRARY; T=0.K  
protons from (n,p)

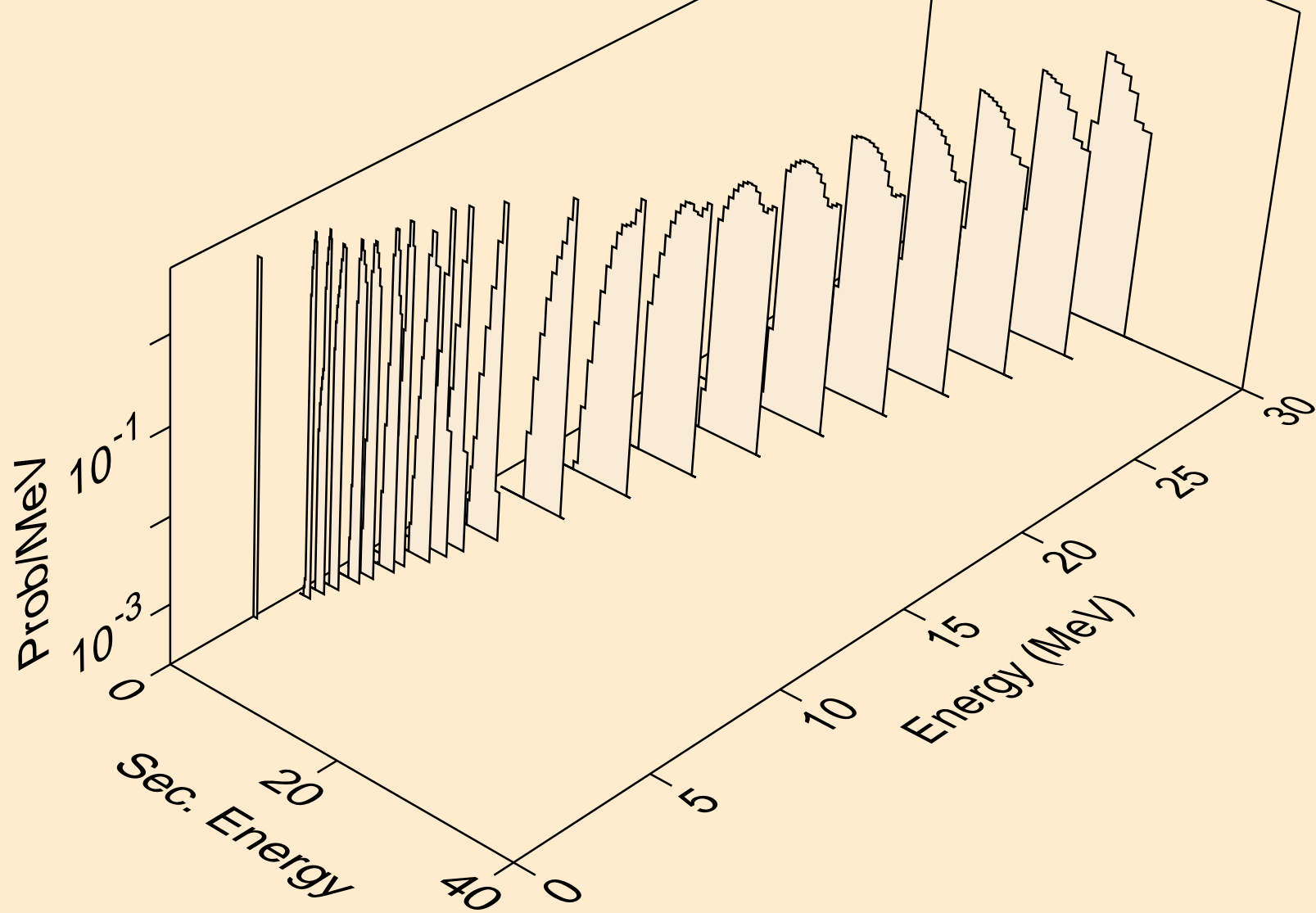

PT203M NEUTRON ACER TENDL-2023 LIBRARY; T=0.K  
protons from (n,2p)

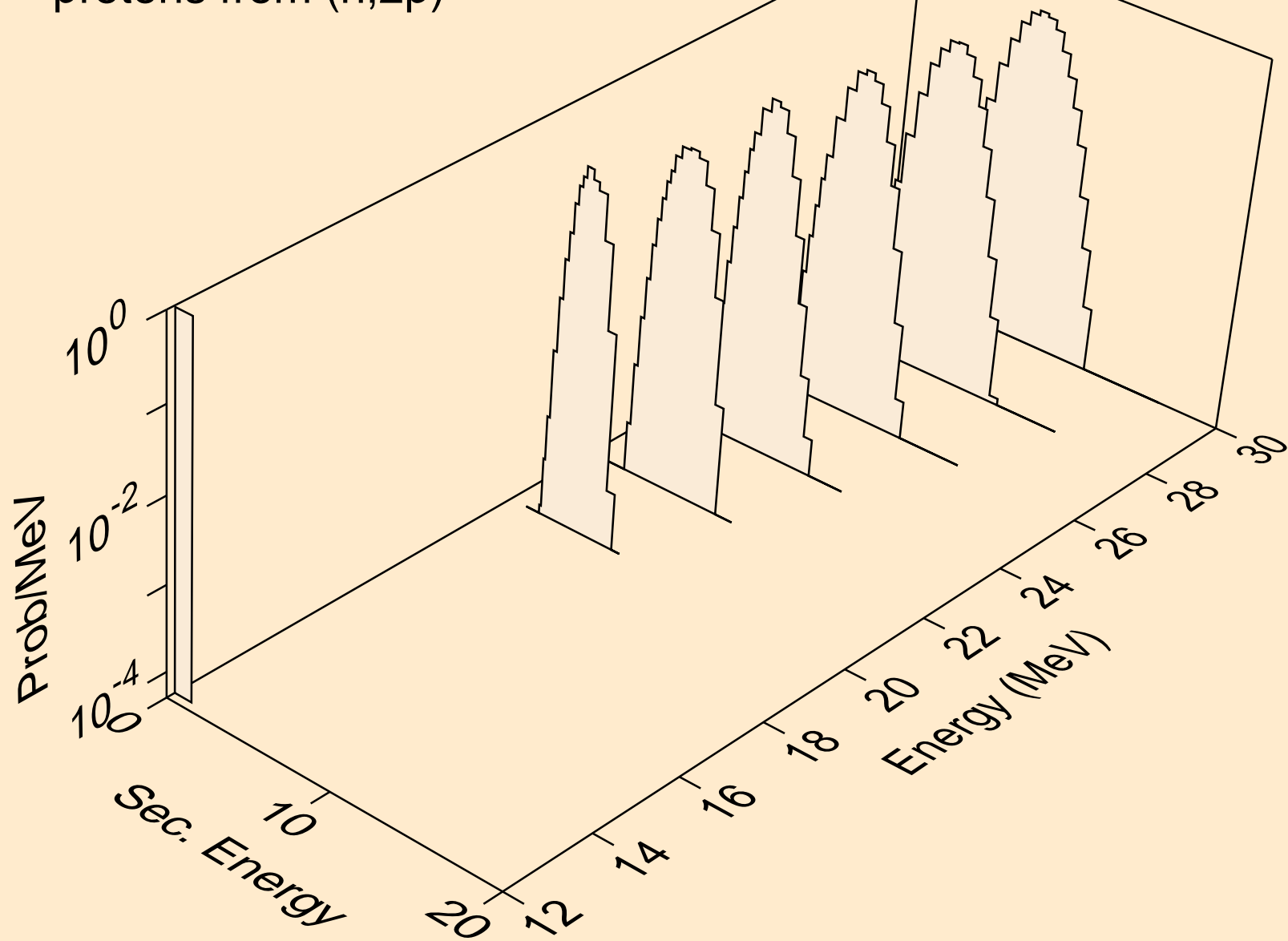

PT203M NEUTRON ACER TENDL-2023 LIBRARY; T=0.K  
deuterons from (n,x)

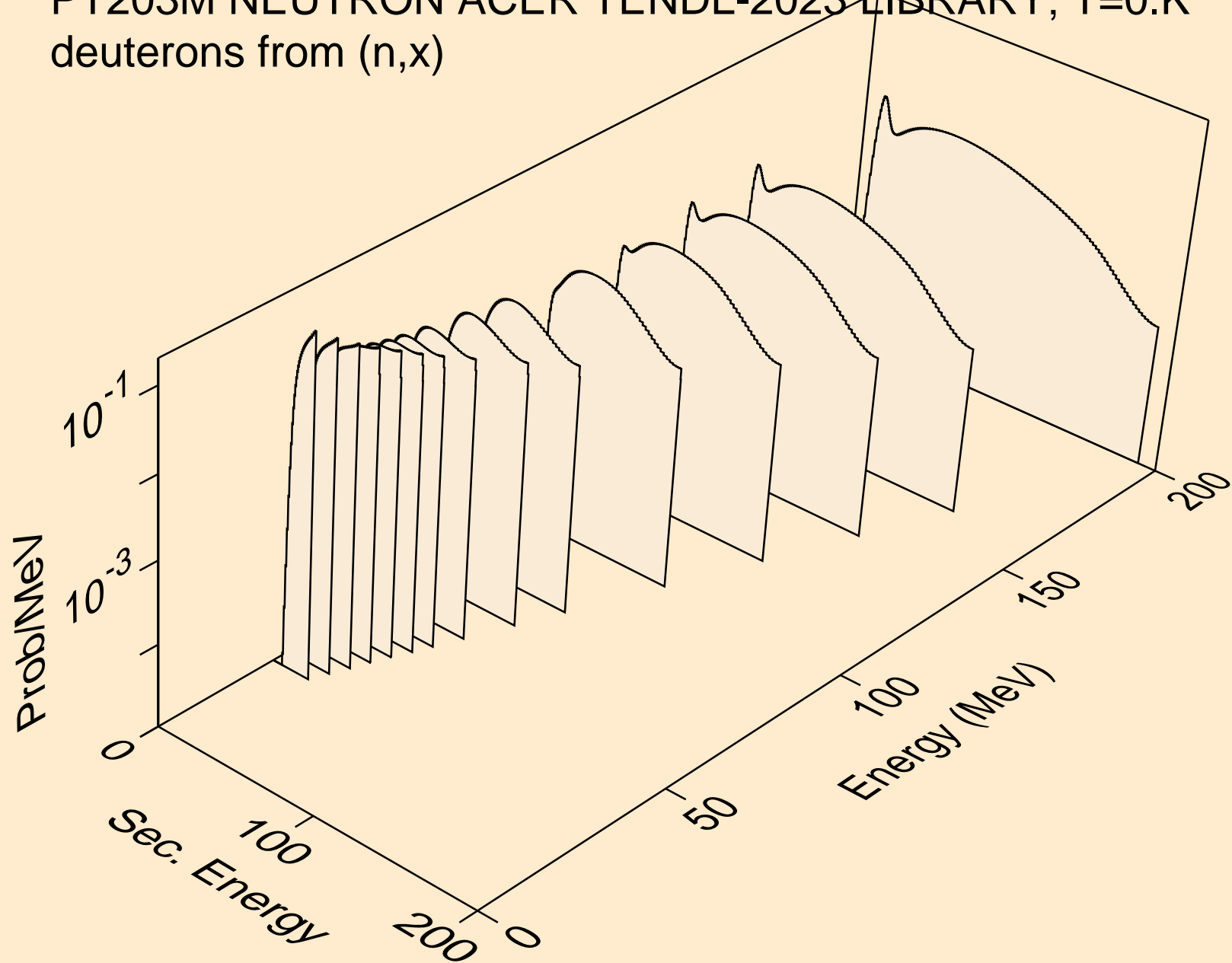

PT203M NEUTRON ACER TENDL-2023 LIBRARY; T=0.K  
deuterons from (n,2nd)

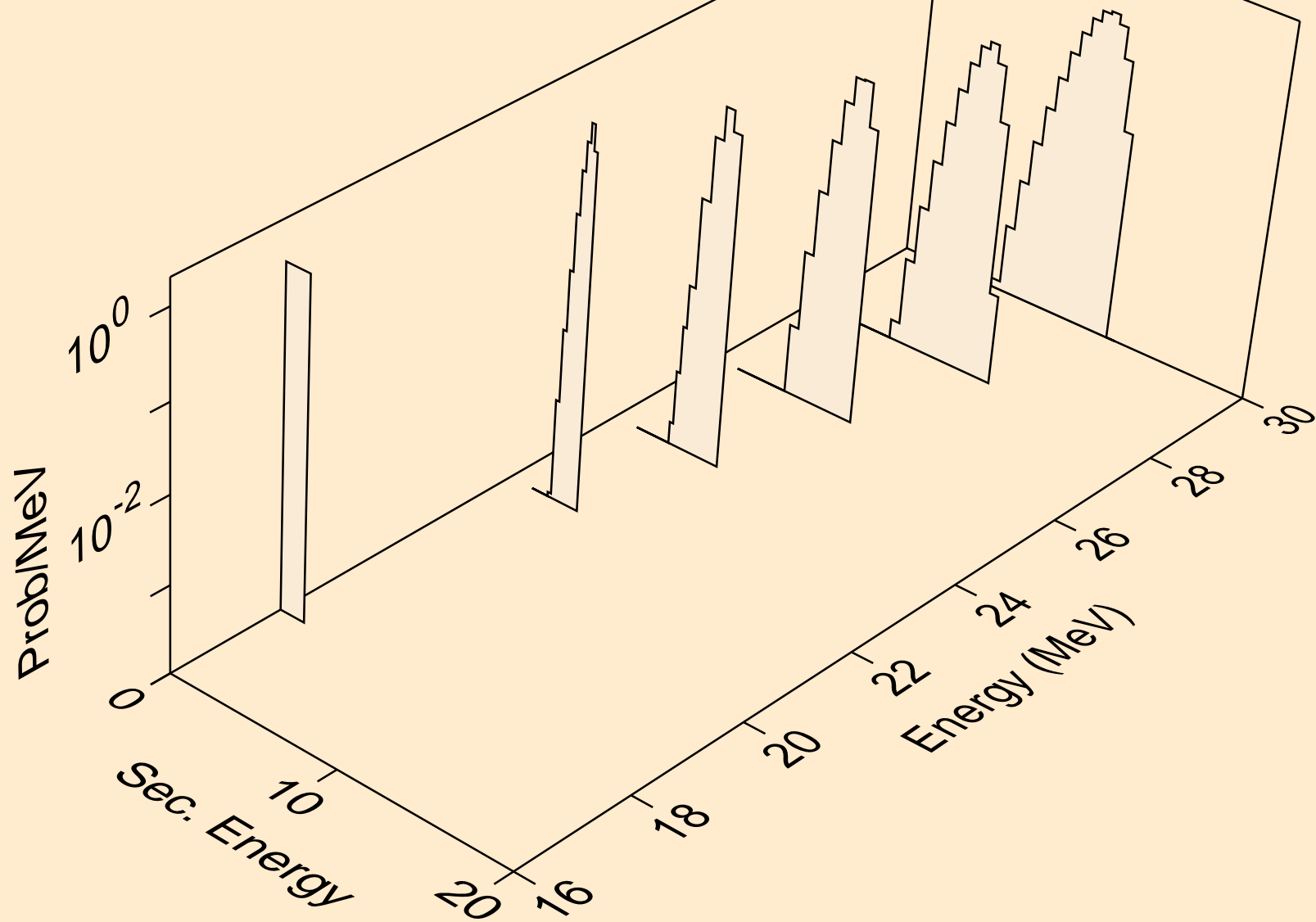



PT203M NEUTRON ACER TENDL-2023 LIBRARY; T=0.K  
deuterons from (n,n\*)d

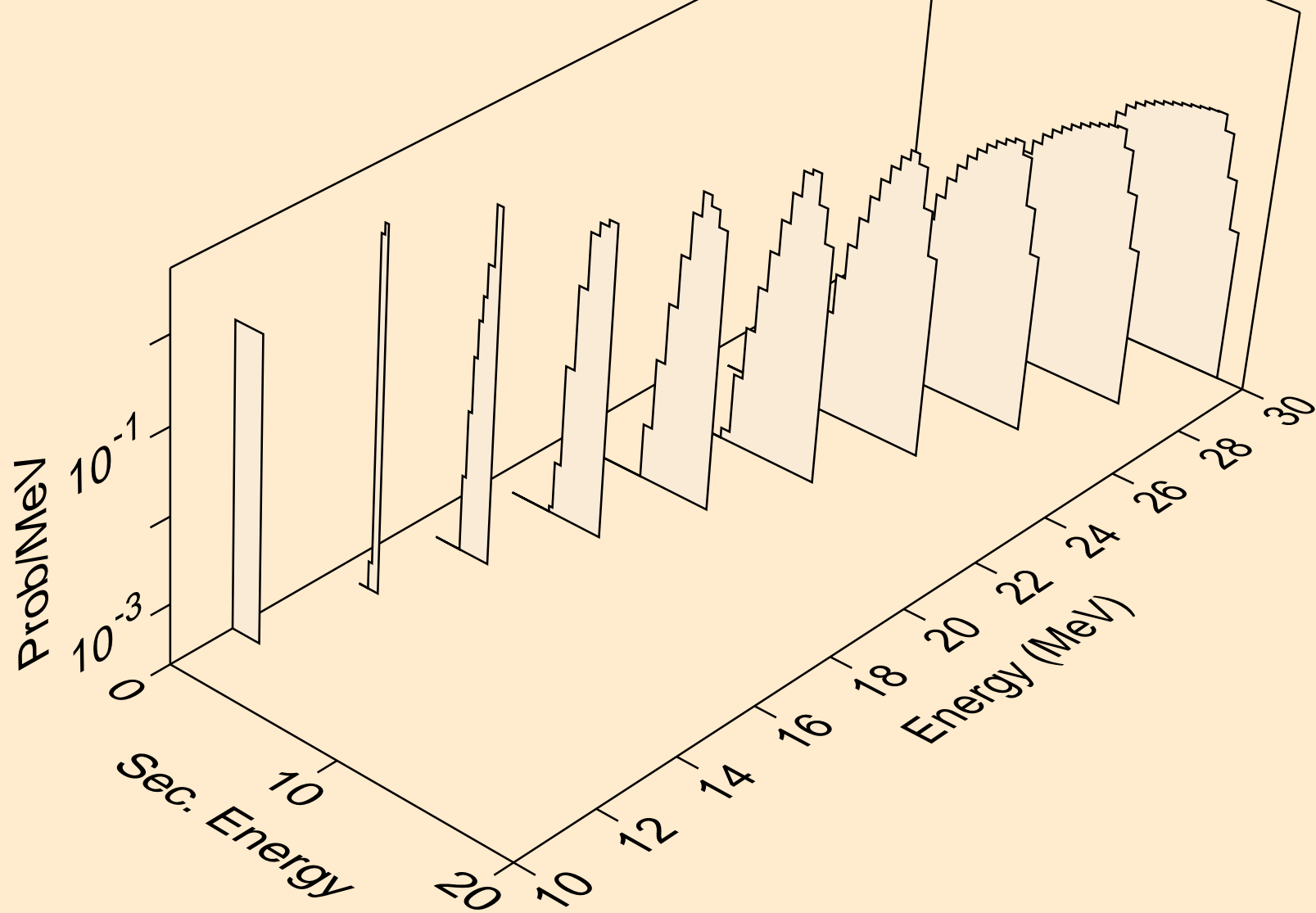

PT203M NEUTRON ACER TENDL-2023 LIBRARY; T=0.K  
deuterons from (n,d)

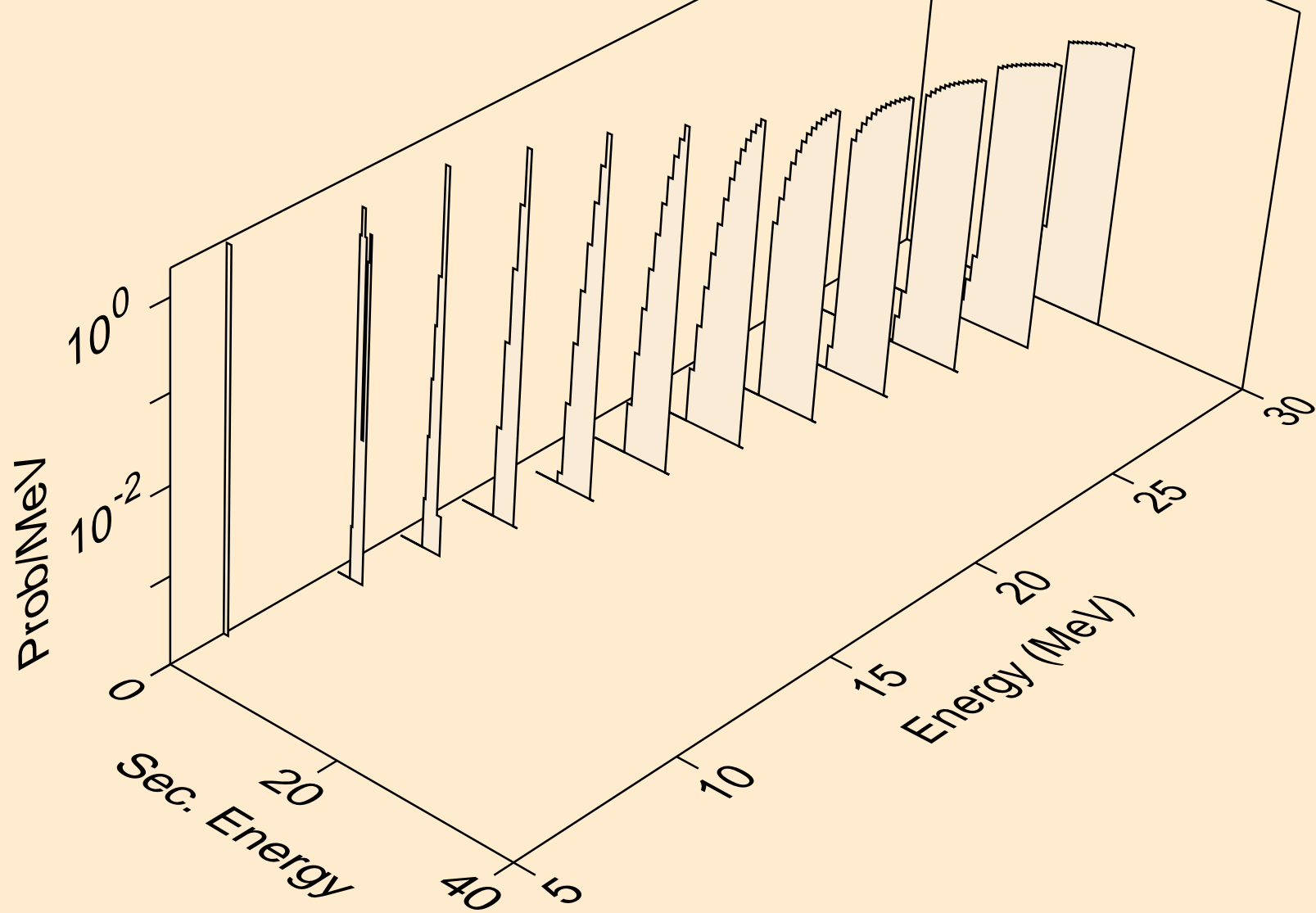

PT203M NEUTRON ACER TENDL-2023 LIBRARY; T=0.K  
tritons from (n,x)

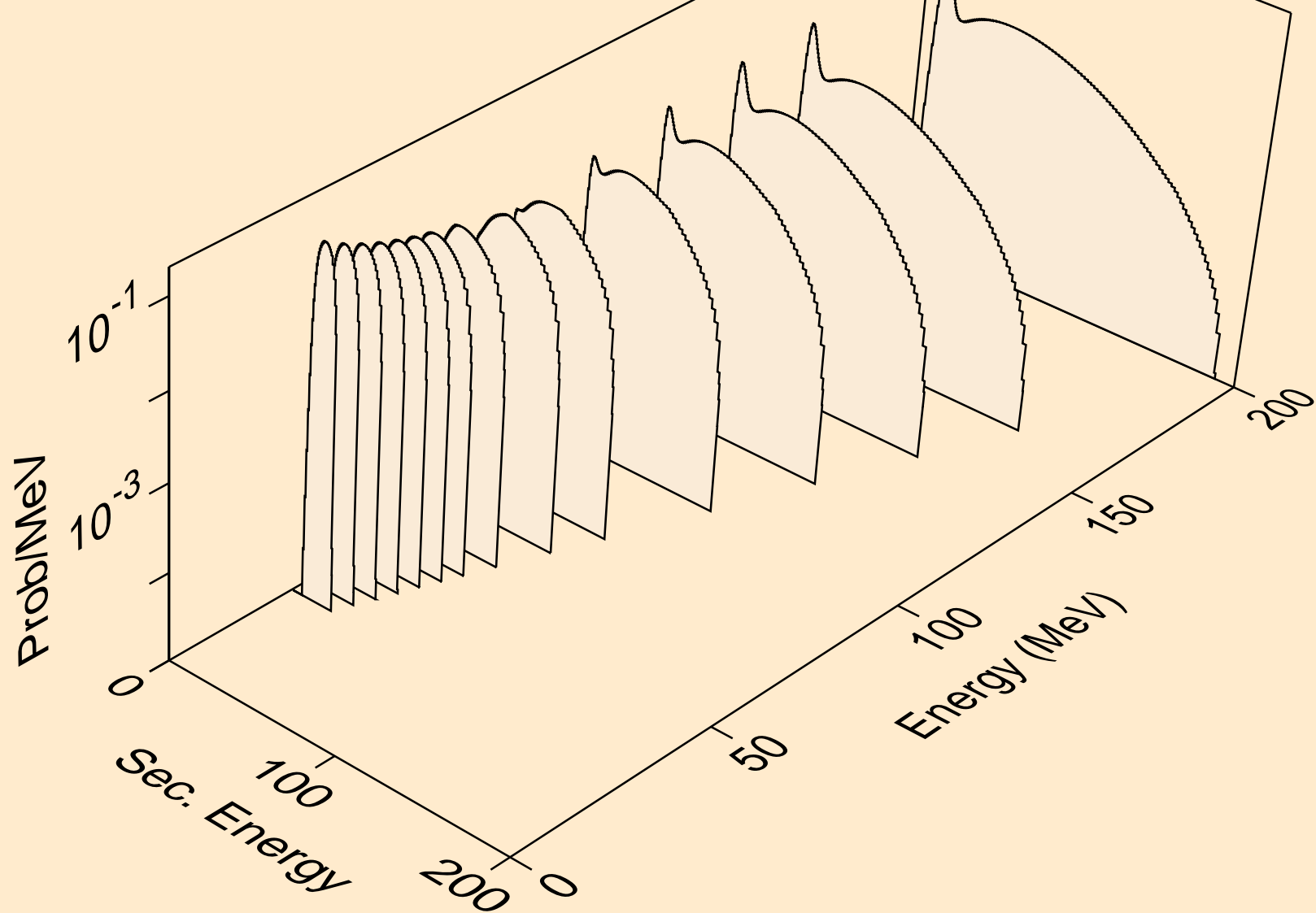

PT203M NEUTRON ACER TENDL-2023 LIBRARY; T=0.K  
tritons from (n,n\*)t

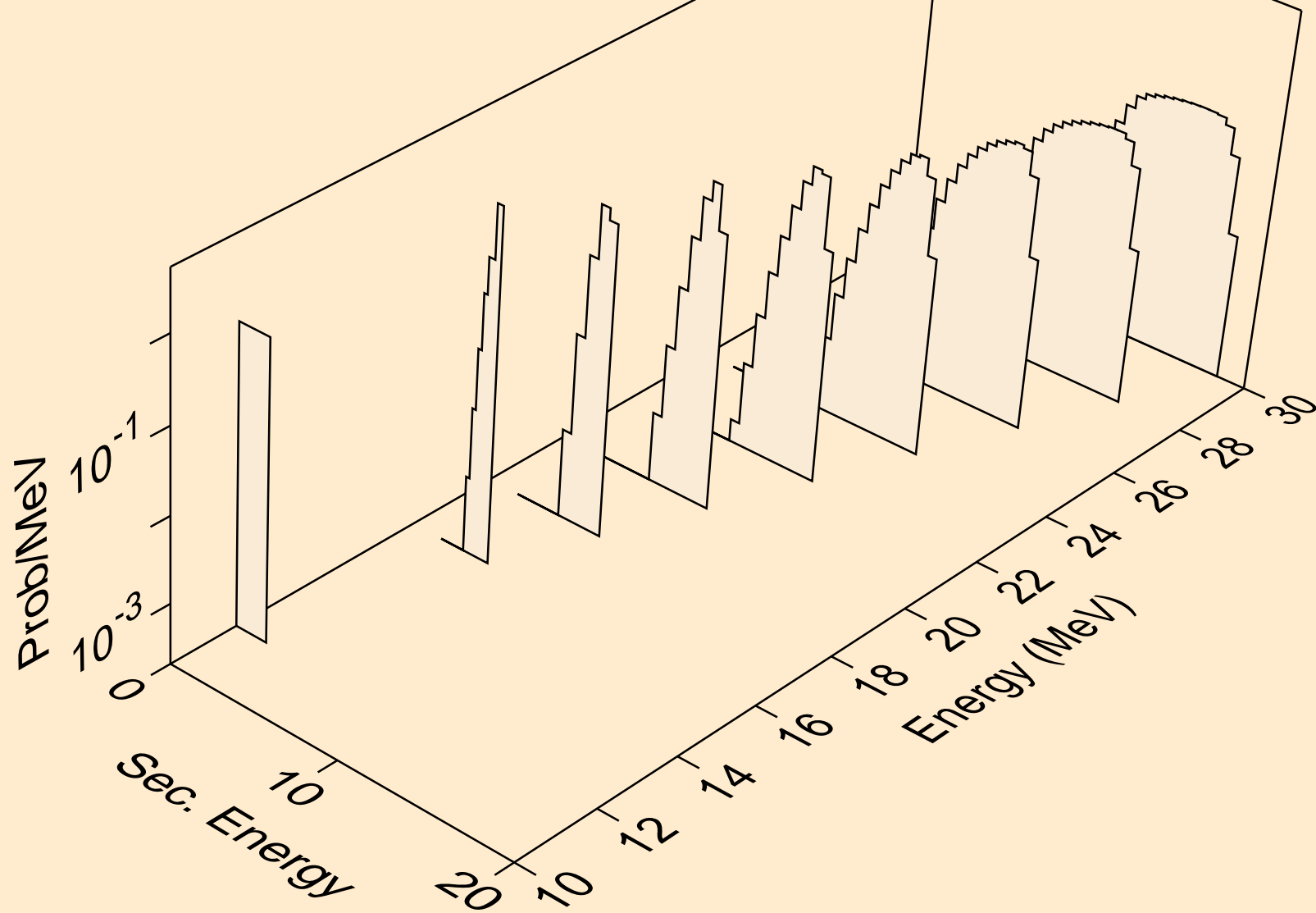

PT203M NEUTRON ACER TENDL-2023 LIBRARY; T=0.K  
tritons from (n,t)

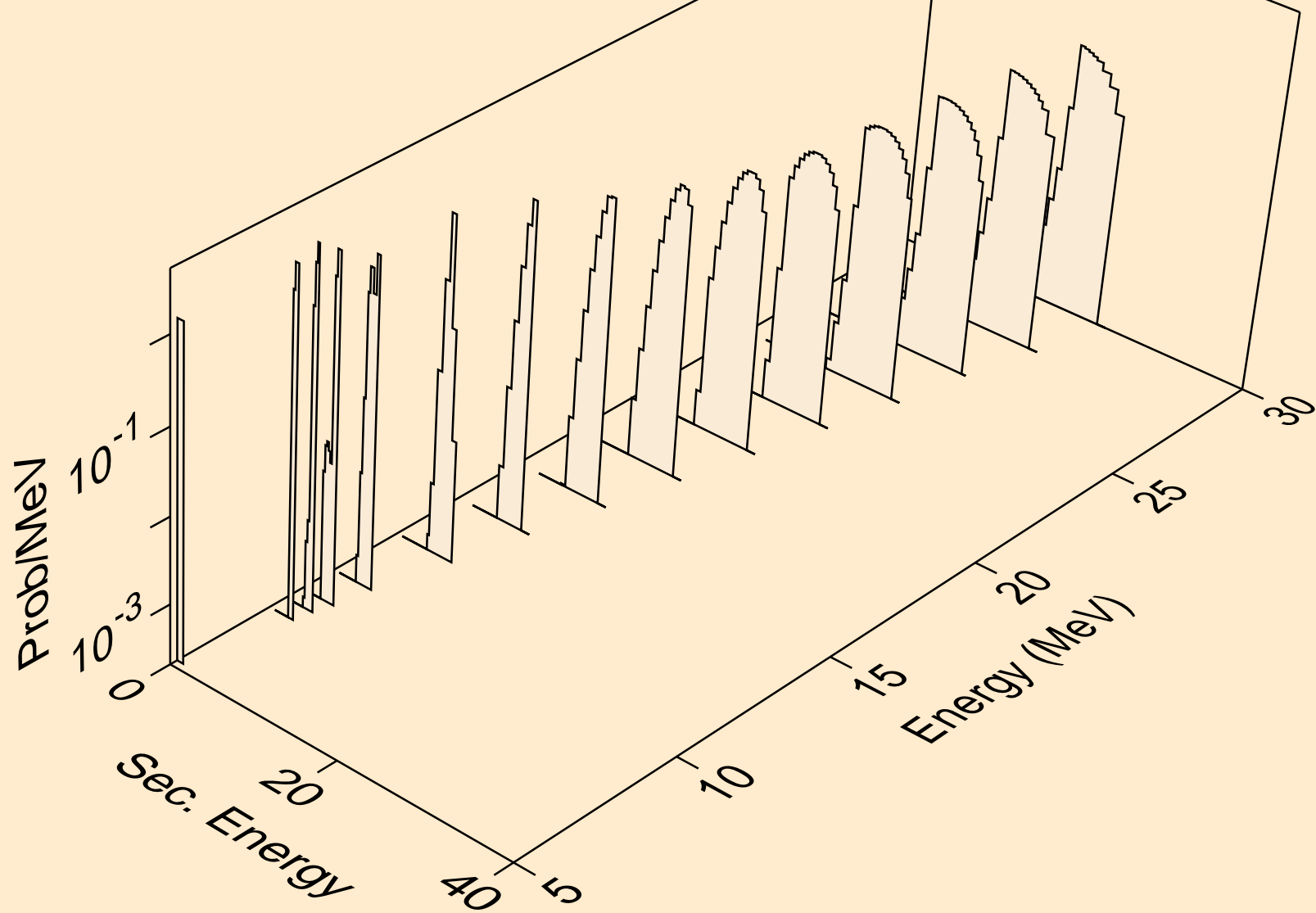

PT203M NEUTRON ACER TENDL-2023 LIBRARY; T=0.K  
he3s from (n,x)

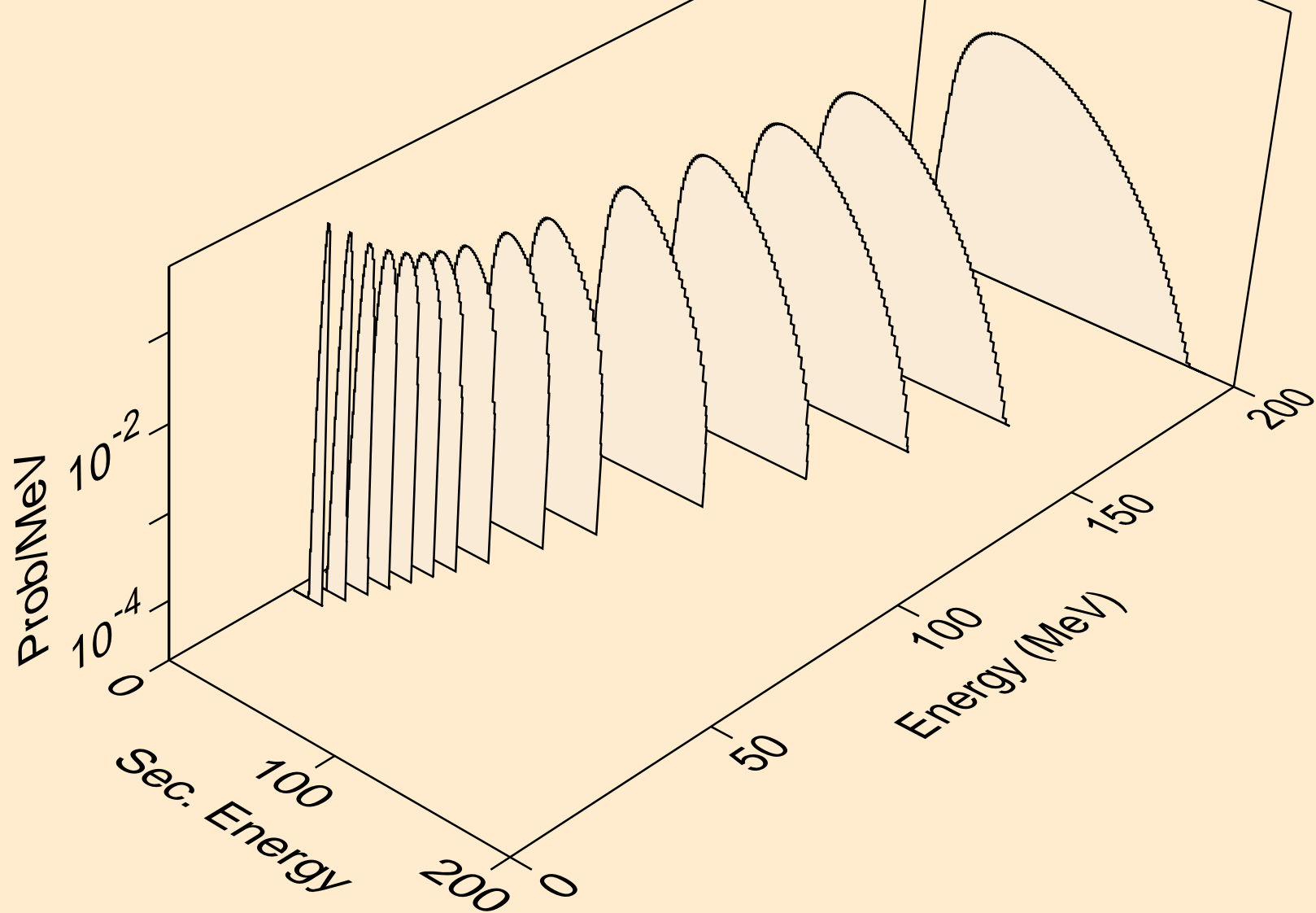

PT203M NEUTRON ACER TENDL-2023 LIBRARY; T=0.K  
he3s from (n,n\*)he3

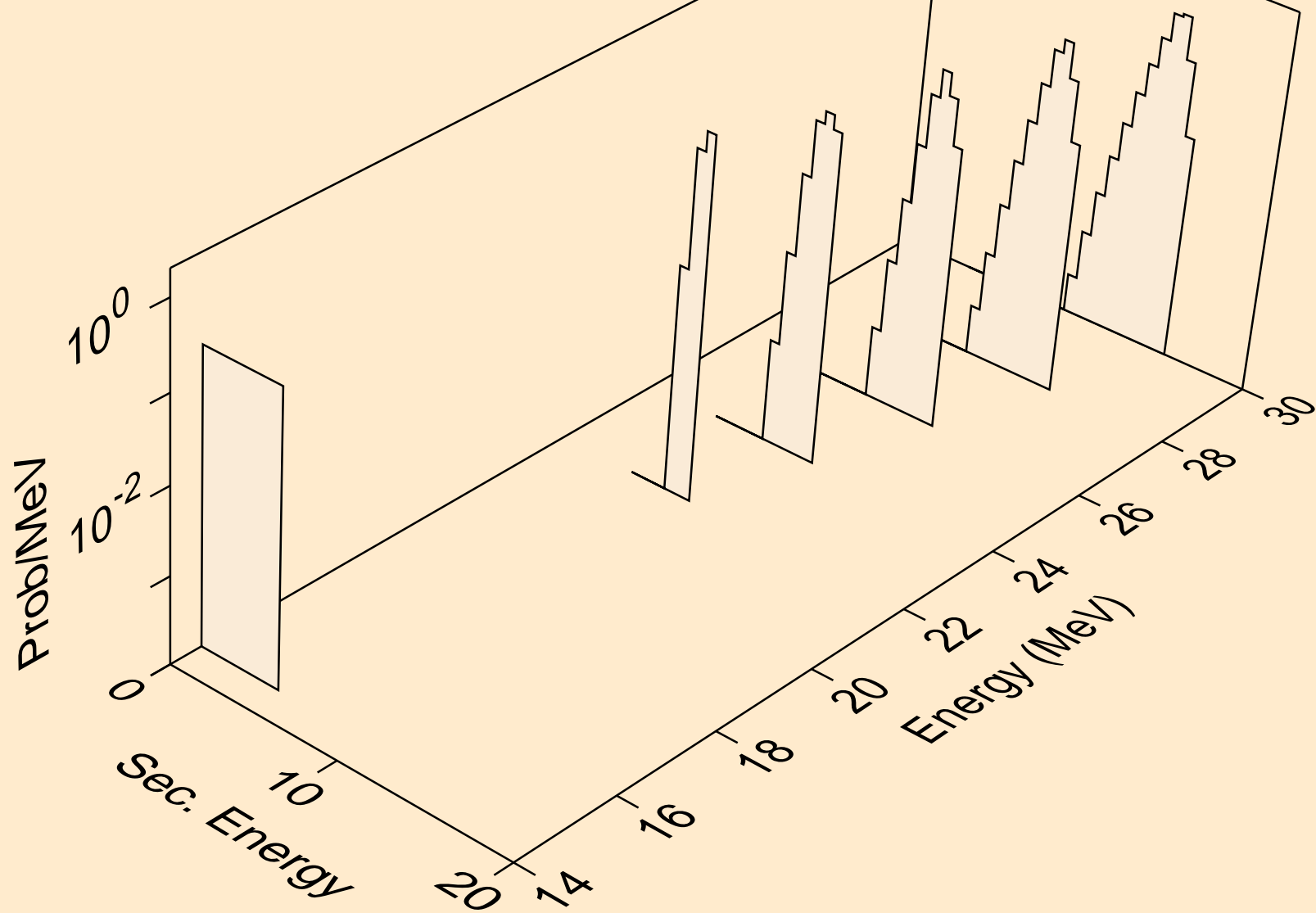

PT203M NEUTRON ACER TENDL-2023 LIBRARY; T=0.K  
he3s from (n,he3)

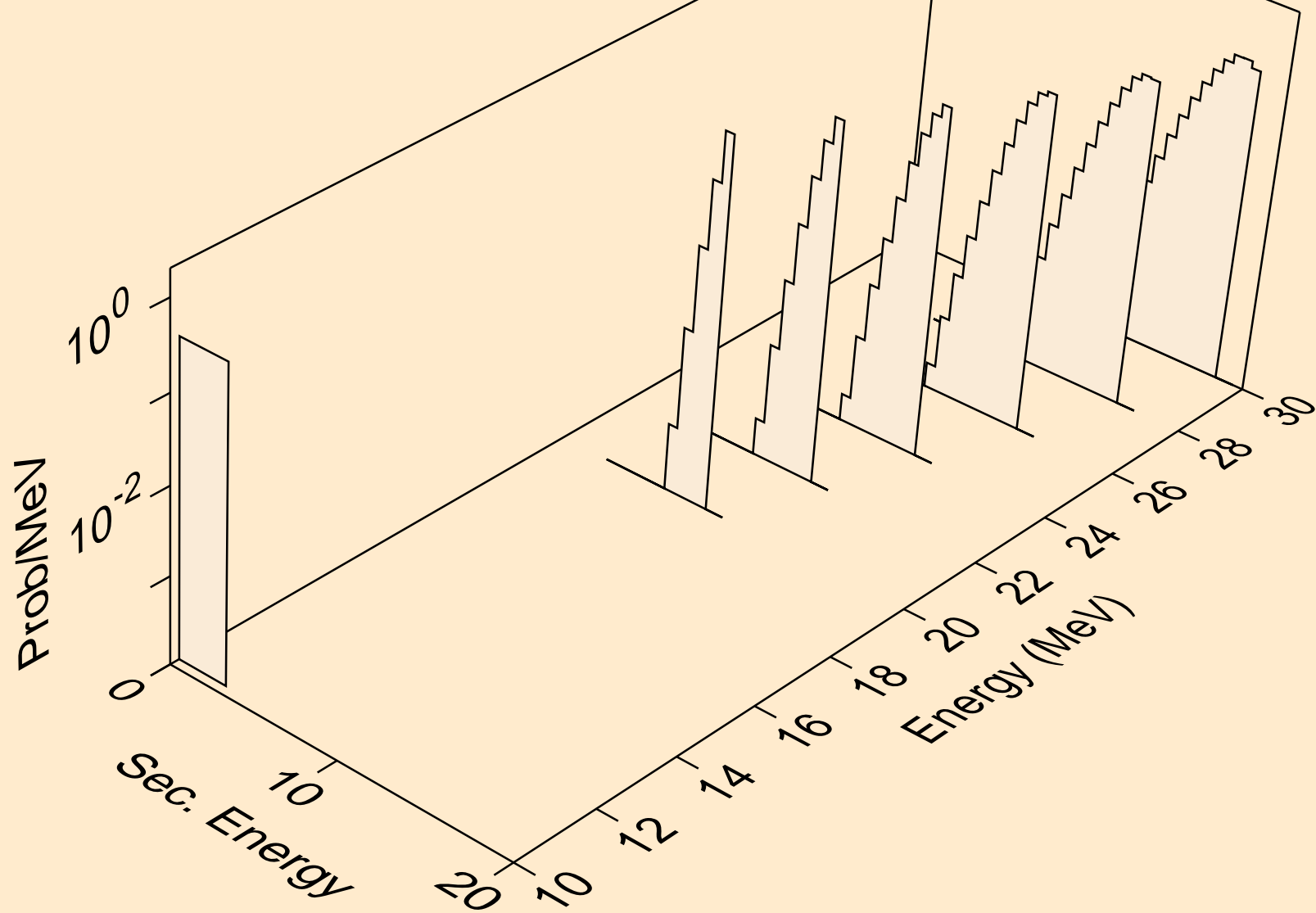



PT203M NEUTRON ACER TENDL-2023 LIBRARY; T=0.K  
alphas from (n,x)

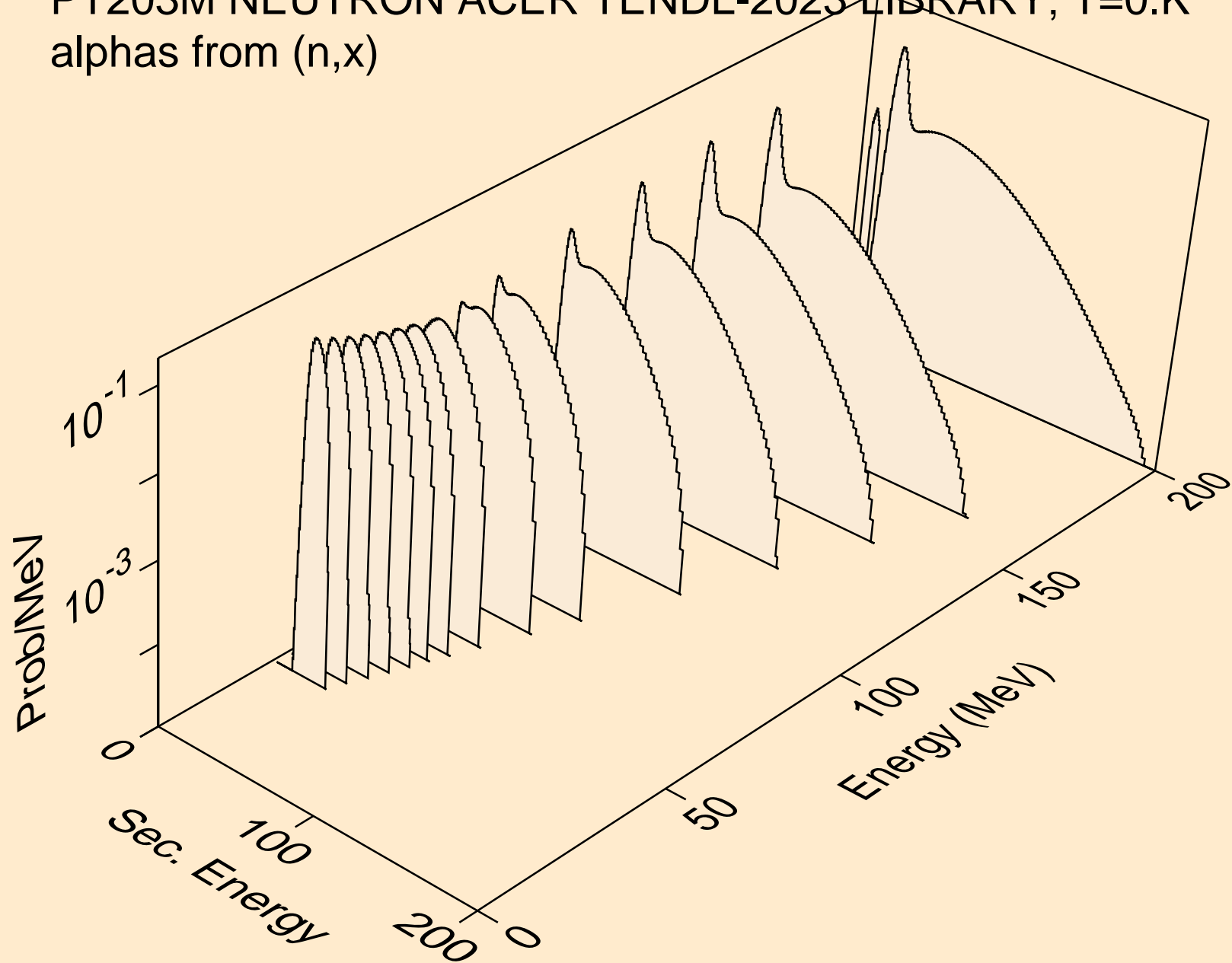

PT203M NEUTRON ACER TENDL-2023 LIBRARY; T=0.K  
alphas from (n,n\*)a

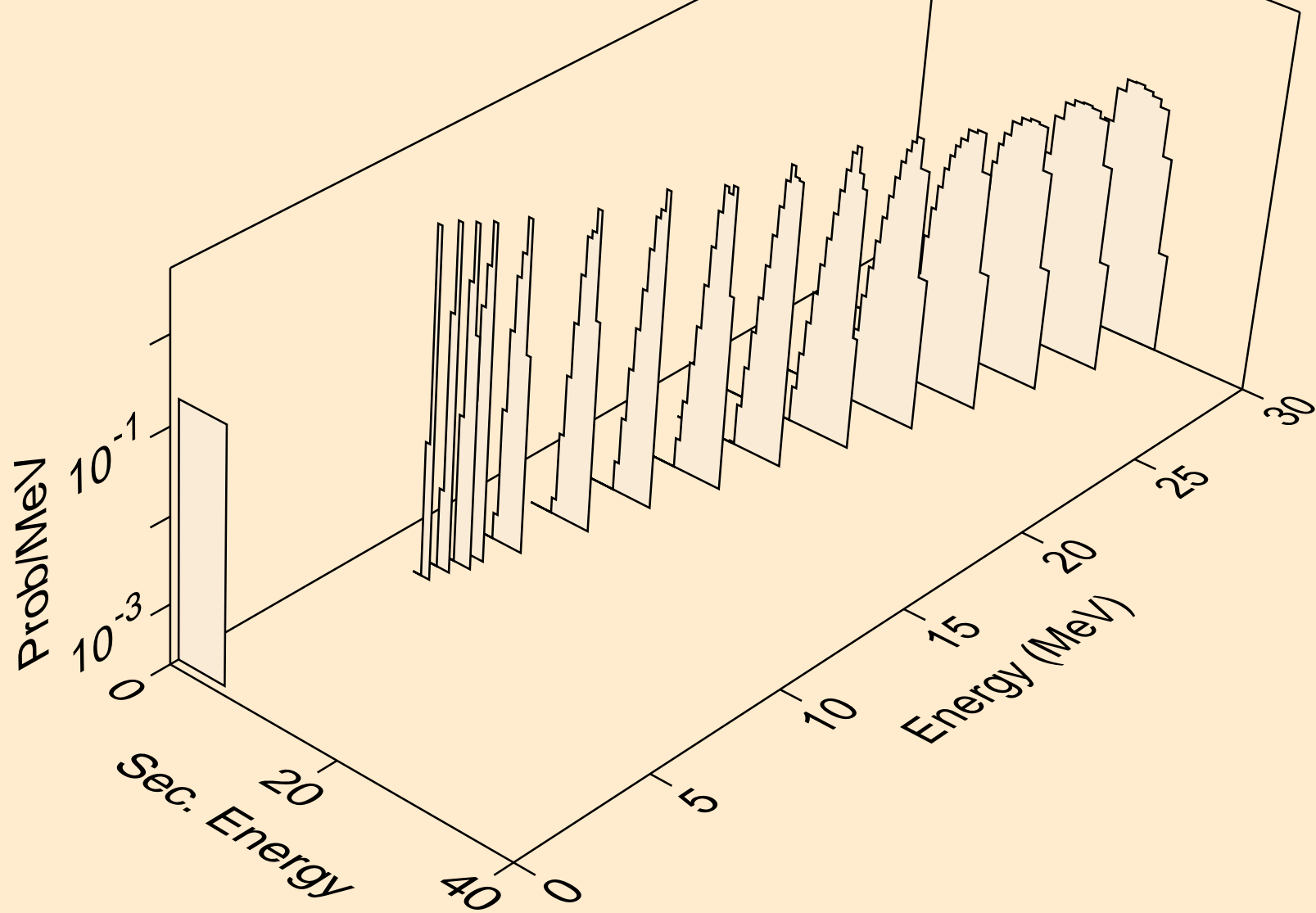

PT203M NEUTRON ACER TENDL-2023 LIBRARY; T=0.K  
alphas from (n,2n)a

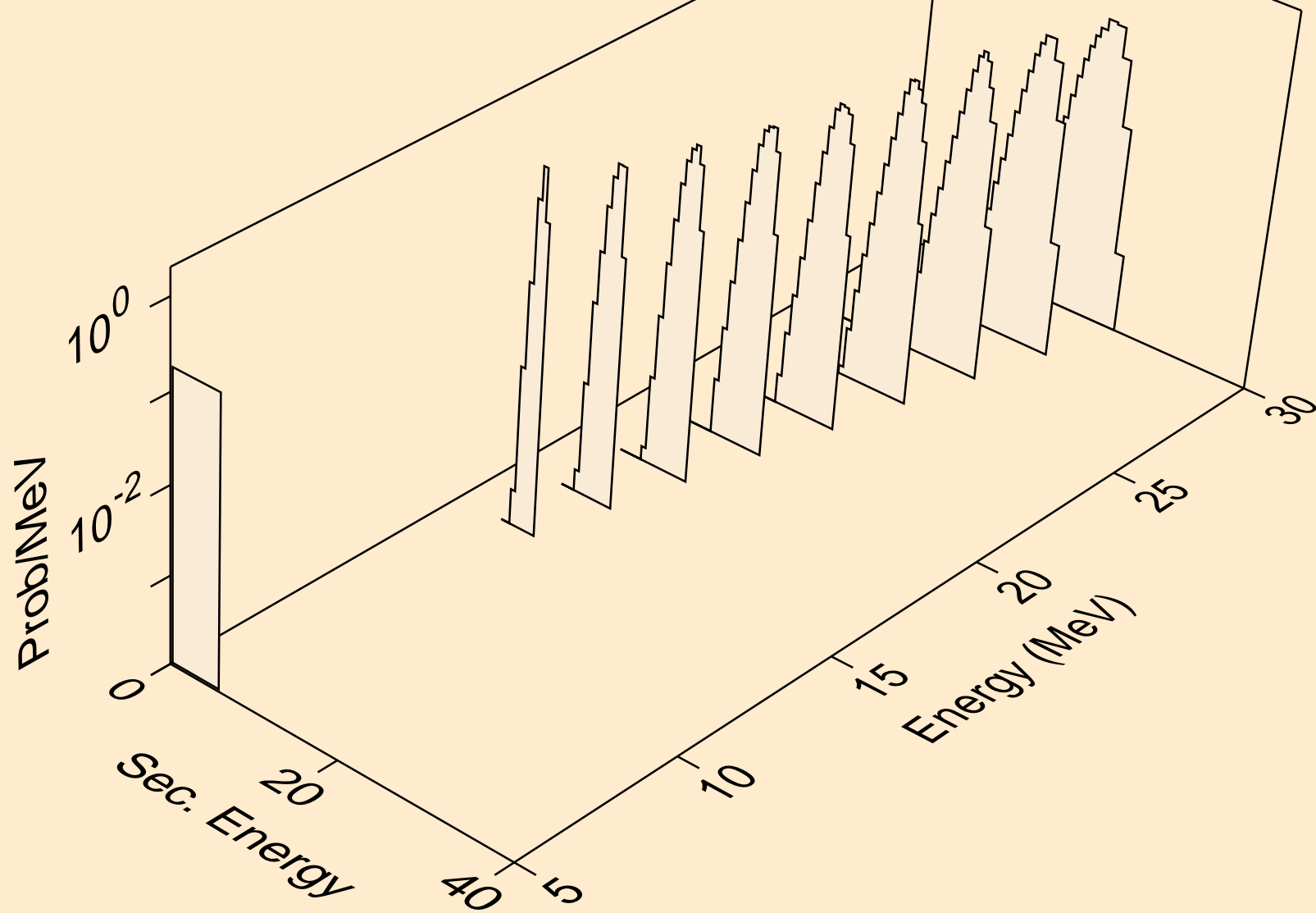

PT203M NEUTRON ACER TENDL-2023 LIBRARY; T=0.K  
alphas from (n,3n)a

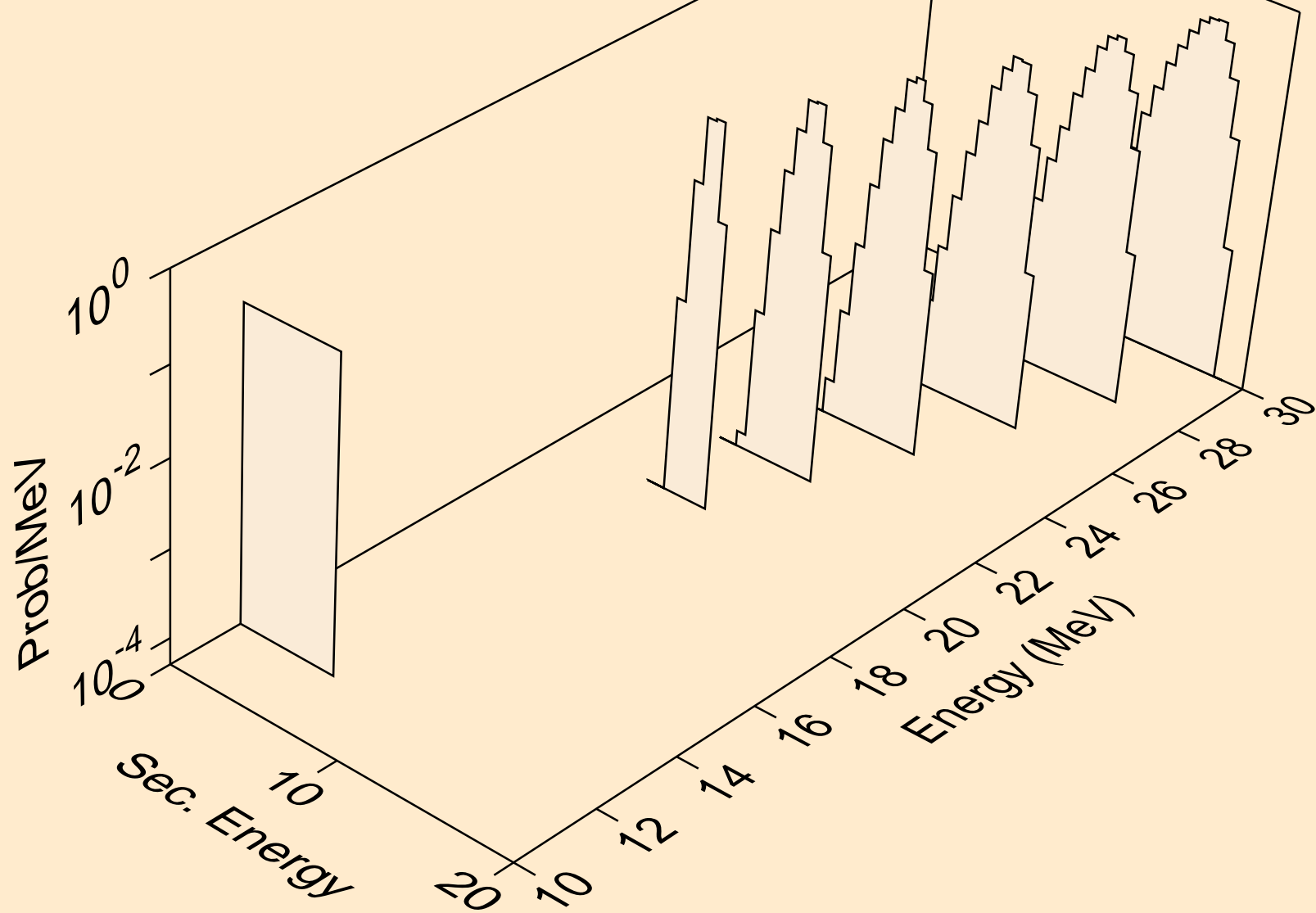

PT203M NEUTRON ACER TENDL-2023 LIBRARY; T=0.K  
alphas from (n,a)

