

# RE172M NEUTRON ACER TENDL-2023 LIBRARY; T=0.K

## Principal cross sections

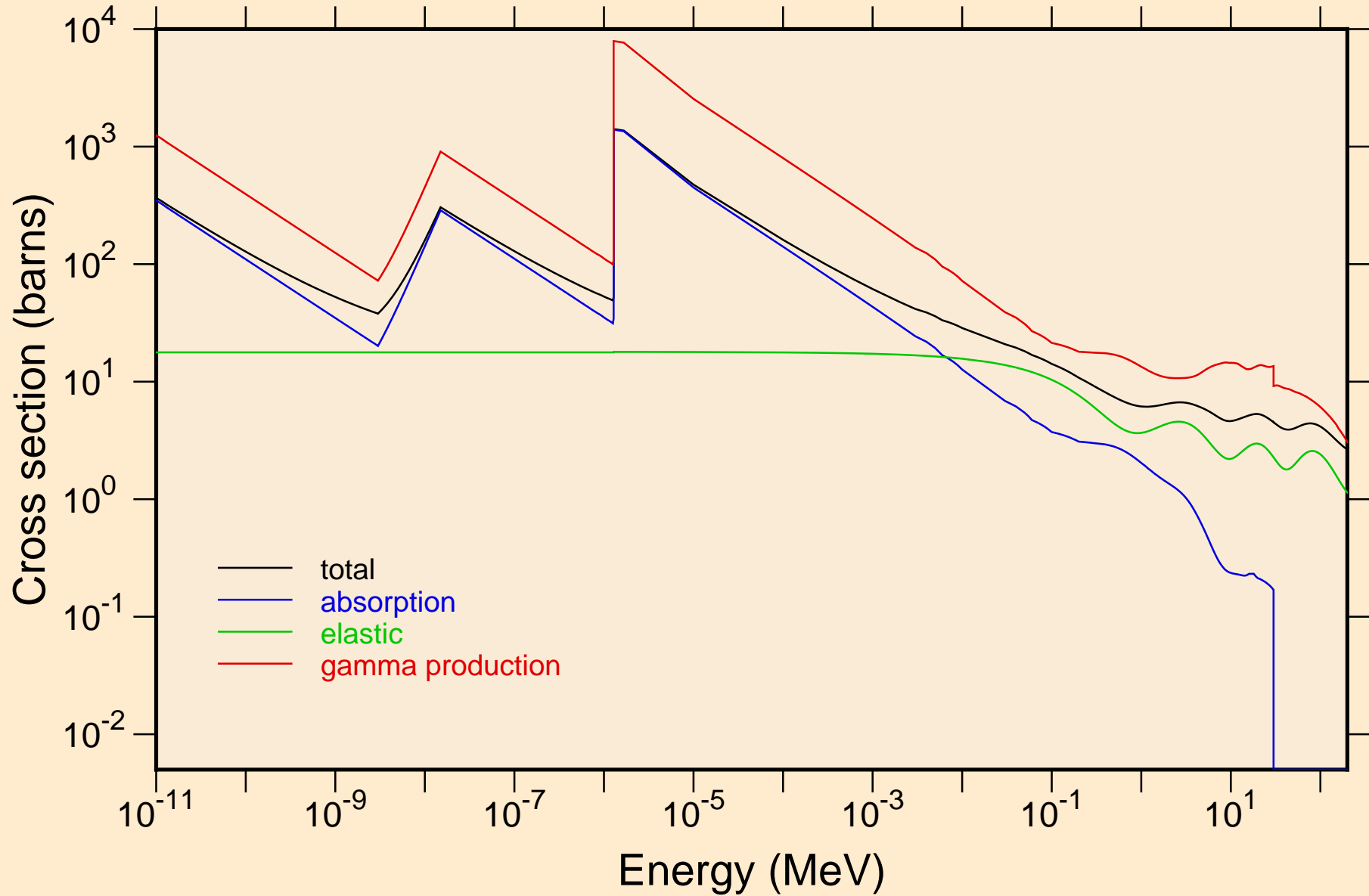

# RE172M NEUTRON ACER TENDL-2023 LIBRARY; T=0.K

## Heating

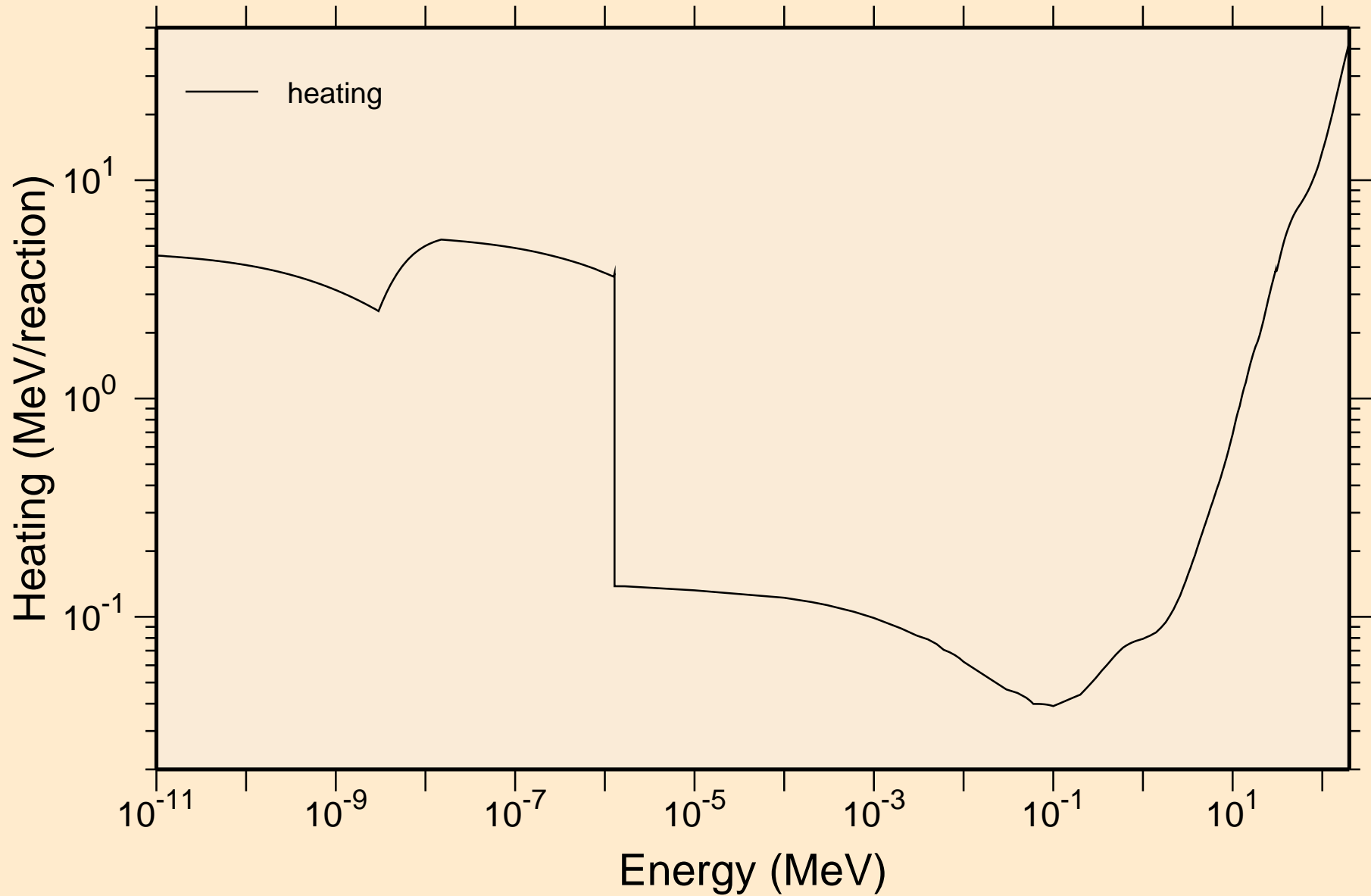

RE172M NEUTRON ACER TENDL-2023 LIBRARY; T=0.K  
Damage

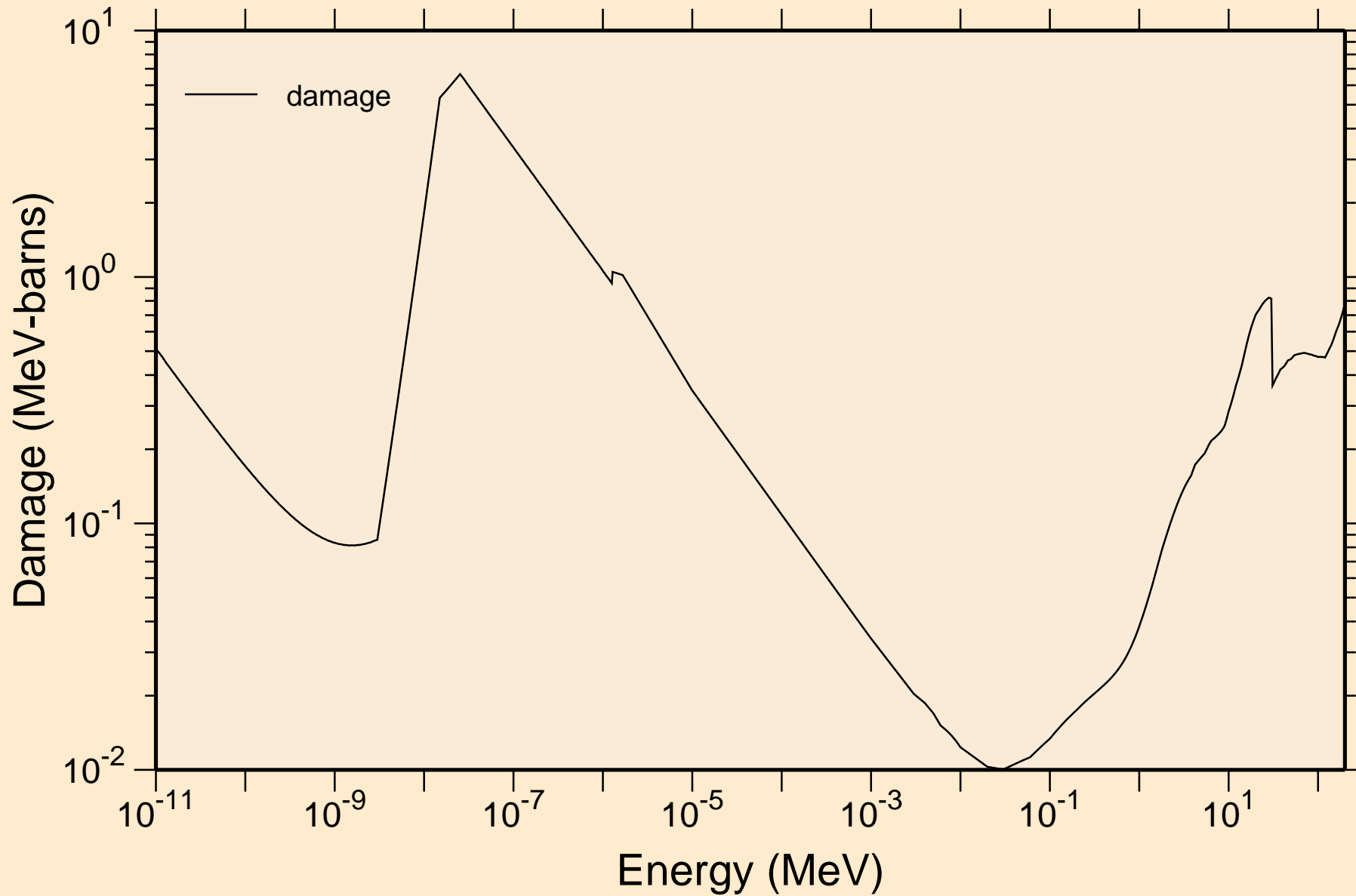

RE172M NEUTRON ACER TENDL-2023 LIBRARY; T=0.K  
Non-threshold reactions

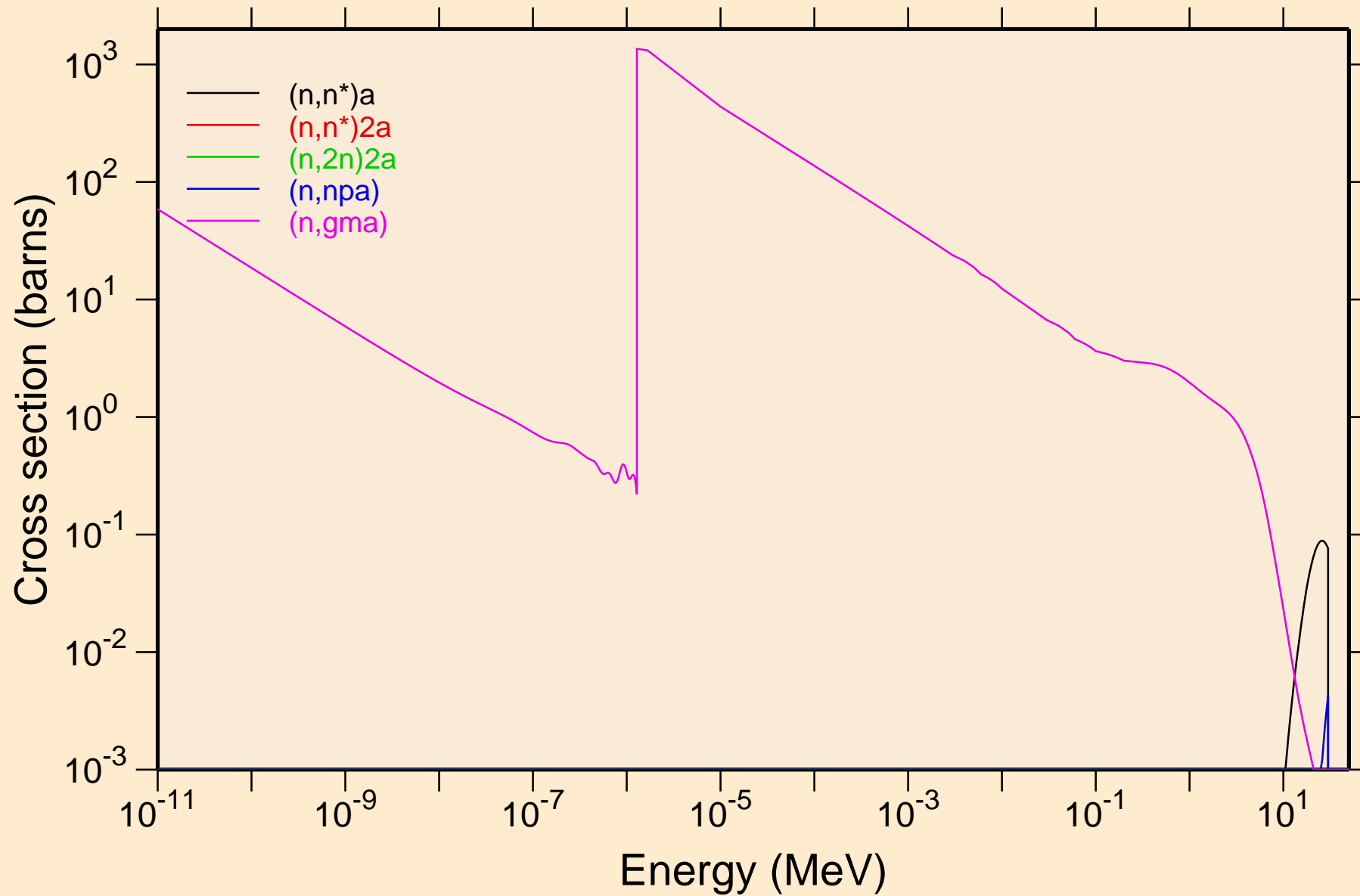

RE172M NEUTRON ACER TENDL-2023 LIBRARY; T=0.K  
Non-threshold reactions

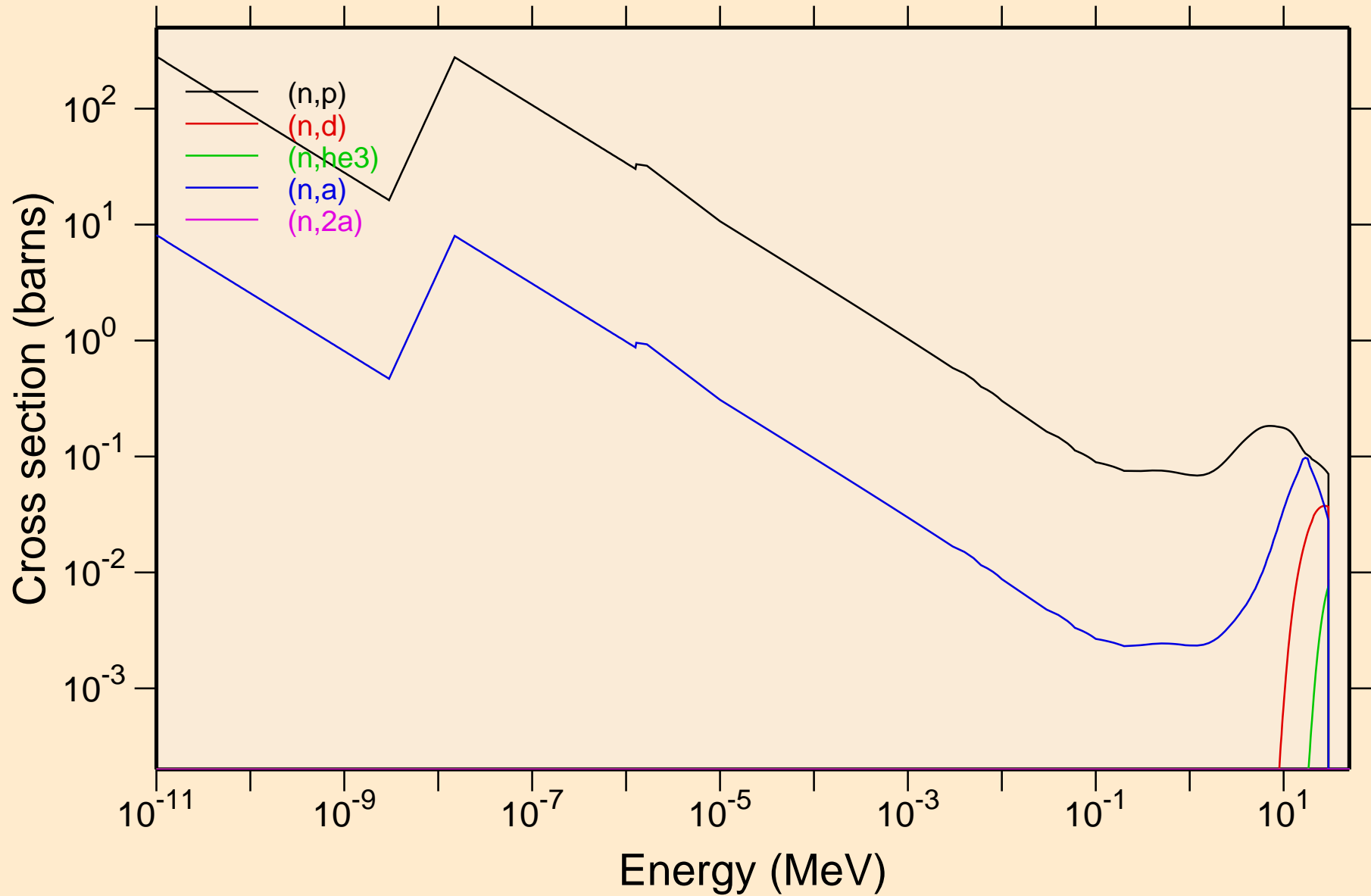



RE172M NEUTRON ACER TENDL-2023 LIBRARY; T=0.K  
Non-threshold reactions

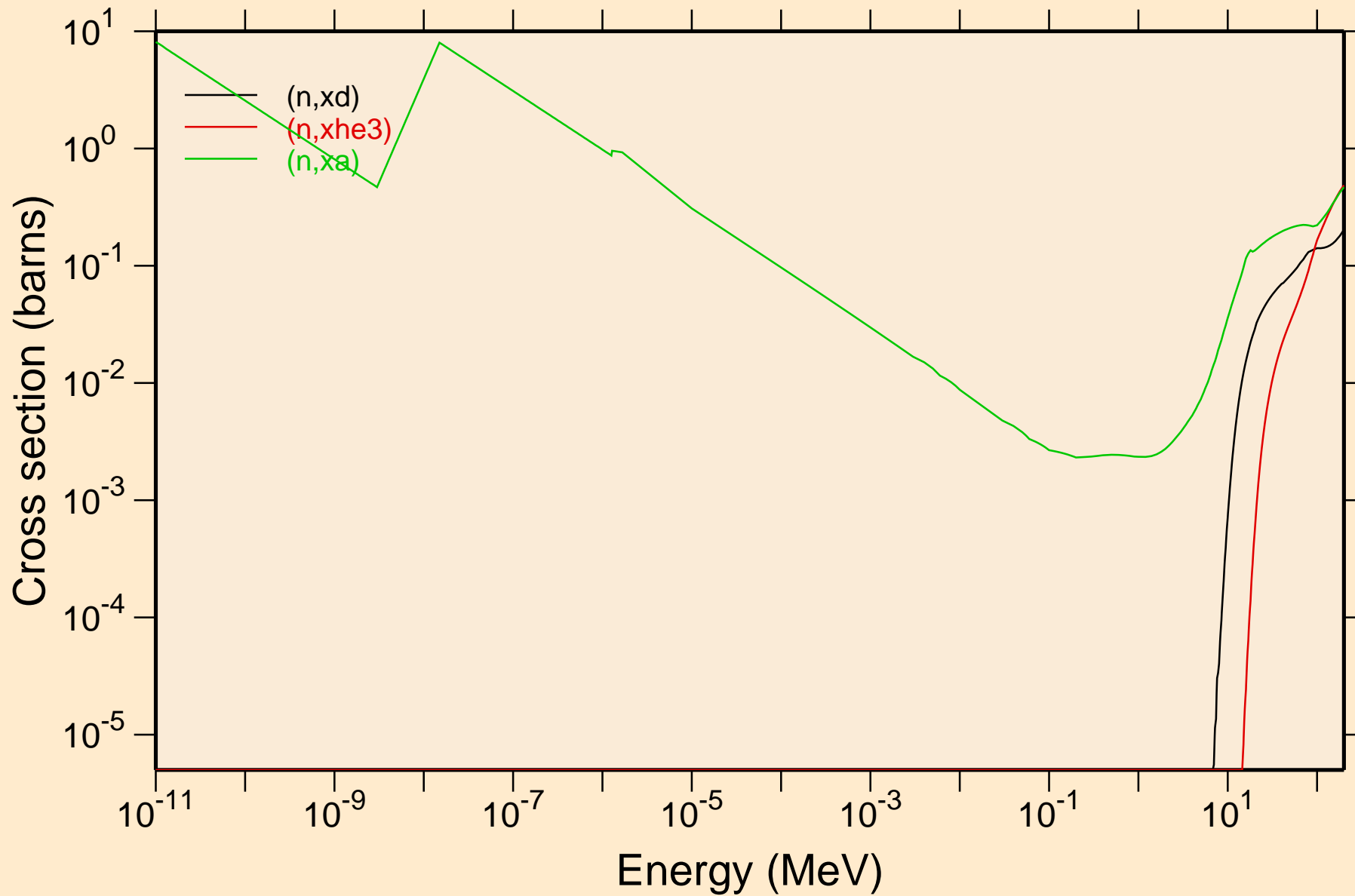

# RE172M NEUTRON ACER TENDL-2023 LIBRARY; T=0.K

## Principal cross sections

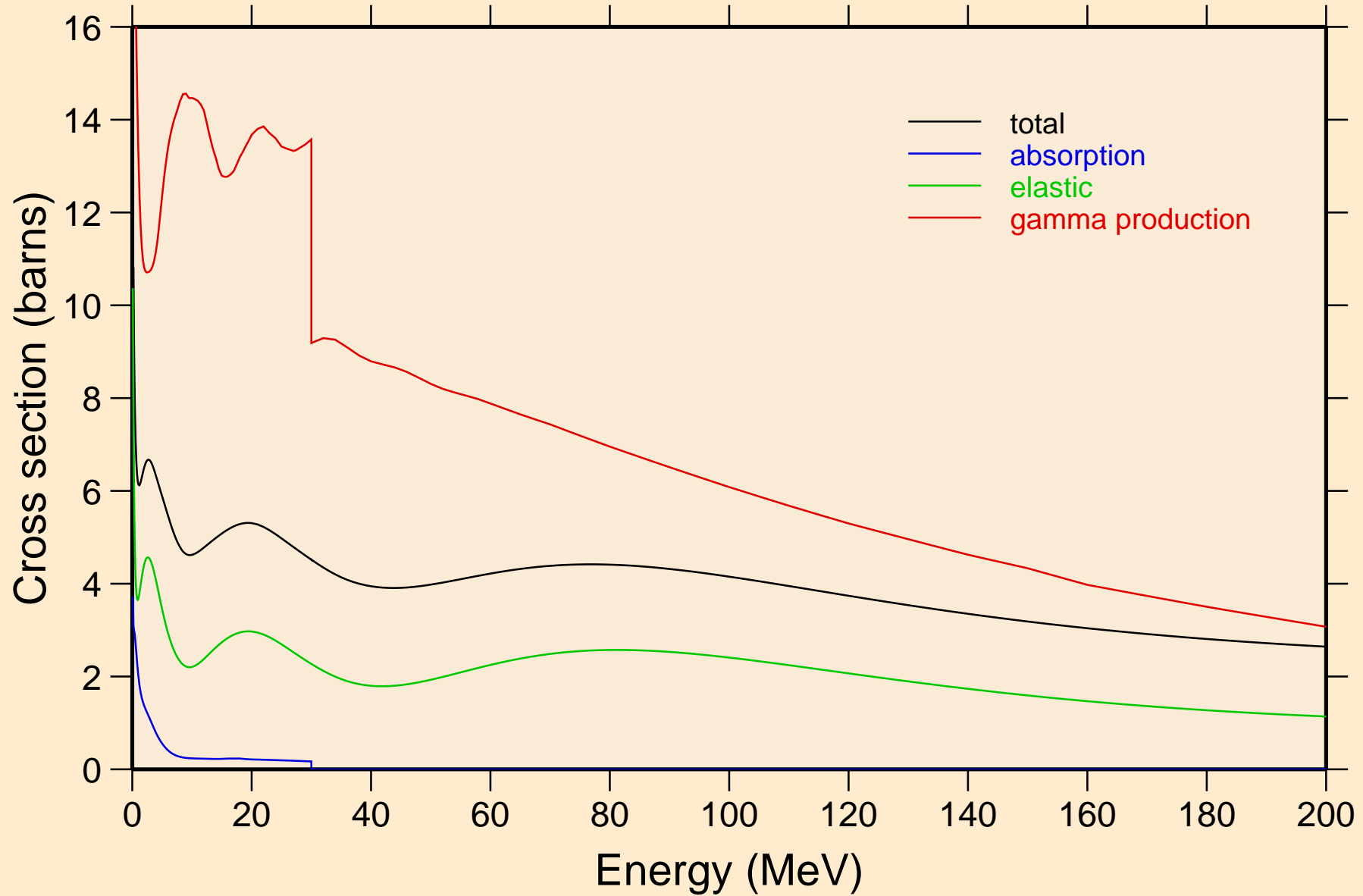



# RE172M NEUTRON ACER TENDL-2023 LIBRARY; T=0.K

## Heating

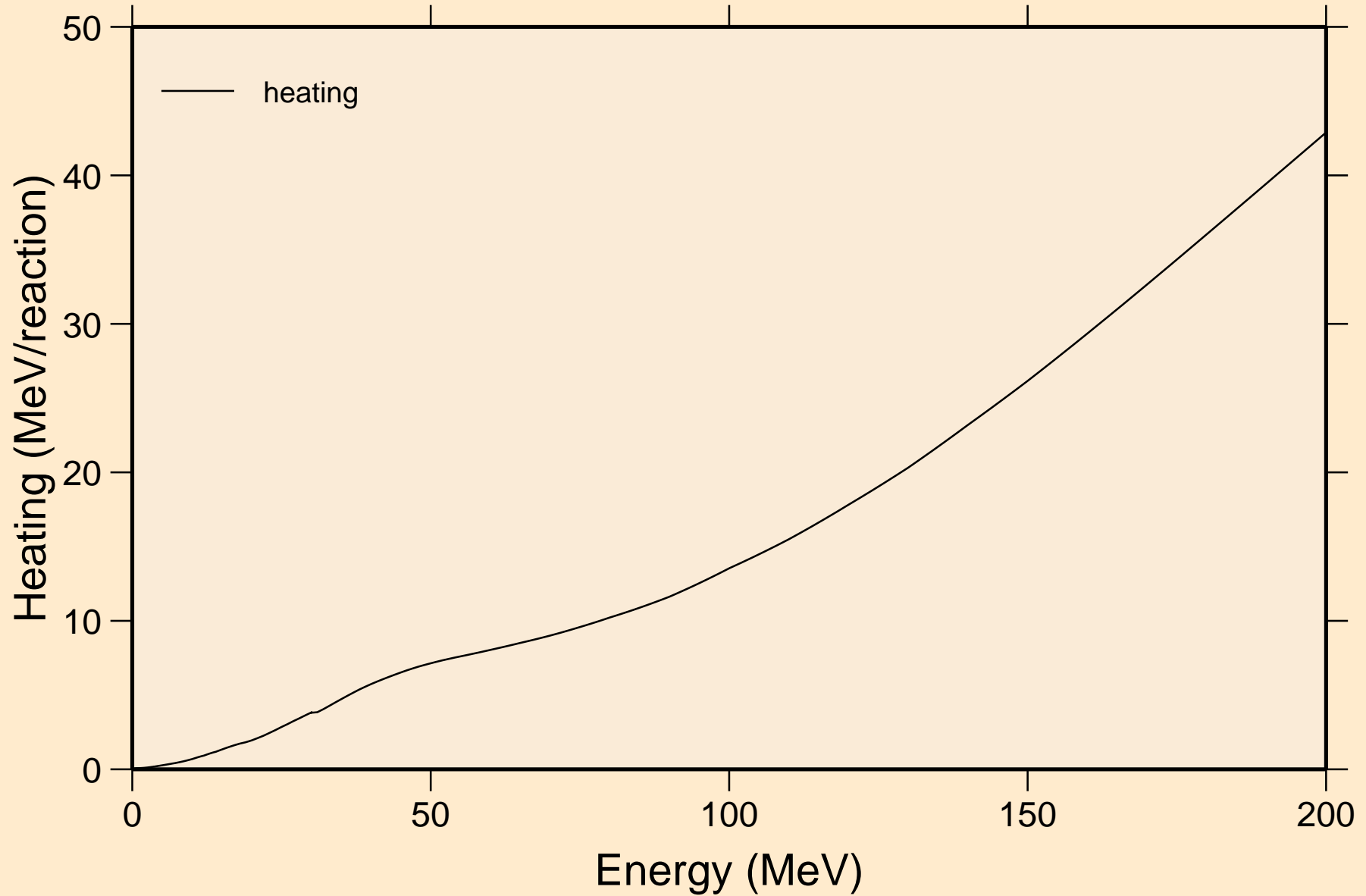

RE172M NEUTRON ACER TENDL-2023 LIBRARY; T=0.K  
Damage

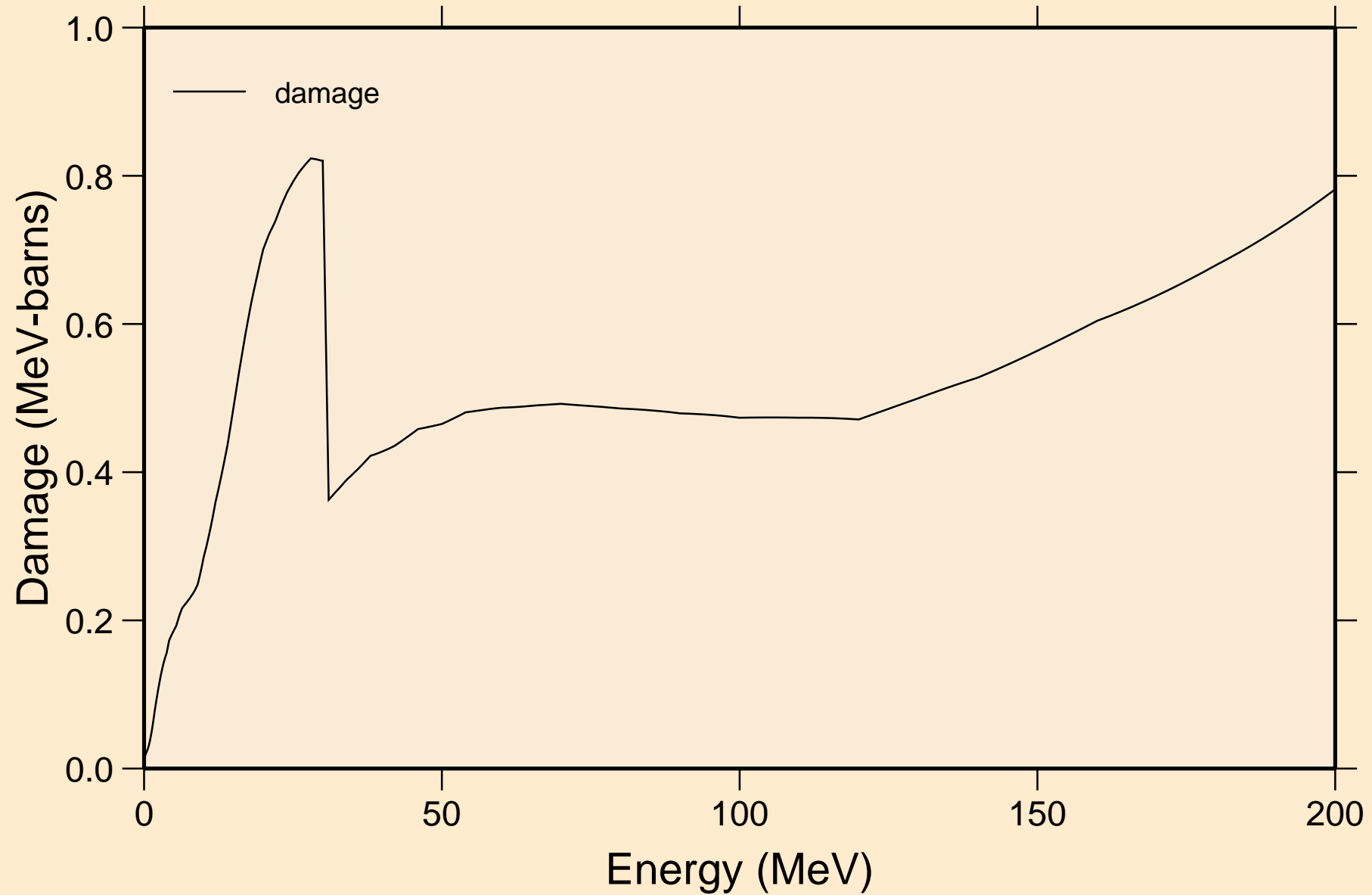

RE172M NEUTRON ACER TENDL-2023 LIBRARY; T=0.K  
Non-threshold reactions

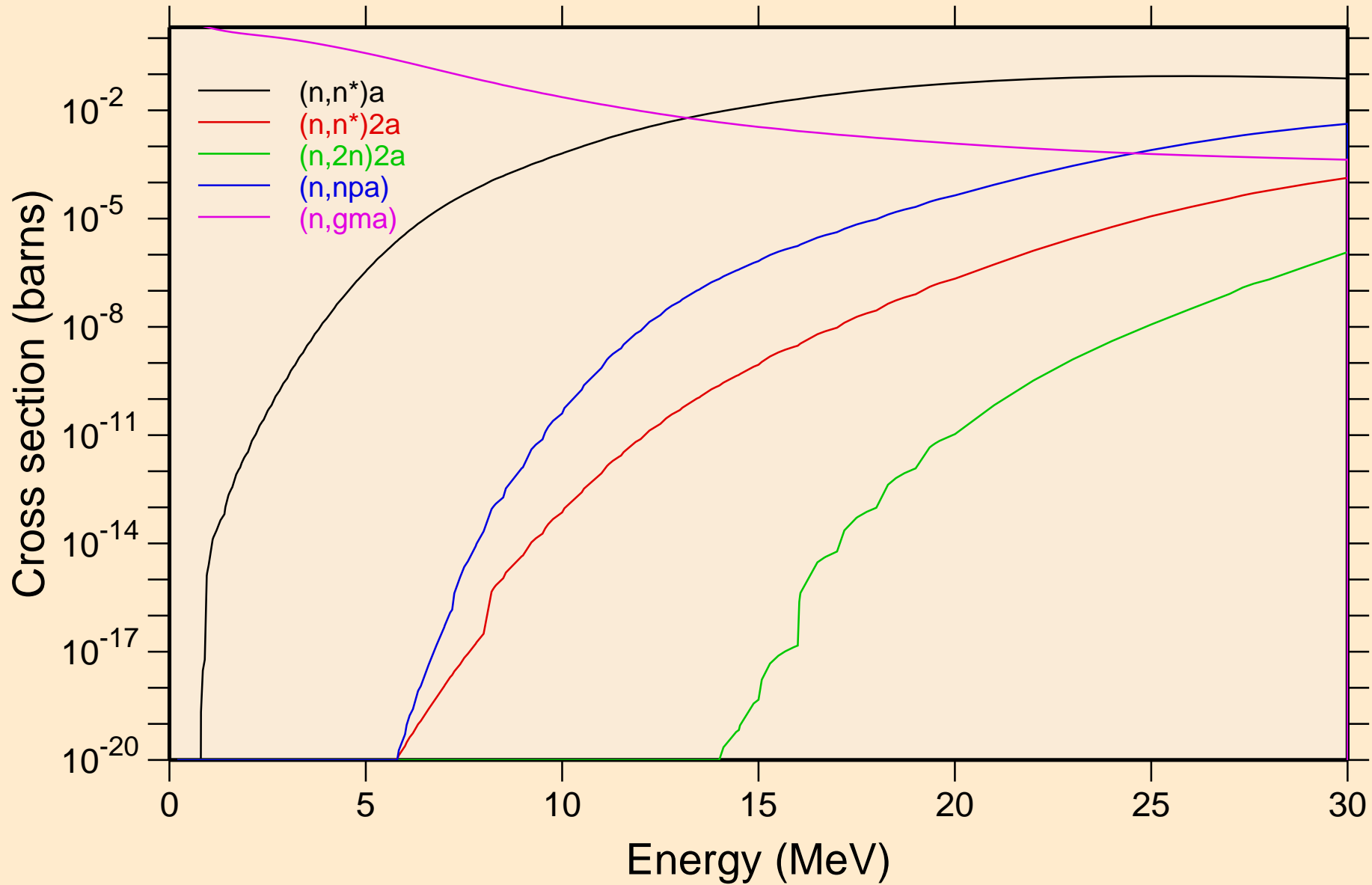

RE172M NEUTRON ACER TENDL-2023 LIBRARY; T=0.K  
Non-threshold reactions

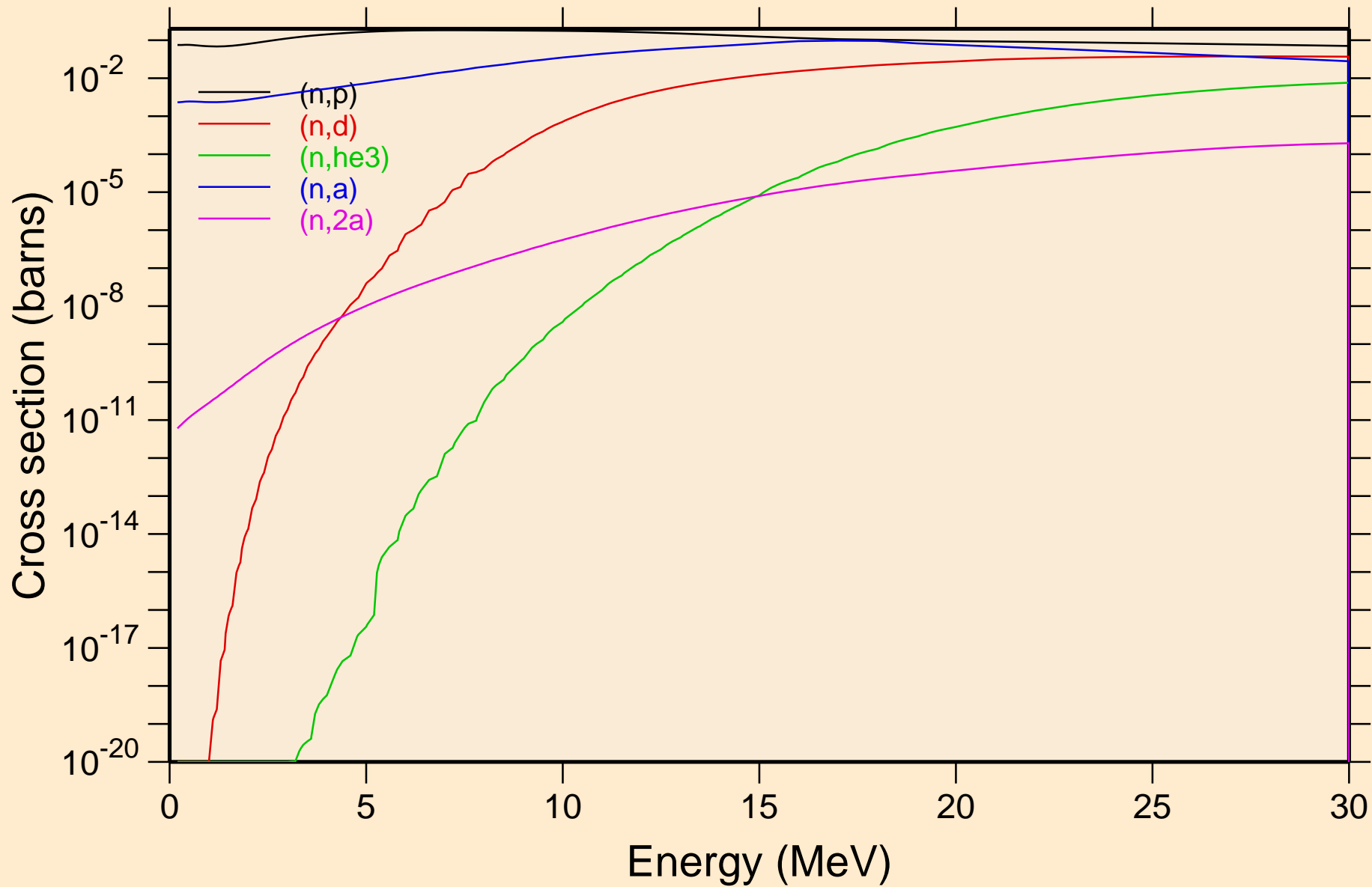

RE172M NEUTRON ACER TENDL-2023 LIBRARY; T=0.K  
Non-threshold reactions

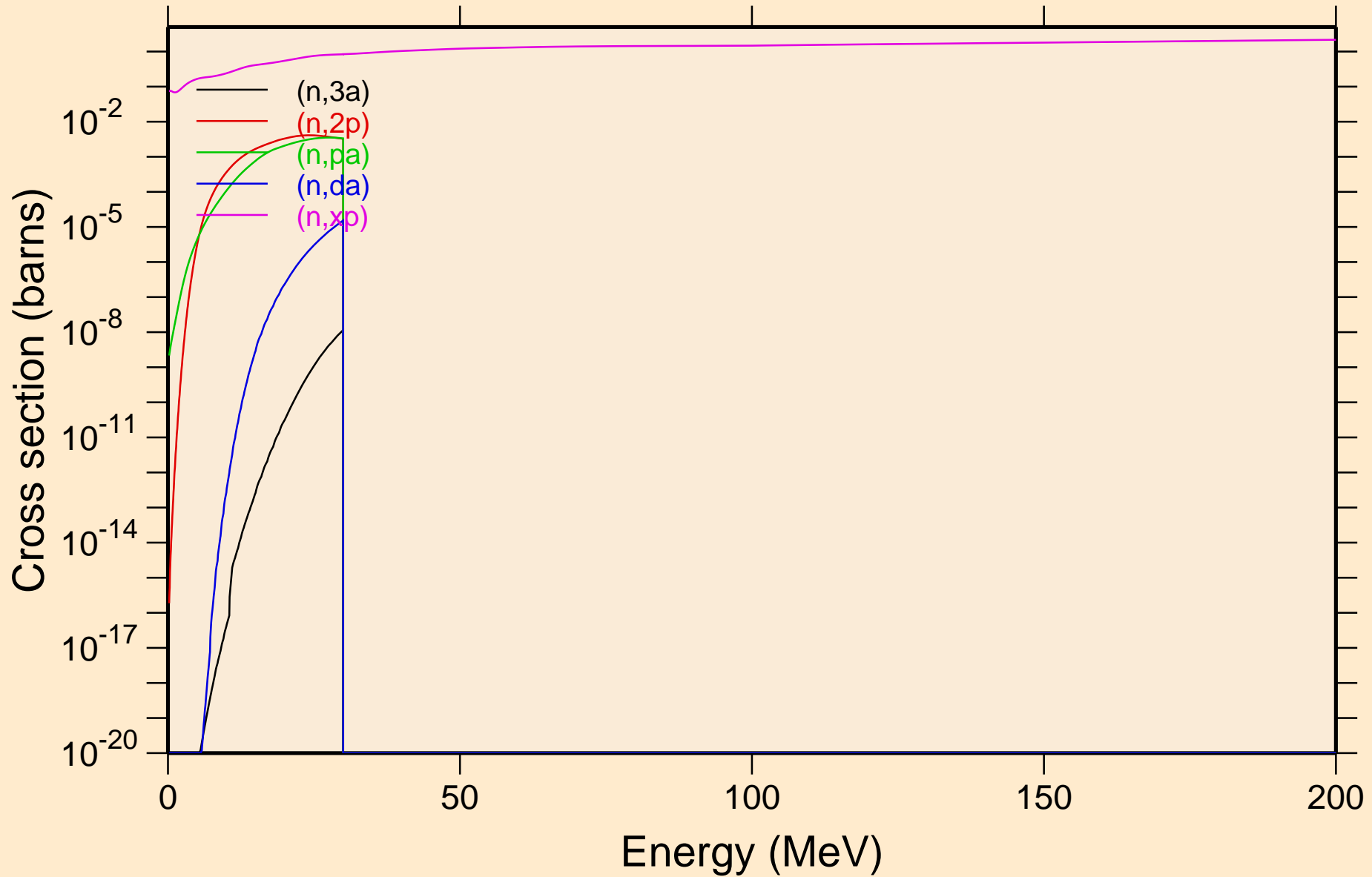

RE172M NEUTRON ACER TENDL-2023 LIBRARY; T=0.K  
Non-threshold reactions

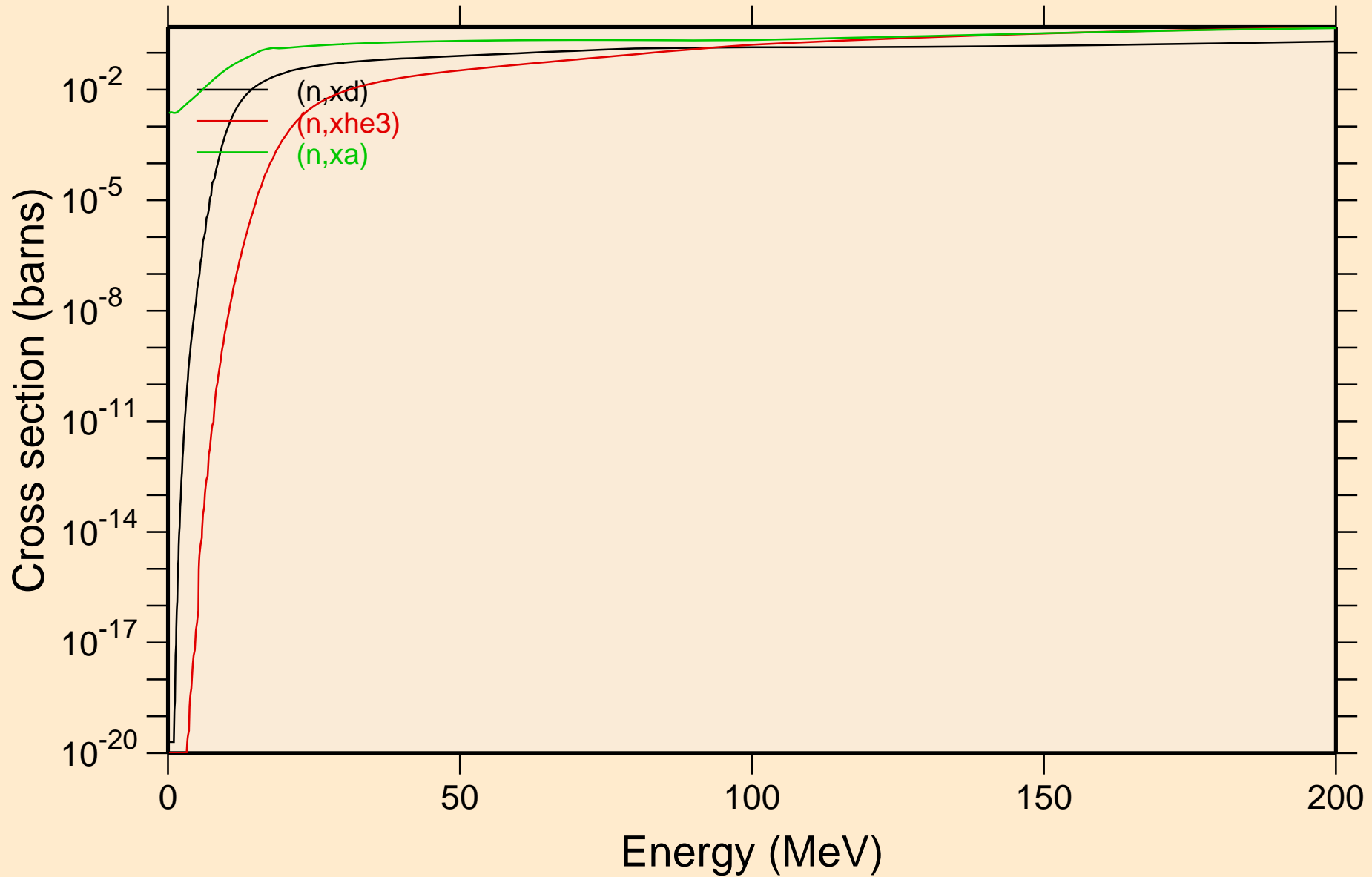

RE172M NEUTRON ACER TENDL-2023 LIBRARY; T=0.K  
Inelastic levels

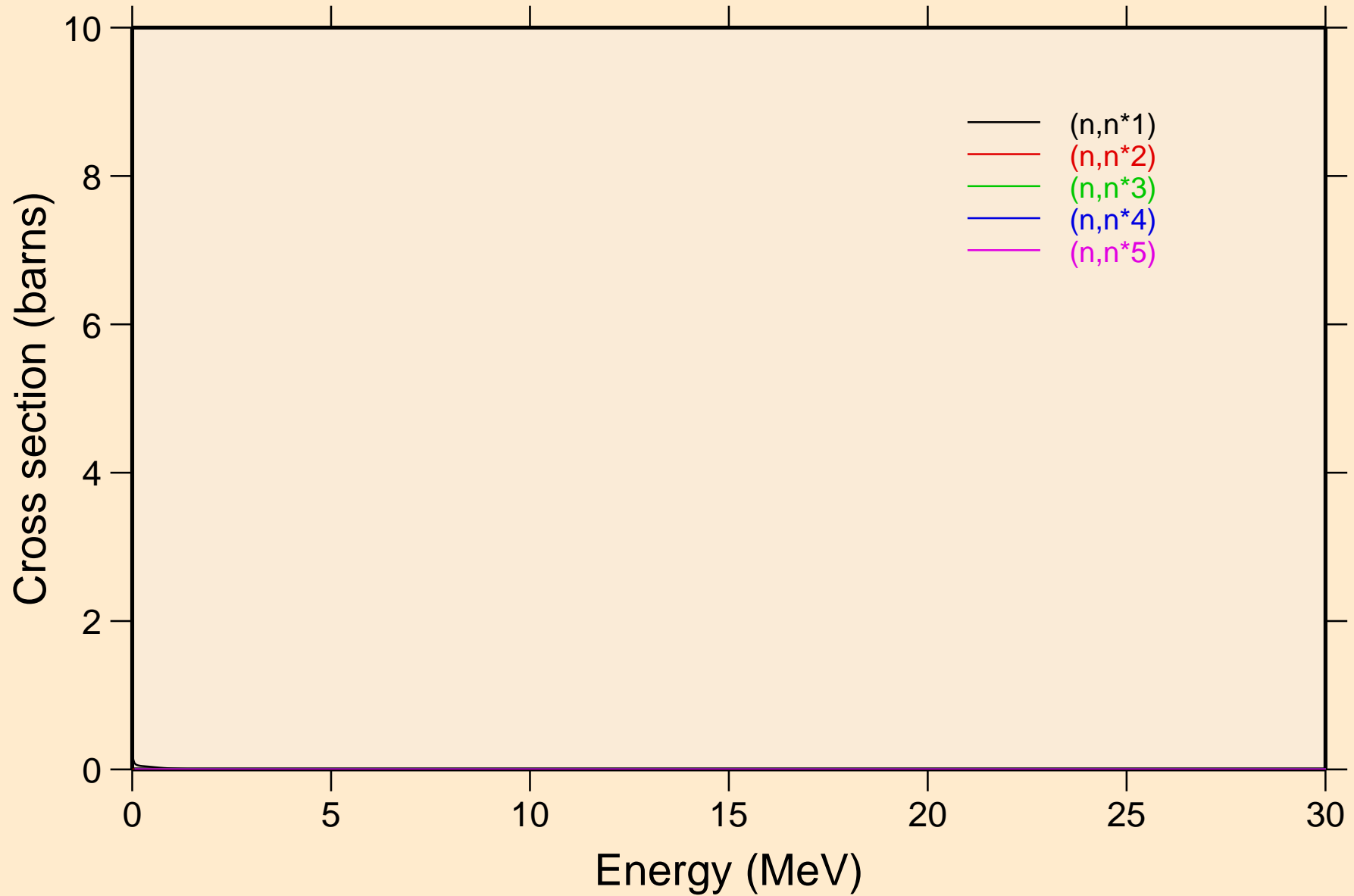

RE172M NEUTRON ACER TENDL-2023 LIBRARY; T=0.K  
Inelastic levels

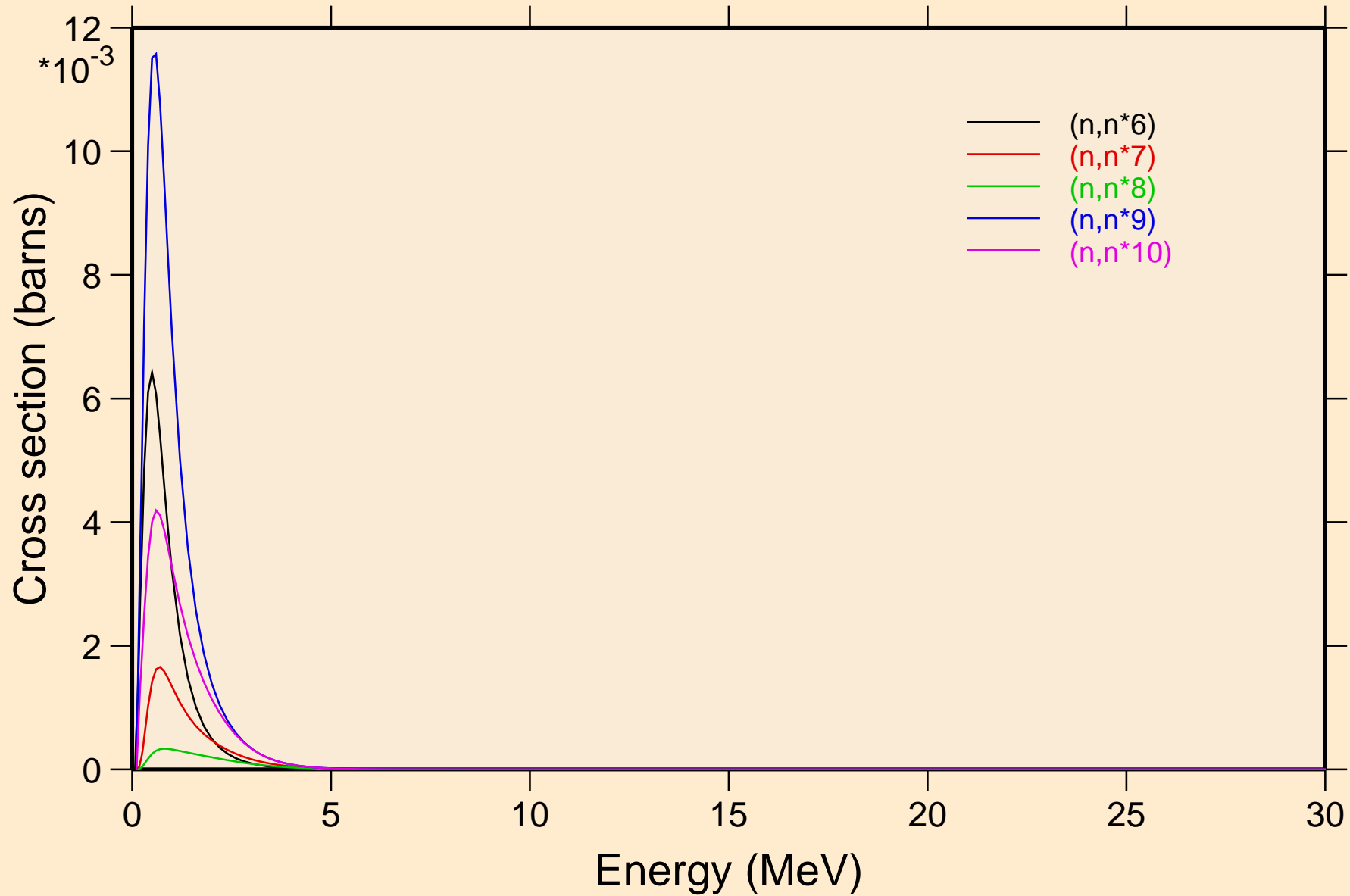



RE172M NEUTRON ACER TENDL-2023 LIBRARY; T=0.K  
Inelastic levels

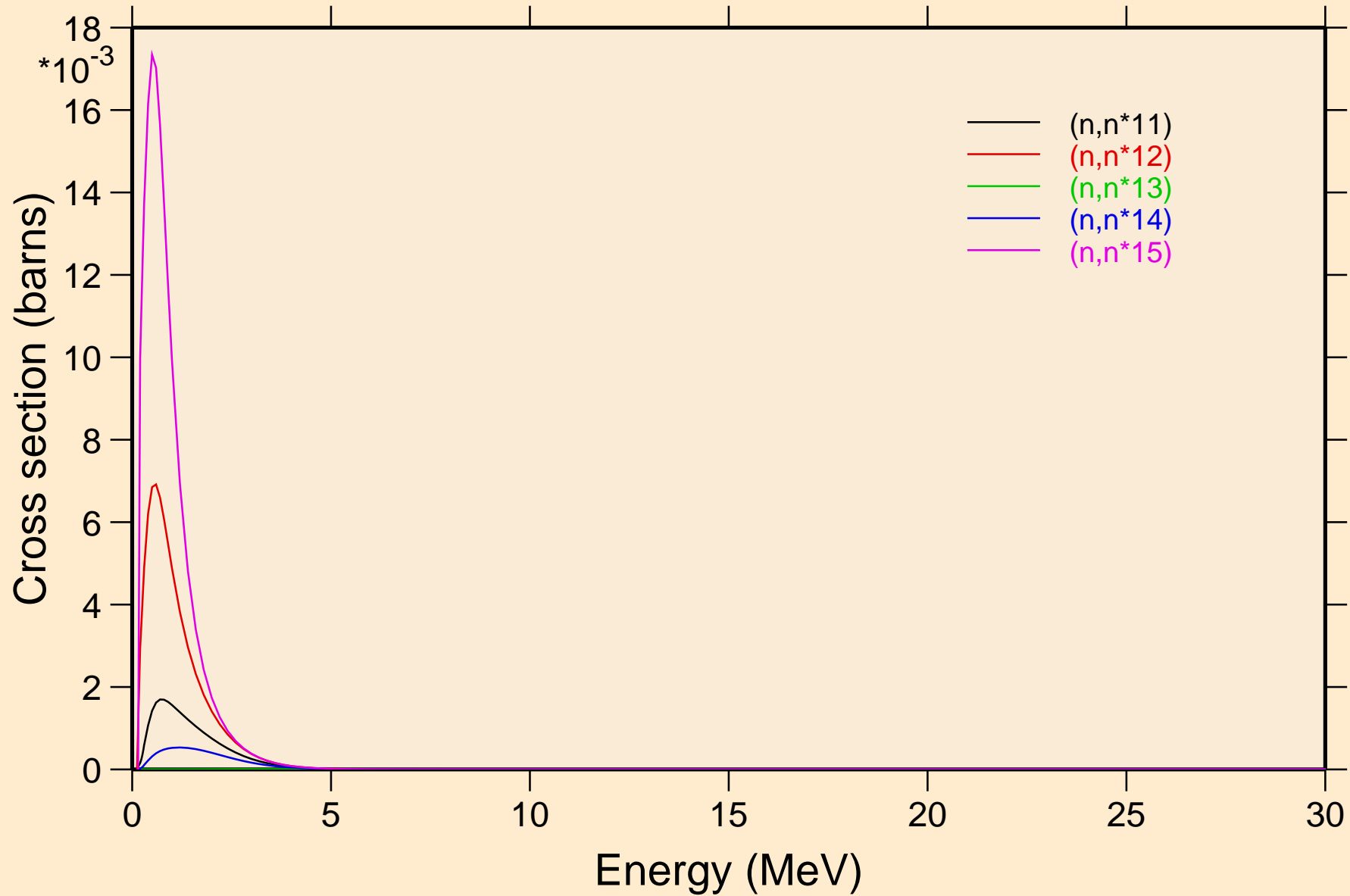

RE172M NEUTRON ACER TENDL-2023 LIBRARY; T=0.K  
Inelastic levels

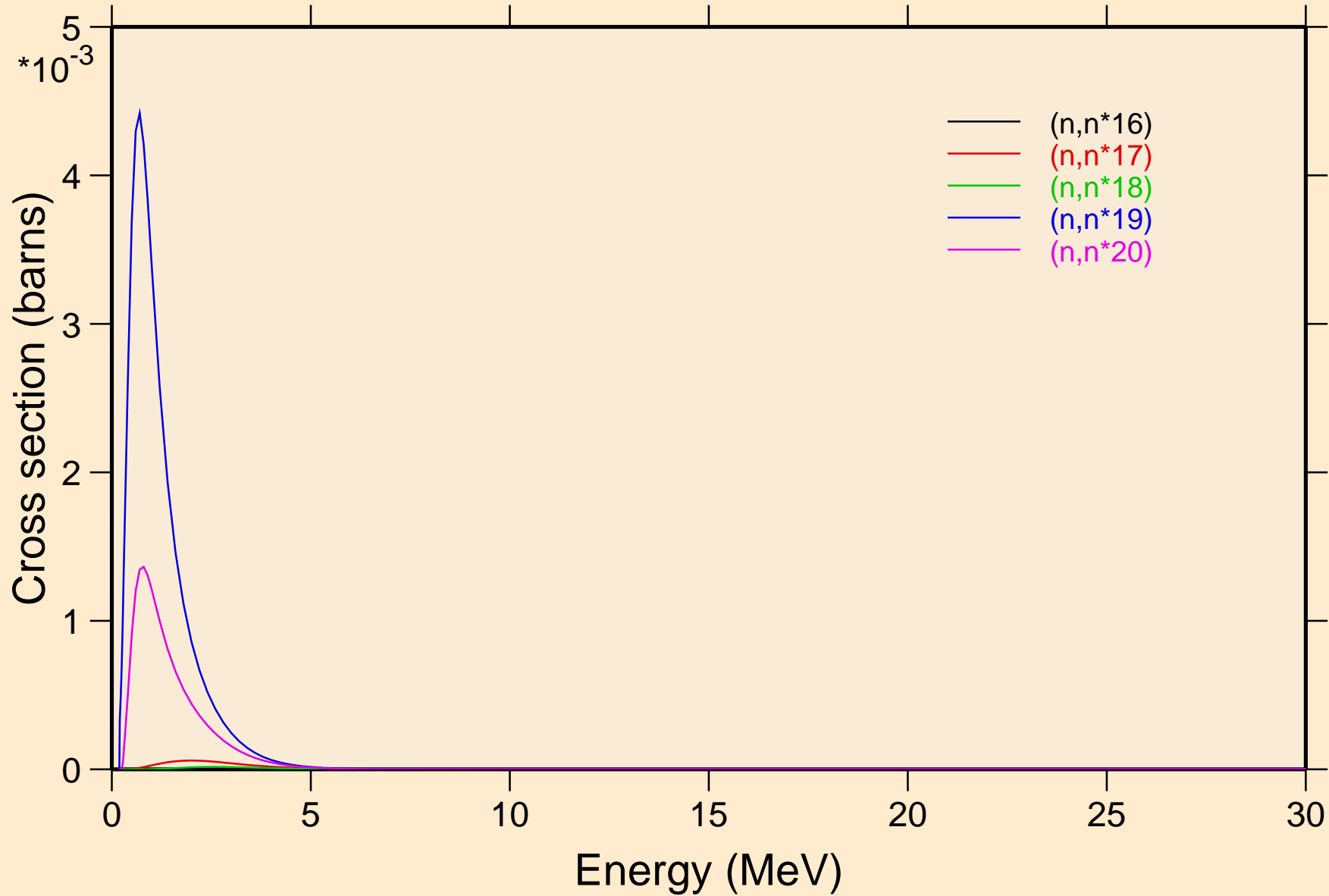

RE172M NEUTRON ACER TENDL-2023 LIBRARY; T=0.K  
Inelastic levels

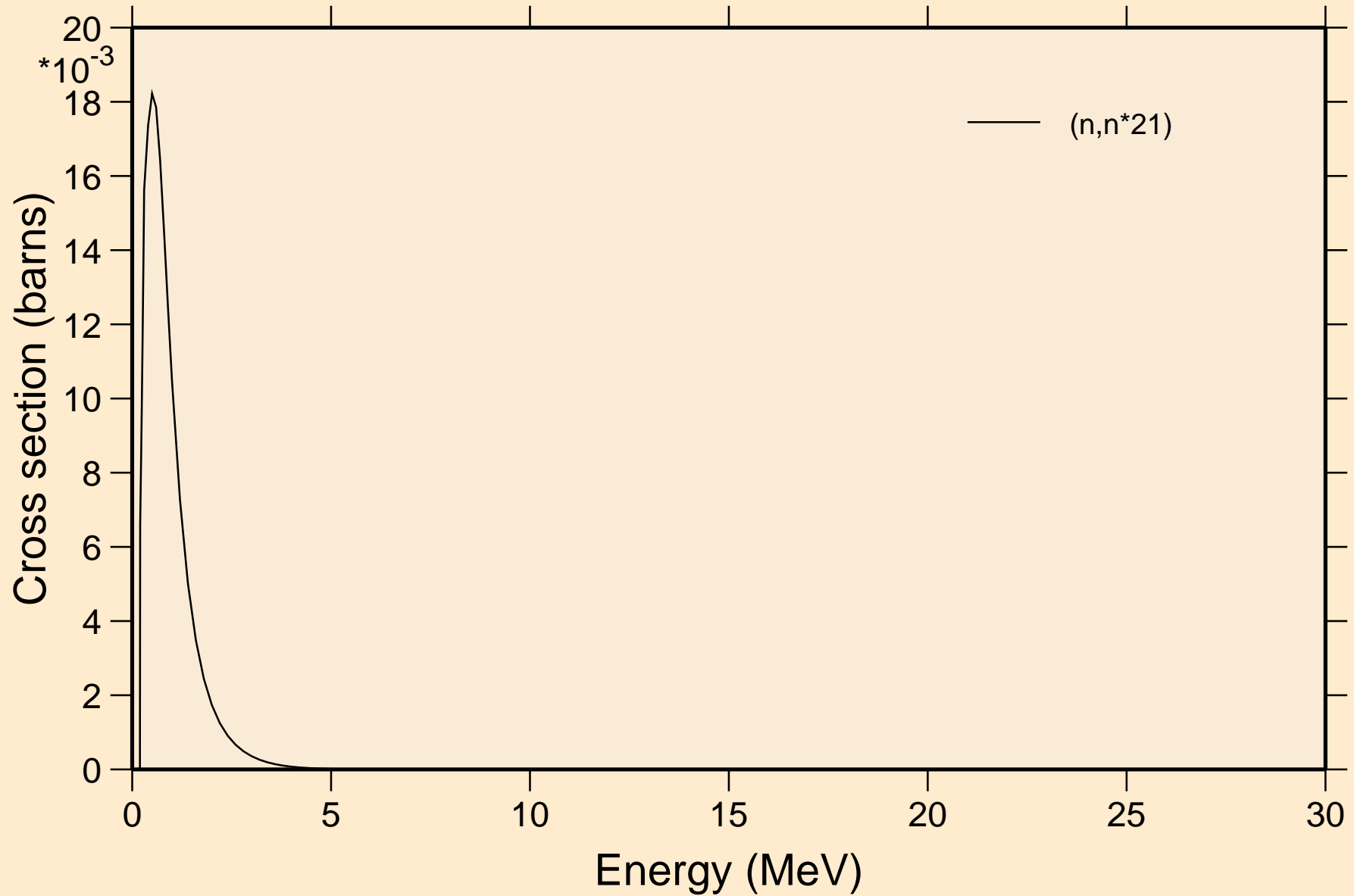

RE172M NEUTRON ACER TENDL-2023 LIBRARY; T=0.K  
Threshold reactions

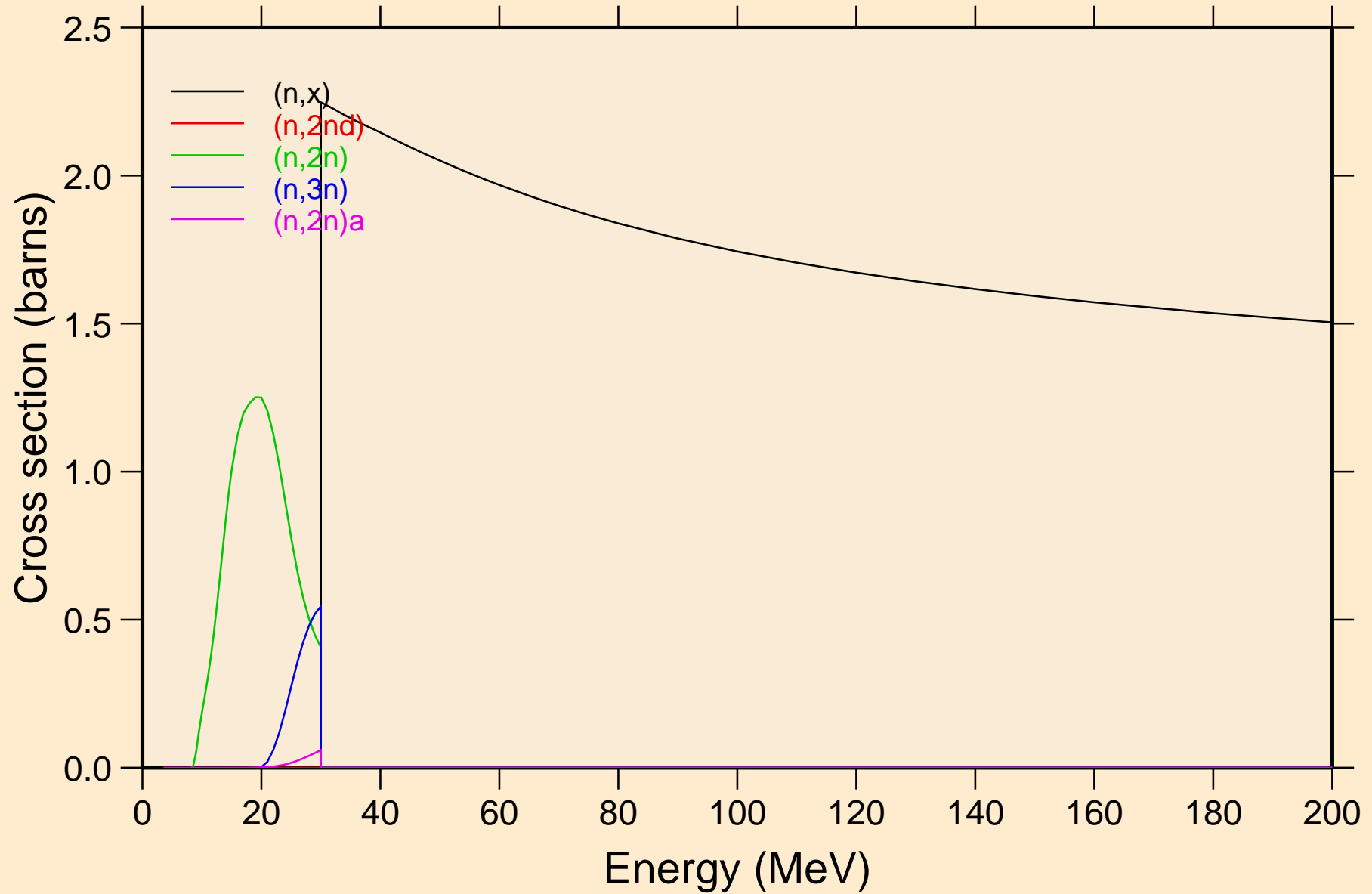

RE172M NEUTRON ACER TENDL-2023 LIBRARY; T=0.K  
Threshold reactions

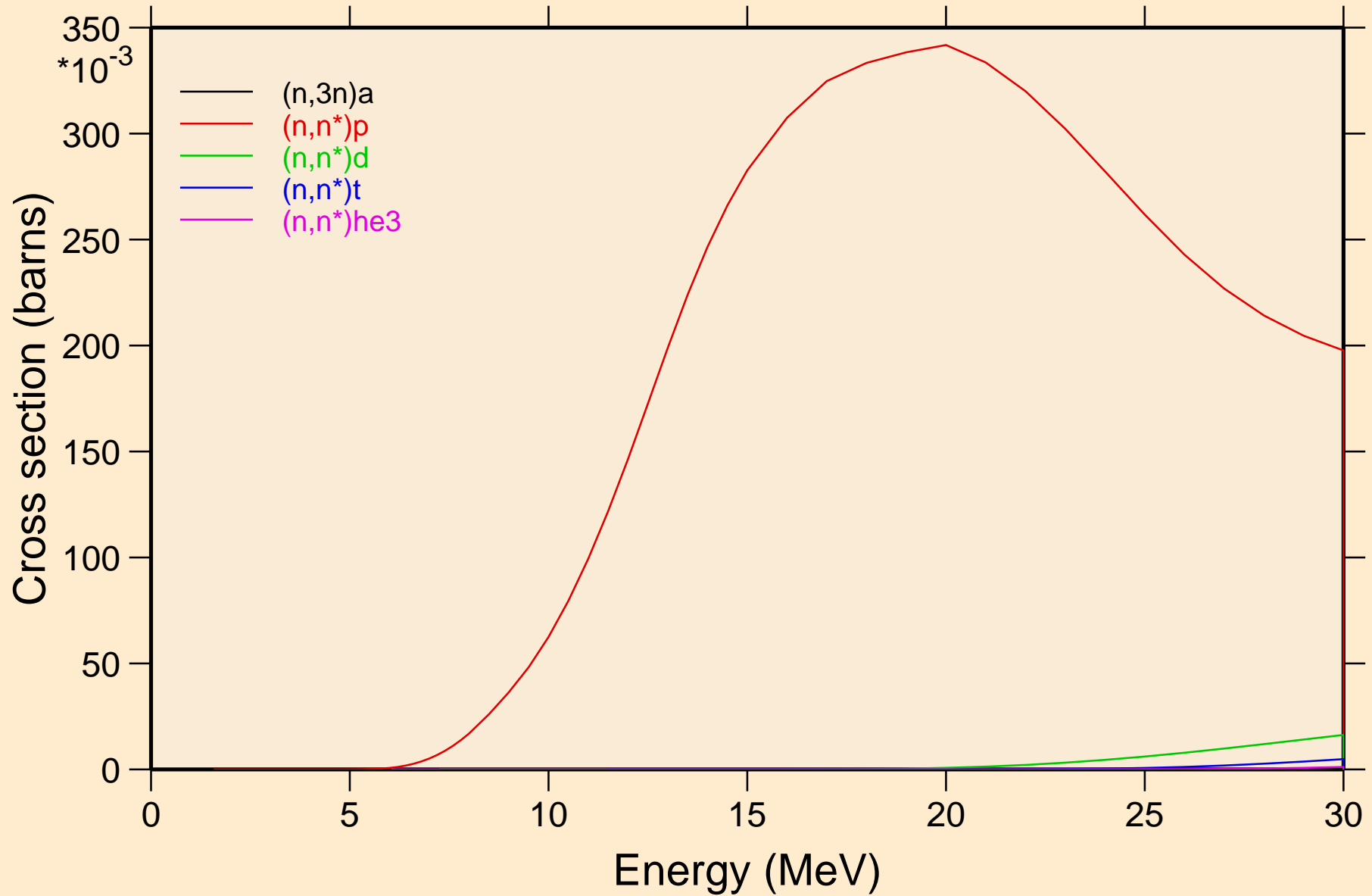

RE172M NEUTRON ACER TENDL-2023 LIBRARY; T=0.K  
Threshold reactions

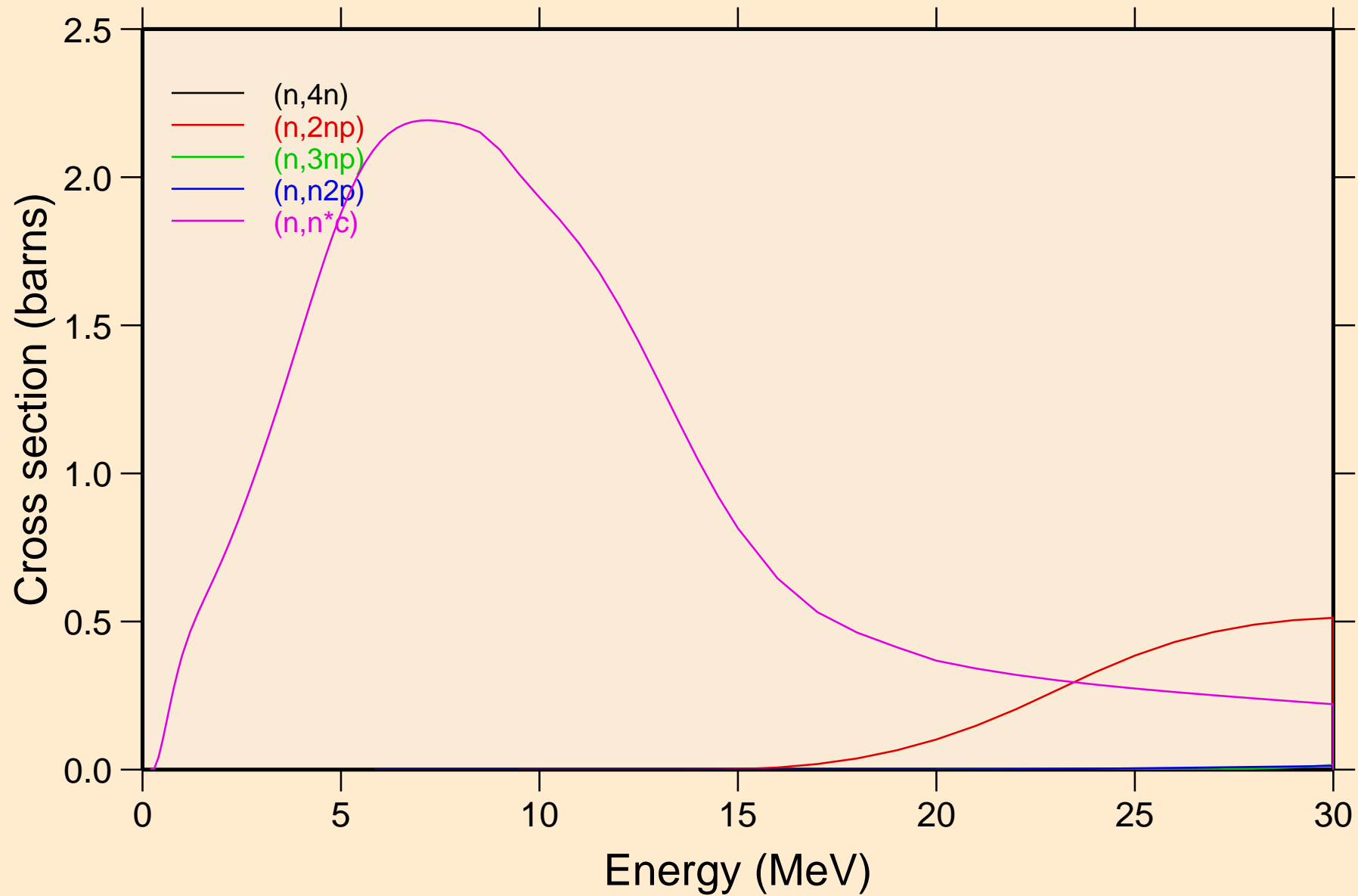

RE172M NEUTRON ACER TENDL-2023 LIBRARY; T=0.K  
Threshold reactions

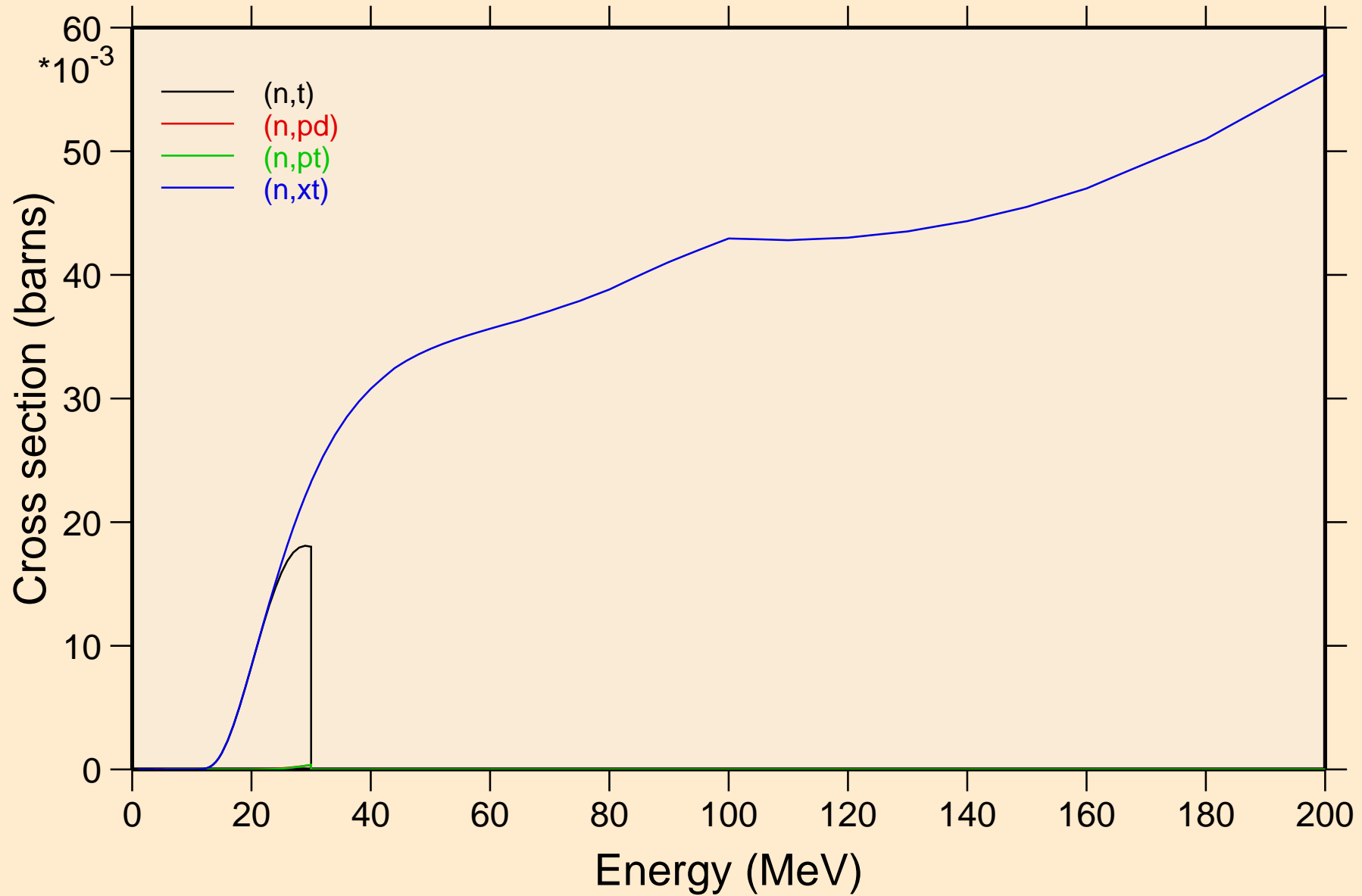

RE172M NEUTRON ACER TENDL-2023 LIBRARY; T=0.K  
angular distribution for elastic

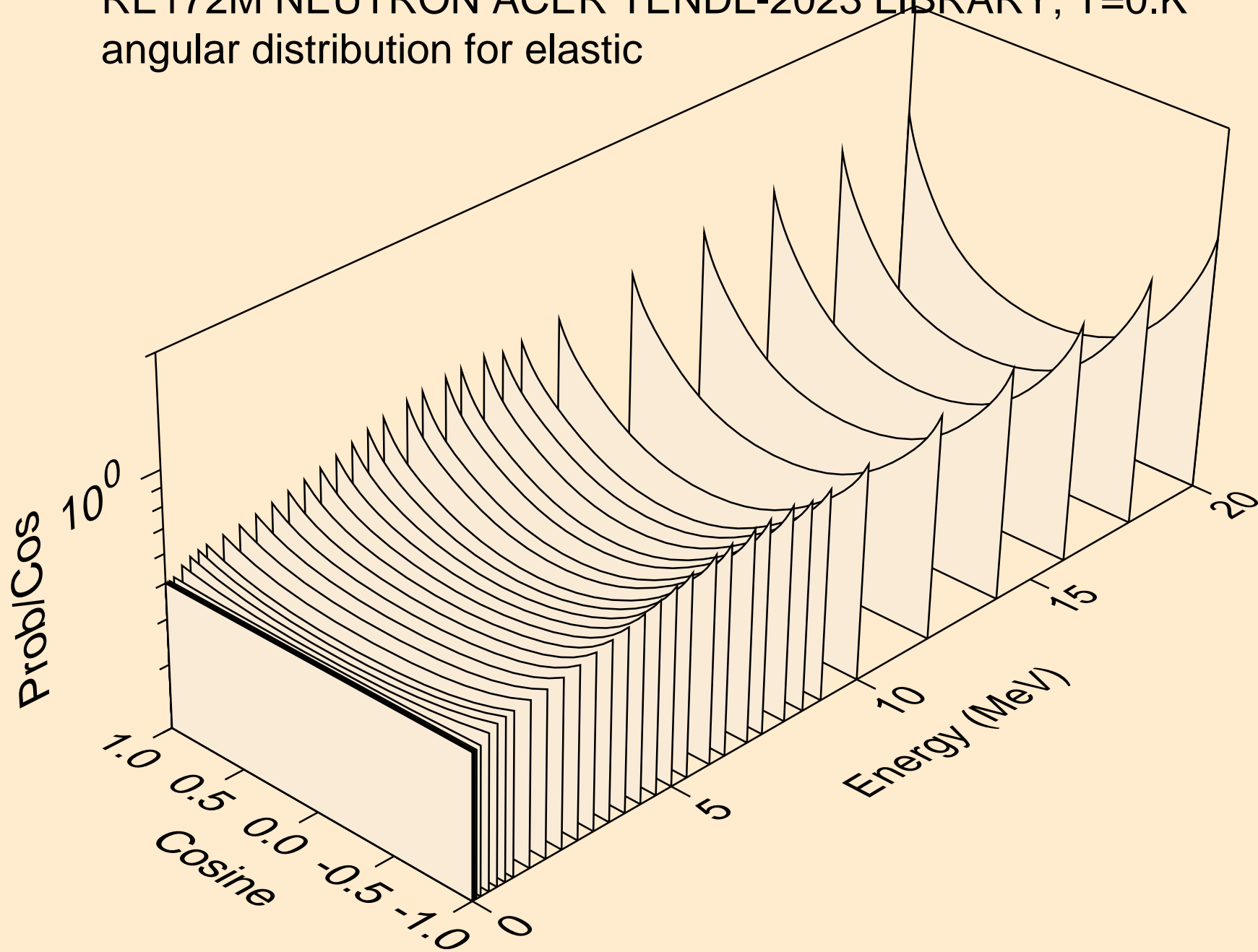



RE172M NEUTRON ACER TENDL-2023 LIBRARY; T=0.K  
angular distribution for elastic

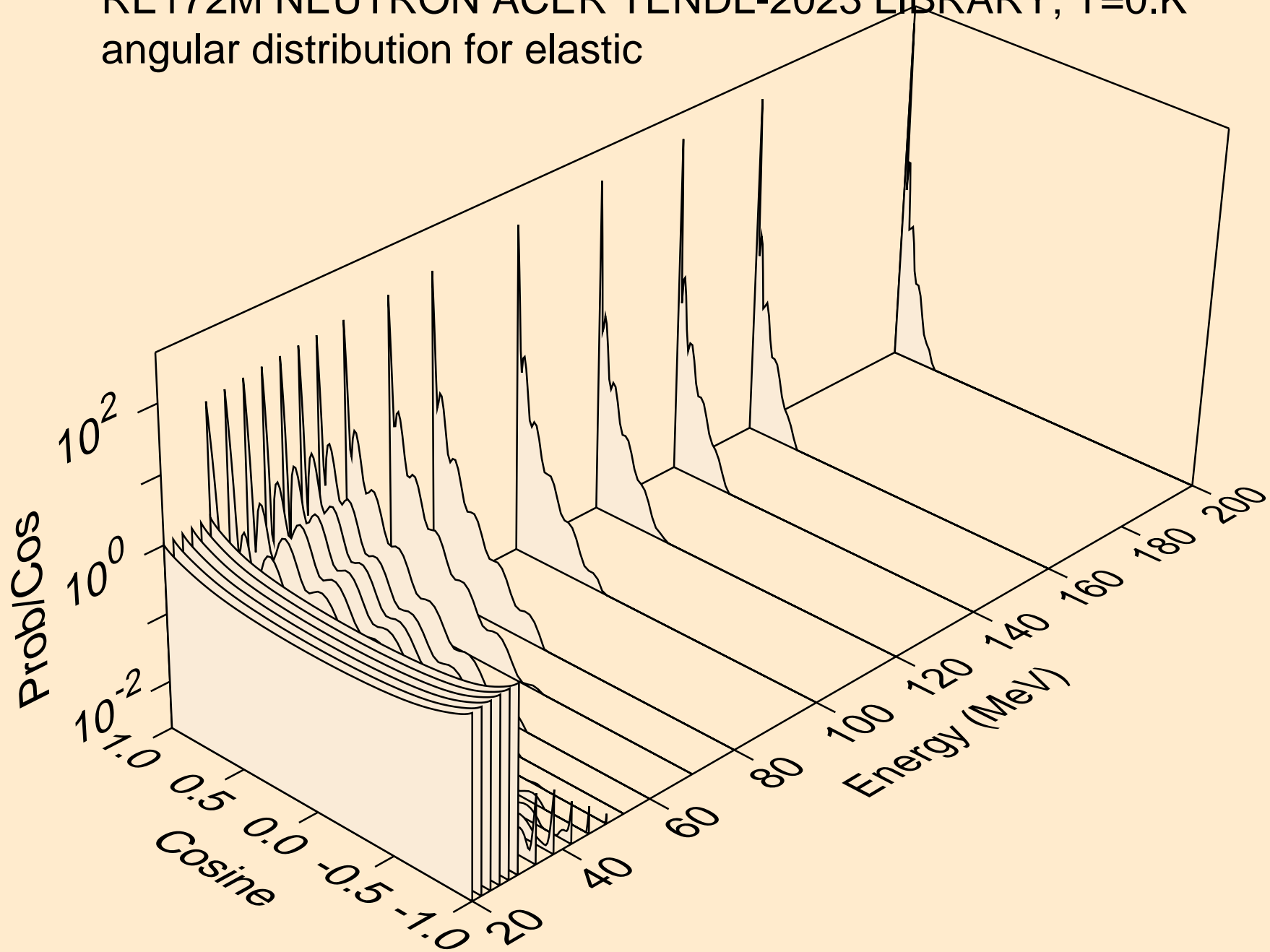

RE172M NEUTRON ACER TENDL-2023 LIBRARY; T=0.K  
angular distribution for (n,n\*1)

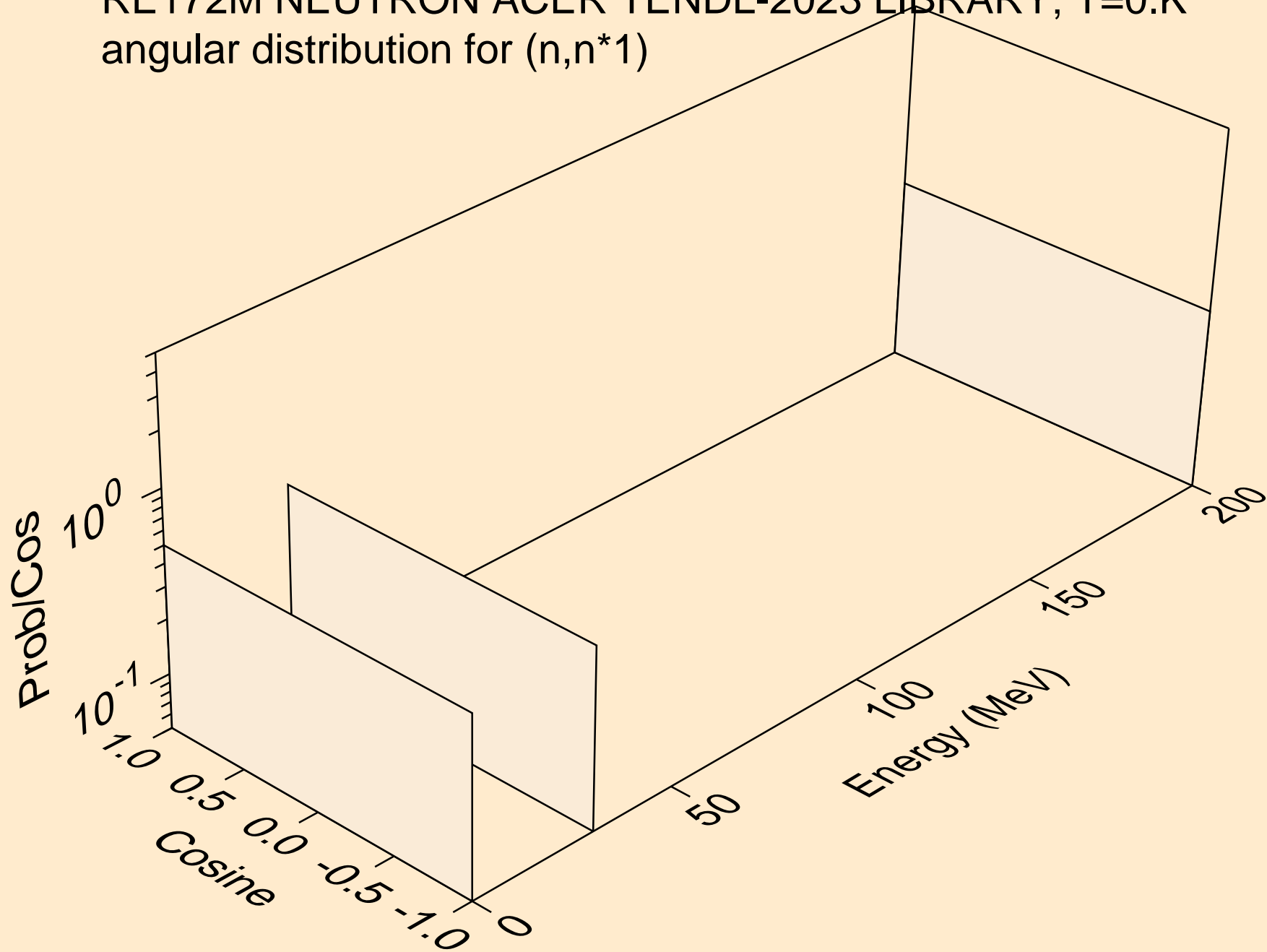

RE172M NEUTRON ACER TENDL-2023 LIBRARY; T=0.K  
angular distribution for (n,n\*2)

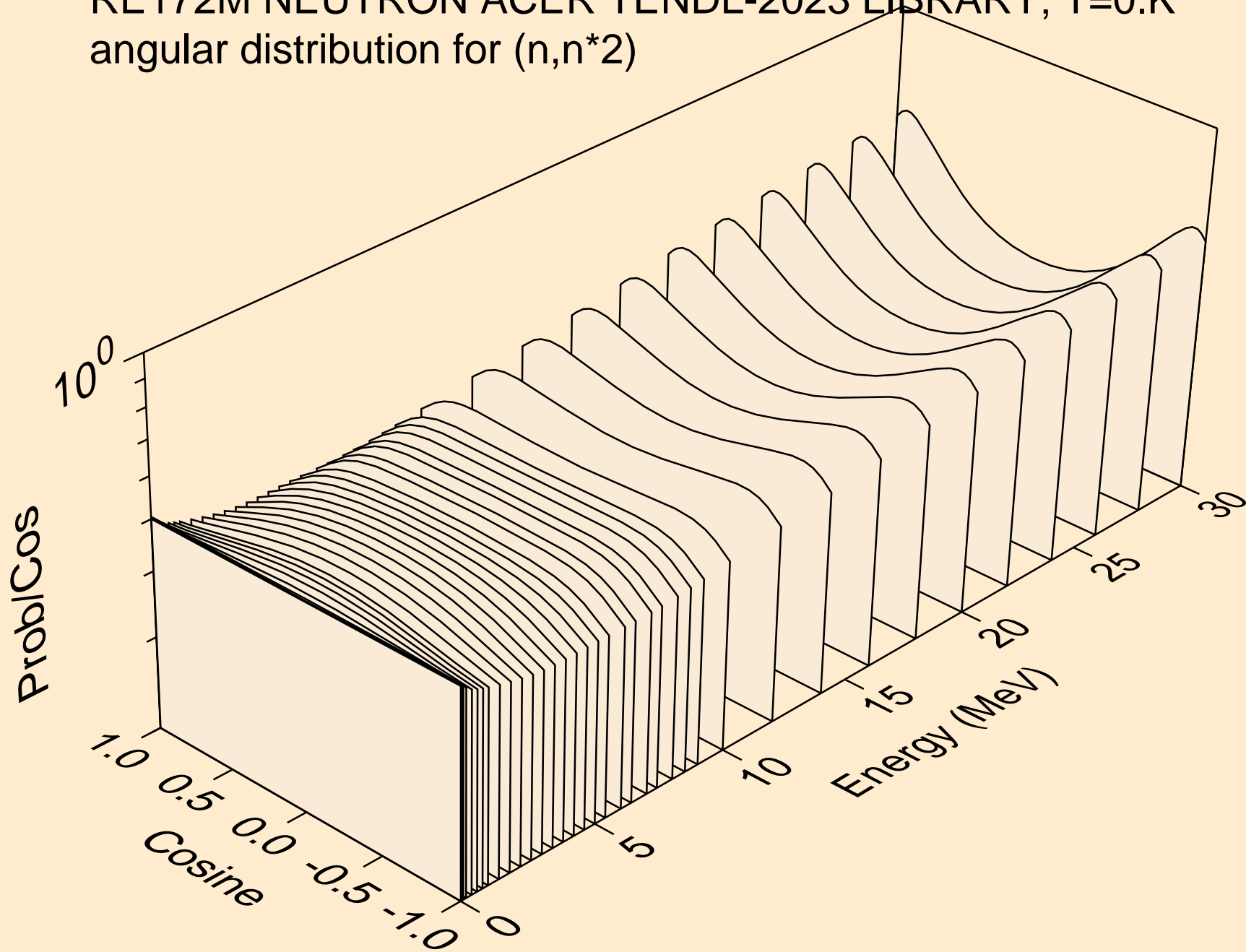

RE172M NEUTRON ACER TENDL-2023 LIBRARY; T=0.K  
angular distribution for (n,n\*3)

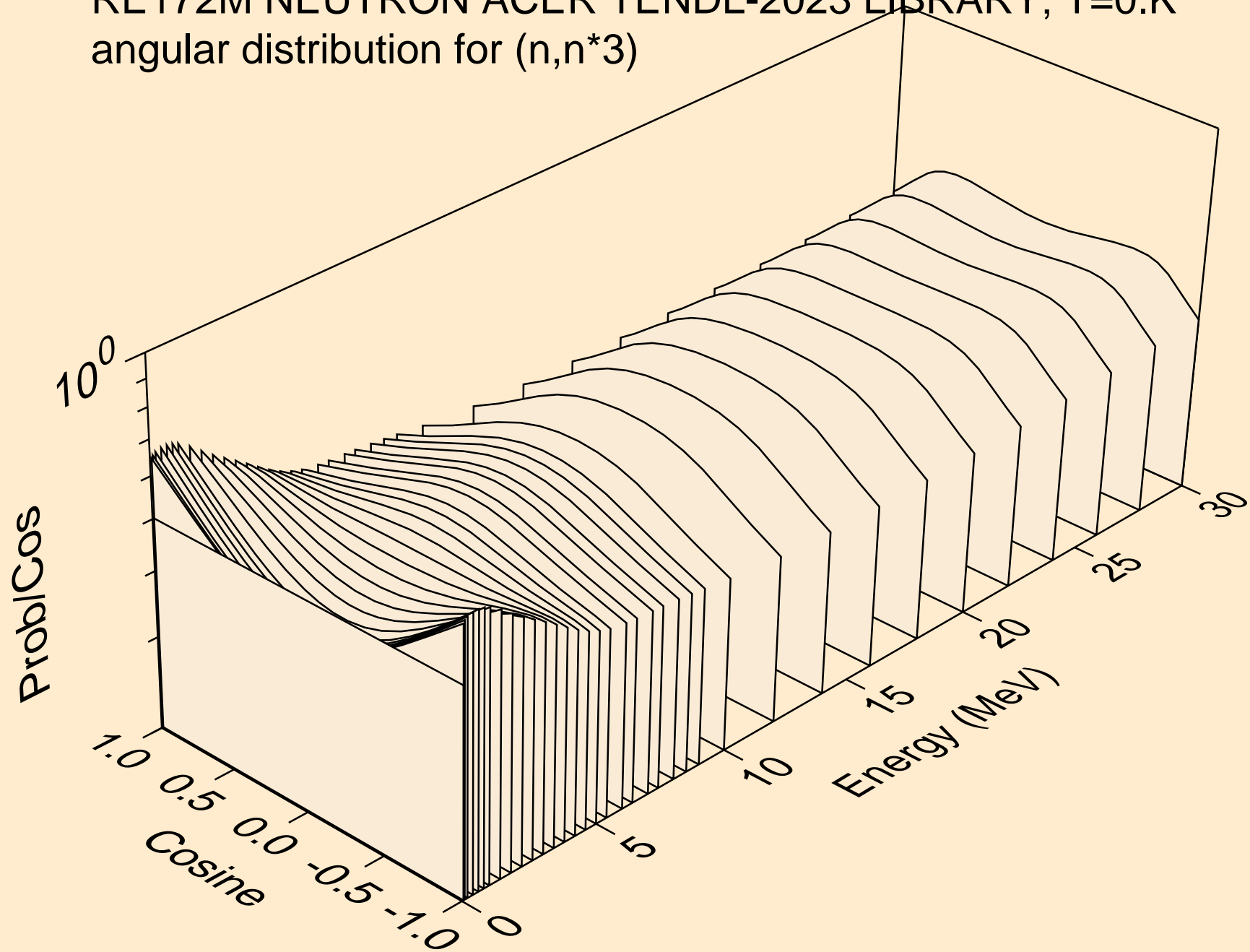

RE172M NEUTRON ACER TENDL-2023 LIBRARY; T=0.K  
angular distribution for (n,n\*4)

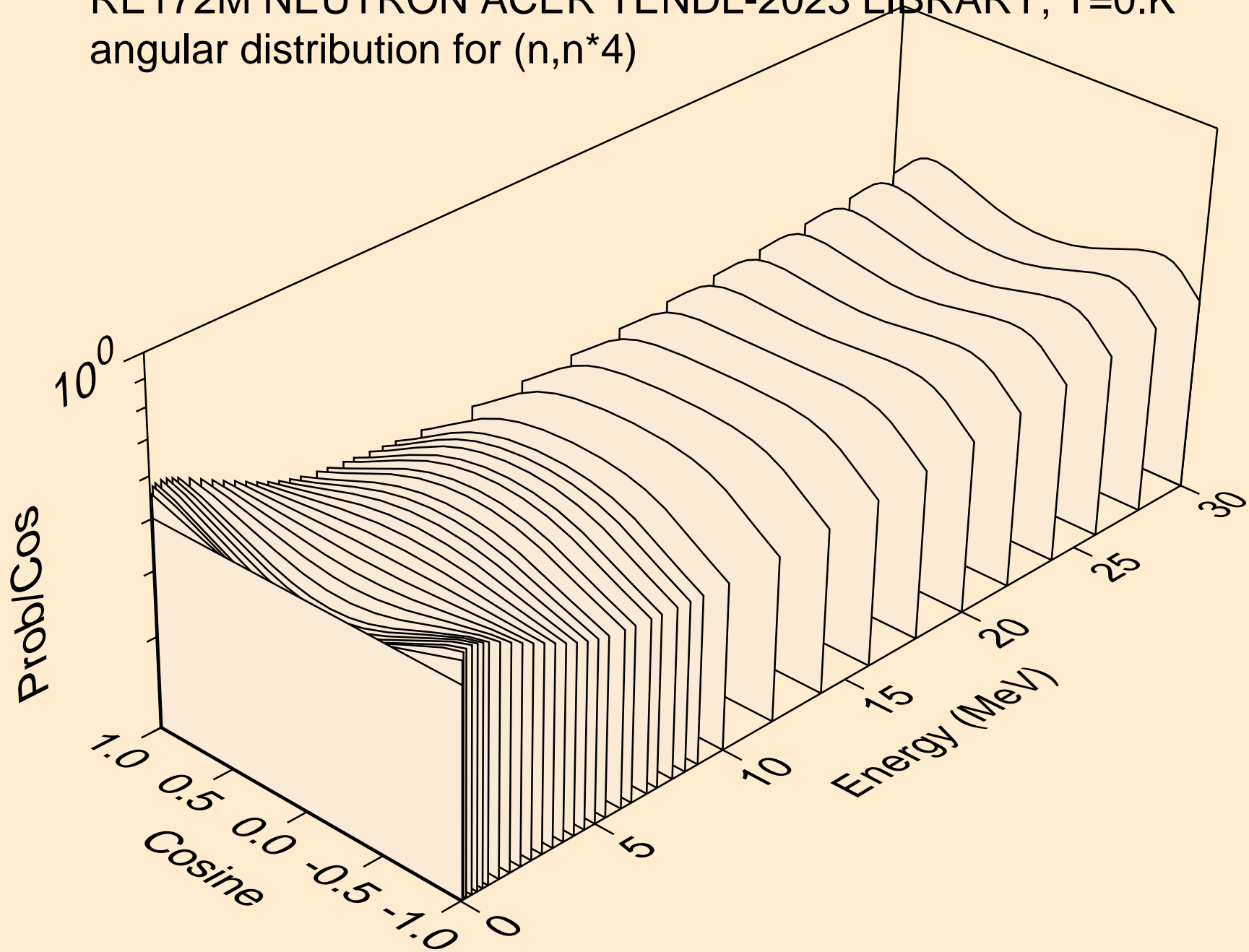

RE172M NEUTRON ACER TENDL-2023 LIBRARY; T=0.K  
angular distribution for (n,n\*5)

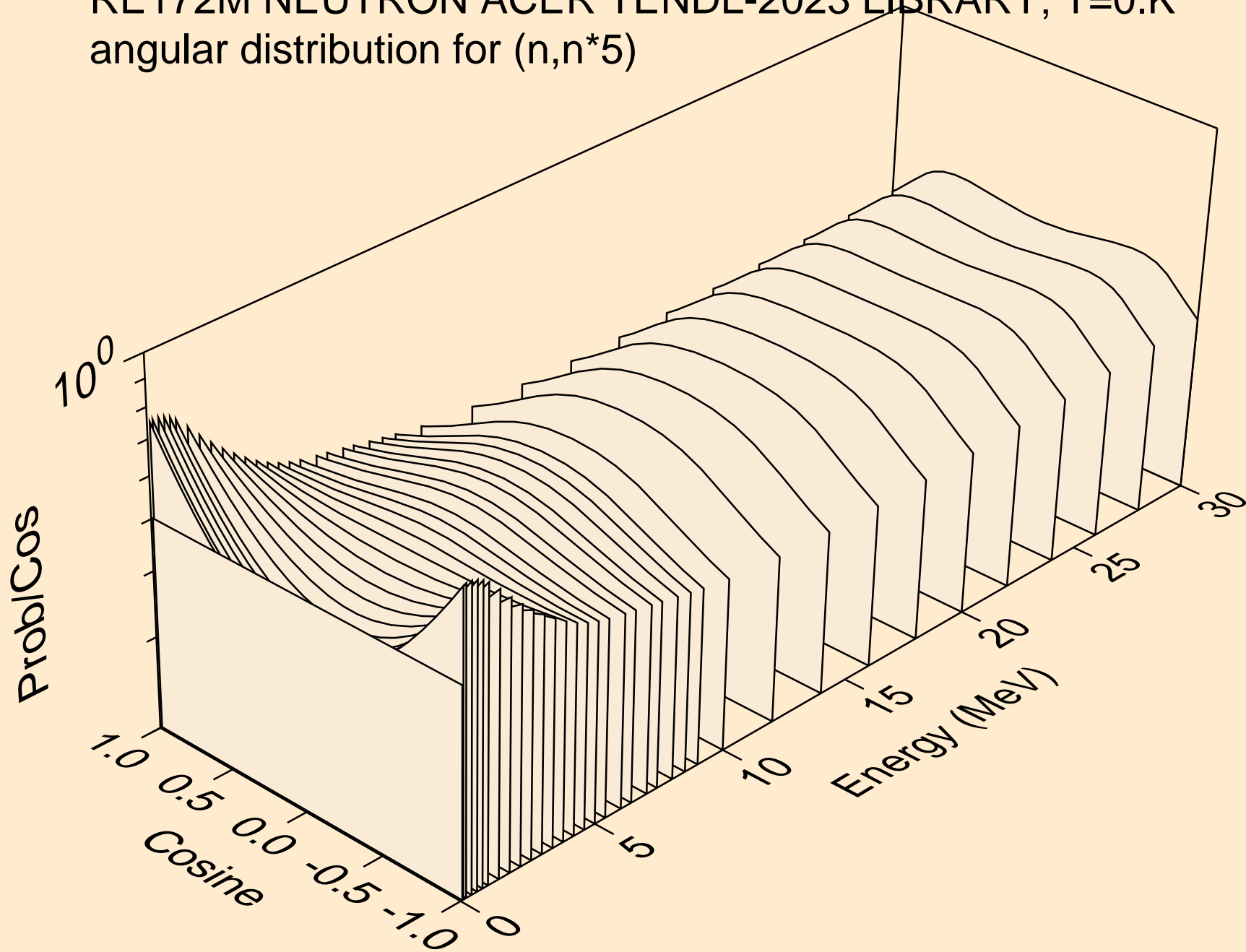

RE172M NEUTRON ACER TENDL-2023 LIBRARY; T=0.K  
angular distribution for (n,n\*6)

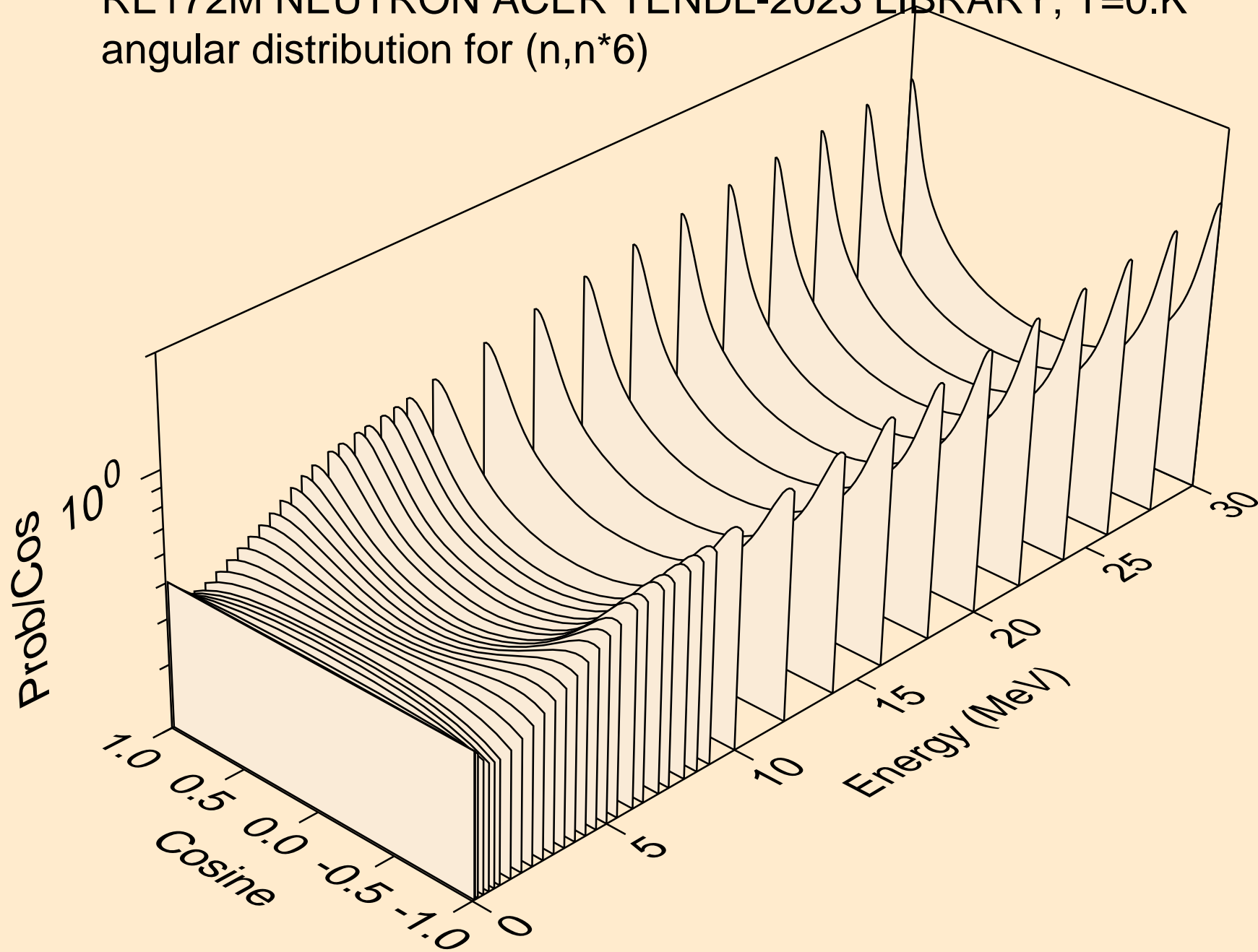

RE172M NEUTRON ACER TENDL-2023 LIBRARY; T=0.K  
angular distribution for (n,n\*7)

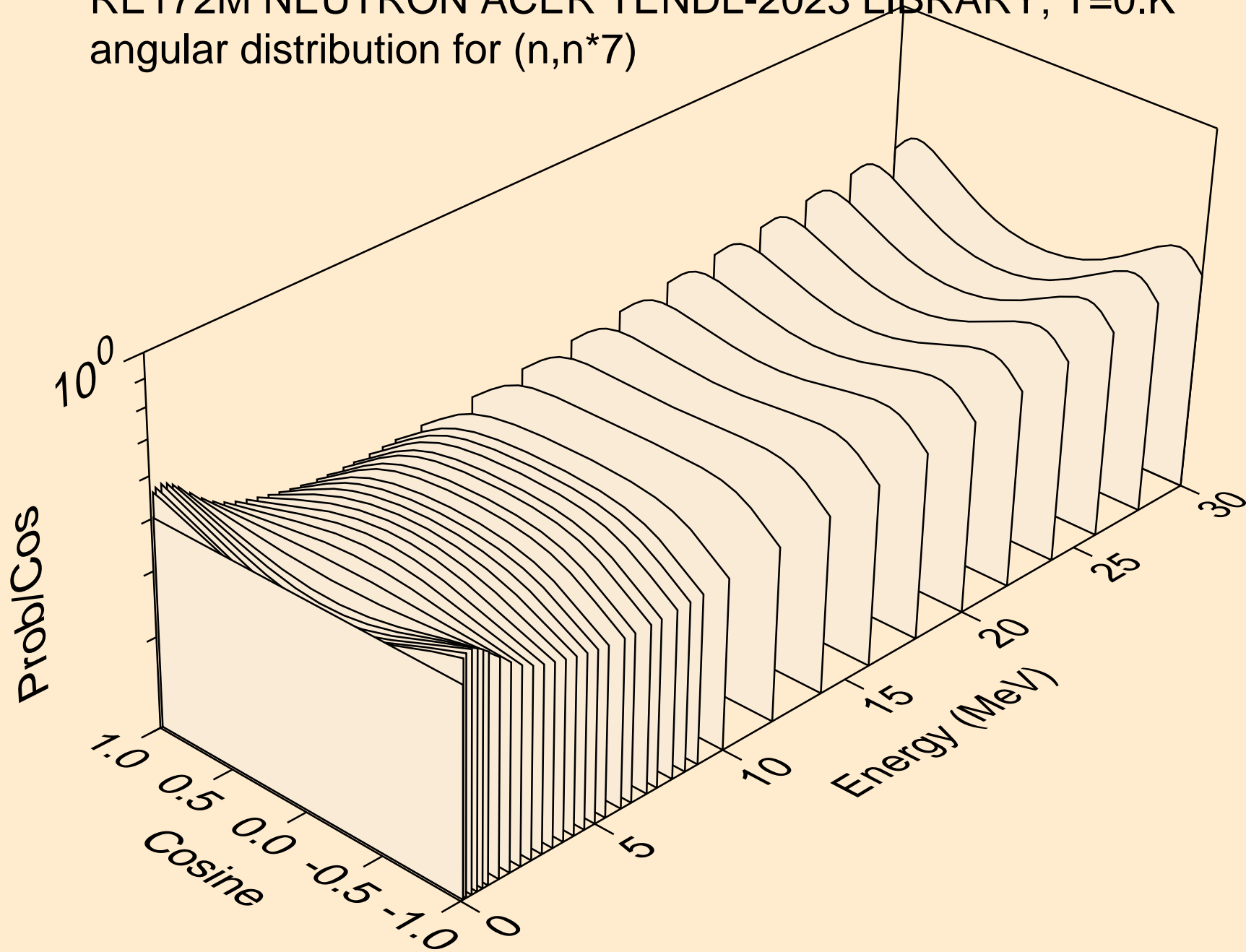



RE172M NEUTRON ACER TENDL-2023 LIBRARY; T=0.K  
angular distribution for (n,n\*8)

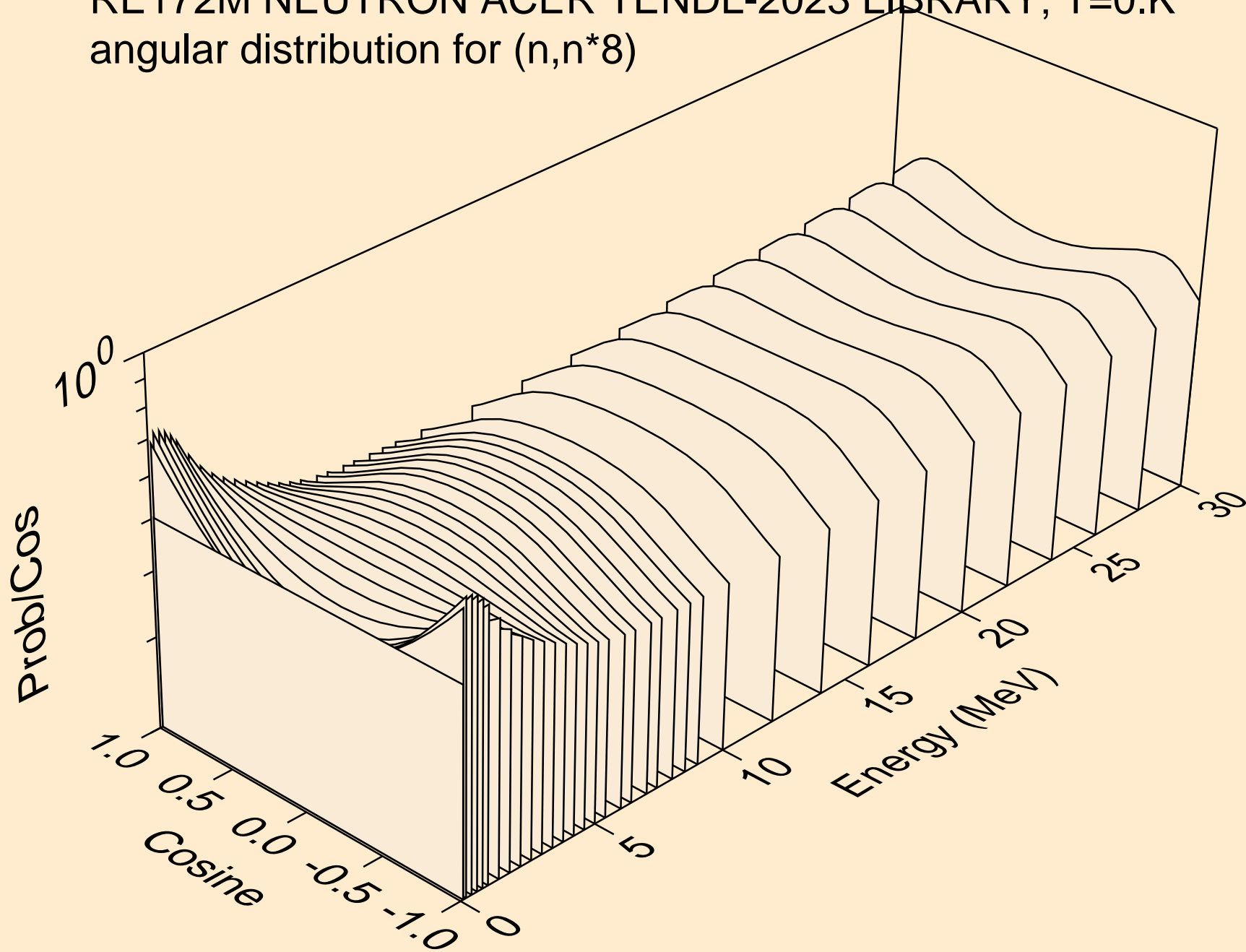

RE172M NEUTRON ACER TENDL-2023 LIBRARY; T=0.K  
angular distribution for (n,n\*9)

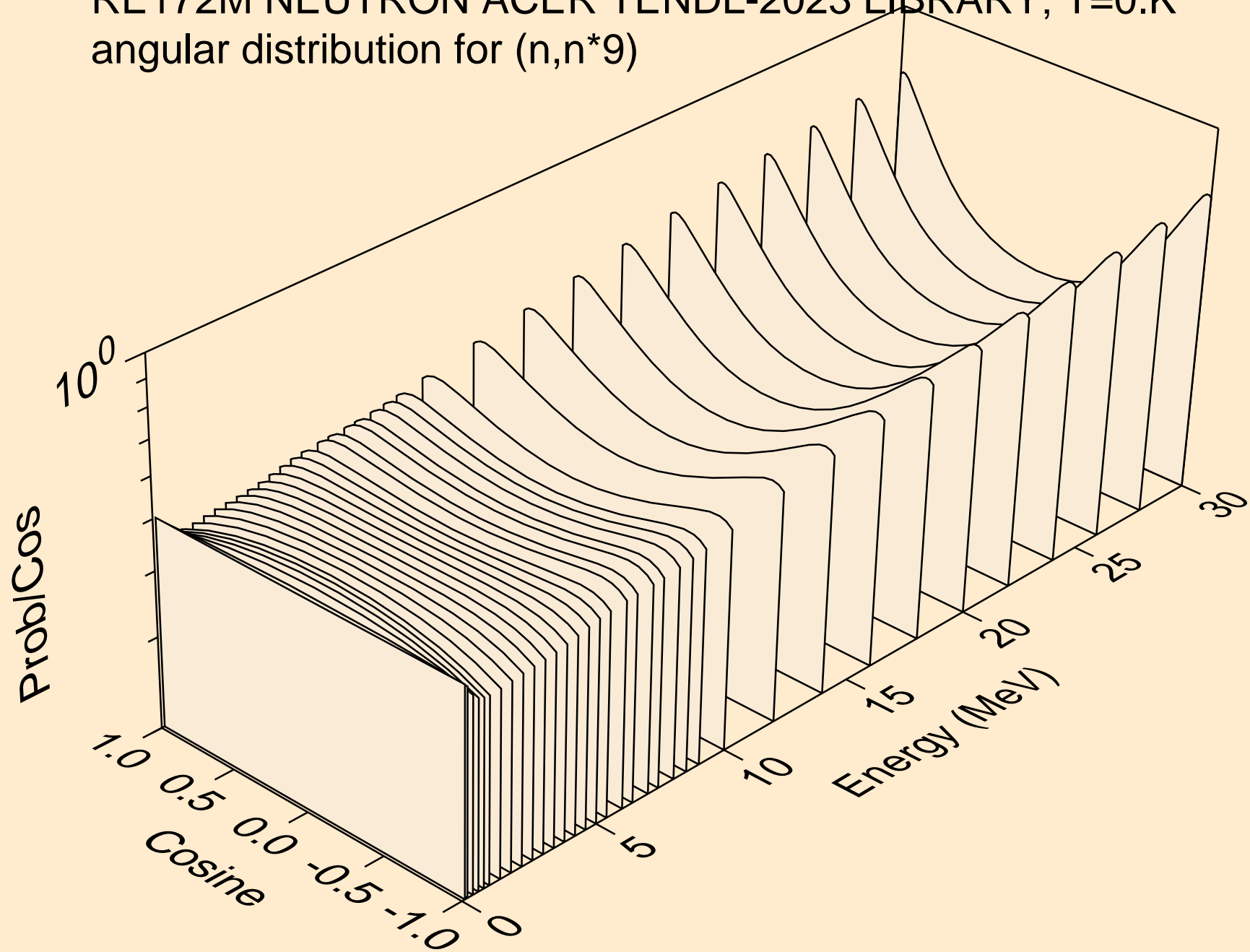

RE172M NEUTRON ACER TENDL-2023 LIBRARY; T=0.K  
angular distribution for (n,n\*10)

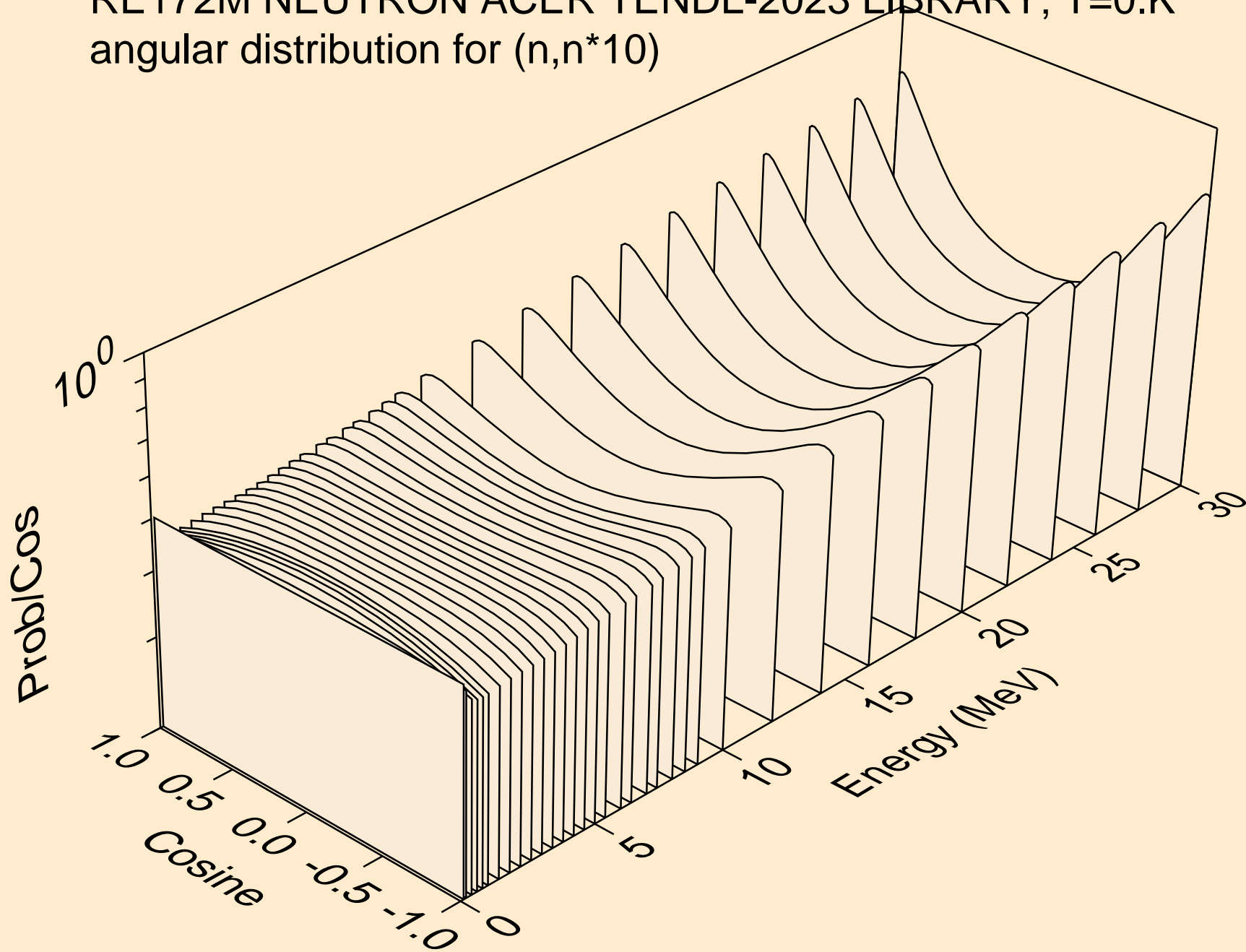

RE172M NEUTRON ACER TENDL-2023 LIBRARY; T=0.K  
angular distribution for (n,n\*11)

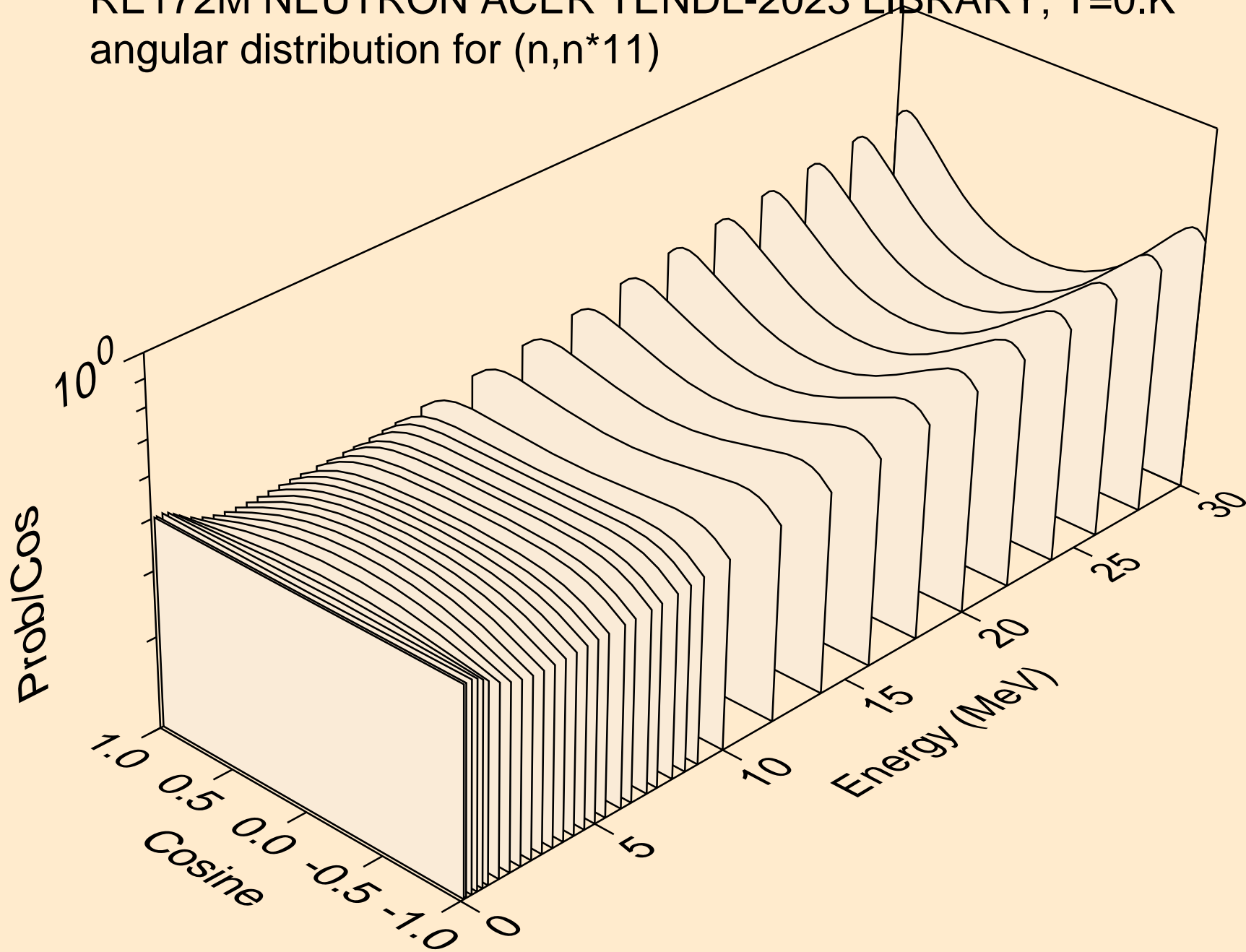

RE172M NEUTRON ACER TENDL-2023 LIBRARY; T=0.K  
angular distribution for (n,n\*12)

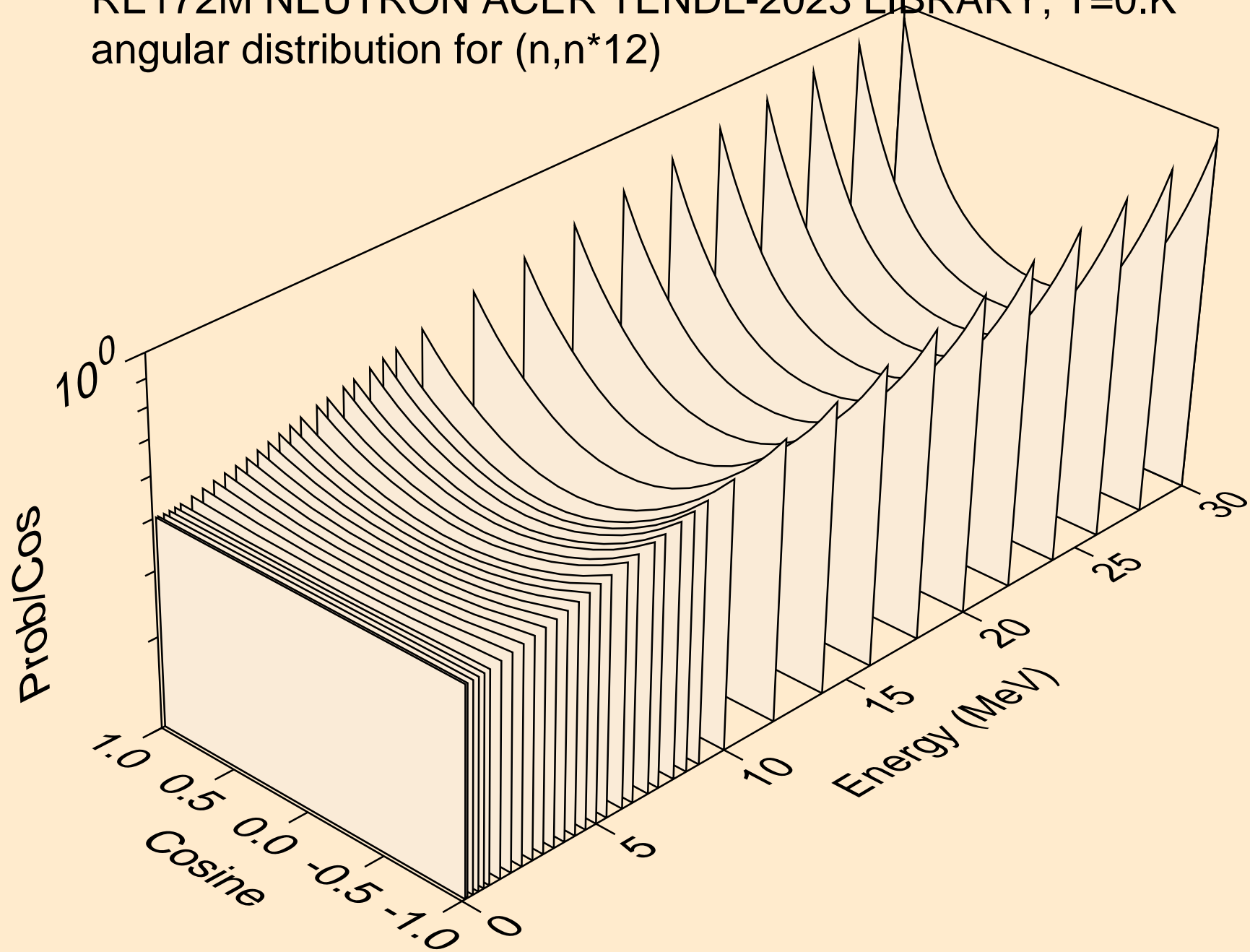

RE172M NEUTRON ACER TENDL-2023 LIBRARY; T=0.K  
angular distribution for (n,n\*13)

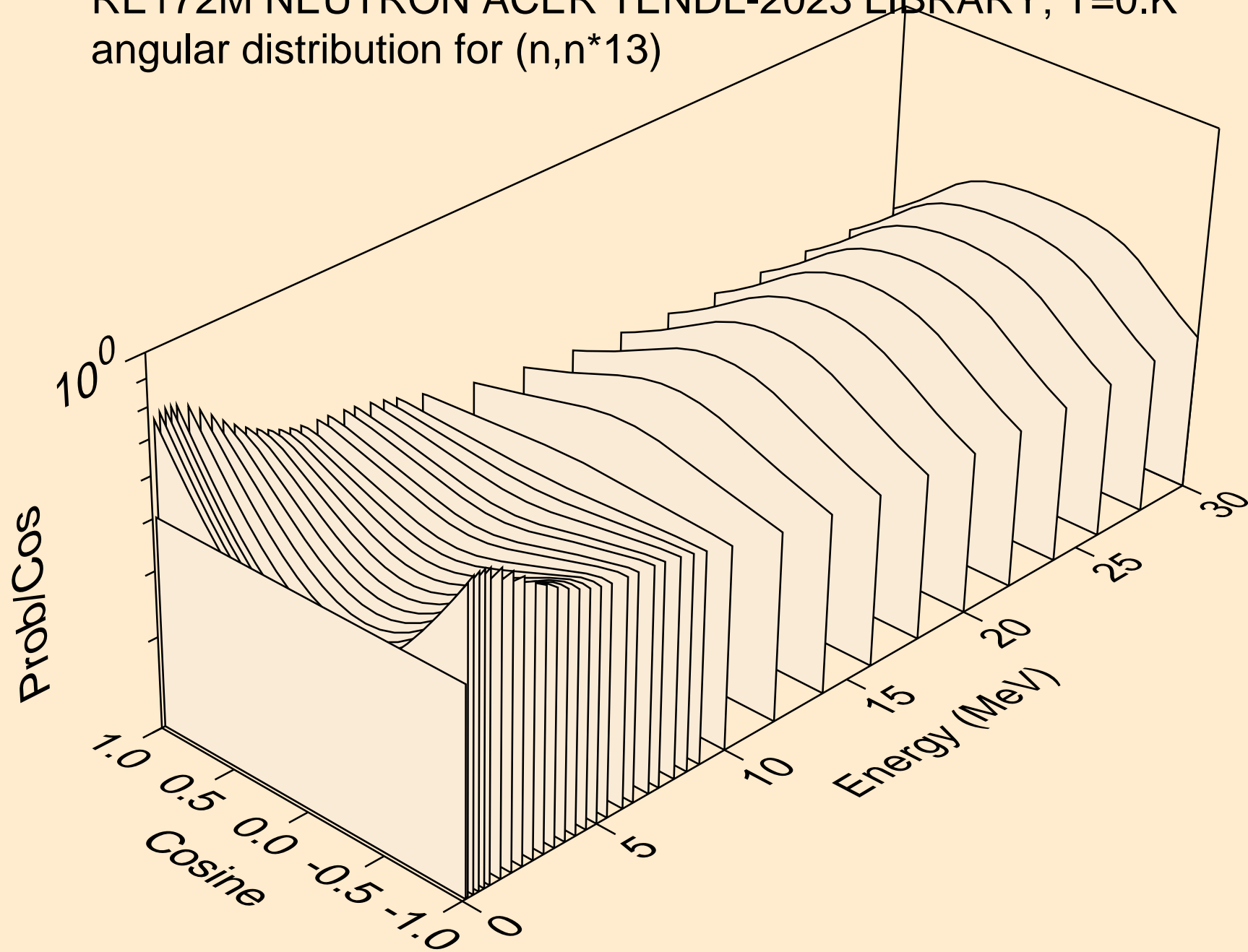

RE172M NEUTRON ACER TENDL-2023 LIBRARY; T=0.K  
angular distribution for (n,n\*14)

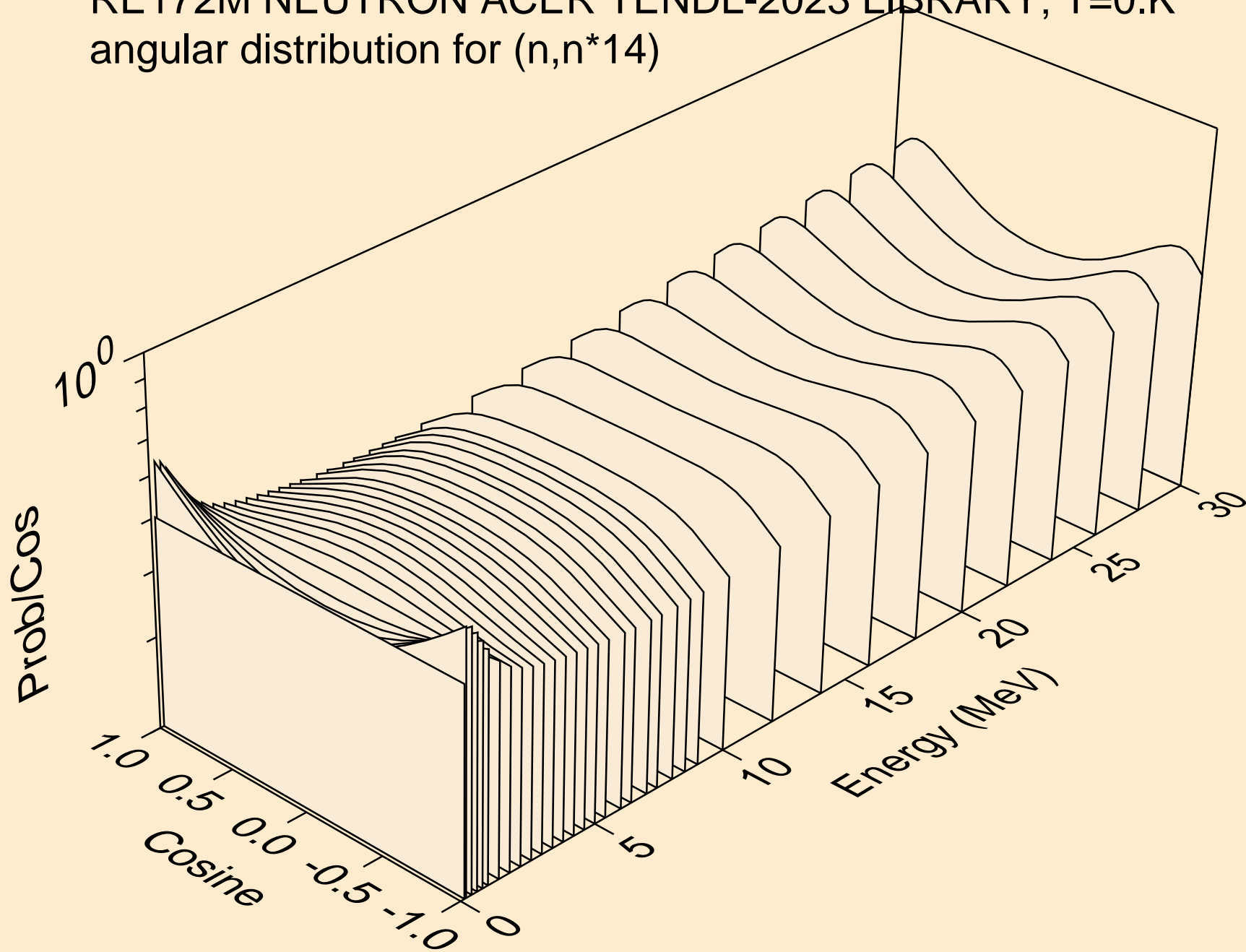

RE172M NEUTRON ACER TENDL-2023 LIBRARY; T=0.K  
angular distribution for (n,n\*15)

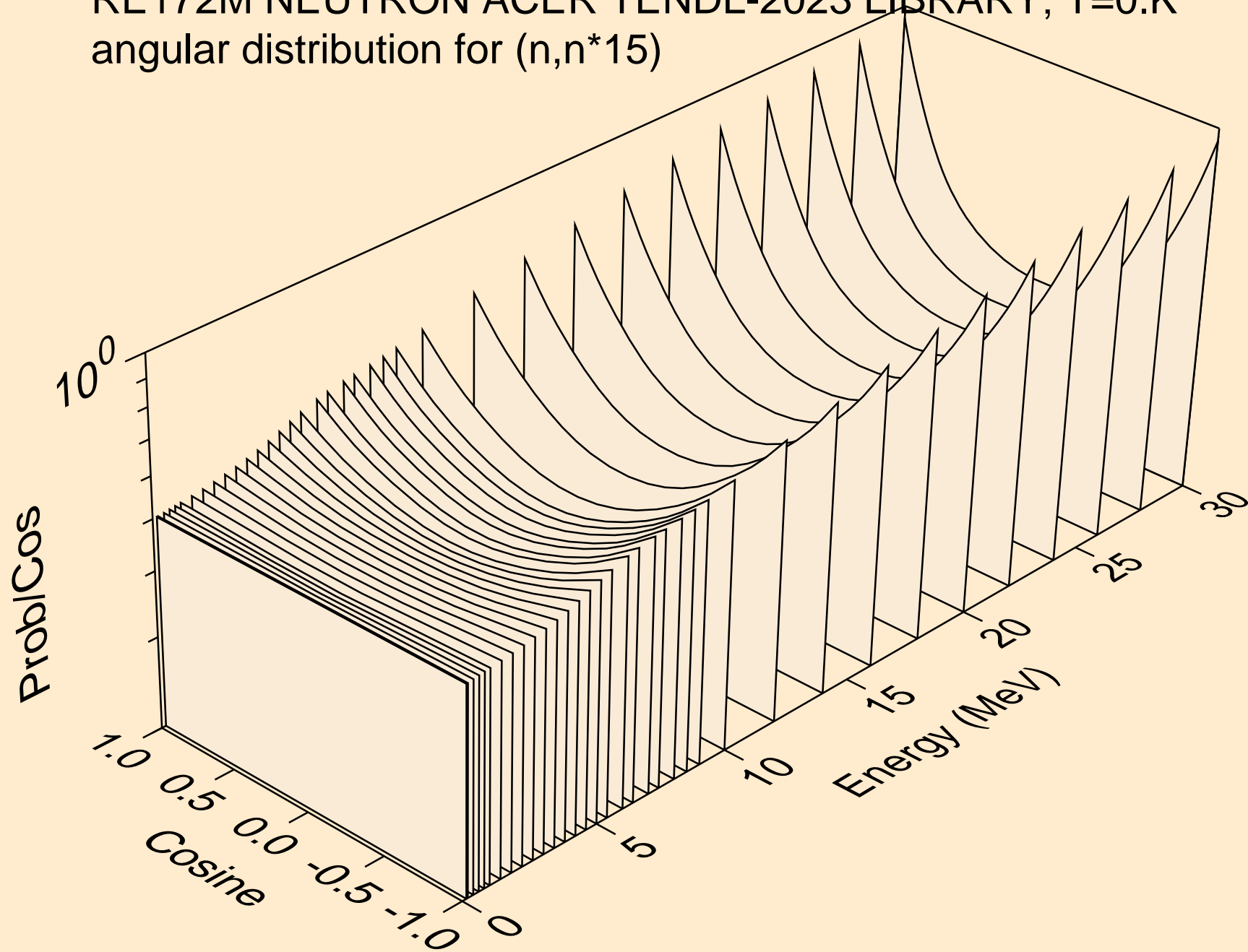



RE172M NEUTRON ACER TENDL-2023 LIBRARY; T=0.K  
angular distribution for (n,n\*16)

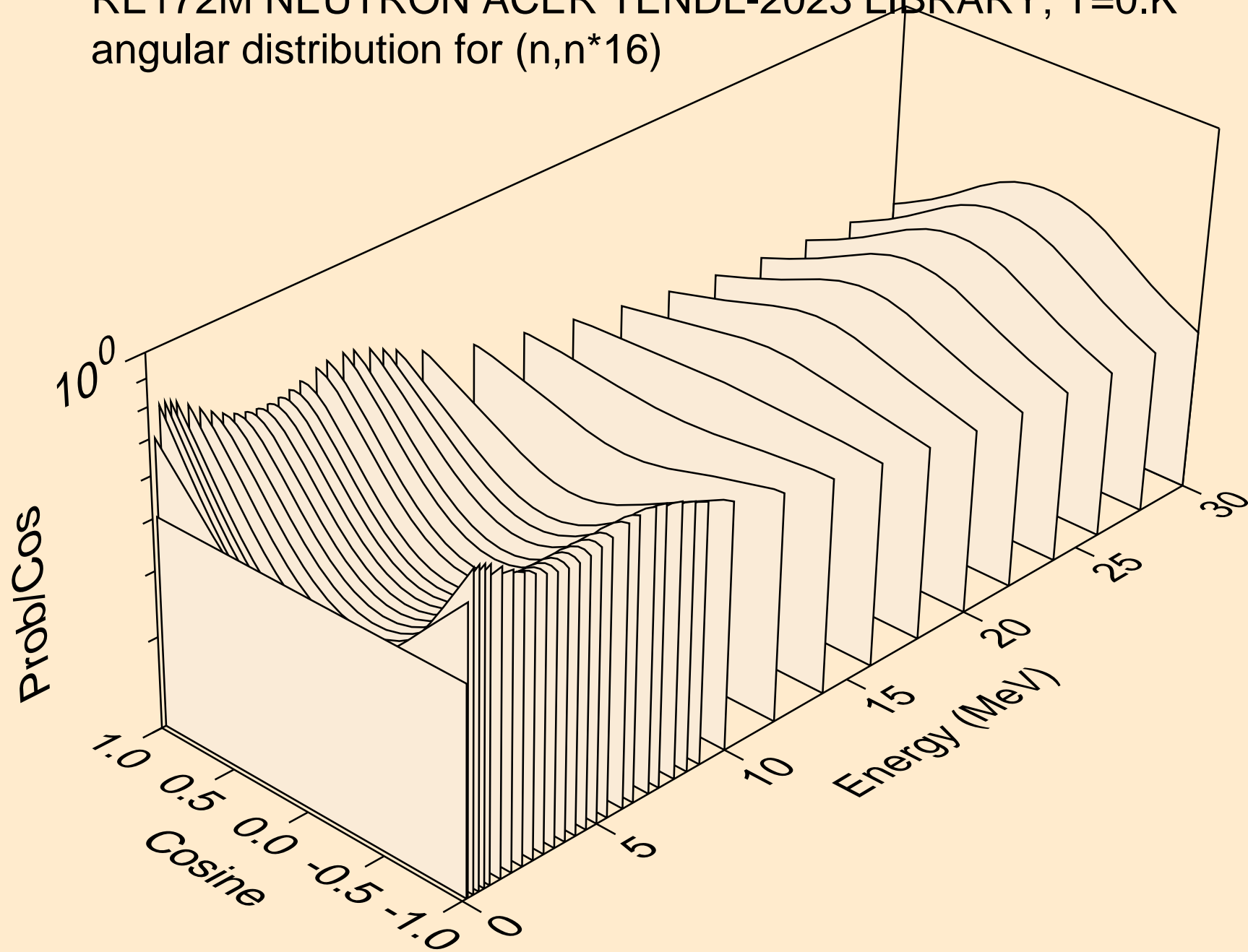

RE172M NEUTRON ACER TENDL-2023 LIBRARY; T=0.K  
angular distribution for (n,n\*17)

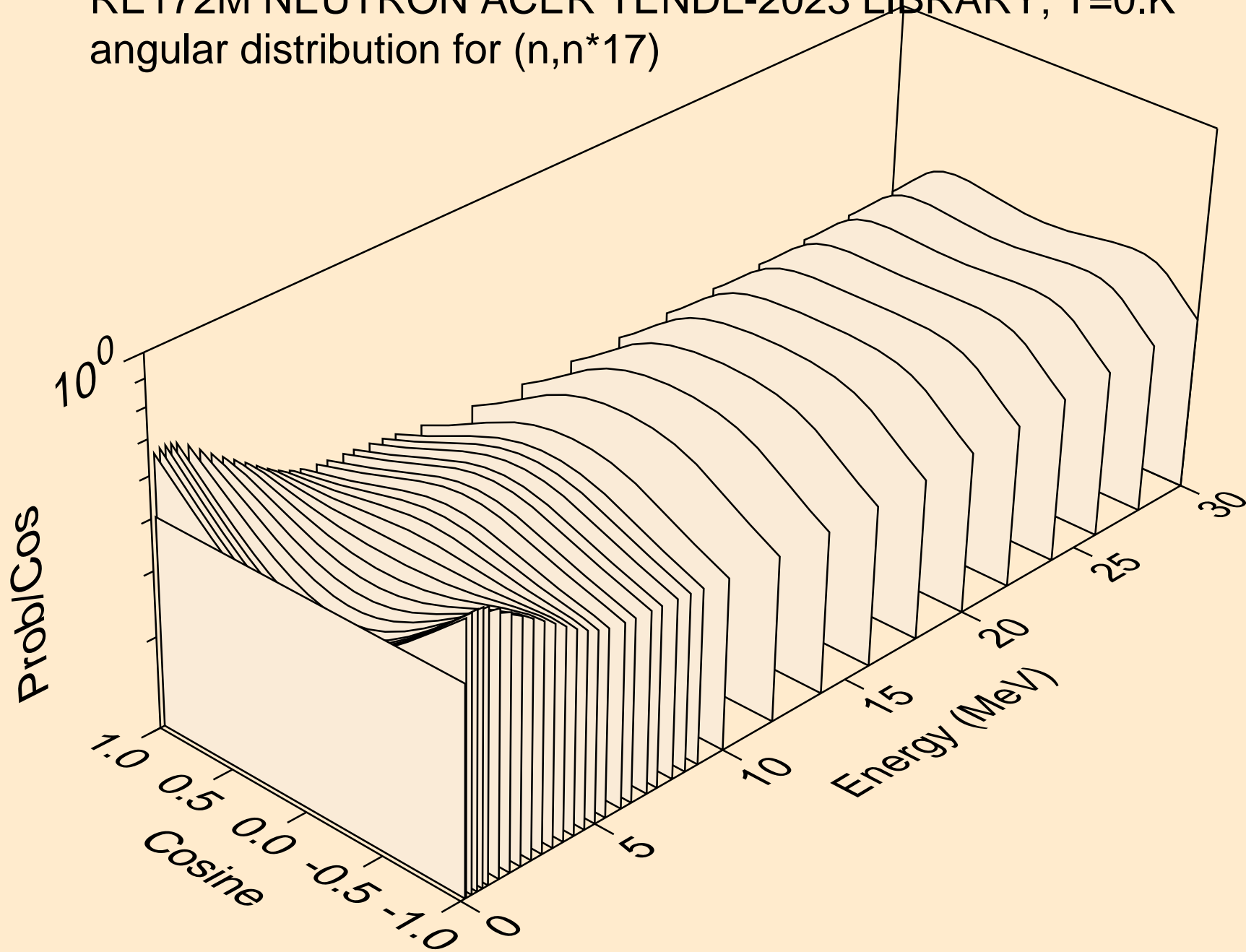

RE172M NEUTRON ACER TENDL-2023 LIBRARY; T=0.K  
angular distribution for (n,n\*18)

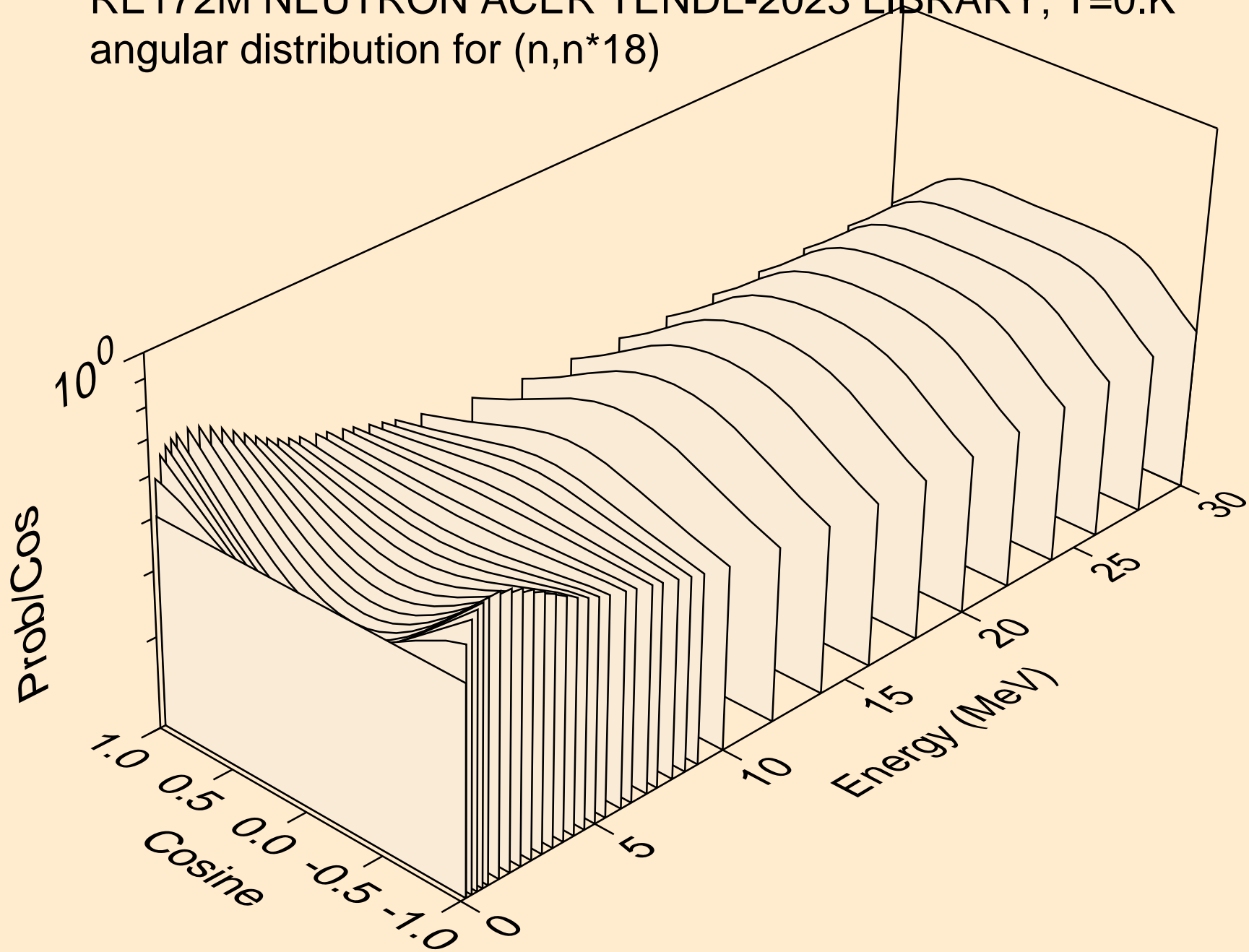

RE172M NEUTRON ACER TENDL-2023 LIBRARY; T=0.K  
angular distribution for (n,n\*19)

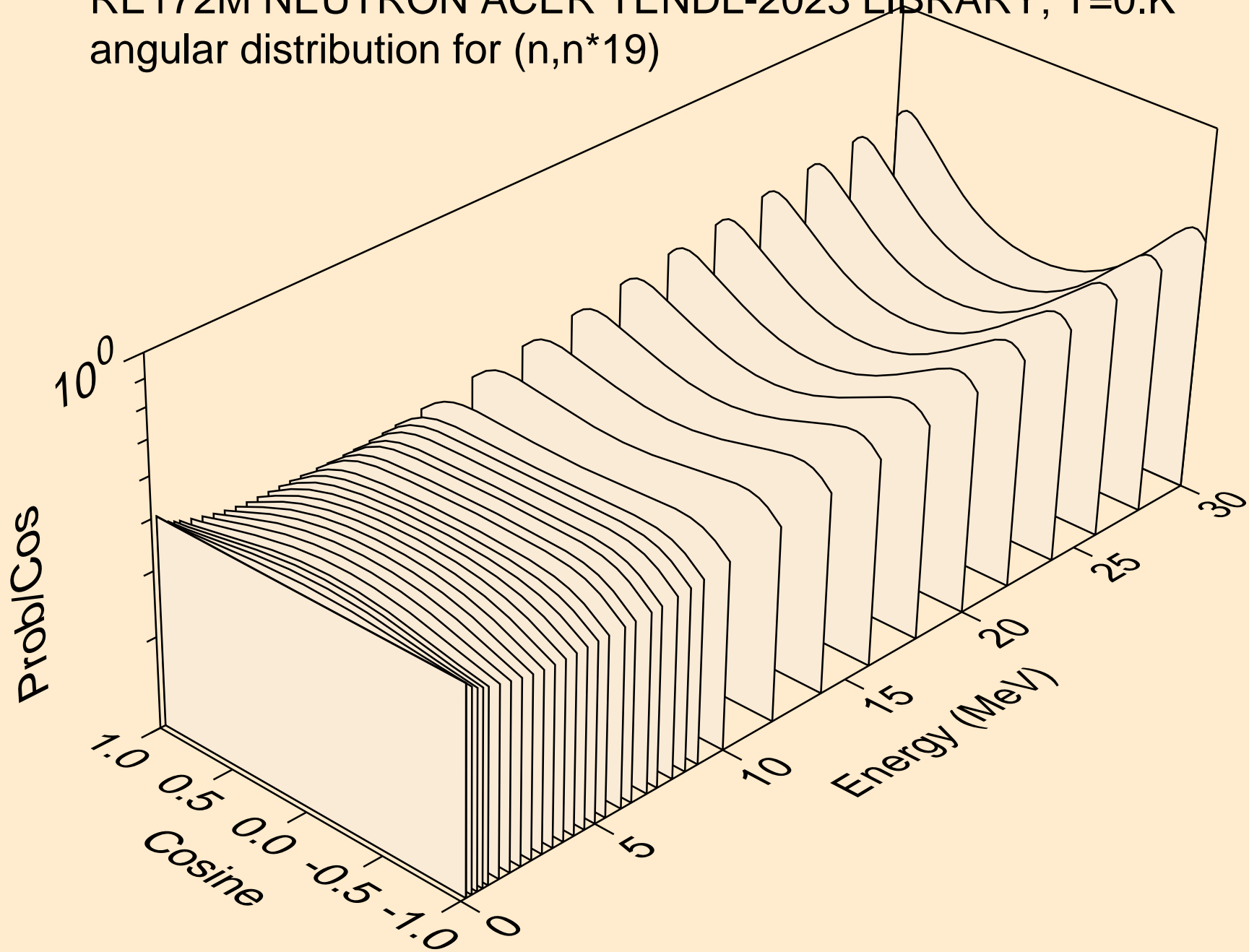

RE172M NEUTRON ACER TENDL-2023 LIBRARY; T=0.K  
angular distribution for (n,n\*20)

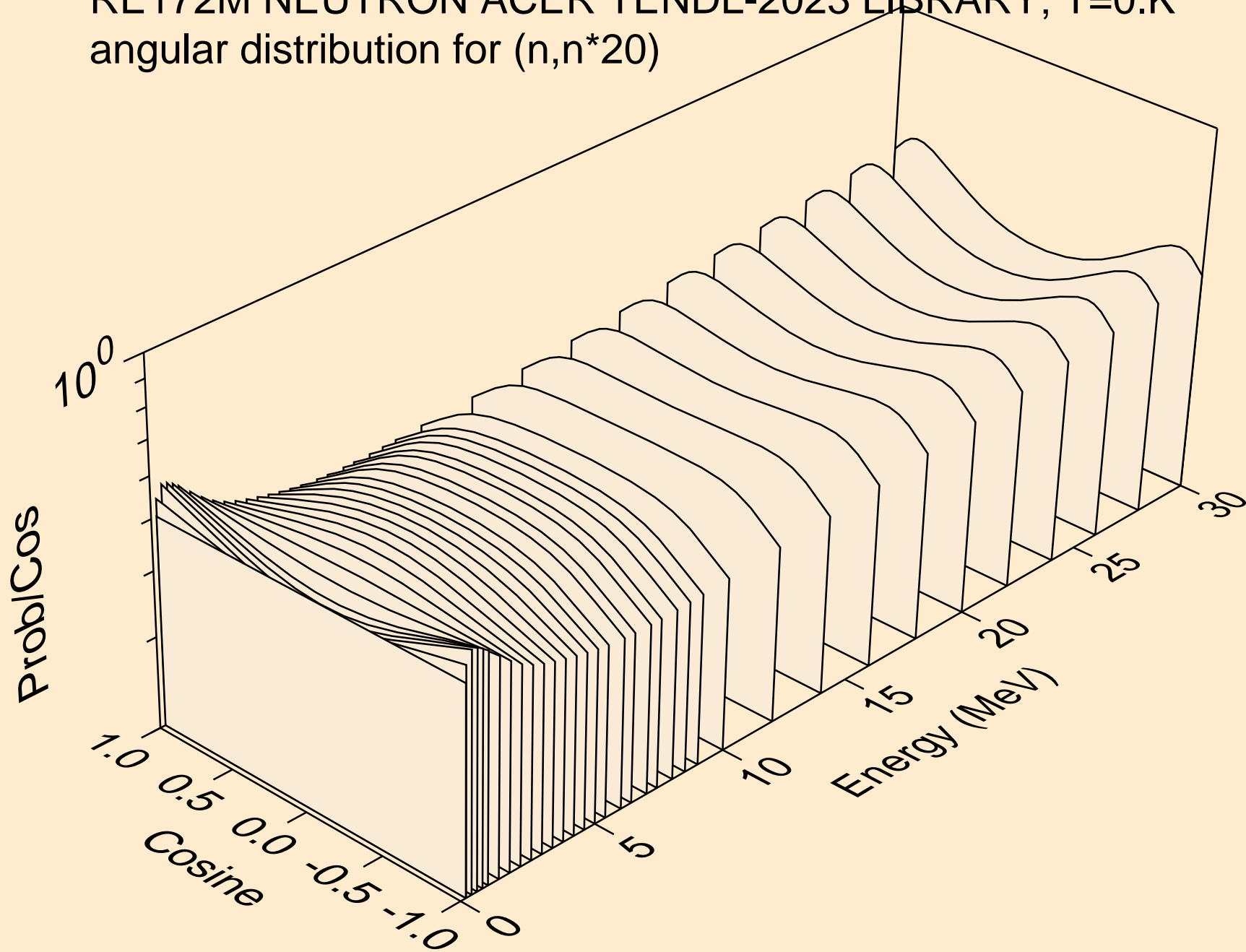

RE172M NEUTRON ACER TENDL-2023 LIBRARY; T=0.K  
angular distribution for (n,n\*21)

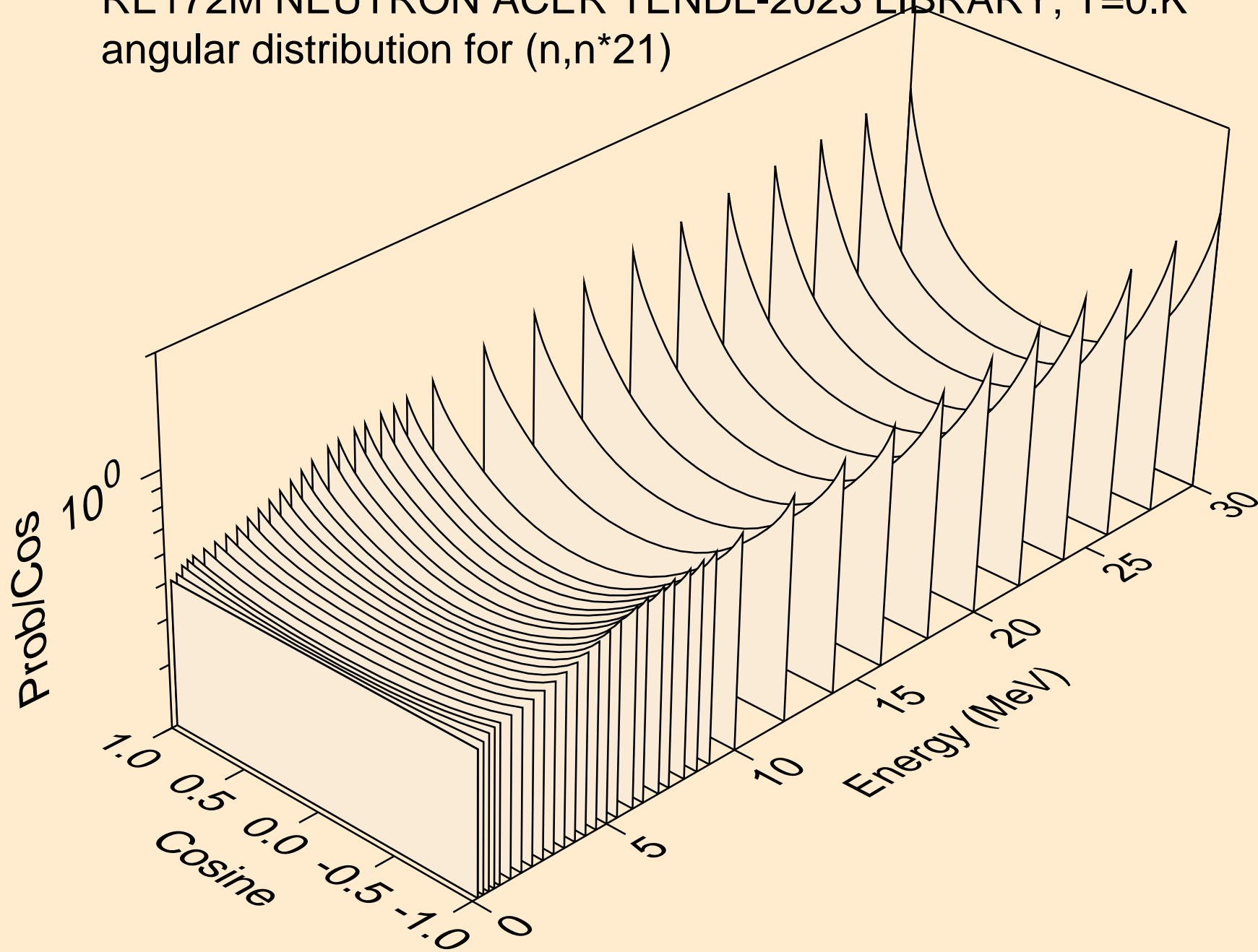

RE172M NEUTRON ACER TENDL-2023 LIBRARY; T=0.K  
Neutron emission for (n,x)

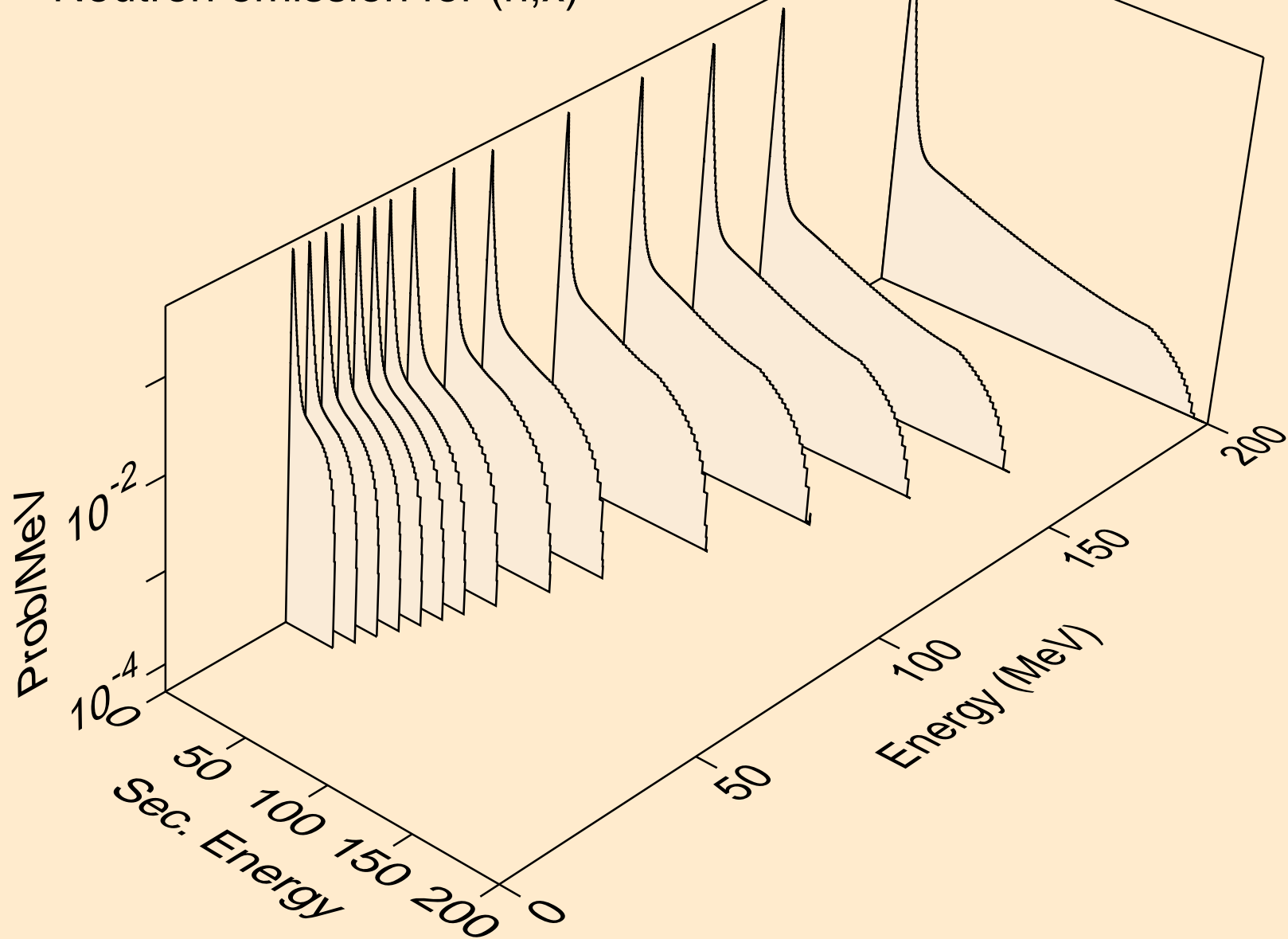

RE172M NEUTRON ACER TENDL-2023 LIBRARY; T=0.K  
Neutron emission for (n,2nd)

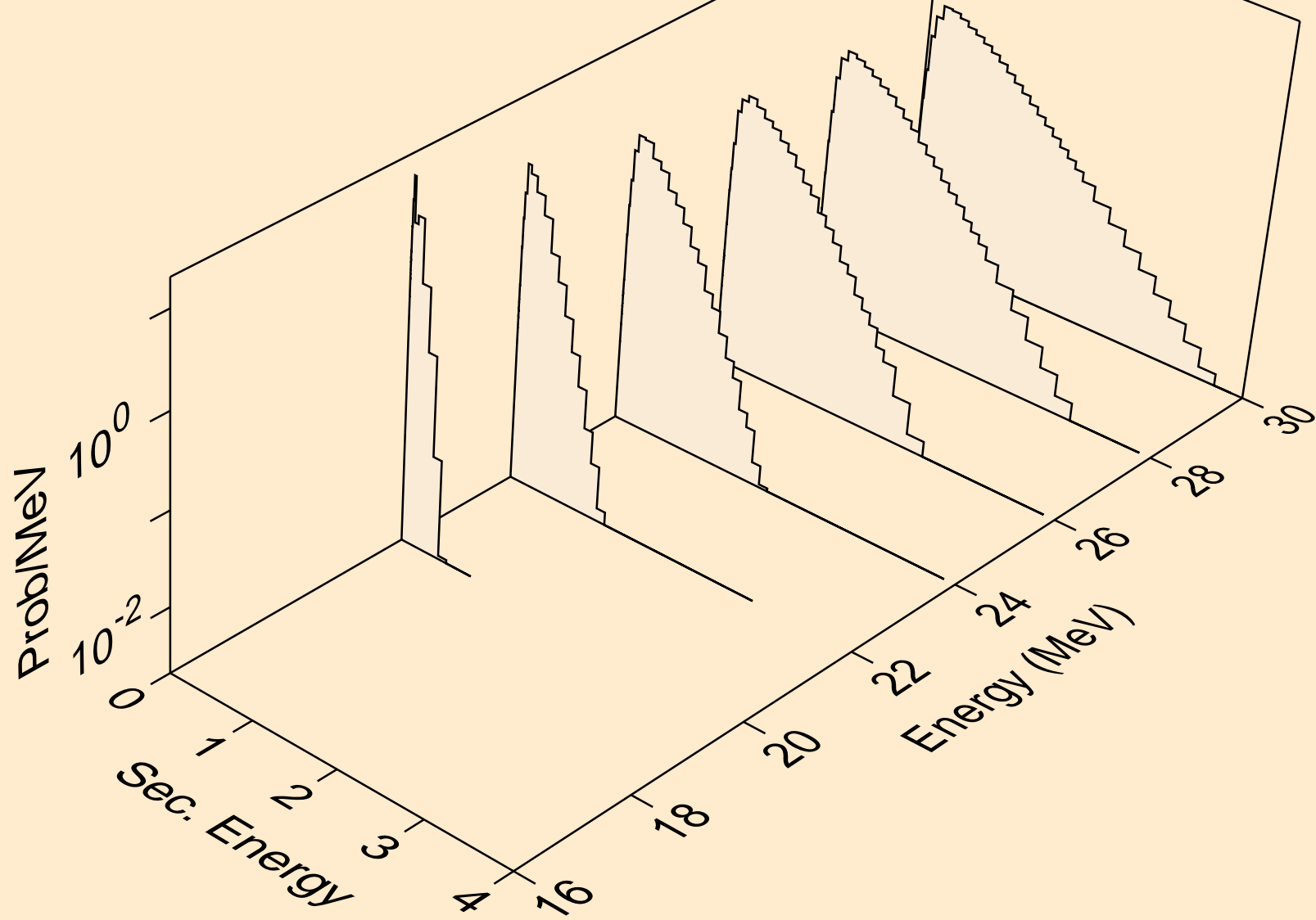



RE172M NEUTRON ACER TENDL-2023 LIBRARY; T=0.K  
Neutron emission for (n,2n)

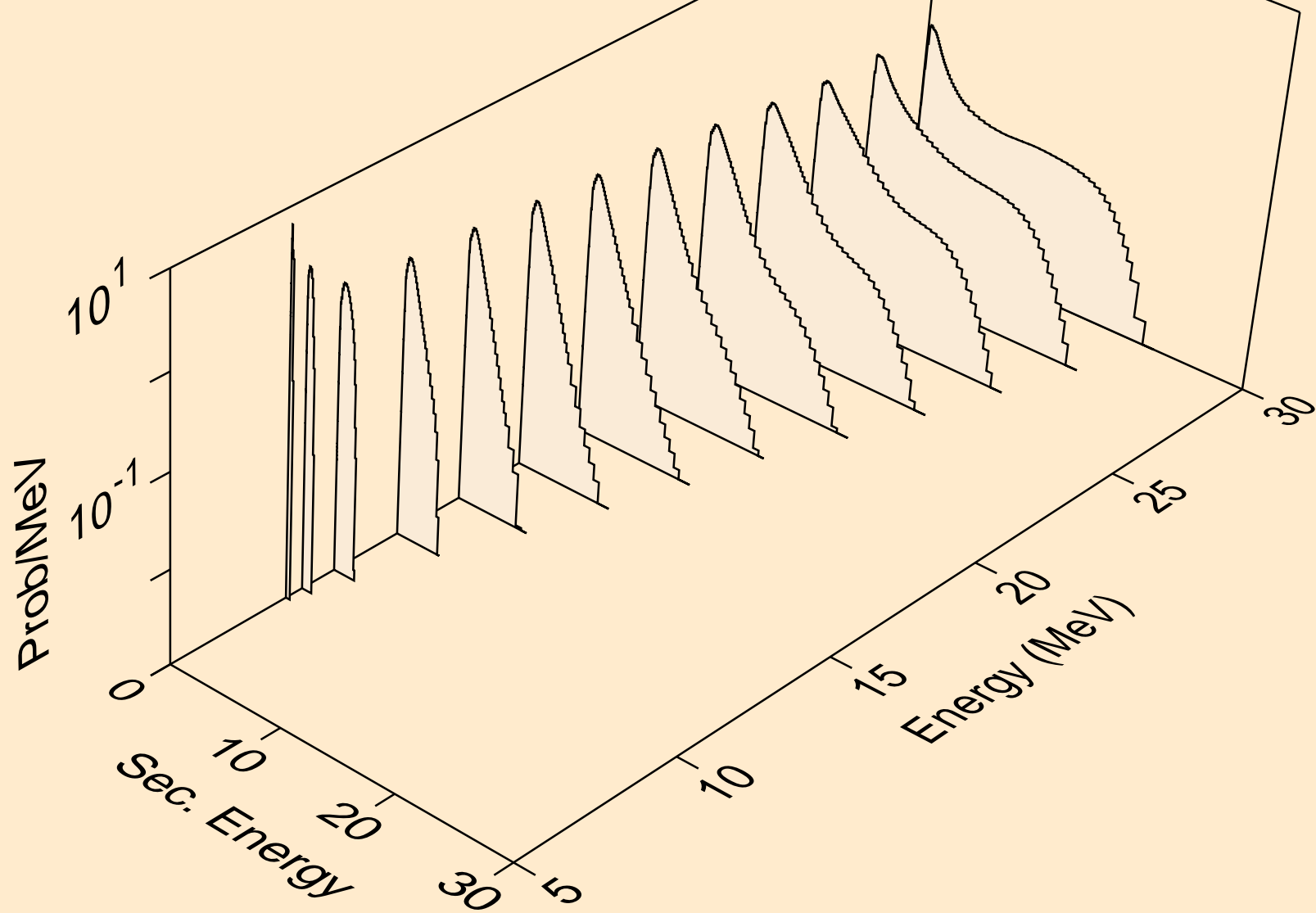

RE172M NEUTRON ACER TENDL-2023 LIBRARY; T=0.K  
Neutron emission for (n,3n)

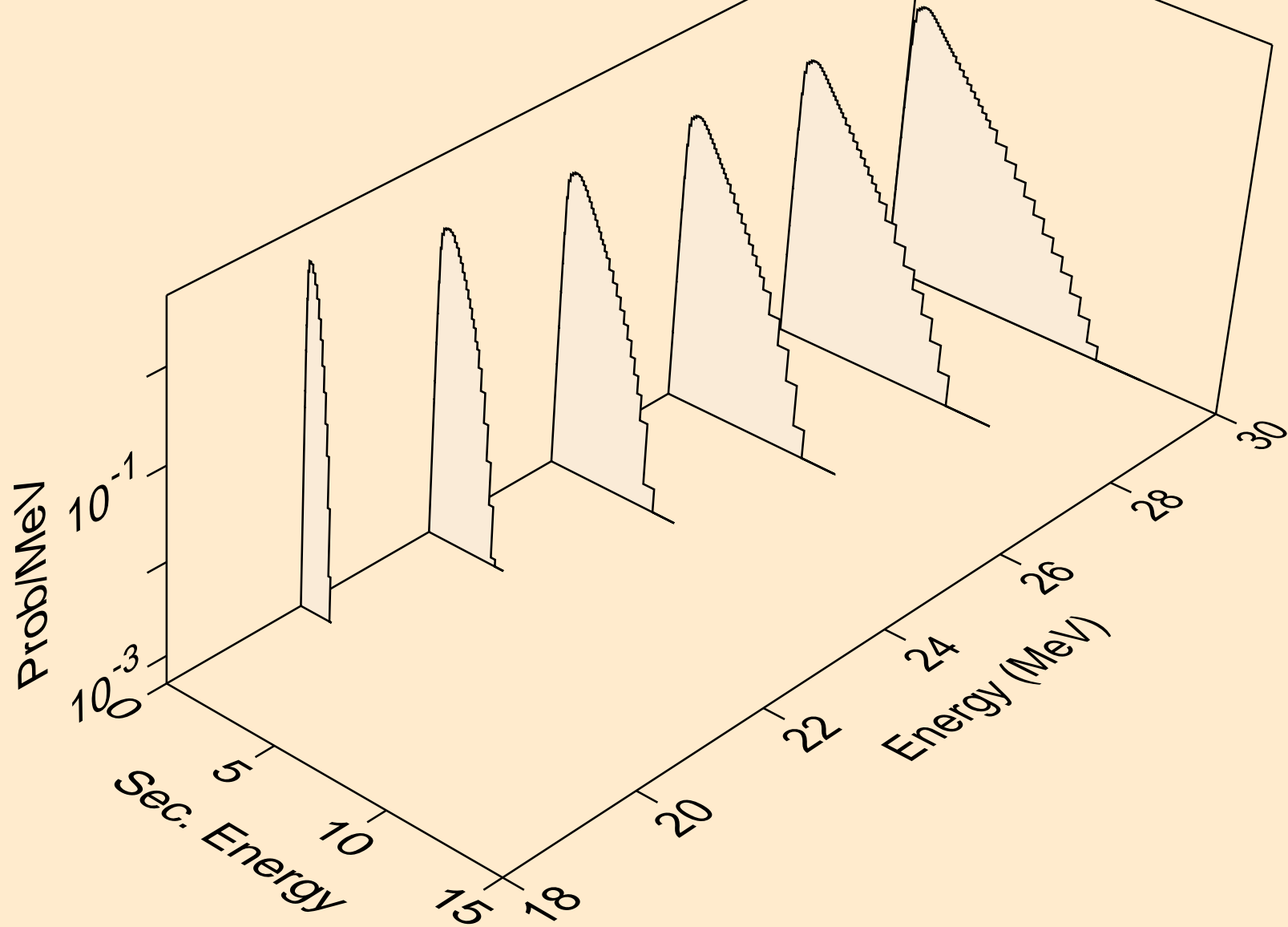

RE172M NEUTRON ACER TENDL-2023 LIBRARY; T=0.K  
Neutron emission for (n,n\*)a

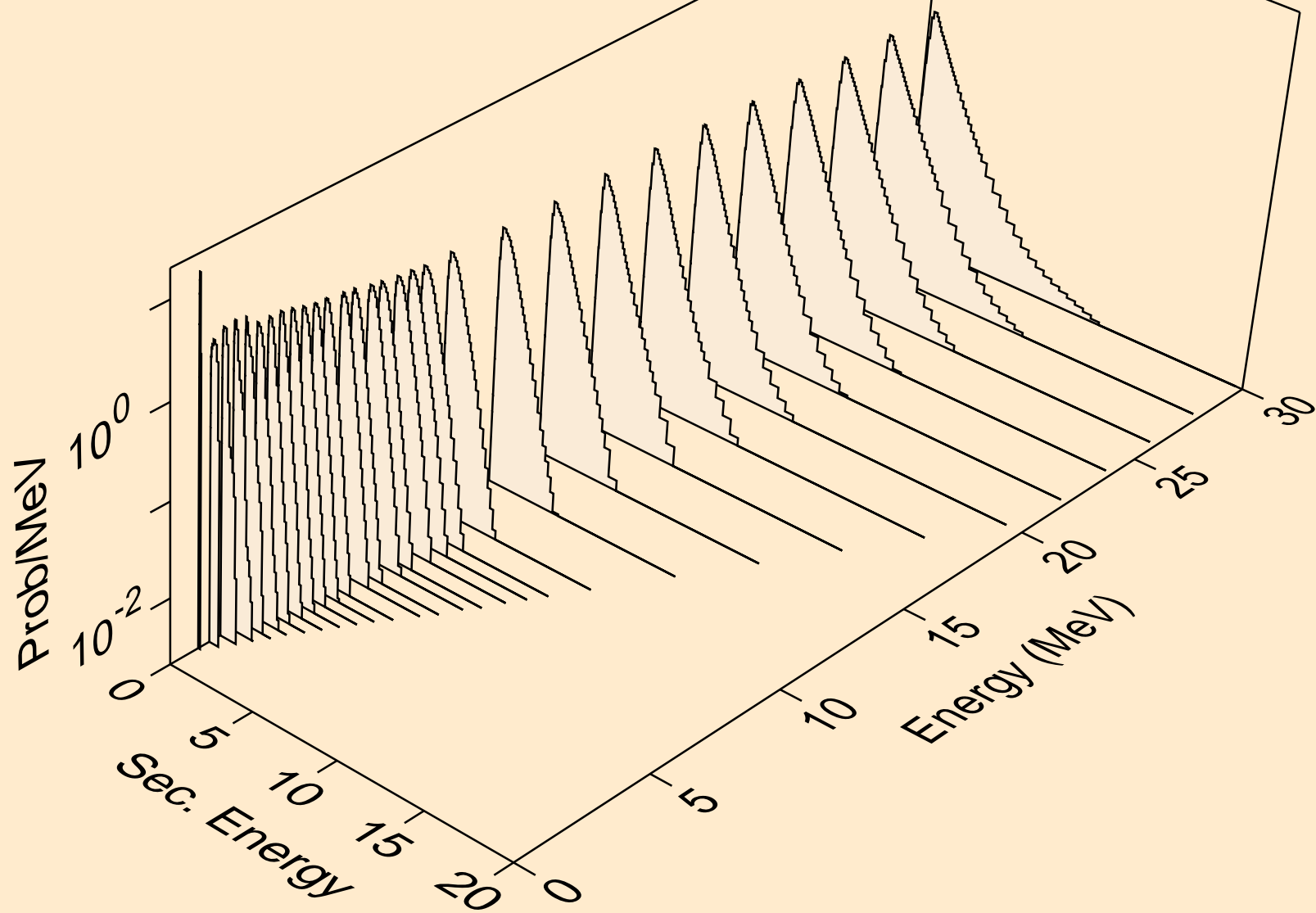

RE172M NEUTRON ACER TENDL-2023 LIBRARY; T=0.K  
Neutron emission for (n,2n)a

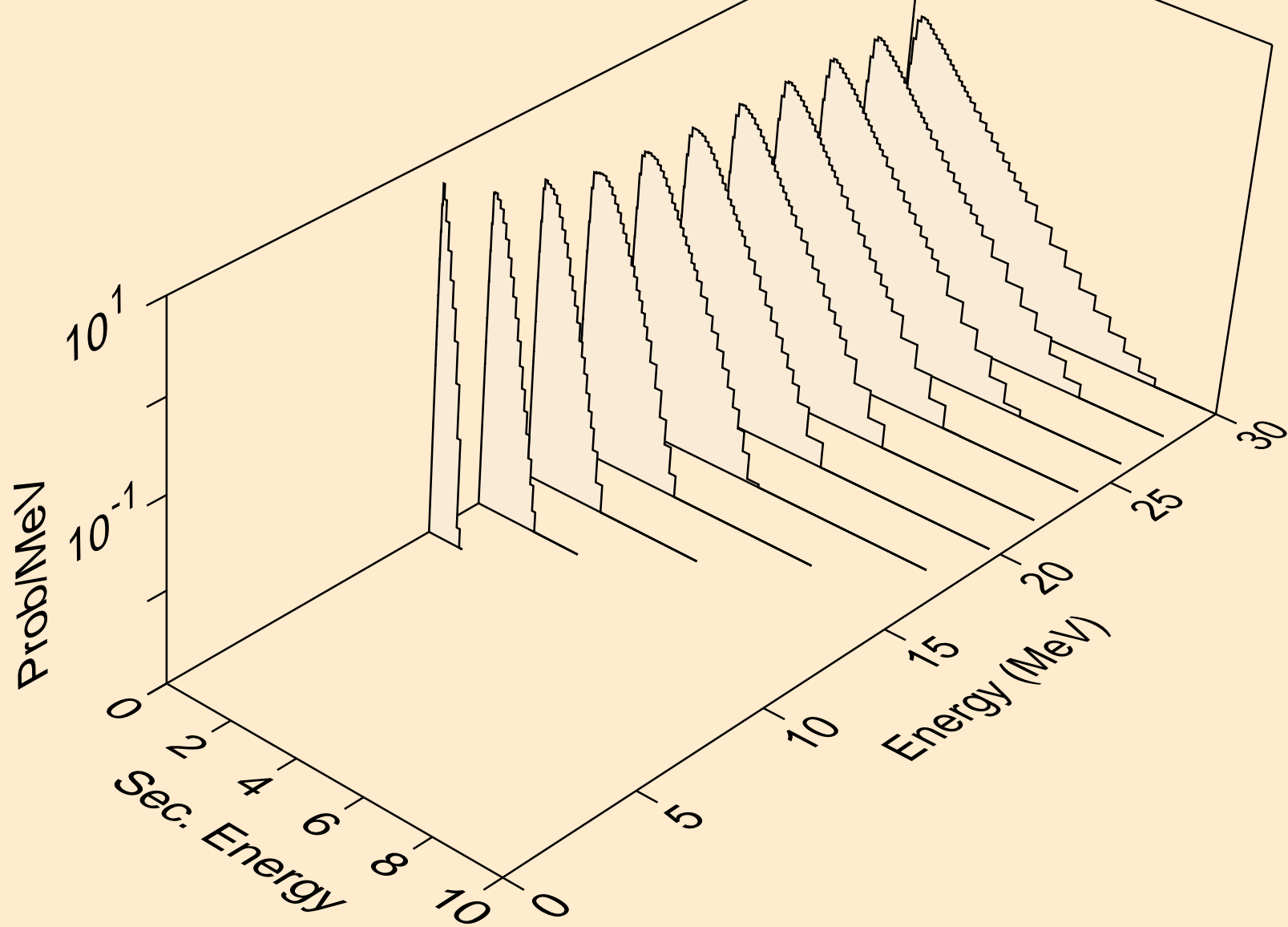

RE172M NEUTRON ACER TENDL-2023 LIBRARY; T=0.K  
Neutron emission for (n,3n)a

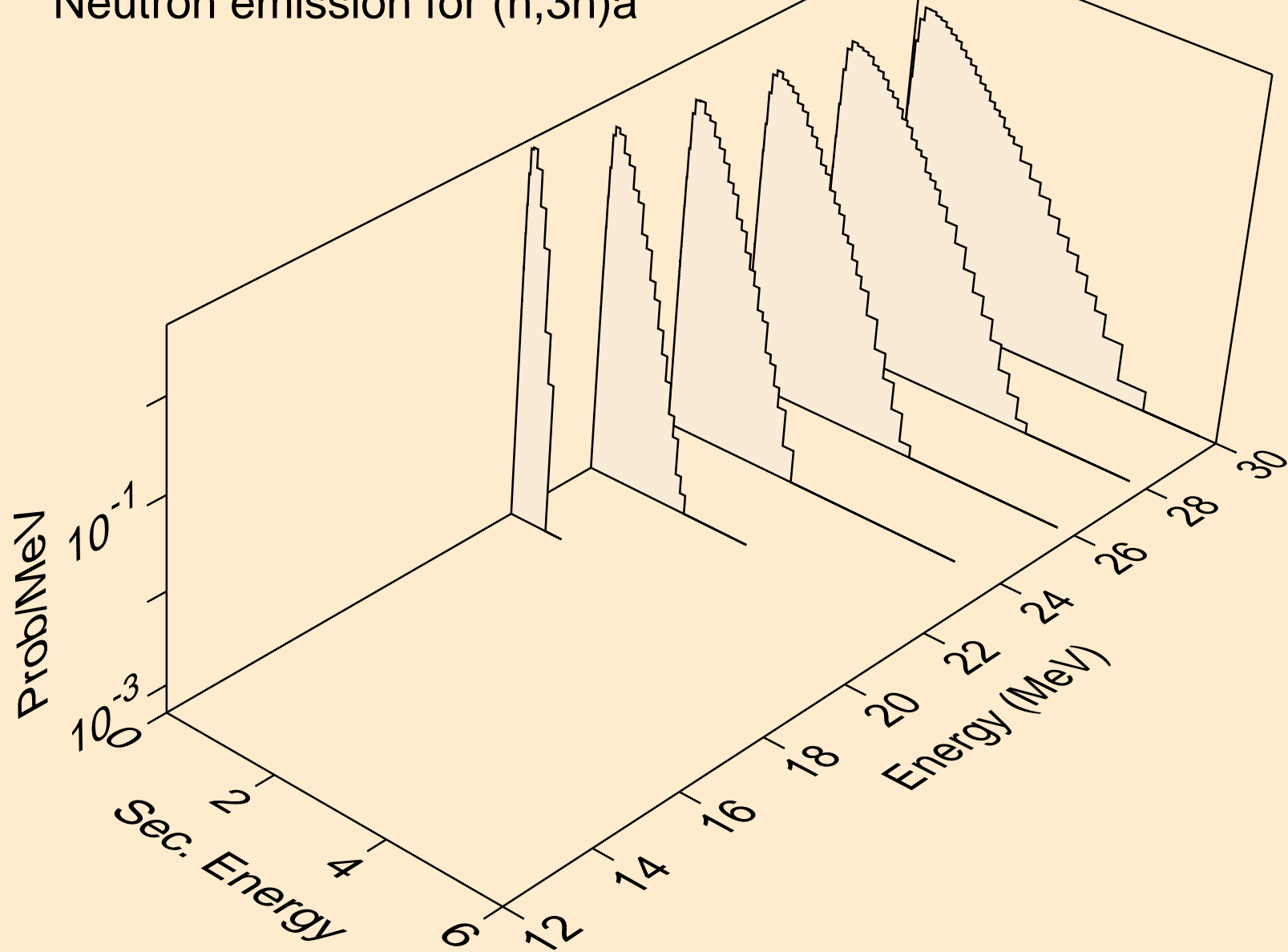

RE172M NEUTRON ACER TENDL-2023 LIBRARY; T=0.K  
Neutron emission for (n,n\*)p

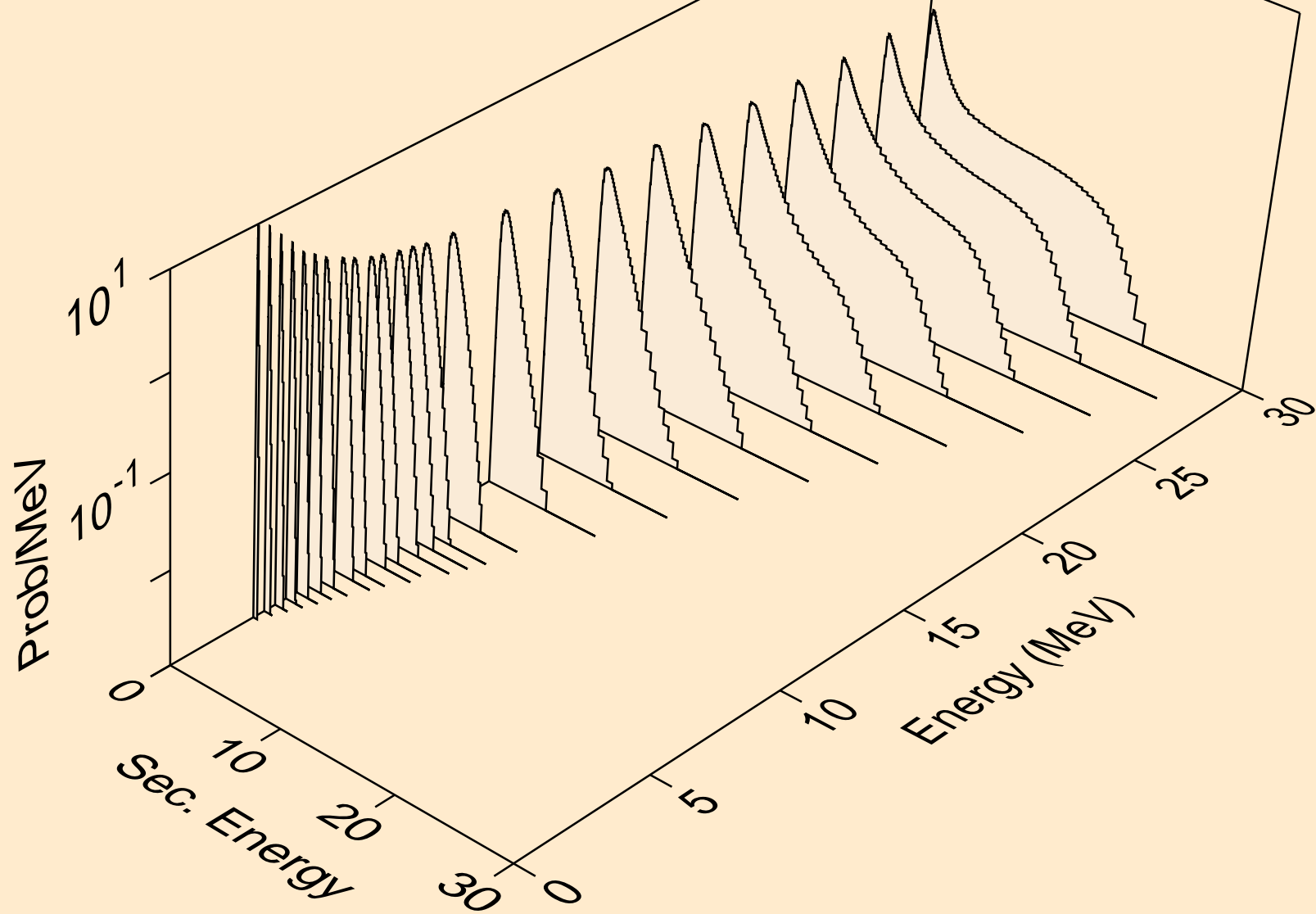

RE172M NEUTRON ACER TENDL-2023 LIBRARY; T=0.K  
Neutron emission for (n,n\*)2a

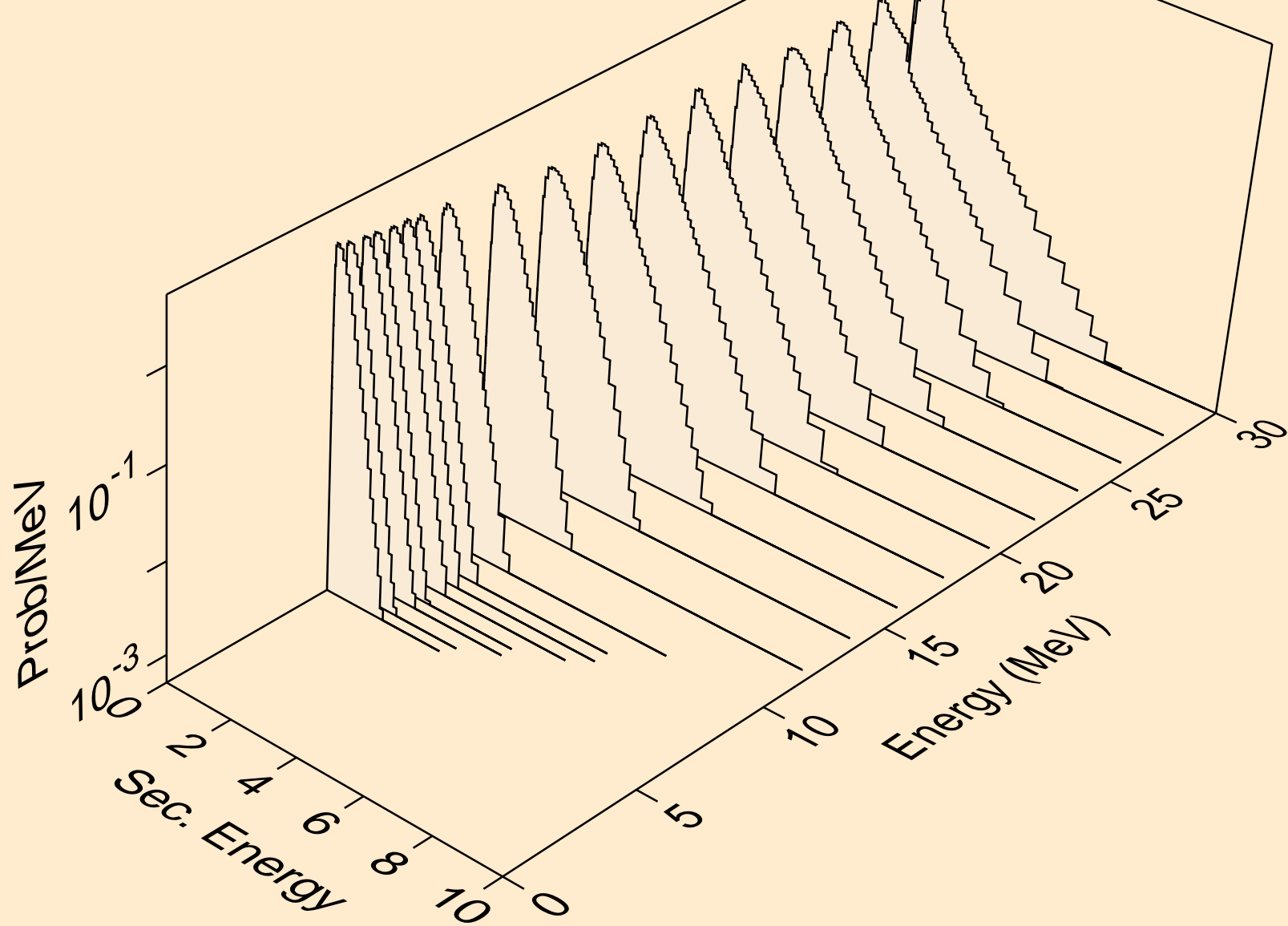

RE172M NEUTRON ACER TENDL-2023 LIBRARY; T=0.K  
Neutron emission for (n,2n)2a

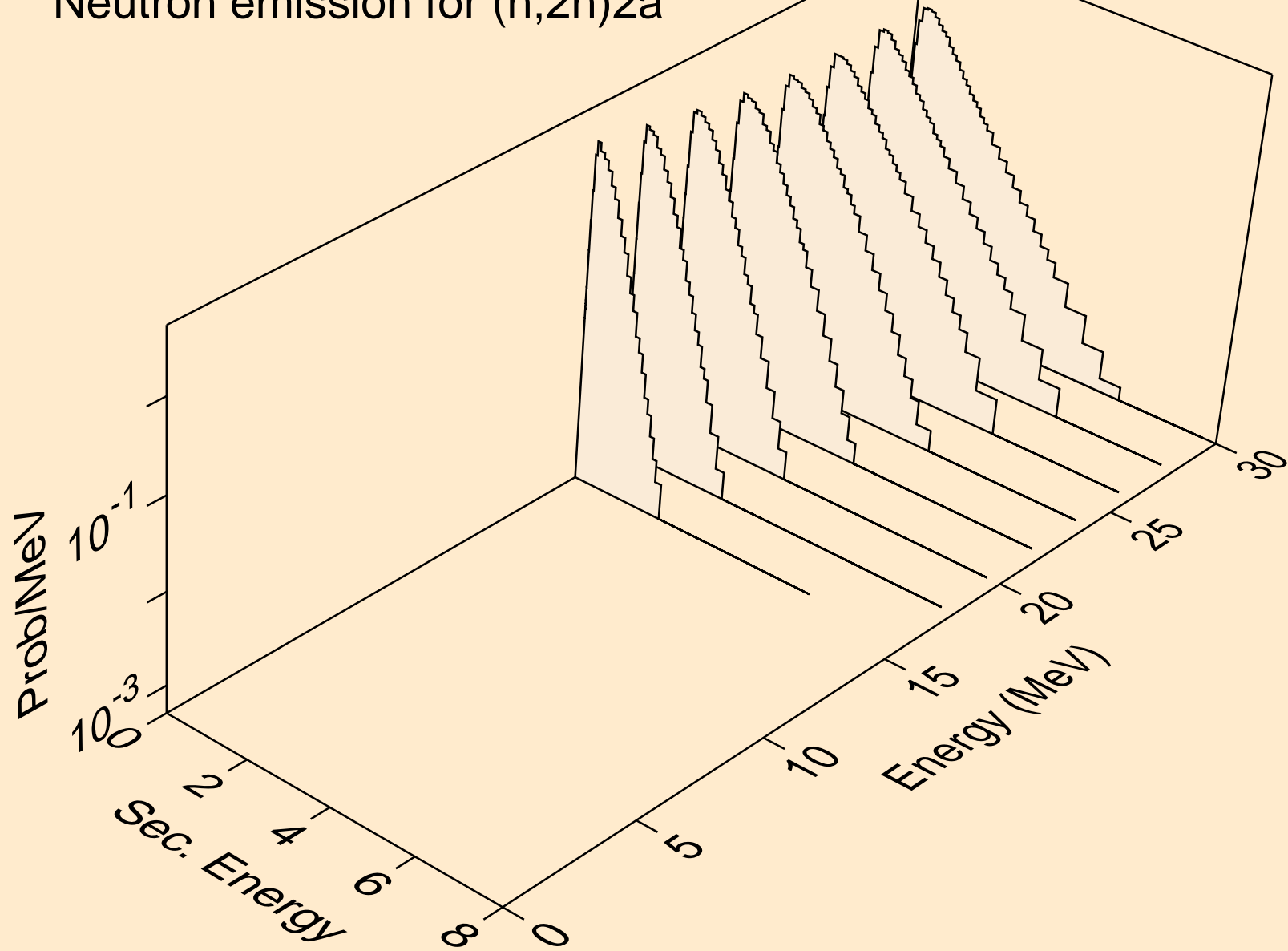



RE172M NEUTRON ACER TENDL-2023 LIBRARY; T=0.K  
Neutron emission for (n,n\*)d

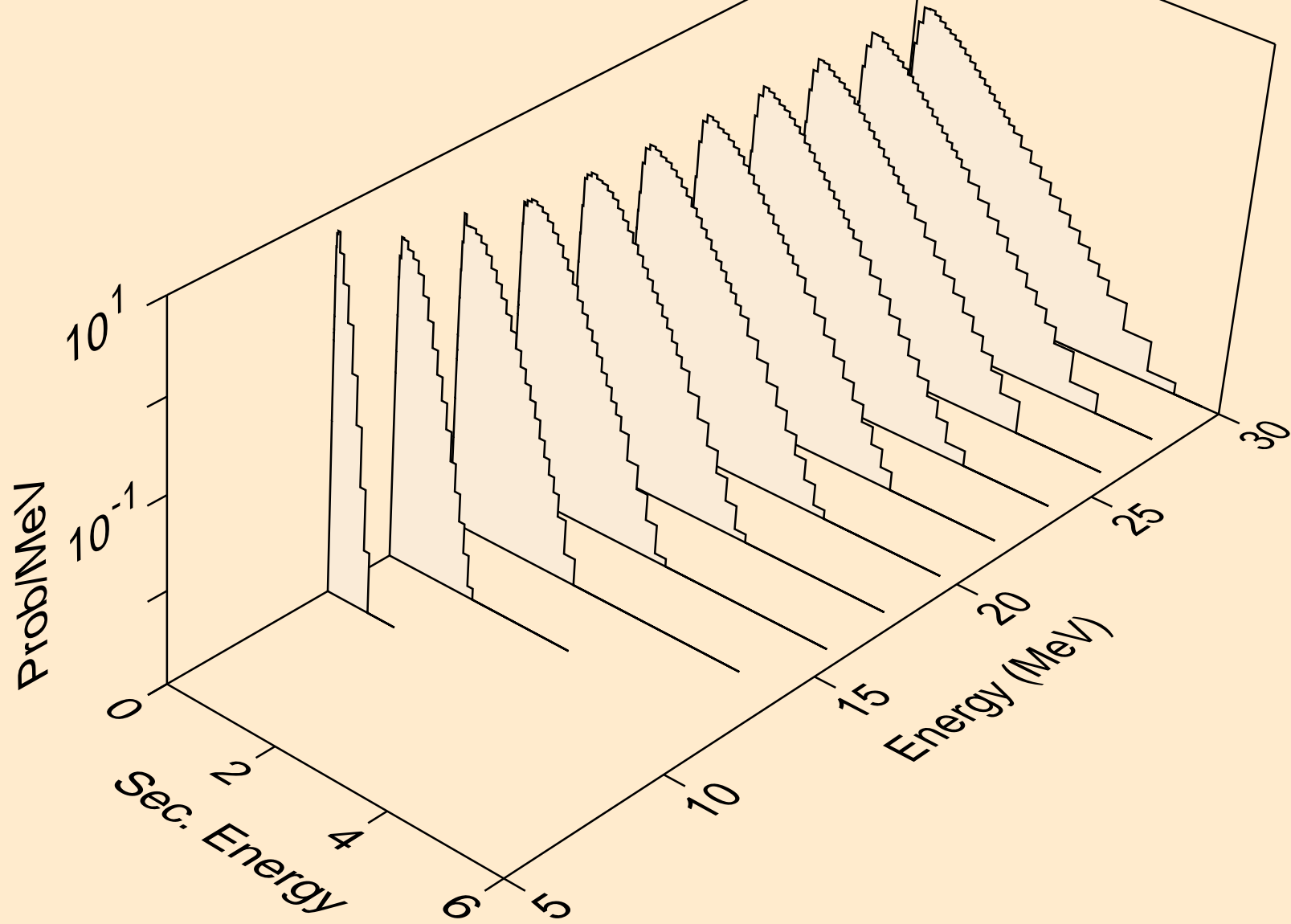

RE172M NEUTRON ACER TENDL-2023 LIBRARY; T=0.K  
Neutron emission for (n,n\*)t

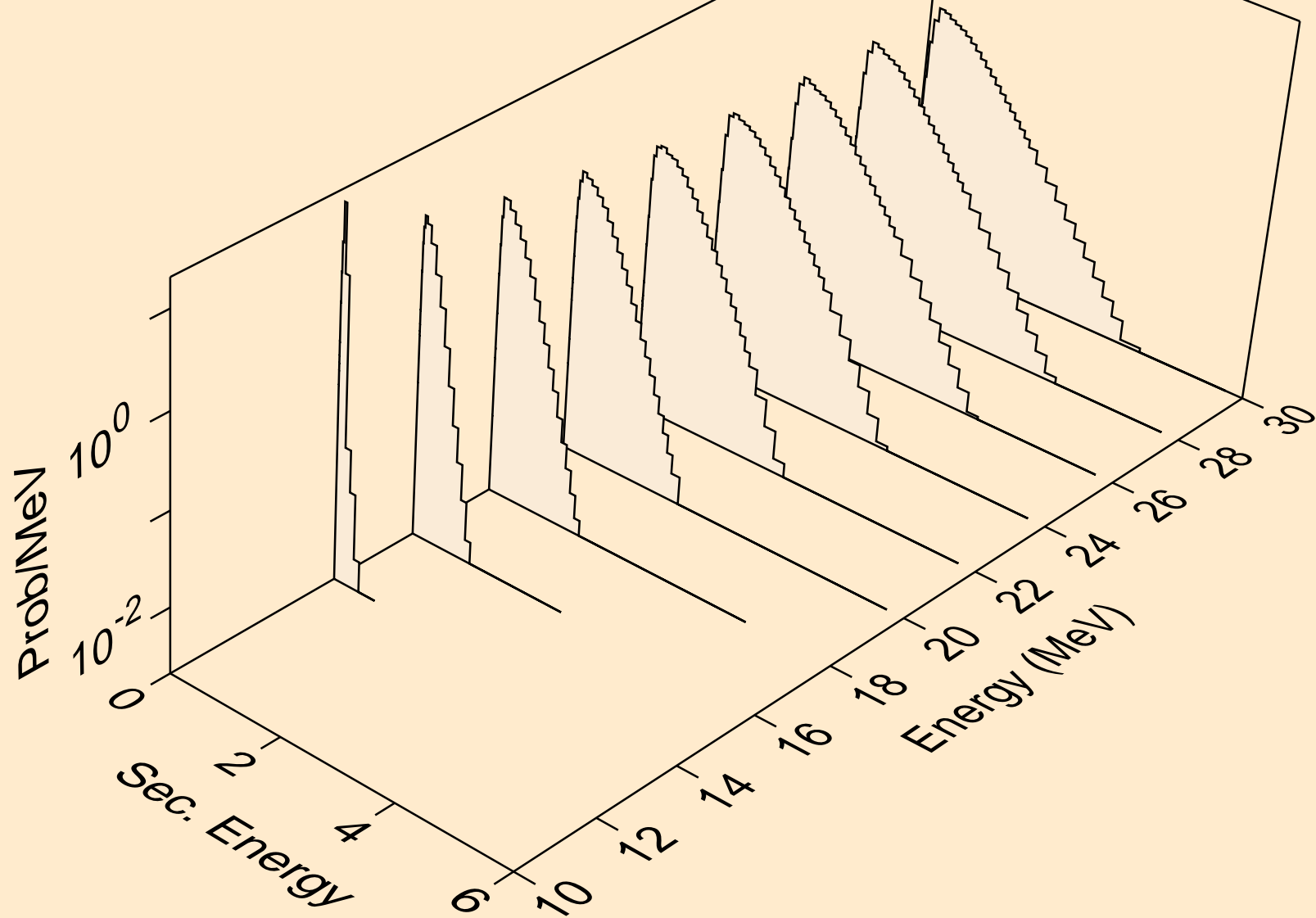

RE172M NEUTRON ACER TENDL-2023 LIBRARY; T=0.K  
Neutron emission for (n,n\*)he3

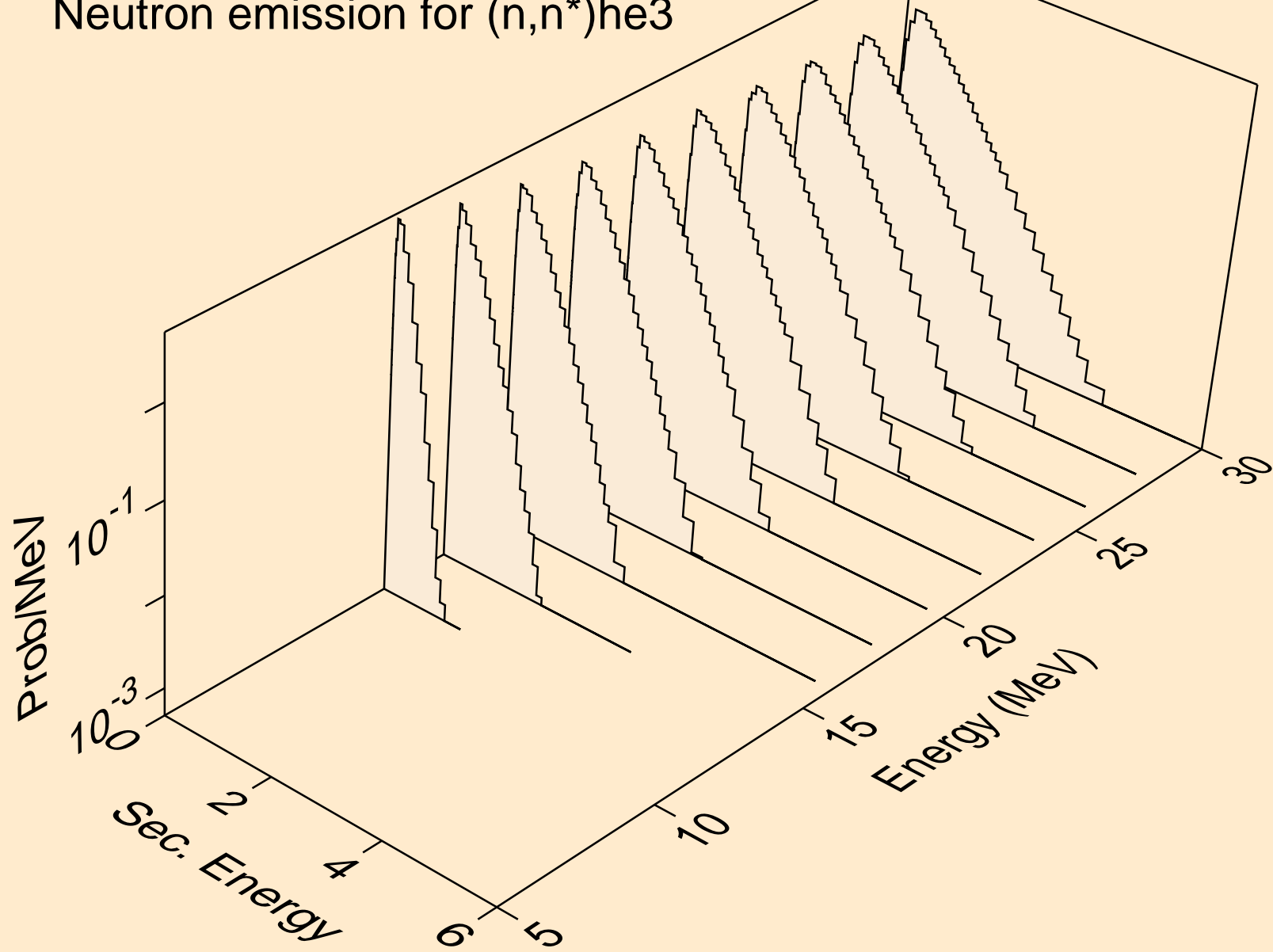

RE172M NEUTRON ACER TENDL-2023 LIBRARY; T=0.K  
Neutron emission for (n,4n)

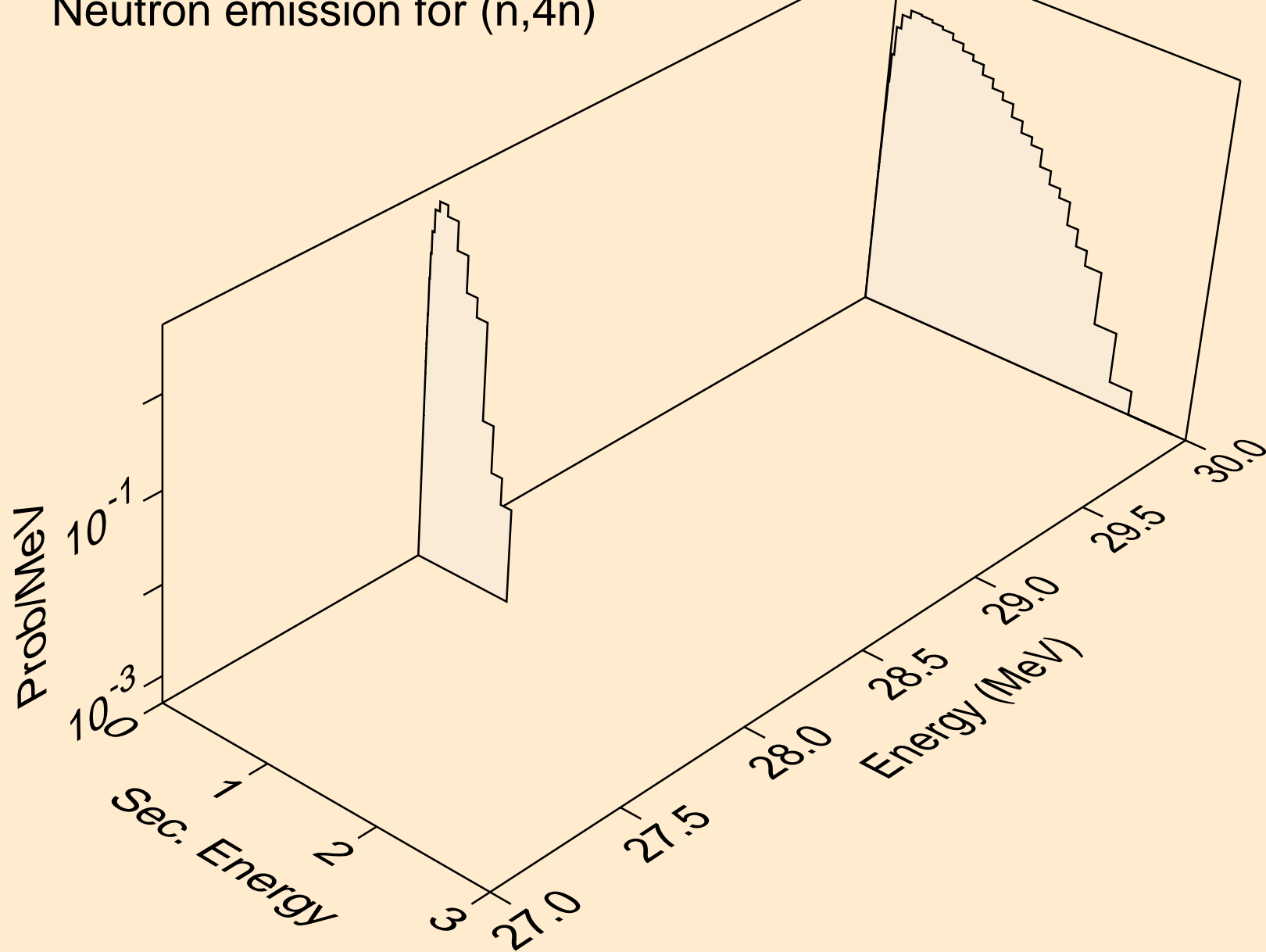

RE172M NEUTRON ACER TENDL-2023 LIBRARY; T=0.K  
Neutron emission for (n,2np)

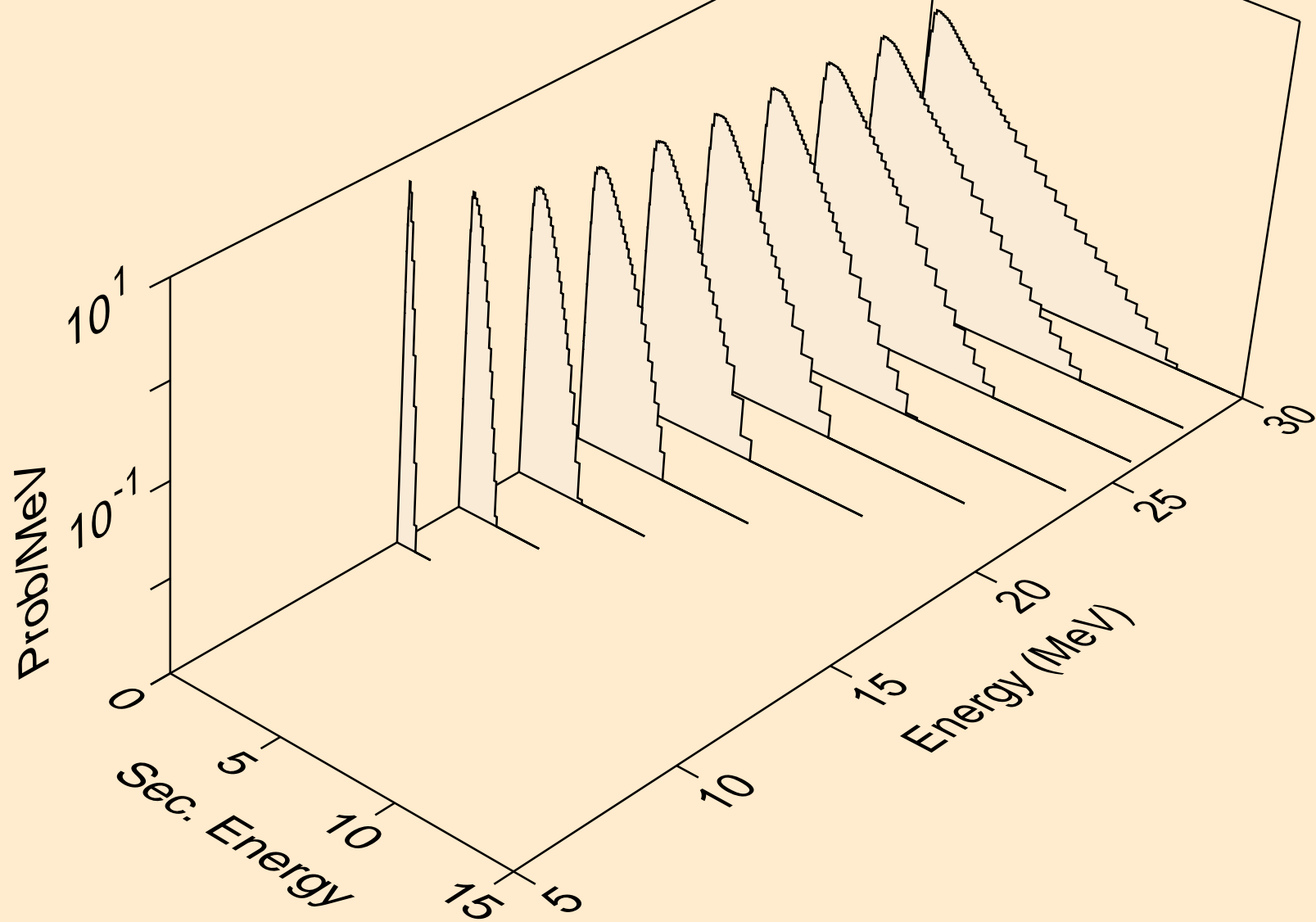

RE172M NEUTRON ACER TENDL-2023 LIBRARY; T=0.K  
Neutron emission for (n,3np)

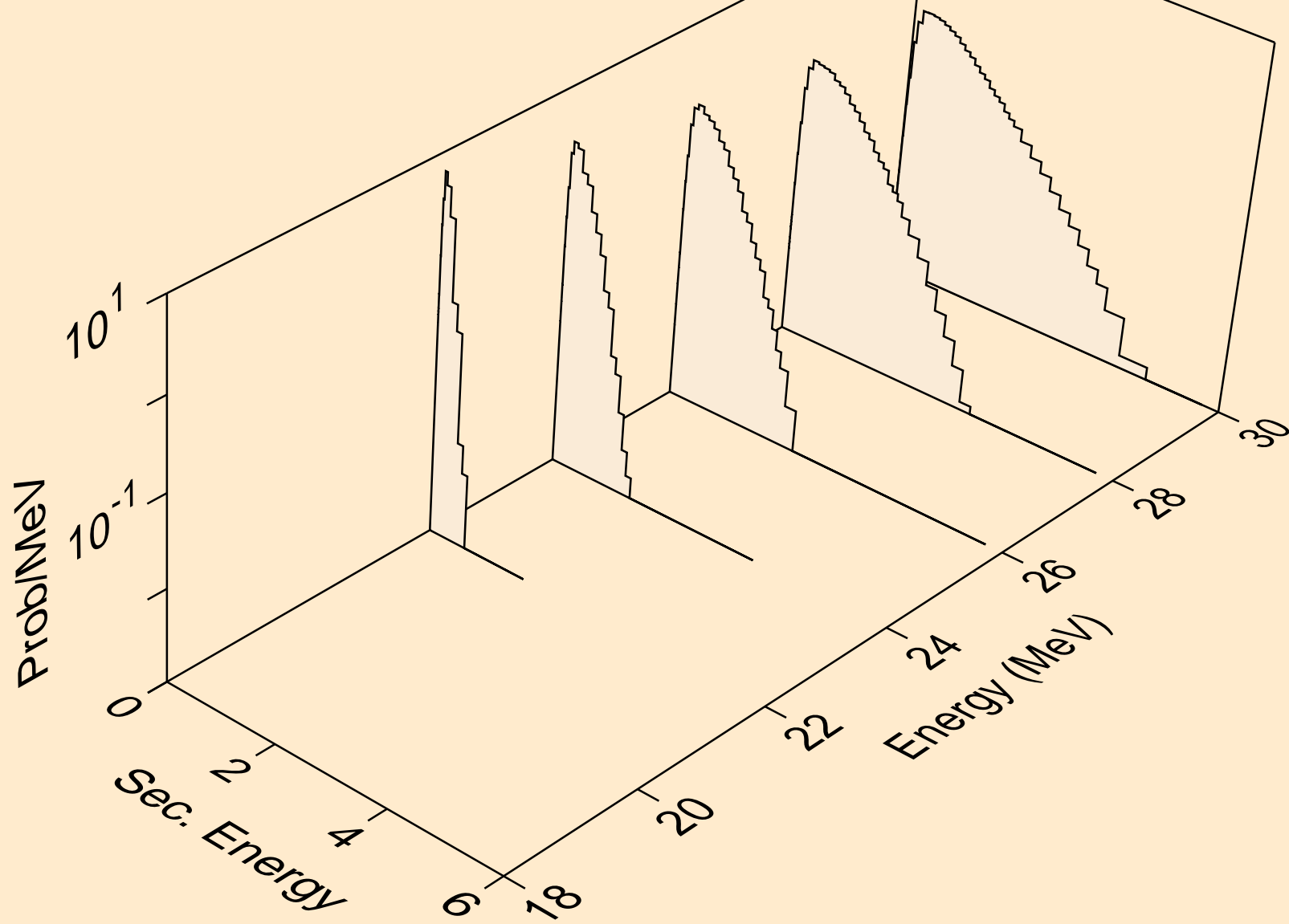

RE172M NEUTRON ACER TENDL-2023 LIBRARY; T=0.K  
Neutron emission for (n,n2p)

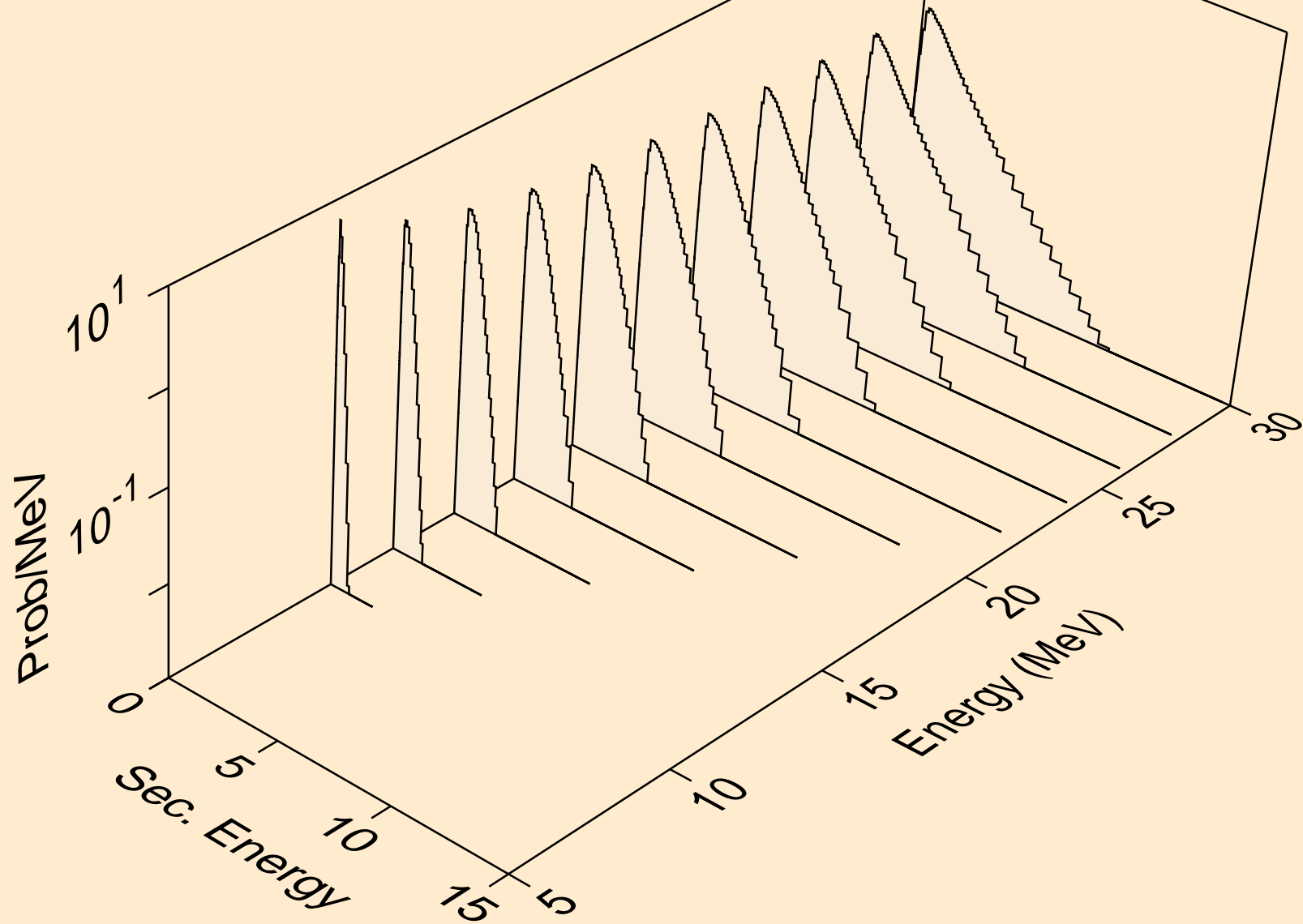

RE172M NEUTRON ACER TENDL-2023 LIBRARY; T=0.K  
Neutron emission for (n,npa)

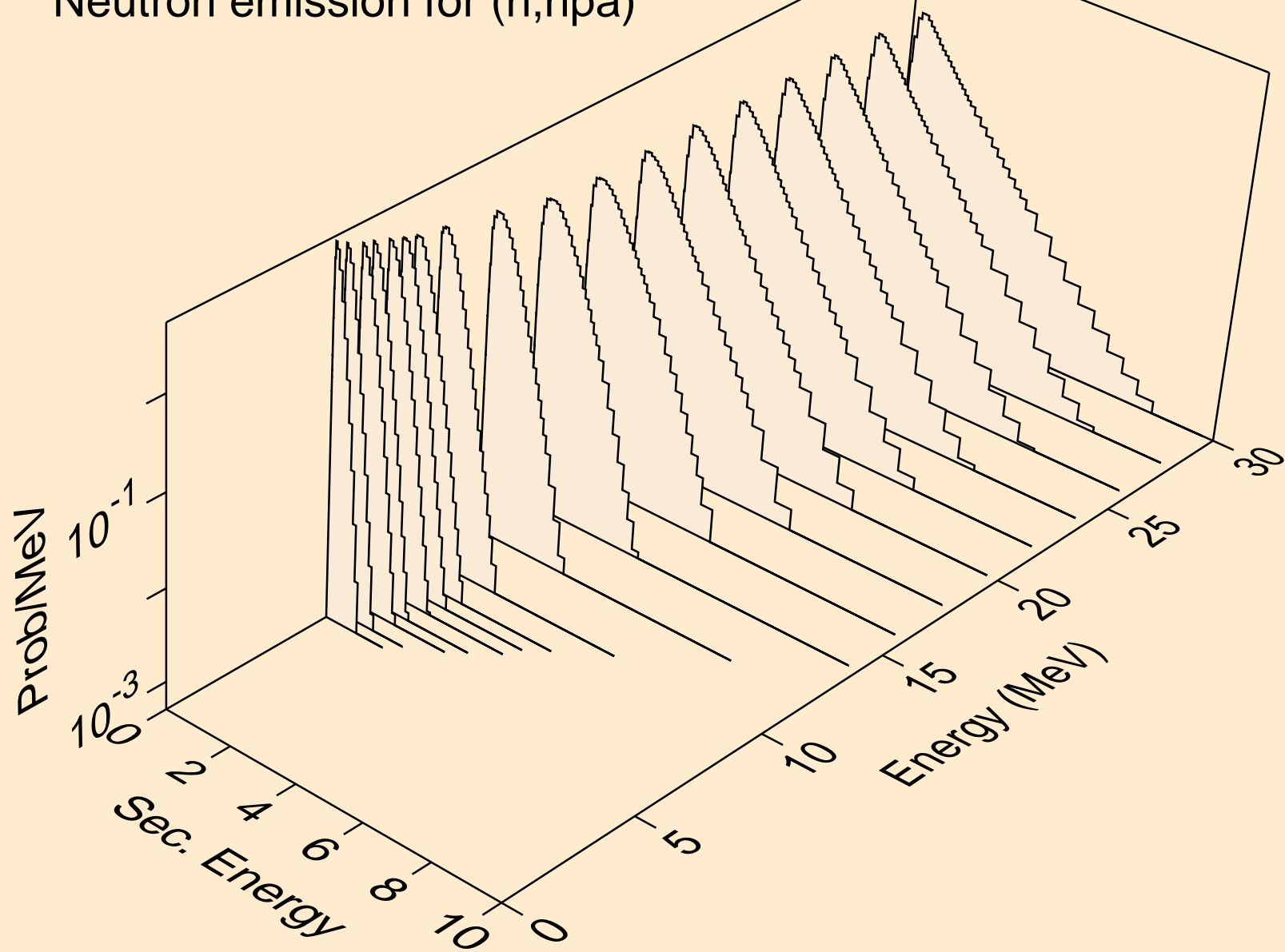



RE172M NEUTRON ACER TENDL-2023 LIBRARY; T=0.K  
Neutron emission for (n,n\*c)

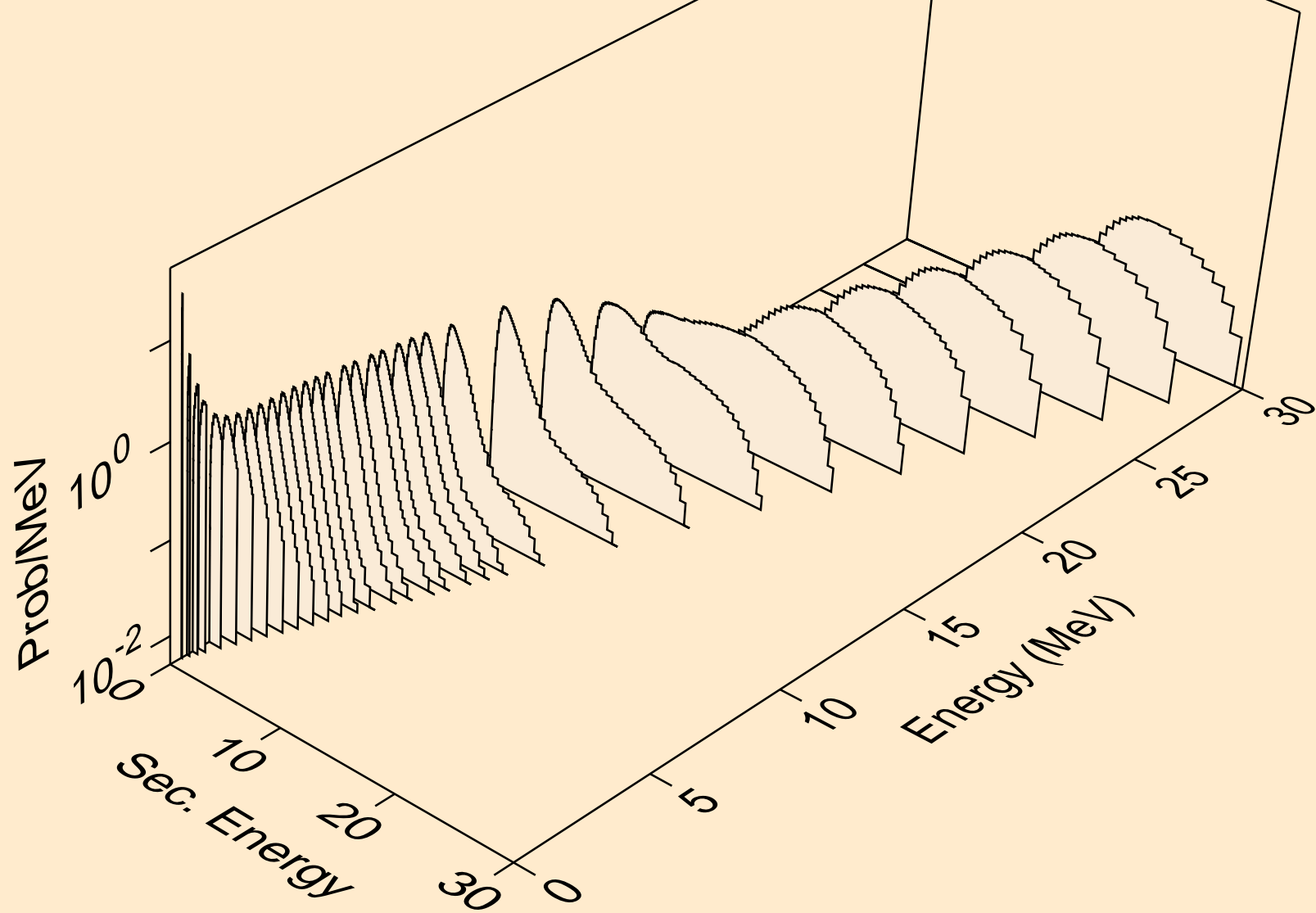

RE172M NEUTRON ACER TENDL-2023 LIBRARY; T=0.K  
Photon emission for (n,x)

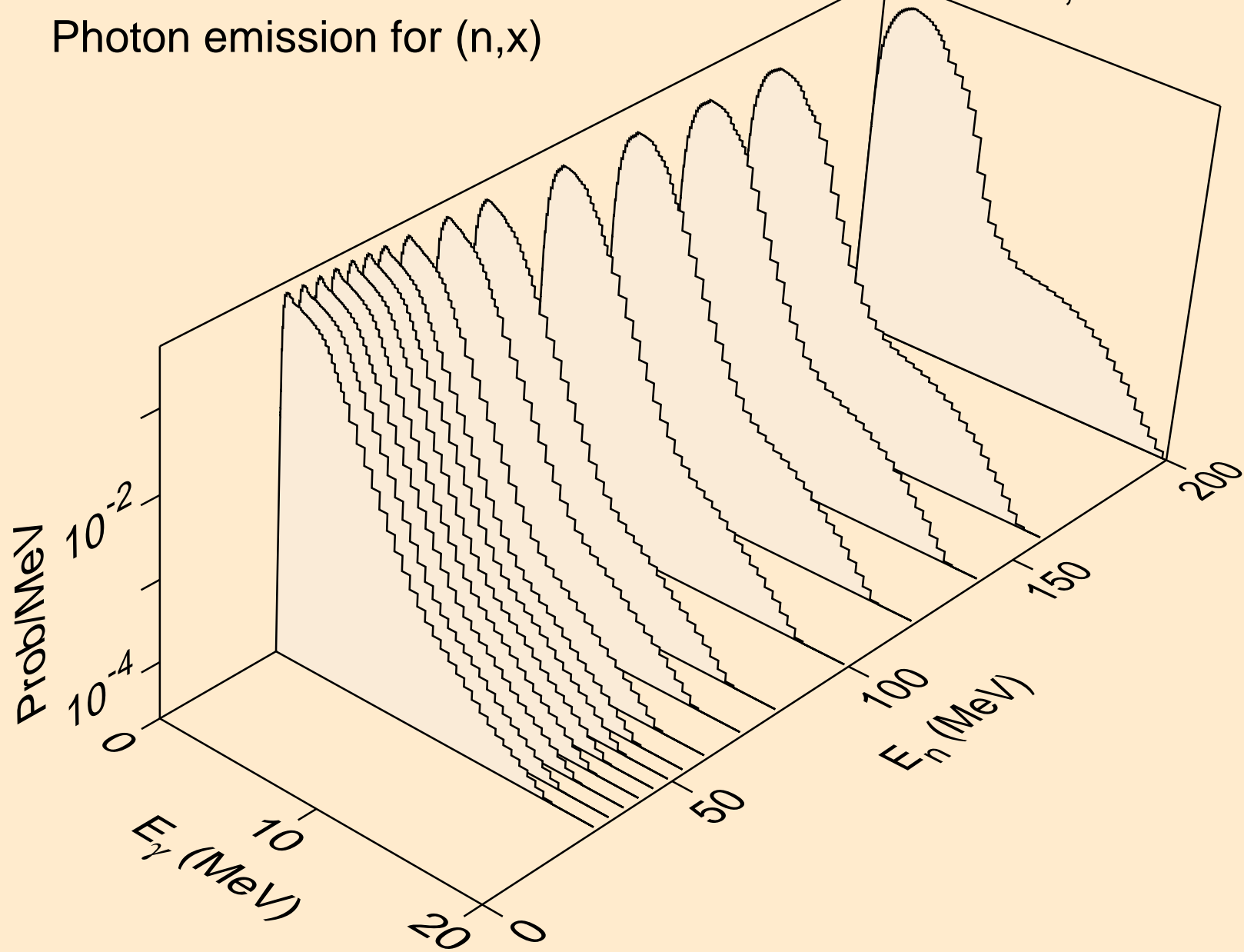

RE172M NEUTRON ACER TENDL-2023 LIBRARY; T=0.K  
Photon emission for (n,2nd)

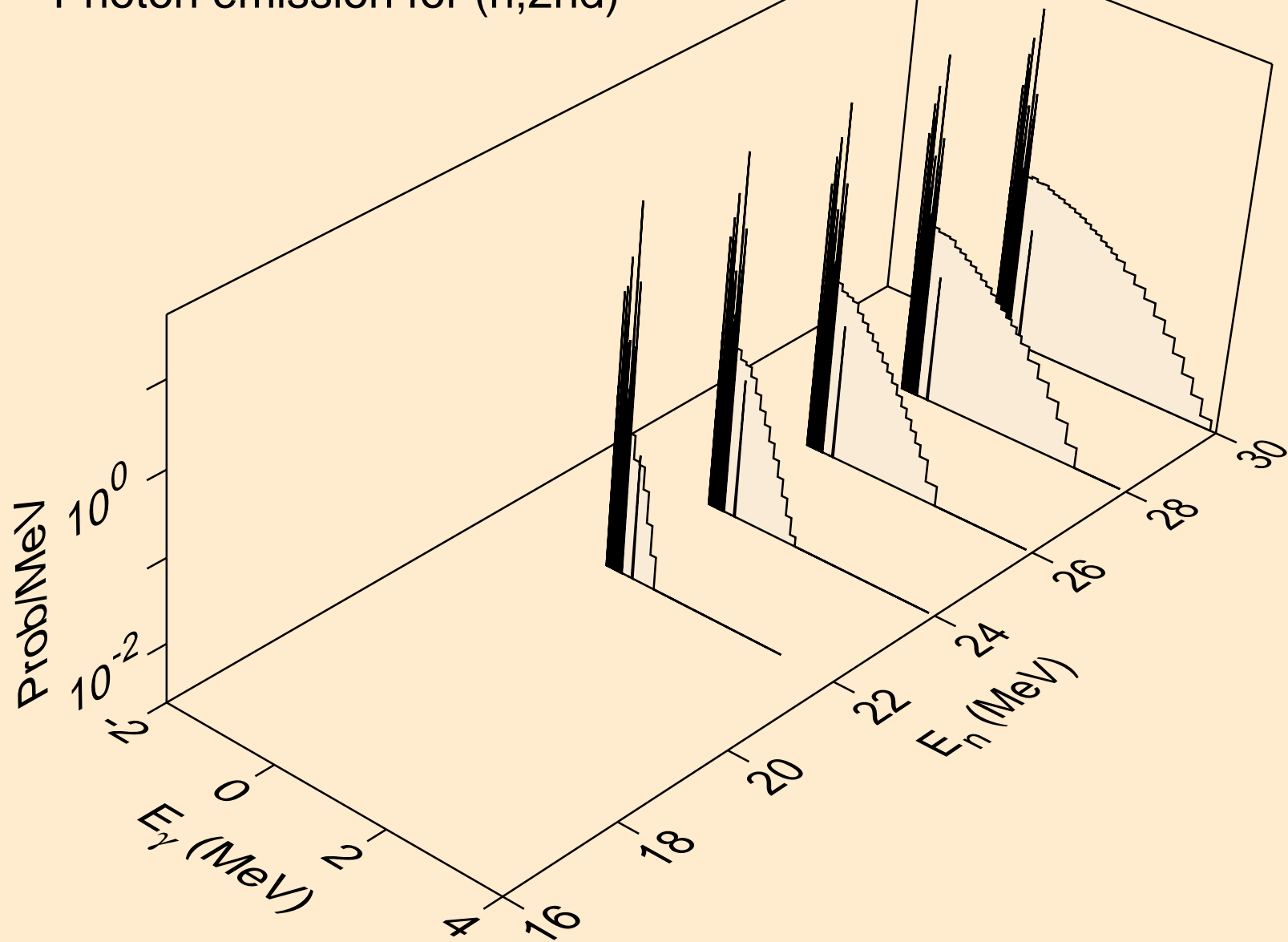

RE172M NEUTRON ACER TENDL-2023 LIBRARY; T=0.K  
Photon emission for (n,2n)

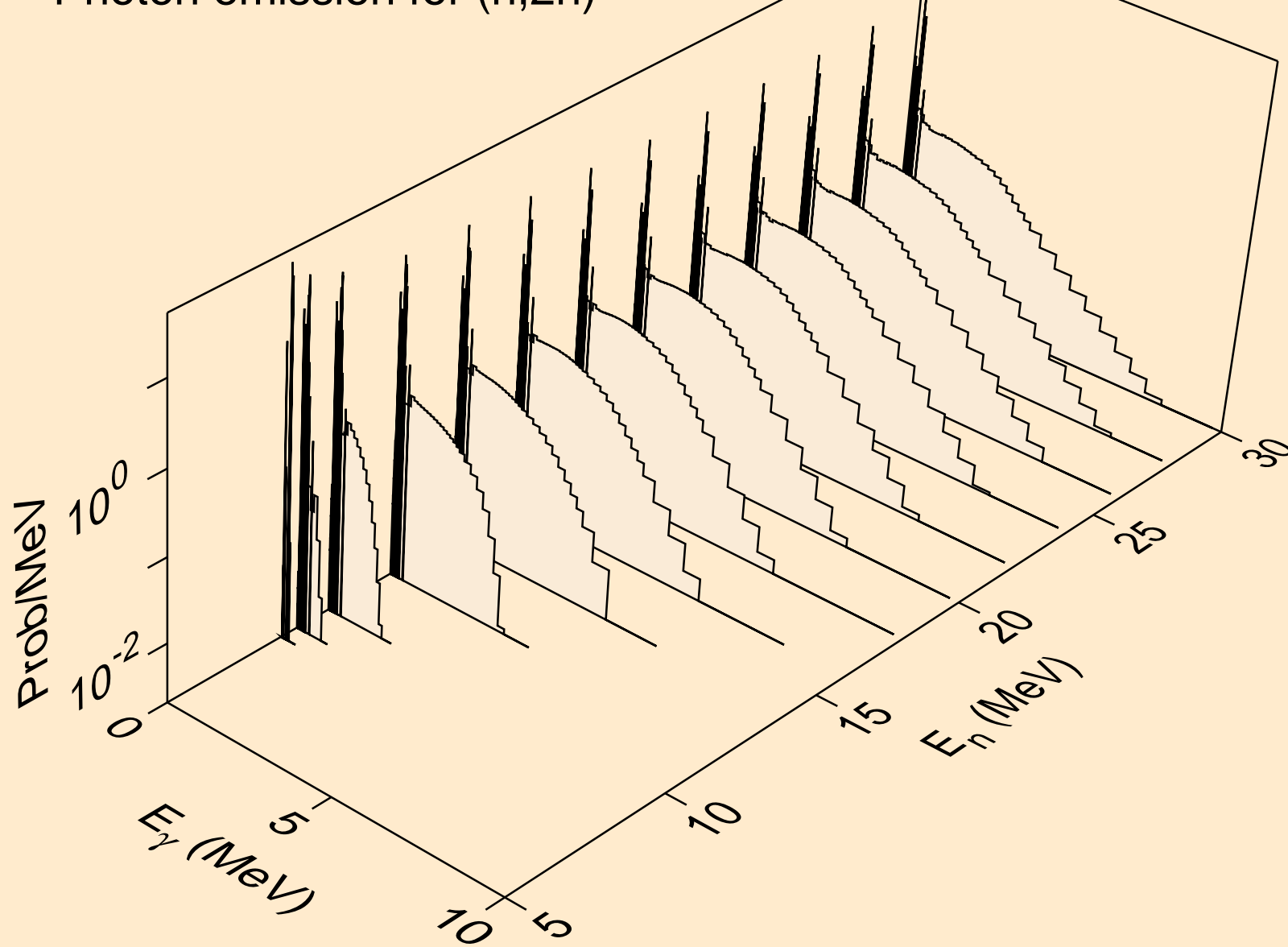

RE172M NEUTRON ACER TENDL-2023 LIBRARY; T=0.K  
Photon emission for (n,3n)

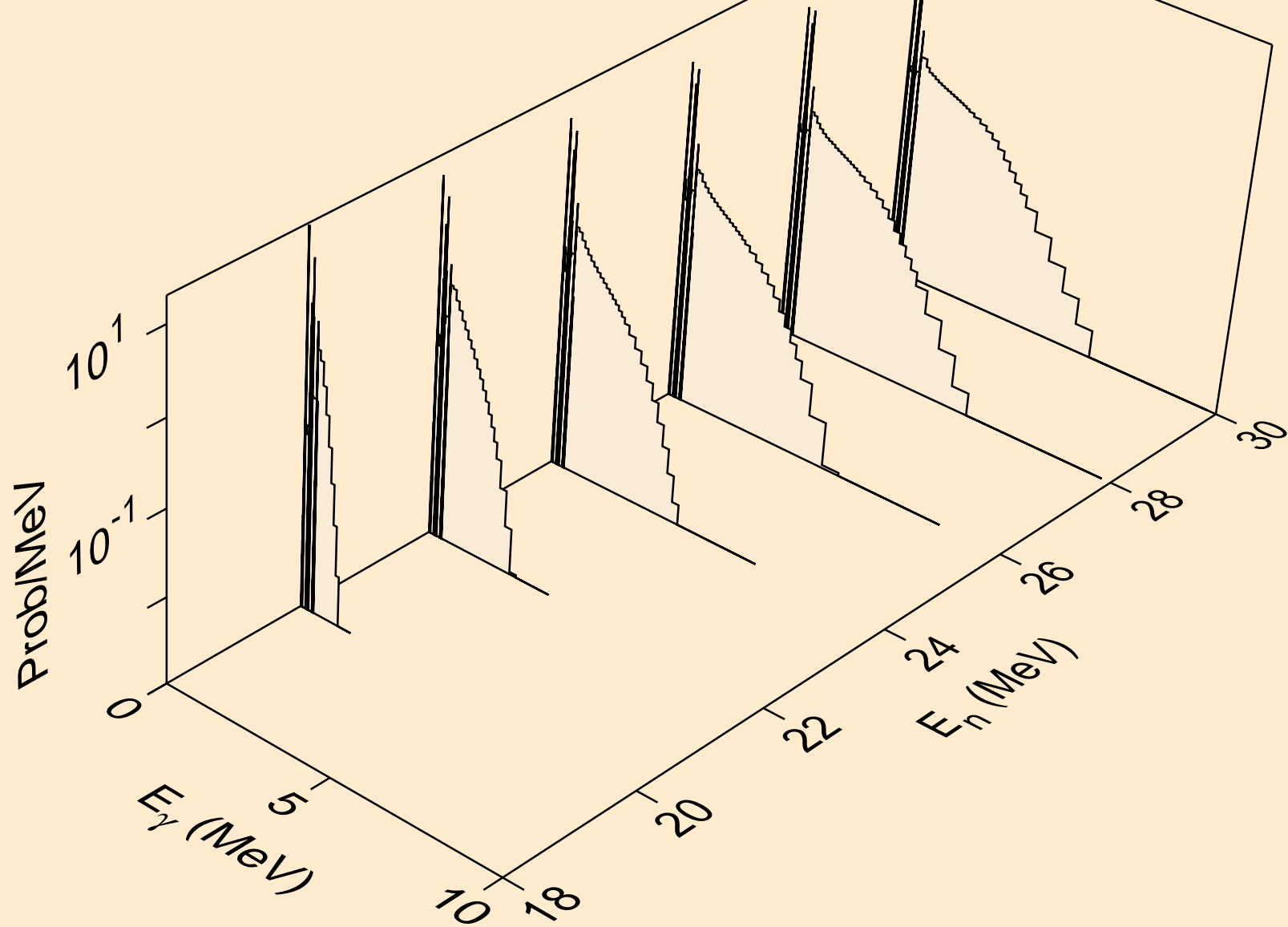

RE172M NEUTRON ACER TENDL-2023 LIBRARY; T=0.K  
Photon emission for (n,n\*)a

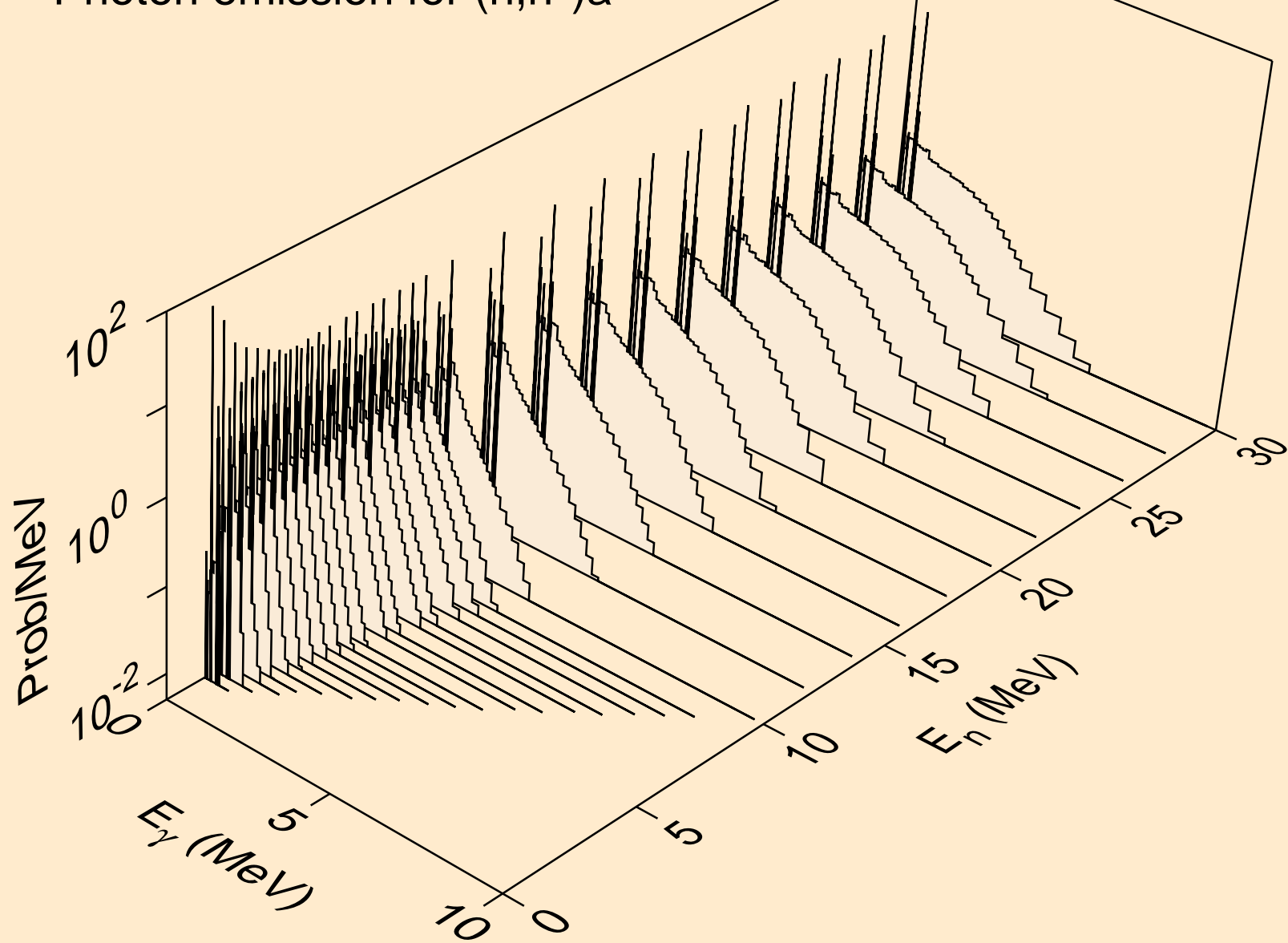

RE172M NEUTRON ACER TENDL-2023 LIBRARY; T=0.K  
Photon emission for (n,2n)a

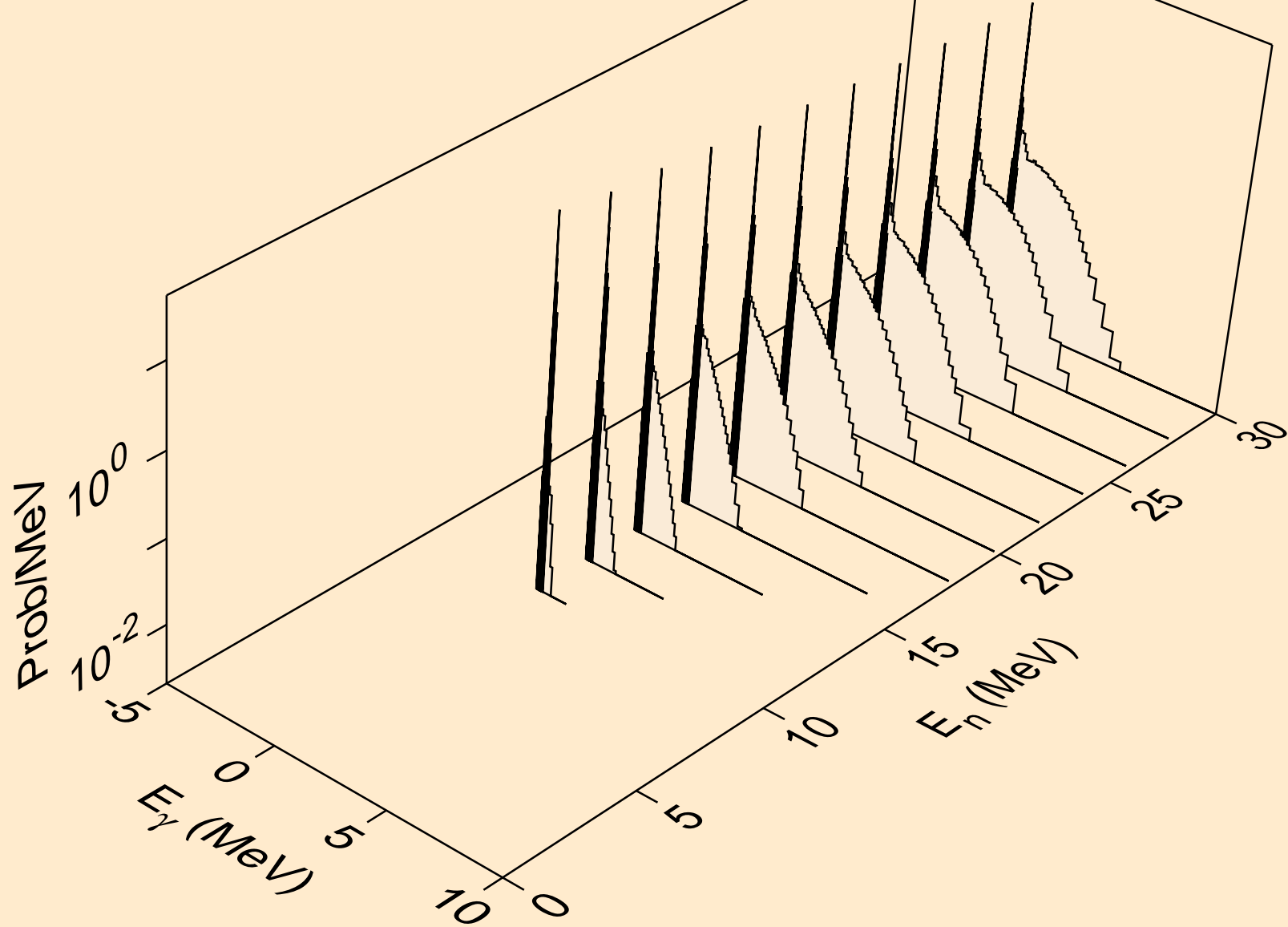

RE172M NEUTRON ACER TENDL-2023 LIBRARY; T=0.K  
Photon emission for (n,3n)a

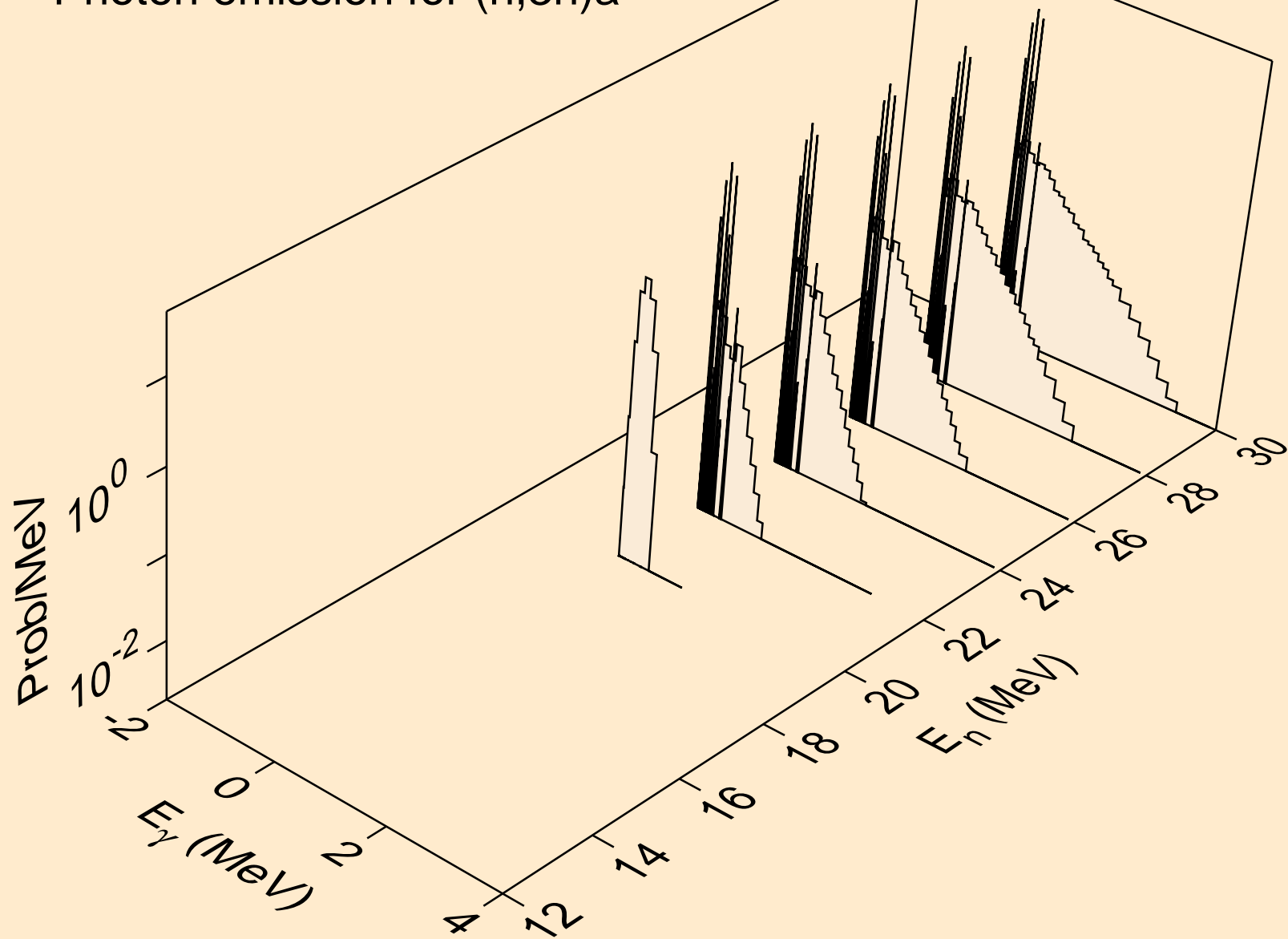



RE172M NEUTRON ACER TENDL-2023 LIBRARY; T=0.K  
Photon emission for (n,n\*)p

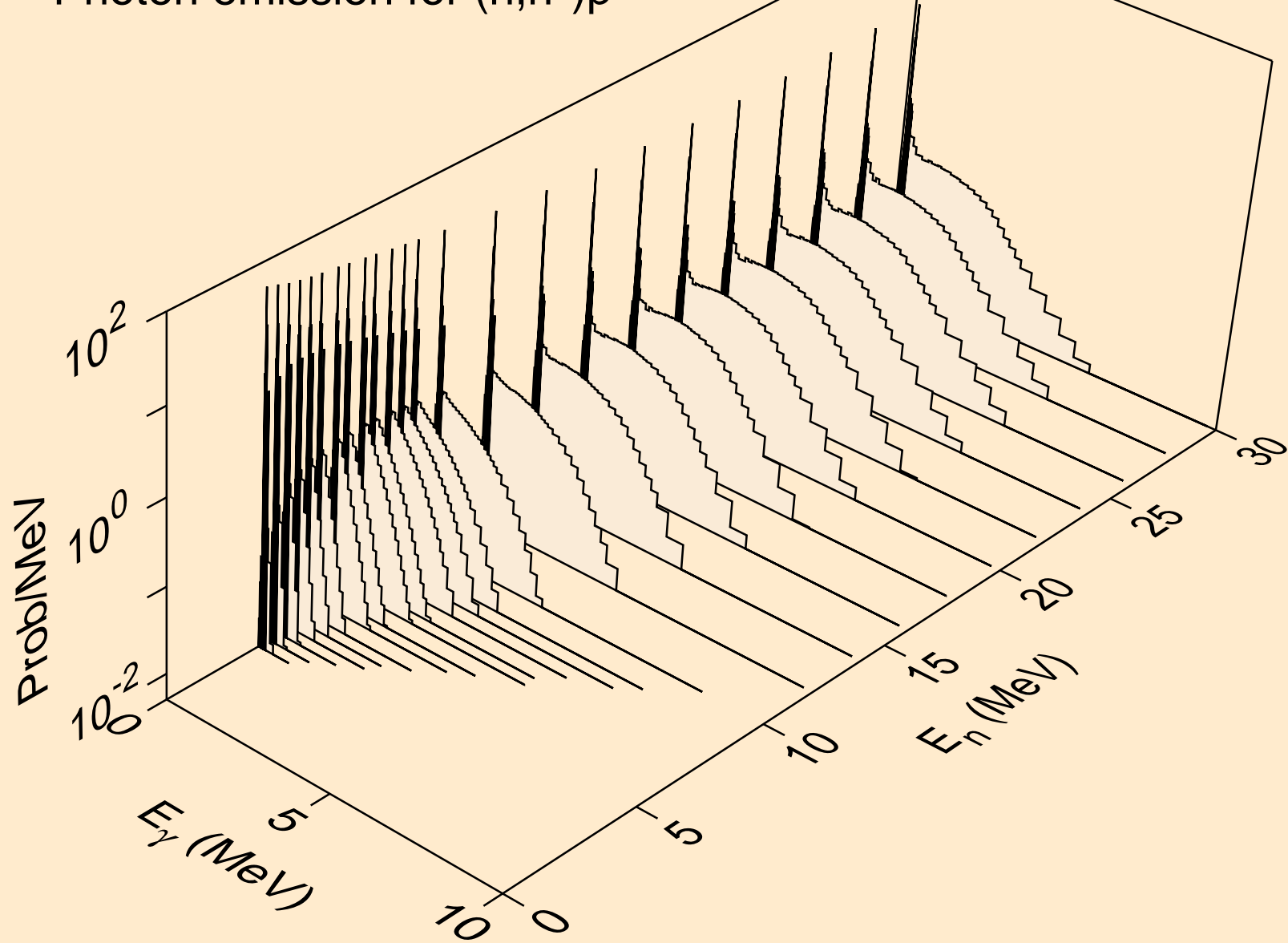

RE172M NEUTRON ACER TENDL-2023 LIBRARY; T=0.K  
Photon emission for (n,n\*)2a

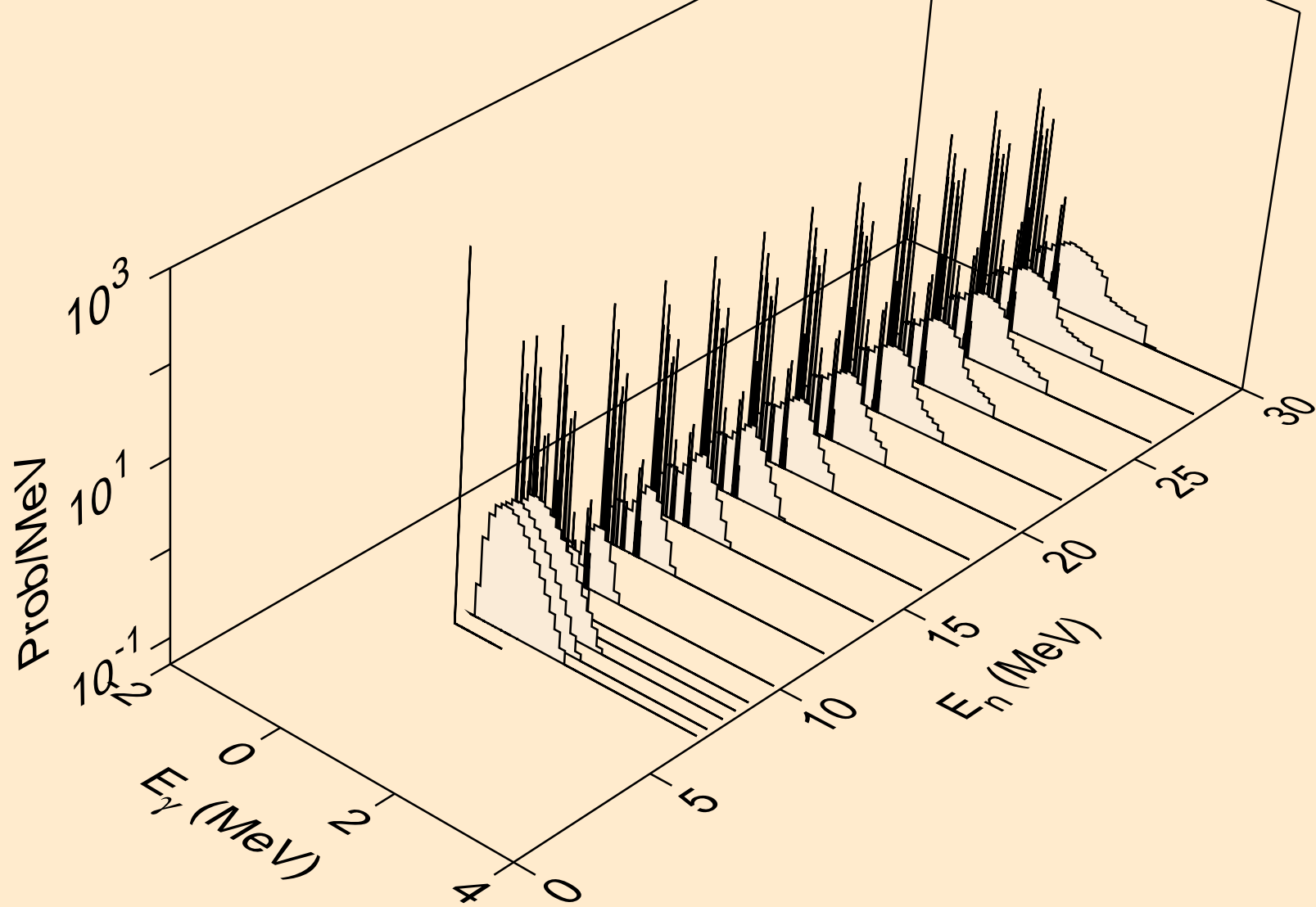

RE172M NEUTRON ACER TENDL-2023 LIBRARY; T=0.K  
Photon emission for (n,2n)2a

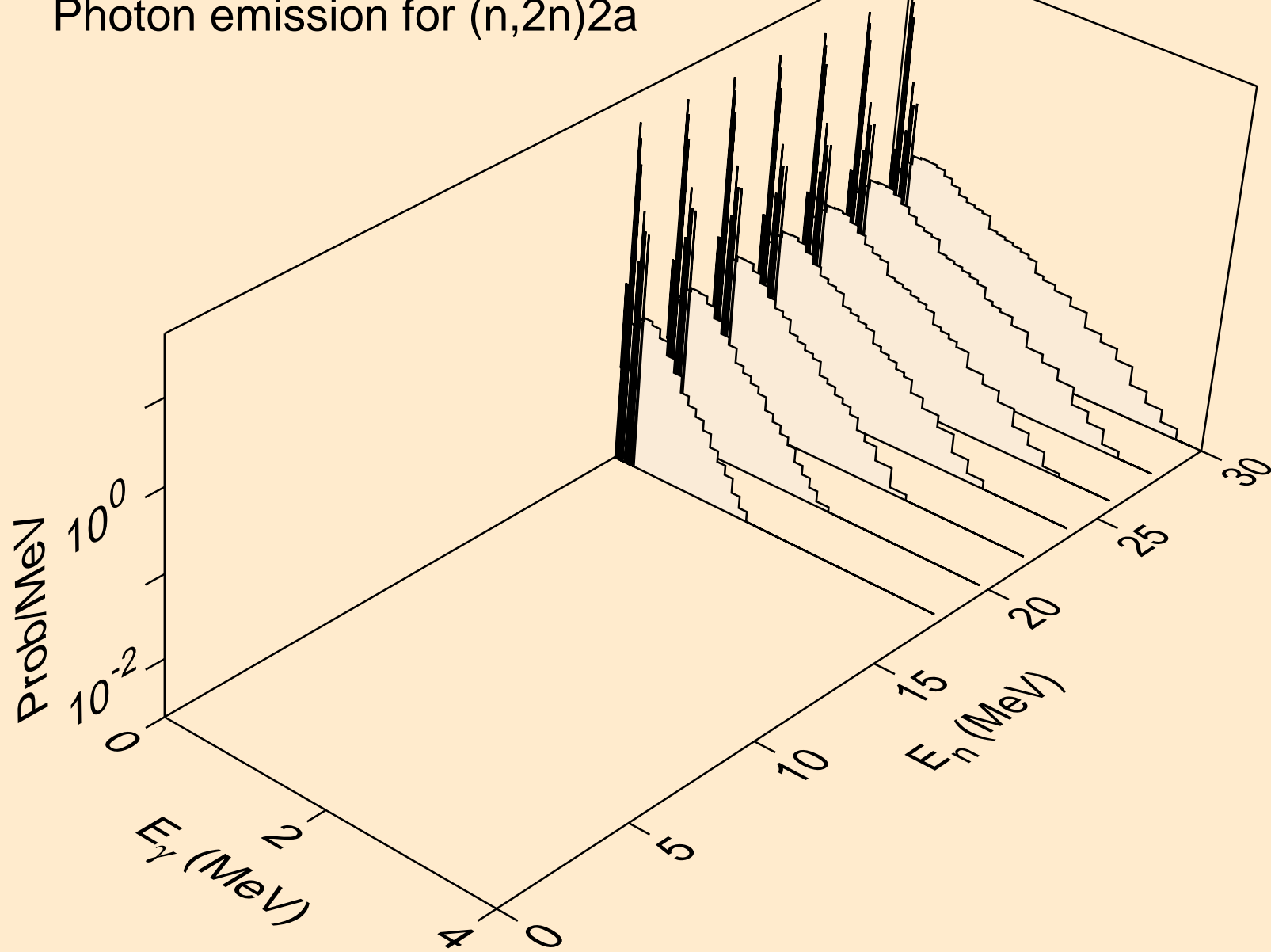

RE172M NEUTRON ACER TENDL-2023 LIBRARY; T=0.K  
Photon emission for (n,n\*)d

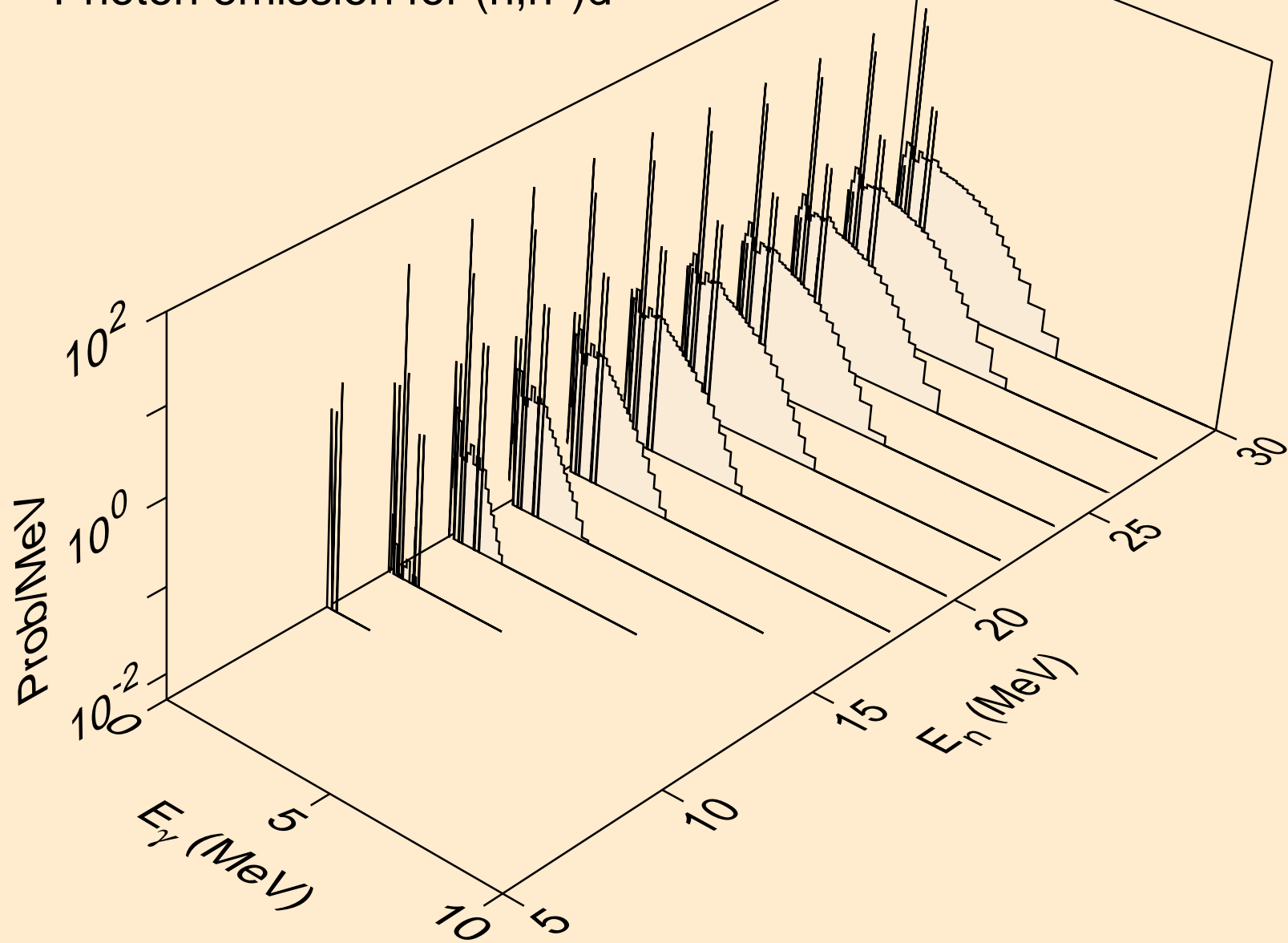

RE172M NEUTRON ACER TENDL-2023 LIBRARY; T=0.K  
Photon emission for (n,n\*)t

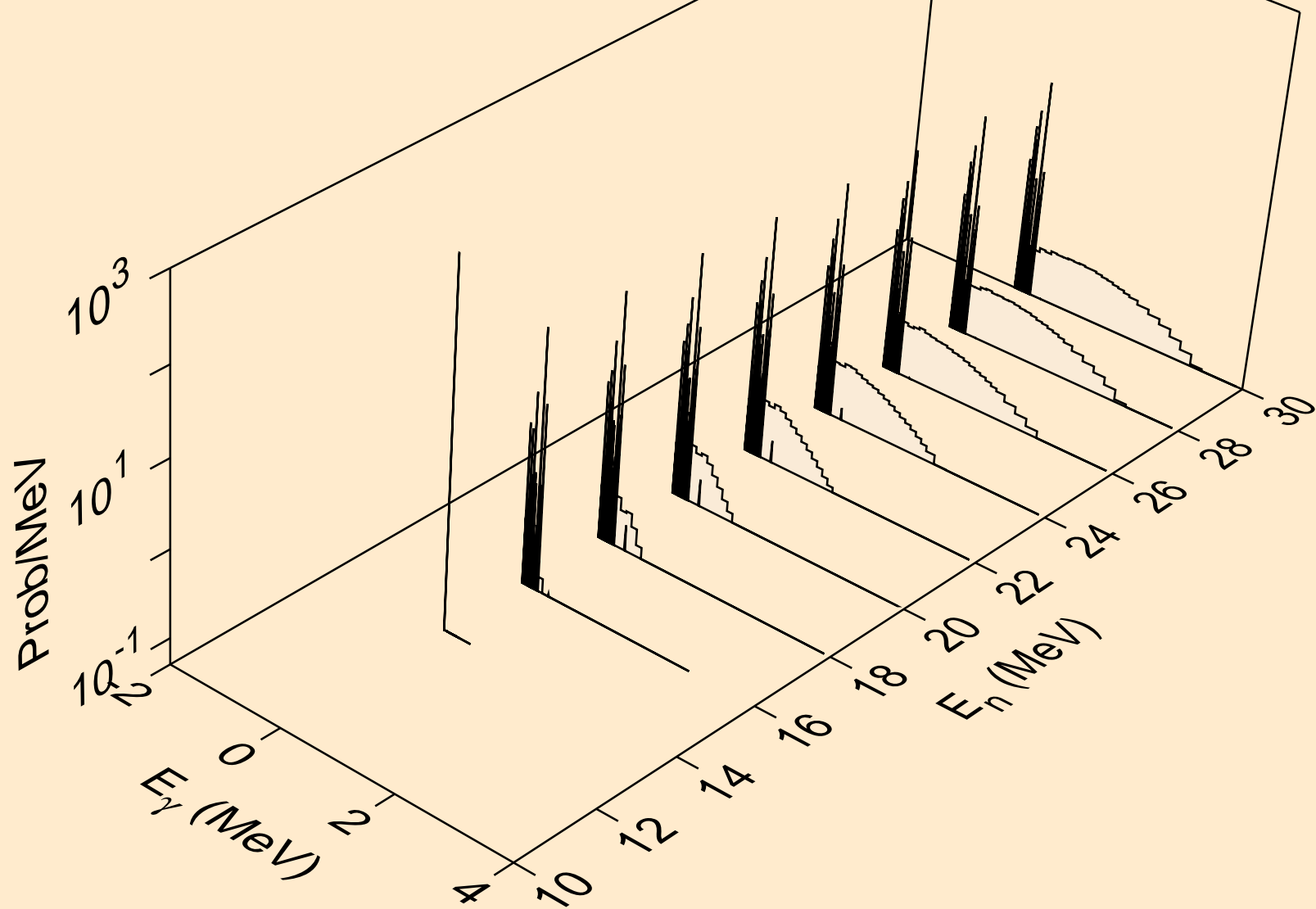

RE172M NEUTRON ACER TENDL-2023 LIBRARY; T=0.K  
Photon emission for (n,n\*)he3

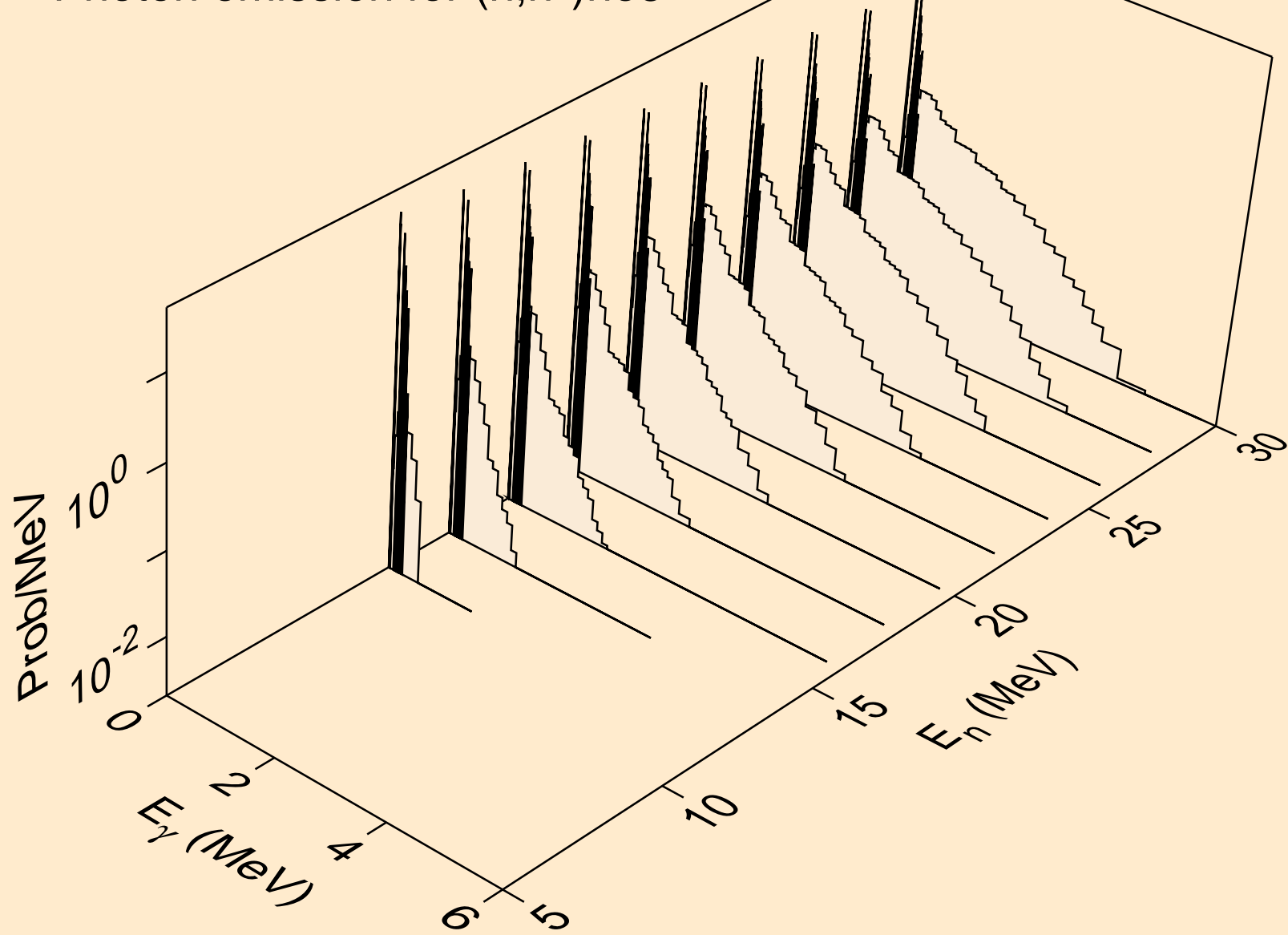

RE172M NEUTRON ACER TENDL-2023 LIBRARY; T=0.K  
Photon emission for (n,4n)

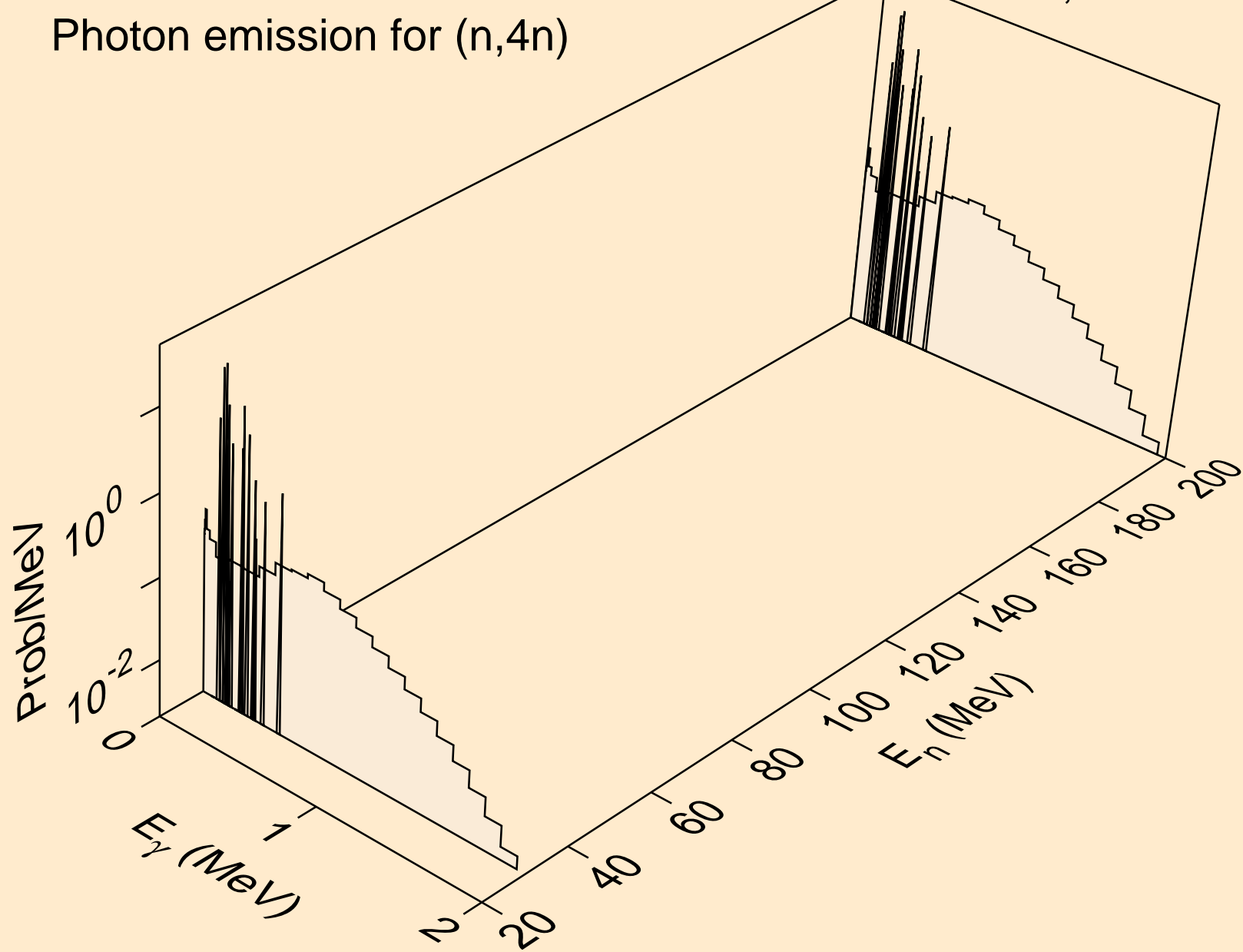

RE172M NEUTRON ACER TENDL-2023 LIBRARY; T=0.K  
Photon emission for (n,2np)

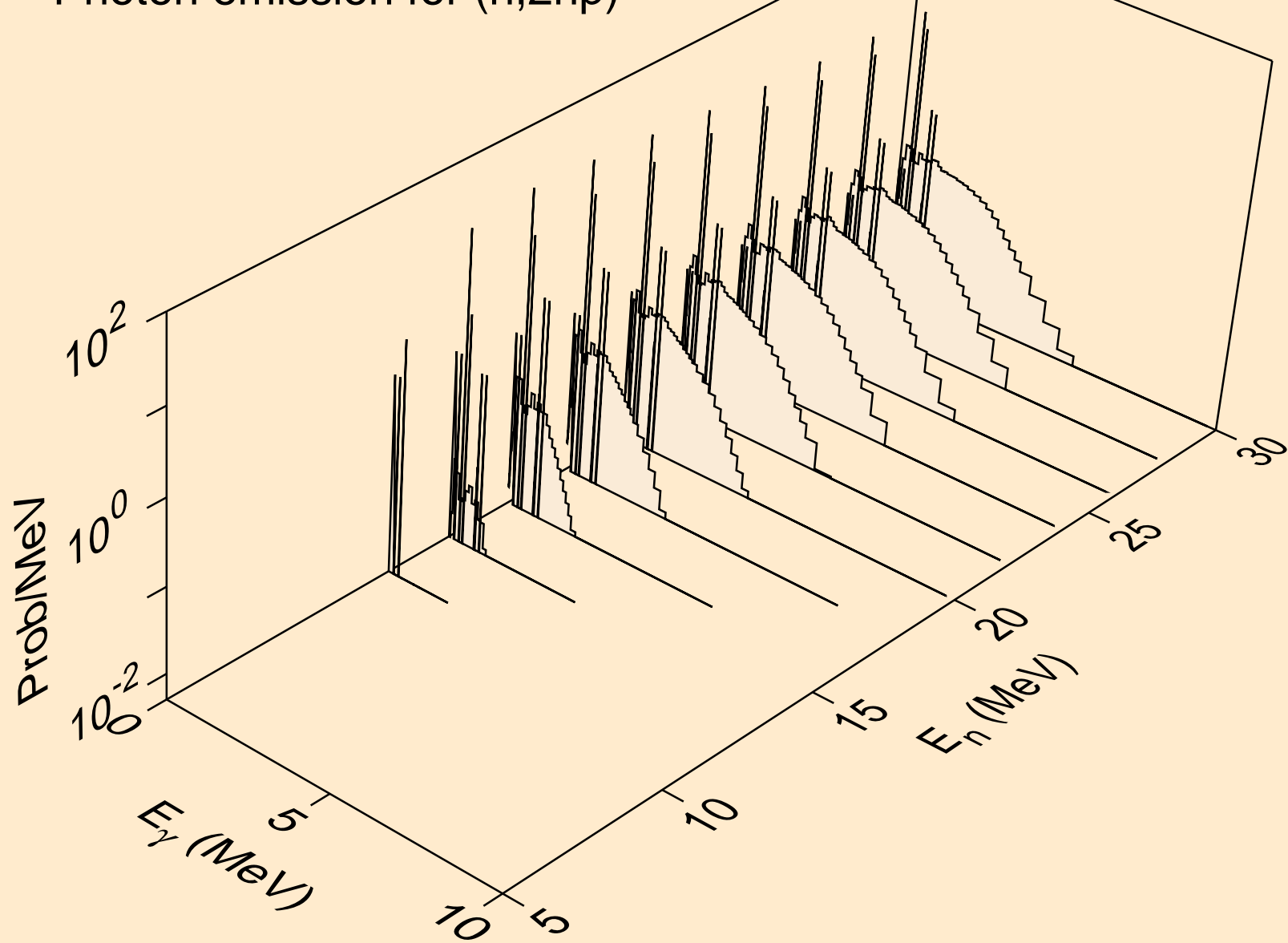



RE172M NEUTRON ACER TENDL-2023 LIBRARY; T=0.K  
Photon emission for (n,3np)

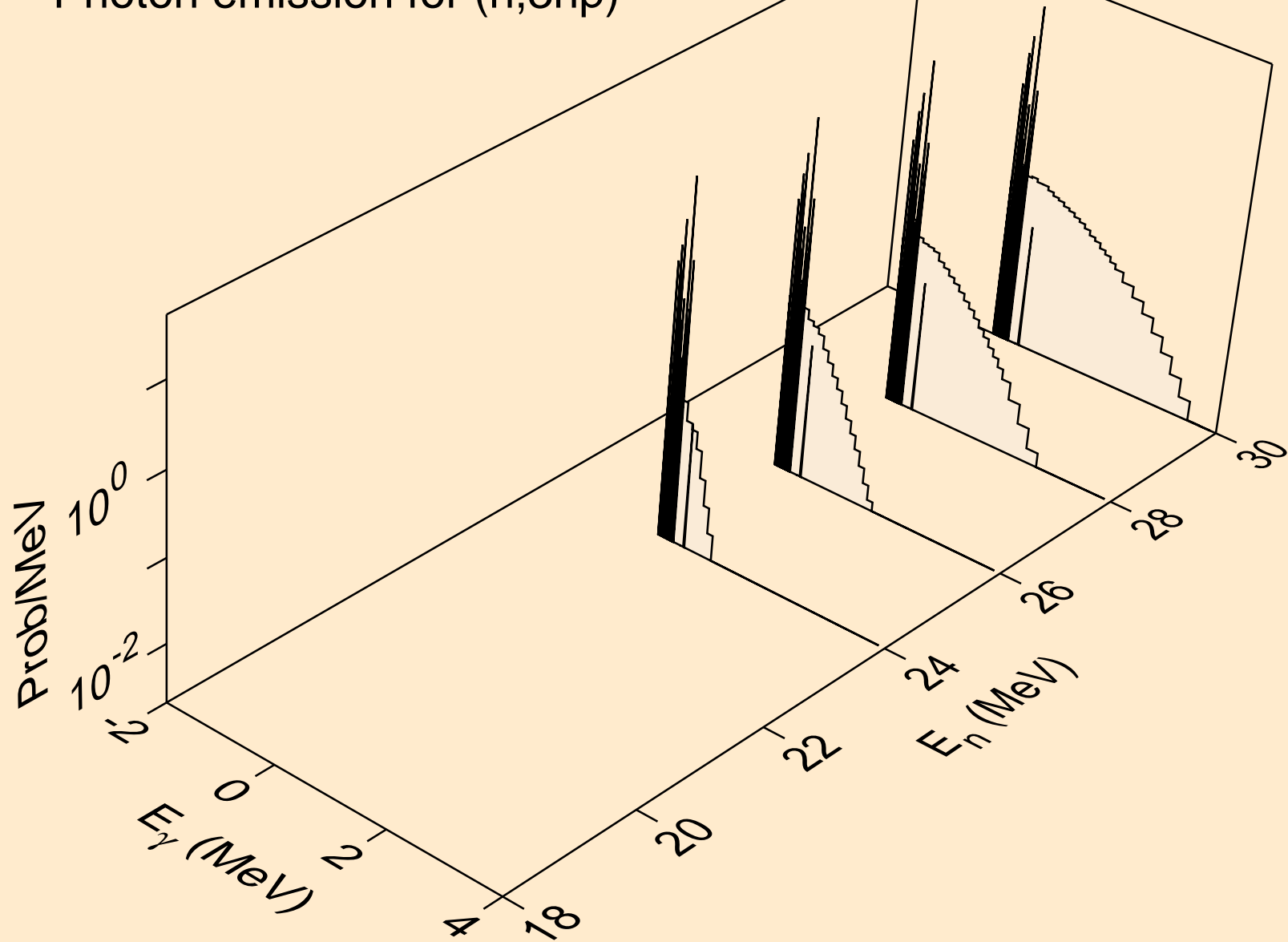

RE172M NEUTRON ACER TENDL-2023 LIBRARY; T=0.K  
Photon emission for (n,n2p)

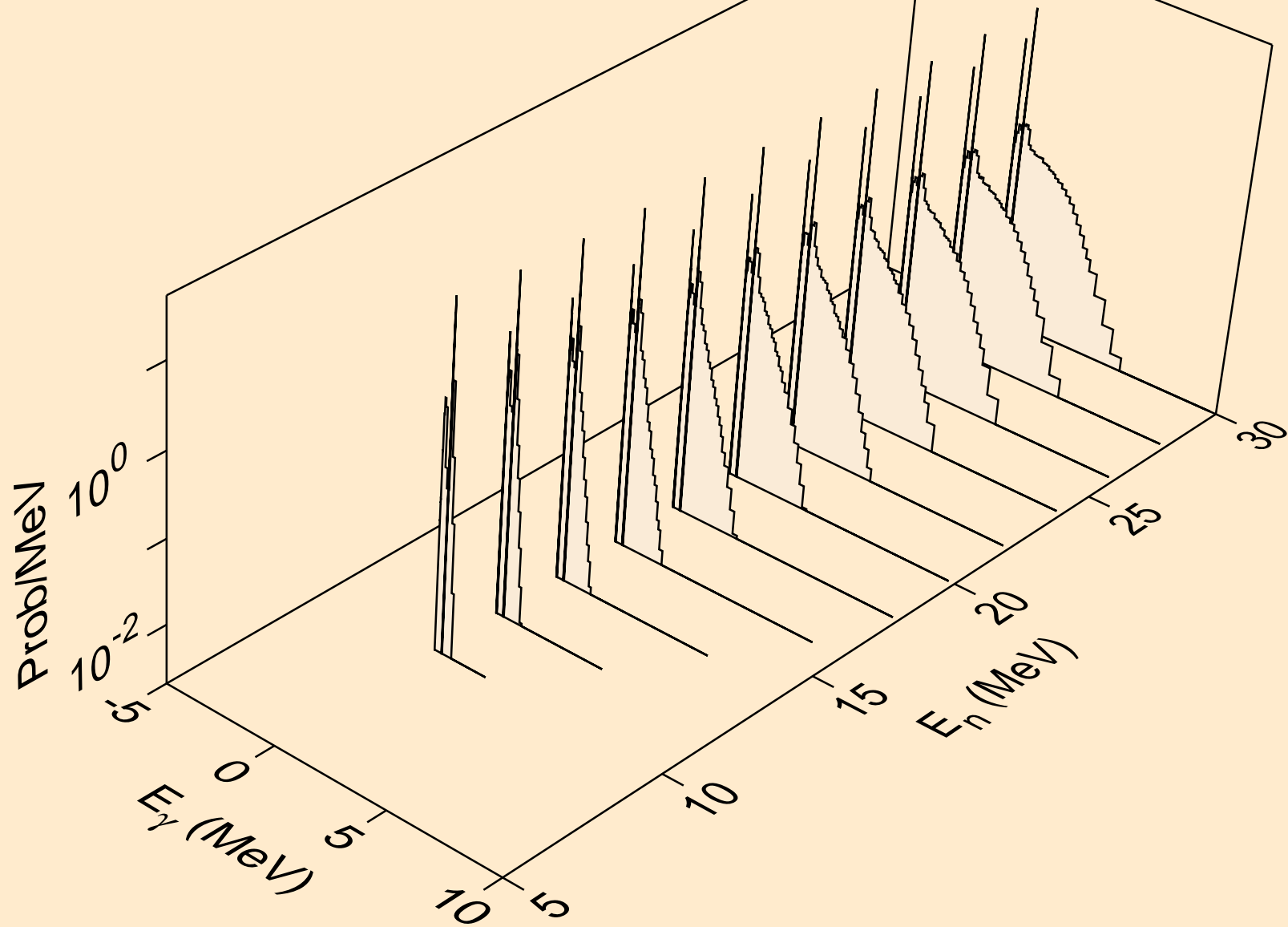

RE172M NEUTRON ACER TENDL-2023 LIBRARY; T=0.K  
Photon emission for (n,npa)

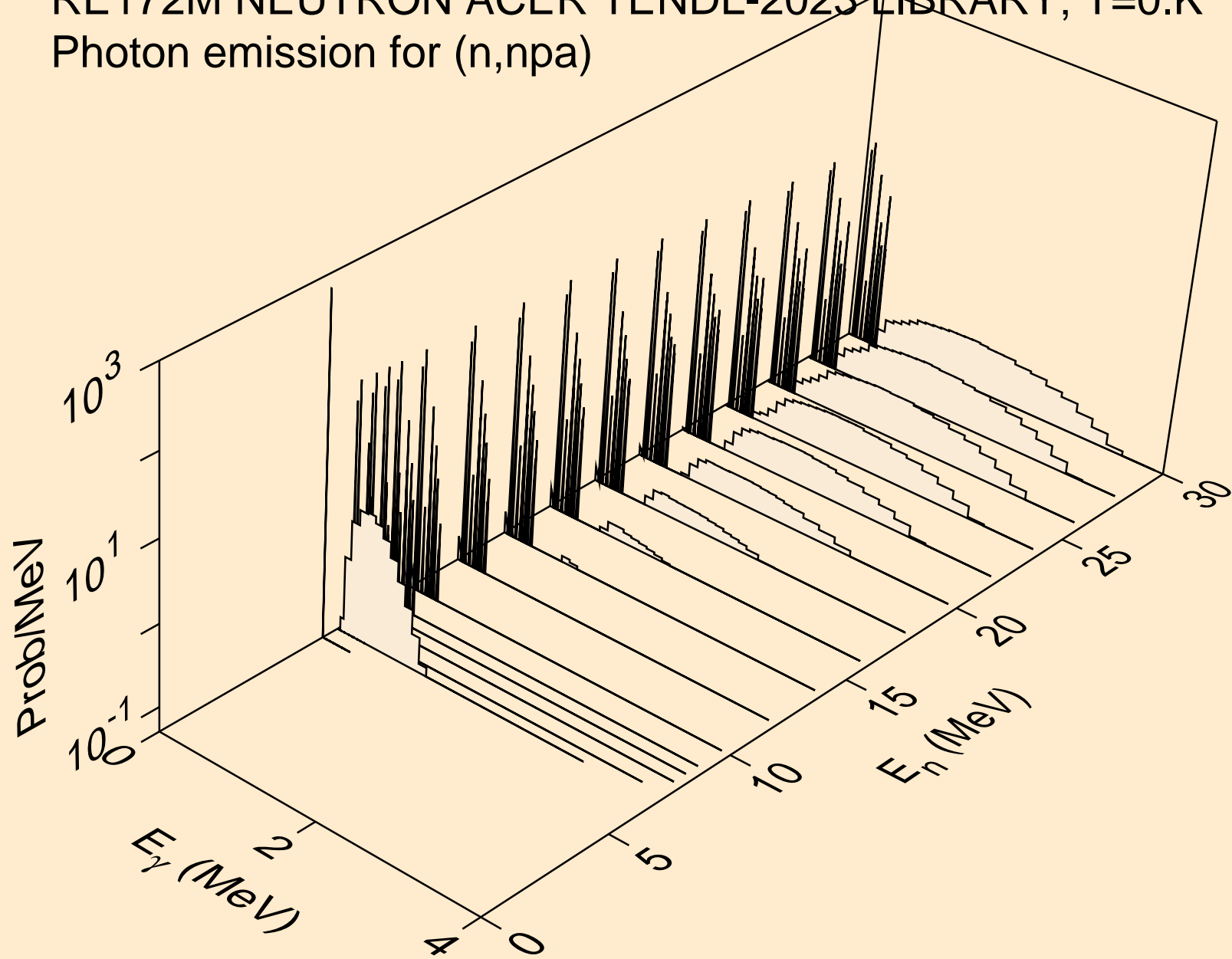

RE172M NEUTRON ACER TENDL-2023 LIBRARY; T=0.K  
Photon emission for (n,n\*2)

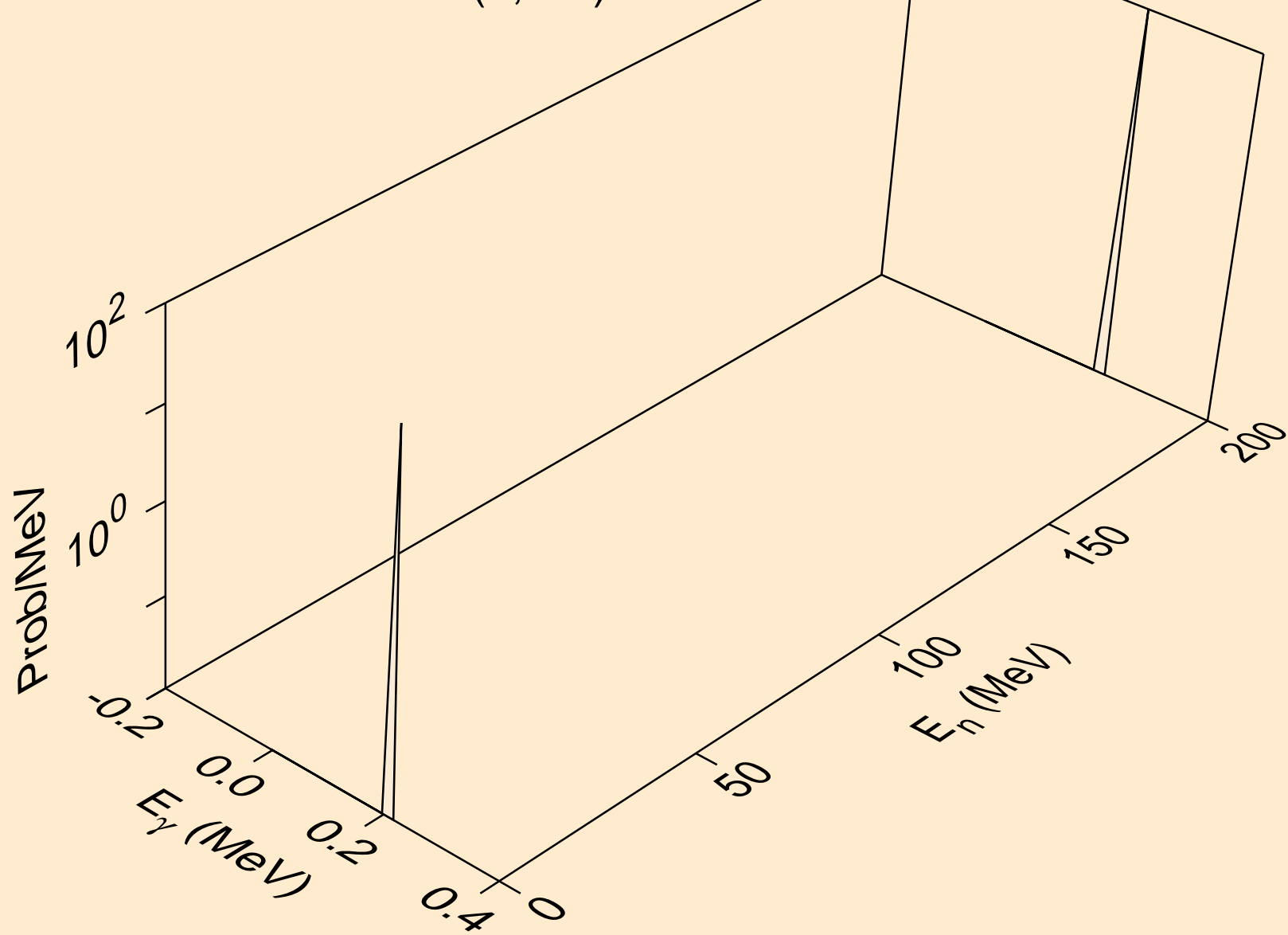

RE172M NEUTRON ACER TENDL-2023 LIBRARY; T=0.K  
Photon emission for (n,n\*3)

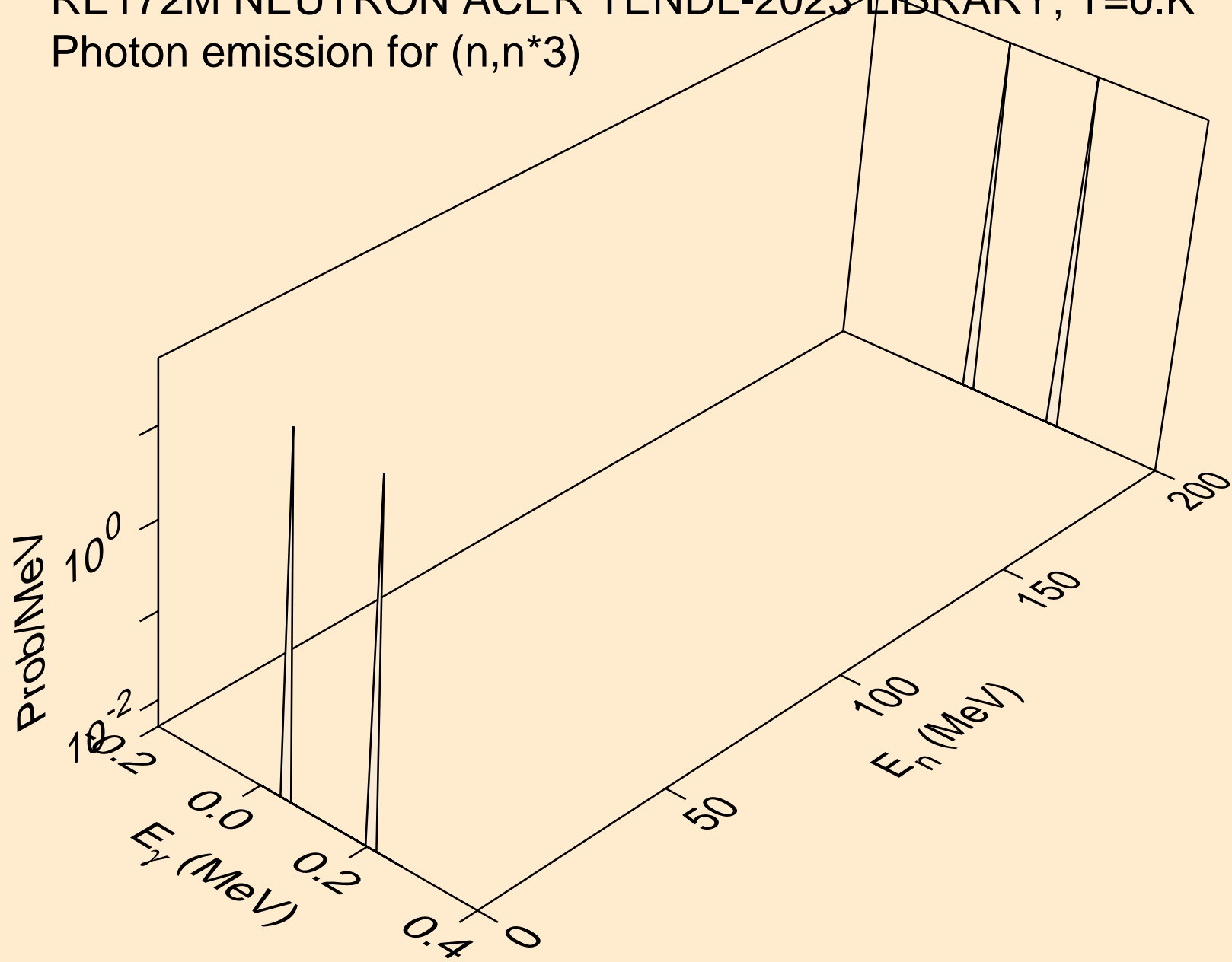

RE172M NEUTRON ACER TENDL-2023 LIBRARY; T=0.K  
Photon emission for (n,n\*4)

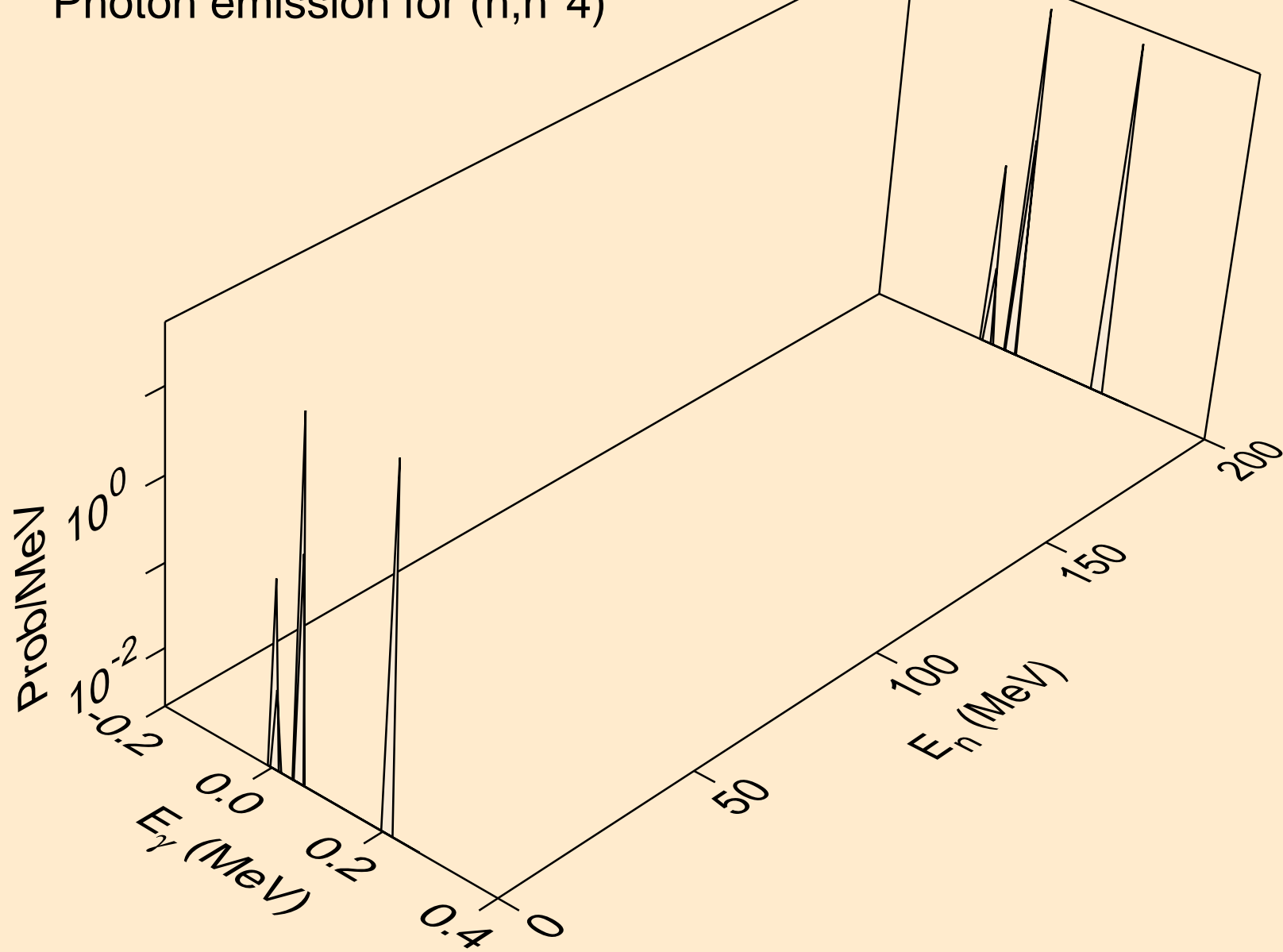

RE172M NEUTRON ACER TENDL-2023 LIBRARY; T=0.K  
Photon emission for (n,n\*5)

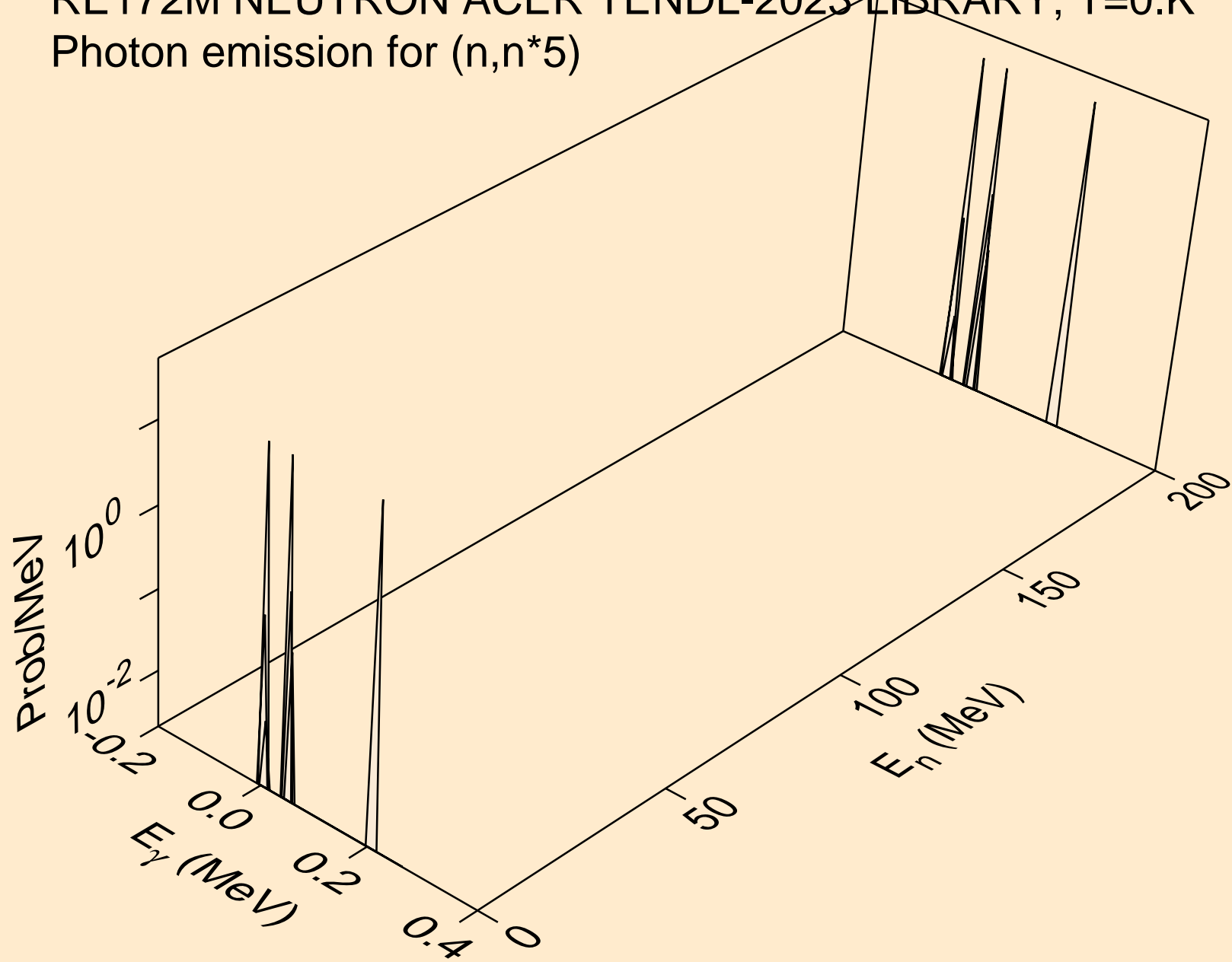

RE172M NEUTRON ACER TENDL-2023 LIBRARY; T=0.K  
Photon emission for (n,n\*6)

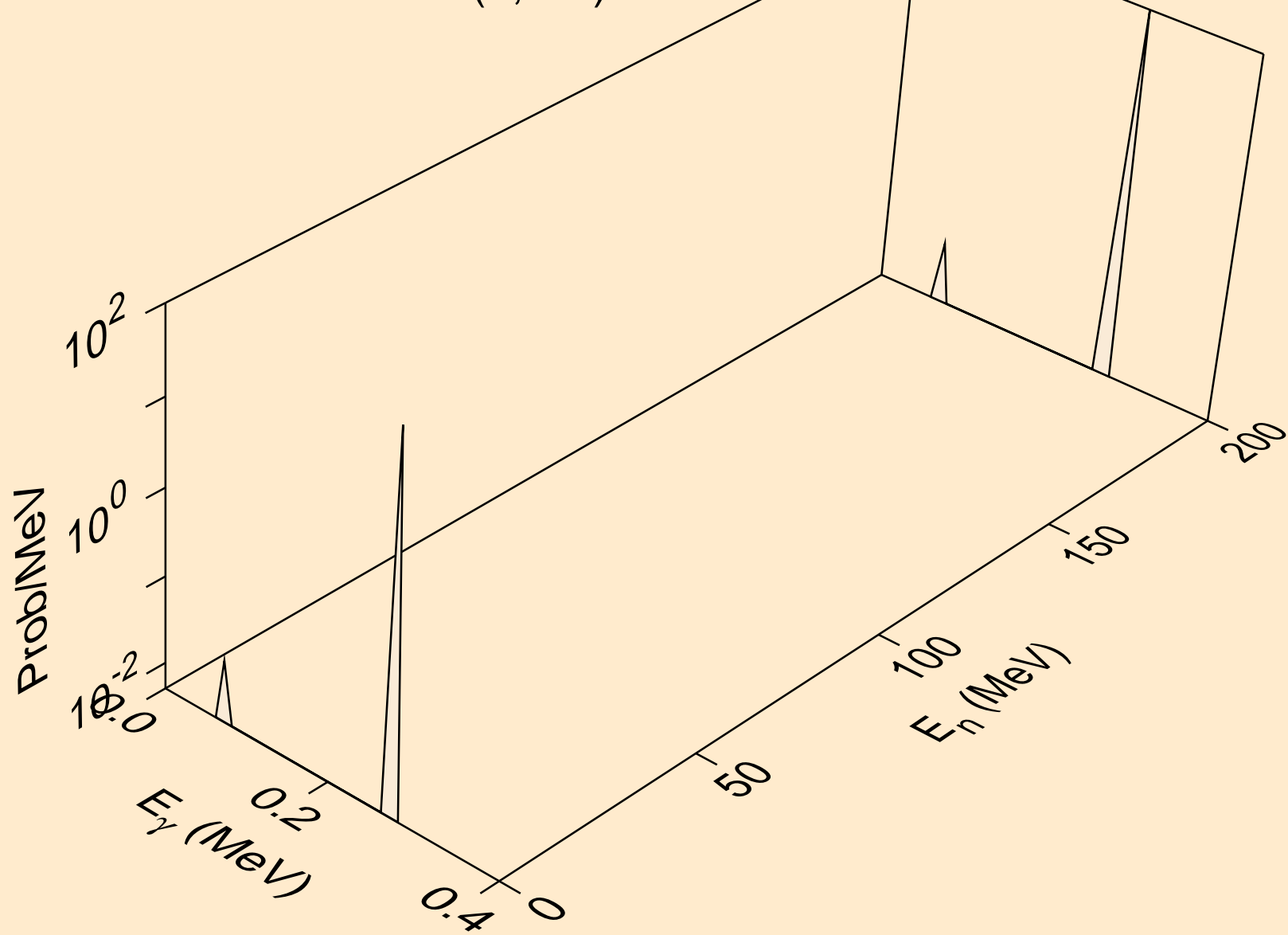



RE172M NEUTRON ACER TENDL-2023 LIBRARY; T=0.K  
Photon emission for (n,n\*7)

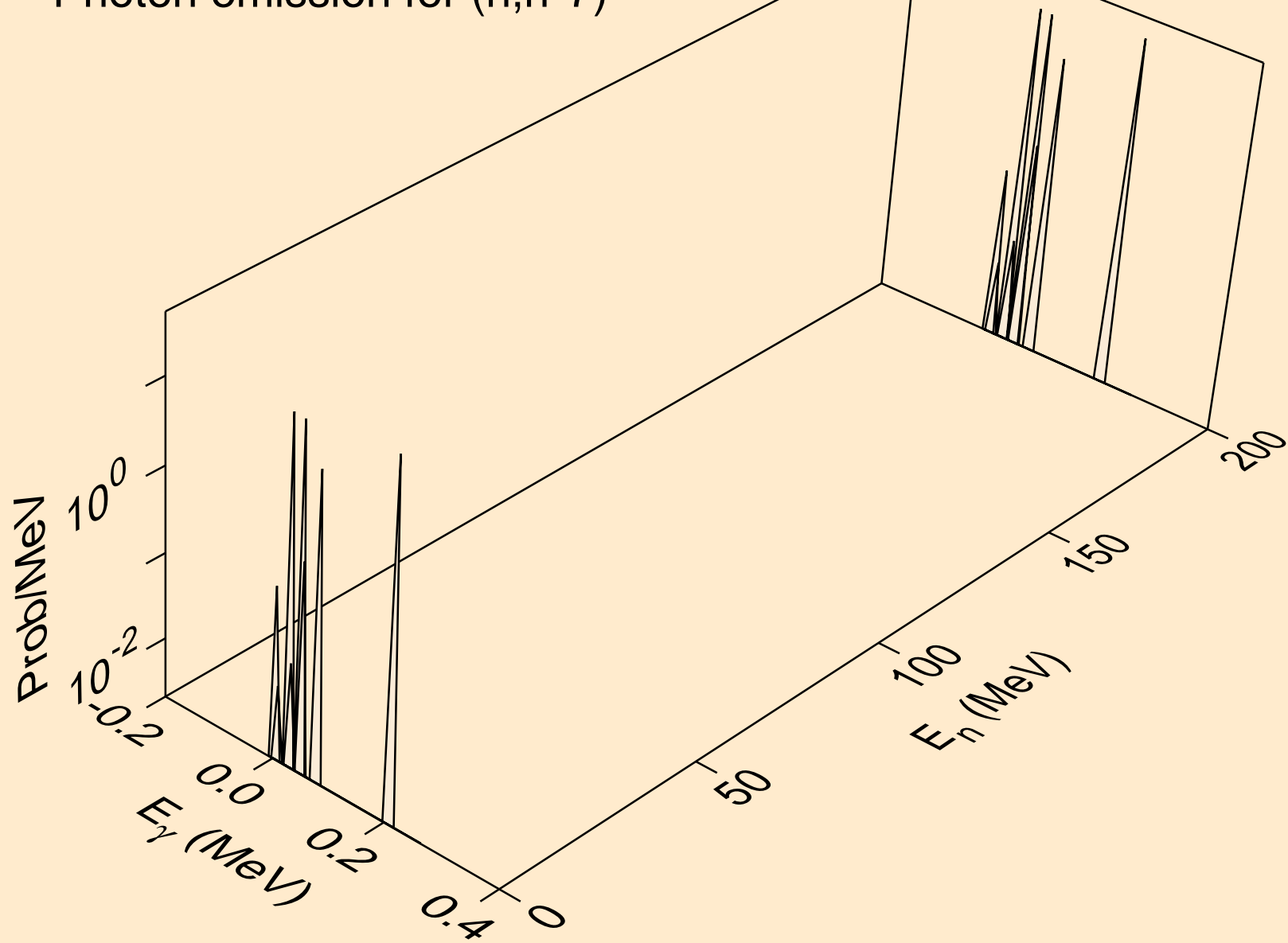

RE172M NEUTRON ACER TENDL-2023 LIBRARY; T=0.K  
Photon emission for (n,n\*8)

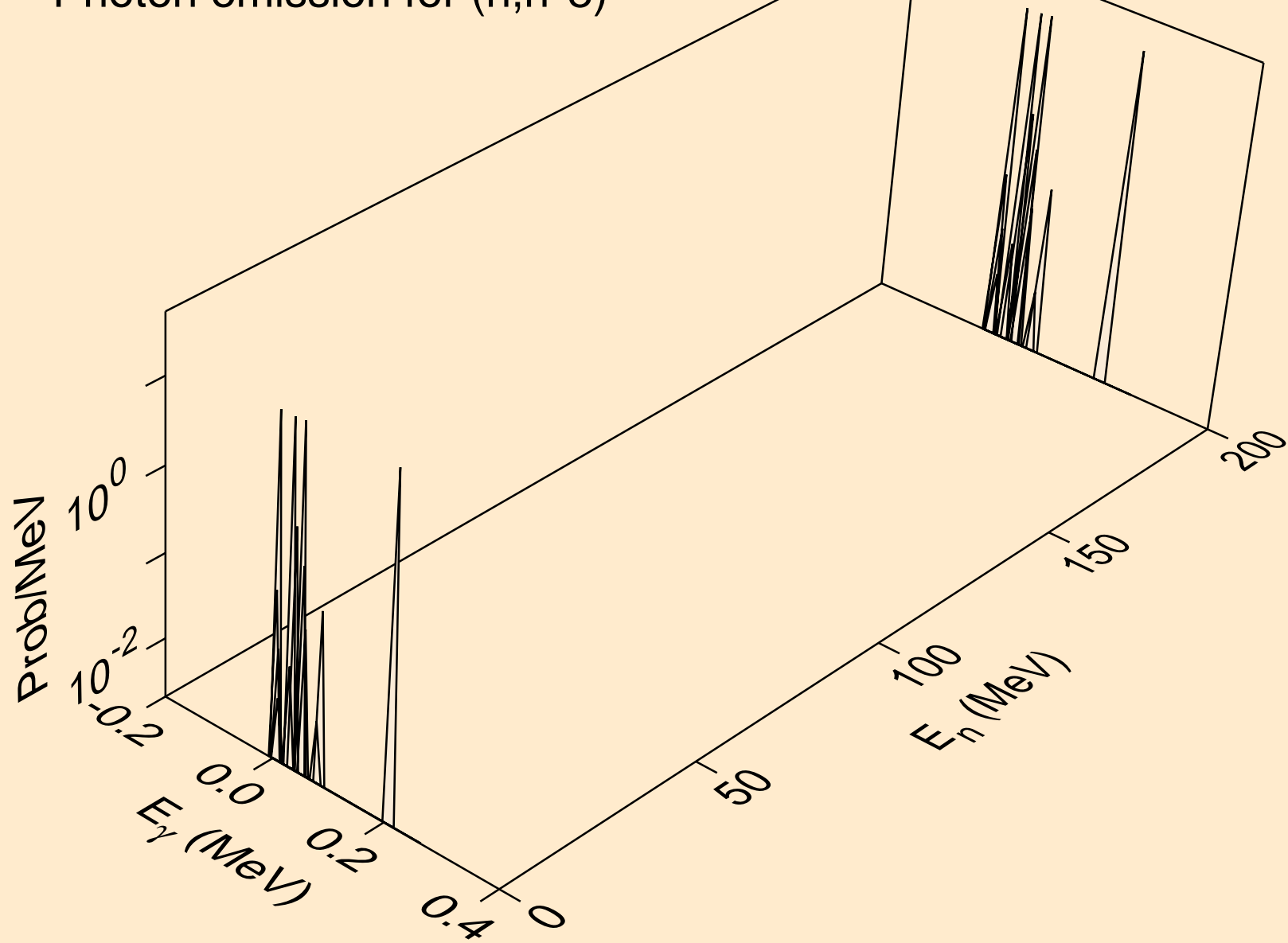

RE172M NEUTRON ACER TENDL-2023 LIBRARY; T=0.K  
Photon emission for (n,n\*9)

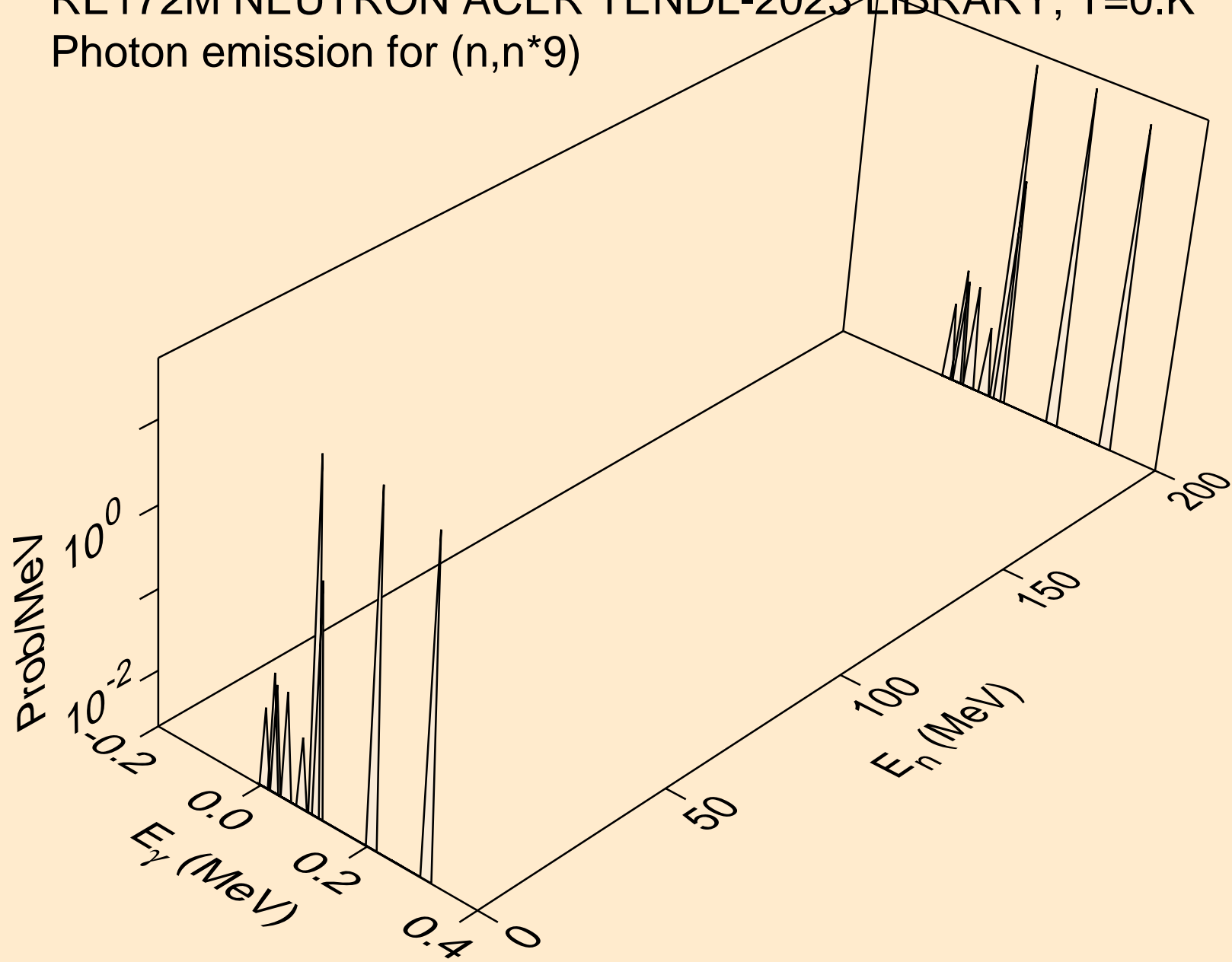

RE172M NEUTRON ACER TENDL-2023 LIBRARY; T=0.K  
Photon emission for (n,n\*10)

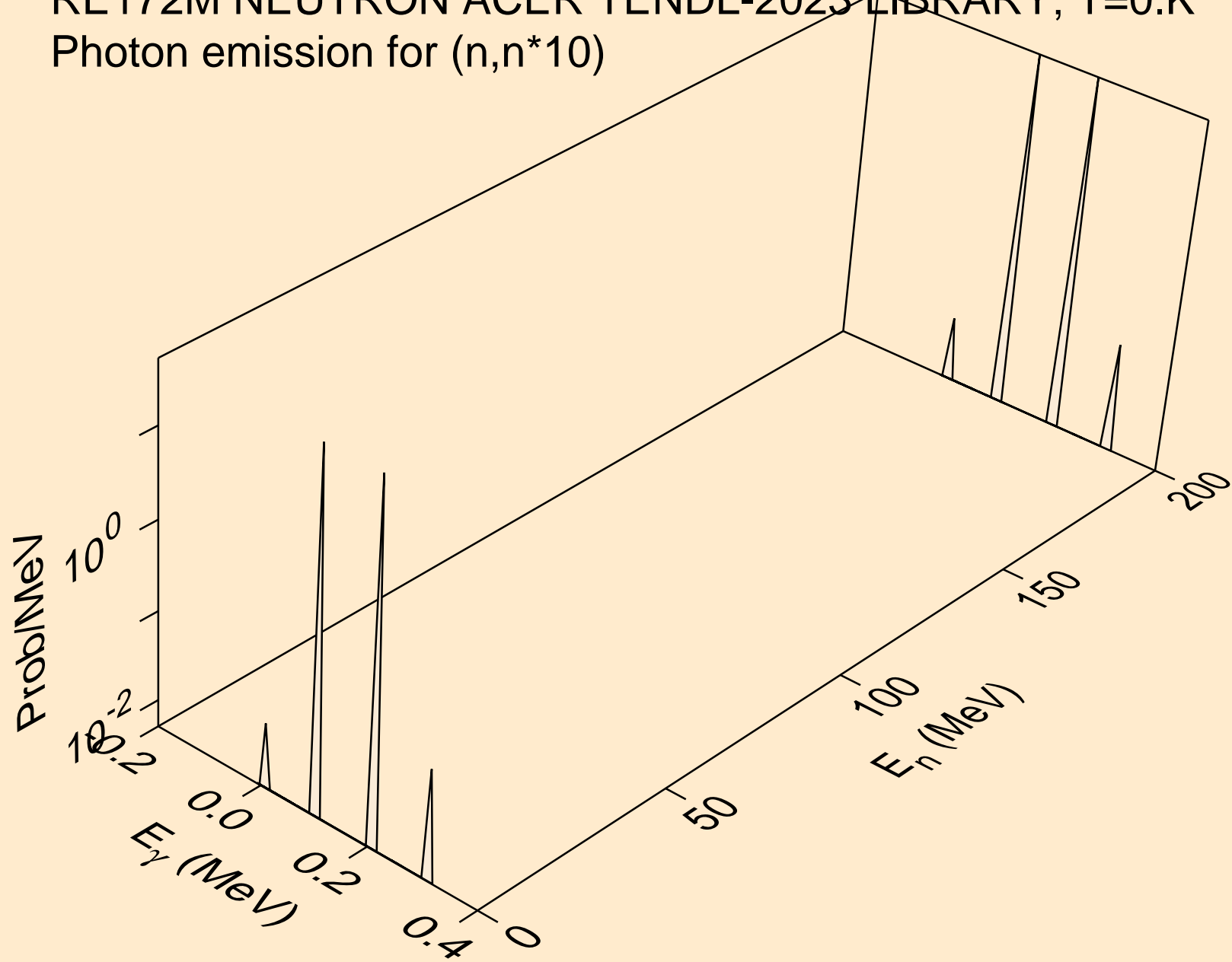

RE172M NEUTRON ACER TENDL-2023 LIBRARY; T=0.K  
Photon emission for (n,n\*11)

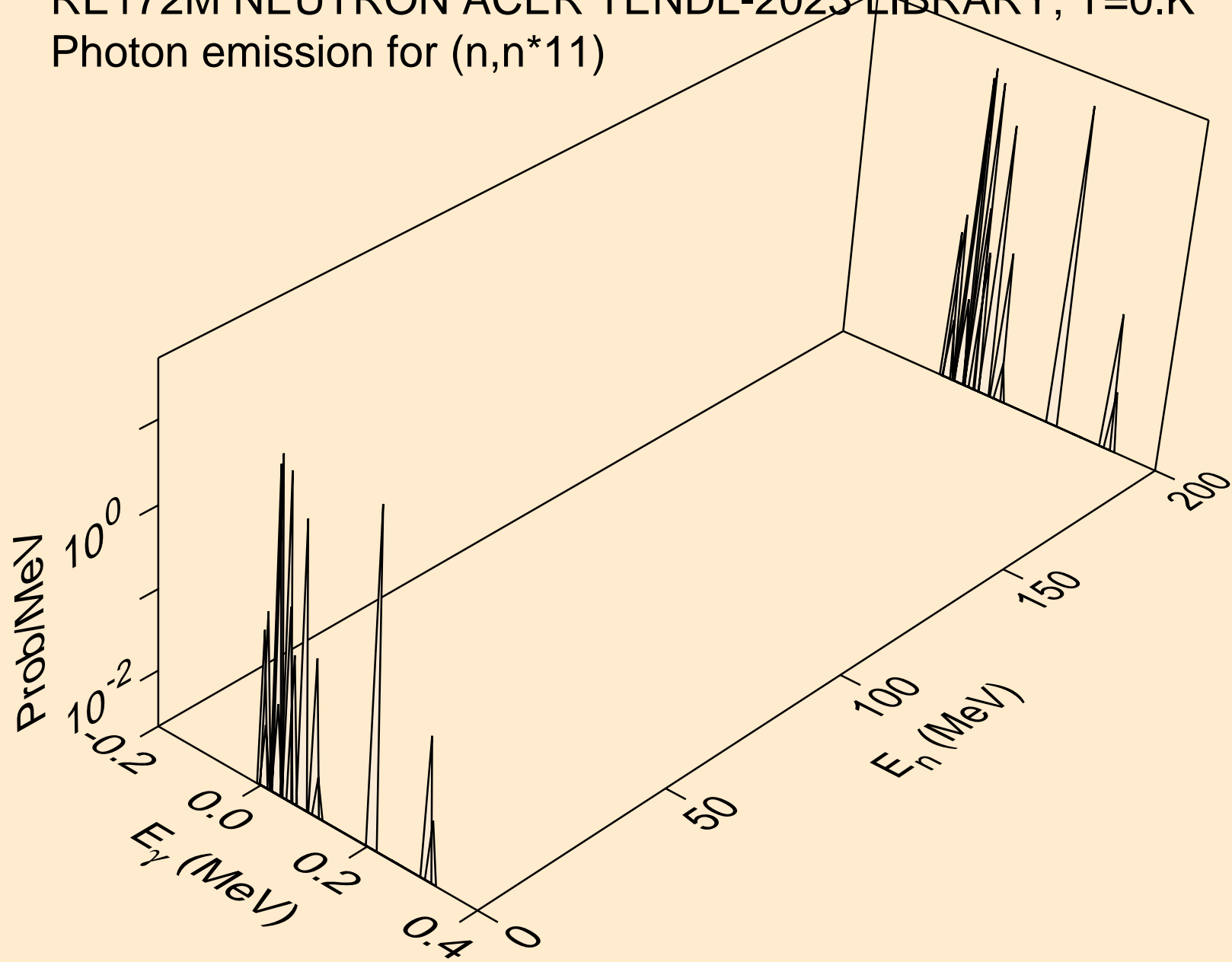

RE172M NEUTRON ACER TENDL-2023 LIBRARY; T=0.K  
Photon emission for (n,n\*12)

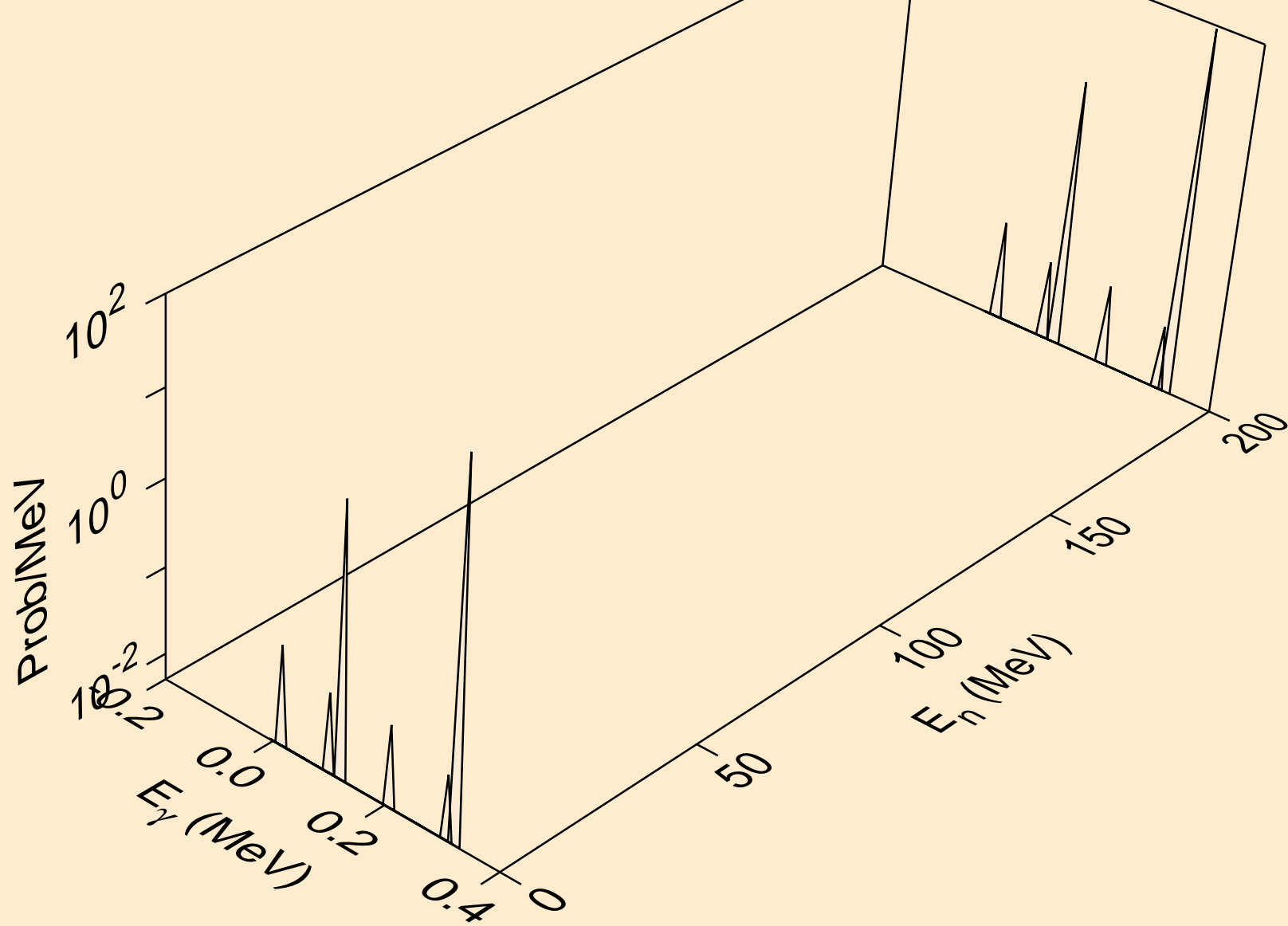

RE172M NEUTRON ACER TENDL-2023 LIBRARY; T=0.K  
Photon emission for (n,n\*13)

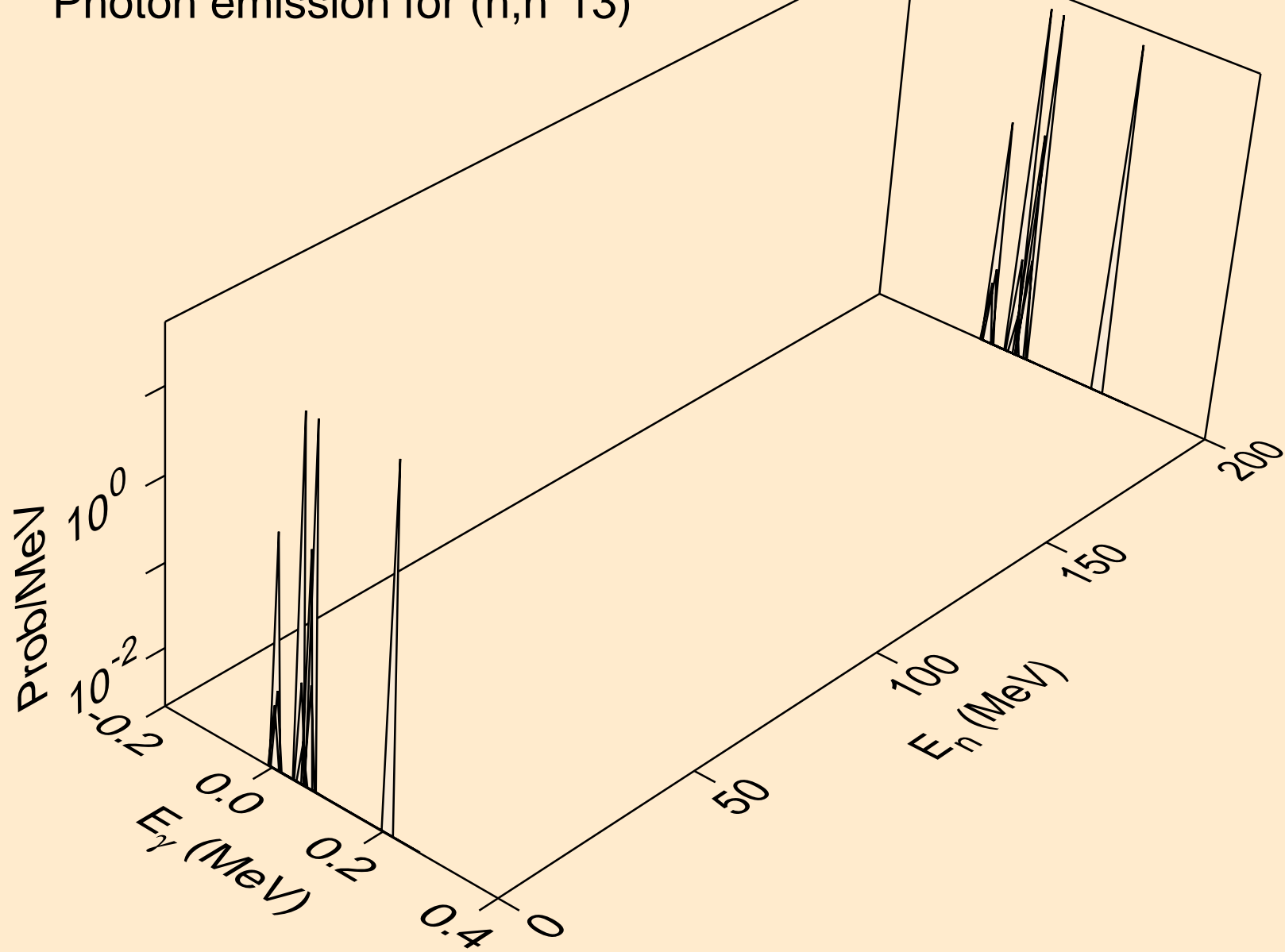

RE172M NEUTRON ACER TENDL-2023 LIBRARY; T=0.K  
Photon emission for (n,n\*14)

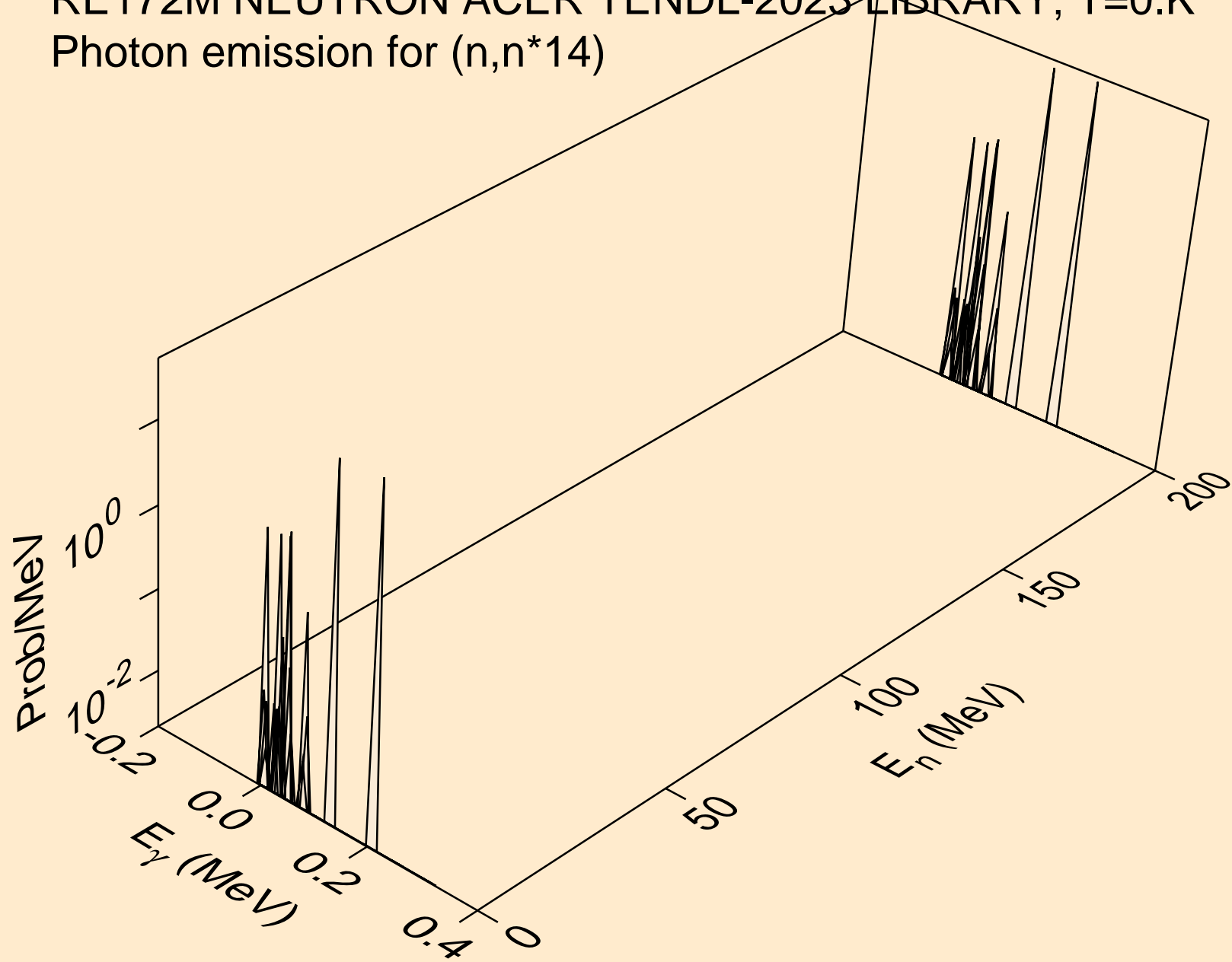



RE172M NEUTRON ACER TENDL-2023 LIBRARY; T=0.K  
Photon emission for (n,n\*15)

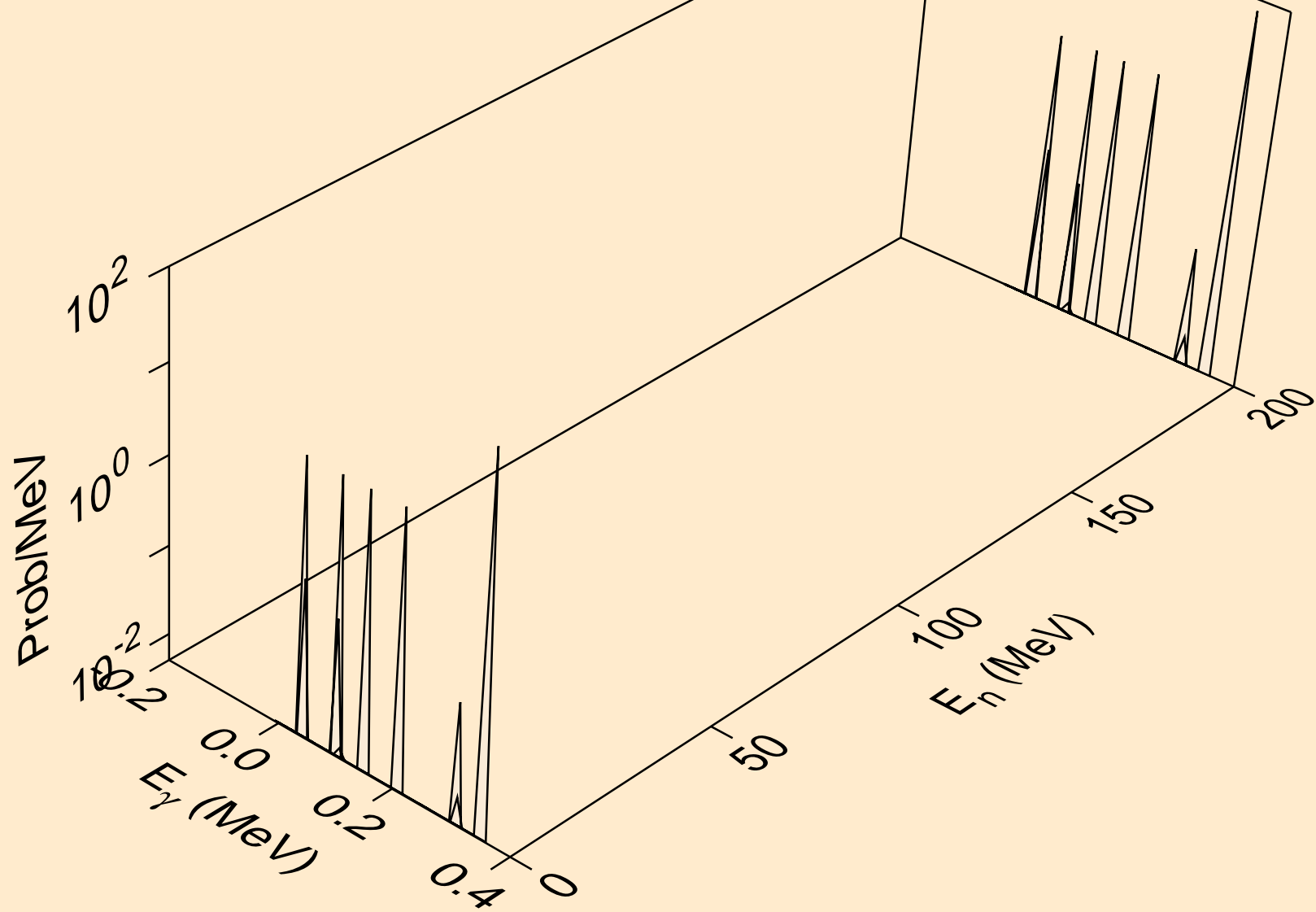

RE172M NEUTRON ACER TENDL-2023 LIBRARY; T=0.K  
Photon emission for (n,n\*16)

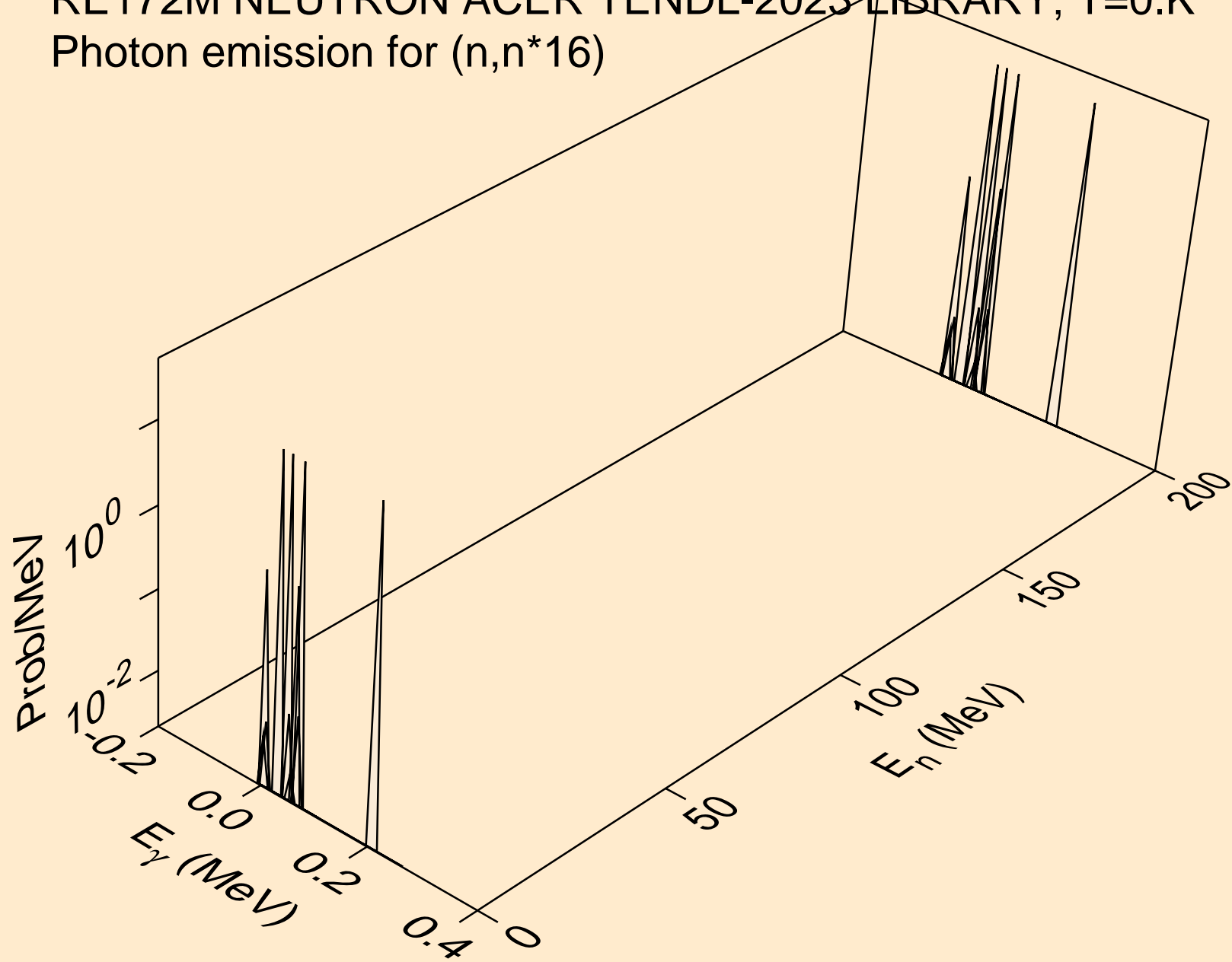

RE172M NEUTRON ACER TENDL-2023 LIBRARY; T=0.K  
Photon emission for (n,n\*17)

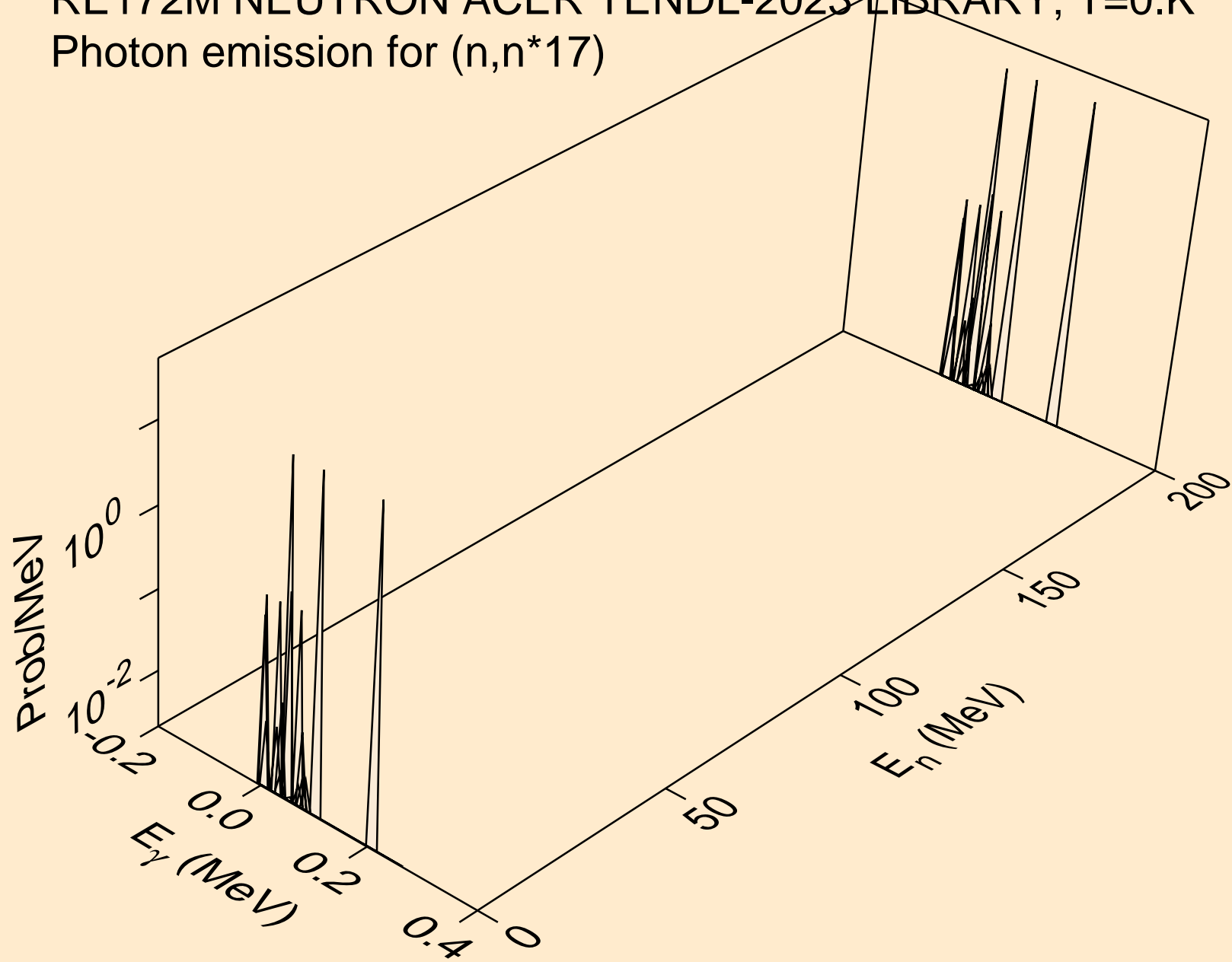

RE172M NEUTRON ACER TENDL-2023 LIBRARY; T=0.K  
Photon emission for (n,n\*18)

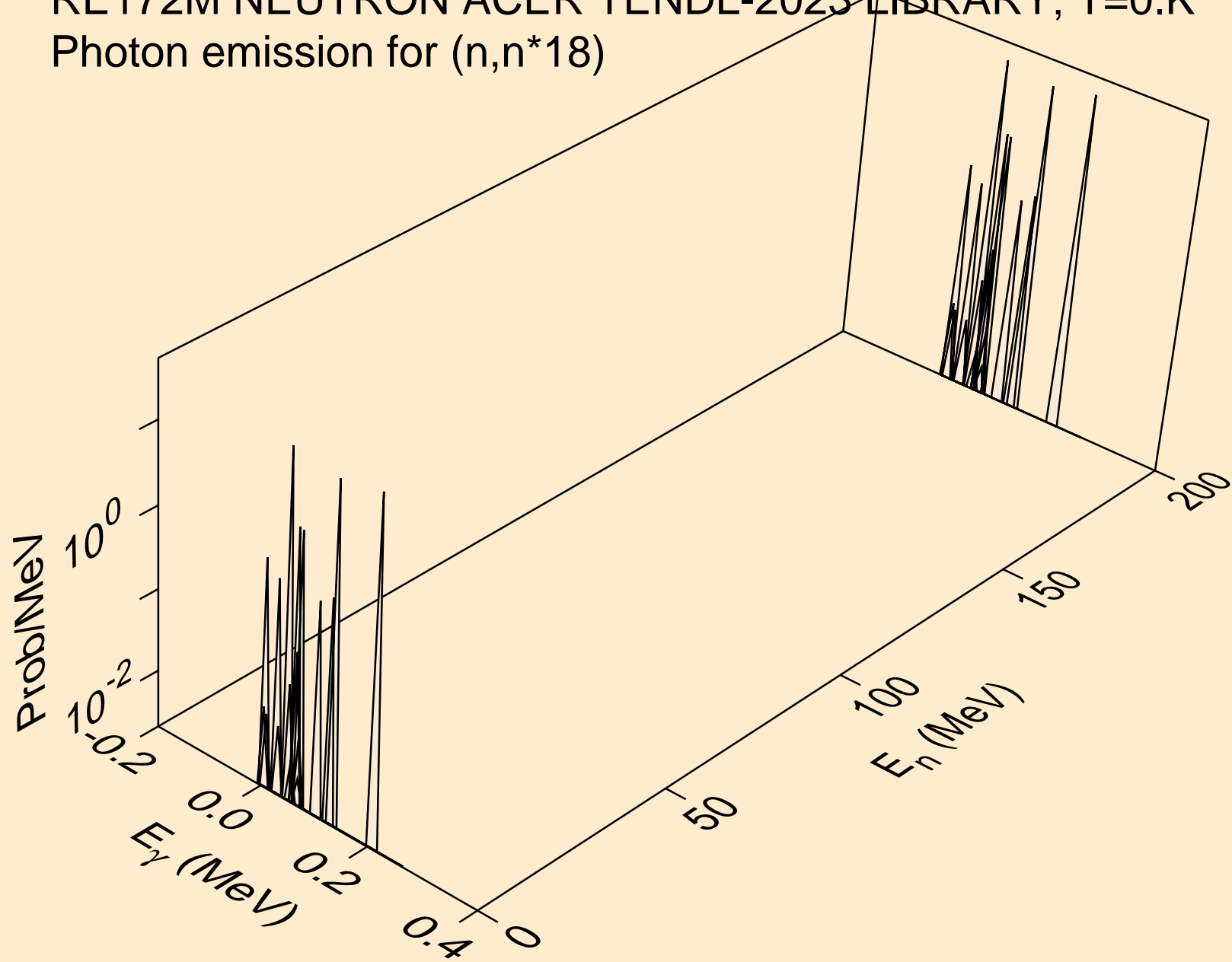

RE172M NEUTRON ACER TENDL-2023 LIBRARY; T=0.K  
Photon emission for (n,n\*19)

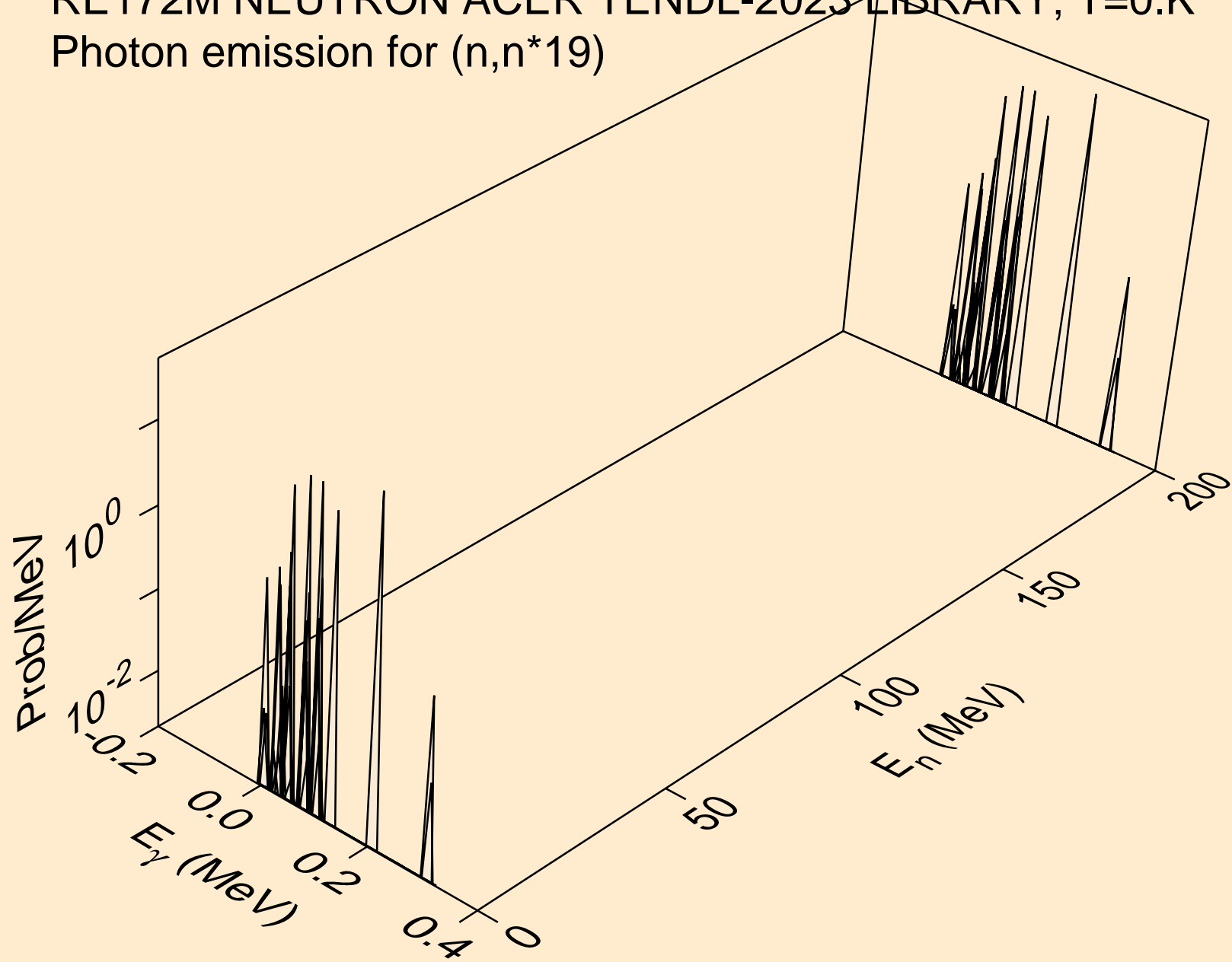

RE172M NEUTRON ACER TENDL-2023 LIBRARY; T=0.K  
Photon emission for (n,n\*20)

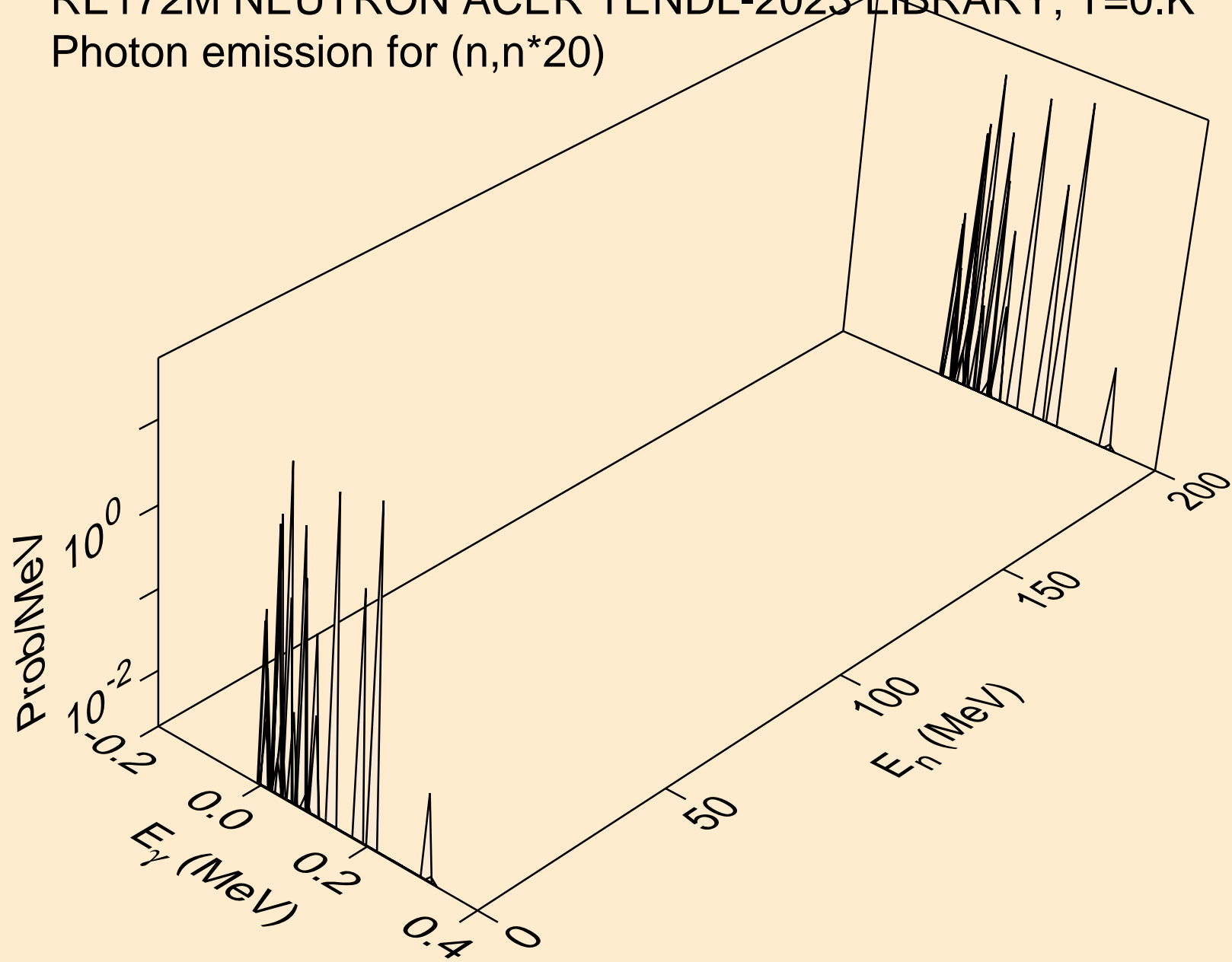

RE172M NEUTRON ACER TENDL-2023 LIBRARY; T=0.K  
Photon emission for (n,n\*21)

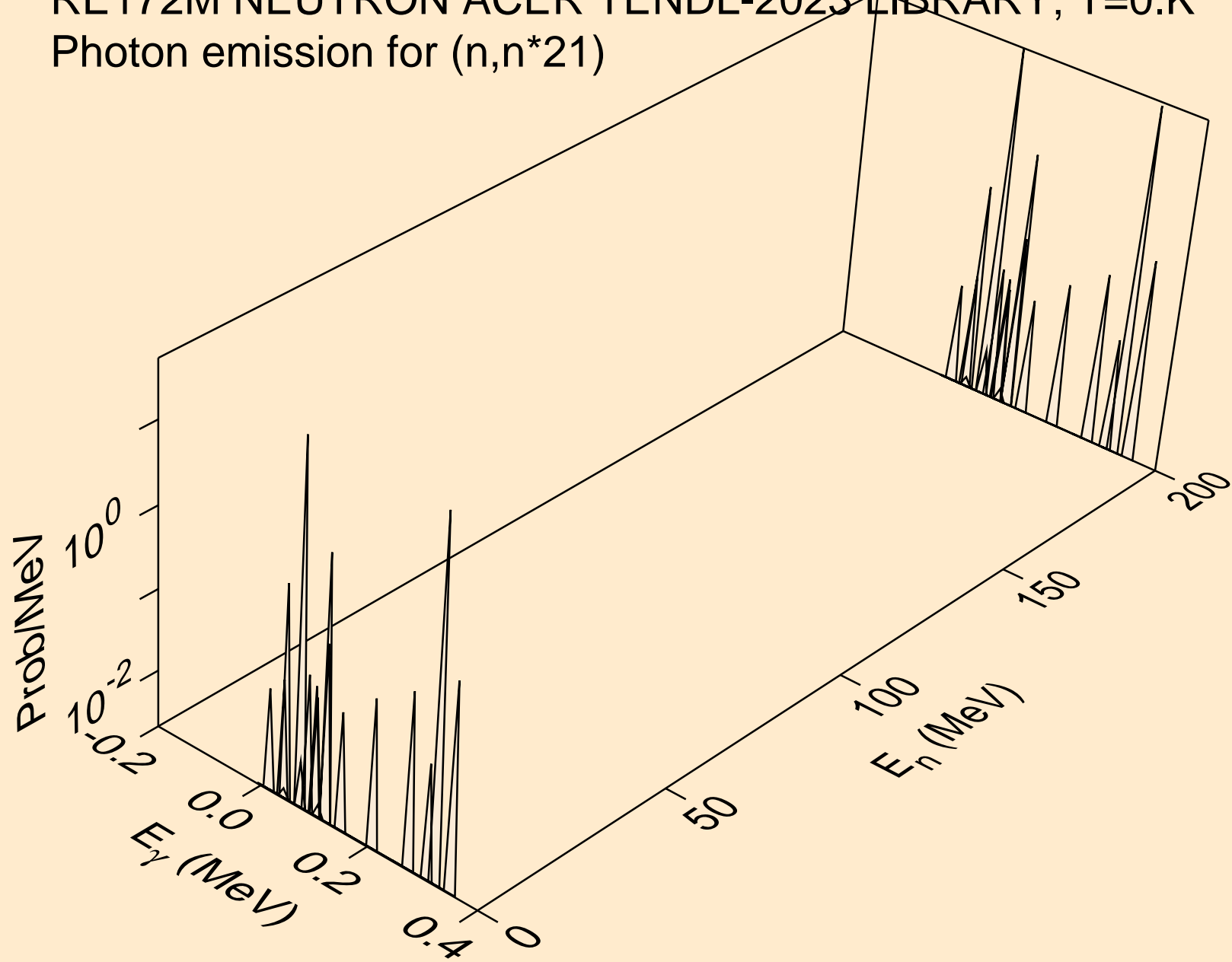

RE172M NEUTRON ACER TENDL-2023 LIBRARY; T=0.K  
Photon emission for (n,n\*c)

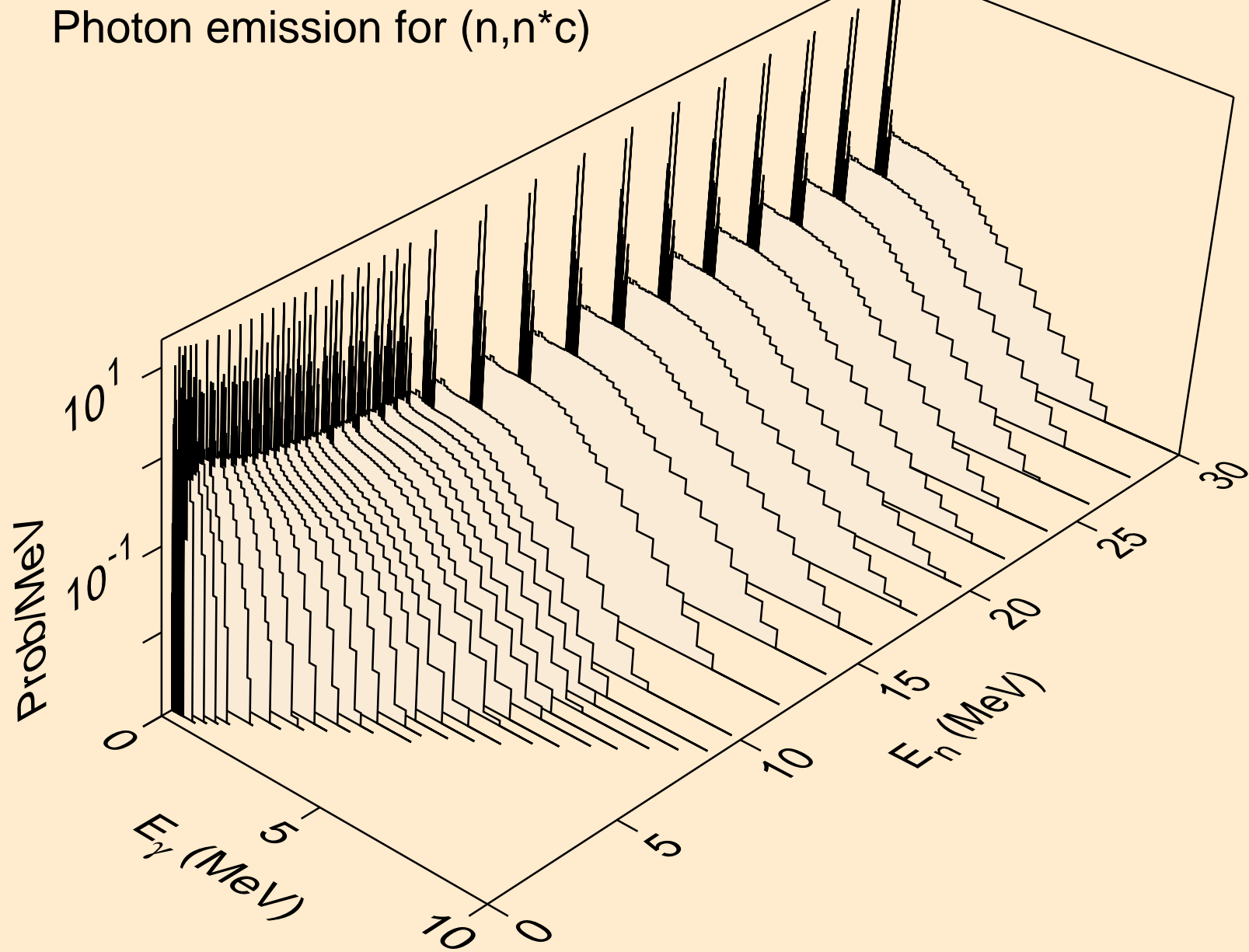



RE172M NEUTRON ACER TENDL-2023 LIBRARY; T=0.K  
Photon emission for (n,gma)

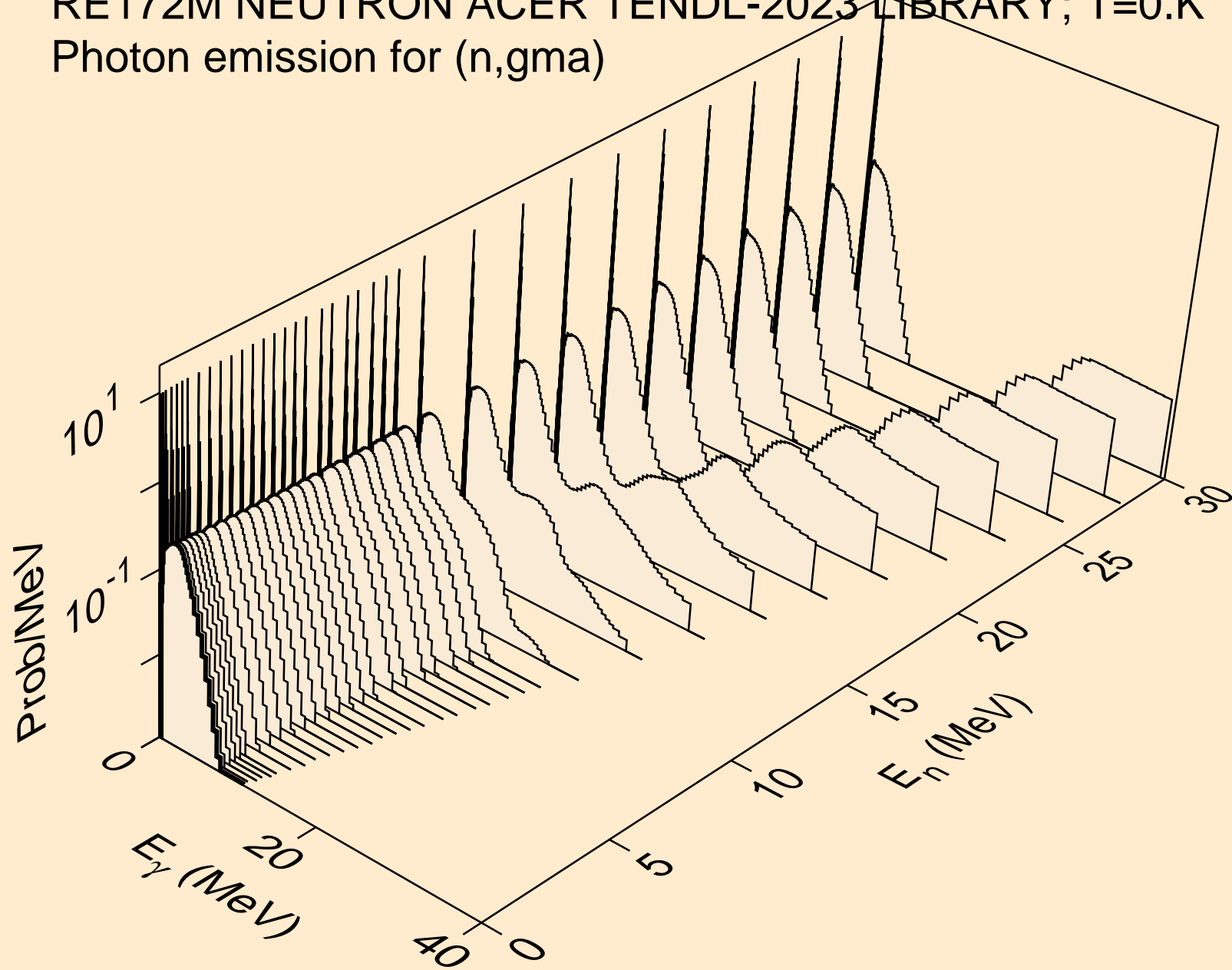

RE172M NEUTRON ACER TENDL-2023 LIBRARY; T=0.K  
Photon emission for (n,p)

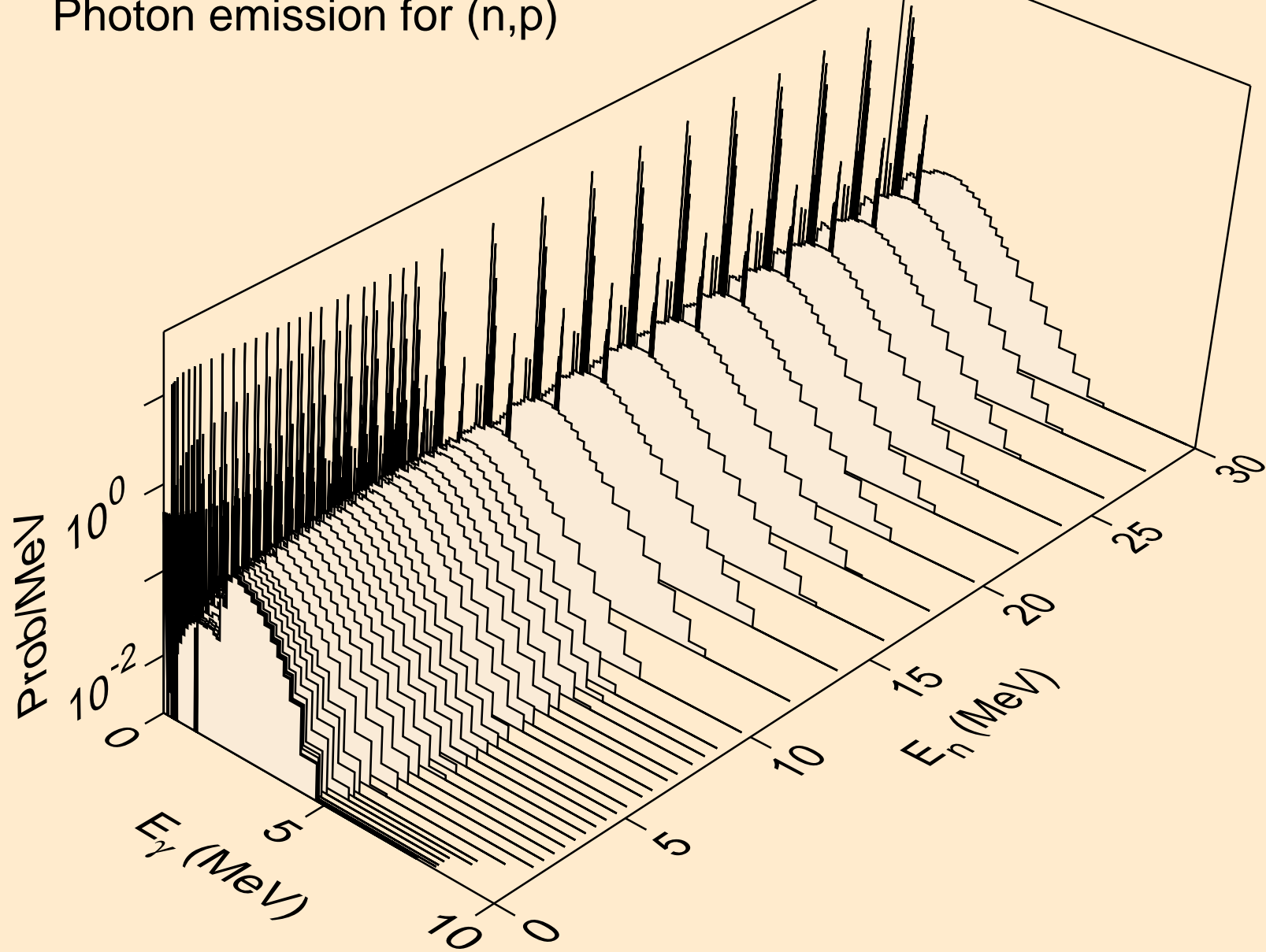

RE172M NEUTRON ACER TENDL-2023 LIBRARY; T=0.K  
Photon emission for (n,d)

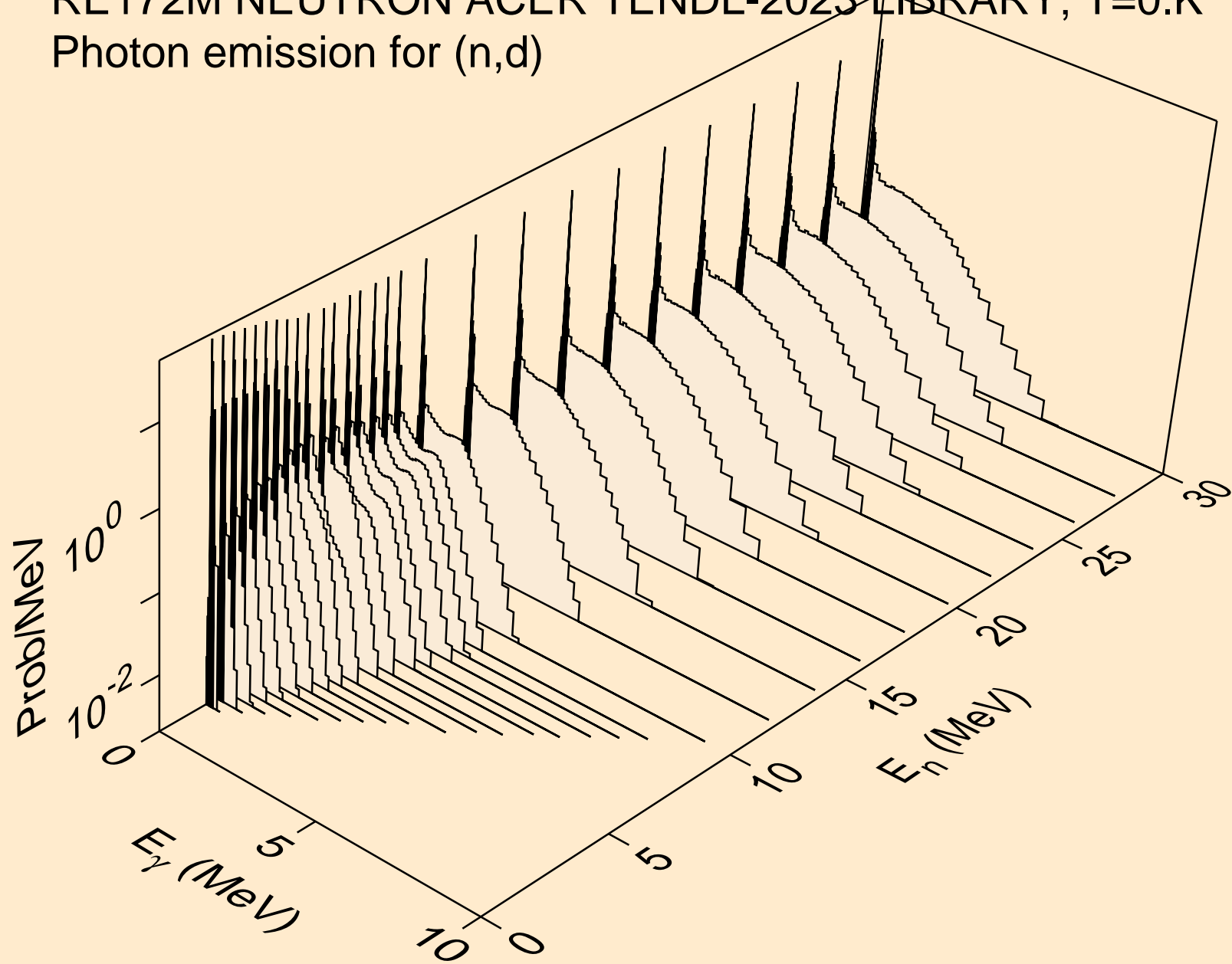

RE172M NEUTRON ACER TENDL-2023 LIBRARY; T=0.K  
Photon emission for (n,t)

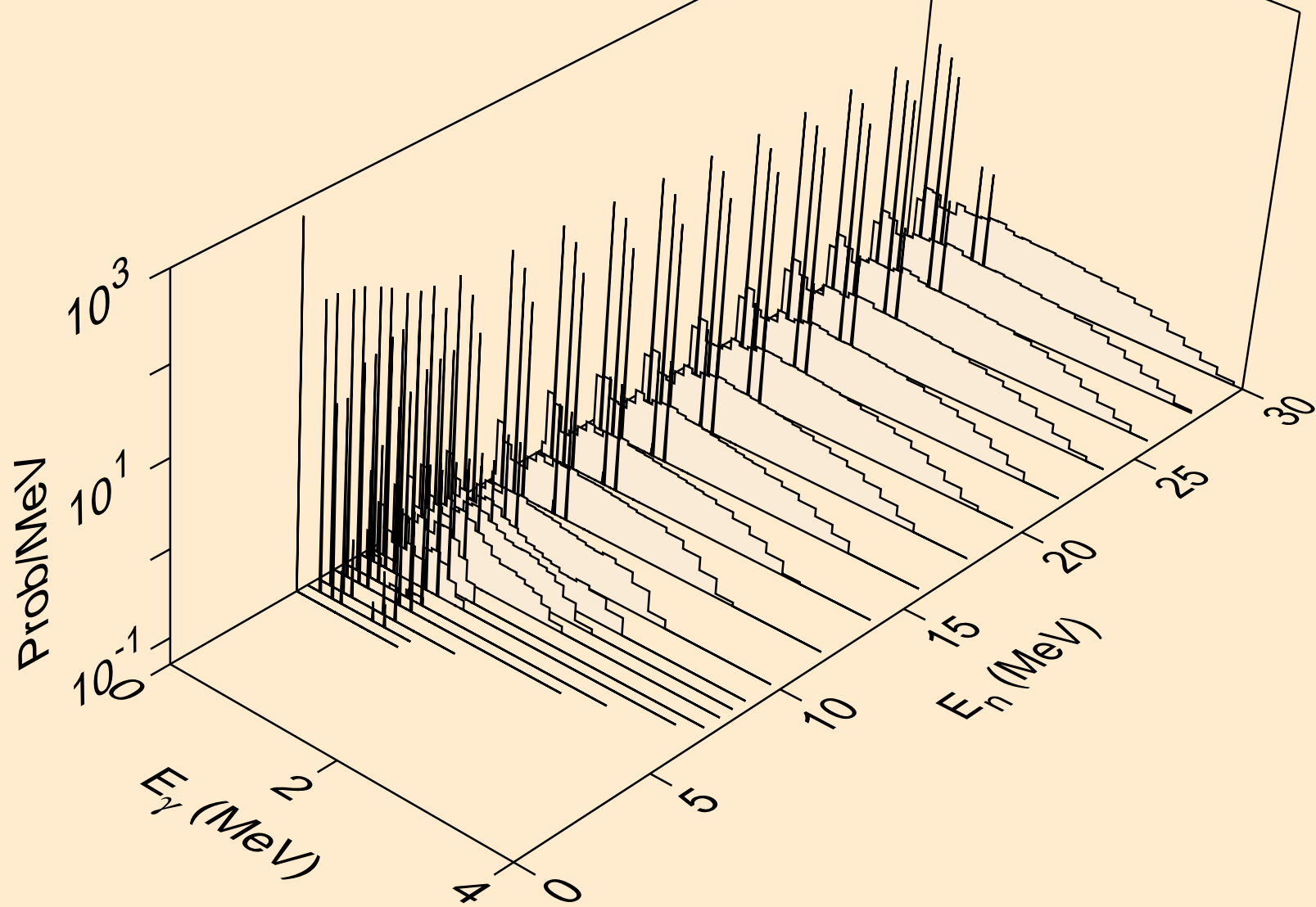

RE172M NEUTRON ACER TENDL-2023 LIBRARY; T=0.K  
Photon emission for (n,he3)

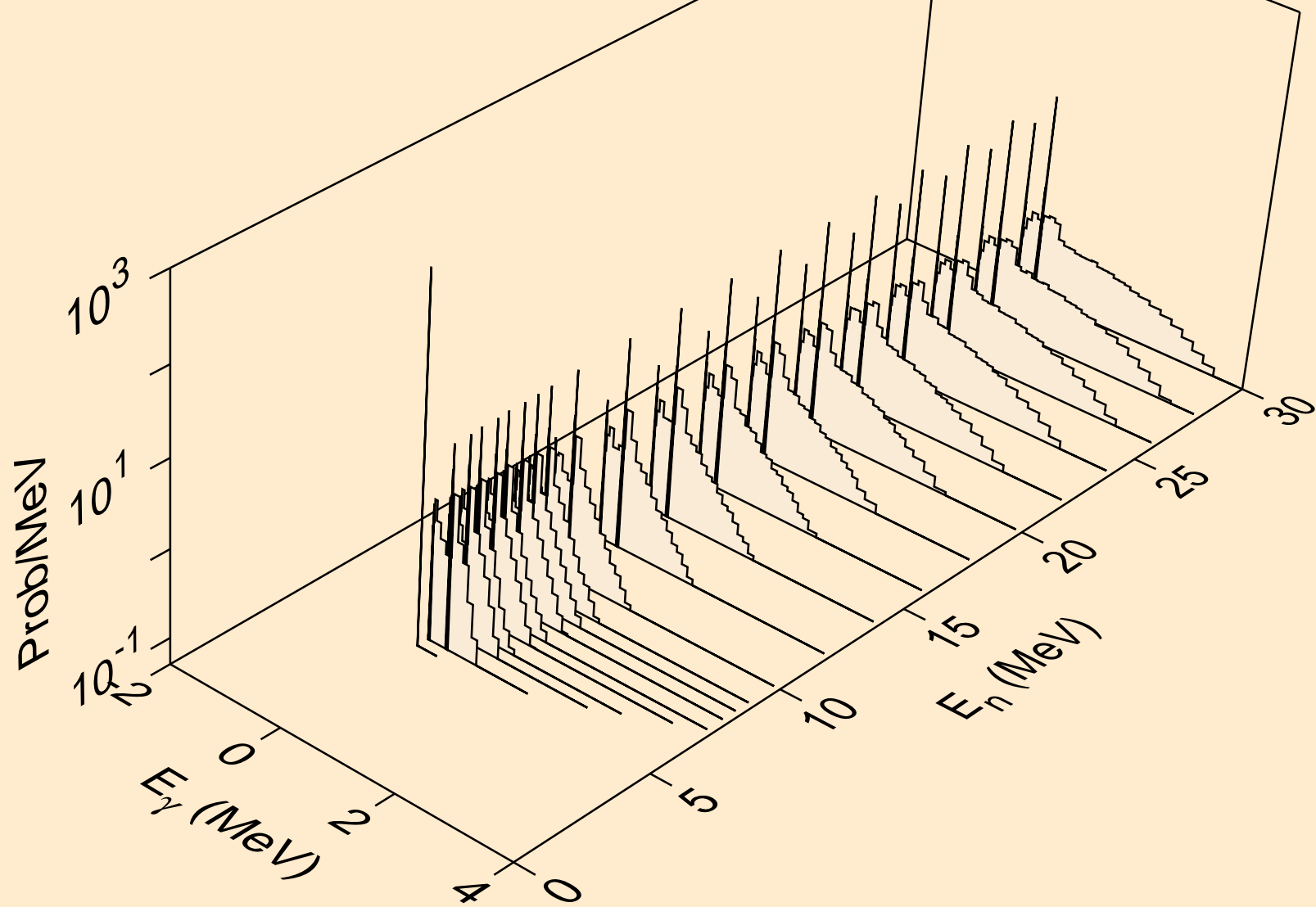

RE172M NEUTRON ACER TENDL-2023 LIBRARY; T=0.K  
Photon emission for (n,a)

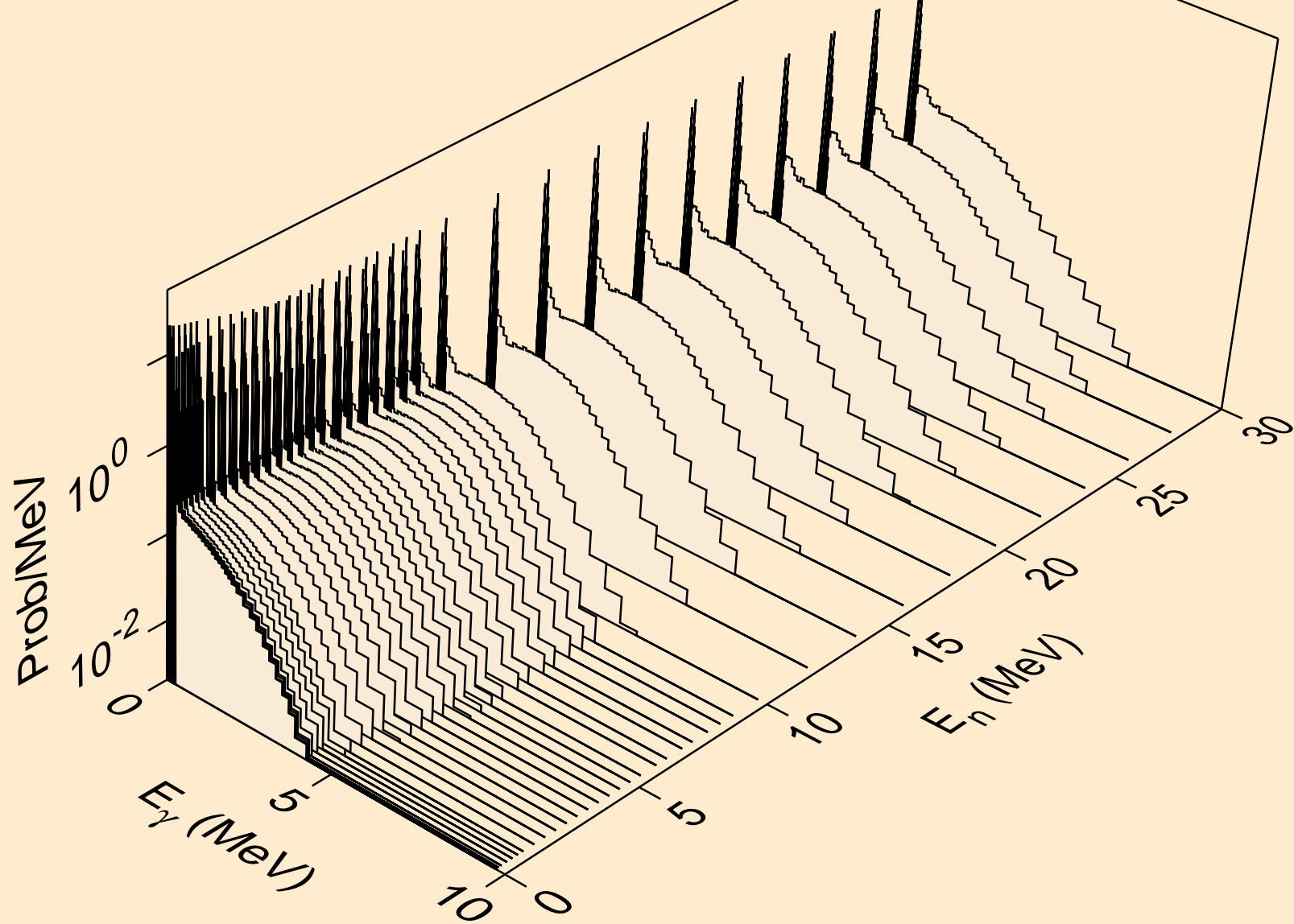

RE172M NEUTRON ACER TENDL-2023 LIBRARY; T=0.K  
Photon emission for (n,2a)

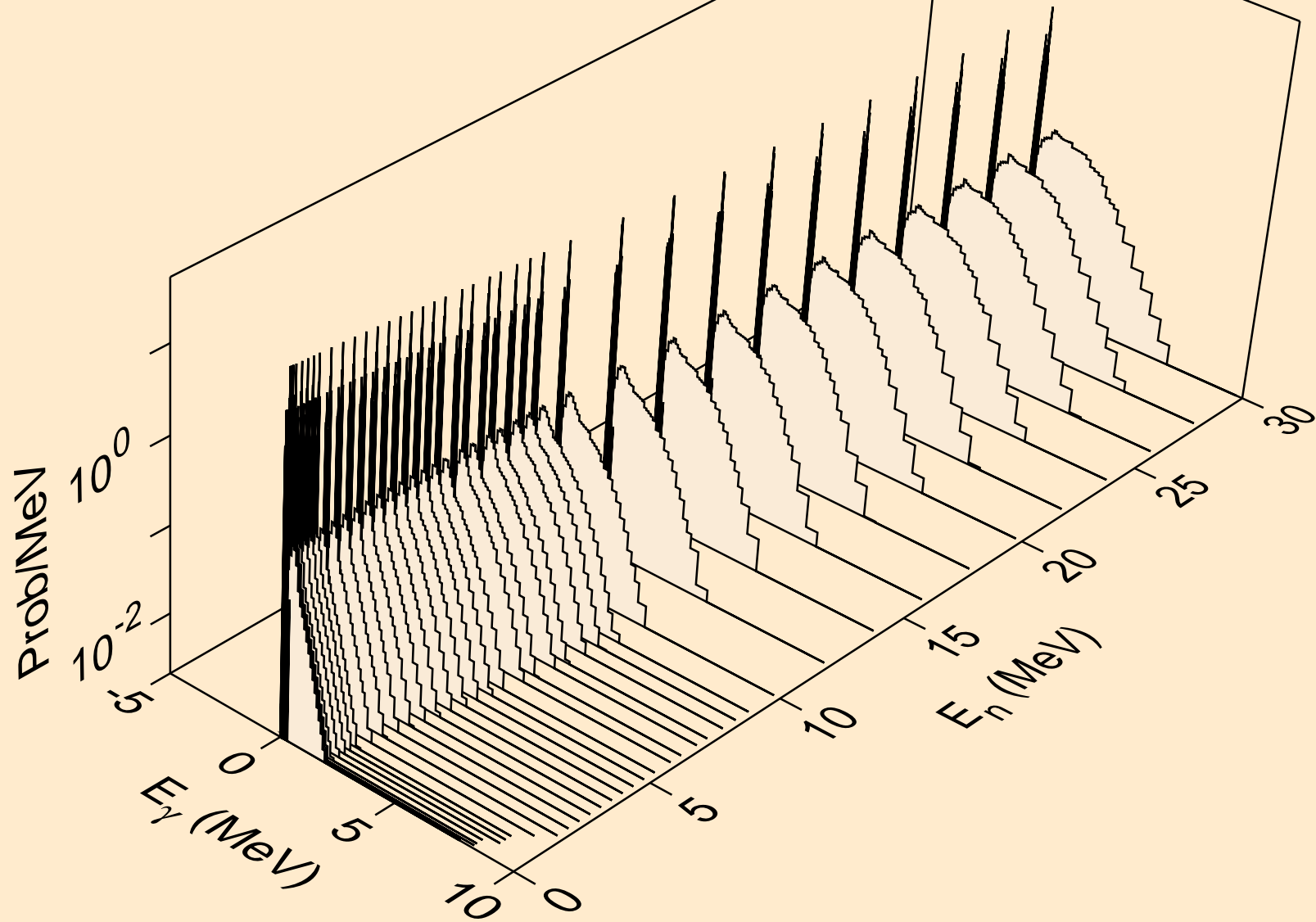

RE172M NEUTRON ACER TENDL-2023 LIBRARY; T=0.K  
Photon emission for (n,3a)

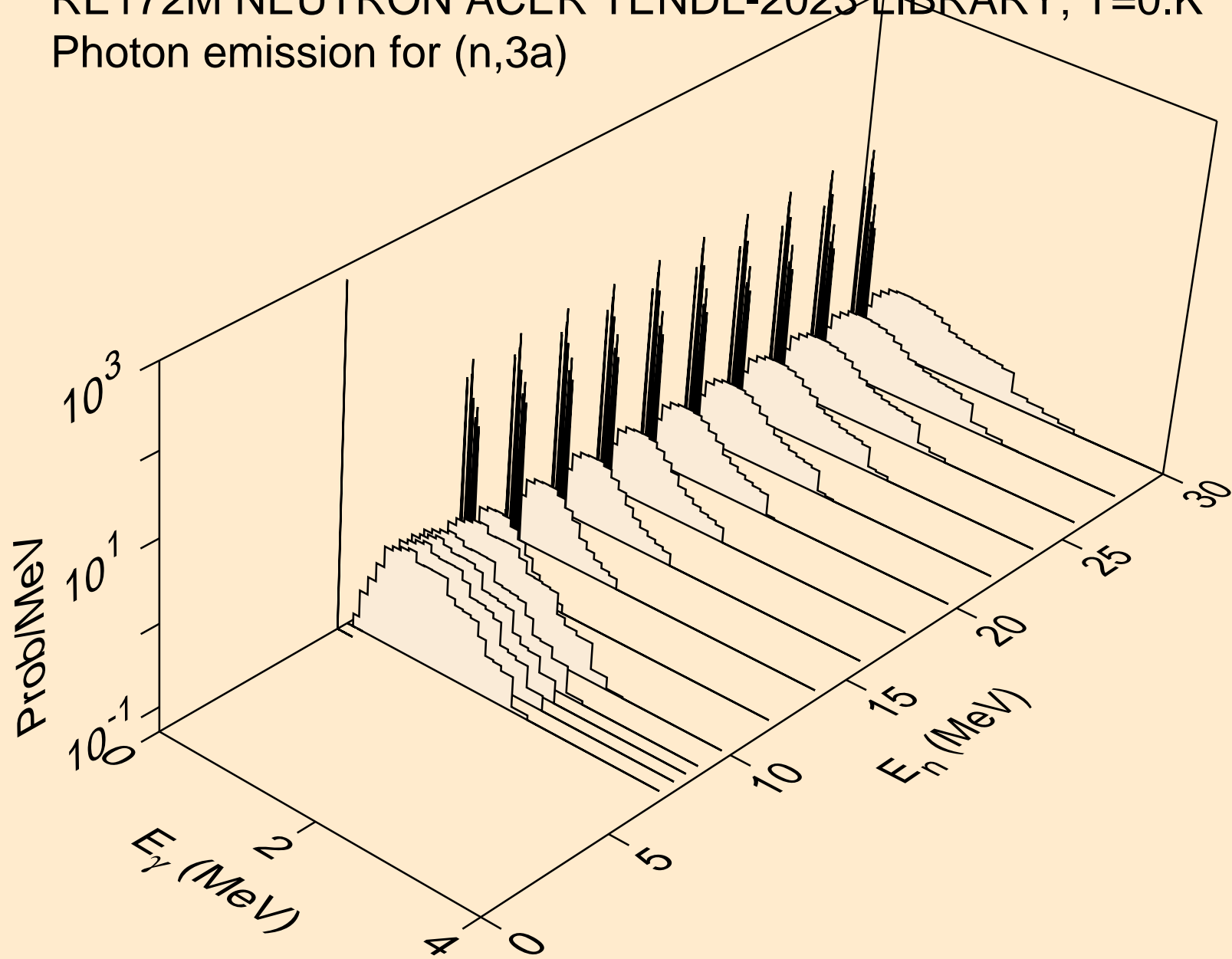



RE172M NEUTRON ACER TENDL-2023 LIBRARY; T=0.K  
Photon emission for (n,2p)

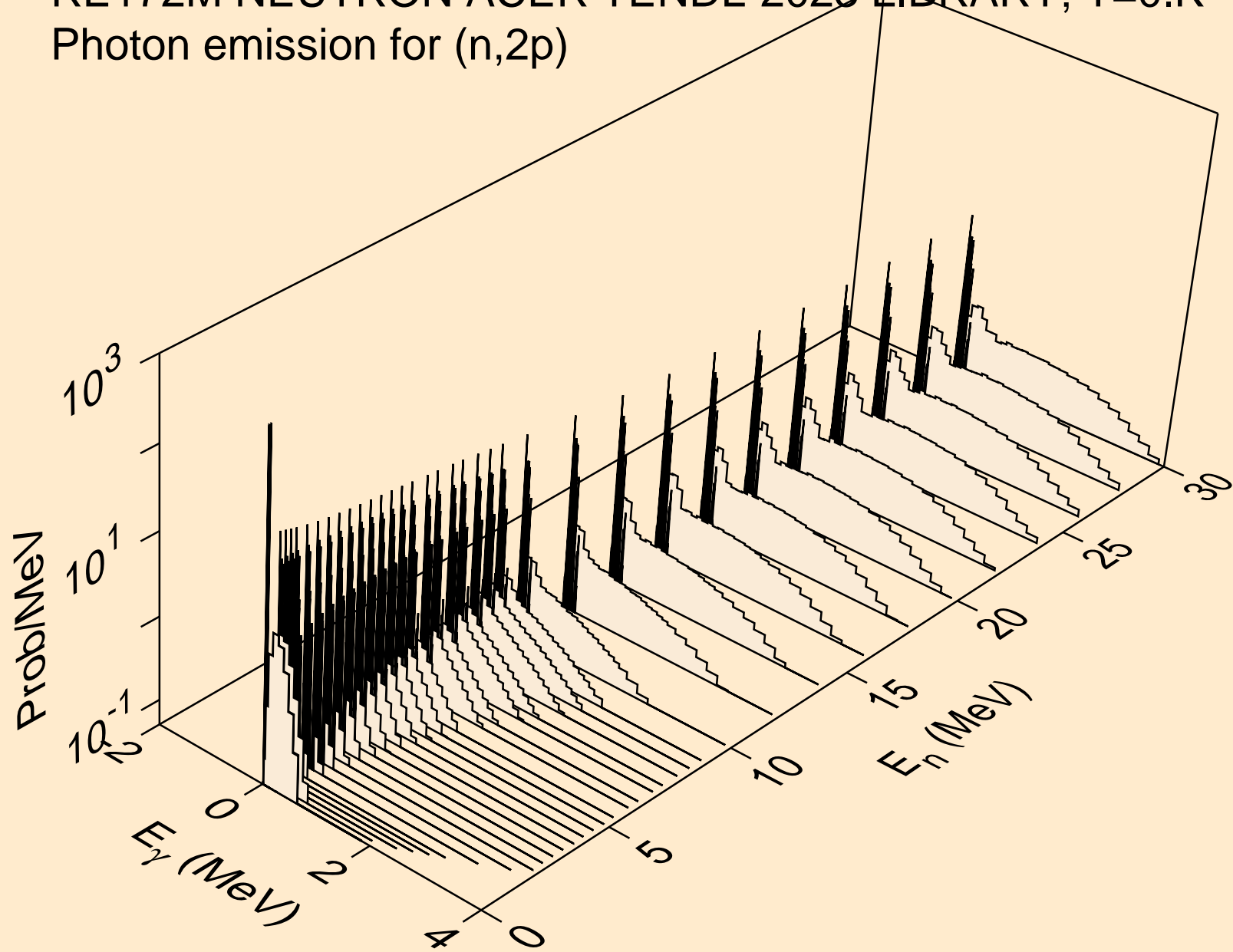

RE172M NEUTRON ACER TENDL-2023 LIBRARY; T=0.K  
Photon emission for (n,p $\alpha$ )

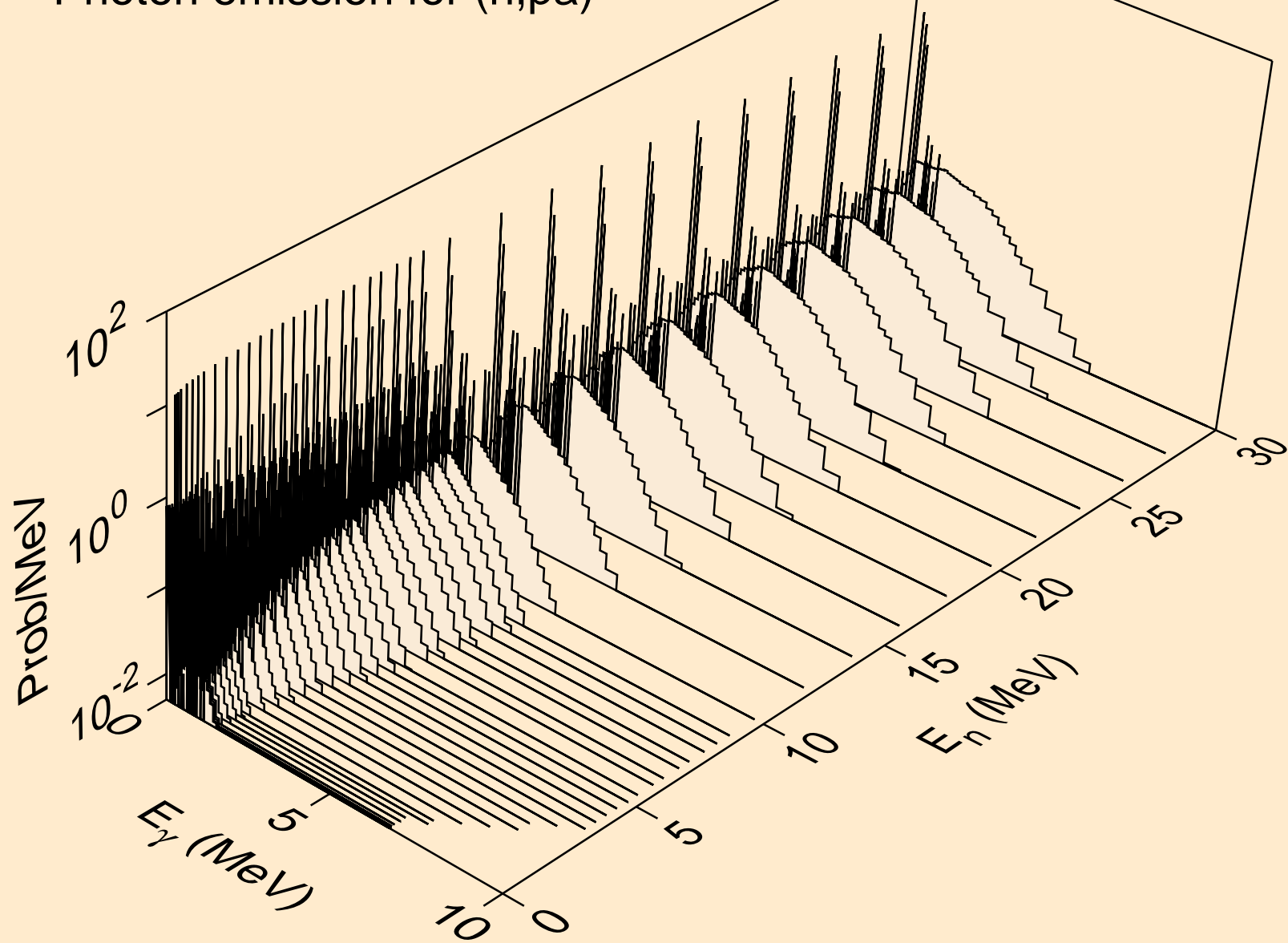

RE172M NEUTRON ACER TENDL-2023 LIBRARY; T=0.K  
Photon emission for (n,pd)

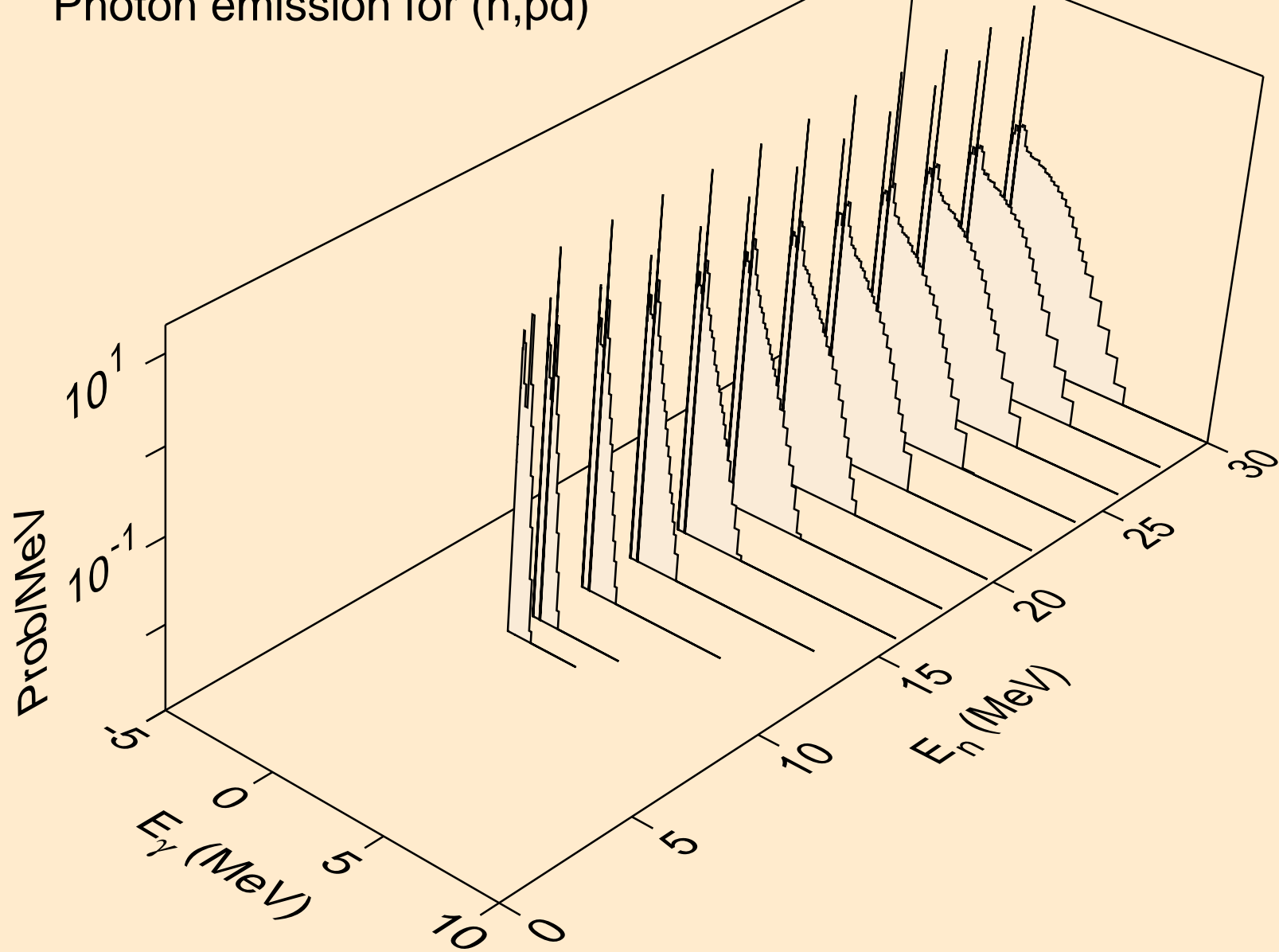

RE172M NEUTRON ACER TENDL-2023 LIBRARY; T=0.K  
Photon emission for (n,pt)

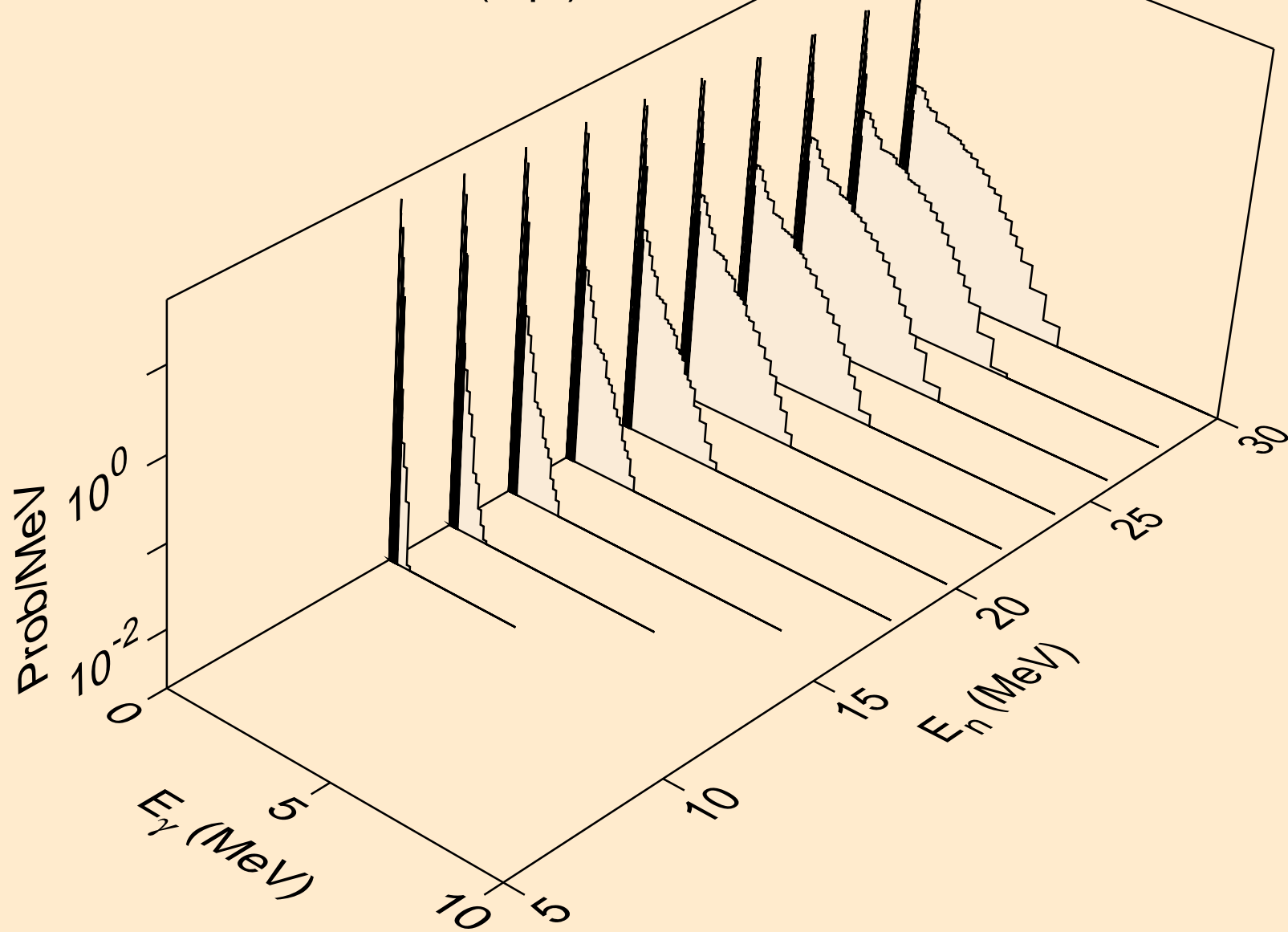

RE172M NEUTRON ACER TENDL-2023 LIBRARY; T=0.K  
Photon emission for (n,da)

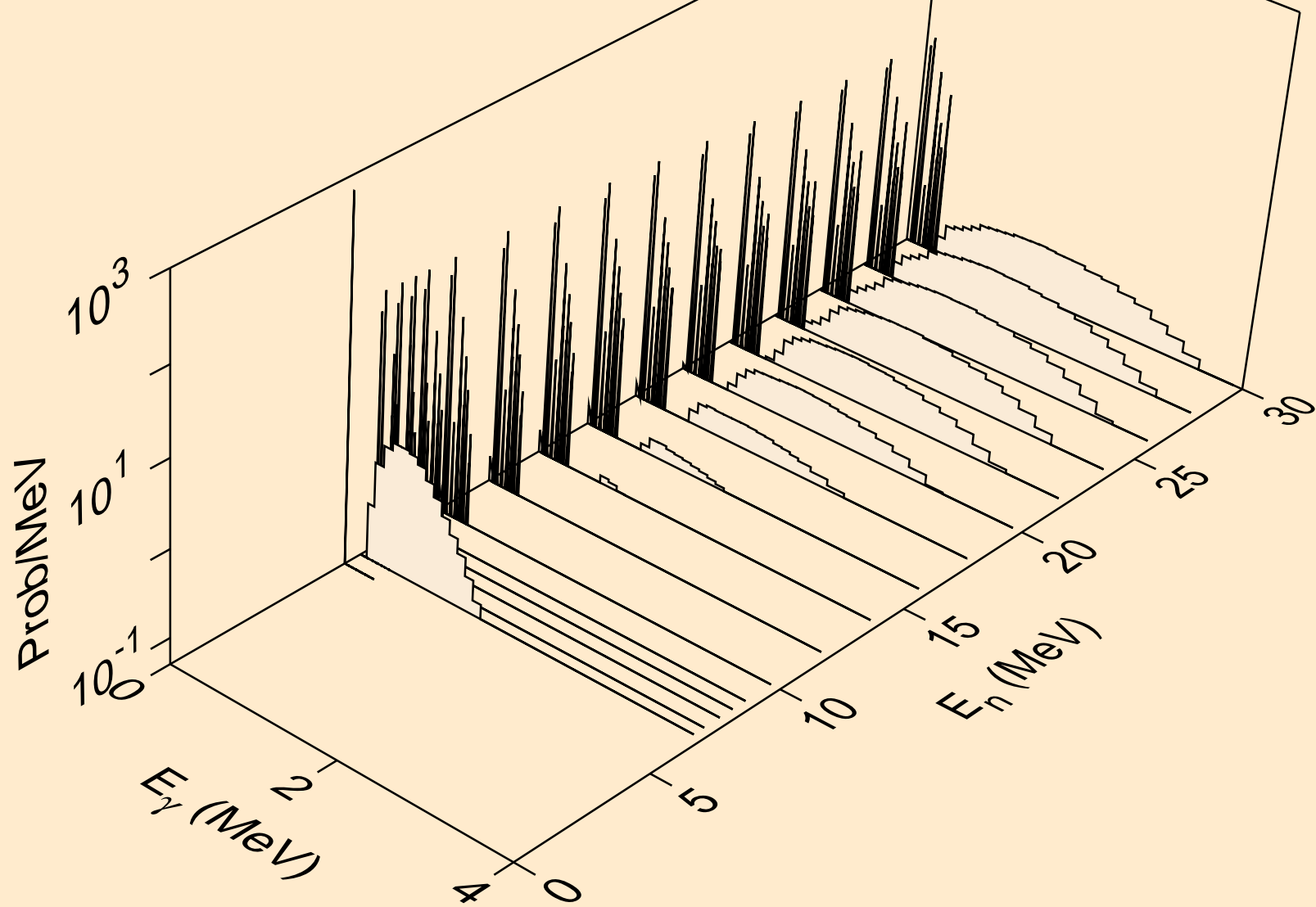

RE172M NEUTRON ACER TENDL-2023 LIBRARY; T=0.K  
thermal capture photon spectrum

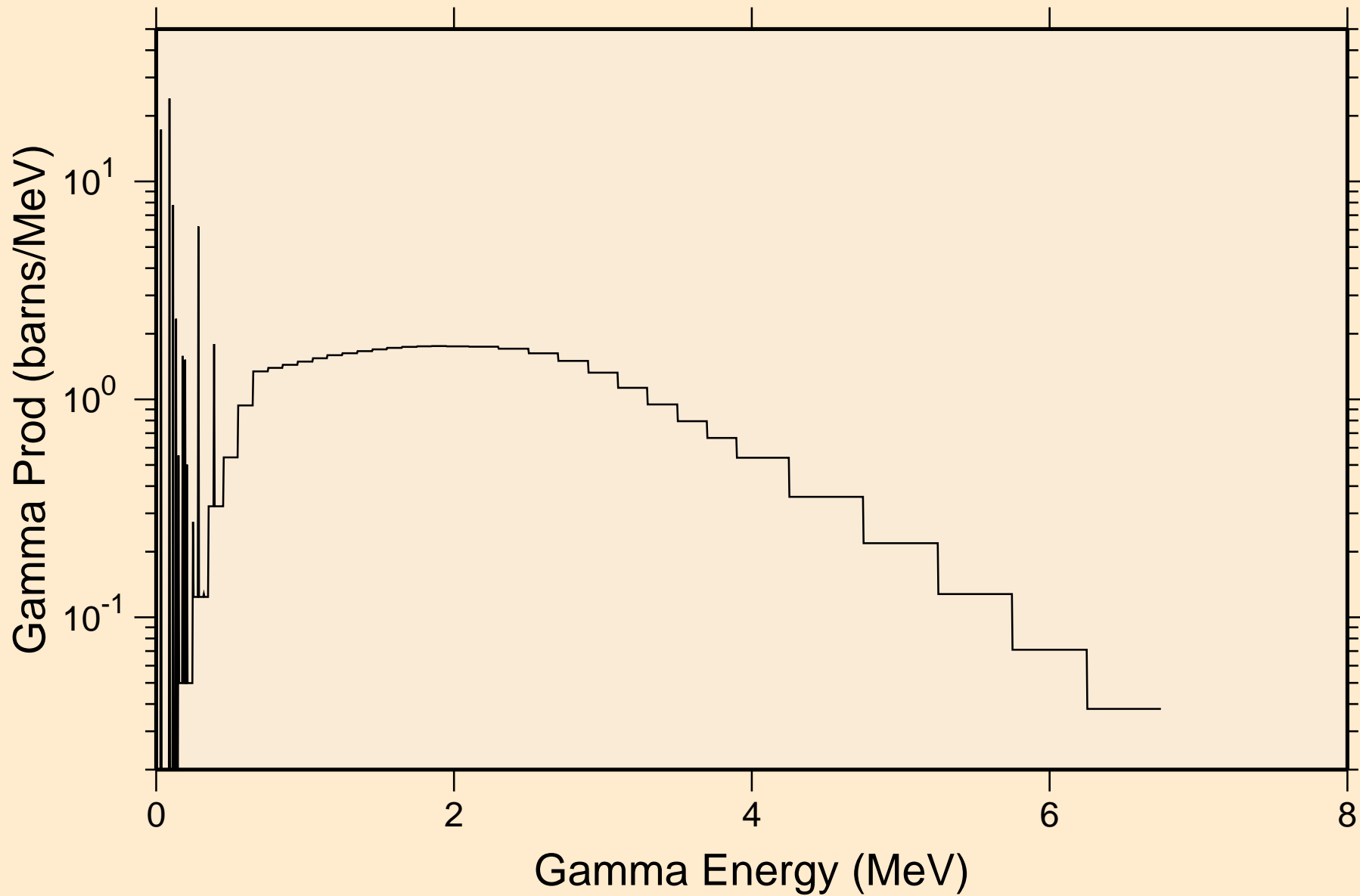

RE172M NEUTRON ACER TENDL-2023 LIBRARY; T=0.K  
14 MeV photon spectrum

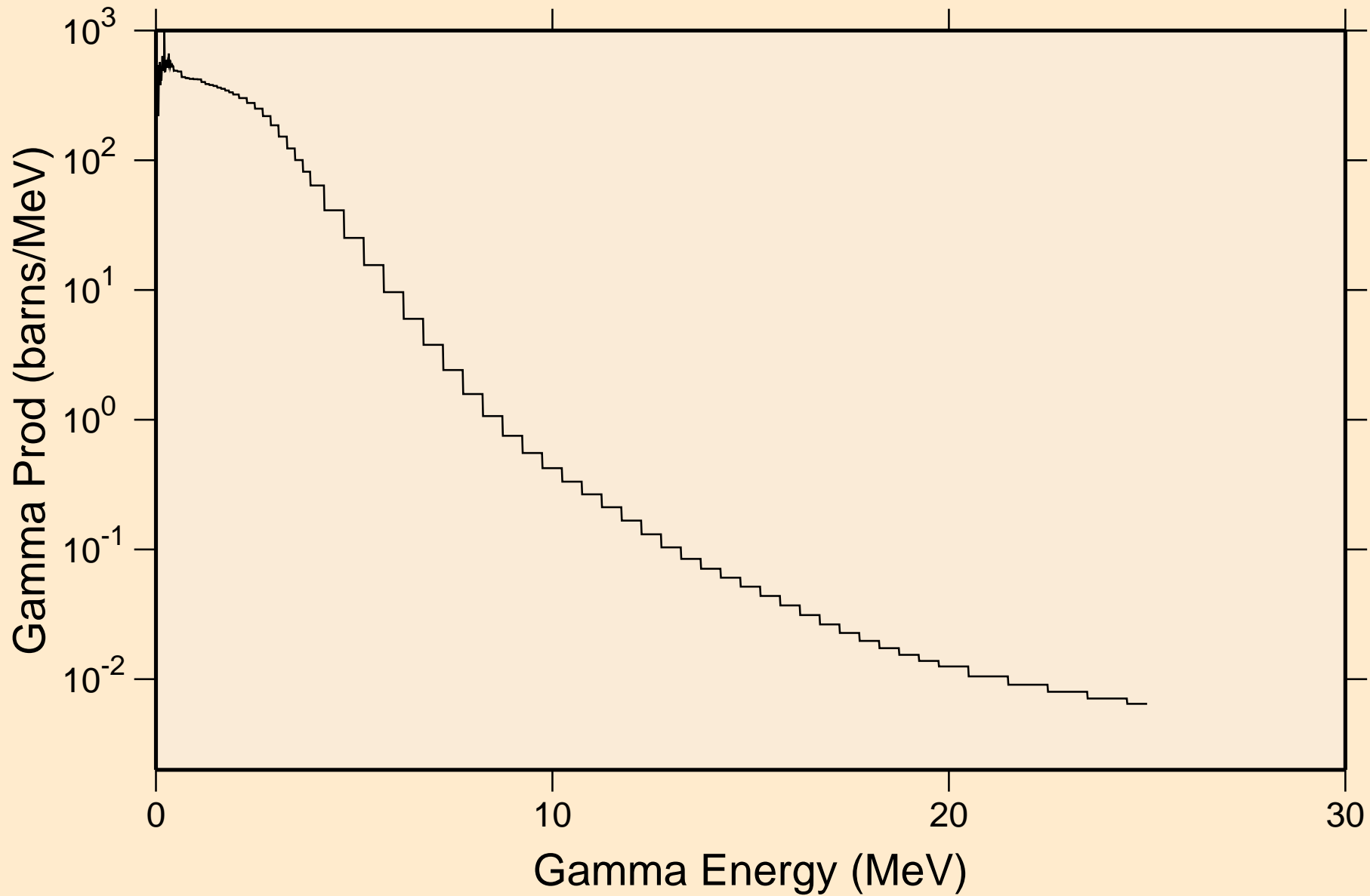

RE172M NEUTRON ACER TENDL-2023 LIBRARY; T=0.K  
Particle heating contributions

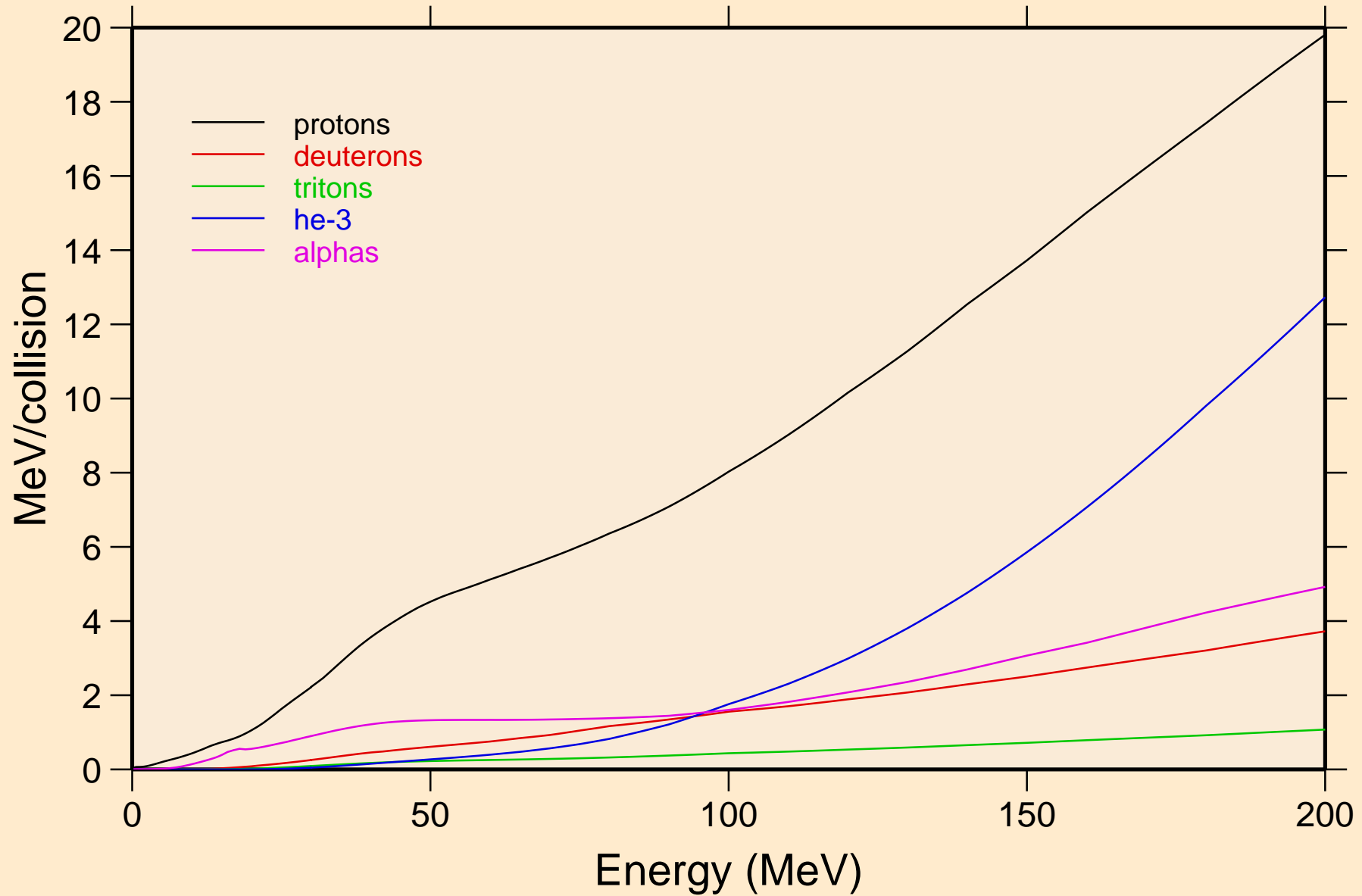



RE172M NEUTRON ACER TENDL-2023 LIBRARY; T=0.K  
Recoil Heating

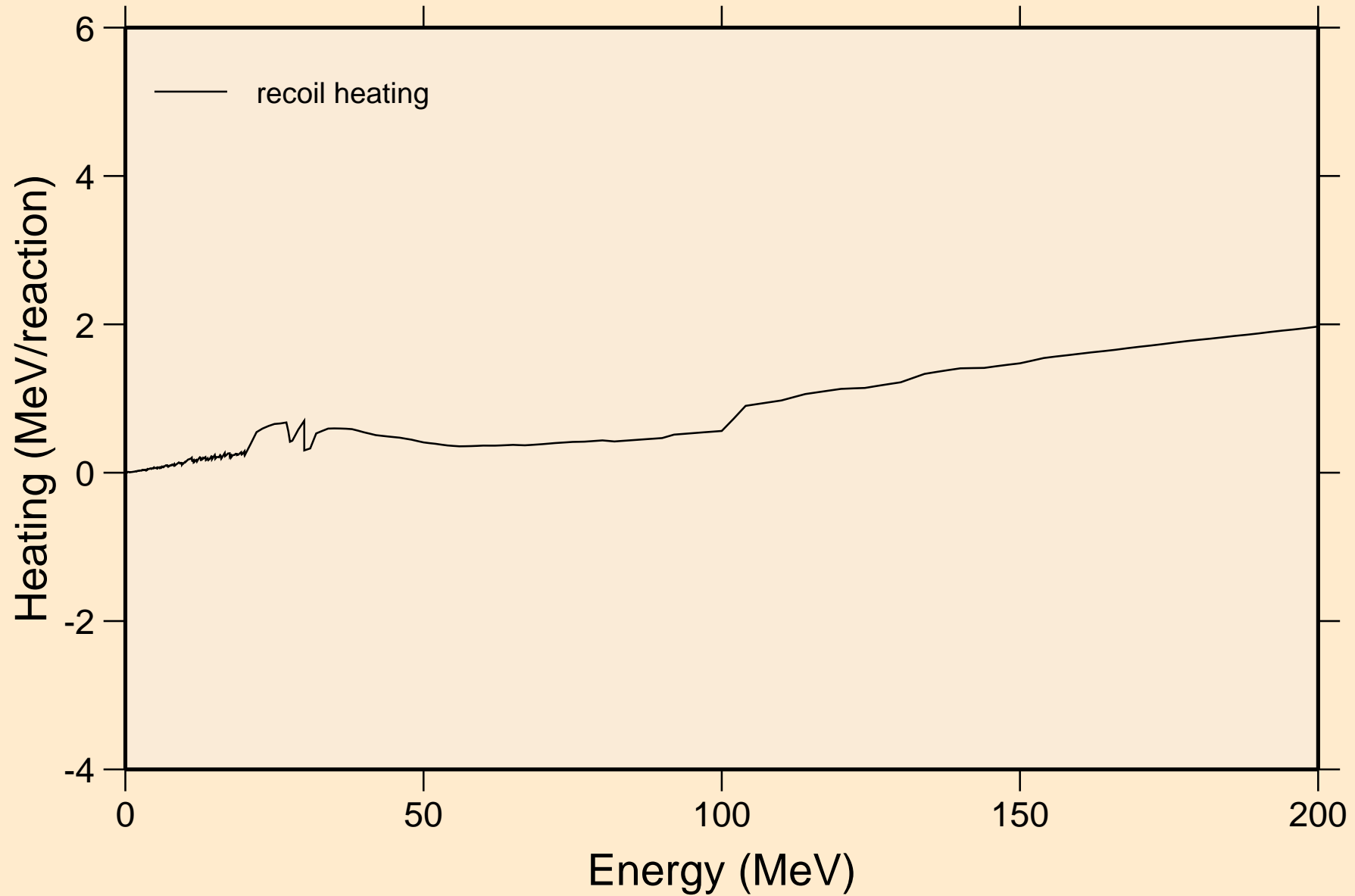

RE172M NEUTRON ACER TENDL-2023 LIBRARY; T=0.K  
Particle production cross sections

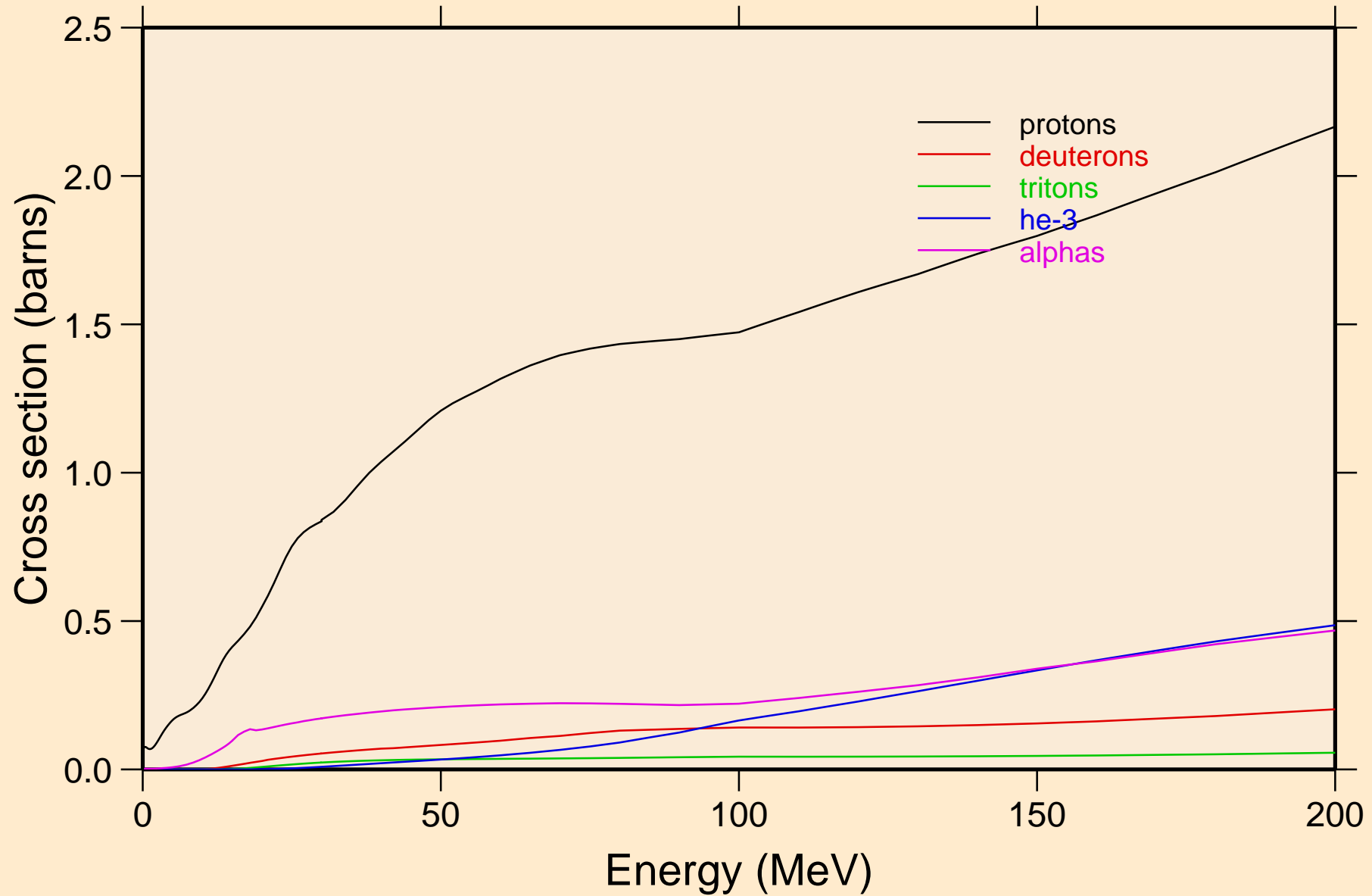

RE172M NEUTRON ACER TENDL-2023 LIBRARY; T=0.K  
protons from (n,x)

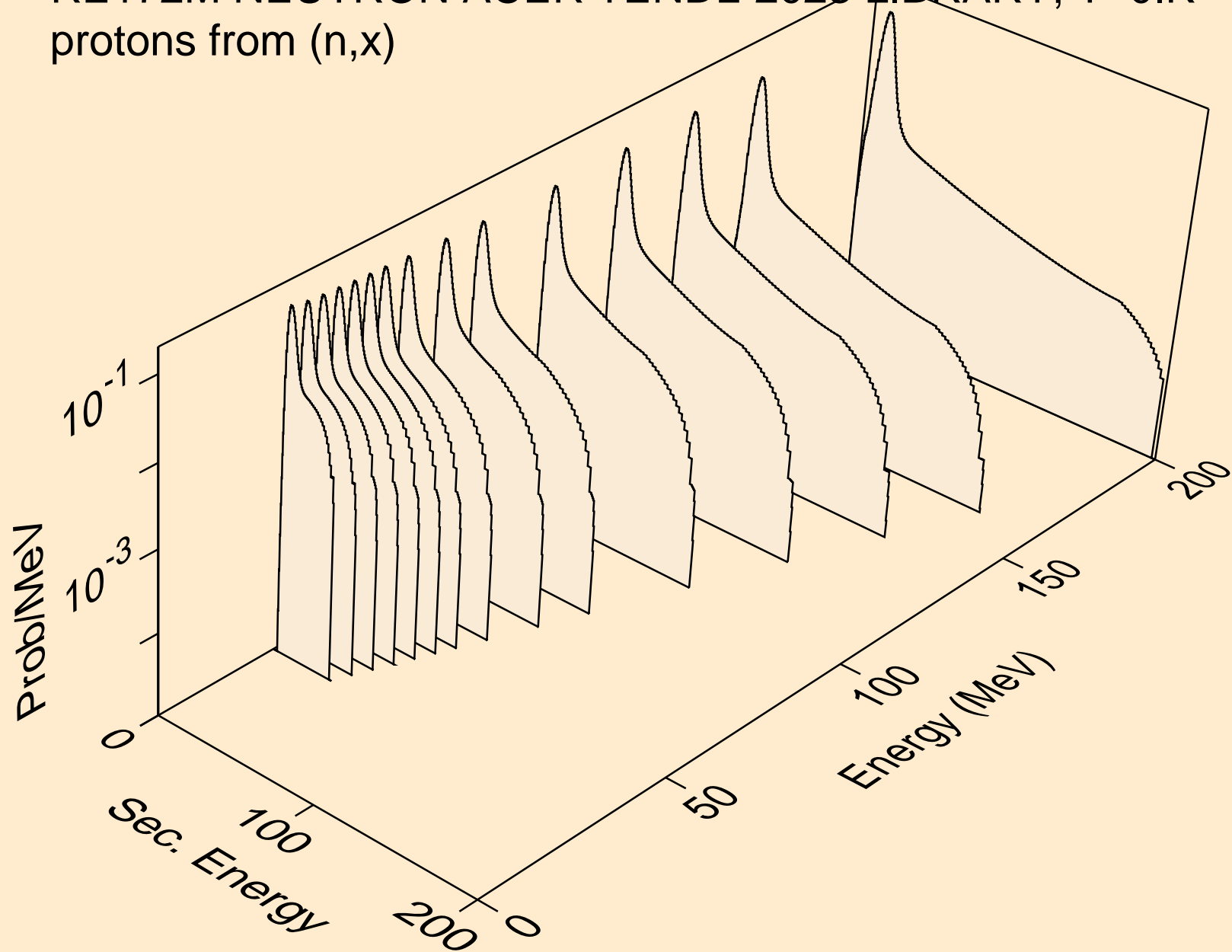

RE172M NEUTRON ACER TENDL-2023 LIBRARY; T=0.K  
protons from (n,n\*)p

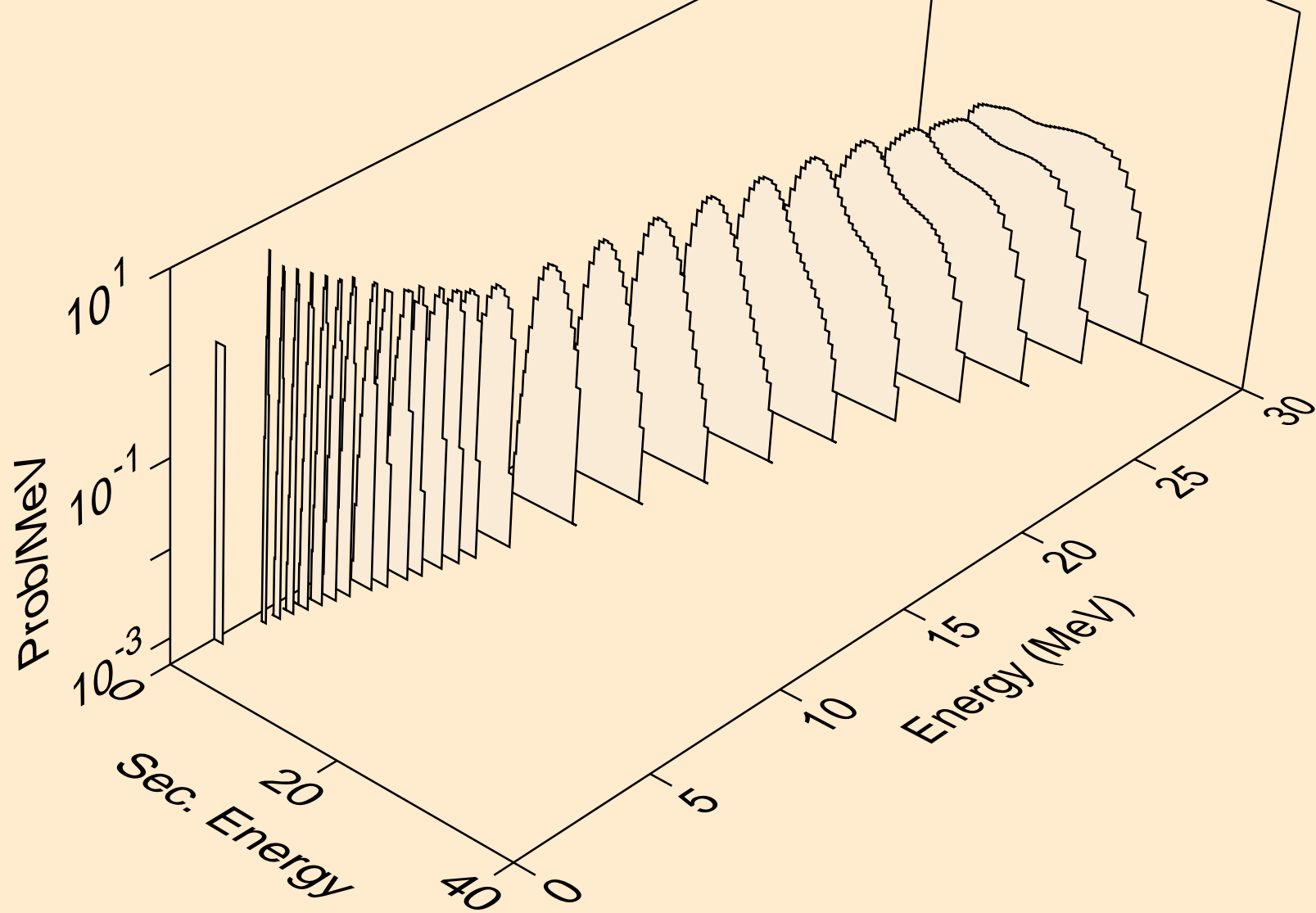

RE172M NEUTRON ACER TENDL-2023 LIBRARY; T=0.K  
protons from (n,2np)

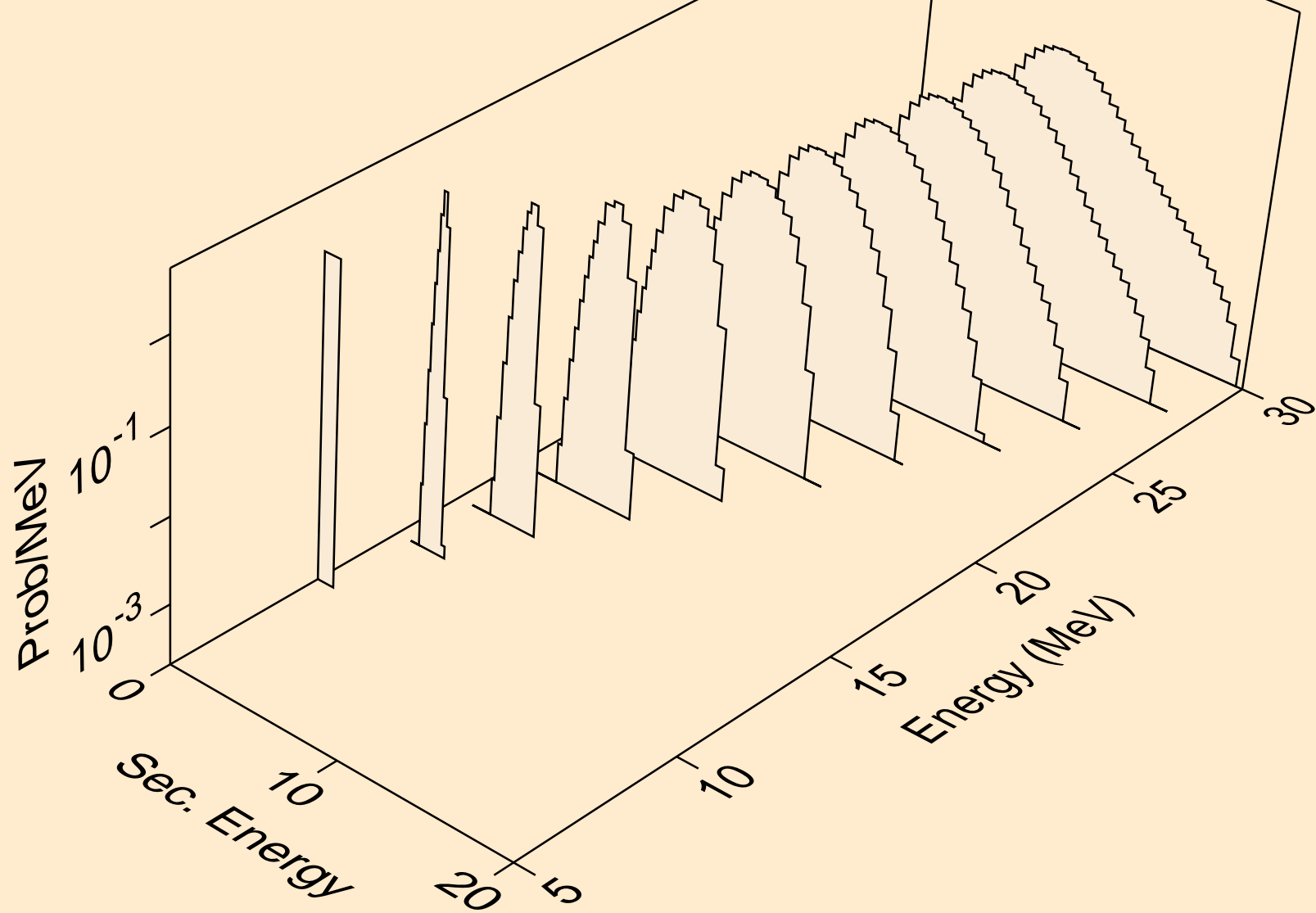

RE172M NEUTRON ACER TENDL-2023 LIBRARY; T=0.K  
protons from (n,3np)

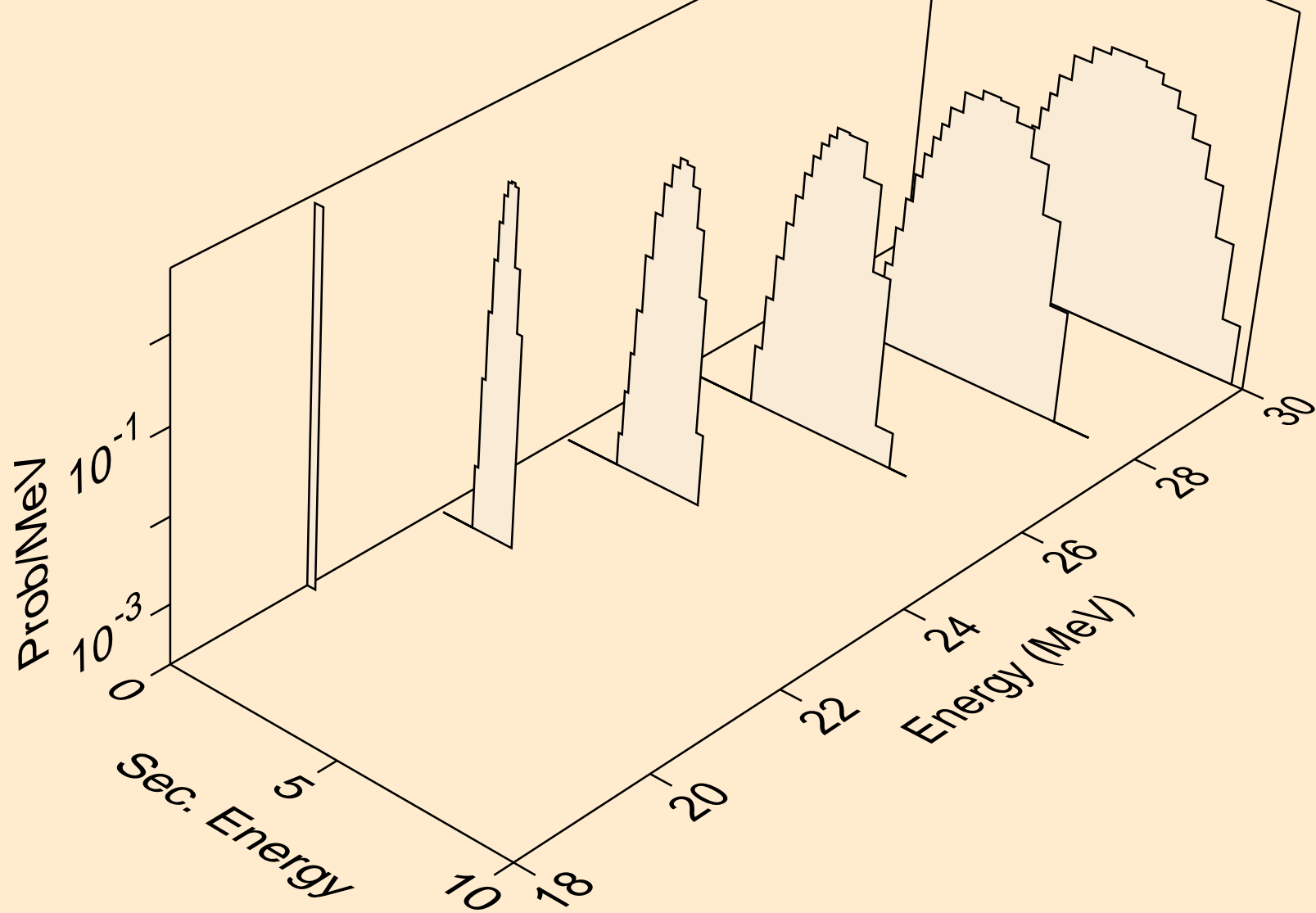

RE172M NEUTRON ACER TENDL-2023 LIBRARY; T=0.K  
protons from (n,n2p)

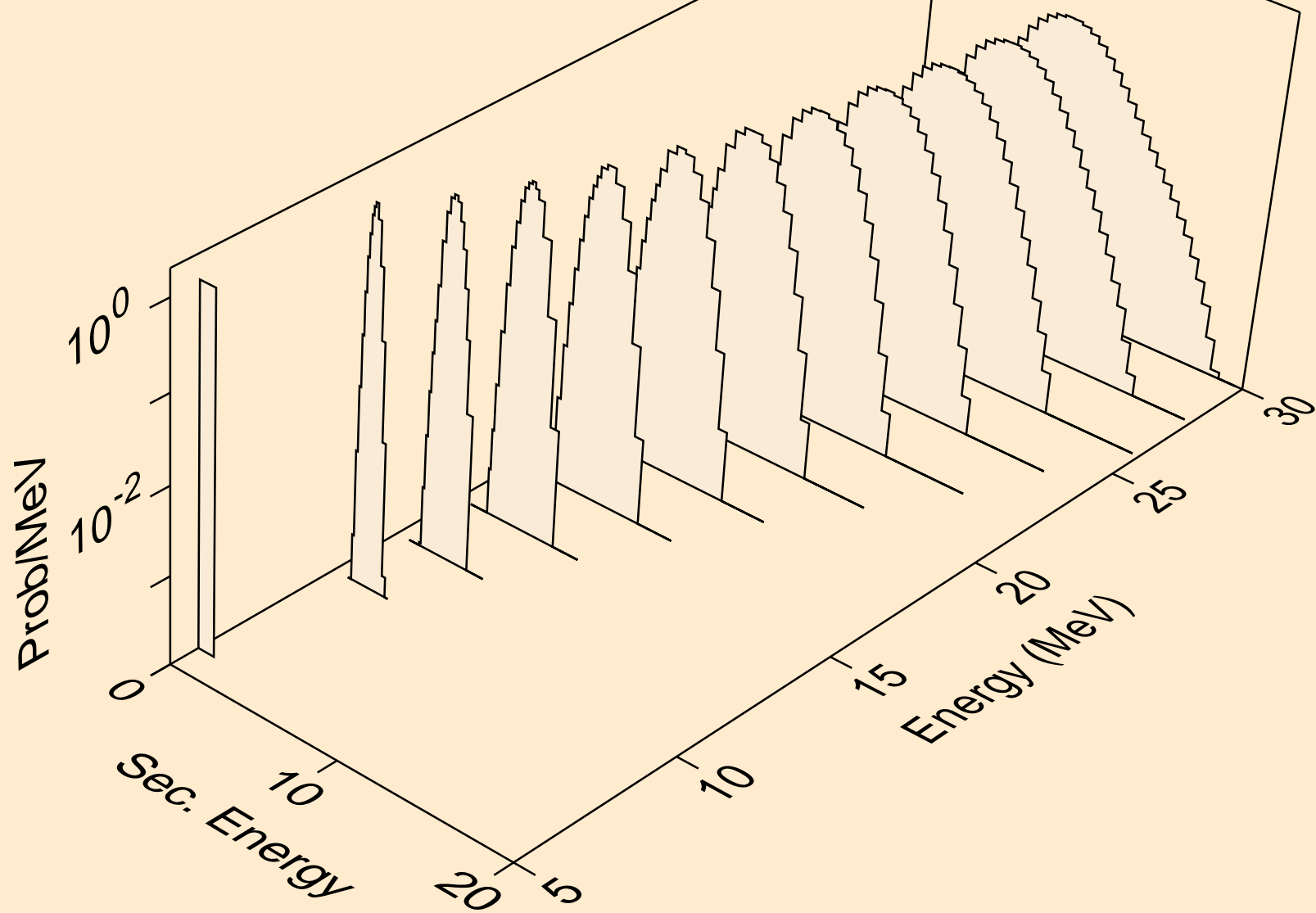

RE172M NEUTRON ACER TENDL-2023 LIBRARY; T=0.K  
protons from (n,npa)

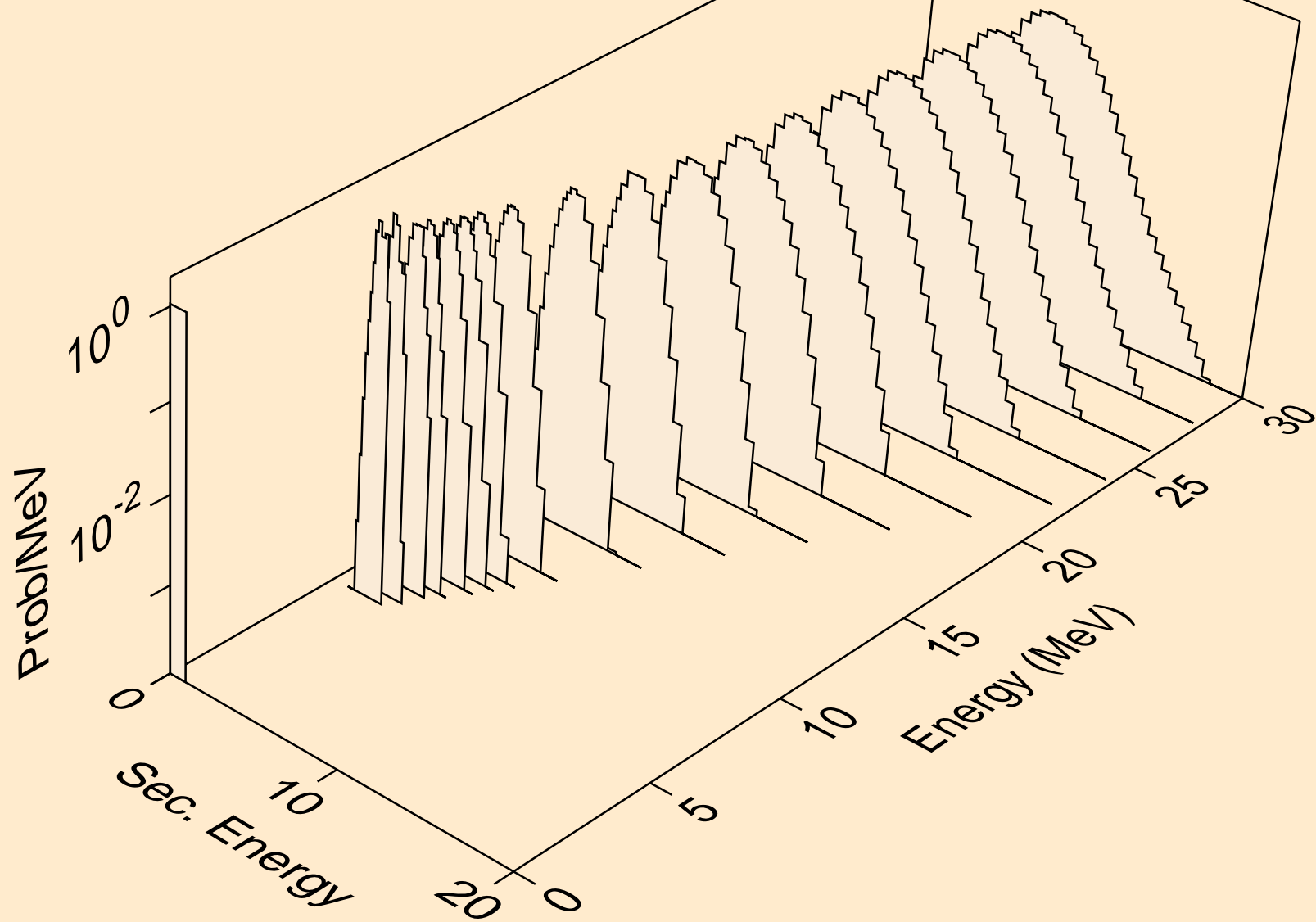



RE172M NEUTRON ACER TENDL-2023 LIBRARY; T=0.K  
protons from (n,p)

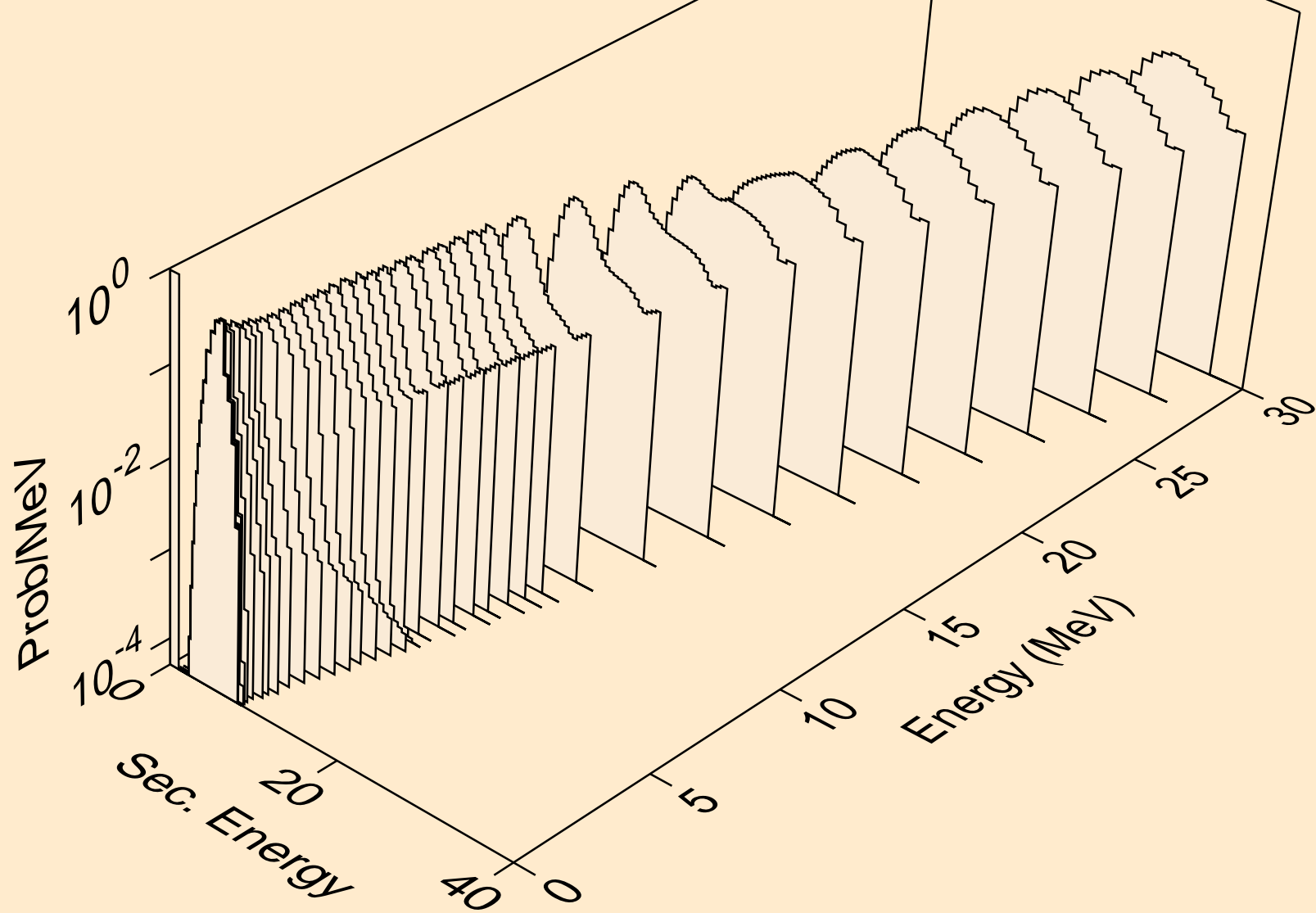

RE172M NEUTRON ACER TENDL-2023 LIBRARY; T=0.K  
protons from (n,2p)

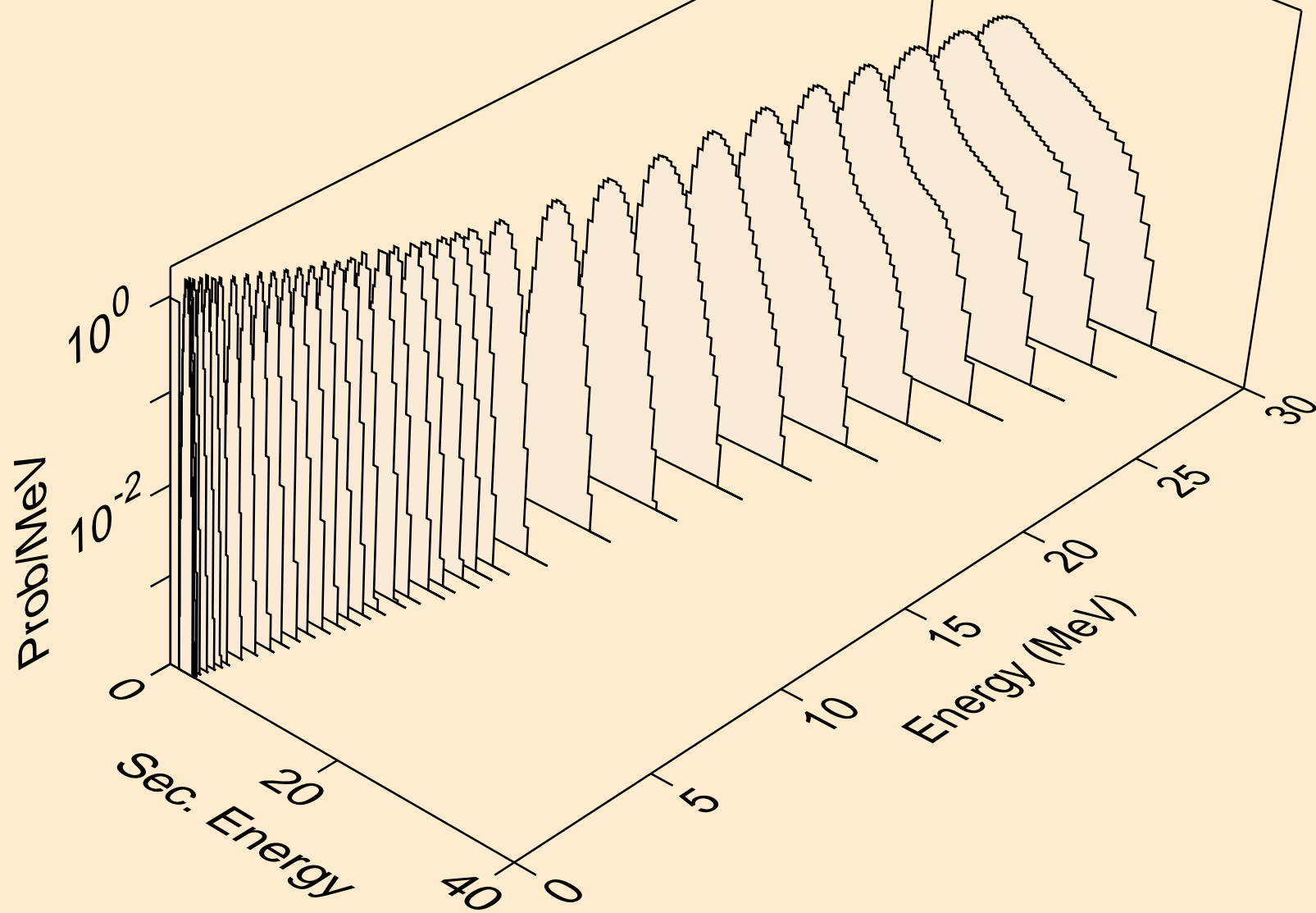

RE172M NEUTRON ACER TENDL-2023 LIBRARY; T=0.K  
protons from (n,p)

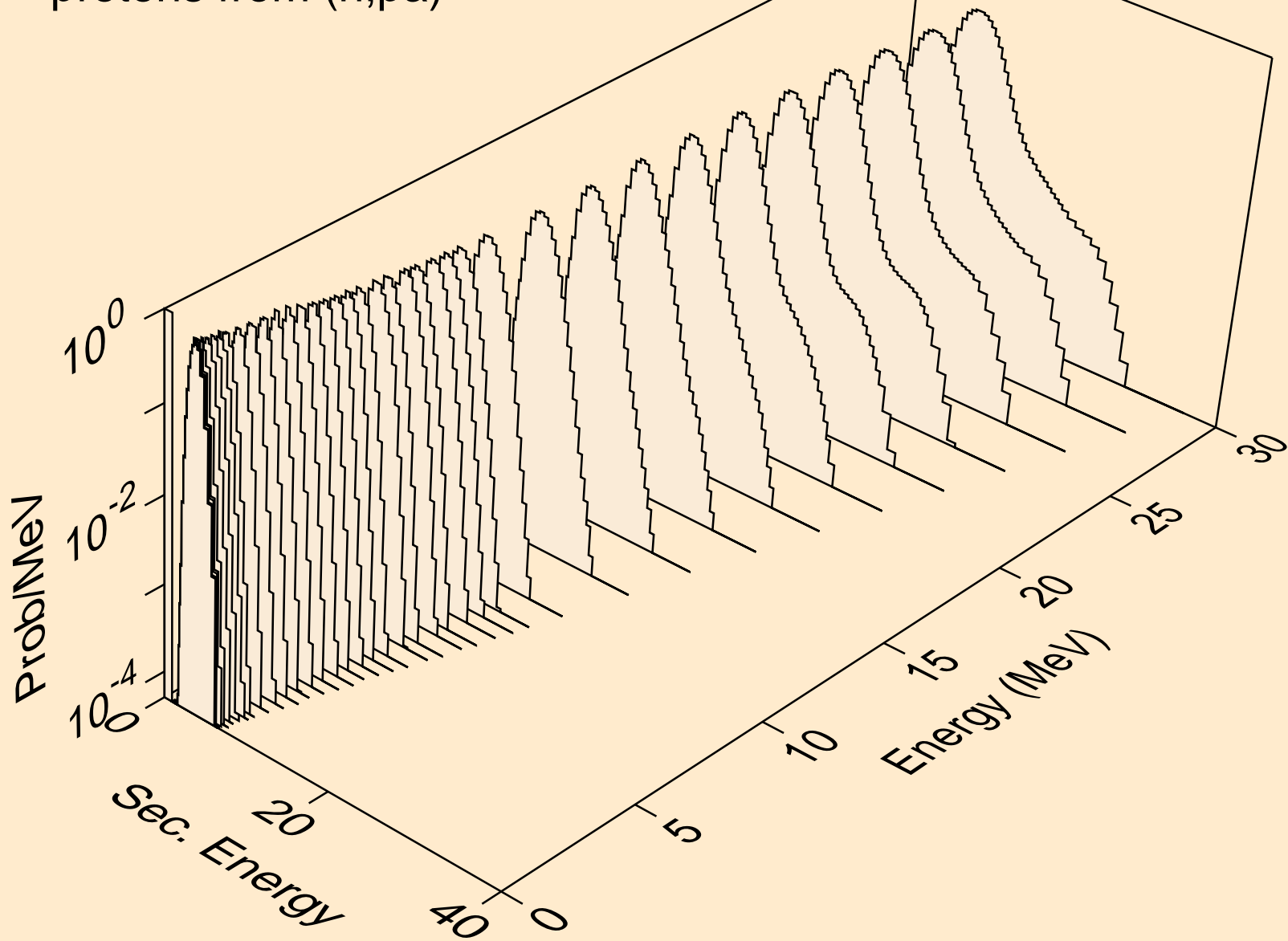

RE172M NEUTRON ACER TENDL-2023 LIBRARY; T=0.K  
protons from (n,pd)

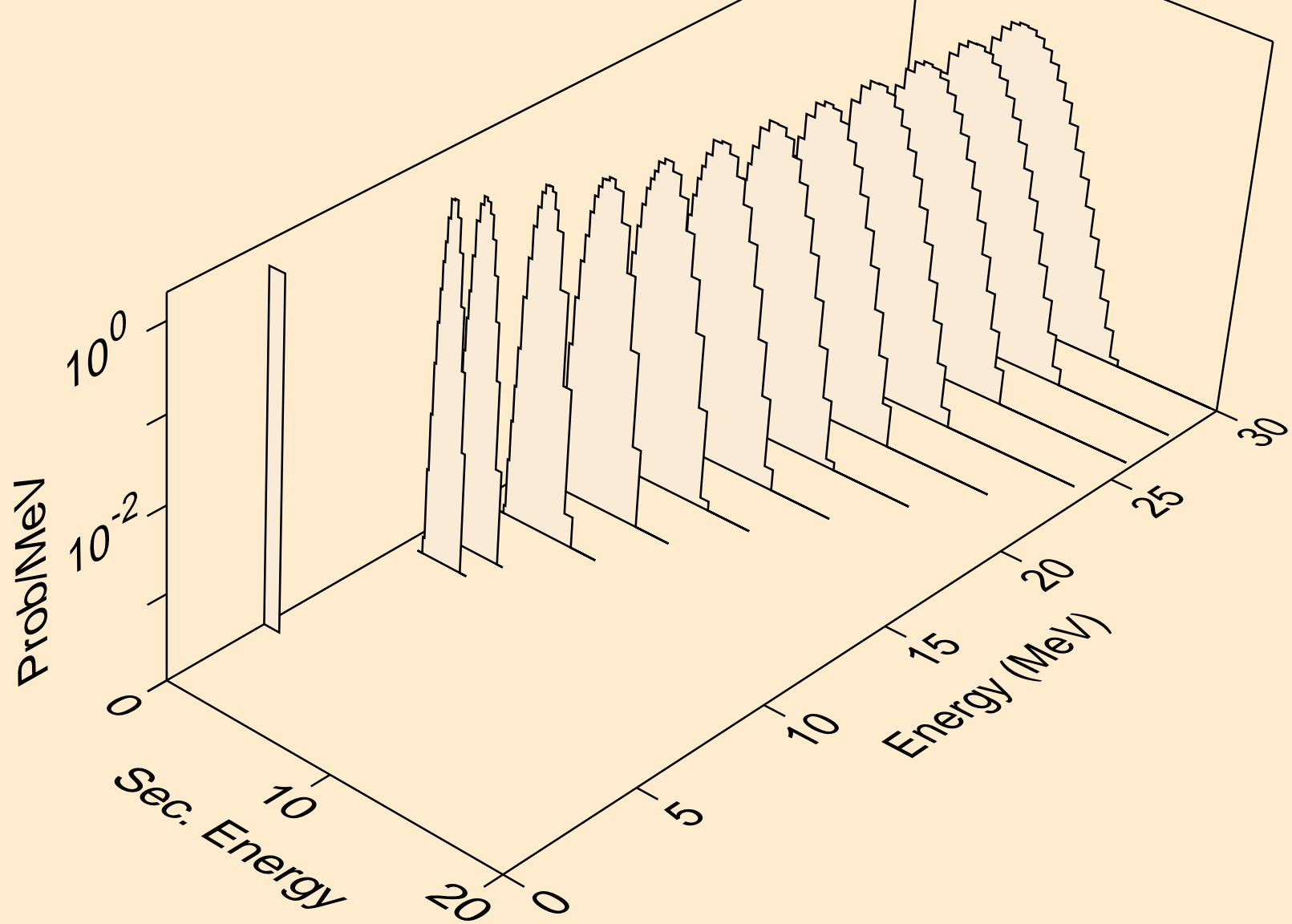

RE172M NEUTRON ACER TENDL-2023 LIBRARY; T=0.K  
protons from (n,pt)

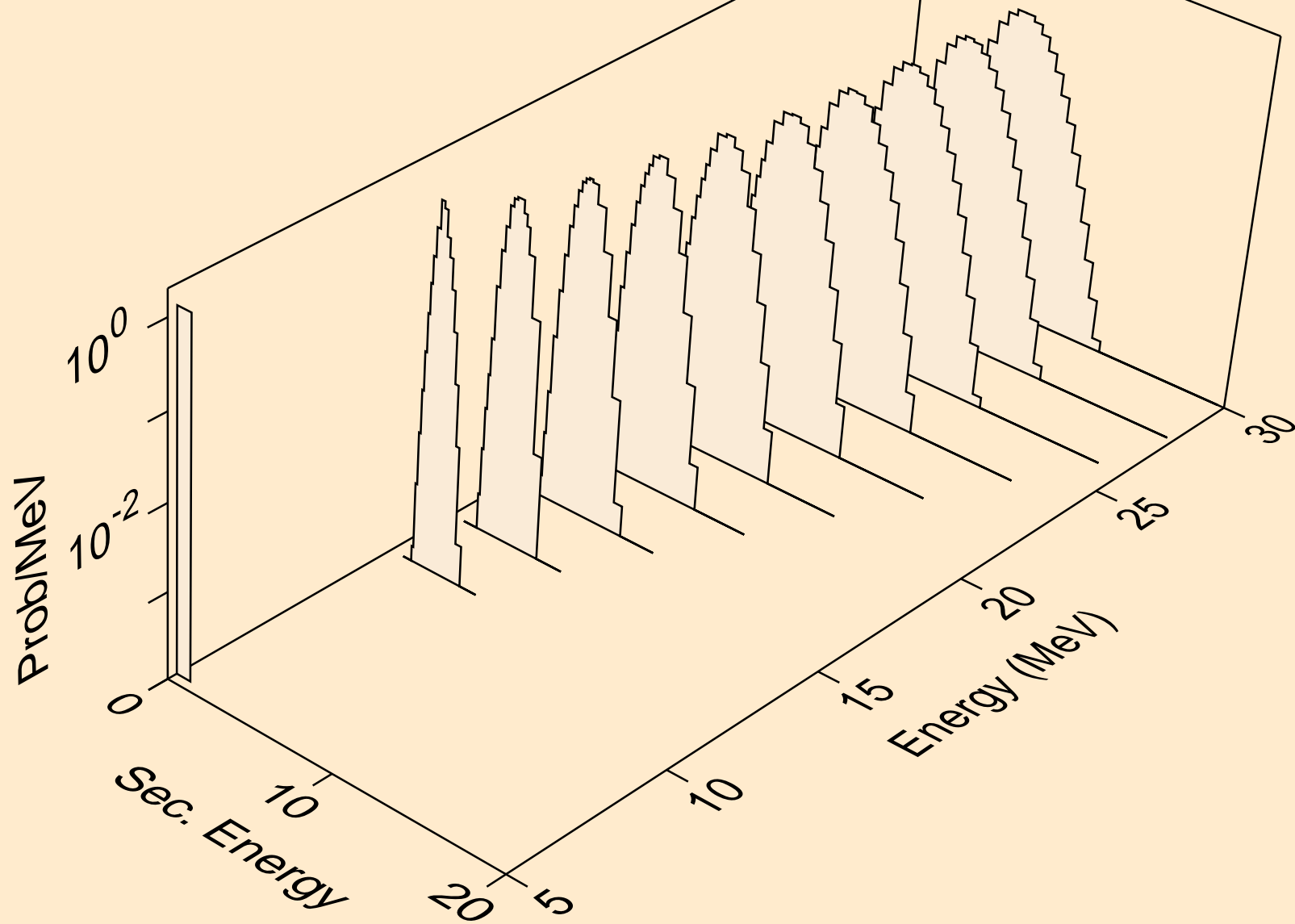

RE172M NEUTRON ACER TENDL-2023 LIBRARY; T=0.K  
deuterons from (n,x)

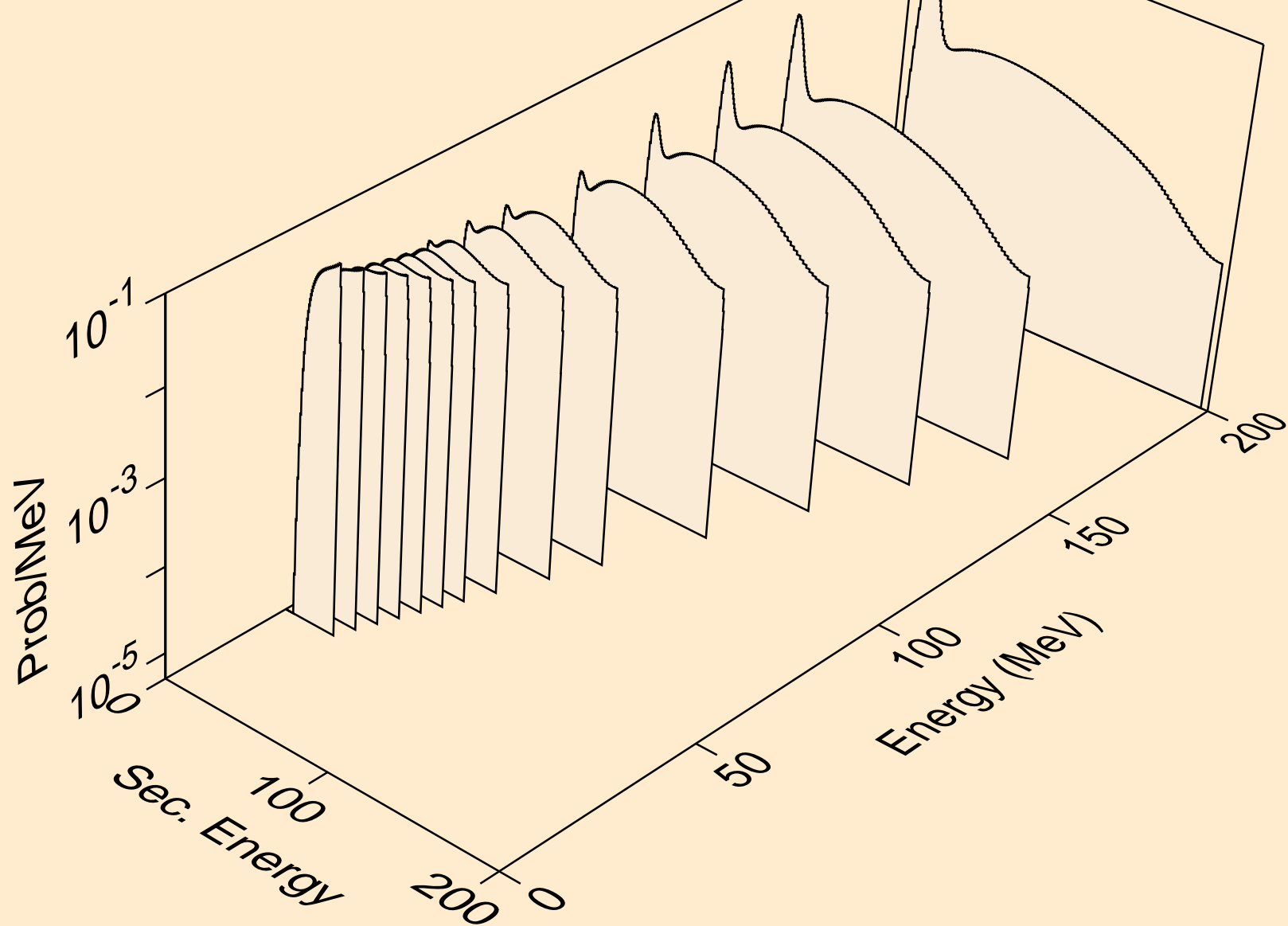

RE172M NEUTRON ACER TENDL-2023 LIBRARY; T=0.K  
deuterons from (n,2nd)

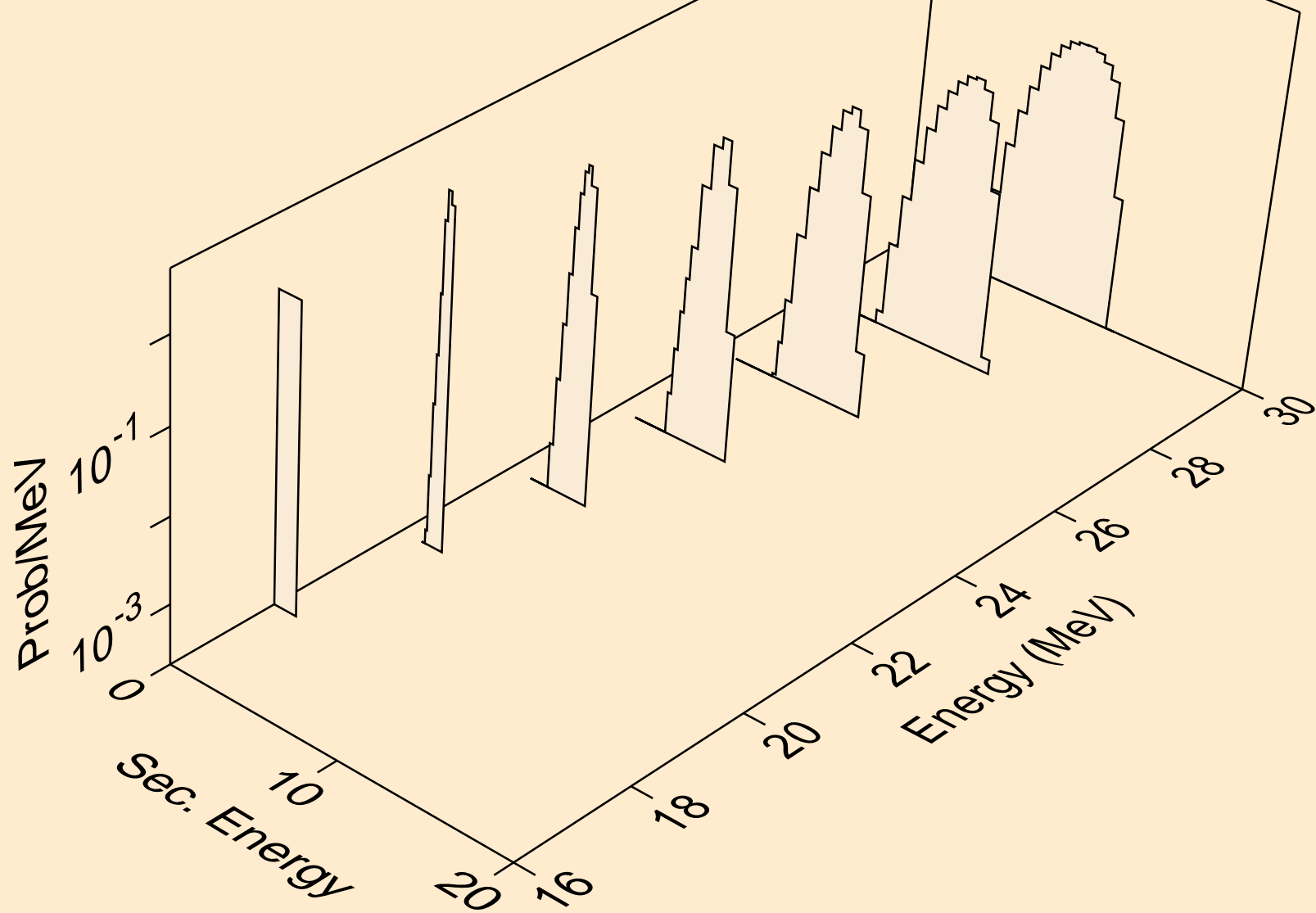

RE172M NEUTRON ACER TENDL-2023 LIBRARY; T=0.K  
deuterons from (n,n\*)d

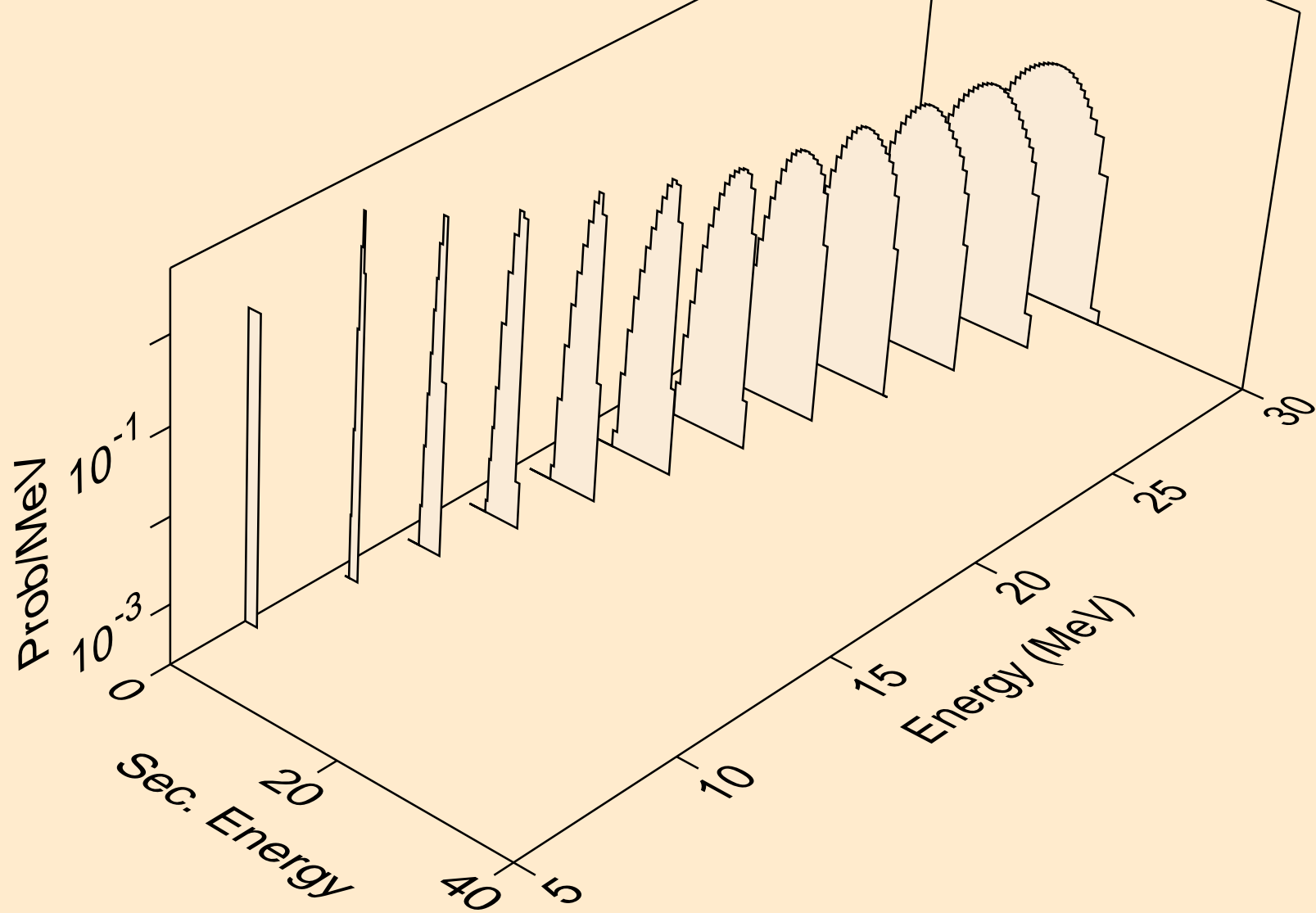



RE172M NEUTRON ACER TENDL-2023 LIBRARY; T=0.K  
deuterons from (n,d)

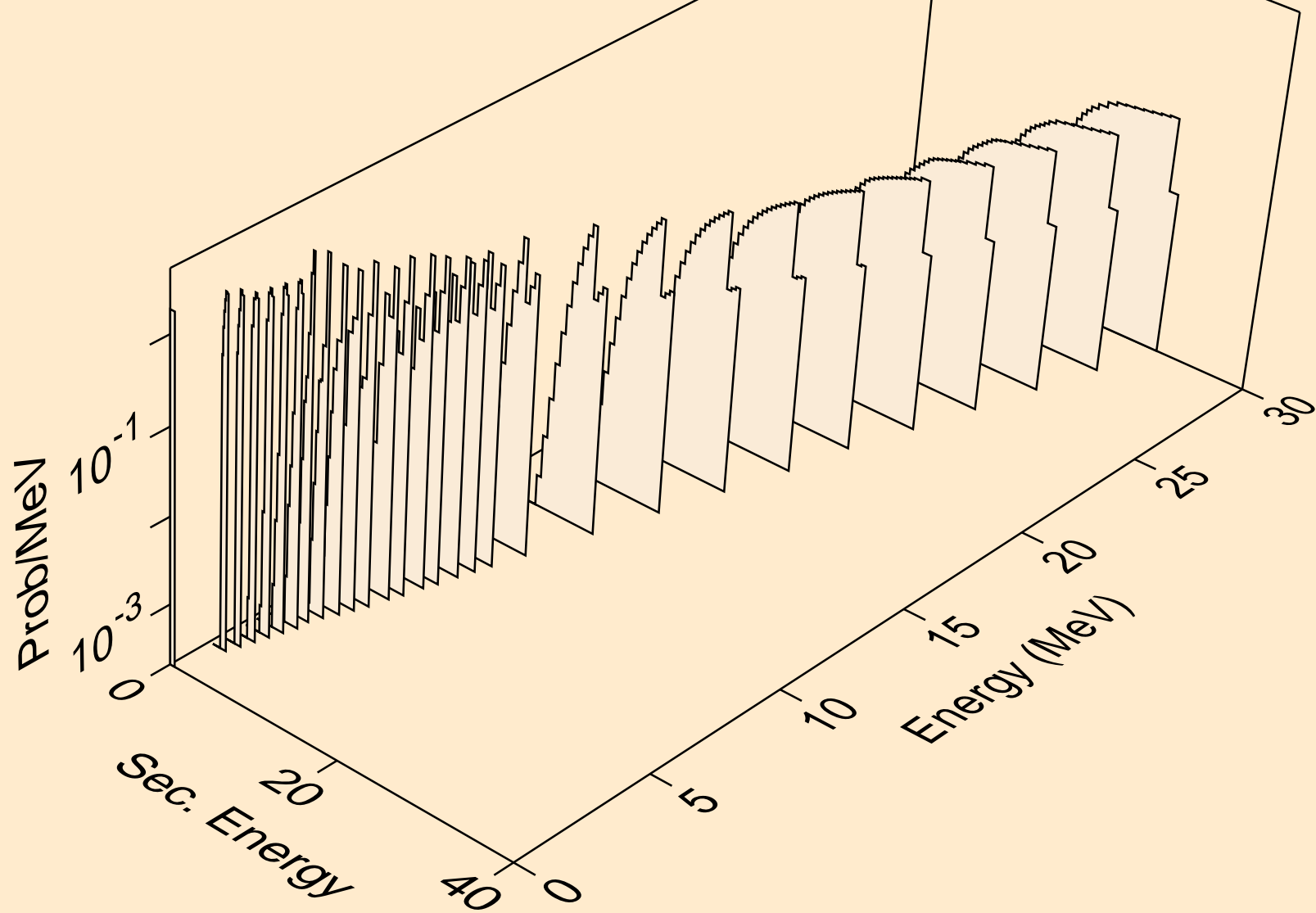

RE172M NEUTRON ACER TENDL-2023 LIBRARY; T=0.K  
deuterons from (n,pd)

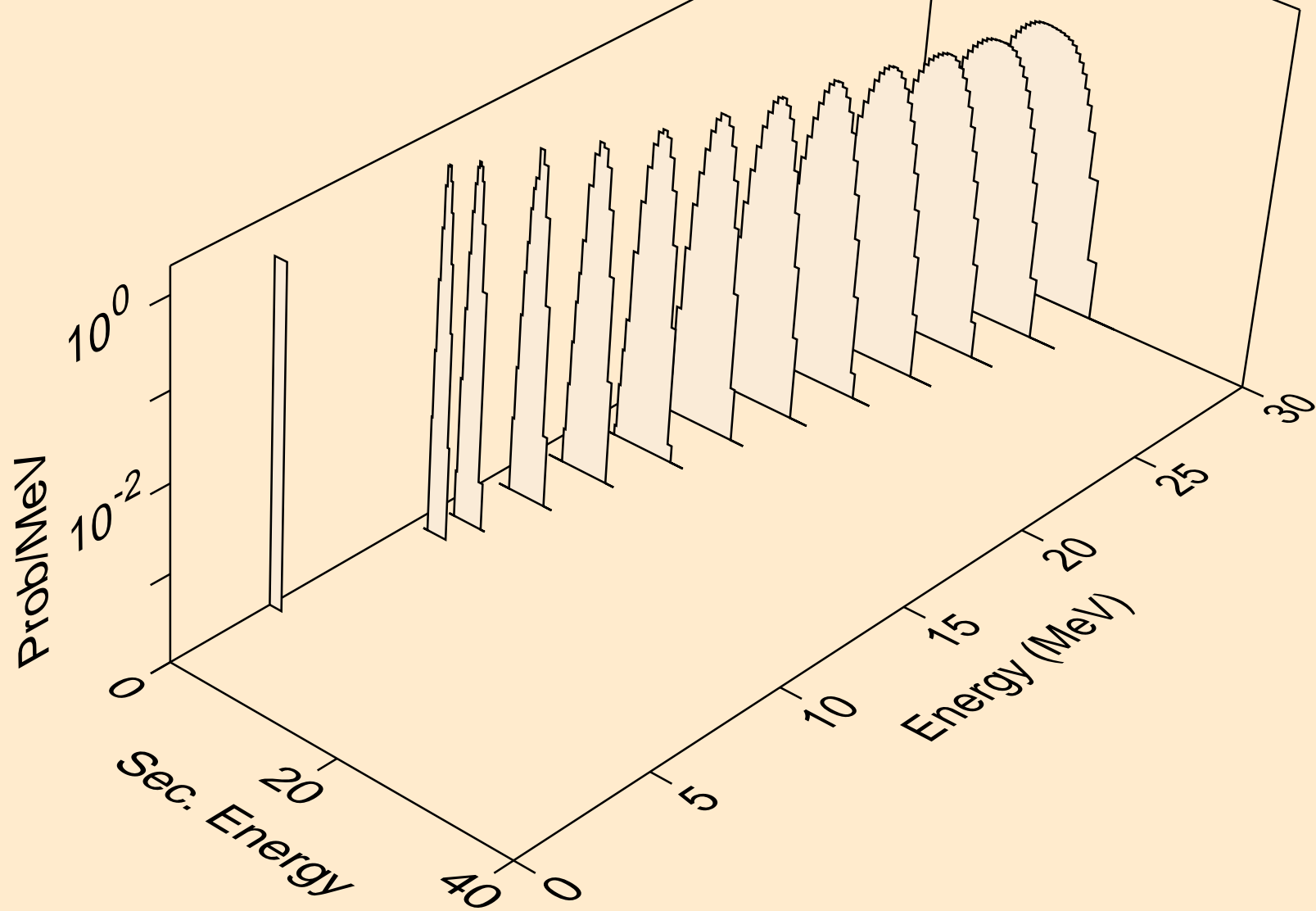

RE172M NEUTRON ACER TENDL-2023 LIBRARY; T=0.K  
deuterons from (n,da)

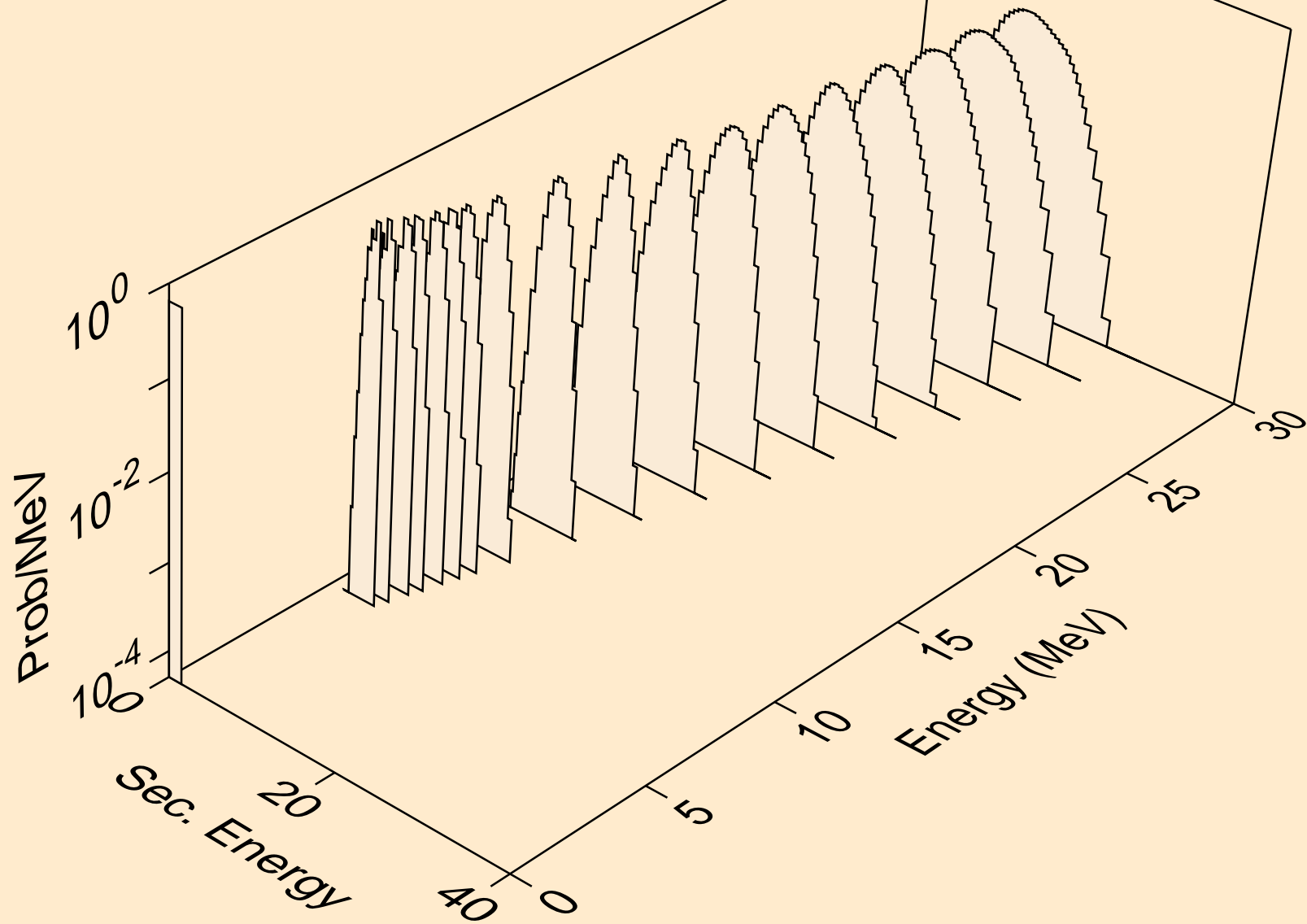

RE172M NEUTRON ACER TENDL-2023 LIBRARY; T=0.K  
tritons from (n,x)

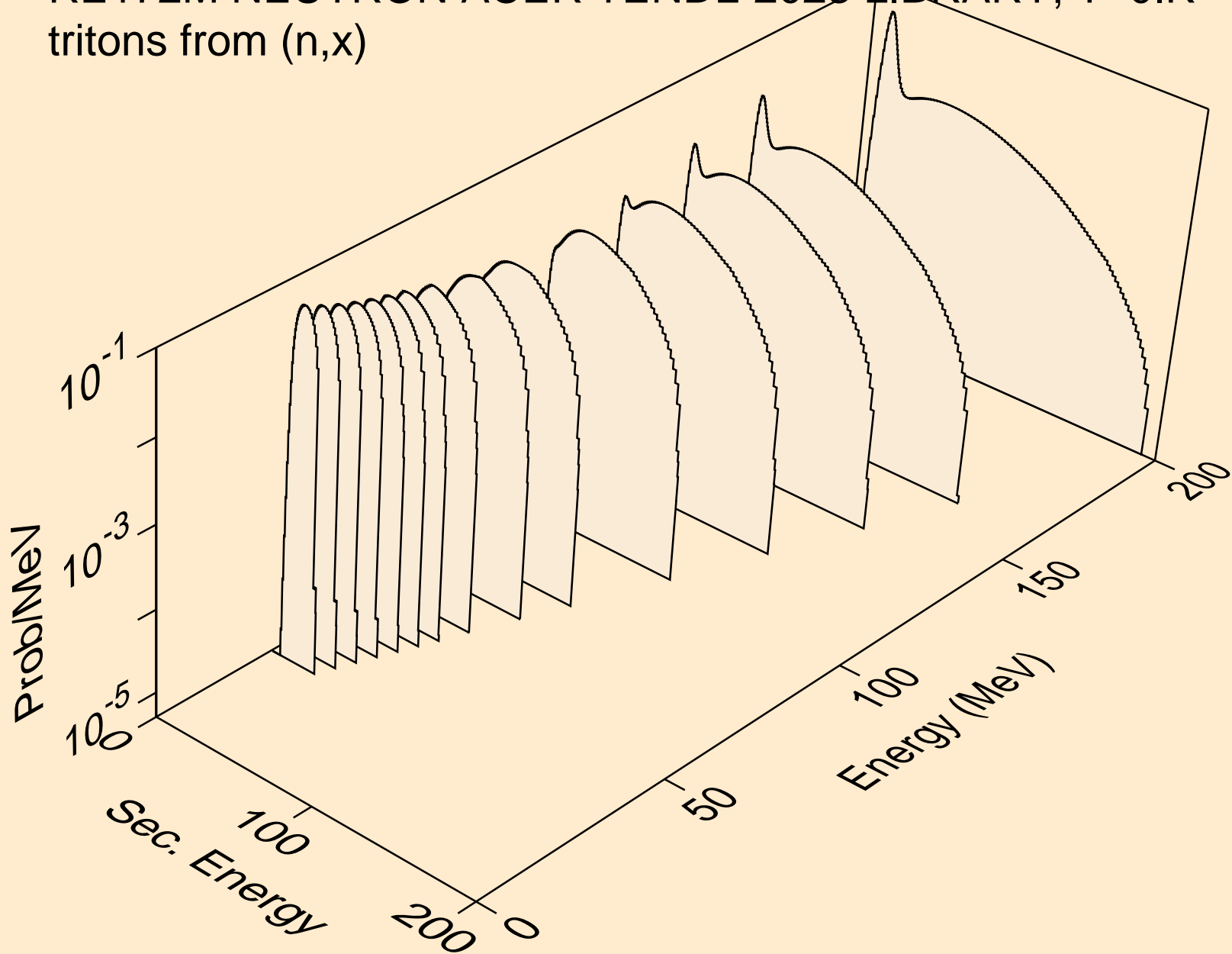

RE172M NEUTRON ACER TENDL-2023 LIBRARY; T=0.K  
tritons from (n,n\*)t

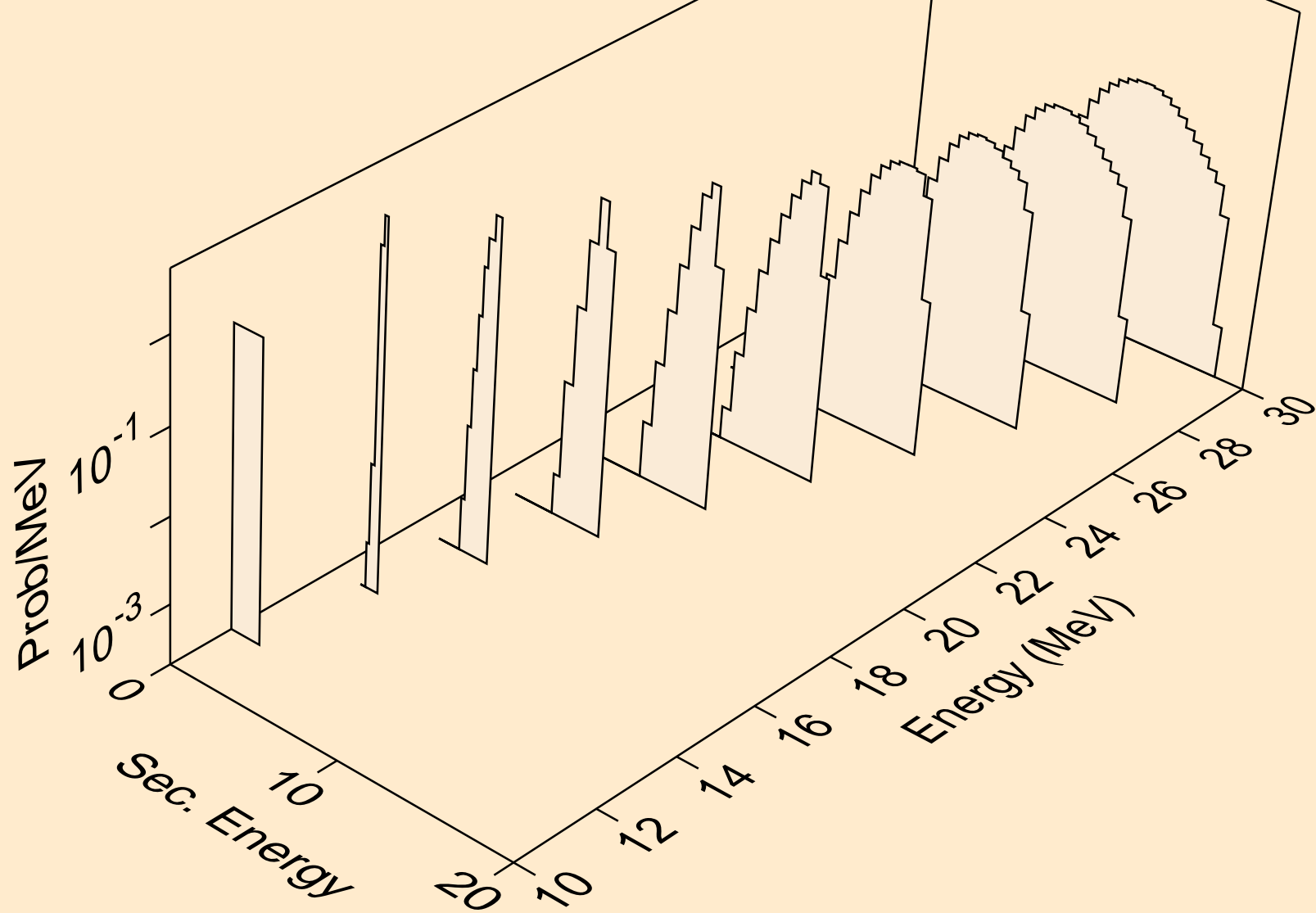

RE172M NEUTRON ACER TENDL-2023 LIBRARY; T=0.K  
tritons from (n,t)

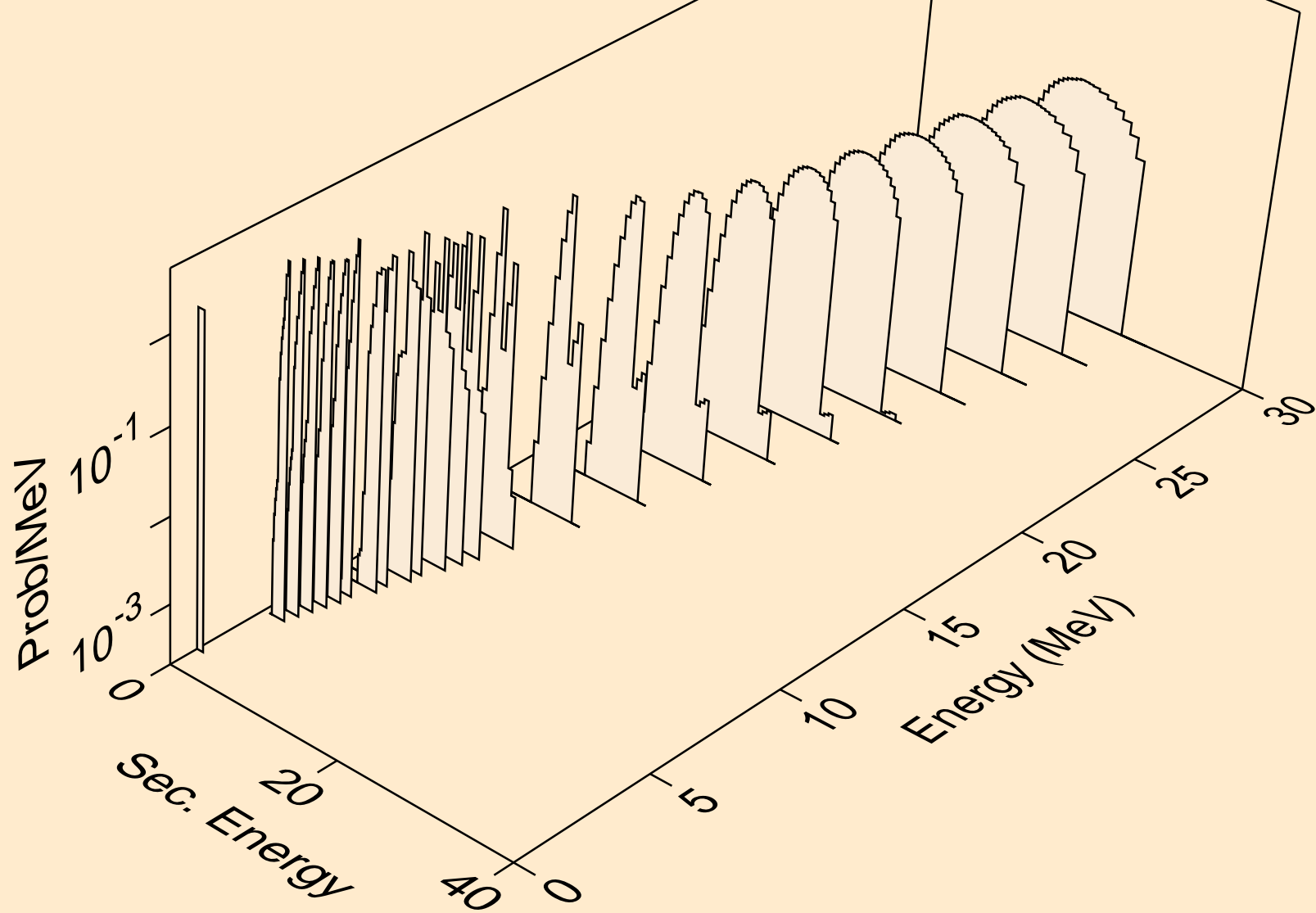

RE172M NEUTRON ACER TENDL-2023 LIBRARY; T=0.K  
tritons from (n,pt)

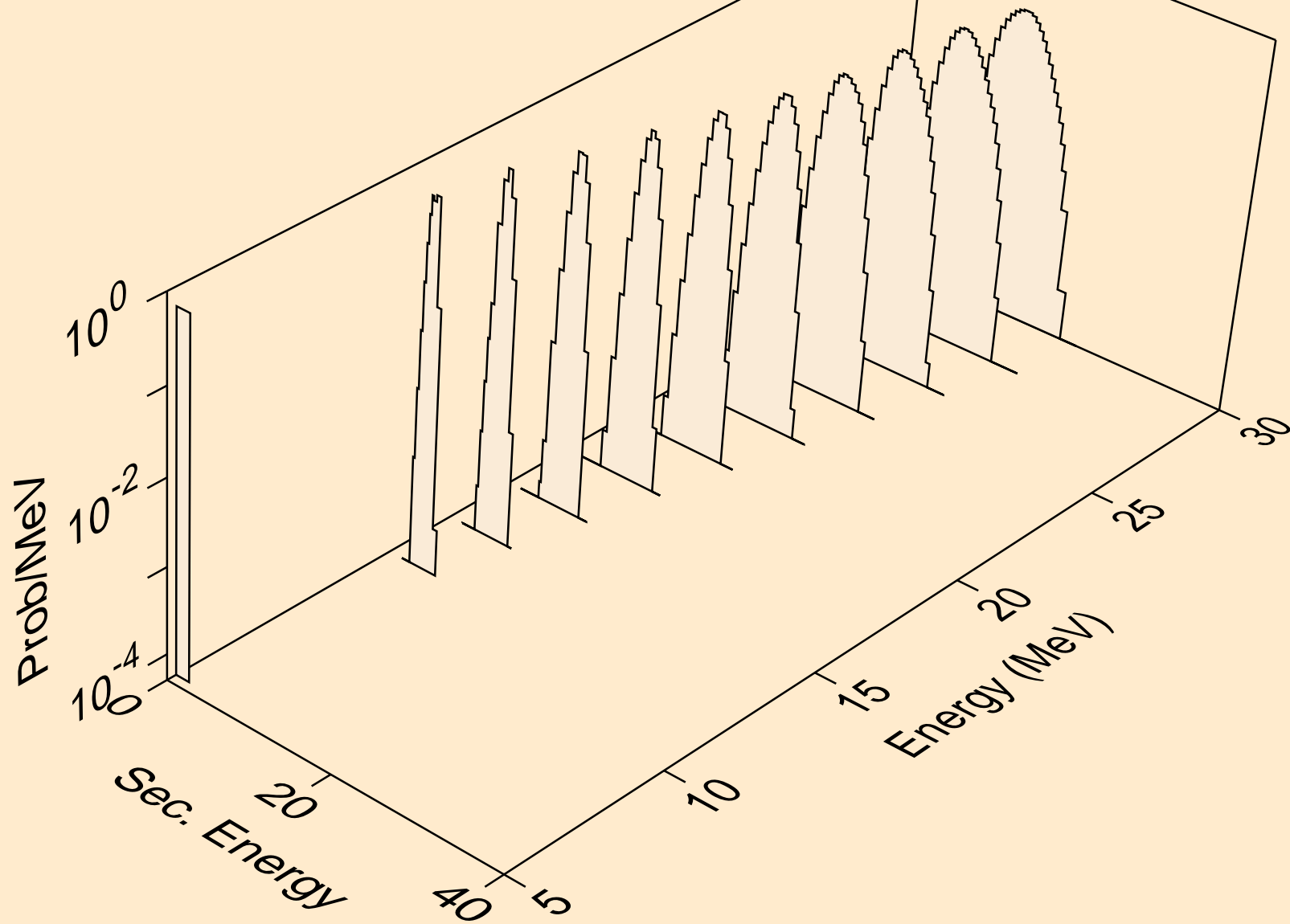

RE172M NEUTRON ACER TENDL-2023 LIBRARY; T=0.K  
he3s from (n,x)

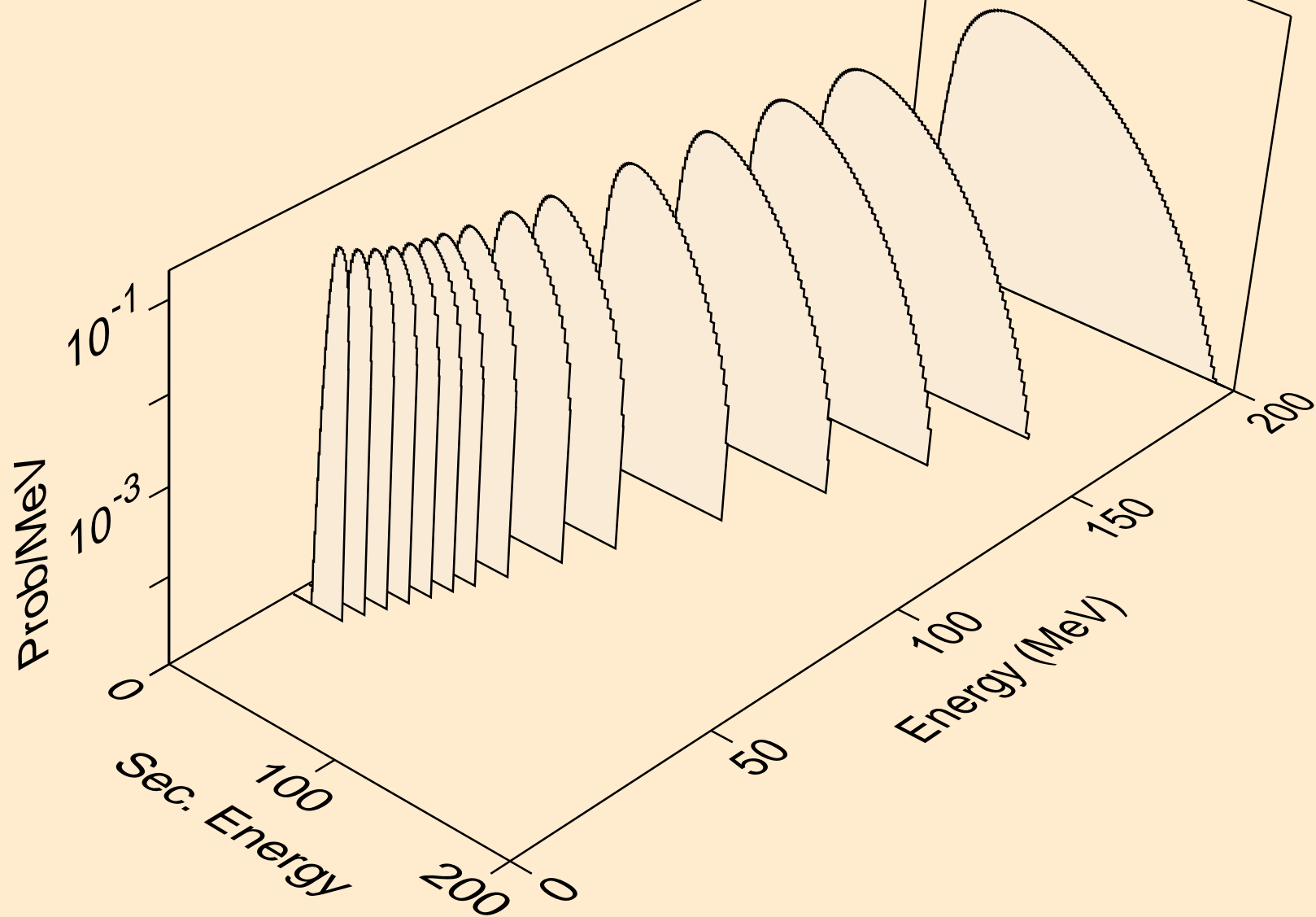



RE172M NEUTRON ACER TENDL-2023 LIBRARY; T=0.K  
he3s from (n,n\*)he3

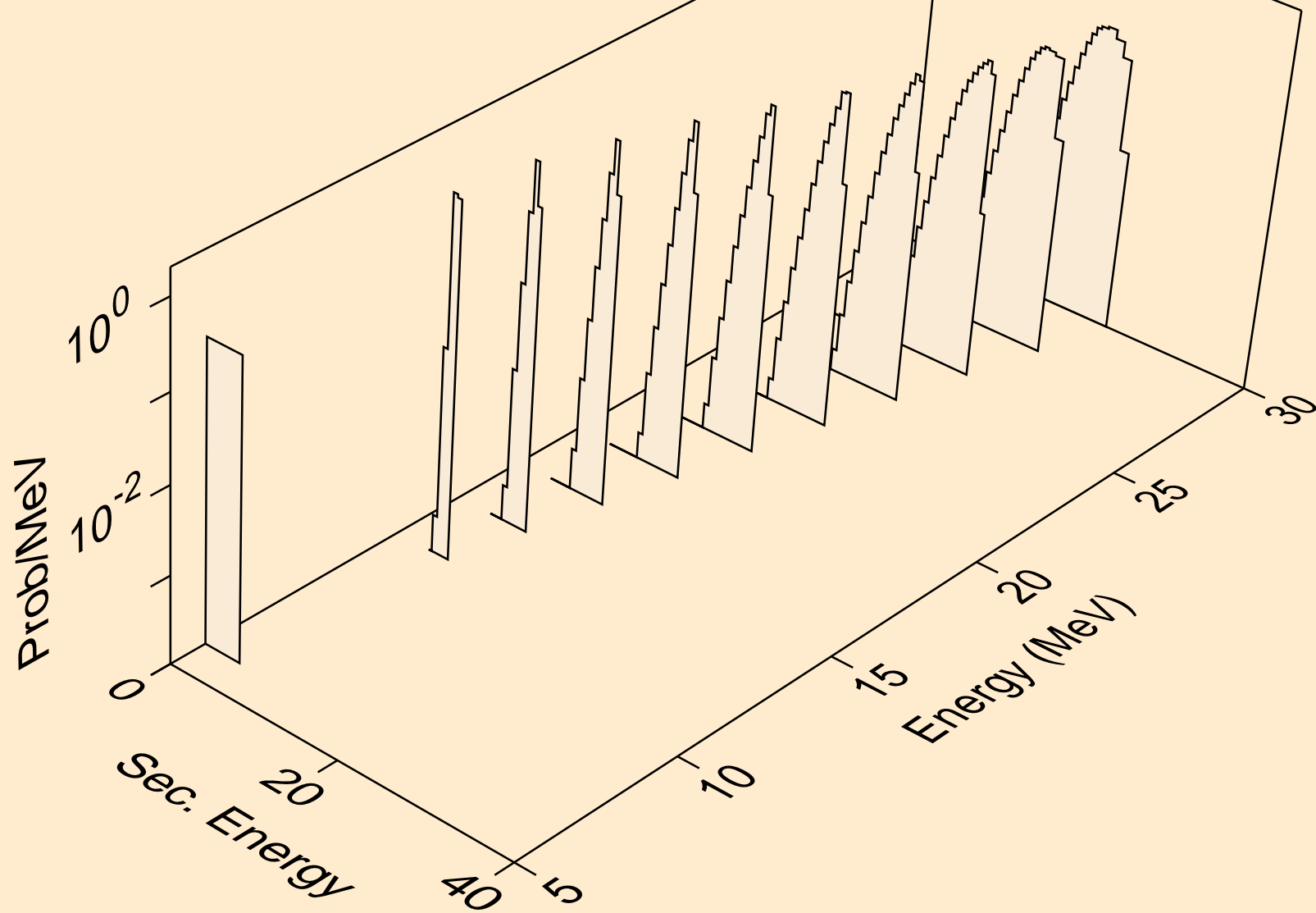

RE172M NEUTRON ACER TENDL-2023 LIBRARY; T=0.K  
he3s from (n,he3)

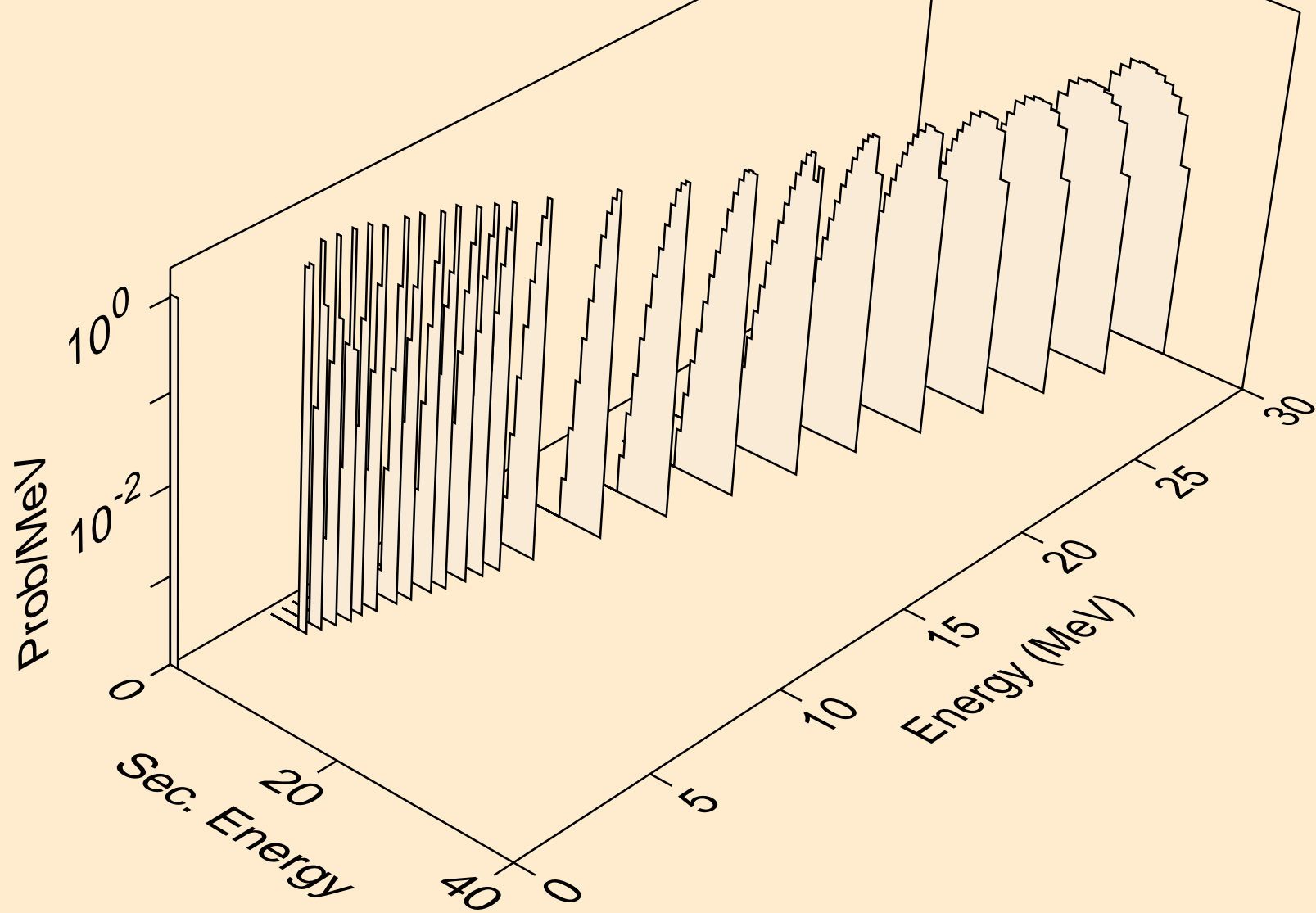

RE172M NEUTRON ACER TENDL-2023 LIBRARY; T=0.K  
alphas from (n,x)

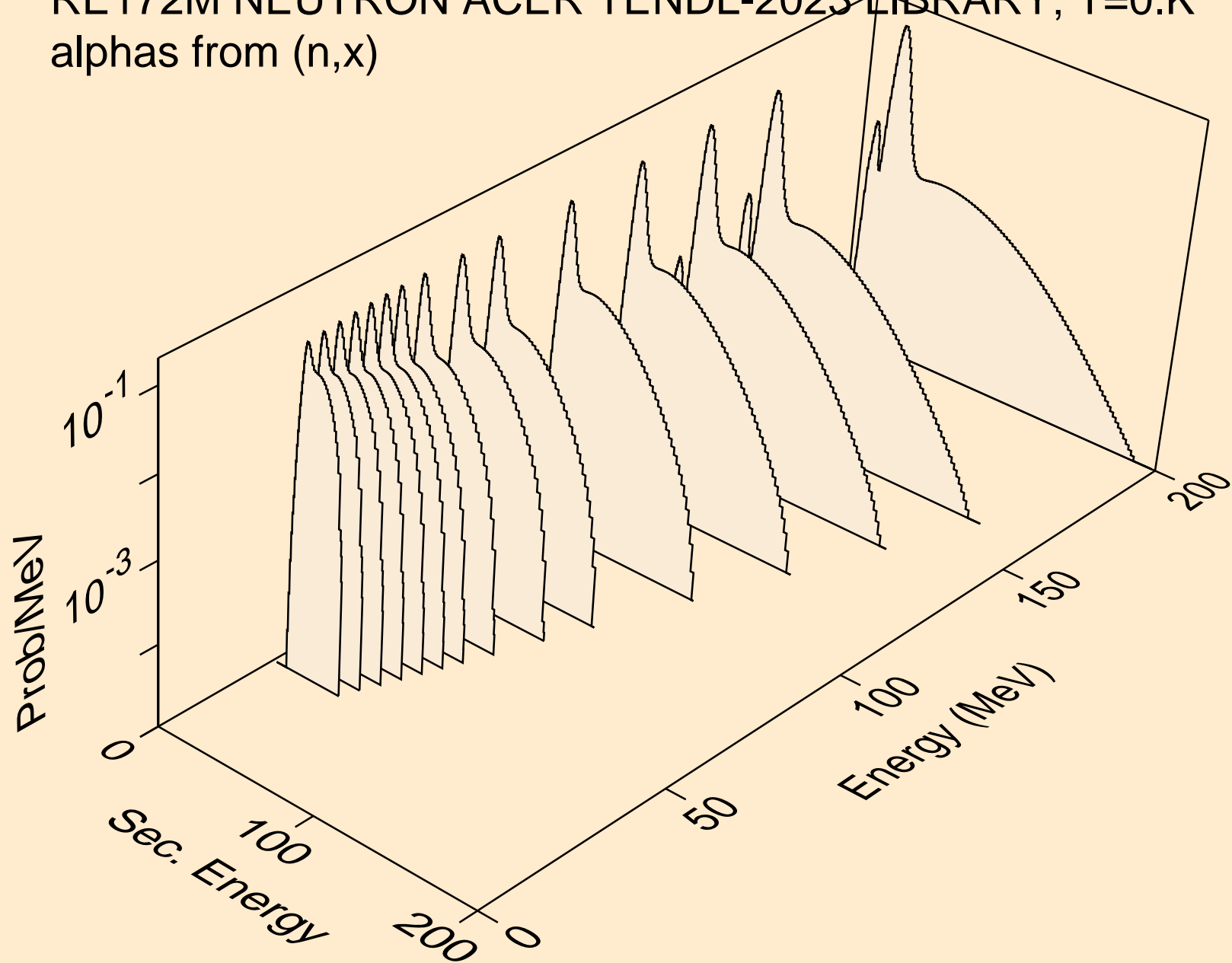

RE172M NEUTRON ACER TENDL-2023 LIBRARY; T=0.K  
alphas from (n,n\*)a

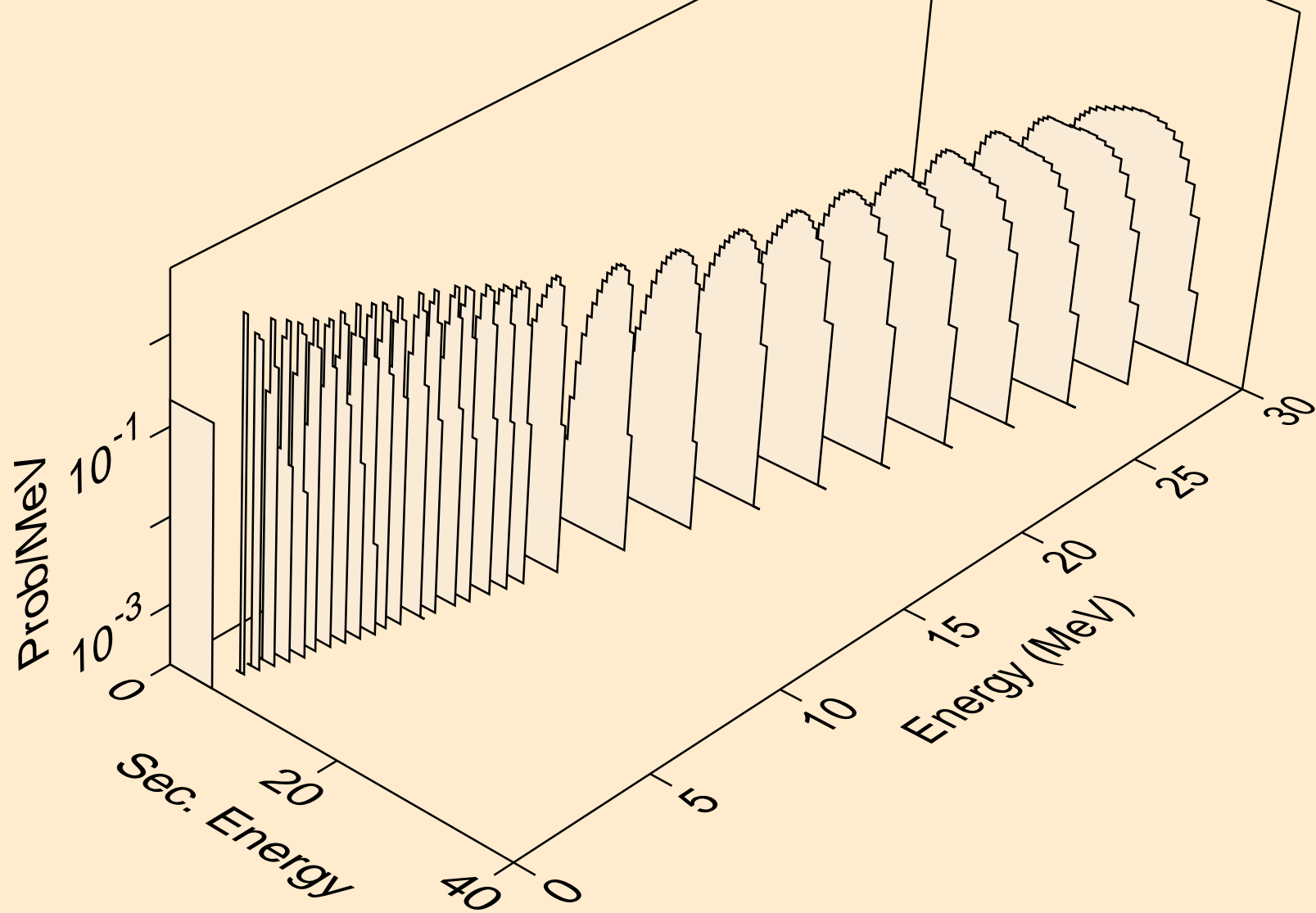

RE172M NEUTRON ACER TENDL-2023 LIBRARY; T=0.K  
alphas from (n,2n)a

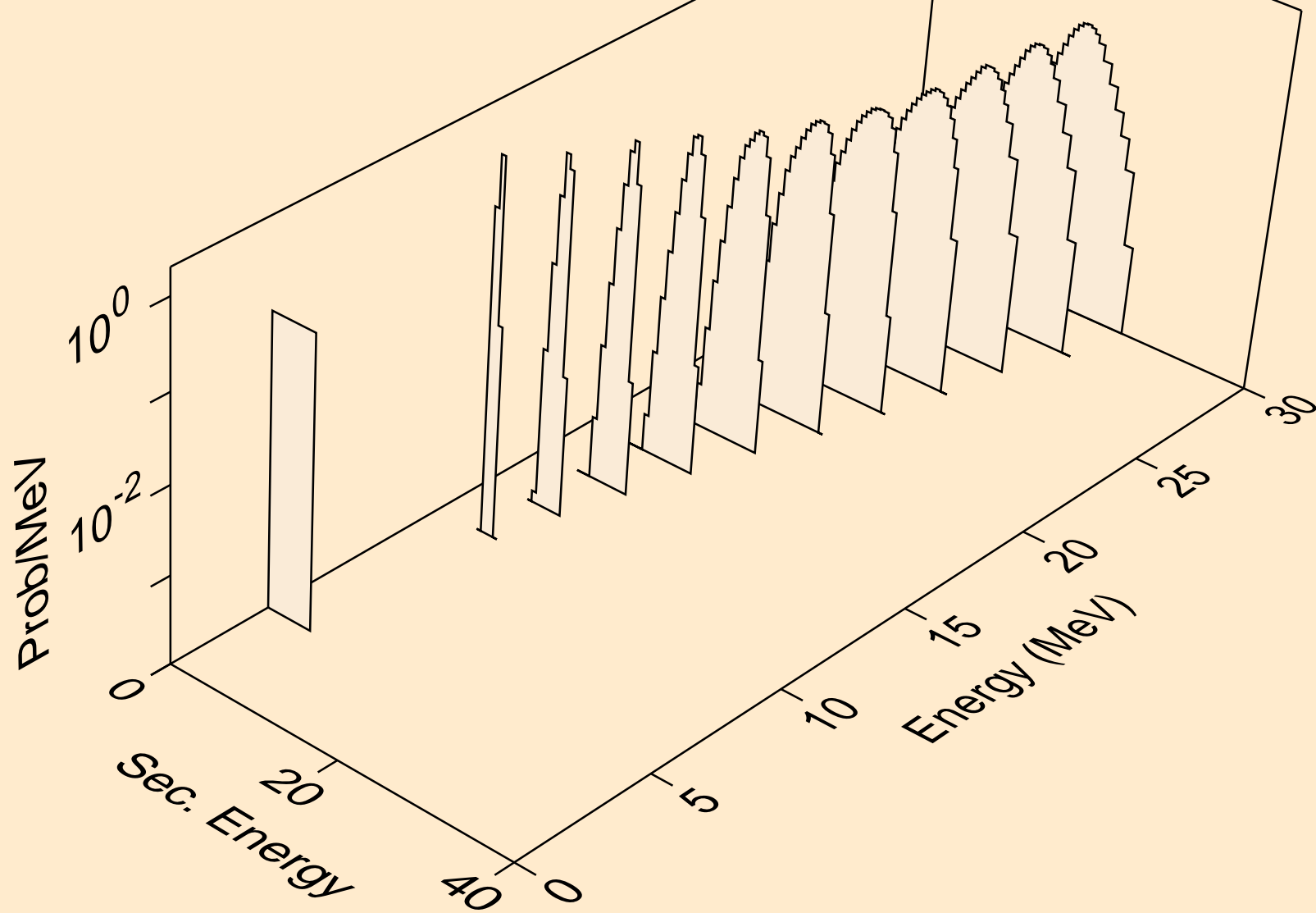

RE172M NEUTRON ACER TENDL-2023 LIBRARY; T=0.K  
alphas from (n,3n)a

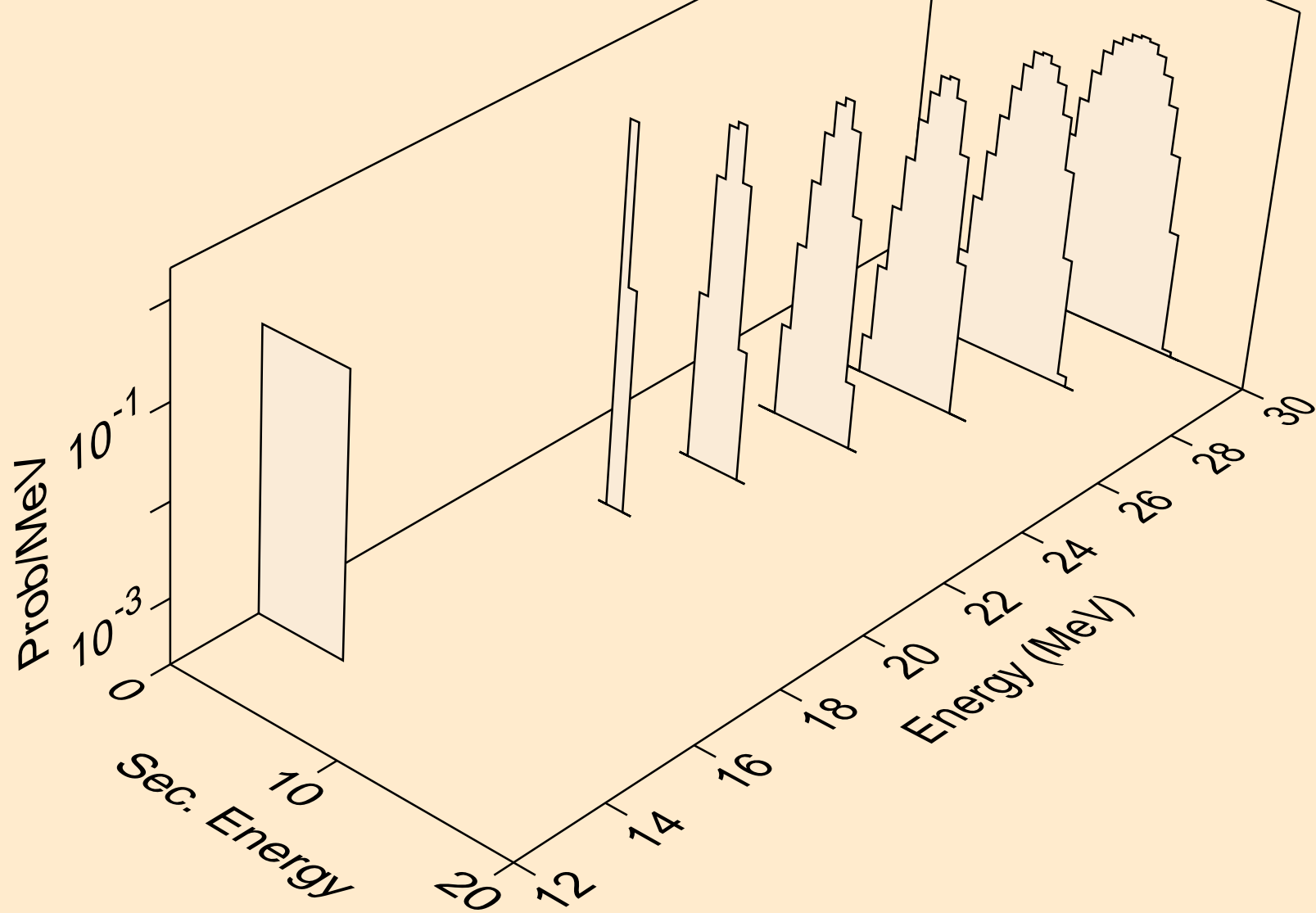

RE172M NEUTRON ACER TENDL-2023 LIBRARY; T=0.K  
alphas from (n,n\*)2a

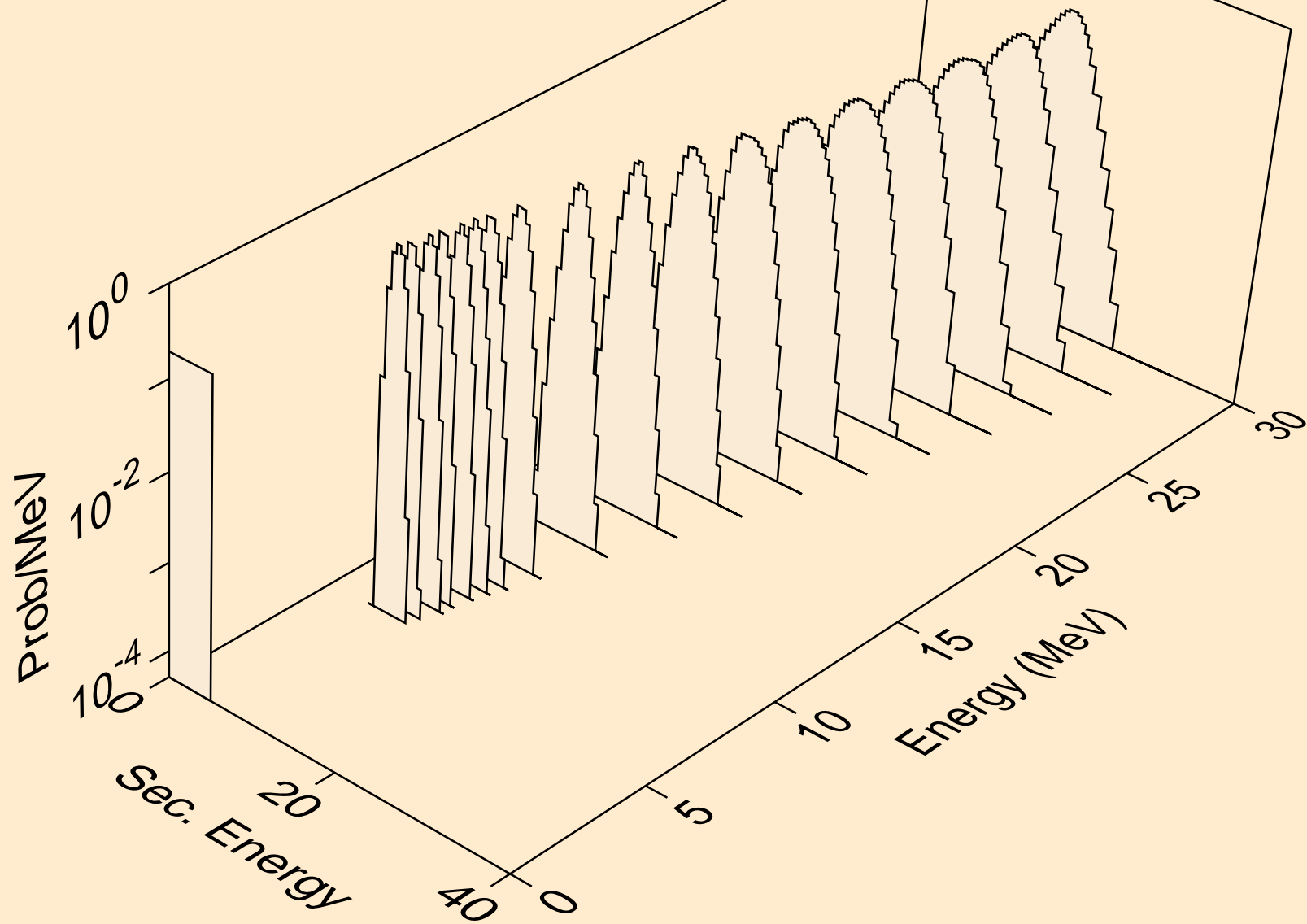

RE172M NEUTRON ACER TENDL-2023 LIBRARY; T=0.K  
alphas from (n,2n)2a

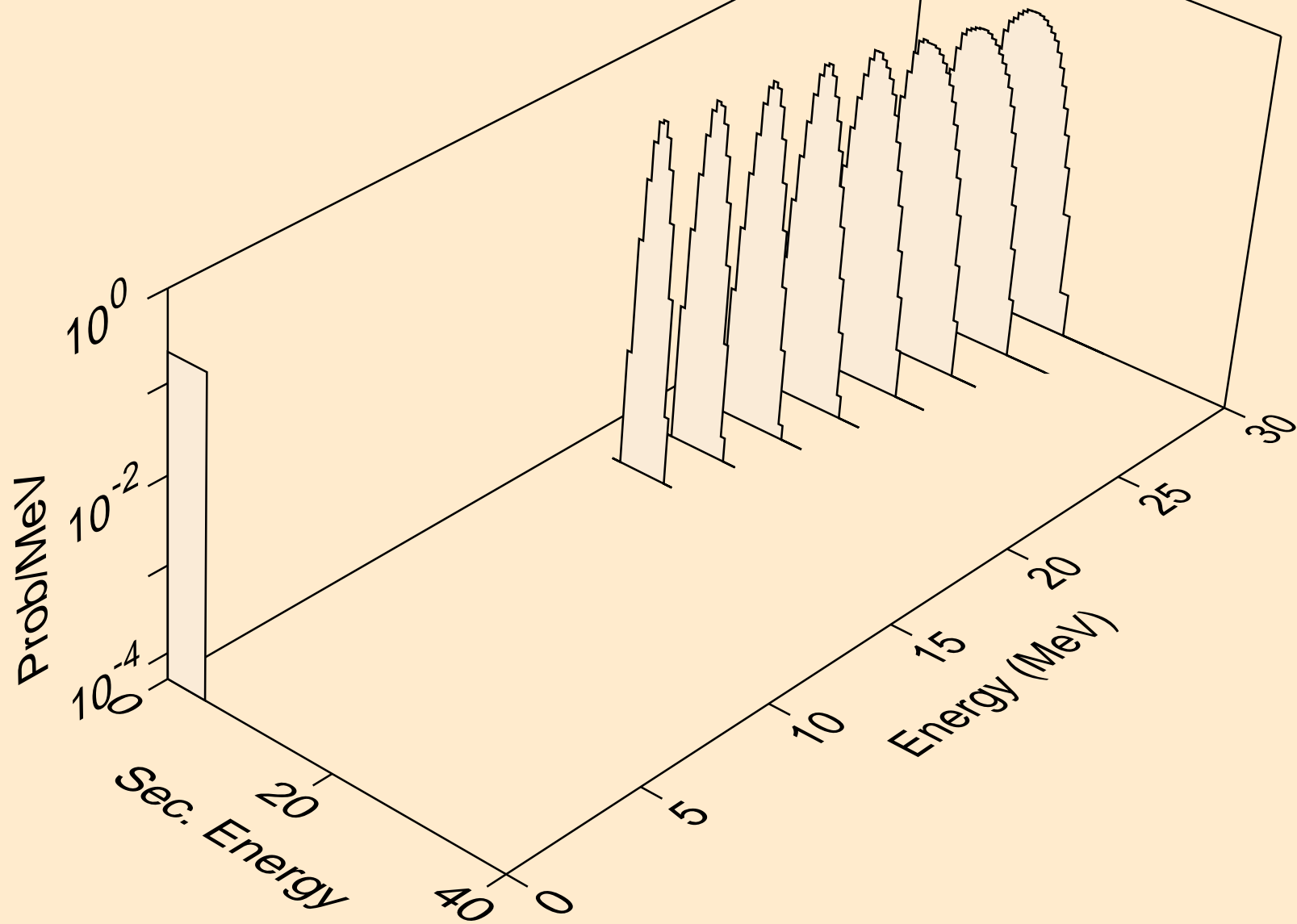



RE172M NEUTRON ACER TENDL-2023 LIBRARY; T=0.K  
alphas from (n,npa)

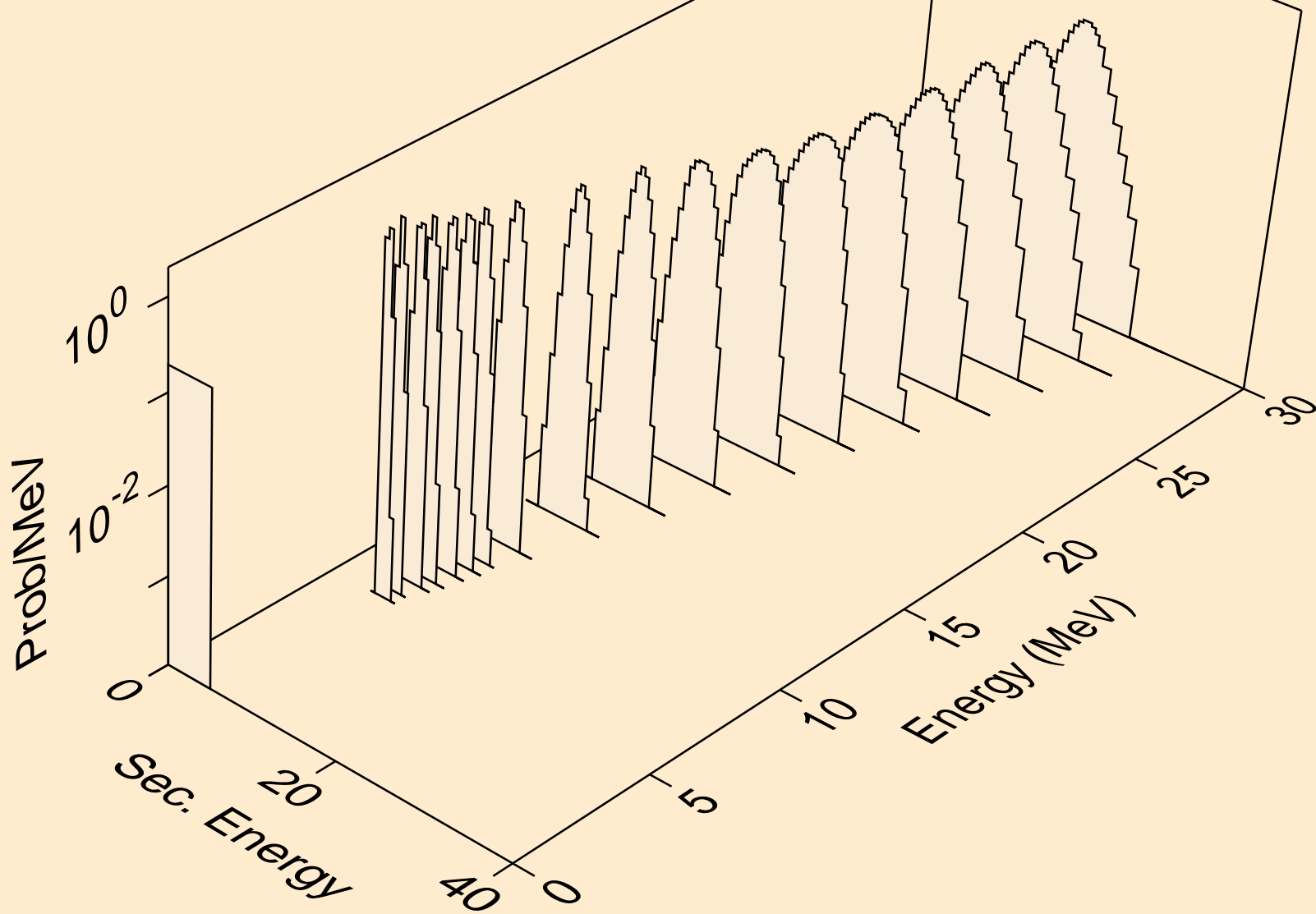

RE172M NEUTRON ACER TENDL-2023 LIBRARY; T=0.K  
alphas from (n,a)

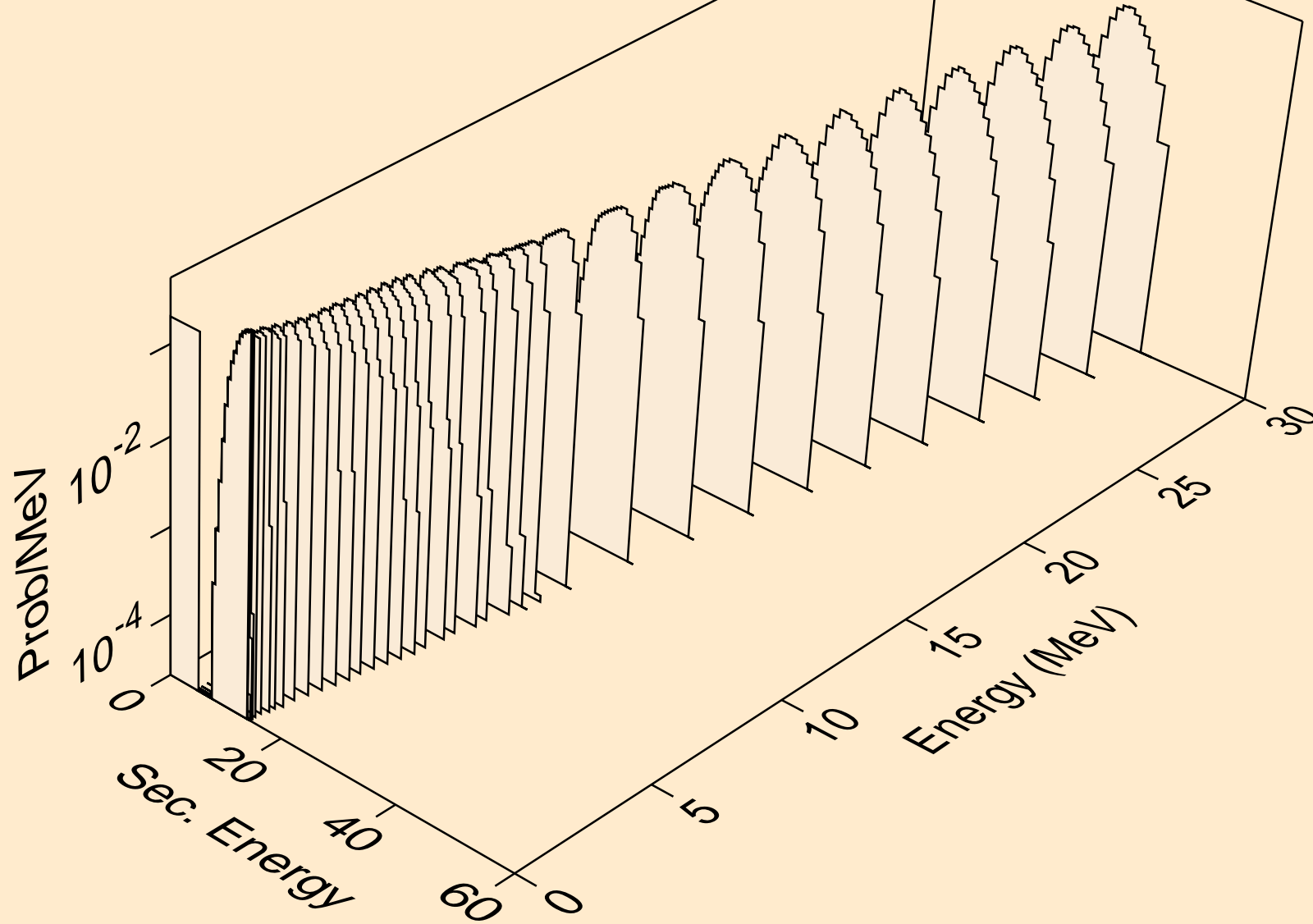

RE172M NEUTRON ACER TENDL-2023 LIBRARY; T=0.K  
alphas from (n,2a)

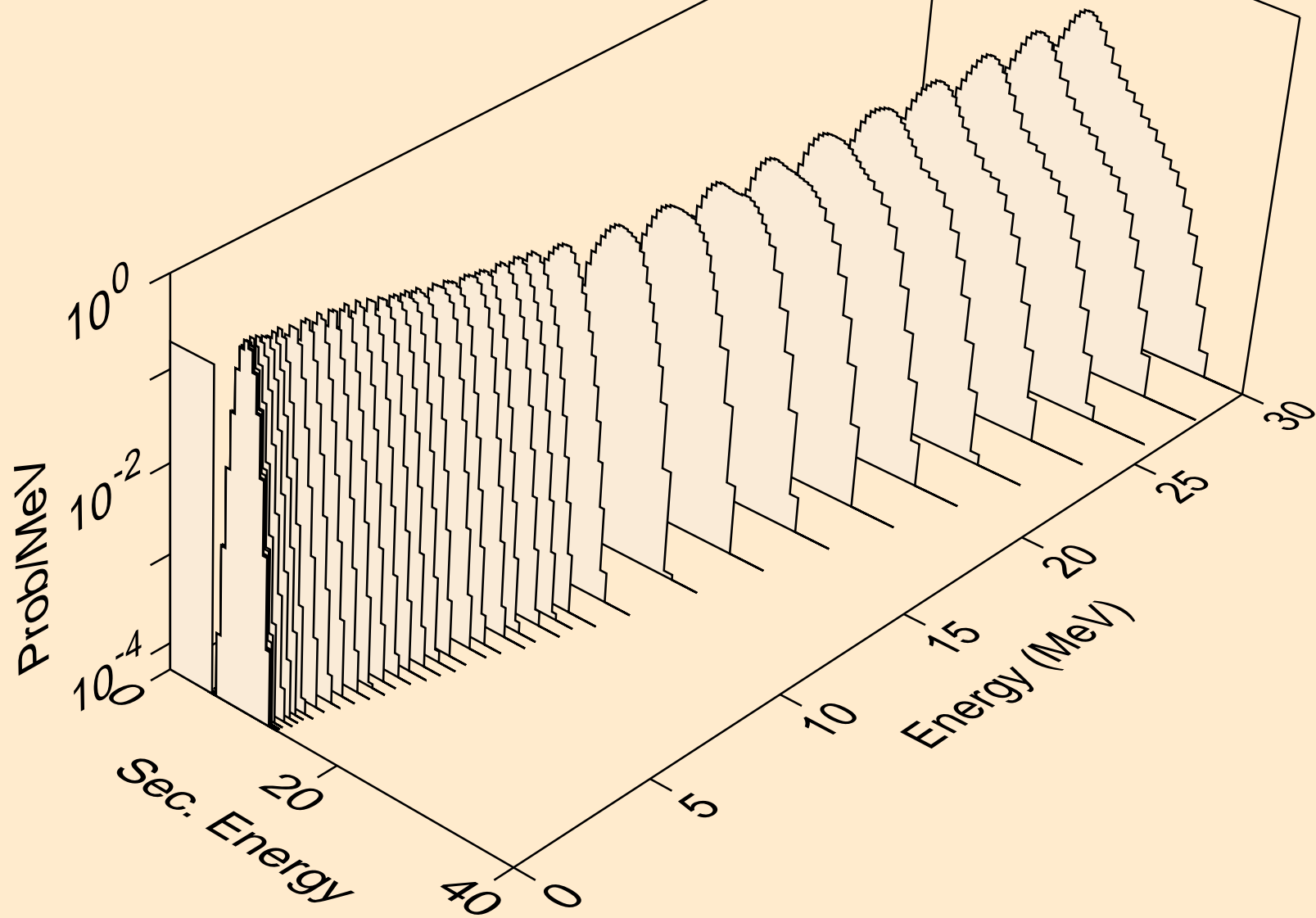

RE172M NEUTRON ACER TENDL-2023 LIBRARY; T=0.K  
alphas from (n,3a)

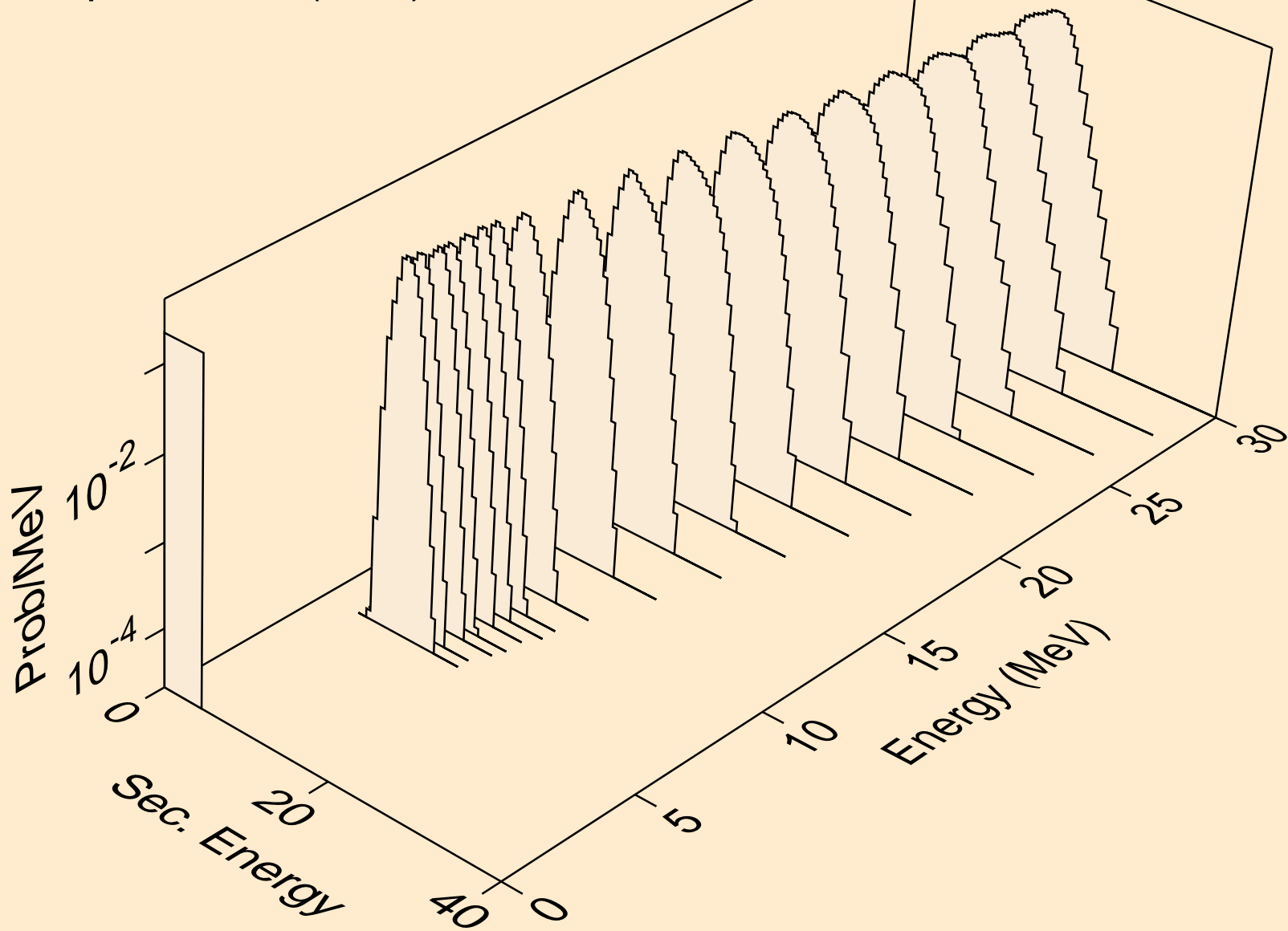

RE172M NEUTRON ACER TENDL-2023 LIBRARY; T=0.K  
alphas from (n,p)

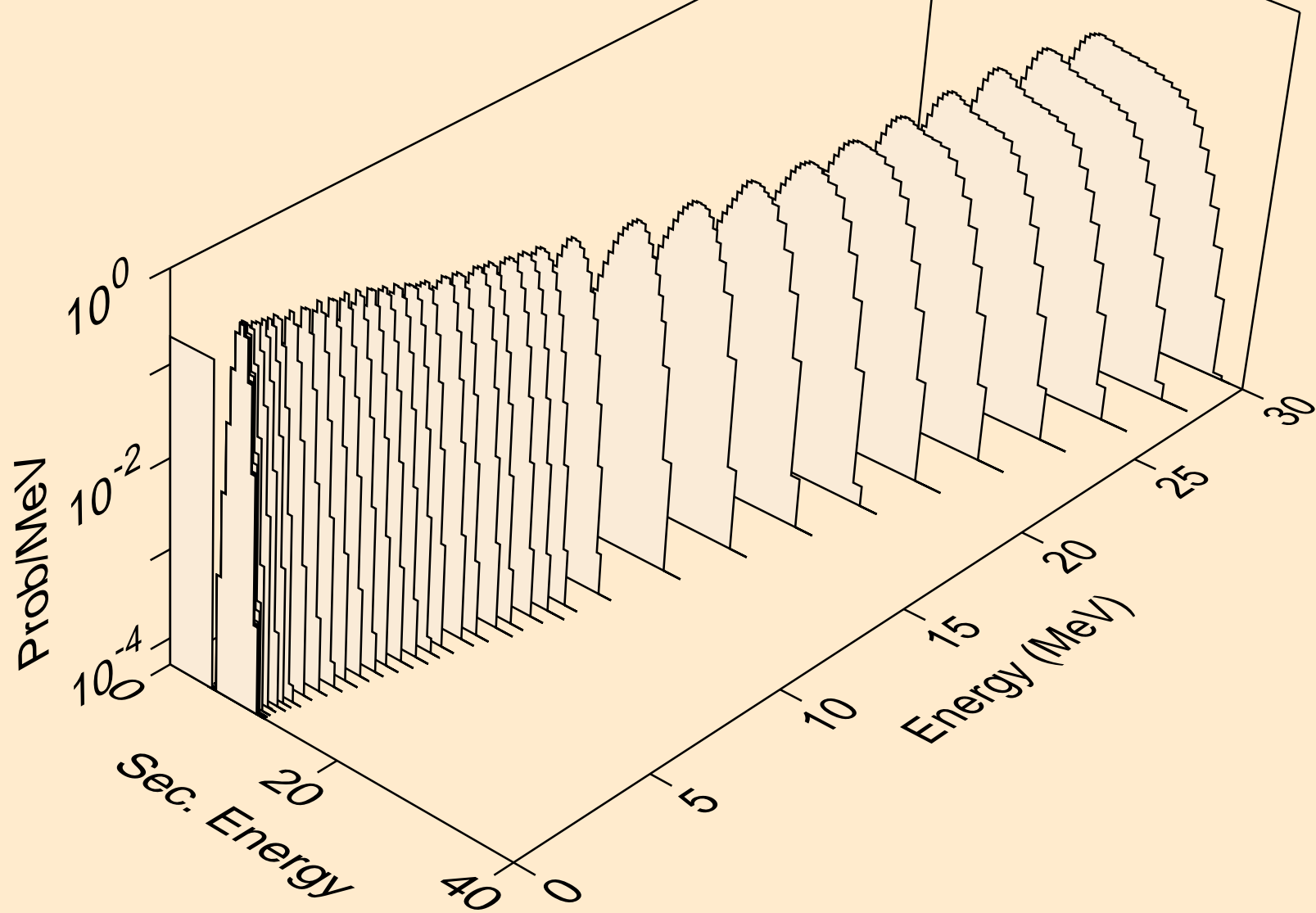

RE172M NEUTRON ACER TENDL-2023 LIBRARY; T=0.K  
alphas from (n,da)

