

# RH098M NEUTRON ACER TENDL-2023 LIBRARY; T=0.K

## Principal cross sections

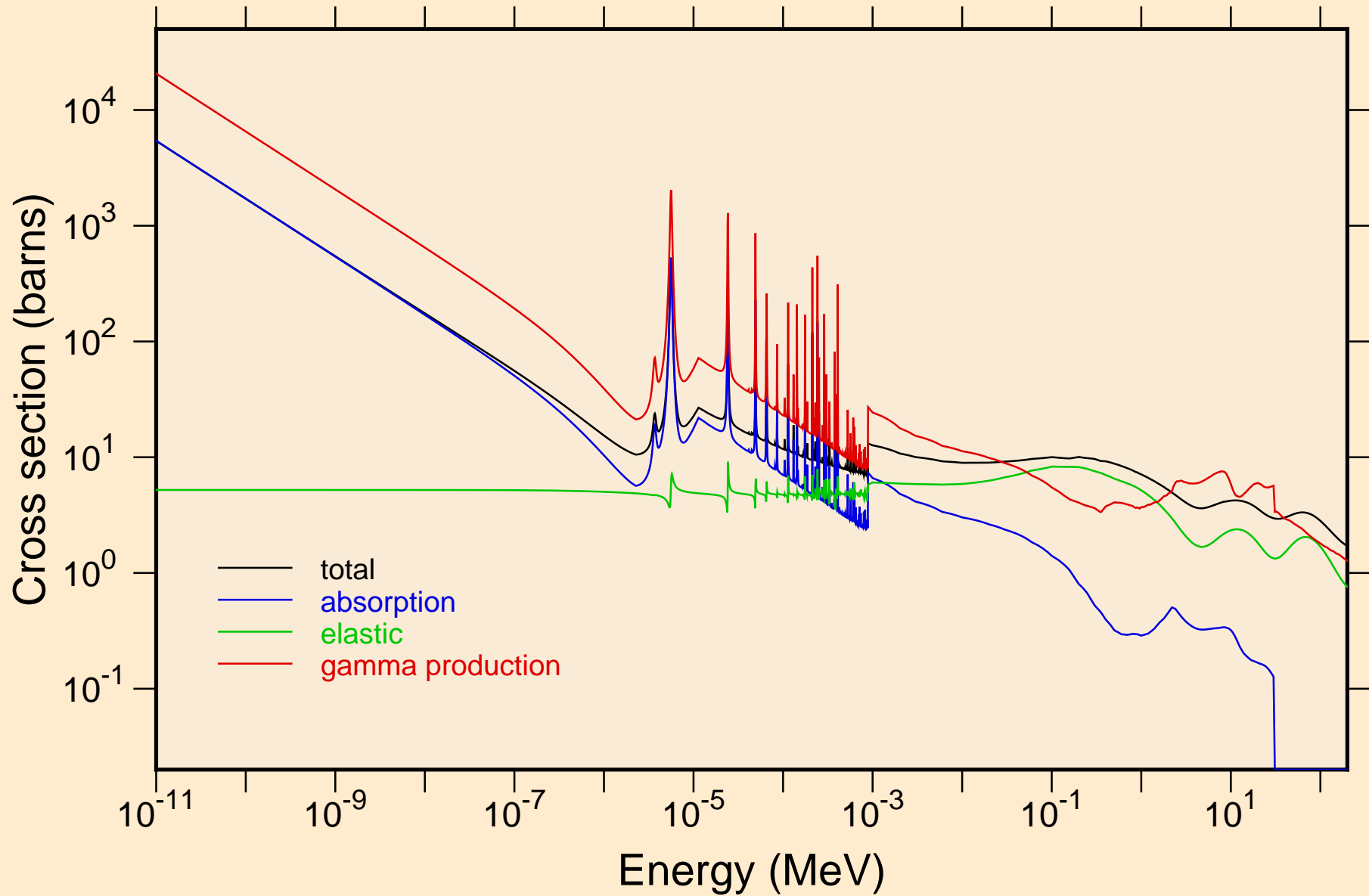

RH098M NEUTRON ACER TENDL-2023 LIBRARY; T=0.K  
resonance total cross section

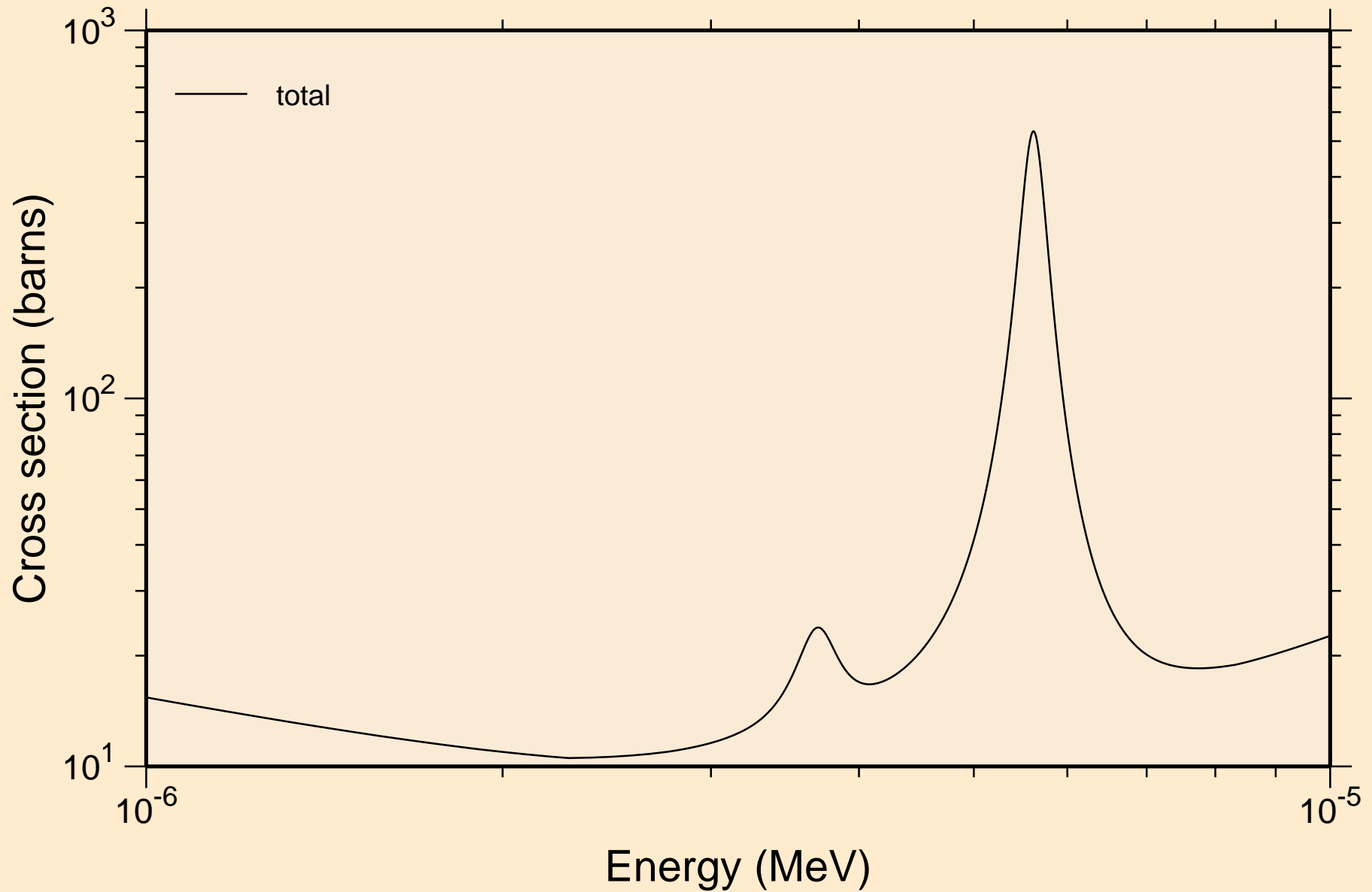

RH098M NEUTRON ACER TENDL-2023 LIBRARY; T=0.K  
resonance total cross section

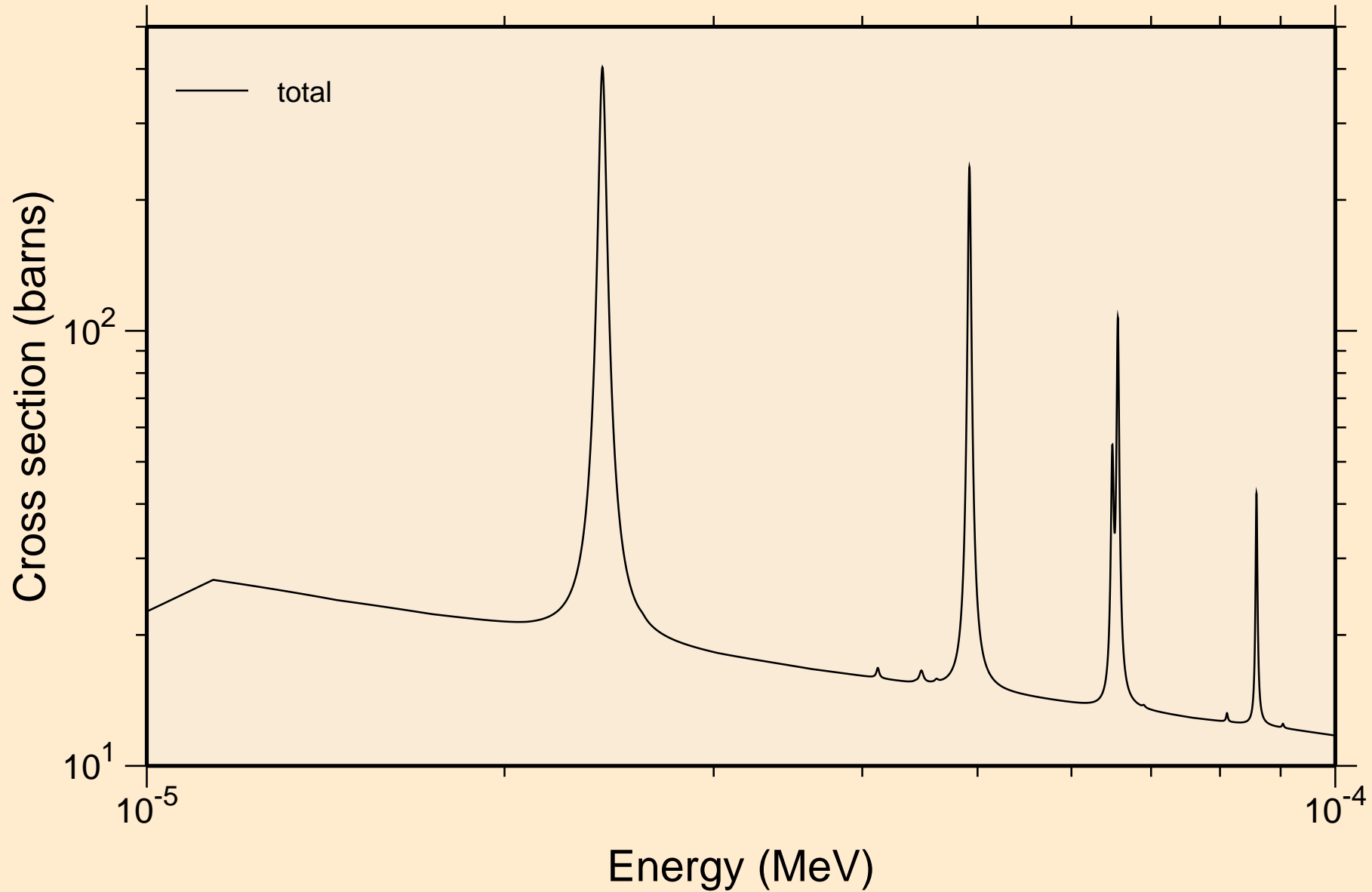

RH098M NEUTRON ACER TENDL-2023 LIBRARY; T=0.K  
resonance total cross section

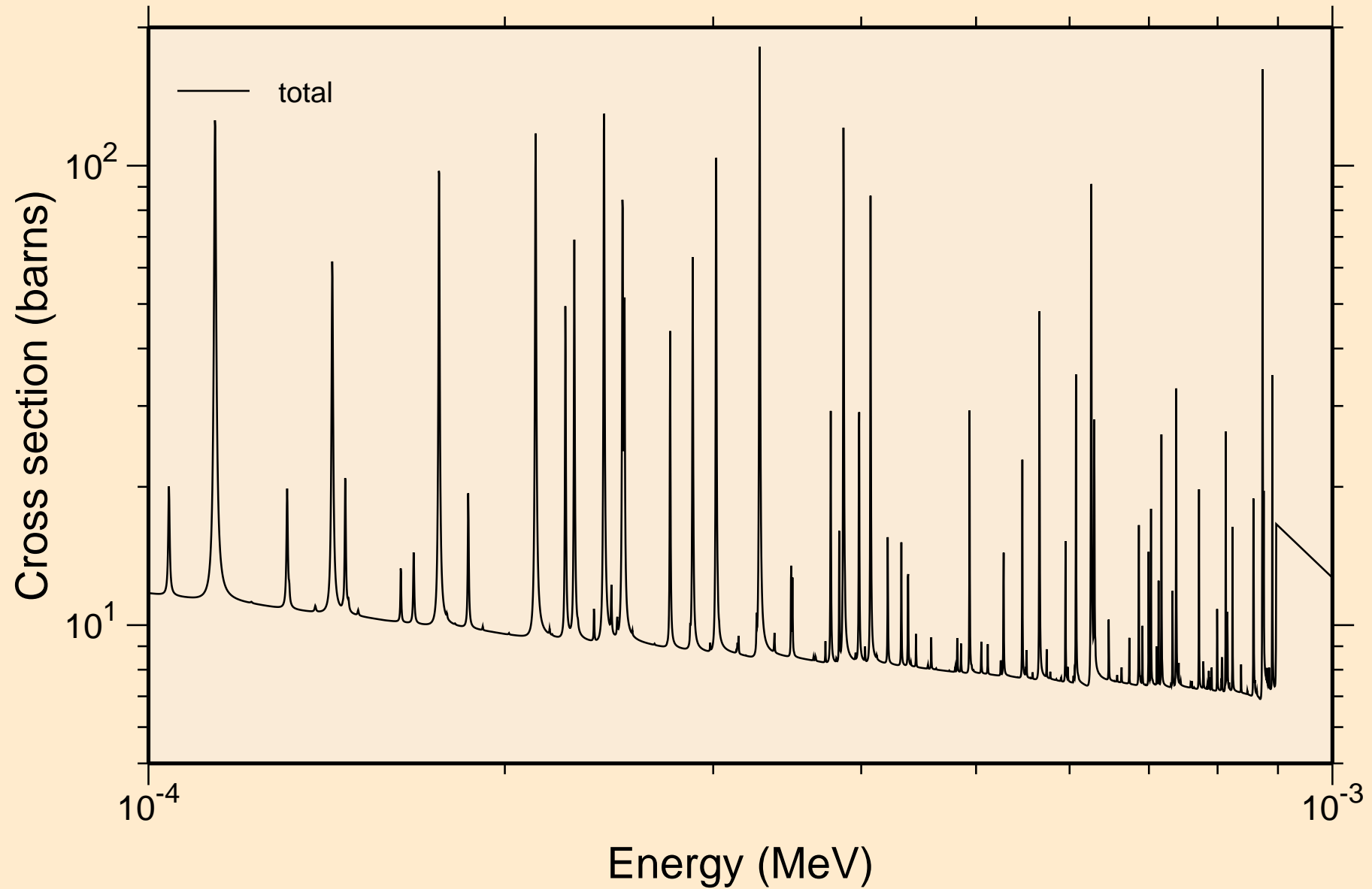

RH098M NEUTRON ACER TENDL-2023 LIBRARY; T=0.K  
resonance total cross section

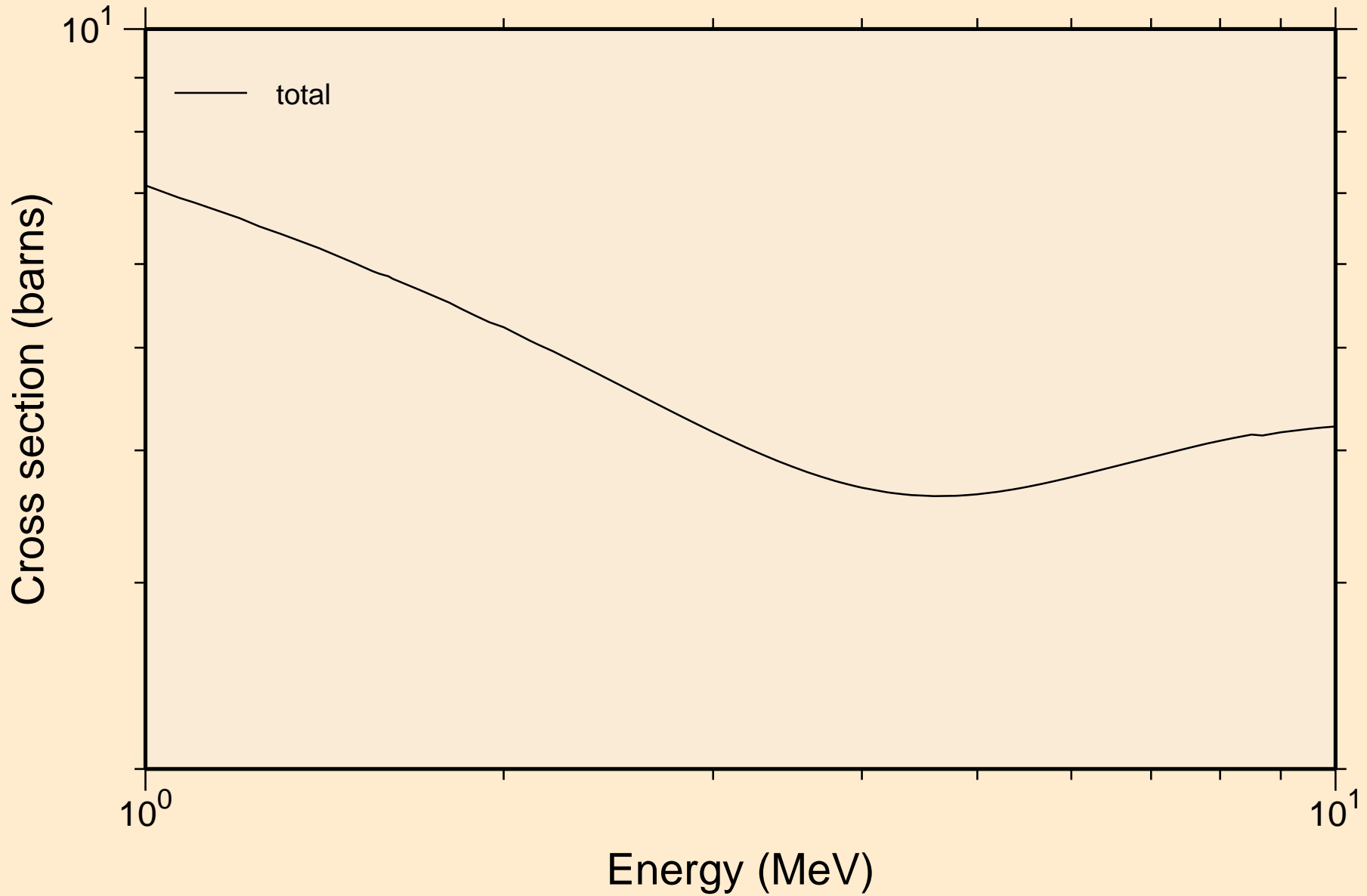

RH098M NEUTRON ACER TENDL-2023 LIBRARY; T=0.K  
resonance absorption cross sections

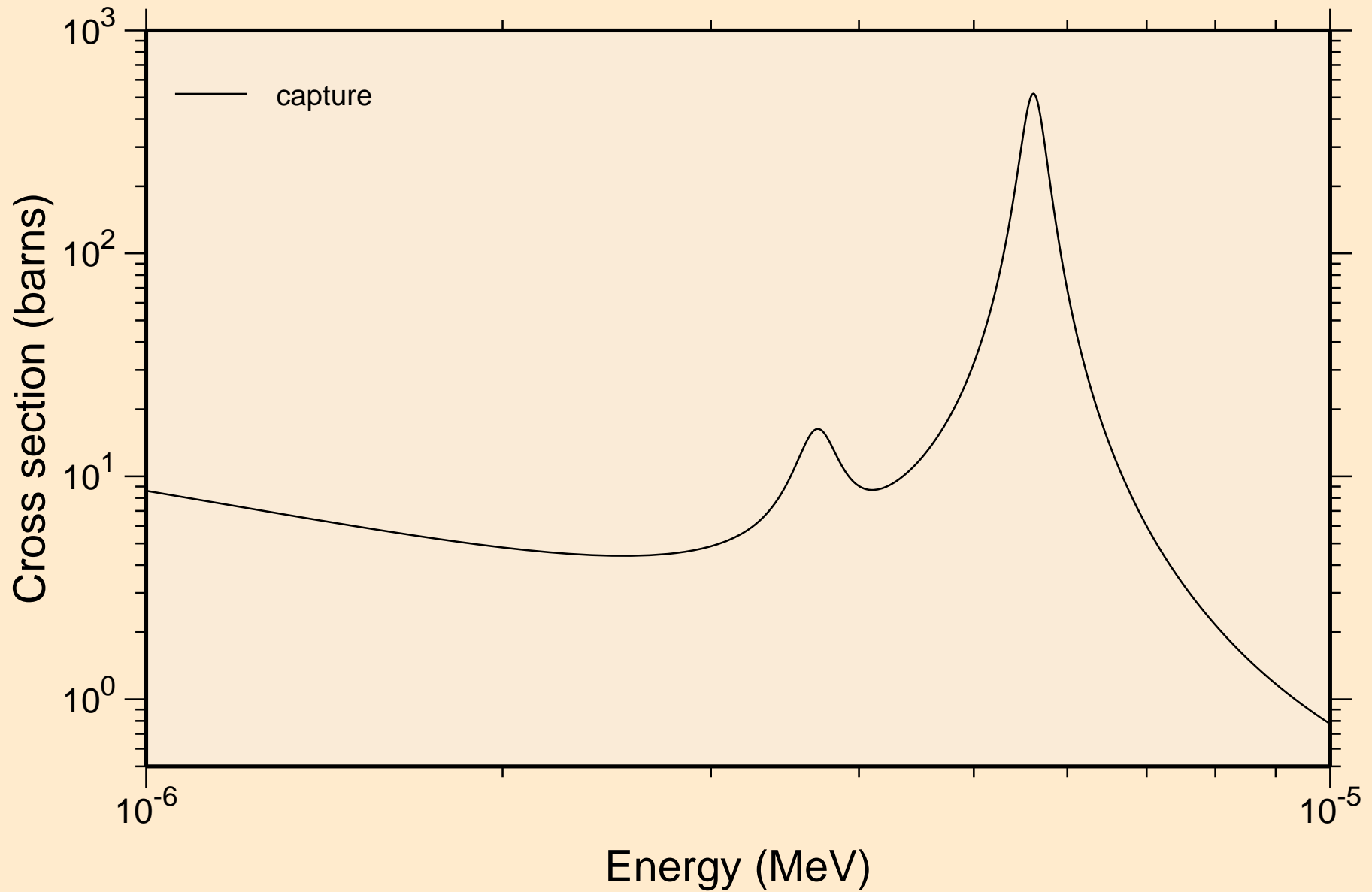

RH098M NEUTRON ACER TENDL-2023 LIBRARY; T=0.K  
resonance absorption cross sections

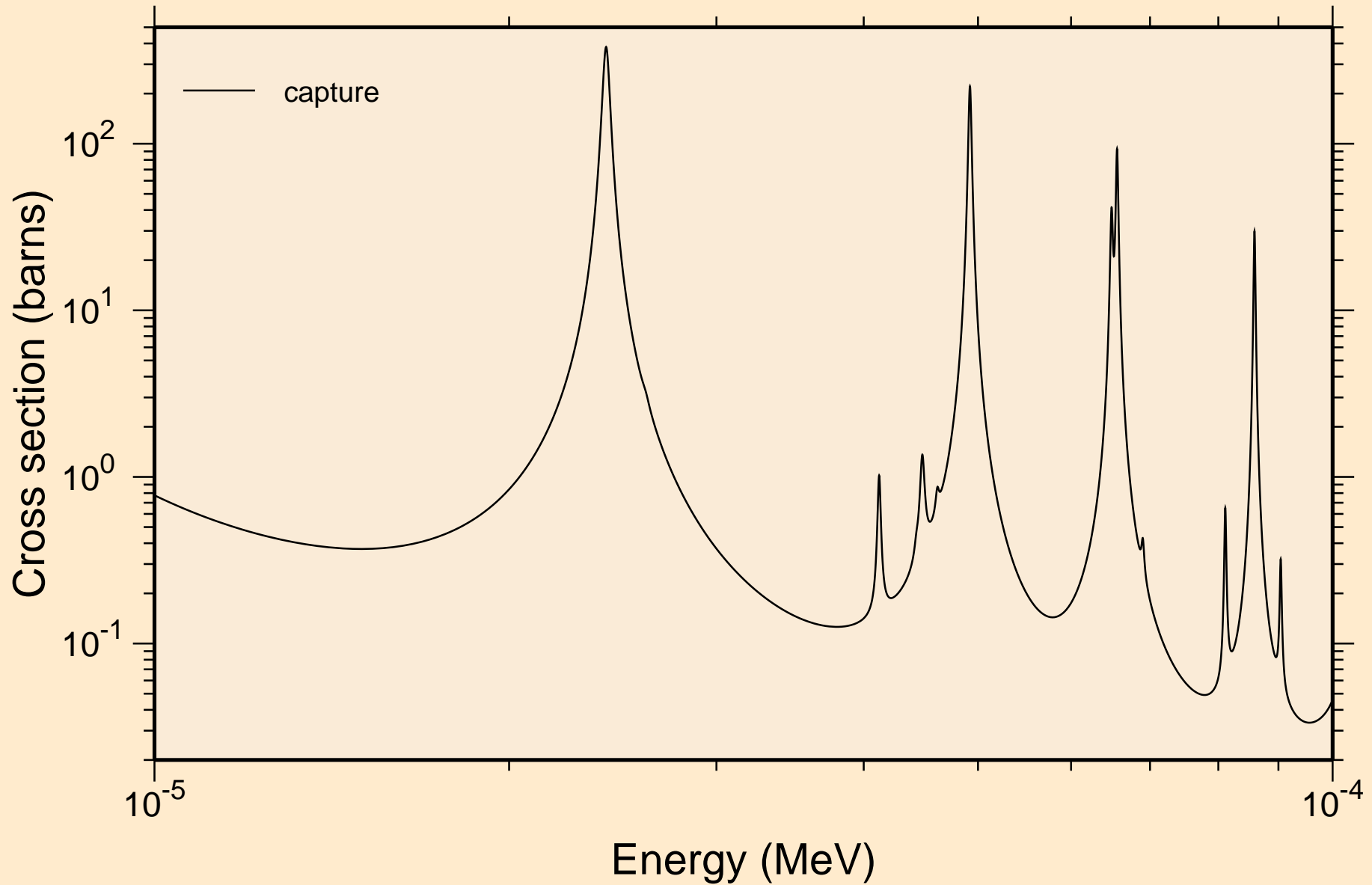

RH098M NEUTRON ACER TENDL-2023 LIBRARY; T=0.K  
resonance absorption cross sections

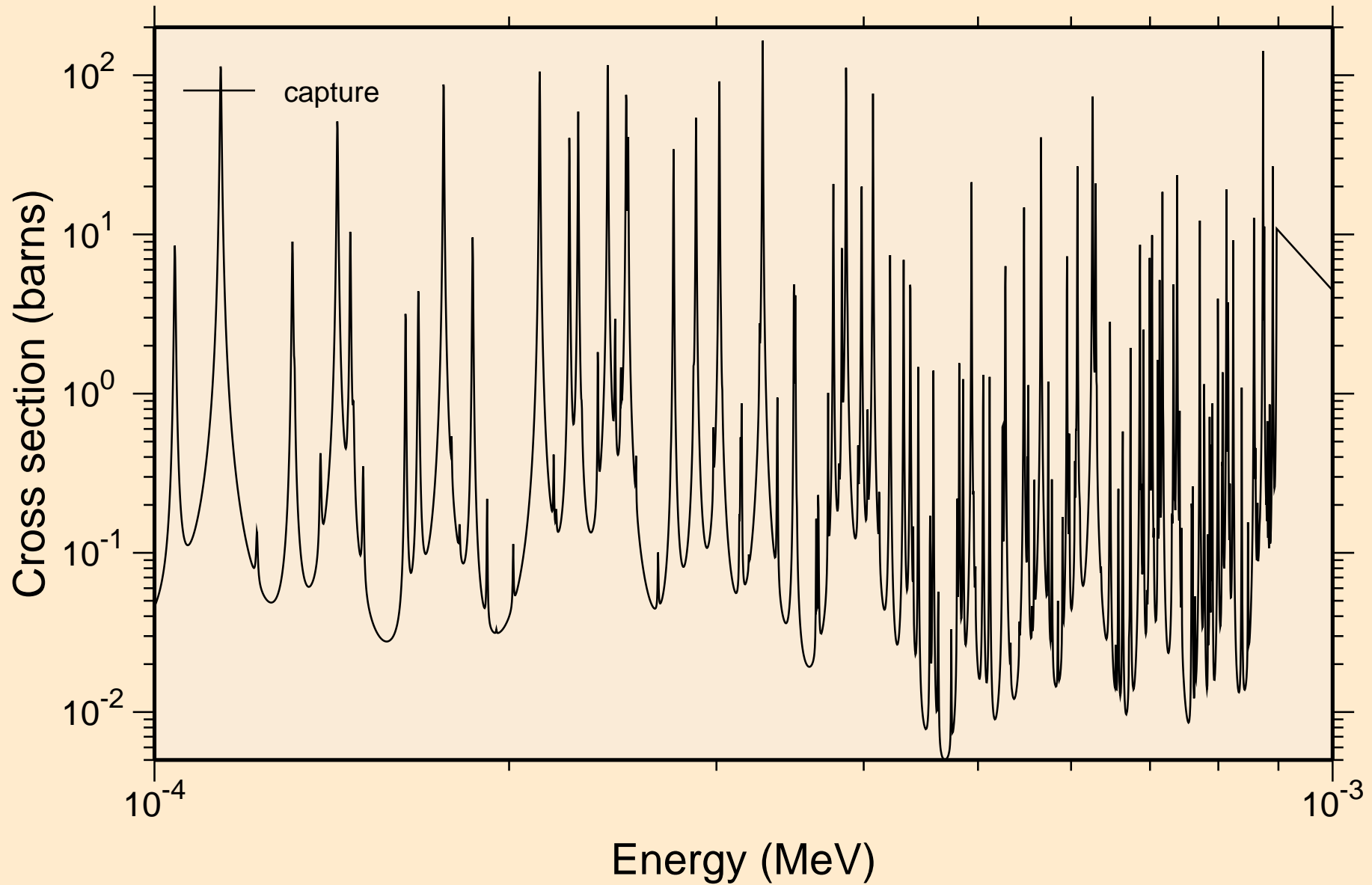



RH098M NEUTRON ACER TENDL-2023 LIBRARY; T=0.K  
resonance absorption cross sections

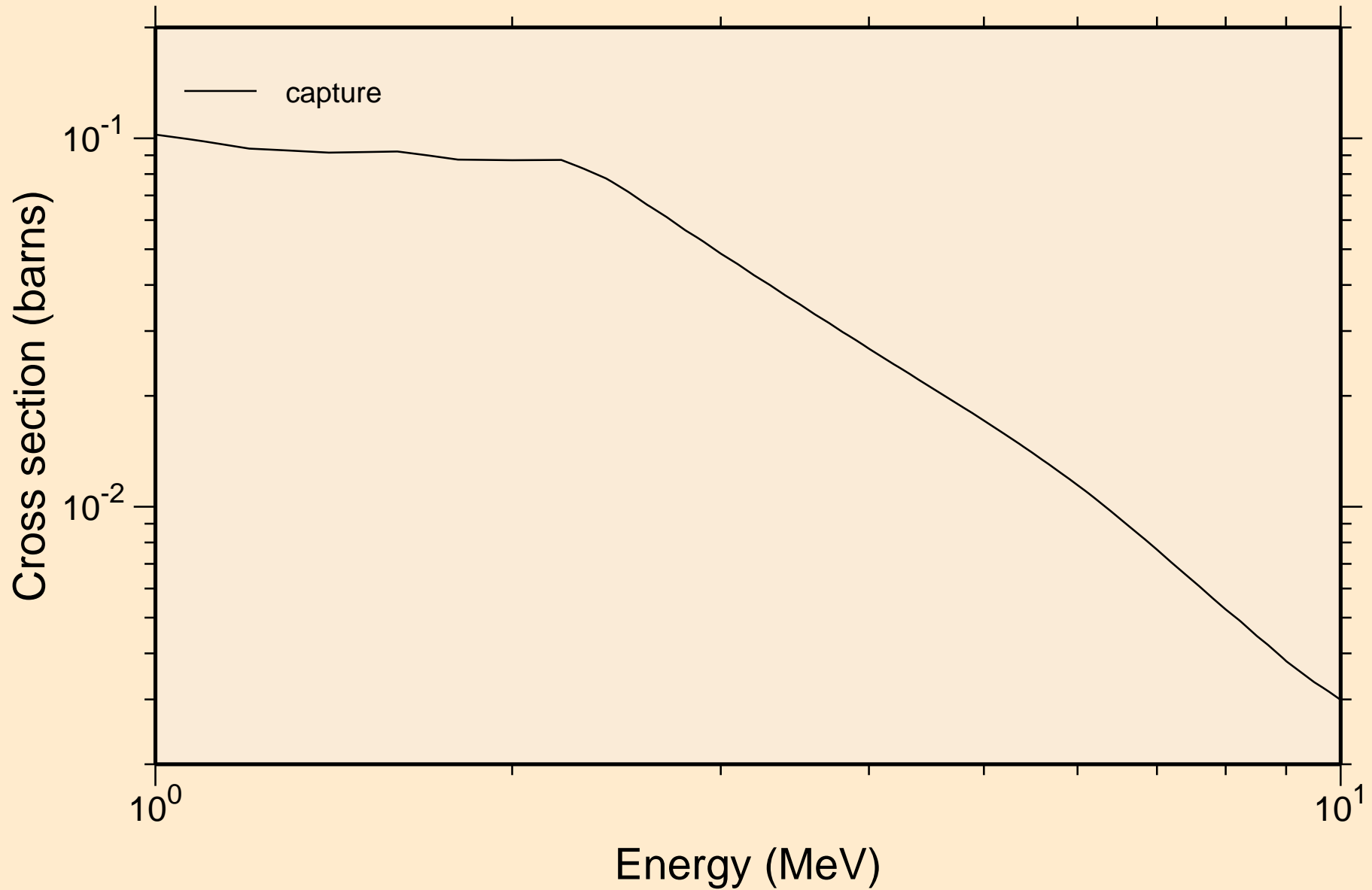

# RH098M NEUTRON ACER TENDL-2023 LIBRARY; T=0.K

## Heating

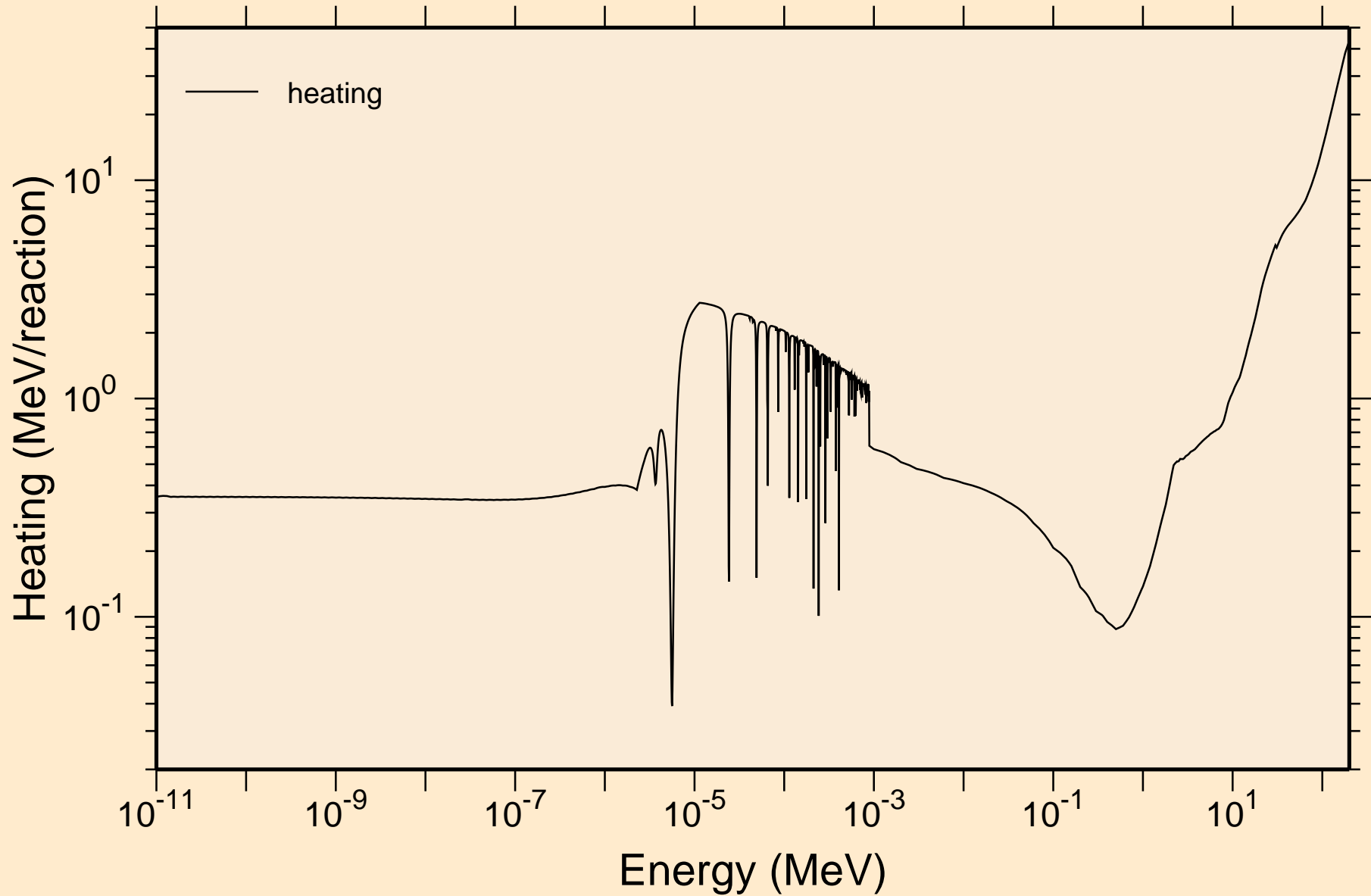

RH098M NEUTRON ACER TENDL-2023 LIBRARY; T=0.K  
Damage

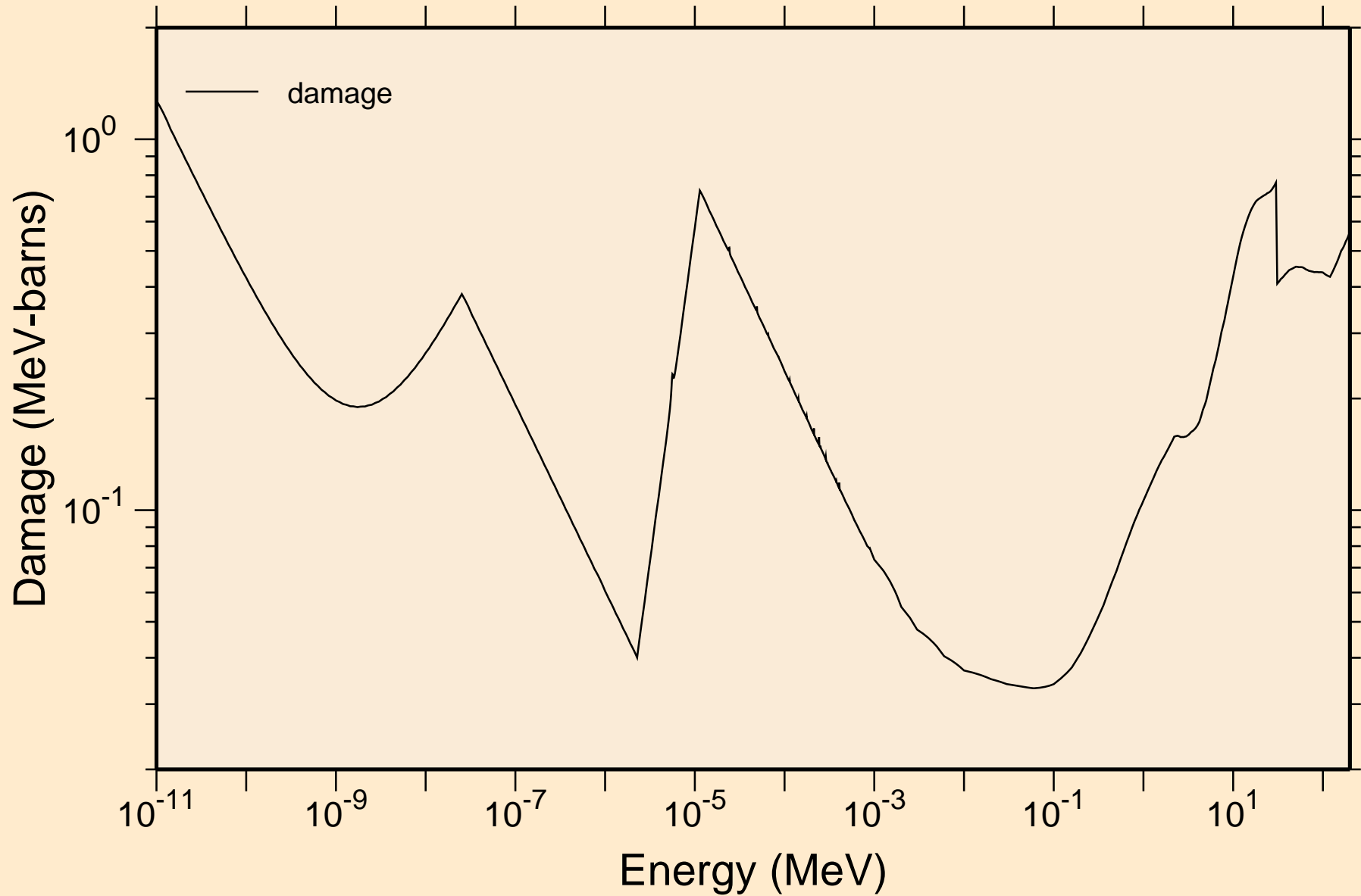

RH098M NEUTRON ACER TENDL-2023 LIBRARY; T=0.K  
Non-threshold reactions

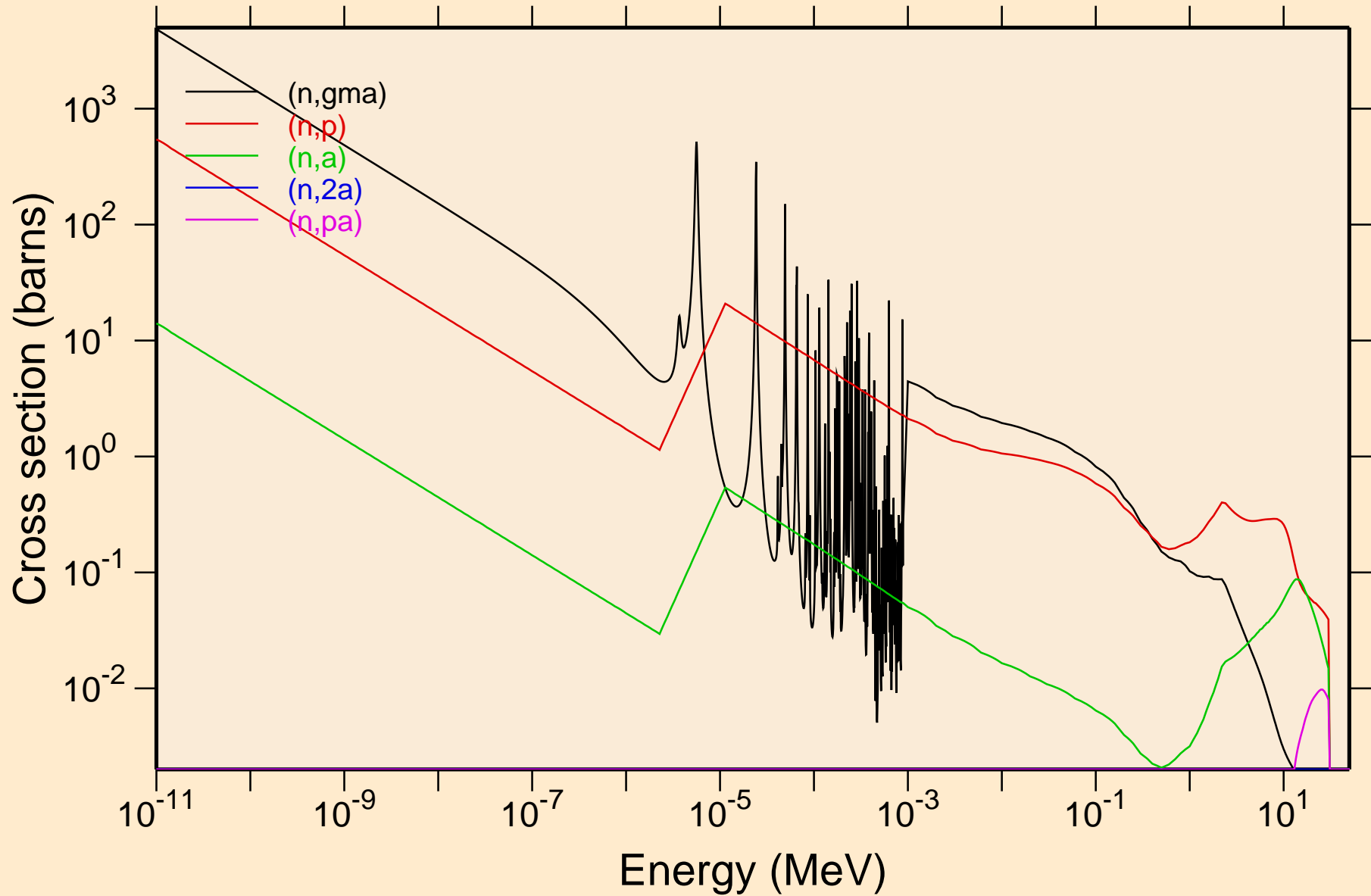

RH098M NEUTRON ACER TENDL-2023 LIBRARY; T=0.K  
Non-threshold reactions

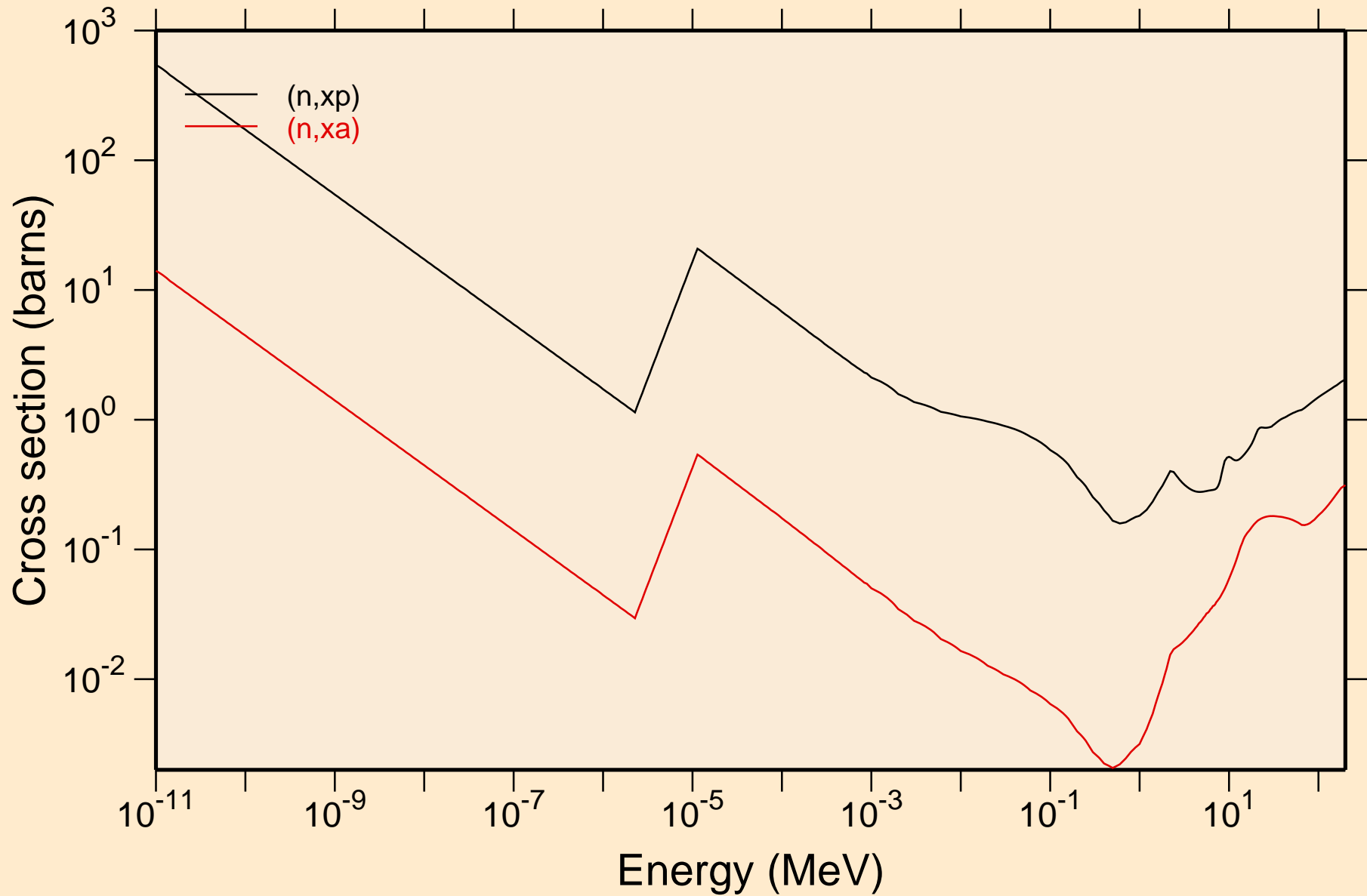

# RH098M NEUTRON ACER TENDL-2023 LIBRARY; T=0.K

## Principal cross sections

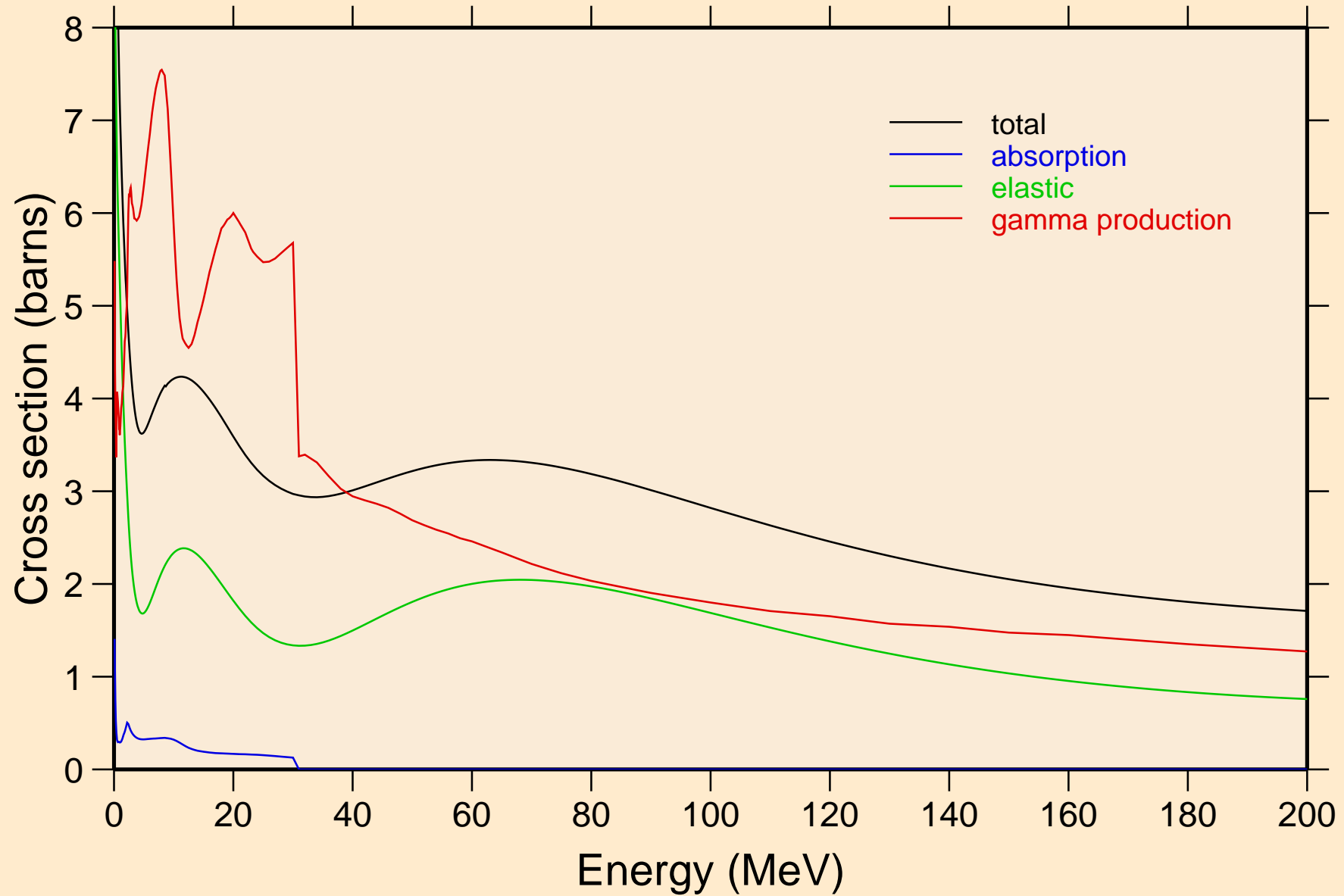

# RH098M NEUTRON ACER TENDL-2023 LIBRARY; T=0.K

## Heating

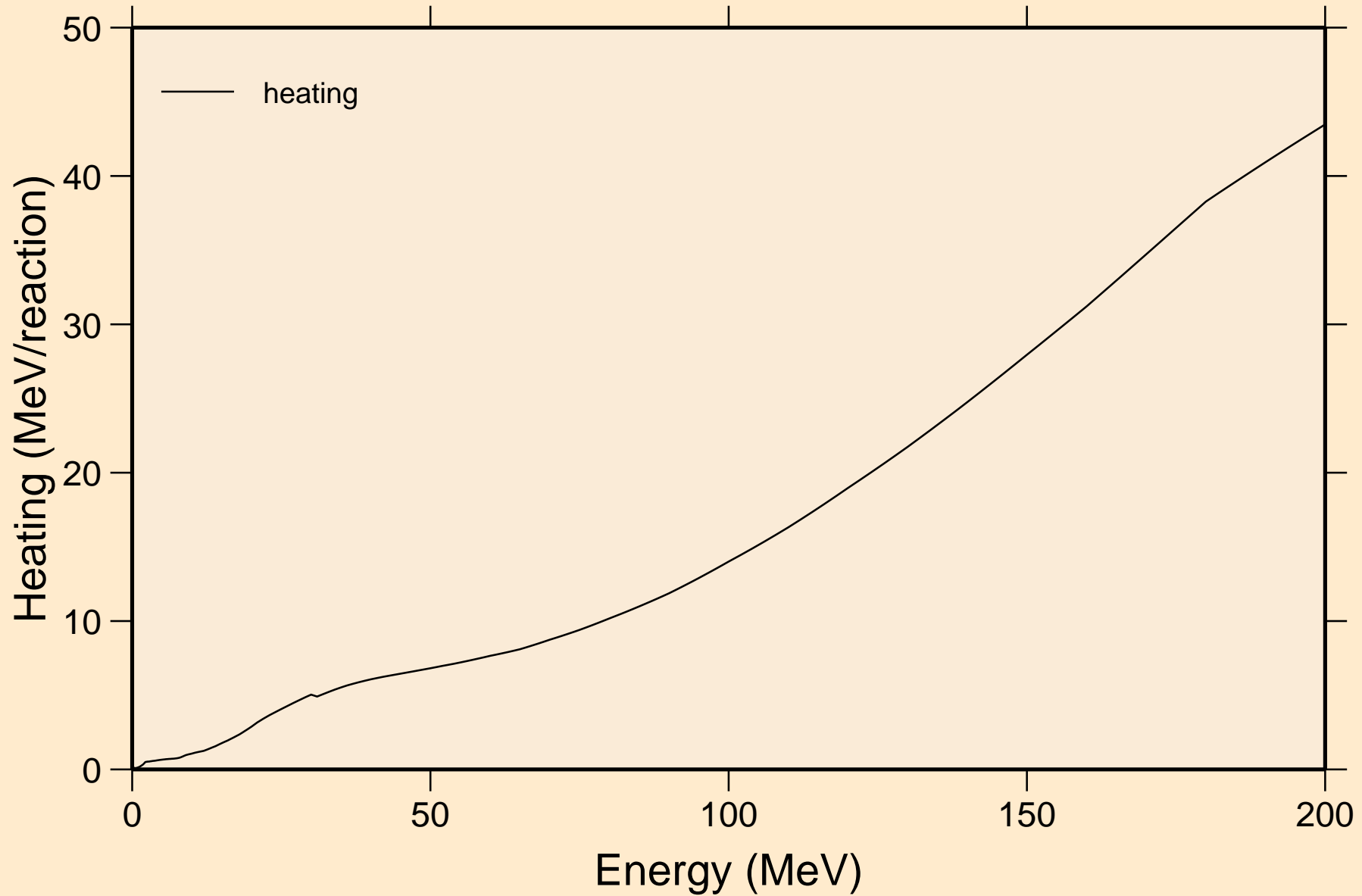

# RH098M NEUTRON ACER TENDL-2023 LIBRARY; T=0.K

## Damage

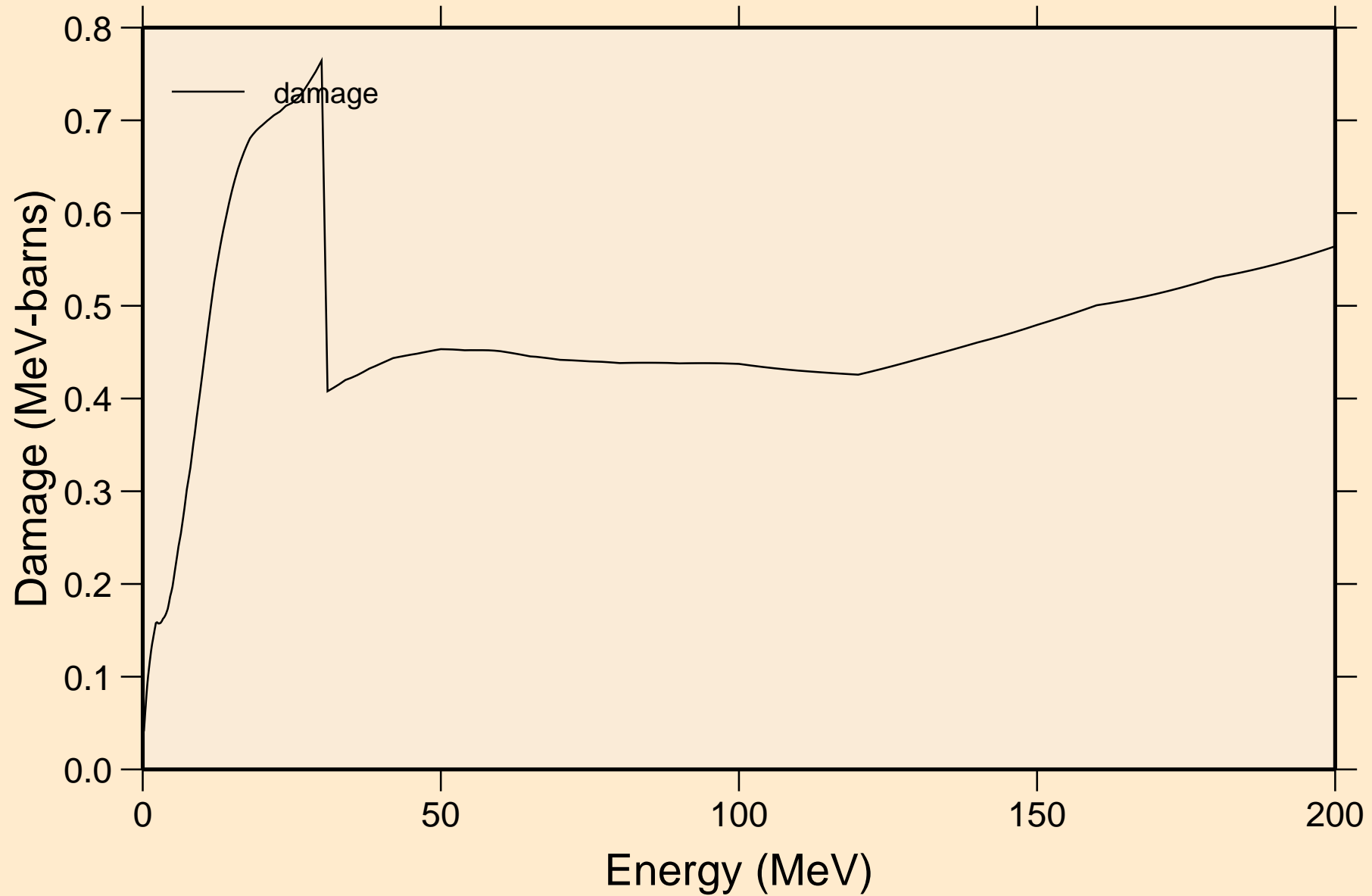



RH098M NEUTRON ACER TENDL-2023 LIBRARY; T=0.K  
Non-threshold reactions

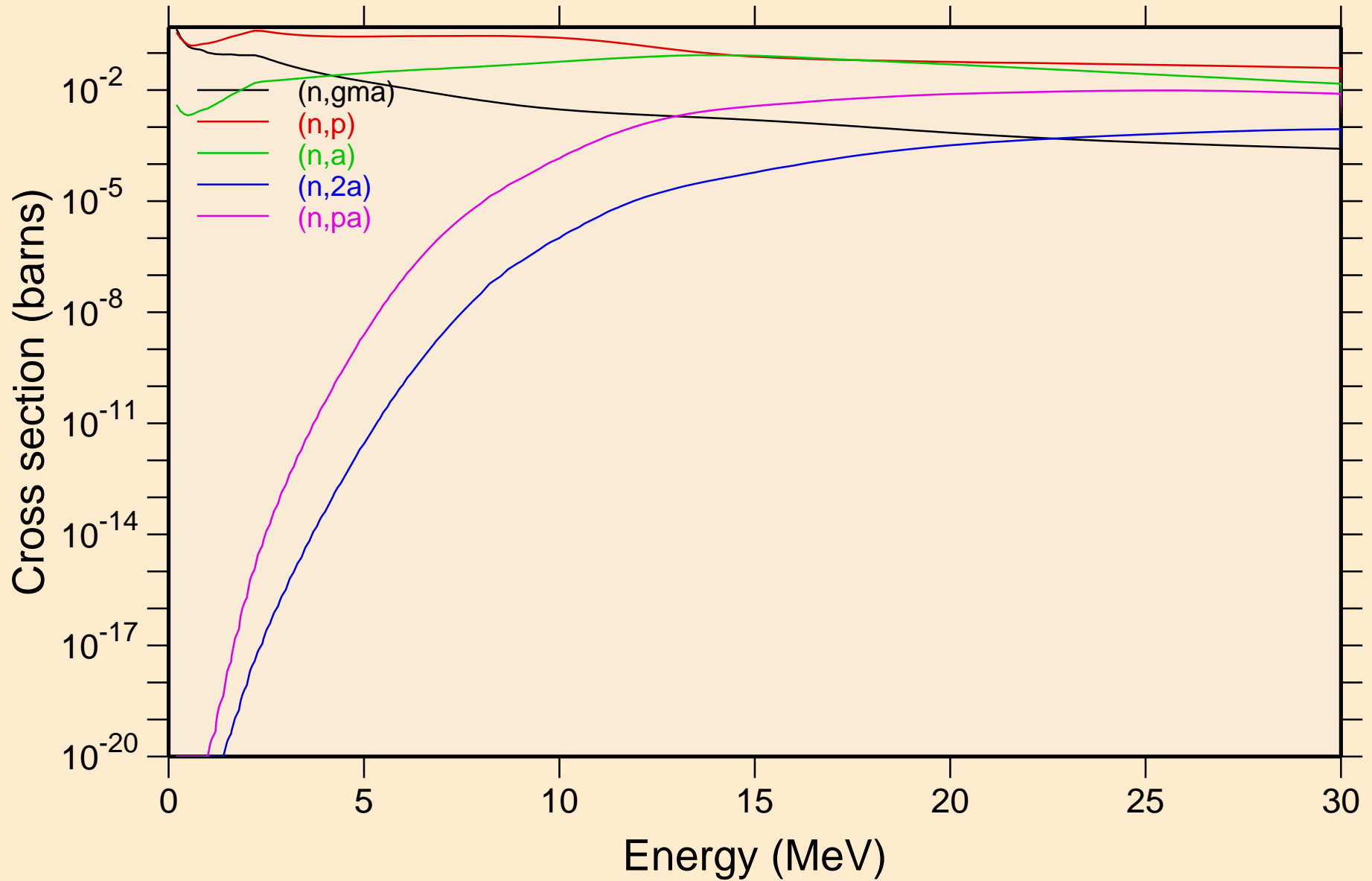

RH098M NEUTRON ACER TENDL-2023 LIBRARY; T=0.K  
Non-threshold reactions

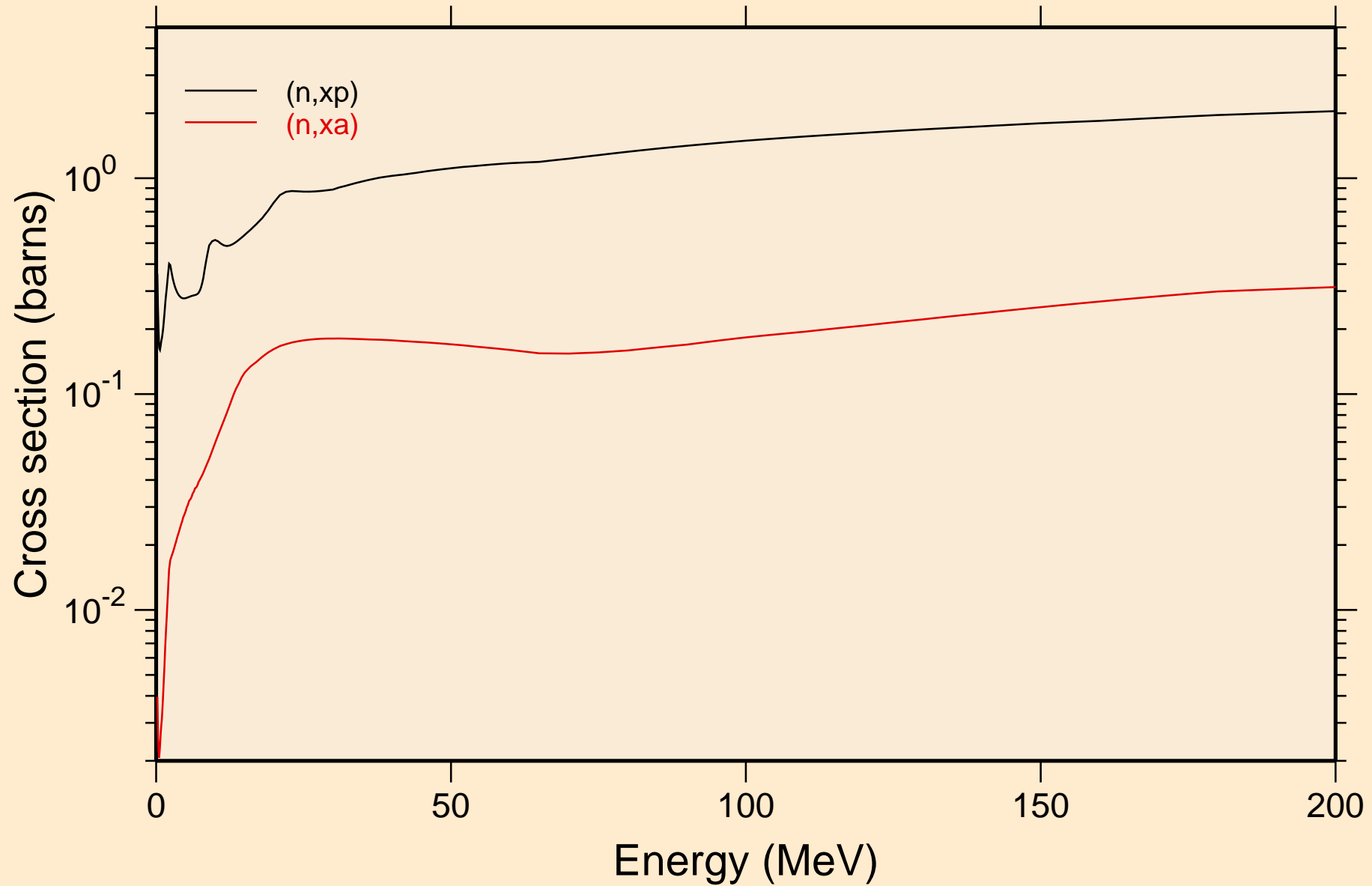

# RH098M NEUTRON ACER TENDL-2023 LIBRARY; T=0.K

## Inelastic levels

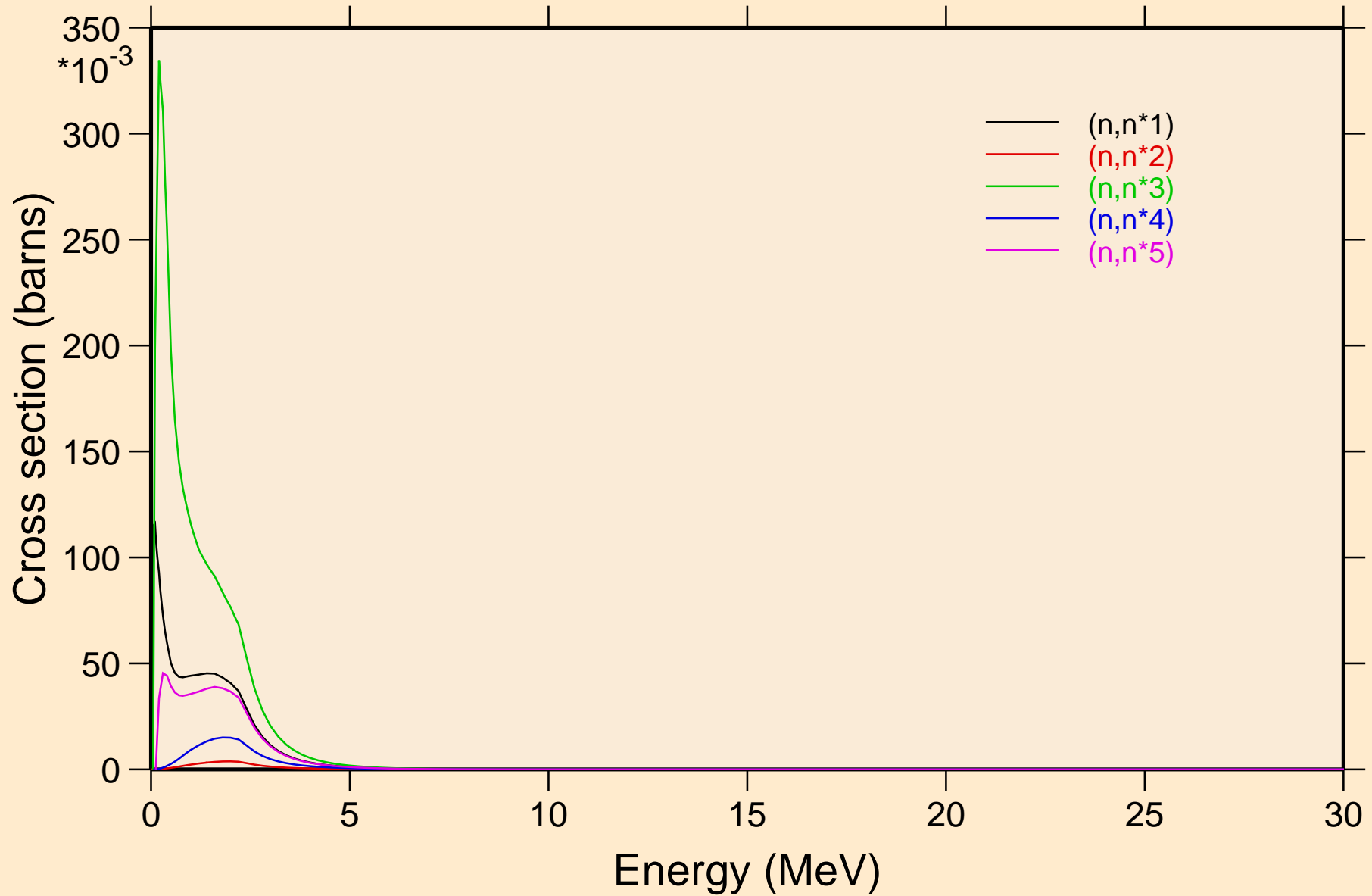

RH098M NEUTRON ACER TENDL-2023 LIBRARY; T=0.K  
Inelastic levels

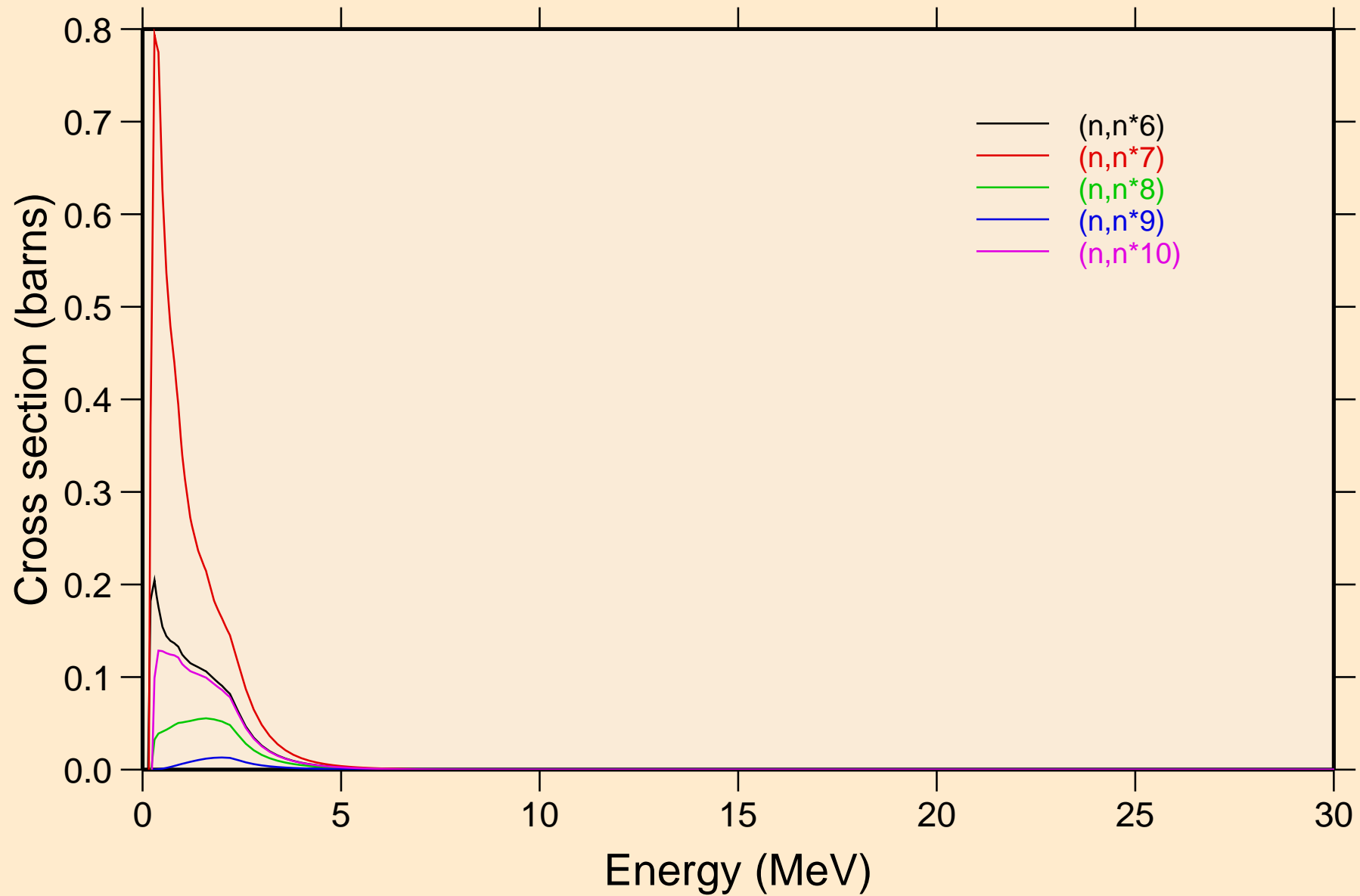

RH098M NEUTRON ACER TENDL-2023 LIBRARY; T=0.K  
Inelastic levels

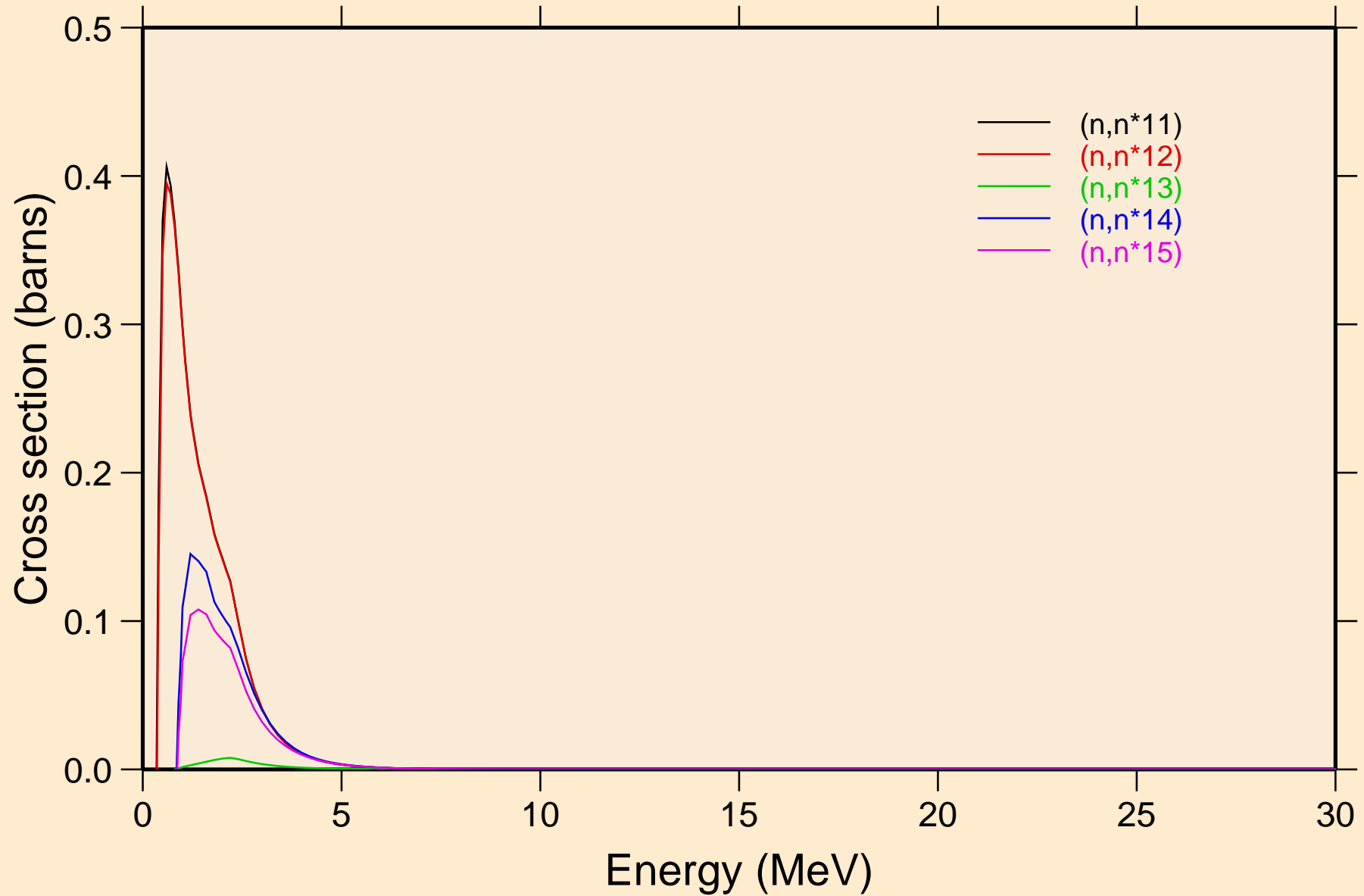

RH098M NEUTRON ACER TENDL-2023 LIBRARY; T=0.K  
Inelastic levels

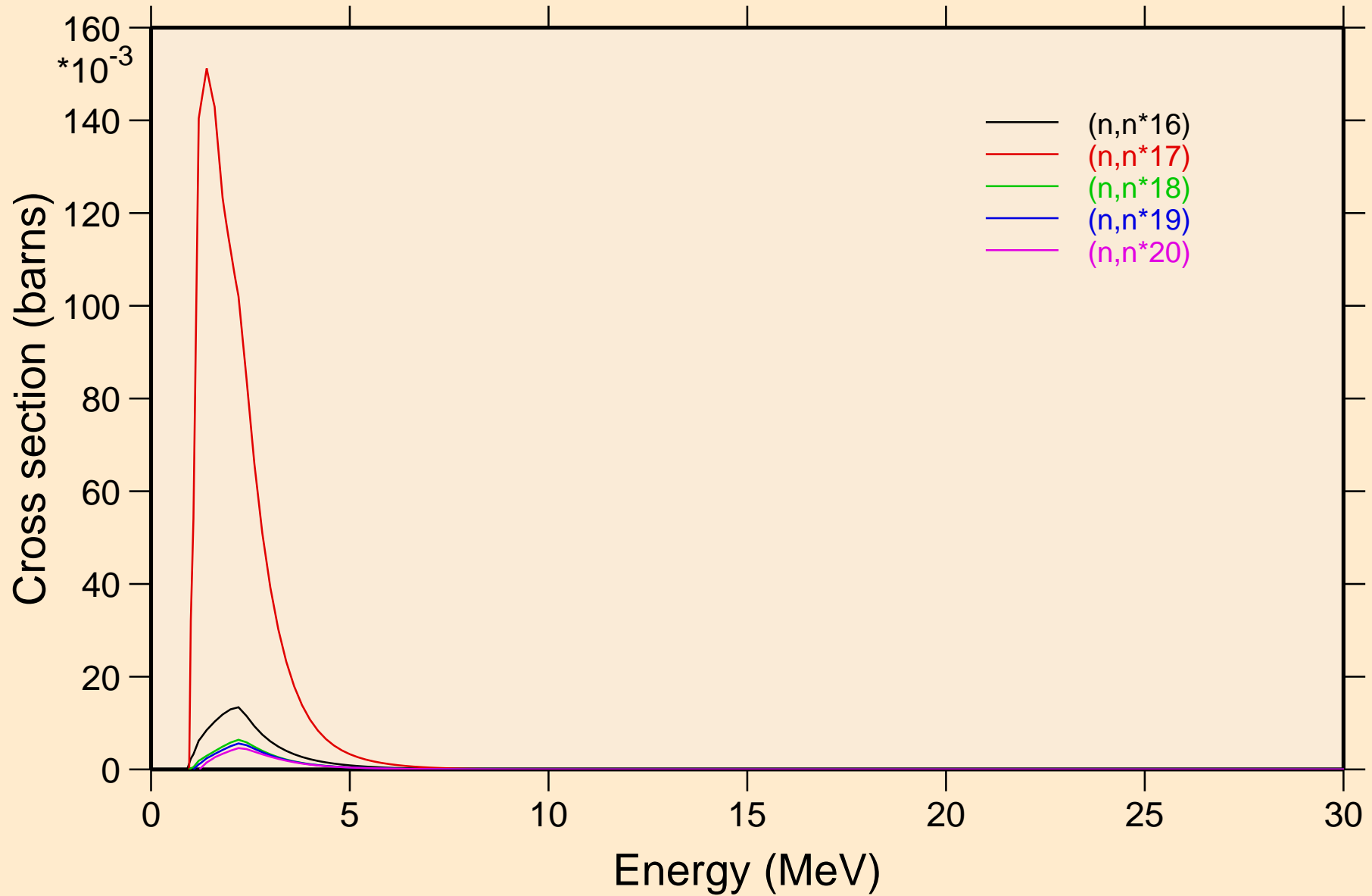

RH098M NEUTRON ACER TENDL-2023 LIBRARY; T=0.K  
Inelastic levels

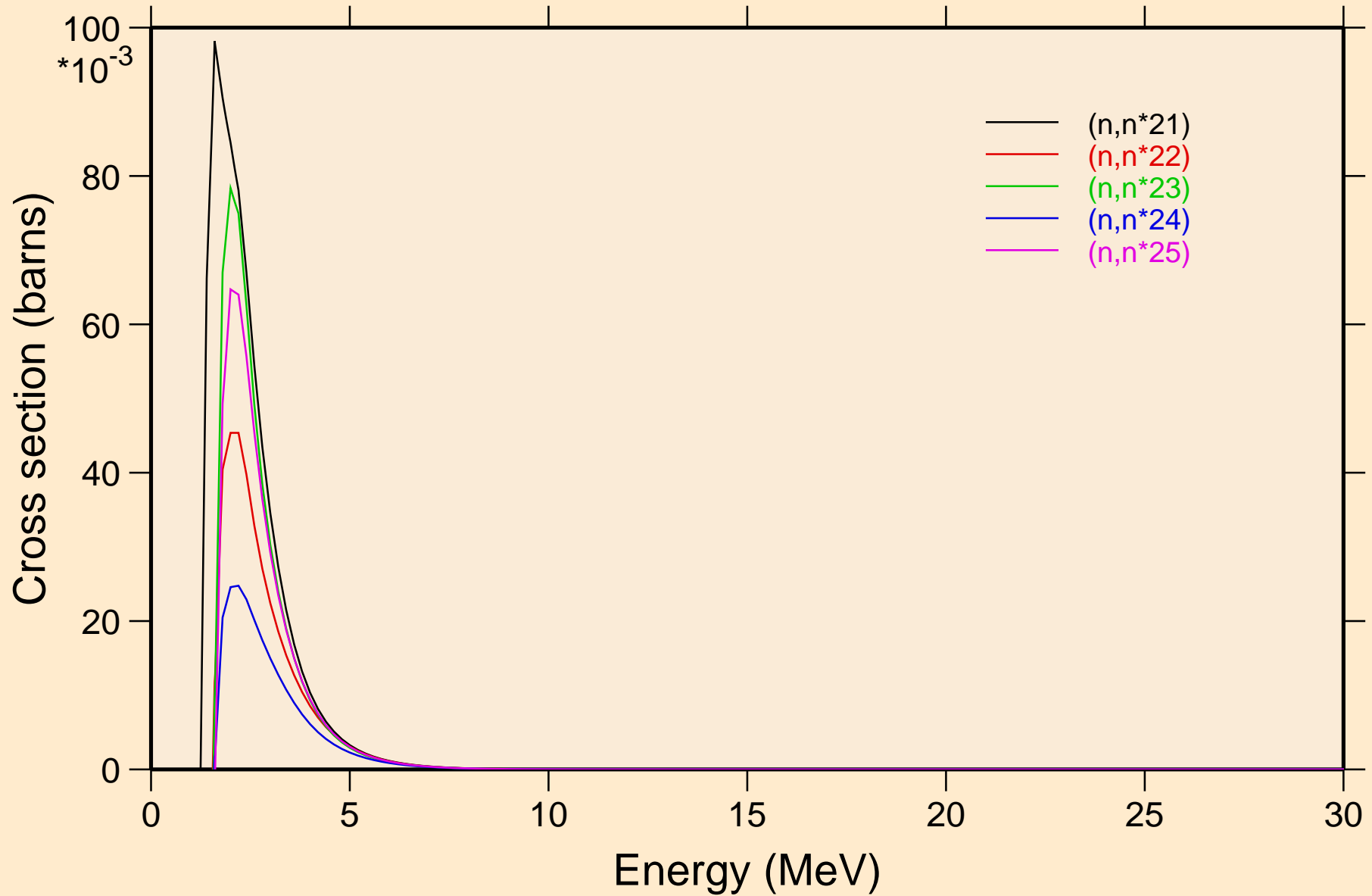

RH098M NEUTRON ACER TENDL-2023 LIBRARY; T=0.K  
Inelastic levels

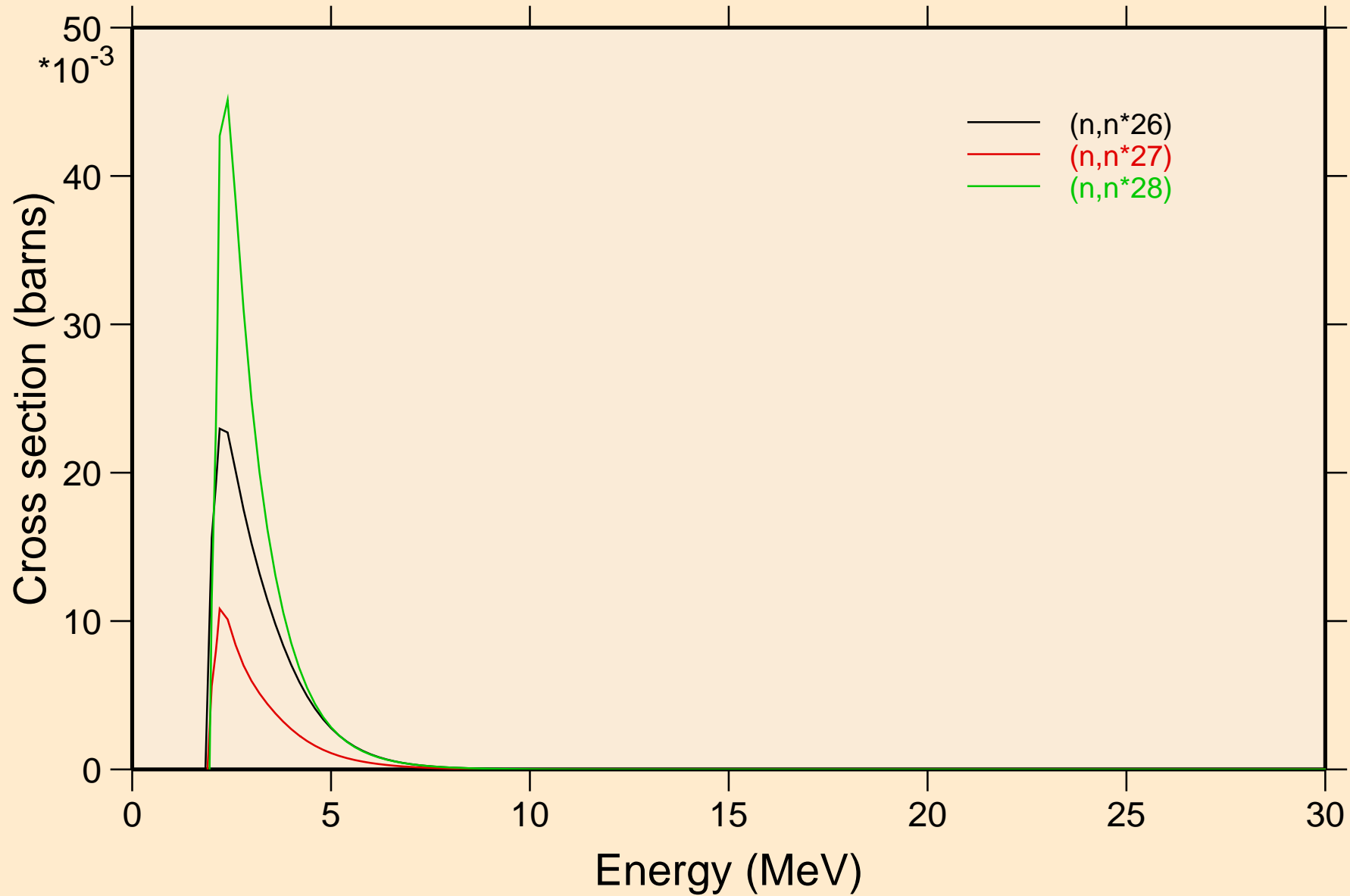



RH098M NEUTRON ACER TENDL-2023 LIBRARY; T=0.K  
Threshold reactions

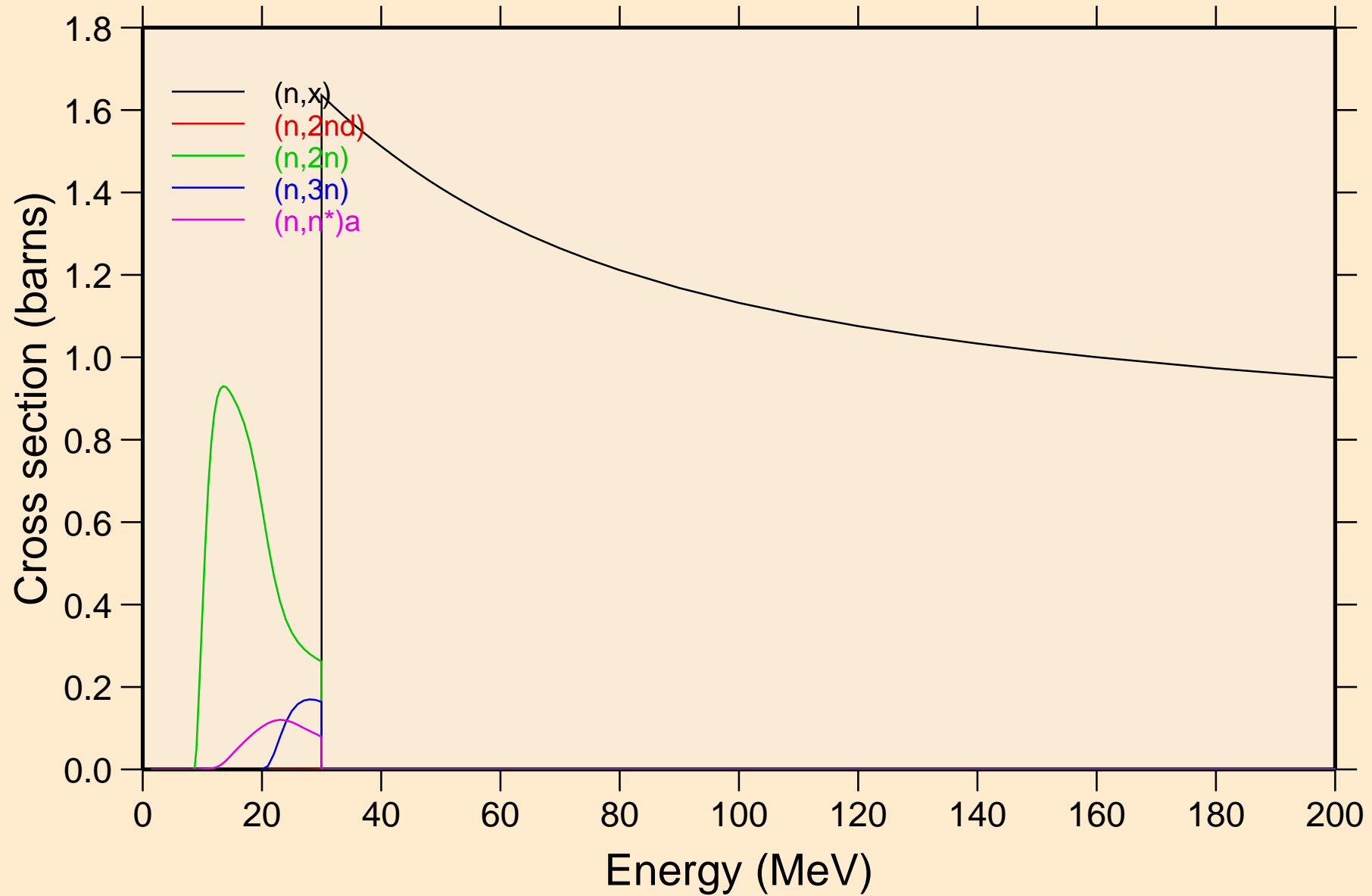

RH098M NEUTRON ACER TENDL-2023 LIBRARY; T=0.K  
Threshold reactions

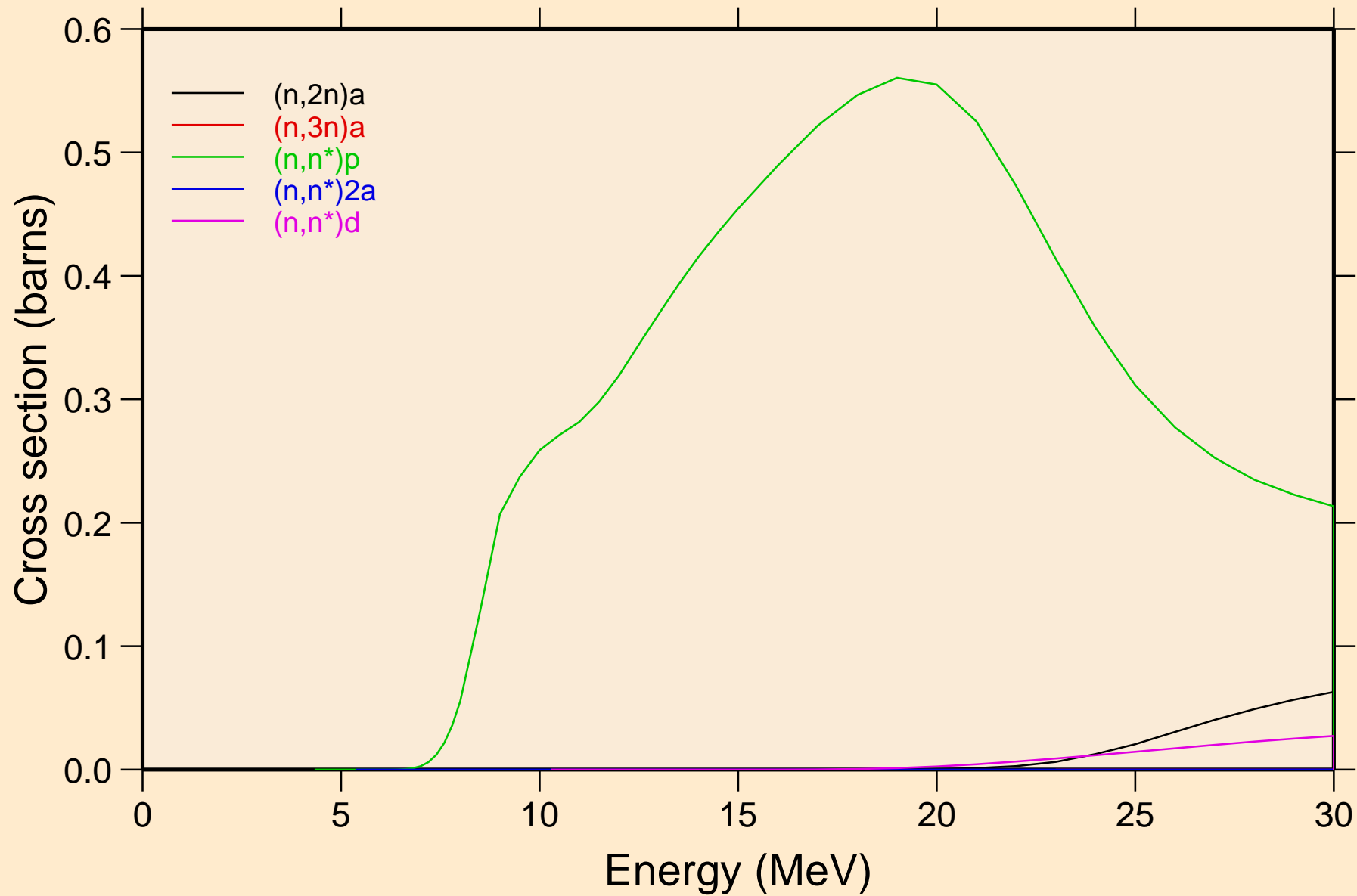

RH098M NEUTRON ACER TENDL-2023 LIBRARY; T=0.K  
Threshold reactions

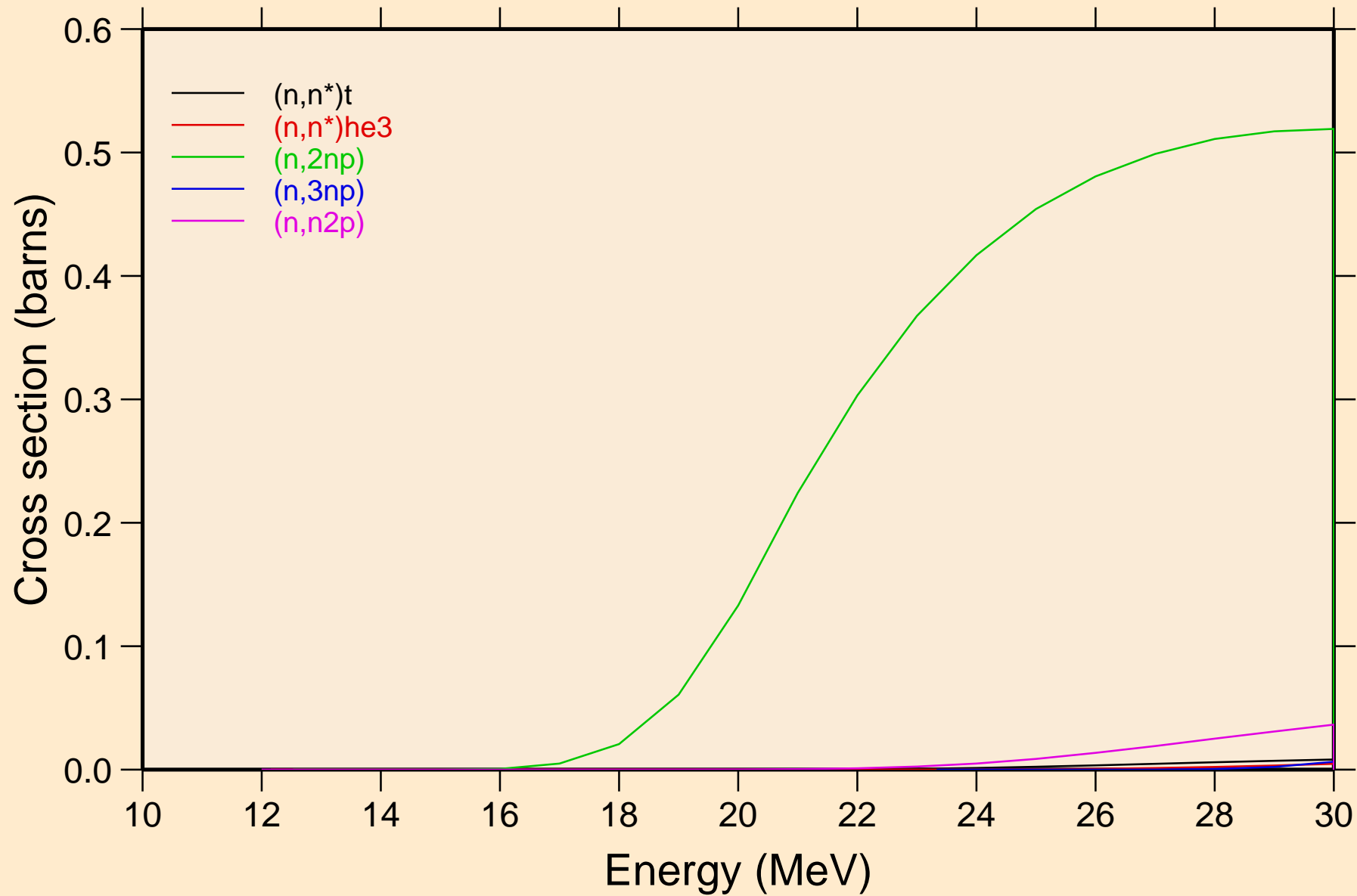

RH098M NEUTRON ACER TENDL-2023 LIBRARY; T=0.K  
Threshold reactions

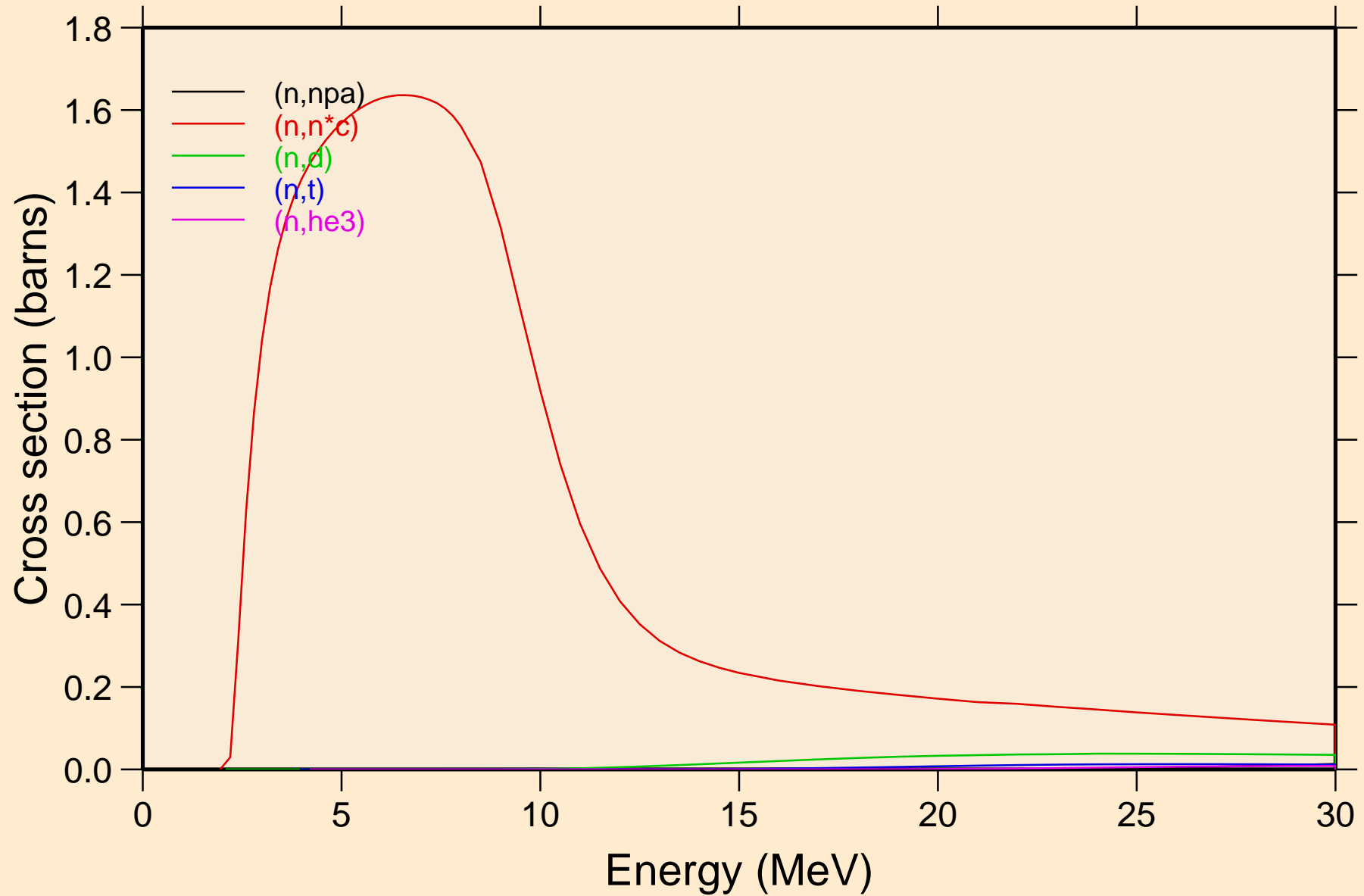

RH098M NEUTRON ACER TENDL-2023 LIBRARY; T=0.K  
Threshold reactions

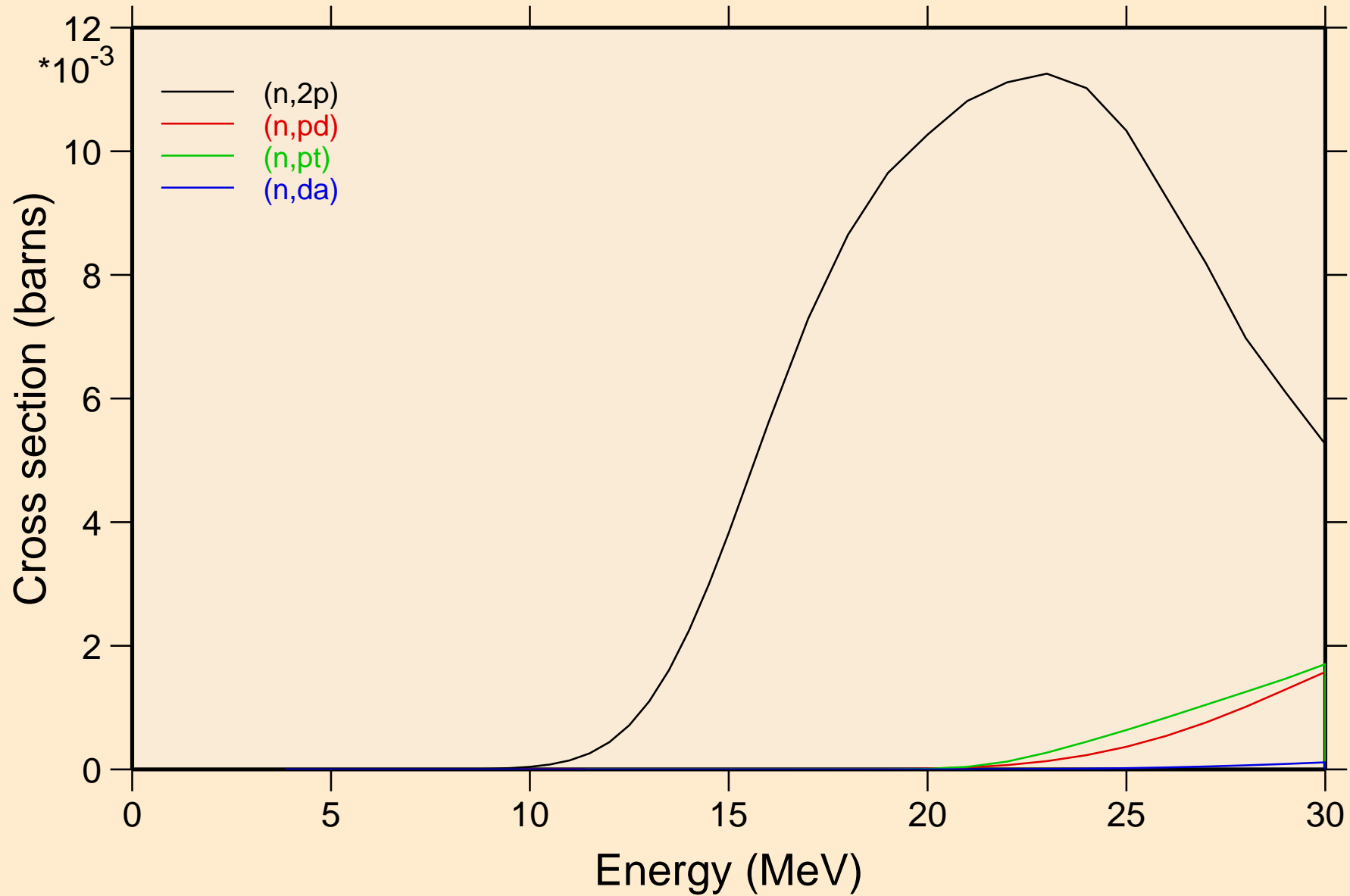

# RH098M NEUTRON ACER TENDL-2023 LIBRARY; T=0.K

## Threshold reactions

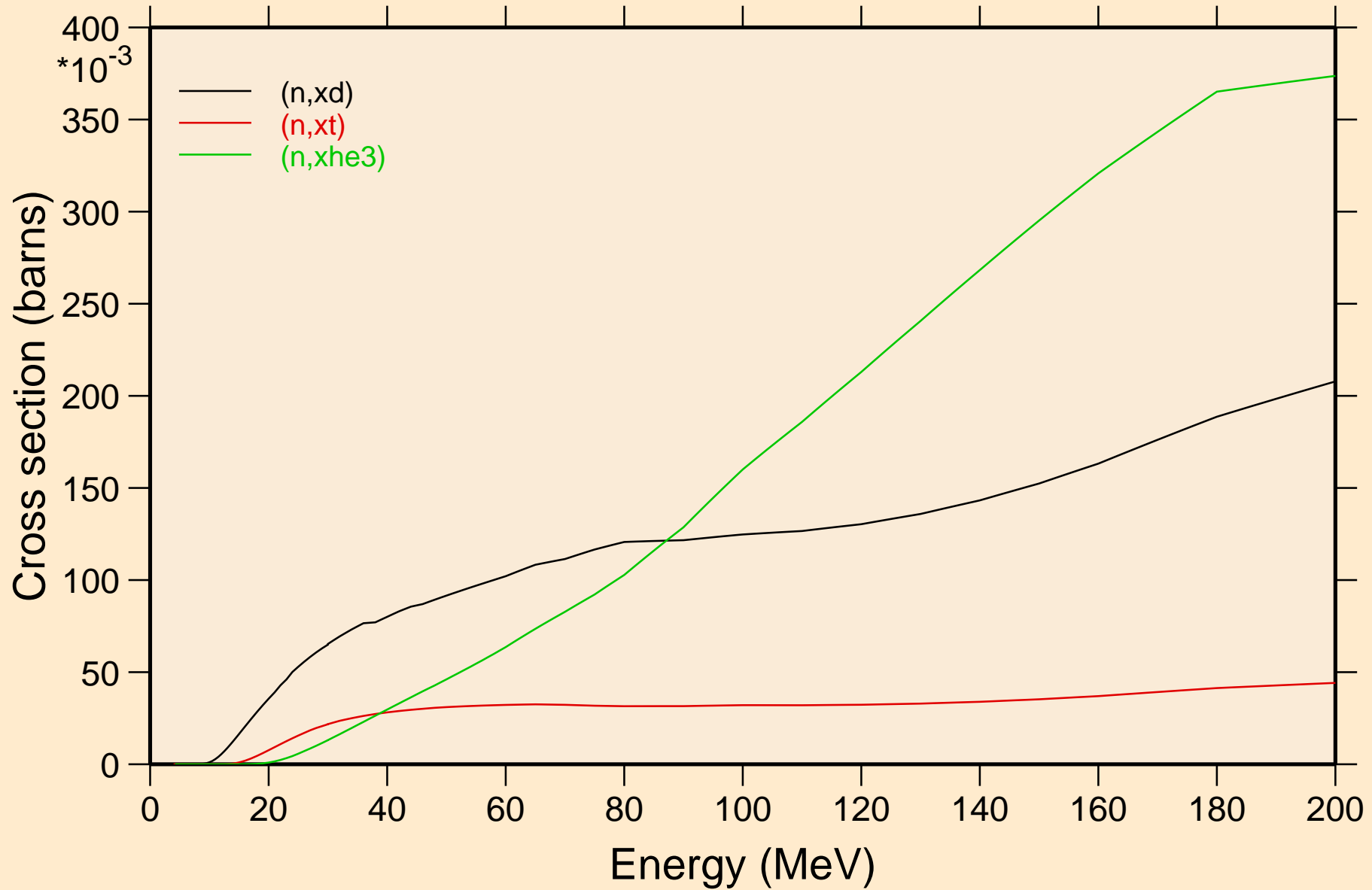

RH098M NEUTRON ACER TENDL-2023 LIBRARY; T=0.K  
angular distribution for elastic

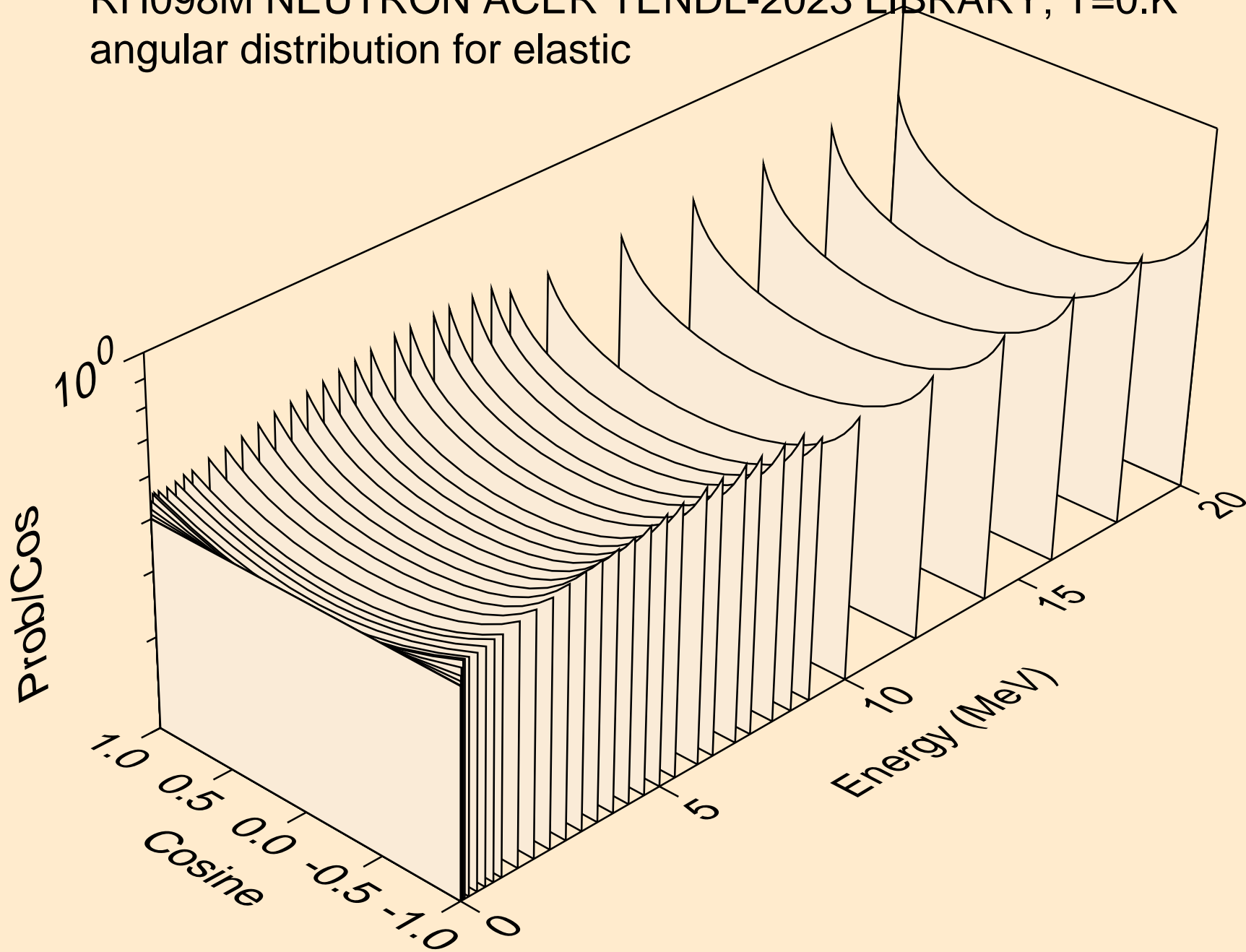

RH098M NEUTRON ACER TENDL-2023 LIBRARY; T=0.K  
angular distribution for elastic

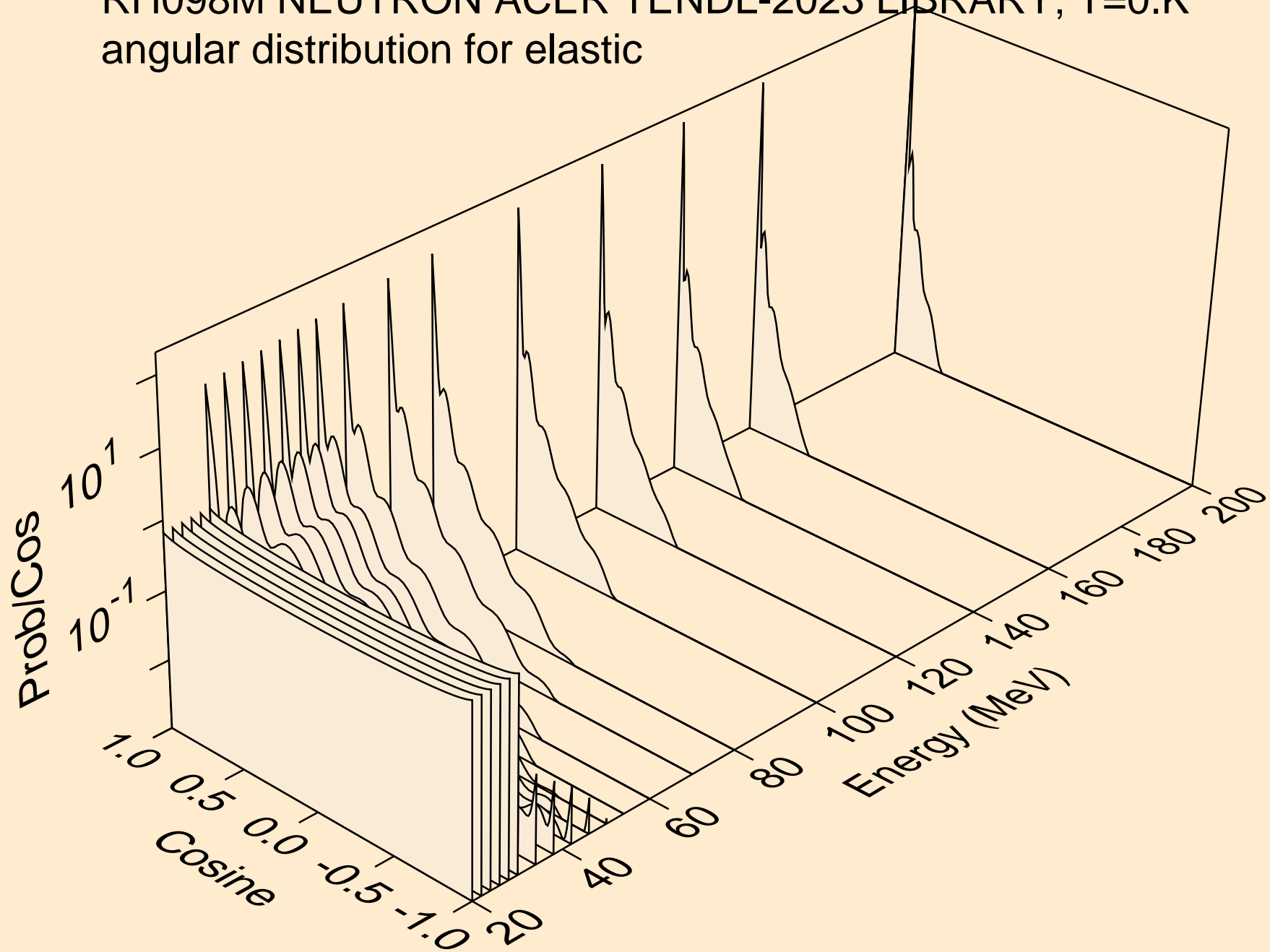



RH098M NEUTRON ACER TENDL-2023 LIBRARY; T=0.K  
angular distribution for (n,n\*1)

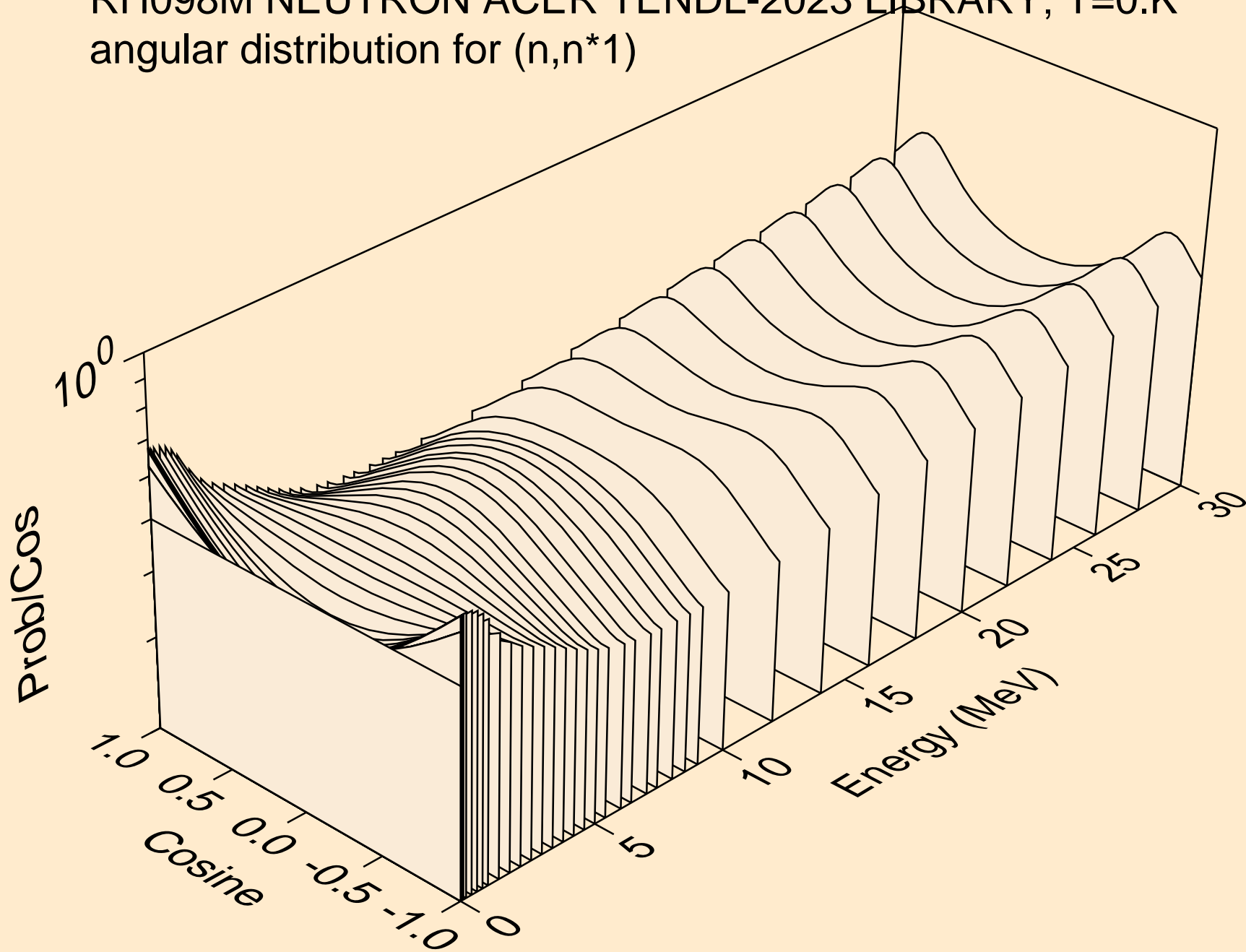

RH098M NEUTRON ACER TENDL-2023 LIBRARY; T=0.K  
angular distribution for (n,n\*2)

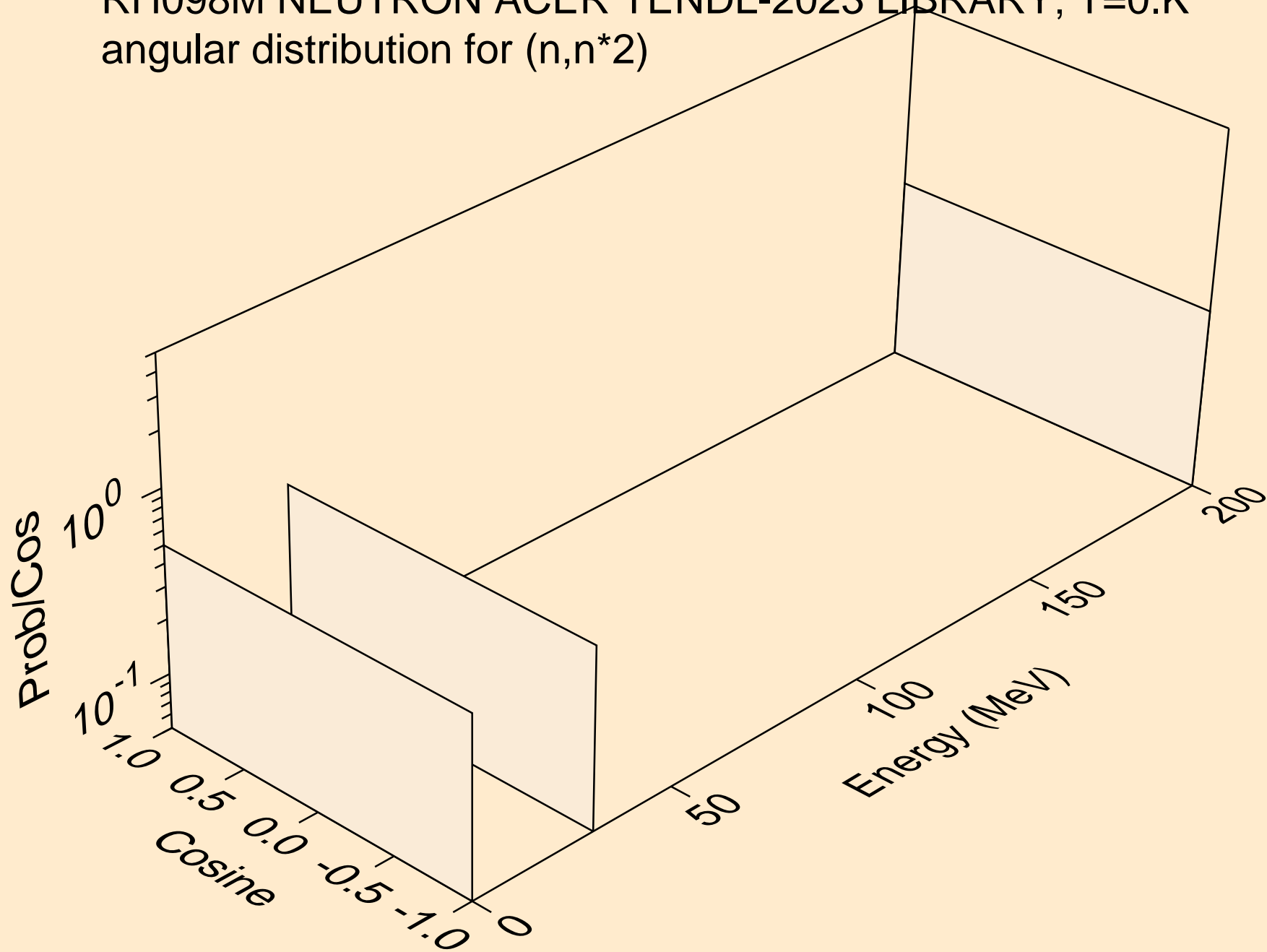

RH098M NEUTRON ACER TENDL-2023 LIBRARY; T=0.K  
angular distribution for (n,n\*3)

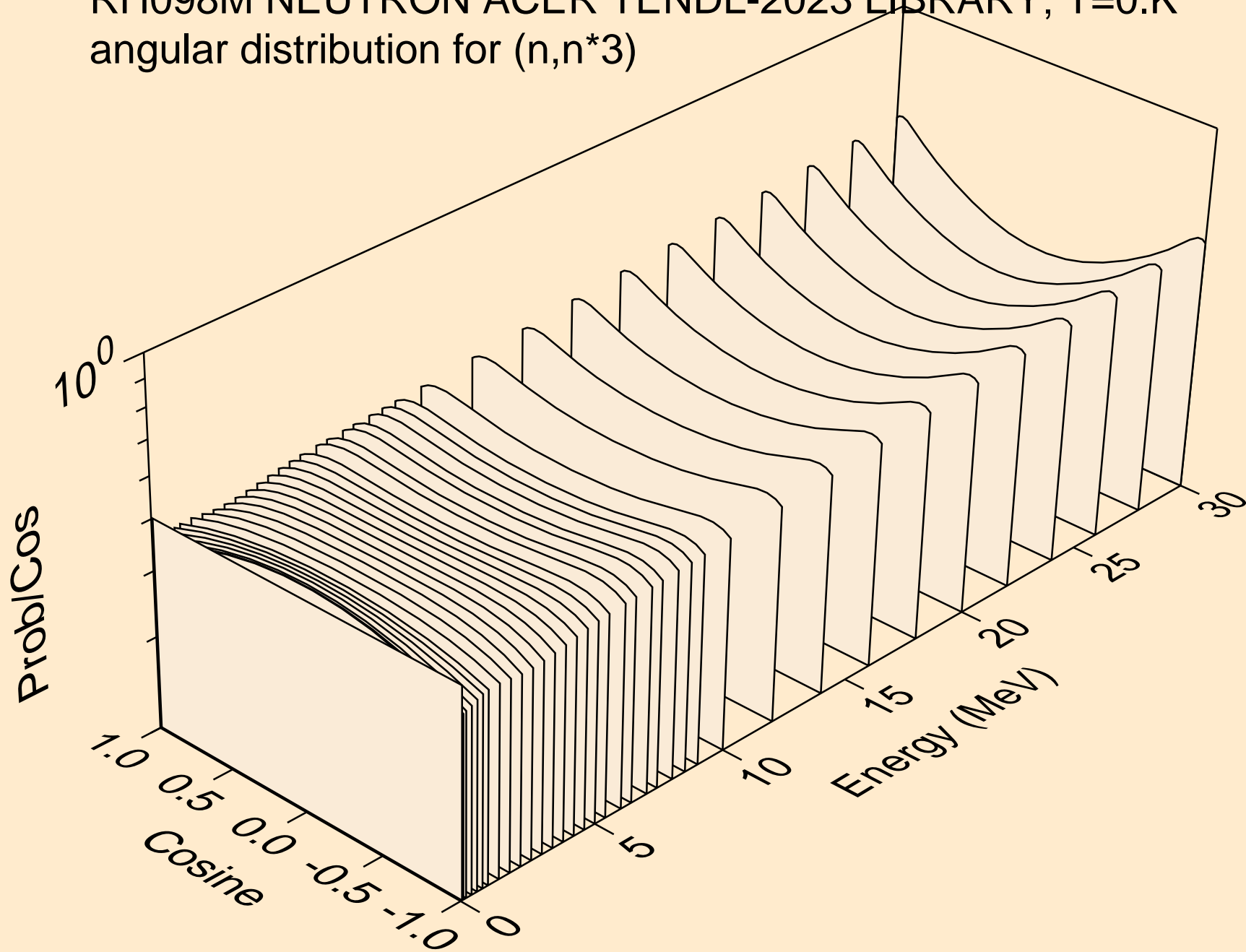

RH098M NEUTRON ACER TENDL-2023 LIBRARY; T=0.K  
angular distribution for (n,n\*4)

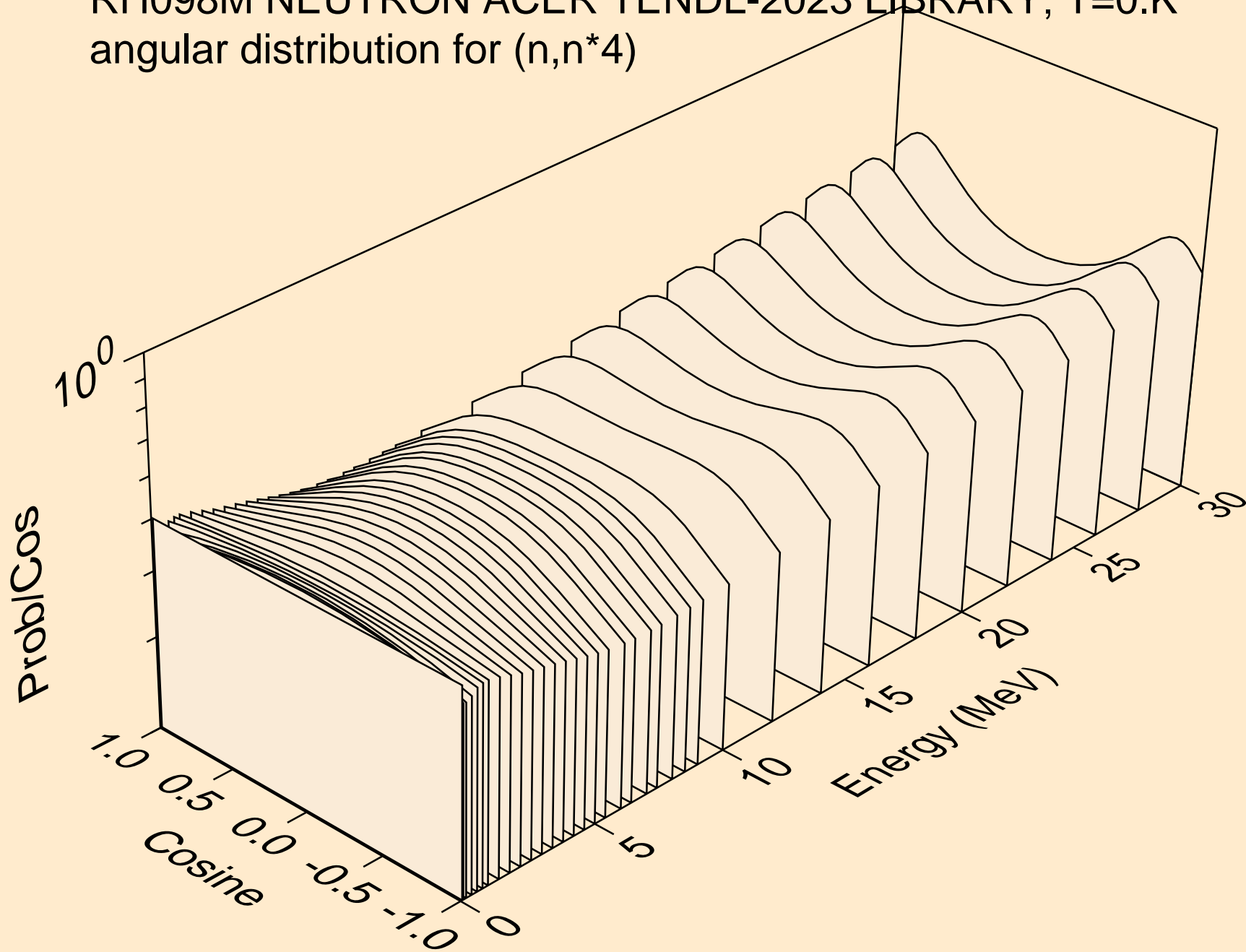

RH098M NEUTRON ACER TENDL-2023 LIBRARY; T=0.K  
angular distribution for (n,n\*5)

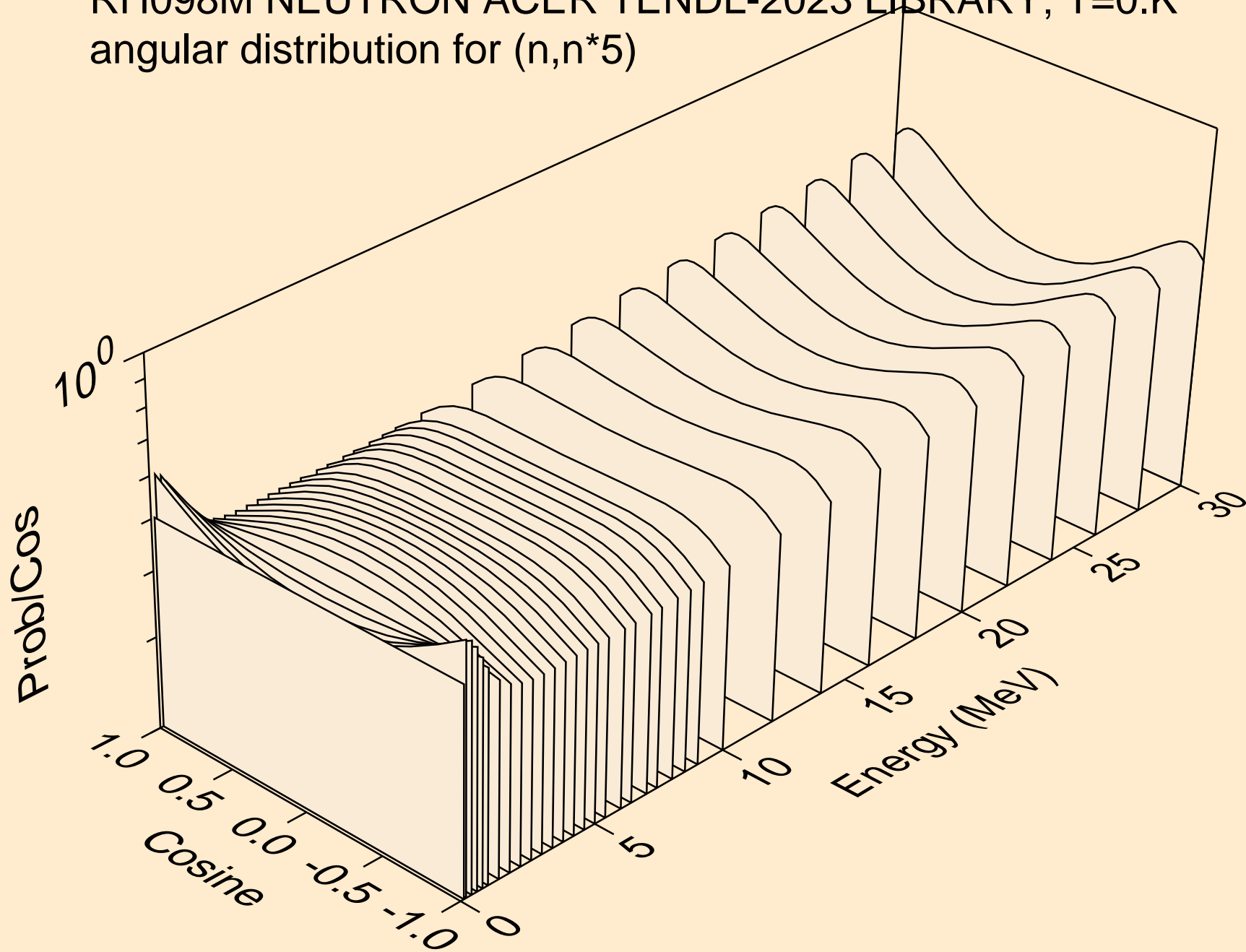

RH098M NEUTRON ACER TENDL-2023 LIBRARY; T=0.K  
angular distribution for (n,n\*6)

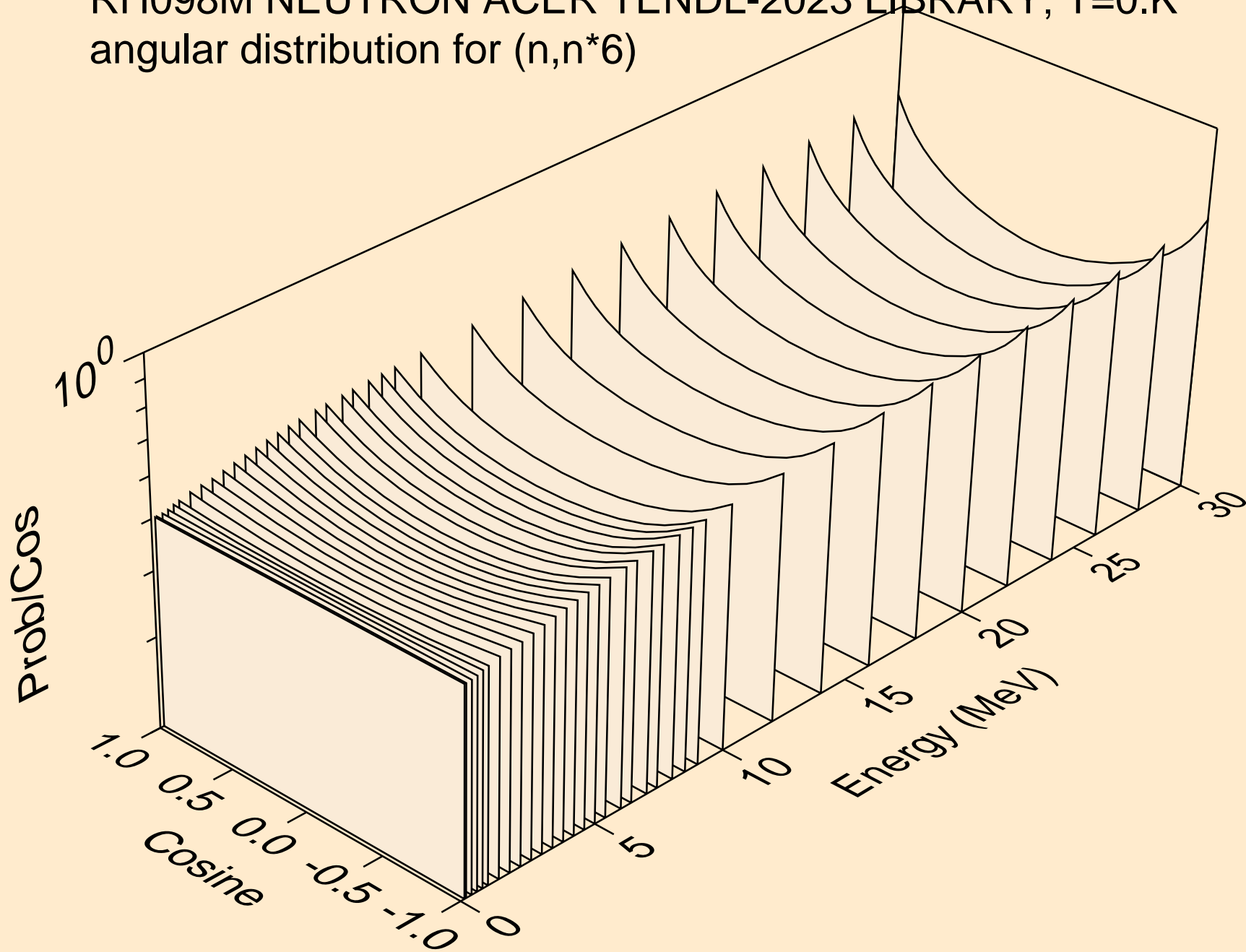

RH098M NEUTRON ACER TENDL-2023 LIBRARY; T=0.K  
angular distribution for (n,n\*7)

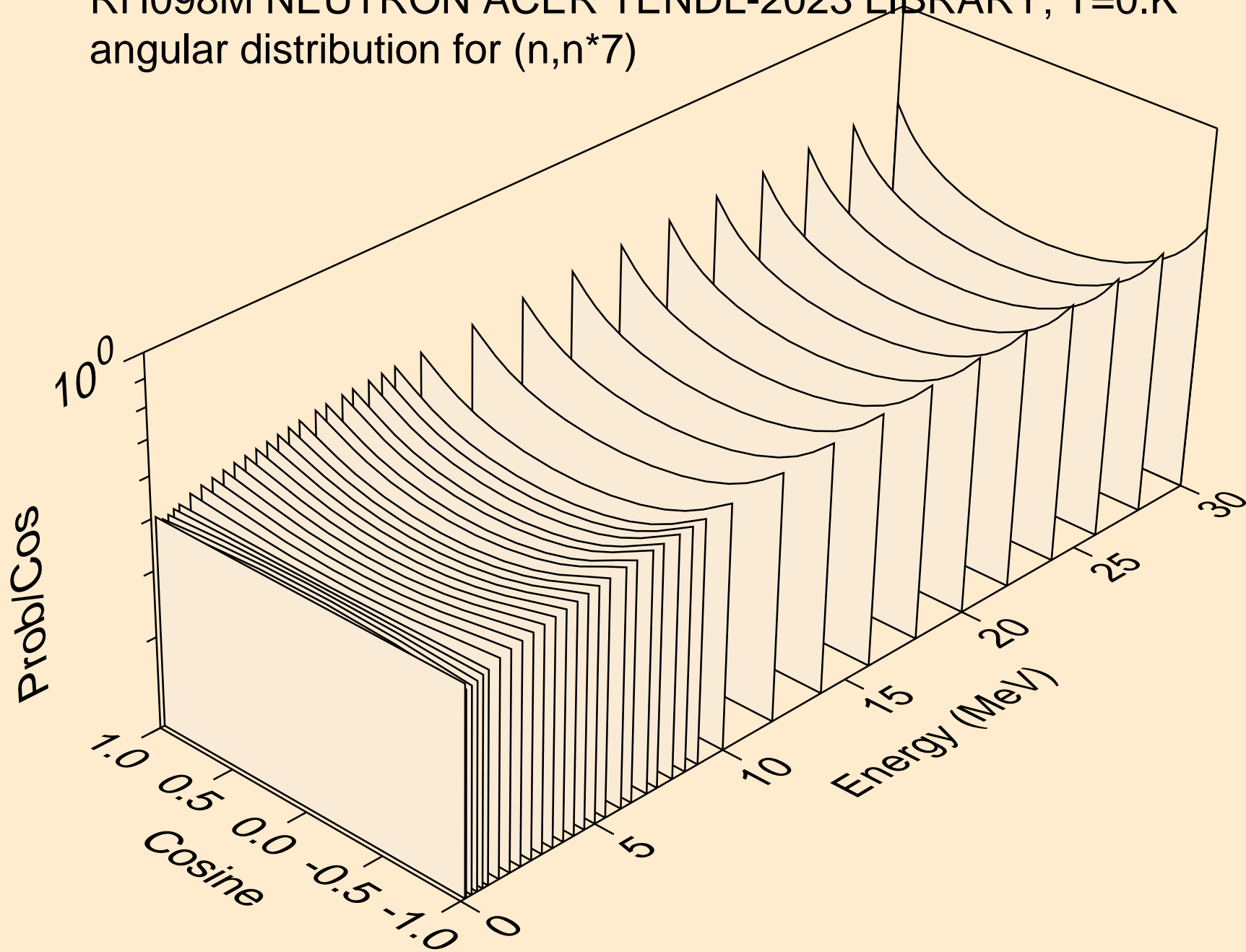

RH098M NEUTRON ACER TENDL-2023 LIBRARY; T=0.K  
angular distribution for (n,n\*8)

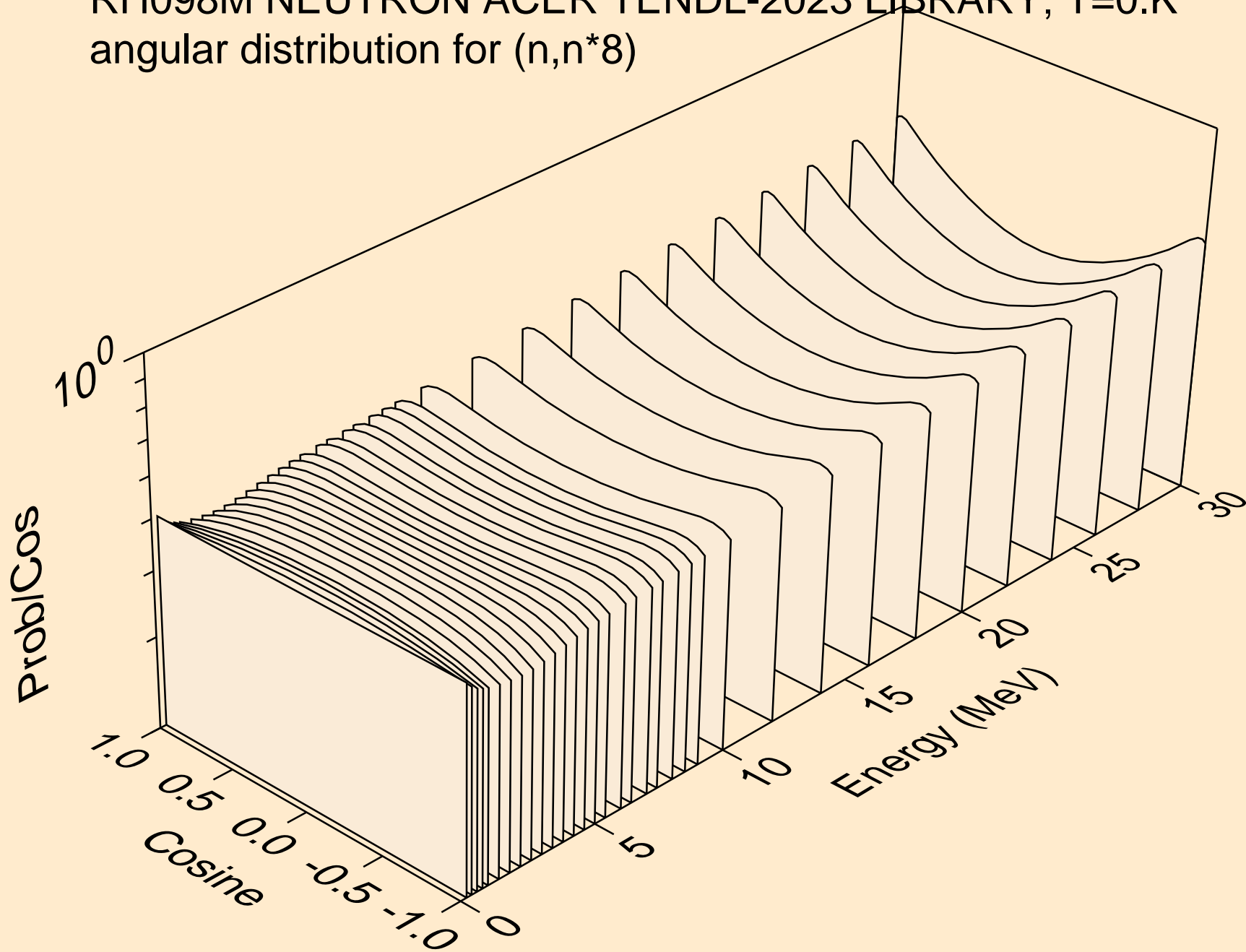



RH098M NEUTRON ACER TENDL-2023 LIBRARY; T=0.K  
angular distribution for (n,n\*9)

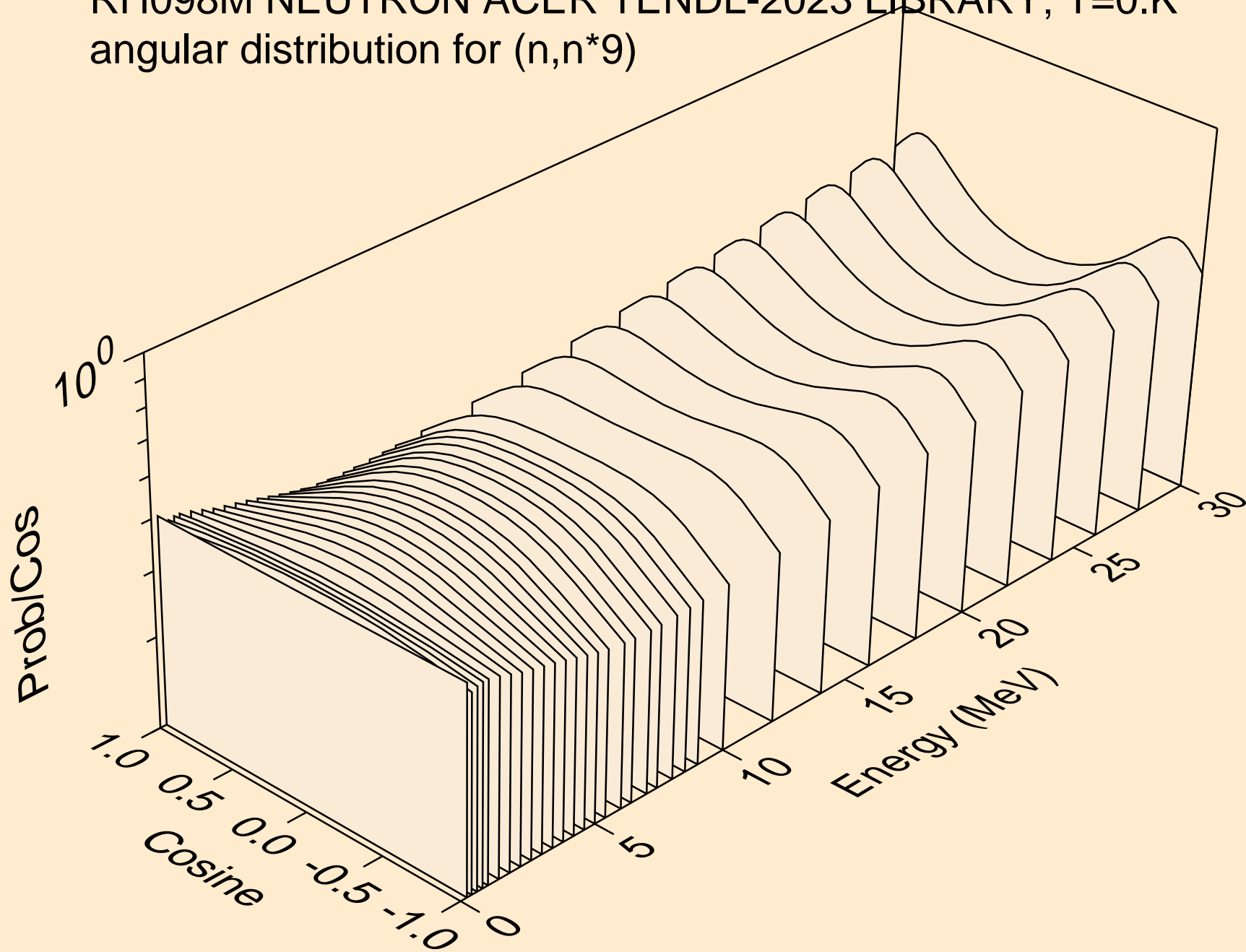

RH098M NEUTRON ACER TENDL-2023 LIBRARY; T=0.K  
angular distribution for (n,n\*10)

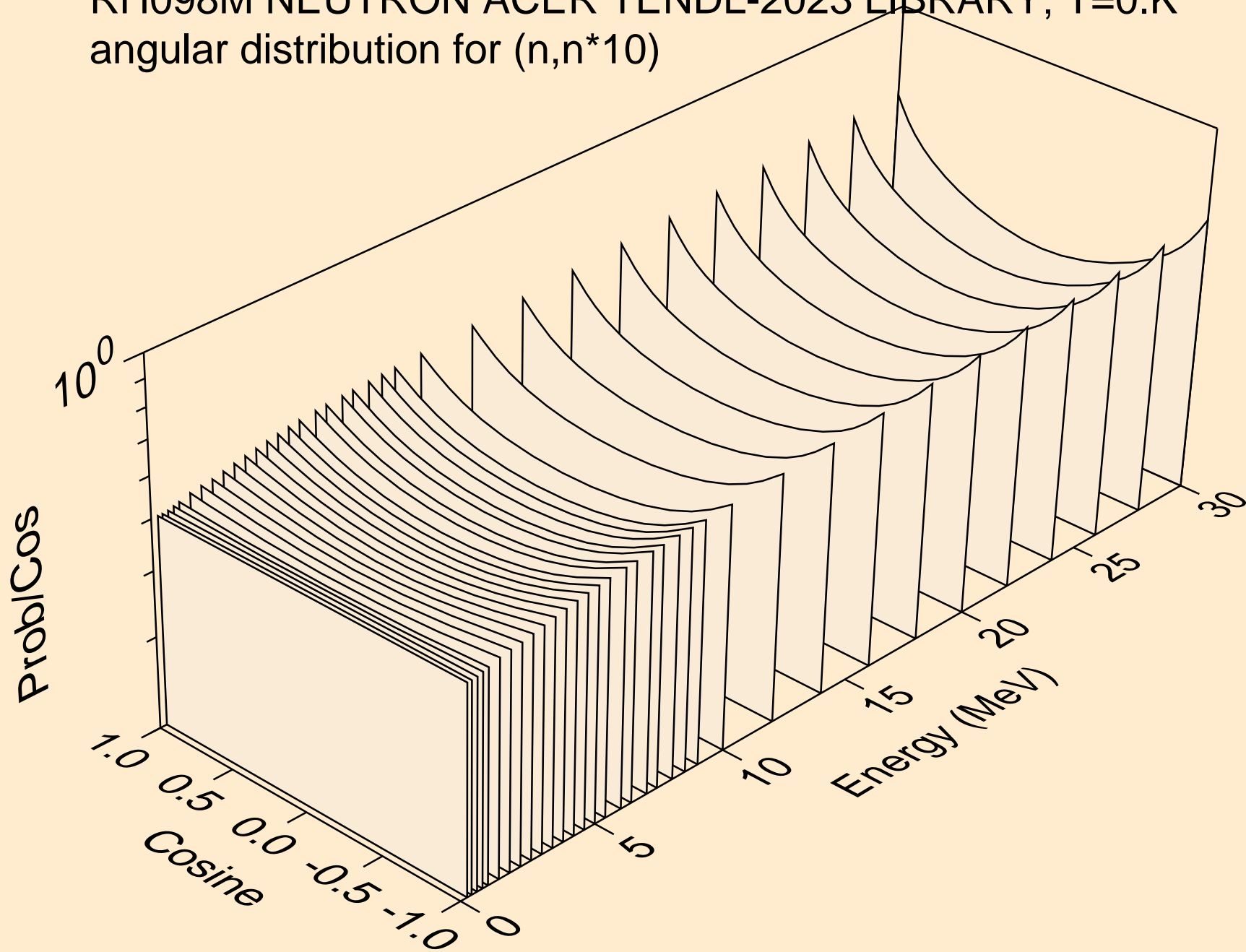

RH098M NEUTRON ACER TENDL-2023 LIBRARY; T=0.K  
angular distribution for (n,n\*11)

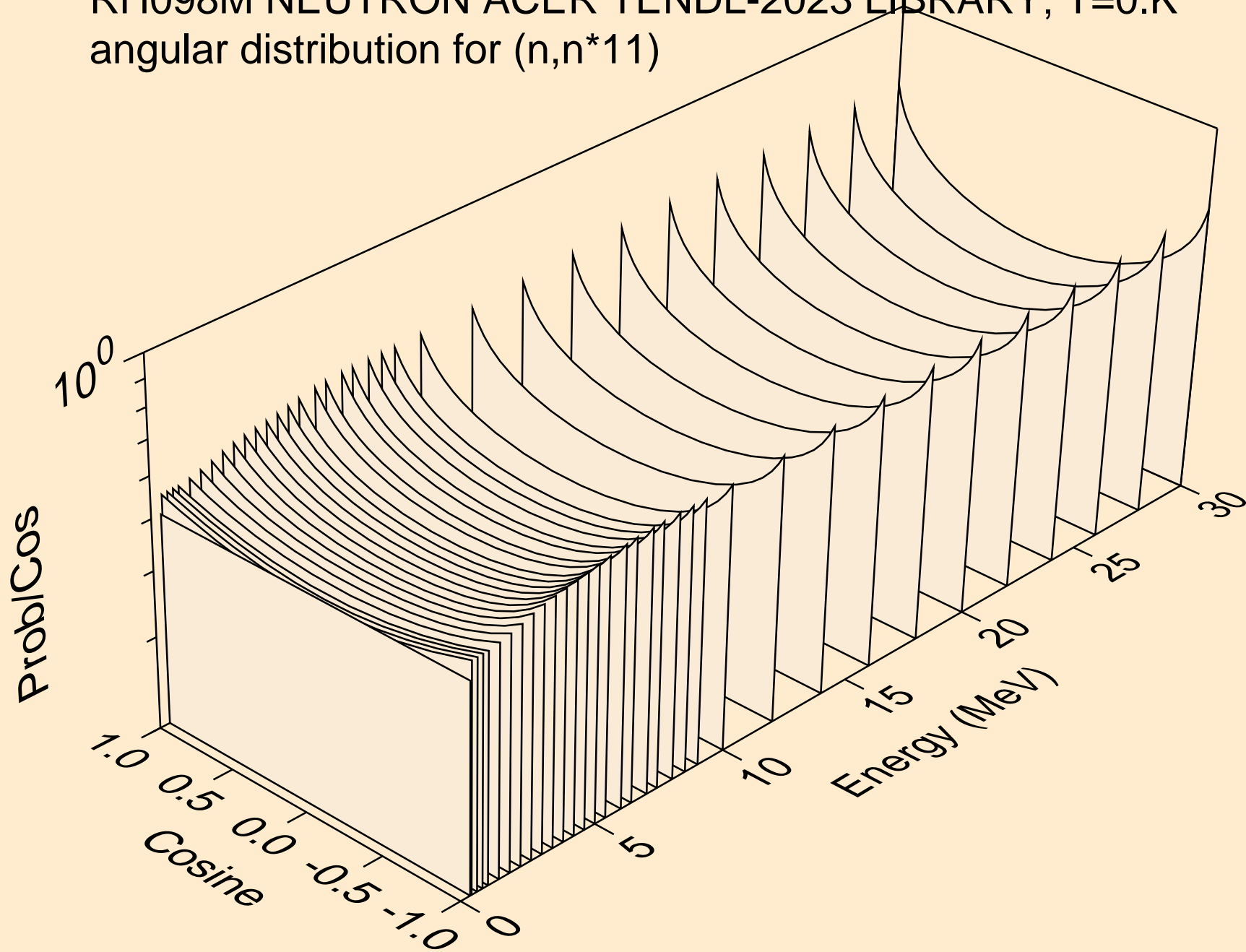

RH098M NEUTRON ACER TENDL-2023 LIBRARY; T=0.K  
angular distribution for (n,n\*12)

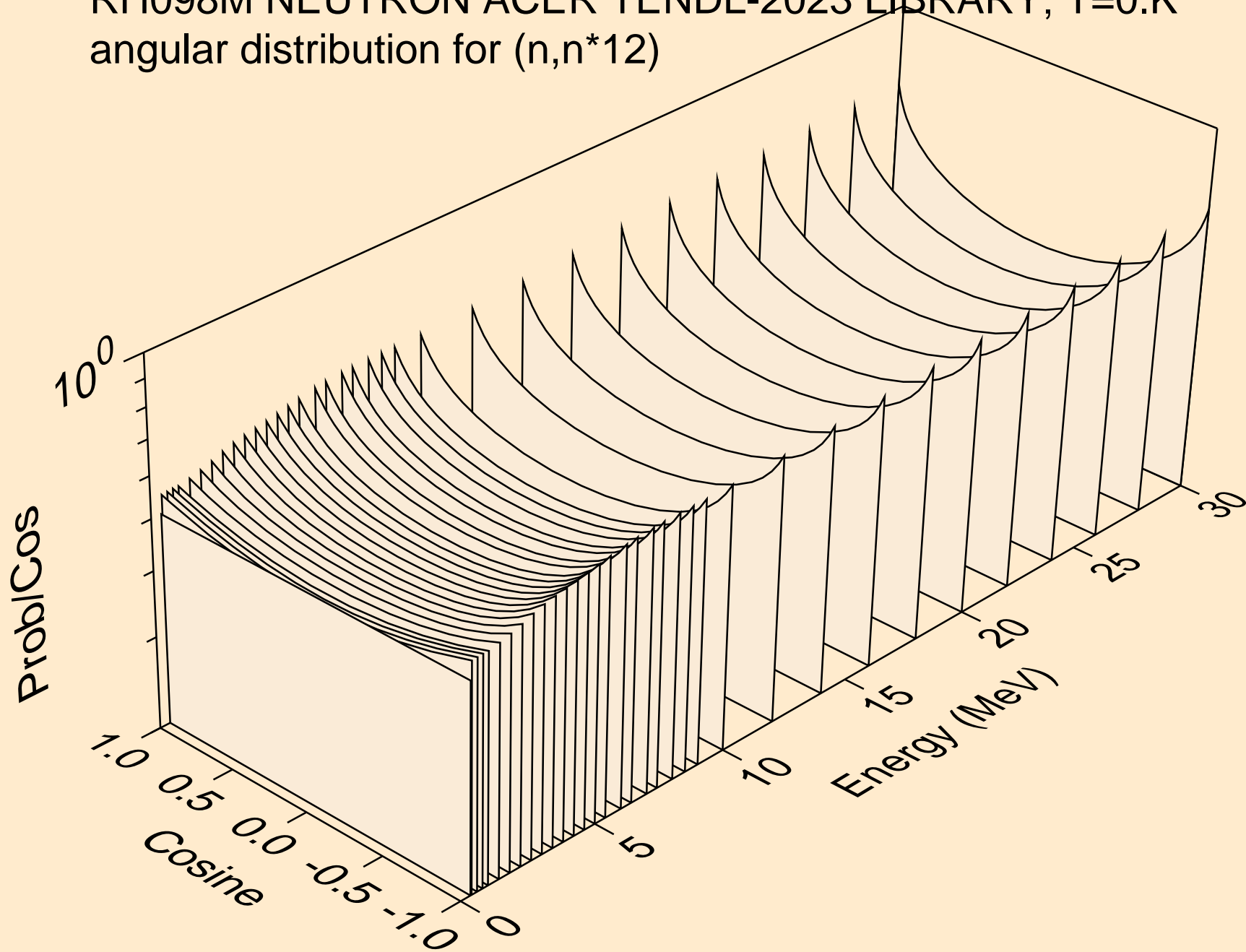

RH098M NEUTRON ACER TENDL-2023 LIBRARY; T=0.K  
angular distribution for (n,n\*13)

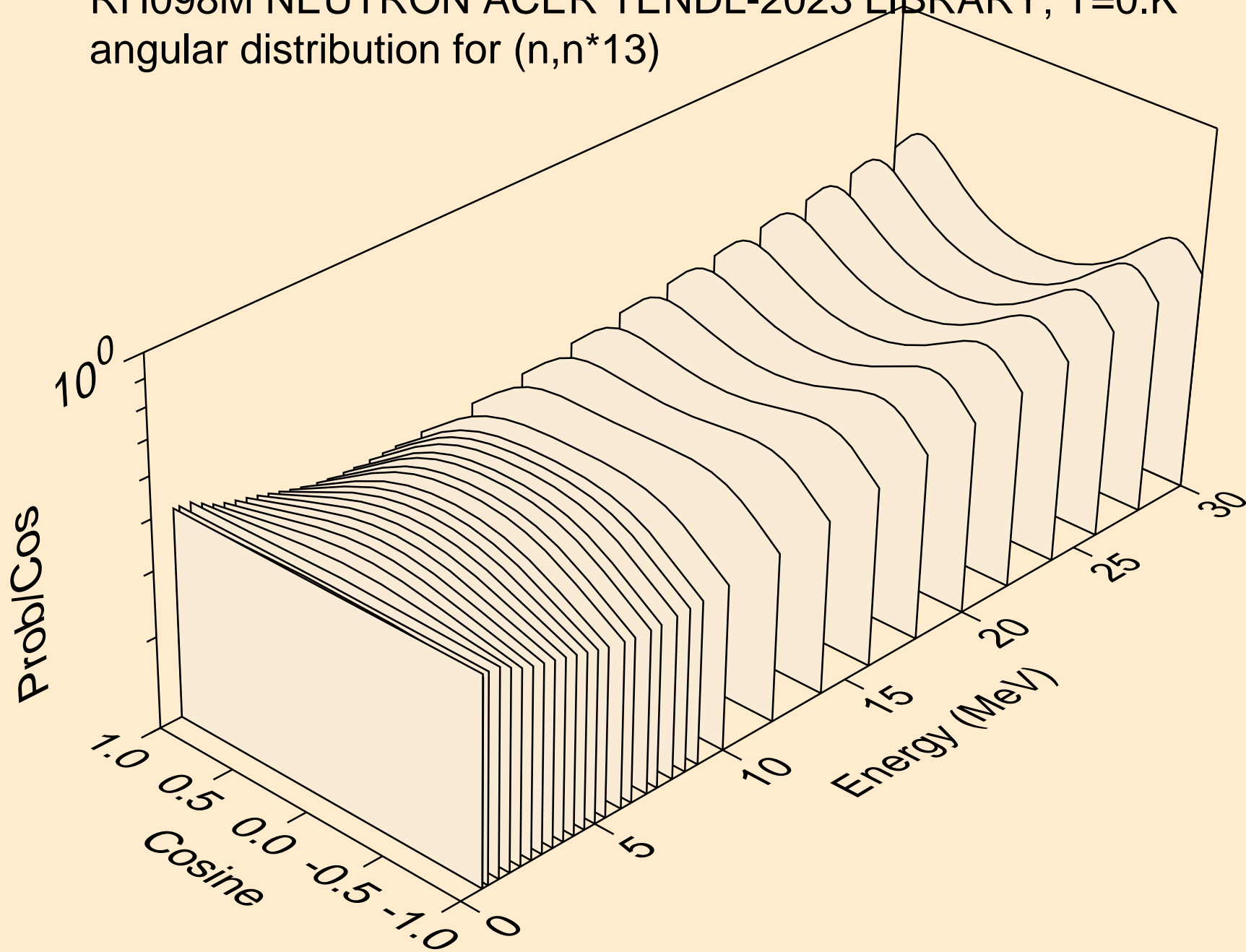

RH098M NEUTRON ACER TENDL-2023 LIBRARY; T=0.K  
angular distribution for (n,n\*14)

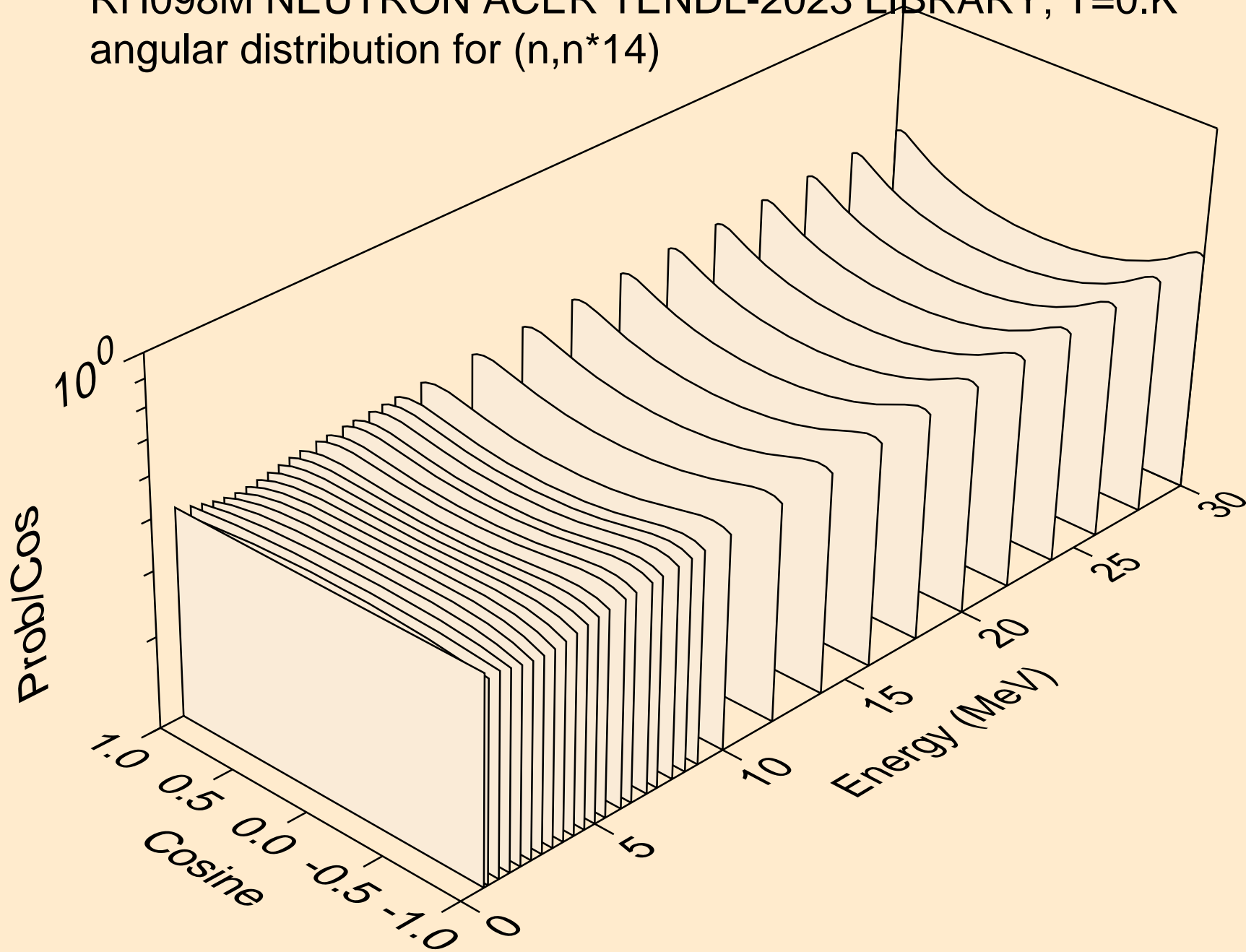

RH098M NEUTRON ACER TENDL-2023 LIBRARY; T=0.K  
angular distribution for (n,n\*15)

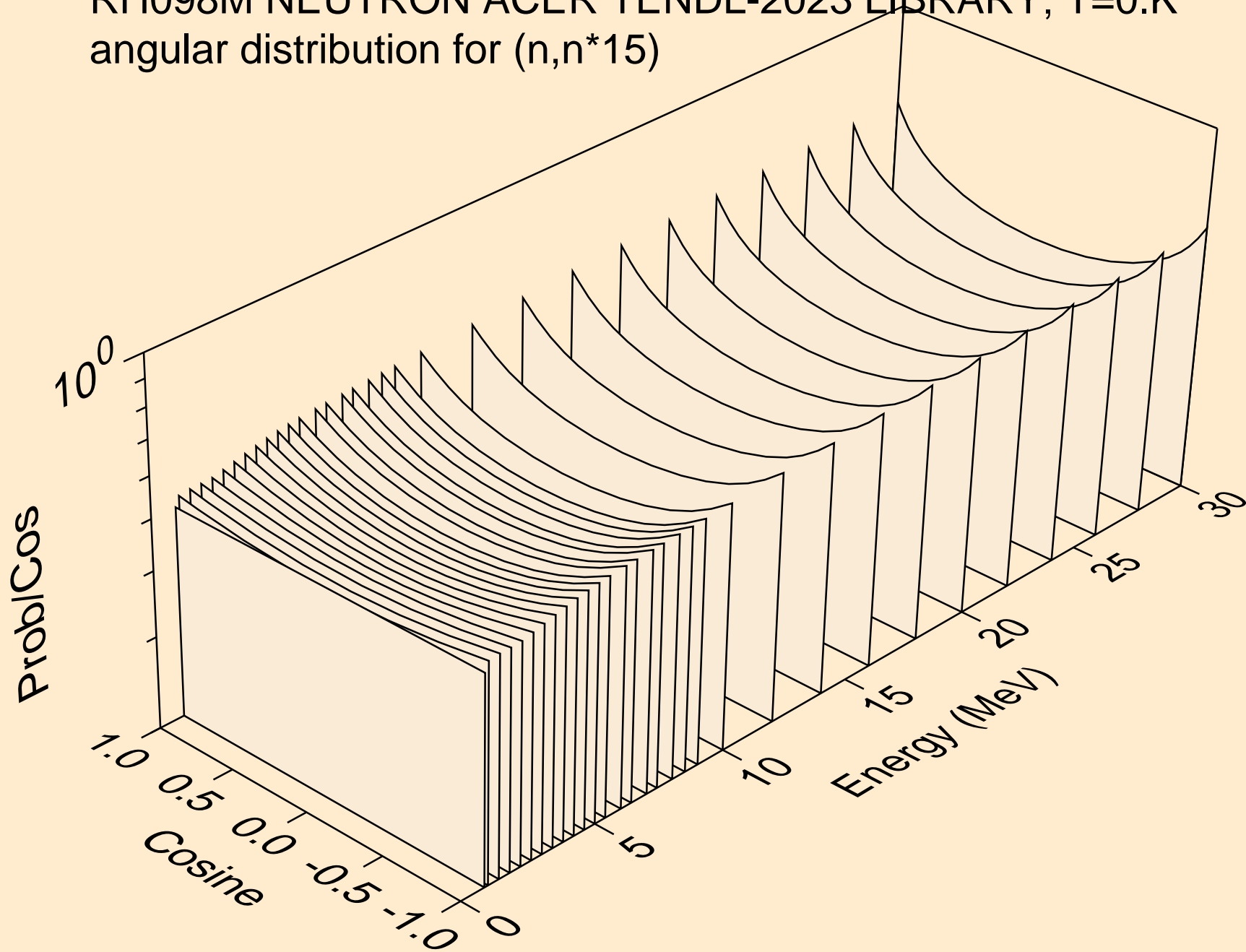

RH098M NEUTRON ACER TENDL-2023 LIBRARY; T=0.K  
angular distribution for (n,n\*16)

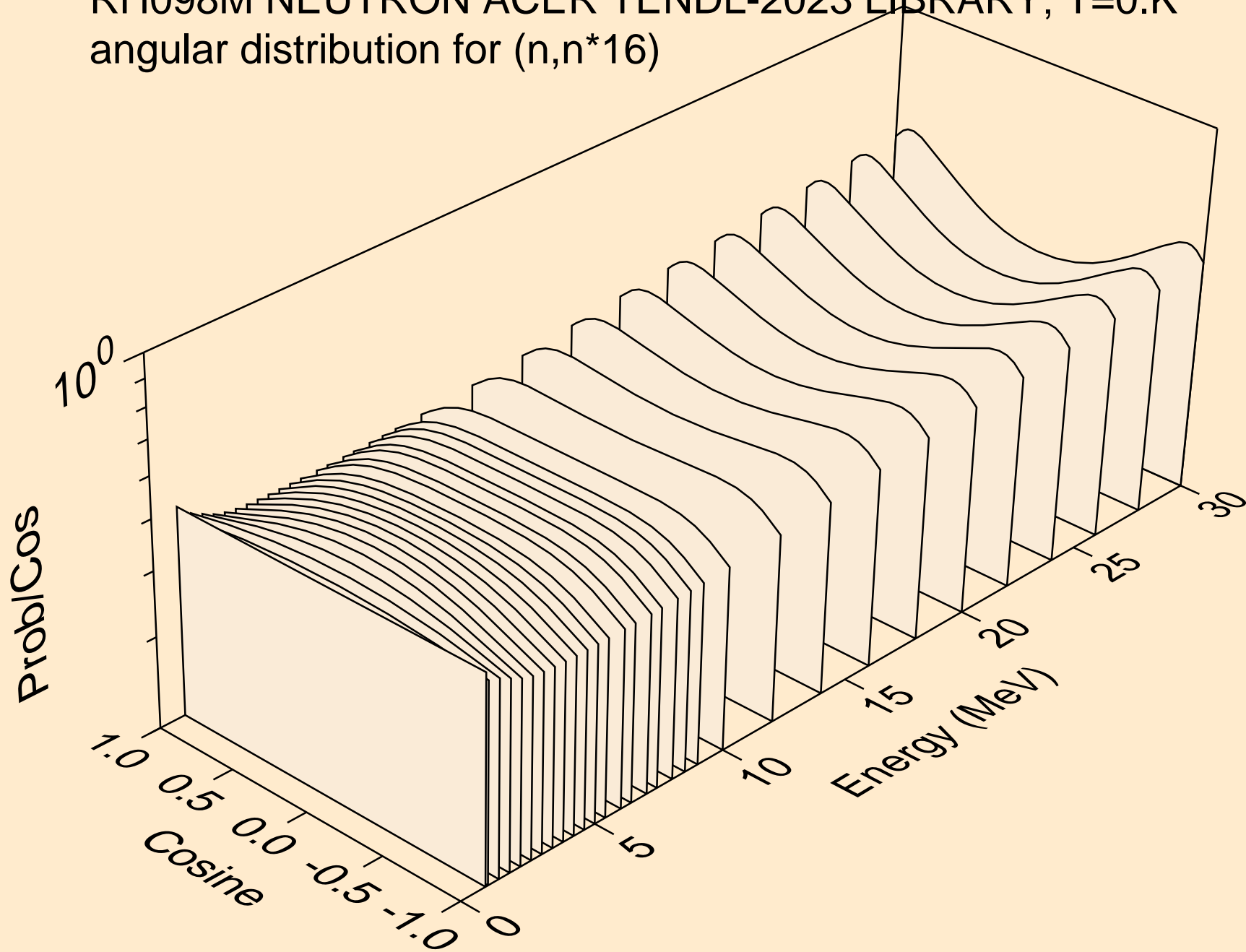



RH098M NEUTRON ACER TENDL-2023 LIBRARY; T=0.K  
angular distribution for (n,n\*17)

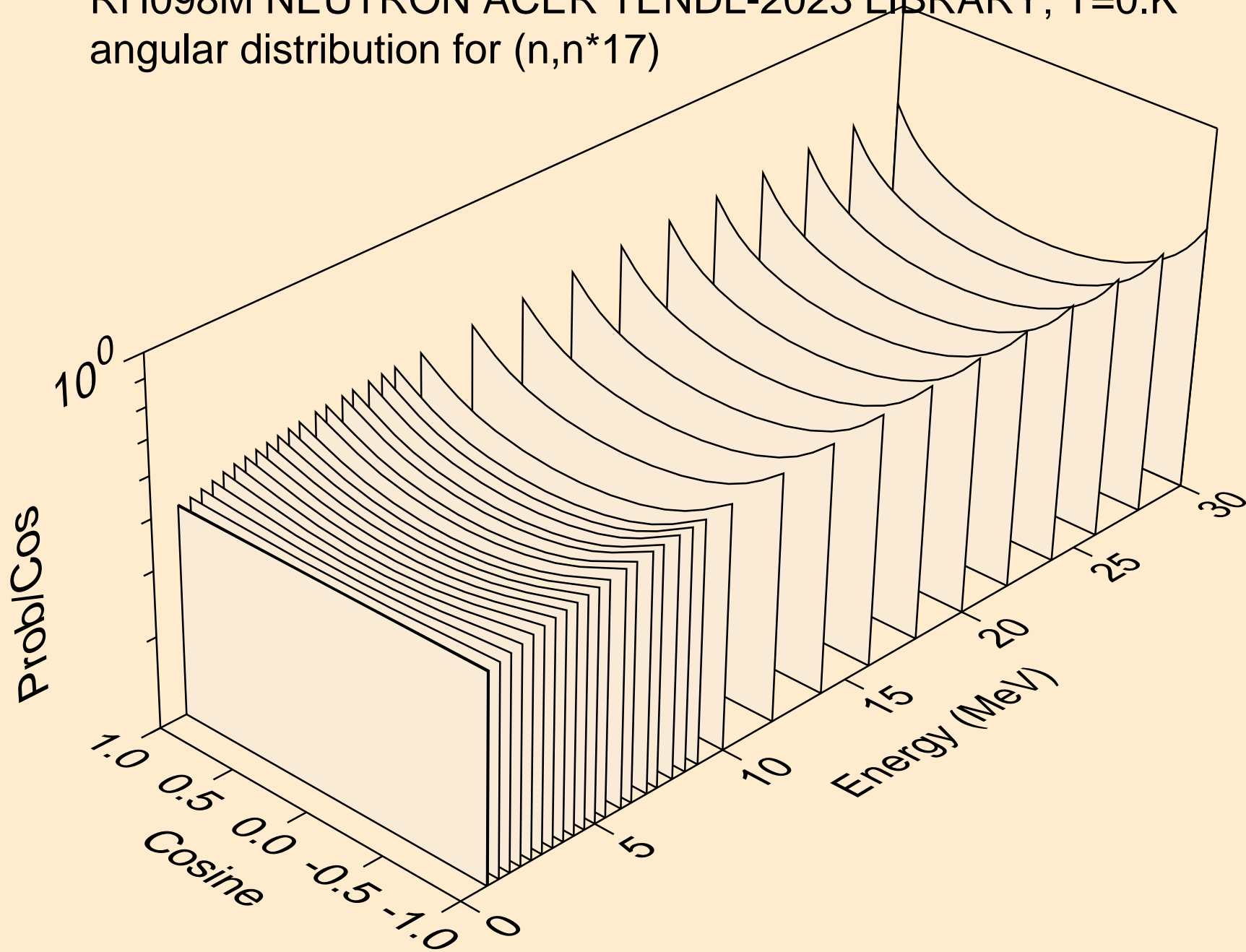

RH098M NEUTRON ACER TENDL-2023 LIBRARY; T=0.K  
angular distribution for (n,n\*18)

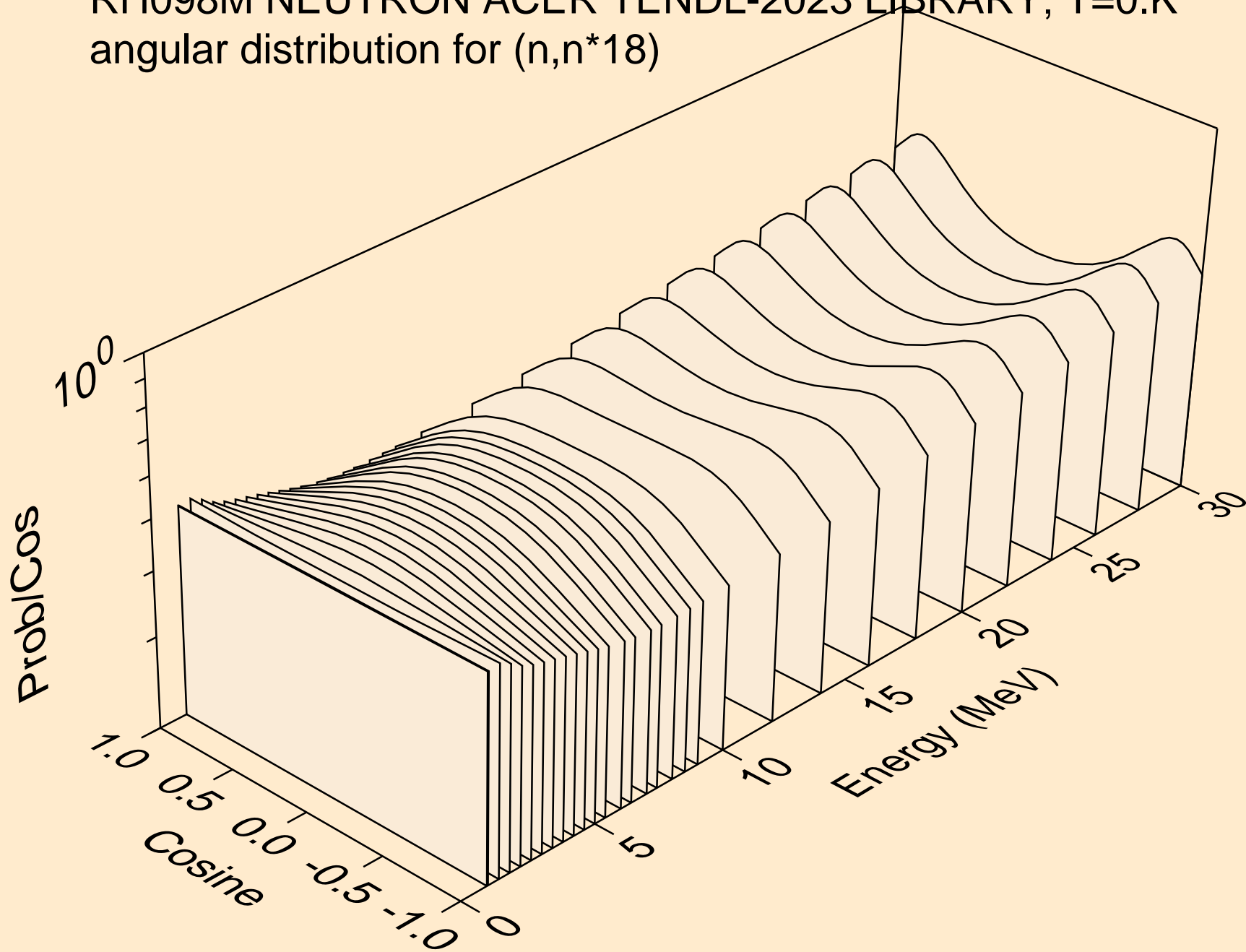

RH098M NEUTRON ACER TENDL-2023 LIBRARY; T=0.K  
angular distribution for (n,n\*19)

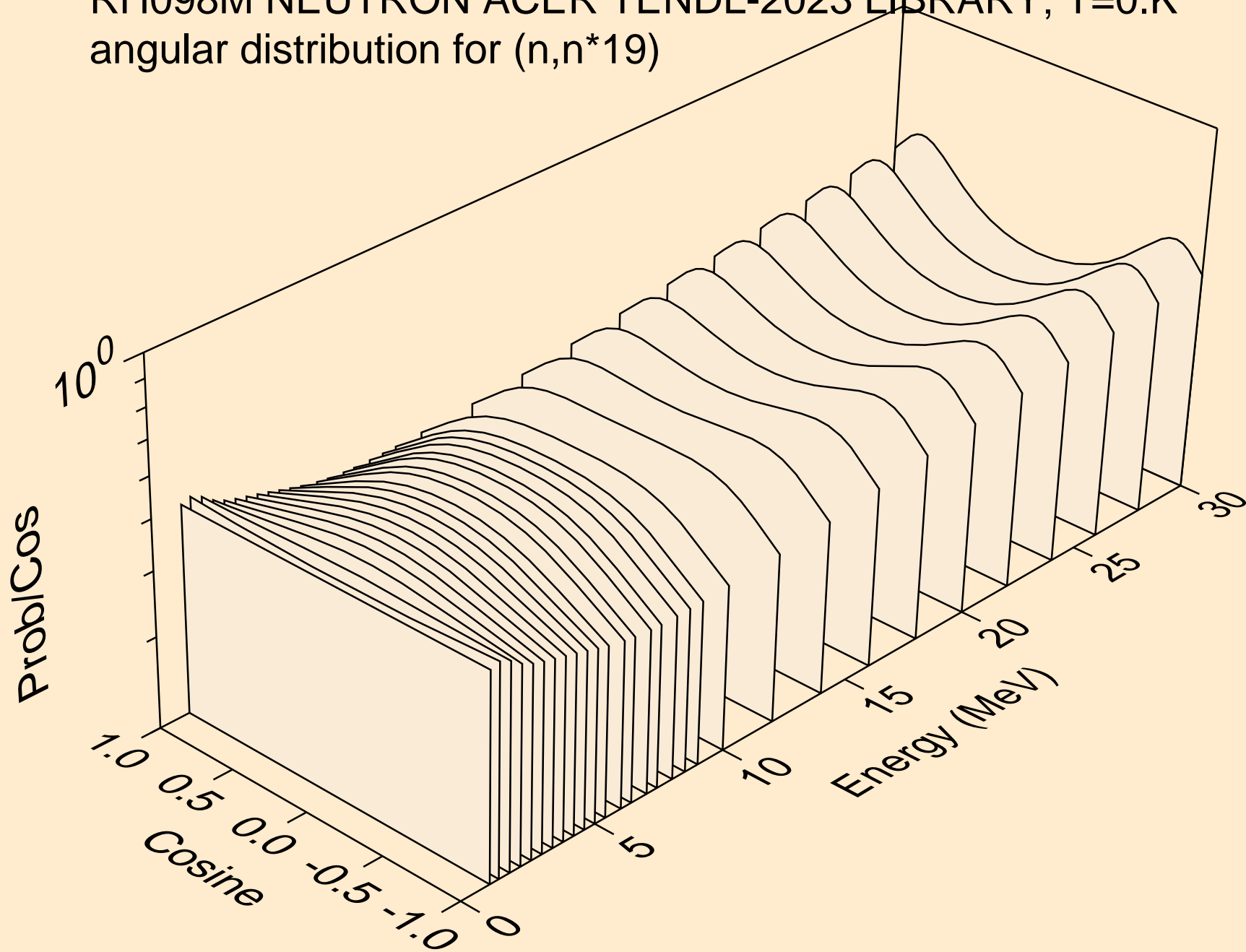

RH098M NEUTRON ACER TENDL-2023 LIBRARY; T=0.K  
angular distribution for (n,n\*20)

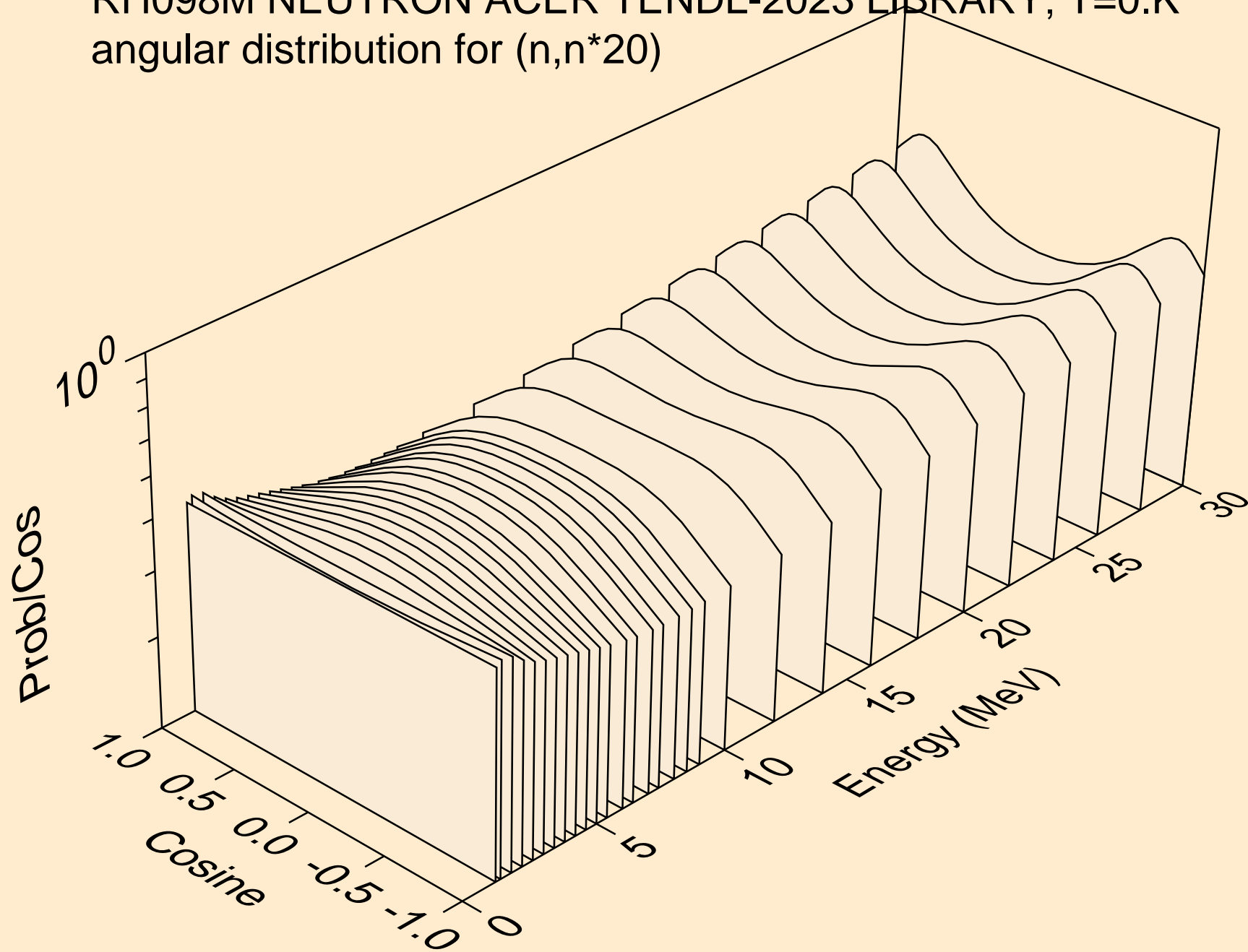

RH098M NEUTRON ACER TENDL-2023 LIBRARY; T=0.K  
angular distribution for (n,n\*21)

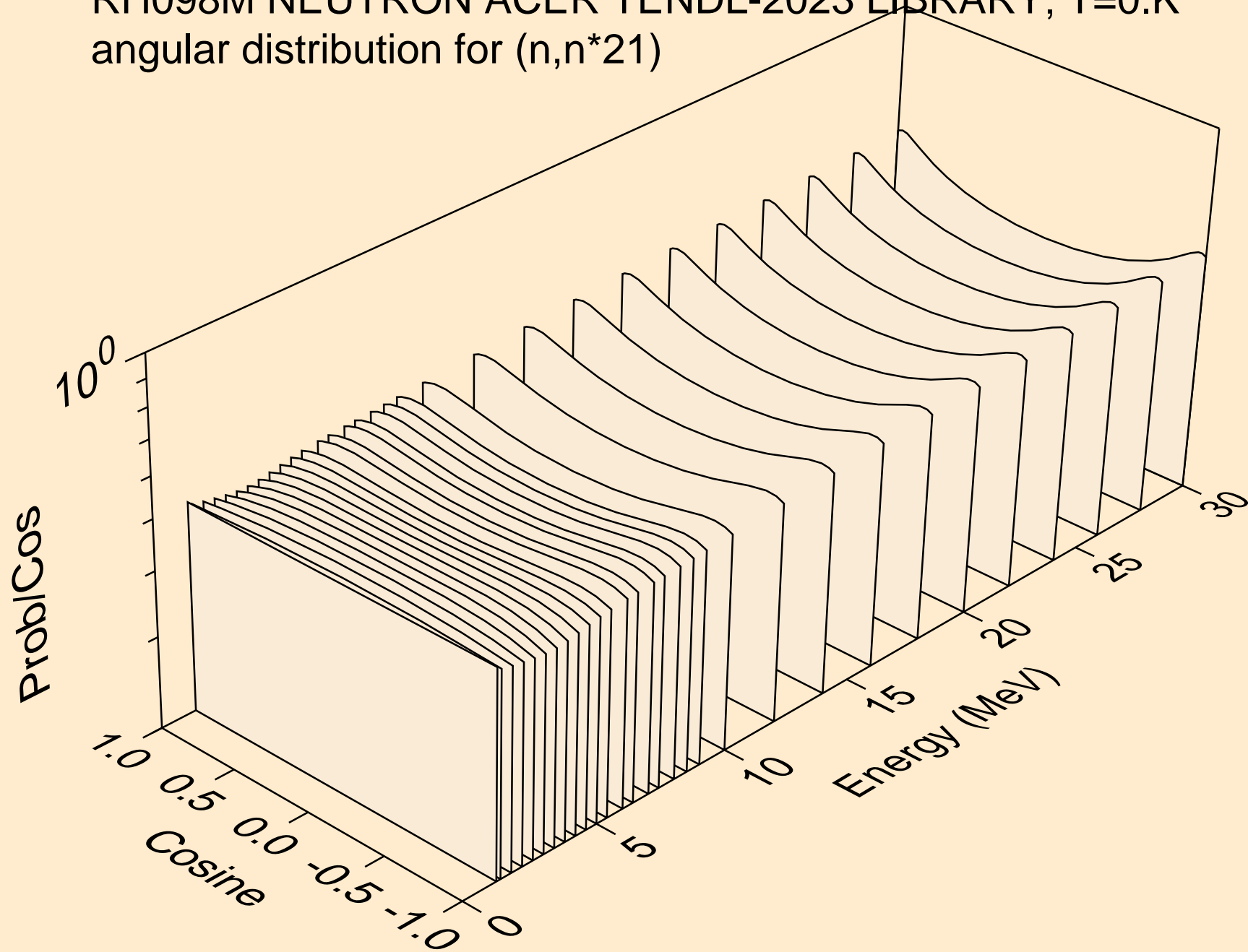

RH098M NEUTRON ACER TENDL-2023 LIBRARY; T=0.K  
angular distribution for (n,n\*22)

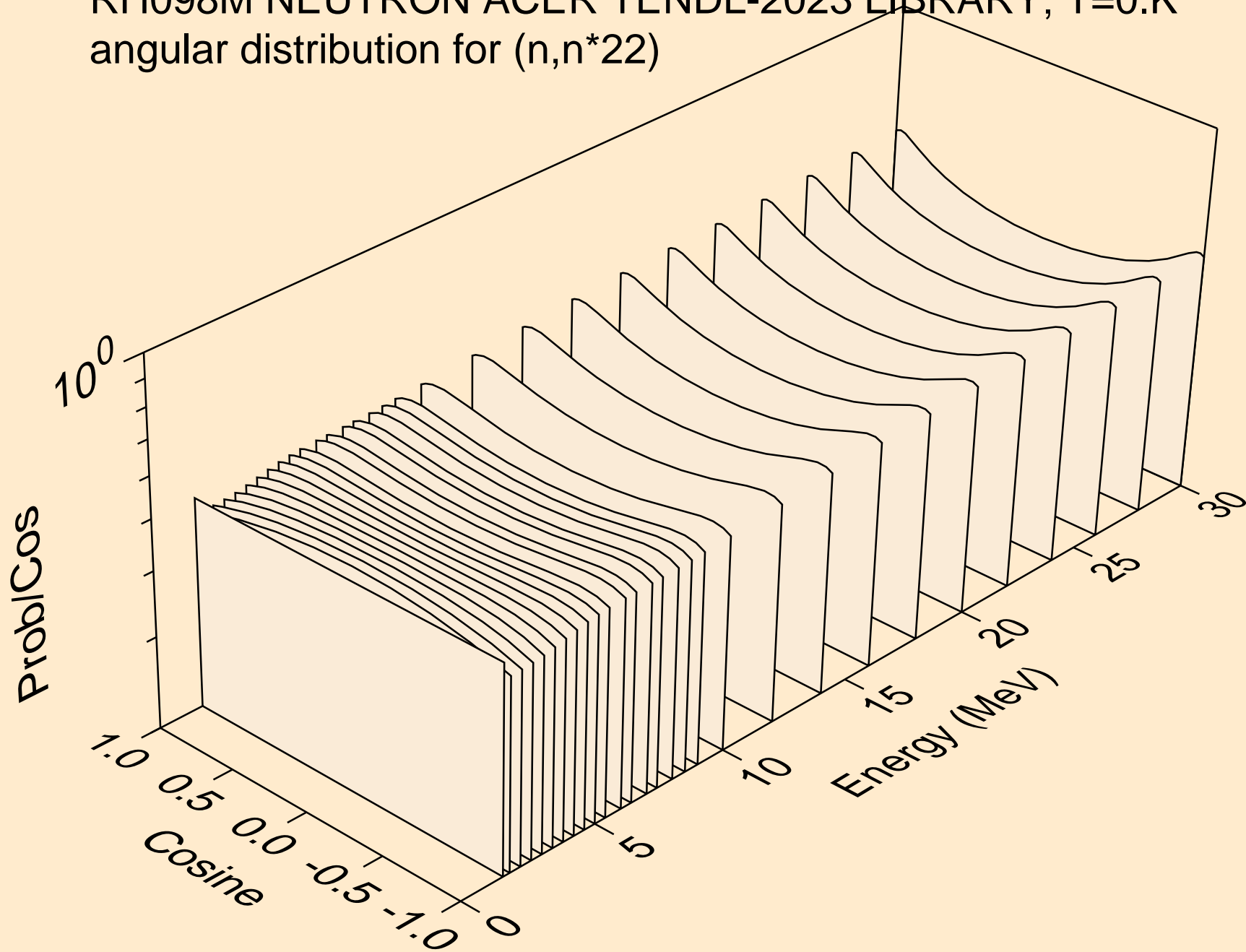

RH098M NEUTRON ACER TENDL-2023 LIBRARY; T=0.K  
angular distribution for (n,n\*23)

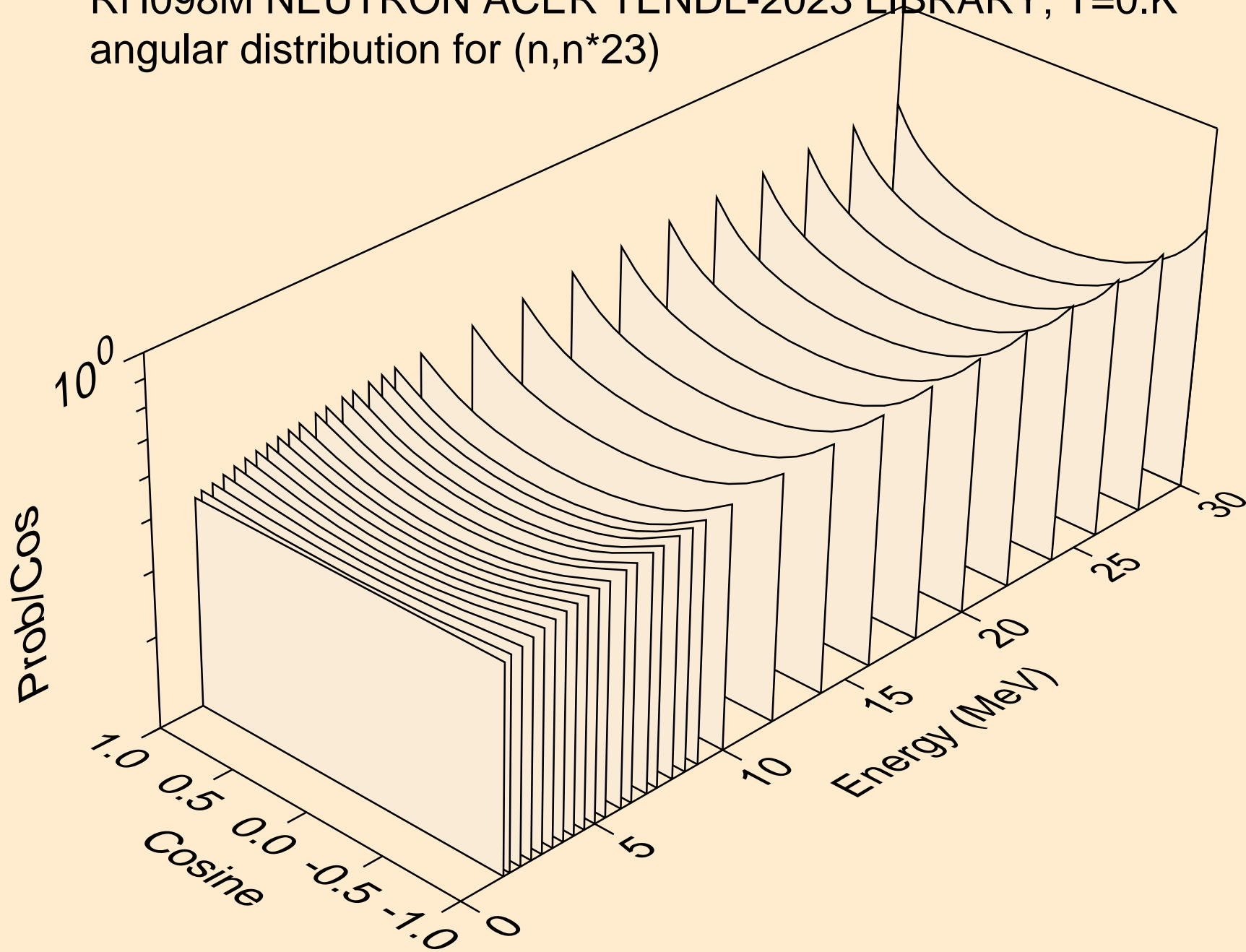

RH098M NEUTRON ACER TENDL-2023 LIBRARY; T=0.K  
angular distribution for (n,n\*24)

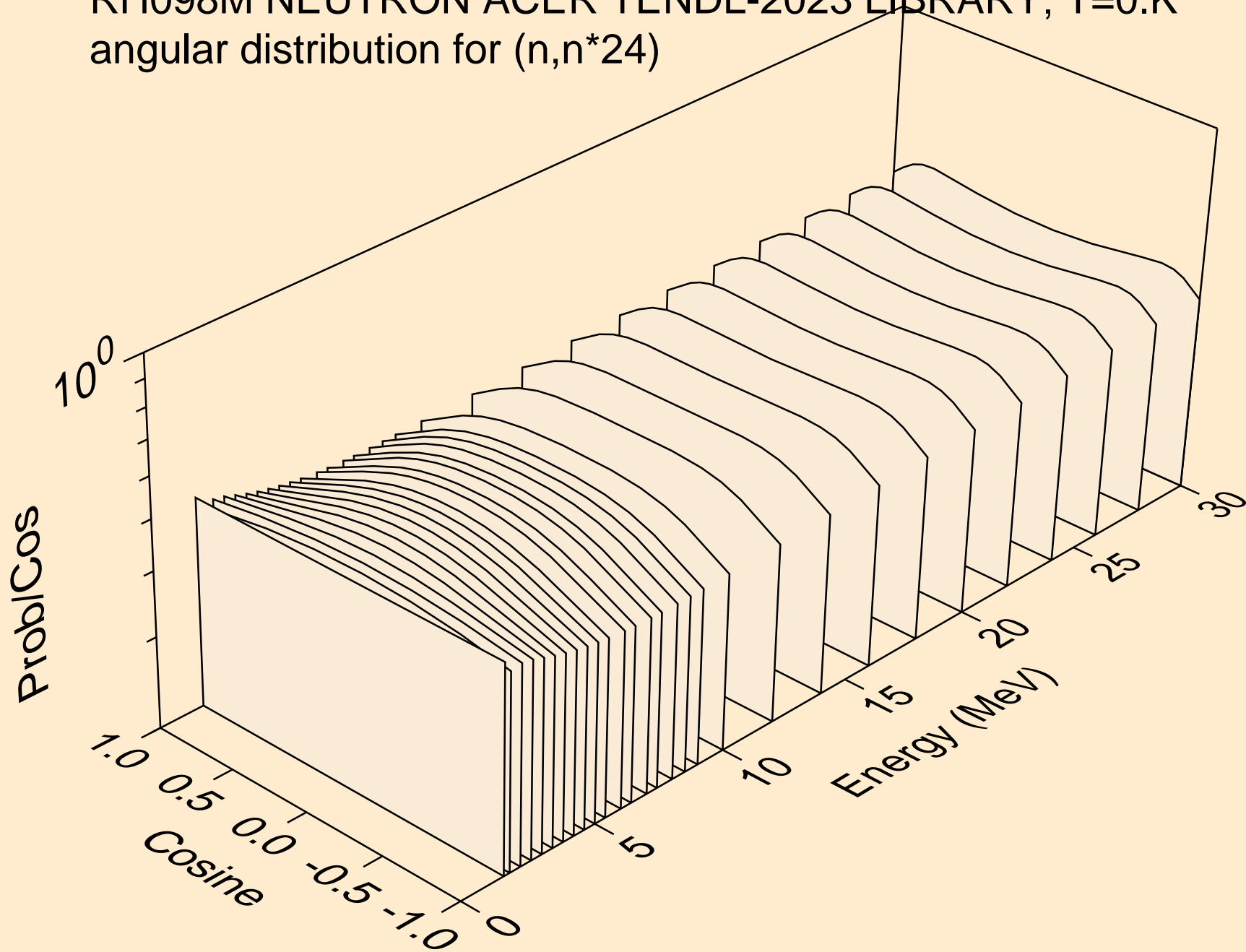



RH098M NEUTRON ACER TENDL-2023 LIBRARY; T=0.K  
angular distribution for (n,n\*25)

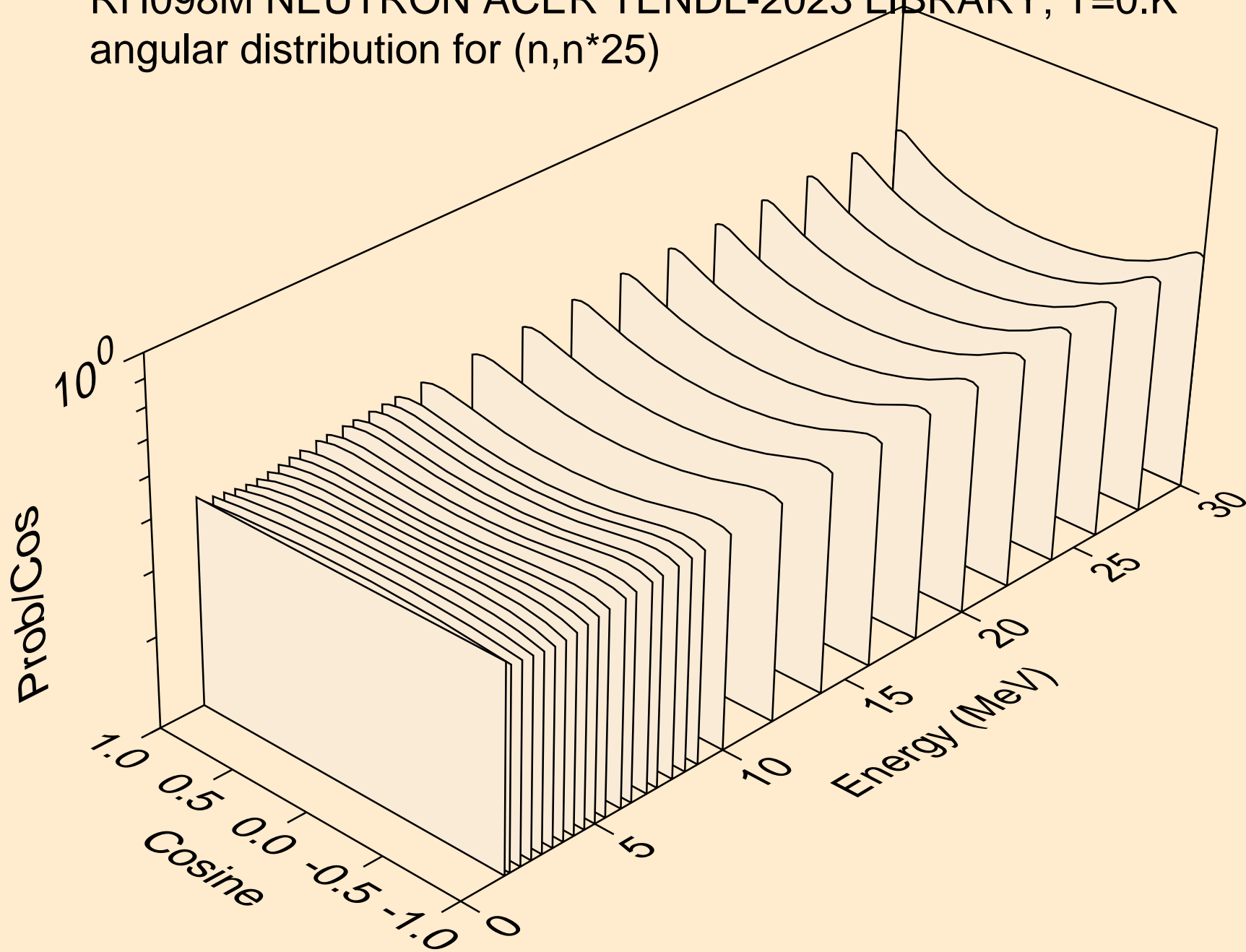

RH098M NEUTRON ACER TENDL-2023 LIBRARY; T=0.K  
angular distribution for (n,n\*26)

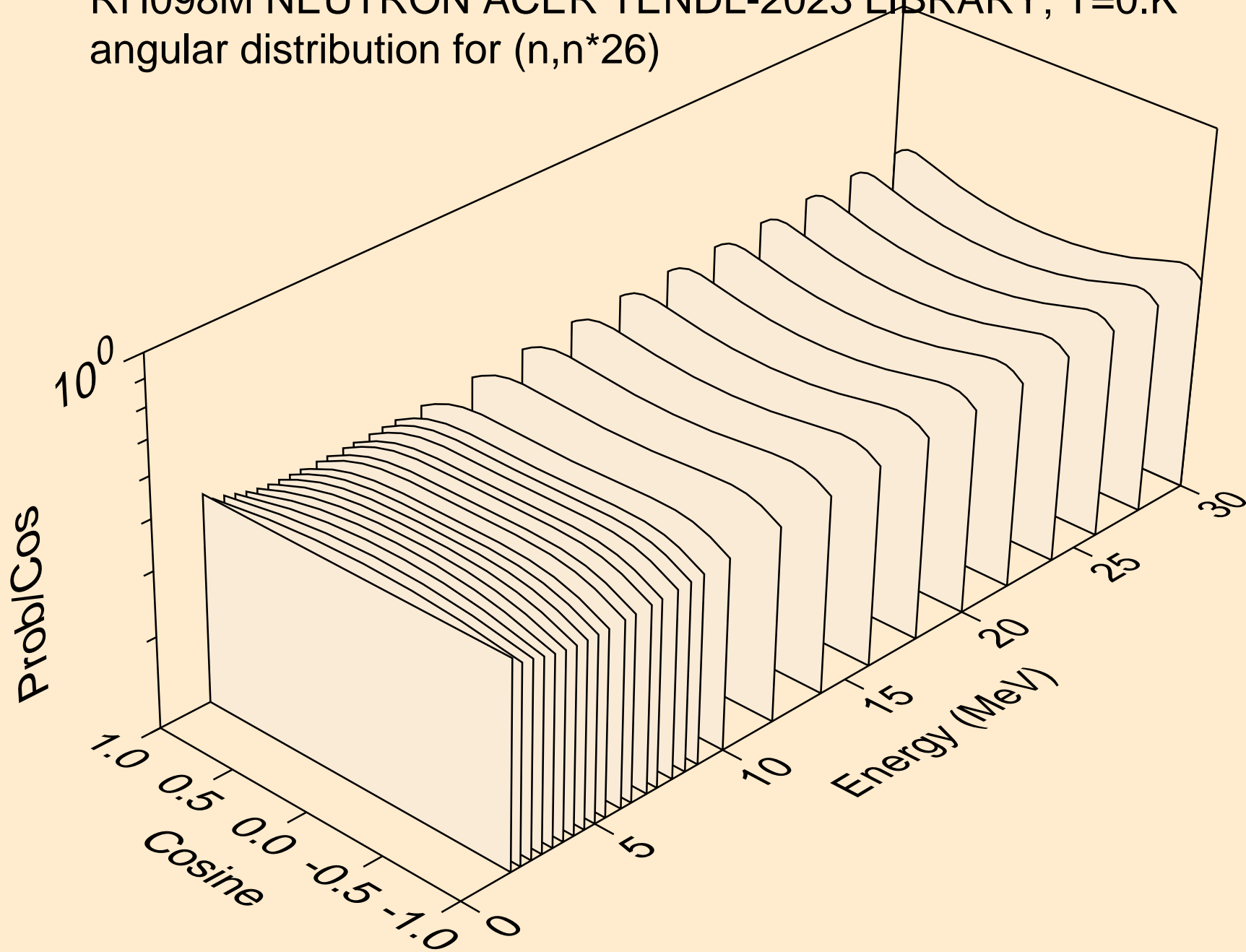

RH098M NEUTRON ACER TENDL-2023 LIBRARY; T=0.K  
angular distribution for (n,n\*27)

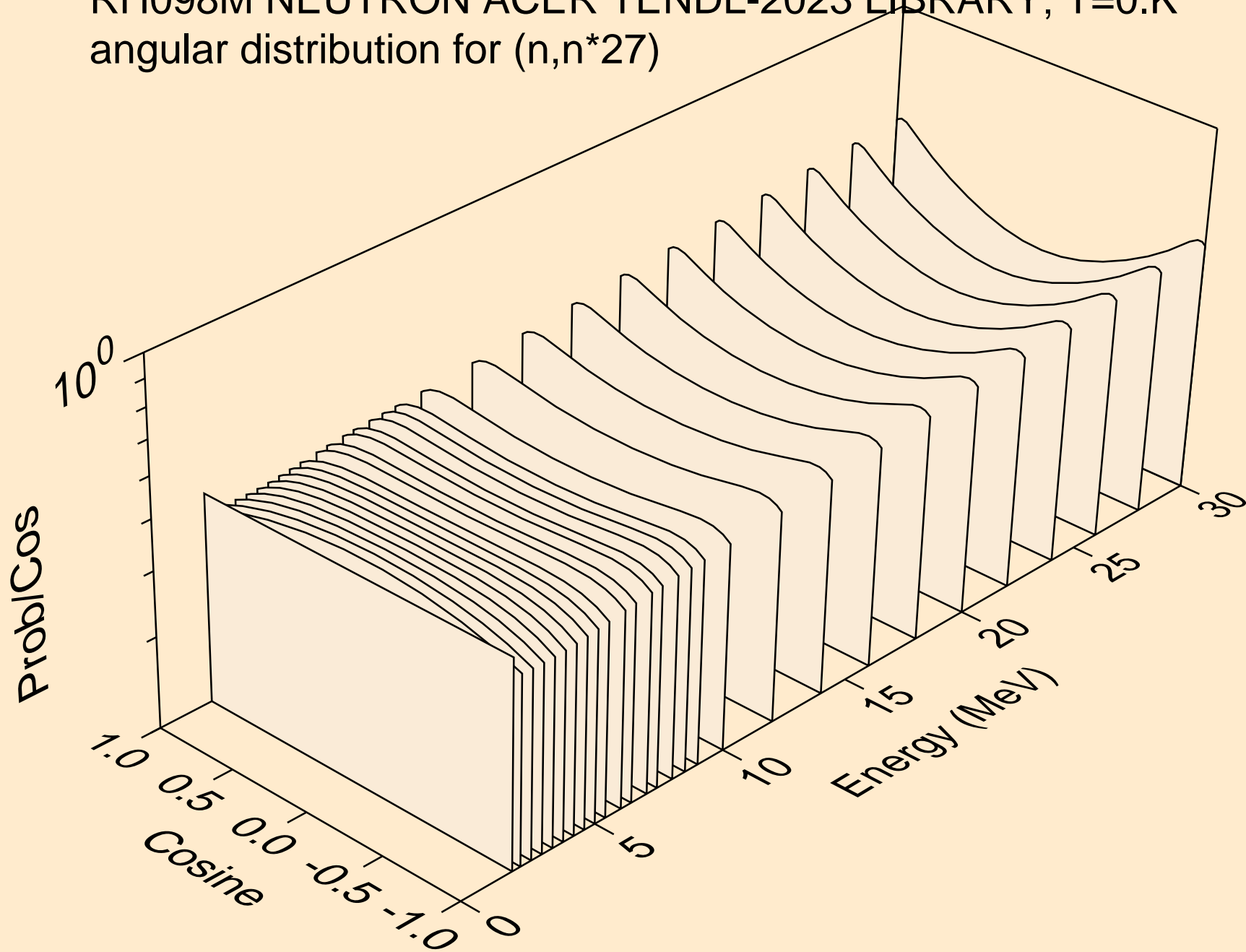

RH098M NEUTRON ACER TENDL-2023 LIBRARY; T=0.K  
angular distribution for (n,n\*28)

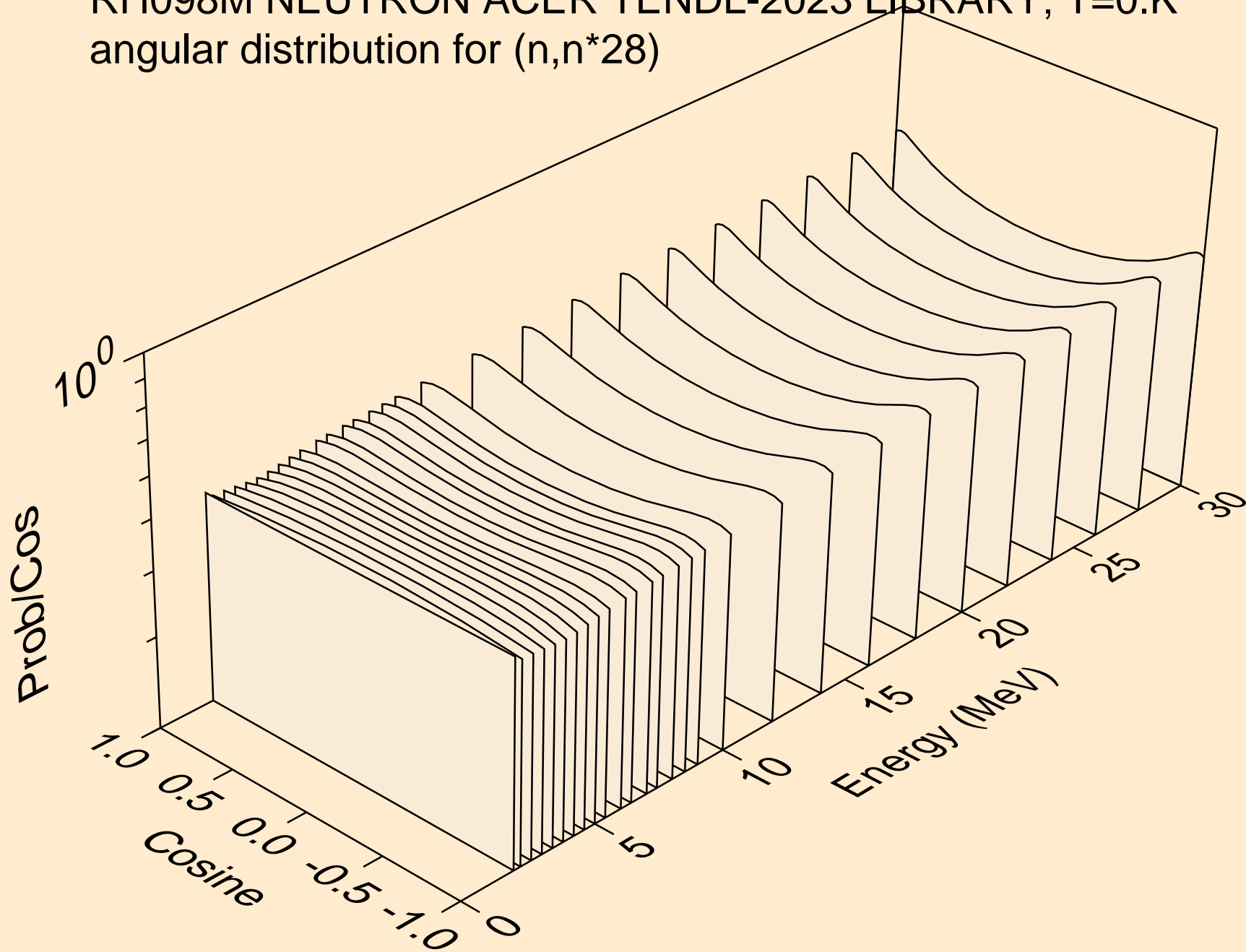

RH098M NEUTRON ACER TENDL-2023 LIBRARY; T=0.K  
Neutron emission for (n,x)

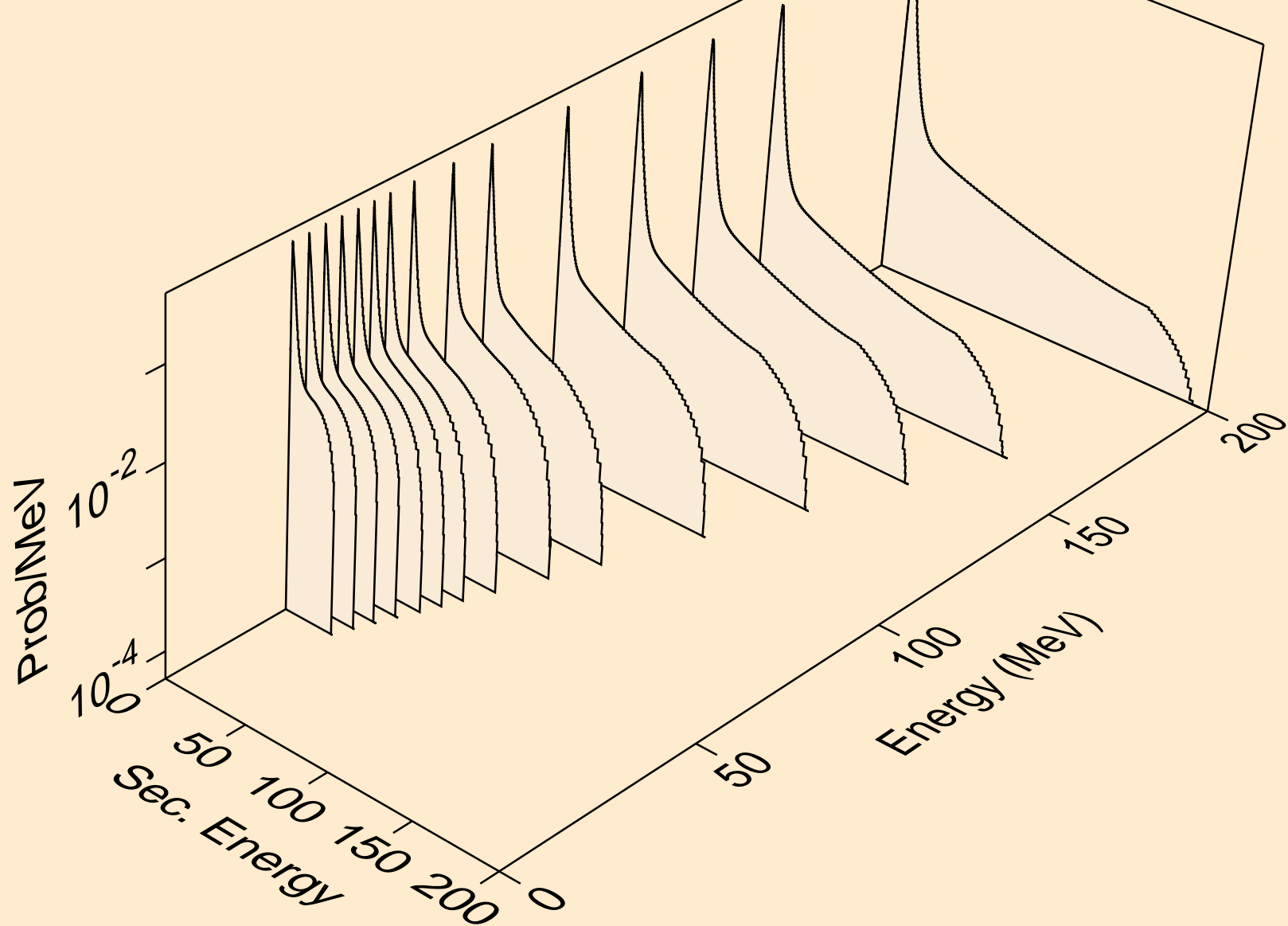

RH098M NEUTRON ACER TENDL-2023 LIBRARY; T=0.K  
Neutron emission for (n,2nd)

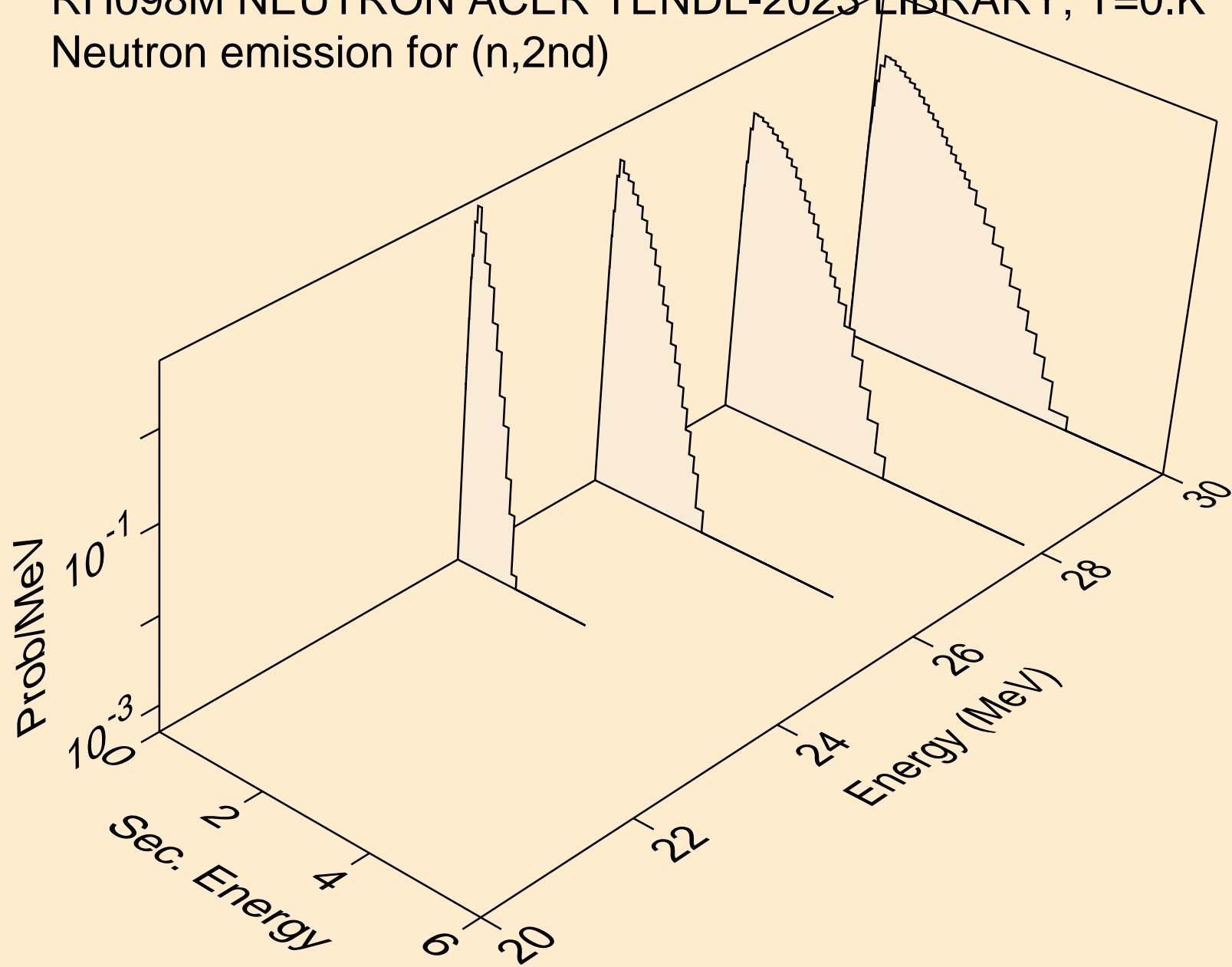

RH098M NEUTRON ACER TENDL-2023 LIBRARY; T=0.K  
Neutron emission for (n,2n)

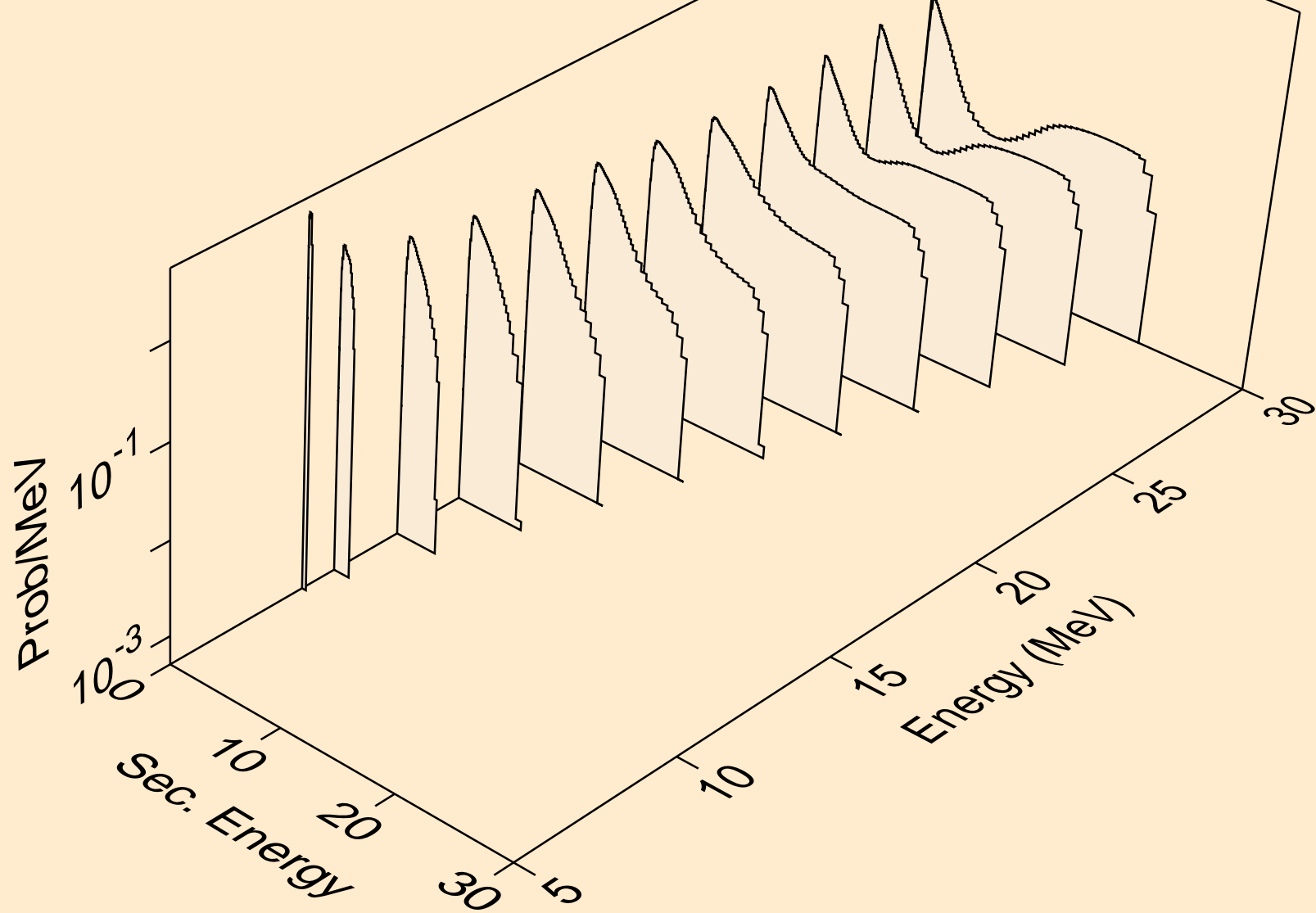

RH098M NEUTRON ACER TENDL-2023 LIBRARY; T=0.K  
Neutron emission for (n,3n)

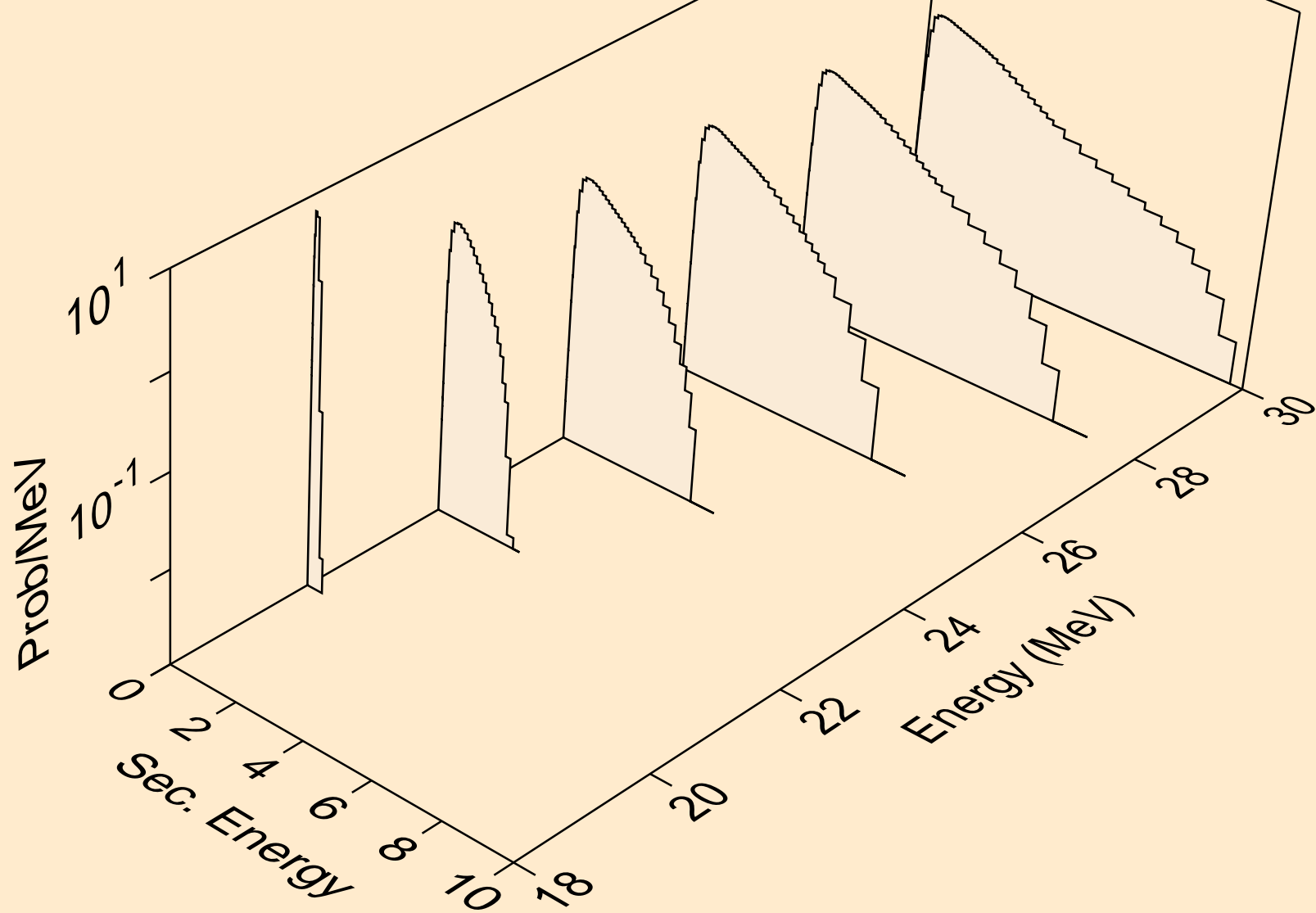



RH098M NEUTRON ACER TENDL-2023 LIBRARY; T=0.K  
Neutron emission for (n,n\*)a

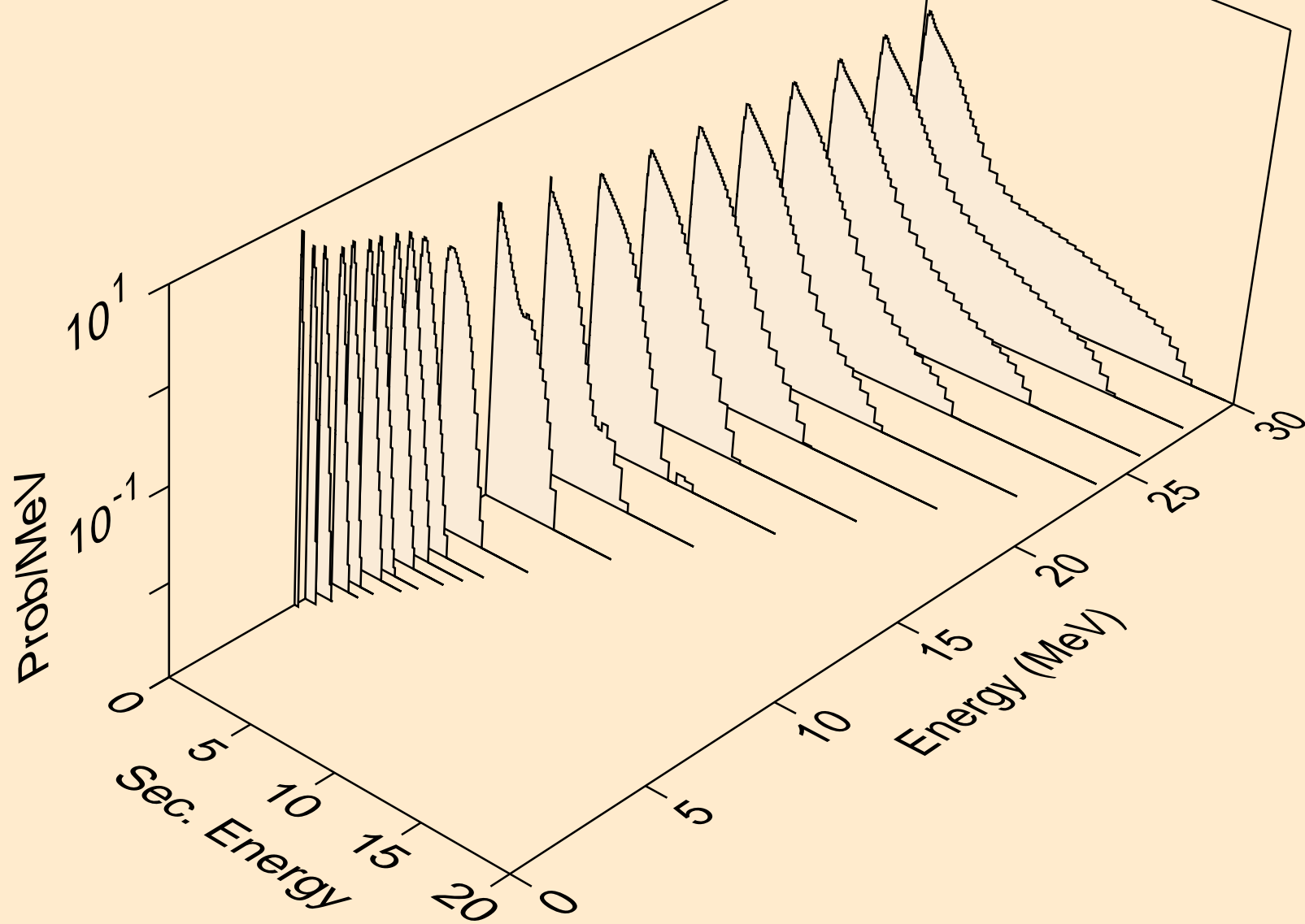

RH098M NEUTRON ACER TENDL-2023 LIBRARY; T=0.K  
Neutron emission for (n,2n)<sub>a</sub>

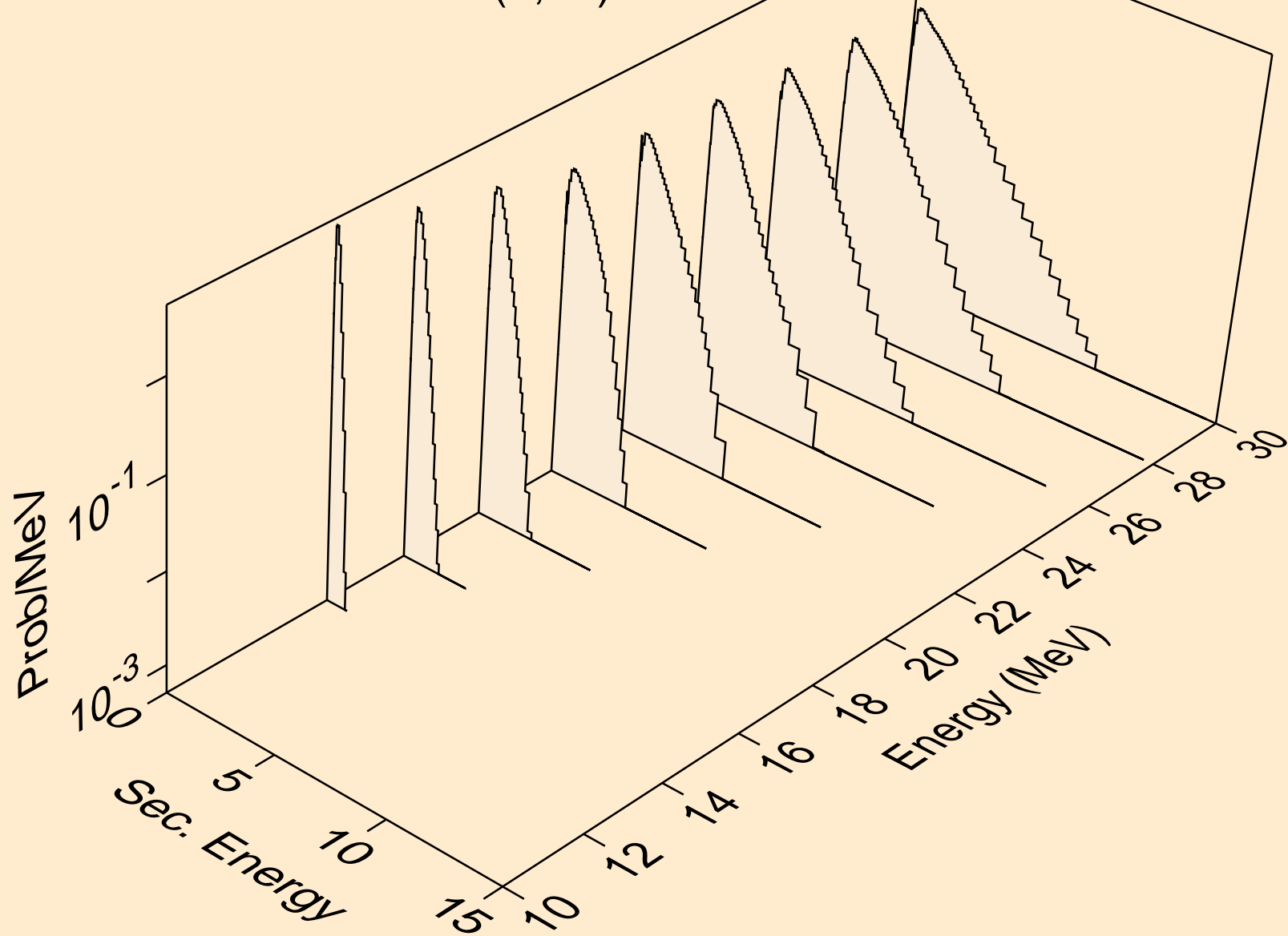

RH098M NEUTRON ACER TENDL-2023 LIBRARY; T=0.K  
Neutron emission for (n,3n)a

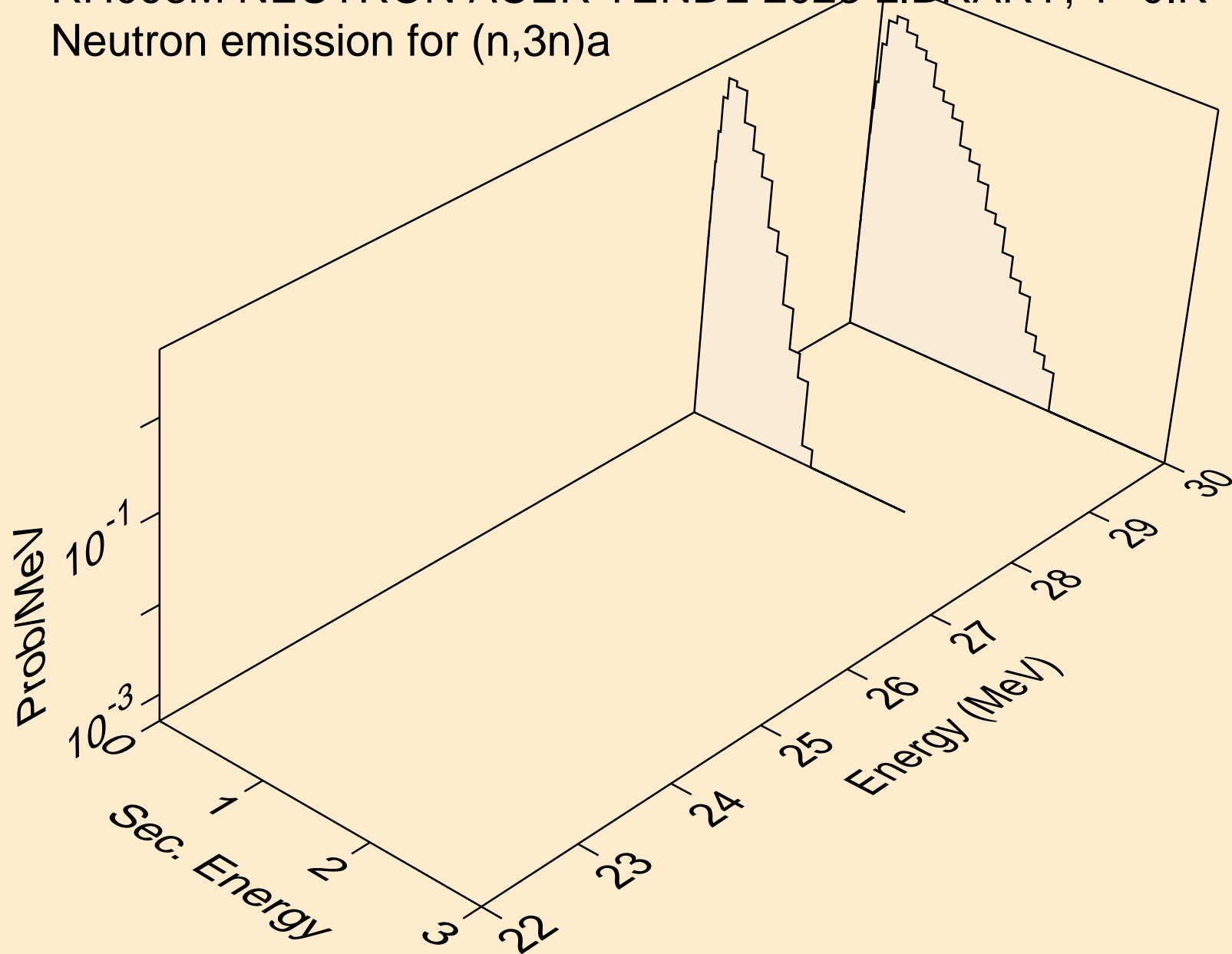

RH098M NEUTRON ACER TENDL-2023 LIBRARY; T=0.K  
Neutron emission for (n,n\*)p

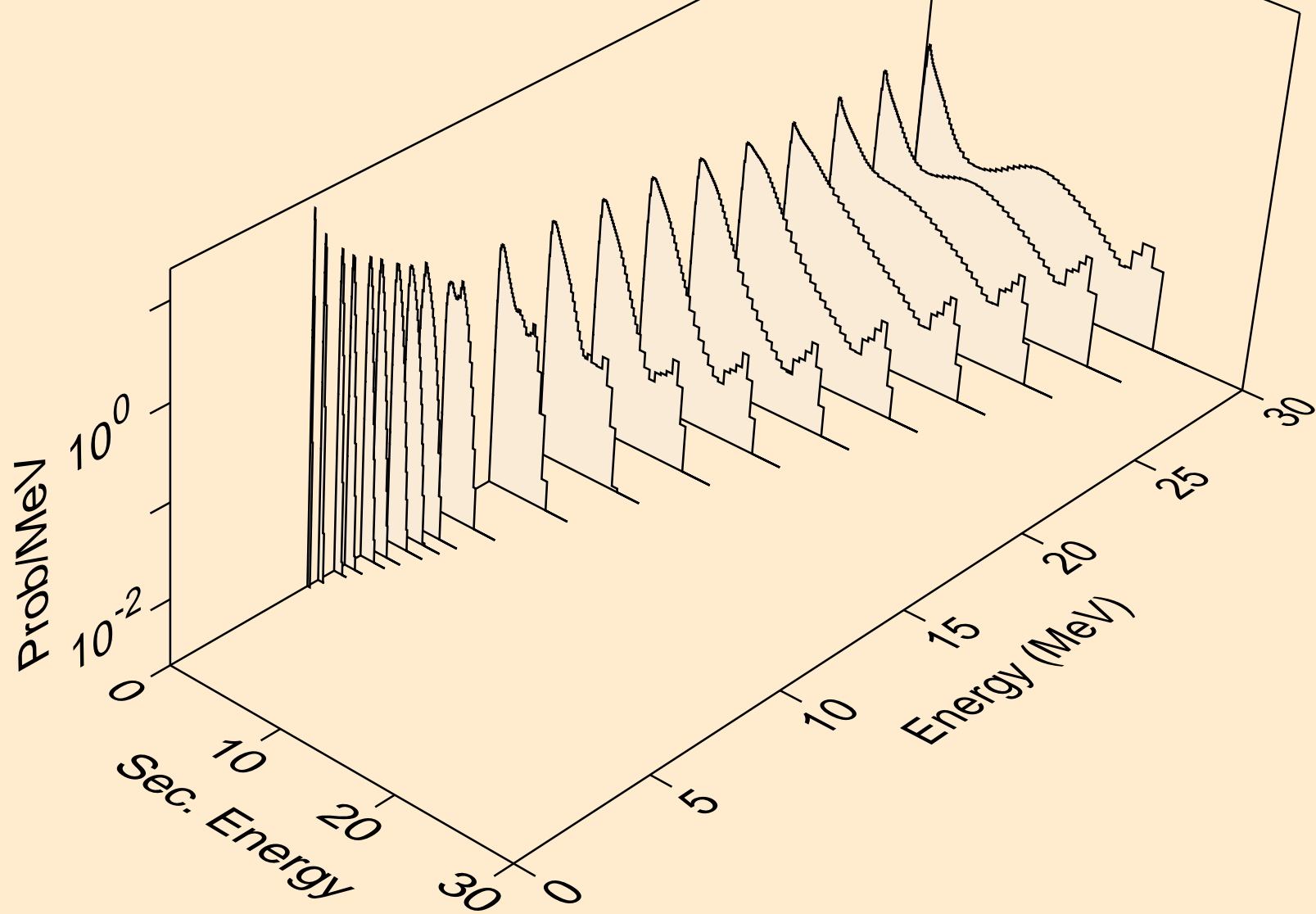

RH098M NEUTRON ACER TENDL-2023 LIBRARY; T=0.K  
Neutron emission for (n,n\*)2a

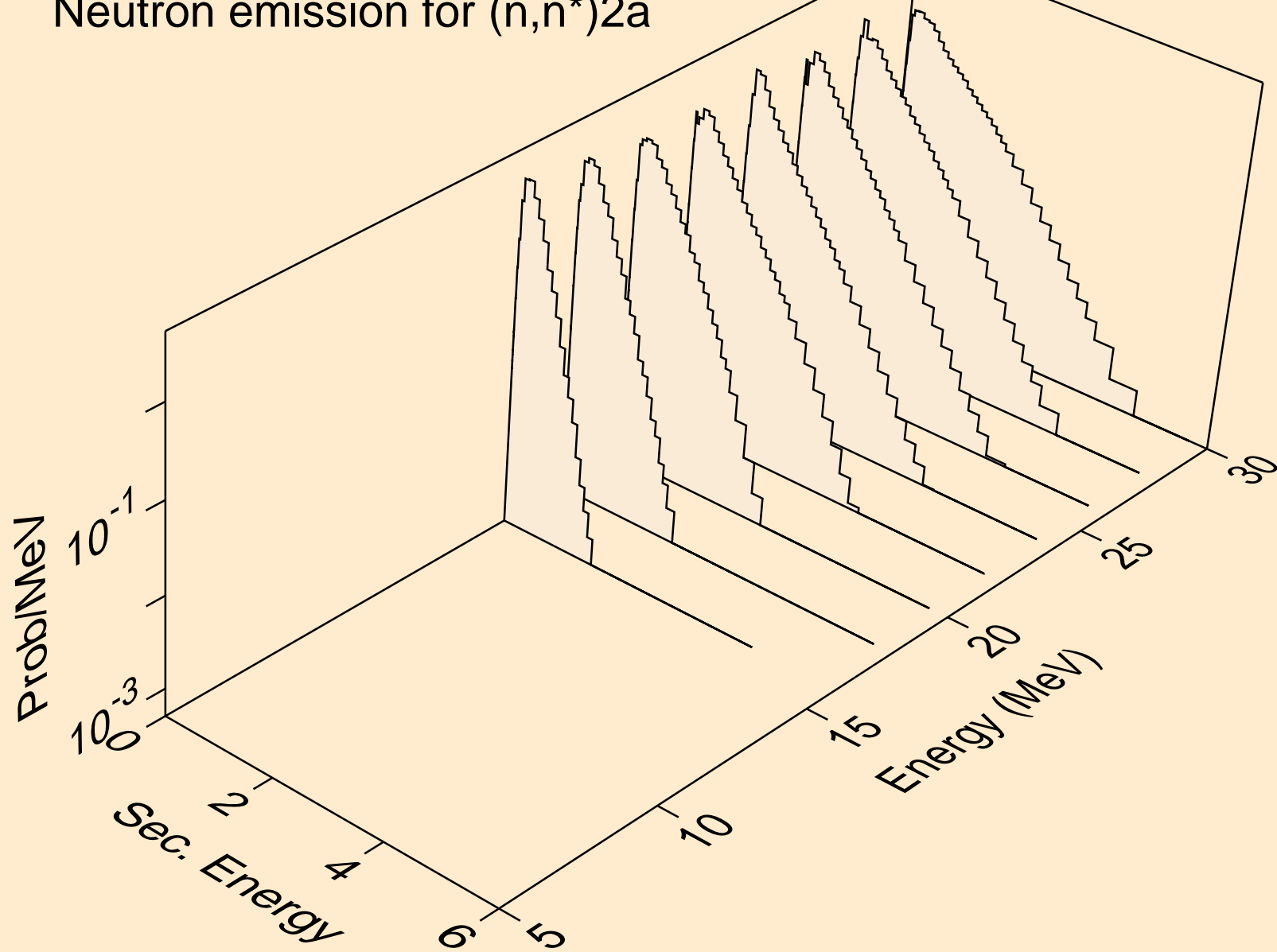

RH098M NEUTRON ACER TENDL-2023 LIBRARY; T=0.K  
Neutron emission for (n,n\*)d

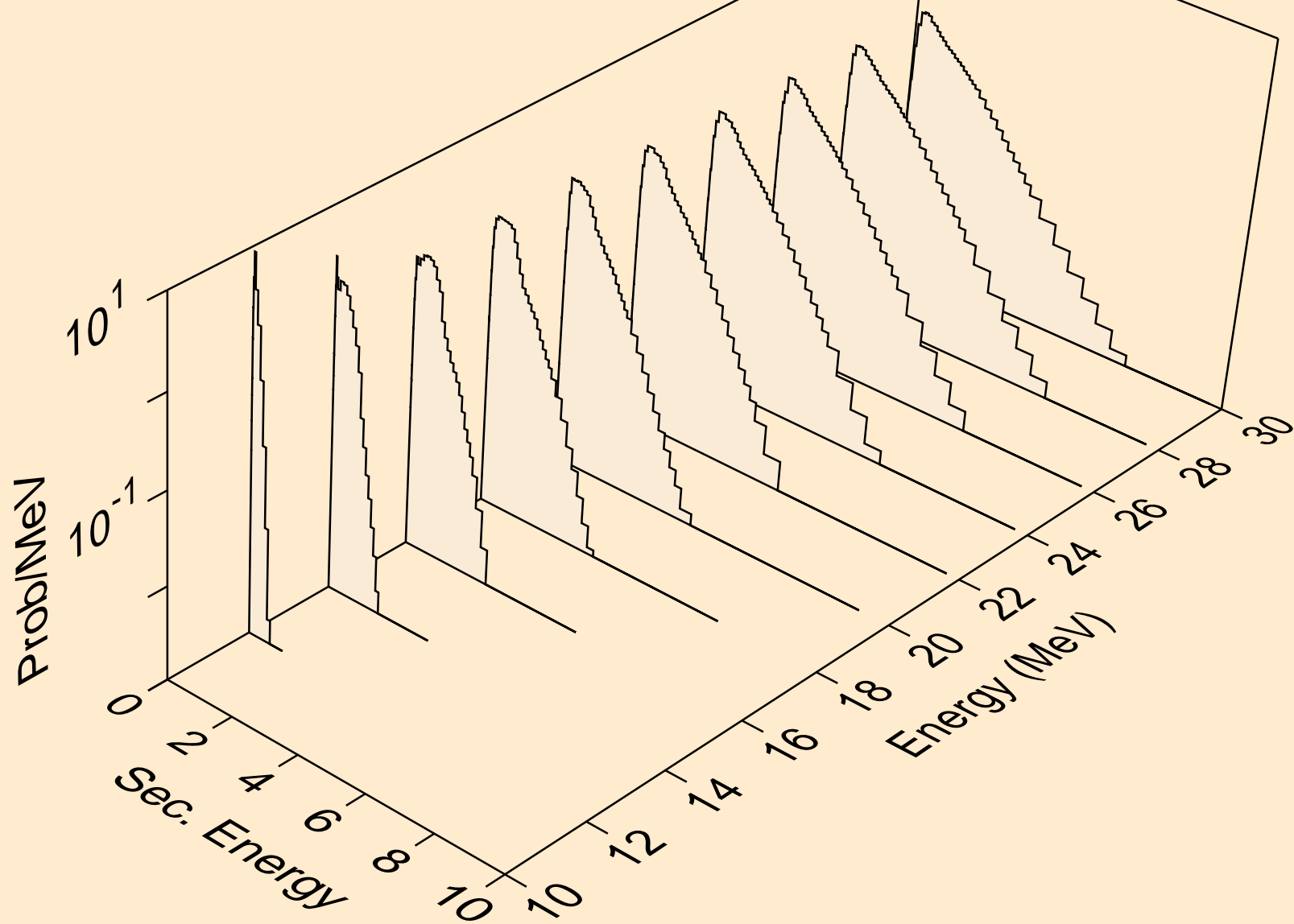

RH098M NEUTRON ACER TENDL-2023 LIBRARY; T=0.K  
Neutron emission for (n,n\*)t

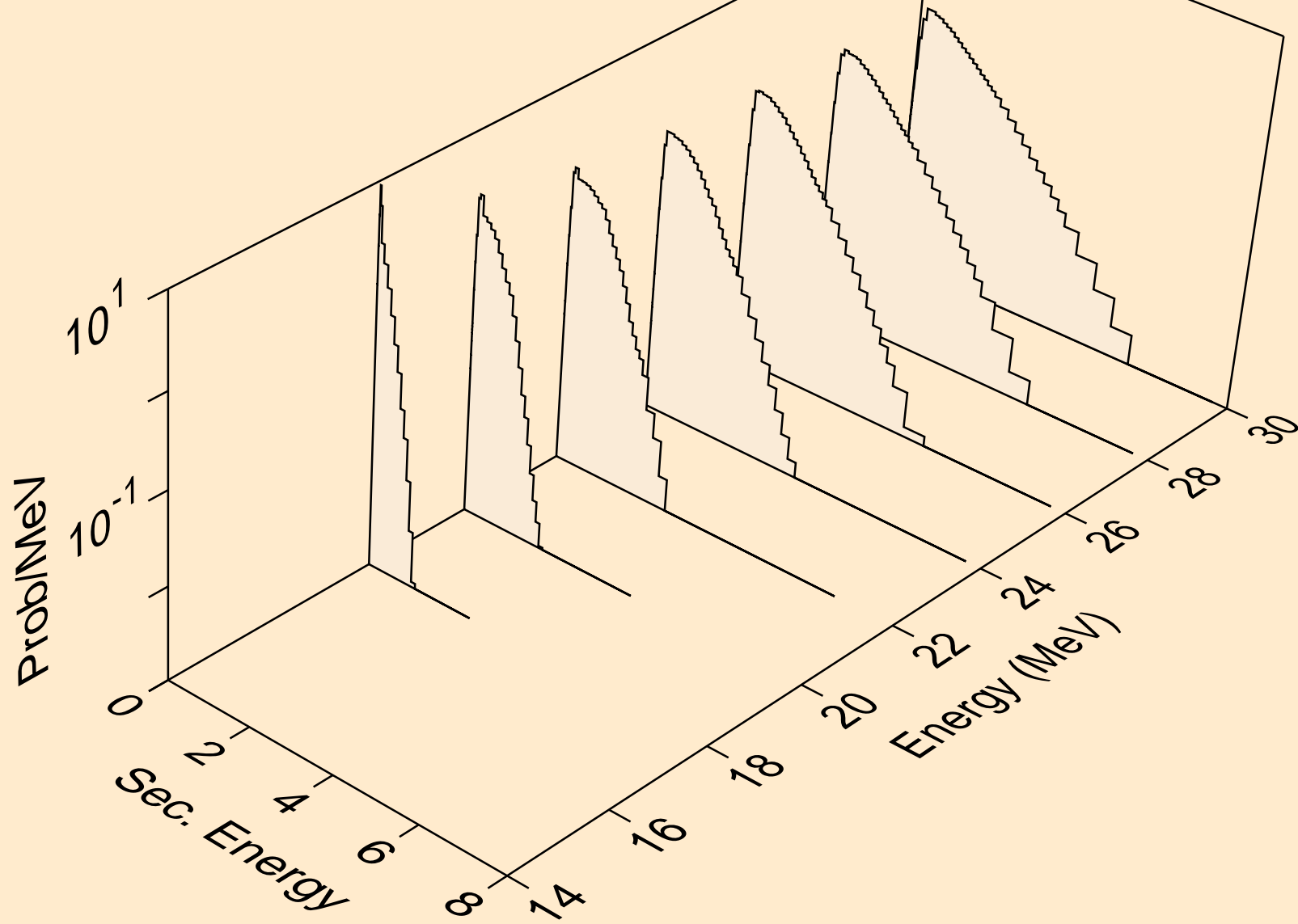

RH098M NEUTRON ACER TENDL-2023 LIBRARY; T=0.K  
Neutron emission for (n,n\*)he3

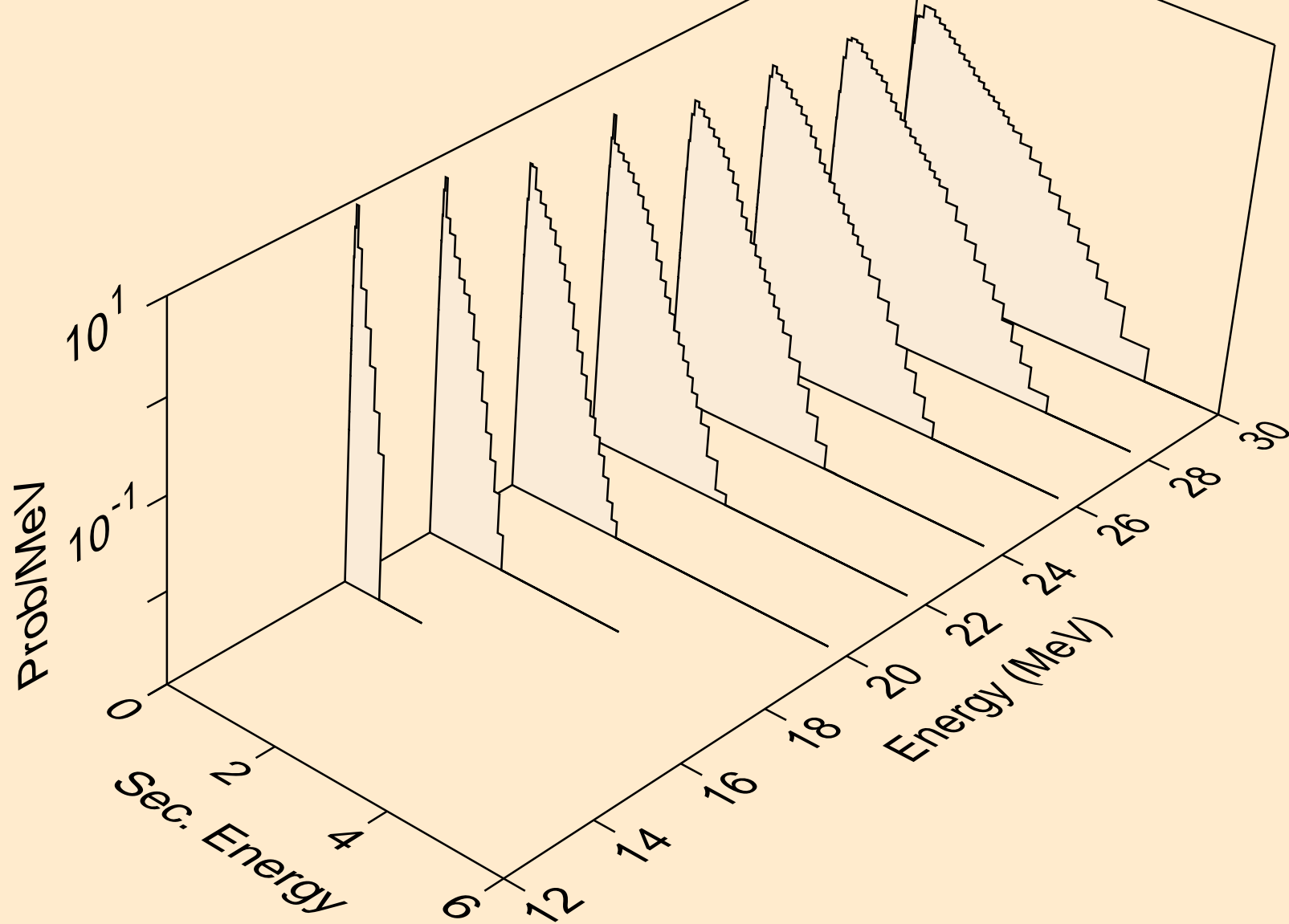



RH098M NEUTRON ACER TENDL-2023 LIBRARY; T=0.K  
Neutron emission for (n,2np)

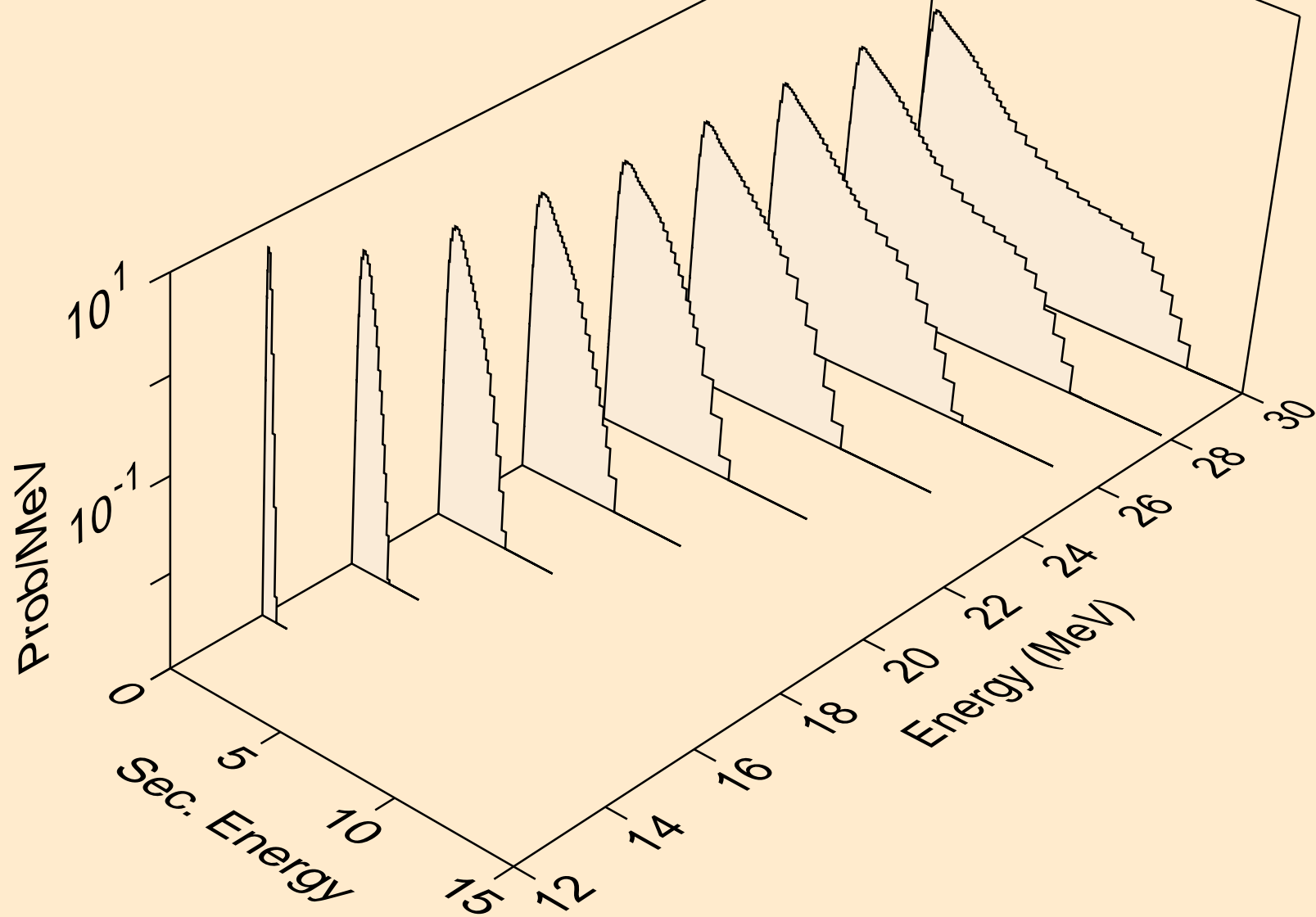

RH098M NEUTRON ACER TENDL-2023 LIBRARY; T=0.K  
Neutron emission for (n,3np)

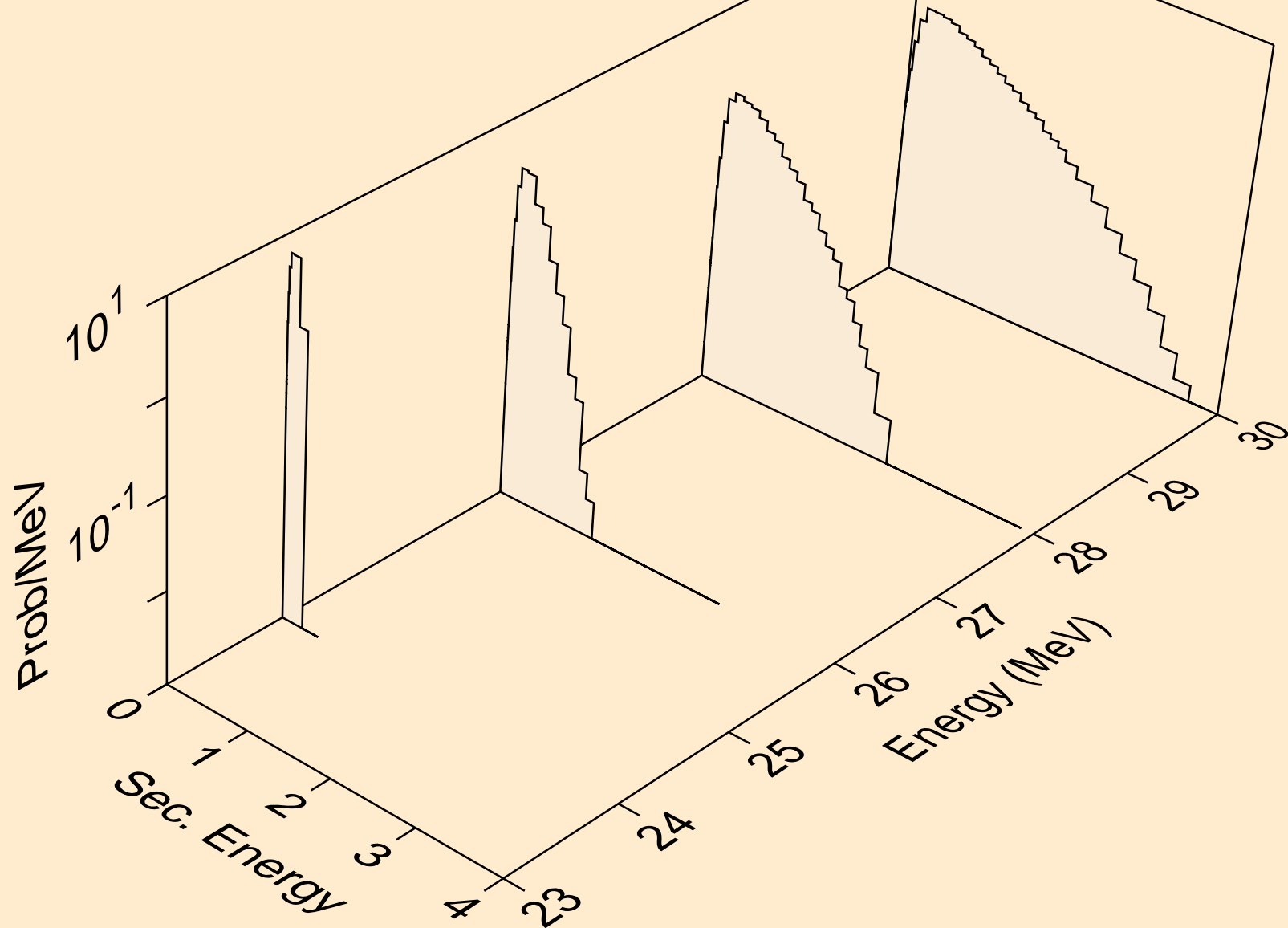

RH098M NEUTRON ACER TENDL-2023 LIBRARY; T=0.K  
Neutron emission for (n,n2p)

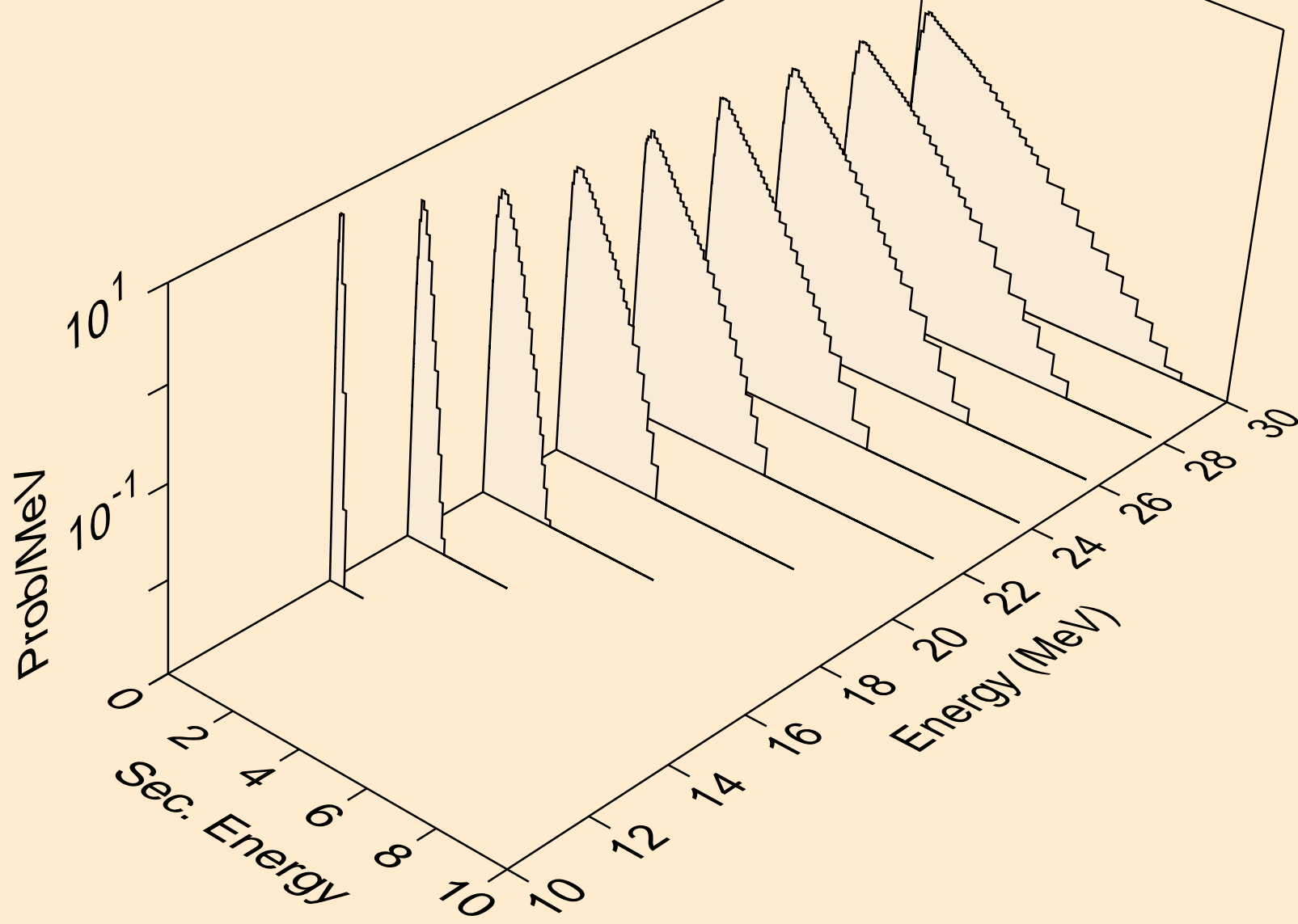

RH098M NEUTRON ACER TENDL-2023 LIBRARY; T=0.K  
Neutron emission for (n,npa)

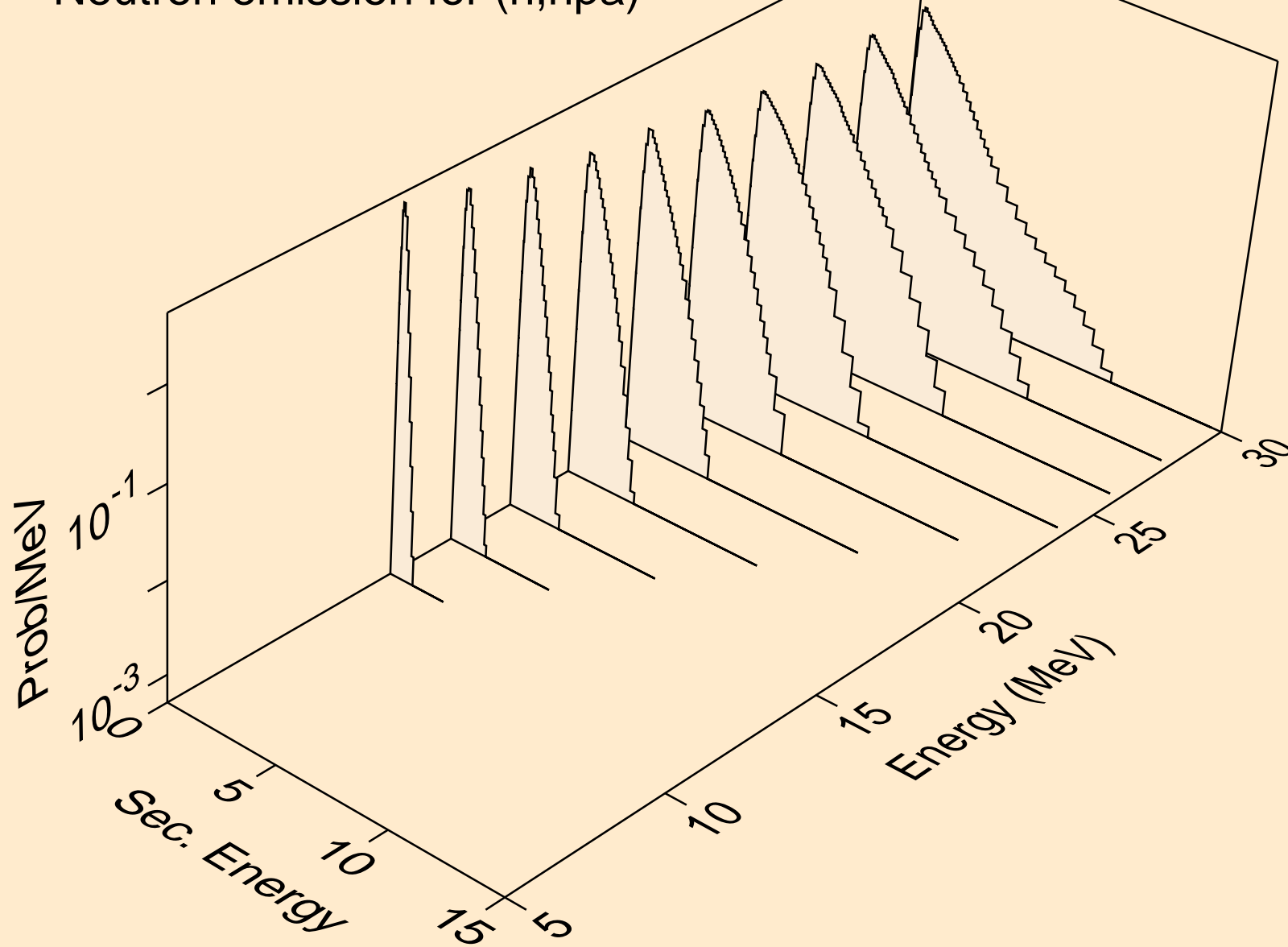

RH098M NEUTRON ACER TENDL-2023 LIBRARY; T=0.K  
Neutron emission for (n,n\*c)

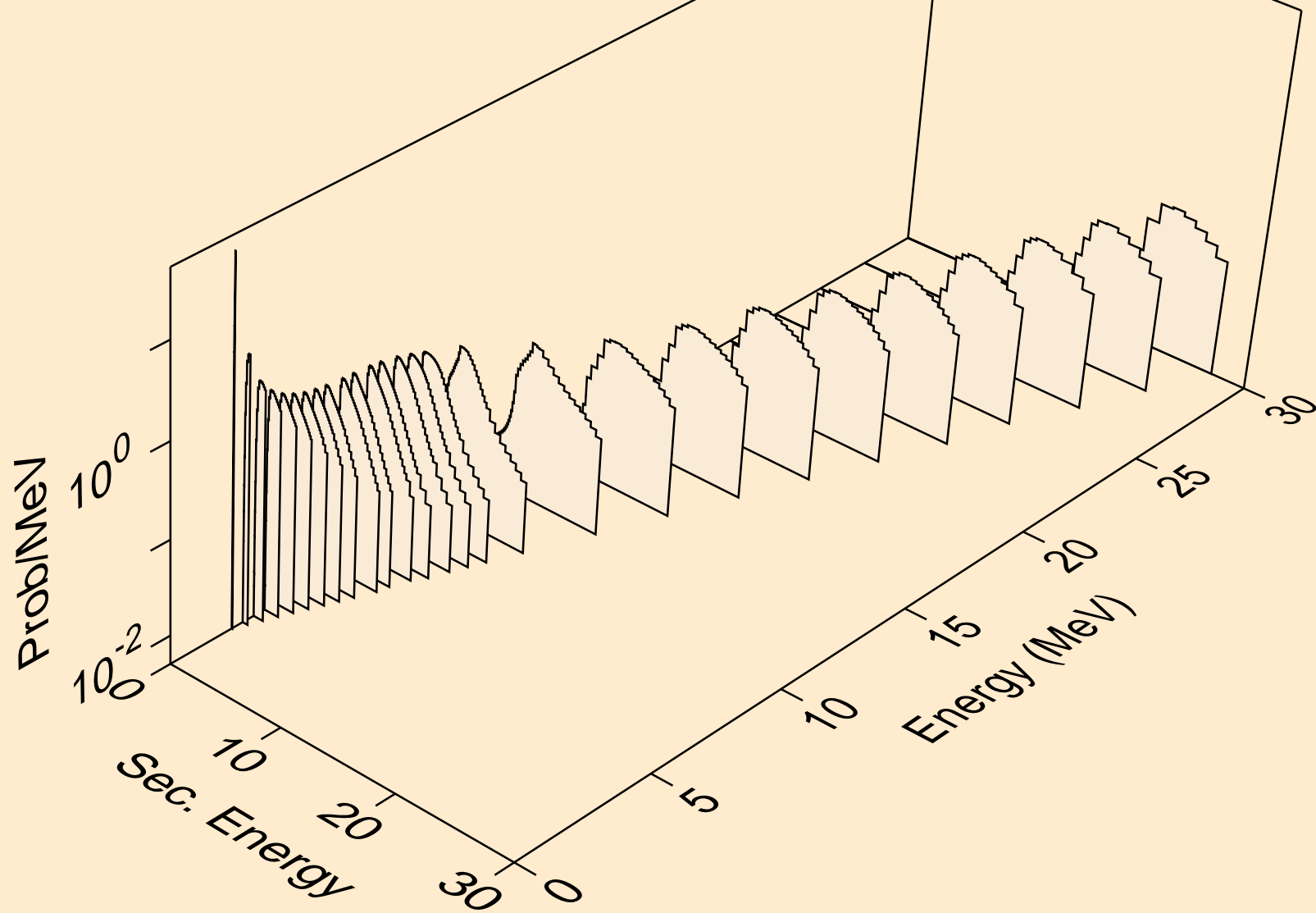

RH098M NEUTRON ACER TENDL-2023 LIBRARY; T=0.K  
Photon emission for (n,x)

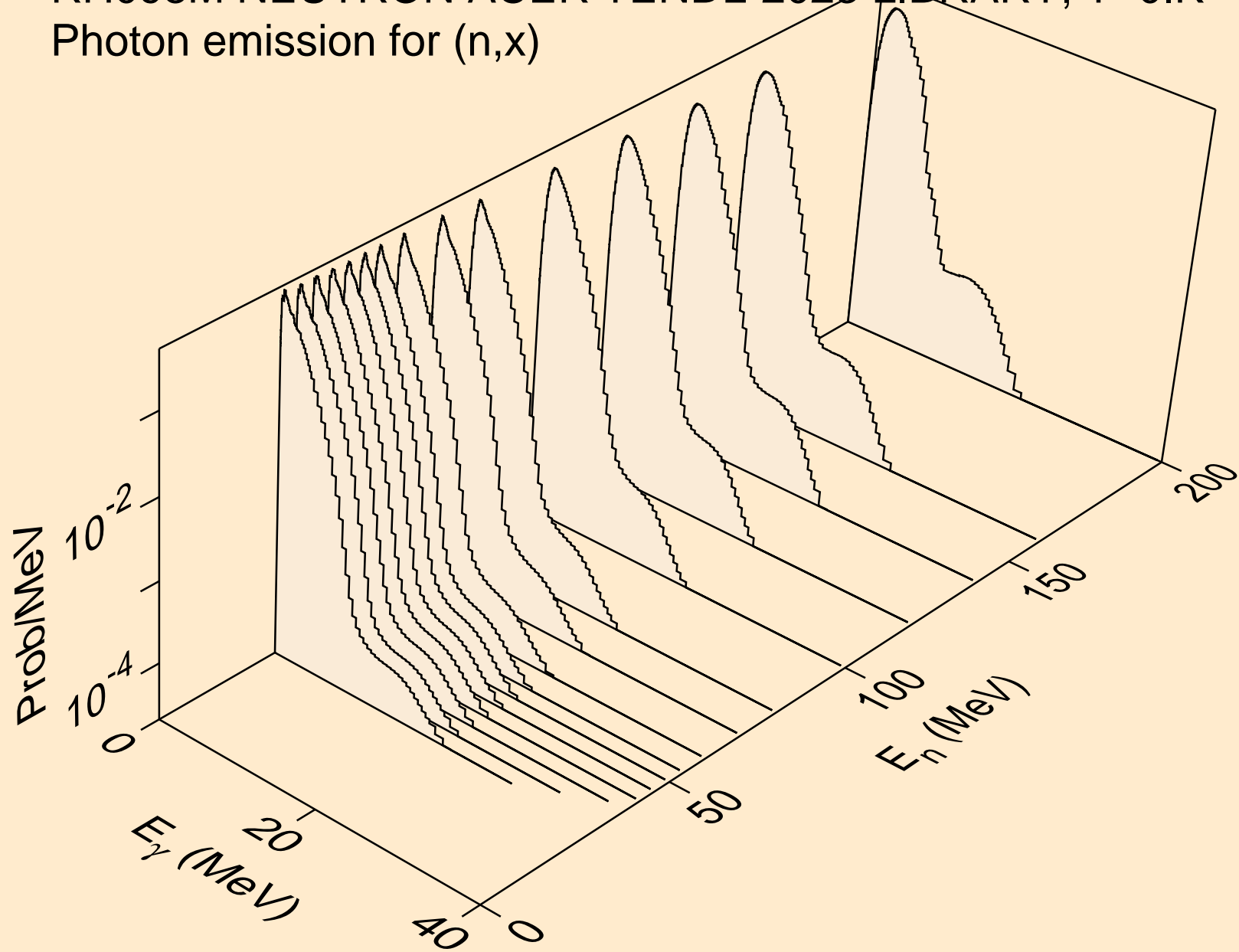

RH098M NEUTRON ACER TENDL-2023 LIBRARY; T=0.K  
Photon emission for (n,2nd)

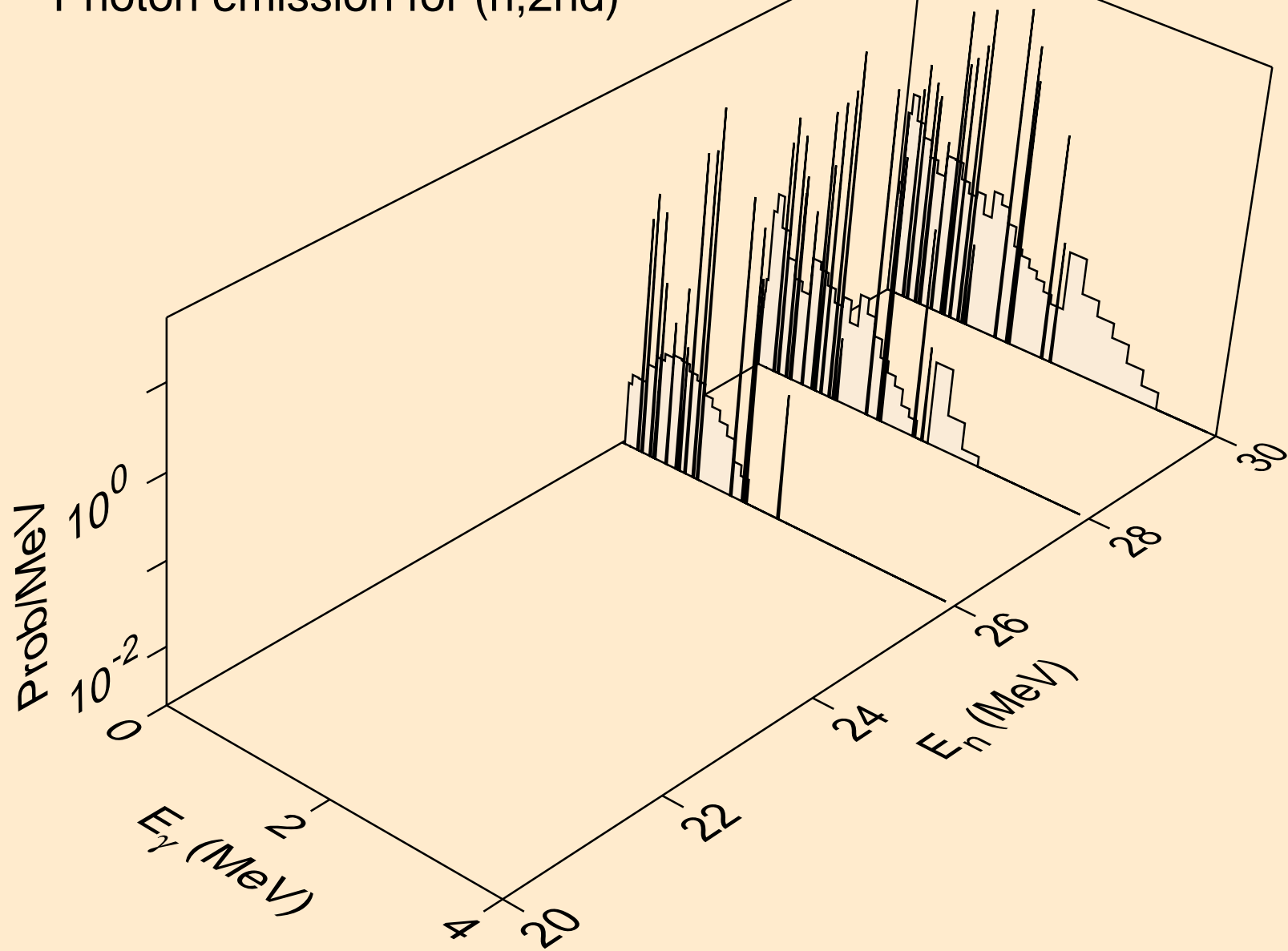

RH098M NEUTRON ACER TENDL-2023 LIBRARY; T=0.K  
Photon emission for (n,2n)

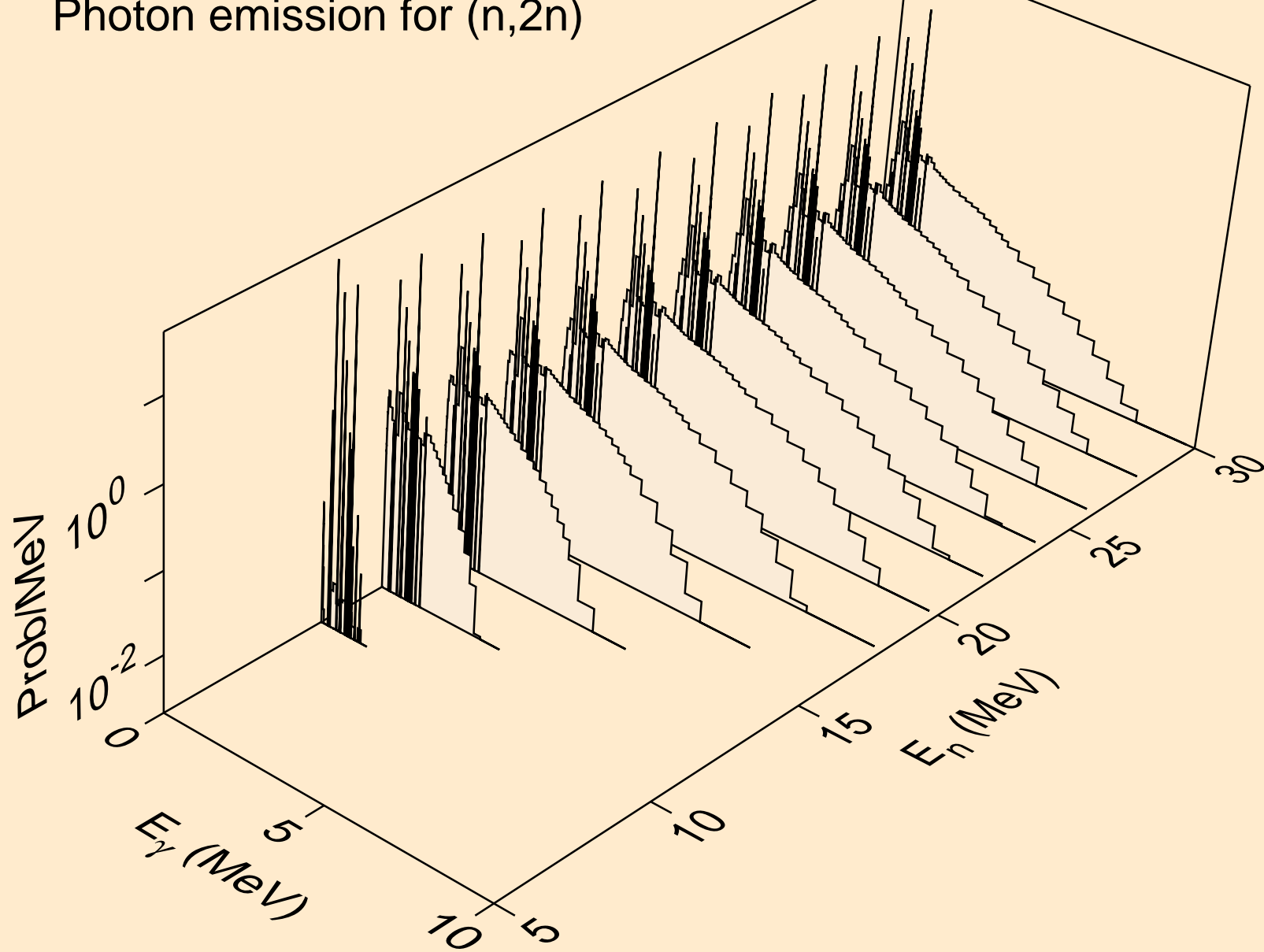



RH098M NEUTRON ACER TENDL-2023 LIBRARY; T=0.K  
Photon emission for (n,3n)

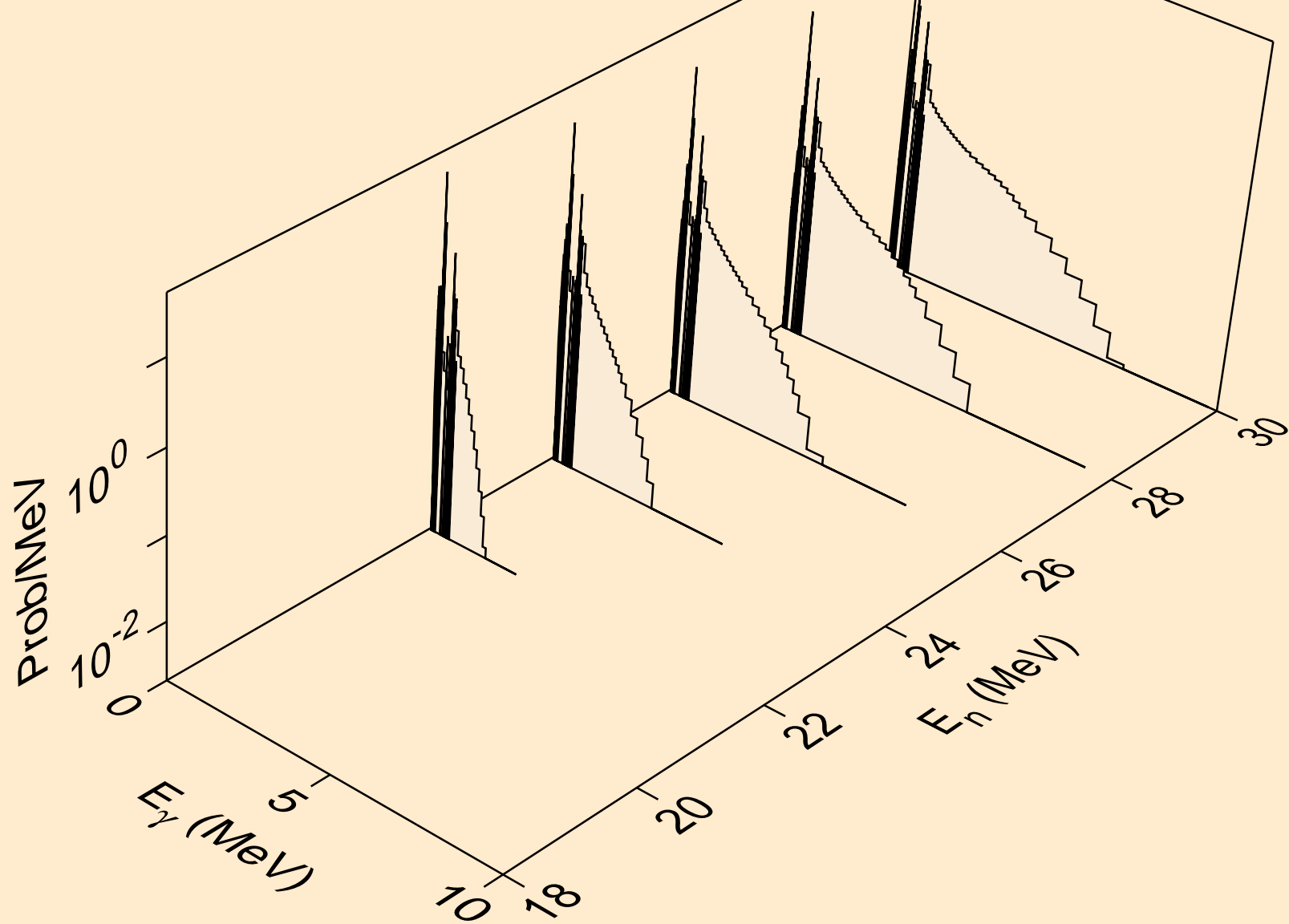

RH098M NEUTRON ACER TENDL-2023 LIBRARY; T=0.K  
Photon emission for (n,n\*)a

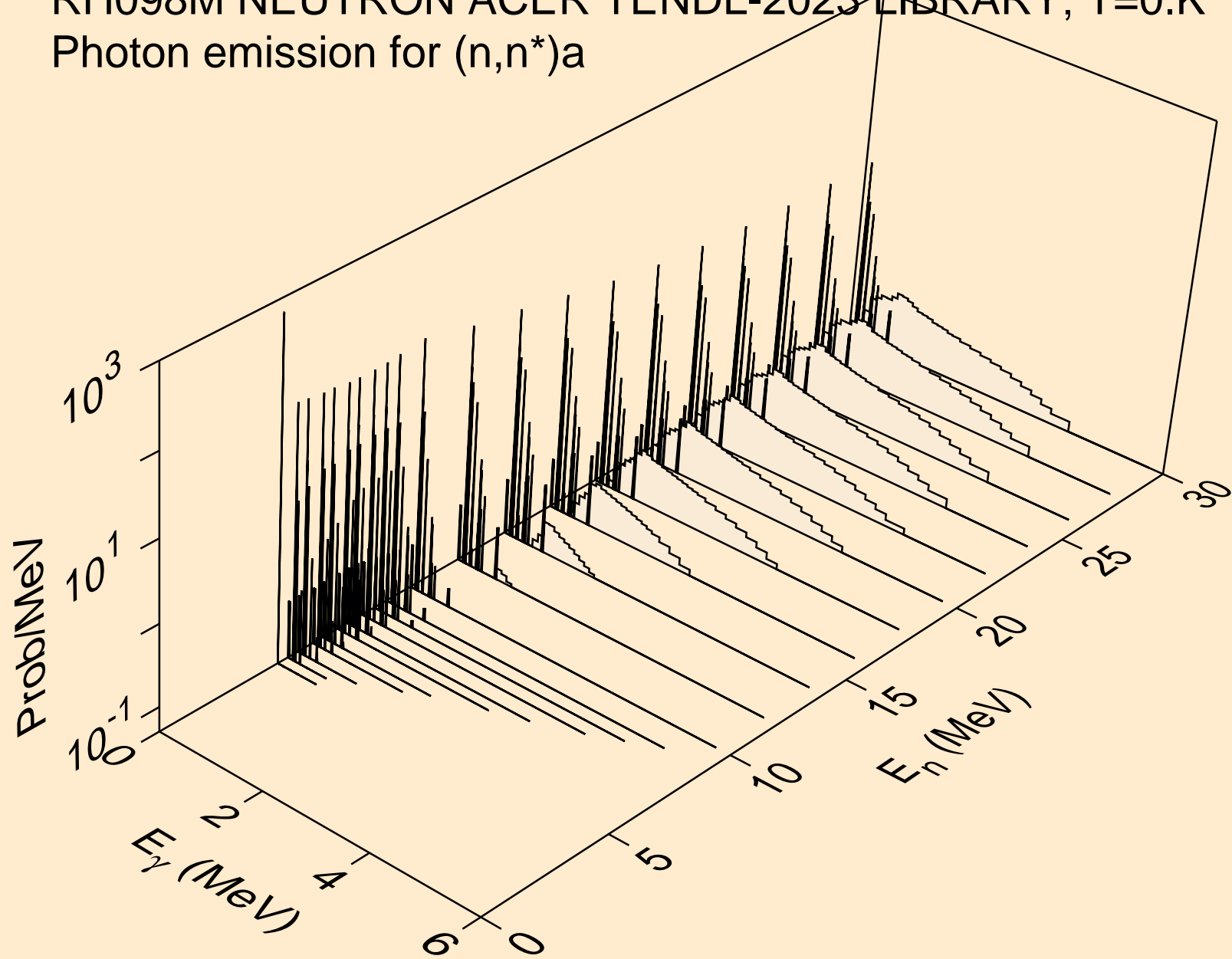

RH098M NEUTRON ACER TENDL-2023 LIBRARY; T=0.K  
Photon emission for (n,2n)a

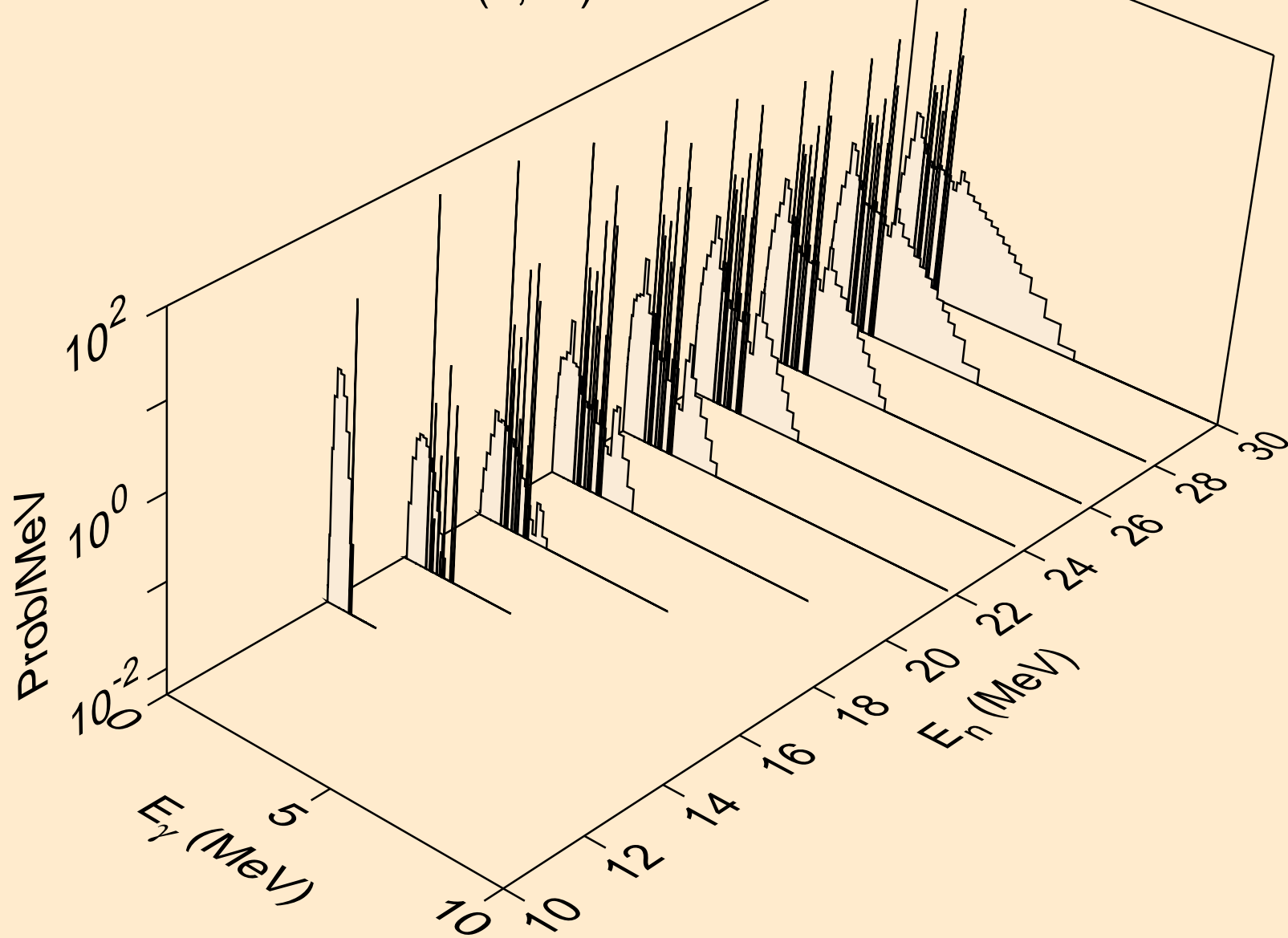

RH098M NEUTRON ACER TENDL-2023 LIBRARY; T=0.K  
Photon emission for (n,3n)a

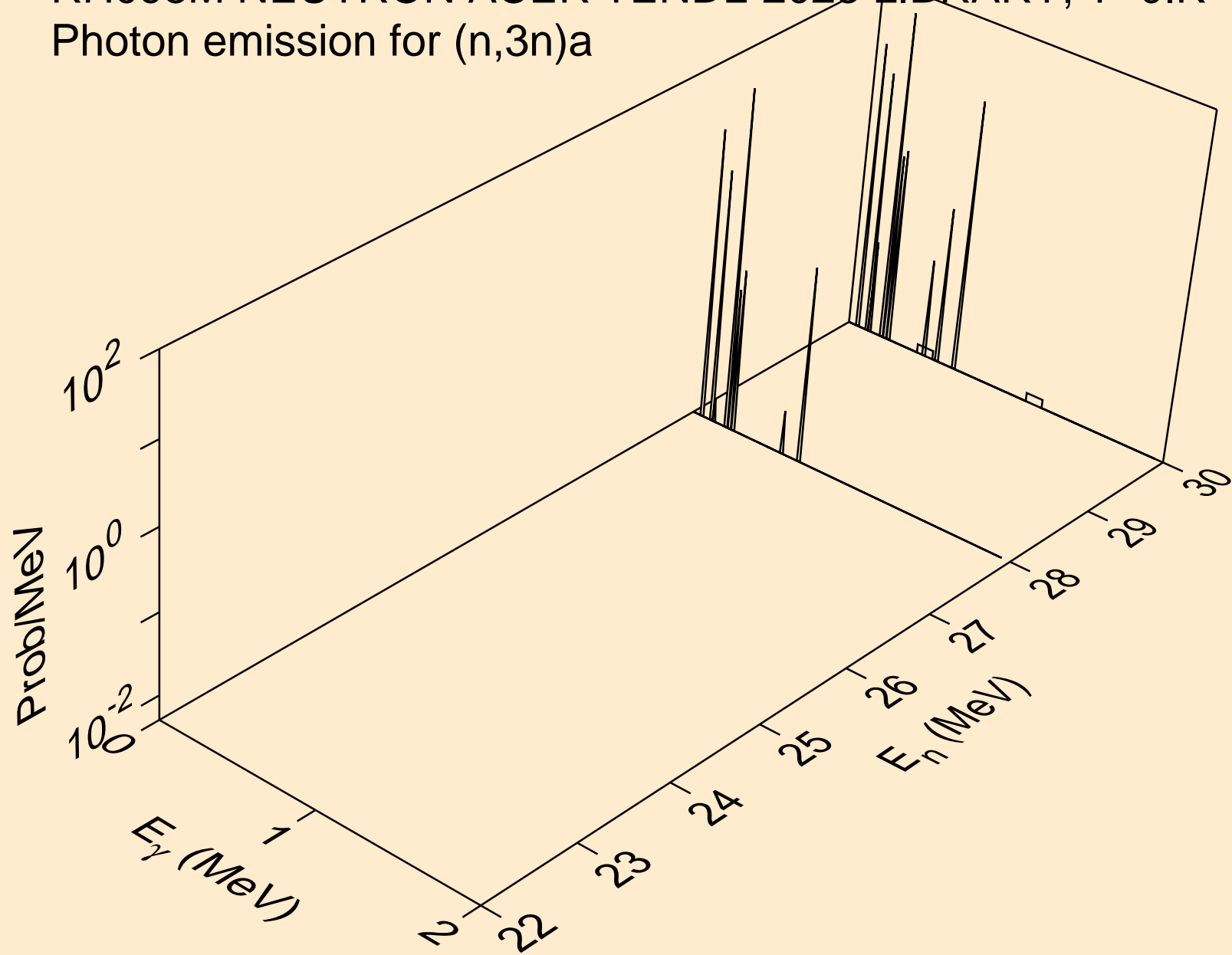

RH098M NEUTRON ACER TENDL-2023 LIBRARY; T=0.K  
Photon emission for (n,n\*)p

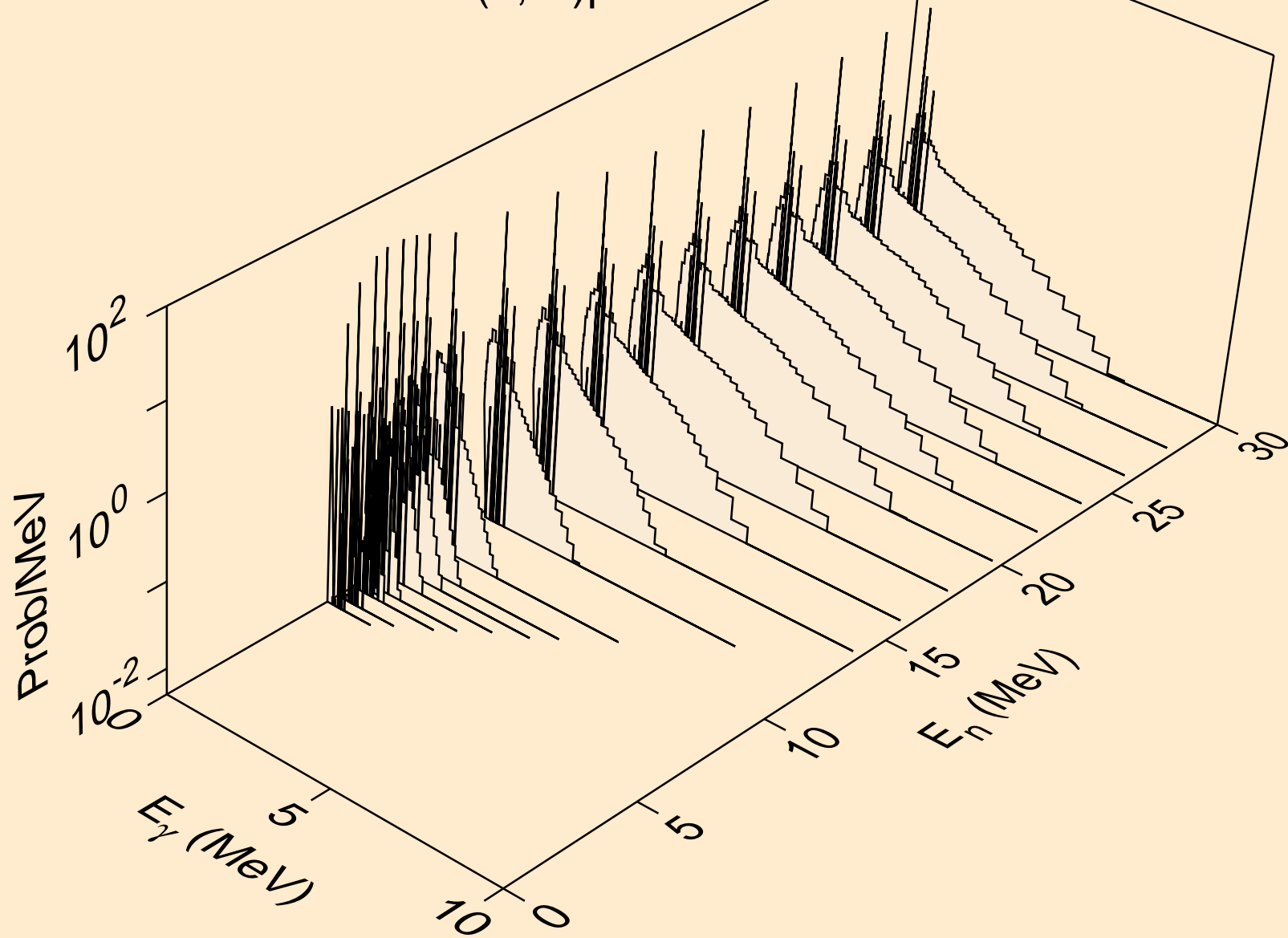

RH098M NEUTRON ACER TENDL-2023 LIBRARY; T=0.K  
Photon emission for (n,n\*)2a

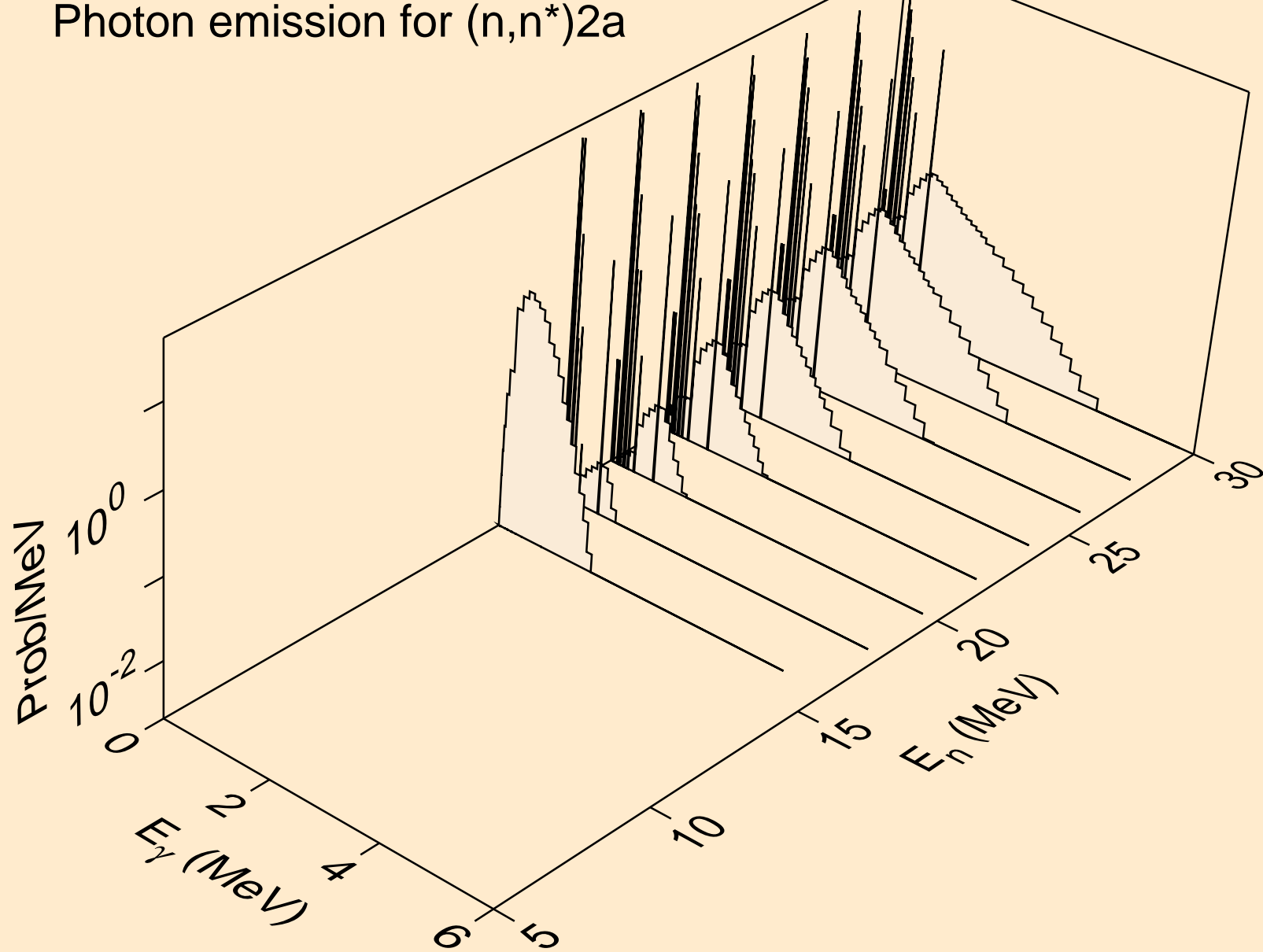

RH098M NEUTRON ACER TENDL-2023 LIBRARY; T=0.K  
Photon emission for (n,n\*)d

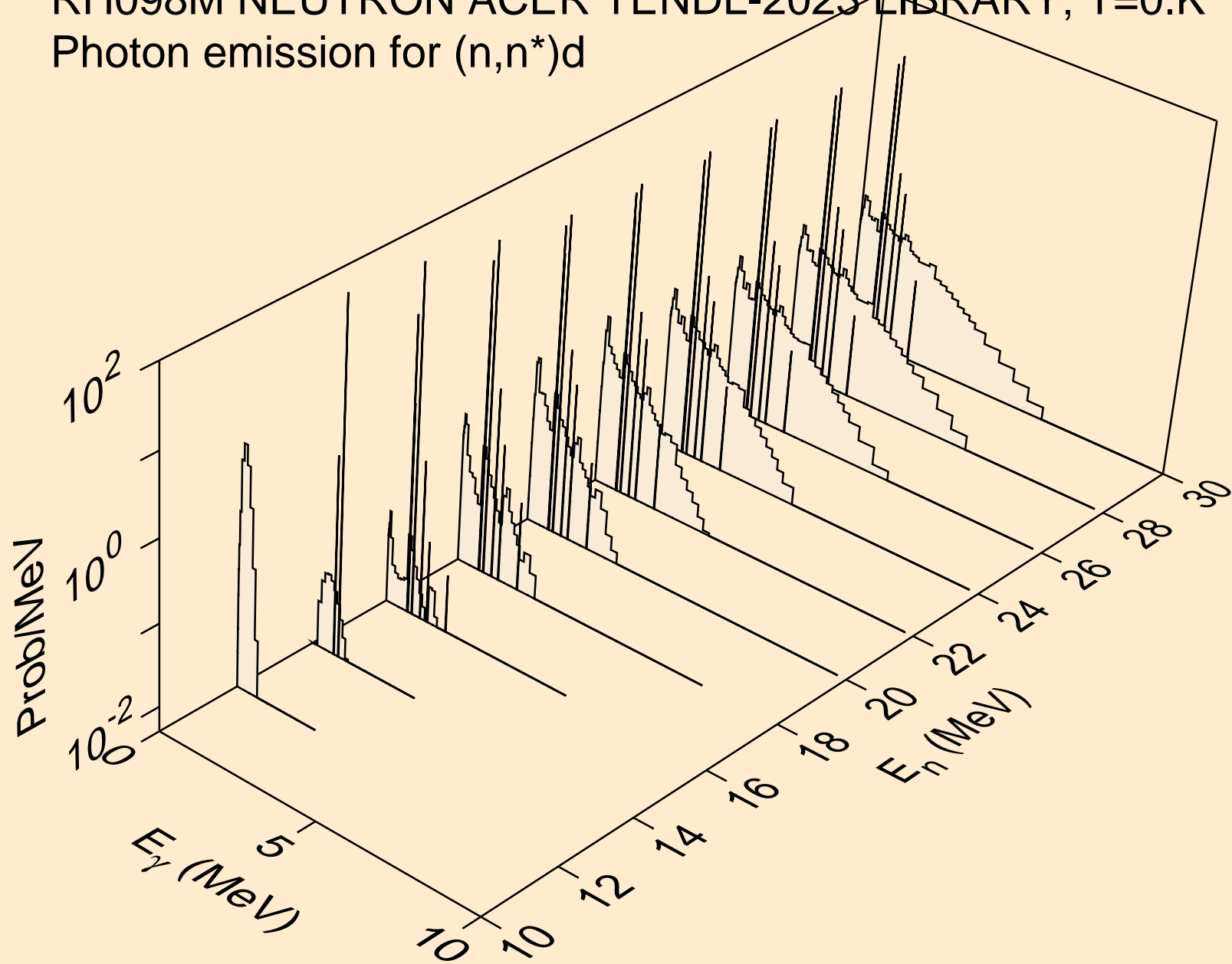

RH098M NEUTRON ACER TENDL-2023 LIBRARY; T=0.K  
Photon emission for (n,n\*)t

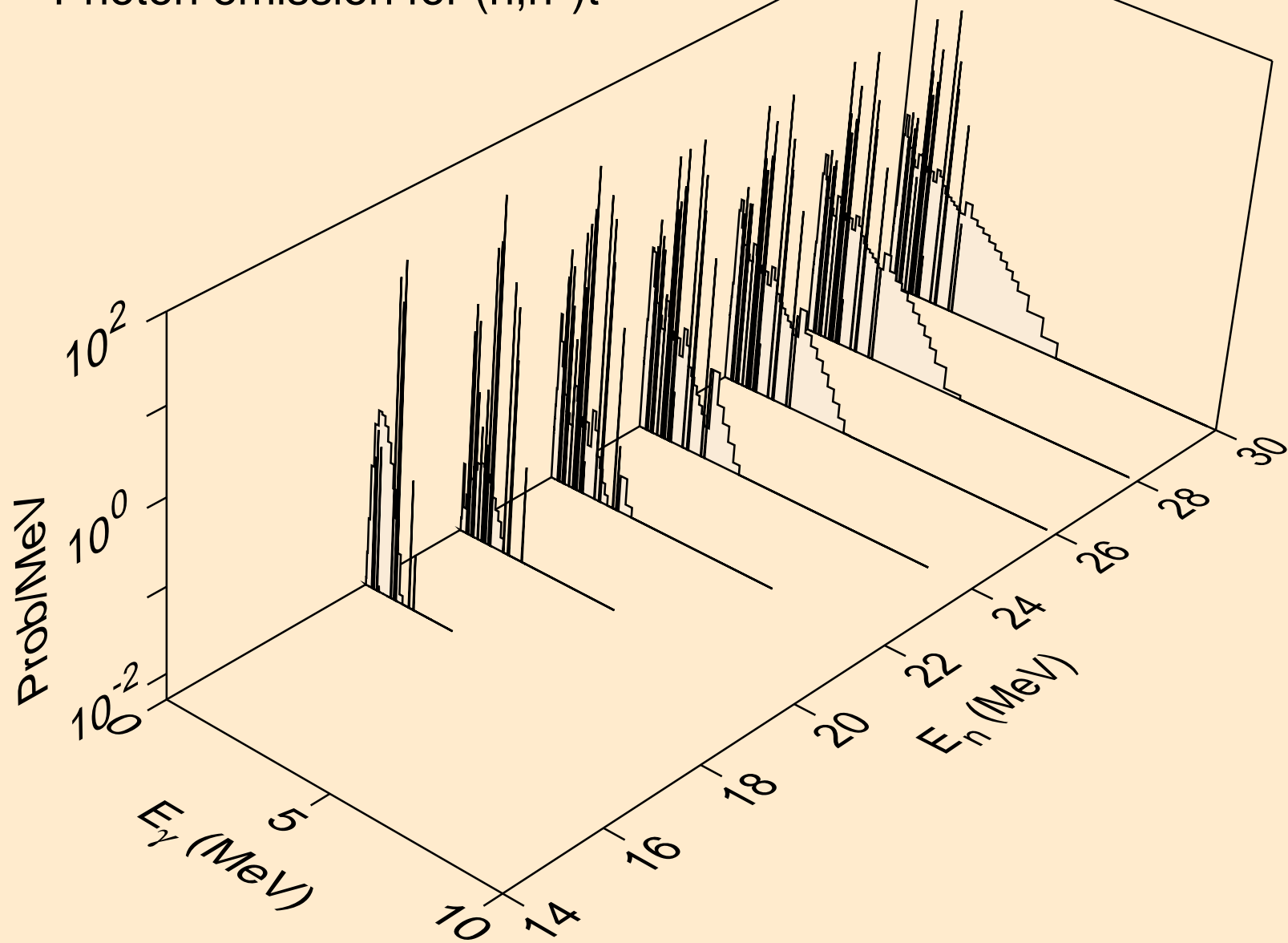



RH098M NEUTRON ACER TENDL-2023 LIBRARY; T=0.K  
Photon emission for (n,n\*)he3

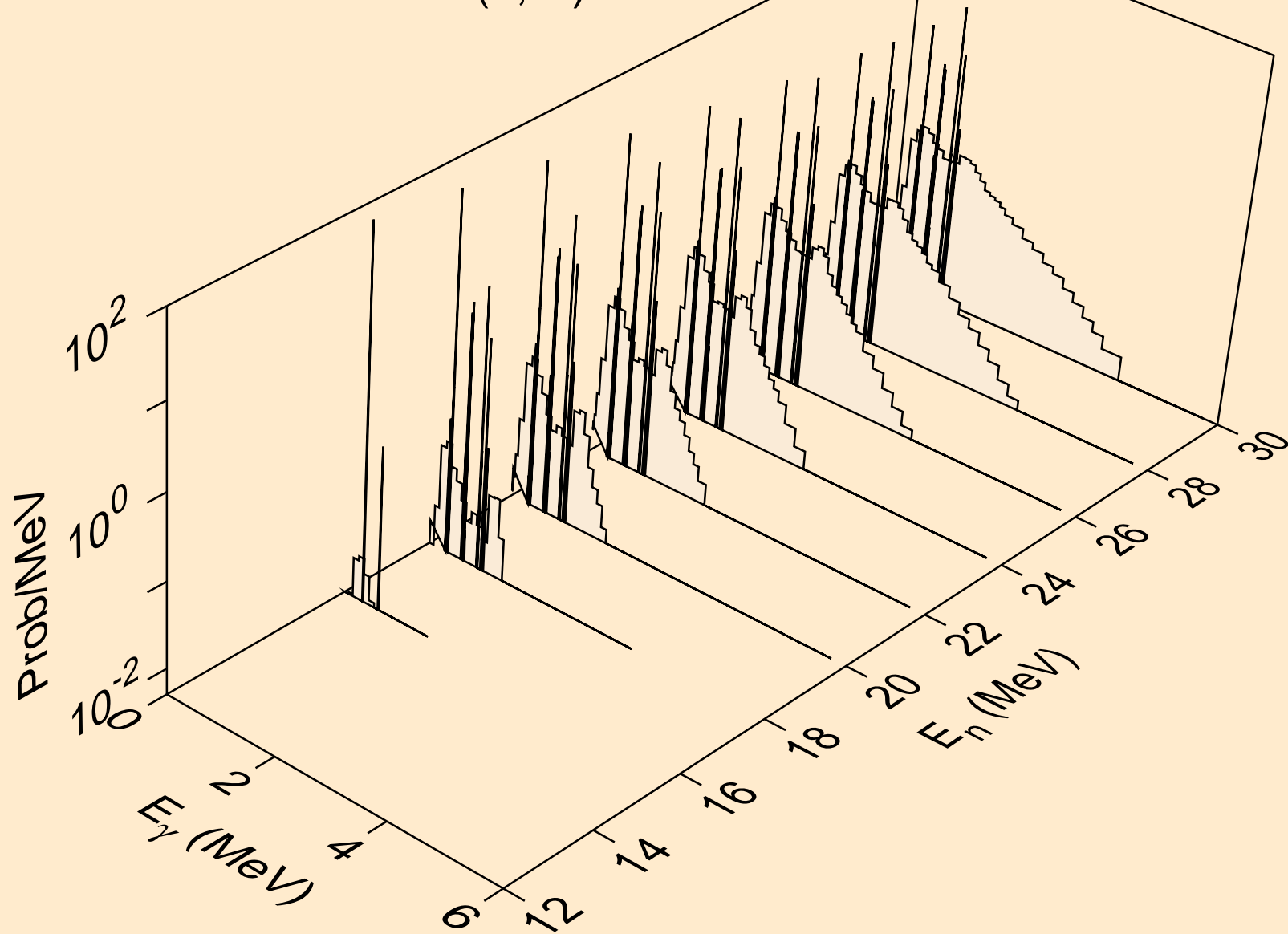

RH098M NEUTRON ACER TENDL-2023 LIBRARY; T=0.K  
Photon emission for (n,2np)

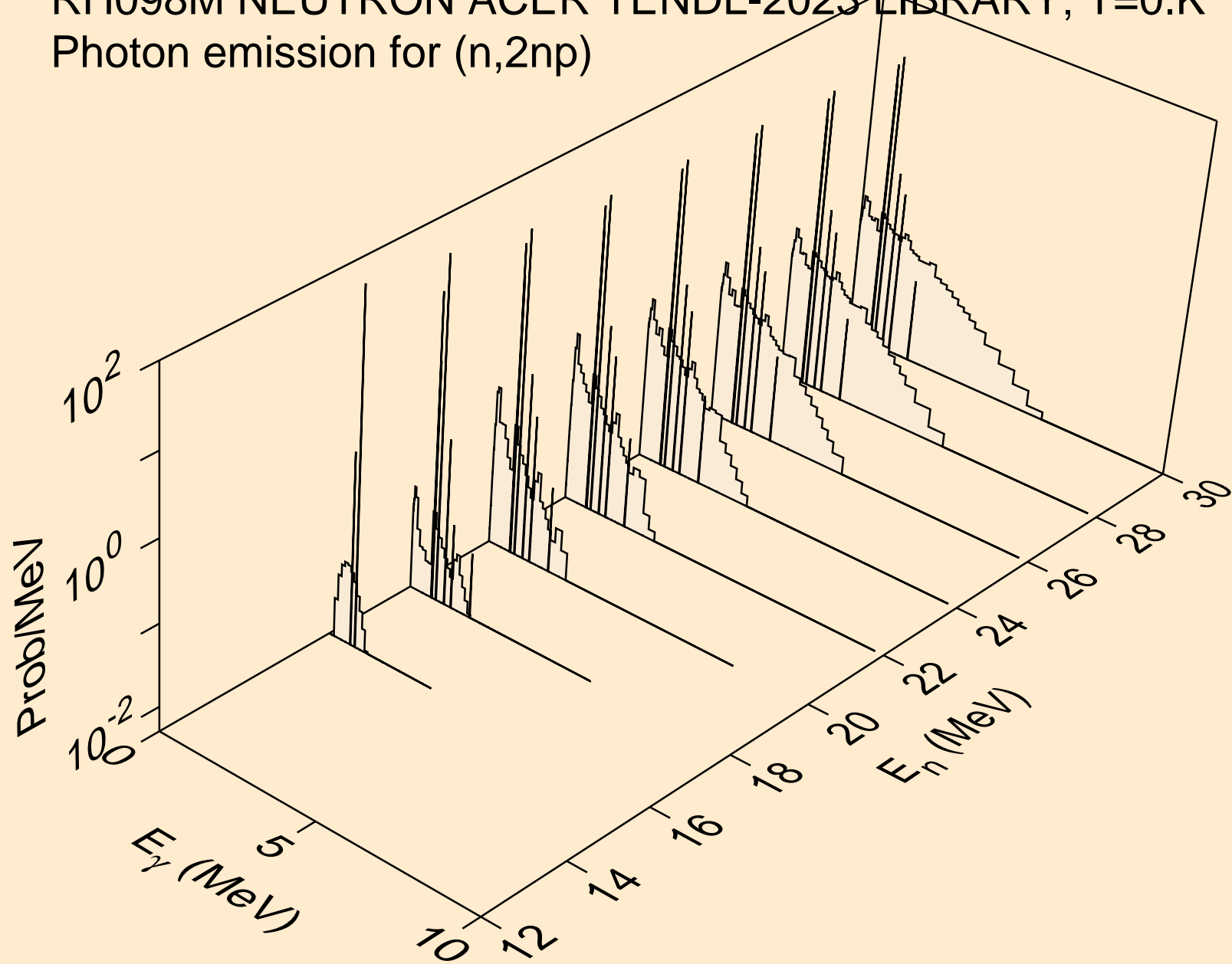

RH098M NEUTRON ACER TENDL-2023 LIBRARY; T=0.K  
Photon emission for (n,3np)

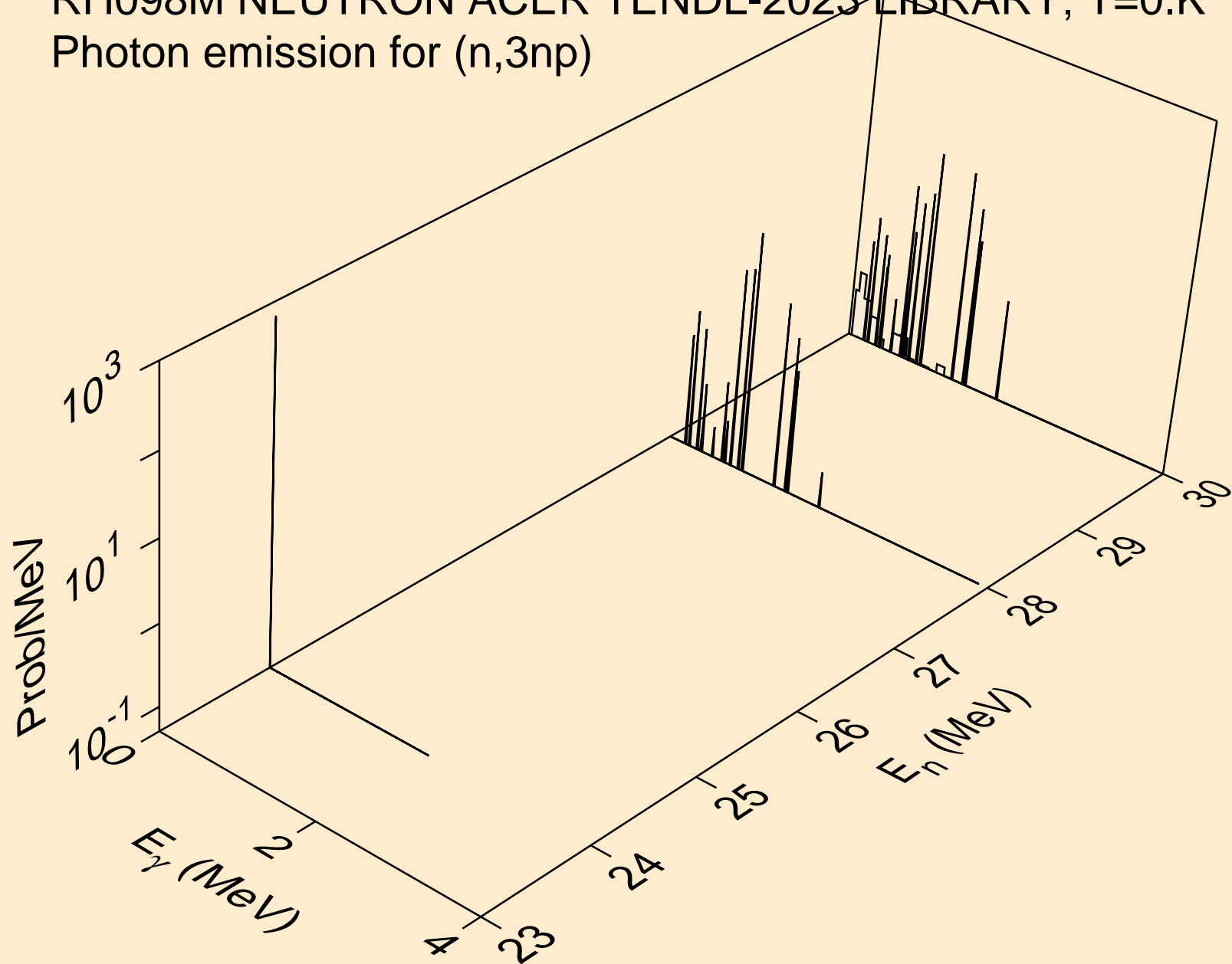

RH098M NEUTRON ACER TENDL-2023 LIBRARY; T=0.K  
Photon emission for (n,n2p)

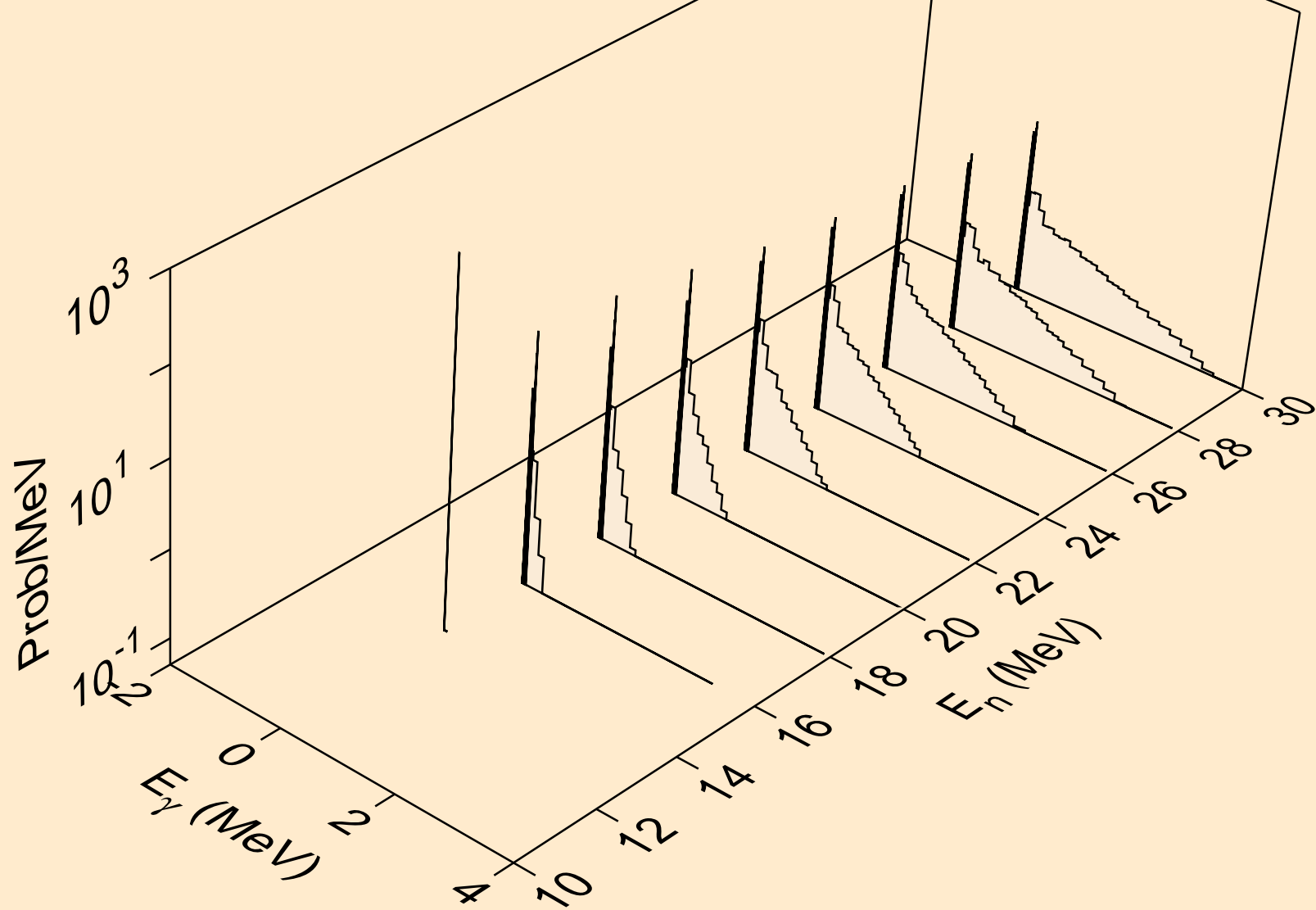

RH098M NEUTRON ACER TENDL-2023 LIBRARY; T=0.K  
Photon emission for (n,npa)

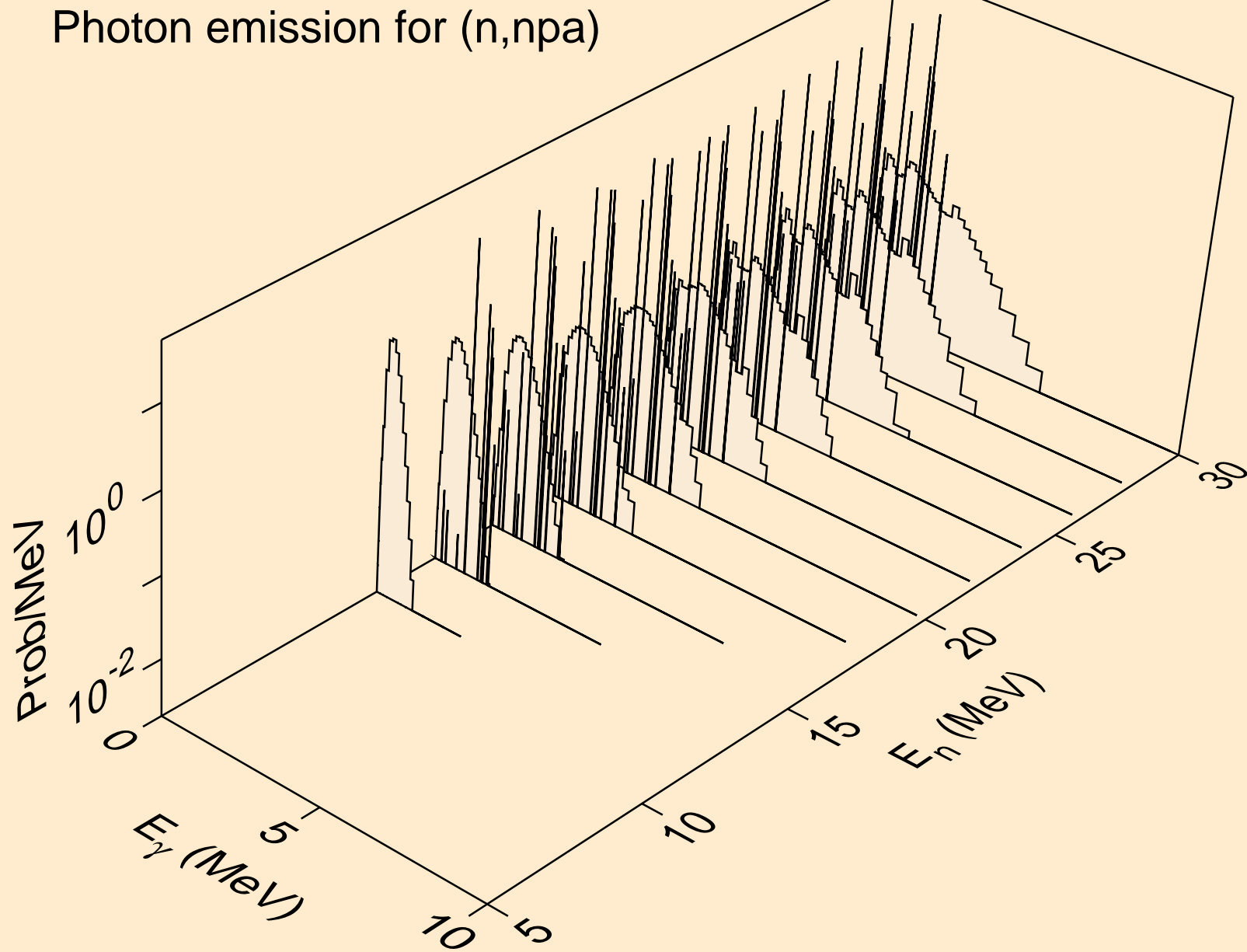

RH098M NEUTRON ACER TENDL-2023 LIBRARY; T=0.K  
Photon emission for (n,n\*1)

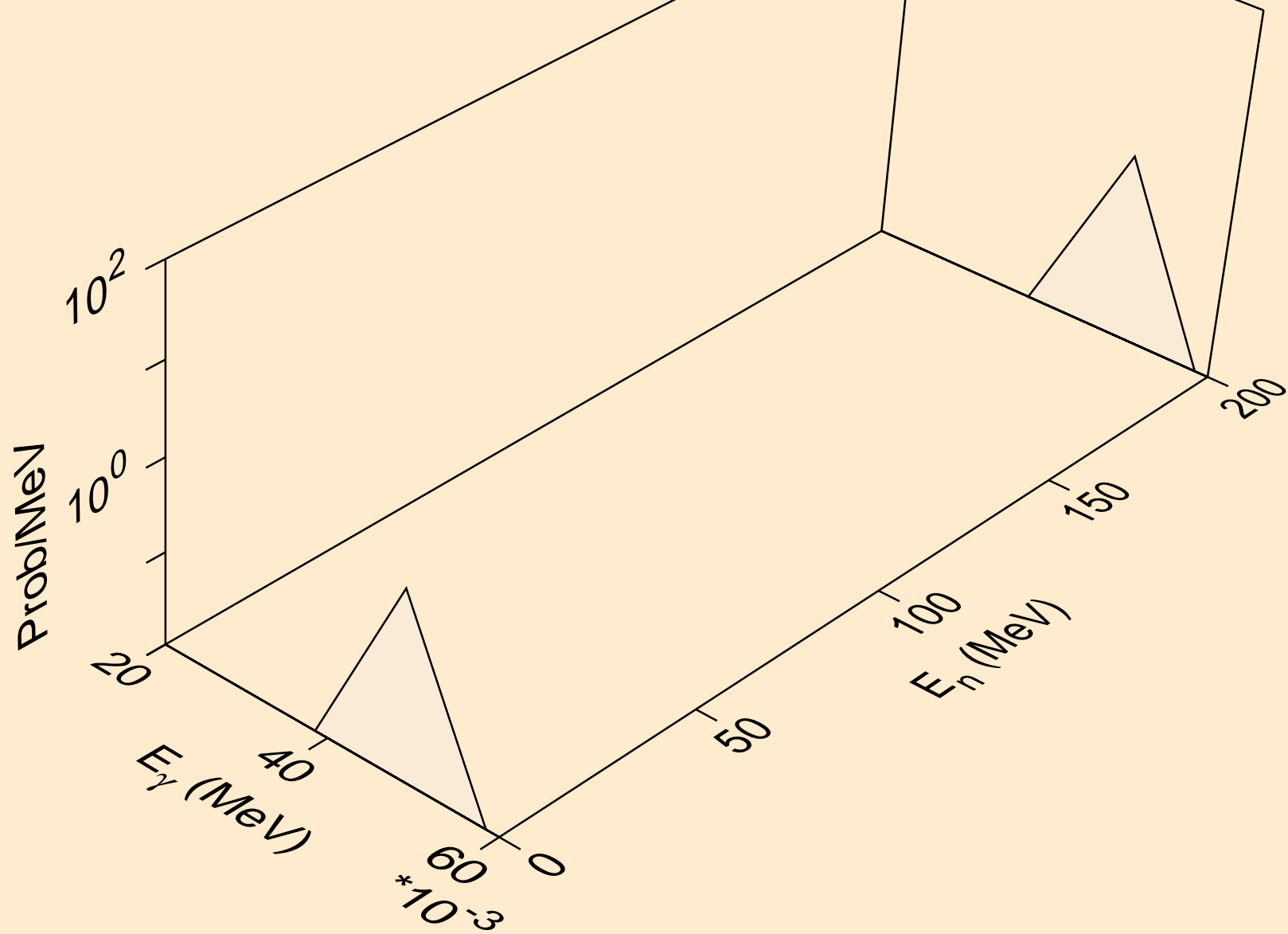

RH098M NEUTRON ACER TENDL-2023 LIBRARY; T=0.K  
Photon emission for (n,n\*3)

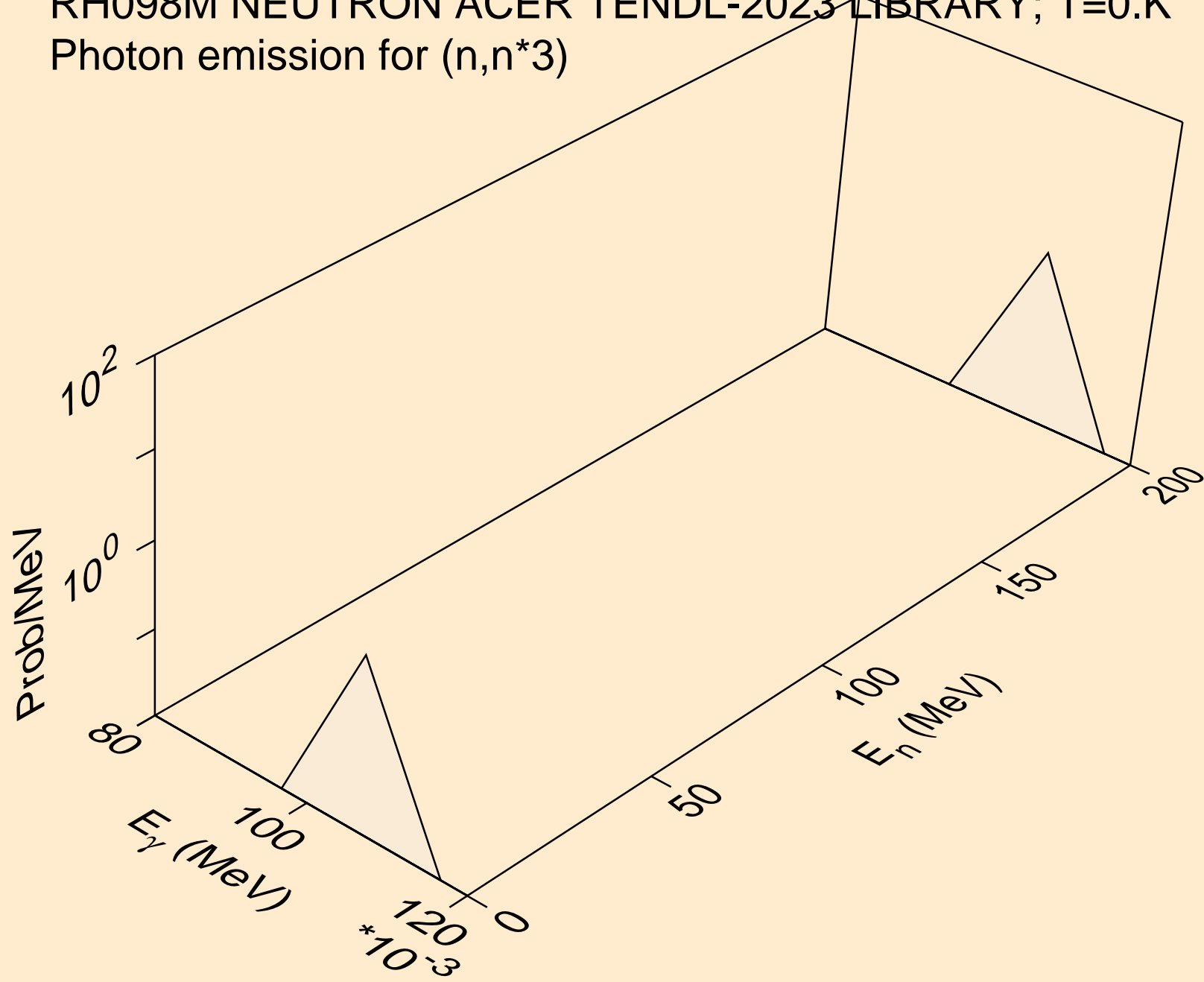

RH098M NEUTRON ACER TENDL-2023 LIBRARY; T=0.K  
Photon emission for (n,n\*4)

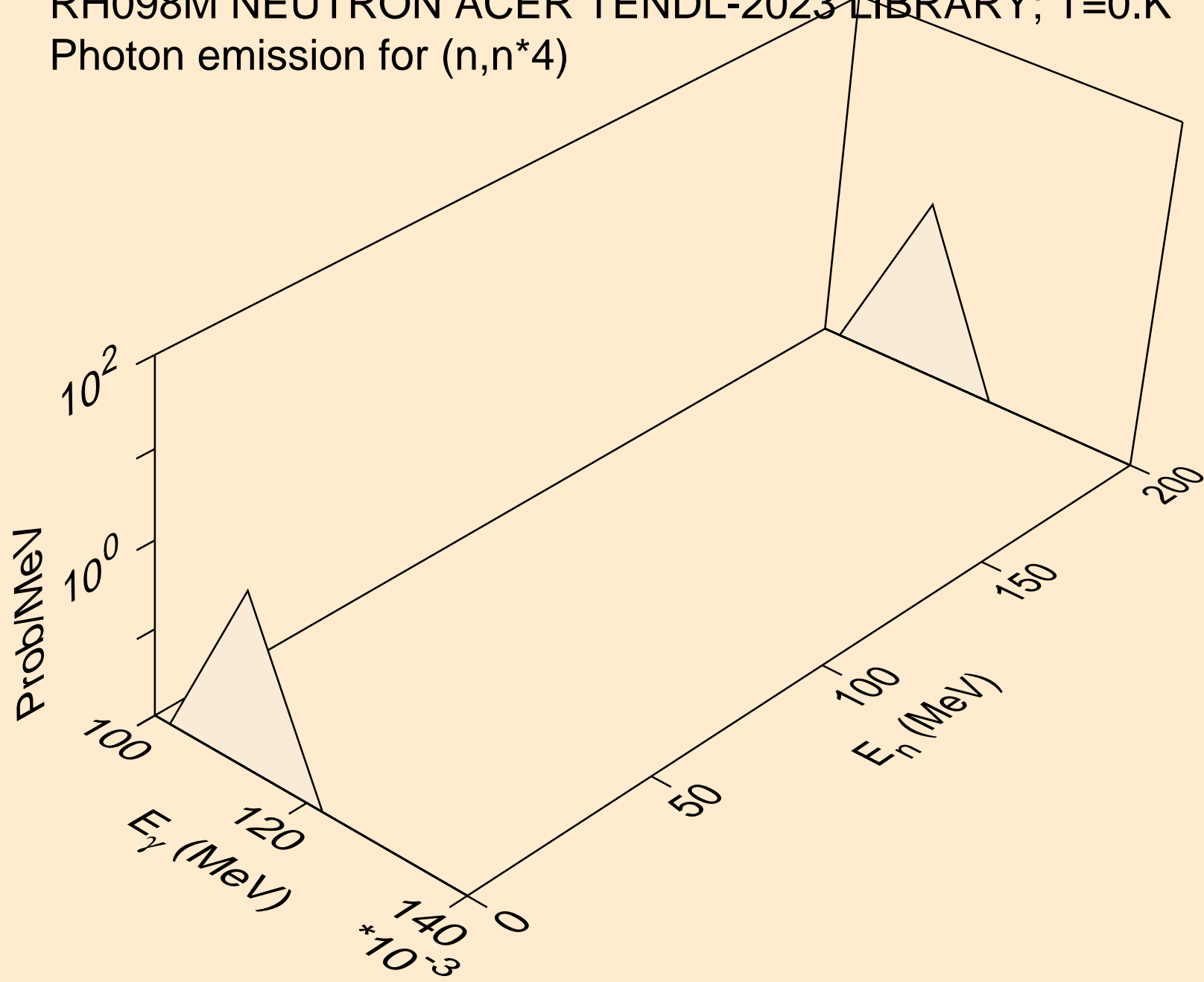



RH098M NEUTRON ACER TENDL-2023 LIBRARY; T=0.K  
Photon emission for (n,n\*5)

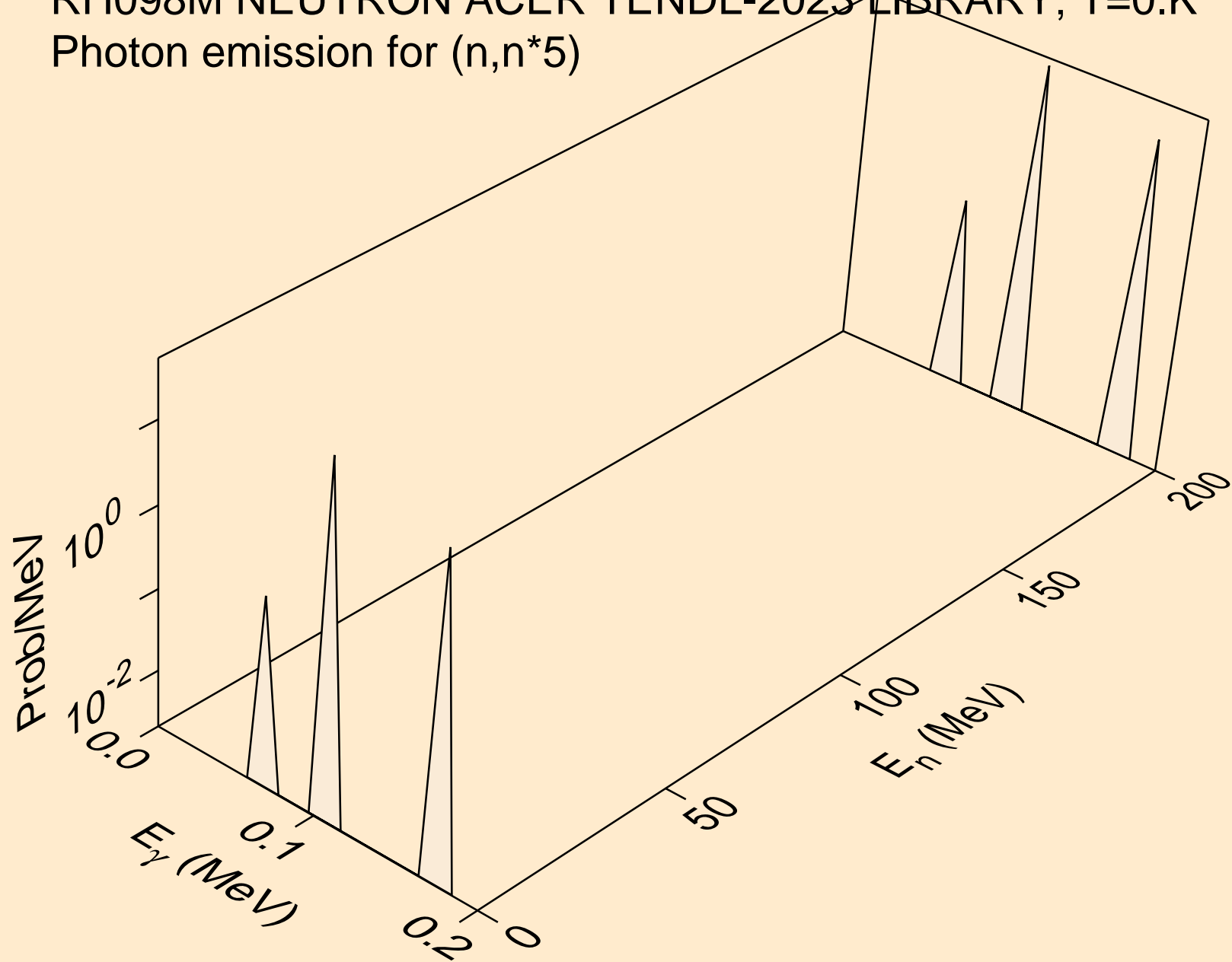

RH098M NEUTRON ACER TENDL-2023 LIBRARY; T=0.K  
Photon emission for (n,n\*6)

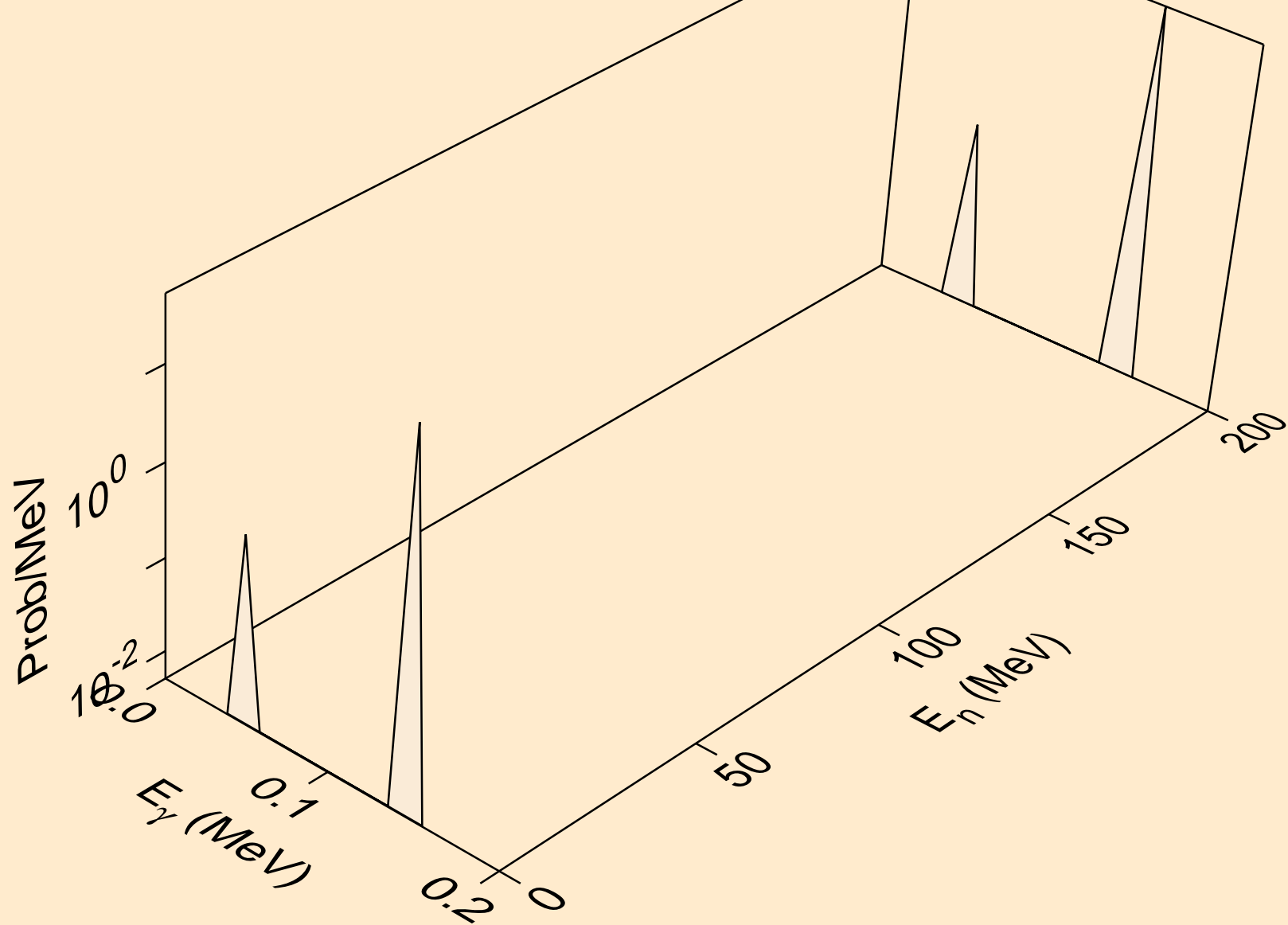

RH098M NEUTRON ACER TENDL-2023 LIBRARY; T=0.K  
Photon emission for (n,n\*7)

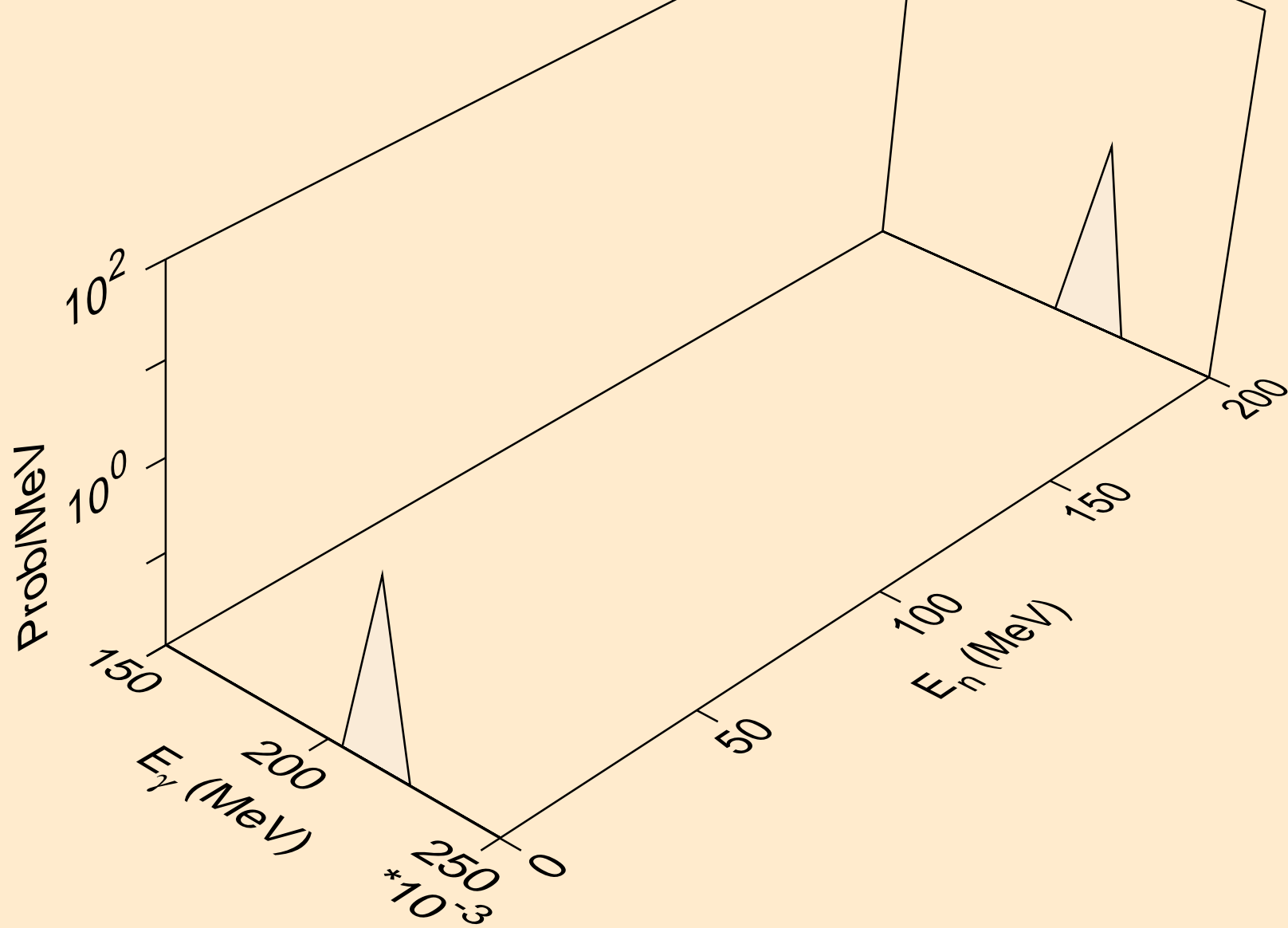

RH098M NEUTRON ACER TENDL-2023 LIBRARY; T=0.K  
Photon emission for (n,n\*8)

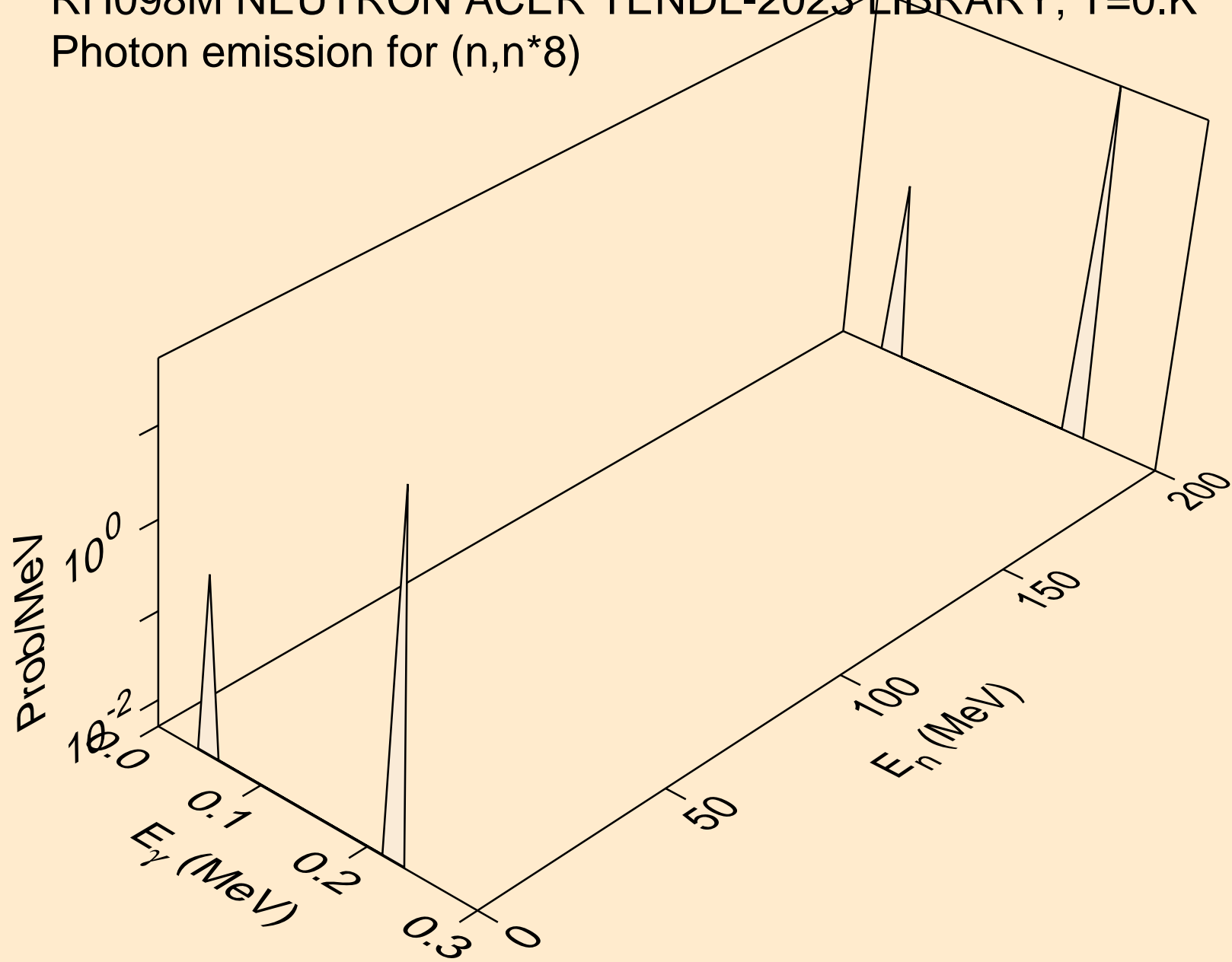

RH098M NEUTRON ACER TENDL-2023 LIBRARY; T=0.K  
Photon emission for (n,n\*9)

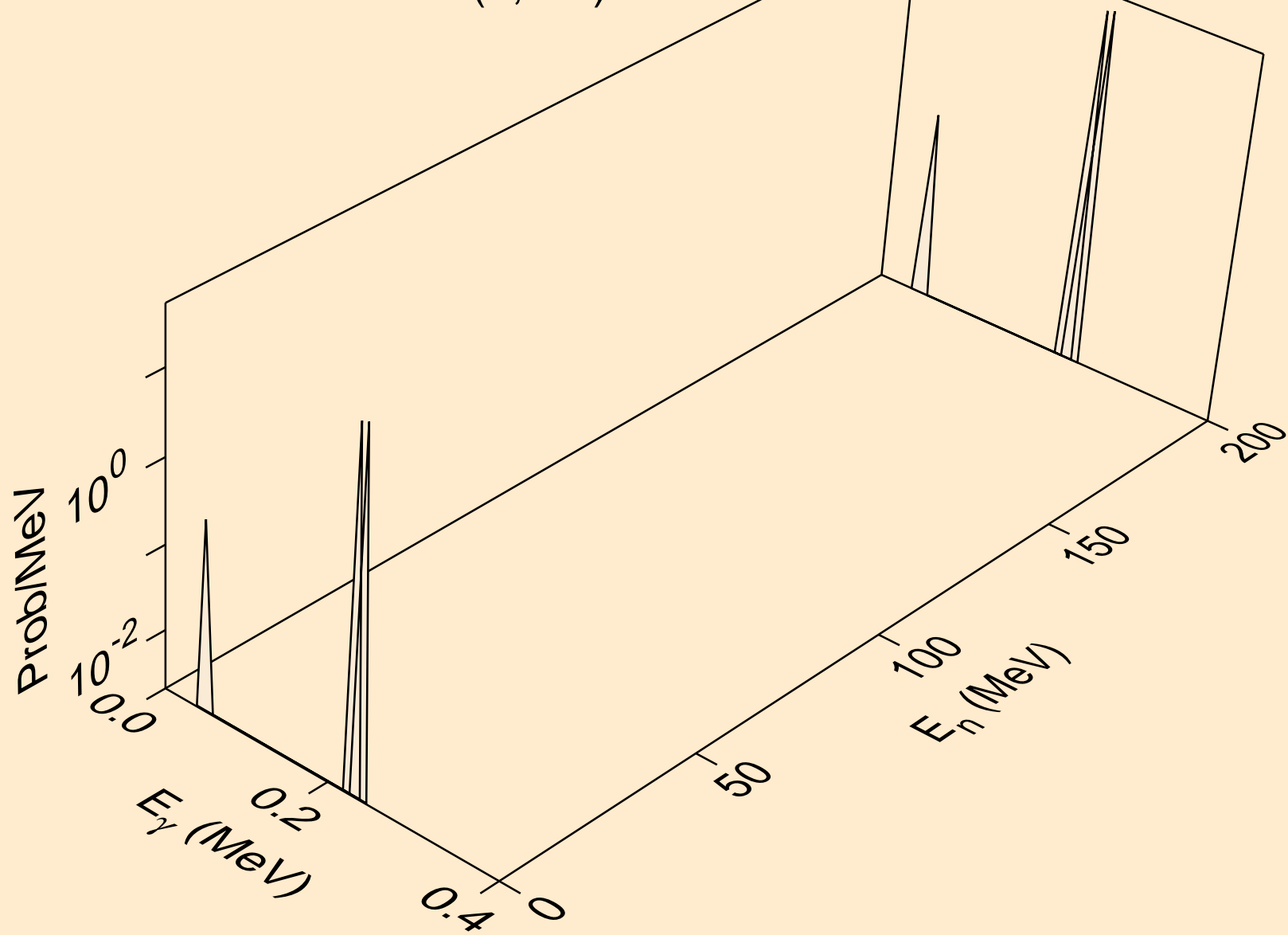

RH098M NEUTRON ACER TENDL-2023 LIBRARY; T=0.K  
Photon emission for (n,n\*10)

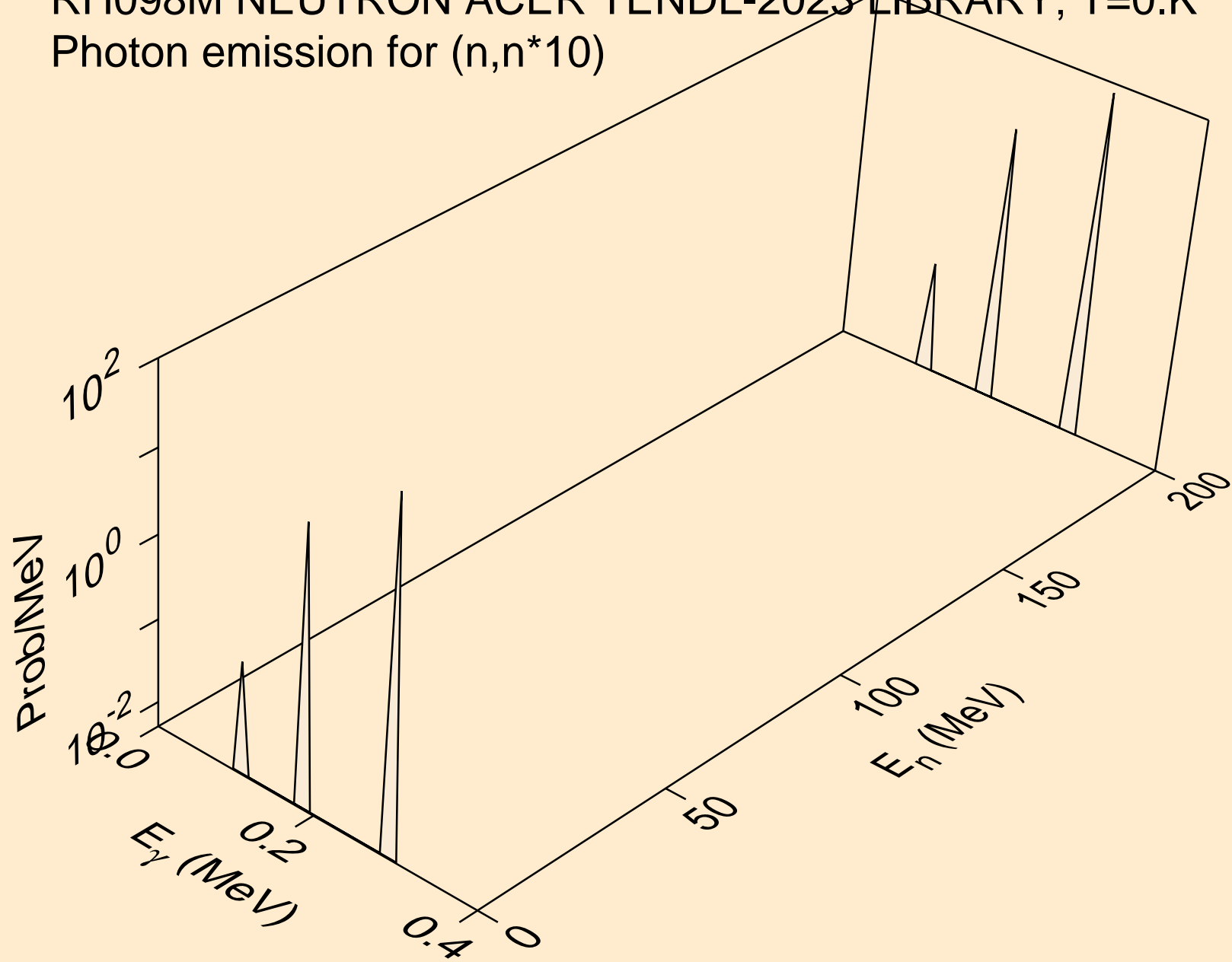

RH098M NEUTRON ACER TENDL-2023 LIBRARY; T=0.K  
Photon emission for (n,n\*11)

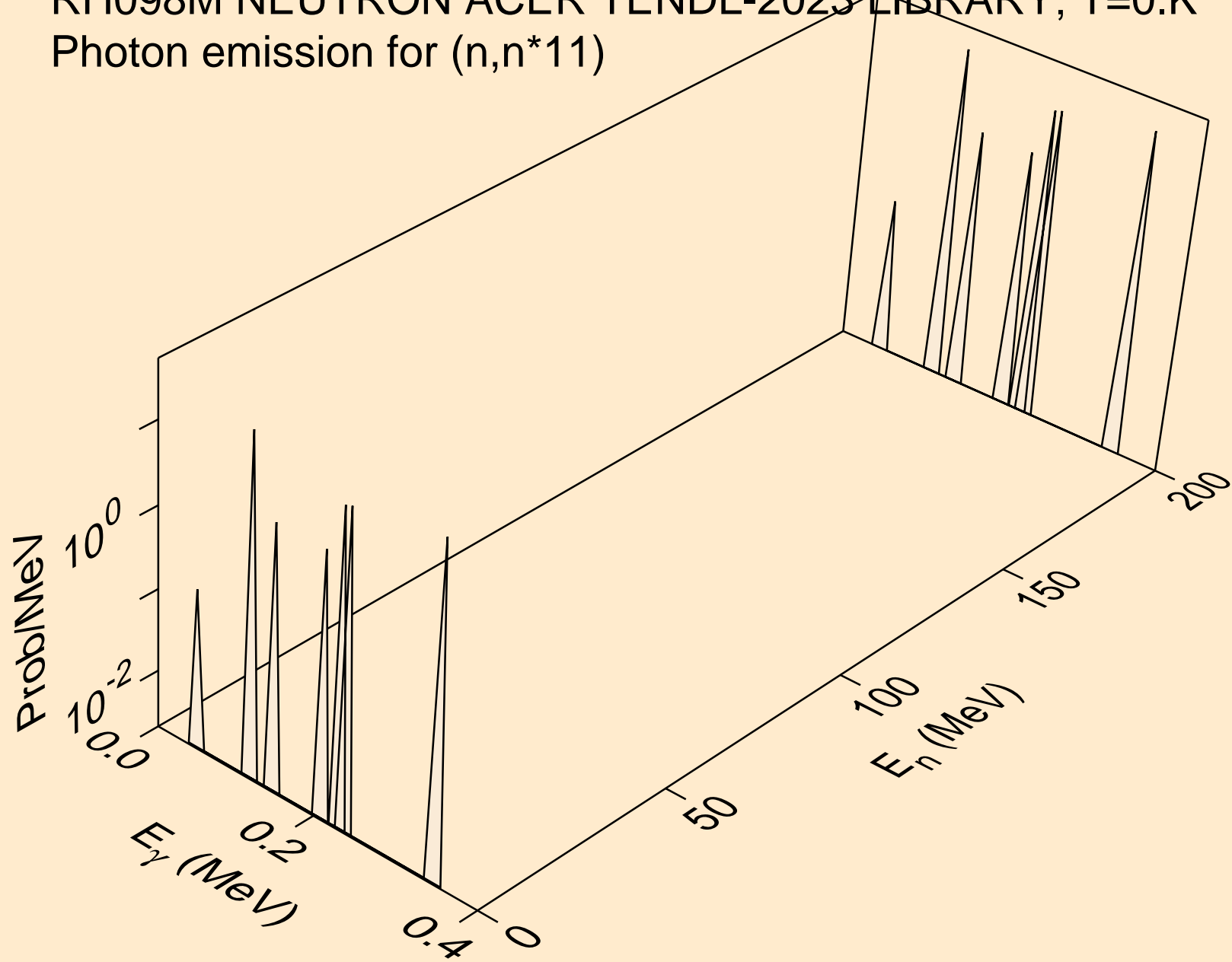

RH098M NEUTRON ACER TENDL-2023 LIBRARY; T=0.K  
Photon emission for (n,n\*12)

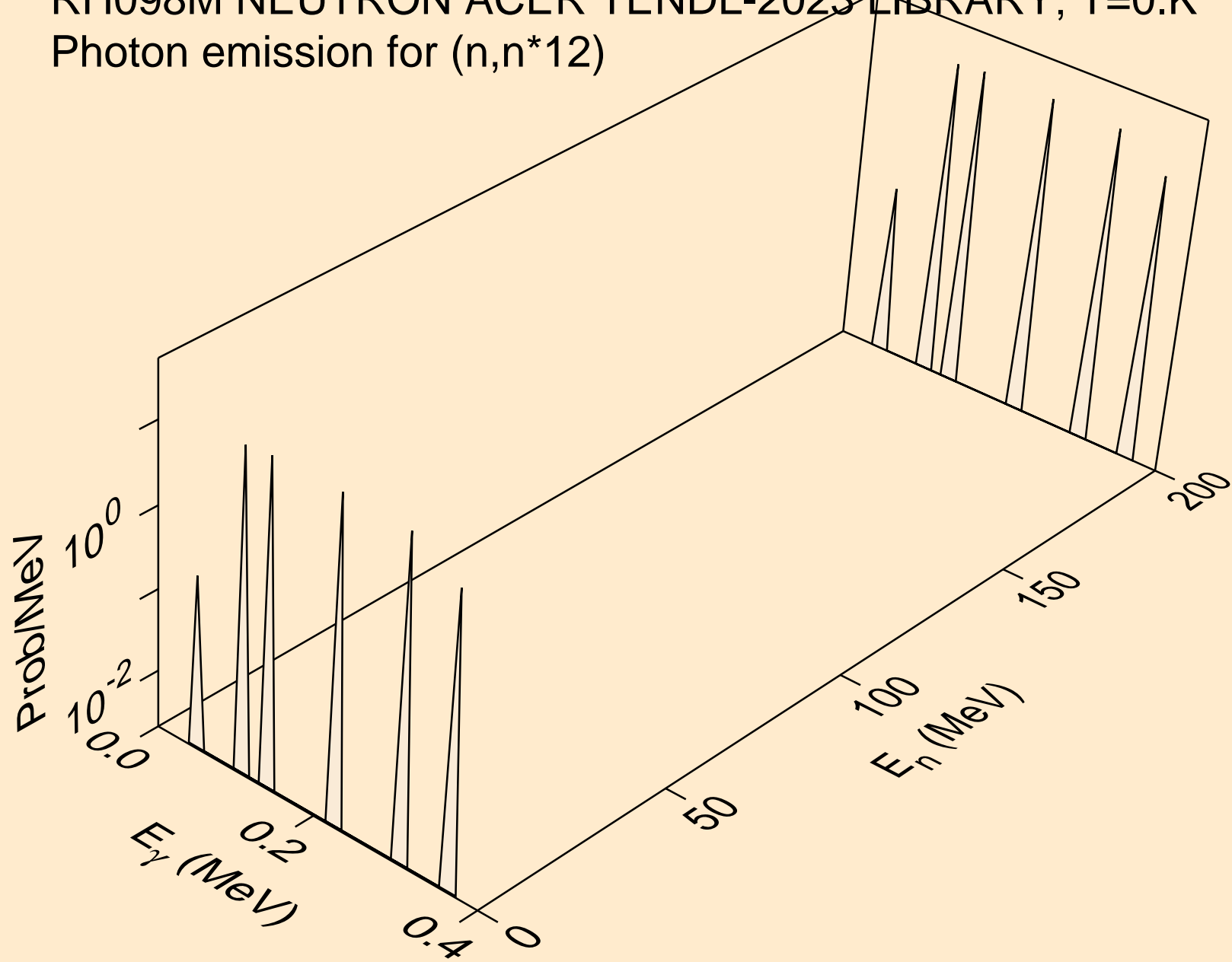



RH098M NEUTRON ACER TENDL-2023 LIBRARY; T=0.K  
Photon emission for (n,n\*13)

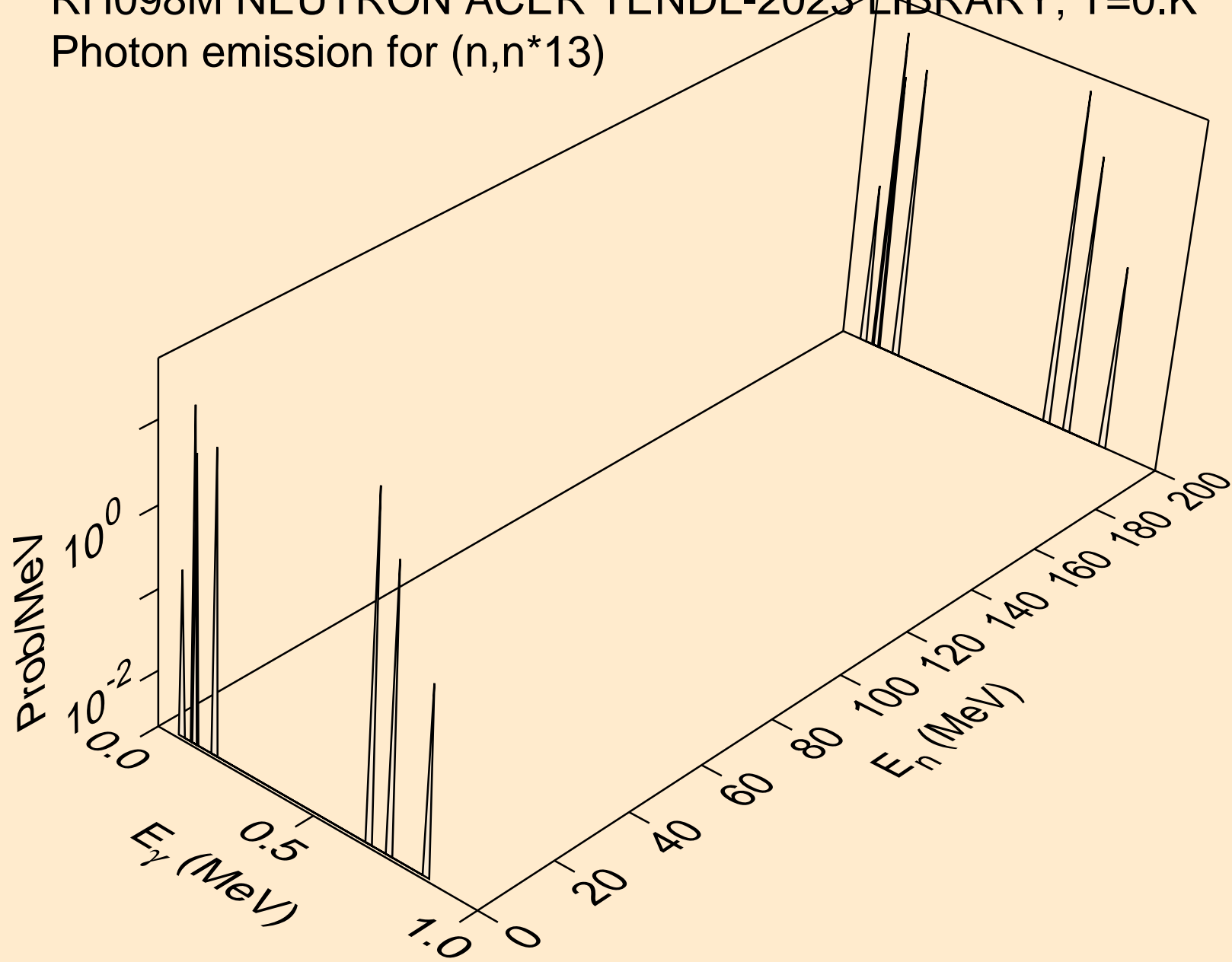

RH098M NEUTRON ACER TENDL-2023 LIBRARY; T=0.K  
Photon emission for (n,n\*14)

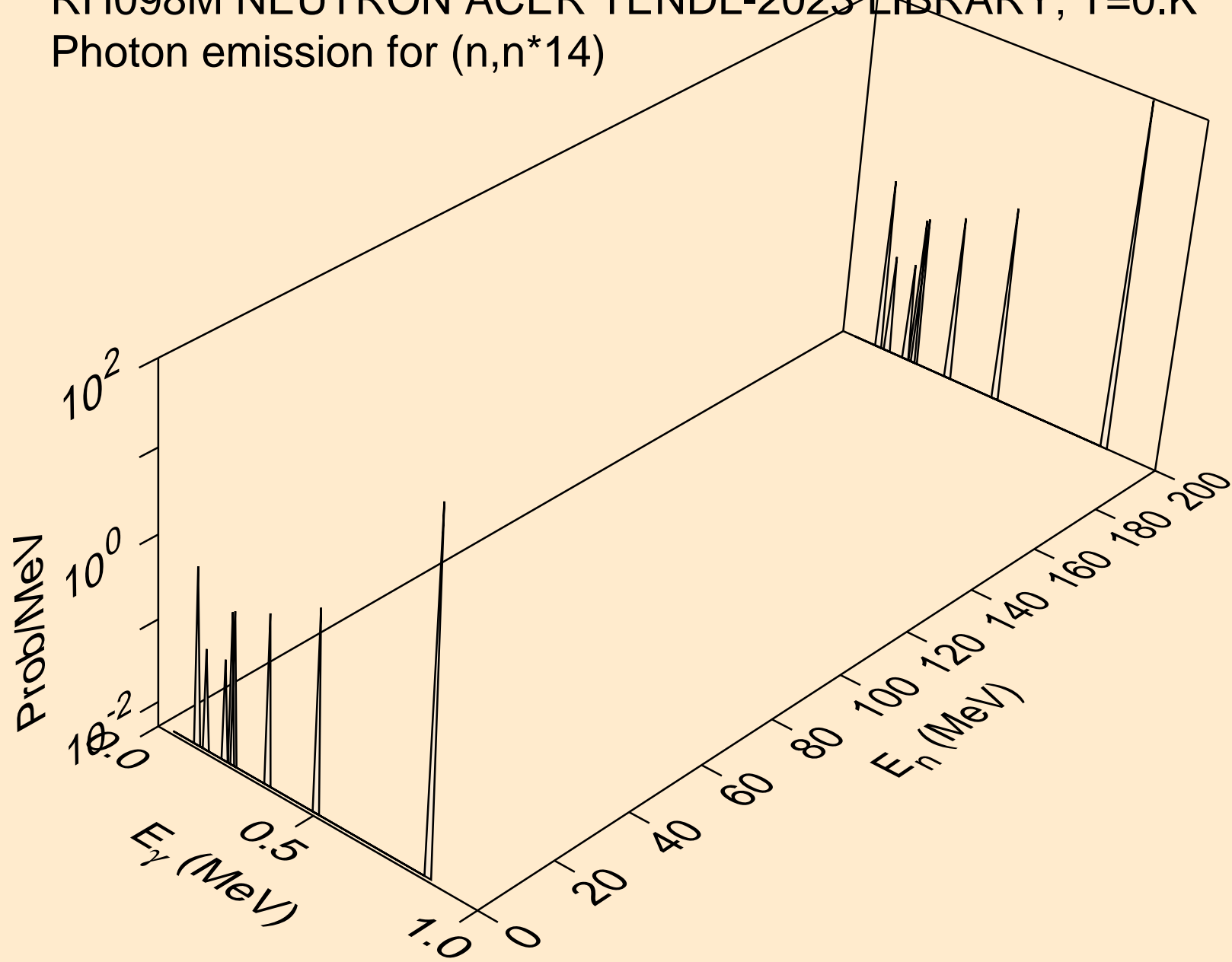

RH098M NEUTRON ACER TENDL-2023 LIBRARY; T=0.K  
Photon emission for (n,n\*15)

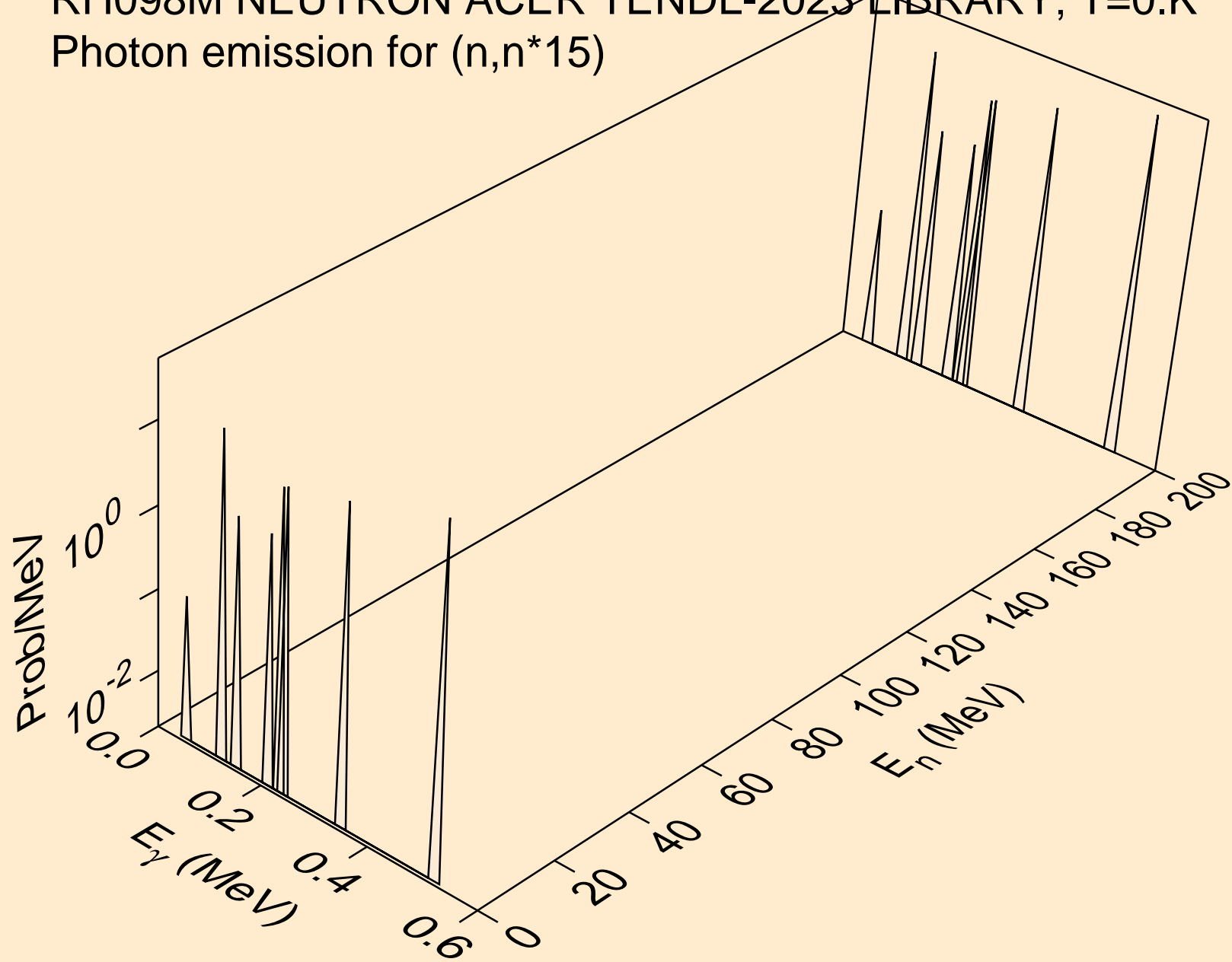

RH098M NEUTRON ACER TENDL-2023 LIBRARY; T=0.K  
Photon emission for (n,n\*16)

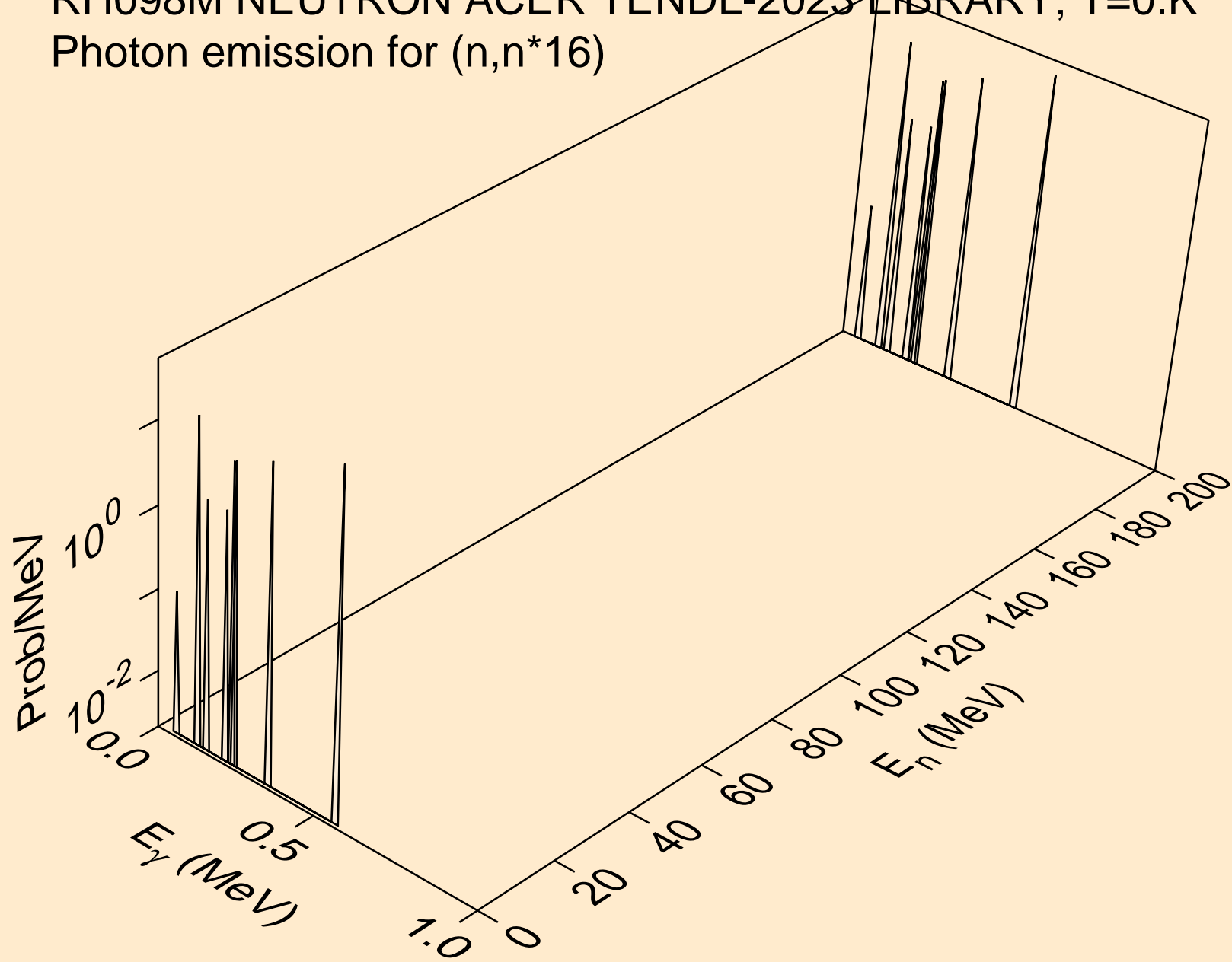

RH098M NEUTRON ACER TENDL-2023 LIBRARY; T=0.K  
Photon emission for (n,n\*17)

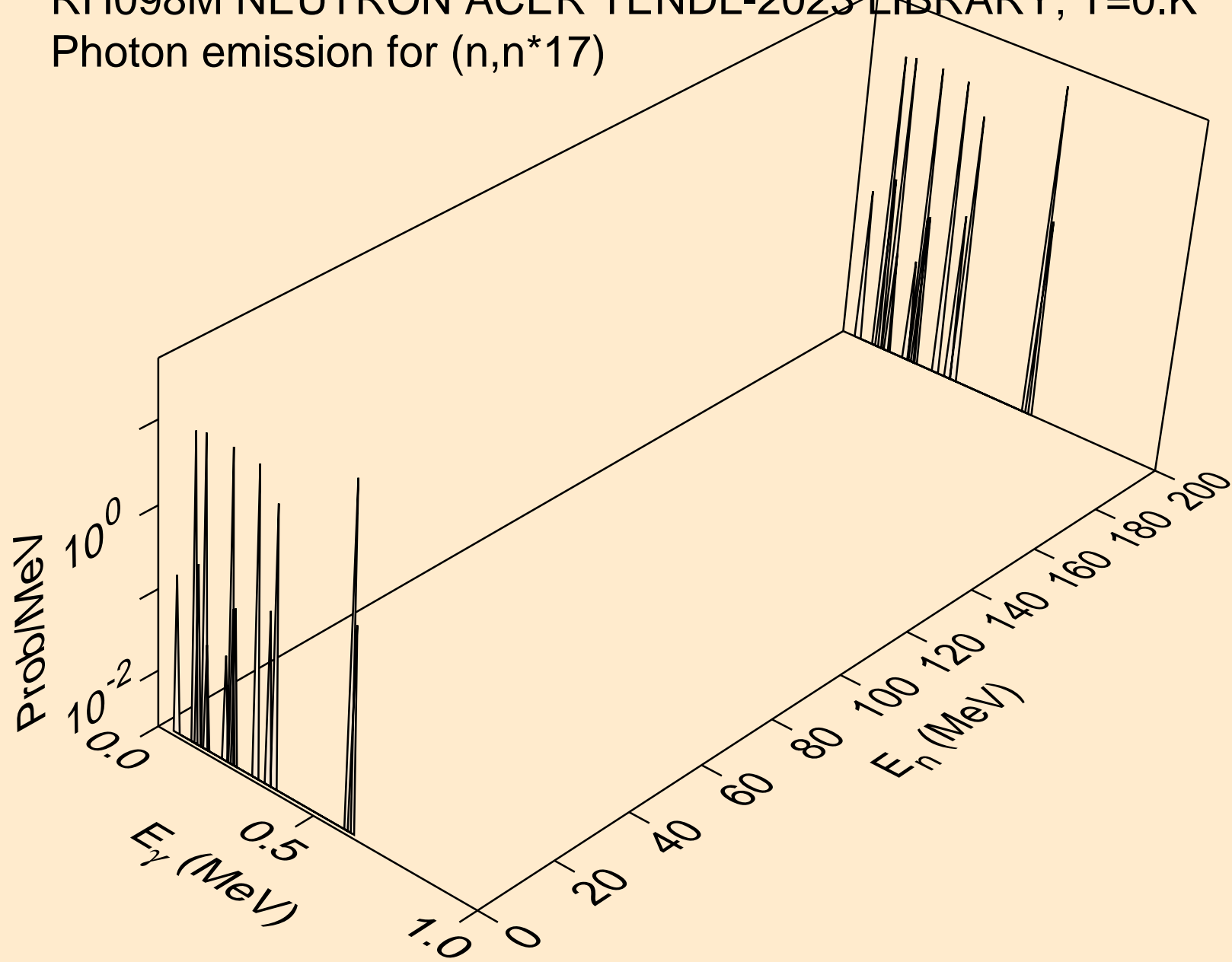

RH098M NEUTRON ACER TENDL-2023 LIBRARY; T=0.K  
Photon emission for (n,n\*18)

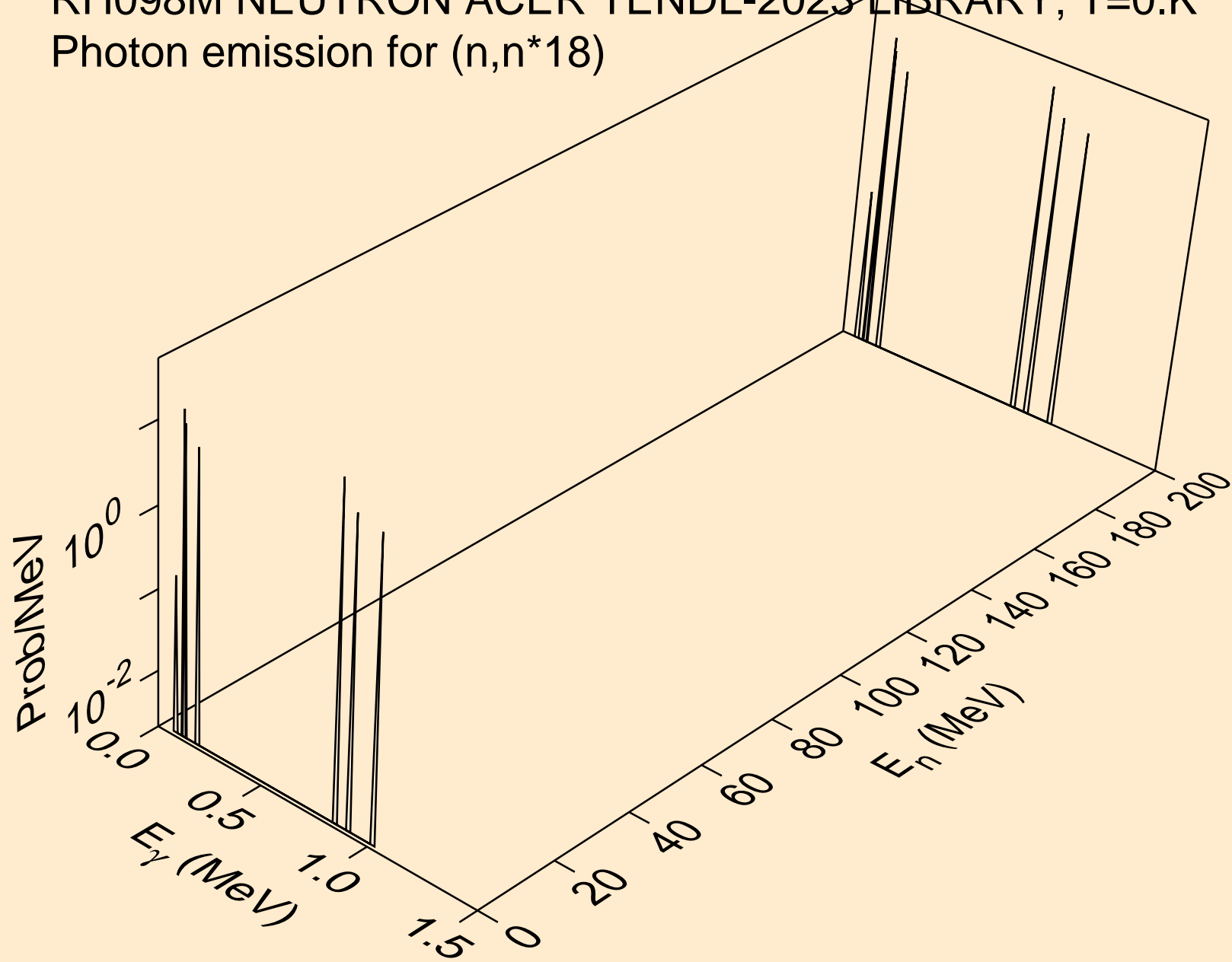

RH098M NEUTRON ACER TENDL-2023 LIBRARY; T=0.K  
Photon emission for (n,n\*19)

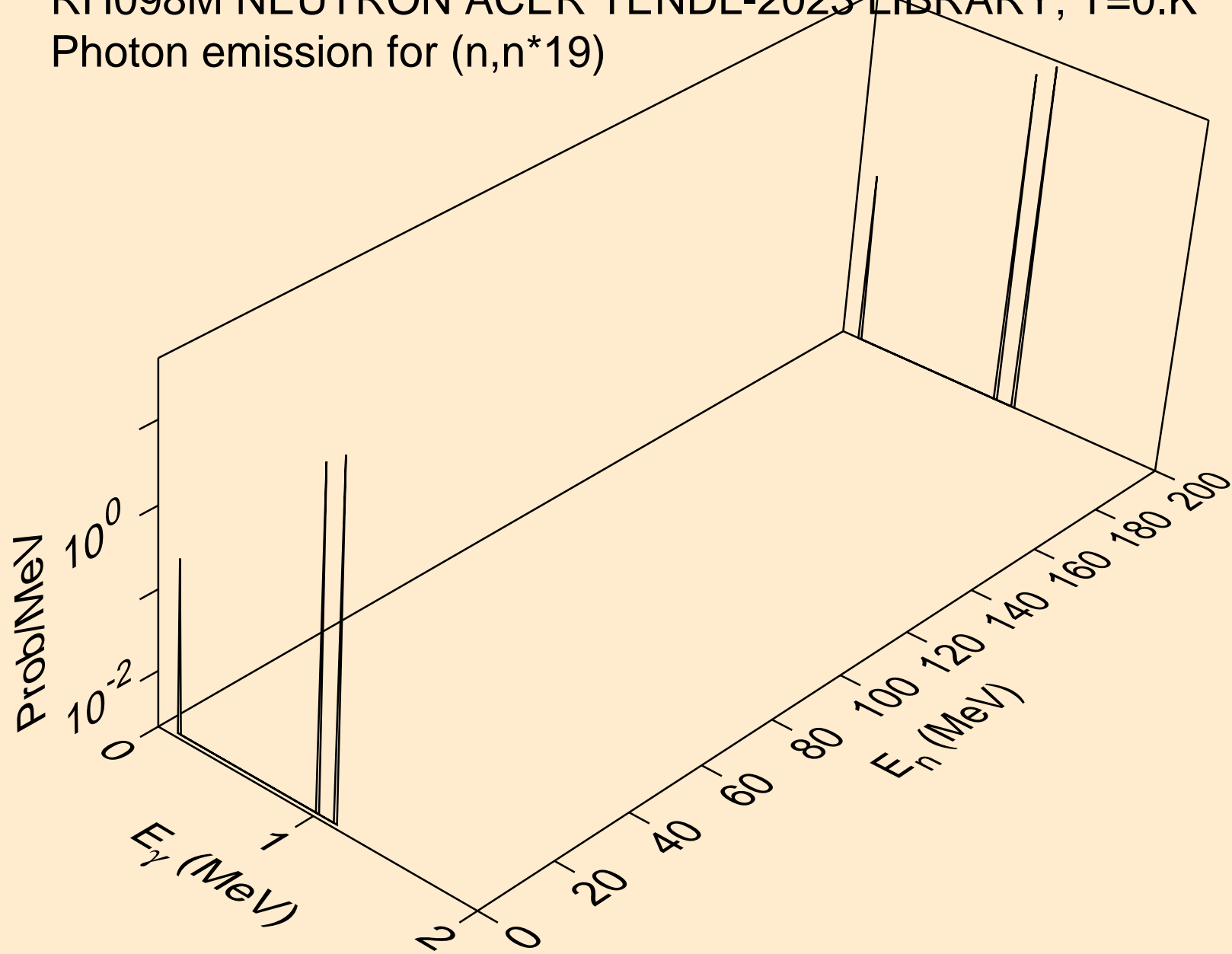

RH098M NEUTRON ACER TENDL-2023 LIBRARY; T=0.K  
Photon emission for (n,n\*20)

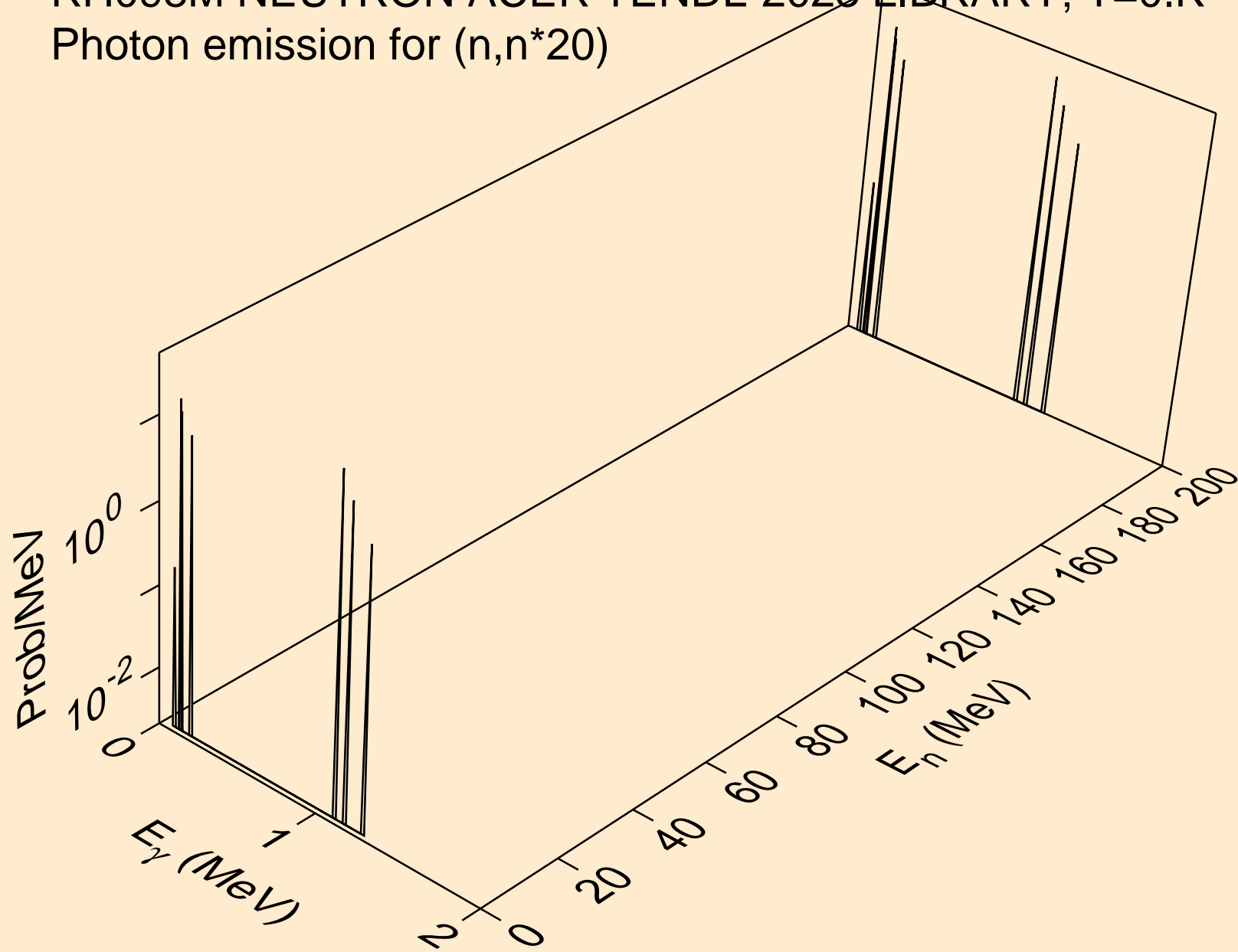



RH098M NEUTRON ACER TENDL-2023 LIBRARY; T=0.K  
Photon emission for (n,n\*21)

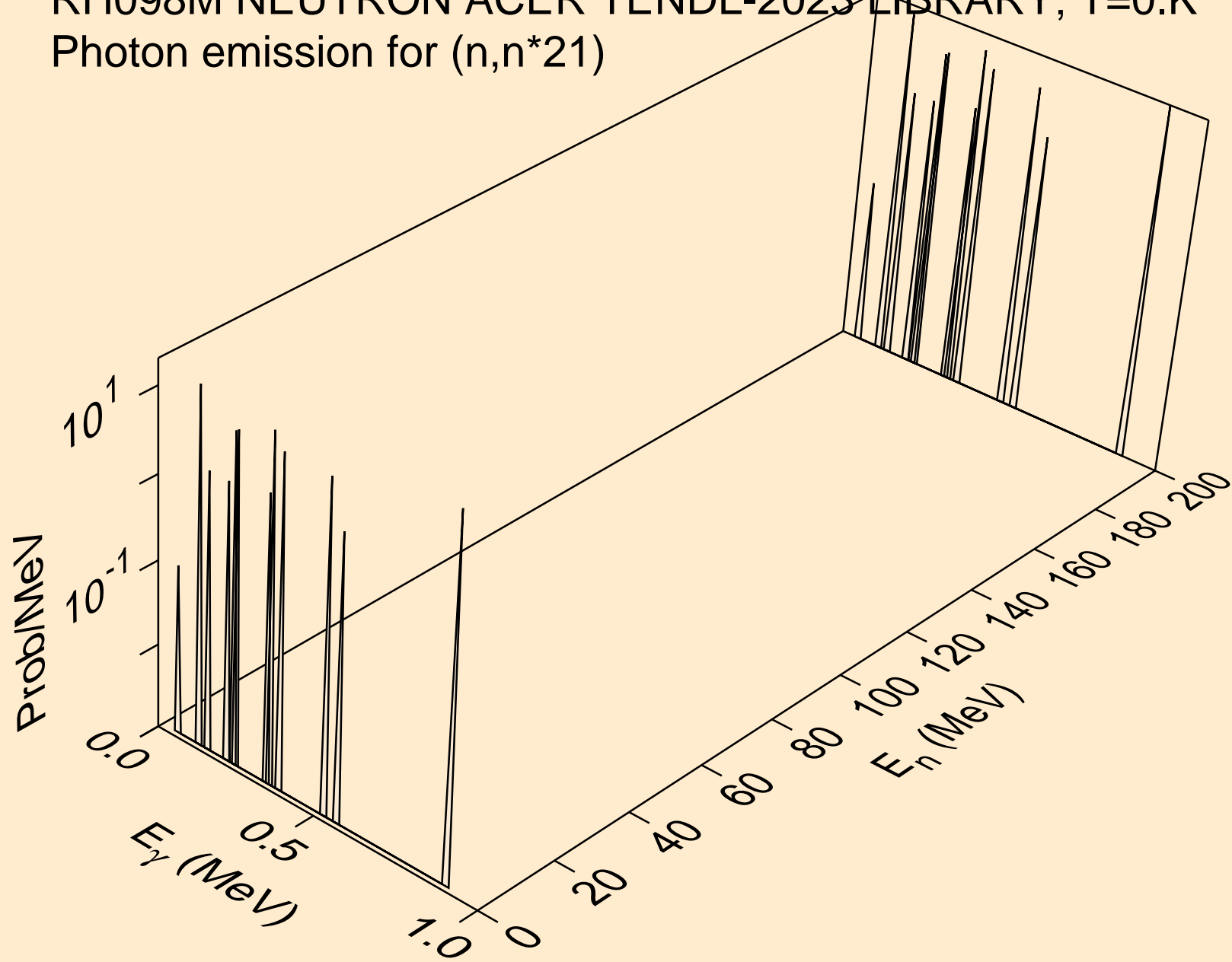

RH098M NEUTRON ACER TENDL-2023 LIBRARY; T=0.K  
Photon emission for (n,n\*22)

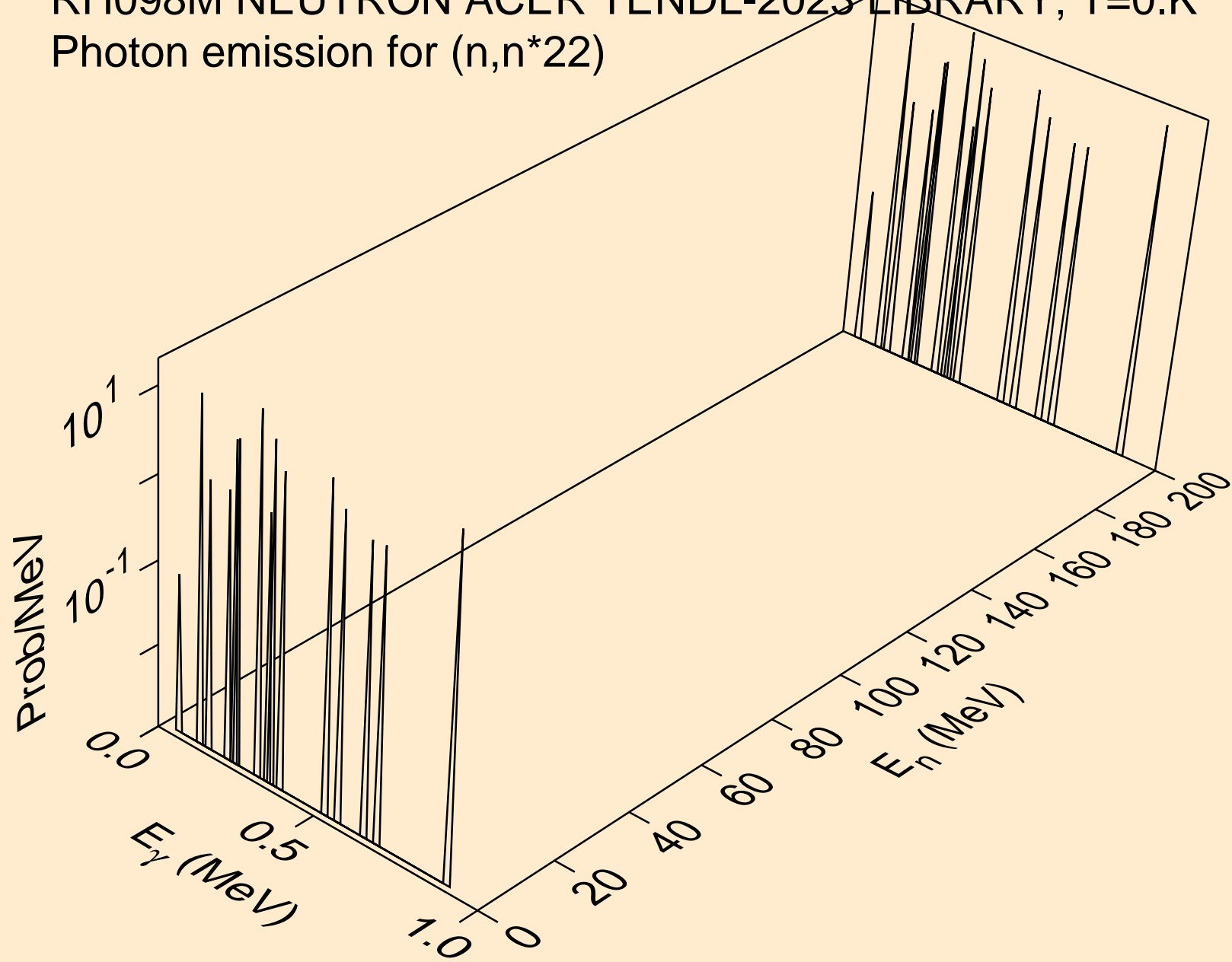

RH098M NEUTRON ACER TENDL-2023 LIBRARY; T=0.K  
Photon emission for (n,n\*23)

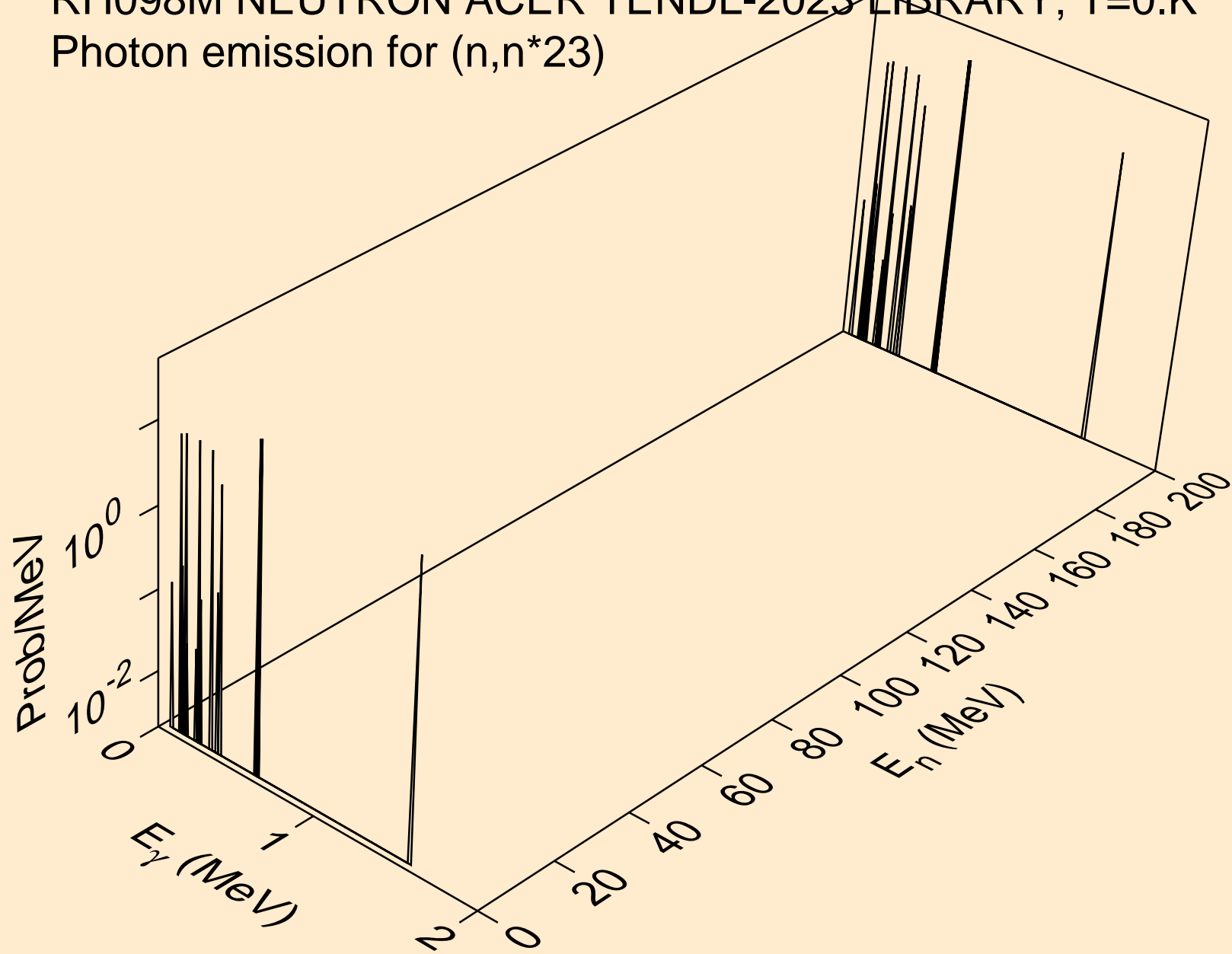

RH098M NEUTRON ACER TENDL-2023 LIBRARY; T=0.K  
Photon emission for (n,n\*24)

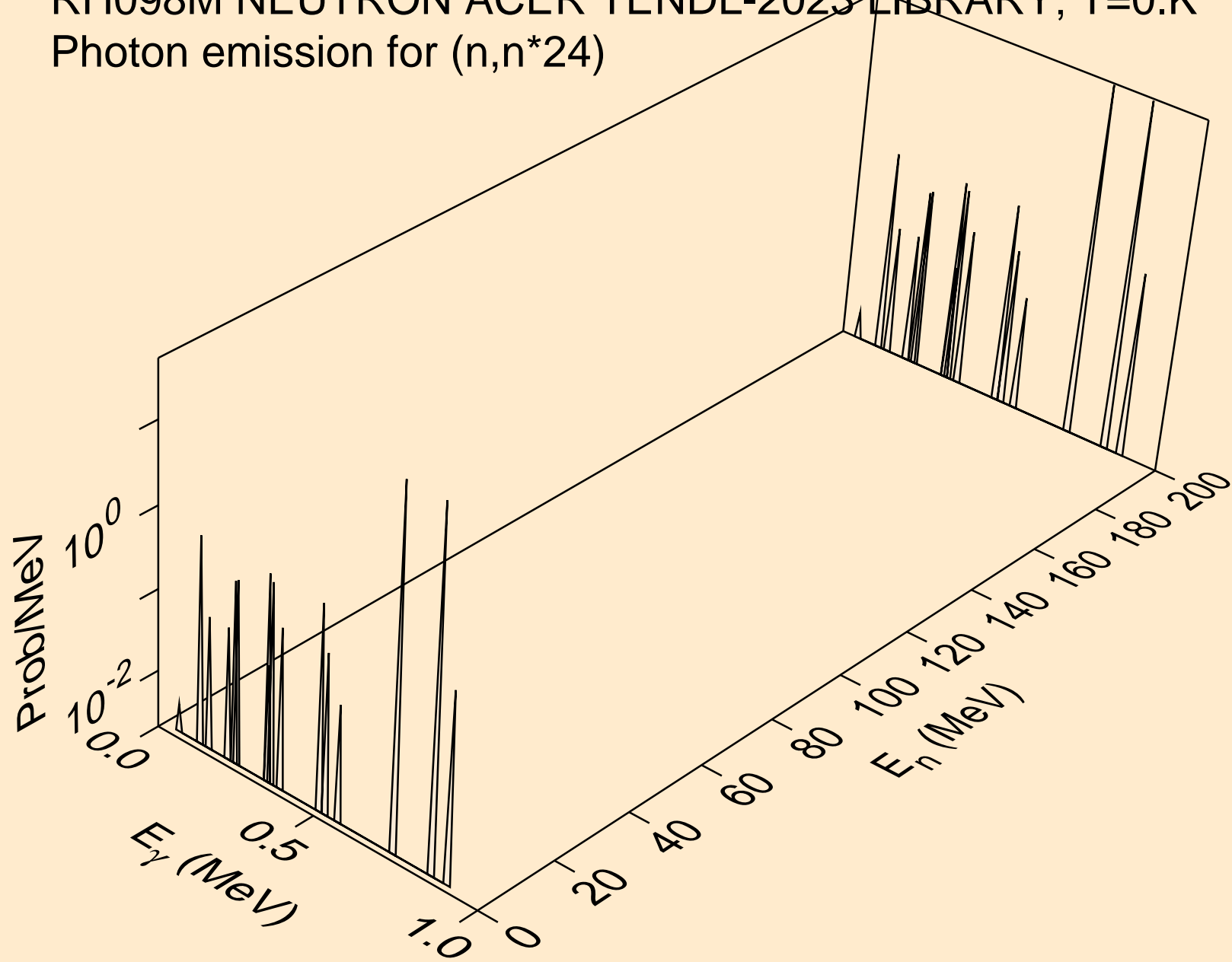

RH098M NEUTRON ACER TENDL-2023 LIBRARY; T=0.K  
Photon emission for (n,n\*25)

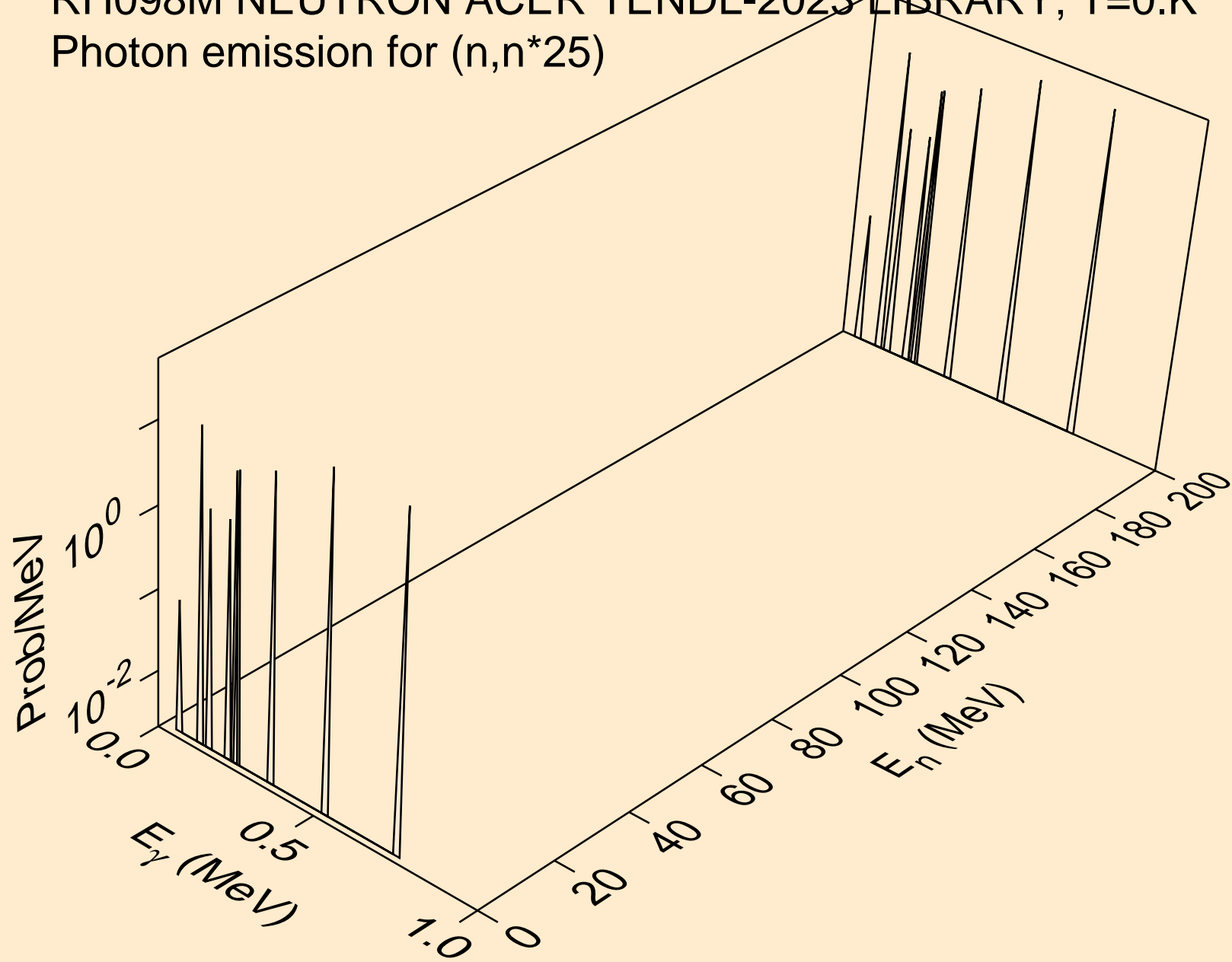

RH098M NEUTRON ACER TENDL-2023 LIBRARY; T=0.K  
Photon emission for (n,n\*26)

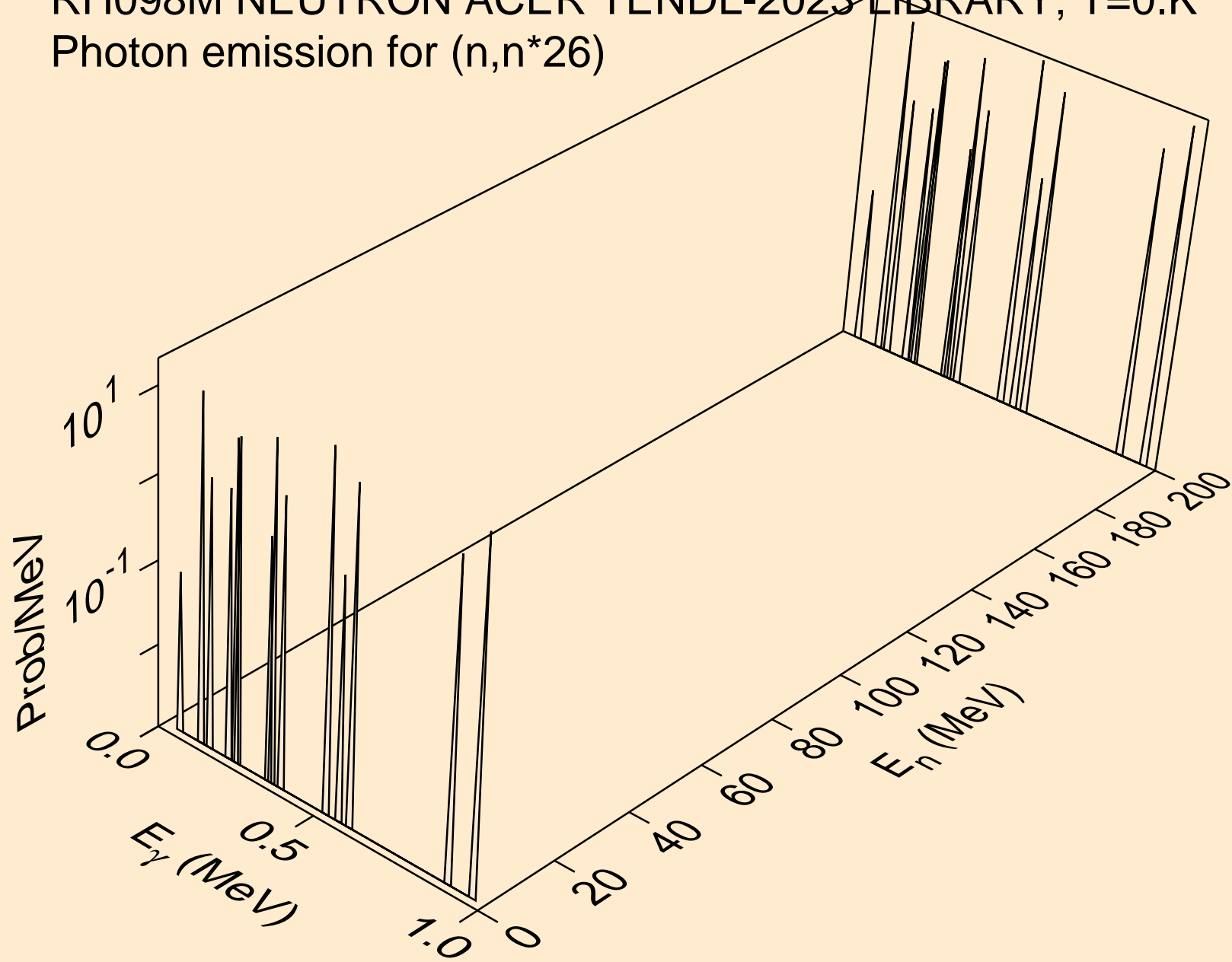

RH098M NEUTRON ACER TENDL-2023 LIBRARY; T=0.K  
Photon emission for (n,n\*27)

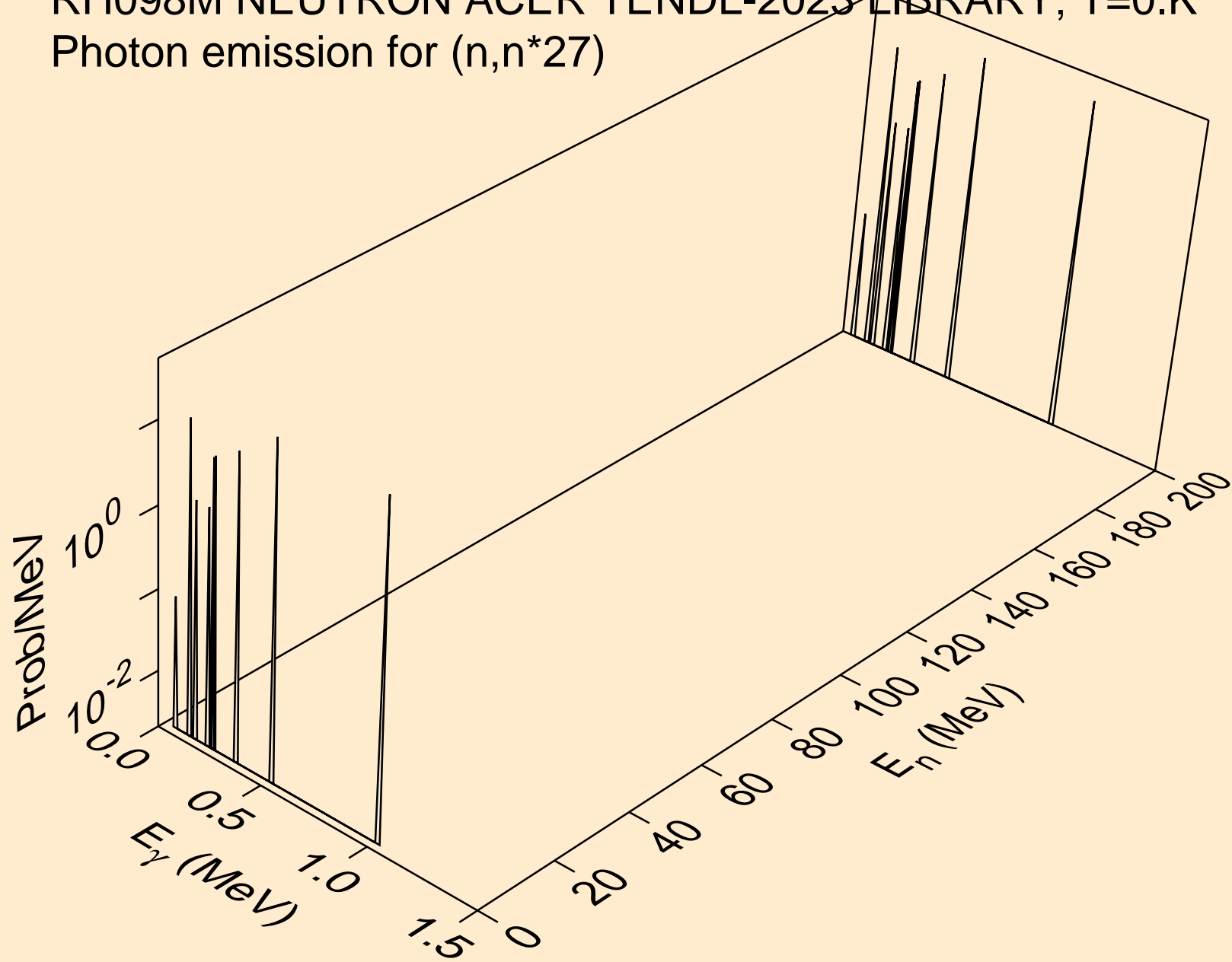

RH098M NEUTRON ACER TENDL-2023 LIBRARY; T=0.K  
Photon emission for (n,n\*28)

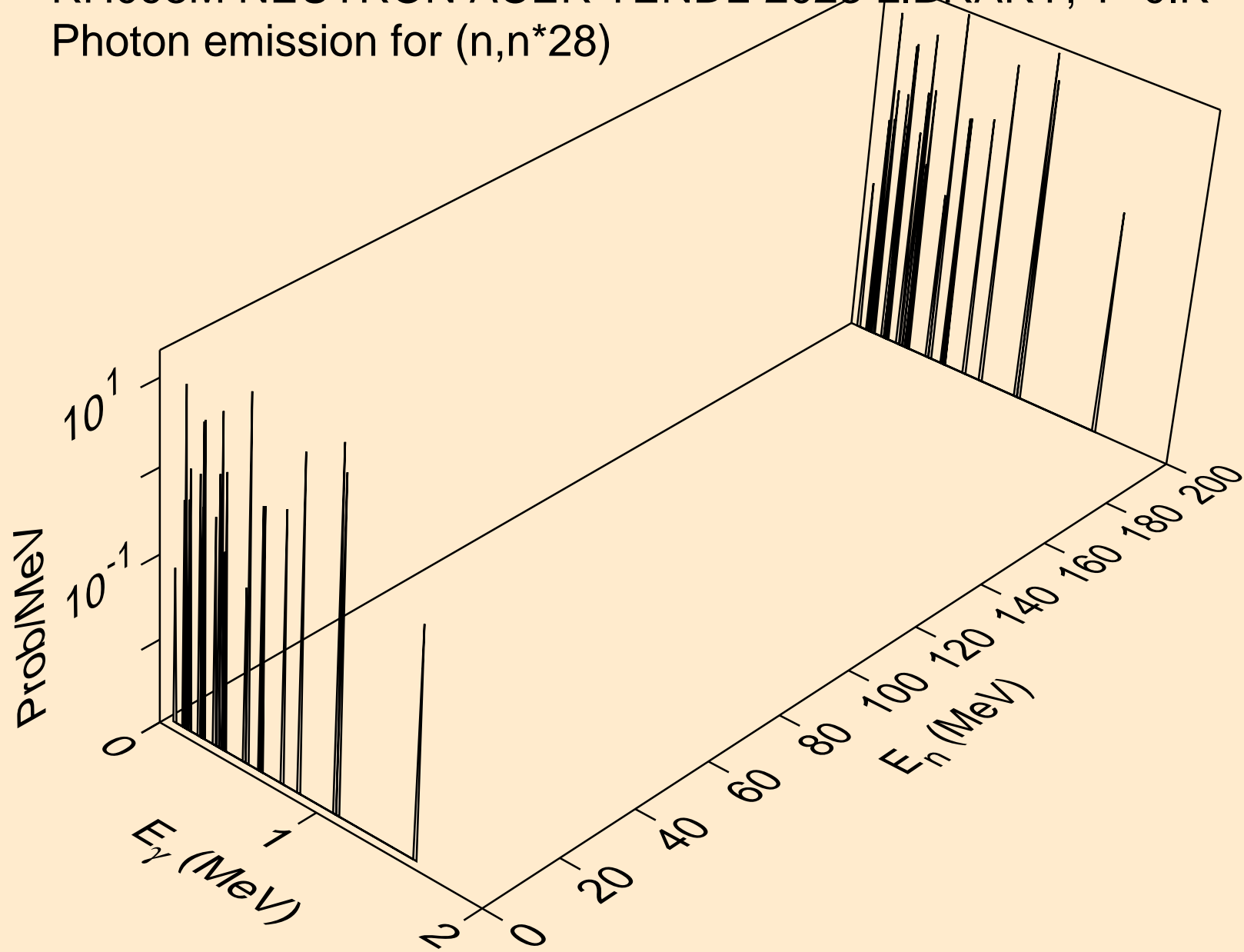



RH098M NEUTRON ACER TENDL-2023 LIBRARY; T=0.K  
Photon emission for (n,n\*c)

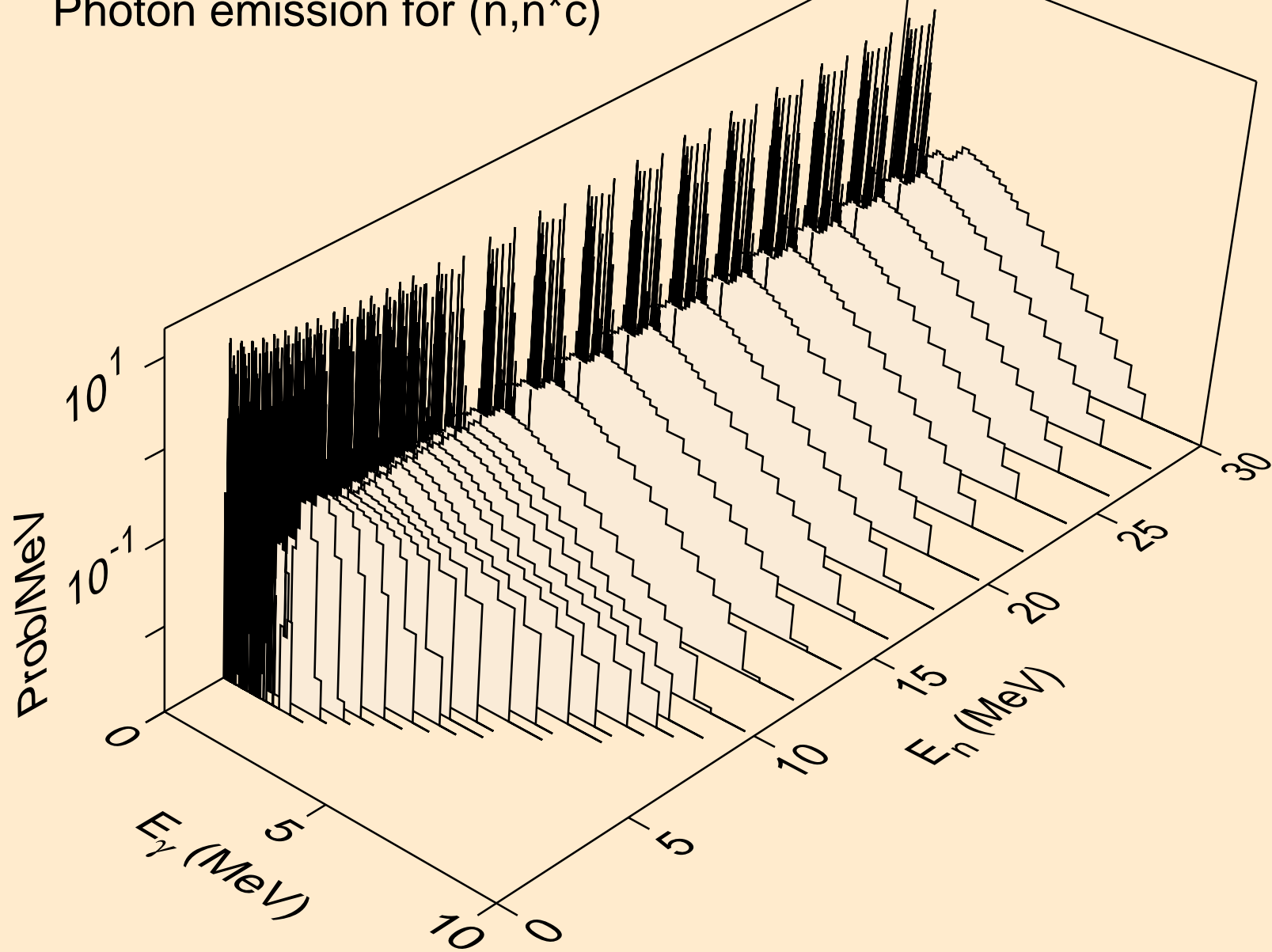

RH098M NEUTRON ACER TENDL-2023 LIBRARY; T=0.K  
Photon emission for (n,gma)

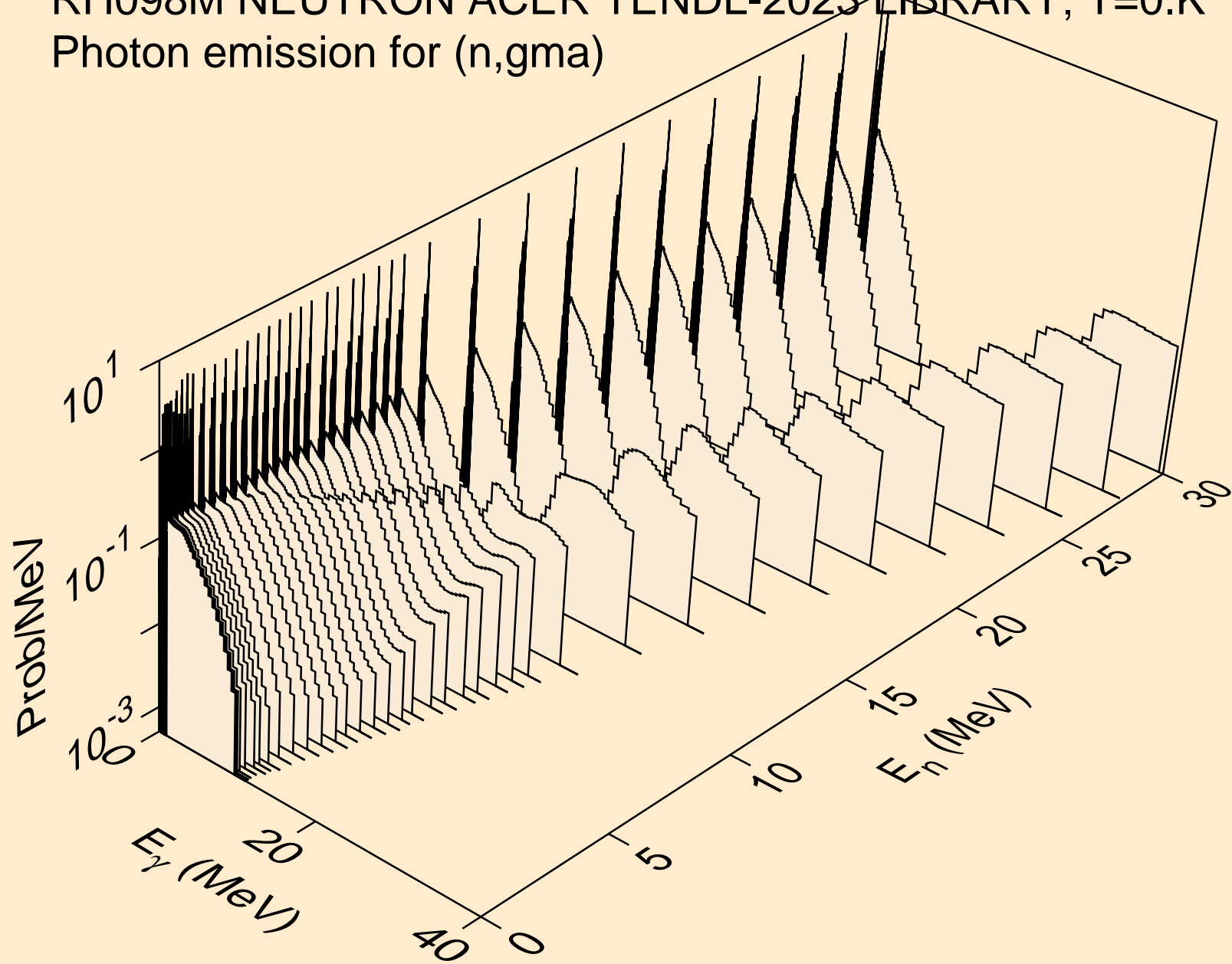

RH098M NEUTRON ACER TENDL-2023 LIBRARY; T=0.K  
Photon emission for (n,p)

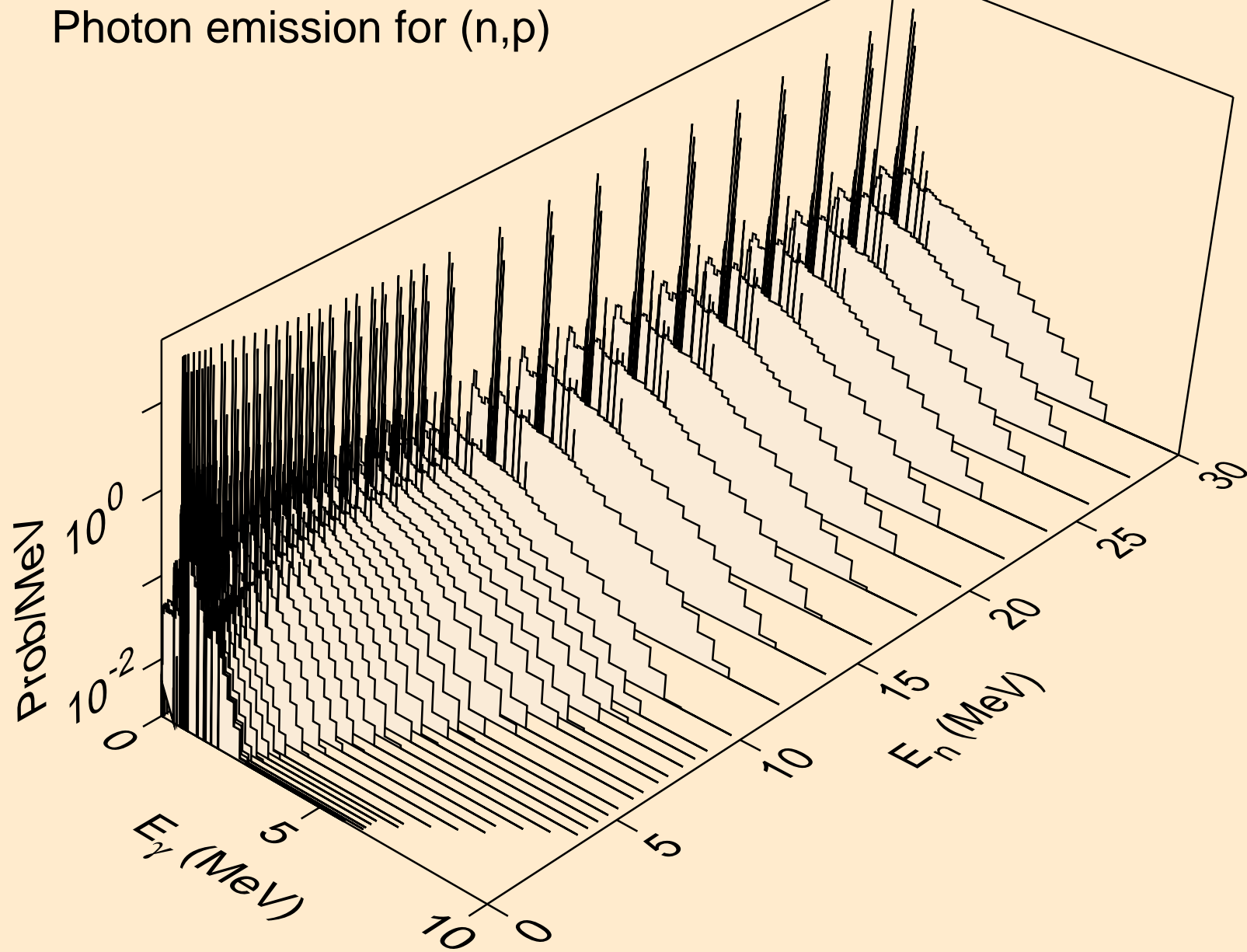

RH098M NEUTRON ACER TENDL-2023 LIBRARY; T=0.K  
Photon emission for (n,d)

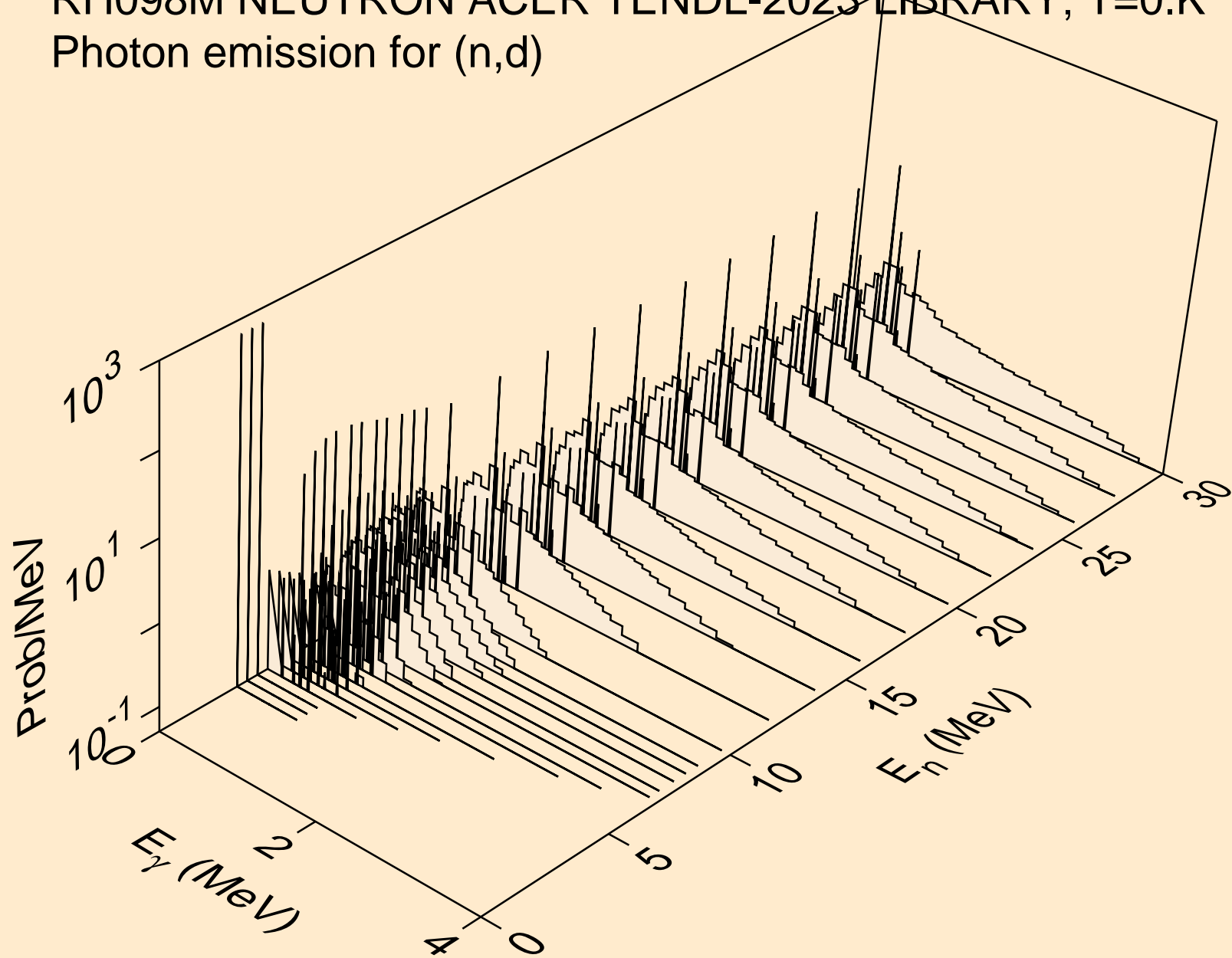

RH098M NEUTRON ACER TENDL-2023 LIBRARY; T=0.K  
Photon emission for (n,t)

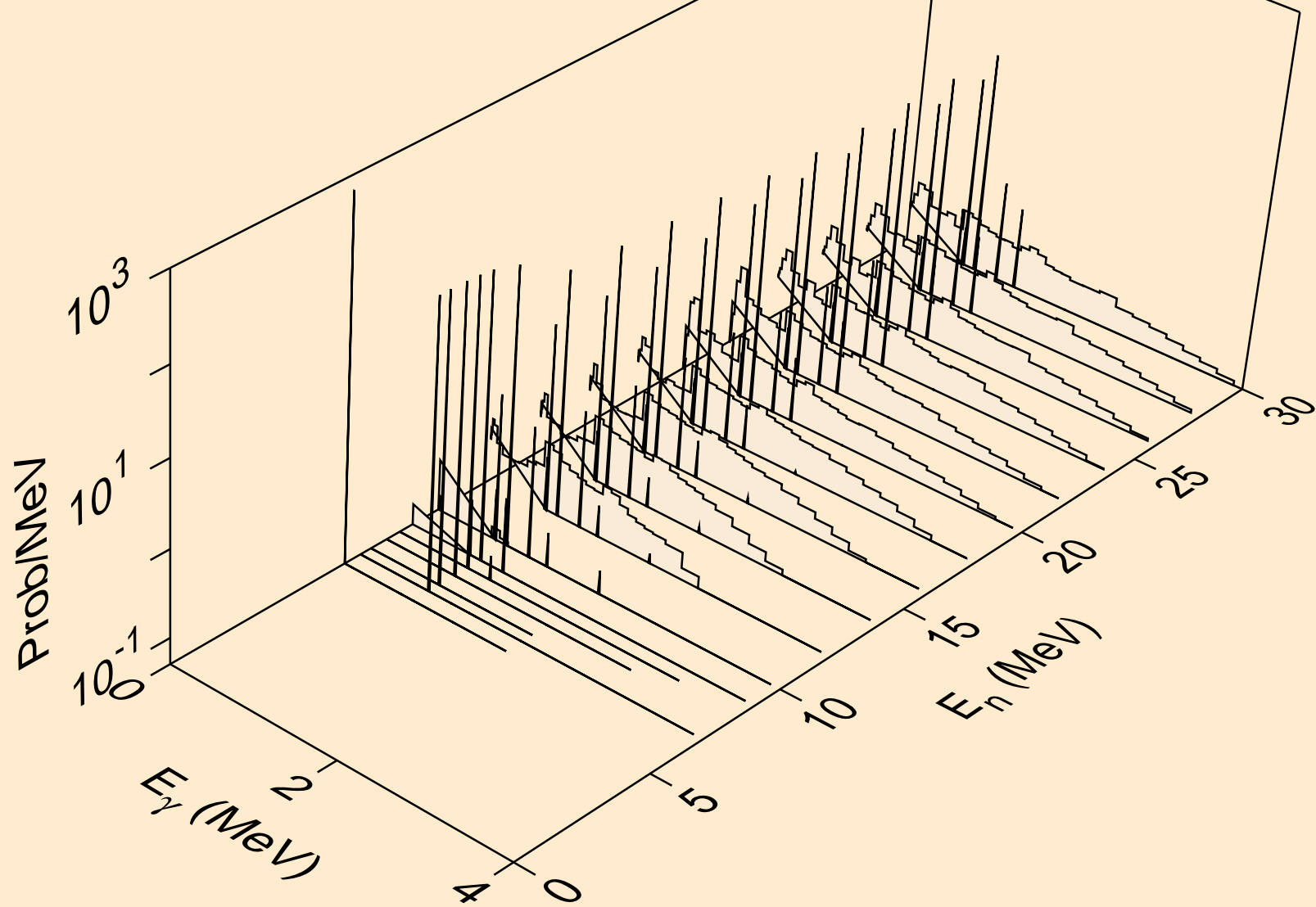

RH098M NEUTRON ACER TENDL-2023 LIBRARY; T=0.K  
Photon emission for (n,he3)

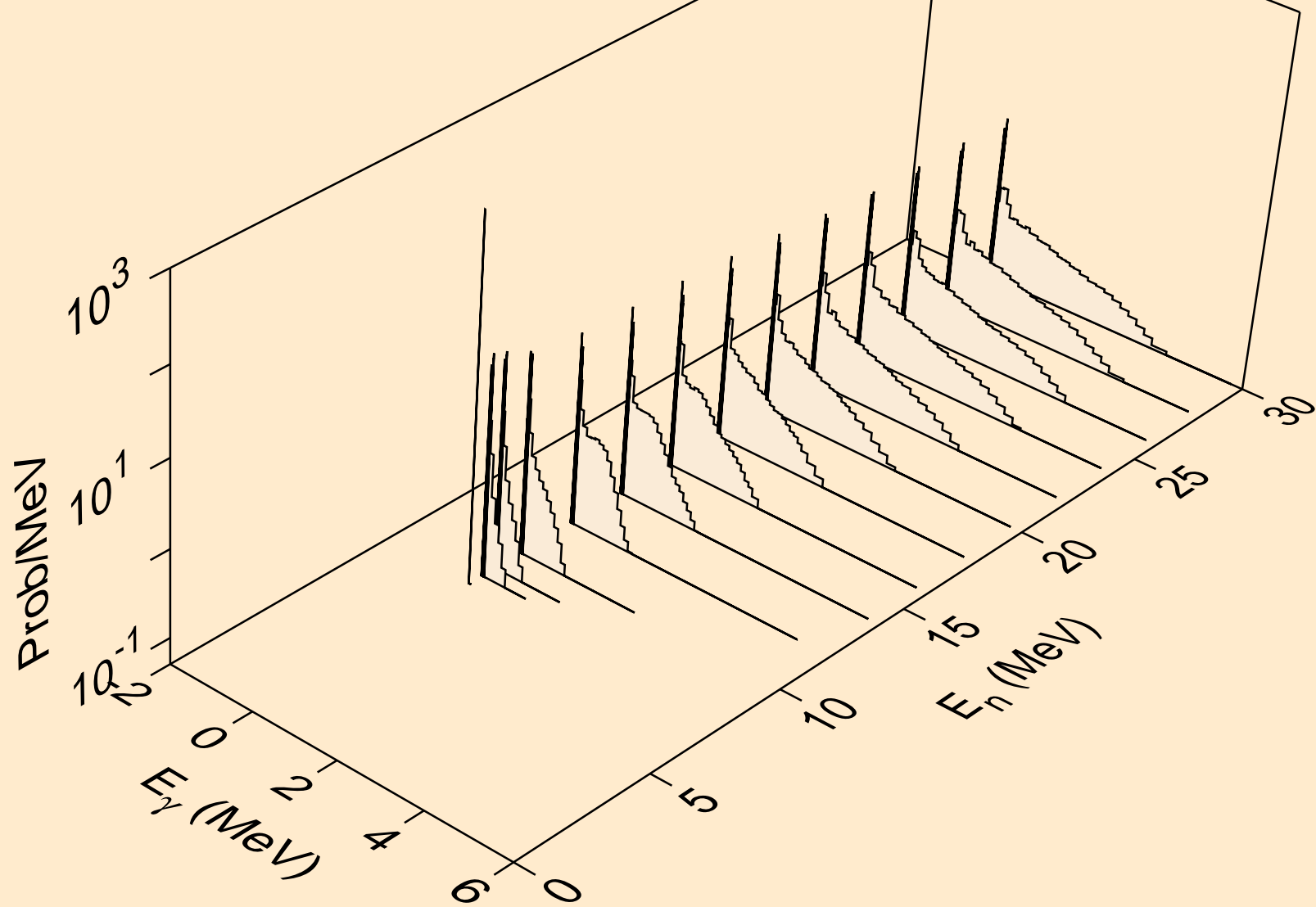

RH098M NEUTRON ACER TENDL-2023 LIBRARY; T=0.K  
Photon emission for (n,a)

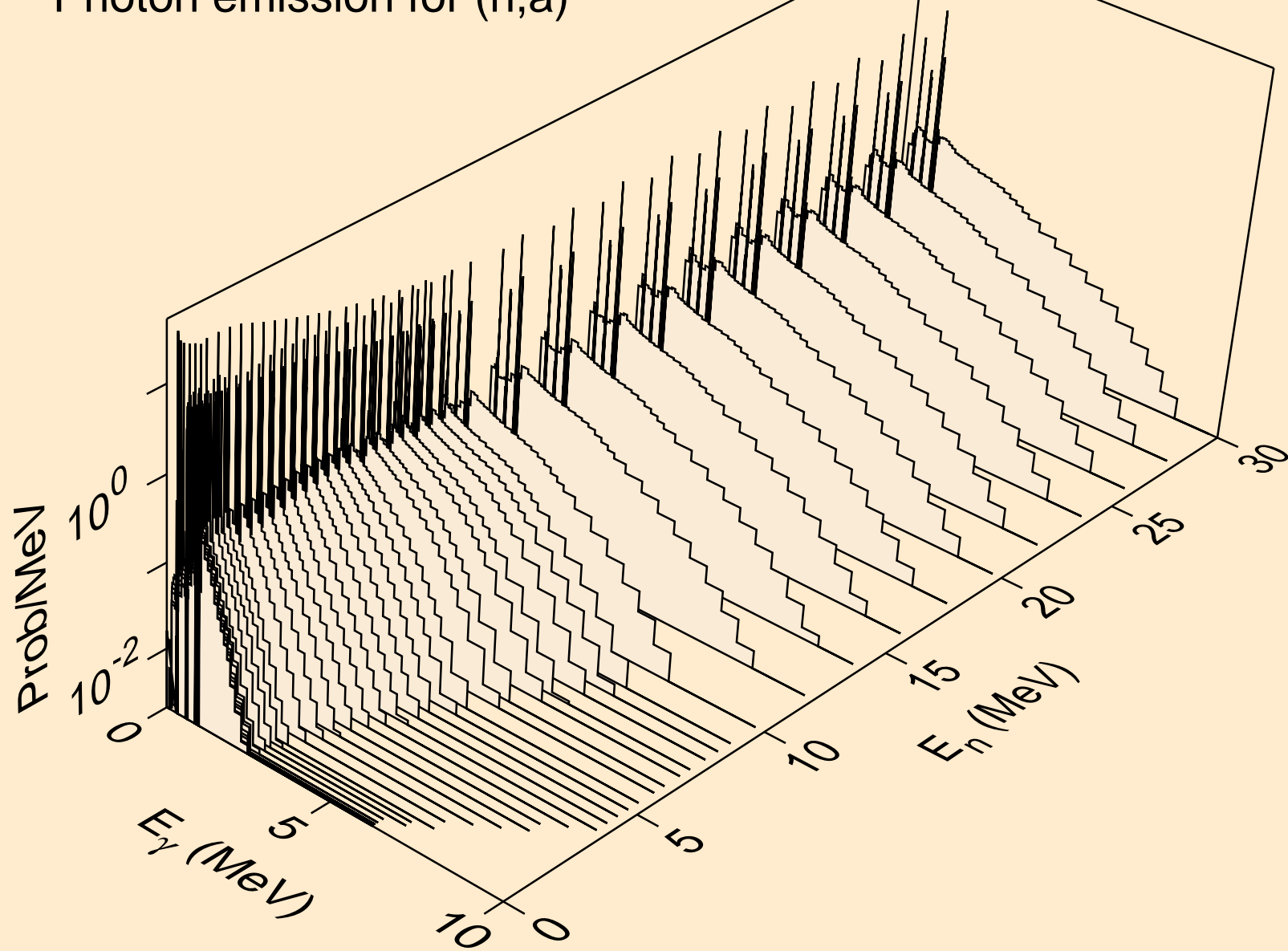

RH098M NEUTRON ACER TENDL-2023 LIBRARY; T=0.K  
Photon emission for (n,2a)

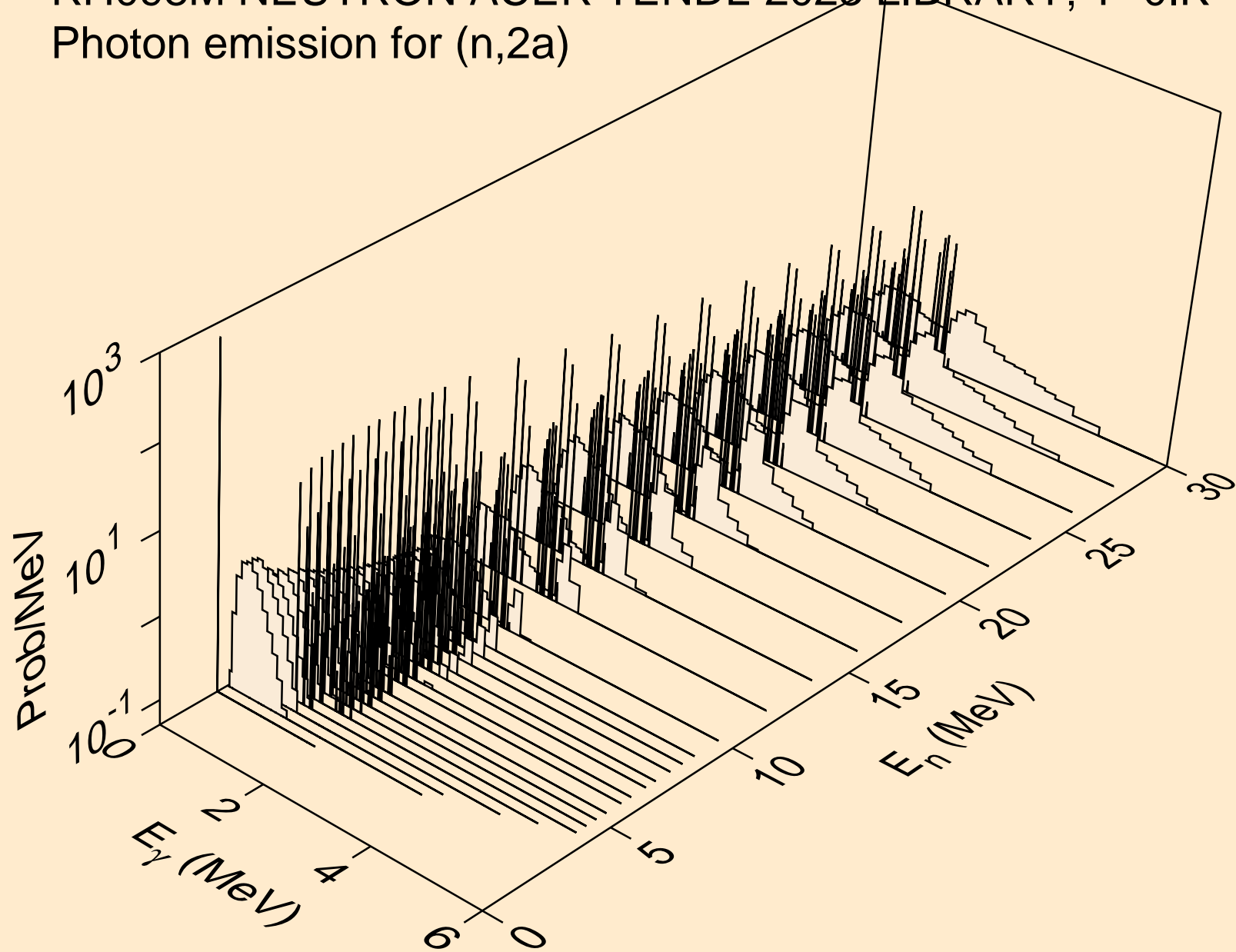



RH098M NEUTRON ACER TENDL-2023 LIBRARY; T=0.K  
Photon emission for (n,2p)

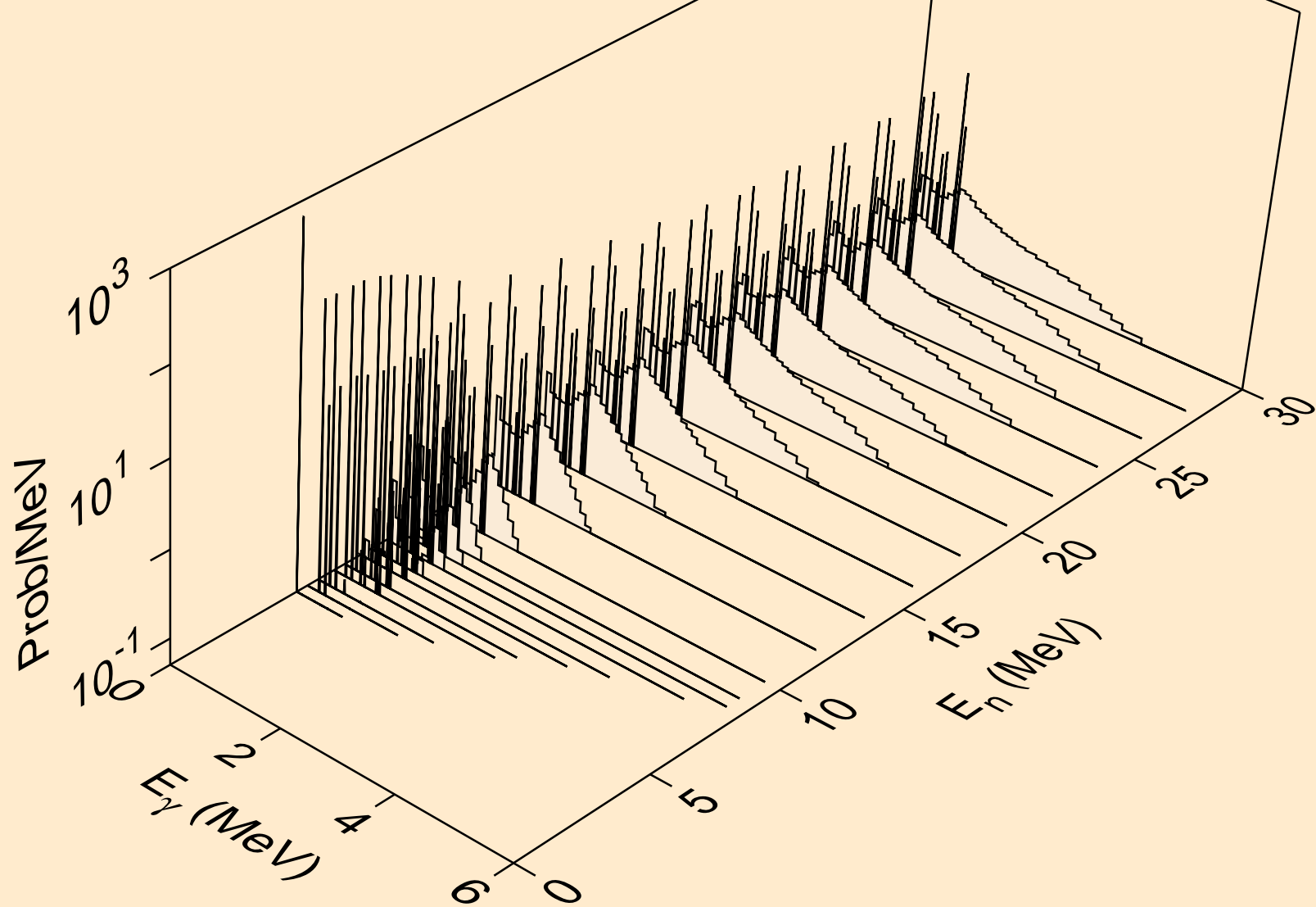

RH098M NEUTRON ACER TENDL-2023 LIBRARY; T=0.K  
Photon emission for (n,p)

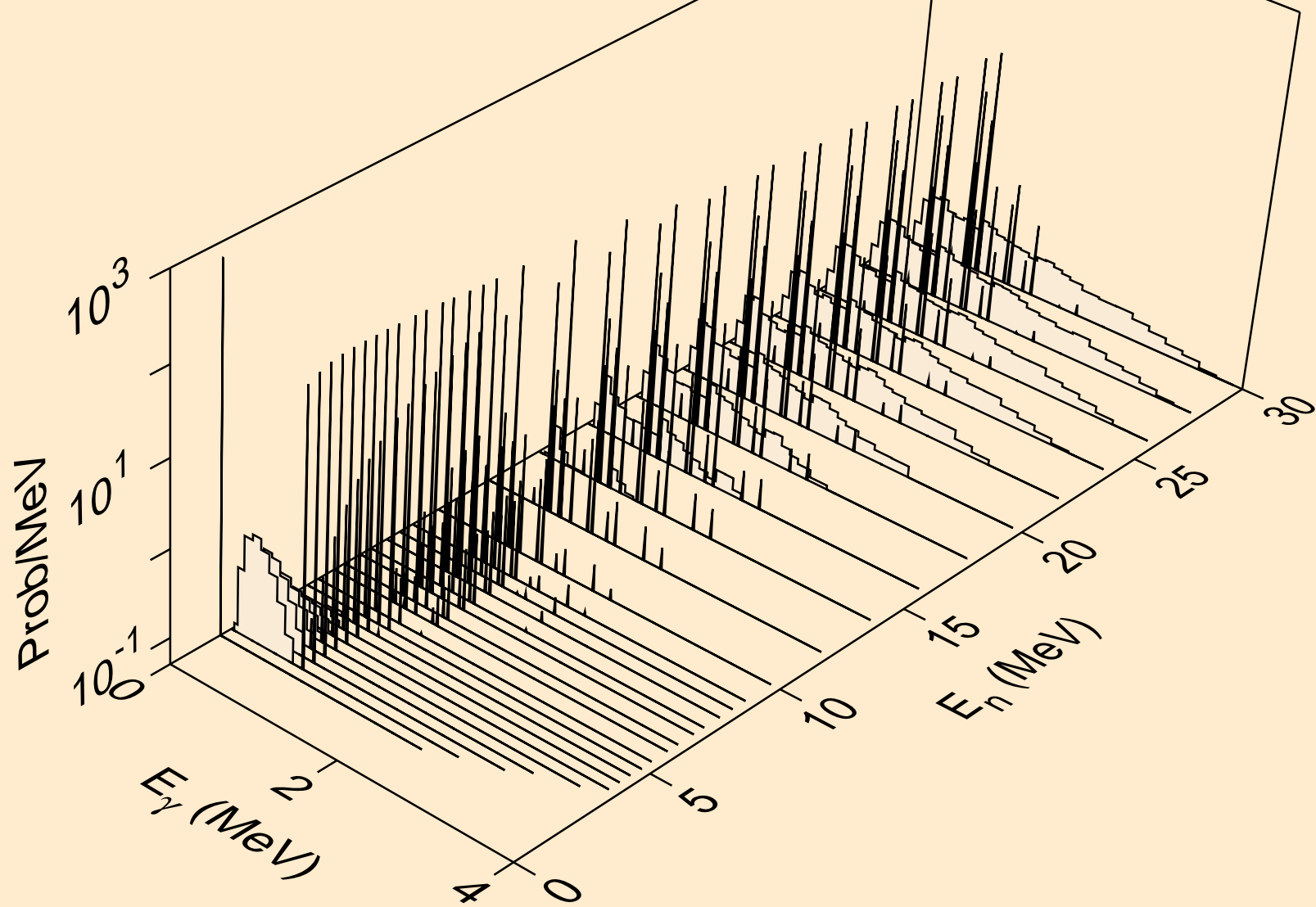

RH098M NEUTRON ACER TENDL-2023 LIBRARY; T=0.K  
Photon emission for (n,pd)

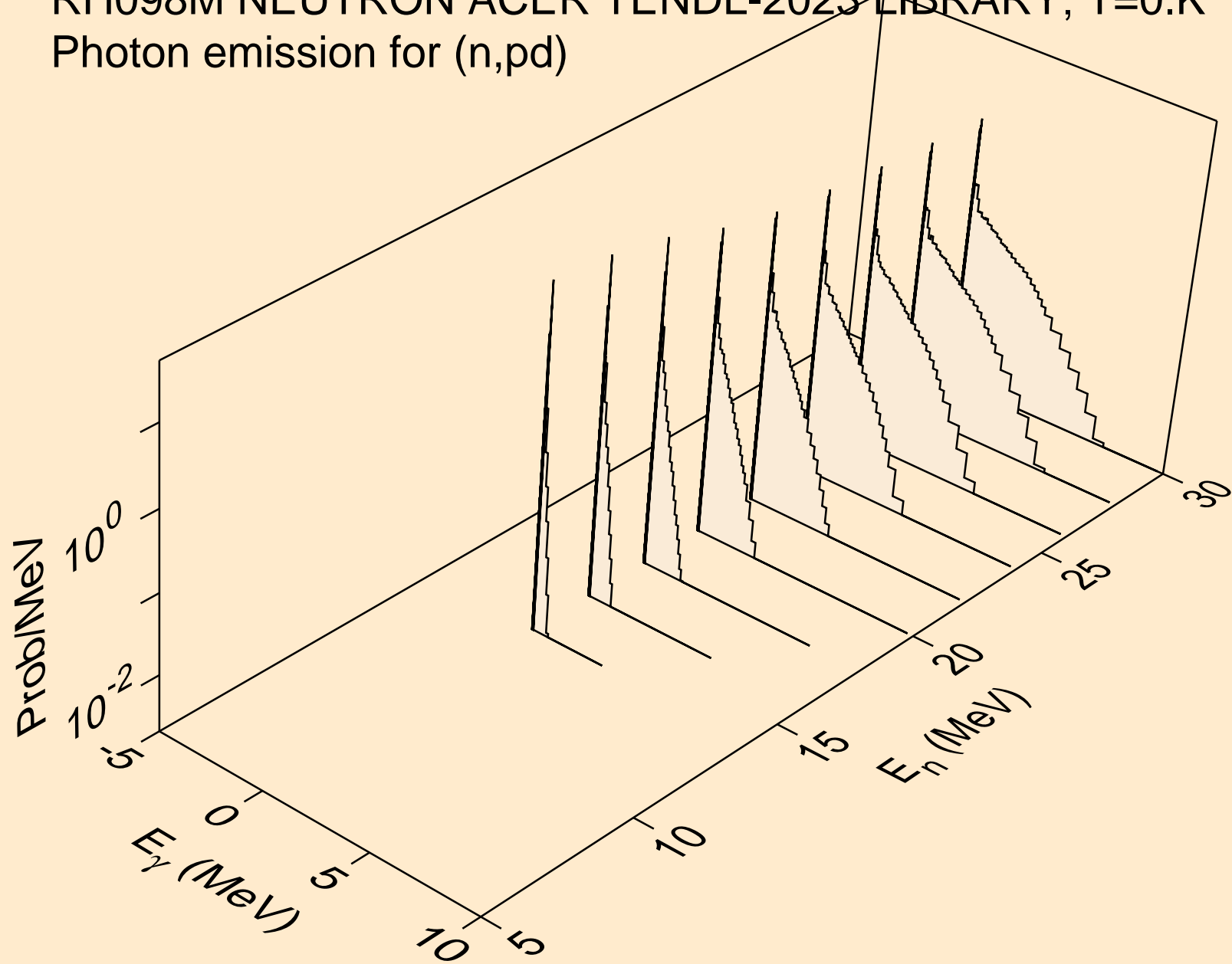

RH098M NEUTRON ACER TENDL-2023 LIBRARY; T=0.K  
Photon emission for (n,pt)

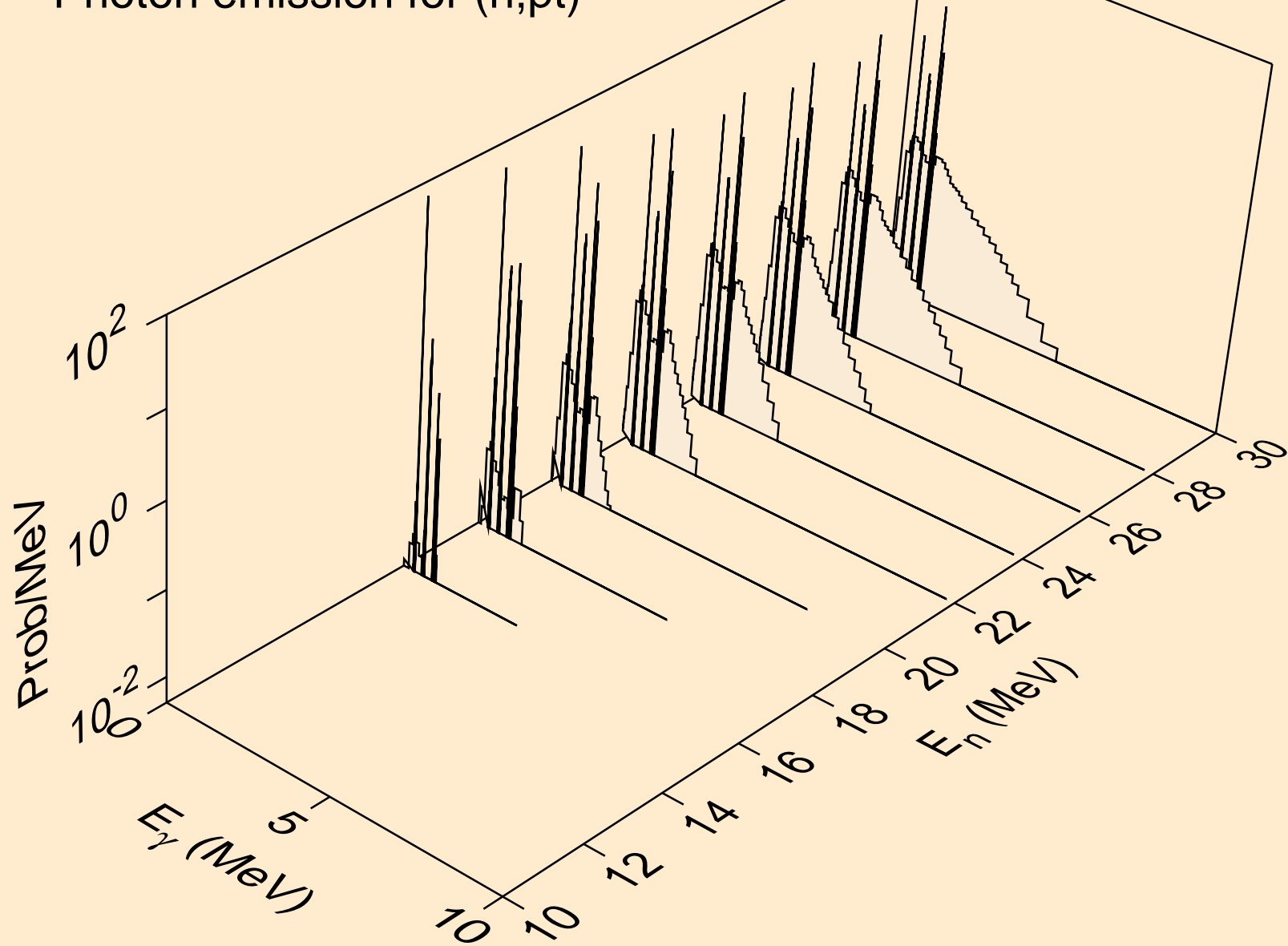

RH098M NEUTRON ACER TENDL-2023 LIBRARY; T=0.K  
Photon emission for (n,da)

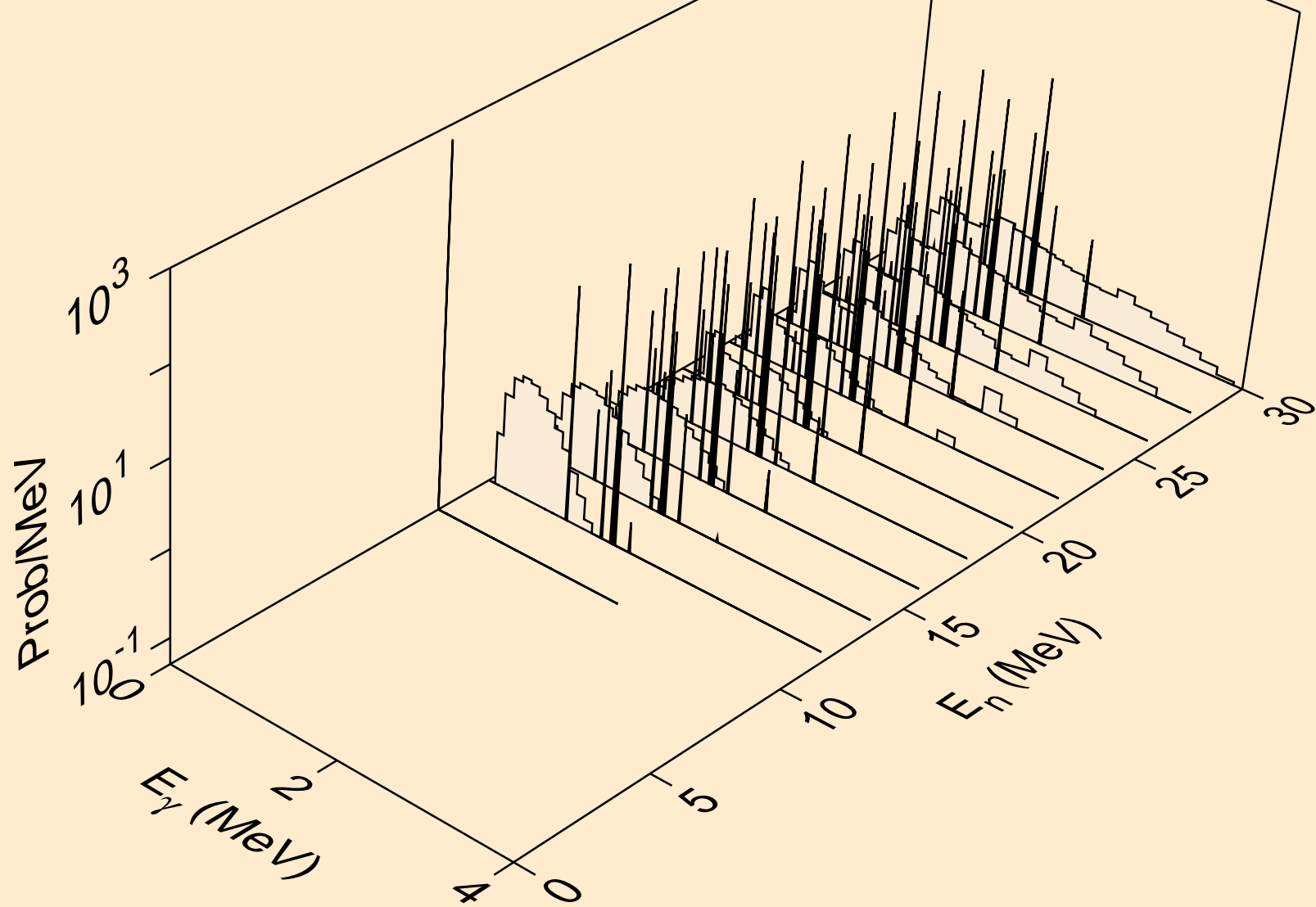

RH098M NEUTRON ACER TENDL-2023 LIBRARY; T=0.K  
thermal capture photon spectrum

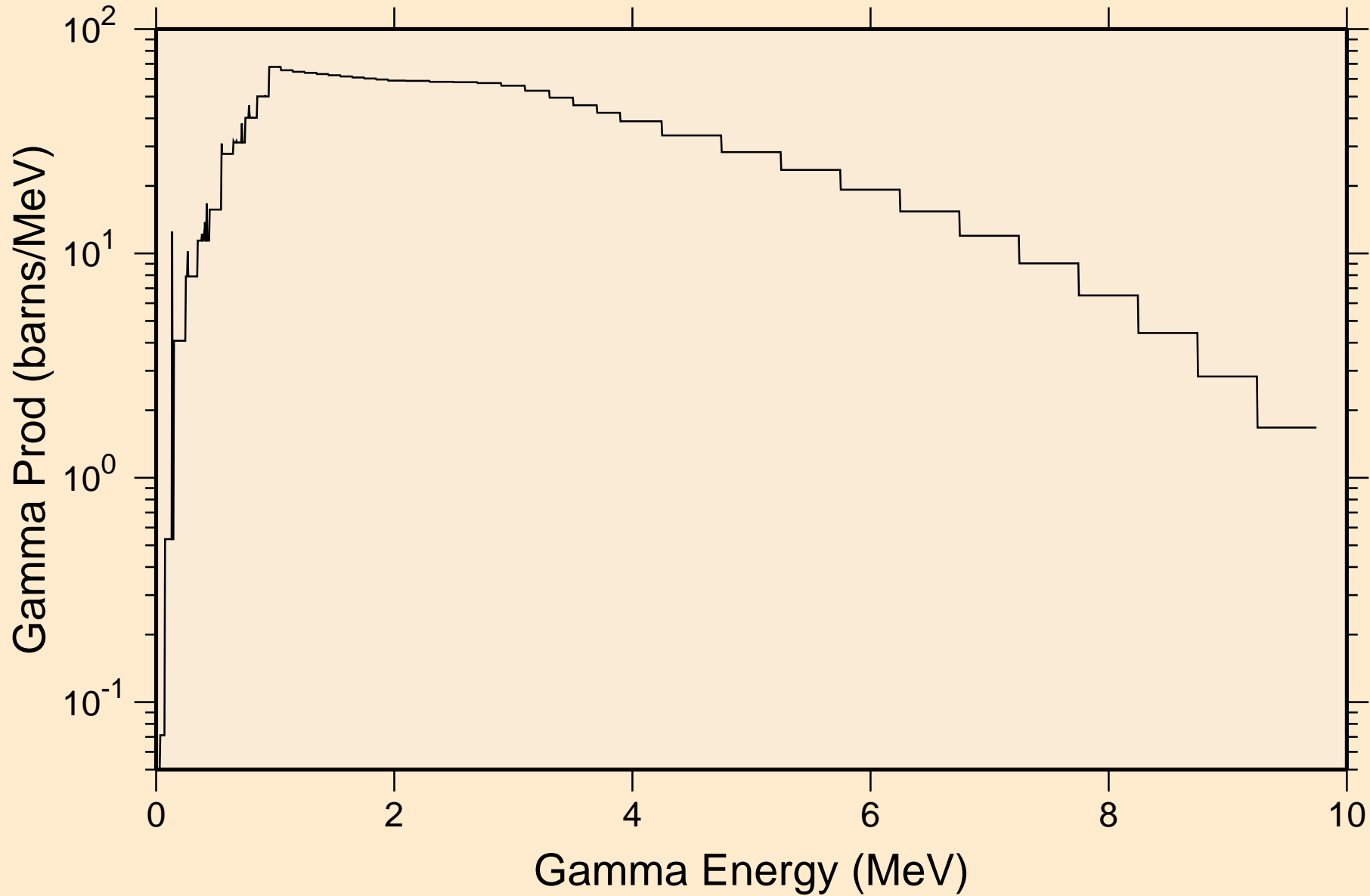

RH098M NEUTRON ACER TENDL-2023 LIBRARY; T=0.K  
14 MeV photon spectrum

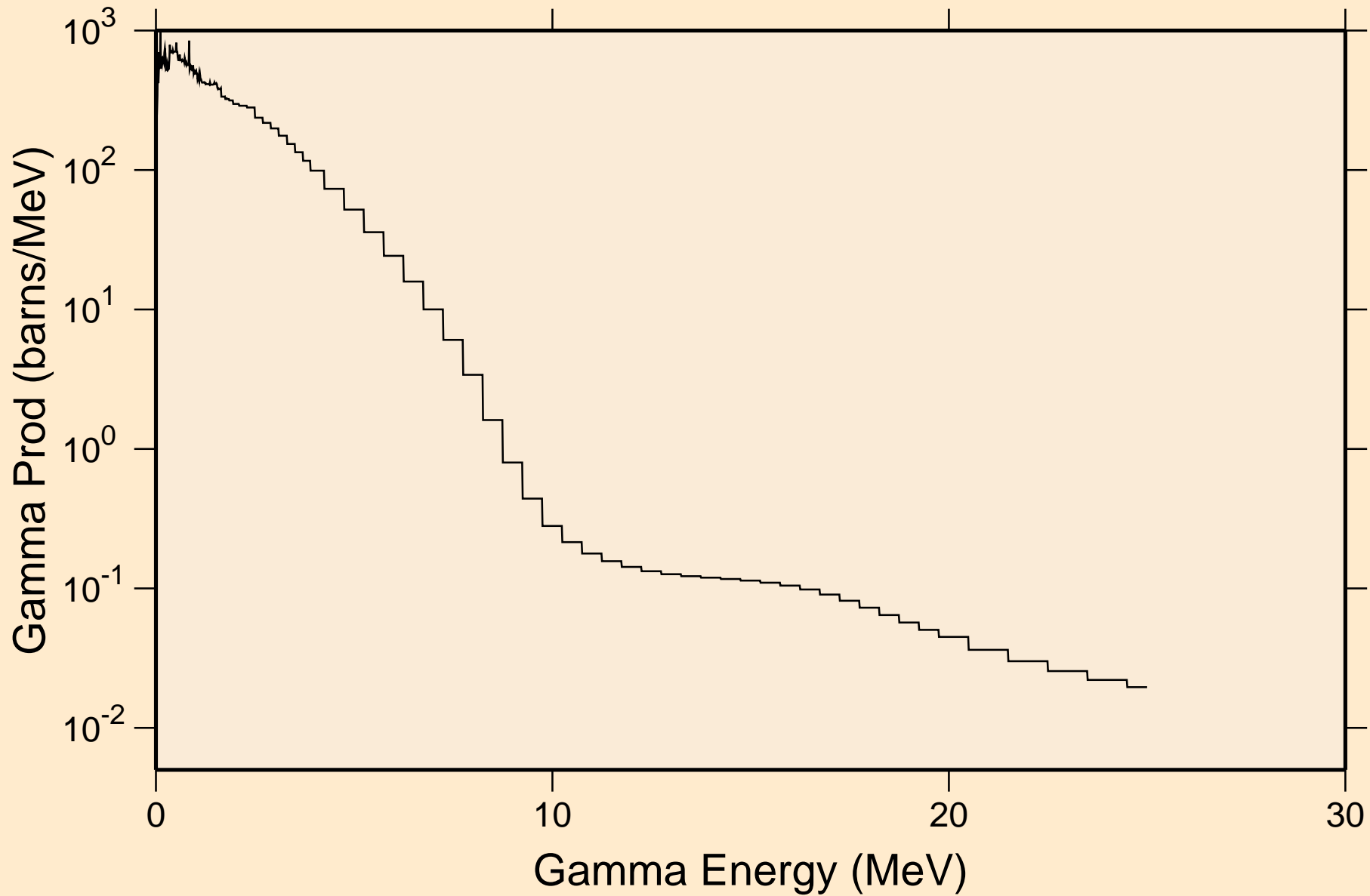

RH098M NEUTRON ACER TENDL-2023 LIBRARY; T=0.K  
Particle heating contributions

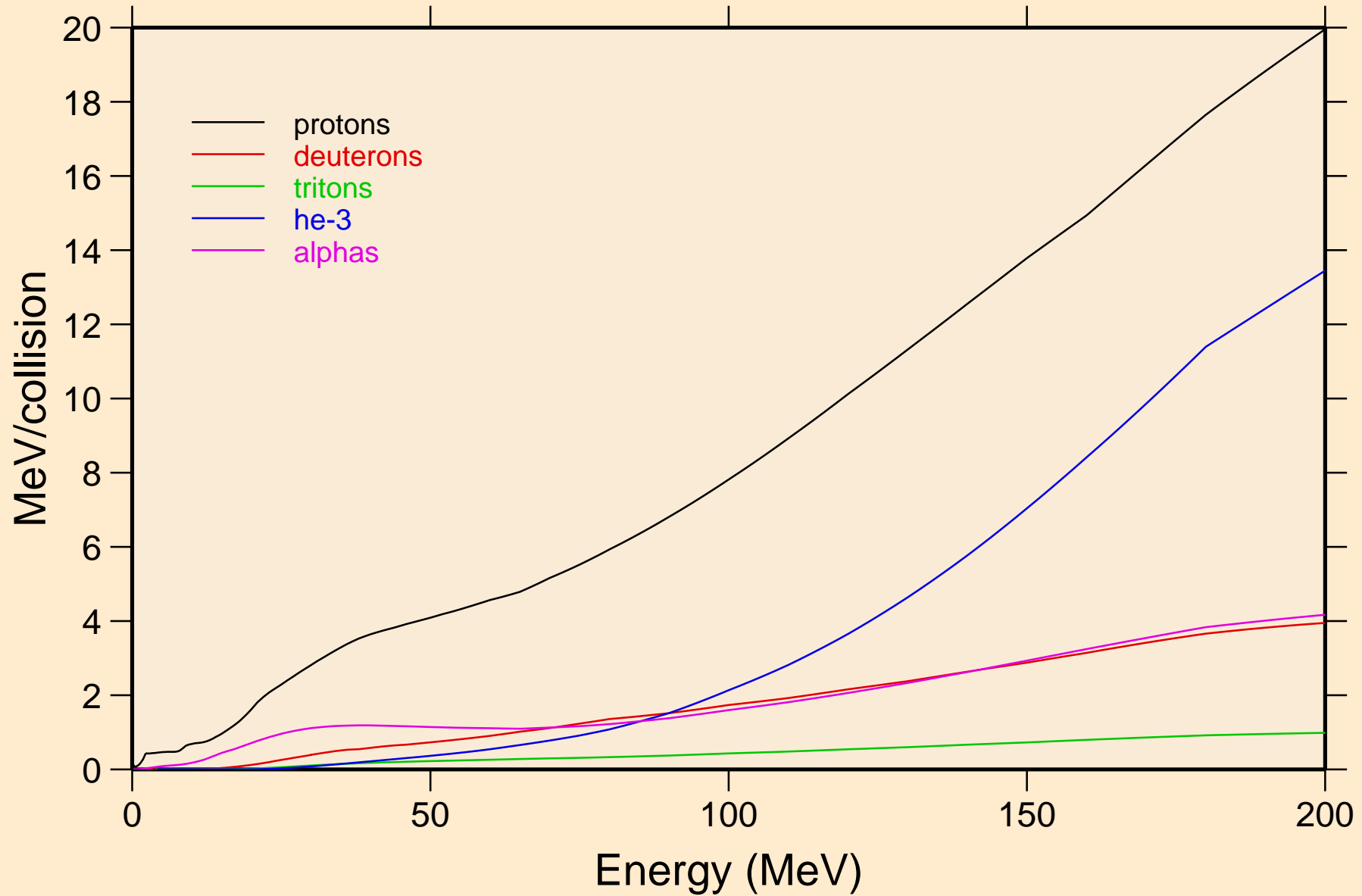



RH098M NEUTRON ACER TENDL-2023 LIBRARY; T=0.K  
Recoil Heating

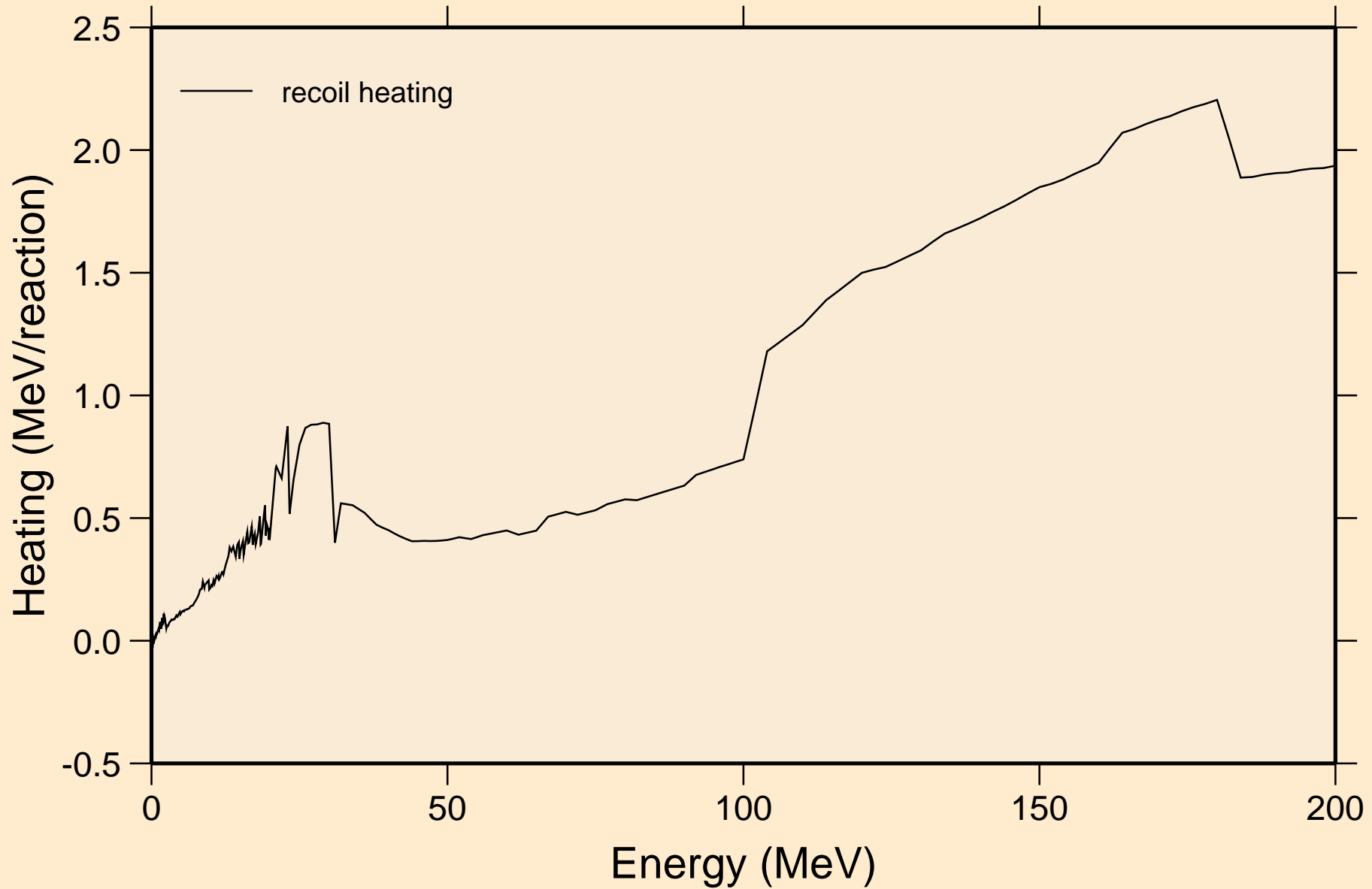

RH098M NEUTRON ACER TENDL-2023 LIBRARY; T=0.K  
Particle production cross sections

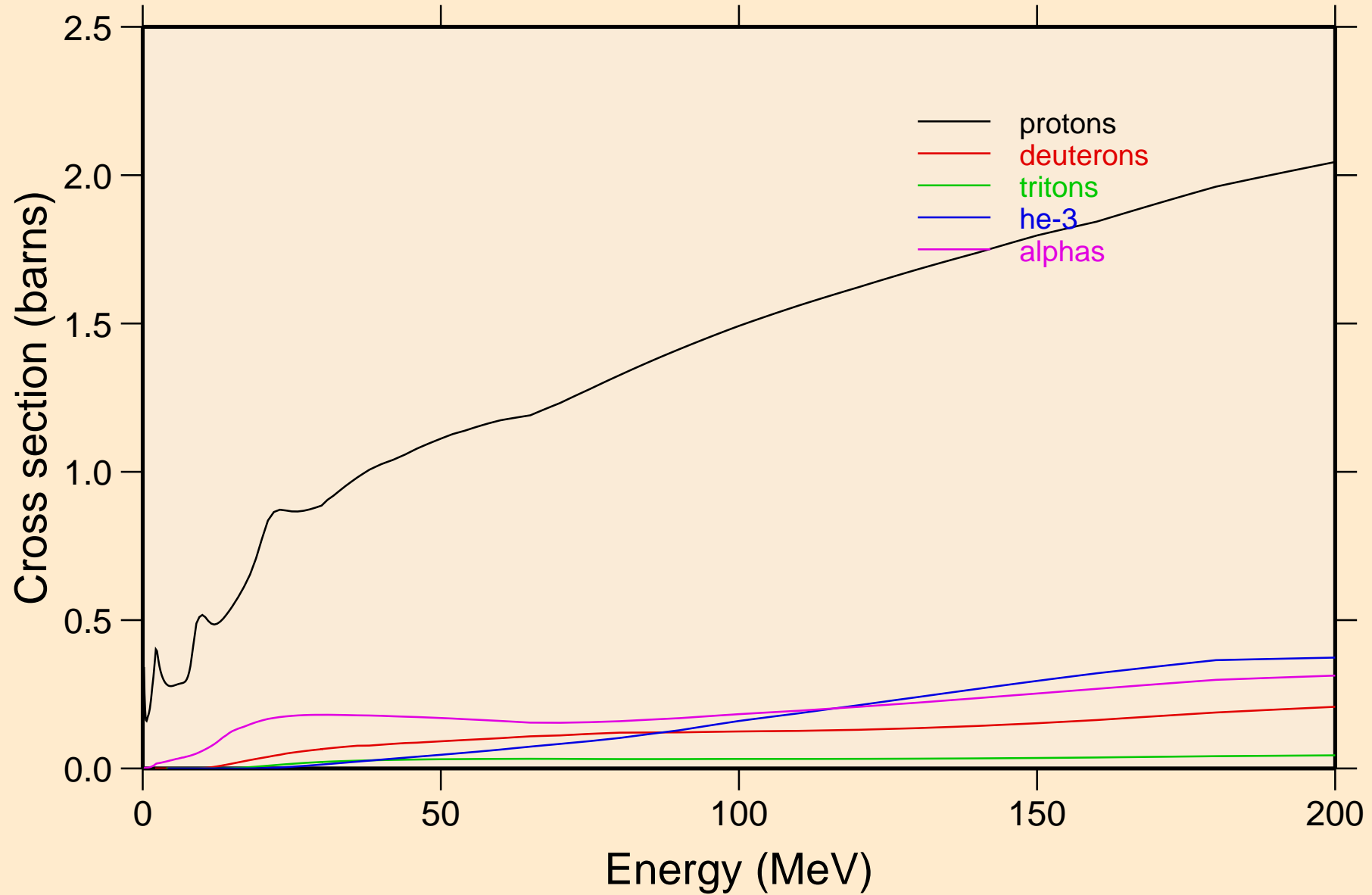

RH098M NEUTRON ACER TENDL-2023 LIBRARY; T=0.K  
protons from (n,x)

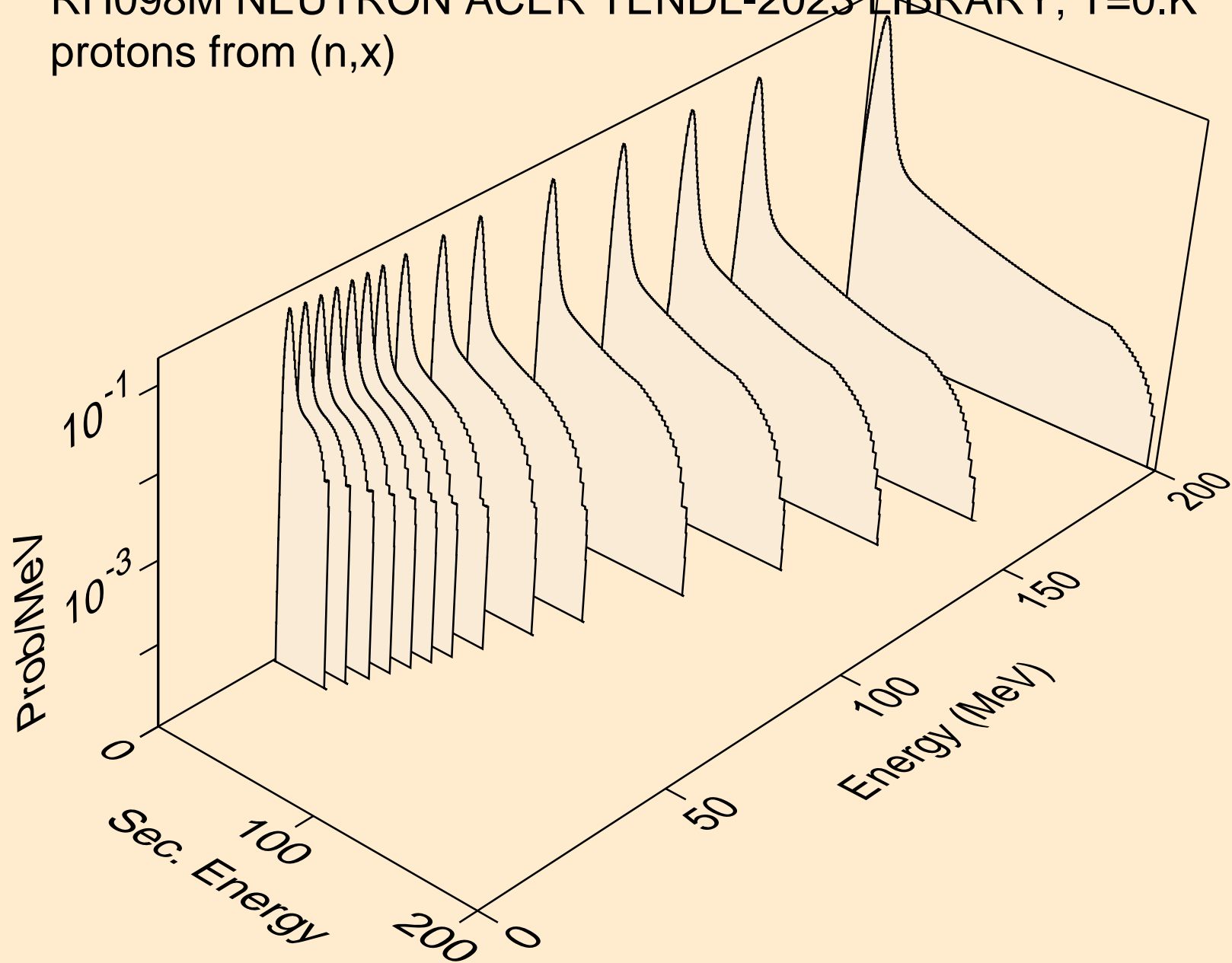

RH098M NEUTRON ACER TENDL-2023 LIBRARY; T=0.K  
protons from (n,n\*)p

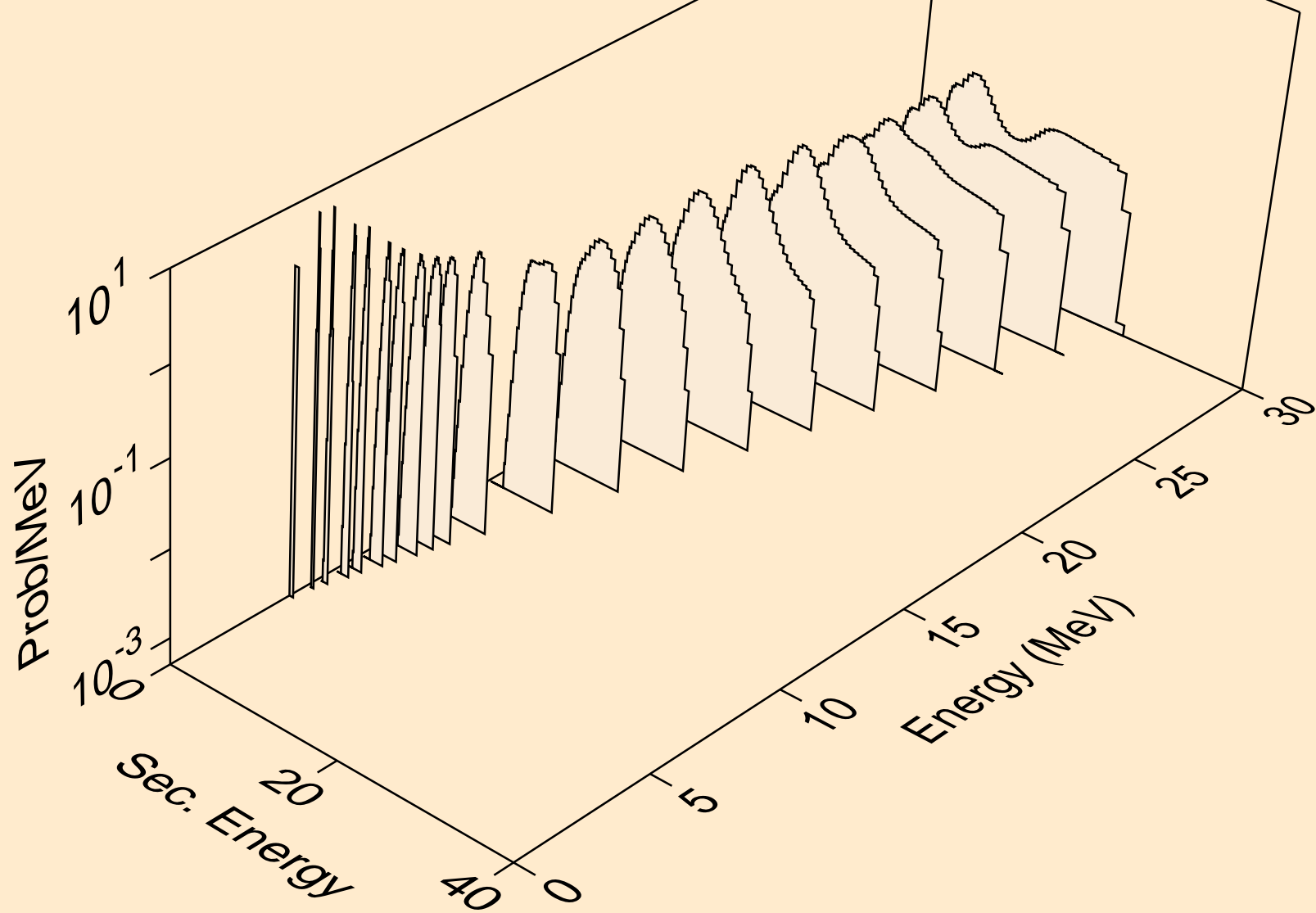

RH098M NEUTRON ACER TENDL-2023 LIBRARY; T=0.K  
protons from (n,2np)

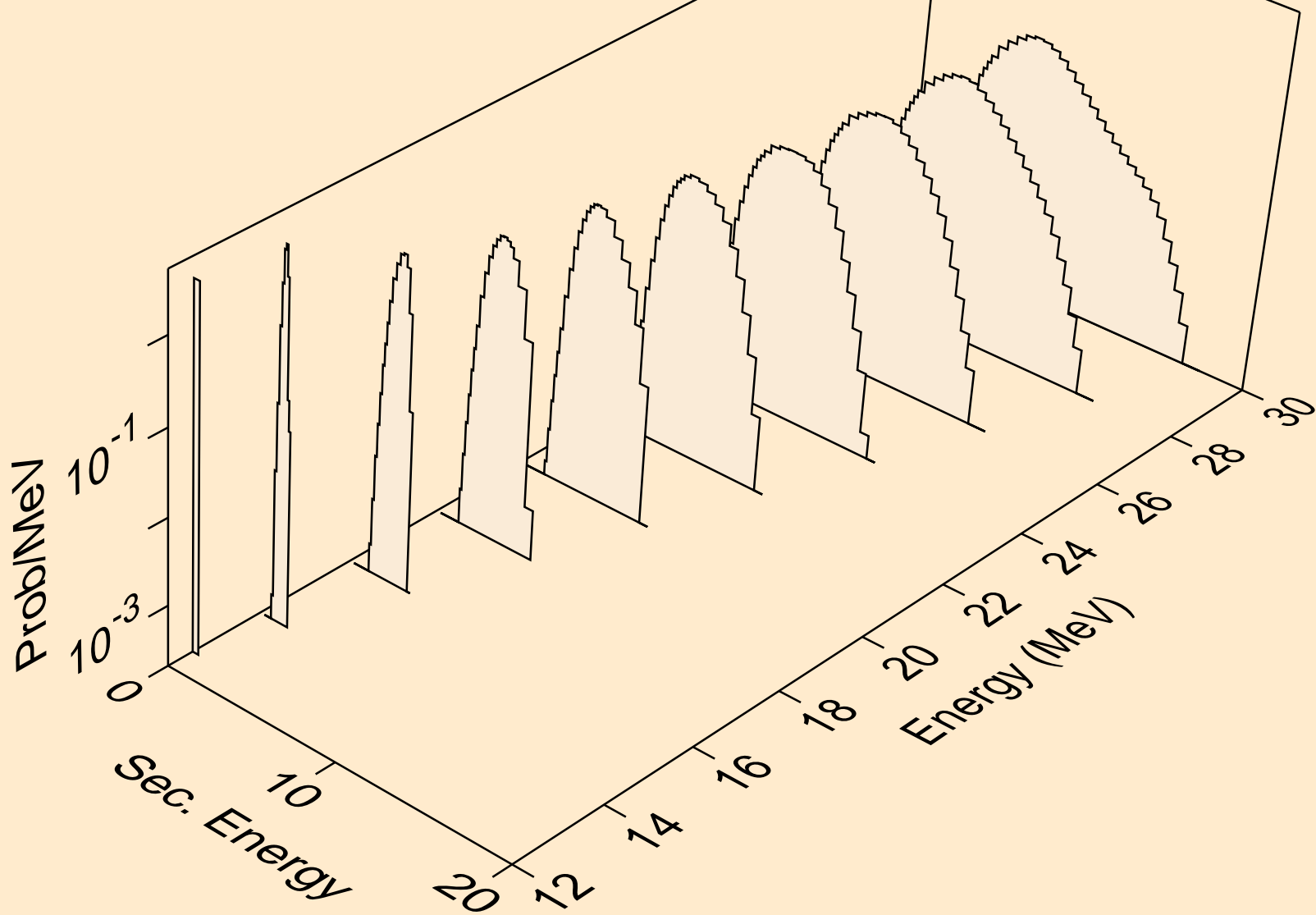

RH098M NEUTRON ACER TENDL-2023 LIBRARY; T=0.K  
protons from (n,3np)

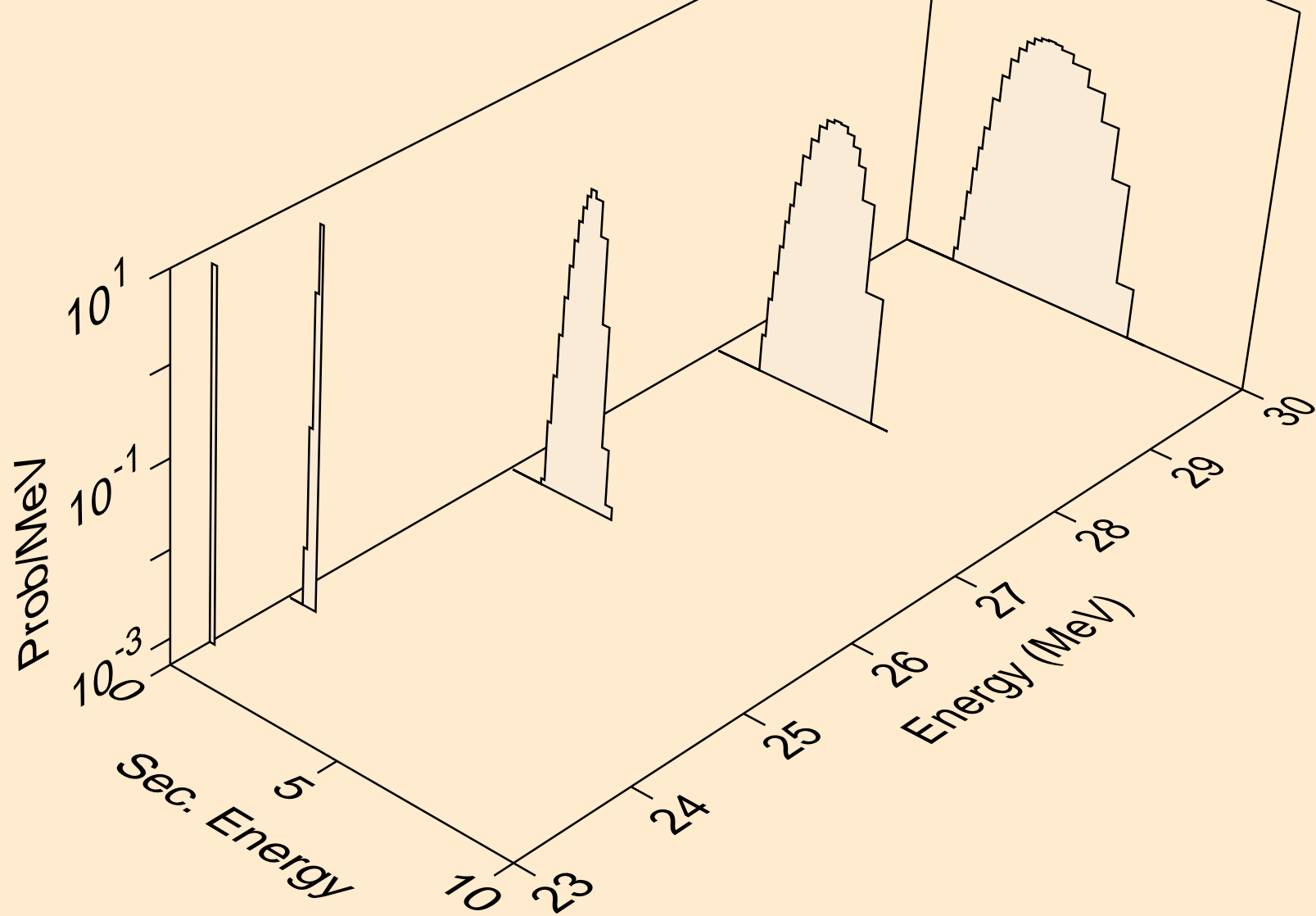

RH098M NEUTRON ACER TENDL-2023 LIBRARY; T=0.K  
protons from (n,n2p)

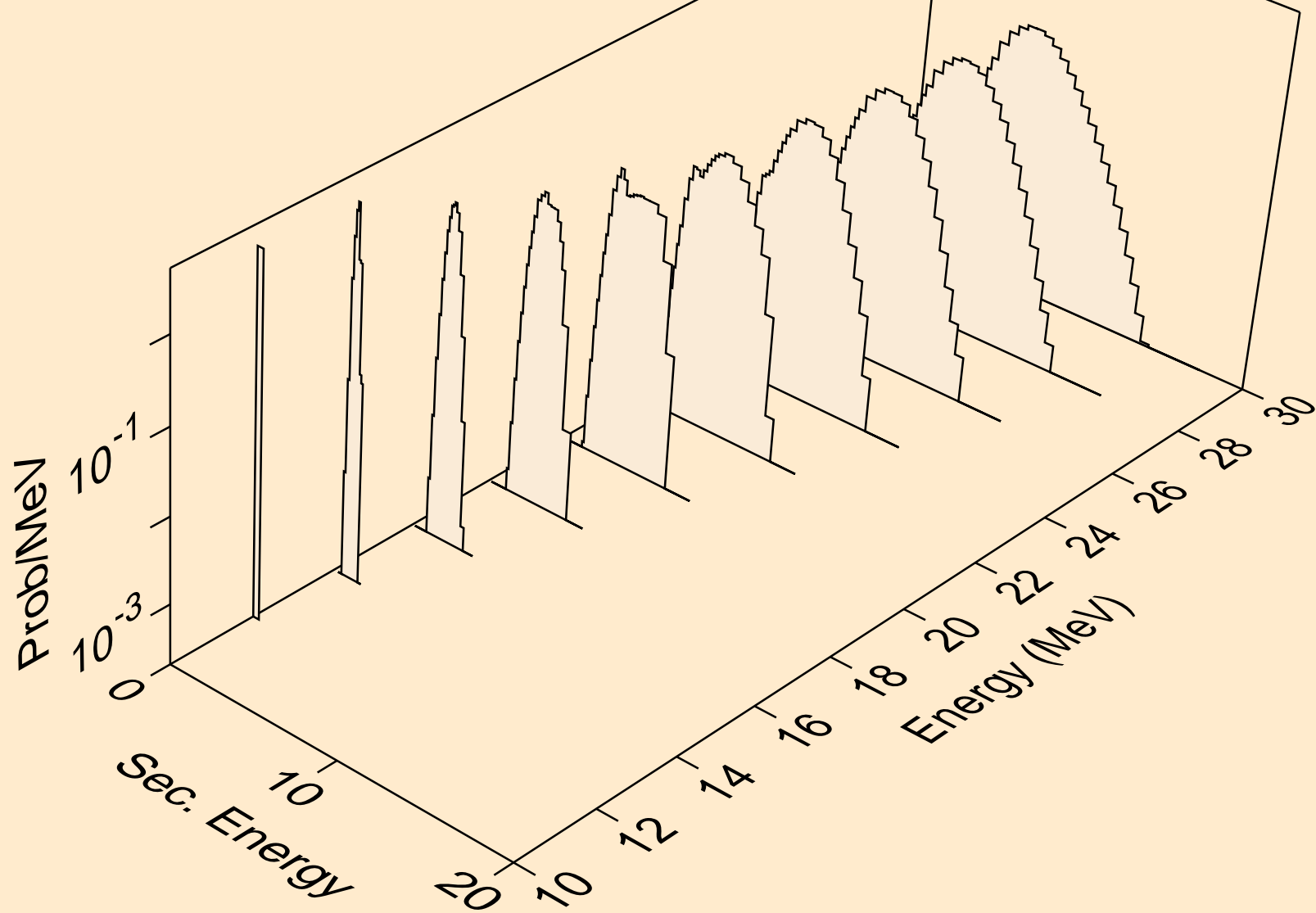

RH098M NEUTRON ACER TENDL-2023 LIBRARY; T=0.K  
protons from (n,npa)

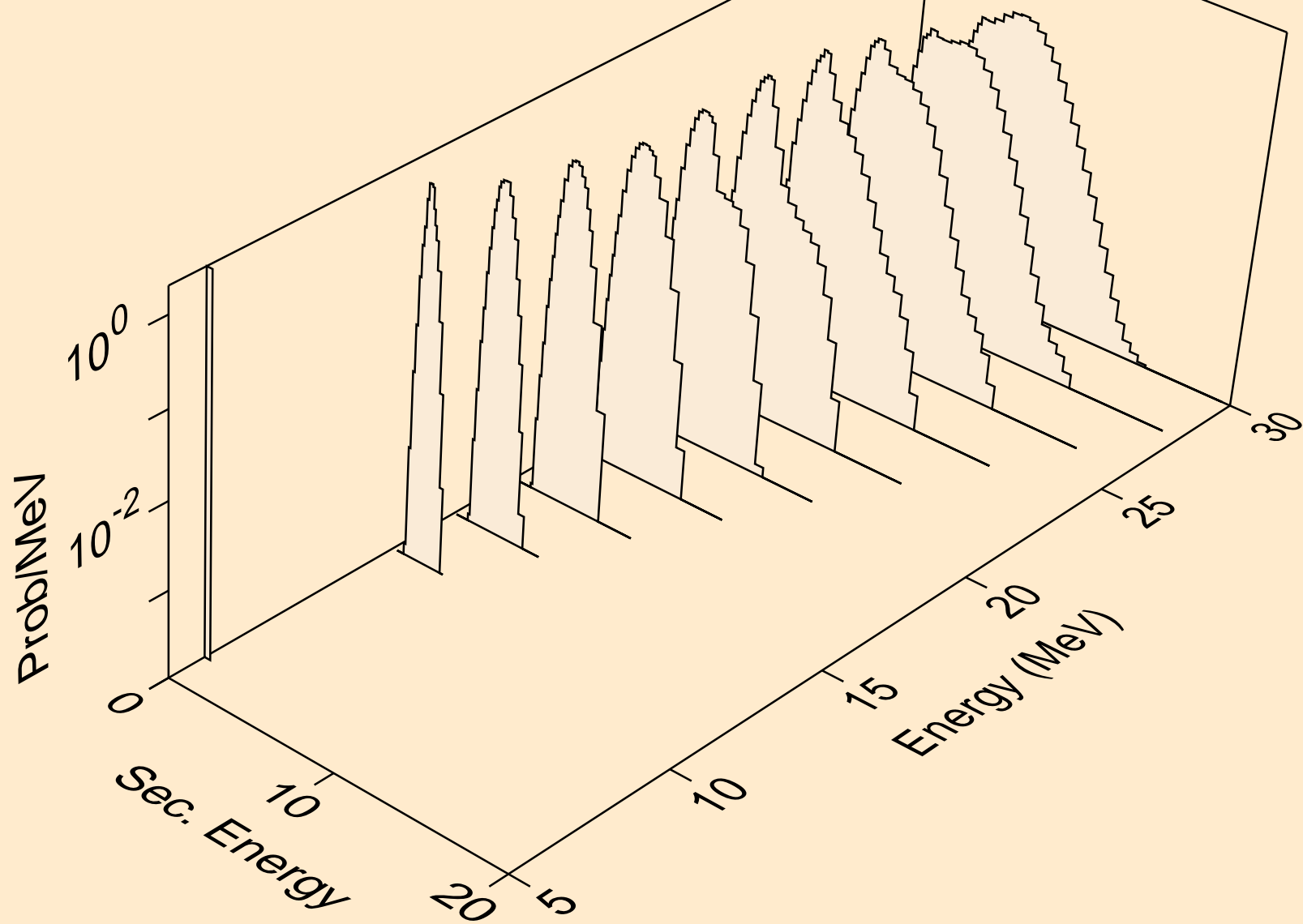



RH098M NEUTRON ACER TENDL-2023 LIBRARY; T=0.K  
protons from (n,p)

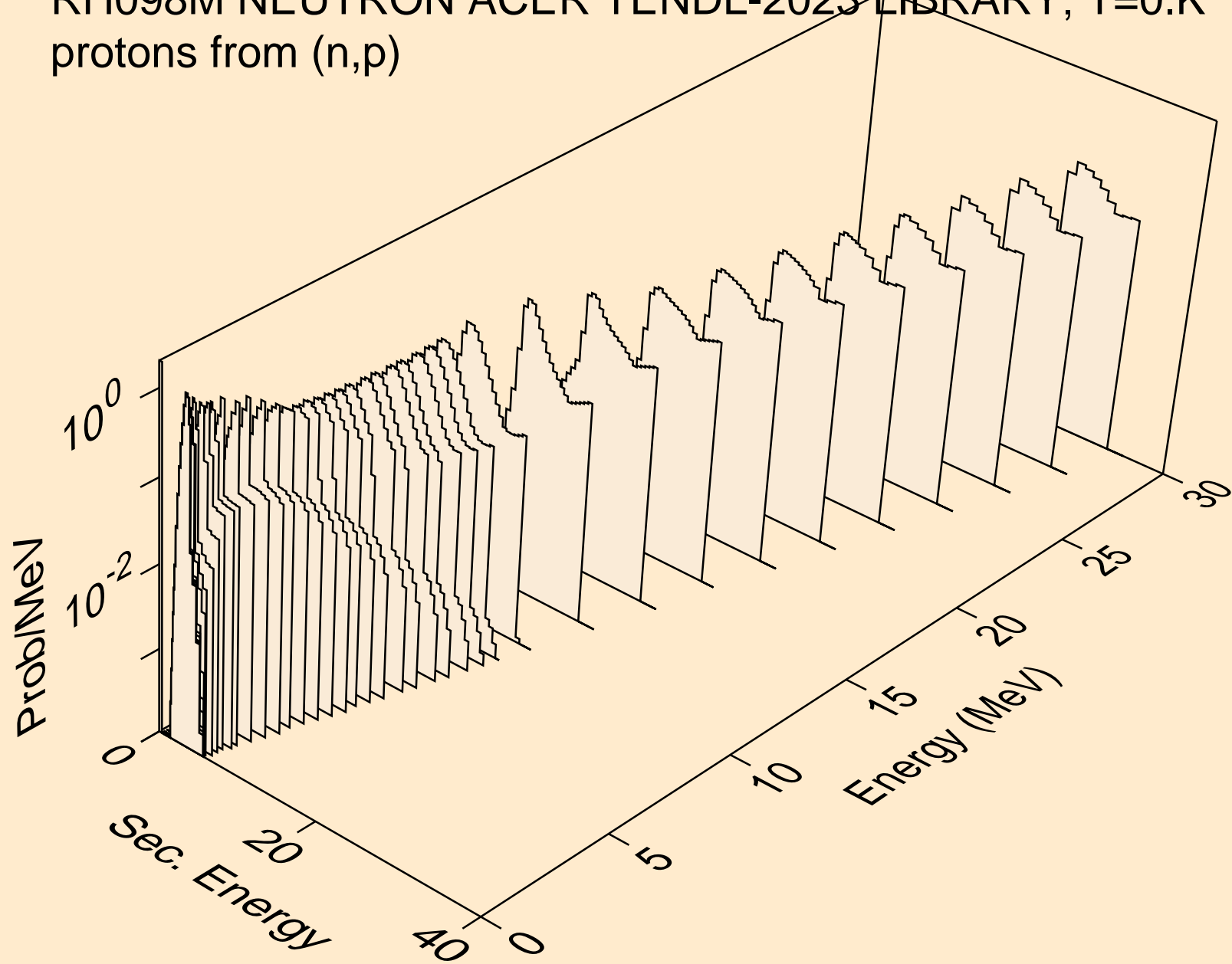

RH098M NEUTRON ACER TENDL-2023 LIBRARY; T=0.K  
protons from (n,2p)

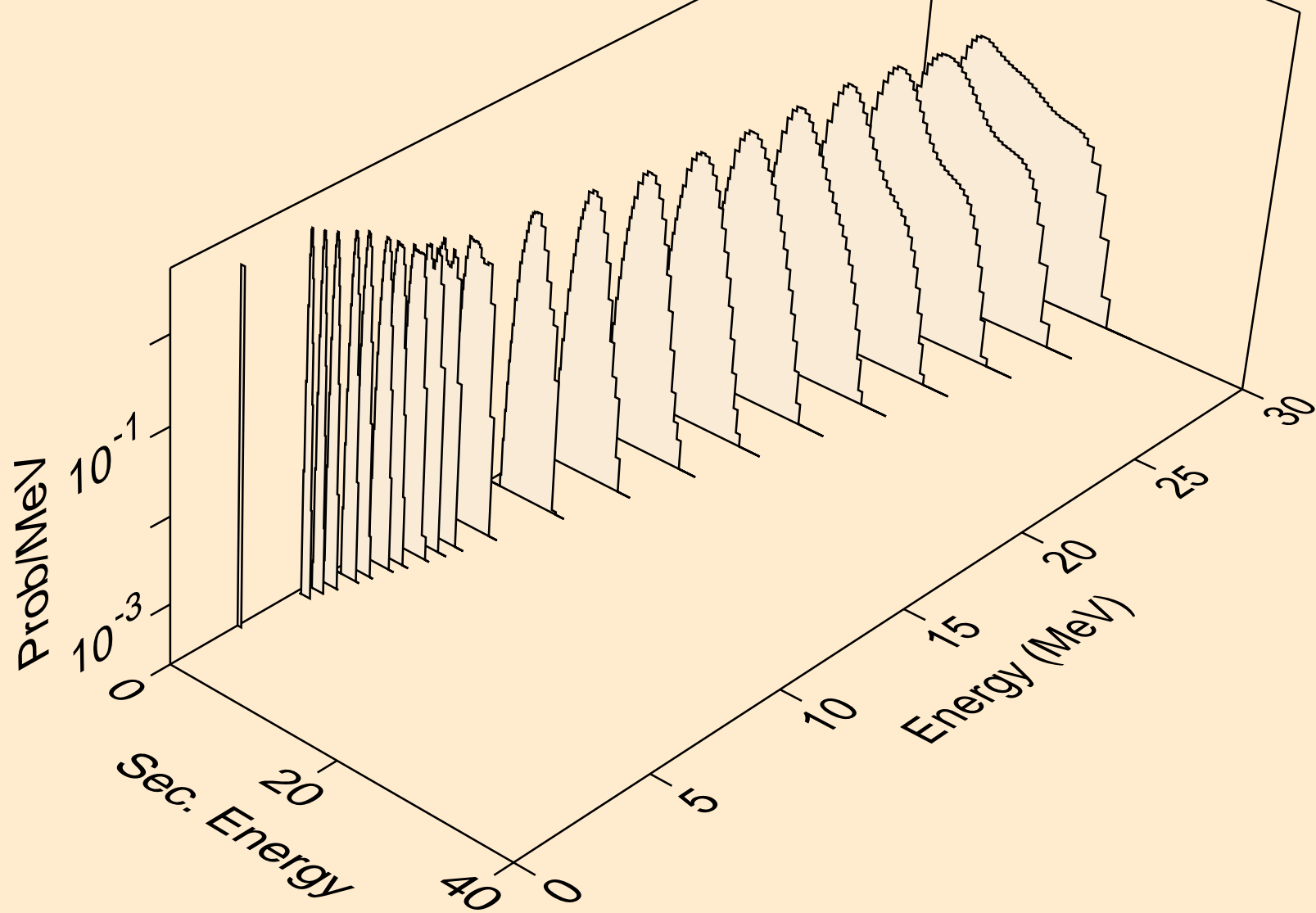

RH098M NEUTRON ACER TENDL-2023 LIBRARY; T=0.K  
protons from (n,p)

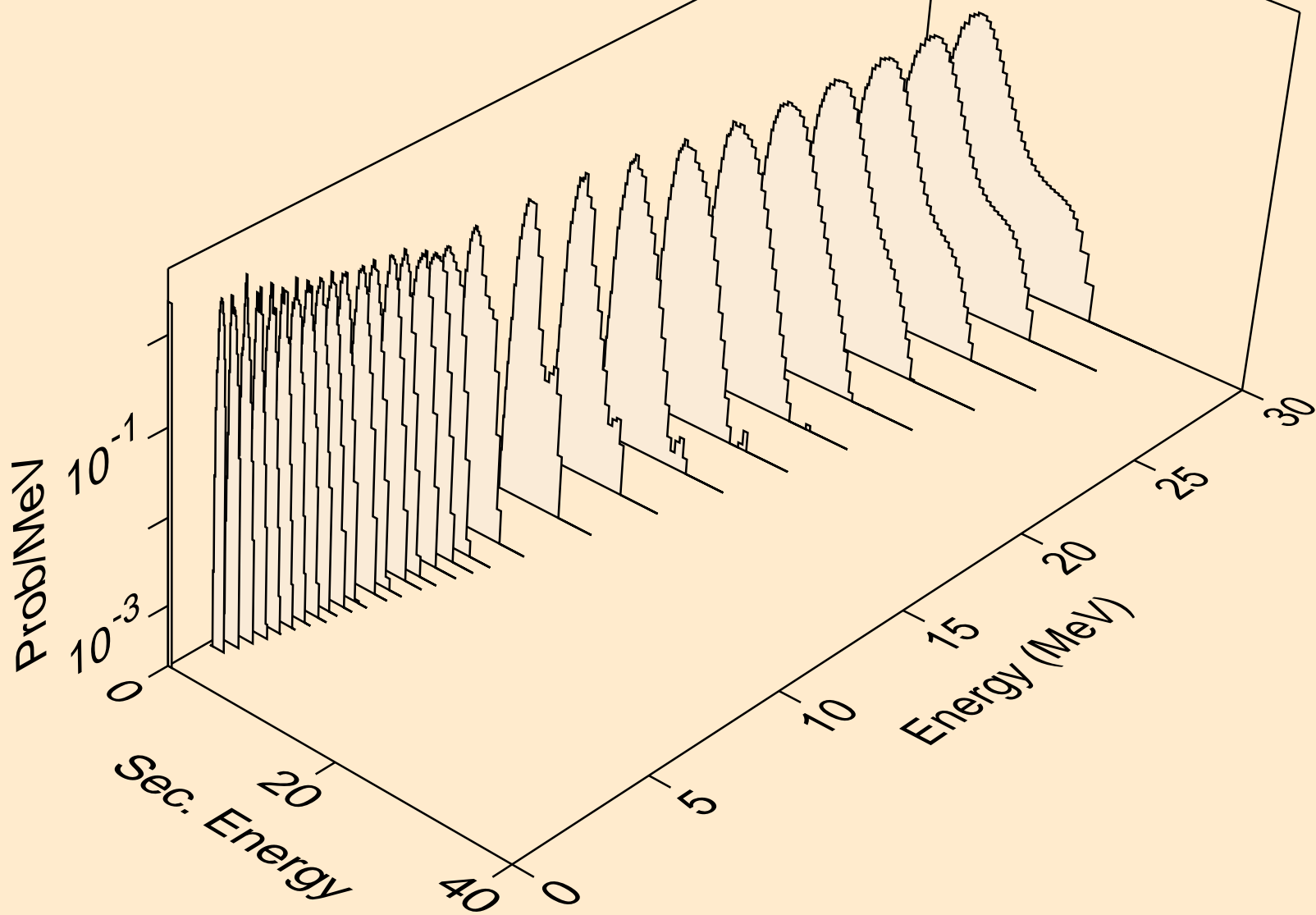

RH098M NEUTRON ACER TENDL-2023 LIBRARY; T=0.K  
protons from (n,pd)

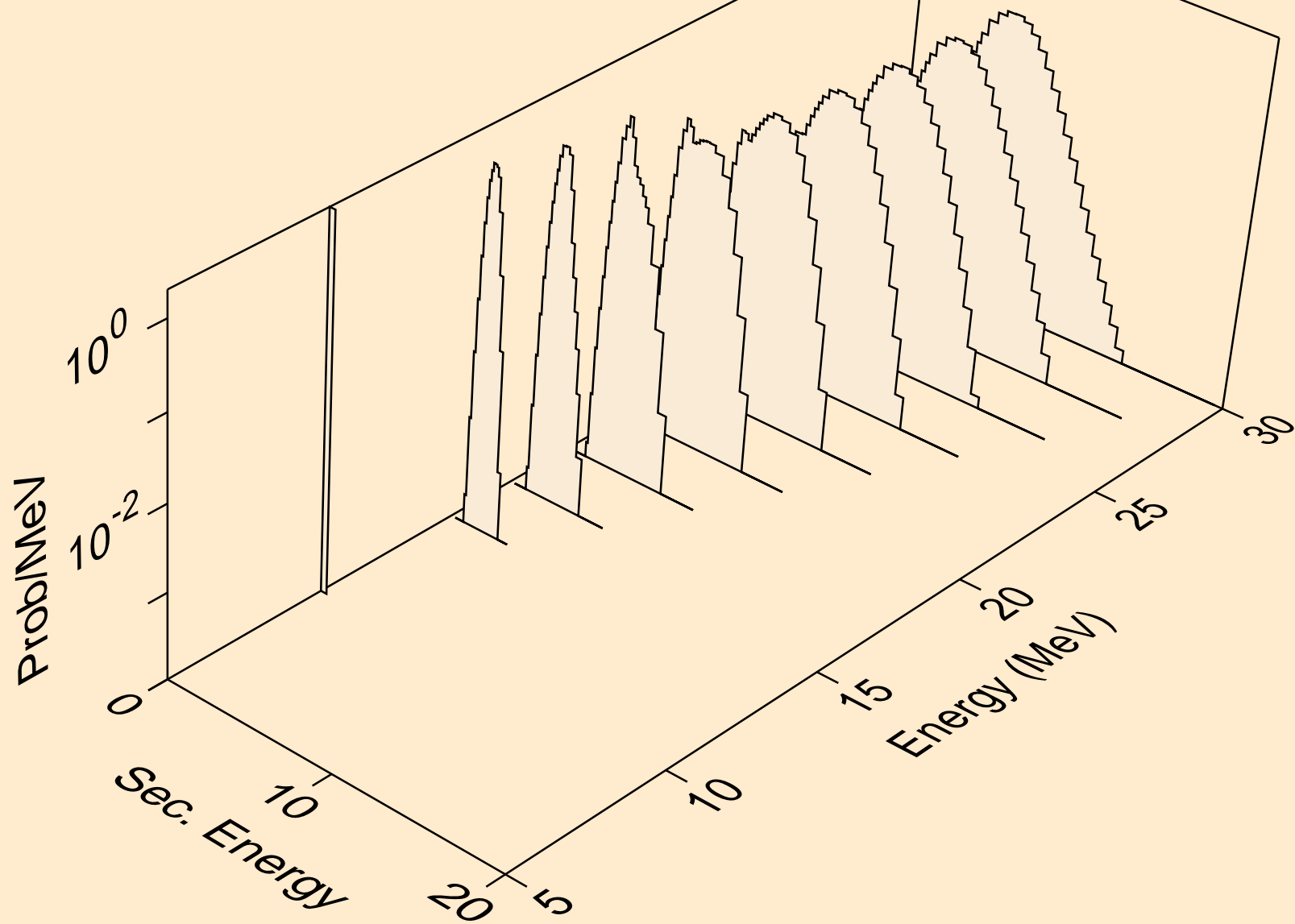

RH098M NEUTRON ACER TENDL-2023 LIBRARY; T=0.K  
protons from (n,pt)

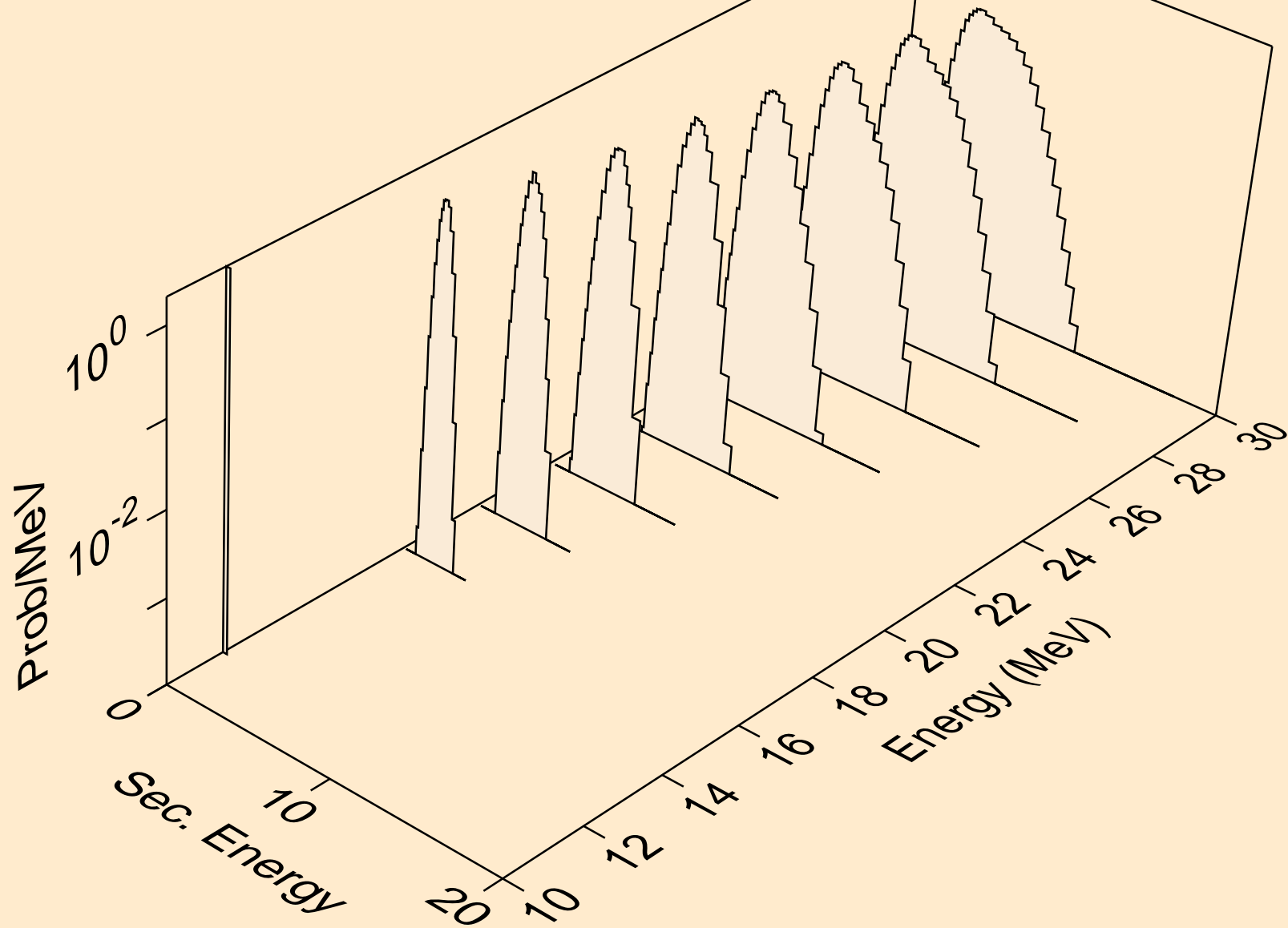

RH098M NEUTRON ACER TENDL-2023 LIBRARY; T=0.K  
deuterons from (n,x)

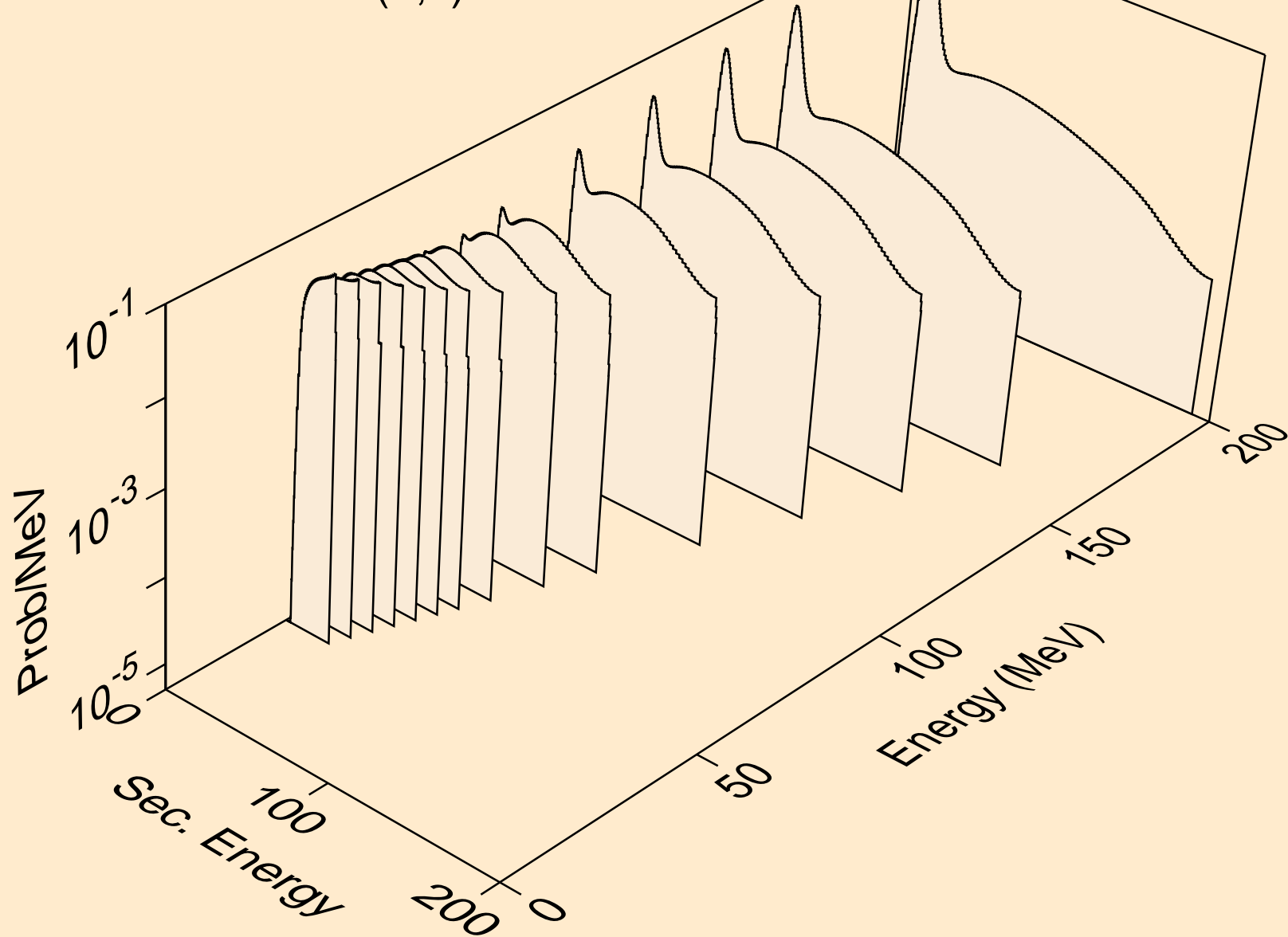

RH098M NEUTRON ACER TENDL-2023 LIBRARY; T=0.K  
deuterons from (n,2nd)

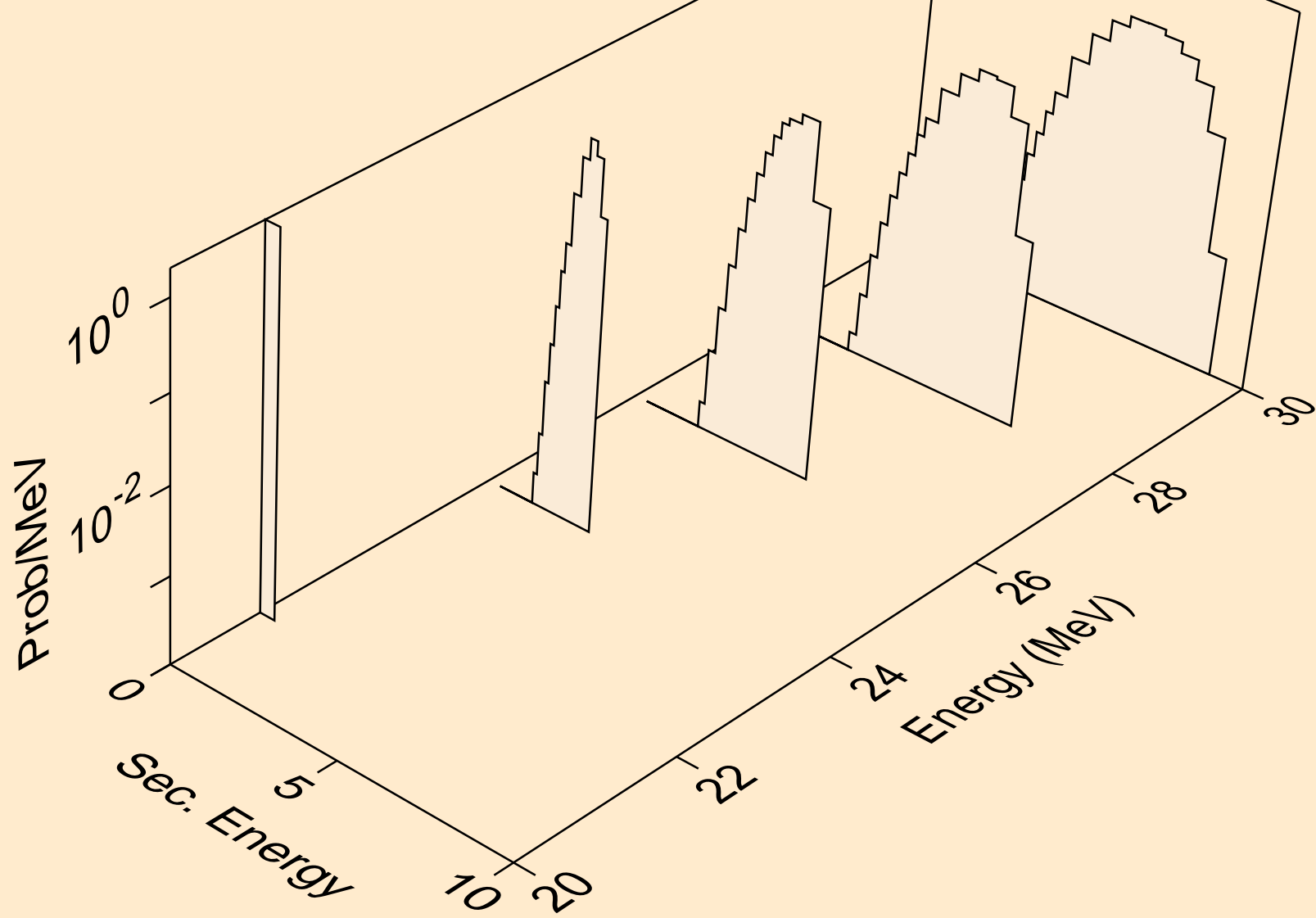

RH098M NEUTRON ACER TENDL-2023 LIBRARY; T=0.K  
deuterons from (n,n\*)d

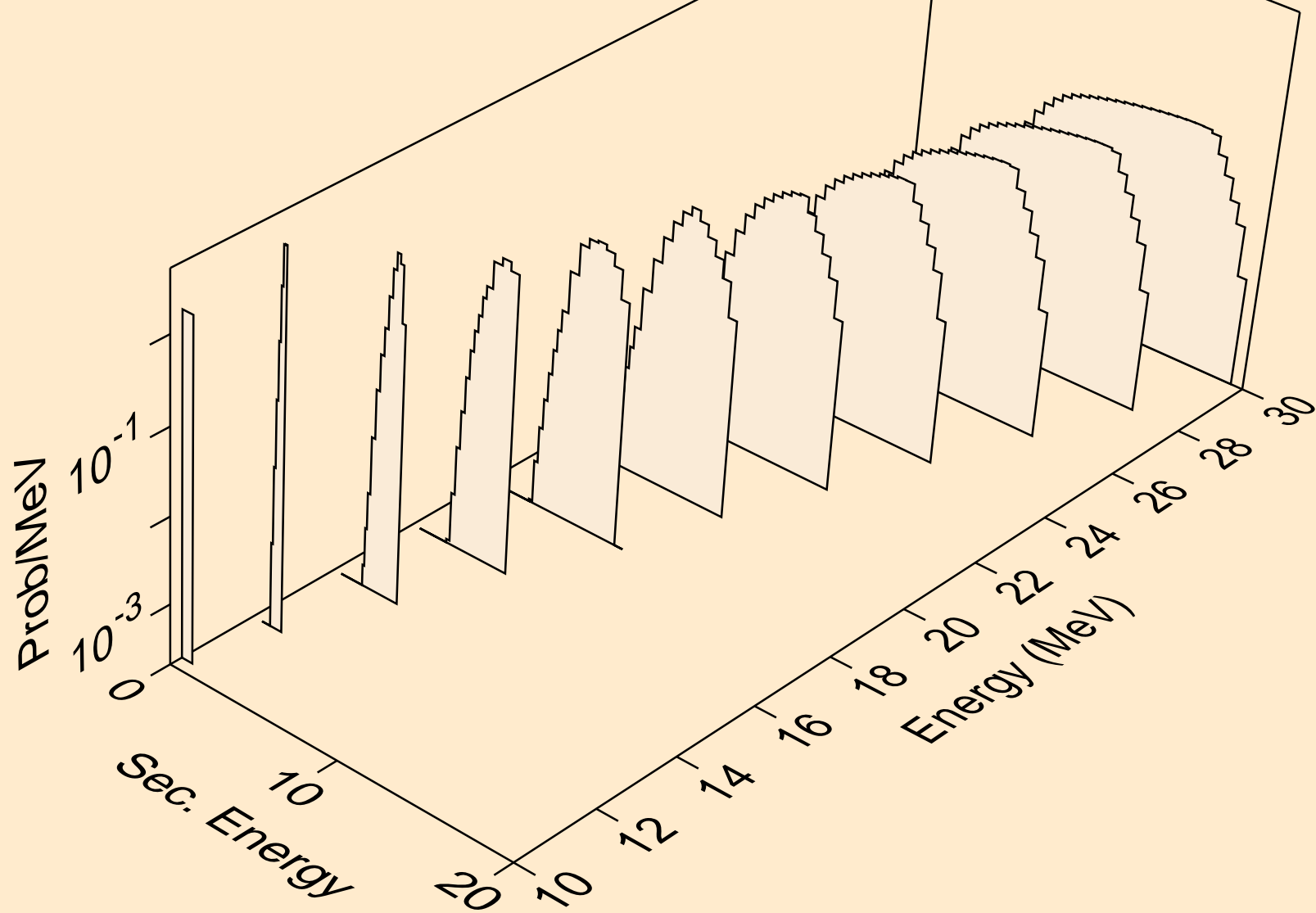



RH098M NEUTRON ACER TENDL-2023 LIBRARY; T=0.K  
deuterons from (n,d)

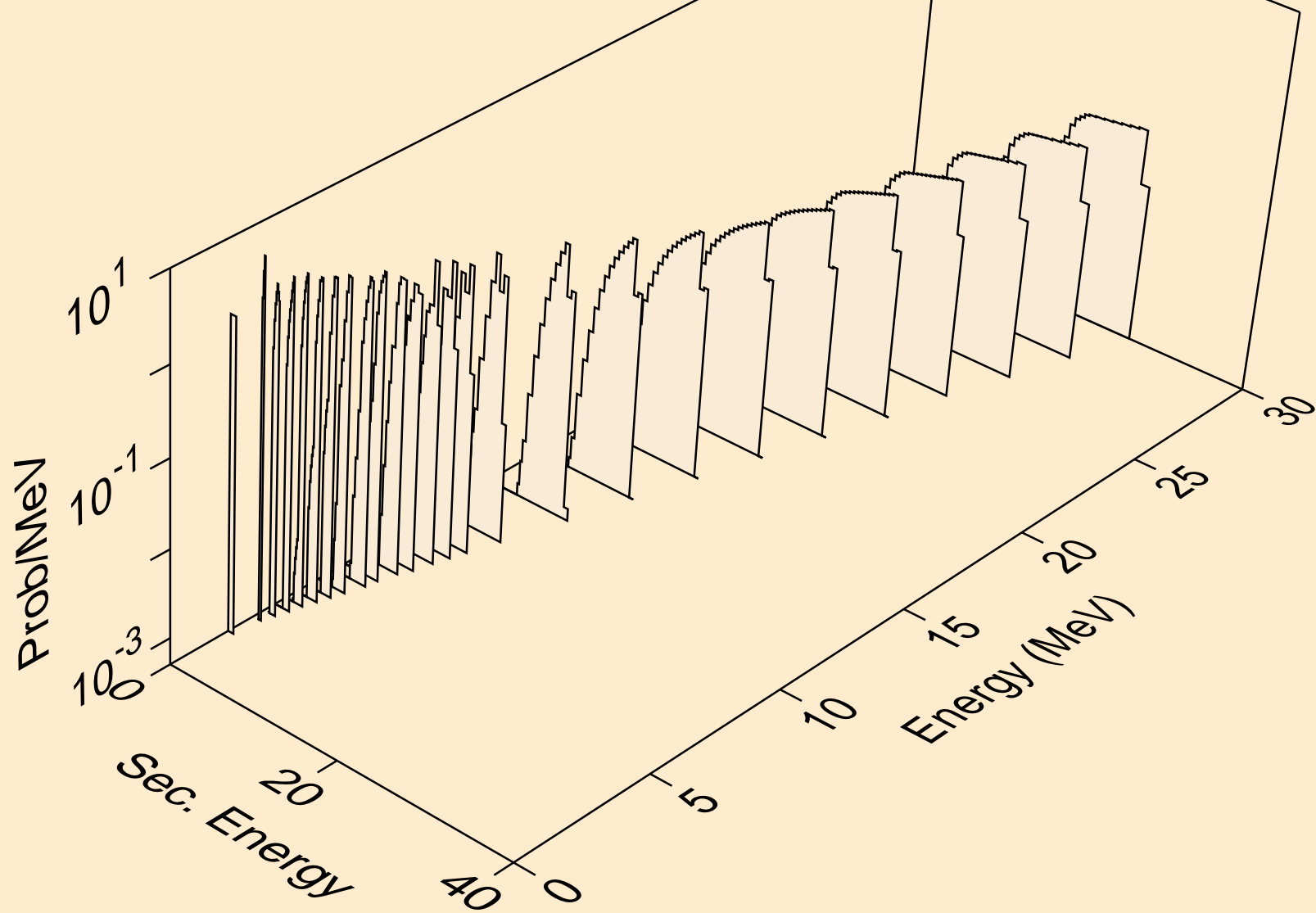

RH098M NEUTRON ACER TENDL-2023 LIBRARY; T=0.K  
deuterons from (n,pd)

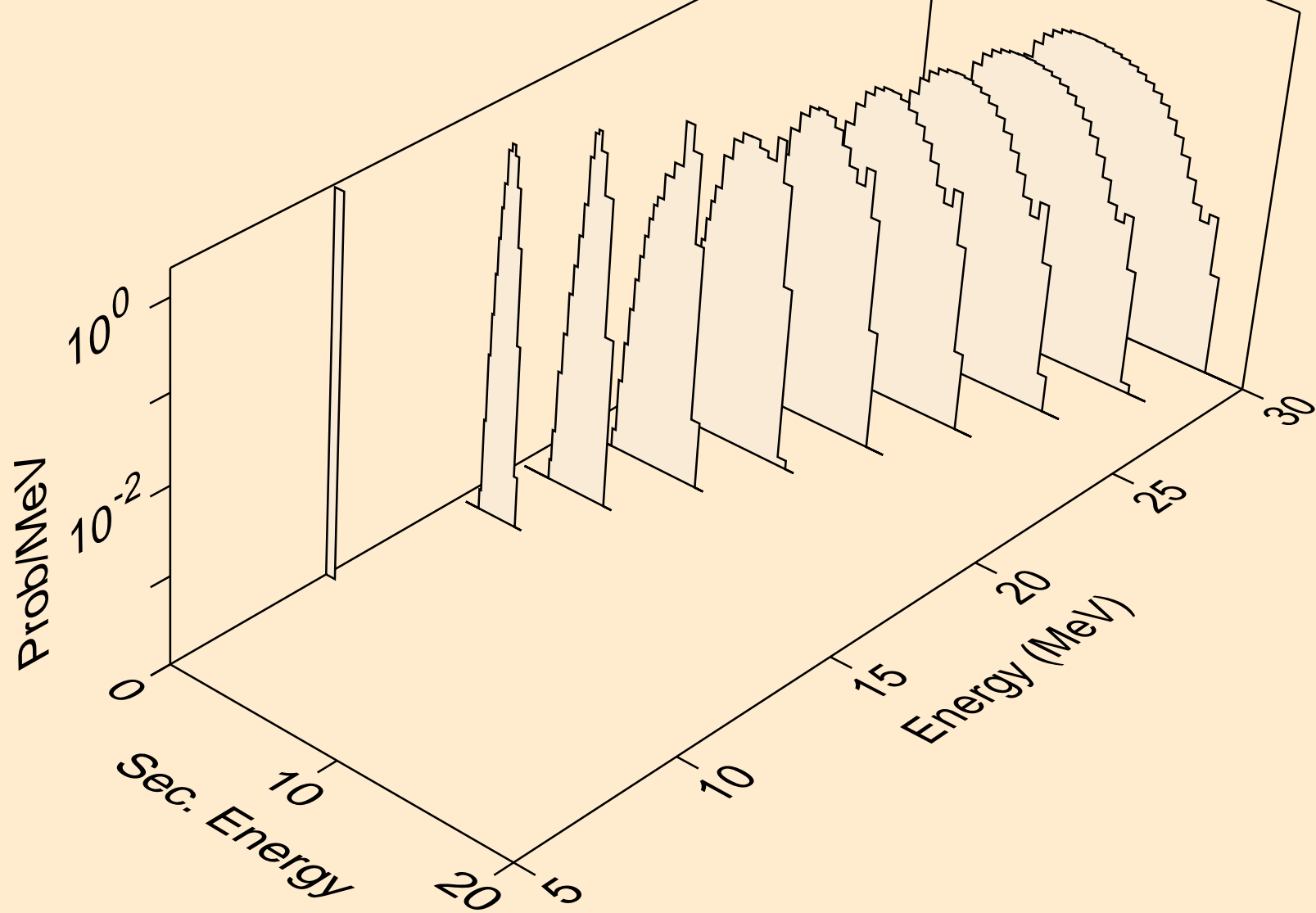

RH098M NEUTRON ACER TENDL-2023 LIBRARY; T=0.K  
deuterons from (n,da)

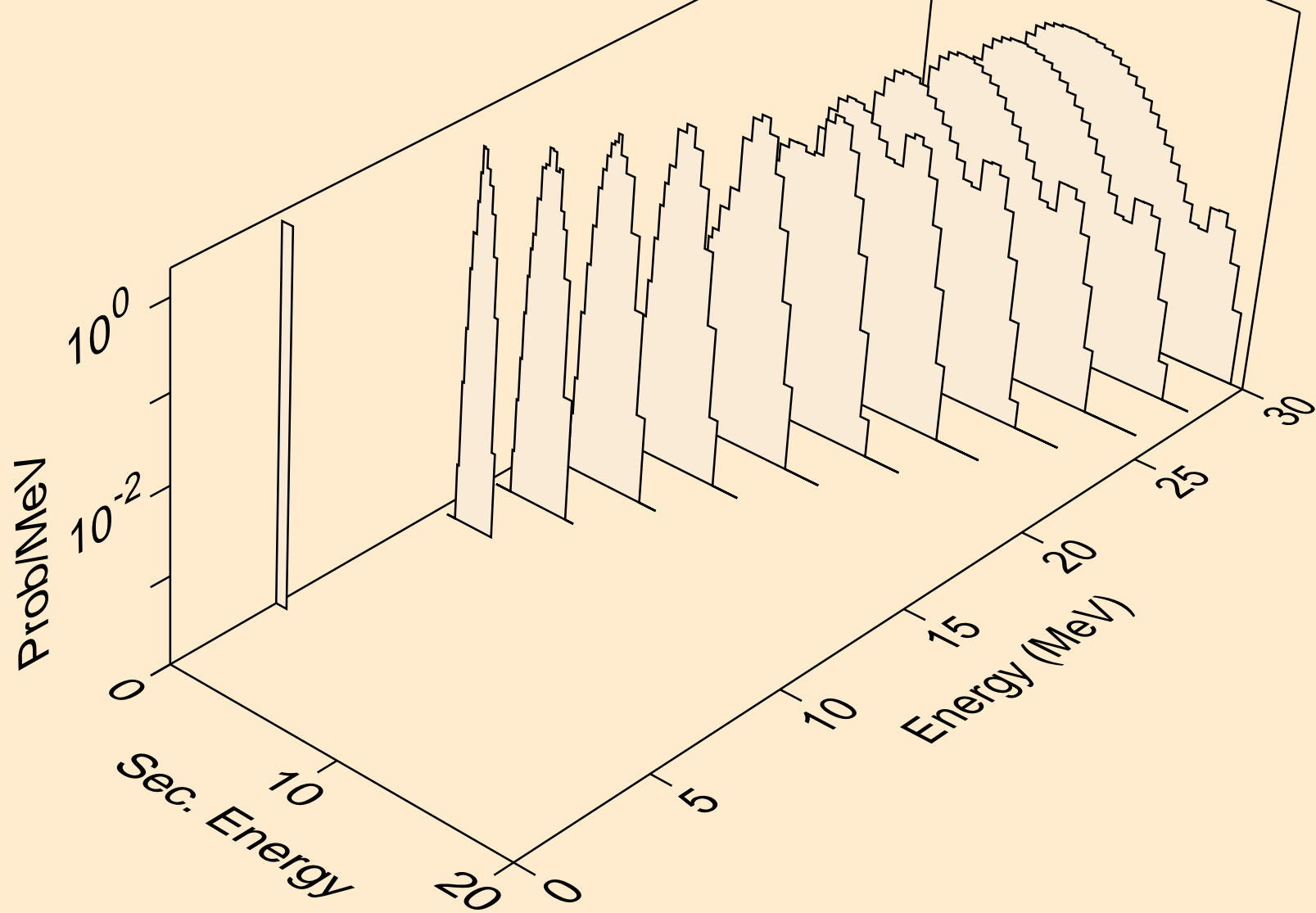

RH098M NEUTRON ACER TENDL-2023 LIBRARY; T=0.K  
tritons from (n,x)

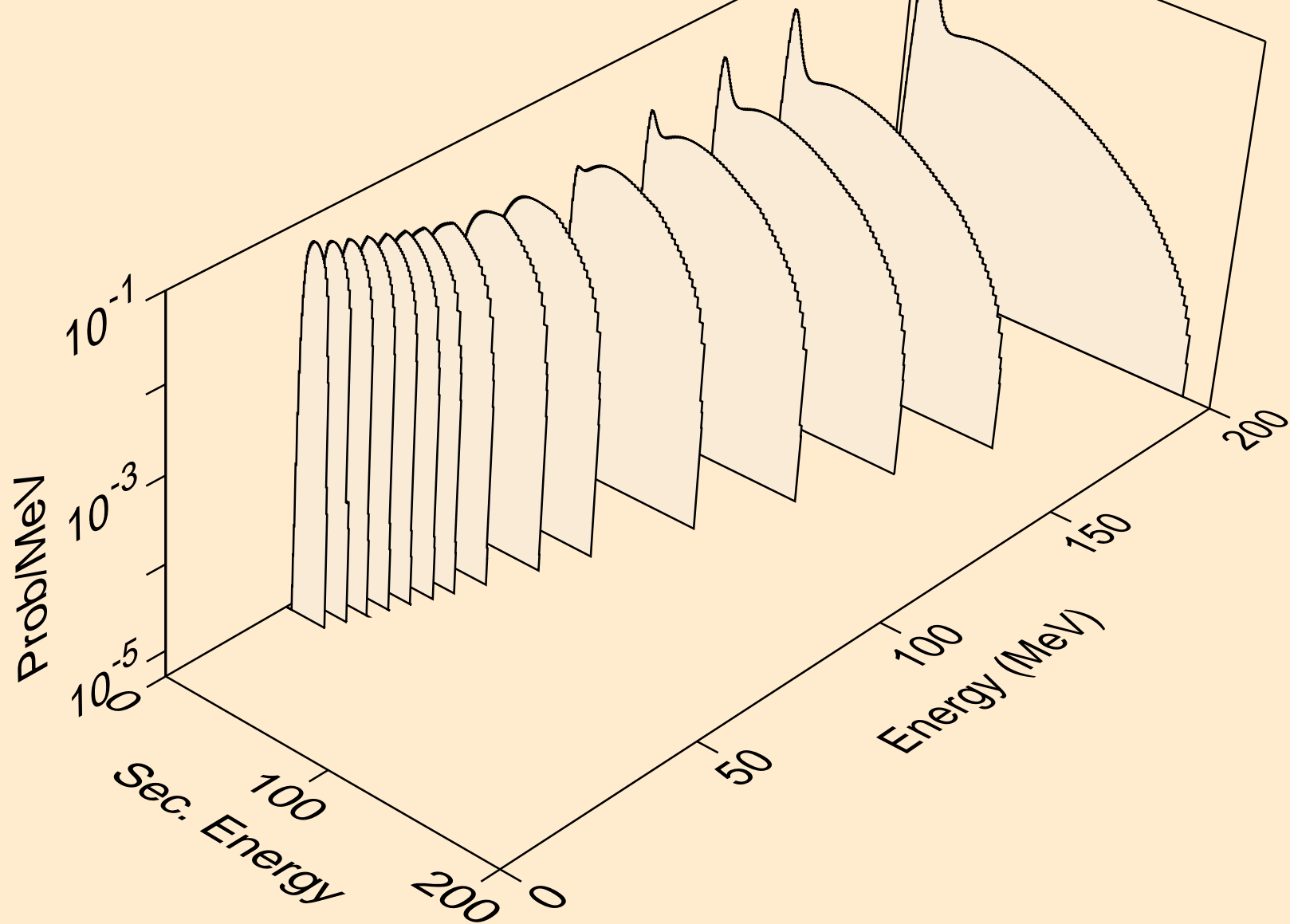

RH098M NEUTRON ACER TENDL-2023 LIBRARY; T=0.K  
tritons from (n,n\*)t

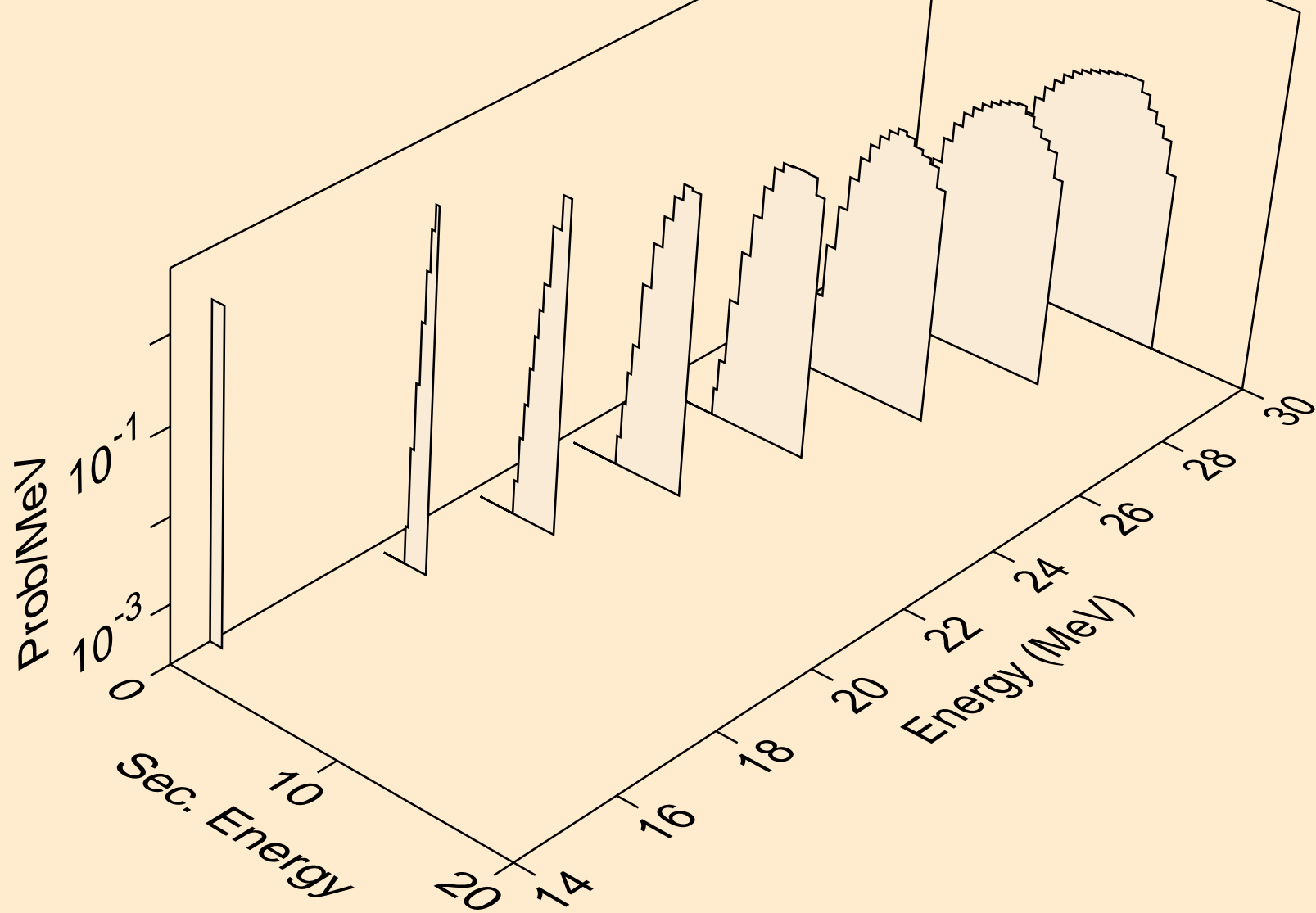

RH098M NEUTRON ACER TENDL-2023 LIBRARY; T=0.K  
tritons from (n,t)

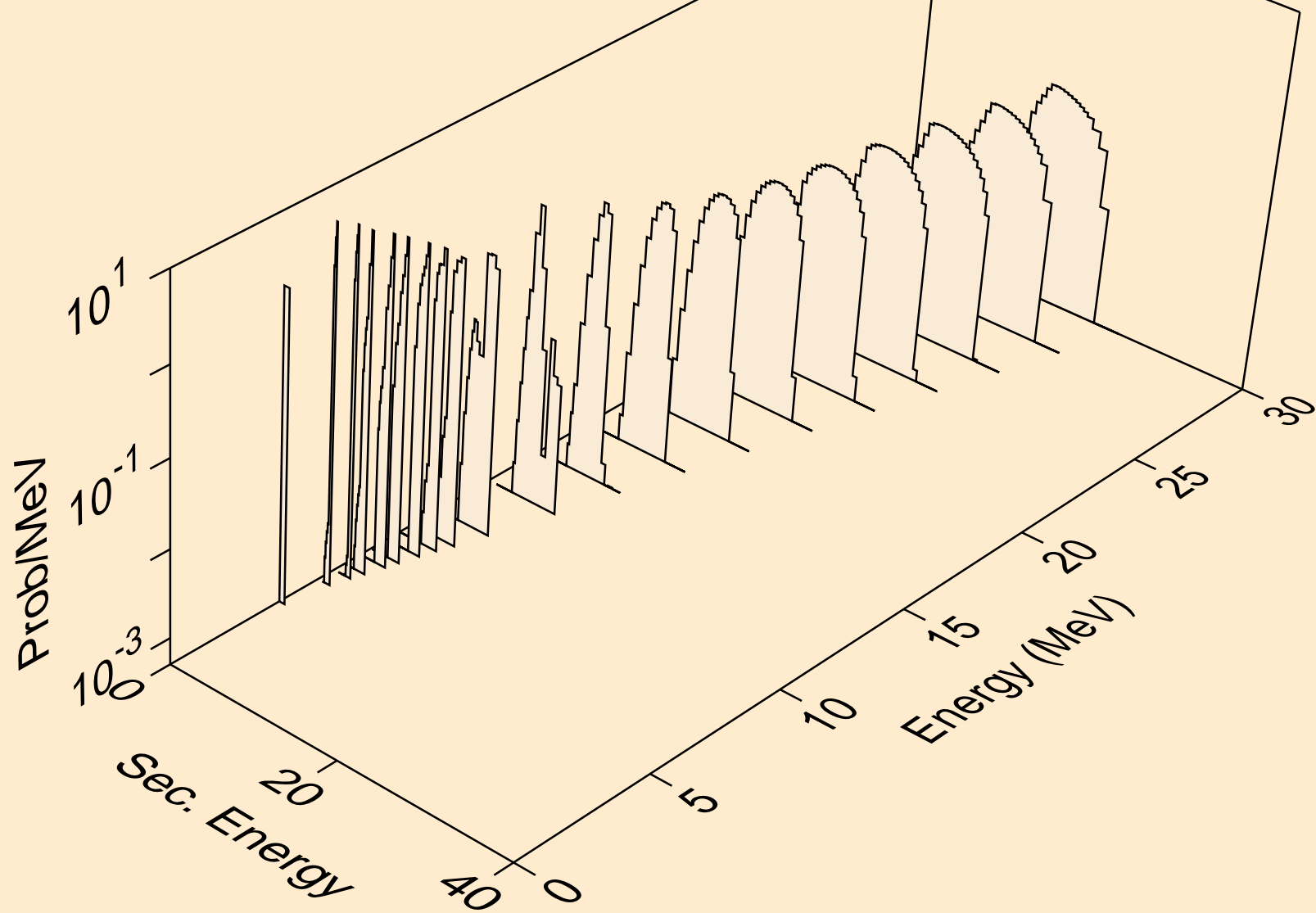

RH098M NEUTRON ACER TENDL-2023 LIBRARY; T=0.K  
tritons from (n,pt)

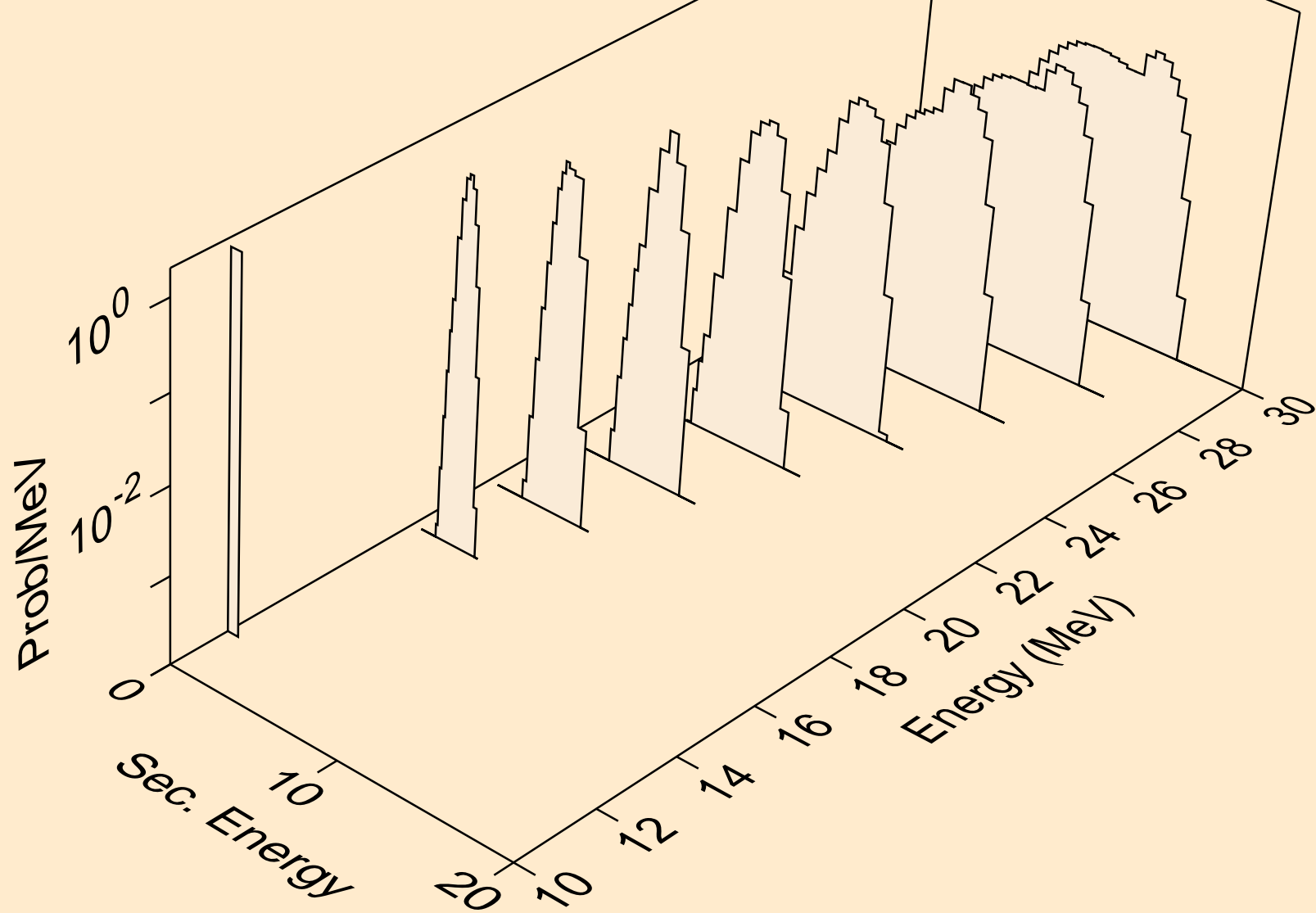

RH098M NEUTRON ACER TENDL-2023 LIBRARY; T=0.K  
he3s from (n,x)

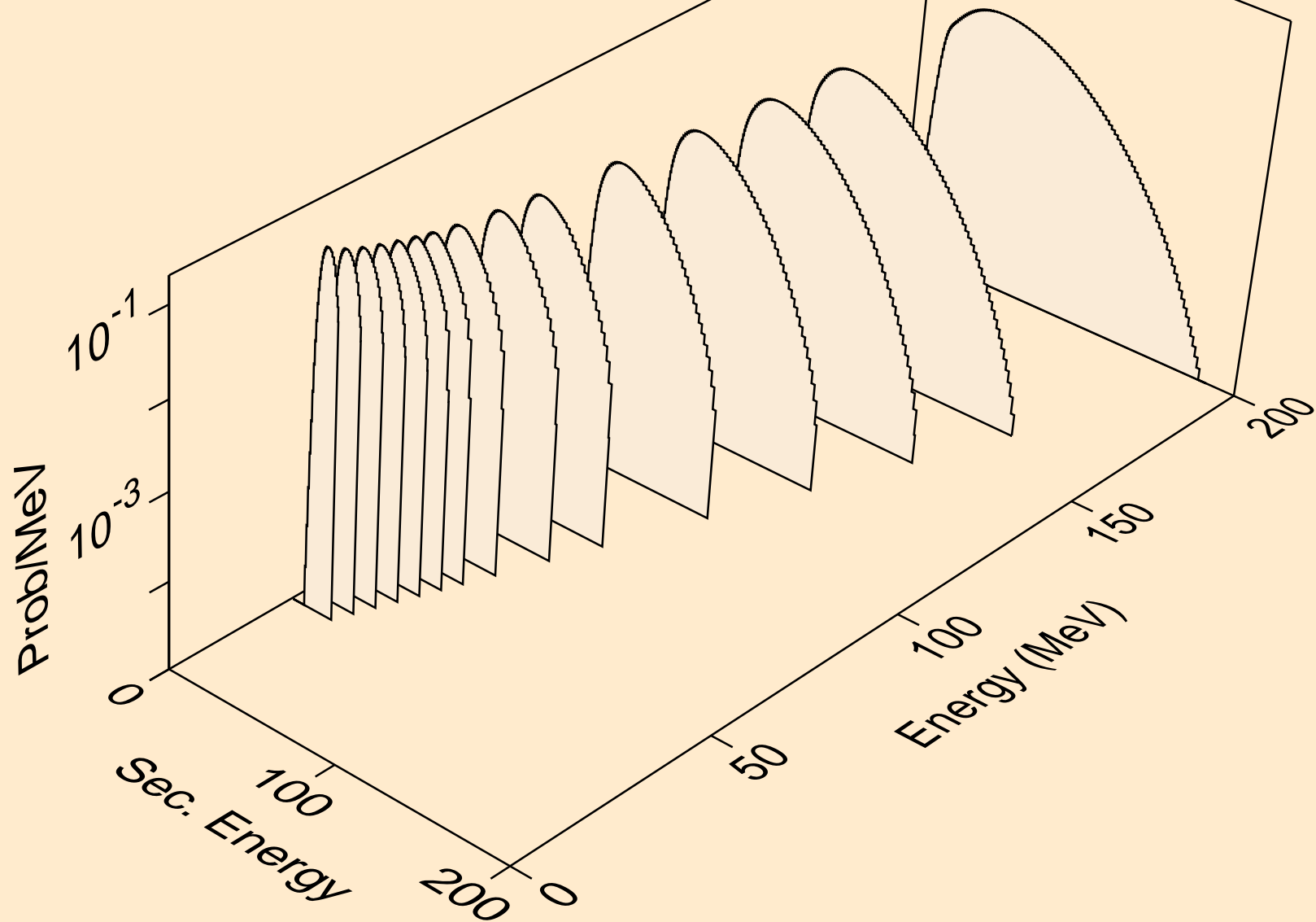



RH098M NEUTRON ACER TENDL-2023 LIBRARY; T=0.K  
he3s from (n,n\*)he3

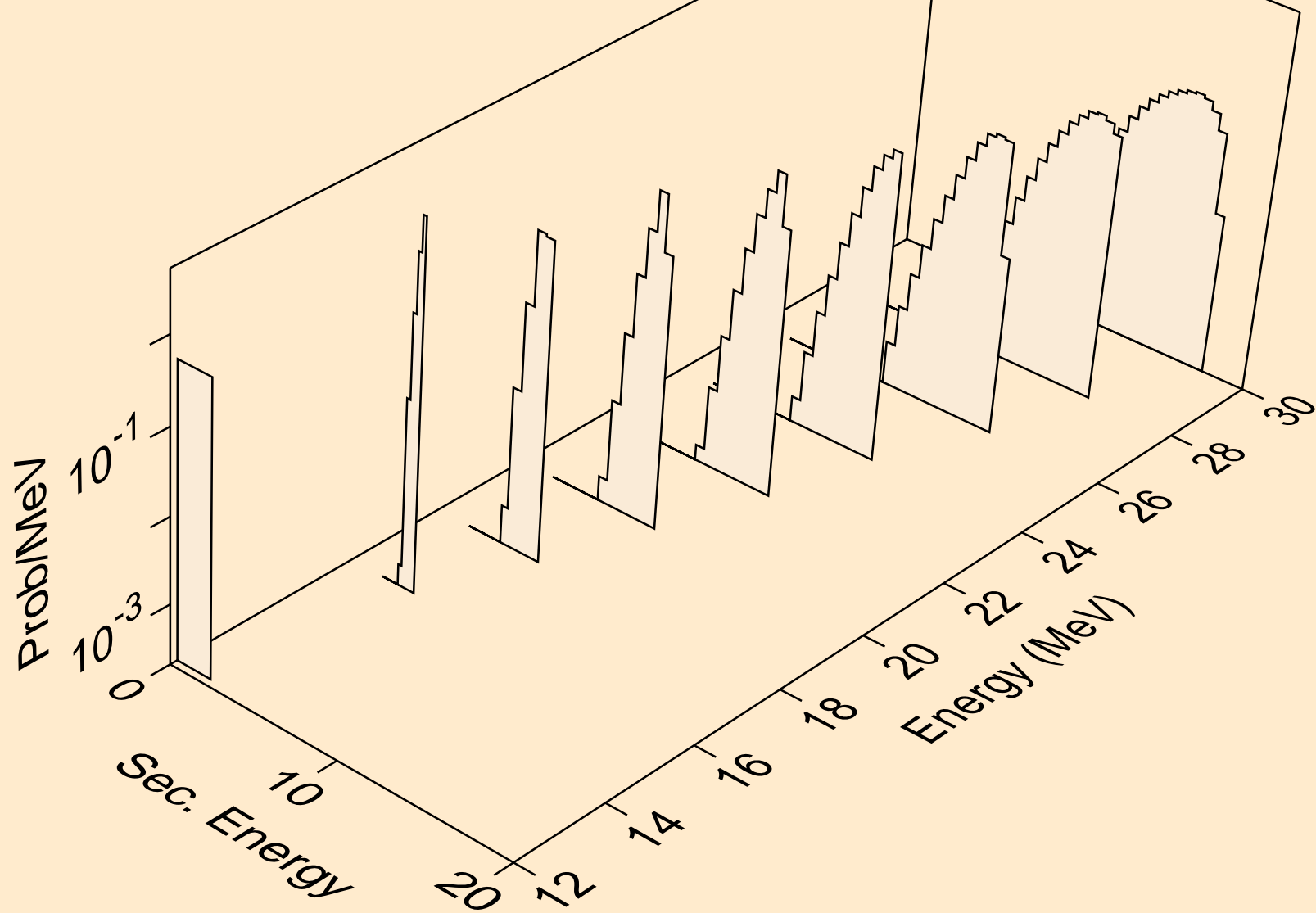

RH098M NEUTRON ACER TENDL-2023 LIBRARY; T=0.K  
he3s from (n,he3)

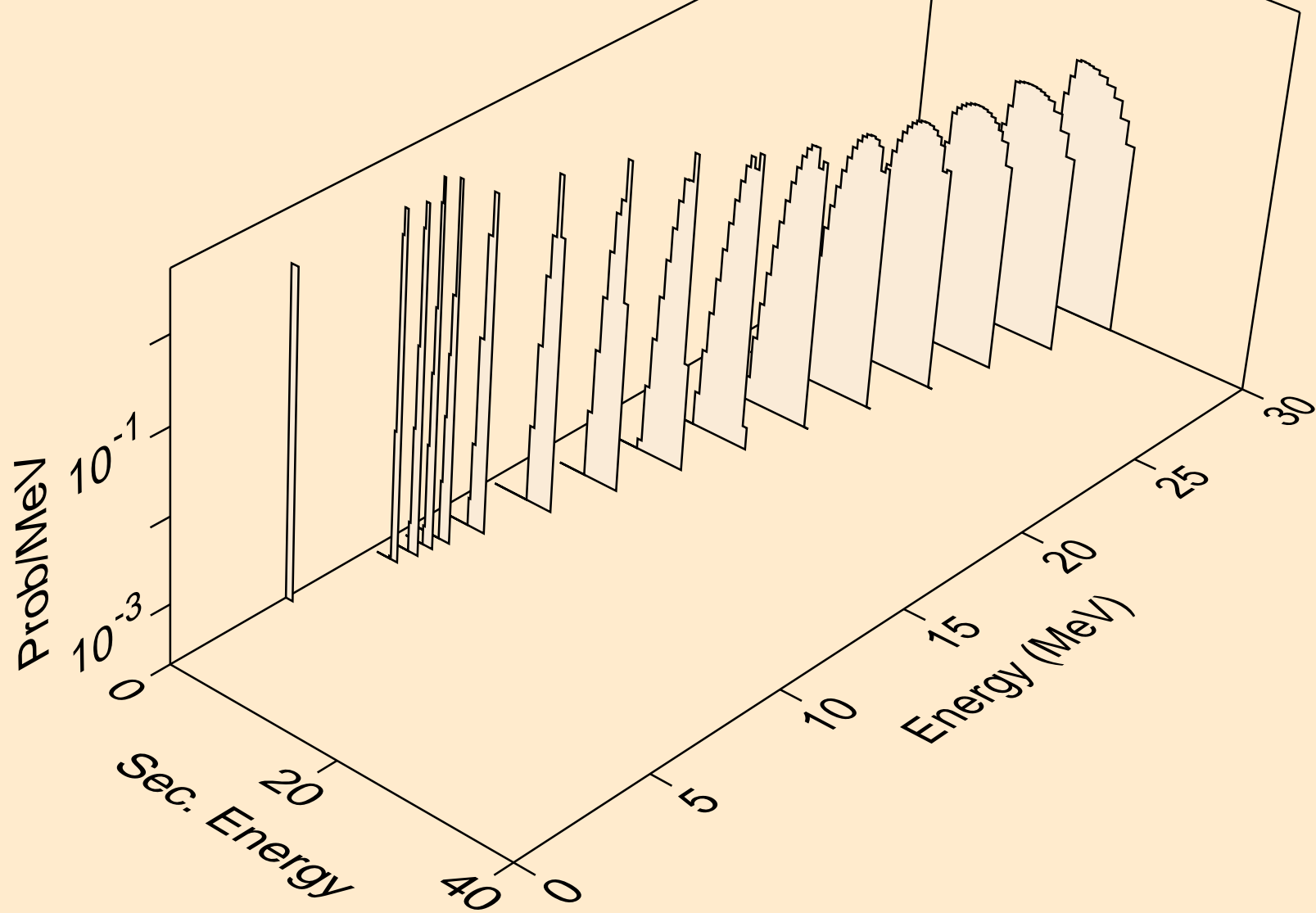

RH098M NEUTRON ACER TENDL-2023 LIBRARY; T=0.K  
alphas from (n,x)

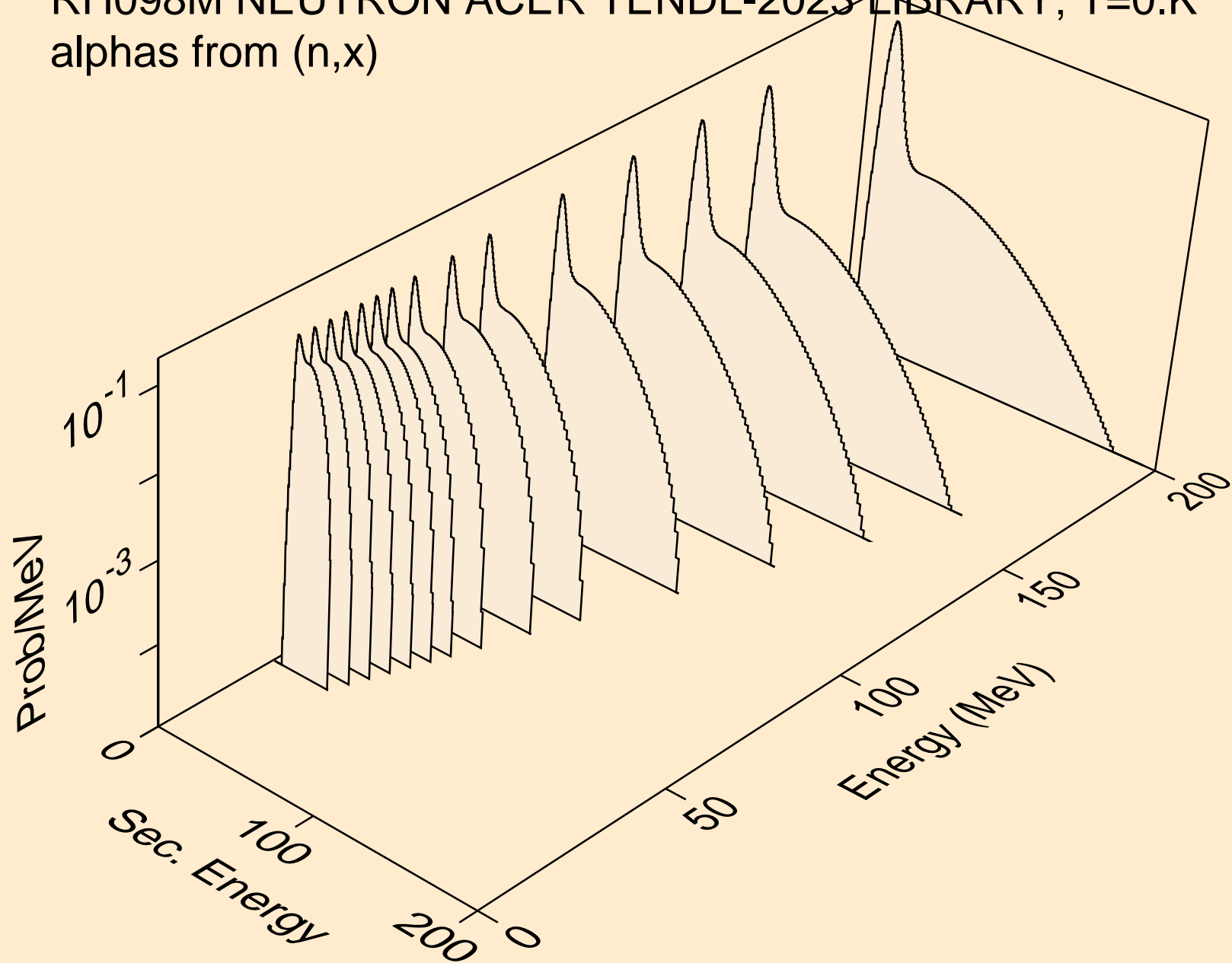

RH098M NEUTRON ACER TENDL-2023 LIBRARY; T=0.K  
alphas from (n,n\*)a

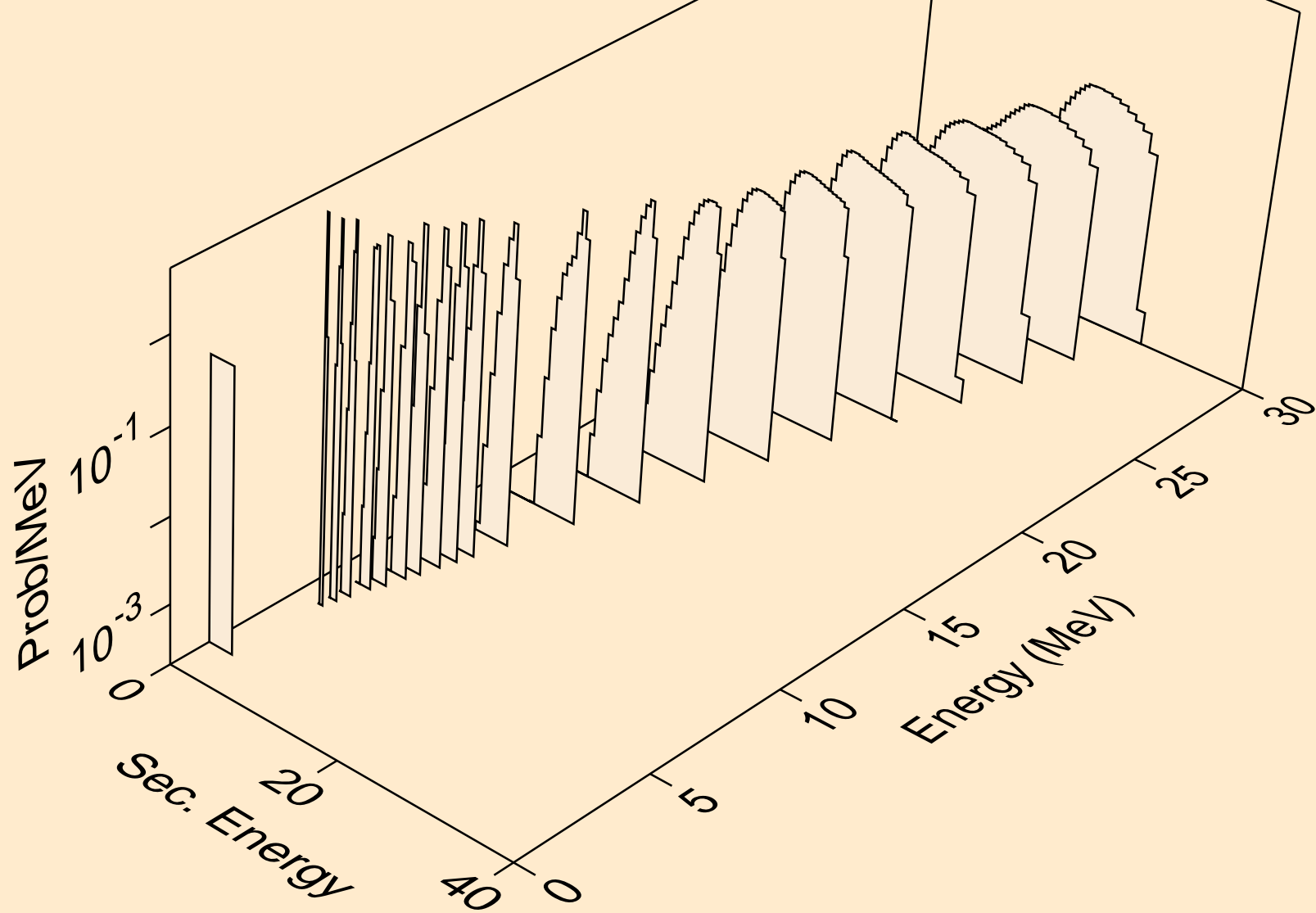

RH098M NEUTRON ACER TENDL-2023 LIBRARY; T=0.K  
alphas from (n,2n)a

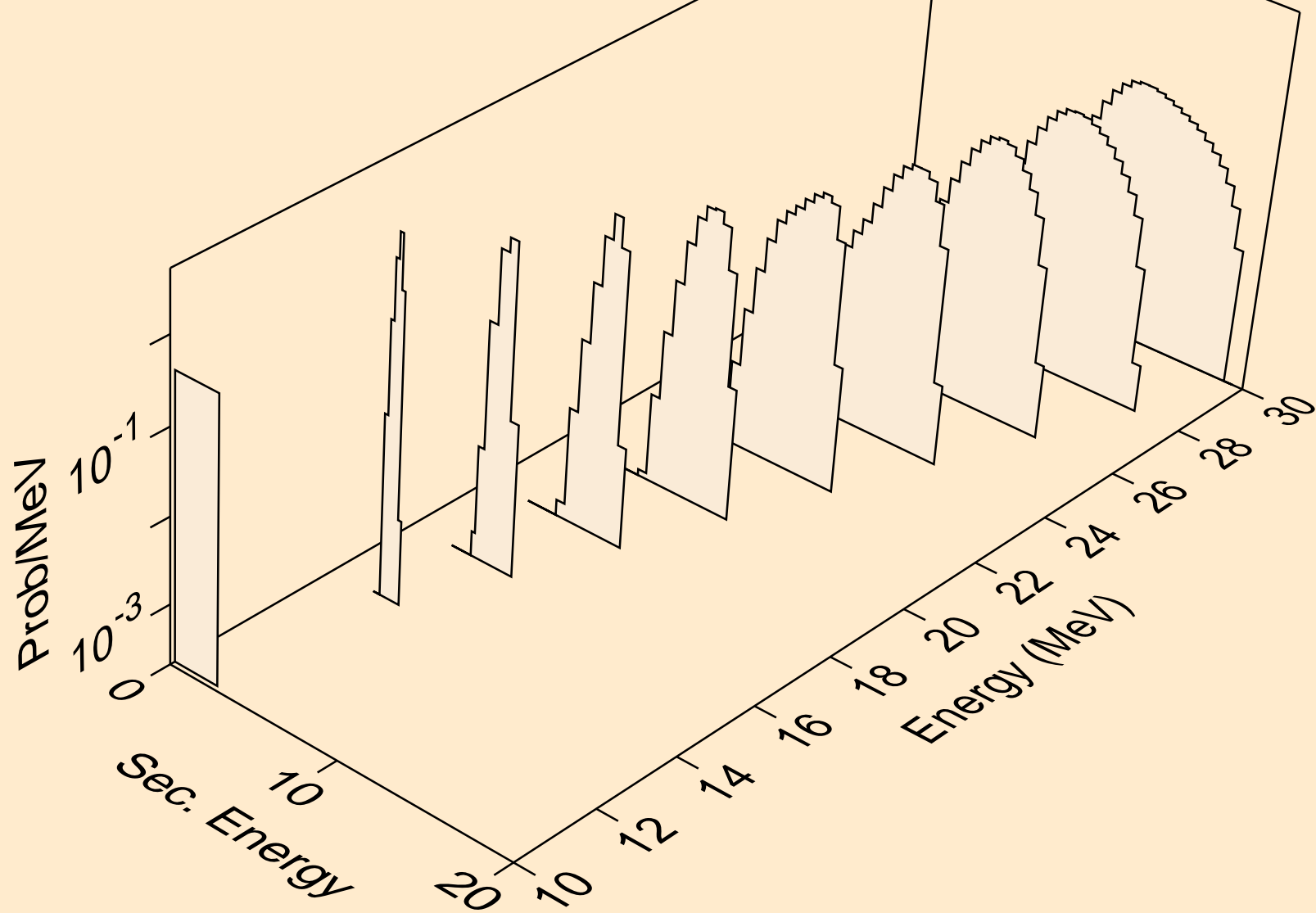

RH098M NEUTRON ACER TENDL-2023 LIBRARY; T=0.K  
alphas from (n,3n)a

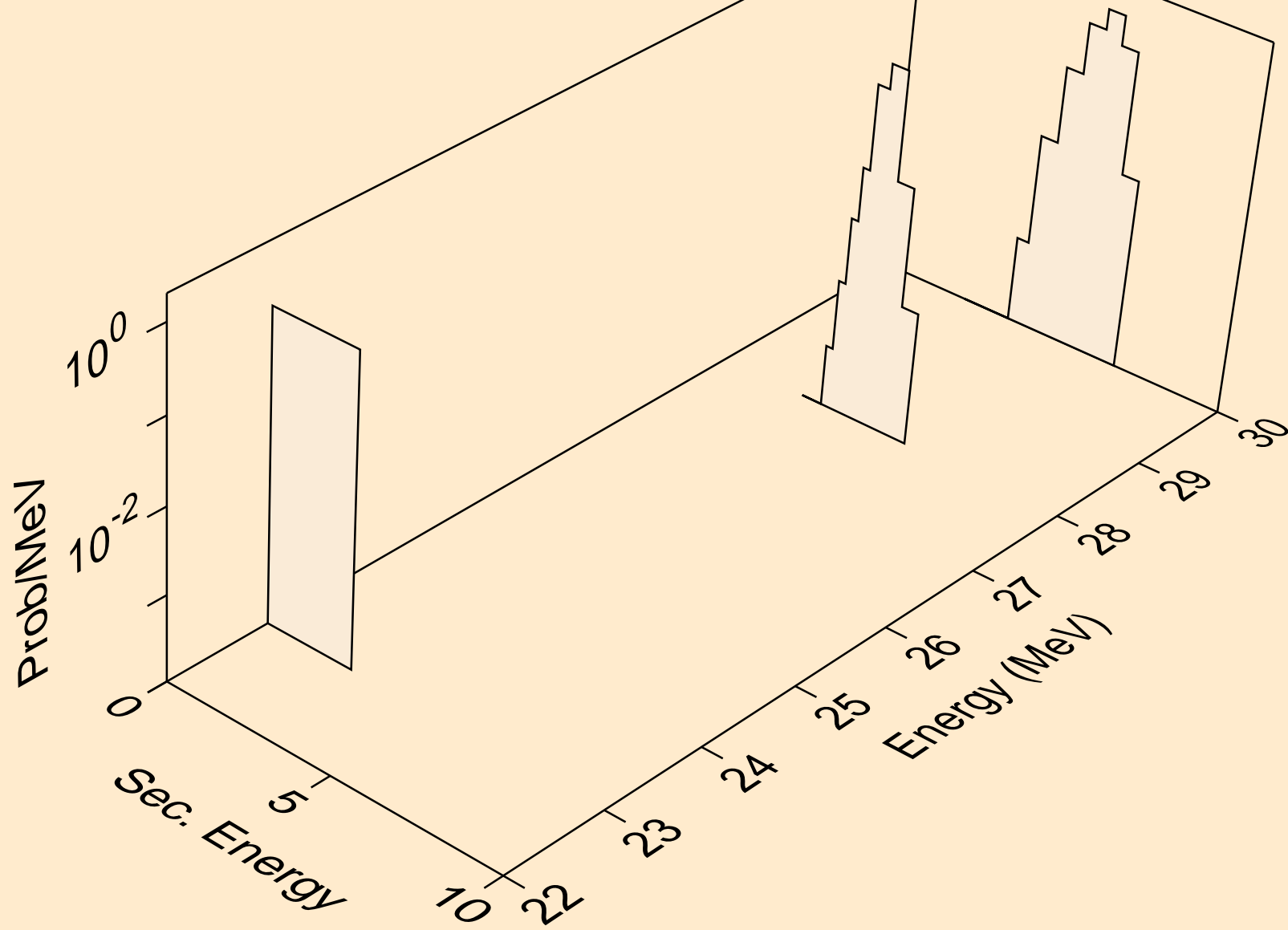

RH098M NEUTRON ACER TENDL-2023 LIBRARY; T=0.K  
alphas from (n,n\*)2a

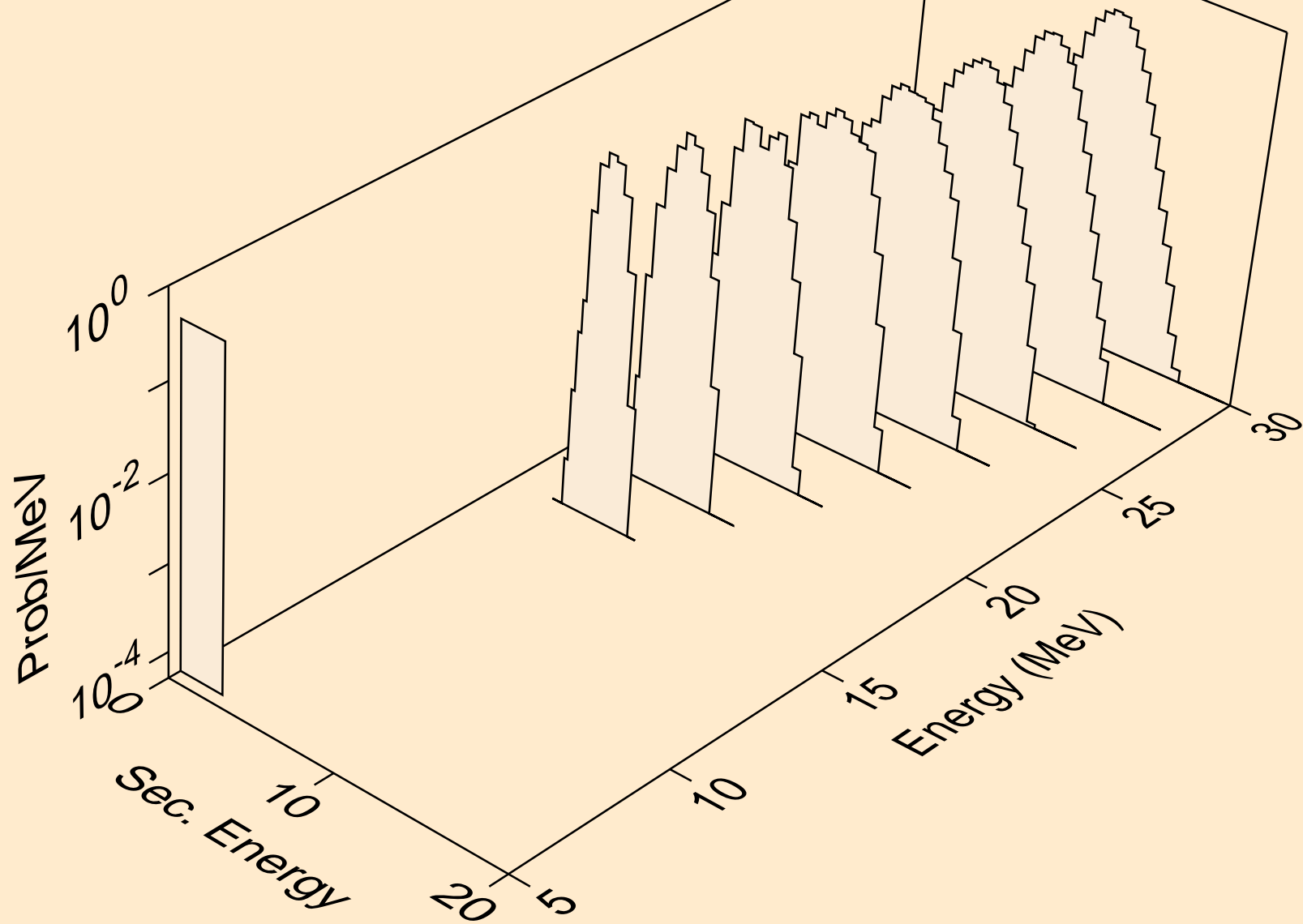

RH098M NEUTRON ACER TENDL-2023 LIBRARY; T=0.K  
alphas from (n,npa)

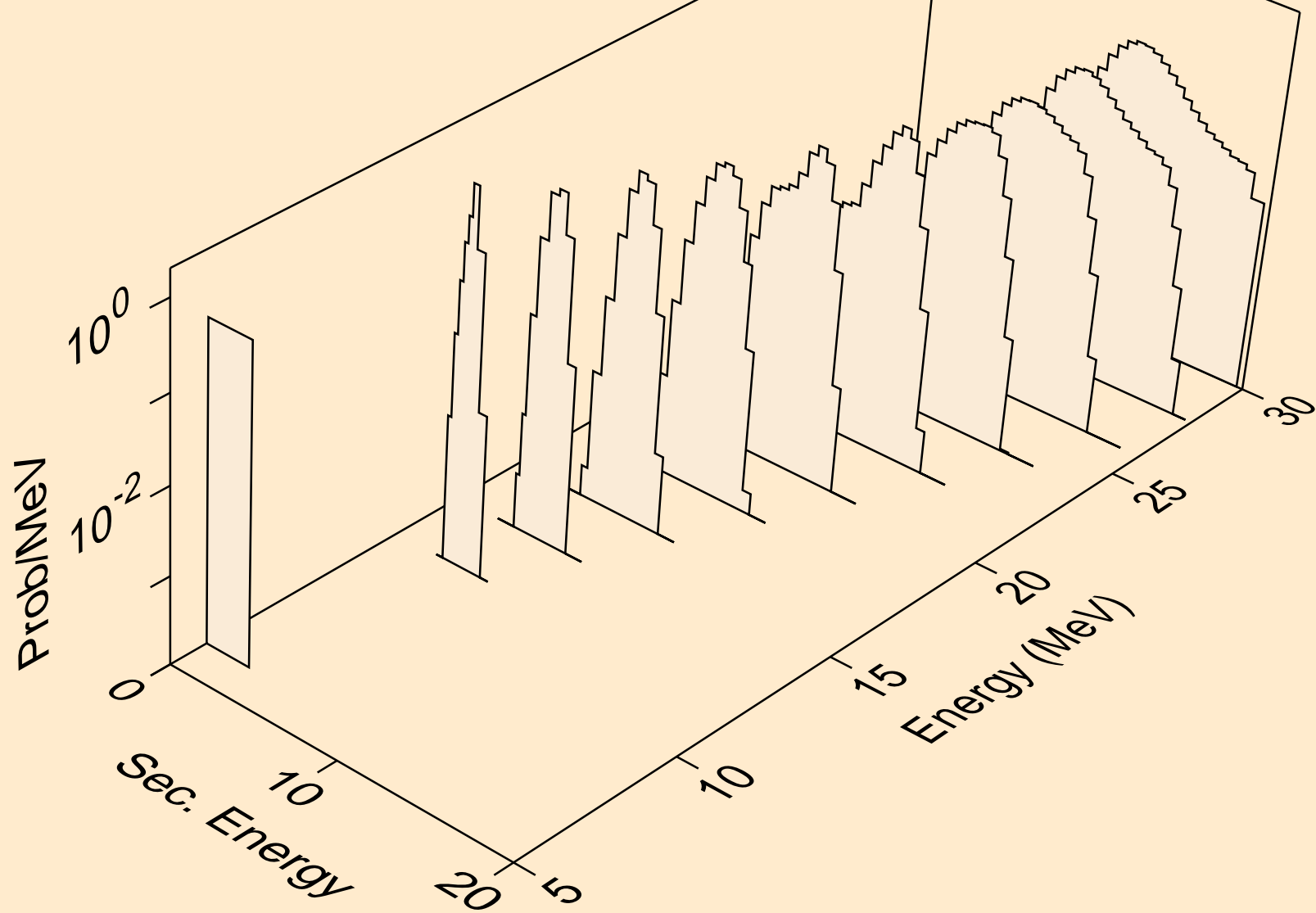



RH098M NEUTRON ACER TENDL-2023 LIBRARY; T=0.K  
alphas from (n,a)

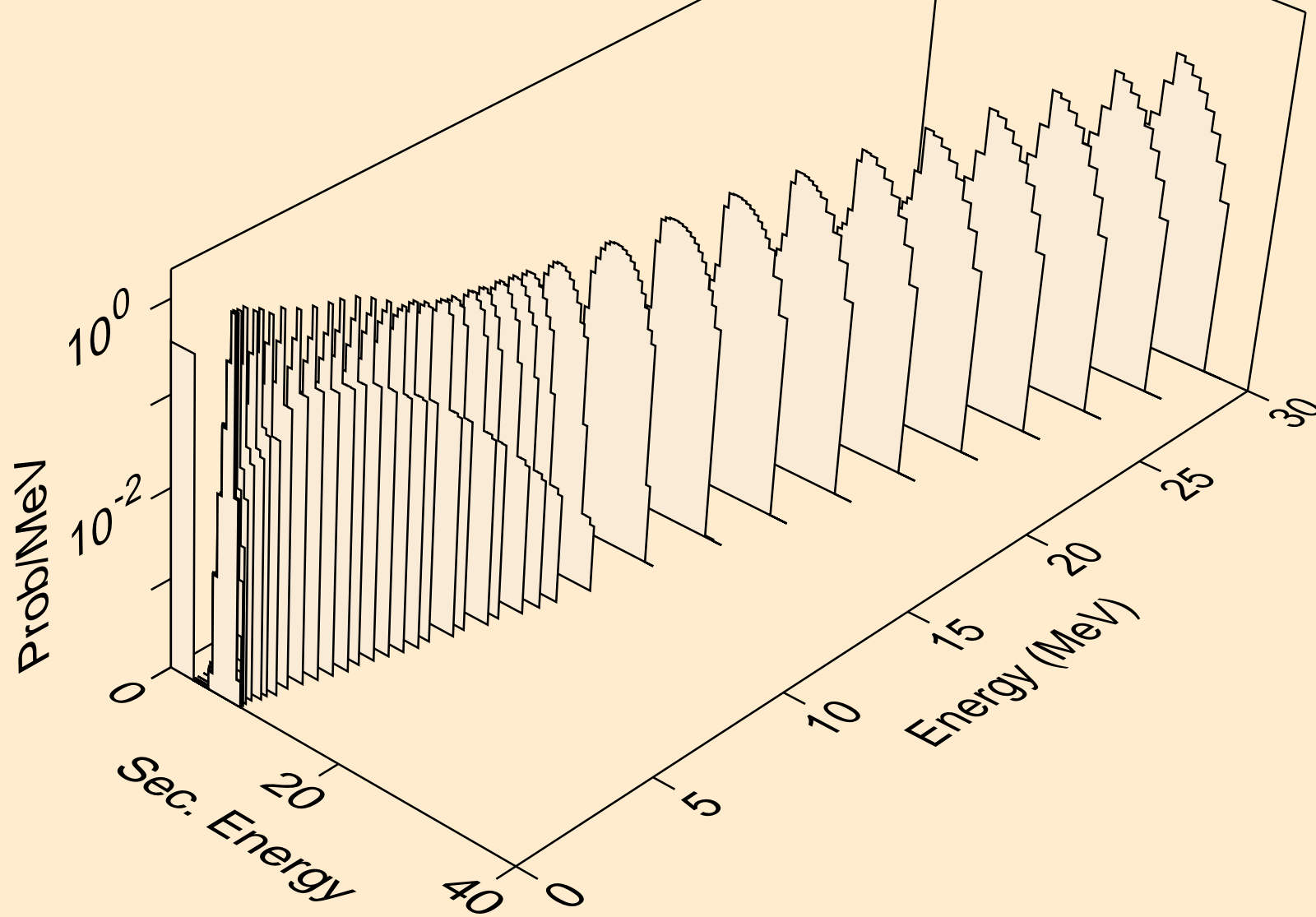

RH098M NEUTRON ACER TENDL-2023 LIBRARY; T=0.K  
alphas from (n,2a)

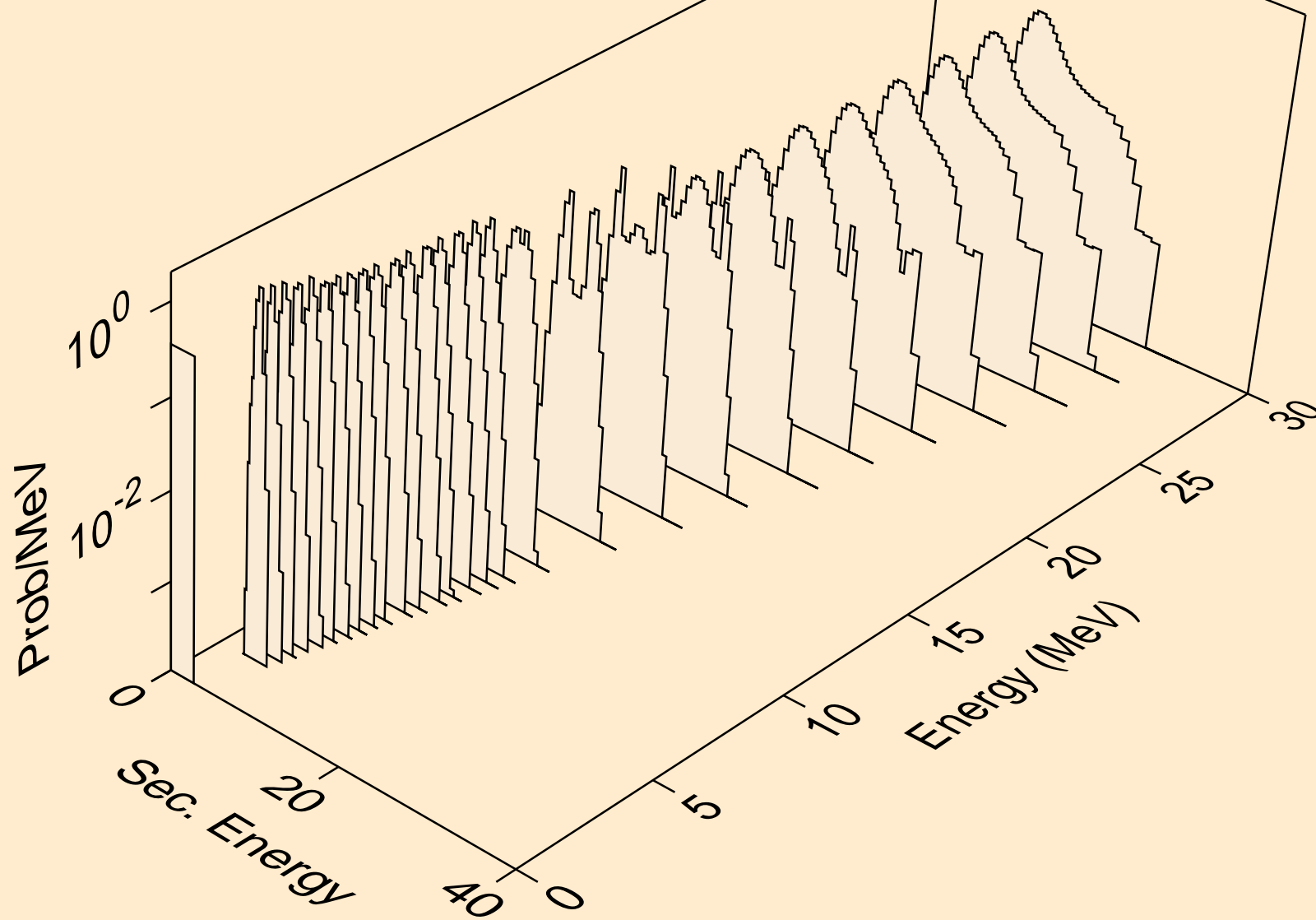

RH098M NEUTRON ACER TENDL-2023 LIBRARY; T=0.K  
alphas from (n,pa)

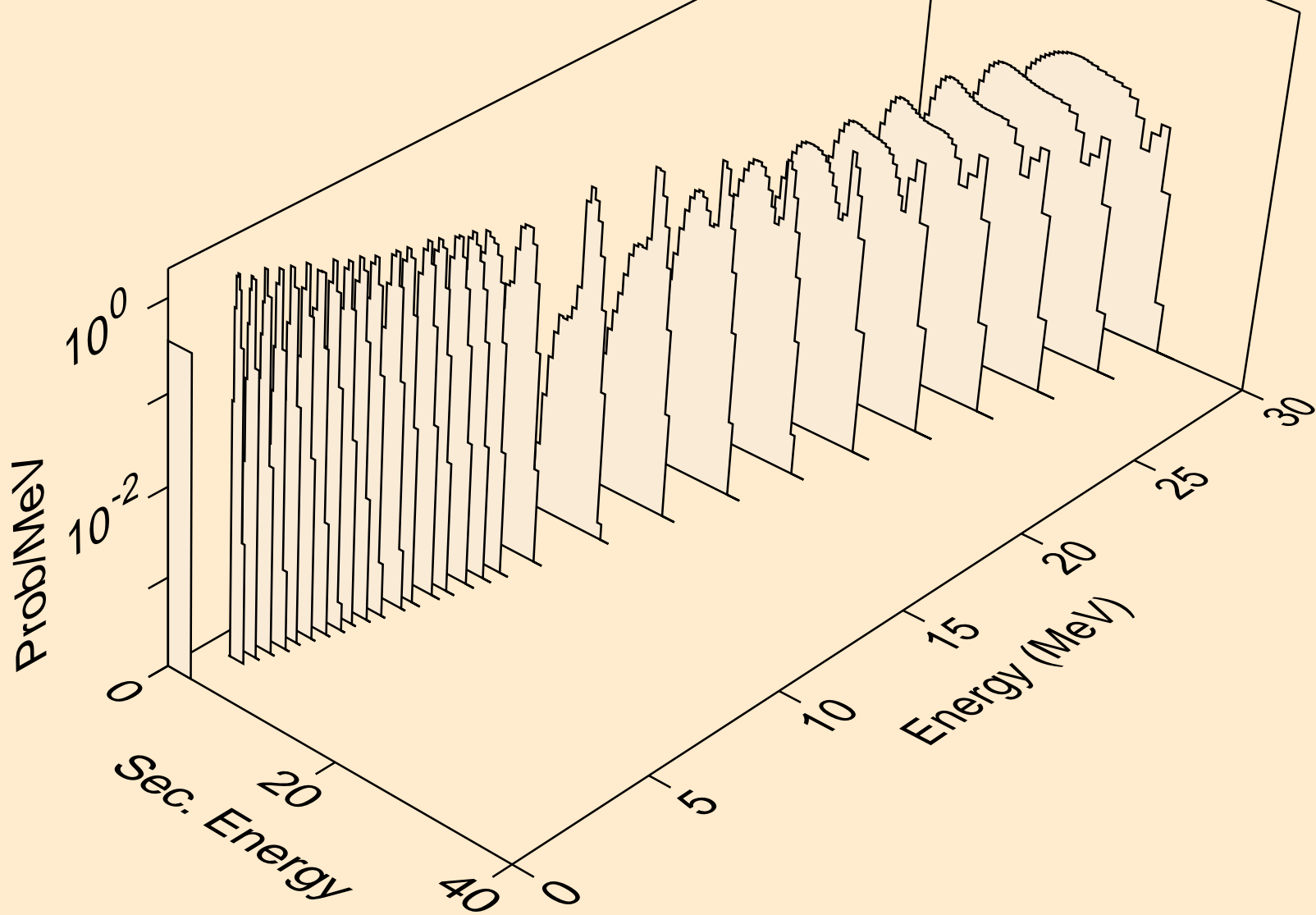

RH098M NEUTRON ACER TENDL-2023 LIBRARY; T=0.K  
alphas from (n,da)

