

SB126M NEUTRON ACER TENDL-2023 LIBRARY; T=0.K

Principal cross sections

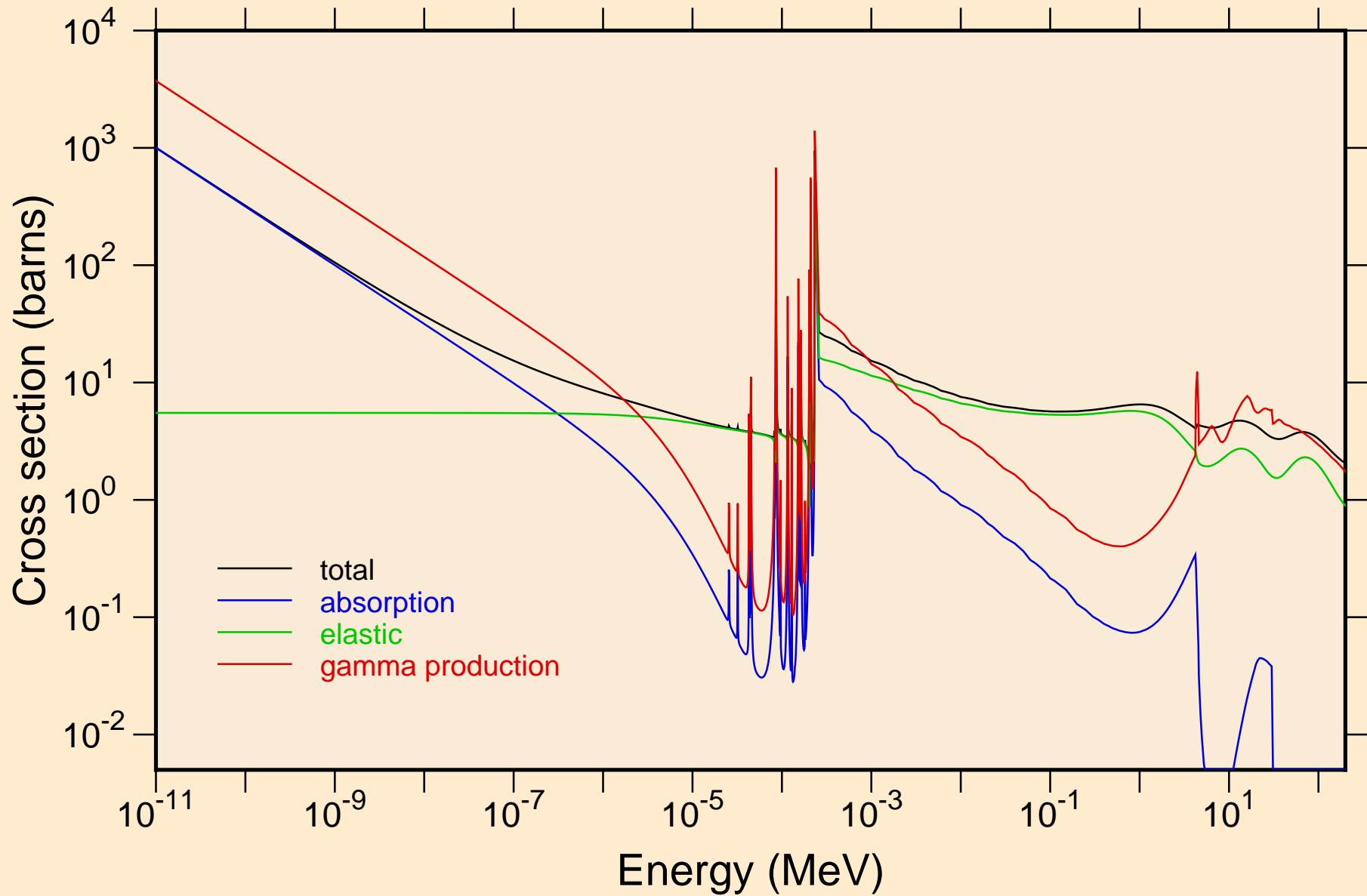

SB126M NEUTRON ACER TENDL-2023 LIBRARY; T=0.K
resonance total cross section

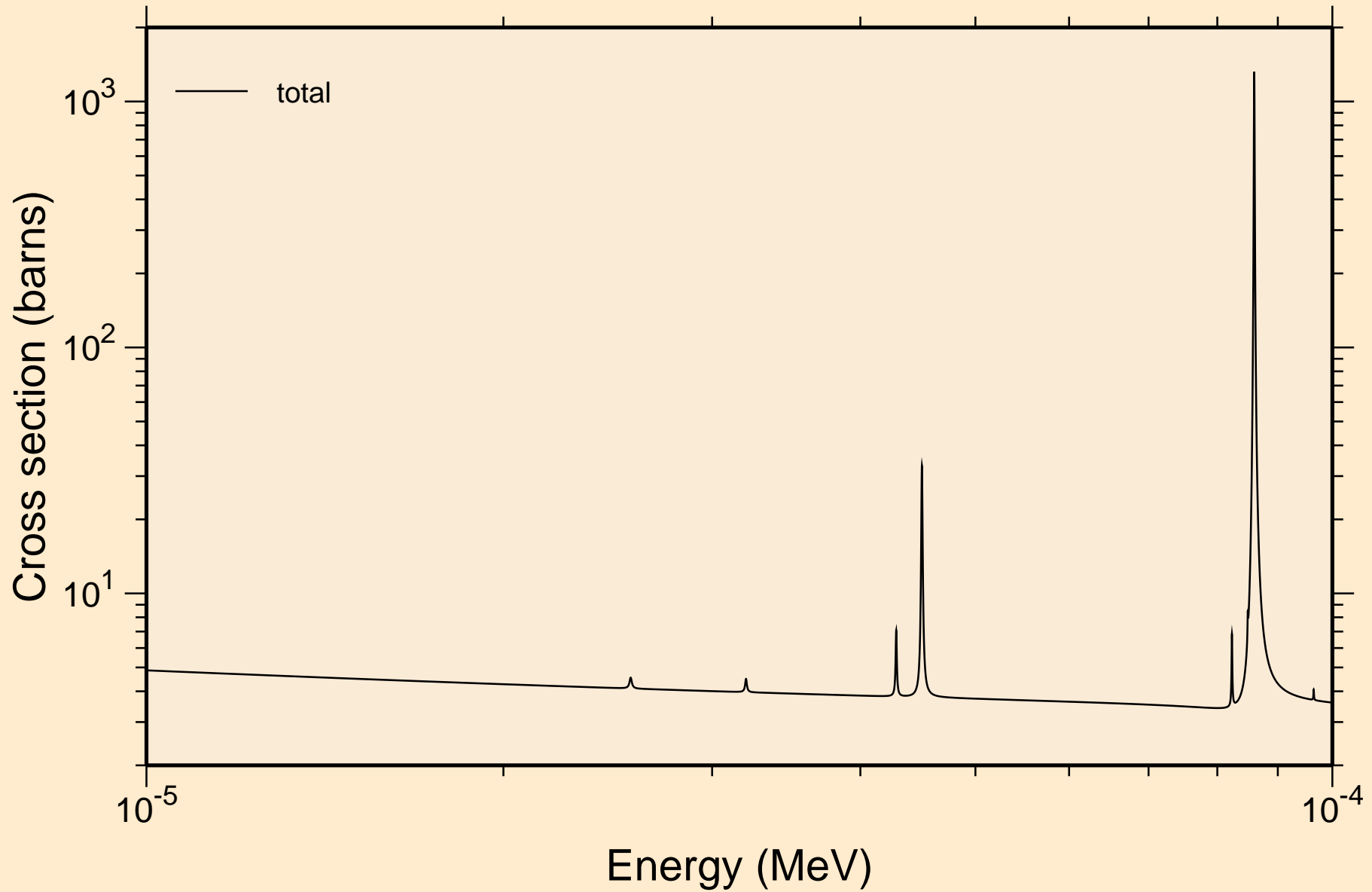

SB126M NEUTRON ACER TENDL-2023 LIBRARY; T=0.K
resonance total cross section

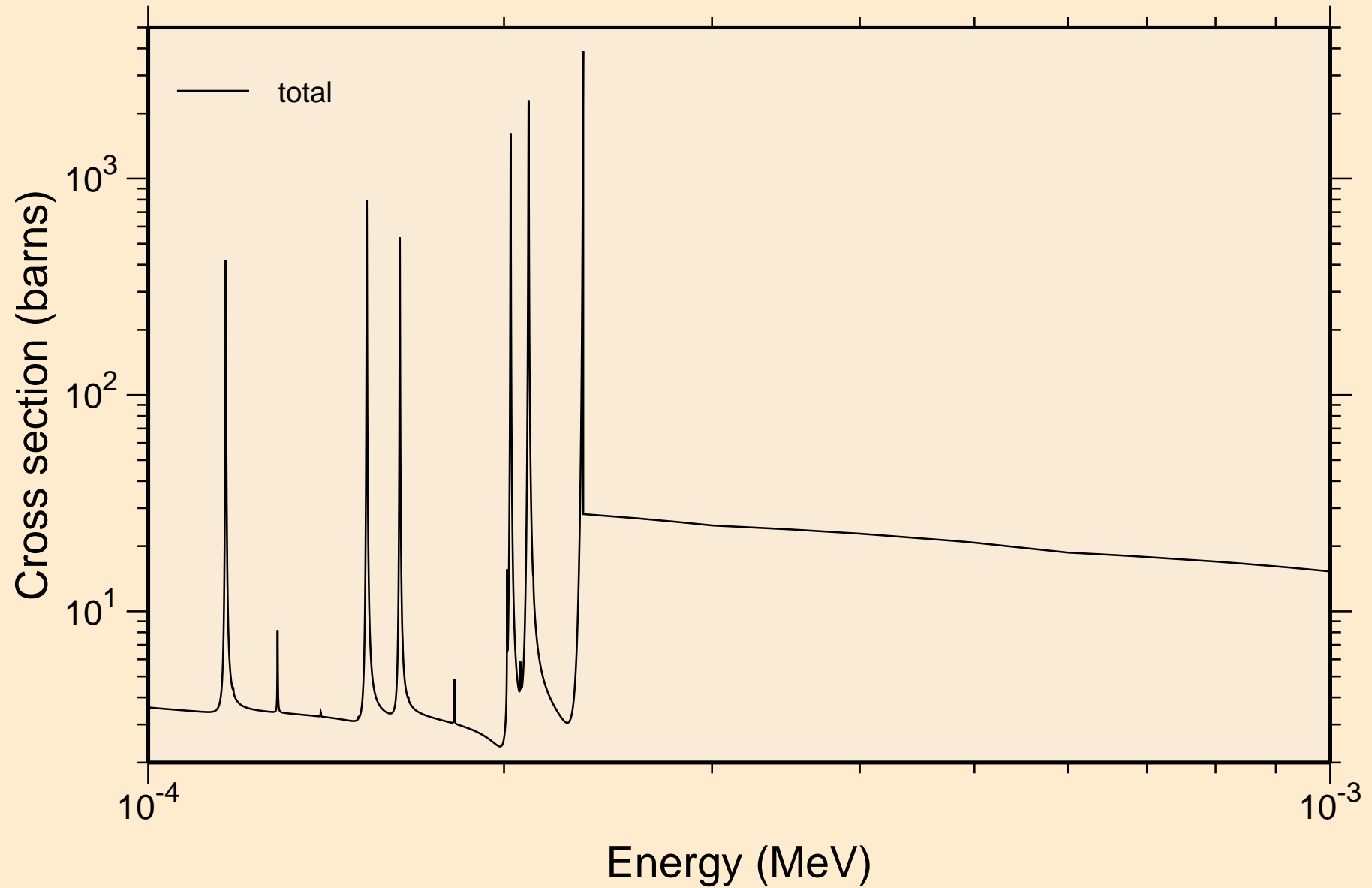

S¹²⁶M NEUTRON ACER TENDL-2023 LIBRARY; T=0.K
resonance total cross section

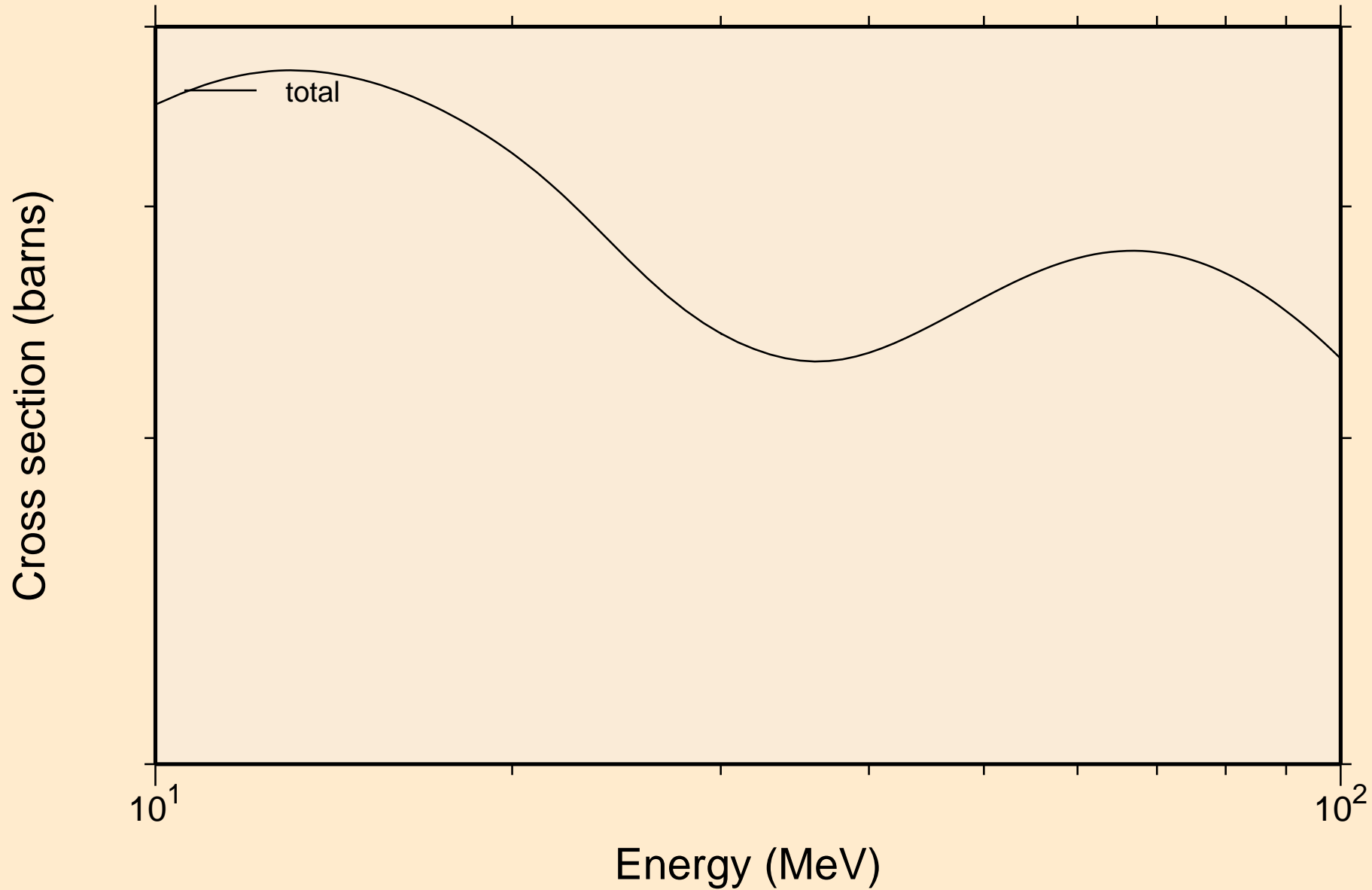

SB126M NEUTRON ACER TENDL-2023 LIBRARY; T=0.K
resonance absorption cross sections

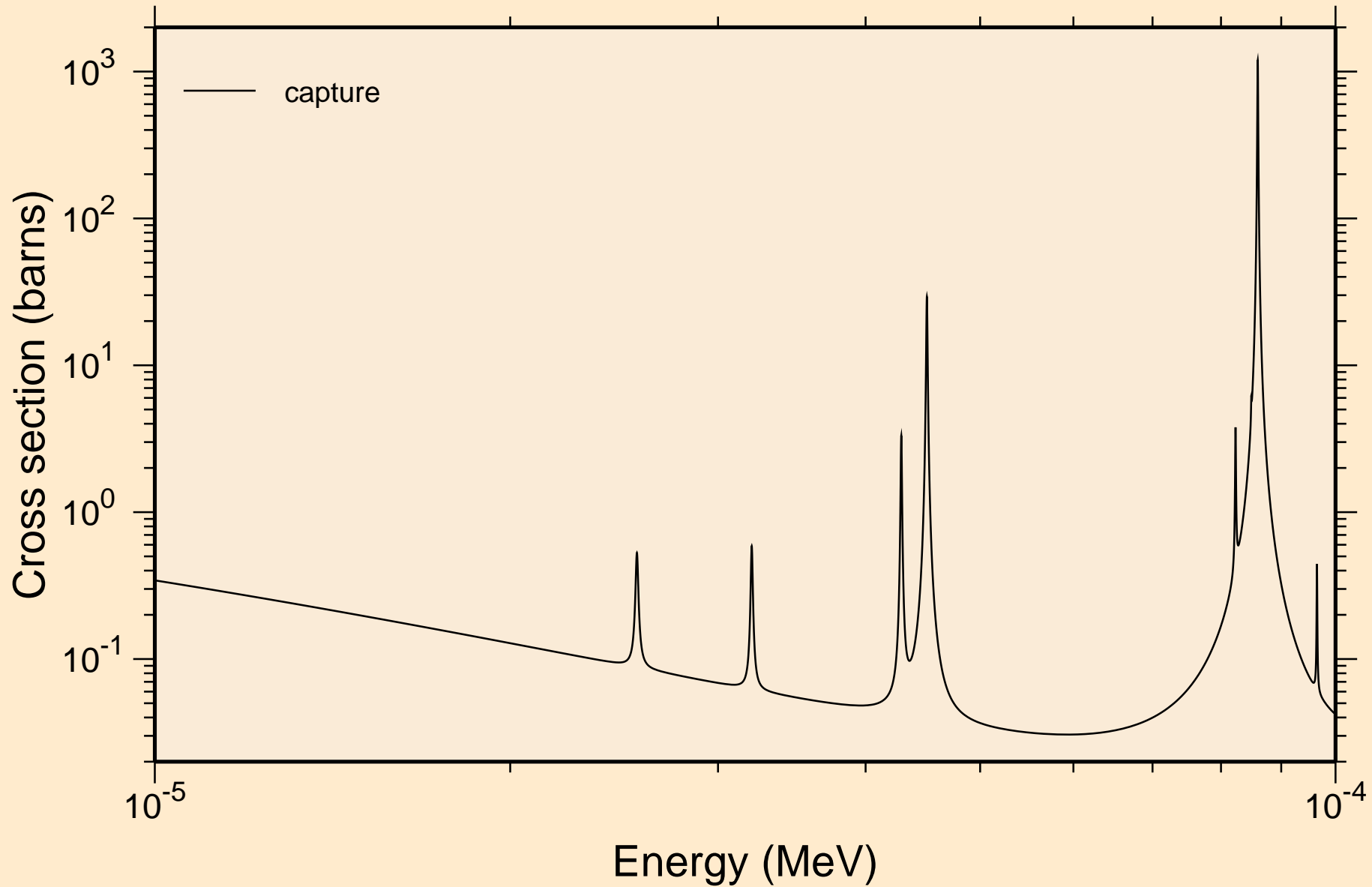

SB126M NEUTRON ACER TENDL-2023 LIBRARY; T=0.K
resonance absorption cross sections

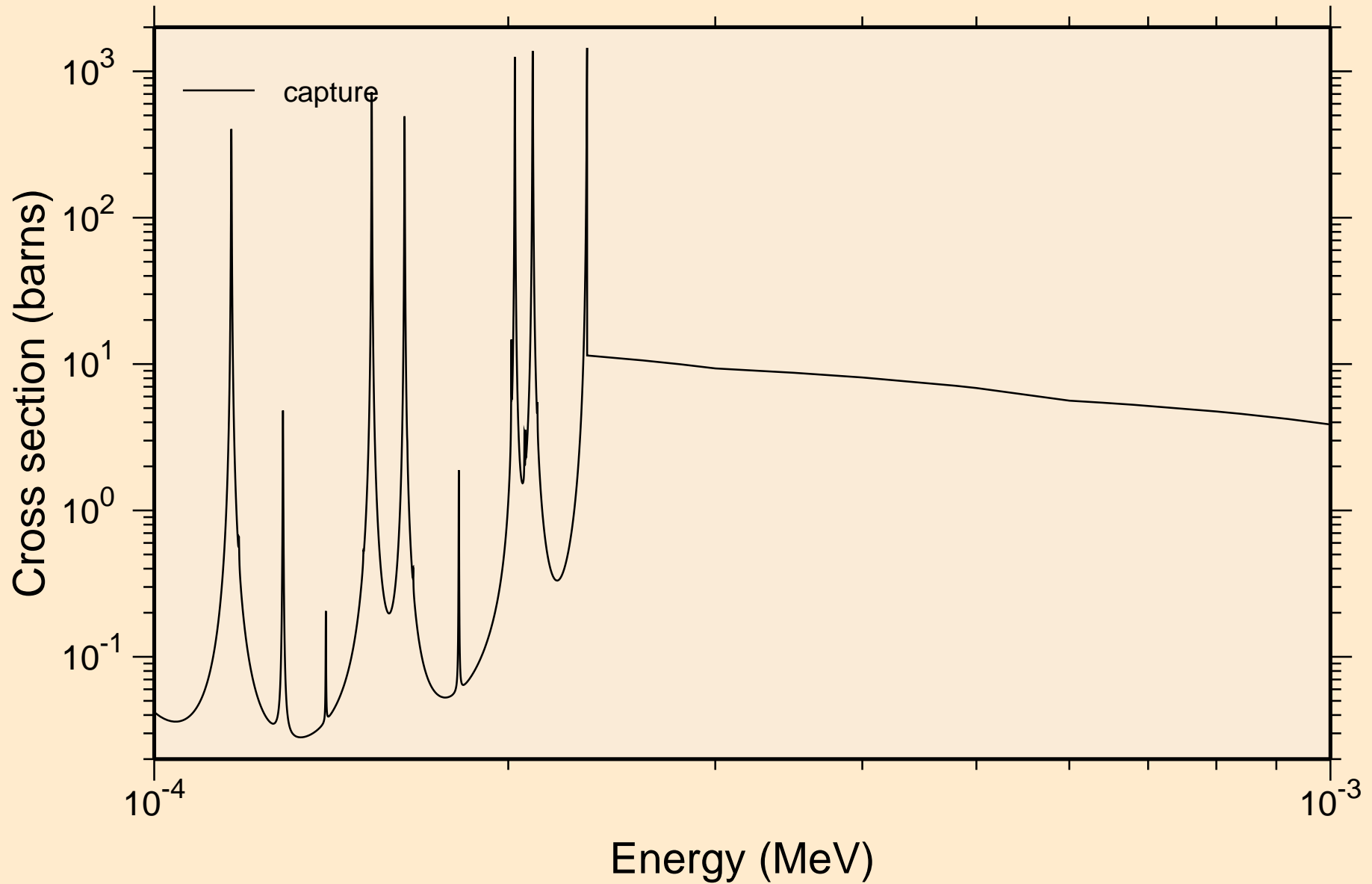

SB126M NEUTRON ACER TENDL-2023 LIBRARY; T=0.K
resonance absorption cross sections

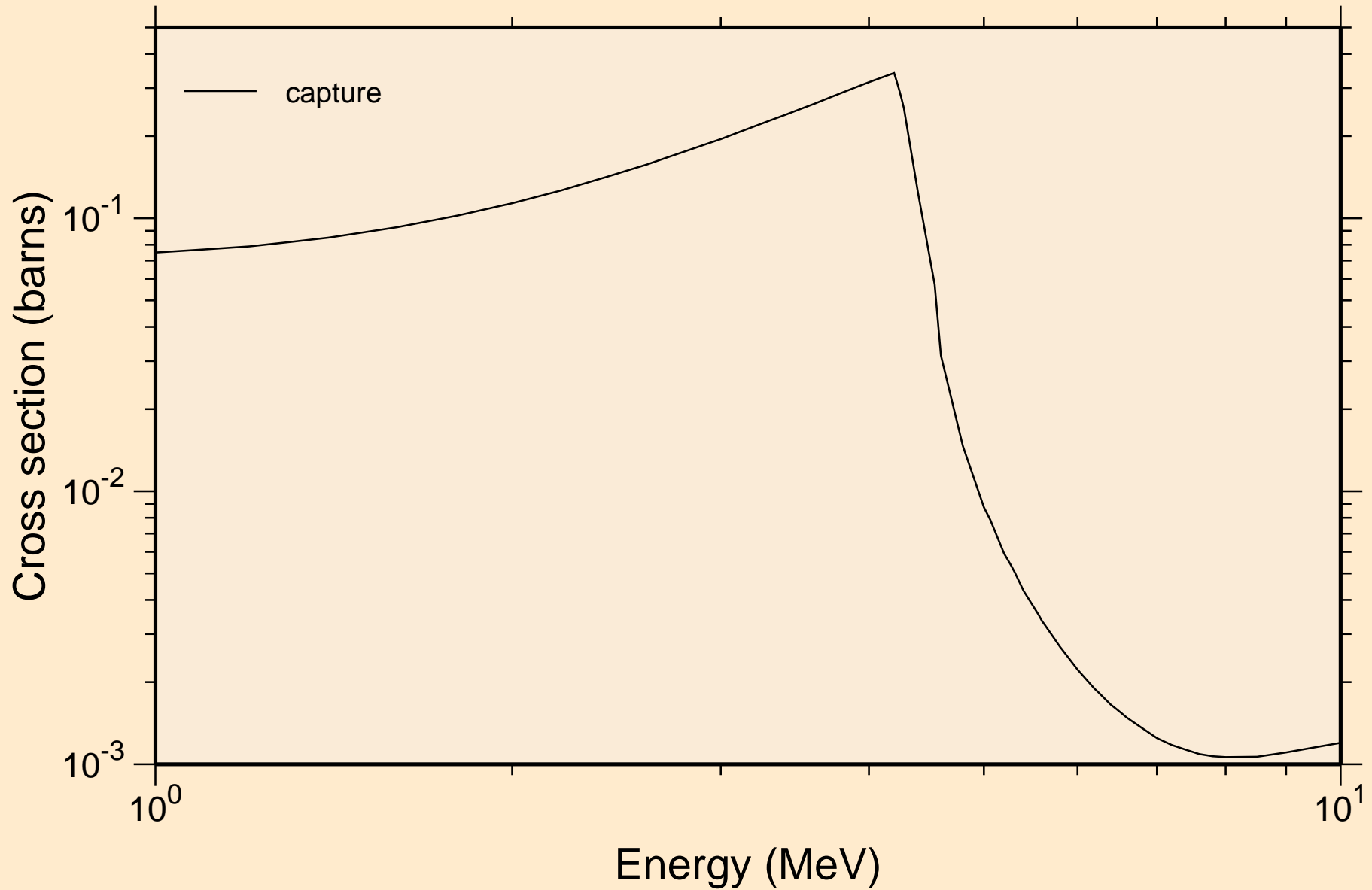

SB126M NEUTRON ACER TENDL-2023 LIBRARY; T=0.K

Heating

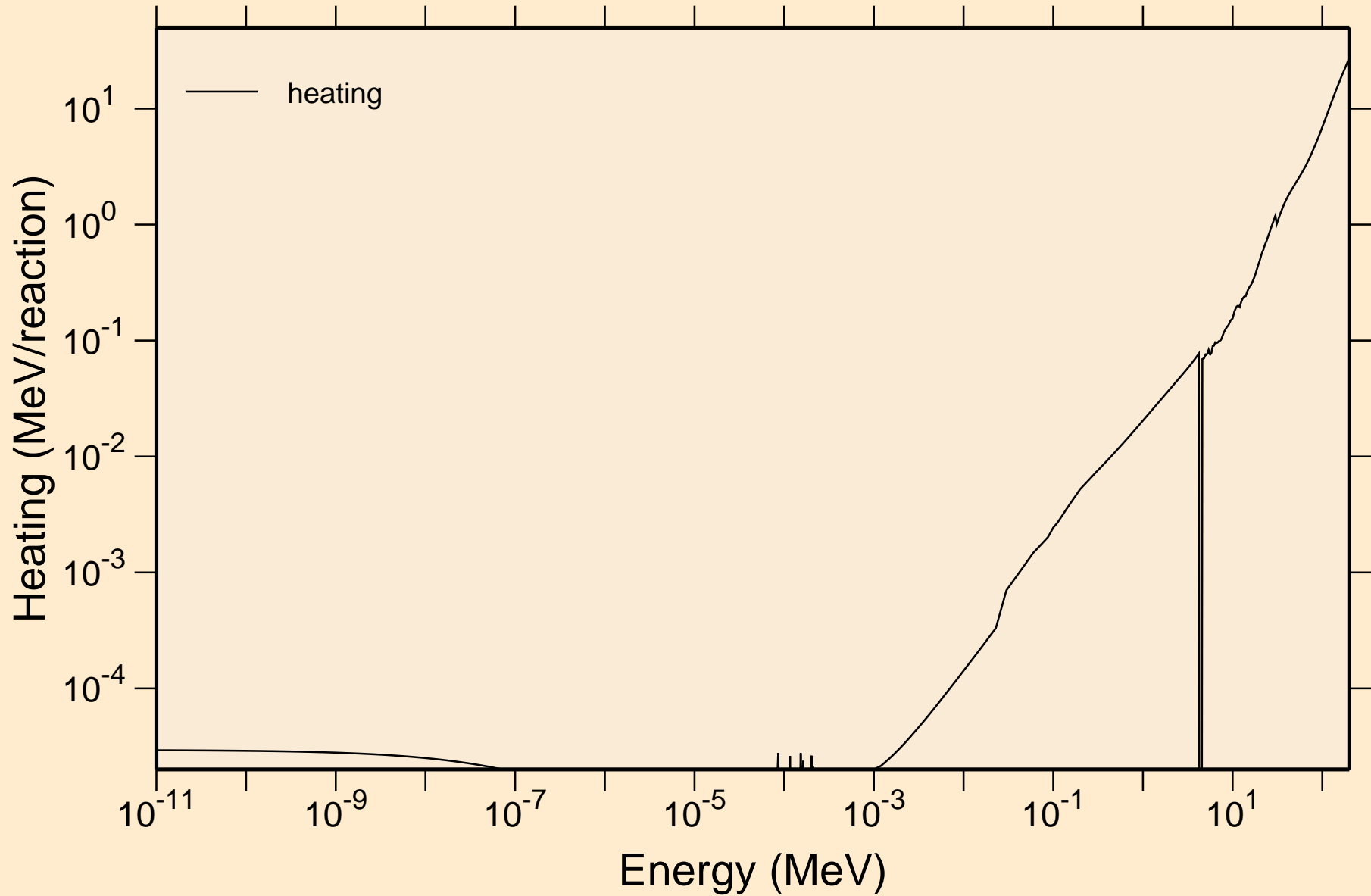

SB126M NEUTRON ACER TENDL-2023 LIBRARY; T=0.K
Damage

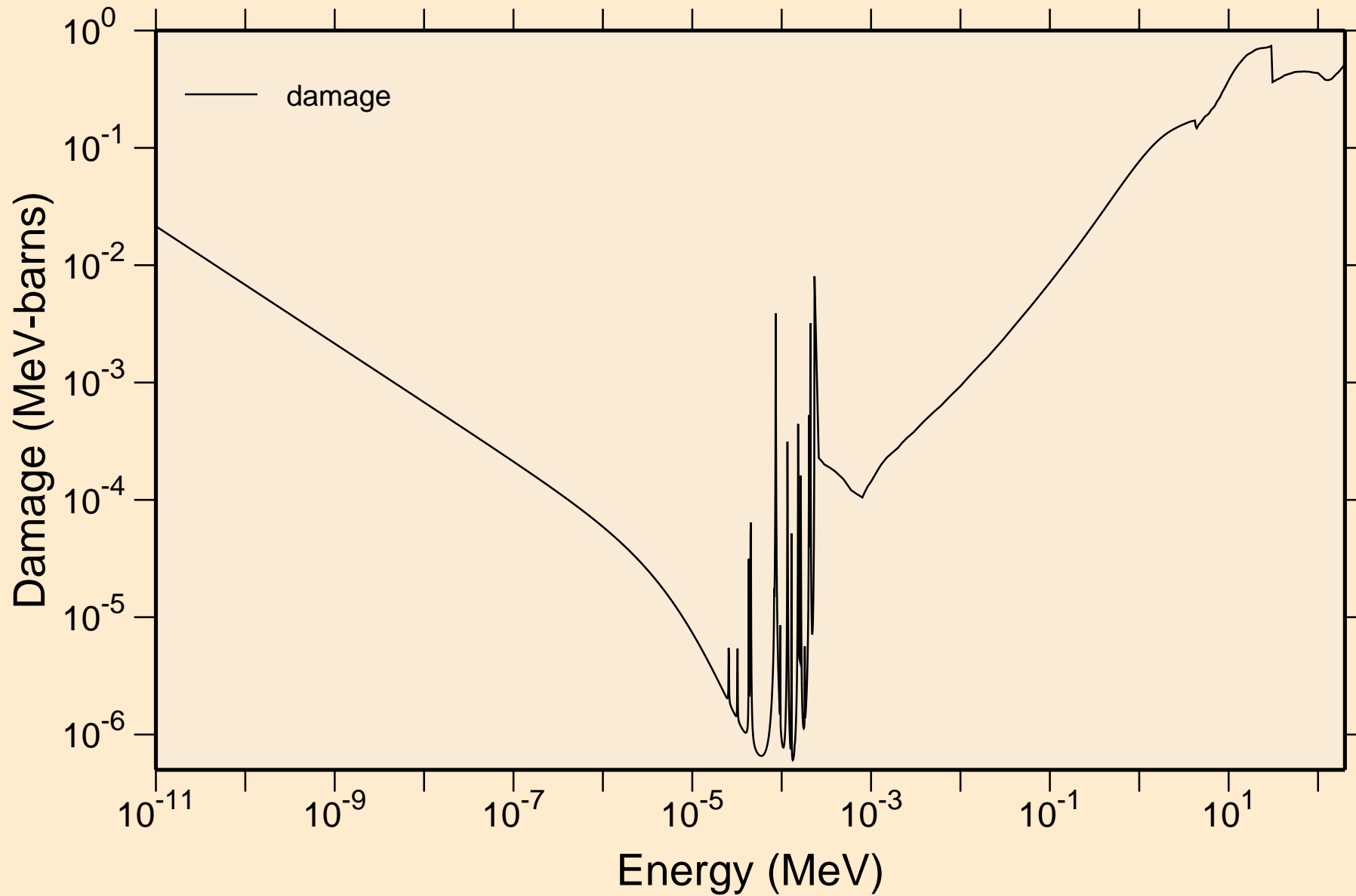

SB126M NEUTRON ACER TENDL-2023 LIBRARY; T=0.K

Non-threshold reactions

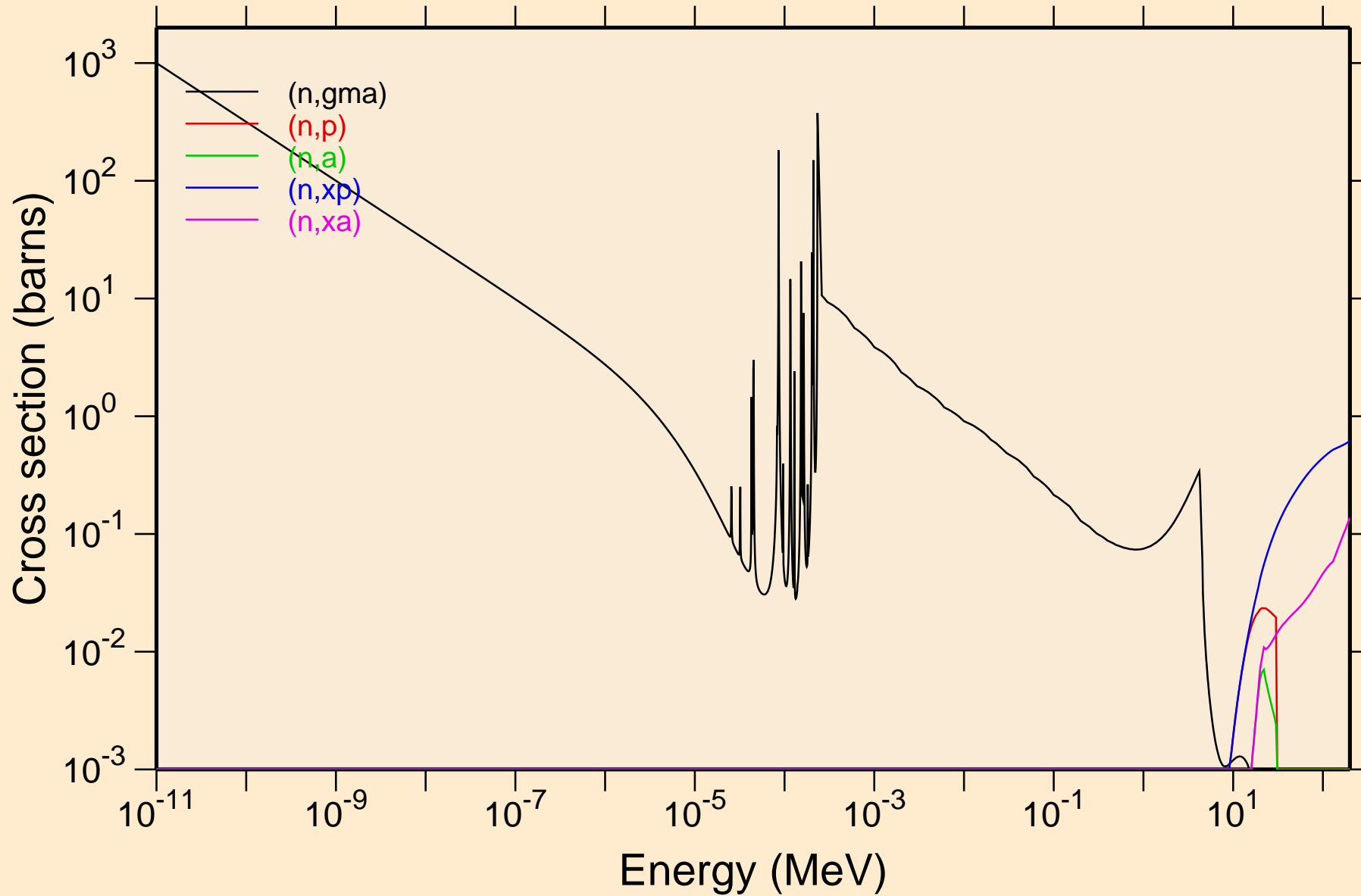

SB126M NEUTRON ACER TENDL-2023 LIBRARY; T=0.K

Principal cross sections

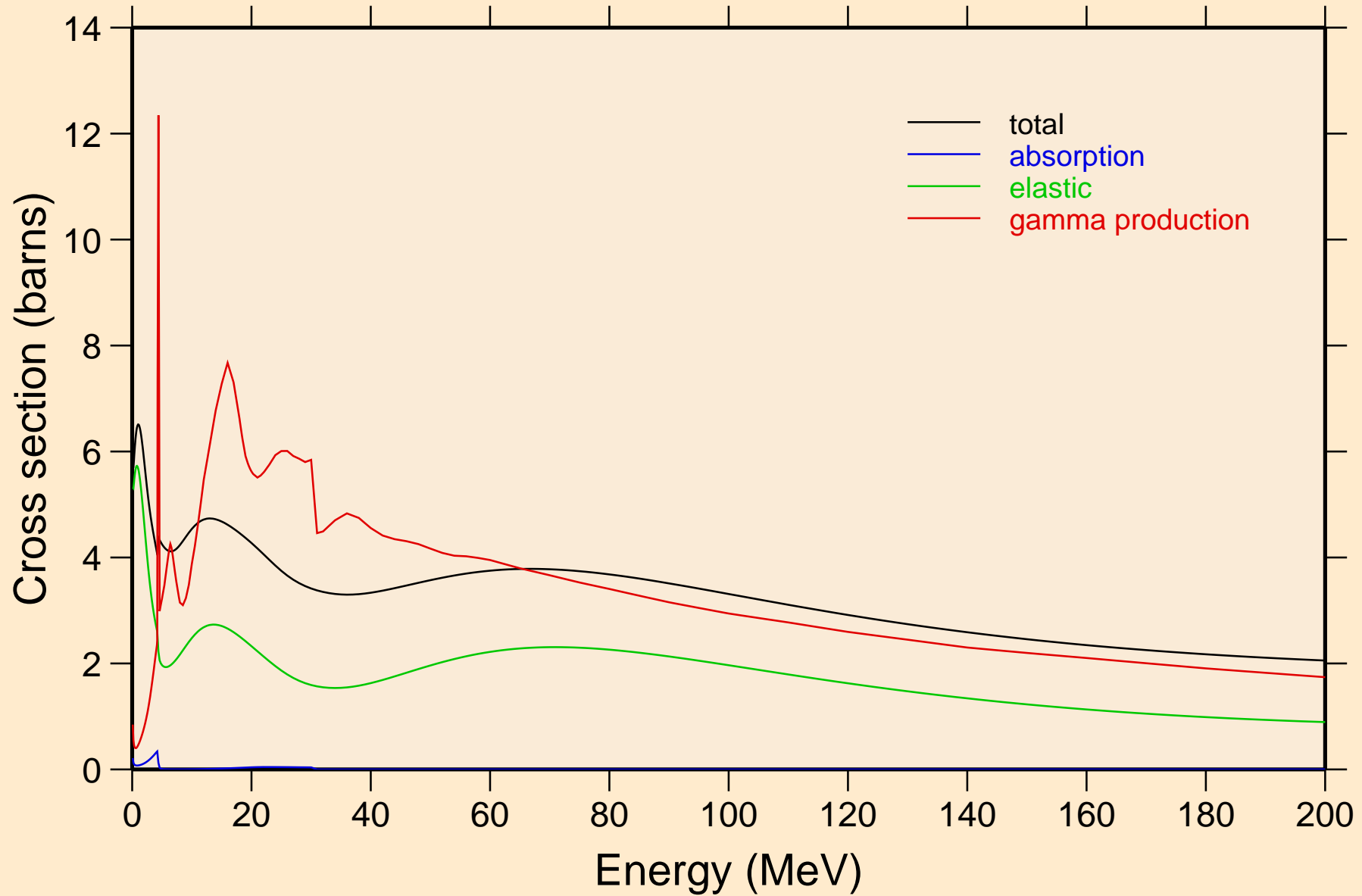

SB126M NEUTRON ACER TENDL-2023 LIBRARY; T=0.K

Heating

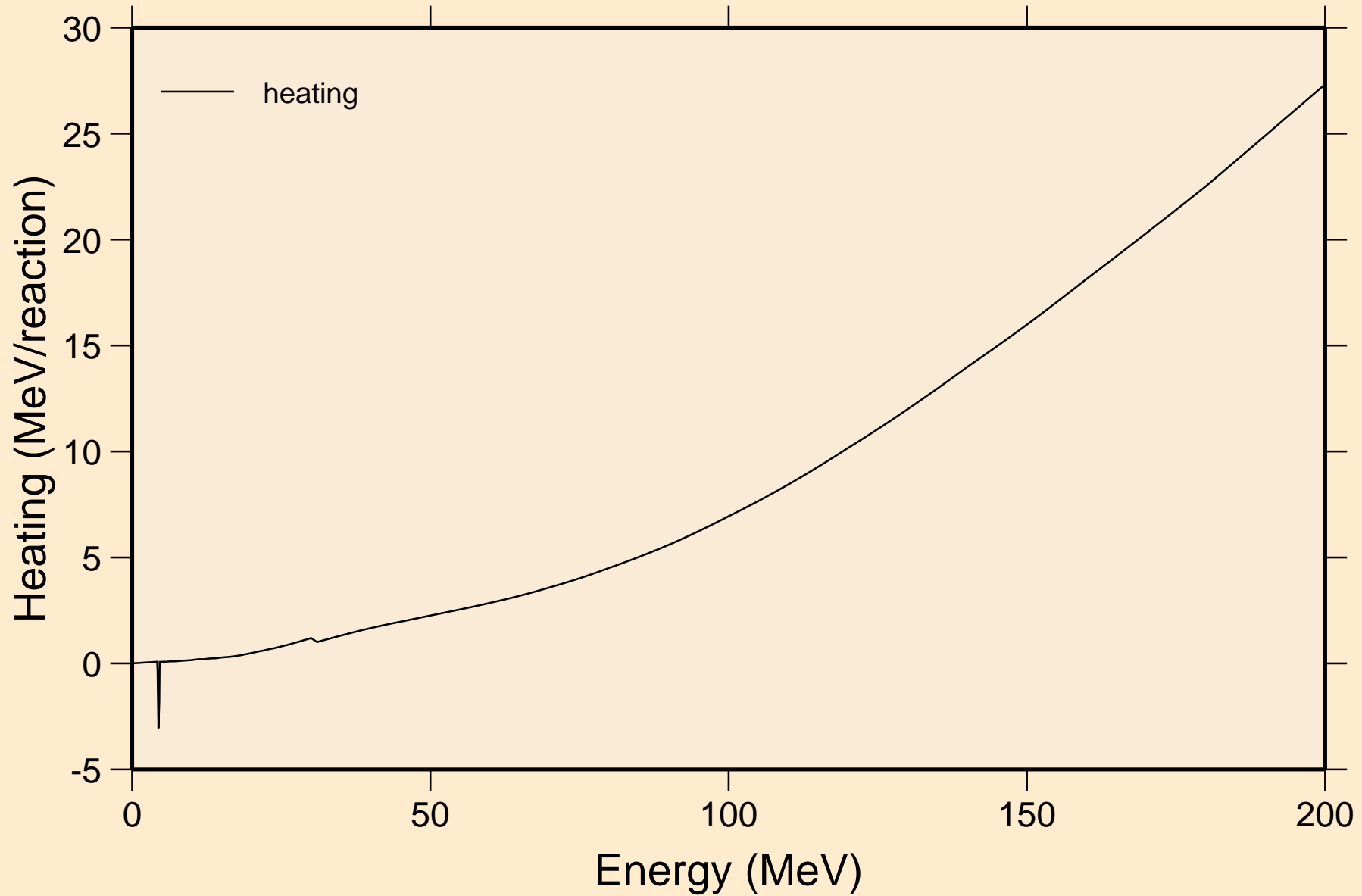

SB126M NEUTRON ACER TENDL-2023 LIBRARY; T=0.K
Damage

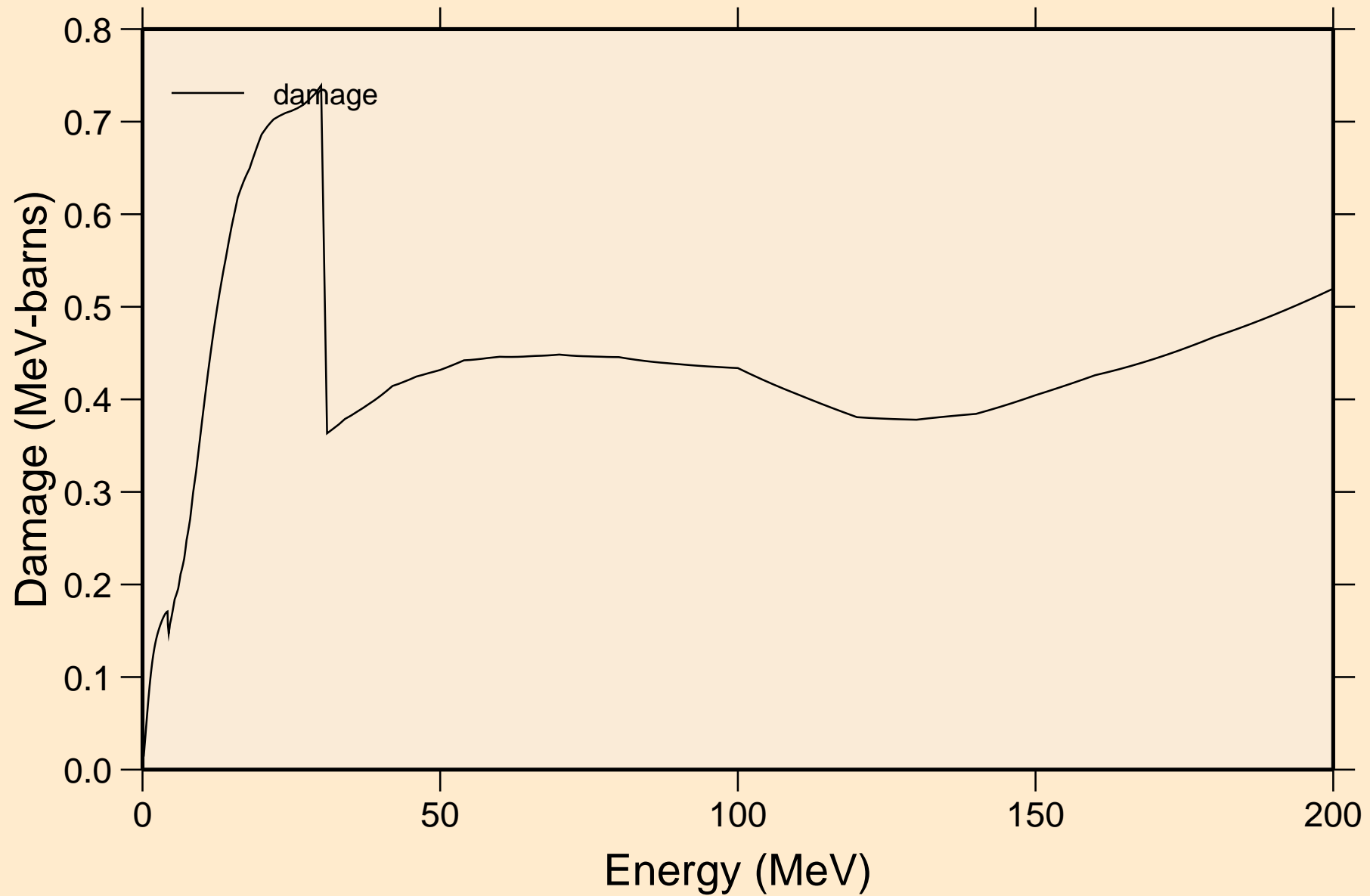

SB126M NEUTRON ACER TENDL-2023 LIBRARY; T=0.K

Non-threshold reactions

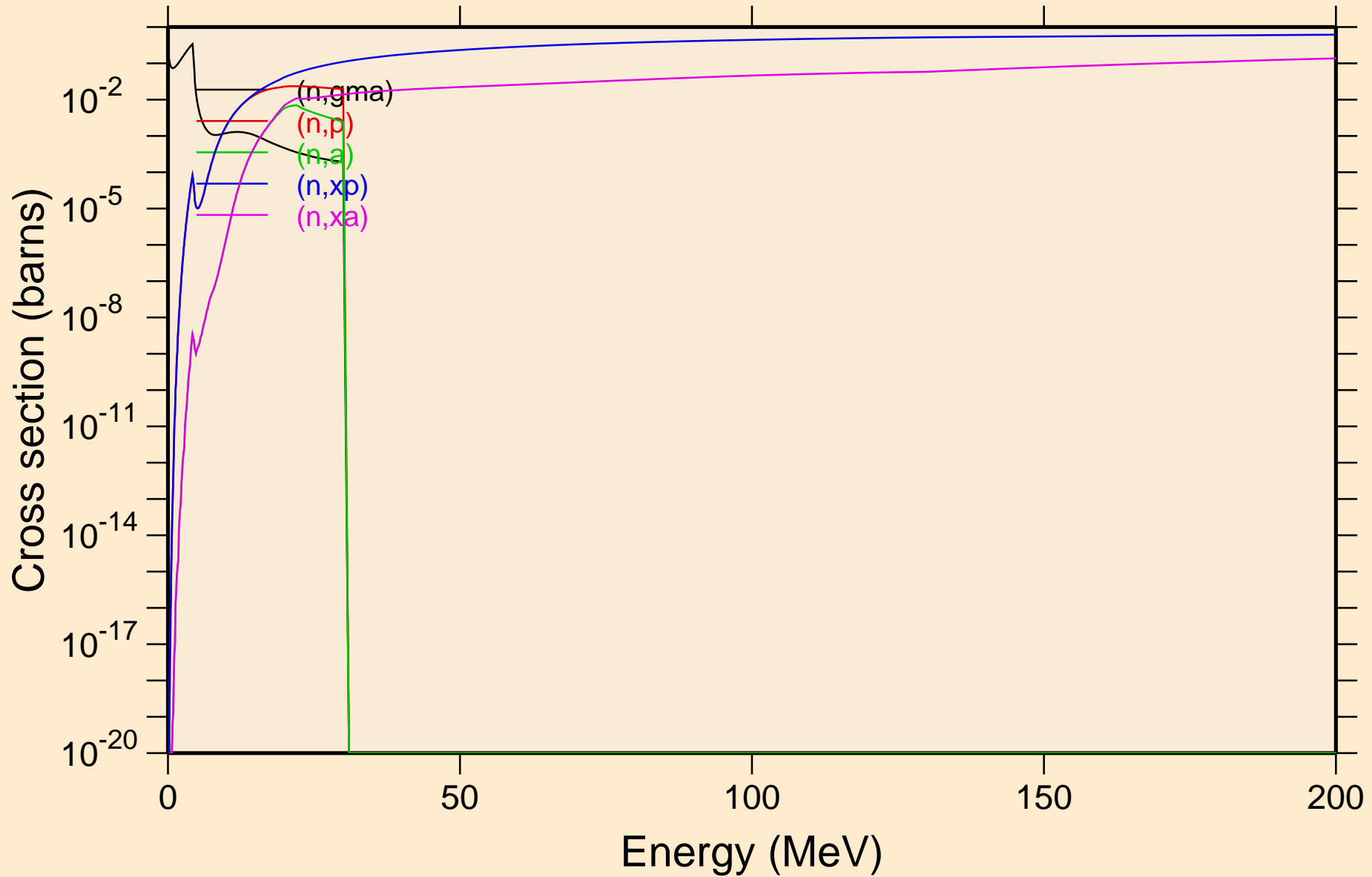

SB126M NEUTRON ACER TENDL-2023 LIBRARY; T=0.K
Inelastic levels

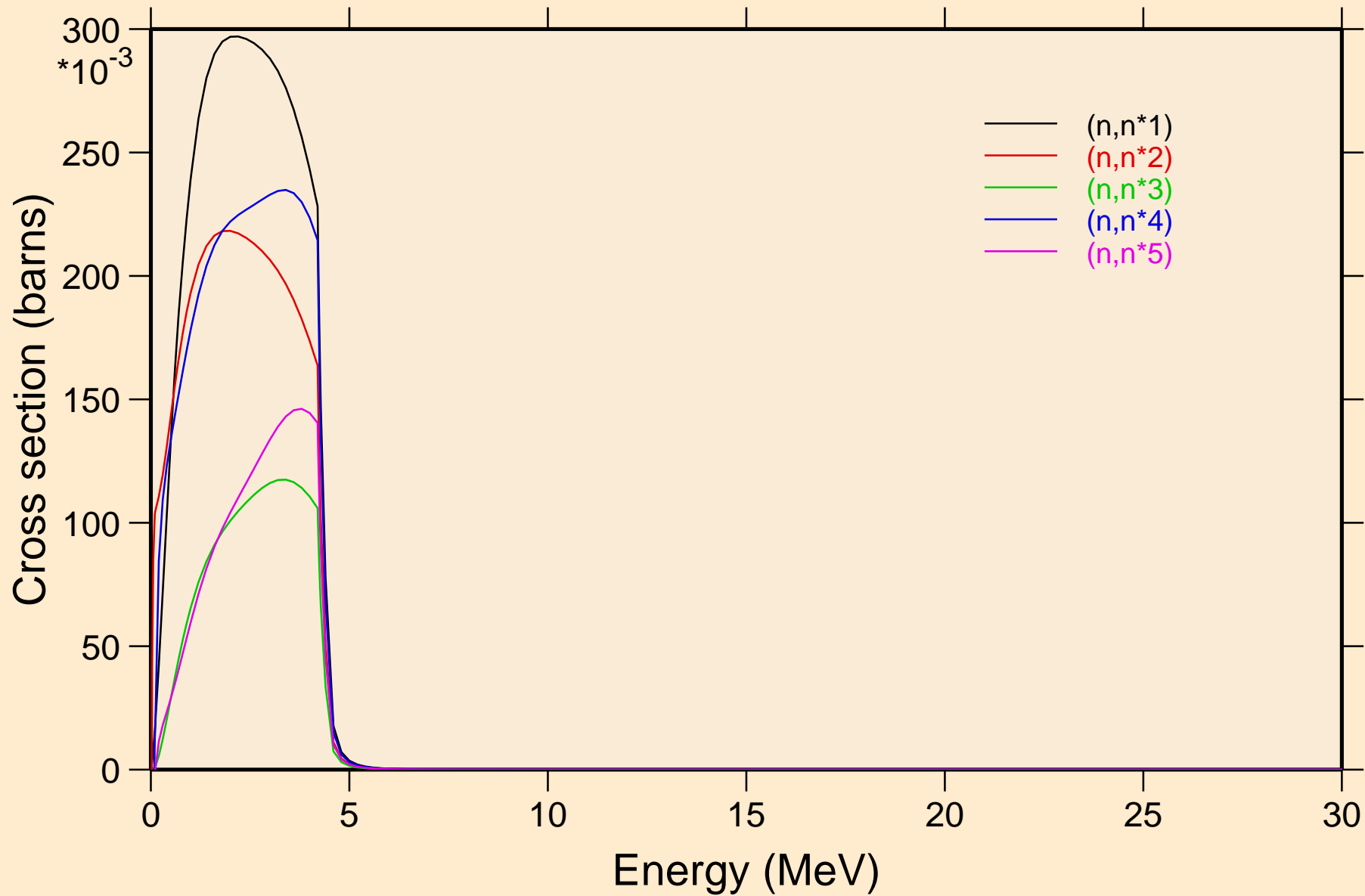

SB126M NEUTRON ACER TENDL-2023 LIBRARY; T=0.K
Inelastic levels

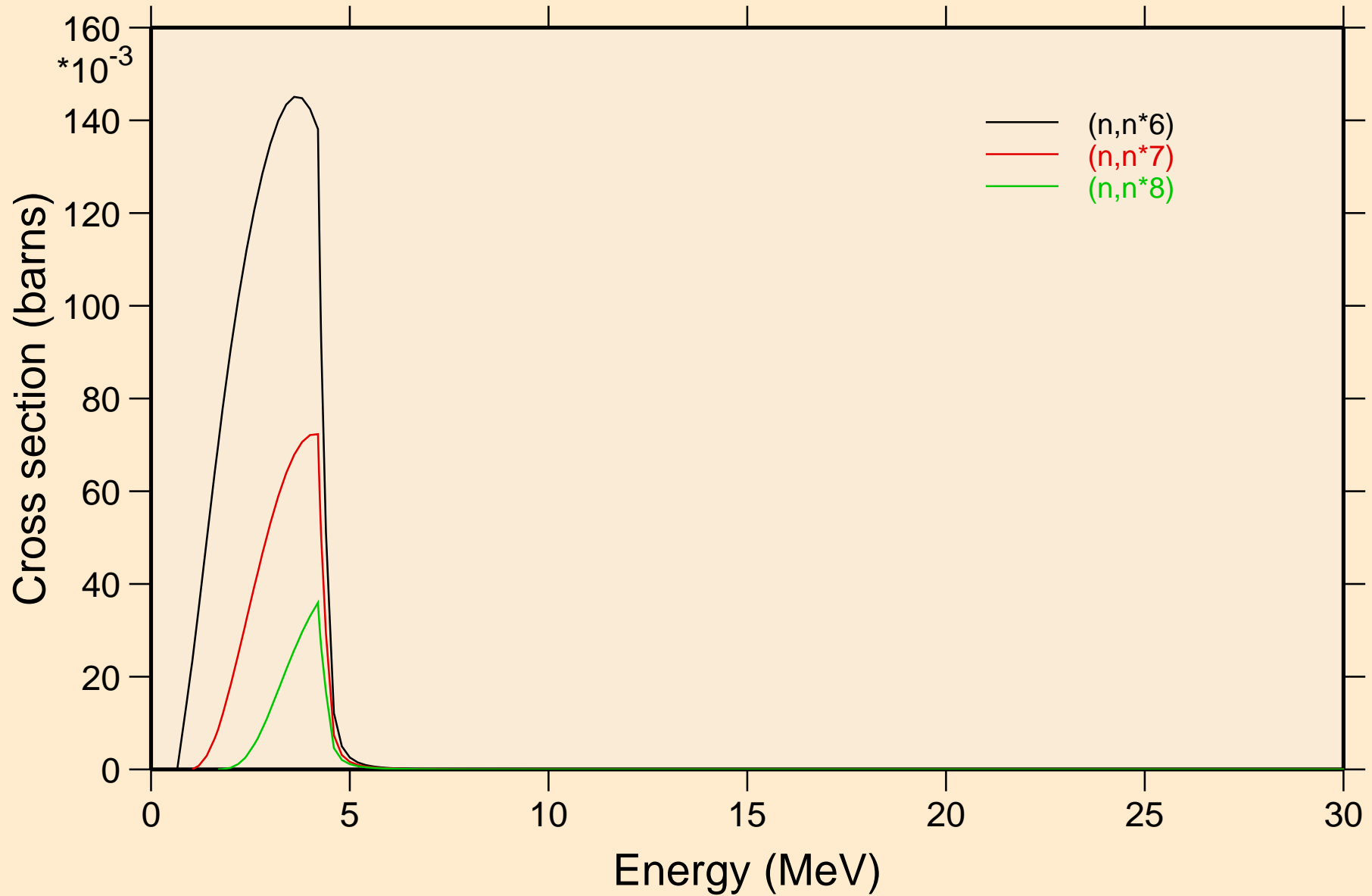

SB126M NEUTRON ACER TENDL-2023 LIBRARY; T=0.K

Threshold reactions

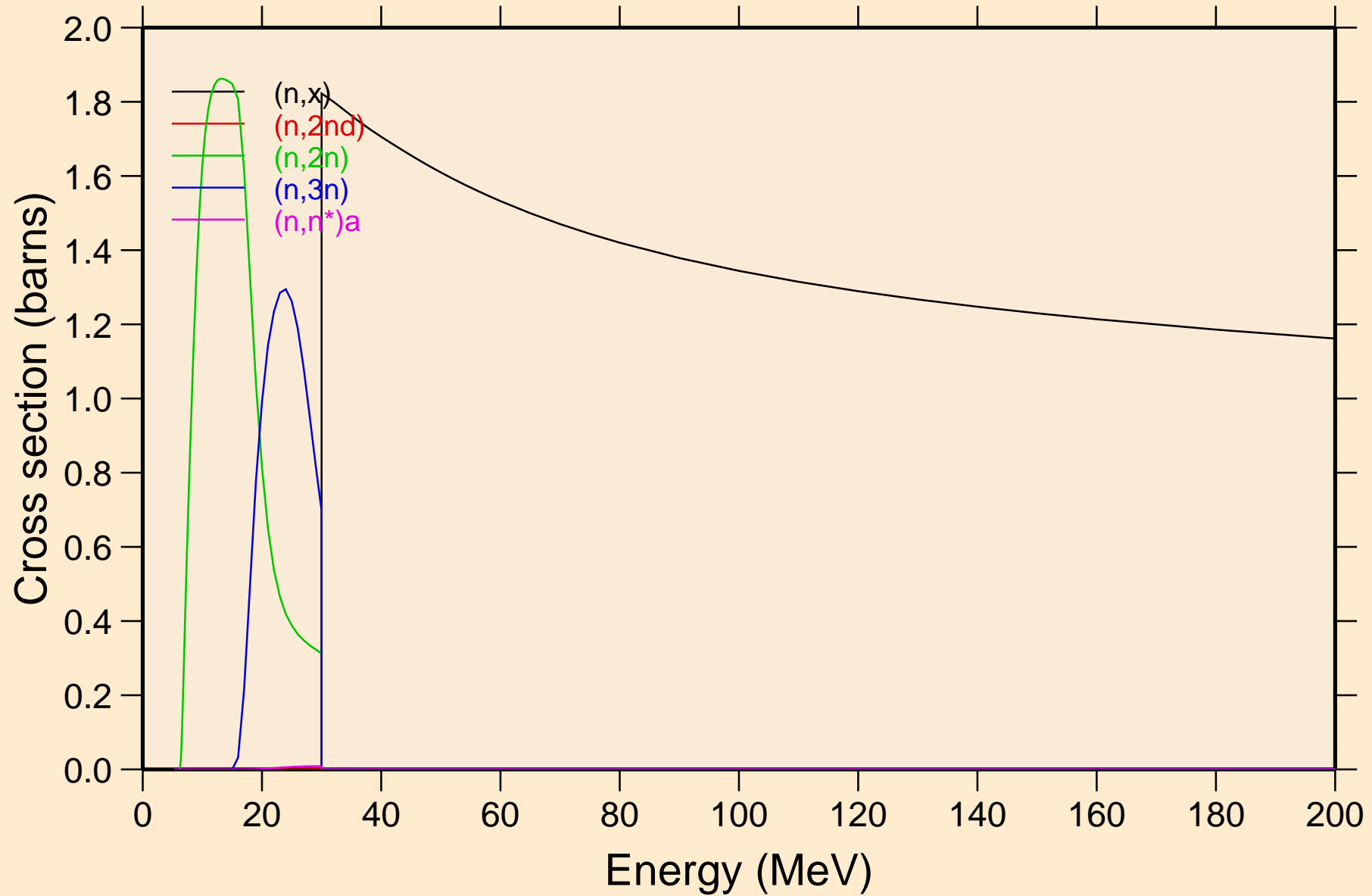

SB126M NEUTRON ACER TENDL-2023 LIBRARY; T=0.K

Threshold reactions

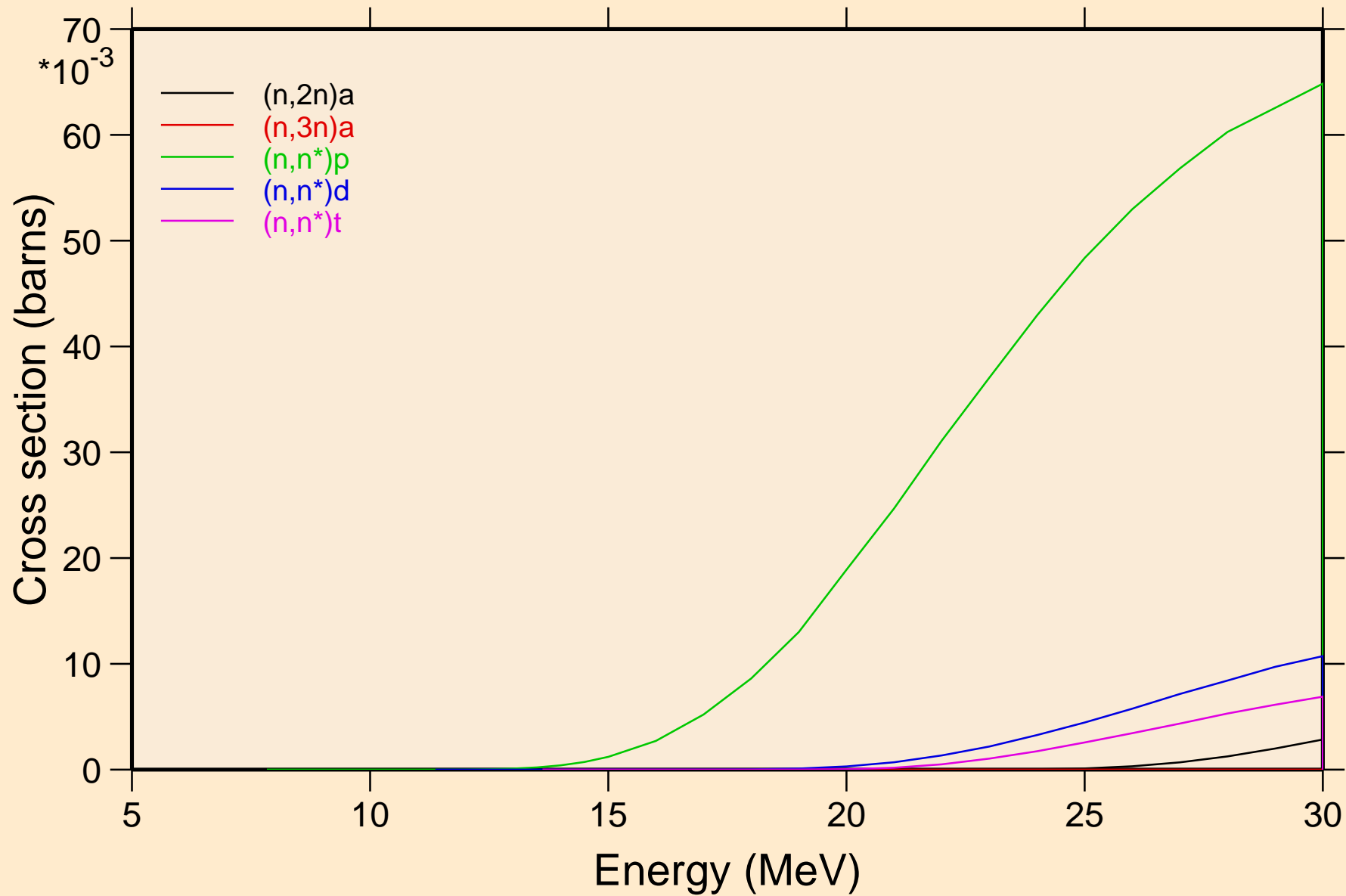

SB126M NEUTRON ACER TENDL-2023 LIBRARY; T=0.K
Threshold reactions

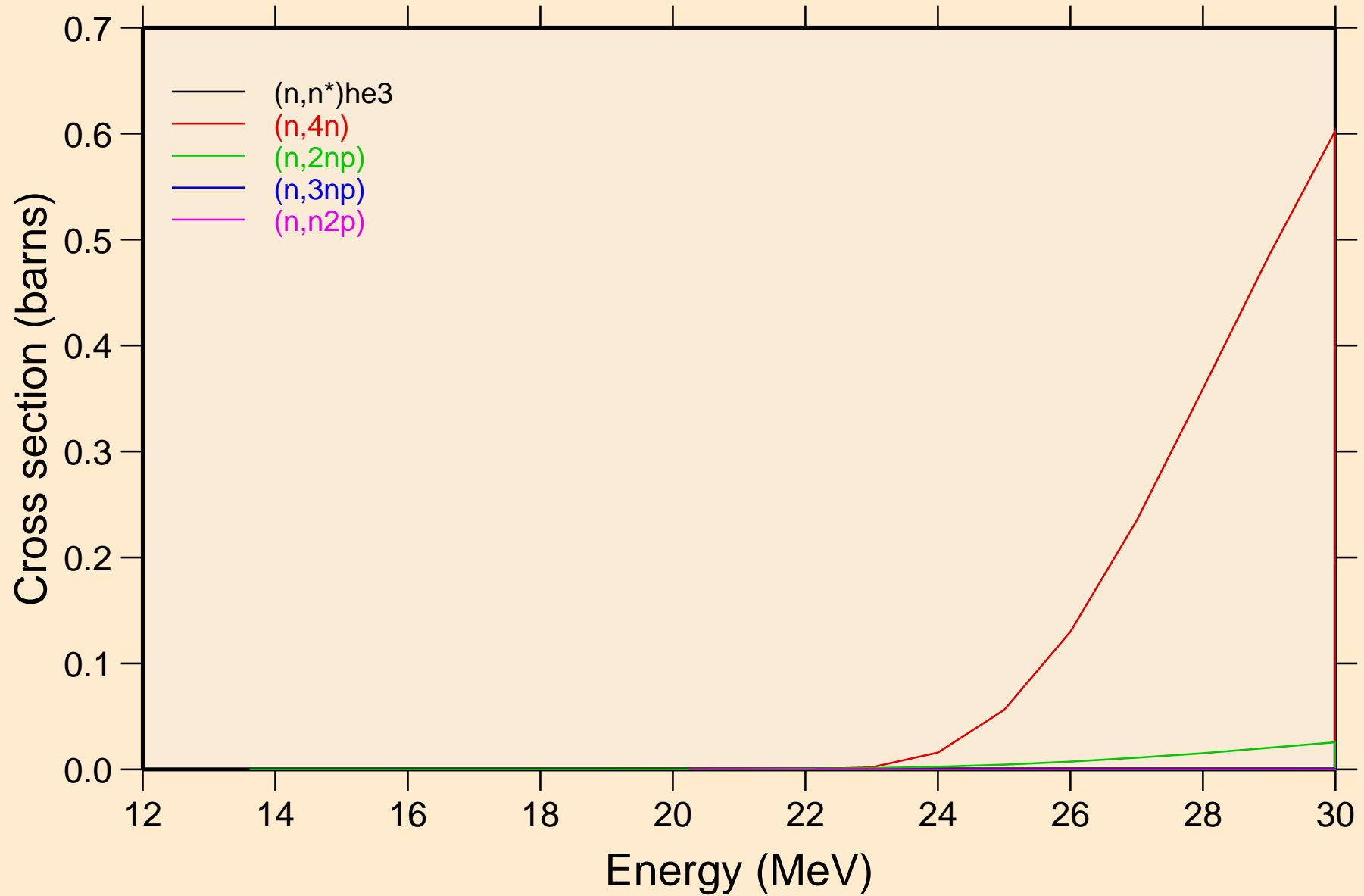

SB126M NEUTRON ACER TENDL-2023 LIBRARY; T=0.K

Threshold reactions

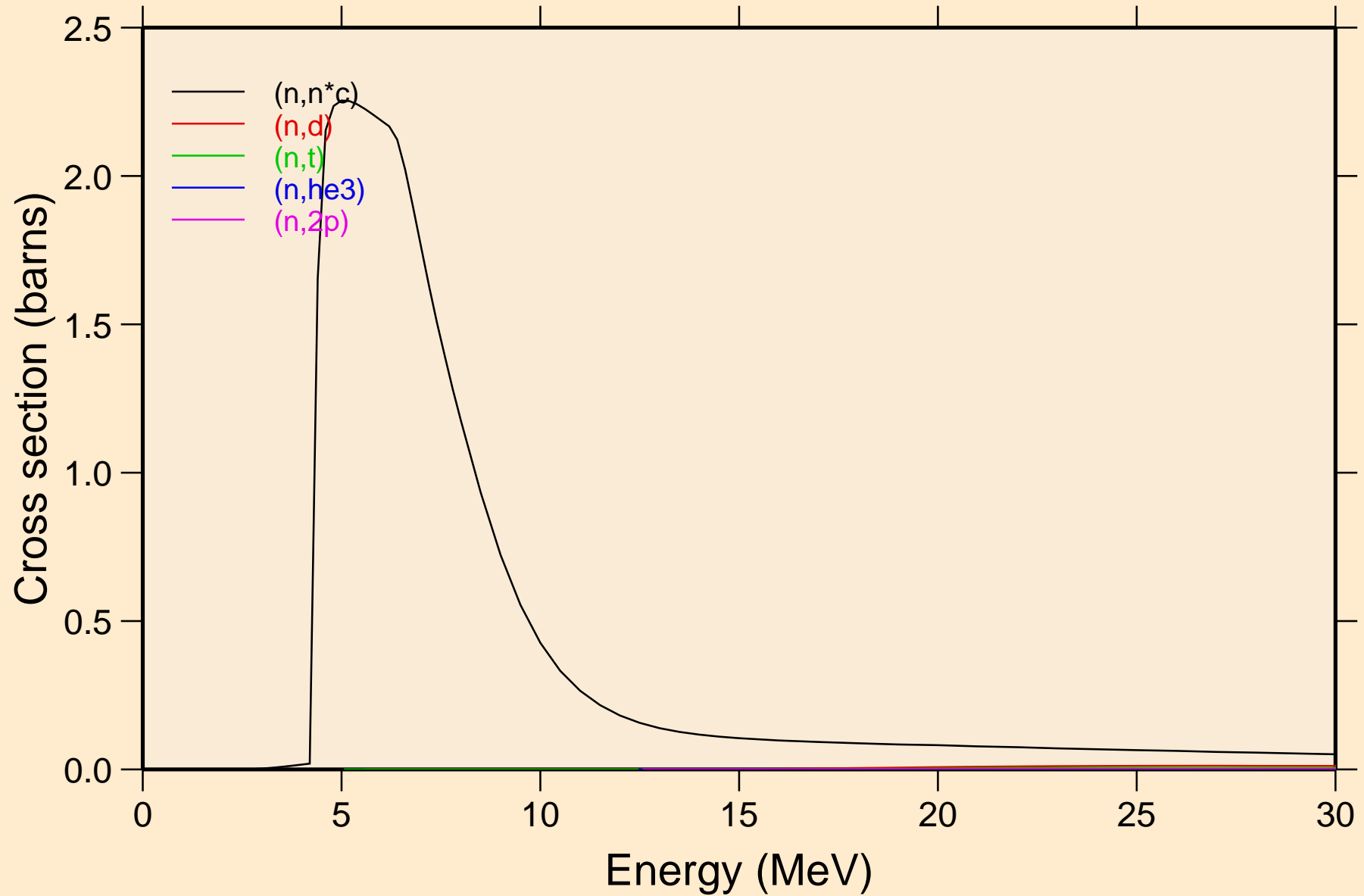

SB126M NEUTRON ACER TENDL-2023 LIBRARY; T=0.K
Threshold reactions

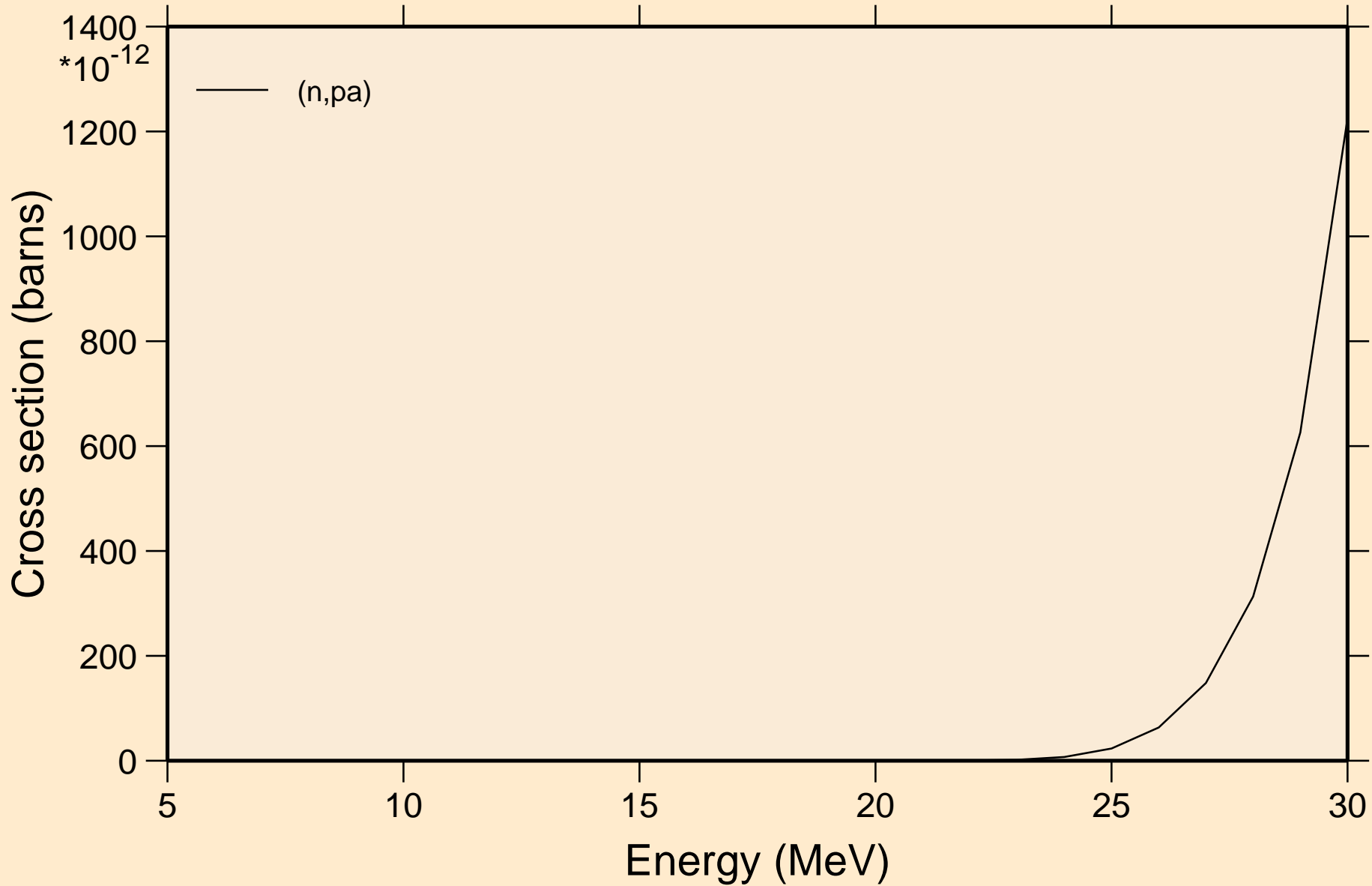

SB126M NEUTRON ACER TENDL-2023 LIBRARY; T=0.K

Threshold reactions

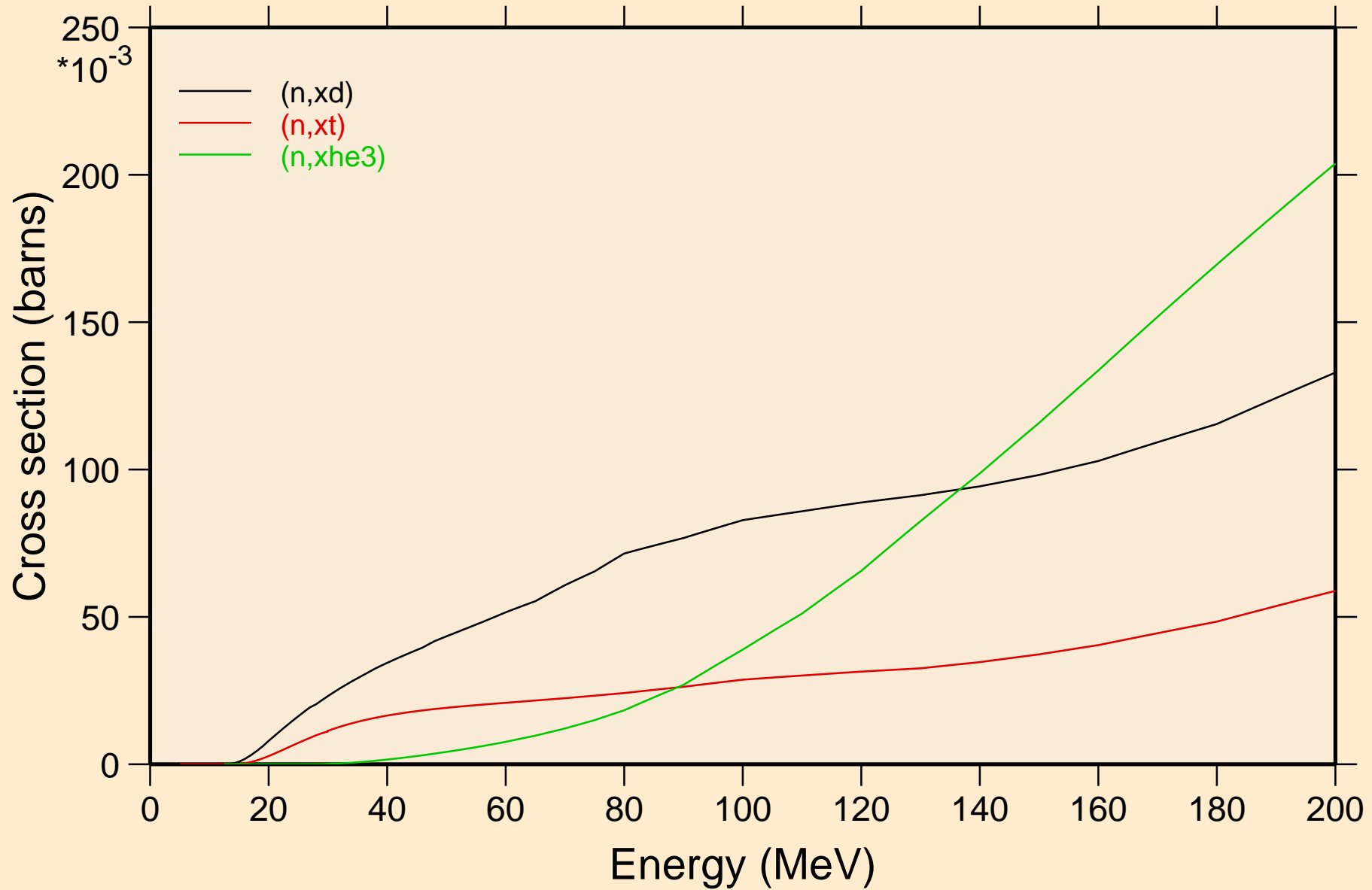

SB126M NEUTRON ACER TENDL-2023 LIBRARY; T=0.K
angular distribution for elastic

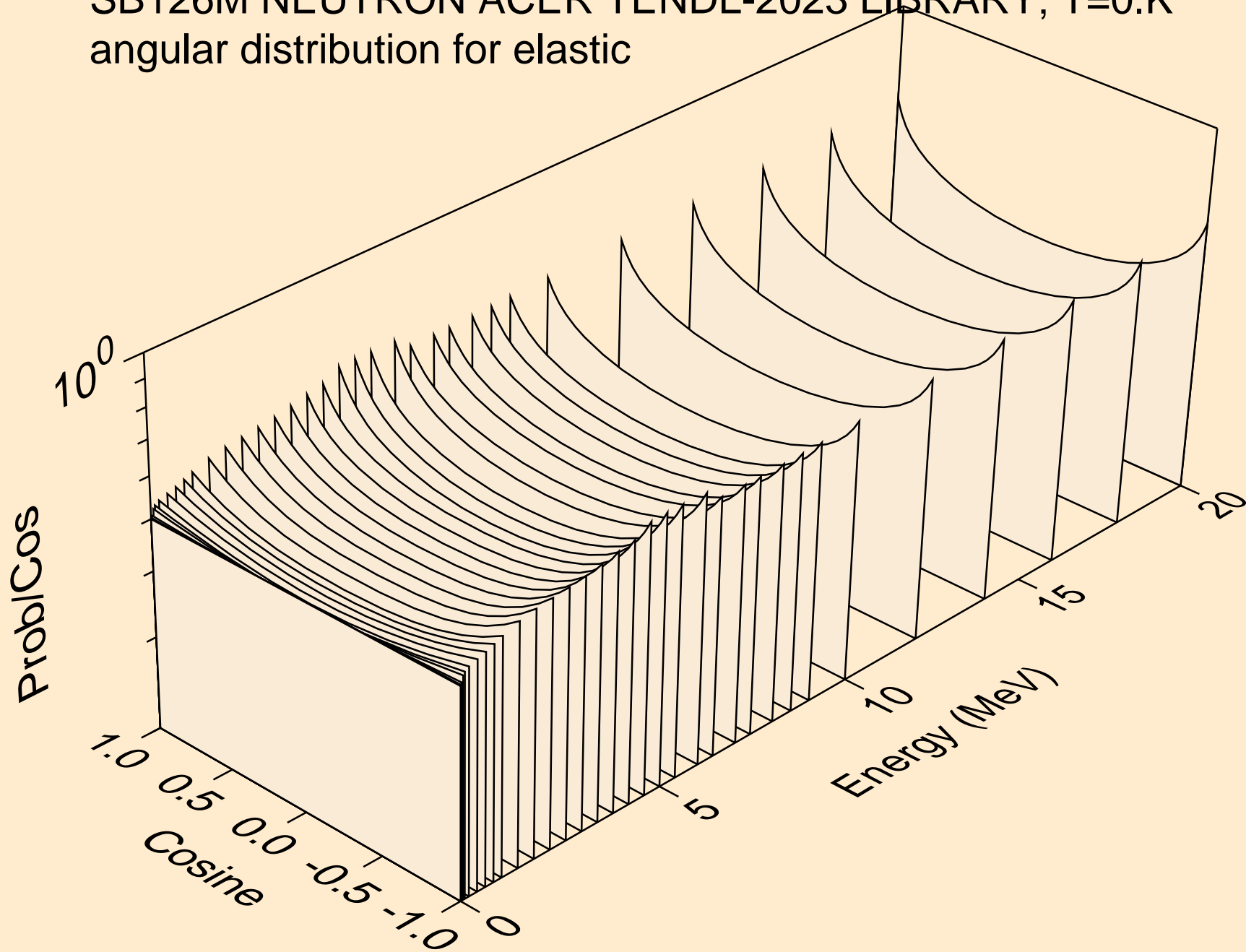

SB126M NEUTRON ACER TENDL-2023 LIBRARY; T=0.K
angular distribution for elastic

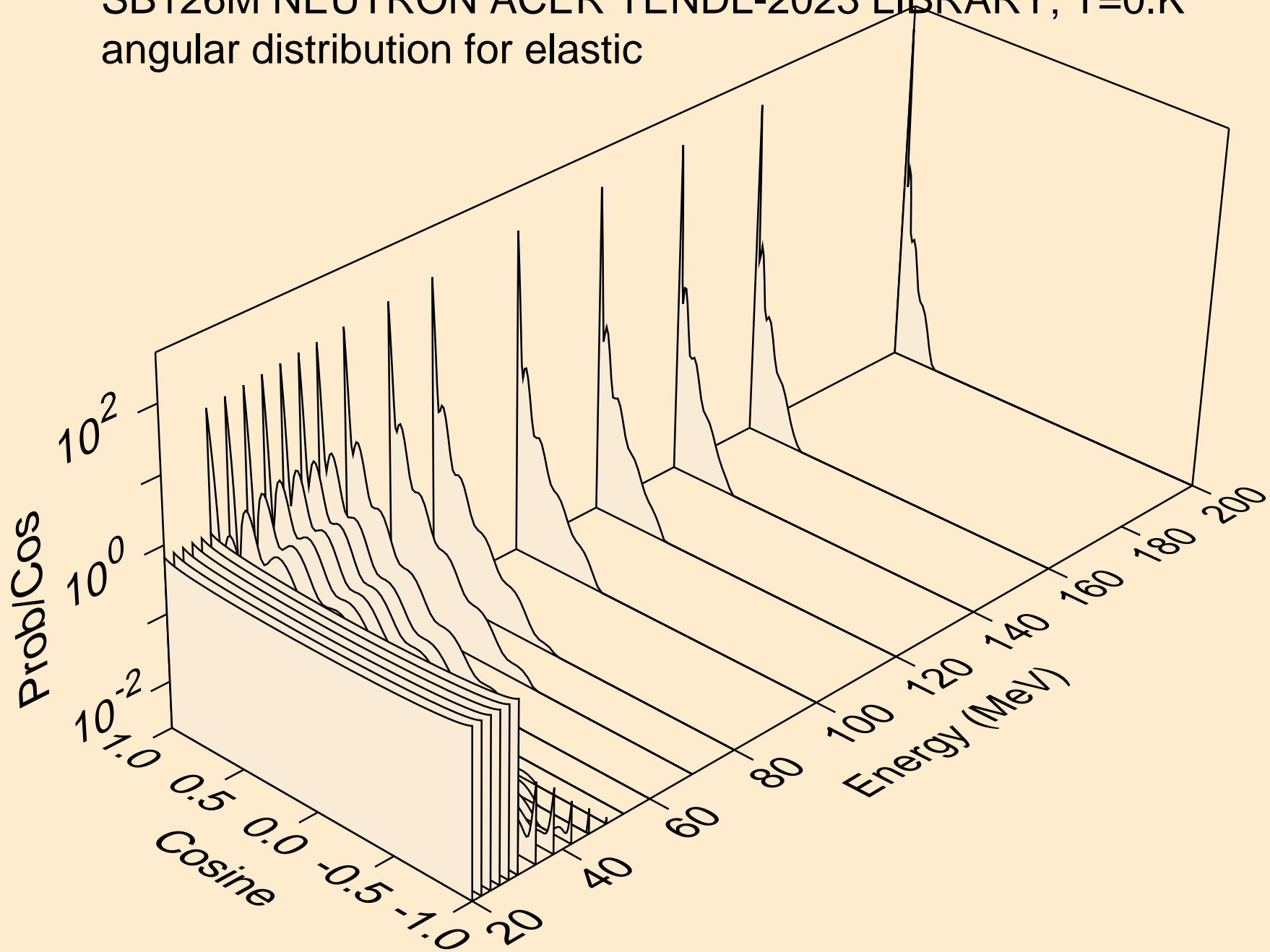

SB126M NEUTRON ACER TENDL-2023 LIBRARY; T=0.K
angular distribution for (n,n*1)

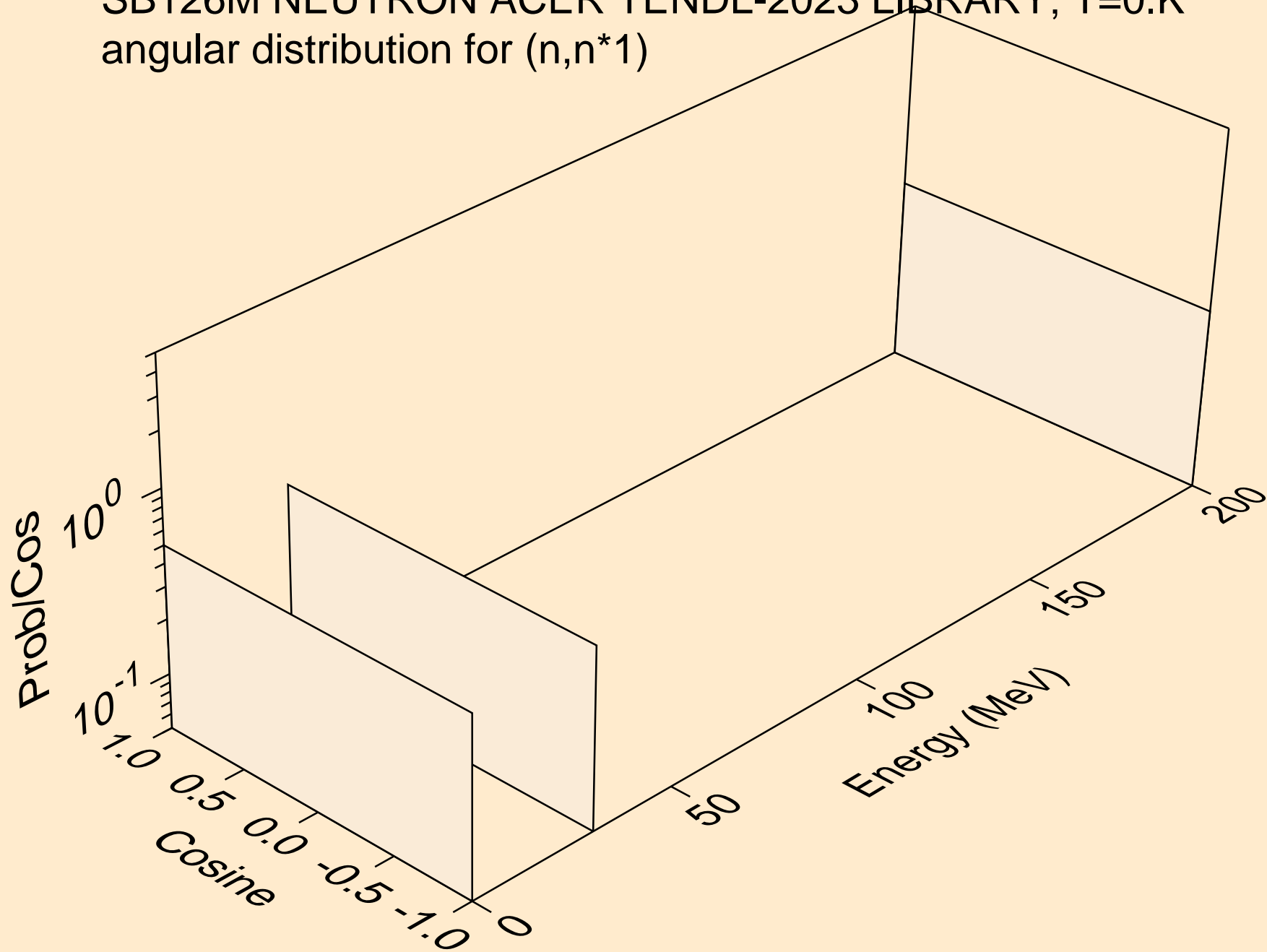

SB126M NEUTRON ACER TENDL-2023 LIBRARY; T=0.K
angular distribution for (n,n*2)

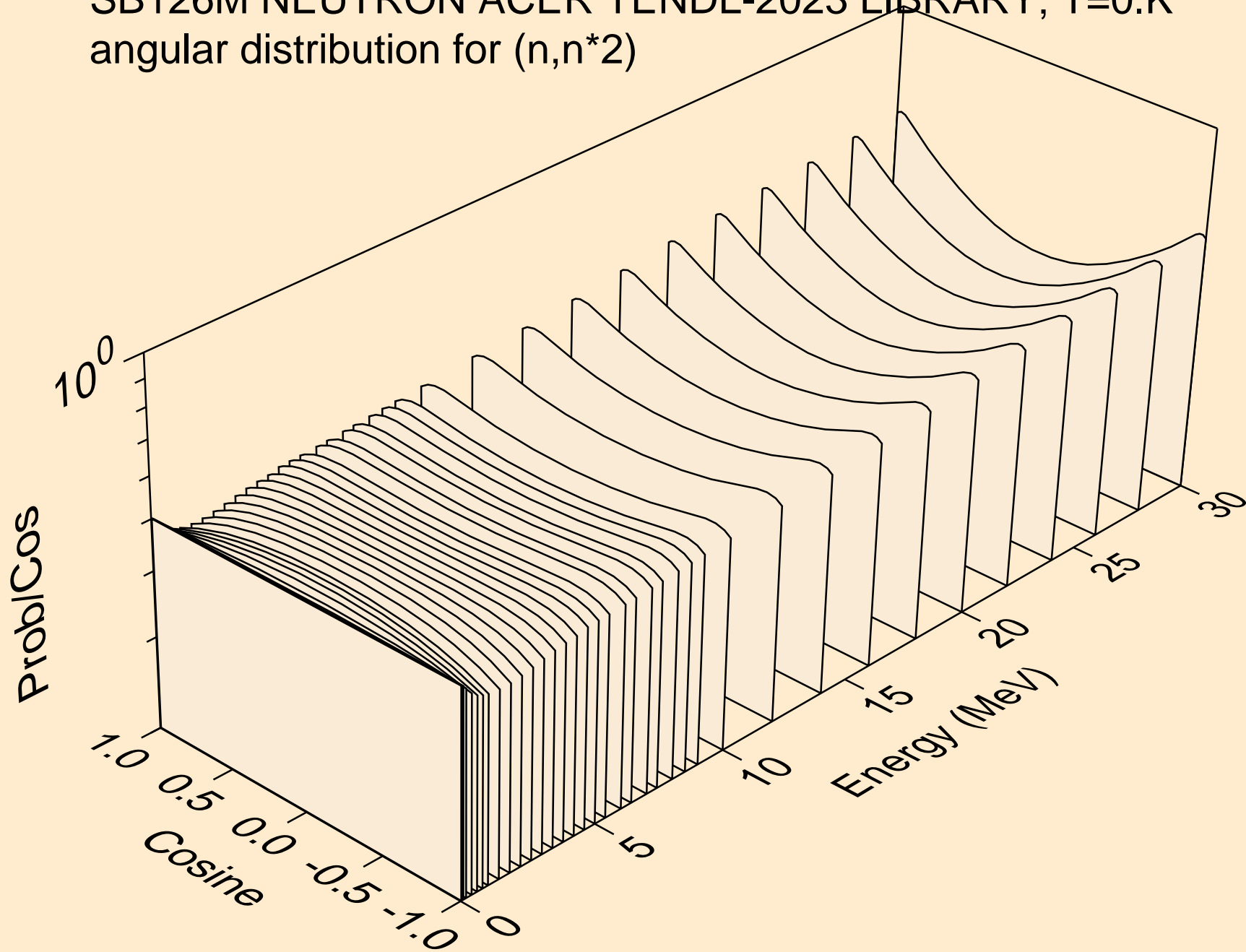

SB126M NEUTRON ACER TENDL-2023 LIBRARY; T=0.K
angular distribution for (n,n*3)

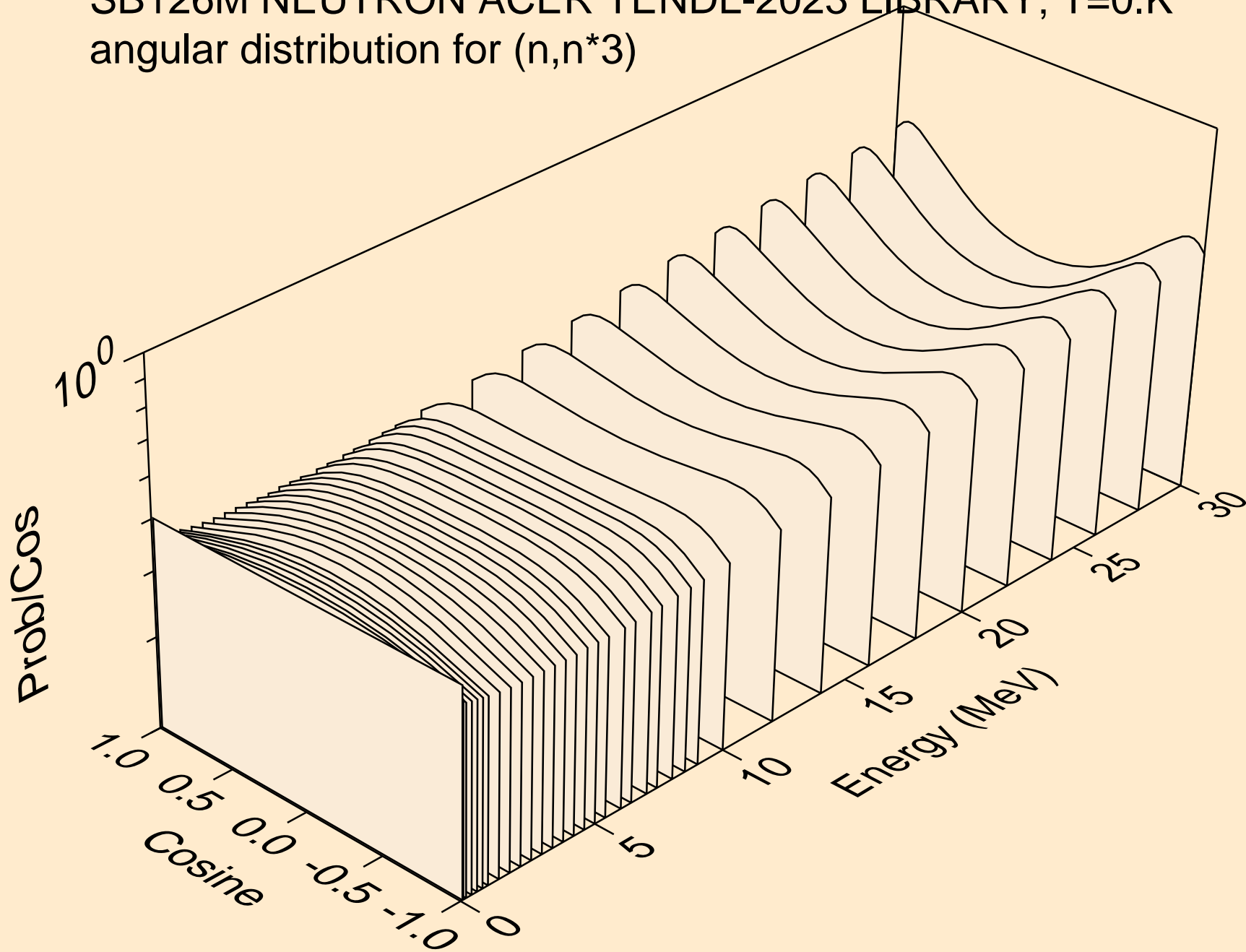

SB126M NEUTRON ACER TENDL-2023 LIBRARY; T=0.K
angular distribution for (n,n*4)

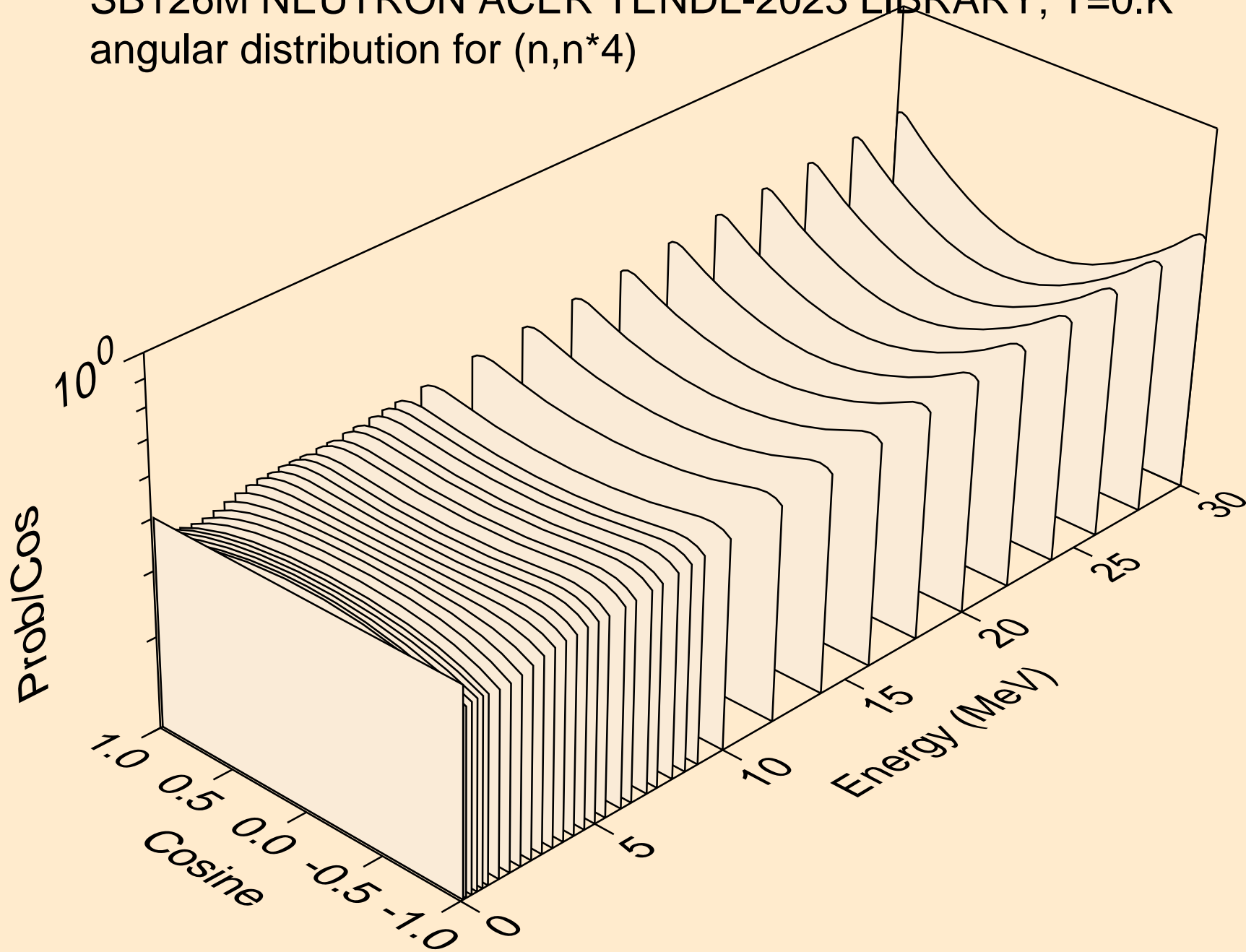

SB126M NEUTRON ACER TENDL-2023 LIBRARY; T=0.K
angular distribution for (n,n*5)

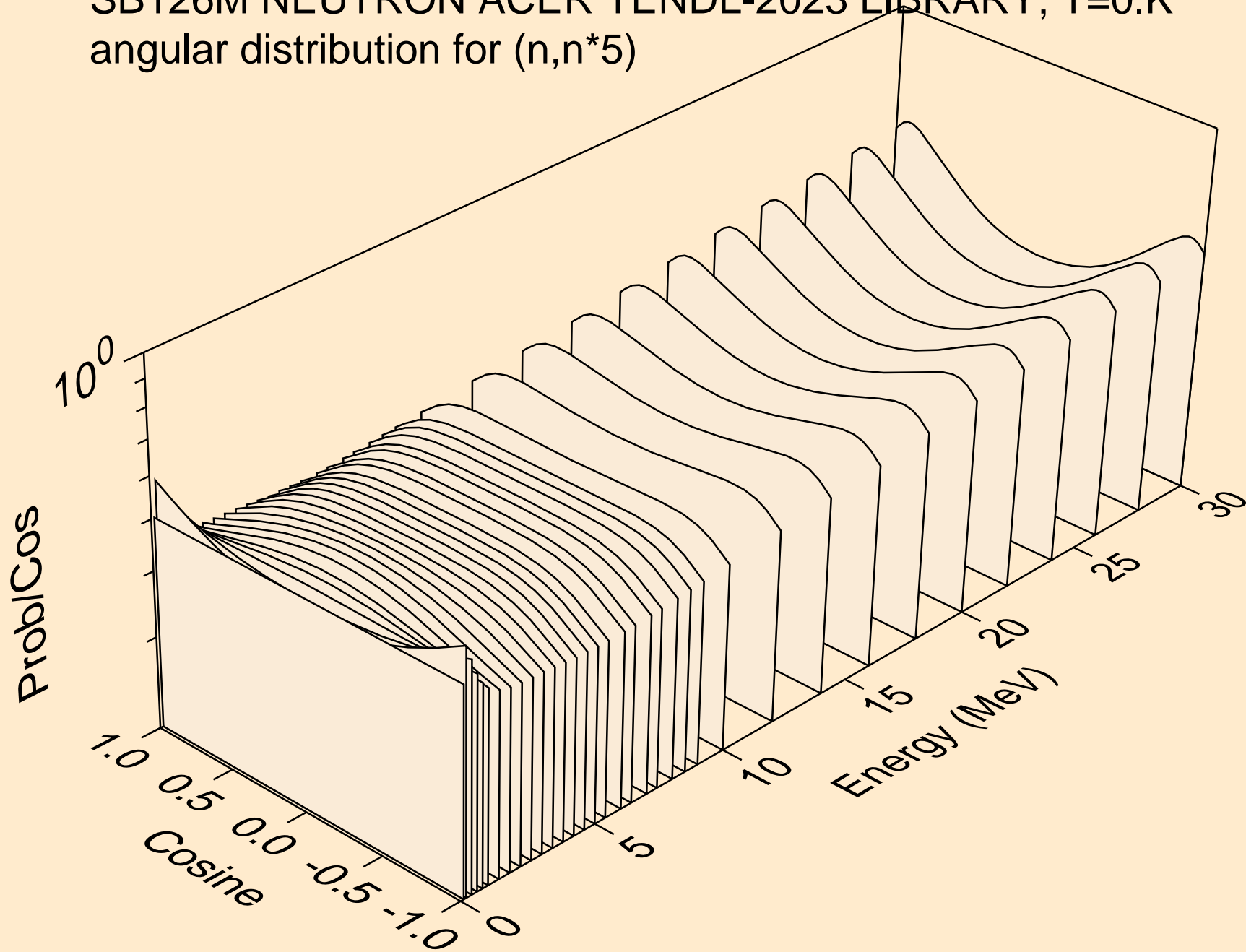

SB126M NEUTRON ACER TENDL-2023 LIBRARY; T=0.K
angular distribution for (n,n*6)

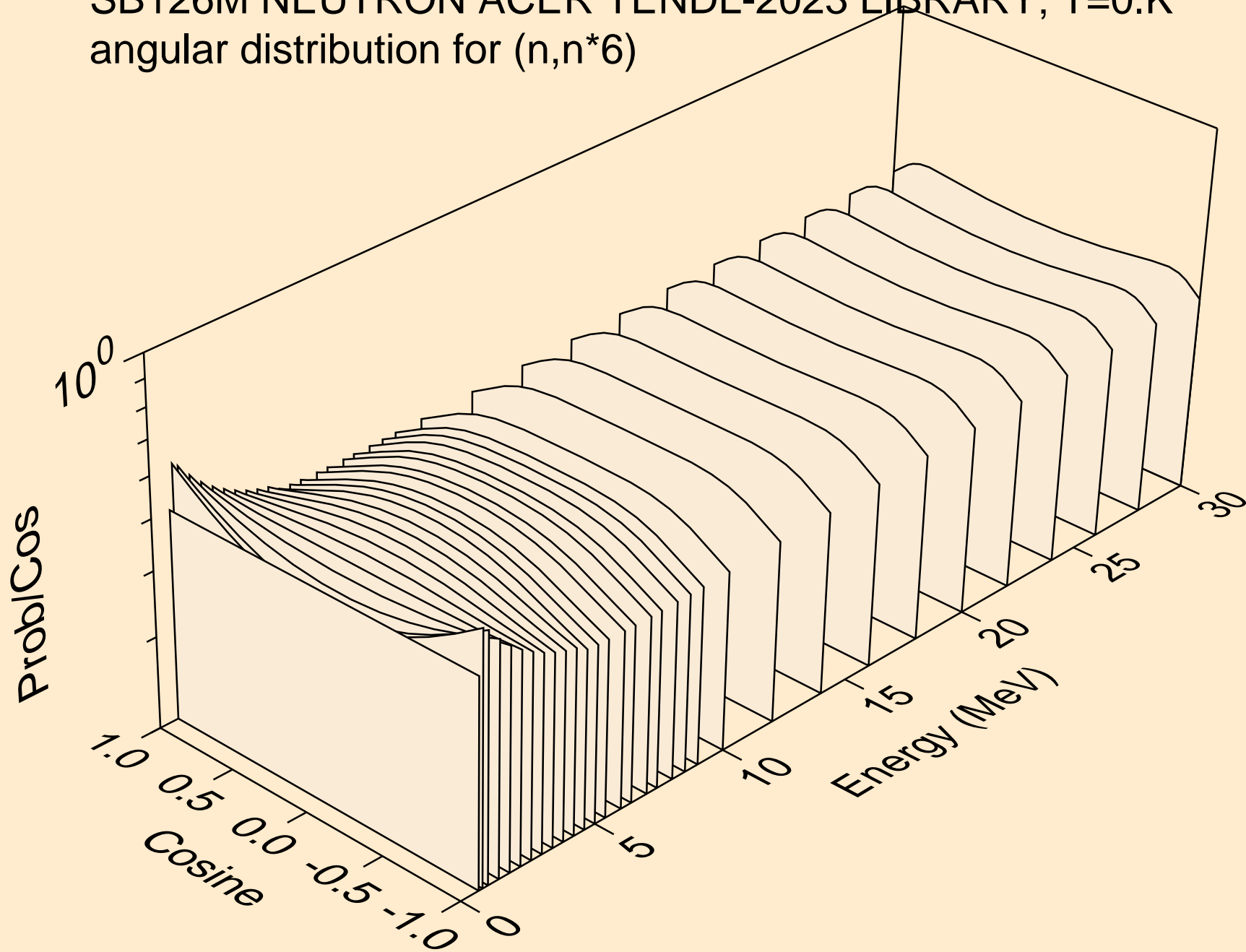

SB126M NEUTRON ACER TENDL-2023 LIBRARY; T=0.K
angular distribution for (n,n*7)

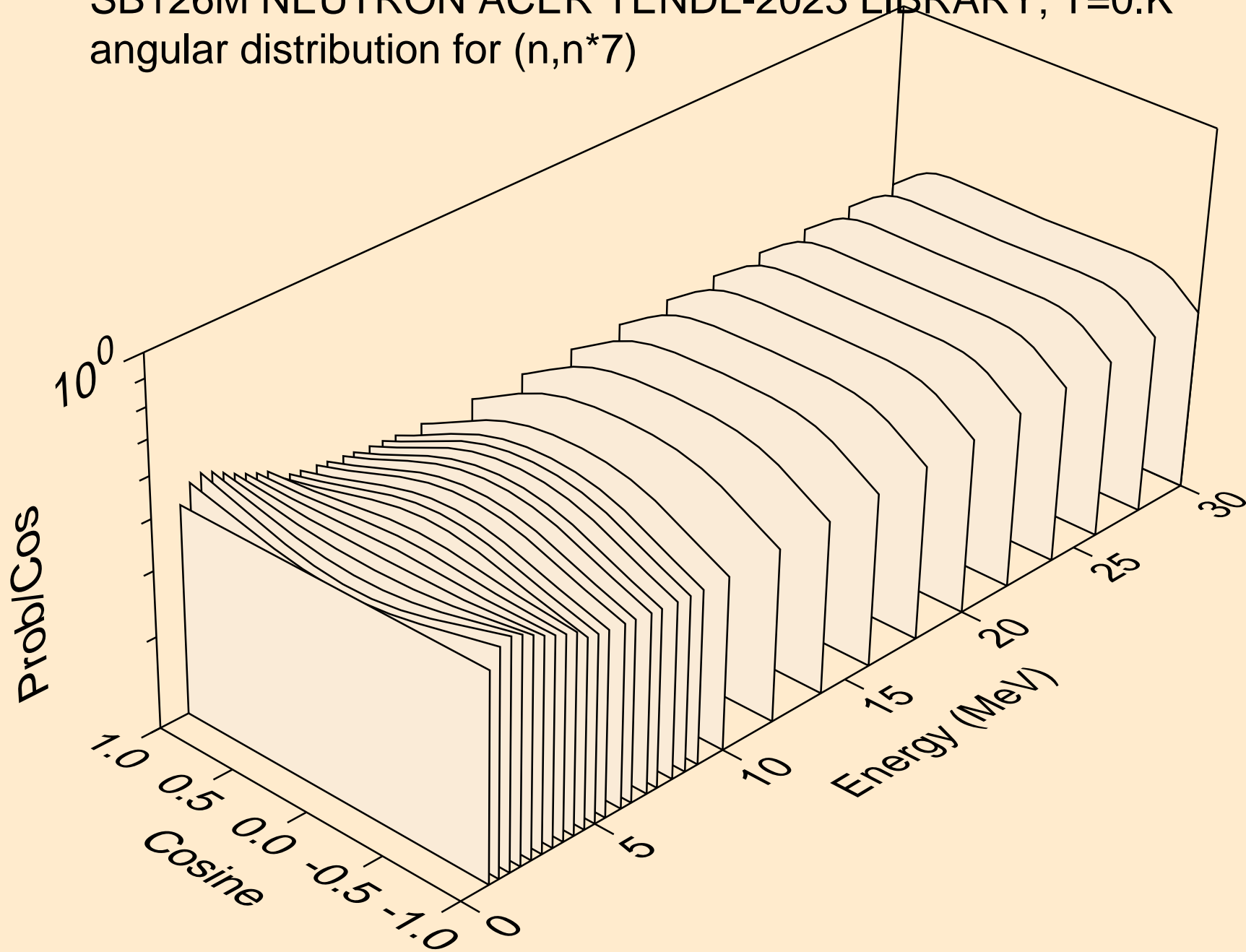

SB126M NEUTRON ACER TENDL-2023 LIBRARY; T=0.K
angular distribution for (n,n*8)

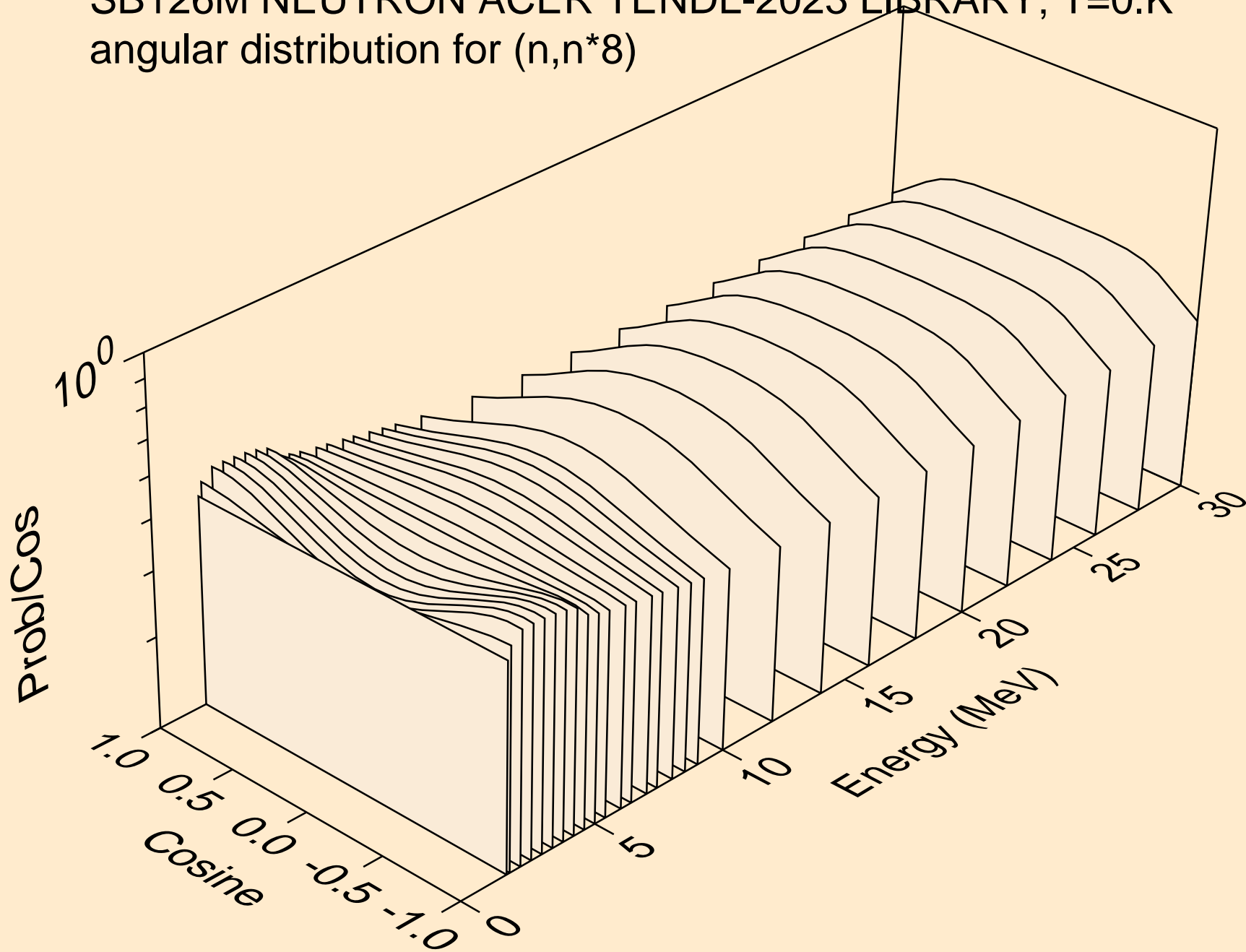

SB126M NEUTRON ACER TENDL-2023 LIBRARY; T=0.K
Neutron emission for (n,x)

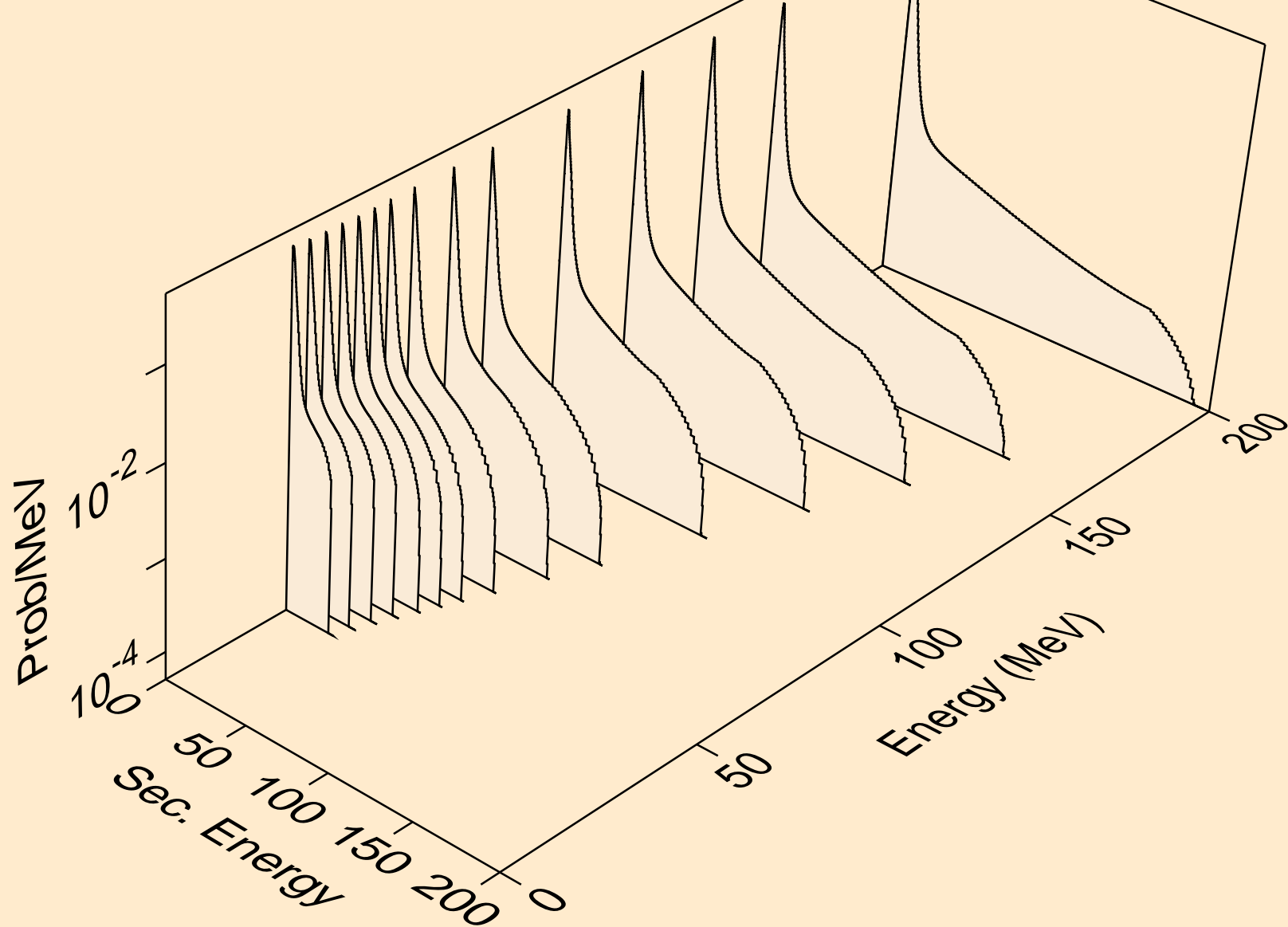

SB126M NEUTRON ACER TENDL-2023 LIBRARY; T=0.K
Neutron emission for (n,2nd)

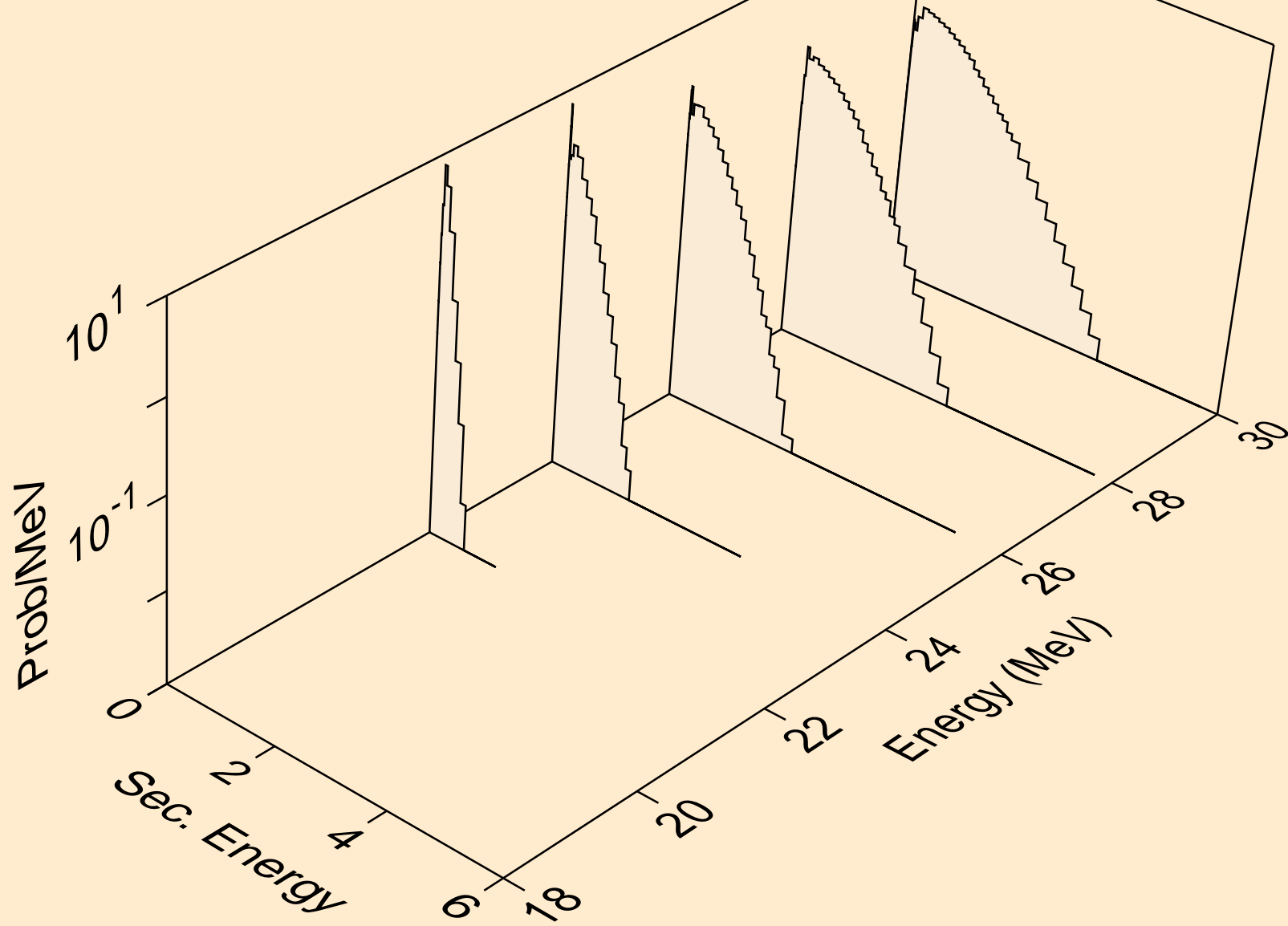

SB126M NEUTRON ACER TENDL-2023 LIBRARY; T=0.K
Neutron emission for (n,2n)

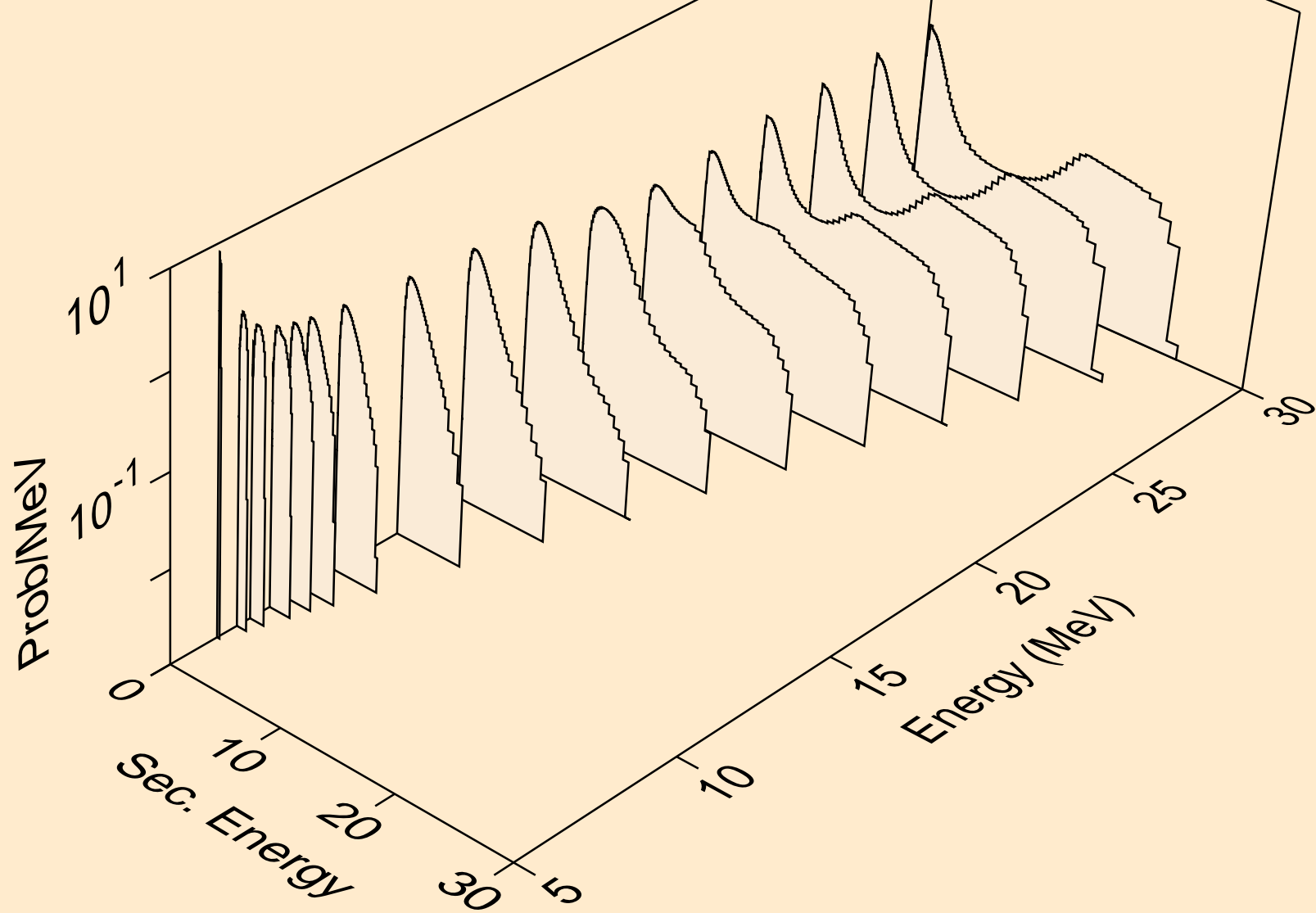

SB126M NEUTRON ACER TENDL-2023 LIBRARY; T=0.K
Neutron emission for (n,3n)

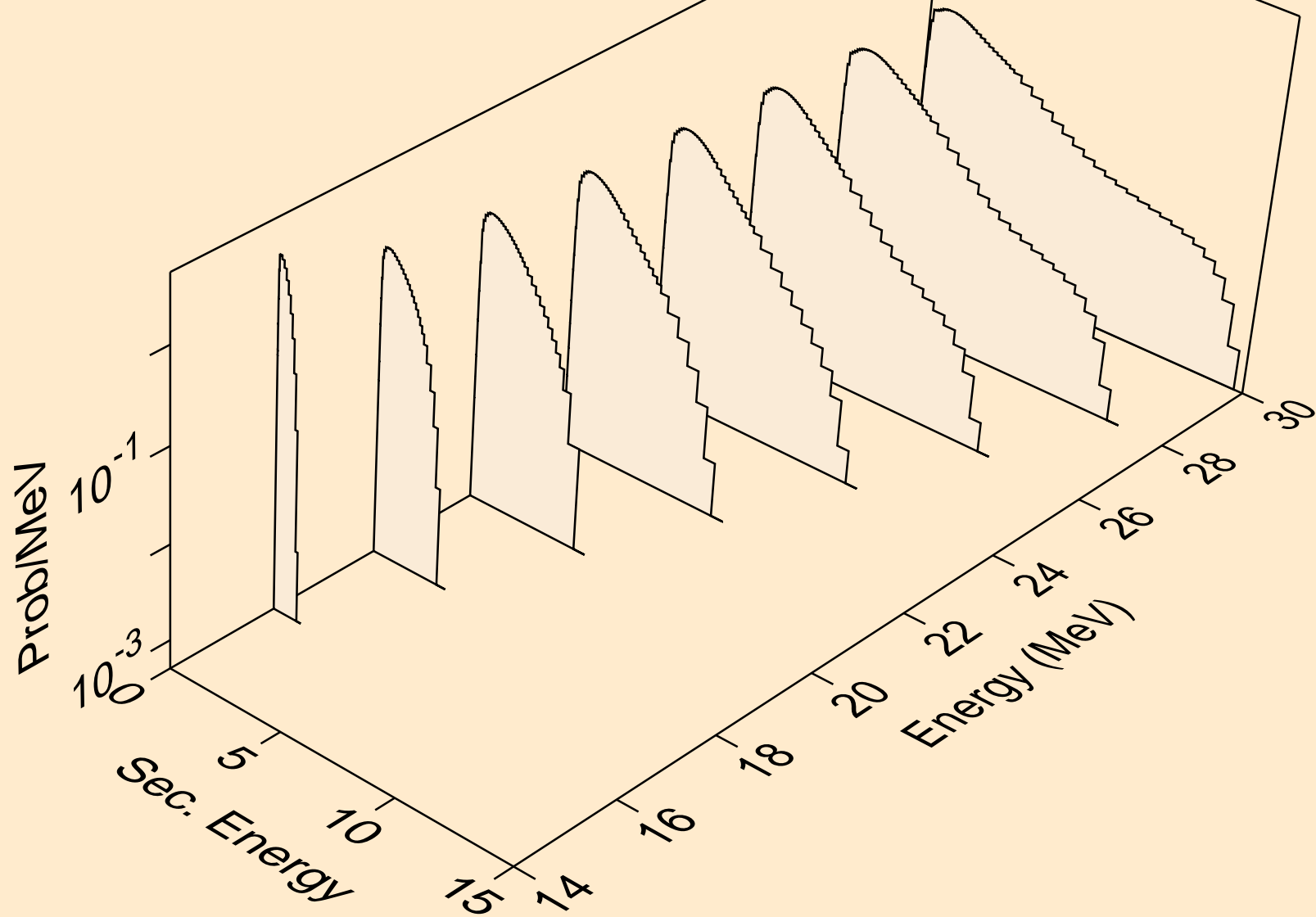

SB126M NEUTRON ACER TENDL-2023 LIBRARY; T=0.K
Neutron emission for (n,n*)a

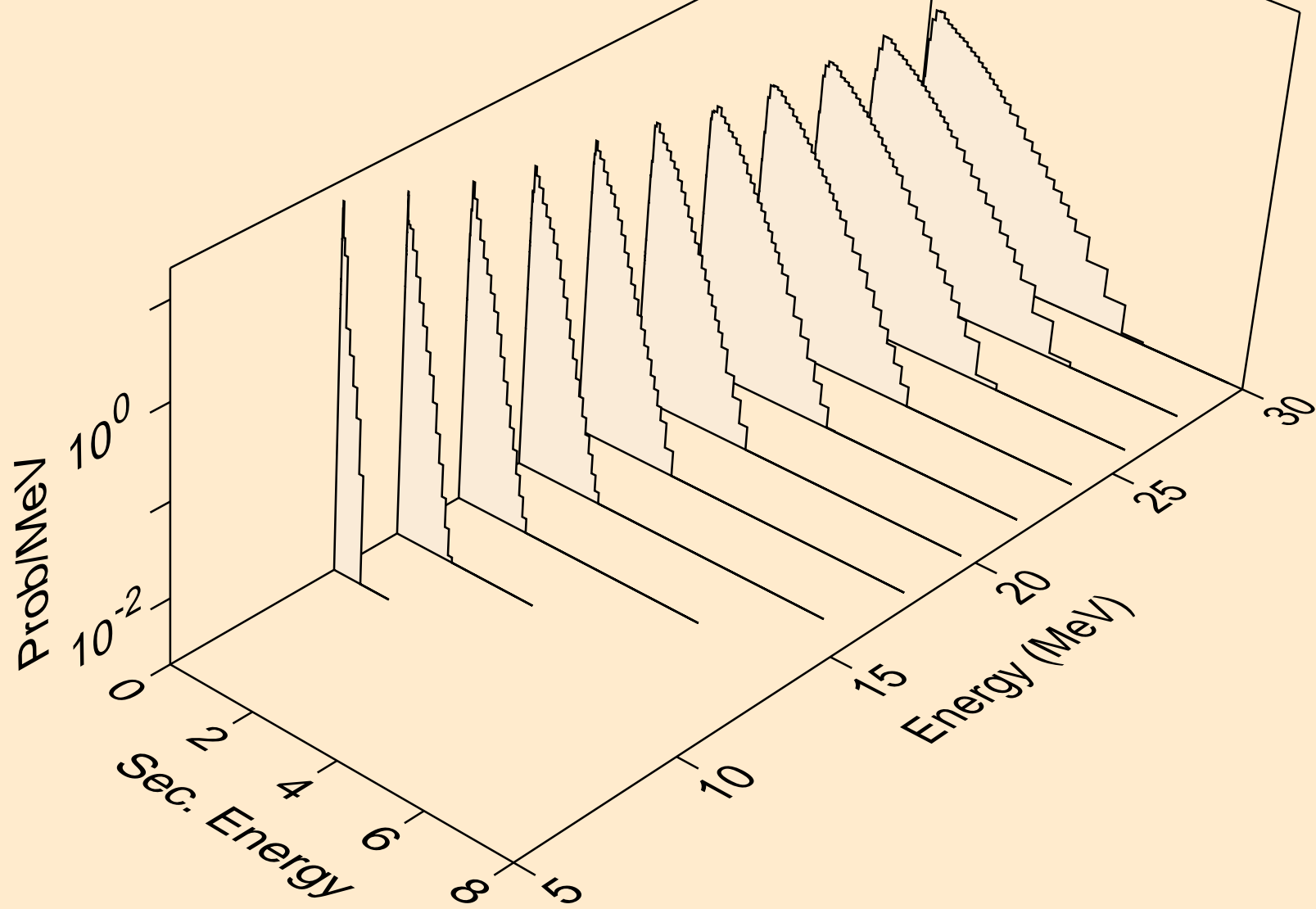

SB126M NEUTRON ACER TENDL-2023 LIBRARY; T=0.K
Neutron emission for (n,2n)a

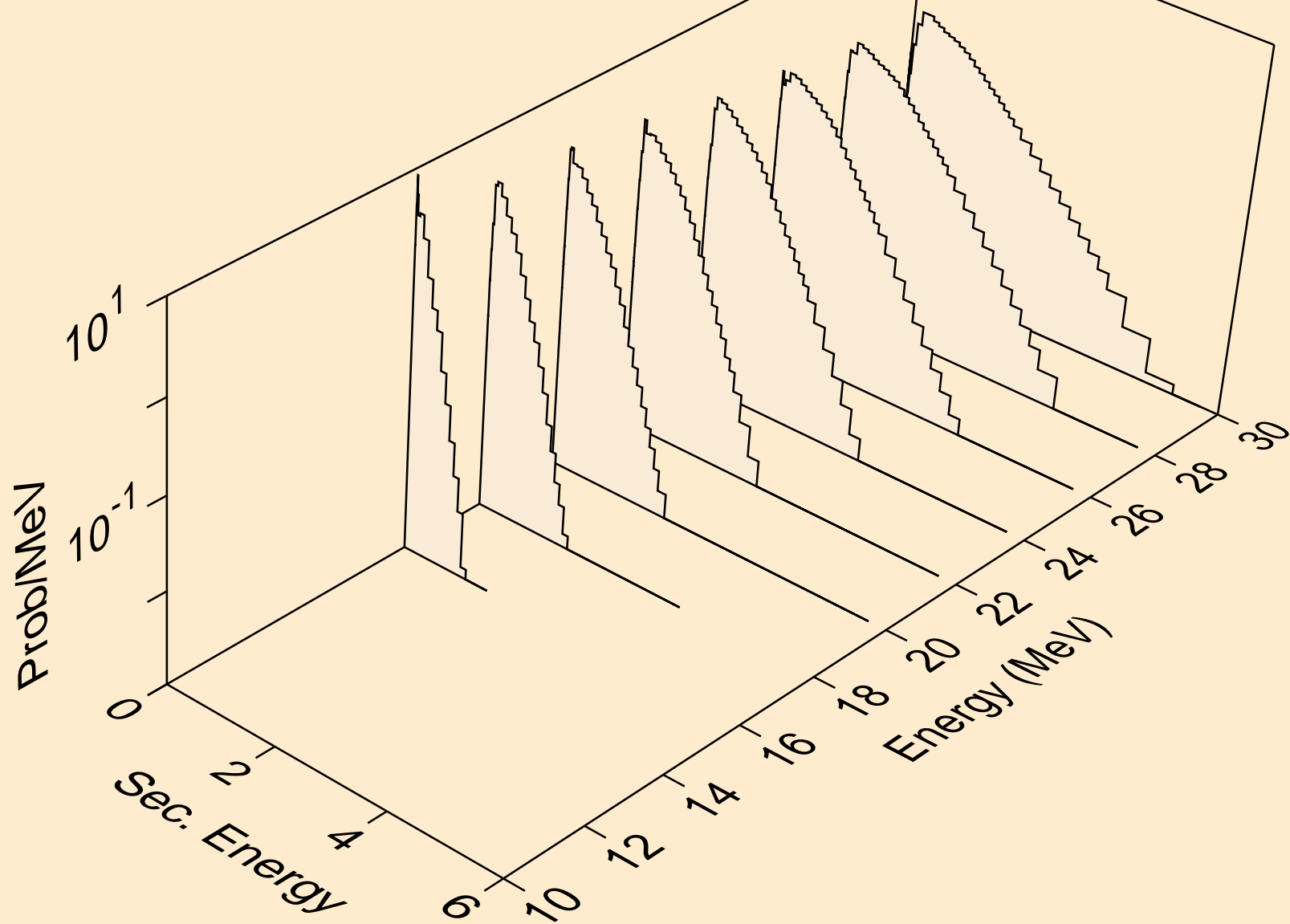

SB126M NEUTRON ACER TENDL-2023 LIBRARY; T=0.K
Neutron emission for (n,3n)a

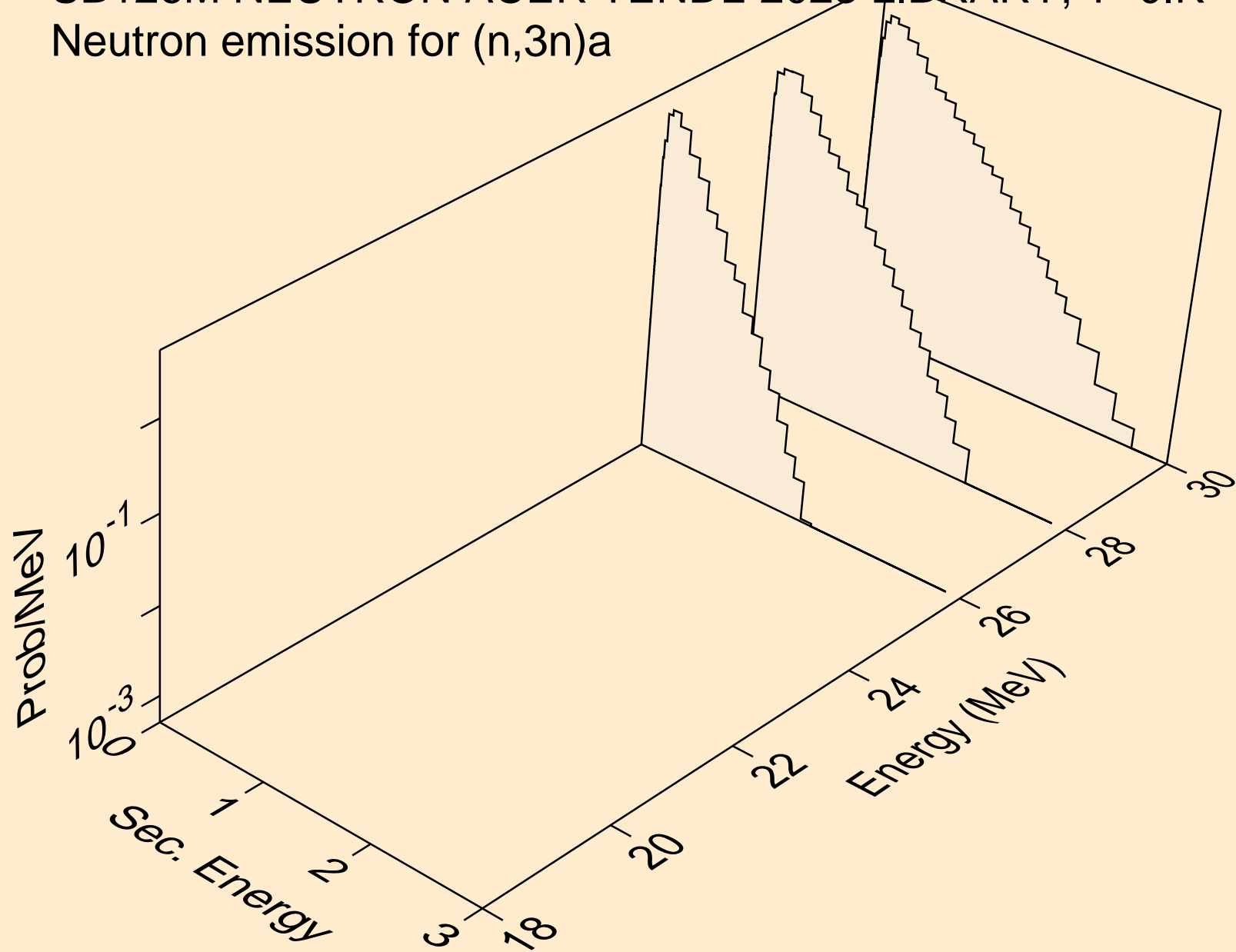

SB126M NEUTRON ACER TENDL-2023 LIBRARY; T=0.K
Neutron emission for (n,n*)p

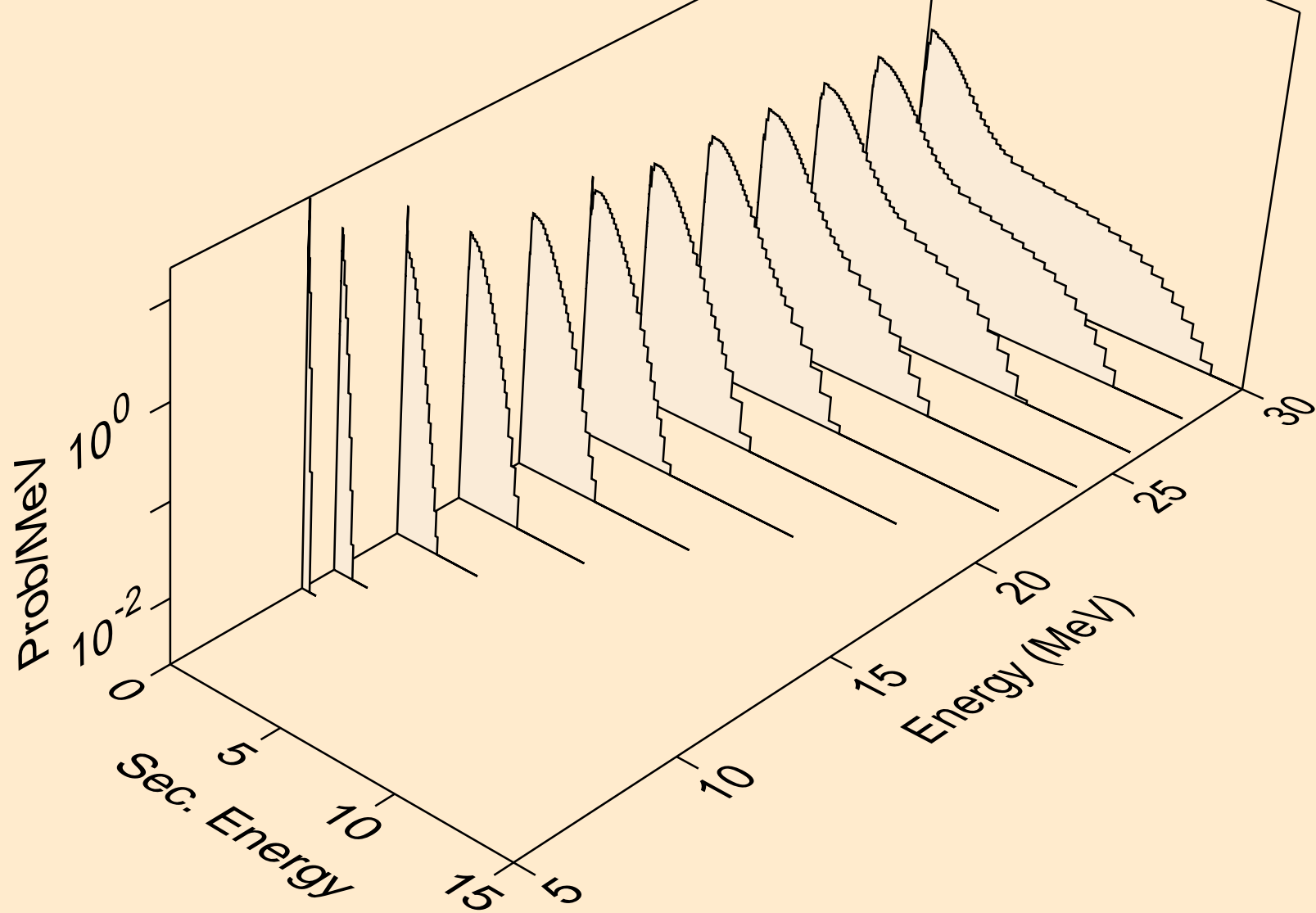

SB126M NEUTRON ACER TENDL-2023 LIBRARY; T=0.K
Neutron emission for (n,n*)d

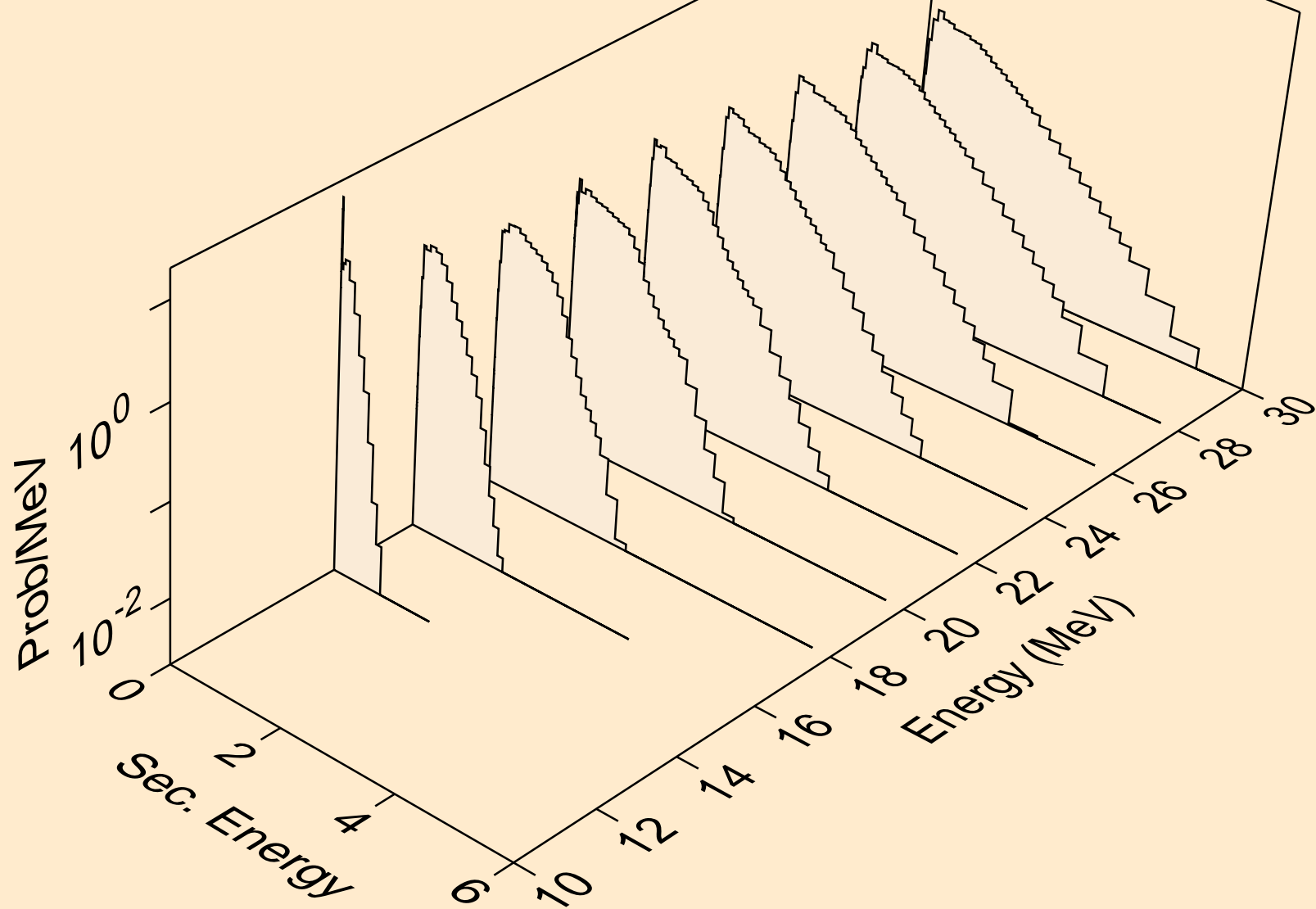

SB126M NEUTRON ACER TENDL-2023 LIBRARY; T=0.K
Neutron emission for (n,n*)t

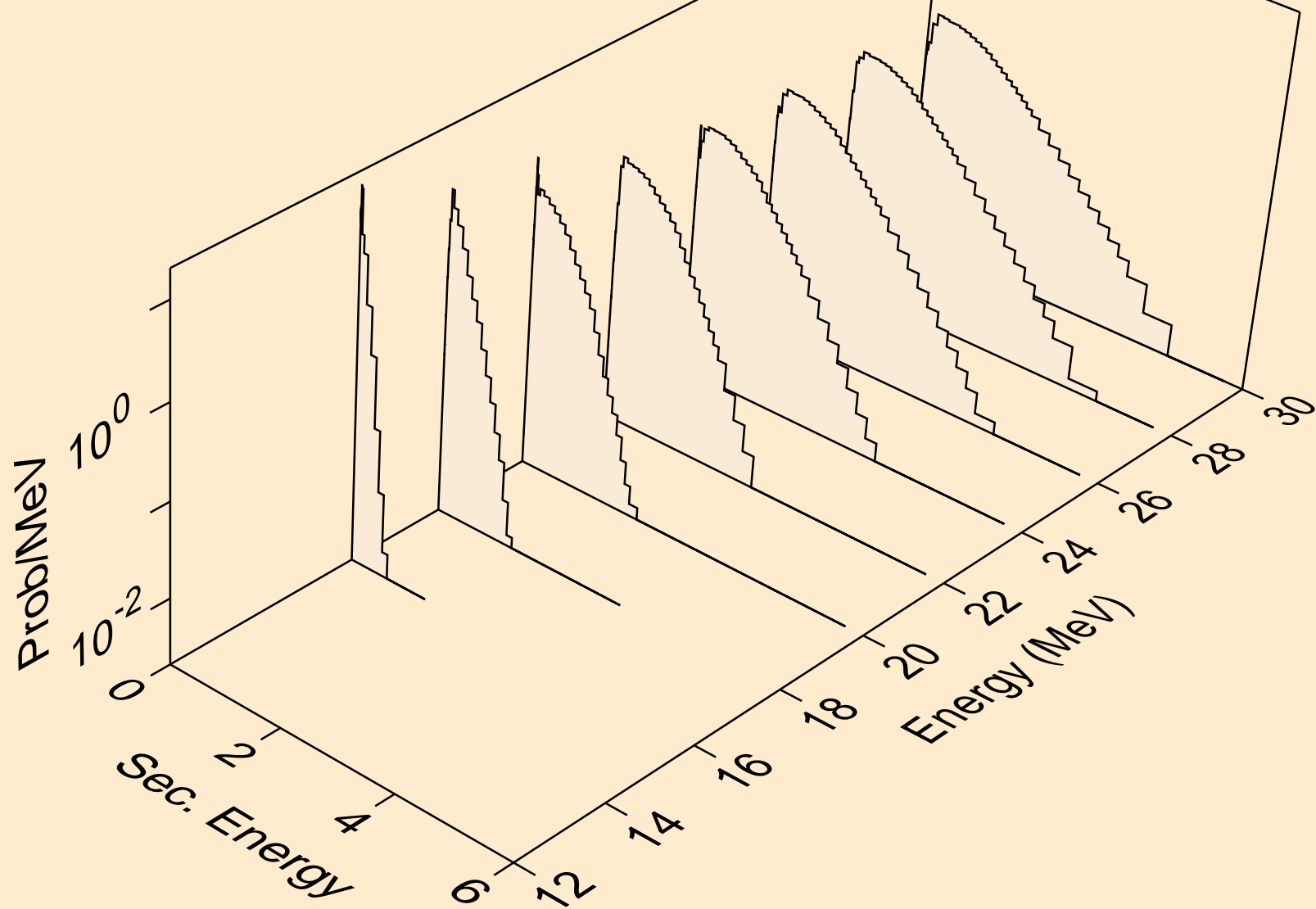

SB126M NEUTRON ACER TENDL-2023 LIBRARY; T=0.K
Neutron emission for (n,n*)he3

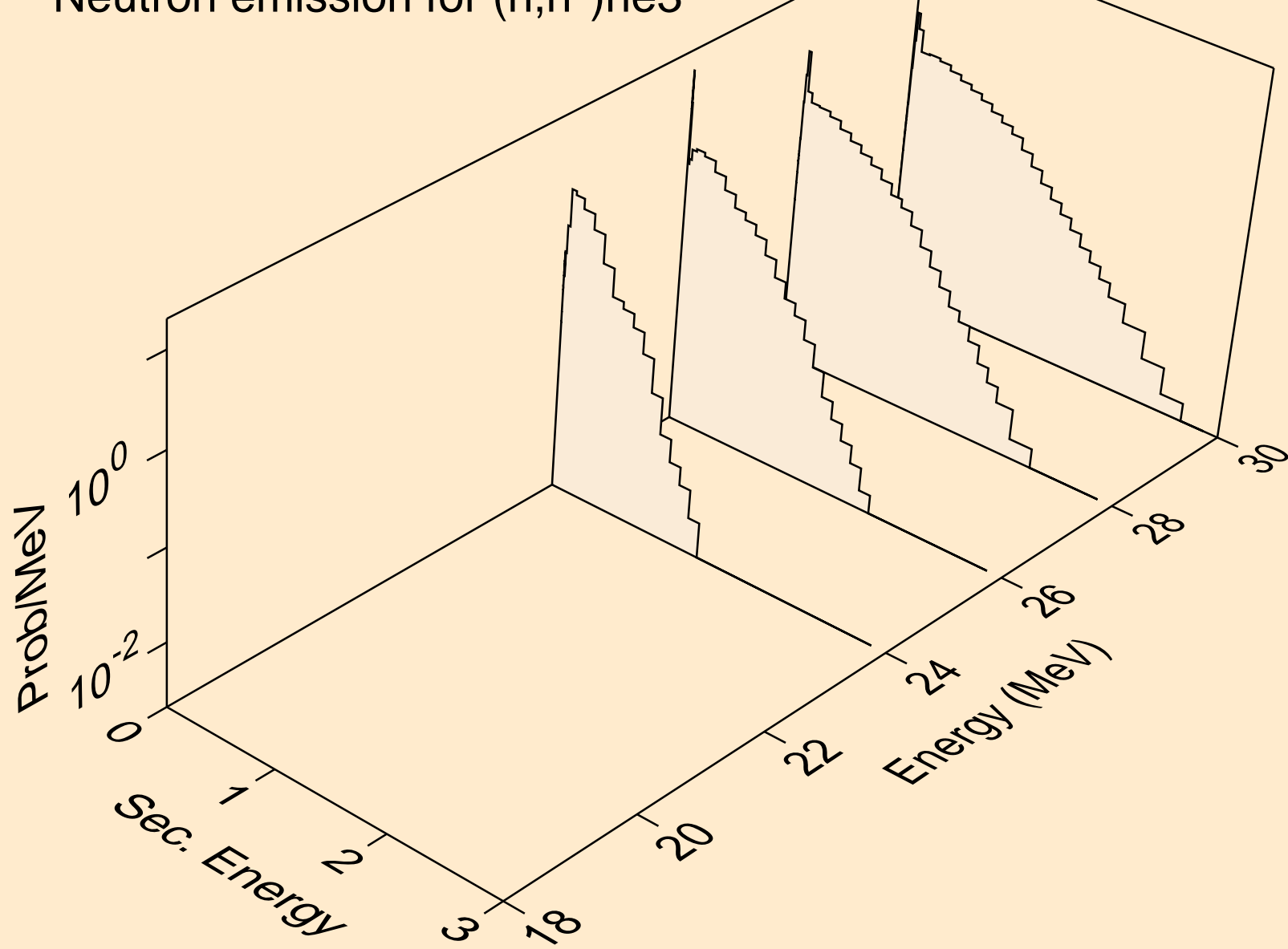

SB126M NEUTRON ACER TENDL-2023 LIBRARY; T=0.K
Neutron emission for (n,4n)

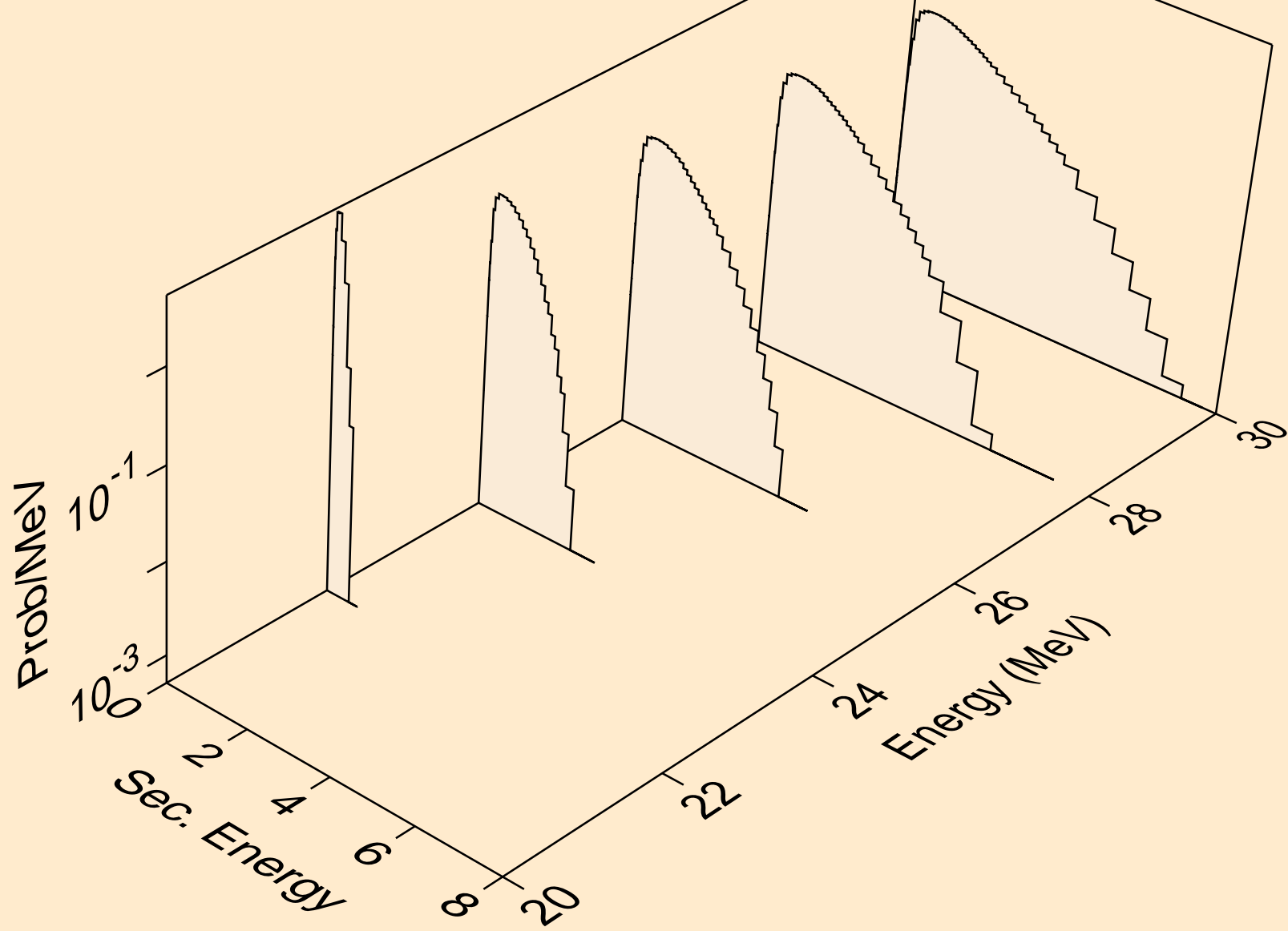

SB126M NEUTRON ACER TENDL-2023 LIBRARY; T=0.K
Neutron emission for (n,2np)

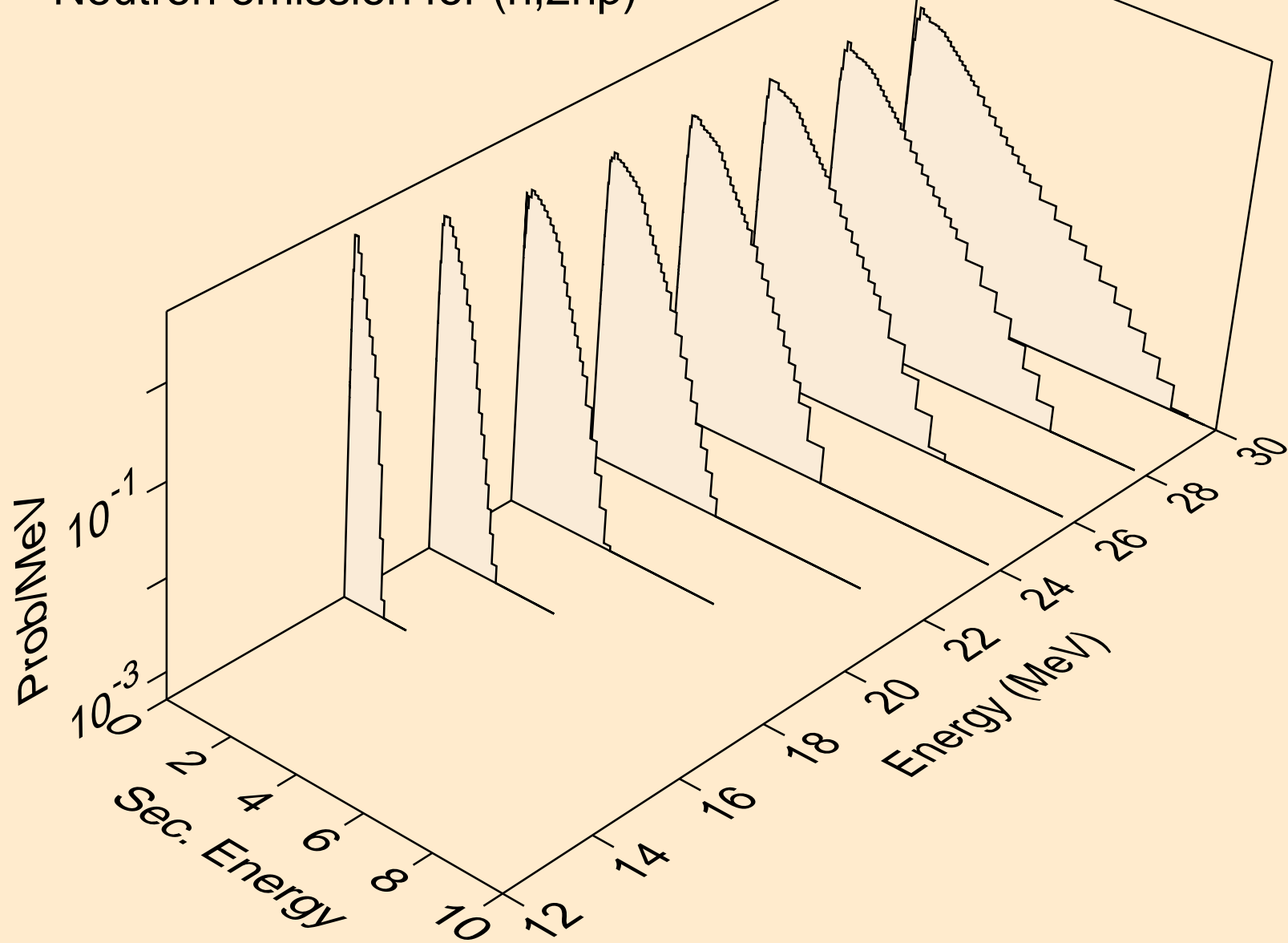

SB126M NEUTRON ACER TENDL-2023 LIBRARY; T=0.K
Neutron emission for (n,3np)

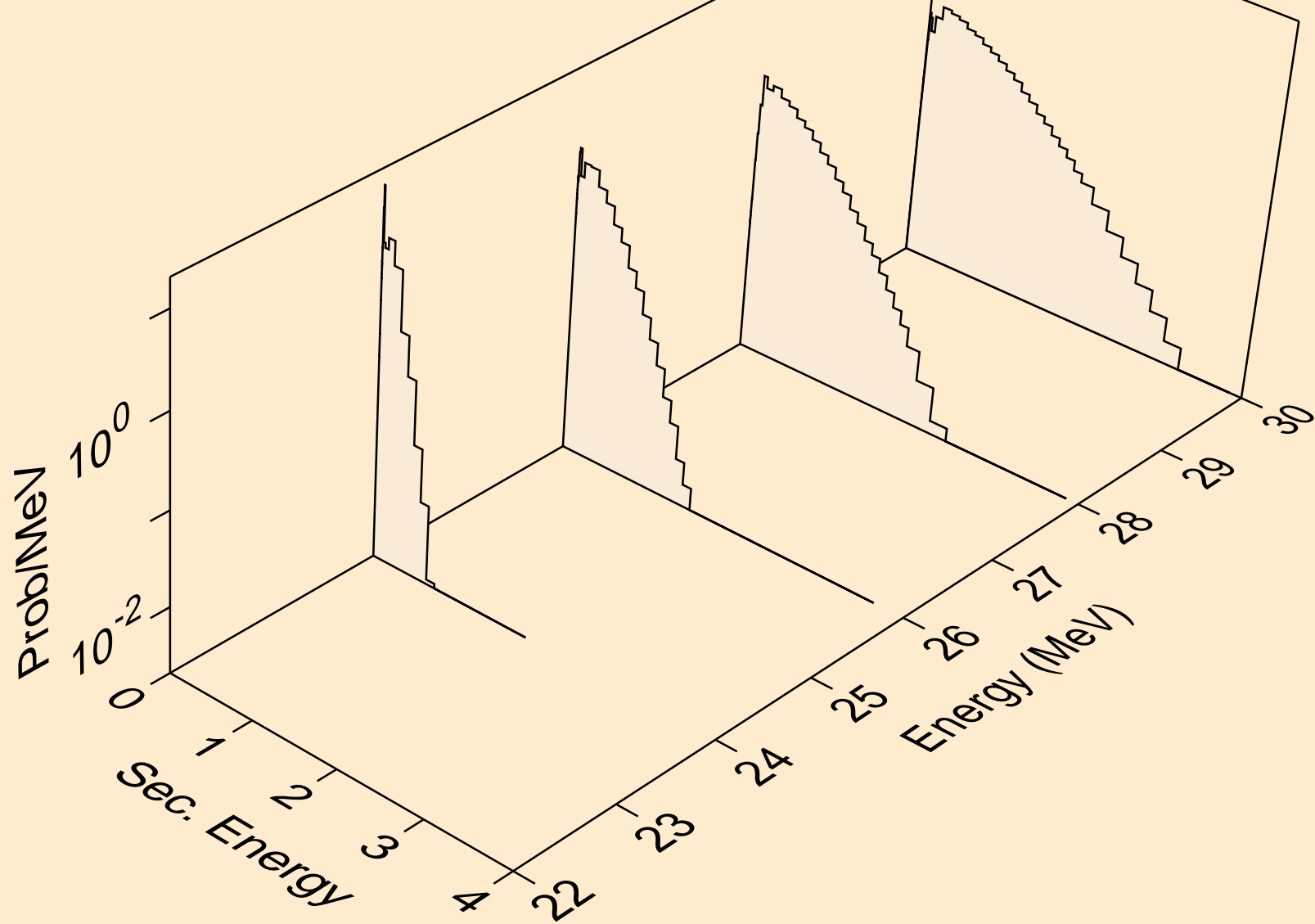

SB126M NEUTRON ACER TENDL-2023 LIBRARY; T=0.K
Neutron emission for (n,n2p)

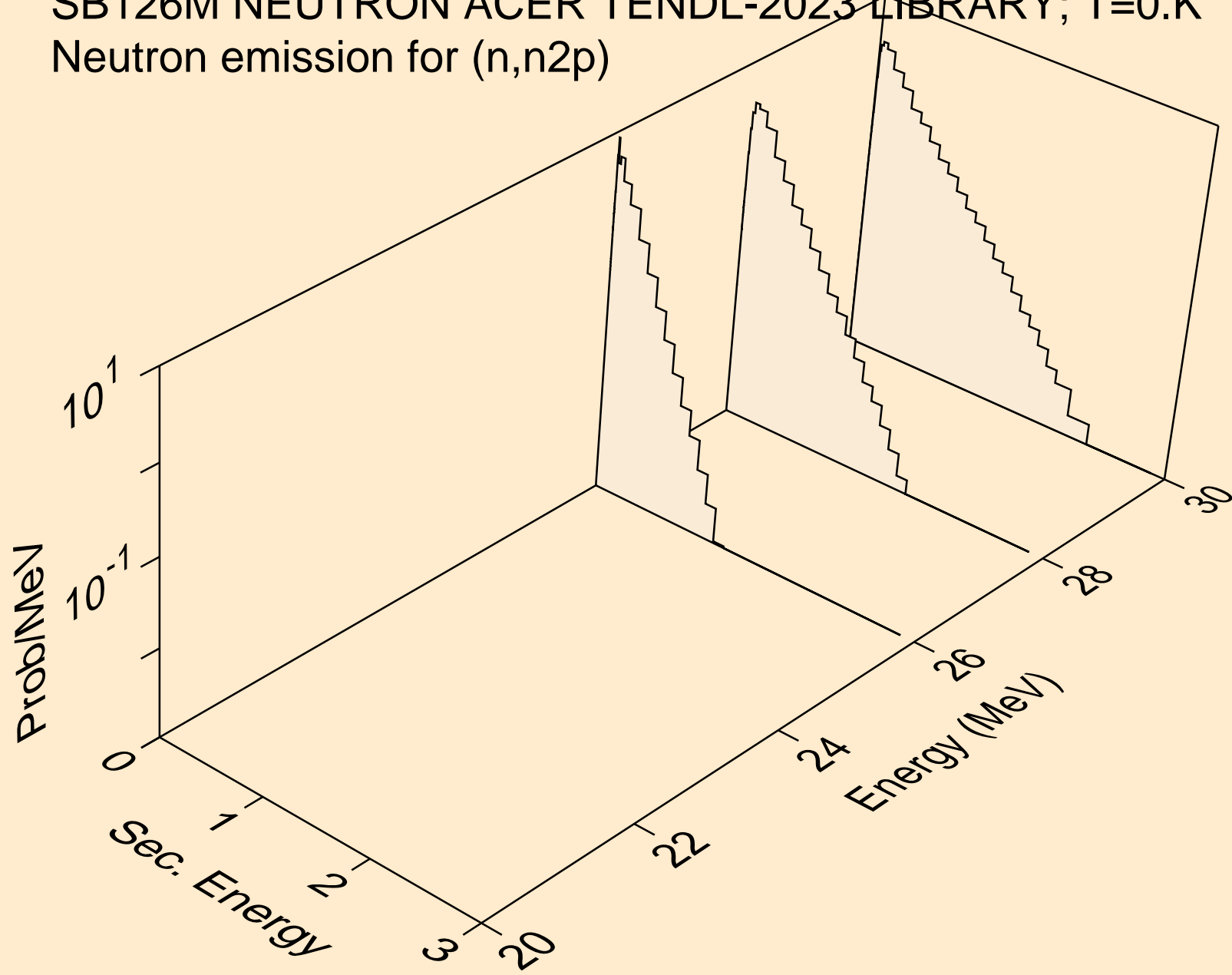

SB126M NEUTRON ACER TENDL-2023 LIBRARY; T=0.K
Neutron emission for (n,n*c)

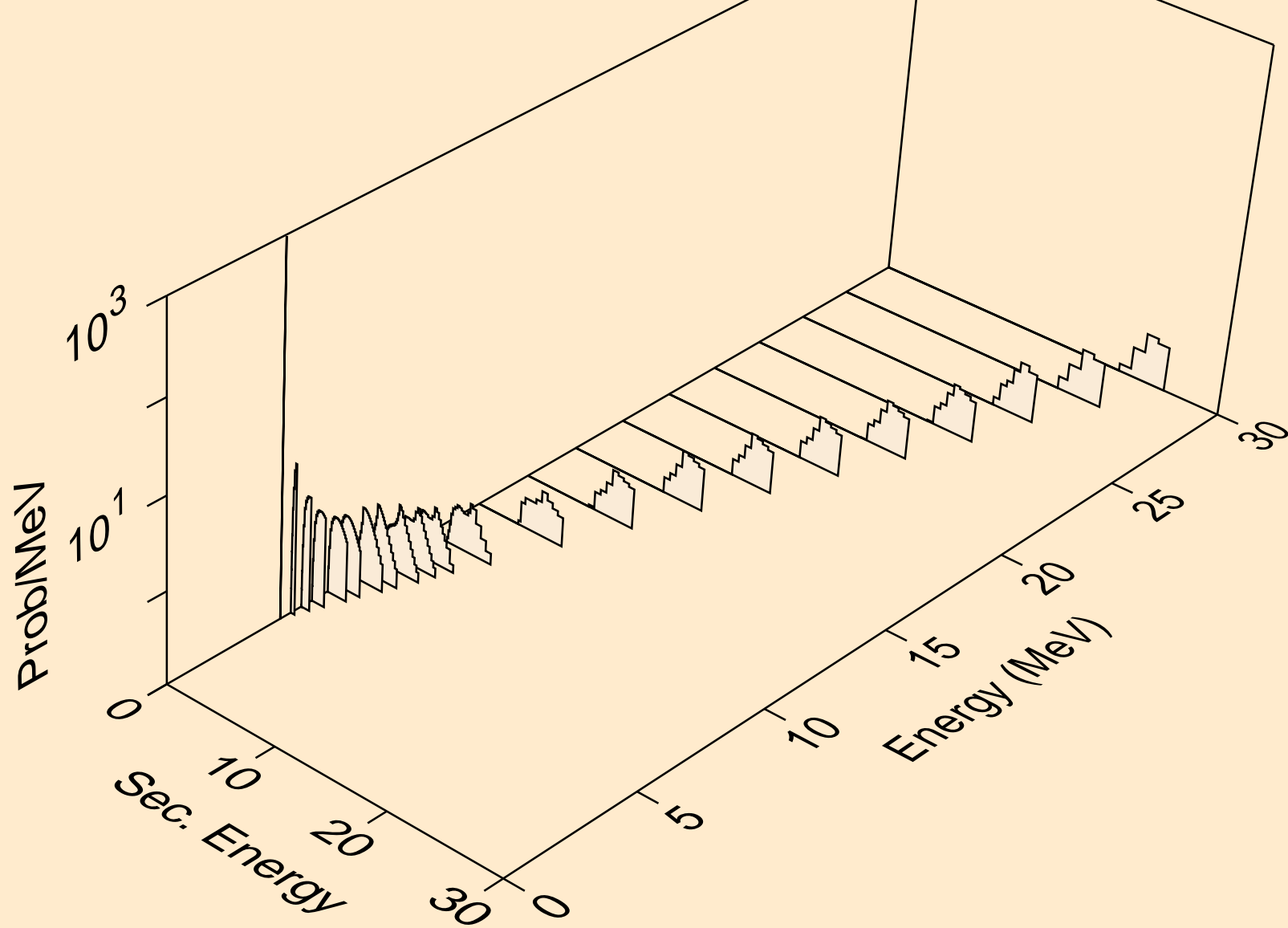

SB126M NEUTRON ACER TENDL-2023 LIBRARY; T=0.K
Photon emission for (n,x)

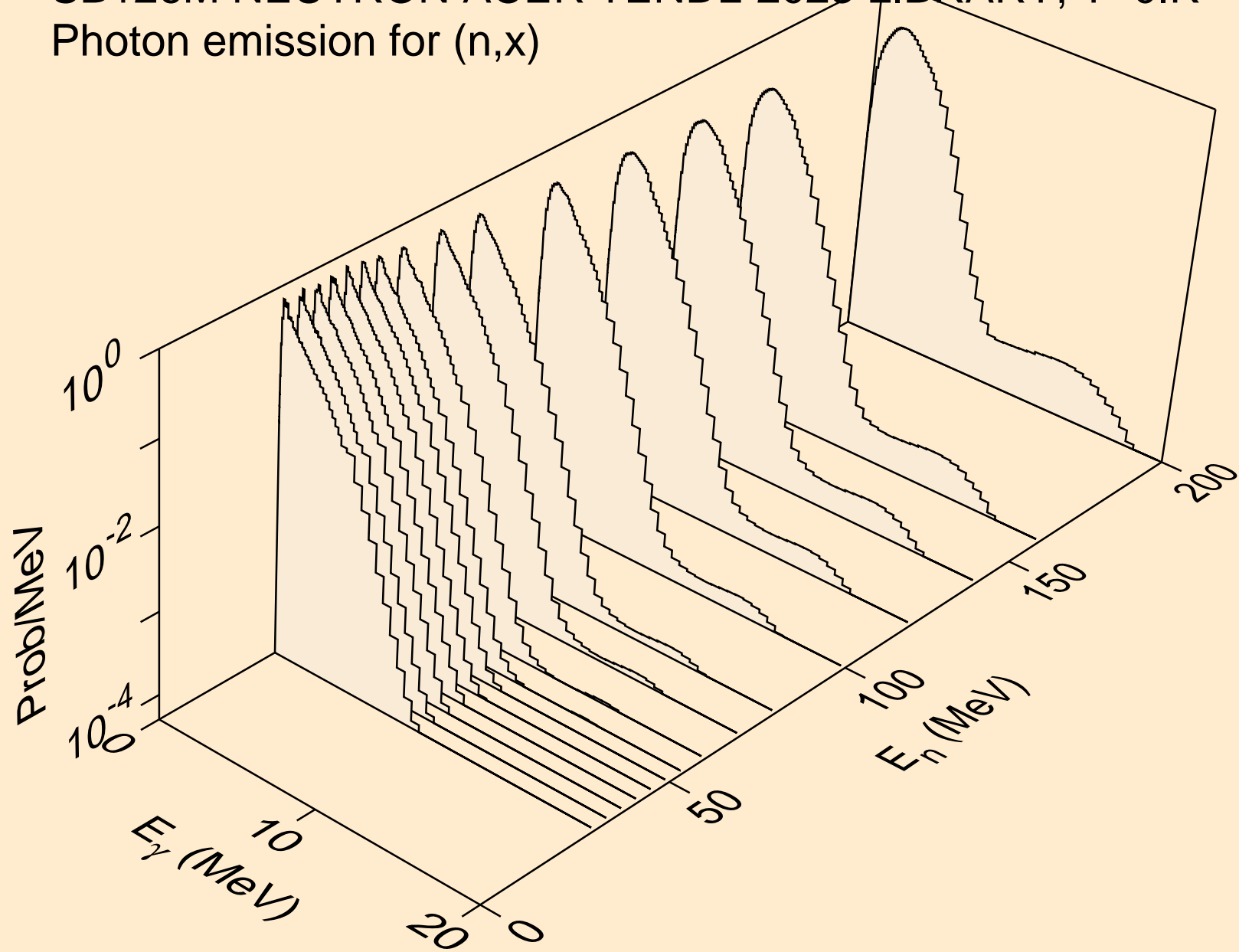

SB126M NEUTRON ACER TENDL-2023 LIBRARY; T=0.K
Photon emission for (n,2nd)

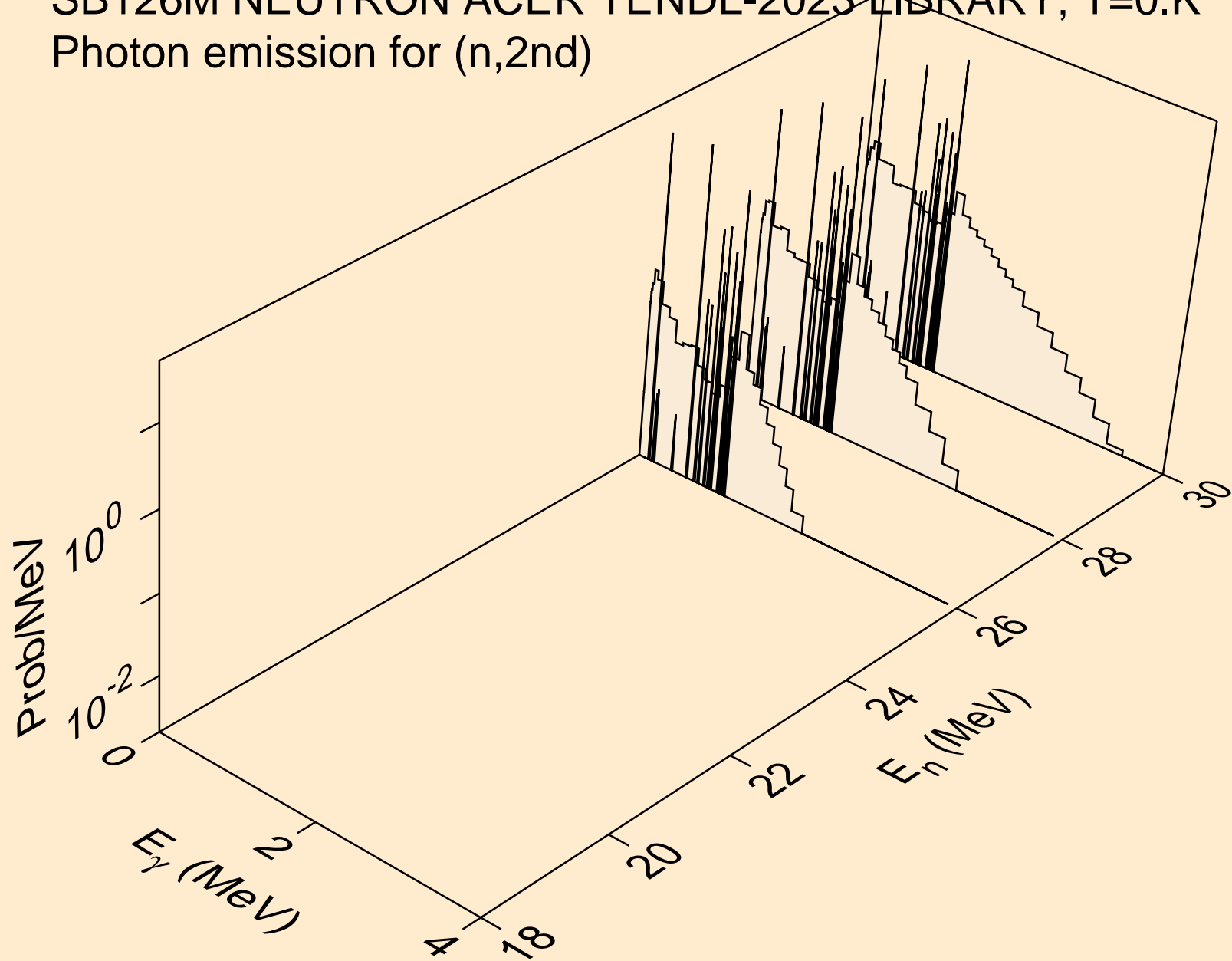

SB126M NEUTRON ACER TENDL-2023 LIBRARY; T=0.K
Photon emission for (n,2n)

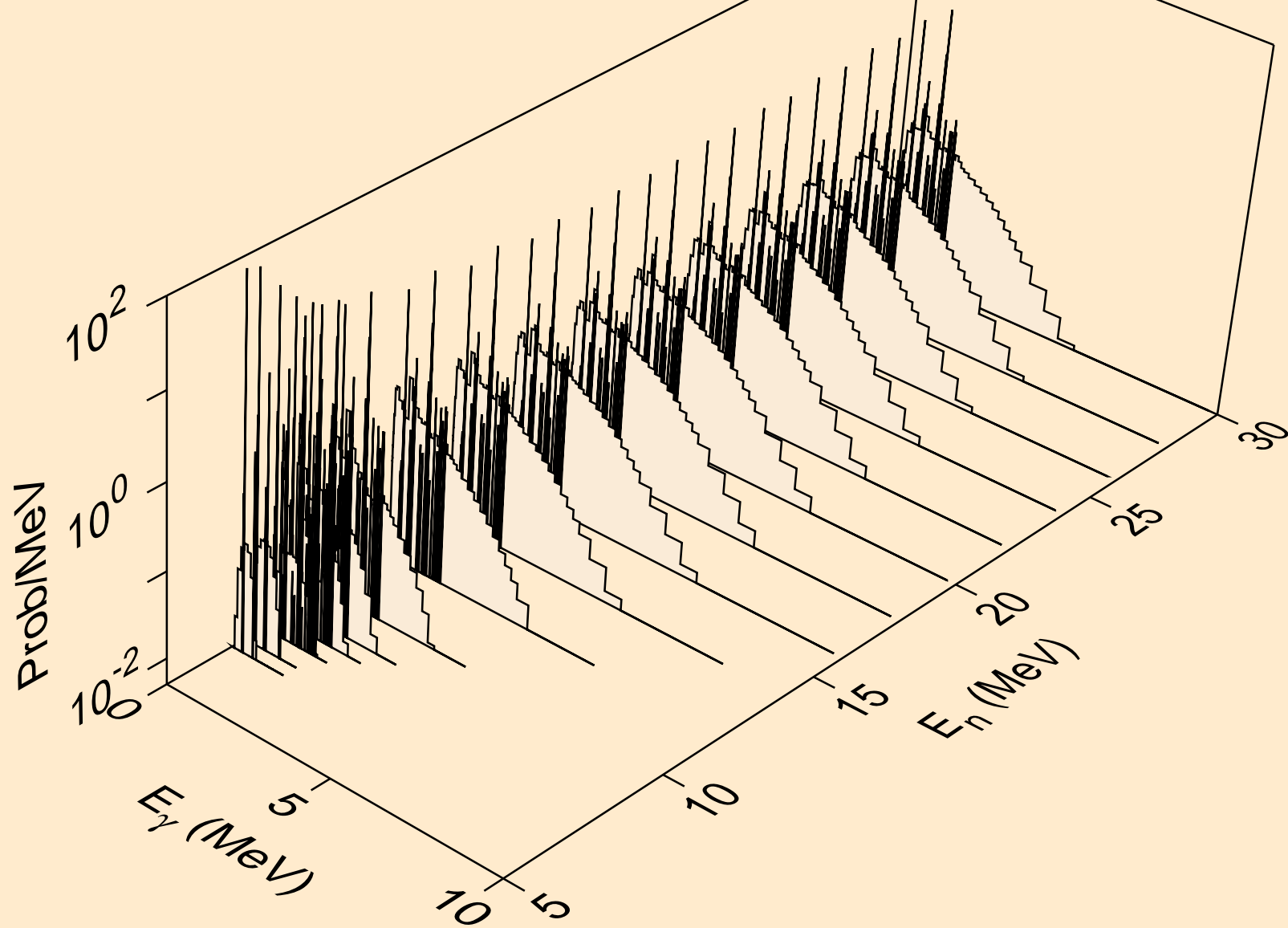

SB126M NEUTRON ACER TENDL-2023 LIBRARY; T=0.K
Photon emission for (n,3n)

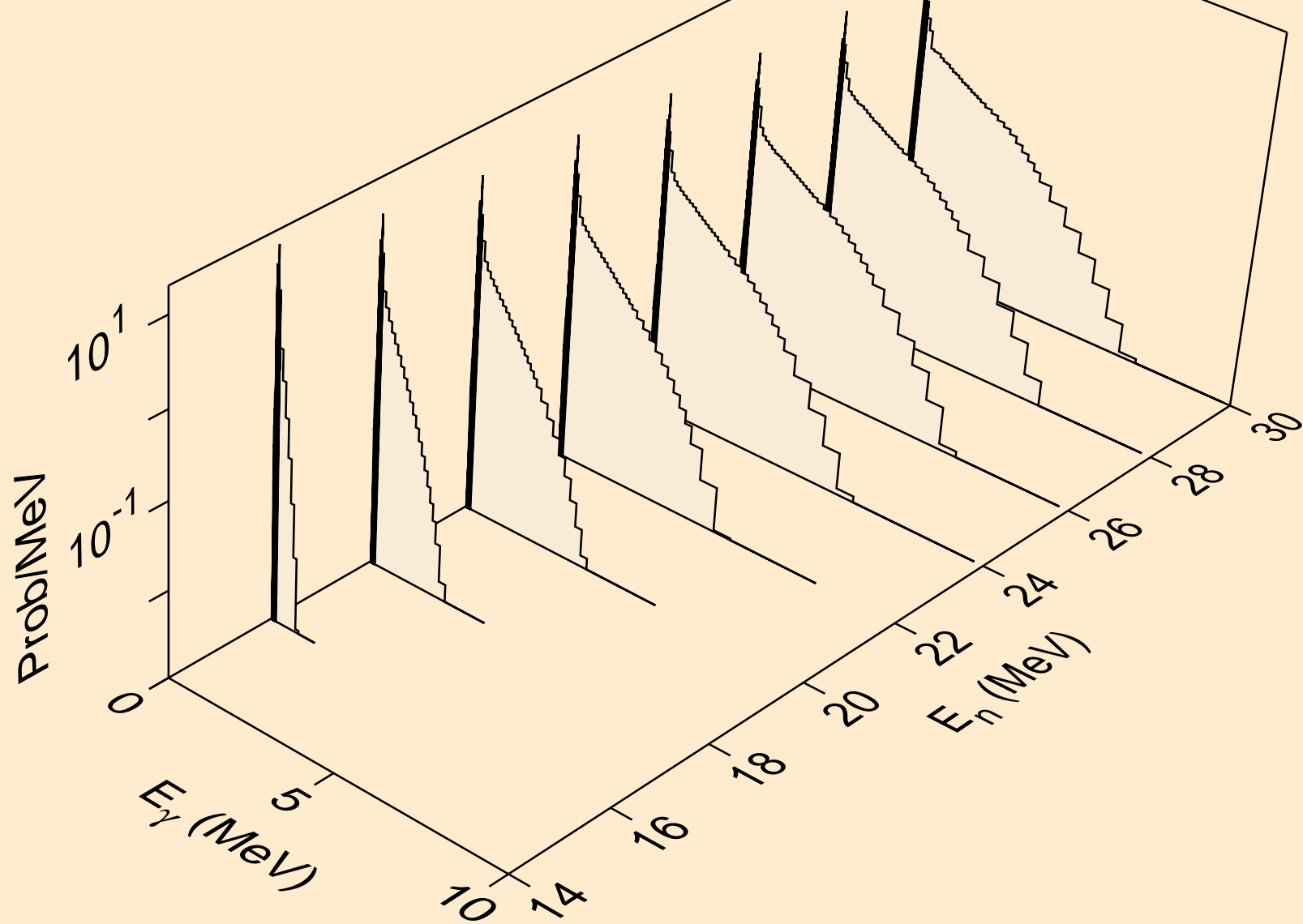

SB126M NEUTRON ACER TENDL-2023 LIBRARY; T=0.K
Photon emission for (n,n*)a

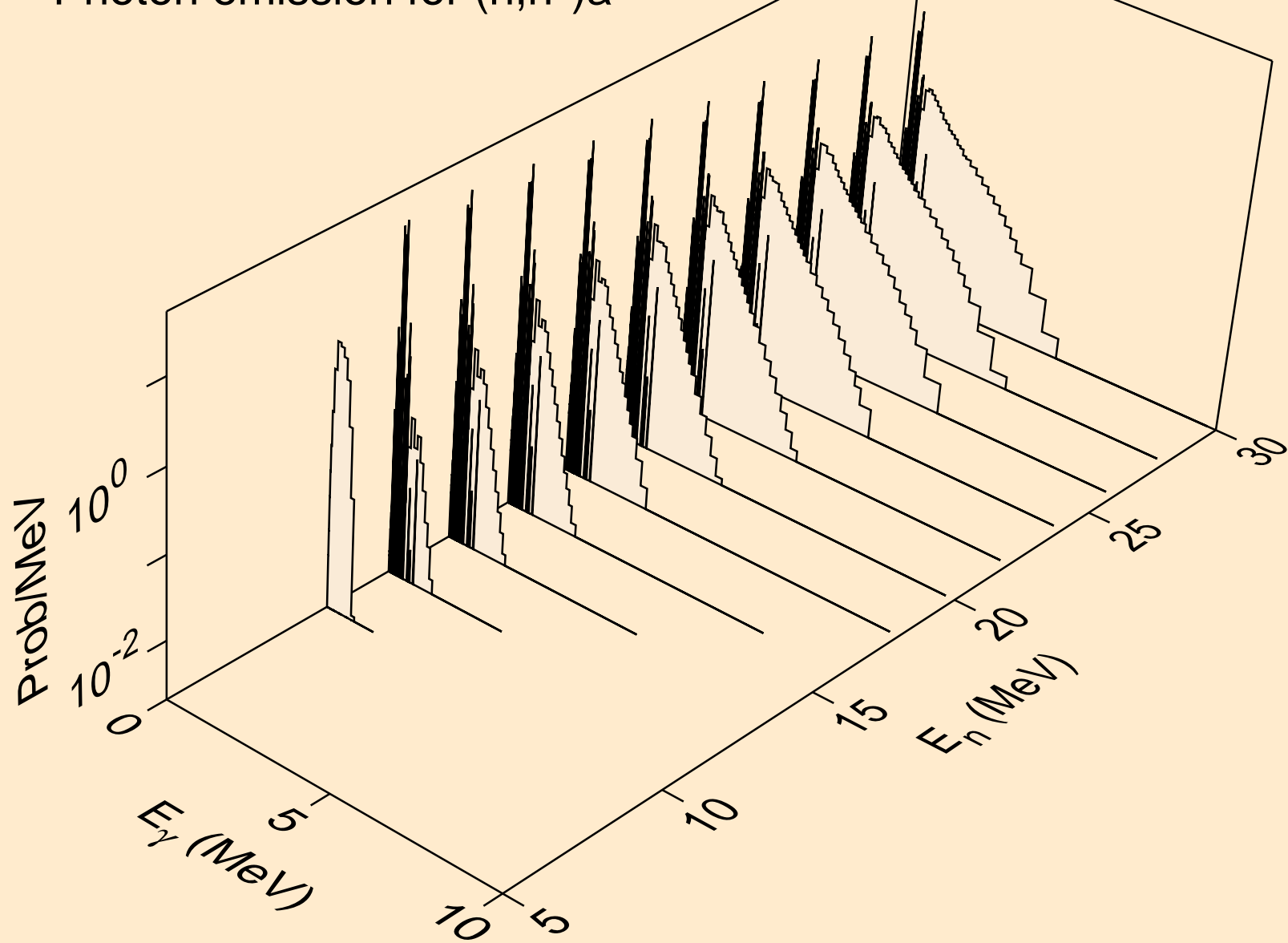

SB126M NEUTRON ACER TENDL-2023 LIBRARY; T=0.K
Photon emission for (n,2n)a

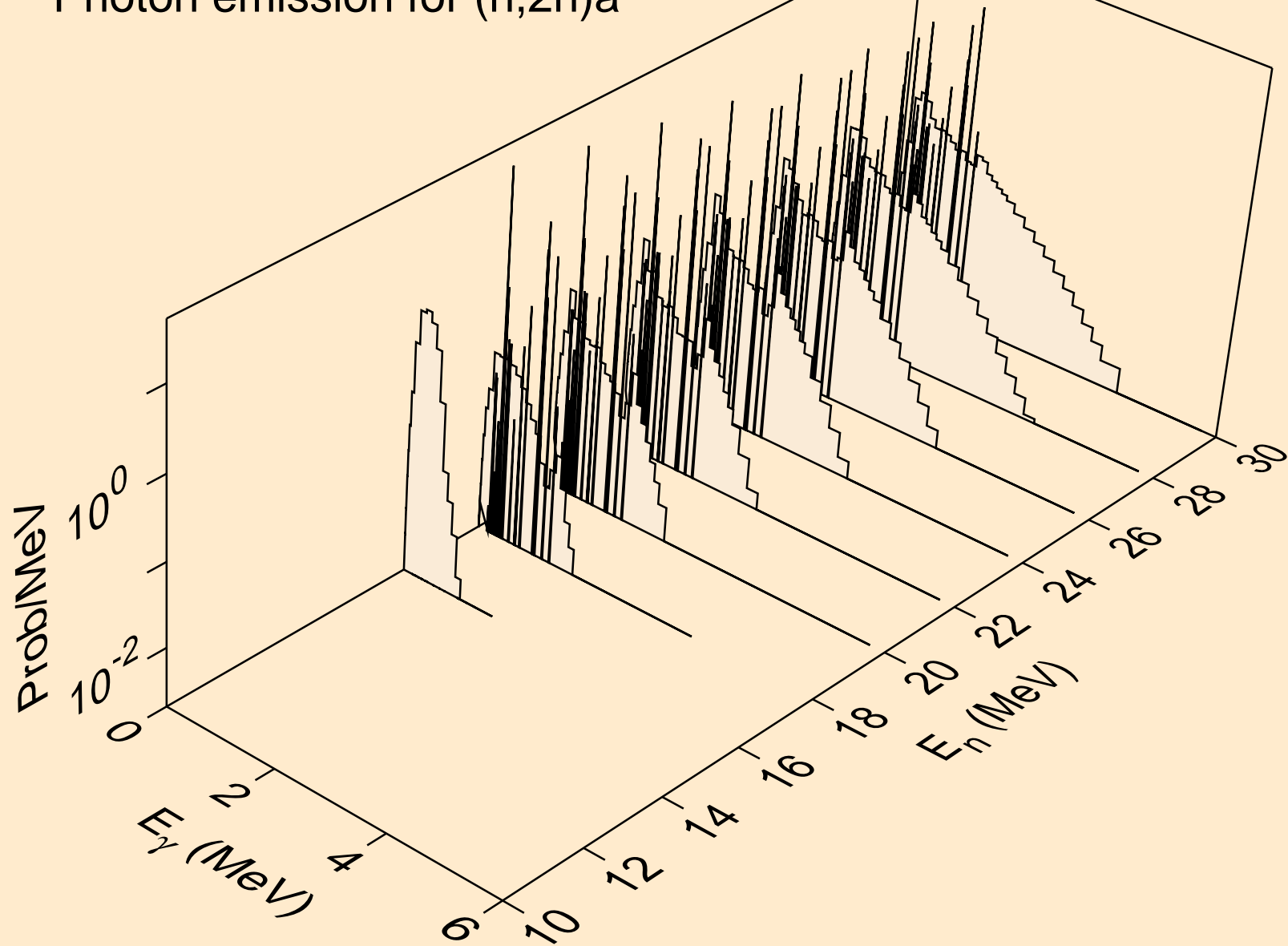

SB126M NEUTRON ACER TENDL-2023 LIBRARY; T=0.K
Photon emission for (n,3n)a

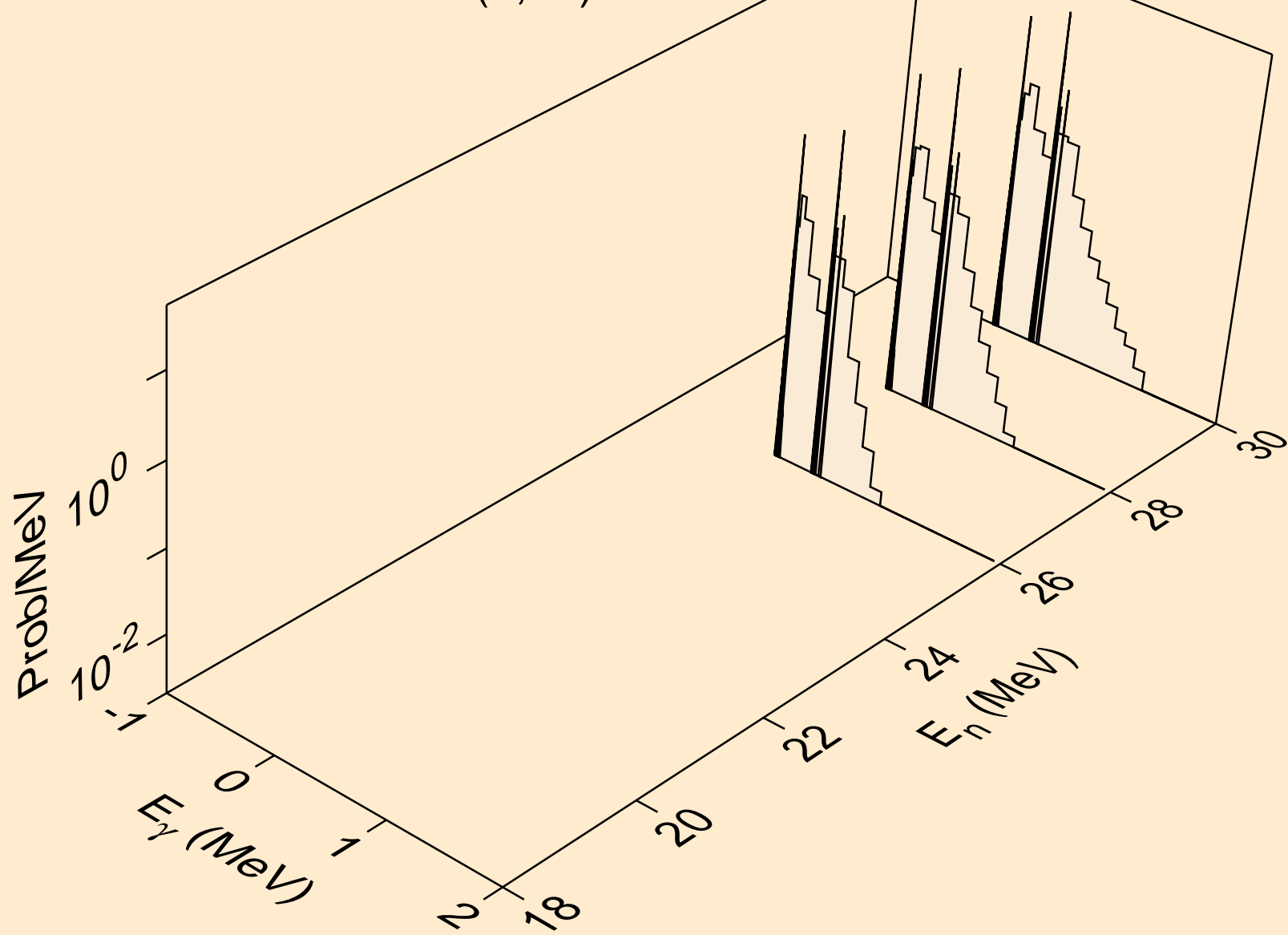

SB126M NEUTRON ACER TENDL-2023 LIBRARY; T=0.K
Photon emission for (n,n*)p

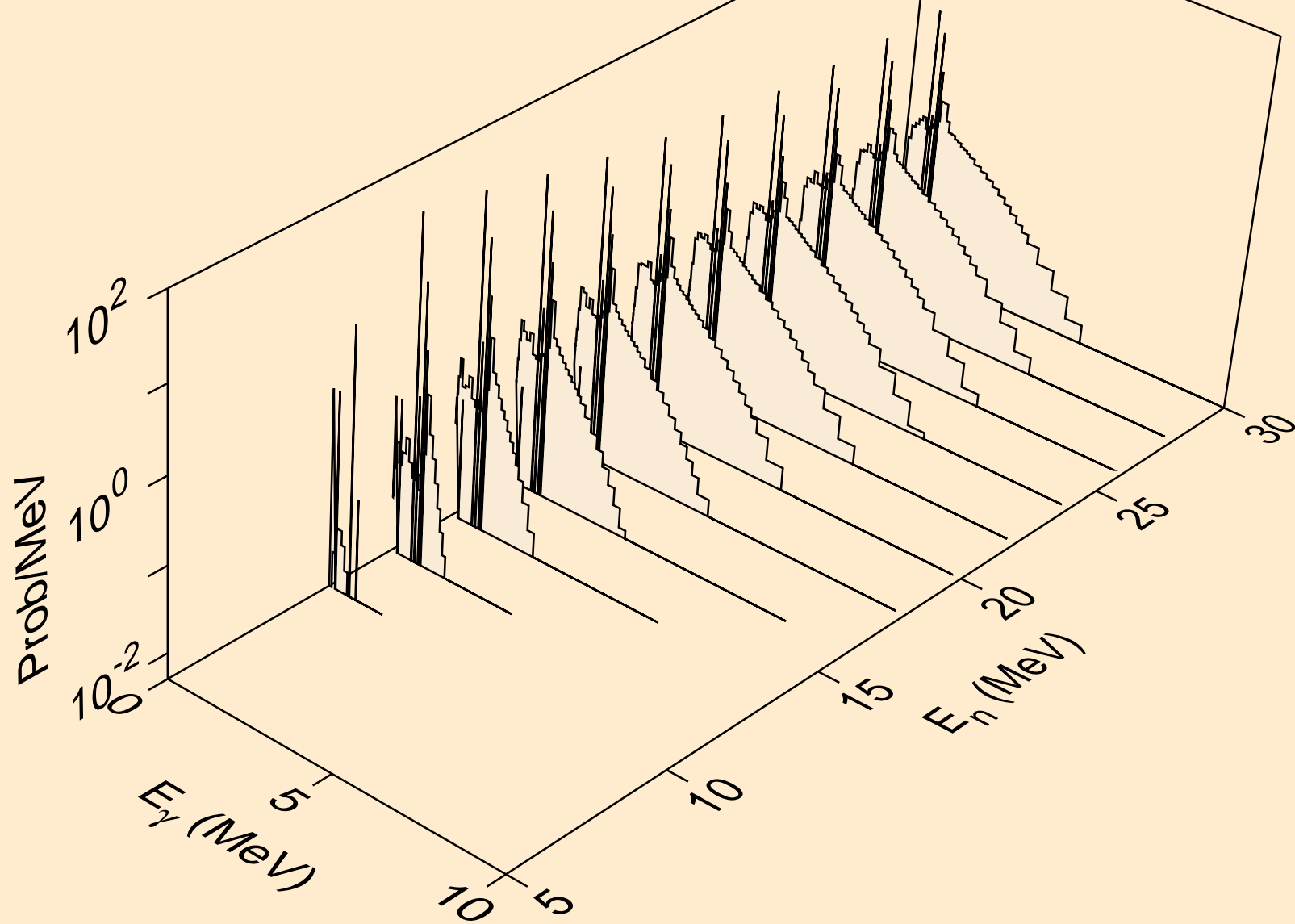

SB126M NEUTRON ACER TENDL-2023 LIBRARY; T=0.K
Photon emission for (n,n*)d

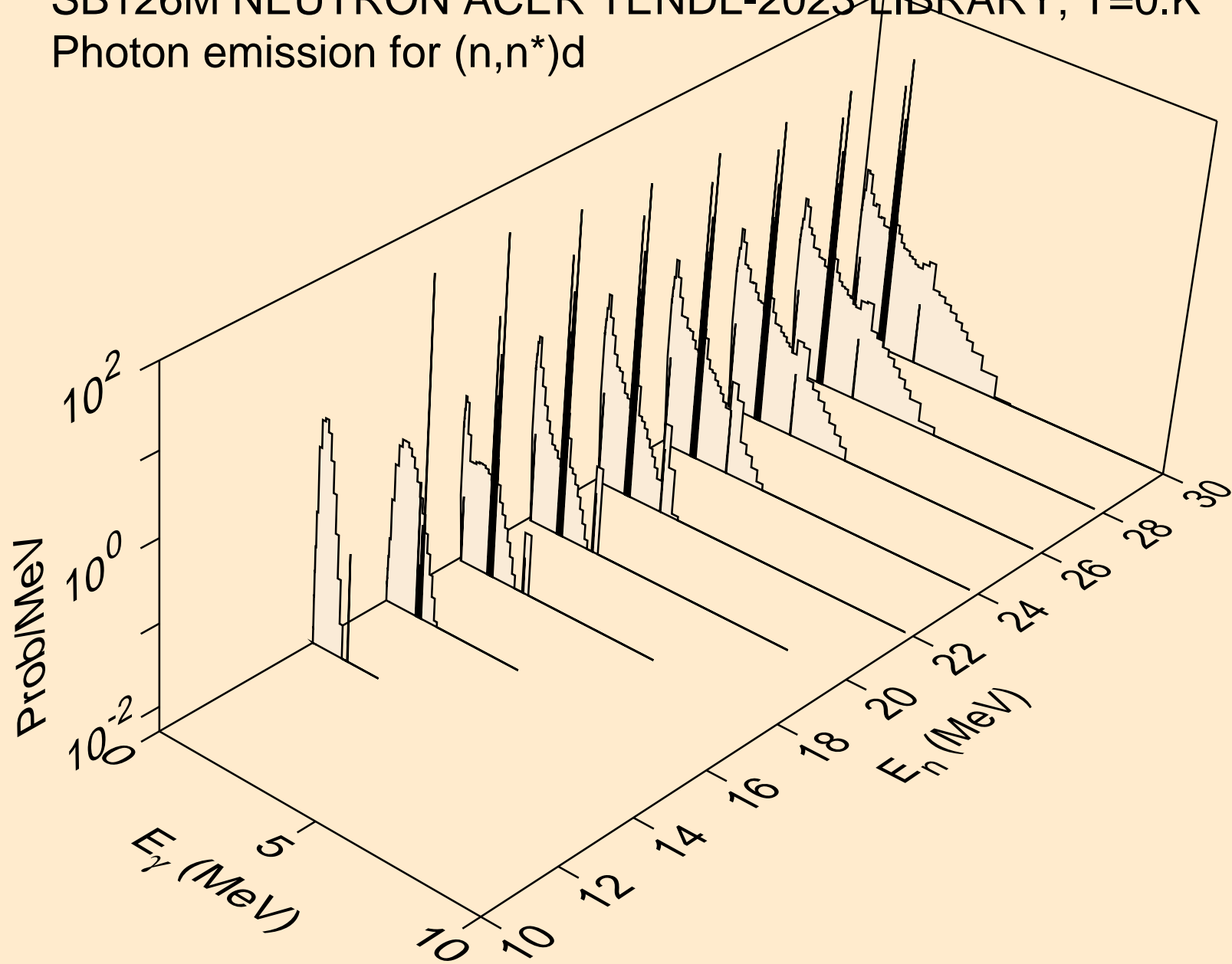

SB126M NEUTRON ACER TENDL-2023 LIBRARY; T=0.K
Photon emission for (n,n*)t

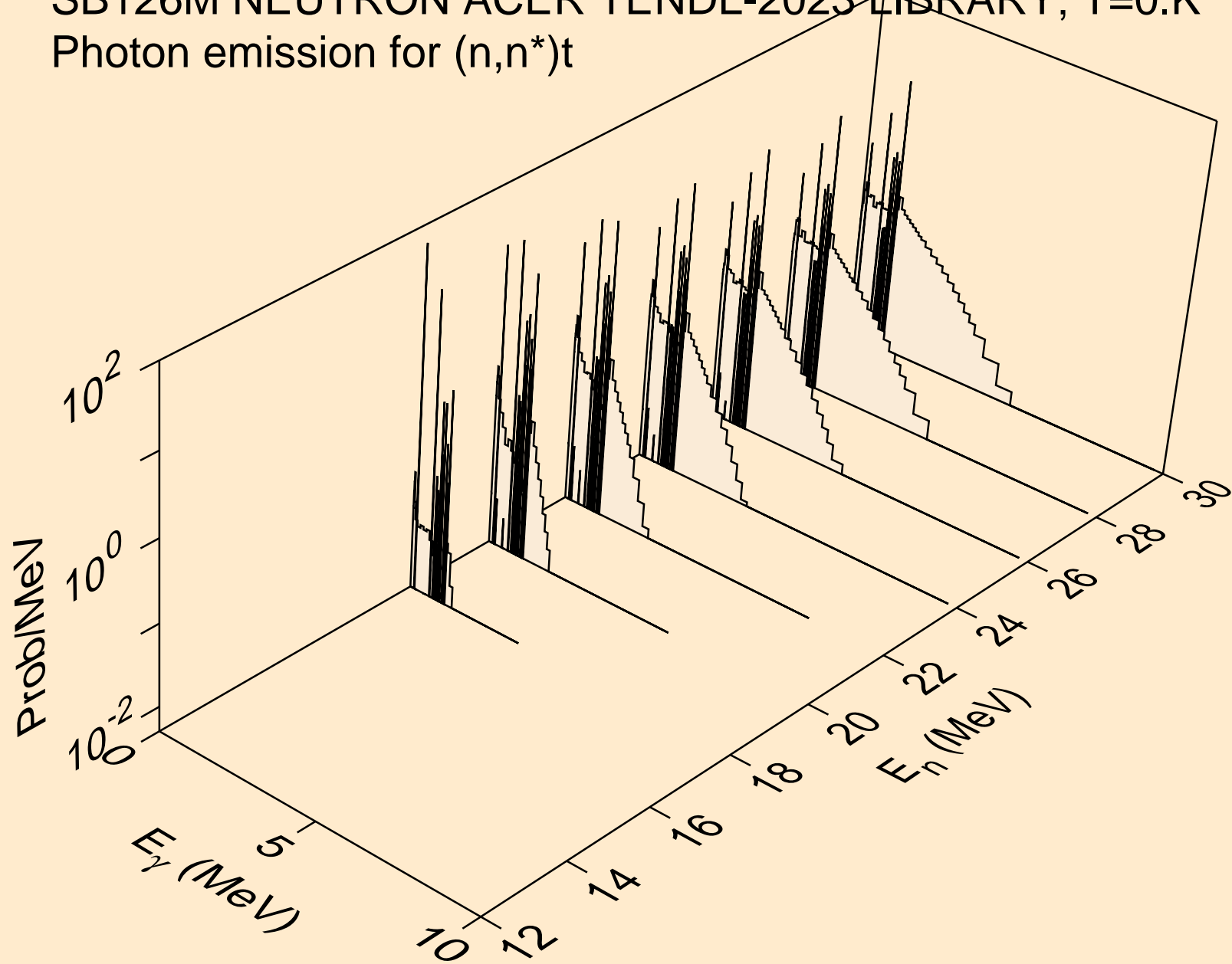

SB126M NEUTRON ACER TENDL-2023 LIBRARY; T=0.K
Photon emission for (n,n*)he3

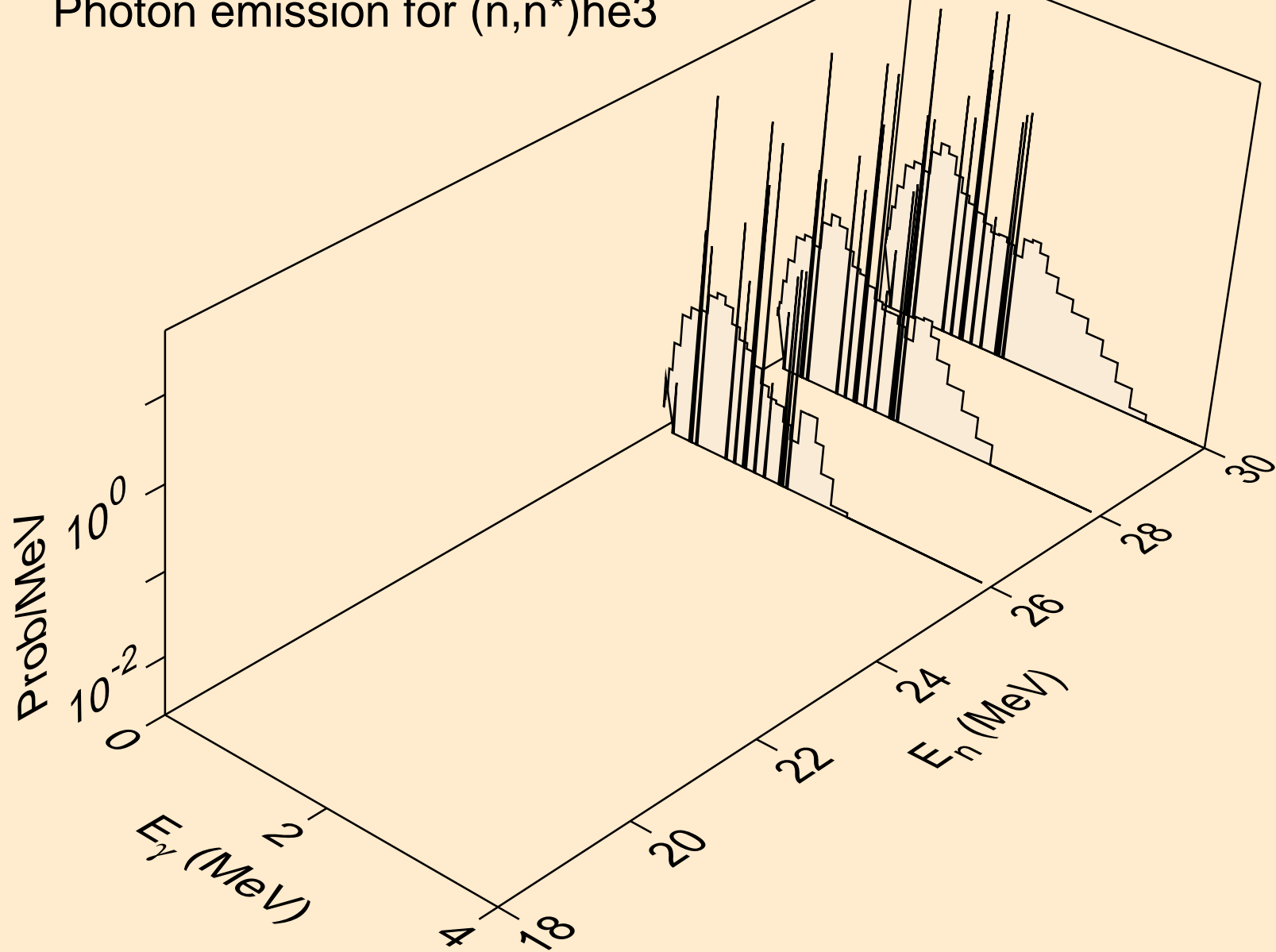

SB126M NEUTRON ACER TENDL-2023 LIBRARY; T=0.K
Photon emission for (n,4n)

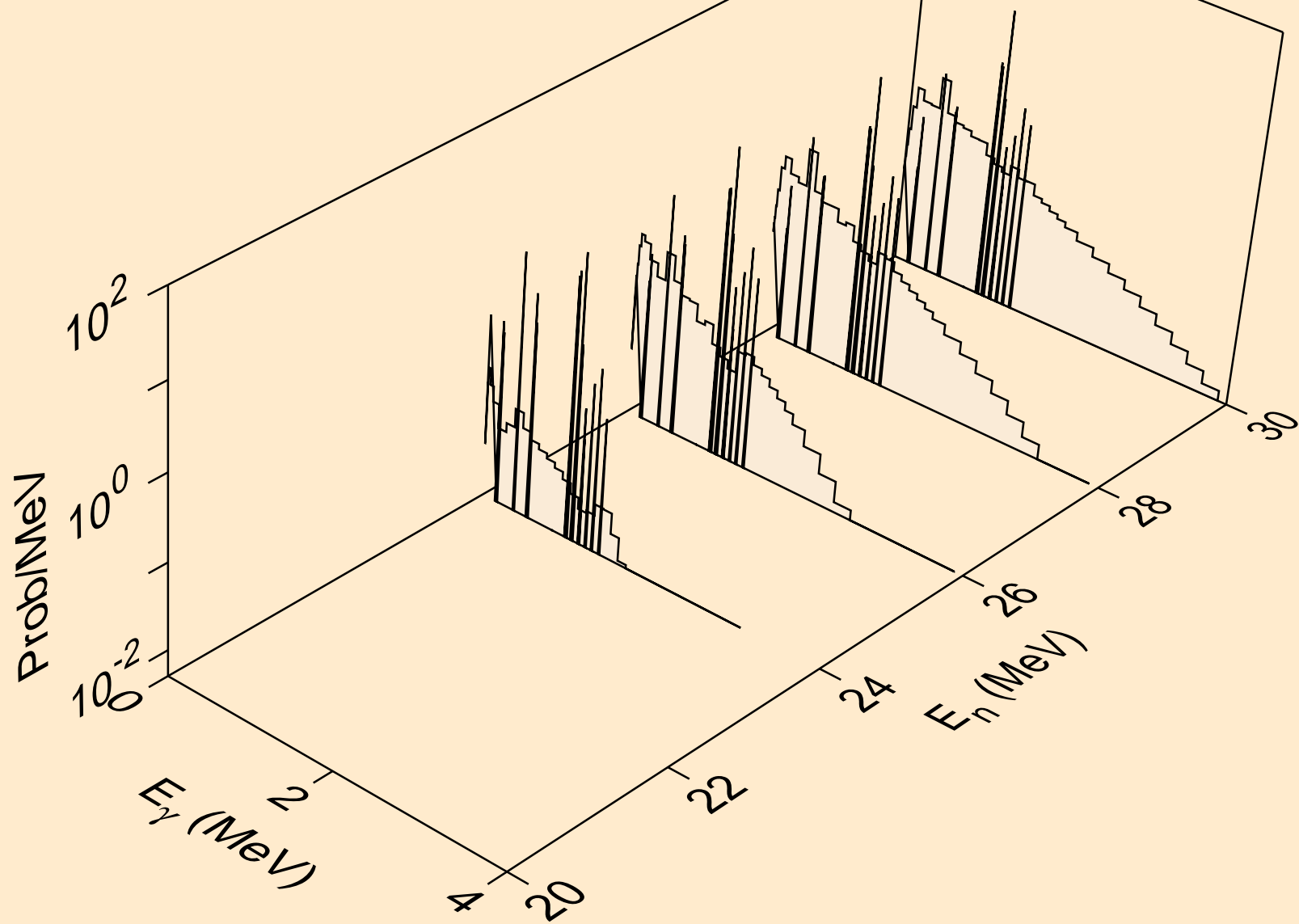

SB126M NEUTRON ACER TENDL-2023 LIBRARY; T=0.K
Photon emission for (n,2np)

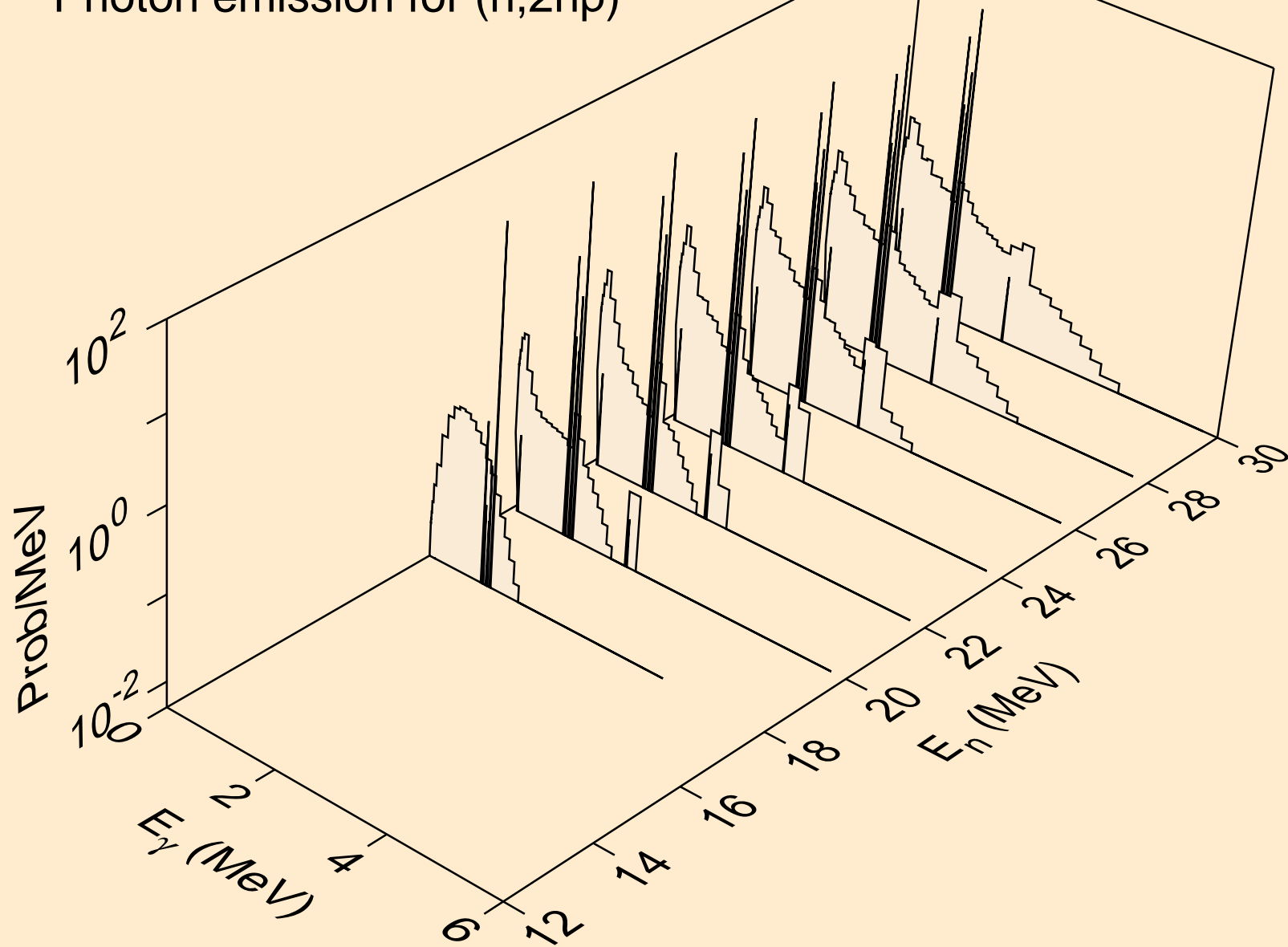

SB126M NEUTRON ACER TENDL-2023 LIBRARY; T=0.K
Photon emission for (n,3np)

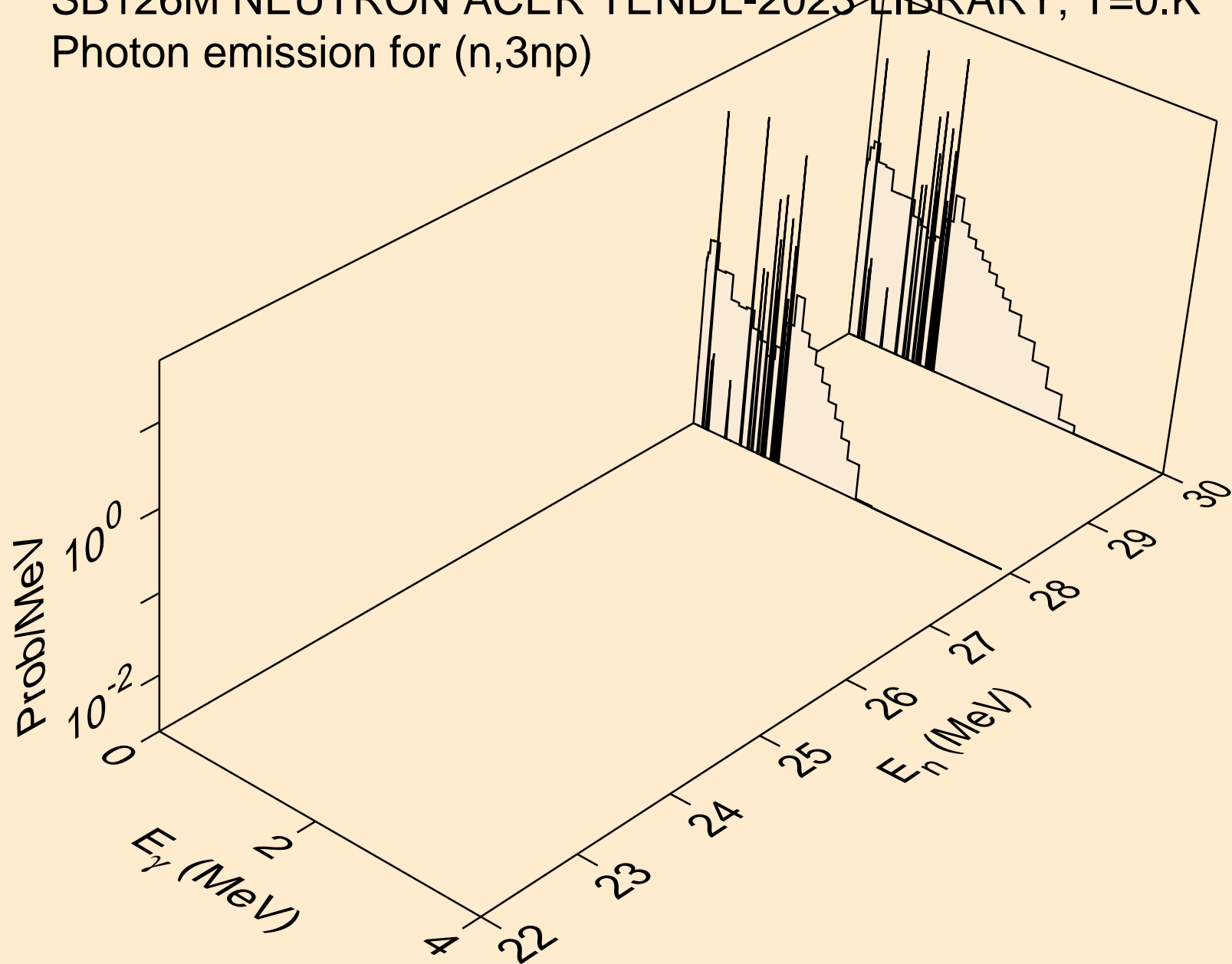

SB126M NEUTRON ACER TENDL-2023 LIBRARY; T=0.K
Photon emission for (n,n2p)

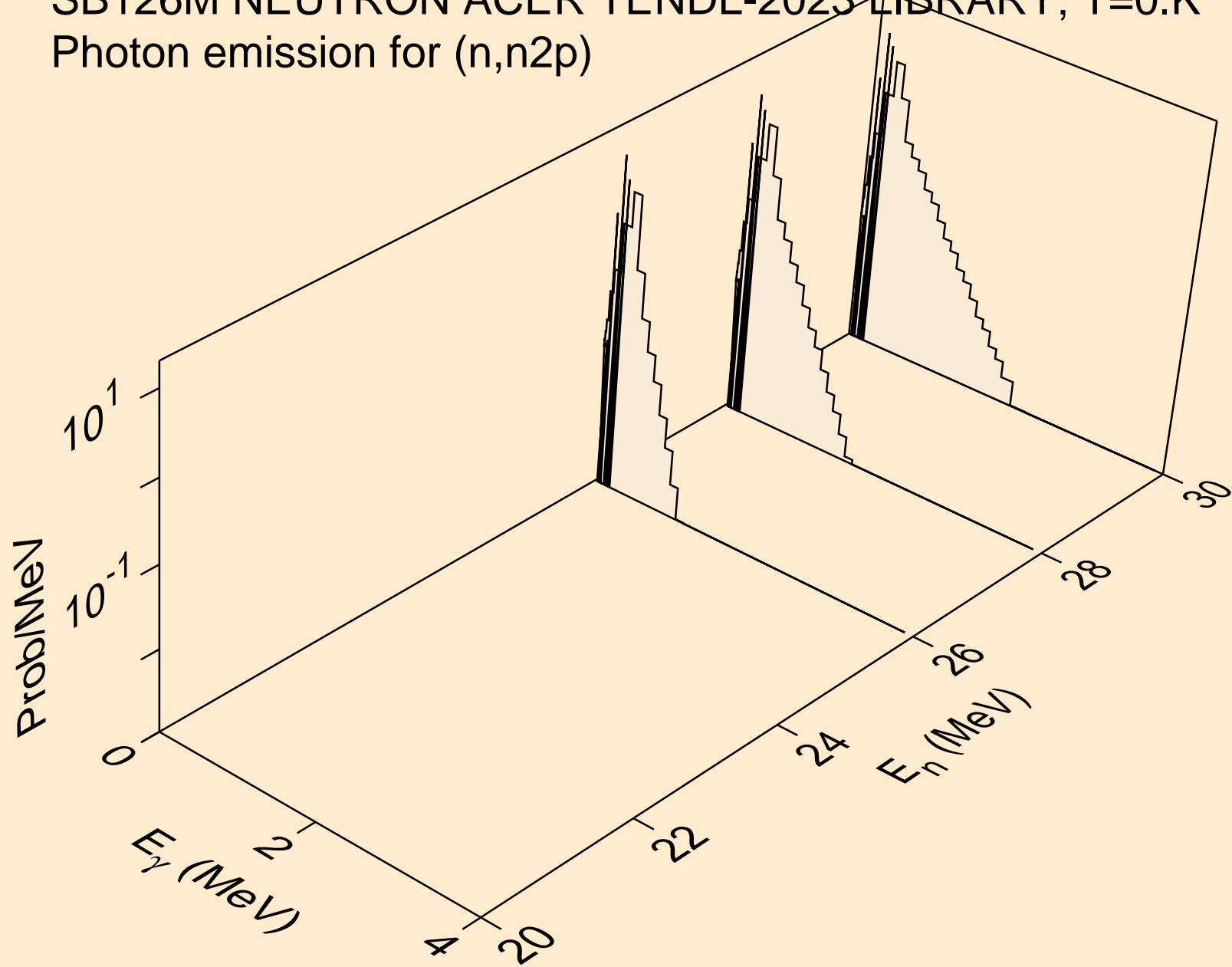

SB126M NEUTRON ACER TENDL-2023 LIBRARY; T=0.K
Photon emission for (n,n*3)

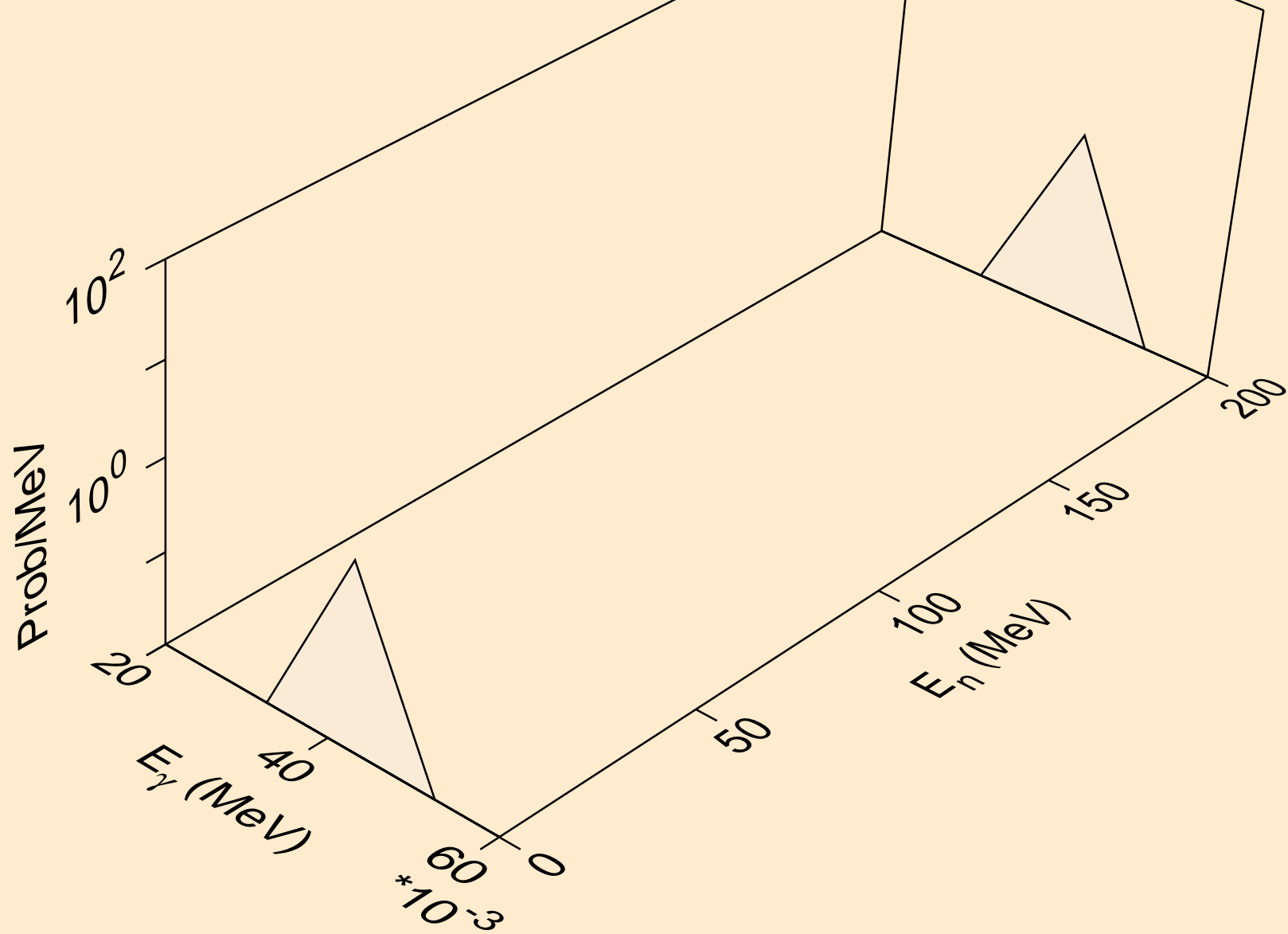

SB126M NEUTRON ACER TENDL-2023 LIBRARY; T=0.K
Photon emission for (n,n*4)

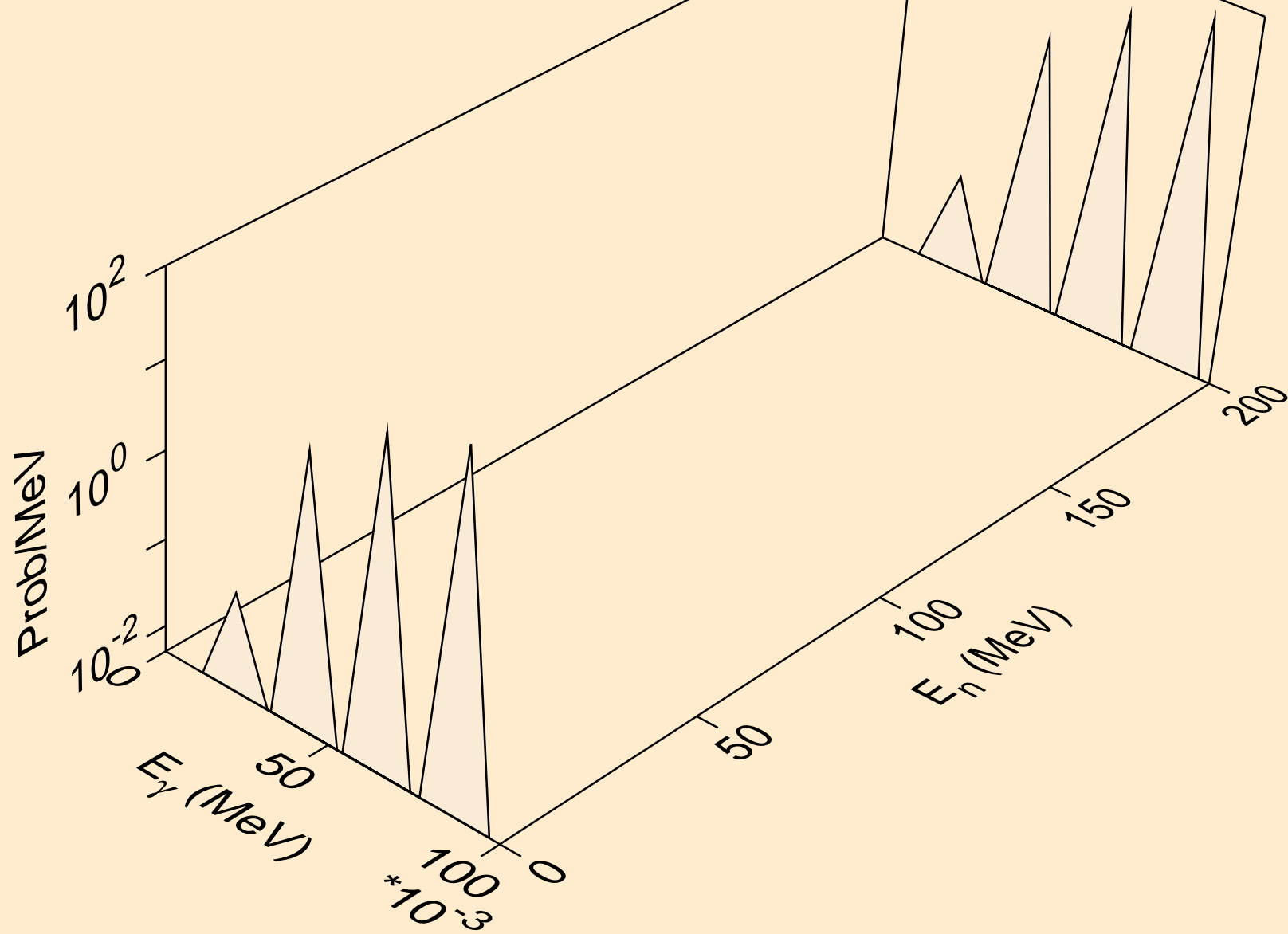

SB126M NEUTRON ACER TENDL-2023 LIBRARY; T=0.K
Photon emission for (n,n*5)

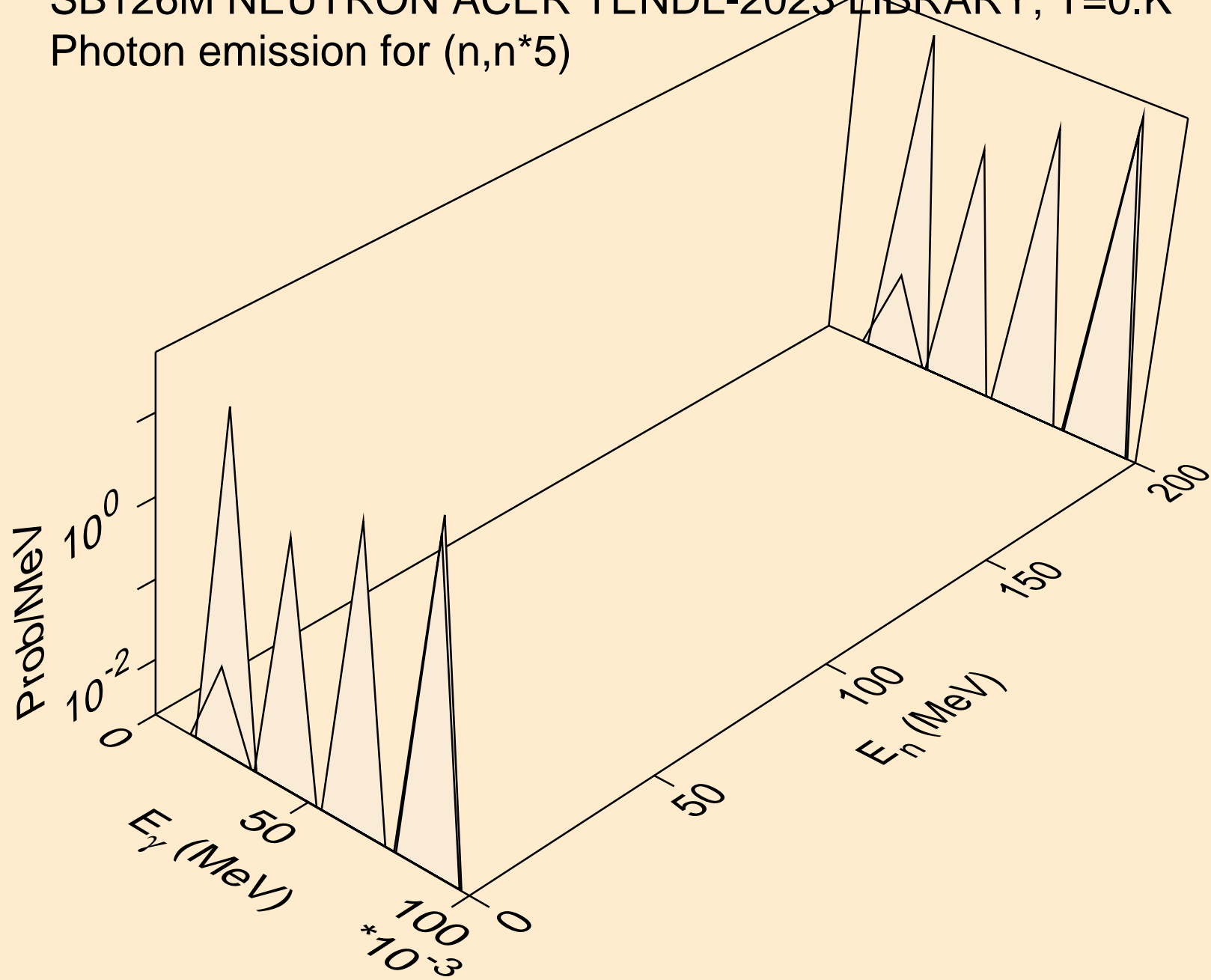

SB126M NEUTRON ACER TENDL-2023 LIBRARY; T=0.K
Photon emission for (n,n*6)

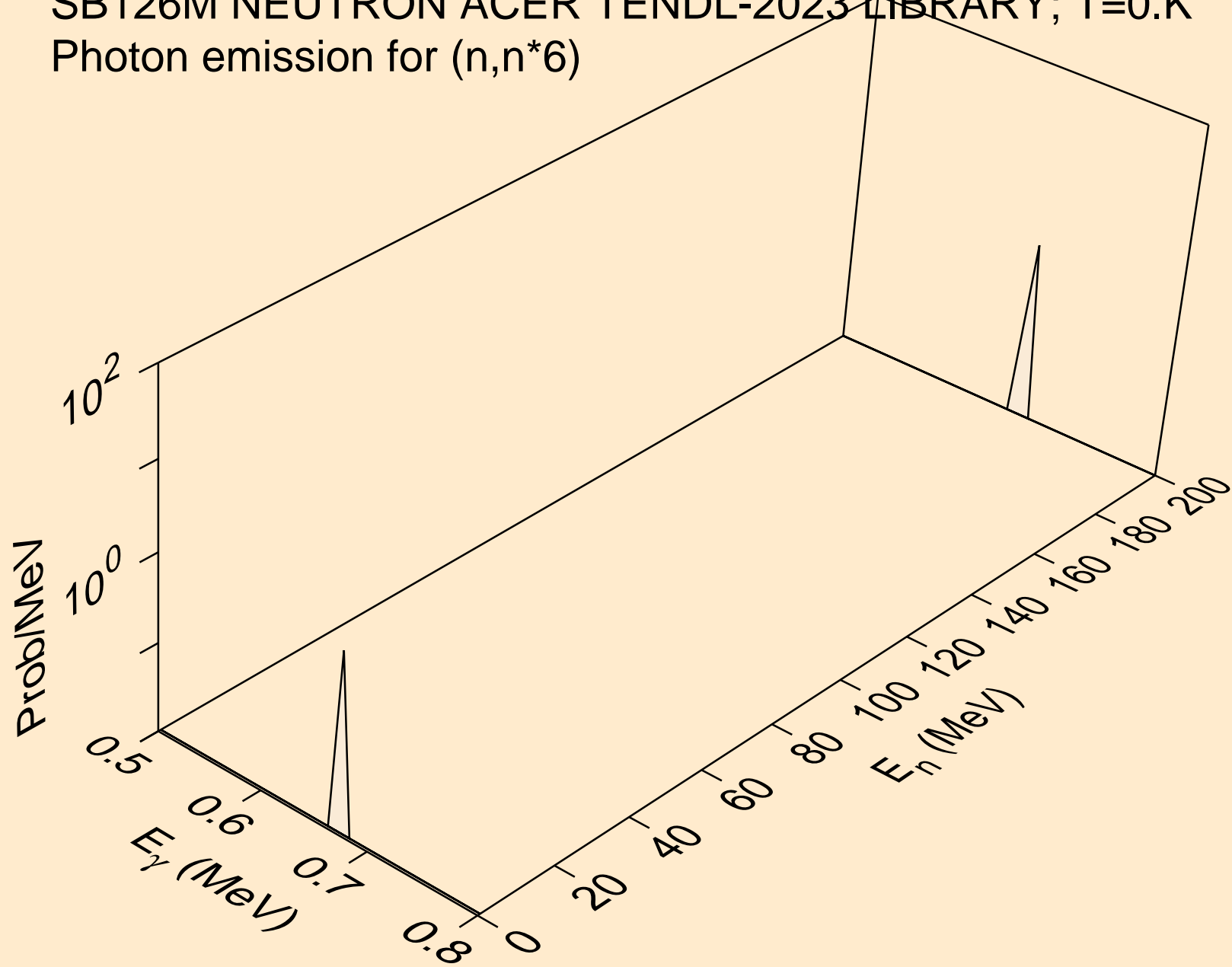

SB126M NEUTRON ACER TENDL-2023 LIBRARY; T=0.K
Photon emission for (n,n*7)

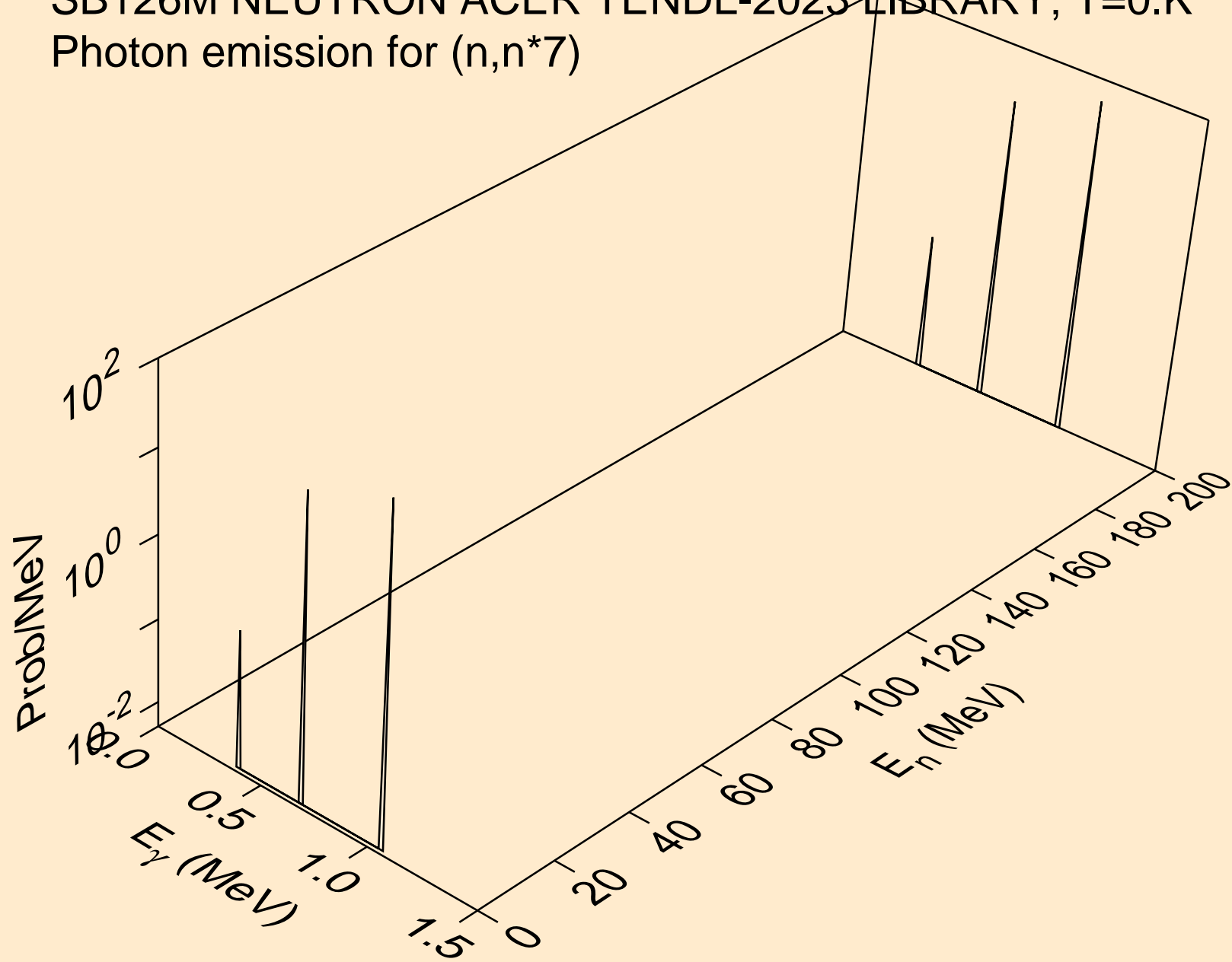

SB126M NEUTRON ACER TENDL-2023 LIBRARY; T=0.K
Photon emission for (n,n*8)

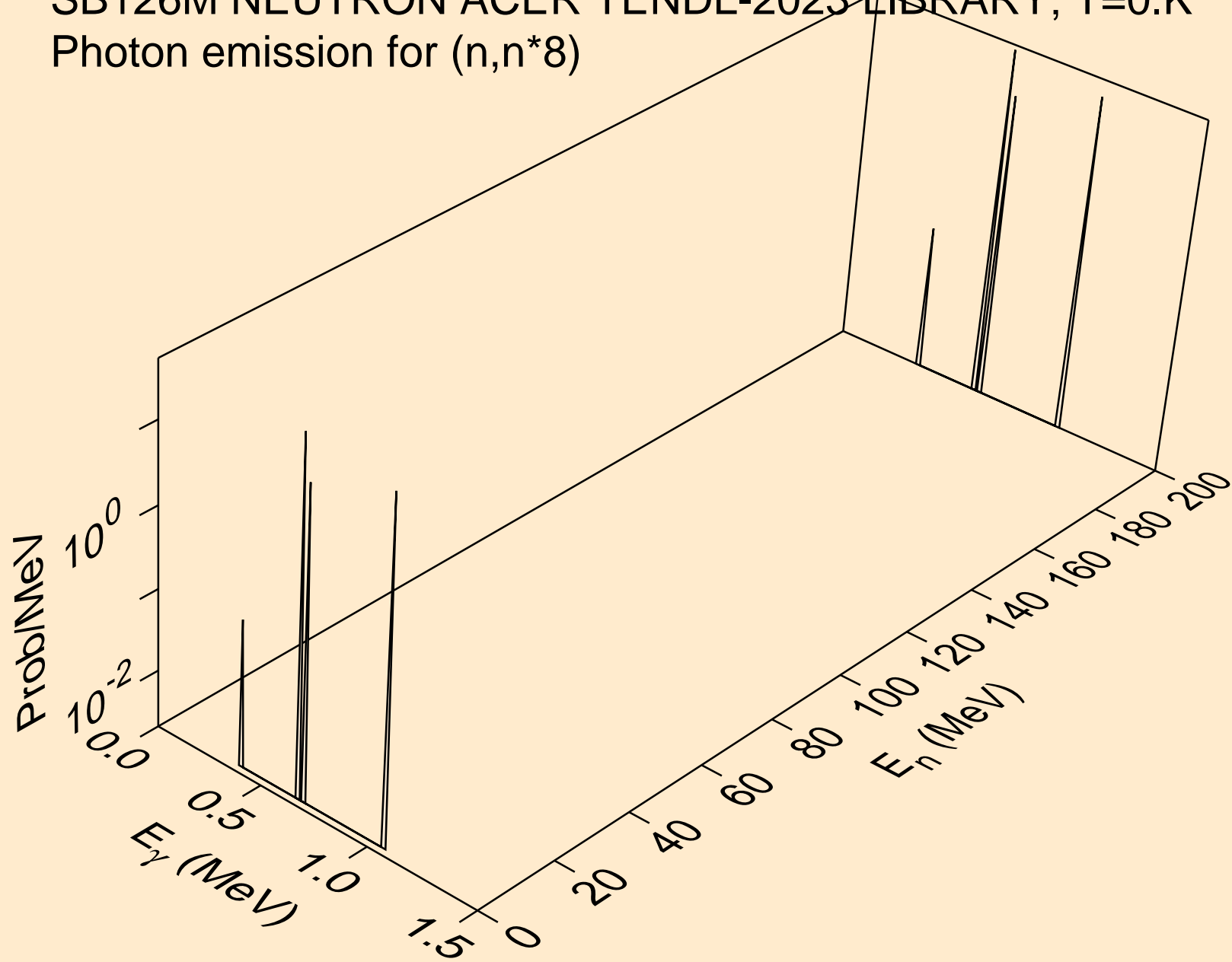

SB126M NEUTRON ACER TENDL-2023 LIBRARY; T=0.K
Photon emission for (n,n*c)

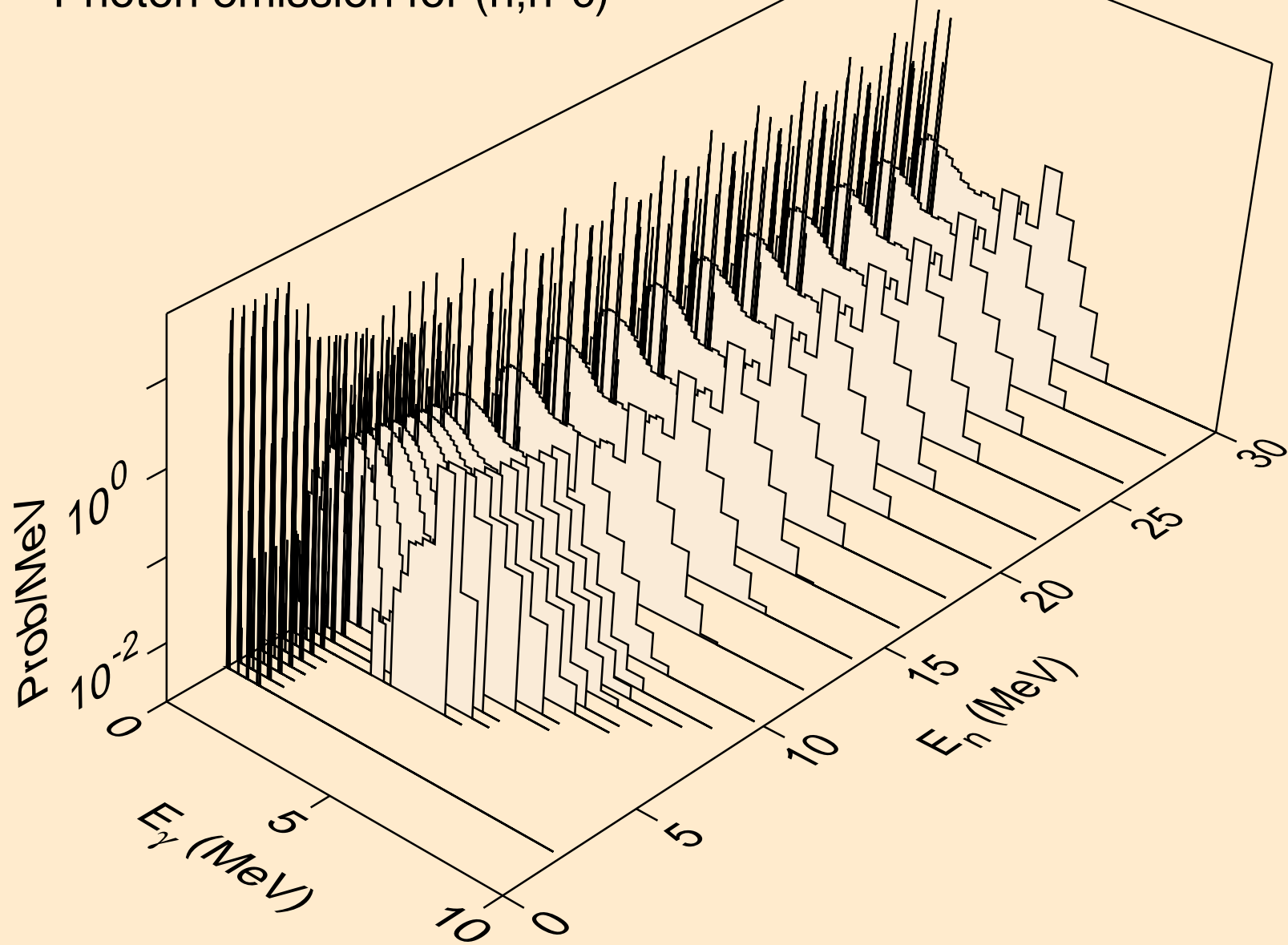

SB126M NEUTRON ACER TENDL-2023 LIBRARY; T=0.K
Photon emission for (n,gma)

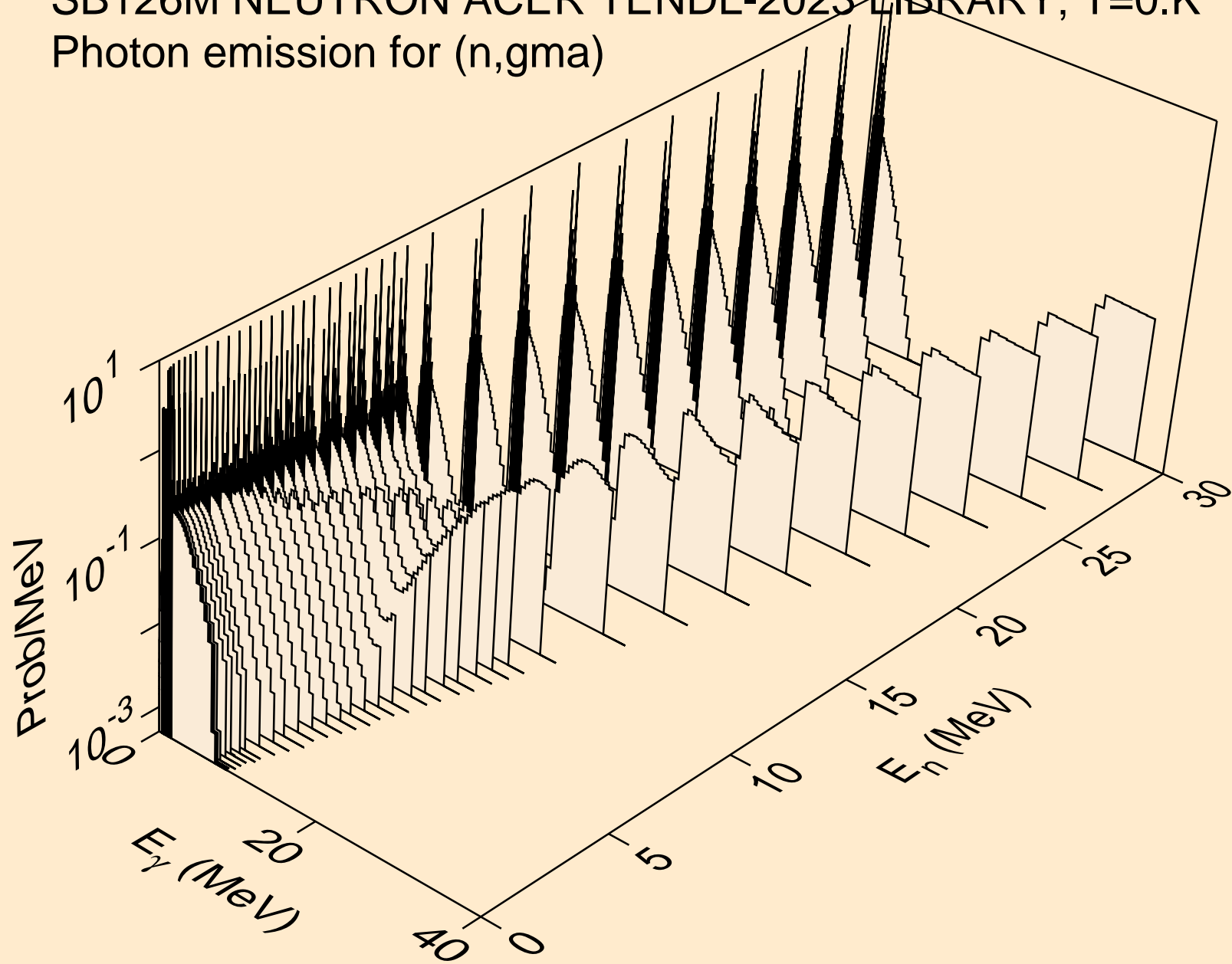

SB126M NEUTRON ACER TENDL-2023 LIBRARY; T=0.K
Photon emission for (n,p)

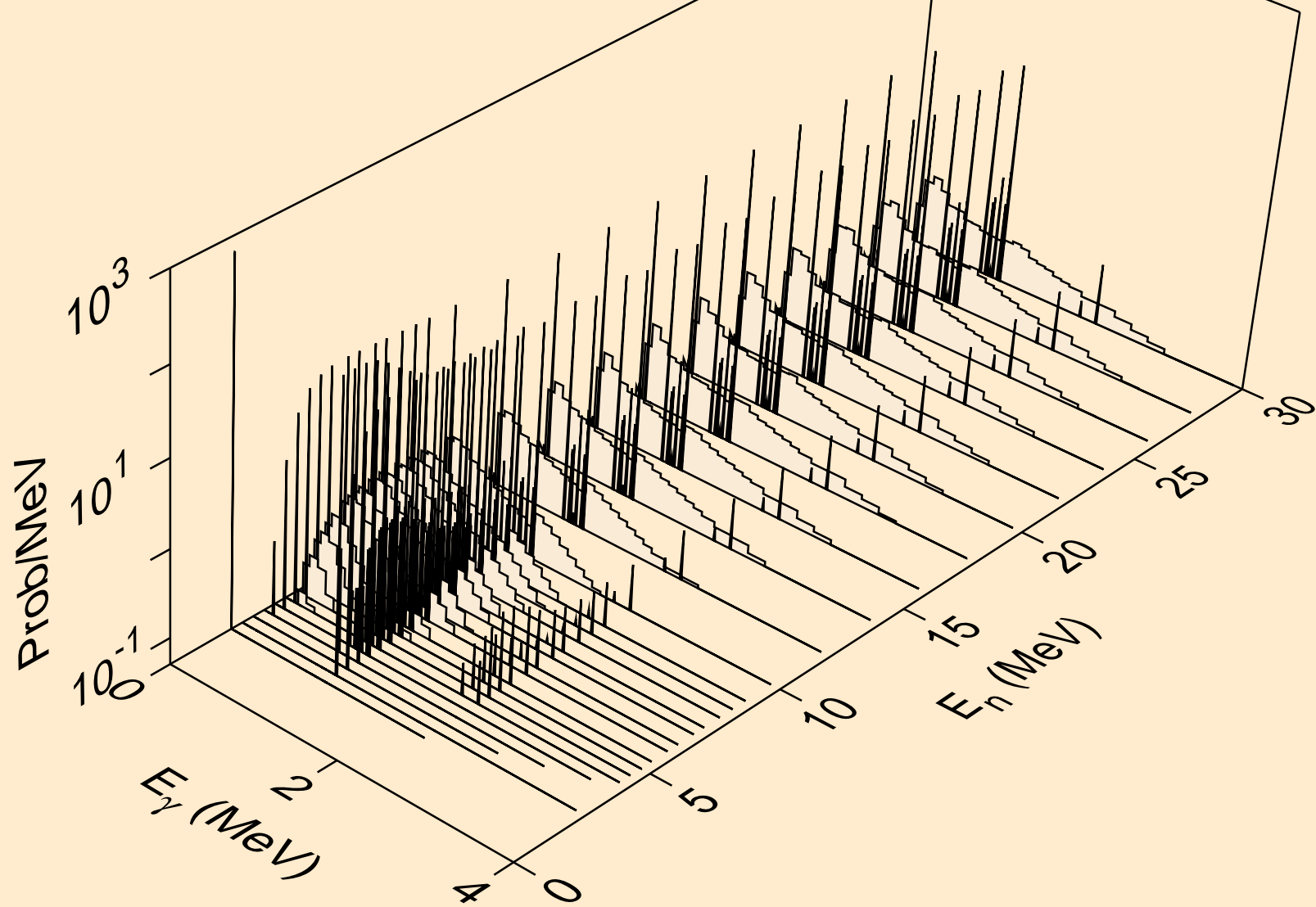

SB126M NEUTRON ACER TENDL-2023 LIBRARY; T=0.K
Photon emission for (n,d)

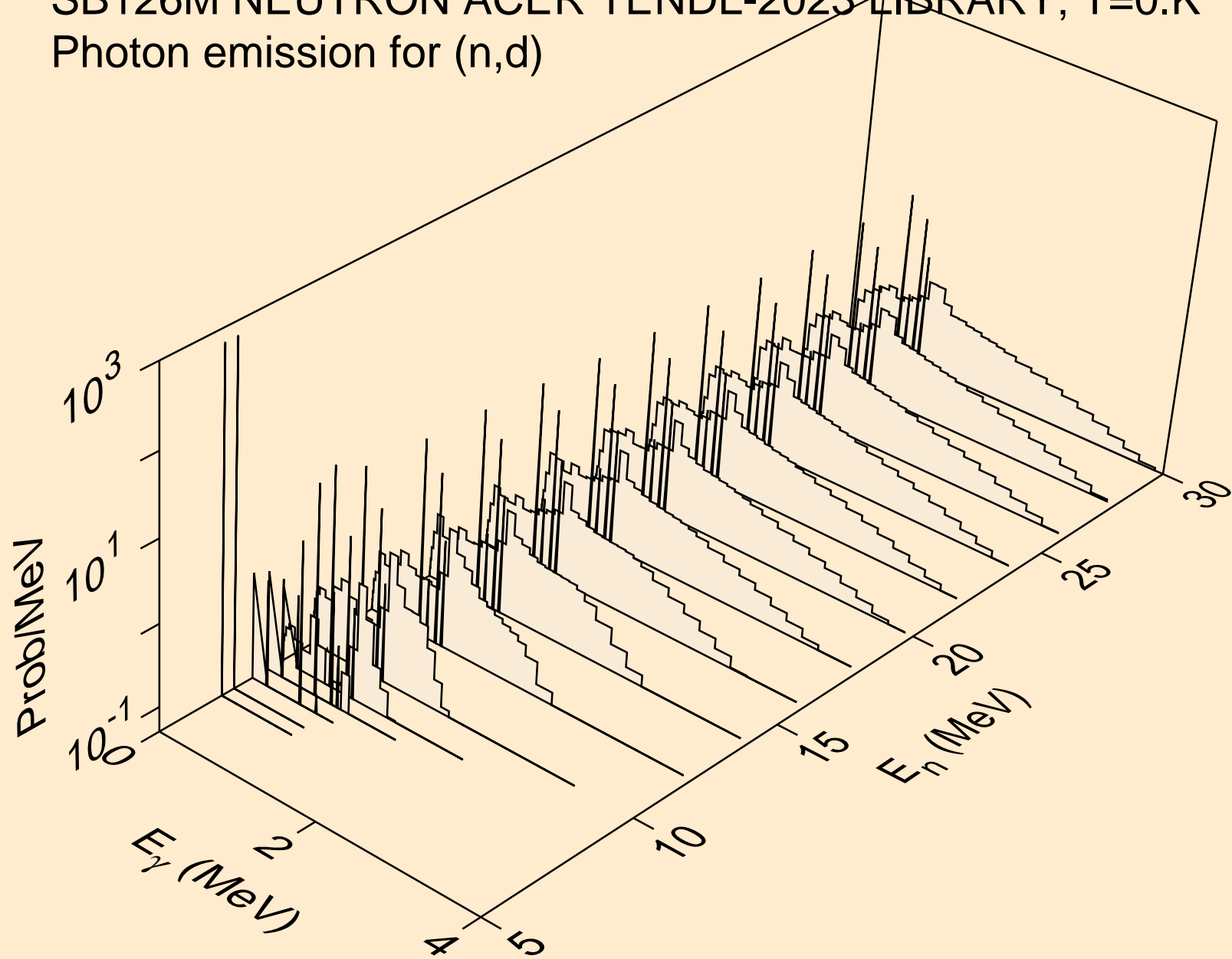

SB126M NEUTRON ACER TENDL-2023 LIBRARY; T=0.K
Photon emission for (n,t)

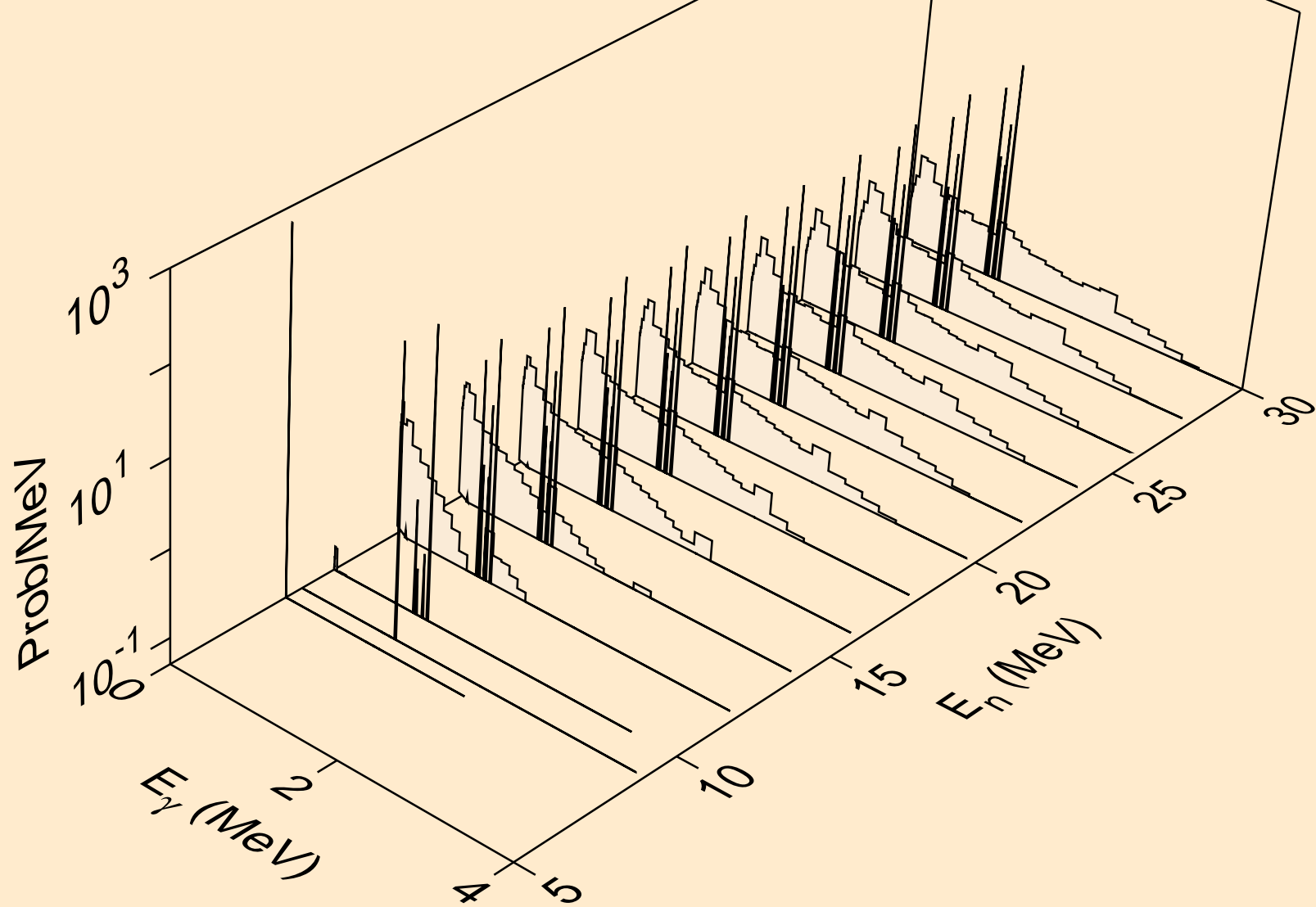

SB126M NEUTRON ACER TENDL-2023 LIBRARY; T=0.K
Photon emission for (n,he3)

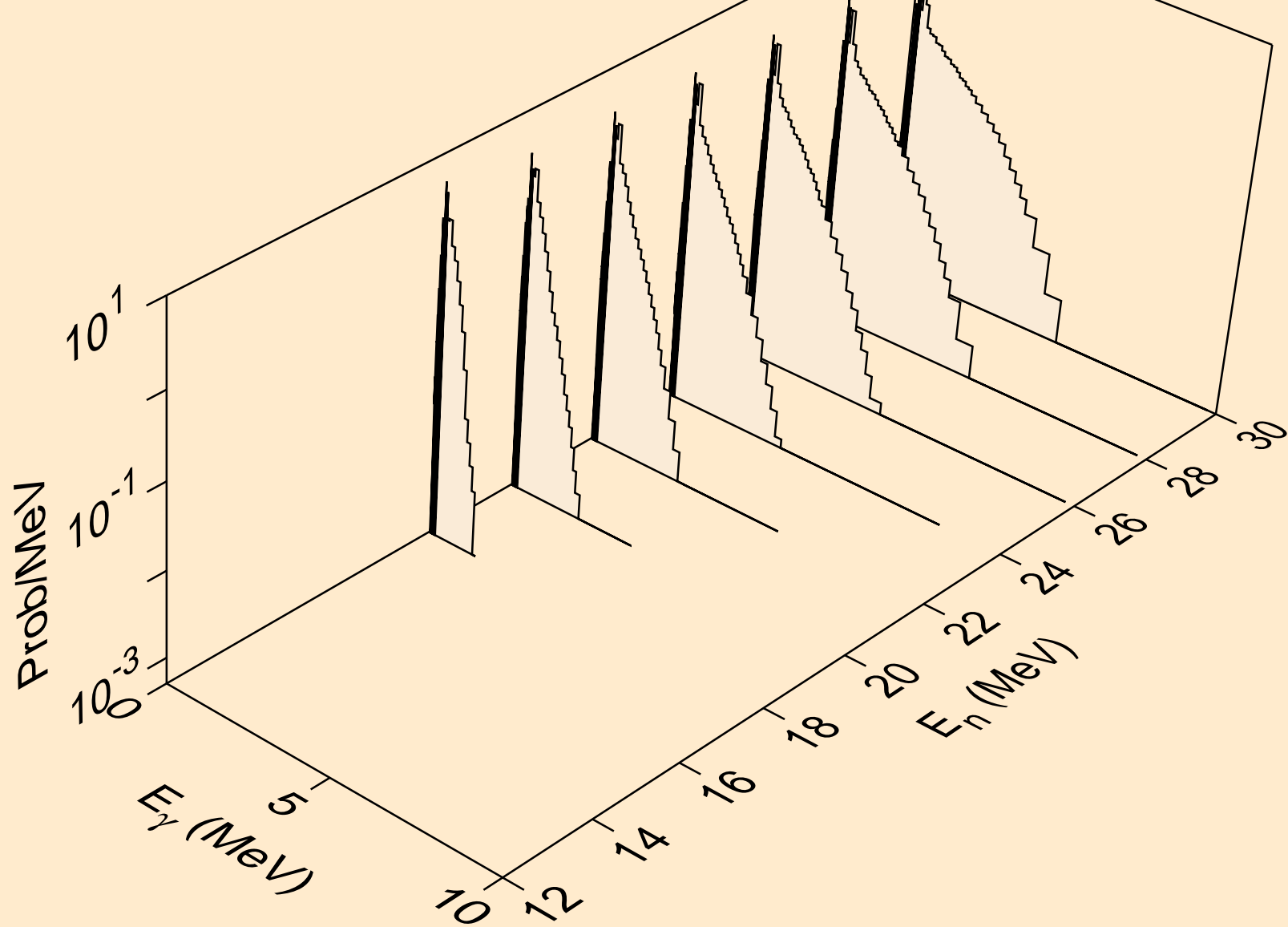

SB126M NEUTRON ACER TENDL-2023 LIBRARY; T=0.K
Photon emission for (n,a)

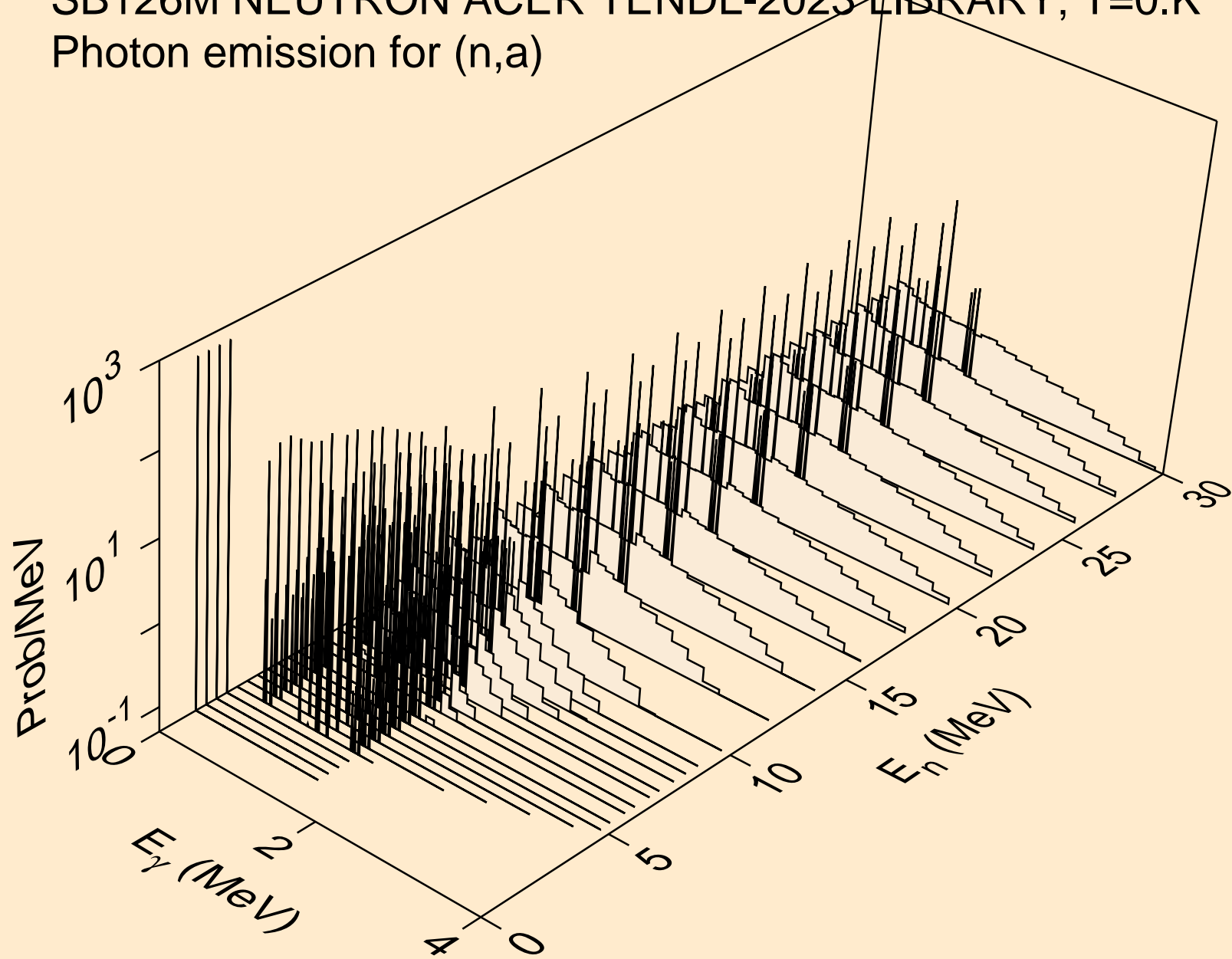

SB126M NEUTRON ACER TENDL-2023 LIBRARY; T=0.K
Photon emission for (n,2p)

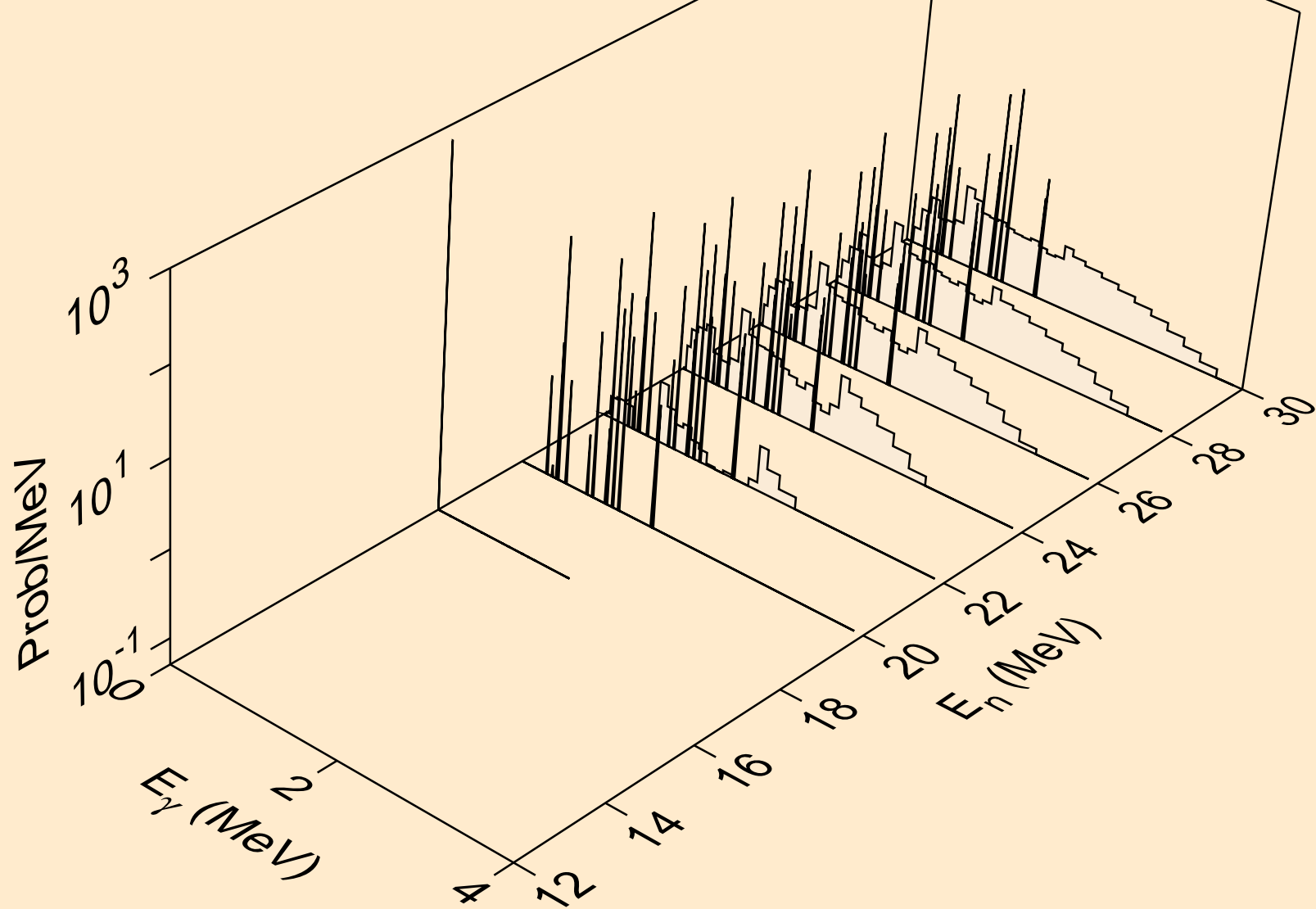

SB126M NEUTRON ACER TENDL-2023 LIBRARY; T=0.K
Photon emission for (n,p)

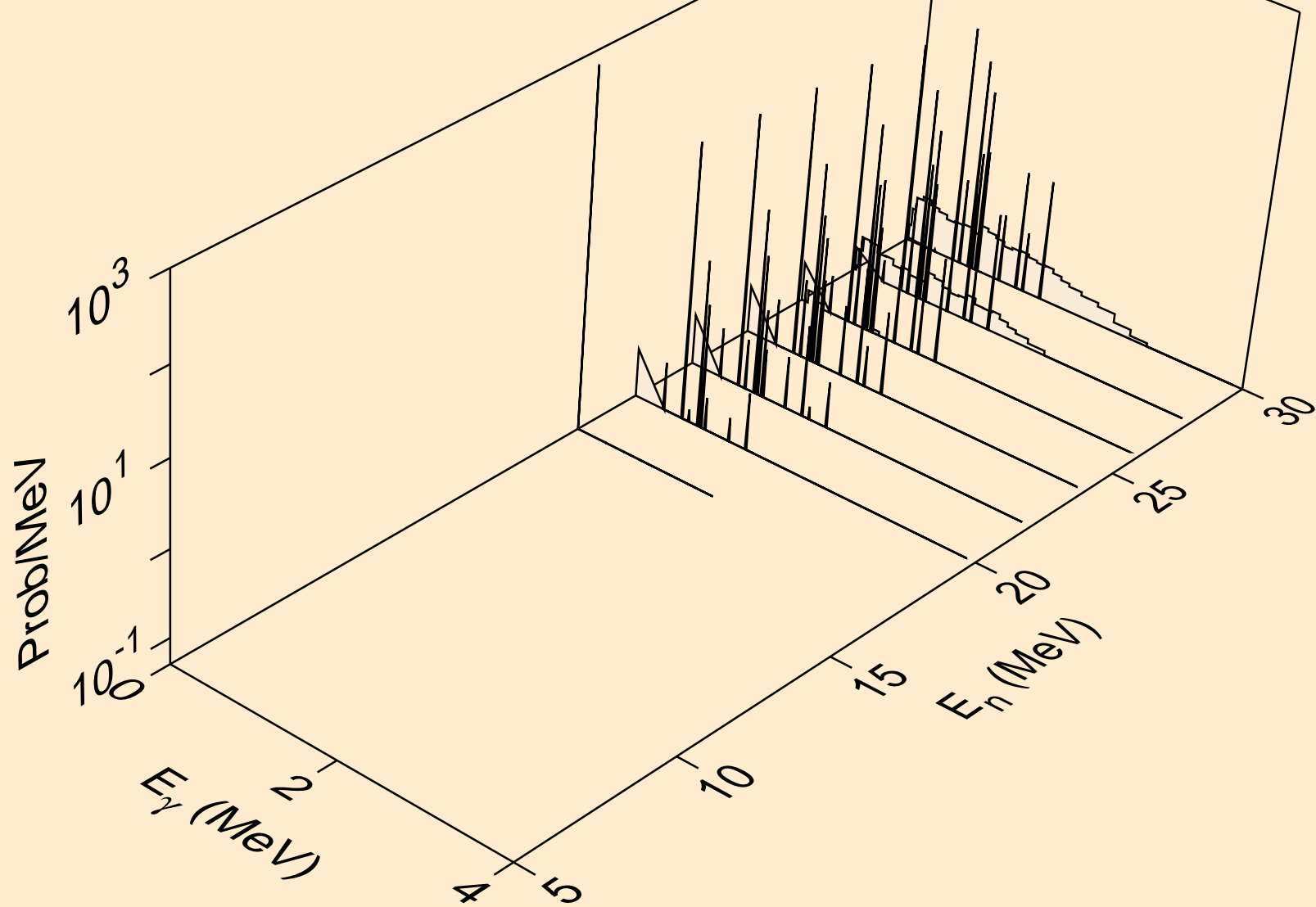

SB126M NEUTRON ACER TENDL-2023 LIBRARY; T=0.K
thermal capture photon spectrum

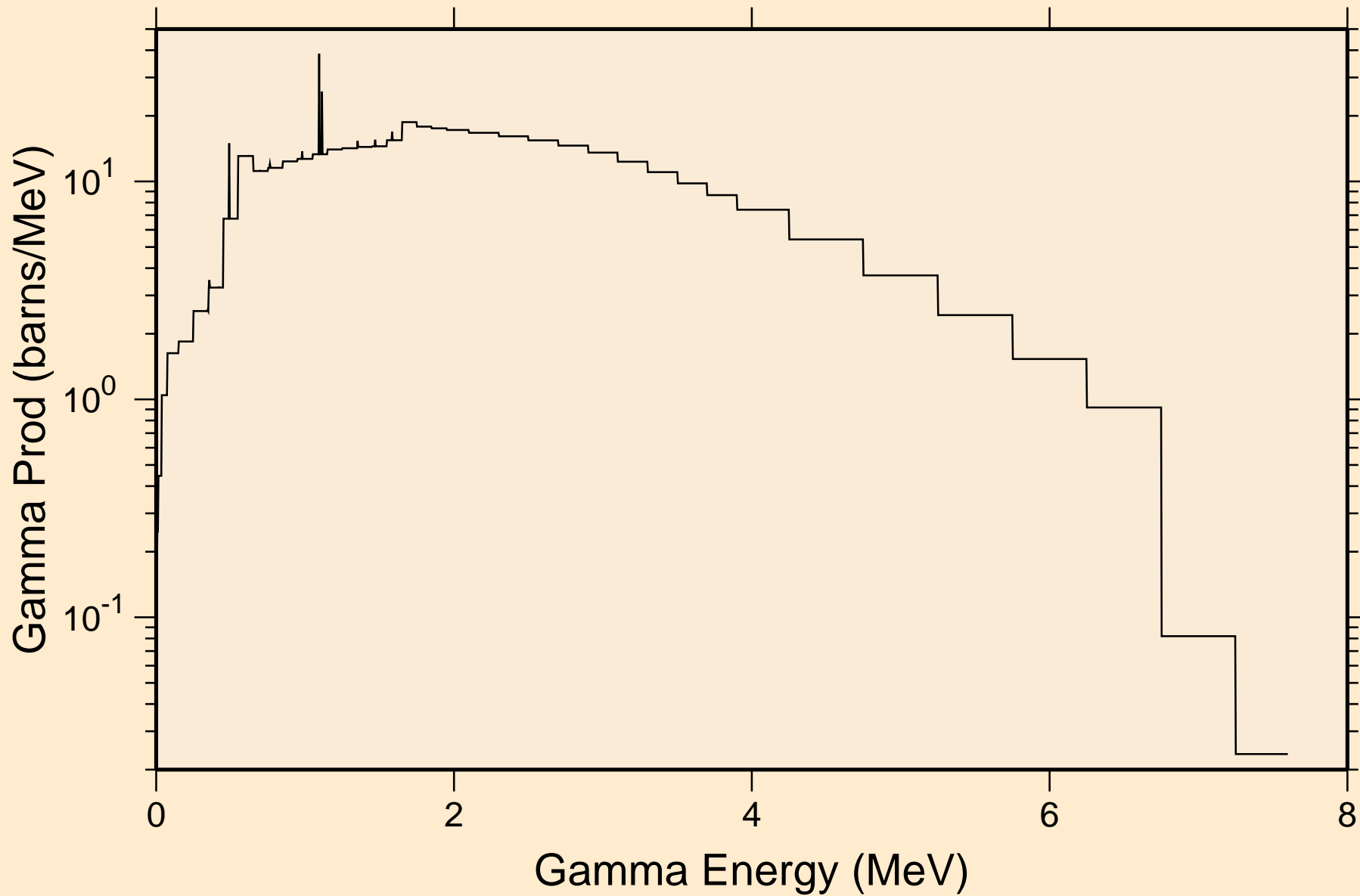

SB126M NEUTRON ACER TENDL-2023 LIBRARY; T=0.K
14 MeV photon spectrum

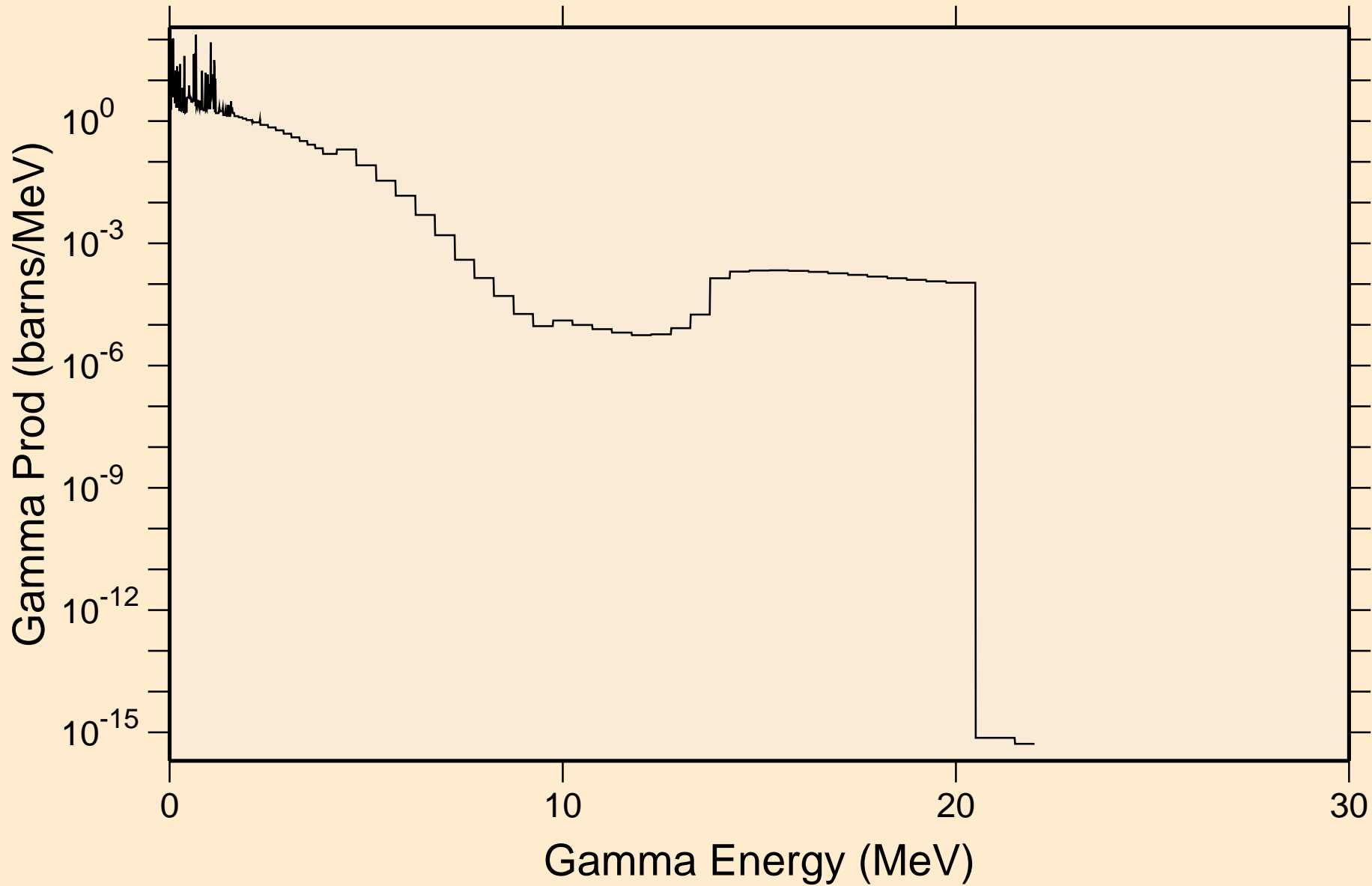

SB126M NEUTRON ACER TENDL-2023 LIBRARY; T=0.K

Particle heating contributions

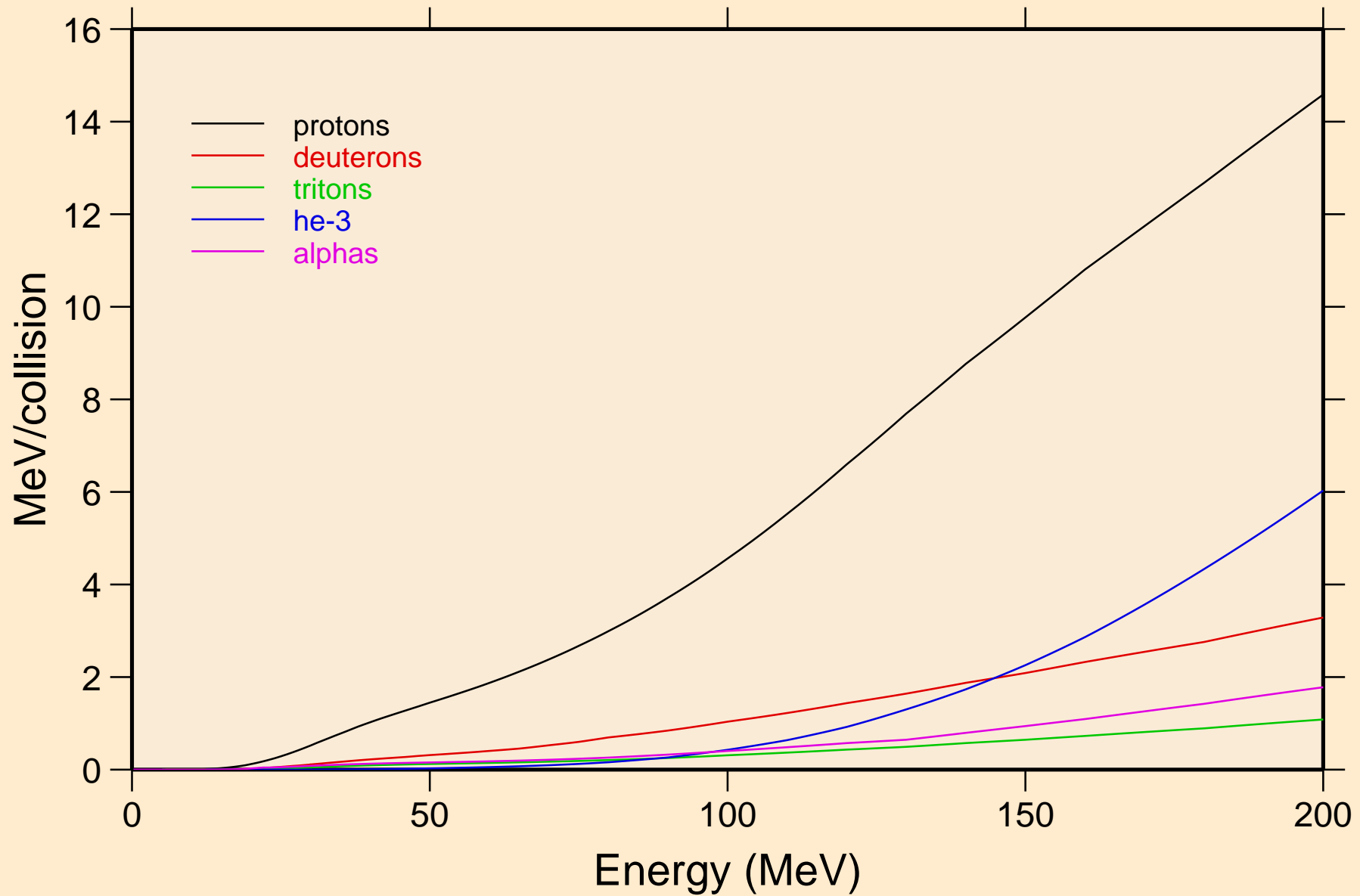

SB126M NEUTRON ACER TENDL-2023 LIBRARY; T=0.K
Recoil Heating

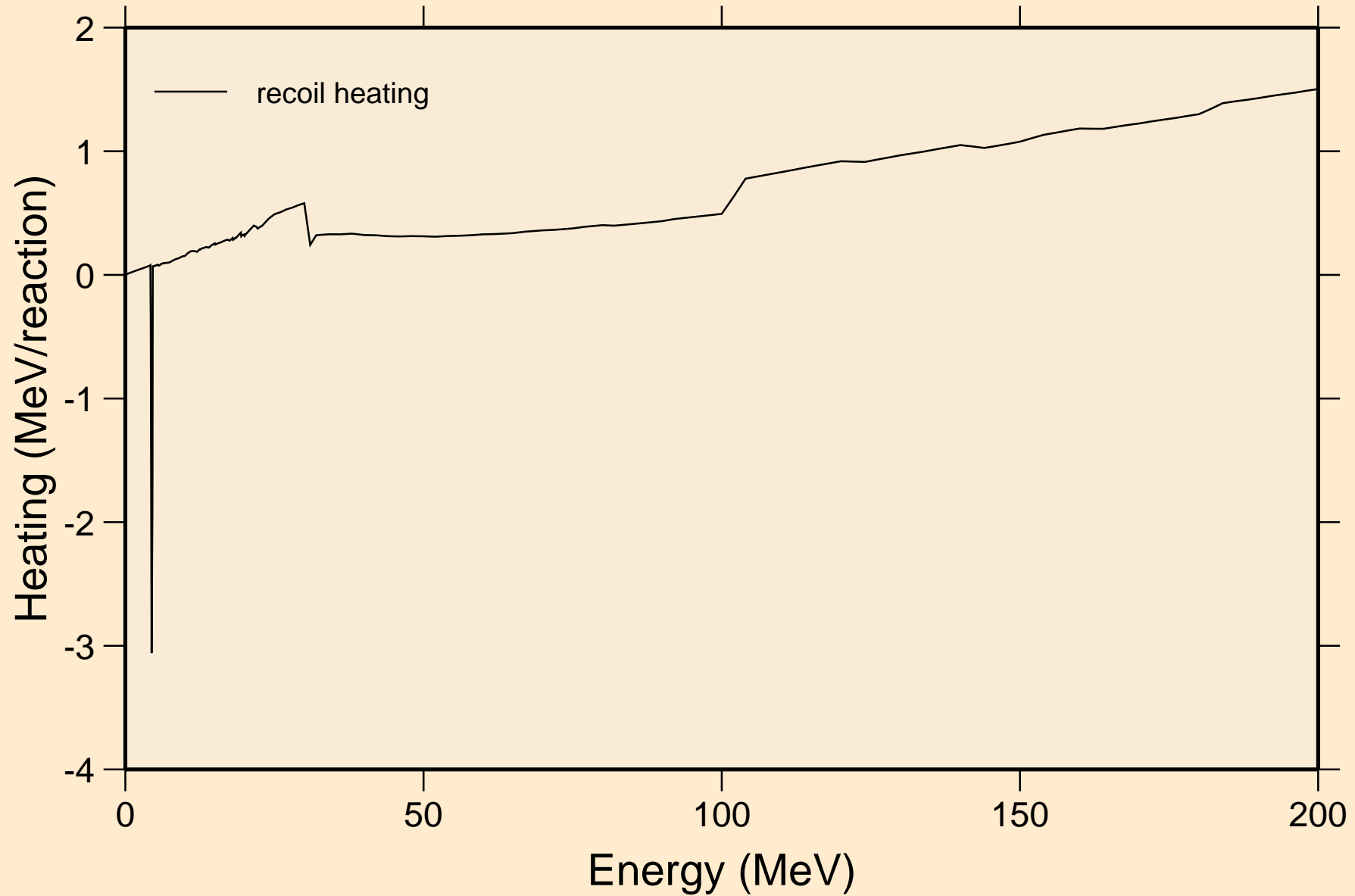

SB126M NEUTRON ACER TENDL-2023 LIBRARY; T=0.K
Particle production cross sections

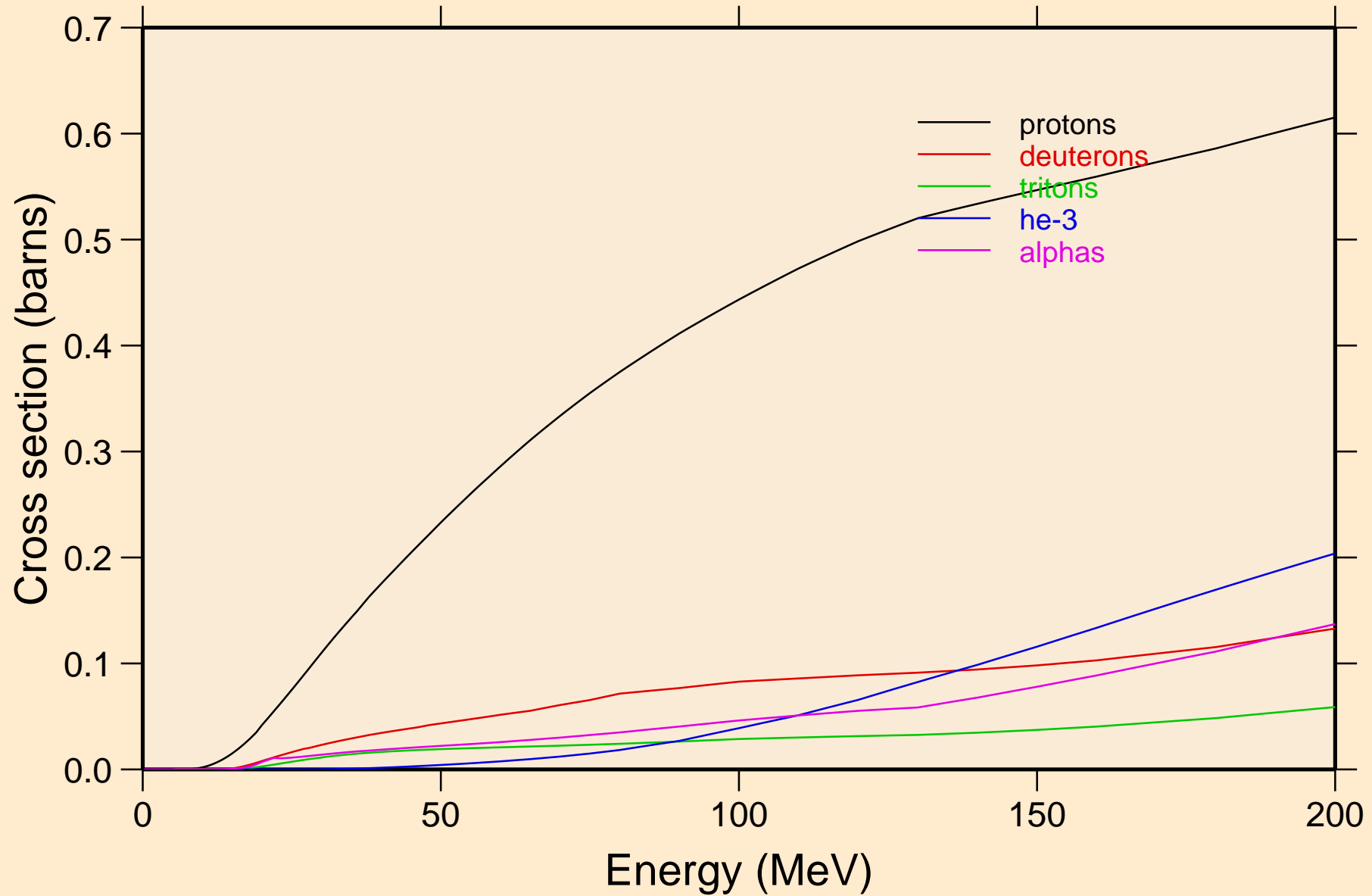

SB126M NEUTRON ACER TENDL-2023 LIBRARY; T=0.K
protons from (n,x)

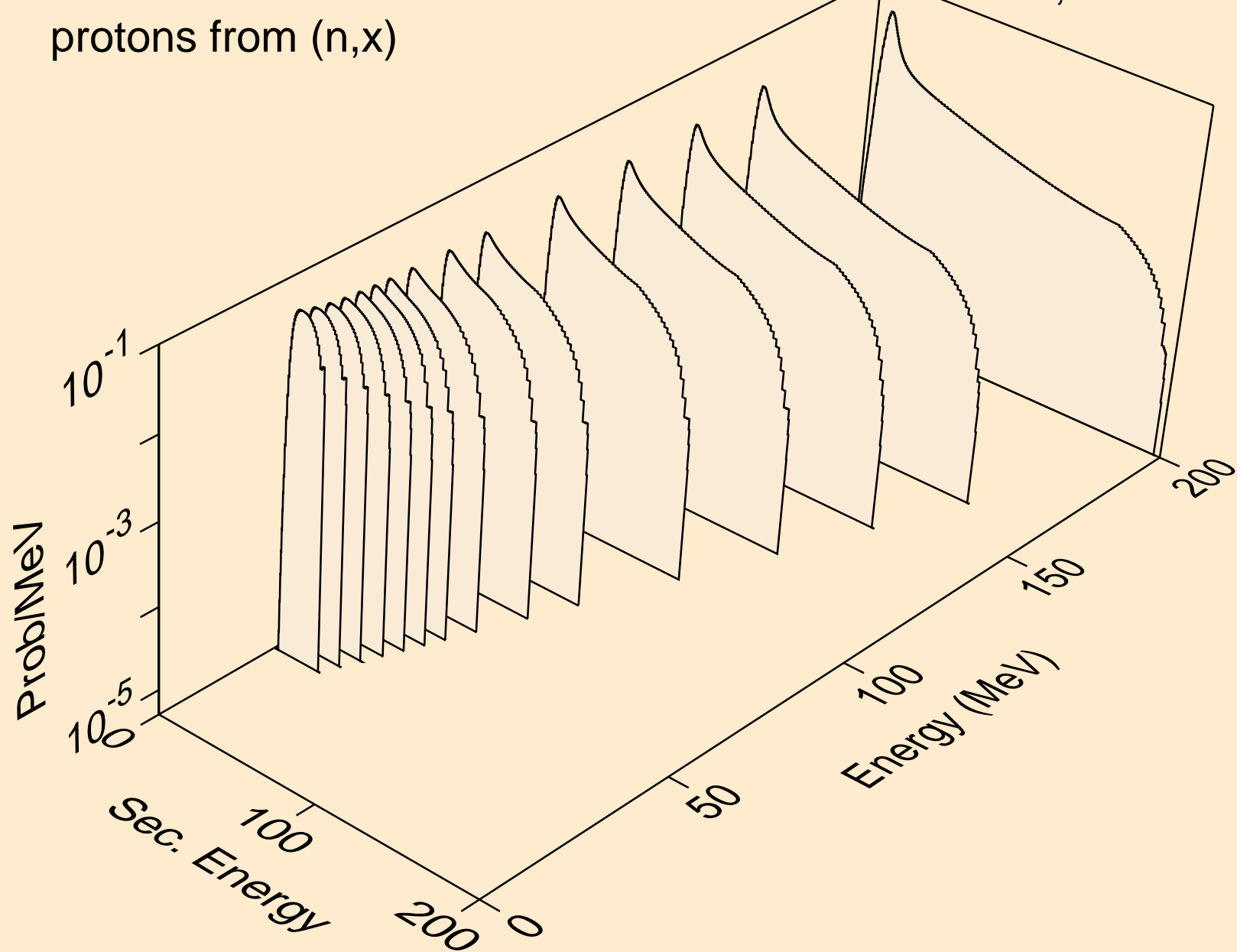

SB126M NEUTRON ACER TENDL-2023 LIBRARY; T=0.K
protons from (n,n*)p

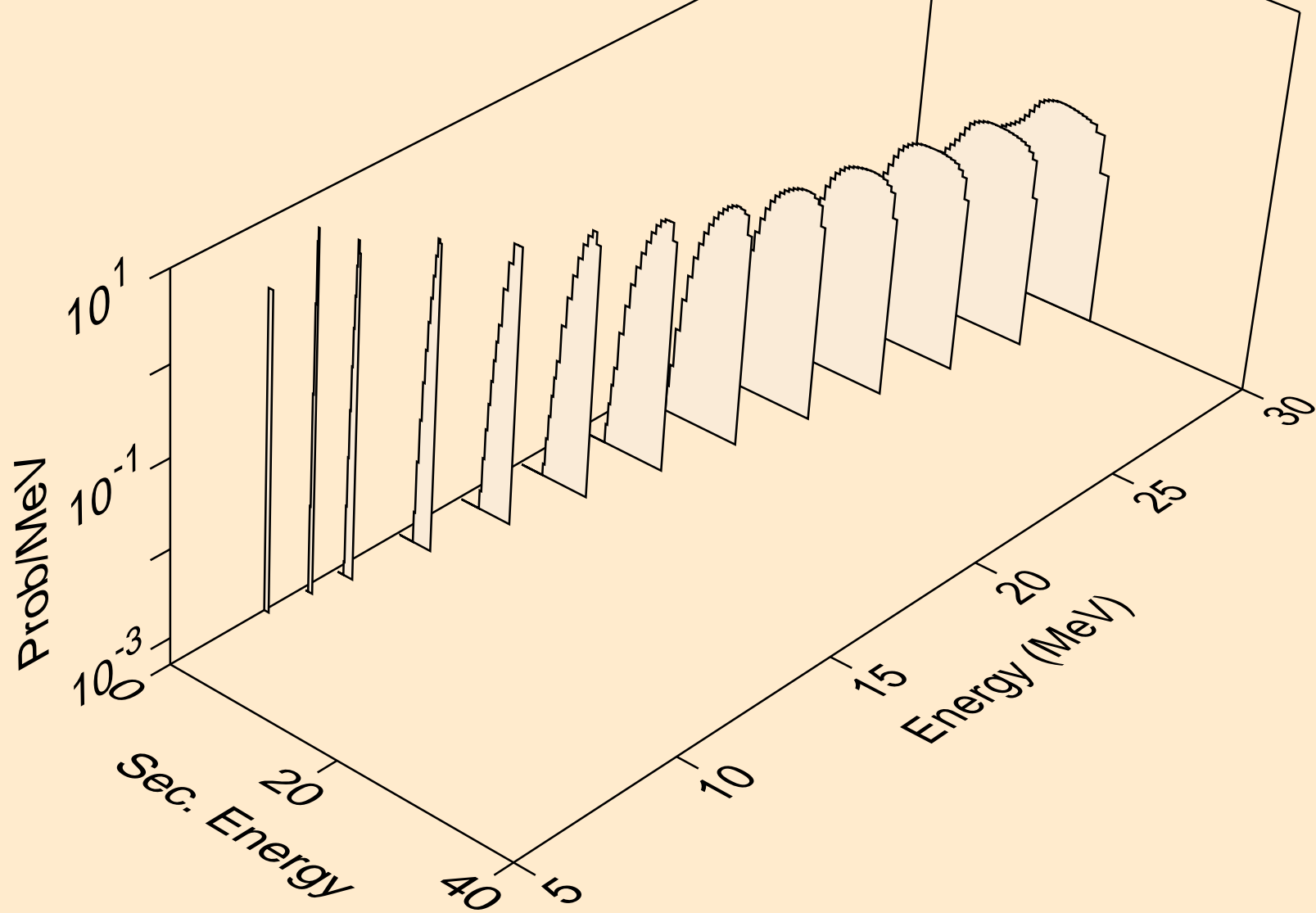

SB126M NEUTRON ACER TENDL-2023 LIBRARY; T=0.K
protons from (n,2np)

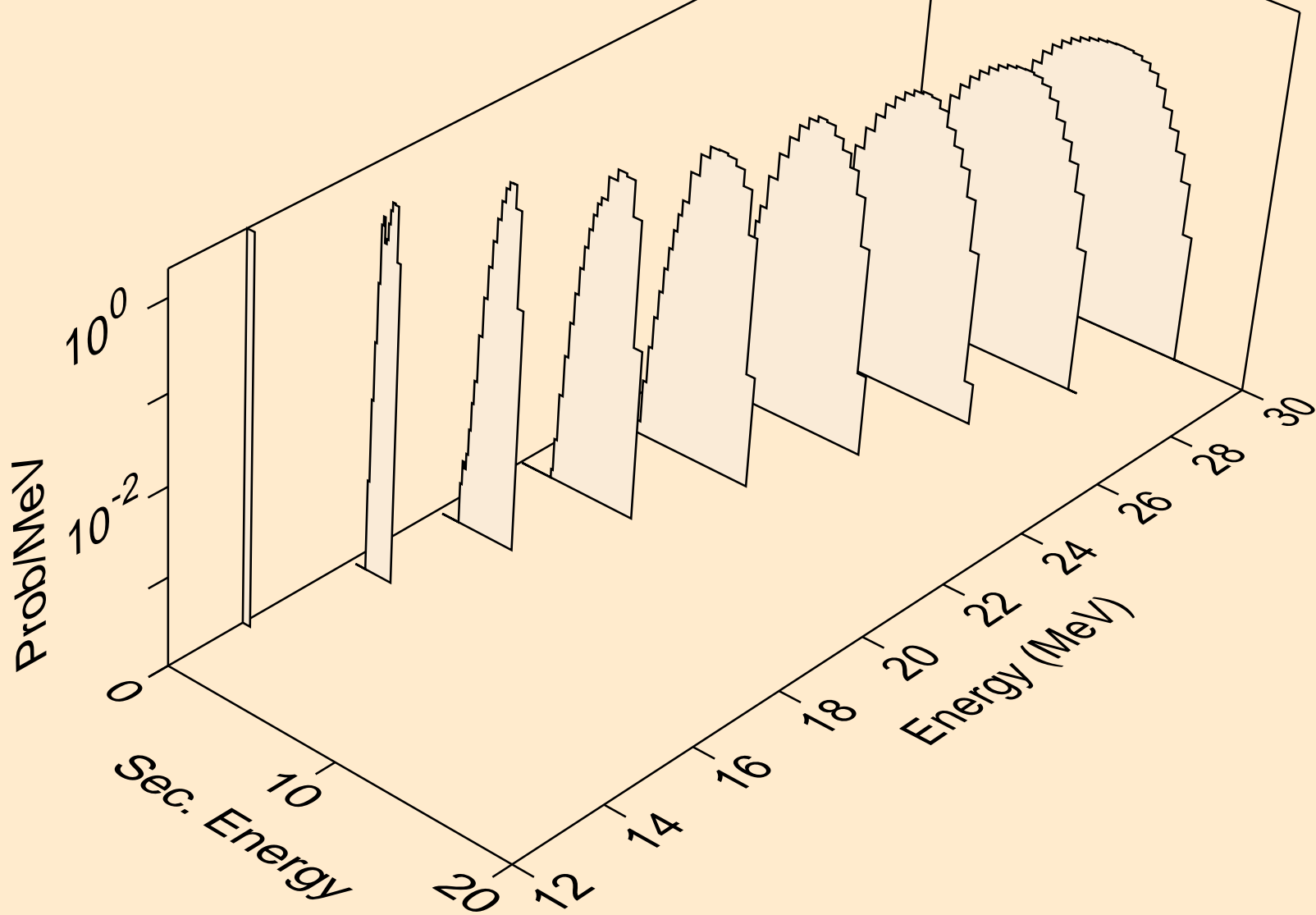

SB126M NEUTRON ACER TENDL-2023 LIBRARY; T=0.K
protons from (n,3np)

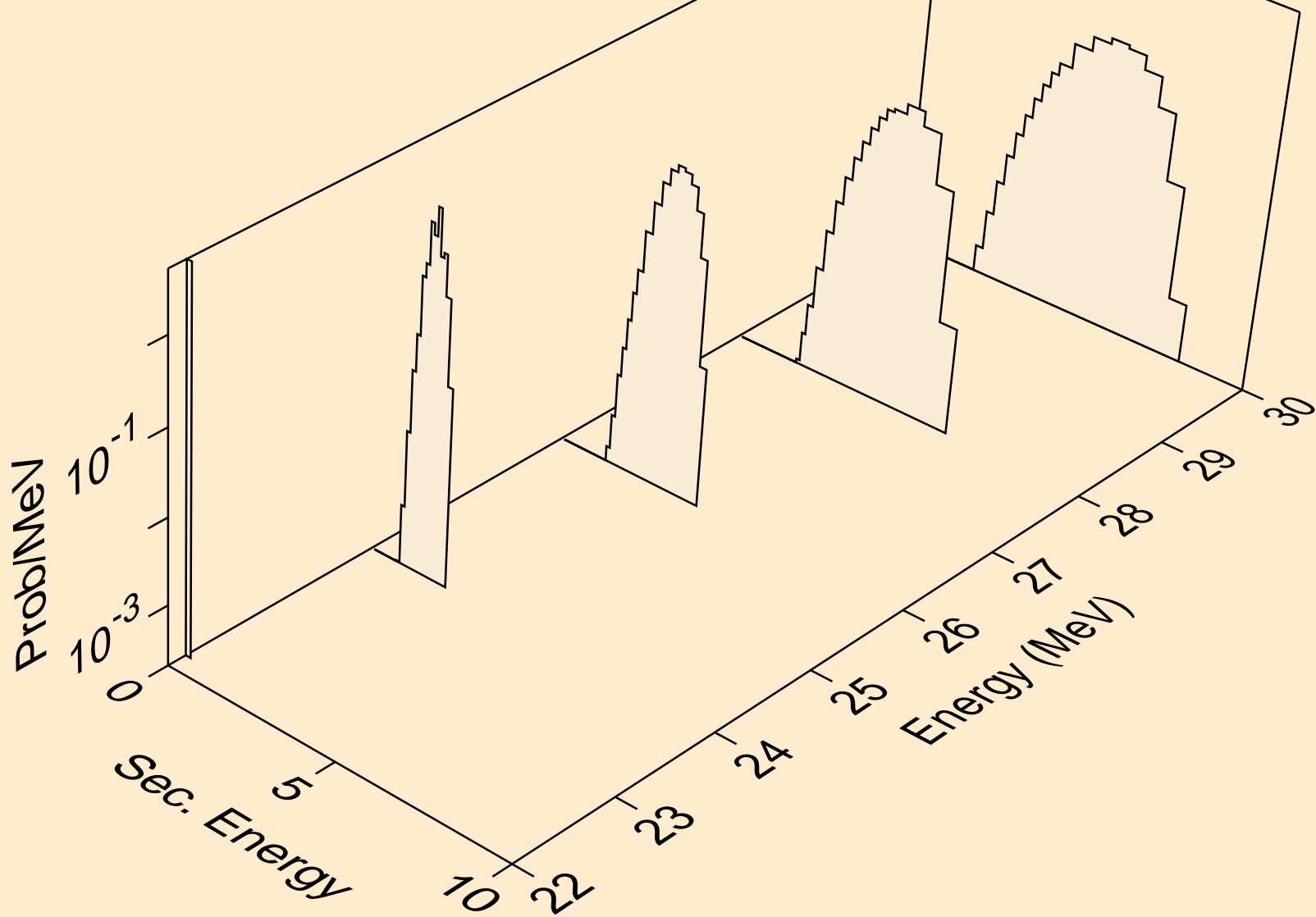

SB126M NEUTRON ACER TENDL-2023 LIBRARY; T=0.K
protons from (n,n2p)

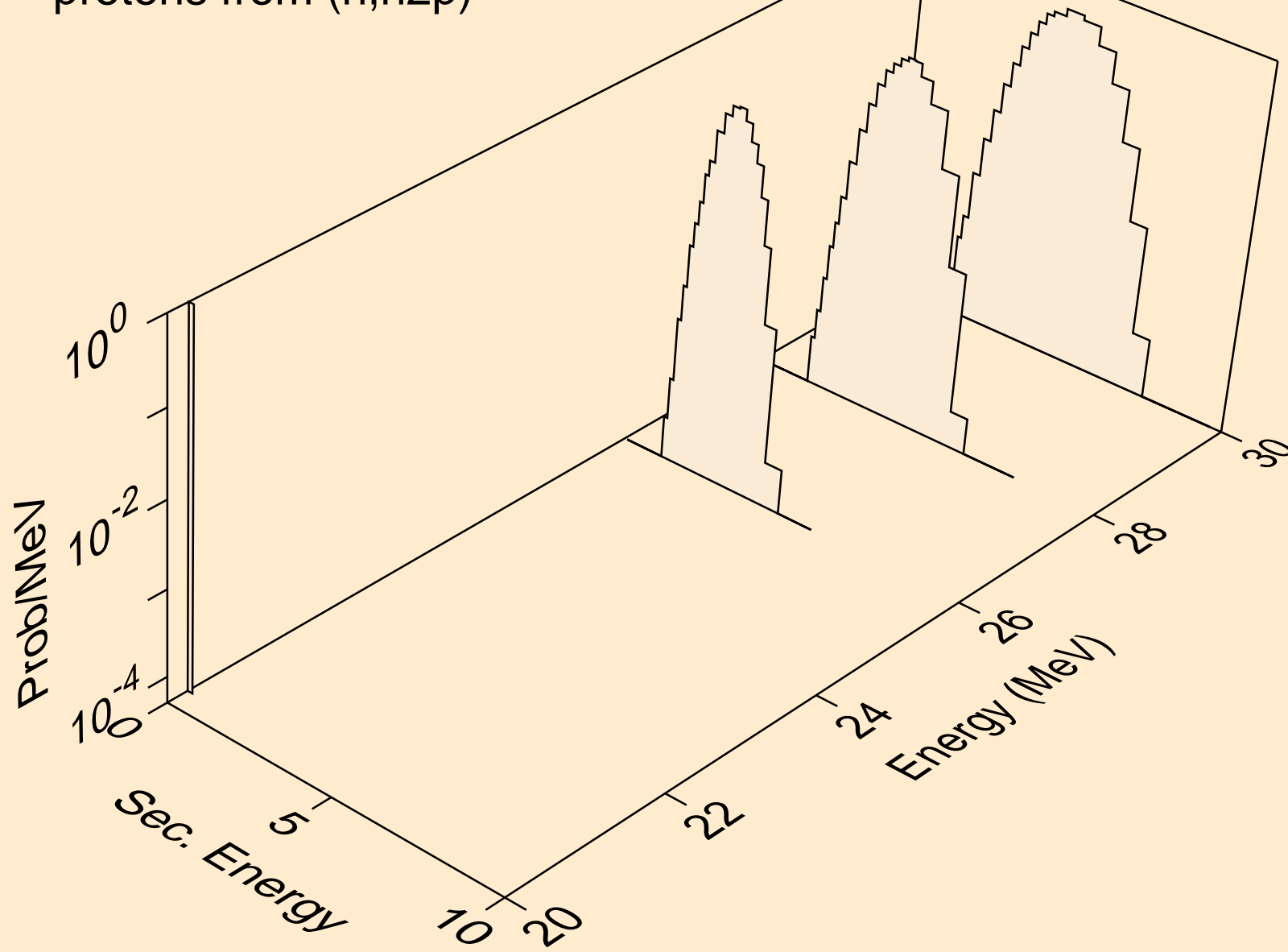

SB126M NEUTRON ACER TENDL-2023 LIBRARY; T=0.K
protons from (n,p)

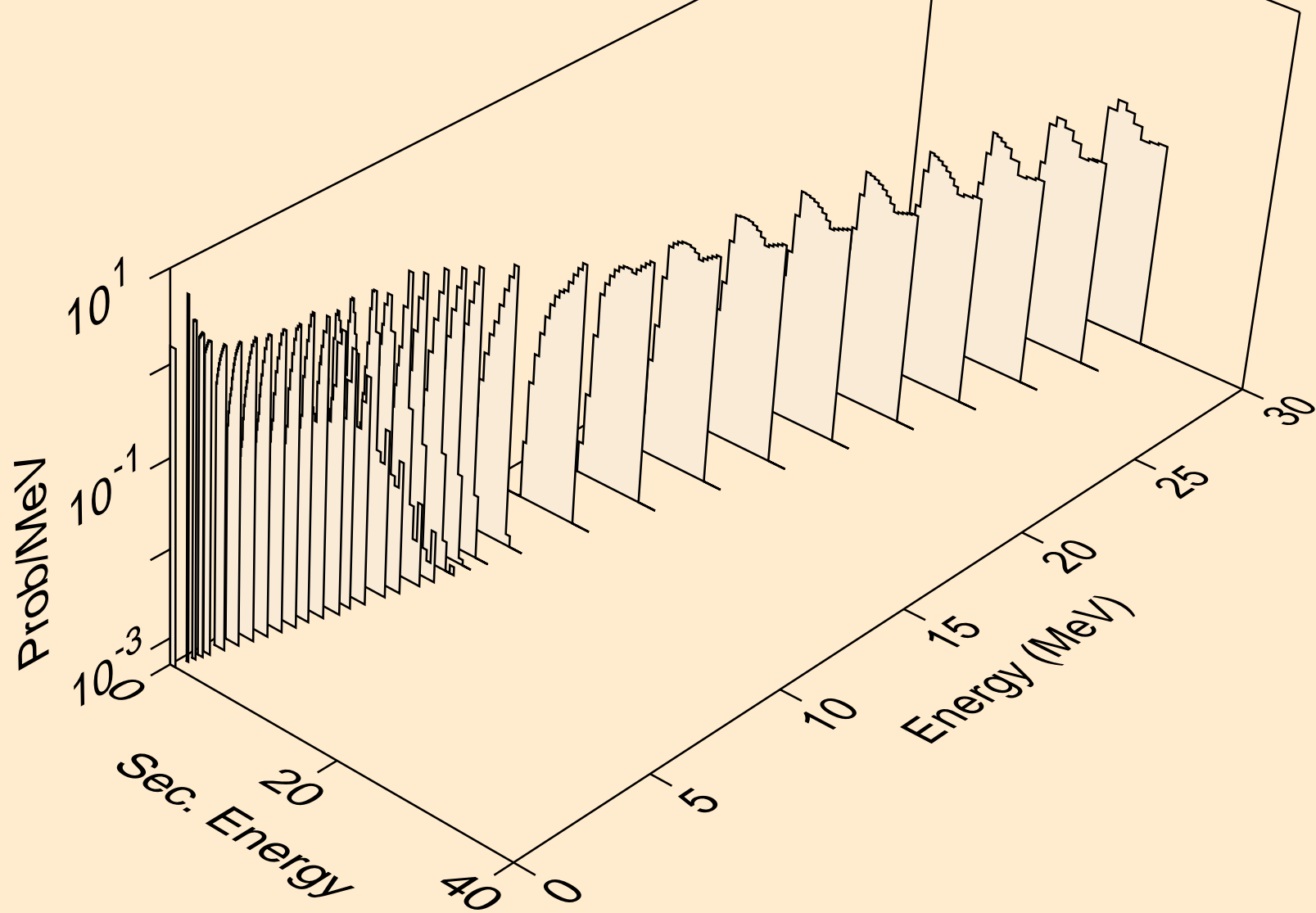

SB126M NEUTRON ACER TENDL-2023 LIBRARY; T=0.K
protons from (n,2p)

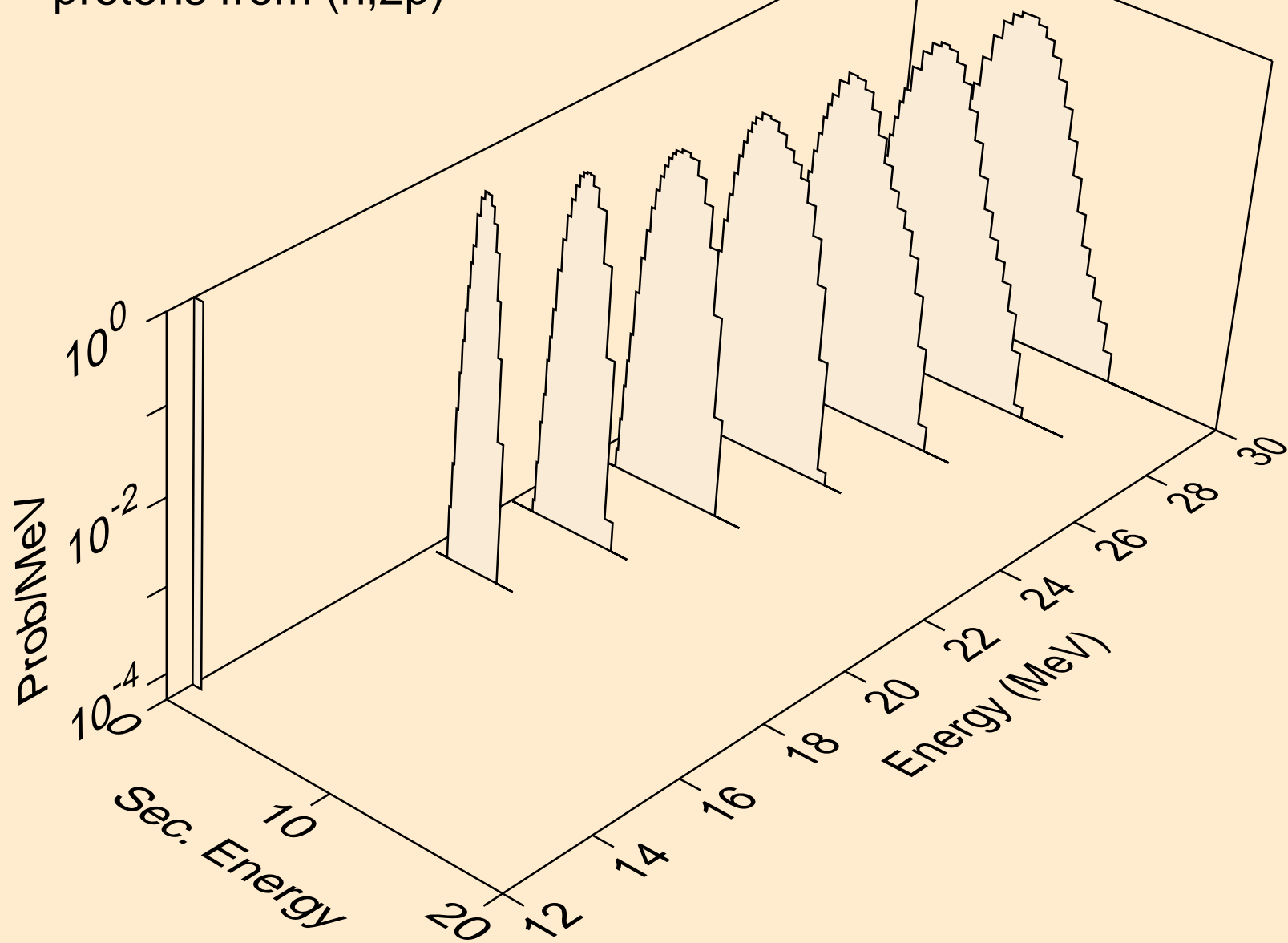

SB126M NEUTRON ACER TENDL-2023 LIBRARY; T=0.K
protons from (n,pa)

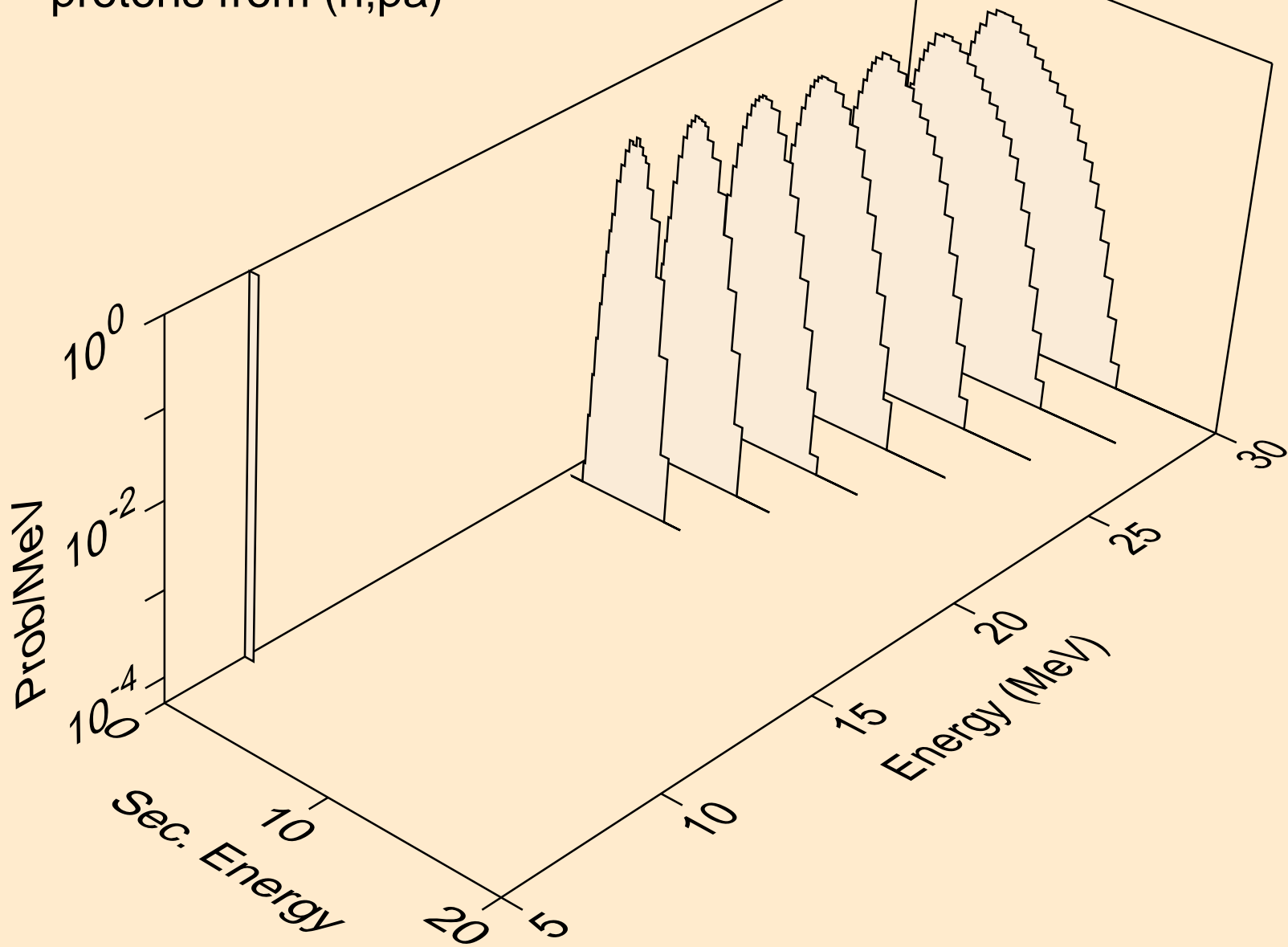

SB126M NEUTRON ACER TENDL-2023 LIBRARY; T=0.K
deuterons from (n,x)

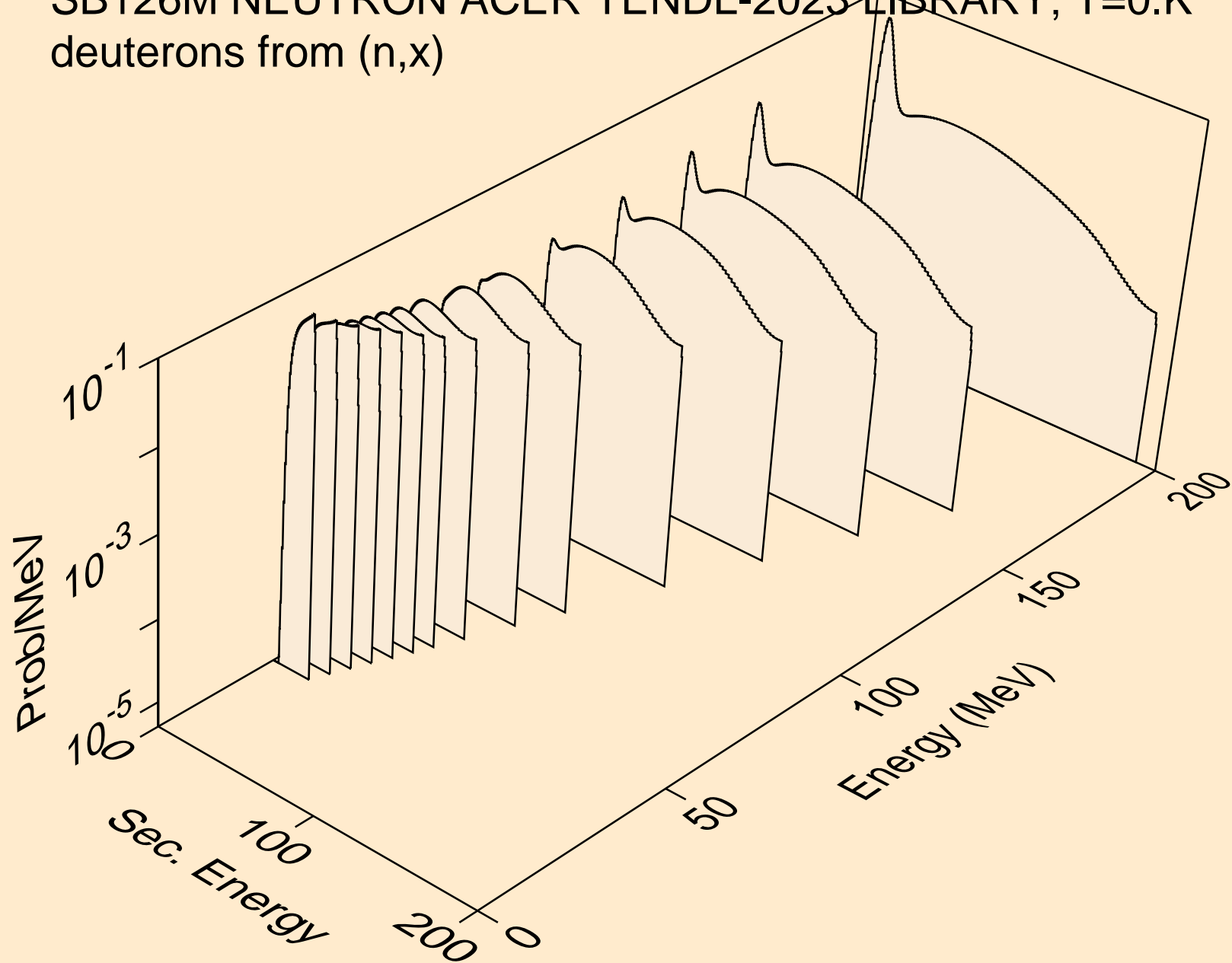

SB126M NEUTRON ACER TENDL-2023 LIBRARY; T=0.K
deuterons from (n,2nd)

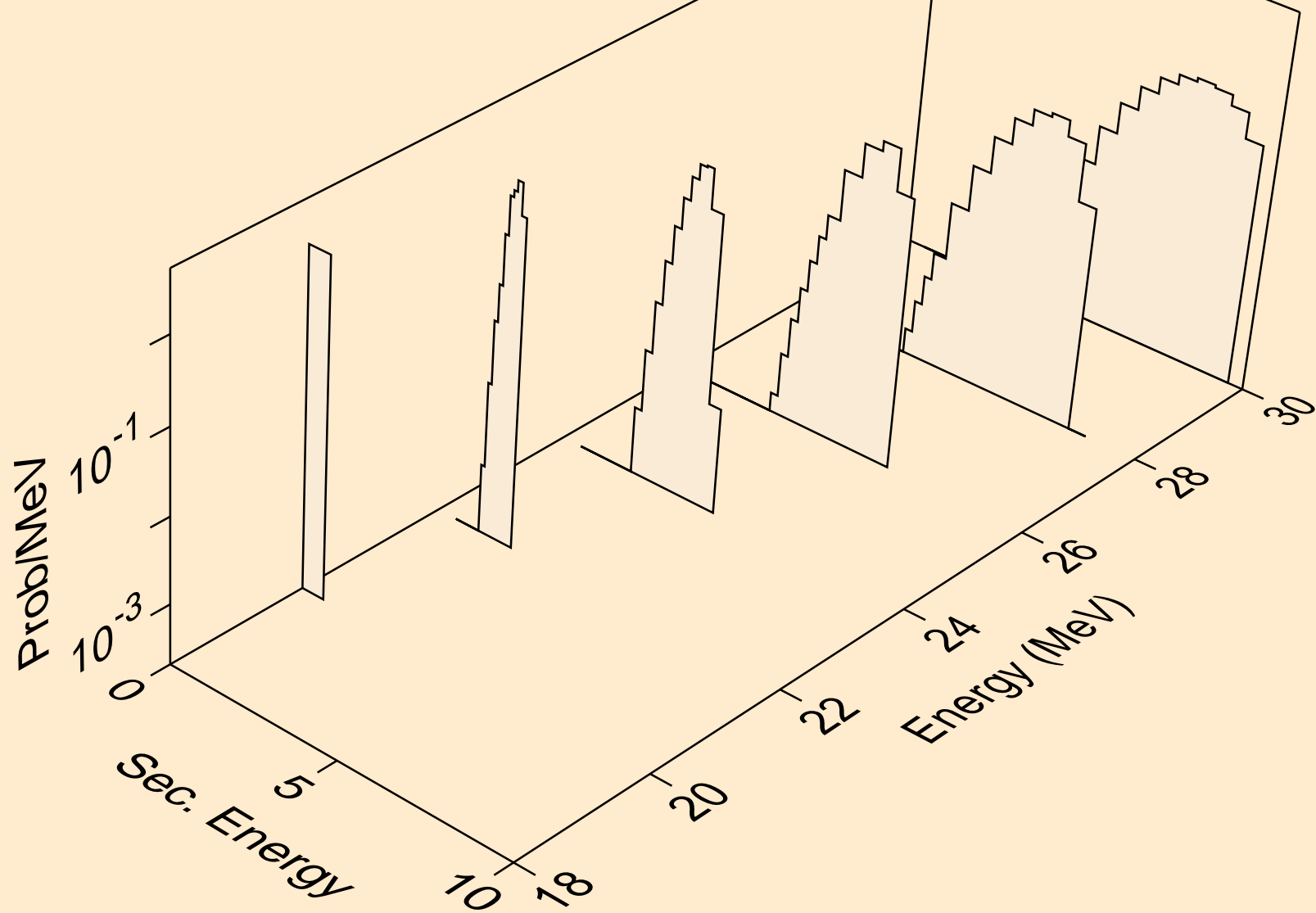

SB126M NEUTRON ACER TENDL-2023 LIBRARY; T=0.K
deuterons from (n,n*)d

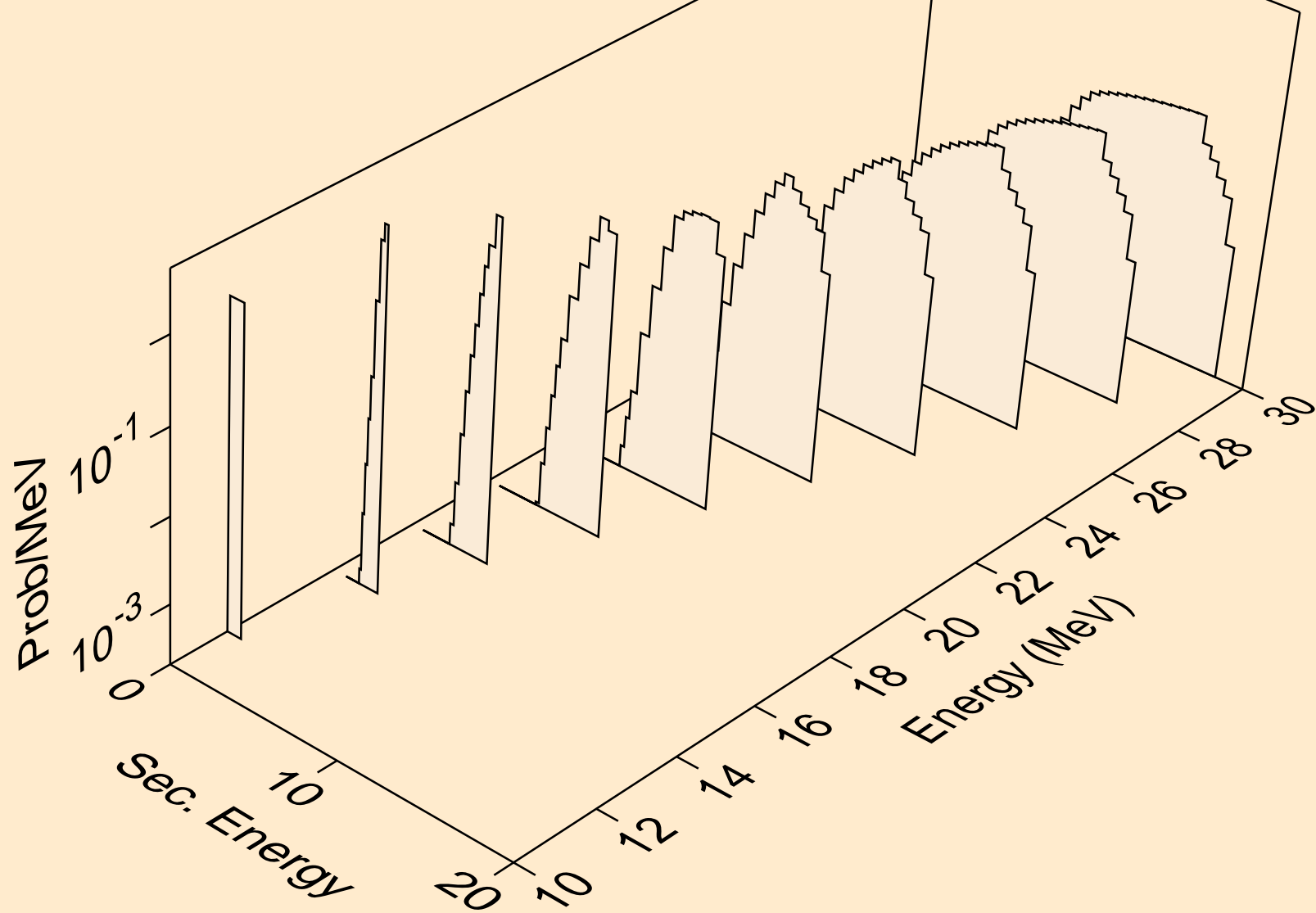

SB126M NEUTRON ACER TENDL-2023 LIBRARY; T=0.K
deuterons from (n,d)

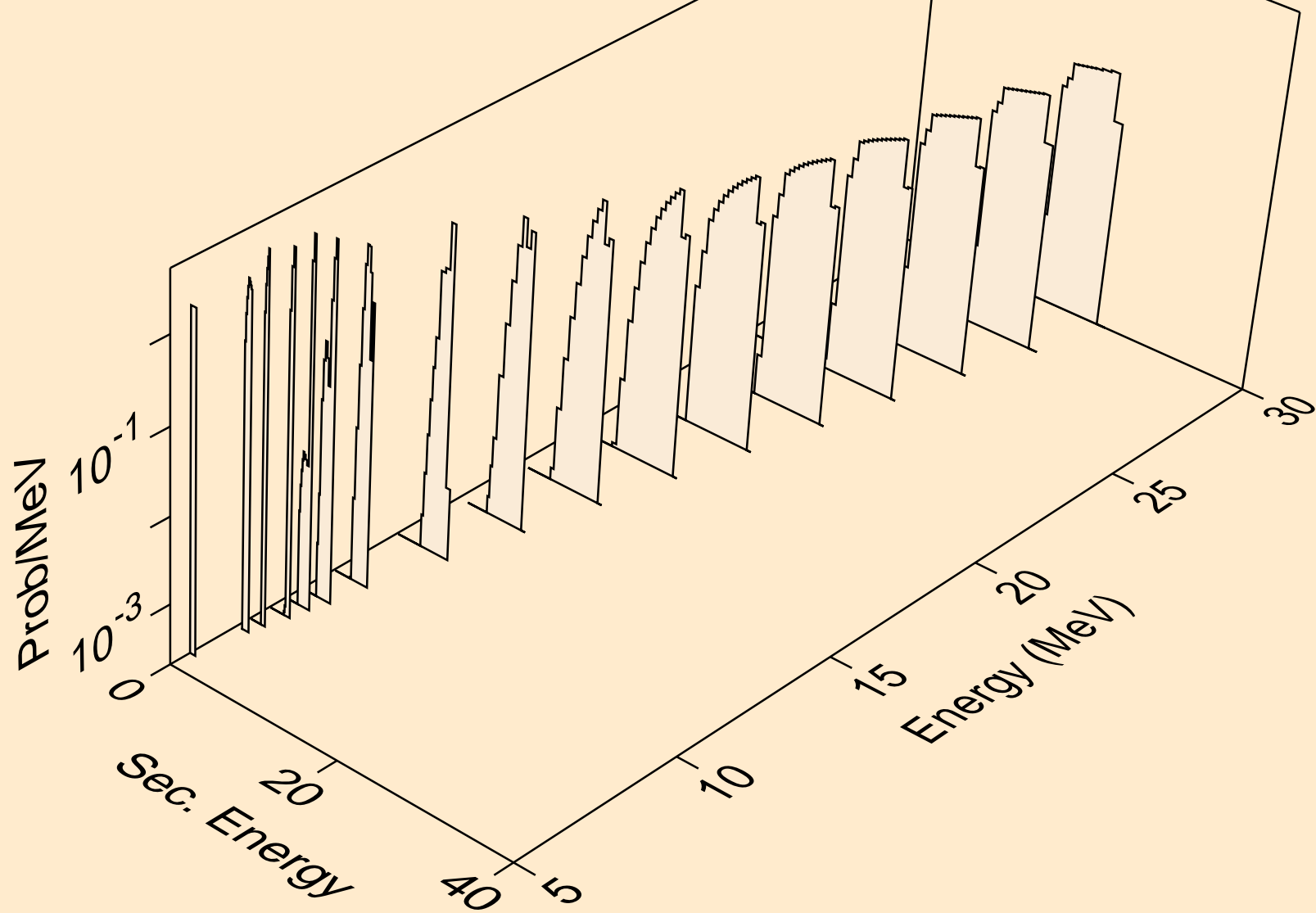

SB126M NEUTRON ACER TENDL-2023 LIBRARY; T=0.K
tritons from (n,x)

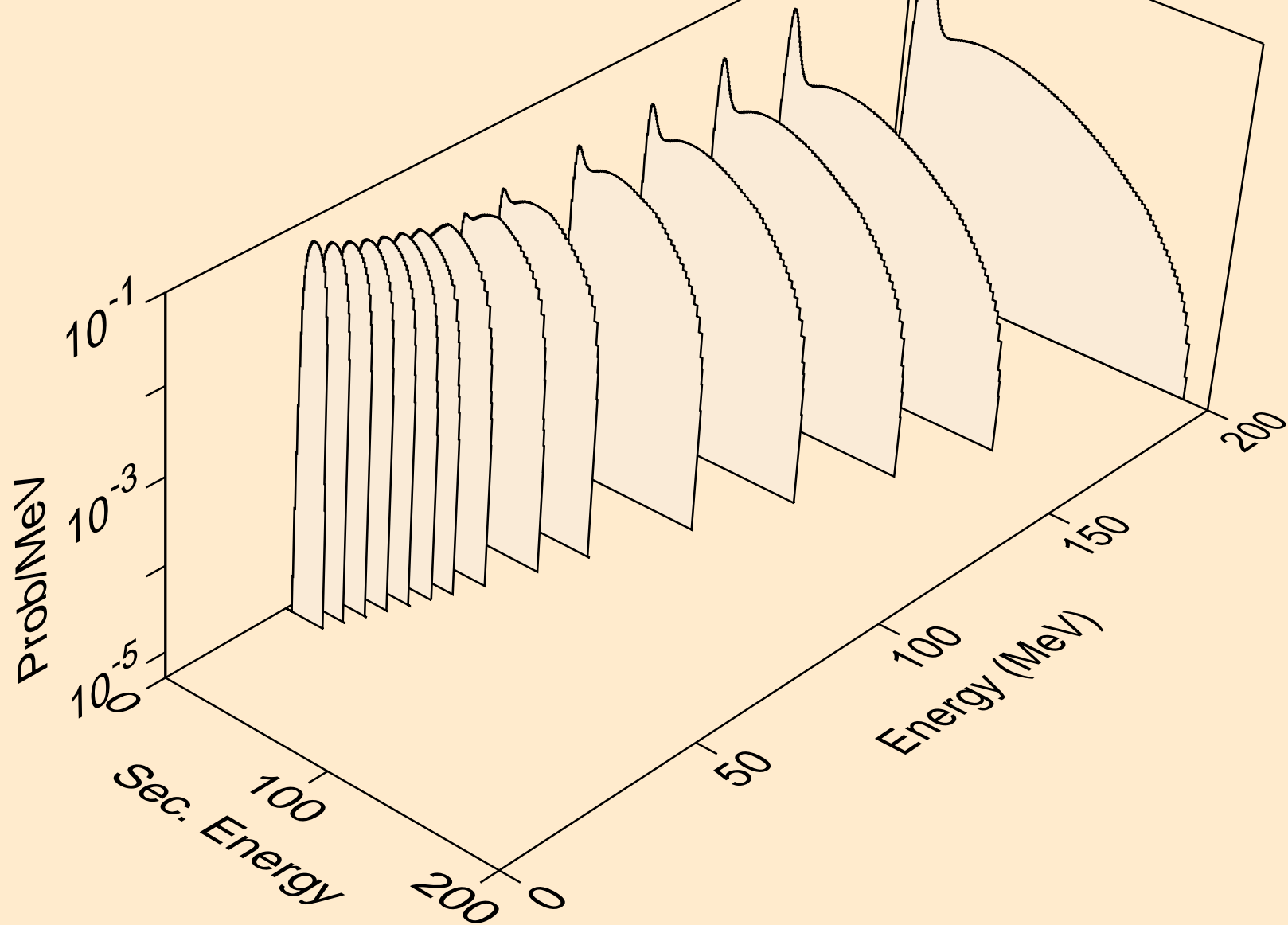

SB126M NEUTRON ACER TENDL-2023 LIBRARY; T=0.K
tritons from (n,n*)t

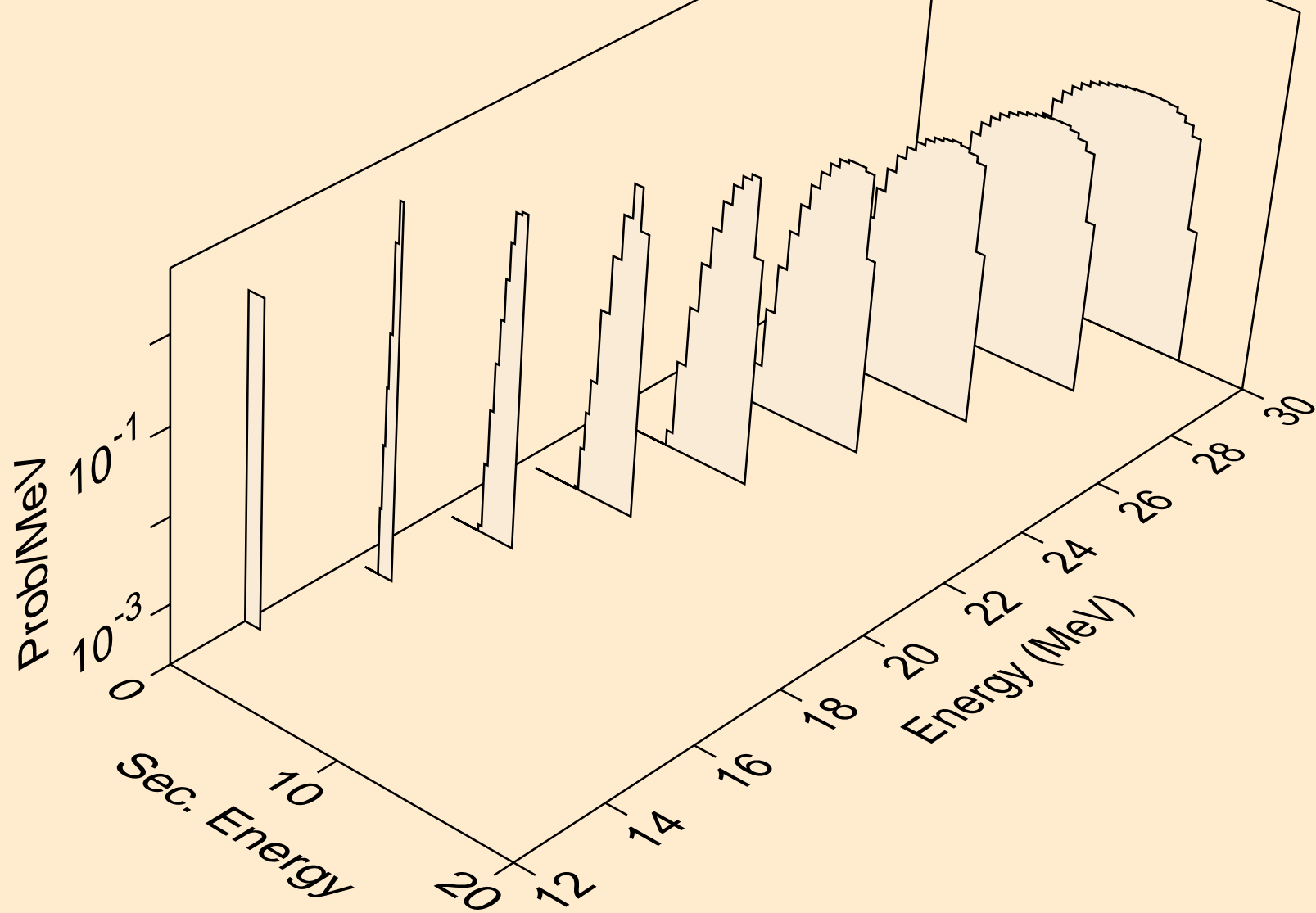

SB126M NEUTRON ACER TENDL-2023 LIBRARY; T=0.K
tritons from (n,t)

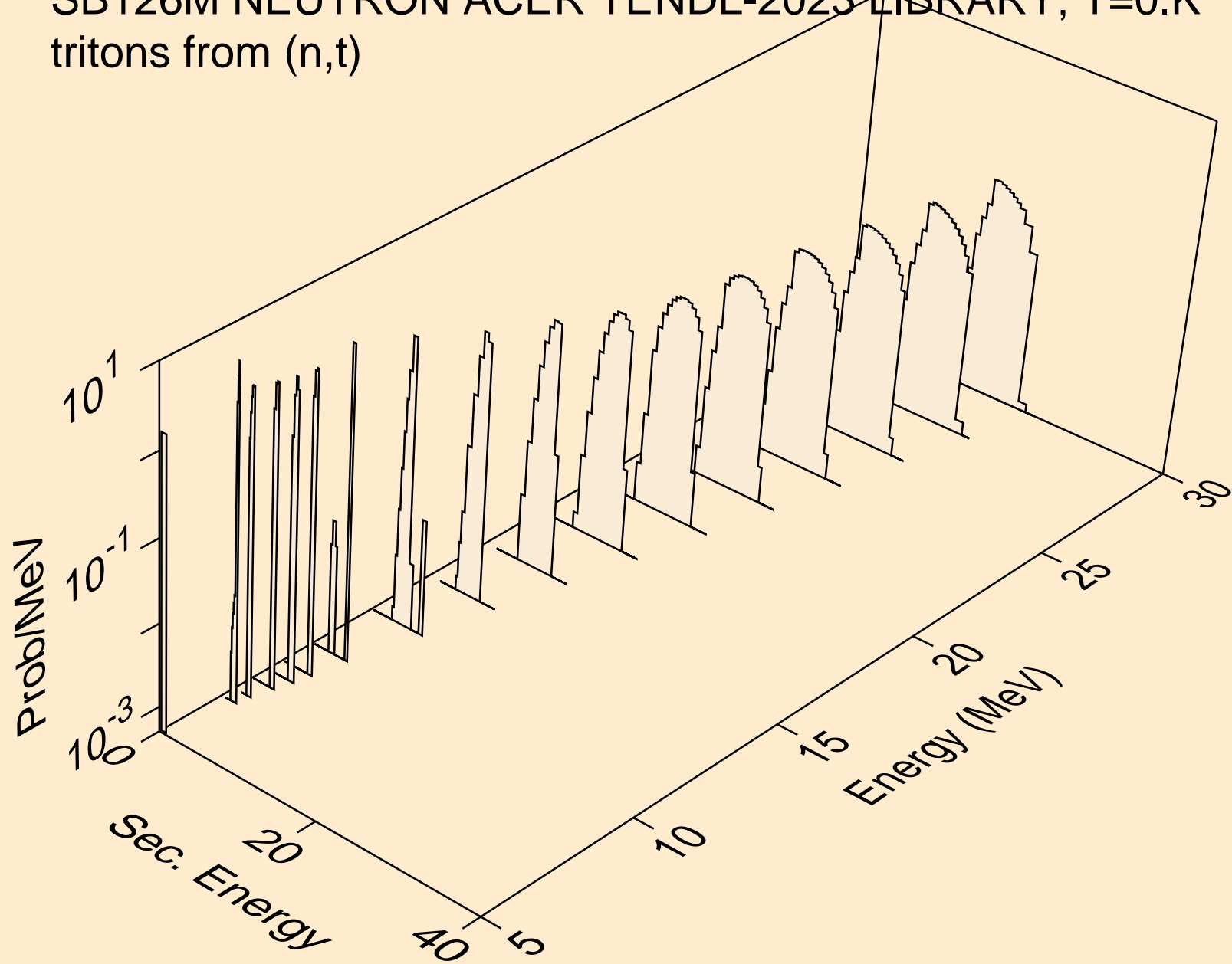

SB126M NEUTRON ACER TENDL-2023 LIBRARY; T=0.K
he3s from (n,x)

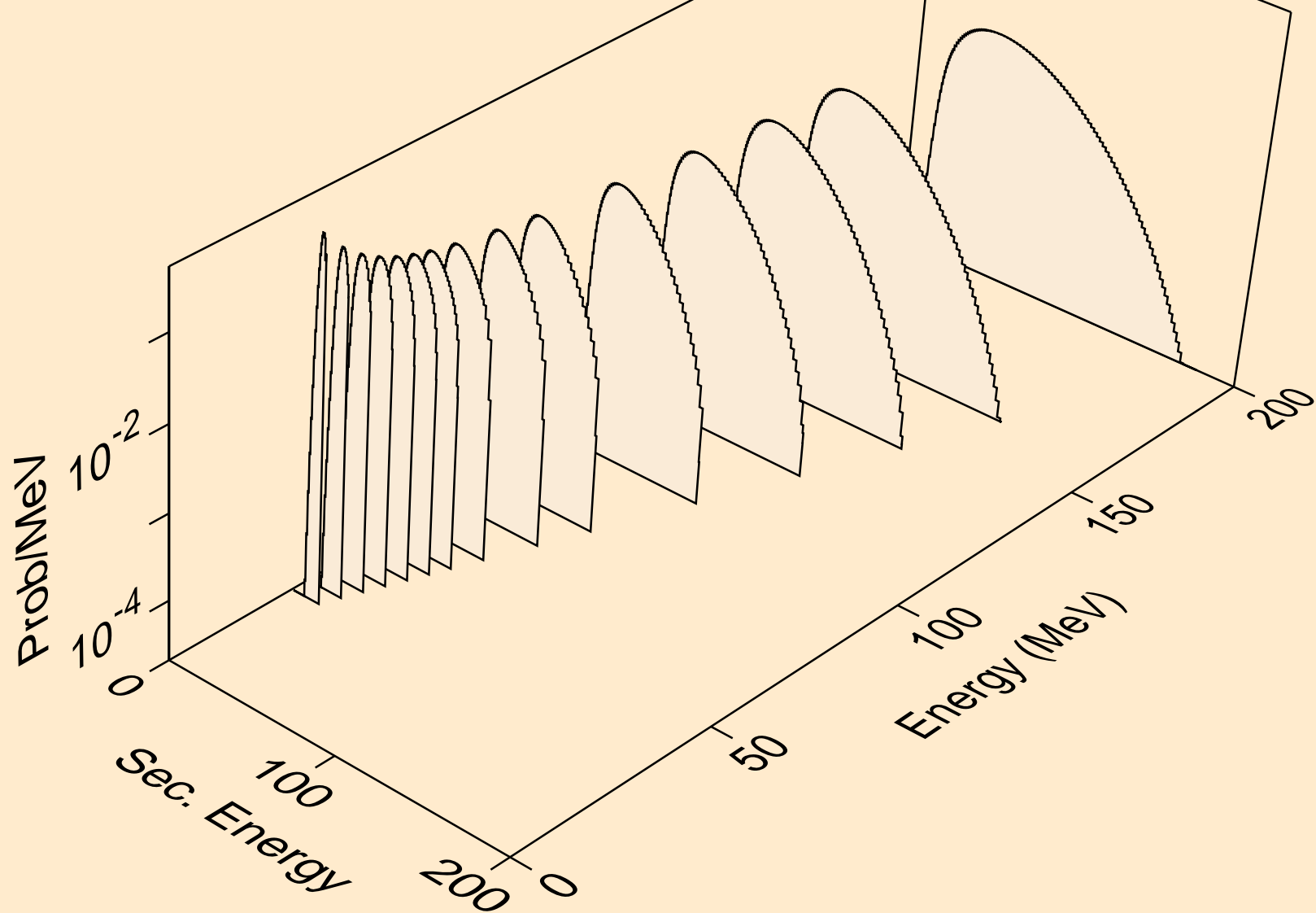

SB126M NEUTRON ACER TENDL-2023 LIBRARY; T=0.K
he3s from (n,n*)he3

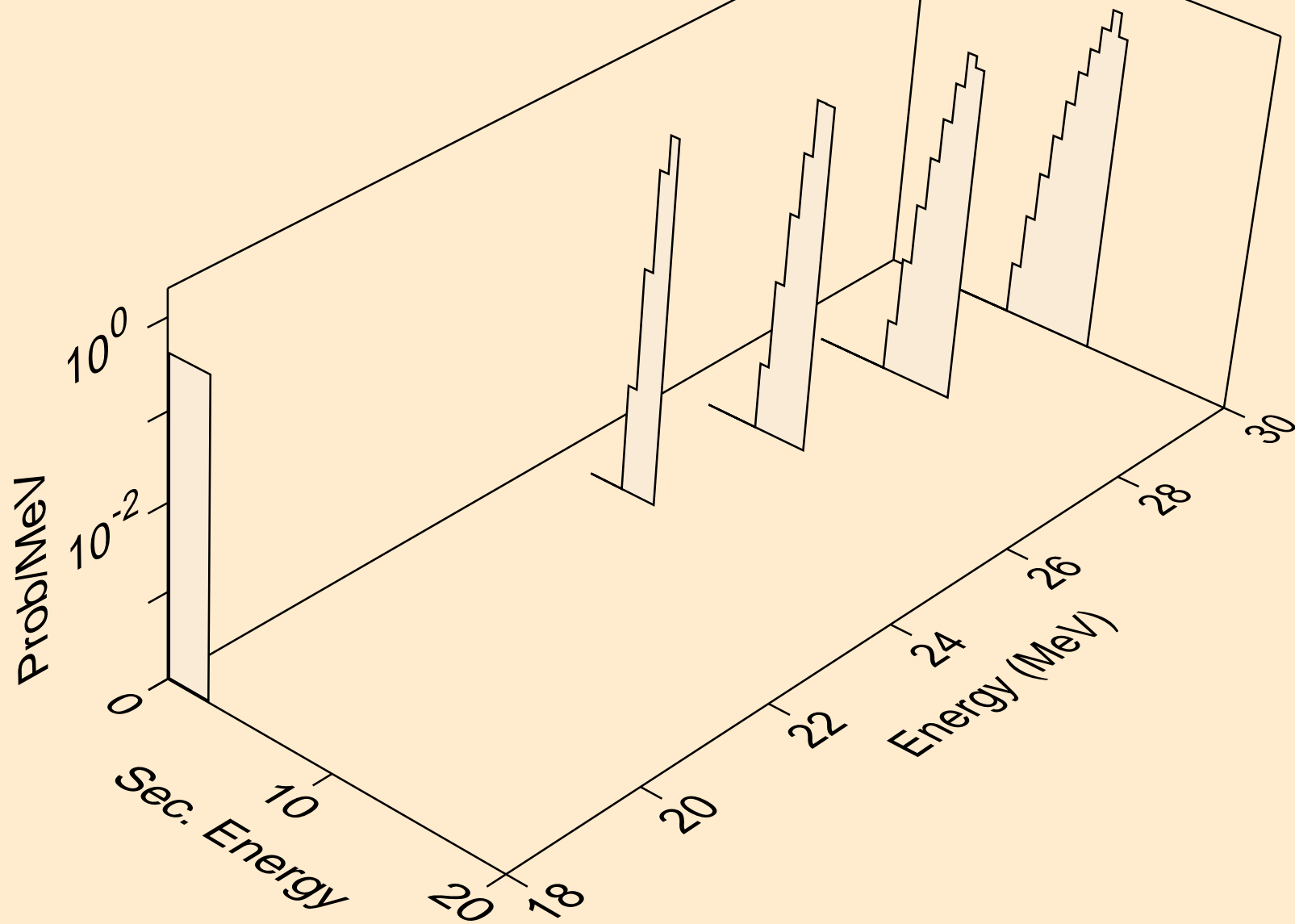

SB126M NEUTRON ACER TENDL-2023 LIBRARY; T=0.K
he3s from (n,he3)

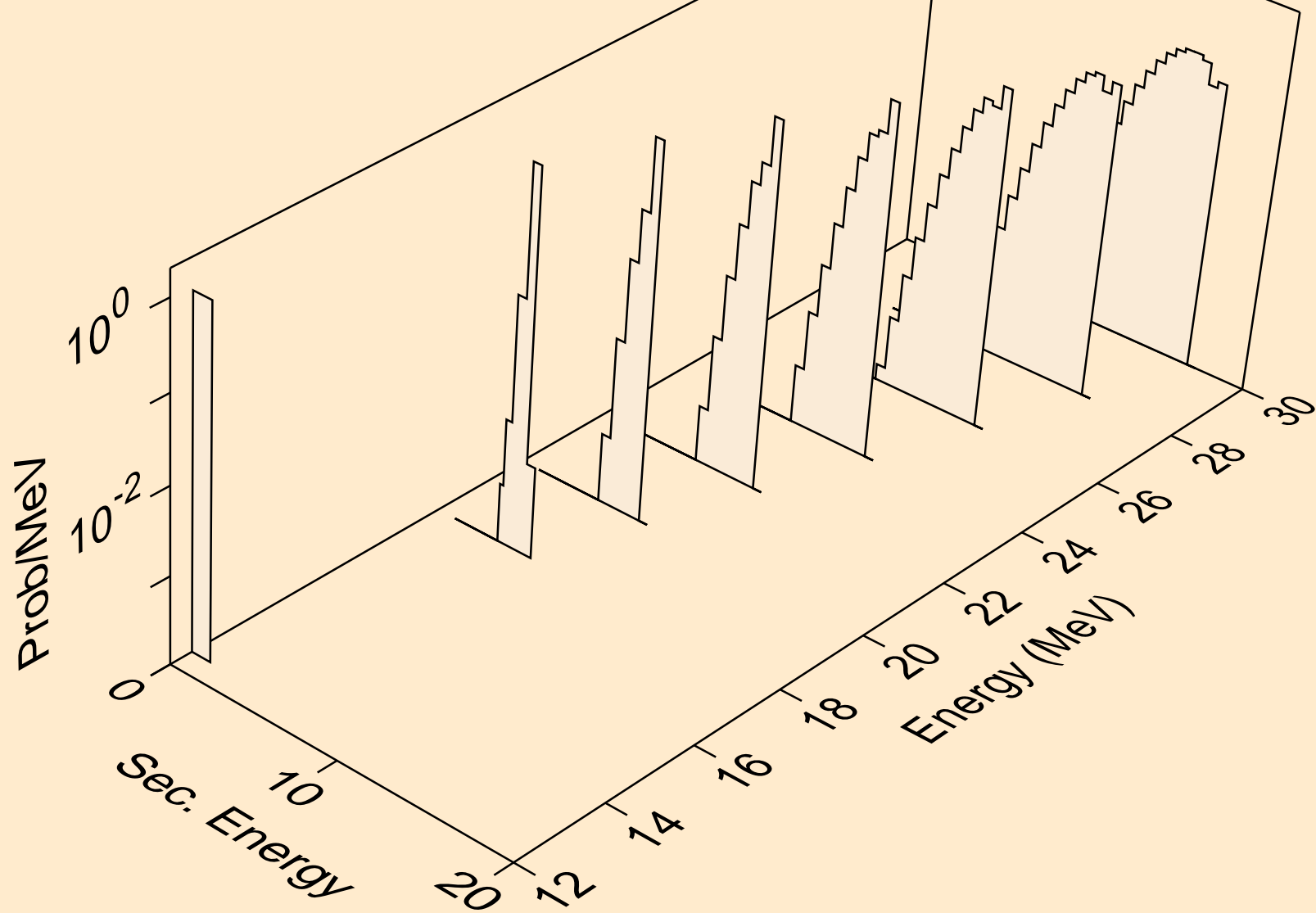

SB126M NEUTRON ACER TENDL-2023 LIBRARY; T=0.K
alphas from (n,x)

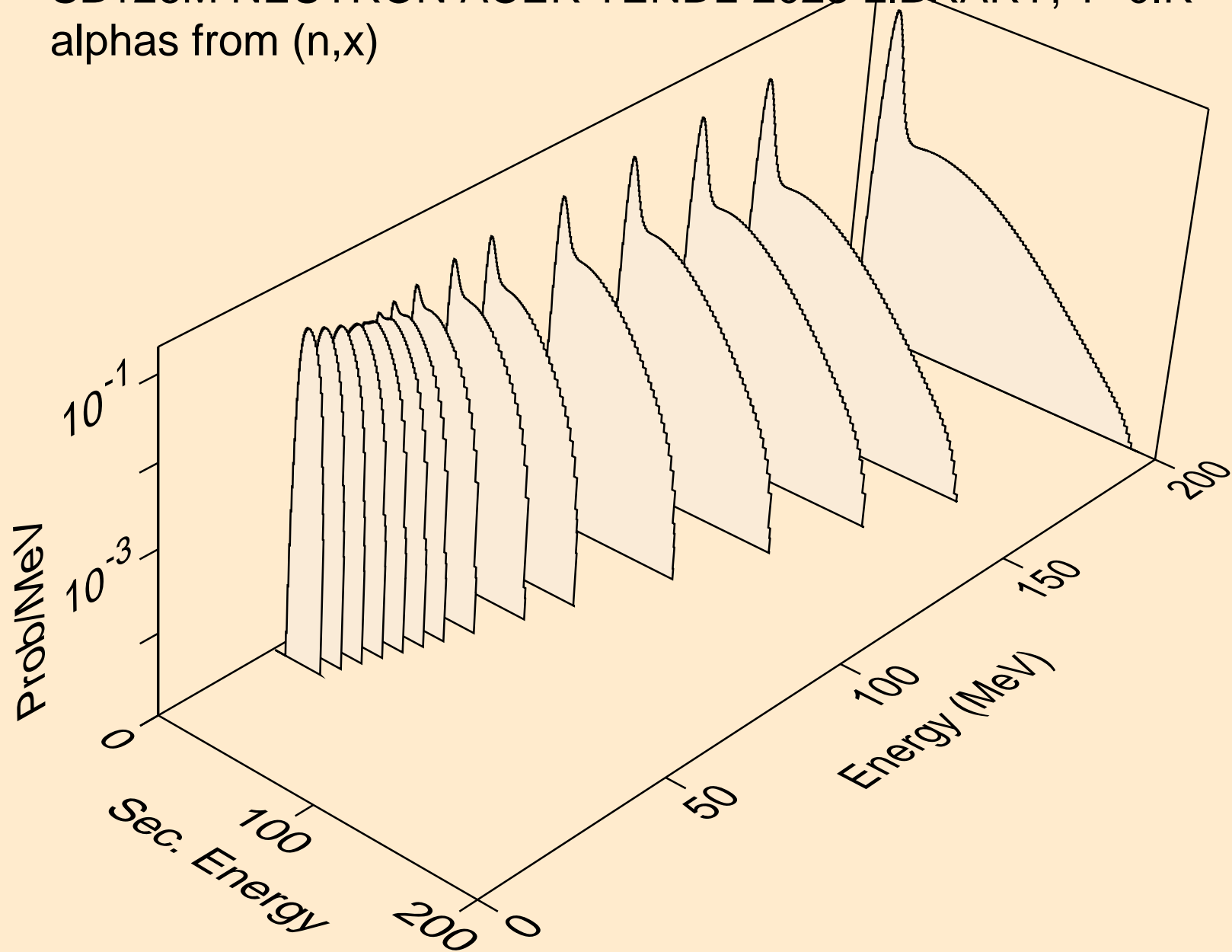

SB126M NEUTRON ACER TENDL-2023 LIBRARY; T=0.K
alphas from (n,n*)a

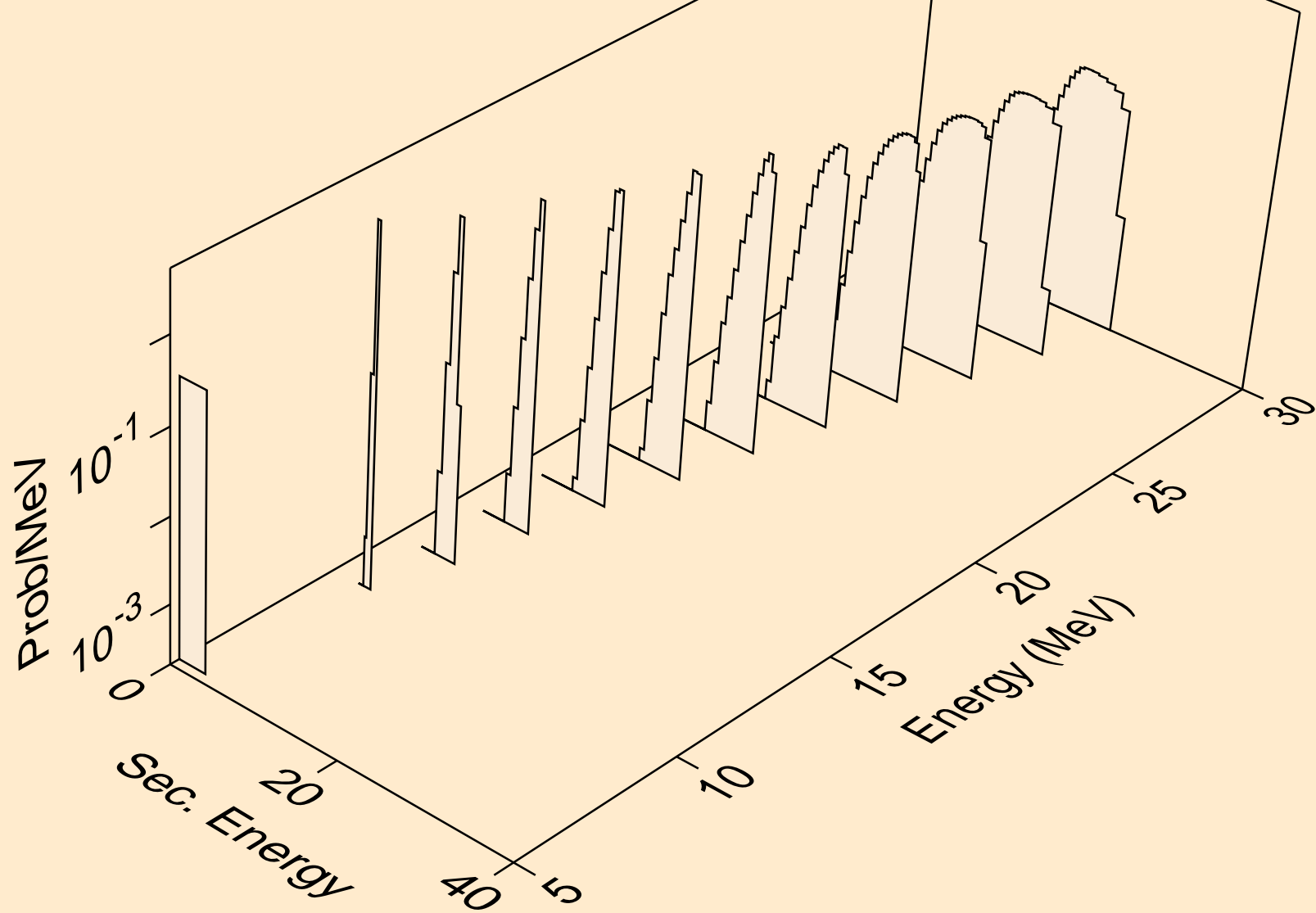

SB126M NEUTRON ACER TENDL-2023 LIBRARY; T=0.K
alphas from (n,2n)a

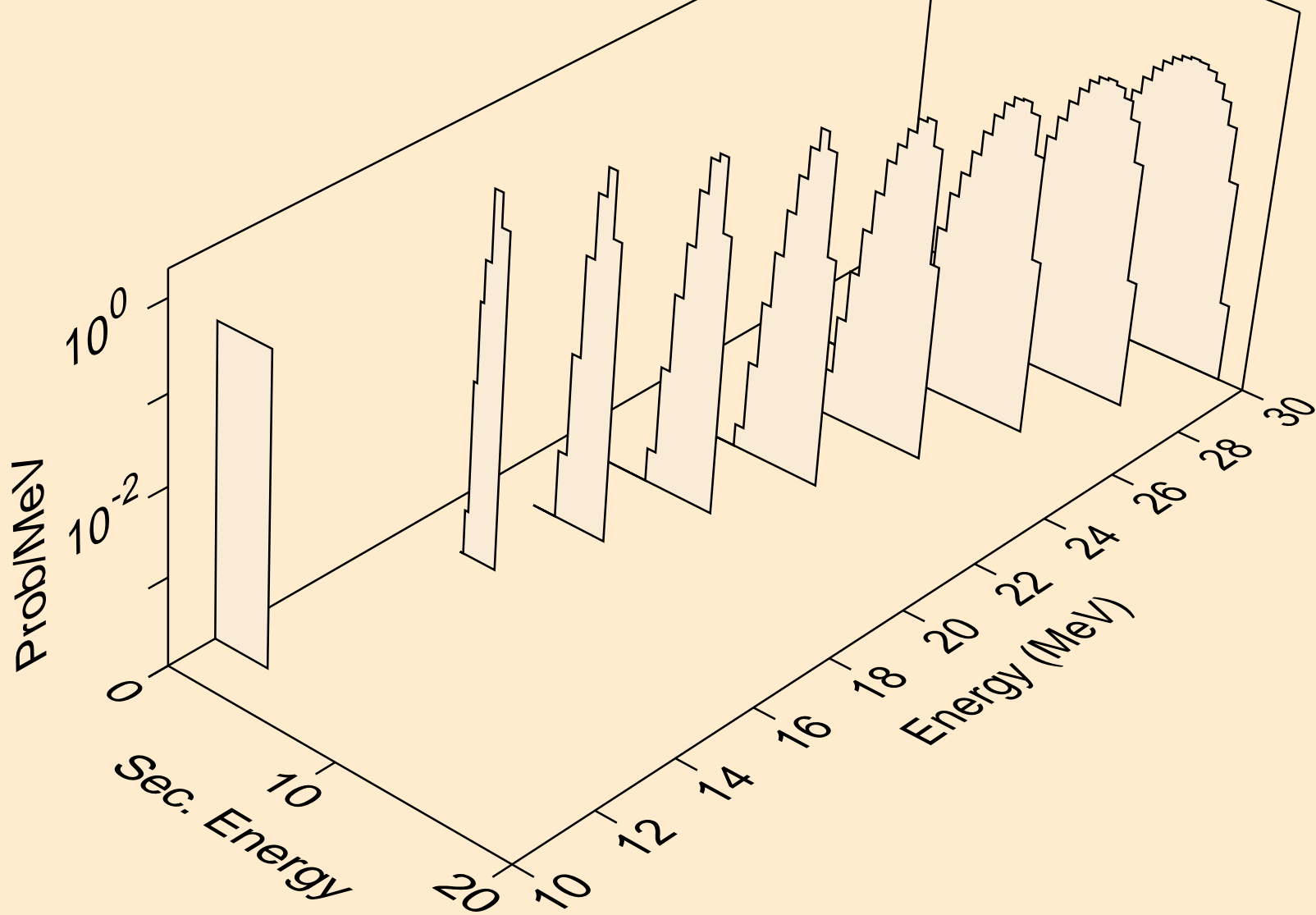

SB126M NEUTRON ACER TENDL-2023 LIBRARY; T=0.K
alphas from (n,3n)a

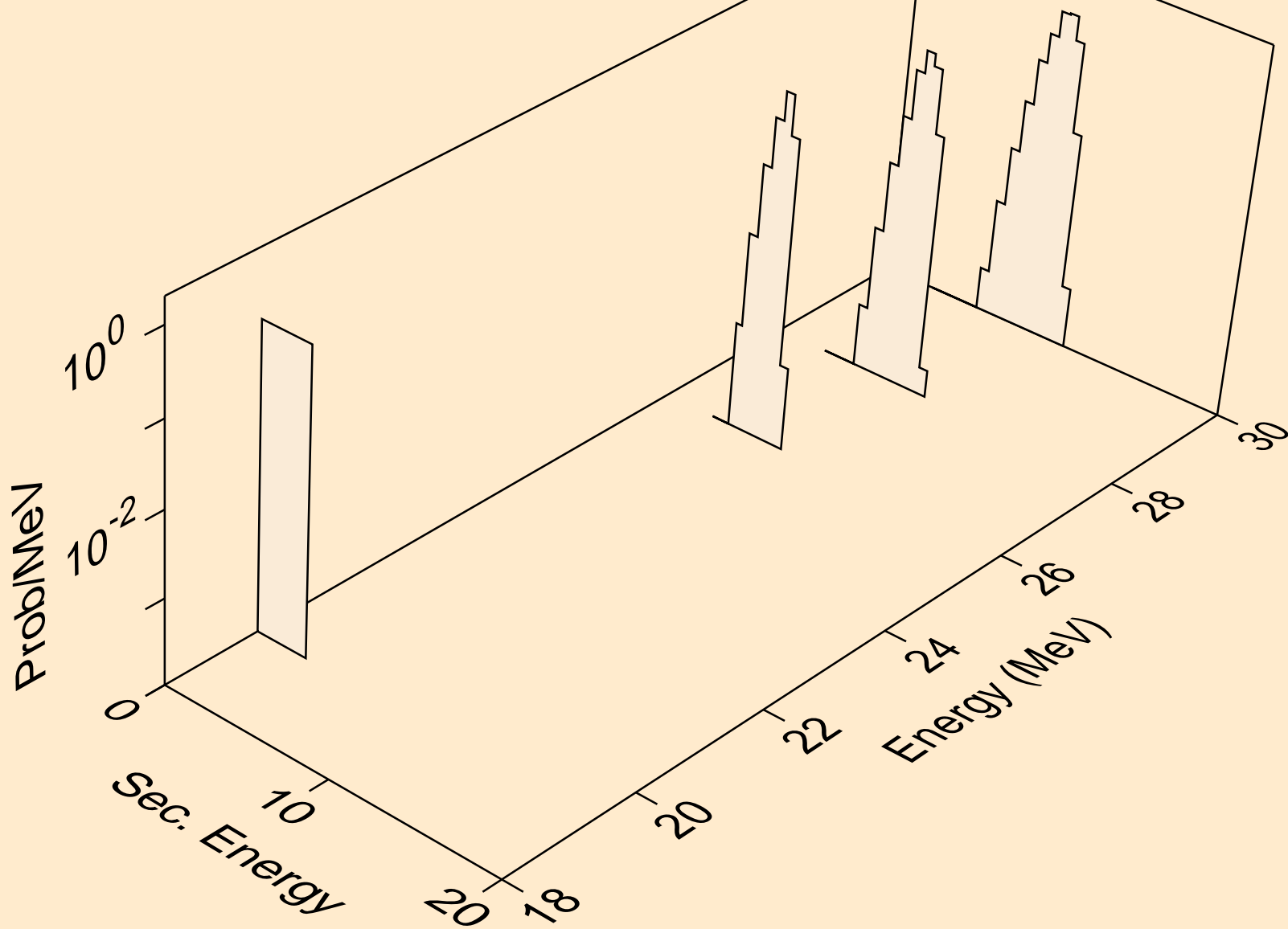

SB126M NEUTRON ACER TENDL-2023 LIBRARY; T=0.K
alphas from (n,a)

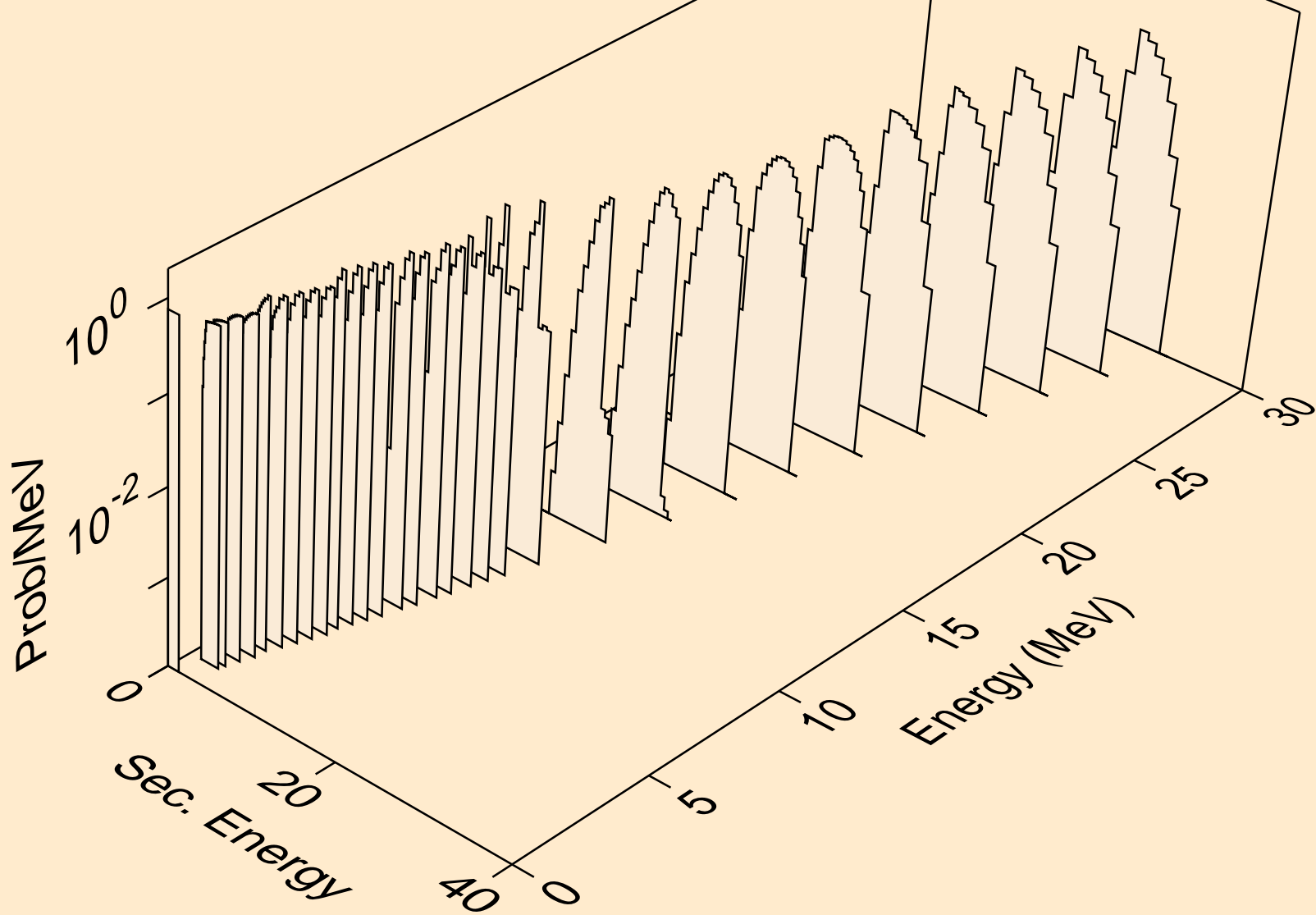

SB126M NEUTRON ACER TENDL-2023 LIBRARY; T=0.K
alphas from (n,pa)

