

# SB126N NEUTRON ACER TENDL-2023 LIBRARY; T=0.K

## Principal cross sections

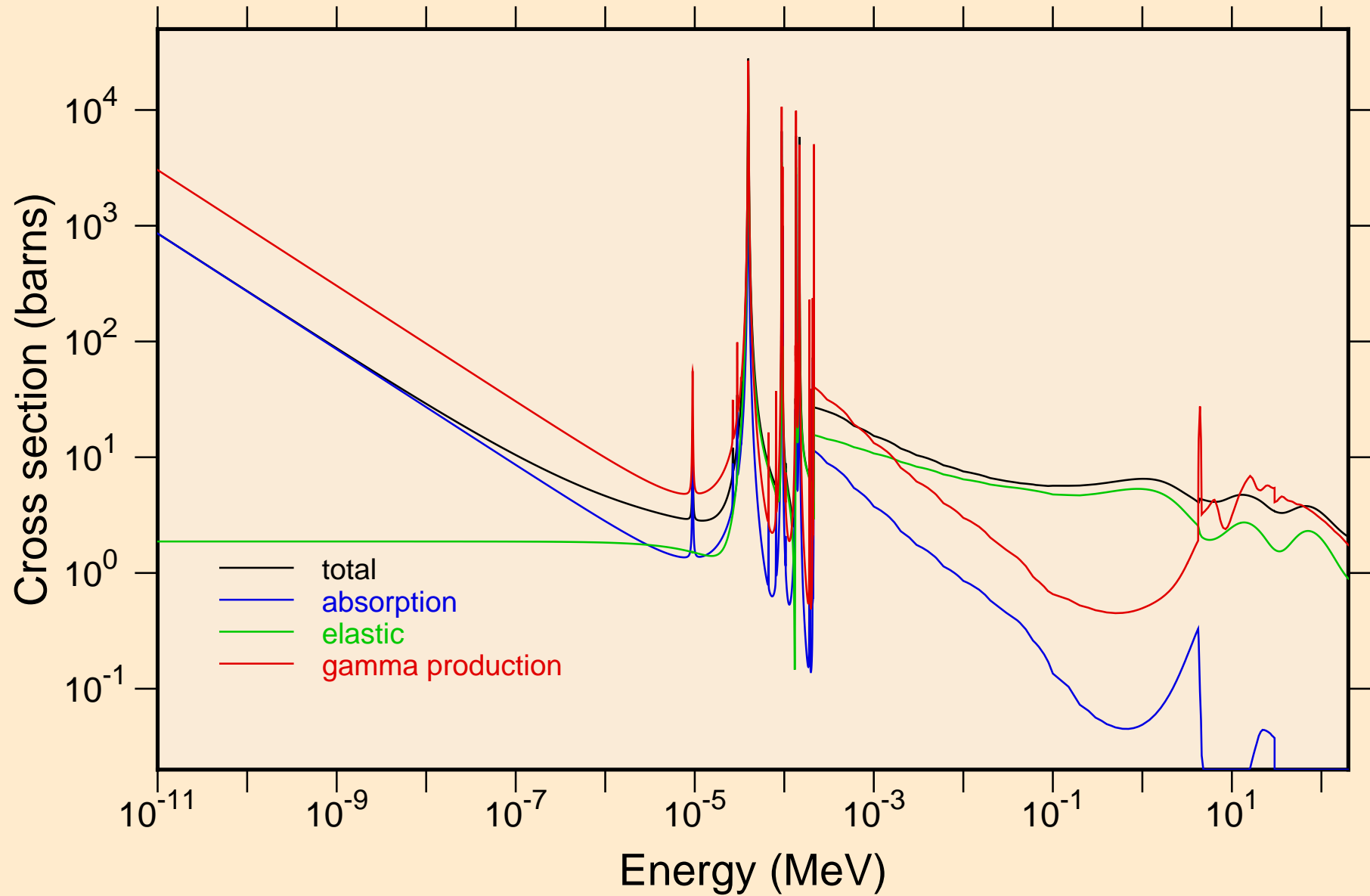

SB126N NEUTRON ACER TENDL-2023 LIBRARY; T=0.K  
resonance total cross section

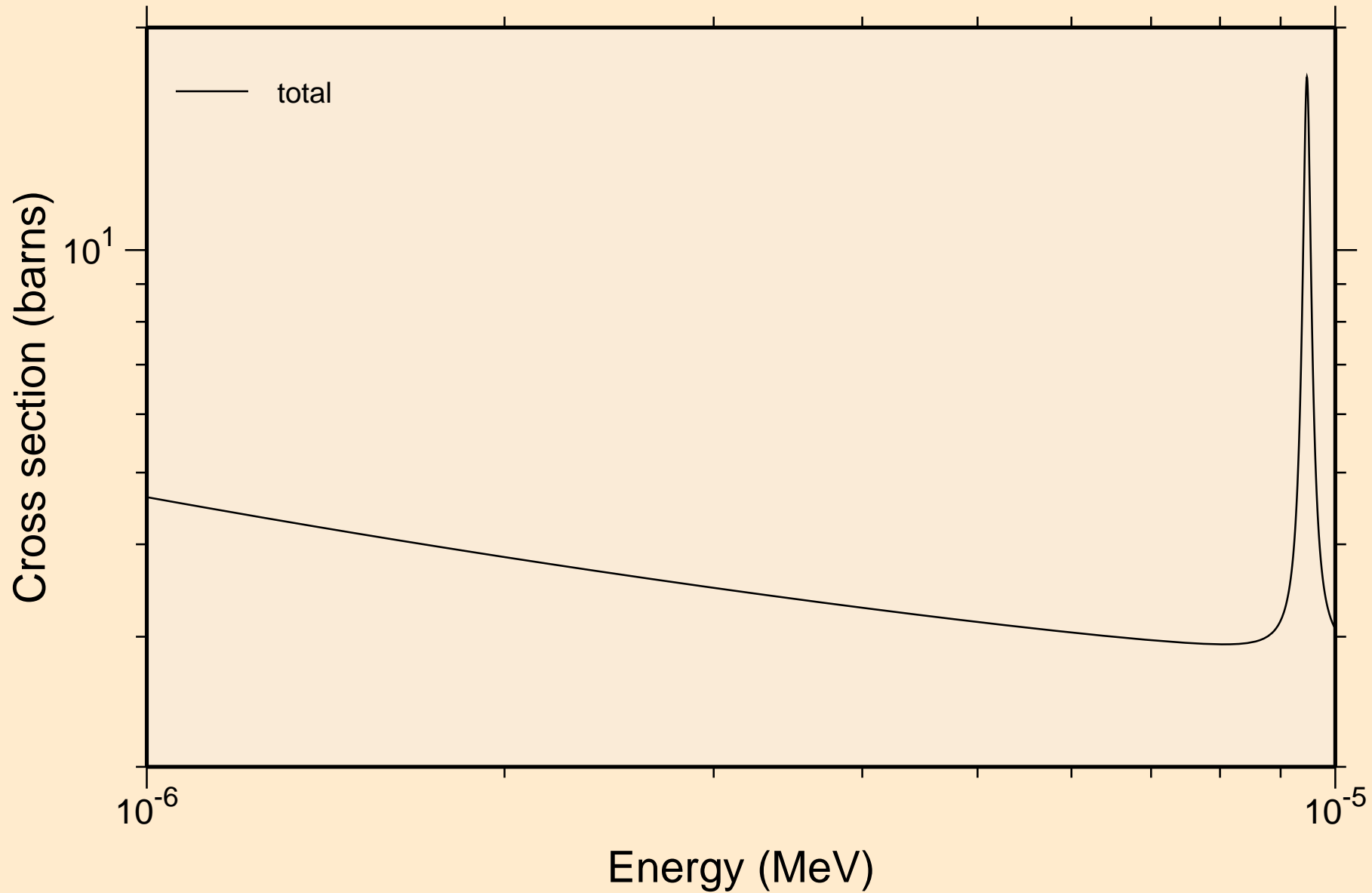

SB126N NEUTRON ACER TENDL-2023 LIBRARY; T=0.K  
resonance total cross section

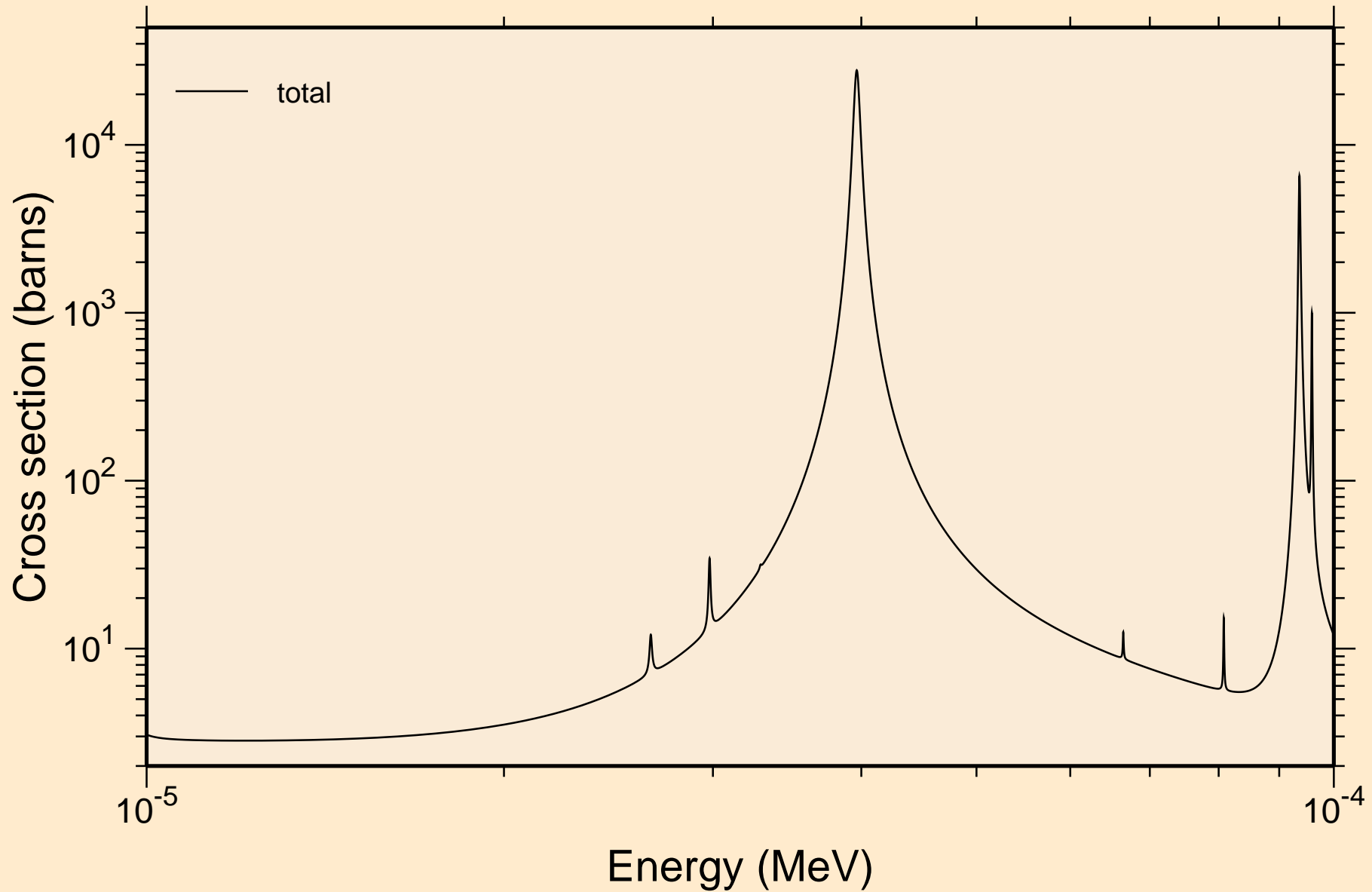

SB126N NEUTRON ACER TENDL-2023 LIBRARY; T=0.K  
resonance total cross section

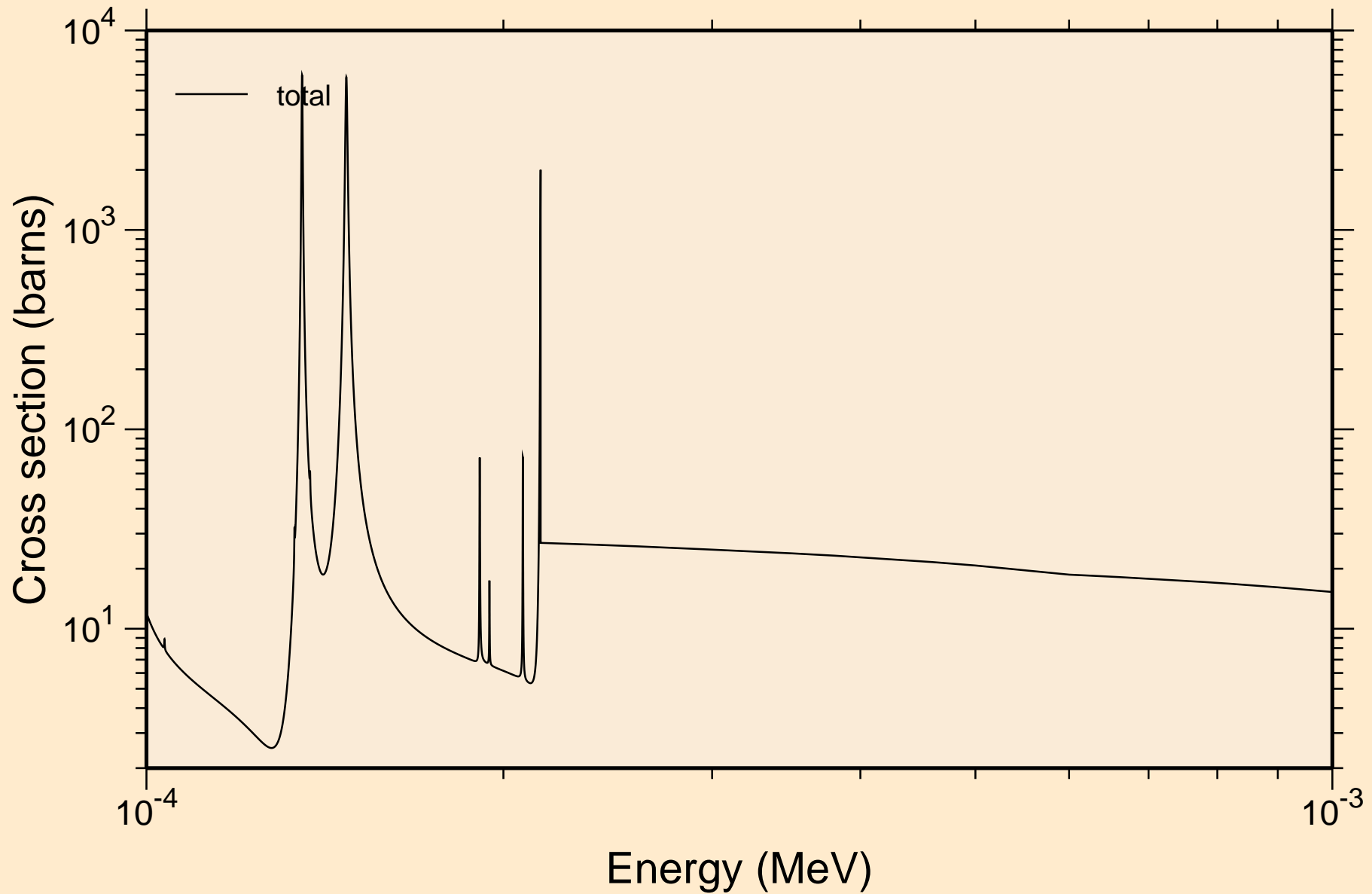

S $\bar{B}$ 126N NEUTRON ACER TENDL-2023 LIBRARY; T=0.K  
resonance total cross section

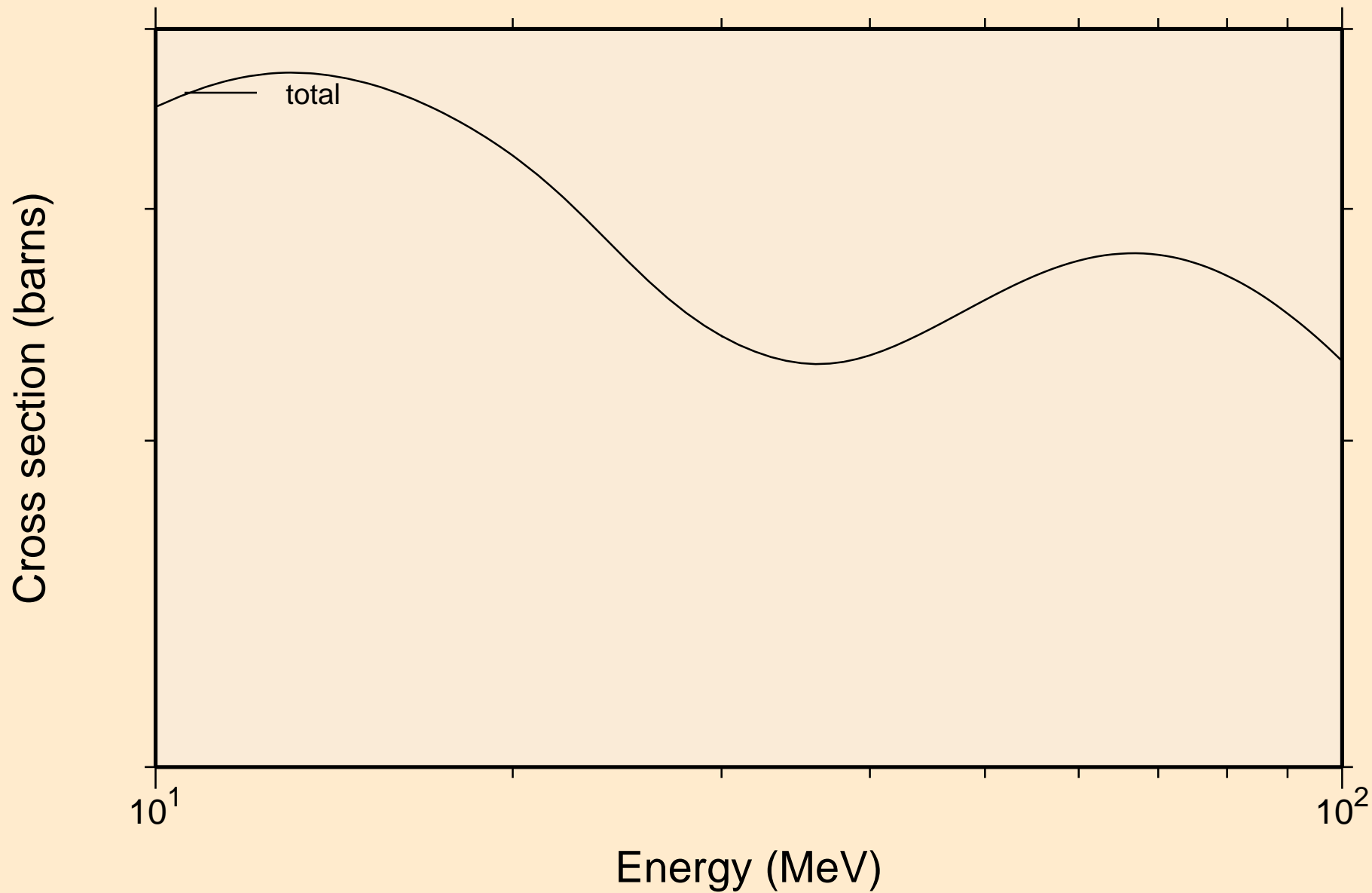

SB126N NEUTRON ACER TENDL-2023 LIBRARY; T=0.K  
resonance absorption cross sections

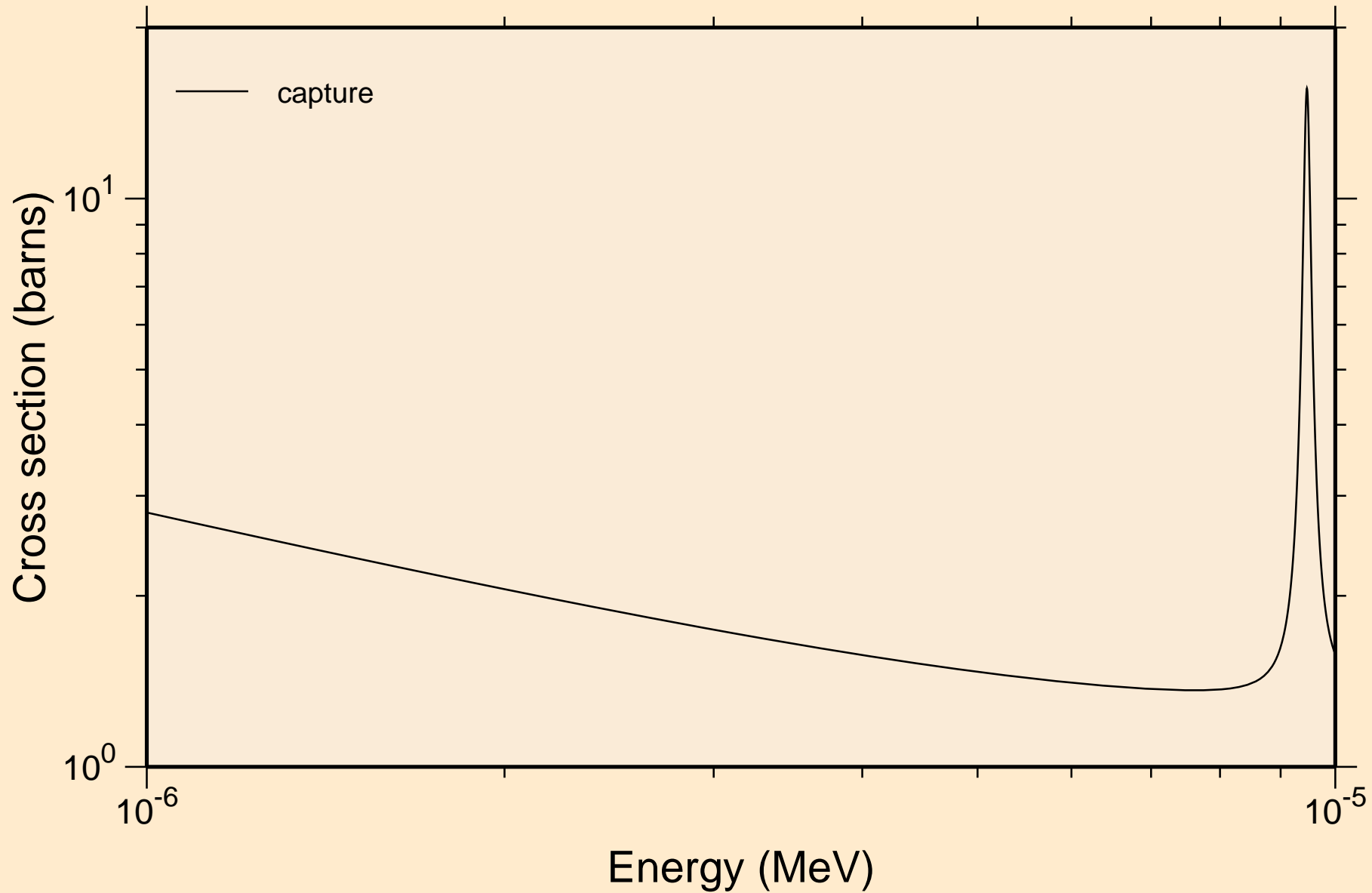

SB126N NEUTRON ACER TENDL-2023 LIBRARY; T=0.K  
resonance absorption cross sections

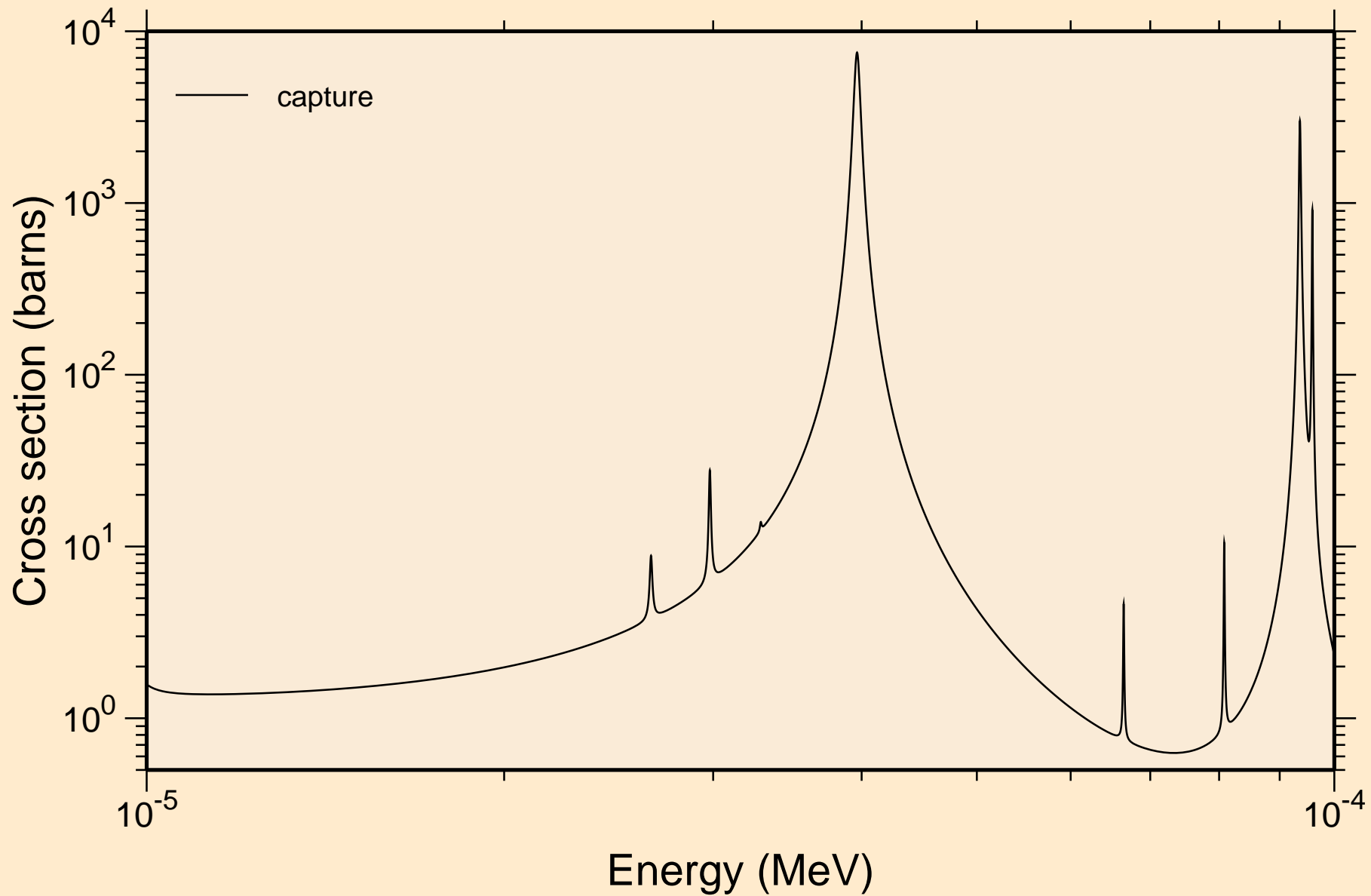

SB126N NEUTRON ACER TENDL-2023 LIBRARY; T=0.K  
resonance absorption cross sections

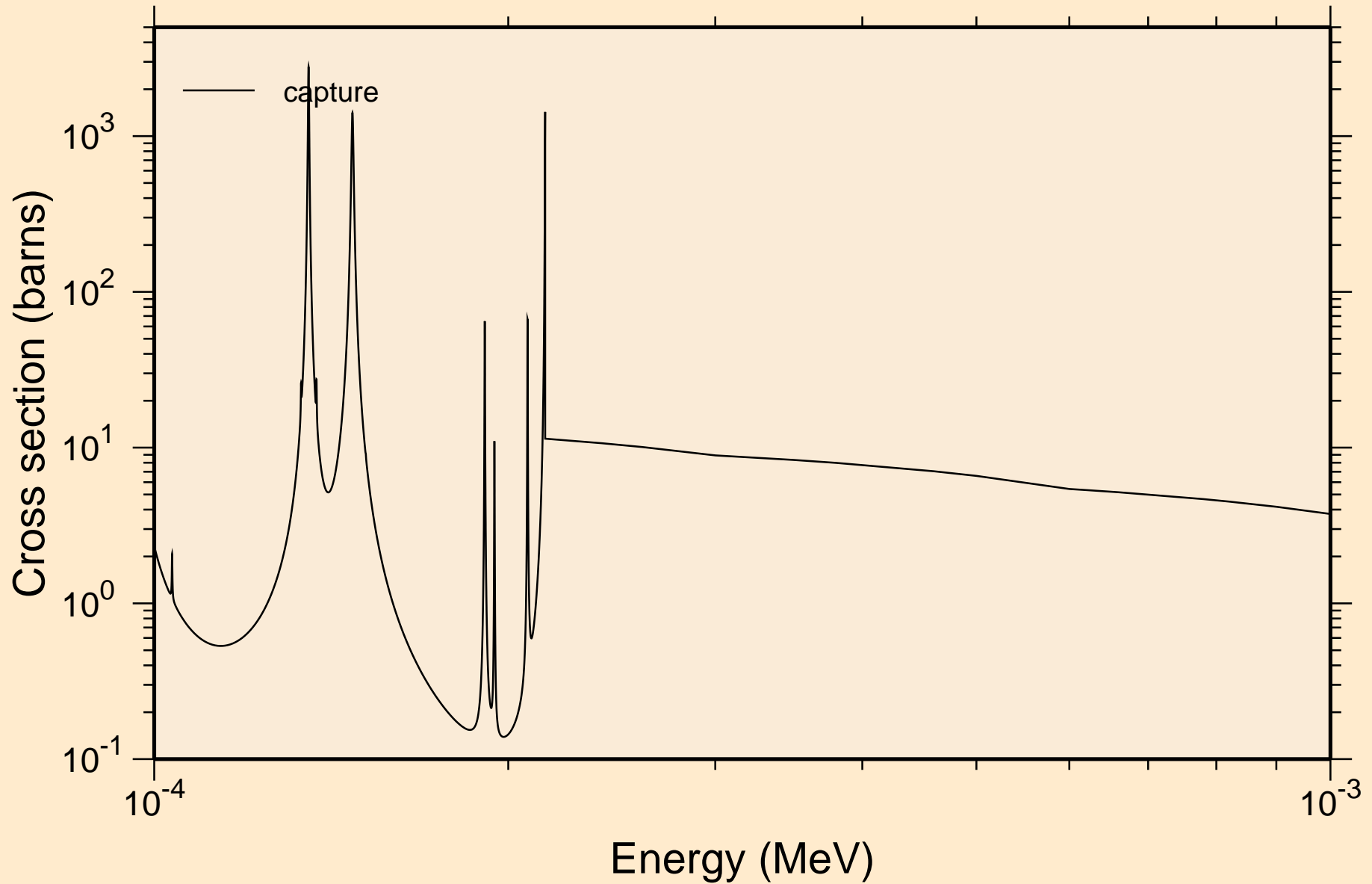



SB126N NEUTRON ACER TENDL-2023 LIBRARY; T=0.K  
resonance absorption cross sections

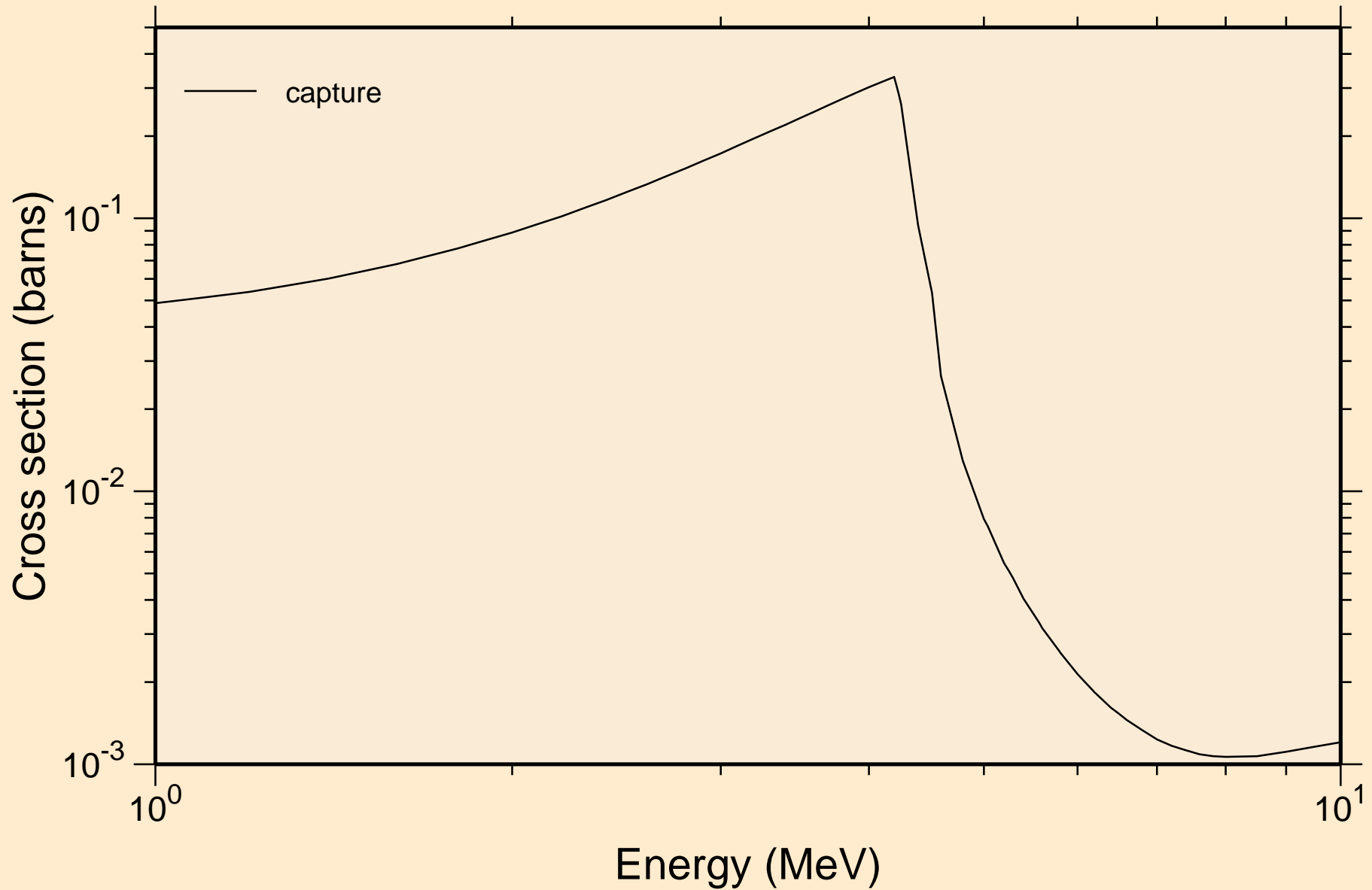

# SB126N NEUTRON ACER TENDL-2023 LIBRARY; T=0.K

## Heating

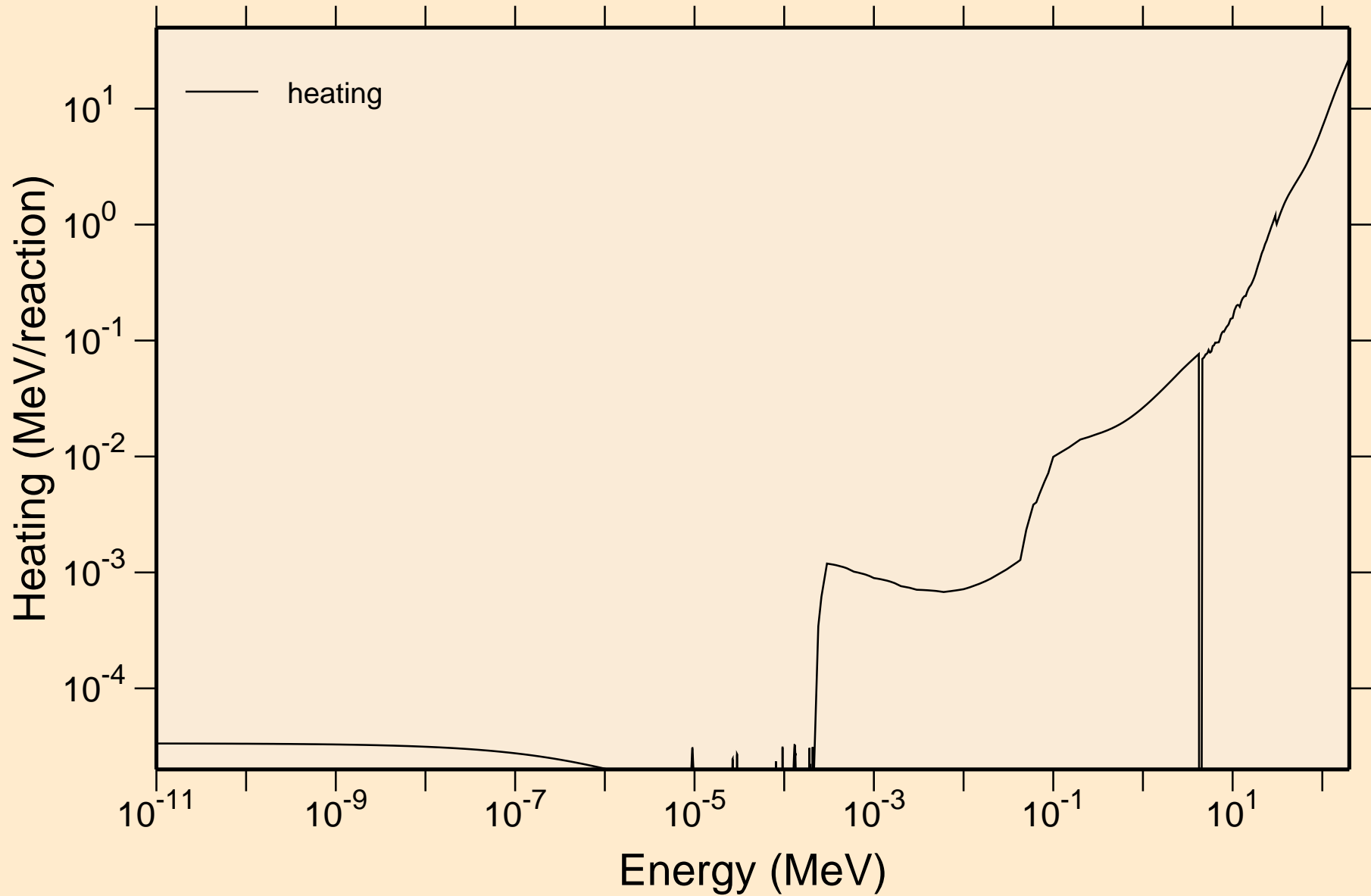

SB126N NEUTRON ACER TENDL-2023 LIBRARY; T=0.K  
Damage

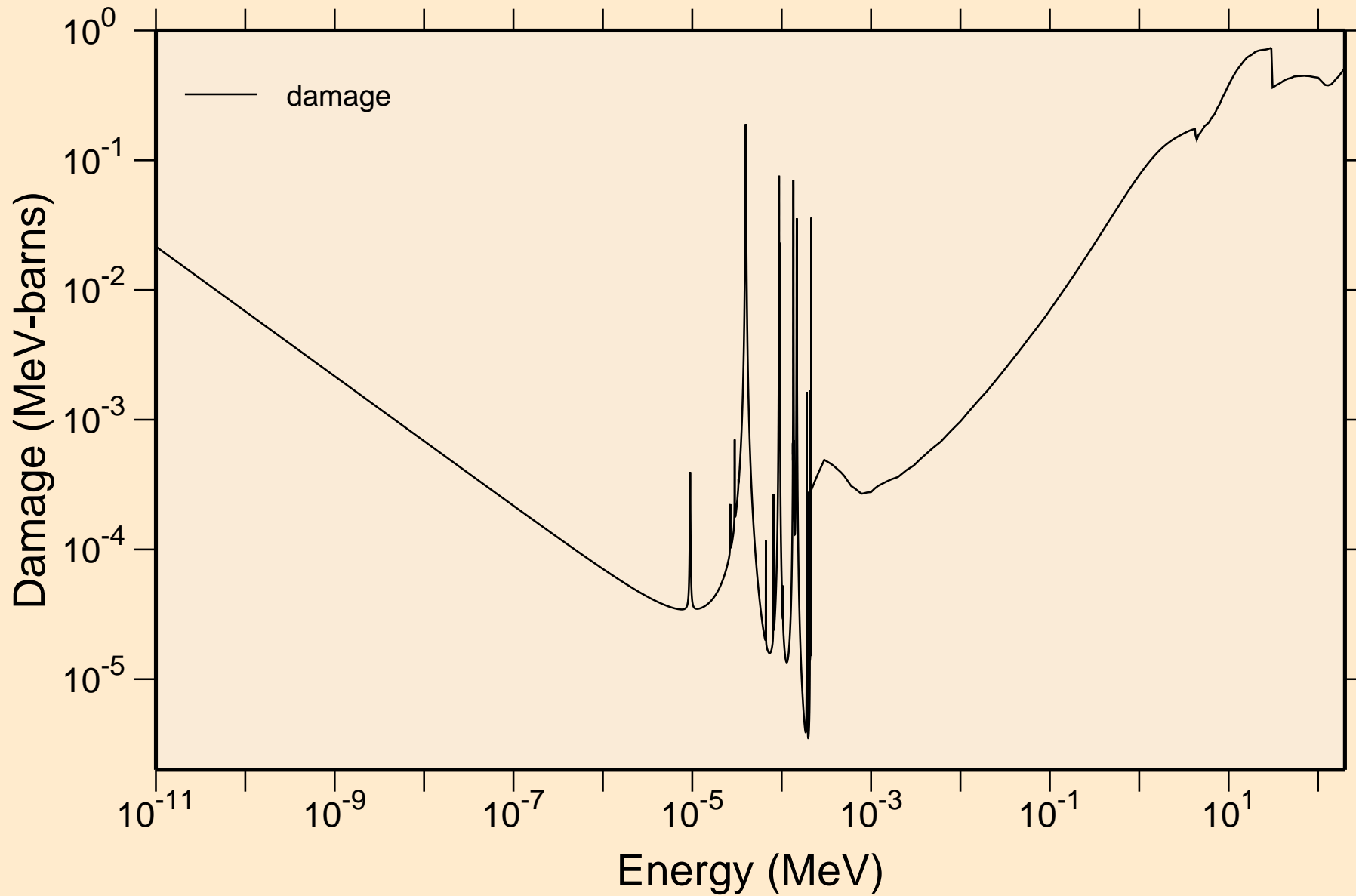

# SB126N NEUTRON ACER TENDL-2023 LIBRARY; T=0.K

## Non-threshold reactions

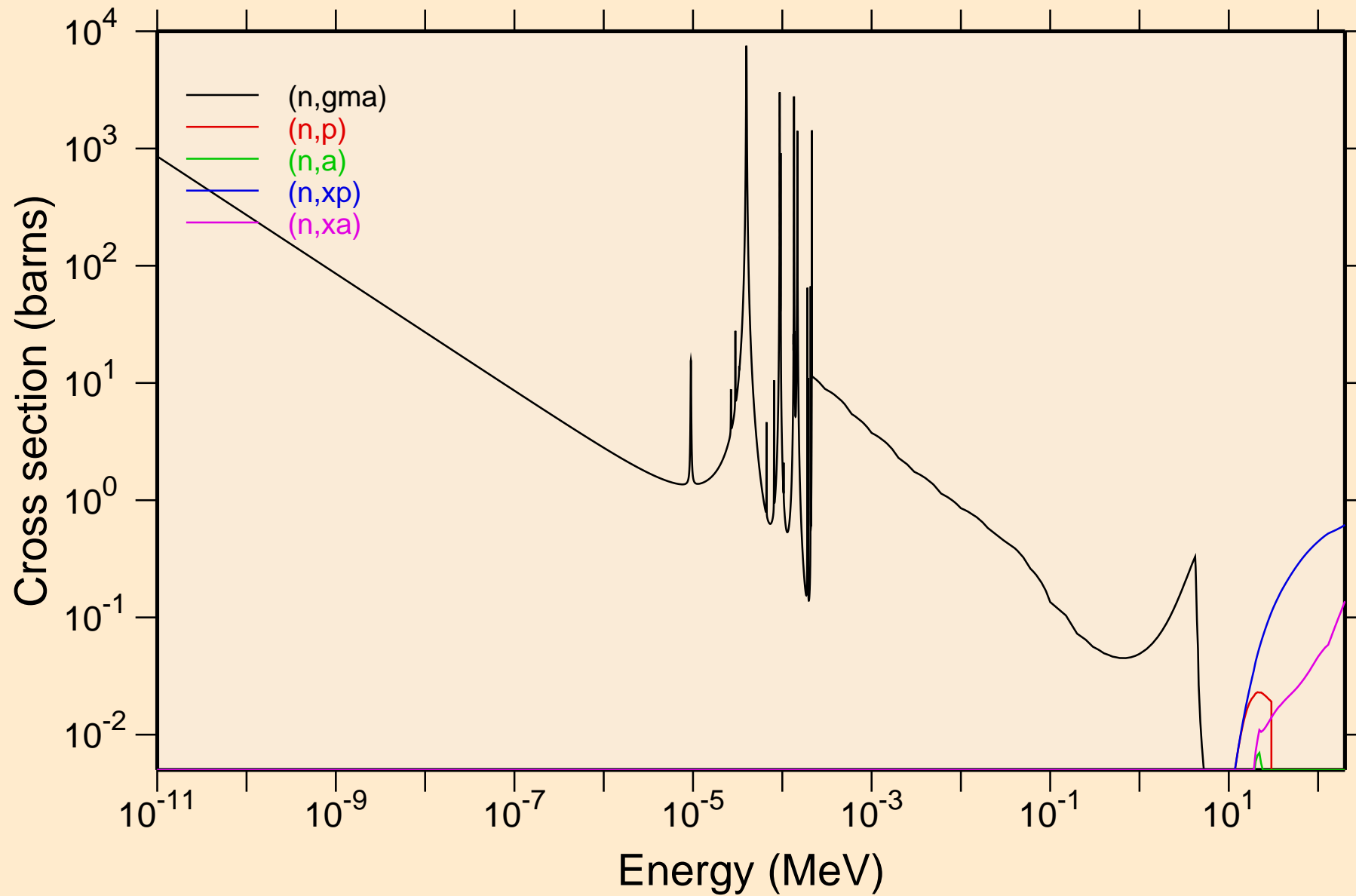

# SB126N NEUTRON ACER TENDL-2023 LIBRARY; T=0.K

## Principal cross sections

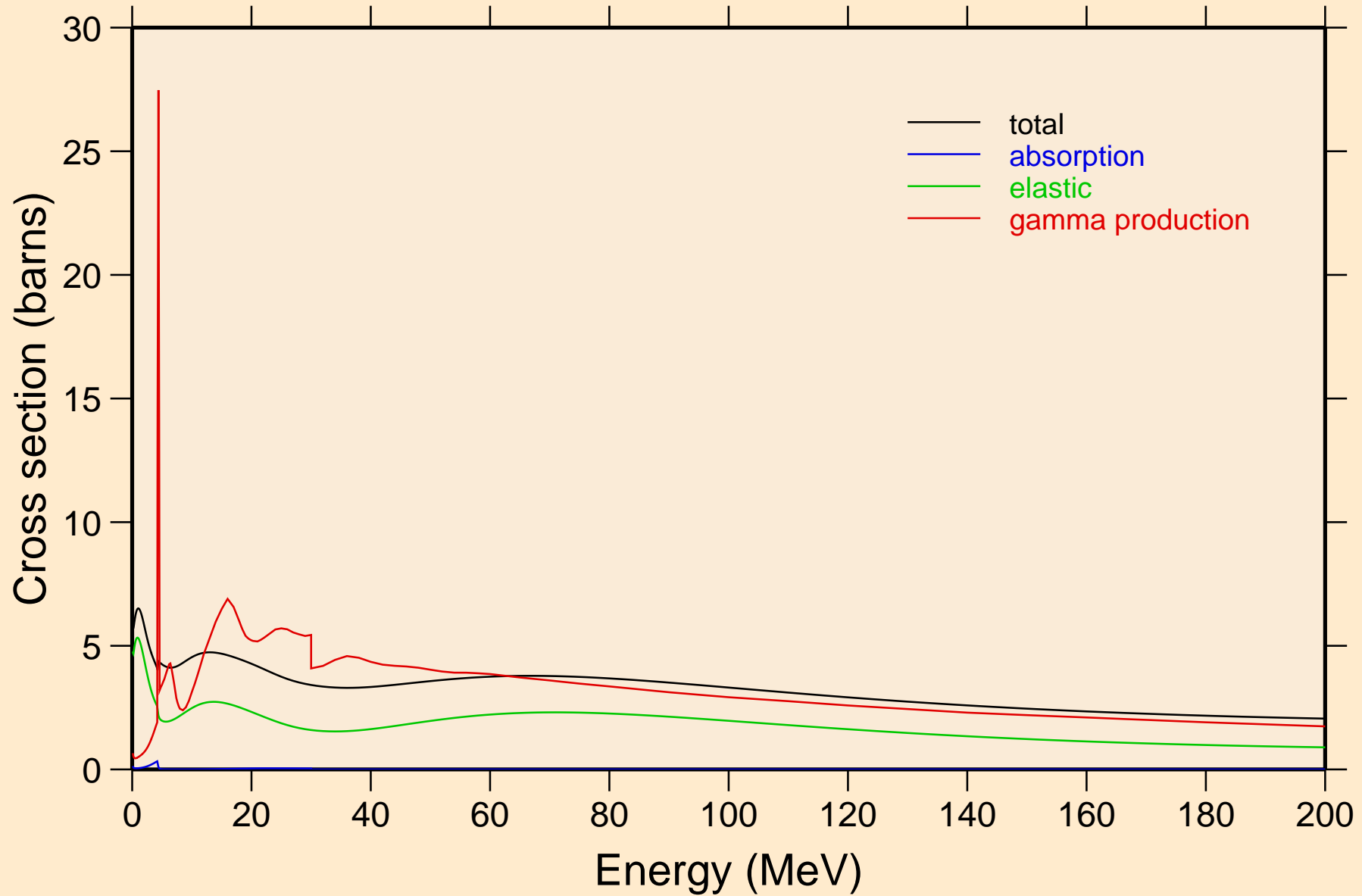

# SB126N NEUTRON ACER TENDL-2023 LIBRARY; T=0.K

## Heating

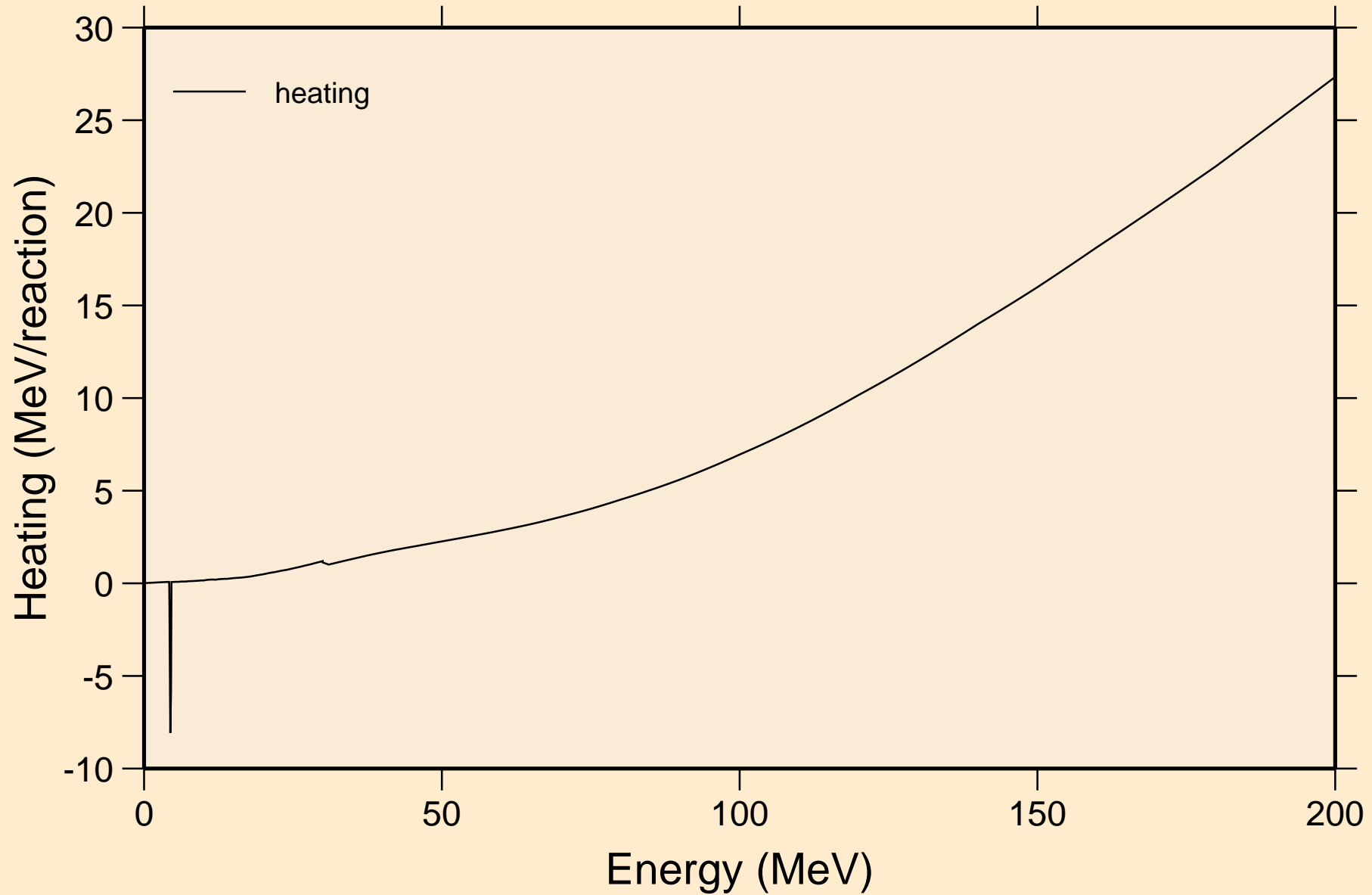

SB126N NEUTRON ACER TENDL-2023 LIBRARY; T=0.K  
Damage

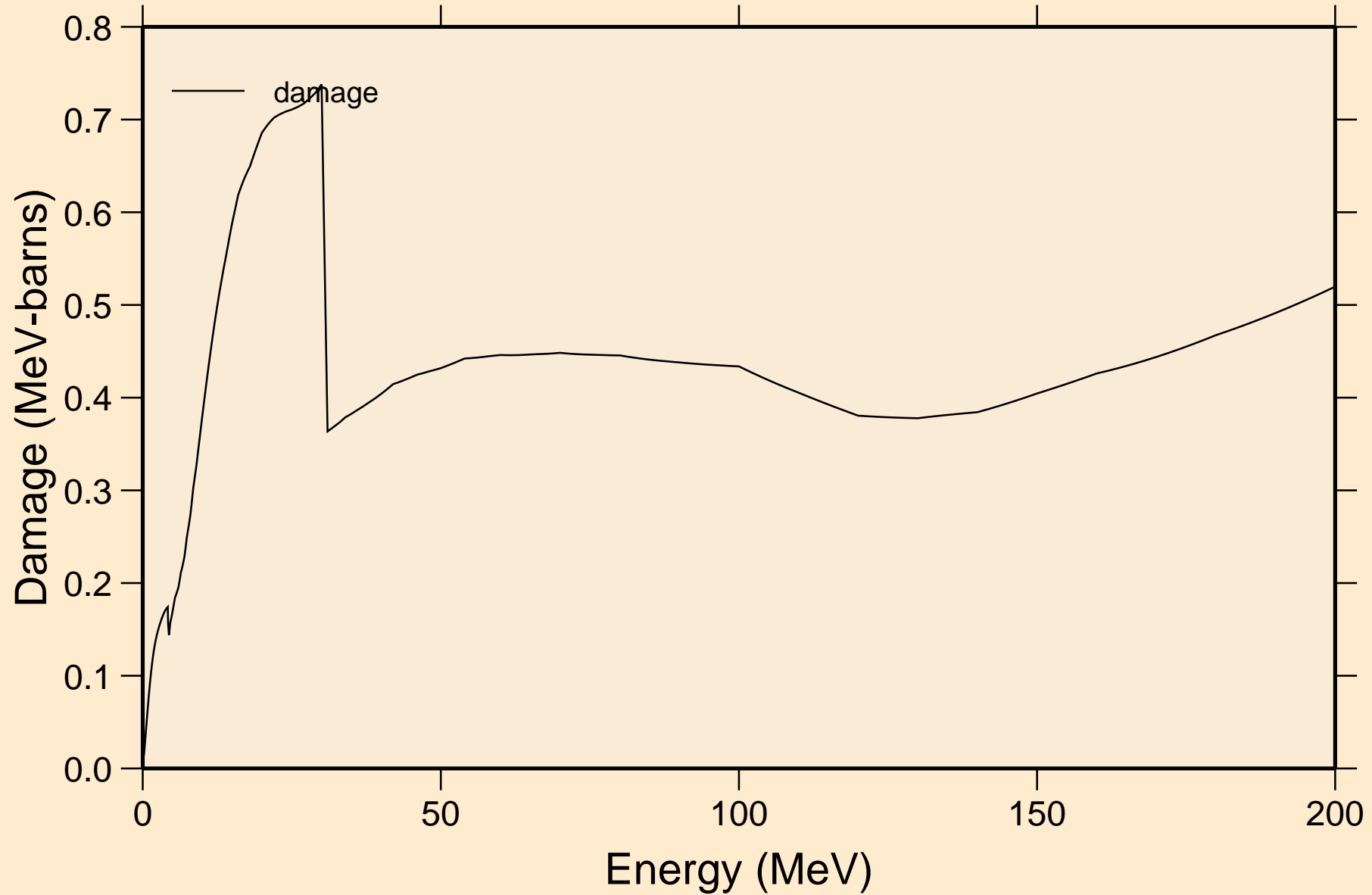

# SB126N NEUTRON ACER TENDL-2023 LIBRARY; T=0.K

## Non-threshold reactions

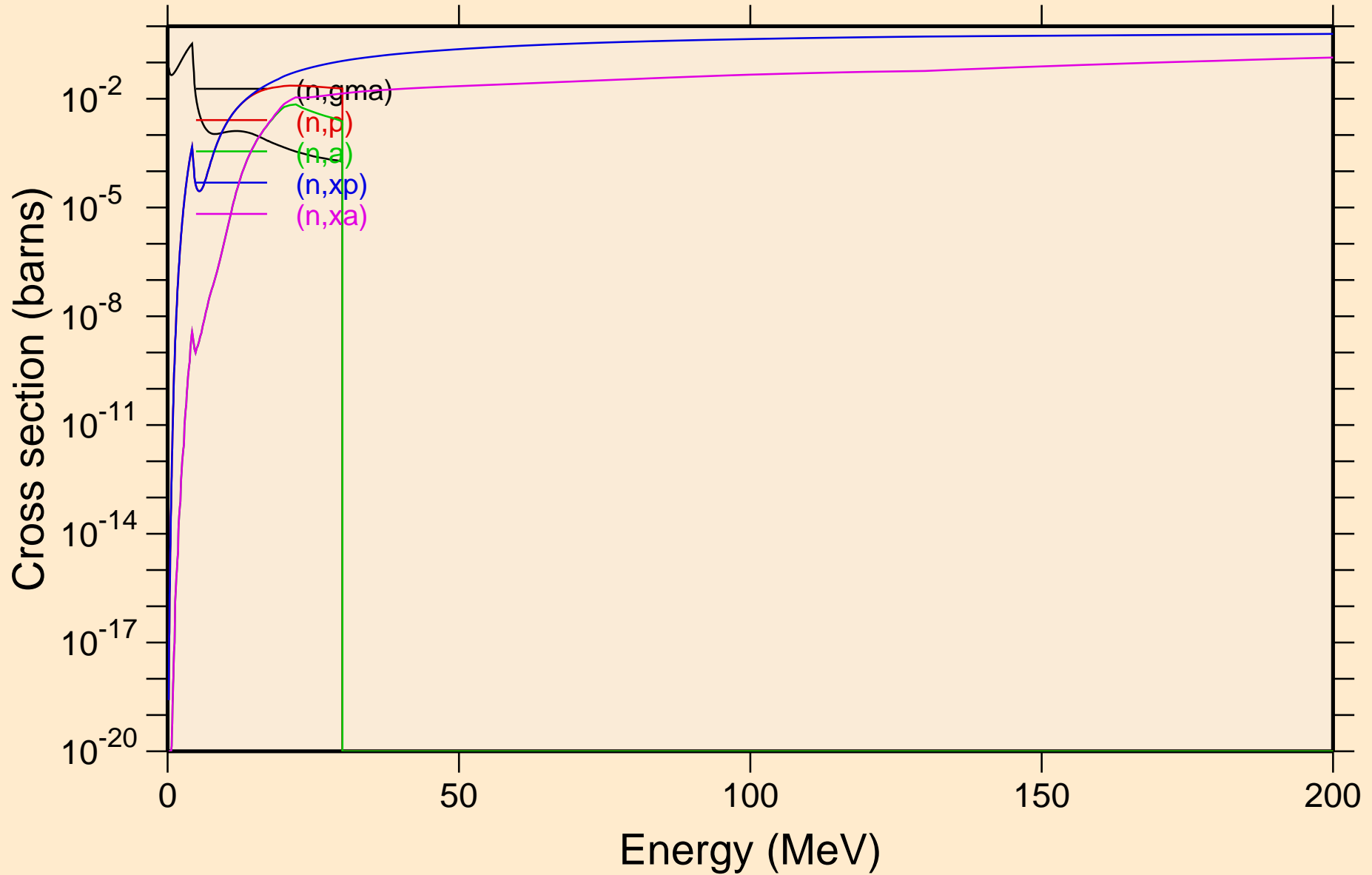



SB126N NEUTRON ACER TENDL-2023 LIBRARY; T=0.K  
Inelastic levels

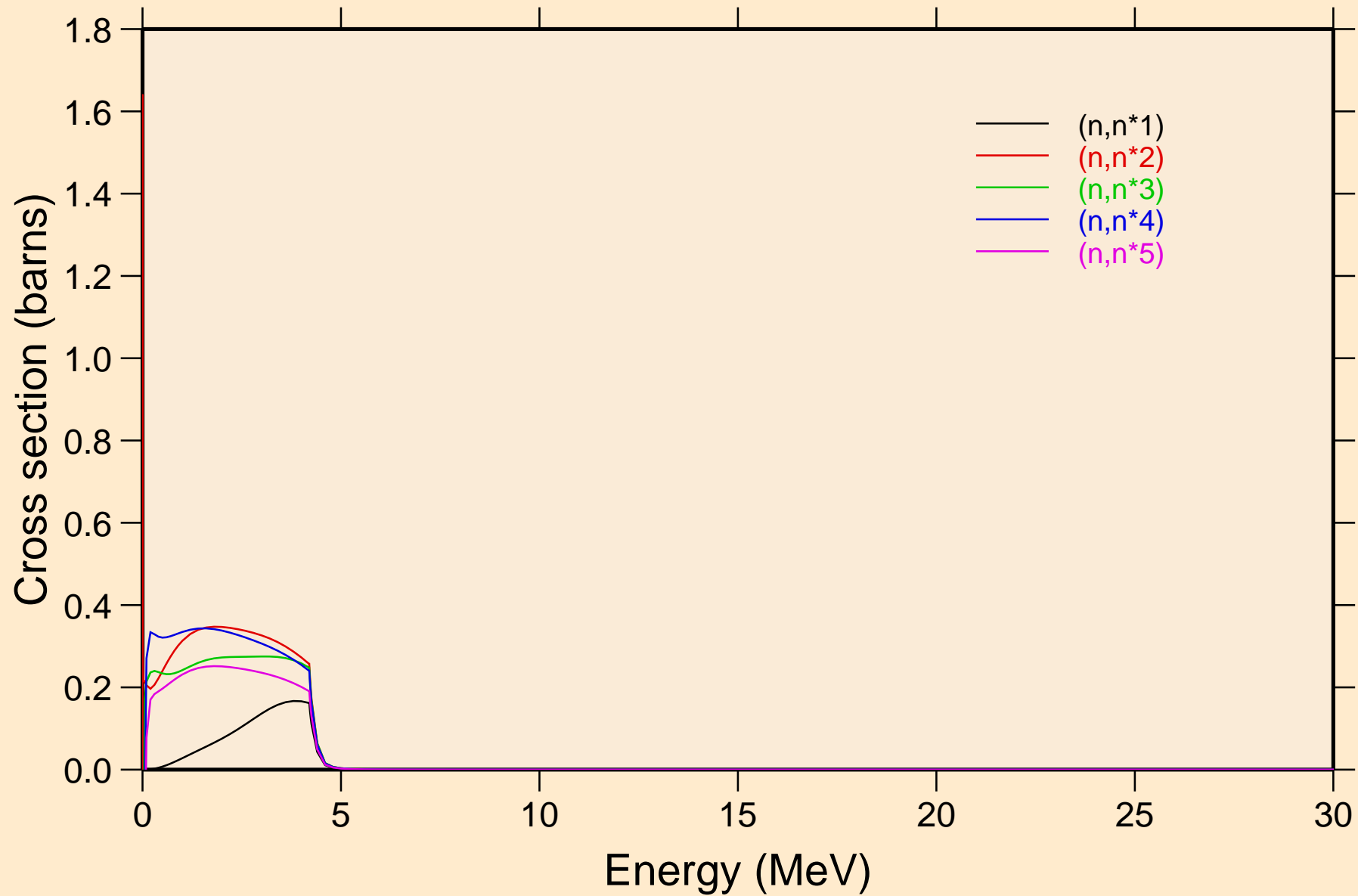

SB126N NEUTRON ACER TENDL-2023 LIBRARY; T=0.K  
Inelastic levels

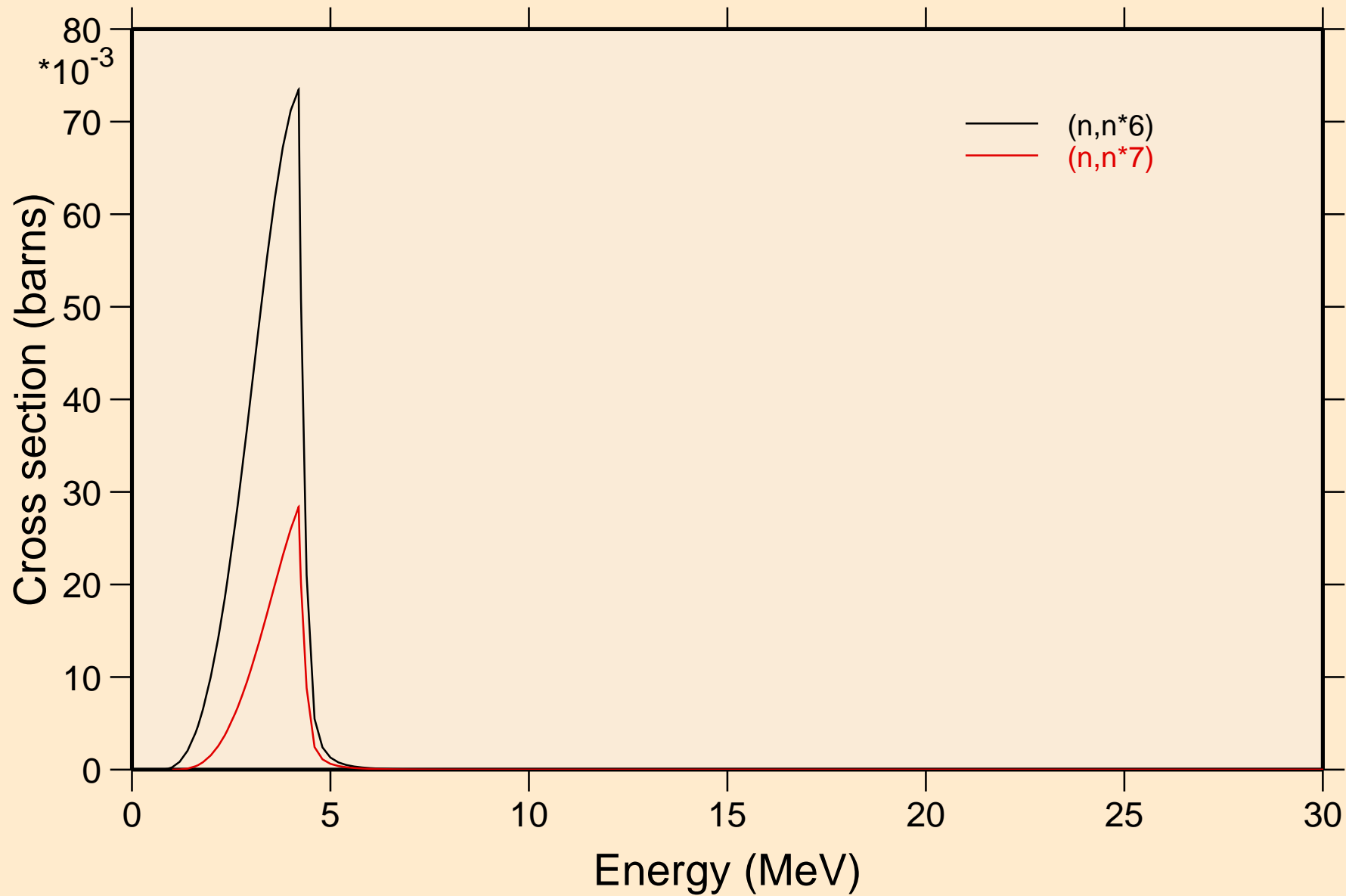

SB126N NEUTRON ACER TENDL-2023 LIBRARY; T=0.K  
Threshold reactions

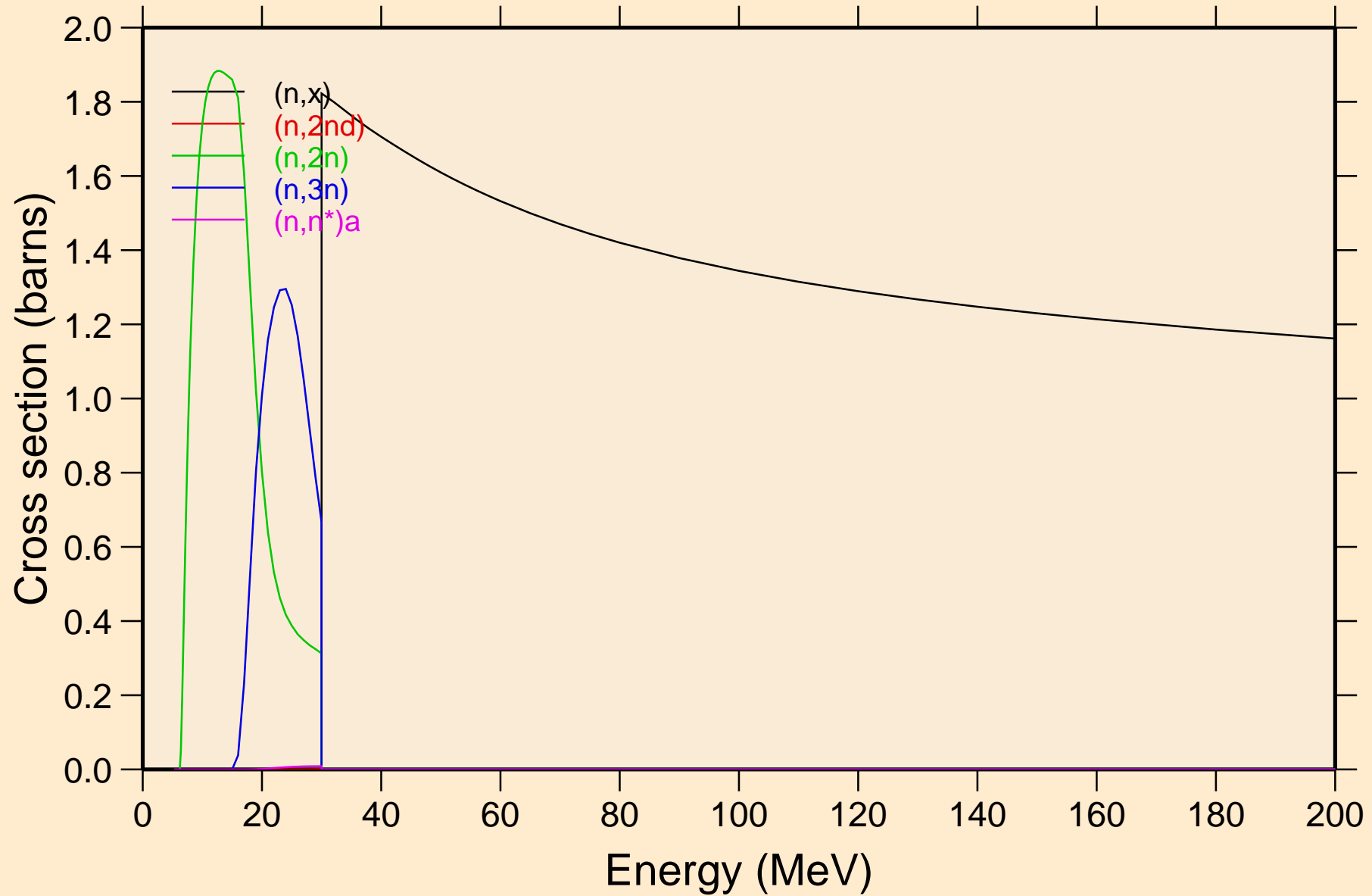

# SB126N NEUTRON ACER TENDL-2023 LIBRARY; T=0.K

## Threshold reactions

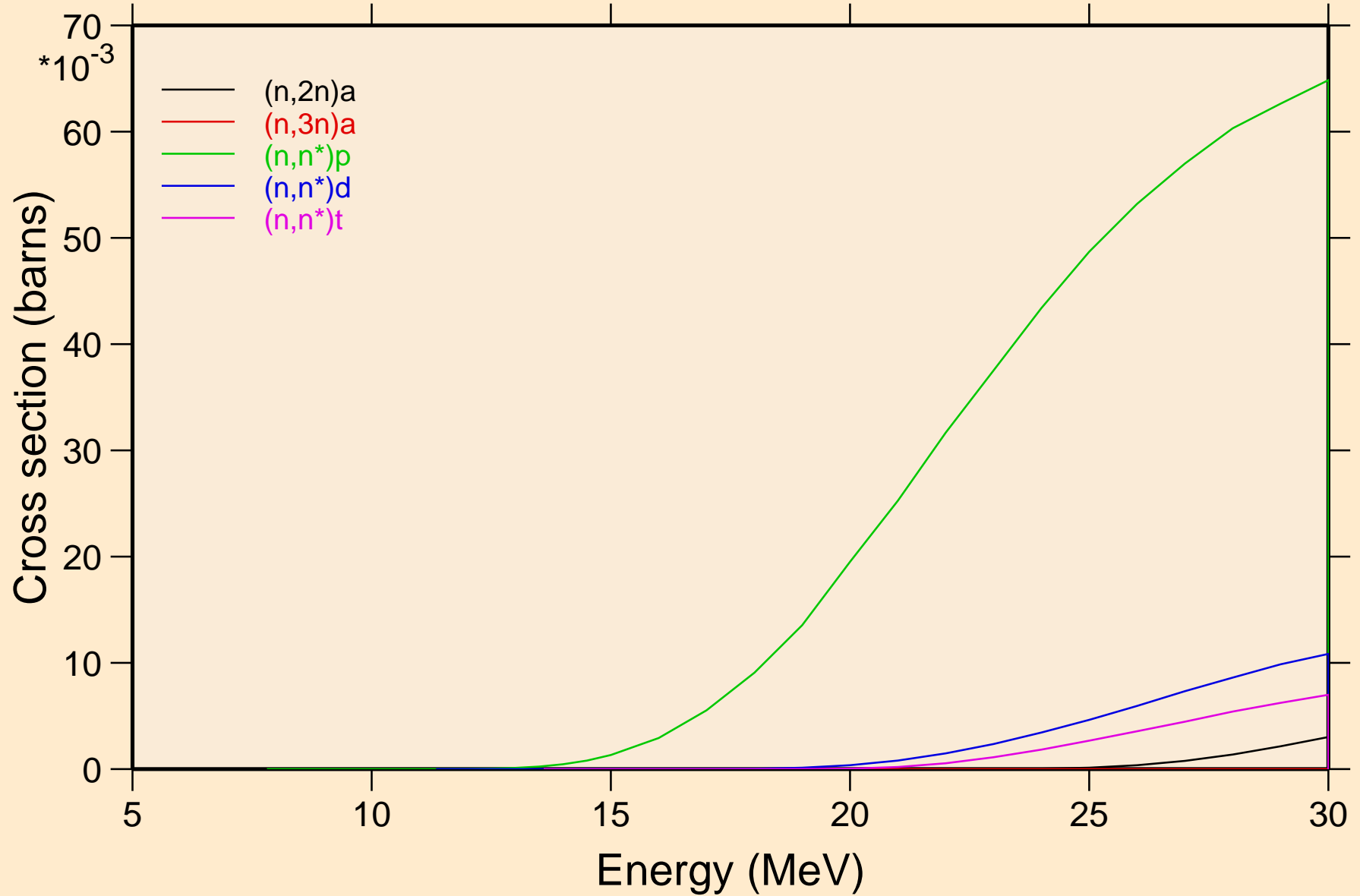

SB126N NEUTRON ACER TENDL-2023 LIBRARY; T=0.K  
Threshold reactions

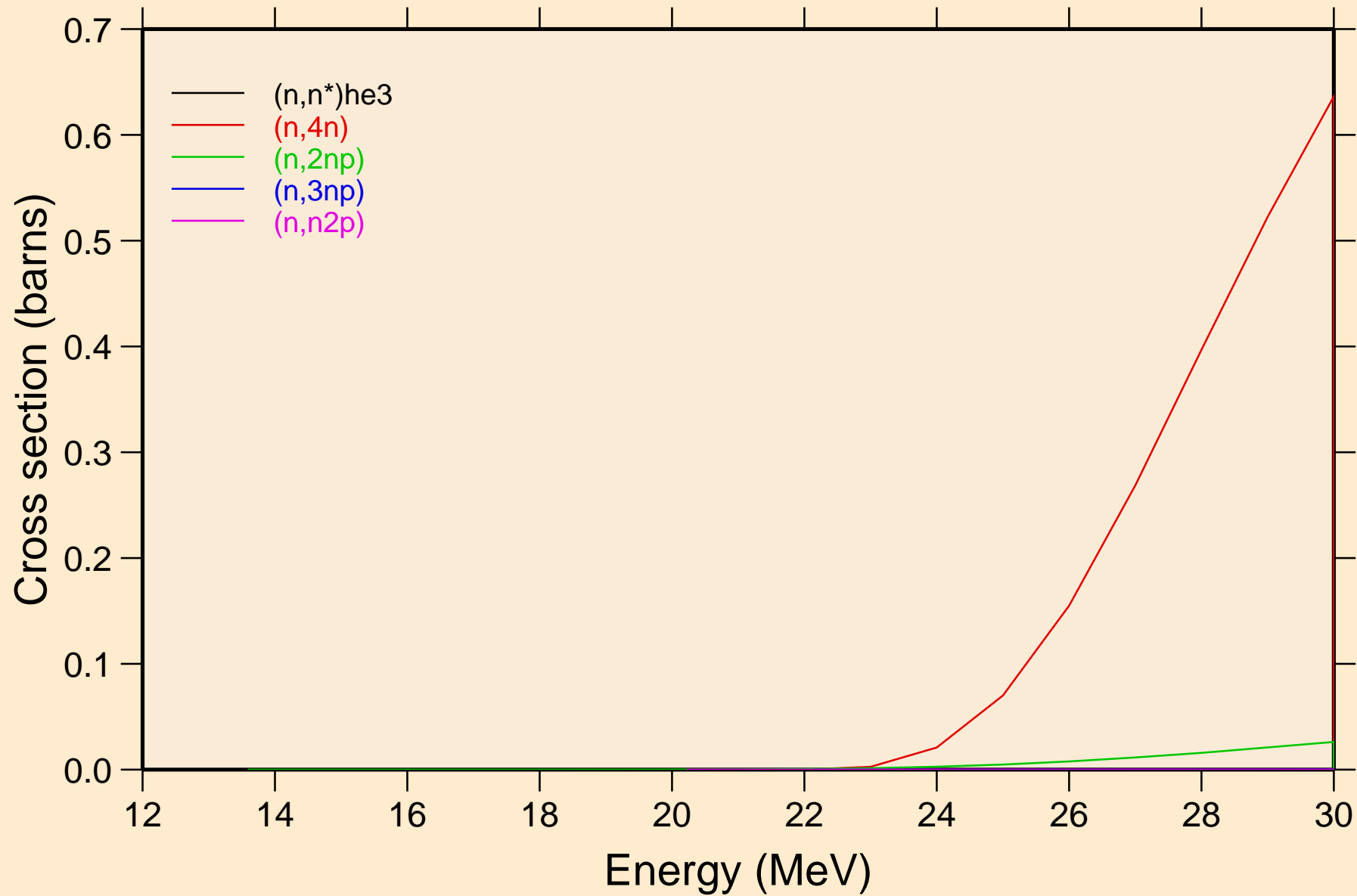

# SB126N NEUTRON ACER TENDL-2023 LIBRARY; T=0.K

## Threshold reactions

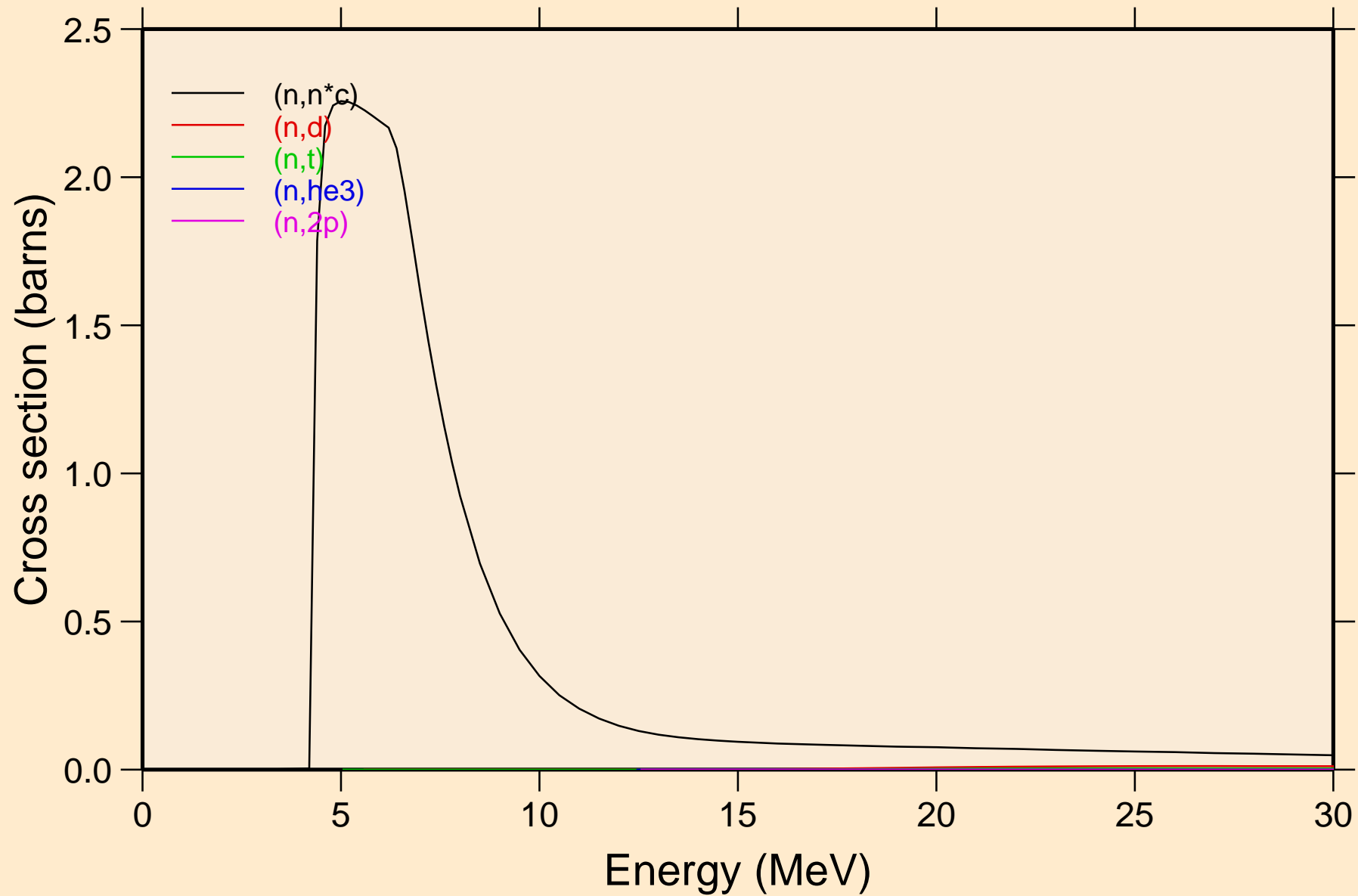

SB126N NEUTRON ACER TENDL-2023 LIBRARY; T=0.K  
Threshold reactions

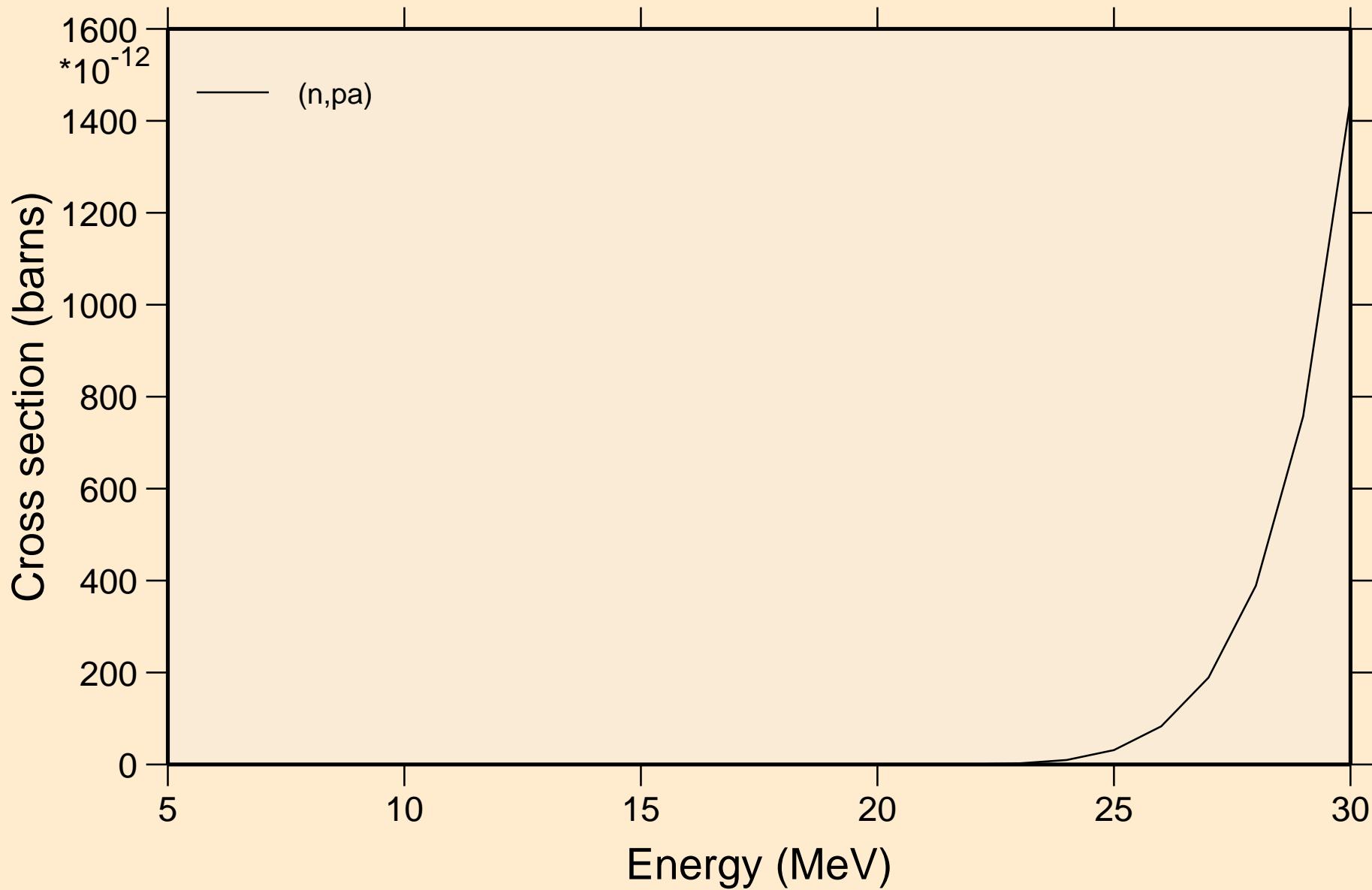

# SB126N NEUTRON ACER TENDL-2023 LIBRARY; T=0.K

## Threshold reactions

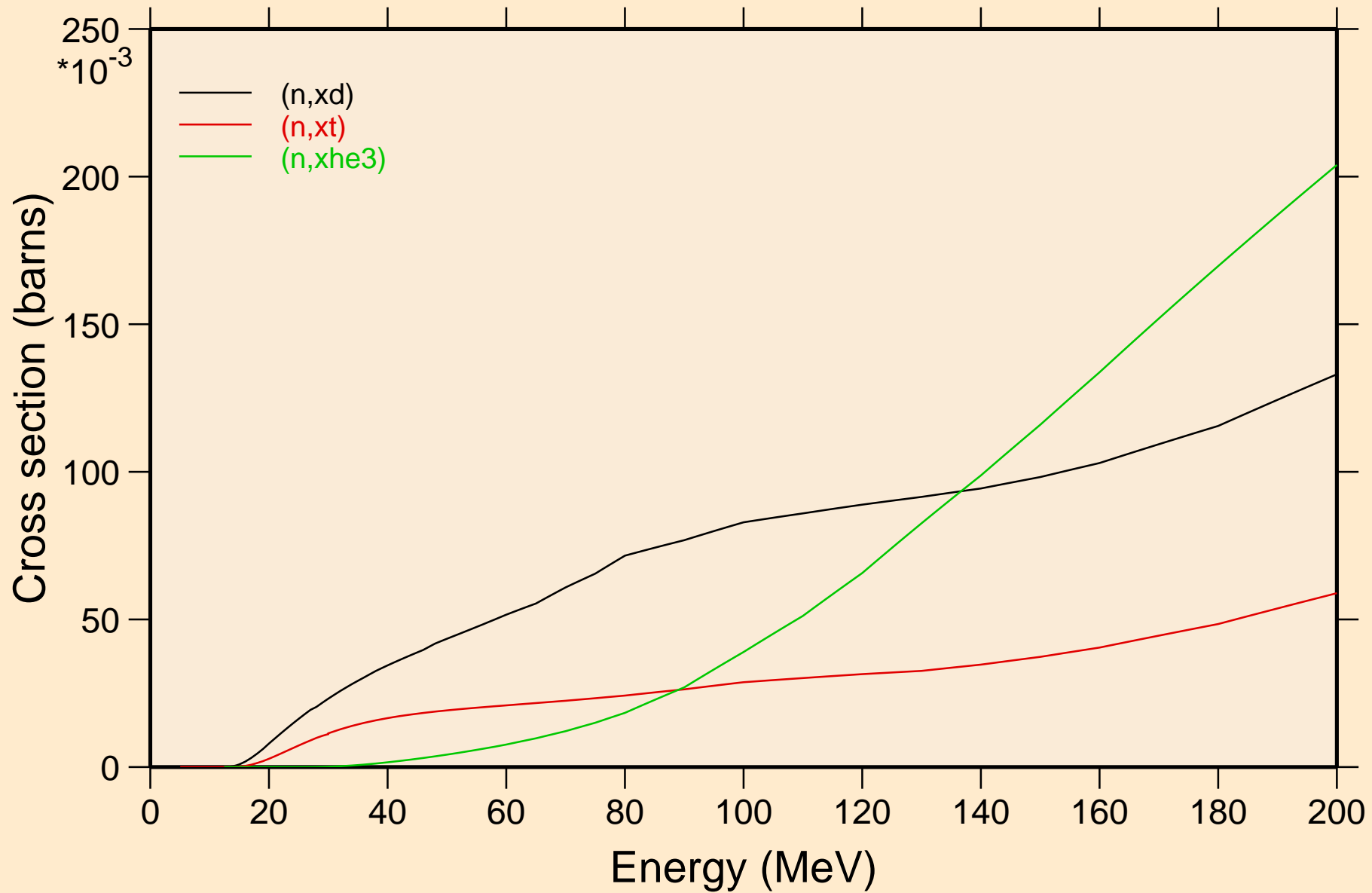



SB126N NEUTRON ACER TENDL-2023 LIBRARY; T=0.K  
angular distribution for elastic

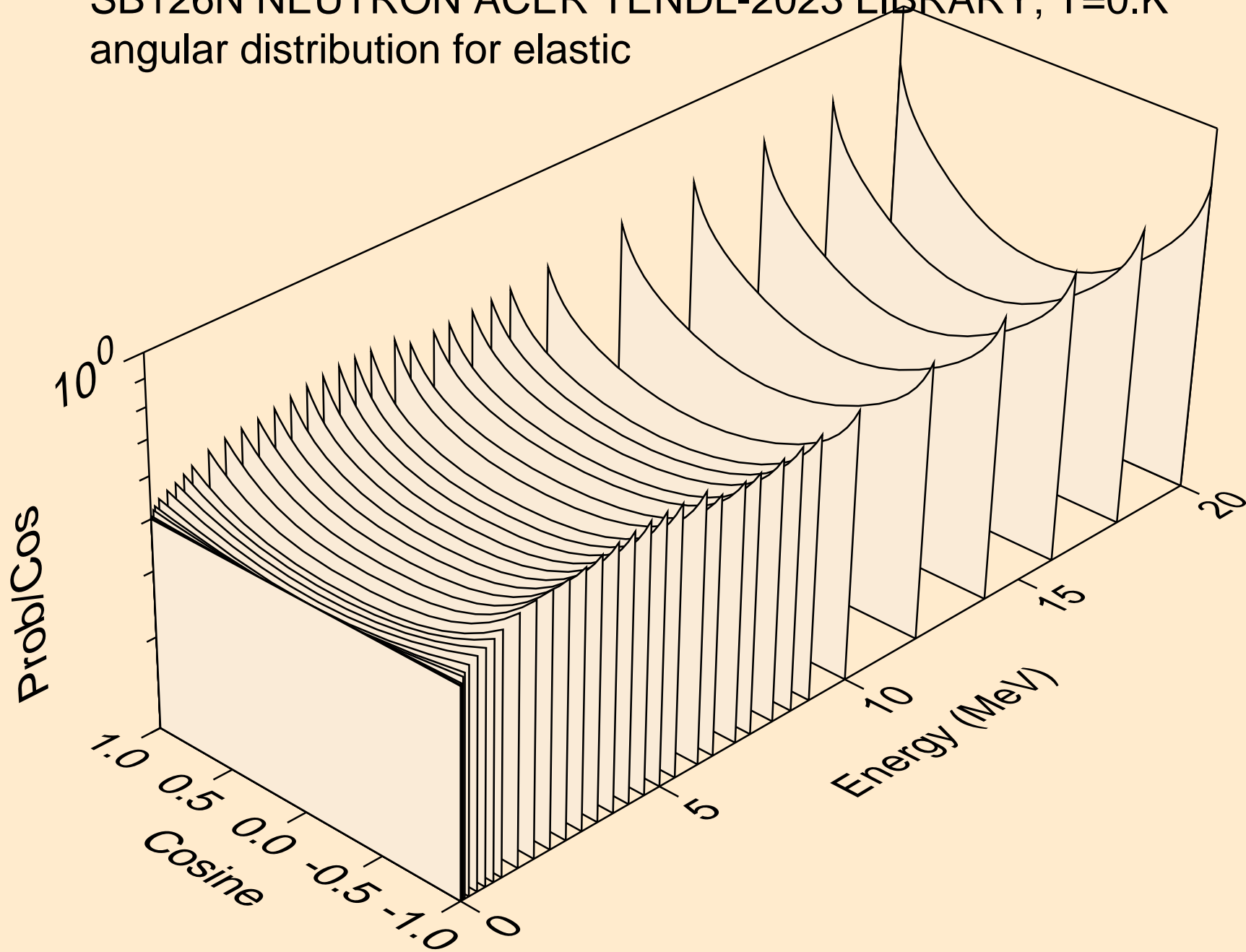

SB126N NEUTRON ACER TENDL-2023 LIBRARY; T=0.K  
angular distribution for elastic

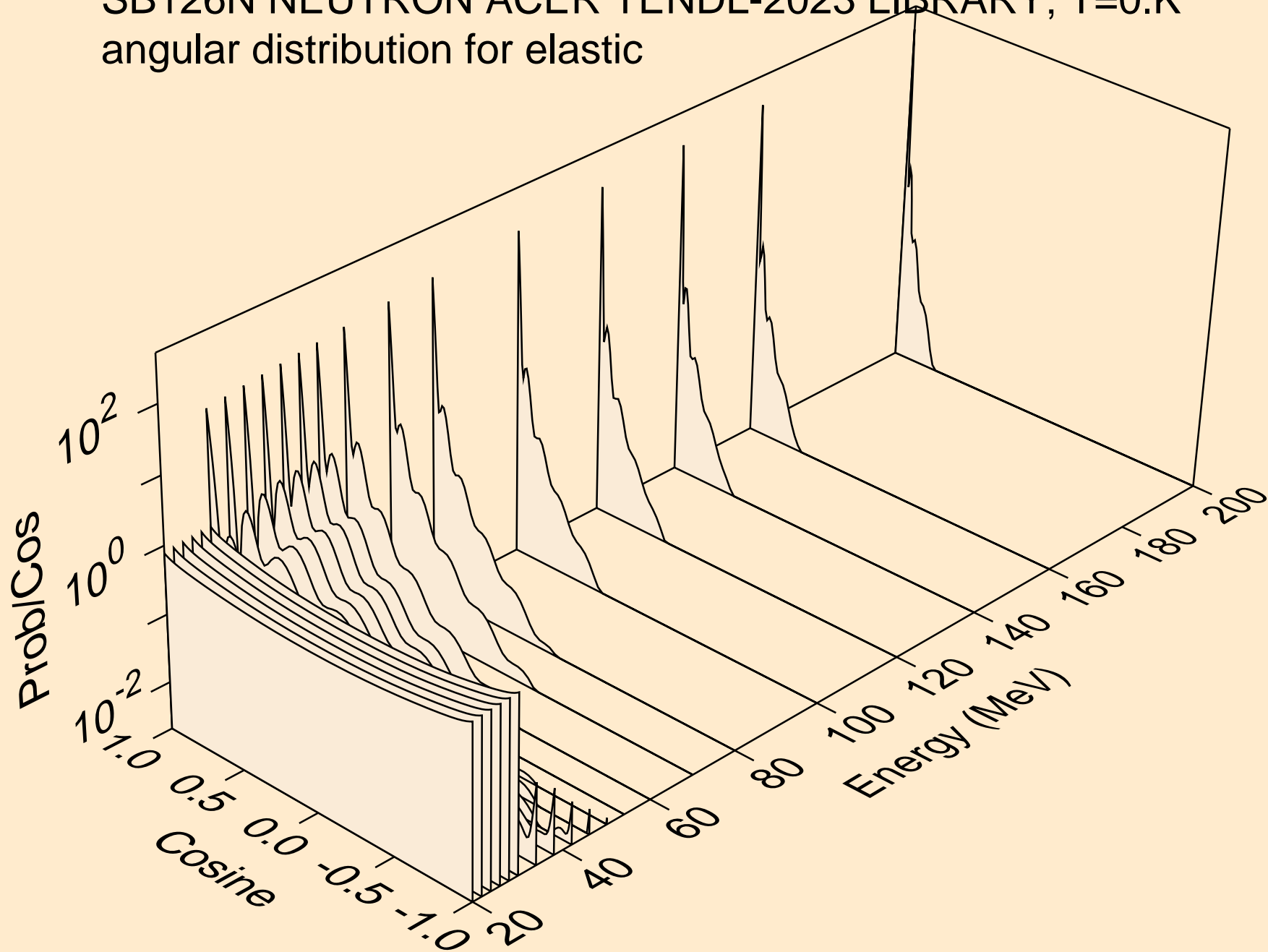

SB126N NEUTRON ACER TENDL-2023 LIBRARY; T=0.K  
angular distribution for (n,n\*1)

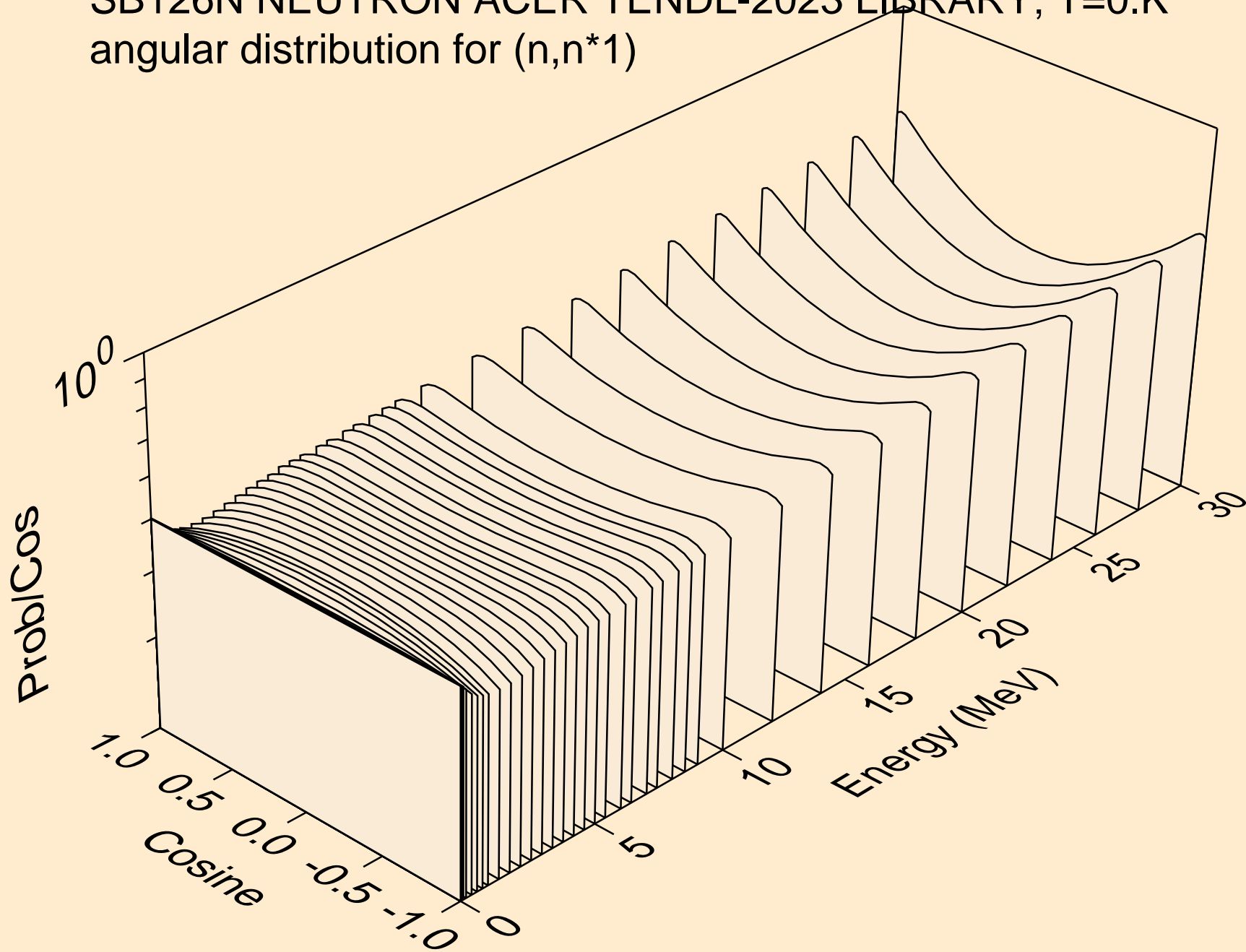

SB126N NEUTRON ACER TENDL-2023 LIBRARY; T=0.K  
angular distribution for (n,n\*2)

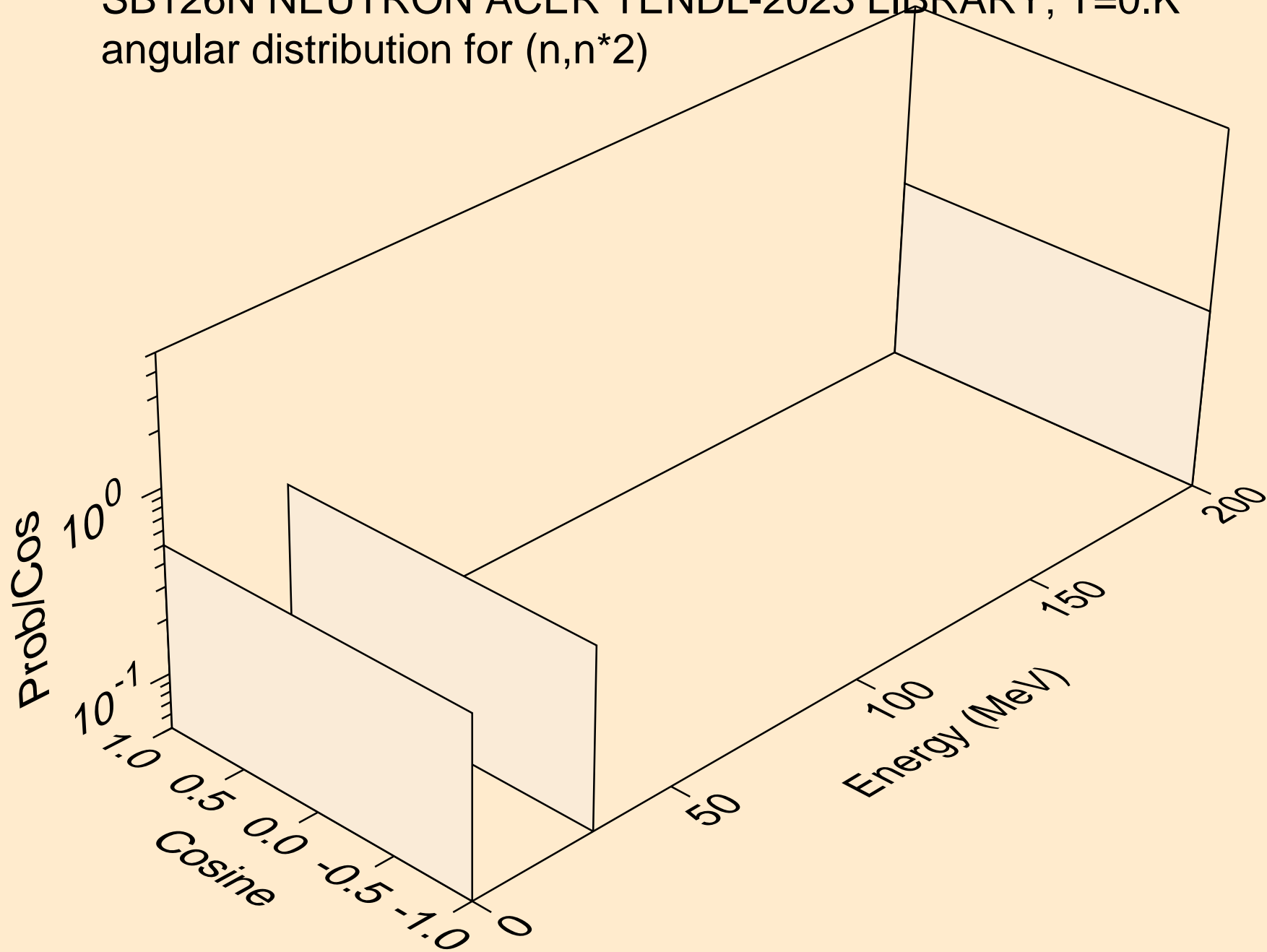

SB126N NEUTRON ACER TENDL-2023 LIBRARY; T=0.K  
angular distribution for (n,n\*3)

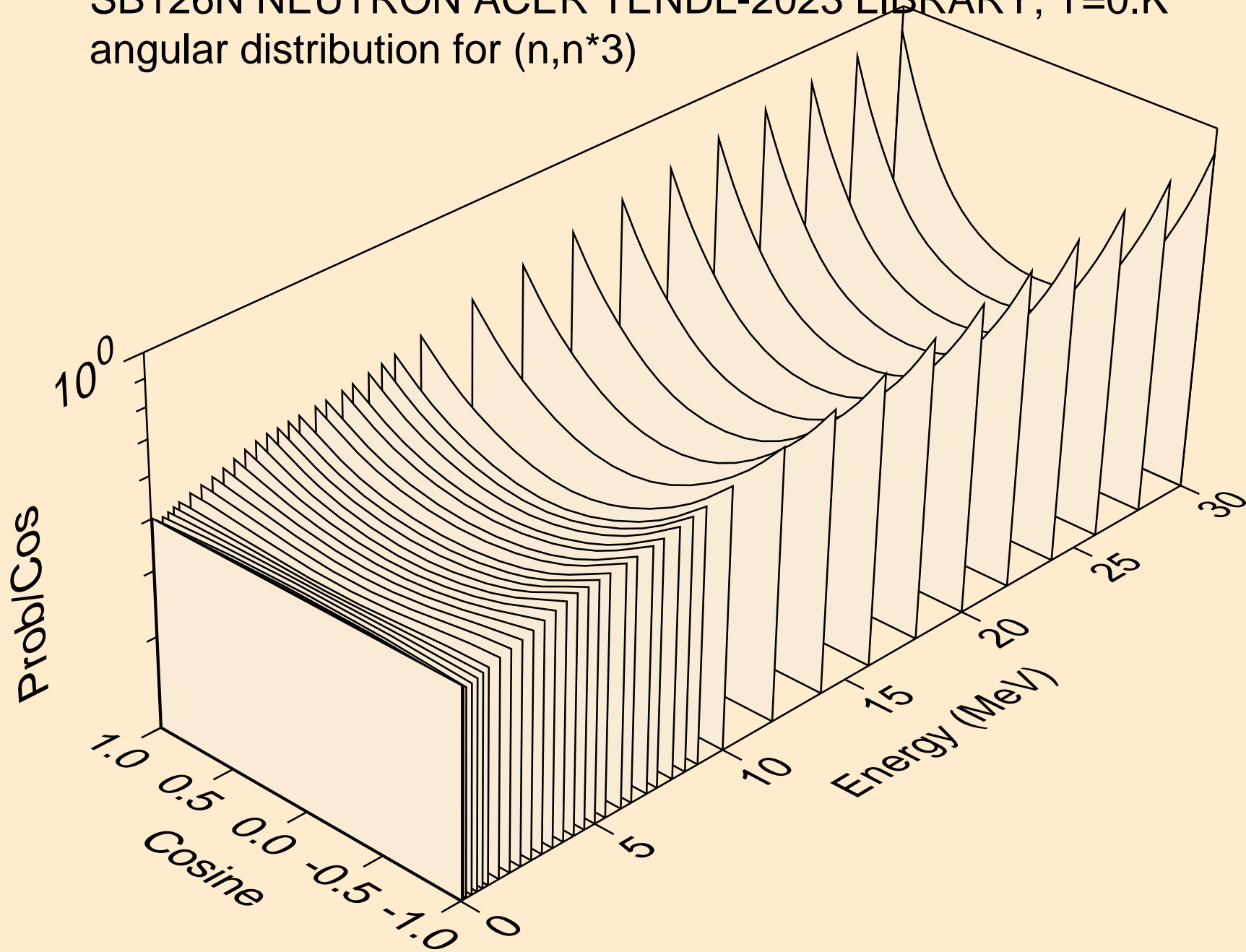

SB126N NEUTRON ACER TENDL-2023 LIBRARY; T=0.K  
angular distribution for (n,n\*4)

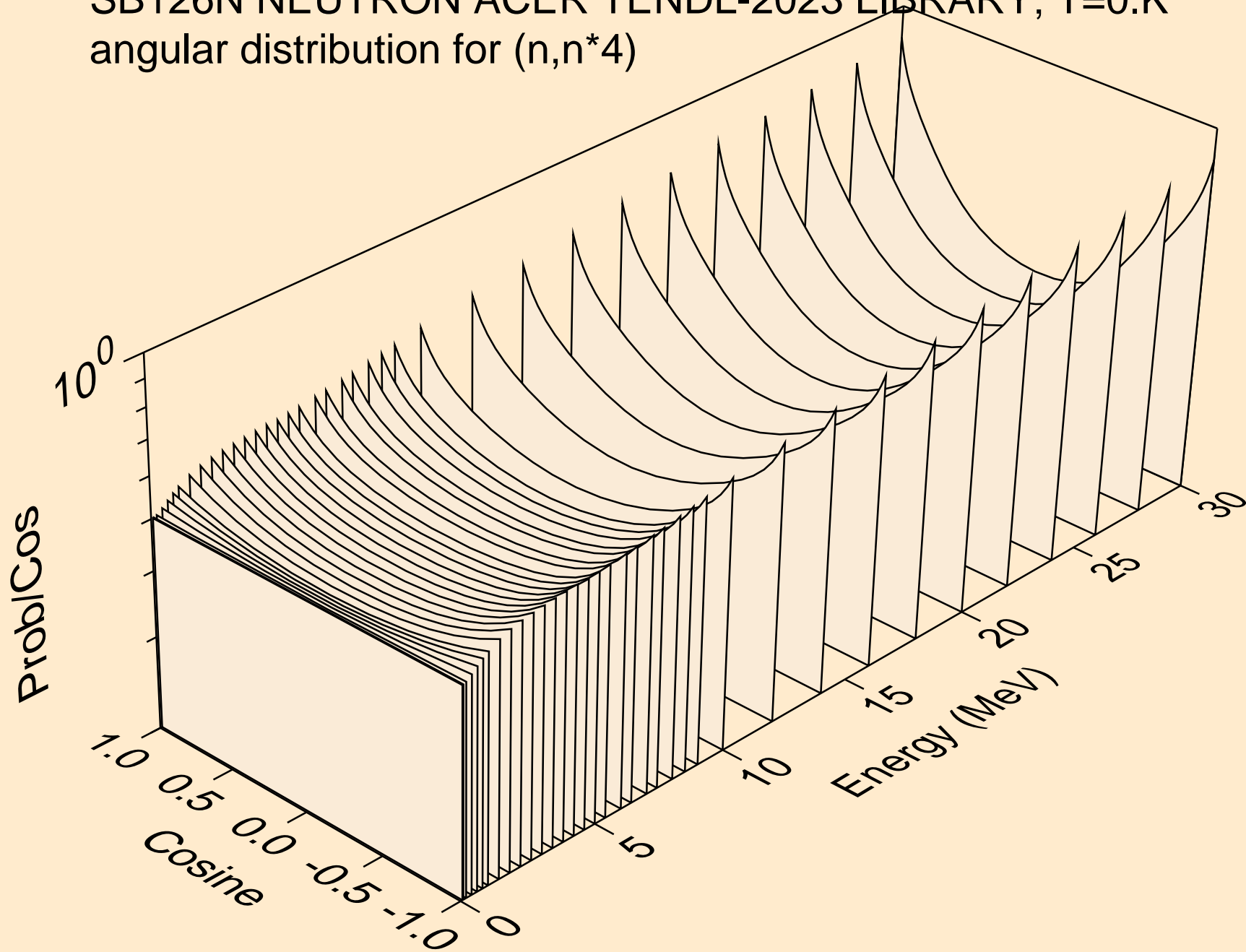

SB126N NEUTRON ACER TENDL-2023 LIBRARY; T=0.K  
angular distribution for (n,n\*5)

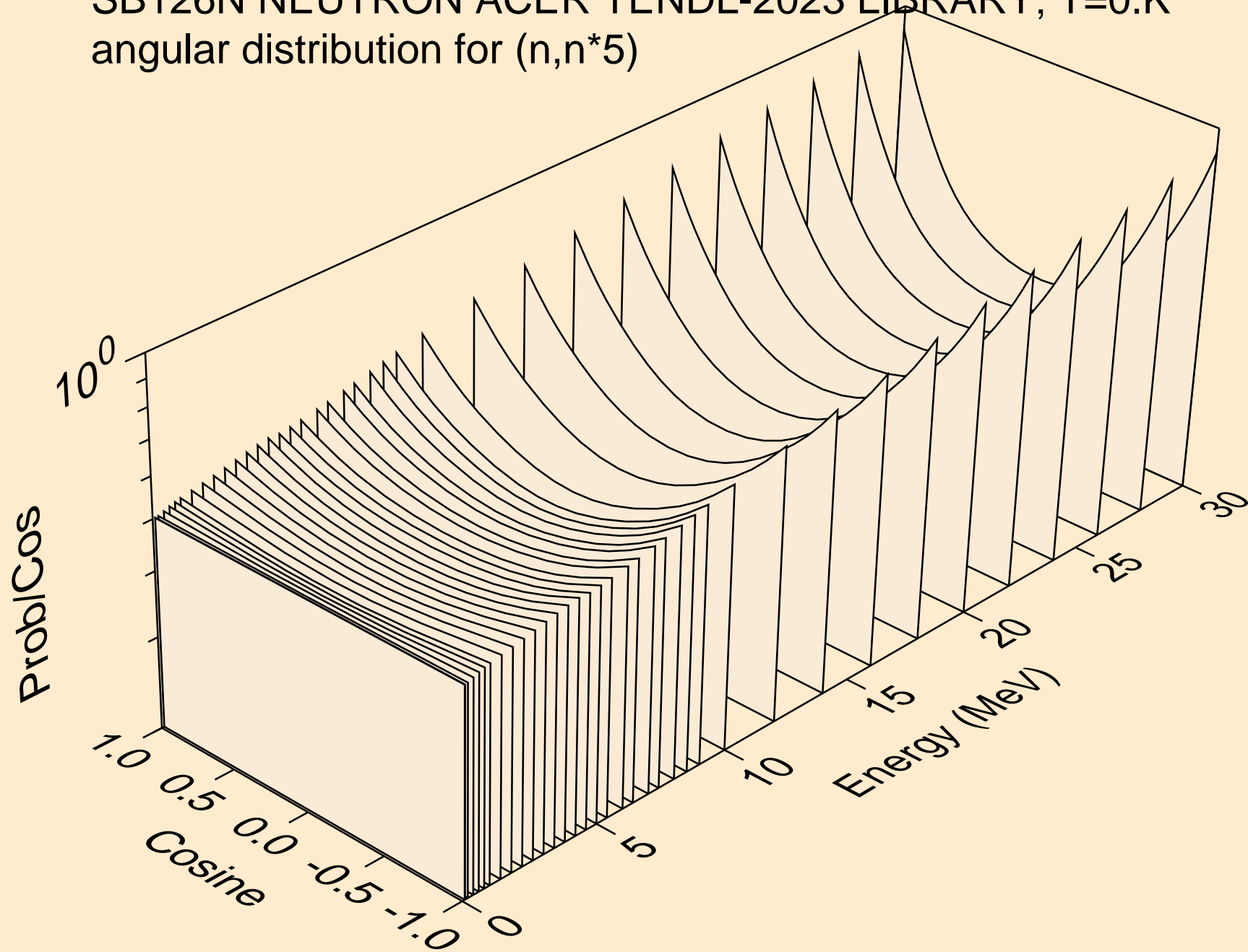

SB126N NEUTRON ACER TENDL-2023 LIBRARY; T=0.K  
angular distribution for (n,n\*6)

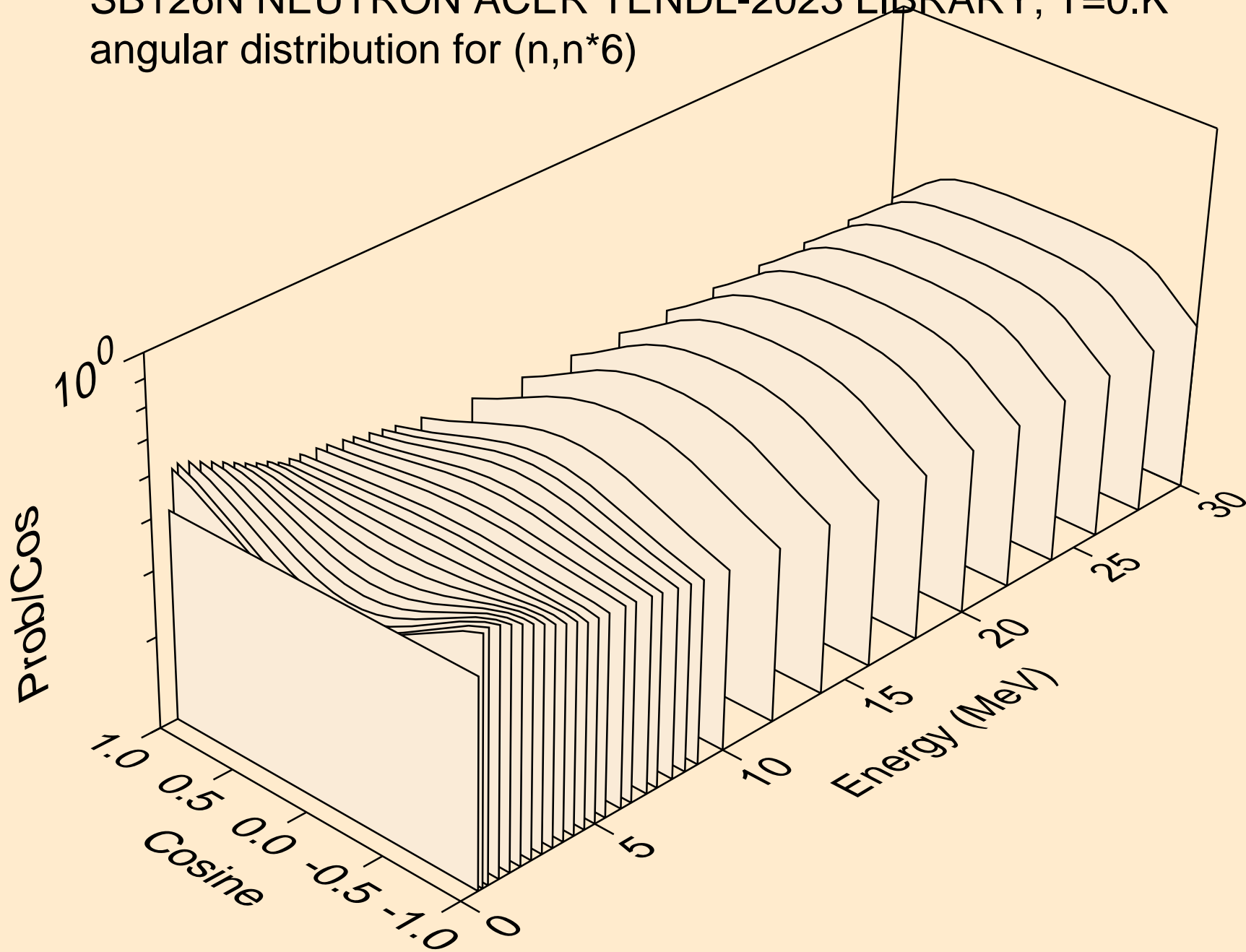



SB126N NEUTRON ACER TENDL-2023 LIBRARY; T=0.K  
angular distribution for (n,n\*7)

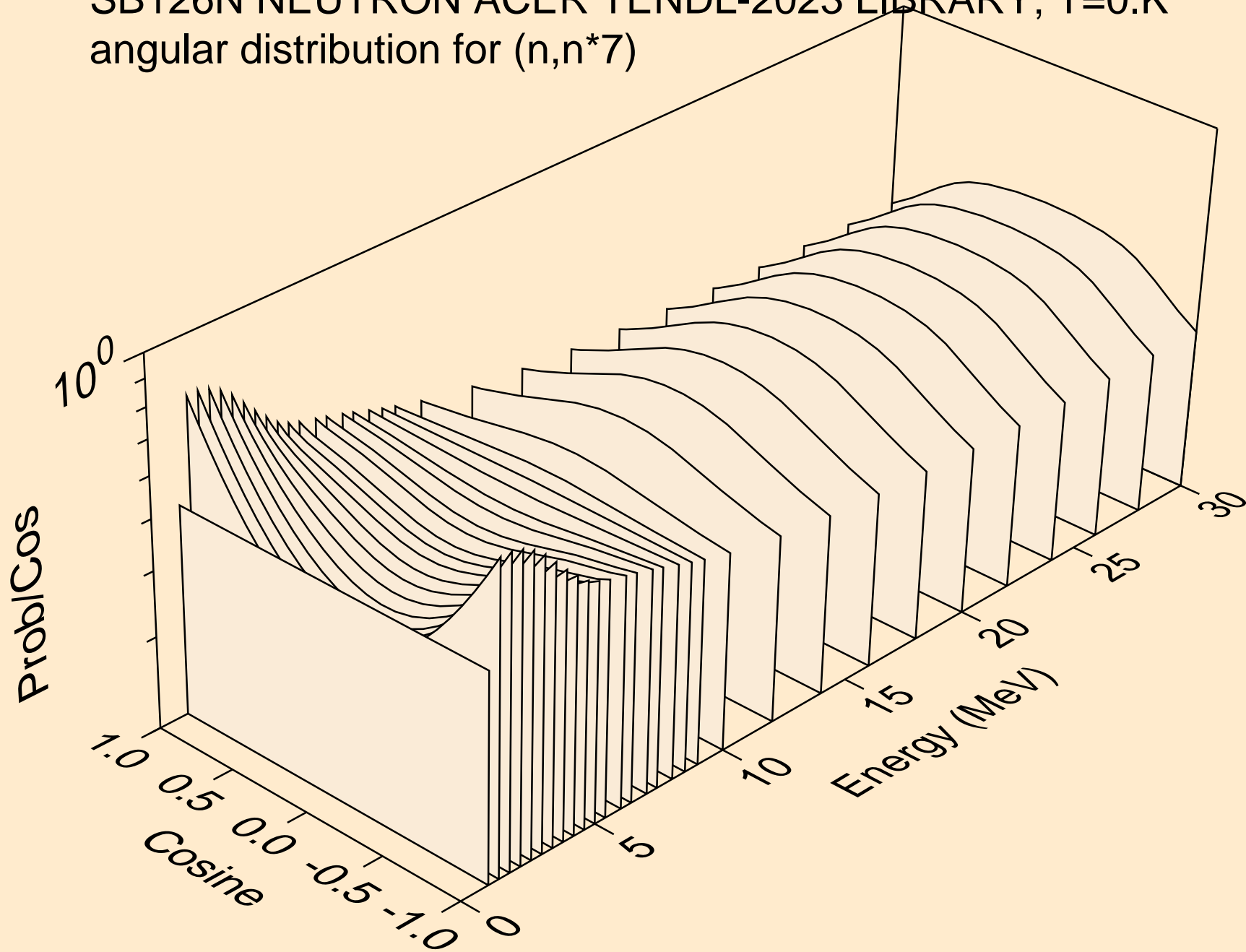

SB126N NEUTRON ACER TENDL-2023 LIBRARY; T=0.K  
Neutron emission for (n,x)

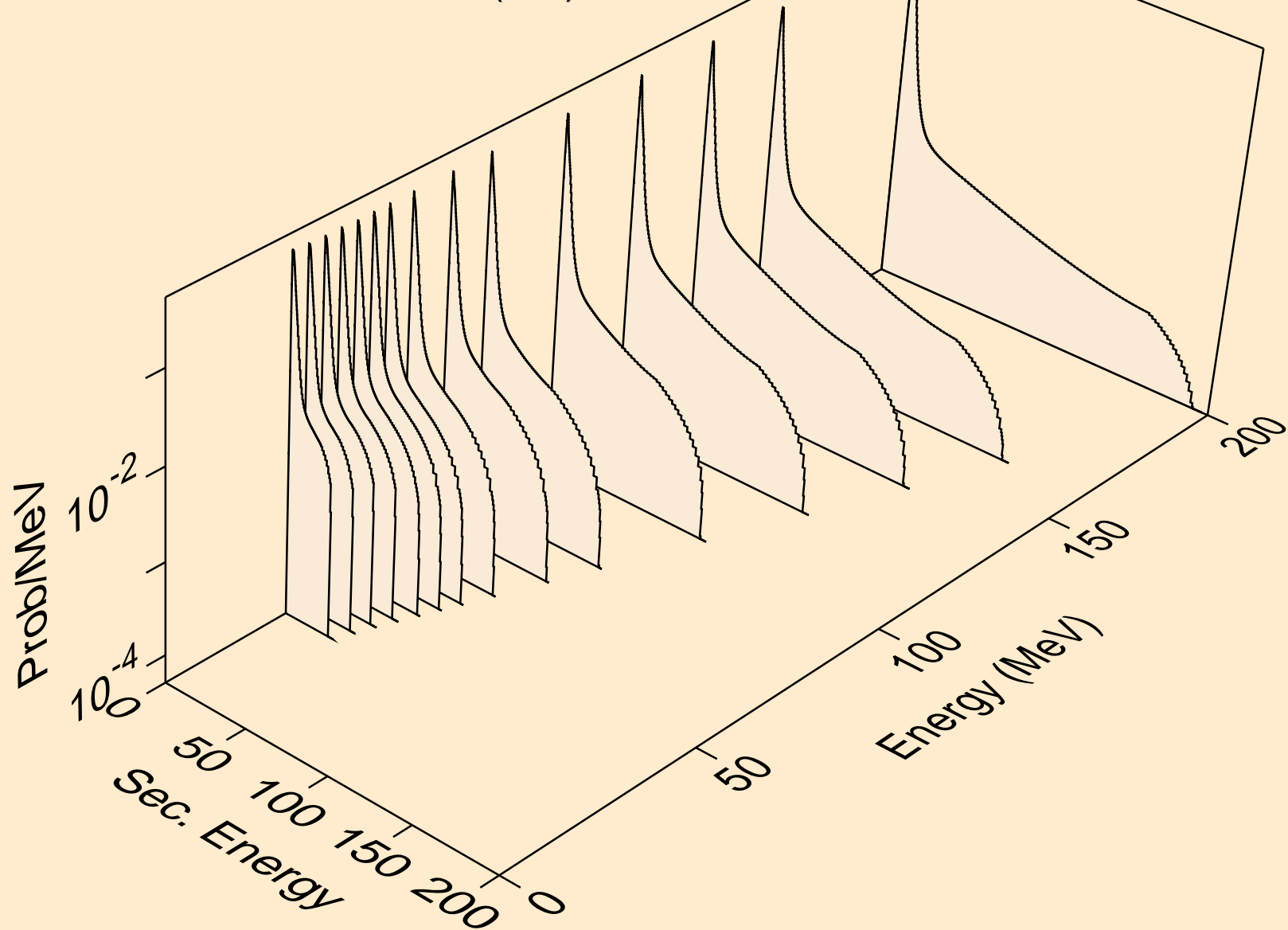

SB126N NEUTRON ACER TENDL-2023 LIBRARY; T=0.K  
Neutron emission for (n,2nd)

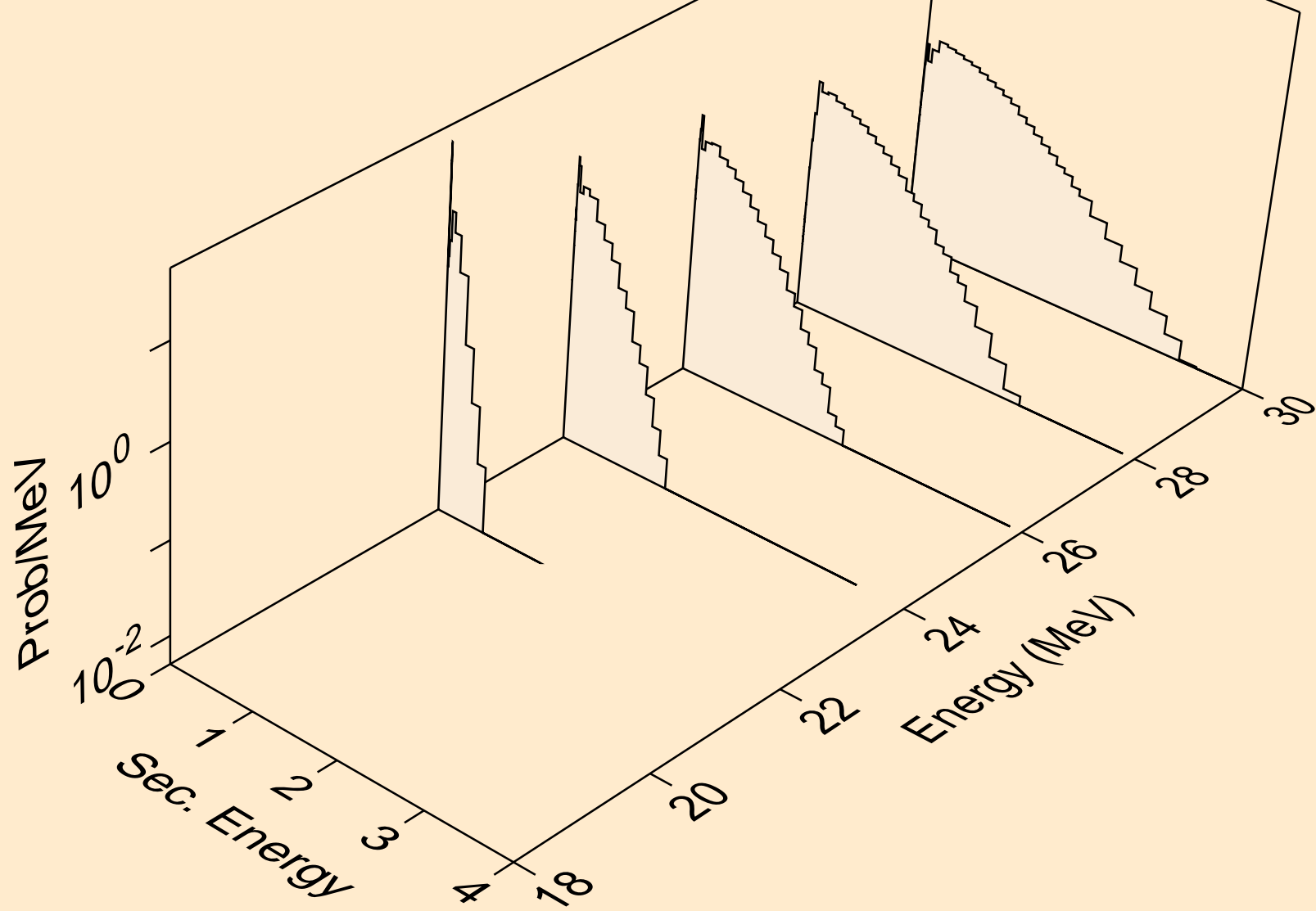

SB126N NEUTRON ACER TENDL-2023 LIBRARY; T=0.K  
Neutron emission for (n,2n)

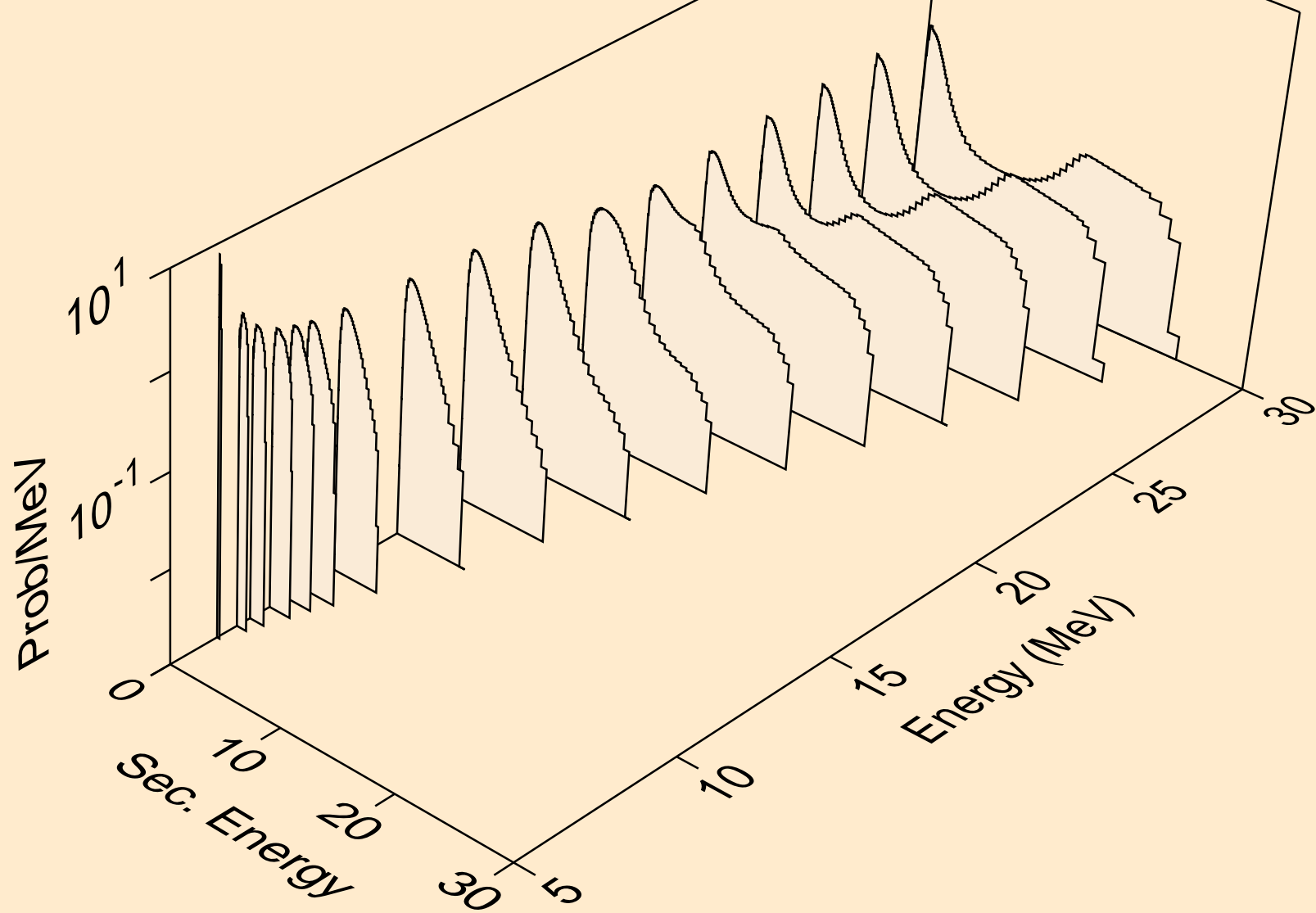

SB126N NEUTRON ACER TENDL-2023 LIBRARY; T=0.K  
Neutron emission for (n,3n)

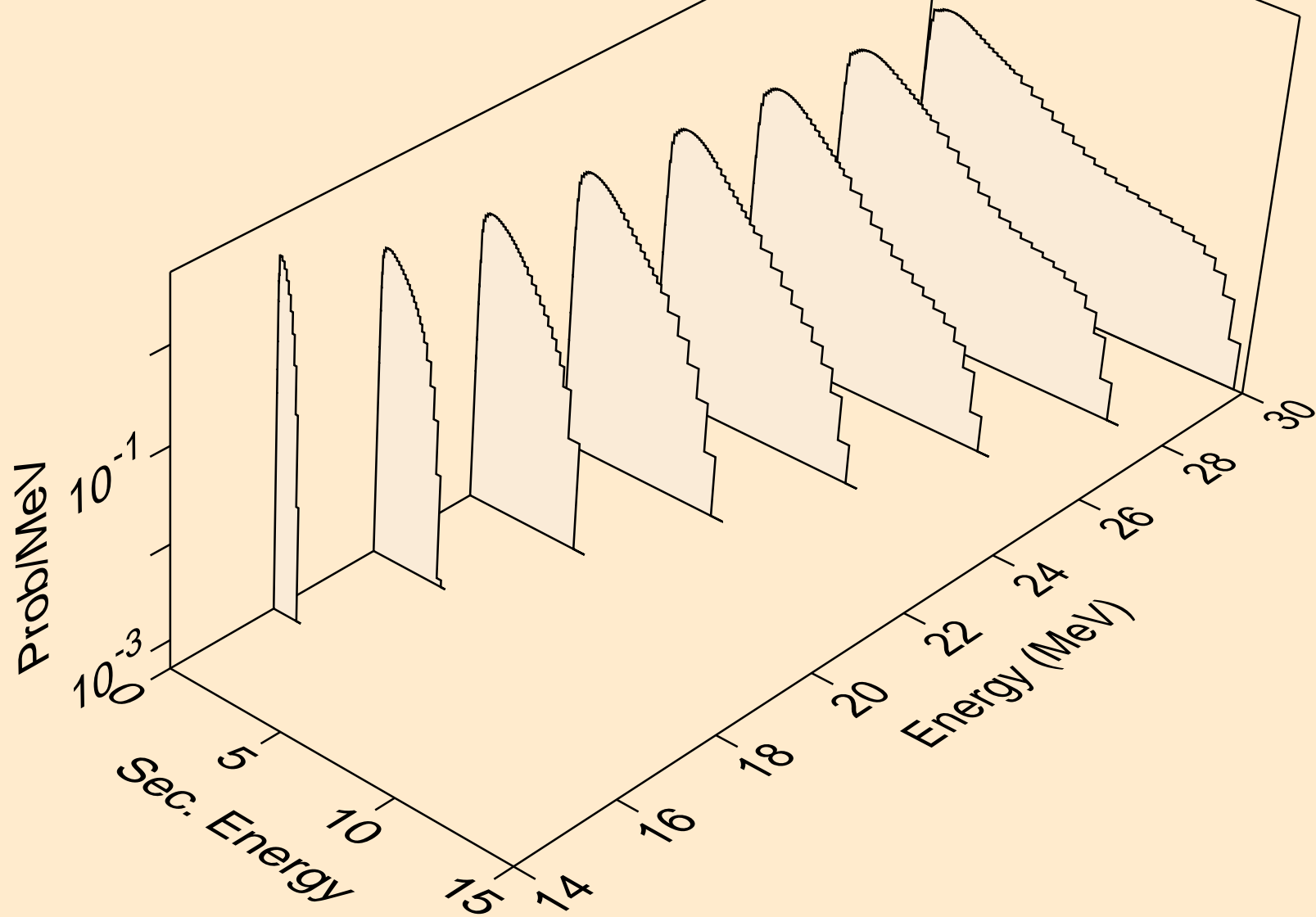

SB126N NEUTRON ACER TENDL-2023 LIBRARY; T=0.K  
Neutron emission for (n,n\*)a

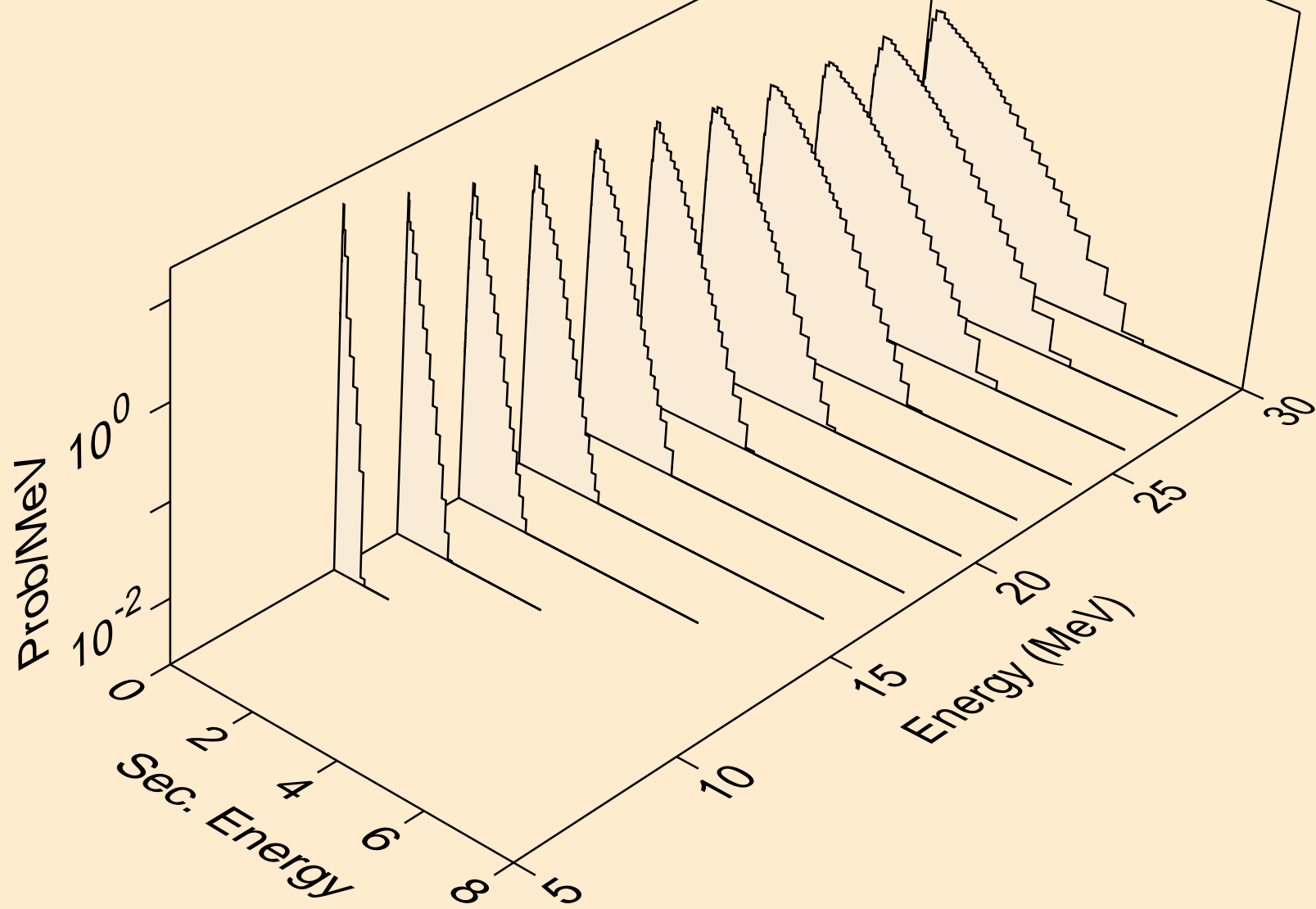

SB126N NEUTRON ACER TENDL-2023 LIBRARY; T=0.K  
Neutron emission for (n,2n)a

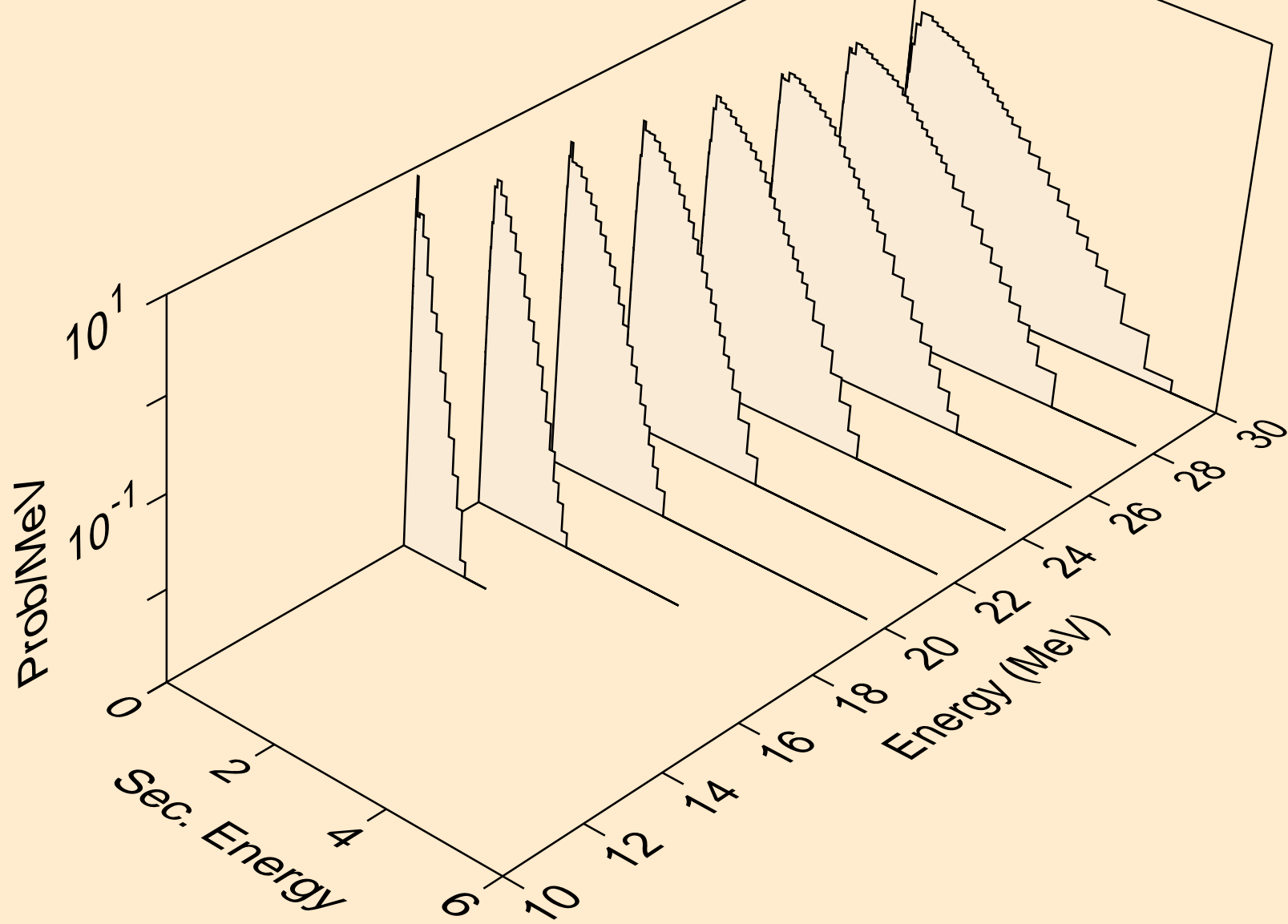

SB126N NEUTRON ACER TENDL-2023 LIBRARY; T=0.K  
Neutron emission for (n,3n)a

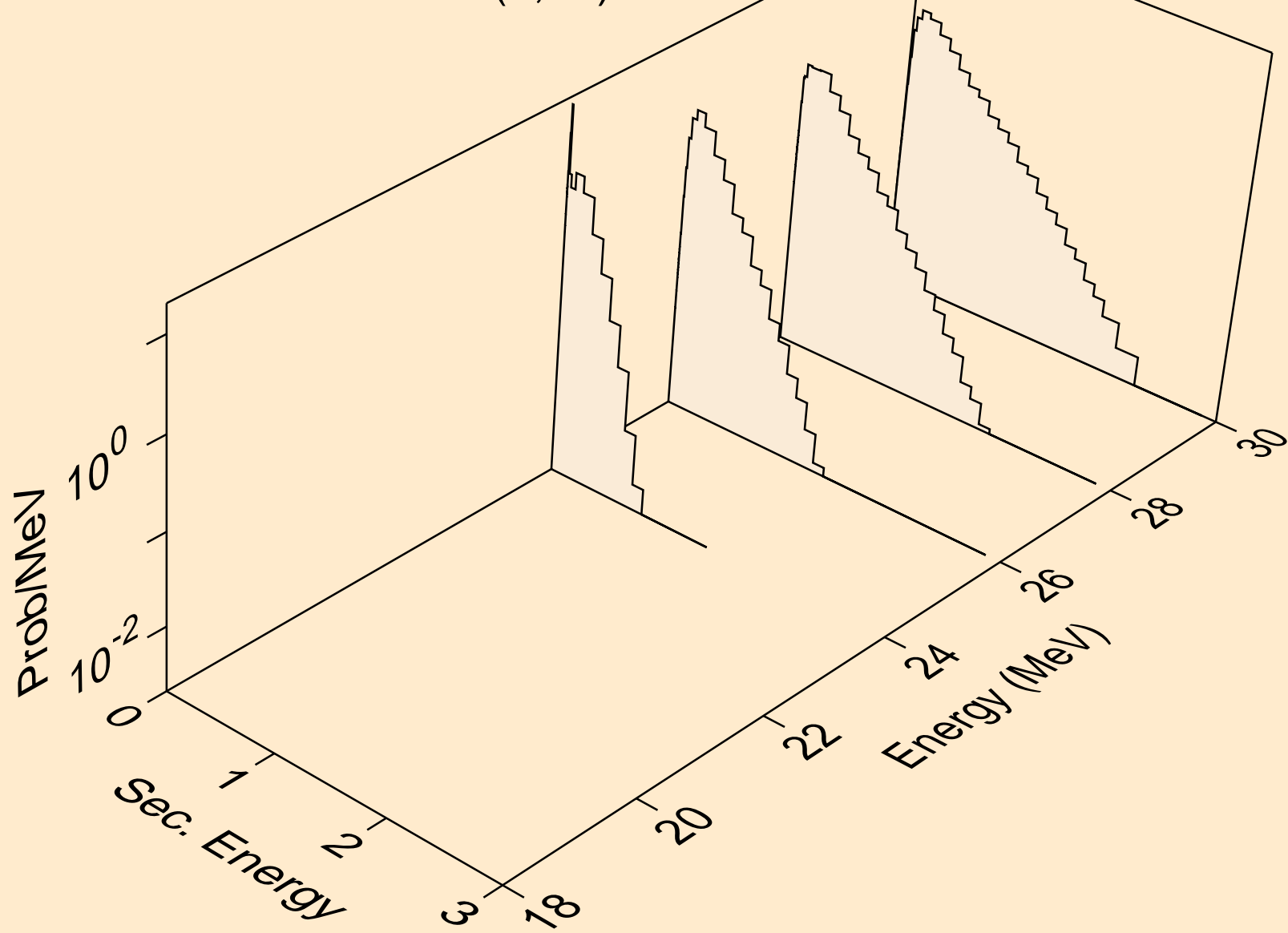



SB126N NEUTRON ACER TENDL-2023 LIBRARY; T=0.K  
Neutron emission for (n,n\*)p

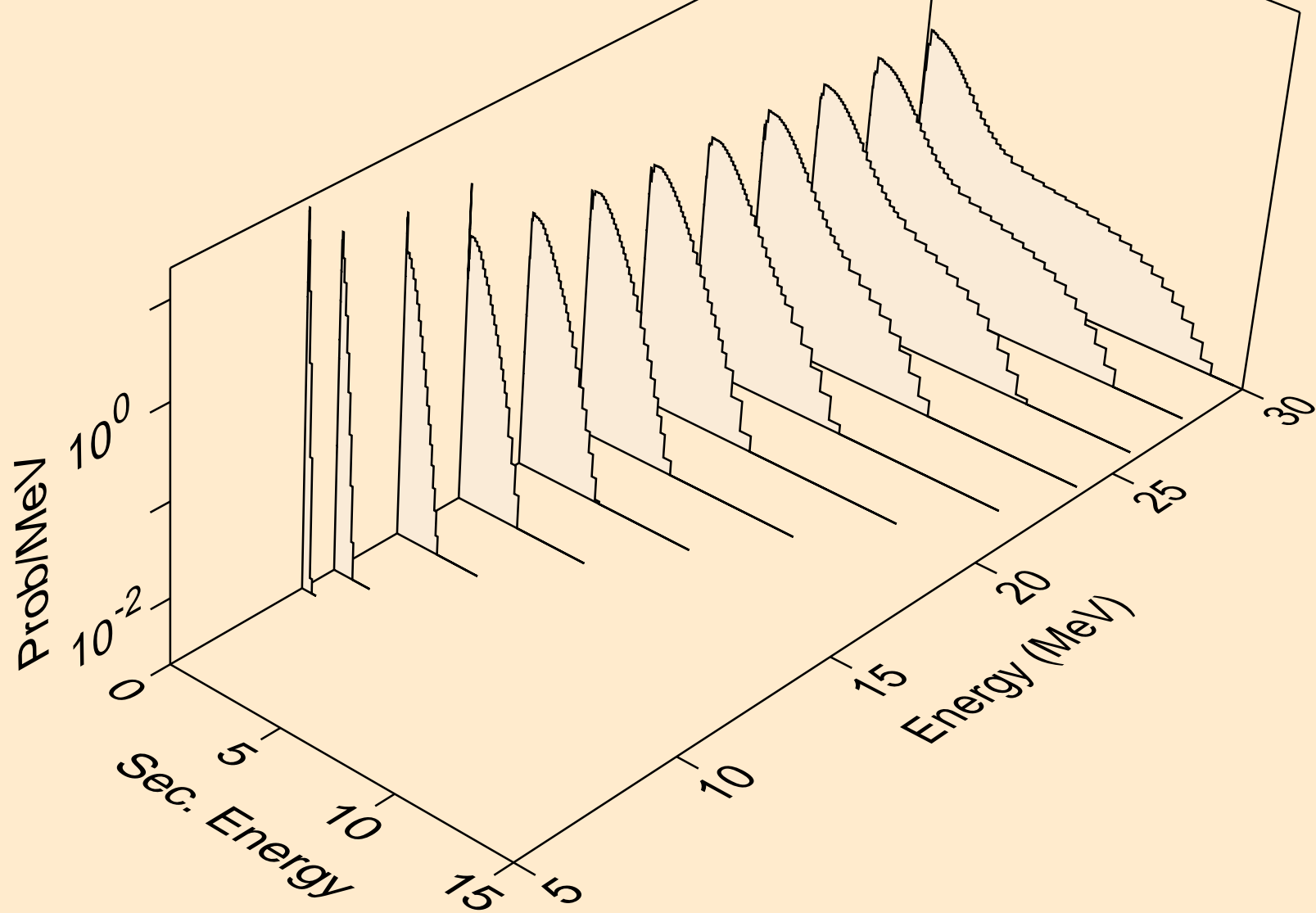

SB126N NEUTRON ACER TENDL-2023 LIBRARY; T=0.K  
Neutron emission for (n,n\*)d

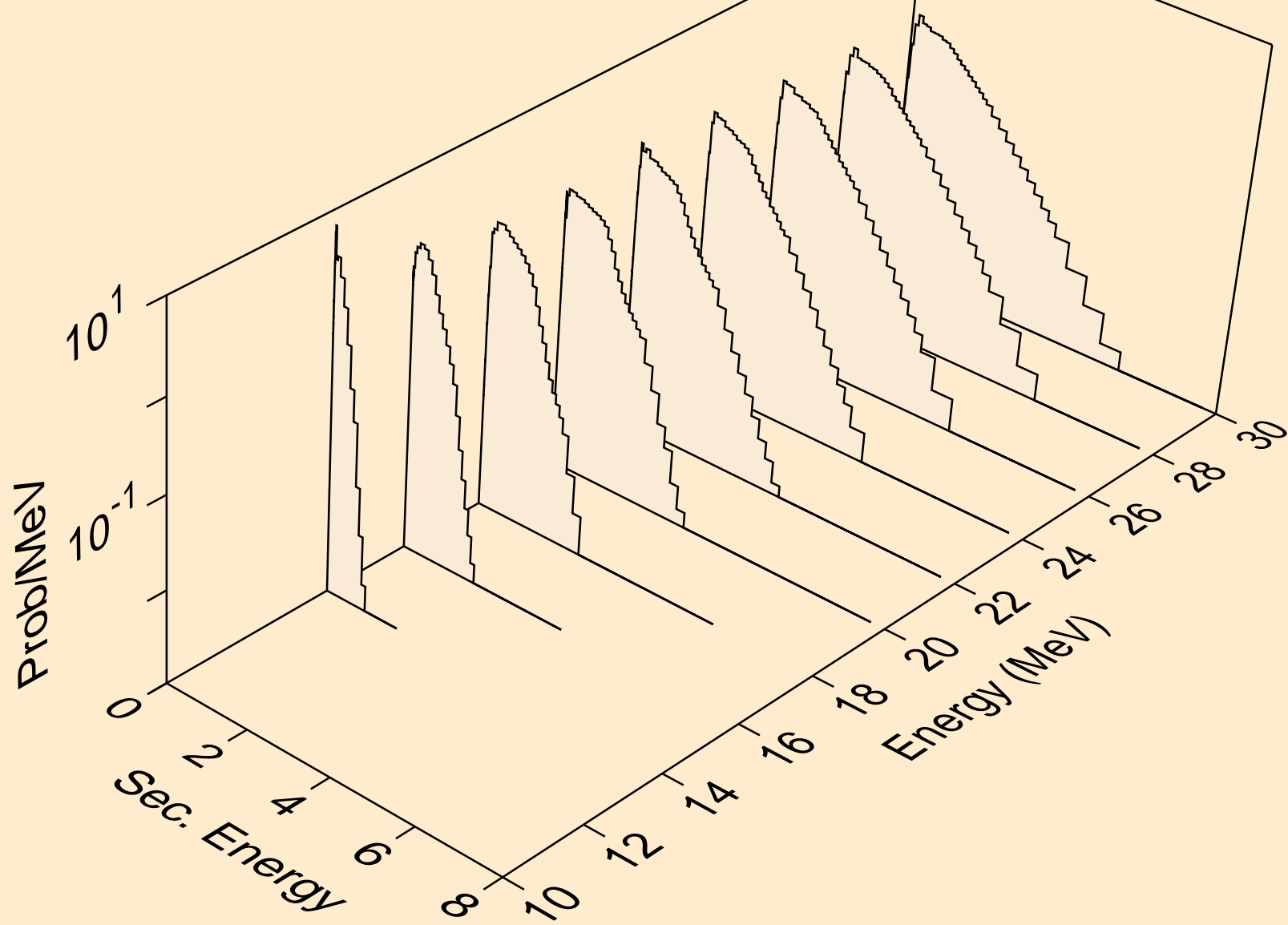

SB126N NEUTRON ACER TENDL-2023 LIBRARY; T=0.K  
Neutron emission for (n,n\*)t

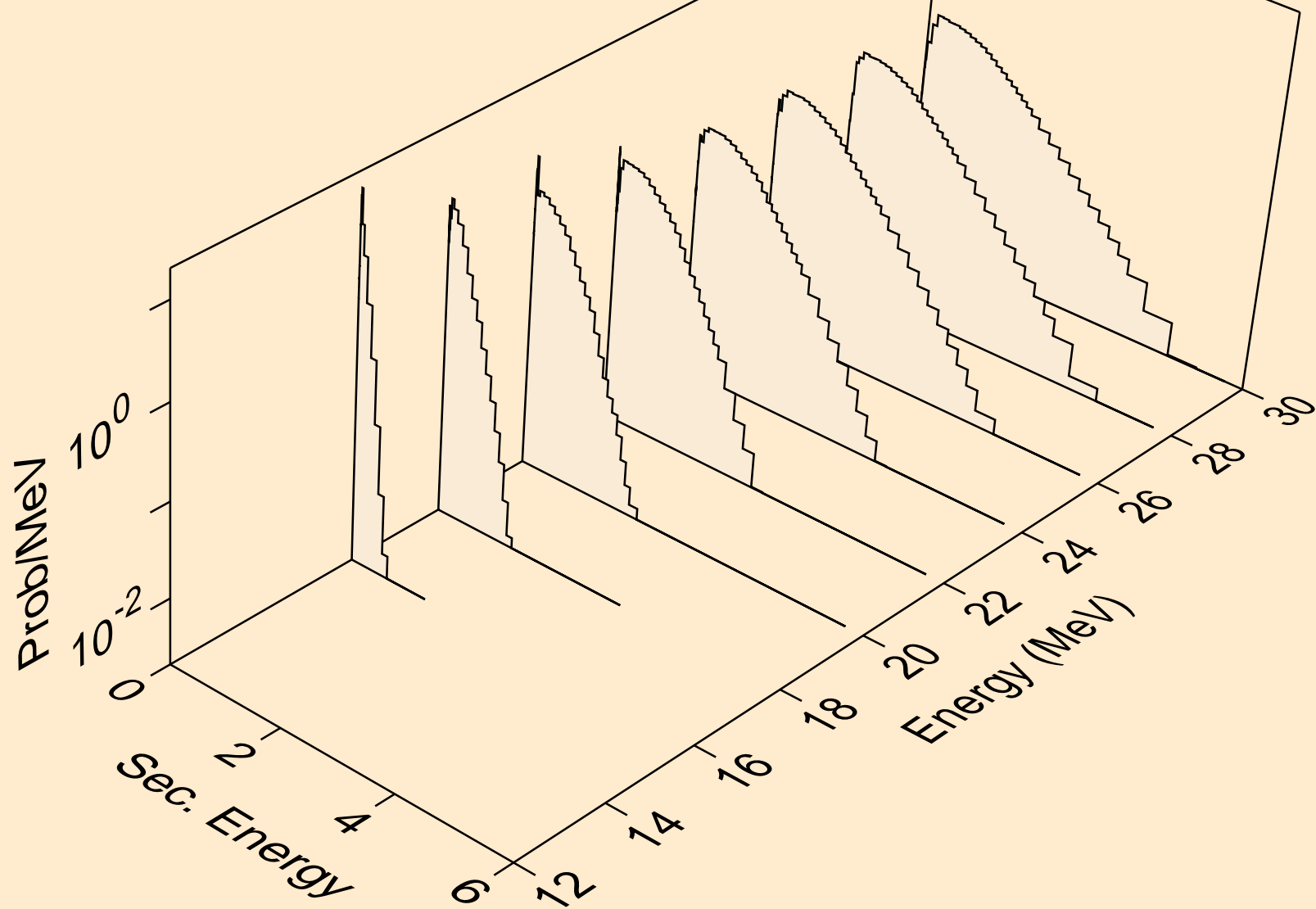

SB126N NEUTRON ACER TENDL-2023 LIBRARY; T=0.K  
Neutron emission for (n,n\*)he3

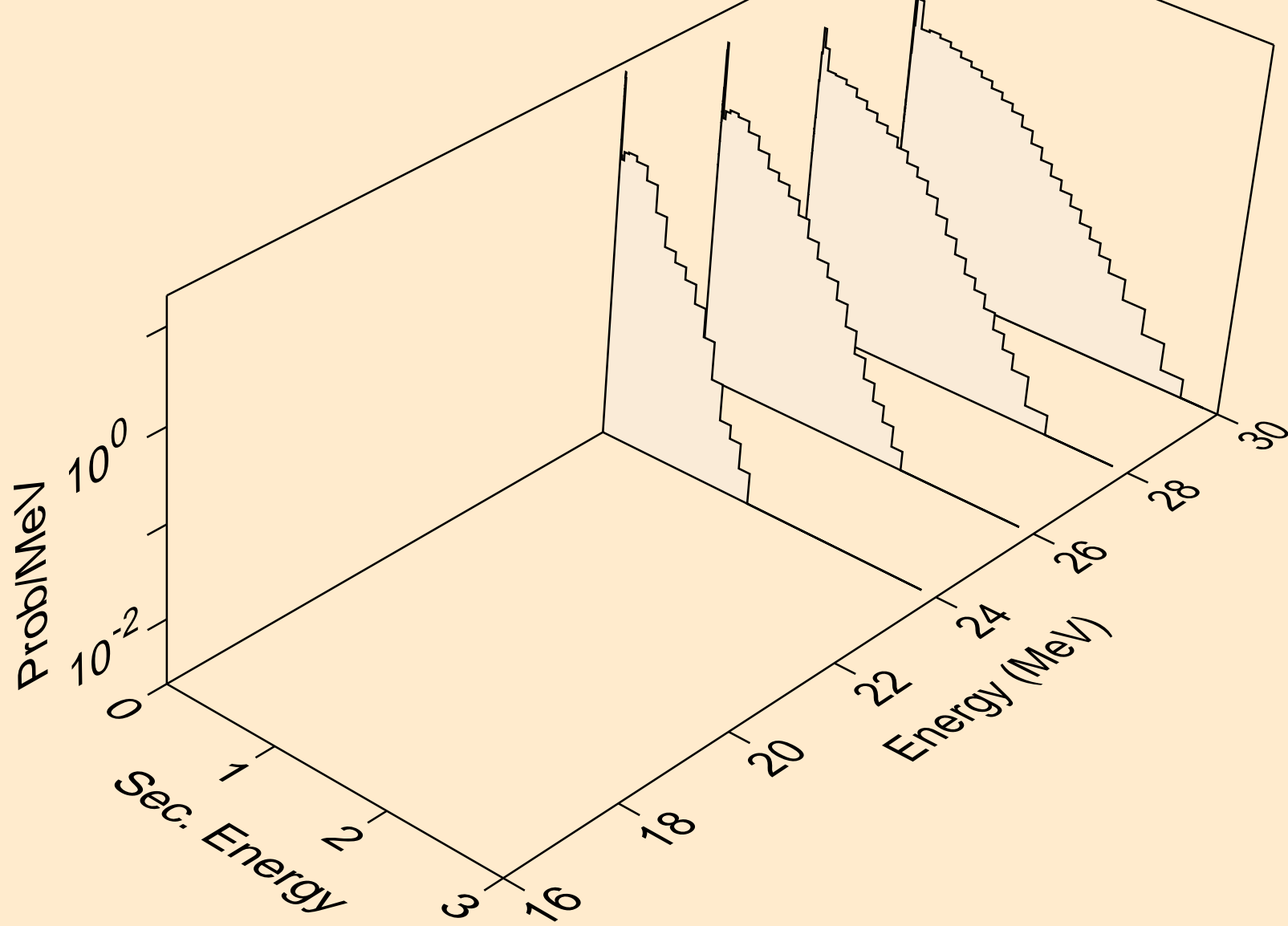

SB126N NEUTRON ACER TENDL-2023 LIBRARY; T=0.K  
Neutron emission for (n,4n)

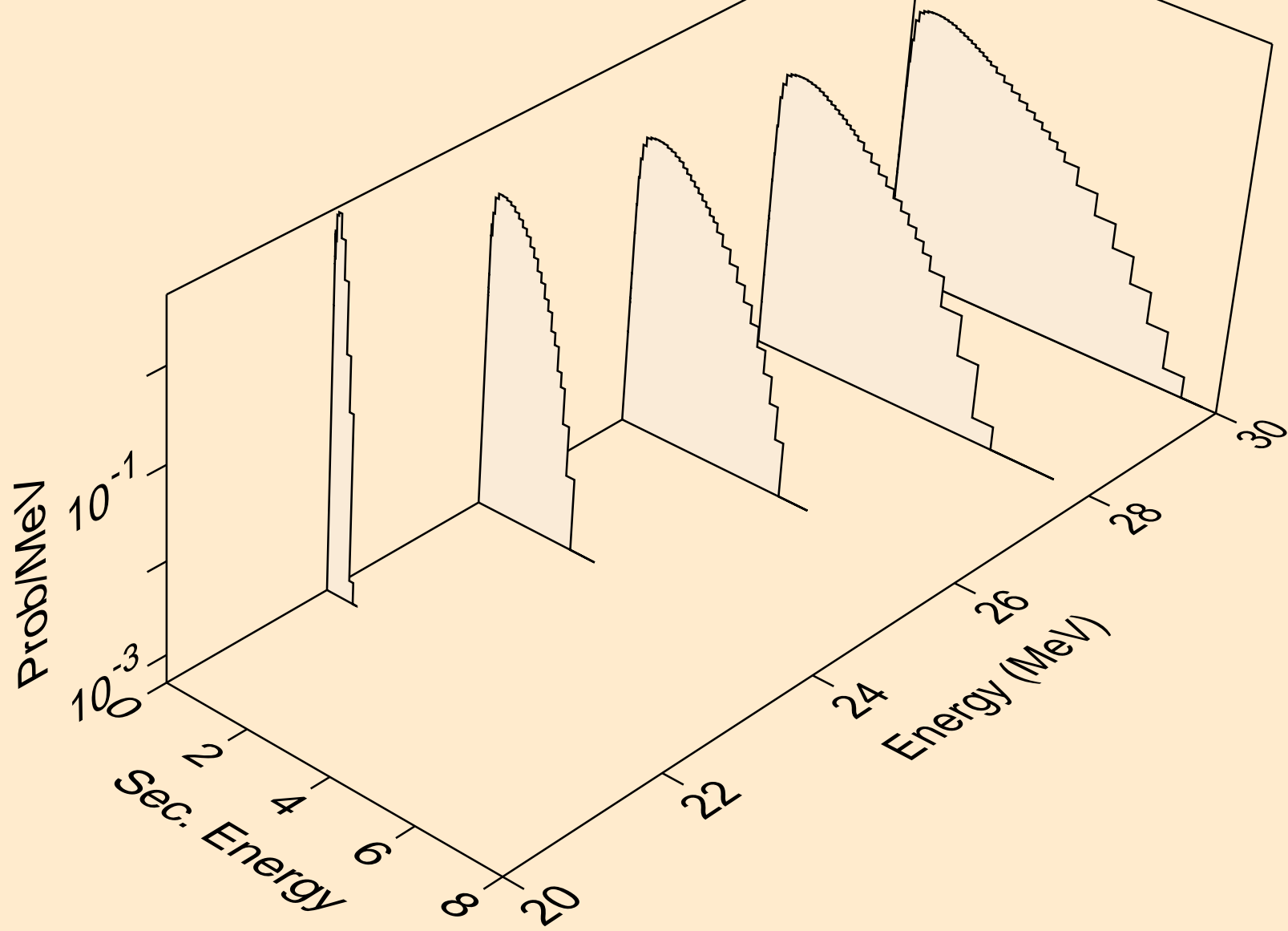

SB126N NEUTRON ACER TENDL-2023 LIBRARY; T=0.K  
Neutron emission for (n,2np)

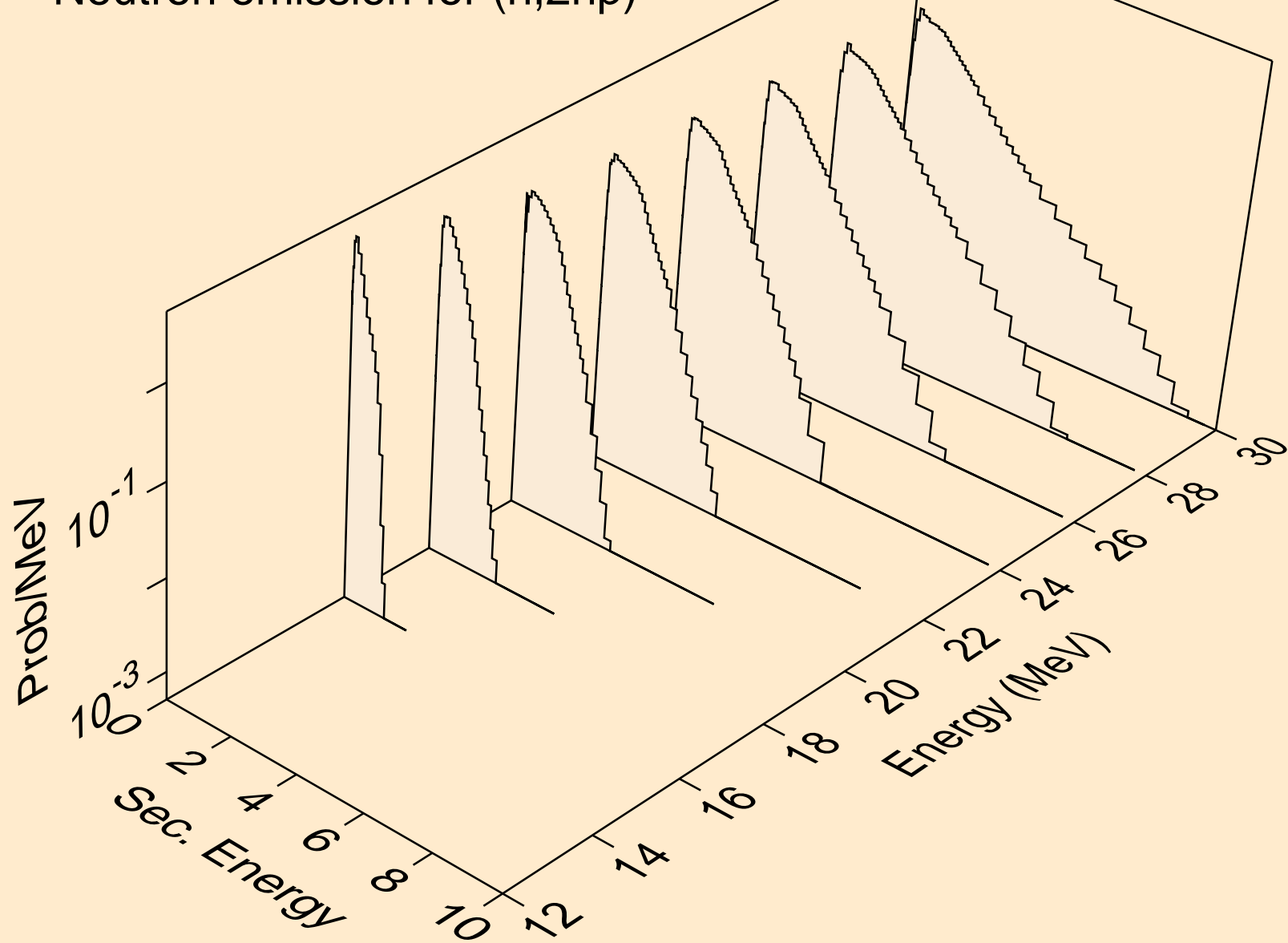

SB126N NEUTRON ACER TENDL-2023 LIBRARY; T=0.K  
Neutron emission for (n,3np)

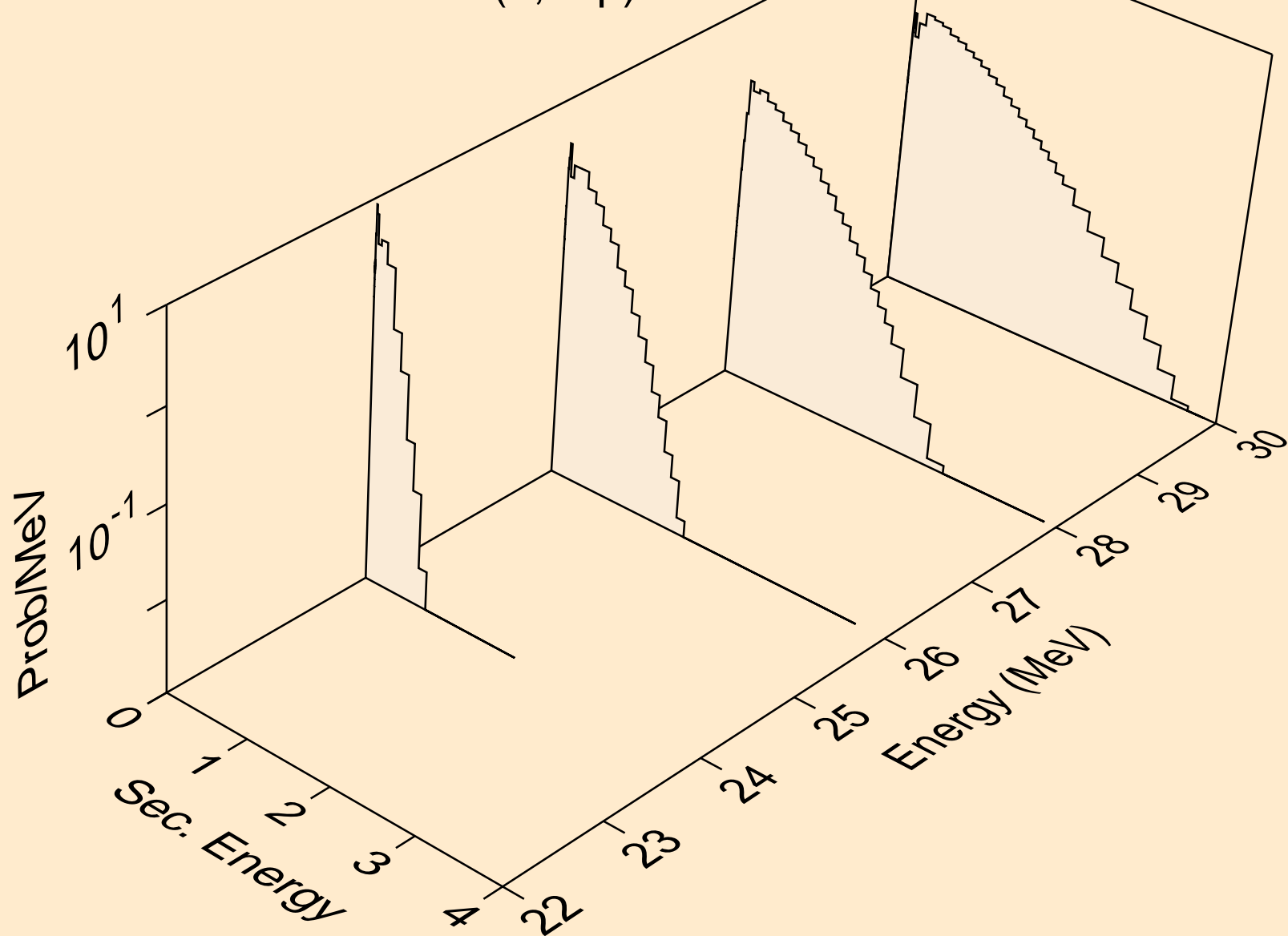

SB126N NEUTRON ACER TENDL-2023 LIBRARY; T=0.K  
Neutron emission for (n,n2p)

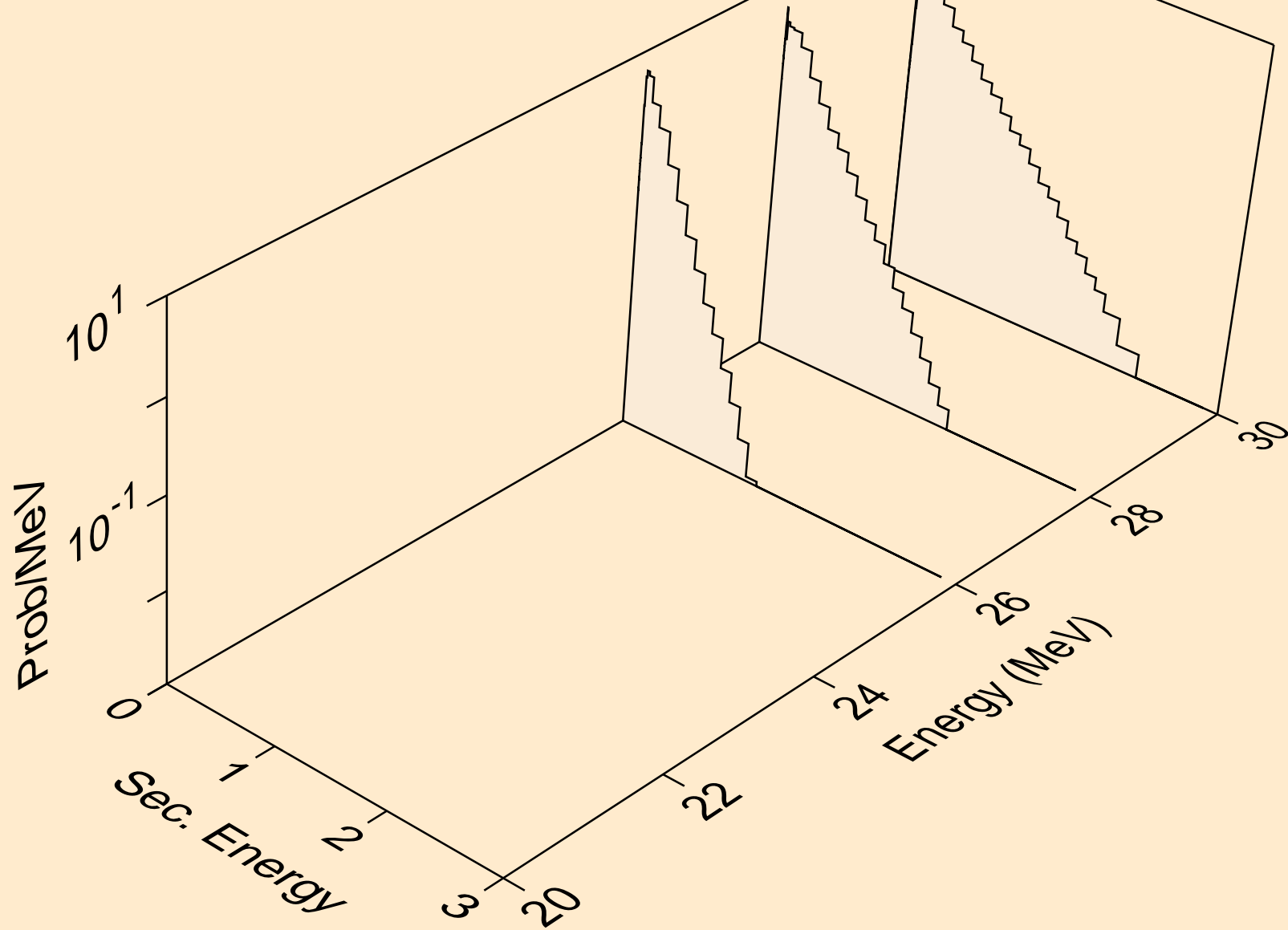



SB126N NEUTRON ACER TENDL-2023 LIBRARY; T=0.K  
Neutron emission for (n,n\*c)

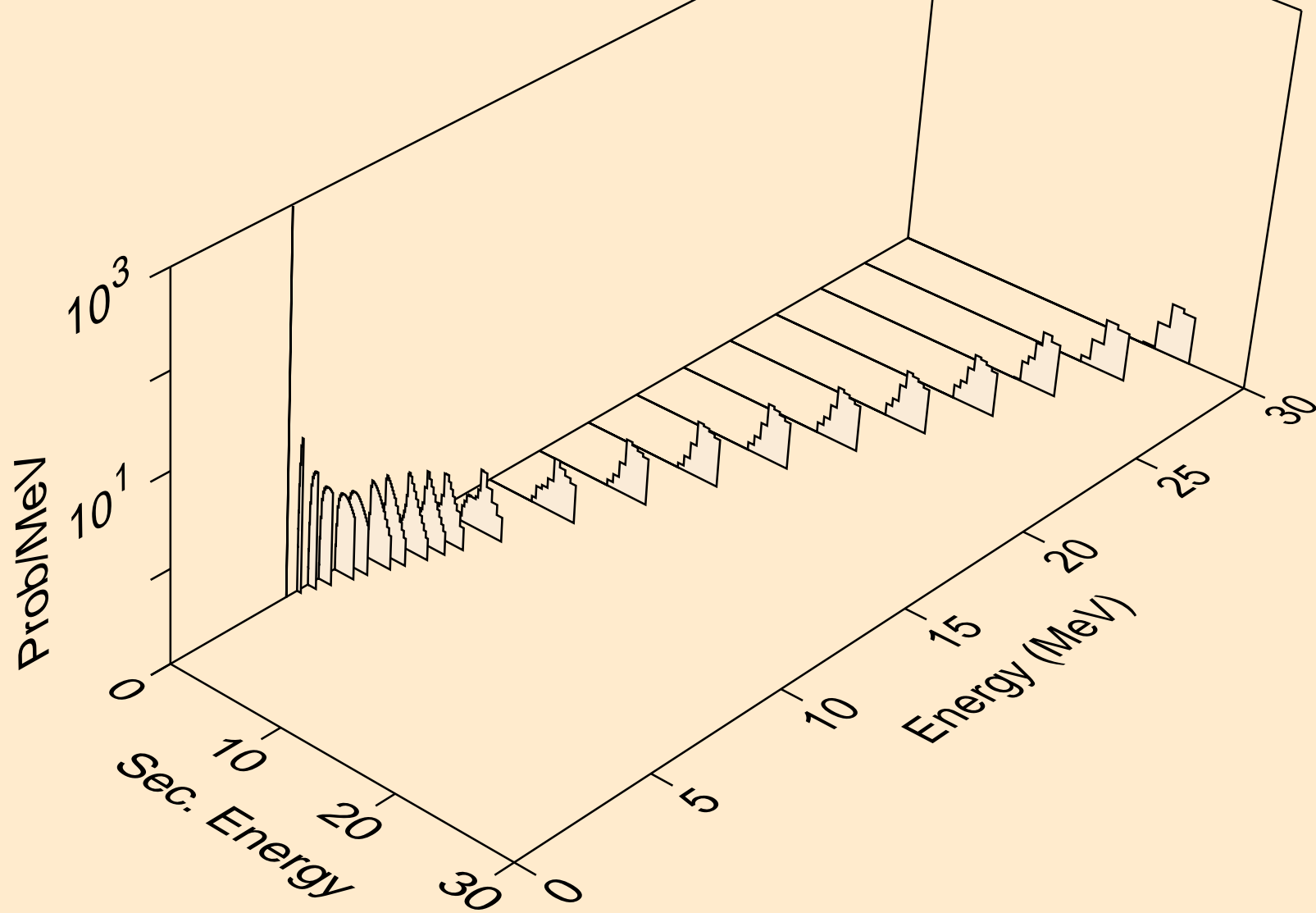

SB126N NEUTRON ACER TENDL-2023 LIBRARY; T=0.K  
Photon emission for (n,x)

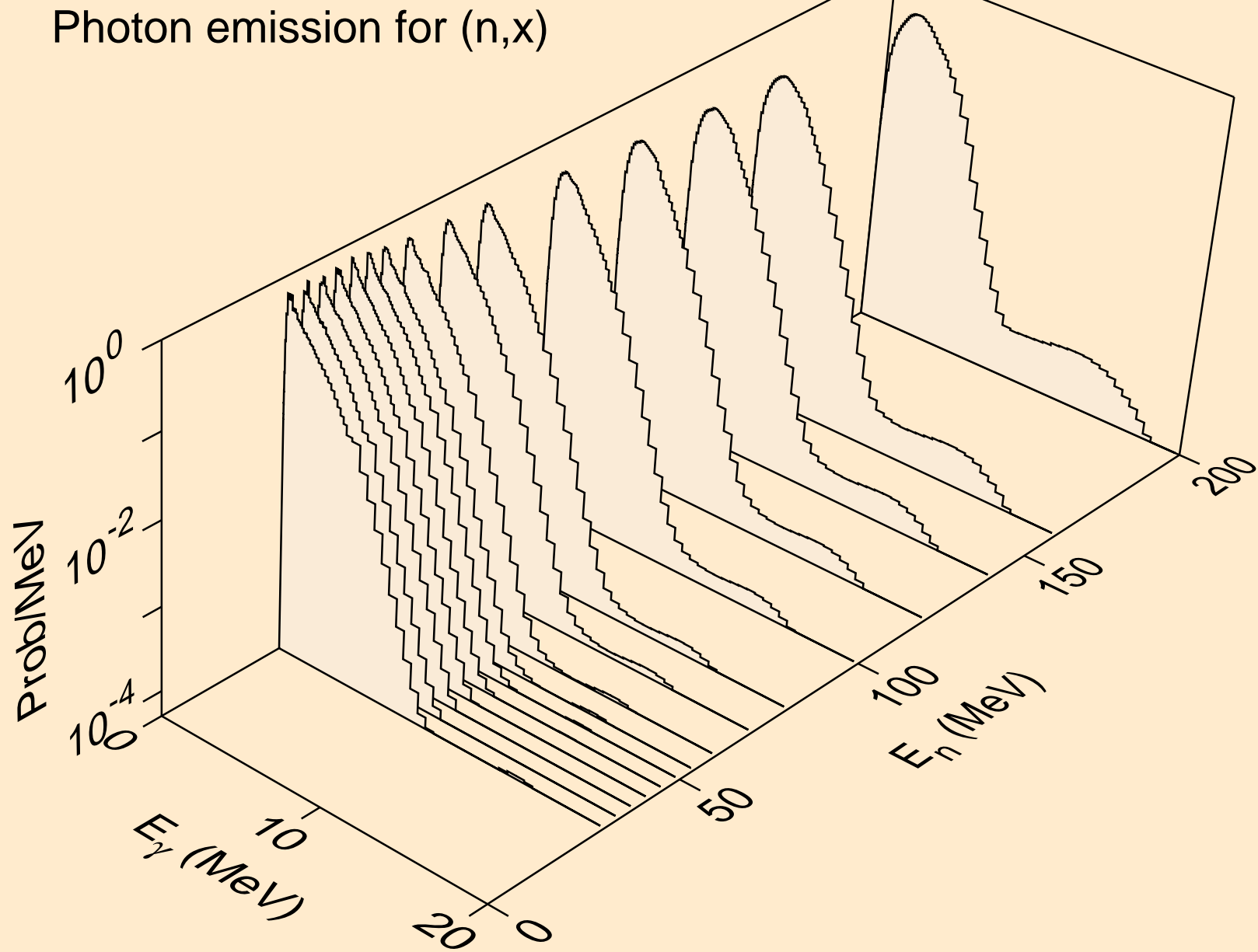

SB126N NEUTRON ACER TENDL-2023 LIBRARY; T=0.K  
Photon emission for (n,2nd)

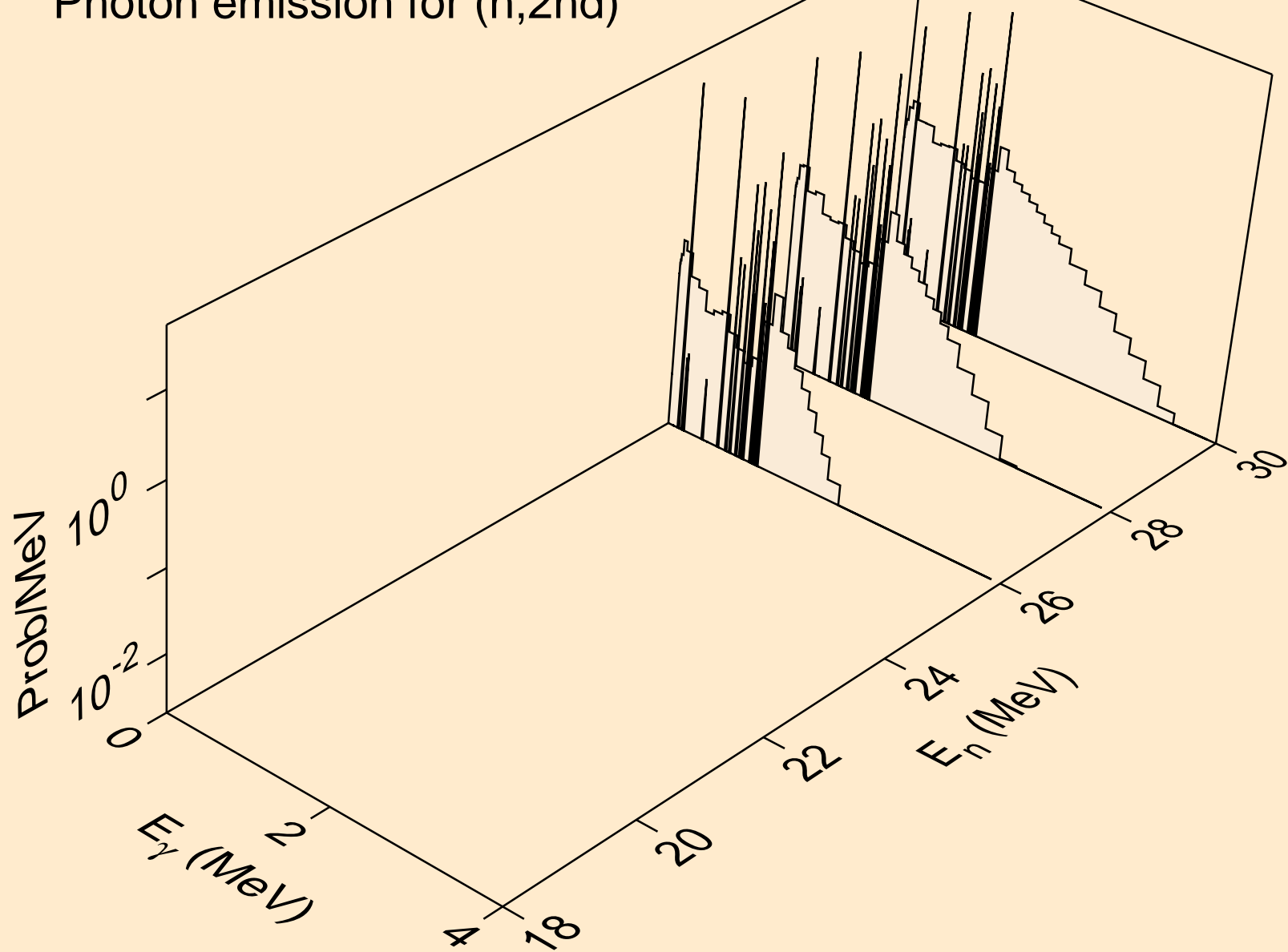

SB126N NEUTRON ACER TENDL-2023 LIBRARY; T=0.K  
Photon emission for (n,2n)

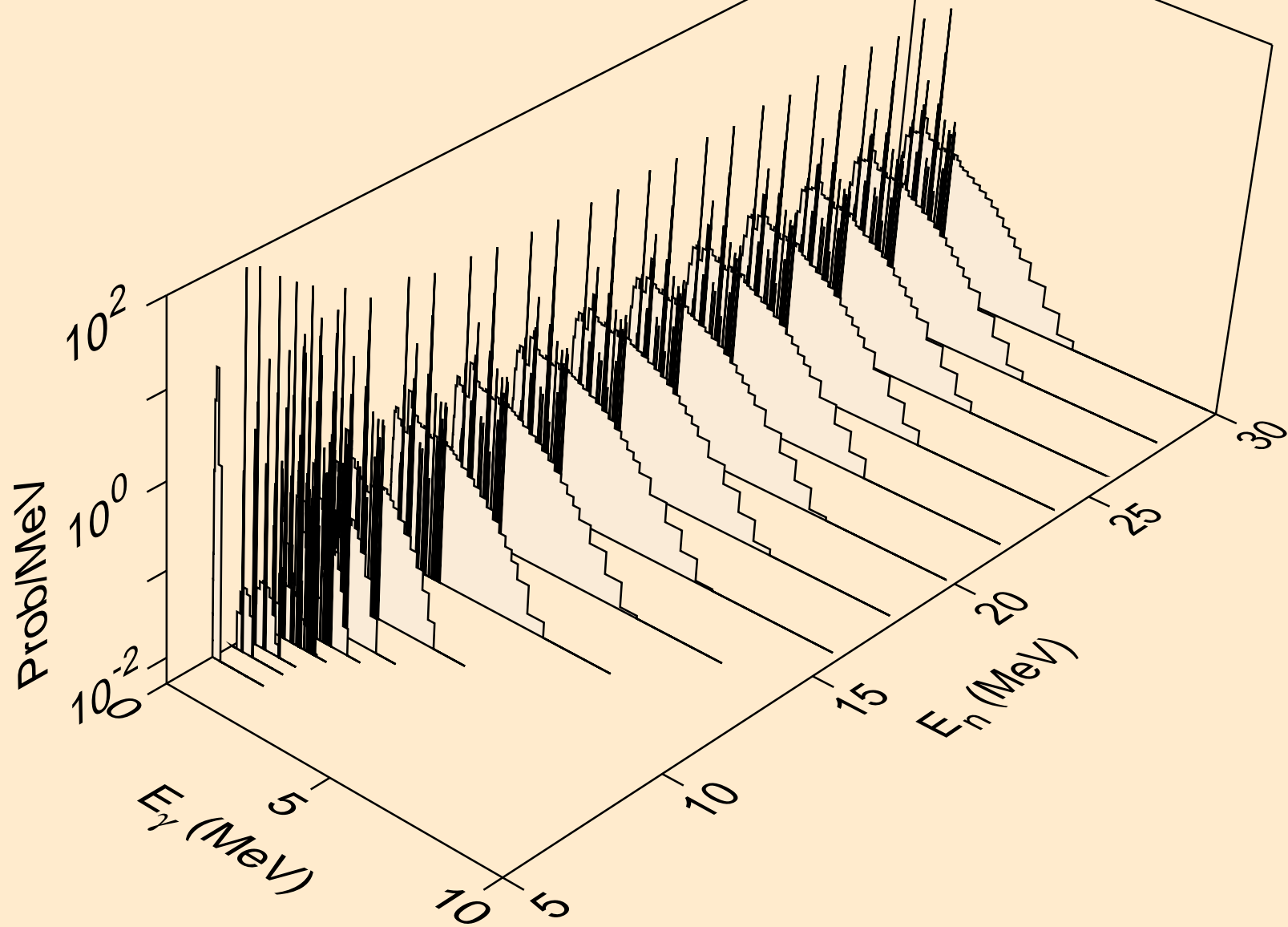

SB126N NEUTRON ACER TENDL-2023 LIBRARY; T=0.K  
Photon emission for (n,3n)

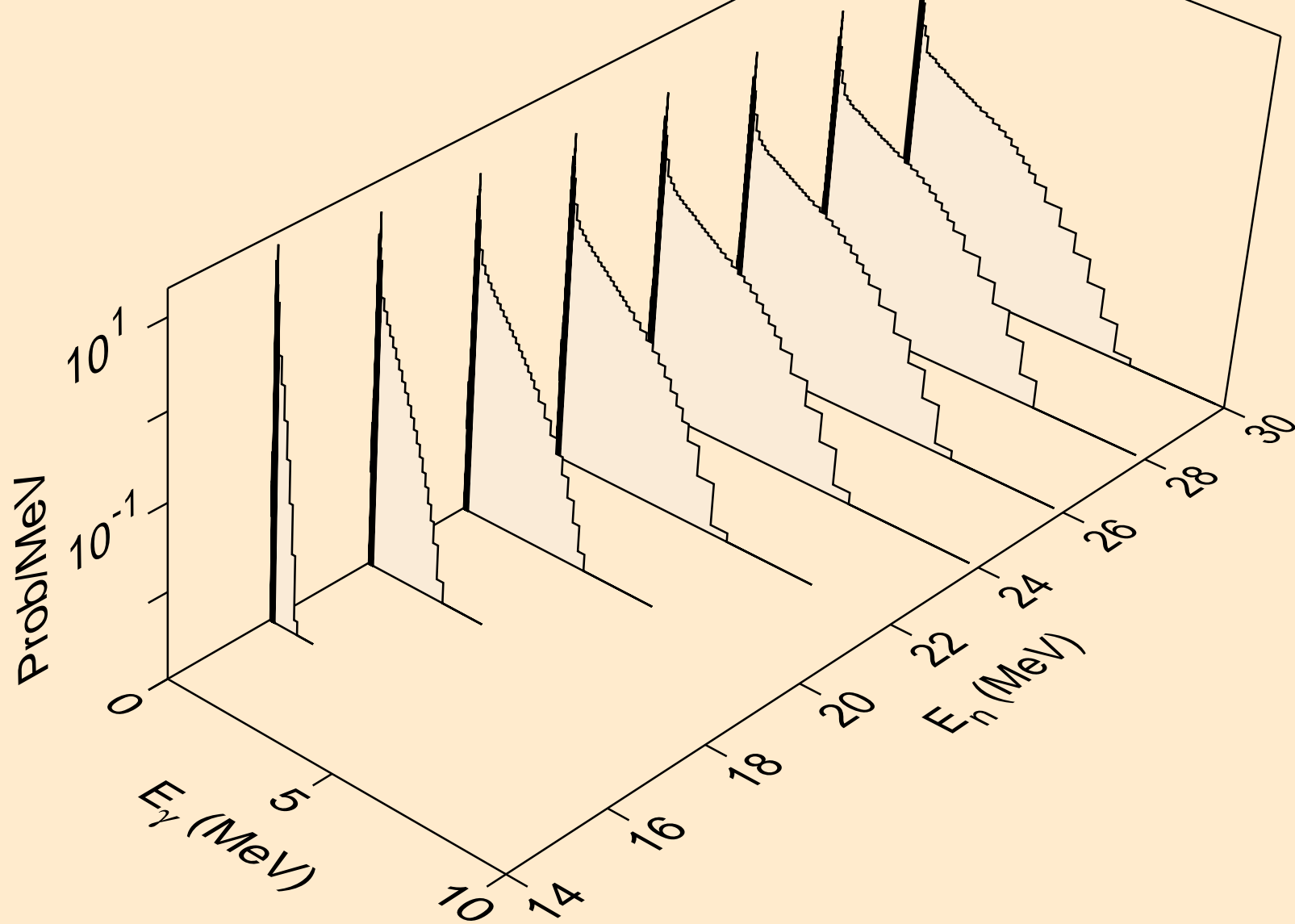

SB126N NEUTRON ACER TENDL-2023 LIBRARY; T=0.K  
Photon emission for (n,n\*)a

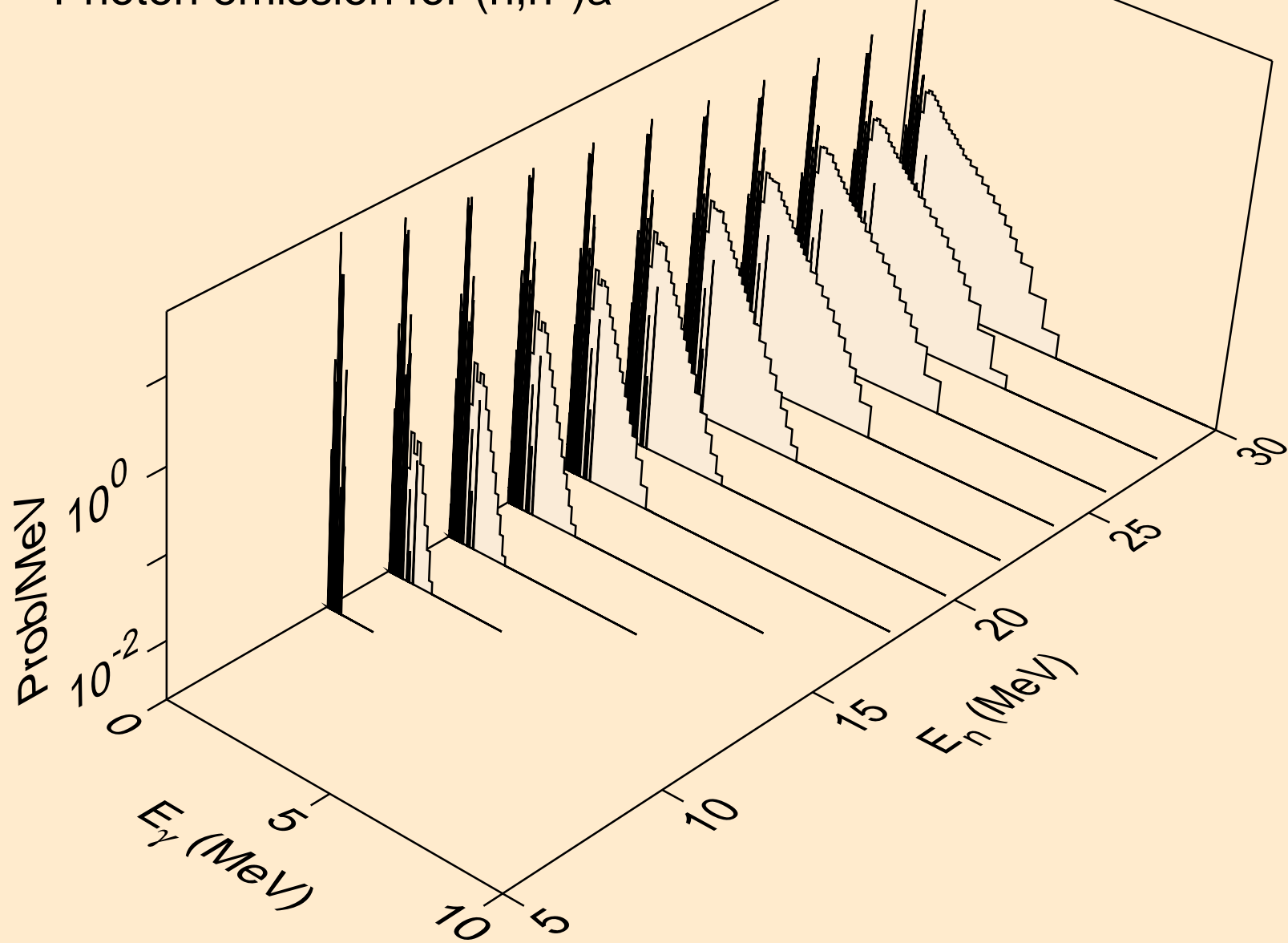

SB126N NEUTRON ACER TENDL-2023 LIBRARY; T=0.K  
Photon emission for (n,2n)a

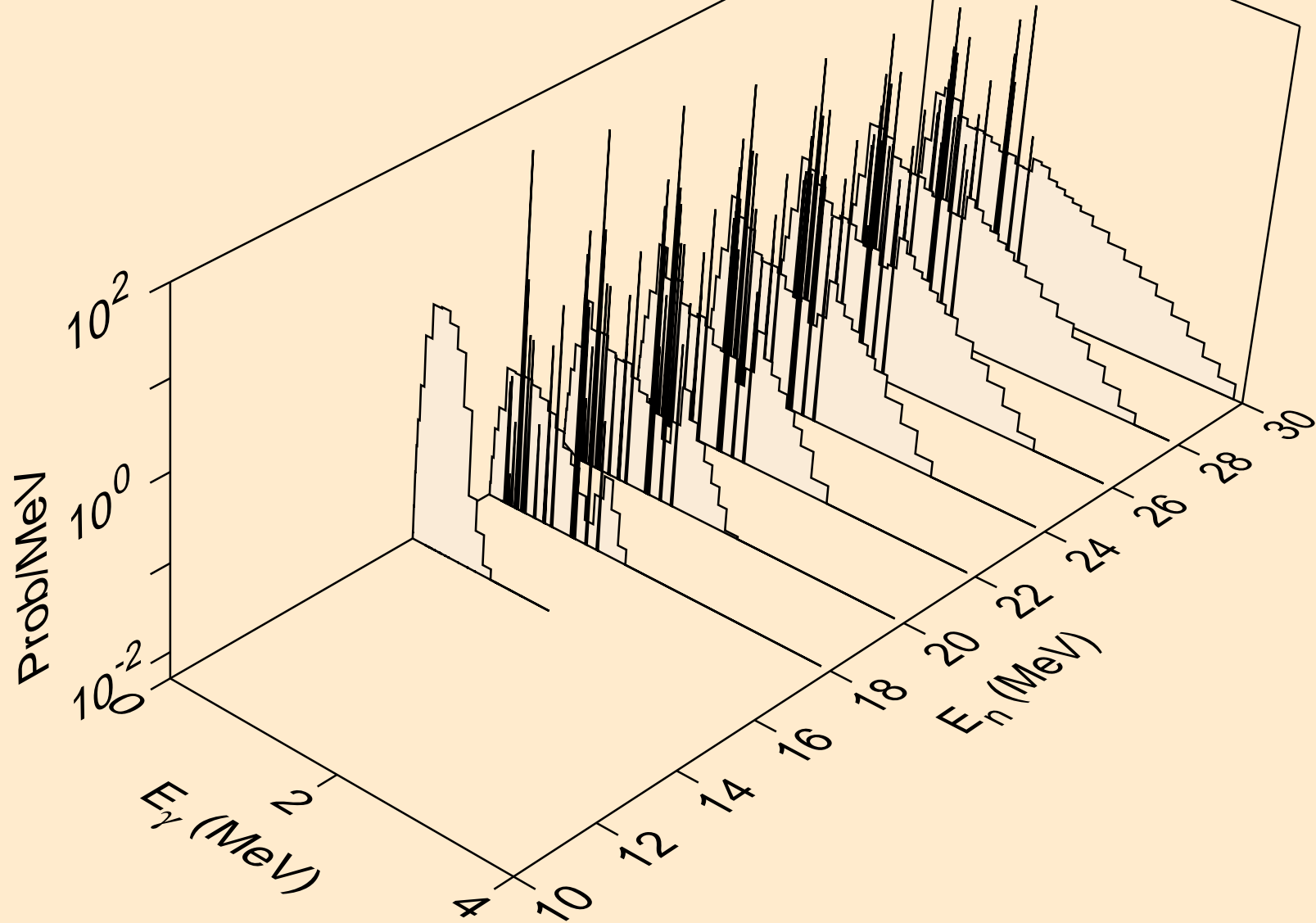

SB126N NEUTRON ACER TENDL-2023 LIBRARY; T=0.K  
Photon emission for (n,3n)a

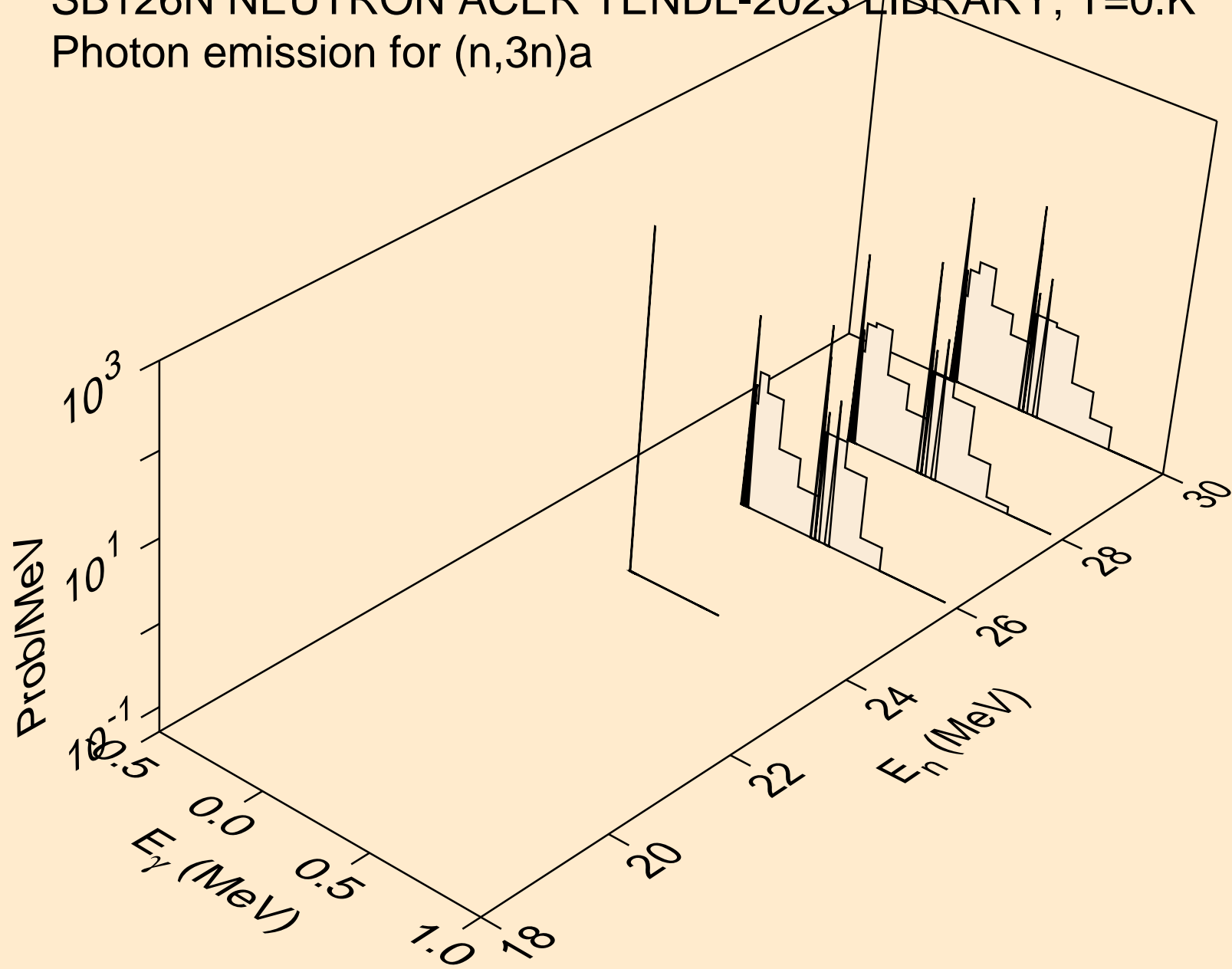



SB126N NEUTRON ACER TENDL-2023 LIBRARY; T=0.K  
Photon emission for (n,n\*)p

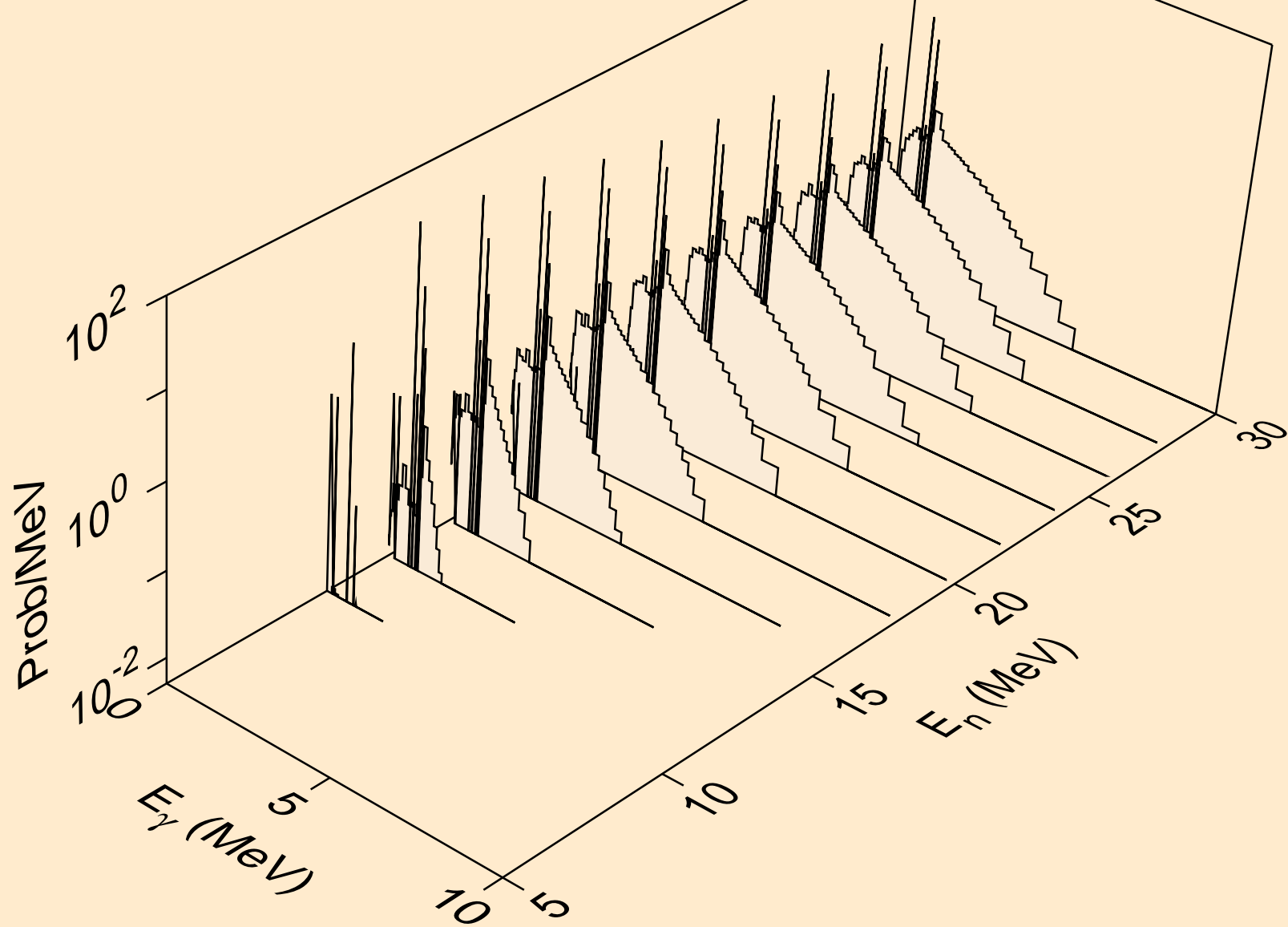

SB126N NEUTRON ACER TENDL-2023 LIBRARY; T=0.K  
Photon emission for (n,n\*)d

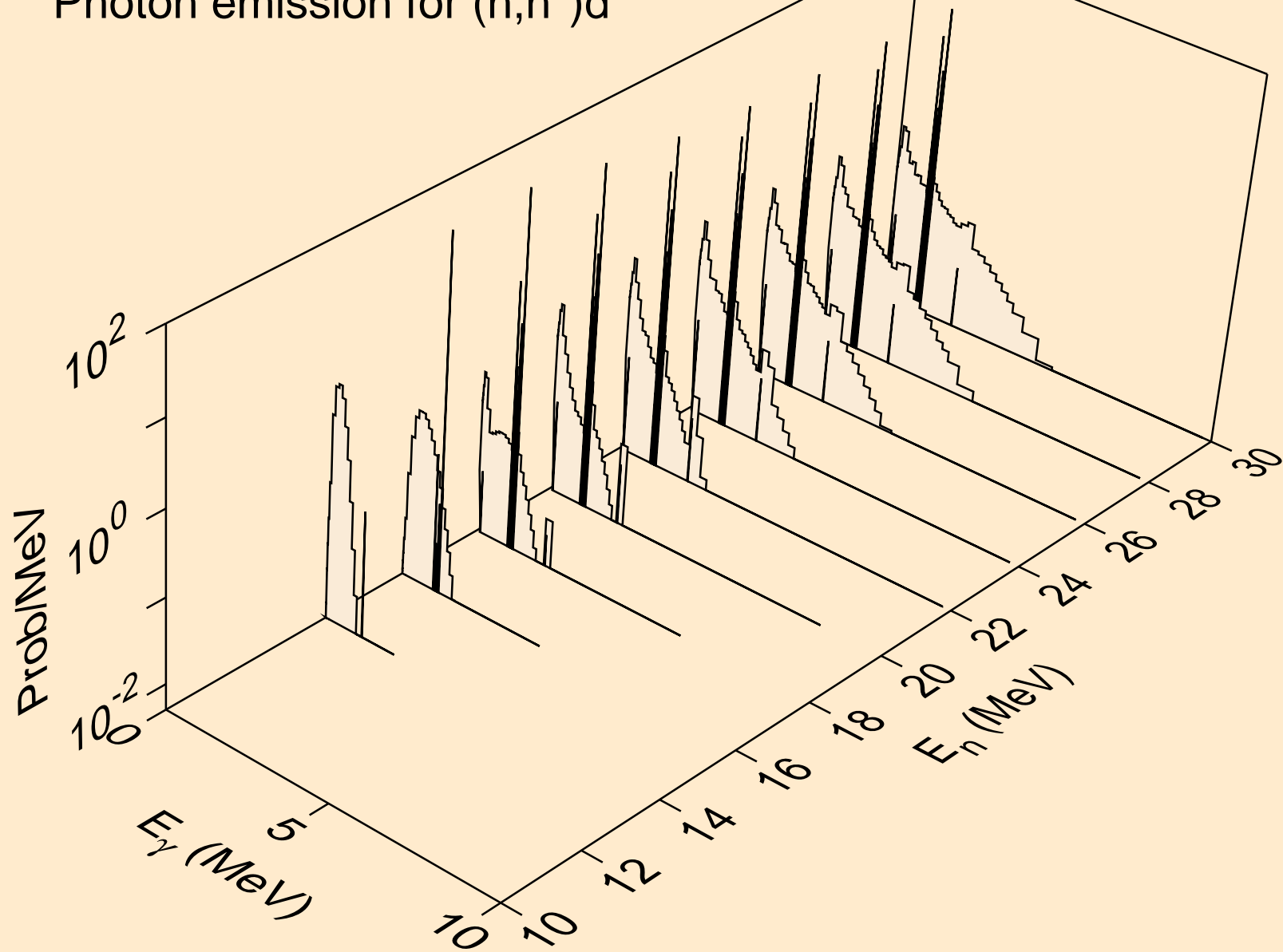

SB126N NEUTRON ACER TENDL-2023 LIBRARY; T=0.K  
Photon emission for (n,n\*)t

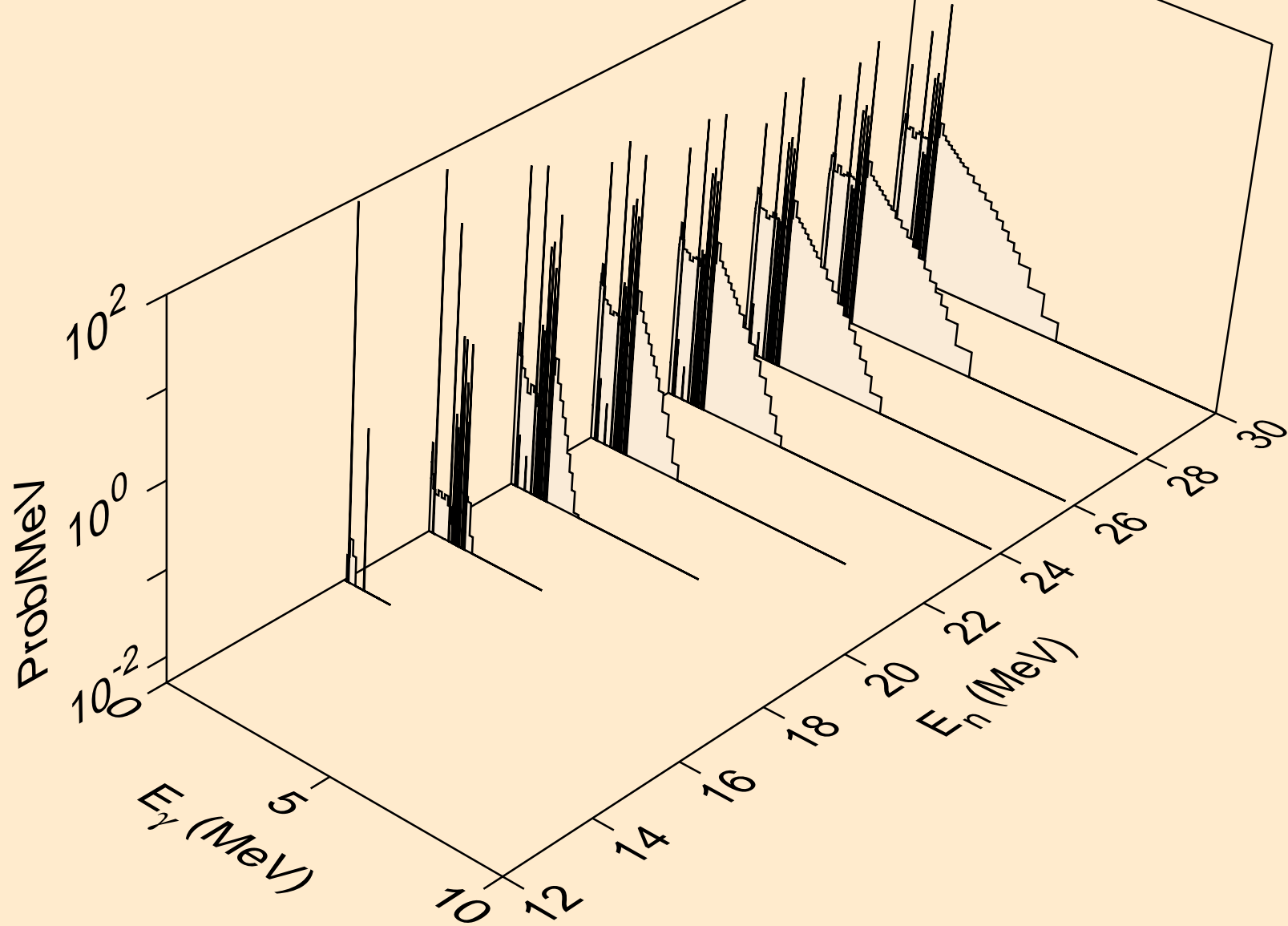

SB126N NEUTRON ACER TENDL-2023 LIBRARY; T=0.K  
Photon emission for (n,n\*)he3

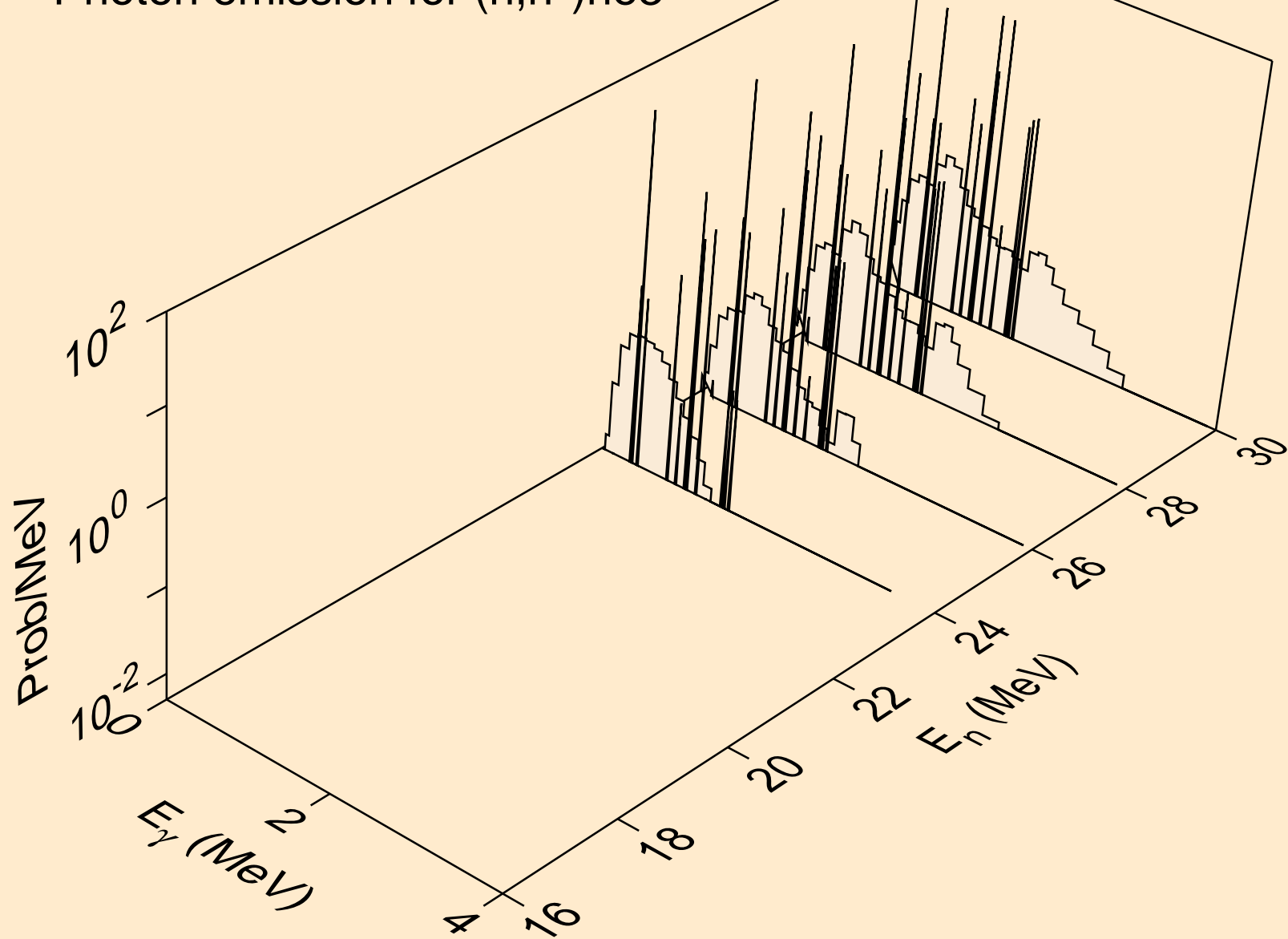

SB126N NEUTRON ACER TENDL-2023 LIBRARY; T=0.K  
Photon emission for (n,4n)

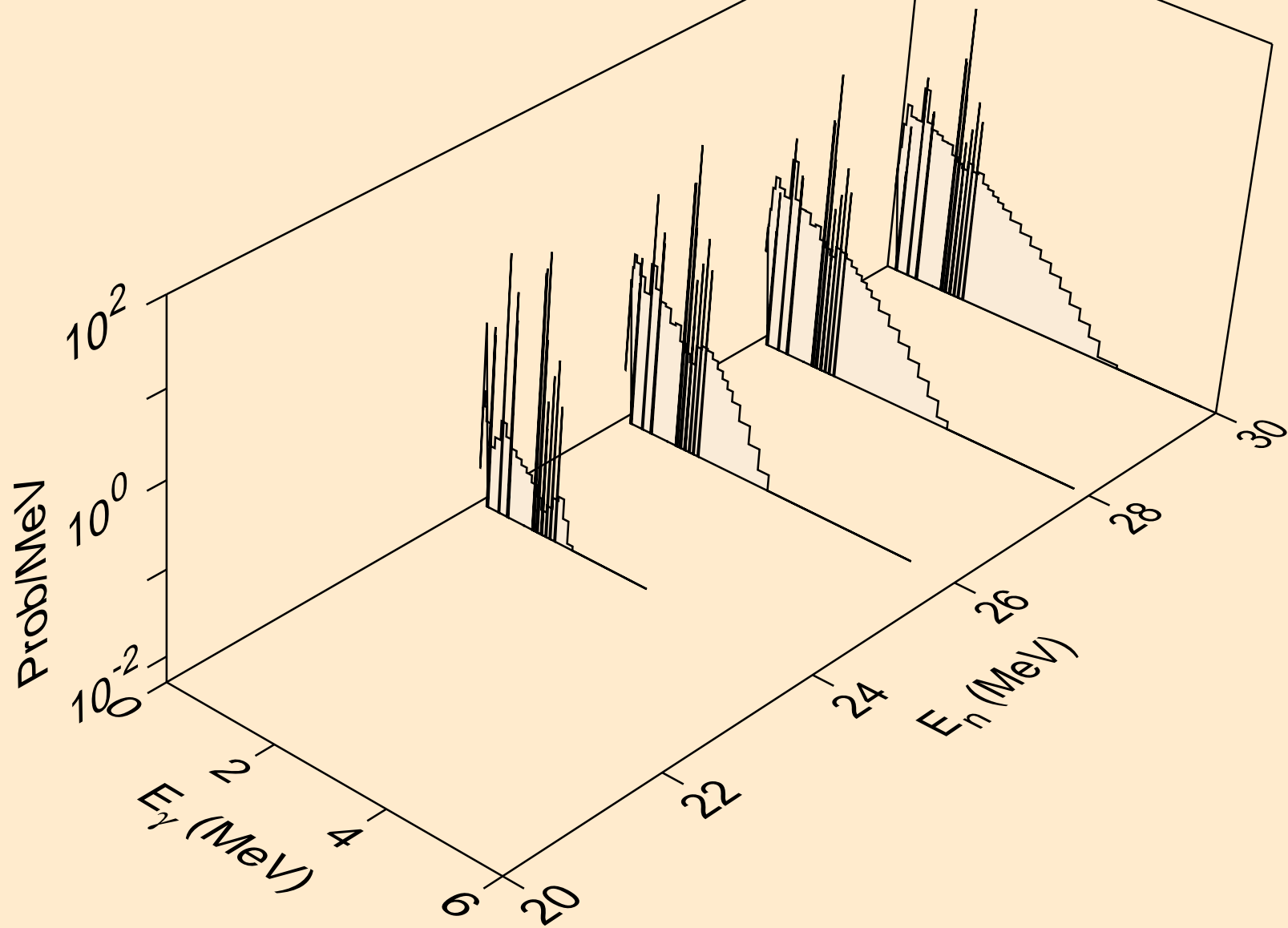

SB126N NEUTRON ACER TENDL-2023 LIBRARY; T=0.K  
Photon emission for (n,2np)

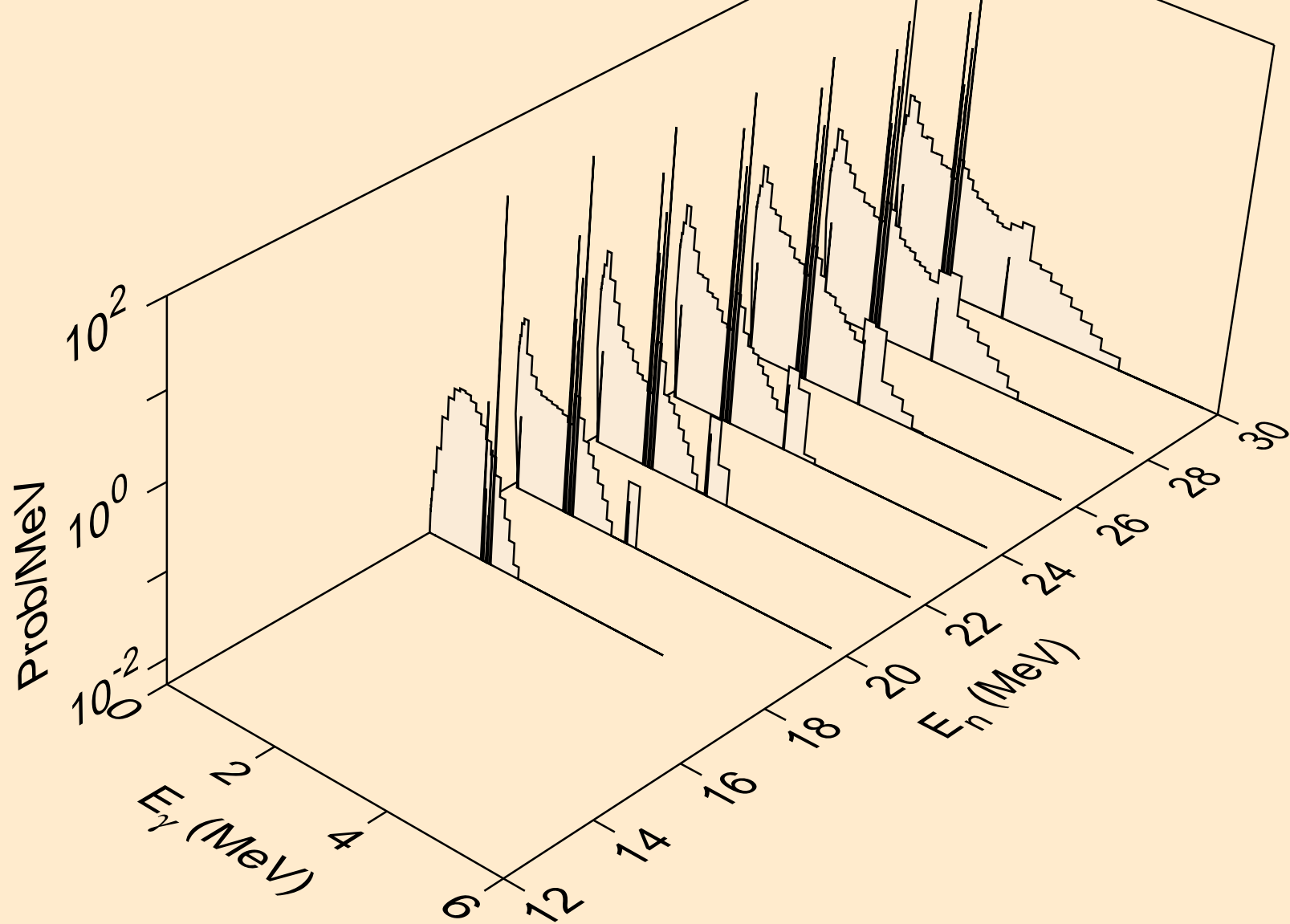

SB126N NEUTRON ACER TENDL-2023 LIBRARY; T=0.K  
Photon emission for (n,3np)

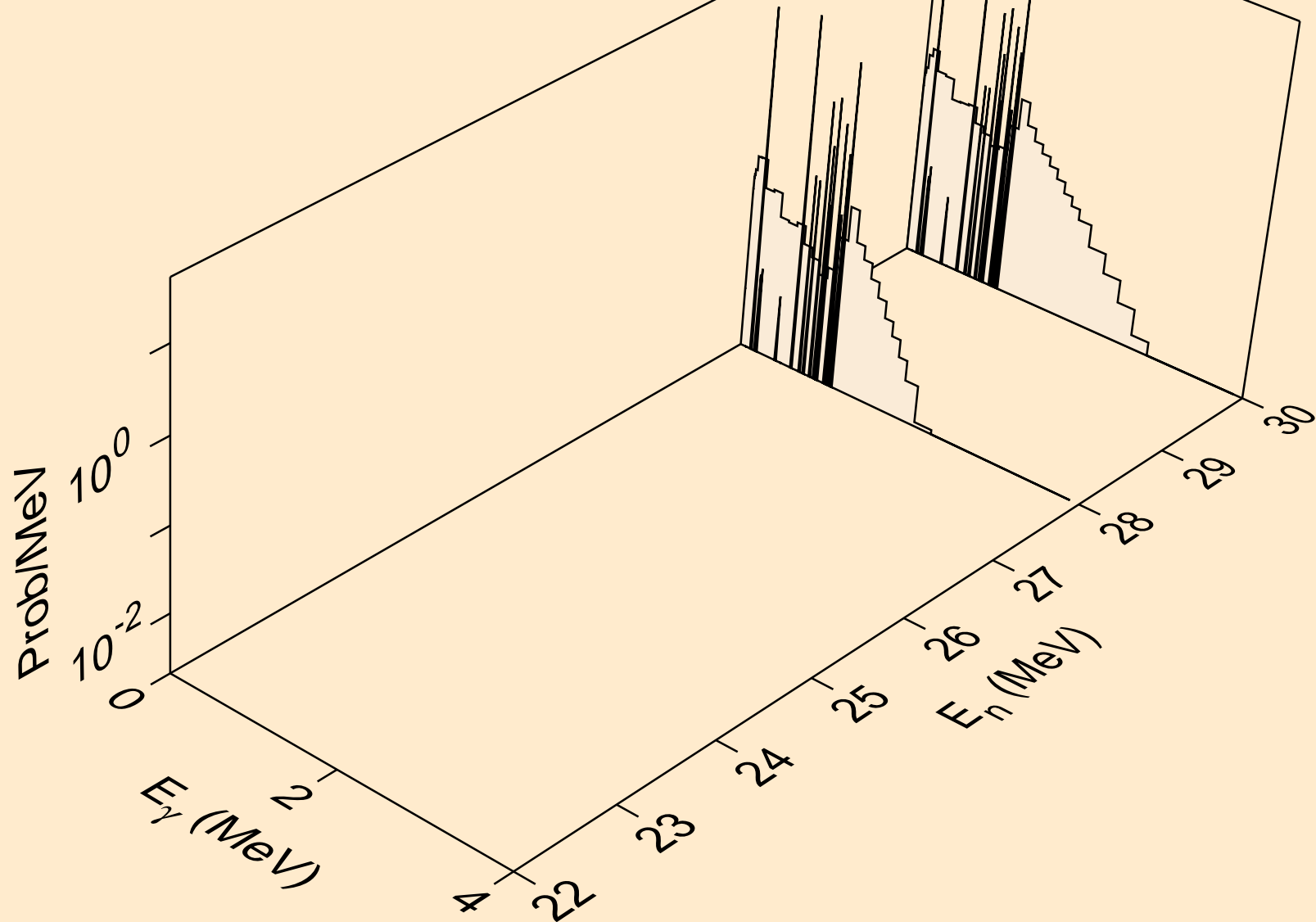

SB126N NEUTRON ACER TENDL-2023 LIBRARY; T=0.K  
Photon emission for (n,n2p)

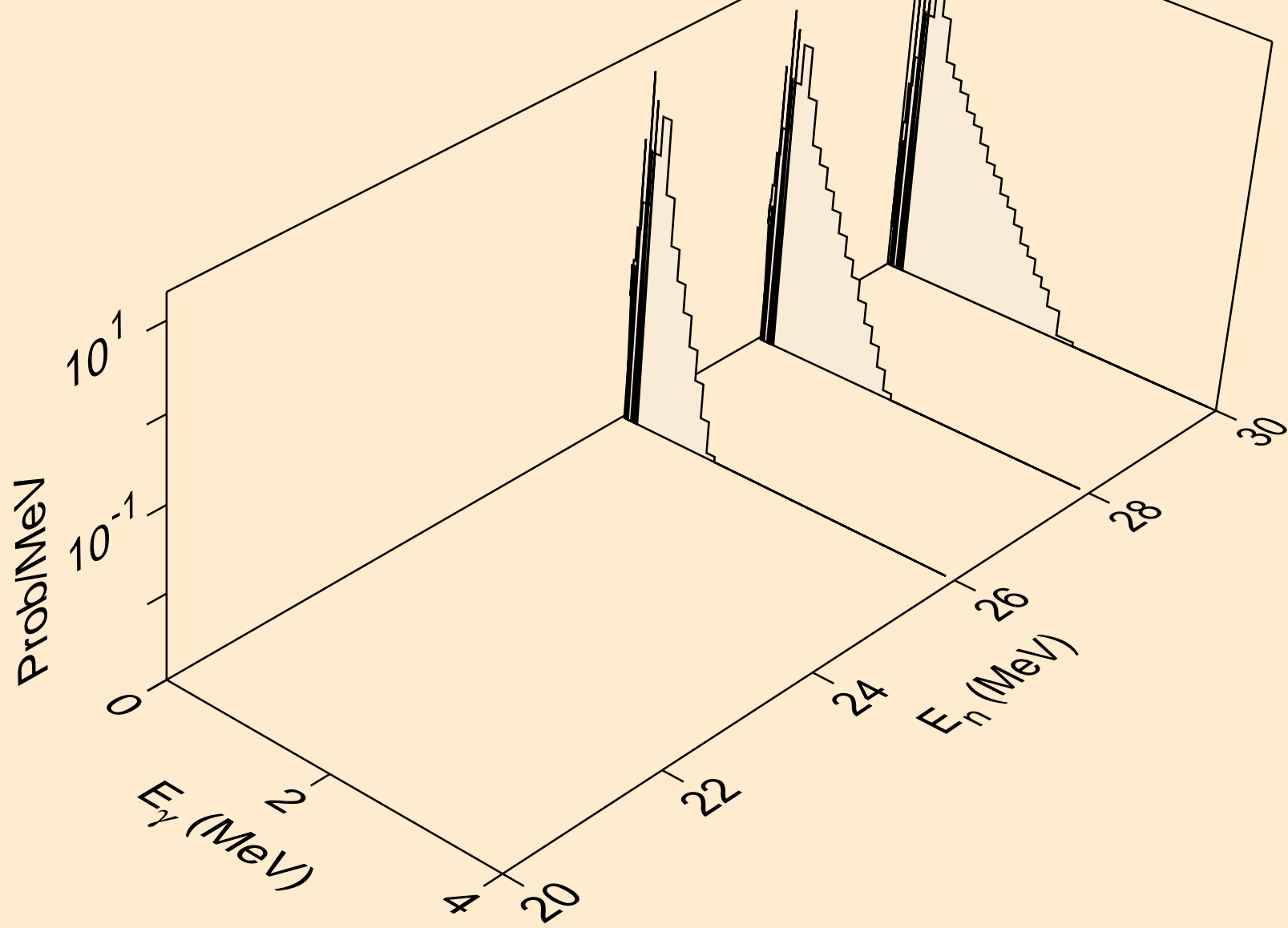



SB126N NEUTRON ACER TENDL-2023 LIBRARY; T=0.K  
Photon emission for (n,n\*3)

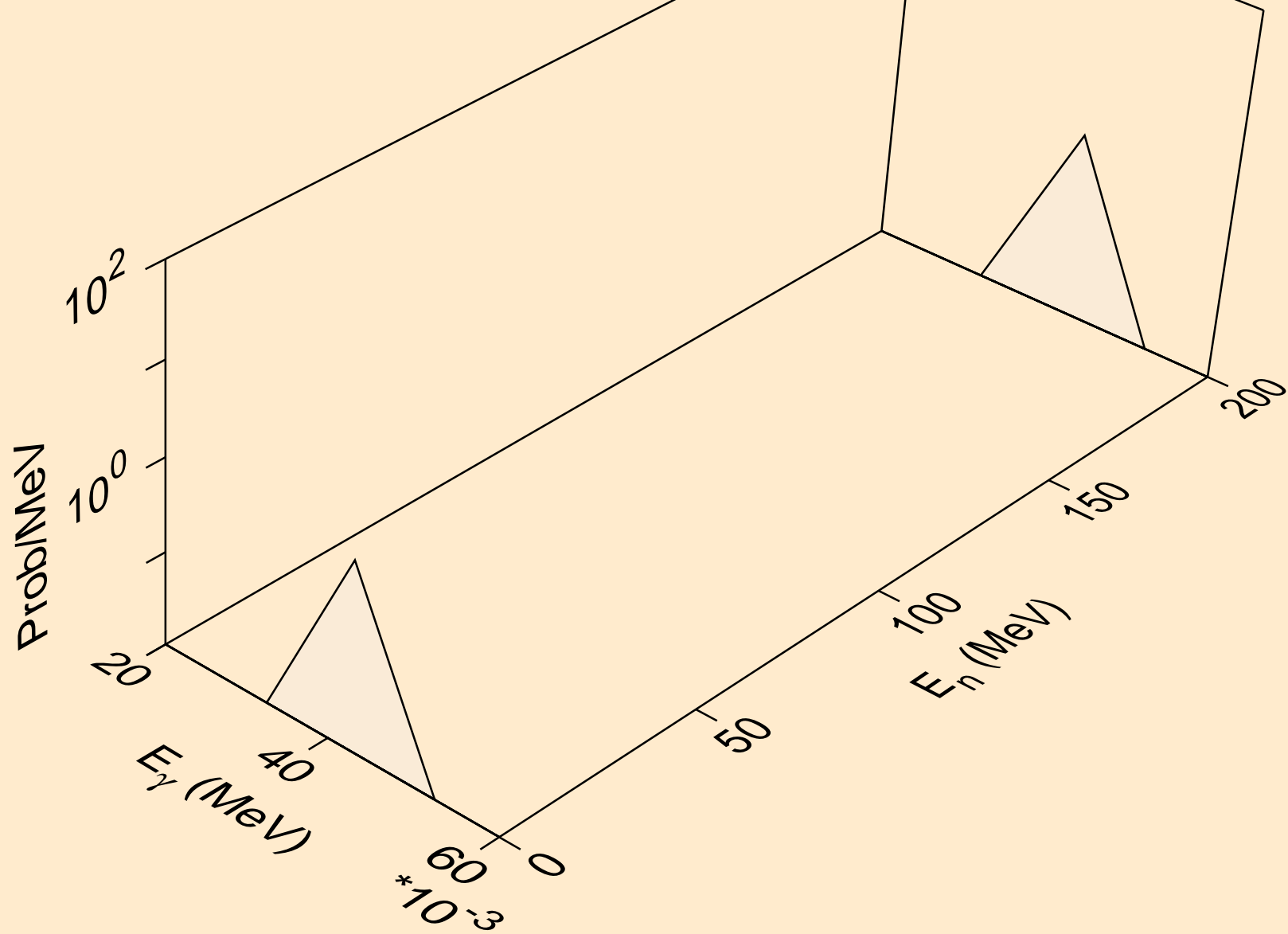

SB126N NEUTRON ACER TENDL-2023 LIBRARY; T=0.K  
Photon emission for (n,n\*4)

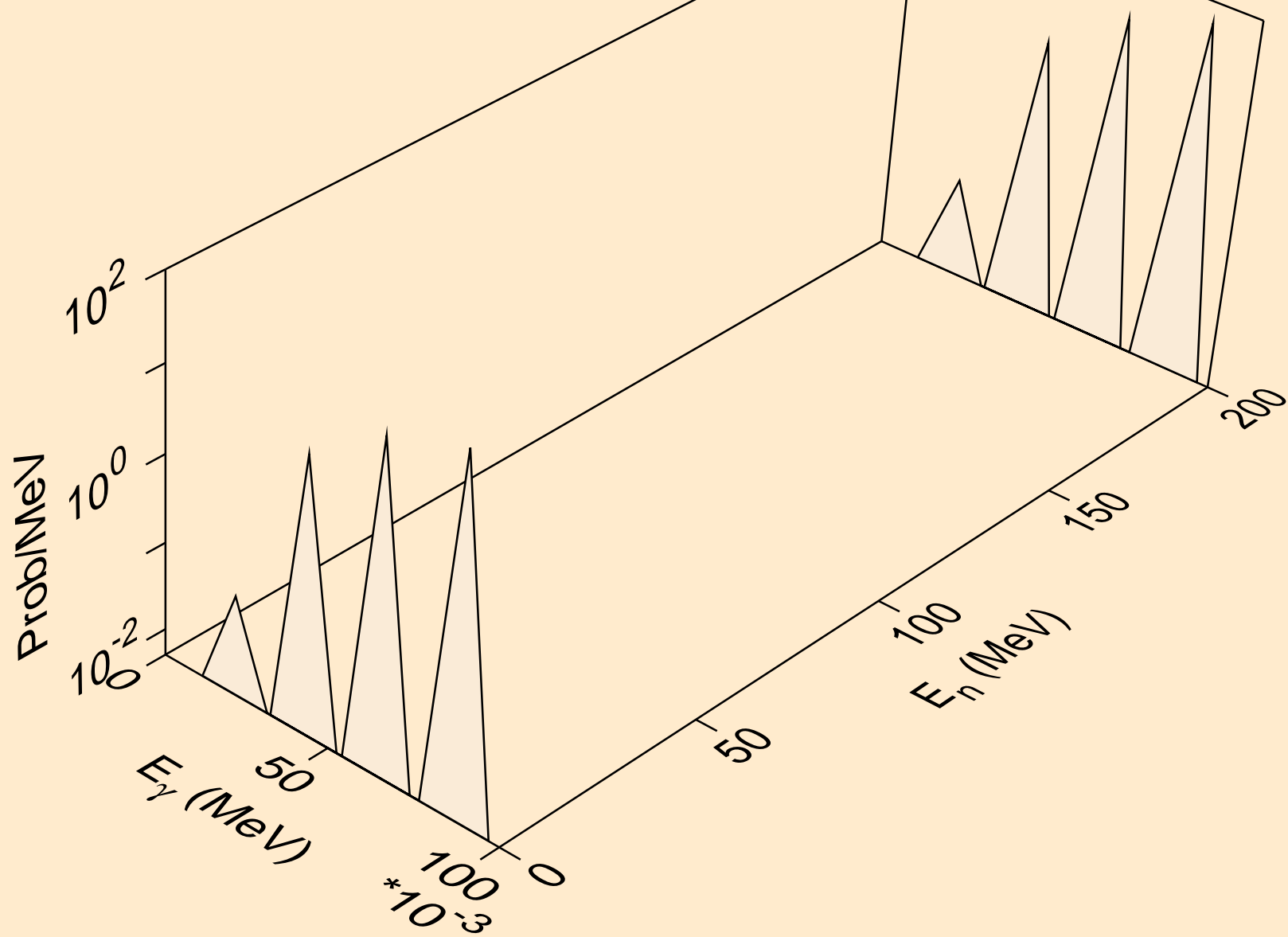

SB126N NEUTRON ACER TENDL-2023 LIBRARY; T=0.K  
Photon emission for (n,n\*5)

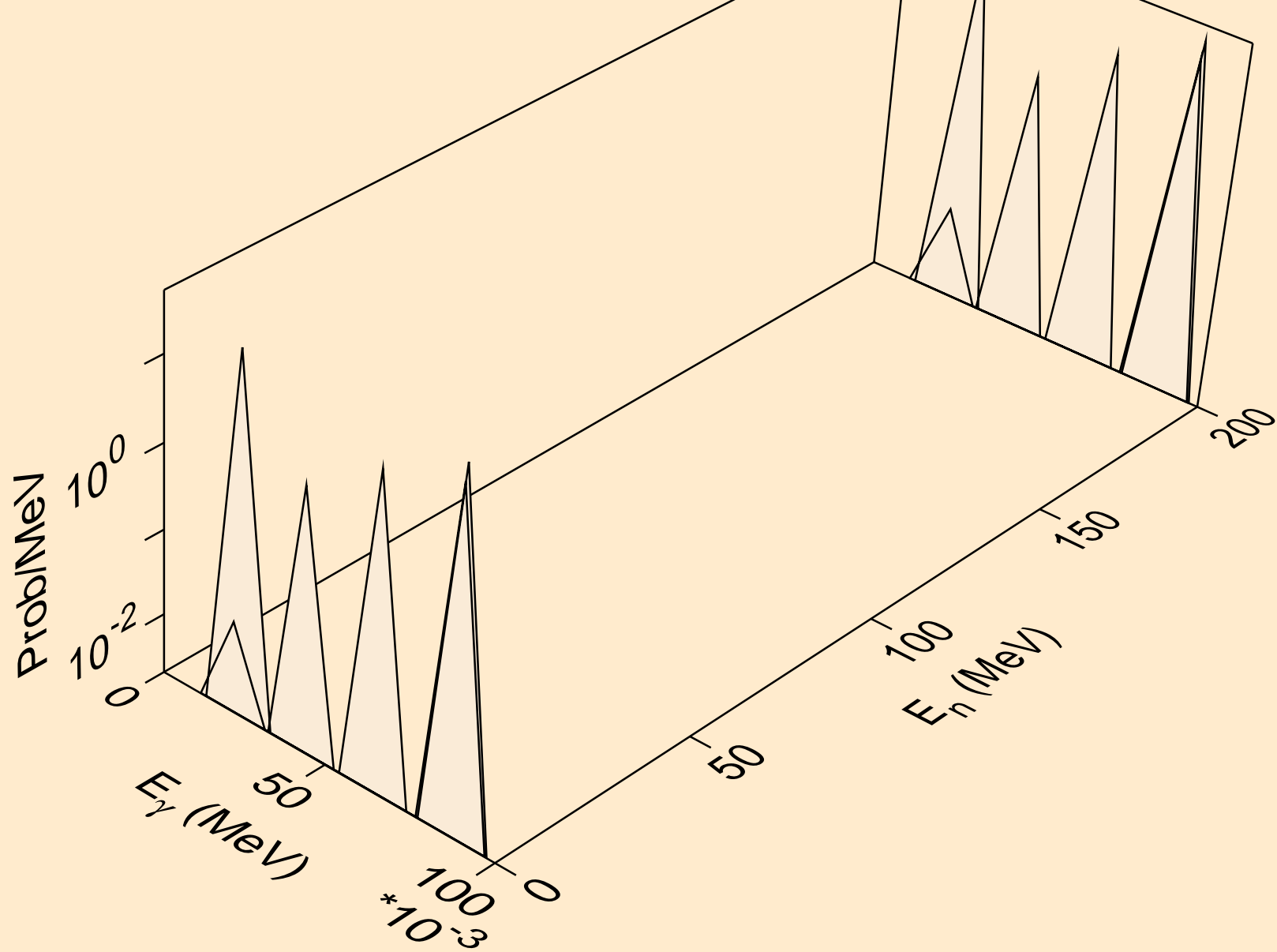

SB126N NEUTRON ACER TENDL-2023 LIBRARY; T=0.K  
Photon emission for (n,n\*6)

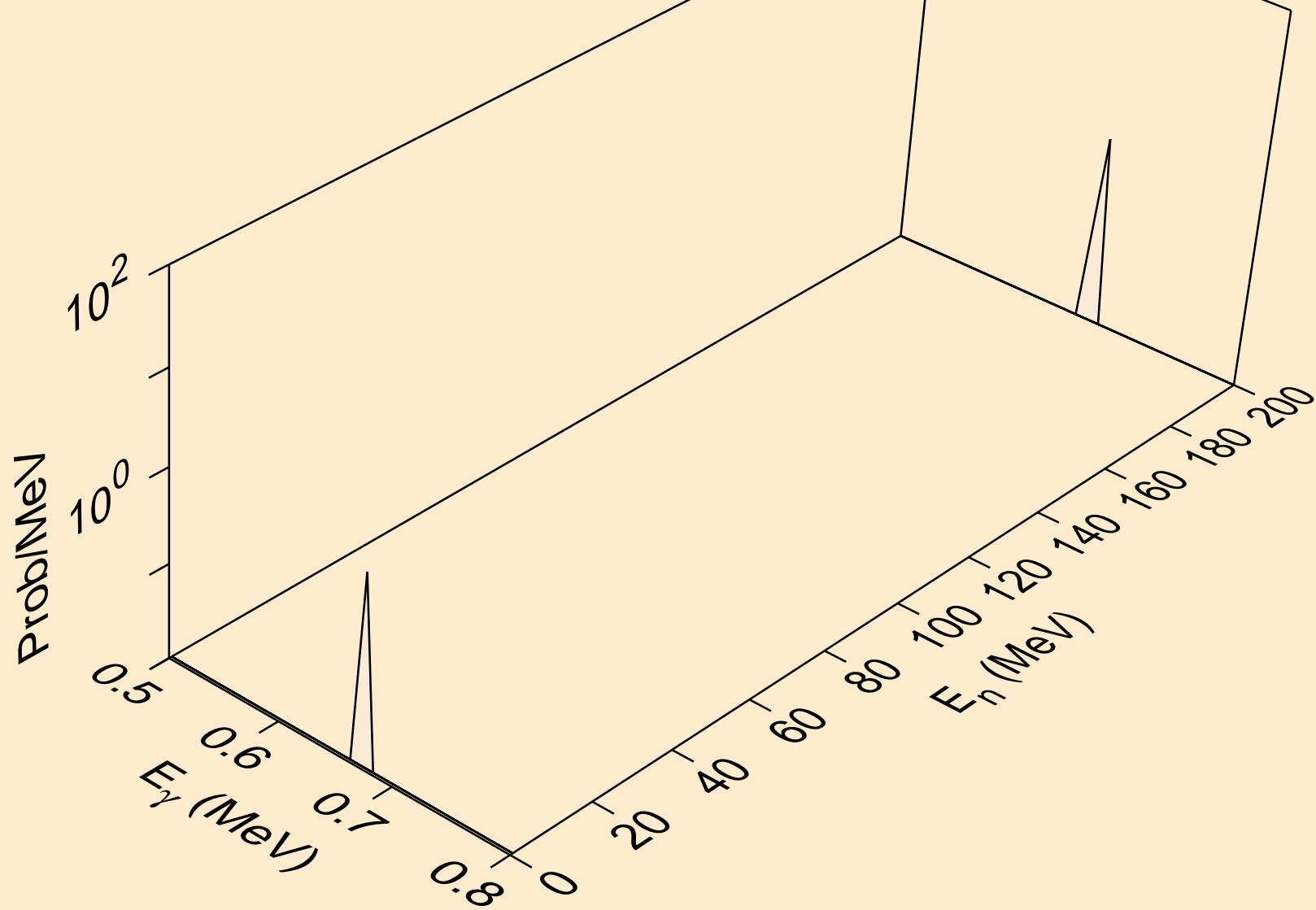

SB126N NEUTRON ACER TENDL-2023 LIBRARY; T=0.K  
Photon emission for (n,n\*7)

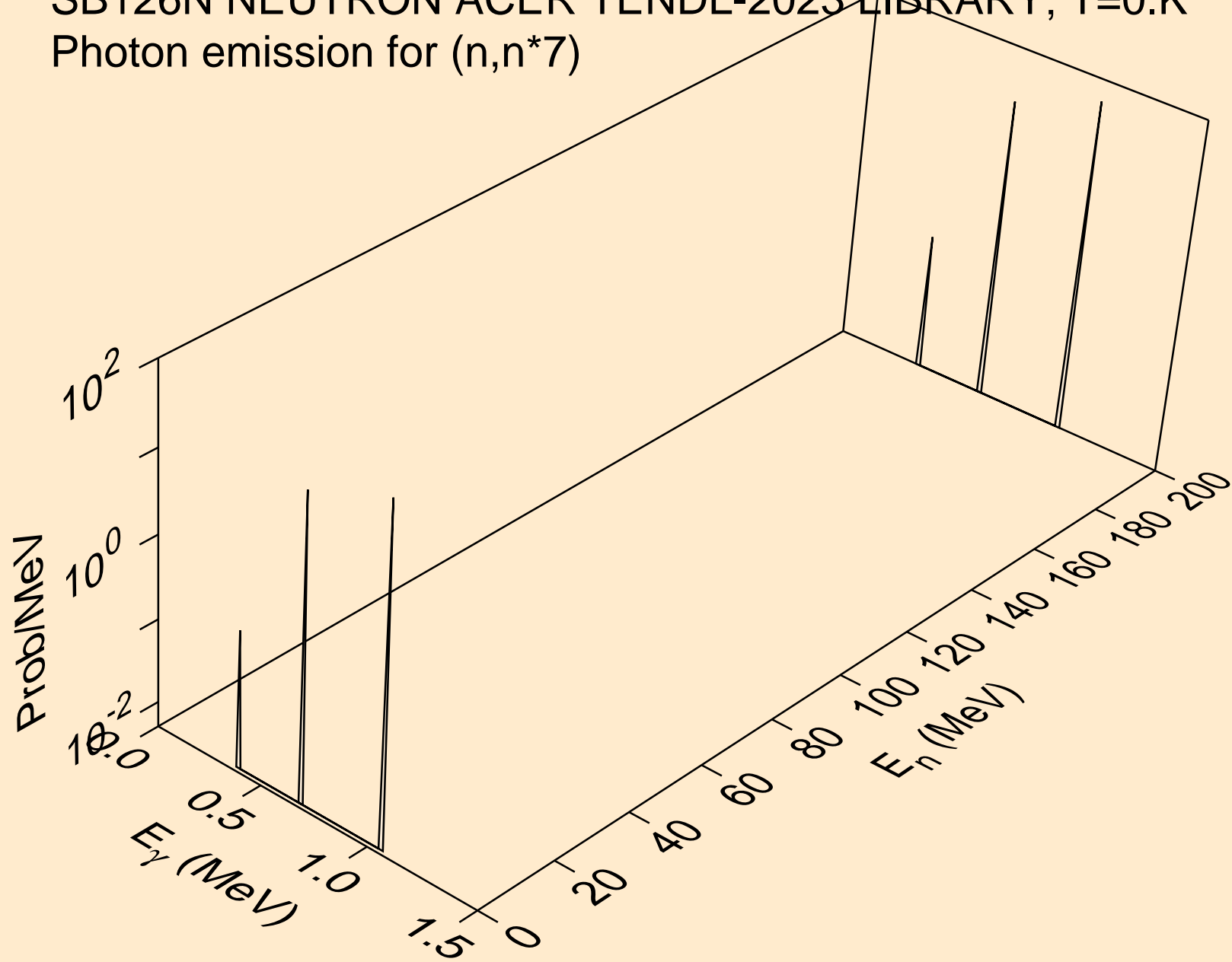

SB126N NEUTRON ACER TENDL-2023 LIBRARY; T=0.K  
Photon emission for (n,n\*c)

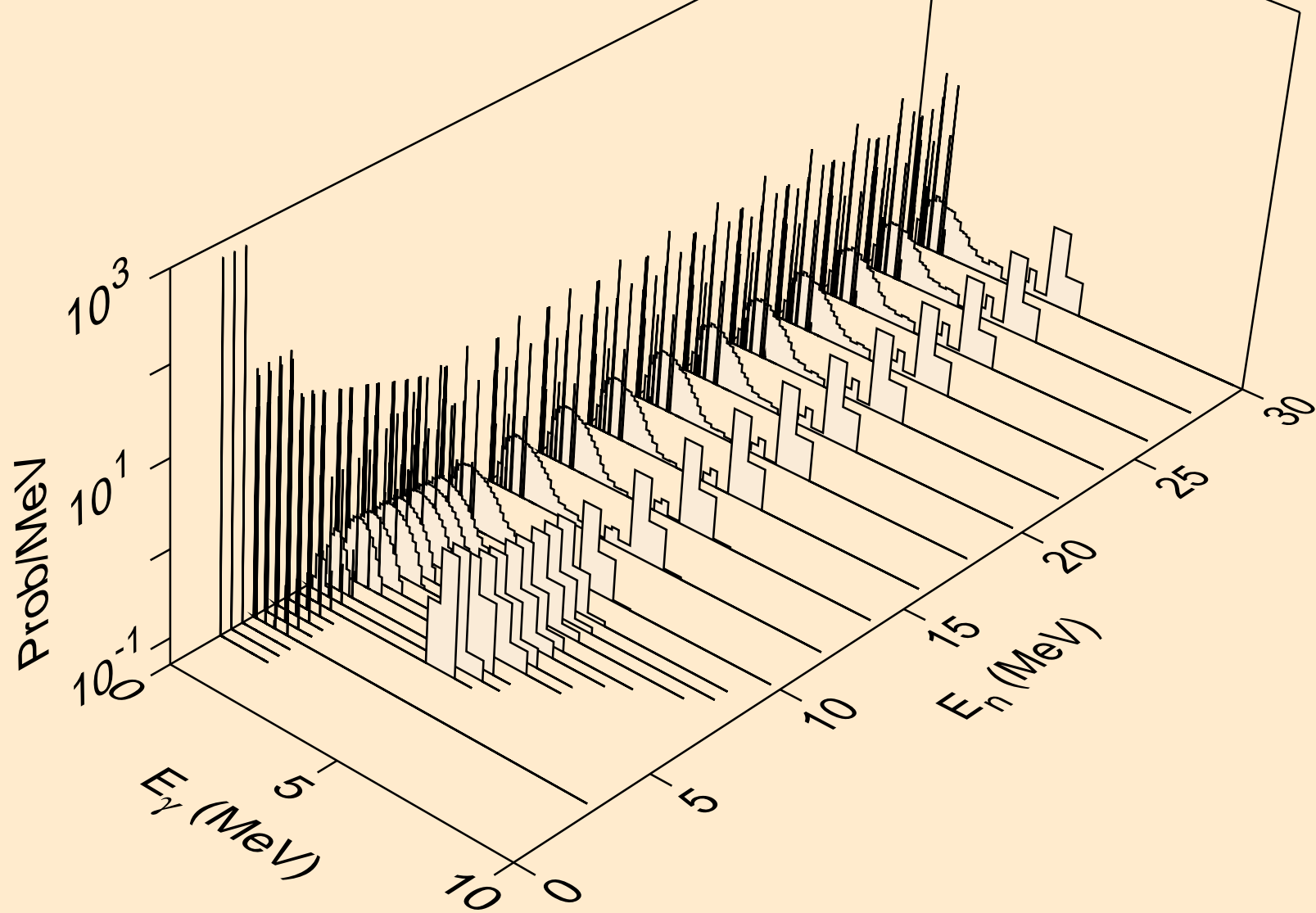

SB126N NEUTRON ACER TENDL-2023 LIBRARY; T=0.K  
Photon emission for (n,gma)

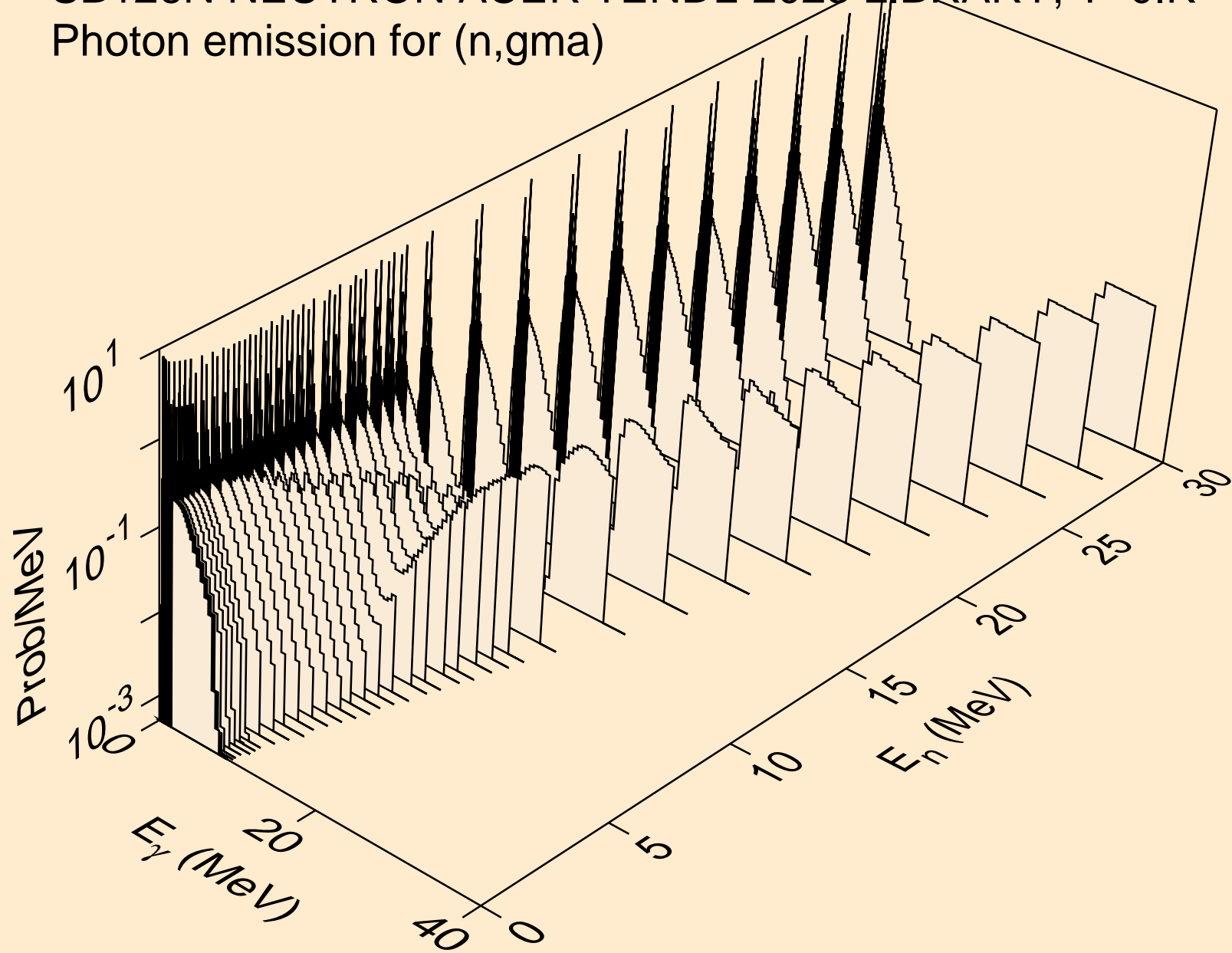

SB126N NEUTRON ACER TENDL-2023 LIBRARY; T=0.K  
Photon emission for (n,p)

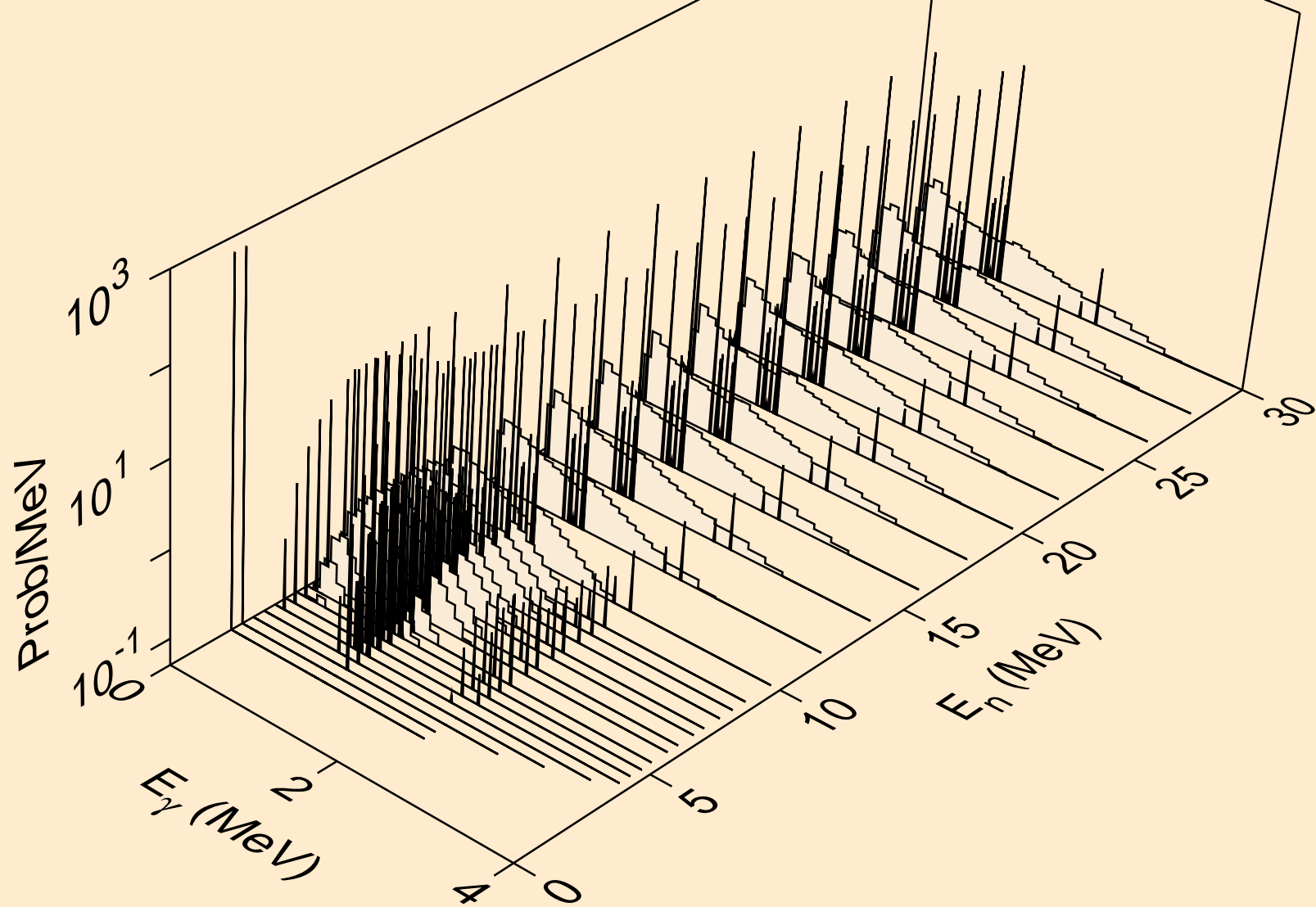



SB126N NEUTRON ACER TENDL-2023 LIBRARY; T=0.K  
Photon emission for (n,d)

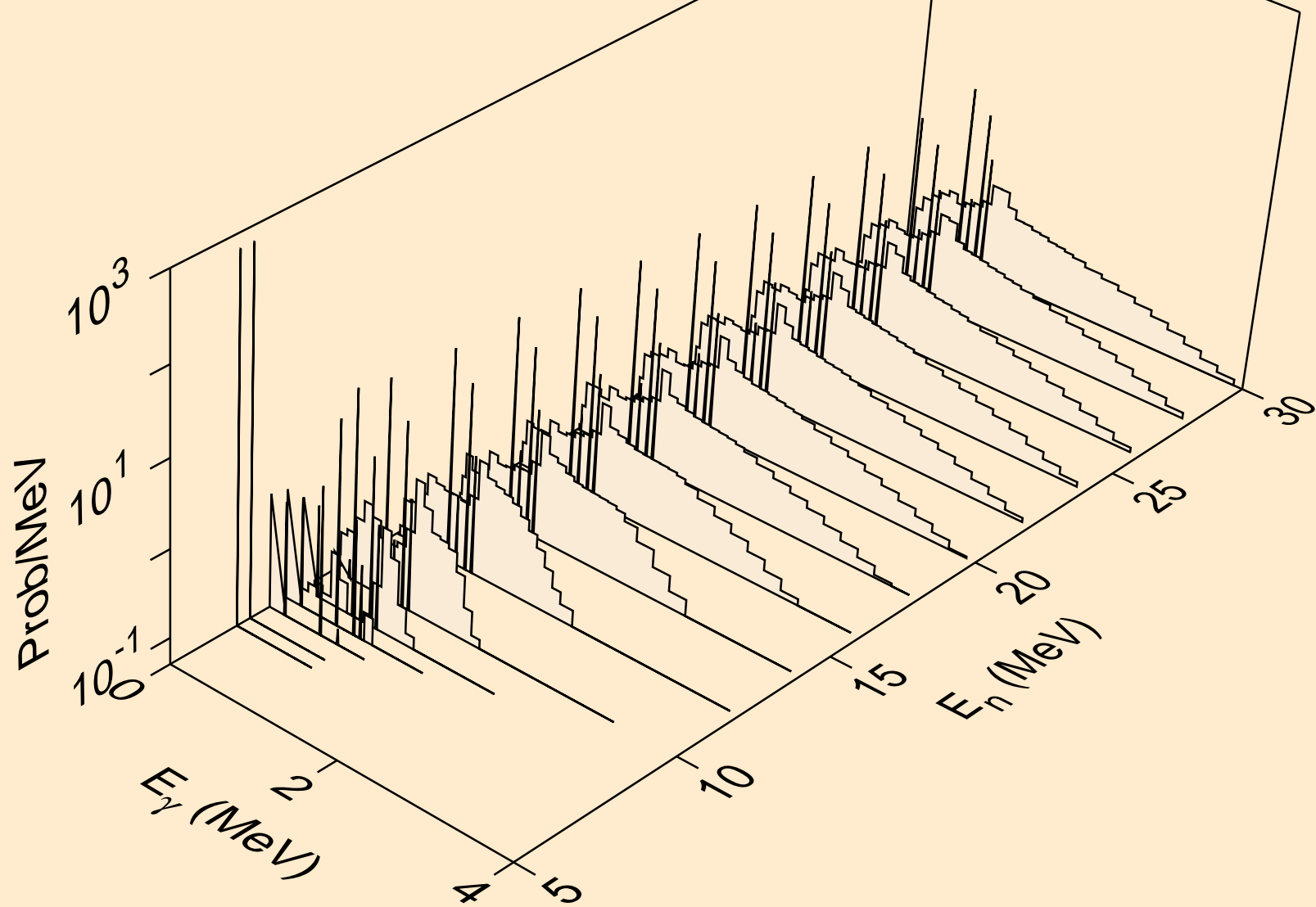

SB126N NEUTRON ACER TENDL-2023 LIBRARY; T=0.K  
Photon emission for (n,t)

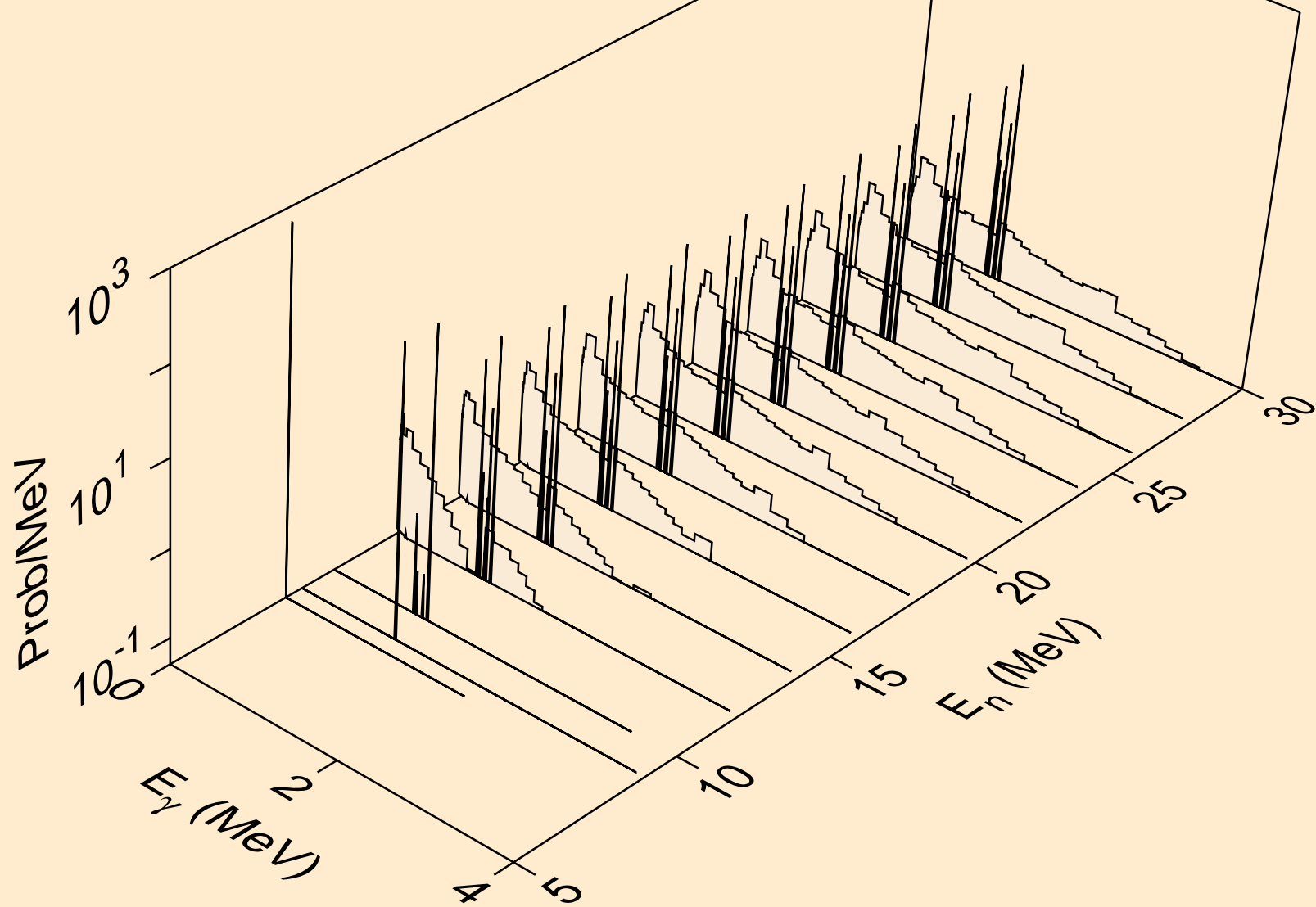

SB126N NEUTRON ACER TENDL-2023 LIBRARY; T=0.K  
Photon emission for (n,he3)

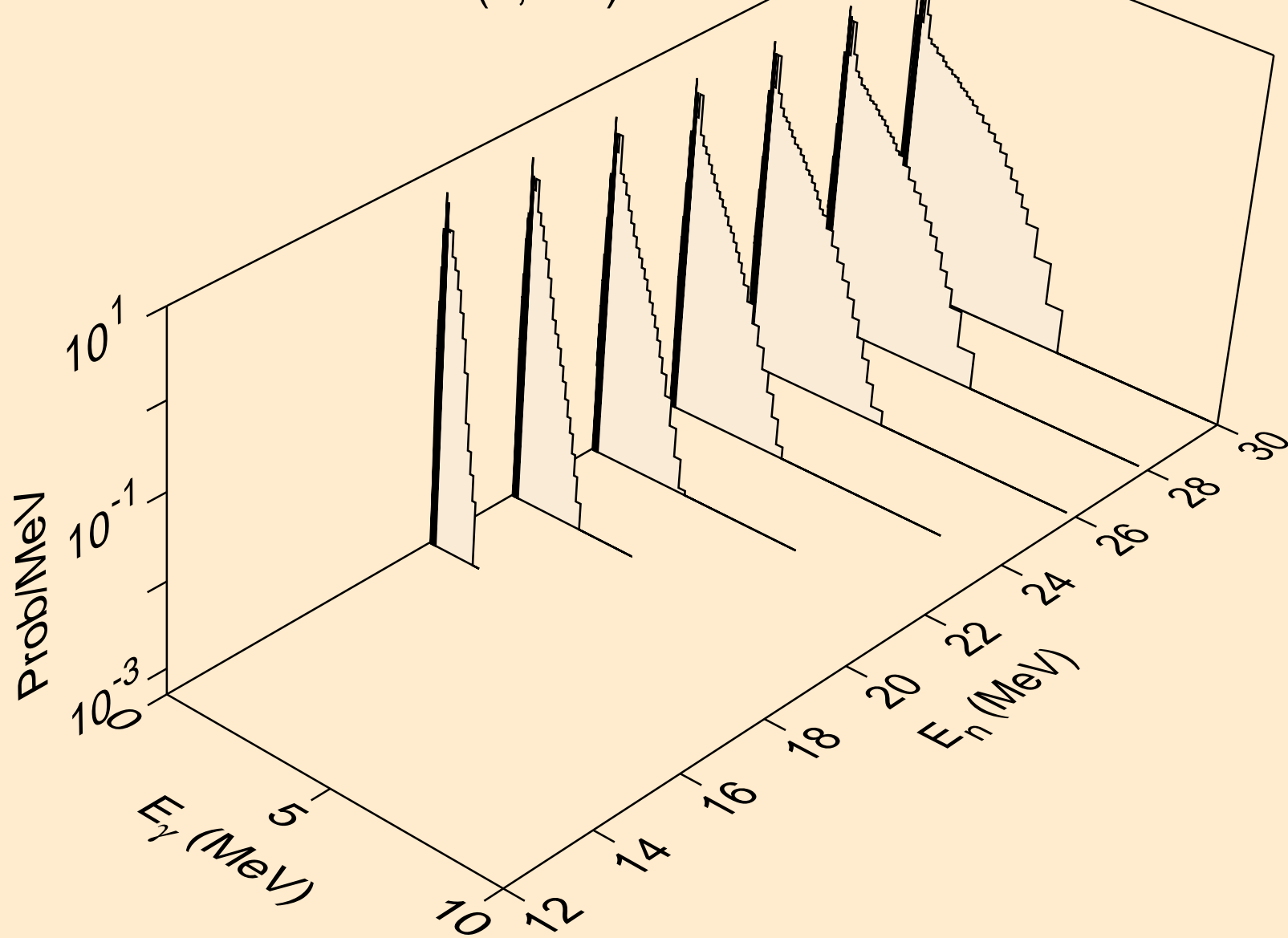

SB126N NEUTRON ACER TENDL-2023 LIBRARY; T=0.K  
Photon emission for (n,a)

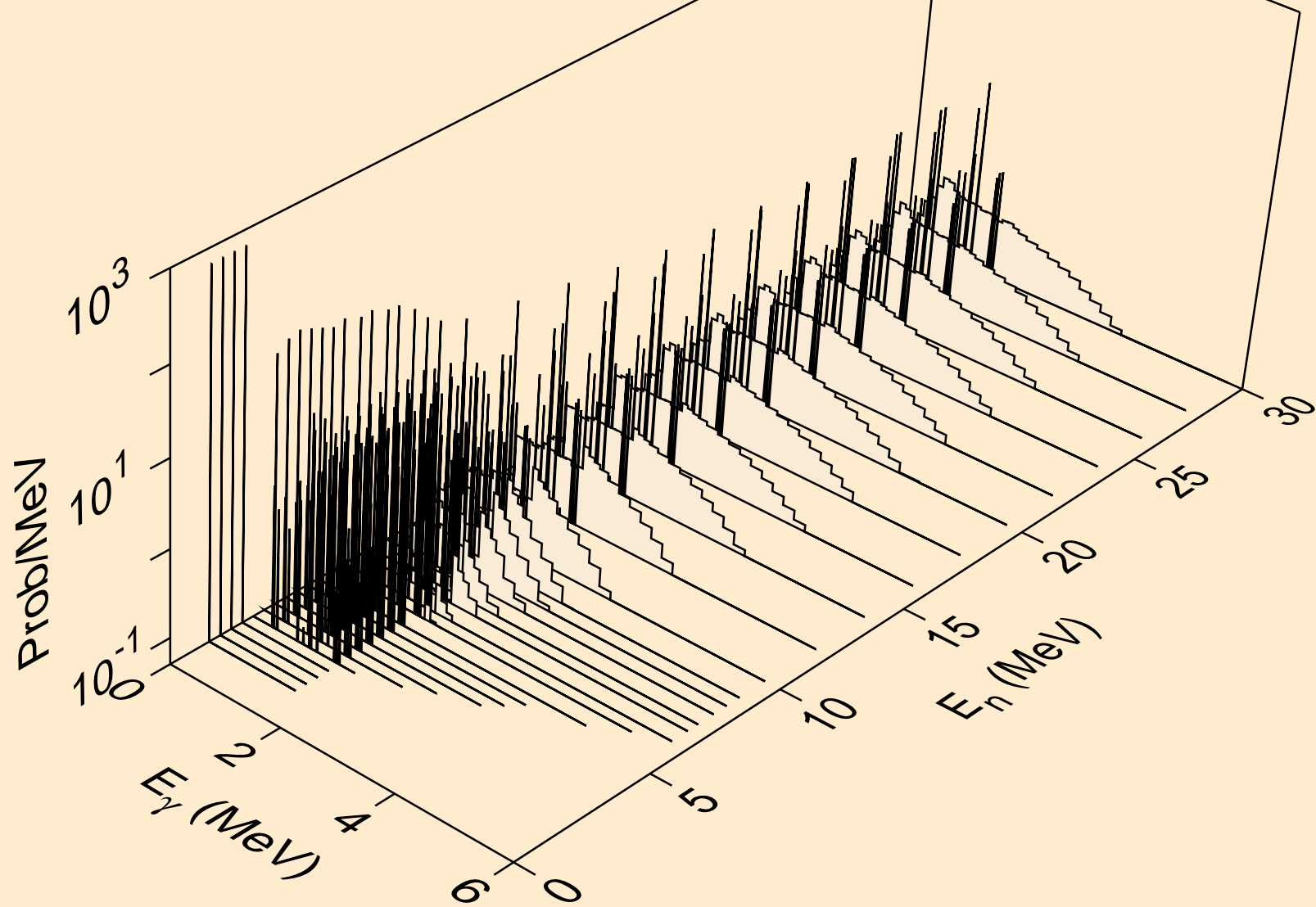

SB126N NEUTRON ACER TENDL-2023 LIBRARY; T=0.K  
Photon emission for (n,2p)

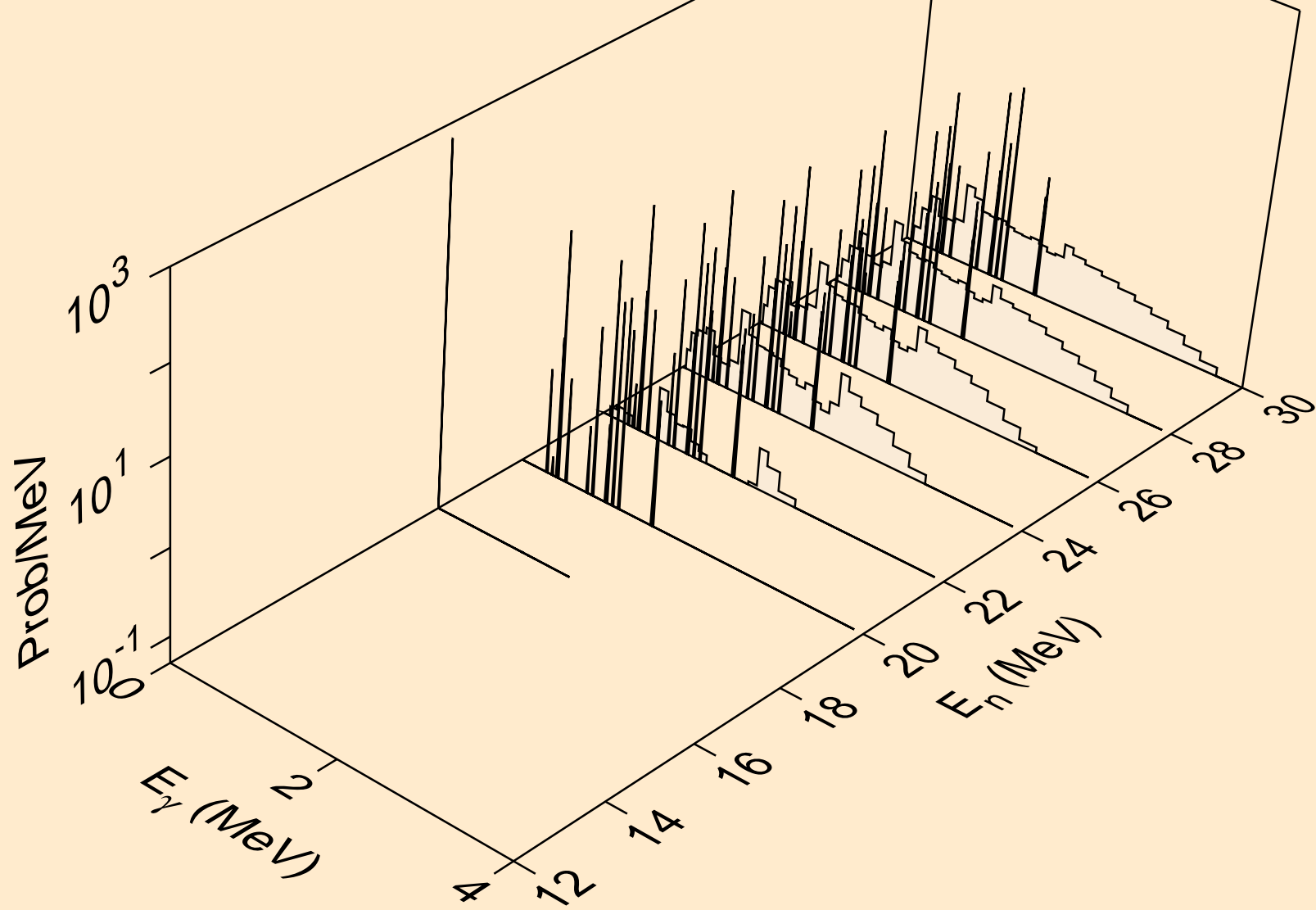

SB126N NEUTRON ACER TENDL-2023 LIBRARY; T=0.K  
Photon emission for (n,p)

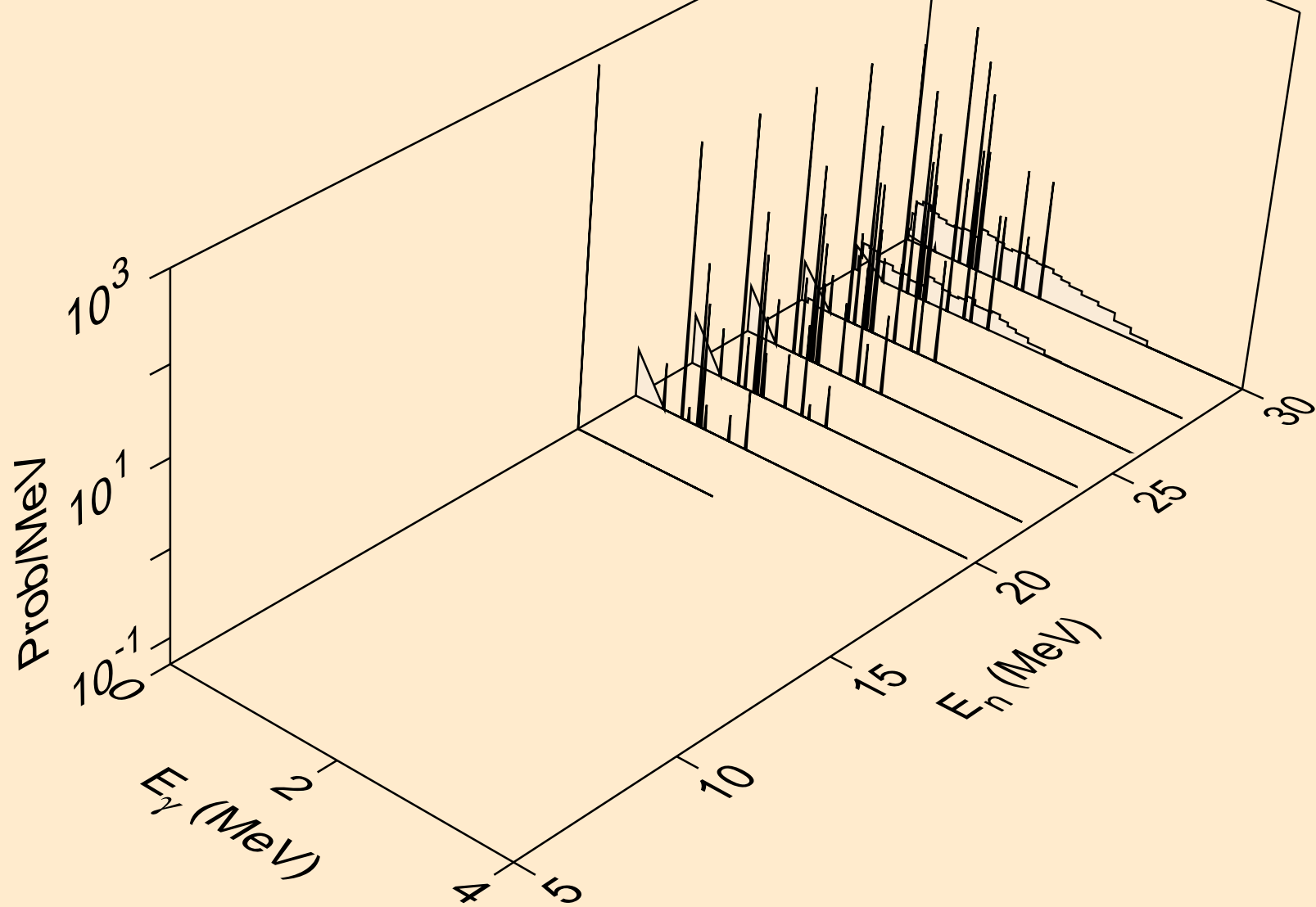

SB126N NEUTRON ACER TENDL-2023 LIBRARY; T=0.K  
thermal capture photon spectrum

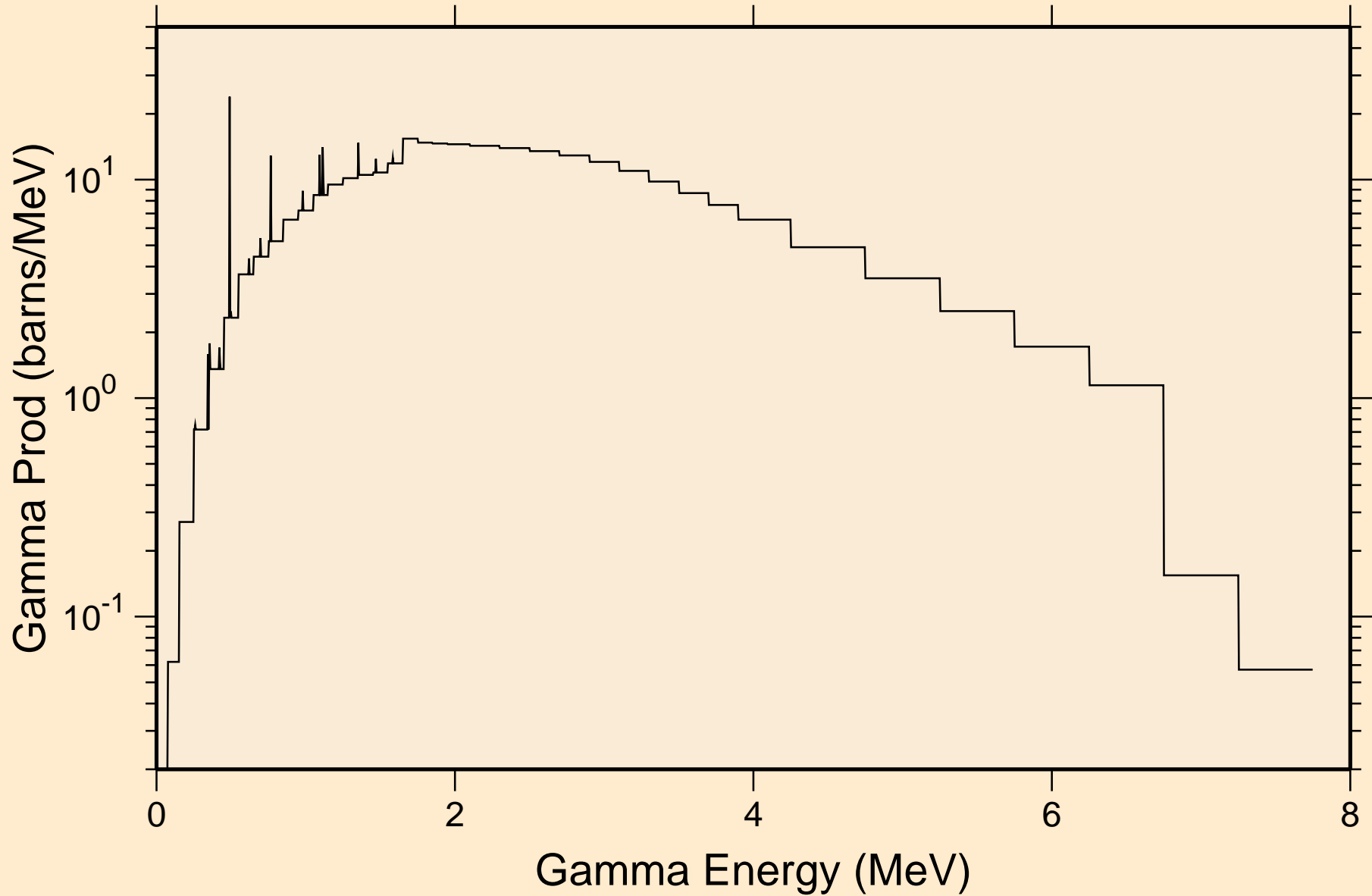

SB126N NEUTRON ACER TENDL-2023 LIBRARY; T=0.K  
14 MeV photon spectrum

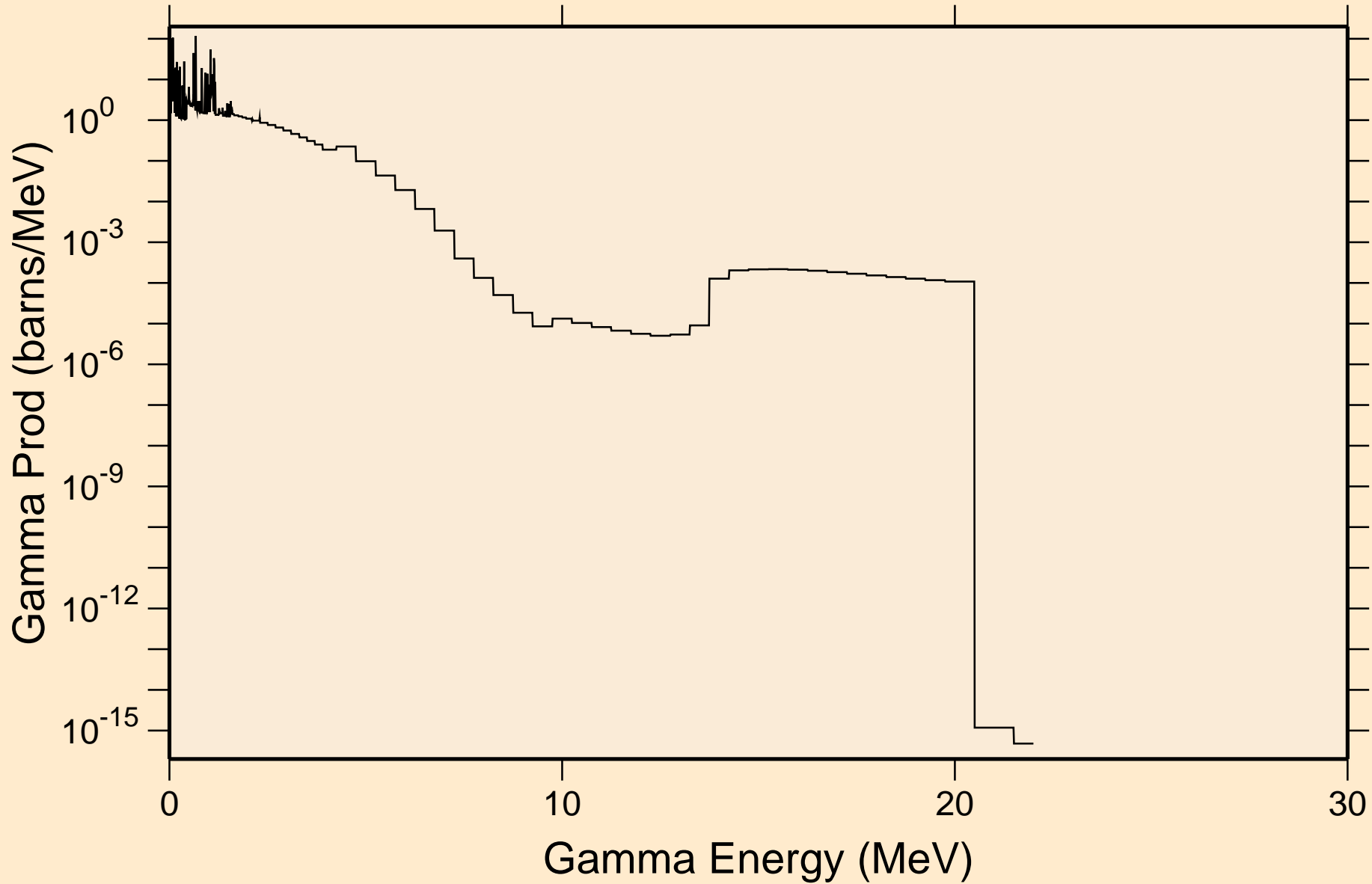



# SB126N NEUTRON ACER TENDL-2023 LIBRARY; T=0.K

## Particle heating contributions

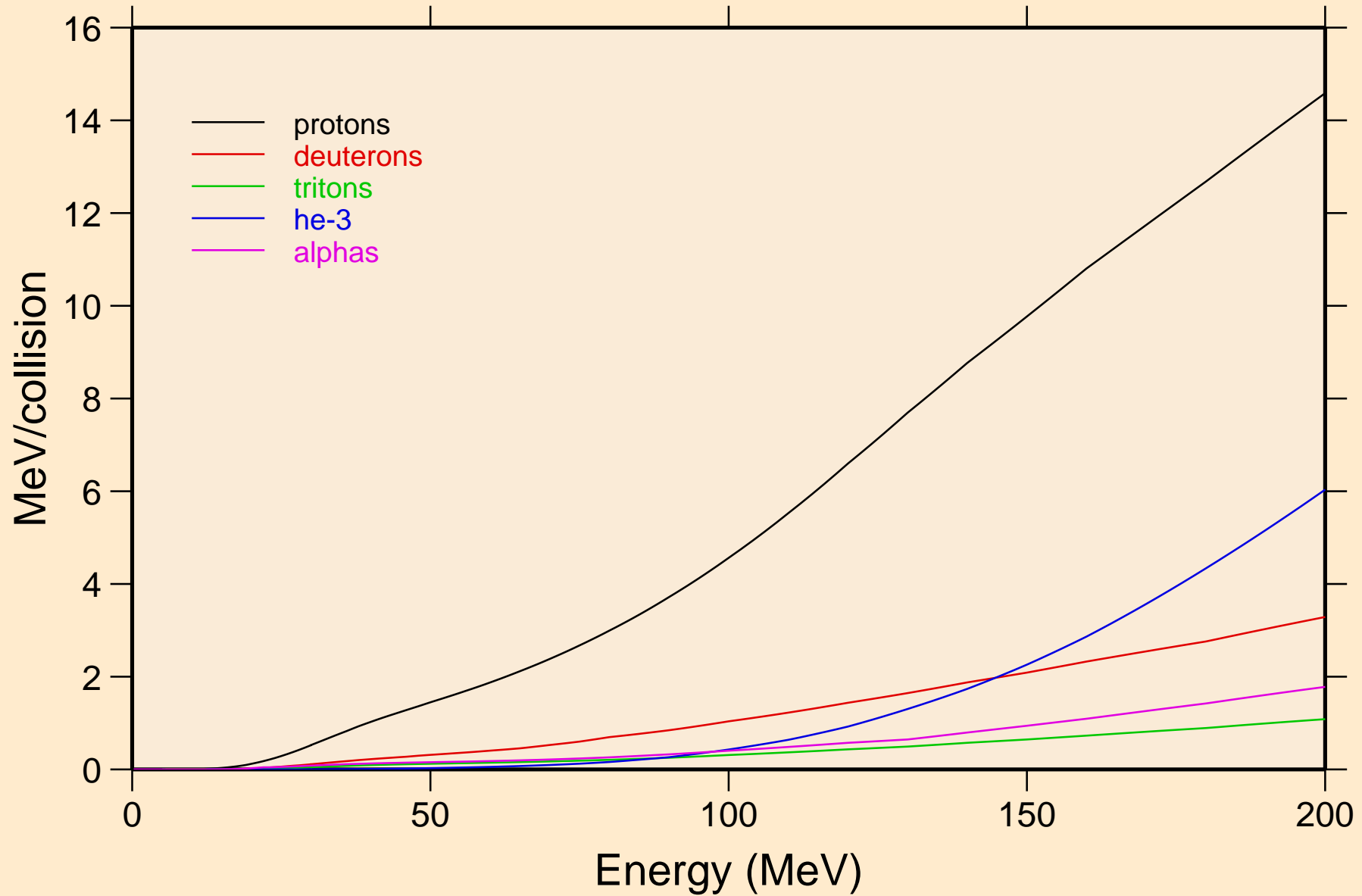

SB126N NEUTRON ACER TENDL-2023 LIBRARY; T=0.K  
Recoil Heating

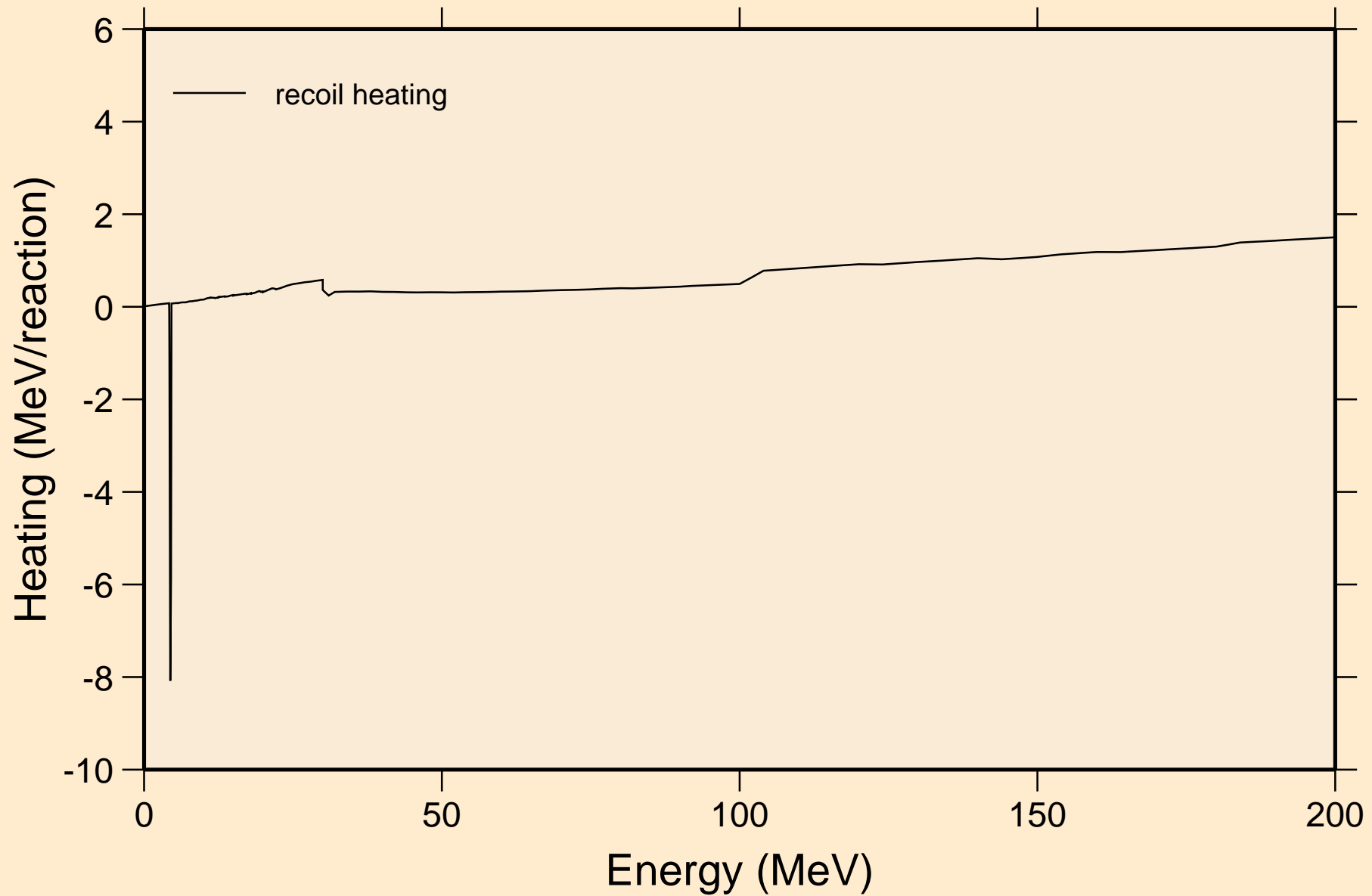

SB126N NEUTRON ACER TENDL-2023 LIBRARY; T=0.K  
Particle production cross sections

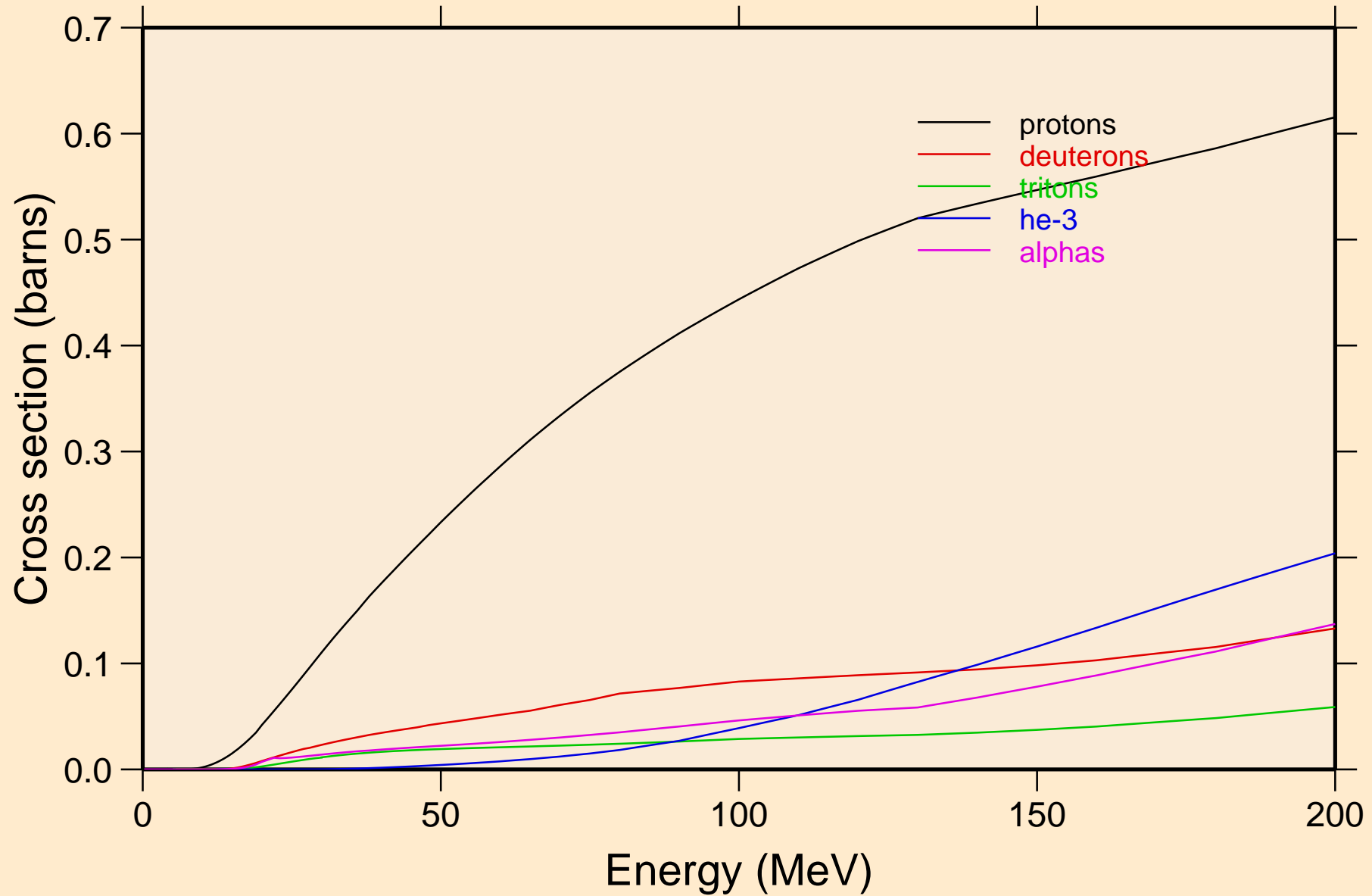

SB126N NEUTRON ACER TENDL-2023 LIBRARY; T=0.K  
protons from (n,x)

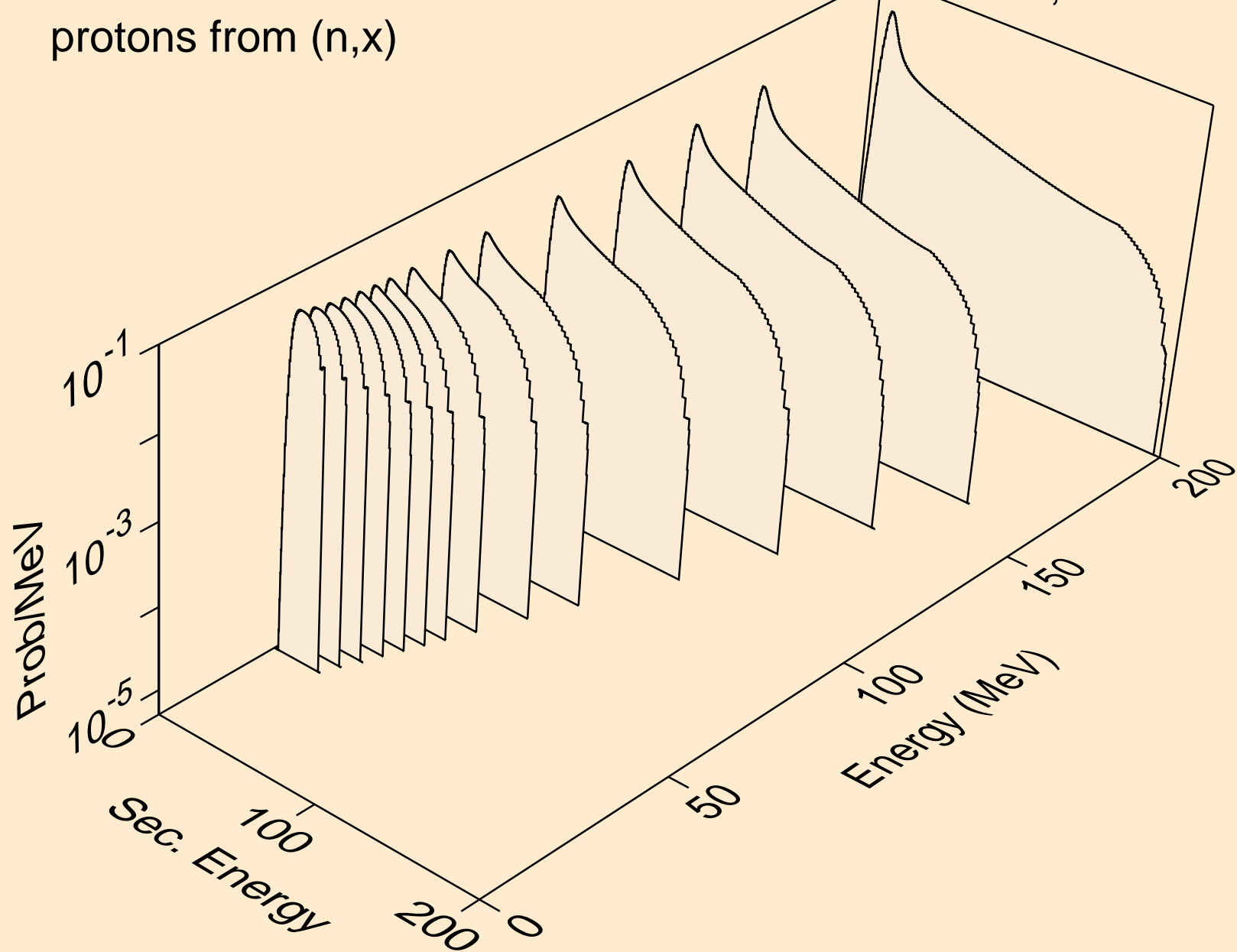

SB126N NEUTRON ACER TENDL-2023 LIBRARY; T=0.K  
protons from (n,n\*)p

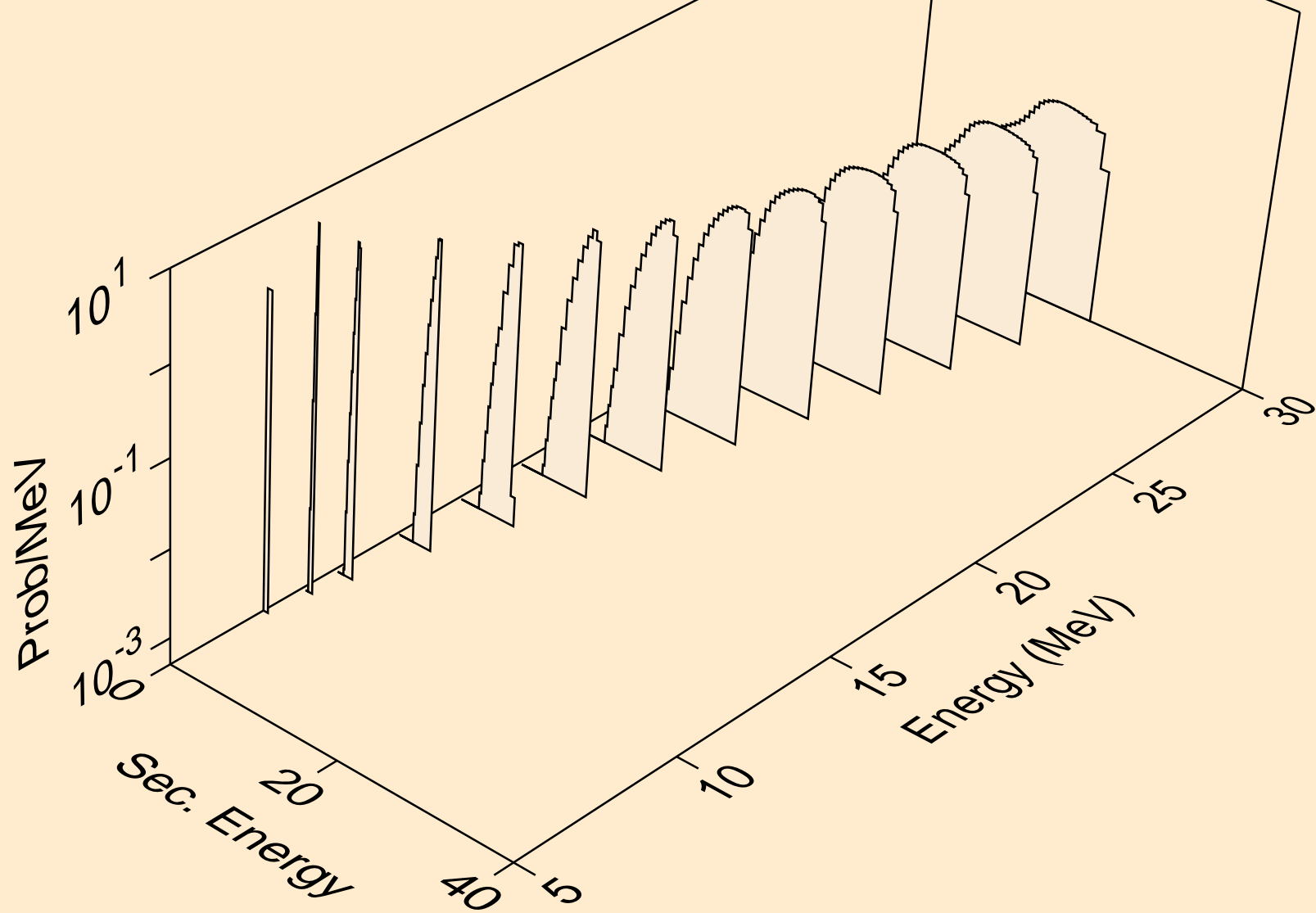

SB126N NEUTRON ACER TENDL-2023 LIBRARY; T=0.K  
protons from (n,2np)

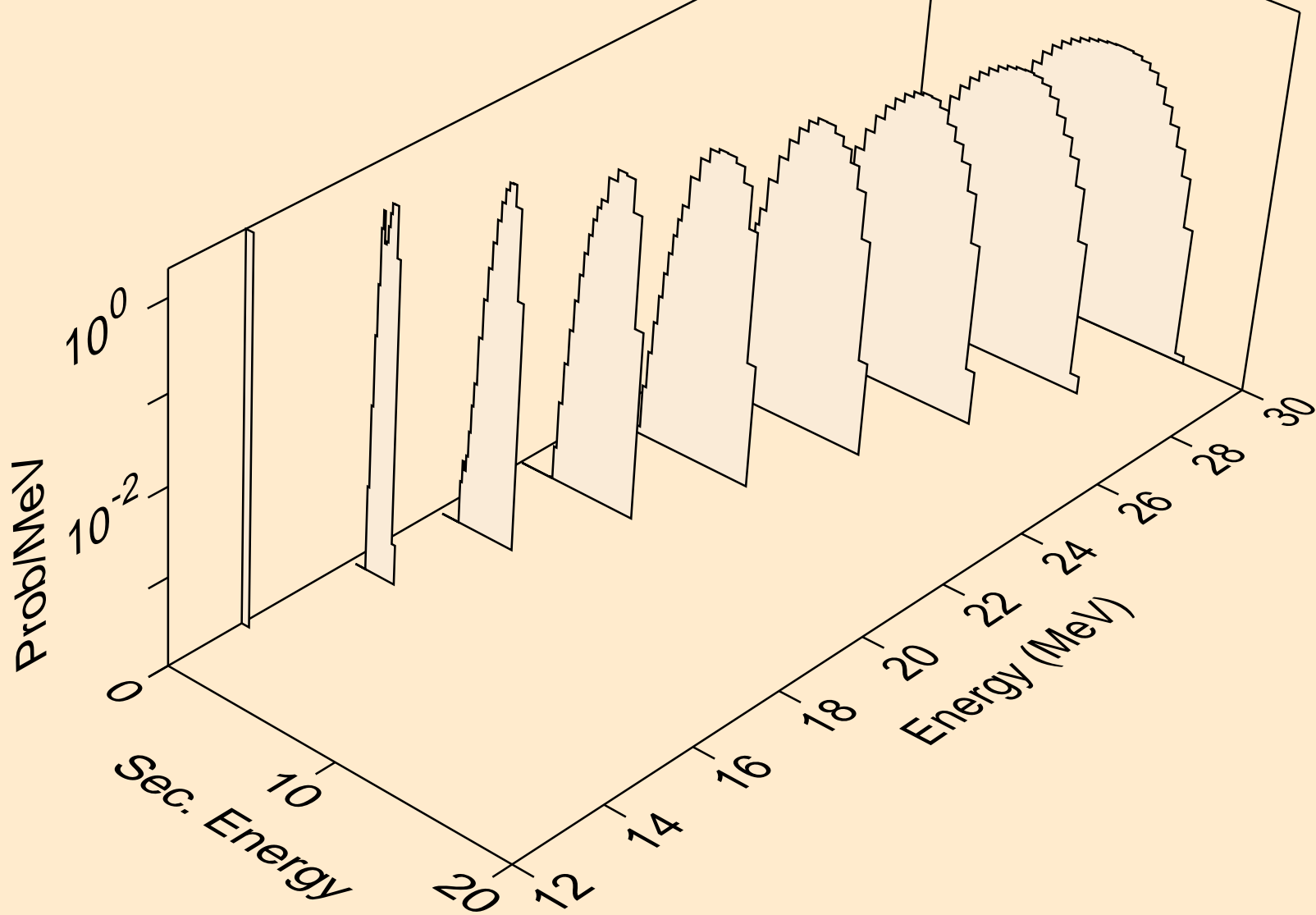

SB126N NEUTRON ACER TENDL-2023 LIBRARY; T=0.K  
protons from (n,3np)

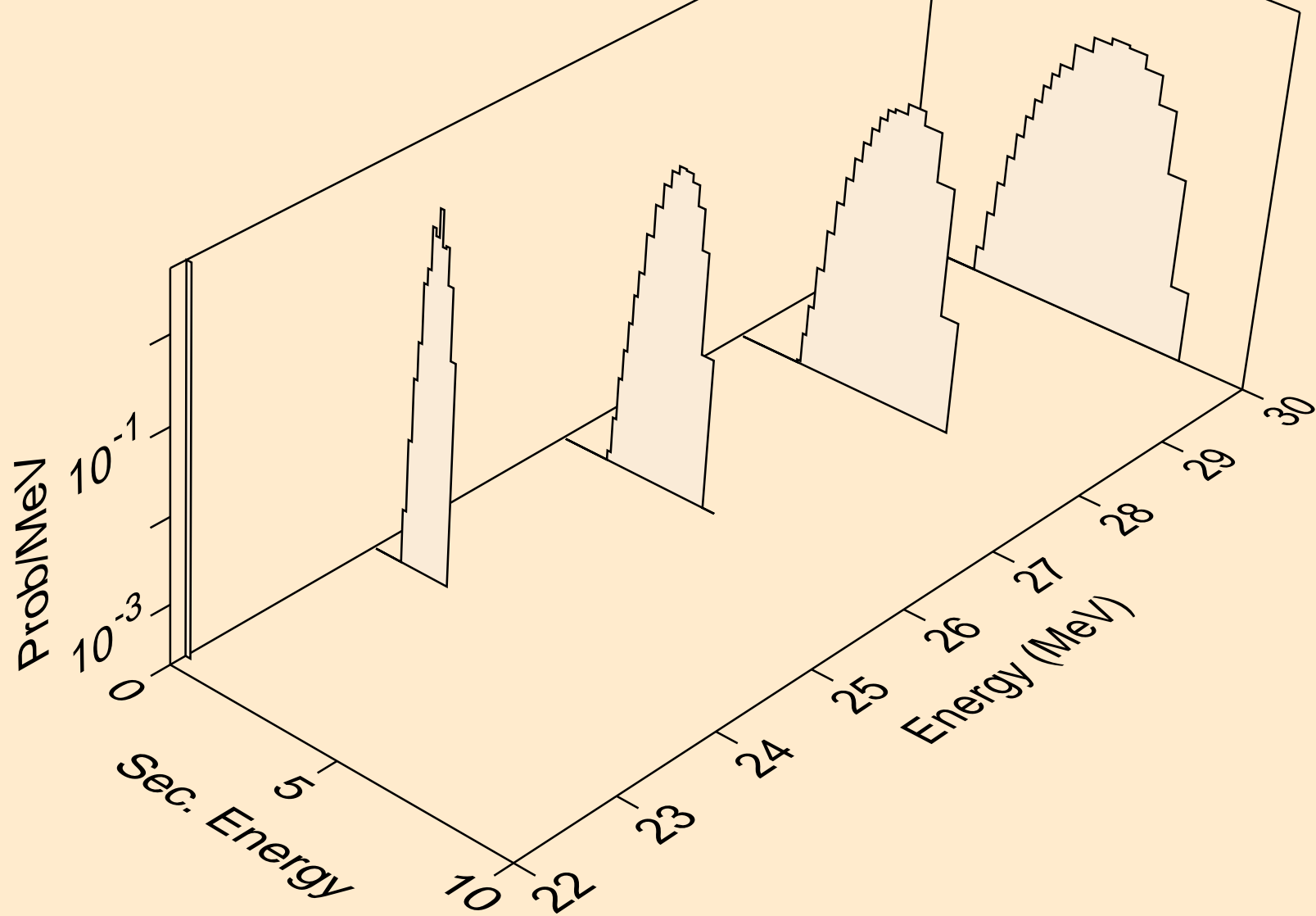

SB126N NEUTRON ACER TENDL-2023 LIBRARY; T=0.K  
protons from (n,n2p)

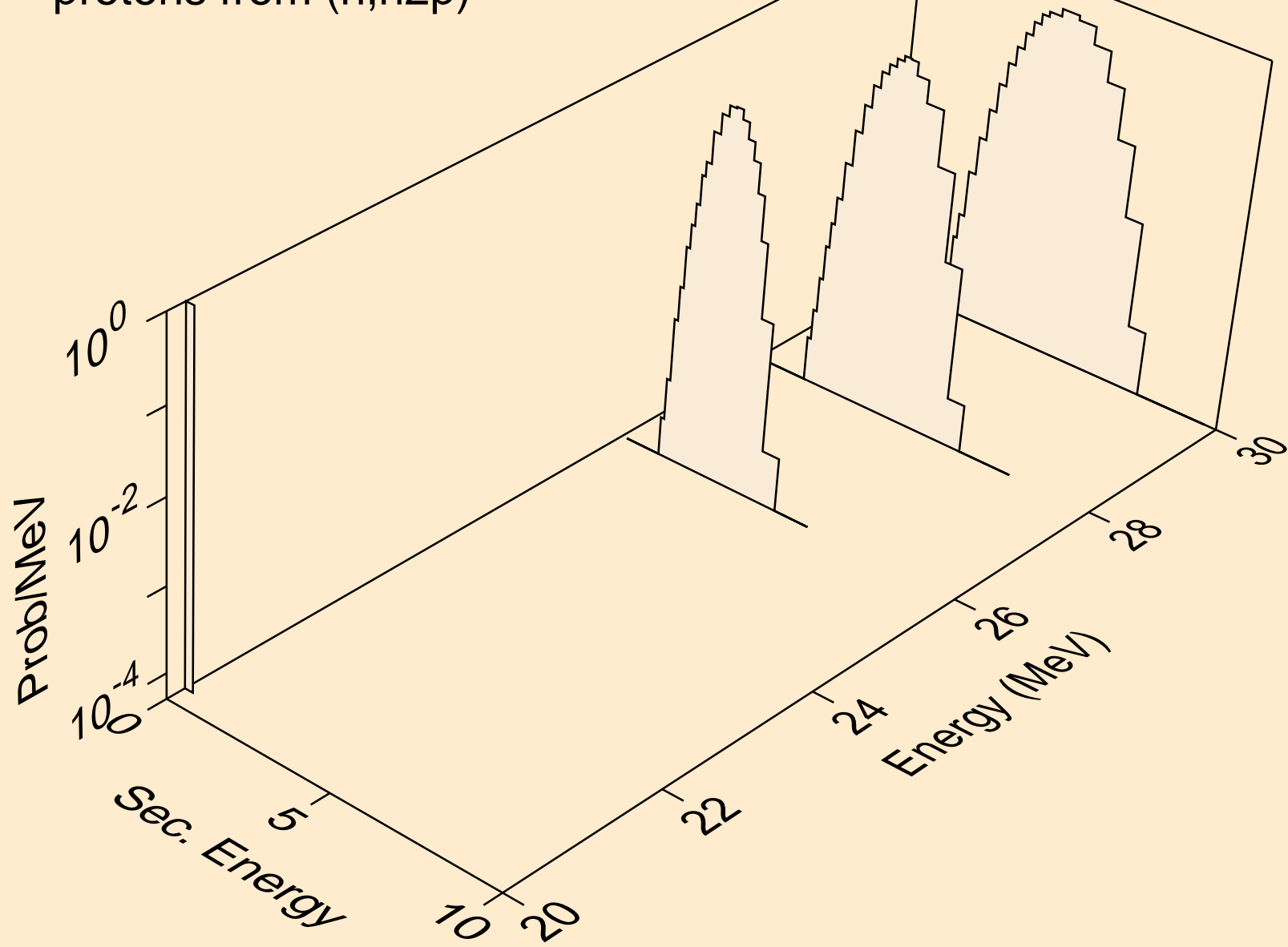



SB126N NEUTRON ACER TENDL-2023 LIBRARY; T=0.K  
protons from (n,p)

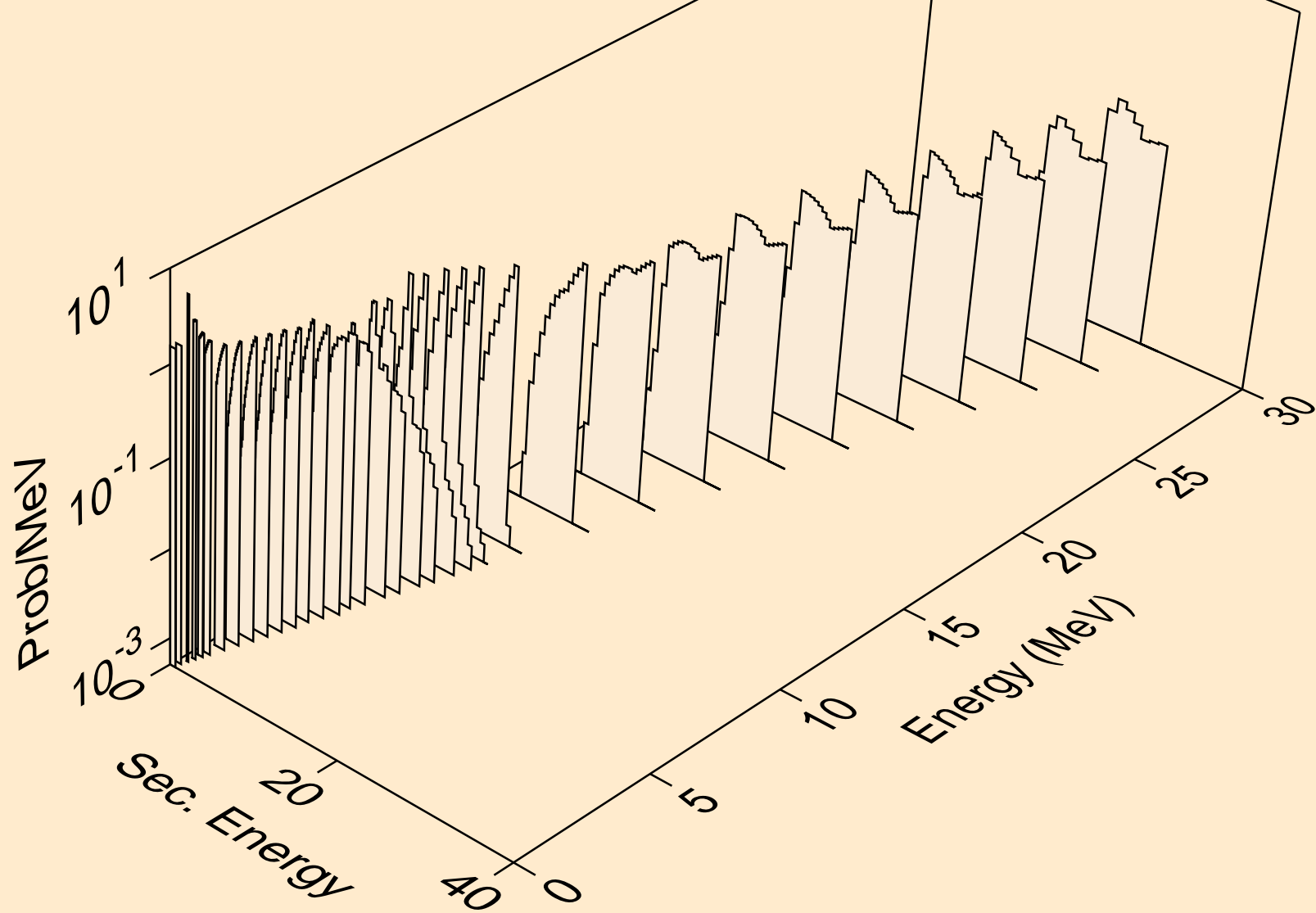

SB126N NEUTRON ACER TENDL-2023 LIBRARY; T=0.K  
protons from (n,2p)

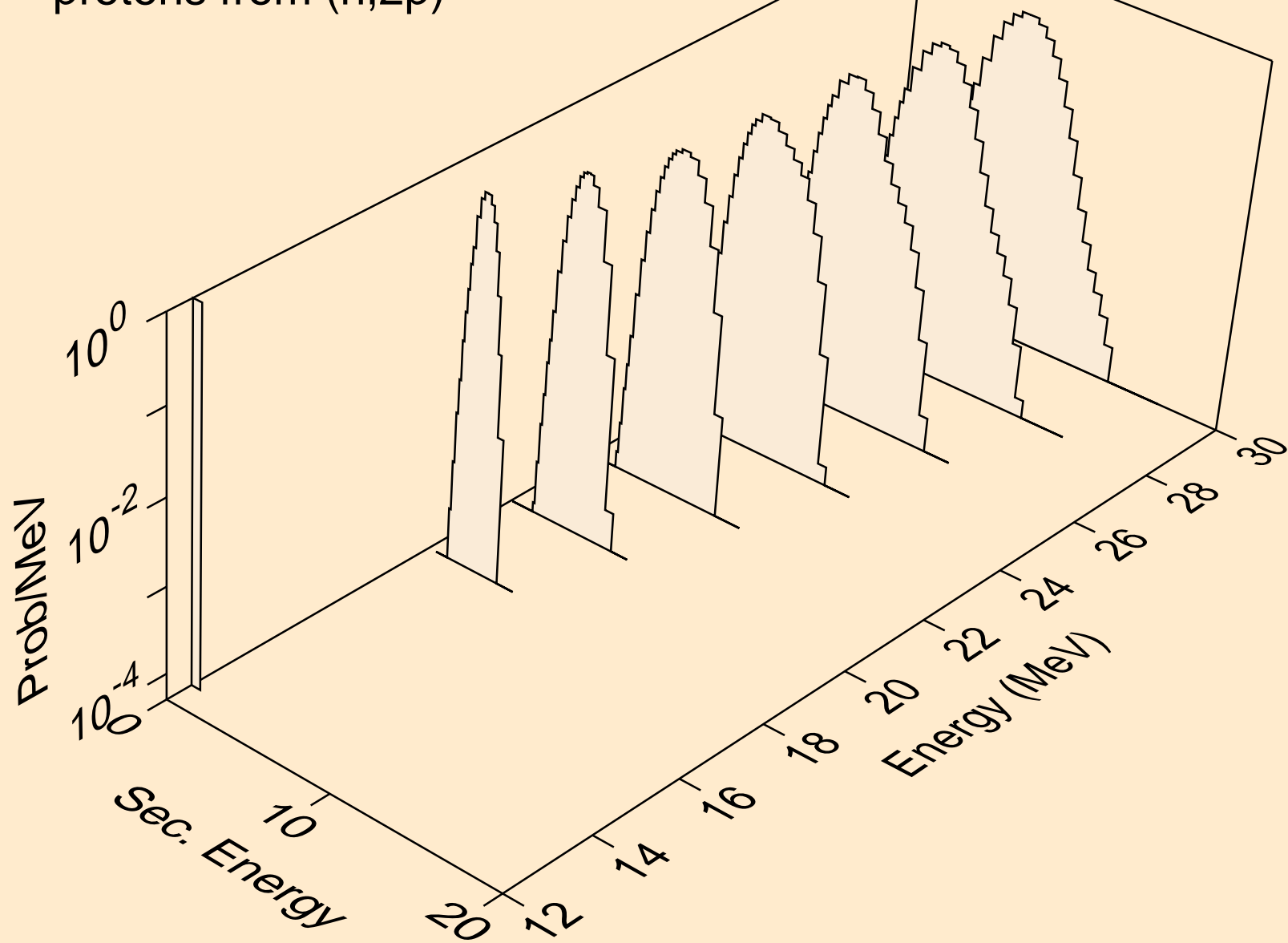

SB126N NEUTRON ACER TENDL-2023 LIBRARY; T=0.K  
protons from (n,pa)

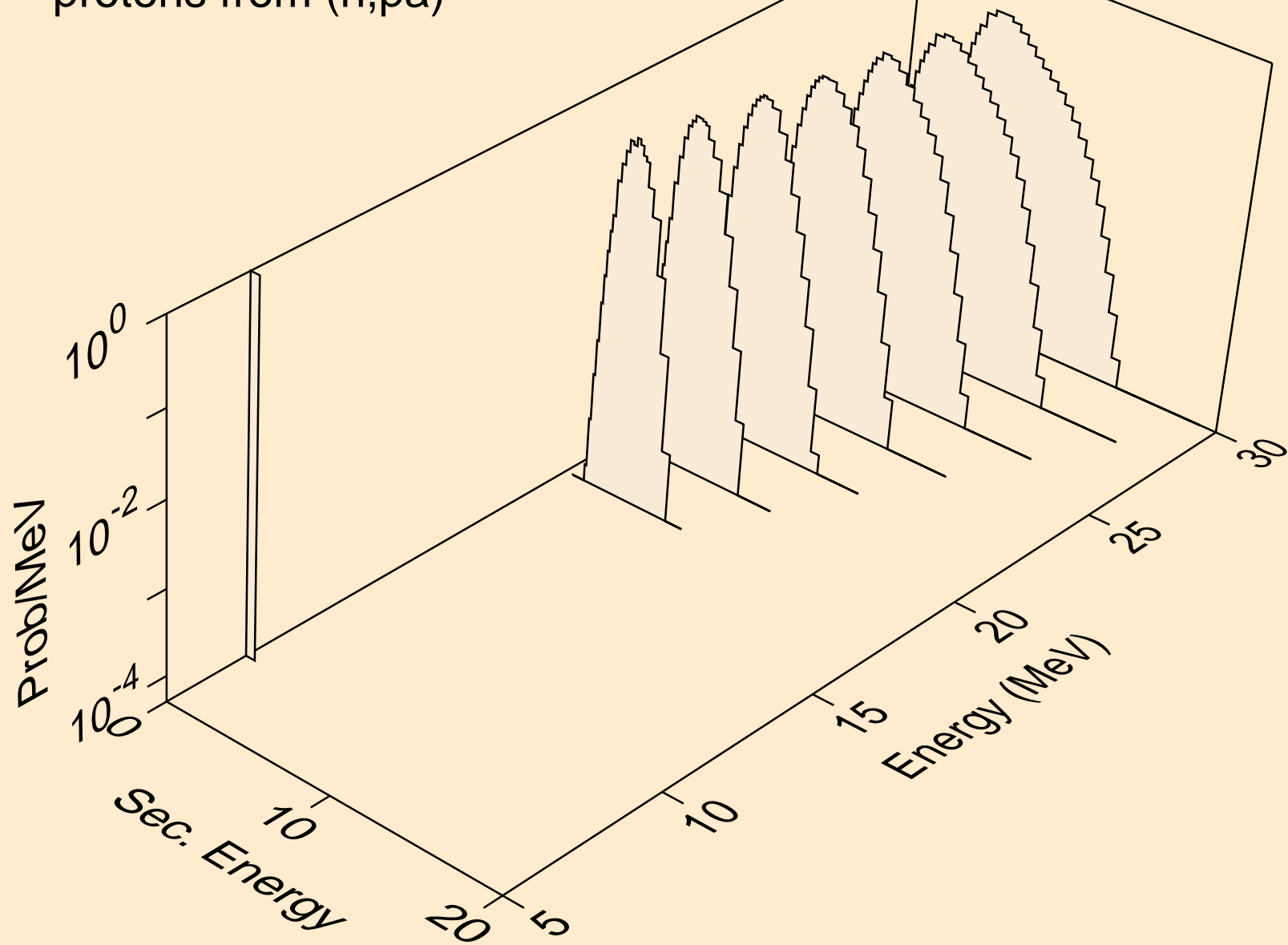

SB126N NEUTRON ACER TENDL-2023 LIBRARY; T=0.K  
deuterons from (n,x)

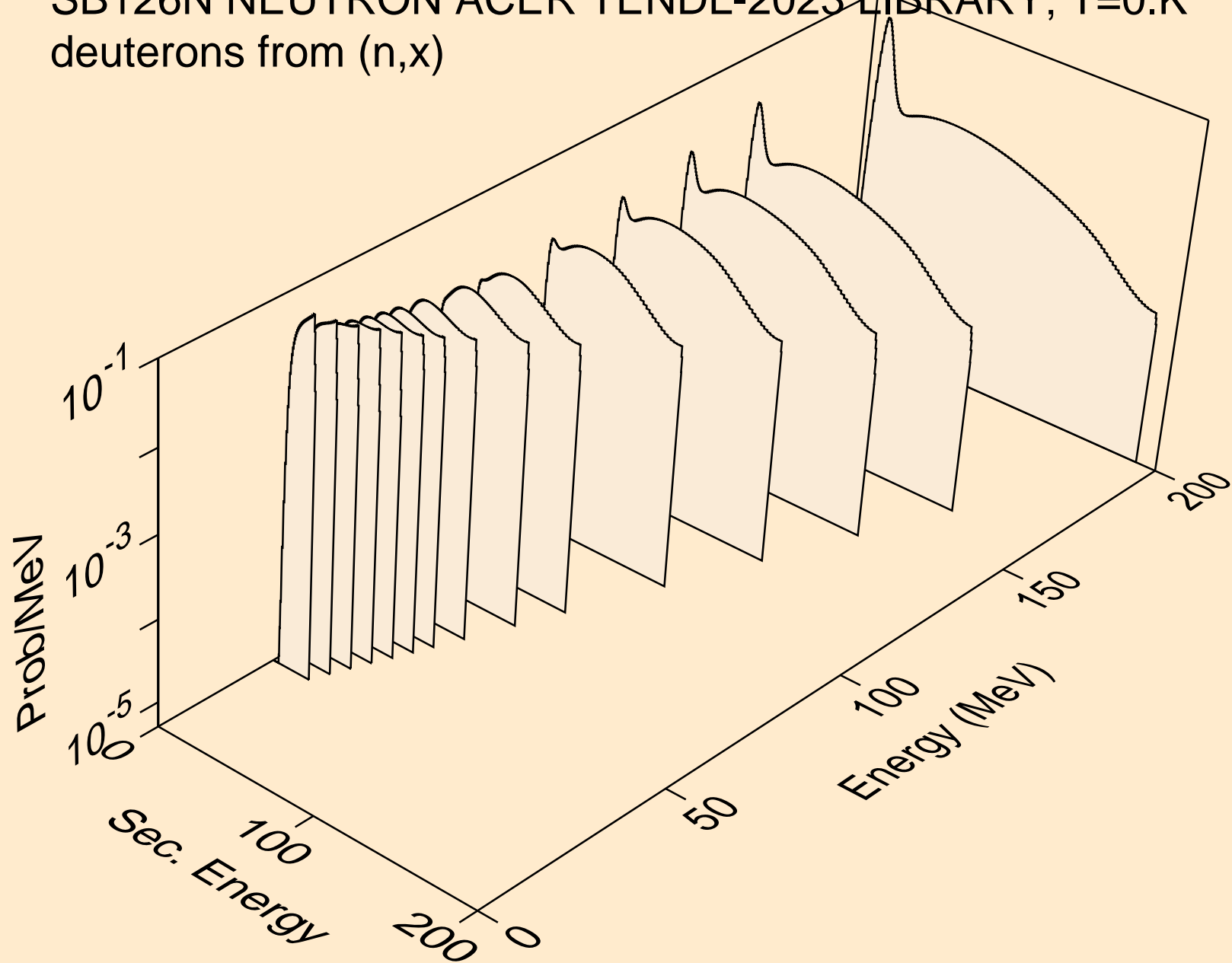

SB126N NEUTRON ACER TENDL-2023 LIBRARY; T=0.K  
deuterons from (n,2nd)

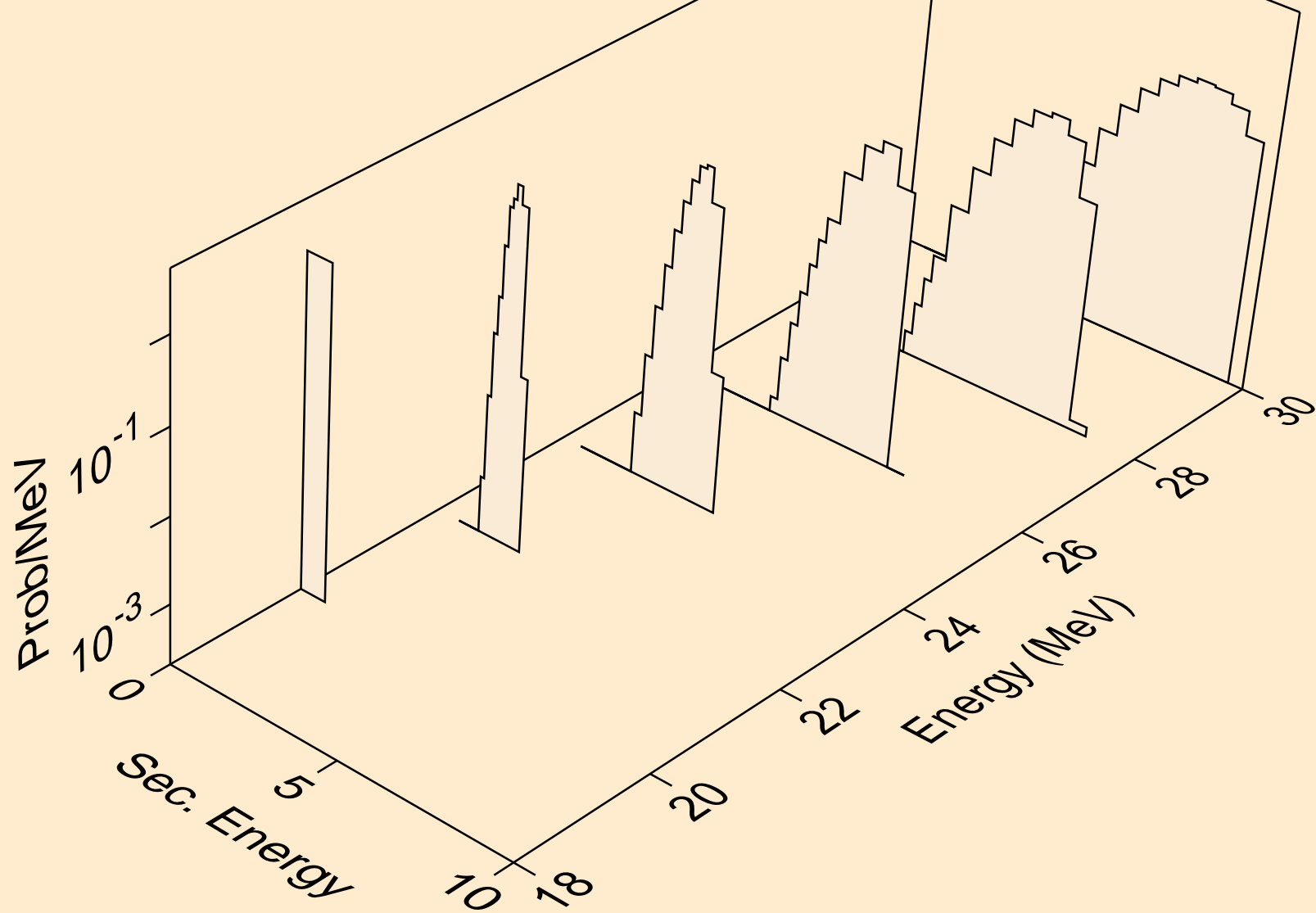

SB126N NEUTRON ACER TENDL-2023 LIBRARY; T=0.K  
deuterons from (n,n\*)d

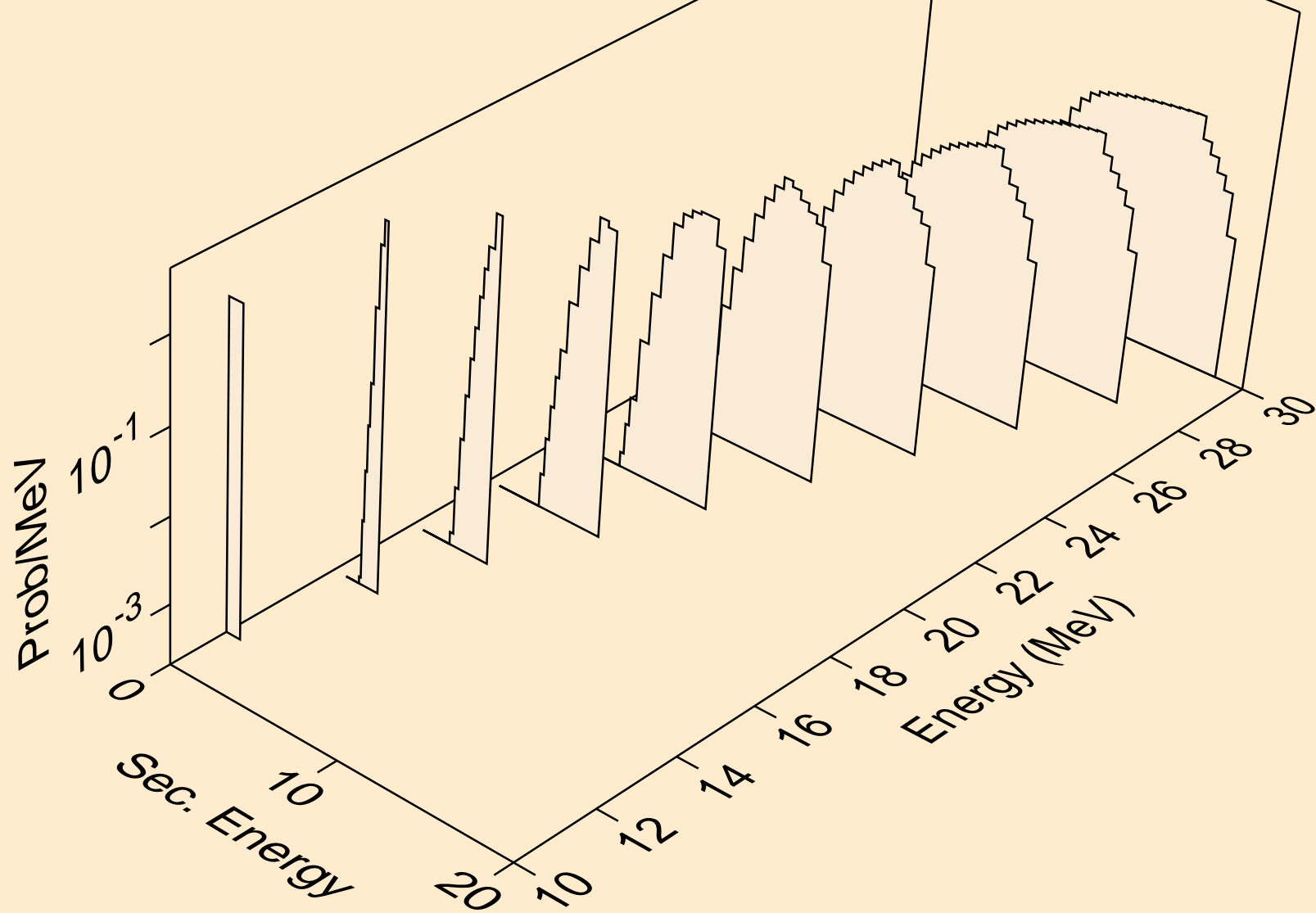

SB126N NEUTRON ACER TENDL-2023 LIBRARY; T=0.K  
deuterons from (n,d)

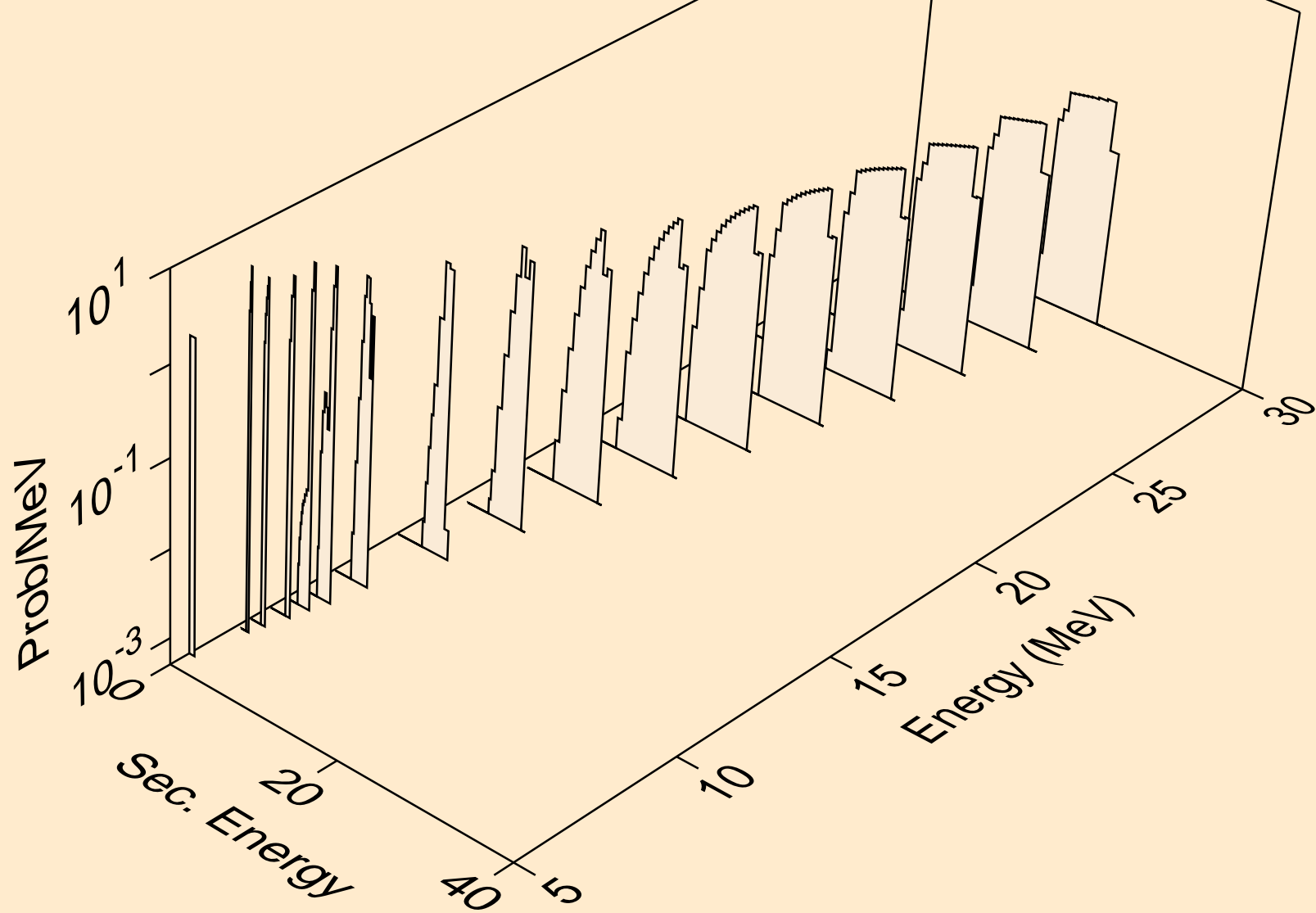

SB126N NEUTRON ACER TENDL-2023 LIBRARY; T=0.K  
tritons from (n,x)

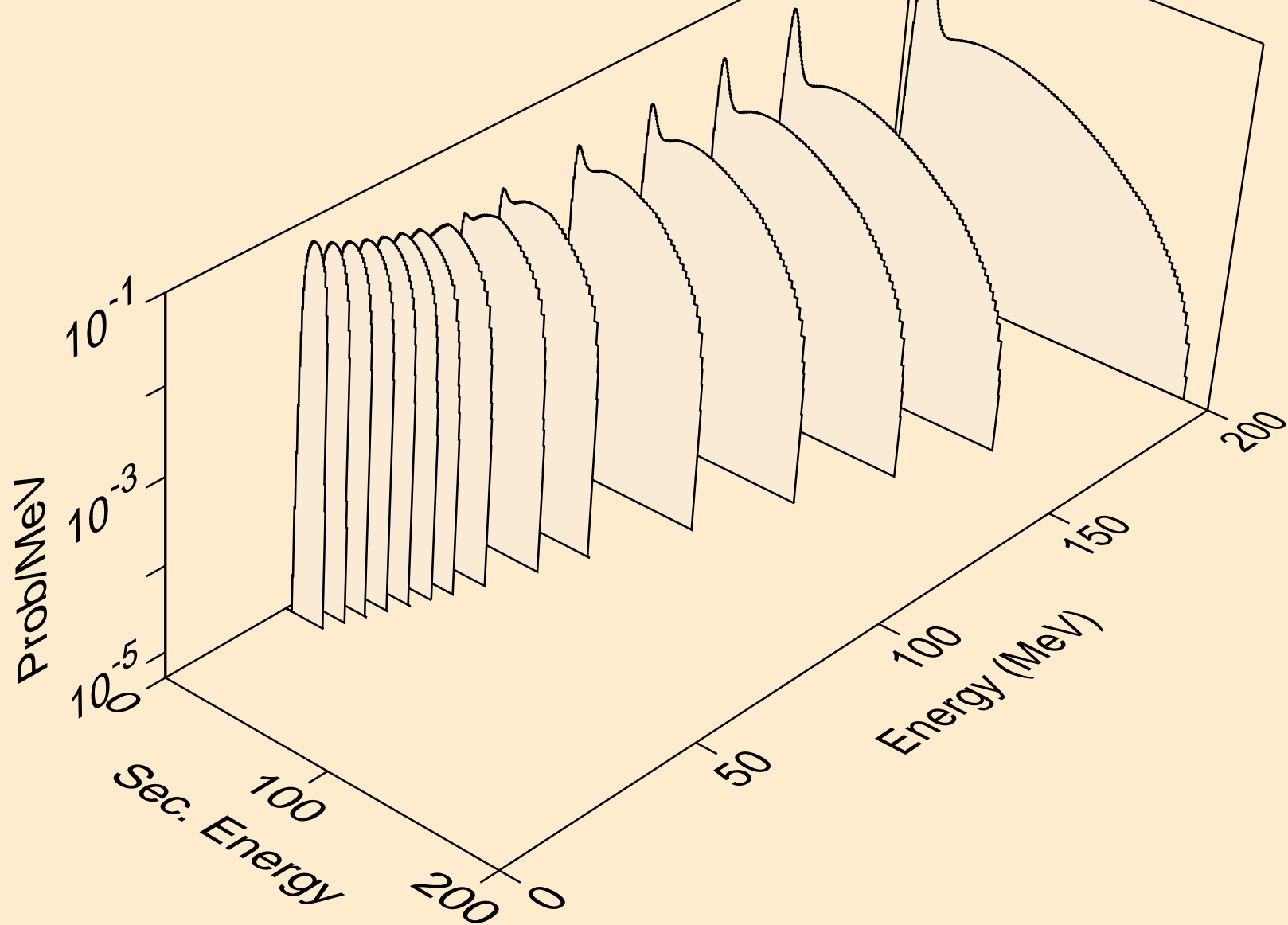



SB126N NEUTRON ACER TENDL-2023 LIBRARY; T=0.K  
tritons from (n,n\*)t

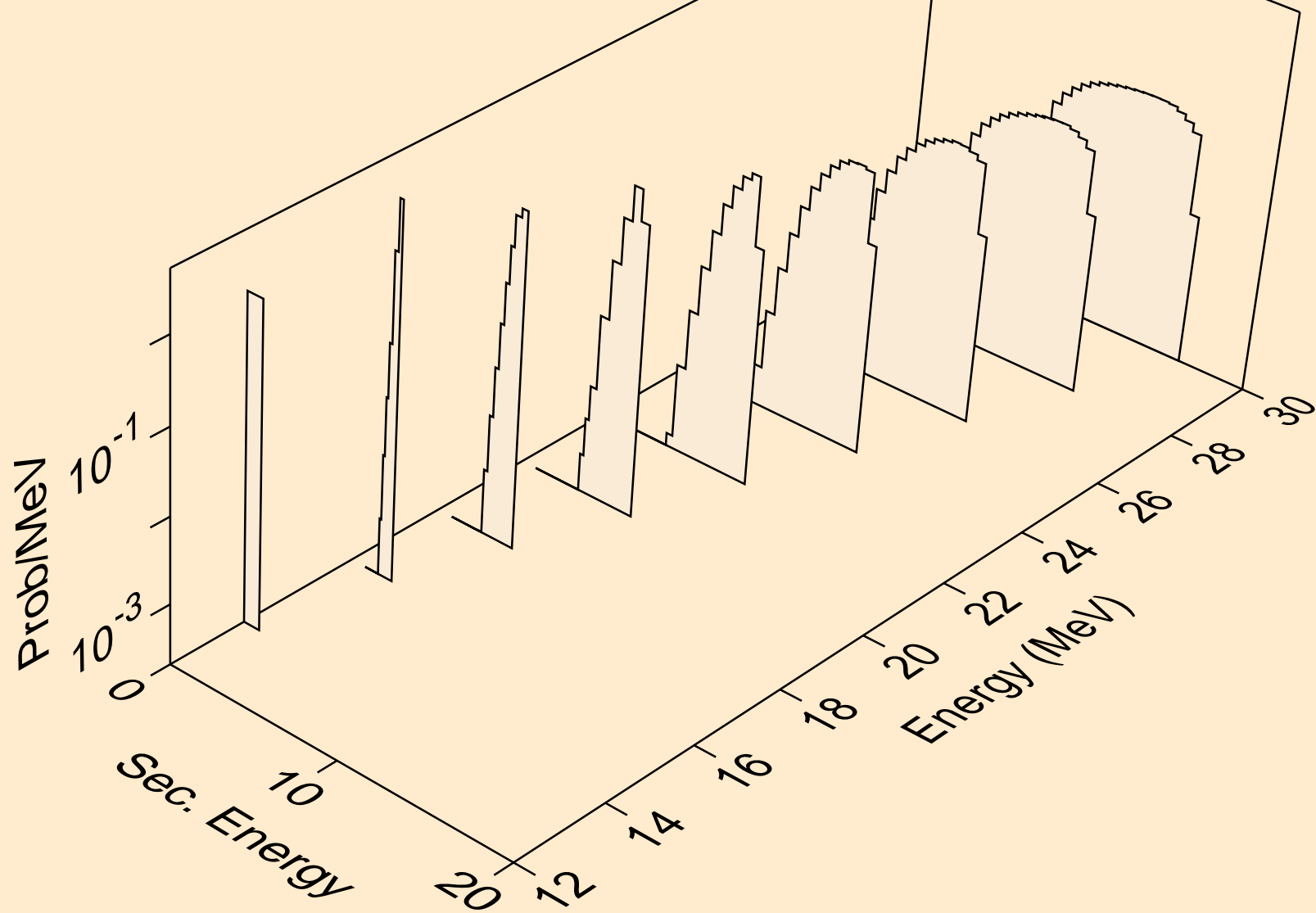

SB126N NEUTRON ACER TENDL-2023 LIBRARY; T=0.K  
tritons from (n,t)

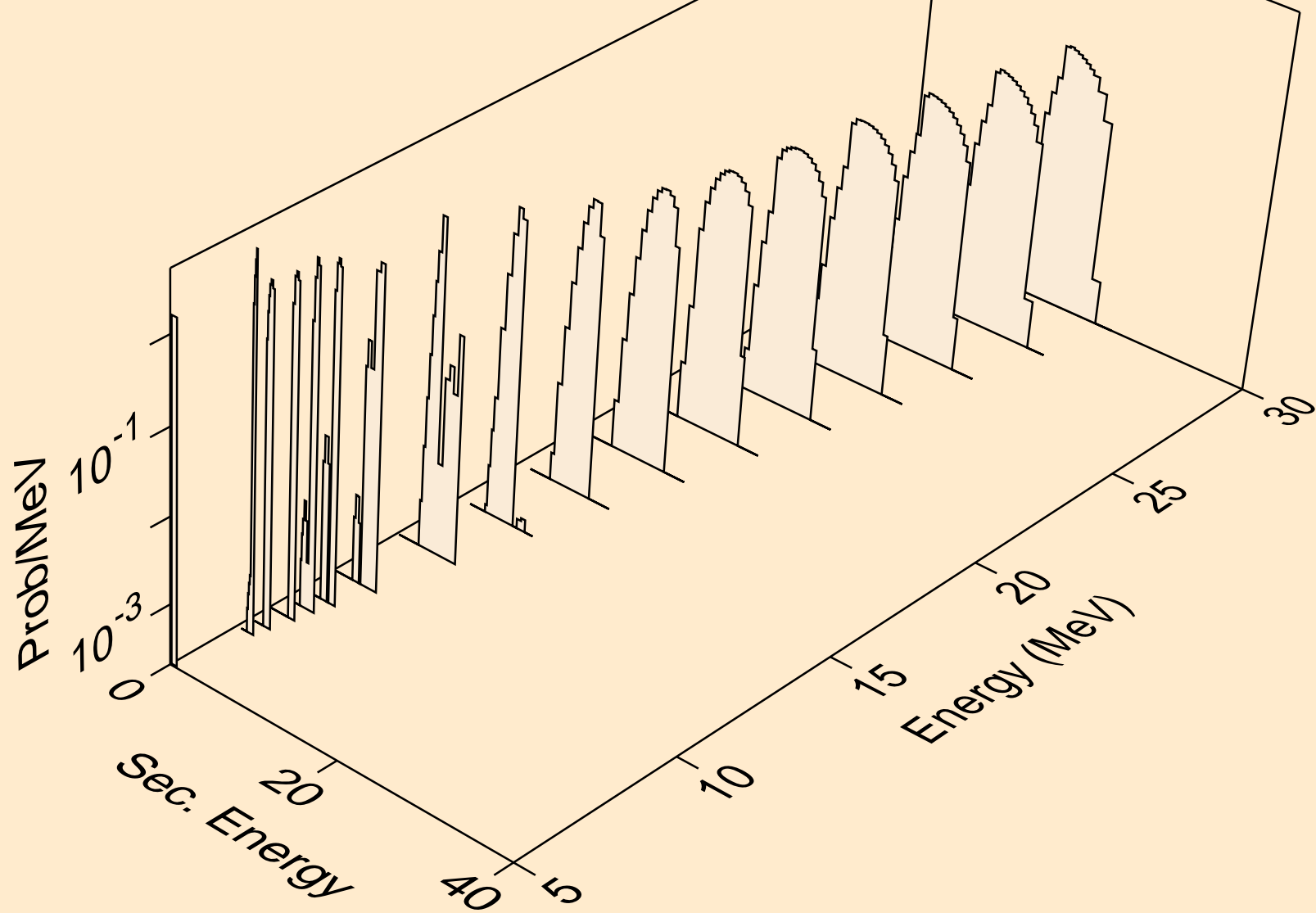

SB126N NEUTRON ACER TENDL-2023 LIBRARY; T=0.K  
he3s from (n,x)

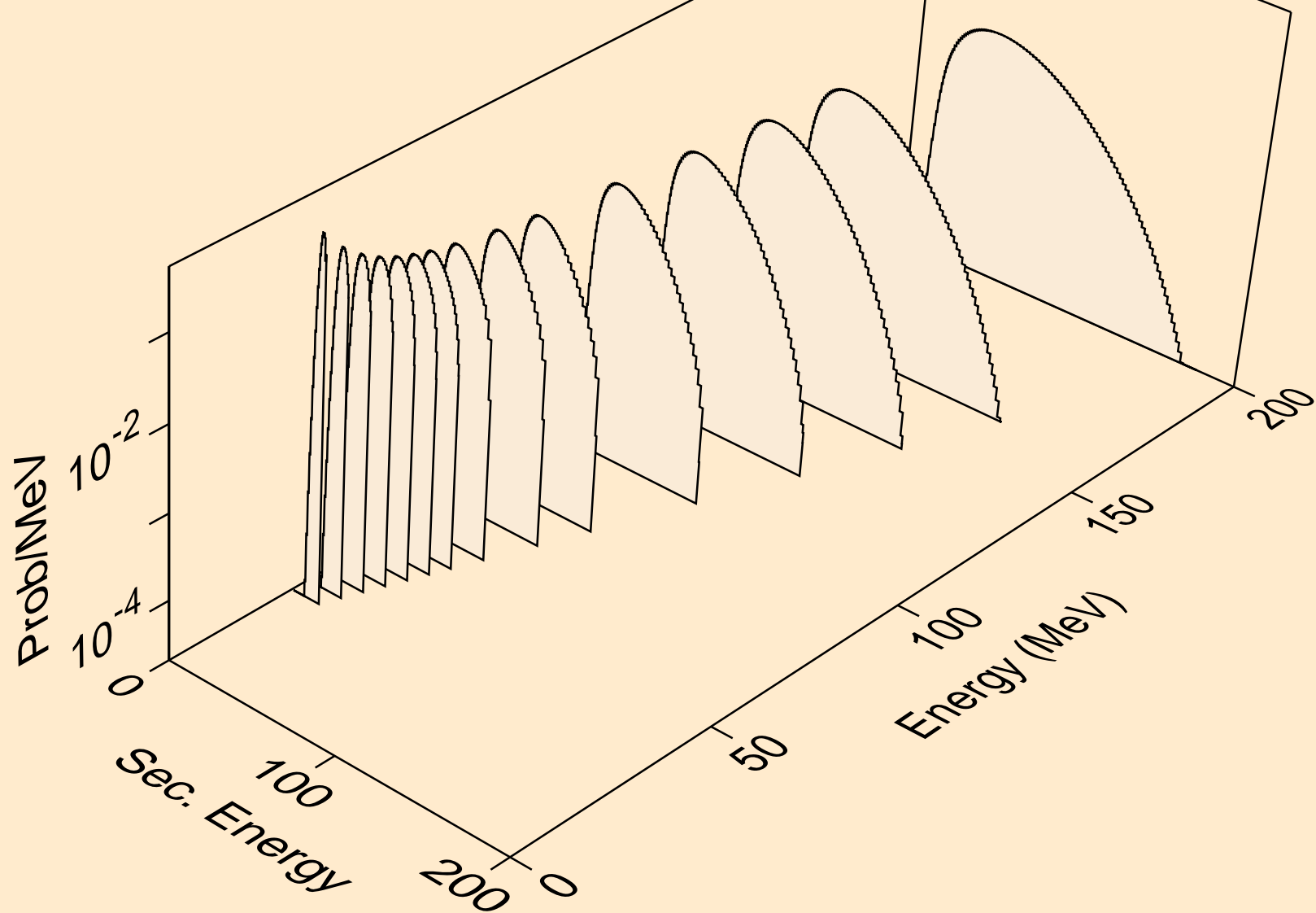

SB126N NEUTRON ACER TENDL-2023 LIBRARY; T=0.K  
he3s from (n,n\*)he3

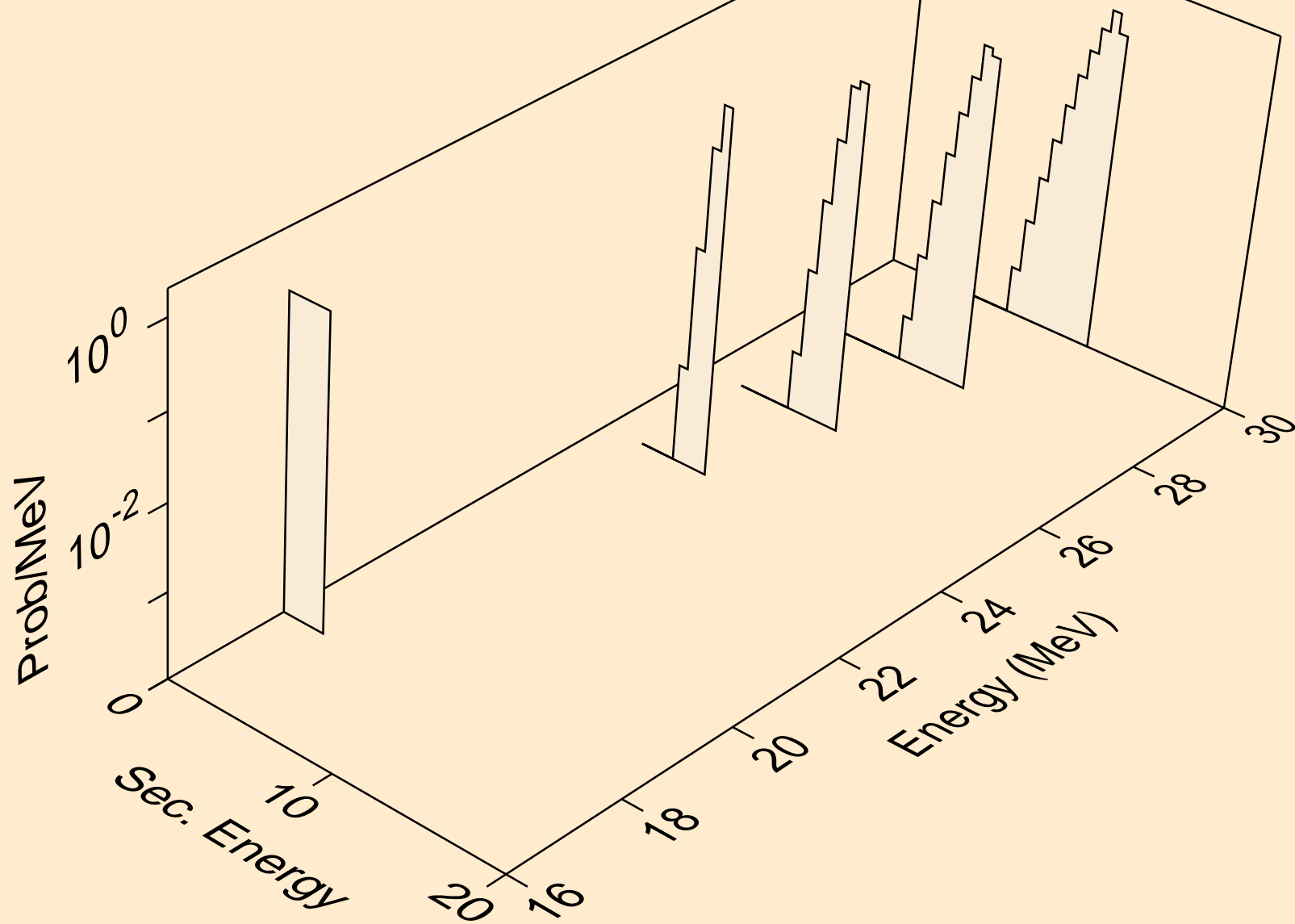

SB126N NEUTRON ACER TENDL-2023 LIBRARY; T=0.K  
he3s from (n,he3)

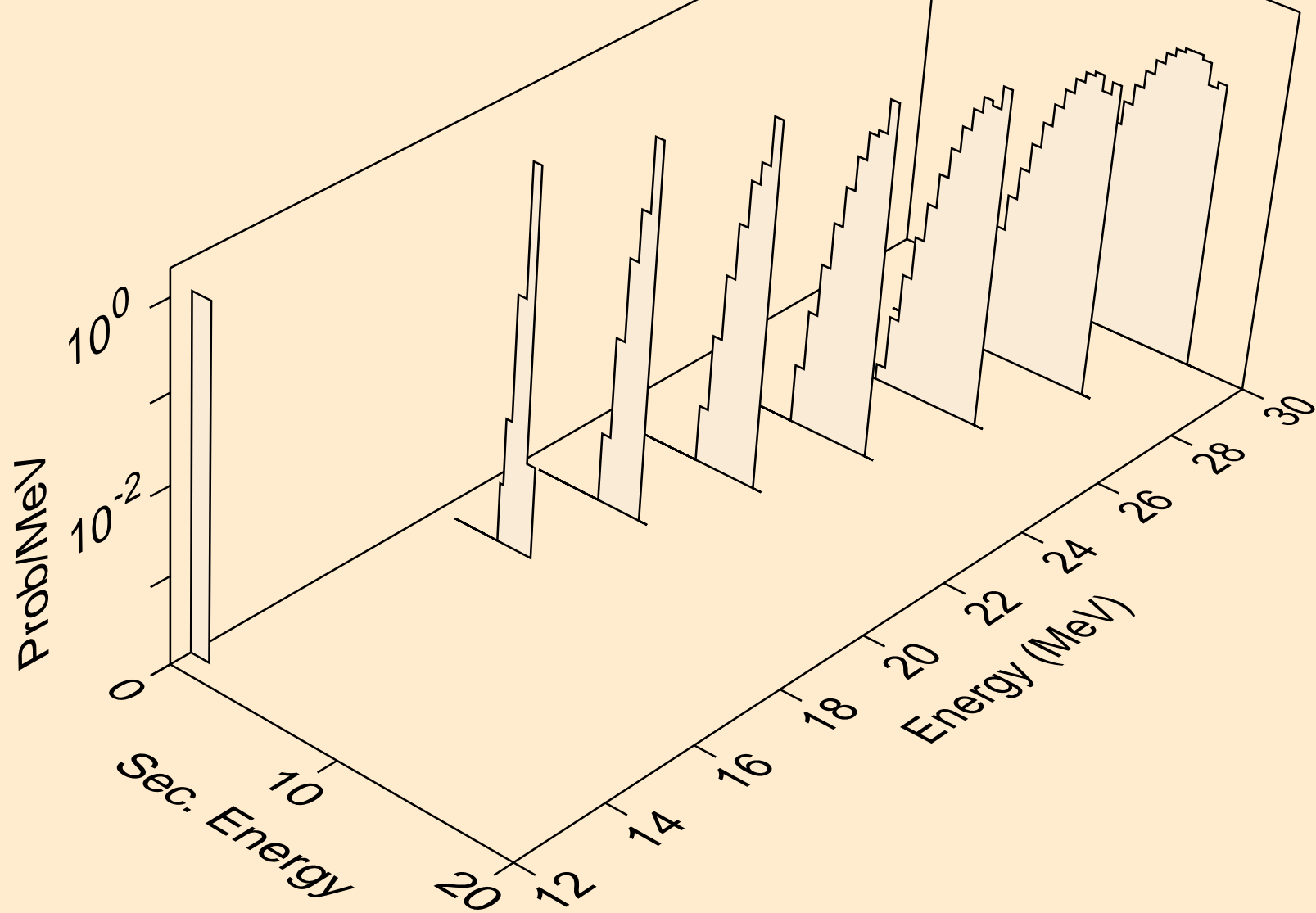

SB126N NEUTRON ACER TENDL-2023 LIBRARY; T=0.K  
alphas from (n,x)

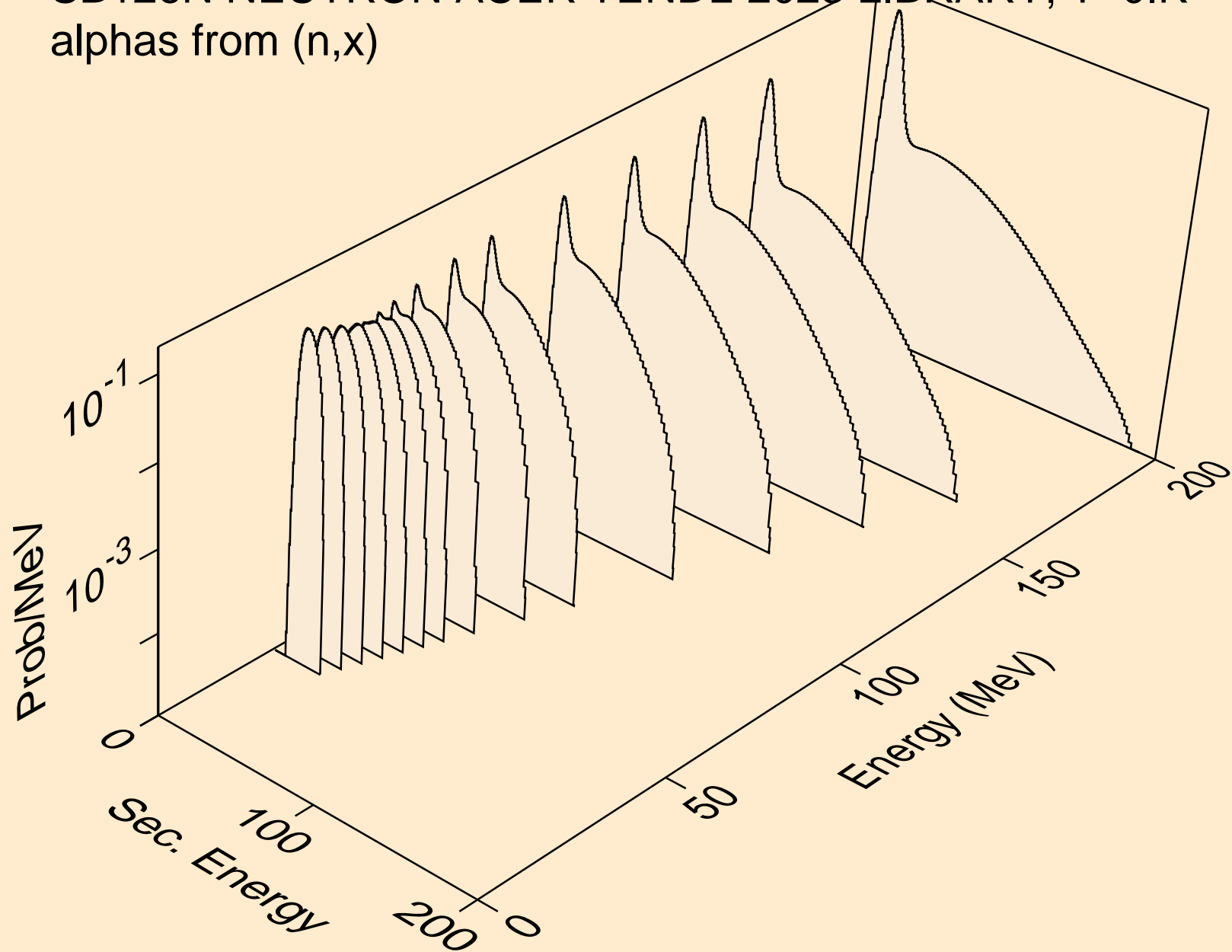

SB126N NEUTRON ACER TENDL-2023 LIBRARY; T=0.K  
alphas from (n,n\*)a

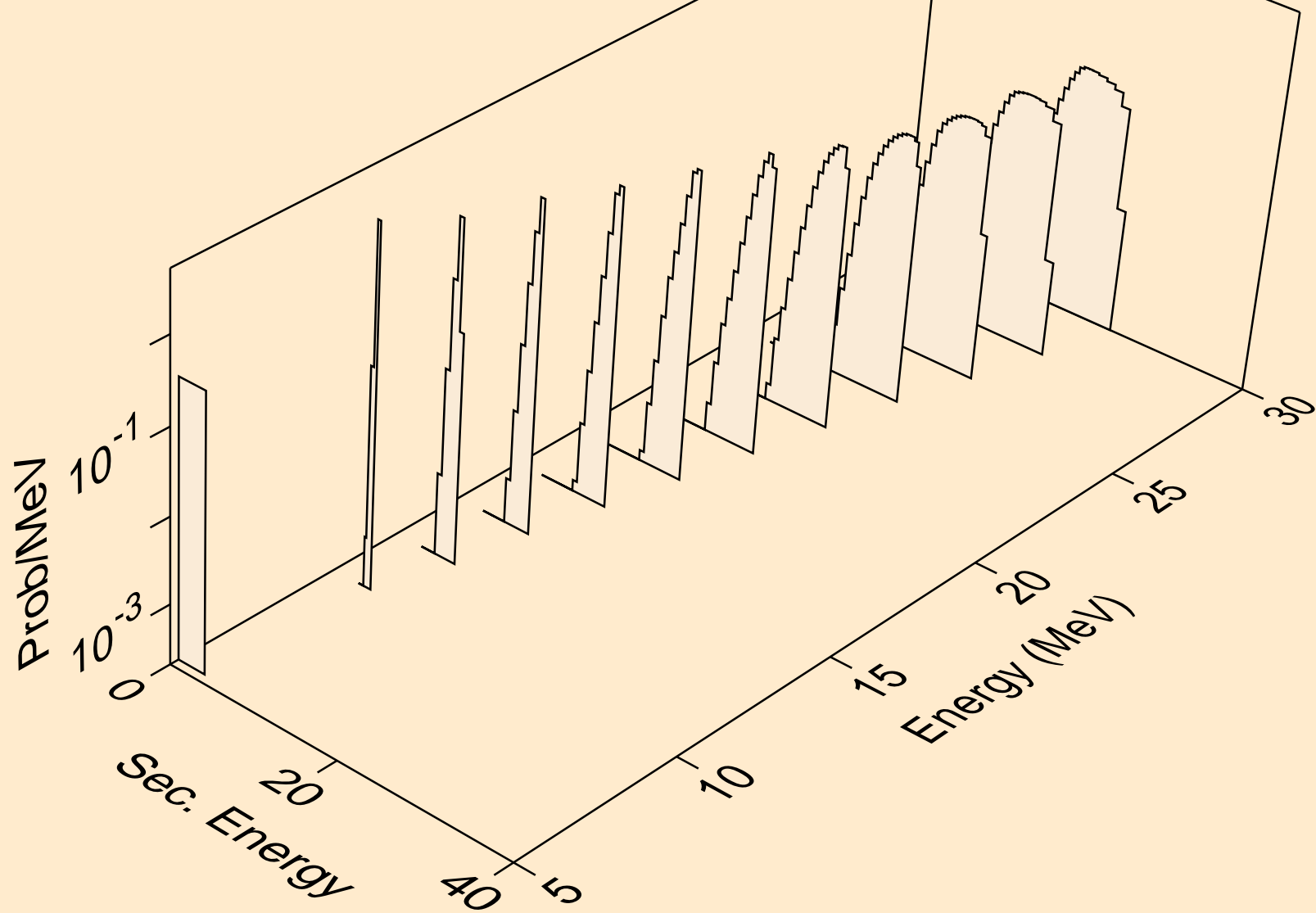

SB126N NEUTRON ACER TENDL-2023 LIBRARY; T=0.K  
alphas from (n,2n)a

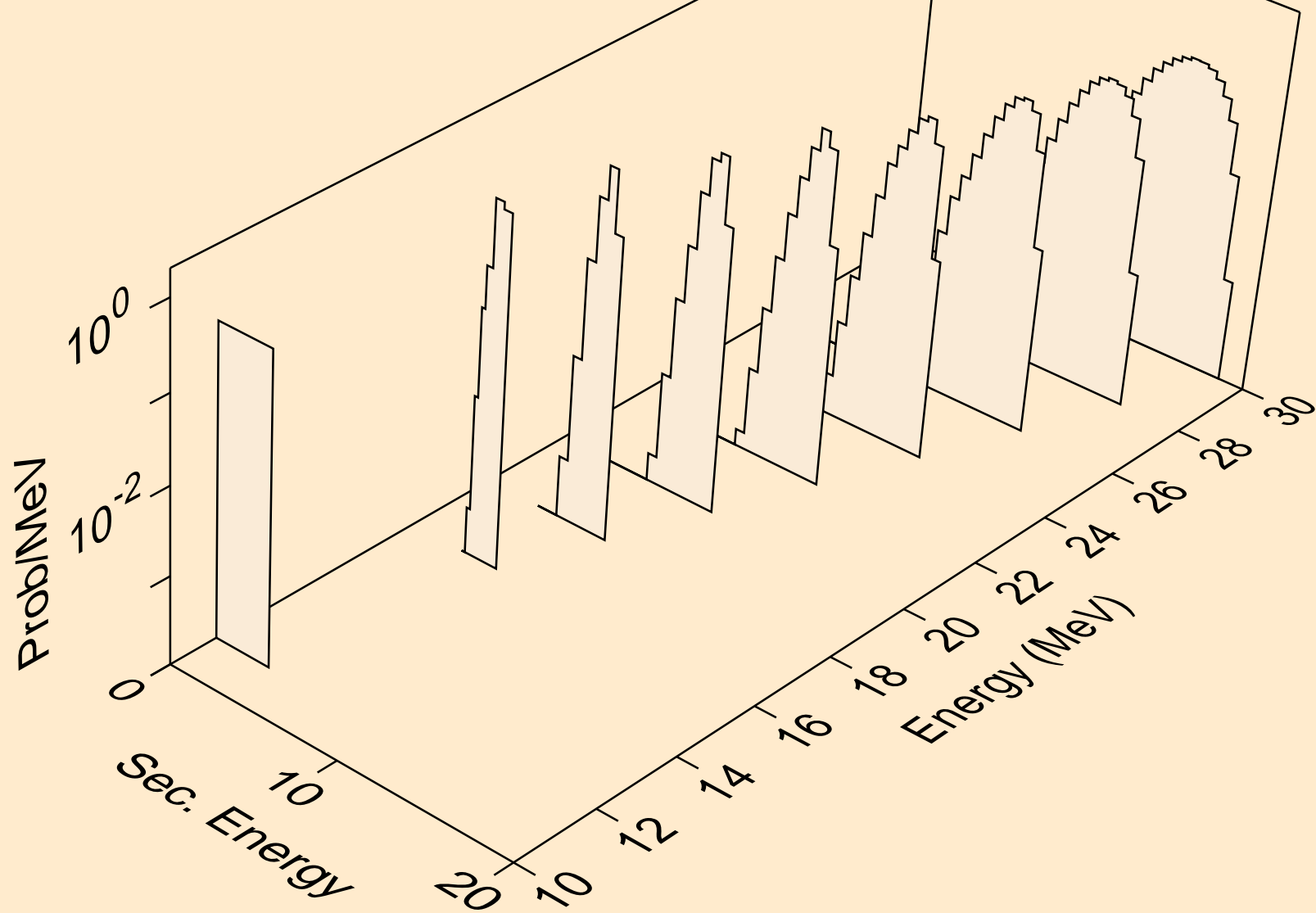



SB126N NEUTRON ACER TENDL-2023 LIBRARY; T=0.K  
alphas from (n,3n)a

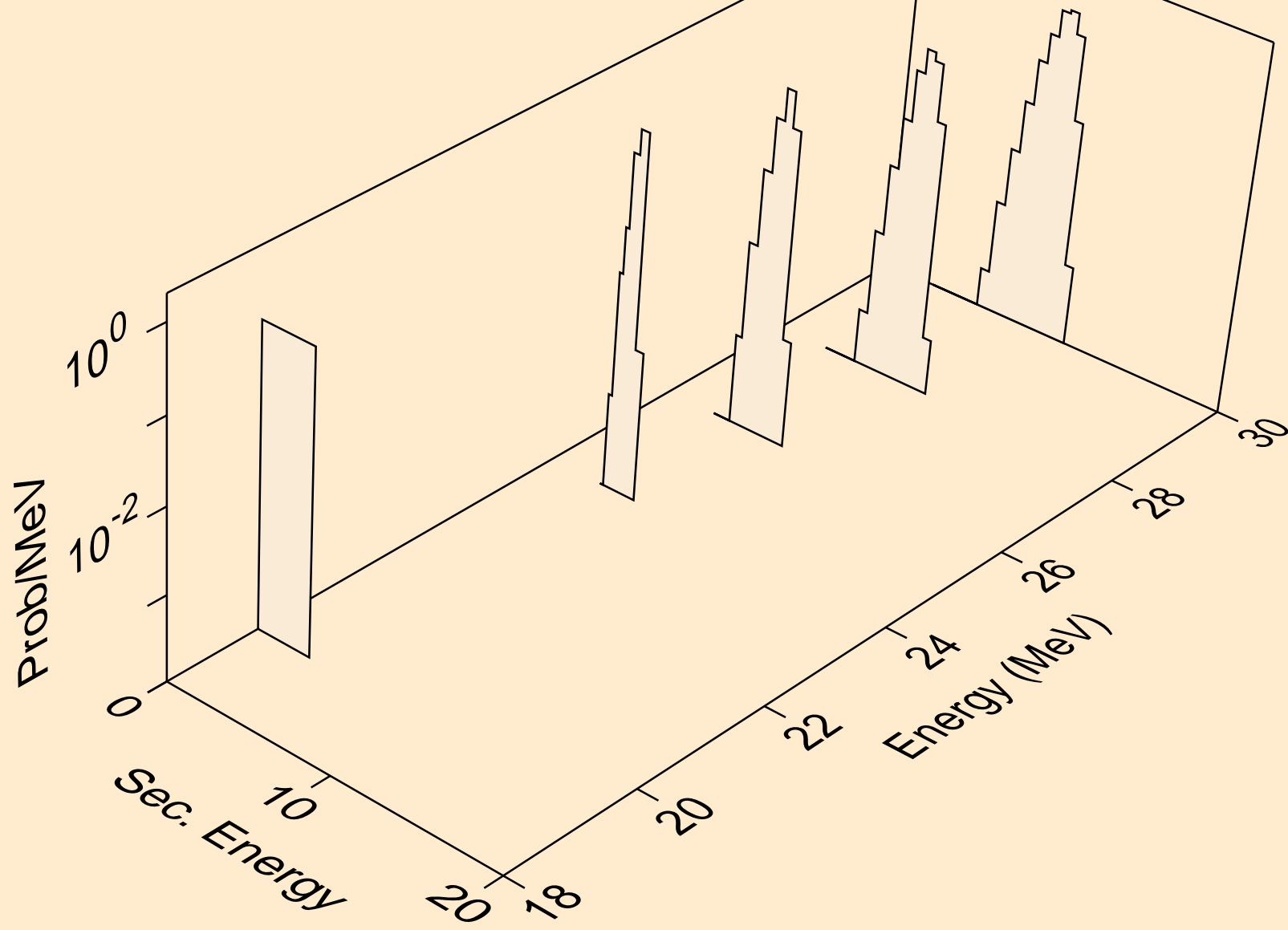

SB126N NEUTRON ACER TENDL-2023 LIBRARY; T=0.K  
alphas from (n,a)

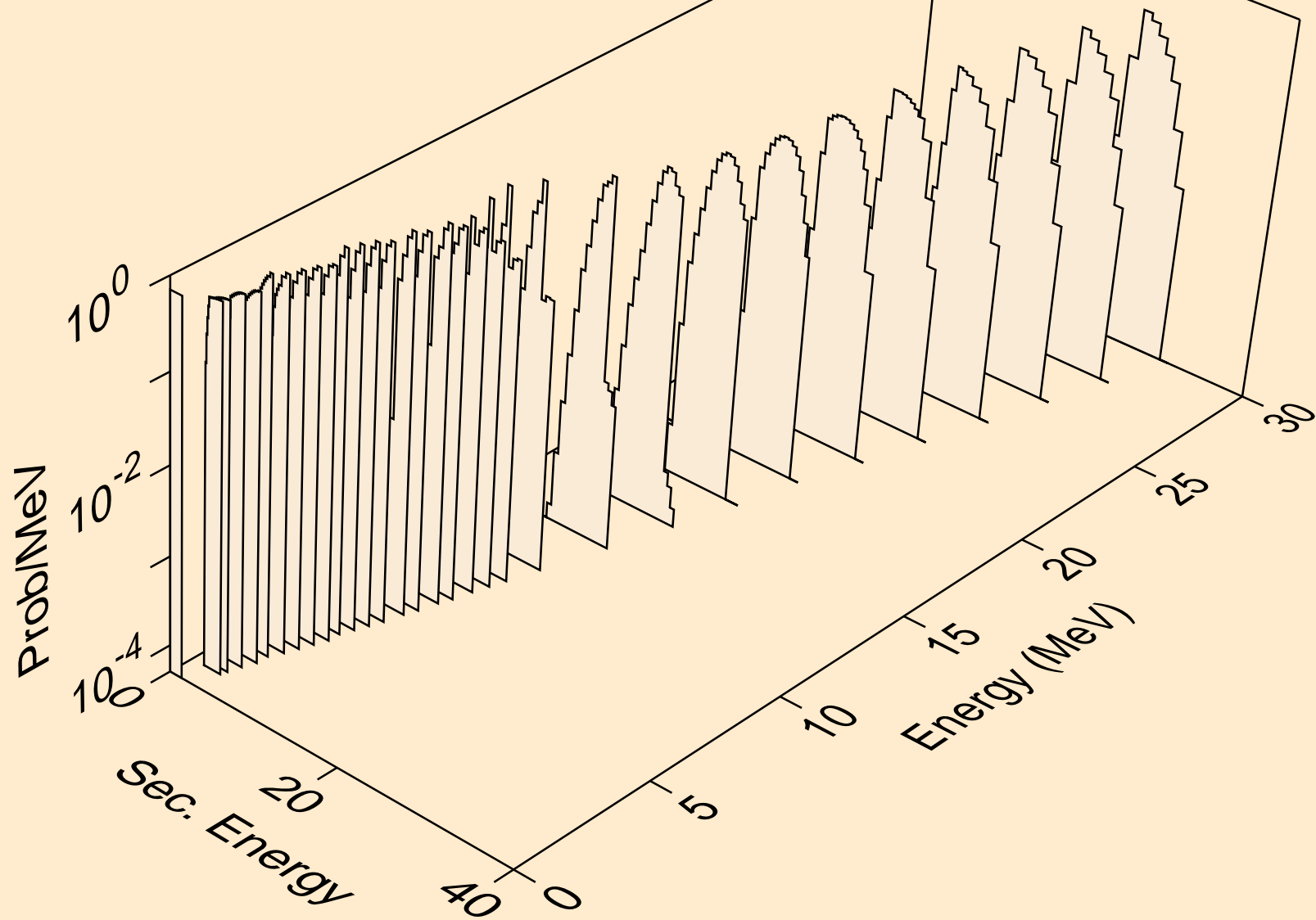

SB126N NEUTRON ACER TENDL-2023 LIBRARY; T=0.K  
alphas from (n,pa)

