

# SB134M NEUTRON ACER TENDL-2023 LIBRARY; T=0.K

## Principal cross sections

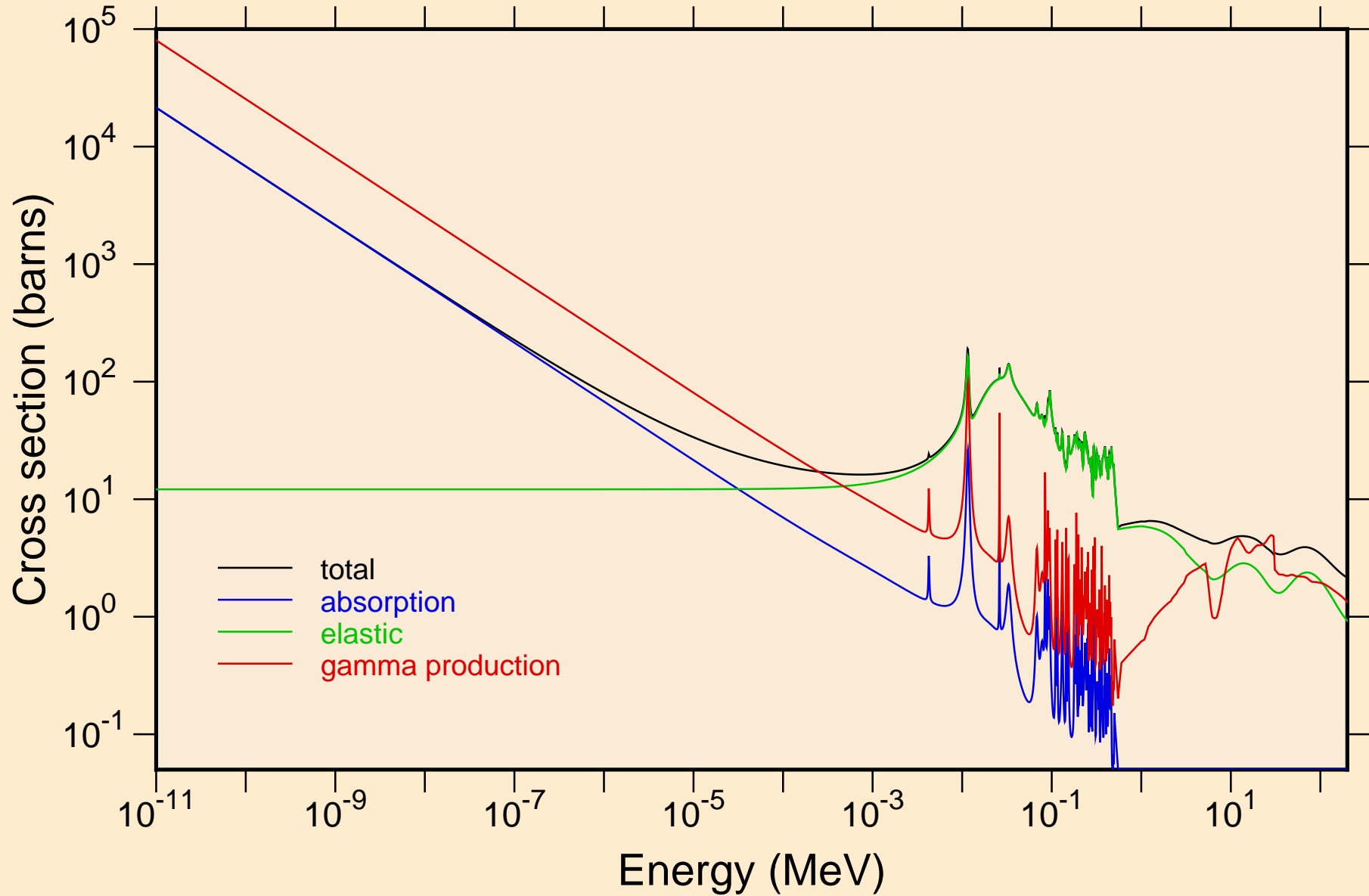

SB134M NEUTRON ACER TENDL-2023 LIBRARY; T=0.K  
resonance total cross section

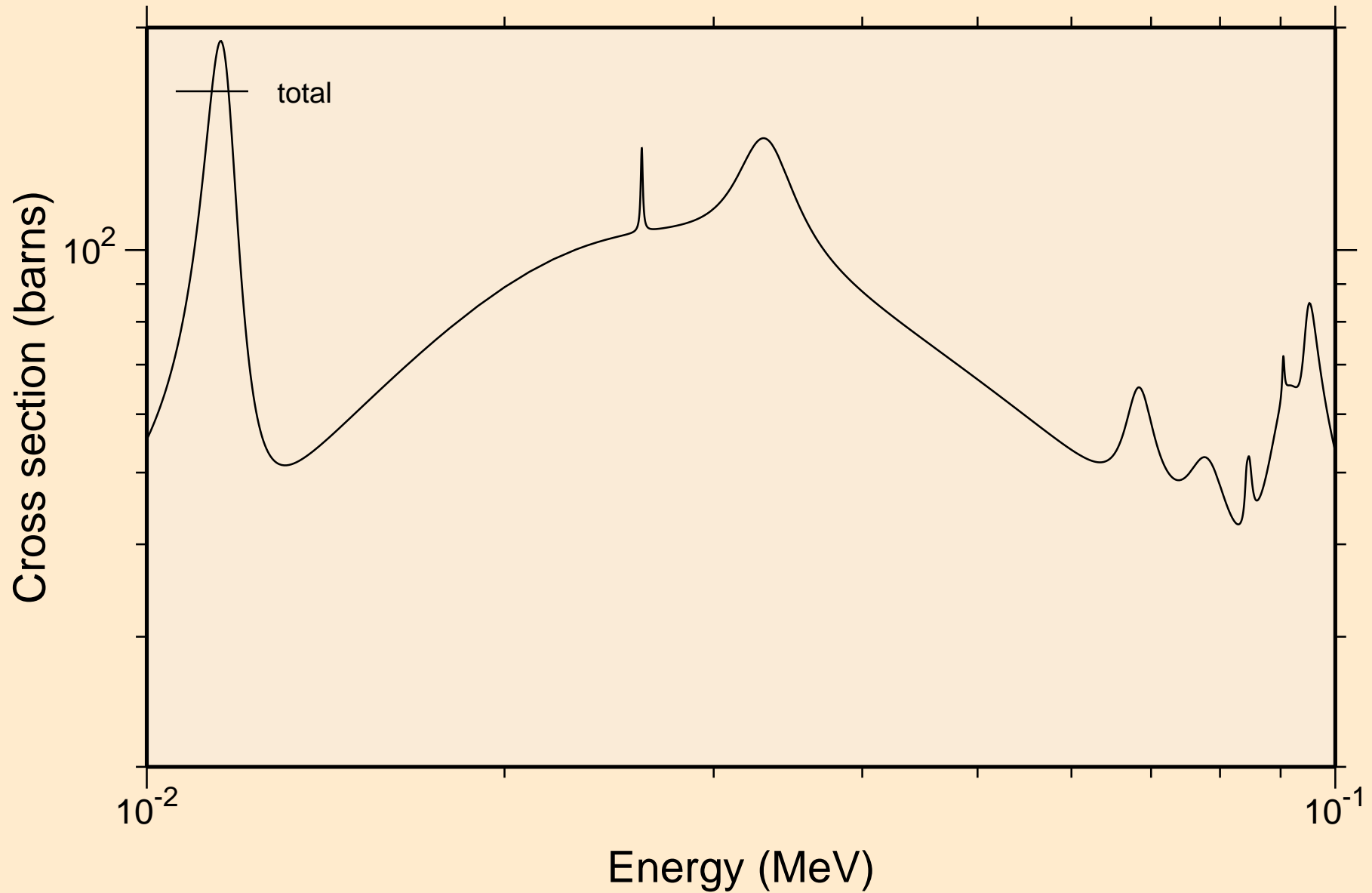

SB134M NEUTRON ACER TENDL-2023 LIBRARY; T=0.K  
resonance total cross section

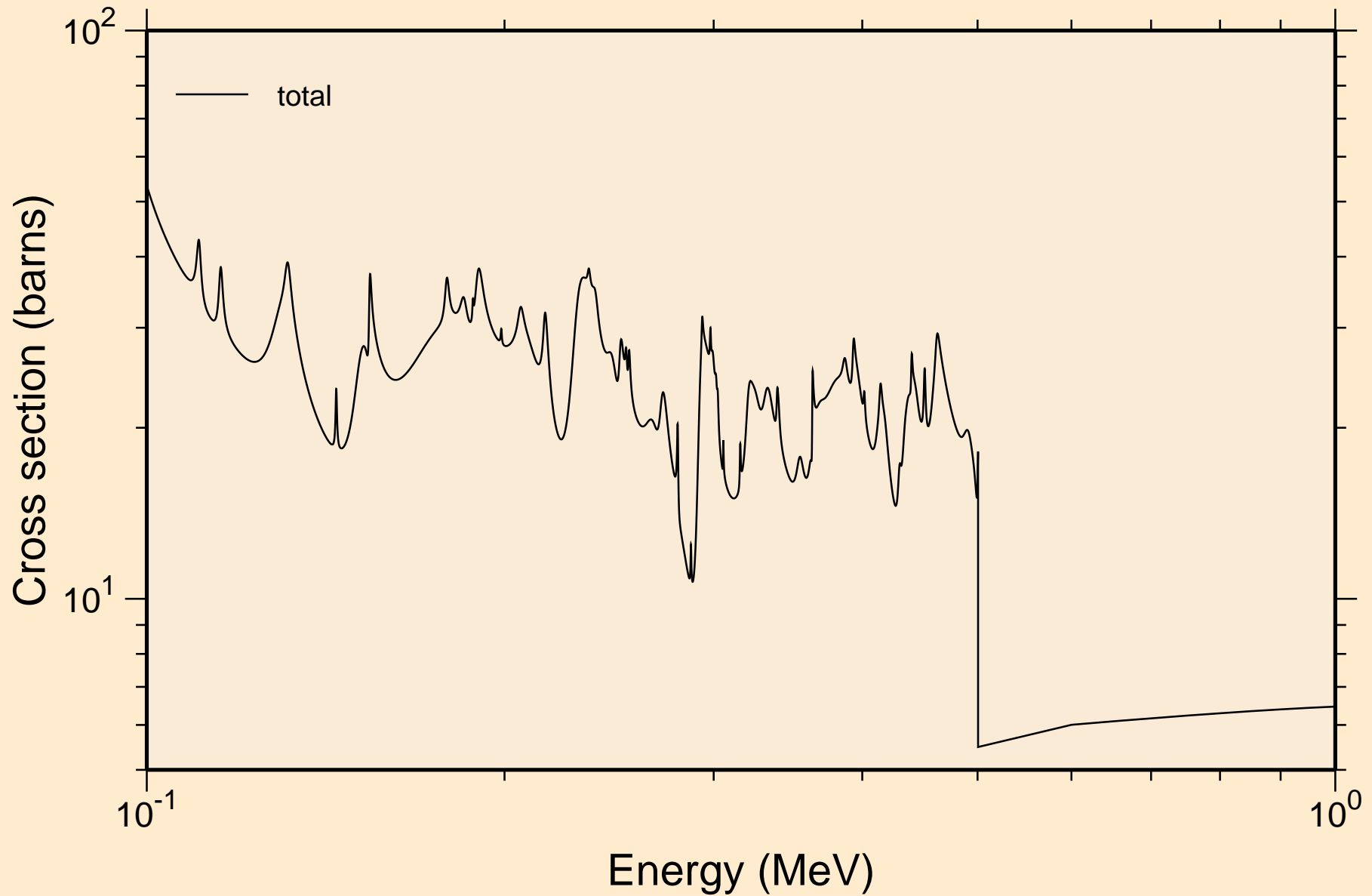

SB134M NEUTRON ACER TENDL-2023 LIBRARY; T=0.K  
resonance total cross section

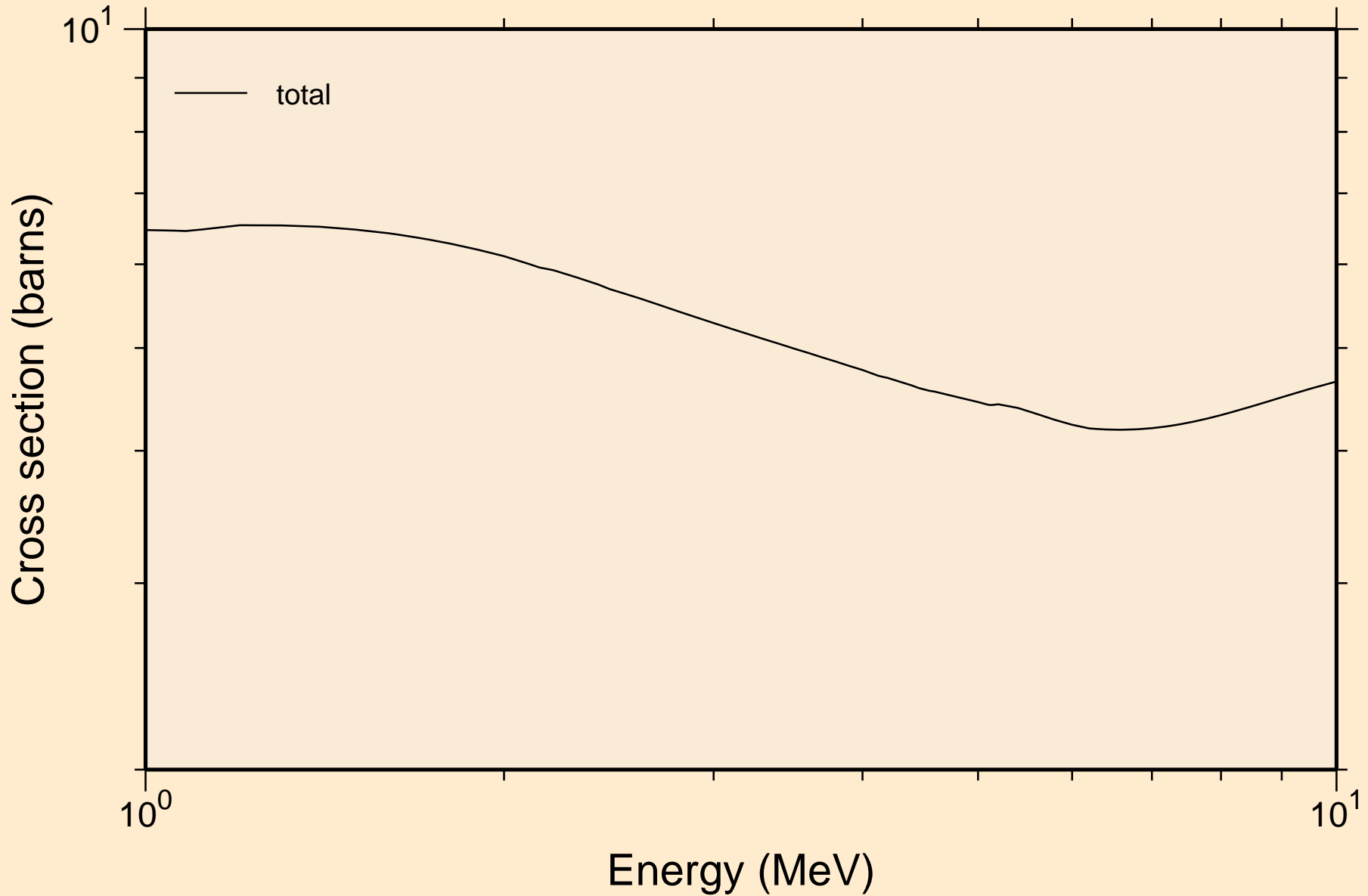

SB134M NEUTRON ACER TENDL-2023 LIBRARY; T=0.K  
resonance absorption cross sections

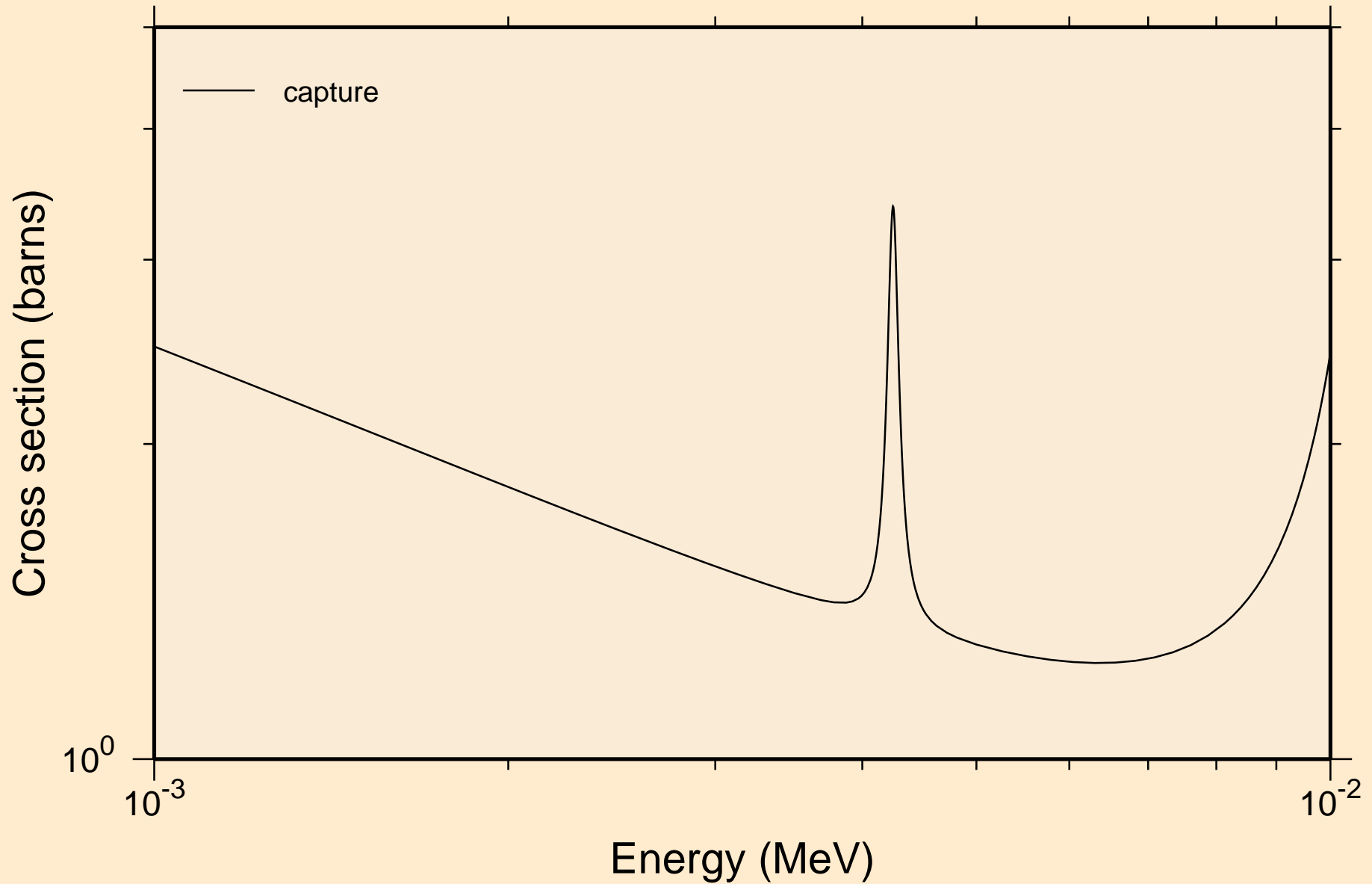

SB134M NEUTRON ACER TENDL-2023 LIBRARY; T=0.K  
resonance absorption cross sections

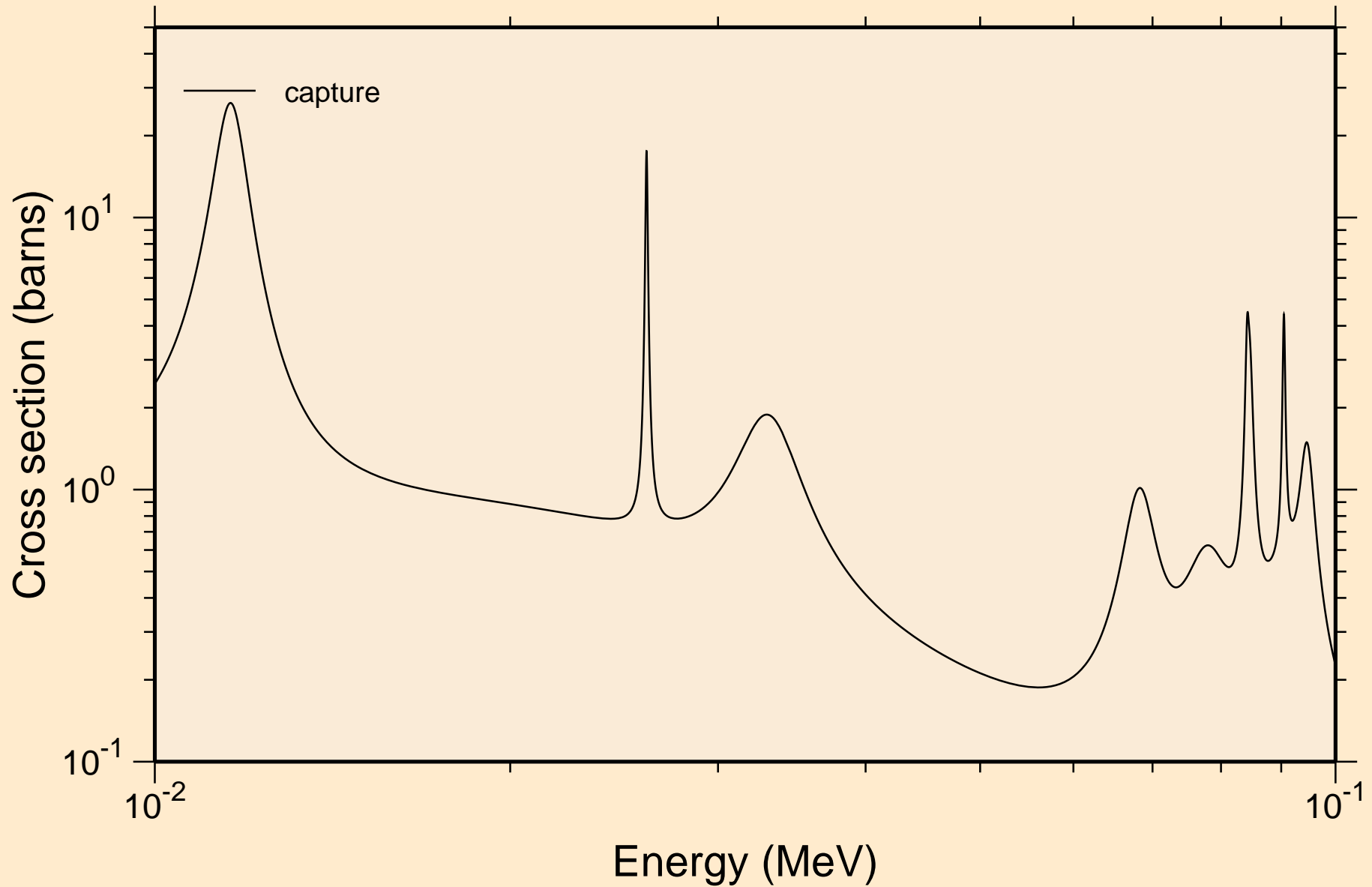

SB134M NEUTRON ACER TENDL-2023 LIBRARY; T=0.K  
resonance absorption cross sections

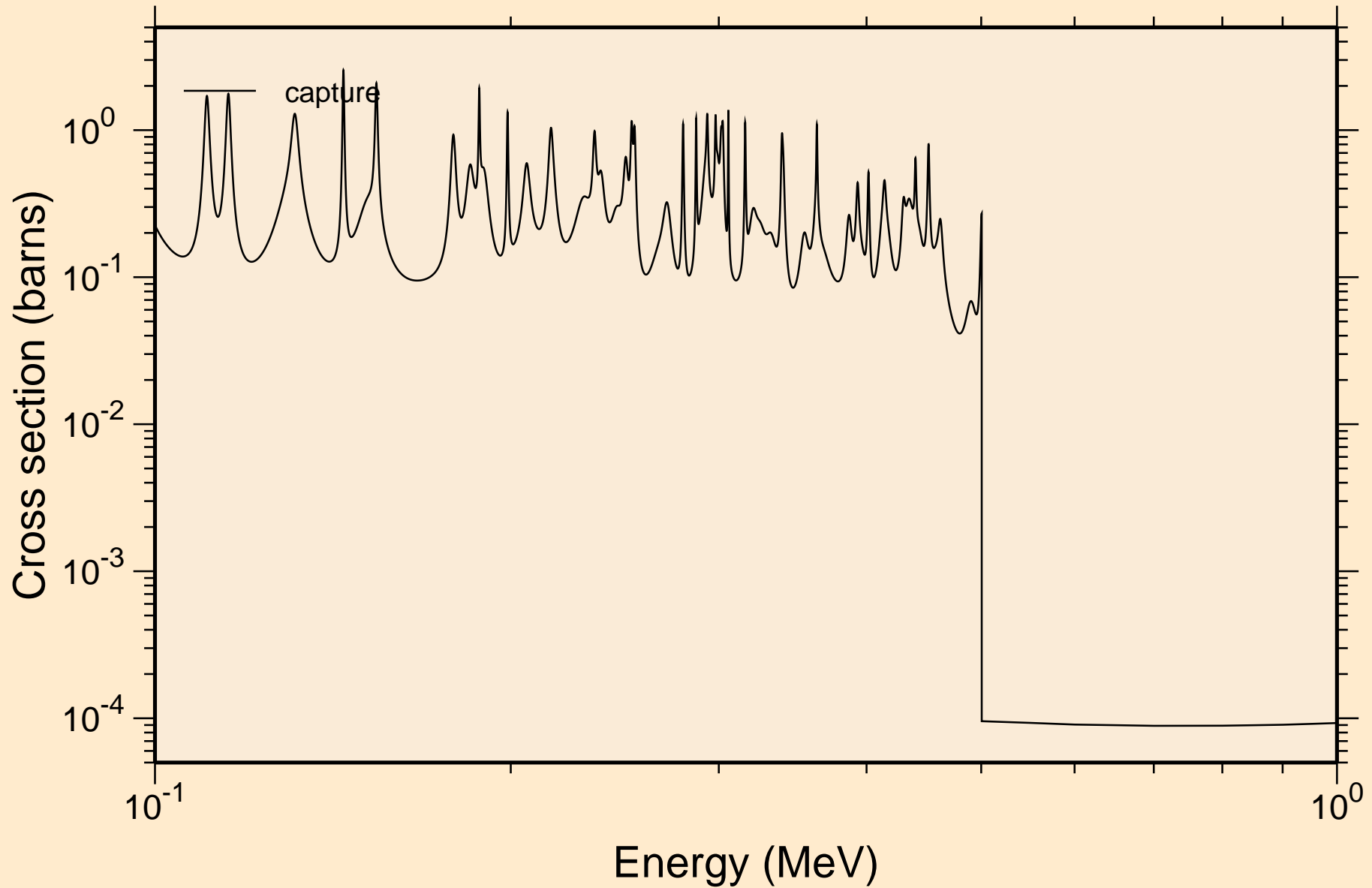

SB134M NEUTRON ACER TENDL-2023 LIBRARY; T=0.K  
resonance absorption cross sections

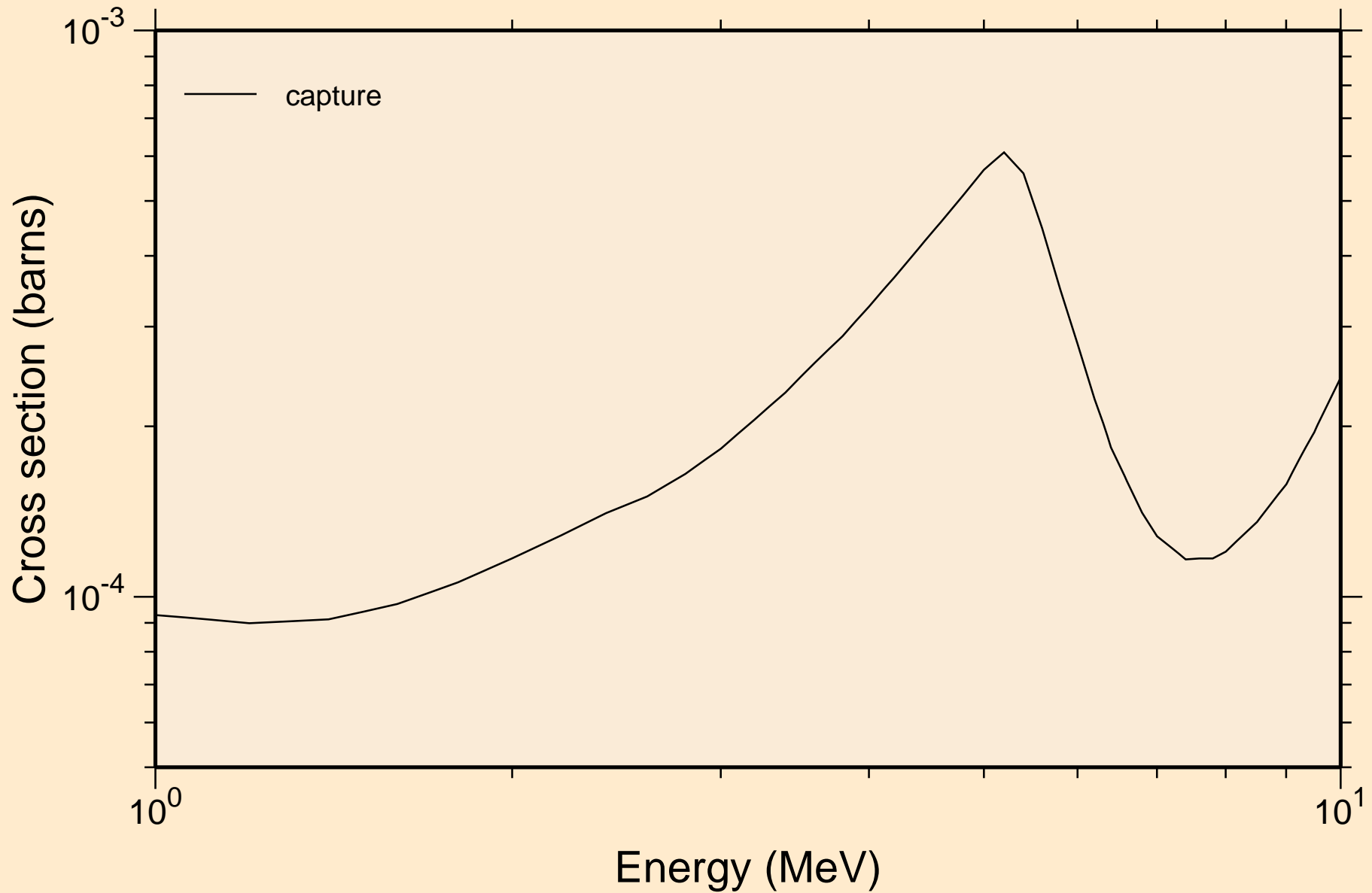



# SB134M NEUTRON ACER TENDL-2023 LIBRARY; T=0.K

## Heating

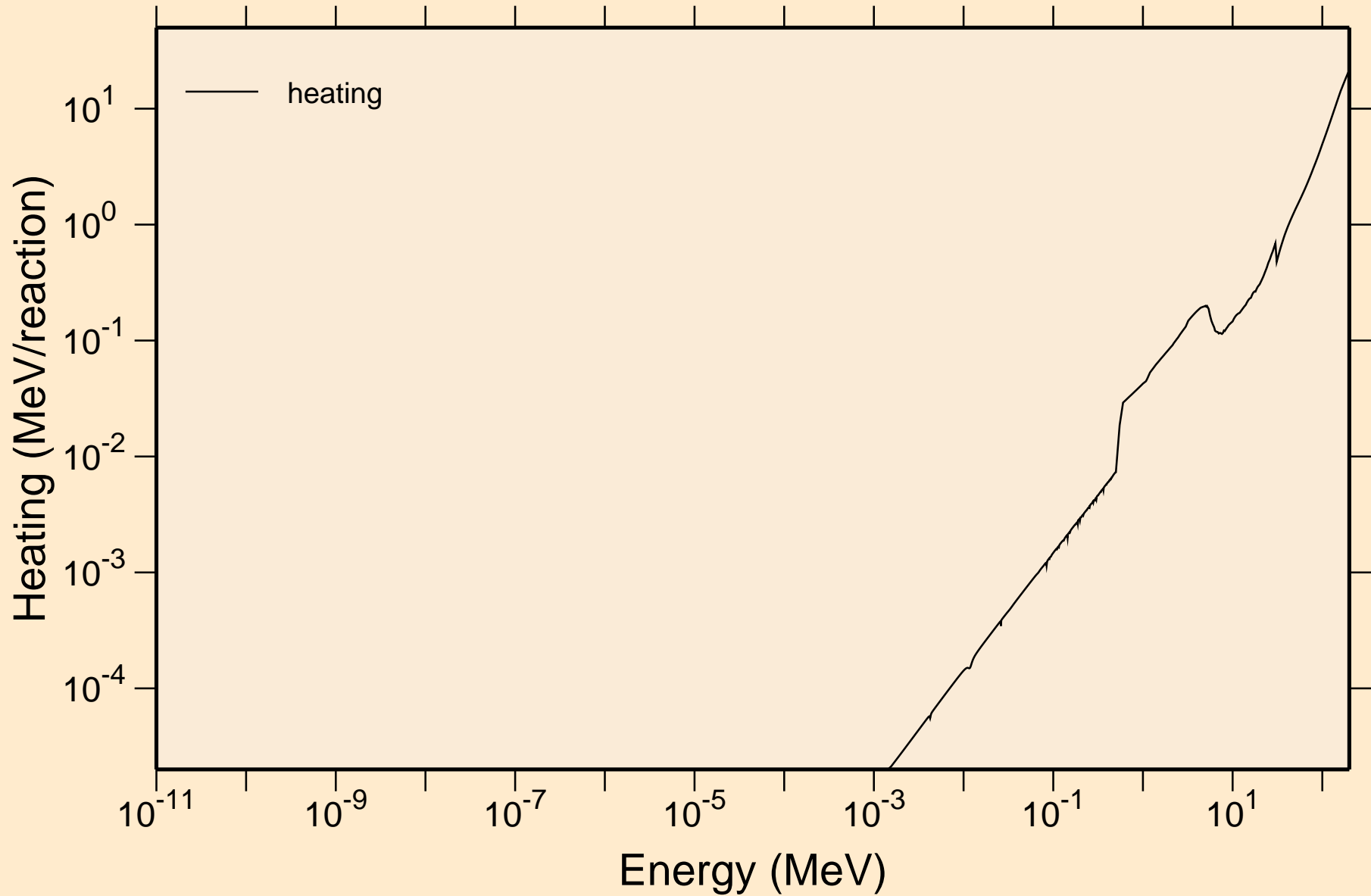

# SB134M NEUTRON ACER TENDL-2023 LIBRARY; T=0.K

## Damage

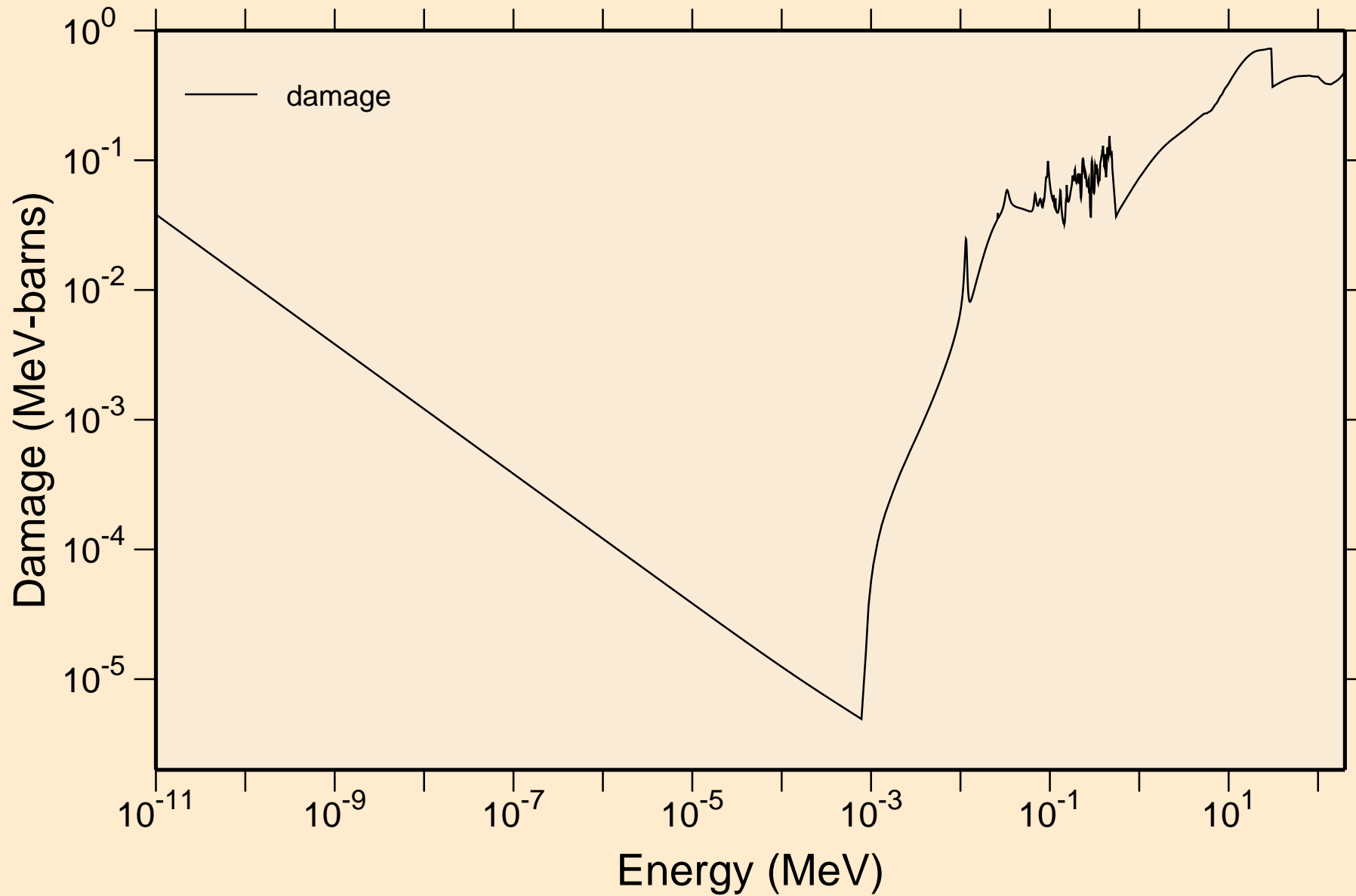

SB134M NEUTRON ACER TENDL-2023 LIBRARY; T=0.K  
Non-threshold reactions

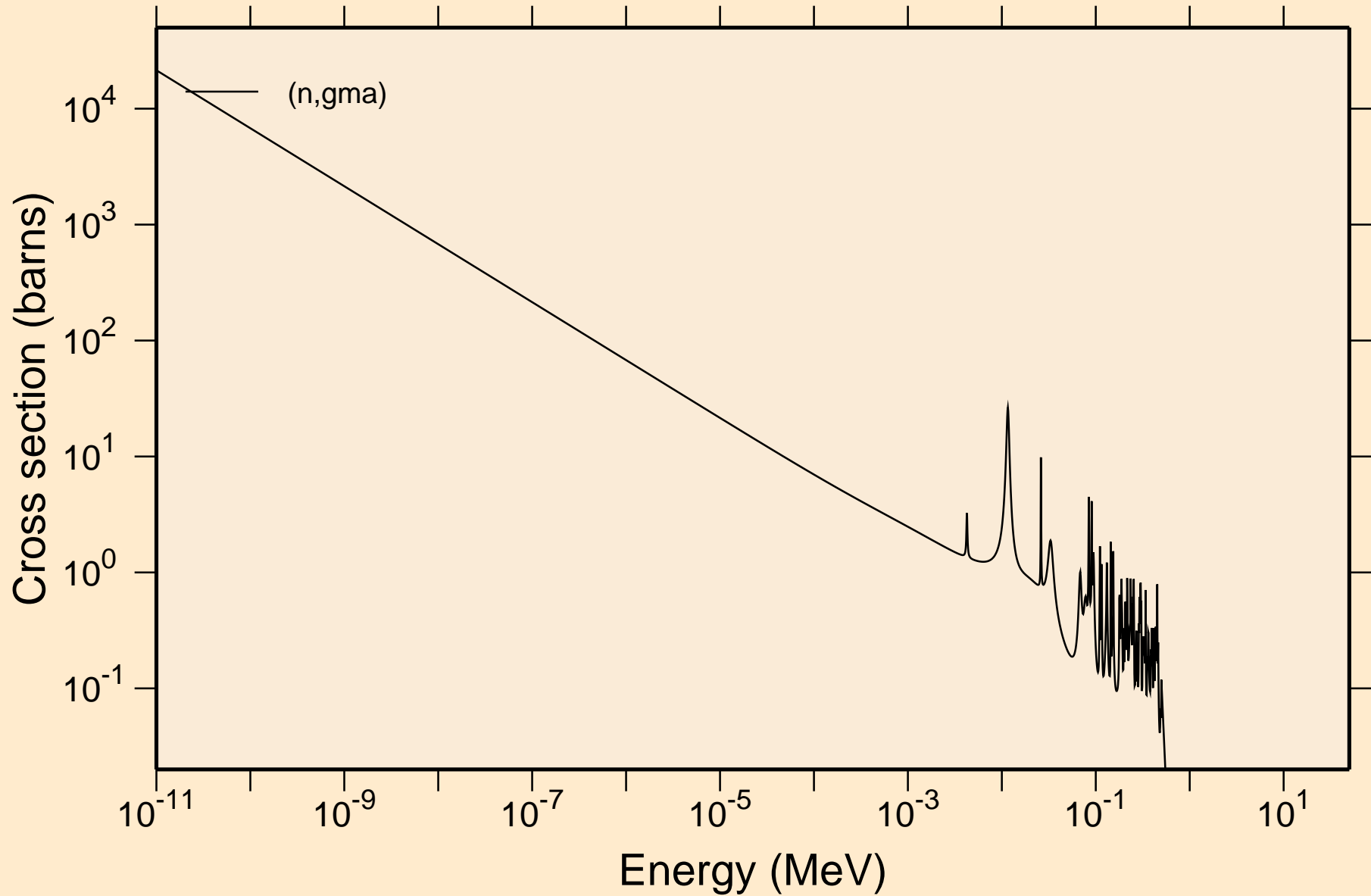

# SB134M NEUTRON ACER TENDL-2023 LIBRARY; T=0.K

## Principal cross sections

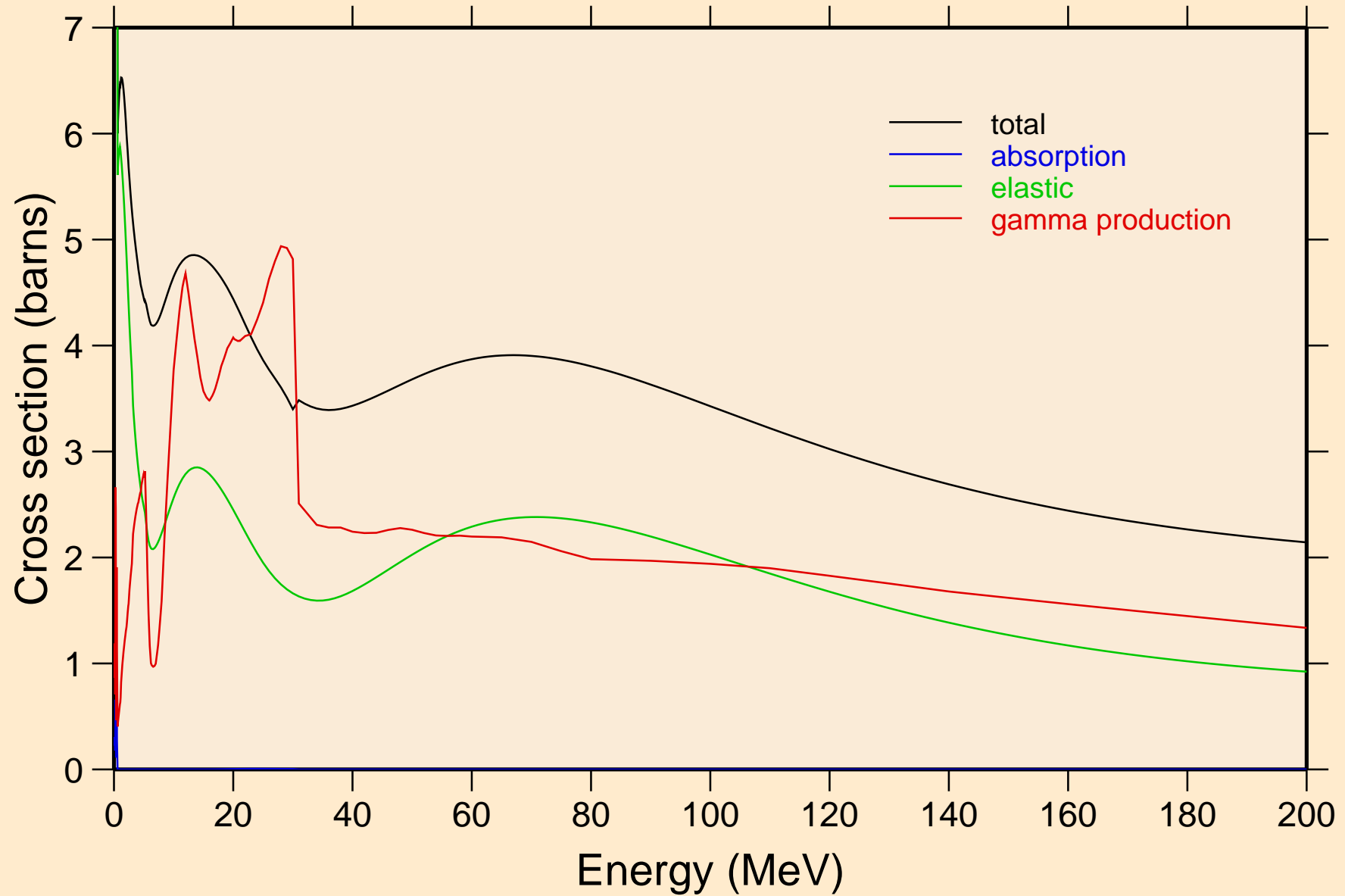

# SB134M NEUTRON ACER TENDL-2023 LIBRARY; T=0.K

## Heating

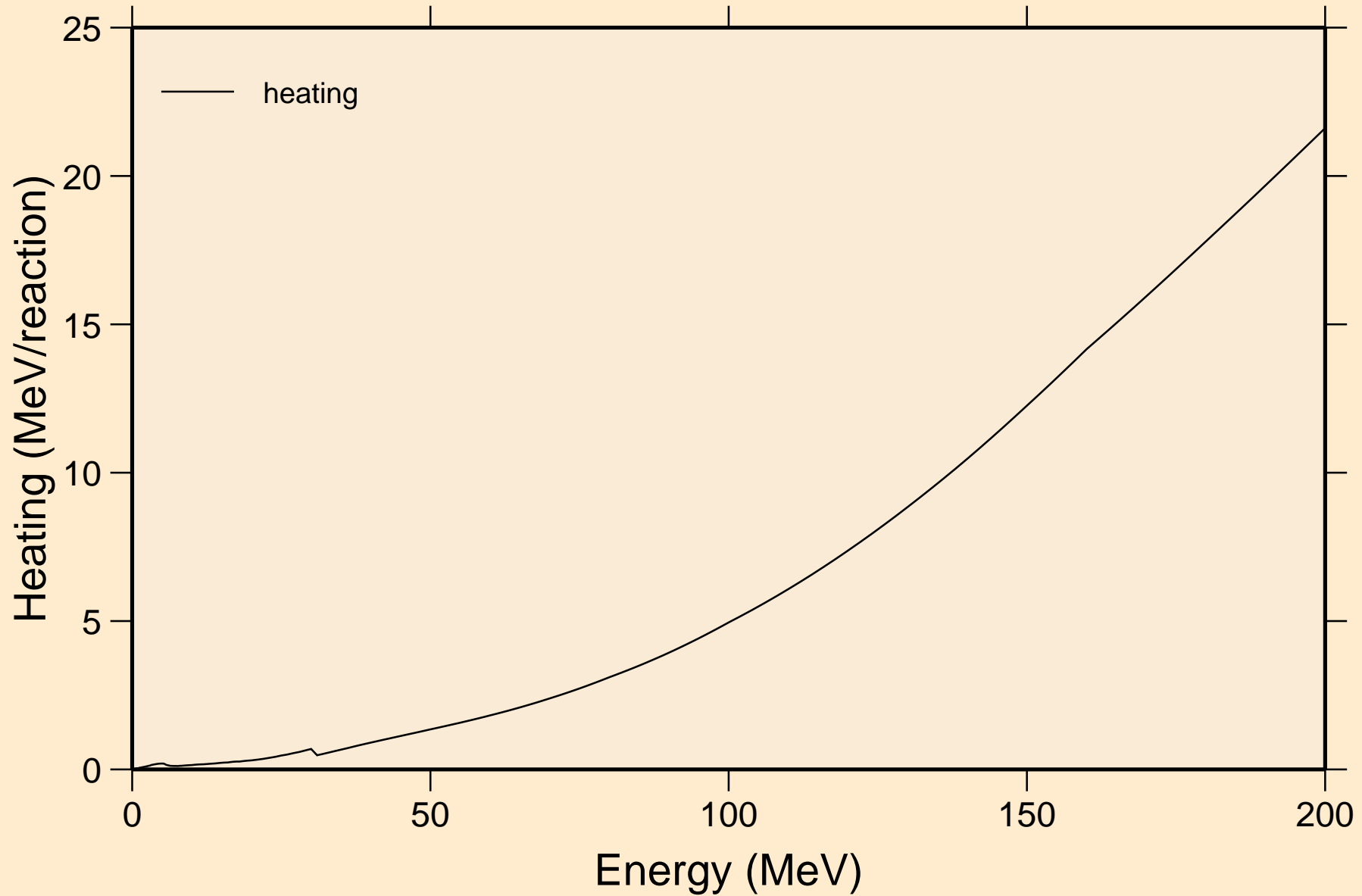

# SB134M NEUTRON ACER TENDL-2023 LIBRARY; T=0.K

## Damage

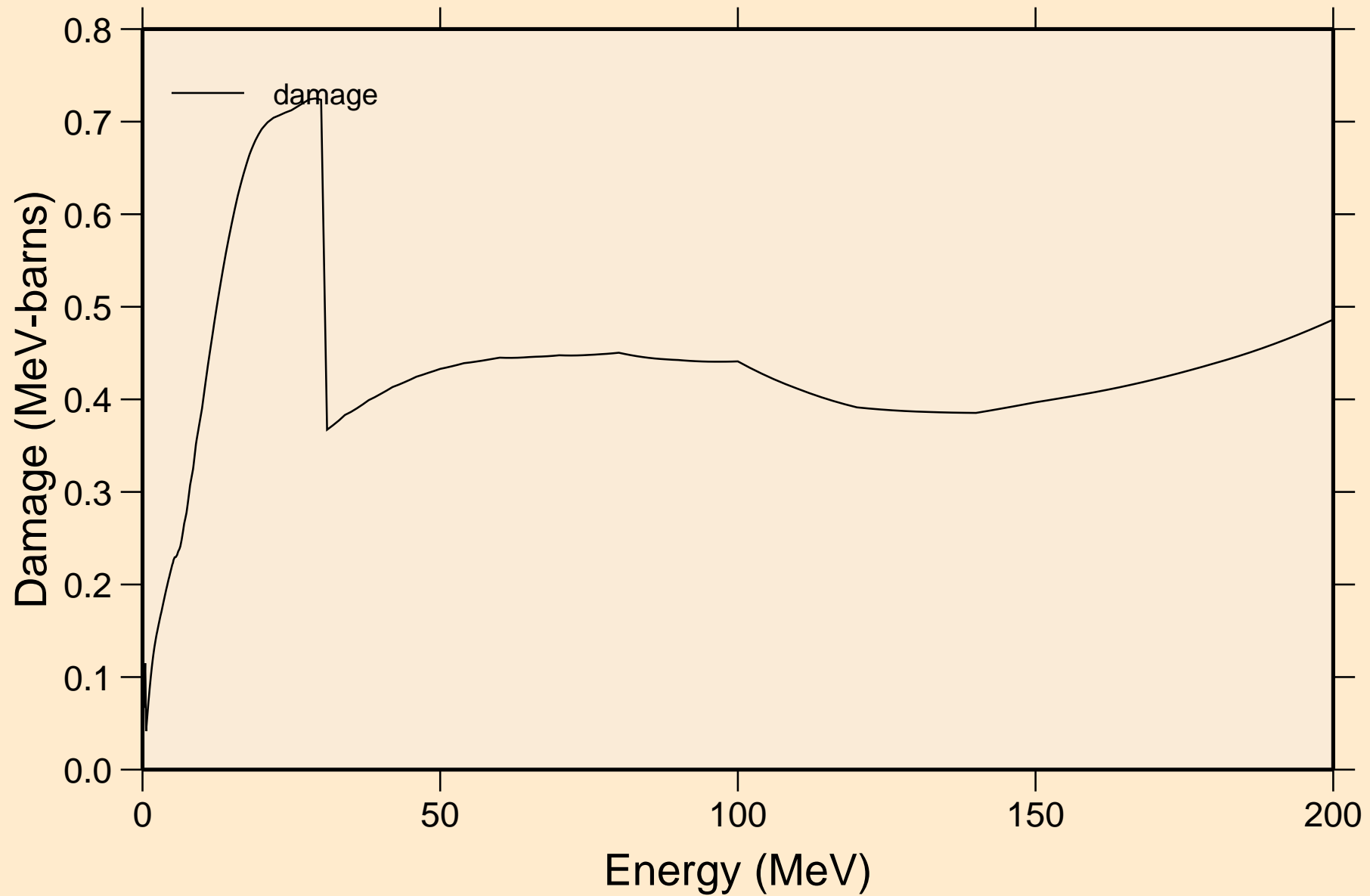

SB134M NEUTRON ACER TENDL-2023 LIBRARY; T=0.K  
Non-threshold reactions

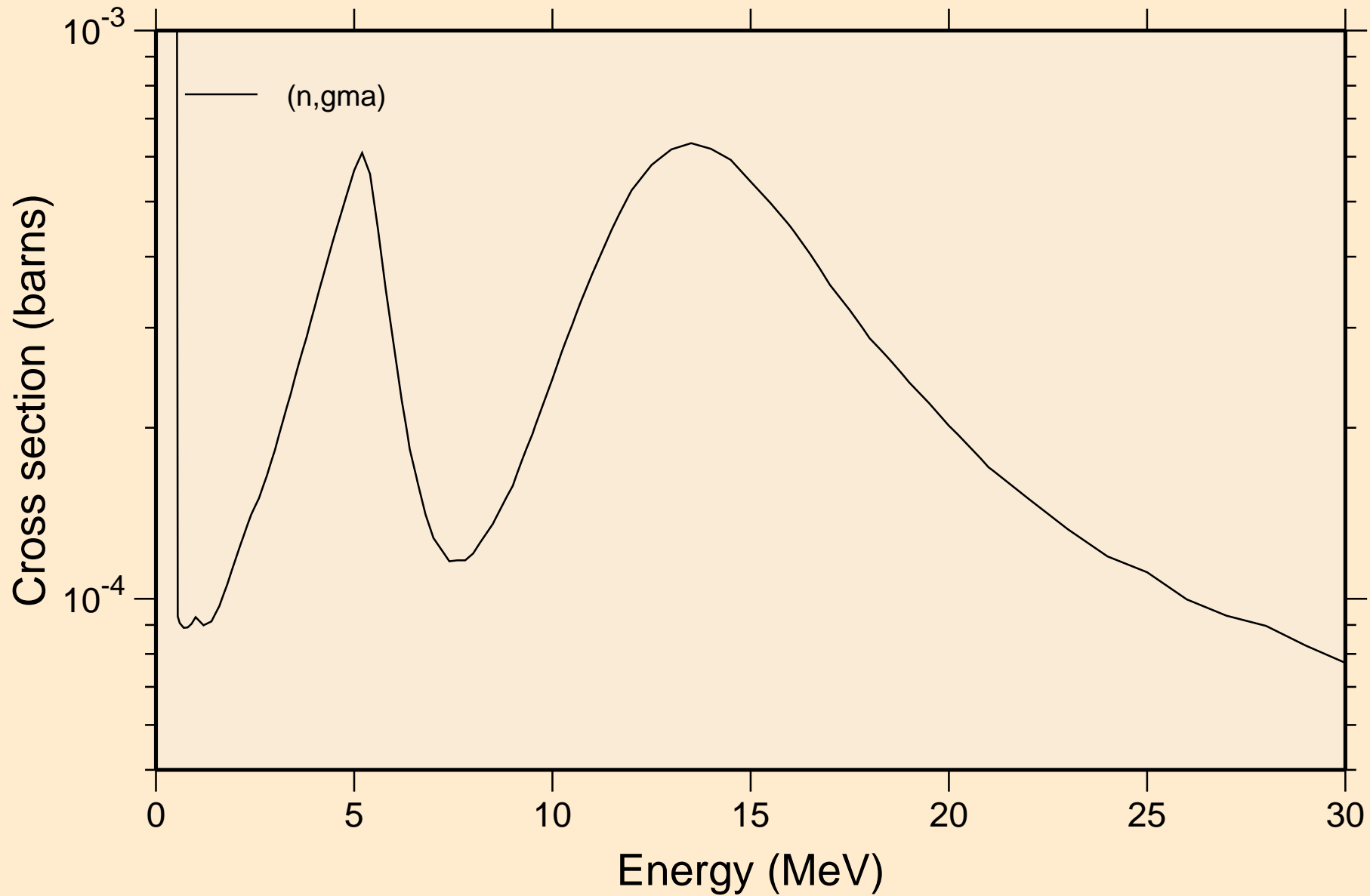

# SB134M NEUTRON ACER TENDL-2023 LIBRARY; T=0.K

## Inelastic levels

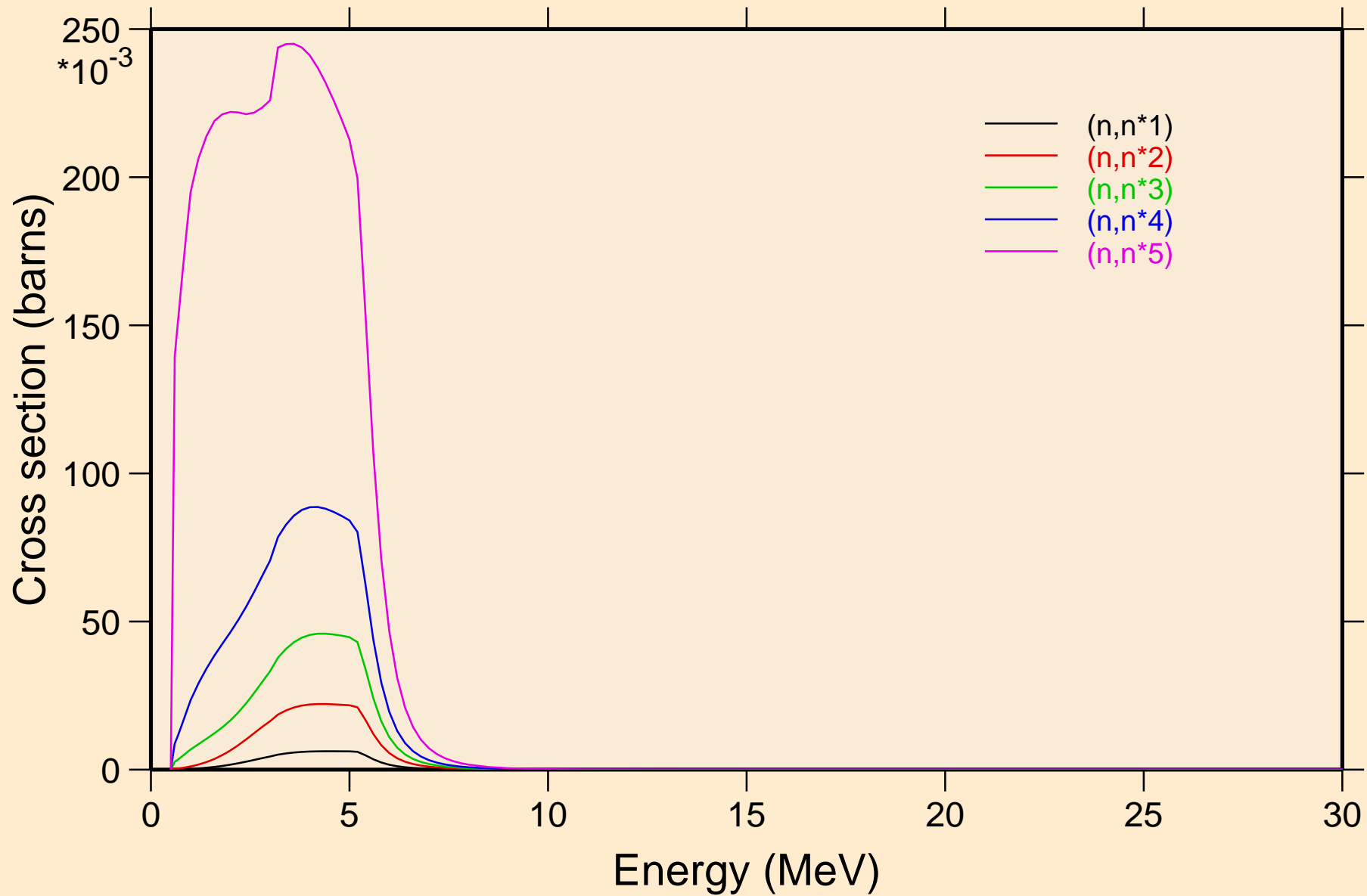



SB134M NEUTRON ACER TENDL-2023 LIBRARY; T=0.K  
Inelastic levels

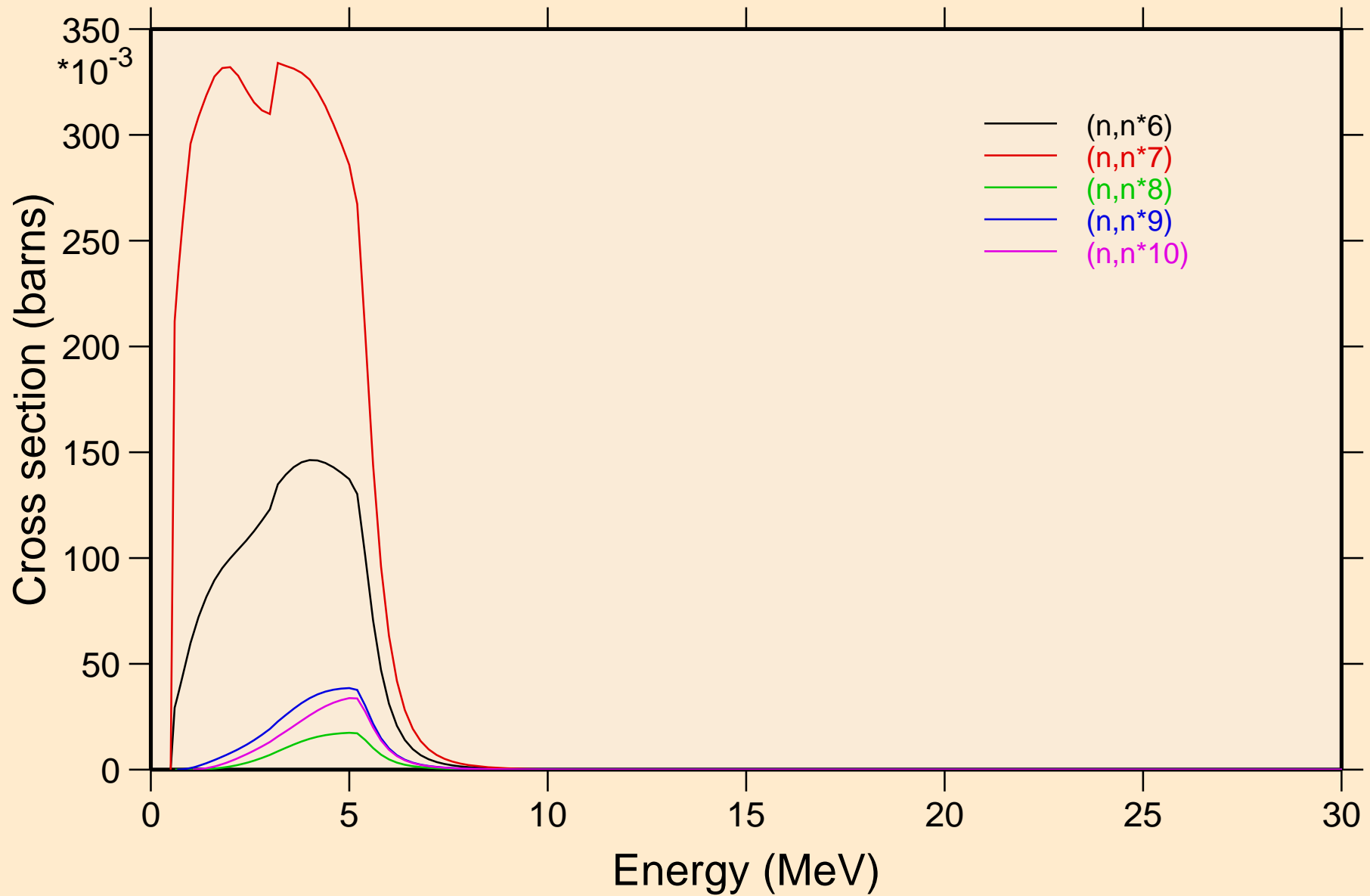

# SB134M NEUTRON ACER TENDL-2023 LIBRARY; T=0.K

## Inelastic levels

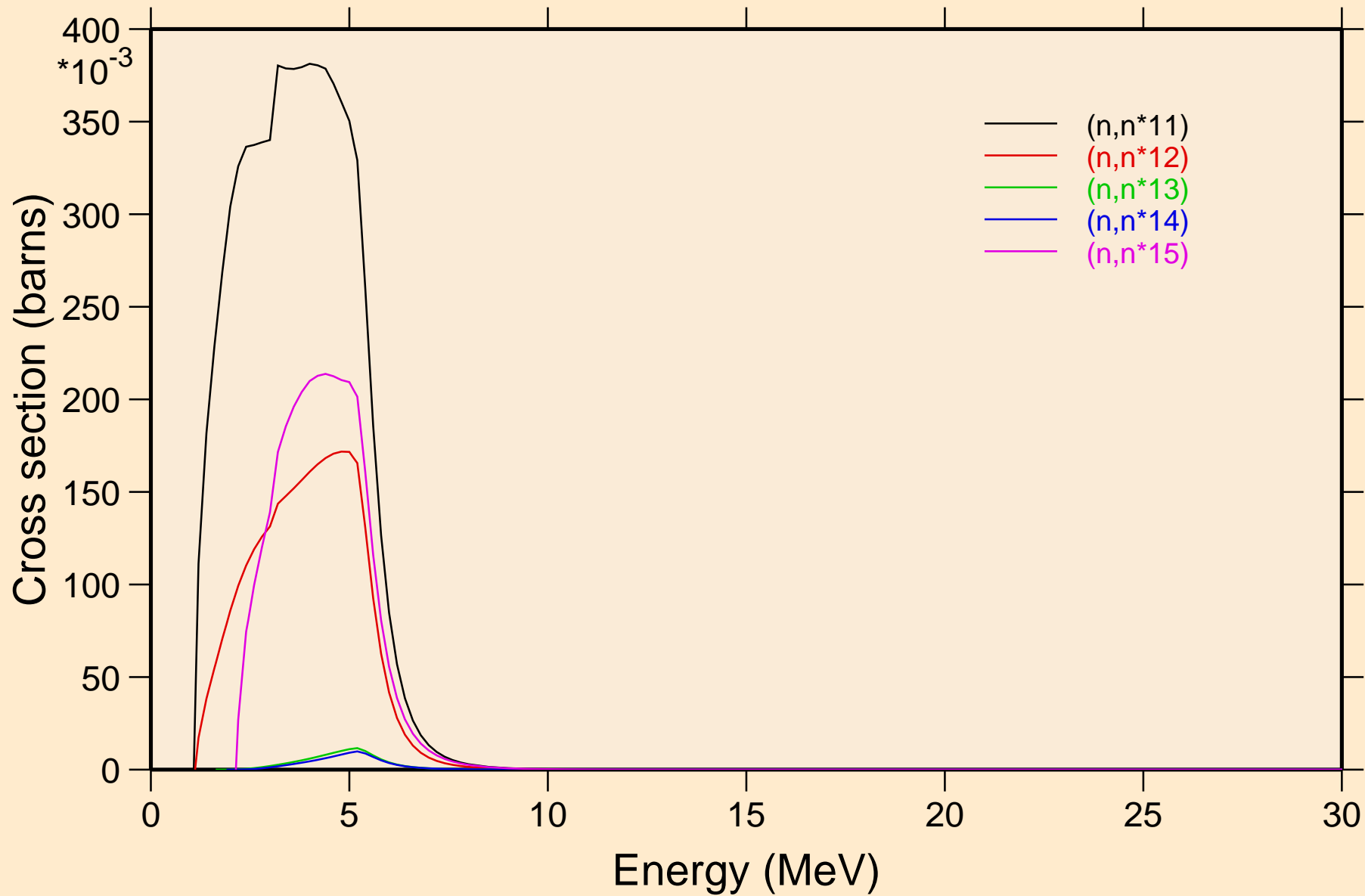

# SB134M NEUTRON ACER TENDL-2023 LIBRARY; T=0.K

## Inelastic levels

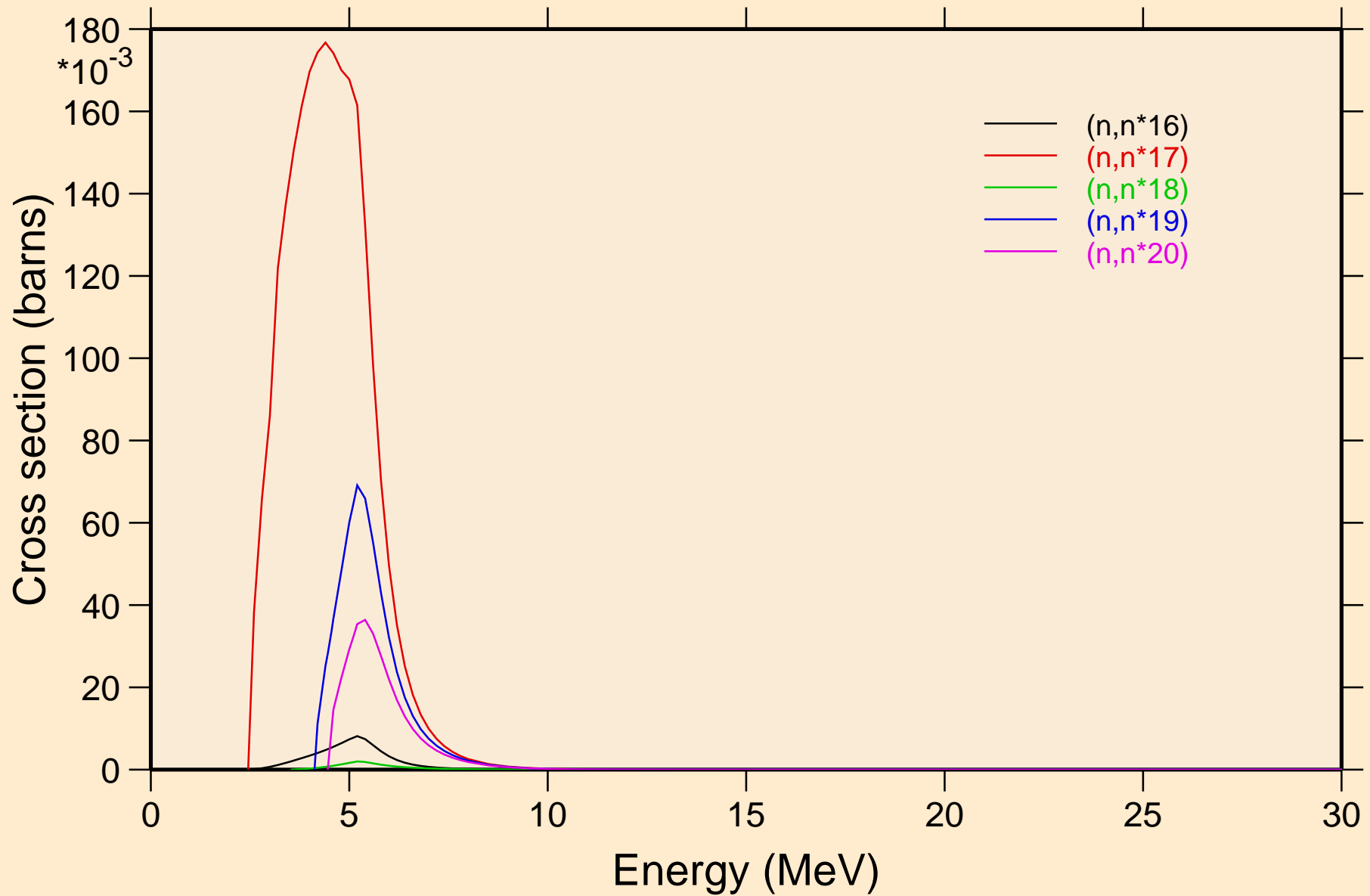

SB134M NEUTRON ACER TENDL-2023 LIBRARY; T=0.K  
Inelastic levels

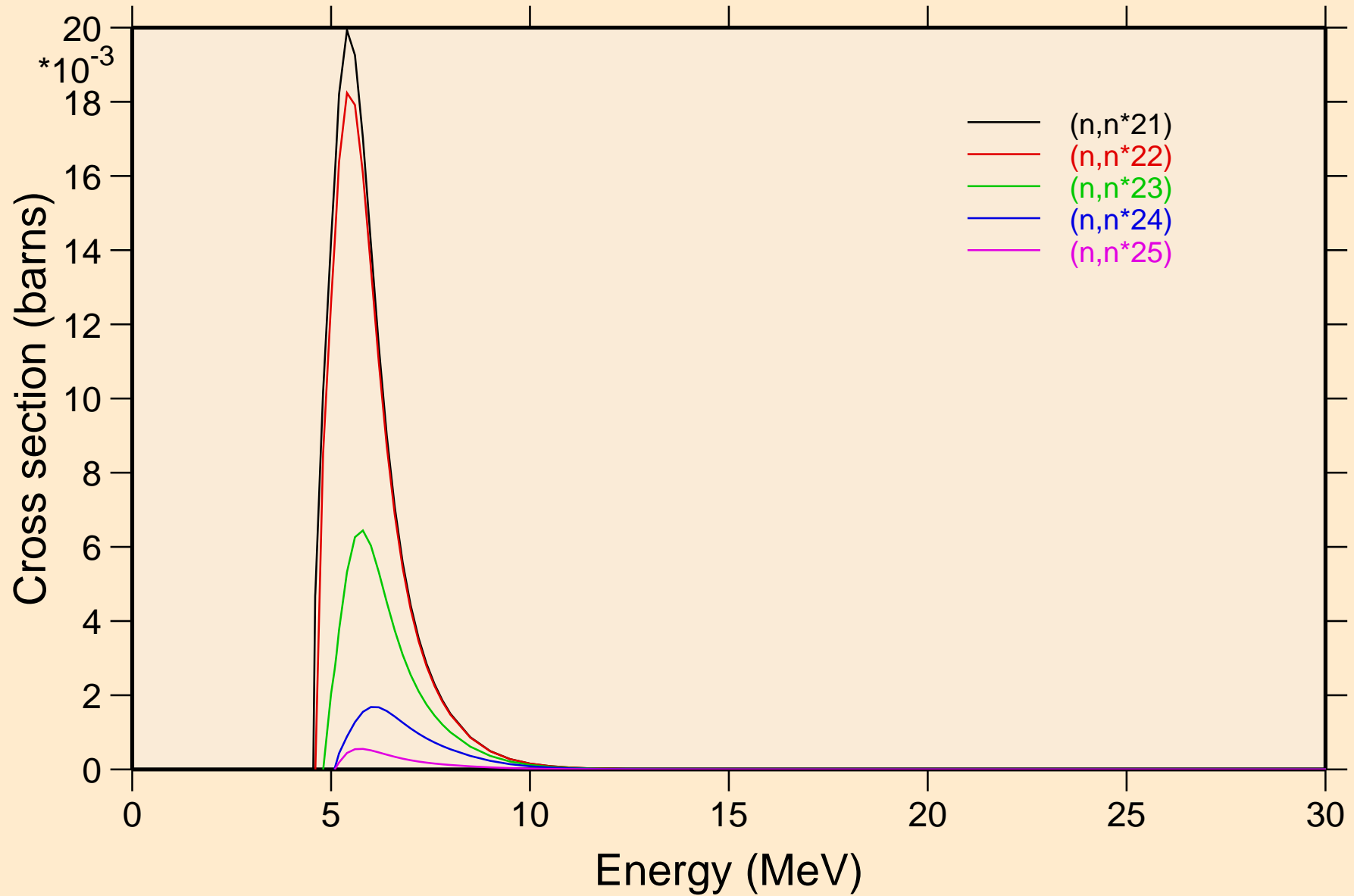

# SB134M NEUTRON ACER TENDL-2023 LIBRARY; T=0.K

## Inelastic levels

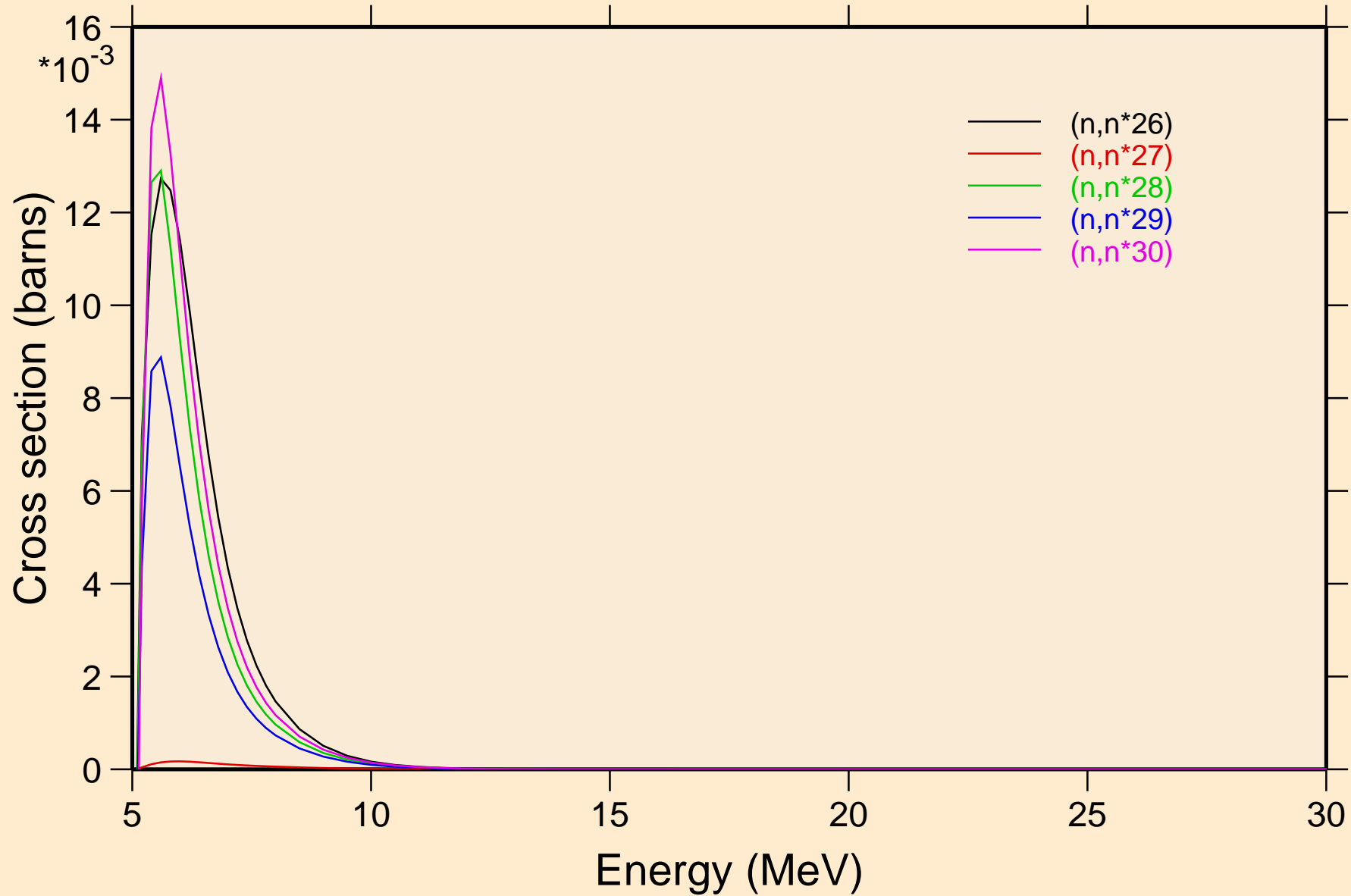

# SB134M NEUTRON ACER TENDL-2023 LIBRARY; T=0.K

## Threshold reactions

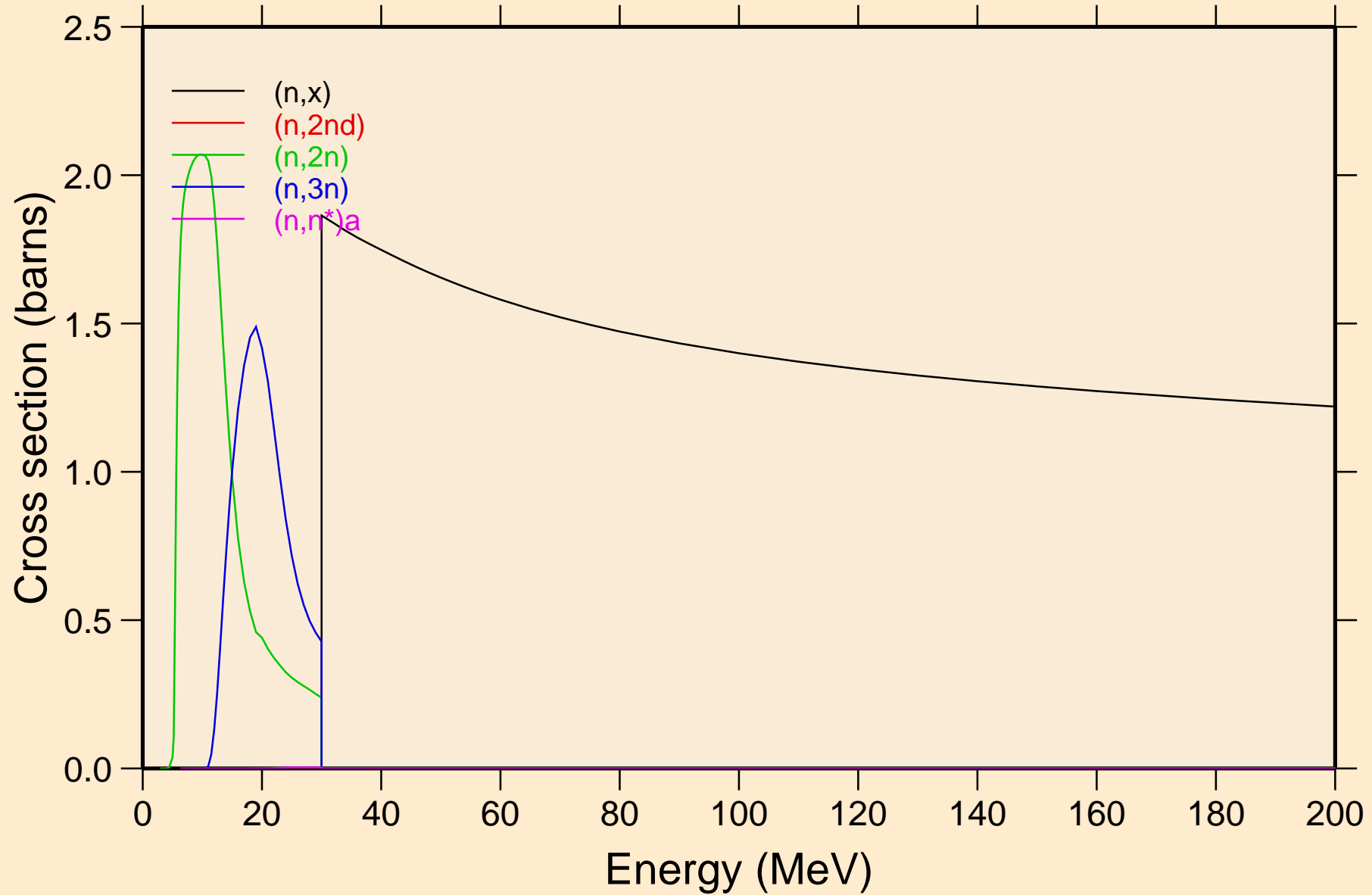

SB134M NEUTRON ACER TENDL-2023 LIBRARY; T=0.K  
Threshold reactions

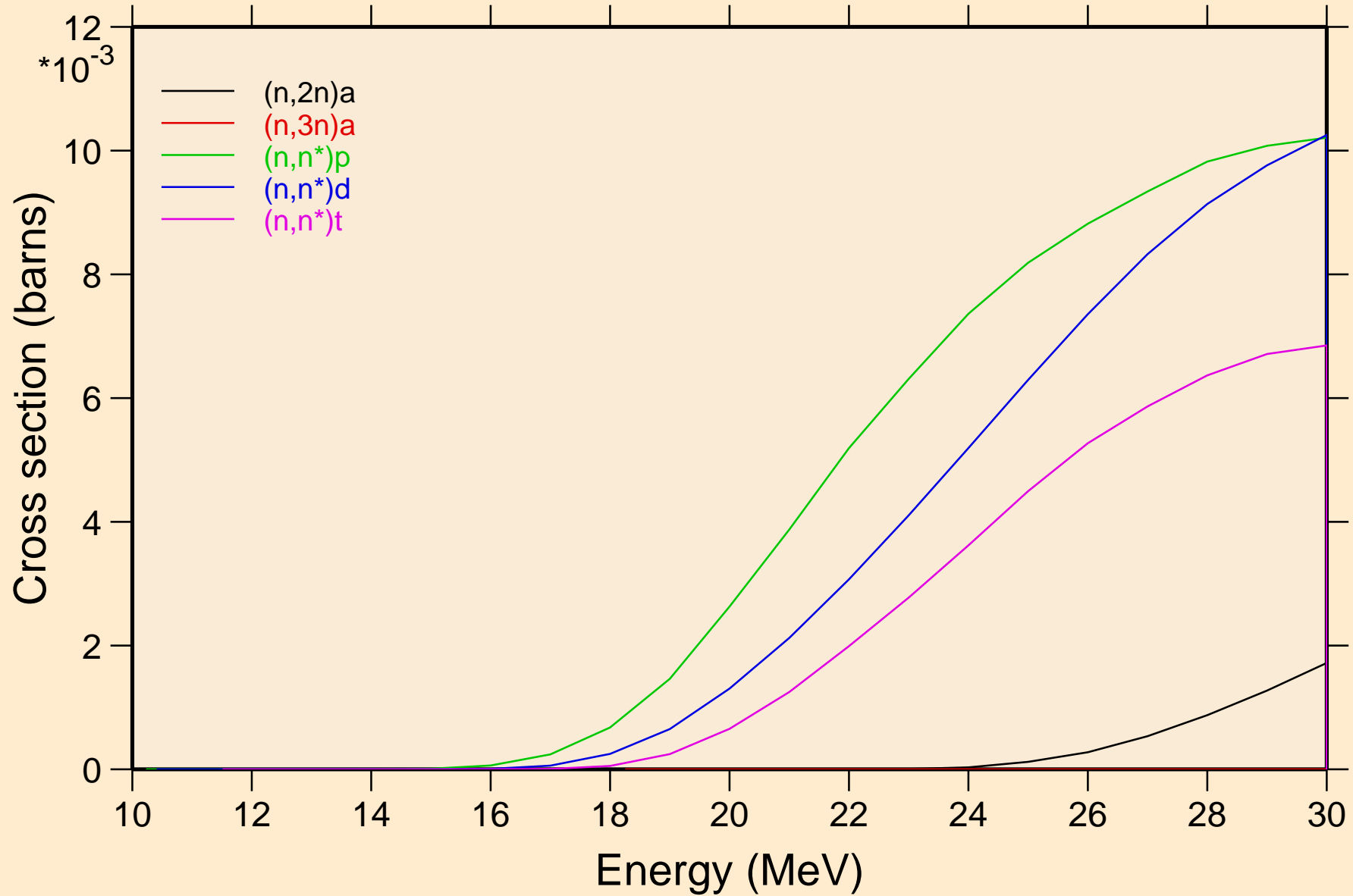

SB134M NEUTRON ACER TENDL-2023 LIBRARY; T=0.K  
Threshold reactions

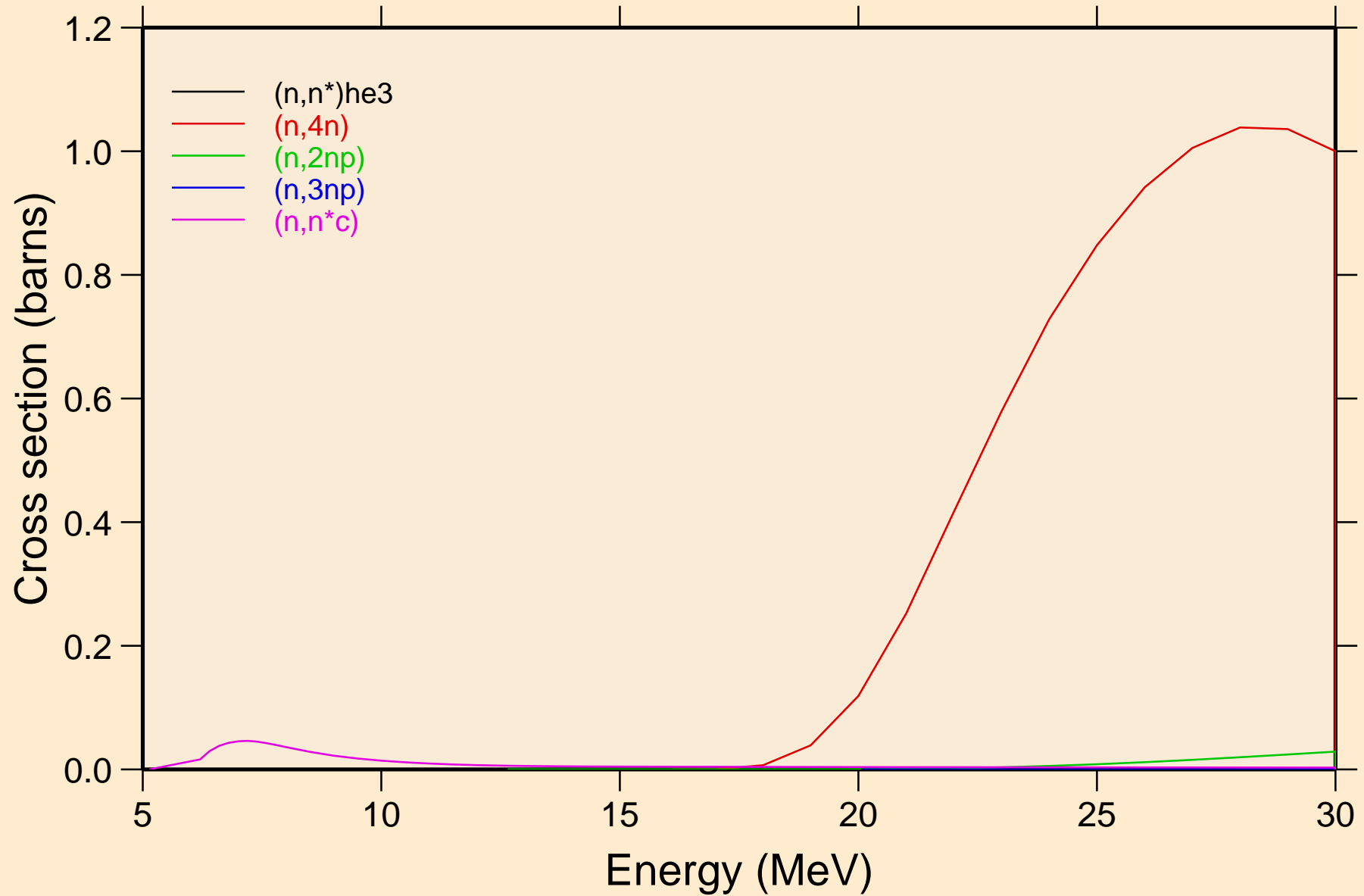



# SB134M NEUTRON ACER TENDL-2023 LIBRARY; T=0.K

## Threshold reactions

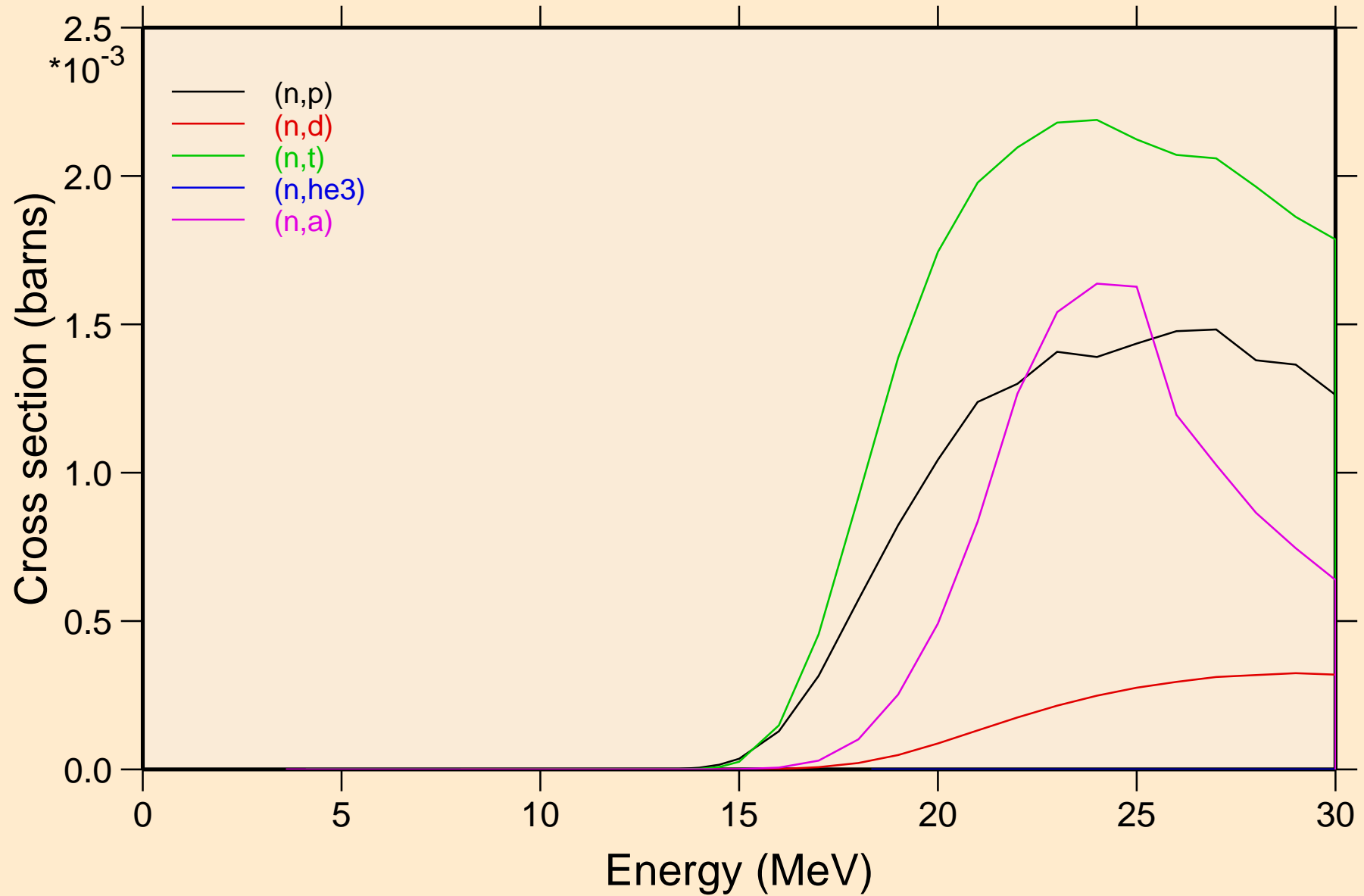

# SB134M NEUTRON ACER TENDL-2023 LIBRARY; T=0.K

## Threshold reactions

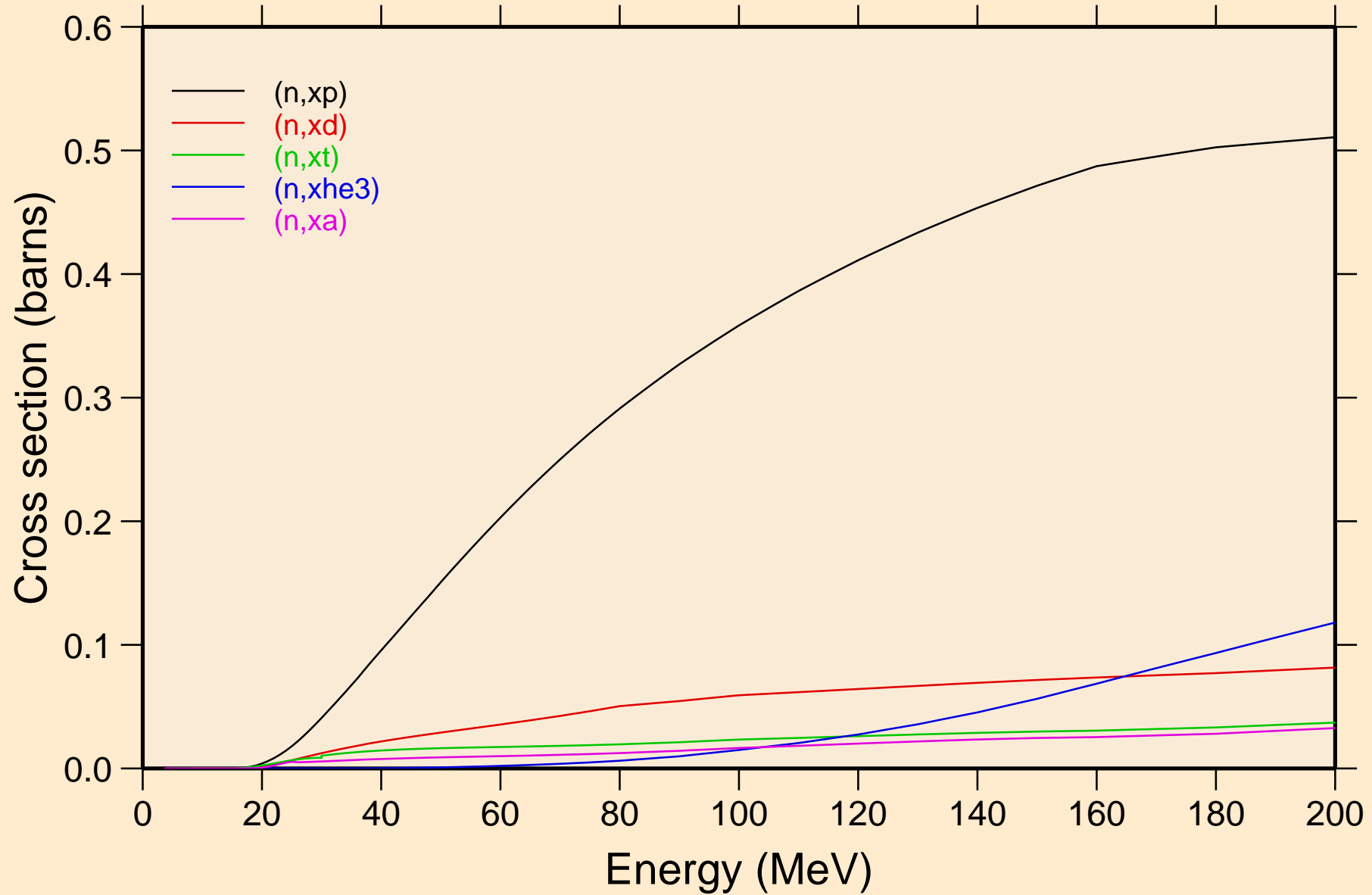

SB134M NEUTRON ACER TENDL-2023 LIBRARY; T=0.K  
angular distribution for elastic

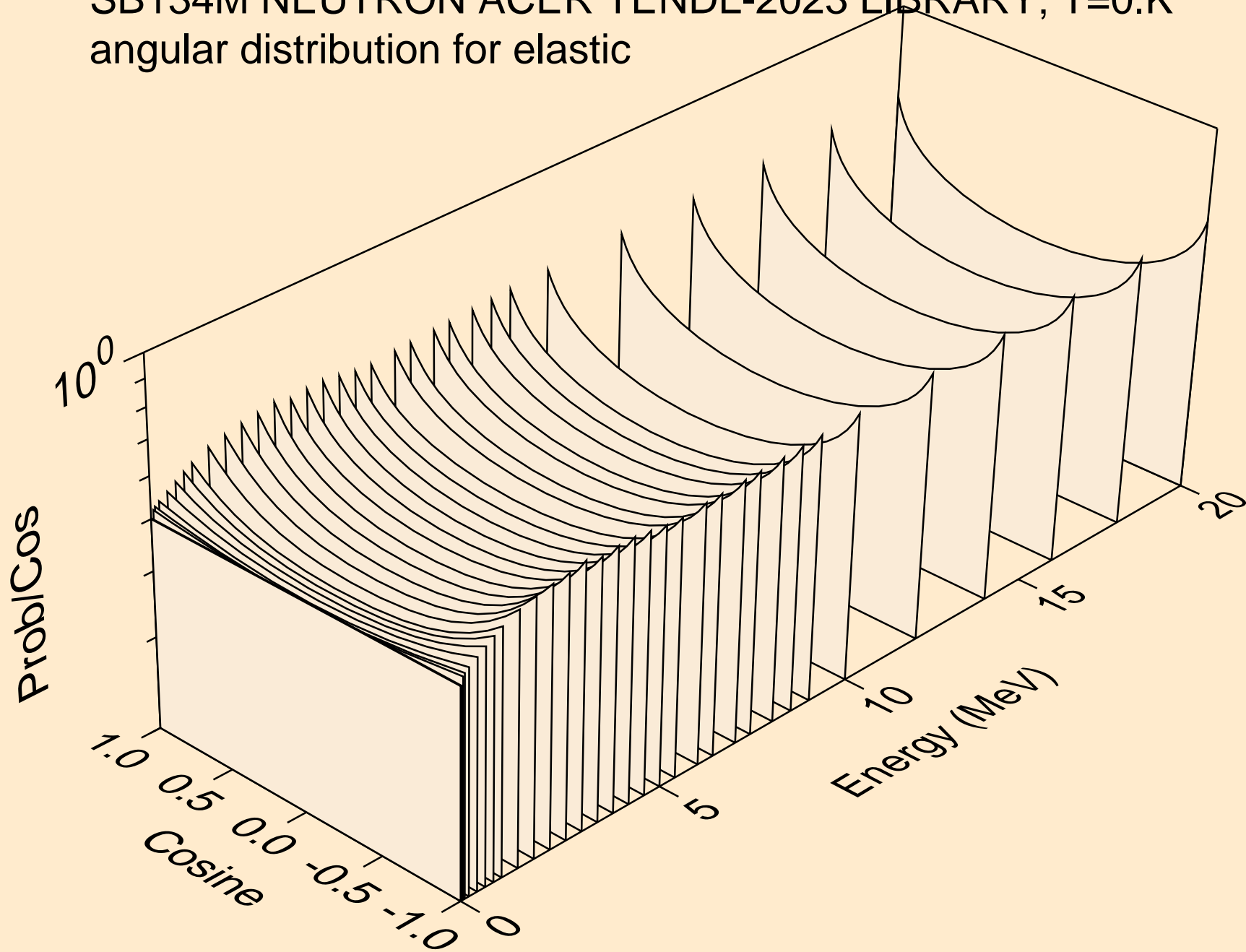

SB134M NEUTRON ACER TENDL-2023 LIBRARY; T=0.K  
angular distribution for elastic

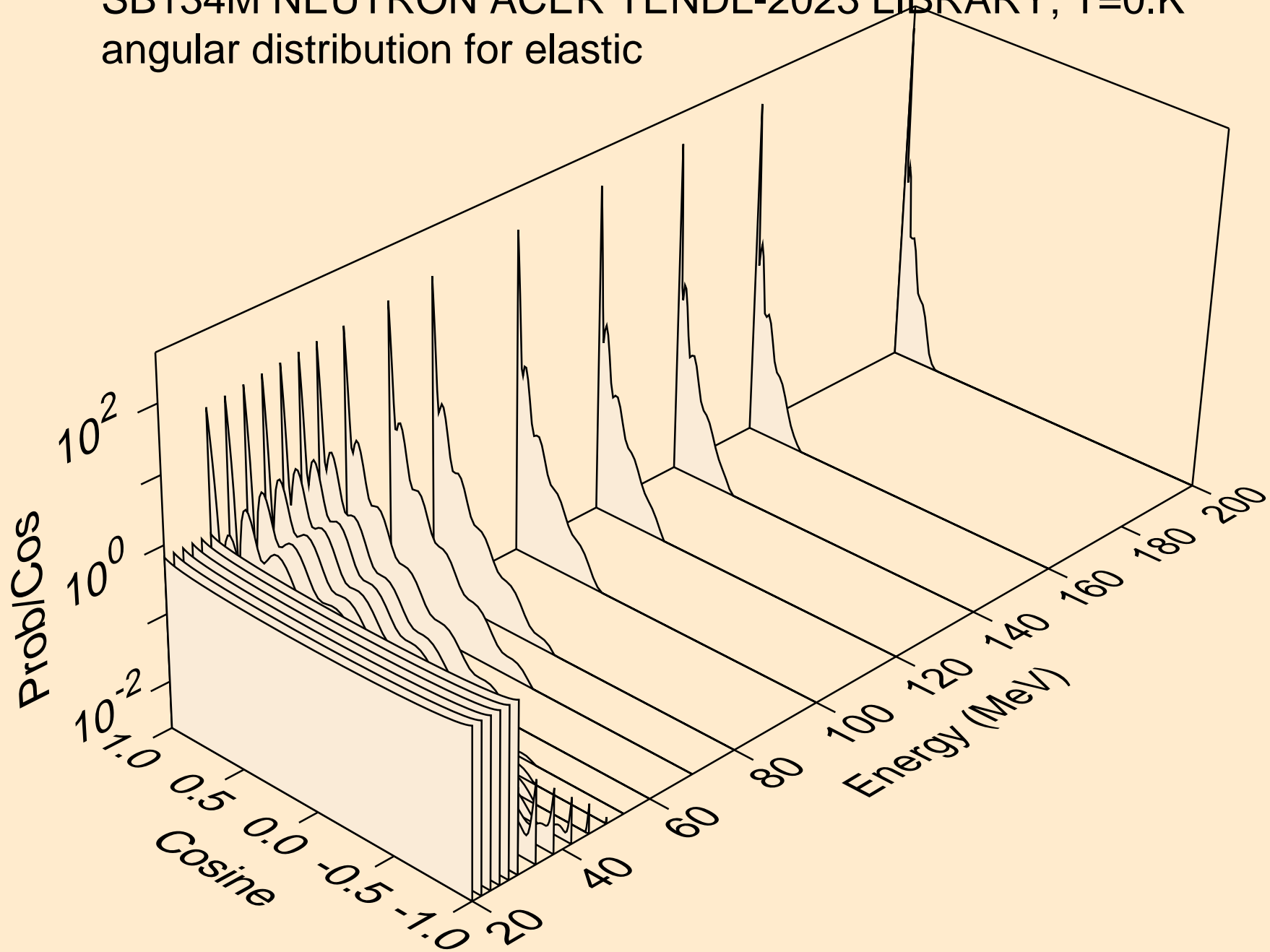

SB134M NEUTRON ACER TENDL-2023 LIBRARY; T=0.K  
angular distribution for (n,n\*1)

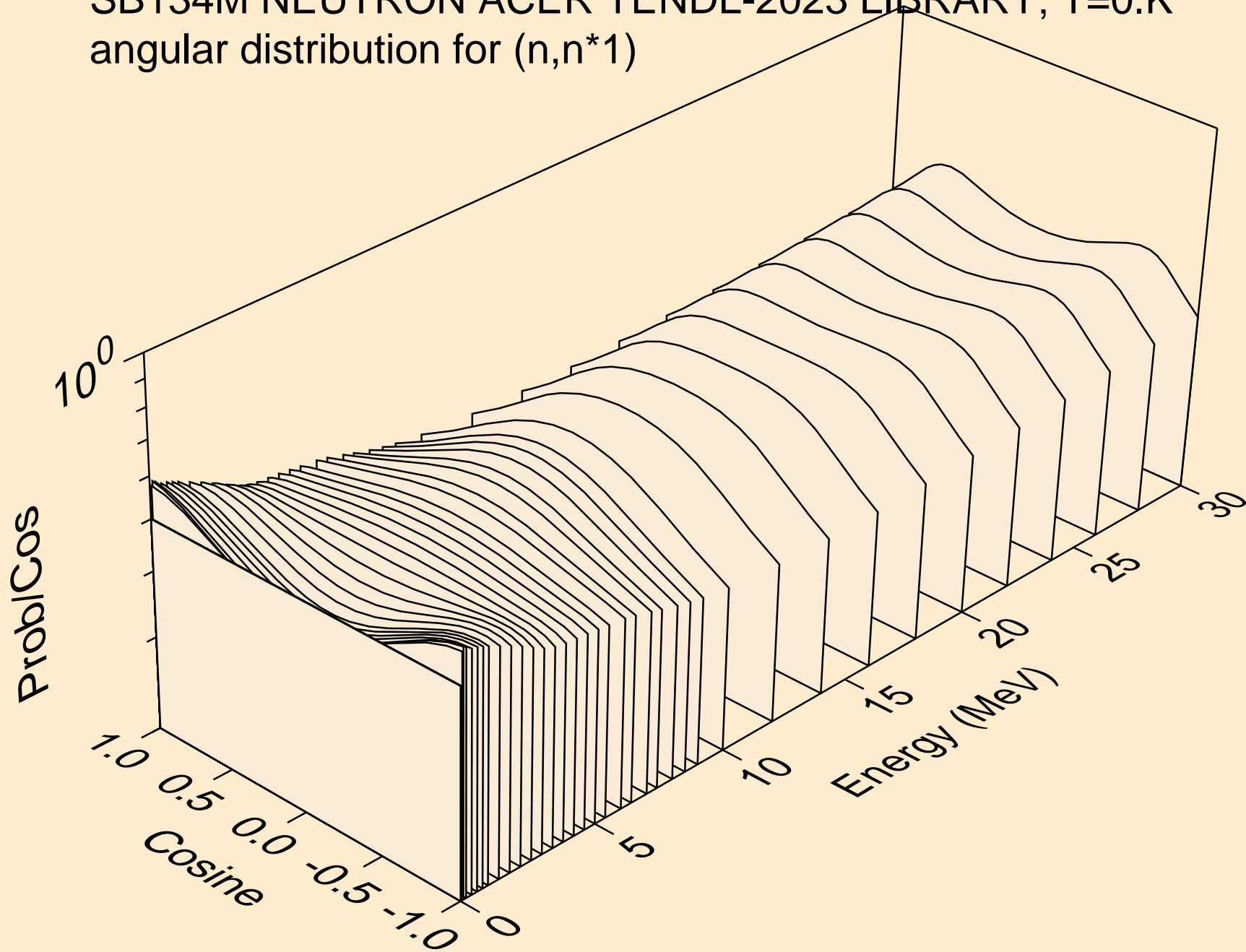

SB134M NEUTRON ACER TENDL-2023 LIBRARY; T=0.K  
angular distribution for (n,n\*2)

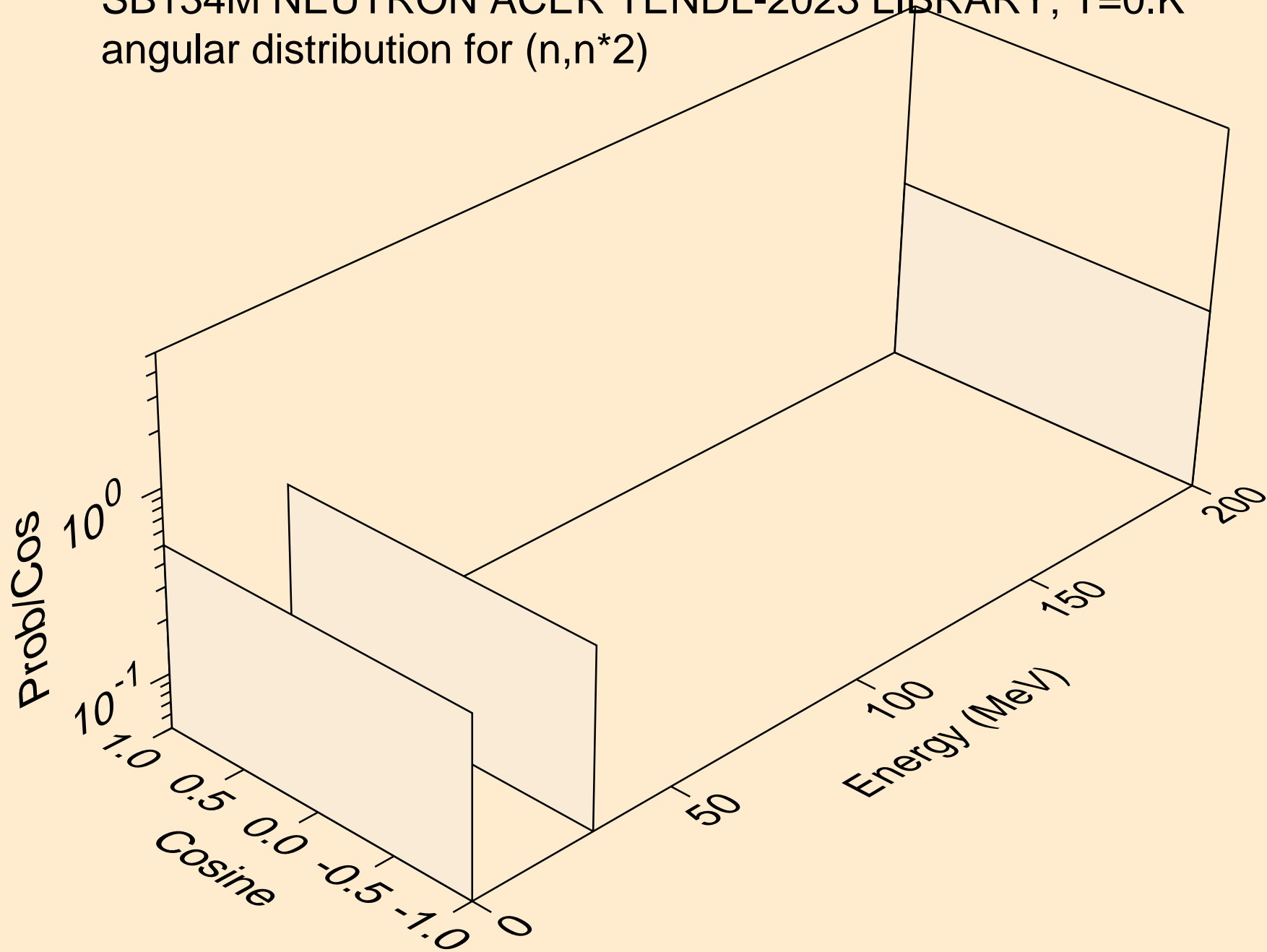

SB134M NEUTRON ACER TENDL-2023 LIBRARY; T=0.K  
angular distribution for (n,n\*3)

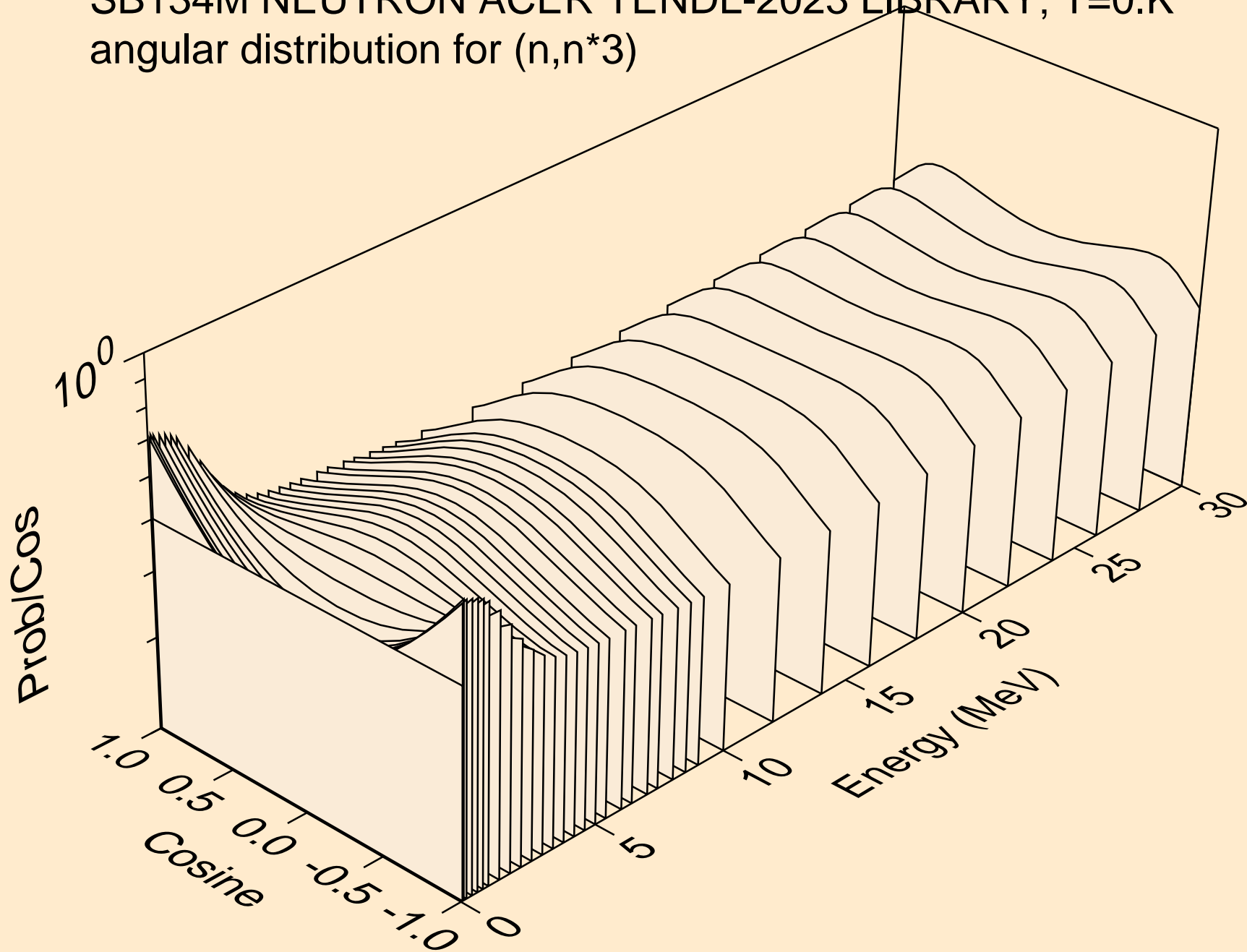

SB134M NEUTRON ACER TENDL-2023 LIBRARY; T=0.K  
angular distribution for (n,n\*4)

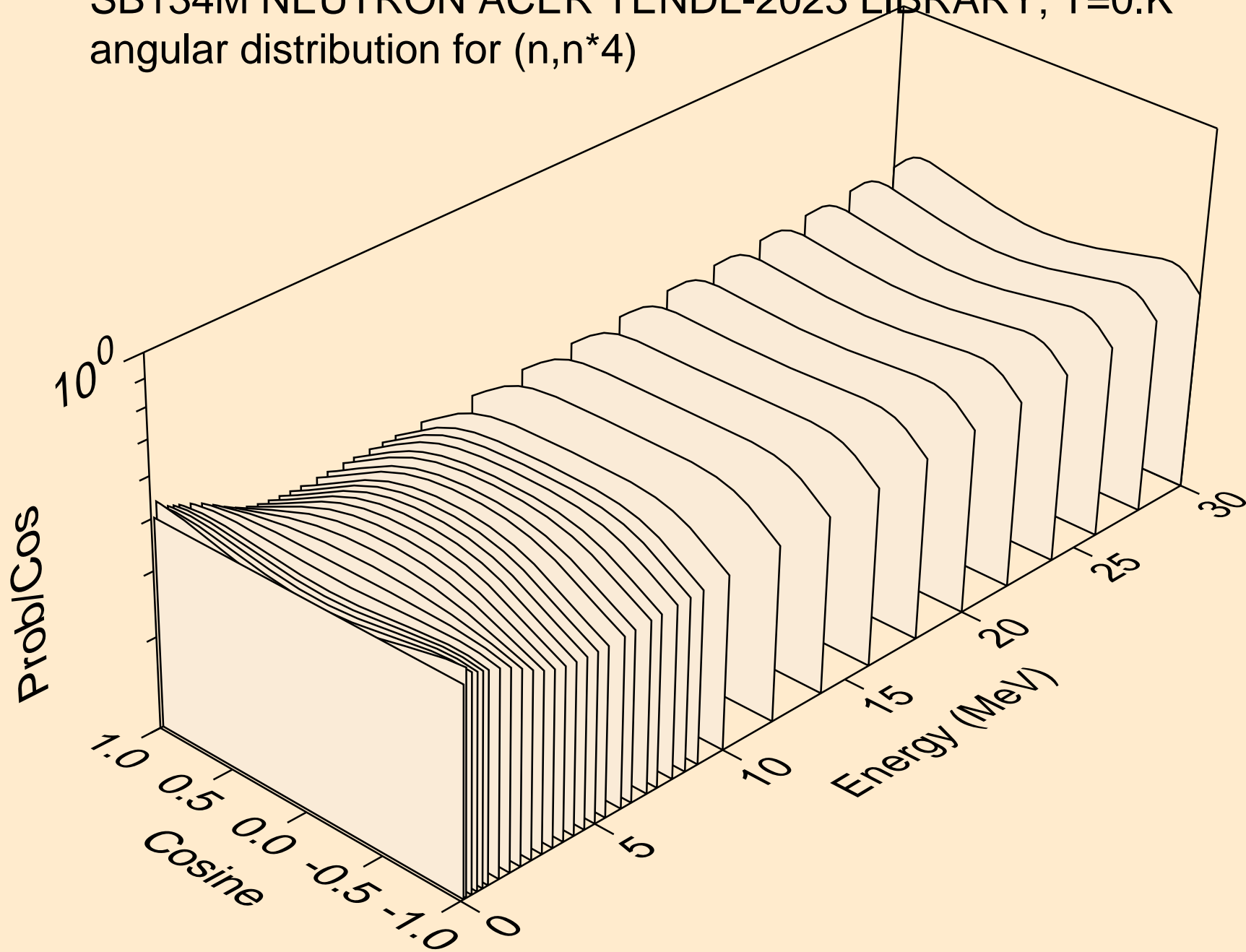



SB134M NEUTRON ACER TENDL-2023 LIBRARY; T=0.K  
angular distribution for (n,n\*5)

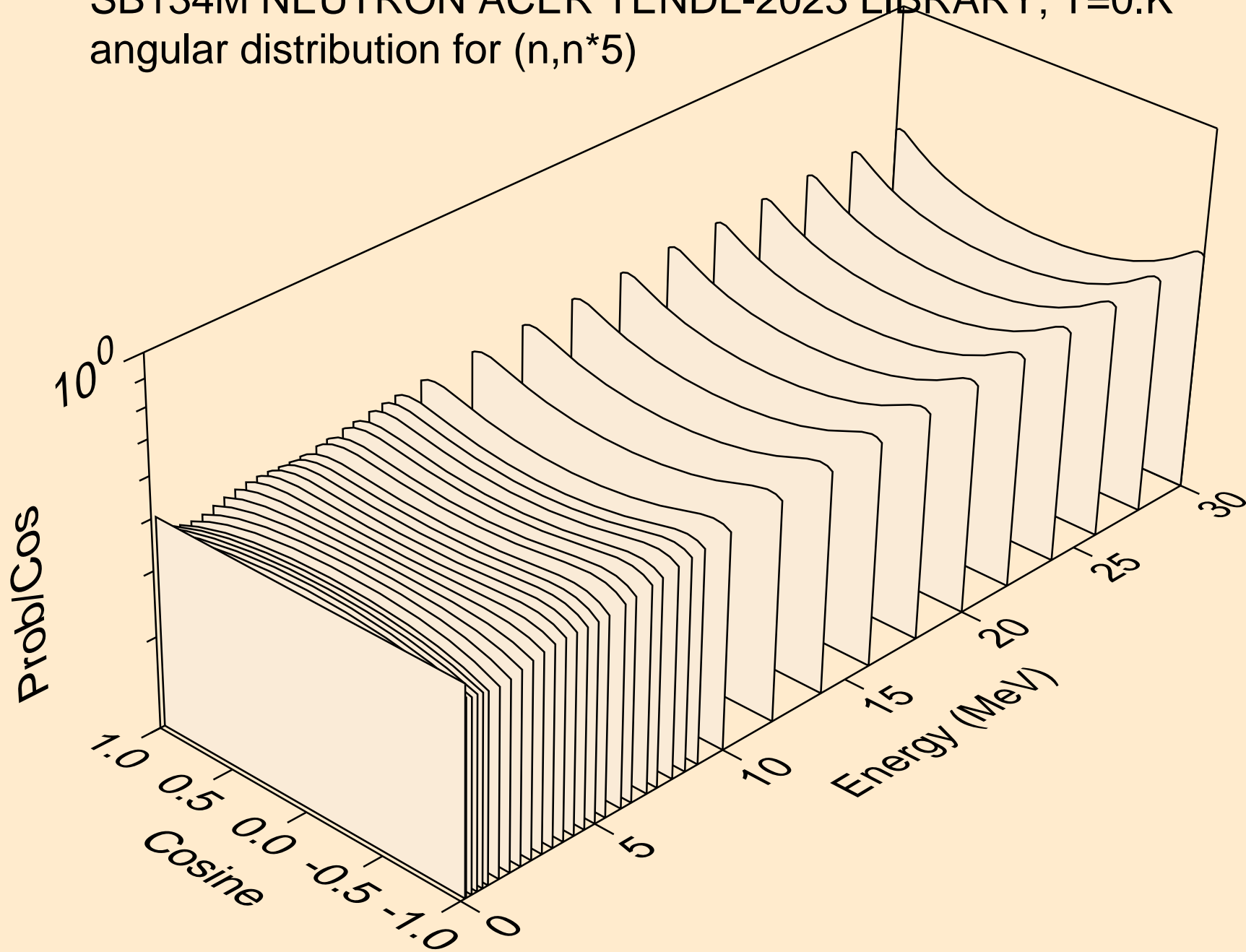

SB134M NEUTRON ACER TENDL-2023 LIBRARY; T=0.K  
angular distribution for (n,n\*6)

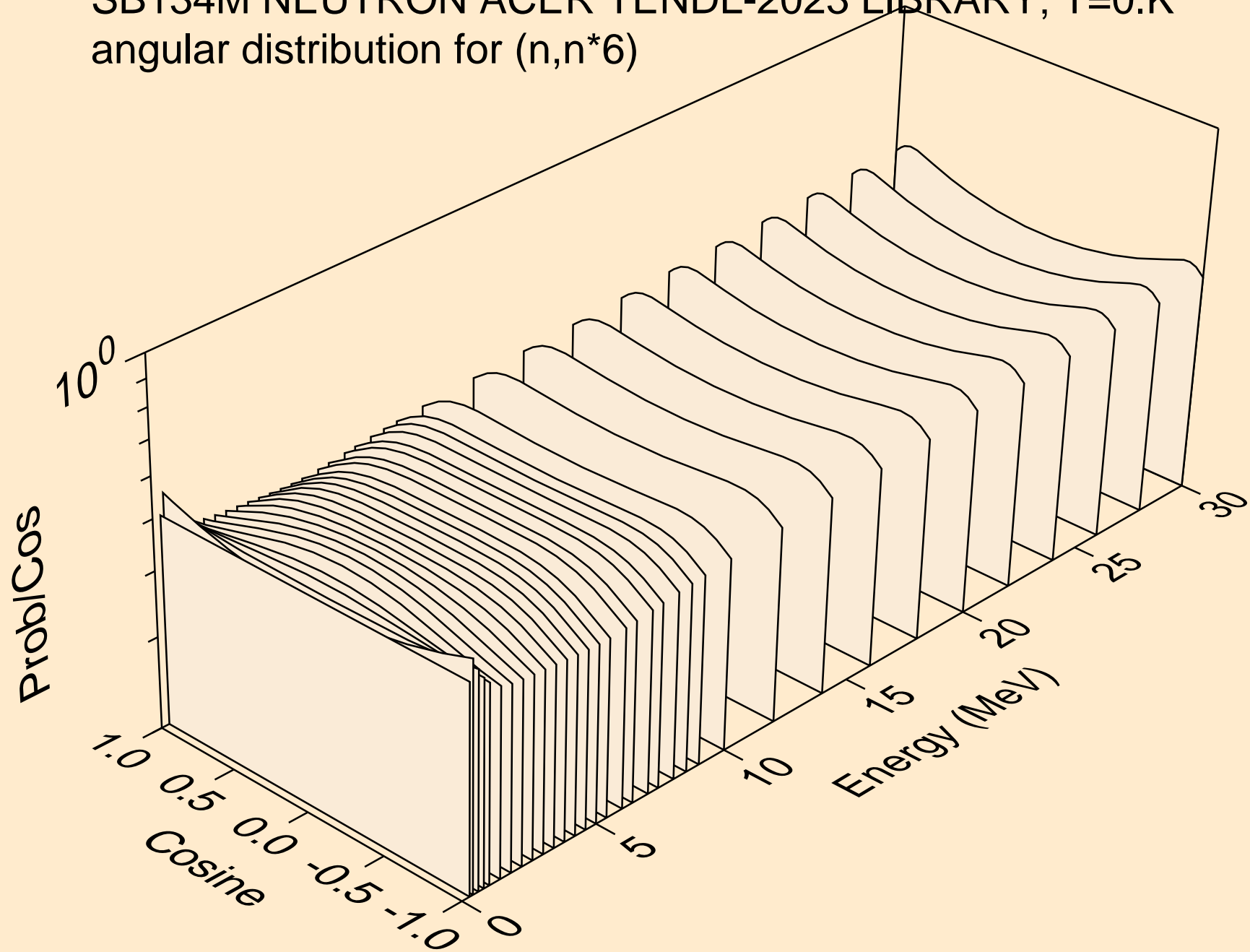

SB134M NEUTRON ACER TENDL-2023 LIBRARY; T=0.K  
angular distribution for (n,n\*7)

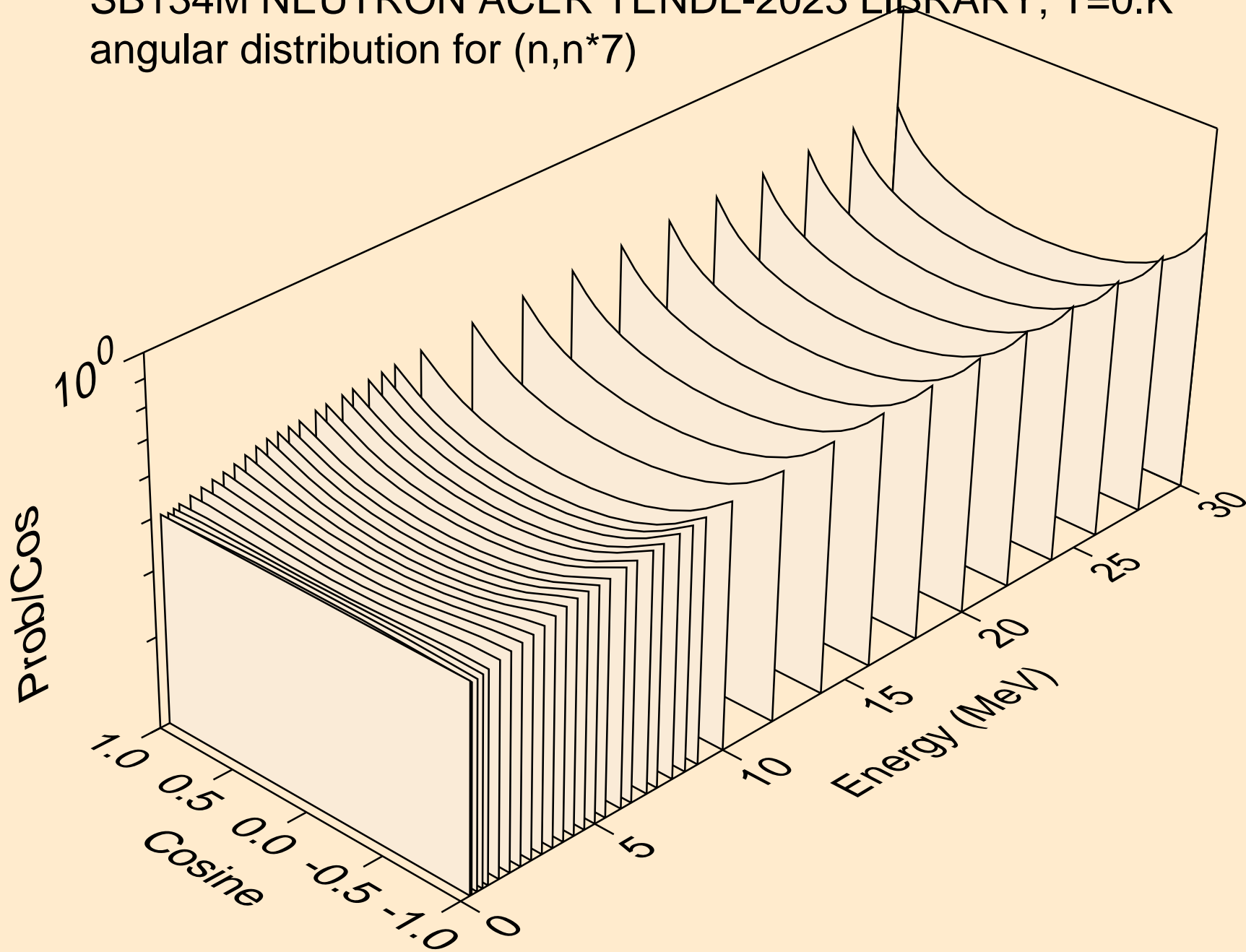

SB134M NEUTRON ACER TENDL-2023 LIBRARY; T=0.K  
angular distribution for (n,n\*8)

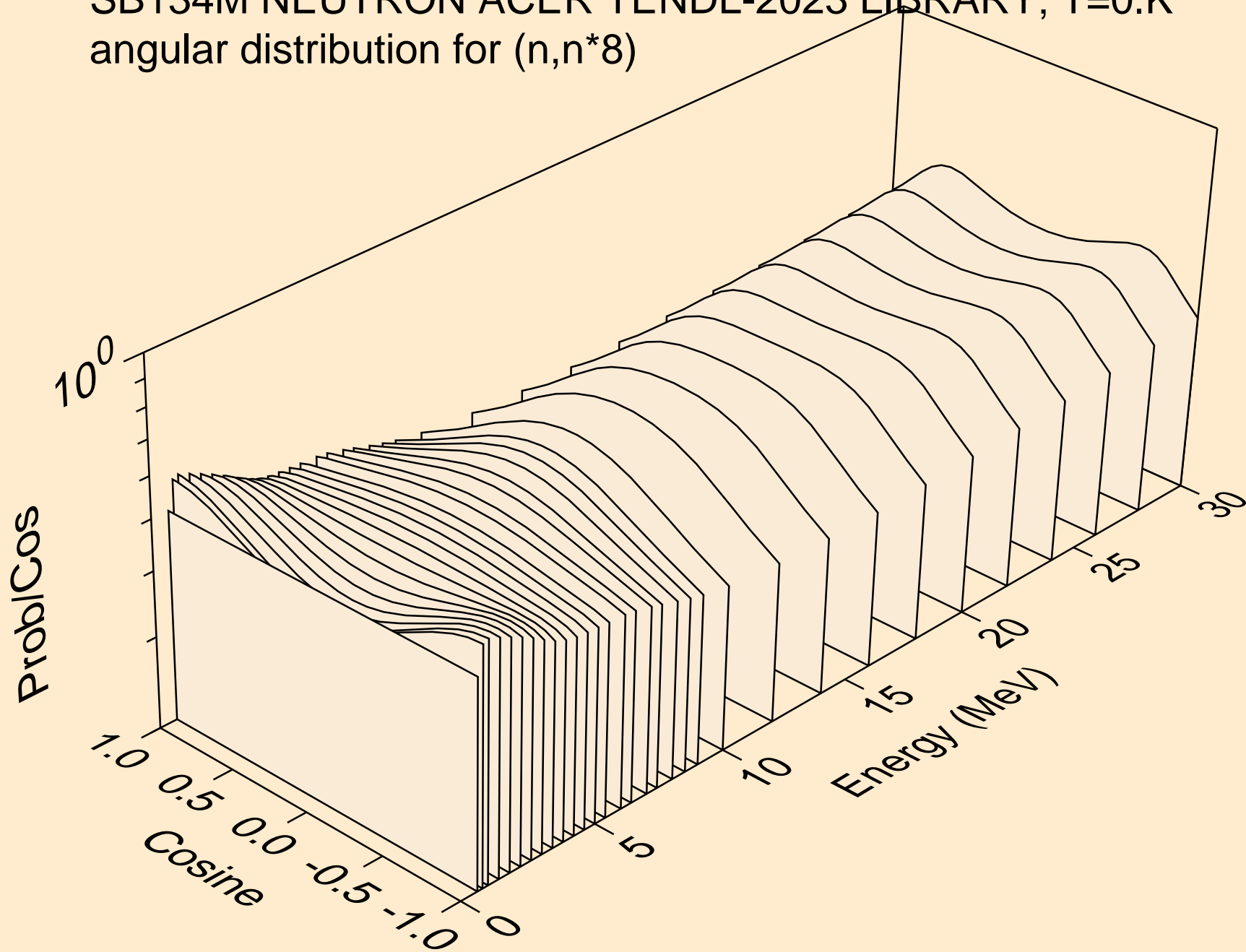

SB134M NEUTRON ACER TENDL-2023 LIBRARY; T=0.K  
angular distribution for (n,n\*9)

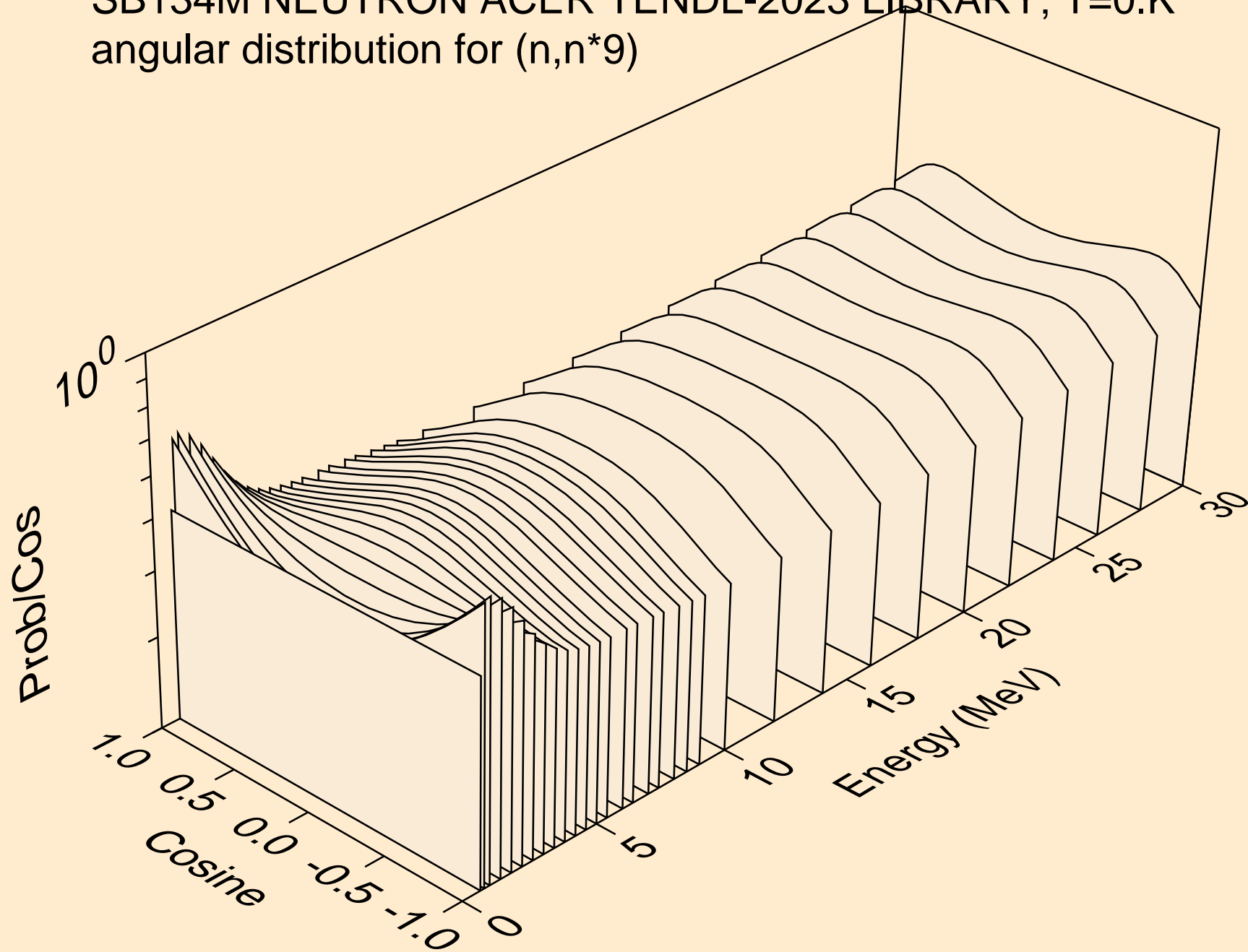

SB134M NEUTRON ACER TENDL-2023 LIBRARY; T=0.K  
angular distribution for (n,n\*10)

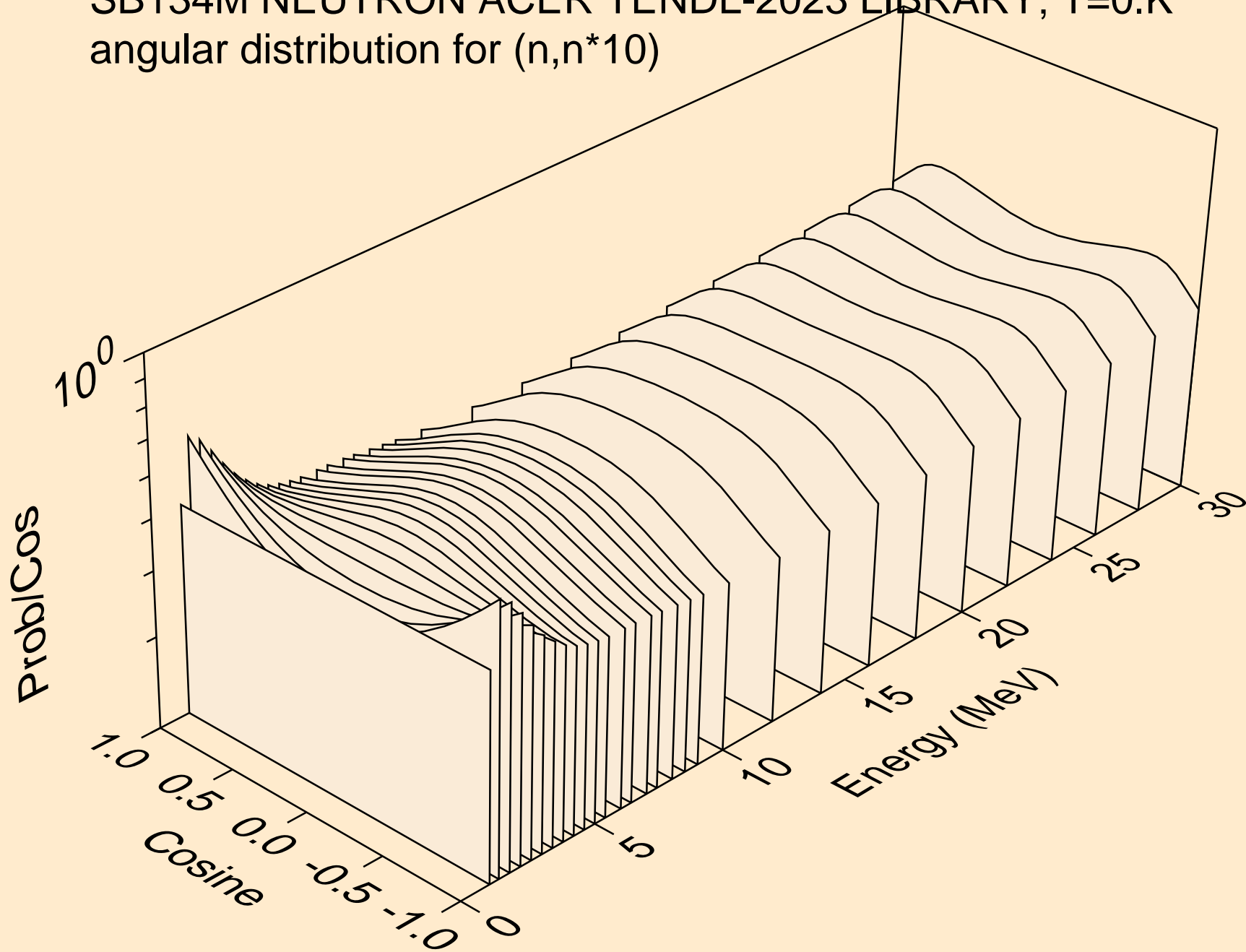

SB134M NEUTRON ACER TENDL-2023 LIBRARY; T=0.K  
angular distribution for (n,n\*11)

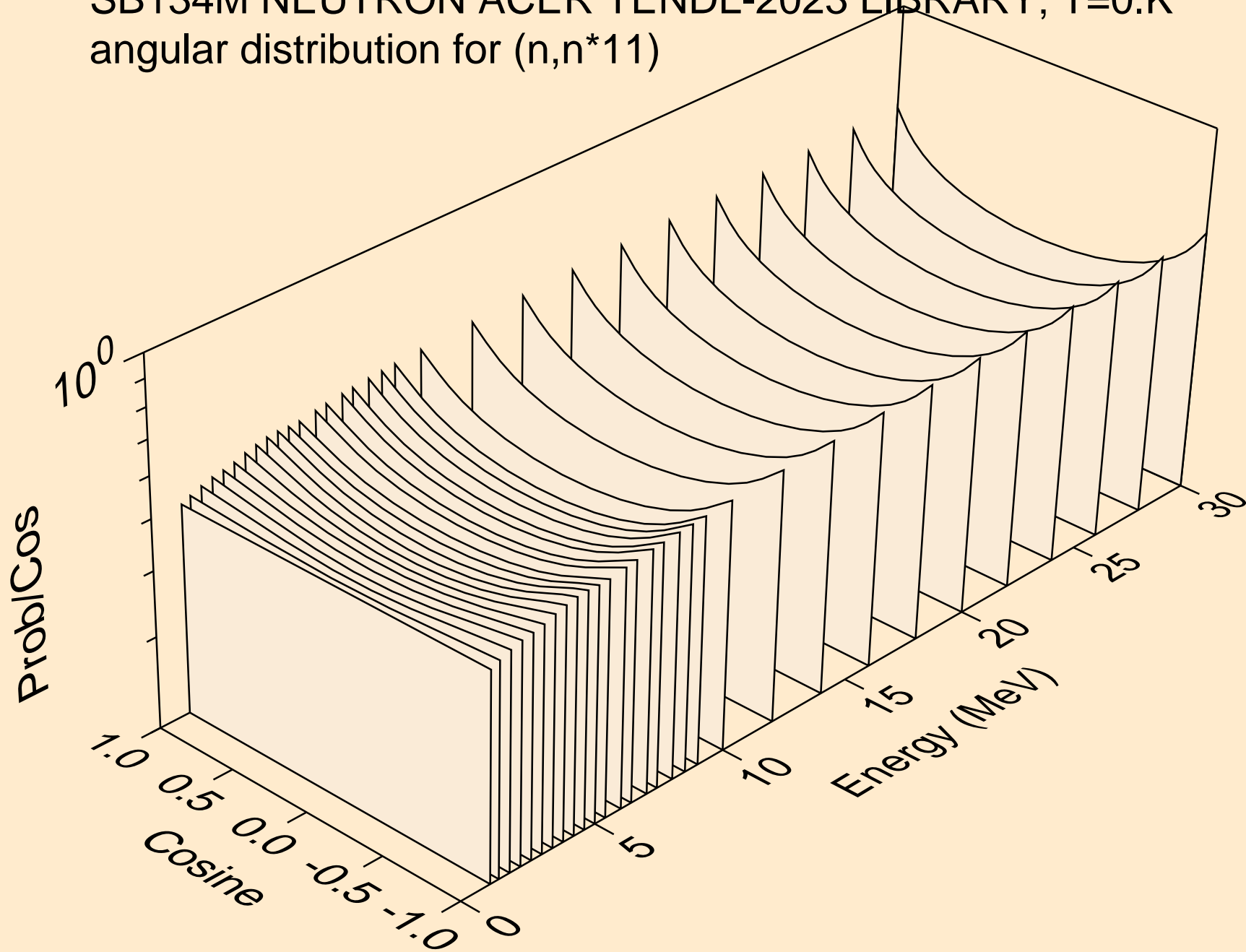

SB134M NEUTRON ACER TENDL-2023 LIBRARY; T=0.K  
angular distribution for (n,n\*12)

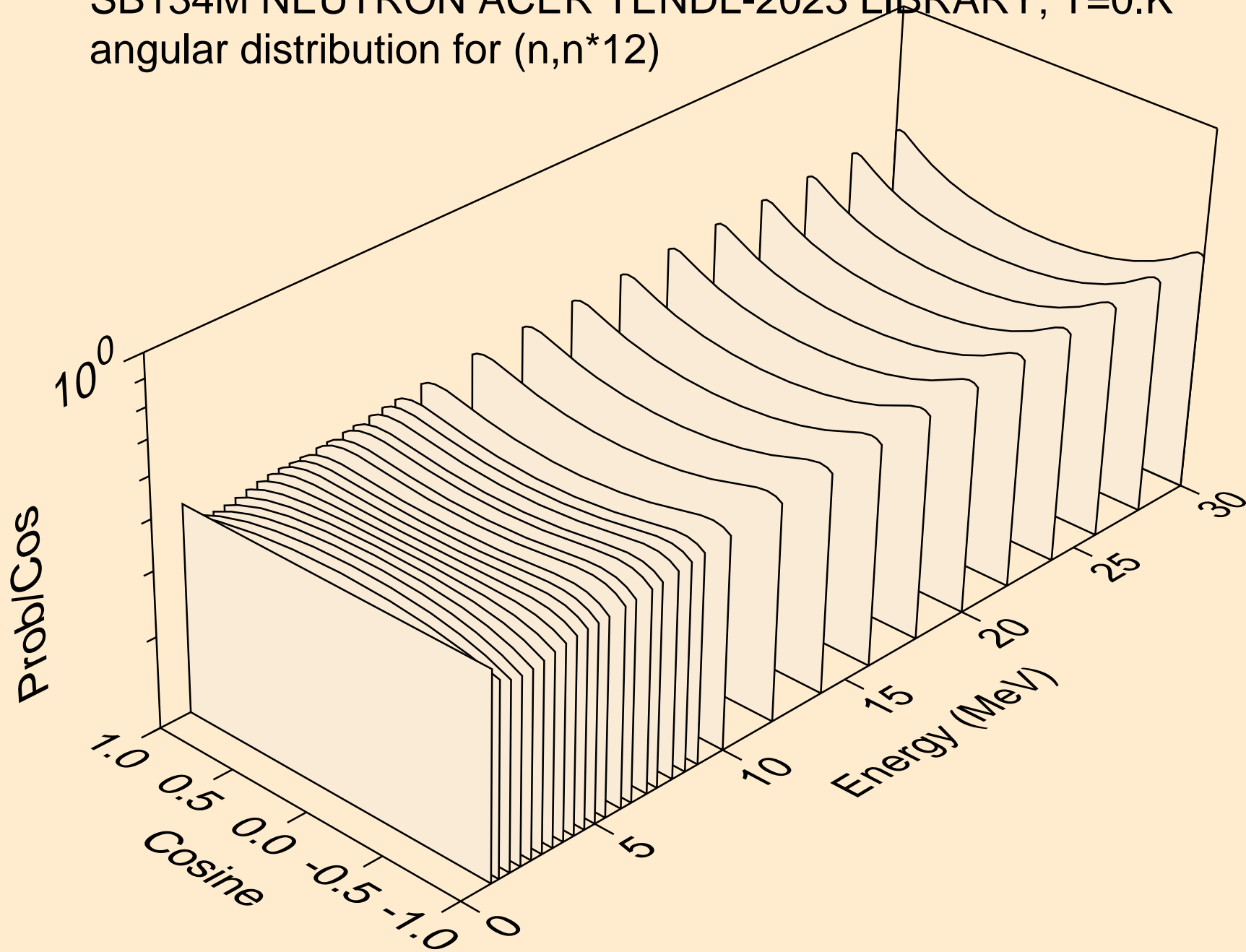



SB134M NEUTRON ACER TENDL-2023 LIBRARY; T=0.K  
angular distribution for (n,n\*13)

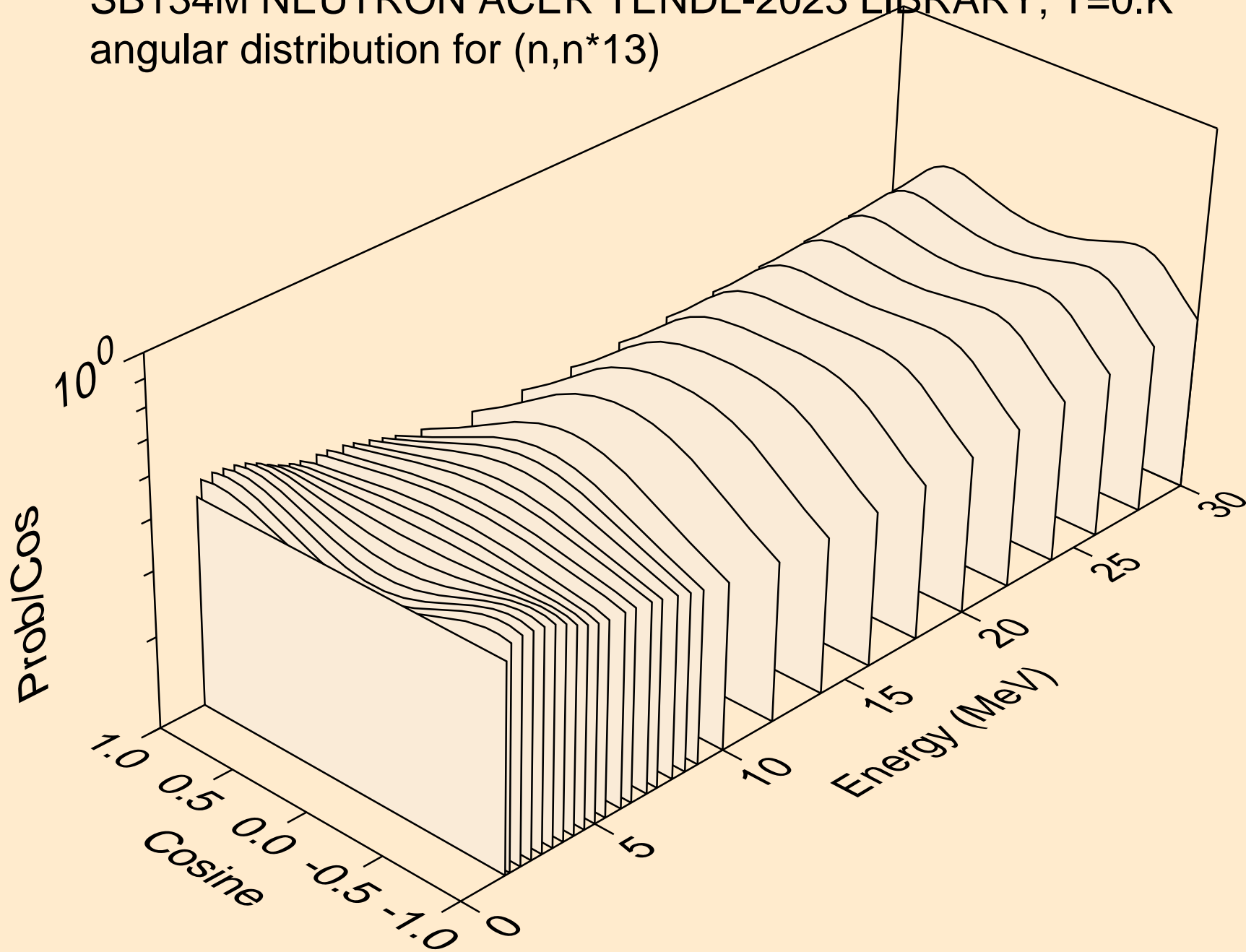

SB134M NEUTRON ACER TENDL-2023 LIBRARY; T=0.K  
angular distribution for (n,n\*14)

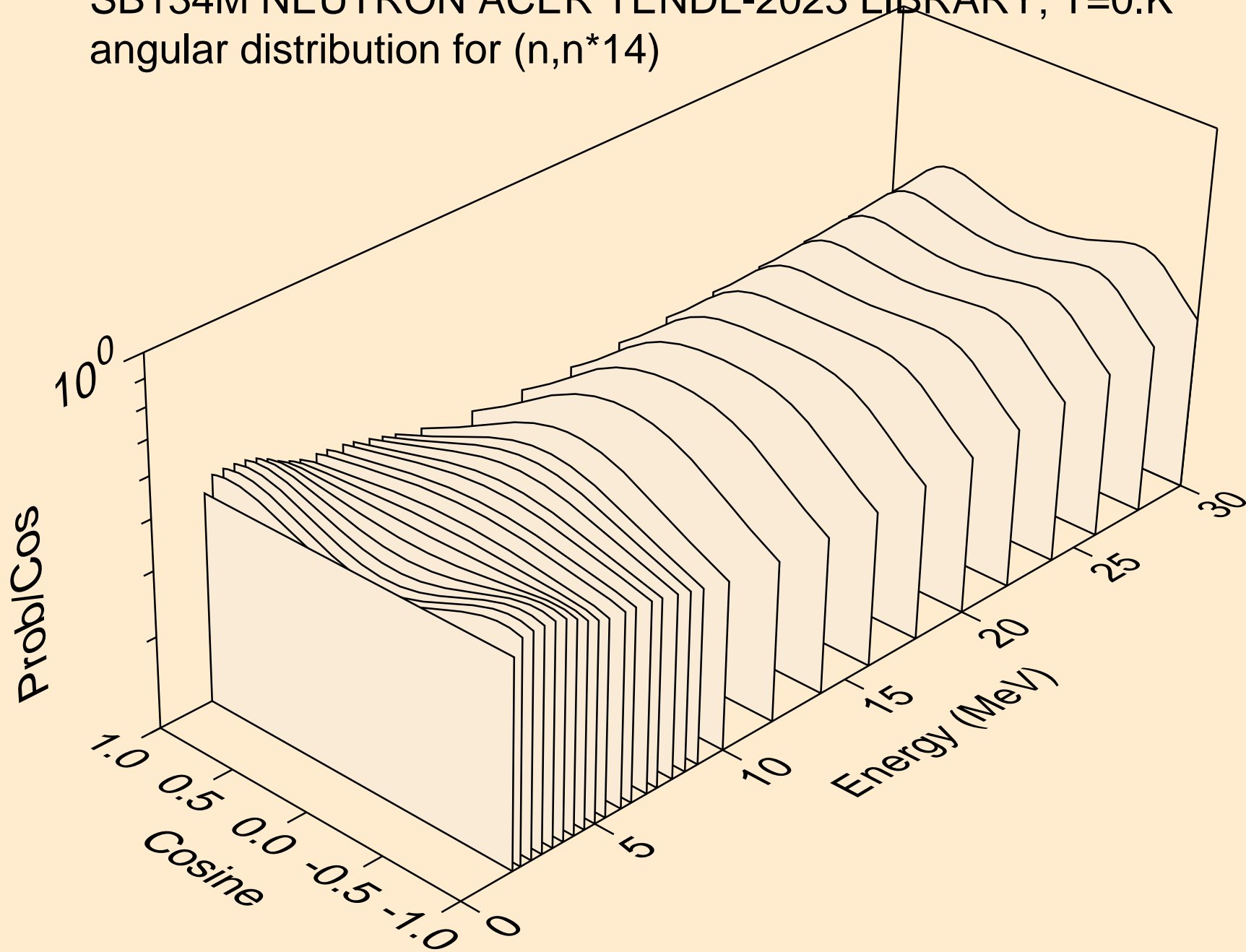

SB134M NEUTRON ACER TENDL-2023 LIBRARY; T=0.K  
angular distribution for (n,n\*15)

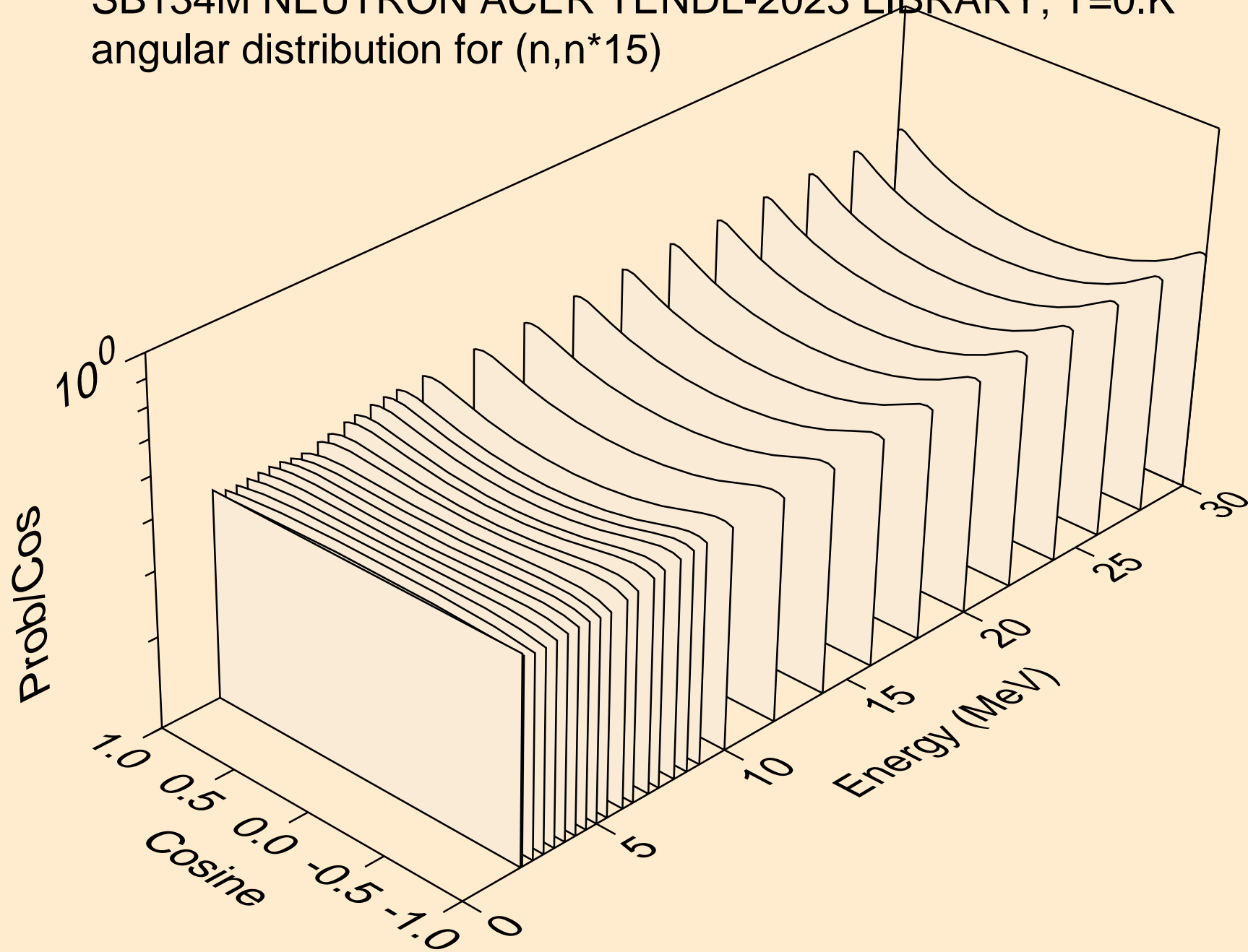

SB134M NEUTRON ACER TENDL-2023 LIBRARY; T=0.K  
angular distribution for (n,n\*16)

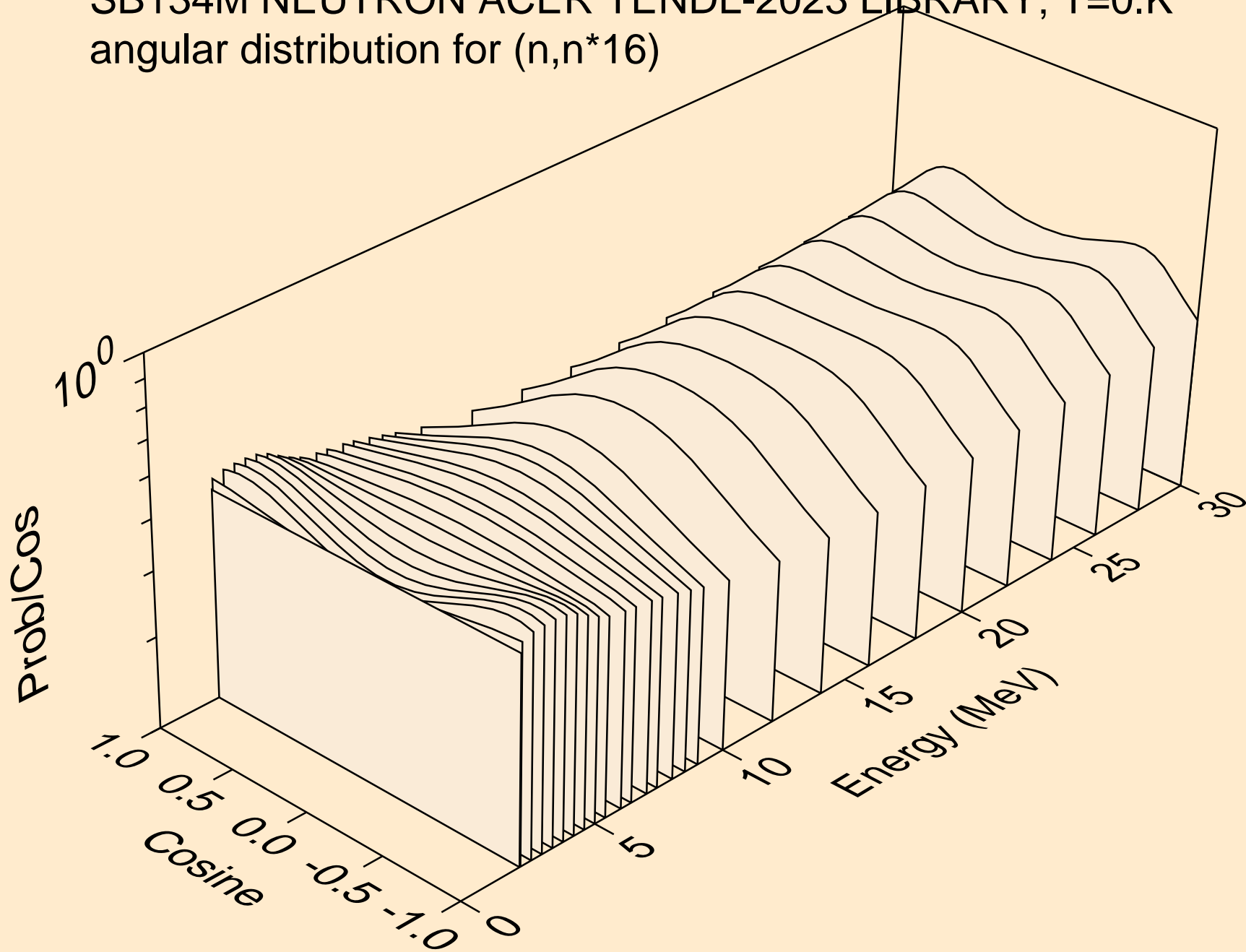

SB134M NEUTRON ACER TENDL-2023 LIBRARY; T=0.K  
angular distribution for (n,n\*17)

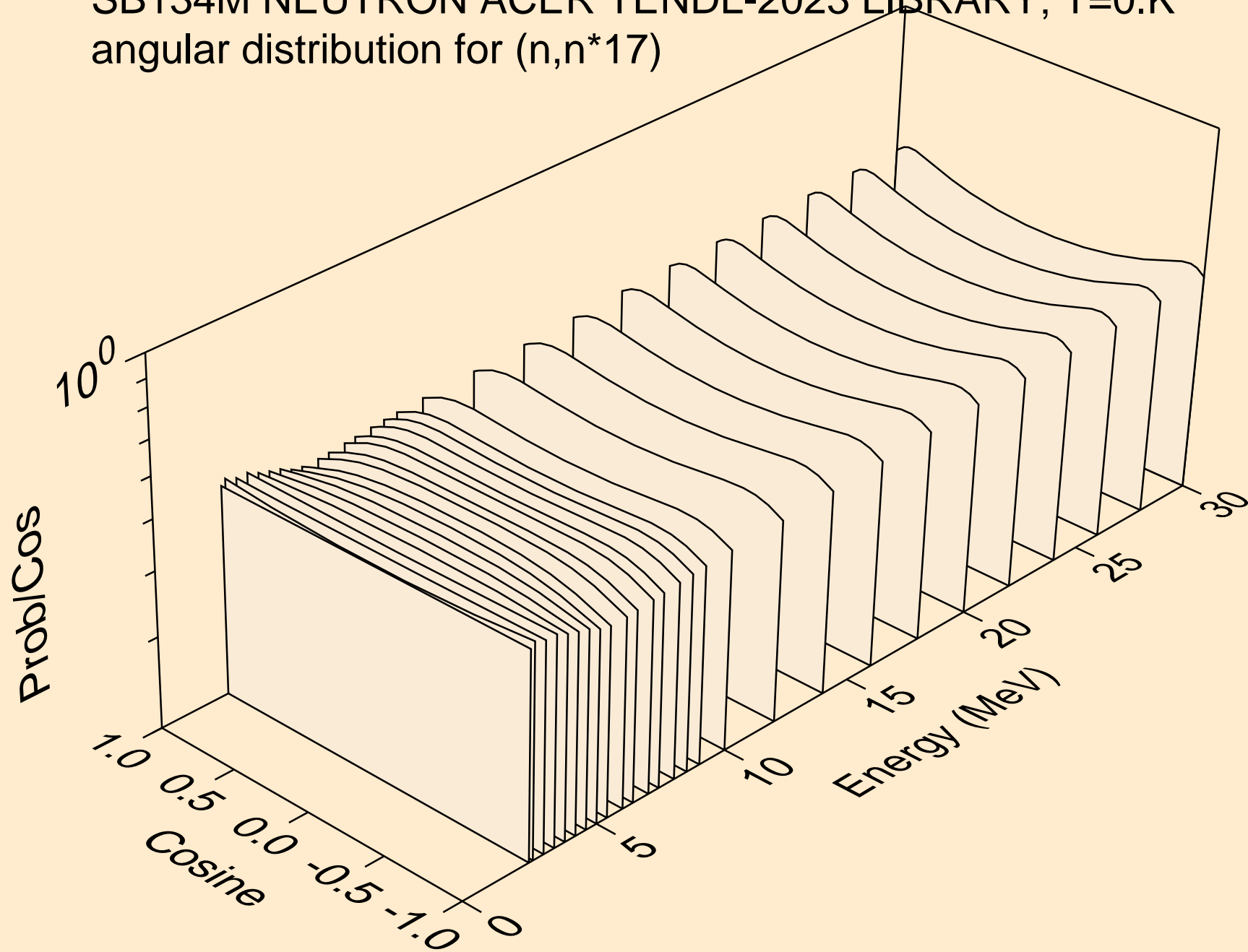

SB134M NEUTRON ACER TENDL-2023 LIBRARY; T=0.K  
angular distribution for (n,n\*18)

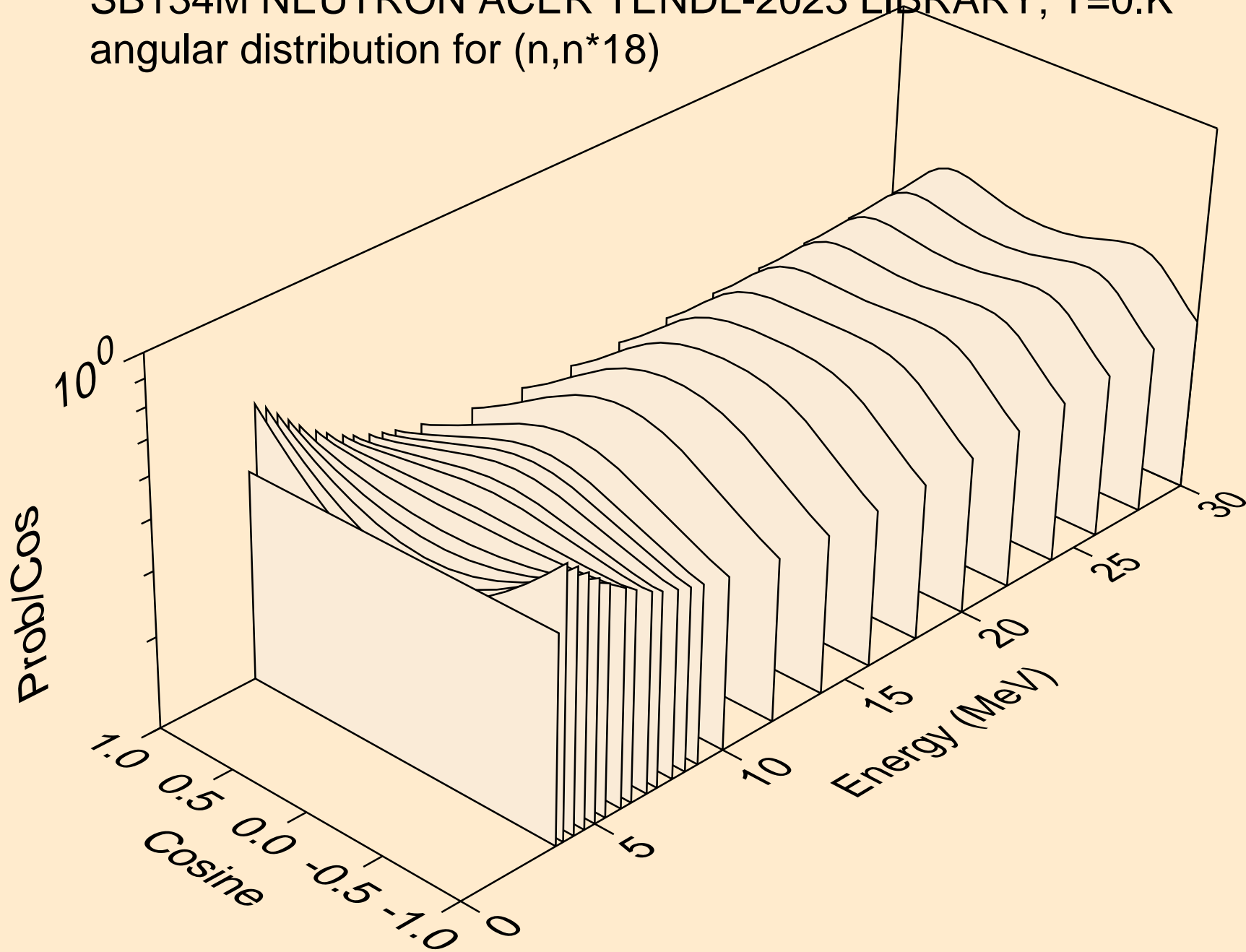

SB134M NEUTRON ACER TENDL-2023 LIBRARY; T=0.K  
angular distribution for (n,n\*19)

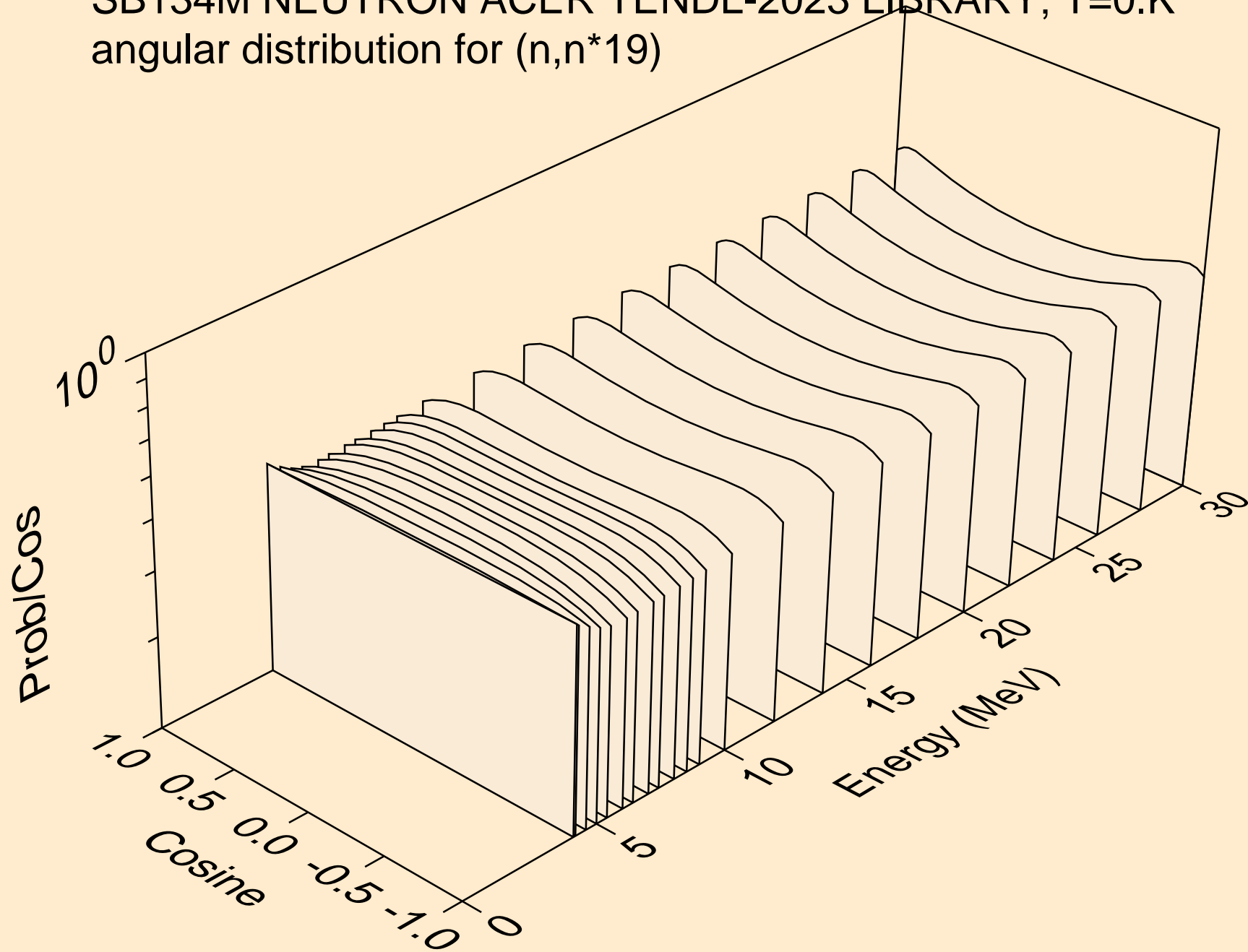

SB134M NEUTRON ACER TENDL-2023 LIBRARY; T=0.K  
angular distribution for (n,n\*20)

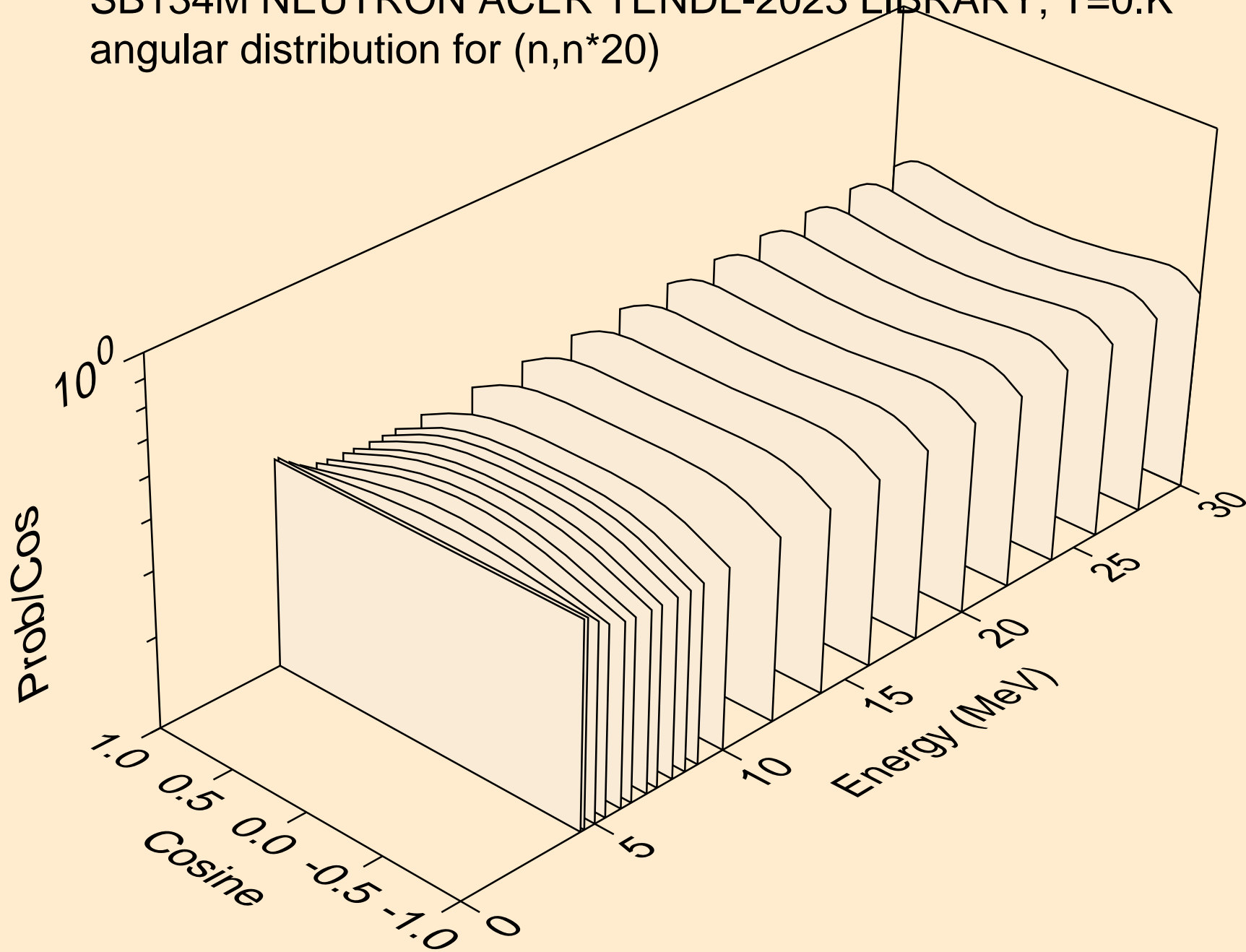



SB134M NEUTRON ACER TENDL-2023 LIBRARY; T=0.K  
angular distribution for (n,n\*21)

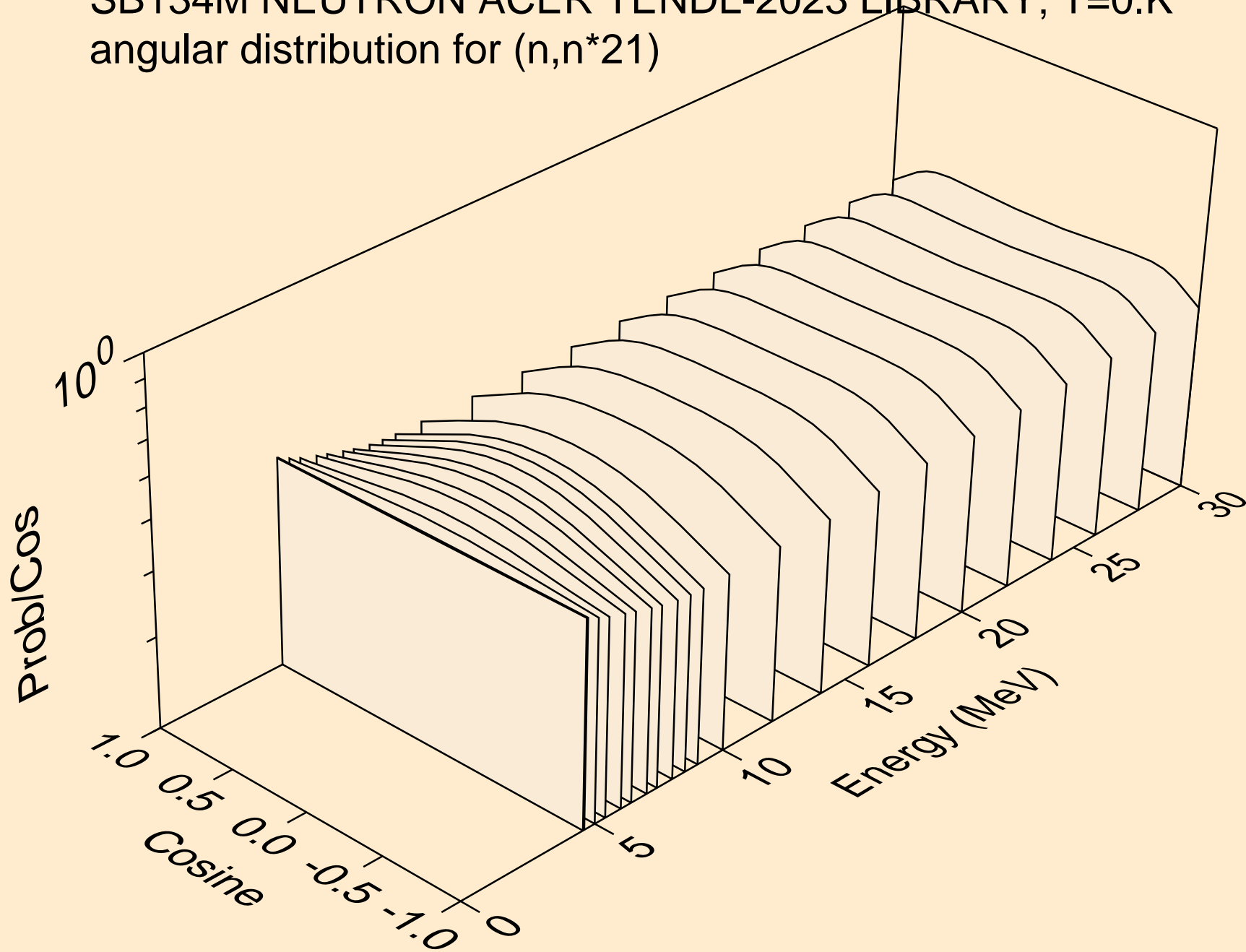

SB134M NEUTRON ACER TENDL-2023 LIBRARY; T=0.K  
angular distribution for (n,n\*22)

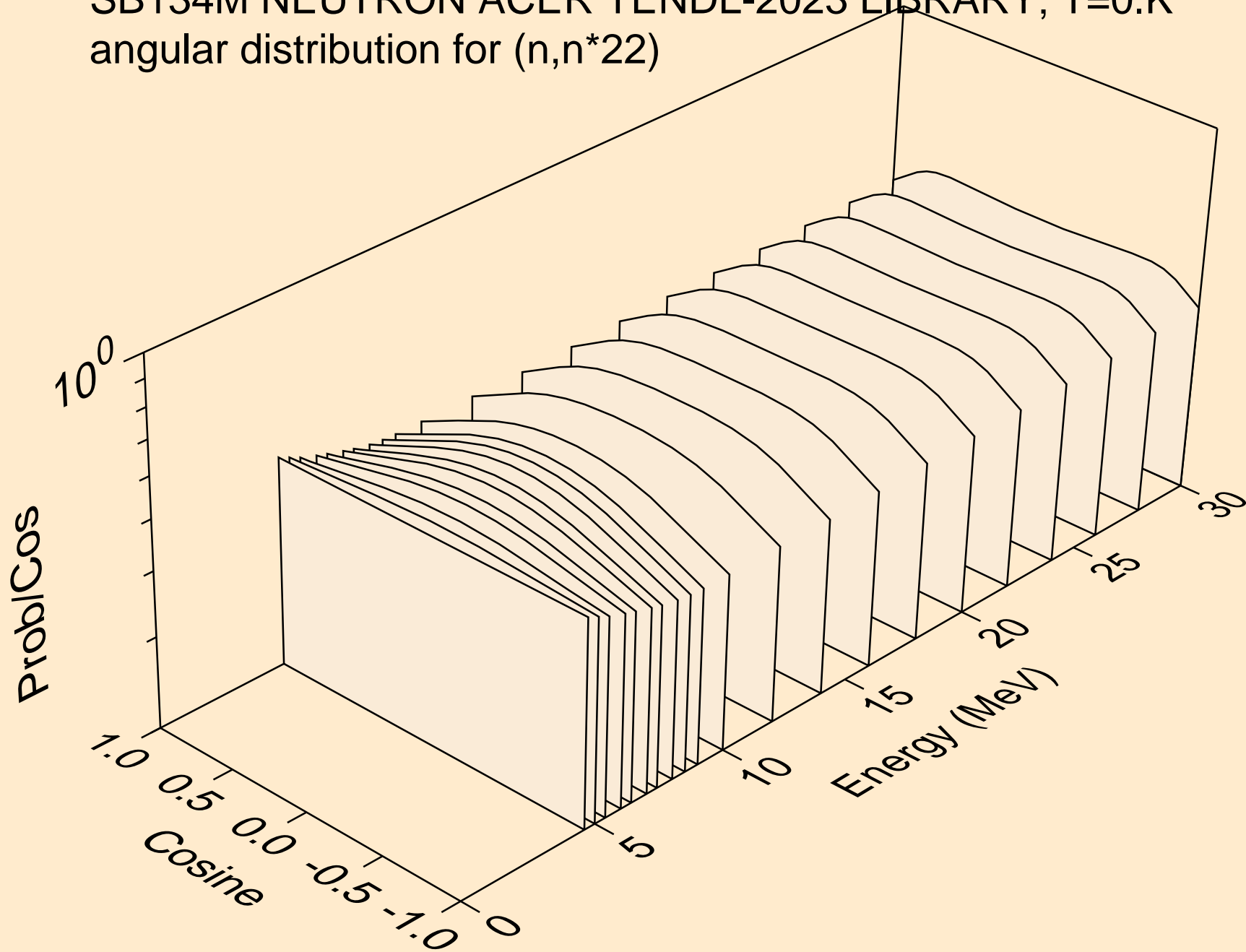

SB134M NEUTRON ACER TENDL-2023 LIBRARY; T=0.K  
angular distribution for (n,n\*23)

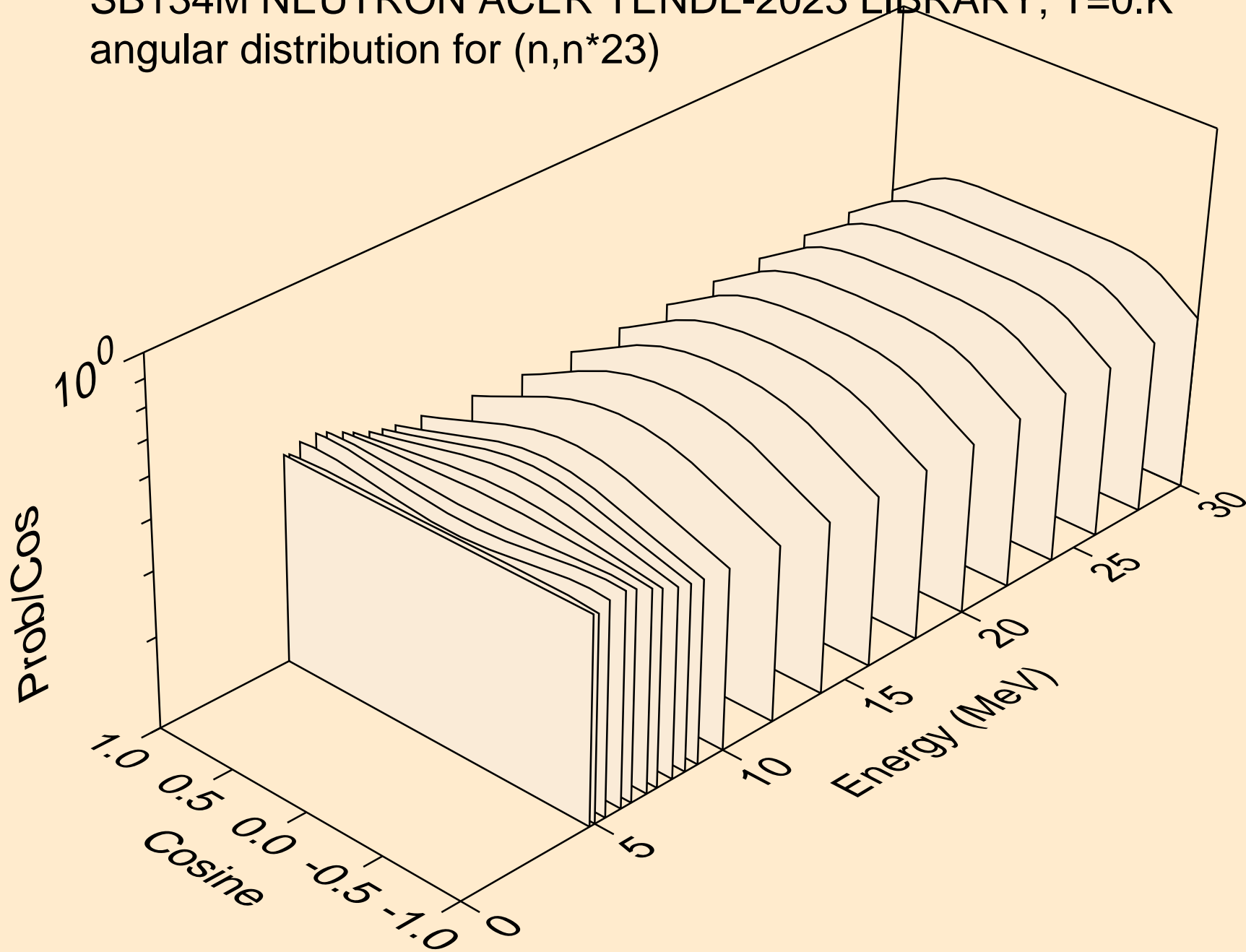

SB134M NEUTRON ACER TENDL-2023 LIBRARY; T=0.K  
angular distribution for (n,n\*24)

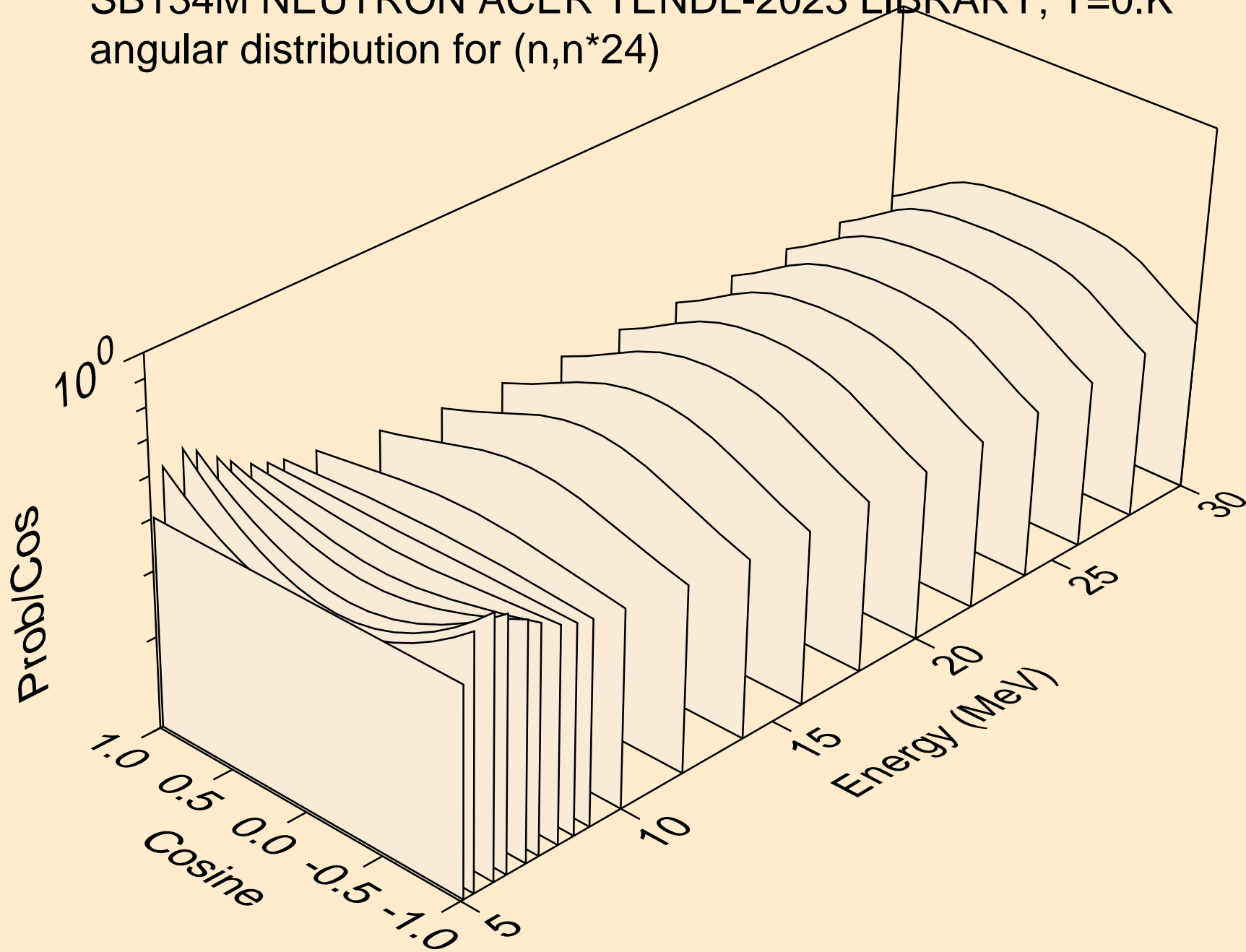

SB134M NEUTRON ACER TENDL-2023 LIBRARY; T=0.K  
angular distribution for (n,n\*25)

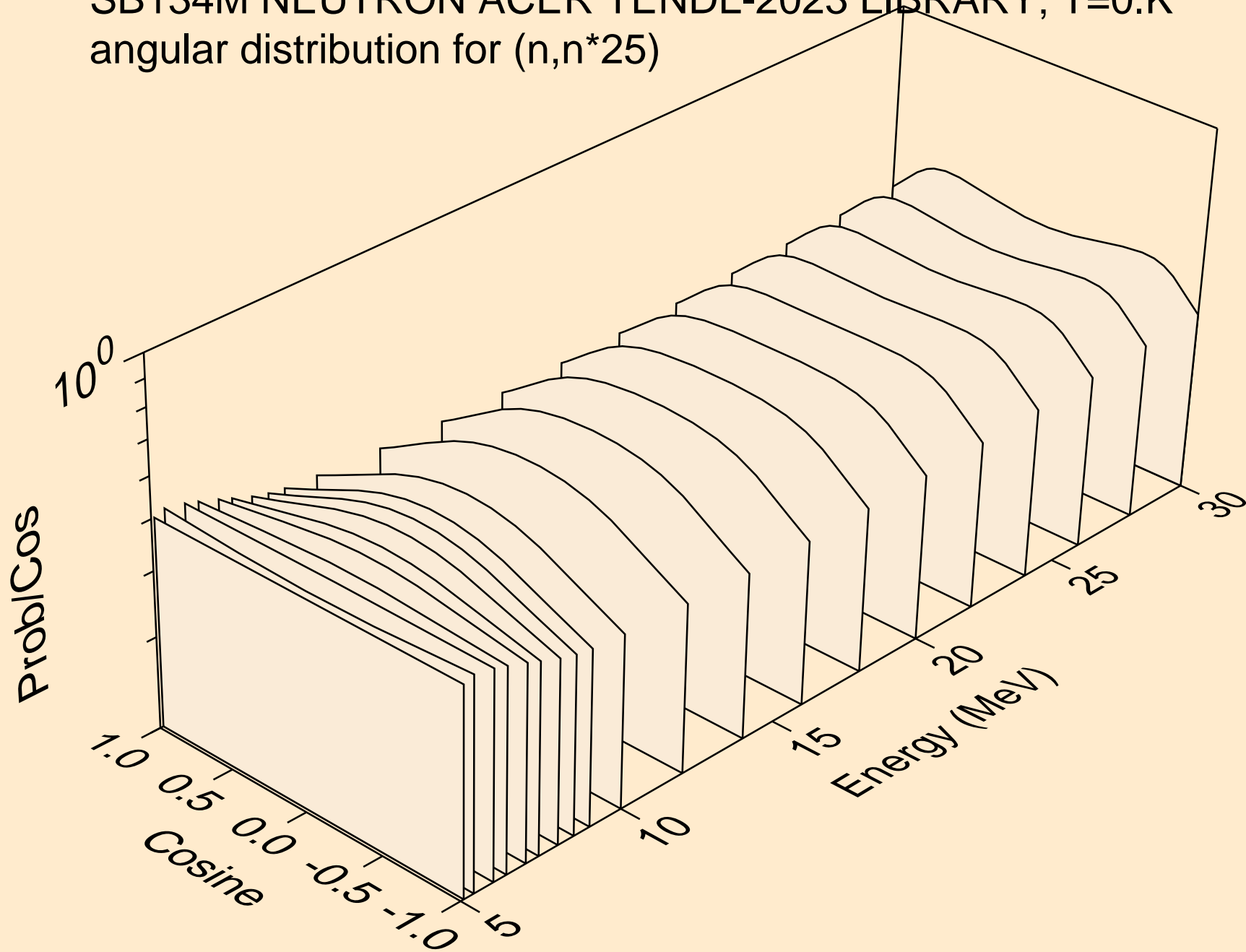

SB134M NEUTRON ACER TENDL-2023 LIBRARY; T=0.K  
angular distribution for (n,n\*26)

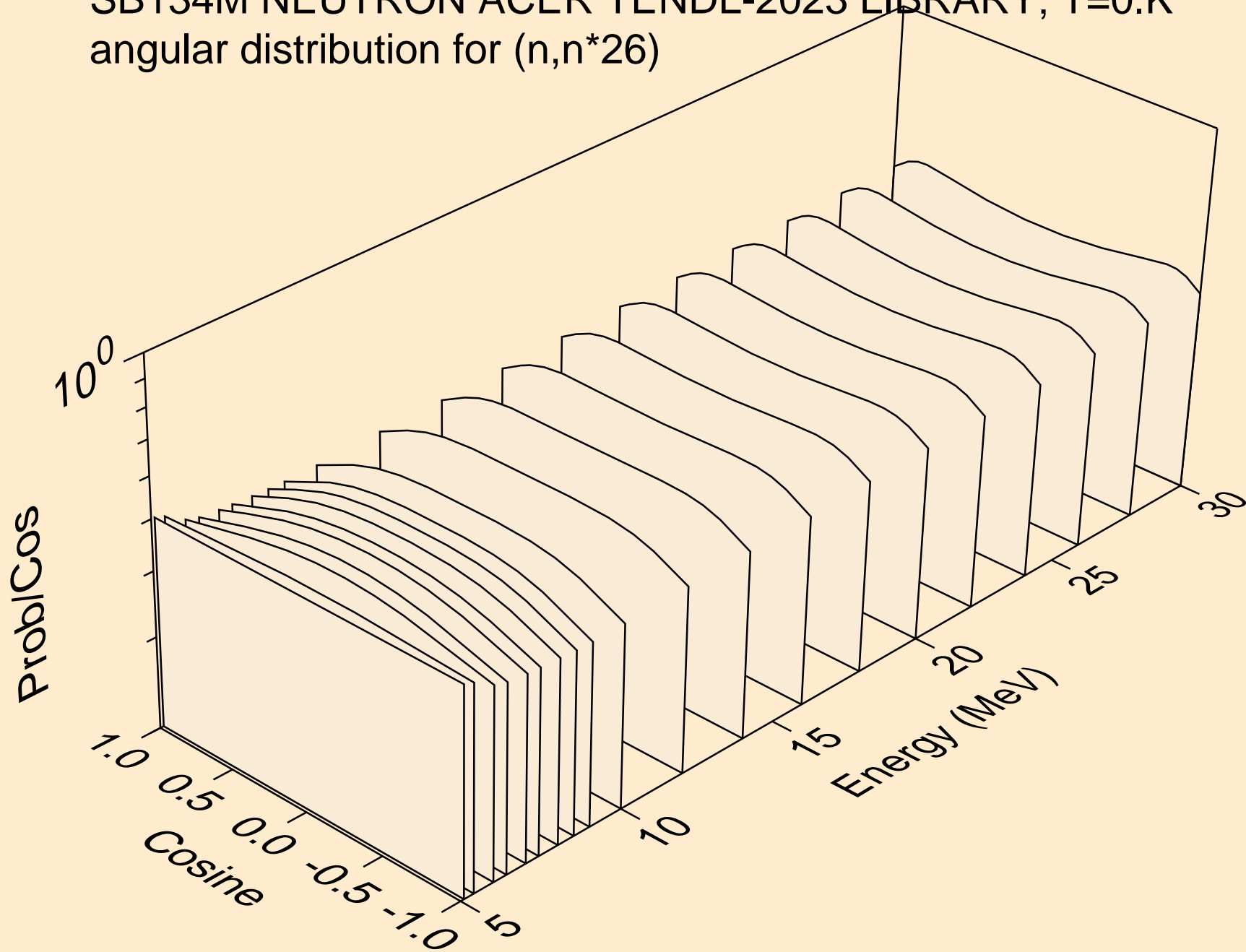

SB134M NEUTRON ACER TENDL-2023 LIBRARY; T=0.K  
angular distribution for (n,n\*27)

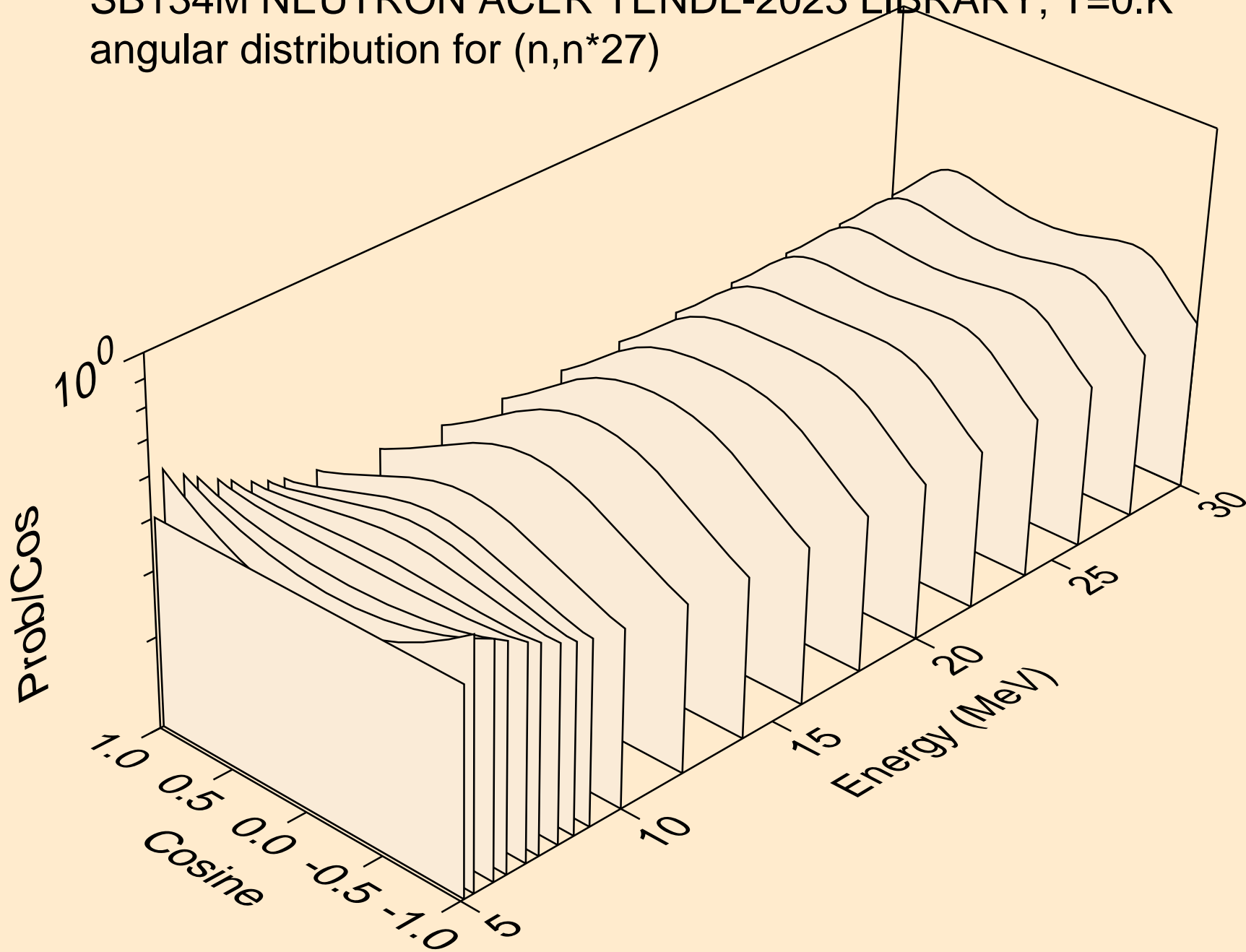

SB134M NEUTRON ACER TENDL-2023 LIBRARY; T=0.K  
angular distribution for (n,n\*28)

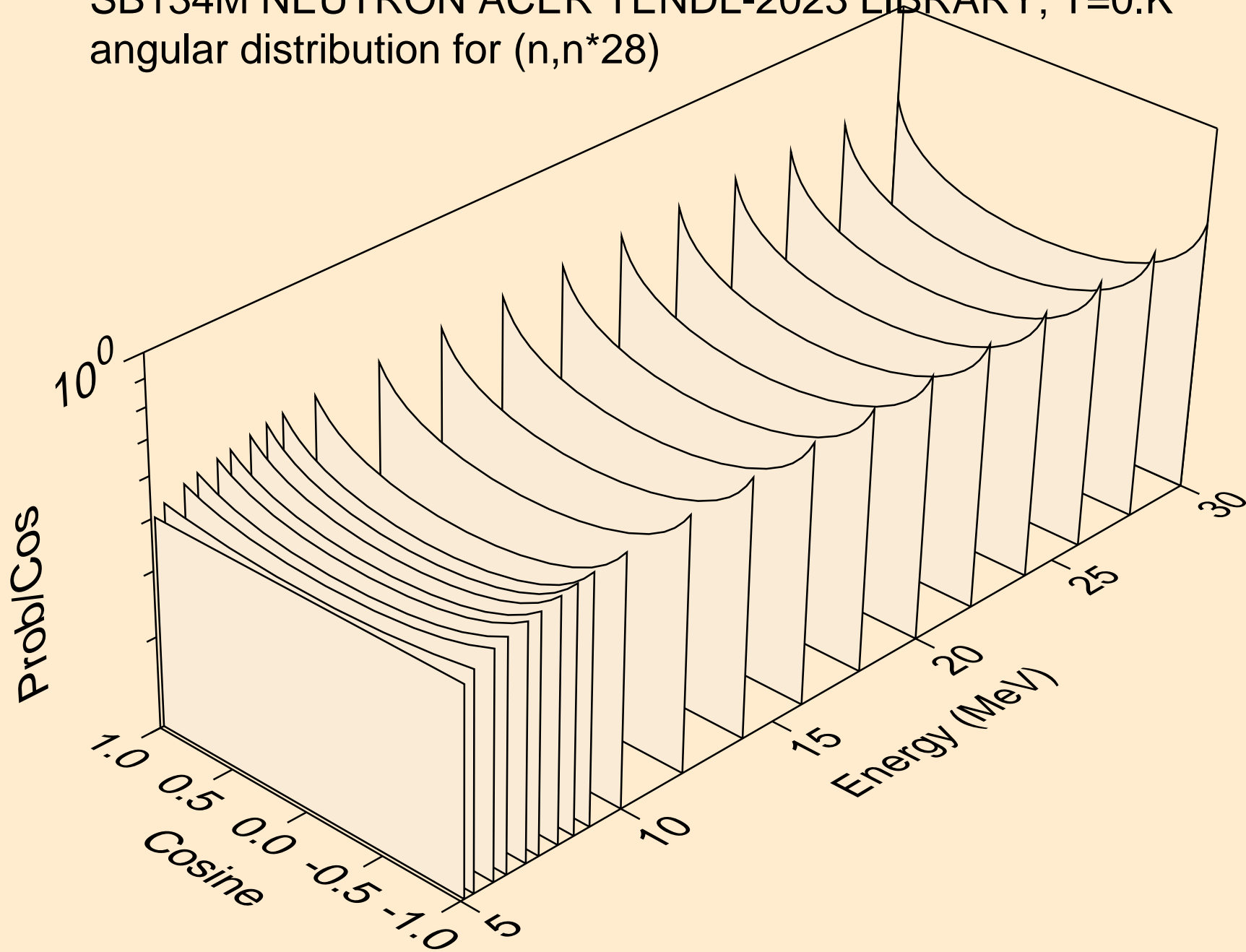



SB134M NEUTRON ACER TENDL-2023 LIBRARY; T=0.K  
angular distribution for (n,n\*29)

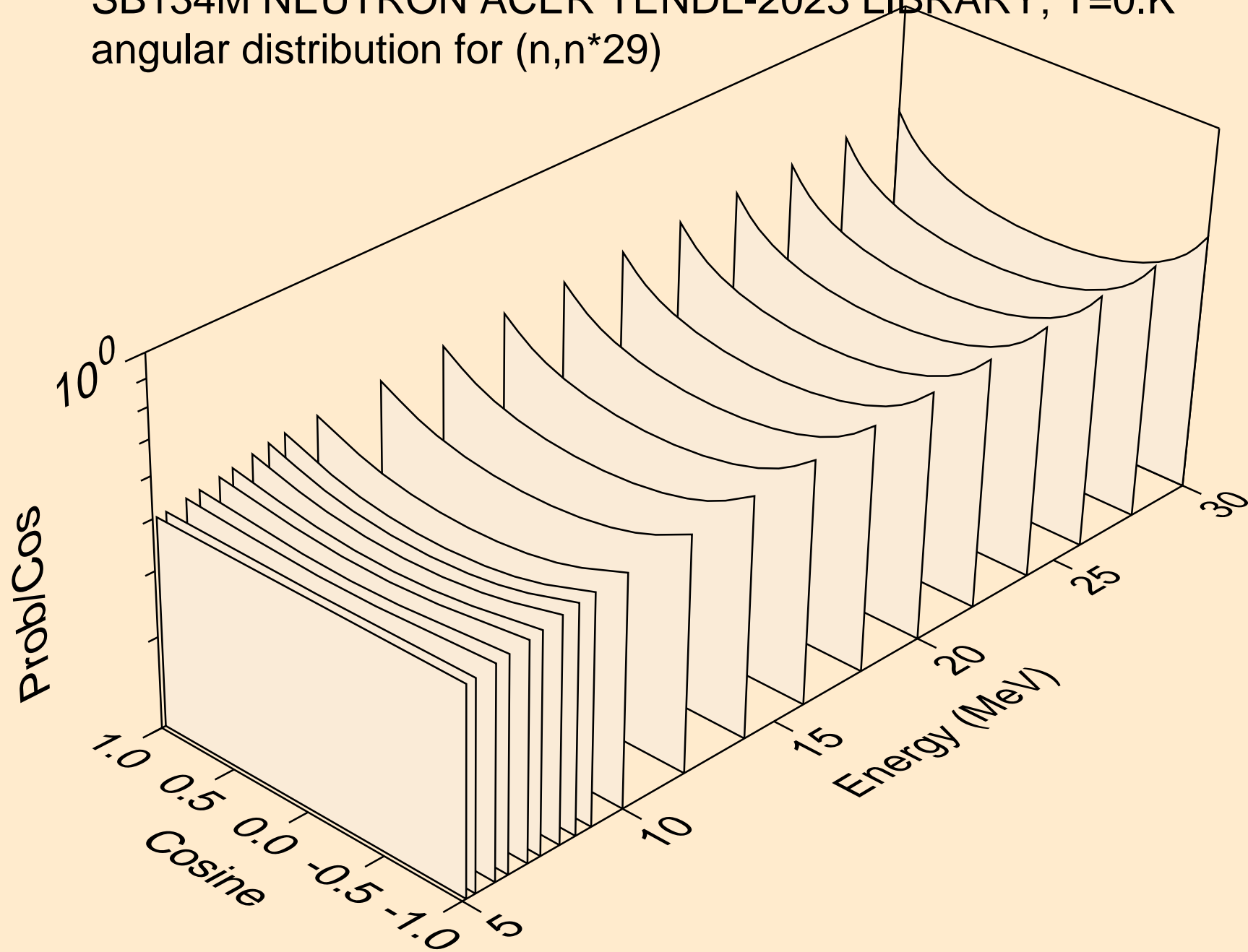

SB134M NEUTRON ACER TENDL-2023 LIBRARY; T=0.K  
angular distribution for (n,n\*30)

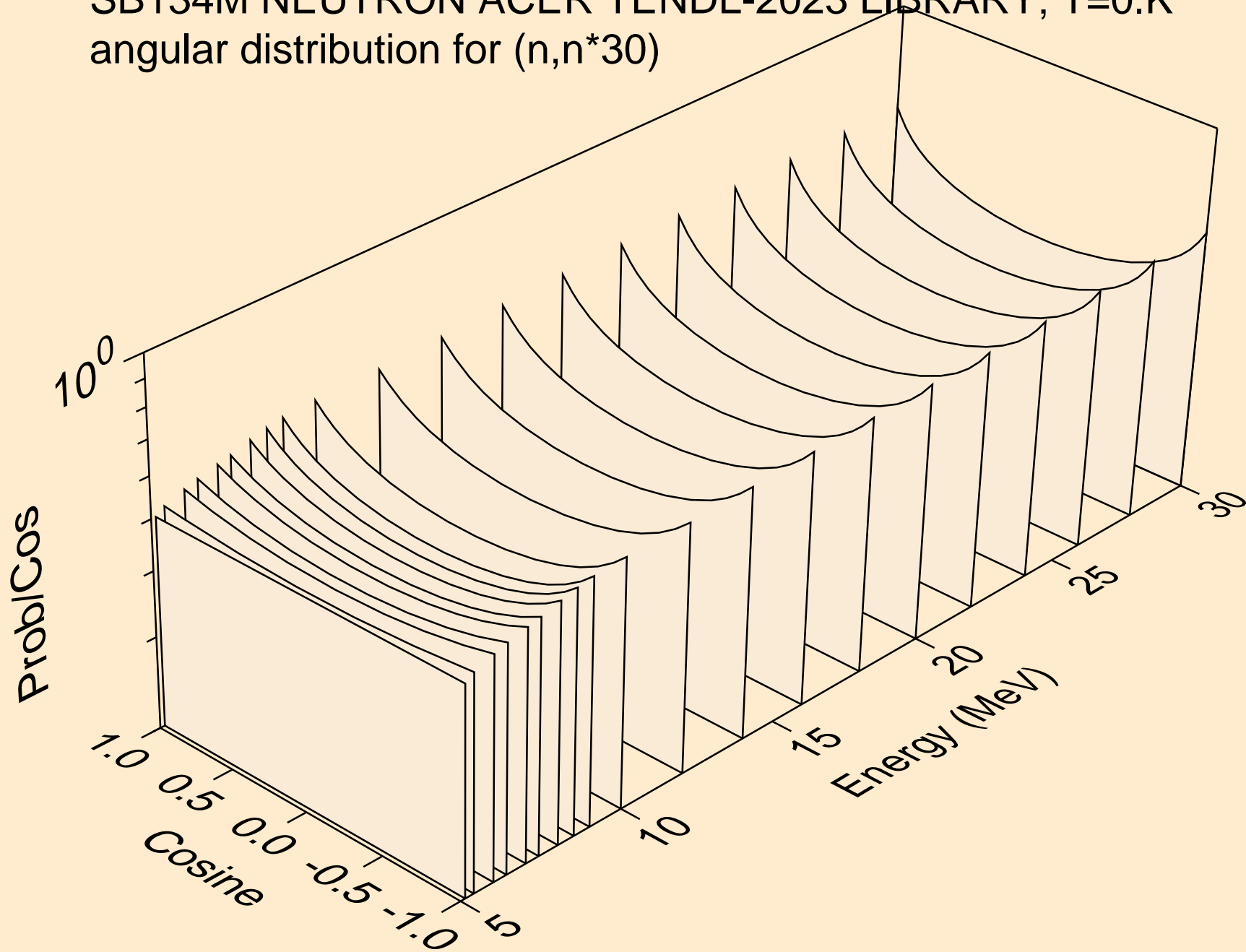

SB134M NEUTRON ACER TENDL-2023 LIBRARY; T=0.K  
Neutron emission for (n,x)

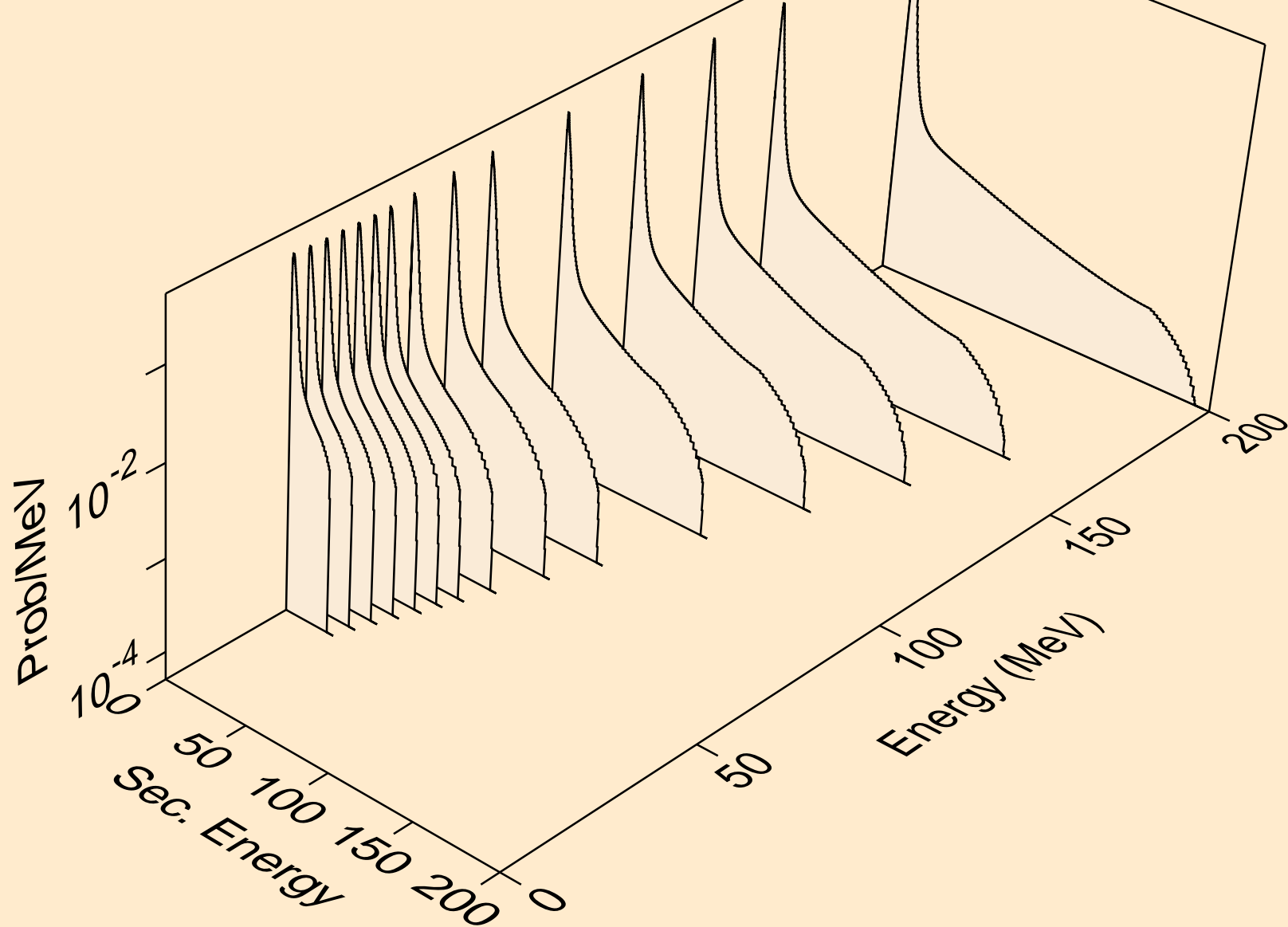

SB134M NEUTRON ACER TENDL-2023 LIBRARY; T=0.K  
Neutron emission for (n,2nd)

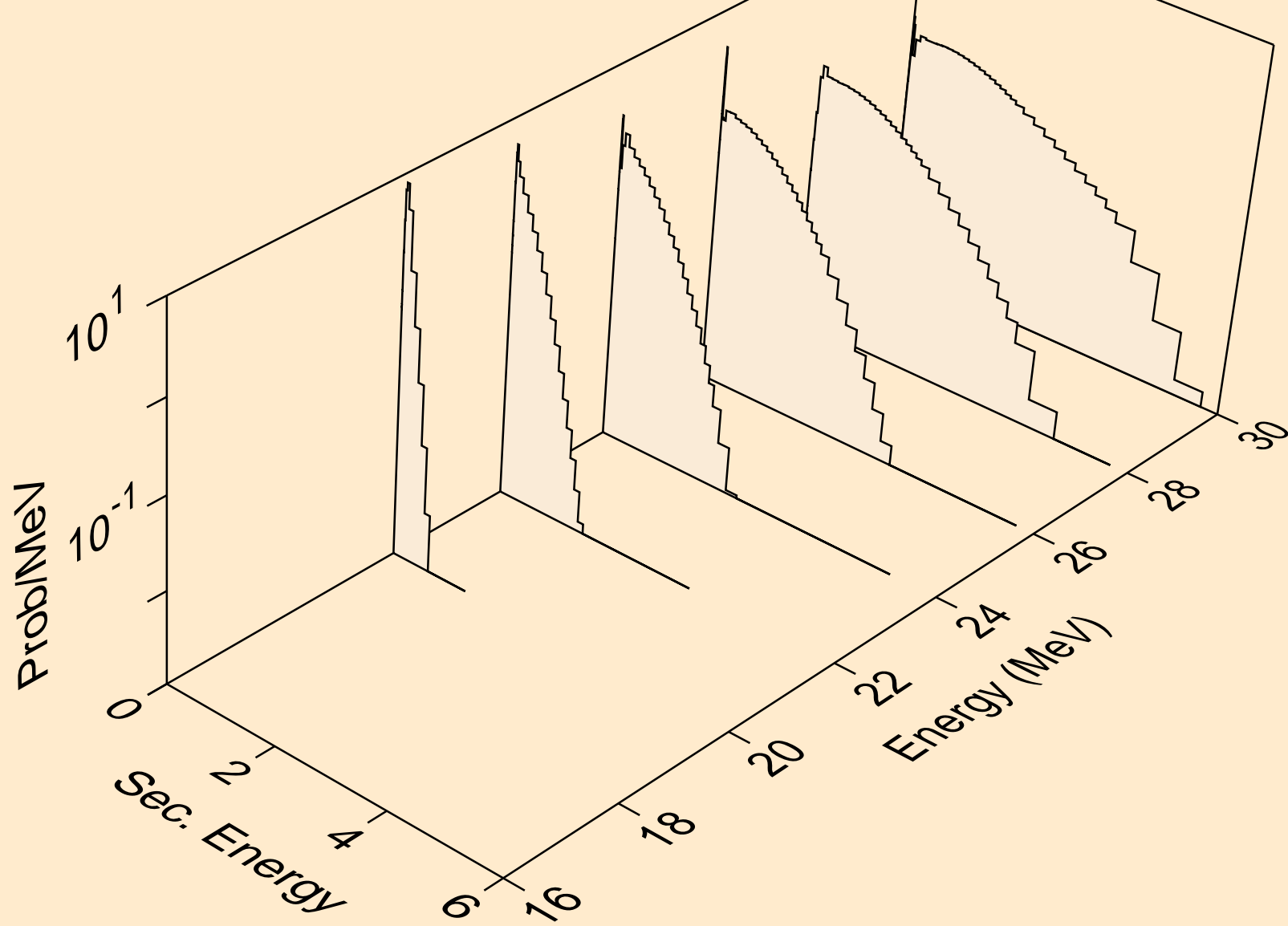

SB134M NEUTRON ACER TENDL-2023 LIBRARY; T=0.K  
Neutron emission for (n,2n)

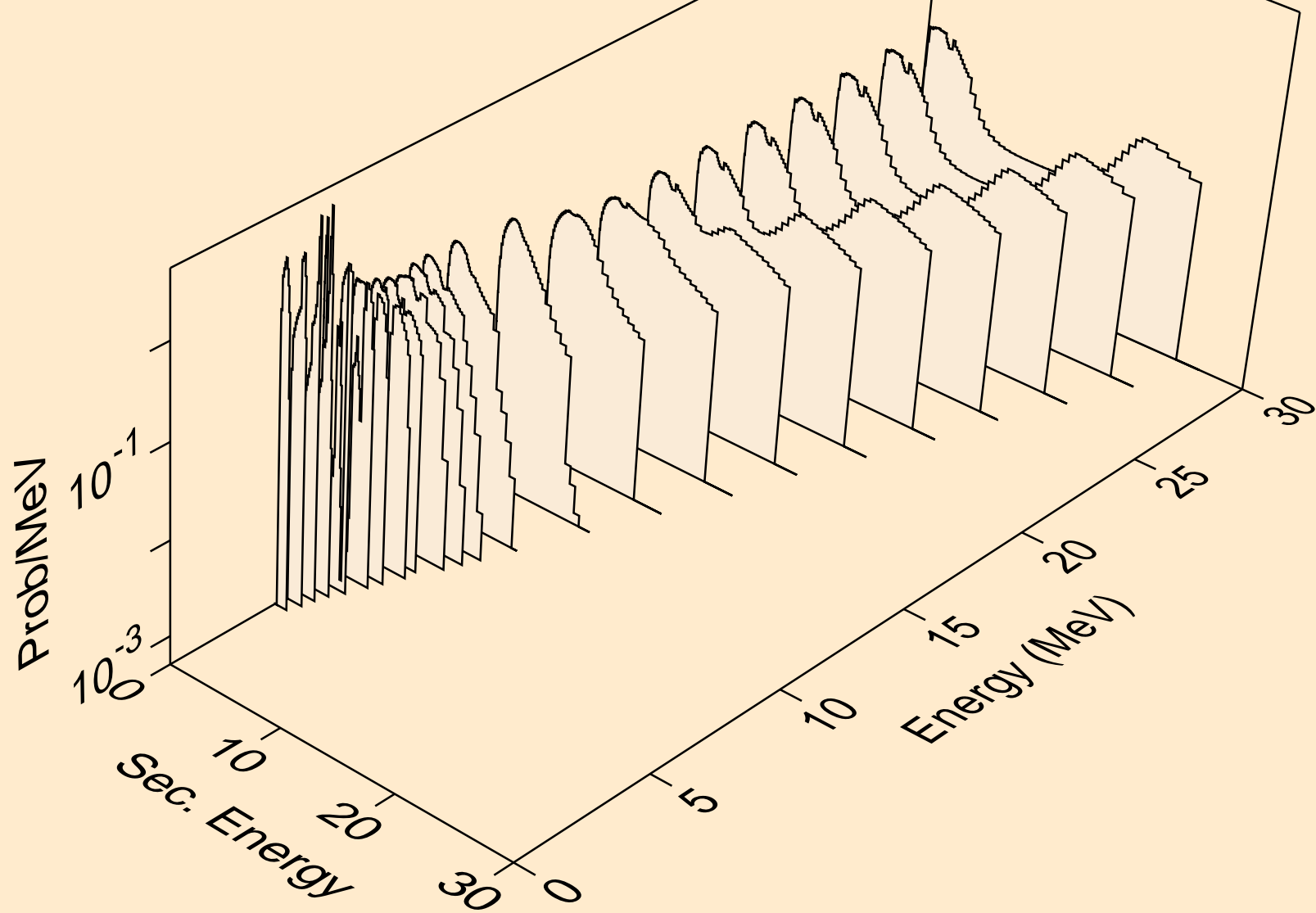

SB134M NEUTRON ACER TENDL-2023 LIBRARY; T=0.K  
Neutron emission for (n,3n)

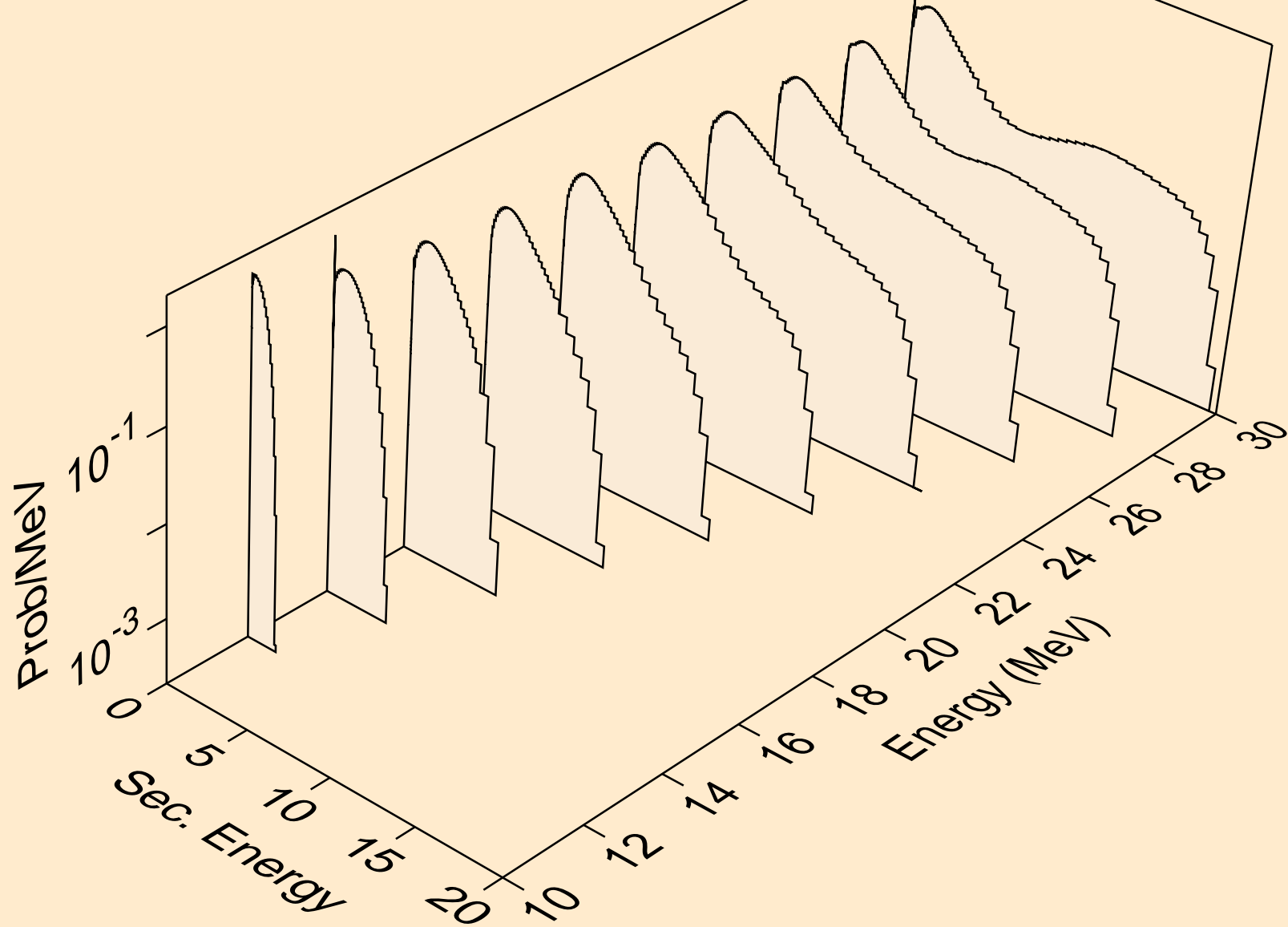

SB134M NEUTRON ACER TENDL-2023 LIBRARY; T=0.K  
Neutron emission for (n,n\*)a

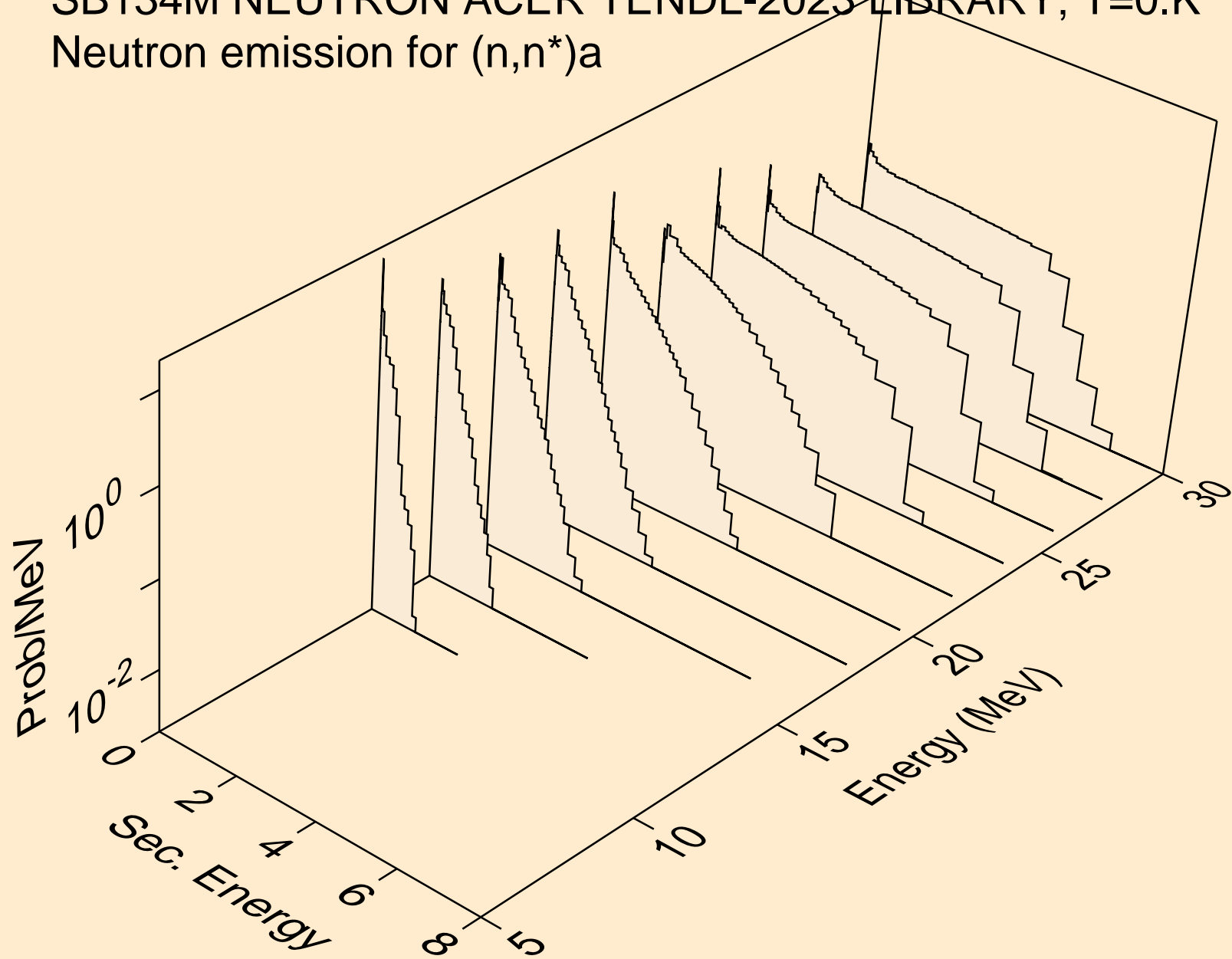

SB134M NEUTRON ACER TENDL-2023 LIBRARY; T=0.K  
Neutron emission for (n,2n)a

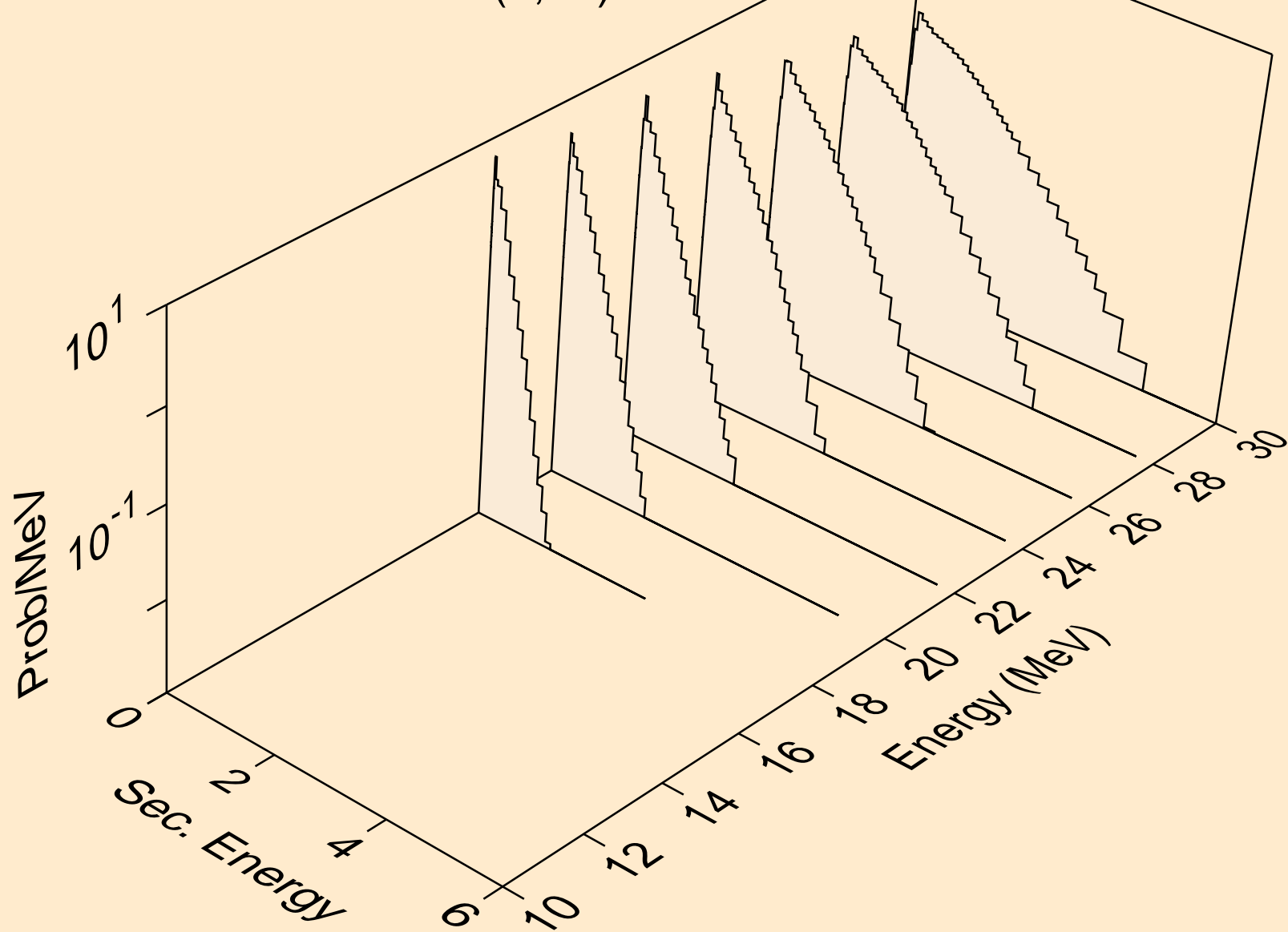



SB134M NEUTRON ACER TENDL-2023 LIBRARY; T=0.K  
Neutron emission for (n,3n)a

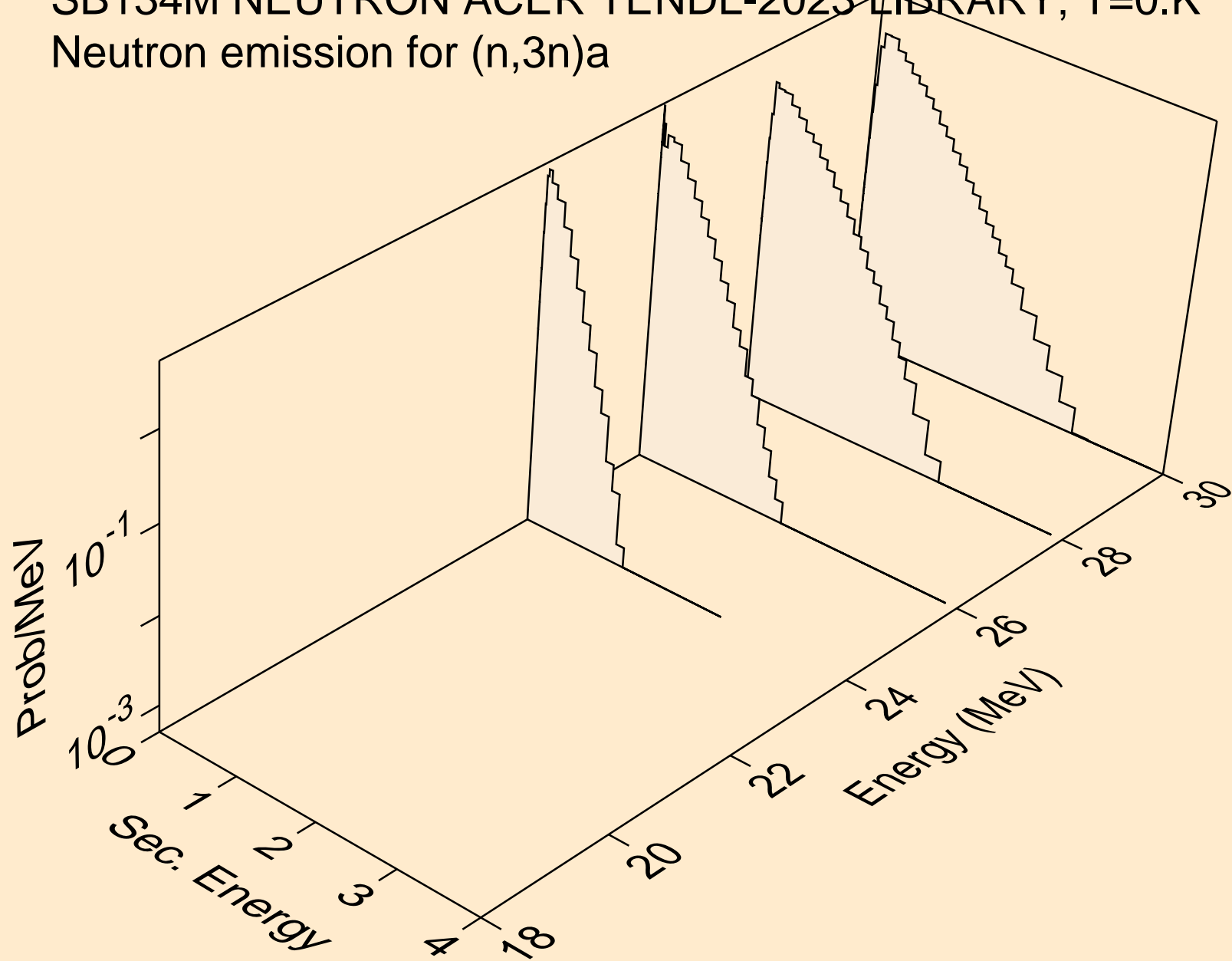

SB134M NEUTRON ACER TENDL-2023 LIBRARY; T=0.K  
Neutron emission for (n,n\*)p

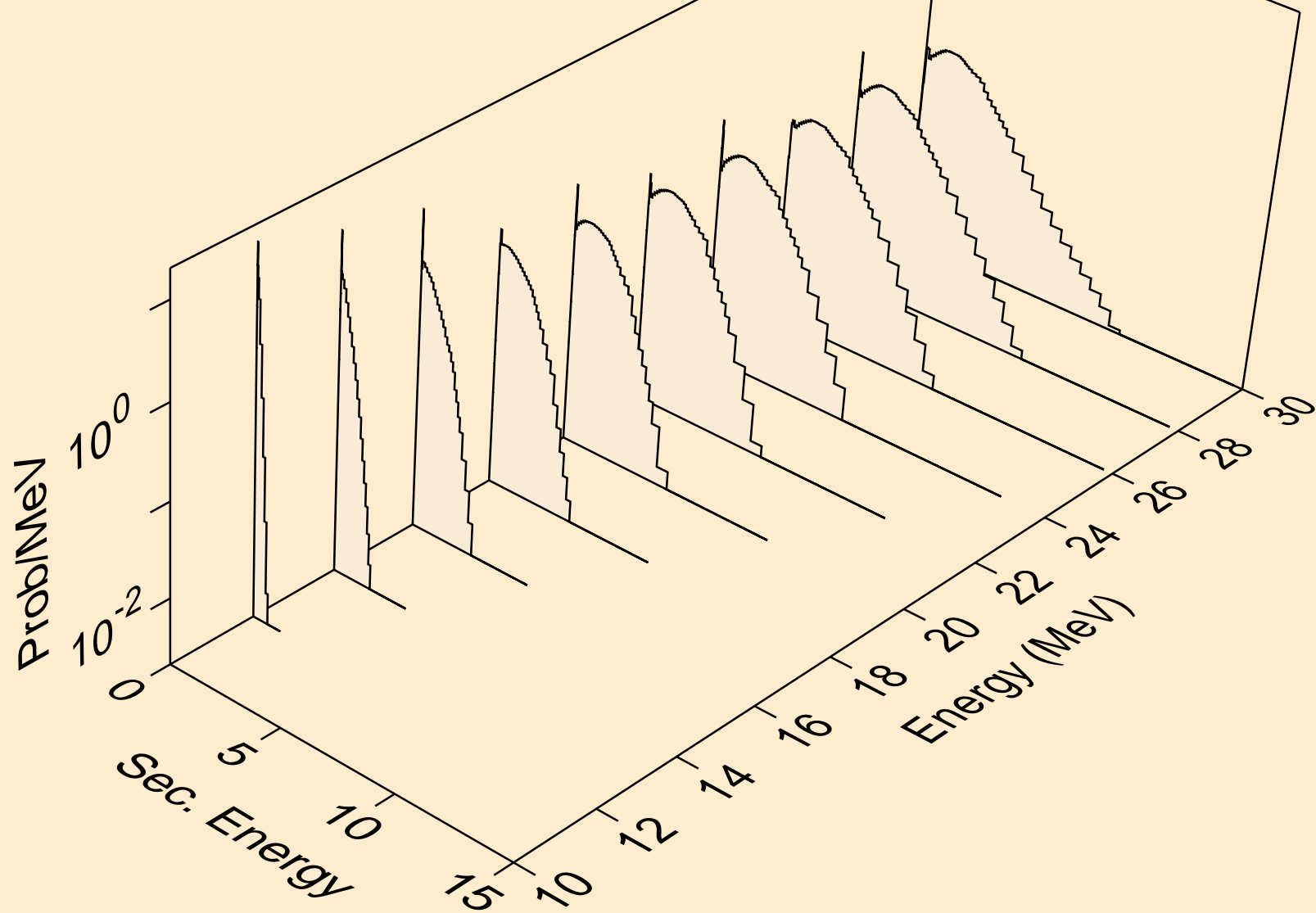

SB134M NEUTRON ACER TENDL-2023 LIBRARY; T=0.K  
Neutron emission for (n,n\*)d

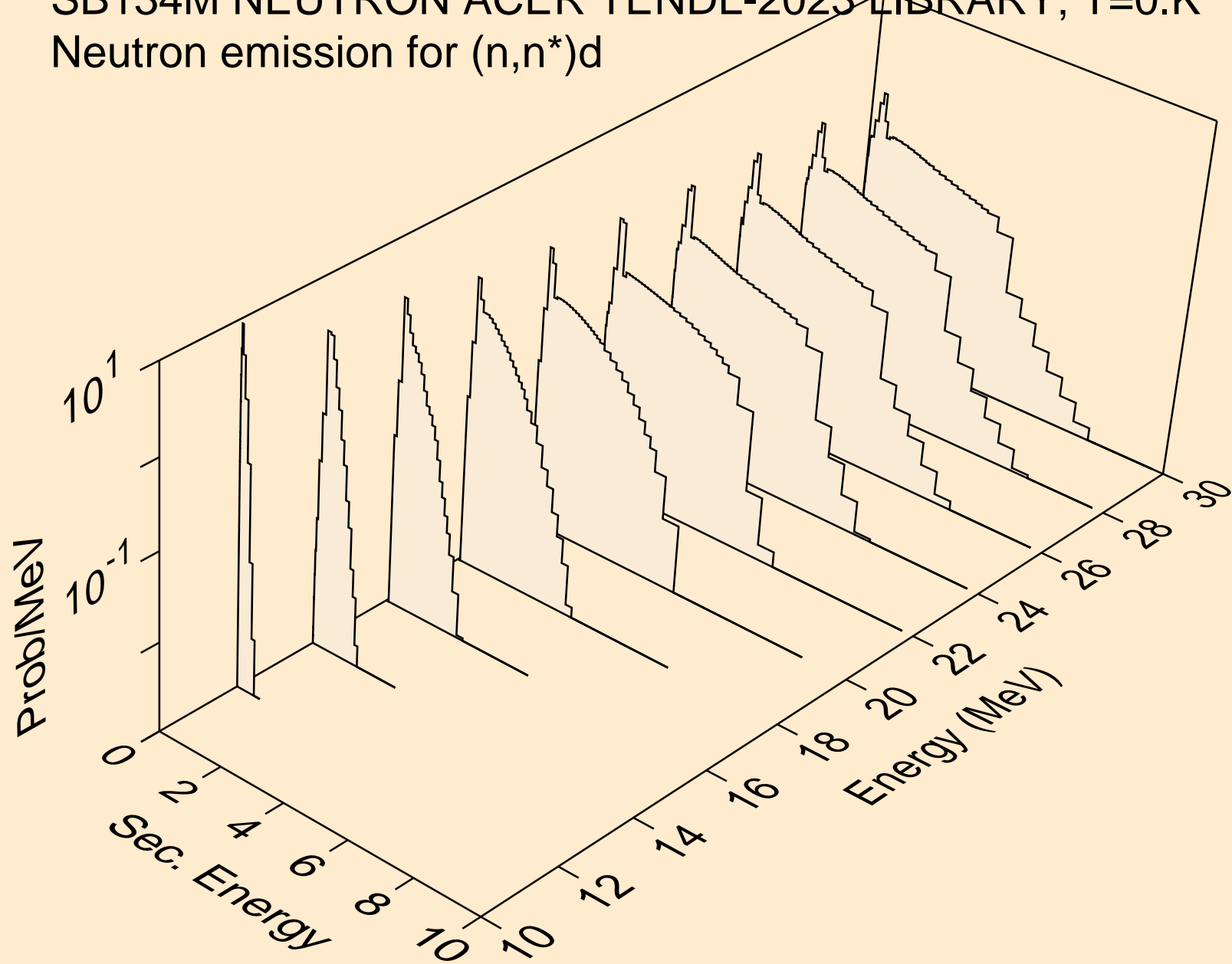

SB134M NEUTRON ACER TENDL-2023 LIBRARY; T=0.K  
Neutron emission for (n,n\*)t

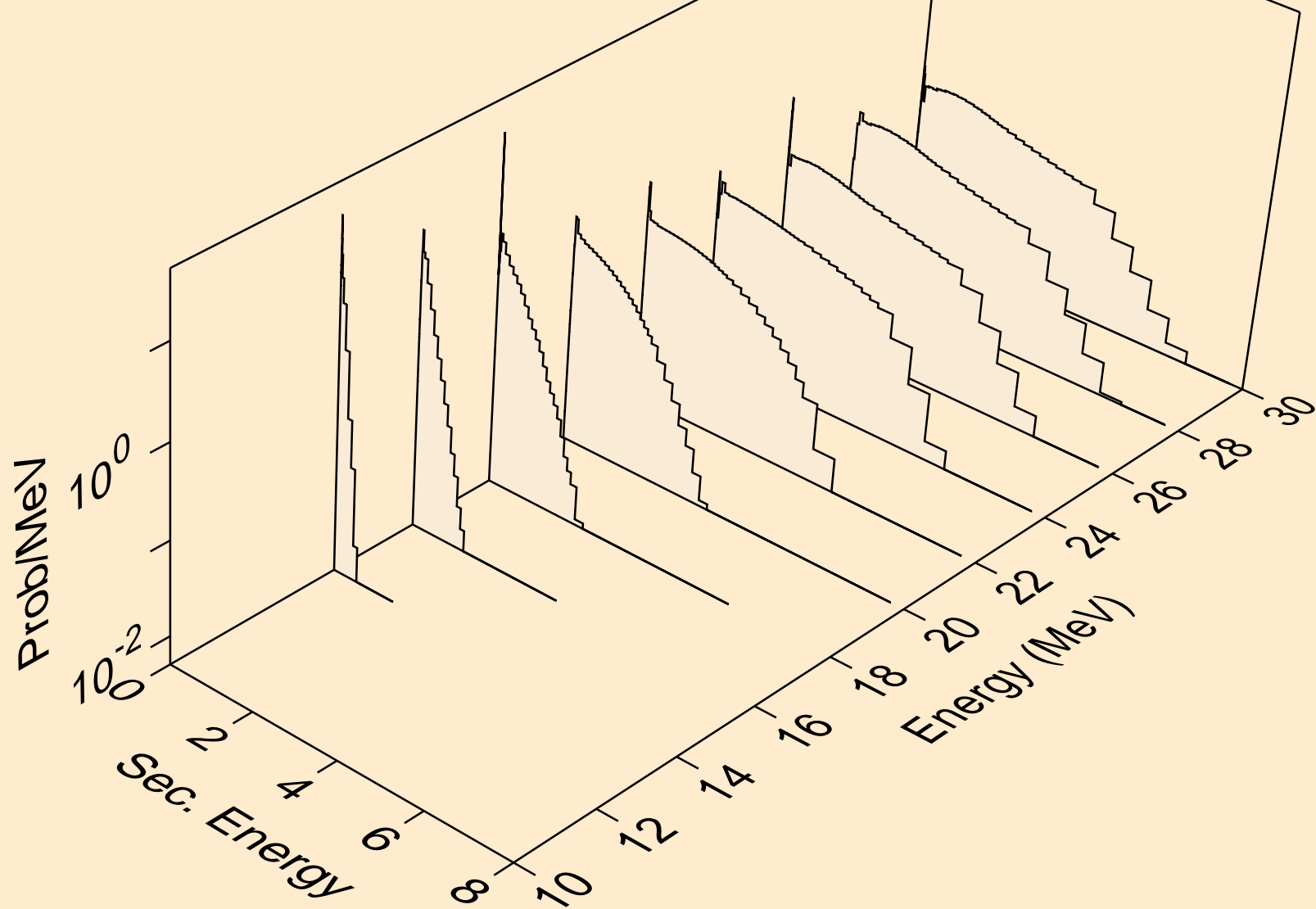

SB134M NEUTRON ACER TENDL-2023 LIBRARY; T=0.K  
Neutron emission for (n,n\*)he3

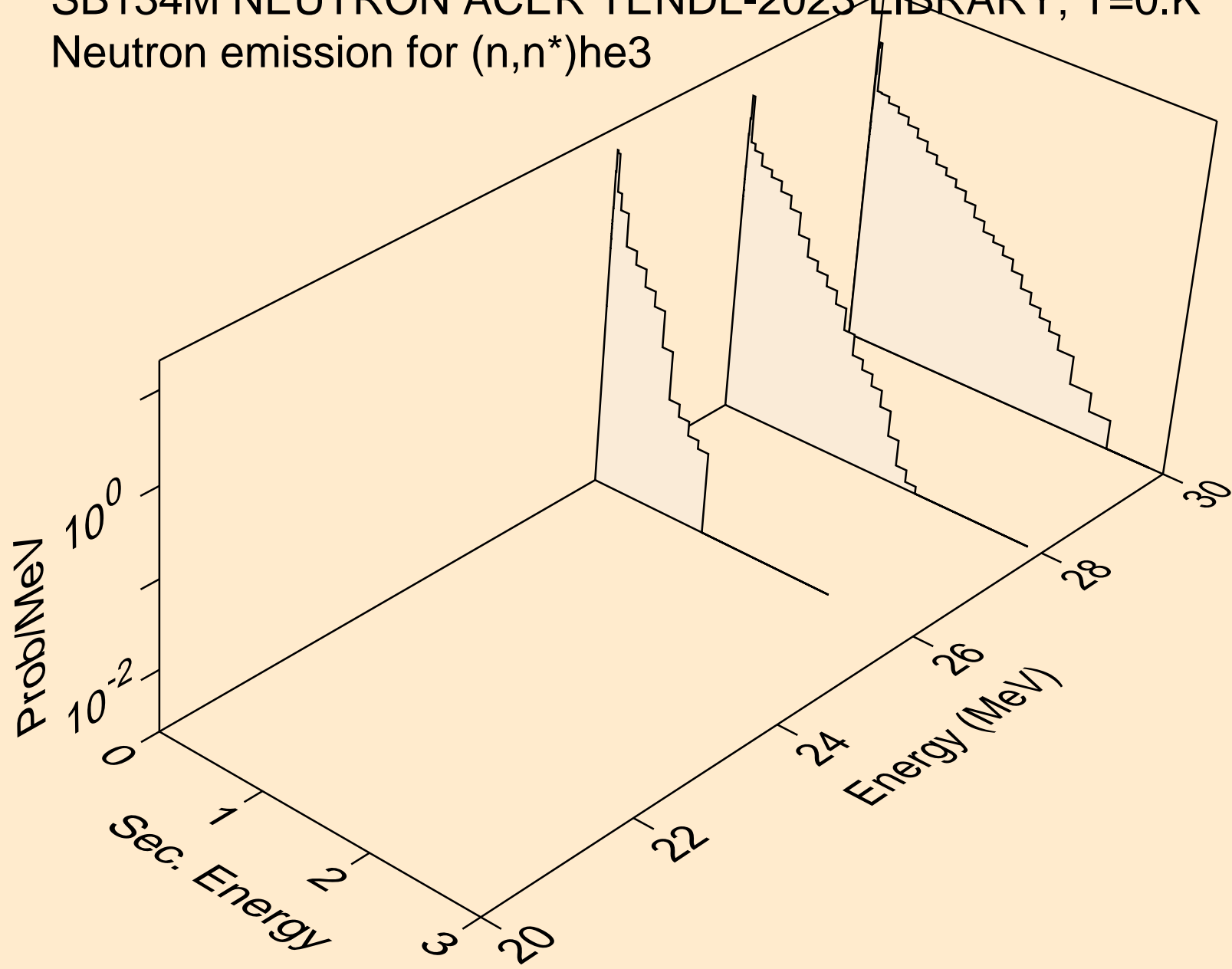

SB134M NEUTRON ACER TENDL-2023 LIBRARY; T=0.K  
Neutron emission for (n,4n)

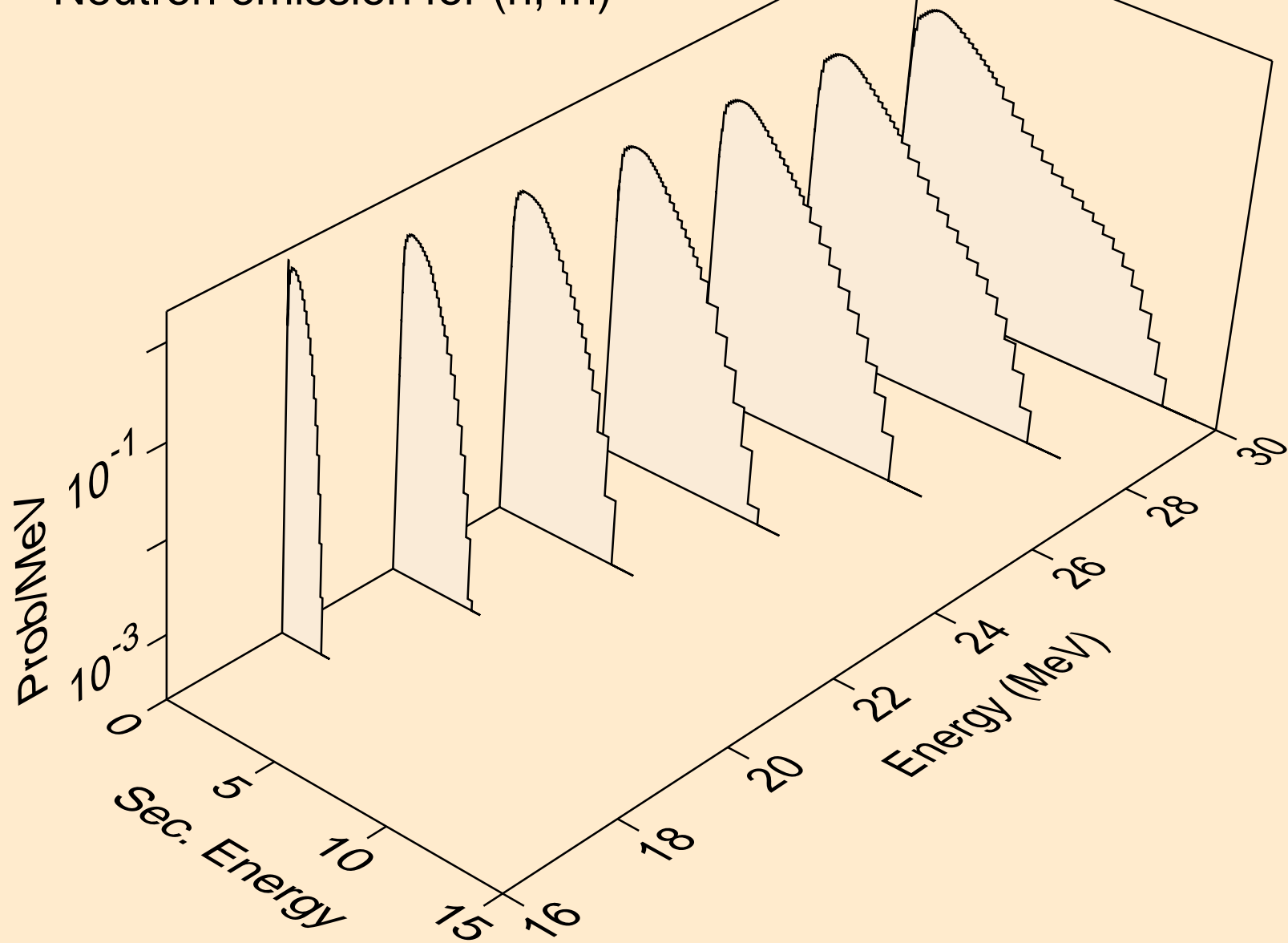

SB134M NEUTRON ACER TENDL-2023 LIBRARY; T=0.K  
Neutron emission for (n,2np)

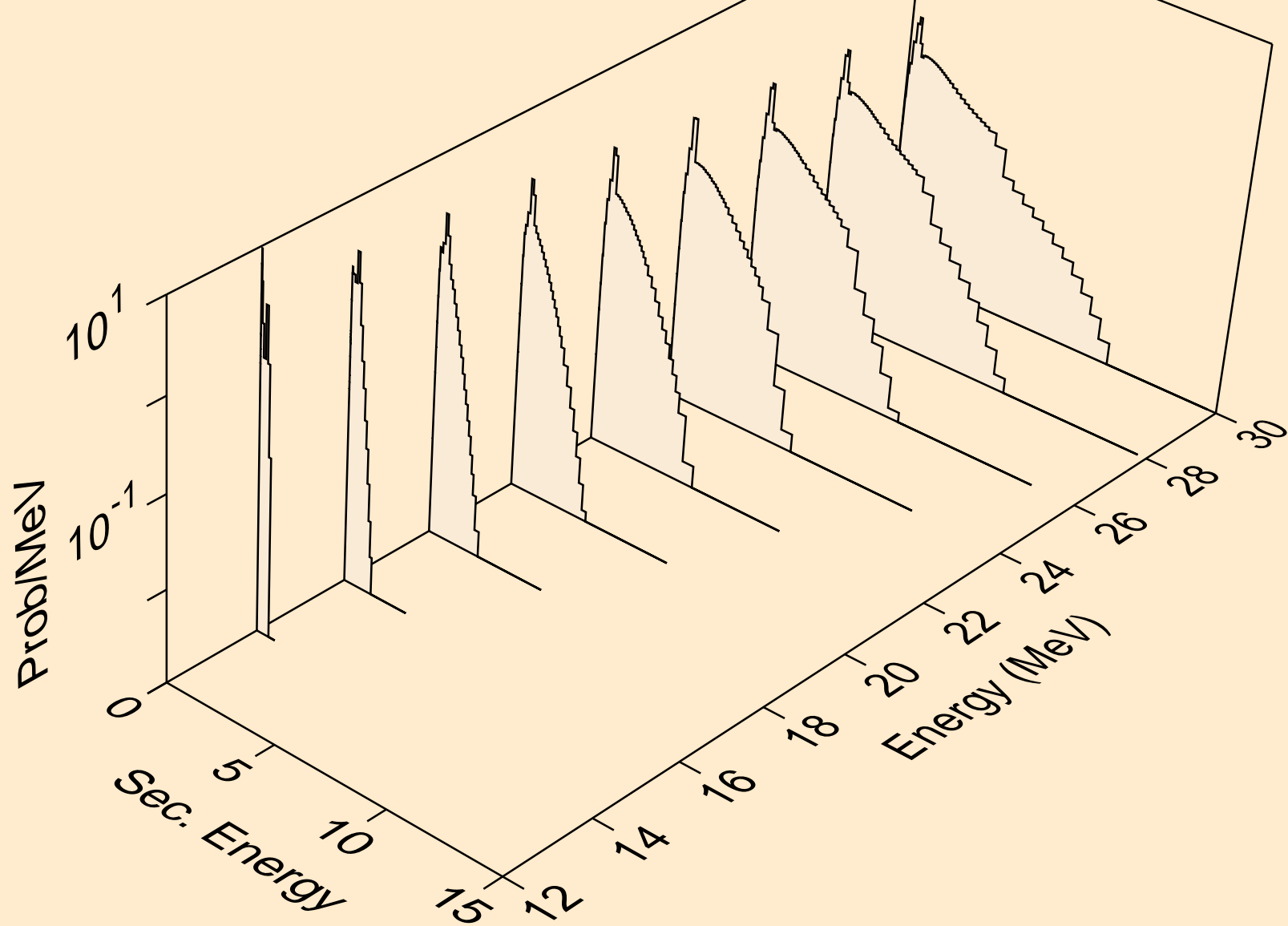

SB134M NEUTRON ACER TENDL-2023 LIBRARY; T=0.K  
Neutron emission for (n,3np)

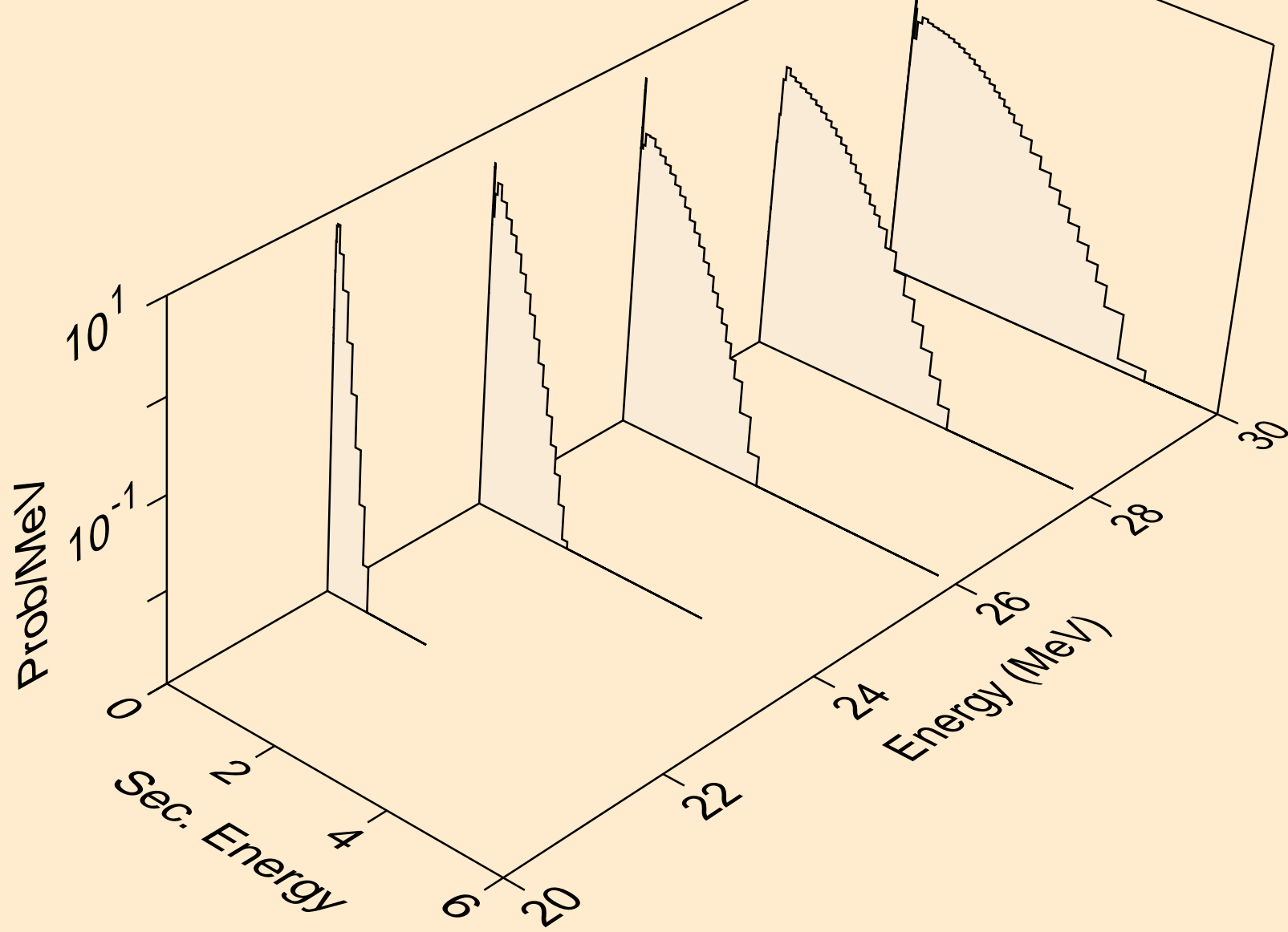



SB134M NEUTRON ACER TENDL-2023 LIBRARY; T=0.K  
Neutron emission for (n,n\*c)

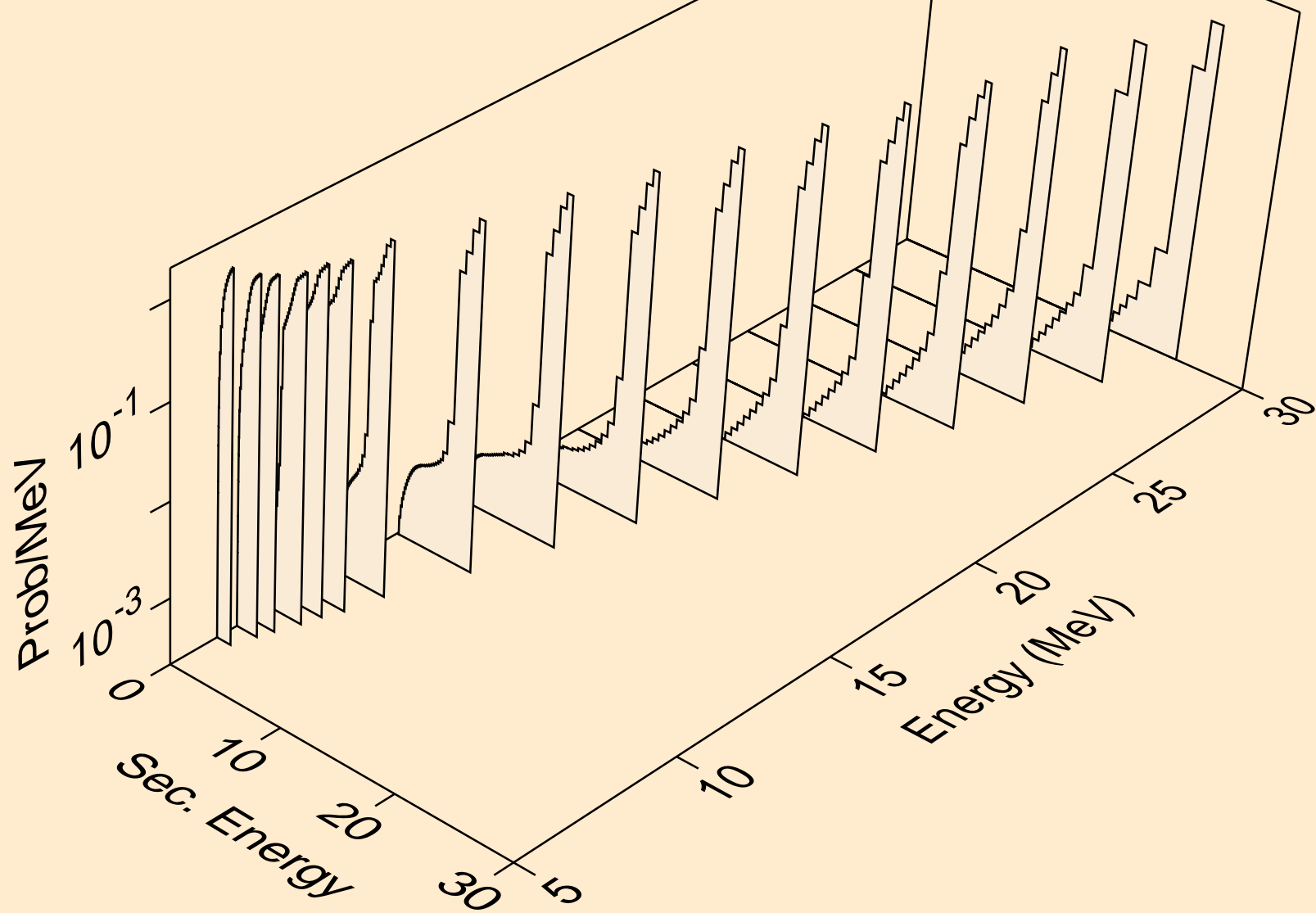

SB134M NEUTRON ACER TENDL-2023 LIBRARY; T=0.K  
Photon emission for (n,x)

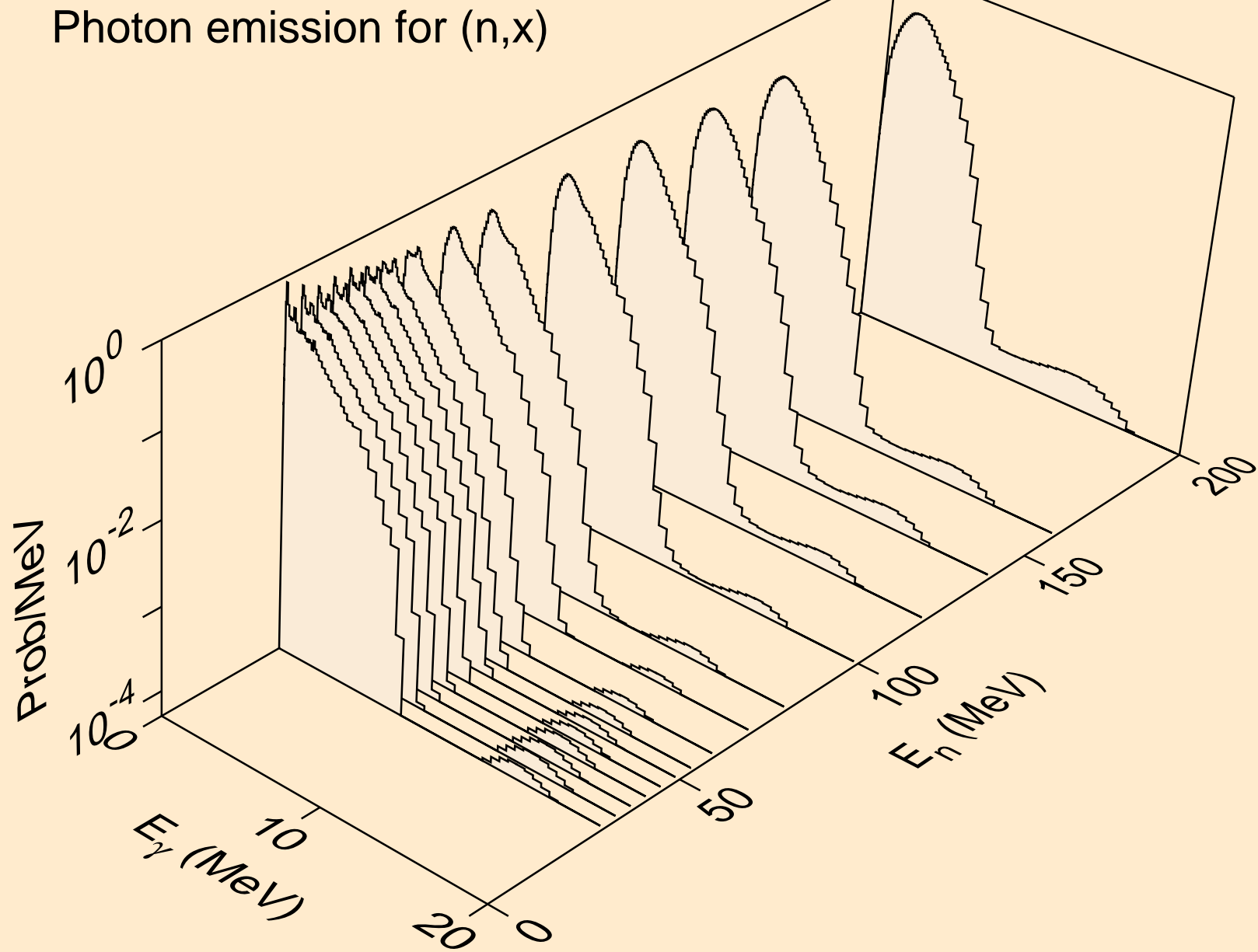

SB134M NEUTRON ACER TENDL-2023 LIBRARY; T=0.K  
Photon emission for (n,2nd)

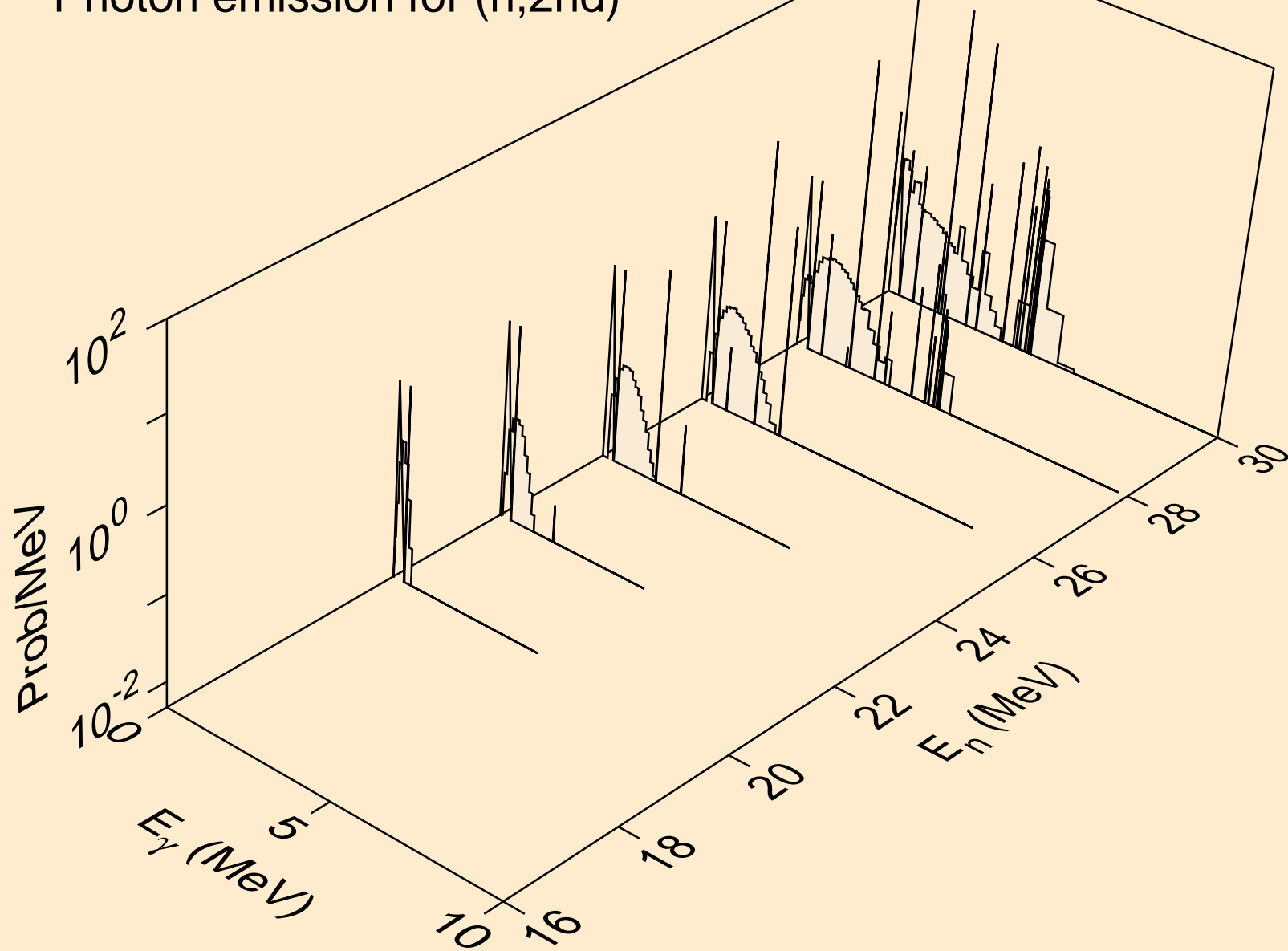

SB134M NEUTRON ACER TENDL-2023 LIBRARY; T=0.K  
Photon emission for (n,2n)

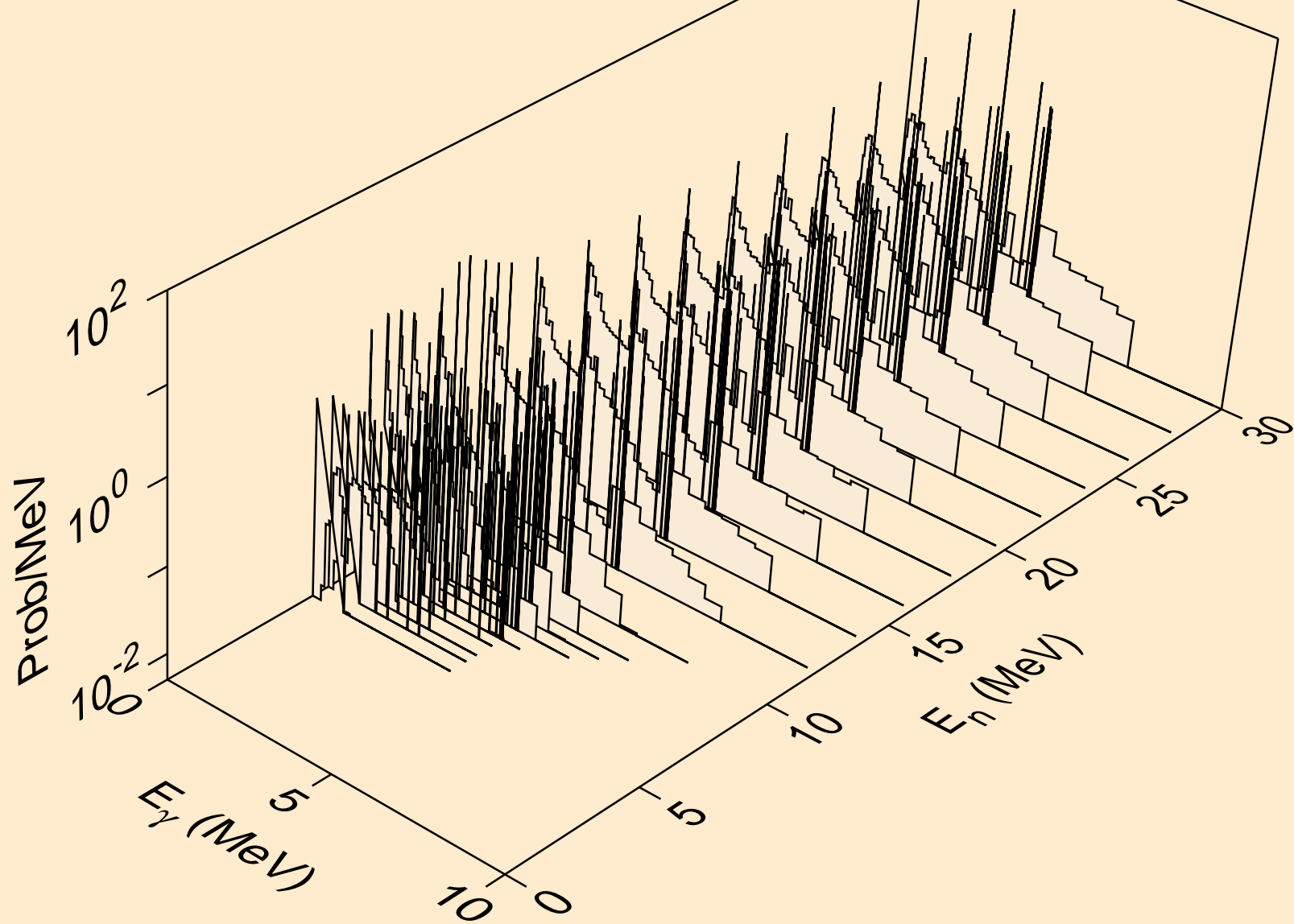

SB134M NEUTRON ACER TENDL-2023 LIBRARY; T=0.K  
Photon emission for (n,3n)

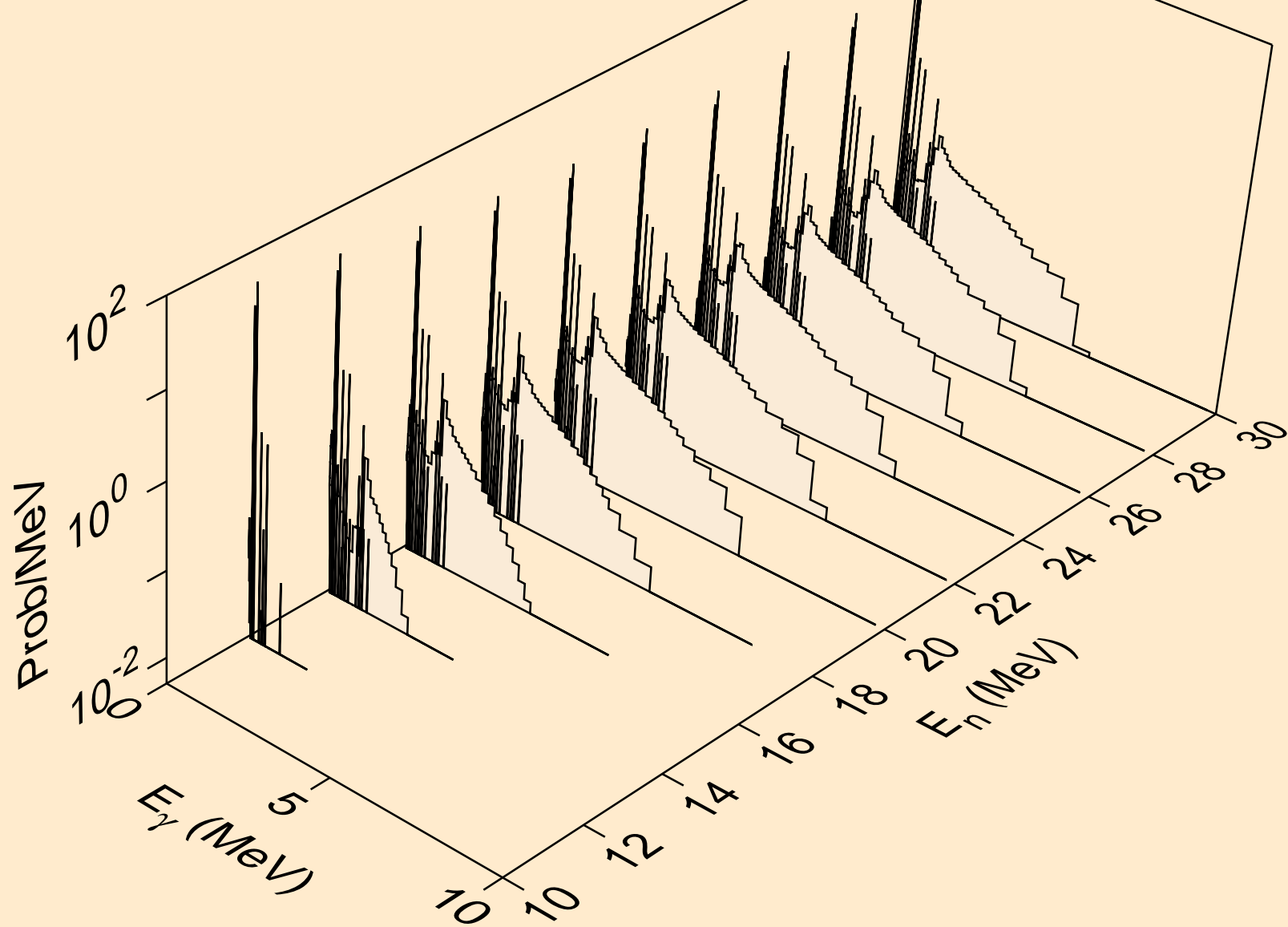

SB134M NEUTRON ACER TENDL-2023 LIBRARY; T=0.K  
Photon emission for (n,n\*)a

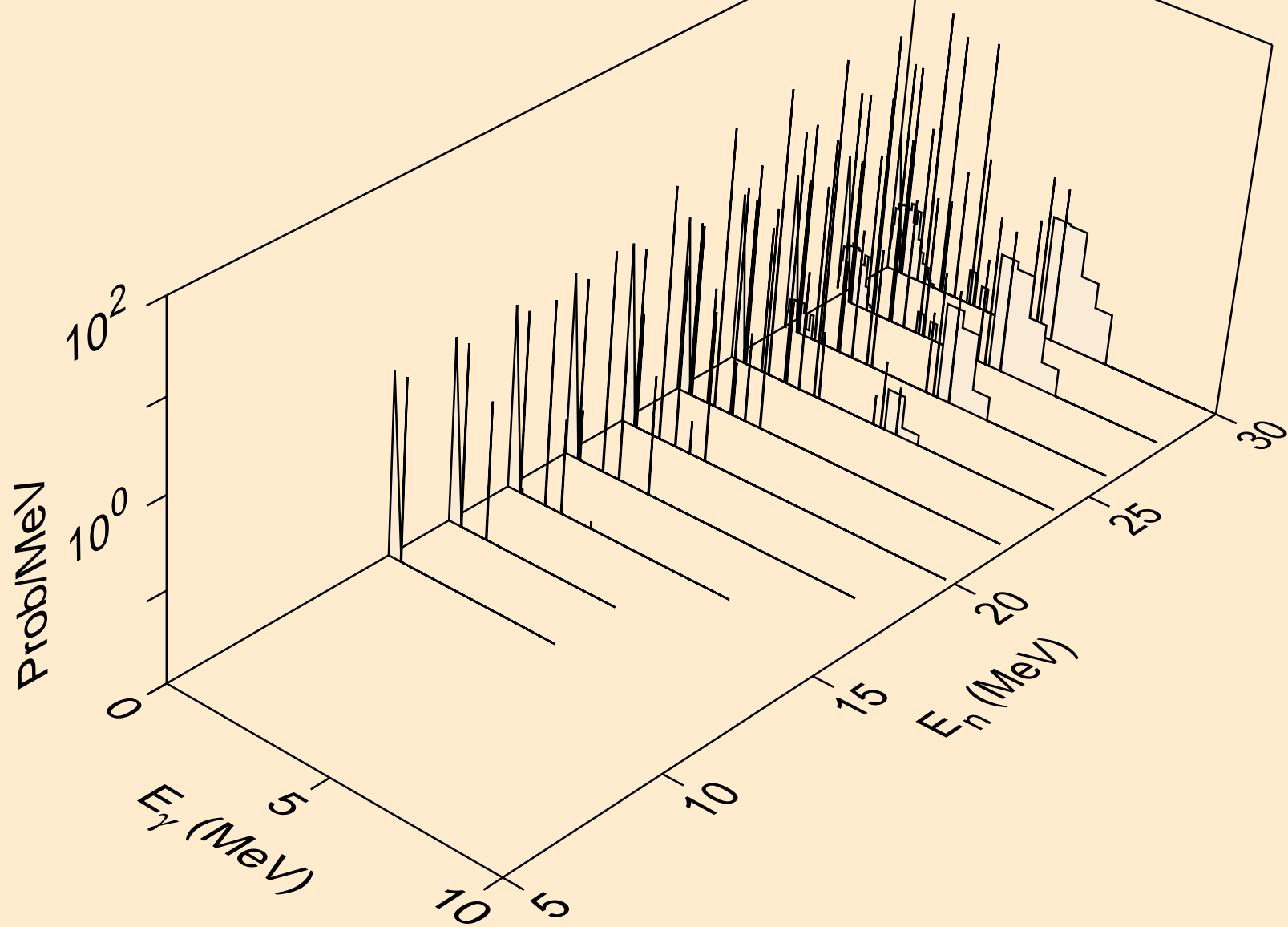

SB134M NEUTRON ACER TENDL-2023 LIBRARY; T=0.K  
Photon emission for (n,2n)a

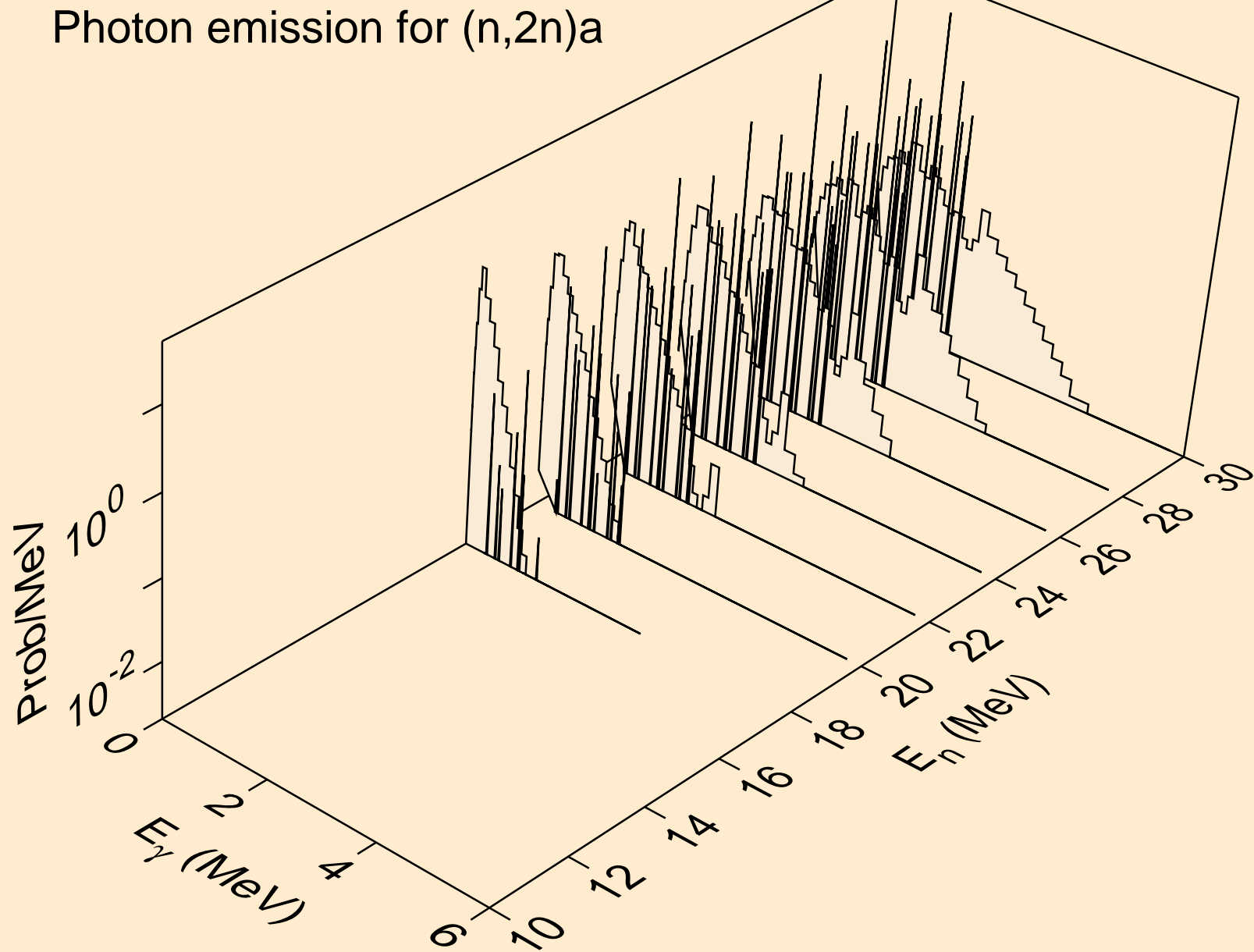

SB134M NEUTRON ACER TENDL-2023 LIBRARY; T=0.K  
Photon emission for (n,3n)a

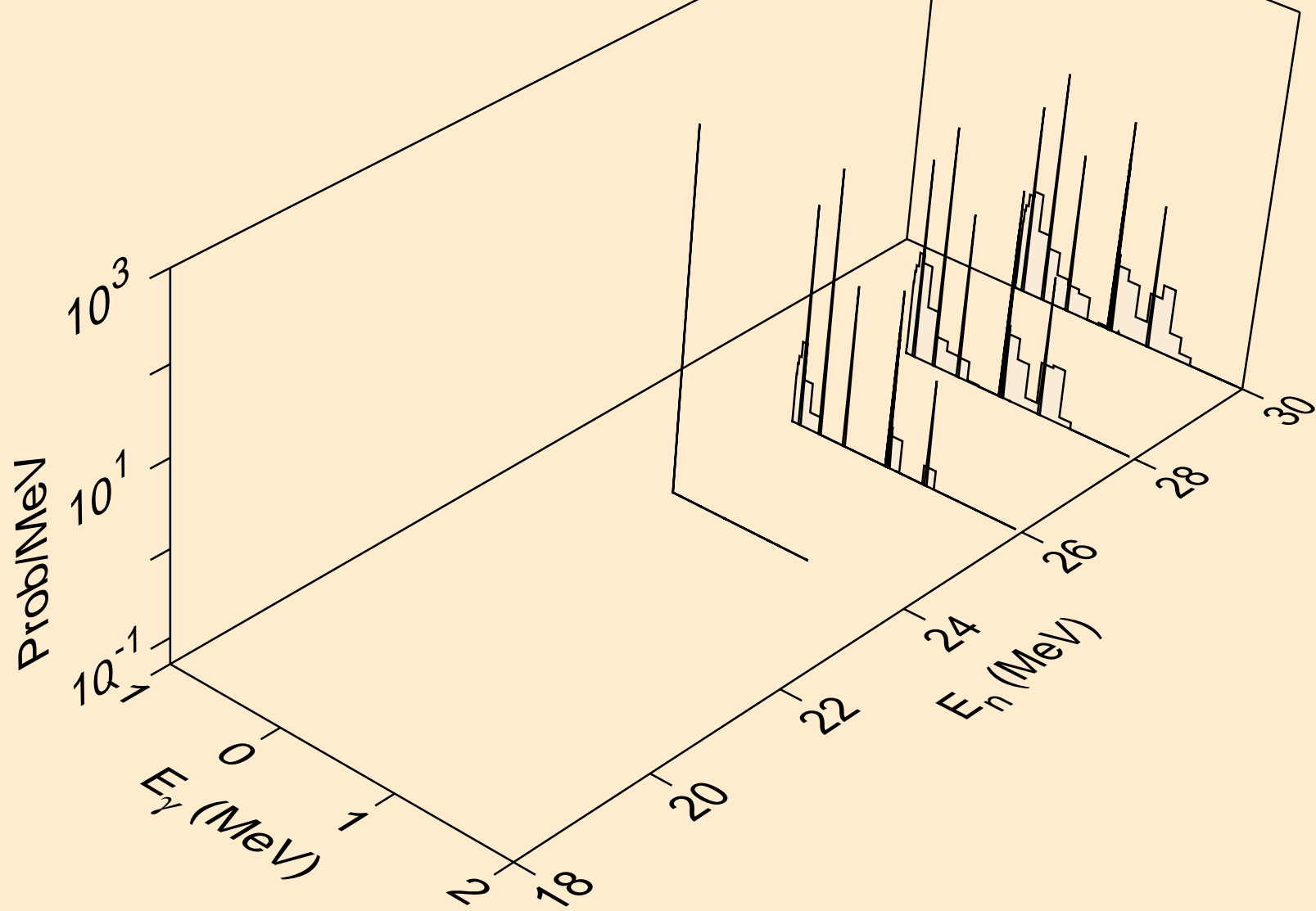



SB134M NEUTRON ACER TENDL-2023 LIBRARY; T=0.K  
Photon emission for (n,n\*)p

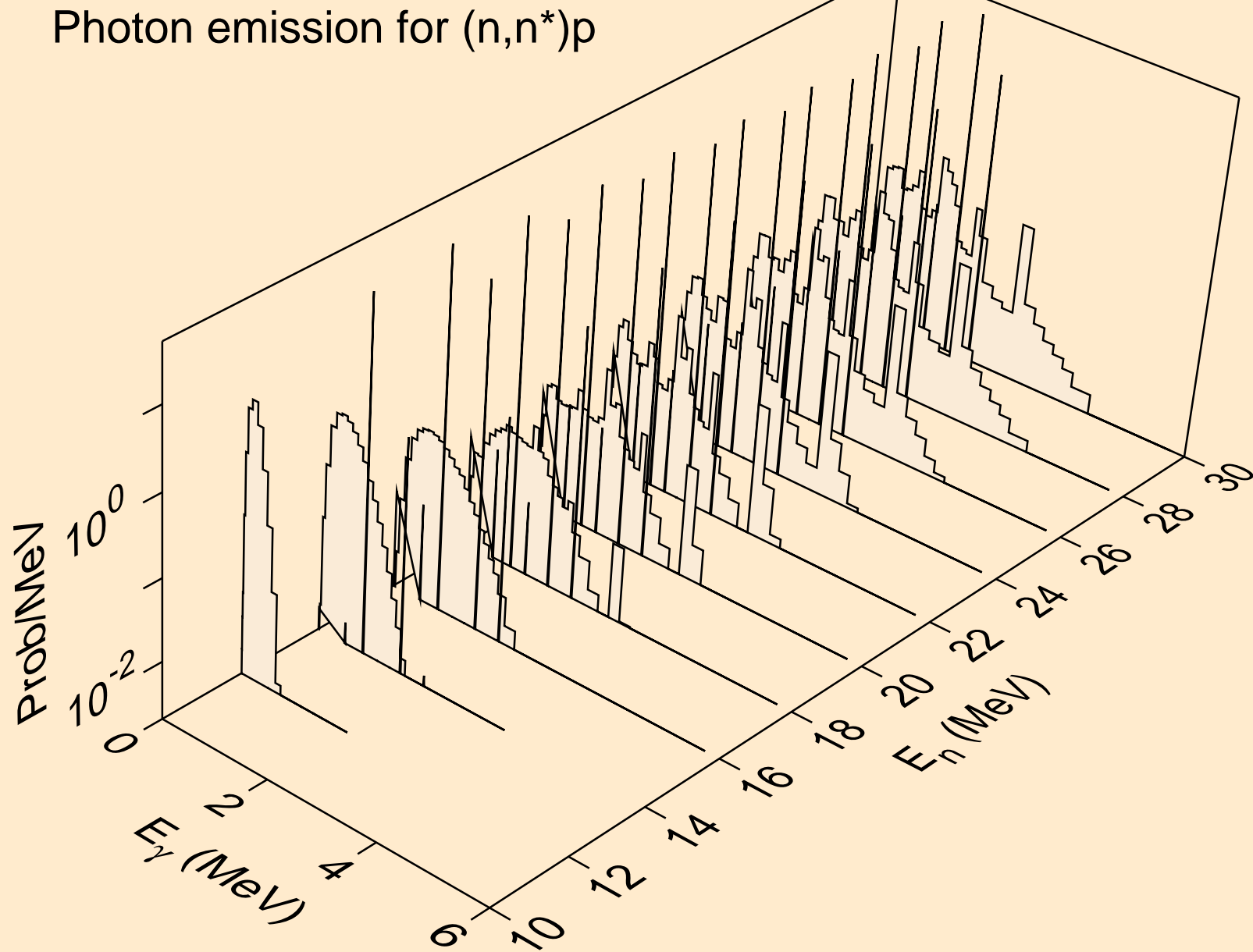

SB134M NEUTRON ACER TENDL-2023 LIBRARY; T=0.K  
Photon emission for (n,n\*)d

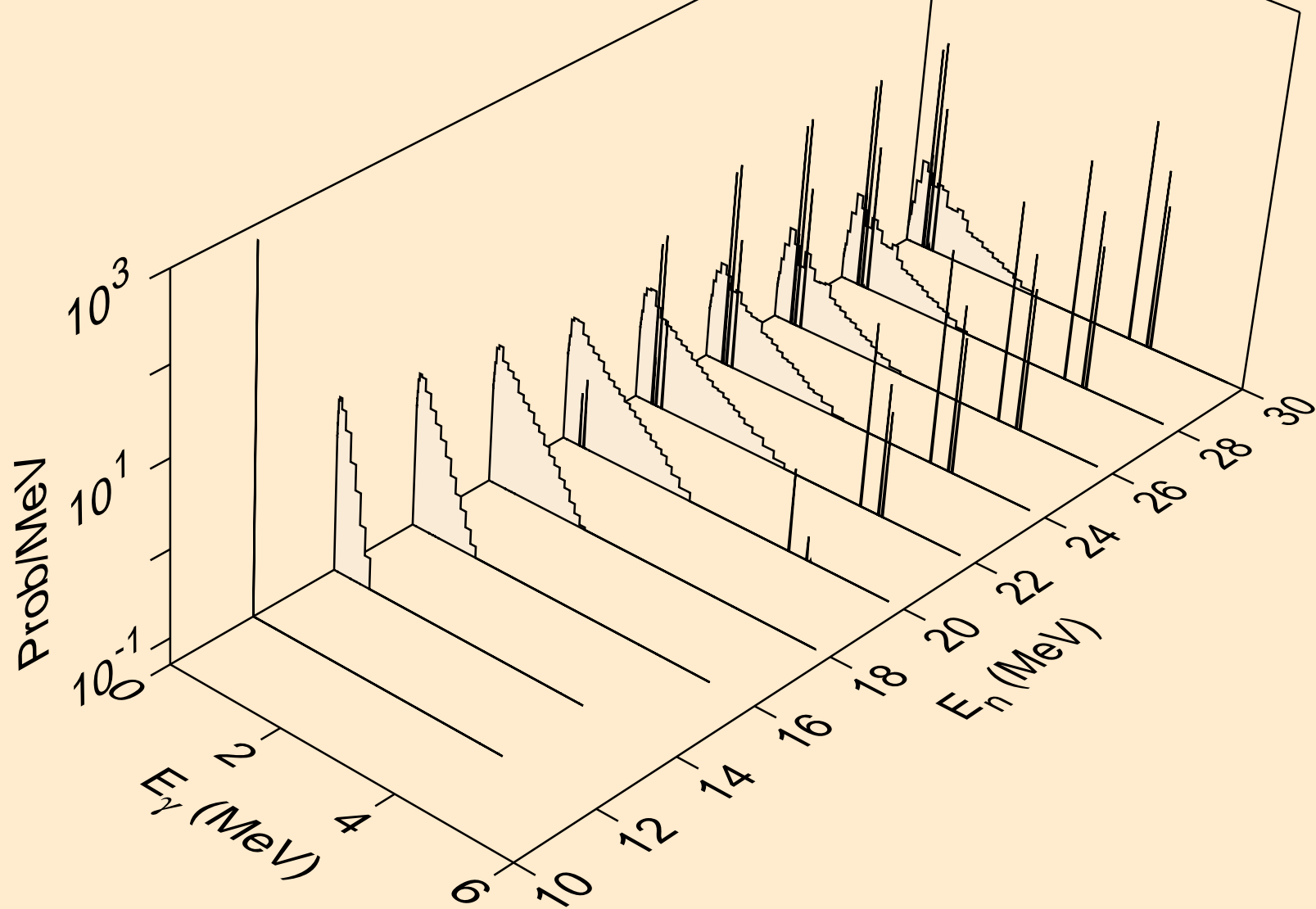

SB134M NEUTRON ACER TENDL-2023 LIBRARY; T=0.K  
Photon emission for (n,n\*)t

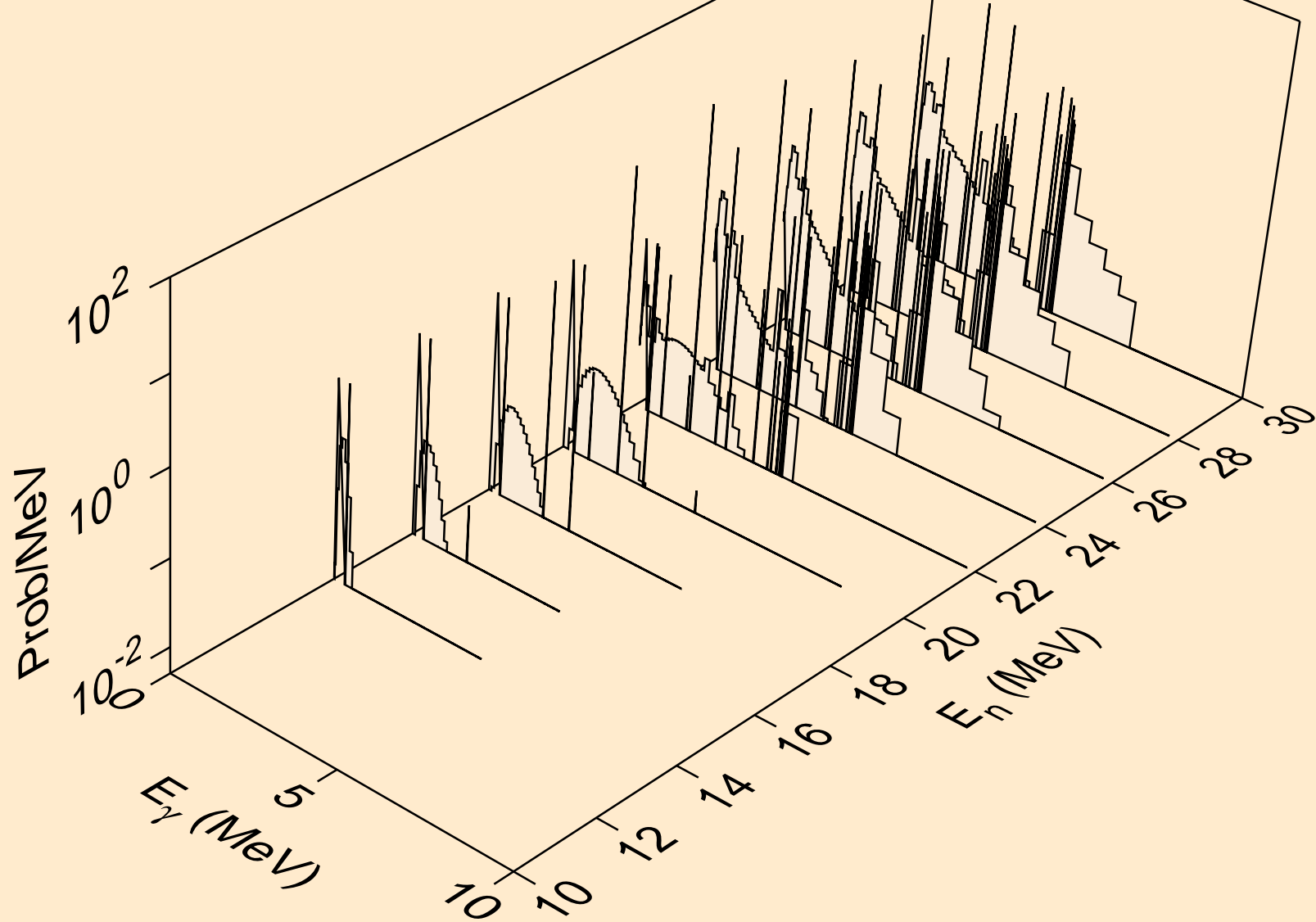

SB134M NEUTRON ACER TENDL-2023 LIBRARY; T=0.K  
Photon emission for (n,n\*)he3

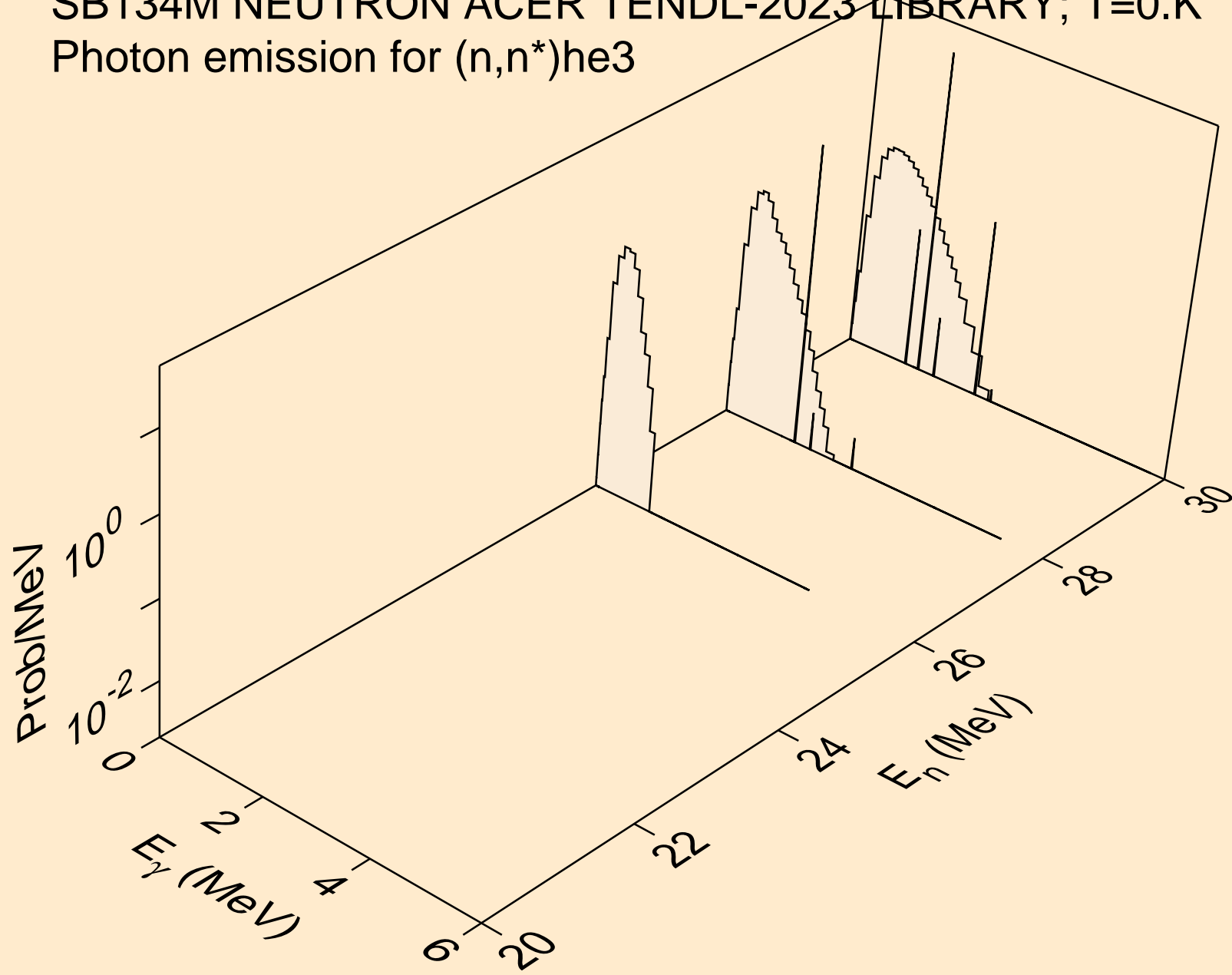

SB134M NEUTRON ACER TENDL-2023 LIBRARY; T=0.K  
Photon emission for (n,4n)

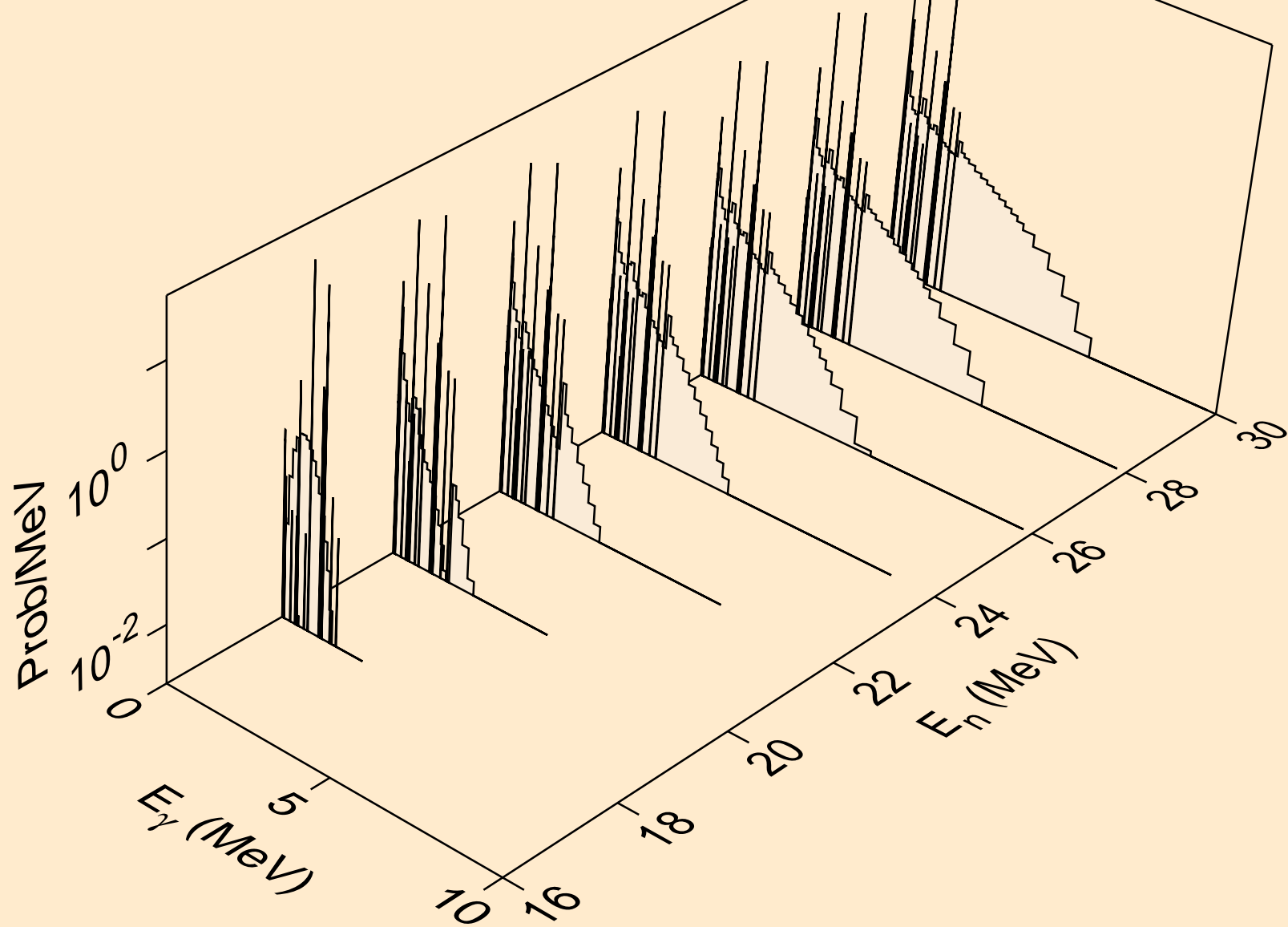

SB134M NEUTRON ACER TENDL-2023 LIBRARY; T=0.K  
Photon emission for (n,2np)

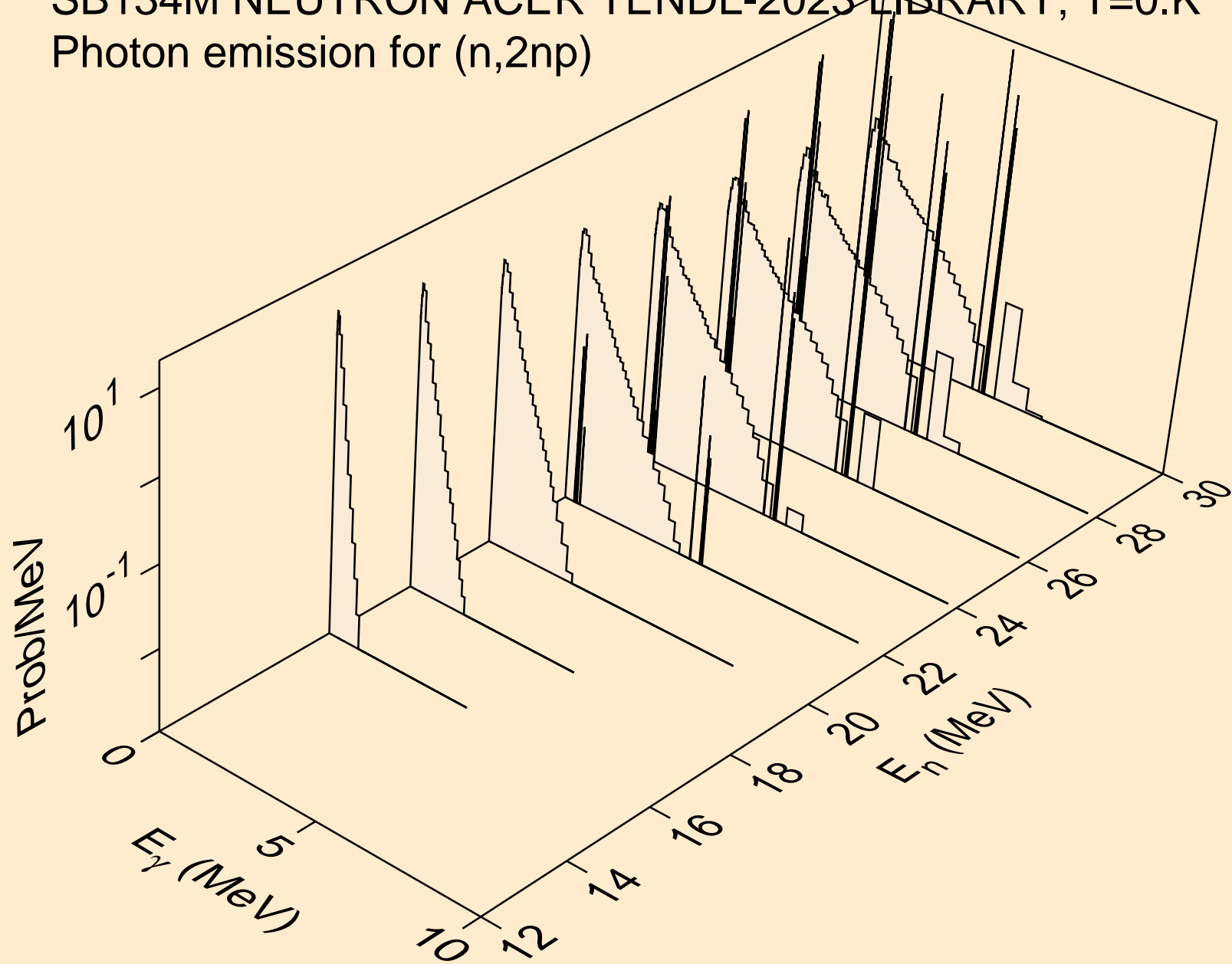

SB134M NEUTRON ACER TENDL-2023 LIBRARY; T=0.K  
Photon emission for (n,3np)

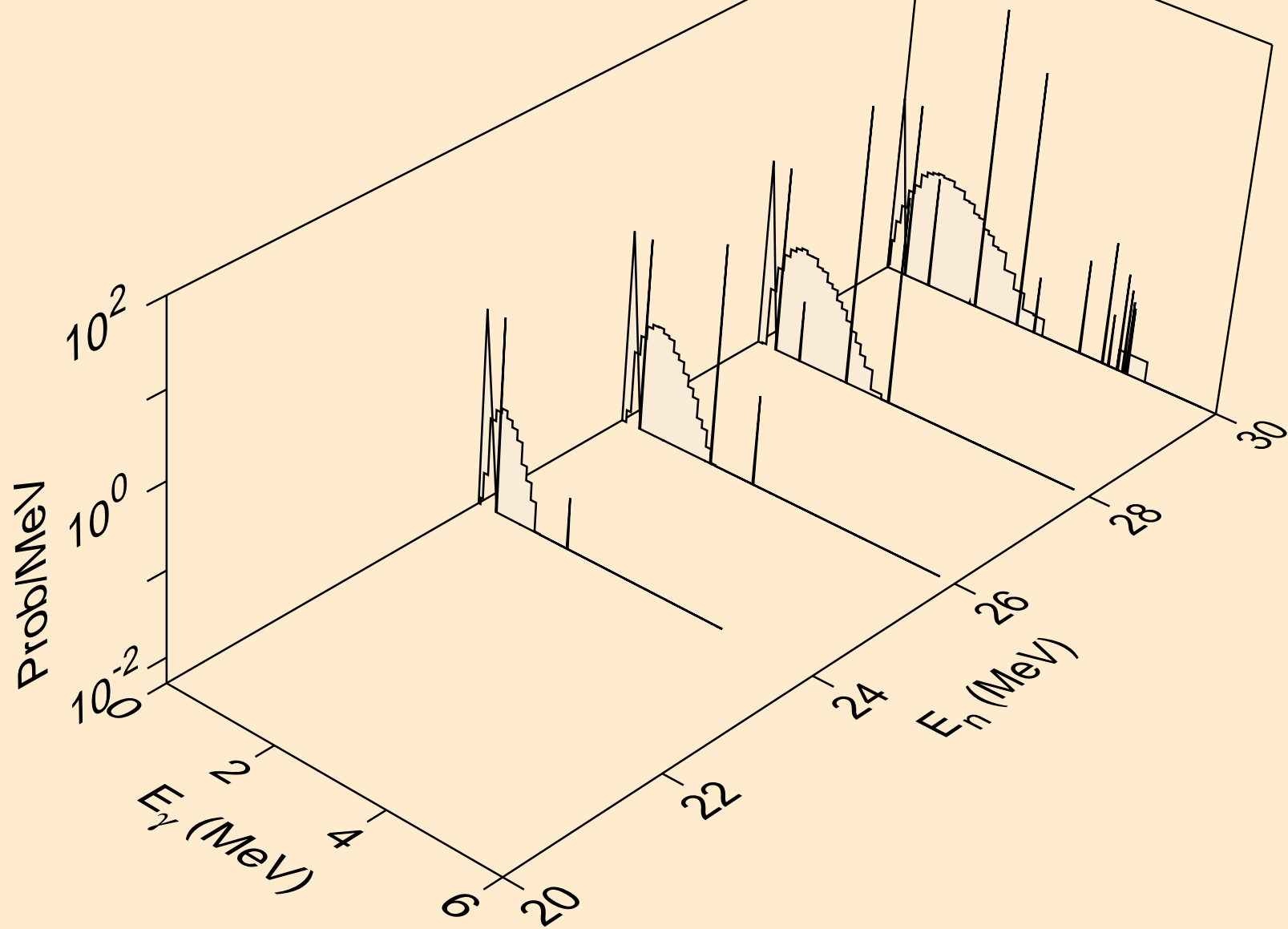

SB134M NEUTRON ACER TENDL-2023 LIBRARY; T=0.K  
Photon emission for (n,n\*1)

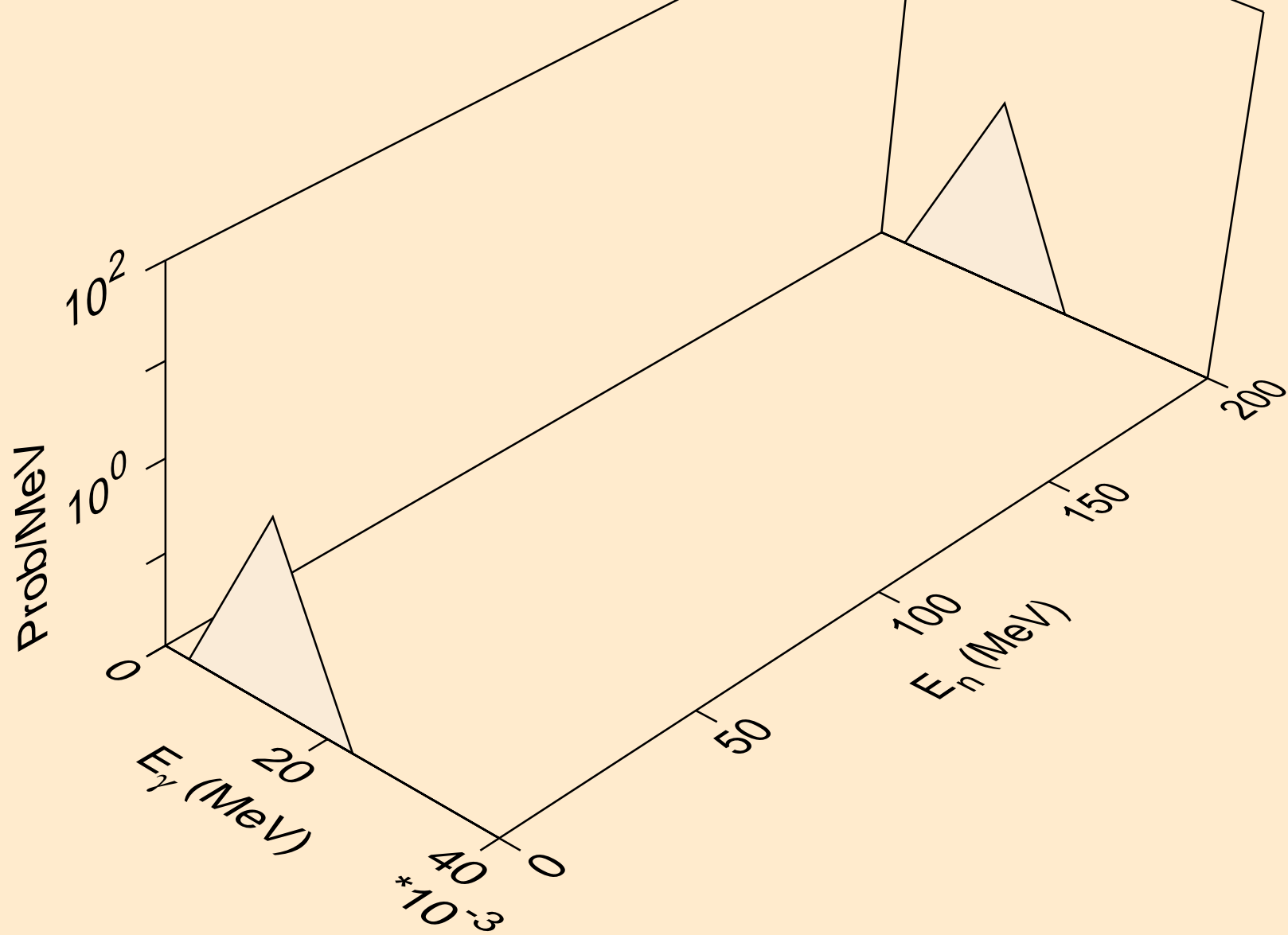



SB134M NEUTRON ACER TENDL-2023 LIBRARY; T=0.K  
Photon emission for (n,n\*3)

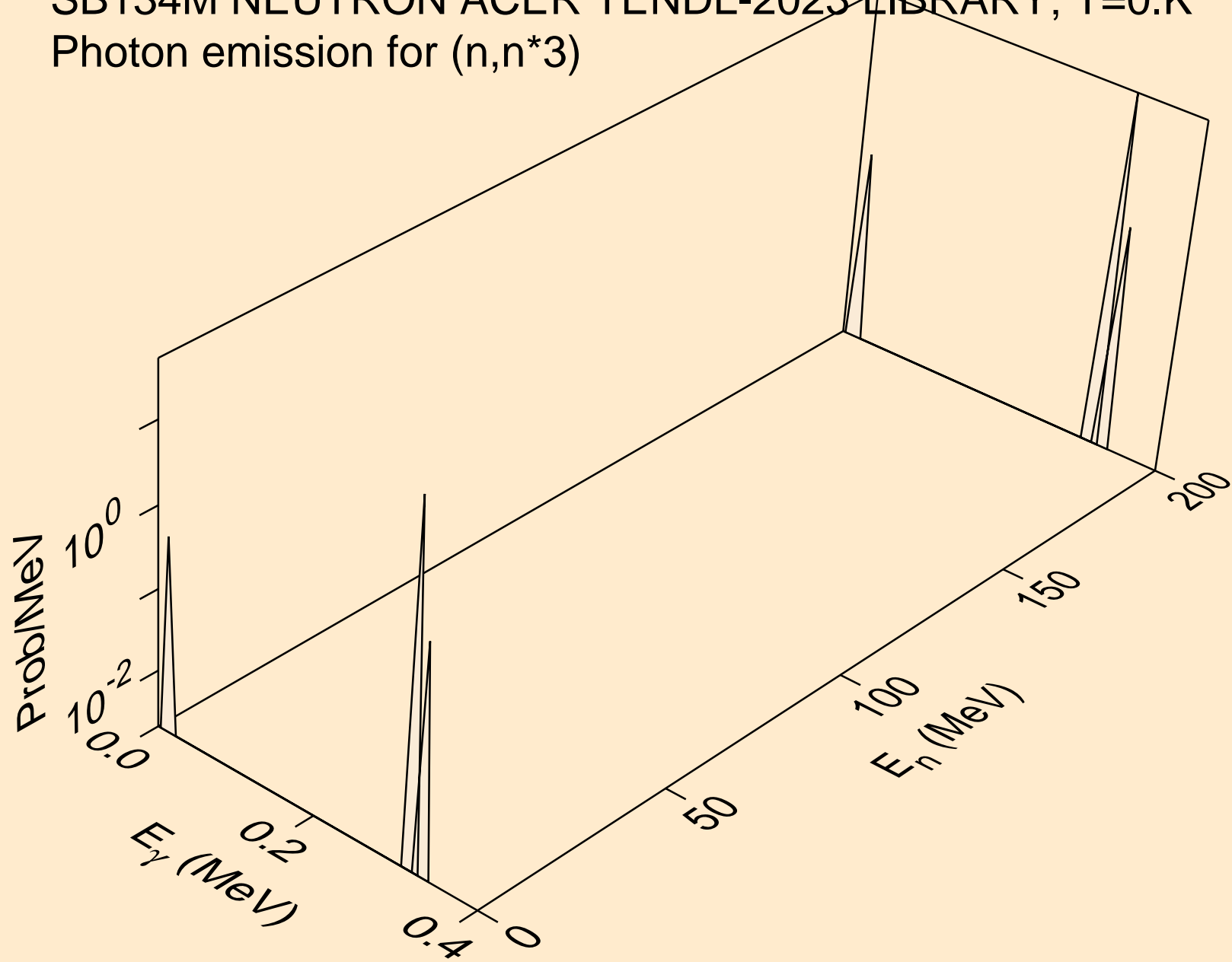

SB134M NEUTRON ACER TENDL-2023 LIBRARY; T=0.K  
Photon emission for (n,n\*4)

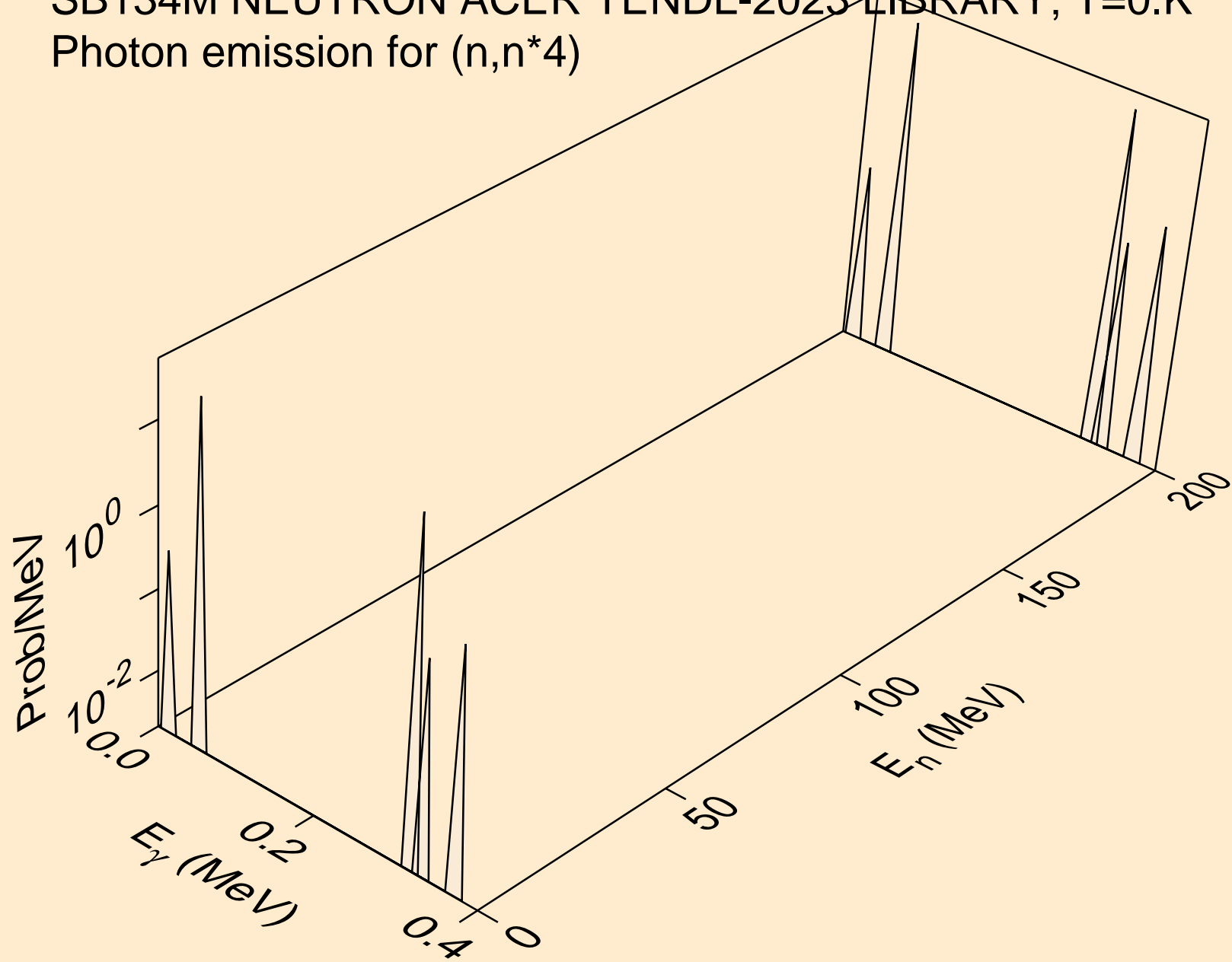

SB134M NEUTRON ACER TENDL-2023 LIBRARY; T=0.K  
Photon emission for (n,n\*5)

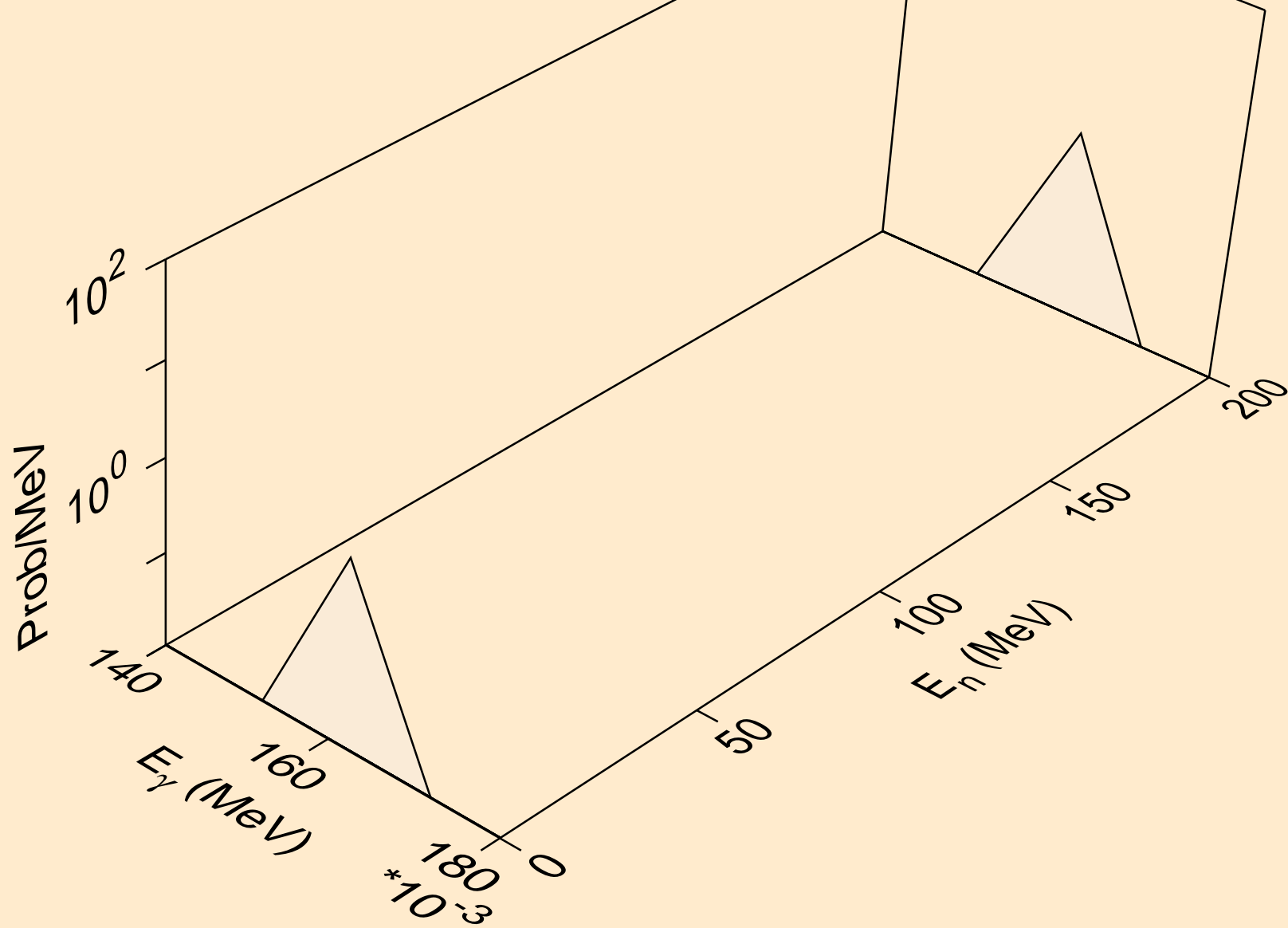

SB134M NEUTRON ACER TENDL-2023 LIBRARY; T=0.K  
Photon emission for (n,n\*6)

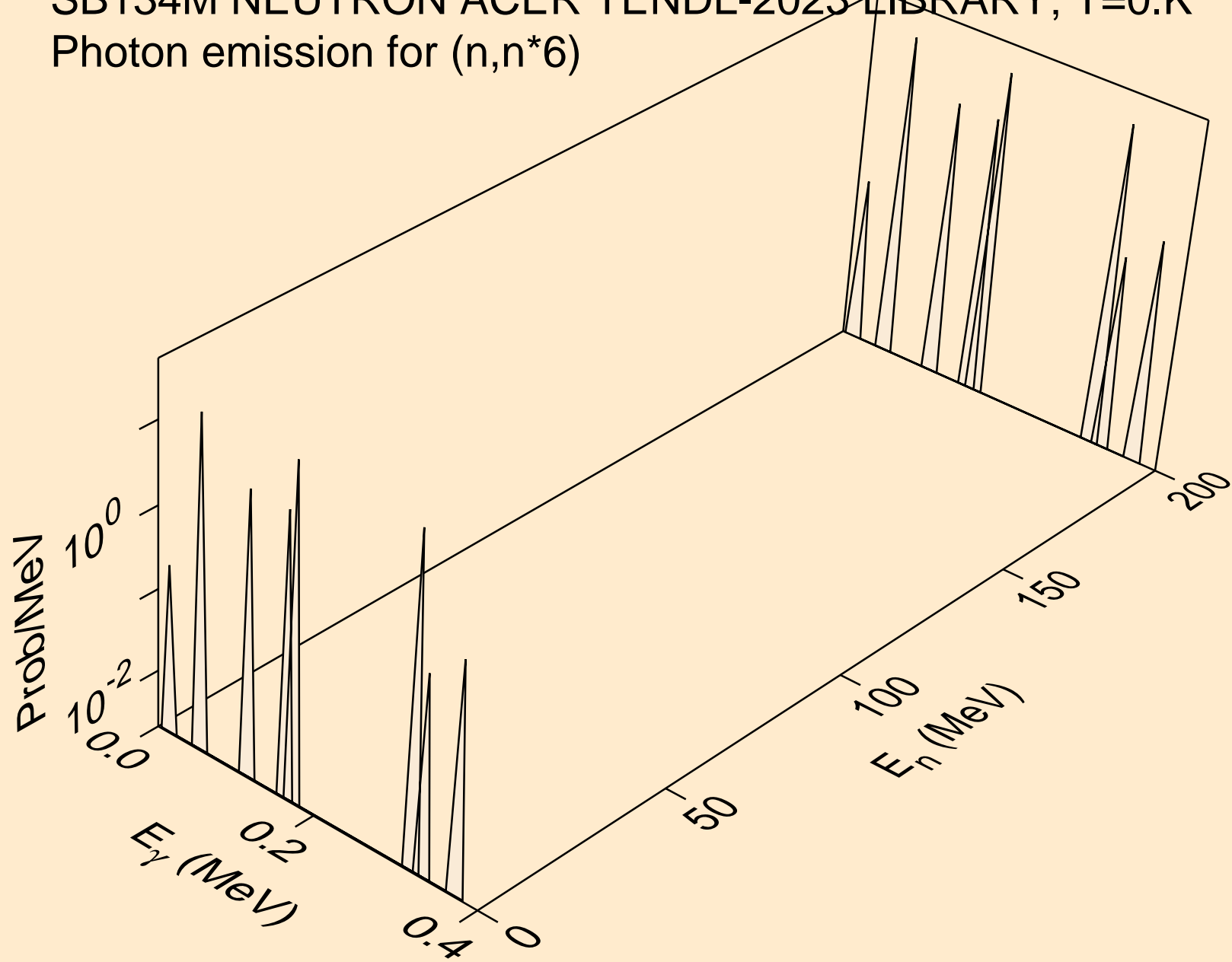

SB134M NEUTRON ACER TENDL-2023 LIBRARY; T=0.K  
Photon emission for (n,n\*7)

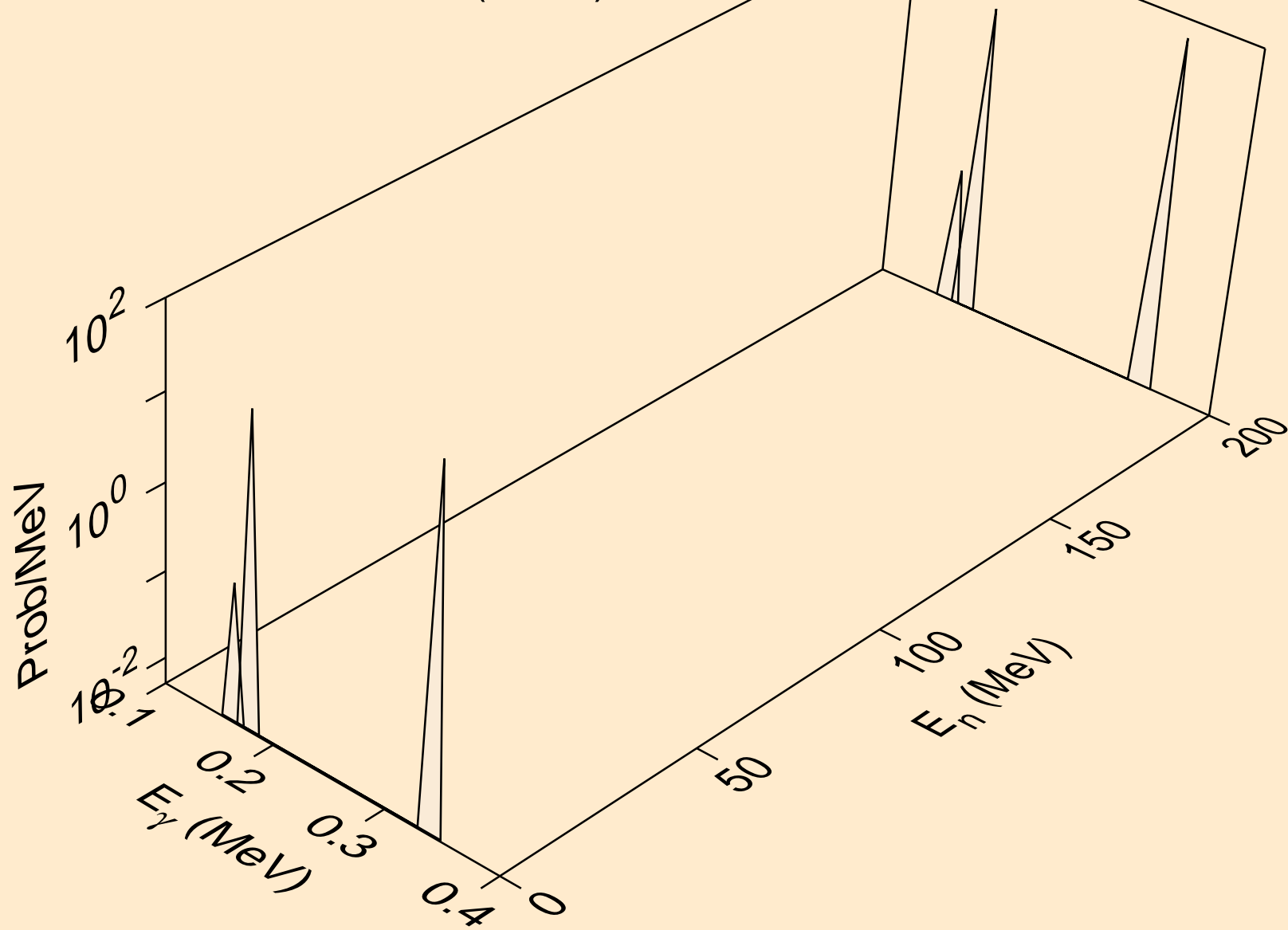

SB134M NEUTRON ACER TENDL-2023 LIBRARY; T=0.K  
Photon emission for (n,n\*8)

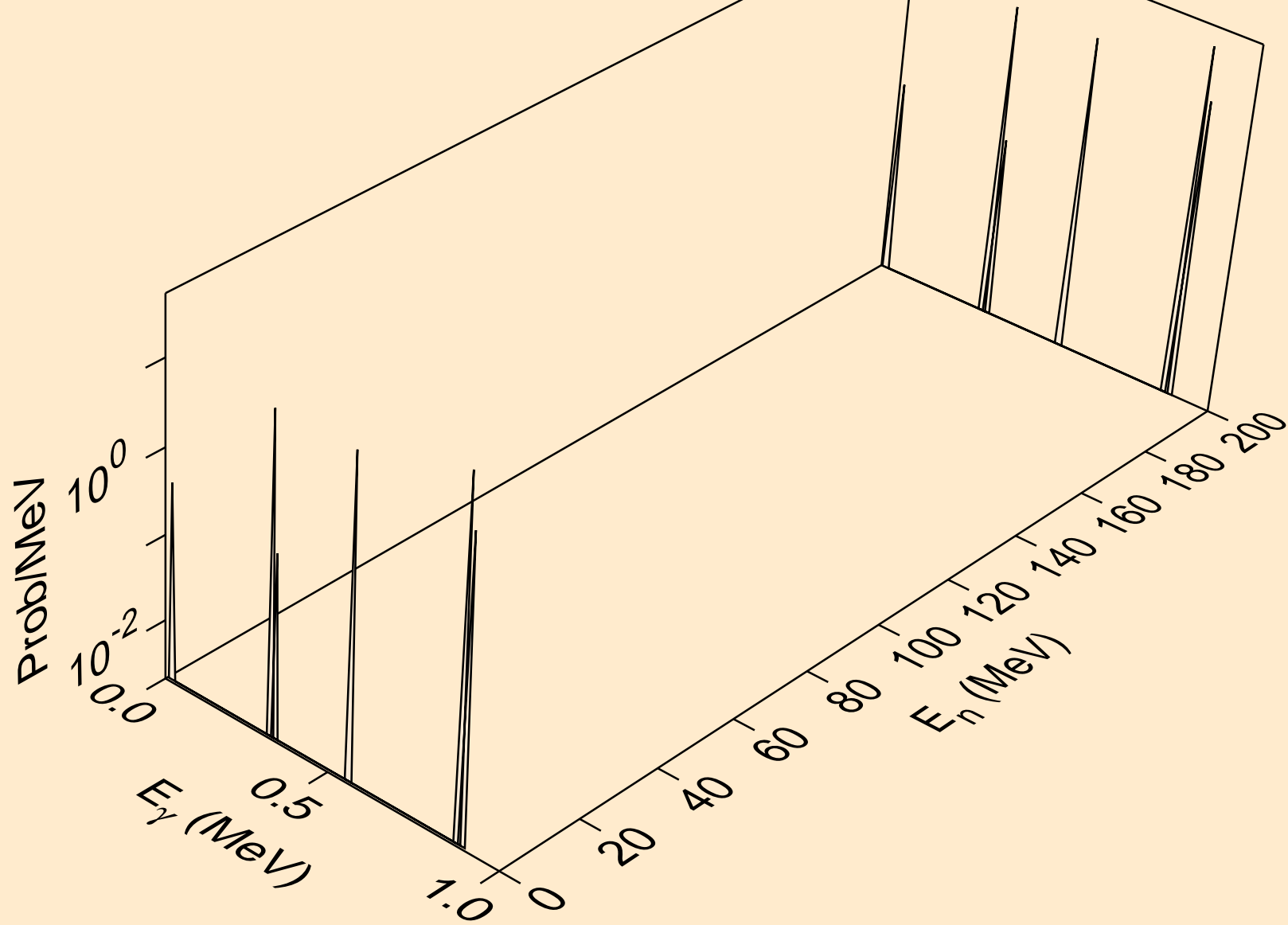

SB134M NEUTRON ACER TENDL-2023 LIBRARY; T=0.K  
Photon emission for (n,n\*9)

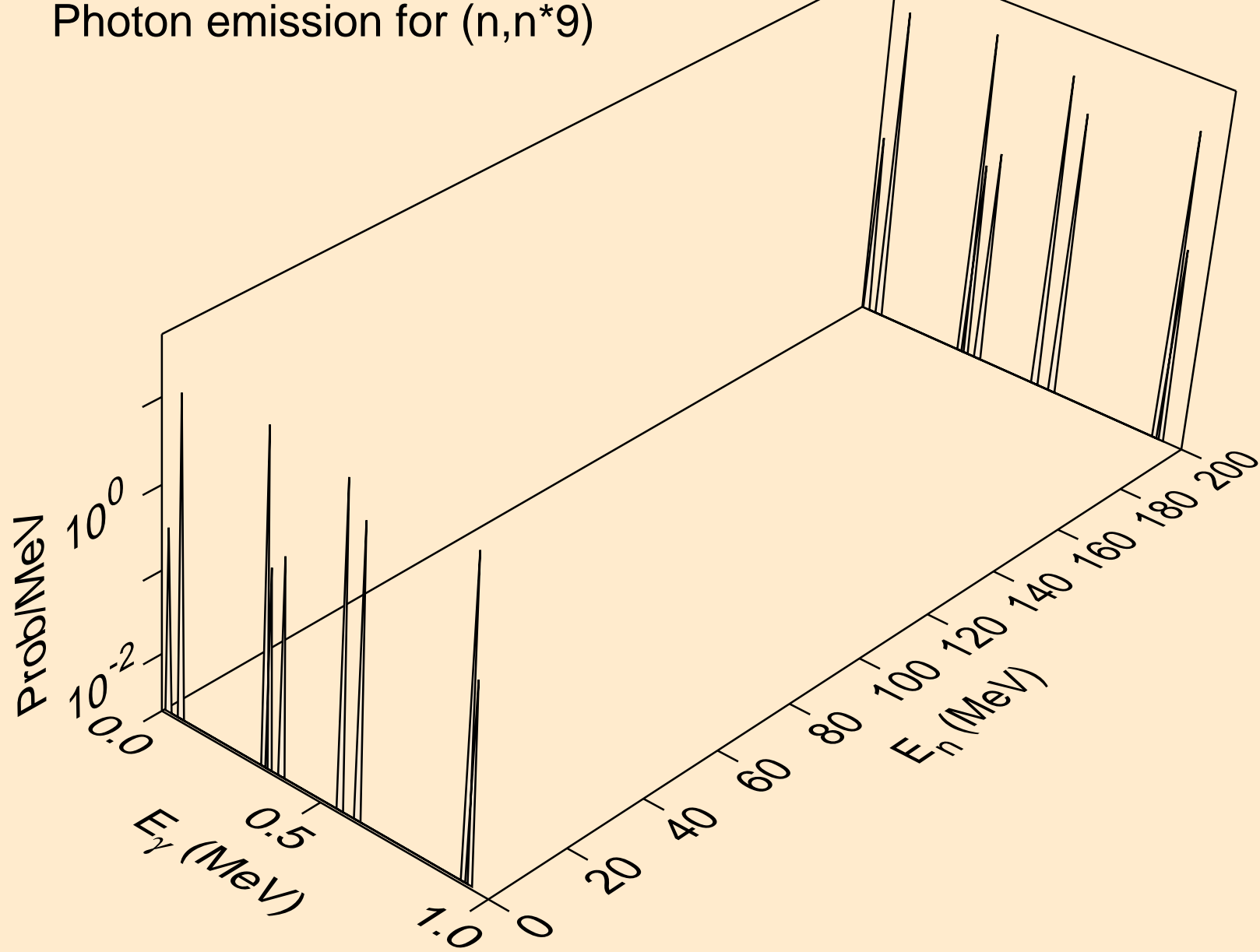

SB134M NEUTRON ACER TENDL-2023 LIBRARY; T=0.K  
Photon emission for (n,n\*10)

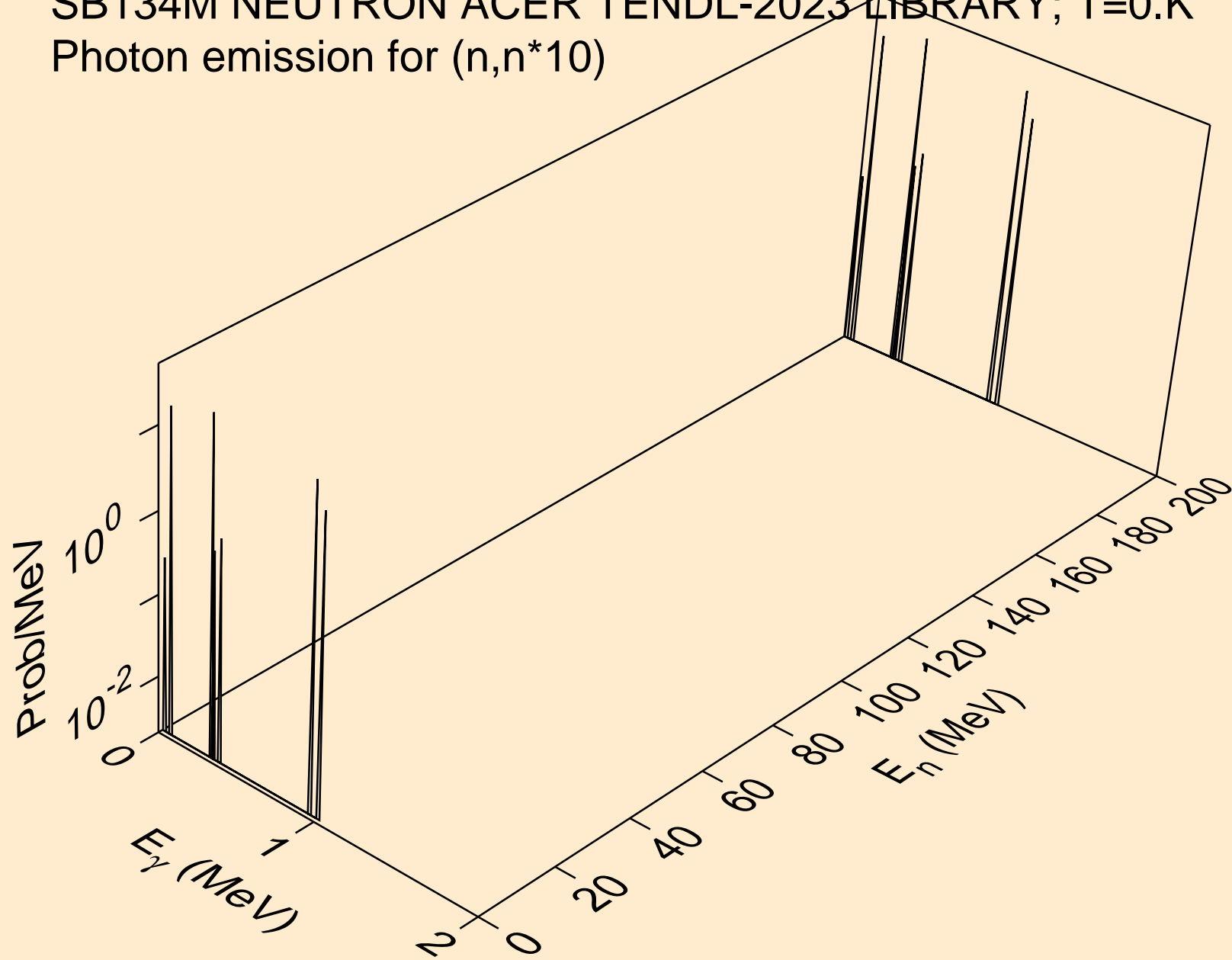



SB134M NEUTRON ACER TENDL-2023 LIBRARY; T=0.K  
Photon emission for (n,n\*11)

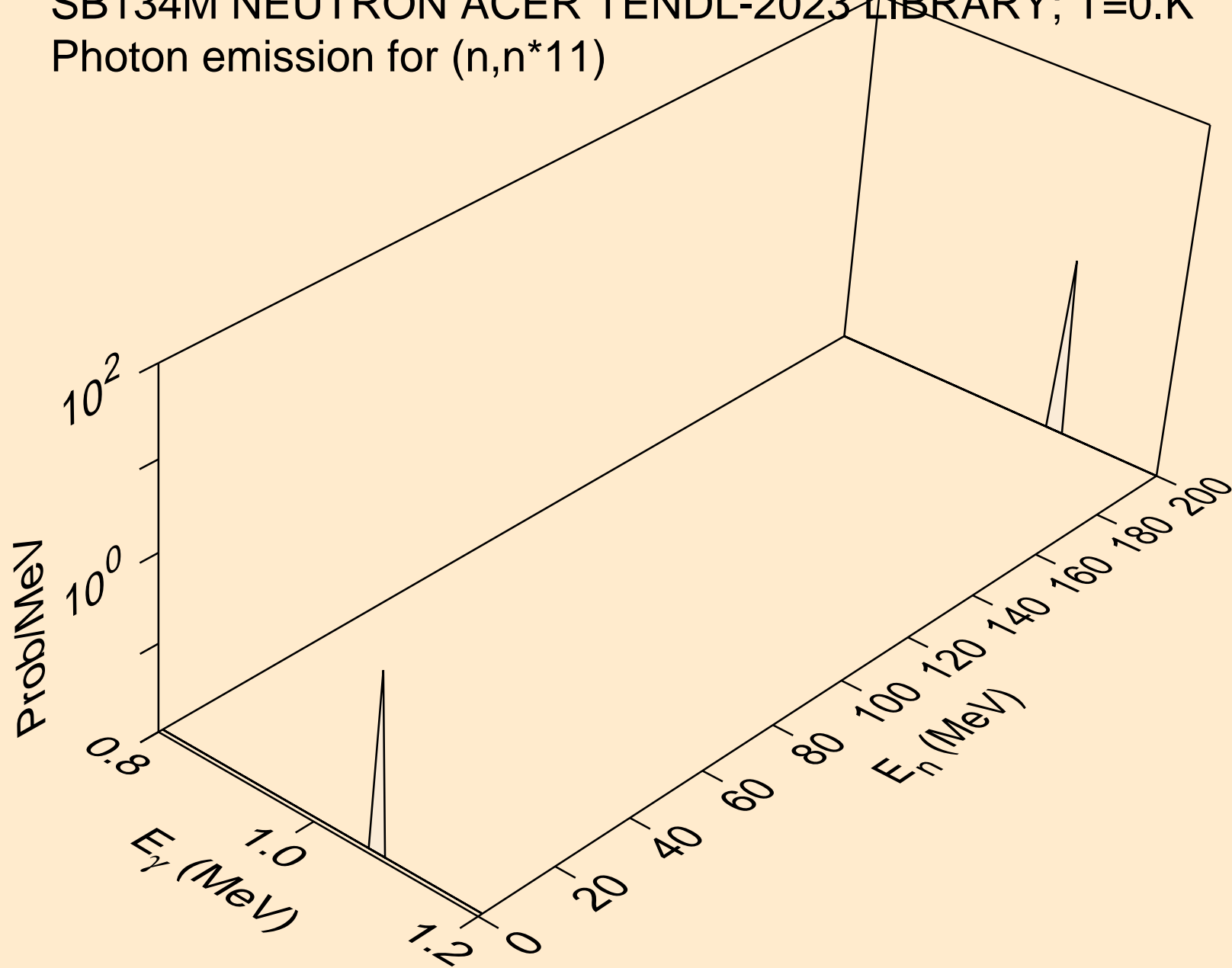

SB134M NEUTRON ACER TENDL-2023 LIBRARY; T=0.K  
Photon emission for (n,n\*12)

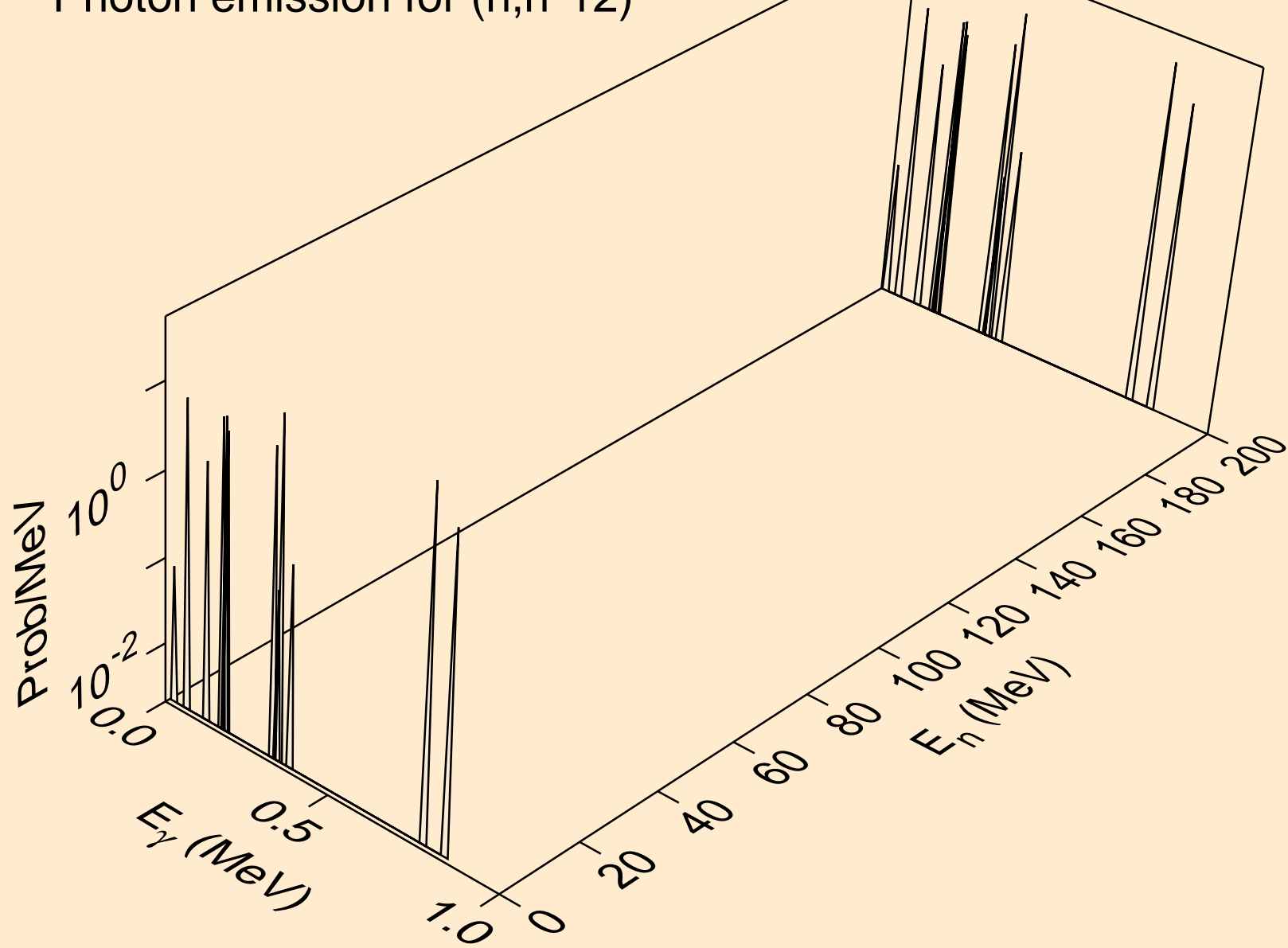

SB134M NEUTRON ACER TENDL-2023 LIBRARY; T=0.K  
Photon emission for (n,n\*13)

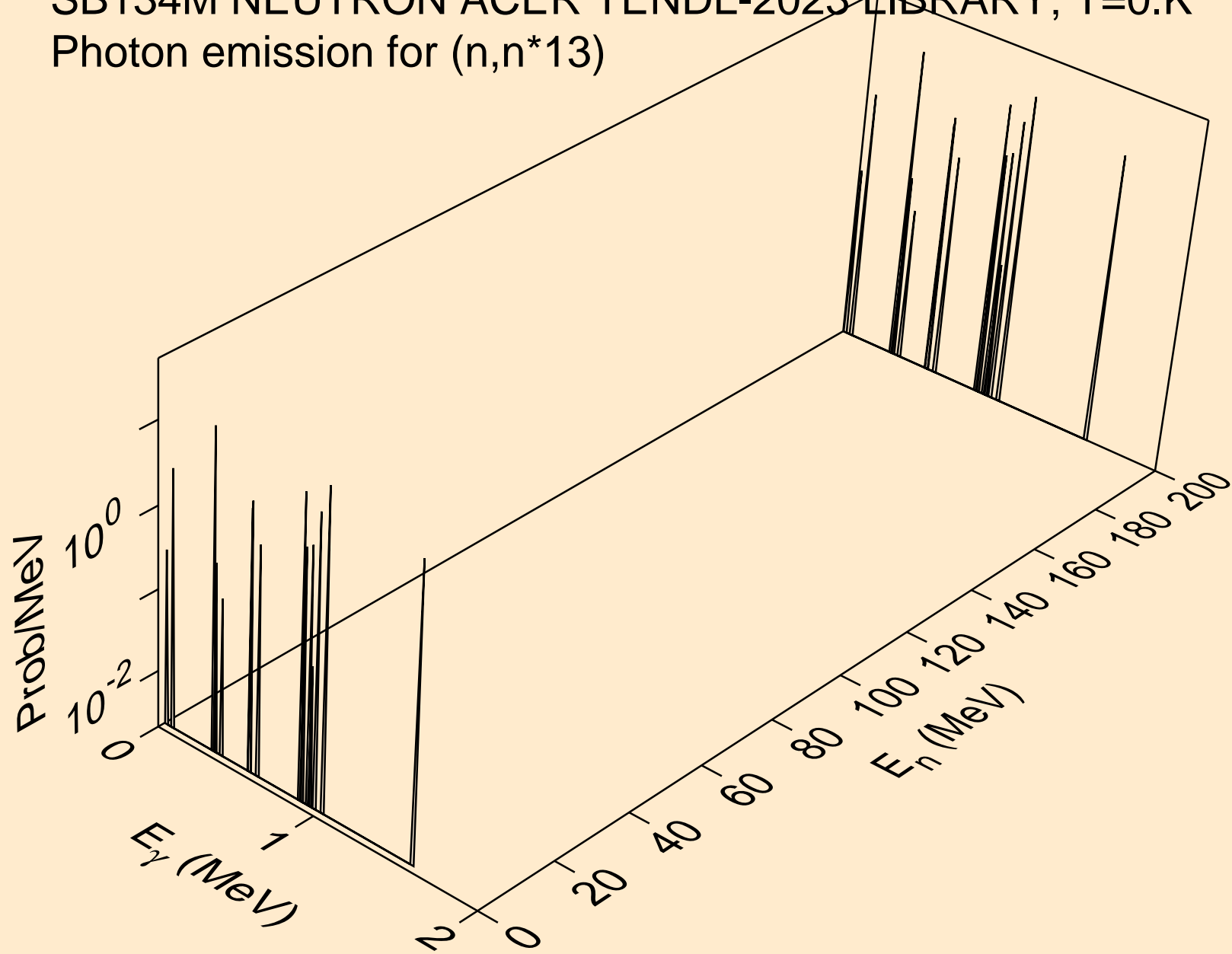

SB134M NEUTRON ACER TENDL-2023 LIBRARY; T=0.K  
Photon emission for (n,n\*14)

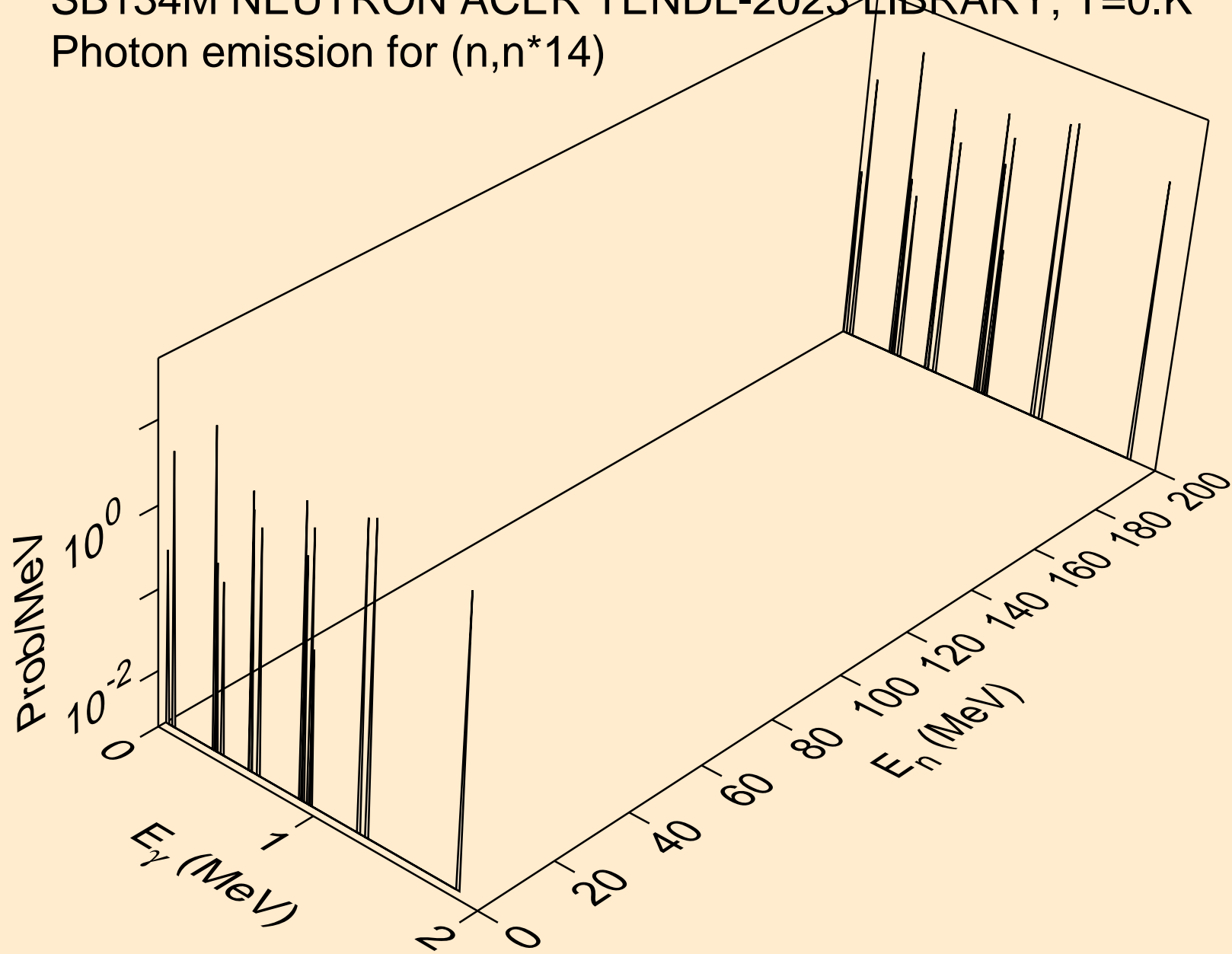

SB134M NEUTRON ACER TENDL-2023 LIBRARY; T=0.K  
Photon emission for (n,n\*15)

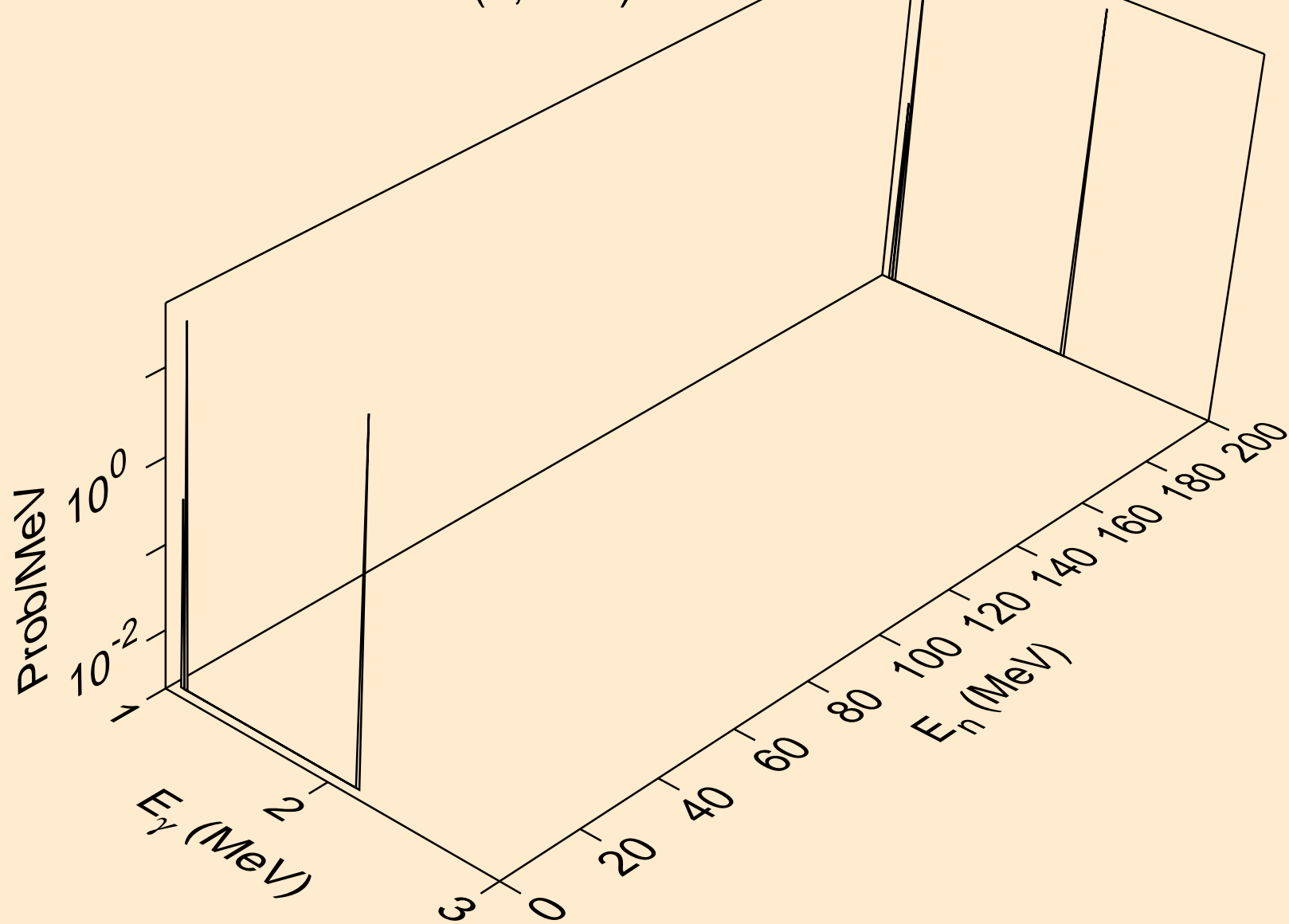

SB134M NEUTRON ACER TENDL-2023 LIBRARY; T=0.K  
Photon emission for (n,n\*16)

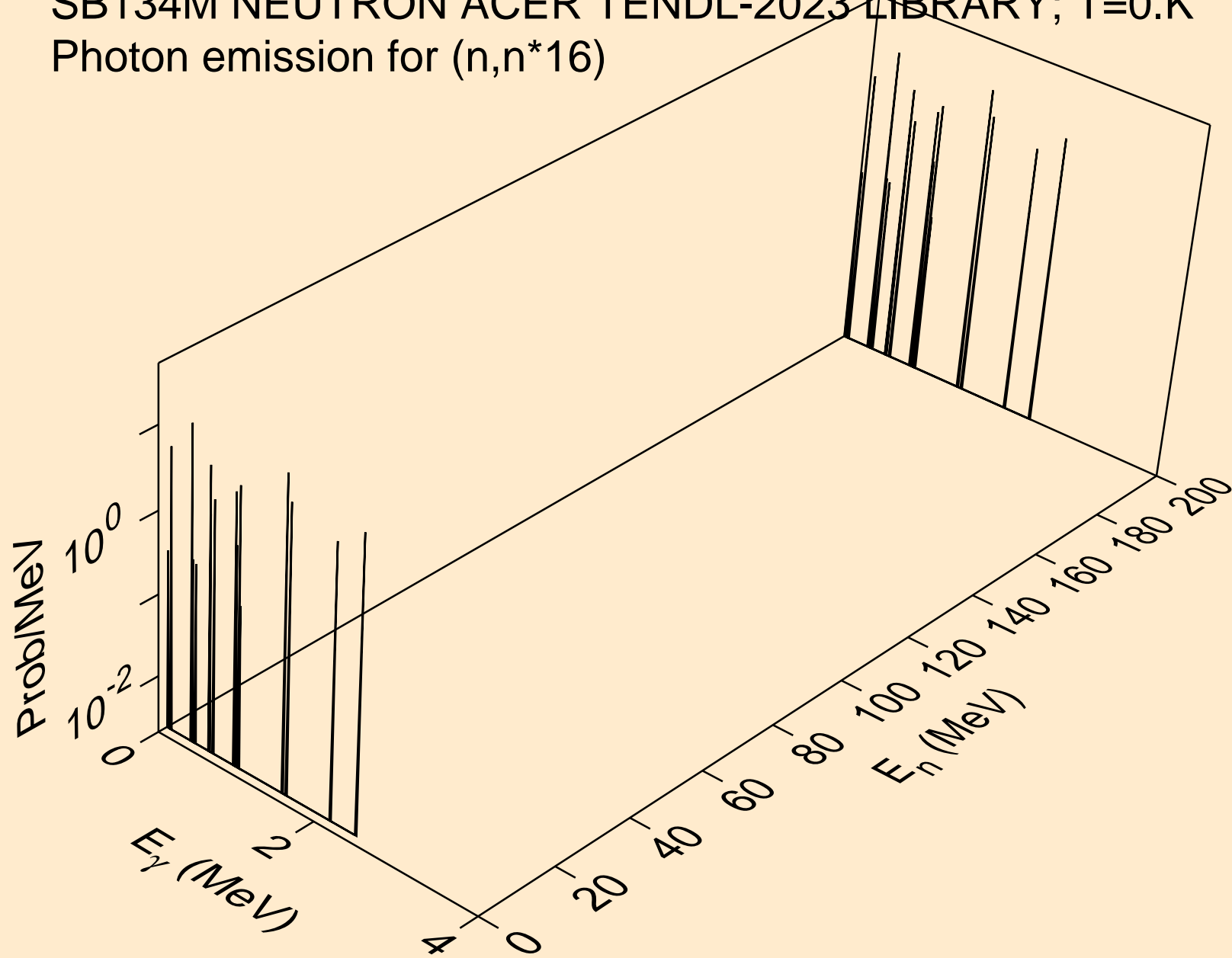

SB134M NEUTRON ACER TENDL-2023 LIBRARY; T=0.K  
Photon emission for (n,n\*17)

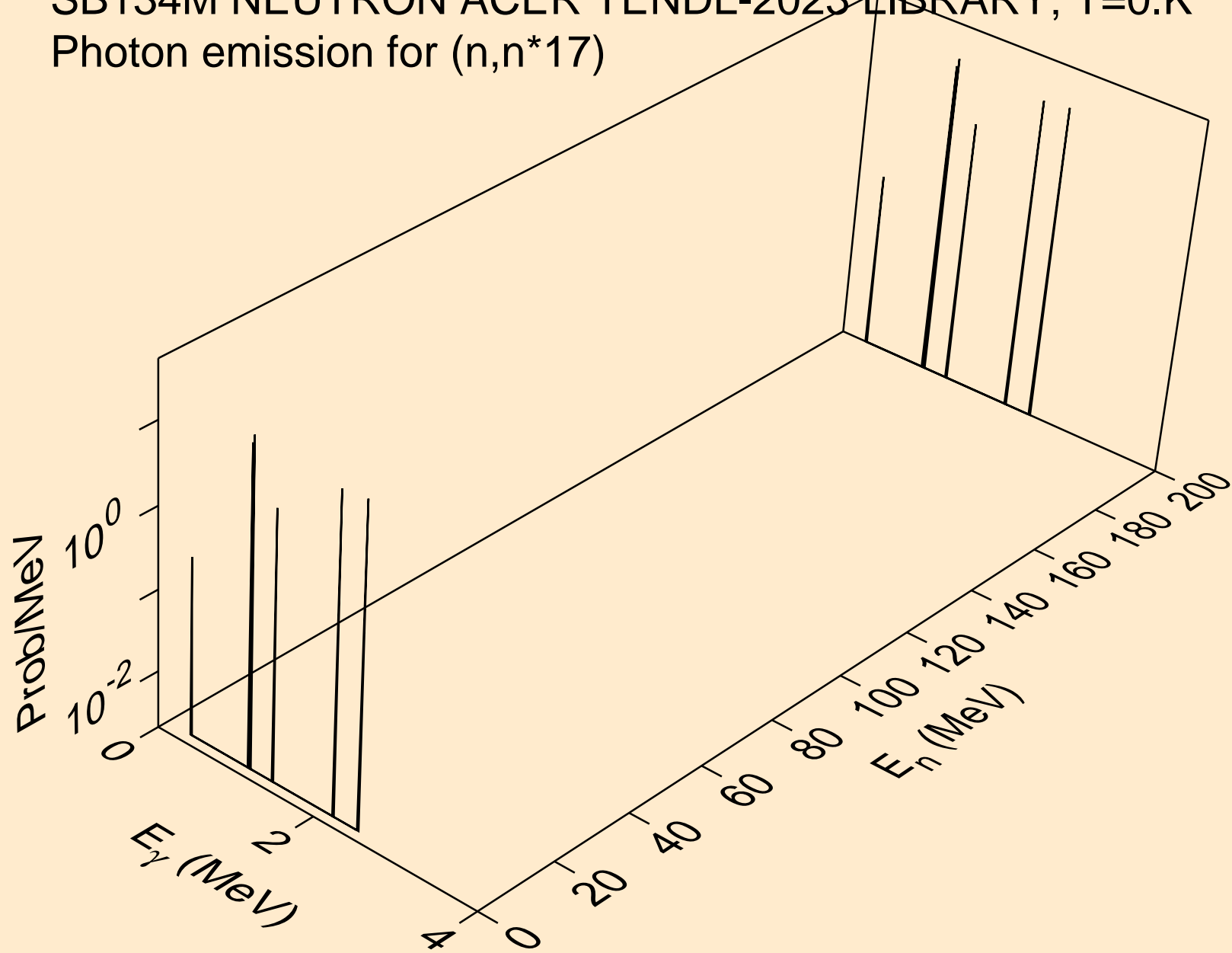

SB134M NEUTRON ACER TENDL-2023 LIBRARY; T=0.K  
Photon emission for (n,n\*18)

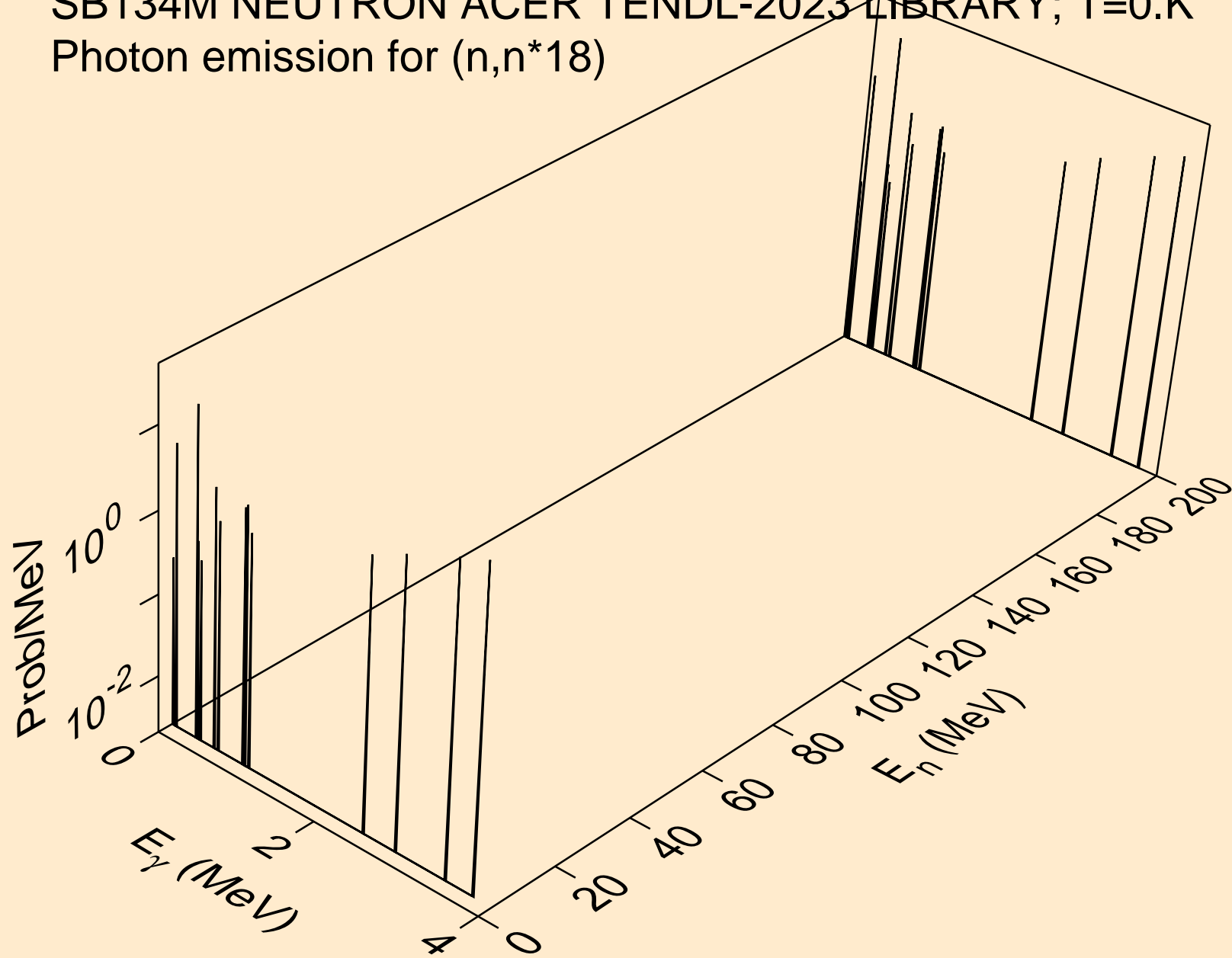



SB134M NEUTRON ACER TENDL-2023 LIBRARY; T=0.K  
Photon emission for (n,n\*19)

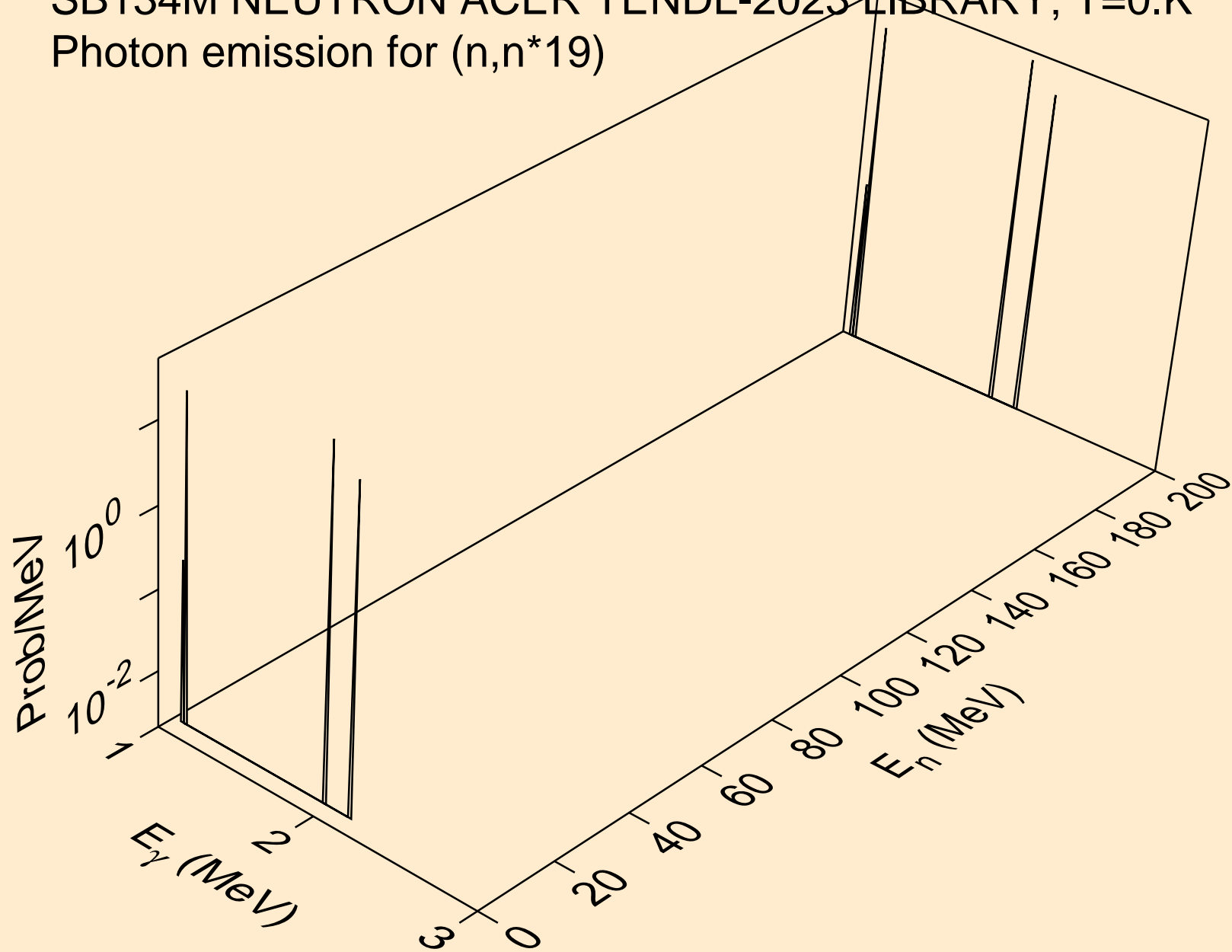

SB134M NEUTRON ACER TENDL-2023 LIBRARY; T=0.K  
Photon emission for (n,n\*20)

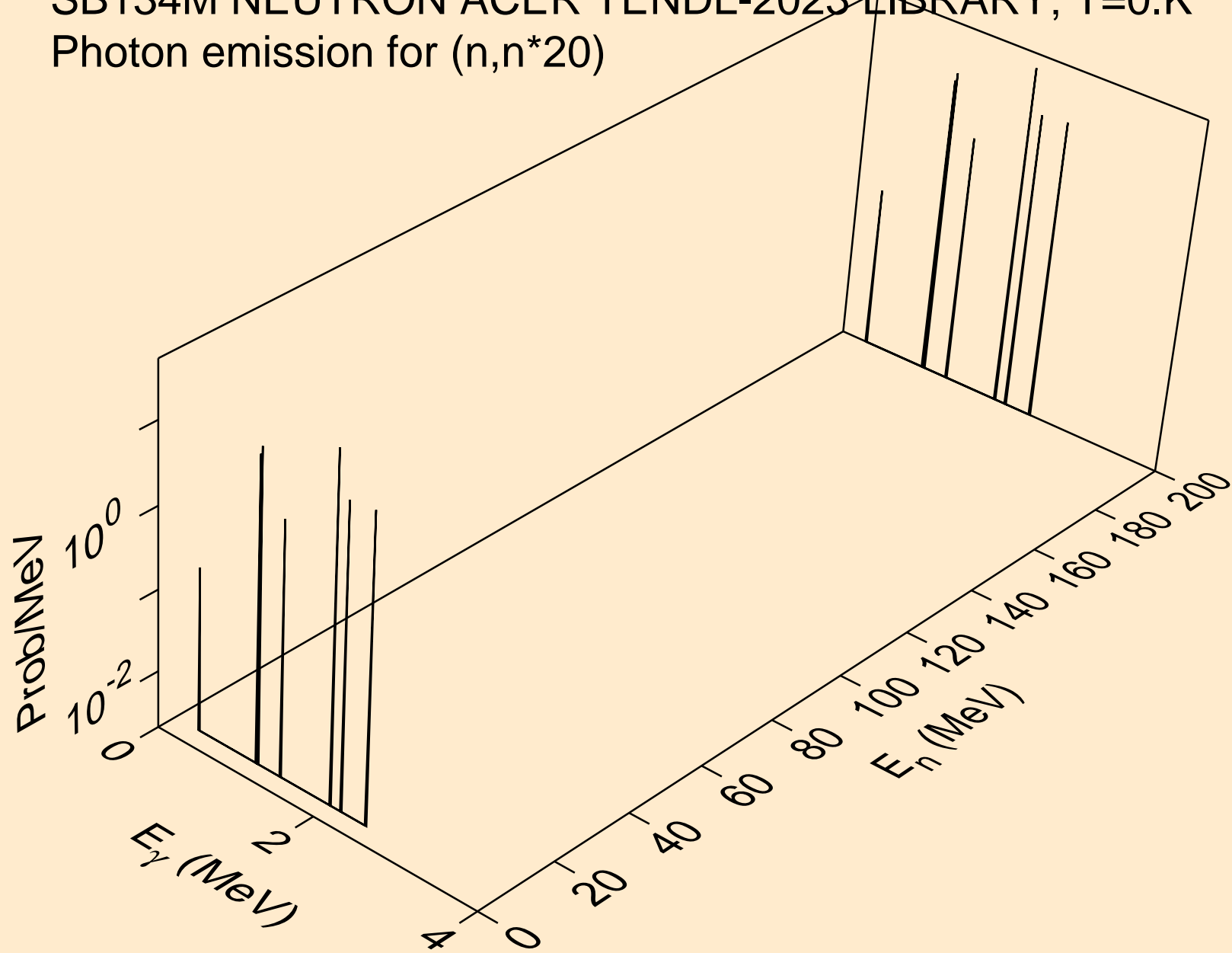

SB134M NEUTRON ACER TENDL-2023 LIBRARY; T=0.K  
Photon emission for (n,n\*21)

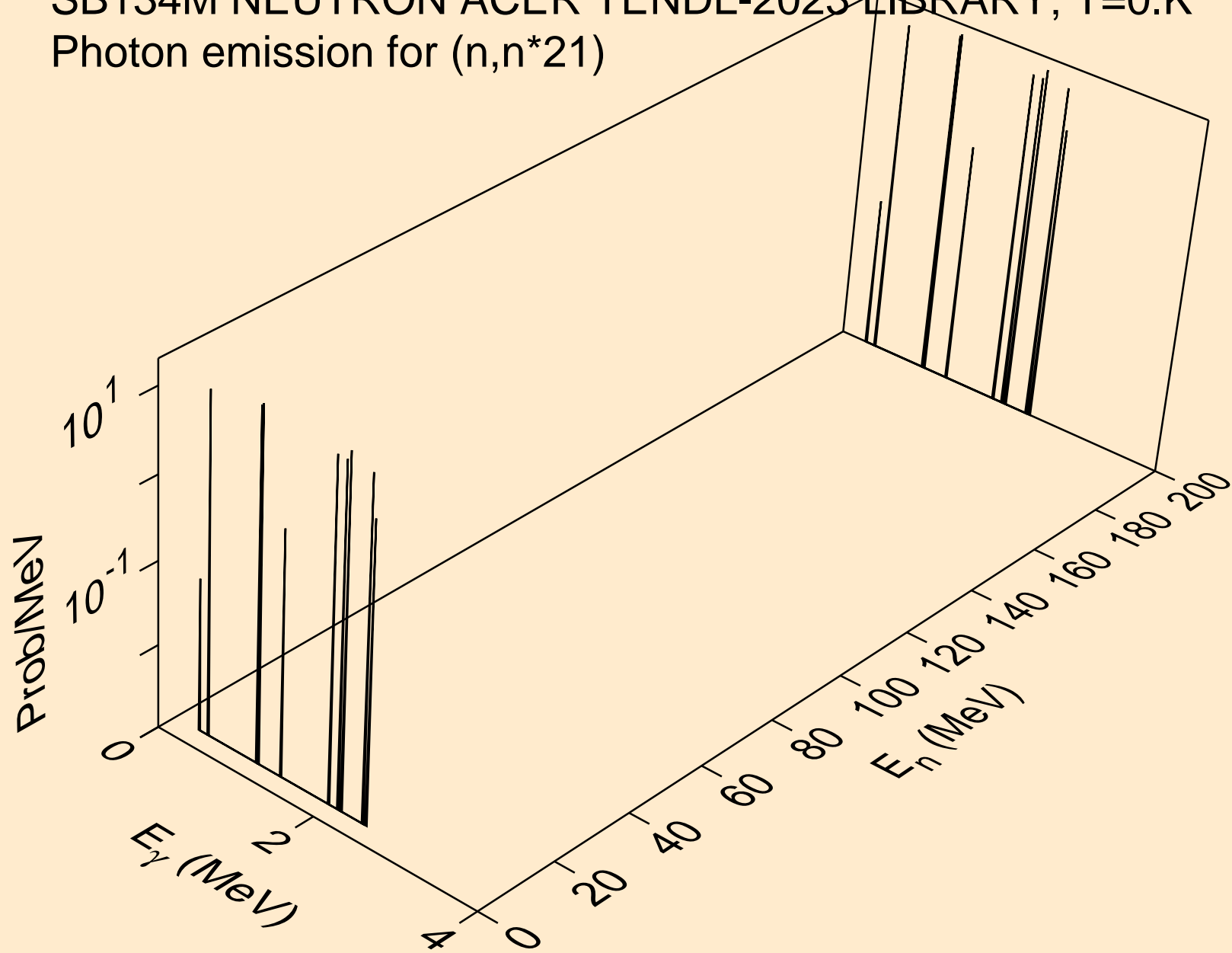

SB134M NEUTRON ACER TENDL-2023 LIBRARY; T=0.K  
Photon emission for (n,n\*22)

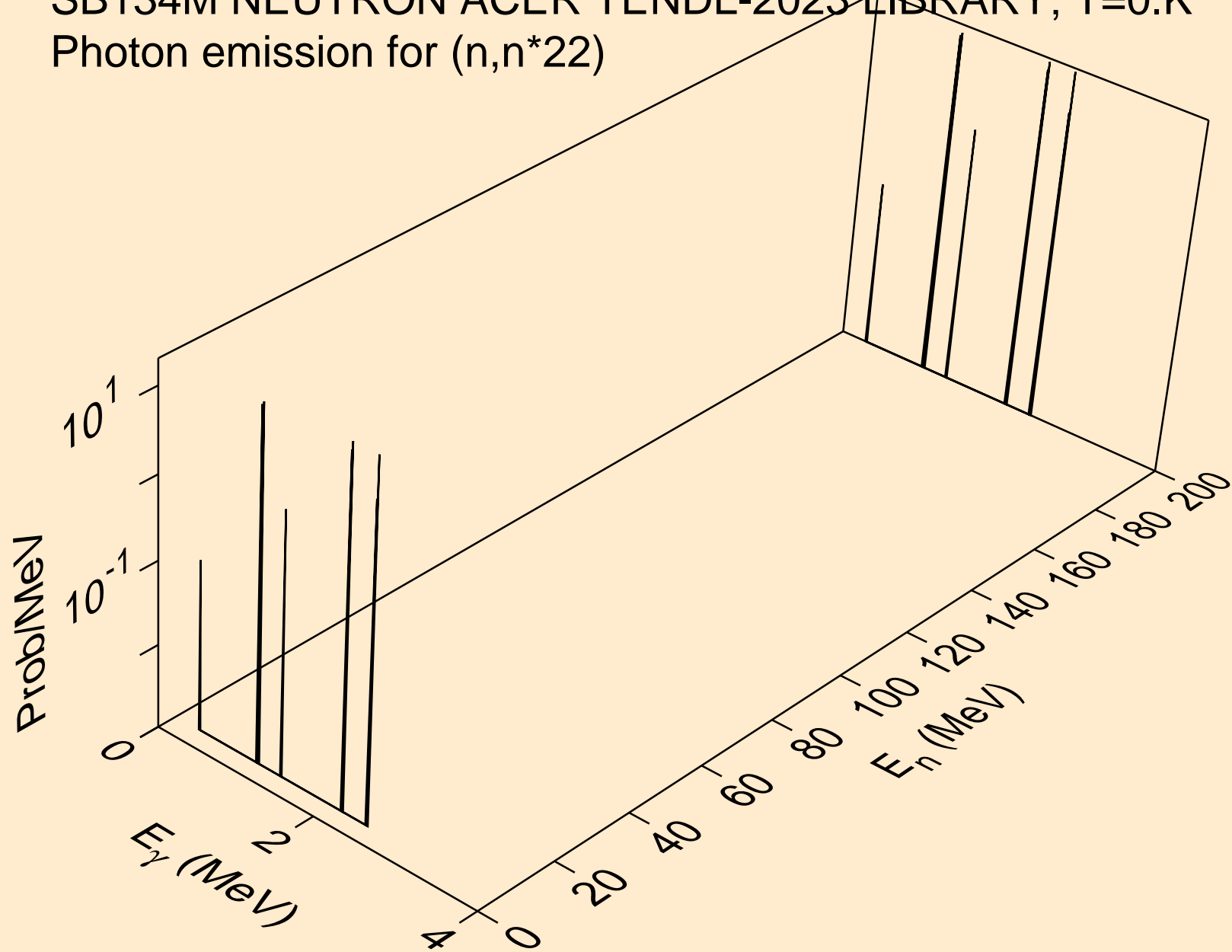

SB134M NEUTRON ACER TENDL-2023 LIBRARY; T=0.K  
Photon emission for (n,n\*23)

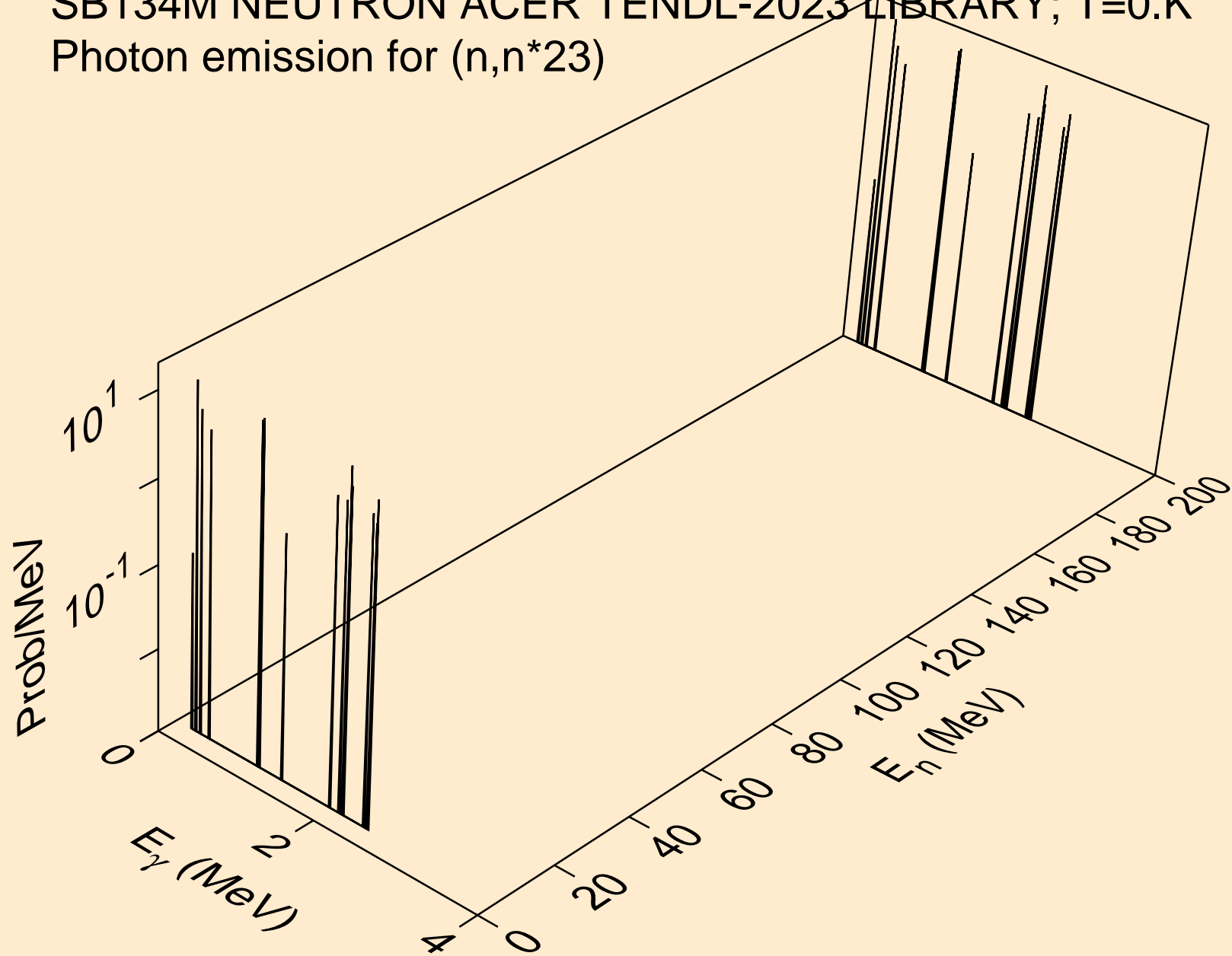

SB134M NEUTRON ACER TENDL-2023 LIBRARY; T=0.K  
Photon emission for (n,n\*24)

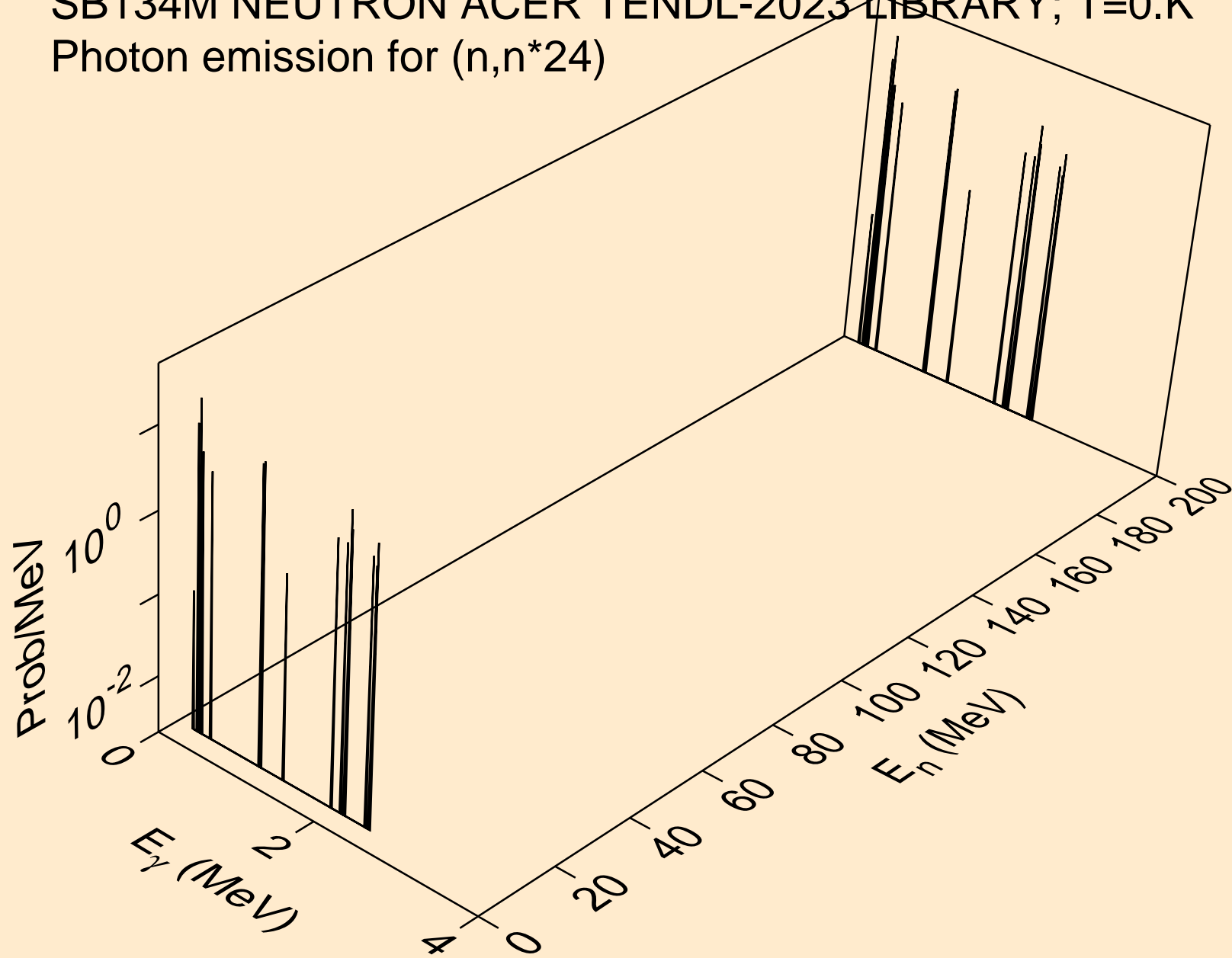

SB134M NEUTRON ACER TENDL-2023 LIBRARY; T=0.K  
Photon emission for (n,n\*25)

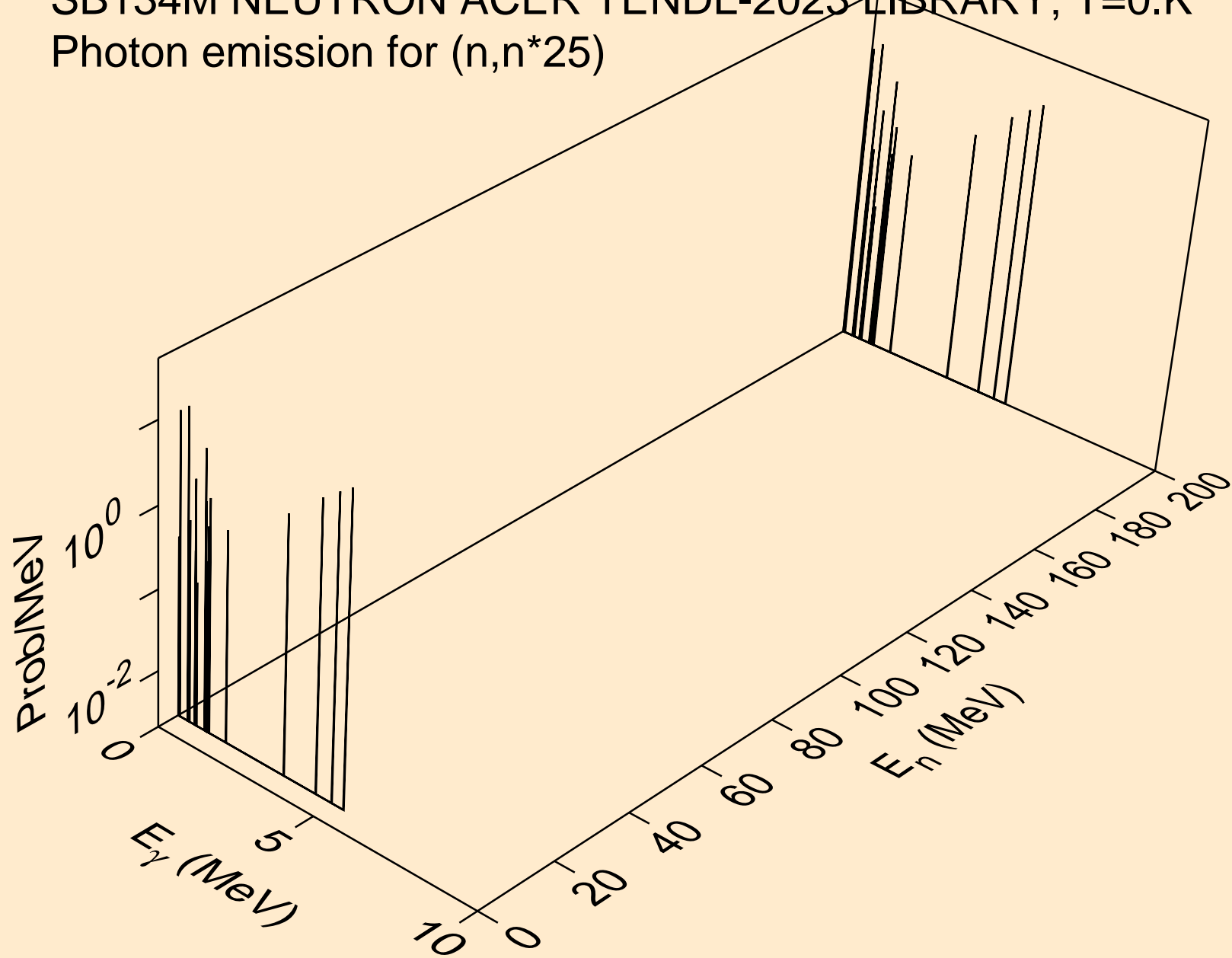

SB134M NEUTRON ACER TENDL-2023 LIBRARY; T=0.K  
Photon emission for (n,n\*26)

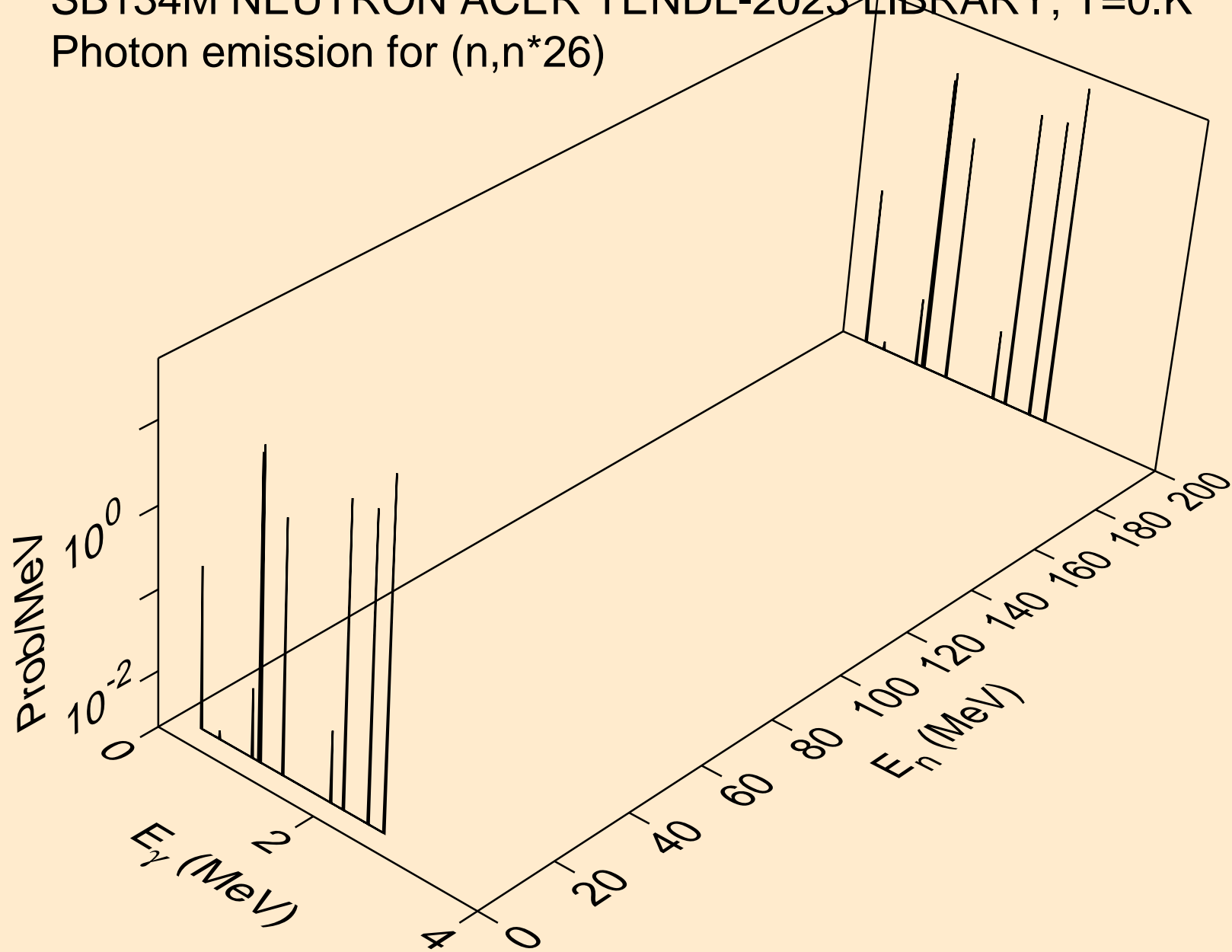



SB134M NEUTRON ACER TENDL-2023 LIBRARY; T=0.K  
Photon emission for (n,n\*27)

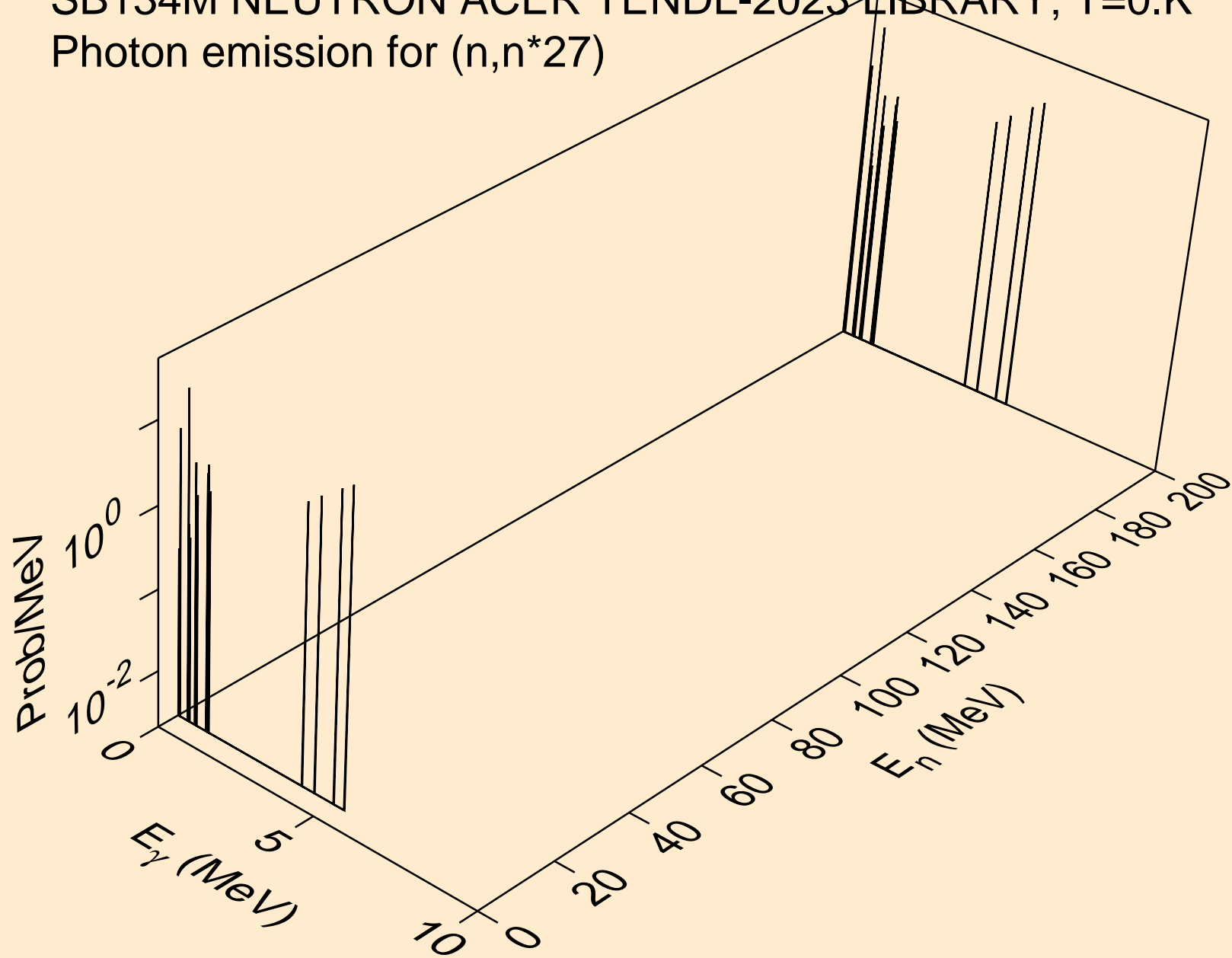

SB134M NEUTRON ACER TENDL-2023 LIBRARY; T=0.K  
Photon emission for (n,n\*28)

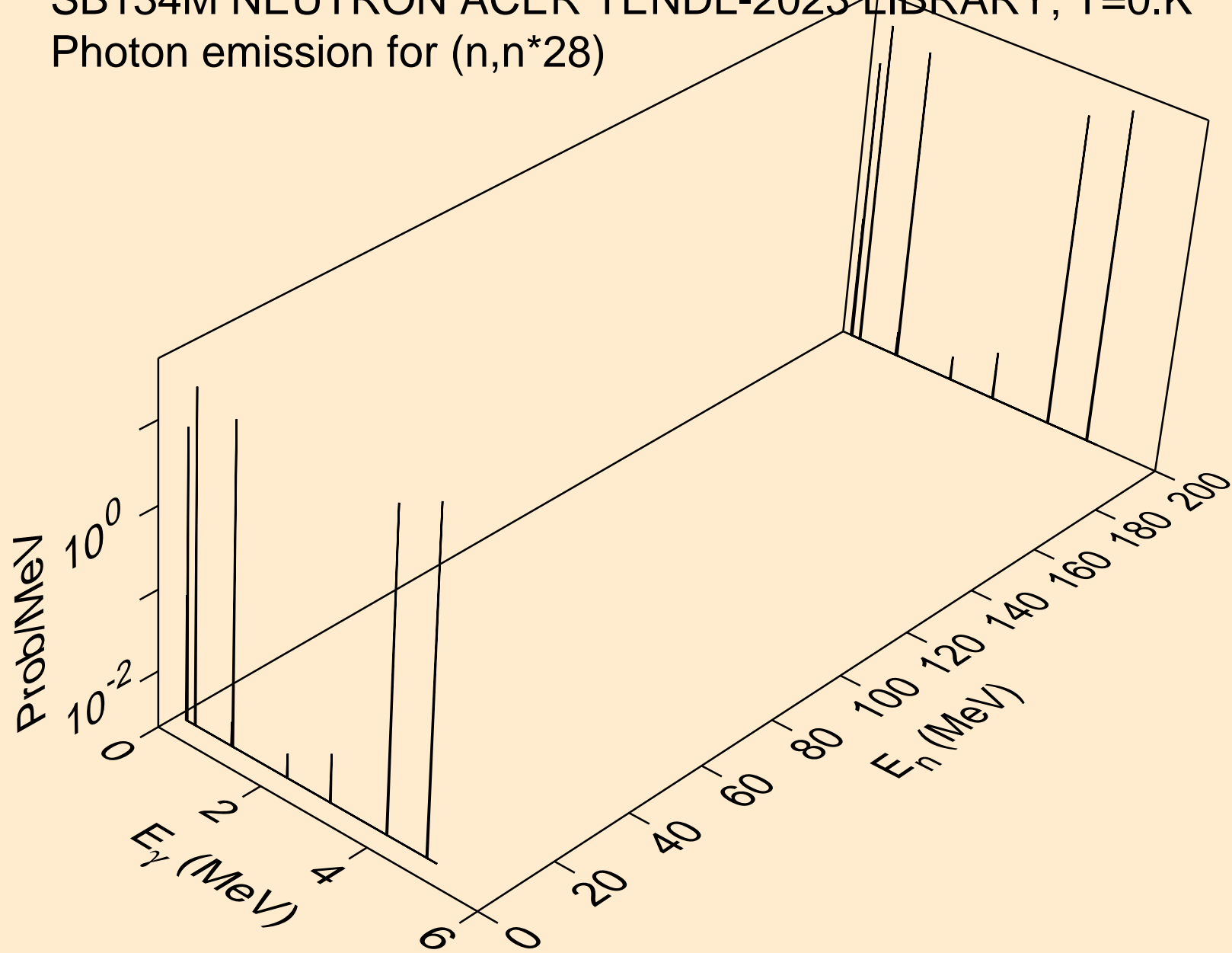

SB134M NEUTRON ACER TENDL-2023 LIBRARY; T=0.K  
Photon emission for (n,n\*29)

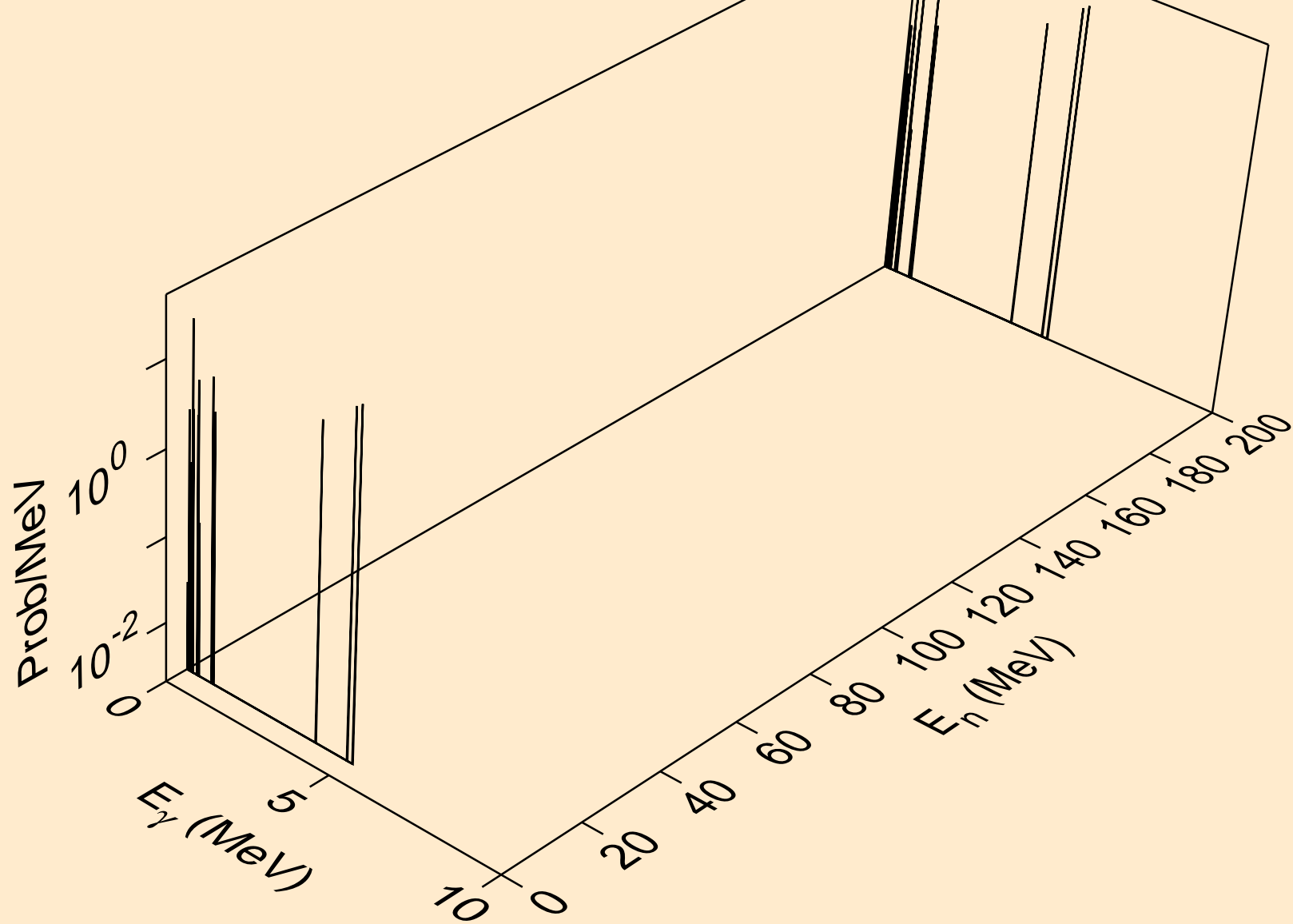

SB134M NEUTRON ACER TENDL-2023 LIBRARY; T=0.K  
Photon emission for (n,n\*30)

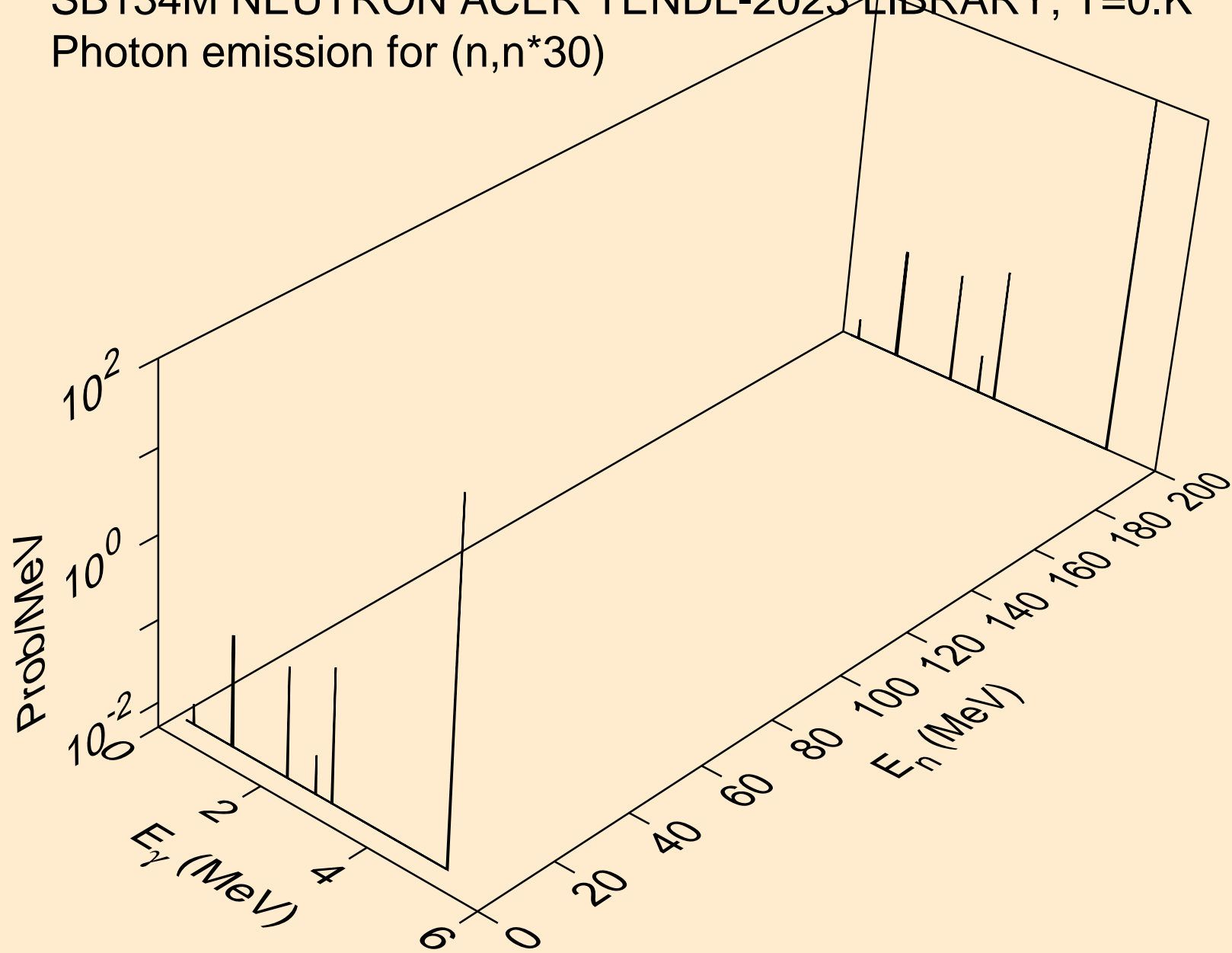

SB134M NEUTRON ACER TENDL-2023 LIBRARY; T=0.K  
Photon emission for (n,n\*c)

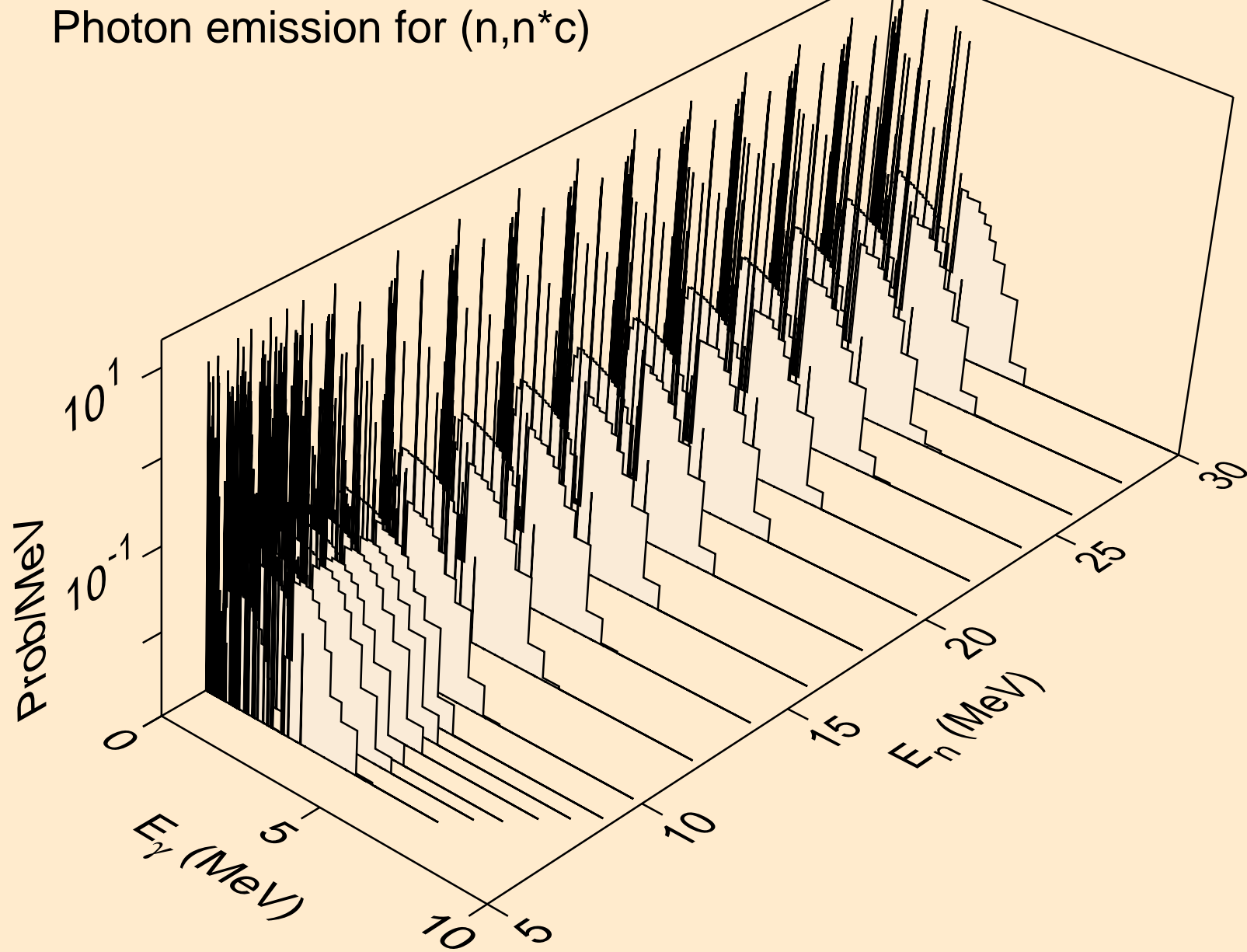

SB134M NEUTRON ACER TENDL-2023 LIBRARY; T=0.K  
Photon emission for (n,gma)

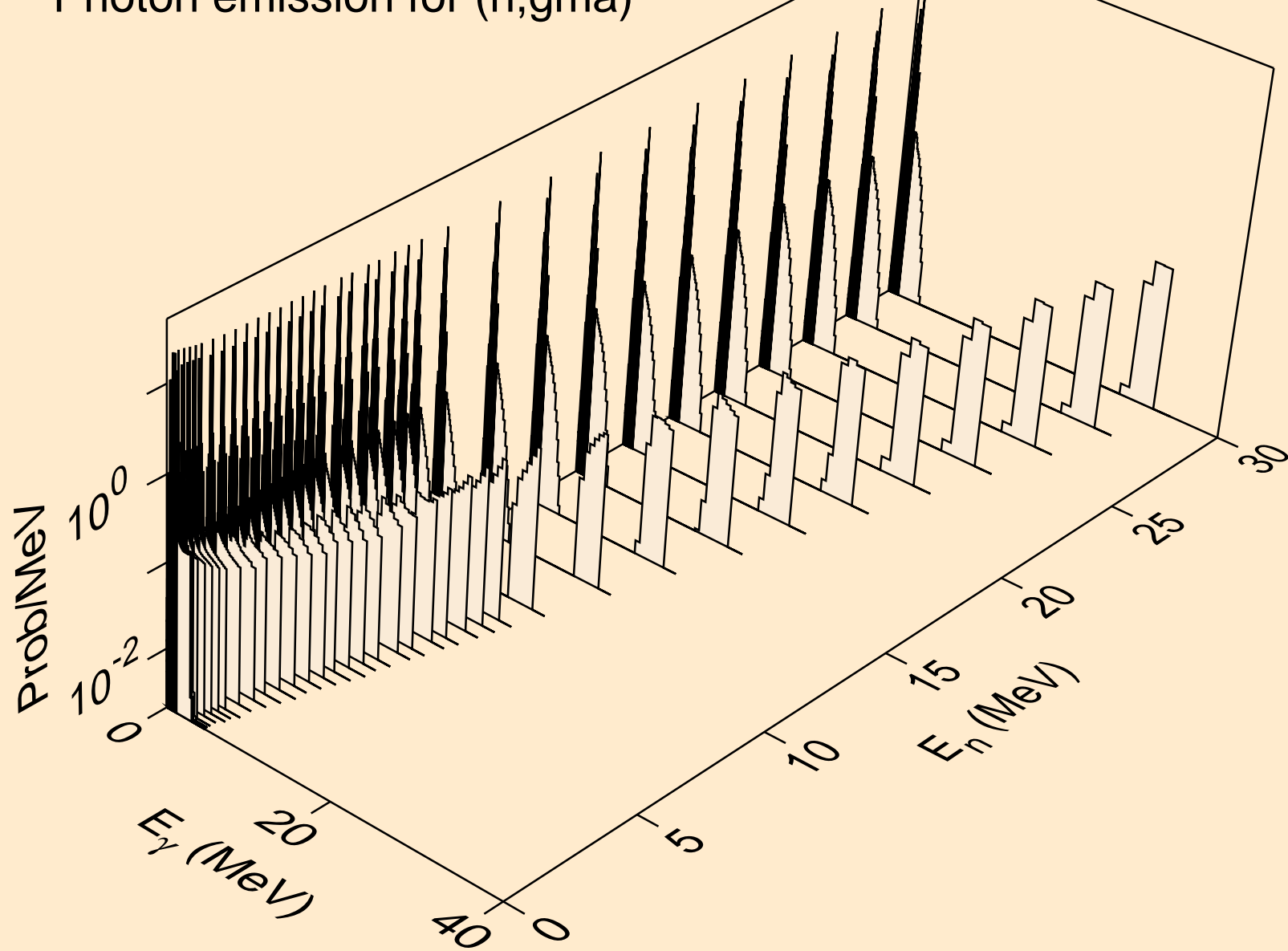

SB134M NEUTRON ACER TENDL-2023 LIBRARY; T=0.K  
Photon emission for (n,p)

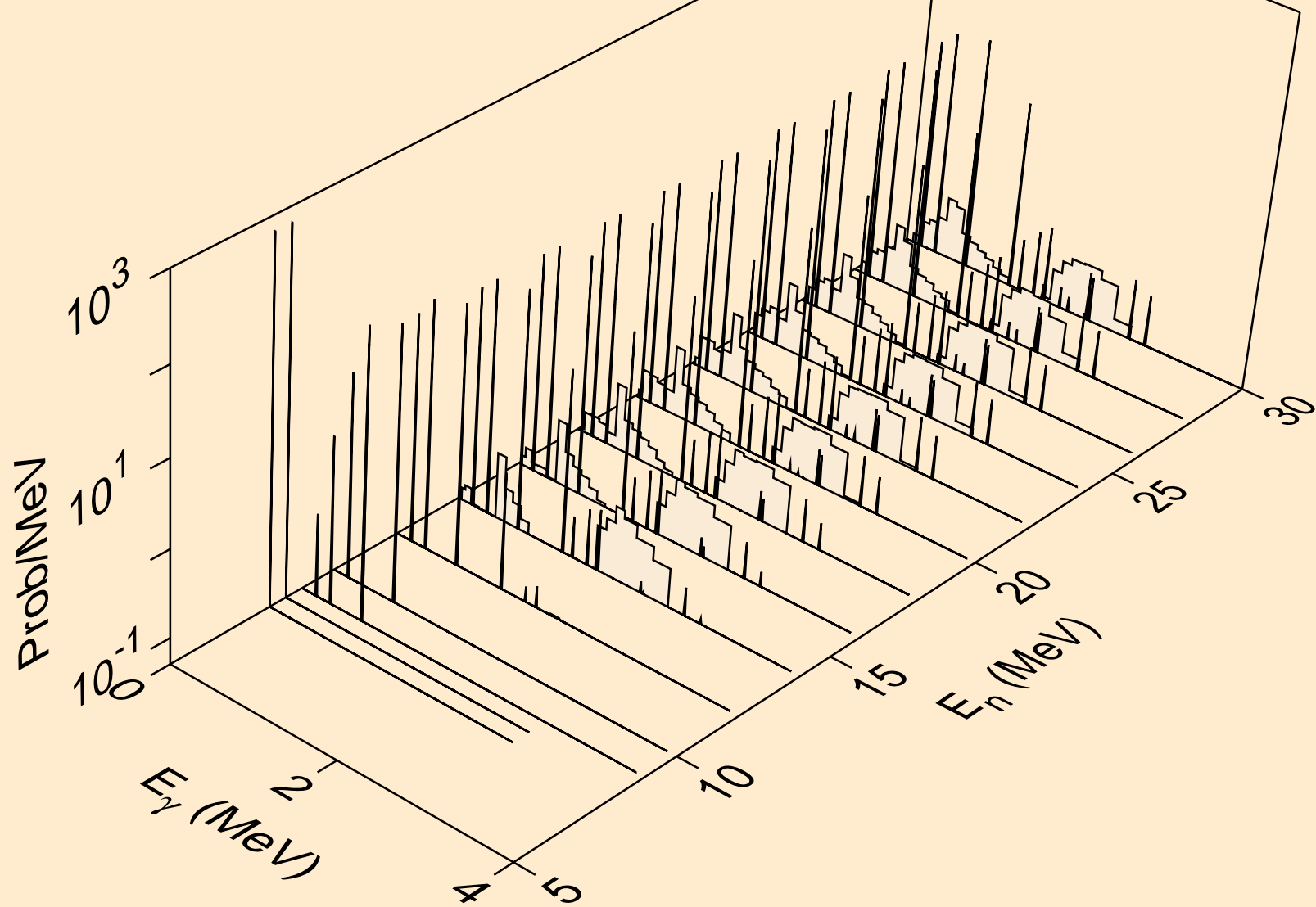

SB134M NEUTRON ACER TENDL-2023 LIBRARY; T=0.K  
Photon emission for (n,d)

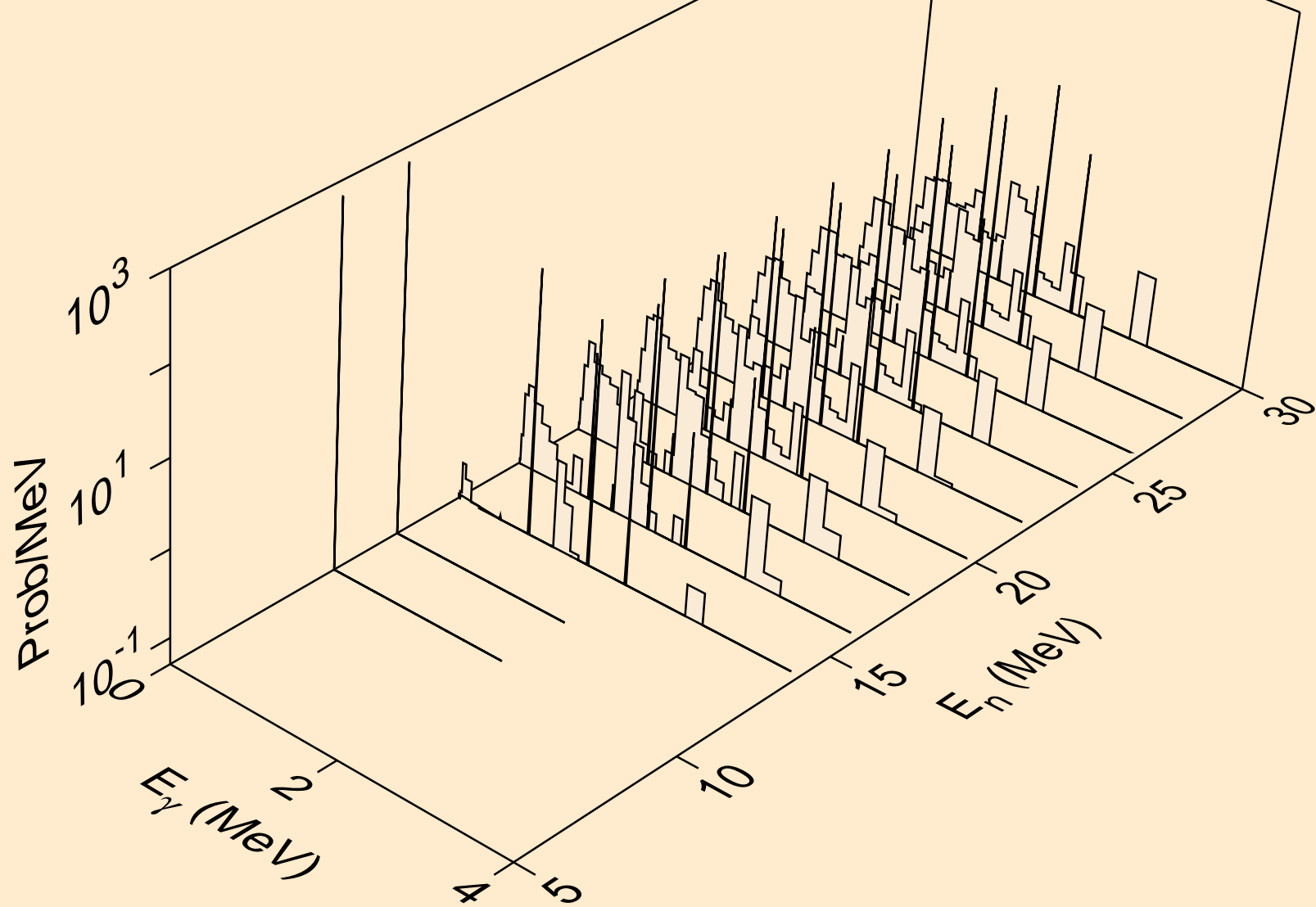



SB134M NEUTRON ACER TENDL-2023 LIBRARY; T=0.K  
Photon emission for (n,t)

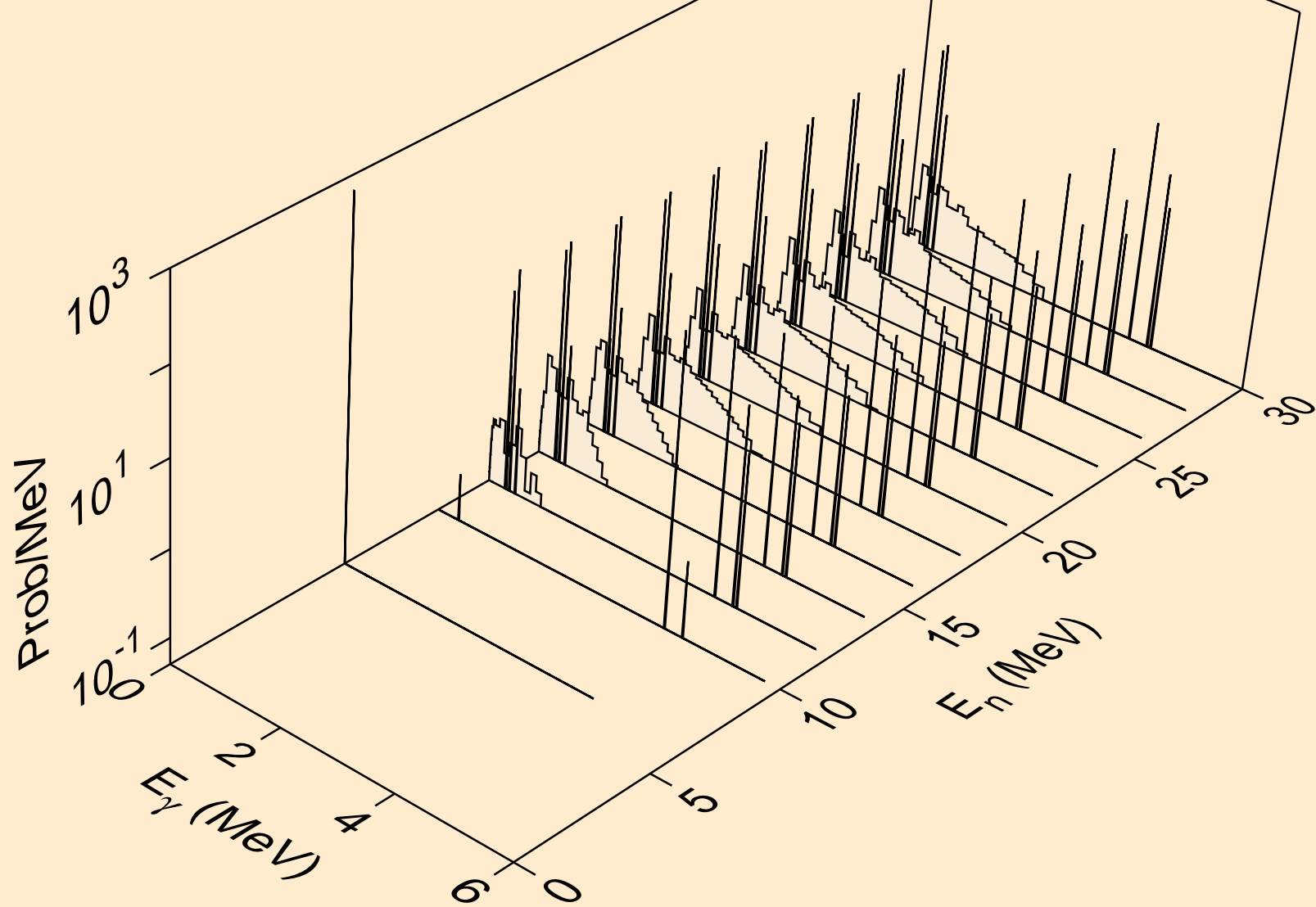

SB134M NEUTRON ACER TENDL-2023 LIBRARY; T=0.K  
Photon emission for (n,he3)

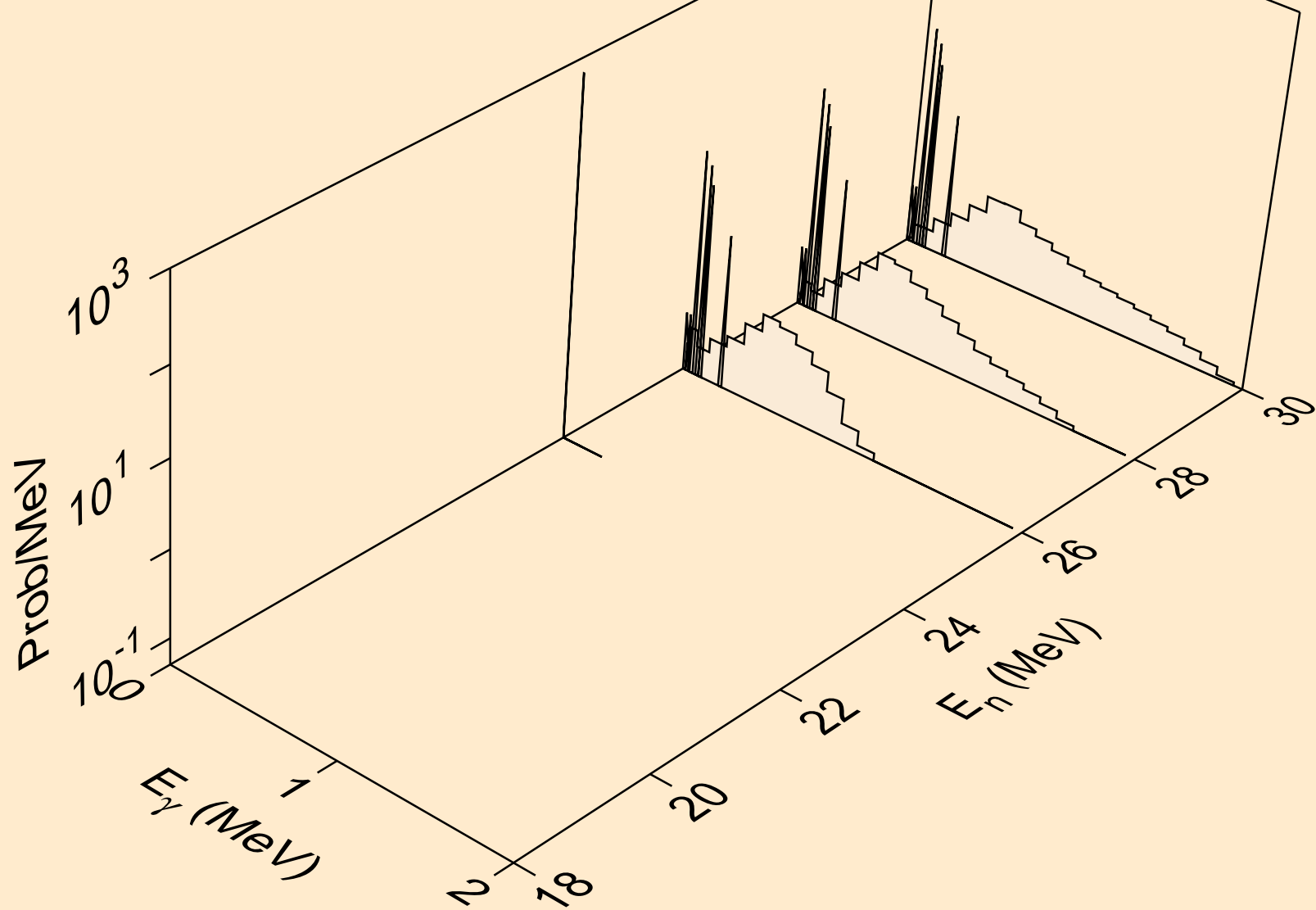

SB134M NEUTRON ACER TENDL-2023 LIBRARY; T=0.K  
Photon emission for (n,a)

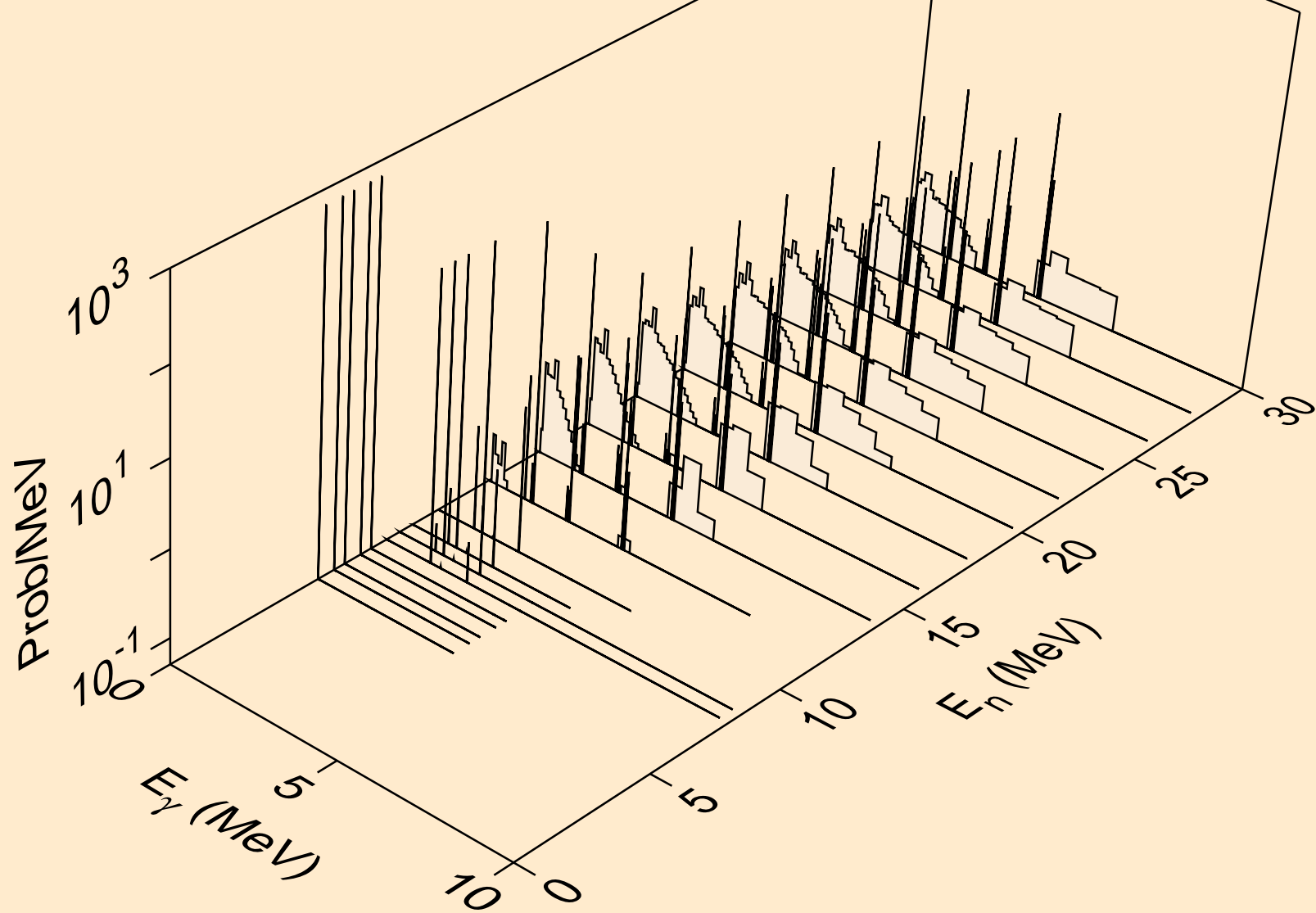

SB134M NEUTRON ACER TENDL-2023 LIBRARY; T=0.K  
thermal capture photon spectrum

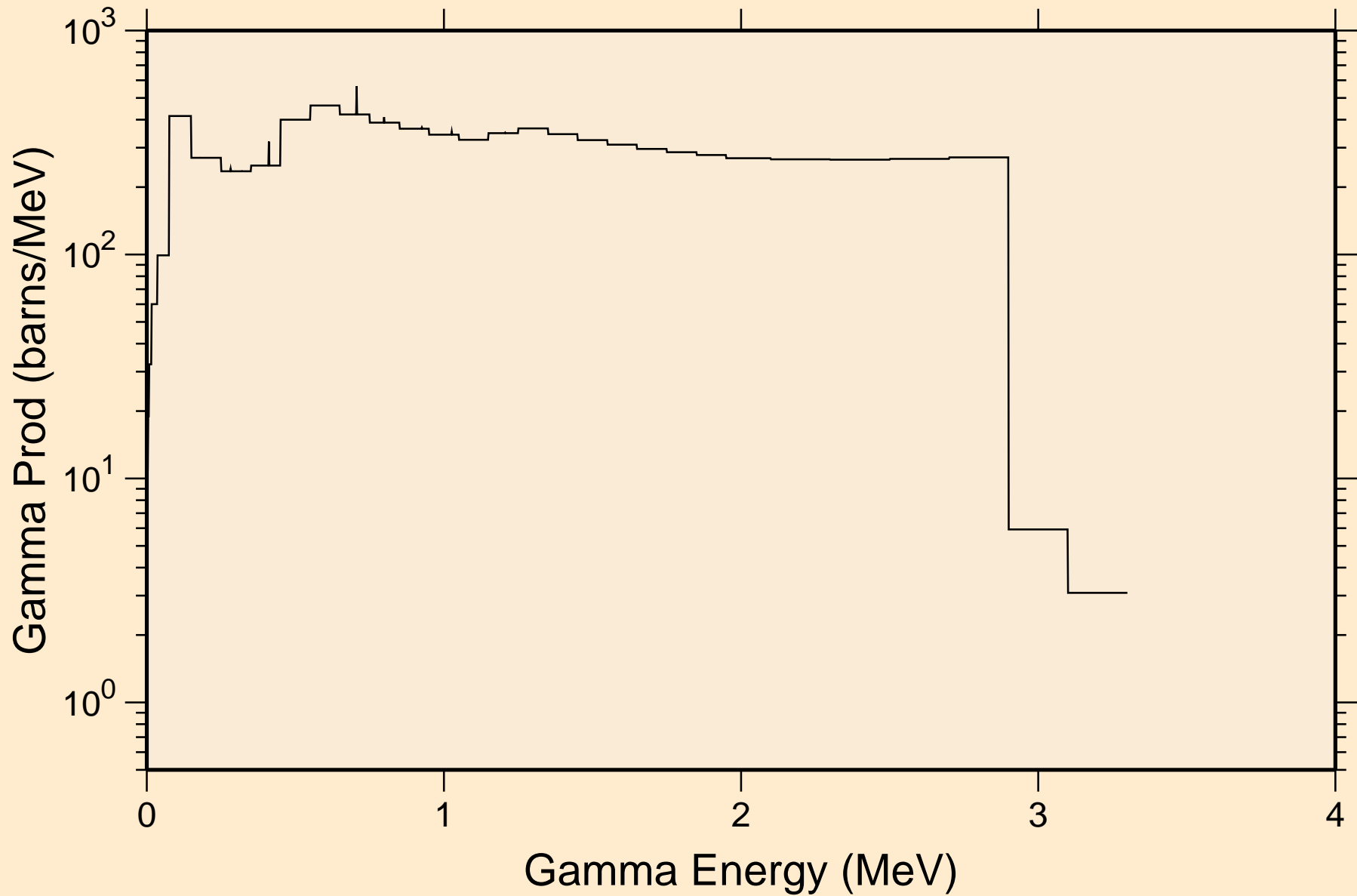

SB134M NEUTRON ACER TENDL-2023 LIBRARY; T=0.K  
14 MeV photon spectrum

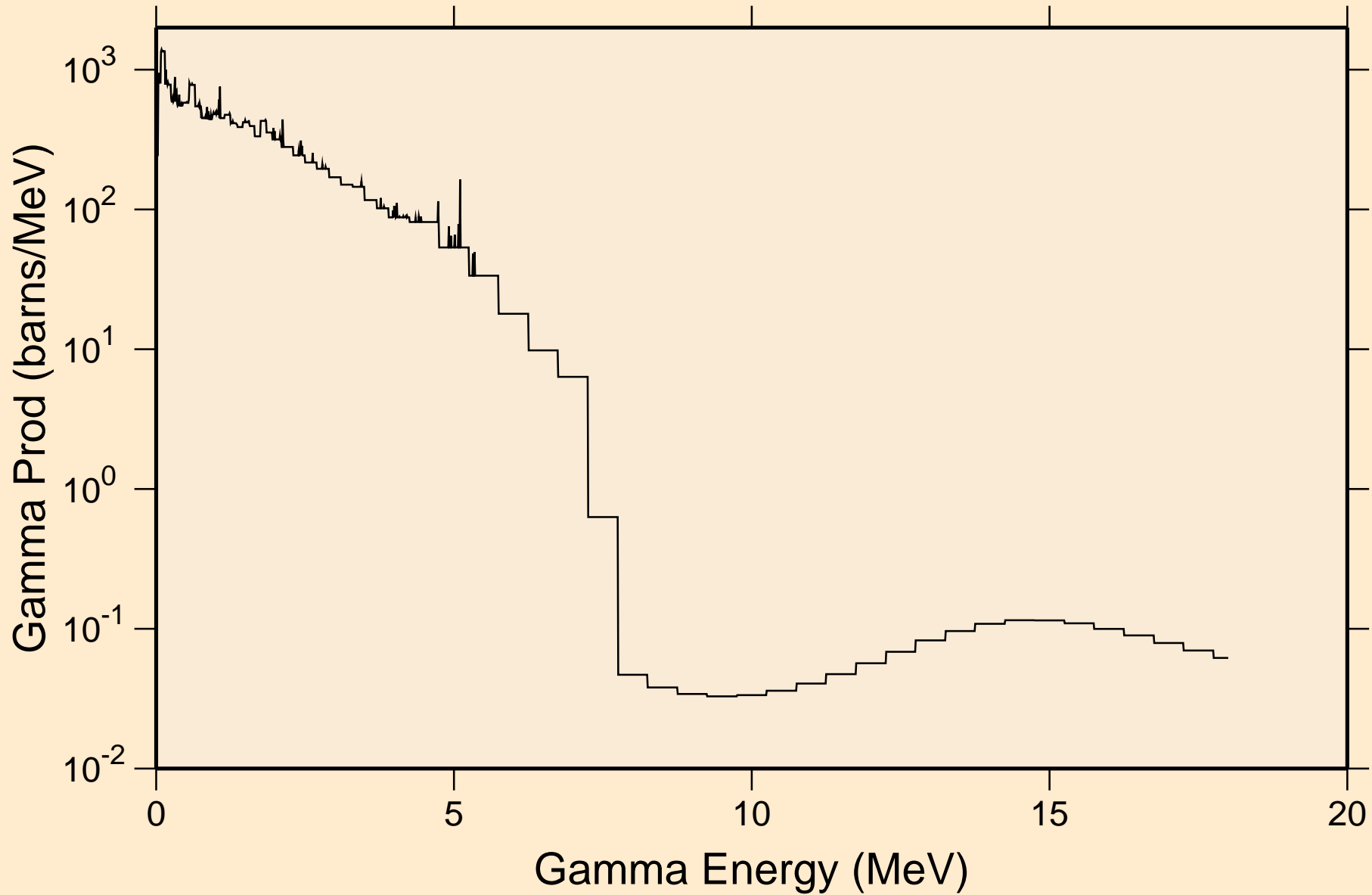

# SB134M NEUTRON ACER TENDL-2023 LIBRARY; T=0.K

## Particle heating contributions

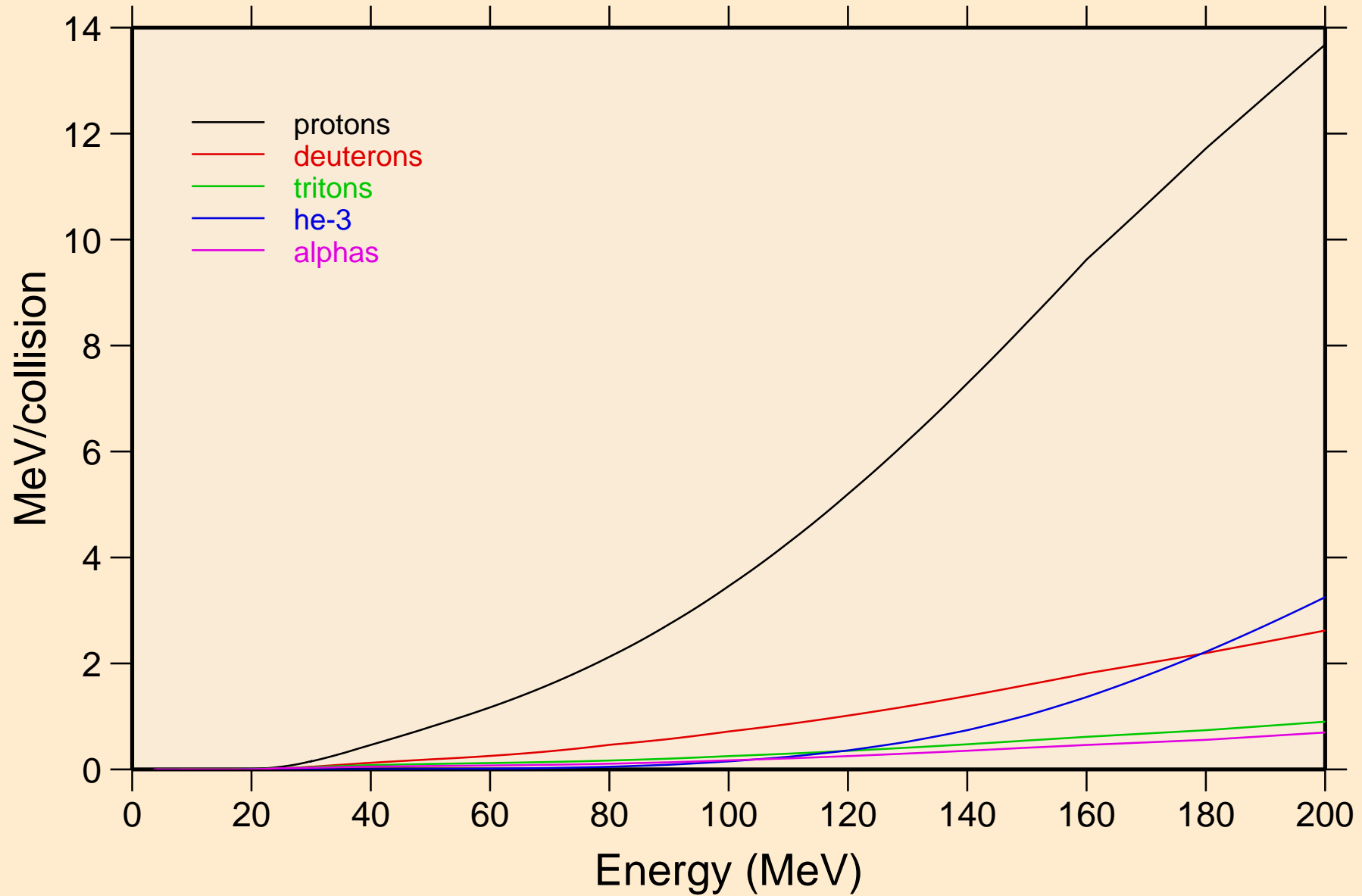

# SB134M NEUTRON ACER TENDL-2023 LIBRARY; T=0.K

## Recoil Heating

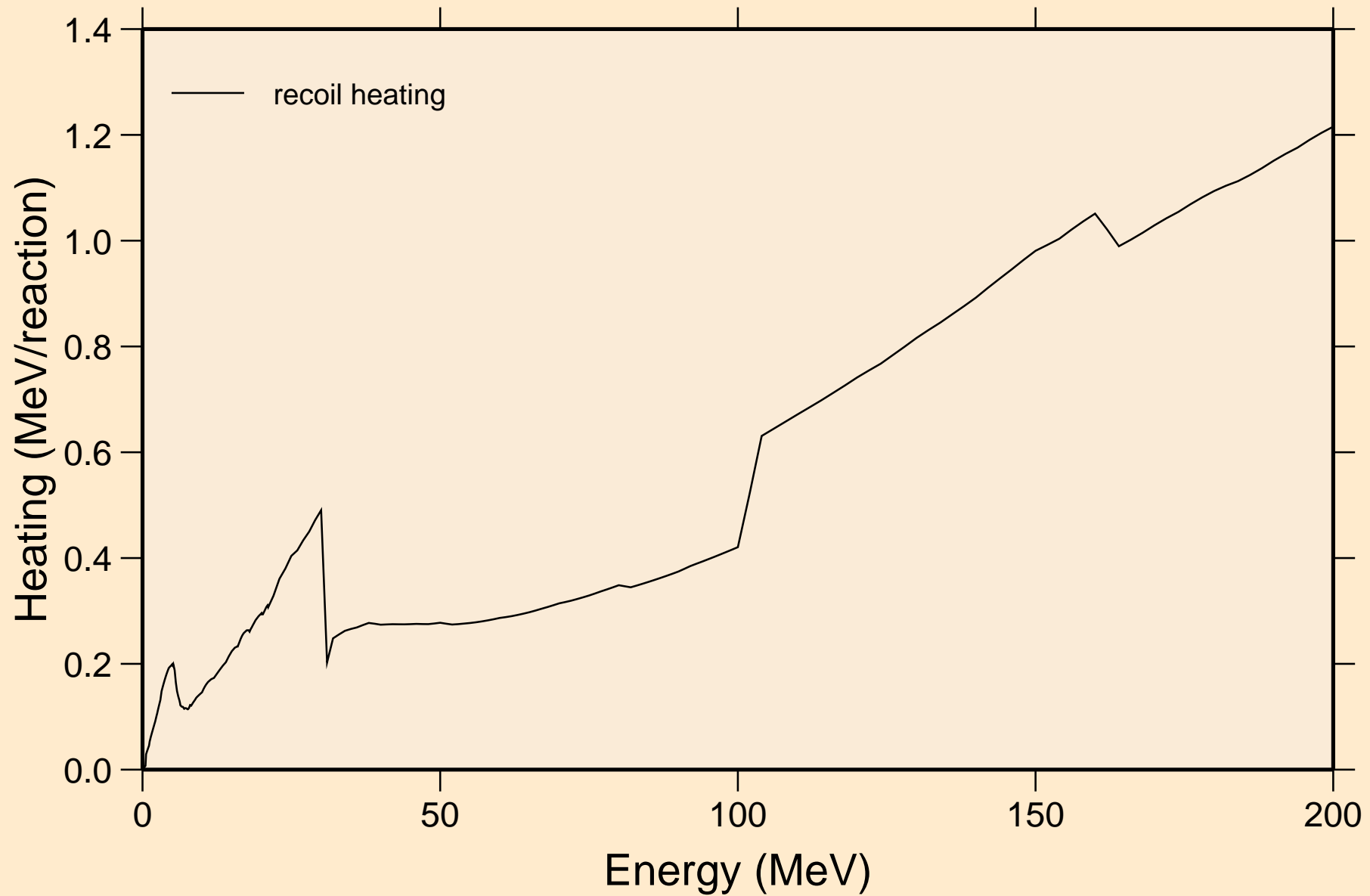

# SB134M NEUTRON ACER TENDL-2023 LIBRARY; T=0.K

## Particle production cross sections

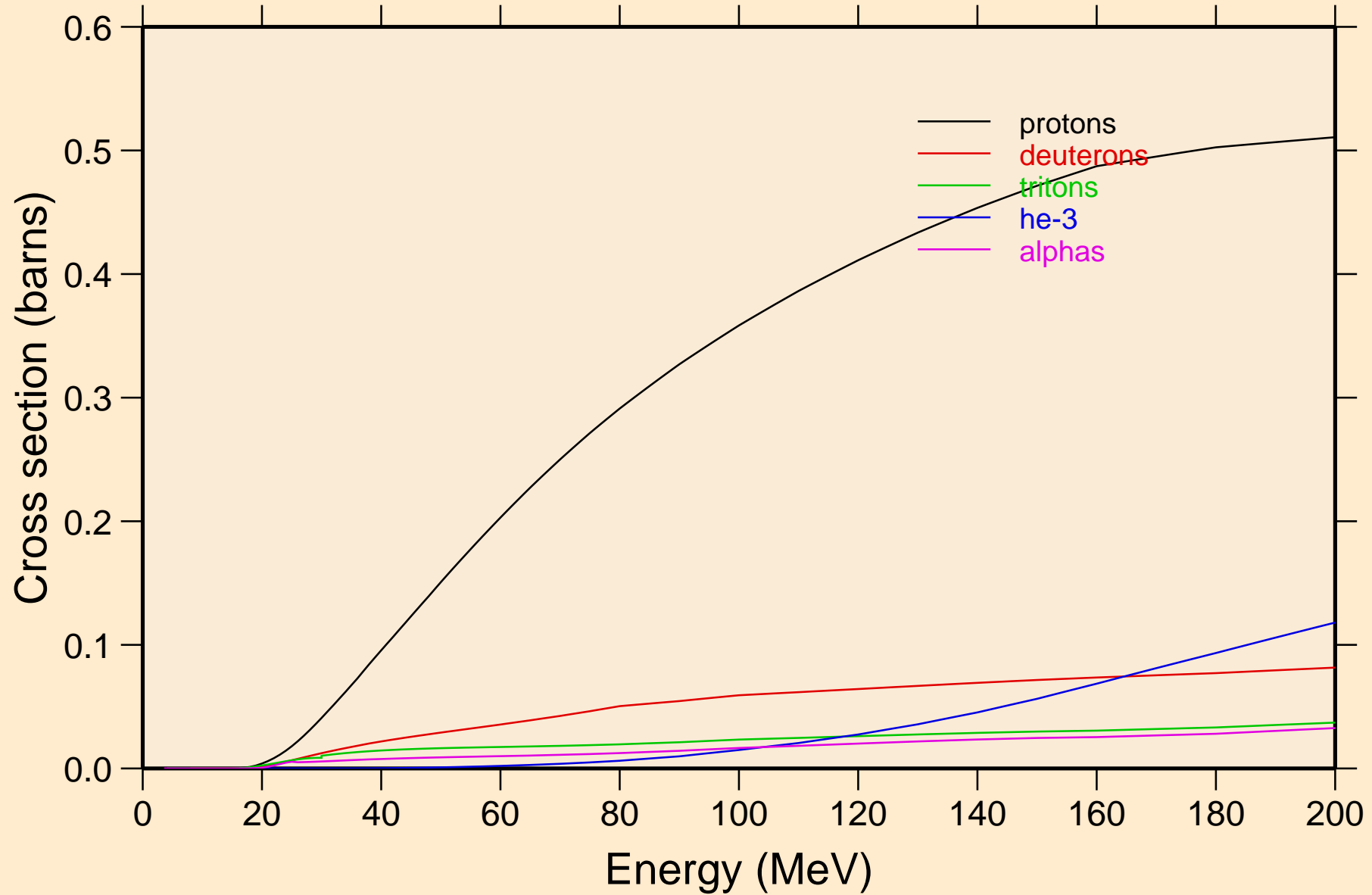



SB134M NEUTRON ACER TENDL-2023 LIBRARY; T=0.K  
protons from (n,x)

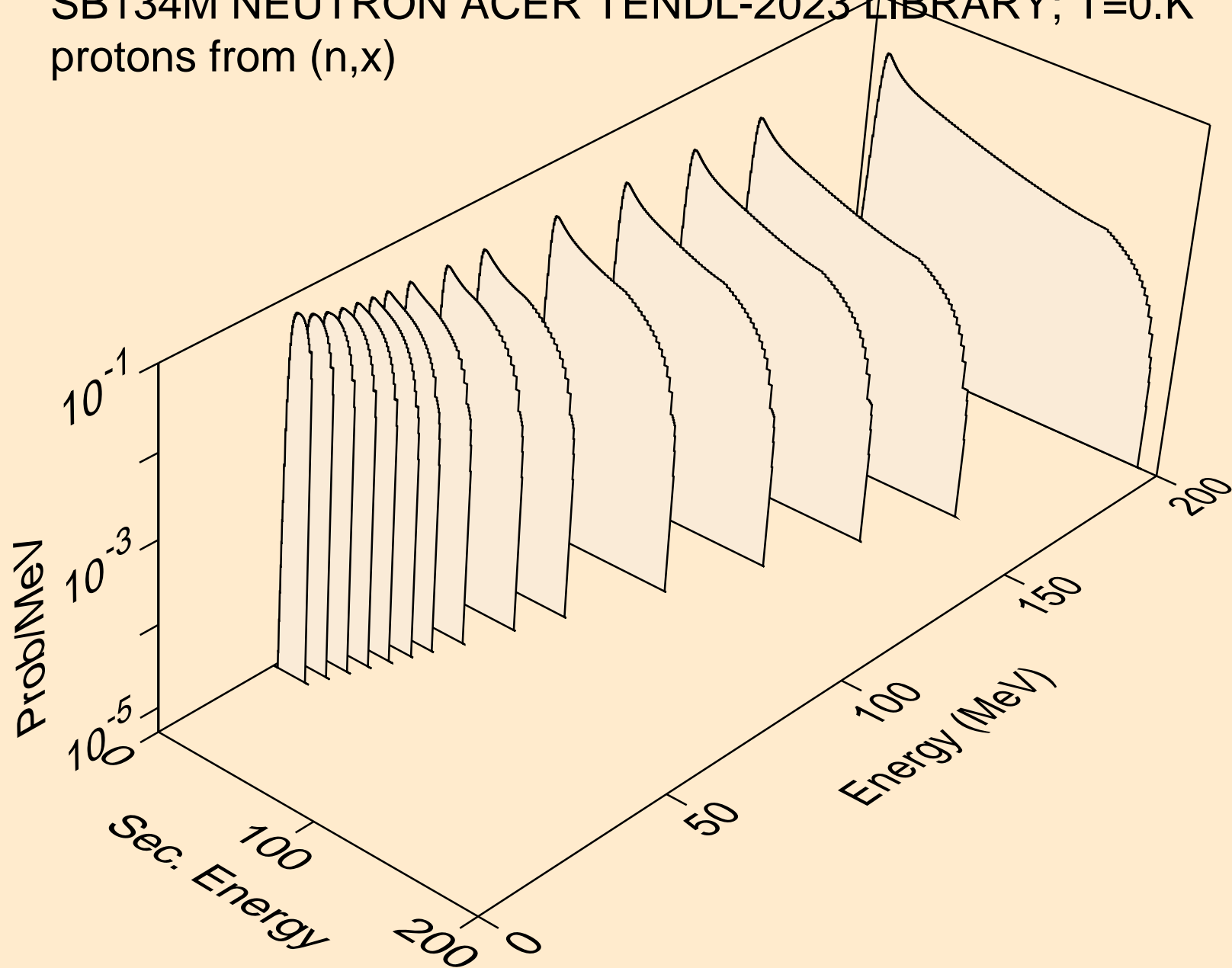

SB134M NEUTRON ACER TENDL-2023 LIBRARY; T=0.K  
protons from (n,n\*)p

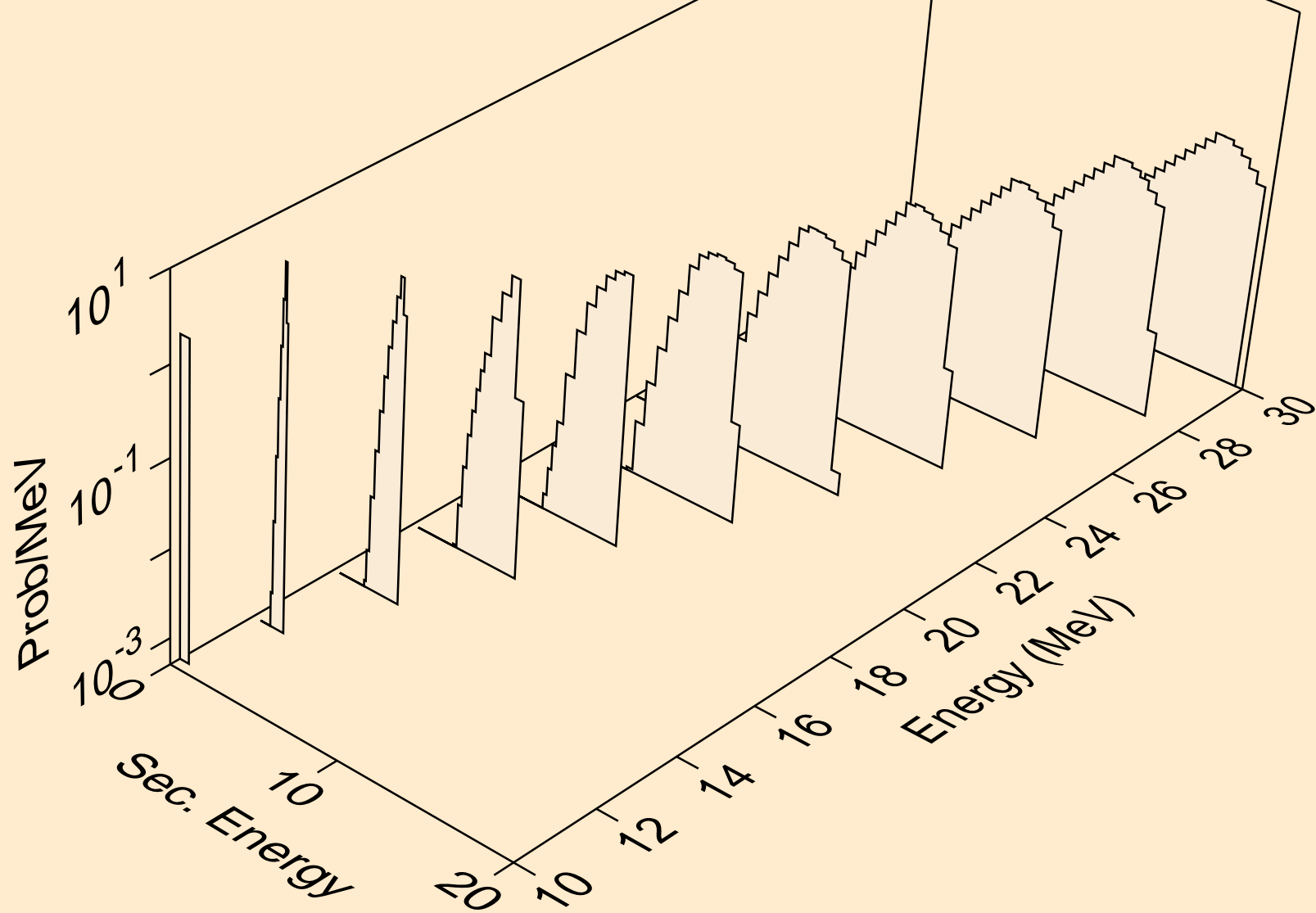

SB134M NEUTRON ACER TENDL-2023 LIBRARY; T=0.K  
protons from (n,2np)

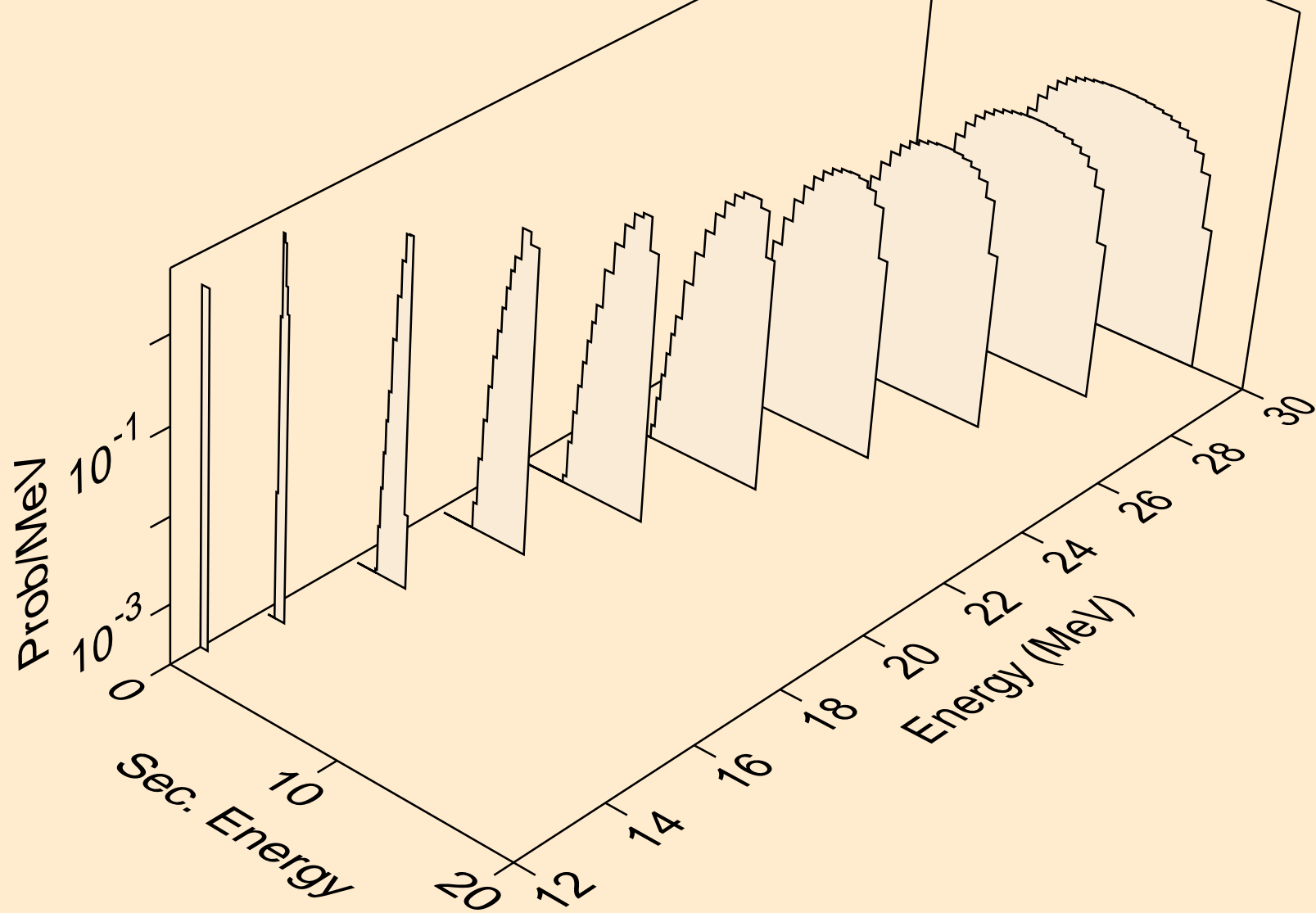

SB134M NEUTRON ACER TENDL-2023 LIBRARY; T=0.K  
protons from (n,3np)

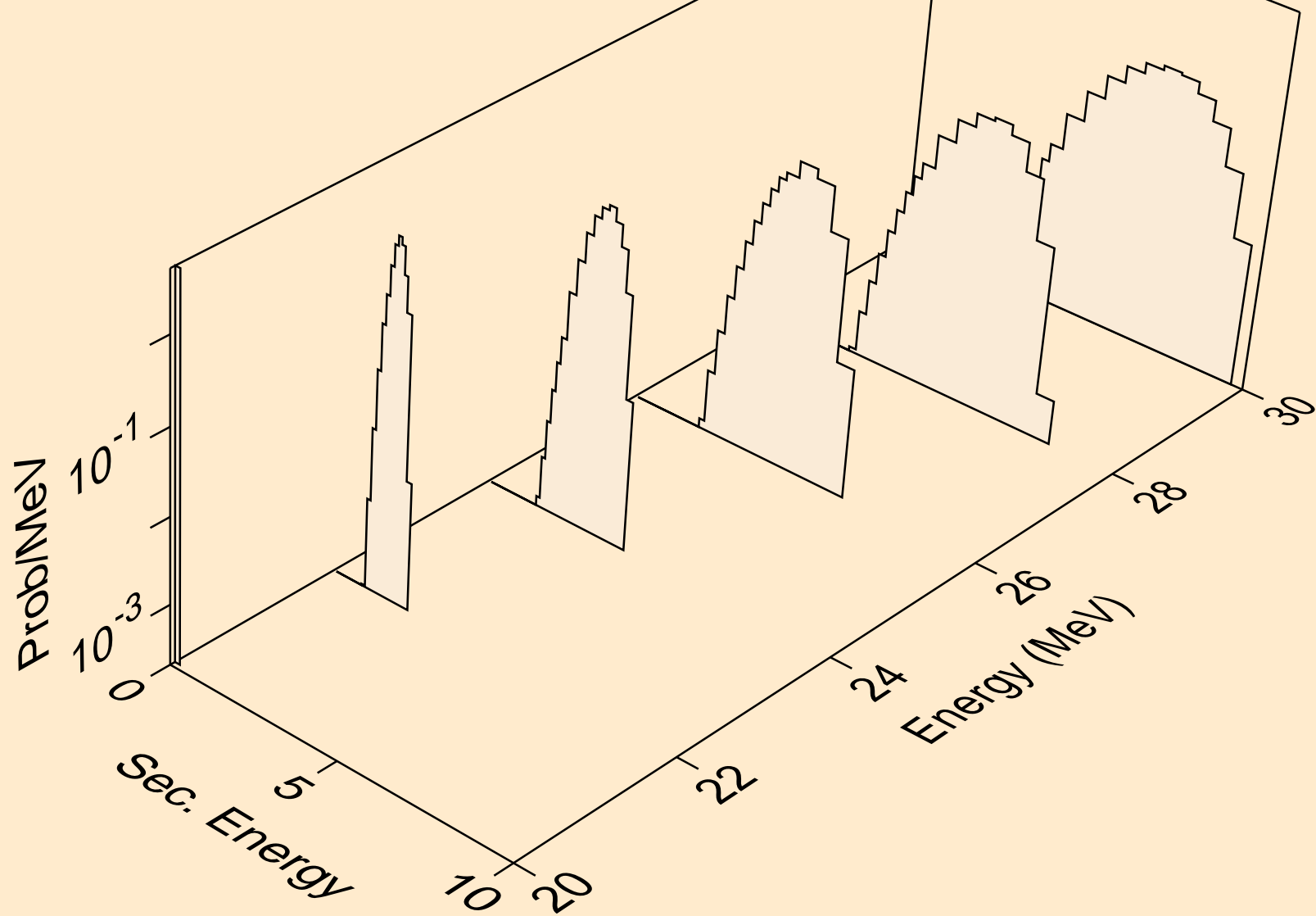

SB134M NEUTRON ACER TENDL-2023 LIBRARY; T=0.K  
protons from (n,p)

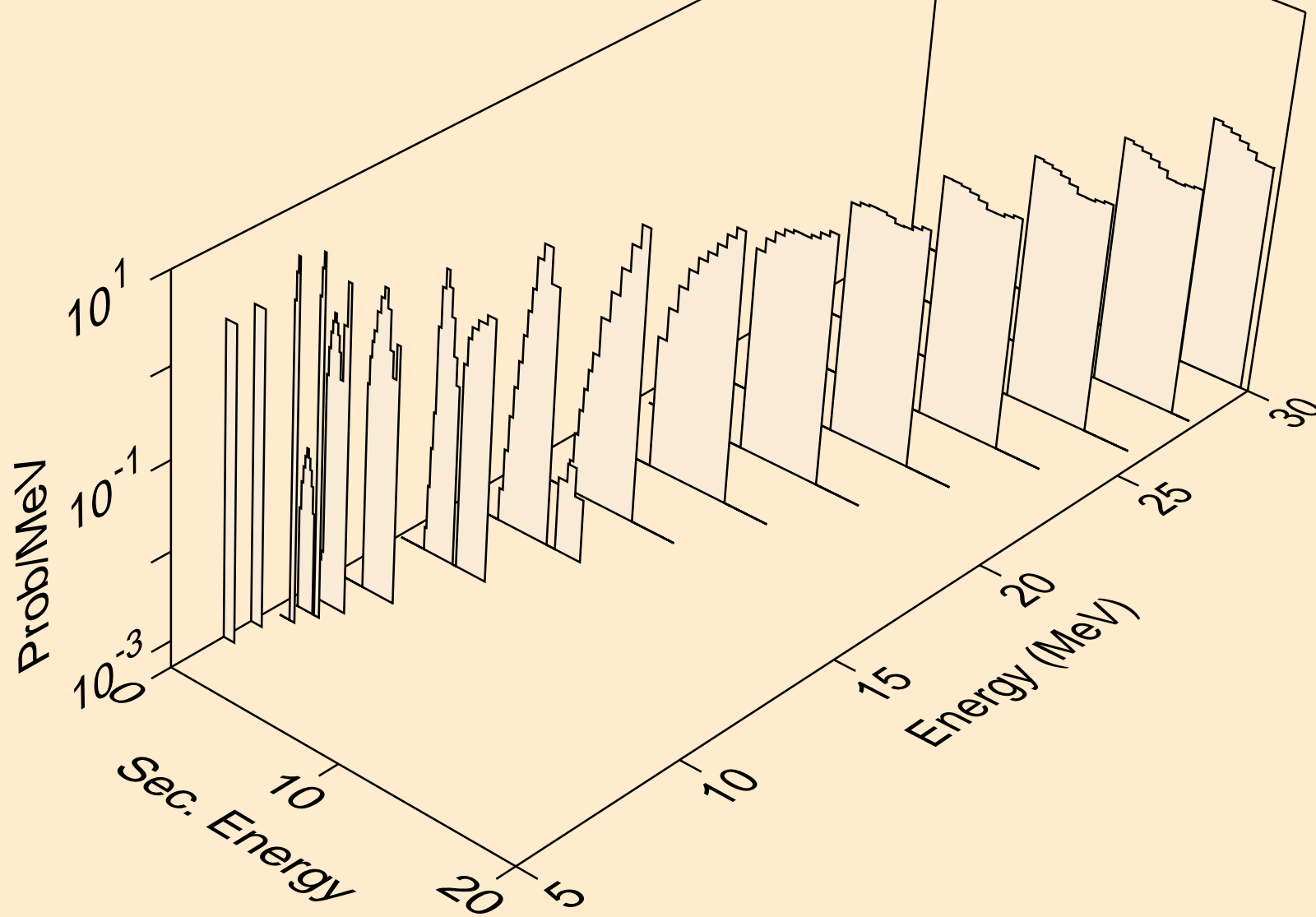

SB134M NEUTRON ACER TENDL-2023 LIBRARY; T=0.K  
deuterons from (n,x)

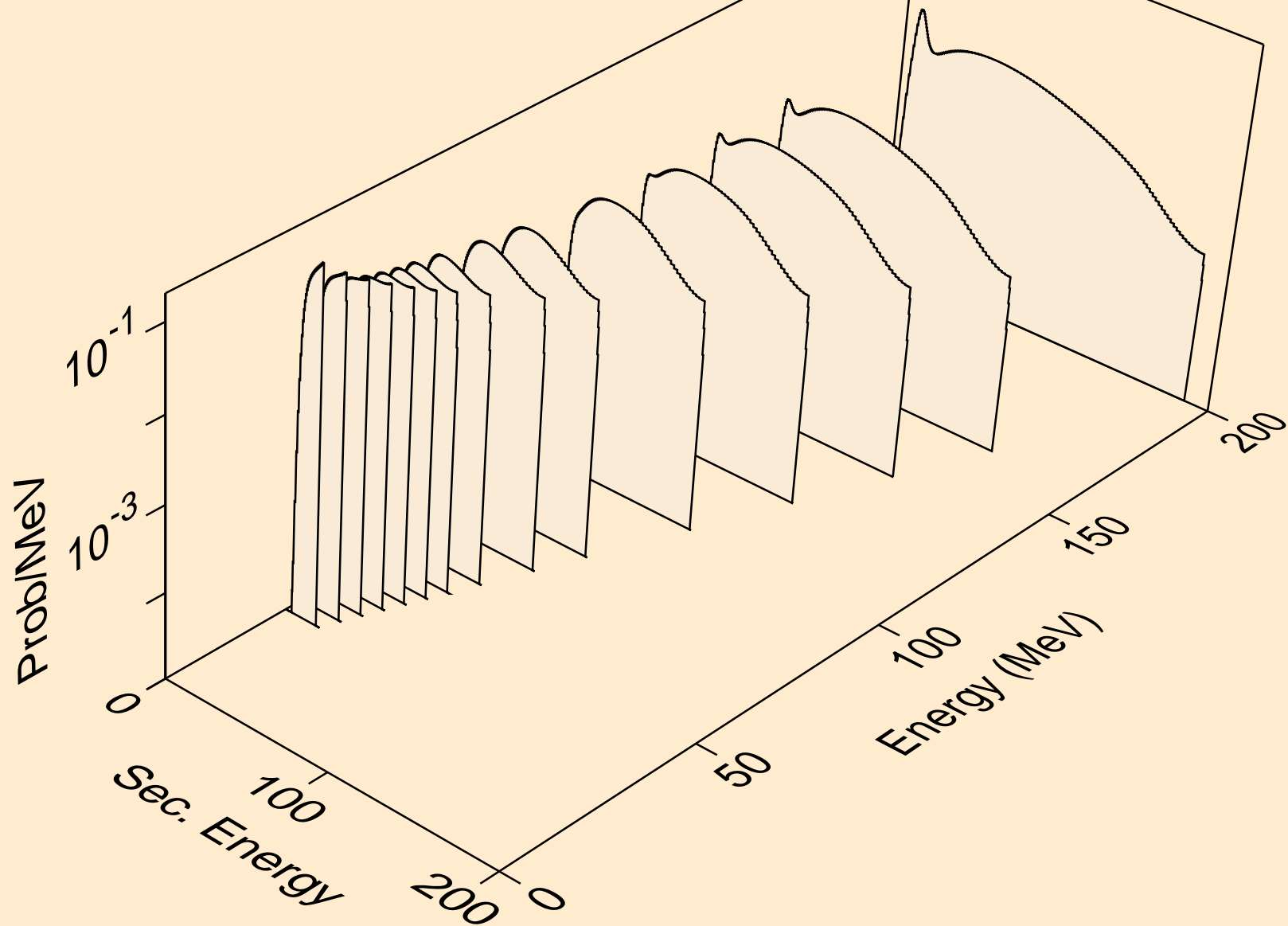

SB134M NEUTRON ACER TENDL-2023 LIBRARY; T=0.K  
deuterons from (n,2nd)

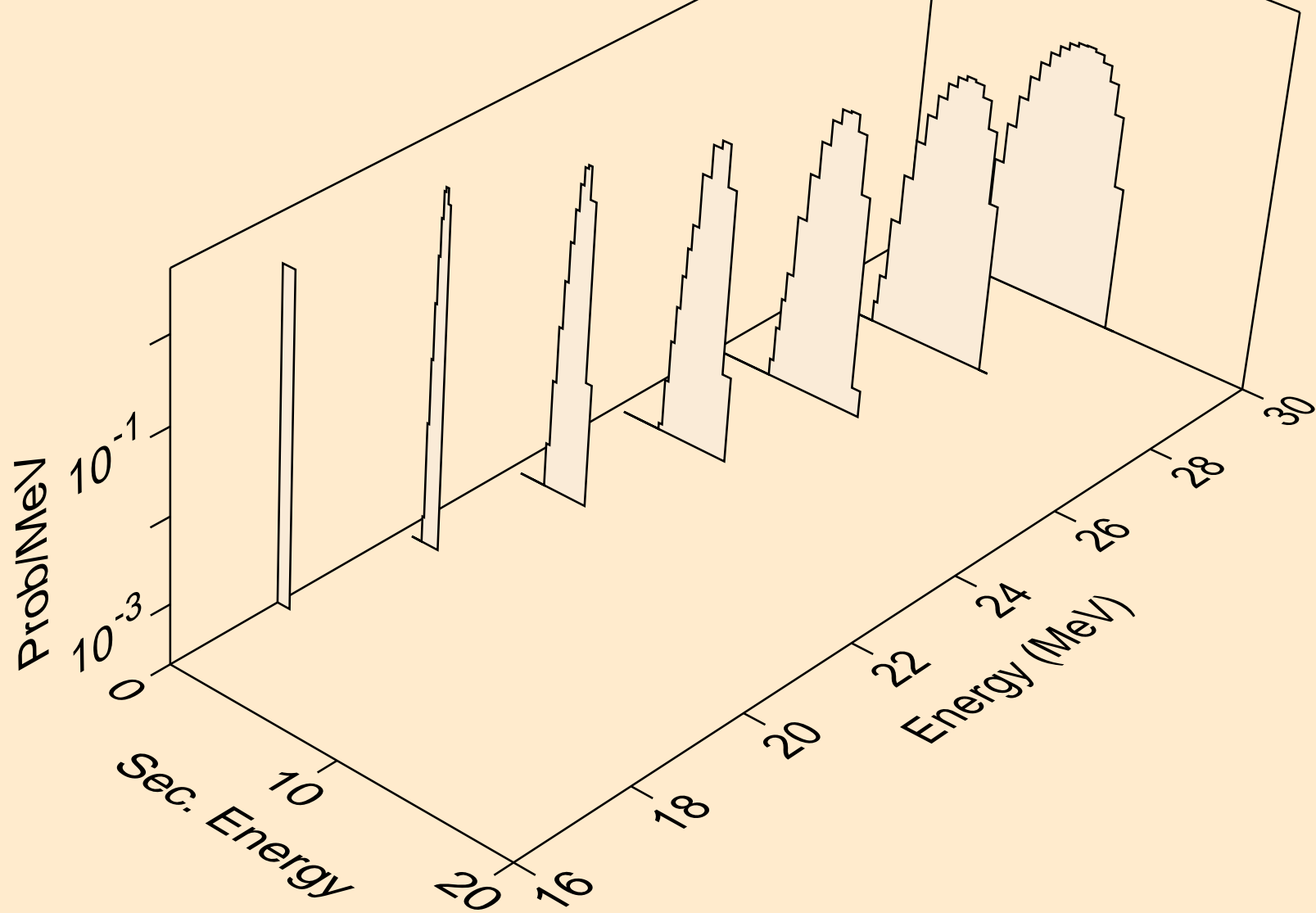

SB134M NEUTRON ACER TENDL-2023 LIBRARY; T=0.K  
deuterons from (n,n\*)d

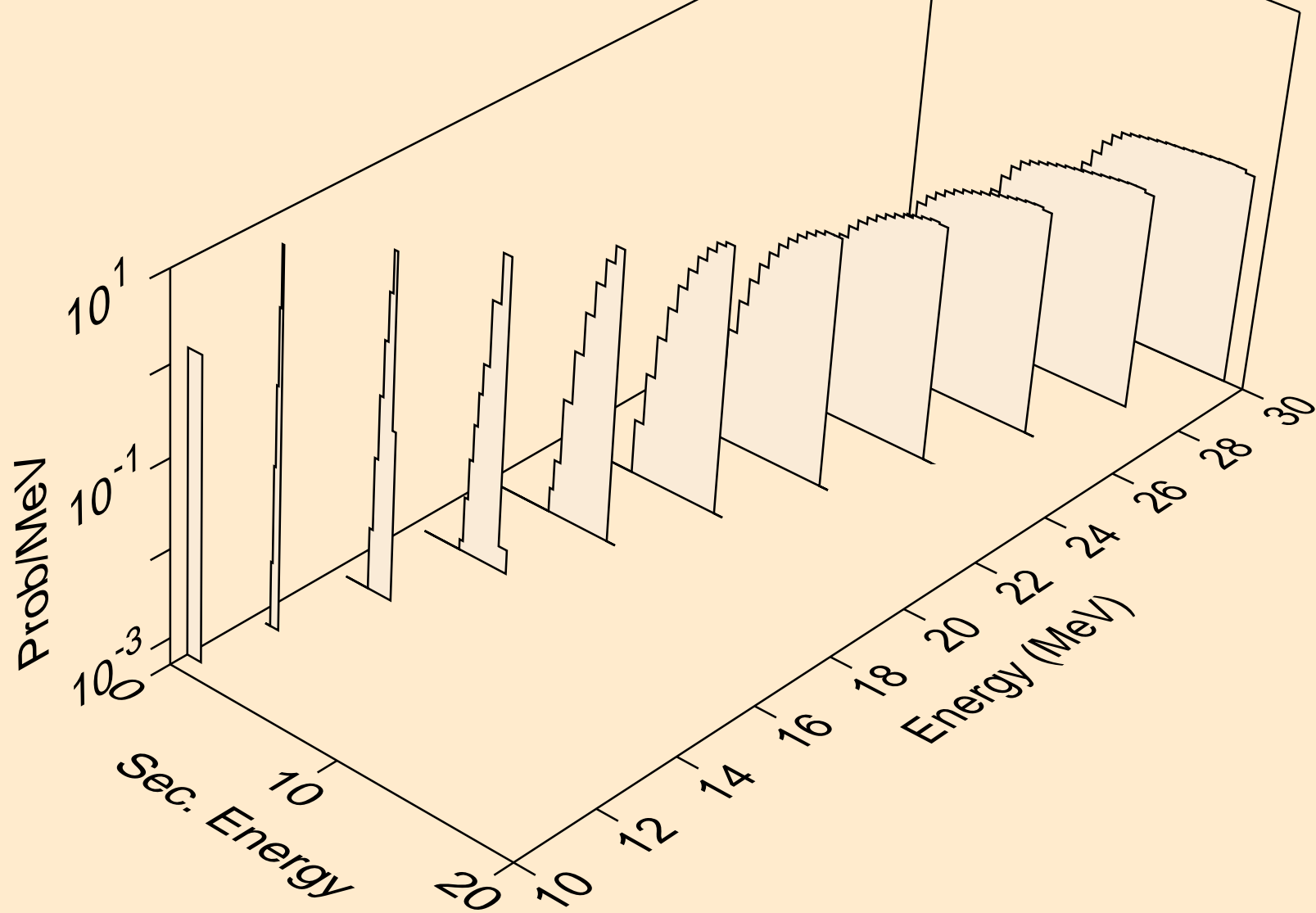



SB134M NEUTRON ACER TENDL-2023 LIBRARY; T=0.K  
deuterons from (n,d)

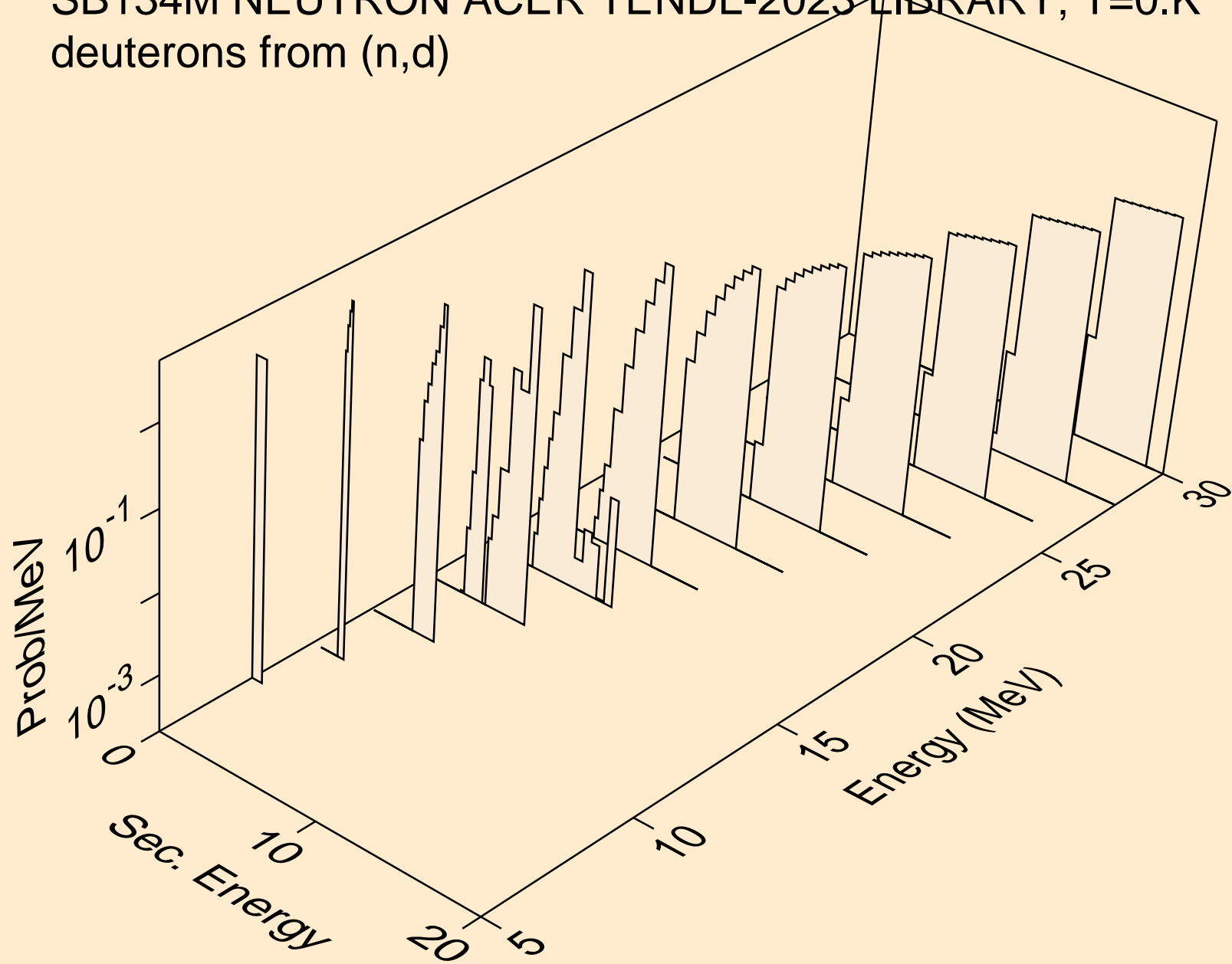

SB134M NEUTRON ACER TENDL-2023 LIBRARY; T=0.K  
tritons from (n,x)

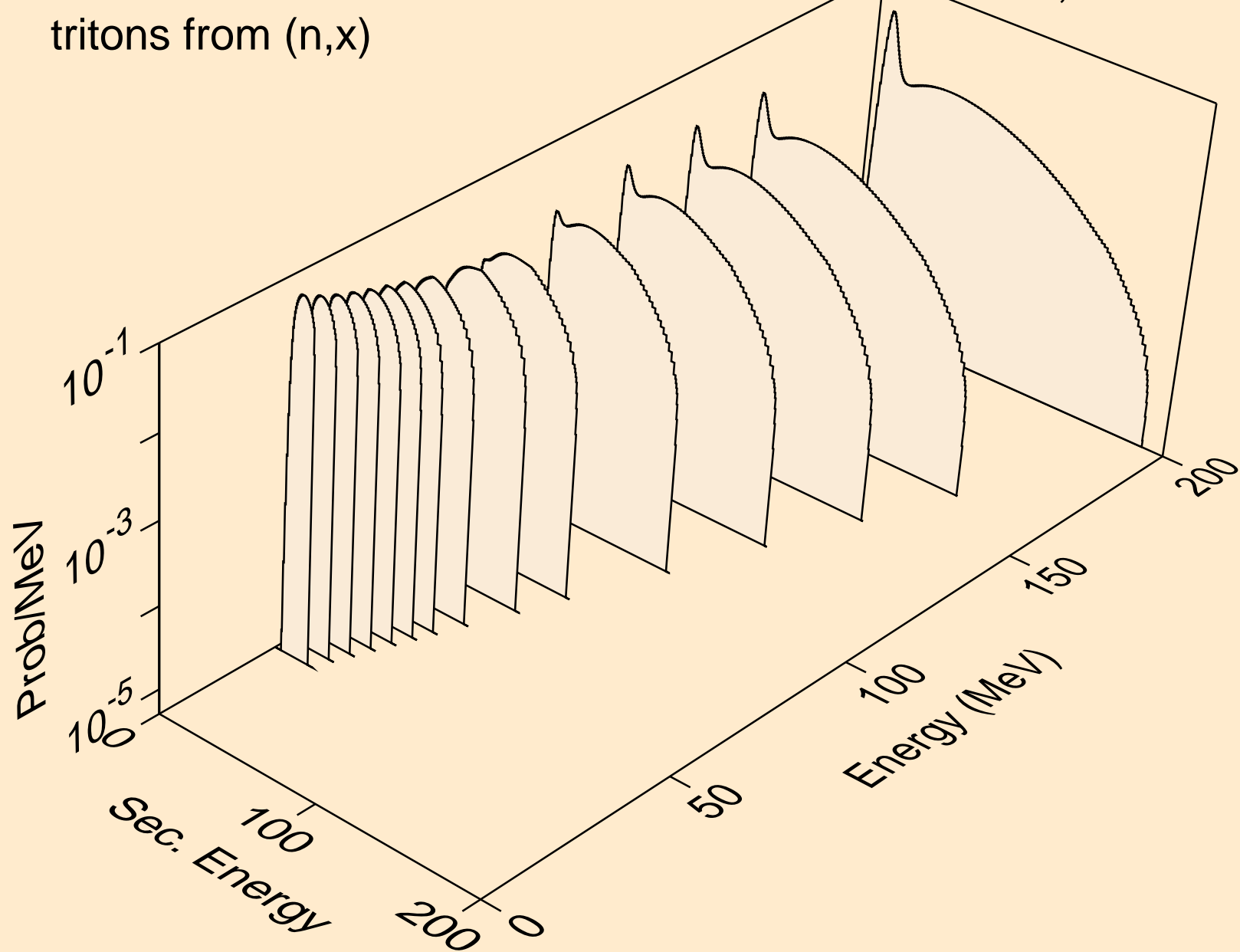

SB134M NEUTRON ACER TENDL-2023 LIBRARY; T=0.K  
tritons from (n,n\*)t

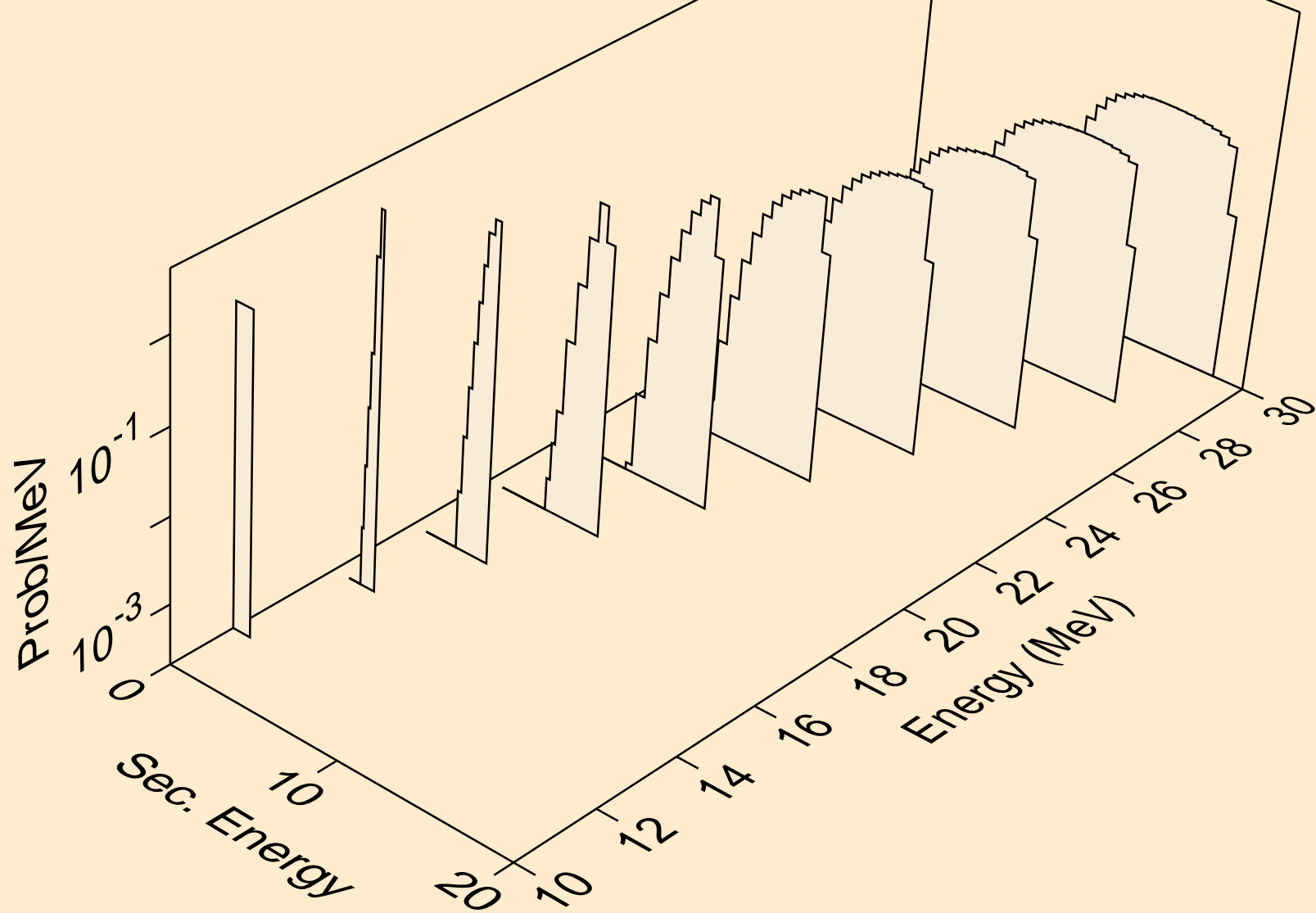

SB134M NEUTRON ACER TENDL-2023 LIBRARY; T=0.K  
tritons from (n,t)

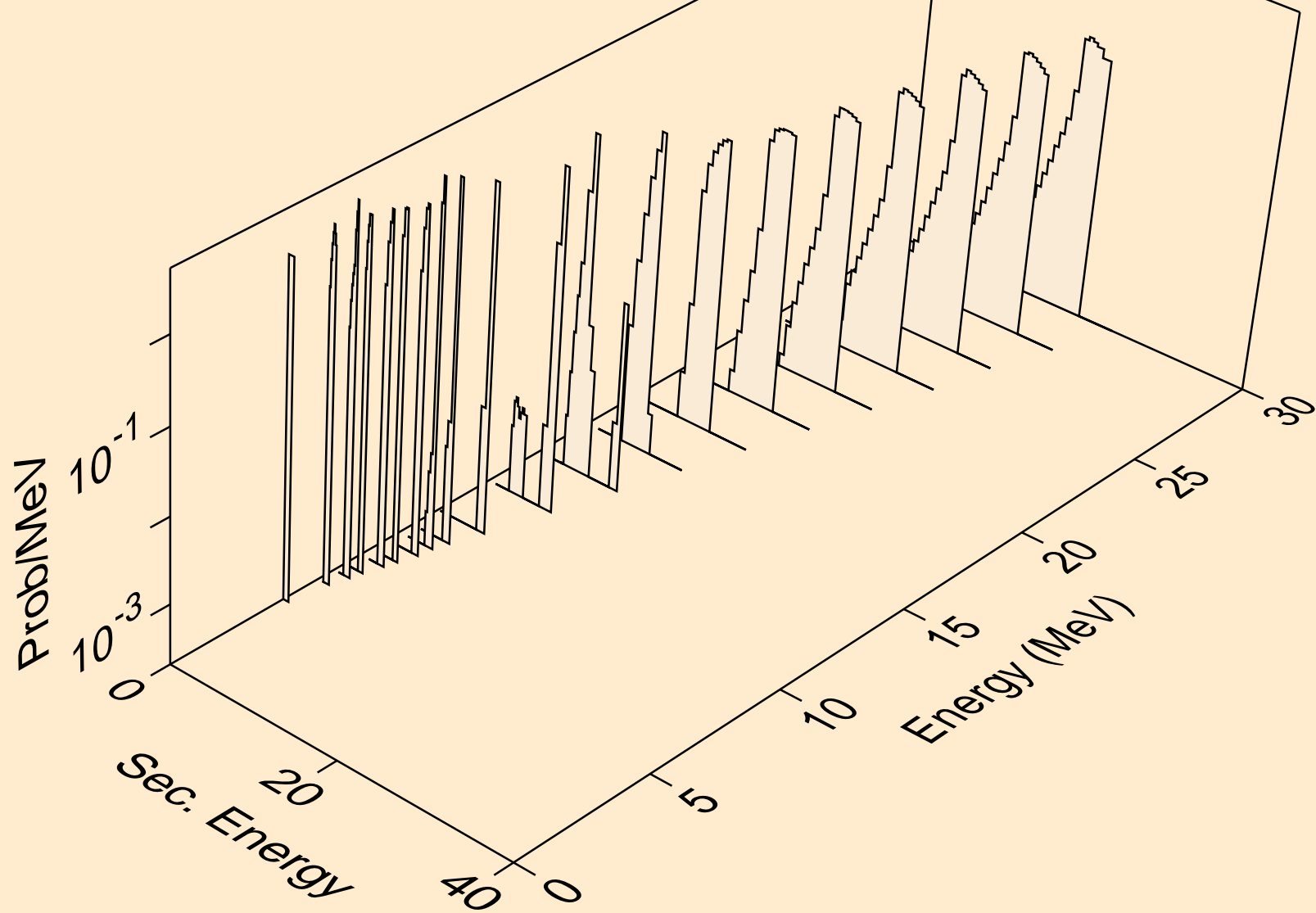

SB134M NEUTRON ACER TENDL-2023 LIBRARY; T=0.K  
he3s from (n,x)

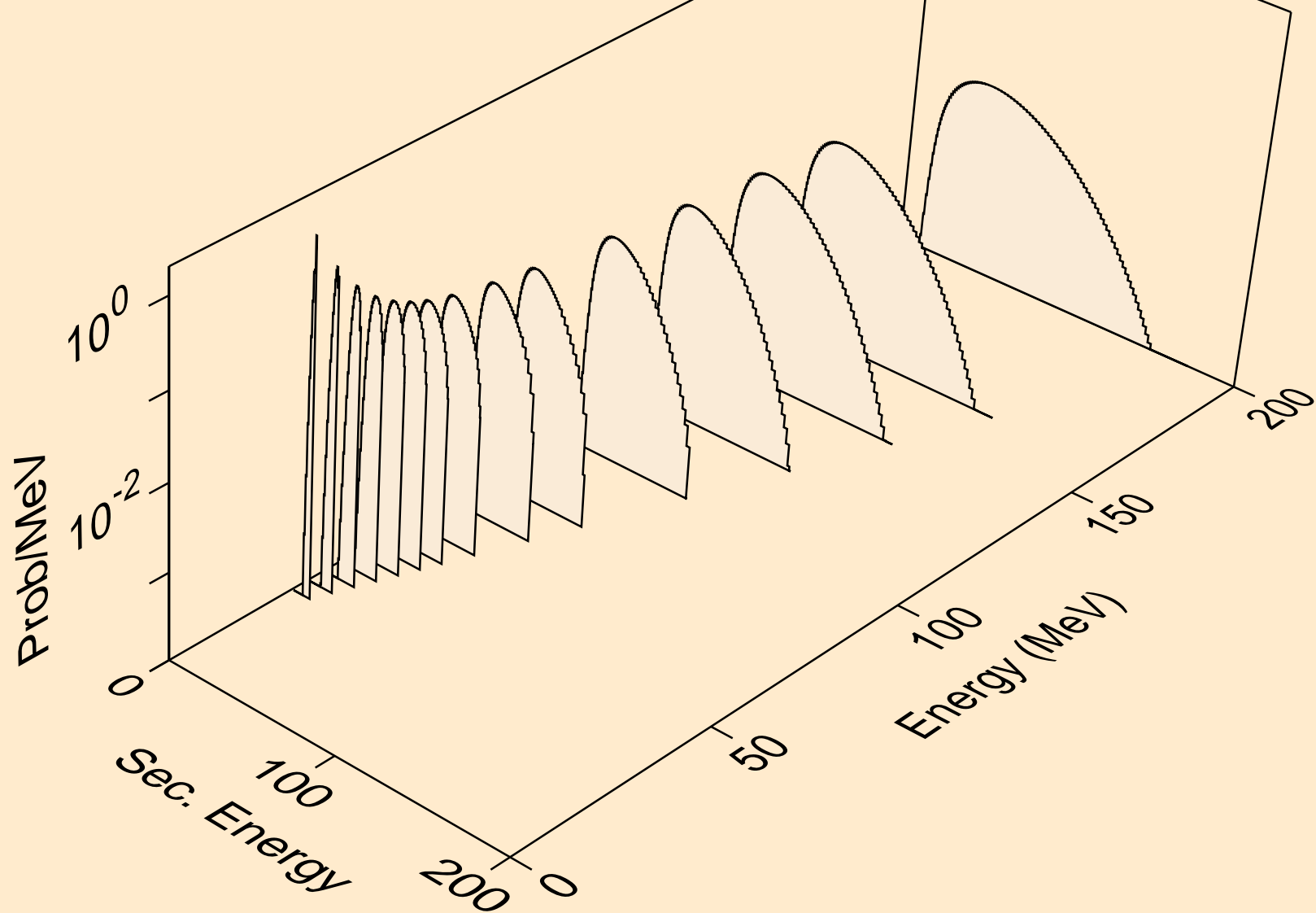

SB134M NEUTRON ACER TENDL-2023 LIBRARY; T=0.K  
he3s from (n,n\*)he3

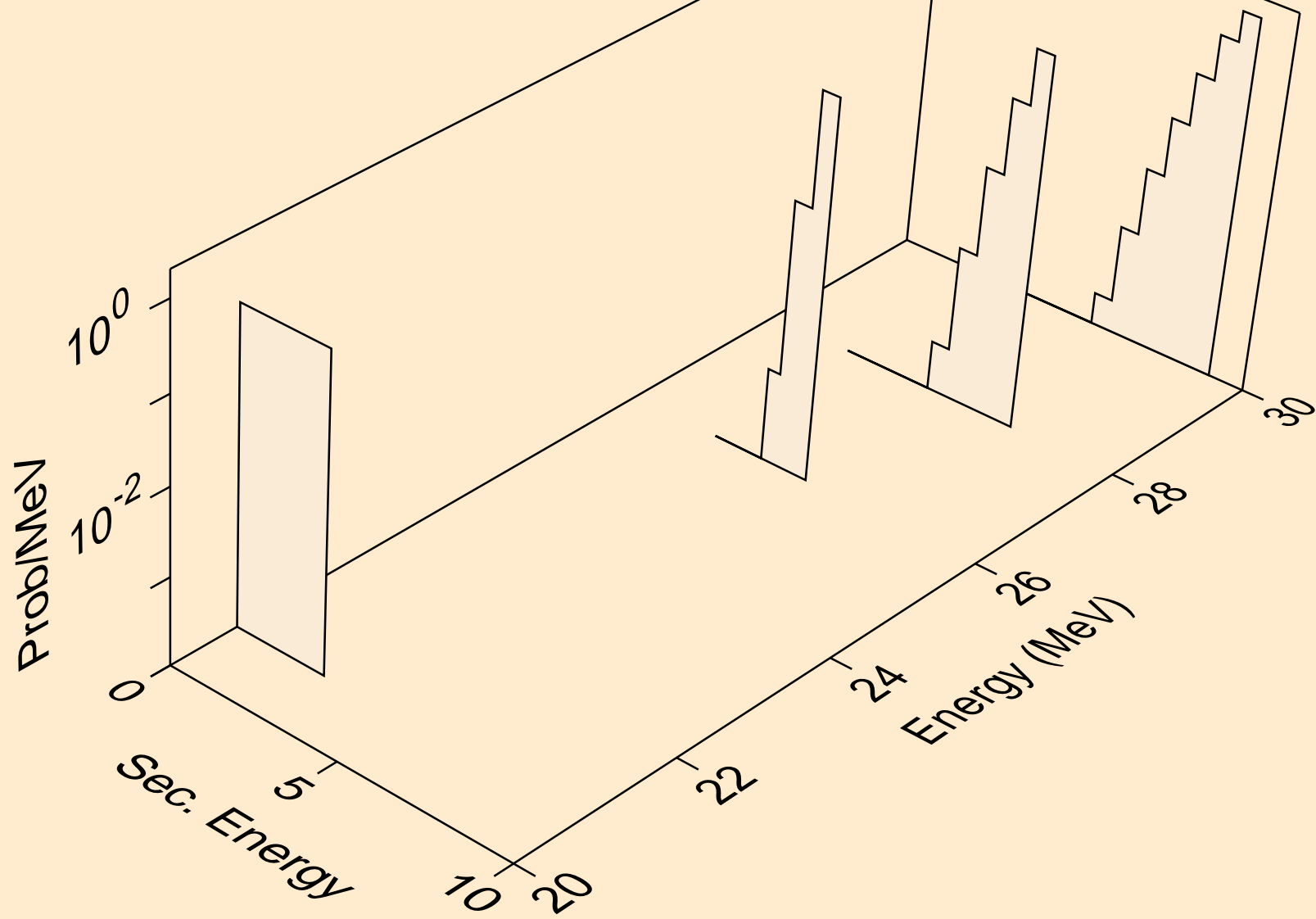

SB134M NEUTRON ACER TENDL-2023 LIBRARY; T=0.K  
he3s from (n,he3)

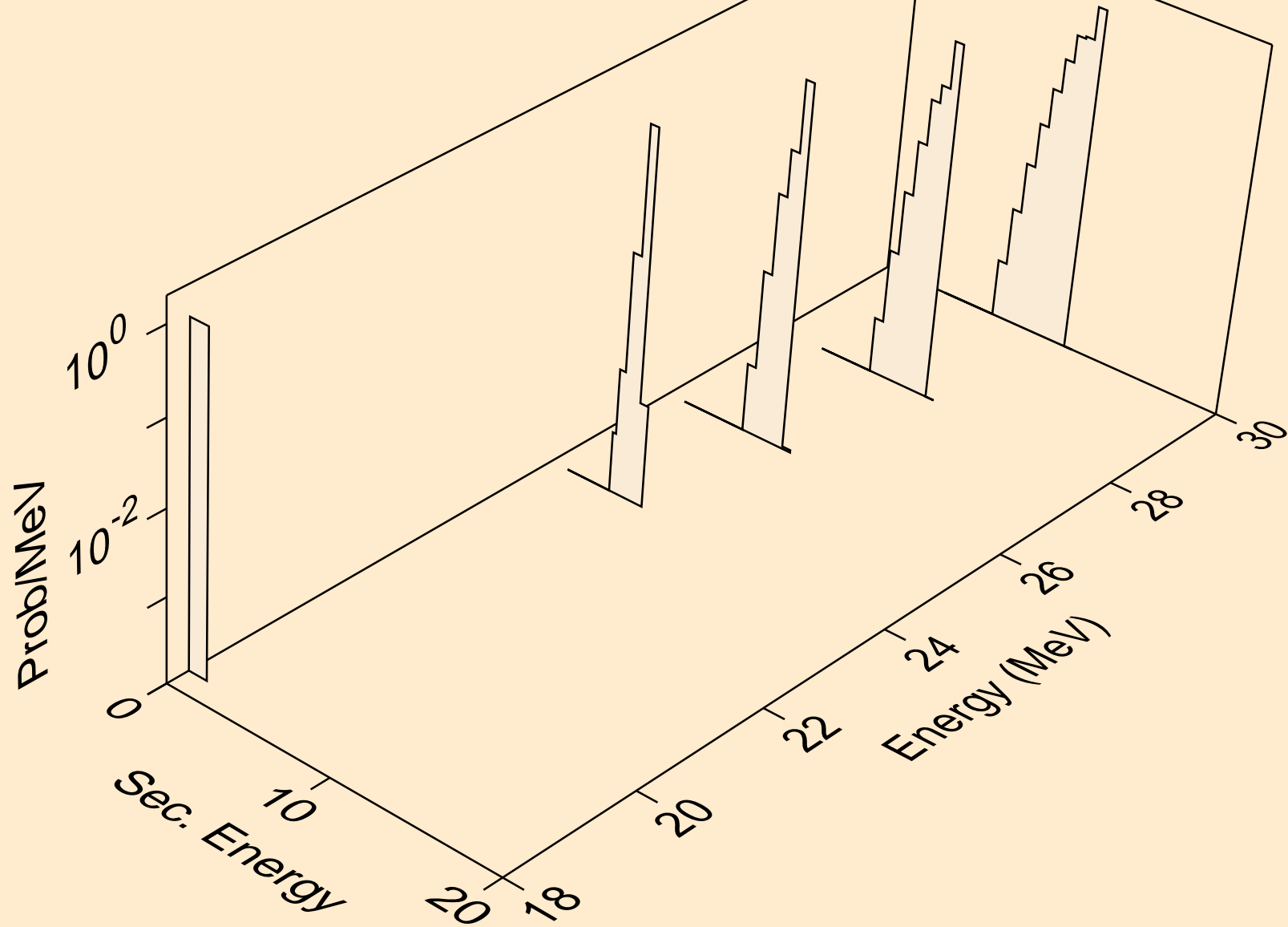

SB134M NEUTRON ACER TENDL-2023 LIBRARY; T=0.K  
alphas from (n,x)

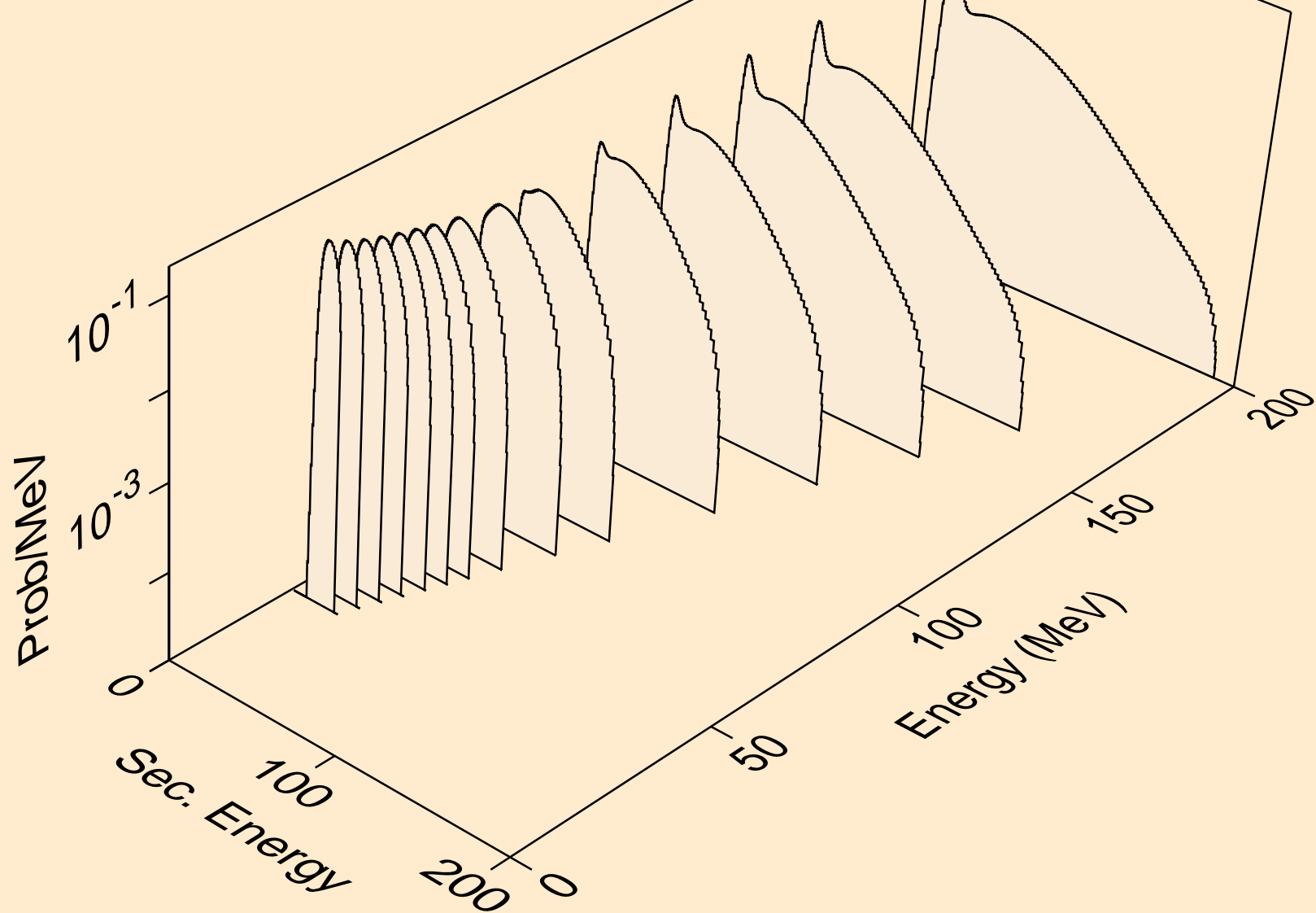



SB134M NEUTRON ACER TENDL-2023 LIBRARY; T=0.K  
alphas from (n,n\*)a

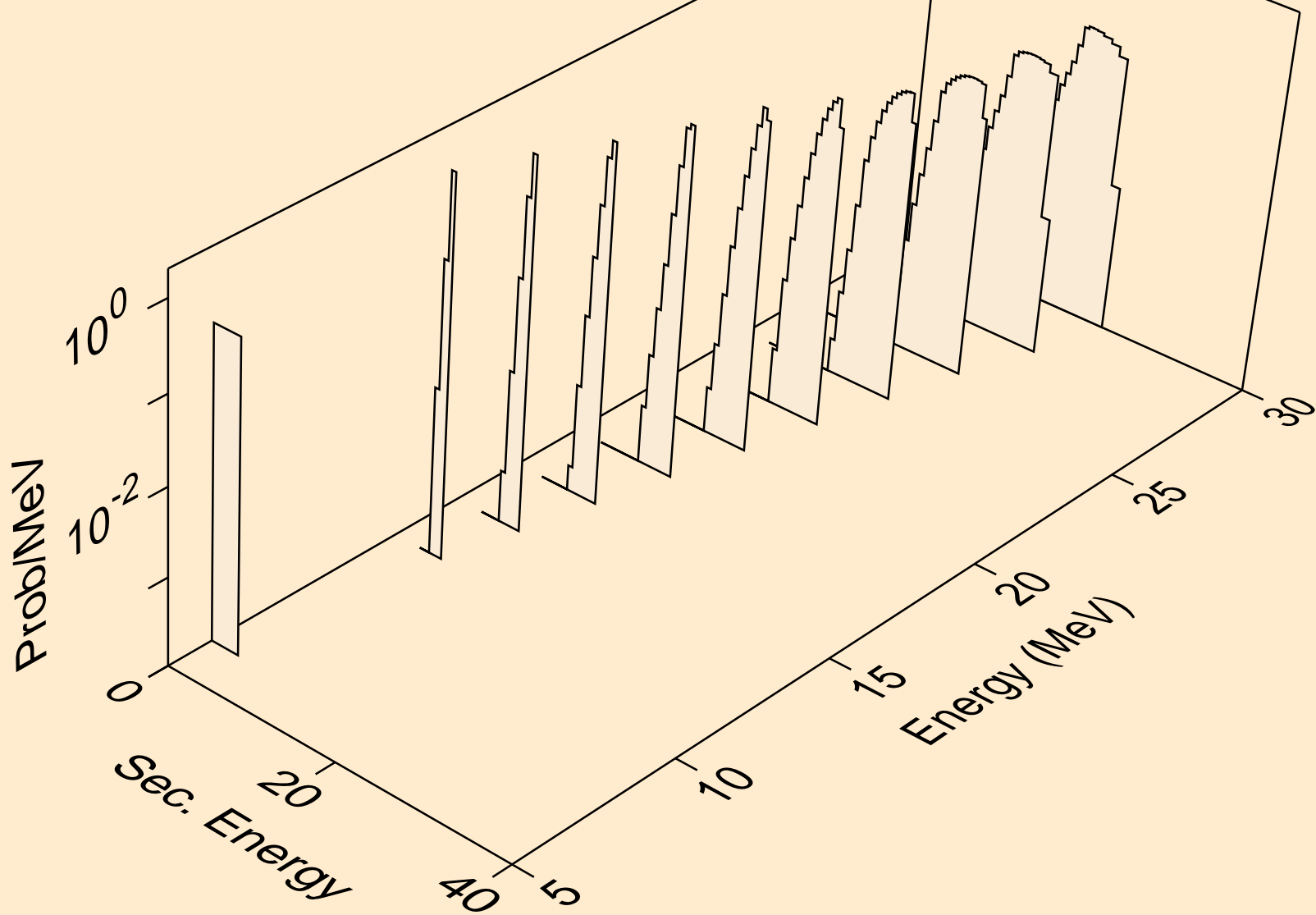

SB134M NEUTRON ACER TENDL-2023 LIBRARY; T=0.K  
alphas from (n,2n)a

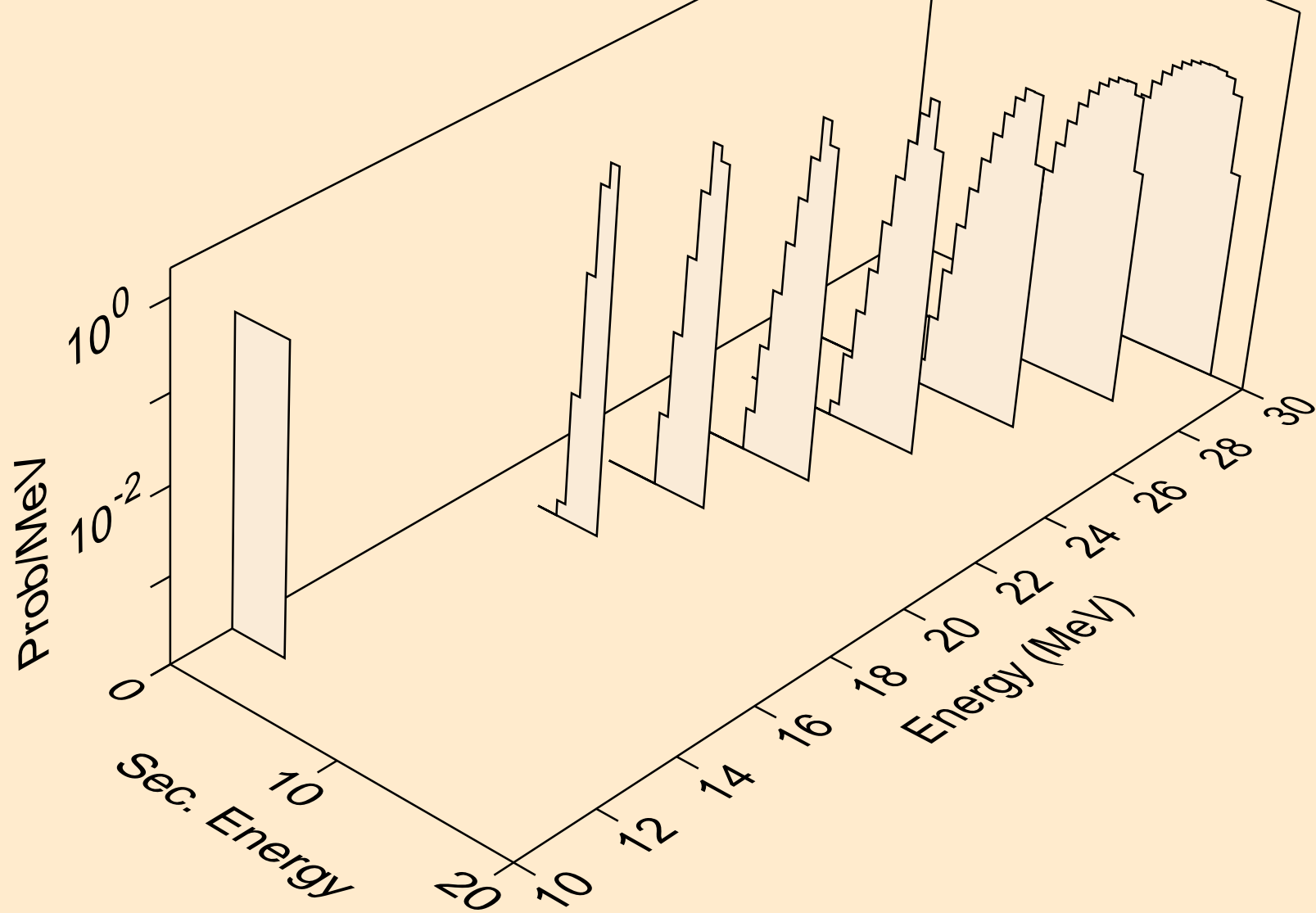

SB134M NEUTRON ACER TENDL-2023 LIBRARY; T=0.K  
alphas from (n,3n)a

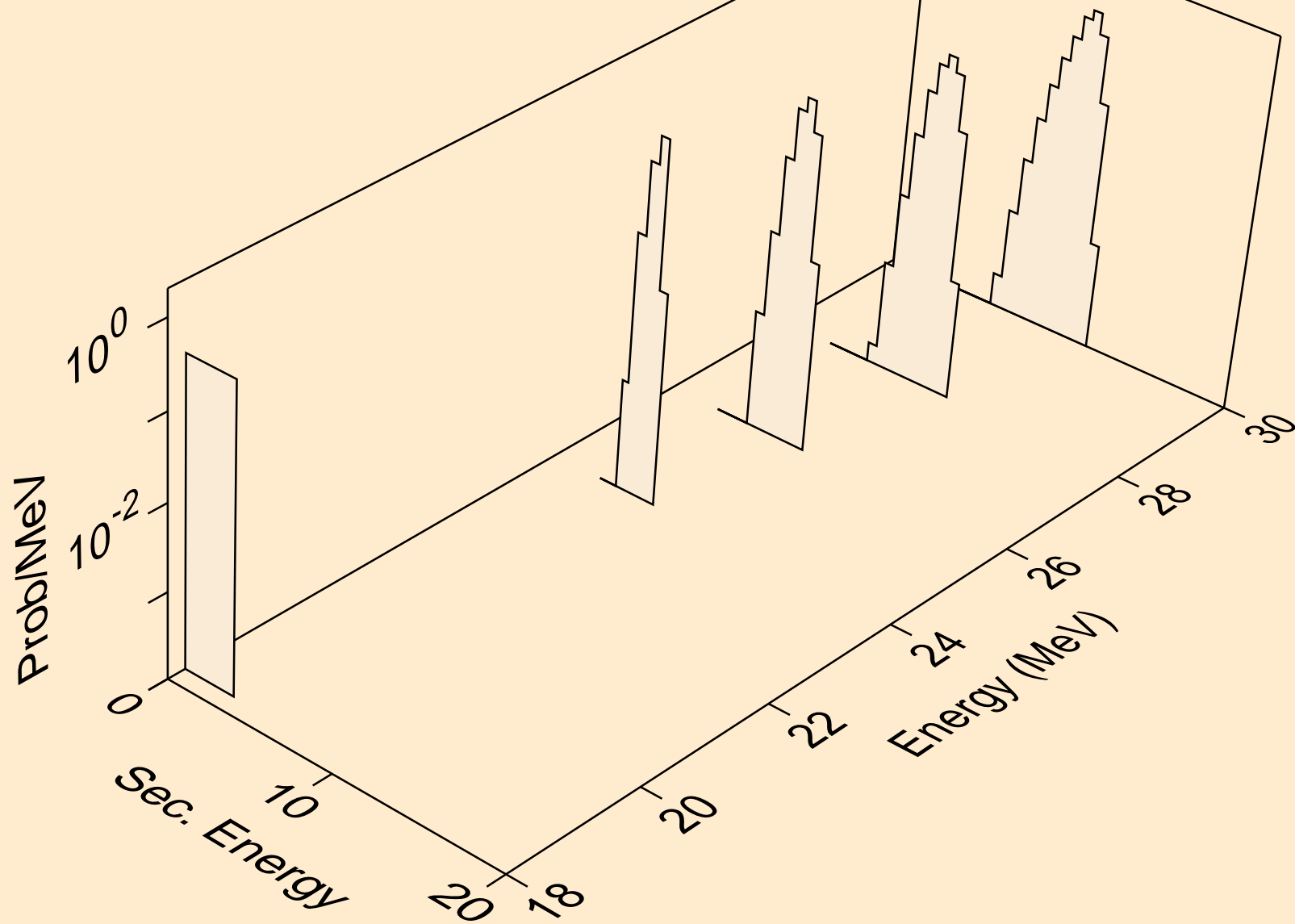

SB134M NEUTRON ACER TENDL-2023 LIBRARY; T=0.K  
alphas from (n,a)

