

# SG272 NEUTRON ACER TENDL-2023 LIBRARY; T=0.K

## Principal cross sections

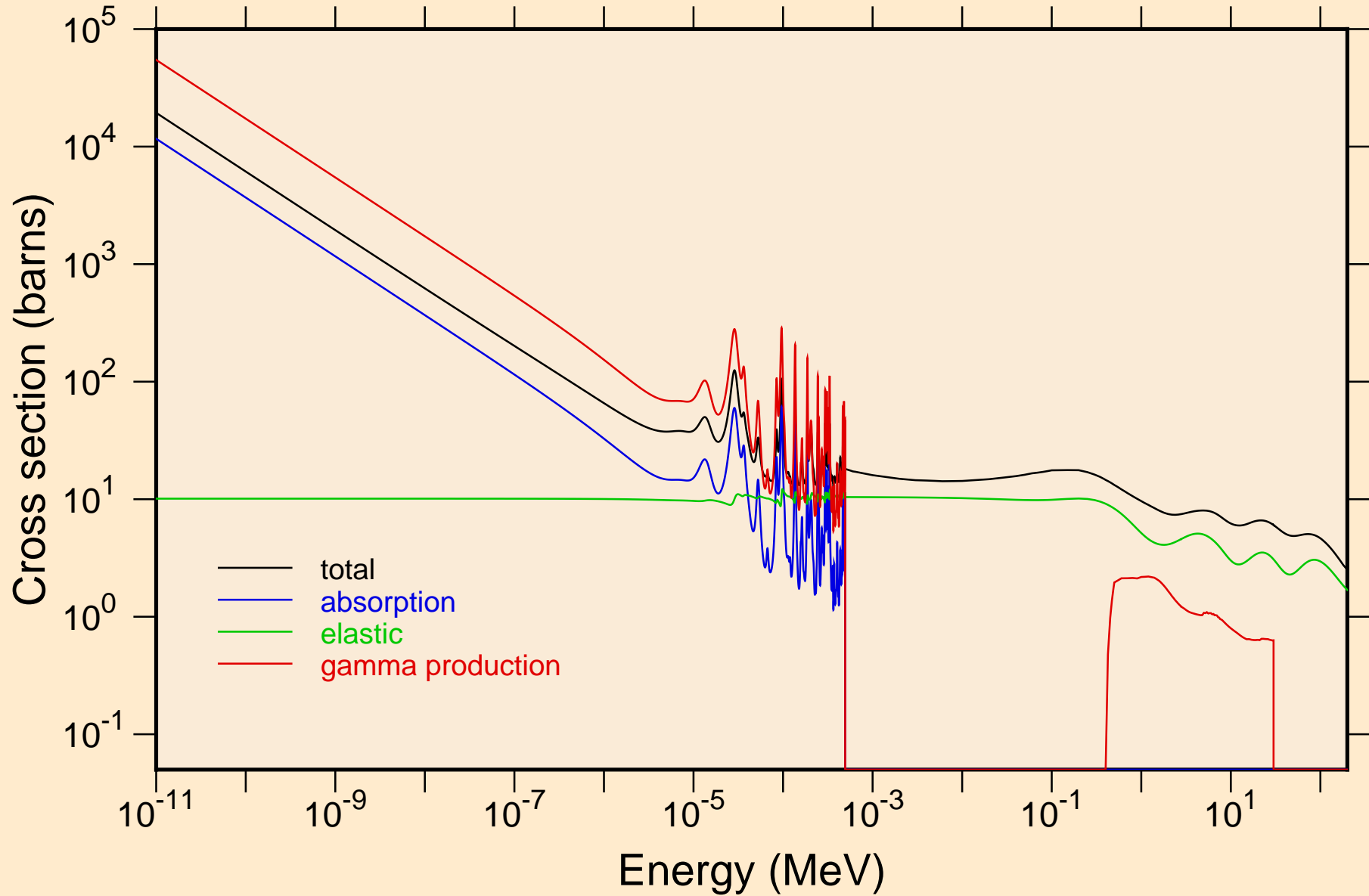

SG272 NEUTRON ACER TENDL-2023 LIBRARY; T=0.K  
resonance total cross section

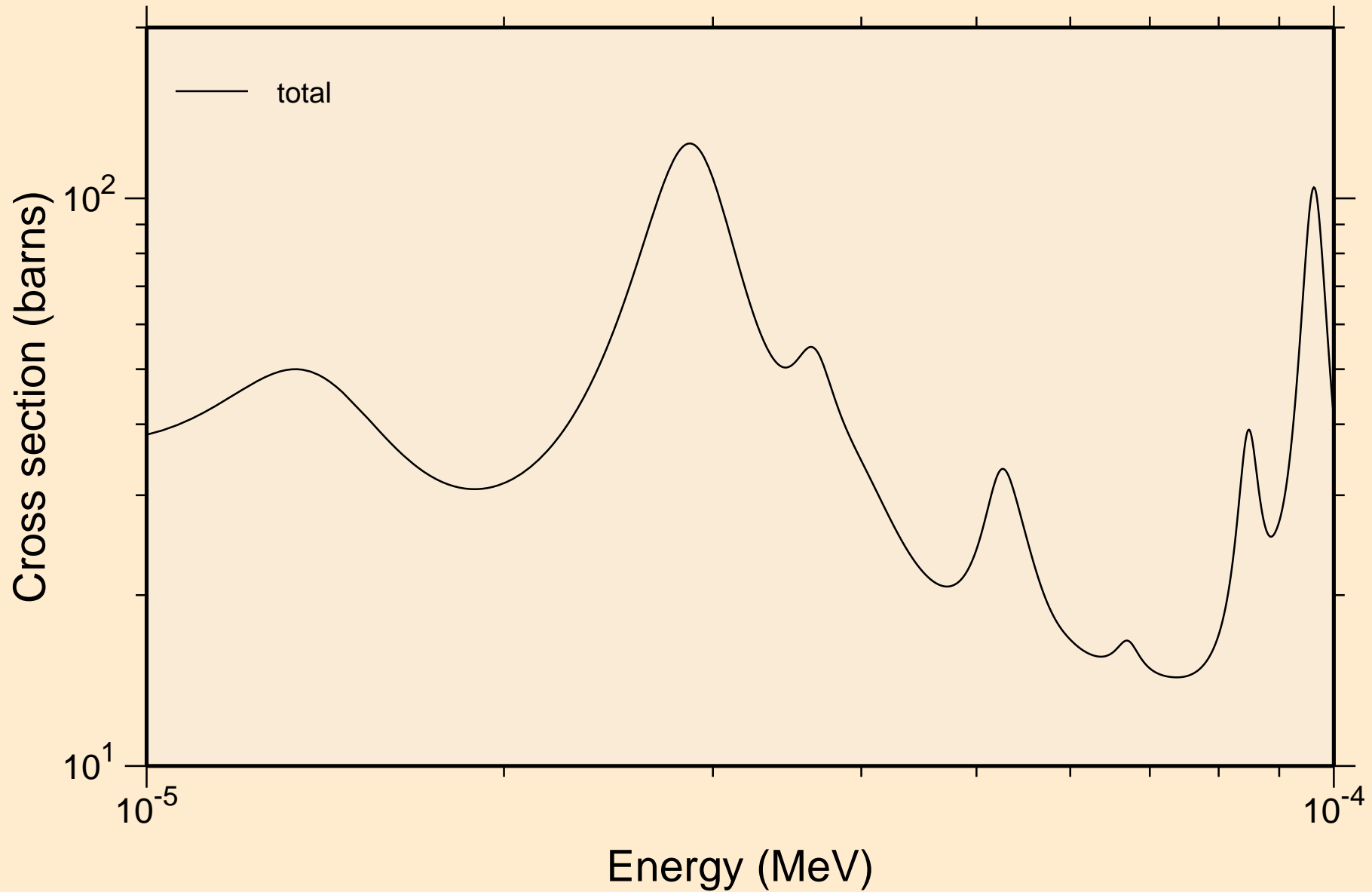

SG272 NEUTRON ACER TENDL-2023 LIBRARY; T=0.K  
resonance total cross section

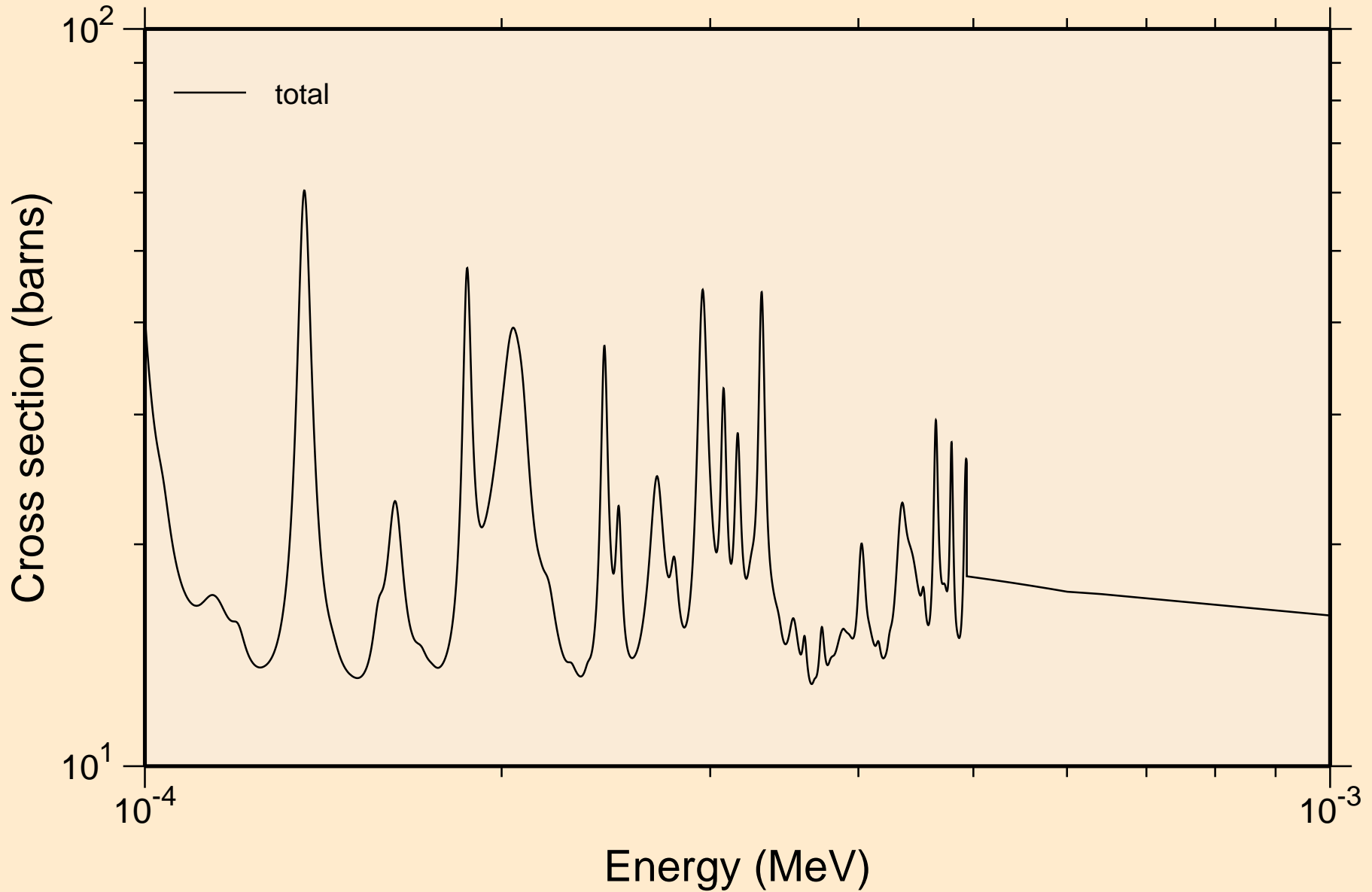

SG272 NEUTRON ACER TENDL-2023 LIBRARY; T=0.K  
resonance total cross section

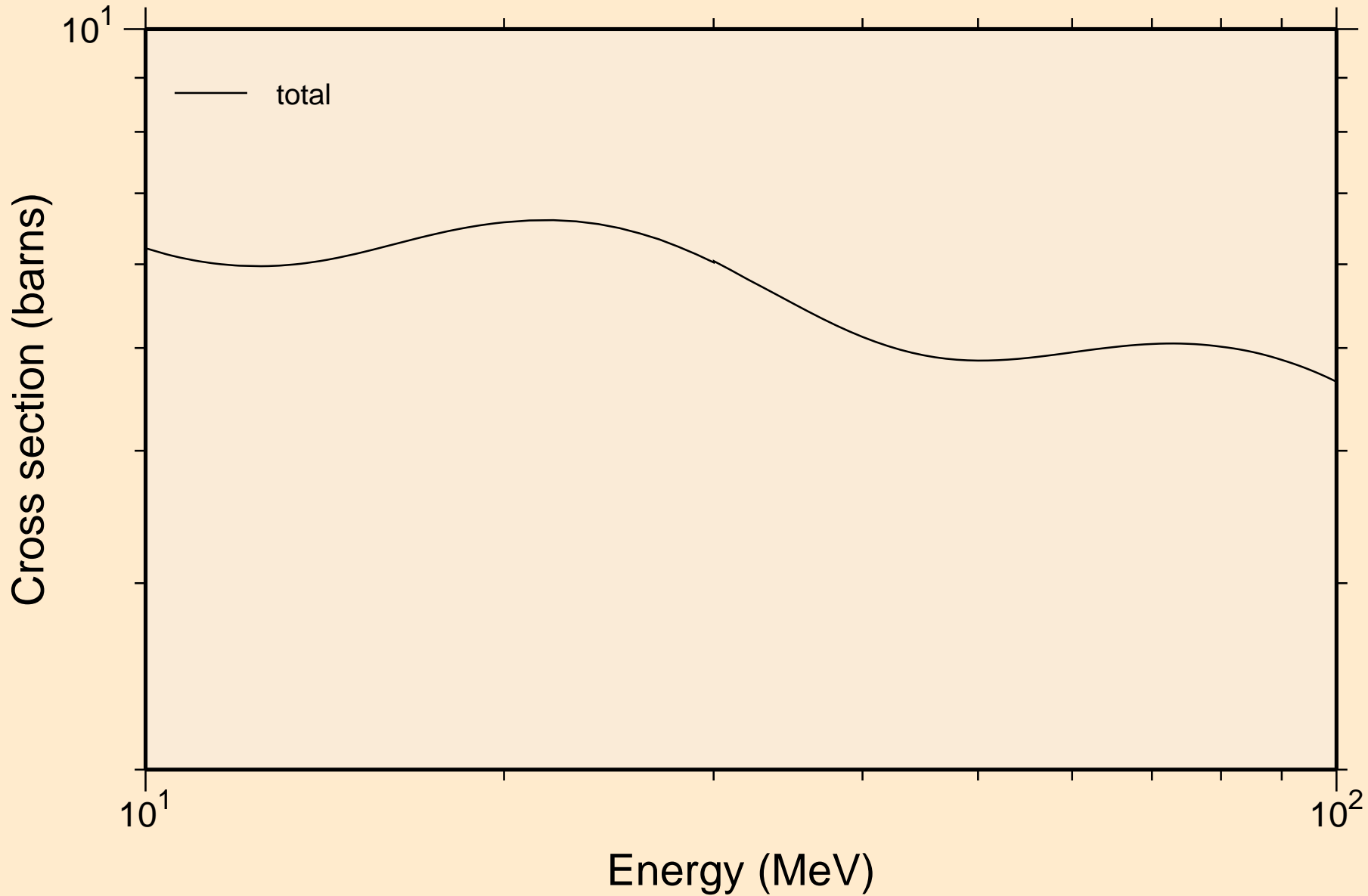

SG272 NEUTRON ACER TENDL-2023 LIBRARY; T=0.K  
resonance absorption cross sections

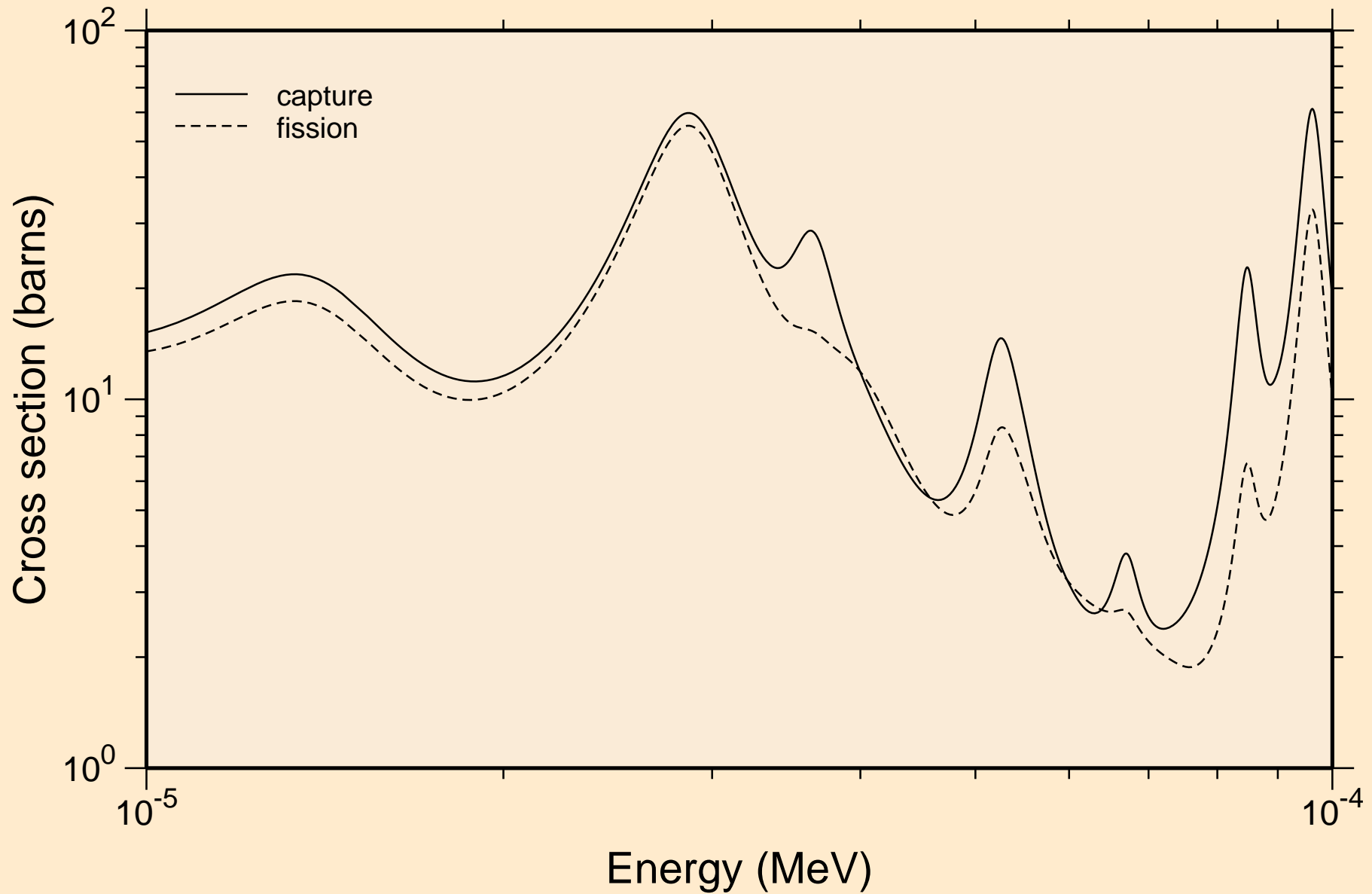

SG272 NEUTRON ACER TENDL-2023 LIBRARY; T=0.K  
resonance absorption cross sections

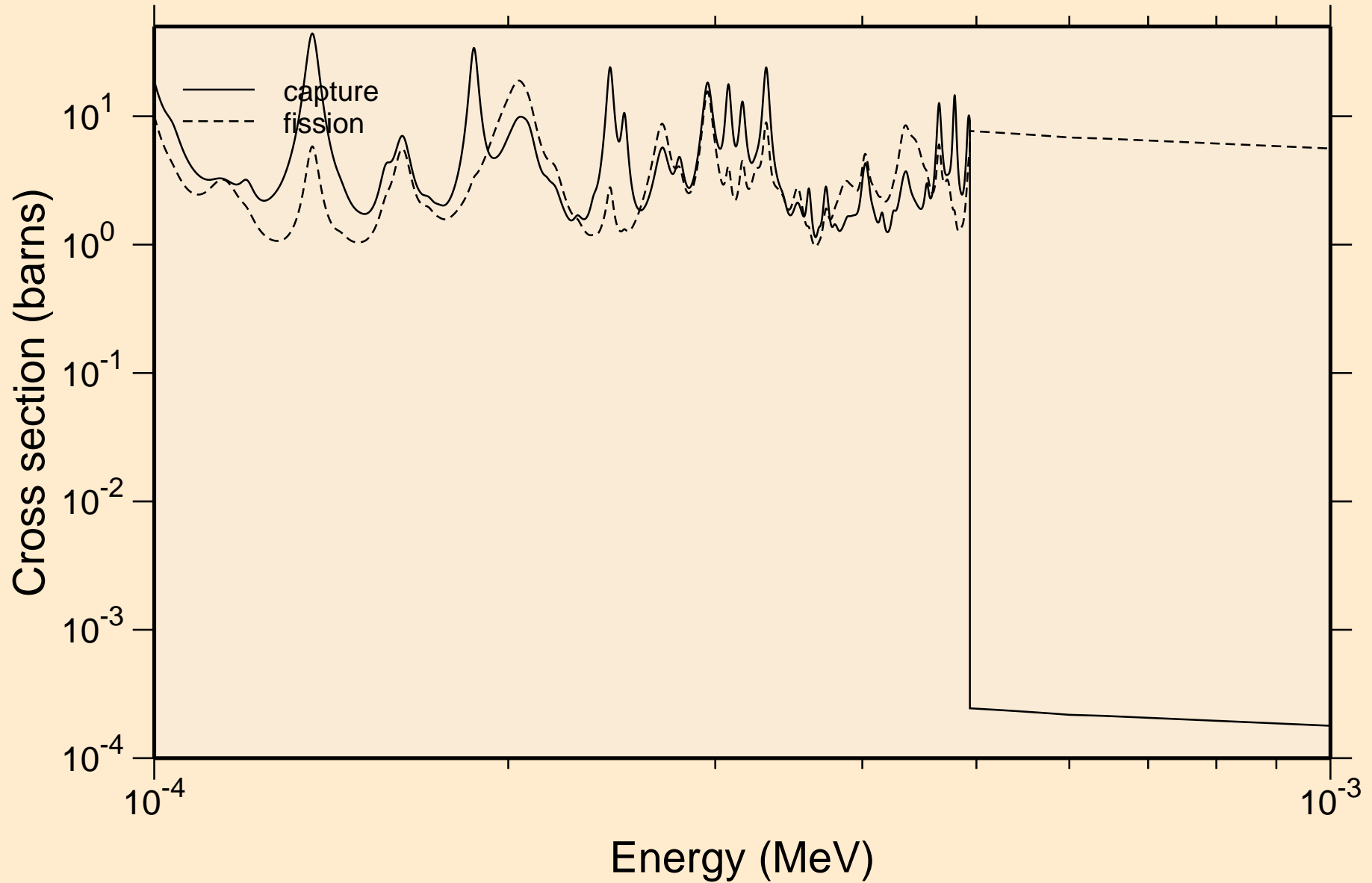

SG272 NEUTRON ACER TENDL-2023 LIBRARY; T=0.K  
resonance absorption cross sections

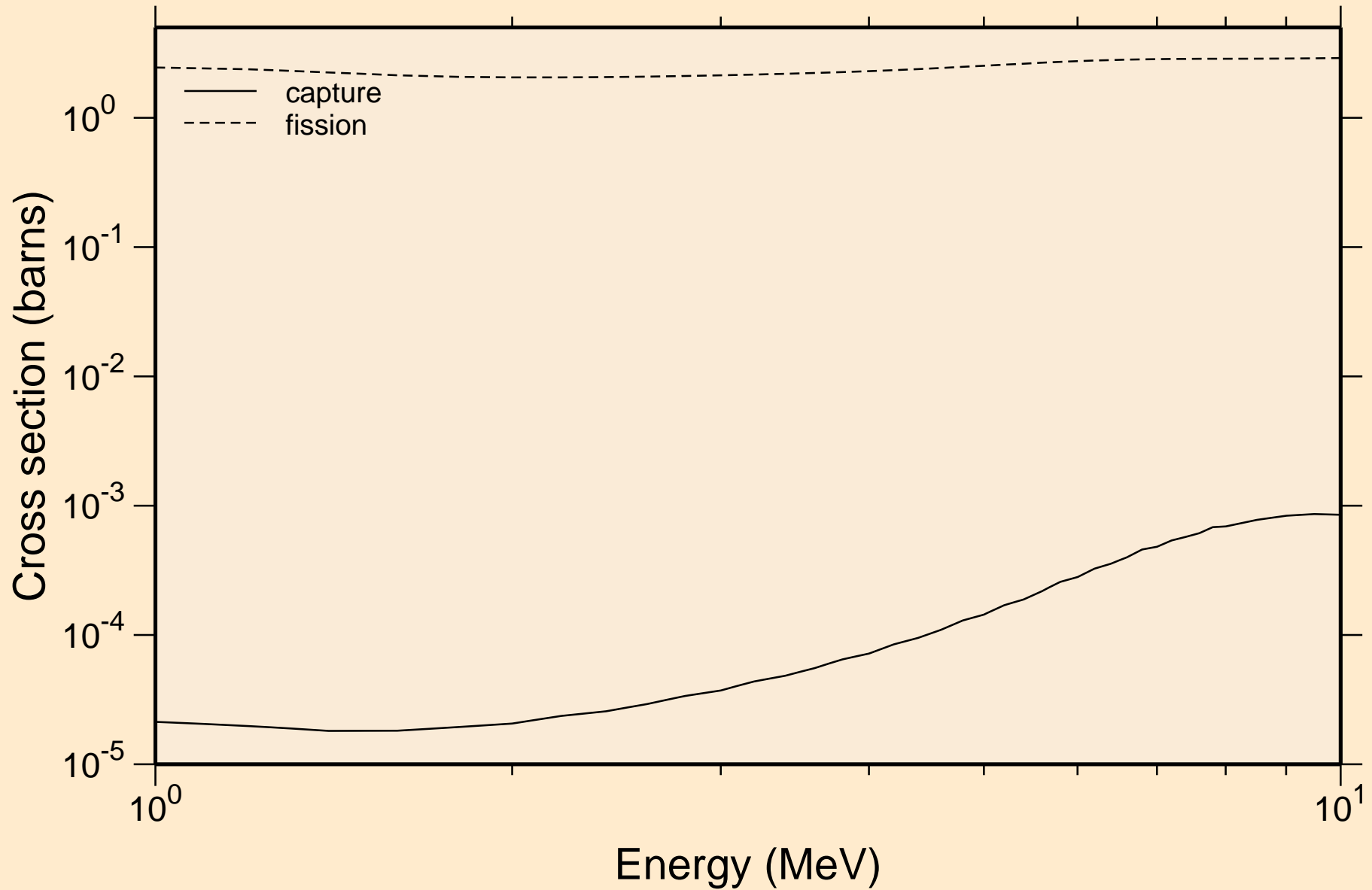

SG272 NEUTRON ACER TENDL-2023 LIBRARY; T=0.K  
Heating

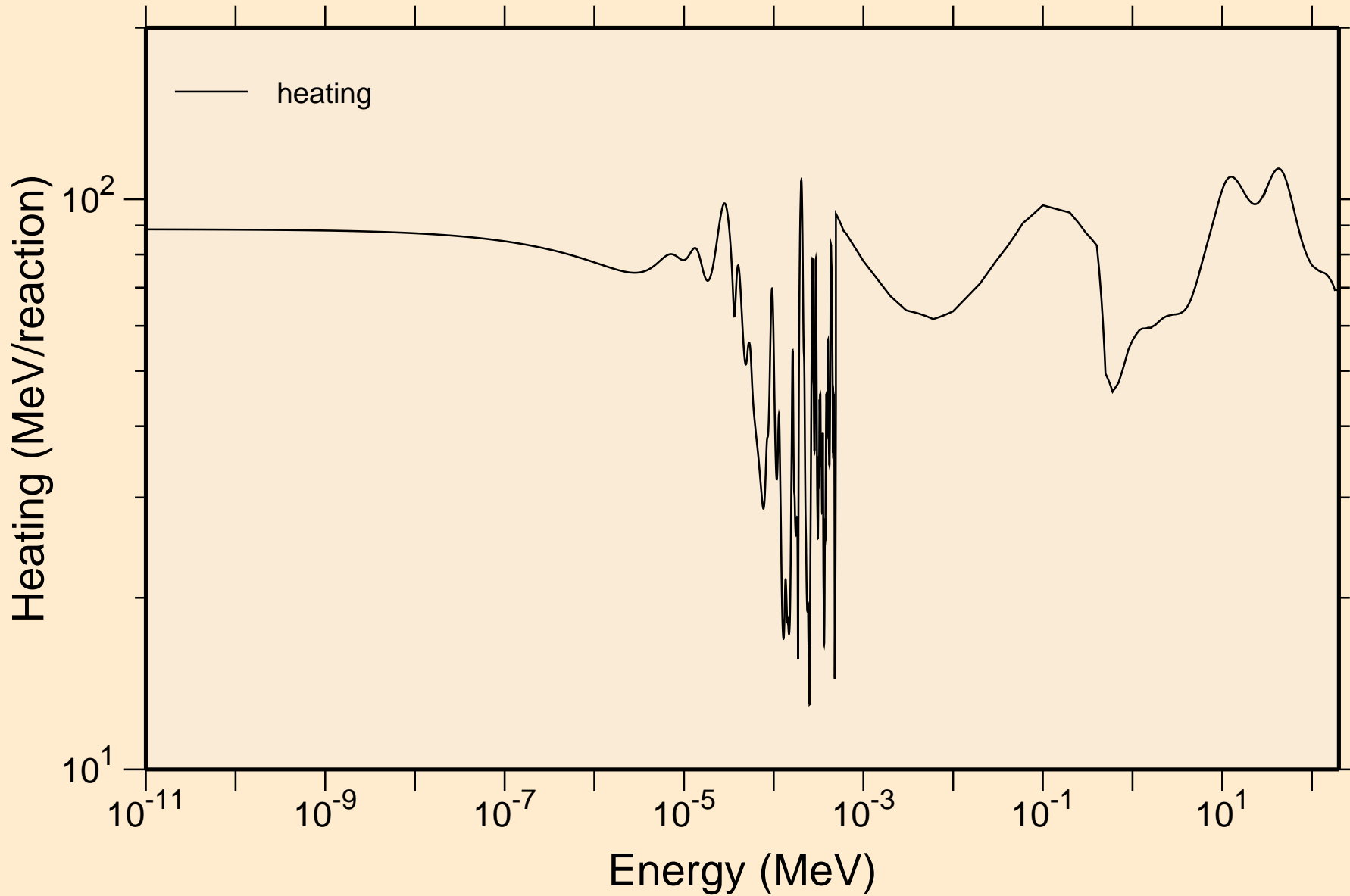



# SG272 NEUTRON ACER TENDL-2023 LIBRARY; T=0.K

## Damage

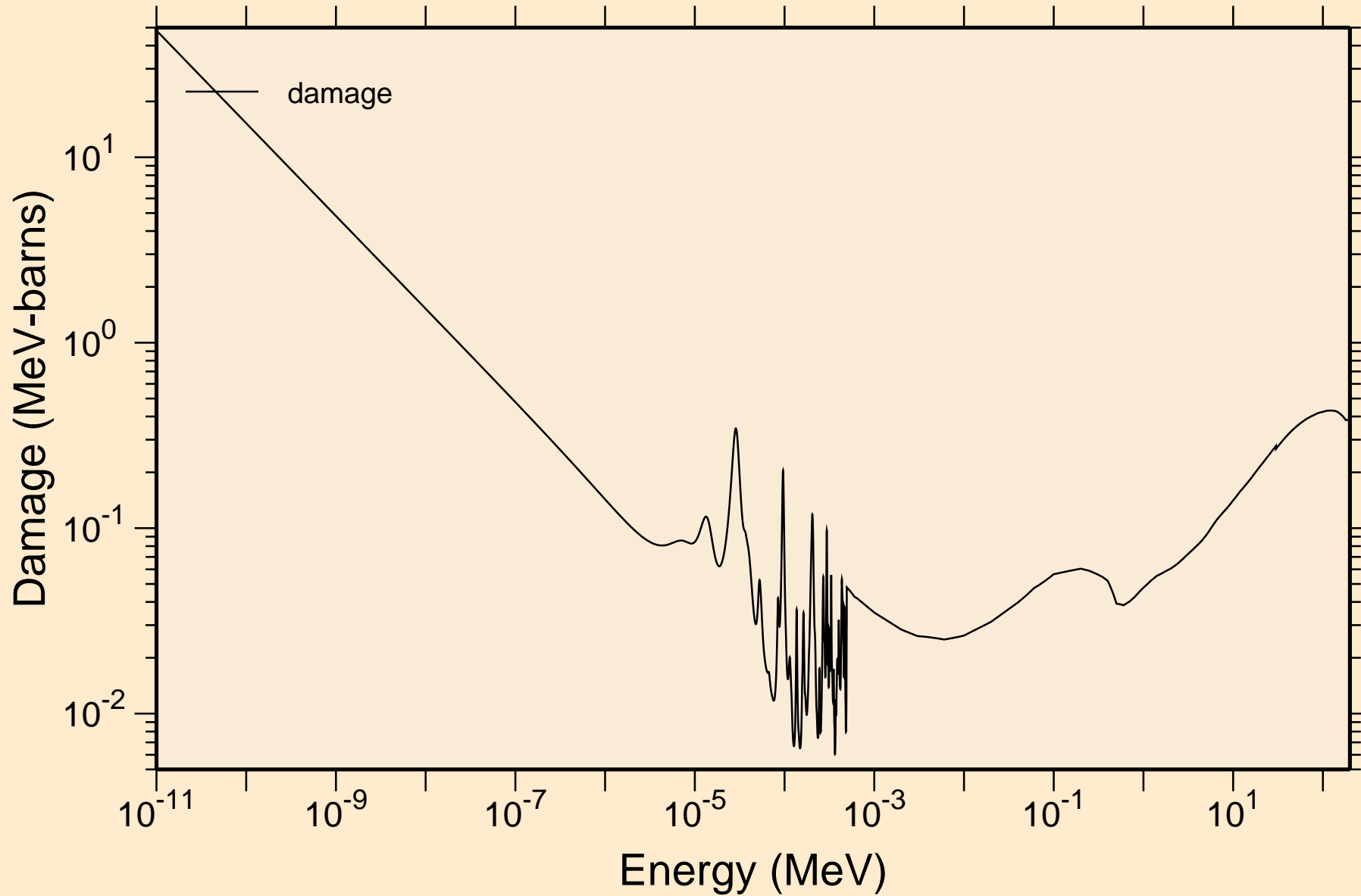

# SG272 NEUTRON ACER TENDL-2023 LIBRARY; T=0.K

## Non-threshold reactions

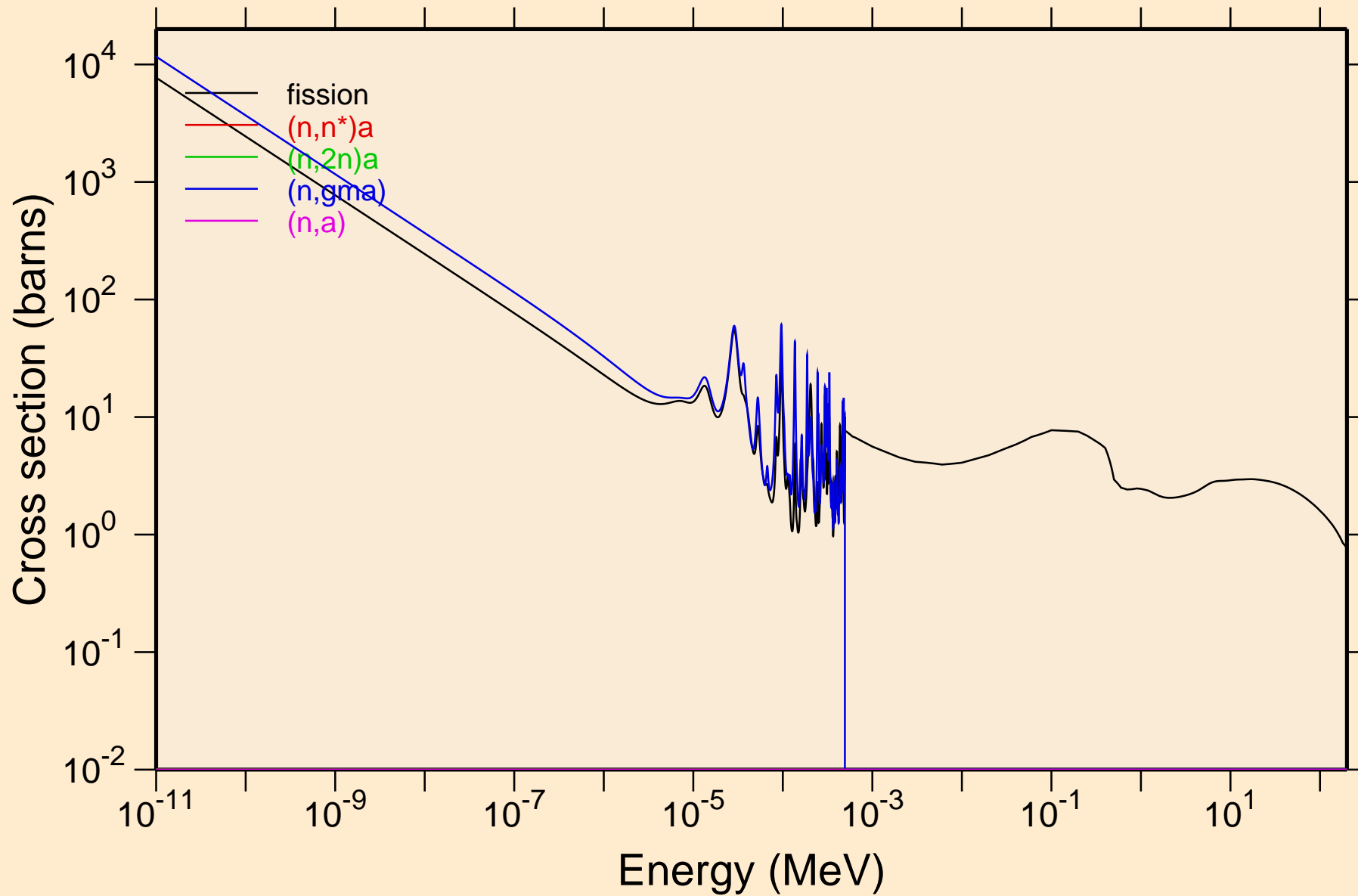

SG272 NEUTRON ACER TENDL-2023 LIBRARY; T=0.K  
Non-threshold reactions

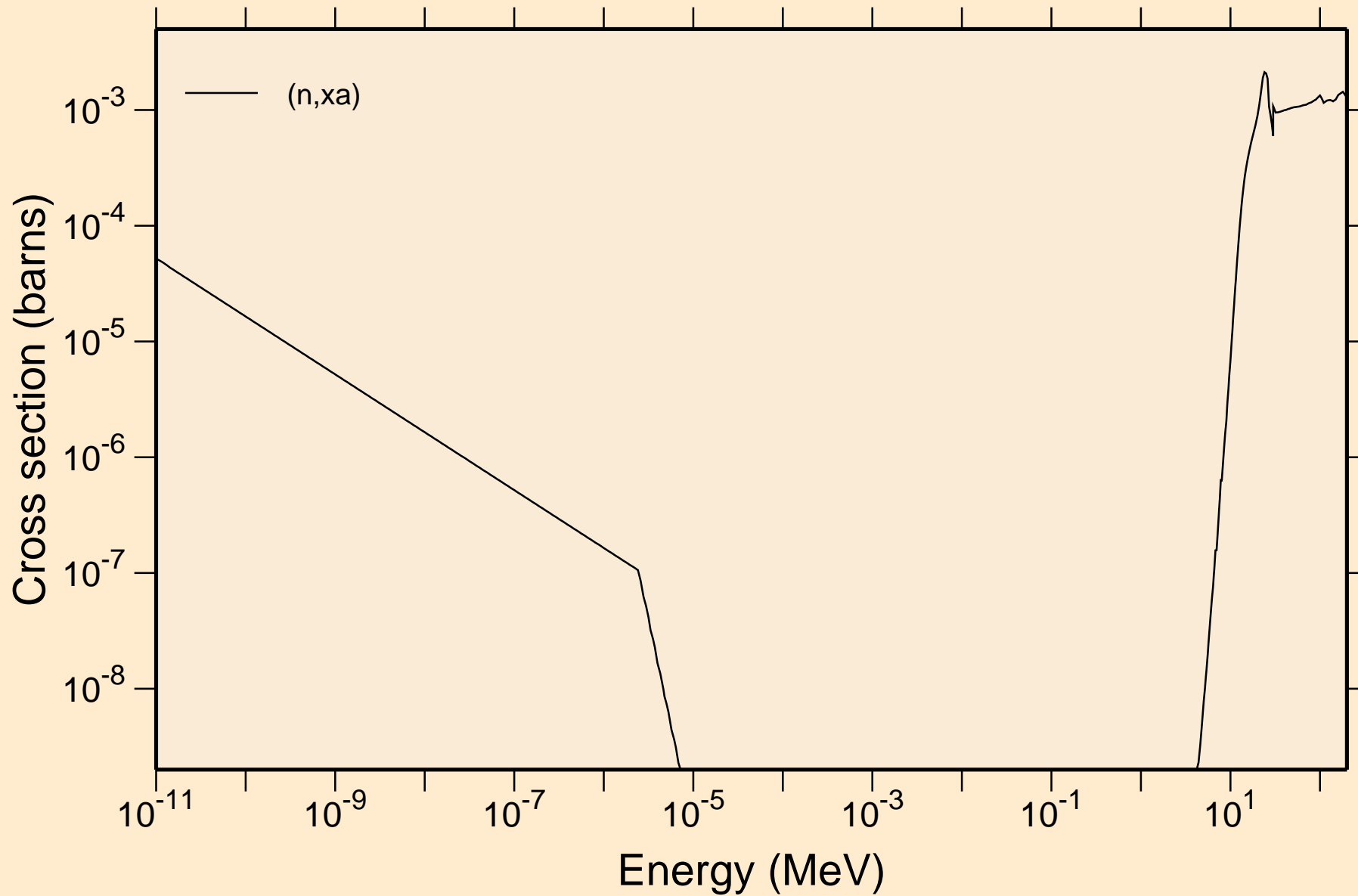

# SG272 NEUTRON ACER TENDL-2023 LIBRARY; T=0.K

## Principal cross sections

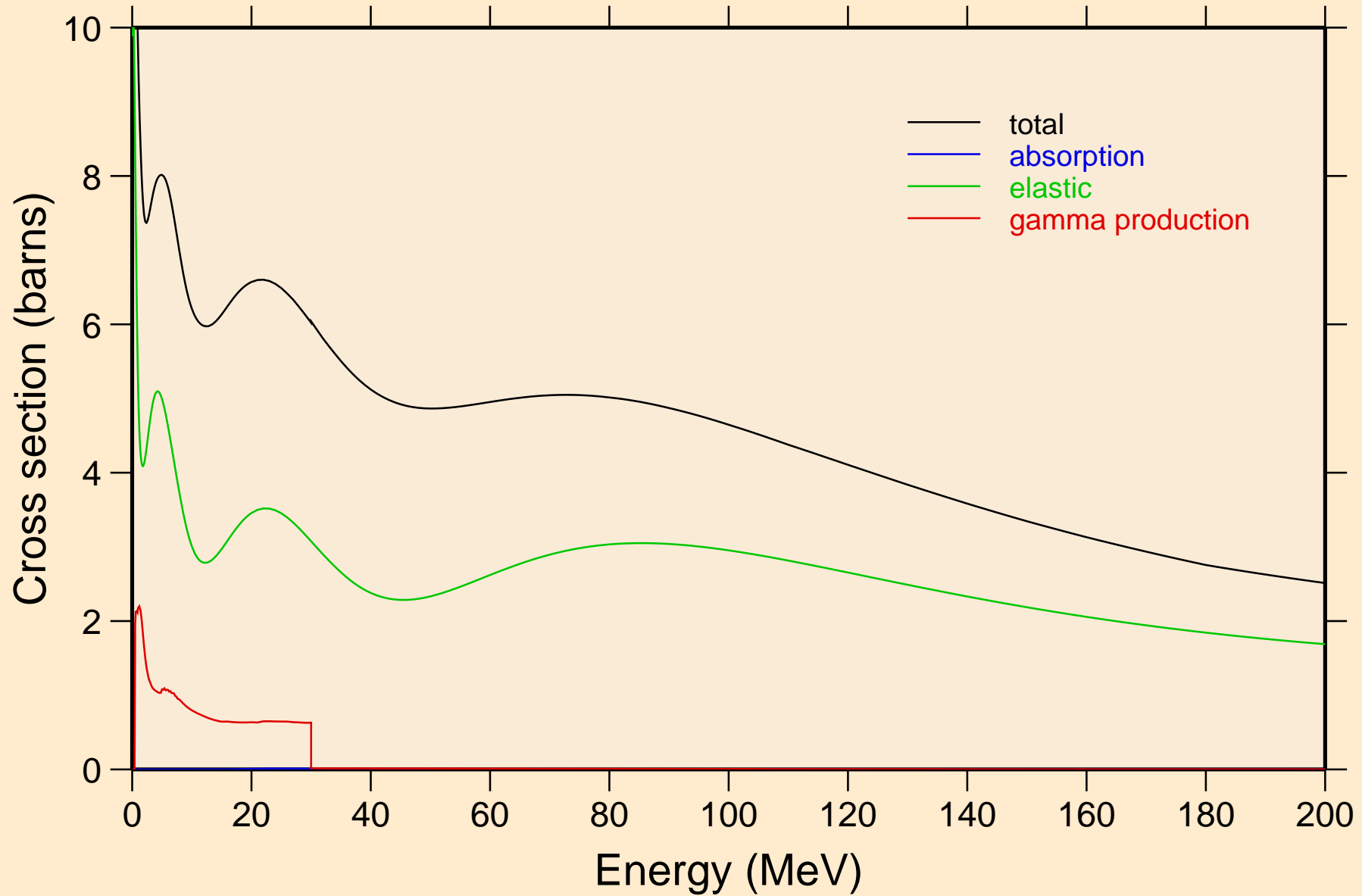

# SG272 NEUTRON ACER TENDL-2023 LIBRARY; T=0.K

## Heating

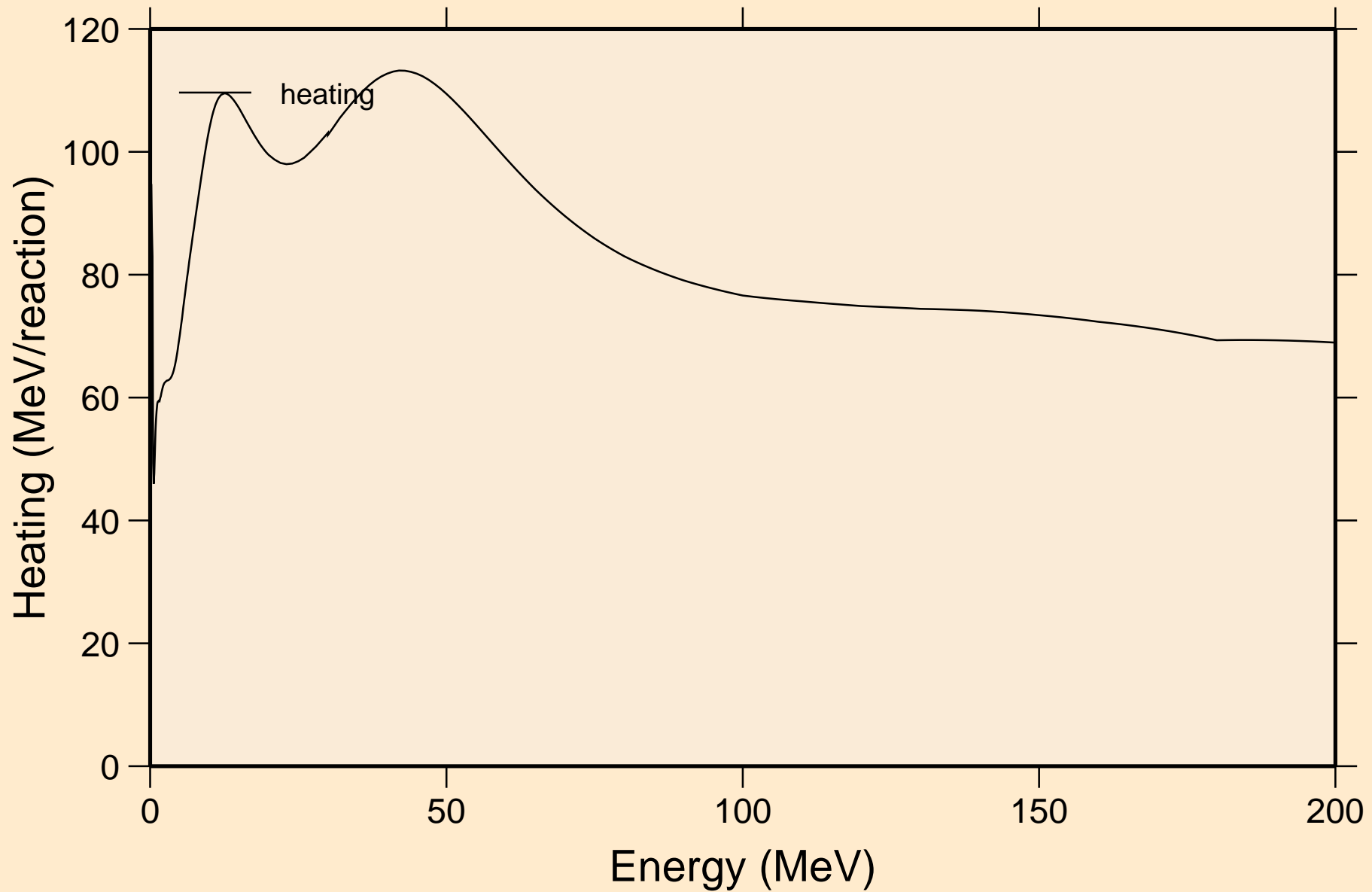

# SG272 NEUTRON ACER TENDL-2023 LIBRARY; T=0.K

## Damage

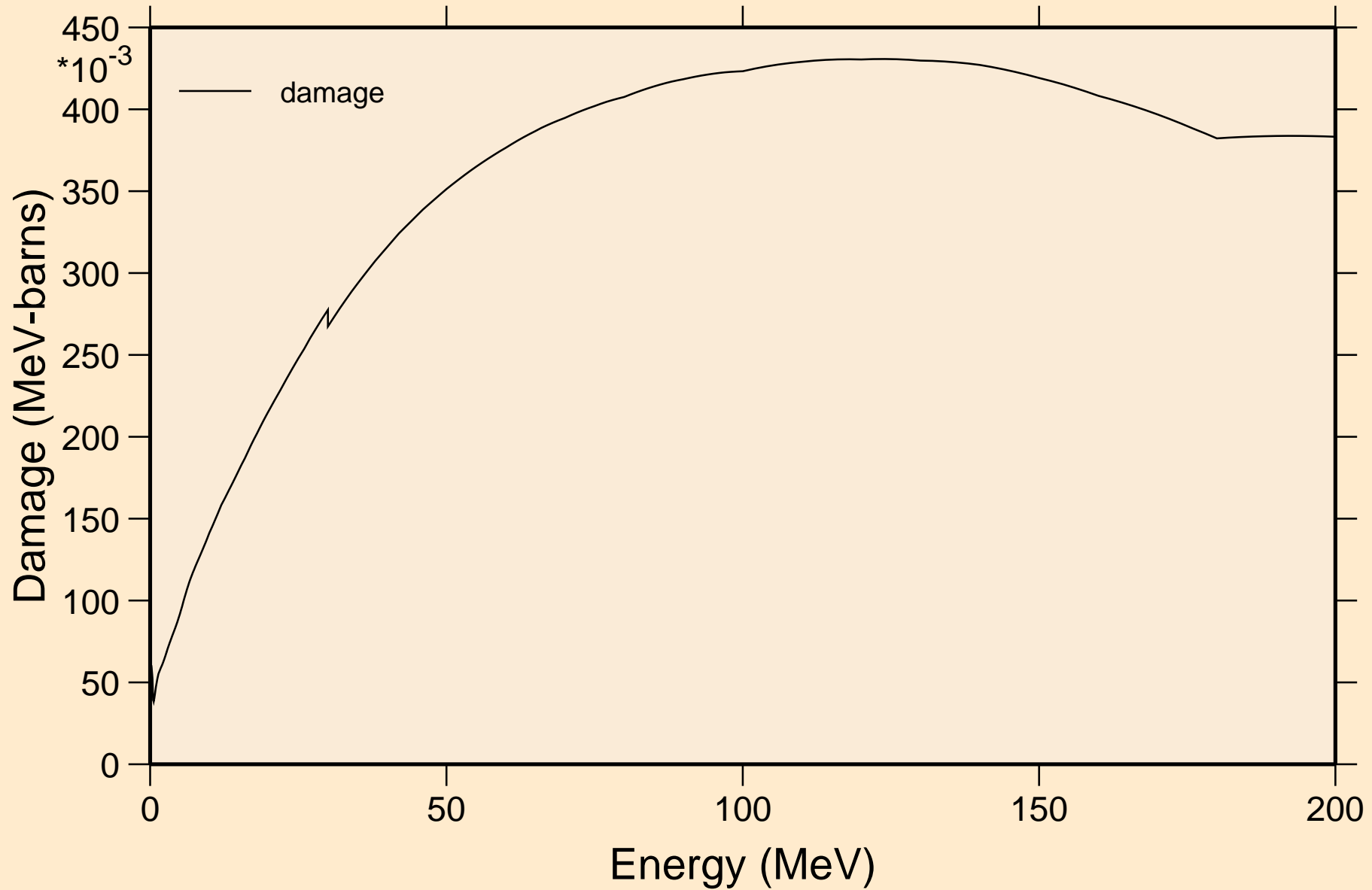

# SG272 NEUTRON ACER TENDL-2023 LIBRARY; T=0.K

## Non-threshold reactions

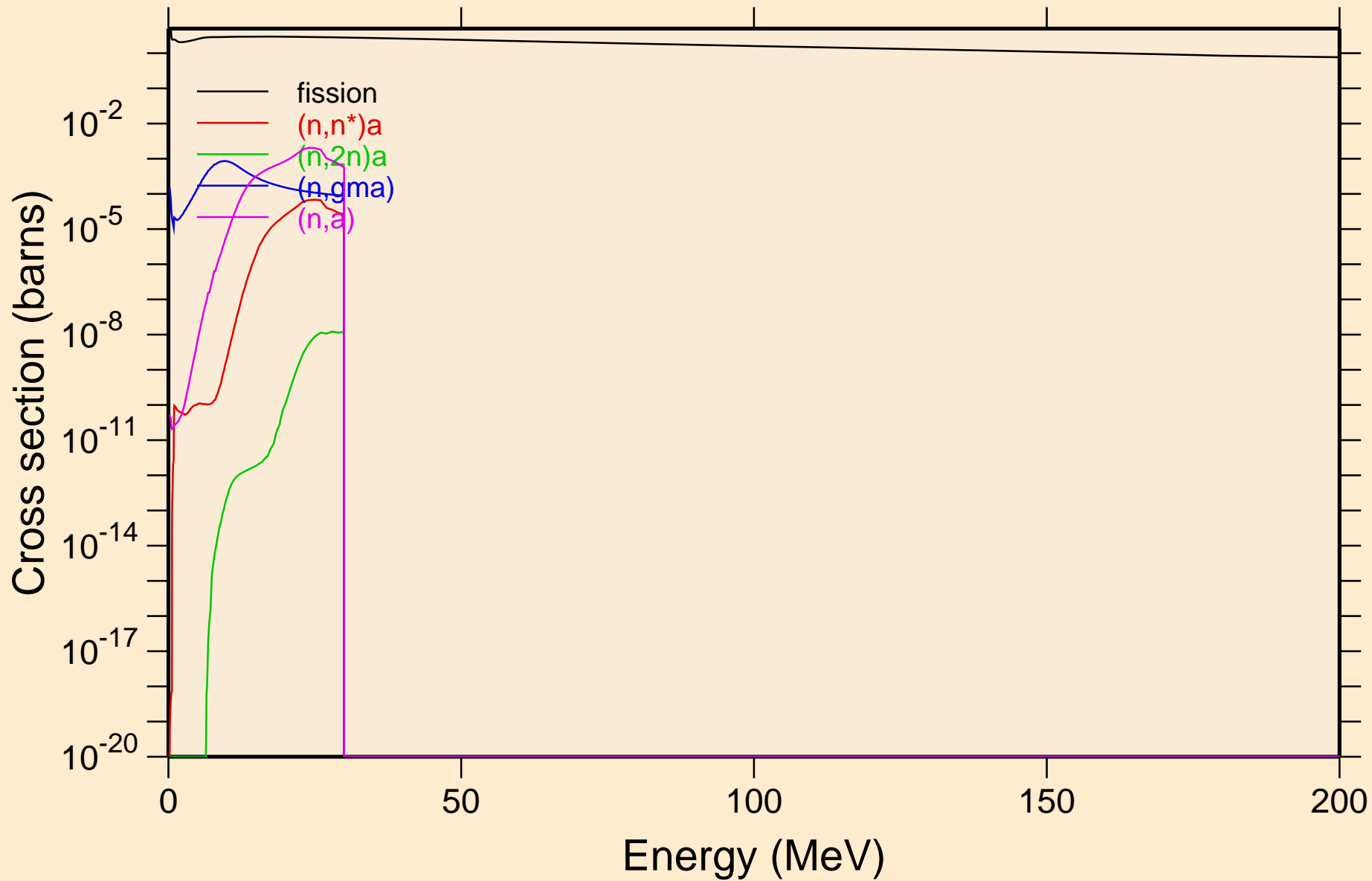

SG272 NEUTRON ACER TENDL-2023 LIBRARY; T=0.K  
Non-threshold reactions

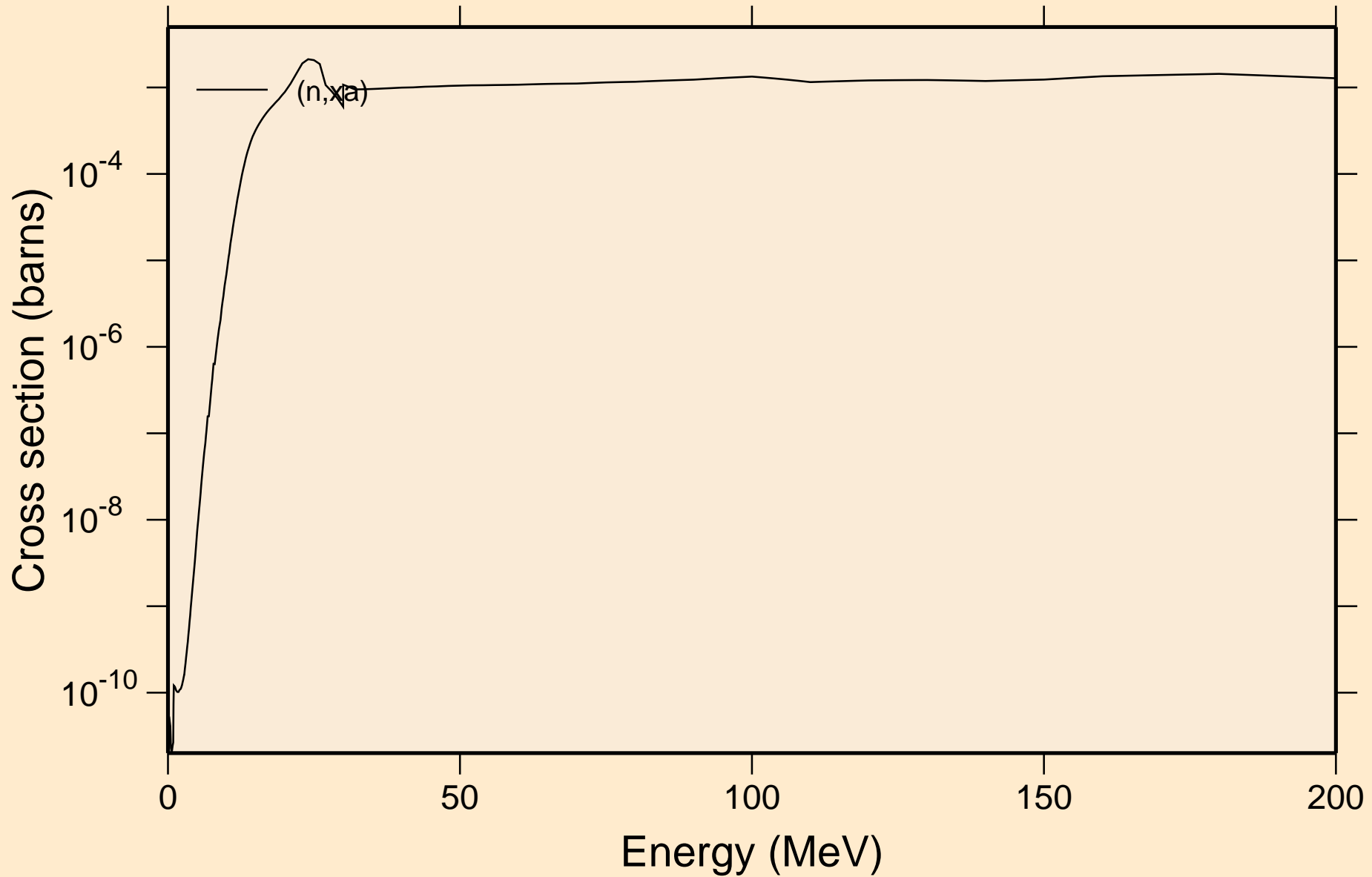



SG272 NEUTRON ACER TENDL-2023 LIBRARY; T=0.K  
Inelastic levels

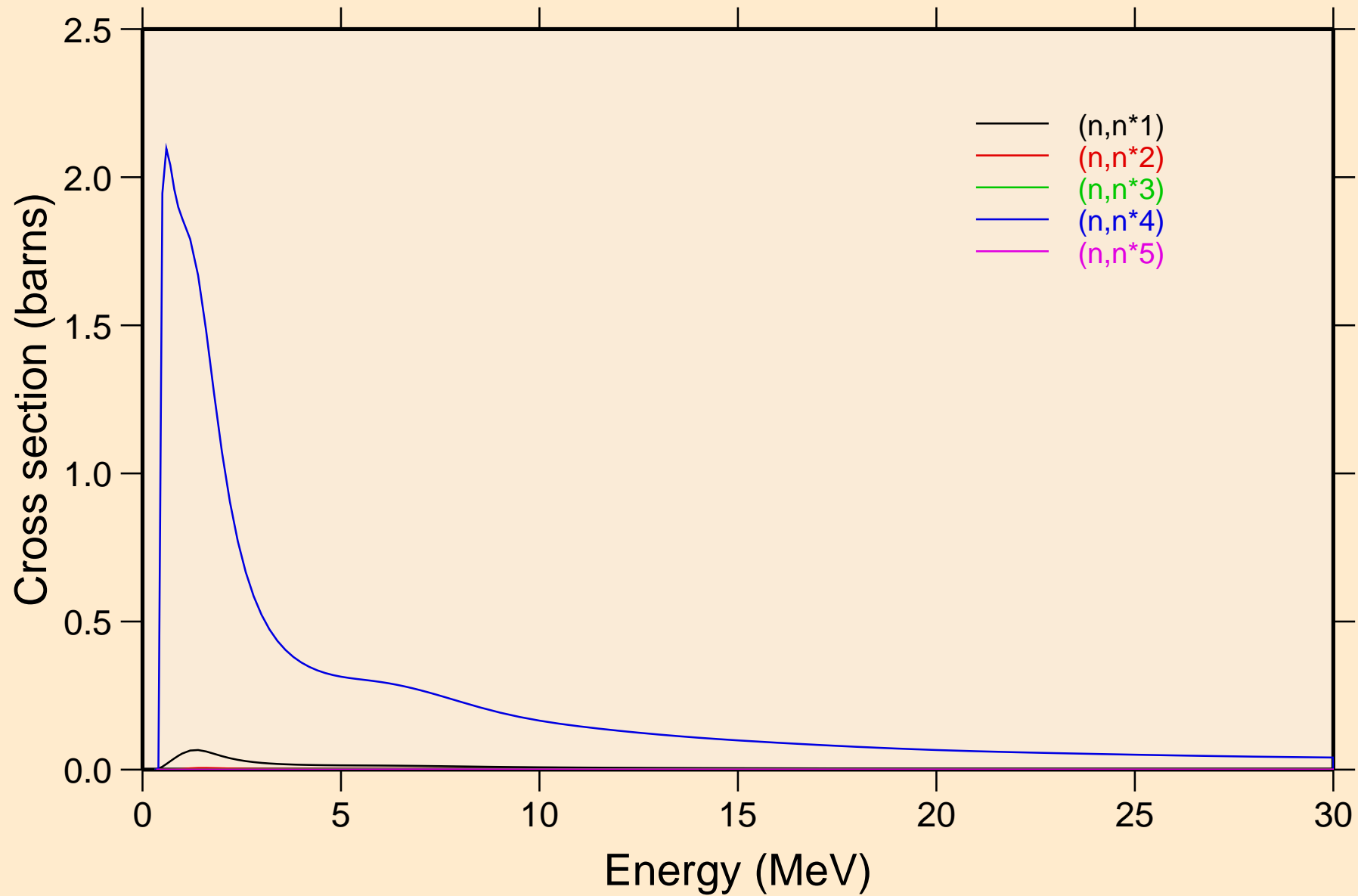

SG272 NEUTRON ACER TENDL-2023 LIBRARY; T=0.K  
Inelastic levels

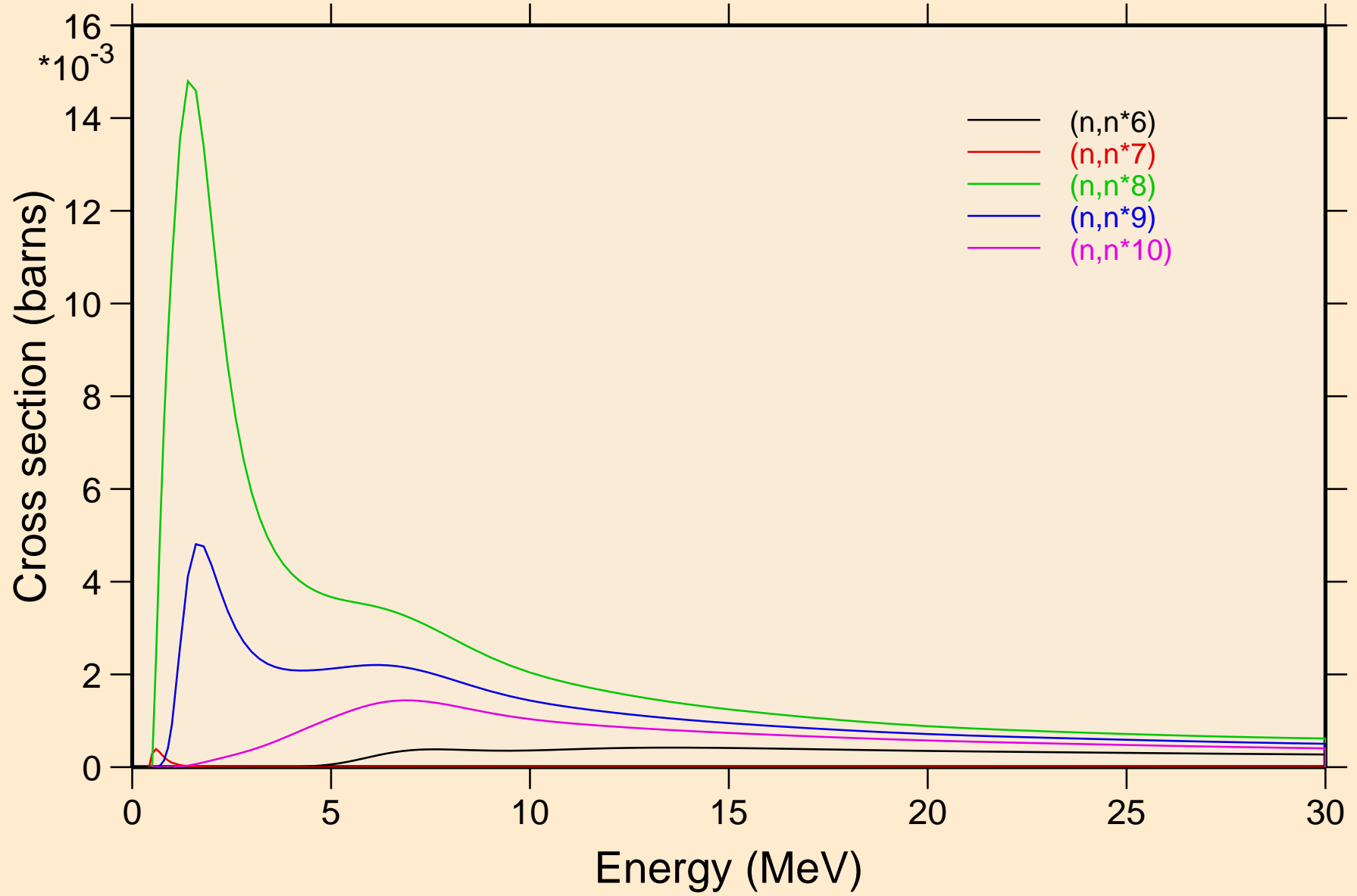

SG272 NEUTRON ACER TENDL-2023 LIBRARY; T=0.K  
Inelastic levels

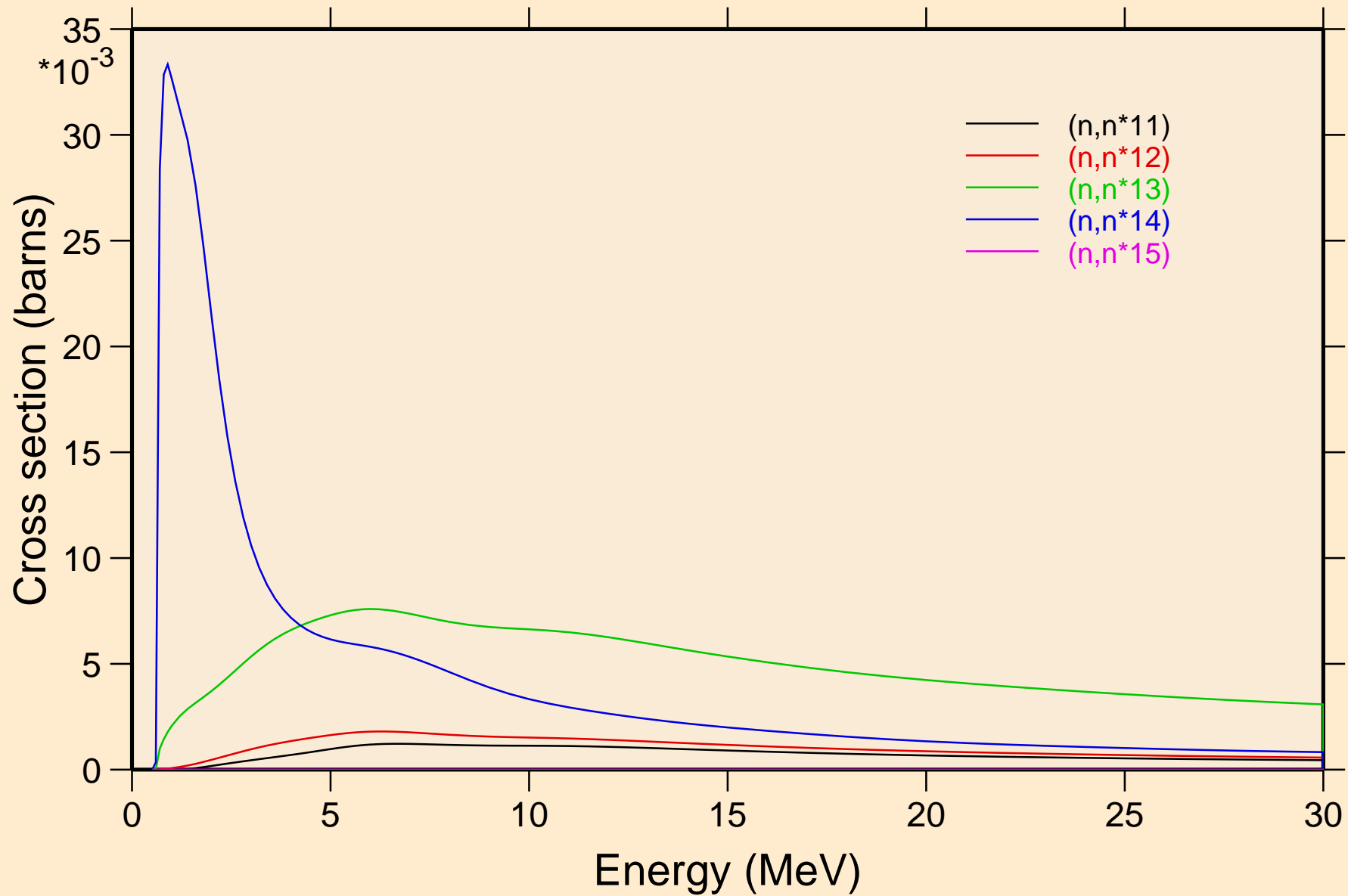

SG272 NEUTRON ACER TENDL-2023 LIBRARY; T=0.K  
Inelastic levels

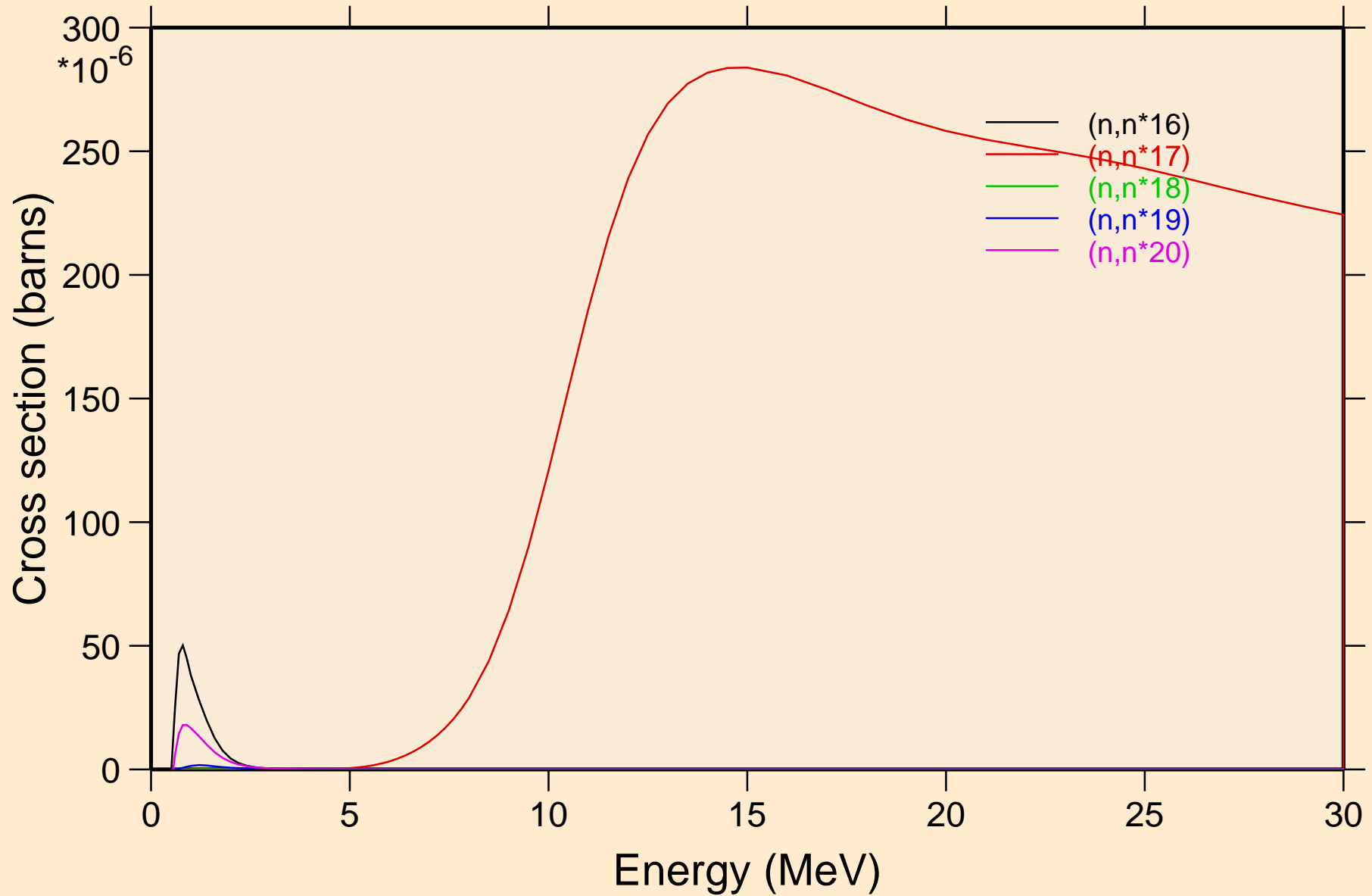

SG272 NEUTRON ACER TENDL-2023 LIBRARY; T=0.K  
Inelastic levels

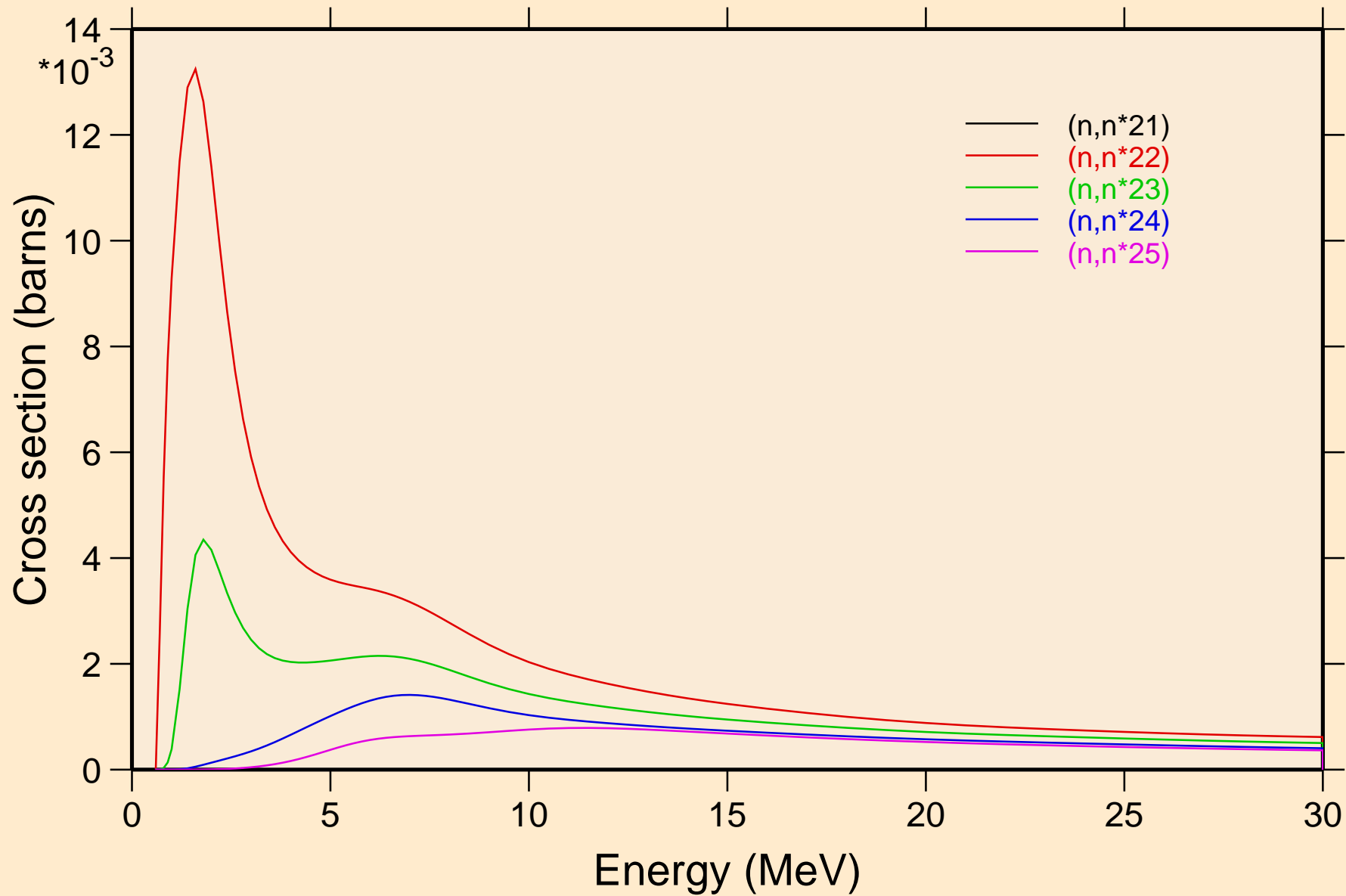

SG272 NEUTRON ACER TENDL-2023 LIBRARY; T=0.K  
Inelastic levels

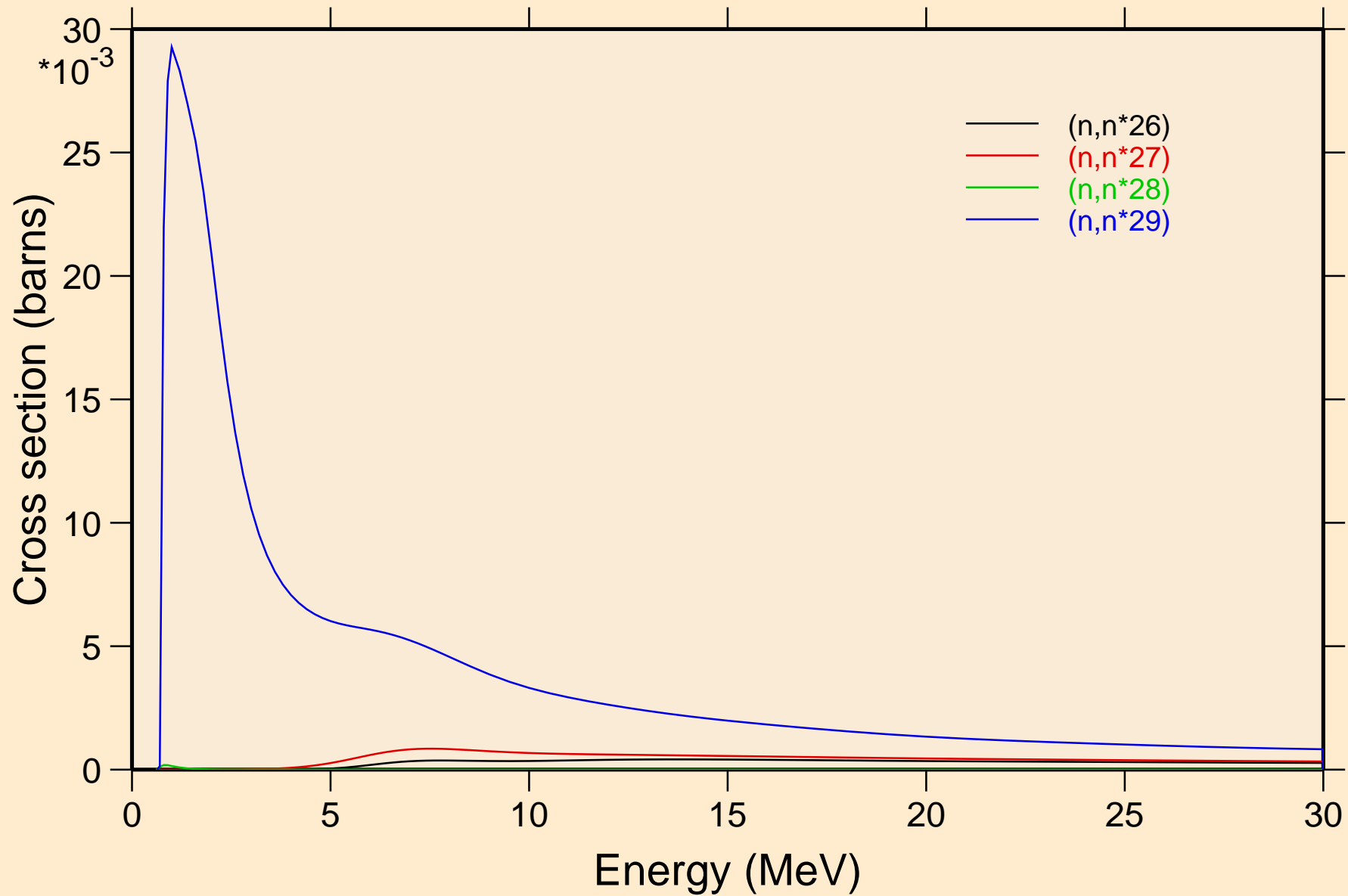

# SG272 NEUTRON ACER TENDL-2023 LIBRARY; T=0.K

## Threshold reactions

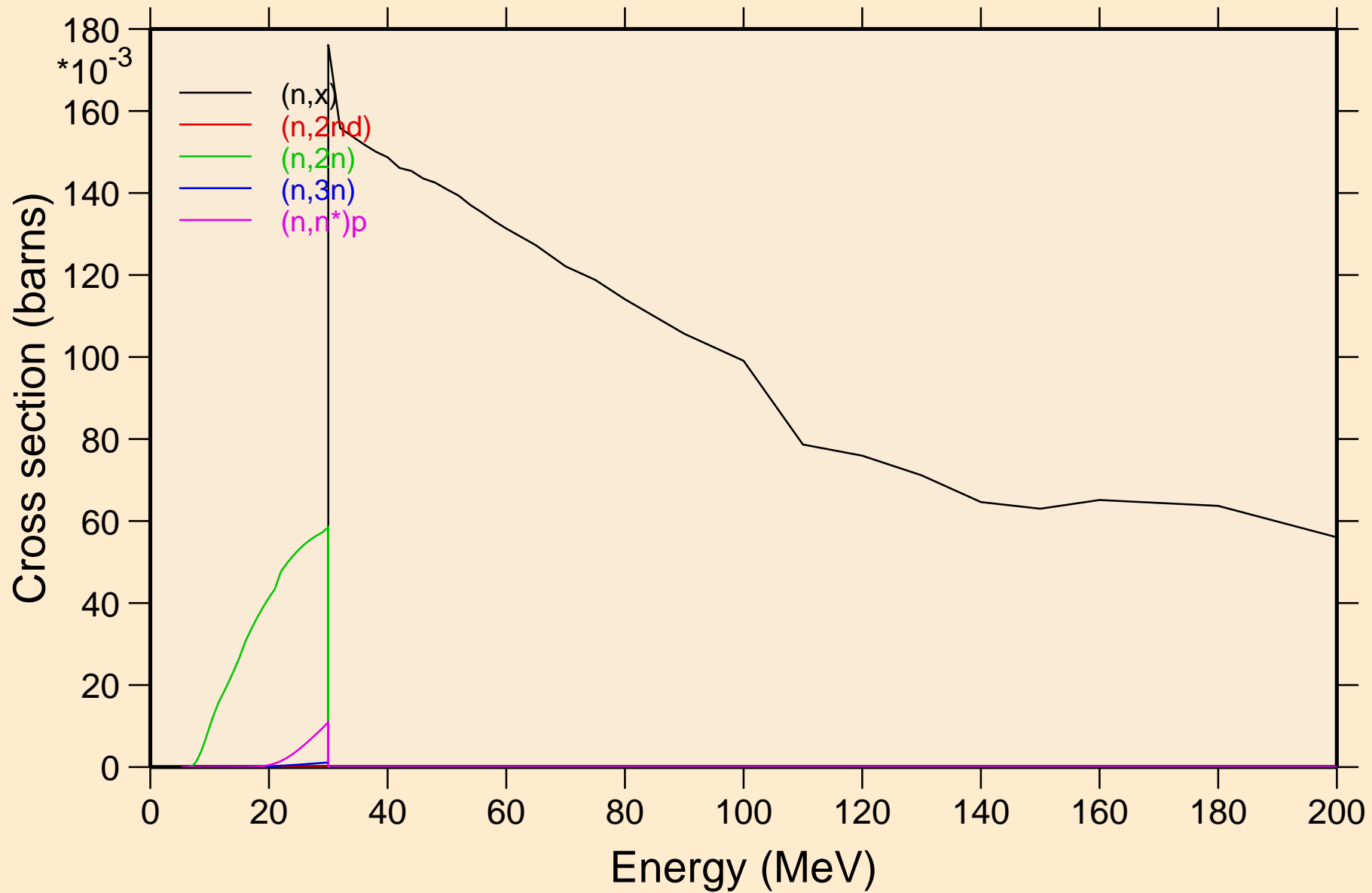

# SG272 NEUTRON ACER TENDL-2023 LIBRARY; T=0.K

## Threshold reactions

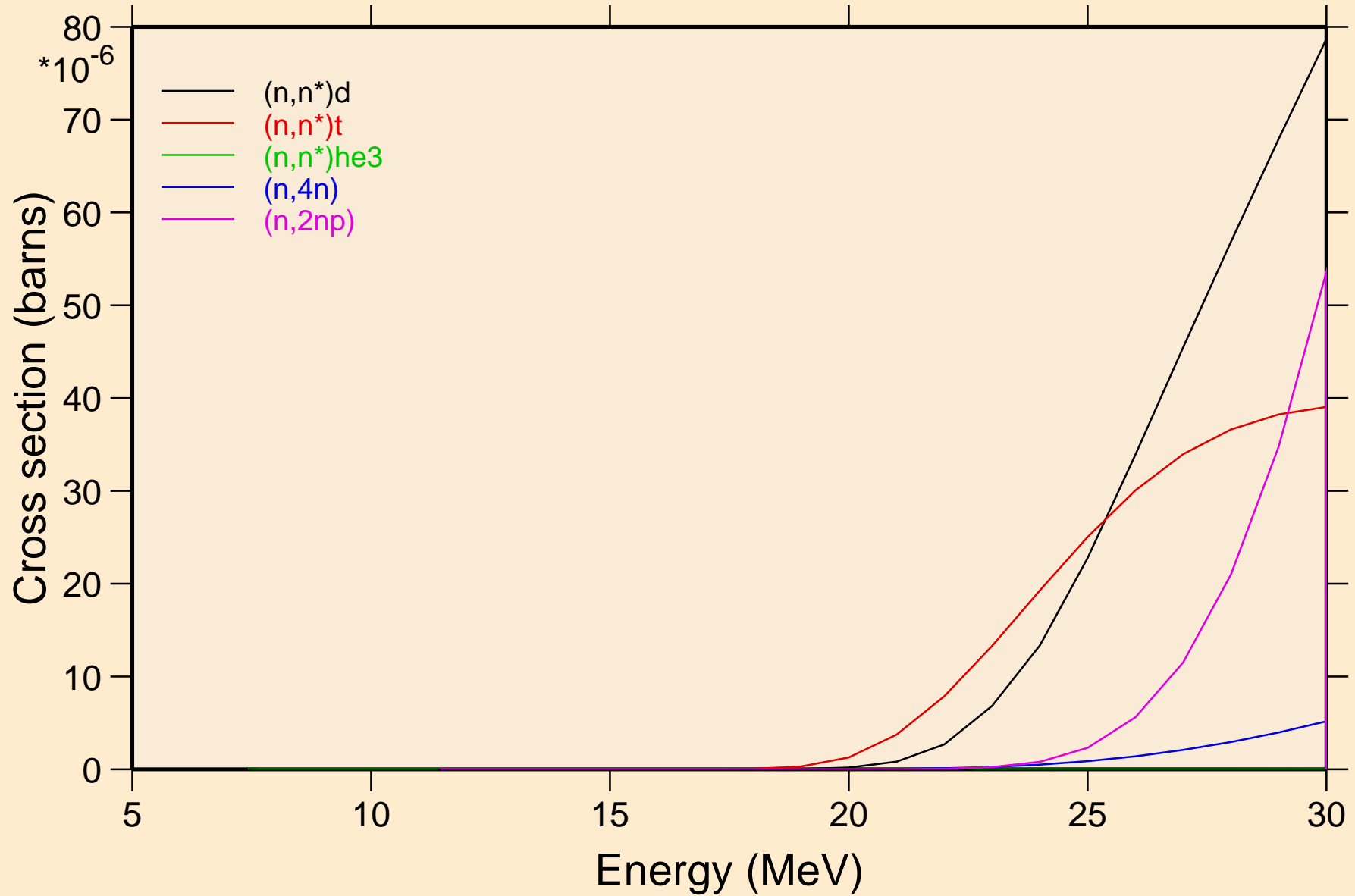



# SG272 NEUTRON ACER TENDL-2023 LIBRARY; T=0.K

## Threshold reactions

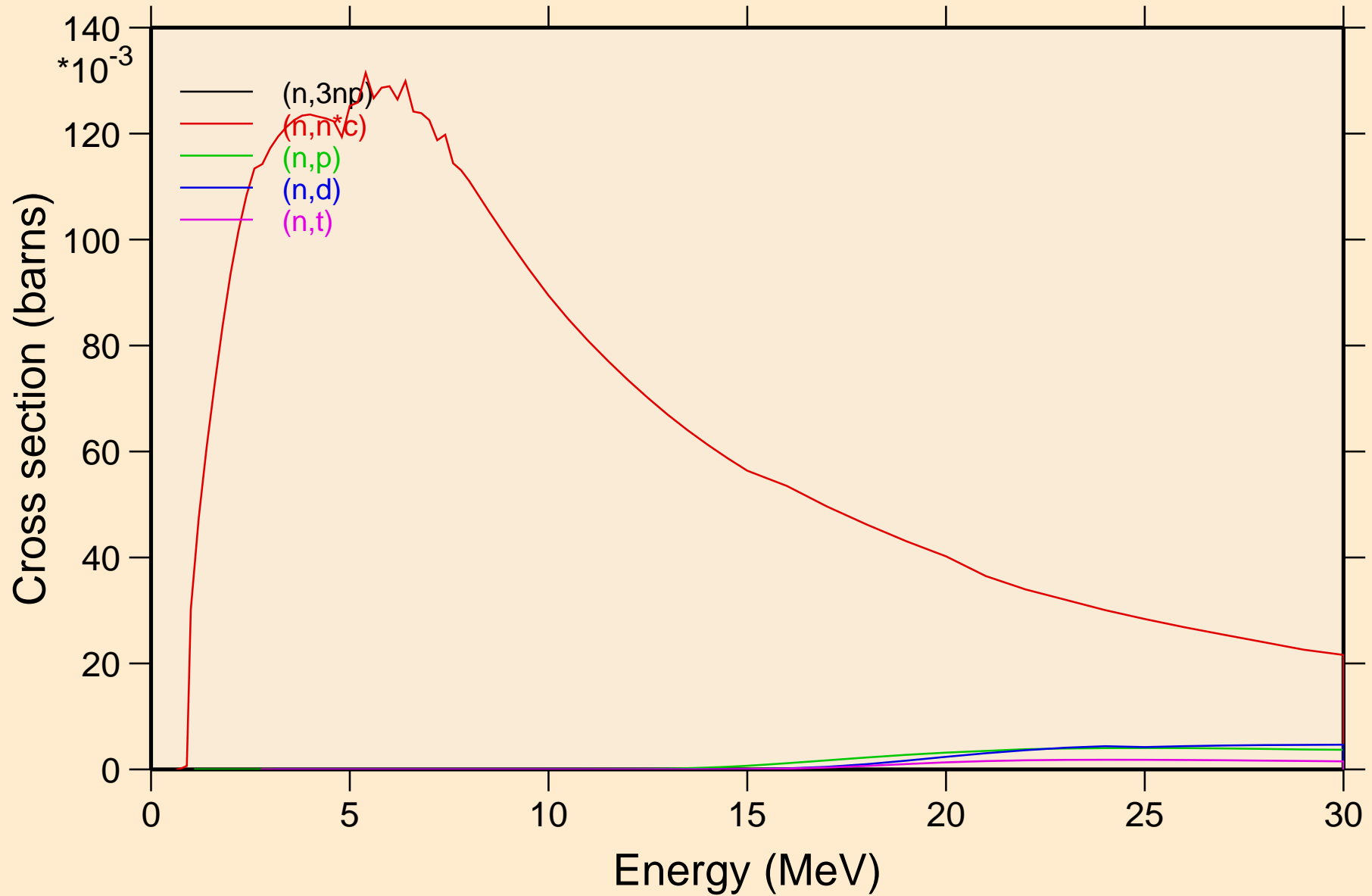

SG272 NEUTRON ACER TENDL-2023 LIBRARY; T=0.K  
Threshold reactions

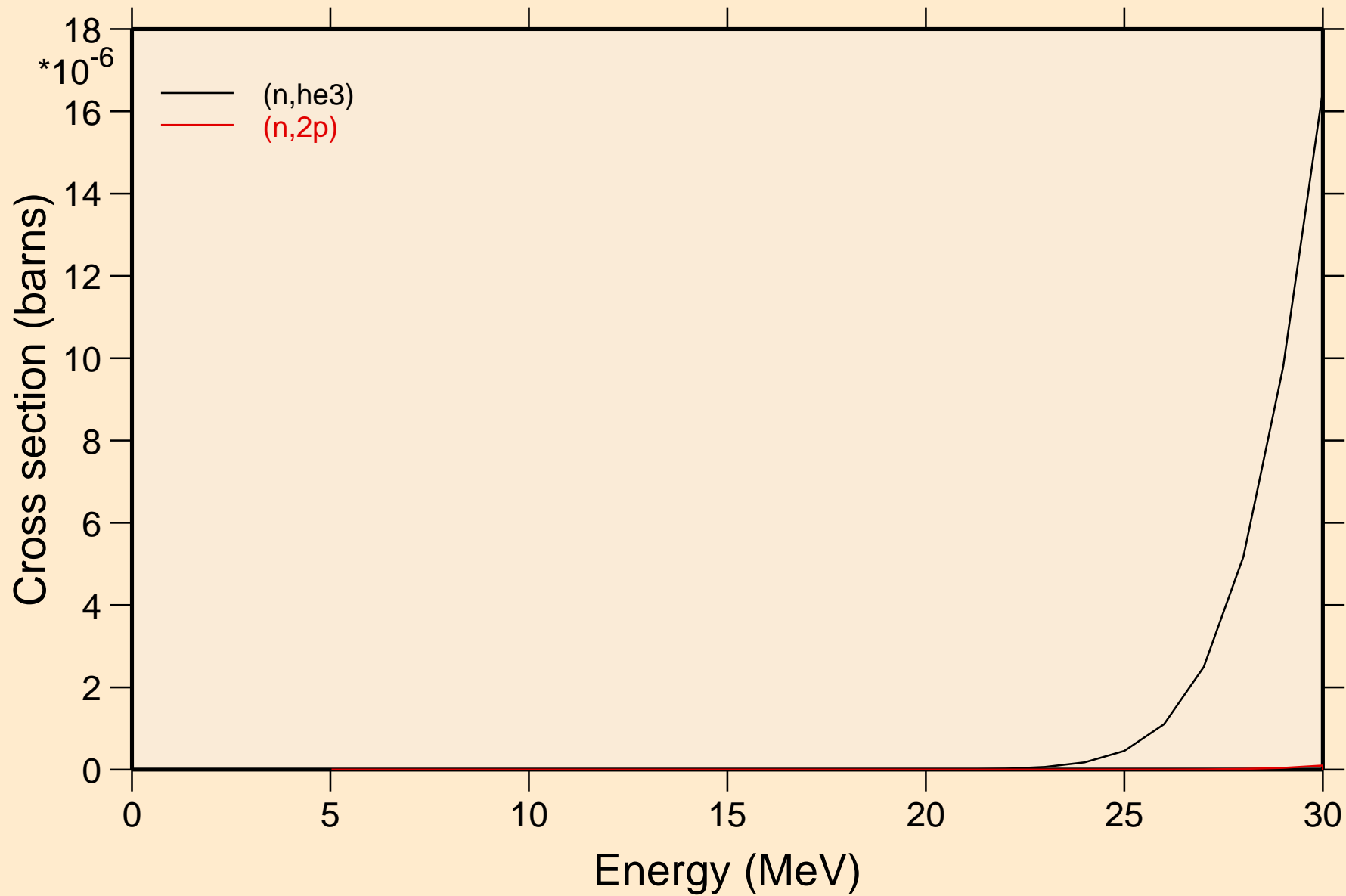

# SG272 NEUTRON ACER TENDL-2023 LIBRARY; T=0.K

## Threshold reactions

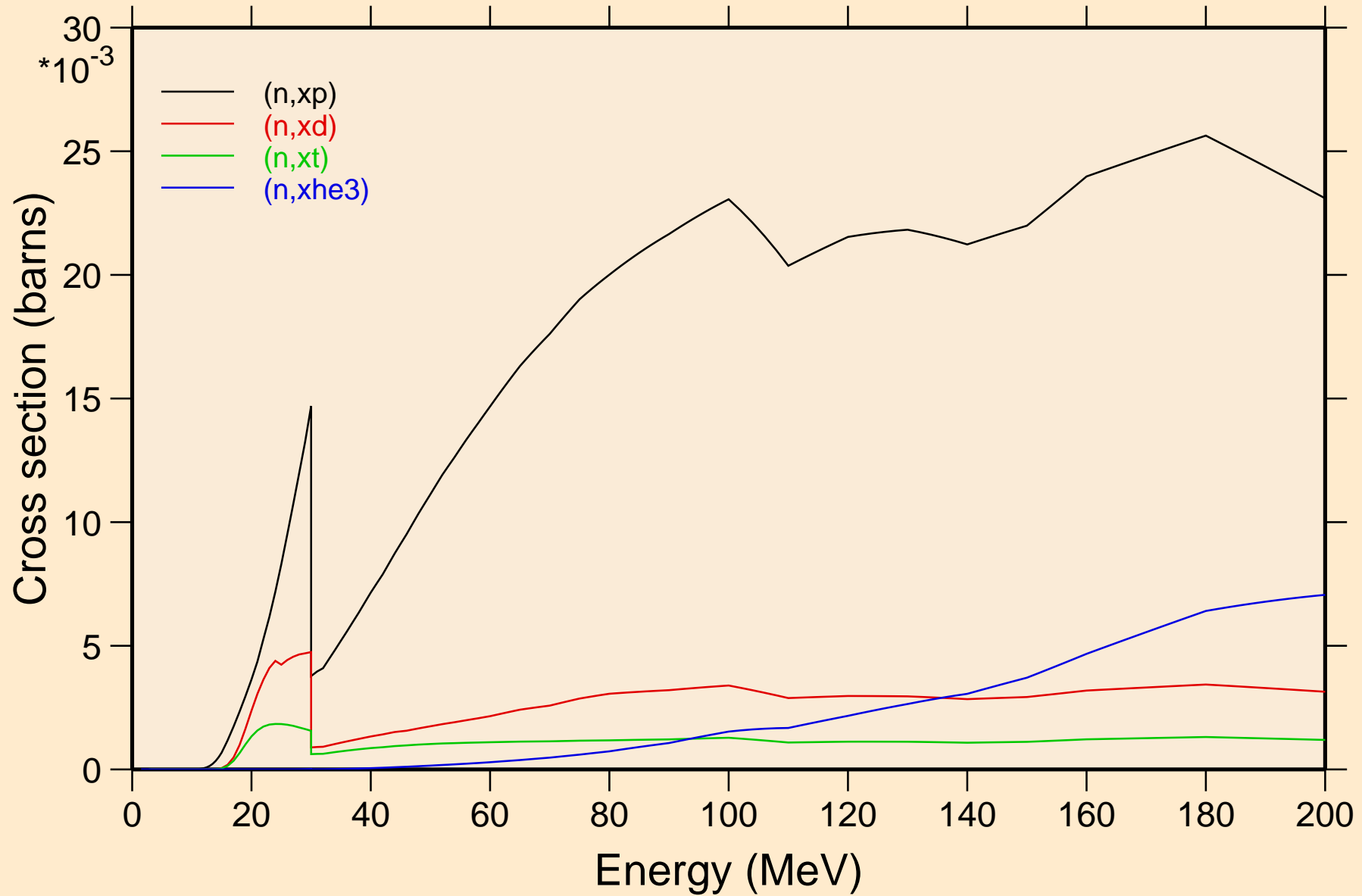

SG272 NEUTRON ACER TENDL-2023 LIBRARY; T=0.K  
angular distribution for elastic

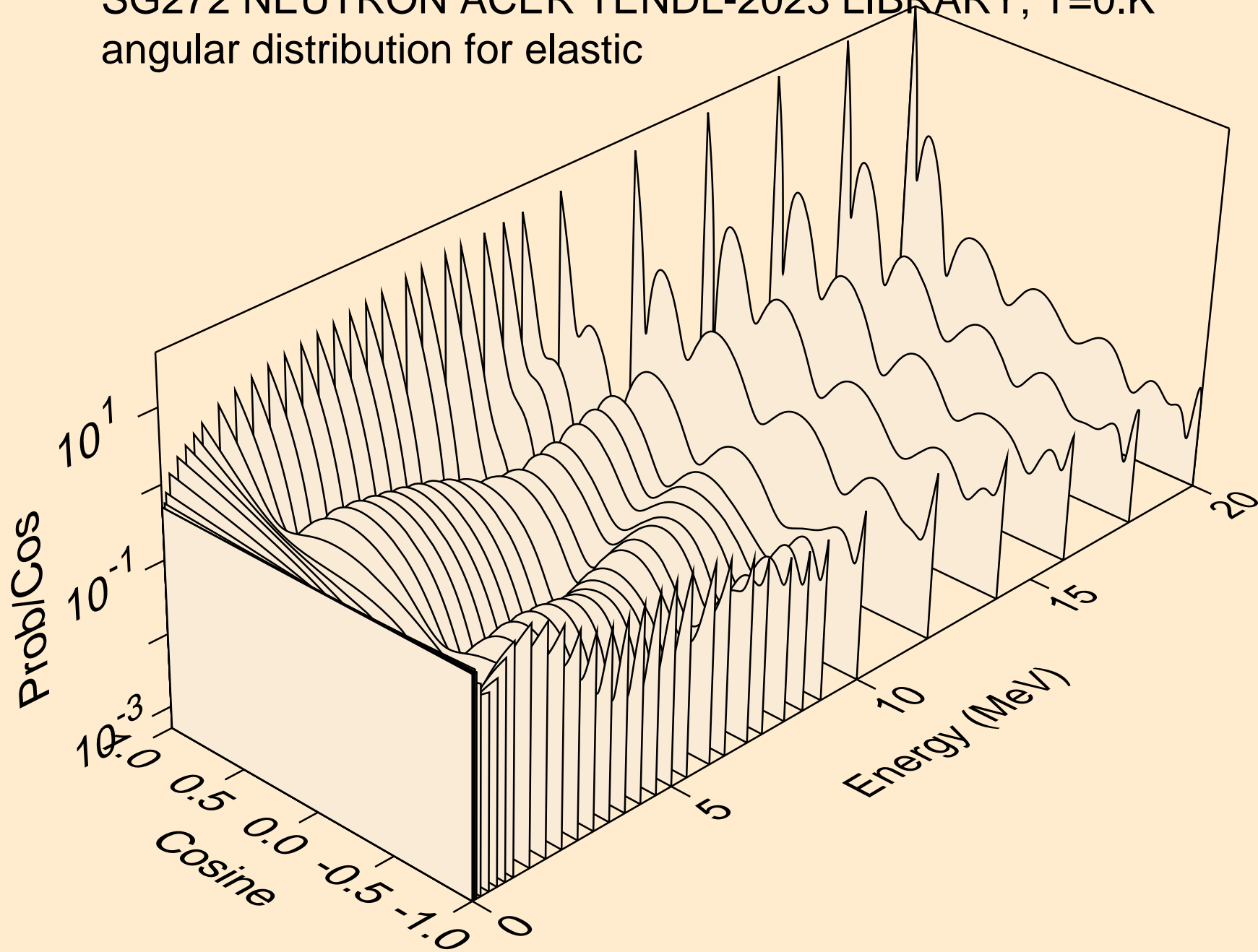

SG272 NEUTRON ACER TENDL-2023 LIBRARY; T=0.K  
angular distribution for elastic

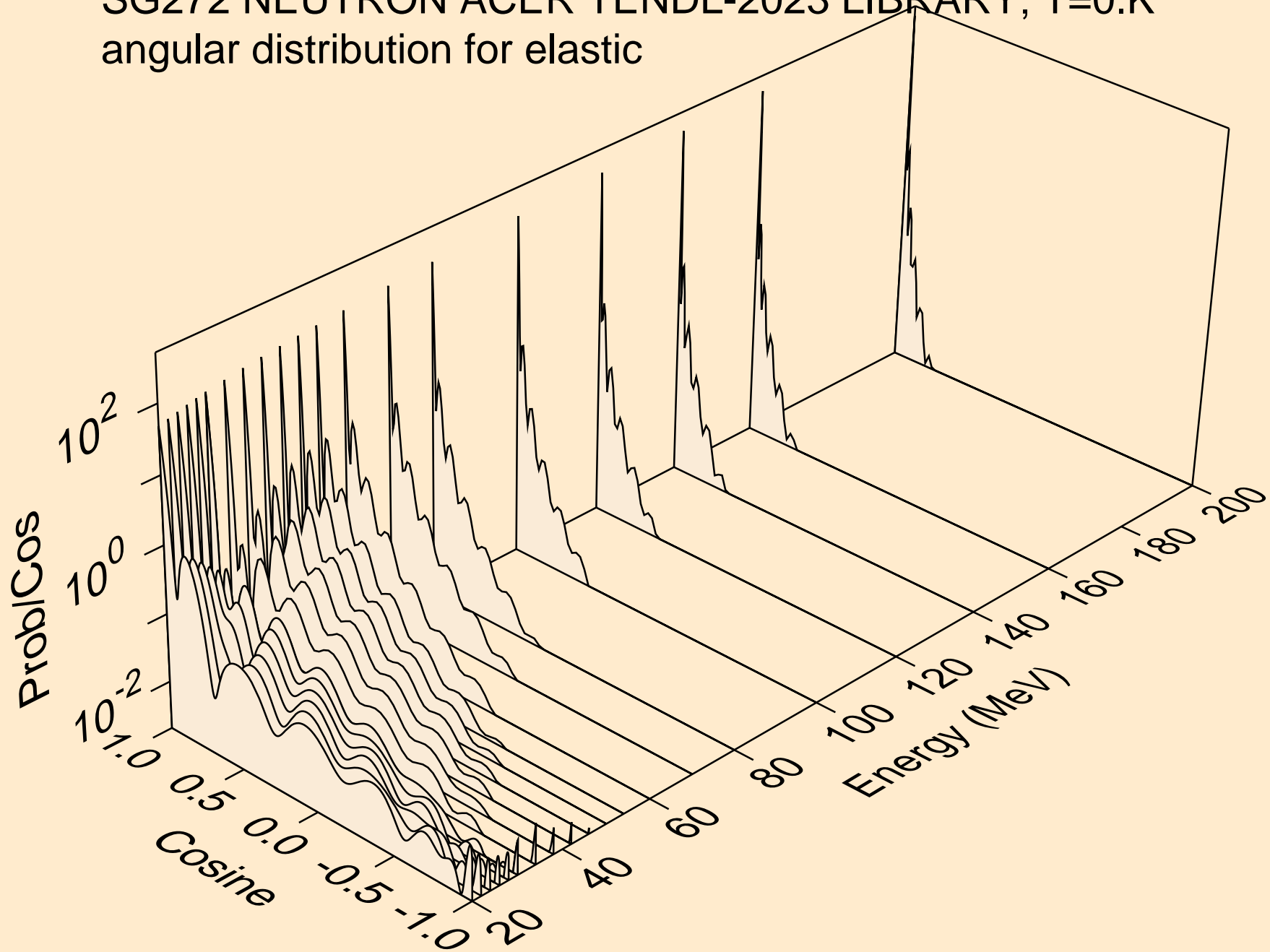

SG272 NEUTRON ACER TENDL-2023 LIBRARY; T=0.K  
angular distribution for (n,n\*1)

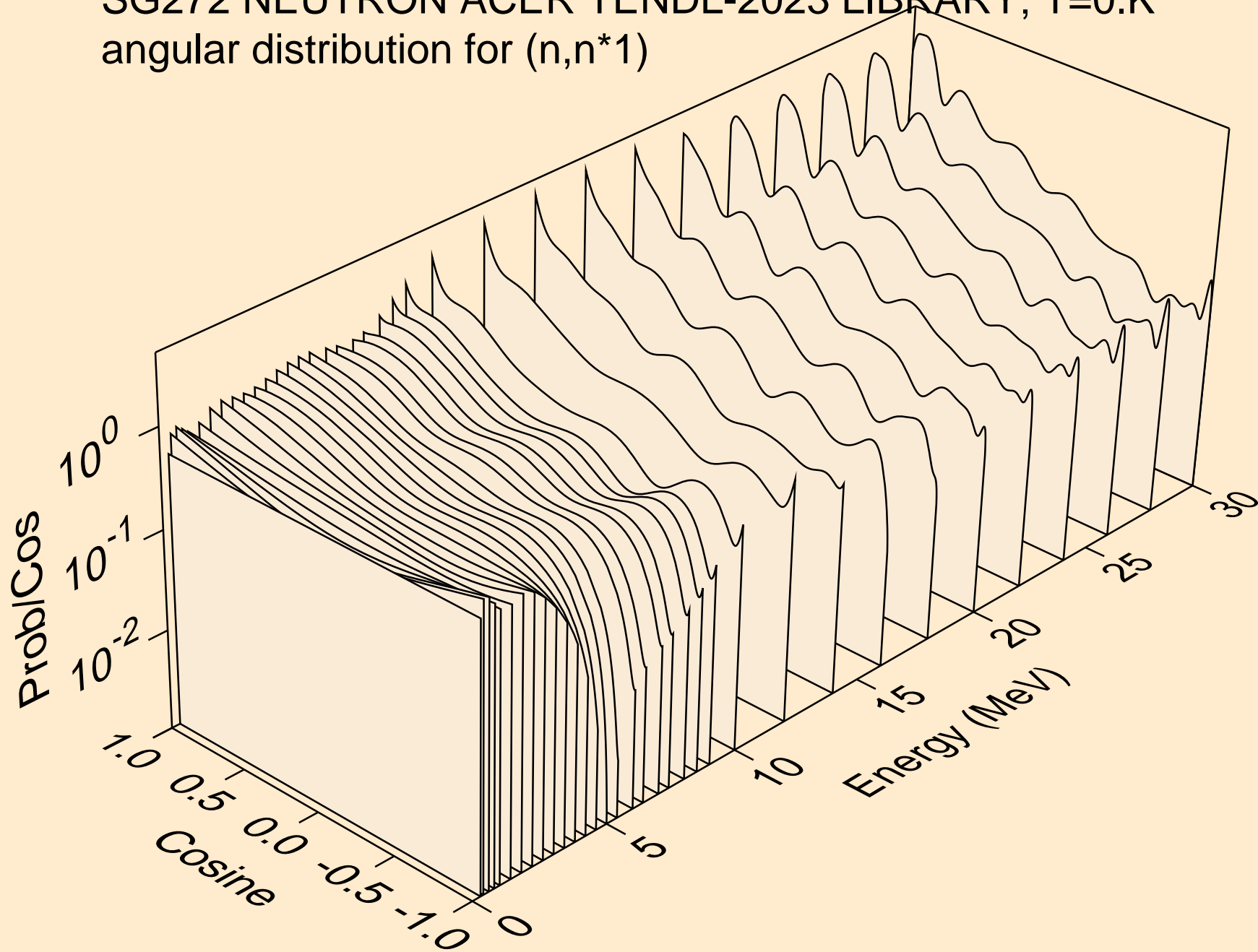

SG272 NEUTRON ACER TENDL-2023 LIBRARY; T=0.K  
angular distribution for (n,n\*2)

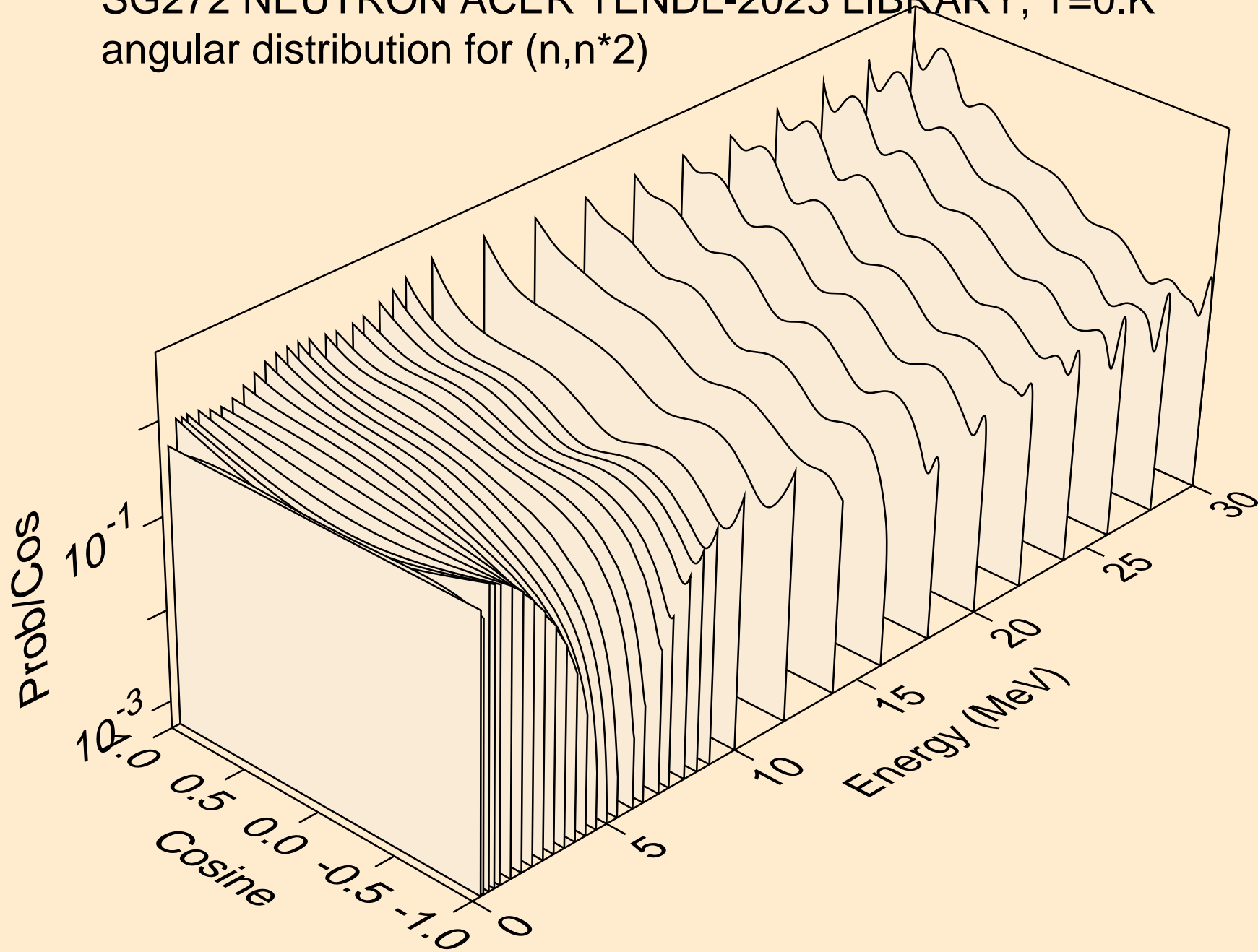

SG272 NEUTRON ACER TENDL-2023 LIBRARY; T=0.K  
angular distribution for (n,n\*3)

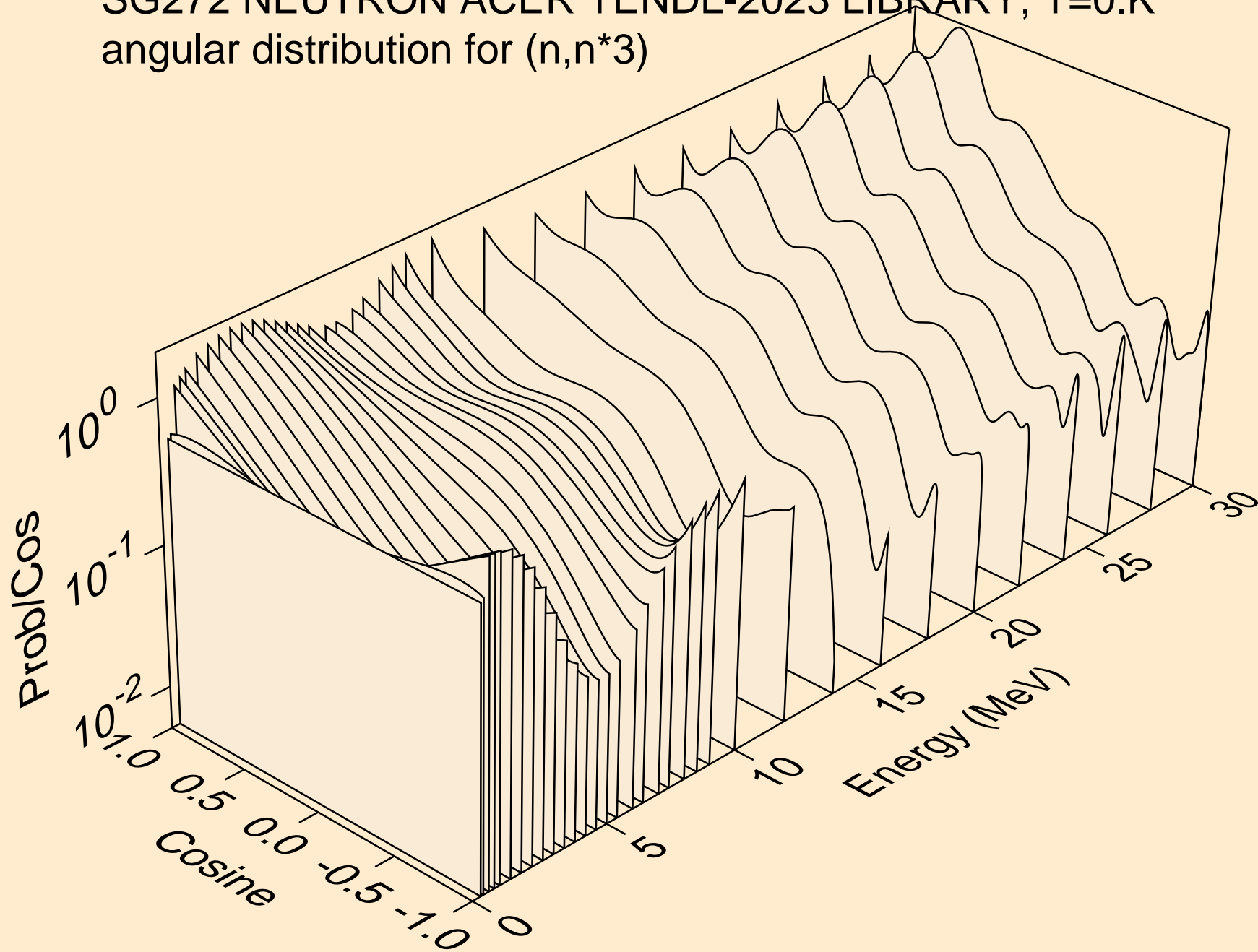



SG272 NEUTRON ACER TENDL-2023 LIBRARY; T=0.K  
angular distribution for (n,n\*4)

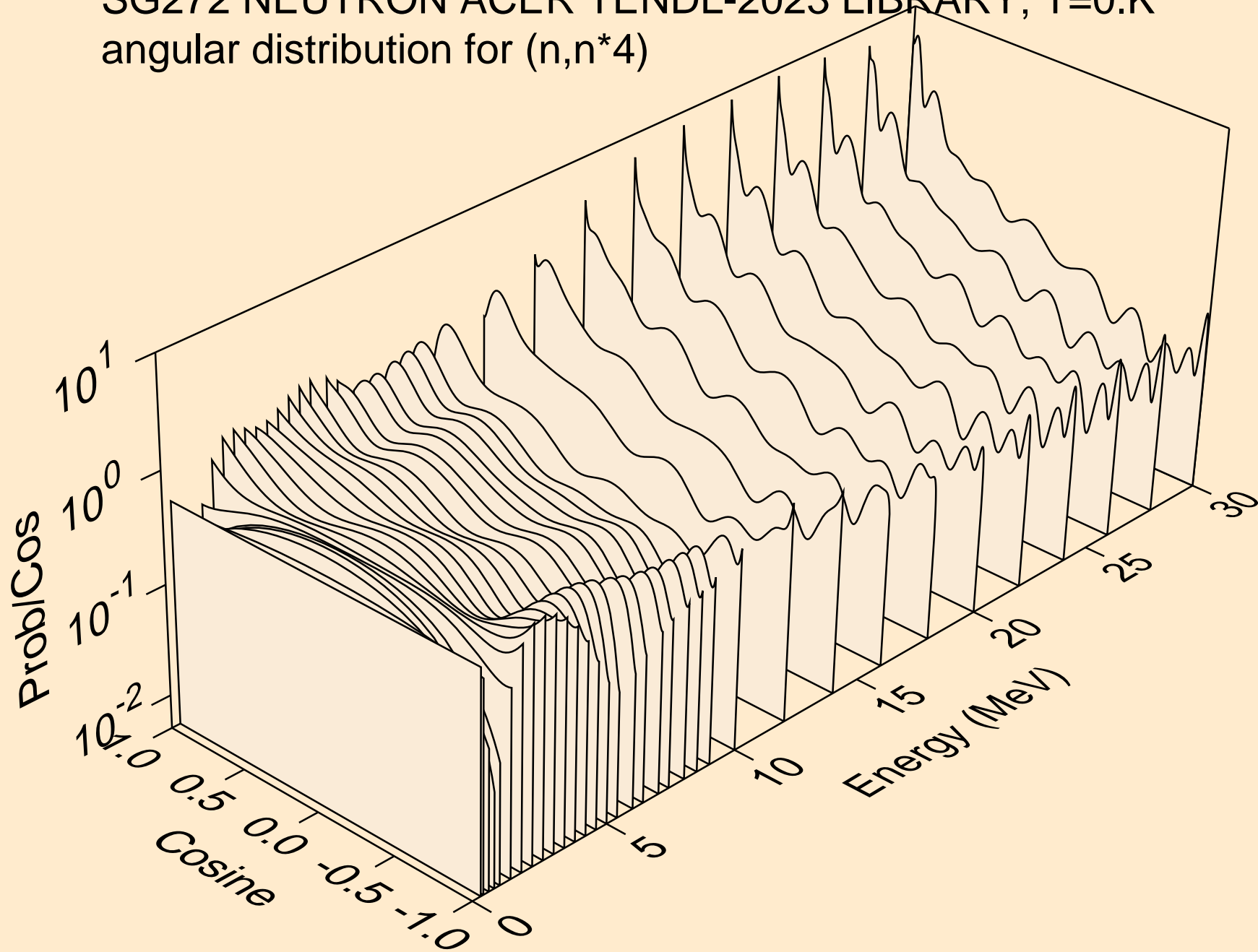

SG272 NEUTRON ACER TENDL-2023 LIBRARY; T=0.K  
angular distribution for (n,n\*5)

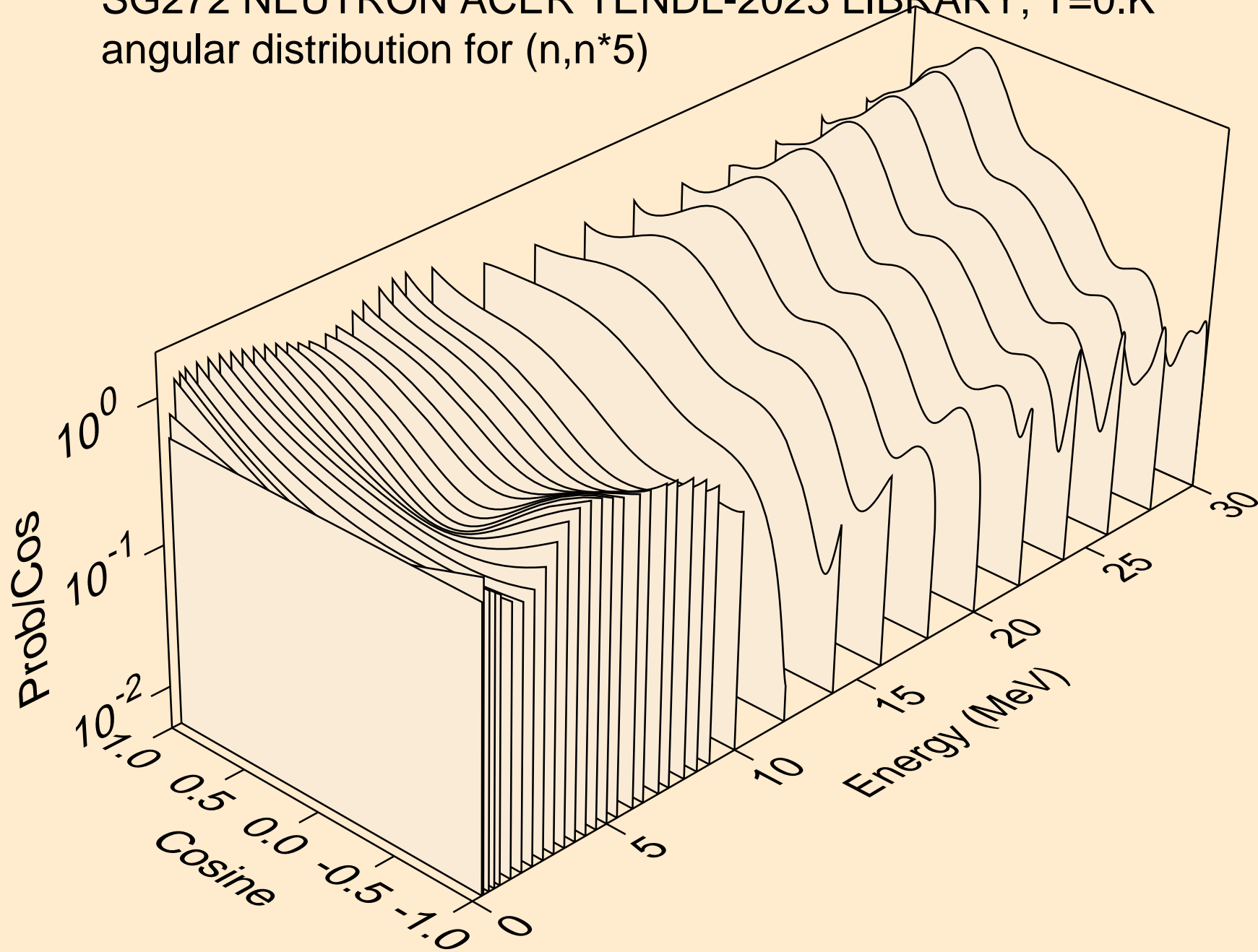

SG272 NEUTRON ACER TENDL-2023 LIBRARY; T=0.K  
angular distribution for (n,n\*6)

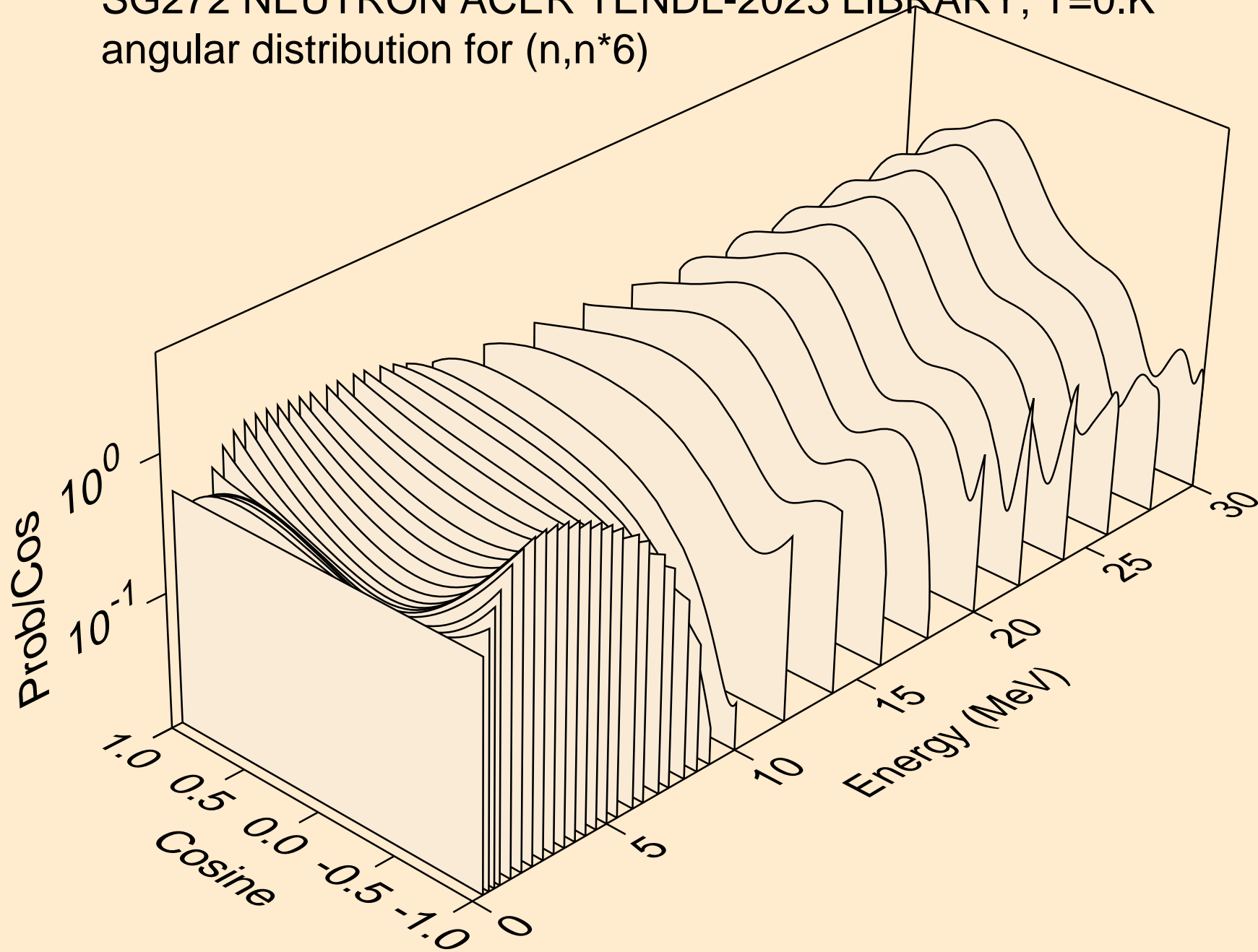

SG272 NEUTRON ACER TENDL-2023 LIBRARY; T=0.K  
angular distribution for (n,n\*7)

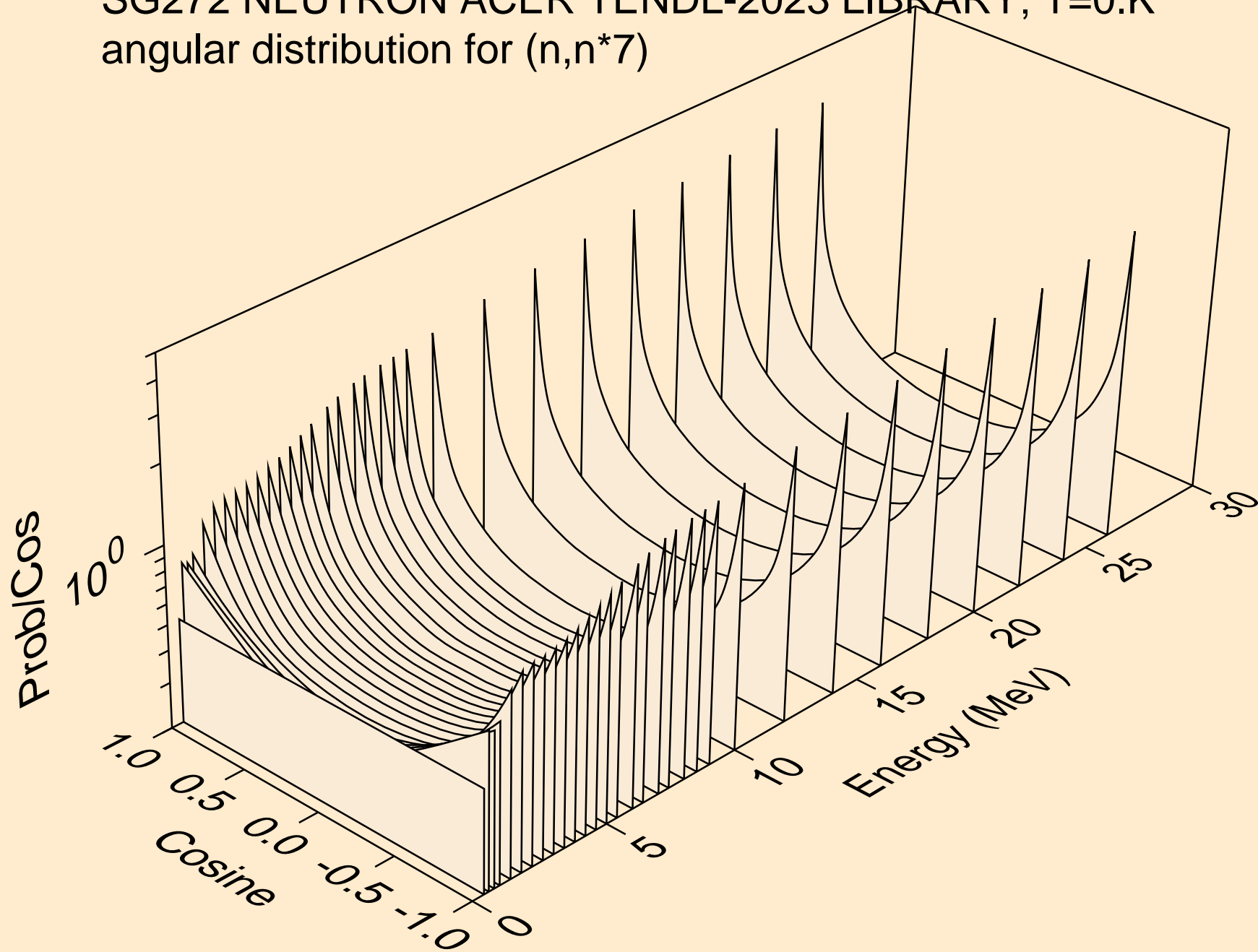

SG272 NEUTRON ACER TENDL-2023 LIBRARY; T=0.K  
angular distribution for (n,n\*8)

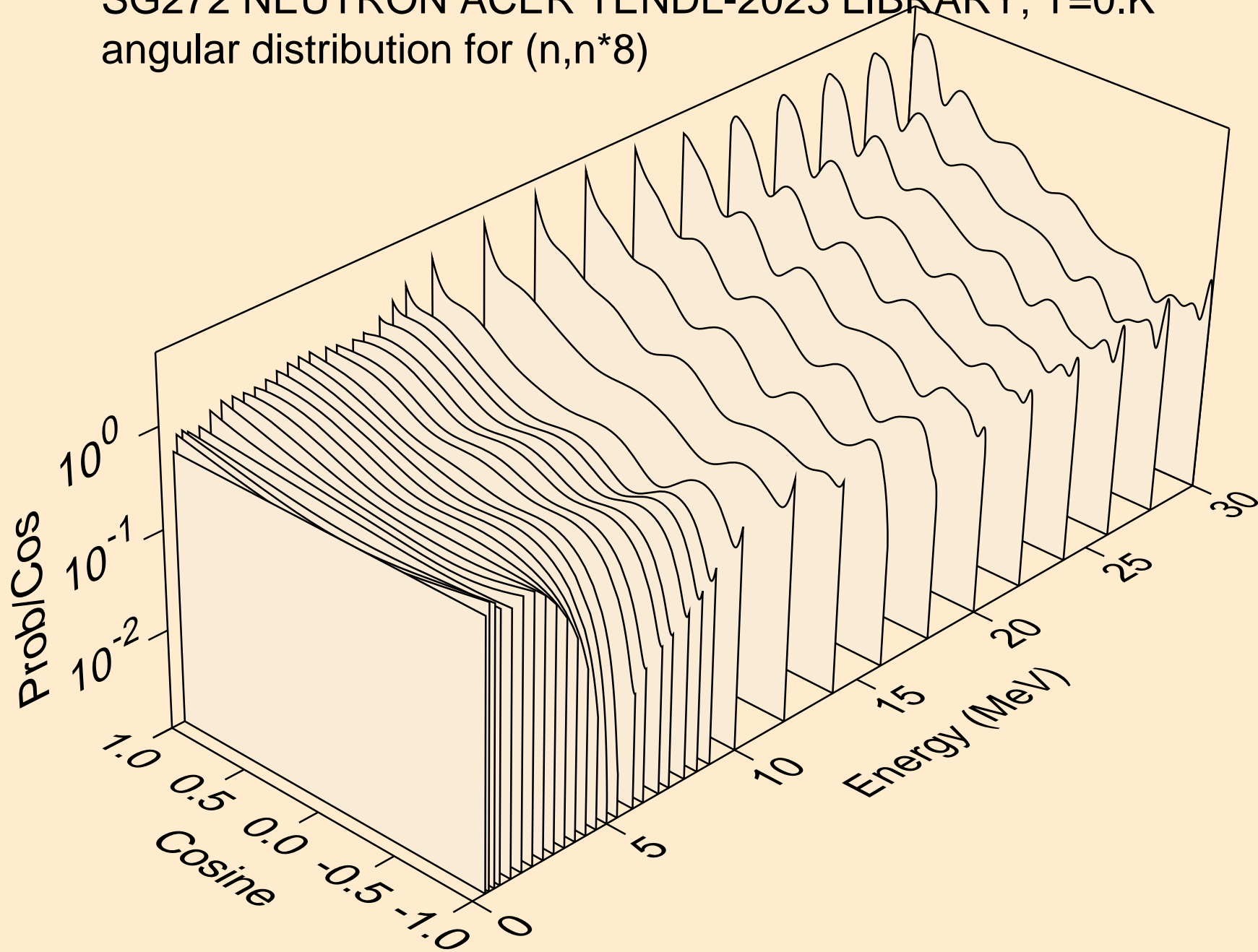

SG272 NEUTRON ACER TENDL-2023 LIBRARY; T=0.K  
angular distribution for (n,n\*9)

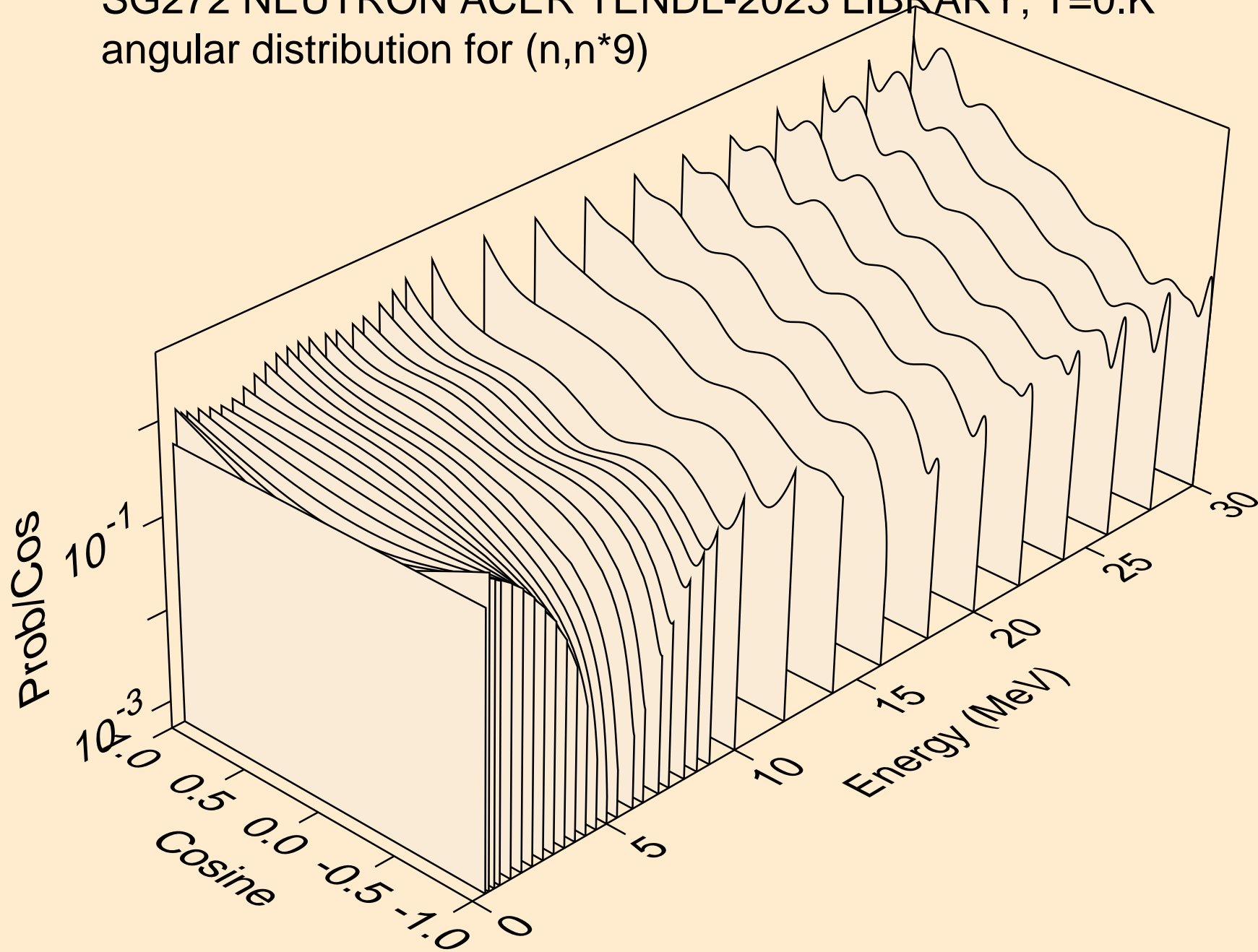

SG272 NEUTRON ACER TENDL-2023 LIBRARY; T=0.K  
angular distribution for (n,n\*10)

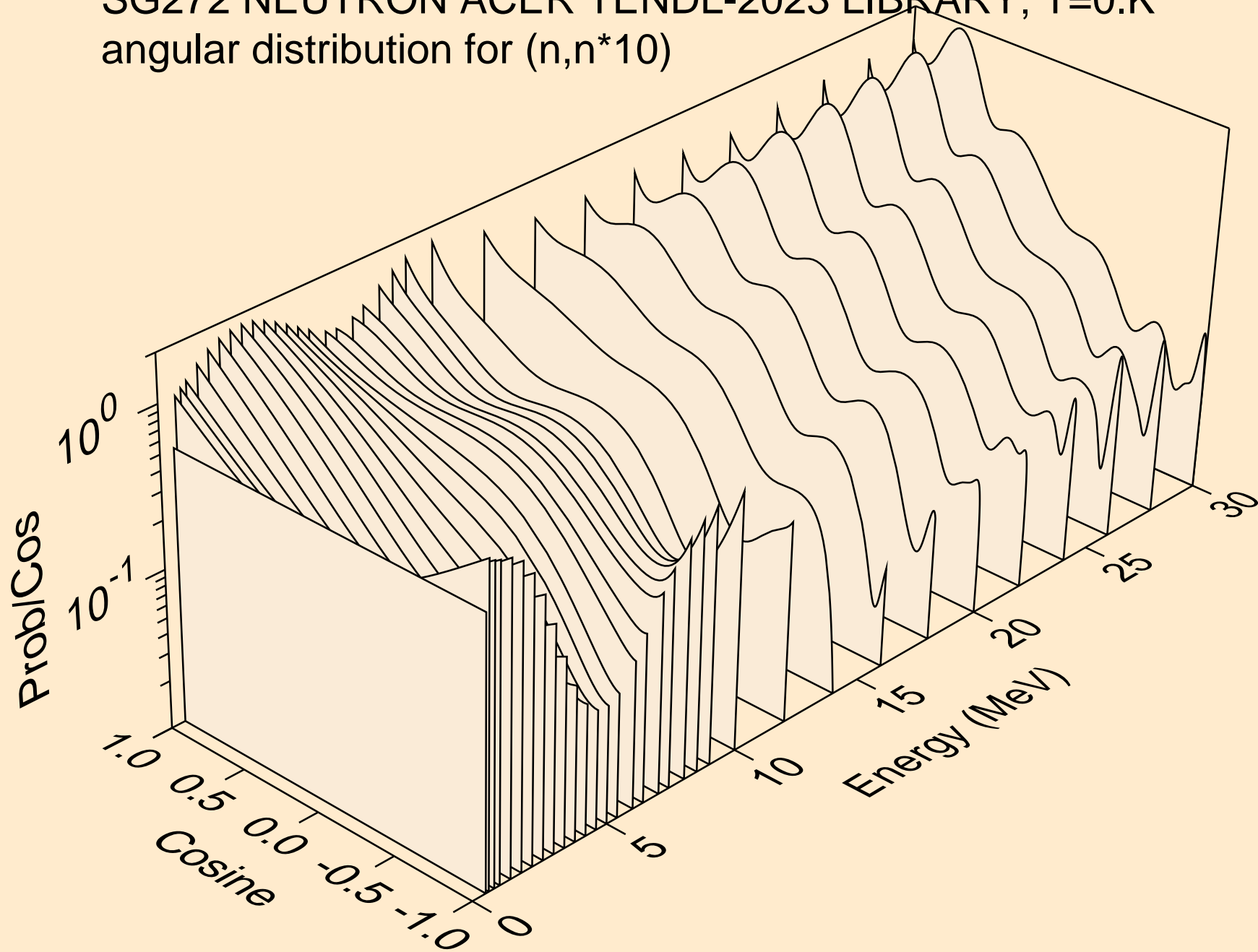

SG272 NEUTRON ACER TENDL-2023 LIBRARY; T=0.K  
angular distribution for (n,n\*11)

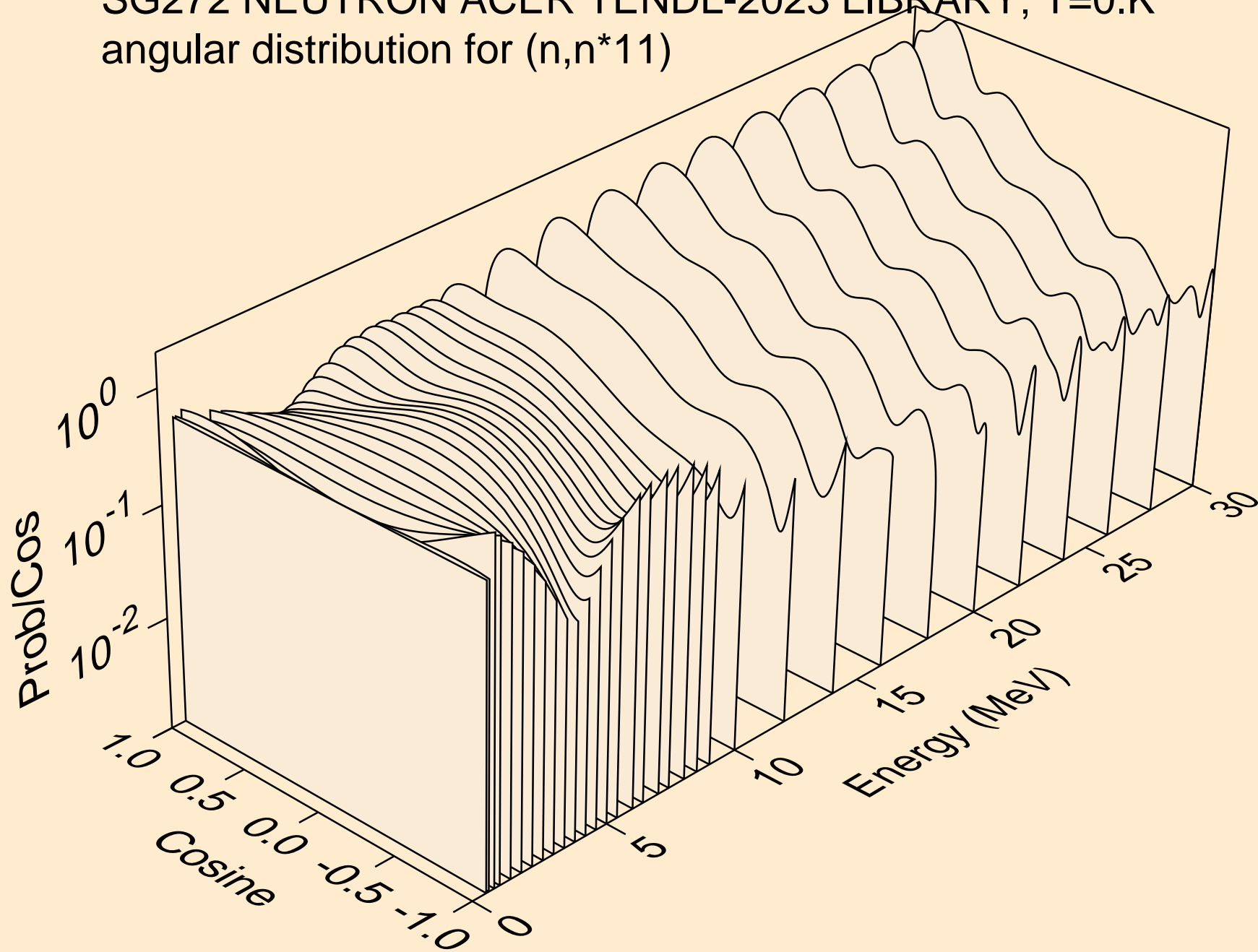



SG272 NEUTRON ACER TENDL-2023 LIBRARY; T=0.K  
angular distribution for (n,n\*12)

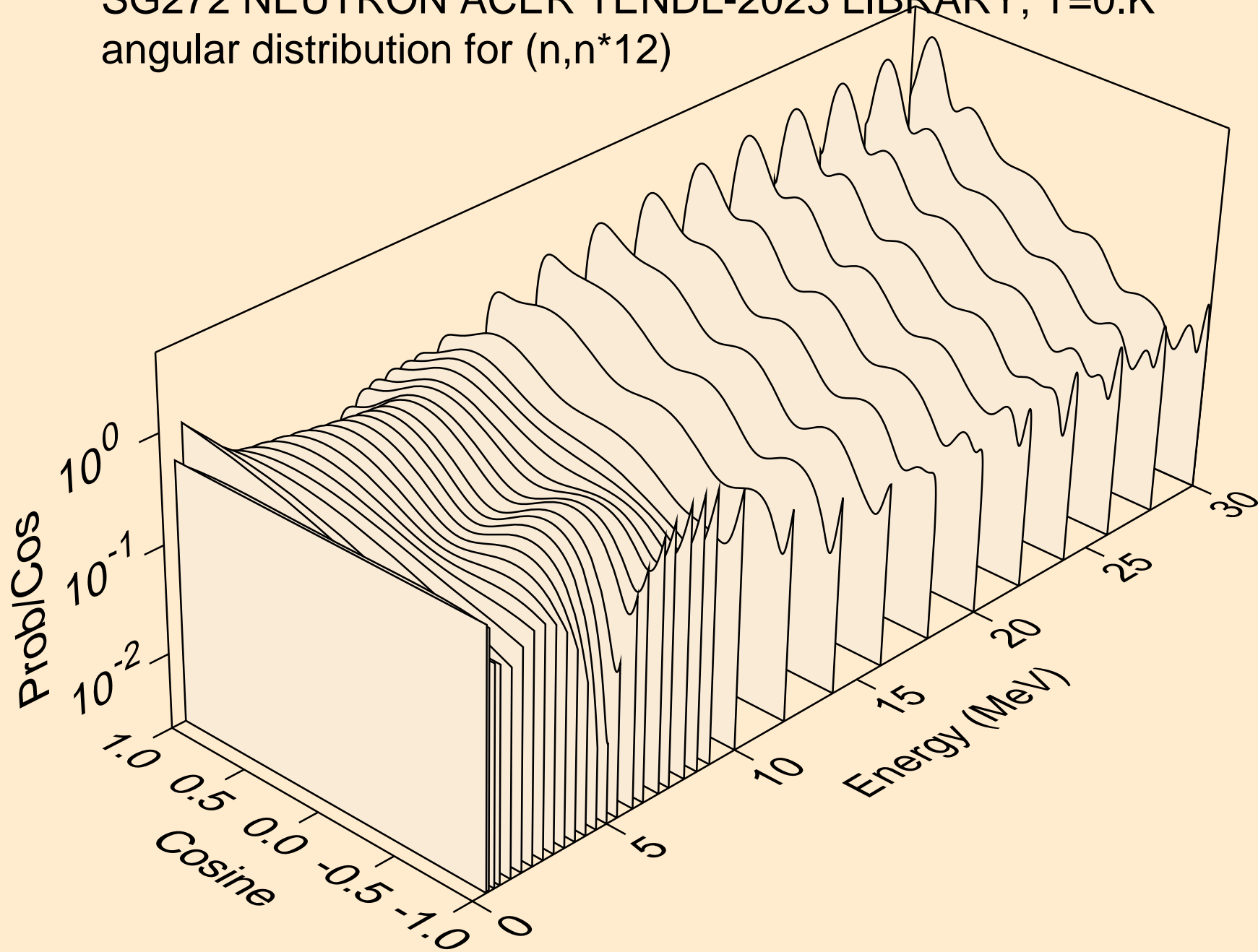

SG272 NEUTRON ACER TENDL-2023 LIBRARY; T=0.K  
angular distribution for (n,n\*13)

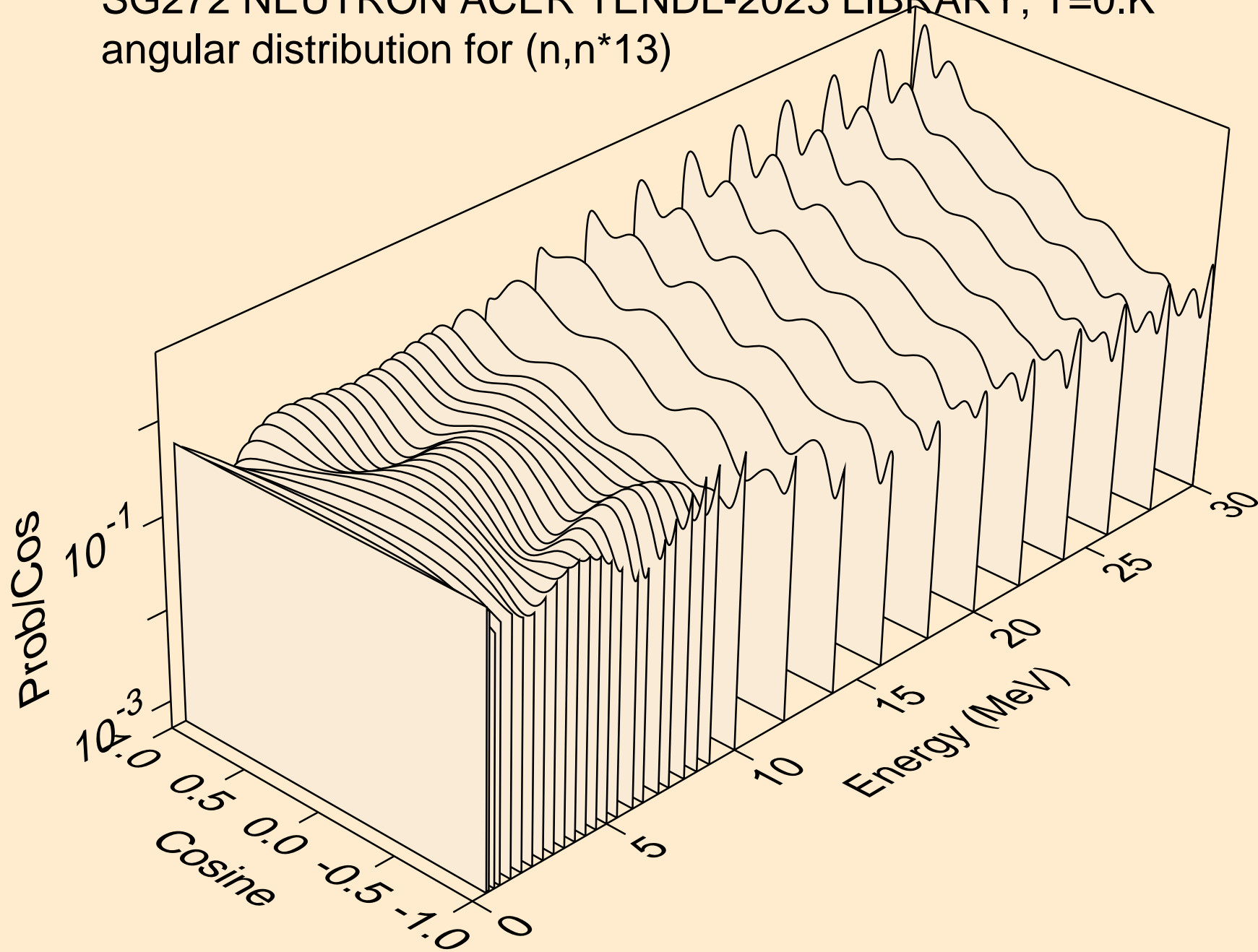

SG272 NEUTRON ACER TENDL-2023 LIBRARY; T=0.K  
angular distribution for (n,n\*14)

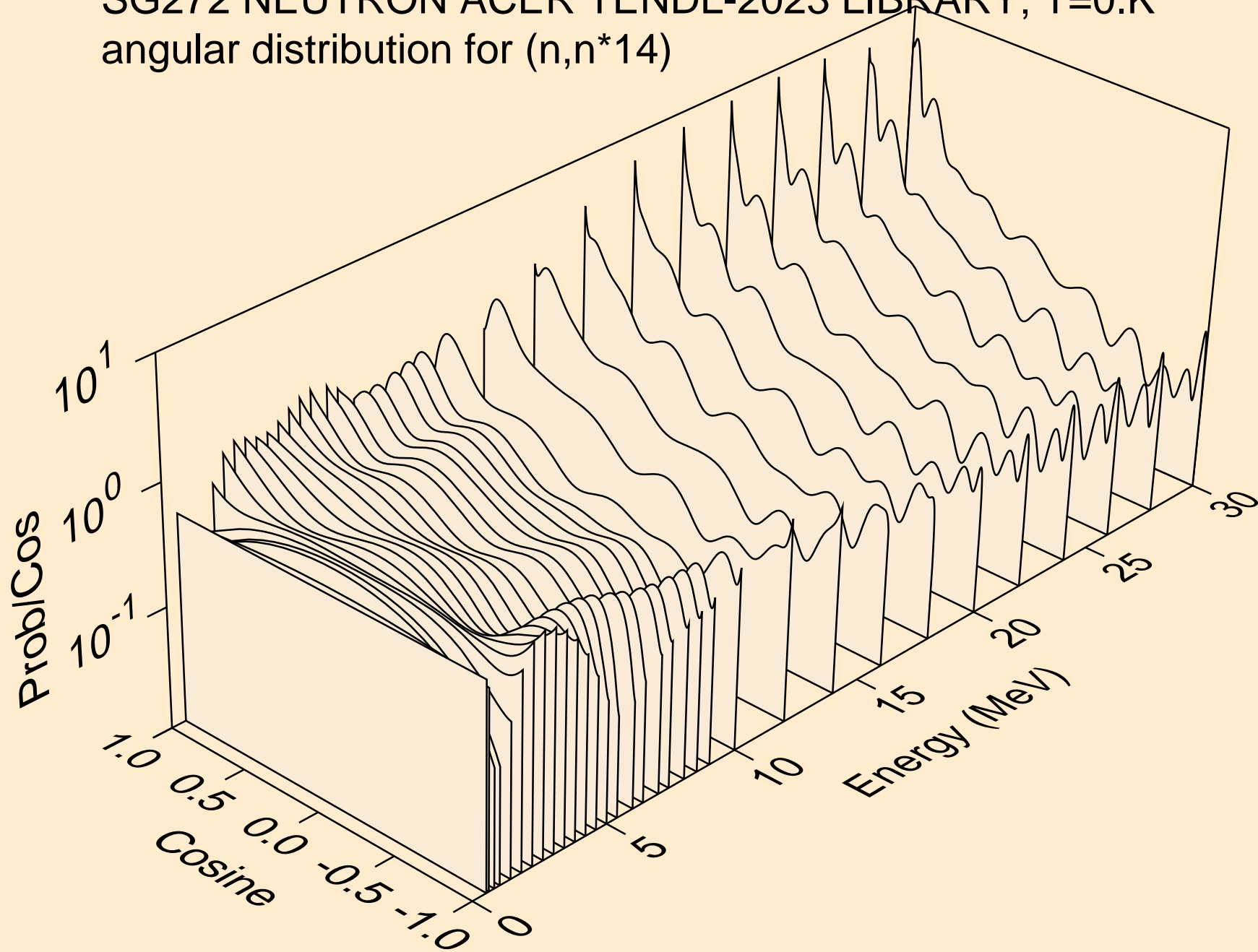

SG272 NEUTRON ACER TENDL-2023 LIBRARY; T=0.K  
angular distribution for (n,n\*15)

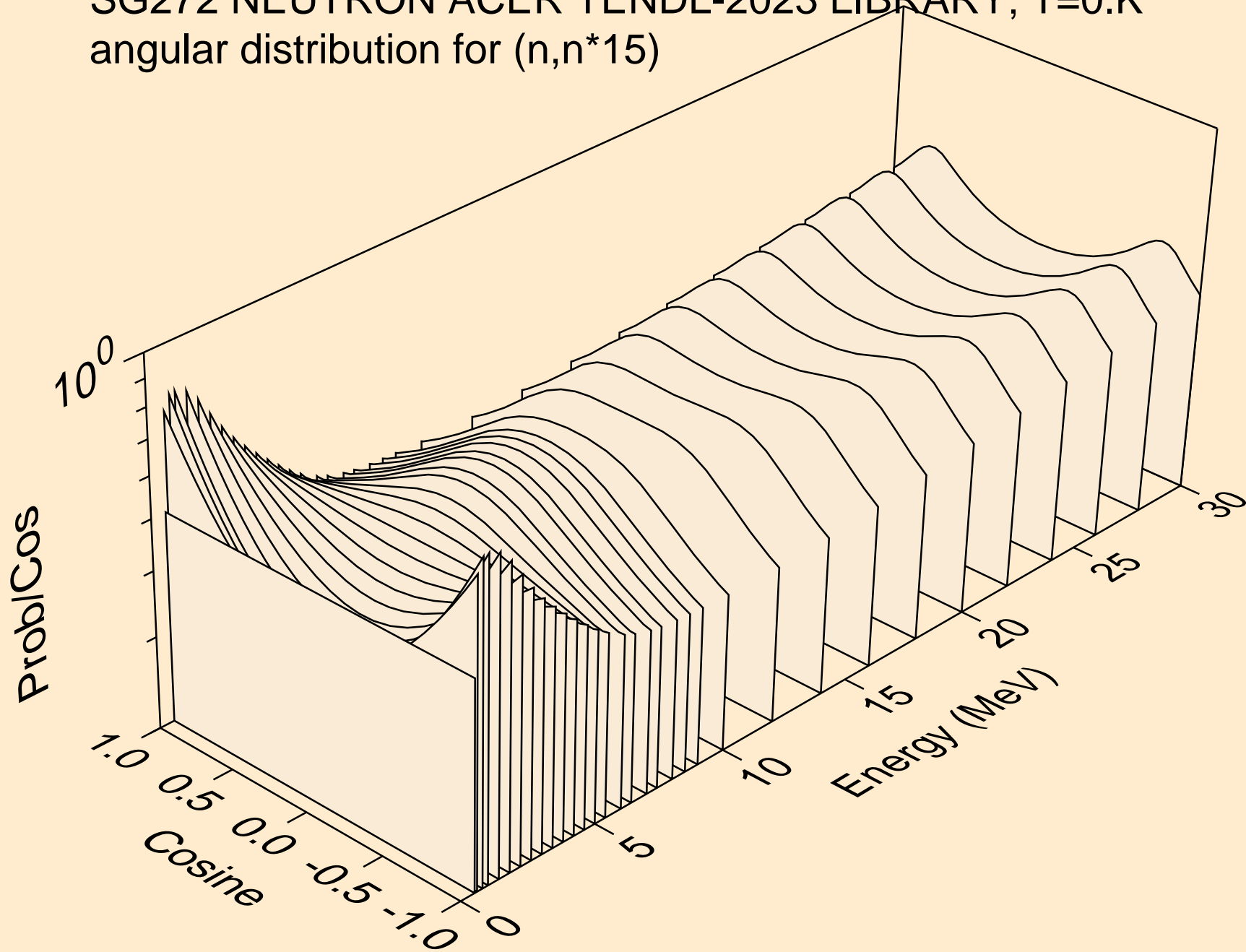

SG272 NEUTRON ACER TENDL-2023 LIBRARY; T=0.K  
angular distribution for (n,n\*16)

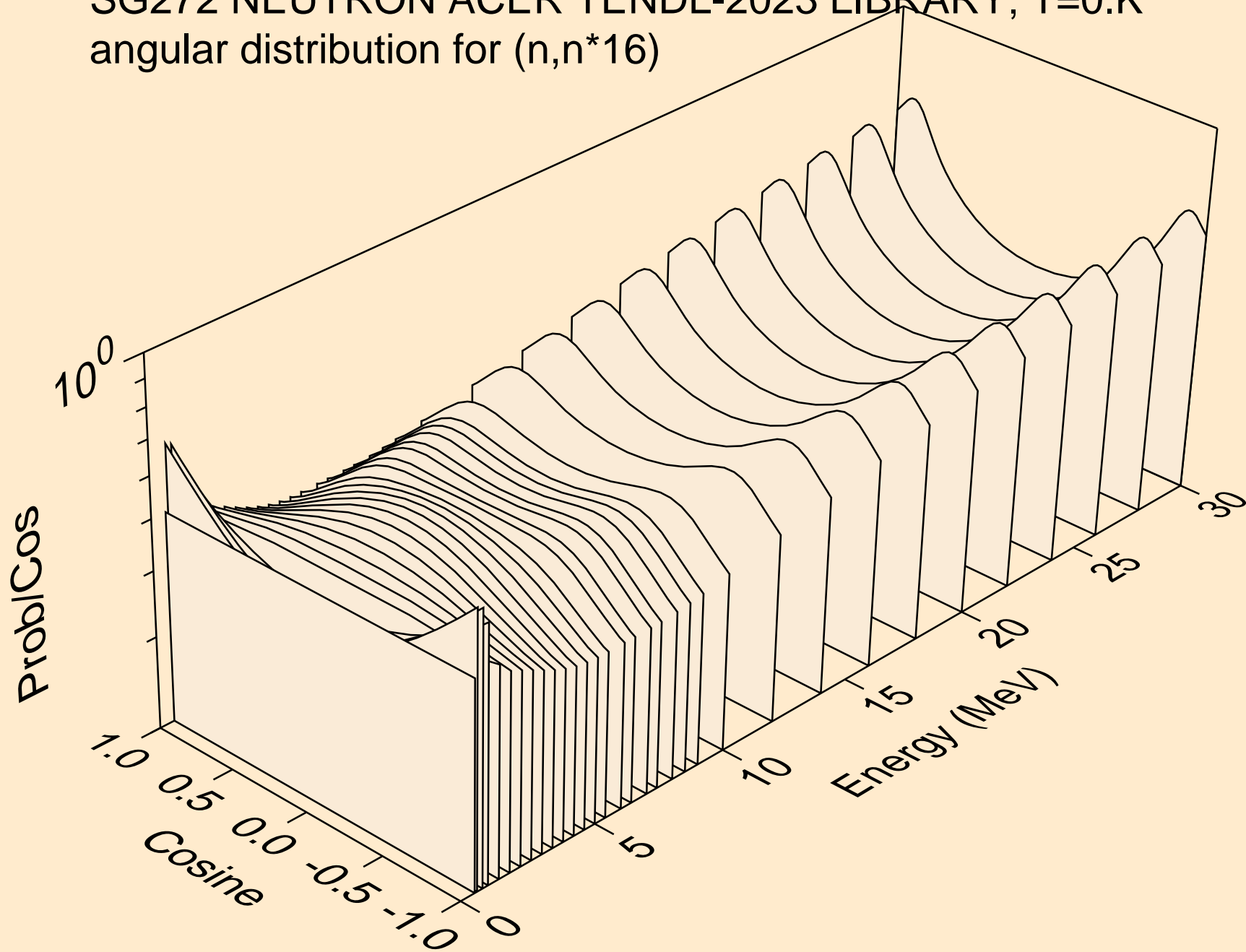

SG272 NEUTRON ACER TENDL-2023 LIBRARY; T=0.K  
angular distribution for (n,n\*17)

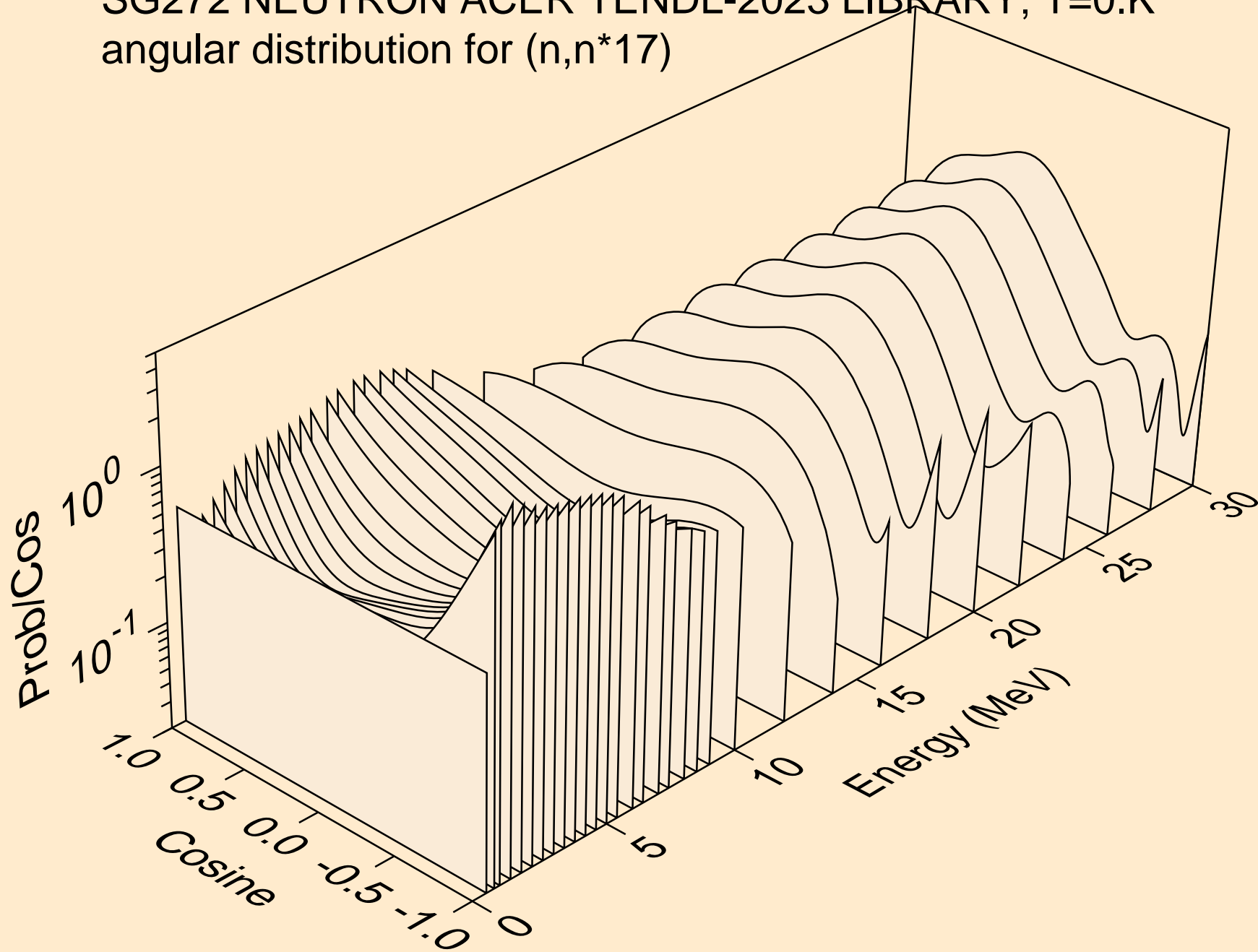

SG272 NEUTRON ACER TENDL-2023 LIBRARY; T=0.K  
angular distribution for (n,n\*18)

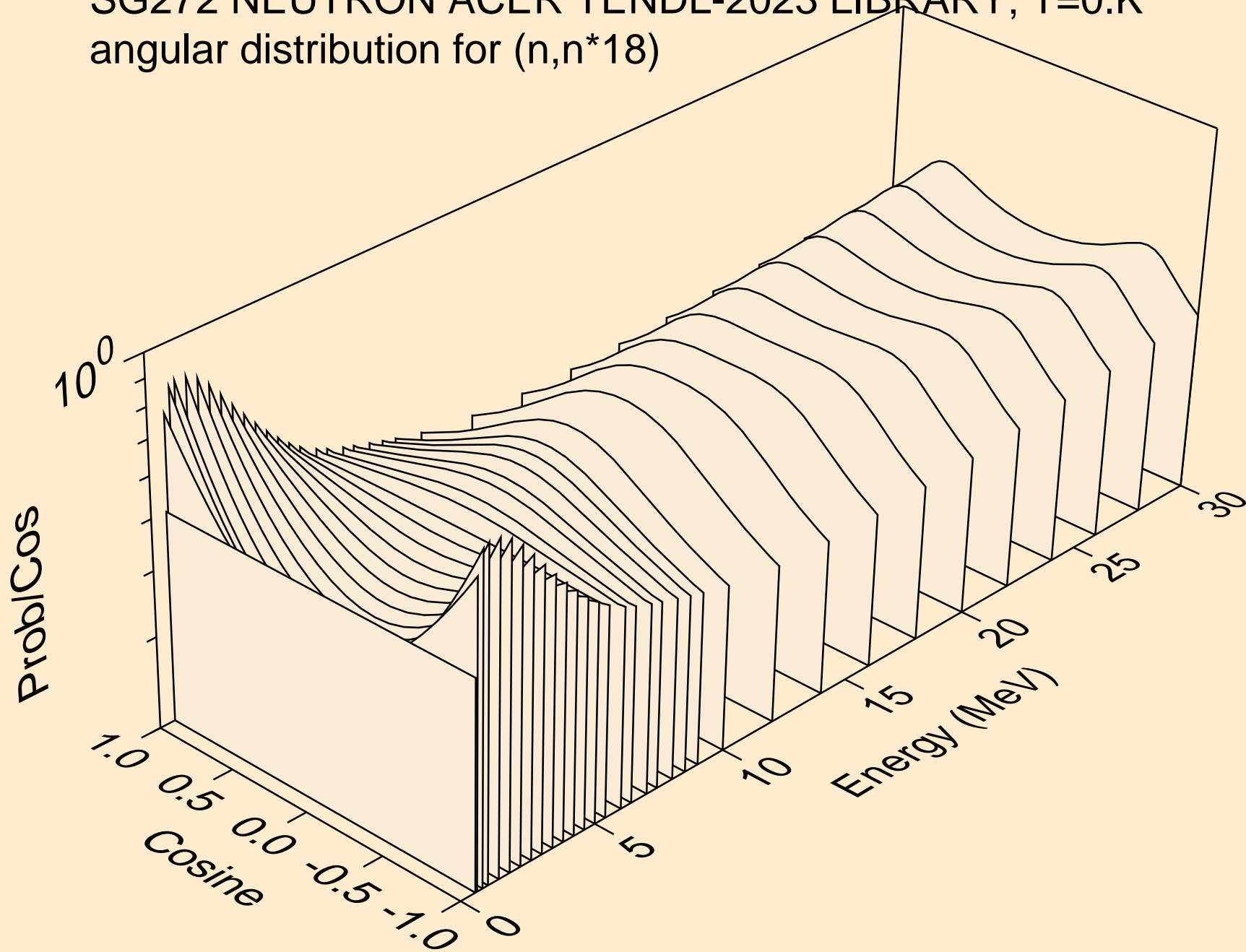

SG272 NEUTRON ACER TENDL-2023 LIBRARY; T=0.K  
angular distribution for (n,n\*19)

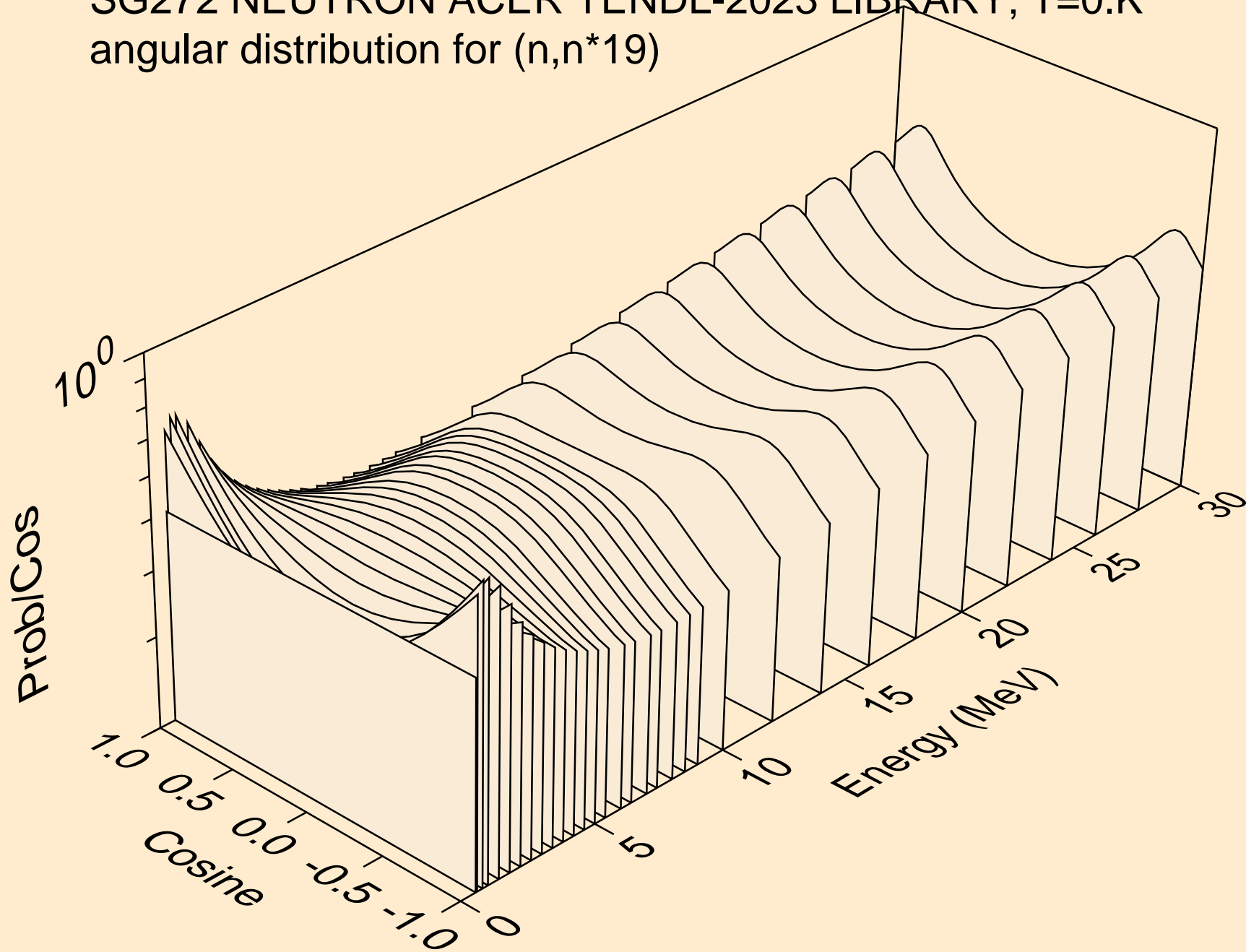



SG272 NEUTRON ACER TENDL-2023 LIBRARY; T=0.K  
angular distribution for (n,n\*20)

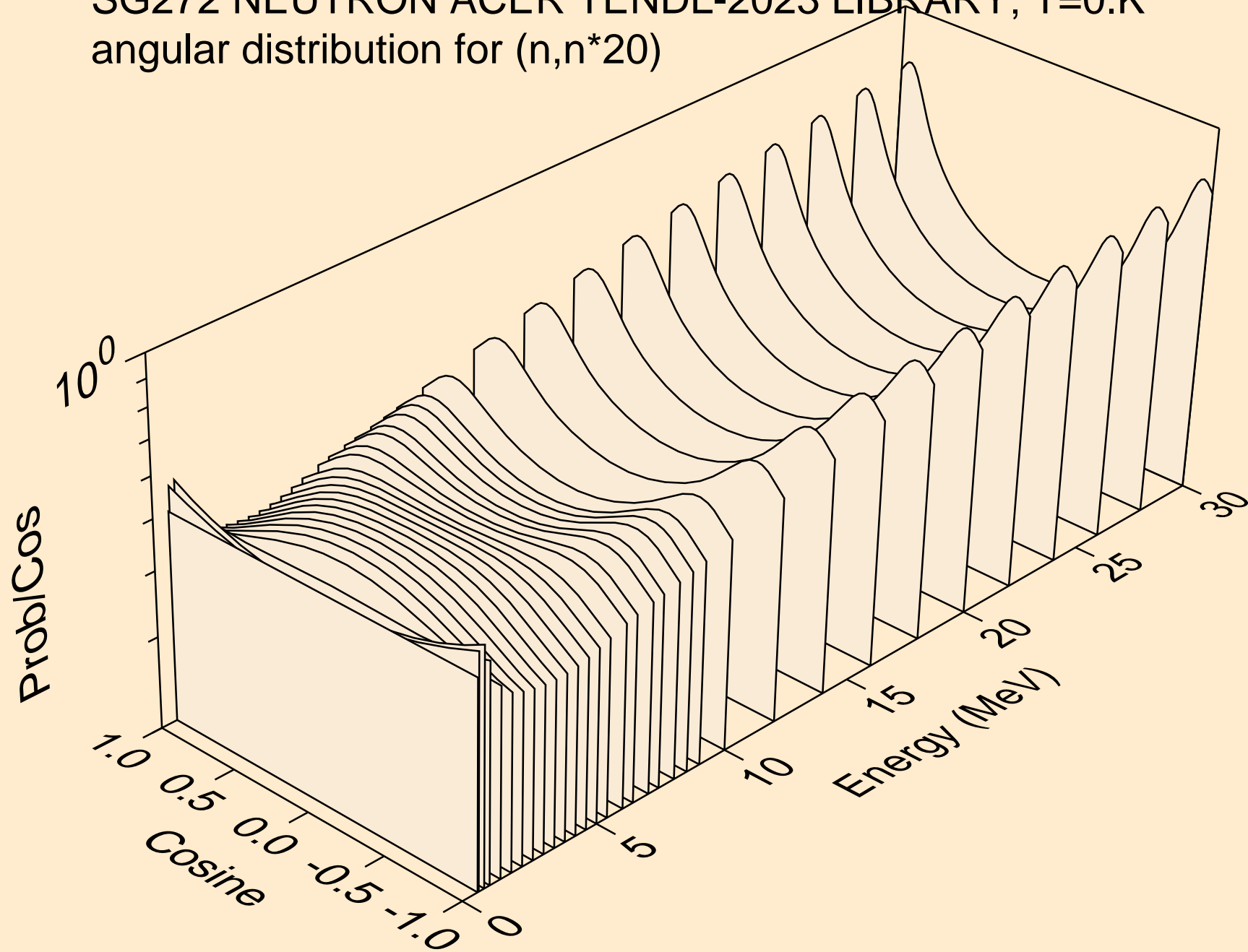

SG272 NEUTRON ACER TENDL-2023 LIBRARY; T=0.K  
angular distribution for (n,n\*21)

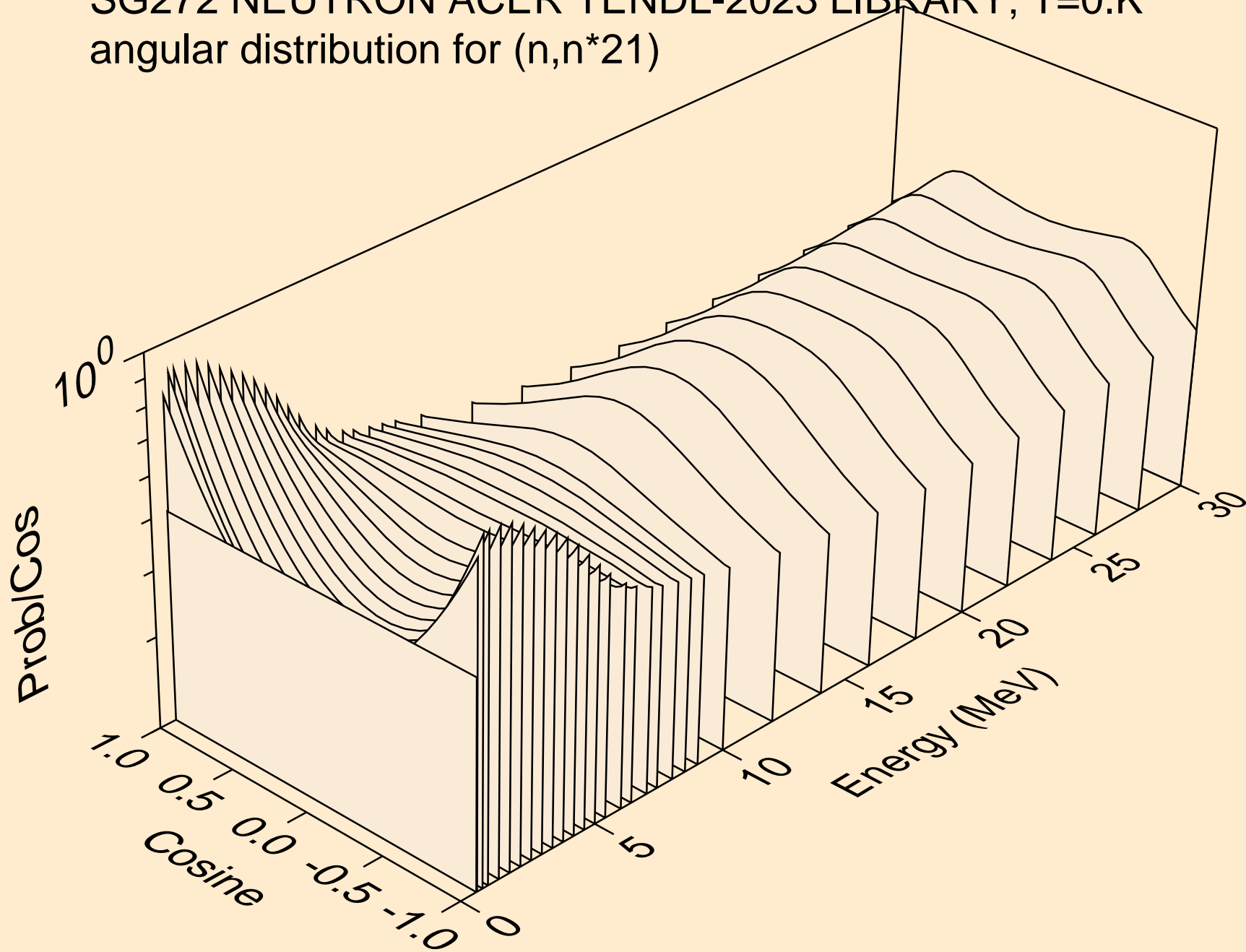

SG272 NEUTRON ACER TENDL-2023 LIBRARY; T=0.K  
angular distribution for (n,n\*22)

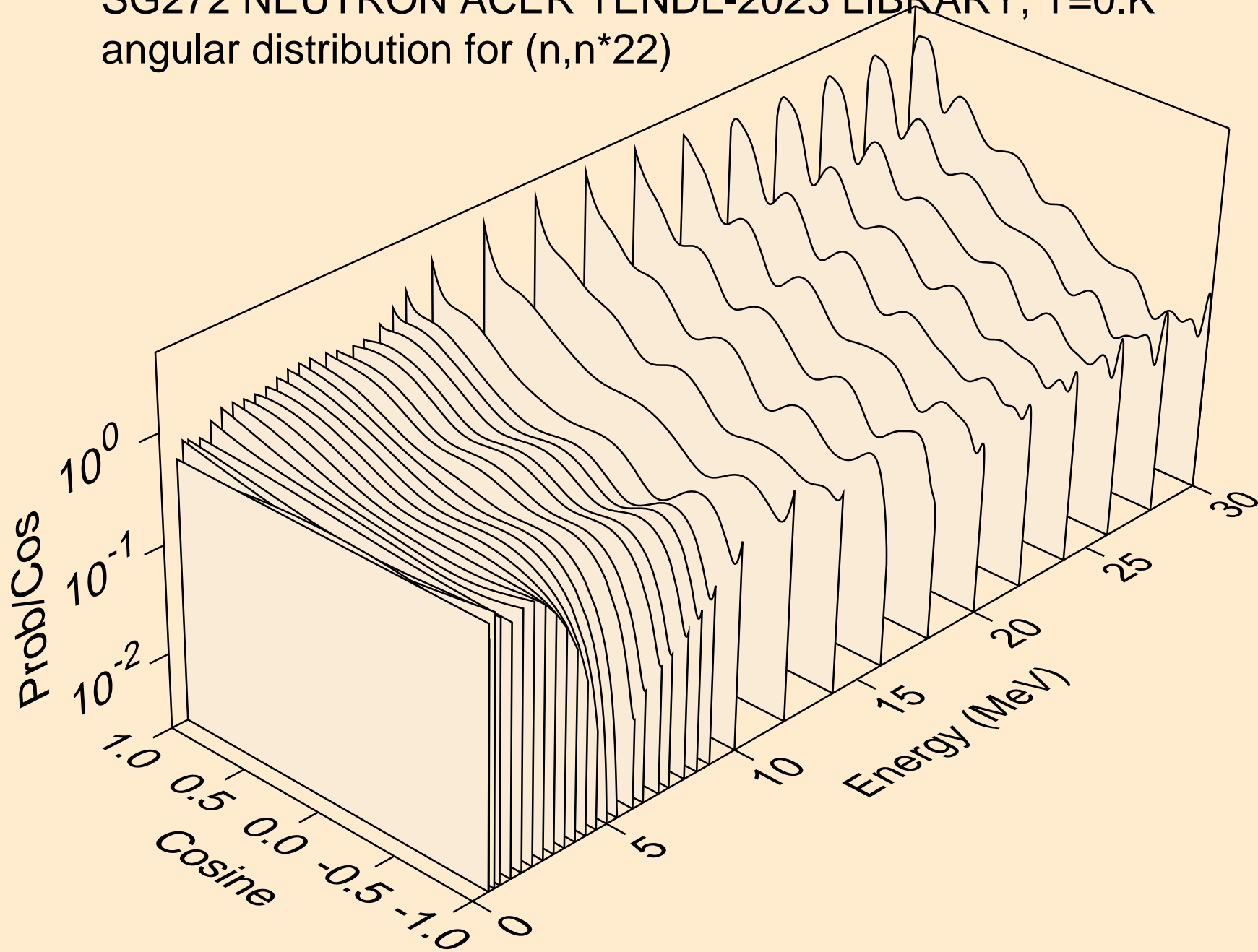

SG272 NEUTRON ACER TENDL-2023 LIBRARY; T=0.K  
angular distribution for (n,n\*23)

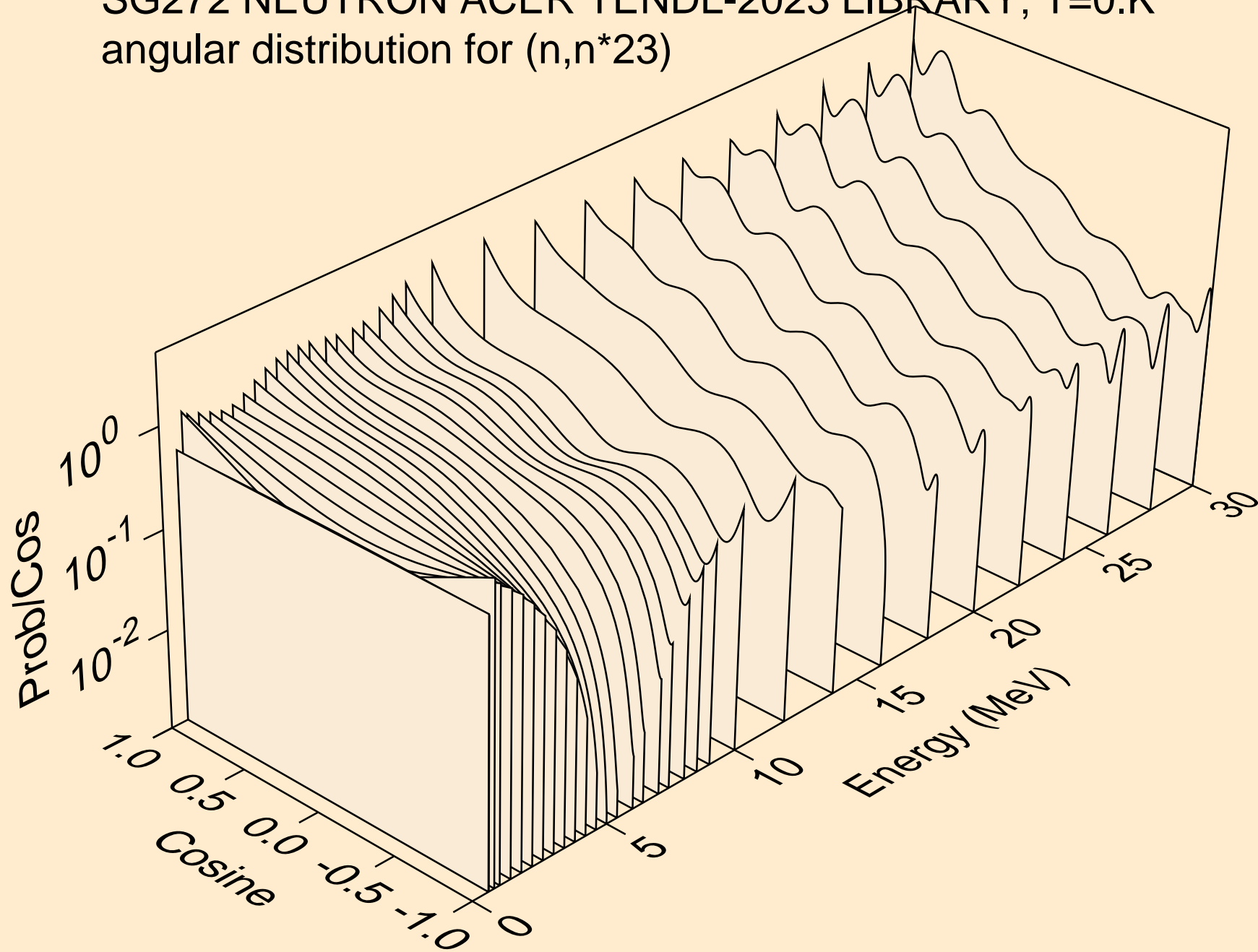

SG272 NEUTRON ACER TENDL-2023 LIBRARY; T=0.K  
angular distribution for (n,n\*24)

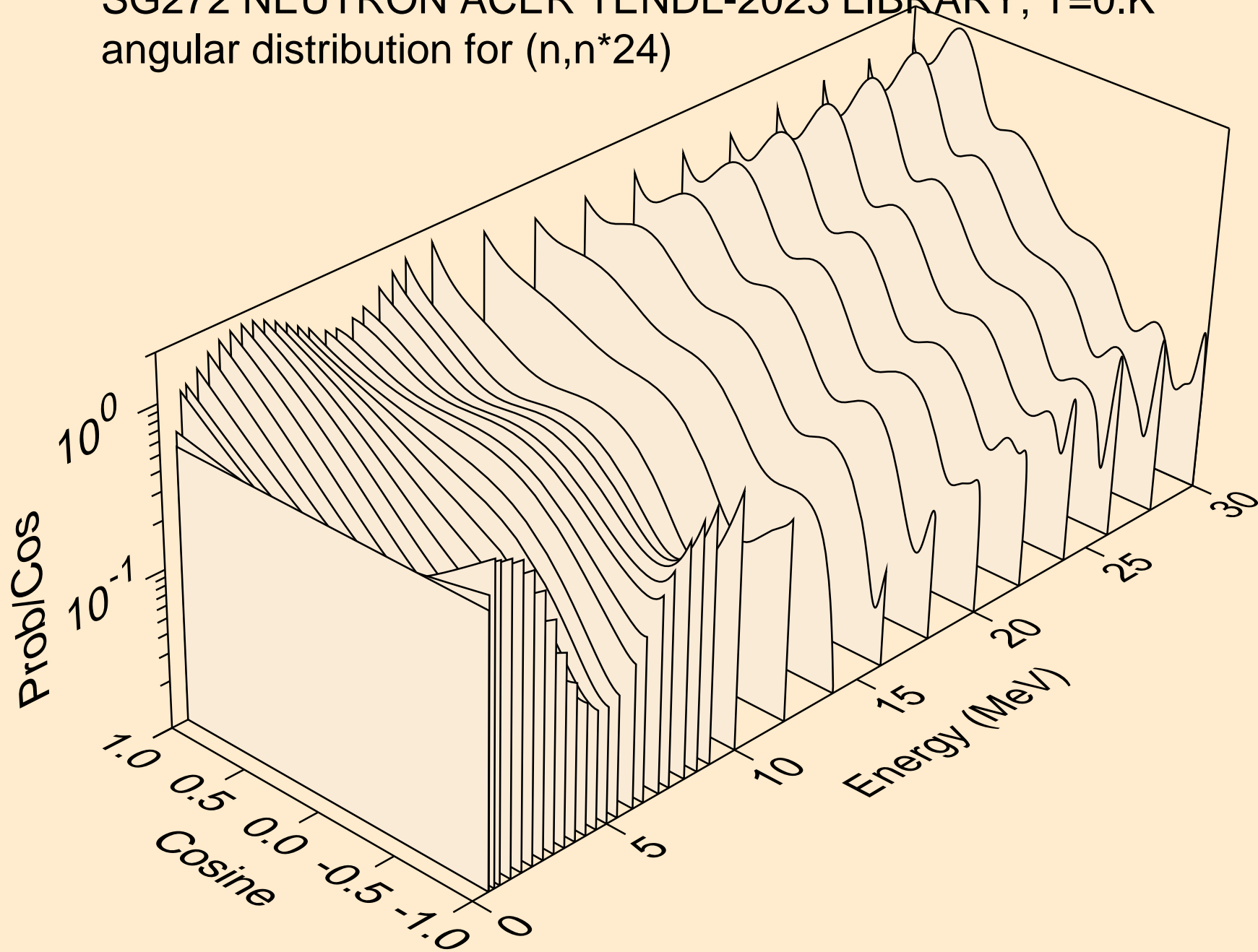

SG272 NEUTRON ACER TENDL-2023 LIBRARY; T=0.K  
angular distribution for (n,n\*25)

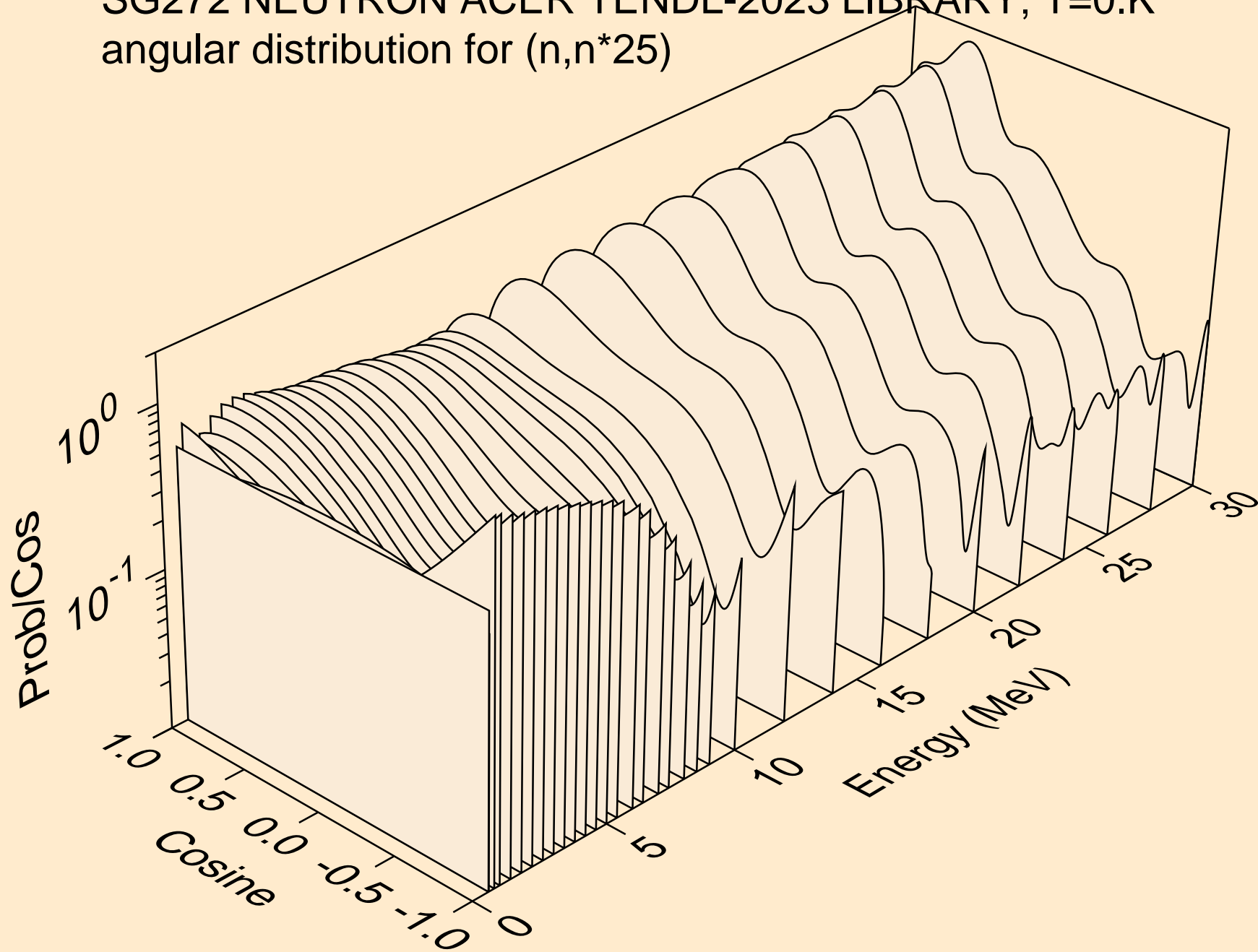

SG272 NEUTRON ACER TENDL-2023 LIBRARY; T=0.K  
angular distribution for (n,n\*26)

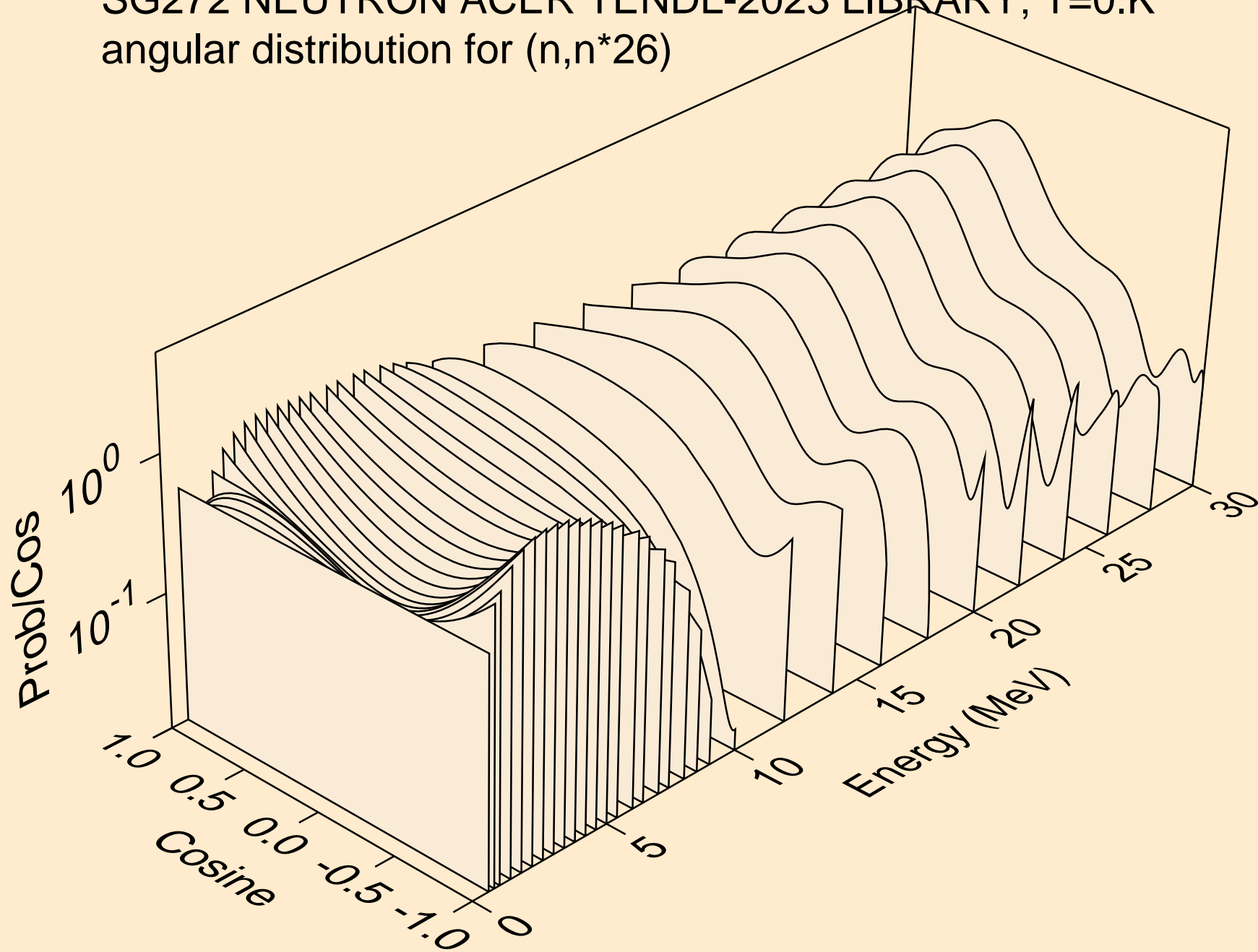

SG272 NEUTRON ACER TENDL-2023 LIBRARY; T=0.K  
angular distribution for (n,n\*27)

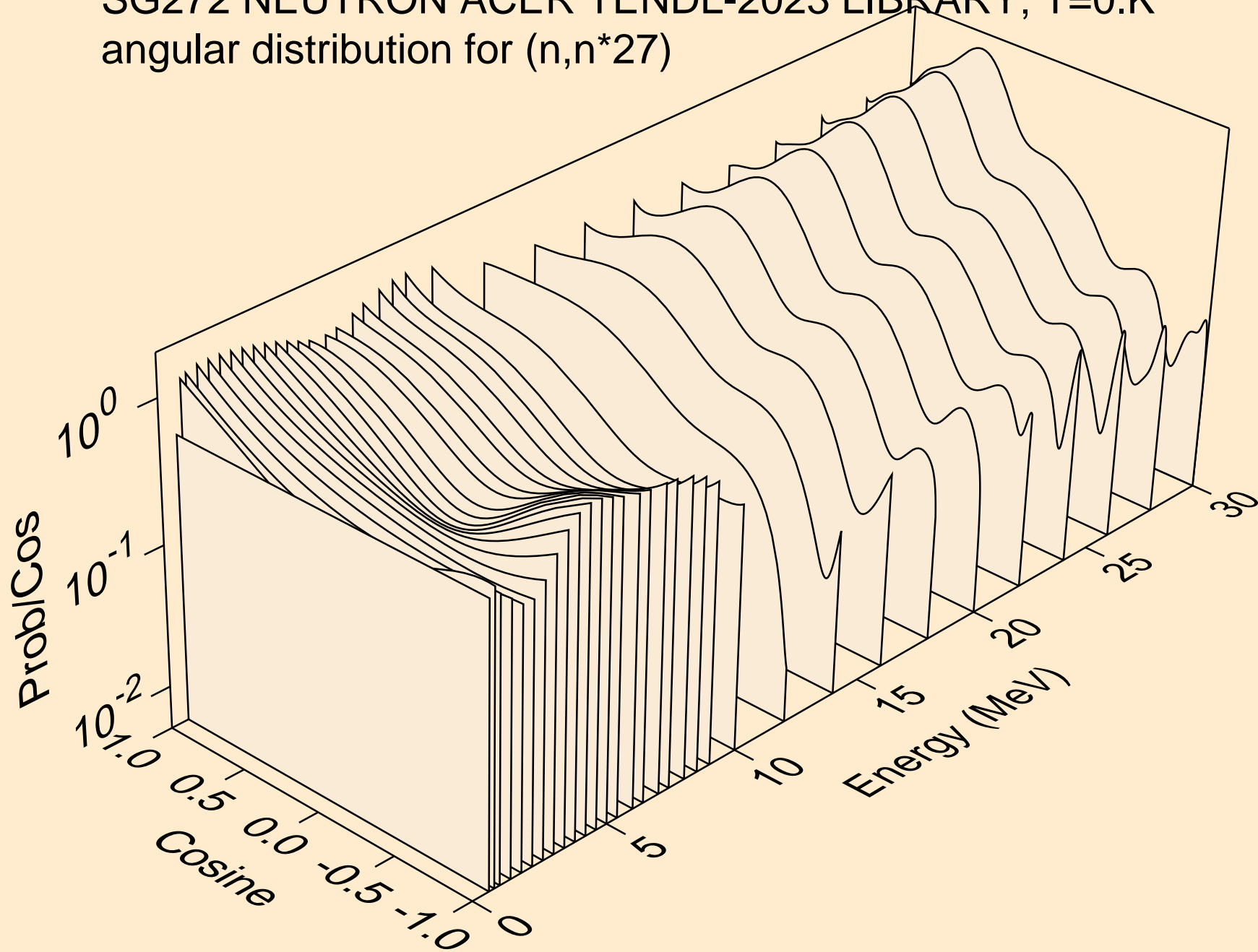



SG272 NEUTRON ACER TENDL-2023 LIBRARY; T=0.K  
angular distribution for (n,n\*28)

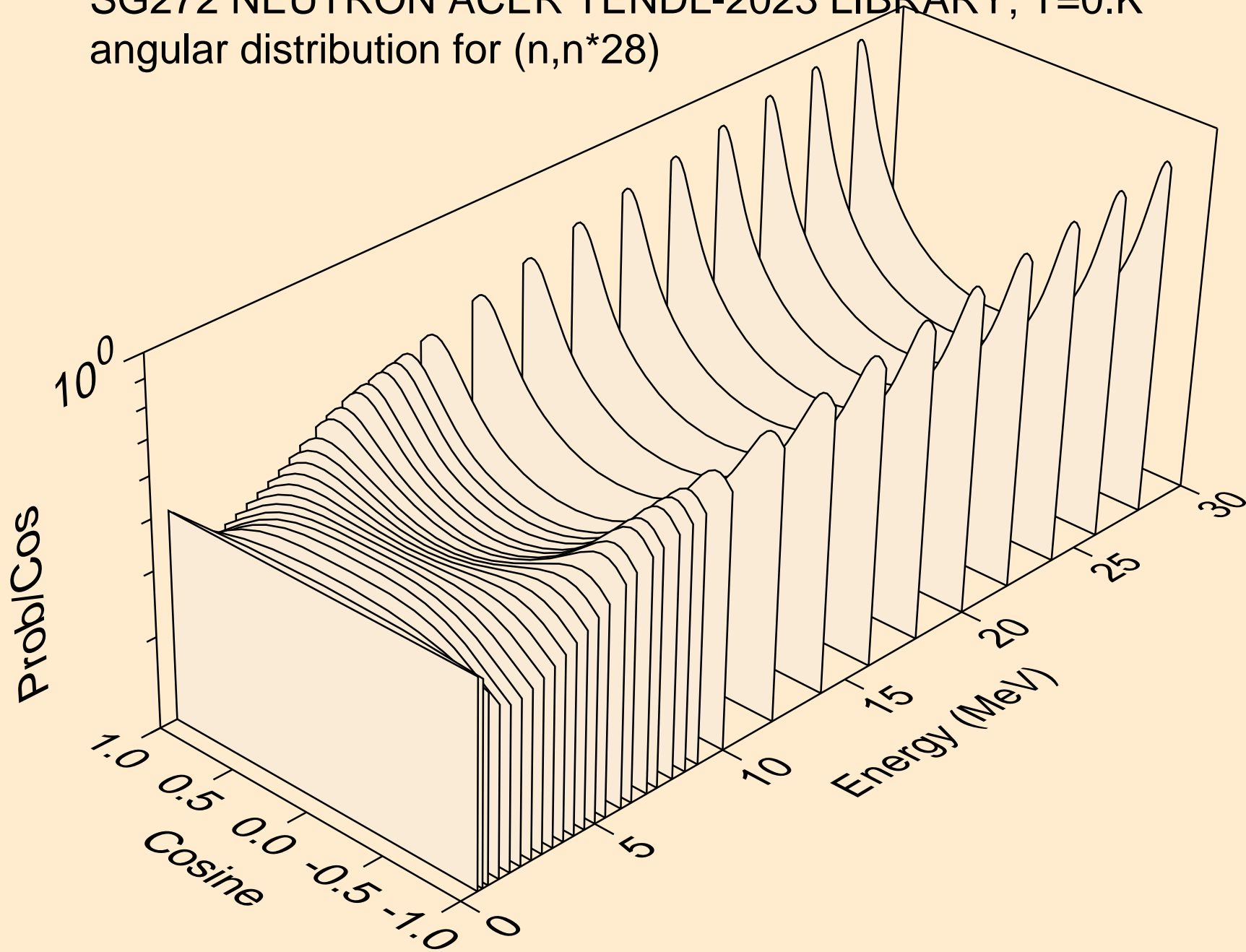

SG272 NEUTRON ACER TENDL-2023 LIBRARY; T=0.K  
angular distribution for (n,n\*29)

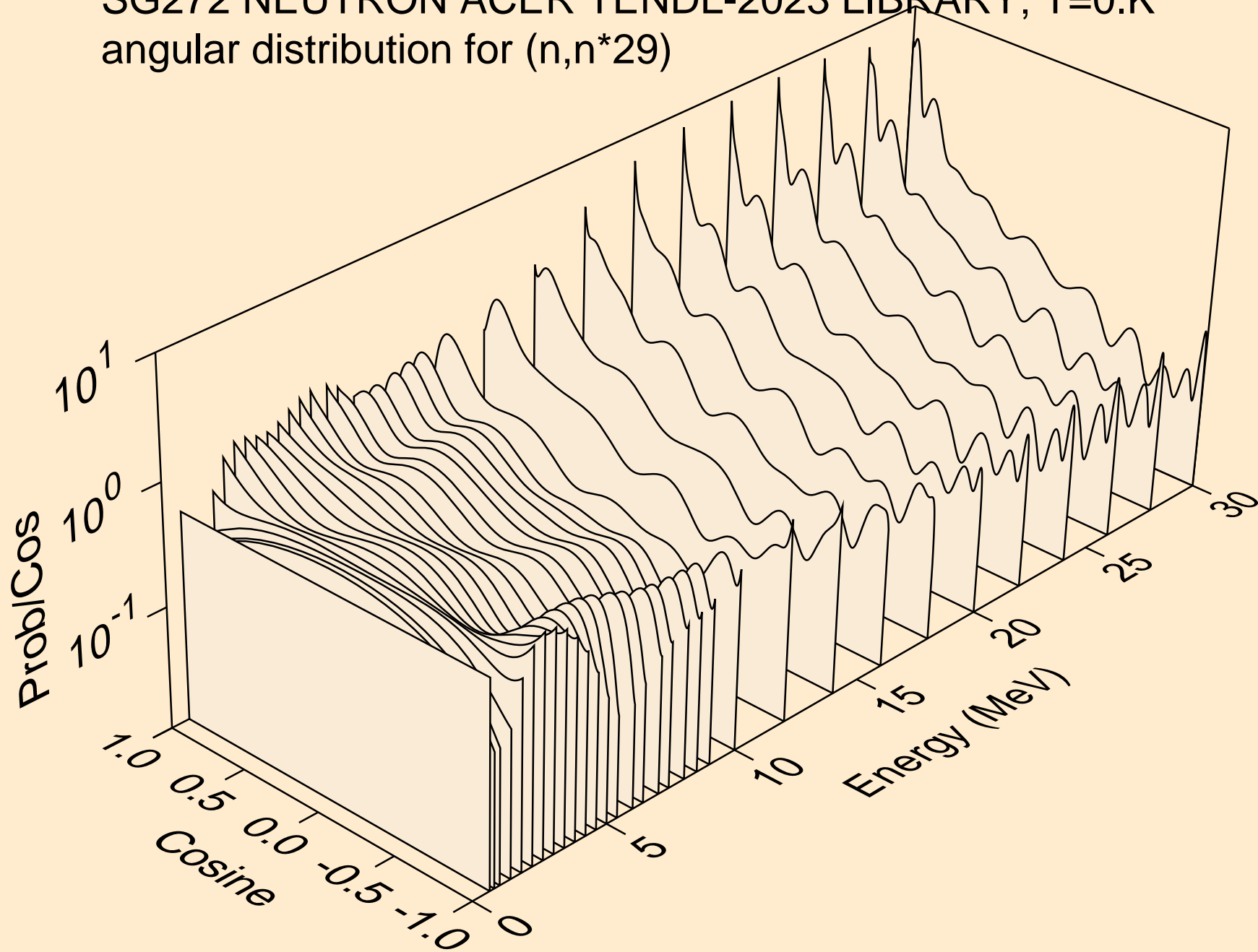

# SG272 NEUTRON ACER TENDL-2023 LIBRARY; T=0.K

Total fission nubar

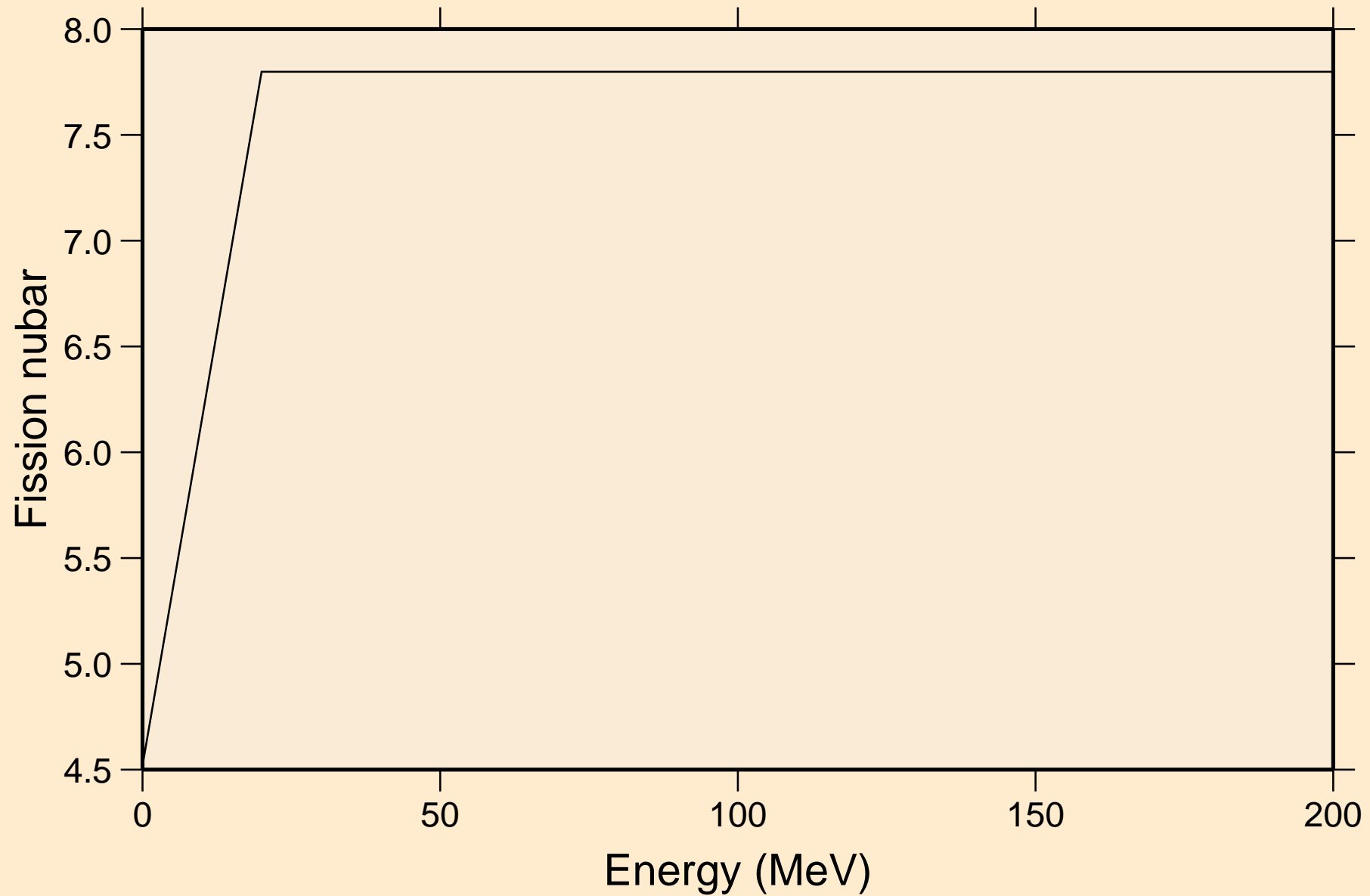

SG272 NEUTRON ACER TENDL-2023 LIBRARY; T=0.K  
Neutron emission for (n,x)

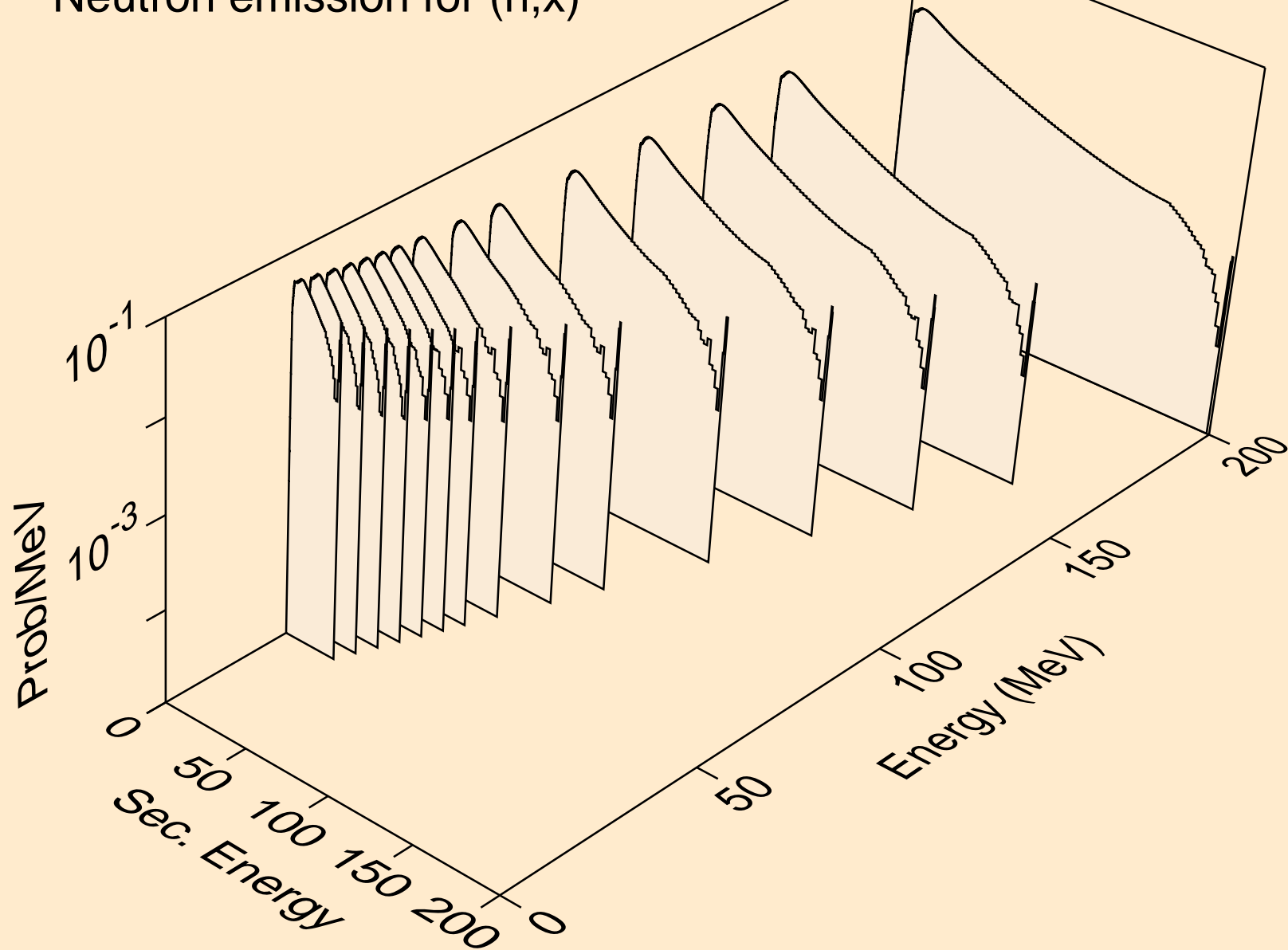

SG272 NEUTRON ACER TENDL-2023 LIBRARY; T=0.K  
Neutron emission for (n,2nd)

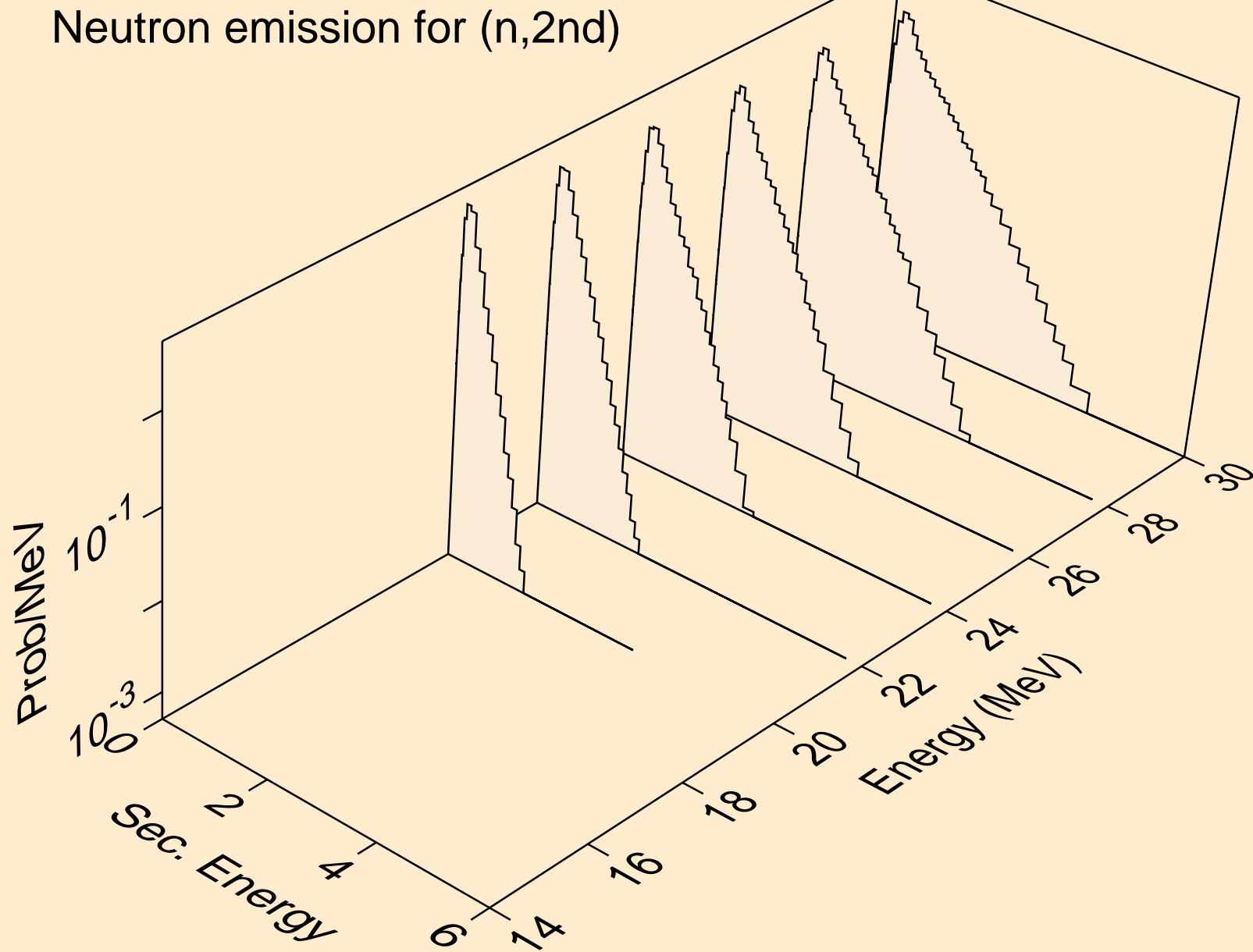

SG272 NEUTRON ACER TENDL-2023 LIBRARY; T=0.K  
Neutron emission for (n,2n)

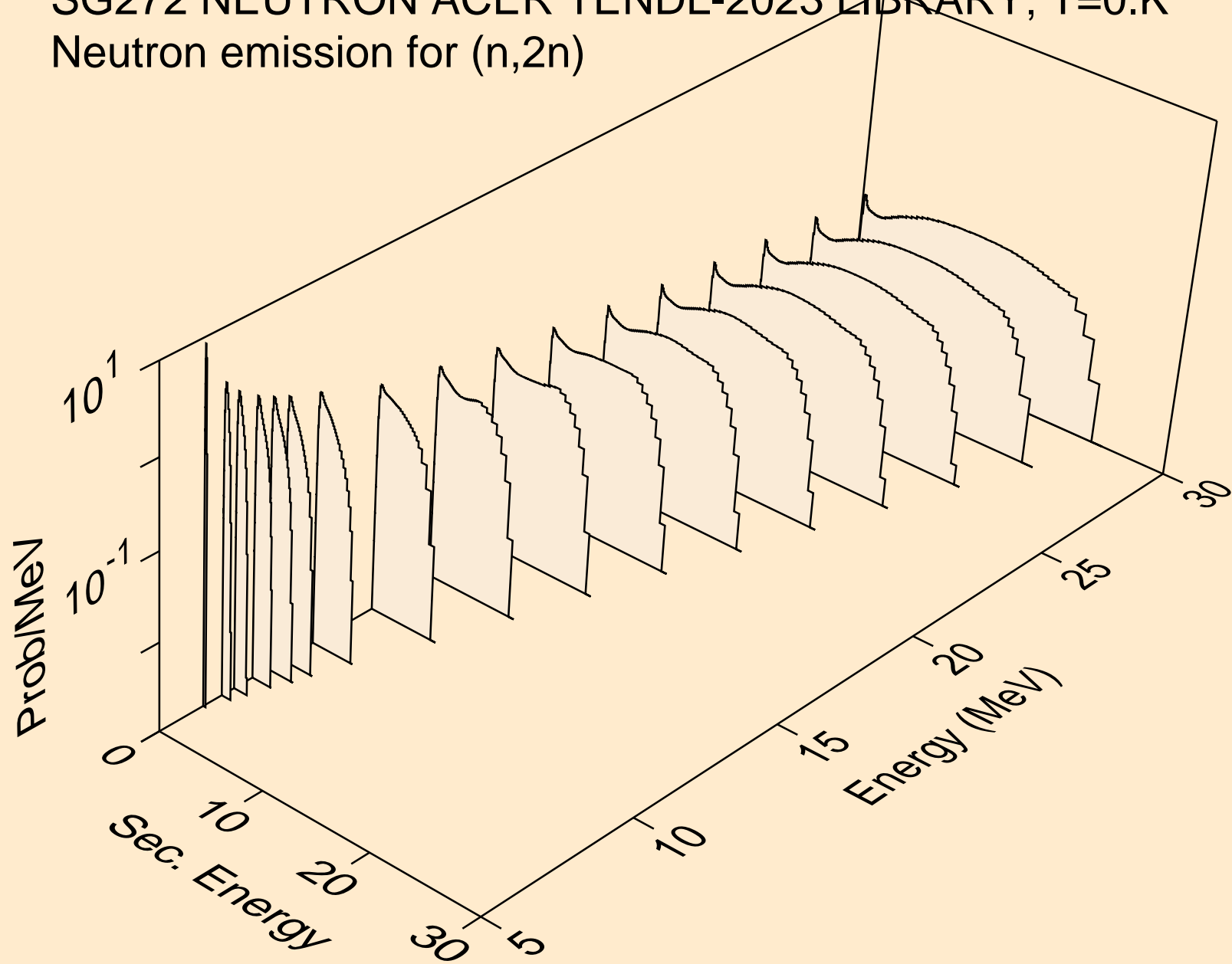

SG272 NEUTRON ACER TENDL-2023 LIBRARY; T=0.K  
Neutron emission for (n,3n)

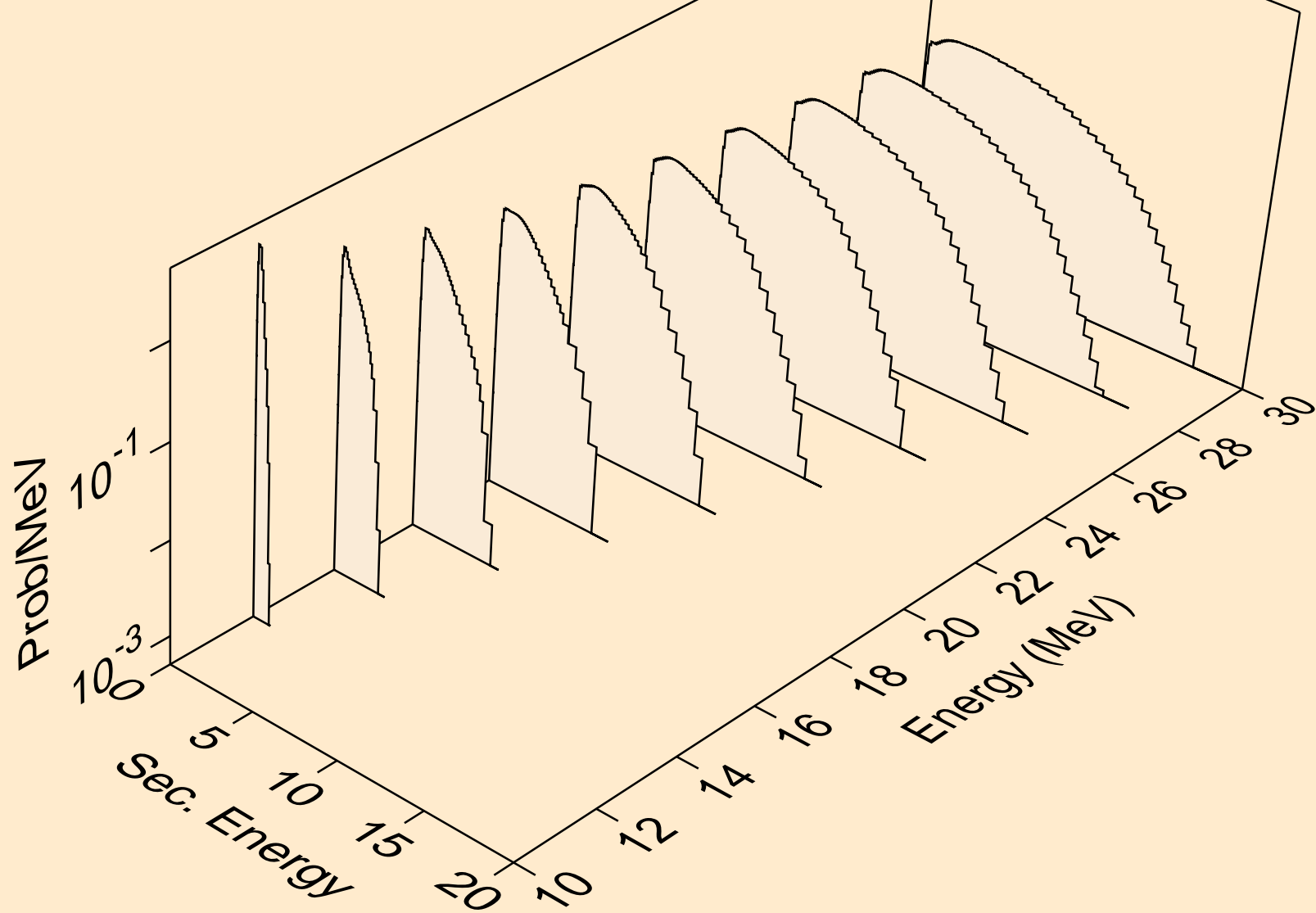

SG272 NEUTRON ACER TENDL-2023 LIBRARY; T=0.K  
Neutron emission for fission

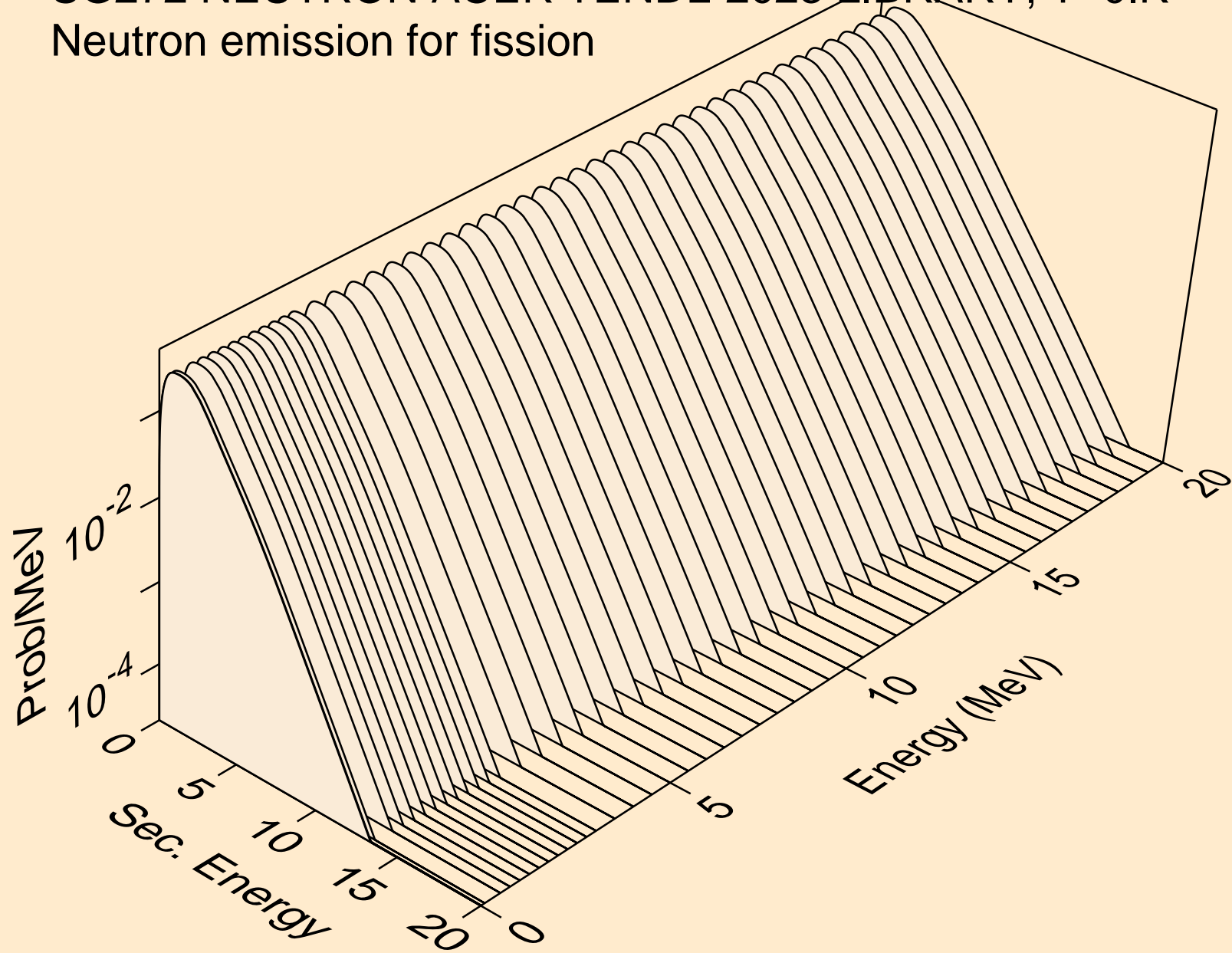



SG272 NEUTRON ACER TENDL-2023 LIBRARY; T=0.K  
Neutron emission for (n,n\*)a

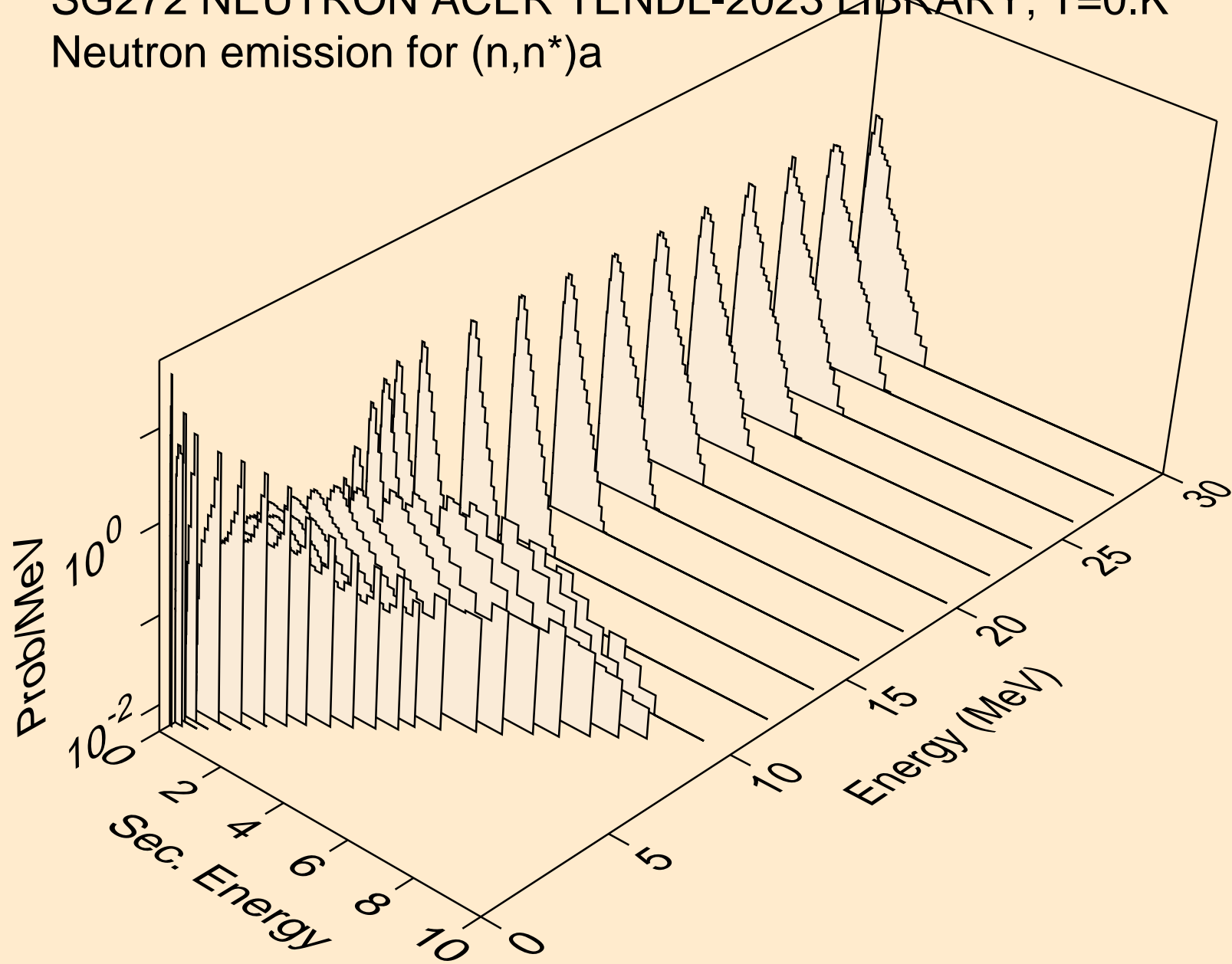

SG272 NEUTRON ACER TENDL-2023 LIBRARY; T=0.K  
Neutron emission for (n,2n)a

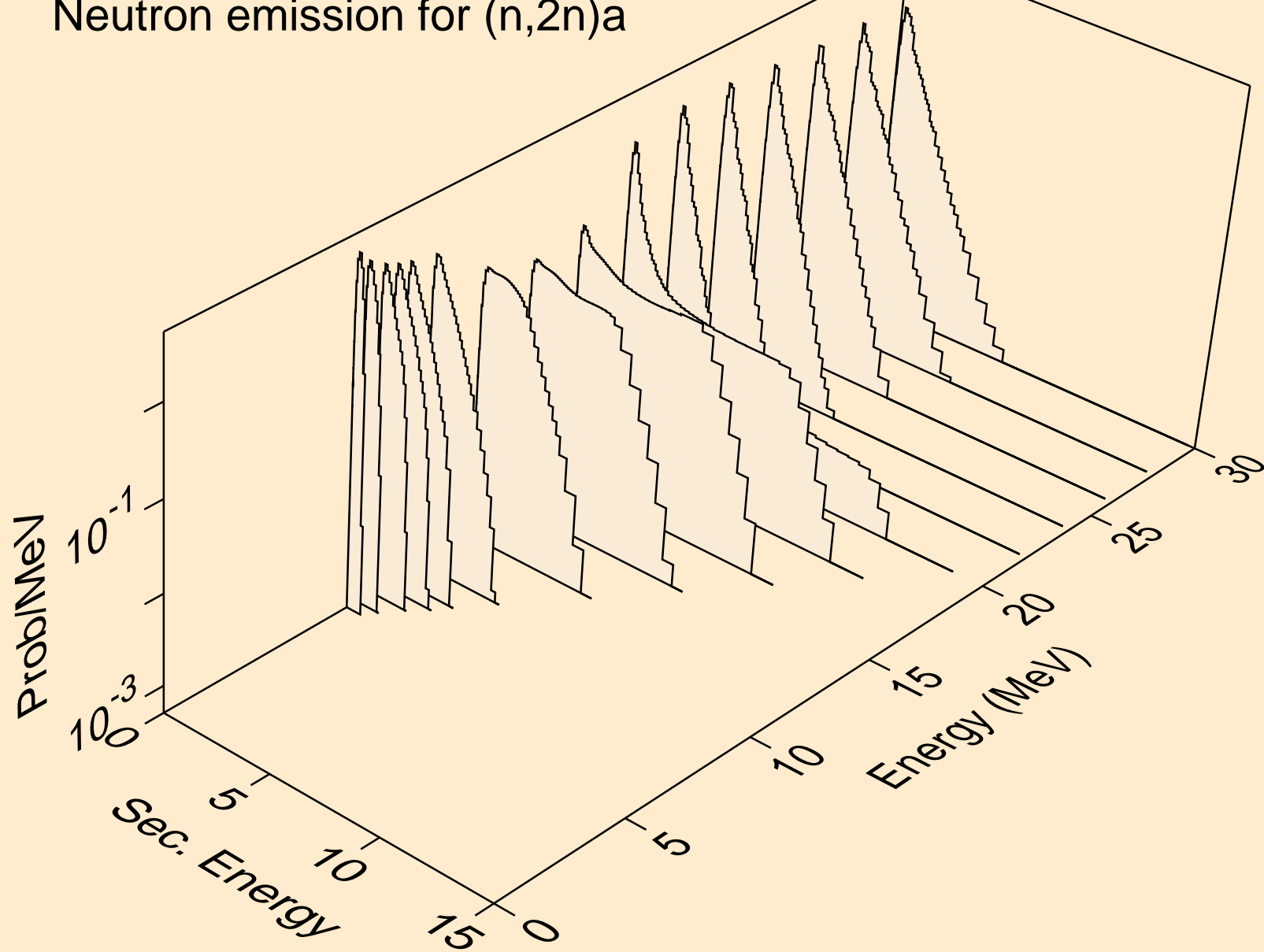

SG272 NEUTRON ACER TENDL-2023 LIBRARY; T=0.K  
Neutron emission for (n,n\*)p

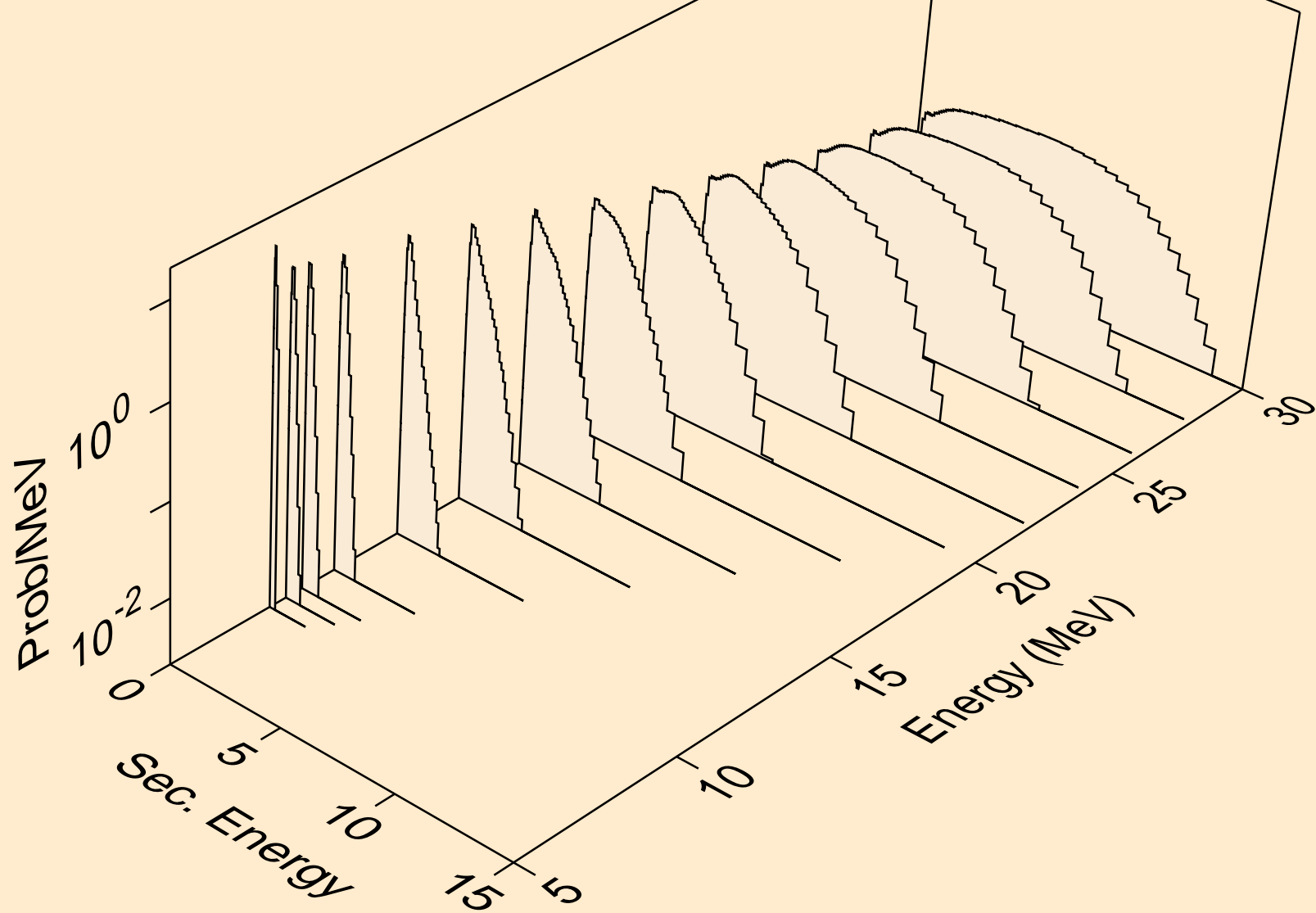

SG272 NEUTRON ACER TENDL-2023 LIBRARY; T=0.K  
Neutron emission for (n,n\*)d

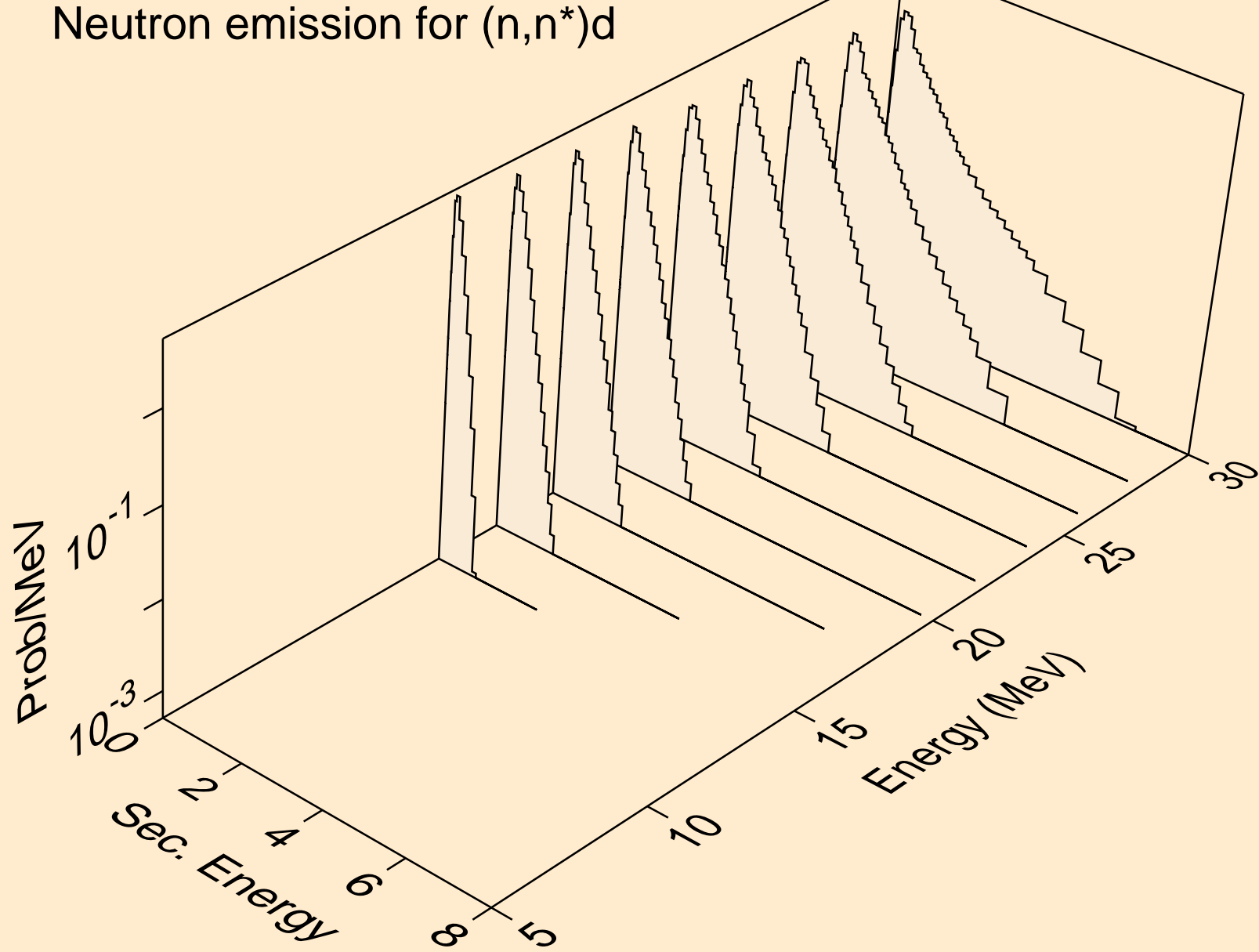

SG272 NEUTRON ACER TENDL-2023 LIBRARY; T=0.K  
Neutron emission for (n,n\*)t

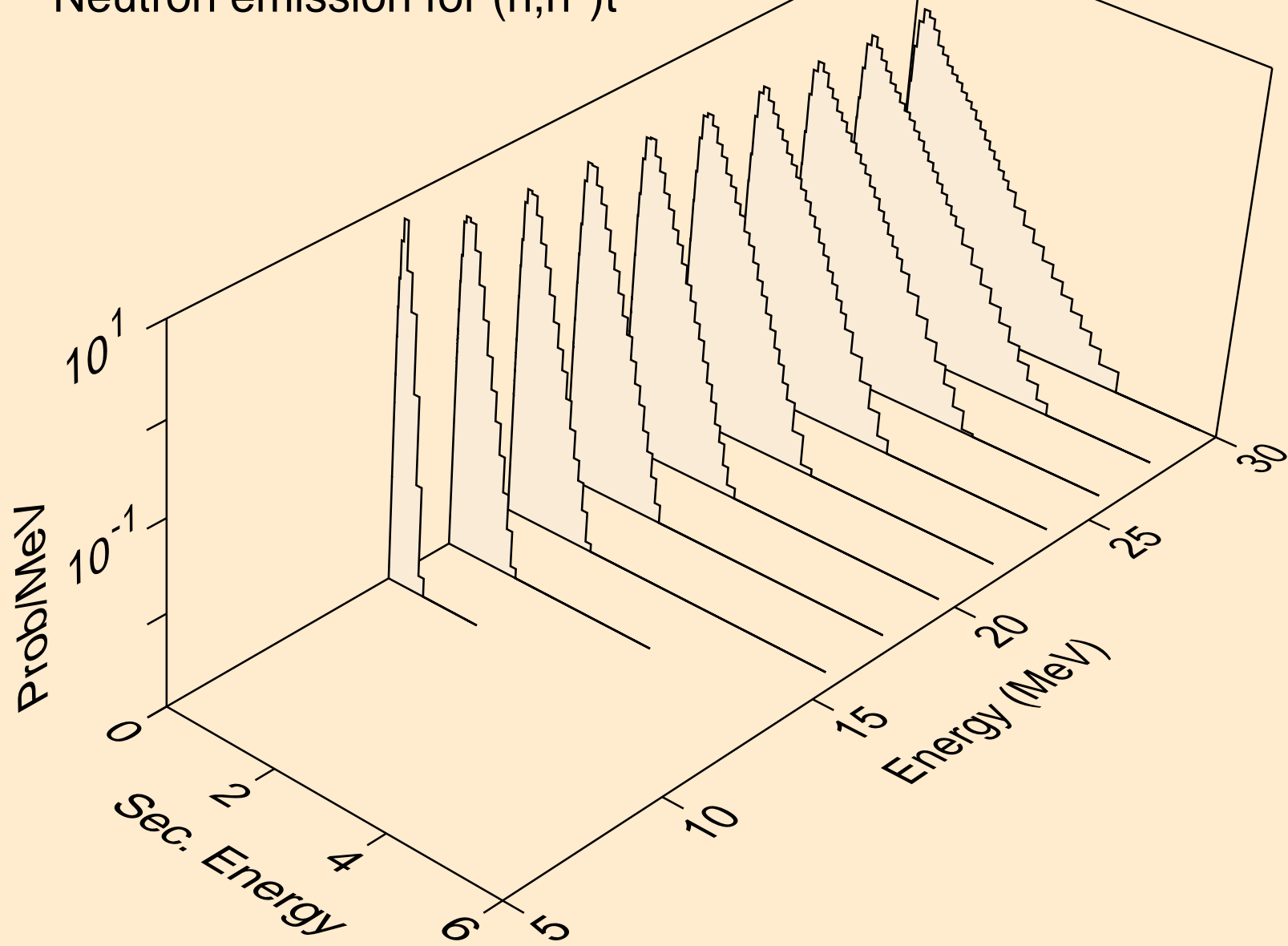

SG272 NEUTRON ACER TENDL-2023 LIBRARY; T=0.K  
Neutron emission for (n,n\*)he3

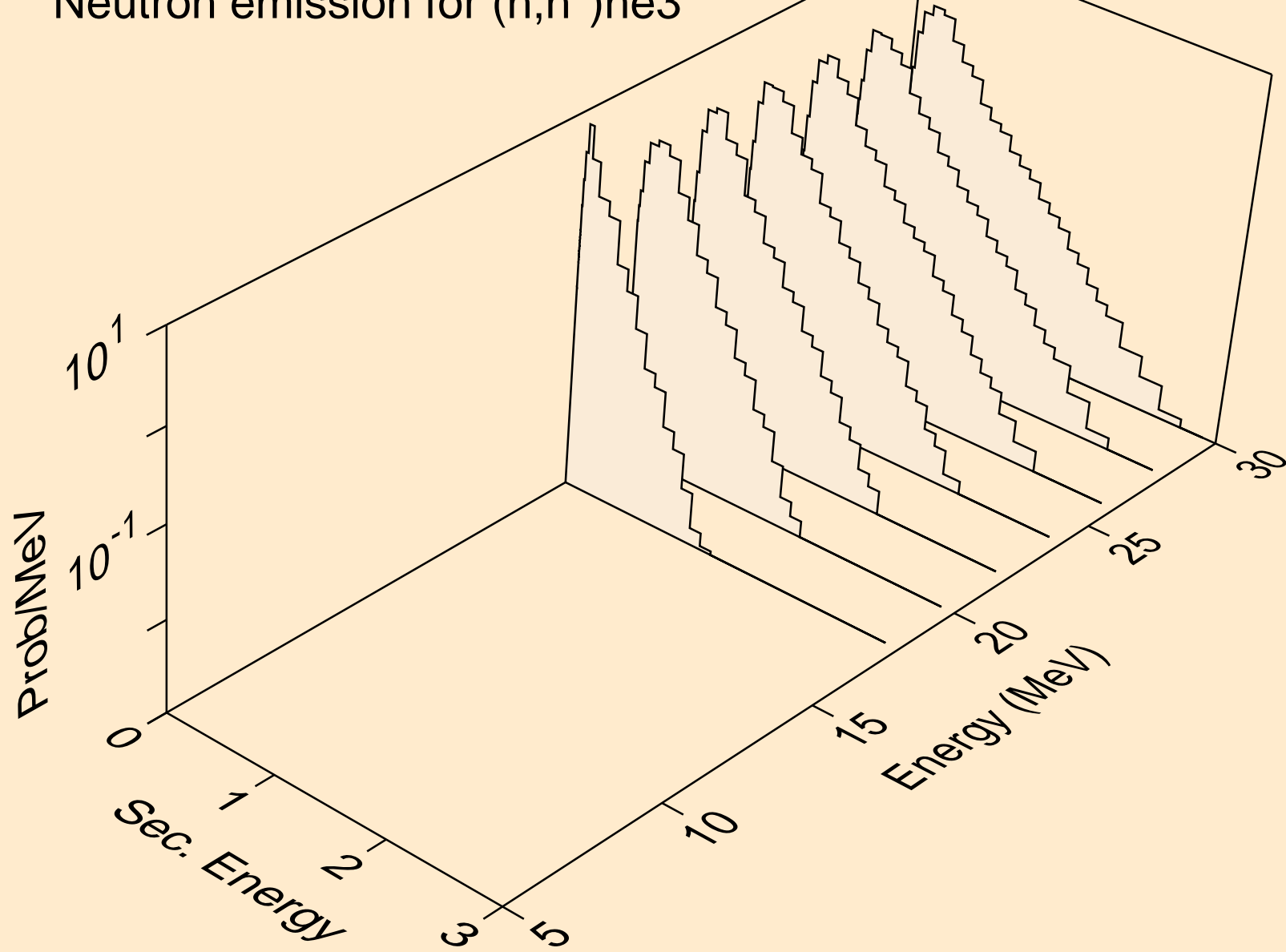

SG272 NEUTRON ACER TENDL-2023 LIBRARY; T=0.K  
Neutron emission for (n,4n)

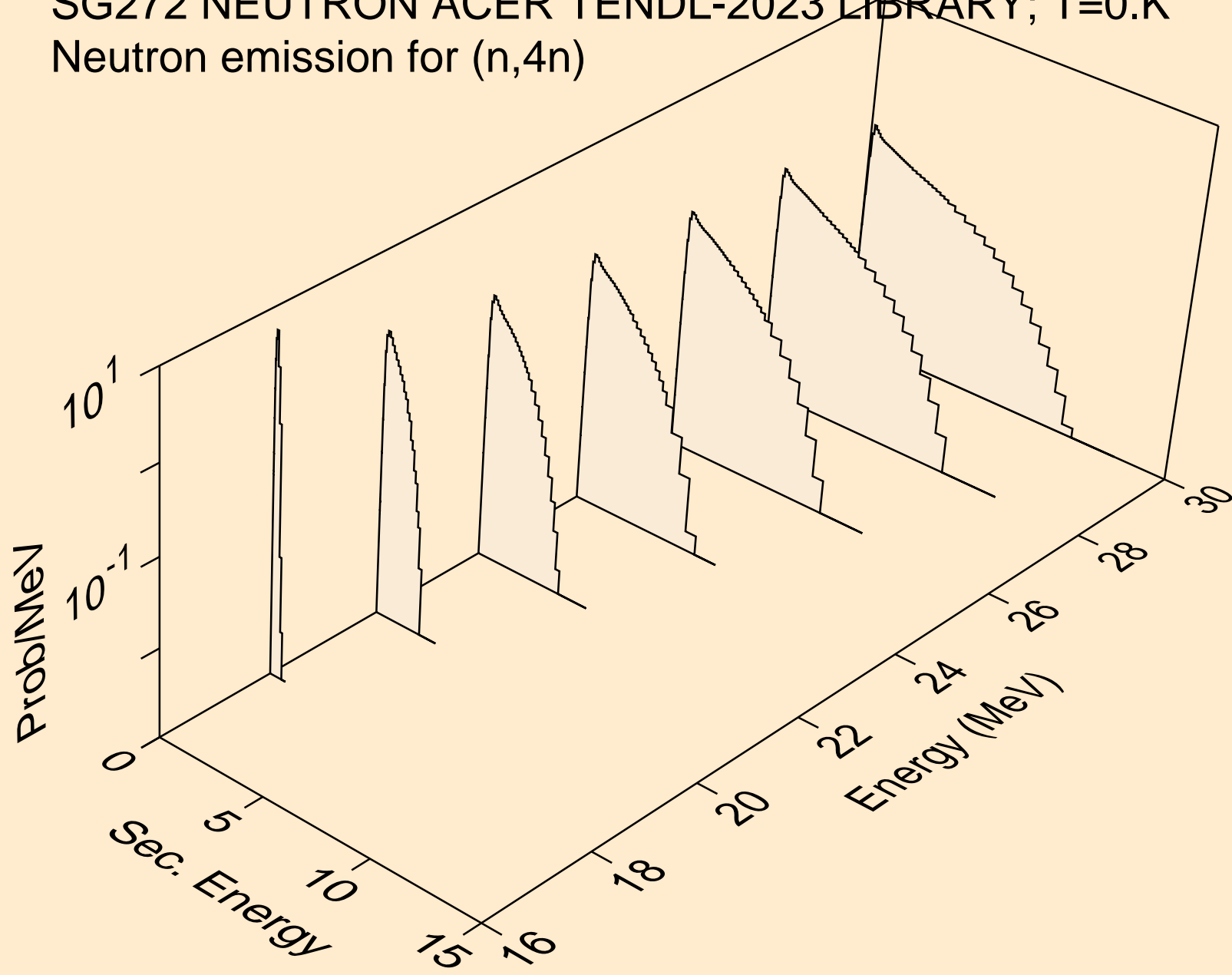

SG272 NEUTRON ACER TENDL-2023 LIBRARY; T=0.K  
Neutron emission for (n,2np)

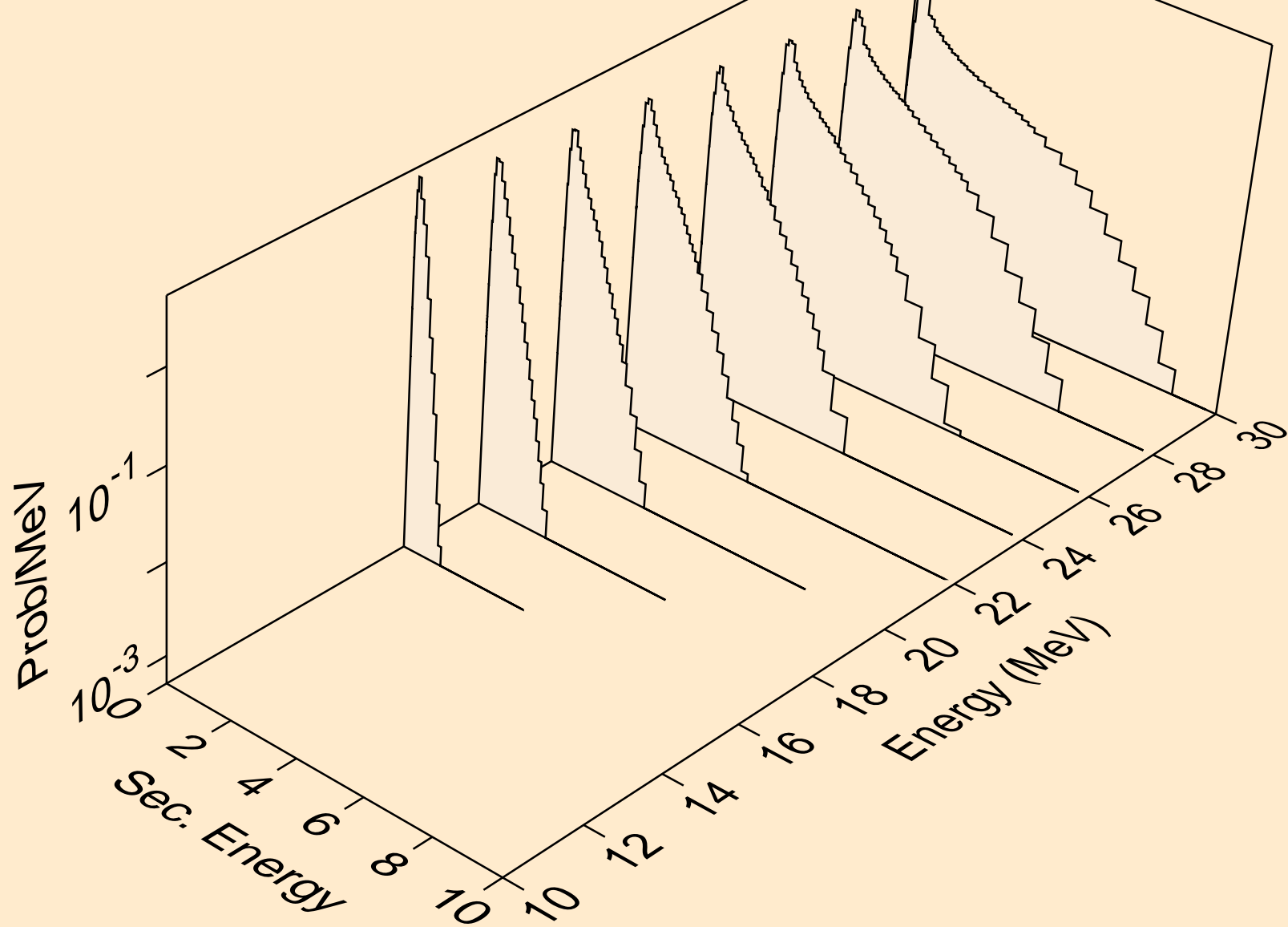



SG272 NEUTRON ACER TENDL-2023 LIBRARY; T=0.K  
Neutron emission for (n,3np)

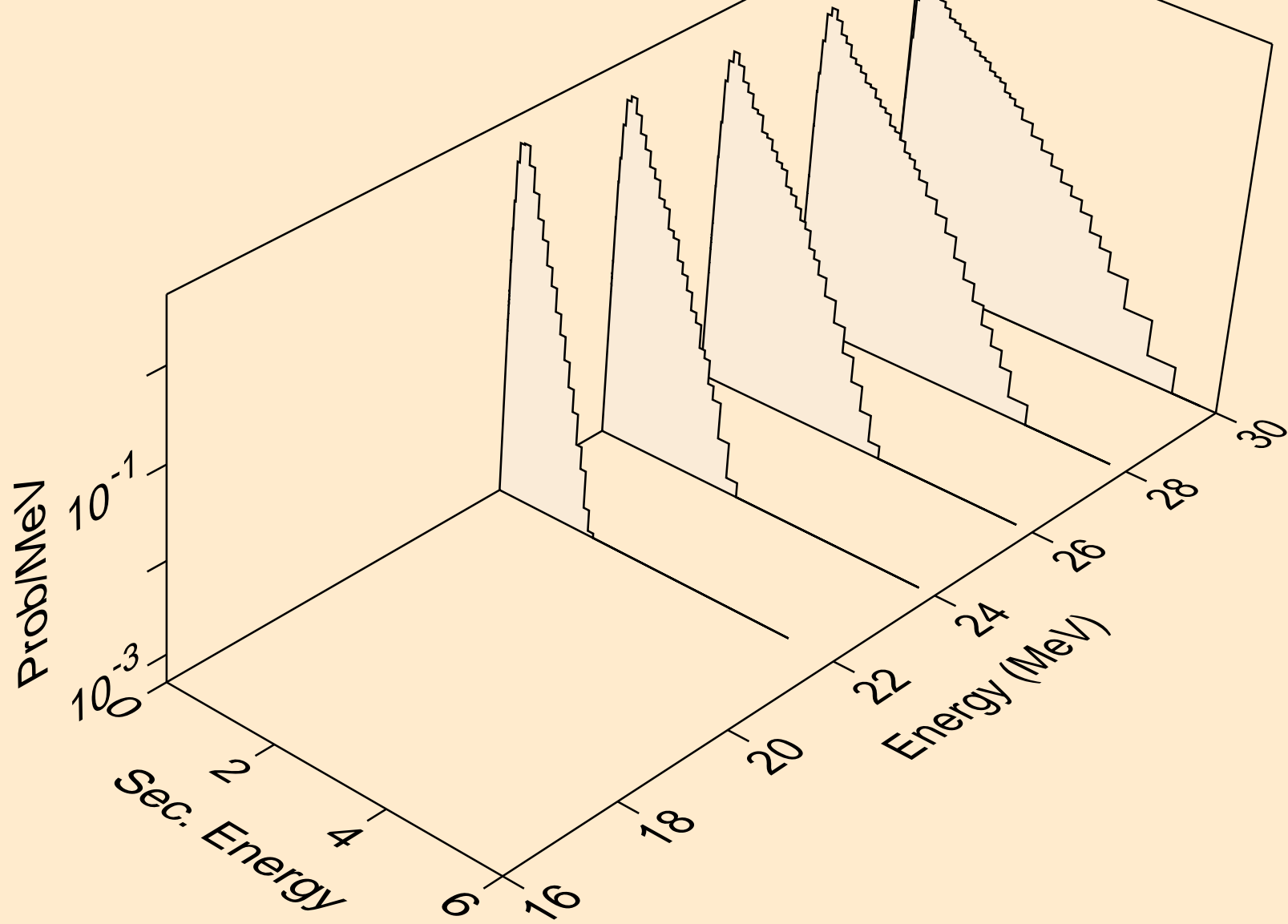

SG272 NEUTRON ACER TENDL-2023 LIBRARY; T=0.K  
Neutron emission for (n,n\*c)

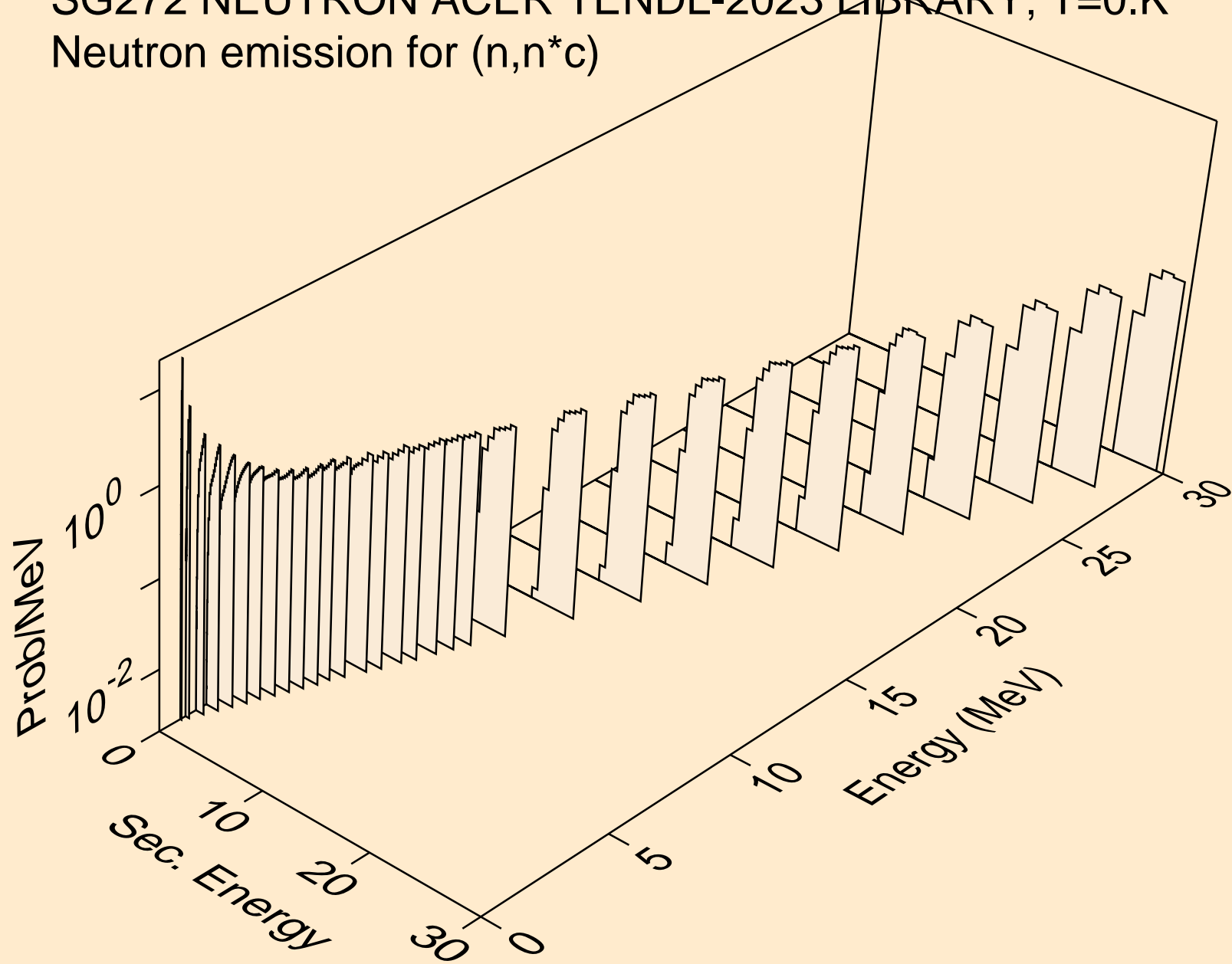

# SG272 NEUTRON ACER TENDL-2023 LIBRARY; T=0.K

Delayed nubar

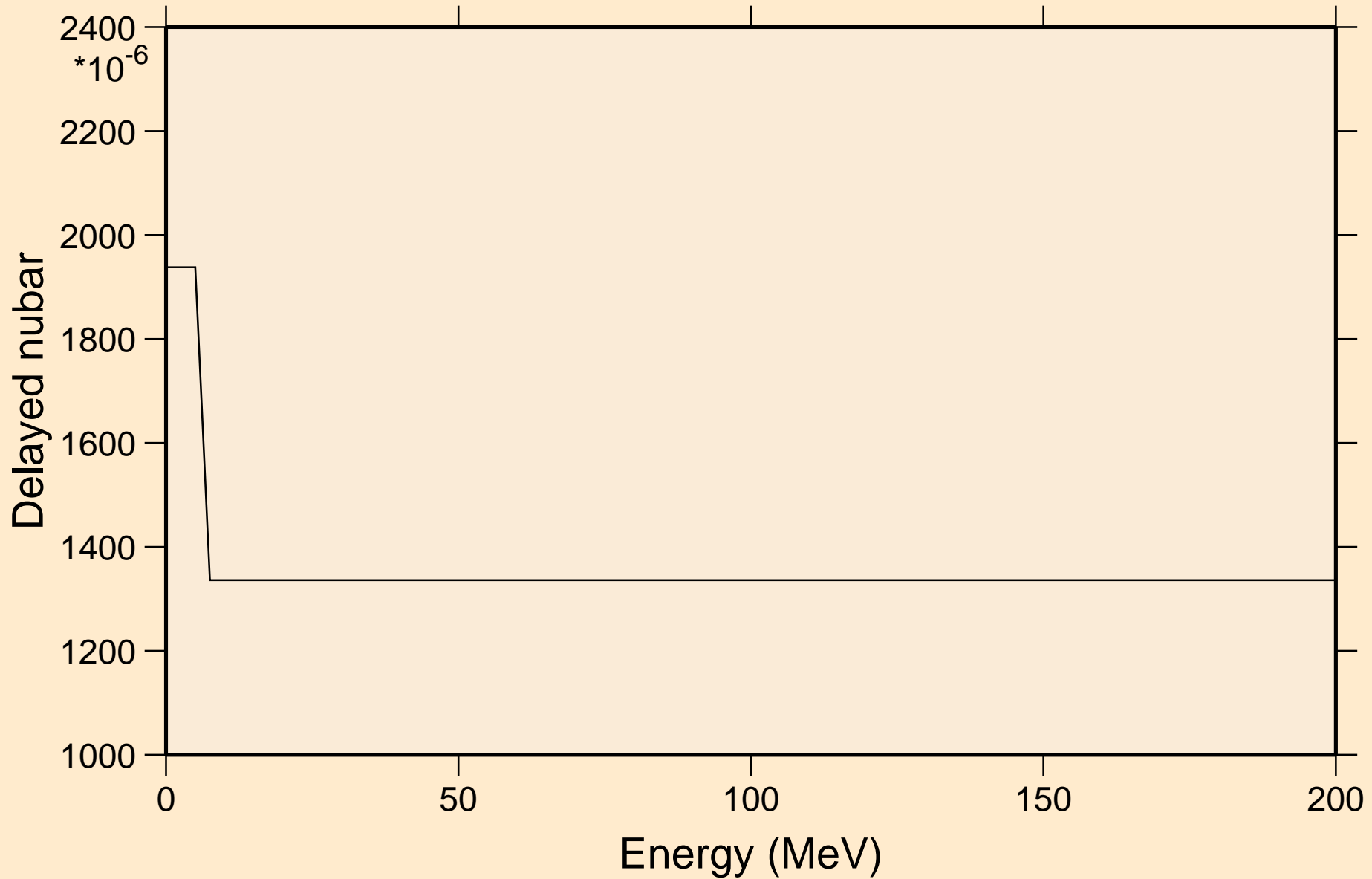

# SG272 NEUTRON ACER TENDL-2023 LIBRARY; T=0.K

## Delayed neutron spectra

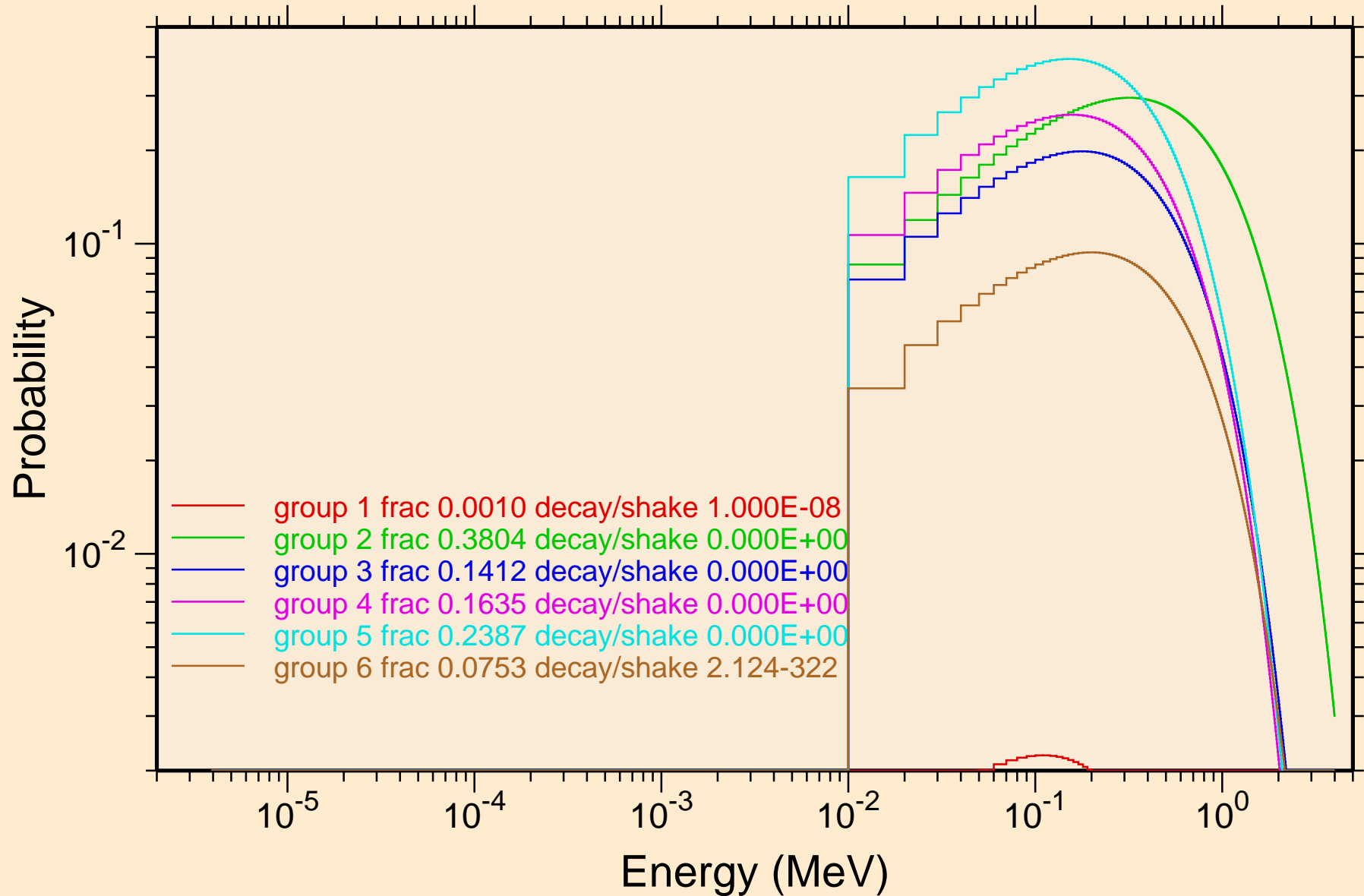

SG272 NEUTRON ACER TENDL-2023 LIBRARY; T=0.K  
Photon emission for (n,x)

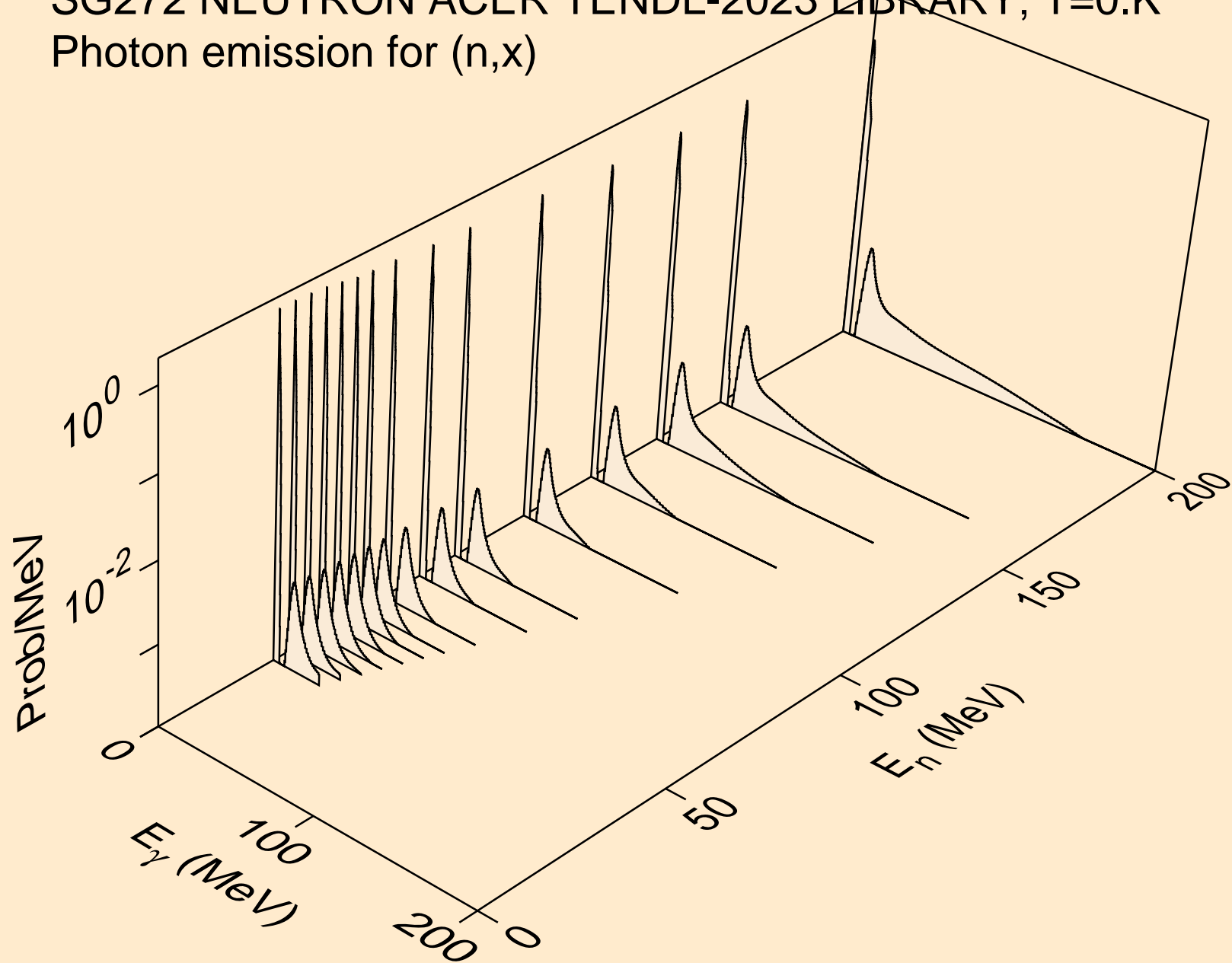

SG272 NEUTRON ACER TENDL-2023 LIBRARY; T=0.K  
Photon emission for (n,2nd)

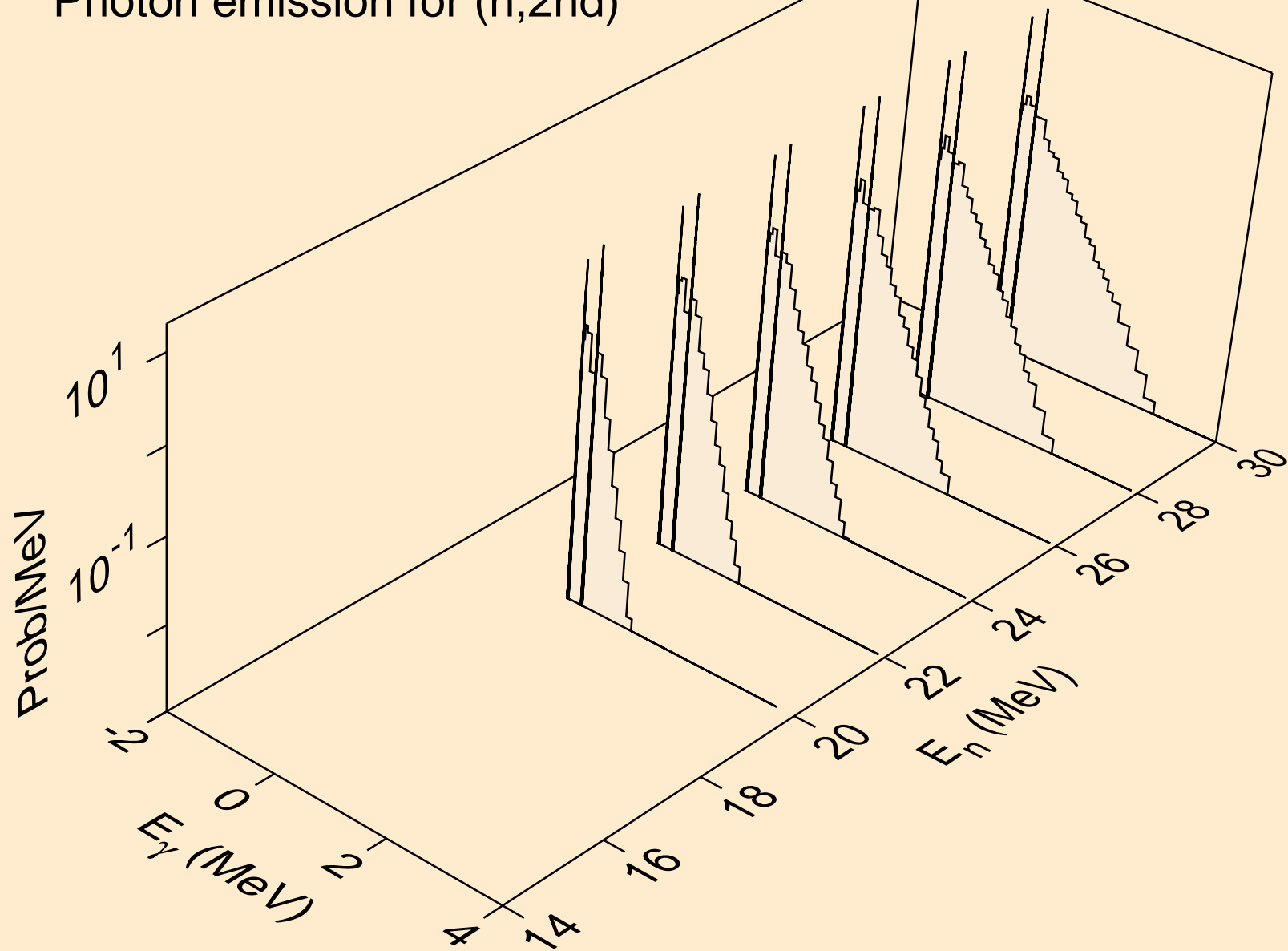

SG272 NEUTRON ACER TENDL-2023 LIBRARY; T=0.K  
Photon emission for (n,2n)

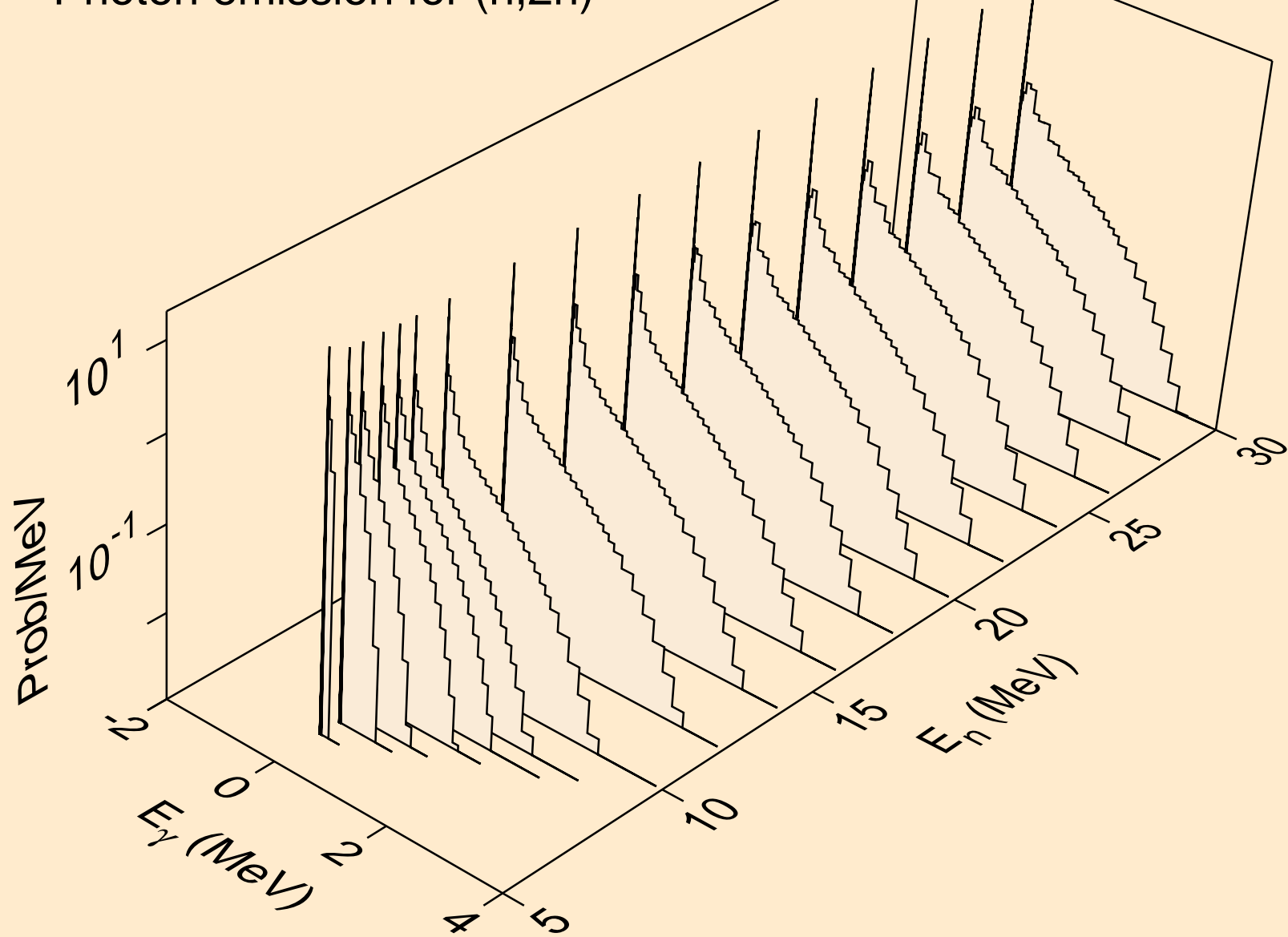

SG272 NEUTRON ACER TENDL-2023 LIBRARY; T=0.K  
Photon emission for (n,3n)

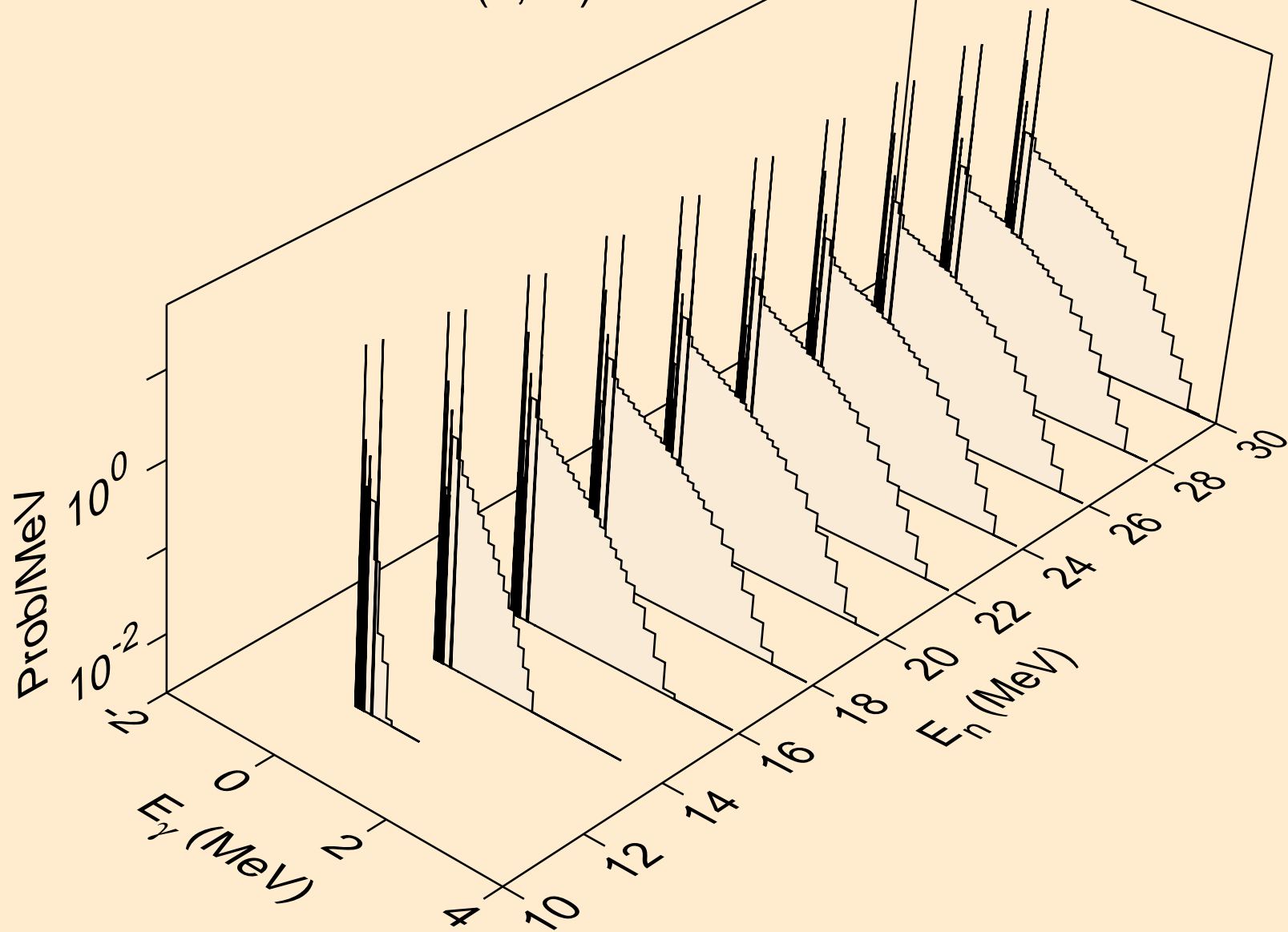



SG272 NEUTRON ACER TENDL-2023 LIBRARY; T=0.K  
Photon emission for (n,n\*)a

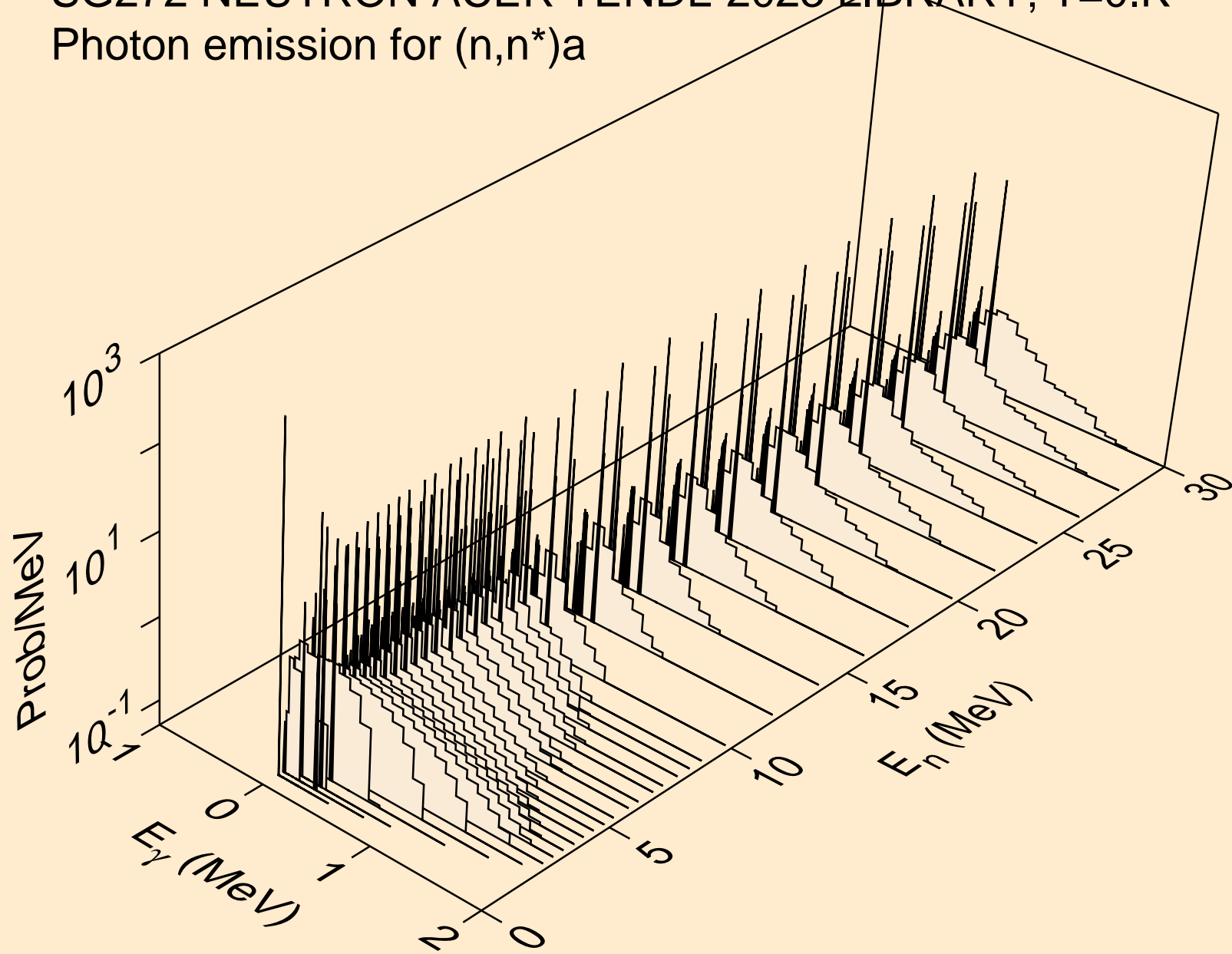

SG272 NEUTRON ACER TENDL-2023 LIBRARY; T=0.K  
Photon emission for (n,2n)a

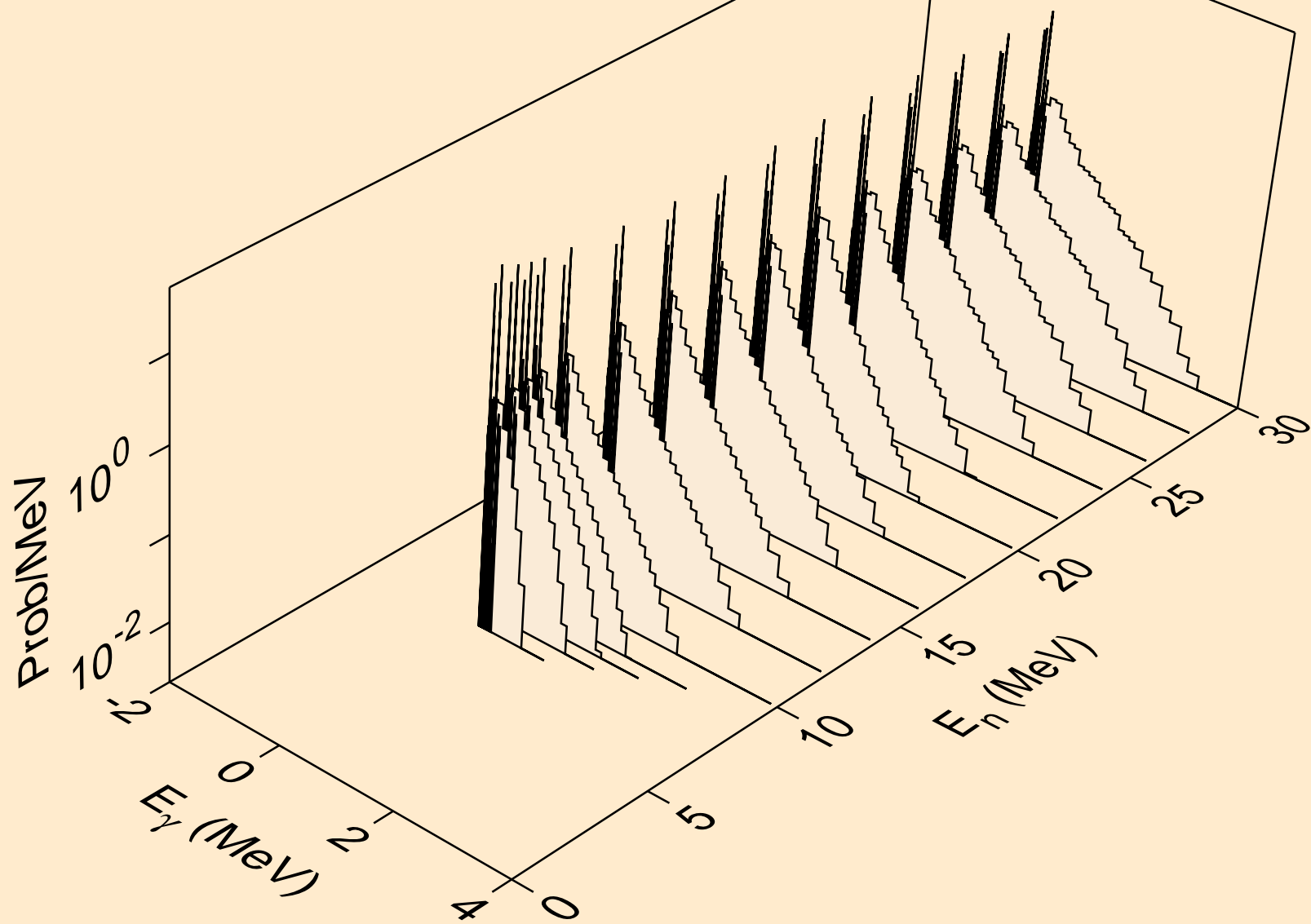

SG272 NEUTRON ACER TENDL-2023 LIBRARY; T=0.K  
Photon emission for (n,n\*)p

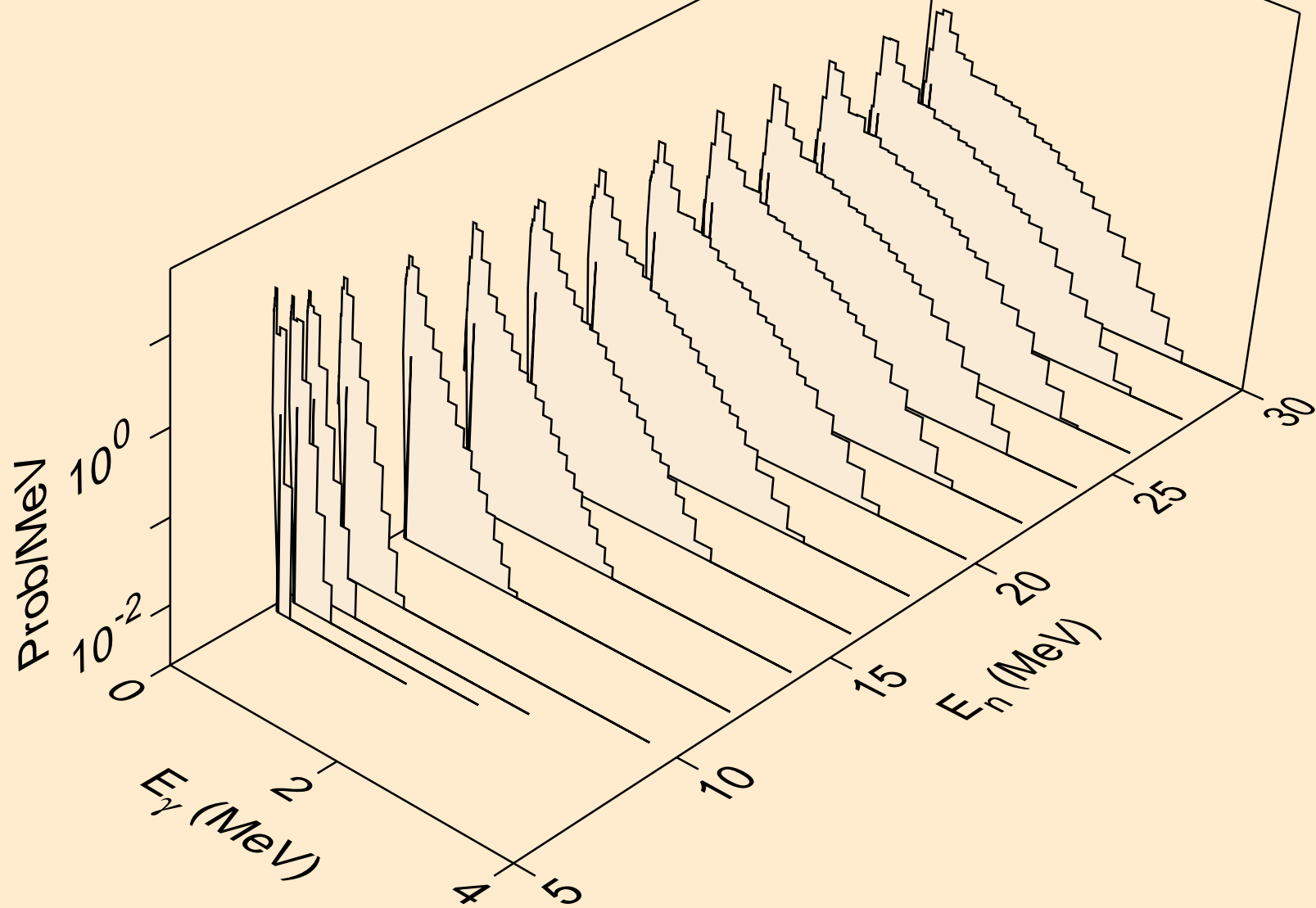

SG272 NEUTRON ACER TENDL-2023 LIBRARY; T=0.K  
Photon emission for (n,n\*)d

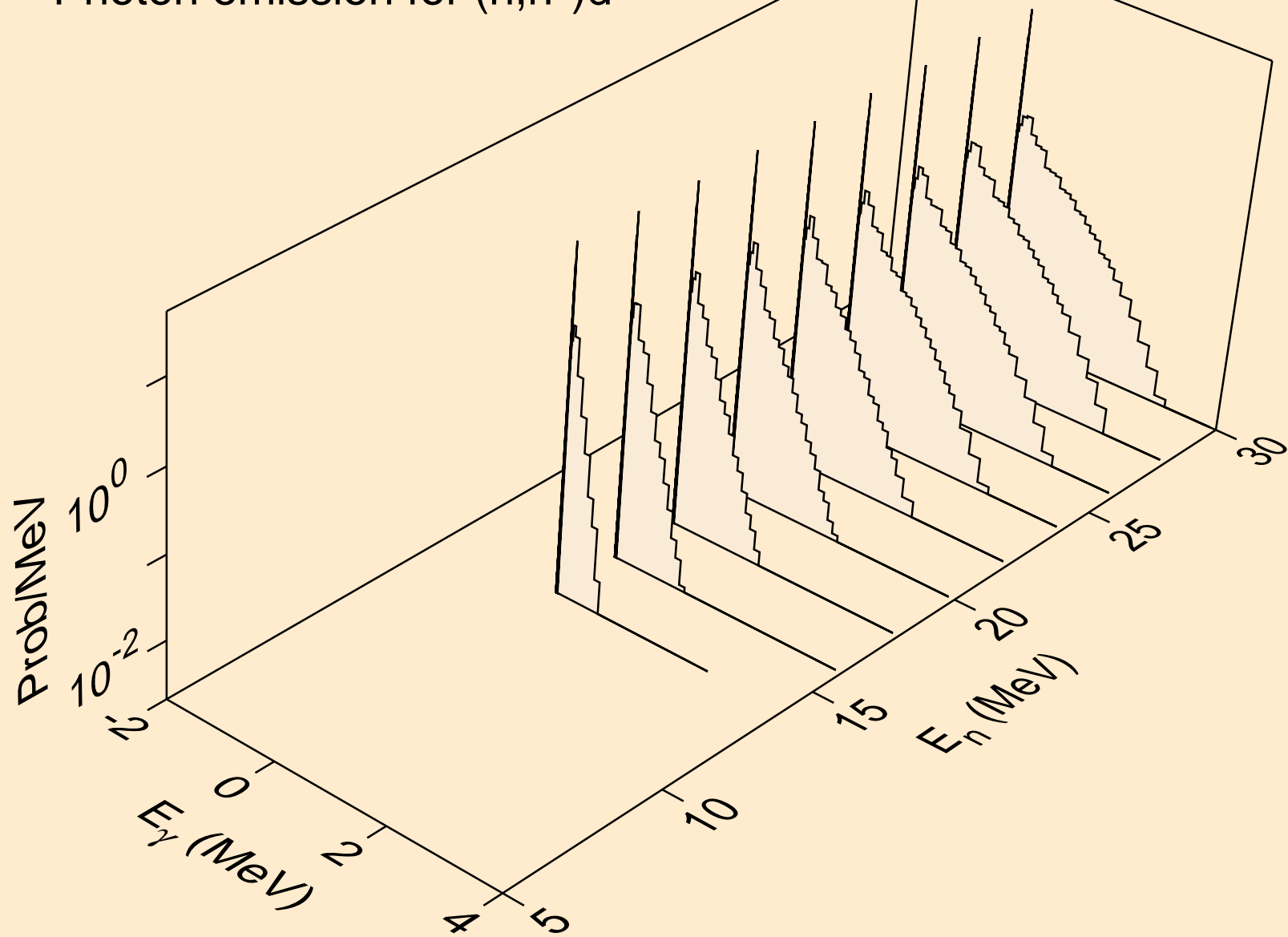

SG272 NEUTRON ACER TENDL-2023 LIBRARY; T=0.K  
Photon emission for (n,n\*)t

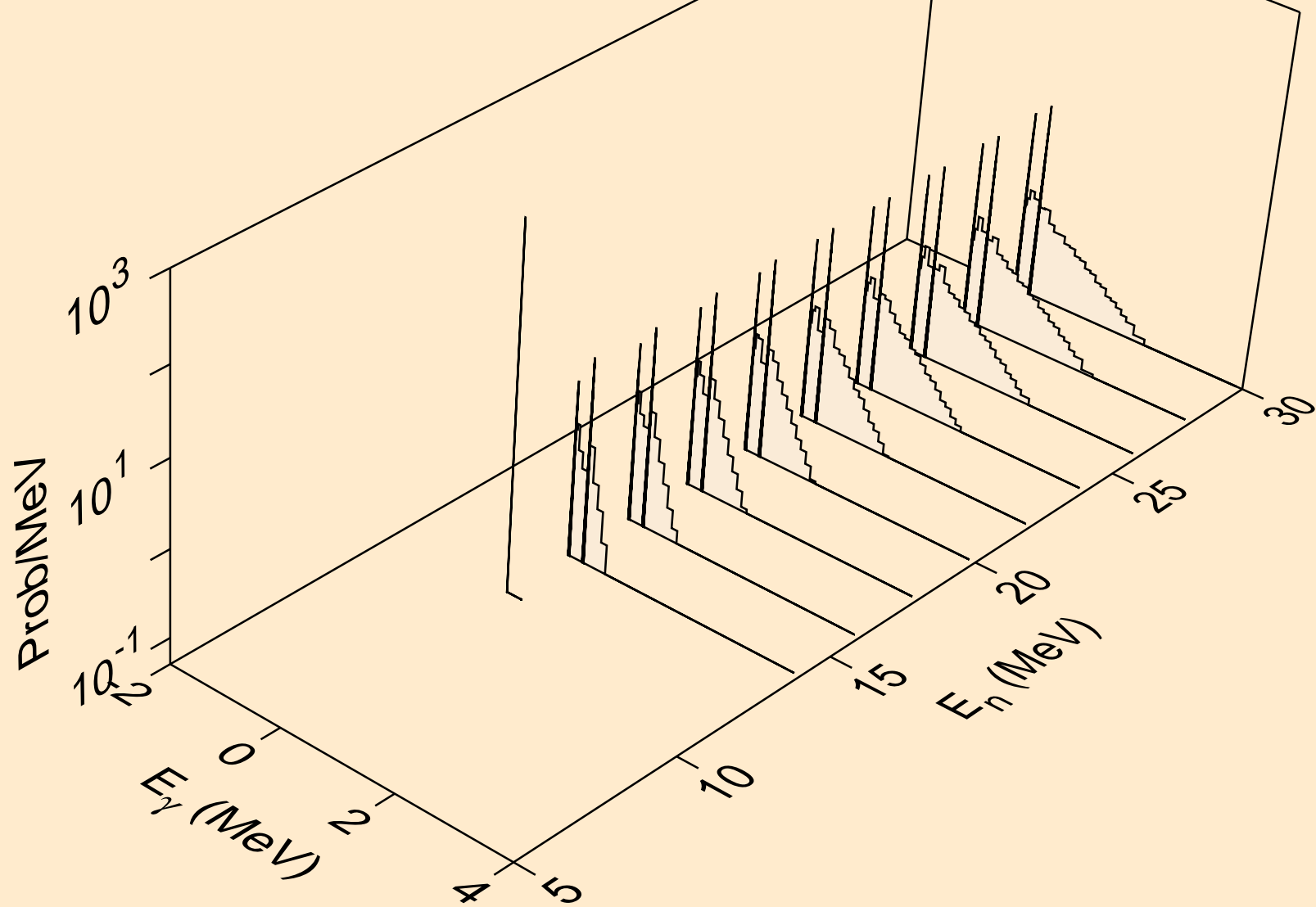

SG272 NEUTRON ACER TENDL-2023 LIBRARY; T=0.K  
Photon emission for (n,n\*)he3

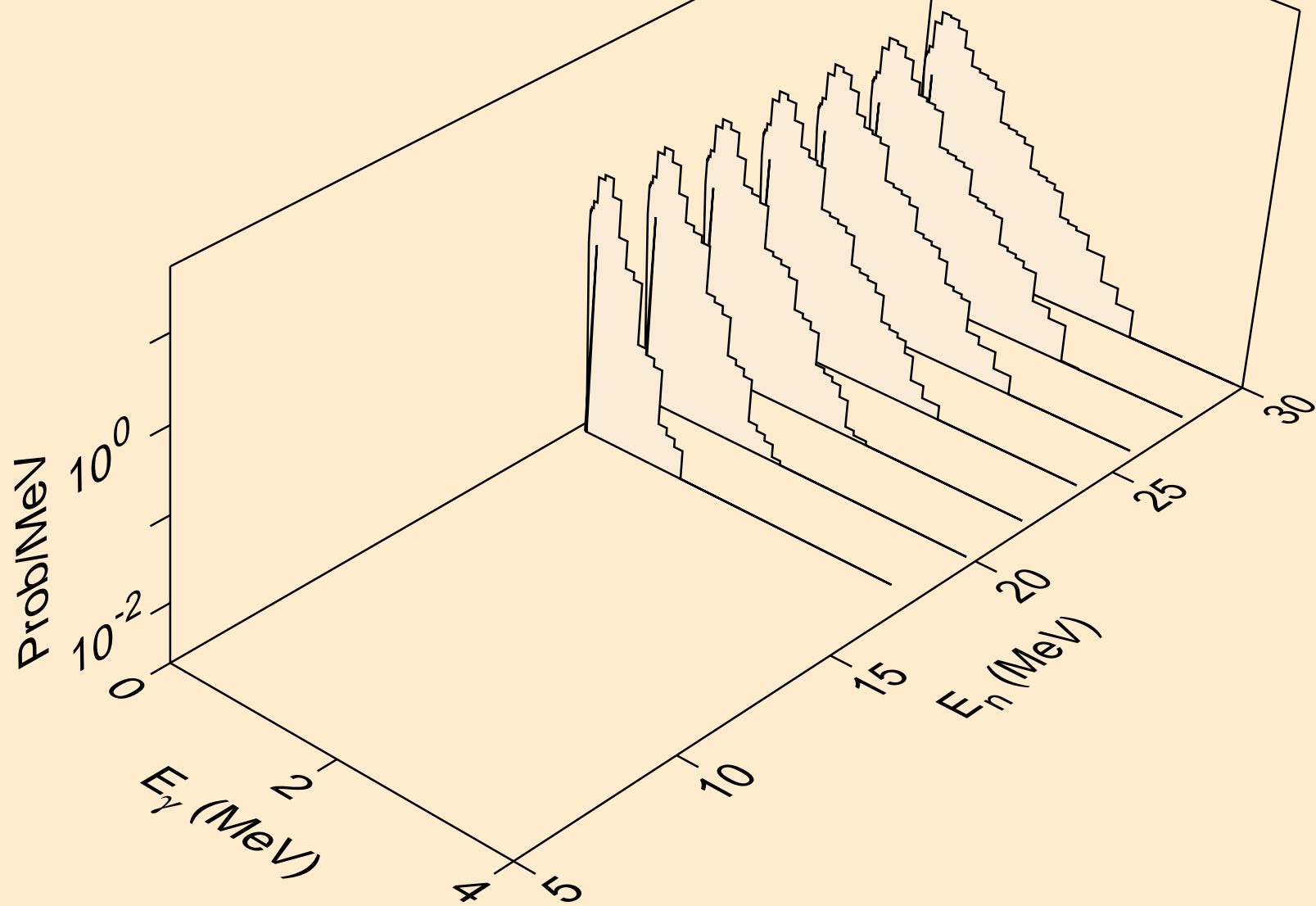

SG272 NEUTRON ACER TENDL-2023 LIBRARY; T=0.K  
Photon emission for (n,4n)

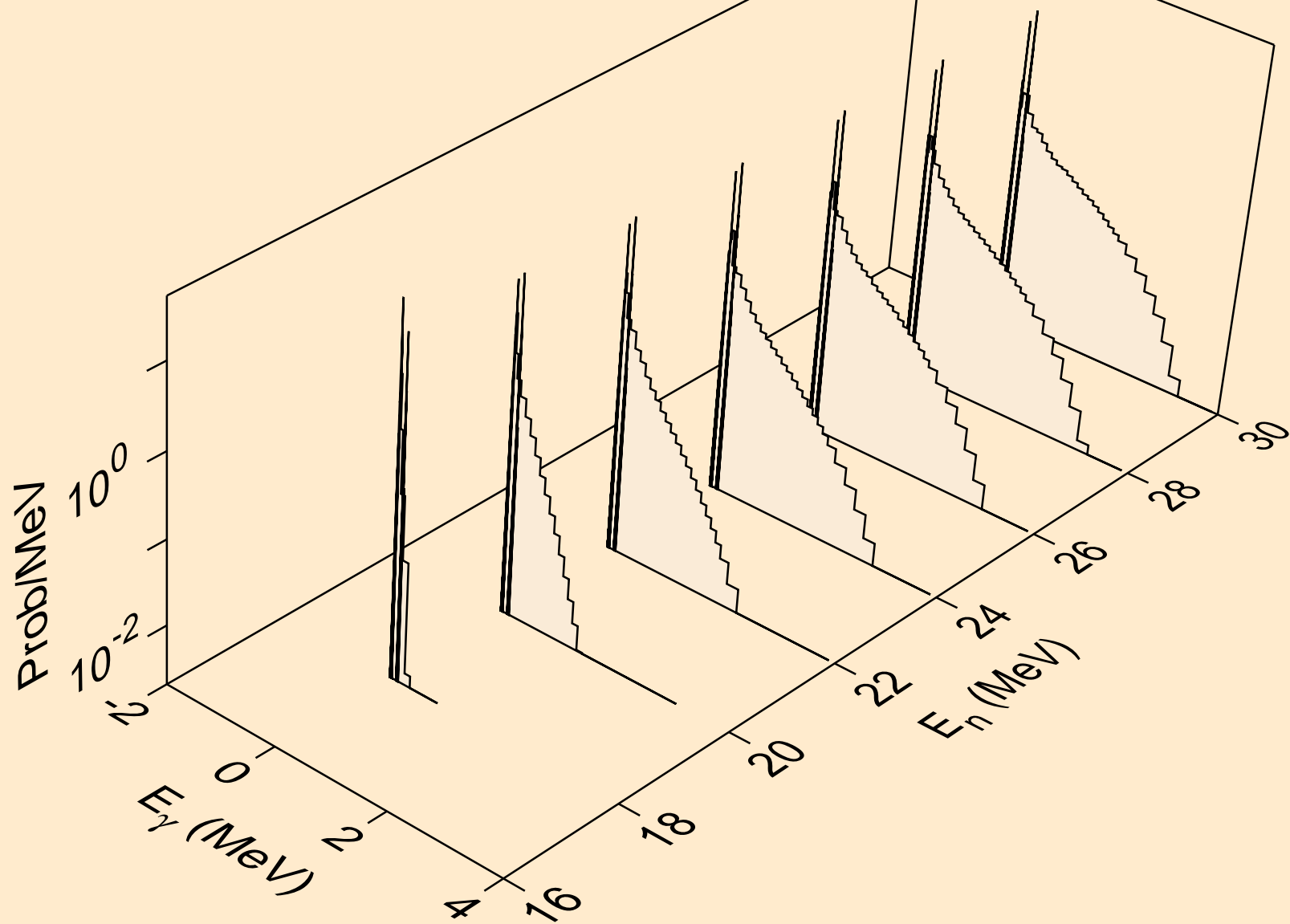

SG272 NEUTRON ACER TENDL-2023 LIBRARY; T=0.K  
Photon emission for (n,2np)

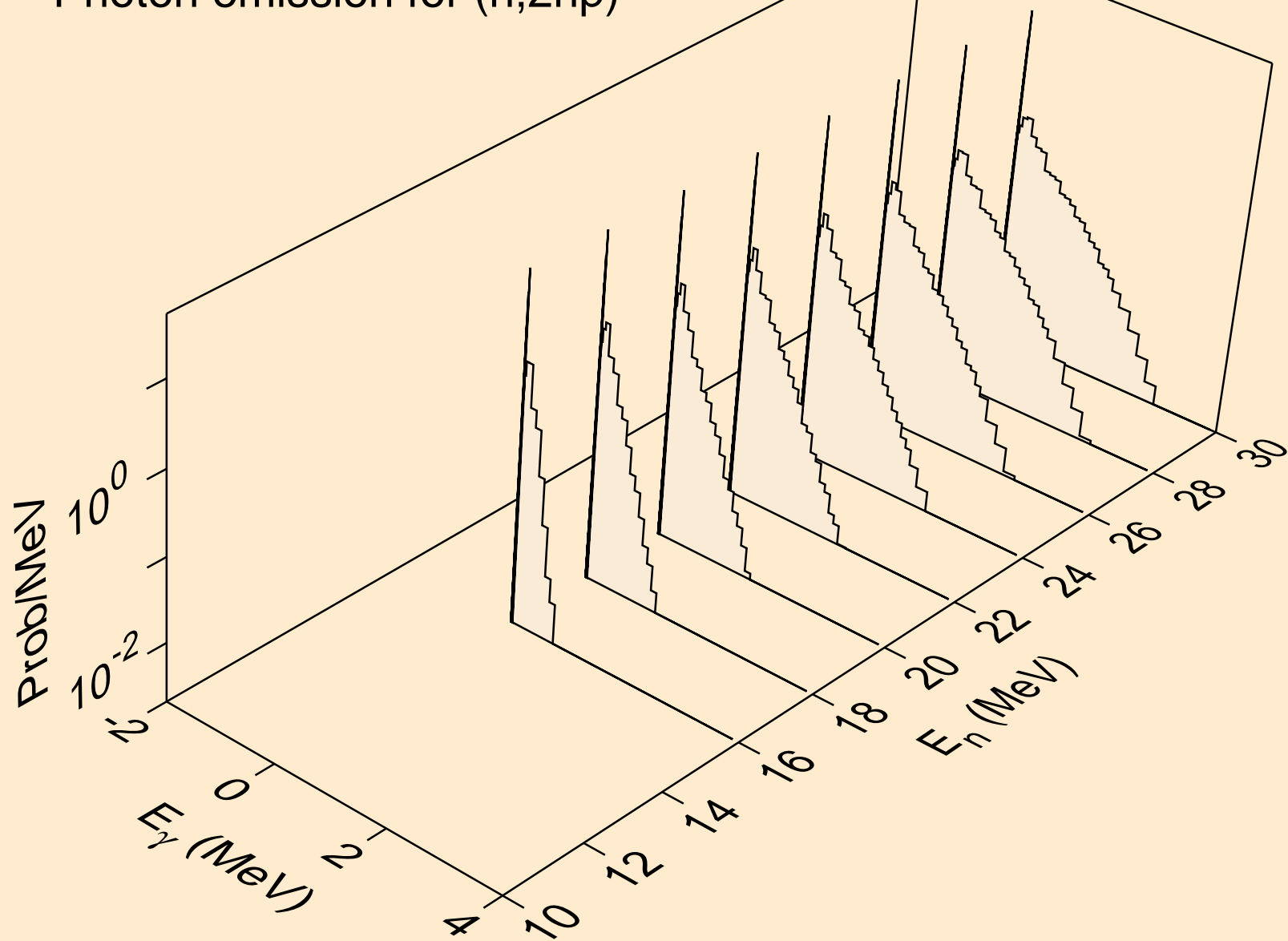



SG272 NEUTRON ACER TENDL-2023 LIBRARY; T=0.K  
Photon emission for (n,3np)

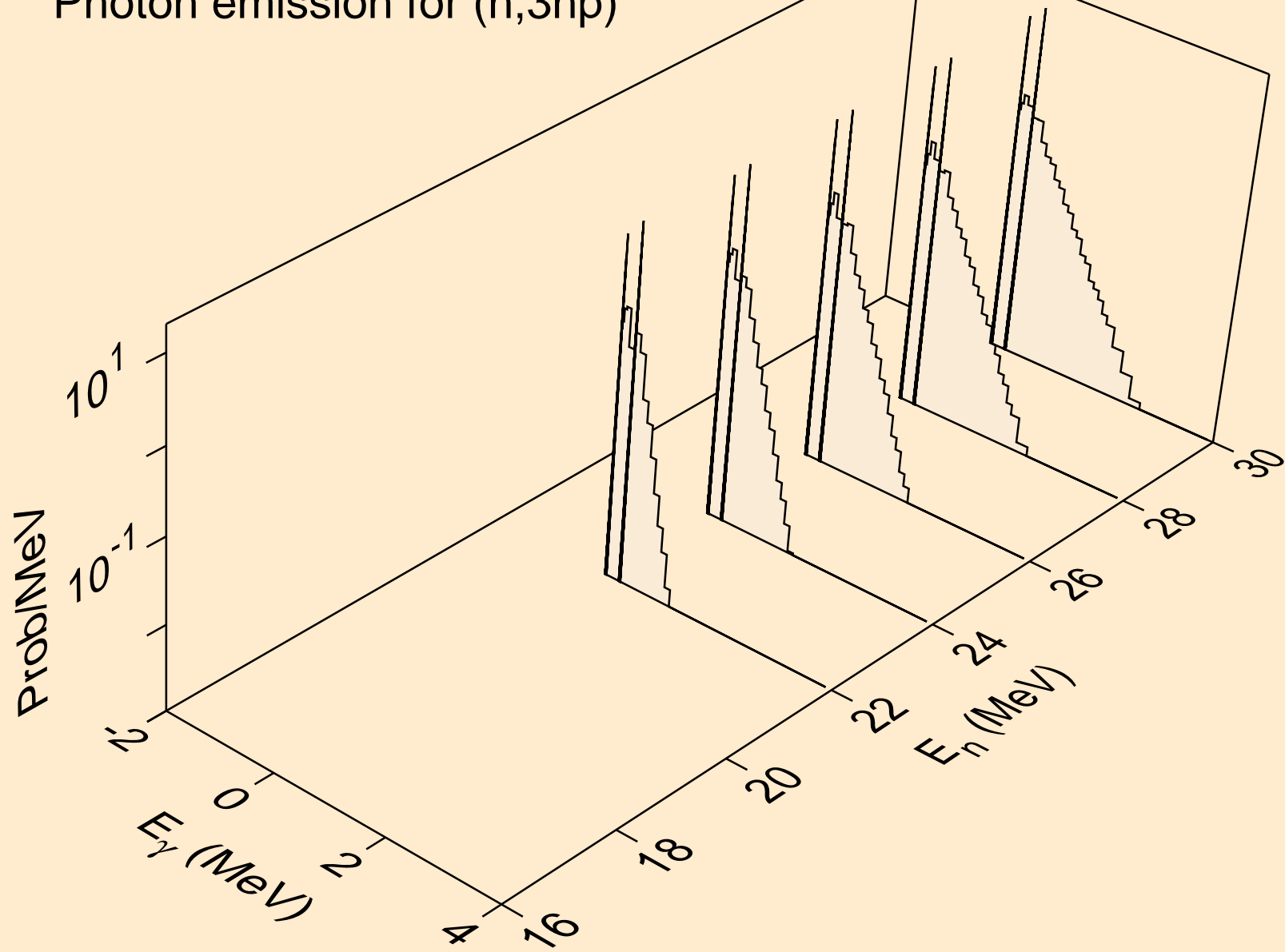

SG272 NEUTRON ACER TENDL-2023 LIBRARY; T=0.K  
Photon emission for (n,n\*c)

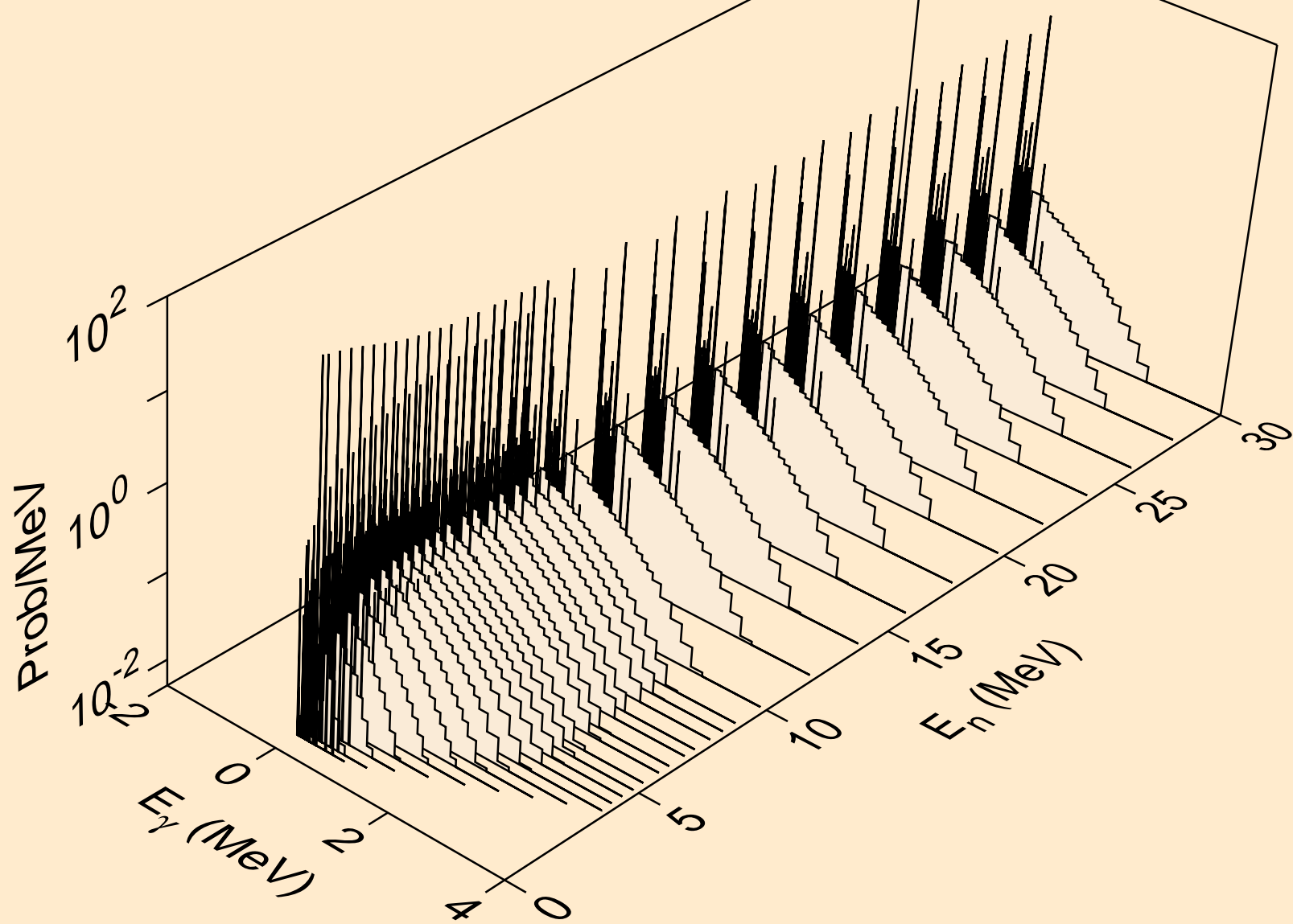

SG272 NEUTRON ACER TENDL-2023 LIBRARY; T=0.K  
Photon emission for (n,gma)

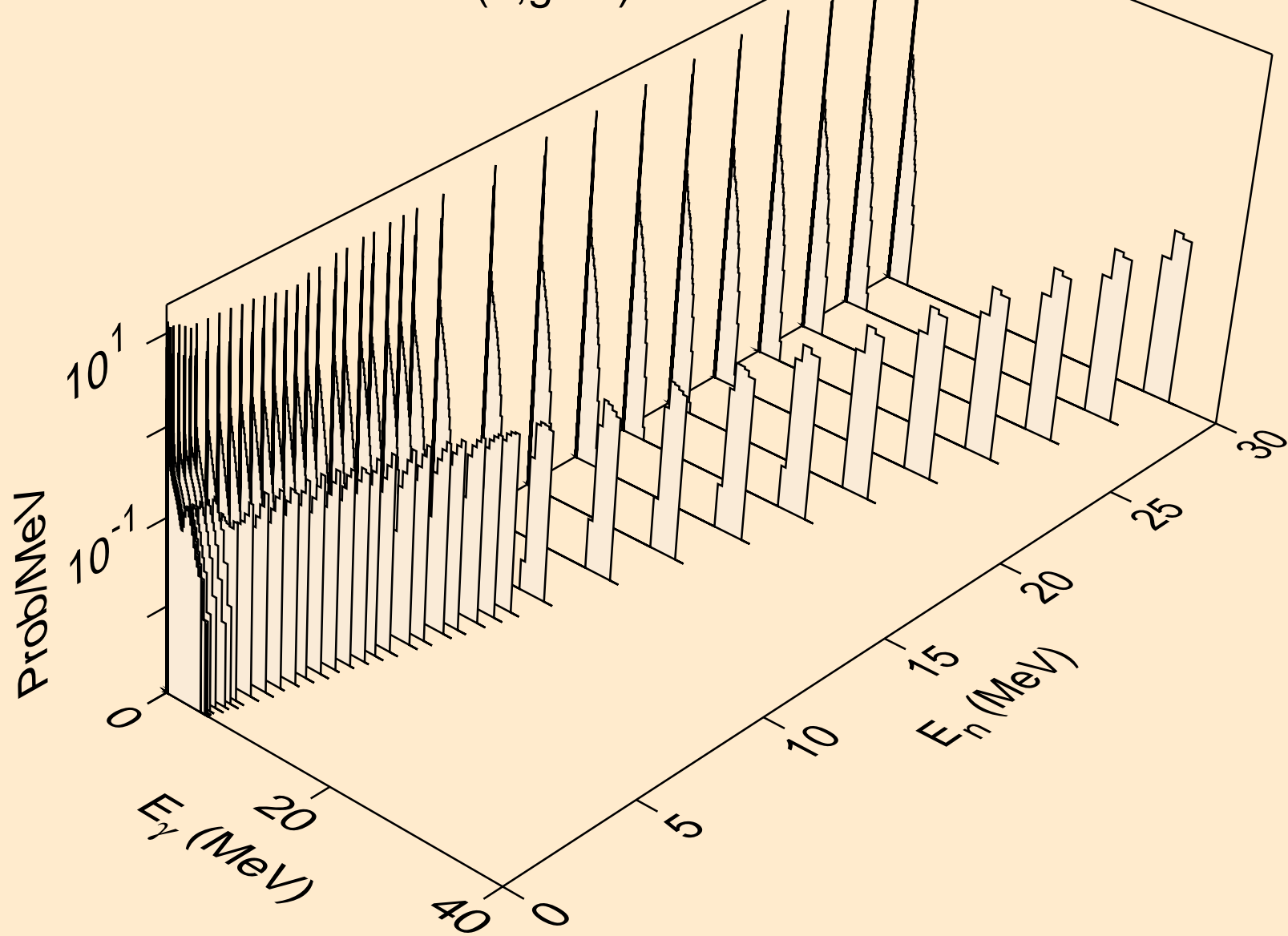

SG272 NEUTRON ACER TENDL-2023 LIBRARY; T=0.K  
Photon emission for (n,p)

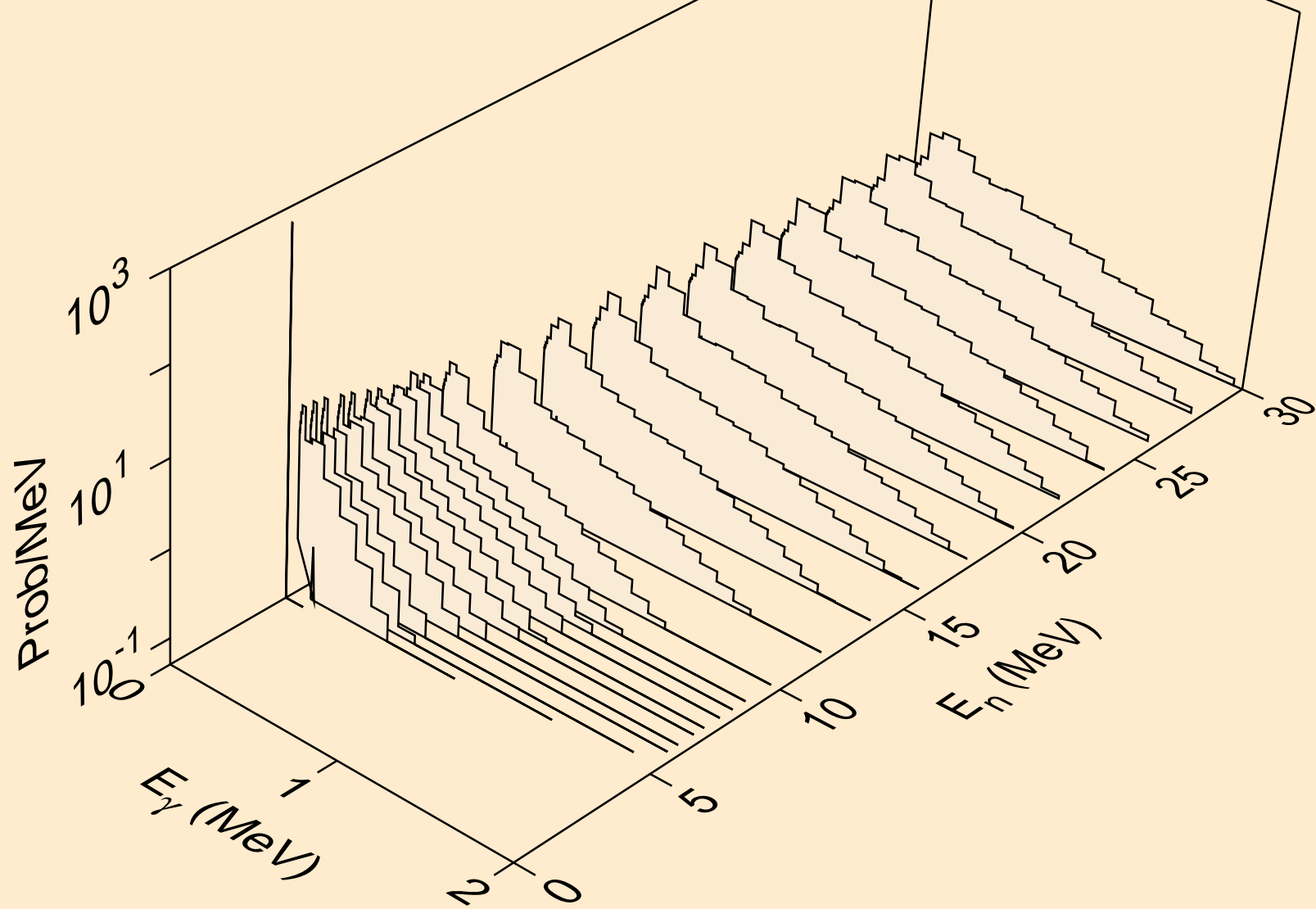

SG272 NEUTRON ACER TENDL-2023 LIBRARY; T=0.K  
Photon emission for (n,d)

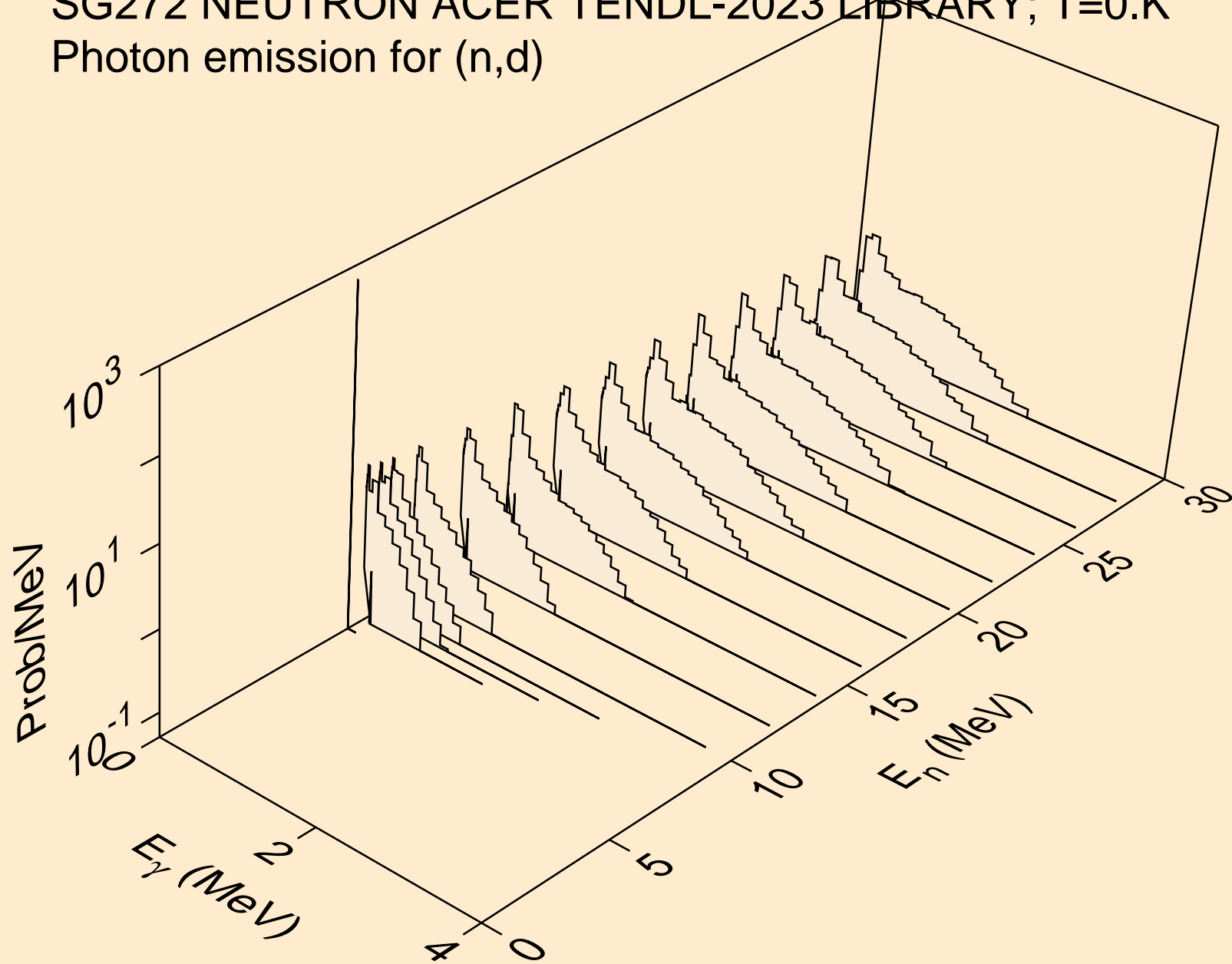

SG272 NEUTRON ACER TENDL-2023 LIBRARY; T=0.K  
Photon emission for (n,t)

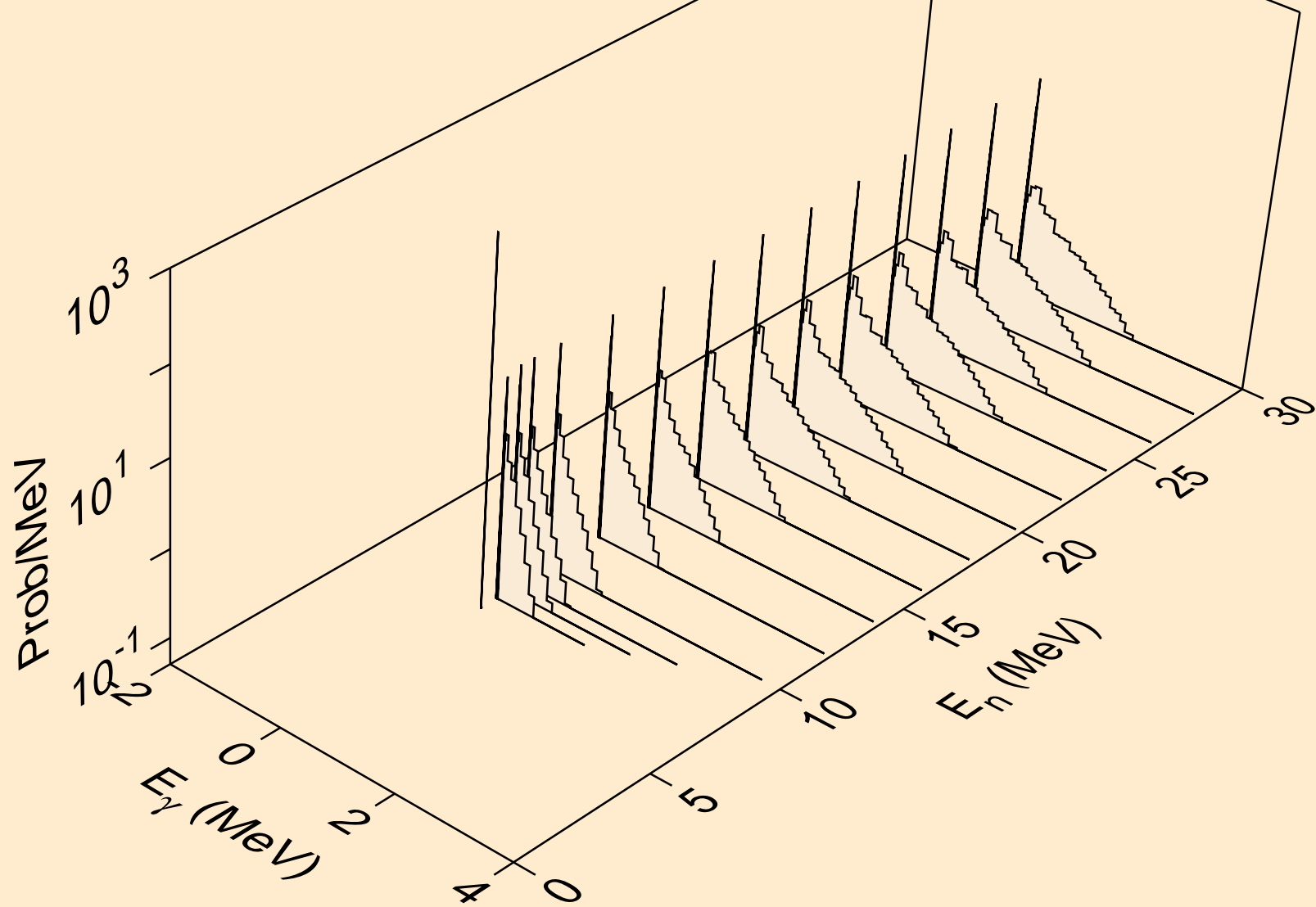

SG272 NEUTRON ACER TENDL-2023 LIBRARY; T=0.K  
Photon emission for (n,he3)

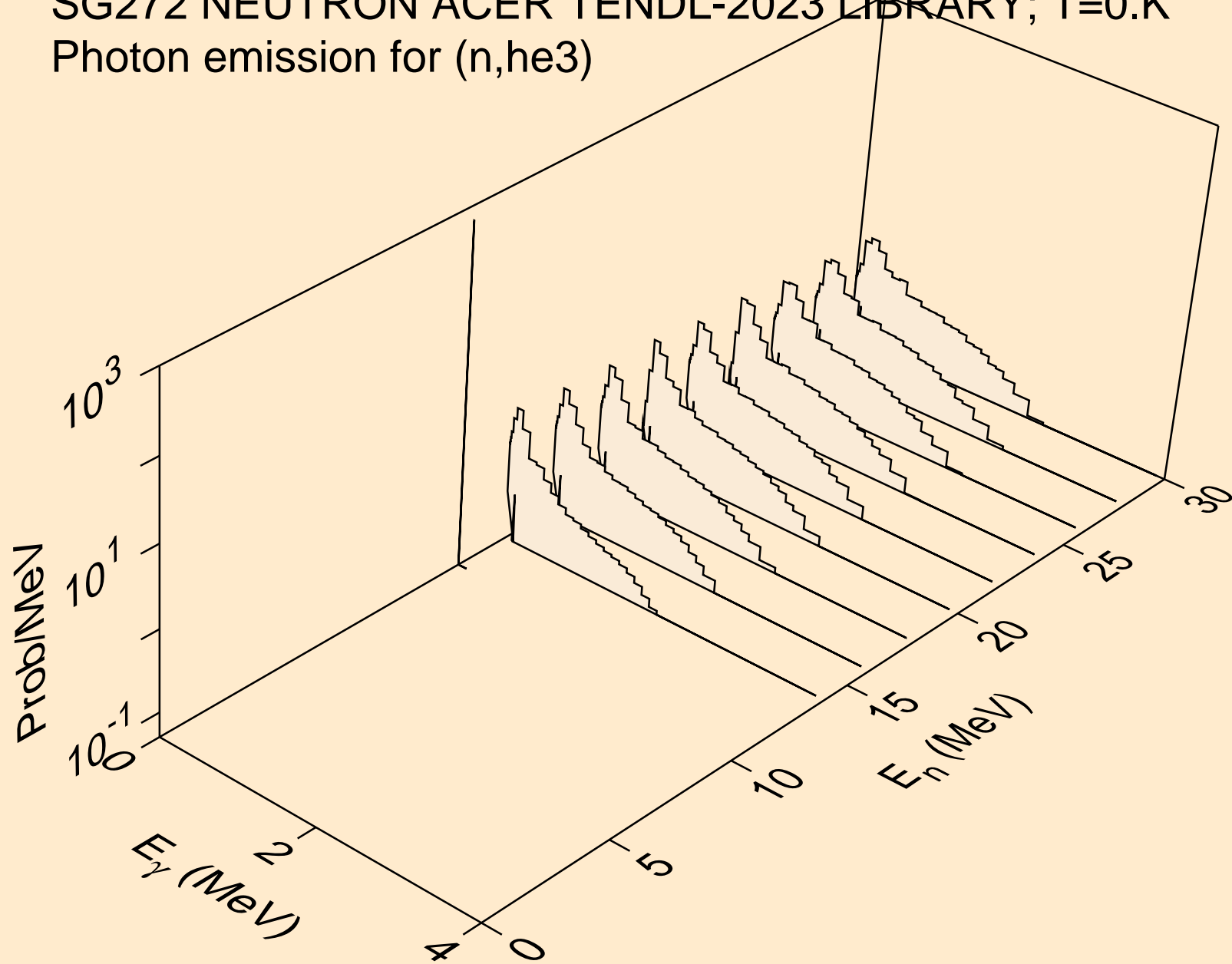

SG272 NEUTRON ACER TENDL-2023 LIBRARY; T=0.K  
Photon emission for (n,a)

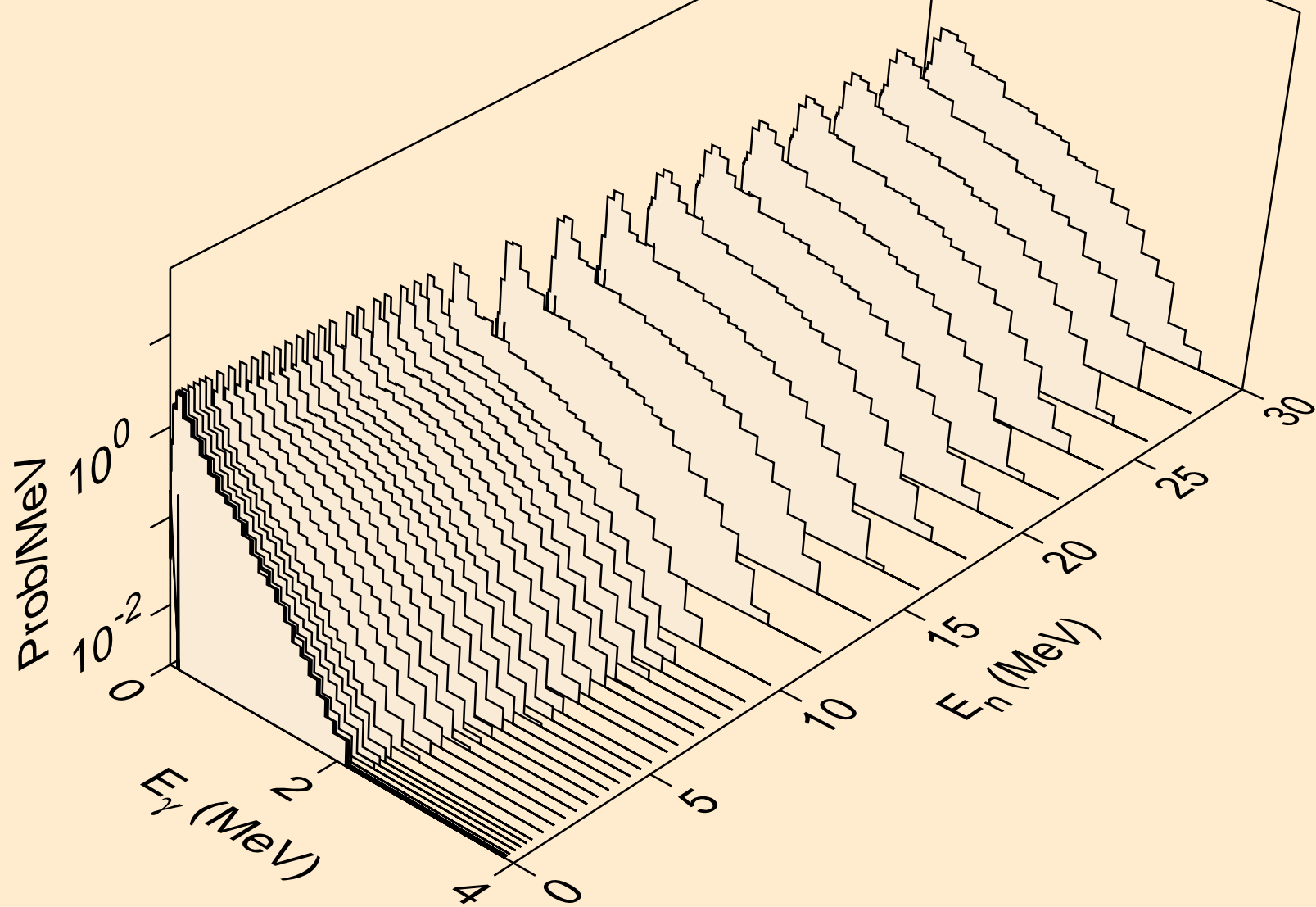



SG272 NEUTRON ACER TENDL-2023 LIBRARY; T=0.K  
Photon emission for (n,2p)

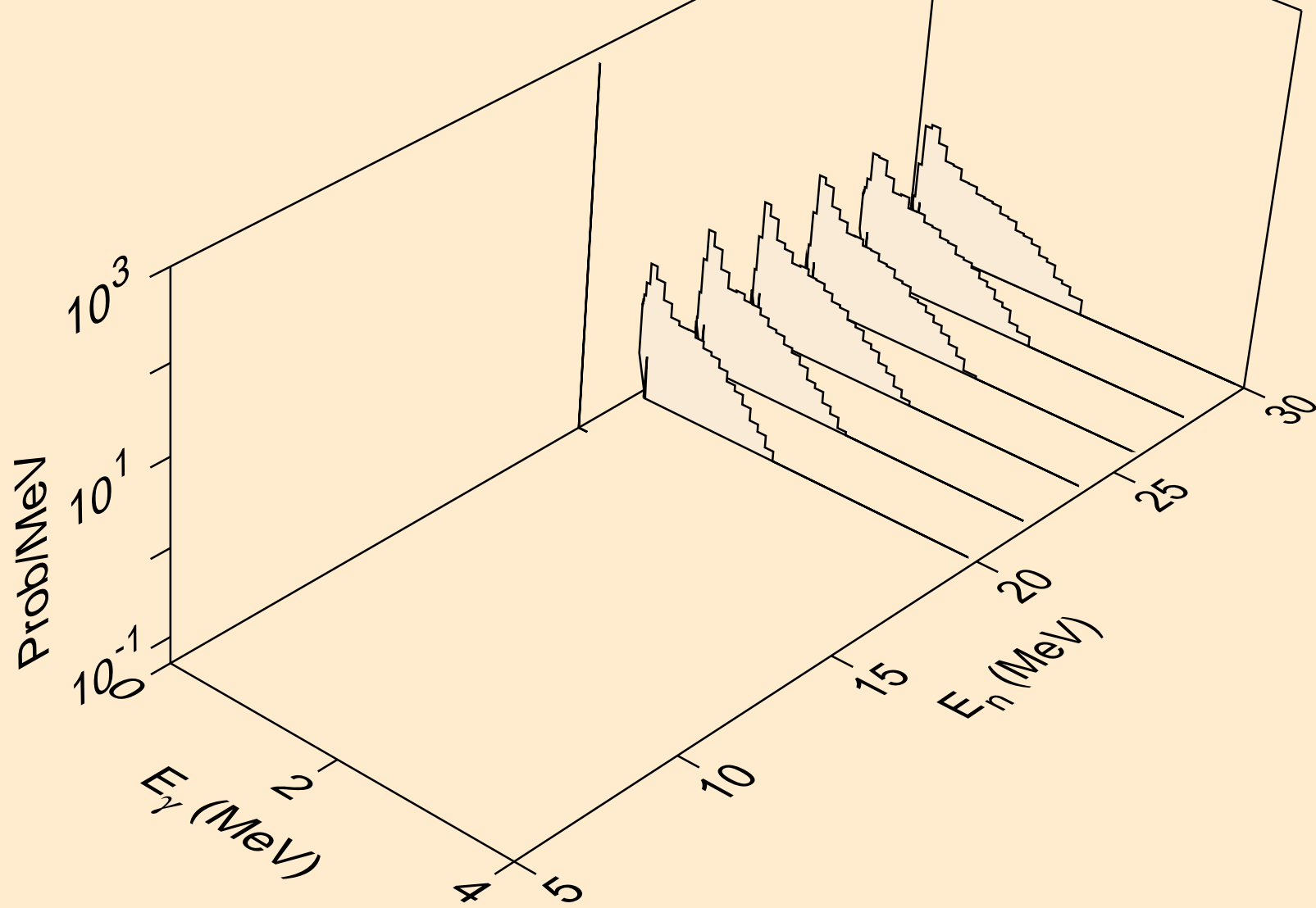

SG272 NEUTRON ACER TENDL-2023 LIBRARY; T=0.K  
thermal capture photon spectrum

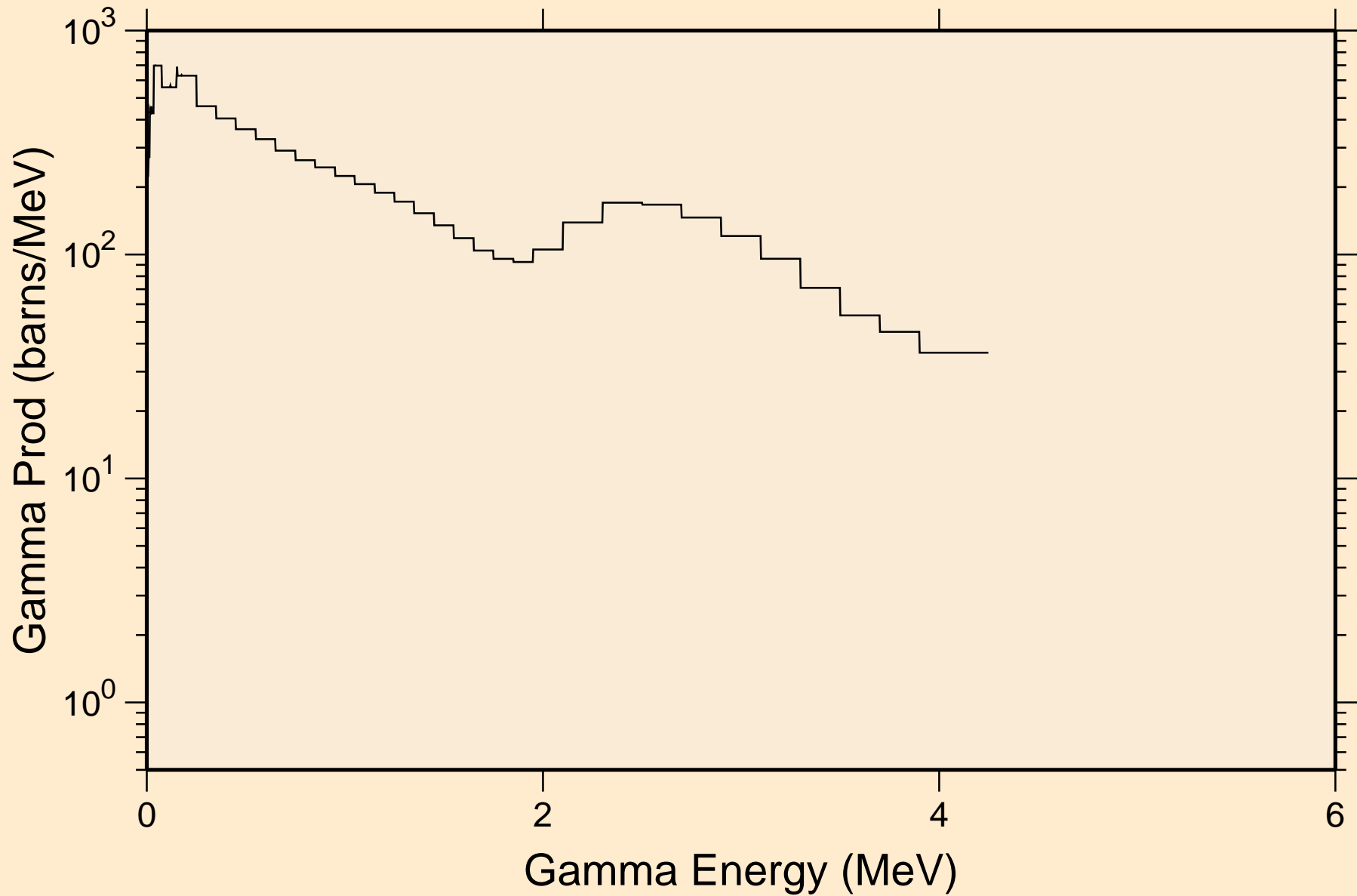

SG272 NEUTRON ACER TENDL-2023 LIBRARY; T=0.K  
14 MeV photon spectrum

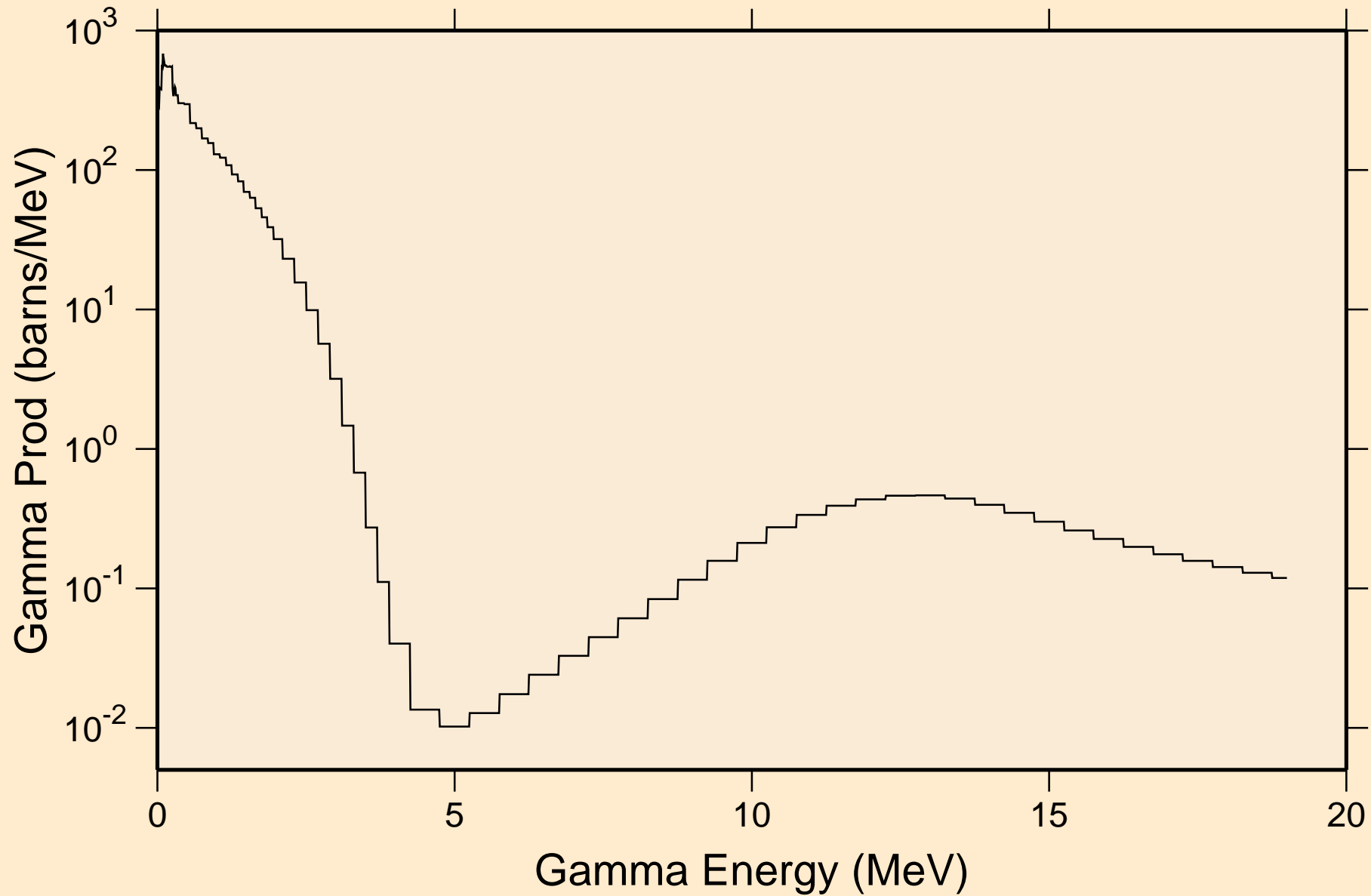

# SG272 NEUTRON ACER TENDL-2023 LIBRARY; T=0.K

## Particle heating contributions

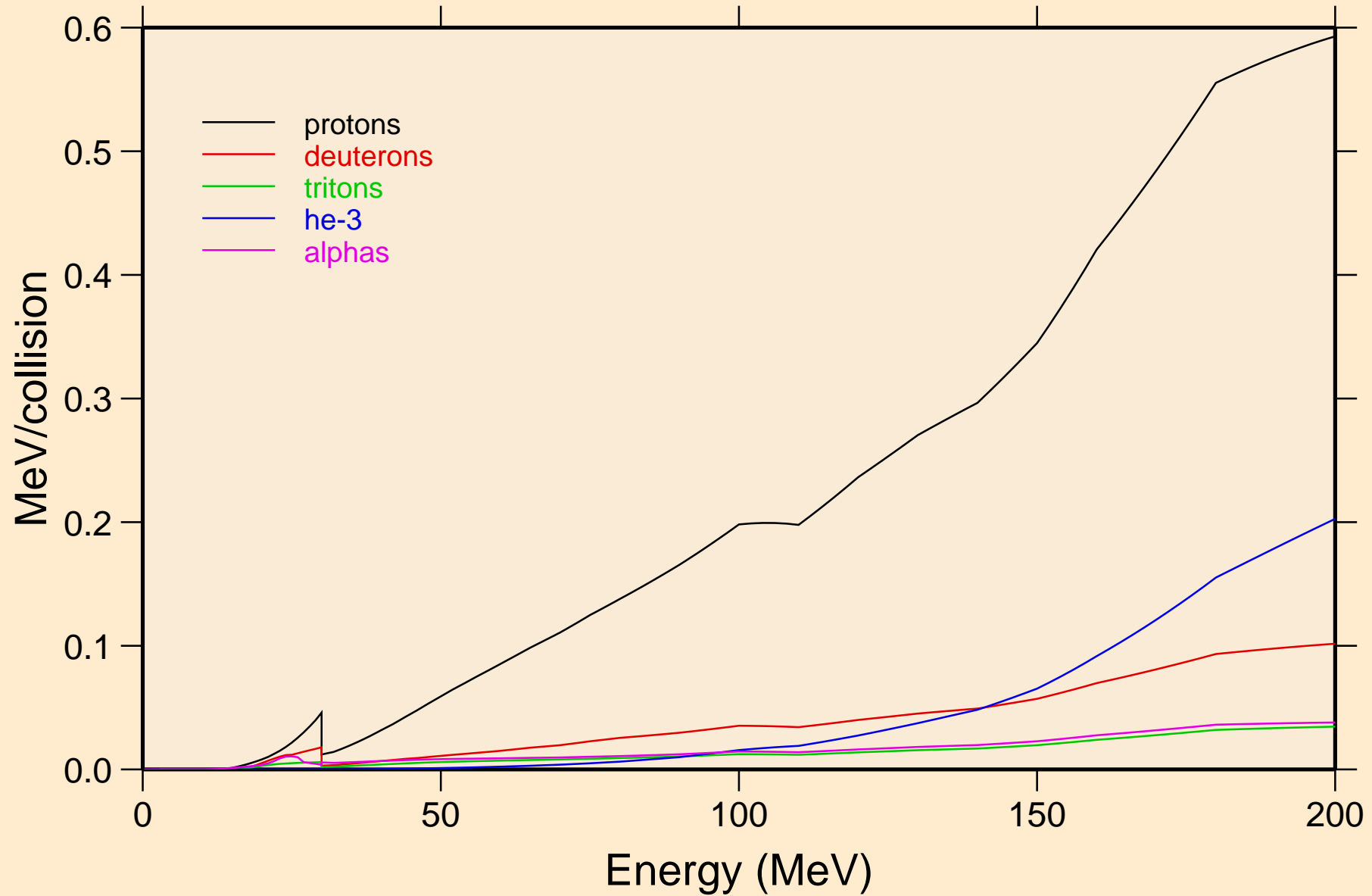

# SG272 NEUTRON ACER TENDL-2023 LIBRARY; T=0.K

## Recoil Heating

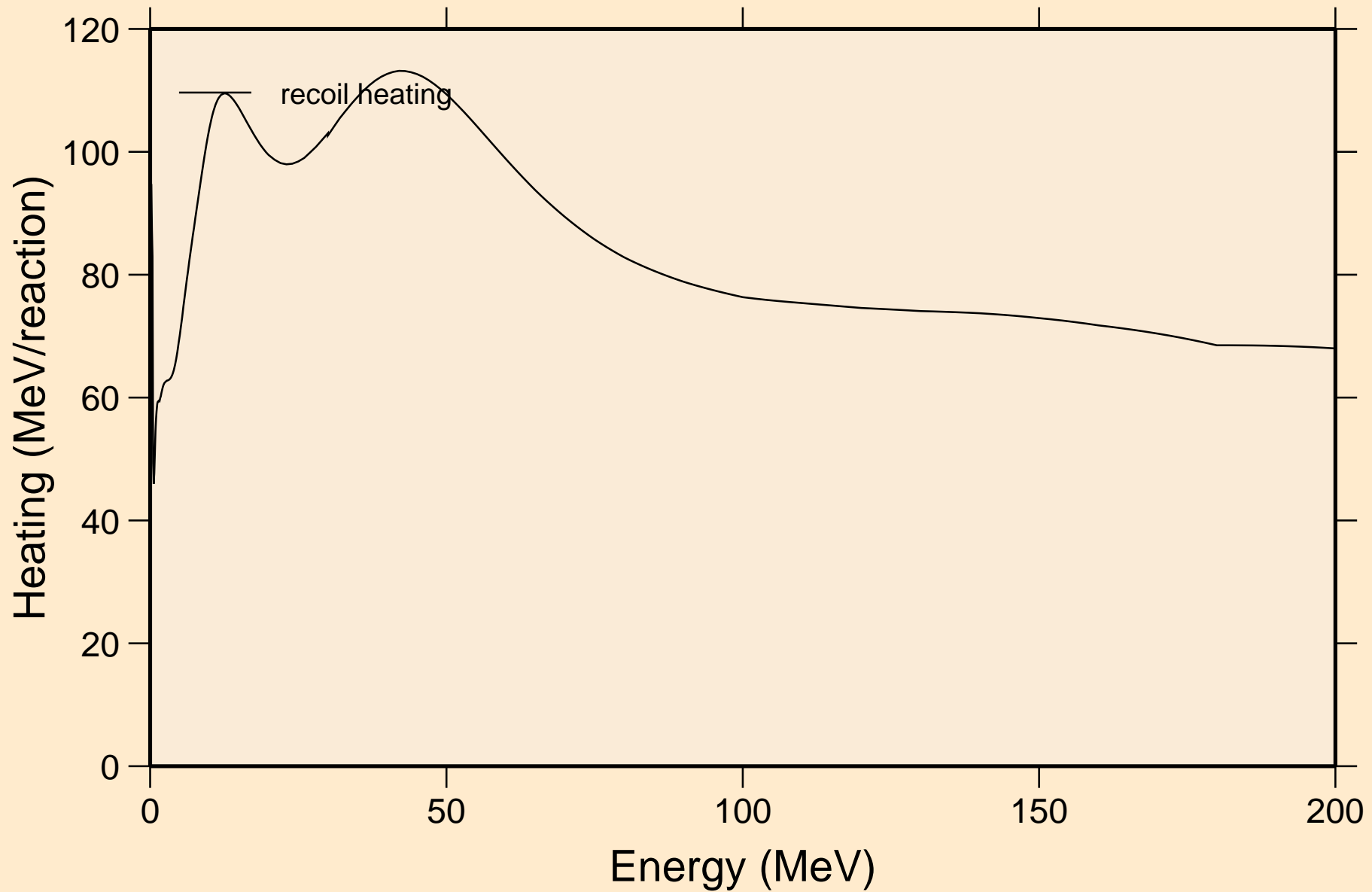

# SG272 NEUTRON ACER TENDL-2023 LIBRARY; T=0.K

## Particle production cross sections

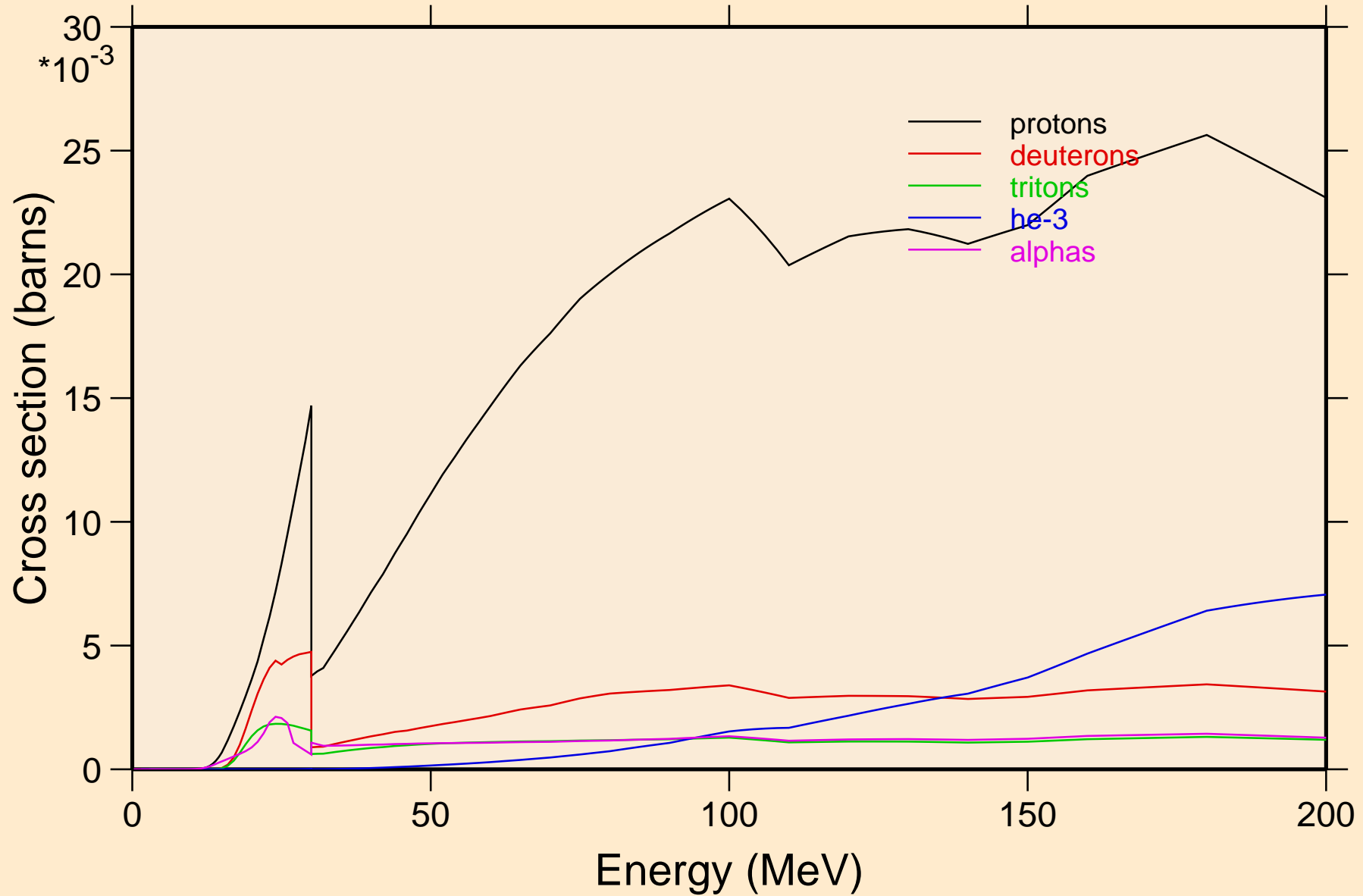

SG272 NEUTRON ACER TENDL-2023 LIBRARY; T=0.K  
protons from (n,x)

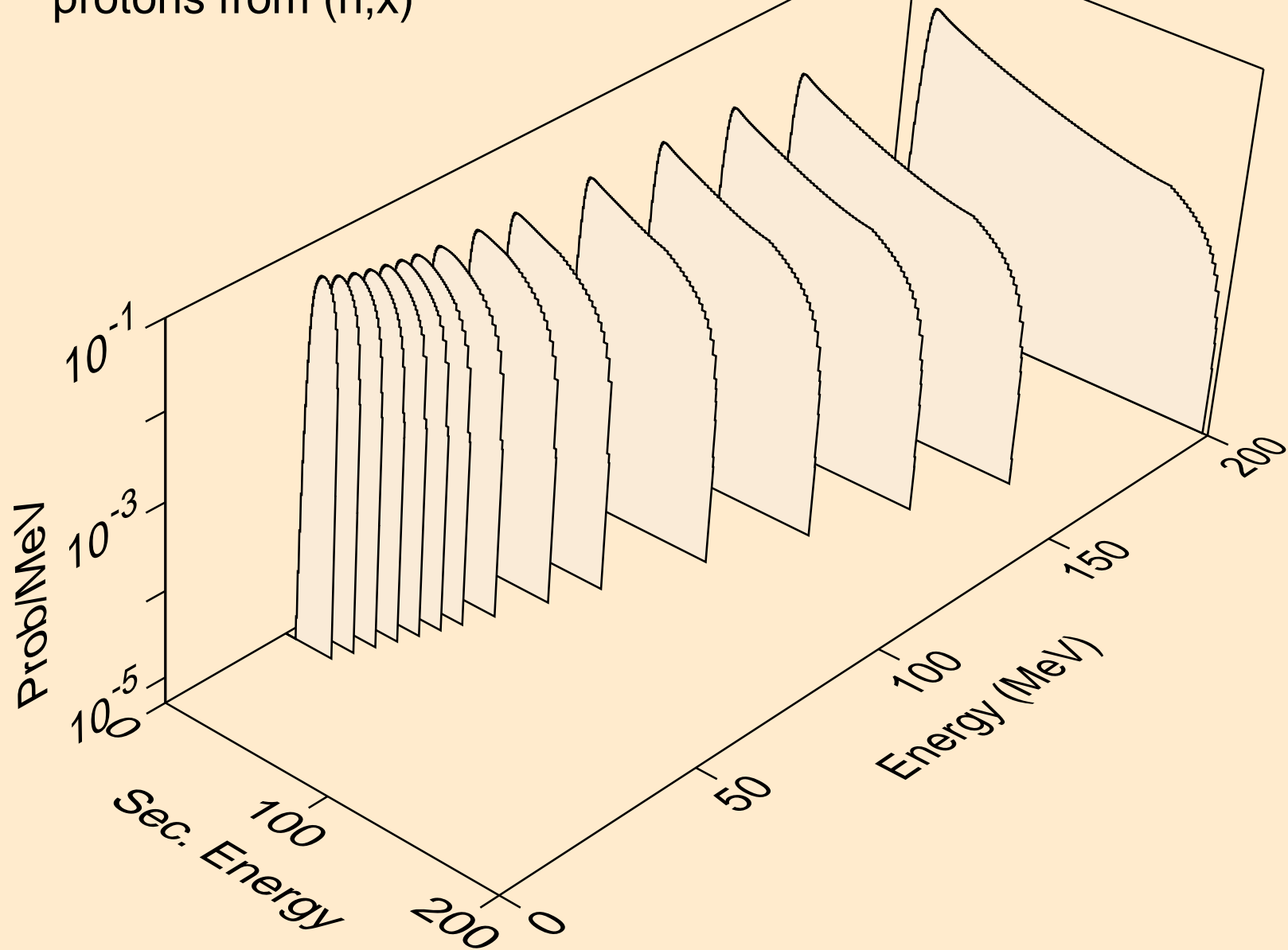

SG272 NEUTRON ACER TENDL-2023 LIBRARY; T=0.K  
protons from (n,n\*)p

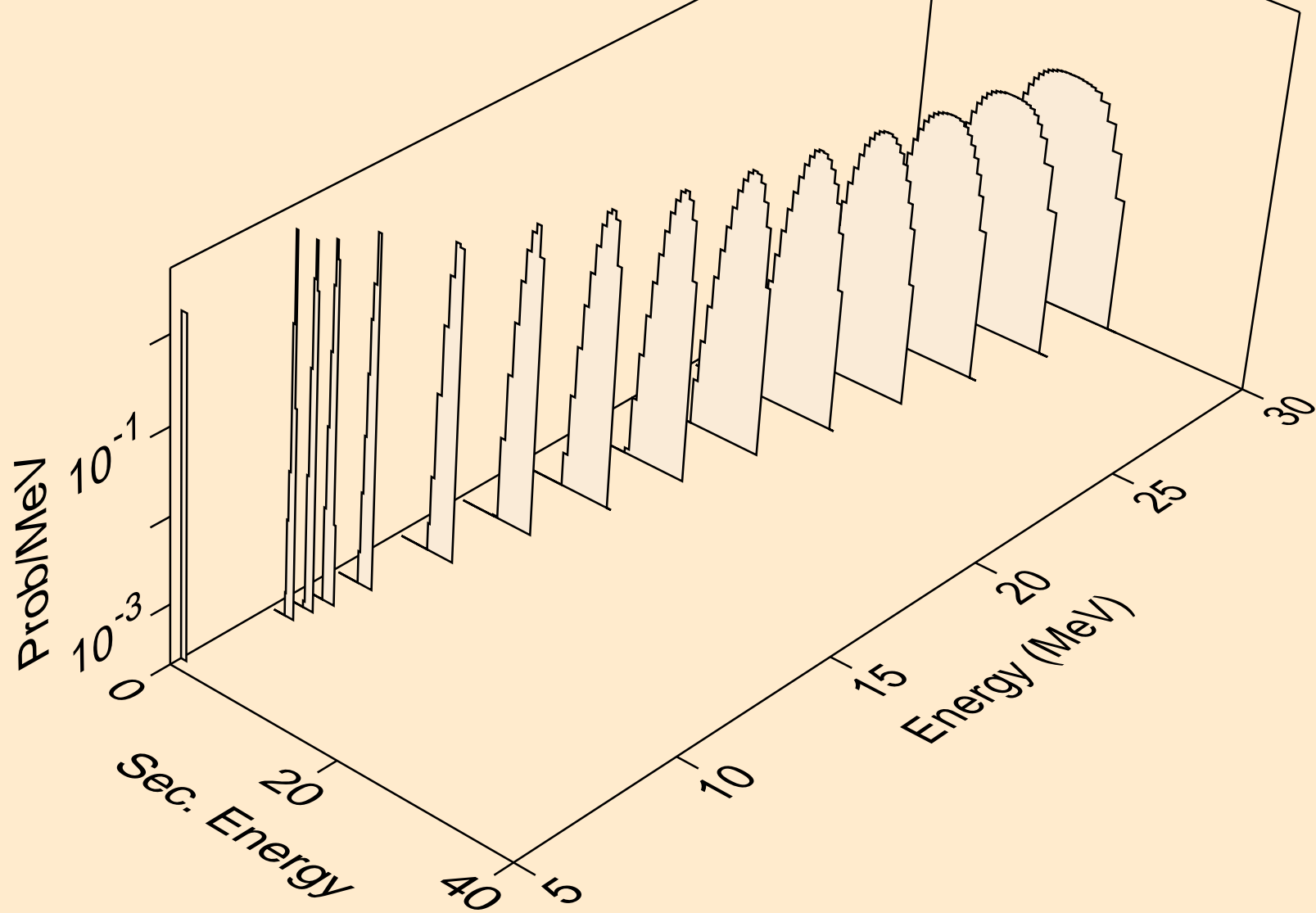



SG272 NEUTRON ACER TENDL-2023 LIBRARY; T=0.K  
protons from (n,2np)

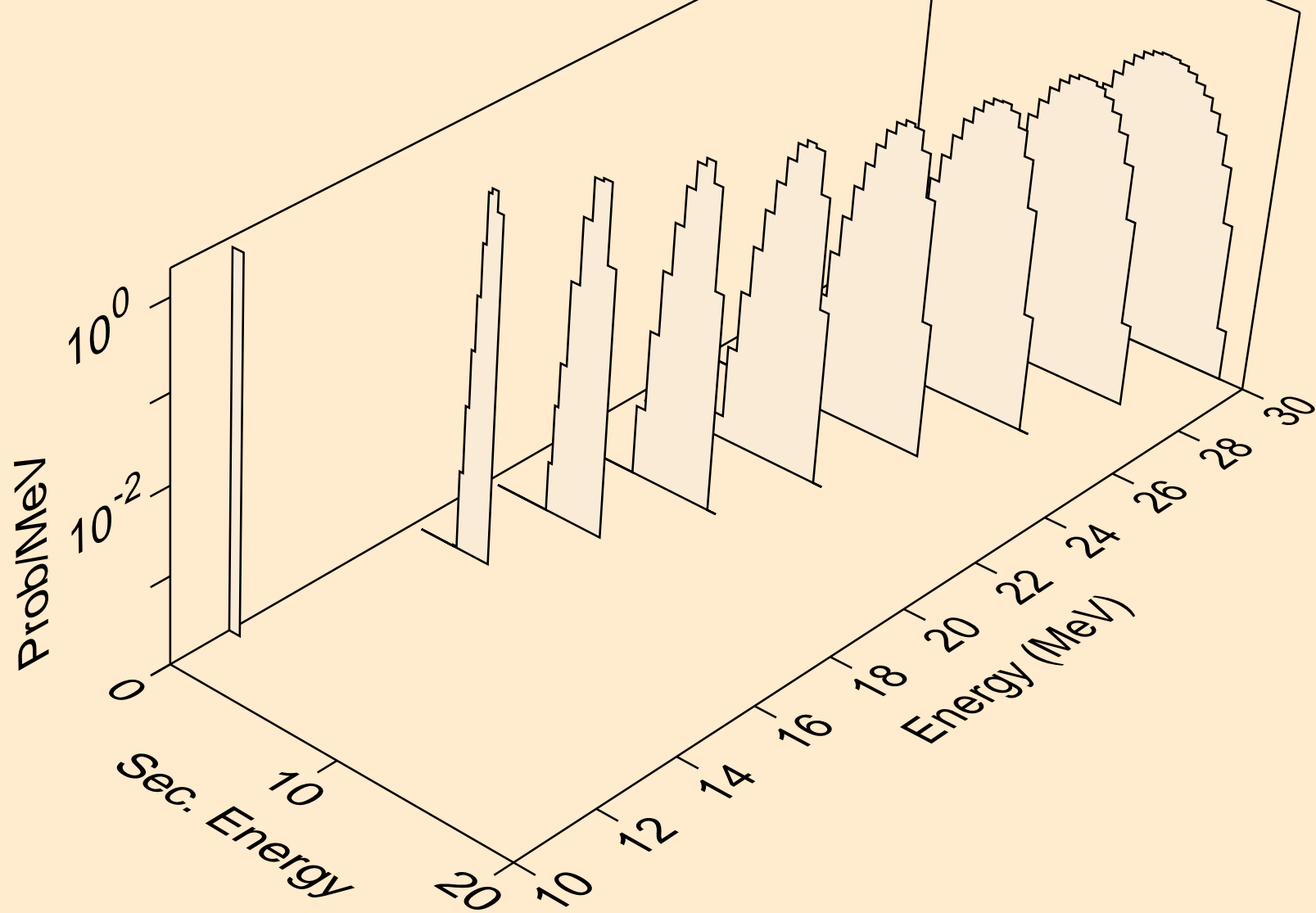

SG272 NEUTRON ACER TENDL-2023 LIBRARY; T=0.K  
protons from (n,3np)

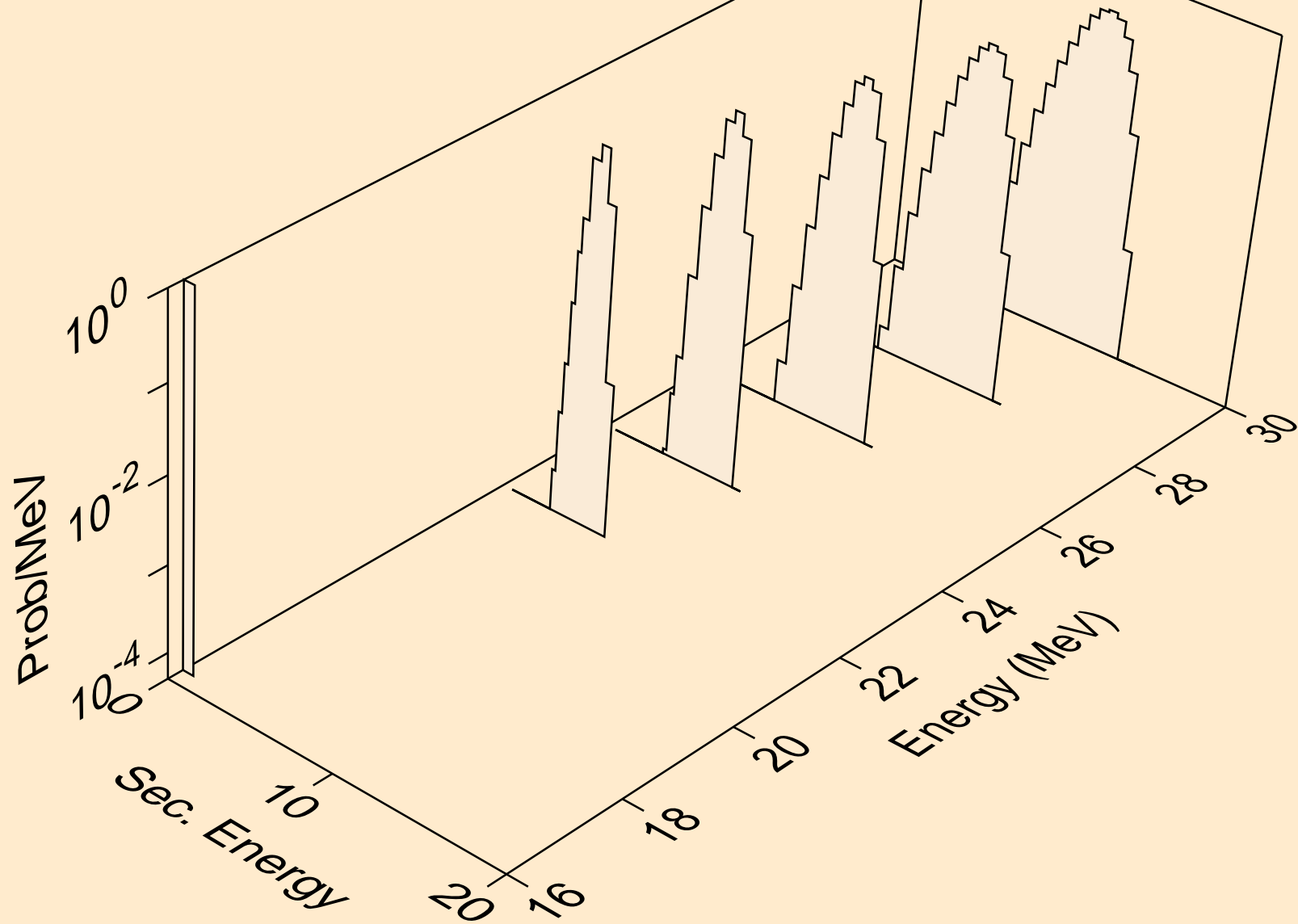

SG272 NEUTRON ACER TENDL-2023 LIBRARY; T=0.K  
protons from (n,p)

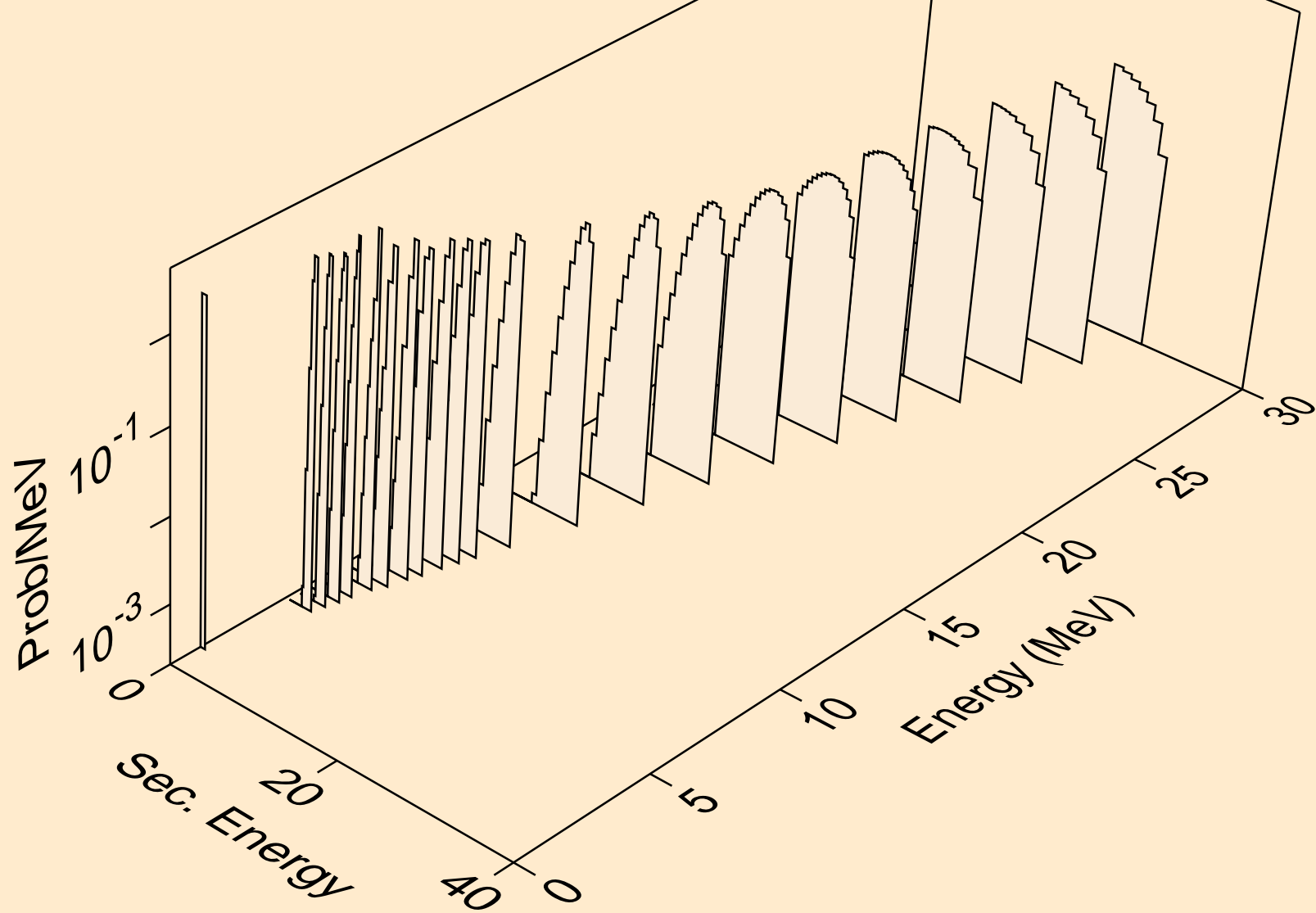

SG272 NEUTRON ACER TENDL-2023 LIBRARY; T=0.K  
protons from (n,2p)

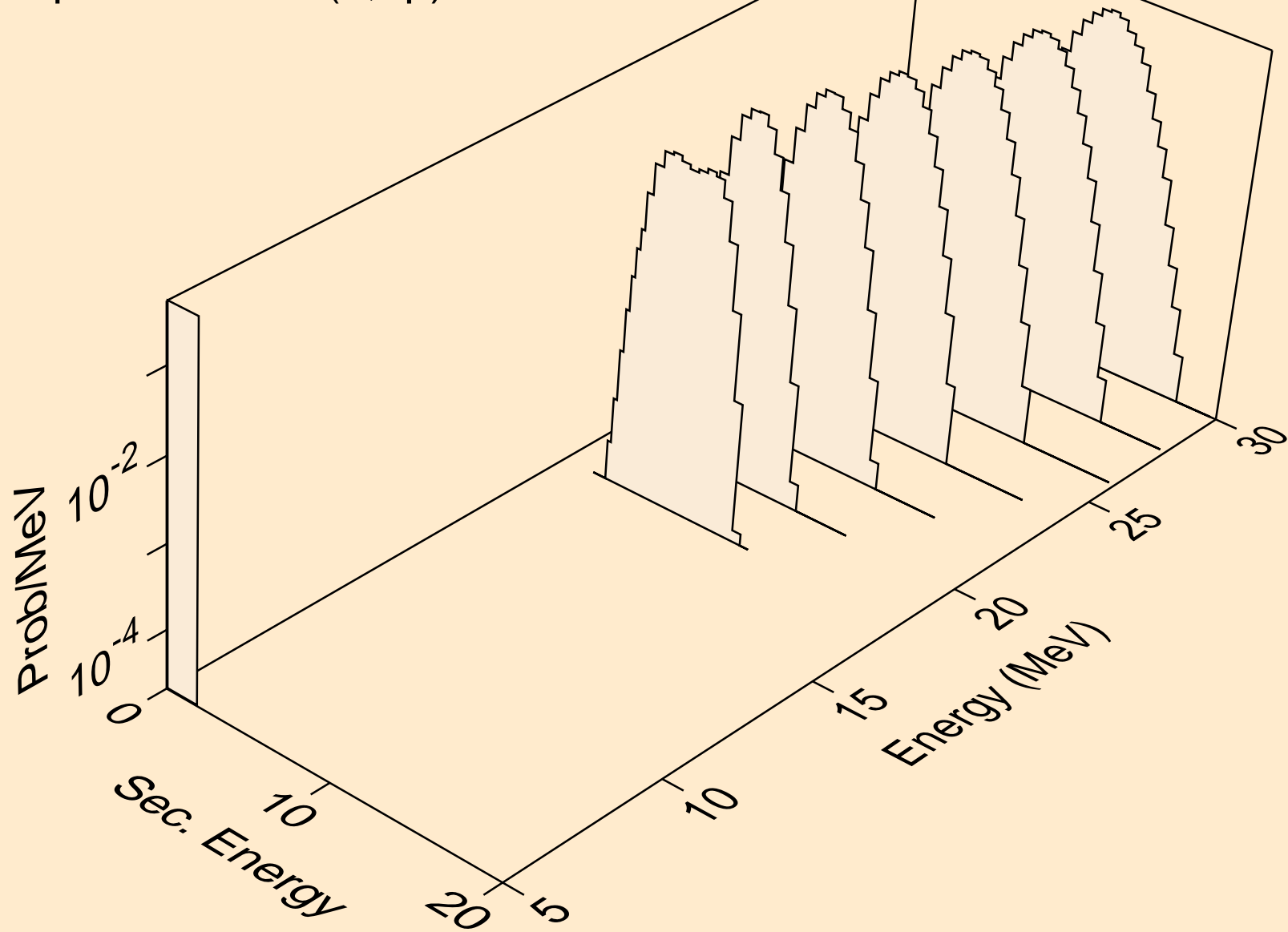

SG272 NEUTRON ACER TENDL-2023 LIBRARY; T=0.K  
deuterons from (n,x)

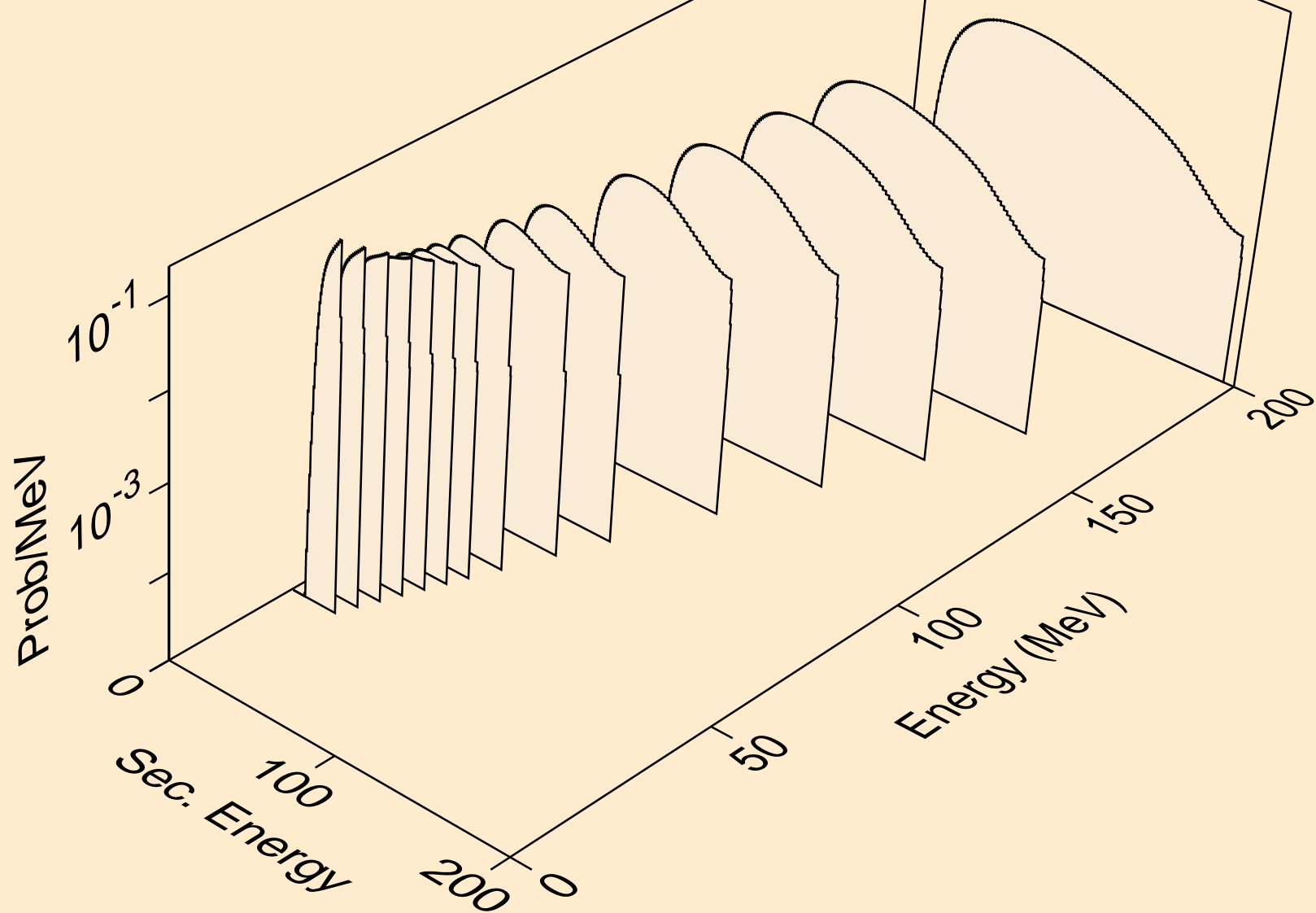

SG272 NEUTRON ACER TENDL-2023 LIBRARY; T=0.K  
deuterons from (n,2nd)

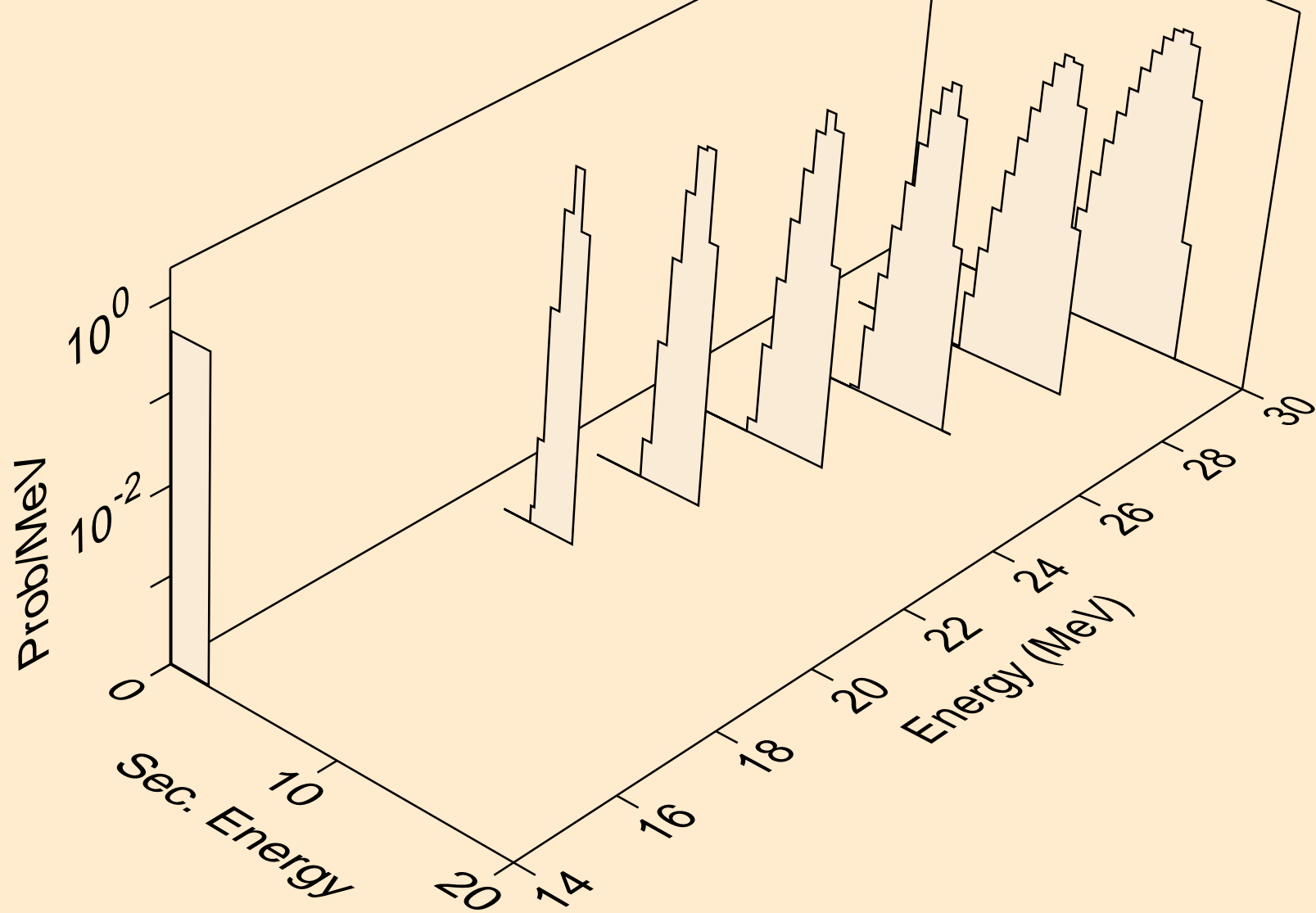

SG272 NEUTRON ACER TENDL-2023 LIBRARY; T=0.K  
deuterons from (n,n\*)d

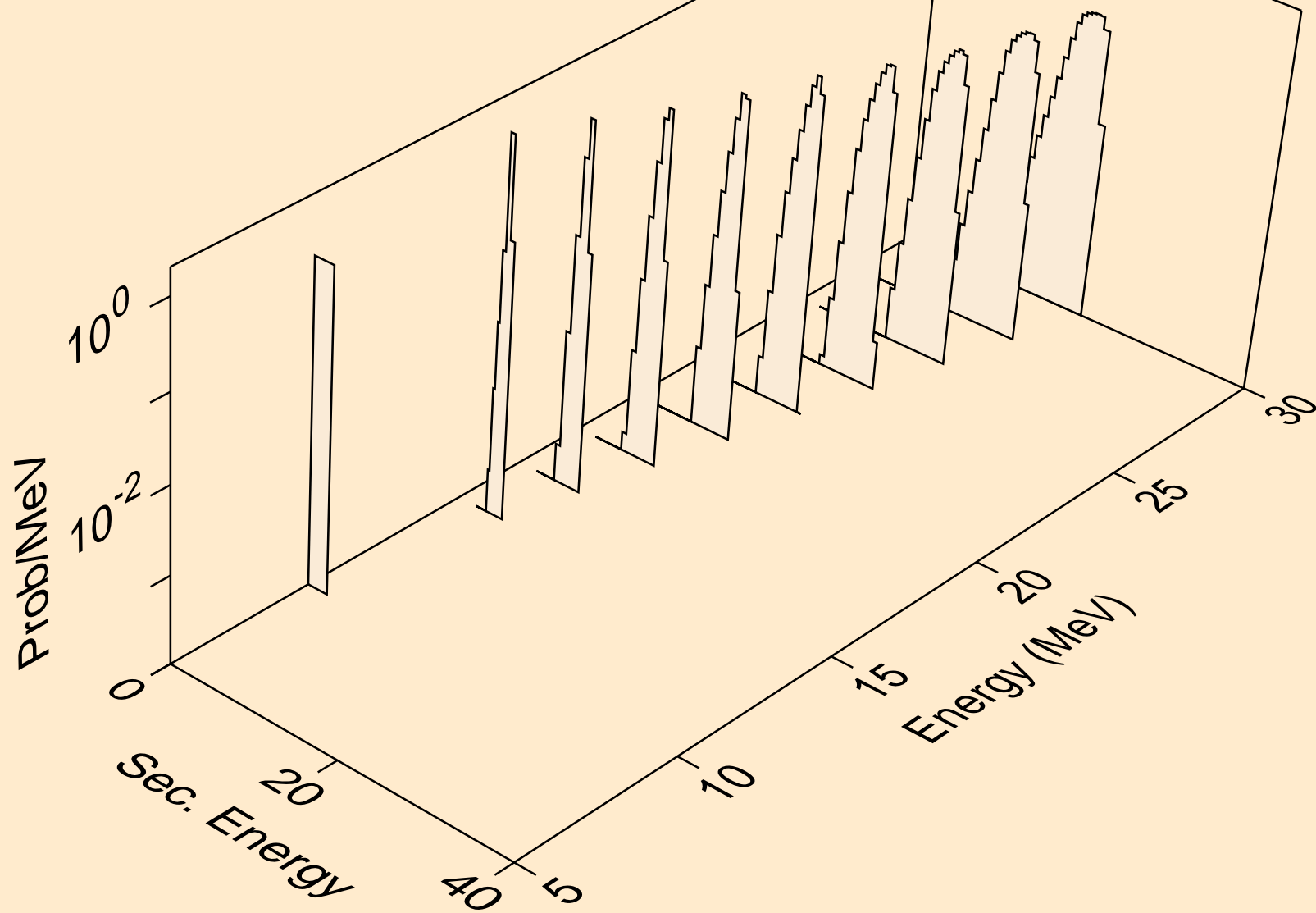

SG272 NEUTRON ACER TENDL-2023 LIBRARY; T=0.K  
deuterons from (n,d)

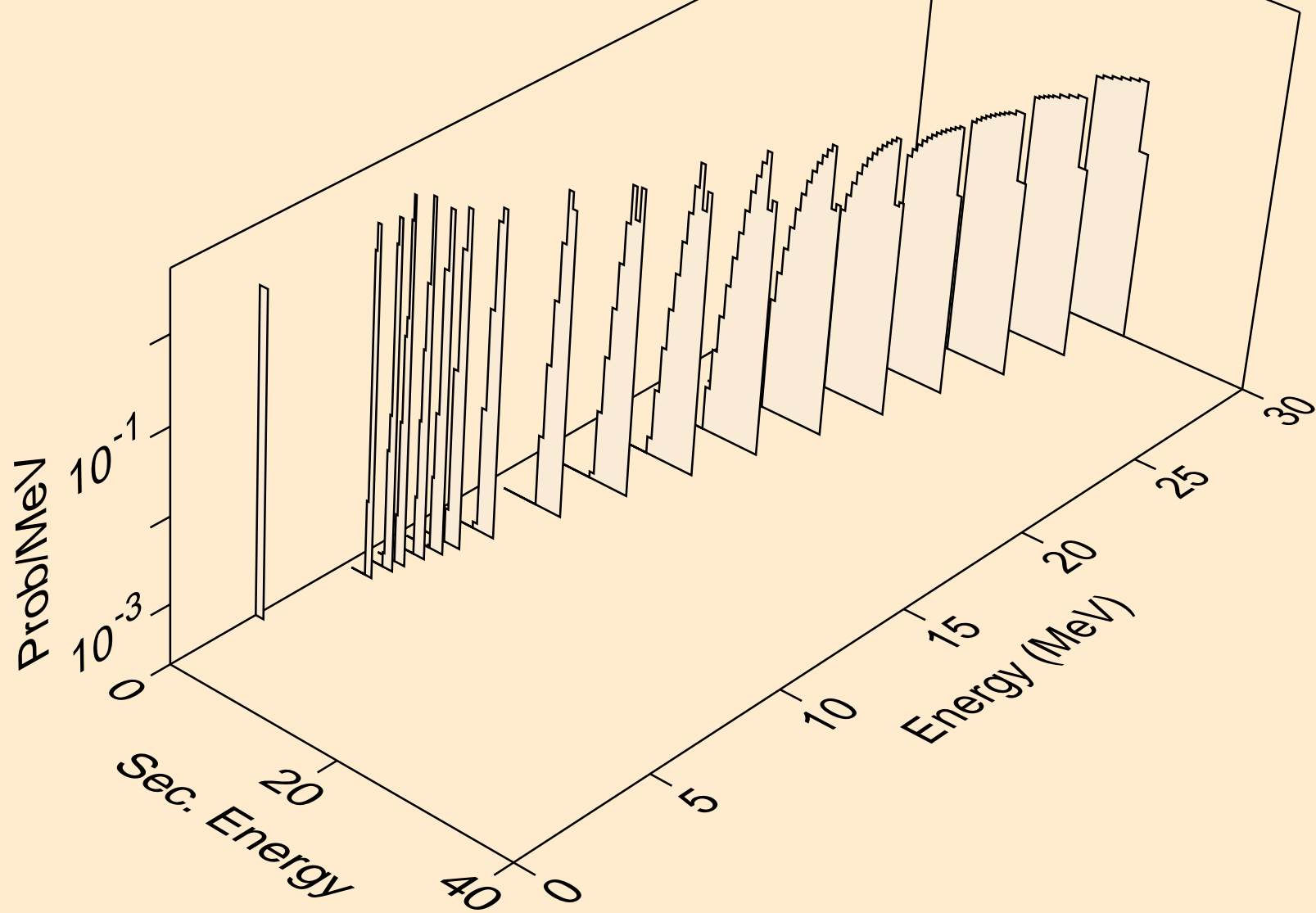



SG272 NEUTRON ACER TENDL-2023 LIBRARY; T=0.K  
tritons from (n,x)

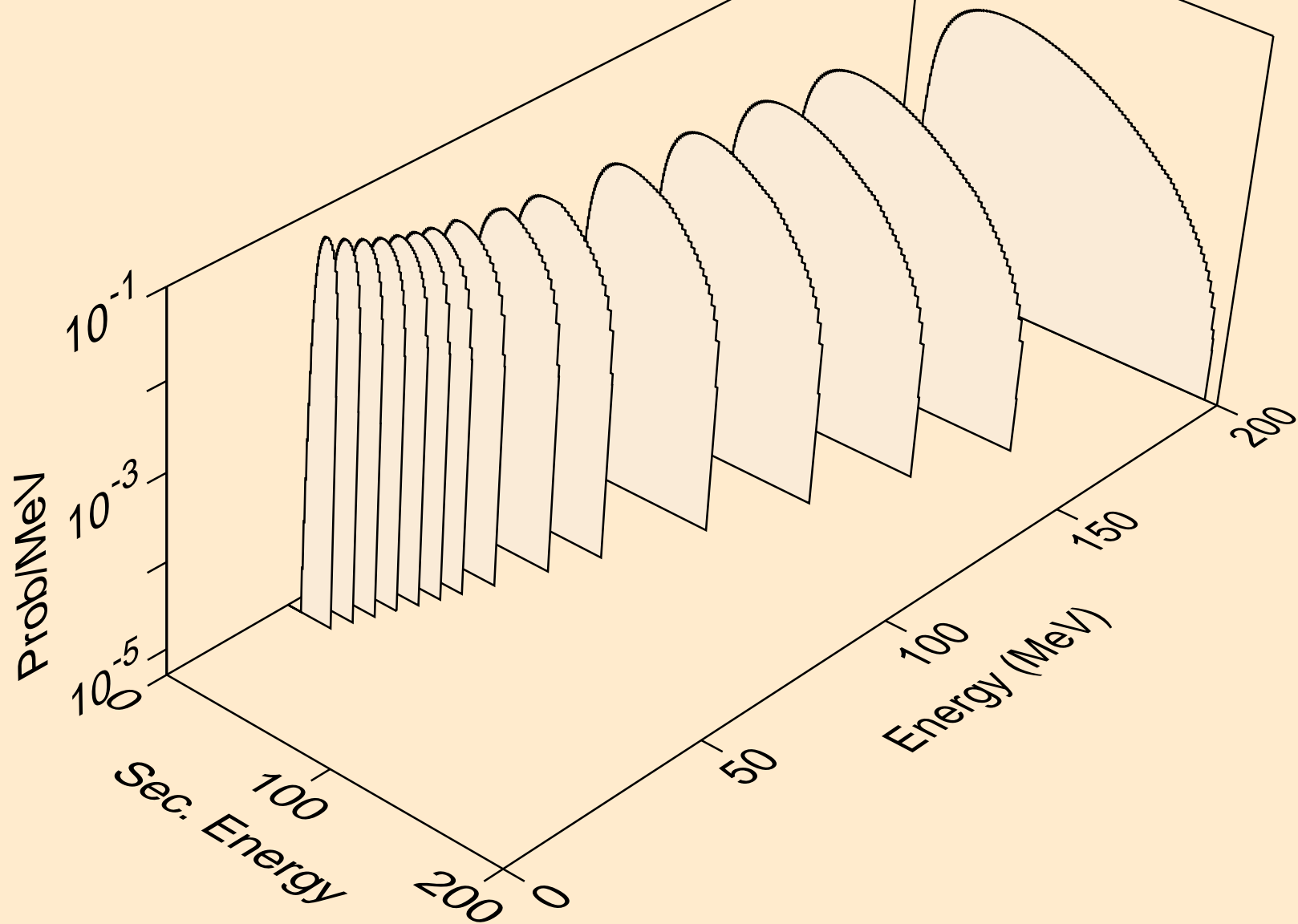

SG272 NEUTRON ACER TENDL-2023 LIBRARY; T=0.K  
tritons from (n,n\*)t

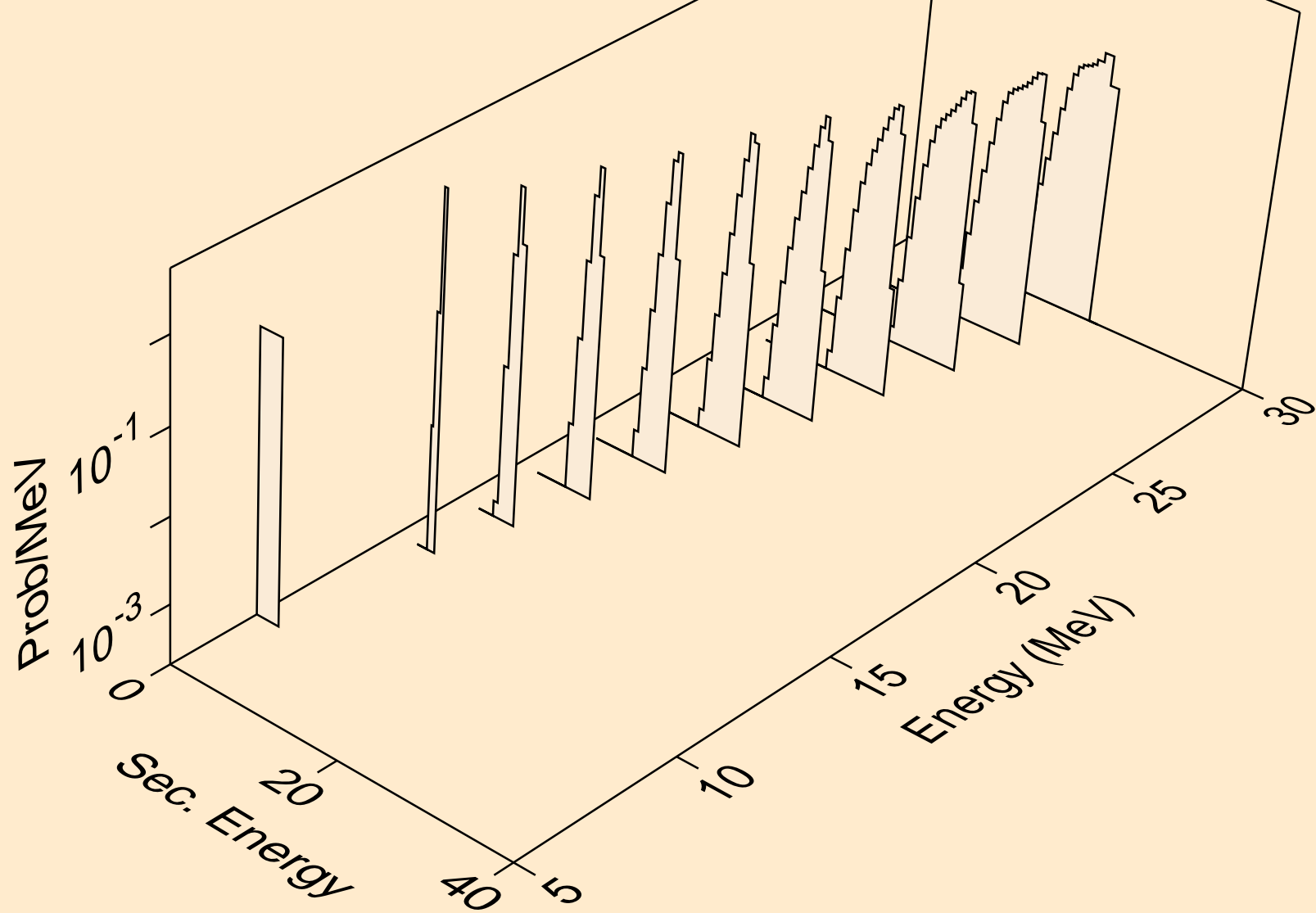

SG272 NEUTRON ACER TENDL-2023 LIBRARY; T=0.K  
tritons from (n,t)

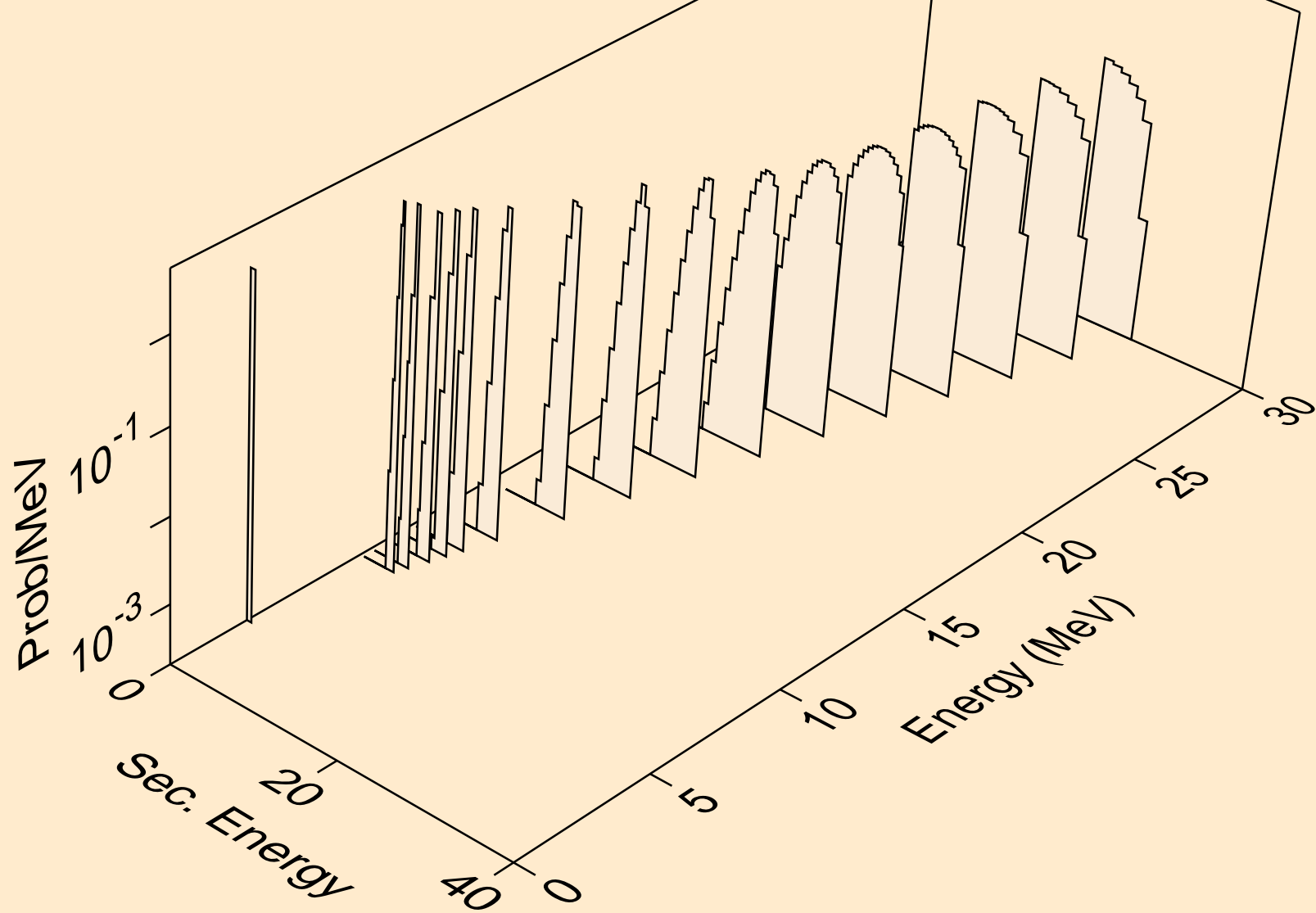

SG272 NEUTRON ACER TENDL-2023 LIBRARY; T=0.K  
he3s from (n,x)

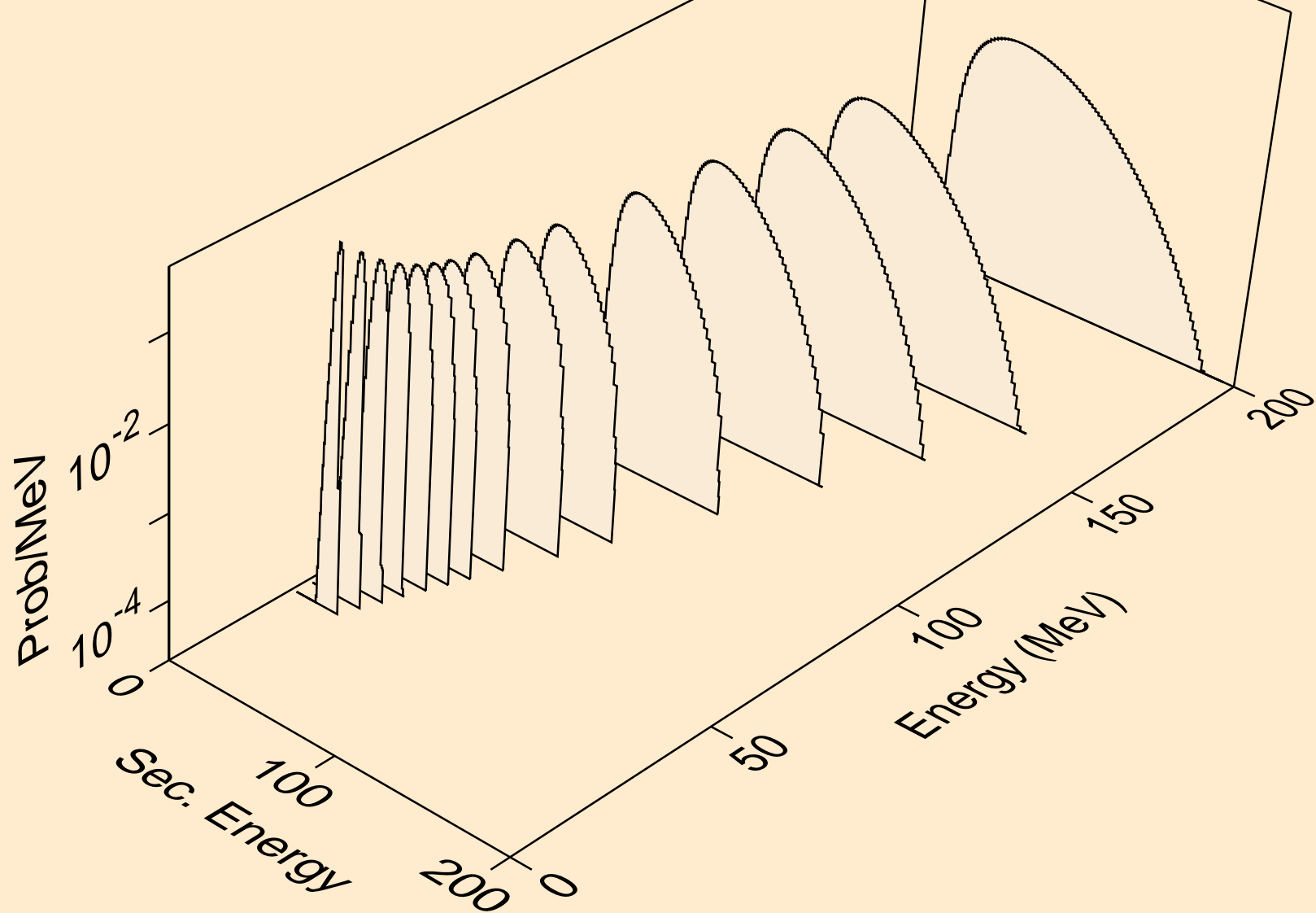

SG272 NEUTRON ACER TENDL-2023 LIBRARY; T=0.K  
he3s from (n,n\*)he3

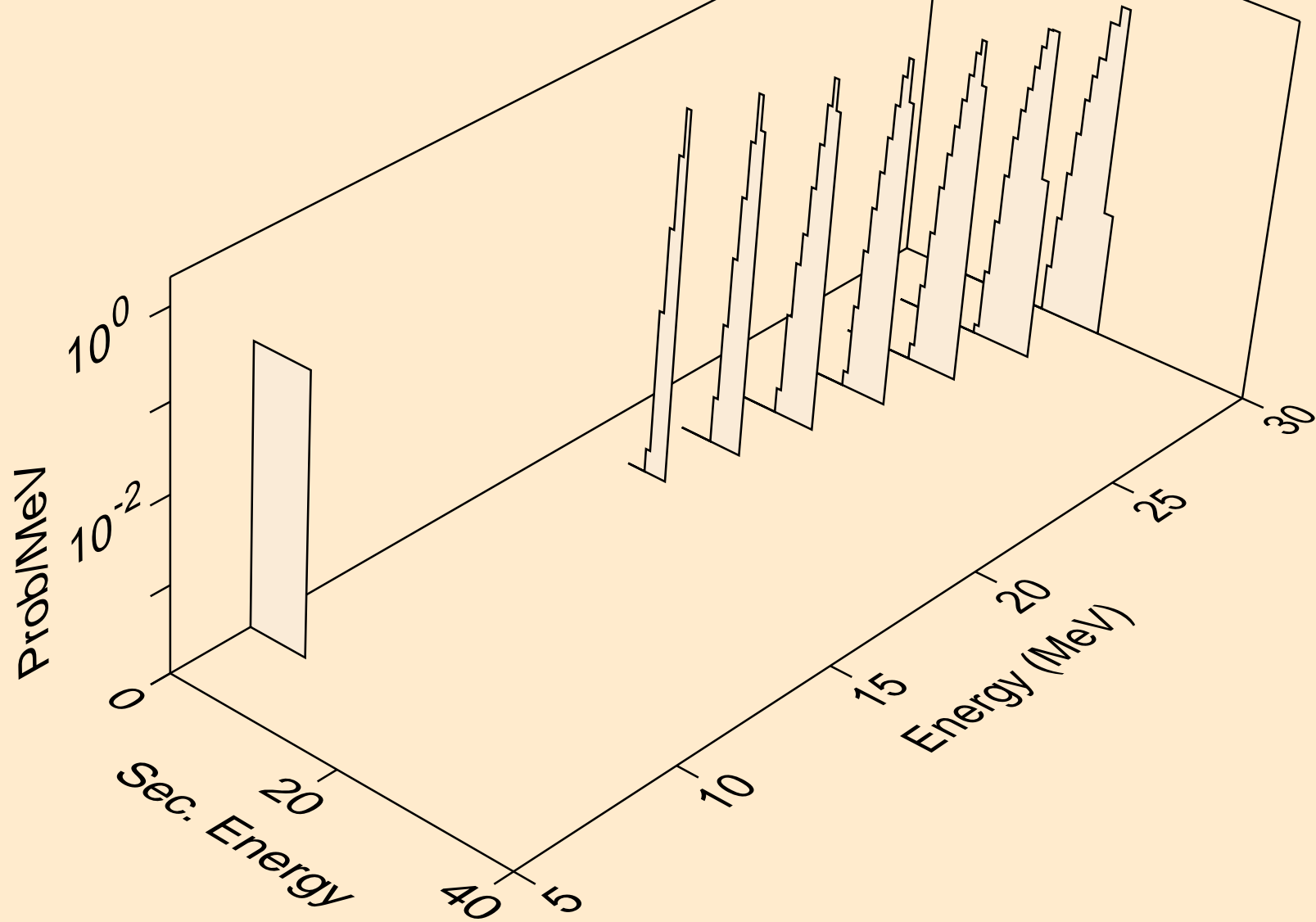

SG272 NEUTRON ACER TENDL-2023 LIBRARY; T=0.K  
he3s from (n,he3)

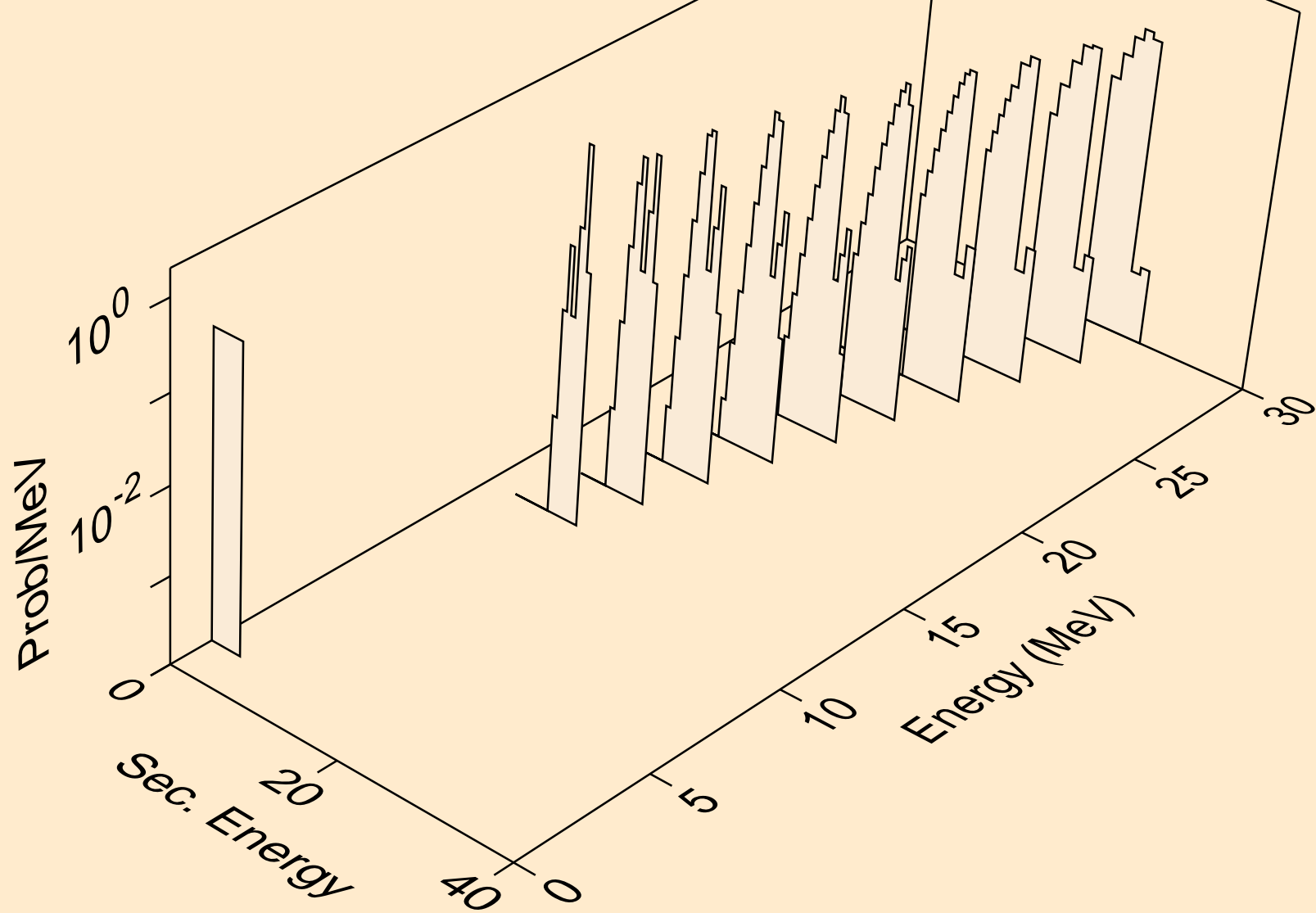

SG272 NEUTRON ACER TENDL-2023 LIBRARY; T=0.K  
alphas from (n,x)

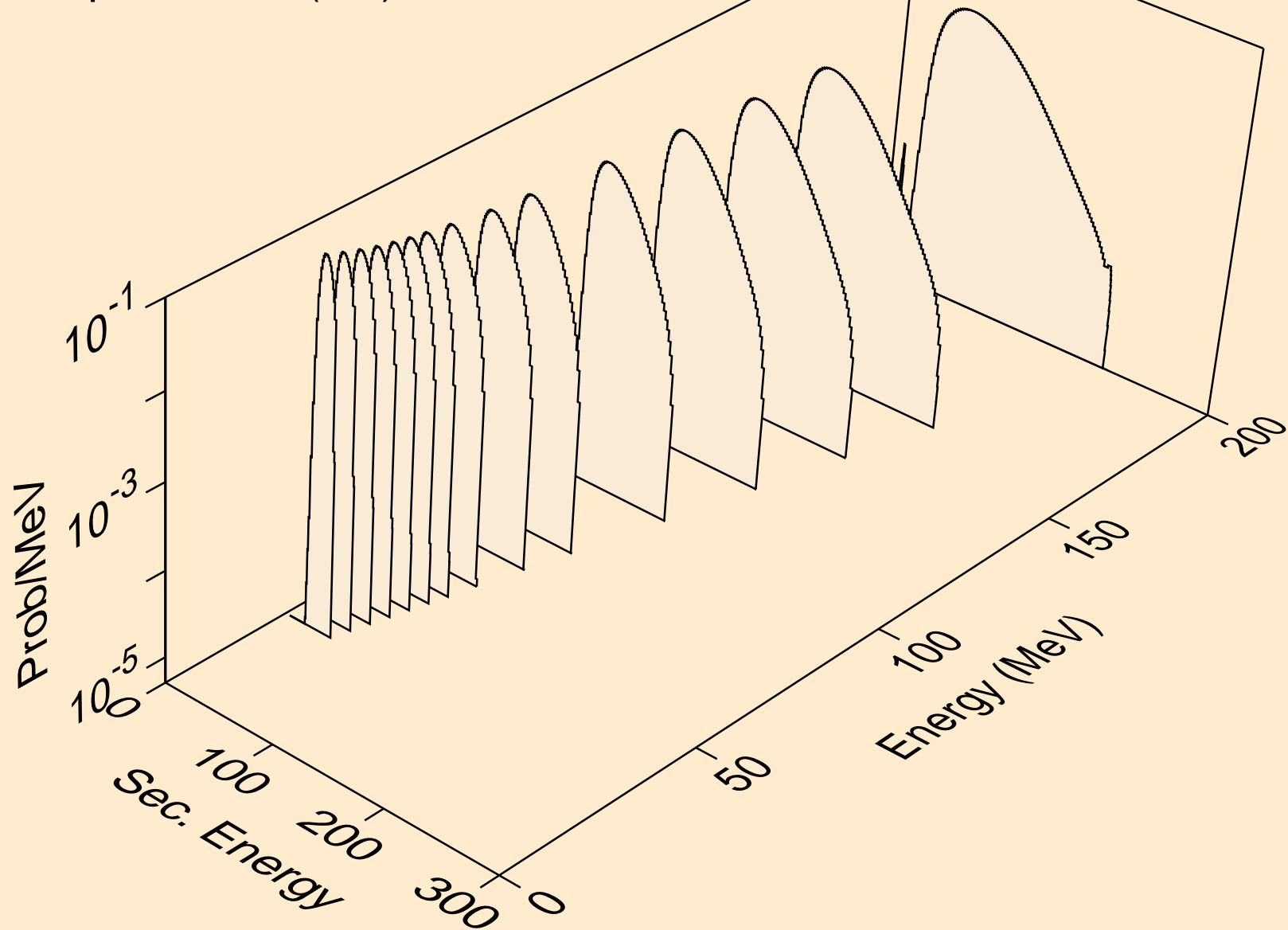

SG272 NEUTRON ACER TENDL-2023 LIBRARY; T=0.K  
alphas from (n,n\*)a

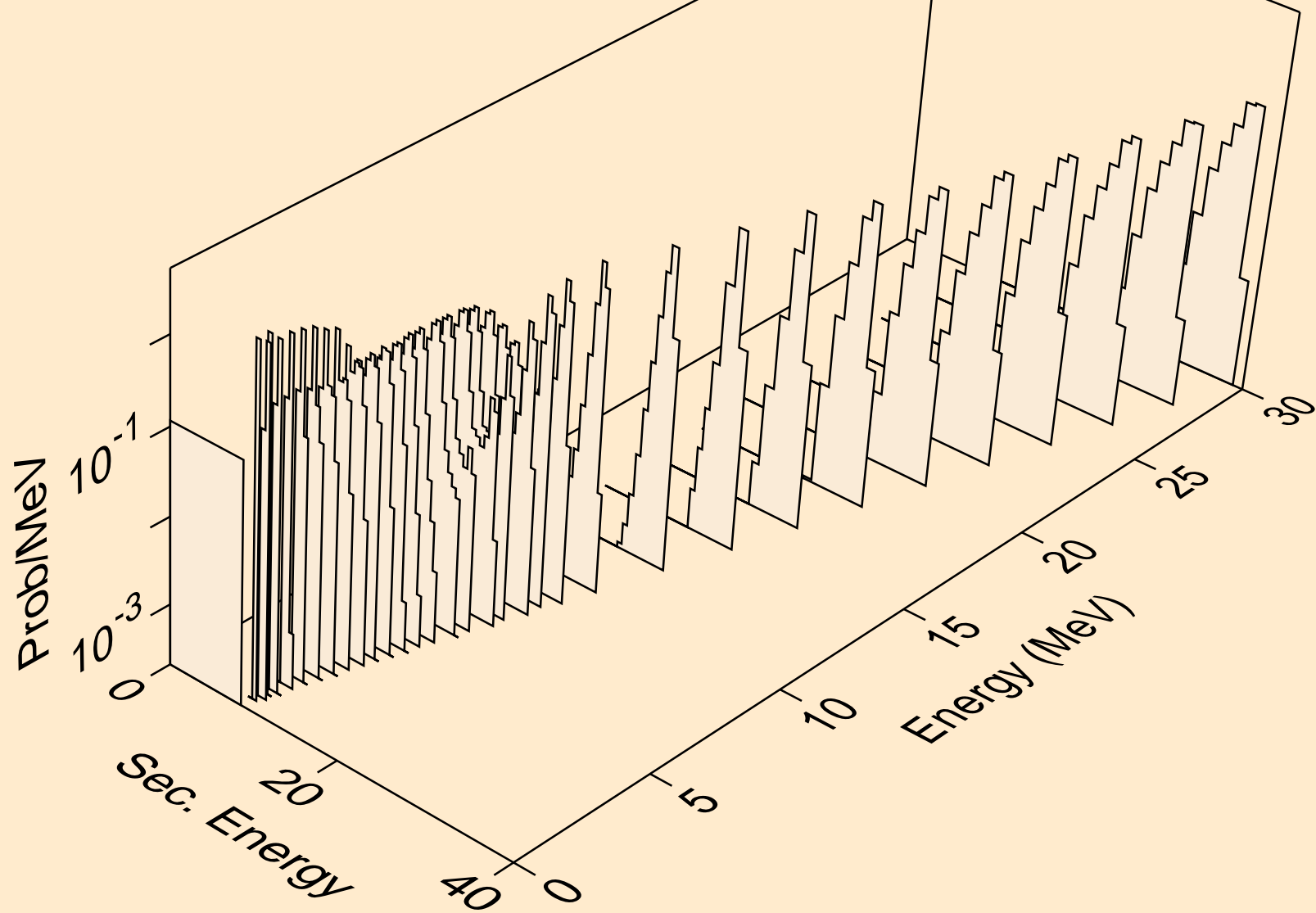



SG272 NEUTRON ACER TENDL-2023 LIBRARY; T=0.K  
alphas from (n,2n)a

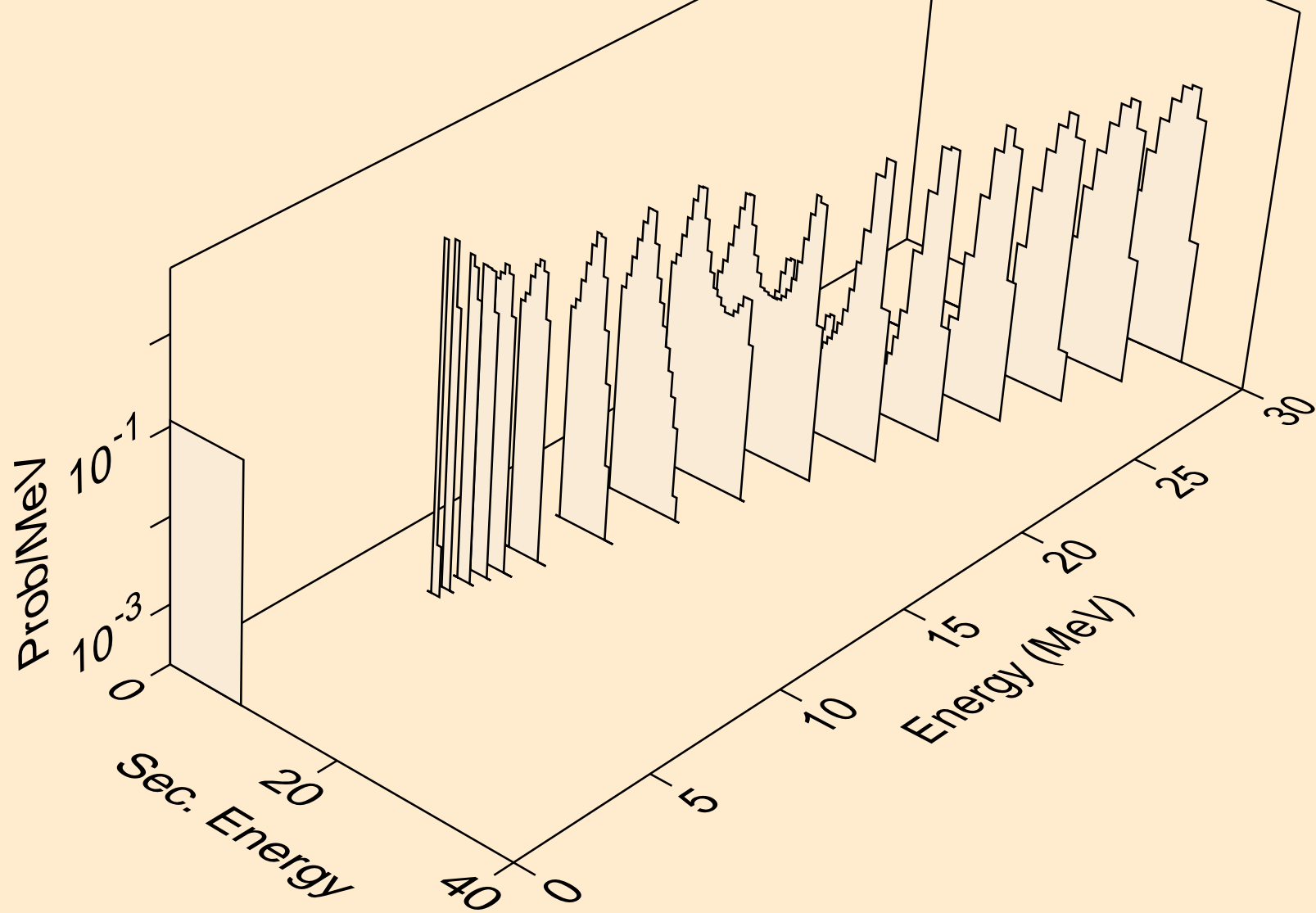

SG272 NEUTRON ACER TENDL-2023 LIBRARY; T=0.K  
alphas from (n,a)

